

# Priority Development Project (PDP) Storm Water Quality Management Plan (SWQMP)

Check if electing for offsite alternative compliance

Engineer of Work:



---

Provide Wet Signature and Stamp Above Line

Prepared For:

Prepared By:

**PASCO LARET SUITER**

**& ASSOCIATES**

CIVIL ENGINEERING + LAND PLANNING + LAND SURVEYING

Date:

---

Approved by: City of San Diego

Date



**THIS PAGE INTENTIONALLY LEFT BLANK FOR DOUBLE-SIDED PRINTING**



Project Name:

## Table of Contents

- Acronyms
- Certification Page
- Submittal Record
- Project Vicinity Map
- FORM DS-560: Storm Water Applicability Checklist
- FORM I-1: Applicability of Permanent, Post-Construction Storm Water BMP Requirements
- HMP Exemption Exhibit (for all hydromodification management exempt projects)
- FORM I-3B: Site Information Checklist for PDPs
- FORM I-4B: Source Control BMP Checklist for PDPs
- FORM I-5B: Site Design BMP Checklist PDPs
- FORM I-6: Summary of PDP Structural BMPs
- Attachment 1: Backup for PDP Pollutant Control BMPs
  - Attachment 1a: DMA Exhibit
  - Attachment 1b: Tabular Summary of DMAs (Worksheet B-1 from Appendix B) and Design Capture Volume Calculations
  - Attachment 1c: FORM I-7 : Worksheet B.3-1 Harvest and Use Feasibility Screening
  - Attachment 1d: Infiltration Feasibility Information(One or more of the following):
    - FORM I-8A: Worksheet C.4-1 Categorization of Infiltration Feasibility Condition based on Geotechnical Conditions
    - Form I-8B: Worksheet C.4-2 Categorization of Infiltration Feasibility Condition based on Groundwater and Water Balance Conditions
    - Infiltration Feasibility Condition Letter
    - Worksheet C.4-3: Infiltration and Groundwater Protection for Full Infiltration BMPs
    - FORM I-9: Worksheet D.5-1 Factor of Safety and Design Infiltration Rate
  - Attachment 1e: Pollutant Control BMP Design Worksheets / Calculations
- Attachment 2: Backup for PDP Hydromodification Control Measures
  - Attachment 2a: Hydromodification Management Exhibit
  - Attachment 2b: Management of Critical Coarse Sediment Yield Areas
  - Attachment 2c: Geomorphic Assessment of Receiving Channels
  - Attachment 2d: Flow Control Facility Design

**Project Name:**

- Attachment 3: Structural BMP Maintenance Plan
  - Maintenance Agreement (Form DS-3247) (when applicable)
- Attachment 4: Copy of Plan Sheets Showing Permanent Storm Water BMPs
- Attachment 5: Project's Drainage Report
- Attachment 6: Project's Geotechnical and Groundwater Investigation Report

Project Name:

## Acronyms

APN	Assessor's Parcel Number
ASBS	Area of Special Biological Significance
BMP	Best Management Practice
CEQA	California Environmental Quality Act
CGP	Construction General Permit
DCV	Design Capture Volume
DMA	Drainage Management Areas
ESA	Environmentally Sensitive Area
GLU	Geomorphic Landscape Unit
GW	Ground Water
HMP	Hydromodification Management Plan
HSG	Hydrologic Soil Group
HU	Harvest and Use
INF	Infiltration
LID	Low Impact Development
LUP	Linear Underground/Overhead Projects
MS4	Municipal Separate Storm Sewer System
N/A	Not Applicable
NPDES	National Pollutant Discharge Elimination System
NRCS	Natural Resources Conservation Service
PDP	Priority Development Project
PE	Professional Engineer
POC	Pollutant of Concern
SC	Source Control
SD	Site Design
SDRWQCB	San Diego Regional Water Quality Control Board
SIC	Standard Industrial Classification
SWPPP	Stormwater Pollutant Protection Plan
SWQMP	Storm Water Quality Management Plan
TMDL	Total Maximum Daily Load
WMAA	Watershed Management Area Analysis
WPCP	Water Pollution Control Program
WQIP	Water Quality Improvement Plan

Project Name:

## Certification Page

### Project Name: Permit Application

I hereby declare that I am the Engineer in Responsible Charge of design of storm water BMPs for this project, and that I have exercised responsible charge over the design of the project as defined in Section 6703 of the Business and Professions Code, and that the design is consistent with the requirements of the Storm Water Standards, which is based on the requirements of SDRWQCB Order No. R9-2013-0001 as amended by R9-2015-0001 and R9-2015-0100 (MS4 Permit).

I have read and understand that the City Engineer has adopted minimum requirements for managing urban runoff, including storm water, from land development activities, as described in the Storm Water Standards. I certify that this PDP SWQMP has been completed to the best of my ability and accurately reflects the project being proposed and the applicable source control and site design BMPs proposed to minimize the potentially negative impacts of this project's land development activities on water quality. I understand and acknowledge that the plan check review of this PDP SWQMP by the City Engineer is confined to a review and does not relieve me, as the Engineer in Responsible Charge of design of storm water BMPs for this project, of my responsibilities for project design.



Engineer of Work's Signature

PE#

Expiration Date

Print Name

Company

Date

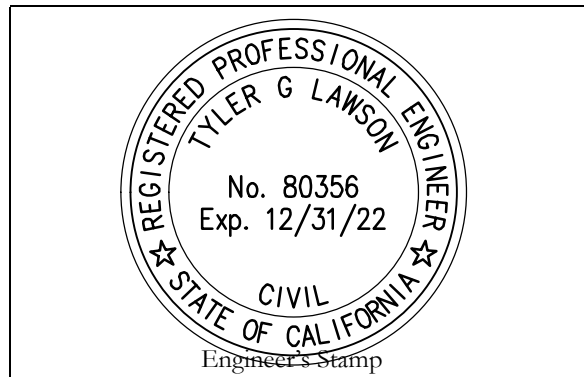

Project Name:

## Submittal Record

Use this Table to keep a record of submittals of this PDP SWQMP. Each time the PDP SWQMP is re-submitted, provide the date and status of the project. In last column indicate changes that have been made or indicate if response to plancheck comments is included. When applicable, insert response to plancheck comments.

<b>Submittal Number</b>	<b>Date</b>	<b>Project Status</b>	<b>Changes</b>
<b>1</b>		<b>Preliminary Design/Planning/CEQA</b> <b>Final Design</b>	<b>Initial Submittal</b>
<b>2</b>		<b>Preliminary Design/Planning/CEQA</b> <b>Final Design</b>	
<b>3</b>		<b>Preliminary Design/Planning/CEQA</b> <b>Final Design</b>	
<b>4</b>		<b>Preliminary Design/Planning/CEQA</b> <b>Final Design</b>	

Project Name:

## Project Vicinity Map

**Project Name:**  
**Permit Application**

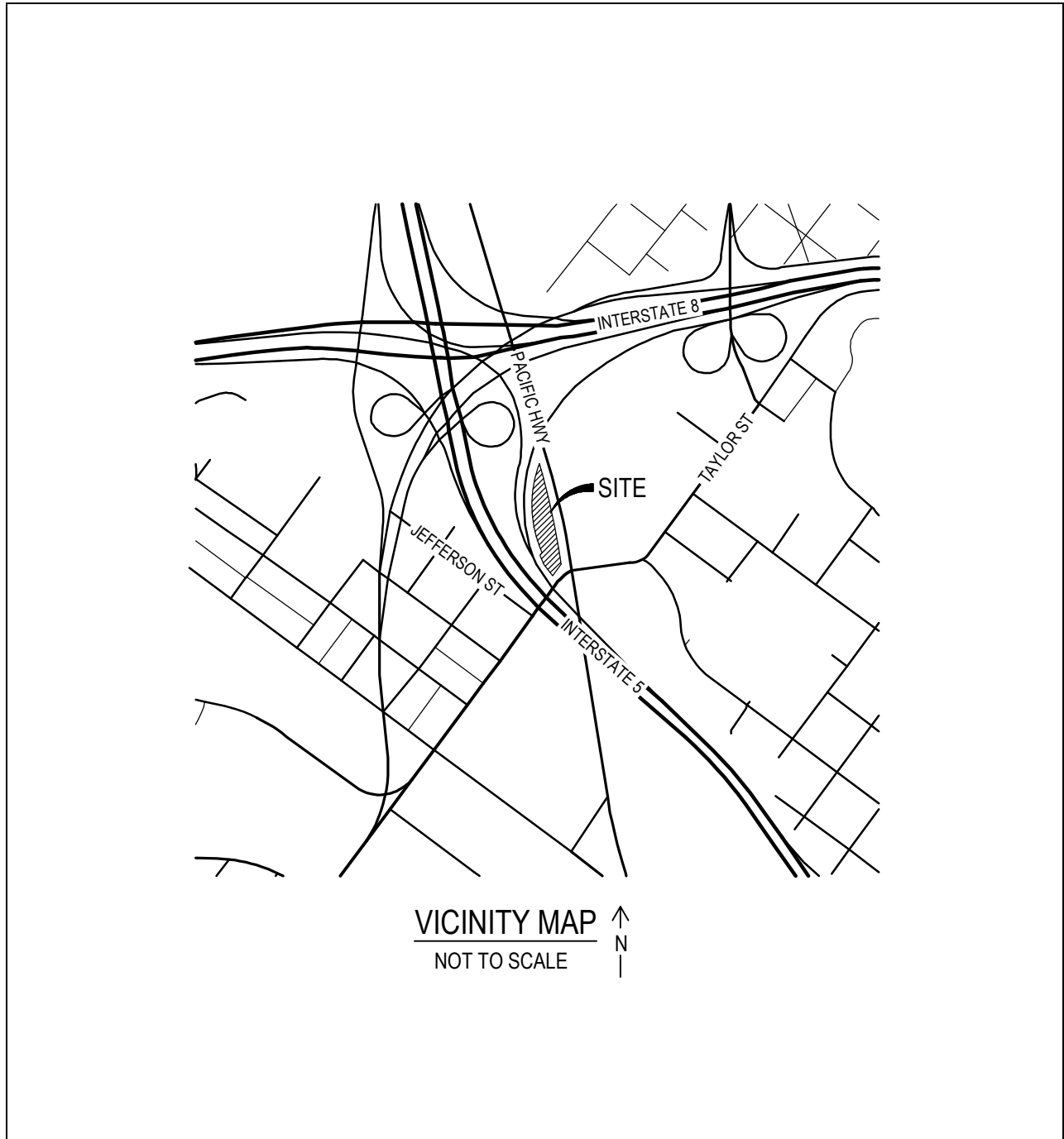

Project Name:

# City of San Diego Form DS-560 Storm Water Requirements Applicability Checklist

Attach DS-560 form.

Project Name:

**THIS PAGE INTENTIONALLY LEFT BLANK FOR DOUBLE-SIDED PRINTING**



FORM  
**DS-560**  
September 2021

# Stormwater Requirements Applicability Checklist

**Project Address:**

**Project Number:**

## SECTION 1: Construction Stormwater Best Management Practices (BMP) Requirements

All construction sites are required to implement construction BMPs per the performance standards in the [Stormwater Standards Manual](#). Some sites are also required to obtain coverage under the State Construction General Permit (CGP)<sup>1</sup>, administered by the [California State Water Resources Control Board](#).

**For all projects, complete Part A - If the project is required to submit a Stormwater Pollution Prevention Plan (SWPPP) or Water Pollution Control Plan (WPCP), continue to Part B.**

### PART A – Determine Construction Phase Stormwater Requirements

1. Is the project subject to California’s statewide General National Pollutant Discharge Elimination System (NPDES) permit for Stormwater Discharges Associated with Construction Activities, also known as the State Construction General Permit (CGP)? (Typically projects with land disturbance greater than or equal to 1 acre.)
 

Yes, SWPPP is required; skip questions 2-4.                       No; proceed to the next question.
2. Does the project propose construction or demolition activity, including but not limited to, clearing, grading, grubbing, excavation, or any other activity resulting in ground disturbance and/or contact with stormwater?
 

Yes, WPCP is required; skip questions 3-4.                       No; proceed to the next question.
3. Does the project propose routine maintenance to maintain the original line and grade, hydraulic capacity, or original purpose of the facility? (Projects such as pipeline/utility replacement)
 

Yes, WPCP is required; skip question 4.                       No; proceed to the next question.
4. Does the project only include the following Permit types listed below?
  - Electrical Permit, Fire Alarm Permit, Fire Sprinkler Permit, Plumbing Permit, Sign Permit, Mechanical Permit, Spa Permit.
  - Individual Right of Way Permits that exclusively include only ONE of the following activities: water service, sewer lateral, or utility service.
  - Right of Way Permits with a project footprint less than 150 linear feet that exclusively include only ONE of the following activities: curb ramp, sidewalk and driveway apron replacement, potholing, curb and gutter replacement, and retaining wall encroachments.

Yes, no document is required.

**Check one of the boxes below and continue to Part B**

- If you checked “Yes” for question 1**, an SWPPP is REQUIRED – **continue to Part B**
- If you checked “No” for question 1 and checked “Yes” for question 2 or 3**, a WPCP is REQUIRED. If the project proposes less than 5,000 square feet of ground disturbance AND has less than a 5-foot elevation change over the entire project area, a Minor WPCP may be required instead. **Continue to Part B**
- If you check “No” for all questions 1-3 and checked “Yes” for question 4**, Part B does not apply, and no document is required. **Continue to Section 2.**

<sup>1</sup> More information on the City’s construction BMP requirements as well as CGP requirements can be found at <http://www.sandiego.gov/stormwater/regulations/index.shtml>

CLEAR FORM

Visit our web site: [sandiego.gov/dsd](http://sandiego.gov/dsd).

Upon request, this information is available in alternative formats for persons with disabilities.

DS-560 (09-21)

**PART B – Determine Construction Site Priority**

This prioritization must be completed within this form, noted on the plans, and included in the SWPPP or WPCP. The city reserves the right to adjust the priority of projects both before and after construction. Construction projects are assigned an inspection frequency based on if the project has a “high threat to water quality.” The City has aligned the local definition of “high threat to water quality” to the risk determination approach of the State Construction General Permit (CGP). The CGP determines risk level based on project specific sediment risk and receiving water risk. Additional inspection is required for projects within the Areas of Special Biological Significance (ASBS) watershed. **NOTE:** The construction priority does **NOT** change construction BMP requirements that apply to projects; rather, it determines the frequency of inspections that will be conducted by city staff.

**Complete Part B and continue to Section 2**

**1. ASBS**

A. Projects located in the ASBS watershed.

**2. High Priority**

- A. Projects that qualify as Risk Level 2 or Risk Level 3 per the Construction General Permit (CGP) and are not located in the ASBS watershed.
- B. Projects that qualify as LUP Type 2 or LUP Type 3 per the CGP and are not located in the ASBS watershed.

**3. Medium Priority**

- A. Projects that are not located in an ASBS watershed or designated as a High priority site.
- B. Projects that qualify as Risk Level 1 or LUP Type 1 per the CGP and are not located in an ASBS watershed.
- C. WPCP projects (>5,000 square feet of ground disturbance) located within the Los Peñasquitos watershed management area.

**4. Low Priority**

A. Projects not subject to a Medium or High site priority designation and are not located in an ASBS watershed.

**Section 2: Construction Stormwater BMP Requirements**

Additional information for determining the requirements is found in the [Stormwater Standards Manual](#).

**PART C – Determine if Not Subject to Permanent Stormwater Requirements**

Projects that are considered maintenance or otherwise not categorized as “new development projects” or “redevelopment projects” according to the [Stormwater Standards Manual](#) are not subject to Permanent Stormwater BMPs.

- **If “yes” is checked for any number in Part C:** Proceed to Part F and check “Not Subject to Permanent Stormwater BMP Requirements.”
- **If “no” is checked for all the numbers in Part C:** Continue to Part D.

1. Does the project only include interior remodels and/or is the project entirely within an existing enclosed structure and does not have the potential to contact stormwater?  
 Yes    No
2. Does the project only include the construction of overhead or underground utilities without creating new impervious surfaces?  
 Yes    No
3. Does the project fall under routine maintenance? Examples include but are not limited to roof or exterior structure surface replacement, resurfacing or reconfiguring surface parking lots or existing roadways without expanding the impervious footprint, and routine replacement of damaged pavement (grinding, overlay and pothole repair).  
 Yes    No

CLEAR FORM

Visit our web site: [sandiego.gov/dsd](http://sandiego.gov/dsd).

Upon request, this information is available in alternative formats for persons with disabilities.

DS-560 (09-21)

**PART D – PDP Exempt Requirements**

PDP Exempt projects are required to implement site design and source control BMPs.

- If “yes” is checked for any questions in Part D, continue to Part F and check the box labeled “PDP Exempt.”
- If “no” is checked for all questions in Part D, continue to Part E.

- Does the project ONLY include new or retrofit sidewalks, bicycle lanes, or trails that:
  - Are designed and constructed to direct stormwater runoff to adjacent vegetated areas, or other non-erodible permeable areas? Or;
  - Are designed and constructed to be hydraulically disconnected from paved streets and roads? Or;
  - Are designed and constructed with permeable pavements or surfaces in accordance with the Green Streets guidance in the City’s Stormwater Standards manual?

Yes, PDP exempt requirements apply       No, proceed to next question
- Does the project ONLY include retrofitting or redeveloping existing paved alleys, streets or roads designed and constructed in accordance with the Green Streets guidance in the [City’s Stormwater Standards Manual](#)?
 

Yes, PDP exempt requirements apply       No, proceed to next question

**PART E – Determine if Project is a Priority Development Project (PDP)**

Projects that match one of the definitions below are subject to additional requirements, including preparation of a Stormwater Quality Management Plan (SWQMP).

- If “yes” is checked for any number in Part E, continue to Part F and check the box labeled “Priority Development Project.”
- If “no” is checked for every number in Part E, continue to Part F and check the box labeled “Standard Development Project.”

- New development that creates 10,000 square feet or more of impervious surfaces collectively over the project site.** This includes commercial, industrial, residential, mixed-use, and public development projects on public or private land.  Yes    No
- Redevelopment project that creates and/or replaces 5,000 square feet or more of impervious surfaces on an existing site of 10,000 square feet or more of impervious surfaces.** This includes commercial, industrial, residential, mixed-use, and public development projects on public or private land.  Yes    No
- New development or redevelopment of a restaurant.** Facilities that sell prepared foods and beverages for consumption, including stationary lunch counters and refreshment stands selling prepared foods and drinks for immediate consumption (Standard Industrial Classification [\(SIC\) 5812](#)), and where the land development creates and/or replaces 5,000 square feet or more of impervious surface.  Yes    No
- New development or redevelopment on a hillside.** The project creates and/or replaces 5,000 square feet or more of impervious surface (collectively over the project site) and where the development will grade on any natural slope that is twenty-five percent or greater.  Yes    No
- New development or redevelopment of a parking lot that creates and/or replaces 5,000 square feet or more of impervious surface (collectively over the project site).**  Yes    No
- New development or redevelopment of streets, roads, highways, freeways, and driveways.** The project creates and/or replaces 5,000 square feet or more of impervious surface (collectively over the project site).  Yes    No

CLEAR FORM

Visit our web site: [sandiego.gov/dsd](http://sandiego.gov/dsd).

Upon request, this information is available in alternative formats for persons with disabilities.

DS-560 (09-21)

- 7. **New development or redevelopment discharging directly to an environmentally sensitive area.** The project creates and/or replaces 2,500 square feet of impervious surface (collectively over the project site), and discharges directly to an Environmentally Sensitive Area (ESA). "Discharging directly to" includes flow that is conveyed overland a distance of 200 feet or less from the project to the ESA, or conveyed in a pipe or open channel any distance as an isolated flow from the project to the ESA (i.e. not commingled with flows from adjacent lands).  Yes  No
  
- 8. **New development or redevelopment projects of retail gasoline outlet (RGO) that create and/or replaces 5,000 square feet of impervious surface.** The development project meets the following criteria: (a) 5,000 square feet or more or (b) has a projected Average Daily Traffic (ADT) of 100 or more vehicles per day.  Yes  No
  
- 9. **New development or redevelopment projects of an automotive repair shop that creates and/or replaces 5,000 square feet or more of impervious surfaces.** Development projects categorized in any one of Standard Industrial Classification (SIC) codes [5013](#), [5014](#), [5541](#), [7532-7534](#) or [7536-7539](#).  Yes  No
  
- 10. **Other Pollutant Generating Project.** These projects are not covered in any of the categories above but involve the disturbance of one or more acres of land and are expected to generate post-construction phase pollutants, including fertilizers and pesticides. This category does not include projects creating less than 5,000 square feet of impervious area and projects containing landscaping without a requirement for the regular use of fertilizers and pesticides (such as a slope stabilization project using native plants). Impervious area calculations need not include linear pathways for infrequent vehicle use, such as emergency maintenance access or bicycle and pedestrian paths if the linear pathways are built with pervious surfaces or if runoff from the pathway sheet flows to adjacent pervious areas.  Yes  No

**PART F** – Select the appropriate category based on the outcomes of Part C through Part E

- 1. The project is **NOT SUBJECT TO PERMANENT STORMWATER REQUIREMENTS**  Yes  No
  
- 2. The project is a **STANDARD DEVELOPMENT PROJECT**. Site design and source control BMP requirements apply. See the [Stormwater Standards Manual](#) for guidance.  Yes  No
  
- 3. The Project is **PDP EXEMPT**. Site design and source control BMP requirements apply. Refer to the [Stormwater Standards Manual](#) for guidance.  Yes  No
  
- 4. The project is a **PRIORITY DEVELOPMENT PROJECT**. Site design, source control and structural pollutant control BMP requirements apply. Refer to the [Stormwater Standards Manual](#) for guidance on determining if the project requires hydromodification plan management.  Yes  No

Name of Owner or Agent

Title

Signature

Date

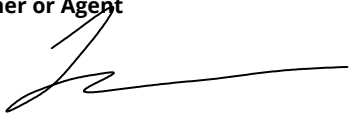

CLEAR FORM

Visit our web site: [sandiego.gov/dsd](http://sandiego.gov/dsd).

Upon request, this information is available in alternative formats for persons with disabilities.

DS-560 (09-21)

Project Name:

Applicability of Permanent, Post-Construction Storm Water BMP Requirements		Form I-1
<b>Project Identification</b>		
Project Name:		
Permit Application Number:		Date:
<b>Determination of Requirements</b>		
<p>The purpose of this form is to identify permanent, post-construction requirements that apply to the project. This form serves as a short <u>summary</u> of applicable requirements, in some cases referencing separate forms that will serve as the backup for the determination of requirements.</p> <p>Answer each step below, starting with <b>Step 1</b> and progressing through each step until reaching "Stop". Refer to the manual sections and/or separate forms referenced in each step below.</p>		
Step	Answer	Progression
<b>Step 1:</b> Is the project a "development project"? See Section 1.3 of the manual (Part 1 of Storm Water Standards) for guidance.	<input type="checkbox"/> Yes	Go to <b>Step 2</b> .
	<input type="checkbox"/> No	<b>Stop.</b> Permanent BMP requirements do not apply. No SWQMP will be required. Provide discussion below.
Discussion / justification if the project is <u>not</u> a "development project" (e.g., the project includes <i>only</i> interior remodels within an existing building):		
<b>Step 2:</b> Is the project a Standard Project, PDP, or PDP Exempt? To answer this item, see Section 1.4 of the manual in its entirety for guidance AND complete Form DS-560, Storm Water Requirements Applicability Checklist.	<input type="checkbox"/> Standard Project	<b>Stop.</b> Standard Project requirements apply
	<input type="checkbox"/> PDP	PDP requirements apply, including PDP SWQMP. Go to <b>Step 3</b> .
	PDP Exempt	<b>Stop.</b> Standard Project requirements apply. Provide discussion and list any additional requirements below.
Discussion / justification, and additional requirements for exceptions to PDP definitions, if applicable:		



Project Name:

Form I-1 Page 2 of 2		
Step	Answer	Progression
<b>Step 3.</b> Is the project subject to earlier PDP requirements due to a prior lawful approval? See Section 1.10 of the manual (Part 1 of Storm Water Standards) for guidance.	<input type="checkbox"/> Yes	Consult the City Engineer to determine requirements. Provide discussion and identify requirements below. Go to <b>Step 4.</b>
	<input type="checkbox"/> No	BMP Design Manual PDP requirements apply. Go to <b>Step 4.</b>
Discussion / justification of prior lawful approval, and identify requirements ( <u>not required if prior lawful approval does not apply</u> ):		
<b>Step 4.</b> Do hydromodification control requirements apply? See Section 1.6 of the manual (Part 1 of Storm Water Standards) for guidance.	<input type="checkbox"/> Yes	PDP structural BMPs required for pollutant control (Chapter 5) and hydromodification control (Chapter 6). Go to <b>Step 5.</b>
	<input type="checkbox"/> No	<b>Stop.</b> PDP structural BMPs required for pollutant control (Chapter 5) only. Provide brief discussion of exemption to hydromodification control below.
Discussion / justification if hydromodification control requirements do <u>not</u> apply:		
<b>Step 5.</b> Does protection of critical coarse sediment yield areas apply? See Section 6.2 of the manual (Part 1 of Storm Water Standards) for guidance.	<input type="checkbox"/> Yes	Management measures required for protection of critical coarse sediment yield areas (Chapter 6.2). <b>Stop.</b>
	<input type="checkbox"/> No	Management measures not required for protection of critical coarse sediment yield areas. Provide brief discussion below. <b>Stop.</b>
Discussion / justification if protection of critical coarse sediment yield areas does <u>not</u> apply:		



Project Name:

## HMP Exemption Exhibit

Attach a HMP Exemption Exhibit that shows direct storm water runoff discharge from the project site to HMP exempt area. Include project area, applicable underground storm drain line and/or concrete lined channels, outfall information and exempt waterbody.  
Reference applicable drawing number(s).

**Exhibit must be provided on 11"x17" or larger paper.**

Project Name:

**THIS PAGE INTENTIONALLY LEFT BLANK FOR DOUBLE-SIDED PRINTING**





# HMP Exempt Systems

San Diego County Regional  
Watershed Management Area Analysis, 2015





**THIS PAGE INTENTIONALLY LEFT BLANK FOR DOUBLE-SIDED PRINTING**

Project Name:

Site Information Checklist For PDPs		Form I-3B
Project Summary Information		
Project Name		
Project Address		
Assessor's Parcel Number(s) (APN(s))		
Permit Application Number		
Project Watershed	Select One: <input type="checkbox"/> San Dieguito River <input type="checkbox"/> Penasquitos <input type="checkbox"/> Mission Bay <input type="checkbox"/> San Diego River <input type="checkbox"/> San Diego Bay <input type="checkbox"/> Tijuana River	
Hydrologic subarea name with Numeric Identifier up to two decimal places (9XX.XX)		
Project Area (total area of Assessor's Parcel(s) associated with the project or total area of the right-of-way)	_____ Acres ( _____ Square Feet)	
Area to be disturbed by the project (Project Footprint)	_____ Acres ( _____ Square Feet)	
Project Proposed Impervious Area (subset of Project Footprint)	_____ Acres ( _____ Square Feet)	
Project Proposed Pervious Area (subset of Project Footprint)	_____ Acres ( _____ Square Feet)	
Note: Proposed Impervious Area + Proposed Pervious Area = Area to be Disturbed by the Project. This may be less than the Project Area.		
The proposed increase or decrease in impervious area in the proposed condition as compared to the pre-project condition	_____ %	



Project Name:

Form I-3B Page 2 of 11	
Description of Existing Site Condition and Drainage Patterns	
Current Status of the Site (select all that apply): <input type="checkbox"/> Existing development <input type="checkbox"/> Previously graded but not built out <input type="checkbox"/> Agricultural or other non-impervious use <input type="checkbox"/> Vacant, undeveloped/natural Description / Additional Information:	
Existing Land Cover Includes (select all that apply): <input type="checkbox"/> Vegetative Cover <input type="checkbox"/> Non-Vegetated Pervious Areas <input type="checkbox"/> Impervious Areas Description / Additional Information:	
Underlying Soil belongs to Hydrologic Soil Group (select all that apply): <input type="checkbox"/> NRCS Type A <input type="checkbox"/> NRCS Type B <input type="checkbox"/> NRCS Type C <input type="checkbox"/> NRCS Type D	
Approximate Depth to Groundwater: <input type="checkbox"/> Groundwater Depth < 5 feet <input type="checkbox"/> 5 feet < Groundwater Depth < 10 feet <input type="checkbox"/> 10 feet < Groundwater Depth < 20 feet <input type="checkbox"/> Groundwater Depth > 20 feet	
Existing Natural Hydrologic Features (select all that apply): <input type="checkbox"/> Watercourses <input type="checkbox"/> Seeps <input type="checkbox"/> Springs <input type="checkbox"/> Wetlands <input type="checkbox"/> None Description / Additional Information:	





Project Name:

Form I-3B Page 4 of 11	
Description of Proposed Site Development and Drainage Patterns	
Project Description / Proposed Land Use and/or Activities:	
List/describe proposed impervious features of the project (e.g., buildings, roadways, parking lots, courtyards, athletic courts, other impervious features):	
List/describe proposed pervious features of the project (e.g., landscape areas):	
Does the project include grading and changes to site topography? <input type="checkbox"/> Yes <input type="checkbox"/> No Description / Additional Information:	



Project Name:

Form I-3B Page 5 of 11

Does the project include changes to site drainage (e.g., installation of new storm water conveyance systems)?

- Yes
- No

If yes, provide details regarding the proposed project site drainage conveyance network, including storm drains, concrete channels, swales, detention facilities, storm water treatment facilities, natural and constructed channels, and the method for conveying offsite flows through or around the proposed project site. Identify all discharge locations from the proposed project site along with a summary of the conveyance system size and capacity for each of the discharge locations. Provide a summary of pre and post-project drainage areas and design flows to each of the runoff discharge locations. Reference the drainage study for detailed calculations.

Description / Additional Information:



Project Name:

Form I-3B Page 6 of 11

Identify whether any of the following features, activities, and/or pollutant source areas will be present (select all that apply):

- Onsite storm drain inlets
- Interior floor drains and elevator shaft sump pumps
- Interior parking garages
- Need for future indoor & structural pest control
- Landscape/outdoor pesticide use
- Pools, spas, ponds, decorative fountains, and other water features
- Food service
- Refuse areas
- Industrial processes
- Outdoor storage of equipment or materials
- Vehicle and equipment cleaning
- Vehicle/equipment repair and maintenance
- Fuel dispensing areas
- Loading docks
- Fire sprinkler test water
- Miscellaneous drain or wash water
- Plazas, sidewalks, and parking lots

Description/Additional Information:



Project Name:

Form I-3B Page 7 of 11	
Identification and Narrative of Receiving Water	
Narrative describing flow path from discharge location(s), through urban storm conveyance system, to receiving creeks, rivers, and lagoons and ultimate discharge location to Pacific Ocean (or bay, lagoon, lake or reservoir, as applicable)	
Provide a summary of all beneficial uses of receiving waters downstream of the project discharge locations	
Identify all ASBS (areas of special biological significance) receiving waters downstream of the project discharge locations	
Provide distance from project outfall location to impaired or sensitive receiving waters	
Summarize information regarding the proximity of the permanent, post-construction storm water BMPs to the City's Multi-Habitat Planning Area and environmentally sensitive lands	



Project Name:

Form I-3B Page 8 of 11			
Identification of Receiving Water Pollutants of Concern			
List any 303(d) impaired water bodies within the path of storm water from the project site to the Pacific Ocean (or bay, lagoon, lake or reservoir, as applicable), identify the pollutant(s)/stressor(s) causing impairment, and identify any TMDLs and/or Highest Priority Pollutants from the WQIP for the impaired water bodies:			
303(d) Impaired Water Body (Refer to Appendix K)	Pollutant(s)/Stressor(s) (Refer to Appendix K)	TMDLs/WQIP Highest Priority Pollutant (Refer to Table 1-4 in Chapter 1)	
Identification of Project Site Pollutants*			
*Identification of project site pollutants is only required if flow-thru treatment BMPs are implemented onsite in lieu of retention or biofiltration BMPs (note the project must also participate in an alternative compliance program unless prior lawful approval to meet earlier PDP requirements is demonstrated)			
Identify pollutants anticipated from the project site based on all proposed use(s) of the site (see Appendix B.6):			
Pollutant	Not Applicable to the Project Site	Anticipated from the Project Site	Also a Receiving Water Pollutant of Concern
Sediment			
Nutrients			
Heavy Metals			
Organic Compounds			
Trash & Debris			
Oxygen Demanding Substances			
Oil & Grease			
Bacteria & Viruses			
Pesticides			



Project Name:

Form I-3B Page 9 of 11	
Hydromodification Management Requirements	
<p>Do hydromodification management requirements apply (see Section 1.6)?</p> <ul style="list-style-type: none"><li><input type="checkbox"/> Yes, hydromodification management flow control structural BMPs required.</li><li><input type="checkbox"/> No, the project will discharge runoff directly to existing underground storm drains discharging directly to water storage reservoirs, lakes, enclosed embayments, or the Pacific Ocean.</li><li><input type="checkbox"/> No, the project will discharge runoff directly to conveyance channels whose bed and bank are concrete-lined all the way from the point of discharge to water storage reservoirs, lakes, enclosed embayments, or the Pacific Ocean.</li><li><input type="checkbox"/> No, the project will discharge runoff directly to an area identified as appropriate for an exemption by the WMAA for the watershed in which the project resides.</li></ul> <p>Description / Additional Information (to be provided if a 'No' answer has been selected above):</p>          <p>Note: If "No" answer has been selected the SWQMP must include an exhibit that shows the storm water conveyance system from the project site to an exempt water body. The exhibit should include details about the conveyance system and the outfall to the exempt water body.</p>	
Critical Coarse Sediment Yield Areas*	
<p><b>*This Section only required if hydromodification management requirements apply</b></p> <p>Based on Section 6.2 and Appendix H does CCSYA exist on the project footprint or in the upstream area draining through the project footprint?</p> <ul style="list-style-type: none"><li><input type="checkbox"/> Yes</li><li><input type="checkbox"/> No</li></ul> <p>Discussion / Additional Information:</p>          	



Project Name:

Form I-3B Page 10 of 11	
<b>Flow Control for Post-Project Runoff*</b>	
<b>*This Section only required if hydromodification management requirements apply</b>	
List and describe point(s) of compliance (POCs) for flow control for hydromodification management (see Section 6.3.1). For each POC, provide a POC identification name or number correlating to the project's HMP Exhibit and a receiving channel identification name or number correlating to the project's HMP Exhibit.	
Has a geomorphic assessment been performed for the receiving channel(s)? <input type="checkbox"/> No, the low flow threshold is $0.1Q_2$ (default low flow threshold) <input type="checkbox"/> Yes, the result is the low flow threshold is $0.1Q_2$ <input type="checkbox"/> Yes, the result is the low flow threshold is $0.3Q_2$ <input type="checkbox"/> Yes, the result is the low flow threshold is $0.5Q_2$ If a geomorphic assessment has been performed, provide title, date, and preparer:	
Discussion / Additional Information: (optional)	



Project Name:

**Form I-3B Page 11 of 11**

**Other Site Requirements and Constraints**

When applicable, list other site requirements or constraints that will influence storm water management design, such as zoning requirements including setbacks and open space, or local codes governing minimum street width, sidewalk construction, allowable pavement types, and drainage requirements.

**Optional Additional Information or Continuation of Previous Sections As Needed**

This space provided for additional information or continuation of information from previous sections as needed.



Project Name:

Source Control BMP Checklist for PDPs		Form I-4B		
<b>Source Control BMPs</b>				
All development projects must implement source control BMPs where applicable and feasible. See Chapter 4 and Appendix E of the BMP Design Manual (Part 1 of the Storm Water Standards) for information to implement source control BMPs shown in this checklist.				
Answer each category below pursuant to the following.				
<ul style="list-style-type: none"> <li>• "Yes" means the project will implement the source control BMP as described in Chapter 4 and/or Appendix E of the BMP Design Manual. Discussion / justification is not required.</li> <li>• "No" means the BMP is applicable to the project but it is not feasible to implement. Discussion / justification must be provided.</li> <li>• "N/A" means the BMP is not applicable at the project site because the project does not include the feature that is addressed by the BMP (e.g., the project has no outdoor materials storage areas). Discussion / justification may be provided.</li> </ul>				
Source Control Requirement		Applied?		
4.2.1 Prevention of Illicit Discharges into the MS4		<input type="checkbox"/> Yes	<input type="checkbox"/> No	<input type="checkbox"/> N/A
Discussion / justification if 4.2.1 not implemented:				
4.2.2 Storm Drain Stenciling or Signage		<input type="checkbox"/> Yes	<input type="checkbox"/> No	<input type="checkbox"/> N/A
Discussion / justification if 4.2.2 not implemented:				
4.2.3 Protect Outdoor Materials Storage Areas from Rainfall, Run-On, Runoff, and Wind Dispersal		<input type="checkbox"/> Yes	<input type="checkbox"/> No	<input type="checkbox"/> N/A
Discussion / justification if 4.2.3 not implemented:				
4.2.4 Protect Materials Stored in Outdoor Work Areas from Rainfall, Run-On, Runoff, and Wind Dispersal		<input type="checkbox"/> Yes	<input type="checkbox"/> No	<input type="checkbox"/> N/A
Discussion / justification if 4.2.4 not implemented:				
4.2.5 Protect Trash Storage Areas from Rainfall, Run-On, Runoff, and Wind Dispersal		<input type="checkbox"/> Yes	<input type="checkbox"/> No	<input type="checkbox"/> N/A
Discussion / justification if 4.2.5 not implemented:				



Project Name:

Form I-4B Page 2 of 2			
Source Control Requirement	Applied?		
4.2.6 Additional BMPs Based on Potential Sources of Runoff Pollutants (must answer for each source listed below)			
On-site storm drain inlets	<input type="checkbox"/> Yes	<input type="checkbox"/> No	<input type="checkbox"/> N/A
Interior floor drains and elevator shaft sump pumps	<input type="checkbox"/> Yes	<input type="checkbox"/> No	<input type="checkbox"/> N/A
Interior parking garages	<input type="checkbox"/> Yes	<input type="checkbox"/> No	<input type="checkbox"/> N/A
Need for future indoor & structural pest control	<input type="checkbox"/> Yes	<input type="checkbox"/> No	<input type="checkbox"/> N/A
Landscape/Outdoor Pesticide Use	<input type="checkbox"/> Yes	<input type="checkbox"/> No	<input type="checkbox"/> N/A
Pools, spas, ponds, decorative fountains, and other water features	<input type="checkbox"/> Yes	<input type="checkbox"/> No	<input type="checkbox"/> N/A
Food service	<input type="checkbox"/> Yes	<input type="checkbox"/> No	<input type="checkbox"/> N/A
Refuse areas	<input type="checkbox"/> Yes	<input type="checkbox"/> No	<input type="checkbox"/> N/A
Industrial processes	<input type="checkbox"/> Yes	<input type="checkbox"/> No	<input type="checkbox"/> N/A
Outdoor storage of equipment or materials	<input type="checkbox"/> Yes	<input type="checkbox"/> No	<input type="checkbox"/> N/A
Vehicle/Equipment Repair and Maintenance	<input type="checkbox"/> Yes	<input type="checkbox"/> No	<input type="checkbox"/> N/A
Fuel Dispensing Areas	<input type="checkbox"/> Yes	<input type="checkbox"/> No	<input type="checkbox"/> N/A
Loading Docks	<input type="checkbox"/> Yes	<input type="checkbox"/> No	<input type="checkbox"/> N/A
Fire Sprinkler Test Water	<input type="checkbox"/> Yes	<input type="checkbox"/> No	<input type="checkbox"/> N/A
Miscellaneous Drain or Wash Water	<input type="checkbox"/> Yes	<input type="checkbox"/> No	<input type="checkbox"/> N/A
Plazas, sidewalks, and parking lots	<input type="checkbox"/> Yes	<input type="checkbox"/> No	<input type="checkbox"/> N/A
SC-6A: Large Trash Generating Facilities	<input type="checkbox"/> Yes	<input type="checkbox"/> No	<input type="checkbox"/> N/A
SC-6B: Animal Facilities	<input type="checkbox"/> Yes	<input type="checkbox"/> No	<input type="checkbox"/> N/A
SC-6C: Plant Nurseries and Garden Centers	<input type="checkbox"/> Yes	<input type="checkbox"/> No	<input type="checkbox"/> N/A
SC-6D: Automotive Facilities	<input type="checkbox"/> Yes	<input type="checkbox"/> No	<input type="checkbox"/> N/A
Discussion / justification if 4.2.6 not implemented. Clearly identify which sources of runoff pollutants are discussed. Justification must be provided for <u>all</u> "No" answers shown above.			



Project Name:

Site Design BMP Checklist for PDPs		Form I-5B	
<b>Site Design BMPs</b>			
<p>All development projects must implement site design BMPs where applicable and feasible. See Chapter 4 and Appendix E of the BMP Design Manual (Part 1 of Storm Water Standards) for information to implement site design BMPs shown in this checklist.</p> <p>Answer each category below pursuant to the following.</p> <ul style="list-style-type: none"> <li>• "Yes" means the project will implement the site design BMP as described in Chapter 4 and/or Appendix E of the BMP Design Manual. Discussion / justification is not required.</li> <li>• "No" means the BMP is applicable to the project but it is not feasible to implement. Discussion / justification must be provided.</li> <li>• "N/A" means the BMP is not applicable at the project site because the project does not include the feature that is addressed by the BMP (e.g., the project site has no existing natural areas to conserve). Discussion / justification may be provided.</li> </ul> <p>A site map with implemented site design BMPs must be included at the end of this checklist.</p>			
Site Design Requirement		Applied?	
4.3.1 Maintain Natural Drainage Pathways and Hydrologic Features		<input type="checkbox"/> Yes	<input type="checkbox"/> No <input type="checkbox"/> N/A
Discussion / justification if 4.3.1 not implemented:			
1-1 Are existing natural drainage pathways and hydrologic features mapped on the site map?		<input type="checkbox"/> Yes	<input type="checkbox"/> No <input type="checkbox"/> N/A
1-2 Are trees implemented? If yes, are they shown on the site map?		<input type="checkbox"/> Yes	<input type="checkbox"/> No <input type="checkbox"/> N/A
1-3 Implemented trees meet the design criteria in 4.3.1 Fact Sheet (e.g. soil volume, maximum credit, etc.)?		<input type="checkbox"/> Yes	<input type="checkbox"/> No <input type="checkbox"/> N/A
1-4 Is tree credit volume calculated using Appendix B.2.2.1 and SD-1 Fact Sheet in Appendix E?		<input type="checkbox"/> Yes	<input type="checkbox"/> No <input type="checkbox"/> N/A
4.3.2 Have natural areas, soils and vegetation been conserved?		<input type="checkbox"/> Yes	<input type="checkbox"/> No <input type="checkbox"/> N/A
Discussion / justification if 4.3.2 not implemented:			





Project Name:

Form I-5B Page 2 of 4			
Site Design Requirement	Applied?		
4.3.3 Minimize Impervious Area	<input type="checkbox"/> Yes	<input type="checkbox"/> No	<input type="checkbox"/> N/A
Discussion / justification if 4.3.3 not implemented:			
4.3.4 Minimize Soil Compaction	<input type="checkbox"/> Yes	<input type="checkbox"/> No	<input type="checkbox"/> N/A
Discussion / justification if 4.3.4 not implemented:			
4.3.5 Impervious Area Dispersion	<input type="checkbox"/> Yes	<input type="checkbox"/> No	<input type="checkbox"/> N/A
Discussion / justification if 4.3.5 not implemented:			
5-1	Is the pervious area receiving runoff from impervious area identified on the site map?	<input type="checkbox"/> Yes	<input type="checkbox"/> No <input type="checkbox"/> N/A
5-2	Does the pervious area satisfy the design criteria in 4.3.5 Fact Sheet in Appendix E (e.g. maximum slope, minimum length, etc.)	<input type="checkbox"/> Yes	<input type="checkbox"/> No <input type="checkbox"/> N/A
5-3	Is impervious area dispersion credit volume calculated using Appendix B.2.1.1 and 4.3.5 Fact Sheet in Appendix E?	<input type="checkbox"/> Yes	<input type="checkbox"/> No <input type="checkbox"/> N/A



Project Name:

Form I-5B Page 3 of 4			
Site Design Requirement	Applied?		
4.3.6 Runoff Collection	<input type="checkbox"/> Yes	<input type="checkbox"/> No	<input type="checkbox"/> N/A
Discussion / justification if 4.3.6 not implemented:			
6a-1 Are green roofs implemented in accordance with design criteria in 4.3.6A Fact Sheet? If yes, are they shown on the site map?	<input type="checkbox"/> Yes	<input type="checkbox"/> No	<input type="checkbox"/> N/A
6a-2 Is the green roof credit volume calculated using Appendix B.2.1.2 and 4.3.6A Fact Sheet in Appendix E?	<input type="checkbox"/> Yes	<input type="checkbox"/> No	<input type="checkbox"/> N/A
6b-1 Are permeable pavements implemented in accordance with design criteria in 4.3.6B Fact Sheet? If yes, are they shown on the site map?	<input type="checkbox"/> Yes	<input type="checkbox"/> No	<input type="checkbox"/> N/A
6b-2 Is the permeable pavement credit volume calculated using Appendix B.2.1.3 and 4.3.6B Fact Sheet in Appendix E?	<input type="checkbox"/> Yes	<input type="checkbox"/> No	<input type="checkbox"/> N/A
4.3.7 Landscaping with Native or Drought Tolerant Species	<input type="checkbox"/> Yes	<input type="checkbox"/> No	<input type="checkbox"/> N/A
Discussion / justification if 4.3.7 not implemented:			
4.3.8 Harvest and Use Precipitation	<input type="checkbox"/> Yes	<input type="checkbox"/> No	<input type="checkbox"/> N/A
Discussion / justification if 4.3.8 not implemented:			
8-1 Are rain barrels implemented in accordance with design criteria in 4.3.8 Fact Sheet? If yes, are they shown on the site map?	<input type="checkbox"/> Yes	<input type="checkbox"/> No	<input type="checkbox"/> N/A
8-2 Is the rain barrel credit volume calculated using Appendix B.2.2.2 and 4.3.8 Fact Sheet in Appendix E?	<input type="checkbox"/> Yes	<input type="checkbox"/> No	<input type="checkbox"/> N/A



Project Name:

Form I-5B Page 4 of 4

Insert Site Map with all site design BMPs identified:

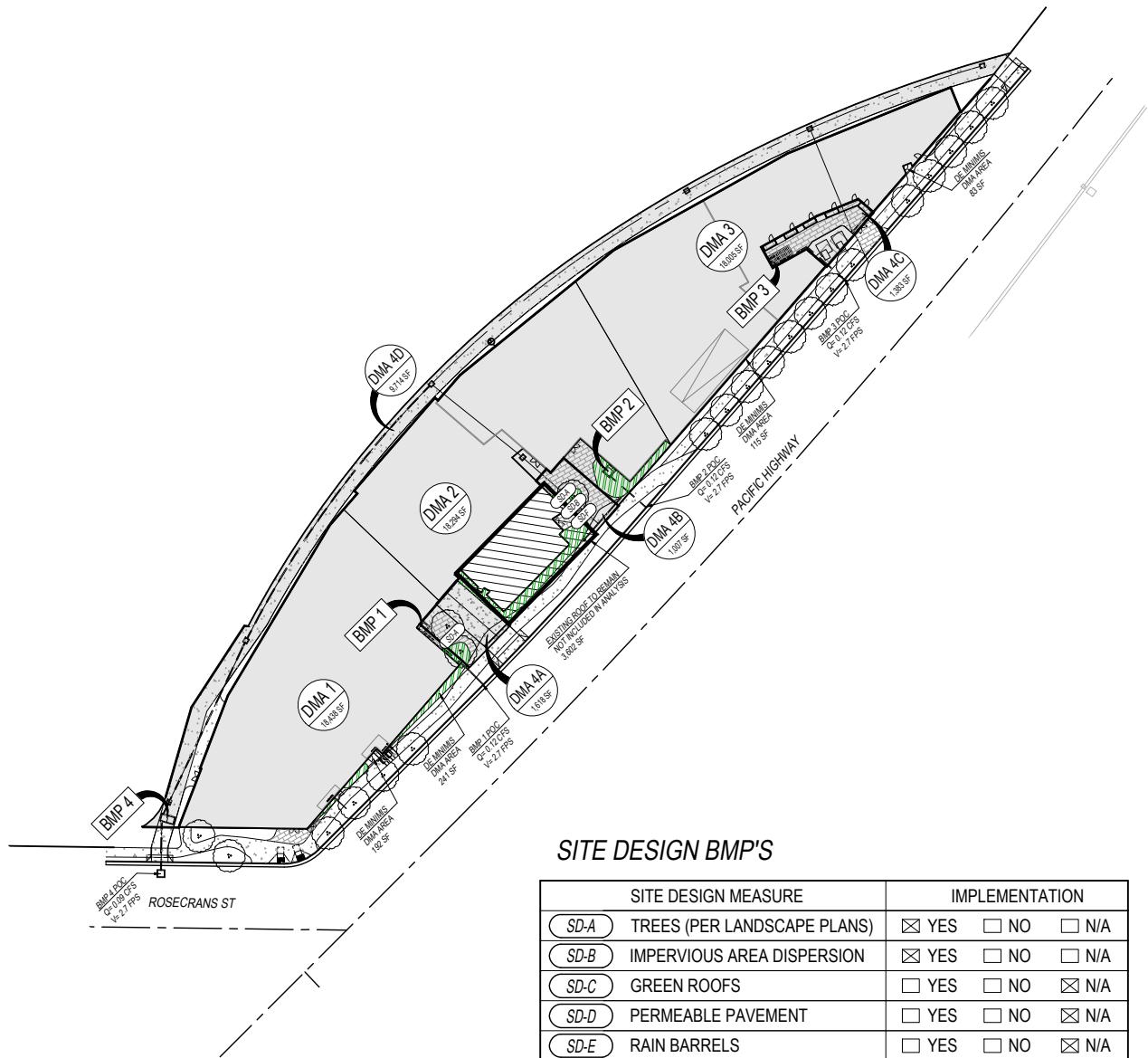

SITE DESIGN BMP'S

SITE DESIGN MEASURE	IMPLEMENTATION
<input checked="" type="checkbox"/> SD-A TREES (PER LANDSCAPE PLANS)	<input checked="" type="checkbox"/> YES <input type="checkbox"/> NO <input type="checkbox"/> N/A
<input checked="" type="checkbox"/> SD-B IMPERVIOUS AREA DISPERSION	<input checked="" type="checkbox"/> YES <input type="checkbox"/> NO <input type="checkbox"/> N/A
<input type="checkbox"/> SD-C GREEN ROOFS	<input type="checkbox"/> YES <input type="checkbox"/> NO <input checked="" type="checkbox"/> N/A
<input type="checkbox"/> SD-D PERMEABLE PAVEMENT	<input type="checkbox"/> YES <input type="checkbox"/> NO <input checked="" type="checkbox"/> N/A
<input type="checkbox"/> SD-E RAIN BARRELS	<input type="checkbox"/> YES <input type="checkbox"/> NO <input checked="" type="checkbox"/> N/A
<input checked="" type="checkbox"/> SD-F AMENDED SOILS	<input checked="" type="checkbox"/> YES <input type="checkbox"/> NO <input type="checkbox"/> N/A





Project Name:

(Continued from page 1)



Project Name:

Form I-6 Page    of    (Copy as many as needed)	
Structural BMP Summary Information	
Structural BMP ID No.	
Construction Plan Sheet No.	
Type of Structural BMP: <input type="checkbox"/> Retention by harvest and use (e.g. HU-1, cistern) <input type="checkbox"/> Retention by infiltration basin (INF-1) <input type="checkbox"/> Retention by bioretention (INF-2) <input type="checkbox"/> Retention by permeable pavement (INF-3) <input type="checkbox"/> Partial retention by biofiltration with partial retention (PR-1) <input type="checkbox"/> Biofiltration (BF-1) <input type="checkbox"/> Flow-thru treatment control with prior lawful approval to meet earlier PDP requirements (provide BMP type/description in discussion section below) <input type="checkbox"/> Flow-thru treatment control included as pre-treatment/forebay for an onsite retention or biofiltration BMP (provide BMP type/description and indicate which onsite retention or biofiltration BMP it serves in discussion section below) <input type="checkbox"/> Flow-thru treatment control with alternative compliance (provide BMP type/description in discussion section below) <input type="checkbox"/> Detention pond or vault for hydromodification management <input type="checkbox"/> Other (describe in discussion section below)	
Purpose: <input type="checkbox"/> Pollutant control only <input type="checkbox"/> Hydromodification control only <input type="checkbox"/> Combined pollutant control and hydromodification control <input type="checkbox"/> Pre-treatment/forebay for another structural BMP <input type="checkbox"/> Other (describe in discussion section below)	
Who will certify construction of this BMP? Provide name and contact information for the party responsible to sign BMP verification form DS-563	
Who will be the final owner of this BMP?	
Who will maintain this BMP into perpetuity?	
What is the funding mechanism for maintenance?	



Project Name:

Form I-6 Page    of    (Copy as many as needed)
Structural BMP ID No.
Construction Plan Sheet No.
Discussion (as needed; must include worksheets showing BMP sizing calculations in the SWQMPs):



Project Name:

Form I-6 Page    of    (Copy as many as needed)	
Structural BMP Summary Information	
Structural BMP ID No.	
Construction Plan Sheet No.	
Type of Structural BMP: <input type="checkbox"/> Retention by harvest and use (e.g. HU-1, cistern) <input type="checkbox"/> Retention by infiltration basin (INF-1) <input type="checkbox"/> Retention by bioretention (INF-2) <input type="checkbox"/> Retention by permeable pavement (INF-3) <input type="checkbox"/> Partial retention by biofiltration with partial retention (PR-1) <input type="checkbox"/> Biofiltration (BF-1) <input type="checkbox"/> Flow-thru treatment control with prior lawful approval to meet earlier PDP requirements (provide BMP type/description in discussion section below) <input type="checkbox"/> Flow-thru treatment control included as pre-treatment/forebay for an onsite retention or biofiltration BMP (provide BMP type/description and indicate which onsite retention or biofiltration BMP it serves in discussion section below) <input type="checkbox"/> Flow-thru treatment control with alternative compliance (provide BMP type/description in discussion section below) <input type="checkbox"/> Detention pond or vault for hydromodification management <input type="checkbox"/> Other (describe in discussion section below)	
Purpose: <input type="checkbox"/> Pollutant control only <input type="checkbox"/> Hydromodification control only <input type="checkbox"/> Combined pollutant control and hydromodification control <input type="checkbox"/> Pre-treatment/forebay for another structural BMP <input type="checkbox"/> Other (describe in discussion section below)	
Who will certify construction of this BMP? Provide name and contact information for the party responsible to sign BMP verification form DS-563	
Who will be the final owner of this BMP?	
Who will maintain this BMP into perpetuity?	
What is the funding mechanism for maintenance?	





Project Name:

Form I-6 Page    of    (Copy as many as needed)
Structural BMP ID No.
Construction Plan Sheet No.
Discussion (as needed; must include worksheets showing BMP sizing calculations in the SWQMPs):



Project Name:

Form I-6 Page    of    (Copy as many as needed)	
Structural BMP Summary Information	
Structural BMP ID No.	
Construction Plan Sheet No.	
Type of Structural BMP: <input type="checkbox"/> Retention by harvest and use (e.g. HU-1, cistern) <input type="checkbox"/> Retention by infiltration basin (INF-1) <input type="checkbox"/> Retention by bioretention (INF-2) <input type="checkbox"/> Retention by permeable pavement (INF-3) <input type="checkbox"/> Partial retention by biofiltration with partial retention (PR-1) <input type="checkbox"/> Biofiltration (BF-1) <input type="checkbox"/> Flow-thru treatment control with prior lawful approval to meet earlier PDP requirements (provide BMP type/description in discussion section below) <input type="checkbox"/> Flow-thru treatment control included as pre-treatment/forebay for an onsite retention or biofiltration BMP (provide BMP type/description and indicate which onsite retention or biofiltration BMP it serves in discussion section below) <input type="checkbox"/> Flow-thru treatment control with alternative compliance (provide BMP type/description in discussion section below) <input type="checkbox"/> Detention pond or vault for hydromodification management <input type="checkbox"/> Other (describe in discussion section below)	
Purpose: <input type="checkbox"/> Pollutant control only <input type="checkbox"/> Hydromodification control only <input type="checkbox"/> Combined pollutant control and hydromodification control <input type="checkbox"/> Pre-treatment/forebay for another structural BMP <input type="checkbox"/> Other (describe in discussion section below)	
Who will certify construction of this BMP? Provide name and contact information for the party responsible to sign BMP verification form DS-563	
Who will be the final owner of this BMP?	
Who will maintain this BMP into perpetuity?	
What is the funding mechanism for maintenance?	



Project Name:

Form I-6 Page    of    (Copy as many as needed)
Structural BMP ID No.
Construction Plan Sheet No.
Discussion (as needed; must include worksheets showing BMP sizing calculations in the SWQMPs):



Project Name:

Form I-6 Page    of    (Copy as many as needed)	
Structural BMP Summary Information	
Structural BMP ID No.	
Construction Plan Sheet No.	
Type of Structural BMP: <input type="checkbox"/> Retention by harvest and use (e.g. HU-1, cistern) <input type="checkbox"/> Retention by infiltration basin (INF-1) <input type="checkbox"/> Retention by bioretention (INF-2) <input type="checkbox"/> Retention by permeable pavement (INF-3) <input type="checkbox"/> Partial retention by biofiltration with partial retention (PR-1) <input type="checkbox"/> Biofiltration (BF-1) <input type="checkbox"/> Flow-thru treatment control with prior lawful approval to meet earlier PDP requirements (provide BMP type/description in discussion section below) <input type="checkbox"/> Flow-thru treatment control included as pre-treatment/forebay for an onsite retention or biofiltration BMP (provide BMP type/description and indicate which onsite retention or biofiltration BMP it serves in discussion section below) <input type="checkbox"/> Flow-thru treatment control with alternative compliance (provide BMP type/description in discussion section below) <input type="checkbox"/> Detention pond or vault for hydromodification management <input type="checkbox"/> Other (describe in discussion section below)	
Purpose: <input type="checkbox"/> Pollutant control only <input type="checkbox"/> Hydromodification control only <input type="checkbox"/> Combined pollutant control and hydromodification control <input type="checkbox"/> Pre-treatment/forebay for another structural BMP <input type="checkbox"/> Other (describe in discussion section below)	
Who will certify construction of this BMP? Provide name and contact information for the party responsible to sign BMP verification form DS-563	
Who will be the final owner of this BMP?	
Who will maintain this BMP into perpetuity?	
What is the funding mechanism for maintenance?	



Project Name:

Form I-6 Page    of    (Copy as many as needed)
Structural BMP ID No.
Construction Plan Sheet No.
Discussion (as needed; must include worksheets showing BMP sizing calculations in the SWQMPs):



Project Name:

**THIS PAGE INTENTIONALLY LEFT BLANK FOR DOUBLE-SIDED PRINTING**

Project Name:

# **Attachment 1**

## **Backup For PDP Pollutant Control BMPs**

This is the cover sheet for Attachment 1.

Project Name:

Indicate which Items are Included:

Attachment Sequence	Contents	Checklist
<b>Attachment 1a</b>	DMA Exhibit (Required) See DMA Exhibit Checklist.	<input checked="" type="checkbox"/> Included
<b>Attachment 1b</b>	Tabular Summary of DMAs Showing DMA ID matching DMA Exhibit, DMA Area, and DMA Type (Required)*  *Provide table in this Attachment OR on DMA Exhibit in Attachment 1a	<input type="checkbox"/> Included on DMA Exhibit in Attachment 1a  <input type="checkbox"/> Included as Attachment 1b, separate from DMA Exhibit
<b>Attachment 1c</b>	Form I-7, Harvest and Use Feasibility Screening Checklist (Required unless the entire project will use infiltration BMPs)  Refer to Appendix B.3-1 of the BMP Design Manual to complete Form I-7.	<input type="checkbox"/> Included  <input type="checkbox"/> Not included because the entire project will use infiltration BMPs
<b>Attachment 1d</b>	Infiltration Feasibility Information. Contents of Attachment 1d depend on the infiltration condition: <ul style="list-style-type: none"><li>• No Infiltration Condition:<ul style="list-style-type: none"><li>○ Infiltration Feasibility Condition Letter (<i>Note: must be stamped and signed by licensed geotechnical engineer</i>)</li><li>○ Form I-8A (optional)</li><li>○ Form I-8B (optional)</li></ul></li><li>• Partial Infiltration Condition:<ul style="list-style-type: none"><li>○ Infiltration Feasibility Condition Letter (<i>Note: must be stamped and signed by licensed geotechnical engineer</i>)</li><li>○ Form I-8A</li><li>○ Form I-8B</li></ul></li><li>• Full Infiltration Condition:<ul style="list-style-type: none"><li>○ Form I-8A</li><li>○ Form I-8B</li><li>○ Worksheet C.4-3</li><li>○ Form I-9</li></ul></li></ul> Refer to Appendices C and D of the BMP Design Manual for guidance.	<input type="checkbox"/> Included  <input type="checkbox"/> Not included because the entire project will use harvest and use BMPs
<b>Attachment 1e</b>	Pollutant Control BMP Design Worksheets / Calculations (Required)  Refer to Appendices B and E of the BMP Design Manual for structural pollutant control BMP design guidelines and site design credit calculations	<input type="checkbox"/> Included



Project Name:

**Use this checklist to ensure the required information has been included on the DMA Exhibit:**

The DMA Exhibit must identify:

- Underlying hydrologic soil group
- Approximate depth to groundwater
- Existing natural hydrologic features (watercourses, seeps, springs, wetlands)
- Critical coarse sediment yield areas to be protected
- Existing topography and impervious areas
- Existing and proposed site drainage network and connections to drainage offsite
- Proposed grading
- Proposed impervious features
- Proposed design features and surface treatments used to minimize imperviousness
- Drainage management area (DMA) boundaries, DMA ID numbers, and DMA areas (square footage or acreage), and DMA type (i.e., drains to BMP, self-retaining, or self-mitigating)
- Potential pollutant source areas and corresponding required source controls (see Chapter 4, Appendix E.1, and Form I-3B)
- Structural BMPs (identify location, type of BMP, size/detail, and include cross-section)

Project Name:

**THIS PAGE INTENTIONALLY LEFT BLANK FOR DOUBLE-SIDED PRINTING**



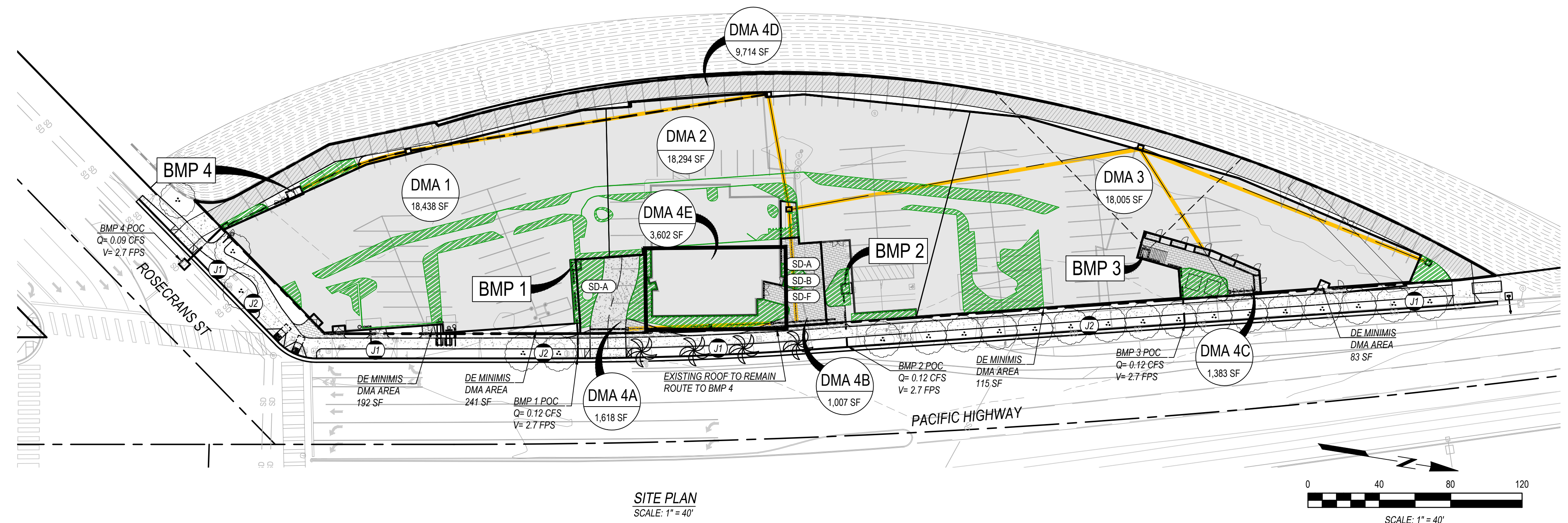
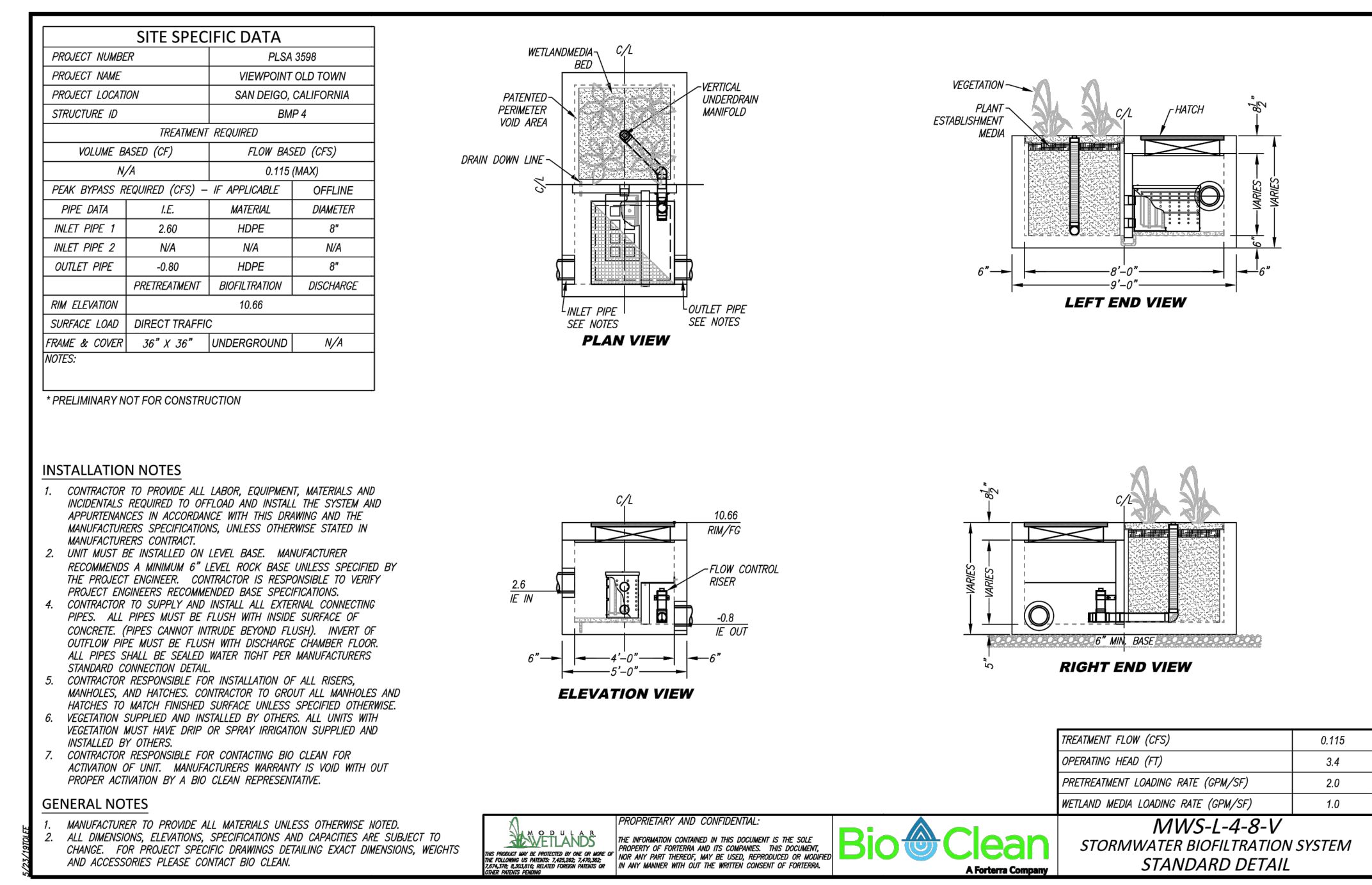
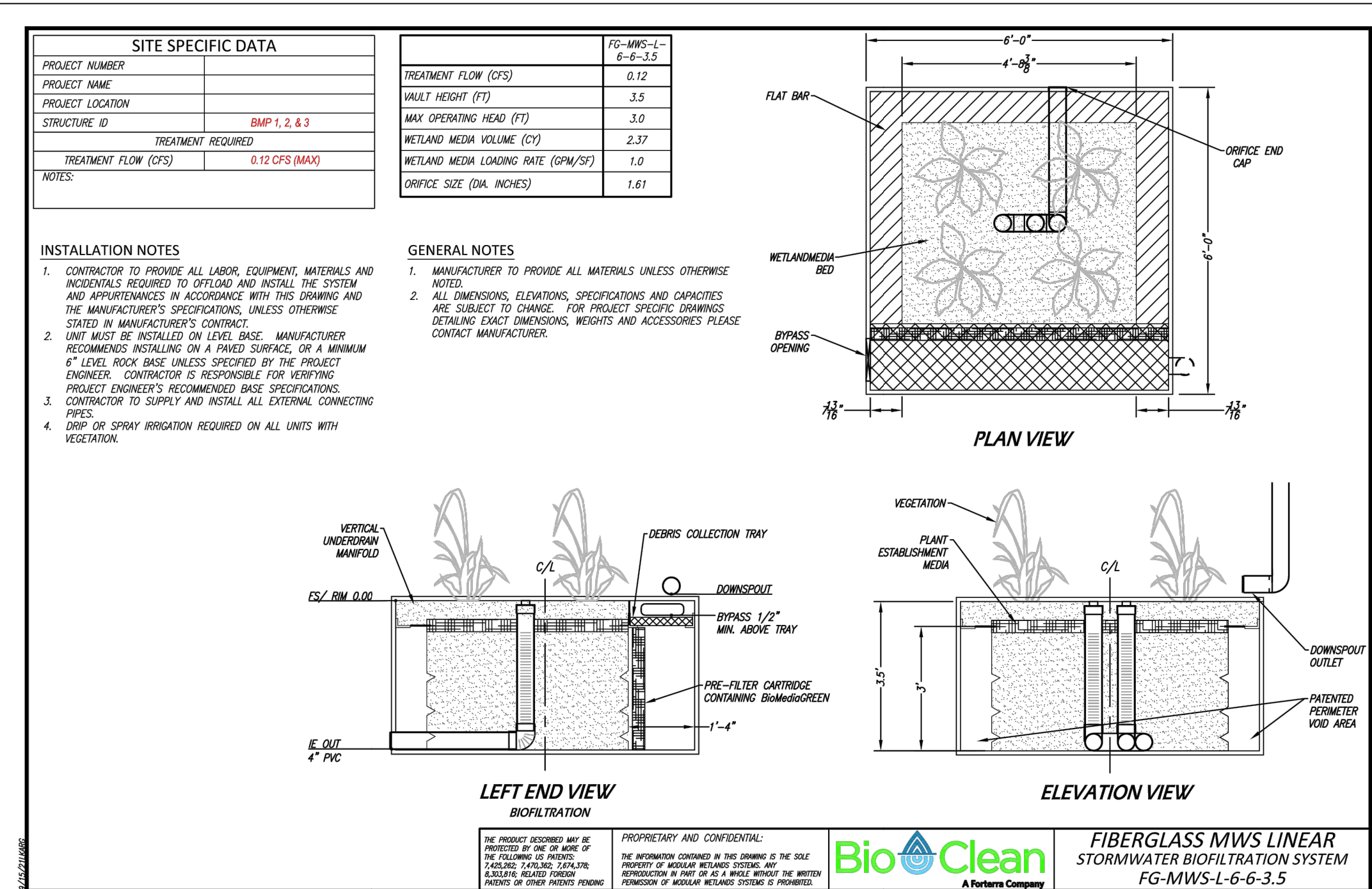

**SITE WORK INFORMATION:**  
TOTAL DISTURBED AREA: 76,154 SF = 1.75 AC  
EXISTING IMPERVIOUS AREA: 76,154 SF = 1.75 AC  
PROPOSED IMPERVIOUS AREA (REPLACED): 76,154 SF = 1.75 AC  
PROPOSED IMPERVIOUS AREA (NEW): 0 SF = 0 AC  
PROPOSED IMPERVIOUS AREA (TOTAL): 76,154 SF = 1.75 AC  
PROPOSED INCREASE IN IMPERVIOUS AREA: 0.0%

**SOIL INFORMATION:**  
SOIL TYPE: TYPE D  
DEPTH TO GROUND WATER: ~10FT (PER SOILS REPORT)

**ROOF AREA RUNOFF CONVEYANCE:**  
THE STORMWATER RUNOFF FROM THE PROPOSED ROOF AREAS SHALL BE CONVEYED THROUGH THE PROPOSED ROOF DRAIN SYSTEMS DESIGNED BY THE PROJECT ARCHITECT ACCORDING TO THE DRAINAGE AREAS SHOWN ON THIS PLAN

**NATURAL HYDROLOGIC FEATURES:**  
NO NATURAL HYDROLOGIC FEATURES (WATERCOURSES, SEEPS, SPRINGS, WETLANDS) EXIST ON THE PROJECT SITE

**COARSE SEDIMENT YIELD**  
NO CRITICAL COARSE SEDIMENT YIELD AREAS TO BE PROTECTED. REFER TO PRIORITY DEVELOPMENT PROJECT SWQMP PREPARED BY PASCO, LARET, SUITER & ASSOCIATES

**GREEN STREET BMP'S**

- (J1) SIDEWALK PLANTER
- (J2) STREET TREES

**SITE DESIGN BMP'S**

SITE DESIGN MEASURE	IMPLEMENTATION
(SD-A) TREES (PER LANDSCAPE PLANS)	<input checked="" type="checkbox"/> YES <input type="checkbox"/> NO <input type="checkbox"/> N/A
(SD-B) IMPERVIOUS AREA DISPERSION	<input checked="" type="checkbox"/> YES <input type="checkbox"/> NO <input type="checkbox"/> N/A
(SD-C) GREEN ROOFS	<input type="checkbox"/> YES <input type="checkbox"/> NO <input checked="" type="checkbox"/> N/A
(SD-D) PERMEABLE PAVEMENT	<input type="checkbox"/> YES <input type="checkbox"/> NO <input checked="" type="checkbox"/> N/A
(SD-E) RAIN BARRELS	<input type="checkbox"/> YES <input type="checkbox"/> NO <input checked="" type="checkbox"/> N/A
(SD-F) AMENDED SOILS	<input checked="" type="checkbox"/> YES <input type="checkbox"/> NO <input type="checkbox"/> N/A

**DMA INFORMATION**

	1	2	3	4
TOTAL AREA (SF)	18438	18294	18005	17324
ROOF (SF)	18438	18294	18005	3602
HARDSCAPE (SF)	16688	17194	16355	10772
LANDSCAPE (SF)	1750**	1100**	1650**	2950
TOTAL IMPERVIOUS (SF)	18438	18294	18005	14374
TOTAL PERVIOUS (SF)	0	0	0	2950
PERCENT IMPERVIOUS (%)	100.0%	100.0%	100.0%	82.9%
BMP TREATMENT	6X6 MWS FG	6X6 MWS FG	6X6 MWS FG	4X8 MWS LINEAR
DCV (CF)	719	713	702	601
CALCULATED FLOW RATE (CFS)	0.114	0.113	0.112	0.10
CERTIFIED TREATMENT CAPACITY (CFS)	0.12	0.12	0.12	0.12

\*\* NOTE: PROPOSED LANDSCAPE AREAS PER ARCHITECTURE & LANDSCAPE ARCHITECTURE PLANS, AND IS WITHIN AMENITY AREAS ON STRUCTURE. THE LANDSCAPE AREAS TABULATED ARE USED SOLELY FOR VOLUME RETENTION CALCULATIONS AND NOT CONSIDERED FOR NET IMPERVIOUS & NET PERVIOUS AREA TABULATION.

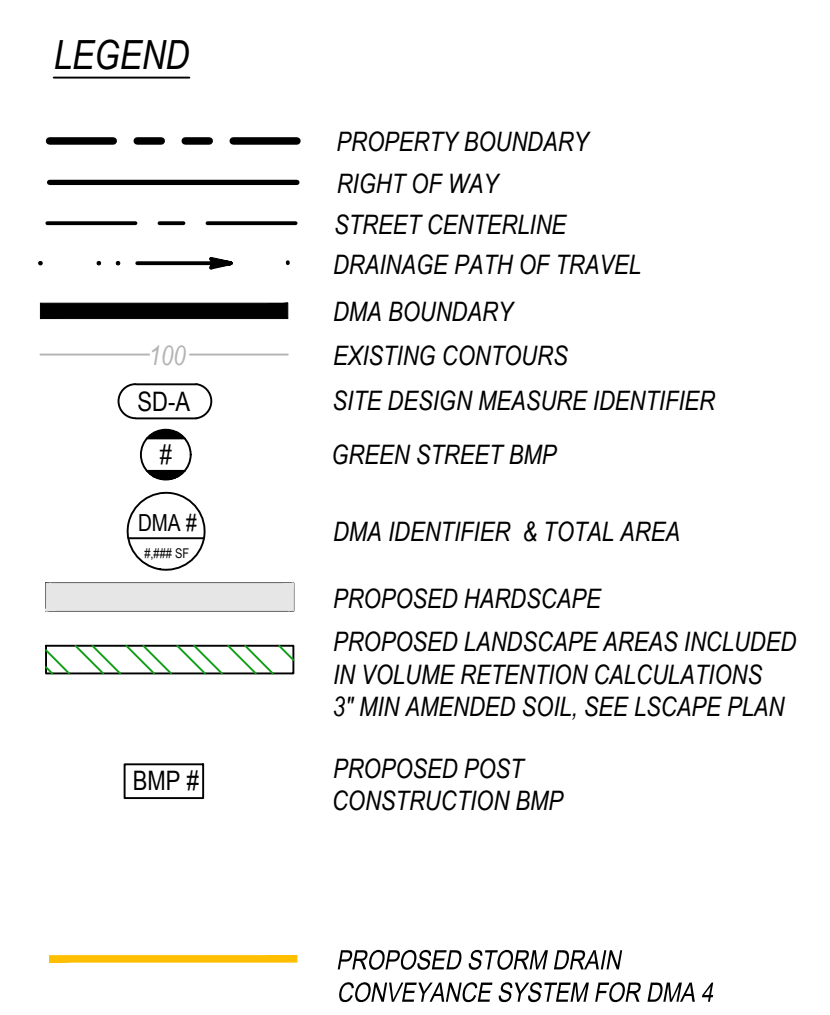

**DMA MAP**

VIEWPOINT OLD TOWN  
DATE: MARCH, 2023

PREPARED BY:  
**PASCO LARET SUITER**  
& ASSOCIATES

San Diego | Solana Beach | Orange County  
Phone 858.259.8212 | www.pisaengineering.com



THIS PAGE INTENTIONALLY LEFT BLANK FOR DOUBLE-SIDED PRINTING

1. Is there a demand for harvested water (check all that apply) at the project site that is reliably present during the wet season?

Toilet and urinal flushing

Landscape irrigation

Other: \_\_\_\_\_

2. If there is a demand; estimate the anticipated average wet season demand over a period of 36 hours. Guidance for planning level demand calculations for toilet/urinal flushing and landscape irrigation is provided in Section B.3.2.  
[Provide a summary of calculations here]

3. Calculate the DCV using worksheet B-2.1.  
DCV = \_\_\_\_\_ (cubic feet)  
[Provide a summary of calculations here]

<p>3a. Is the 36-hour demand greater than or equal to the DCV?</p> <p style="text-align: center;">Yes / No    ⇒</p> <p style="text-align: center;">↓</p>	<p>3b. Is the 36-hour demand greater than 0.25DCV but less than the full DCV?</p> <p style="text-align: center;"><input type="checkbox"/> Yes / No    ⇒</p> <p style="text-align: center;">↓</p>	<p>3c. Is the 36-hour demand less than 0.25DCV?</p> <p style="text-align: center;">Yes</p> <p style="text-align: center;">↓</p>
--	--	---

<p>Harvest and use appears to be feasible. Conduct more detailed evaluation and sizing calculations to confirm that DCV can be used at an adequate rate to meet drawdown criteria.</p>	<p>Harvest and use may be feasible. Conduct more detailed evaluation and sizing calculations to determine feasibility. Harvest and use may only be able to be used for a portion of the site, or (optionally) the storage may need to be upsized to meet long term capture targets while draining in longer than 36 hours.</p>	<p>Harvest and use is considered to be infeasible.</p>
--	--	--

Is harvest and use feasible based on further evaluation?  
 Yes, refer to Appendix E to select and size harvest and use BMPs.  
 No, select alternate BMPs.

Project Name:

**THIS PAGE INTENTIONALLY LEFT BLANK FOR DOUBLE-SIDED PRINTING**

Categorization of Infiltration Feasibility Condition based on Geotechnical Conditions <sup>1</sup>		Worksheet C.4-1: Form I-8A <sup>2</sup>
<b>Part 1 - Full Infiltration Feasibility Screening Criteria</b>		
DMA(s) Being Analyzed:		Project Phase:
<b>Criteria 1: Infiltration Rate Screening</b>		
1A	<p>Is the mapped hydrologic soil group according to the NRCS Web Soil Survey or UC Davis Soil Web Mapper Type A or B and corroborated by available site soil data<sup>3</sup>?</p> <p><input type="checkbox"/> Yes; the DMA may feasibly support full infiltration. Answer “Yes” to Criteria 1 Result or continue to Step 1B if the applicant elects to perform infiltration testing.</p> <p><input type="checkbox"/> No; the mapped soil types are A or B but is not corroborated by available site soil data (continue to Step 1B).</p> <p><input type="checkbox"/> No; the mapped soil types are C, D, or “urban/unclassified” and is corroborated by available site soil data. <b>Answer “No” to Criteria 1 Result.</b></p> <p><input type="checkbox"/> No; the mapped soil types are C, D, or “urban/unclassified” but is not corroborated by available site soil data (continue to Step 1B).</p>	
1B	<p>Is the reliable infiltration rate calculated using planning phase methods from Table D.3-1?</p> <p><input type="checkbox"/> Yes; Continue to Step 1C.</p> <p><input type="checkbox"/> No; Skip to Step 1D.</p>	
1C	<p>Is the reliable infiltration rate calculated using planning phase methods from Table D.3-1 greater than 0.5 inches per hour?</p> <p><input type="checkbox"/> Yes; the DMA may feasibly support full infiltration. Answer “Yes” to Criteria 1 Result.</p> <p><input type="checkbox"/> No; full infiltration is not required. Answer “No” to Criteria 1 Result.</p>	
1D	<p><b>Infiltration Testing Method.</b> Is the selected infiltration testing method suitable during the design phase (see Appendix D.3)? Note: Alternative testing standards may be allowed with appropriate rationales and documentation.</p> <p><input type="checkbox"/> Yes; continue to Step 1E.</p> <p><input type="checkbox"/> <b>No</b>; select an appropriate infiltration testing method.</p>	

<sup>1</sup> Note that it is not required to investigate each and every criterion in the worksheet, a single “no” answer in Part 1, Part 2, Part 3, or Part 4 determines a full, partial, or no infiltration condition.

<sup>2</sup> This form must be completed each time there is a change to the site layout that would affect the infiltration feasibility condition. Previously completed forms shall be retained to document the evolution of the site storm water design.

<sup>3</sup> Available data includes site-specific sampling or observation of soil types or texture classes, such as obtained from borings or test pits necessary to support other design elements.



Categorization of Infiltration Feasibility Condition based on Geotechnical Conditions		Worksheet C.4-1: Form I-8A <sup>2</sup>
1E	<p><b>Number of Percolation/Infiltration Tests.</b> Does the infiltration testing method performed satisfy the minimum number of tests specified in Table D.3-2?</p> <p><input type="checkbox"/> Yes; continue to Step 1F.</p> <p><input type="checkbox"/> No; conduct appropriate number of tests.</p>	
1F	<p><b>Factor of Safety.</b> Is the suitable Factor of Safety selected for full infiltration design? See guidance in D.5; Tables D.5-1 and D.5-2; and Worksheet D.5-1 (Form I-9).</p> <p><input type="checkbox"/> Yes; continue to Step 1G.</p> <p><input type="checkbox"/> No; select appropriate factor of safety.</p>	
1G	<p><b>Full Infiltration Feasibility.</b> Is the average measured infiltration rate divided by the Factor of Safety greater than 0.5 inches per hour?</p> <p><input type="checkbox"/> Yes; answer “Yes” to Criteria 1 Result.</p> <p><input type="checkbox"/> No; answer “No” to Criteria 1 Result.</p>	
Criteria 1 Result	<p>Is the estimated reliable infiltration rate greater than 0.5 inches per hour within the DMA where runoff can reasonably be routed to a BMP?</p> <p><input type="checkbox"/> Yes; the DMA may feasibly support full infiltration. Continue to Criteria 2.</p> <p><input type="checkbox"/> No; full infiltration is not required. Skip to Part 1 Result.</p>	
<p>Summarize infiltration testing methods, testing locations, replicates, and results and summarize estimates of reliable infiltration rates according to procedures outlined in D.5. Documentation should be included in project geotechnical report.</p>		





Categorization of Infiltration Feasibility Condition based on Geotechnical Conditions		Worksheet C.4-1: Form I-8A <sup>2</sup>	
<b>Criteria 2: Geologic/Geotechnical Screening</b>			
2A	<p>If all questions in Step 2A are answered “Yes,” continue to Step 2B.</p> <p>For any “No” answer in Step 2A answer “No” to Criteria 2, and submit an “Infiltration Feasibility Condition Letter” that meets the requirements in Appendix C.1.1. The geologic/geotechnical analyses listed in Appendix C.2.1 do not apply to the DMA because one of the following setbacks cannot be avoided and therefore result in the DMA being in a no infiltration condition. The setbacks must be the closest horizontal radial distance from the surface edge (at the overflow elevation) of the BMP.</p>		
2A-1	Can the proposed full infiltration BMP(s) avoid areas with existing fill materials greater than 5 feet thick below the infiltrating surface?	<input type="checkbox"/> Yes	<input type="checkbox"/> No
2A-2	Can the proposed full infiltration BMP(s) avoid placement within 10 feet of existing underground utilities, structures, or retaining walls?	<input type="checkbox"/> Yes	<input type="checkbox"/> No
2A-3	Can the proposed full infiltration BMP(s) avoid placement within 50 feet of a natural slope (>25%) or within a distance of 1.5H from fill slopes where H is the height of the fill slope?	<input type="checkbox"/> Yes	<input type="checkbox"/> No
2B	<p>When full infiltration is determined to be feasible, a geotechnical investigation report must be prepared that considers the relevant factors identified in Appendix C.2.1.</p> <p>If all questions in Step 2B are answered “Yes,” then answer “Yes” to Criteria 2 Result. If there are “No” answers continue to Step 2C.</p>		
2B-1	<p><b>Hydroconsolidation.</b> Analyze hydroconsolidation potential per approved ASTM standard due to a proposed full infiltration BMP.</p> <p>Can full infiltration BMPs be proposed within the DMA without increasing hydroconsolidation risks?</p>	<input type="checkbox"/> Yes	<input type="checkbox"/> No
2B-2	<p><b>Expansive Soils.</b> Identify expansive soils (soils with an expansion index greater than 20) and the extent of such soils due to proposed full infiltration BMPs.</p> <p>Can full infiltration BMPs be proposed within the DMA without increasing expansive soil risks?</p>	<input type="checkbox"/> Yes	<input type="checkbox"/> No



Categorization of Infiltration Feasibility Condition based on Geotechnical Conditions		Worksheet C.4-1: Form I-8A <sup>2</sup>	
2B-3	<p><b>Liquefaction.</b> If applicable, identify mapped liquefaction areas. Evaluate liquefaction hazards in accordance with Section 6.4.2 of the City of San Diego's Guidelines for Geotechnical Reports (2011 or most recent edition). Liquefaction hazard assessment shall take into account any increase in groundwater elevation or groundwater mounding that could occur as a result of proposed infiltration or percolation facilities.</p> <p>Can full infiltration BMPs be proposed within the DMA without increasing liquefaction risks?</p>	<input type="checkbox"/> Yes	<input type="checkbox"/> No
2B-4	<p><b>Slope Stability.</b> If applicable, perform a slope stability analysis in accordance with the ASCE and Southern California Earthquake Center (2002) Recommended Procedures for Implementation of DMG Special Publication 117, Guidelines for Analyzing and Mitigating Landslide Hazards in California to determine minimum slope setbacks for full infiltration BMPs. See the City of San Diego's Guidelines for Geotechnical Reports (2011) to determine which type of slope stability analysis is required.</p> <p>Can full infiltration BMPs be proposed within the DMA without increasing slope stability risks?</p>	<input type="checkbox"/> Yes	<input type="checkbox"/> No
2B-5	<p><b>Other Geotechnical Hazards.</b> Identify site-specific geotechnical hazards not already mentioned (refer to Appendix C.2.1).</p> <p>Can full infiltration BMPs be proposed within the DMA without increasing risk of geologic or geotechnical hazards not already mentioned?</p>	<input type="checkbox"/> Yes	<input type="checkbox"/> No
2B-6	<p><b>Setbacks.</b> Establish setbacks from underground utilities, structures, and/or retaining walls. Reference applicable ASTM or other recognized standard in the geotechnical report.</p> <p>Can full infiltration BMPs be proposed within the DMA using established setbacks from underground utilities, structures, and/or retaining walls?</p>	<input type="checkbox"/> Yes	<input type="checkbox"/> No



Categorization of Infiltration Feasibility Condition based on Geotechnical Conditions		Worksheet C.4-1: Form I-8A <sup>2</sup>	
2C	<p><b>Mitigation Measures.</b> Propose mitigation measures for each geologic/geotechnical hazard identified in Step 2B. Provide a discussion of geologic/geotechnical hazards that would prevent full infiltration BMPs that cannot be reasonably mitigated in the geotechnical report. See Appendix C.2.1.8 for a list of typically reasonable and typically unreasonable mitigation measures.</p> <p>Can mitigation measures be proposed to allow for full infiltration BMPs? If the question in Step 2 is answered “Yes,” then answer “Yes” to Criteria 2 Result.</p> <p>If the question in Step 2C is answered “No,” then answer “No” to Criteria 2 Result.</p>	<input type="checkbox"/> Yes	<input type="checkbox"/> No
Criteria 2 Result	Can infiltration greater than 0.5 inches per hour be allowed without increasing risk of geologic or geotechnical hazards that cannot be reasonably mitigated to an acceptable level?	<input type="checkbox"/> Yes	<input type="checkbox"/> No
Summarize findings and basis; provide references to related reports or exhibits.			
<b>Part 1 Result – Full Infiltration Geotechnical Screening<sup>4</sup></b>		<b>Result</b>	
<p>If answers to both Criteria 1 and Criteria 2 are “Yes”, a full infiltration design is potentially feasible based on Geotechnical conditions only.</p> <p>If either answer to Criteria 1 or Criteria 2 is “No”, a full infiltration design is not required.</p>		<input type="checkbox"/> Full infiltration Condition <input type="checkbox"/> Complete Part 2	

<sup>4</sup> To be completed using gathered site information and best professional judgement considering the definition of MEP in the MS4 Permit. Additional testing and/or studies may be required by City Engineer to substantiate findings.



Categorization of Infiltration Feasibility Condition based on Geotechnical Conditions		Worksheet C.4-1: Form I-8A <sup>2</sup>
<b>Part 2 – Partial vs. No Infiltration Feasibility Screening Criteria</b>		
DMA(s) Being Analyzed:		Project Phase:
<b>Criteria 3 : Infiltration Rate Screening</b>		
3A	<p><b>NRCS Type C, D, or “urban/unclassified”:</b> Is the mapped hydrologic soil group according to the NRCS Web Soil Survey or UC Davis Soil Web Mapper is Type C, D, or “urban/unclassified” and corroborated by available site soil data?</p> <p><input type="checkbox"/> Yes; the site is mapped as C soils and a reliable infiltration rate of 0.15 in/hr. is used to size partial infiltration BMPS. Answer “Yes” to Criteria 3 Result.</p> <p><input type="checkbox"/> Yes; the site is mapped as D soils or “urban/unclassified” and a reliable infiltration rate of 0.05 in/hr. is used to size partial infiltration BMPS. Answer “Yes” to Criteria 3 Result.</p> <p><input type="checkbox"/> No; infiltration testing is conducted (refer to Table D.3-1), continue to Step 3B.</p>	
3B	<p><b>Infiltration Testing Result:</b> Is the reliable infiltration rate (i.e. average measured infiltration rate/2) greater than 0.05 in/hr. and less than or equal to 0.5 in/hr?</p> <p><input type="checkbox"/> Yes; the site may support partial infiltration. Answer “Yes” to Criteria 3 Result.</p> <p><input type="checkbox"/> No; the reliable infiltration rate (i.e. average measured rate/2) is less than 0.05 in/hr., partial infiltration is not required. Answer “No” to Criteria 3 Result.</p>	
Criteria 3 Result	<p>Is the estimated reliable infiltration rate (i.e., average measured infiltration rate/2) greater than or equal to 0.05 inches/hour and less than or equal to 0.5 inches/hour at any location within each DMA where runoff can reasonably be routed to a BMP?</p> <p><input type="checkbox"/> Yes; Continue to Criteria 4.</p> <p><input type="checkbox"/> No: Skip to Part 2 Result.</p>	
<p>Summarize infiltration testing and/or mapping results (i.e. soil maps and series description used for infiltration rate).</p>		



Categorization of Infiltration Feasibility Condition based on Geotechnical Conditions		Worksheet C.4-1: Form I-8A <sup>2</sup>	
<b>Criteria 4: Geologic/Geotechnical Screening</b>			
4A	<p>If all questions in Step 4A are answered “Yes,” continue to Step 2B.</p> <p>For any “No” answer in Step 4A answer “No” to Criteria 4 Result, and submit an “Infiltration Feasibility Condition Letter” that meets the requirements in Appendix C.1.1. The geologic/geotechnical analyses listed in Appendix C.2.1 do not apply to the DMA because one of the following setbacks cannot be avoided and therefore result in the DMA being in a no infiltration condition. The setbacks must be the closest horizontal radial distance from the surface edge (at the overflow elevation) of the BMP.</p>		
4A-1	Can the proposed partial infiltration BMP(s) avoid areas with existing fill materials greater than 5 feet thick?	<input type="checkbox"/> Yes	<input type="checkbox"/> No
4A-2	Can the proposed partial infiltration BMP(s) avoid placement within 10 feet of existing underground utilities, structures, or retaining walls?	<input type="checkbox"/> Yes	<input type="checkbox"/> No
4A-3	Can the proposed partial infiltration BMP(s) avoid placement within 50 feet of a natural slope (>25%) or within a distance of 1.5H from fill slopes where H is the height of the fill slope?	<input type="checkbox"/> Yes	<input type="checkbox"/> No
4B	<p>When full infiltration is determined to be feasible, a geotechnical investigation report must be prepared that considers the relevant factors identified in Appendix C.2.1.</p> <p>If all questions in Step 4B are answered “Yes,” then answer “Yes” to Criteria 4 Result. If there are any “No” answers continue to Step 4C.</p>		
4B-1	<p><b>Hydroconsolidation.</b> Analyze hydroconsolidation potential per approved ASTM standard due to a proposed full infiltration BMP.</p> <p>Can partial infiltration BMPs be proposed within the DMA without increasing hydroconsolidation risks?</p>	<input type="checkbox"/> Yes	<input type="checkbox"/> No
4B-2	<p><b>Expansive Soils.</b> Identify expansive soils (soils with an expansion index greater than 20) and the extent of such soils due to proposed full infiltration BMPs.</p> <p>Can partial infiltration BMPs be proposed within the DMA without increasing expansive soil risks?</p>	<input type="checkbox"/> Yes	<input type="checkbox"/> No
4B-3	<p><b>Liquefaction.</b> If applicable, identify mapped liquefaction areas. Evaluate liquefaction hazards in accordance with Section 6.4.2 of the City of San Diego's Guidelines for Geotechnical Reports (2011). Liquefaction hazard assessment shall take into account any increase in groundwater elevation or groundwater mounding that could occur as a result of proposed infiltration or percolation facilities.</p> <p>Can partial infiltration BMPs be proposed within the DMA without increasing liquefaction risks?</p>	<input type="checkbox"/> Yes	<input type="checkbox"/> No



Categorization of Infiltration Feasibility Condition based on Geotechnical Conditions		Worksheet C.4-1: Form I-8A <sup>2</sup>	
4B-4	<p><b>Slope Stability.</b> If applicable, perform a slope stability analysis in accordance with the ASCE and Southern California Earthquake Center (2002) Recommended Procedures for Implementation of DMG Special Publication 117, Guidelines for Analyzing and Mitigating Landslide Hazards in California to determine minimum slope setbacks for full infiltration BMPs. See the City of San Diego's Guidelines for Geotechnical Reports (2011) to determine which type of slope stability analysis is required.</p> <p>Can partial infiltration BMPs be proposed within the DMA without increasing slope stability risks?</p>	<input type="checkbox"/> Yes	<input type="checkbox"/> No
4B-5	<p><b>Other Geotechnical Hazards.</b> Identify site-specific geotechnical hazards not already mentioned (refer to Appendix C.2.1).</p> <p>Can partial infiltration BMPs be proposed within the DMA without increasing risk of geologic or geotechnical hazards not already mentioned?</p>	<input type="checkbox"/> Yes	<input type="checkbox"/> No
4B-6	<p><b>Setbacks.</b> Establish setbacks from underground utilities, structures, and/or retaining walls. Reference applicable ASTM or other recognized standard in the geotechnical report.</p> <p>Can partial infiltration BMPs be proposed within the DMA using recommended setbacks from underground utilities, structures, and/or retaining walls?</p>	<input type="checkbox"/> Yes	<input type="checkbox"/> No
4C	<p><b>Mitigation Measures.</b> Propose mitigation measures for each geologic/geotechnical hazard identified in Step 4B. Provide a discussion on geologic/geotechnical hazards that would prevent partial infiltration BMPs that cannot be reasonably mitigated in the geotechnical report. See Appendix C.2.1.8 for a list of typically reasonable and typically unreasonable mitigation measures.</p> <p>Can mitigation measures be proposed to allow for partial infiltration BMPs? If the question in Step 4C is answered "Yes," then answer "Yes" to Criteria 4 Result. If the question in Step 4C is answered "No," then answer "No" to Criteria 4 Result.</p>	<input type="checkbox"/> Yes	<input type="checkbox"/> No
Criteria 4 Result	<p>Can infiltration of greater than or equal to 0.05 inches/hour and less than or equal to 0.5 inches/hour be allowed without increasing the risk of geologic or geotechnical hazards that cannot be reasonably mitigated to an acceptable level?</p>	<input type="checkbox"/> Yes	<input type="checkbox"/> No



**Categorization of Infiltration Feasibility Condition based on Geotechnical Conditions**

**Worksheet C.4-1: Form I-8A<sup>2</sup>**

Summarize findings and basis; provide references to related reports or exhibits.

**Part 2 – Partial Infiltration Geotechnical Screening Result<sup>5</sup>**

**Result**

If answers to both Criteria 3 and Criteria 4 are “Yes”, a partial infiltration design is potentially feasible based on geotechnical conditions only.

If answers to either Criteria 3 or Criteria 4 is “No”, then infiltration of any volume is considered to be infeasible within the site.

Partial Infiltration Condition

No Infiltration Condition

<sup>5</sup> To be completed using gathered site information and best professional judgement considering the definition of MEP in the MS4 Permit. Additional testing and/or studies may be required by City Engineer to substantiate findings.



Compact (high rate) Biofiltration BMP Checklist		Form I-10
<p>Compact (high rate) biofiltration BMPs have a media filtration rate greater than 5 in/hr. and a media surface area smaller than 3% of contributing area times adjusted runoff factor. Compact biofiltration BMPs are typically proprietary BMPs that may qualify as biofiltration.</p> <p>A compact biofiltration BMP may satisfy the pollutant control requirements for a DMA onsite in some cases. This depends on the characteristics of the DMA <b>and</b> the performance certification/data of the BMP. If the pollutant control requirements for a DMA are met onsite, then the DMA is not required to participate in an offsite storm water alternative compliance program to meet its pollutant control obligations.</p> <p>An applicant using a compact biofiltration BMP to meet the pollutant control requirements onsite must complete Section 1 of this form and include it in the PDP SWQMP. A separate form must be completed for each DMA. In instances where the City Engineer does not agree with the applicant's determination, Section 2 of this form will be completed by the City and returned to the applicant.</p>		
<p><b>Section 1: Biofiltration Criteria Checklist (Appendix F)</b></p> <p>Refer to Part 1 of the Storm Water Standards to complete this section. When separate forms/worksheets are referenced below, the applicant must also complete these separate forms/worksheets (as applicable) and include in the PDP SWQMP. The criteria numbers below correspond to the criteria numbers in Appendix F.</p>		
Criteria	Answer	Progression
<p><b>Criteria 1 and 3:</b></p> <p>What is the infiltration condition of the DMA?</p> <p>Refer to Section 5.4.2 and Appendix C of the BMP Design Manual (Part 1 of Storm Water Standards) for guidance.</p> <p>Applicant must complete and include the following in the PDP SWQMP submittal to support the feasibility determination:</p> <ul style="list-style-type: none"> <li>• Infiltration Feasibility Condition Letter; or</li> <li>• Worksheet C.4-1: Form I-8A and Worksheet C.4-2: Form I-8B.</li> </ul> <p>Applicant must complete and include all applicable sizing worksheets in the SWQMP submittal</p>	<input type="checkbox"/> Full Infiltration Condition	<p><b>Stop.</b> Compact biofiltration BMP is not allowed.</p>
	<input type="checkbox"/> Partial Infiltration Condition	<p>Compact biofiltration BMP is only allowed, if the target volume retention is met onsite (Refer to Table B.5-1 in Appendix B.5). Use Worksheet B.5-2 in Appendix B.5 to estimate the target volume retention (Note: retention in this context means reduction).</p> <p>If the required volume reduction is achieved <b>proceed to Criteria 2.</b></p> <p>If the required volume reduction is not achieved, compact biofiltration BMP is not allowed. <b>Stop.</b></p>
	<input type="checkbox"/> No Infiltration Condition	<p>Compact biofiltration BMP is allowed if volume retention criteria in Table B.5-1 in Appendix B.5 for the no infiltration condition is met. Compliance with this criterion must be documented in the PDP SWQMP.</p> <p>If the criteria in Table B.5-1 is met <b>proceed to Criteria 2.</b></p> <p>If the criteria in Table B.5-1 is not met, compact biofiltration BMP is not allowed. <b>Stop.</b></p>







**GEOTECHNICAL**  
**MATERIALS**  
**SPECIAL INSPECTION**

DVBE ♦ SBE ♦ SDVOSB ♦ SLBE

Viewpoint Development LLC  
Mr. Chris Livoni  
1635 Pacific Ranch Drive  
Encinitas, CA 92024

July 18, 2022  
NOVA Project No. 2021073

**Subject:** Infiltration Feasibility Condition Letter  
Viewpoint Old Town Apartments  
4620 Pacific Highway, San Diego, California

**References:** NOVA Services, Inc., 2022. *Report Geotechnical Investigation, Viewpoint Old Town Apartments, 4620 Pacific Highway, San Diego, California*, NOVA Project No. 2021069, July 18, 2022.  
carrierjohnson + culture (CJC), 2022, *Viewpoint Old Town, 46220 Pacific Hwy, San Diego, CA 92110*, 38 Sheets, Plot Date 3/31/2022.  
City San Diego, 2021, Stormwater Standards Manual, Effective Date: May 2021.  
City of San Diego. 2008, Seismic Safety Study, Grid 20, dated April 3.

Dear Mr. Livoni,

The intent of this letter is to provide the findings of an assessment by NOVA Services, Inc. (NOVA) of the infiltration conditions and related feasibility for permanent stormwater Best Management Practices ('stormwater BMPs') for drainage management areas (DMAs) at the above-referenced site.

The assessment has been prepared by NOVA for the Viewpoint Old Town Apartments. NOVA is retained by Viewpoint Development as Geotechnical Engineer-of-Record (GEOR) for the project.

The assessment provides an analysis of the infiltration feasibility in accordance with the criteria detailed in Section C.1.1 Simple Feasibility Criteria of the referenced City of San Diego BMP Design Manual (San Diego 2021). Based on these criteria, it is NOVA's opinion that this site should be considered to have a 'no-infiltration' condition.

## **EXISTING GEOLOGIC AND GEOTECHNICAL CONDITIONS**

Section C.1 of the BMP Manual states that if one of the standard setbacks listed cannot be achieved, the DMA may classify as a 'no infiltration condition'. Consideration of the existing fill thickness across the site and the location of the proposed BMPs, preclude the implementation of infiltration for the proposed BMPs.

As reported in NOVA 2022 and presented in Figure 1, the entire site is mapped on the regional geologic map as “af” a deep layer of undocumented artificial fill. Based on our subsurface investigation, this layer is approximately 15 feet deep. The BMP manual states that full and partial infiltration BMPs should not be placed within existing fill soils greater than 5 feet thick.

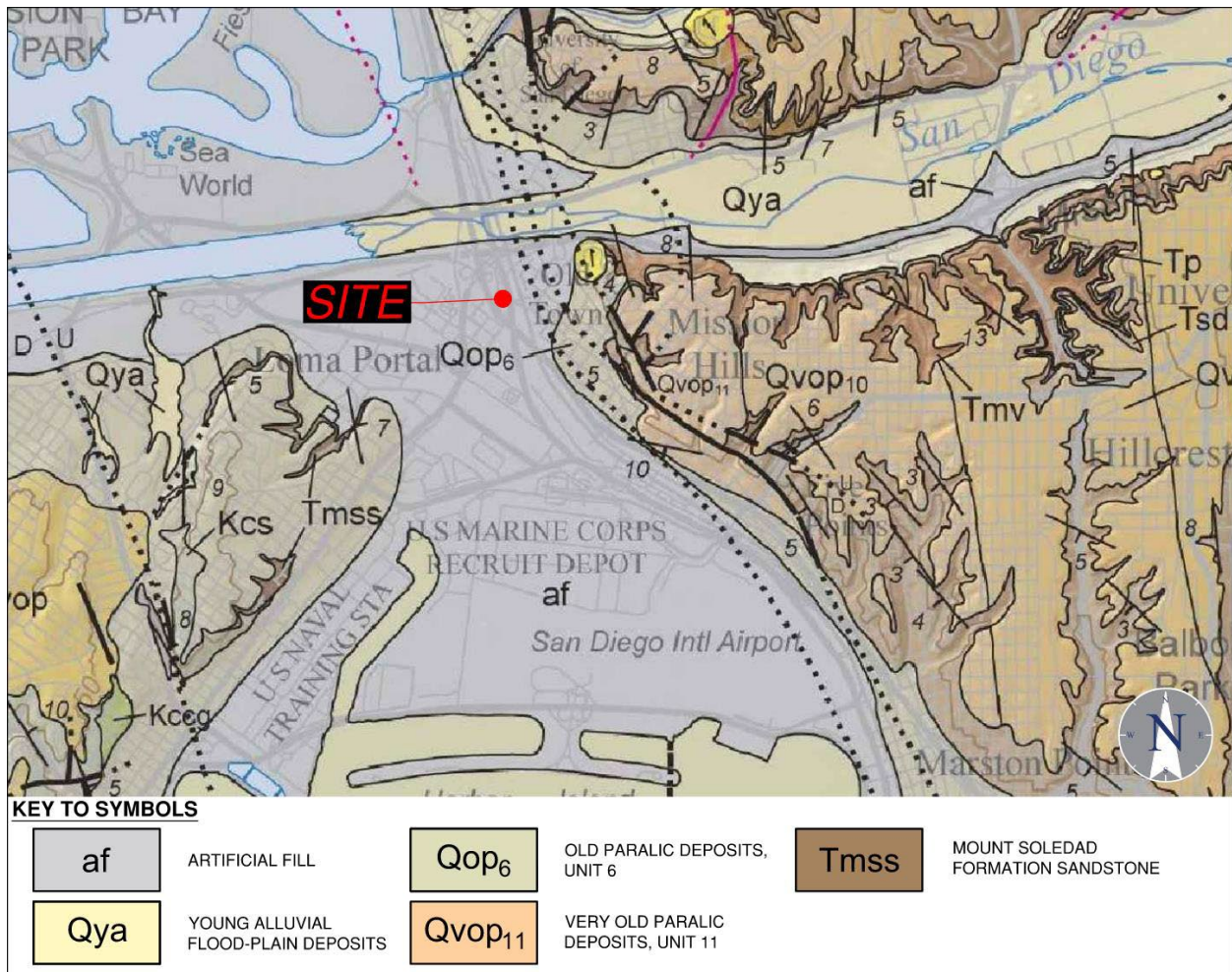

Figure 1. Regional Geology Map (Kennedy and Tan, 2008)

In addition, groundwater was measured at elevation +0.3 feet mean sea level- 9.7 feet below the existing ground surface. If infiltration were to be allowed, the infiltration surface would be far less than the recommended 10 feet of vertical separation between the infiltration surface and groundwater.

Finally, as shown in Figure 2, this site is mapped by the City of San Diego Seismic Safety Study as an area highly susceptible to liquefaction. NOVA has provided a liquefaction analysis on the site and determined that ground improvements or deep foundations are necessary to mitigate settlement caused by liquefaction.





- *The development status of the site prior to the project application (i.e., new development with raw ungraded land, or redevelopment with existing graded conditions).*

The approximately 1.75-acre site is comprised of APN's 442-740-03-00, 442-740-06-00, 442-740-07-00, nominally located at 4620 Pacific Highway in San Diego. The site is bounded on the east by Pacific Highway. The arcuate-shaped connector between Interstate 5 North to Interstate 8 East bounds the site to the north and west, with Rosecrans Street to the south.

The site is level, ranging from an elevation of +10 feet mean sea level (msl) on the north side of the site to +11 feet msl on the southern portion of the site. The site is currently occupied by the single-level Perry's Cafe and a surrounding asphalt parking lot. A 4-foot to 6-foot tall retaining wall bounds the site along the Caltrans I-5/I-8 connector.

Available historic photography indicates that the grading for the existing restaurant building and parking lot was completed between 1962 and 1964.

- *The history of design discussions for the project footprint, resulting in the final design determination.*

NOVA has not been involved in design discussions pertaining to the project footprint. The footprint appears to maximize the available area for use as apartment units and the associated parking.

- *Full/partial infiltration BMP standard setbacks to underground utilities, structures, retaining walls, fill slopes, and natural slopes applicable to the DMA that prevent full/partial infiltration.*

As discussed previously, based on the BMP Manual, full and partial BMPs should not be sited within existing fill soils greater than 5 feet thick. As may be seen by a review of Figure 1 and boring logs in NOVA 2022, the site is covered by fill soils greater than 5 feet in thickness.

- *The physical impairments (i.e., fire road egress, public safety considerations, etc.) that prevent full/partial infiltration.*

The addition of stormwater into liquefiable soils is a risk to public safety.

- *The consideration of site design alternatives to achieve partial/full infiltration within the BMP.*

Based on high groundwater, deep fills, and liquefiable soils, stormwater infiltration should not be performed at this site. There are no viable design alternatives, as these conditions are uniform across the site.

- *The extent site design BMP requirements were included in the overall design.*

The Site Development Plan indicates that four DMAs are included in this project. Three are roof filtration systems and one is hardscape (CJC, 2022).



July 18, 2022

- *Conclusion of recommendation from the geotechnical engineer regarding the DMA's infiltration condition.*

In conclusion, given the deep fill condition, the shallow groundwater, and the liquefiable nature of the soils, it is NOVA's opinion that the risk of geologic or geotechnical hazards cannot be reasonably mitigated to an acceptable level at the site.

- *An Exhibit for all applicable DMAs that clearly labels:*
  - *Proposed development areas and development type.*
  - *All applicable features and setbacks that prevent partial or full infiltration, including underground utilities, structures, retaining walls, fill slopes, natural slopes, and existing fill materials greater than 5 feet.*
  - *Potential locations for structural BMPs.*
  - *Areas where full/partial infiltration BMPs cannot be proposed.*

See Plate 1 within NOVA 2022 for development areas and a cross-section of the proposed development. The development is five stories of residential apartments over one at-grade podium level with a partial subterranean parking level. Fill between 15 to 16 feet is mapped below the site, groundwater is located less than 10 feet below ground surface and the soils are liquefiable, therefore infiltration BMPs may not be proposed anywhere at this site.

### CLOSURE

NOVA appreciates the opportunity to be of service to Viewpoint Development on this project. Should you have any questions regarding this letter or other matters, please contact the undersigned at 858.292.7575 x 413.

Sincerely,  
**NOVA Services, Inc.**

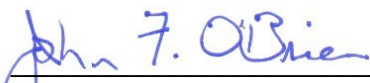
  
John F. O'Brien, PE, GE  
Principal Engineer



  
Melissa Stayner, PG, CEG  
Senior Engineering Geologist

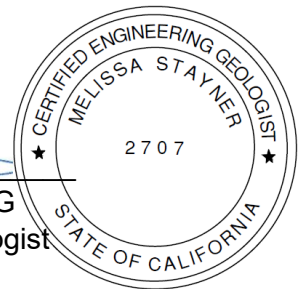

Project Name:

**THIS PAGE INTENTIONALLY LEFT BLANK FOR DOUBLE-SIDED PRINTING**

**Provide basis for Criteria 1 and 3:**

**Feasibility Analysis:**

Summarize findings and include either infiltration feasibility condition letter or Worksheet C.4-1: Form I-8A and Worksheet C.4-2: Form I-8B in the PDP SWQMP submittal.

**If Partial Infiltration Condition:**

Provide documentation that target volume retention is met (include Worksheet B.5-2 in the PDP SWQMP submittal). Worksheet B.5-7 in Appendix B.5 can be used to estimate volume retention benefits from landscape areas.

**If No Infiltration Condition:**

Provide documentation that the volume retention performance standard is met (include Worksheet B.5-2 in the PDP SWQMP submittal) in the PDP SWQMP submittal. Worksheet B.5-6 in Appendix B.5 can be used to document that the performance standard is met.

Criteria	Answer	Progression
<p><b>Criteria 2:</b></p> <p>Is the compact biofiltration BMP sized to meet the performance standard from the MS4 Permit?</p> <p>Refer to Appendix B.5 and Appendix F.2 of the BMP Design Manual (Part 1 of Storm Water Standards) for guidance.</p>	<input type="checkbox"/> Meets Flow based Criteria	<p>Use guidance from <b>Appendix F.2.2</b> to size the compact biofiltration BMP to meet the flow based criteria. Include the calculations in the PDP SWQMP.</p> <p>Use parameters for sizing consistent with manufacturer guidelines and conditions of its third party certifications (i.e. a BMP certified at a loading rate of 1 gpm/sq. ft. cannot be designed using a loading rate of 1.5 gpm/sq. ft.)</p> <p><b>Proceed to Criteria 4.</b></p>
	<input type="checkbox"/> Meets Volume based Criteria	<p>Provide documentation that the compact biofiltration BMP has a total static (i.e. non-routed) storage volume, including pore-spaces and pre-filter detention volume (Refer to Appendix B.5 for a schematic) of at least 0.75 times the portion of the DCV not reliably retained onsite.</p> <p><b>Proceed to Criteria 4.</b></p>
	<input type="checkbox"/> Does not Meet either criteria	<p><b>Stop.</b> Compact biofiltration BMP is not allowed.</p>





**Provide basis for Criteria 2:**

Provide documentation that the BMP meets the numeric criteria and is designed consistent with the manufacturer guidelines and conditions of its third-party certification (i.e., loading rate, etc., as applicable).

Criteria	Answer	Progression
<p><b>Criteria 4:</b></p> <p>Does the compact biofiltration BMP meet the pollutant treatment performance standard for the projects most significant pollutants of concern?</p> <p>Refer to Appendix B.6 and Appendix F.1 of the BMP Design Manual (Part 1 of Storm Water Standards) for guidance.</p>	<input type="checkbox"/> Yes, meets the TAPE certification.	Provide documentation that the compact BMP has an appropriate TAPE certification for the projects most significant pollutants of concern. <b>Proceed to Criteria 5.</b>
	<input type="checkbox"/> Yes, through other third-party documentation	Acceptance of third-party documentation is at the discretion of the City Engineer. The City engineer will consider, (a) the data submitted; (b) representativeness of the data submitted; and (c) consistency of the BMP performance claims with pollutant control objectives in Table F.1-2 and Table F.1-1 while making this determination. If a compact biofiltration BMP is not accepted, a written explanation/ reason will be provided in Section 2. <b>Proceed to Criteria 5.</b>
	<input type="checkbox"/> No	<b>Stop.</b> Compact biofiltration BMP is not allowed.

**Provide basis for Criteria 4:**

Provide documentation that identifies the projects most significant pollutants of concern and TAPE certification or other third party documentation that shows that the compact biofiltration BMP meets the pollutant treatment performance standard for the projects most significant pollutants of concern.





Compact (high rate) Biofiltration BMP Checklist		Form I-10
Criteria	Answer	Progression
<p><b>Criteria 5:</b> Is the compact biofiltration BMP designed to promote appropriate biological activity to support and maintain treatment process? Refer to Appendix F of the BMP Design Manual (Part 1 of Storm Water Standards) for guidance.</p>	<input type="checkbox"/> Yes	Provide documentation that the compact biofiltration BMP support appropriate biological activity. Refer to Appendix F for guidance. <b>Proceed to Criteria 6.</b>
	<input type="checkbox"/> No	<b>Stop.</b> Compact biofiltration BMP is not allowed.
<p><b>Provide basis for Criteria 5:</b></p> <p>Provide documentation that appropriate biological activity is supported by the compact biofiltration BMP to maintain treatment process.</p>		
Criteria	Answer	Progression
<p><b>Criteria 6:</b> Is the compact biofiltration BMP designed with a hydraulic loading rate to prevent erosion, scour and channeling within the BMP?</p>	<input type="checkbox"/> Yes	Provide documentation that the compact biofiltration BMP is used in a manner consistent with manufacturer guidelines and conditions of its third-party certification. <b>Proceed to Criteria 7.</b>
	<input type="checkbox"/> No	<b>Stop.</b> Compact biofiltration BMP is not allowed.
<p><b>Provide basis for Criteria 6:</b></p> <p>Provide documentation that the BMP meets the numeric criteria and is designed consistent with the manufacturer guidelines and conditions of its third-party certification (i.e., maximum tributary area, maximum inflow velocities, etc., as applicable).</p>		



Compact (high rate) Biofiltration BMP Checklist		Form I-10
Criteria	Answer	Progression
<p><b>Criteria 7:</b> Is the compact biofiltration BMP maintenance plan consistent with manufacturer guidelines and conditions of its third-party certification (i.e., maintenance activities, frequencies)?</p>	<input type="checkbox"/> Yes, and the compact BMP is privately owned, operated and not in the public right of way.	<p>Submit a maintenance agreement that will also include a statement that the BMP will be maintained in accordance with manufacturer guidelines and conditions of third-party certification.</p> <p><b>Stop.</b> The compact biofiltration BMP meets the required criteria.</p>
	<input type="checkbox"/> Yes, and the BMP is either owned or operated by the City or in the public right of way.	<p>Approval is at the discretion of the City Engineer. The city engineer will consider maintenance requirements, cost of maintenance activities, relevant previous local experience with operation and maintenance of the BMP type, ability to continue to operate the system in event that the vending company is no longer operating as a business or other relevant factors while making the determination.</p> <p><b>Stop.</b> Consult the City Engineer for a determination.</p>
	<input type="checkbox"/> No	<p><b>Stop.</b> Compact biofiltration BMP is not allowed.</p>
<p><b>Provide basis for Criteria 7:</b></p> <p>Include copy of manufacturer guidelines and conditions of third-party certification in the maintenance agreement. PDP SWQMP must include a statement that the compact BMP will be maintained in accordance with manufacturer guidelines and conditions of third-party certification.</p>		







Project Name:

**THIS PAGE INTENTIONALLY LEFT BLANK FOR DOUBLE-SIDED PRINTING**

		<b>Project Name</b> VIEWPOINT OLD TOWN (PERRY'S)		
		<b>BMP ID</b> BMP 1		
<b>Sizing Method for Volume Retention Criteria</b>			<b>Worksheet B.5-2</b>	
1	Area draining to the BMP	18438	sq. ft.	
2	Adjusted runoff factor for drainage area (Refer to Appendix B.1 and B.2)	0.9		
3	85 <sup>th</sup> percentile 24-hour rainfall depth	0.52	inches	
4	Design capture volume [Line 1 x Line 2 x (Line 3/12)]	719	cu. ft.	
<b>Volume Retention Requirement</b>				
5	Measured infiltration rate in the DMA  Note:  When mapped hydrologic soil groups are used enter 0.10 for NRCS Type D soils and for NRCS Type C soils enter 0.30  When in no infiltration condition and the actual measured infiltration rate is unknown enter 0.0 if there are geotechnical and/or groundwater hazards identified in Appendix C or	0	in/hr.	
6	Factor of safety	2		
7	Reliable infiltration rate, for biofiltration BMP sizing [Line 5 / Line 6]	0	in/hr.	
8	Average annual volume reduction target (Figure B.5-2) When Line 7 > 0.01 in/hr. = Minimum (40, 166.9 x Line 7 + 6.62)  When Line 7 ≤ 0.01 in/hr. = 3.5%	3.5	%	
9	Fraction of DCV to be retained (Figure B.5-3) When Line 8 > 8% = $0.0000013 \times \text{Line } 8^3 - 0.000057 \times \text{Line } 8^2 + 0.0086 \times \text{Line } 8 - 0.014$  When Line 8 ≤ 8% = 0.023	0.023		
10	Target volume retention [Line 9 x Line 4]	17	cu. ft.	

		<b>Project Name</b> VIEWPOINT OLD TOWN (PERRY'S)	
		<b>BMP ID</b> BMP 1	
<b>Volume Retention for No Infiltration Condition</b>			<b>Worksheet B.5-6</b>
1	Area draining to the biofiltration BMP	18438	sq. ft.
2	Adjusted runoff factor for drainage area (Refer to Appendix B.1 and B.2)	1	
3	Effective impervious area draining to the BMP [Line 1 x Line 2]	18438	sq. ft.
4	Required area for Evapotranspiration [Line 3 x 0.03]	553	sq. ft.
5	Biofiltration BMP Footprint	36	sq. ft.
<b>Landscape Area (must be identified on DS-3247)</b>			
	<b>Identification</b>	<b>1</b>	<b>2</b>
		<b>3</b>	<b>4</b>
		<b>5</b>	
6	Landscape area that meet the requirements in SD-B and SD-F Fact Sheet (sq. ft.)	1750	
7	Impervious area draining to the landscape area (sq. ft.)	16688	
8	Impervious to Pervious Area ratio [Line 7/Line 6]	9.54	0.00
9	Effective Credit Area If (Line 8 >1.5, Line 6, Line 7/1.5)	1750	0
10	Sum of Landscape area [sum of Line 9 Id's 1 to 5]		1750
11	Provided footprint for evapotranspiration [Line 5 + Line 10]		1786
<b>Volume Retention Performance Standard</b>			
12	Is Line 11 ≥ Line 4?	Volume Retention Performance Standard is Met	
13	Fraction of the performance standard met through the BMP footprint and/or landscaping [Line 11/Line 4]	3.23	
14	Target Volume Retention [Line 10 from Worksheet B.5.2]	17	cu. ft.
15	Volume retention required from other site design BMPs [(1-Line 13) x Line 14]	-36.88171578	cu. ft.
<b>Site Design BMP</b>			
	<b>Identification</b>	<b>Site Design Type</b>	<b>Credit</b>
16	1		cu. ft.
	2		cu. ft.
	3		cu. ft.
	4		cu. ft.
	5		cu. ft.
	Sum of volume retention benefits from other site design BMPs (e.g. trees; rain barrels etc.). [sum of Line 16 Credits for Id's 1 to 5] Provide documentation of how the site design credit is calculated in the PDP SWQMP.	0	cu. ft.
17	Is Line 16 ≥ Line 15?	Volume Retention Performance Standard is Met	

		<b>Project Name</b>	VIEWPOINT OLD TOWN (PERRY'S)	
		<b>BMP ID</b>	BMP 1	
<b>Volume Retention From Amended Soils</b>			<b>Worksheet B.5-7</b>	
1	Impervious area draining to the pervious area		16688	sq. ft.
2	Pervious area (must meet the requirements in SD-B and SD-F Fact Sheets)		1750	sq. ft.
3	Dispersion Ratio [Line 1/Line 2] Note: This worksheet is not applicable when Line 3 > 50 or Line 3 < 0.25		9.54	
4	Adjusted runoff factor [(Line 1 * 0.9 + Line 2 * 0.1) / (Line 1 + Line 2)]		0.82	
5	85th percentile 24-hour rainfall depth		0.52	inches
6	Design capture volume [(Line 1 + Line 2) x Line 4 x (Line 5/12)]		655	cu. ft.
7	Amendment Depth (Choose from 3", 6", 9", 12", 15" and 18")		3	inches
8	Storage [(porosity – field capacity) + 0.5 * (field capacity – wilting point)]		0.25	in./in.
9	Pervious Storage [Line 2 * (Line 7/12) * Line 8]		109	cu. ft.
10	Fraction of DCV [Line 9 / Line 6]		0.17	
11	Measured Infiltration Rate  When mapped hydrologic soil groups are used enter 0.10 for NRCS Type D soils and for NRCS Type C soils enter 0.30  When in no infiltration condition and the actual measured infiltration rate is unknown enter 0.0 if there are geotechnical and/or groundwater hazards identified in Appendix C or enter 0.05		0	in/hr.
12	Factor of Safety		2	
13	Reliable Infiltration Rate [Line 11/Line 12]		0	in/hr.
14	Dispersion Credit (Based on Figures B.5.6 to B.5.11; Line 10 and Line 13)		0.047	
15	Volume retention due to amendment [Line 1 * (Line 5/12) * Line 14]		34	cu. ft.

		<b>Project Name</b> VIEWPOINT OLD TOWN (PERRY'S)	
		<b>BMP ID</b> BMP 2	
<b>Volume Retention for No Infiltration Condition</b>			<b>Worksheet B.5-6</b>
1	Area draining to the biofiltration BMP	18294	sq. ft.
2	Adjusted runoff factor for drainage area (Refer to Appendix B.1 and B.2)	1	
3	Effective impervious area draining to the BMP [Line 1 x Line 2]	18294	sq. ft.
4	Required area for Evapotranspiration [Line 3 x 0.03]	549	sq. ft.
5	Biofiltration BMP Footprint	36	sq. ft.
<b>Landscape Area (must be identified on DS-3247)</b>			
	<b>Identification</b>	<b>1</b>	<b>2</b>
		<b>3</b>	<b>4</b>
		<b>5</b>	
6	Landscape area that meet the requirements in SD-B and SD-F Fact Sheet (sq. ft.)	1100	
7	Impervious area draining to the landscape area (sq. ft.)	17194	
8	Impervious to Pervious Area ratio [Line 7/Line 6]	15.63	0.00
9	Effective Credit Area If (Line 8 >1.5, Line 6, Line 7/1.5)	1100	0
10	Sum of Landscape area [sum of Line 9 Id's 1 to 5]		1100
11	Provided footprint for evapotranspiration [Line 5 + Line 10]		1136
<b>Volume Retention Performance Standard</b>			
12	Is Line 11 ≥ Line 4?	Volume Retention Performance Standard is Met	
13	Fraction of the performance standard met through the BMP footprint and/or landscaping [Line 11/Line 4]	2.07	
14	Target Volume Retention [Line 10 from Worksheet B.5.2]	16	cu. ft.
15	Volume retention required from other site design BMPs [(1-Line 13) x Line 14]	-17.55839826	cu. ft.
<b>Site Design BMP</b>			
	<b>Identification</b>	<b>Site Design Type</b>	<b>Credit</b>
16	1		cu. ft.
	2		cu. ft.
	3		cu. ft.
	4		cu. ft.
	5		cu. ft.
	Sum of volume retention benefits from other site design BMPs (e.g. trees; rain barrels etc.). [sum of Line 16 Credits for Id's 1 to 5] Provide documentation of how the site design credit is calculated in the PDP SWQMP.	0	cu. ft.
17	Is Line 16 ≥ Line 15?	Volume Retention Performance Standard is Met	





		<b>Project Name</b> VIEWPOINT OLD TOWN (PERRY'S)		
		<b>BMP ID</b> BMP 2		
<b>Sizing Method for Volume Retention Criteria</b>			<b>Worksheet B.5-2</b>	
1	Area draining to the BMP	18294	sq. ft.	
2	Adjusted runoff factor for drainage area (Refer to Appendix B.1 and B.2)	0.9		
3	85 <sup>th</sup> percentile 24-hour rainfall depth	0.52	inches	
4	Design capture volume [Line 1 x Line 2 x (Line 3/12)]	713	cu. ft.	
<b>Volume Retention Requirement</b>				
5	Measured infiltration rate in the DMA  Note:  When mapped hydrologic soil groups are used enter 0.10 for NRCS Type D soils and for NRCS Type C soils enter 0.30  When in no infiltration condition and the actual measured infiltration rate is unknown enter 0.0 if there are geotechnical and/or groundwater hazards identified in Appendix C or	0	in/hr.	
6	Factor of safety	2		
7	Reliable infiltration rate, for biofiltration BMP sizing [Line 5 / Line 6]	0	in/hr.	
8	Average annual volume reduction target (Figure B.5-2) When Line 7 > 0.01 in/hr. = Minimum (40, 166.9 x Line 7 + 6.62)  When Line 7 ≤ 0.01 in/hr. = 3.5%	3.5	%	
9	Fraction of DCV to be retained (Figure B.5-3) When Line 8 > 8% = $0.0000013 \times \text{Line } 8^3 - 0.000057 \times \text{Line } 8^2 + 0.0086 \times \text{Line } 8 - 0.014$  When Line 8 ≤ 8% = 0.023	0.023		
10	Target volume retention [Line 9 x Line 4]	16	cu. ft.	

		<b>Project Name</b>	VIEWPOINT OLD TOWN (PERRY'S)	
		<b>BMP ID</b>	BMP 2	
<b>Volume Retention From Amended Soils</b>			<b>Worksheet B.5-7</b>	
1	Impervious area draining to the pervious area	17194	sq. ft.	
2	Pervious area (must meet the requirements in SD-B and SD-F Fact Sheets)	1100	sq. ft.	
3	Dispersion Ratio [Line 1/Line 2] Note: This worksheet is not applicable when Line 3 > 50 or Line 3 < 0.25	15.63		
4	Adjusted runoff factor [(Line 1 * 0.9 + Line 2 * 0.1) / (Line 1 + Line 2)]	0.85		
5	85th percentile 24-hour rainfall depth	0.52	inches	
6	Design capture volume [(Line 1 + Line 2) x Line 4 x (Line 5/12)]	674	cu. ft.	
7	Amendment Depth (Choose from 3", 6", 9", 12", 15" and 18")	3	inches	
8	Storage [(porosity – field capacity) + 0.5 * (field capacity – wilting point)]	0.25	in./in.	
9	Pervious Storage [Line 2 * (Line 7/12) * Line 8]	69	cu. ft.	
10	Fraction of DCV [Line 9 / Line 6]	0.1		
11	<p>Measured Infiltration Rate</p> <p>When mapped hydrologic soil groups are used enter 0.10 for NRCS Type D soils and for NRCS Type C soils enter 0.30</p> <p>When in no infiltration condition and the actual measured infiltration rate is unknown enter 0.0 if there are geotechnical and/or groundwater hazards identified in Appendix C or enter 0.05</p>	0	in/hr.	
12	Factor of Safety	2		
13	Reliable Infiltration Rate [Line 11/Line 12]	0	in/hr.	
14	Dispersion Credit (Based on Figures B.5.6 to B.5.11; Line 10 and Line 13)	0.023		
15	Volume retention due to amendment [Line 1 * (Line 5/12) * Line 14]	17	cu. ft.	

		<b>Project Name</b> VIEWPOINT OLD TOWN (PERRY'S)		
		<b>BMP ID</b> BMP 3		
<b>Sizing Method for Volume Retention Criteria</b>			<b>Worksheet B.5-2</b>	
1	Area draining to the BMP	18005	sq. ft.	
2	Adjusted runoff factor for drainage area (Refer to Appendix B.1 and B.2)	0.9		
3	85 <sup>th</sup> percentile 24-hour rainfall depth	0.52	inches	
4	Design capture volume [Line 1 x Line 2 x (Line 3/12)]	702	cu. ft.	
<b>Volume Retention Requirement</b>				
5	Measured infiltration rate in the DMA  Note:  When mapped hydrologic soil groups are used enter 0.10 for NRCS Type D soils and for NRCS Type C soils enter 0.30  When in no infiltration condition and the actual measured infiltration rate is unknown enter 0.0 if there are geotechnical and/or groundwater hazards identified in Appendix C or	0	in/hr.	
6	Factor of safety	2		
7	Reliable infiltration rate, for biofiltration BMP sizing [Line 5 / Line 6]	0	in/hr.	
8	Average annual volume reduction target (Figure B.5-2) When Line 7 > 0.01 in/hr. = Minimum (40, 166.9 x Line 7 + 6.62)  When Line 7 ≤ 0.01 in/hr. = 3.5%	3.5	%	
9	Fraction of DCV to be retained (Figure B.5-3) When Line 8 > 8% = 0.0000013 x Line 8 <sup>3</sup> - 0.000057 x Line 8 <sup>2</sup> + 0.0086 x Line 8 - 0.014  When Line 8 ≤ 8% = 0.023	0.023		
10	Target volume retention [Line 9 x Line 4]	16	cu. ft.	

		<b>Project Name</b> VIEWPOINT OLD TOWN (PERRY'S)	
		<b>BMP ID</b> BMP 3	
<b>Volume Retention for No Infiltration Condition</b>			<b>Worksheet B.5-6</b>
1	Area draining to the biofiltration BMP	18005	sq. ft.
2	Adjusted runoff factor for drainage area (Refer to Appendix B.1 and B.2)	1	
3	Effective impervious area draining to the BMP [Line 1 x Line 2]	18005	sq. ft.
4	Required area for Evapotranspiration [Line 3 x 0.03]	540	sq. ft.
5	Biofiltration BMP Footprint	36	sq. ft.
<b>Landscape Area (must be identified on DS-3247)</b>			
	<b>Identification</b>	<b>1</b>	<b>2</b>
		<b>3</b>	<b>4</b>
		<b>5</b>	
6	Landscape area that meet the requirements in SD-B and SD-F Fact Sheet (sq. ft.)	1650	
7	Impervious area draining to the landscape area (sq. ft.)	16355	
8	Impervious to Pervious Area ratio [Line 7/Line 6]	9.91	0.00
9	Effective Credit Area If (Line 8 >1.5, Line 6, Line 7/1.5)	1650	0
10	Sum of Landscape area [sum of Line 9 Id's 1 to 5]	1650	sq. ft.
11	Provided footprint for evapotranspiration [Line 5 + Line 10]	1686	sq. ft.
<b>Volume Retention Performance Standard</b>			
12	Is Line 11 ≥ Line 4?	Volume Retention Performance Standard is Met	
13	Fraction of the performance standard met through the BMP footprint and/or landscaping [Line 11/Line 4]	3.12	
14	Target Volume Retention [Line 10 from Worksheet B.5.2]	16	cu. ft.
15	Volume retention required from other site design BMPs [(1-Line 13) x Line 14]	-34.2390282	cu. ft.
<b>Site Design BMP</b>			
	<b>Identification</b>	<b>Site Design Type</b>	<b>Credit</b>
16	1		cu. ft.
	2		cu. ft.
	3		cu. ft.
	4		cu. ft.
	5		cu. ft.
	Sum of volume retention benefits from other site design BMPs (e.g. trees; rain barrels etc.). [sum of Line 16 Credits for Id's 1 to 5] Provide documentation of how the site design credit is calculated in the PDP SWQMP.	0	cu. ft.
17	Is Line 16 ≥ Line 15?	Volume Retention Performance Standard is Met	

		<b>Project Name</b>	VIEWPOINT OLD TOWN (PERRY'S)	
		<b>BMP ID</b>	BMP 3	
<b>Volume Retention From Amended Soils</b>			<b>Worksheet B.5-7</b>	
1	Impervious area draining to the pervious area	16355	sq. ft.	
2	Pervious area (must meet the requirements in SD-B and SD-F Fact Sheets)	1650	sq. ft.	
3	Dispersion Ratio [Line 1/Line 2] Note: This worksheet is not applicable when Line 3 > 50 or Line 3 < 0.25	9.91		
4	Adjusted runoff factor [(Line 1 * 0.9 + Line 2 * 0.1) / (Line 1 + Line 2)]	0.83		
5	85th percentile 24-hour rainfall depth	0.52	inches	
6	Design capture volume [(Line 1 + Line 2) x Line 4 x (Line 5/12)]	648	cu. ft.	
7	Amendment Depth (Choose from 3", 6", 9", 12", 15" and 18")	3	inches	
8	Storage [(porosity – field capacity) + 0.5 * (field capacity – wilting point)]	0.25	in./in.	
9	Pervious Storage [Line 2 * (Line 7/12) * Line 8]	103	cu. ft.	
10	Fraction of DCV [Line 9 / Line 6]	0.16		
11	<p>Measured Infiltration Rate</p> <p>When mapped hydrologic soil groups are used enter 0.10 for NRCS Type D soils and for NRCS Type C soils enter 0.30</p> <p>When in no infiltration condition and the actual measured infiltration rate is unknown enter 0.0 if there are geotechnical and/or groundwater hazards identified in Appendix C or enter 0.05</p>	0	in/hr.	
12	Factor of Safety	2		
13	Reliable Infiltration Rate [Line 11/Line 12]	0	in/hr.	
14	Dispersion Credit (Based on Figures B.5.6 to B.5.11; Line 10 and Line 13)	0.044		
15	Volume retention due to amendment [Line 1 * (Line 5/12) * Line 14]	31	cu. ft.	

		<b>Project Name</b>	VIEWPOINT OLD TOWN (PERRY'S)	
		<b>BMP ID</b>	BMP 4	
<b>Sizing Method for Volume Retention Criteria</b>		<b>Worksheet B.5-2</b>		
1	Area draining to the BMP	17324	sq. ft.	
2	Adjusted runoff factor for drainage area (Refer to Appendix B.1 and B.2)	0.8		
3	85 <sup>th</sup> percentile 24-hour rainfall depth	0.52	inches	
4	Design capture volume [Line 1 x Line 2 x (Line 3/12)]	601	cu. ft.	
<b>Volume Retention Requirement</b>				
5	Measured infiltration rate in the DMA  Note: When mapped hydrologic soil groups are used enter 0.10 for NRCS Type D soils and for NRCS Type C soils enter 0.30  When in no infiltration condition and the actual measured infiltration rate is unknown enter 0.0 if there are geotechnical and/or groundwater hazards identified in Appendix C	0	in/hr.	
6	Factor of safety	2		
7	Reliable infiltration rate, for biofiltration BMP sizing [Line 5 / Line 6]	0	in/hr.	
8	Average annual volume reduction target (Figure B.5-2) When Line 7 > 0.01 in/hr. = Minimum (40, 166.9 x Line 7 + 6.62)  When Line 7 ≤ 0.01 in/hr. = 3.5%	3.5	%	
9	Fraction of DCV to be retained (Figure B.5-3) When Line 8 > 8% = $0.0000013 \times \text{Line } 8^3 - 0.000057 \times \text{Line } 8^2 + 0.0086 \times \text{Line } 8 - 0.014$  When Line 8 ≤ 8% = 0.023	0.023		
10	Target volume retention [Line 9 x Line 4]	14	cu. ft.	

		<b>Project Name</b> VIEWPOINT OLD TOWN (PERRY'S)	
		<b>BMP ID</b> BMP 4	
<b>Volume Retention for No Infiltration Condition</b>			<b>Worksheet B.5-6</b>
1	Area draining to the biofiltration BMP	17324	sq. ft.
2	Adjusted runoff factor for drainage area (Refer to Appendix B.1 and B.2)	1	
3	Effective impervious area draining to the BMP [Line 1 x Line 2]	17324	sq. ft.
4	Required area for Evapotranspiration [Line 3 x 0.03]	520	sq. ft.
5	Biofiltration BMP Footprint	36	sq. ft.
<b>Landscape Area (must be identified on DS-3247)</b>			
	<b>Identification</b>	<b>1</b>	<b>2</b>
		<b>3</b>	<b>4</b>
		<b>5</b>	
6	Landscape area that meet the requirements in SD-B and SD-F Fact Sheet (sq. ft.)	2950	
7	Impervious area draining to the landscape area (sq. ft.)	14374	
8	Impervious to Pervious Area ratio [Line 7/Line 6]	4.87	0.00
9	Effective Credit Area If (Line 8 >1.5, Line 6, Line 7/1.5)	2950	0
10	Sum of Landscape area [sum of Line 9 Id's 1 to 5]		2950
11	Provided footprint for evapotranspiration [Line 5 + Line 10]		2986
<b>Volume Retention Performance Standard</b>			
12	Is Line 11 ≥ Line 4?	Volume Retention Performance Standard is Met	
13	Fraction of the performance standard met through the BMP footprint and/or landscaping [Line 11/Line 4]	5.75	
14	Target Volume Retention [Line 10 from Worksheet B.5.2]	14	cu. ft.
15	Volume retention required from other site design BMPs [(1-Line 13) x Line 14]	-65.61176267	cu. ft.
<b>Site Design BMP</b>			
	<b>Identification</b>	<b>Site Design Type</b>	<b>Credit</b>
16	1		cu. ft.
	2		cu. ft.
	3		cu. ft.
	4		cu. ft.
	5		cu. ft.
	Sum of volume retention benefits from other site design BMPs (e.g. trees; rain barrels etc.). [sum of Line 16 Credits for Id's 1 to 5] Provide documentation of how the site design credit is calculated in the PDP SWQMP.		0
17	Is Line 16 ≥ Line 15?	Volume Retention Performance Standard is Met	

		<b>Project Name</b> VIEWPOINT OLD TOWN (PERRY'S)	
		<b>BMP ID</b> BMP 4	
<b>Volume Retention From Amended Soils</b>		<b>Worksheet B.5-7</b>	
1	Impervious area draining to the pervious area	14374	sq. ft.
2	Pervious area (must meet the requirements in SD-B and SD-F Fact Sheets)	2950	sq. ft.
3	Dispersion Ratio [Line 1/Line 2] Note: This worksheet is not applicable when Line 3 > 50 or Line 3 < 0.25	4.87	
4	Adjusted runoff factor $[(\text{Line } 1 * 0.9 + \text{Line } 2 * 0.1) / (\text{Line } 1 + \text{Line } 2)]$	0.76	
5	85th percentile 24-hour rainfall depth	0.52	inches
6	Design capture volume $[(\text{Line } 1 + \text{Line } 2) * \text{Line } 4 * (\text{Line } 5/12)]$	571	cu. ft.
7	Amendment Depth (Choose from 3", 6", 9", 12", 15" and 18")	3	inches
8	Storage $[(\text{porosity} - \text{field capacity}) + 0.5 * (\text{field capacity} - \text{wilting point})]$	0.25	in./in.
9	Pervious Storage $[\text{Line } 2 * (\text{Line } 7/12) * \text{Line } 8]$	184	cu. ft.
10	Fraction of DCV $[\text{Line } 9 / \text{Line } 6]$	0.32	
11	<p>measured infiltration rate</p> <p>When mapped hydrologic soil groups are used enter 0.10 for NRCS Type D soils and for NRCS Type C soils enter 0.30</p> <p>When in no infiltration condition and the actual measured infiltration rate is unknown enter 0.0 if there are geotechnical and/or groundwater hazards identified in Appendix C or enter 0.05</p>	0	in/hr.
12	Factor of Safety	2	
13	Reliable Infiltration Rate $[\text{Line } 11/\text{Line } 12]$	0	in/hr.
14	Dispersion Credit (Based on Figures B.5.6 to B.5.11; Line 10 and Line 13)	0.088	
15	Volume retention due to amendment $[\text{Line } 1 * (\text{Line } 5/12) * \text{Line } 14]$	55	cu. ft.



		<b>Project Name</b>	VIEWPOINT OLD TOWN (PERRY'S)		
		<b>BMP ID</b>	BMP 1		
<b>Flow-Thru Design Flows</b>		<b>Worksheet B.6-1</b>			
1	DCV	DCV	719	cubic-feet	
2	DCV Retained	DCV <sub>retained</sub>	0	cubic-feet	
3	DCV Biofiltered	DCV <sub>biofiltered</sub>	0	cubic-feet	
4	DCV requiring flow-thru (Line 1 - Line 2 - 0.67*Line 3)	DCV <sub>flow-thru</sub>	719	cubic-feet	
5	Adjusted factor (Line 4 / Line 1)	AF=	1	unitless	
6	Design rainfall intensity	i=	0.2	in/hr.	
7	Area tributary to BMP (s)	A=	0.42	acres	
8	Area-weighted runoff factor (estimated using Appendix B.2)	C=	0.9	unitless	
9	Calculated Flow Rate = AF x (C x I x A)	Q=	0.08	cfs	
10	Design Flow Rate (1.5*Line 9)	Q <sub>design</sub> =	0.11	cfs	

1. Adjustment factor shall be estimated considering only retention and biofiltration BMPs located upstream of flow-thru BMPs. That is, if the flow-thru BMP is upstream of the project's retention and biofiltration BMPs then the flow-thru BMP shall be sized using an adjustment factor of 1.
2. Volume based (e.g., dry extended detention basin) flow-thru treatment control BMPs shall be sized to the volume in Line 4 and flow based (e.g., vegetated swales) shall be sized to flow rate in Line 9. Sand filter and media filter can be designed either by volume in Line 4 or flow rate in Line 9.
3. Proprietary BMPs, if used, shall provide certified treatment capacity equal to or greater than the calculated flow rate in Line 9; certified treatment capacity per unit shall be consistent with third party certifications.

		<b>Project Name</b>	VIEWPOINT OLD TOWN (PERRY'S)		
		<b>BMP ID</b>	BMP 2		
<b>Flow-Thru Design Flows</b>		<b>Worksheet B.6-1</b>			
1	DCV	DCV	713	cubic-feet	
2	DCV Retained	DCV <sub>retained</sub>	0	cubic-feet	
3	DCV Biofiltered	DCV <sub>biofiltered</sub>	0	cubic-feet	
4	DCV requiring flow-thru (Line 1 - Line 2 - 0.67*Line 3)	DCV <sub>flow-thru</sub>	713	cubic-feet	
5	Adjusted factor (Line 4 / Line 1)	AF=	1	unitless	
6	Design rainfall intensity	i=	0.2	in/hr.	
7	Area tributary to BMP (s)	A=	0.42	acres	
8	Area-weighted runoff factor (estimated using Appendix B.2)	C=	0.9	unitless	
9	Calculated Flow Rate = AF x (C x I x A)	Q=	0.08	cfs	
10	Design Flow Rate (1.5*Line 9)	Q <sub>design</sub> =	0.11	cfs	

1. Adjustment factor shall be estimated considering only retention and biofiltration BMPs located upstream of flow-thru BMPs. That is, if the flow-thru BMP is upstream of the project's retention and biofiltration BMPs then the flow-thru BMP shall be sized using an adjustment factor of 1.
2. Volume based (e.g., dry extended detention basin) flow-thru treatment control BMPs shall be sized to the volume in Line 4 and flow based (e.g., vegetated swales) shall be sized to flow rate in Line 9. Sand filter and media filter can be designed either by volume in Line 4 or flow rate in Line 9.
3. Proprietary BMPs, if used, shall provide certified treatment capacity equal to or greater than the calculated flow rate in Line 9; certified treatment capacity per unit shall be consistent with third party certifications.

		<b>Project Name</b>	VIEWPOINT OLD TOWN (PERRY'S)		
		<b>BMP ID</b>	BMP 3		
<b>Flow-Thru Design Flows</b>		<b>Worksheet B.6-1</b>			
1	DCV	DCV	702	cubic-feet	
2	DCV Retained	DCV <sub>retained</sub>	0	cubic-feet	
3	DCV Biofiltered	DCV <sub>biofiltered</sub>	0	cubic-feet	
4	DCV requiring flow-thru (Line 1 - Line 2 - 0.67*Line 3)	DCV <sub>flow-thru</sub>	702	cubic-feet	
5	Adjusted factor (Line 4 / Line 1)	AF=	1	unitless	
6	Design rainfall intensity	i=	0.2	in/hr.	
7	Area tributary to BMP (s)	A=	0.41	acres	
8	Area-weighted runoff factor (estimated using Appendix B.2)	C=	0.9	unitless	
9	Calculated Flow Rate = AF x (C x I x A)	Q=	0.07	cfs	
10	Design Flow Rate (1.5*Line 9)	Q <sub>design</sub> =	0.11	cfs	

1. Adjustment factor shall be estimated considering only retention and biofiltration BMPs located upstream of flow-thru BMPs. That is, if the flow-thru BMP is upstream of the project's retention and biofiltration BMPs then the flow-thru BMP shall be sized using an adjustment factor of 1.
2. Volume based (e.g., dry extended detention basin) flow-thru treatment control BMPs shall be sized to the volume in Line 4 and flow based (e.g., vegetated swales) shall be sized to flow rate in Line 9. Sand filter and media filter can be designed either by volume in Line 4 or flow rate in Line 9.
3. Proprietary BMPs, if used, shall provide certified treatment capacity equal to or greater than the calculated flow rate in Line 9; certified treatment capacity per unit shall be consistent with third party certifications.

		<b>Project Name</b>	VIEWPOINT OLD TOWN (PERRY'S)		
		<b>BMP ID</b>	BMP 4		
<b>Flow-Thru Design Flows</b>		<b>Worksheet B.6-1</b>			
1	DCV	DCV	601	cubic-feet	
2	DCV Retained	DCV <sub>retained</sub>	0	cubic-feet	
3	DCV Biofiltered	DCV <sub>biofiltered</sub>	0	cubic-feet	
4	DCV requiring flow-thru (Line 1 - Line 2 - 0.67*Line 3)	DCV <sub>flow-thru</sub>	601	cubic-feet	
5	Adjusted factor (Line 4 / Line 1)	AF=	1	unitless	
6	Design rainfall intensity	i=	0.2	in/hr.	
7	Area tributary to BMP (s)	A=	0.40	acres	
8	Area-weighted runoff factor (estimated using Appendix B.2)	C=	0.8	unitless	
9	Calculated Flow Rate = AF x (C x I x A)	Q=	0.06	cfs	
10	Design Flow Rate (1.5*Line 9)	Q <sub>design</sub> =	0.10	cfs	

1. Adjustment factor shall be estimated considering only retention and biofiltration BMPs located upstream of flow-thru BMPs. That is, if the flow-thru BMP is upstream of the project's retention and biofiltration BMPs then the flow-thru BMP shall be sized using an adjustment factor of 1.
2. Volume based (e.g., dry extended detention basin) flow-thru treatment control BMPs shall be sized to the volume in Line 4 and flow based (e.g., vegetated swales) shall be sized to flow rate in Line 9. Sand filter and media filter can be designed either by volume in Line 4 or flow rate in Line 9.
3. Proprietary BMPs, if used, shall provide certified treatment capacity equal to or greater than the calculated flow rate in Line 9; certified treatment capacity per unit shall be consistent with third party certifications.

SITE SPECIFIC DATA	
PROJECT NUMBER	
PROJECT NAME	
PROJECT LOCATION	
STRUCTURE ID	BMP 1, 2, 3
TREATMENT REQUIRED	
TREATMENT FLOW (CFS)	0.12 CFS (MAX)
NOTES:	

	FG-MWS-L-6-6-3.5
TREATMENT FLOW (CFS)	0.12
VAULT HEIGHT (FT)	3.5
MAX OPERATING HEAD (FT)	3.0
WETLAND MEDIA VOLUME (CY)	2.37
WETLAND MEDIA LOADING RATE (GPM/SF)	1.0
ORIFICE SIZE (DIA. INCHES)	1.61

### INSTALLATION NOTES

1. CONTRACTOR TO PROVIDE ALL LABOR, EQUIPMENT, MATERIALS AND INCIDENTALS REQUIRED TO OFFLOAD AND INSTALL THE SYSTEM AND APPURTENANCES IN ACCORDANCE WITH THIS DRAWING AND THE MANUFACTURER'S SPECIFICATIONS, UNLESS OTHERWISE STATED IN MANUFACTURER'S CONTRACT.
2. UNIT MUST BE INSTALLED ON LEVEL BASE. MANUFACTURER RECOMMENDS INSTALLING ON A PAVED SURFACE, OR A MINIMUM 6" LEVEL ROCK BASE UNLESS SPECIFIED BY THE PROJECT ENGINEER. CONTRACTOR IS RESPONSIBLE FOR VERIFYING PROJECT ENGINEER'S RECOMMENDED BASE SPECIFICATIONS.
3. CONTRACTOR TO SUPPLY AND INSTALL ALL EXTERNAL CONNECTING PIPES.
4. DRIP OR SPRAY IRRIGATION REQUIRED ON ALL UNITS WITH VEGETATION.

### GENERAL NOTES

1. MANUFACTURER TO PROVIDE ALL MATERIALS UNLESS OTHERWISE NOTED.
2. ALL DIMENSIONS, ELEVATIONS, SPECIFICATIONS AND CAPACITIES ARE SUBJECT TO CHANGE. FOR PROJECT SPECIFIC DRAWINGS DETAILING EXACT DIMENSIONS, WEIGHTS AND ACCESSORIES PLEASE CONTACT MANUFACTURER.

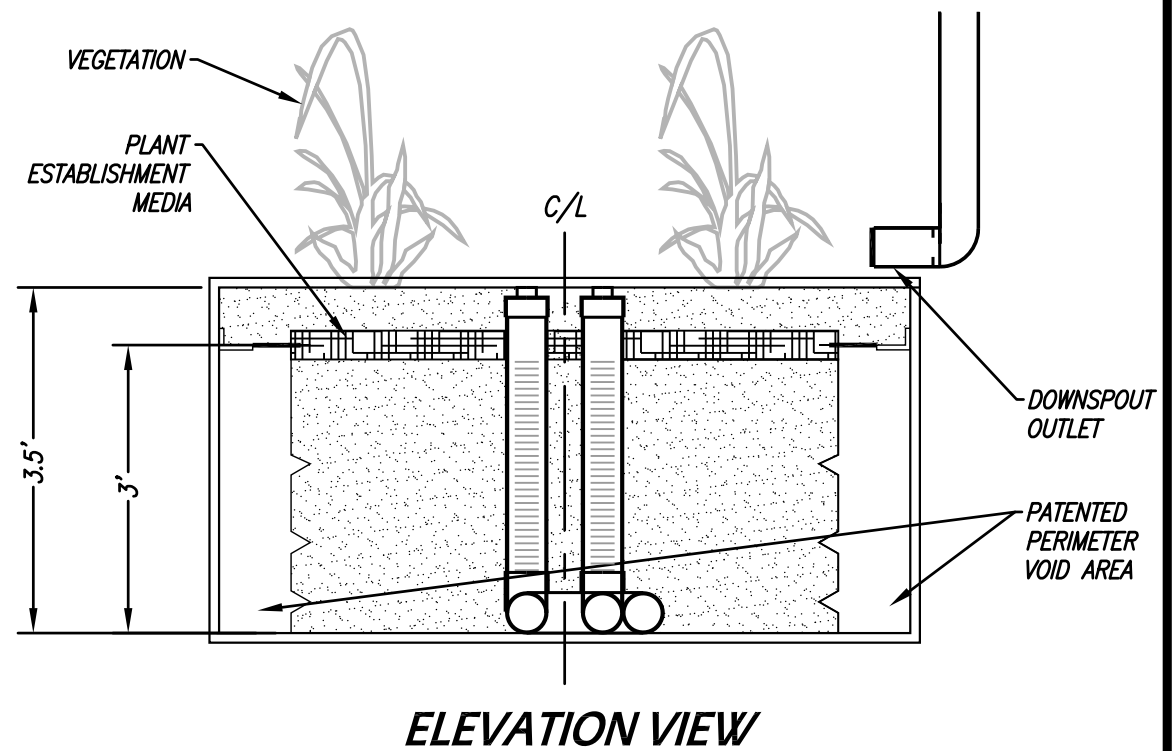
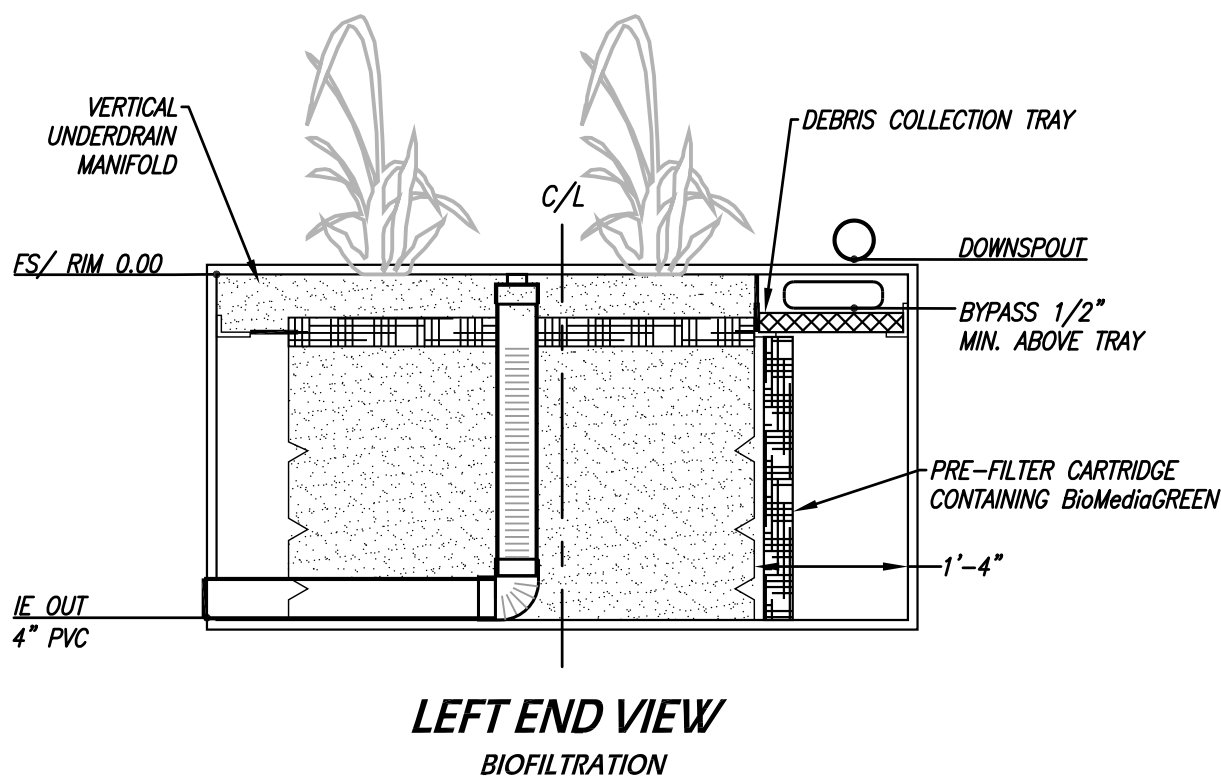
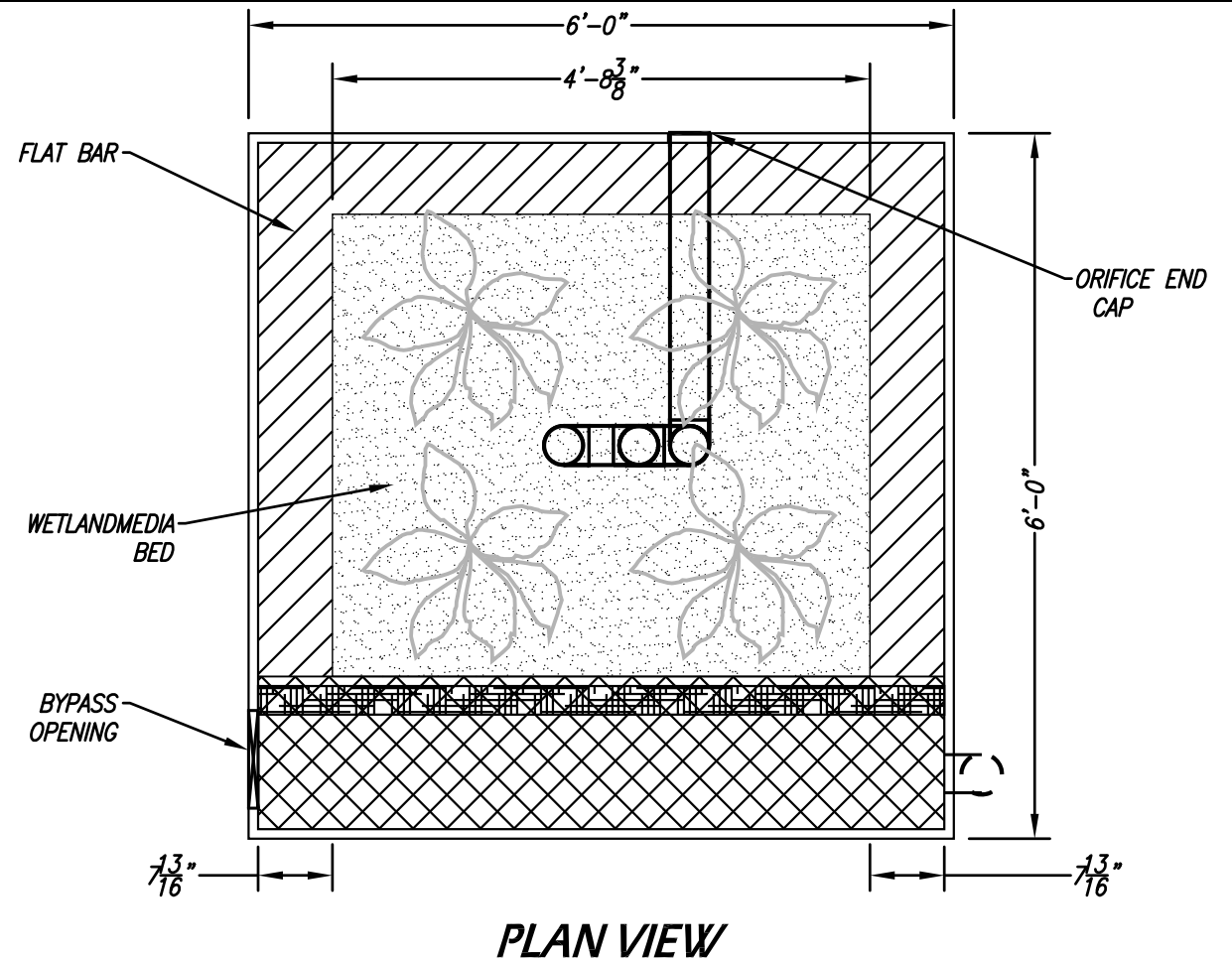

**LEFT END VIEW**  
BIOFILTRATION

**ELEVATION VIEW**

THE PRODUCT DESCRIBED MAY BE PROTECTED BY ONE OR MORE OF THE FOLLOWING US PATENTS: 7,425,262; 7,470,362; 7,674,378; 8,303,816; RELATED FOREIGN PATENTS OR OTHER PATENTS PENDING

PROPRIETARY AND CONFIDENTIAL:  
THE INFORMATION CONTAINED IN THIS DRAWING IS THE SOLE PROPERTY OF MODULAR WETLANDS SYSTEMS. ANY REPRODUCTION IN PART OR AS A WHOLE WITHOUT THE WRITTEN PERMISSION OF MODULAR WETLANDS SYSTEMS IS PROHIBITED.



**FIBERGLASS MWS LINEAR**  
STORMWATER BIOFILTRATION SYSTEM  
FG-MWS-L-6-6-3.5

9/15/21/KARG



SITE SPECIFIC DATA			
PROJECT NUMBER			
PROJECT NAME			
PROJECT LOCATION			
STRUCTURE ID			
TREATMENT REQUIRED			
VOLUME BASED (CF)		FLOW BASED (CFS)	
N/A			
PEAK BYPASS REQUIRED (CFS) – IF APPLICABLE			
PIPE DATA	I.E.	MATERIAL	DIAMETER
INLET PIPE 1			
INLET PIPE 2			
OUTLET PIPE			
	PRETREATMENT	BIOFILTRATION	DISCHARGE
RIM ELEVATION			
SURFACE LOAD			
FRAME & COVER	36" X 36"		N/A
NOTES:			

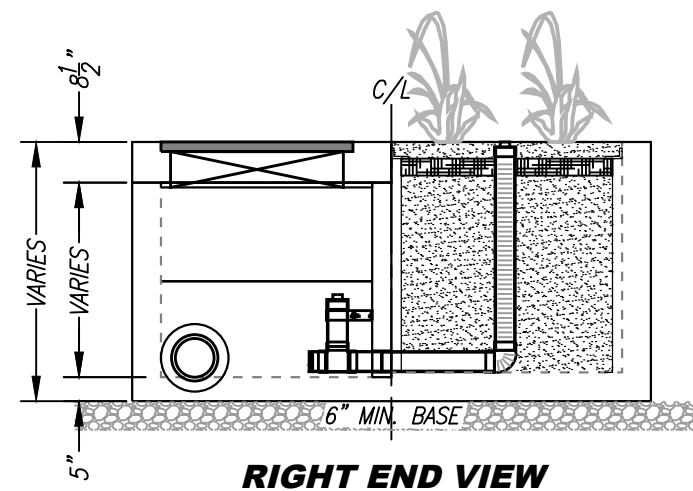
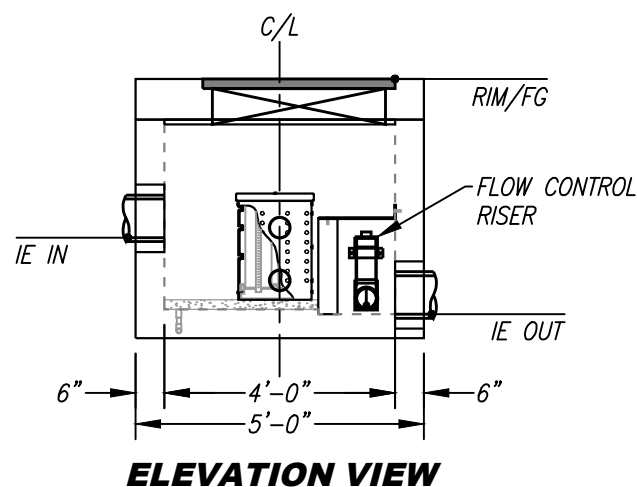
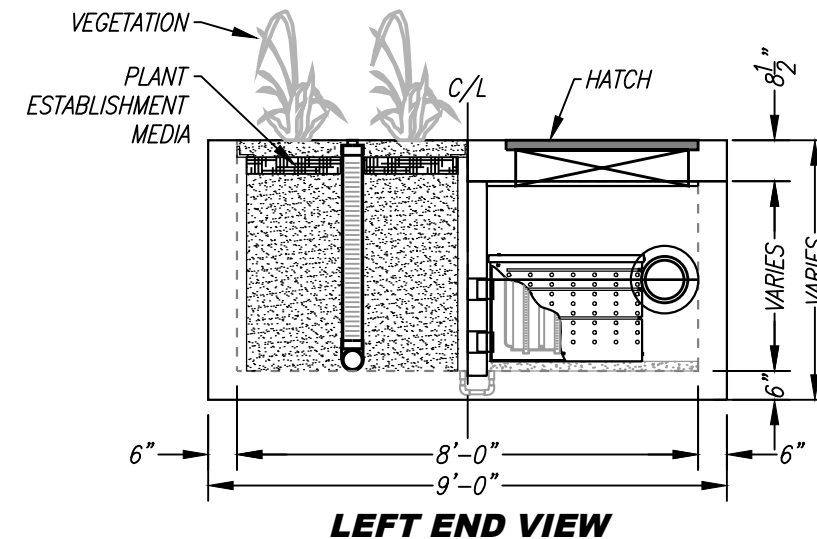
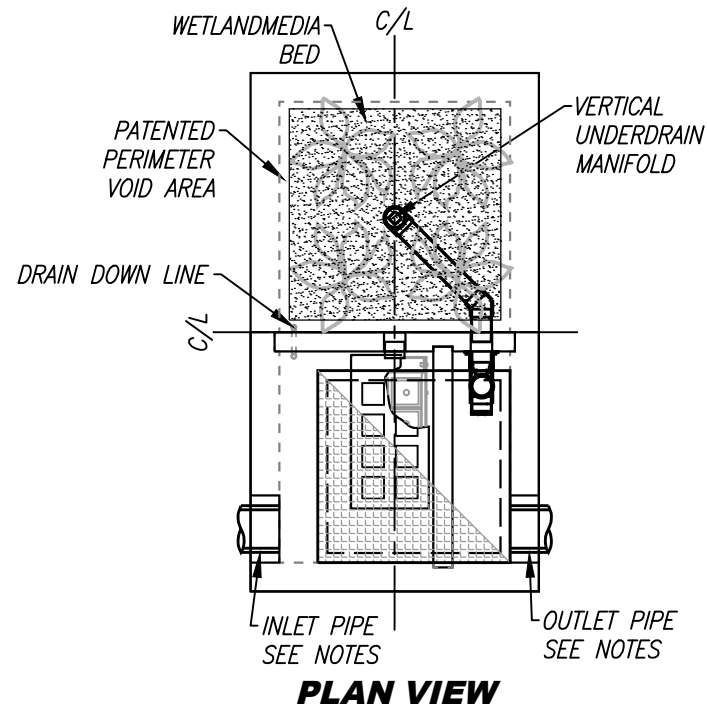

**INSTALLATION NOTES**

1. CONTRACTOR TO PROVIDE ALL LABOR, EQUIPMENT, MATERIALS AND INCIDENTALS REQUIRED TO OFFLOAD AND INSTALL THE SYSTEM AND APPURTENANCES IN ACCORDANCE WITH THIS DRAWING AND THE MANUFACTURERS SPECIFICATIONS, UNLESS OTHERWISE STATED IN MANUFACTURERS CONTRACT.
2. UNIT MUST BE INSTALLED ON LEVEL BASE. MANUFACTURER RECOMMENDS A MINIMUM 6" LEVEL ROCK BASE UNLESS SPECIFIED BY THE PROJECT ENGINEER. CONTRACTOR IS RESPONSIBLE TO VERIFY PROJECT ENGINEERS RECOMMENDED BASE SPECIFICATIONS.
4. CONTRACTOR TO SUPPLY AND INSTALL ALL EXTERNAL CONNECTING PIPES. ALL PIPES MUST BE FLUSH WITH INSIDE SURFACE OF CONCRETE. (PIPES CANNOT INTRUDE BEYOND FLUSH). INVERT OF OUTFLOW PIPE MUST BE FLUSH WITH DISCHARGE CHAMBER FLOOR. ALL PIPES SHALL BE SEALED WATER TIGHT PER MANUFACTURERS STANDARD CONNECTION DETAIL.
5. CONTRACTOR RESPONSIBLE FOR INSTALLATION OF ALL RISERS, MANHOLES, AND HATCHES. CONTRACTOR TO GROUT ALL MANHOLES AND HATCHES TO MATCH FINISHED SURFACE UNLESS SPECIFIED OTHERWISE.
6. VEGETATION SUPPLIED AND INSTALLED BY OTHERS. ALL UNITS WITH VEGETATION MUST HAVE DRIP OR SPRAY IRRIGATION SUPPLIED AND INSTALLED BY OTHERS.
7. CONTRACTOR RESPONSIBLE FOR CONTACTING BIO CLEAN FOR ACTIVATION OF UNIT. MANUFACTURERS WARRANTY IS VOID WITH OUT PROPER ACTIVATION BY A BIO CLEAN REPRESENTATIVE.

**GENERAL NOTES**

1. MANUFACTURER TO PROVIDE ALL MATERIALS UNLESS OTHERWISE NOTED.
2. ALL DIMENSIONS, ELEVATIONS, SPECIFICATIONS AND CAPACITIES ARE SUBJECT TO CHANGE. FOR PROJECT SPECIFIC DRAWINGS DETAILING EXACT DIMENSIONS, WEIGHTS AND ACCESSORIES PLEASE CONTACT BIO CLEAN.

TREATMENT FLOW (CFS)	
OPERATING HEAD (FT)	
PRETREATMENT LOADING RATE (GPM/SF)	
WETLAND MEDIA LOADING RATE (GPM/SF)	

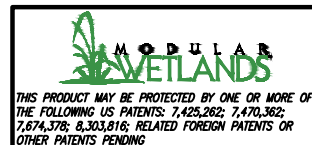

PROPRIETARY AND CONFIDENTIAL:  
 THE INFORMATION CONTAINED IN THIS DOCUMENT IS THE SOLE PROPERTY OF FORTERRA AND ITS COMPANIES. THIS DOCUMENT, NOR ANY PART THEREOF, MAY BE USED, REPRODUCED OR MODIFIED IN ANY MANNER WITH OUT THE WRITTEN CONSENT OF FORTERRA.



**MWS-L-4-8-V**  
**STORMWATER BIOFILTRATION SYSTEM**  
**STANDARD DETAIL**



**December 2019**

**GENERAL USE LEVEL DESIGNATION FOR BASIC, ENHANCED, AND PHOSPHORUS TREATMENT**

**For the**

**MWS-Linear Modular Wetland**

**Ecology's Decision:**

Based on Modular Wetland Systems, Inc. application submissions, including the Technical Evaluation Report, dated April 1, 2014, Ecology hereby issues the following use level designation:

1. General use level designation (GULD) for the MWS-Linear Modular Wetland Stormwater Treatment System for Basic treatment
  - Sized at a hydraulic loading rate of 1 gallon per minute (gpm) per square foot (sq ft) of wetland cell surface area. For moderate pollutant loading rates (low to medium density residential basins), size the Prefilters at 3.0 gpm/sq ft of cartridge surface area. For high loading rates (commercial and industrial basins), size the Prefilters at 2.1 gpm/sq ft of cartridge surface area.
2. General use level designation (GULD) for the MWS-Linear Modular Wetland Stormwater Treatment System for Phosphorus treatment
  - Sized at a hydraulic loading rate of 1 gallon per minute (gpm) per square foot (sq ft) of wetland cell surface area. For moderate pollutant loading rates (low to medium density residential basins), size the Prefilters at 3.0 gpm/sq ft of cartridge surface area. For high loading rates (commercial and industrial basins), size the Prefilters at 2.1 gpm/sq ft of cartridge surface area.
3. General use level designation (GULD) for the MWS-Linear Modular Wetland Stormwater Treatment System for Enhanced treatment
  - Sized at a hydraulic loading rate of 1 gallon per minute (gpm) per square foot (sq ft) of wetland cell surface area. For moderate pollutant loading rates (low to medium density residential basins), size the Prefilters at 3.0 gpm/sq ft of cartridge surface area. For high loading rates (commercial and industrial basins), size the Prefilters at 2.1 gpm/sq ft of cartridge surface area.



4. Ecology approves the MWS - Linear Modular Wetland Stormwater Treatment System units for Basic, Phosphorus, and Enhanced treatment at the hydraulic loading rate listed above. Designers shall calculate the water quality design flow rates using the following procedures:

- Western Washington: For treatment installed upstream of detention or retention, the water quality design flow rate is the peak 15-minute flow rate as calculated using the latest version of the Western Washington Hydrology Model or other Ecology-approved continuous runoff model.
- Eastern Washington: For treatment installed upstream of detention or retention, the water quality design flow rate is the peak 15-minute flow rate as calculated using one of the three methods described in Chapter 2.2.5 of the Stormwater Management Manual for Eastern Washington (SWMMEW) or local manual.
- Entire State: For treatment installed downstream of detention, the water quality design flow rate is the full 2-year release rate of the detention facility.

5. These use level designations have no expiration date but may be revoked or amended by Ecology, and are subject to the conditions specified below.

**Ecology's Conditions of Use:**

Applicants shall comply with the following conditions:

1. Design, assemble, install, operate, and maintain the MWS – Linear Modular Wetland Stormwater Treatment System units, in accordance with Modular Wetland Systems, Inc. applicable manuals and documents and the Ecology Decision.
2. Each site plan must undergo Modular Wetland Systems, Inc. review and approval before site installation. This ensures that site grading and slope are appropriate for use of a MWS – Linear Modular Wetland Stormwater Treatment System unit.
3. MWS – Linear Modular Wetland Stormwater Treatment System media shall conform to the specifications submitted to, and approved by, Ecology.
4. The applicant tested the MWS – Linear Modular Wetland Stormwater Treatment System with an external bypass weir. This weir limited the depth of water flowing through the media, and therefore the active treatment area, to below the root zone of the plants. This GULD applies to MWS – Linear Modular Wetland Stormwater Treatment Systems whether plants are included in the final product or not.
5. Maintenance: The required maintenance interval for stormwater treatment devices is often dependent upon the degree of pollutant loading from a particular drainage basin. Therefore, Ecology does not endorse or recommend a “one size fits all” maintenance cycle for a particular model/size of manufactured filter treatment device.

- Typically, Modular Wetland Systems, Inc. designs MWS - Linear Modular Wetland systems for a target prefilter media life of 6 to 12 months.
- Indications of the need for maintenance include effluent flow decreasing to below the design flow rate or decrease in treatment below required levels.
- Owners/operators must inspect MWS - Linear Modular Wetland systems for a minimum of twelve months from the start of post-construction operation to determine site-specific

maintenance schedules and requirements. You must conduct inspections monthly during the wet season, and every other month during the dry season. (According to the SWMMWW, the wet season in western Washington is October 1 to April 30. According to SWMMEW, the wet season in eastern Washington is October 1 to June 30). After the first year of operation, owners/operators must conduct inspections based on the findings during the first year of inspections.

- Conduct inspections by qualified personnel, follow manufacturer's guidelines, and use methods capable of determining either a decrease in treated effluent flowrate and/or a decrease in pollutant removal ability.
- When inspections are performed, the following findings typically serve as maintenance triggers:
  - Standing water remains in the vault between rain events, or
  - Bypass occurs during storms smaller than the design storm.
  - If excessive floatables (trash and debris) are present (but no standing water or excessive sedimentation), perform a minor maintenance consisting of gross solids removal, not prefilter media replacement.
  - Additional data collection will be used to create a correlation between pretreatment chamber sediment depth and pre-filter clogging (see *Issues to be Addressed by the Company* section below)

6. Discharges from the MWS - Linear Modular Wetland Stormwater Treatment System units shall not cause or contribute to water quality standards violations in receiving waters.

Applicant: Modular Wetland Systems, Inc.  
Applicant's Address: 5796 Armada Drive, Suite 250  
Carlsbad, CA 92008

**Application Documents:**

- *Original Application for Conditional Use Level Designation*, Modular Wetland System, Linear Stormwater Filtration System Modular Wetland Systems, Inc., January 2011
- *Quality Assurance Project Plan: Modular Wetland system – Linear Treatment System performance Monitoring Project*, draft, January 2011.
- *Revised Application for Conditional Use Level Designation*, Modular Wetland System, Linear Stormwater Filtration System Modular Wetland Systems, Inc., May 2011
- *Memorandum: Modular Wetland System-Linear GULD Application Supplementary Data*, April 2014
- *Technical Evaluation Report: Modular Wetland System Stormwater Treatment System Performance Monitoring*, April 2014.

**Applicant's Use Level Request:**

General use level designation as a Basic, Enhanced, and Phosphorus treatment device in accordance with Ecology's Guidance for Evaluating Emerging Stormwater Treatment Technologies Technology Assessment Protocol – Ecology (TAPE) January 2011 Revision.

**Applicant's Performance Claims:**

- The MWS – Linear Modular wetland is capable of removing a minimum of 80-percent of TSS from stormwater with influent concentrations between 100 and 200 mg/l.
- The MWS – Linear Modular wetland is capable of removing a minimum of 50-percent of Total Phosphorus from stormwater with influent concentrations between 0.1 and 0.5 mg/l.
- The MWS – Linear Modular wetland is capable of removing a minimum of 30-percent of dissolved Copper from stormwater with influent concentrations between 0.005 and 0.020 mg/l.
- The MWS – Linear Modular wetland is capable of removing a minimum of 60-percent of dissolved Zinc from stormwater with influent concentrations between 0.02 and 0.30 mg/l.

**Ecology Recommendations:**

- Modular Wetland Systems, Inc. has shown Ecology, through laboratory and field-testing, that the MWS - Linear Modular Wetland Stormwater Treatment System filter system is capable of attaining Ecology's Basic, Total phosphorus, and Enhanced treatment goals.

**Findings of Fact:**Laboratory Testing

The MWS-Linear Modular wetland has the:

- Capability to remove 99 percent of total suspended solids (using Sil-Co-Sil 106) in a quarter-scale model with influent concentrations of 270 mg/L.
- Capability to remove 91 percent of total suspended solids (using Sil-Co-Sil 106) in laboratory conditions with influent concentrations of 84.6 mg/L at a flow rate of 3.0 gpm per square foot of media.
- Capability to remove 93 percent of dissolved Copper in a quarter-scale model with influent concentrations of 0.757 mg/L.
- Capability to remove 79 percent of dissolved Copper in laboratory conditions with influent concentrations of 0.567 mg/L at a flow rate of 3.0 gpm per square foot of media.
- Capability to remove 80.5-percent of dissolved Zinc in a quarter-scale model with influent concentrations of 0.95 mg/L at a flow rate of 3.0 gpm per square foot of media.
- Capability to remove 78-percent of dissolved Zinc in laboratory conditions with influent concentrations of 0.75 mg/L at a flow rate of 3.0 gpm per square foot of media.

## Field Testing

- Modular Wetland Systems, Inc. conducted monitoring of an MWS-Linear (Model # MWS-L-4-13) from April 2012 through May 2013, at a transportation maintenance facility in Portland, Oregon. The manufacturer collected flow-weighted composite samples of the system's influent and effluent during 28 separate storm events. The system treated approximately 75 percent of the runoff from 53.5 inches of rainfall during the monitoring period. The applicant sized the system at 1 gpm/sq ft. (wetland media) and 3gpm/sq ft. (prefilter).
- Influent TSS concentrations for qualifying sampled storm events ranged from 20 to 339 mg/L. Average TSS removal for influent concentrations greater than 100 mg/L (n=7) averaged 85 percent. For influent concentrations in the range of 20-100 mg/L (n=18), the upper 95 percent confidence interval about the mean effluent concentration was 12.8 mg/L.
- Total phosphorus removal for 17 events with influent TP concentrations in the range of 0.1 to 0.5 mg/L averaged 65 percent. A bootstrap estimate of the lower 95 percent confidence limit (LCL95) of the mean total phosphorus reduction was 58 percent.
- The lower 95 percent confidence limit of the mean percent removal was 60.5 percent for dissolved zinc for influent concentrations in the range of 0.02 to 0.3 mg/L (n=11). The lower 95 percent confidence limit of the mean percent removal was 32.5 percent for dissolved copper for influent concentrations in the range of 0.005 to 0.02 mg/L (n=14) at flow rates up to 28 gpm (design flow rate 41 gpm). Laboratory test data augmented the data set, showing dissolved copper removal at the design flow rate of 41 gpm (93 percent reduction in influent dissolved copper of 0.757 mg/L).

## **Issues to be addressed by the Company:**

1. Modular Wetland Systems, Inc. should collect maintenance and inspection data for the first year on all installations in the Northwest in order to assess standard maintenance requirements for various land uses in the region. Modular Wetland Systems, Inc. should use these data to establish required maintenance cycles.
2. Modular Wetland Systems, Inc. should collect pre-treatment chamber sediment depth data for the first year of operation for all installations in the Northwest. Modular Wetland Systems, Inc. will use these data to create a correlation between sediment depth and pre-filter clogging.

## **Technology Description:**

Download at <http://www.modularwetlands.com/>

## **Contact Information:**

Applicant: Zach Kent  
BioClean A Forterra Company.  
5796 Armada Drive, Suite 250  
Carlsbad, CA 92008  
[zach.kent@forterrabp.com](mailto:zach.kent@forterrabp.com)

Applicant website: <http://www.modularwetlands.com/>

Ecology web link: <http://www.ecy.wa.gov/programs/wg/stormwater/newtech/index.html>

Ecology: Douglas C. Howie, P.E.  
Department of Ecology  
Water Quality Program  
(360) 407-6444  
[douglas.howie@ecy.wa.gov](mailto:douglas.howie@ecy.wa.gov)

**Revision History**

<b>Date</b>	<b>Revision</b>
June 2011	Original use-level-designation document
September 2012	Revised dates for TER and expiration
January 2013	Modified Design Storm Description, added Revision Table, added maintenance discussion, modified format in accordance with Ecology standard
December 2013	Updated name of Applicant
April 2014	Approved GULD designation for Basic, Phosphorus, and Enhanced treatment
December 2015	Updated GULD to document the acceptance of MWS-Linear Modular Wetland installations with or without the inclusion of plants
July 2017	Revised Manufacturer Contact Information (name, address, and email)
December 2019	Revised Manufacturer Contact Address

## E.18 BF-1 Biofiltration



Location: 43<sup>rd</sup> Street and Logan Avenue, San Diego, California

<b>MS4 Permit Category</b>
Biofiltration
<b>Manual Category</b>
Biofiltration
<b>Applicable Performance Standard</b>
Pollutant Control
Flow Control
<b>Primary Benefits</b>
Treatment
Volume Reduction (Incidental)
Peak Flow Attenuation (Optional)

### Description

Biofiltration (Bioretention with underdrain) facilities are vegetated surface water systems that filter water through vegetation, and soil or engineered media prior to discharge via underdrain or overflow to the downstream conveyance system. Bioretention with underdrain facilities are commonly incorporated into the site within parking lot landscaping, along roadsides, and in open spaces. Because these types of facilities have limited or no infiltration, they are typically designed to provide enough hydraulic head to move flows through the underdrain connection to the storm drain system. Treatment is achieved through filtration, sedimentation, sorption, biochemical processes and plant uptake.

Typical bioretention with underdrain components include:

- Inflow distribution mechanisms (e.g, perimeter flow spreader or filter strips)
- Energy dissipation mechanism for concentrated inflows (e.g., splash blocks or riprap)
- Shallow surface ponding for captured flows
- Side slope and basin bottom vegetation selected based on expected climate and ponding depth
- Non-floating mulch layer
- Media layer (planting mix or engineered media) capable of supporting vegetation growth
- Filter course layer (aka choking layer) consisting of aggregate to prevent the migration of fines into uncompacted native soils or the aggregate storage layer
- Aggregate storage layer with underdrain(s)
- Impermeable liner or uncompacted native soils at the bottom of the facility
- Overflow structure

## Appendix E: BMP Design Fact Sheets

### Design Adaptations for Project Goals

**Biofiltration Treatment BMP for storm water pollutant control.** The system is lined or un-lined to provide incidental infiltration, and an underdrain is provided at the bottom to carry away filtered runoff. This configuration is considered to provide biofiltration treatment via flow through the media layer. Storage provided above the underdrain within surface ponding, media, and aggregate storage is considered included in the biofiltration treatment volume. Saturated storage within the aggregate storage layer can be added to this design by raising the underdrain above the bottom of the aggregate storage layer or via an internal weir structure designed to maintain a specific water level elevation.

**Integrated storm water flow control and pollutant control configuration.** The system can be designed to provide flow rate and duration control by primarily providing increased surface ponding and/or having a deeper aggregate storage layer above the underdrain. This will allow for significant detention storage, which can be controlled via inclusion of an outlet structure at the downstream end of the underdrain.

### Recommended Siting Criteria

Siting Criteria	Intent/Rationale
<ul style="list-style-type: none"> <li>□ Placement observes geotechnical recommendations regarding potential hazards (e.g., slope stability, landslides, liquefaction zones) and setbacks (e.g., slopes, foundations, utilities).</li> </ul>	<p>Must not negatively impact existing site geotechnical concerns.</p>
<ul style="list-style-type: none"> <li>□ An impermeable liner or other hydraulic restriction layer is included if site constraints indicate that infiltration or lateral flows should not be allowed.</li> </ul>	<p>Lining prevents storm water from impacting groundwater and/or sensitive environmental or geotechnical features. Incidental infiltration, when allowable, can aid in pollutant removal and groundwater recharge.</p>
<ul style="list-style-type: none"> <li>□ Contributing tributary area shall be <math>\leq 5</math> acres (<math>\leq 1</math> acre preferred).</li> </ul>	<p>Bigger BMPs require additional design features for proper performance. Contributing tributary area greater than 5 acres may be allowed at the discretion of the City Engineer if the following conditions are met: 1) incorporate design features (e.g. flow spreaders) to minimizing short circuiting of flows in the BMP and 2) incorporate additional design features requested by the City Engineer for proper performance of the regional BMP.</p>
<ul style="list-style-type: none"> <li>□ Finish grade of the facility is <math>\leq 2\%</math>.</li> </ul>	<p>Flatter surfaces reduce erosion and channelization within the facility.</p>



Example Schematic Design – Plan and Section View

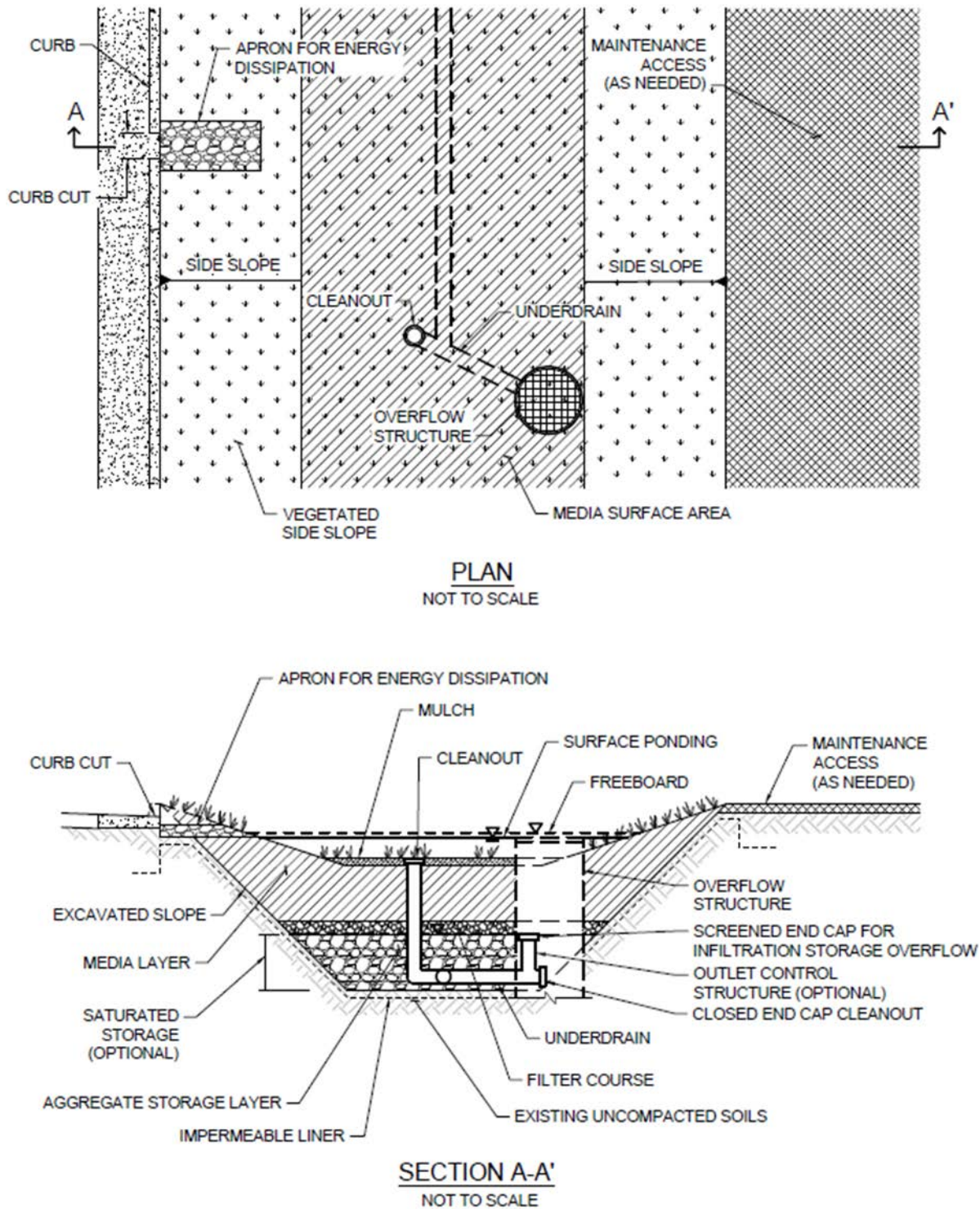

Figure E.18-1 : Typical Plan and Section View of a Biofiltration BMP

## Appendix E: BMP Design Fact Sheets

### Recommended BMP Component Dimensions

BMP Component	Dimension	Intent/Rationale
Freeboard	≥ 2 inches	Freeboard provides room for head over overflow structures and minimizes risk of uncontrolled surface discharge.
Surface Ponding	≥ 6 and ≤ 12 inches	<p>The minimum ponding depth is required so that the runoff is uniformly spread throughout the basin (minimizes the likelihood of short circuiting). Deep surface ponding raises safety concerns.</p> <p>When the BMP is adjoining walkways the minimum surface ponding depth can be reduced to 4 inches.</p> <p>Surface ponding depth greater than 12 inches (for additional pollutant control or surface outlet structures or flow-control orifices) may be allowed at the discretion of the City Engineer if the following conditions are met: 1) surface ponding depth drawdown time is less than 24 hours; and 2) safety issues and fencing requirements are considered (typically ponding greater than 18" will require a fence) and 3) potential for elevated clogging risk is evaluated (Worksheet B.5.4).</p>
Ponding Area Side Slopes	3H:1V or shallower	Gentler side slopes are safer, less prone to erosion, able to establish vegetation more quickly and easier to maintain.
Mulch	≥ 3 inches	Mulch will suppress weeds and maintain moisture for plant growth.
Media Layer	≥ 18 inches	A deep media layer provides additional filtration and supports plants with deeper roots. Where the minimum depth of 18 inches is used, only shallow-rooted species shall be planted. A minimum 24-inch media layer shall typically be required to support vegetation, with a minimum 36-inch media layer depth required for trees.
Filter Course	6 inches	To reduce clogging potential, a two-layer filter course (aka choking stone system) is used consisting of one 3" layer of clean and washed ASTM 33 Fine Aggregate Sand overlying a 3" layer of ASTM No 8 Stone (Appendix F.4). This specification has been developed to maintain permeability while limiting the migration of media material into the stone reservoir and underdrain system.
Underdrain Diameter	≥ 8 inches	Minimum diameter required for maintenance by City crews. For privately maintained BMPs, a minimum underdrain diameter of 6 inches is allowed.
Cleanout Diameter	≥ 8 inches	Facilitates simpler cleaning, when needed. For privately maintained BMPs, cleanout diameter of 6 inches is allowed.

Deviations to the recommended BMP component dimensions may be approved at the discretion of the City Engineer if it is determined to be appropriate.

### Design Criteria and Considerations

Bioretention with underdrain must meet the following design criteria. Deviations from the below criteria may be approved at the discretion of the City Engineer if it is determined to be appropriate:

Design Criteria	Intent/Rationale
<b>Surface Ponding</b>	
<ul style="list-style-type: none"> <li>□ Surface ponding is limited to a 24-hour drawdown time.</li> </ul>	<p>Surface ponding limited to 24 hour for plant health.</p> <p>Surface ponding drawdown time greater than 24-hours but less than 96 hours may be allowed at the discretion of the City Engineer if certified by a landscape architect or agronomist.</p>
<b>Vegetation</b>	
<ul style="list-style-type: none"> <li>□ Plantings are suitable for the climate and expected ponding depth. A plant list to aid in selection can be found in Appendix E.26.</li> </ul>	<p>Plants suited to the climate and ponding depth are more likely to survive.</p>
<ul style="list-style-type: none"> <li>□ An irrigation system with a connection to water supply should be provided as needed.</li> </ul>	<p>Seasonal irrigation might be needed to keep plants healthy.</p>
<b>Mulch</b>	
<ul style="list-style-type: none"> <li>□ A minimum of 3 inches of well-aged, shredded hardwood mulch that has been stockpiled or stored for at least 12 months is provided.</li> </ul>	<p>Mulch will suppress weeds and maintain moisture for plant growth. Aging mulch kills pathogens and weed seeds and allows the beneficial microbes to multiply.</p>
<b>Media Layer</b>	
<ul style="list-style-type: none"> <li>□ Media maintains a minimum filtration rate of 5 in/hr. over lifetime of facility. Additional Criteria for media hydraulic conductivity described in the bioretention soil media model specification (Appendix F.3)</li> </ul>	<p>A filtration rate of at least 5 inches per hour allows soil to drain between events. The initial rate should be higher than long term target rate to account for clogging over time. However an excessively high initial rate can have a negative impact on treatment performance, therefore an upper limit is needed.</p>

## Appendix E: BMP Design Fact Sheets

Design Criteria	Intent/Rationale
<p>Media shall be a minimum 18 inches deep for filtration purposes, with a minimum 24-inch media layer depth typically required to support vegetation and a minimum 36-inch media layer depth required for trees. Media shall meet the following specifications.</p> <p>Model bioretention soil media specification provided in Appendix F.3 or</p> <ul style="list-style-type: none"> <li>□ County of San Diego Low Impact Development Handbook: Appendix G - Bioretention Soil Specification (June 2014, unless superseded by more recent edition).</li> </ul> <p>Alternatively, for proprietary designs and custom media mixes not meeting the media specifications, the media meets the pollutant treatment performance criteria in Section F.1.</p>	<p>A deep media layer provides additional filtration and supports plants with deeper roots.</p> <p>Standard specifications shall be followed.</p> <p>For non-standard or proprietary designs, compliance with Appendix F.1 ensures that adequate treatment performance will be provided.</p>
<ul style="list-style-type: none"> <li>□ Media surface area is 3% of contributing area times adjusted runoff factor or greater. Unless demonstrated that the BMP surface area can be smaller than 3%.</li> </ul>	<p>Greater surface area to tributary area ratios: a) maximizes volume retention as required by the MS4 Permit and b) decrease loading rates per square foot and therefore increase longevity.</p> <p>Adjusted runoff factor is to account for site design BMPs implemented upstream of the BMP (such as rain barrels, impervious area dispersion, etc.). Refer to Appendix B.2 guidance.</p> <p>Refer to Appendix B.5 for guidance to support use of smaller than 3% footprint..</p>
<ul style="list-style-type: none"> <li>□ Where receiving waters are impaired or have a TMDL for nutrients, the system is designed with nutrient sensitive media design (see fact sheet BF-2).</li> </ul>	<p>Potential for pollutant export is partly a function of media composition; media design must minimize potential for export of nutrients, particularly where receiving waters are impaired for nutrients.</p>
<h3>Filter Course Layer</h3>	
<ul style="list-style-type: none"> <li>□ A filter course is used to prevent migration of fines through layers of the facility. Filter fabric is not used.</li> </ul>	<p>Migration of media can cause clogging of the aggregate storage layer void spaces or subgrade and can result in poor water quality performance for turbidity and suspended solids. Filter fabric is more likely to clog.</p>
<ul style="list-style-type: none"> <li>□ Filter course is washed and free of fines.</li> </ul>	<p>Washing aggregate will help eliminate fines that could clog the facility and impede infiltration.</p>
<ul style="list-style-type: none"> <li>□ To reduce clogging potential, a two-layer filter course (aka choking stone system) is used consisting of one 3" layer of clean and washed ASTM 33 Fine Aggregate Sand overlying a 3" layer of ASTM No 8 Stone (Appendix F.4).</li> </ul>	<p>This specification has been developed to maintain permeability while limiting the migration of media material into the stone reservoir and underdrain system.</p>

Design Criteria	Intent/Rationale
<b>Aggregate Storage Layer</b>	
<ul style="list-style-type: none"> <li>□ ASTM #57 open graded stone is used for the storage layer and a two layer filter course (detailed above) is used above this layer</li> </ul>	<p>This layer provides additional storage capacity. ASTM #8 stone provides an acceptable choking/bridging interface with the particles in ASTM #57 stone.</p>
<ul style="list-style-type: none"> <li>□ The depth of aggregate provided (12-inch typical) and storage layer configuration is adequate for providing conveyance for underdrain flows to the outlet structure.</li> </ul>	<p>Proper storage layer configuration and underdrain placement will minimize facility drawdown time.</p>
<b>Inflow, Underdrain, and Outflow Structures</b>	
<ul style="list-style-type: none"> <li>□ Inflow, underdrains and outflow structures are accessible for inspection and maintenance.</li> </ul>	<p>Maintenance will prevent clogging and ensure proper operation of the flow control structures.</p>
<ul style="list-style-type: none"> <li>□ Inflow velocities are limited to 3 ft./s or less or use energy dissipation methods. (e.g., riprap, level spreader) for concentrated inflows.</li> </ul>	<p>High inflow velocities can cause erosion, scour and/or channeling.</p>
<ul style="list-style-type: none"> <li>□ Curb cut inlets are at least 18 inches wide, have a 4-6 inch reveal (drop) and an apron and energy dissipation as needed.</li> </ul>	<p>Inlets must not restrict flow and apron prevents blockage from vegetation as it grows in. Energy dissipation prevents erosion.</p>
<ul style="list-style-type: none"> <li>□ Underdrain outlet elevation should be a minimum of 3 inches above the bottom elevation of the aggregate storage layer.</li> </ul>	<p>A minimal separation from subgrade or the liner lessens the risk of fines entering the underdrain and can improve hydraulic performance by allowing perforations to remain unblocked.</p>
<ul style="list-style-type: none"> <li>□ Minimum underdrain diameter is 8 inches.</li> </ul>	<p>Minimum diameter required for maintenance by City crews. For privately maintained BMPs, a minimum underdrain diameter of 6 inches is allowed.</p>
<ul style="list-style-type: none"> <li>□ Underdrains are made of slotted, PVC pipe conforming to ASTM D 3034 or equivalent or corrugated, HDPE pipe conforming to AASHTO 252M or equivalent.</li> </ul>	<p>Slotted underdrains provide greater intake capacity, clog resistant drainage, and reduced entrance velocity into the pipe, thereby reducing the chances of solids migration.</p>
<ul style="list-style-type: none"> <li>□ An underdrain cleanout with a minimum 8-inch diameter and lockable cap is placed every 50 feet as required based on underdrain length.</li> </ul>	<p>Properly spaced cleanouts will facilitate underdrain maintenance. For privately maintained BMPs, cleanout diameter of 6 inches is allowed.</p>
<ul style="list-style-type: none"> <li>□ Overflow is safely conveyed to a downstream storm drain system or discharge point Size overflow structure to pass 100-year peak flow for on-line infiltration basins and water quality peak flow for off-line basins.</li> </ul>	<p>Planning for overflow lessens the risk of property damage due to flooding.</p>

**Conceptual Design and Sizing Approach for Storm Water Pollutant Control Only**





## Appendix E: BMP Design Fact Sheets

To design bioretention with underdrain for storm water pollutant control only (no flow control required), the following steps should be taken:

1. Verify that siting and design criteria have been met, including placement requirements, contributing tributary area, maximum side and finish grade slopes, and the recommended media surface area tributary ratio.
2. Calculate the DCV per **Appendix B** based on expected site design runoff for tributary areas.
3. Use the sizing worksheet presented in **Appendix B.5** to size biofiltration BMPs.

### Conceptual Design and Sizing Approach when Storm Water Flow Control is Applicable

Control of flow rates and/or durations will typically require significant surface ponding and/or aggregate storage volumes, and therefore the following steps should be taken prior to determination of storm water pollutant control design. Pre-development and allowable post-project flow rates and durations should be determined as discussed in Chapter 6 of the manual.

1. Verify that siting and design criteria have been met, including placement requirements, contributing tributary area, maximum side and finish grade slopes, and the recommended media surface area tributary ratio.
2. Iteratively determine the facility footprint area, surface ponding and/or aggregate storage layer depth required to provide detention storage to reduce flow rates and durations to allowable limits. Flow rates and durations can be controlled from detention storage by altering outlet structure orifice size(s) and/or water control levels. Multi-level orifices can be used within an outlet structure to control the full range of flows.
3. If biofiltration with underdrain cannot fully provide the flow rate and duration control required by this manual, an upstream or downstream structure with significant storage volume such as an underground vault can be used to provide remaining controls.
4. After biofiltration with underdrain has been designed to meet flow control requirements, calculations must be completed to verify if storm water pollutant control requirements to treat the DCV have been met.

BMP Applicability and Selection for Green Street Exemption			Form J-1
<b>Project Identification</b>			
Project Name:			
Permit Application Number:			Date:
<b>Project Characterization and Selection Synopsis</b>			
<p>The purpose of this form is to guide the selection of BMPs, given project specific constraints to meet the Green Streets exemption as defined in Appendix J.2 of the BMP Design Manual. In order to qualify for a PDP exemption, the project must incorporate all applicable Green Street BMP elements described in Appendix J.2, based on the applicability guidance provided in Appendix J.2.</p> <p>Complete the sections below providing detailed justification for each selection.</p>			
<p><b>Step 1: Does this project include retrofitting or redevelopment of an existing alley, street, or roadway criteria?</b> Exemptions do not apply for projects that construct new alleys, streets, or roadways. See Appendix J for additional guidance on distinguishing between redevelopment of a street and new development.</p> <p><input type="checkbox"/> Yes    <input type="checkbox"/> No (if No is selected, the Green Street exemption is not applicable)</p>			
Provide a brief overview of the project, key details, and site-specific opportunities and constraints:			
<p><b>Step 2: Complete the BMP-specific applicability checklists on the following pages and attach them to this form. Complete forms for all BMPs, including those that were used and those that were not used.</b></p>			
<p><b>Step 3: Summarize the BMP(s) that were selected through the guidance process (Select all that apply):</b></p>			
BMP Type	Applicable?	Used?	Summary of justification for Inclusion or Finding of Non-applicability
Vegetated Swales	<input type="checkbox"/>	<input type="checkbox"/>	
Sidewalk Planters	<input type="checkbox"/>	<input type="checkbox"/>	
Curb Extensions	<input type="checkbox"/>	<input type="checkbox"/>	
Permeable Surfaces	<input type="checkbox"/>	<input type="checkbox"/>	
Green Gutters	<input type="checkbox"/>	<input type="checkbox"/>	
Rain Gardens	<input type="checkbox"/>	<input type="checkbox"/>	
Trees	<input type="checkbox"/>	<input type="checkbox"/>	
Other_____	<input type="checkbox"/>	<input type="checkbox"/>	





**Form J-1 Page 2 of 8: Vegetated Swale**

**Brief Description:** Vegetated Swales are shallow, open channels that are designed to remove storm water pollutants by physically straining/filtering runoff through vegetation in the channel.

Site Type (Check all that apply):	Street Type	Rating <sup>1</sup>	Present in Project?
	Residential Streets	●	<input type="checkbox"/>
	Commercial Street/ Business District	○	<input type="checkbox"/>
	Collector Street	●	<input type="checkbox"/>
	Arterial and Boulevard	●	<input type="checkbox"/>
	Alleys	○	<input type="checkbox"/>
	Parking Areas	●	<input type="checkbox"/>
Key Opportunities for Vegetated Swales (Check all that apply):	Parkway strips		<input type="checkbox"/>
	Medians		<input type="checkbox"/>
	Long, mostly continuous space		<input type="checkbox"/>
	Other (must justify below)		<input type="checkbox"/>
Site-Specific Factors (Check all that apply):	<b>Favorable Conditions for Vegetated Swales</b>		
	Slope > 1% and <3%		<input type="checkbox"/>
	Conveying run-on to a site		<input type="checkbox"/>
	Infiltration is partially feasible or not feasible		<input type="checkbox"/>
	Long continuous segments available		<input type="checkbox"/>
	More parkway width		<input type="checkbox"/>
	<b>Unfavorable Conditions for Vegetated Swales</b>		
	Available width is < 8 feet		<input type="checkbox"/>
	Frequent driveway interruption		<input type="checkbox"/>
	ROW width too limited		<input type="checkbox"/>
<b>Summary of Findings:</b>			
Were Vegetated Swales determined to be applicable as part of the Green Streets BMP plan? <input type="checkbox"/> Yes <input type="checkbox"/> No		If yes, were they used? <input type="checkbox"/> Yes <input type="checkbox"/> No	
Provide discussion/justifications for selections and decisions above:			

<sup>1</sup>

- High applicability within this category, however may still be limited by site-specific factors
- Generally applicable in this category; largely dependent on site-specific factors
- Limited applicability within this category; may still be applicable in some cases; should be considered



**Form J-1 Page 3 of 8: Sidewalk Planters**

**Brief Description:** A planter imbedded in the sidewalk designed to manage storm water runoff from the adjacent roadway and sidewalk.

Site Type (Check all that apply):	Street Type	Rating <sup>2</sup>	Present in Project?
	Residential Streets	⊙	<input type="checkbox"/>
	Commercial Street/ Business District	⊙	<input type="checkbox"/>
	Collector Street	●	<input type="checkbox"/>
	Arterial and Boulevard	●	<input type="checkbox"/>
	Alleys	○	<input type="checkbox"/>
	Parking Areas	⊙	<input type="checkbox"/>
Key Opportunities for Sidewalk Planters (Check all that apply):	Parkway strips		<input type="checkbox"/>
	Medians		<input type="checkbox"/>
	Between driveways		<input type="checkbox"/>
	Other (must justify below)		<input type="checkbox"/>
Site-Specific Factors (Check all that apply):	Favorable Conditions for Sidewalk Planters		
	Slope <4%		<input type="checkbox"/>
	Wide sidewalks		<input type="checkbox"/>
	More parkway width		<input type="checkbox"/>
	Unfavorable Conditions for Sidewalk Planters		
	Conflicts with car egress		<input type="checkbox"/>
	ROW width too limited		<input type="checkbox"/>
<b>Summary of Findings:</b>			
Were Sidewalk Planters determined to be applicable as part of the Green Streets BMP plan? <input type="checkbox"/> Yes <input type="checkbox"/> No		If yes, were they used? <input type="checkbox"/> Yes <input type="checkbox"/> No	
Provide discussion/justifications for selections and decisions above:			

<sup>2</sup> ● High applicability within this category, however may still be limited by site-specific factors  
 ⊙ Generally applicable in this category; largely dependent on site-specific factors  
 ○ Limited applicability within this category; may still be applicable in some cases; should be considered



**Form J-1 Page 4 of 8: Curb Extensions**

**Brief Description:** Curb extensions expand the edge of the sidewalk into the roadway or parking area and allow storm water runoff to collect and infiltrate through a detention area of porous media.

Site Type (Check all that apply):	Street Type	Rating <sup>3</sup>	Present in Project?
	Residential Streets	●	<input type="checkbox"/>
	Commercial Street/ Business District	●	<input type="checkbox"/>
	Collector Street	⊙	<input type="checkbox"/>
	Arterial and Boulevard	⊙	<input type="checkbox"/>
	Alleys	○	<input type="checkbox"/>
	Parking Areas	⊙	<input type="checkbox"/>
Key Opportunities for Curb Extensions (Check all that apply):	Intersections		<input type="checkbox"/>
	Parking area		<input type="checkbox"/>
	Other (must justify below)		<input type="checkbox"/>
Site-Specific Factors (Check all that apply):	Favorable Conditions for Curb Extensions		
	Slope <4%		<input type="checkbox"/>
	Traffic calming needed		<input type="checkbox"/>
	Unfavorable Conditions for Curb Extensions		
	Conflicts with bike lanes		<input type="checkbox"/>
	Site distance issues at intersection		<input type="checkbox"/>
<b>Summary of Findings:</b>			
Were Curb Extensions determined to be applicable as part of the Green Streets BMP plan? <input type="checkbox"/> Yes <input type="checkbox"/> No		If yes, were they used? <input type="checkbox"/> Yes <input type="checkbox"/> No	
Provide discussion/justifications for selections and decisions above:			

<sup>3</sup> ● High applicability within this category, however may still be limited by site-specific factors  
 ⊙ Generally applicable in this category; largely dependent on site-specific factors  
 ○ Limited applicability within this category; may still be applicable in some cases; should be considered



**Form J-1 Page 5 of 8: Permeable Surfaces**

**Brief Description:** Permeable surfaces are pavement that allows for percolation through void spaces into subsurface layers.

Site Type (Check all that apply):	Street Type	Rating <sup>4</sup>	Present in Project?
	Residential Streets	●	<input type="checkbox"/>
	Commercial Street/ Business District	●	<input type="checkbox"/>
	Collector Street	⊙	<input type="checkbox"/>
	Arterial and Boulevard	⊙	<input type="checkbox"/>
	Alleys	●	<input type="checkbox"/>
	Parking Areas	⊙	<input type="checkbox"/>
Key Opportunities for Permeable Surfaces (Check all that apply):	Sidewalks		<input type="checkbox"/>
	Parking strips		<input type="checkbox"/>
	Shoulders		<input type="checkbox"/>
	Low traffic roadways		<input type="checkbox"/>
	Other (must justify below)		<input type="checkbox"/>
Site-Specific Factors (Check all that apply):	Favorable Conditions for Permeable Surfaces		
	Slope < 2-3%		<input type="checkbox"/>
	Conveying limited run-on to a site		<input type="checkbox"/>
	Low traffic area		<input type="checkbox"/>
	Unfavorable Conditions for Permeable Surfaces		
	High traffic area		<input type="checkbox"/>
	Run-on has high sediment load		<input type="checkbox"/>
<b>Summary of Findings:</b>			
Were Permeable Surfaces determined to be applicable as part of the Green Streets BMP plan? <input type="checkbox"/> Yes <input type="checkbox"/> No		If yes, were they used? <input type="checkbox"/> Yes <input type="checkbox"/> No	
Provide discussion/justifications for selections and decisions above:			

<sup>4</sup> ● High applicability within this category, however may still be limited by site-specific factors  
 ⊙ Generally applicable in this category; largely dependent on site-specific factors  
 ○ Limited applicability within this category; may still be applicable in some cases; should be considered



**Form J-1 Page 6 of 8: Green Gutters**

**Brief Description:** Green Gutters are shallow and narrow strips of landscaping in a typical curb and gutter location with a lower elevation than the street gutter elevation to allow capture of storm water from the sidewalk and street.

Site Type (Check all that apply):	<b>Street Type</b>	<b>Rating<sup>5</sup></b>	<b>Present in Project?</b>
	Residential Streets	○	<input type="checkbox"/>
	Commercial Street/ Business District	⊙	<input type="checkbox"/>
	Collector Street	●	<input type="checkbox"/>
	Arterial and Boulevard	●	<input type="checkbox"/>
	Alleys	⊙	<input type="checkbox"/>
	Parking Areas	○	<input type="checkbox"/>
Key Opportunities for Green Gutters (Check all that apply):	Parkway strips		<input type="checkbox"/>
	Medians		<input type="checkbox"/>
	Long, mostly continuous space		<input type="checkbox"/>
	Other (must justify below)		<input type="checkbox"/>
Site-Specific Factors (Check all that apply):	<b>Favorable Conditions for Green Gutters</b>		
	Slope > 1% and <3%		<input type="checkbox"/>
	Conveying run-on to a site		<input type="checkbox"/>
	Infiltration is partially feasible or not feasible		<input type="checkbox"/>
	Long continuous segments available		<input type="checkbox"/>
	Narrower spaces (as little as 2 to 3 feet)		<input type="checkbox"/>
	<b>Unfavorable Conditions for Green Gutters</b>		
Frequent driveway interruption		<input type="checkbox"/>	
ROW width too limited		<input type="checkbox"/>	
<b>Summary of Findings:</b>			
Were Green Gutters determined to be applicable as part of the Green Streets BMP plan? <input type="checkbox"/> Yes <input type="checkbox"/> No		If yes, were they used? <input type="checkbox"/> Yes <input type="checkbox"/> No	
Provide discussion/justifications for selections and decisions above:			

- <sup>5</sup> ● High applicability within this category, however may still be limited by site-specific factors
- ⊙ Generally applicable in this category; largely dependent on site-specific factors
- Limited applicability within this category; may still be applicable in some cases; should be considered



**Form J-1 Page 7 of 8: Rain Gardens**

**Brief Description:** Rain Gardens are shallow detention basins with vegetation that temporarily store water to allow for infiltration of the stored volume. Rain Gardens could be bioretention or biofiltration with partial retention or a biofiltration BMP.

Site Type (Check all that apply):	Street Type	Rating <sup>6</sup>	Present in Project?
	Residential Streets	⦿	<input type="checkbox"/>
	Commercial Street/ Business District	⦿	<input type="checkbox"/>
	Collector Street	⦿	<input type="checkbox"/>
	Arterial and Boulevard	⦿	<input type="checkbox"/>
	Alleys	○	<input type="checkbox"/>
	Parking Areas	●	<input type="checkbox"/>
Key Opportunities for Rain Gardens (Check all that apply):	Irregularly shaped areas in ROW		<input type="checkbox"/>
	Broad and flat areas		<input type="checkbox"/>
	Other (must justify below)		<input type="checkbox"/>
Site-Specific Factors (Check all that apply):	Favorable Conditions for Rain Gardens		
	Slope <2%		<input type="checkbox"/>
	Infiltration is partially feasible or not feasible		<input type="checkbox"/>
	Large area available		
	Unfavorable Conditions for Rain Gardens		
	Slope > 2%		<input type="checkbox"/>
	ROW too limited		<input type="checkbox"/>
<b>Summary of Findings:</b>			
Were Rain Gardens determined to be applicable as part of the Green Streets BMP plan? <input type="checkbox"/> Yes <input type="checkbox"/> No		If yes, were they used? <input type="checkbox"/> Yes <input type="checkbox"/> No	
Provide discussion/justifications for selections and decisions above:			

<sup>6</sup> ● High applicability within this category, however may still be limited by site-specific factors  
 ⦿ Generally applicable in this category; largely dependent on site-specific factors  
 ○ Limited applicability within this category; may still be applicable in some cases; should be considered



Form J-1 Page 8 of 8: Trees

**Brief Description:** Trees planted in the sidewalk right-of-way provide rainfall interception and infiltration benefits and typically supplement other storm water management tools.

Site Type (Check all that apply):	Street Type	Rating <sup>7</sup>	Present in Project?
	Residential Streets	●	<input type="checkbox"/>
	Commercial Street/ Business District	◎	<input type="checkbox"/>
	Collector Street	◎	<input type="checkbox"/>
	Arterial and Boulevard	◎	<input type="checkbox"/>
	Alleys	◎	<input type="checkbox"/>
	Parking Areas	●	<input type="checkbox"/>
Key Opportunities for Trees (Check all that apply):	Parkway strips		<input type="checkbox"/>
	Medians		<input type="checkbox"/>
	Irregularly shaped areas		<input type="checkbox"/>
	Extra ROW on back side of sidewalk		<input type="checkbox"/>
	Other (must justify below)		<input type="checkbox"/>
Site-Specific Factors (Check all that apply):	Favorable Conditions for Trees		
	Located outside of clear zone		<input type="checkbox"/>
	Infiltration is feasible		<input type="checkbox"/>
	ROW not limiting		
	Unfavorable Conditions for Trees		
	Limited space for root growth		<input type="checkbox"/>
Clear zone issues		<input type="checkbox"/>	
<b>Summary of Findings:</b>			
Were Trees determined to be applicable as part of the Green Streets BMP plan? <input type="checkbox"/> Yes <input type="checkbox"/> No		If yes, were they used? <input type="checkbox"/> Yes <input type="checkbox"/> No	
Provide discussion/justifications for selections and decisions above:			

<sup>7</sup> ● High applicability within this category, however may still be limited by site-specific factors  
 ◎ Generally applicable in this category; largely dependent on site-specific factors  
 ○ Limited applicability within this category; may still be applicable in some cases; should be considered





Project Name:

# Attachment 2

## Backup for PDP Hydromodification Control Measures

This is the cover sheet for Attachment 2.

Mark this box if this attachment is empty because the project is exempt from PDP hydromodification management requirements.

Project Name:

Indicate which Items are Included:

Attachment Sequence	Contents	Checklist
<b>Attachment 2a</b>	Hydromodification Management Exhibit (Required)	<input type="checkbox"/> Included See Hydromodification Management Exhibit Checklist.
<b>Attachment 2b</b>	Management of Critical Coarse Sediment Yield Areas (WMAA Exhibit is required, additional analyses are optional)  See Section 6.2 of the BMP Design Manual.	<input type="checkbox"/> Exhibit showing project drainage boundaries marked on WMAA Critical Coarse Sediment Yield Area Map (Required)  Optional analyses for Critical Coarse Sediment Yield Area Determination <input type="checkbox"/> 6.2.1 Verification of Geomorphic Landscape Units Onsite <input type="checkbox"/> 6.2.2 Downstream Systems Sensitivity to Coarse Sediment <input type="checkbox"/> 6.2.3 Optional Additional Analysis of Potential Critical Coarse Sediment Yield Areas Onsite
<b>Attachment 2c</b>	Geomorphic Assessment of Receiving Channels (Optional)  See Section 6.3.4 of the BMP Design Manual.	<input type="checkbox"/> Not Performed <input type="checkbox"/> Included <input type="checkbox"/> Submitted as separate stand-alone document
<b>Attachment 2d</b>	Flow Control Facility Design and Structural BMP Drawdown Calculations (Required)  Overflow Design Summary for each structural BMP  See Chapter 6 and Appendix G of the BMP Design Manual	<input type="checkbox"/> Included <input type="checkbox"/> Submitted as separate stand-alone document



Project Name:

**Use this checklist to ensure the required information has been included on the Hydromodification Management Exhibit:**

The Hydromodification Management Exhibit must identify:

- Underlying hydrologic soil group
- Approximate depth to groundwater
- Existing natural hydrologic features (watercourses, seeps, springs, wetlands)
- Critical coarse sediment yield areas to be protected OR provide a separate map showing that the project site is outside of any critical coarse sediment yield areas
- Existing topography
- Existing and proposed site drainage network and connections to drainage offsite
- Proposed grading
- Proposed impervious features
- Proposed design features and surface treatments used to minimize imperviousness
- Point(s) of Compliance (POC) for Hydromodification Management  
Existing and proposed drainage boundary and drainage area to each POC (when necessary, create separate exhibits for pre-development and post-project conditions)
- Structural BMPs for hydromodification management (identify location, type of BMP, and size/detail).

Project Name:

**THIS PAGE INTENTIONALLY LEFT BLANK FOR DOUBLE-SIDED PRINTING**

Project Name:

# **Attachment 3 Structural BMP Maintenance Information**

This is the cover sheet for Attachment 3.

Project Name:

**THIS PAGE INTENTIONALLY LEFT BLANK FOR DOUBLE-SIDED PRINTING**

**Project Name:**

**Indicate which Items are Included:**

Attachment Sequence	Contents	Checklist
<b>Attachment 3</b>	Maintenance Agreement (Form DS-3247) (when applicable)	<input type="checkbox"/> Included <input type="checkbox"/> Not applicable



Project Name:

**Use this checklist to ensure the required information has been included in the Structural BMP Maintenance Information Attachment:**

**Attachment 3:** For private entity operation and maintenance, Attachment 3 must include a Storm Water Management and Discharge Control Maintenance Agreement (Form DS-3247). The following information must be included in the exhibits attached to the maintenance agreement:

- Vicinity map
- Site design BMPs for which DCV reduction is claimed for meeting the pollutant control obligations.
- BMP and HMP location and dimensions
- BMP and HMP specifications/cross section/model
- Maintenance recommendations and frequency
- LID features such as (permeable paver and LS location, dim, SF).



**THE CITY OF SAN DIEGO**

RECORDING REQUESTED BY:  
**THE CITY OF SAN DIEGO**  
AND WHEN RECORDED MAIL TO:

\_\_\_\_\_  
\_\_\_\_\_  
\_\_\_\_\_

(THIS SPACE IS FOR RECORDER'S USE ONLY)

**STORM WATER MANAGEMENT AND DISCHARGE CONTROL MAINTENANCE AGREEMENT**

APPROVAL NUMBER:

ASSESSOR'S PARCEL NUMBER:

PROJECT NUMBER:

\_\_\_\_\_

\_\_\_\_\_

\_\_\_\_\_

This agreement is made by and between the City of San Diego, a municipal corporation [City] and

\_\_\_\_\_;

the owner or duly authorized representative of the owner [Property Owner] of property located at

\_\_\_\_\_

(PROPERTY ADDRESS)

and more particularly described as:

\_\_\_\_\_

(LEGAL DESCRIPTION OF PROPERTY)

in the City of San Diego, County of San Diego, State of California.

Property Owner is required pursuant to the City of San Diego Municipal Code, Chapter 4, Article 3, Division 3, Chapter 14, Article 2, Division 2, and the Land Development Manual, Storm Water Standards, to enter into a Storm Water Management and Discharge Control Maintenance Agreement [Maintenance Agreement] for the installation and maintenance of Permanent Storm Water Best Management Practices [Permanent Storm Water BMPs] prior to the issuance of construction/grading permits. The Maintenance Agreement is intended to ensure the establishment and maintenance of Permanent Storm Water BMPs on site, as described in the attached exhibit(s), the project's Storm Water Quality Management Plan [SWQMP] and Grading and/or Improvement Plan Drawing No(s), or Building Plan Project No(s): \_\_\_\_\_.

Property Owner wishes to obtain a building/engineering/grading permit according to the Grading and/or Improvement Plan Drawing No(s) or Building Plan Project No(s): \_\_\_\_\_.

**Continued on Page 2**

NOW, THEREFORE, the parties agree as follows:

1. Property Owner shall have prepared, or if qualified, shall prepare an Operation and Maintenance Procedure [OMP] for Permanent Storm Water BMPs, satisfactory to the City, according to the attached exhibit(s), consistent with the Grading and/or Improvement Plan Drawing No(s), or Building Plan Project No(s): \_\_\_\_\_.
2. Property Owner shall install, maintain, and repair or replace all Permanent Storm Water BMPs within the property, according to the OMP guidelines as described in the attached exhibit(s), the project's SWQMP, and Grading and/or Improvement Plan Drawing No(s), or Building Plan Project No(s) \_\_\_\_\_.
3. Property Owner shall maintain operation and maintenance records for at least five (5) years. These records shall be made available to the City for inspection upon request at any time.

This Maintenance Agreement shall commence upon execution of this document by all parties named hereon, and shall run with the land.

Executed by the City of San Diego and by Property Owner in San Diego, California.

See Attached Exhibit(s): \_\_\_\_\_

\_\_\_\_\_  
(PROPERTY OWNER SIGNATURE)

\_\_\_\_\_  
(PRINT NAME AND TITLE)

\_\_\_\_\_  
(COMPANY/ORGANIZATION NAME)

\_\_\_\_\_  
(DATE)

**THE CITY OF SAN DIEGO**

APPROVED:

\_\_\_\_\_  
(DEPUTY CITY ENGINEER SIGNATURE)

\_\_\_\_\_  
(PRINT NAME)

\_\_\_\_\_  
(DATE)

**NOTE: ALL SIGNATURES MUST INCLUDE NOTARY ACKNOWLEDGEMENT PER CIVIL CODE SEC. 1180 ET.SEQ.**

SITE DESIGN, SOURCE CONTROL AND POLLUTANT CONTROL BMP OPERATION & MAINTENANCE PROCEDURE

STORM WATER MANAGEMENT AND DISCHARGE CONTROL MAINTENANCE AGREEMENT APPROVAL NO.:

O&M RESPONSIBLE PARTY DESIGNEE: PROPERTY OWNER HOA / CITY / OTHER

BMP DESCRIPTION	INSPECTION FREQUENCY	MAINTENANCE FREQUENCY	MAINTENANCE METHOD	QTY	INCLUDED IN O&M MANUAL		SHEET NUMBER(S)
					YES	NO	
SITE DESIGN ELEMENTS DESCRIPTION: LANDSCAPING	ANNUAL	AS NEEDED	REMOVE AND PROPERLY DISPOSE ACCUMULATED MATERIALS	N/A	<input checked="" type="checkbox"/>	<input type="checkbox"/>	N/A
SOURCE CONTROL ELEMENTS DESCRIPTION: ON-SITE INLETS	ANNUAL	AS NEEDED	REMOVE AND REPLACE CLOGGED SURFACE SOILS MOWING AND DEBRIS COLLECTION	N/A	<input checked="" type="checkbox"/>	<input type="checkbox"/>	N/A
POLLUTANT CONTROL BMP(S) DESCRIPTION: MODULAR WETLAND SYSTEM	6 -12 MON.	6 -12 MON.	REMOVE AND PROPERLY DISPOSE ACCUMULATED MATERIALS REPLACE CARTRIDGE FILTER AND DRAIN DOWN FILTER MEDIA TRIM VEGETATION AS NEEDED	4	<input checked="" type="checkbox"/>	<input type="checkbox"/>	5

HMP EXEMPT  YES



SITE ADDRESS:  
4620 PACIFIC HIGHWAY  
SAN DIEGO CA 92110

APN:  
442-740-03-00; 442-740-06-00; 442-740-07-00

ABBREVIATED LEGAL DESCRIPTION:  
 PARCEL 1:  
LOT 1 & 2 OF JENNINGS TRACT, MAP 5632  
 PARCEL 2:  
PORTION OF LOT 16 & 17, SUNNICHSEN'S SUBDIVISION, MAP 1574  
 PARCEL 3:  
PARTS OF LOTS 1-5, BLOCK 376, MAP 420  
 PARCEL 4:  
PORTION OF BLOCK 366, ROGER'S SUBDIVISION, MAP 429

VICINITY MAP  
NOT TO SCALE



**SITE WORK INFORMATION:**

TOTAL DISTURBED AREA: 76,154 SF = 1.75 AC  
 EXISTING IMPERVIOUS AREA: 76,154 SF = 1.75 AC  
 PROPOSED IMPERVIOUS AREA (REPLACED): 76,154 SF = 1.75 AC  
 PROPOSED IMPERVIOUS AREA (NEW): 0 SF = 0 AC  
 PROPOSED IMPERVIOUS AREA (TOTAL): 76,154 SF = 1.75 AC  
 PROPOSED INCREASE IN IMPERVIOUS AREA: 0.0%

**SOIL INFORMATION:**

SOIL TYPE: TYPE D  
 DEPTH TO GROUND WATER: ~10FT (PER SOILS REPORT)

**ROOF AREA RUNOFF CONVEYANCE:**

THE STORMWATER RUNOFF FROM THE PROPOSED ROOF AREAS SHALL BE CONVEYED THROUGH THE PROPOSED ROOF DRAIN SYSTEMS DESIGNED BY THE PROJECT ARCHITECT ACCORDING TO THE DRAINAGE AREAS SHOWN ON THIS PLAN

**NATURAL HYDROLOGIC FEATURES:**

NO NATURAL HYDROLOGIC FEATURES (WATERCOURSES, SEEPS, SPRINGS, WETLANDS) EXIST ON THE PROJECT SITE

**COARSE SEDIMENT YIELD**

NO CRITICAL COARSE SEDIMENT YIELD AREAS TO BE PROTECTED. REFER TO PRIORITY DEVELOPMENT PROJECT SWQMP PREPARED BY PASCO, LARET, SUITER & ASSOCIATES

**GREEN STREET BMP'S**

- J1** SIDEWALK PLANTER
- J2** STREET TREES

**SITE DESIGN BMP'S**

SITE DESIGN MEASURE	IMPLEMENTATION
<b>(SD-A)</b> TREES (PER LANDSCAPE PLANS)	<input checked="" type="checkbox"/> YES <input type="checkbox"/> NO <input type="checkbox"/> N/A
<b>(SD-B)</b> IMPERVIOUS AREA DISPERSION	<input checked="" type="checkbox"/> YES <input type="checkbox"/> NO <input type="checkbox"/> N/A
<b>(SD-C)</b> GREEN ROOFS	<input type="checkbox"/> YES <input type="checkbox"/> NO <input checked="" type="checkbox"/> N/A
<b>(SD-D)</b> PERMEABLE PAVEMENT	<input type="checkbox"/> YES <input type="checkbox"/> NO <input checked="" type="checkbox"/> N/A
<b>(SD-E)</b> RAIN BARRELS	<input type="checkbox"/> YES <input type="checkbox"/> NO <input checked="" type="checkbox"/> N/A
<b>(SD-F)</b> AMENDED SOILS	<input checked="" type="checkbox"/> YES <input type="checkbox"/> NO <input type="checkbox"/> N/A

**DMA INFORMATION**

	1	2	3	4
TOTAL AREA (SF)	18438	18294	18005	17324
ROOF (SF)	18438	18294	18005	3602
HARDSCAPE (SF)	16688	17194	16355	10772
LANDSCAPE (SF)	1750**	1100**	1650**	2950
TOTAL IMPERVIOUS (SF)	18438	18294	18005	14374
TOTAL PERVIOUS (SF)	0	0	0	2950
PERCENT IMPERVIOUS (%)	100.0%	100.0%	100.0%	82.9%
BMP TREATMENT	6X6 MWS FG	6X6 MWS FG	6X6 MWS FG	4X8 MWS LINEAR
DCV (CF)	719	713	702	601
CALCULATED FLOW RATE (CFS)	0.114	0.113	0.112	0.10
CERTIFIED TREATMENT CAPACITY (CFS)	0.12	0.12	0.12	0.12

\*\* NOTE: PROPOSED LANDSCAPE AREAS PER ARCHITECTURE & LANDSCAPE ARCHITECTURE PLANS, AND IS WITHIN AMENITY AREAS ON STRUCTURE. THE LANDSCAPE AREAS TABULATED ARE USED SOLELY FOR VOLUME RETENTION CALCULATIONS AND NOT CONSIDERED FOR NET IMPERVIOUS & NET PERVIOUS AREA TABULATION.

**LEGEND**

- PROPERTY BOUNDARY
- RIGHT OF WAY
- STREET CENTERLINE
- DRAINAGE PATH OF TRAVEL
- DMA BOUNDARY
- EXISTING CONTOURS
- SITE DESIGN MEASURE IDENTIFIER
- GREEN STREET BMP
- DMA IDENTIFIER & TOTAL AREA
- PROPOSED HARDSCAPE
- PROPOSED LANDSCAPE AREAS INCLUDED IN VOLUME RETENTION CALCULATIONS 3" MIN AMENDED SOIL, SEE LSCAPE PLAN
- PROPOSED POST CONSTRUCTION BMP

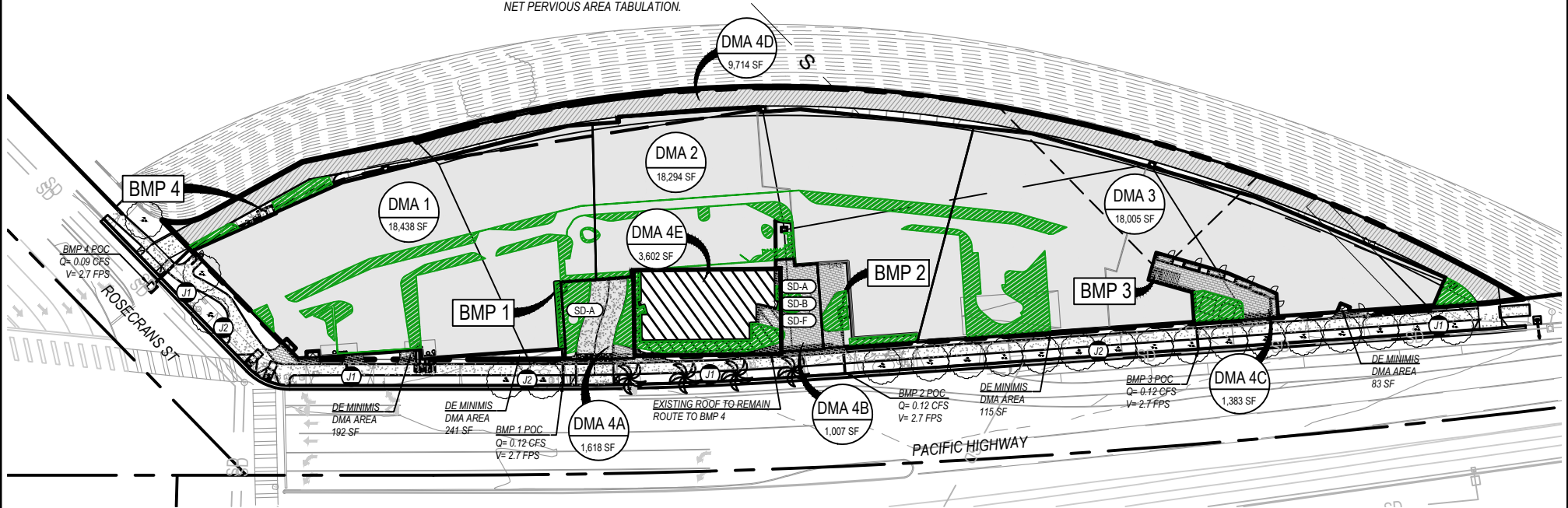

**SITE PLAN WITH BMP LOCATIONS**

NOT TO SCALE

SITE SPECIFIC DATA	
PROJECT NUMBER	
PROJECT NAME	
PROJECT LOCATION	
STRUCTURE ID	BMP 1, 2, & 3
TREATMENT REQUIRED	
TREATMENT FLOW (CFS)	0.12 CFS (MAX)
NOTES:	

	FG-MWS-L-6-6-3.5
TREATMENT FLOW (CFS)	0.12
Vault Height (FT)	3.5
MAX OPERATING HEAD (FT)	3.0
WETLAND MEDIA VOLUME (CY)	2.37
WETLAND MEDIA LOADING RATE (GPM/SF)	1.0
ORIFICE SIZE (DIA. INCHES)	1.61

**INSTALLATION NOTES**

1. CONTRACTOR TO PROVIDE ALL LABOR, EQUIPMENT, MATERIALS AND INCIDENTALS REQUIRED TO OFFLOAD AND INSTALL THE SYSTEM AND APPURTENANCES IN ACCORDANCE WITH THIS DRAWING AND THE MANUFACTURER'S SPECIFICATIONS, UNLESS OTHERWISE STATED IN MANUFACTURER'S CONTRACT.
2. UNIT MUST BE INSTALLED ON LEVEL BASE. MANUFACTURER RECOMMENDS INSTALLING ON A PAVED SURFACE, OR A MINIMUM 6" LEVEL ROCK BASE UNLESS SPECIFIED BY THE PROJECT ENGINEER. CONTRACTOR IS RESPONSIBLE FOR VERIFYING PROJECT ENGINEER'S RECOMMENDED BASE SPECIFICATIONS.
3. CONTRACTOR TO SUPPLY AND INSTALL ALL EXTERNAL CONNECTING PIPES.
4. DRIP OR SPRAY IRRIGATION REQUIRED ON ALL UNITS WITH VEGETATION.

**GENERAL NOTES**

1. MANUFACTURER TO PROVIDE ALL MATERIALS UNLESS OTHERWISE NOTED.
2. ALL DIMENSIONS, ELEVATIONS, SPECIFICATIONS AND CAPACITIES ARE SUBJECT TO CHANGE. FOR PROJECT SPECIFIC DRAWINGS DETAILING EXACT DIMENSIONS, WEIGHTS AND ACCESSORIES PLEASE CONTACT MANUFACTURER.

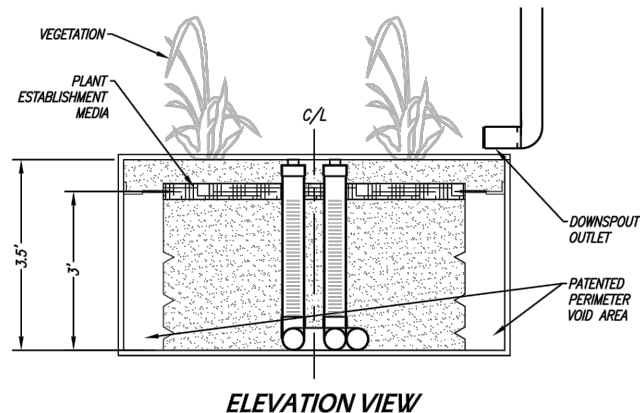
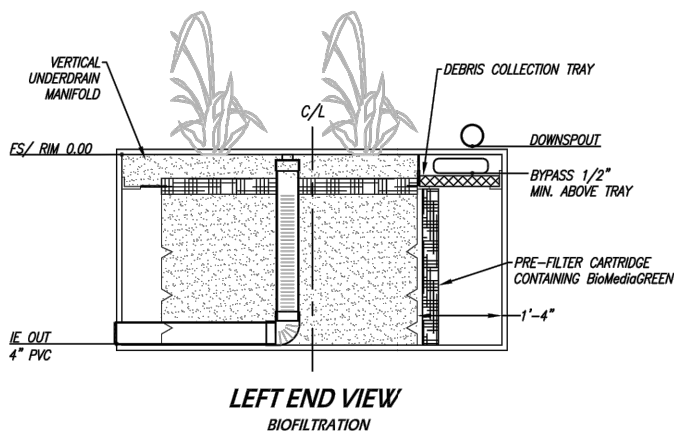
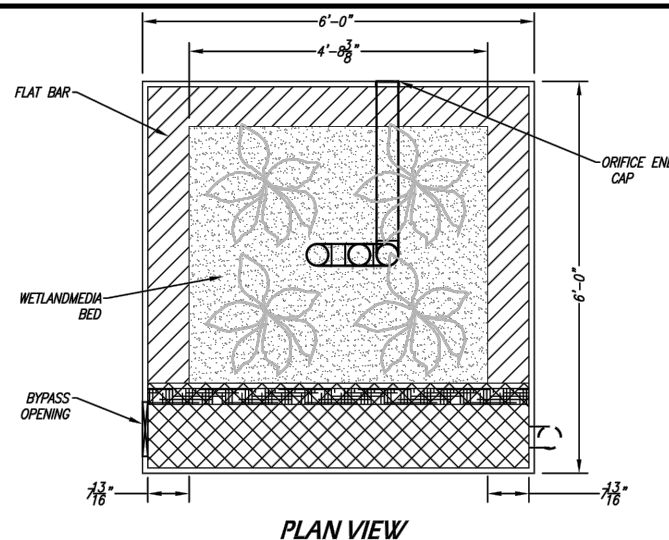

THE PRODUCT DESCRIBED MAY BE PROTECTED BY ONE OR MORE OF THE FOLLOWING US PATENTS: 7,425,202; 7,470,502; 7,674,378; & 3,032,816; RELATED FOREIGN PATENTS OR OTHER PATENTS PENDING.

PROPRIETARY AND CONFIDENTIAL: THE INFORMATION CONTAINED IN THIS DRAWING IS THE SOLE PROPERTY OF MODULAR WETLANDS SYSTEMS. ANY REPRODUCTION IN PART OR AS A WHOLE WITHOUT THE WRITTEN PERMISSION OF MODULAR WETLANDS SYSTEMS IS PROHIBITED.



FIBERGLASS MWS LINEAR STORMWATER BIOFILTRATION SYSTEM FG-MWS-L-6-6-3.5

TYPICAL DETAIL - 6'X6' MODULAR WETLAND SYSTEM

NOT TO SCALE

SITE SPECIFIC DATA			
PROJECT NUMBER	PLSA 3598		
PROJECT NAME	VIEWPOINT OLD TOWN		
PROJECT LOCATION	SAN DIEGO, CALIFORNIA		
STRUCTURE ID	BMP 4		
TREATMENT REQUIRED			
VOLUME BASED (CF)	FLOW BASED (CFS)		
N/A	0.115 (MAX)		
PEAK BYPASS REQUIRED (CFS) - IF APPLICABLE OFFLINE			
PIPE DATA	I.E.	MATERIAL	DIAMETER
INLET PIPE 1	2.60	HDPE	8"
INLET PIPE 2	N/A	N/A	N/A
OUTLET PIPE	-0.80	HDPE	8"
	PRETREATMENT	BIOFILTRATION	DISCHARGE
RIM ELEVATION	10.66		
SURFACE LOAD	DIRECT TRAFFIC		
FRAME & COVER	36" X 36"	UNDERGROUND	N/A
NOTES:			

\* PRELIMINARY NOT FOR CONSTRUCTION

**INSTALLATION NOTES**

- CONTRACTOR TO PROVIDE ALL LABOR, EQUIPMENT, MATERIALS AND INCIDENTALS REQUIRED TO OFFLOAD AND INSTALL THE SYSTEM AND APPURTENANCES IN ACCORDANCE WITH THIS DRAWING AND THE MANUFACTURERS SPECIFICATIONS, UNLESS OTHERWISE STATED IN MANUFACTURERS CONTRACT.
- UNIT MUST BE INSTALLED ON LEVEL BASE. MANUFACTURER RECOMMENDS A MINIMUM 6" LEVEL ROCK BASE UNLESS SPECIFIED BY THE PROJECT ENGINEER. CONTRACTOR IS RESPONSIBLE TO VERIFY PROJECT ENGINEERS RECOMMENDED BASE SPECIFICATIONS.
- CONTRACTOR TO SUPPLY AND INSTALL ALL EXTERNAL CONNECTING PIPES. ALL PIPES MUST BE FLUSH WITH INSIDE SURFACE OF CONCRETE. (PIPES CANNOT INTRUDE BEYOND FLUSH). INVERT OF OUTFLOW PIPE MUST BE FLUSH WITH DISCHARGE CHAMBER FLOOR. ALL PIPES SHALL BE SEALED WATER TIGHT PER MANUFACTURERS STANDARD CONNECTION DETAIL.
- CONTRACTOR RESPONSIBLE FOR INSTALLATION OF ALL RISERS, MANHOLES, AND HATCHES. CONTRACTOR TO GROUT ALL MANHOLES AND HATCHES TO MATCH FINISHED SURFACE UNLESS SPECIFIED OTHERWISE.
- VEGETATION SUPPLIED AND INSTALLED BY OTHERS. ALL UNITS WITH VEGETATION MUST HAVE DRIP OR SPRAY IRRIGATION SUPPLIED AND INSTALLED BY OTHERS.
- CONTRACTOR RESPONSIBLE FOR CONTRACTING BIO CLEAN FOR ACTIVATION OF UNIT. MANUFACTURERS WARRANTY IS VOID WITH OUT PROPER ACTIVATION BY A BIO CLEAN REPRESENTATIVE.

**GENERAL NOTES**

- MANUFACTURER TO PROVIDE ALL MATERIALS UNLESS OTHERWISE NOTED.
- ALL DIMENSIONS, ELEVATIONS, SPECIFICATIONS AND CAPACITIES ARE SUBJECT TO CHANGE. FOR PROJECT SPECIFIC DRAWINGS DETAILING EXACT DIMENSIONS, WEIGHTS AND ACCESSORIES PLEASE CONTACT BIO CLEAN.

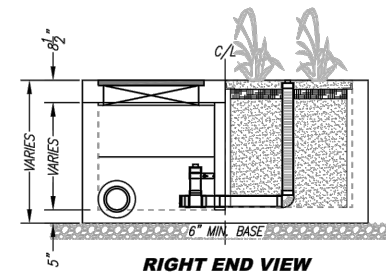
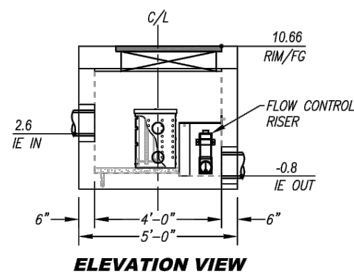
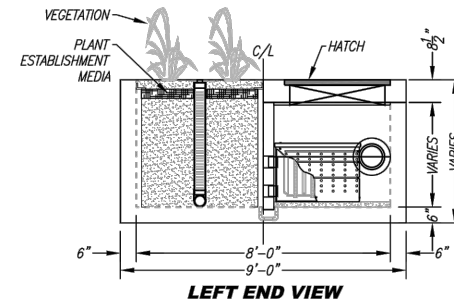
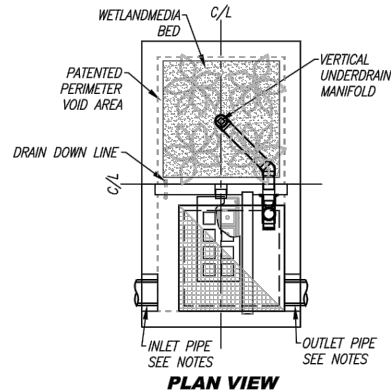

TREATMENT FLOW (CFS)	0.115
OPERATING HEAD (FT)	3.4
PRETREATMENT LOADING RATE (GPM/SF)	2.0
WETLAND MEDIA LOADING RATE (GPM/SF)	1.0

**MWS-L-4-8-V**  
STORMWATER BIOFILTRATION SYSTEM  
STANDARD DETAIL



PROPRIETARY AND CONFIDENTIAL:  
THE INFORMATION CONTAINED IN THIS DOCUMENT IS THE SOLE PROPERTY OF FORTERRA AND ITS COMPANIES. THIS DOCUMENT, NOR ANY PART THEREOF, MAY BE USED, REPRODUCED OR MODIFIED IN ANY MANNER WITHOUT THE WRITTEN CONSENT OF FORTERRA.



TYPICAL DETAIL - 4'X8' MODULAR WETLAND SYSTEM

NOT TO SCALE



Project Name:

# **Attachment 4**

## **Copy of Plan Sheets Showing Permanent Storm Water BMPs**

This is the cover sheet for Attachment 4.



Project Name:

**Use this checklist to ensure the required information has been included on the plans:**

The plans must identify:

- Structural BMP(s) with ID numbers matching Form I-6 Summary of PDP Structural BMPs
- The grading and drainage design shown on the plans must be consistent with the delineation of DMAs shown on the DMA exhibit
- Details and specifications for construction of structural BMP(s)
- Signage indicating the location and boundary of structural BMP(s) as required by the City Engineer
- How to access the structural BMP(s) to inspect and perform maintenance
- Features that are provided to facilitate inspection (e.g., observation ports, cleanouts, silt posts, or other features that allow the inspector to view necessary components of the structural BMP and compare to maintenance thresholds)
- Manufacturer and part number for proprietary parts of structural BMP(s) when applicable
- Maintenance thresholds specific to the structural BMP(s), with a location-specific frame of reference (e.g., level of accumulated materials that triggers removal of the materials, to be identified based on viewing marks on silt posts or measured with a survey rod with respect to a fixed benchmark within the BMP)
- Recommended equipment to perform maintenance
- When applicable, necessary special training or certification requirements for inspection and maintenance personnel such as confined space entry or hazardous waste management
- Include landscaping plan sheets showing vegetation requirements for vegetated structural BMP(s)
- All BMPs must be fully dimensioned on the plans
- When proprietary BMPs are used, site specific cross section with outflow, inflow and model number shall be provided. Broucher photocopies are not allowed.



# VIEWPOINT OLD TOWN SITE DEVELOPMENT PERMIT

NDP # XXXXXX

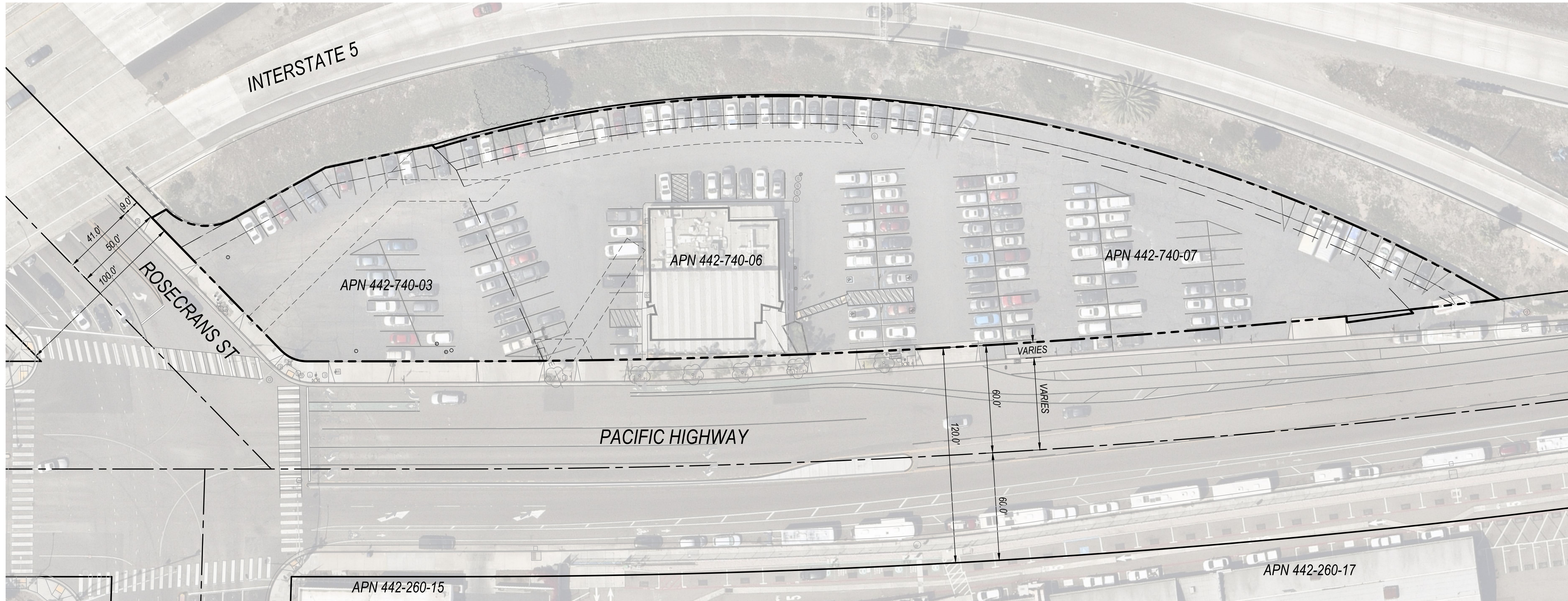

**SCOPE OF WORK:**  
SITE DEVELOPMENT FOR THE CONSTRUCTION OF SIX-STORY MIXED USE BUILDING AND PRESERVATION OF EXISTING STRUCTURE.

**OWNER:**  
VIEWPOINT DEVELOPMENT LLC  
2011 PALOMAR AIRPORT RD SUITE 101-102  
CARLSBAD, CA 92011

**ARCHITECT:**  
CARRIER JOHNSON  
185 W ST 8500  
SAN DIEGO, CA 92101  
PHONE: 619-239-2353

**CIVIL ENGINEER:**  
PASCO LARET SUITER & ASSOCIATES  
1911 SAN DIEGO, SUITE 100  
SAN DIEGO, CA 92110  
PHONE: 619-259-8212

**SOILS ENGINEER:**  
COMPANY  
ADDRESS  
PHONE

**SITE ADDRESS:**  
4620 PACIFIC HIGHWAY  
SAN DIEGO CA 92110

**APN:**  
442-740-03-00, 442-740-06-00, 442-740-07-00

**ABBREVIATED LEGAL DESCRIPTION:**  
PARCEL 1:  
LOT 1 & 2 OF JENNINGS TRACT, MAP 5632  
PARCEL 2:  
PORTION OF LOT 16 & 17, SUNNICHSENS SUBDIVISION, MAP 1574  
PARCEL 3:  
PARTS OF LOTS 1-5, BLOCK 376, MAP 420  
PARCEL 4:  
PORTION OF BLOCK 366, ROGER'S SUBDIVISION, MAP 429

**LOT SIZE:**  
EXISTING:  
GROSS: 76,154 SF = 1.75 AC  
LESS 1,241 SF = 0.03 AC FOR ROW ESMT  
NET: 74,913 SF = 1.72 AC  
PROPOSED:  
GROSS/NET: 72,720 SF = 1.67 AC

**PROJECT INFORMATION:**  
EXISTING ZONE: OTMCR-1.3, OTCC-1.1  
PROPOSED ZONE: OTMCR-1.3  
COMMUNITY PLAN: OLD TOWN SAN DIEGO

EXISTING USE: COMMERCIAL  
PROPOSED USE: MIXED USE

**OVERLAY ZONES:**  
AIRPORT APPROACH OVERLAY ZONE (AAOZ-400-450)  
TRANSIT AREA OVERLAY ZONE (TAOZ)

LAMBERT COORDINATES: 214-1707  
NAD83 COORDINATES: 1856-6269

EXISTING LOTS: 4  
PROPOSED LOTS: 4 (WITH PROPOSED LOT TIE AGREEMENT)

**SETBACKS**

REQUIRED	PROPOSED
FRONT: 0' (MIN 10' (MAX))	0'
REAR: 5'	5'
SIDEYARD: 5'	5'
STREET SIDEYARD: 10'	10'

**SITE WORK INFORMATION:**  
TOTAL DISTURBED AREA: 76,154 SF = 1.75 AC  
EXISTING IMPERVIOUS AREA: 76,154 SF = 1.75 AC  
PROPOSED IMPERVIOUS AREA (REPLACED): 76,154 SF = 1.75 AC  
PROPOSED IMPERVIOUS AREA (NEW): 0 SF = 0 AC  
PROPOSED IMPERVIOUS AREA (TOTAL): 76,154 SF = 1.75 AC

**EARTHWORK QUANTITIES:**  
CUT: 7,800 CY  
FILL: 200 CY  
EXPORT: 7,600 CY  
MAX CUT DEPTH UNDER BUILDING FOOTPRINT: 11.0 FT  
MAX FILL DEPTH UNDER BUILDING FOOTPRINT: 1.5 FT  
MAX CUT DEPTH OUTSIDE BUILDING FOOTPRINT: 2.2 FT  
MAX FILL DEPTH OUTSIDE BUILDING FOOTPRINT: 1.5 FT

**EXPORT QUANTITIES NOTE:**  
THE PROJECT PROPOSED TO EXPORT 7,600 CUBIC YARD OF MATERIAL FROM THIS SITE. ALL EXPORT MATERIAL SHALL BE DISCHARGED TO A LEGAL DISPOSAL SITE. THE APPROVAL OF THIS PROJECT DOES NOT ALLOW PROCESSING AND SALE OF THE MATERIAL. ALL SUCH ACTIVITIES REQUIRE A SEPARATE CONDITIONAL USE PERMIT.

**UTILITIES:**  
NOTE: UNDERGROUND UTILITIES SHOWN HEREON ARE PER AVAILABLE RECORD DRAWINGS & INFORMATION.  
WATER: CITY OF SAN DIEGO  
SEWER: CITY OF SAN DIEGO  
GAS & ELECTRIC: SDG&E  
FIRE & POLICE PROTECTION: CITY OF SAN DIEGO  
CABLE TV: COX SPECTRUM  
FIBER OPTIC: AT&T, COX SPECTRUM  
SCHOOLS: SAN DIEGO UNIFIED SCHOOL DISTRICT

**CARRIER JOHNSON + CULTURE**  
architecture + environments + brand strategy + graphics

**VIEWPOINT OLD TOWN**  
4620 PACIFIC HIGHWAY  
SAN DIEGO, CA 92110

**LEGAL DESCRIPTION**

THE LAND REFERRED TO HEREIN BELOW IS SITUATED IN THE CITY OF SAN DIEGO, IN THE COUNTY OF SAN DIEGO, STATE OF CALIFORNIA, AND IS DESCRIBED AS FOLLOWS:

**PARCEL 1:**  
LOTS 1 AND 2 OF JENNINGS TRACT, IN THE CITY OF SAN DIEGO, COUNTY OF SAN DIEGO, STATE OF CALIFORNIA, ACCORDING TO MAP THEREOF NO. 5632, FILED IN THE OFFICE OF THE COUNTY RECORDER OCTOBER 06, 1965.

**PARCEL 2:**  
THOSE PORTIONS OF LOTS 16 AND 17 OF SUNNICHSENS SUBDIVISION, IN THE CITY OF SAN DIEGO, COUNTY OF SAN DIEGO, STATE OF CALIFORNIA, ACCORDING TO MAP THEREOF NO. 1574, FILED IN THE OFFICE OF THE COUNTY RECORDER OF SAN DIEGO COUNTY, DESCRIBED AS FOLLOWS:

BEGINNING AT A POINT IN THE SOUTHEASTERLY LINE OF SAID LOT 16 DISTANT THEREON SOUTH 38°11'52" WEST (RECORD SOUTH 36°10' WEST) (DEED SOUTH 36°38'54" WEST) 74.24 FEET FROM THE MOST EASTERLY CORNER OF LOT 18 OF SAID MAP NO. 1574, THENCE SOUTHERLY 89°11'32" EAST ALONG SAID SOUTHEASTERLY LINE 23.47 FEET, THENCE NORTH 35°27'02" WEST 32.83 FEET (DEED NORTH 38° WEST) TO A POINT ON THE ARC OF A 31 FOOT RADIUS CURVE CONCAVE WESTERLY, A RADIAL LINE OF SAID CURVE BEARS NORTH 54°32'58" EAST (DEED NORTH 52° EAST) TO SAID POINT, THENCE SOUTHERLY AND SOUTHWESTERLY ALONG SAID CURVE 40.39 FEET THROUGH AN ANGLE OF 14°38'54", THENCE SOUTH 36°27'17" EAST 8.15 FEET (DEED SOUTH 39°10'15" EAST) TO THE POINT OF BEGINNING.

**PARCEL 3:**  
THOSE PARTS OF LOTS 1 THROUGH 5, BLOCK 376, OF CORRECTED PLAT OF SUBDIVISION OF BLOCKS 368, 369, 374, 375 AND 376 OF OLD SAN DIEGO ACCORDING TO MAP THEREOF NO. 420 FILED NOVEMBER 25, 1887 IN THE OFFICE OF THE COUNTY RECORDER OF SAN DIEGO COUNTY AND "PLAN OF OLD SAN DIEGO" MADE BY JAMES PASCOE IN 1870, A COPY OF WHICH WAS FILED AS MISCELLANEOUS MAP NO. 40 IN THE OFFICE OF SAID COUNTY RECORDER; THOSE PARTS OF LOTS 6 THROUGH 8, AND OF LOT 19, BLOCK 366, AND OF LOTS 12 THROUGH 17, BLOCK 367 AS SHOWN ON E.O. ROGERS SUBDIVISION OF BLOCKS 370, 373, 368 AND 367 OF OLD SAN DIEGO FILED ON OCTOBER 11, 1887 IN THE OFFICE OF SAID COUNTY RECORDER AS MAP NO. 429 AND AS SHOWN ON SAID "PLAN OF OLD SAN DIEGO" LYING WITHIN A STRIP OF LAND 15 FEET WIDE, WESTERLY AND NORTHWESTERLY OF THE FOLLOWING DESCRIBED LINE:

BEGINNING AT THE SOUTHERLY TERMINUS OF COURSE (4) AS DESCRIBED IN DEED TO THE STATE OF CALIFORNIA RECORDED MAY 17, 1965 AS INSTRUMENT NO. 87802 OF OFFICIAL RECORDS IN THE OFFICE OF SAID COUNTY RECORDER; THENCE ALONG THE FOLLOWING NUMBERED COURSES: (1) NORTHERLY FROM A RADIAL BEARING SOUTH 54°24'48" WEST, ALONG A NON-TANGENT CURVE CONCAVE TO THE EAST, HAVING A RADIUS OF 650 FEET THROUGH CENTRAL ANGLE OF 26°30'13" A DISTANCE OF 300.68 FEET TO A POINT OF COMPOUND CURVATURE; (2) NORTHERLY FROM A RADIAL BEARING NORTH 88°56'59" WEST, ALONG A CURVE CONCAVE TO THE EAST, HAVING A RADIUS OF 850 FEET THROUGH A CENTRAL ANGLE OF 19°28'54", A DISTANCE OF 274.16 FEET TO A POINT ON THE WESTERLY LINE OF THAT PARCEL OF LAND CONVEYED TO THE STATE OF CALIFORNIA BY DEED RECORDED JUNE 20, 1942 IN BOOK 1350, PAGE 442 OF OFFICIAL RECORDS, TOGETHER WITH THE UNDERLYING FEE INTEREST, IF ANY, APPURTENANT TO THE ABOVE DESCRIBED PROPERTY IN AND TO THE ADJOINING PUBLIC WAYS.

THE SOUTHERLY TERMINUS OF THE WESTERLY LINE OF THE HEREBY DESCRIBED 15 FOOT STRIP OF LAND SHALL BE EXTENDED TO MEET A LINE WHICH BEARS SOUTH 36°38'58" WEST, FROM THE SAID POINT OF BEGINNING, THENCE NORTHERLY TERMINUS OF SAID WESTERLY LINE SHALL BE EXTENDED TO MEET A NON-TANGENT CURVE, WHICH BEARS NORTHERLY FROM A RADIAL BEARING NORTH 70°28'03" WEST, CONCAVE TO THE EAST, HAVING A RADIUS OF 4.94 FEET THROUGH A CENTRAL ANGLE OF 1°27'12", A DISTANCE OF 125.31 FEET, THE POINT OF BEGINNING OF LAST SAID CURVE BEING THE NORTHERLY TERMINUS POINT OF COURSE (2) HEREBY ABOVE DESCRIBED.

THE BEARINGS AND DISTANCES USED IN THE ABOVE DESCRIPTION ARE ON THE CALIFORNIA COORDINATE SYSTEM ZONE 6 GRID DISTANCES EQUAL GROUND LEVEL DISTANCES.

**PARCEL 4:**  
THAT PART OF THAT PORTION OF BLOCK 366 OF E. O. ROGERS SUBDIVISION OF BLOCK 370, 373, 368 AND 367 OF OLD SAN DIEGO, ACCORDING TO MAP NO. 429 FILED IN THE OFFICE OF THE RECORDER OF SAN DIEGO COUNTY, OCTOBER 11, 1887 AS SAID PORTION WAS CONVEYED TO THE STATE OF CALIFORNIA BY DEED RECORDED SEPTEMBER 02, 1964 AS INSTRUMENT NO. 160494 OF OFFICIAL RECORDS OF SAID COUNTY, SAID PART HEREBY CONVEYED LYING SOUTHEASTERLY OF AND CONTIGUOUS TO THE SOUTHERLY SIDE LINE OF THAT FIFTEEN FOOT WIDE STRIP OF LAND CONVEYED TO SAN DIEGO TRUST AND SAVINGS BANK, AS TRUSTEE, RECORDED AUGUST 01, 1969 AS INSTRUMENT NO. 140370 OF OFFICIAL RECORDS.

EXCEPT THEREFROM THAT PORTION LYING WITHIN THE BOUNDARIES OF PARCEL 1 DESCRIBED ABOVE.

## STATE DENSITY BONUS LAW CONCESSIONS / INCENTIVES

THE PROJECT REQUESTS WAIVERS OF DEVELOPMENT STANDARDS AND IS ALLOTTED INCENTIVES BY PROVIDING AFFORDABLE HOUSING PURSUANT TO STATE DENSITY BONUS LAW (SDBL), CA GOVERNMENT CODE 65915.

REQUESTED INCENTIVES (8) ALLOWED AS AFFORDABLE HOUSING BONUS PER SDMC 143.070(D) TABLE 143.07A FOR >15% VERY-LOW INCOME AFFORDABLE UNITS (FOOTNOTE 2) AND TABLE 143.07C FOR 10% MODERATE INCOME AFFORDABLE UNITS (3) PROVIDED); REFER TO ARCHITECTURAL PLANS FOR ADDITIONAL CALCULATIONS.

- REQUESTED INCENTIVES - REFER TO ARCHITECTURAL PLANS FOR ADDITIONAL INFORMATION.
- USE INCENTIVE TO DEVIATE FROM MAX STRUCTURE HEIGHT (SDMC 1516.0119 TABLE 1516-01E)
  - USE INCENTIVE TO DEVIATE FROM MAX. NUMBER OF STORIES (SDMC 1516.0119 TABLE 1516-01E)
  - USE INCENTIVE TO DEVIATE FROM MAX. LOT COVERAGE (%) (SDMC 1516.0119 TABLE 1516-01E)
  - USE INCENTIVE TO DEVIATE FROM 20% MINIMUM TRANSPARENCY OF THE STREET WALL AREA (SDMC 1516.10271 b)(1))
  - USE INCENTIVE TO DEVIATE FROM THE REQUIRED 20% COMMON OPEN SPACE (TABLE 1516-01G, SDMC 1516.01271(c)(3))
  - USE INCENTIVE TO DEVIATE FROM RESTRICTION ON ENCROACHMENTS ABOVE THE PUBLIC RIGHT-OF-WAY WITH PRIVATE RESIDENT BALCONIES (SDMC 1516.01280(a)(4)).
  - RESERVED
  - RESERVED

**NOTE:**  
THE PROPOSED PROJECT WILL COMPLY WITH ALL THE REQUIREMENTS OF THE CURRENT CITY OF SAN DIEGO STORM WATER STANDARDS MANUAL BEFORE A GRADING OR BUILDING PERMIT IS ISSUED. IT IS THE RESPONSIBILITY OF THE OWNER/DESIGNER/APPLICANT TO ENSURE THAT THE CURRENT STORM WATER PERMANENT BMP DESIGN STANDARDS ARE INCORPORATED INTO THE PROJECT.

**NOTE:**  
NO TREES NOR SHRUBS MORE THAN 5-FT IN HEIGHT AT MATURITY ARE ALLOWED WITHIN 10-FT OF ANY PUBLIC SEWER OR SEWER LATERAL, NOR WITHIN 5-FT OF PUBLIC WATER MAINS, WATER SERVICES, OR FIRE HYDRANTS.

**NOTE:**  
ALL WATER LINES SERVING THIS DEVELOPMENT MUST PASS THROUGH A PERMITTED, PRIVATE, ABOVE GROUND BACKFLOW PREVENTION DEVICE (BFPD) TO BE SHOWN ON BUILDING OR GRADING PLAN.

**NOTE:**  
AN EMINA WILL BE PROCESSED DURING THE PROCESSING OF CONSTRUCTION DOCUMENTS FOR ALL PRIVATE ENCROACHMENTS INTO THE RIGHT OF WAY, INCLUDING PRIVATE STORM DRAIN CONNECTIONS, DRIVEWAYS, SIDEWALKS, UNDERPASS, ENHANCED PAVING, LANDSCAPING, IRRIGATION, & PRIVATE SEWER LATERALS.

**NOTE:**  
AN ENCROACHMENT MAINTENANCE AGREEMENT WILL BE PROCESSED DURING THE PROCESSING OF CONSTRUCTION DOCUMENTS FOR ALL PRIVATE STRUCTURAL ENCROACHMENTS INTO THE RIGHT OF WAY, INCLUDING BUILDING OVERHANGS, ROOFS, AND BALCONIES.

**NOTE:**  
THE OWNER/PERMITTEE SHALL BE RESPONSIBLE FOR ANY DAMAGE CAUSED TO CITY OF SAN DIEGO WATER AND SEWER FACILITIES IN THE VICINITY OF THE PROJECT SITE DUE TO CONSTRUCTION ACTIVITIES ASSOCIATED WITH THIS PROJECT, IN ACCORDANCE WITH SDMC 142.0607. IN THE EVENT THAT ANY SUCH FACILITY LOSES INTEGRITY, THE OWNER/PERMITTEE SHALL REPAIR OR RECONSTRUCT ANY DAMAGED FACILITIES IN A MANNER SATISFACTORY TO THE PUBLIC UTILITIES DIRECTOR AND CITY ENGINEER.

**NOTE:**  
SUBJECT PROPERTY CONSISTS OF FOUR SEPARATE PARCELS OWNED BY A SINGLE ENTITY. A LOT TIE AGREEMENT ACROSS ALL PARCELS WITHIN PROPERTY WILL BE PROCESSED PRIOR TO START OF CONSTRUCTION.

**TOPOGRAPHY:**  
TOPOGRAPHY OBTAINED BY FIELD SURVEY. PREPARED BY PASCO LARET SUITER & ASSOCIATES 1911 SAN DIEGO AVENUE SUITE 100 SAN DIEGO, CA 92110 PHONE: 619-259-8212

**BENCHMARK:**  
ELEVATIONS SHOWN HEREON ARE BASED ON: FOUND BRASS PLUS PER CITY OF SAN DIEGO VERTICAL BENCH BOOK LOCATED AT THE NE CORNER OF TOP OF CURB PACIFIC HIGHWAY AND ROSECRANS ST. PUBLISHED ELEVATION ON SHEET 496. ELEVATION: 10.574' DATUM: NGVD 29

**BASIS OF BEARINGS:**  
THE CALIFORNIA COORDINATE SYSTEM, NAD 83 (CCS83) EPOCH 1991.35, ZONE 6, AS DETERMINED LOCALLY BY A LINE BETWEEN FIRST ORDER CONTROL STATIONS 240 AND 157 BEING A GRID BEARING OF N 02°02'24" E AS DERIVED FROM GEODETIC VALUES SHOWN ON RECORD OF SURVEY 14492, COUNTY OF SAN DIEGO SURVEY CONTROL, FILED ON MARCH 31, 1994 AS FILE NUMBER 1994-0214720 IN THE OFFICE OF THE COUNTY RECORDER OF SAN DIEGO COUNTY.

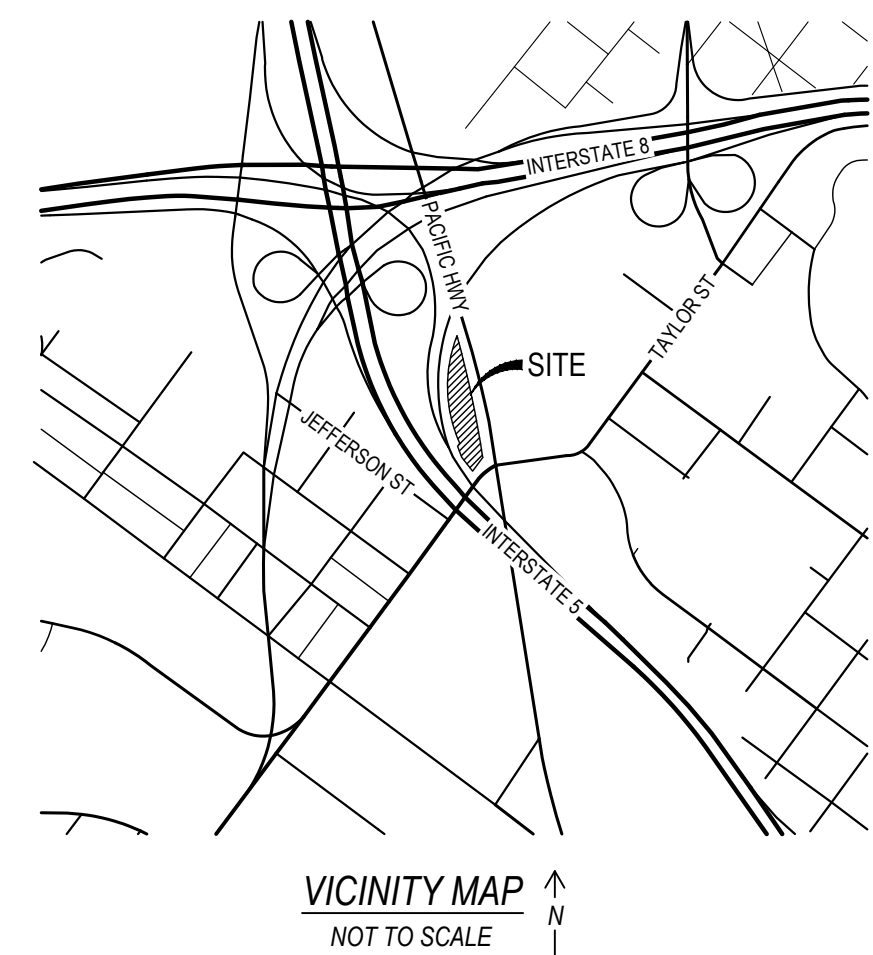
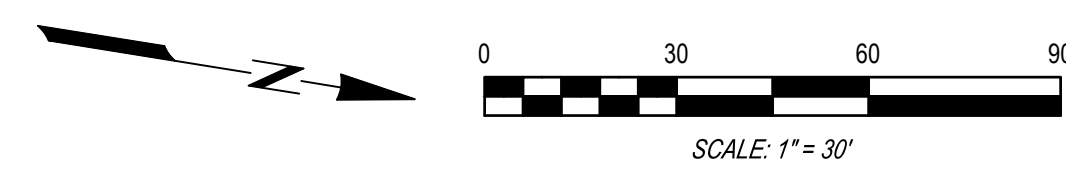

ISSUES:

NO	DESCRIPTION	DATE

**LEGEND**

PROPERTY LINE / PROJECT BOUNDARY	---
RIGHT OF WAY LINE	---
STREET CENTERLINE	---
LOT LINE	---
EASEMENT	---



PROJECT NO:  
PLSA 3598  
FILE NAME:  
WHITE CENTRAL FILE PATH NUMBER  
(I.E. P:\0001\00\BIM-Central\Fac\0001\_00\central.rvt)  
DRAWN BY: CJB CHECKED BY: TGL  
PLOT DATE:  
March 15, 2023  
TITLE:

TITLE SHEET (CIVIL)

**SHEET INDEX**  
C1.0 TITLE SHEET  
C2.0 EXISTING EASEMENTS & SITE CONDITIONS  
C3.0 PRELIMINARY GRADING & UTILITY PLAN  
C4.0 SITE SECTIONS & DETAILS

PREPARED BY:  
**PASCO LARET SUITER & ASSOCIATES**  
San Diego | Solana Beach | Orange County  
Phone 619.259.8212 | www.plsaengineering.com

DRAWING NO:  
**C1.0**



# VIEWPOINT OLD TOWN SITE DEVELOPMENT PERMIT

NDP # XXXXXX

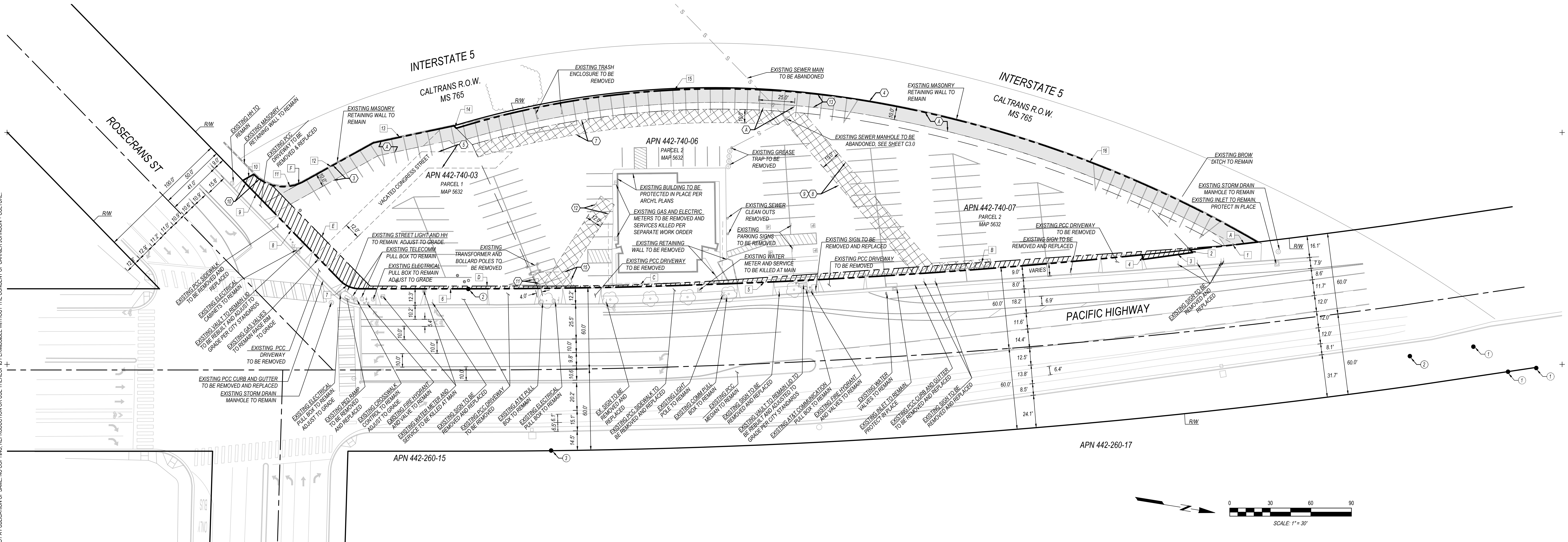

### EASEMENTS OF RECORD

- ITEMS A THROUGH D, 1, AND 2 ARE NON MAPPING ITEMS AND THEREFORE ARE NOT SHOWN HEREON.
- ⑦ STATE OF CALIFORNIA HOLDER OF AN EASEMENT FOR CONSTRUCTING AND MAINTAINING AND RETAINING WALL FOOTING TOGETHER WITH THE RIGHT OF INGRESS THEREON AND EGRESS THEREFROM PURPOSES RECORDED JUNE 03, 1964 PER INSTRUMENT NO 99183 OF OFFICIAL RECORDS. **EASEMENT TO REMAIN.**
- ⑦ RELINQUISHMENT OF ACCESS RIGHTS RECORDED JUNE 3, 1964 PER INSTRUMENT NO 99183, RECORDED JANUARY 5, 1966 PER INSTRUMENT NO 2236, RECORDED AUGUST 1, 1969 PER INSTRUMENT NO 140370, RECORDED OCTOBER 10, 1973 PER INSTRUMENT NO 73-285467 ALL OF OFFICIAL RECORDS. **RELINQUISHMENT TO REMAIN.**
- ③ SAN DIEGO GAS AND ELECTRIC COMPANY HOLDER OF AN EASEMENT FOR PUBLIC UTILITIES, INGRESS AND EGRESS PURPOSES RECORDED AUGUST 20, 1966 PER INSTRUMENT NO 152282 OF OFFICIAL RECORDS. **EASEMENT TO BE QUITCLAIMED.**
- ITEM 6 IS A NON MAPPING ITEM AND THEREFORE IS NOT SHOWN HEREON.
- ⑦ 10 FOOT PRIVATE EASEMENT TO LOT 1 AS OFFERED FOR DEDICATION AND SHOWN ON SAID MAP NO 5632. **VOID UNDER COMMON OWNERSHIP**
- ② CITY OF SAN DIEGO HOLDER OF INGRESS AND EGRESS FOR THE CONSTRUCTION AND MAINTENANCE OF RESTRICTED GENERAL UTILITY EASEMENT AS STATED IN THE OWNERS CERTIFICATE AND SHOWN ON SAID MAP NO 5632. **EASEMENT TO BE VACATED**
- ⑦ CITY OF SAN DIEGO HOLDER OF RESTRICTED GENERAL UTILITY EASEMENT AS OFFERED FOR DEDICATION AND SHOWN ON SAID MAP NO 5632. **EASEMENT TO BE VACATED.**

- ⑩ STATE OF CALIFORNIA HOLDER OF AN EASEMENT FOR CONSTRUCTING AND MAINTAINING A RETAINING WALL FOOTING TOGETHER WITH THE RIGHT OF INGRESS AND EGRESS PURPOSES RECORDED JANUARY 5, 1966 PER INSTRUMENT NO 2236 OF OFFICIAL RECORDS. **EASEMENT TO REMAIN.**
- ⑦ SAN DIEGO GAS AND ELECTRIC COMPANY HOLDER OF AN EASEMENT FOR PUBLIC UTILITIES, INGRESS AND EGRESS PURPOSES RECORDED JANUARY 26, 1966 PER INSTRUMENT NO 14997 OF OFFICIAL RECORDS. **EASEMENT TO BE QUITCLAIMED.**
- ② SAN DIEGO GAS AND ELECTRIC COMPANY HOLDER OF AN EASEMENT FOR PUBLIC UTILITIES, INGRESS AND EGRESS PURPOSES RECORDED APRIL 22, 1966 PER INSTRUMENT NO 87558 OF OFFICIAL RECORDS. **EASEMENT TO BE QUITCLAIMED.**
- ⑦ STATE OF CALIFORNIA HOLDER OF AN EASEMENT FOR CONSTRUCTING AND MAINTAINING A RETAINING WALL FOOTING TOGETHER WITH THE RIGHT OF INGRESS AND EGRESS PURPOSES RECORDED AUGUST 1, 1969 PER INSTRUMENT NO 140370 OF OFFICIAL RECORDS. **EASEMENT TO REMAIN.**
- ITEM 14 IS A NON MAPPING ITEM AND THEREFORE IS NOT SHOWN HEREON.
- ③ SAN DIEGO GAS AND ELECTRIC COMPANY HOLDER OF AN EASEMENT FOR PUBLIC UTILITIES, INGRESS AND EGRESS PURPOSES RECORDED SEPTEMBER 7, 1979 PER INSTRUMENT NO 79-378238 OF OFFICIAL RECORDS. **EASEMENT TO BE QUITCLAIMED.**
- ITEMS 16 THROUGH 23 ARE NON MAPPING ITEMS AND THEREFORE ARE NOT SHOWN HEREON.

### FOUND MONUMENTS

- ① FOUND LEAD & DISK, ILLEGIBLE, PER MAP 5632.
- ② FOUND LEAD & DISK STAMPED "LS 7019" PER ROS 20588
- ③ FOUND 3/4" IRON PIPE WITH DISK, ILLEGIBLE, PER ROS 1344, SEE ROS 20588.

EXISTING PROPERTY LINE DATA TABLE					
ID	BEARING	LENGTH	RADIUS	ARC LENGTH	DELTA
1	N 15°35'47" W	50.33'	4940.00'	50.33'	0°35'01"
2	N 37°08'11" E	2.82'			
3	S 17°01'39" E	37.17'			
4	S 75°06'22" W	3.48'			
5	N 11°39'53" W	499.17'	4940.00'	499.38'	5°47'31"
6	S 90°36'49" E	60.39'			
7	N 13°46'04" E	15.55'	20.00'	15.97'	45°45'46"
8	S 36°38'57" W	79.99'			
9	S 36°38'57" W	23.22'			
10	N 39°09'12" W	9.21'			
11	N 00°57'54" W	37.39'	31.00'	40.14'	74°11'04"
12	N 38°03'25" W	59.00'			
13	N 21°03'11" W	60.76'			
14	N 38°42'27" E	2.50'			
15	S 12°28'38" E	314.03'	665.00'	317.02'	27°18'52"
16	S 11°03'16" W	297.38'	865.00'	298.87'	19°47'47"

PROPOSED DEDICATION DATA TABLE					
ID	BEARING	LENGTH	RADIUS	ARC LENGTH	DELTA
A	N 15°46'13" W	20.36'	4940.00'	20.36'	0°14'10"
B	N 13°04'23" W	367.74'			
C	N 11°05'36" W	137.21'	1986.00'	137.24'	3°57'34"
D	N 09°06'49" W	132.17'			
E	N 36°38'57" E	104.15'			
F	N 15°33'43" W	23.72'	31.00'	24.34'	44°39'25"

### LEGEND

- PROPERTY LINE / PROJECT BOUNDARY
- RIGHT OF WAY LINE
- STREET CENTERLINE
- EXISTING LOT LINE
- EXISTING EASEMENT
- PROPOSED DEDICATION
- PROPOSED VACATION/QUITCLAIM
- PROPOSED EASEMENT
- PROPOSED EASEMENTS
- PROPOSED 10-FT UTILITY EASEMENT FOR EXISTING PUBLIC SEWER MAIN

### GENERAL NOTES:

1. FIELD SURVEY FOR THIS SITE WAS PERFORMED APRIL 7, 2021.
2. SUBJECT PROPERTY LIES WITHIN FLOOD ZONE "X" (AREA OF MINIMAL FLOOD HAZARD) PER FEMA FLOOD INSURANCE RATE MAP NO. 060703C1614H EFFECTIVE DATE OF 12/20/2019.
3. UNDERGROUND UTILITIES SHOWN ARE FROM RECORD INFORMATION AND READILY OBSERVABLE EVIDENCE FOUND IN THE FIELD.
4. SURVEY AND EASEMENTS SHOWN FROM A.L.T.A. BY PASCO, LARET, SUTTER & ASSOCIATES DATED JANUARY 19, 2022.
5. RECORD DOCUMENTS AND TITLE WORK WERE PROVIDED TO THE SURVEYOR BY CHICAGO TITLE COMPANY, ORDER NO 00141066-994-LT-DB WITH AN EFFECTIVE DATE OF NOVEMBER 19, 2020.

### SITE NOTES:

- TRANSIT STOPS: NO EXISTING OR PROPOSED TRANSIT STOPS WITHIN PROJECT FRONTAGE. NEAREST TRANSIT STOP: OLD TOWN STATION, APPROXIMATELY 500 FT SOUTHWEST OF SITE.
- HYDRANTS: TWO EXISTING HYDRANTS WITHIN PROJECT FRONTAGE TO REMAIN. ONE PROPOSED HYDRANT WITHIN PACIFIC HIGHWAY FRONTAGE. SEE SHEET C3.0.
- CURB CUTS: EXISTING: (6) CURB CUTS WITHIN PACIFIC HIGHWAY FRONTAGE (2) CURB CUTS WITHIN ROSECRANS FRONTAGE PROPOSED: (2) CURB CUTS WITHIN PACIFIC HIGHWAY FRONTAGE (SEE SHEET C3.0) (1) CURB CUT WITHIN ROSECRANS FRONTAGE (SEE SHEET C3.0)

ISSUES:  
NO DESCRIPTION DATE



PROJECT NO:  
PLSA 3598  
FILE NAME:  
WHITE CENTRAL FILE PATH NUMBER  
(I.E. P:\0000\00\BIM-Central\Fac\0000\_00-central.rvt)  
DRAWN BY: CJB CHECKED BY: TGL  
PLOT DATE:  
March 15, 2023  
TITLE:

EXISTING EASEMENTS & SITE CONDITIONS

PREPARED BY:  
**PASCO LARET SUTTER & ASSOCIATES**  
San Diego | Solana Beach | Orange County  
Phone 858.259.8212 | www.pisaengineering.com

DRAWING NO:  
**C2.0**

ALL IDEAS, DESIGN ARRANGEMENTS AND PLANS INDICATED OR REPRESENTED BY THIS DRAWING ARE OWNED BY AND THE PROPERTY OF CARRIER, JOHNSON + CULTURE AND WERE CREATED, ENCLOSED AND DEVELOPED FOR USE ON AND IN CONNECTION WITH THIS PROJECT. NONE OF SUCH IDEAS, DESIGN ARRANGEMENTS OR PLANS SHALL BE USED BY, OR DISCLOSED TO ANY PERSON, FIRM OR CORPORATION FOR ANY PURPOSE WHATSOEVER WITHOUT THE WRITTEN PERMISSION OF CARRIER, JOHNSON + CULTURE. FILING THESE DRAWINGS OR SPECIFICATIONS WITH ANY PUBLIC AGENCY IS NOT A PUBLICATION OF SAME. NO COPYING, REPRODUCTION OR USE THEREOF IS PERMISSIBLE WITHOUT THE CONSENT OF CARRIER, JOHNSON + CULTURE.







# VIEWPOINT OLD TOWN SITE DEVELOPMENT PERMIT

NDP # XXXXXX

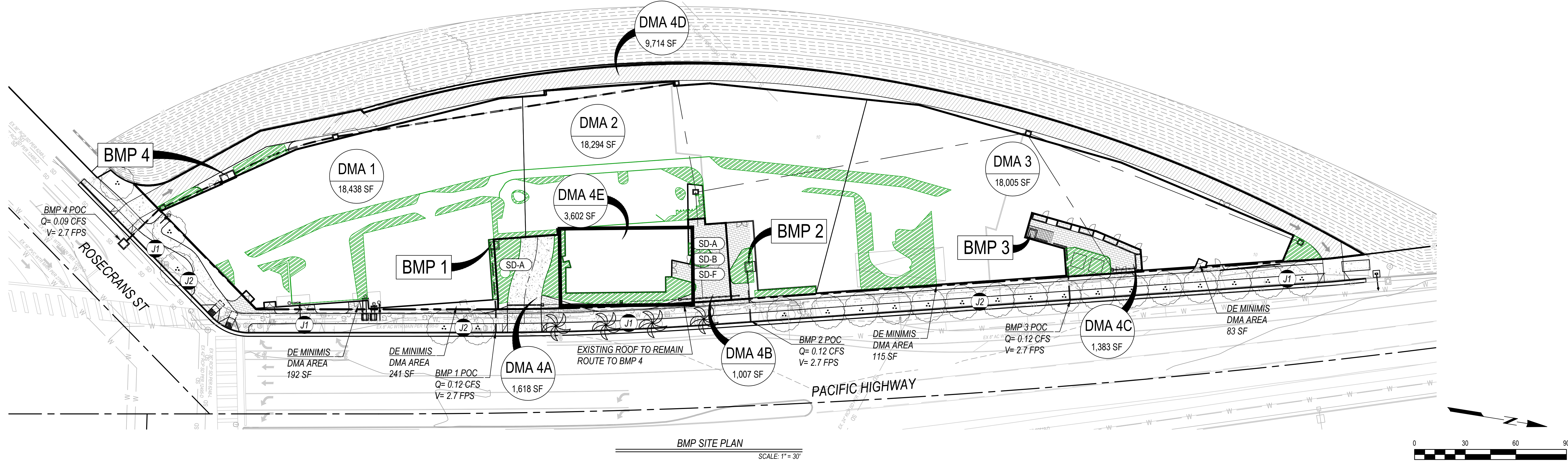

**SITE WORK INFORMATION:**  
 TOTAL DISTURBED AREA: 76,154 SF = 1.75 AC  
 EXISTING IMPERVIOUS AREA: 76,154 SF = 1.75 AC  
 PROPOSED IMPERVIOUS AREA (REPLACED): 76,154 SF = 1.75 AC  
 PROPOSED IMPERVIOUS AREA (NEW): 0 SF = 0 AC  
 PROPOSED IMPERVIOUS AREA (TOTAL): 76,154 SF = 1.75 AC  
 PROPOSED INCREASE IN IMPERVIOUS AREA: 0.0%

**SOIL INFORMATION:**  
 SOIL TYPE: TYPE D  
 DEPTH TO GROUND WATER: ~10FT (PER SOILS REPORT)

**ROOF AREA RUNOFF CONVEYANCE:**  
 THE STORMWATER RUNOFF FROM THE PROPOSED ROOF AREAS SHALL BE CONVEYED THROUGH THE PROPOSED ROOF DRAIN SYSTEMS DESIGNED BY THE PROJECT ARCHITECT ACCORDING TO THE DRAINAGE AREAS SHOWN ON THIS PLAN

**NATURAL HYDROLOGIC FEATURES:**  
 NO NATURAL HYDROLOGIC FEATURES (WATERCOURSES, SEEPS, SPRINGS, WETLANDS) EXIST ON THE PROJECT SITE

**COARSE SEDIMENT YIELD:**  
 NO CRITICAL COARSE SEDIMENT YIELD AREAS TO BE PROTECTED. REFER TO PRIORITY DEVELOPMENT PROJECT SWMP PREPARED BY PASCO, LARET, SUTTER & ASSOCIATES

- GREEN STREET BMP'S**
- J1 SIDEWALK PLANTER
  - J2 STREET TREES

**SITE DESIGN BMP'S**

SITE DESIGN MEASURE	IMPLEMENTATION
(SD-A) TREES (PER LANDSCAPE PLANS)	<input checked="" type="checkbox"/> YES <input type="checkbox"/> NO <input type="checkbox"/> N/A
(SD-B) IMPERVIOUS AREA DISPERSION	<input checked="" type="checkbox"/> YES <input type="checkbox"/> NO <input type="checkbox"/> N/A
(SD-C) GREEN ROOFS	<input type="checkbox"/> YES <input type="checkbox"/> NO <input checked="" type="checkbox"/> N/A
(SD-D) PERMEABLE PAVEMENT	<input type="checkbox"/> YES <input type="checkbox"/> NO <input checked="" type="checkbox"/> N/A
(SD-E) RAIN BARRELS	<input type="checkbox"/> YES <input type="checkbox"/> NO <input checked="" type="checkbox"/> N/A
(SD-F) AMENDED SOILS	<input checked="" type="checkbox"/> YES <input type="checkbox"/> NO <input type="checkbox"/> N/A

**DMA INFORMATION**

	1	2	3	4
TOTAL AREA (SF)	18438	18294	18005	17324
ROOF (SF)	18438	18294	18005	3602
HARDSCAPE (SF)	16688	17194	16355	10772
LANDSCAPE (SF)	1750**	1100**	1650**	2950
TOTAL IMPERVIOUS (SF)	18438	18294	18005	14374
TOTAL PERVIOUS (SF)	0	0	0	2950
PERCENT IMPERVIOUS (%)	100.0%	100.0%	100.0%	82.9%
BMP TREATMENT	6X6 MWS FG	6X6 MWS FG	6X6 MWS FG	4X3 MWS LINEAR
DCV (CF)	719	713	702	601
CALCULATED FLOW RATE (CFS)	0.114	0.113	0.112	0.10
CERTIFIED TREATMENT CAPACITY (CFS)	0.12	0.12	0.12	0.12

\*\* NOTE: PROPOSED LANDSCAPE AREAS PER ARCHITECTURE & LANDSCAPE ARCHITECTURE PLANS, AND IS WITHIN AMENITY AREAS ON STRUCTURE. THE LANDSCAPE AREAS TABULATED ARE USED SOLELY FOR VOLUME RETENTION CALCULATIONS AND NOT CONSIDERED FOR NET IMPERVIOUS & NET PERVIOUS AREA TABULATION.

**LEGEND**

- PROPERTY BOUNDARY
- RIGHT OF WAY
- STREET CENTERLINE
- DRAINAGE PATH OF TRAVEL
- DMA BOUNDARY
- EXISTING CONTOURS
- SITE DESIGN MEASURE IDENTIFIER
- GREEN STREET BMP
- DMA IDENTIFIER & TOTAL AREA
- PROPOSED HARDSCAPE
- PROPOSED LANDSCAPE AREAS INCLUDED IN VOLUME RETENTION CALCULATIONS 3" MIN AMENDED SOIL, SEE LSCLAPE PLAN
- PROPOSED POST CONSTRUCTION BMP

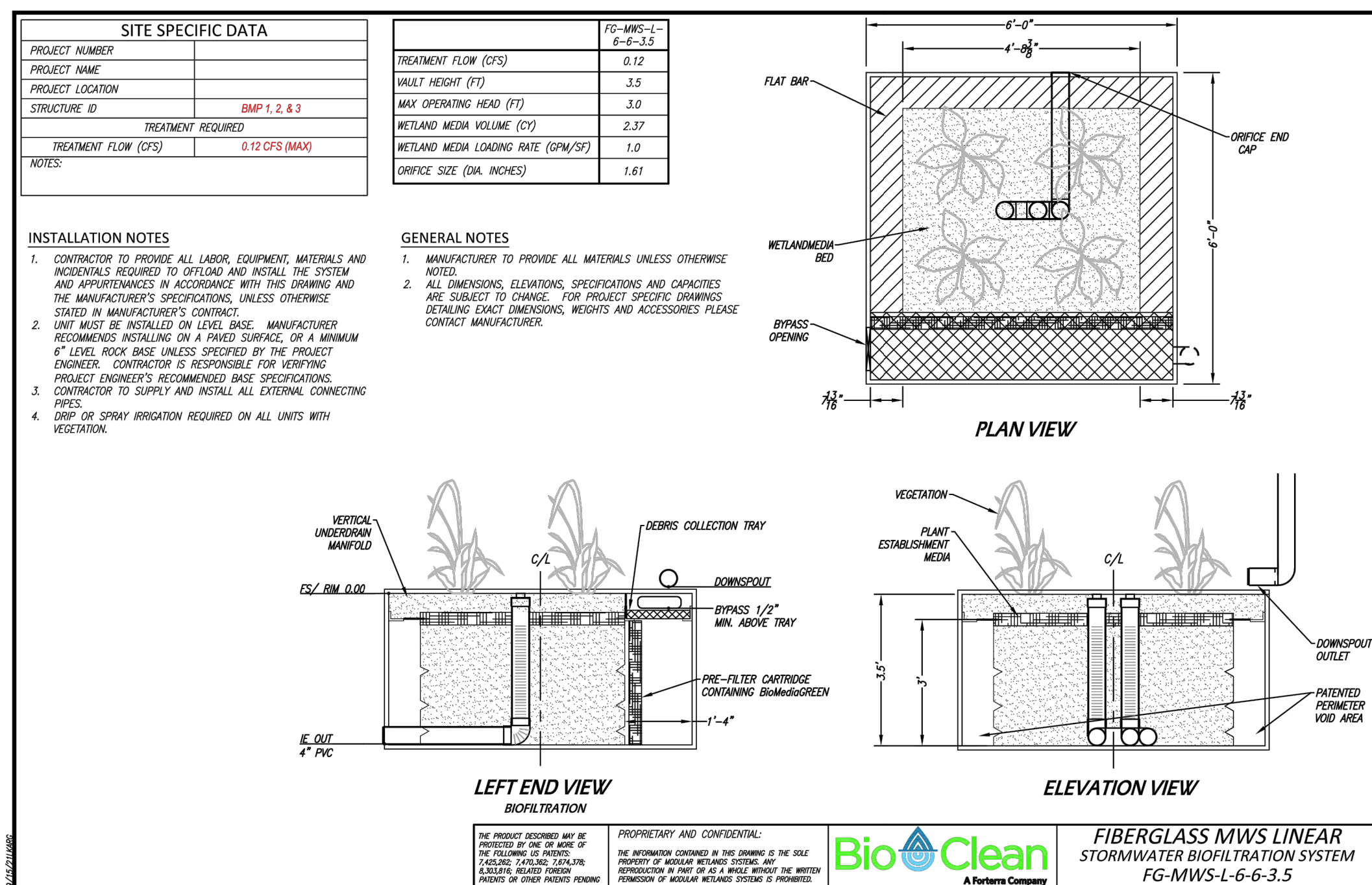

DETAIL: MWS PLANTER (BMP 1, 2, 3)  
NOT TO SCALE

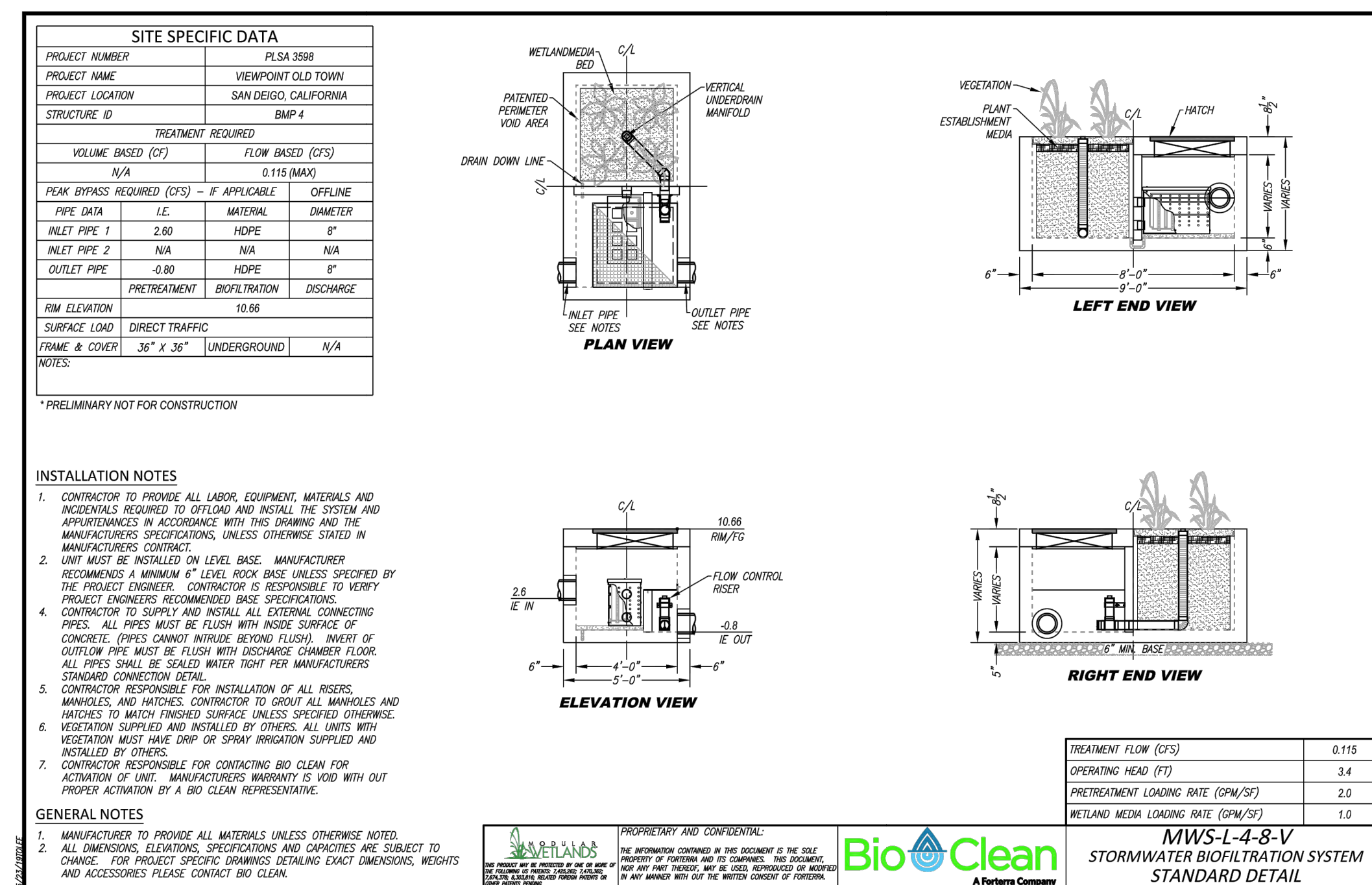

DETAIL: MWS VAULT (BMP 4)  
NOT TO SCALE

ISSUES:	NO	DESCRIPTION	DATE



PROJECT NO: PLSA 3598  
 FILE NAME: VIEWPOINT OLD TOWN PERMIT  
 DRAWN BY: CJB  
 CHECKED BY: TGL  
 PLOT DATE: March 15, 2023  
 TITLE:

PRELIMINARY  
 BMP PLAN

PREPARED BY:  
**PASCO LARET SUTTER & ASSOCIATES**  
 San Diego | Solana Beach | Orange County  
 Phone 858.259.8212 | www.plsaengineering.com

DRAWING NO:

C3.1



# VIEWPOINT OLD TOWN SITE DEVELOPMENT PERMIT

NDP # XXXXXX

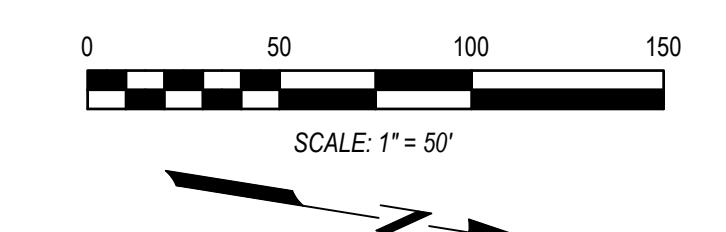
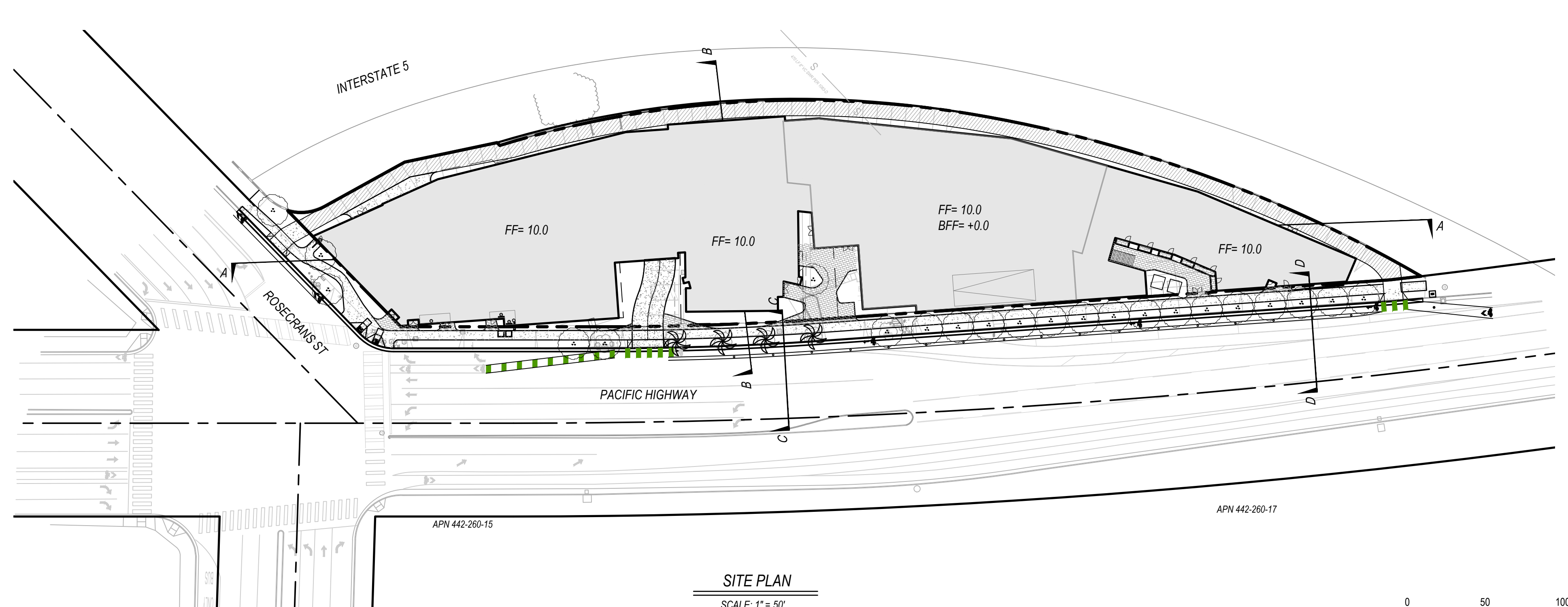
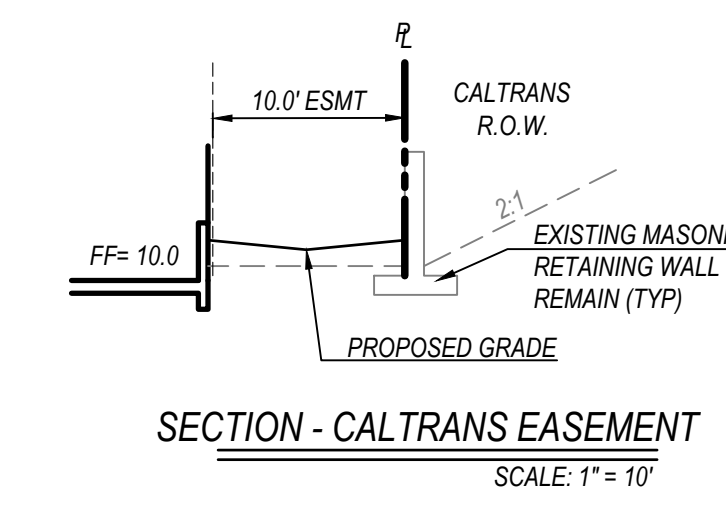
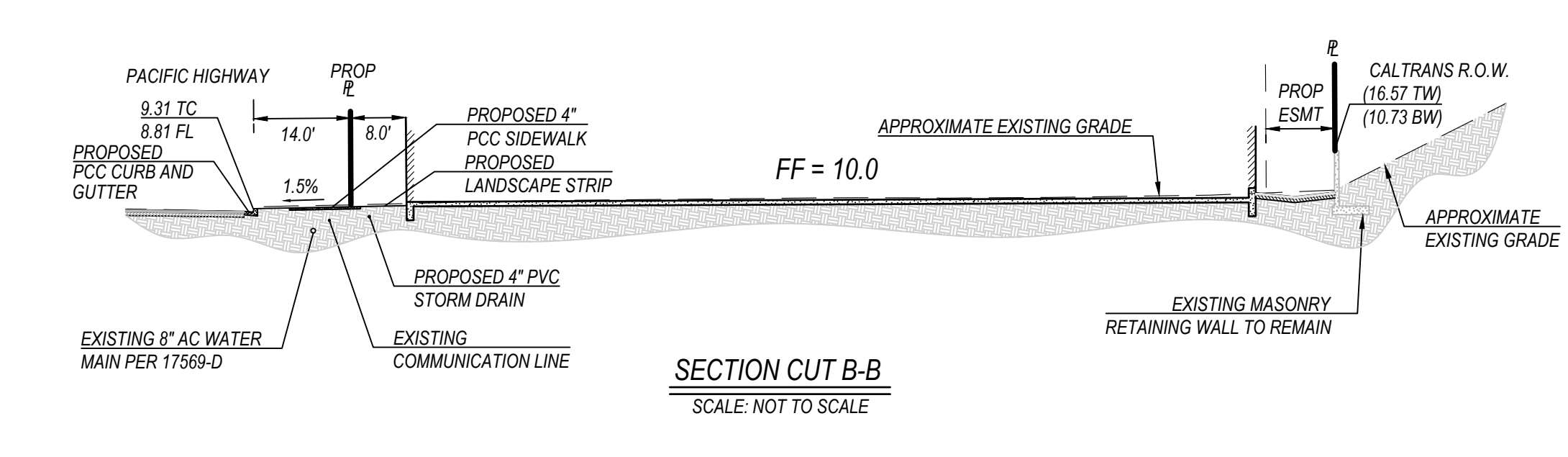
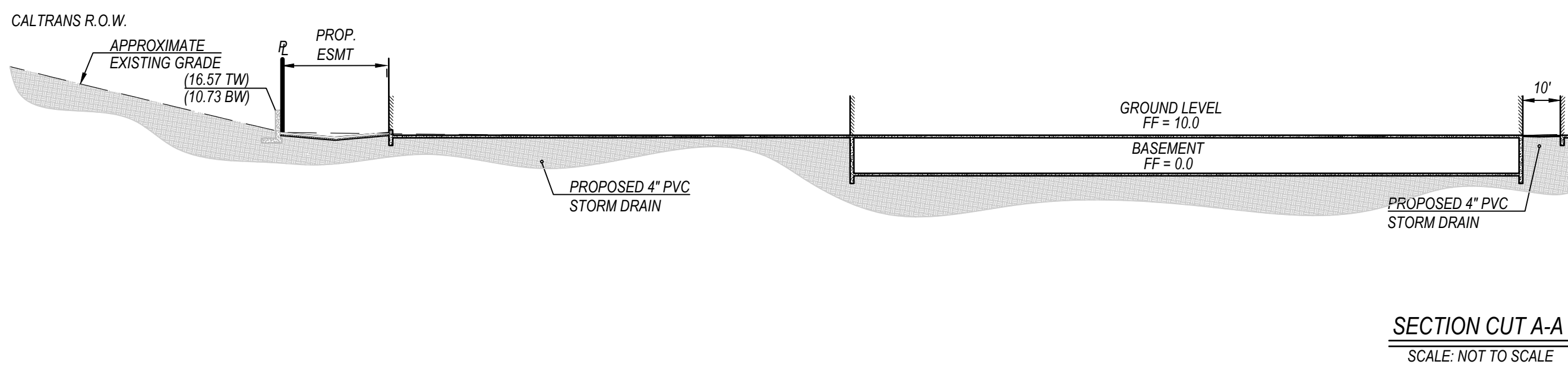
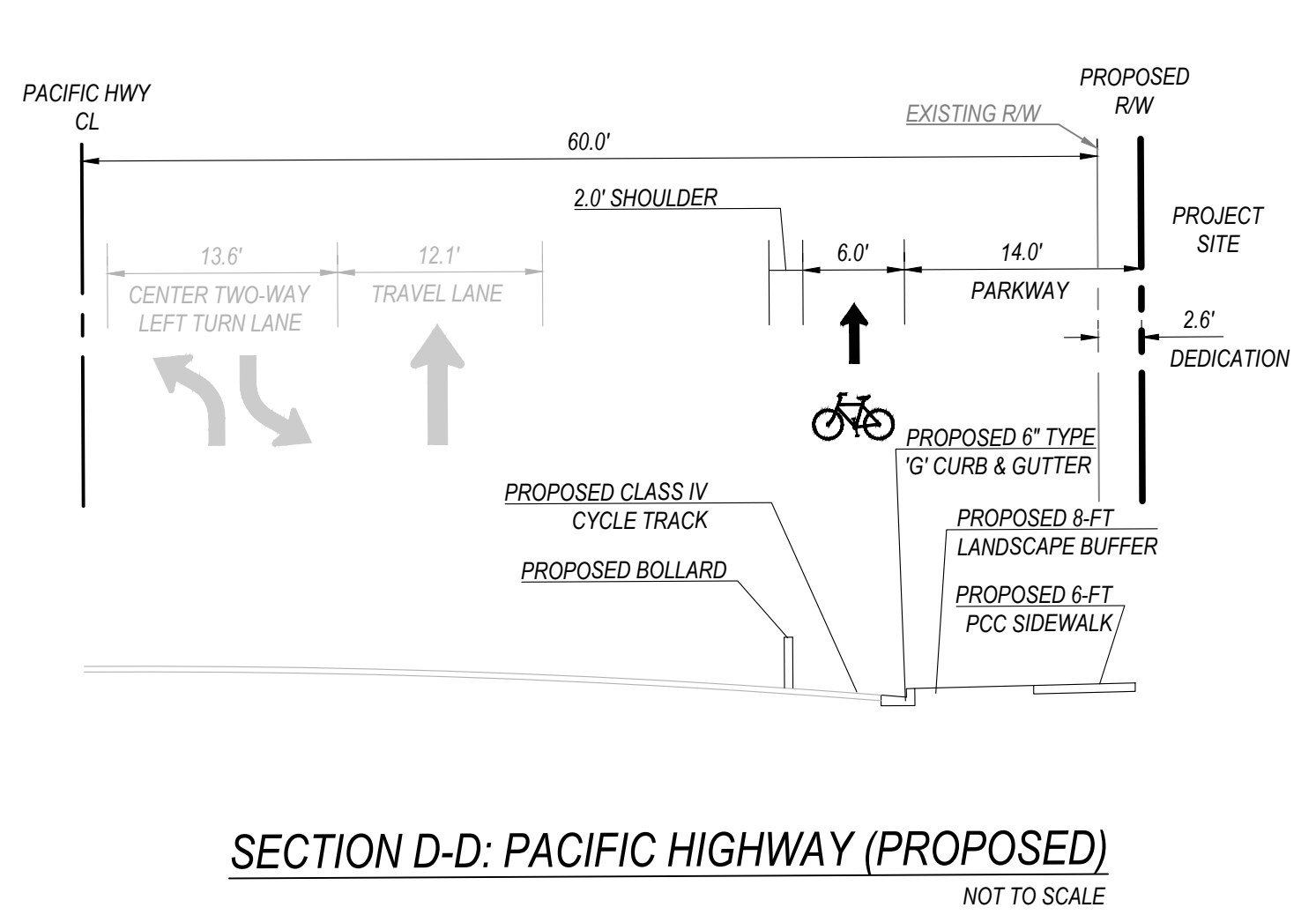
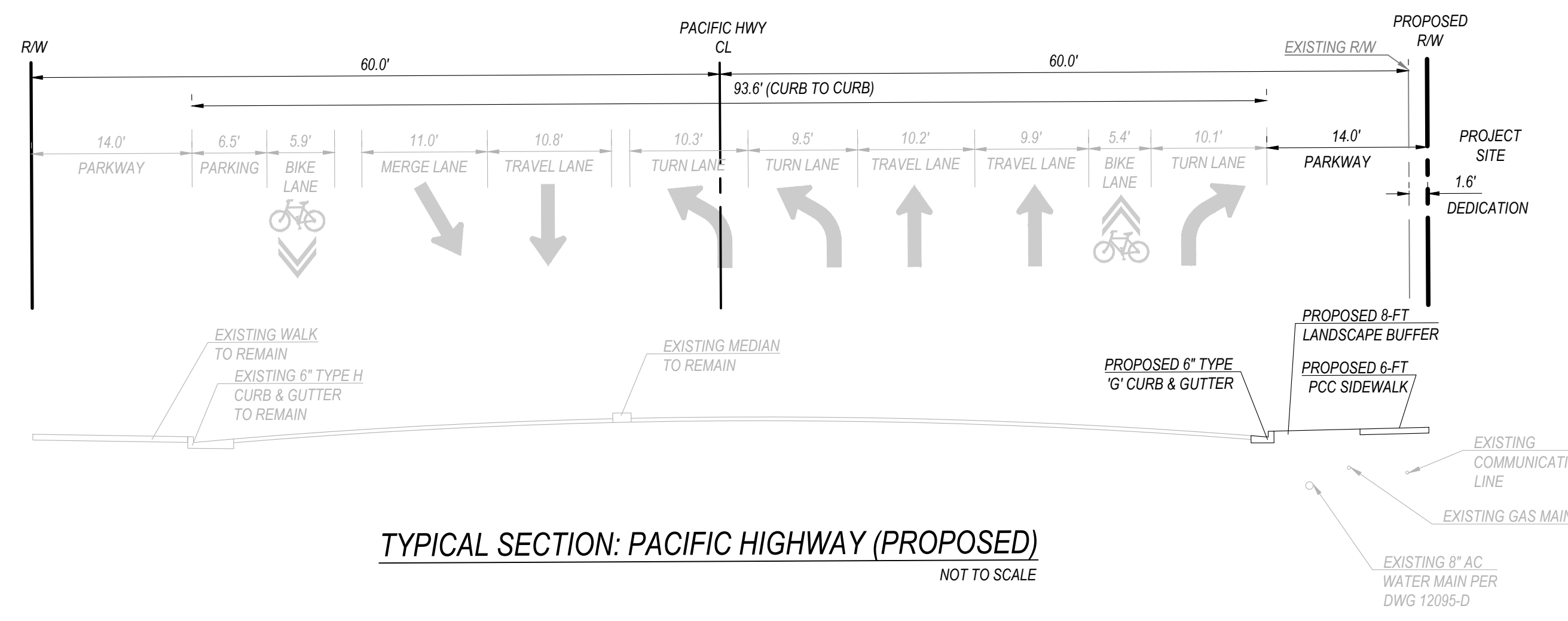
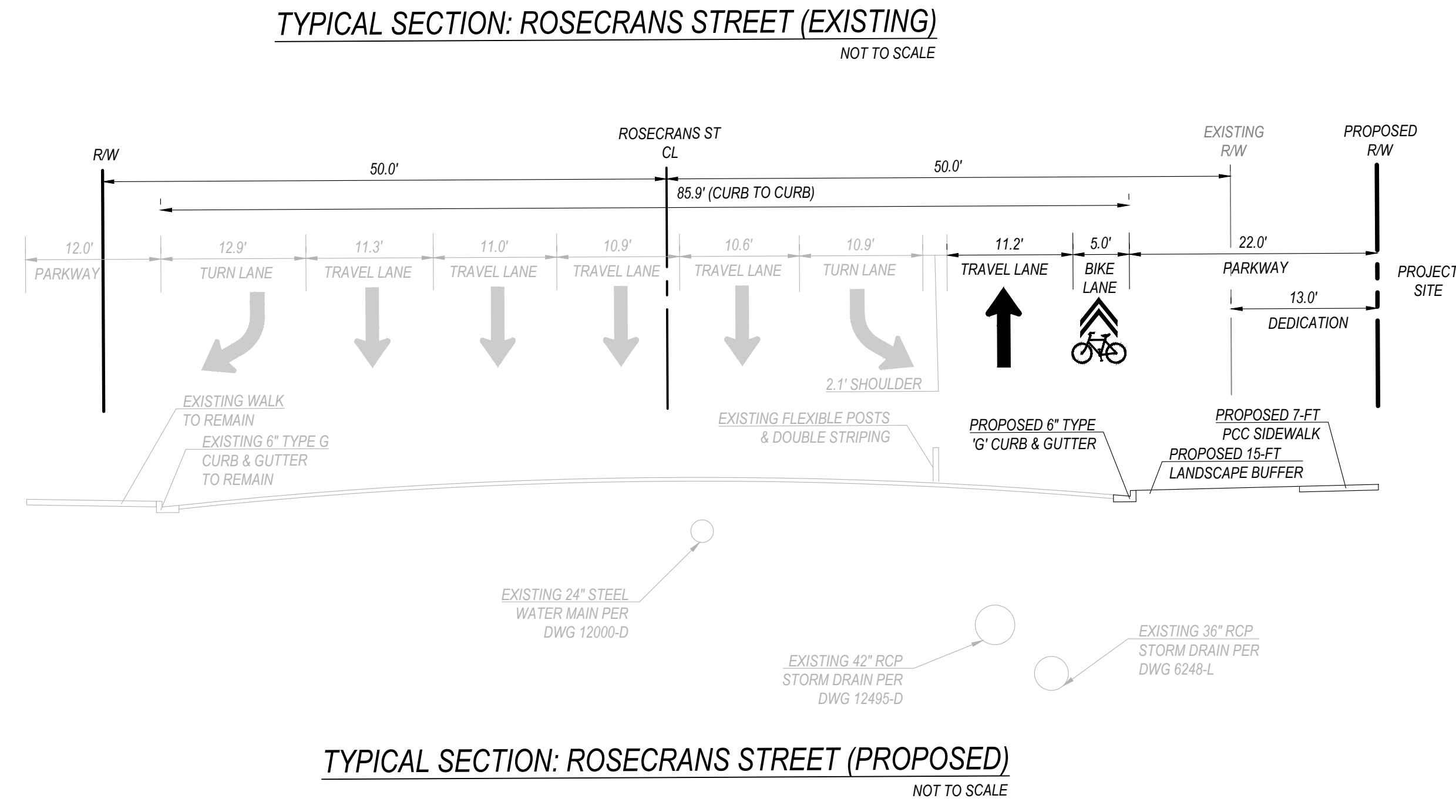
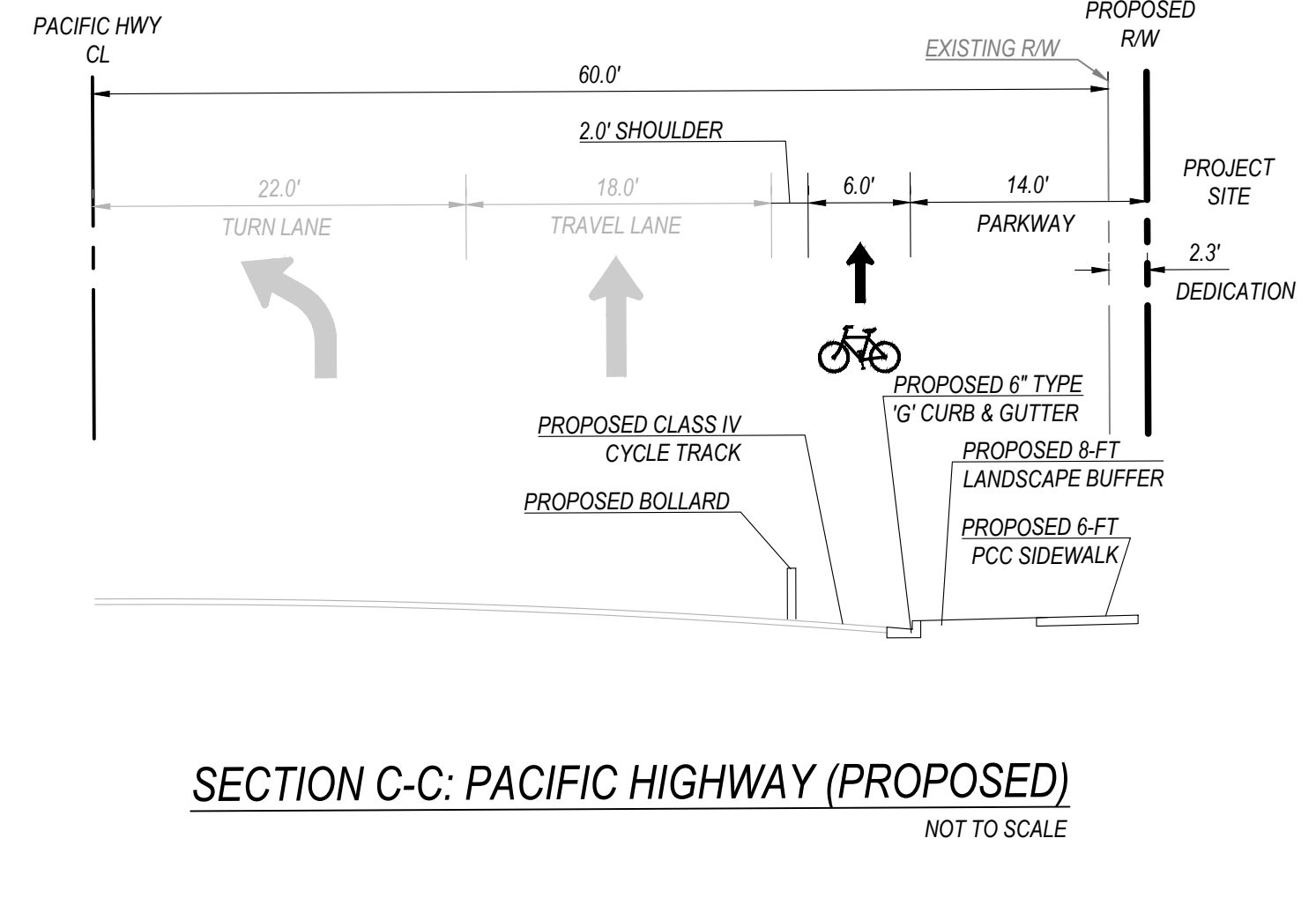
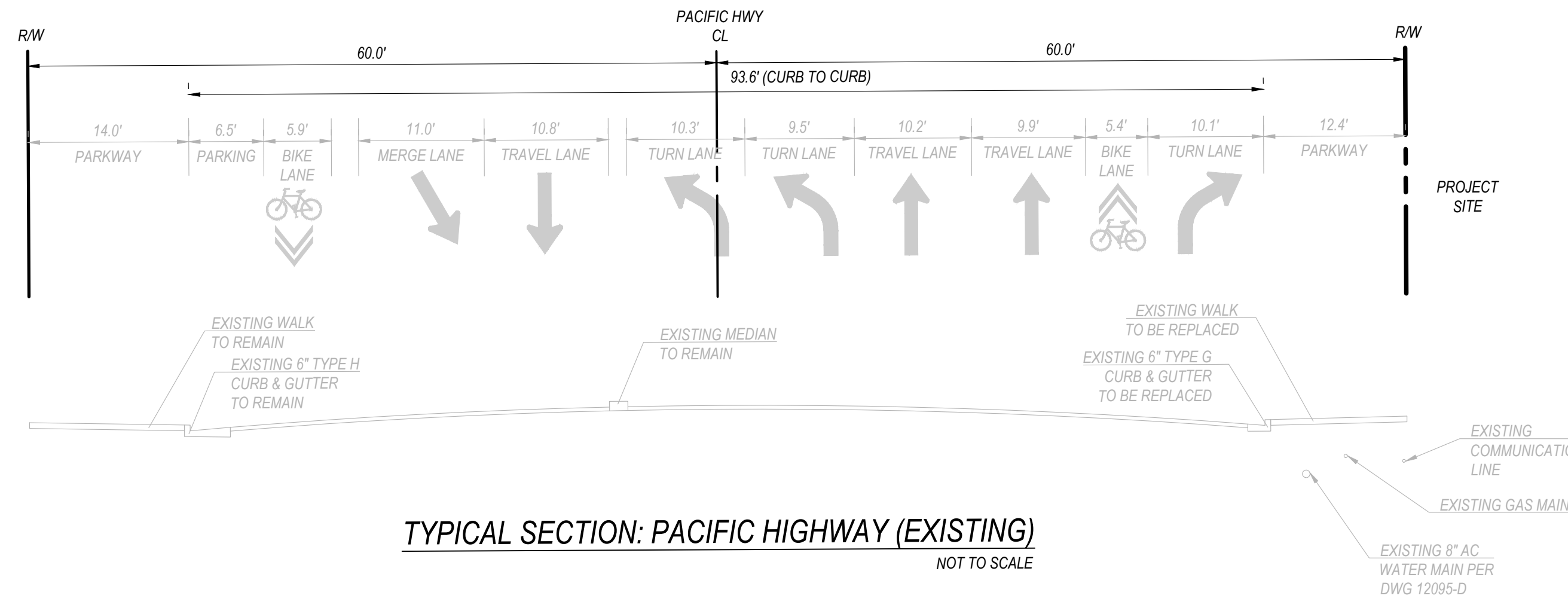
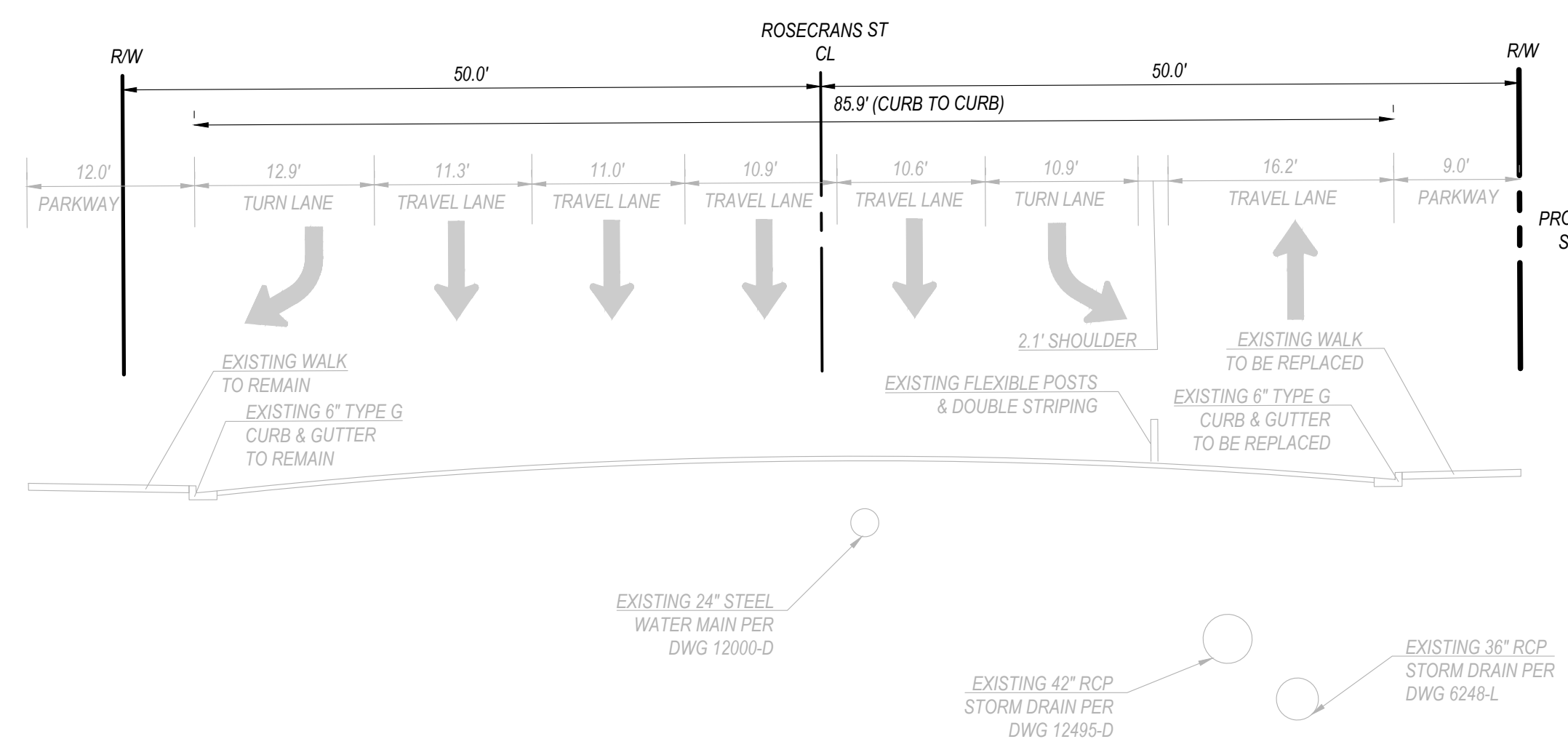

ISSUES:

NO	DESCRIPTION	DATE



PROJECT NO:  
PLSA 3598  
FILE NAME:  
WHITE CENTRAL FILE PATH NUMBER:  
(I.E. P:\0000\00\BIM-Central\Fac\0000\_00-central.rvt)  
DRAWN BY: CJB CHECKED BY: TGL  
PLOT DATE:  
March 15, 2023  
TITLE:

PREPARED BY:  
**PASCO LARET SUITER & ASSOCIATES**  
San Diego | Solana Beach | Orange County  
Phone 858.259.8212 | www.plsaengineering.com

VIEWPOINT OLD TOWN  
4620 PACIFIC HIGHWAY  
SAN DIEGO, CA 92110  
DRAWING NO:  
**C4.0**

ALL IDEAS, DESIGN ARRANGEMENTS AND PLANS INDICATED OR REPRESENTED BY THIS DRAWING ARE OWNED BY, AND THE PROPERTY OF, CARRIER, JOHNSON + CULTURE AND WERE CREATED AND DEVELOPED FOR USE ON, AND IN CONNECTION WITH, THIS PROJECT. NONE OF SUCH IDEAS, DESIGN ARRANGEMENTS OR PLANS SHALL BE USED BY, OR DISCLOSED TO ANY PERSON, FIRM OR CORPORATION FOR ANY PURPOSE WHATSOEVER WITHOUT THE WRITTEN PERMISSION OF CARRIER, JOHNSON + CULTURE. FILING THESE DRAWINGS OR SPECIFICATIONS WITH ANY PUBLIC AGENCY IS NOT A PUBLICATION OF SAME. NO COPYING, REPRODUCTION OR USE THEREOF IS PERMISSIBLE WITHOUT THE CONSENT OF CARRIER, JOHNSON + CULTURE.







# VIEWPOINT OLD TOWN SITE DEVELOPMENT PERMIT

NDP # XXXXXX

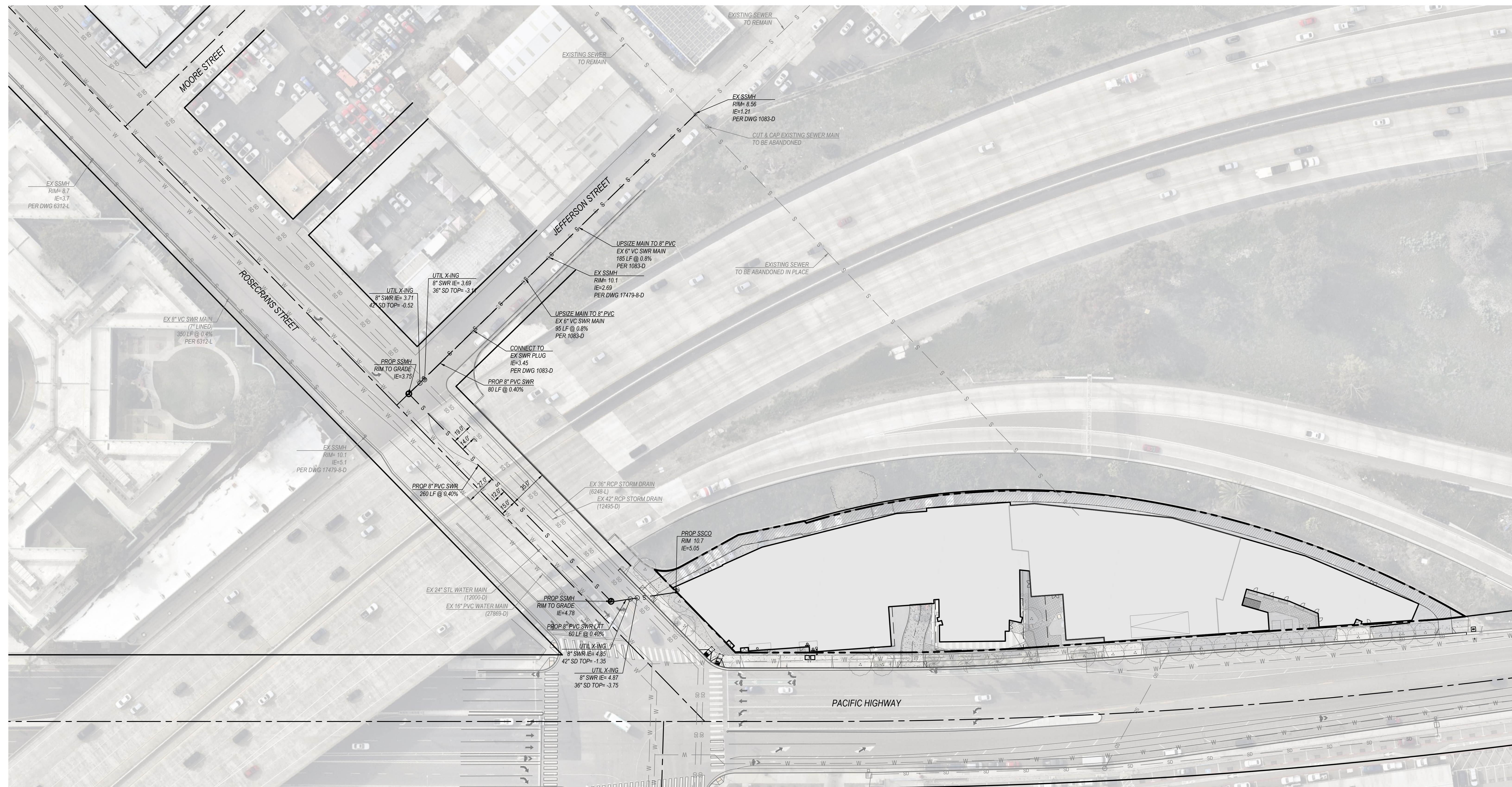

SEWER MAIN EXTENSION PLAN

SCALE: 1" = 40'

ISSUES:	NO	DESCRIPTION	DATE



PROJECT NO:	PLSA 3598
FILE NAME:	WPFA_CENTRAL_PLSA3598.rvt
DRAWN BY:	CJB
CHECKED BY:	TGL
PLOT DATE:	March 15, 2023
TITLE:	

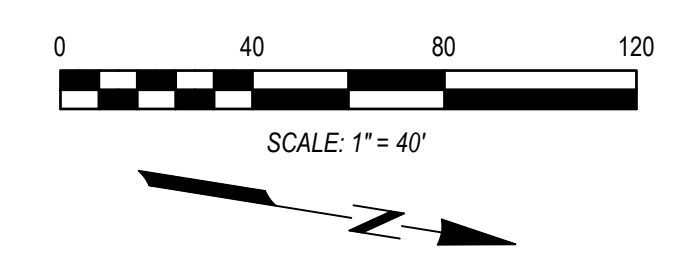

PREPARED BY:  
**PASCO LARET SUITER & ASSOCIATES**  
San Diego | Solana Beach | Orange County  
Phone 858.259.8212 | www.plsaengineering.com

SEWER MAIN  
EXTENSION  
PLAN

DRAWING NO:

C4.2

ALL IDEAS, DESIGN ARRANGEMENTS AND PLANS INDICATED OR REPRESENTED BY THIS DRAWING ARE OWNED BY, AND THE PROPERTY OF, CARRIERJOHNSON + CULTURE AND WERE CREATED, DEVELOPED AND DELIVERED FOR USE ON AND IN CONNECTION WITH THIS PROJECT. NONE OF SUCH IDEAS, DESIGN ARRANGEMENTS OR PLANS SHALL BE USED BY, OR DISCLOSED TO ANY PERSON, FIRM OR CORPORATION FOR ANY PURPOSE WHATSOEVER WITHOUT THE WRITTEN PERMISSION OF CARRIERJOHNSON + CULTURE. FILING THESE DRAWINGS OR SPECIFICATIONS WITH ANY PUBLIC AGENCY IS NOT A PUBLICATION OF SAME. NO COPYING, REPRODUCTION OR USE THEREOF IS PERMISSIBLE WITHOUT THE CONSENT OF CARRIERJOHNSON + CULTURE.



**THIS PAGE INTENTIONALLY LEFT BLANK FOR DOUBLE-SIDED PRINTING**

Project Name:

# Attachment 5 Drainage Report

Attach project's drainage report. Refer to Drainage Design Manual to determine the reporting requirements.

Project Name:

**THIS PAGE INTENTIONALLY LEFT BLANK FOR DOUBLE-SIDED PRINTING**

# PRELIMINARY DRAINAGE STUDY

## VIEWPOINT OLD TOWN

4620 PACIFIC HIGHWAY  
SAN DIEGO, CA 92110

PRJ-1056469

APN: 442-740-03, 442-740-06, 442-740-07

PREPARED FOR:

**VIEWPOINT DEVELOPMENT LLC**

2011 PALOMAR AIRPORT RD SUITE 101-182  
CARLSBAD, CA 92011

PREPARED BY:

**PASCO, LARET, SUITER & ASSOCIATES**

1911 SAN DIEGO AVENUE, SUITE 100  
SAN DIEGO, CA 92110



Handwritten signature of Tyler G. Lawson in black ink.

---

TYLER G LAWSON, PE

RCE 80356

EXP 12-31-22

# PASCO LARET SUITER

**& ASSOCIATES**

CIVIL ENGINEERING + LAND PLANNING + LAND SURVEYING

PREPARED: MARCH 31, 2022

REVISED: AUGUST 19, 2022

FINAL: DECEMBER 7, 2022



# TABLE OF CONTENTS

1.0 INTRODUCTION .....	1
1.1 PROJECT DESCRIPTION.....	1
1.2 EXISTING CONDITIONS.....	1
1.3 PROPOSED CONDITIONS .....	1
2.0 METHODOLOGY.....	2
2.1 RATIONAL METHOD .....	2
2.2 RUNOFF COEFFICIENT .....	3
2.3 RAINFALL INTENSITY .....	3
2.4 TRIBUTARY AREAS .....	3
3.0 CALCULATIONS & RESULTS .....	3
3.1 EXISTING VERSUS PROPOSED PEAK FLOW .....	3
3.2 CONCLUSION .....	4
APPENDIX 1: HYDROLOGY CALCULATIONS & SUPPORT MATERIAL	
APPENDIX 2: DRAINAGE EXHIBITS	

## **1.0 INTRODUCTION**

### **1.1 PROJECT DESCRIPTION**

The 1.75 acre site is located at the northwest corner of the intersection of Pacific Highway and Rosecrans Street in San Diego, California. Currently, the 4-parcel site consists of a commercial building with associated parking, landscaping, and associated improvements. The proposed project includes the demolition of the existing parking area, rehabilitation of the existing building, and the construction of a four-story residential development with subterranean parking, associated amenities, hardscape, landscaping, and site improvements. The project also proposes improvements along the project frontage, including new sidewalk, driveway, landscape strip, and other surface improvements typical of this type of development.

This project is designed in accordance with the January 2017 Edition of the Drainage Design Manual, the 2016 San Diego Storm Water Standards Manual (Updated May 2021) and complies with the Regional Water Quality Control Board Region 9 MS4 Permit, Order No. R9-2015-0100. The project does not propose work adjacent to federally regulated waters, and therefore Sections 401 & 404 of the Federal Clean Water Act (CWA) are not applicable.

### **1.2 EXISTING CONDITIONS**

The 1.75 acre site is generally flat, with a gentle slope towards Rosecrans Street and Pacific Highway. The existing condition is 100% impervious, with area coverage consisting of parking lot or structure. The site receives no offsite drainage due to the existing retaining wall that channels stormwater into an inlet within Pacific Highway, north of the project site. The existing site does not appear to have any on-site storm drainage conveyance network. The existing on-site structure conveys roof drainage via downspouts that release at grade. Stormwater sheet flows south to Rosecrans Street or flows east to Pacific Highway. Public stormwater infrastructure exists within the right-of-way which captures the stormwater from the gutter and routes it to a public stormwater lift station approximately 300-feet east of the project site. The station releases stormwater into a 66" culvert which discharges into the San Diego River, which flows into the Pacific Ocean.

The 100-year storm peak pre-project runoff is approximately 6.54 CFS. The peak stormwater runoff was calculated using the Rational Method ( $Q=CIA$ ) as shown in Equation A-1 of the City of San Diego Drainage Design Manual. The 4.4 in/hour intensity was determined from the City of San Diego Drainage Design Manual's Intensity-Duration-Frequency Design Chart, Figure A-1, using the minimum allowable time of concentration ( $T_C$ ) of 5.0 minutes. A runoff coefficient of 0.85 was calculated using the Runoff Coefficient for commercial land use as outlined in Table A-1 of the Drainage Design Manual. Refer to Appendix 1 of this report for supporting calculations and exhibits.

### **1.3 PROPOSED CONDITIONS**

The project proposes the development of a new multi-family residential structure with associated landscaping, hardscape, and improvements. The proposed project is conservatively modelled to be 100% impervious. It is anticipated that the final condition will be less than 100% impervious. The proposed condition includes a piped stormwater conveyance network to capture, treat, and discharge on-site stormwater into the public storm drain network within the right-of-way along project frontage. The site proposes new connections into the public storm drain system but does not alter the ultimate drainage basin area captured and routed to the downstream infrastructure. The project proposes three curb outlets that discharge into the existing curb & gutter along Pacific Highway. The project proposes one cleanout along Rosecrans Street, connecting into the existing 36" storm drain network.

The project is classified as a Priority Development Project, and therefore pollutant removal and hydromodification management measures are implemented to demonstrate compliance with the Regional MS4 Permit. In addition, site design measures for storm water runoff are proposed where feasible.

The proposed project will not increase the amount of impervious area on-site and, therefore, will not increase the post-project peak runoff. The roof runoff is collected and conveyed to the proposed onsite Post Construction BMP's for water quality treatment prior to release. Because there is no increase in peak runoff, no onsite detention or retention is required for this project. The post-project condition has been delineated with two (2) drainage basins: one basin discharging to the storm drain within Rosecrans Street, and one basin discharging to the storm drain within Pacific Highway.

The 100-year storm peak post-project runoff is approximately 6.54 CFS. The peak stormwater runoff was calculated using the Rational Method ( $Q=CIA$ ) as shown in Equation A-1 of the City of San Diego Drainage Design Manual. The 4.4 in/hour intensity was determined from the City of San Diego Drainage Design Manual's Intensity-Duration-Frequency Design Chart, Figure A-1, using the minimum allowable time of concentration ( $T_c$ ) of 5.0 minutes. The proposed use of the project is multi-unit residential, but due to the fact that the entire project area is nearly 100% impervious, a runoff coefficient of 0.85 was used. This coefficient was chosen to match the pre-development runoff coefficient, due to the fact that the pre-development condition is also 100% impervious. Refer to Appendix 1 of this report for supporting calculations and exhibits.

## **2.0 METHODOLOGY**

The proposed project has been analyzed to determine the peak runoff flow for 100-year, 6-hour rainfall event using the Rational Method per the City of San Diego Drainage Design Manual (Section 1-102.3). The Runoff Coefficient, C, for the existing and proposed conditions were selected using Table A-1 in the Appendix A of the City of San Diego Drainage Design Manual. The time of concentration ( $T_c$ ) for all existing and proposed drainage areas were calculated using the minimum 5.0 minutes, which yields an intensity of 4.4 inches per hour, in accordance with the City of San Diego's Intensity-Duration-Frequency Design Chart (Figure A-1 in the City of San Diego Drainage Design Manual). A copy of this Figure has been added to Appendix 1 of this report for reference.

The proposed LID best management practices have been sized and located such that all runoff will be directed to landscape planters or through pervious areas where feasible before ultimately discharging to the downstream storm drain system.

## **2.1 RATIONAL METHOD**

As mentioned above, runoff from the project site was calculated for the 100-year, 6-hour storm event. Runoff was calculated using the Rational Method which is given by the following equation:

$$Q = C I A \qquad \text{Equation A-1 of City of SD Drainage Design Manual}$$

Where:

Q = Flow rate in cubic feet per second (cfs)

C = Runoff coefficient (*Determined from Table A-1 of City of SD Drainage Design Manual*)

I = Rainfall Intensity in inches per hour (in/hr)

A = Drainage basin area in acres, (ac)

Rational Method calculations were performed using the City of San Diego Drainage Design Manual Equation A-1, as shown above.

## 2.2 RUNOFF COEFFICIENT

The runoff coefficients for the project were selected from Table A-1 from the City of San Diego Drainage Design Manual (January 2017), using the values for commercial land use in the pre-project and post-development condition (C= 0.85).

## 2.3 RAINFALL INTENSITY

Rainfall intensity was determined using the Rainfall Intensity-Duration-Frequency Curves shown in Section A.1.3 of the City of San Diego Drainage Design Manual (January 2017). Based on a 5.0-minute time of concentration, an intensity of 4.4 inches per hour is used in accordance with Figure A-1.

## 2.4 TRIBUTARY AREAS

Drainage basins are delineated in the Post-Project Hydrology Exhibit in Appendix 2 and graphically portray the tributary area for each drainage basin. Each drainage basin has been defined by the area being conveyed to each curb outlet location discharging from the property. Ultimately, runoff is all conveyed east to the public stormwater infrastructure in Pacific Highway and Rosecrans Street, converging at the lift station.

## 3.0 CALCULATIONS & RESULTS

### 3.1 EXISTING VERSUS PROPOSED PEAK FLOW

Below are a series of tables which summarize the calculations provided in Appendix 1 of this report.

<b>SITE IMPERVIOUS AREA COMPOSITION</b>				
	Total Impervious Area (Acres)	Total Pervious Area (Acres)	% Impervious Surfaces	Runoff Coefficient "C"
Existing	1.75	0	100%	0.85
Proposed	1.75	0	100%	0.85

TABLE 1: RUNOFF COEFFICIENT "C" COMPARISON

The table above shows the difference in the runoff coefficient, "C", between the existing and proposed condition. For additional explanation on how each runoff coefficient was calculated, refer to Appendix 1 of this report.

<b>EXISTING DRAINAGE FLOWS</b>			
Drainage Area	Size (Acres)	I <sub>100</sub> (in/hour)	Q <sub>100</sub> (CFS)
EX-1	1.75	4.40	6.538

TABLE 2: EXISTING CONDITION PEAK DRAINAGE FLOW RATES

Table 2 above lists the peak flow rates for the project site in the existing condition for the respective rainfall events.

<b>PROPOSED DRAINAGE FLOWS</b>			
Drainage Area	Size (Acres)	I <sub>100</sub> (in/hour)	Q <sub>100</sub> (CFS)
PR-1	1.75	4.40	6.538

TABLE 3: PROPOSED CONDITION PEAK DRAINAGE FLOW RATES

The table above lists the unmitigated peak flow rates for the project site for the proposed condition for the 100-year, 6-hour storm event. In the existing and proposed conditions, all water discharging to the public right-of-way offsite eventually confluences in the public storm drain prior to the lift station mid-block off Taylor Street, 300-ft east of the project.



PEAK DRAINAGE FLOW COMPARISON				
	Drainage Area (Acres)	Runoff Coefficient "C"	Q <sub>100</sub> (CFS)	V <sub>100</sub> (ft <sup>3</sup> )
Existing	1.75	0.85	6.538	13,486
Proposed	1.75	0.85	6.538	13,486

TABLE 4: EXISTING & PROPOSED PEAK FLOW RATES & PRECIPITATION VOLUME

Table 4 above shows a comparison between the peak flow rates and precipitation volume for the proposed condition and the existing condition.

### 3.2 CONCLUSION

As shown in Table 4, the project maintains the existing the peak runoff rate and runoff volume for the design storms analyzed when comparing the pre-project condition to the unmitigated post-project condition. Because the post-development condition does not increase the peak flow or volume, no additional detention volume is required to comply with the Regional MS4 Permit requirements for hydromodification management.

The project proposes a piped conveyance storm drain network to capture, treat, and release stormwater from the project site into the public storm drain infrastructure, matching the existing ultimate point of discharge. See Appendix 1 for supporting calculations and exhibits.

**APPENDIX 1: HYDROLOGY CALCULATIONS & SUPPORT MATERIAL**

**PRE-PROJECT HYDROLOGY**

Drainage Area	Area Description	Total Area (Ac)	Total Area (sq-ft)	Total Impervious Area (Sq-Ft)	% Impervious	% Pervious	Weighted Runoff Coefficient	Peak Runoff Q: (CFS)	Peak Runoff Volume: (cu-ft)
EX-1	Existing Site	1.748	76,154	76,154	100%	0%	0.85	6.54	13,486
Totals:		1.748	76,154				0.85	6.54	13,486

**POST-PROJECT HYDROLOGY**

BMP Location	Basin Description	Total Area (Ac)	Total Area (sq-ft)	Total Impervious Area (Sq-Ft)	% Impervious	% Pervious	Weighted Runoff Coefficient	Peak Runoff Q: (CFS)	Peak Runoff Volume: (cu-ft)
PR-1	Proposed Site	1.748	76,154	76,154	100%	0%	0.85	6.54	13,486
Totals:		1.75	76,154				0.70	6.54	13,486

100 Yr Storm (TC = 5.0 min)	
Intensity:	4.40 in/hr
Precip:	2.50 in

Runoff Coefficient	
Pre-Project	0.85
Post-Project	0.85

**Detention Calculations**

Pre-Project Peak Runoff Volume: 13,486 cu-ft  
 Post-Project Peak Runoff Volume (Unmitigated): 13,486 cu-ft  
 Delta Peak Runoff Volume (Post Unmitigated - Pre): 0 cu-ft

Results: No additional hydromodification / detention required

**Table A-1. Runoff Coefficients for Rational Method**

Land Use	Runoff Coefficient (C)
	Soil Type <sup>(1)</sup>
<b>Residential:</b>	
Single Family	0.55
Multi-Units	0.70
Mobile Homes	0.65
Rural (lots greater than 1/2 acre)	0.45
<b>Commercial <sup>(2)</sup></b>	
80% Impervious	0.85
<b>Industrial <sup>(2)</sup></b>	
90% Impervious	0.95

**Note:**

<sup>(1)</sup> Type D soil to be used for all areas.

<sup>(2)</sup> Where actual conditions deviate significantly from the tabulated imperviousness values of 80% or 90%, the values given for coefficient C, may be revised by multiplying 80% or 90% by the ratio of actual imperviousness to the tabulated imperviousness. However, in case shall the final coefficient be less than 0.50. For example: Consider commercial property on D soil.

Actual imperviousness	=	50%
Tabulated imperviousness	=	80%
Revised C	=	$(50/80) \times 0.85 = 0.53$

The values in Table A-1 are typical for urban areas. However, if the basin contains rural or agricultural land use, parks, golf courses, or other types of nonurban land use that are expected to be permanent, the appropriate value should be selected based upon the soil and cover and approved by the City.

### **A.1.3. Rainfall Intensity**

The rainfall intensity (I) is the rainfall in inches per hour (in/hr.) for a duration equal to the T<sub>c</sub> for a selected storm frequency. Once a particular storm frequency has been selected for design and a T<sub>c</sub> calculated for the drainage area, the rainfall intensity can be determined from the Intensity-Duration-Frequency Design Chart (Figure A-1).





APPENDIX A: RATIONAL METHOD AND MODIFIED RATIONAL METHOD

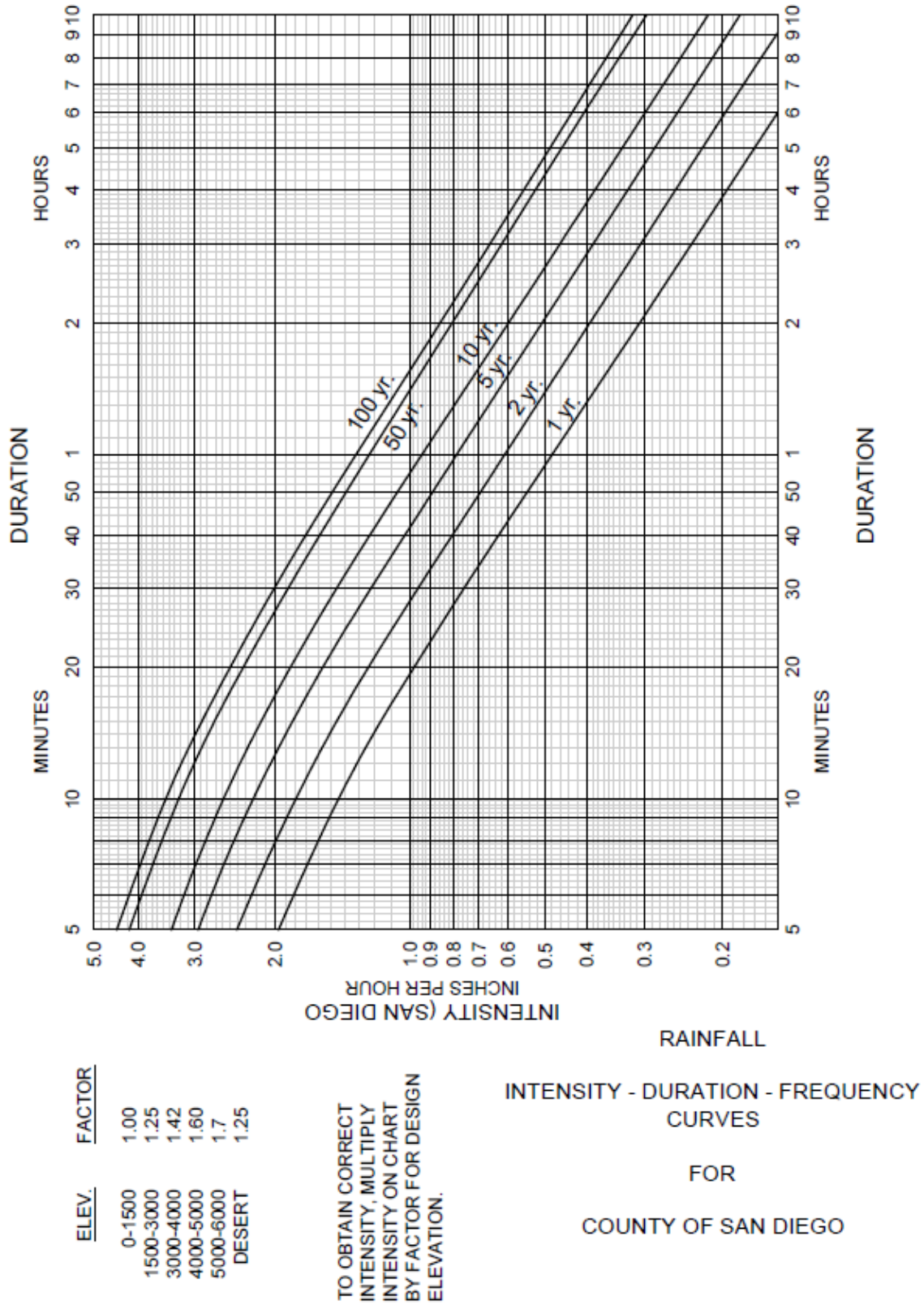

Figure A-1. Intensity-Duration-Frequency Design Chart



APPENDIX A: RATIONAL METHOD AND MODIFIED RATIONAL METHOD

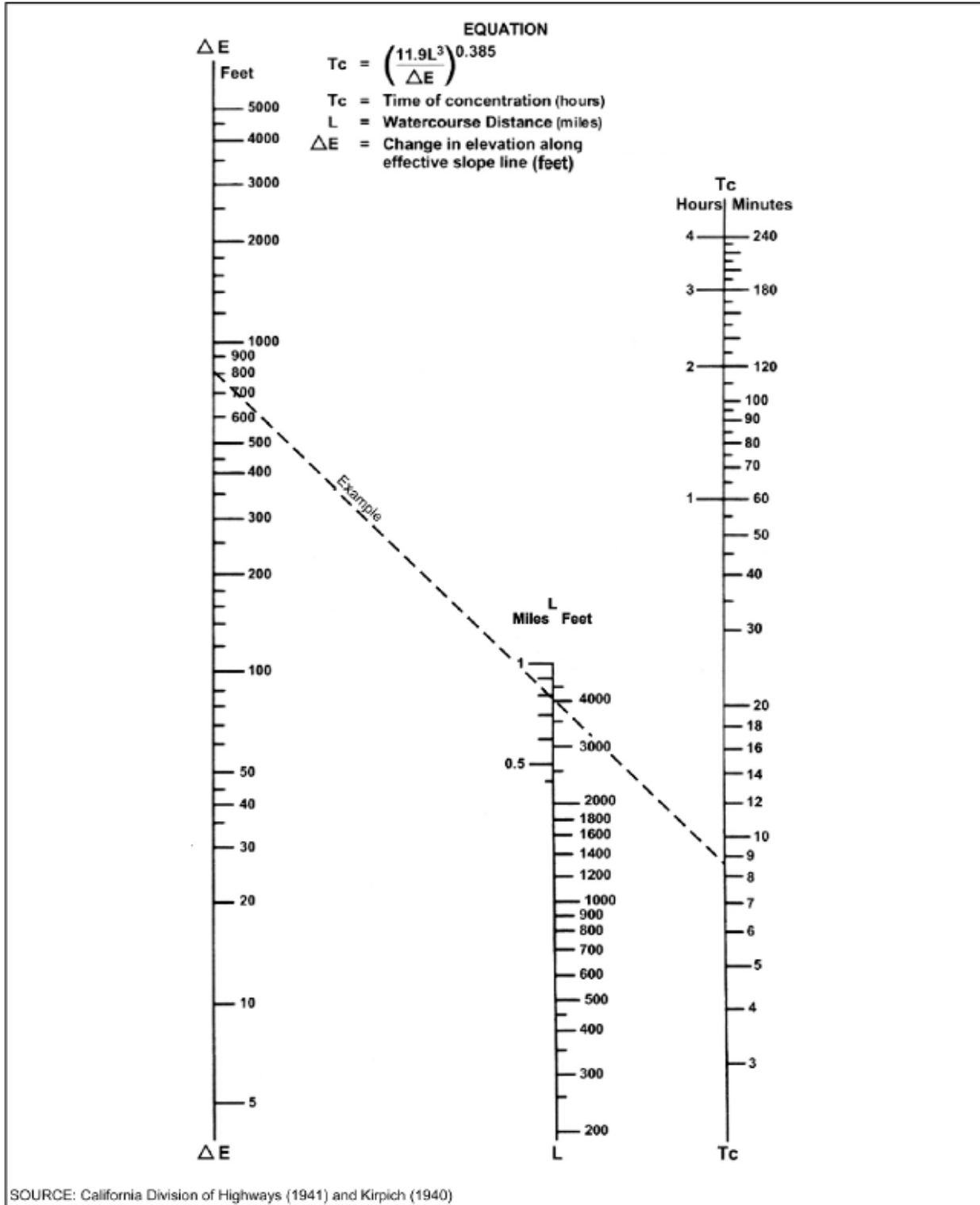

Figure A-2. Nomograph for Determination of  $T_c$  for Natural Watersheds

**Note:** Add ten minutes to the computed time of concentration from Figure A-2.



APPENDIX A: RATIONAL METHOD AND MODIFIED RATIONAL METHOD

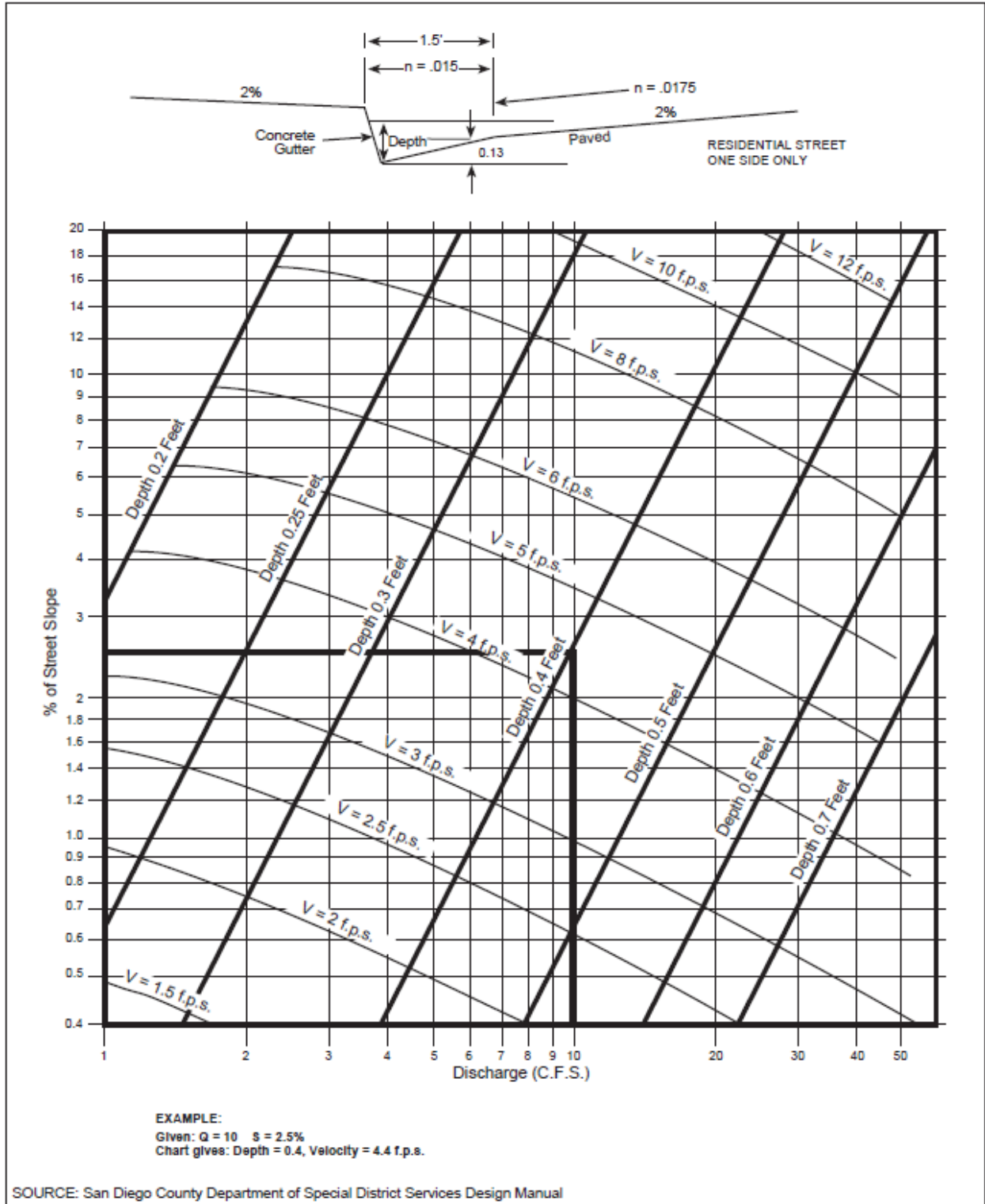

Figure A-5. Gutter and Roadway Discharge - Velocity Chart

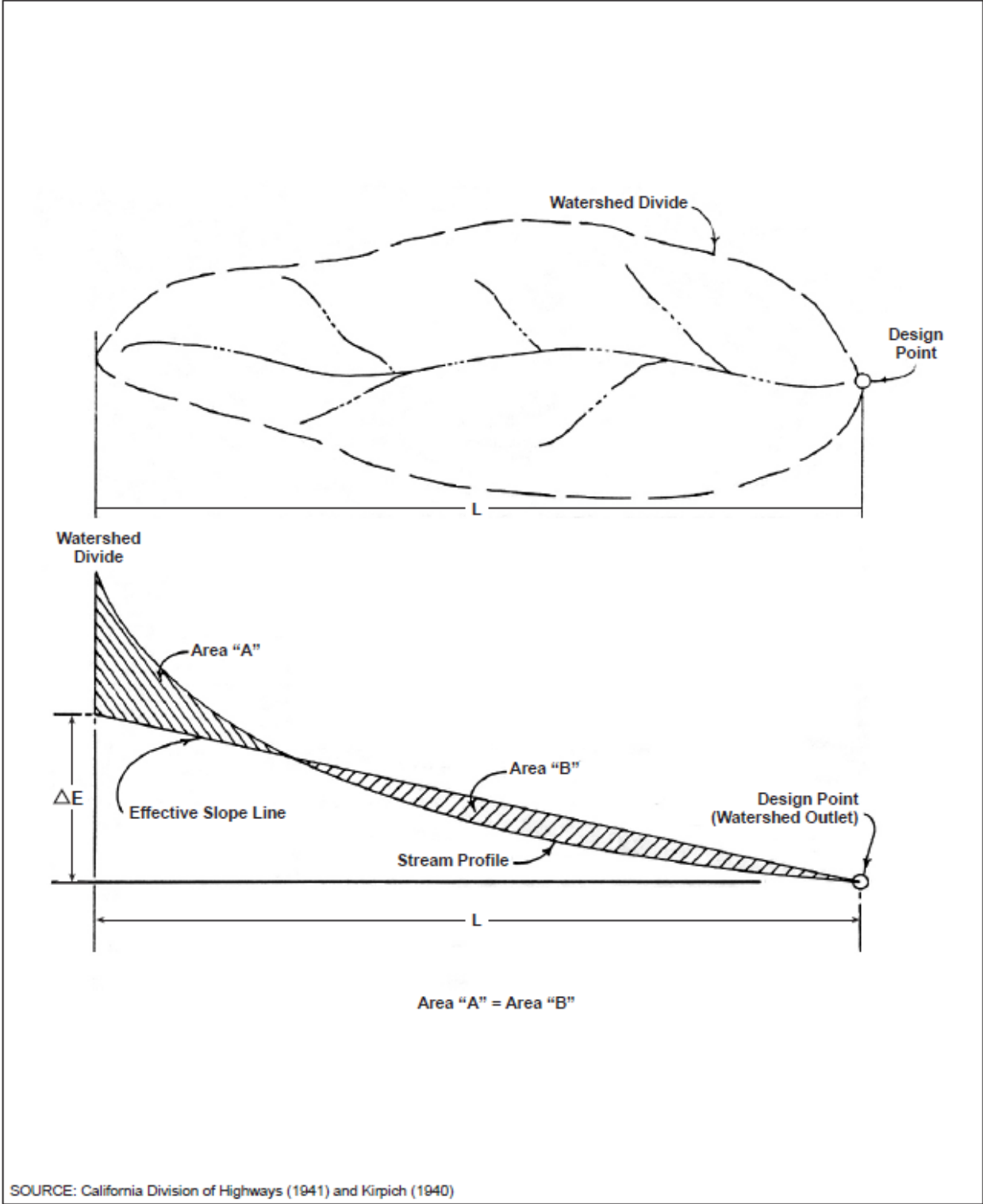

Figure A-3. Computation of Effective Slope for Natural Watersheds



APPENDIX B: NRCS HYDROLOGIC METHOD

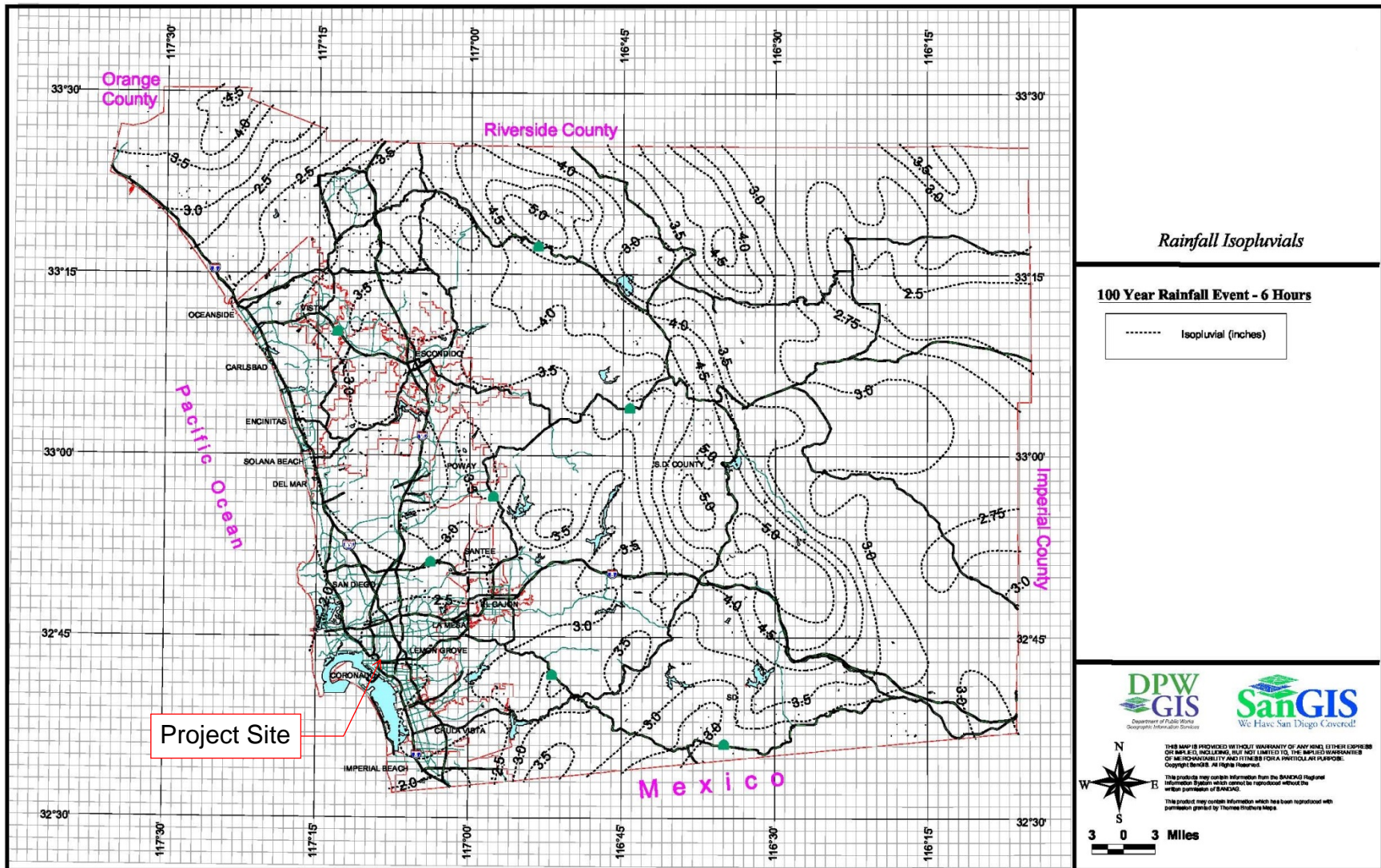

Figure B-2. 100-Year 6-Hour Isopluvials.



**APPENDIX 2: DRAINAGE EXHIBITS**

Project Name:

**THIS PAGE INTENTIONALLY LEFT BLANK FOR DOUBLE-SIDED PRINTING**

# VIEWPOINT OLD TOWN

## EXISTING HYDROLOGY EXHIBIT

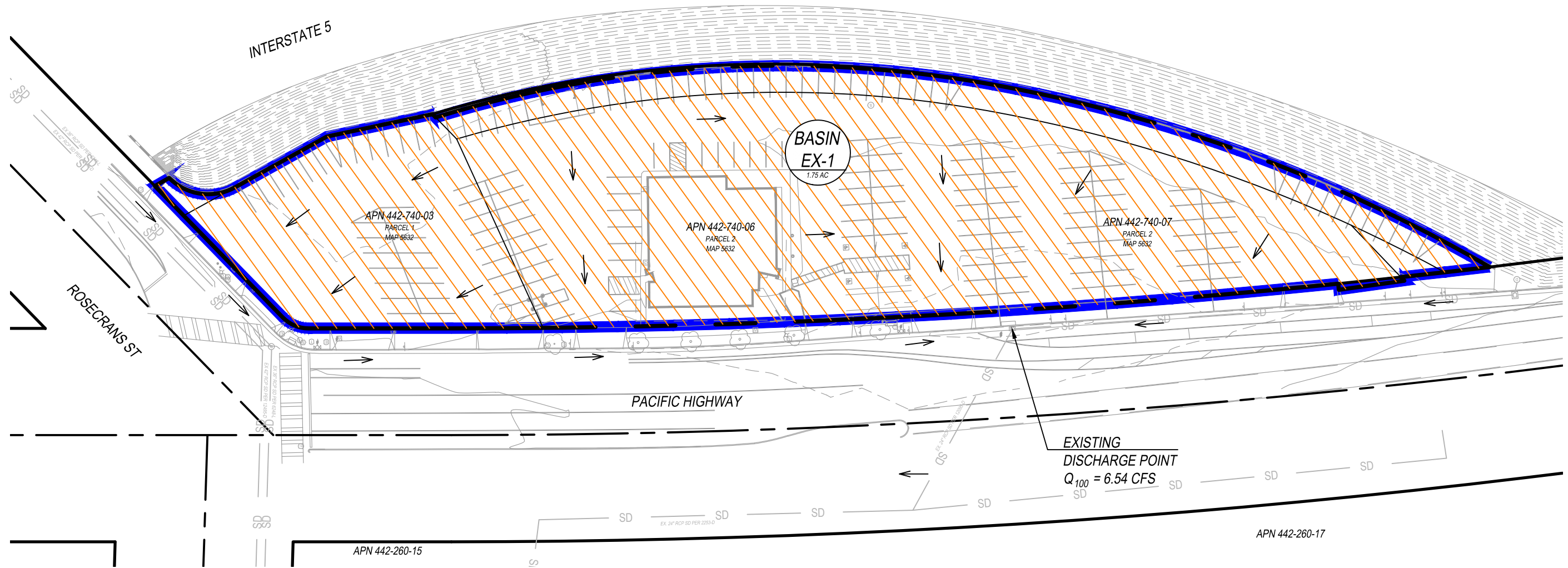

### LEGEND

SUBJECT PROPERTY / LIMIT OF WORK	
EXISTING RIGHT-OF-WAY / ADJACENT LOT LINE	
CENTERLINE OF ROAD	
EXISTING CONTOUR	
EXISTING FLOW DIRECTION	
EXISTING MAJOR DRAINAGE BASIN BOUNDARY	
EXISTING IMPERVIOUS AREA	

### BASIN EX-1: AREA CALCULATIONS

TOTAL BASIN AREA	76,154 SF (1.75 AC)
BASIN EXISTING IMPERVIOUS AREA	76,154 SF (1.75 AC)
BASIN EXISTING PERVIOUS AREA	0 SF (0.0 AC)
% IMPERVIOUS	100.00%
$C$	0.85
$Q_{100}$	$=C \cdot I \cdot A$
$Q_{100}$	$= (0.85) \cdot (4.4 \text{ IN/HR}) \cdot (1.75 \text{ AC})$
$Q_{100}$	$= 6.54 \text{ CFS}$

\*ASSUME TYPE D SOILS; EXISTING LAND USE IS COMMERCIAL.  
 RUNOFF COEFFICIENT OF 0.85 USED IN ACCORDANCE WITH APPENDIX A OF  
 CITY OF SAN DIEGO DRAINAGE DESIGN MANUAL.

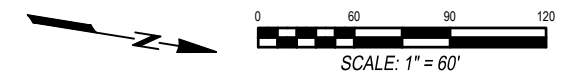

PREPARED BY:  
**PASCO LARET SUITER**  
 & ASSOCIATES  
 San Diego | Solana Beach | Orange County  
 Phone 858.259.8212 | www.plsaengineering.com



# VIEWPOINT OLD TOWN

## PROPOSED HYDROLOGY EXHIBIT

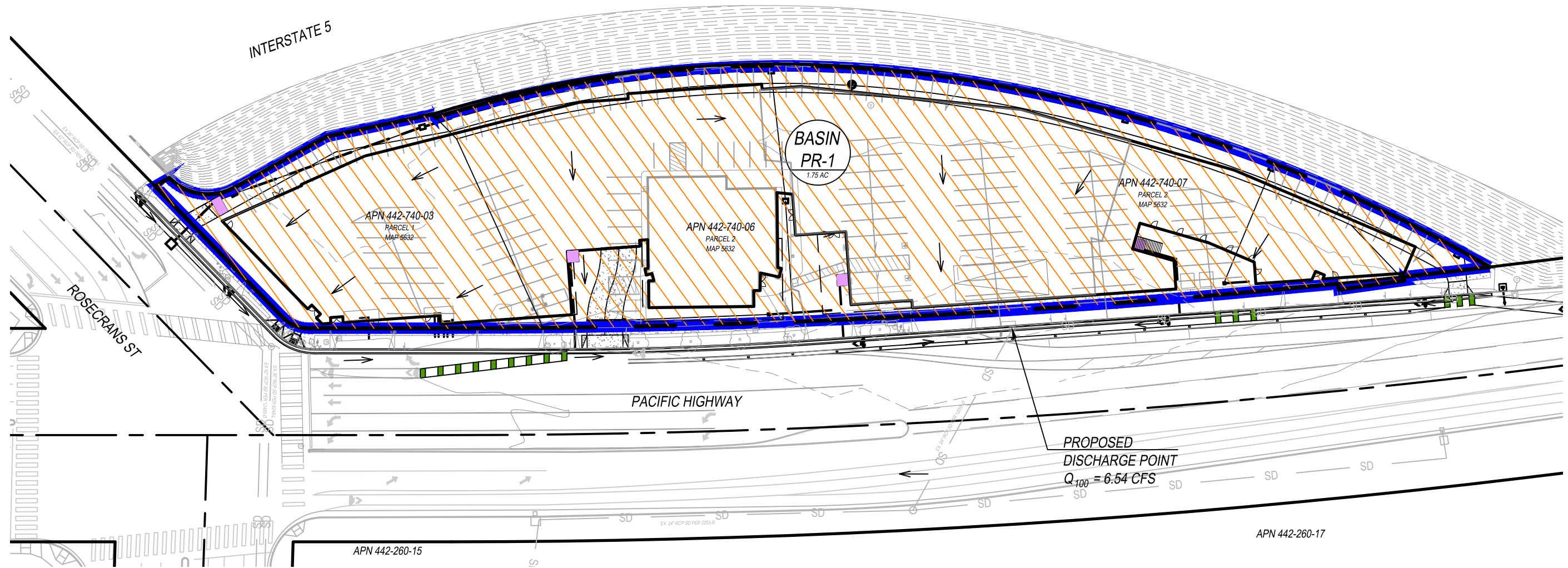

### LEGEND

SUBJECT PROPERTY / LIMIT OF WORK	
EXISTING RIGHT-OF-WAY / ADJACENT LOT LINE	
CENTERLINE OF ROAD	
EXISTING CONTOUR	
PROPOSED FLOW DIRECTION	
PROPOSED MAJOR DRAINAGE BASIN BOUNDARY	
PROPOSED IMPERVIOUS AREA	
PROPOSED POST CONSTRUCTION BMP	

### BASIN PR-1: AREA CALCULATIONS

TOTAL BASIN AREA	76,154 SF (1.75 AC)
BASIN EXISTING IMPERVIOUS AREA	76,154 SF (1.75 AC)
BASIN EXISTING PERVIOUS AREA	0 SF (0.0 AC)
% IMPERVIOUS	100.00%
C	0.85
$Q_{100}$	$=C \cdot I \cdot A$
$Q_{100}$	$= (0.85) \cdot (4.4 \text{ IN/HR}) \cdot (1.75 \text{ AC})$
$Q_{100}$	$= 6.54 \text{ CFS}$

\*ASSUME TYPE D SOILS; PROPOSED LAND USE IS MULTI-FAMILY RESIDENTIAL. RUNOFF COEFFICIENT OF 0.85 TO MATCH EXISTING LAND USE CONDITION.

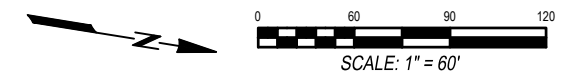

PREPARED BY:  
**PASCO LARET SUITER**  
 & ASSOCIATES  
 San Diego | Solana Beach | Orange County  
 Phone 858.259.8212 | www.plsaengineering.com



Project Name:

# **Attachment 6**

## **Geotechnical and Groundwater Investigation Report**

Attach project's geotechnical and groundwater investigation report. Refer to Appendix C.4 to determine the reporting requirements.

Project Name:

**THIS PAGE INTENTIONALLY LEFT BLANK FOR DOUBLE-SIDED PRINTING**

# GEOTECHNICAL INVESTIGATION

## Viewpoint Old Town Apartments 4620 Pacific Highway, San Diego, California



Prepared for:  
Viewpoint Development LLC  
1635 Pacific Ranch Drive  
Encinitas, CA 92024

NOVA Project No. 2021073  
July 18, 2022



4373 Viewridge Avenue  
Suite B  
San Diego, California 92123  
858.292.7575

944 Calle Amanecer  
Suite F  
San Clemente, CA 92673  
949.388.7710

[www.usa-nova.com](http://www.usa-nova.com)



**GEOTECHNICAL**  
**MATERIALS**  
**SPECIAL INSPECTION**

DVBE ♦ SBE ♦ SDVOSB ♦ SLBE

Chris Livoni  
Viewpoint Development LLC  
1635 Pacific Ranch Drive  
Encinitas, CA 92024

July 18, 2022  
NOVA Project No. 2021073

Subject: Geotechnical Investigation  
Viewpoint Old Town Apartments  
4620 Pacific Highway, San Diego, California

Dear Mr. Livoni:

NOVA Services, Inc. (NOVA) is pleased to present this report describing the geotechnical investigation performed for the proposed Viewpoint Old Town Apartments project. The scope of work performed for this investigation was in general conformance with the scope of work presented in NOVA's proposal dated July 6, 2022, as authorized on July 17, 2022.

NOVA appreciates the opportunity to be of service to Viewpoint Development LLC on this most interesting project. If you have any questions regarding this report, please call us at 858.292.7575 x 413.

Sincerely,  
**NOVA Services, Inc.**

Melissa Stayner, PG, CEG  
Senior Engineering Geologist

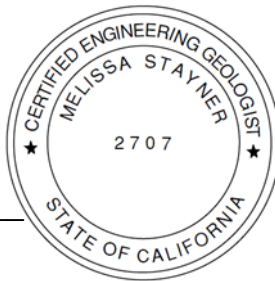

John F. O'Brien, PE, GE  
Principal Geotechnical Engineer





---

## GEOTECHNICAL INVESTIGATION

### Viewpoint Old Town Apartments 4620 Pacific Highway, San Diego, California

---

#### TABLE OF CONTENTS

<b>1. INTRODUCTION</b> .....	<b>1</b>
<b>2. SCOPE OF WORK</b> .....	<b>3</b>
2.1. Field Investigation .....	3
2.1.1 Overview.....	3
2.1.2 Geotechnical Borings.....	4
2.1.3 CPT Soundings.....	4
2.1.4 Geophysical.....	4
2.2. Laboratory Testing .....	4
2.3. Analysis and Report Preparation.....	4
<b>3. SITE AND PROJECT DESCRIPTION</b> .....	<b>5</b>
3.1. Site Description and Use.....	5
3.1.1 Description.....	5
3.1.2 Use .....	5
3.2. Proposed Development.....	5
3.2.1 Design Basis.....	5
3.2.2 Architectural.....	5
3.2.3 Structural.....	6
3.2.4 Civil.....	7
3.2.5 Potential for Earthwork.....	7
<b>4. GEOLOGY AND SUBSURFACE CONDITIONS</b> .....	<b>8</b>
4.1. Regional Geology.....	8
4.2. Site-Specific Geology .....	9
<b>5. GEOLOGIC, SOIL AND SITING HAZARDS</b> .....	<b>12</b>
5.1. Faulting and Surface Rupture.....	12
5.1.1 Regional.....	12





5.1.2	<i>Faulting in the Site Vicinity</i> .....	12
5.2.	City of San Diego Seismic Safety Study .....	12
5.3.	Site Class .....	14
5.4.	Liquefaction .....	15
5.5.	Landslides and Slope Stability .....	18
5.6.	Flooding, Tsunamis, and Seiches .....	18
5.7.	Subsidence .....	18
5.8.	Hydro-Consolidation .....	19
<b>6.</b>	<b>CONCLUSIONS</b> .....	<b>20</b>
<b>7.</b>	<b>RECOMMENDATIONS</b> .....	<b>21</b>
7.1.	Earthwork .....	21
7.1.1	<i>General</i> .....	21
7.1.2	<i>Site Preparation</i> .....	21
7.1.3	<i>Compacted Fill</i> .....	21
7.1.4	<i>Imported Soil</i> .....	22
7.1.5	<i>Subgrade Stabilization</i> .....	22
7.1.6	<i>Excavation Characteristics</i> .....	22
7.1.7	<i>Oversized Material</i> .....	22
7.1.8	<i>Grading Plan Review</i> .....	22
7.2.	Ground Improvement .....	22
7.2.1	<i>Potentially Applicable Ground Improvement Technologies</i> .....	22
7.2.2	<i>Preferred Ground Improvement Technology</i> .....	25
7.3.	Temporary Excavations .....	25
7.3.1	<i>Responsibility</i> .....	25
7.3.2	<i>Unbraced Excavations</i> .....	26
7.3.3	<i>Braced Excavations</i> .....	26
7.4.	Construction Dewatering .....	27
7.5.	Permanent Slopes and Surface Drainage .....	27
7.5.1	<i>Permanent Slopes</i> .....	27
7.5.2	<i>Surface Drainage</i> .....	28
7.6.	Shallow Foundations .....	28
7.6.1	<i>General</i> .....	28
7.6.2	<i>Spread Footings</i> .....	28



---

7.6.3	<i>Interior Slabs-On-Grade</i> .....	29
7.6.4	<i>Foundation Settlement</i> .....	29
7.6.5	<i>Foundation Plan Review</i> .....	29
7.6.6	<i>Foundation Excavation Observations</i> .....	29
7.7.	Hardscape.....	29
7.7.1	<i>Subgrade Preparation</i> .....	29
7.7.2	<i>Hardscape Section</i> .....	30
7.8.	Conventional Retaining Walls.....	30
7.8.1	<i>Foundation Preparation</i> .....	30
7.8.2	<i>Wall Pressures</i> .....	30
7.8.3	<i>Seismic Increment</i> .....	31
7.8.4	<i>Drainage</i> .....	31
7.8.5	<i>Backfill</i> .....	31
7.8.6	<i>Elevator Pits</i> .....	32
7.9.	Pipelines .....	33
7.10.	Pavements .....	33
7.10.1	<i>Subgrade Preparation</i> .....	33
7.10.2	<i>Pavement Sections</i> .....	34
7.11.	Corrosivity .....	34
<b>8.</b>	<b>INFILTRATION FEASIBILITY</b> .....	<b>35</b>
<b>9.</b>	<b>CLOSURE</b> .....	<b>36</b>
<b>10.</b>	<b>REFERENCES</b> .....	<b>37</b>
10.1.	Site Specific .....	37
10.2.	Design.....	37
10.3.	Site Setting.....	38

## List of Figures

- Figure 1-1. Site Vicinity Map
- Figure 1-2. Site Location Map
- Figure 2-1. Locations of Subsurface Explorations
- Figure 3-1. Architectural Schematic
- Figure 3-2. West-East Elevation Schematic
- Figure 4-1. Regional Geology Map

---

## List of Figures (continued)

- Figure 4-2. Fill/Alluvial Deposits in Boring B-1
- Figure 4-3. Bay Sediments in Boring B-1
- Figure 4-4. Old Paralac Deposits in Boring B-1
- Figure 5-1. Fault Map
- Figure 5-2. Site Location on City of San Diego Seismic Safety Study Map
- Figure 5-3. Estimate of Post-Liquefaction Settlement, CPT-1
- Figure 5-4. Estimates of Liquefaction-Related Settlement,  $PGA_M = 0.69 g$
- Figure 5-5. Estimates for Post Liquefaction-Related Settlement for Varying PGA
- Figure 7-1. Ground Improvement Techniques for Soils of Varying Gradation
- Figure 7-2. Idealized DSM Grid Pattern
- Figure 7-3. Gradation of Soils Most Adaptable to Vibratory Compaction
- Figure 7-4. Typical Conventional Retaining Wall Backdrain Detail

## List of Tables

- Table 5-1. DSHA Input Parameters
- Table 5-2. 2019 California Building Code/ASCE 7-16 Site-Specific Parameters
- Table 7-1. AC and PCC Pavement Sections

## List of Plates

- Plate 1 Subsurface Investigation Map and Geologic Cross-Section AA'

## List of Appendices

- Appendix A Use of the Geotechnical Report
- Appendix B Boring Logs
- Appendix C Logs of the CPT Soundings
- Appendix D Results of Shear Wave Traverse and Site-Specific Ground Motion Hazard Analysis
- Appendix E Laboratory Testing
- Appendix F Liquefaction Analyses
- Appendix G Infiltration Feasibility Condition Letter

## 1. INTRODUCTION

This report presents the results of the geotechnical investigation performed by NOVA Services, Inc. (NOVA) for the Viewpoint Old Town Apartments project located at 4620 Pacific Highway in San Diego (hereinafter 'the site'). The project will consist of design and construction of five stories of residential units over a parking podium. The objective of NOVA's work is to characterize the subsurface in a manner sufficient to develop recommendations for geotechnical-related development of the project.

Figure 1-1 presents a site vicinity map. Figure 1-2 presents a site location map.



Figure 1-1. Site Vicinity Map



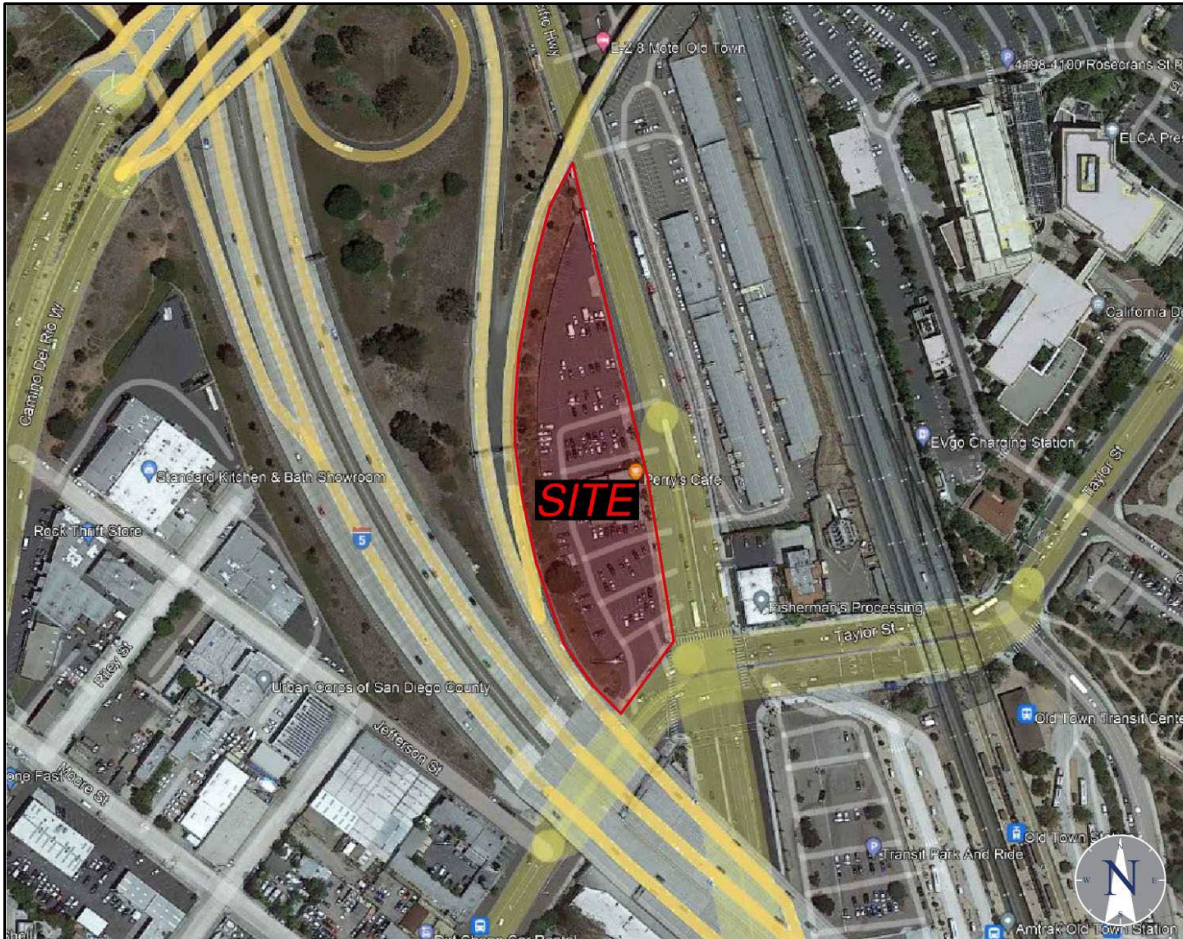

**Figure 1-2. Site Location Map**  
(Source: Google Earth, 2022)



## 2. SCOPE OF WORK

### 2.1. Field Investigation

#### 2.1.1 Overview

NOVA's field investigation consisted of a visual reconnaissance of the site and the subsurface exploration summarized below.

- Geotechnical Borings. Two geotechnical borings (B-1 and B-2) were drilled to depths of about 16½ and 71½ feet below the existing ground surface (bgs).
- CPT Soundings. Three cone penetrometer test (CPT) soundings were advanced to depths of between about 40 and 90 feet bgs.
- Geophysical. A shear wave traverse (S-1) was performed to estimate the average shear wave velocity within the top 100 feet ( $V_{s100}$ ) of the subsurface materials beneath the site.

Figure 2-1 depicts the approximate locations of the subsurface explorations. Plate 1 following the text of the report presents a Subsurface Investigation Map in a larger scale.

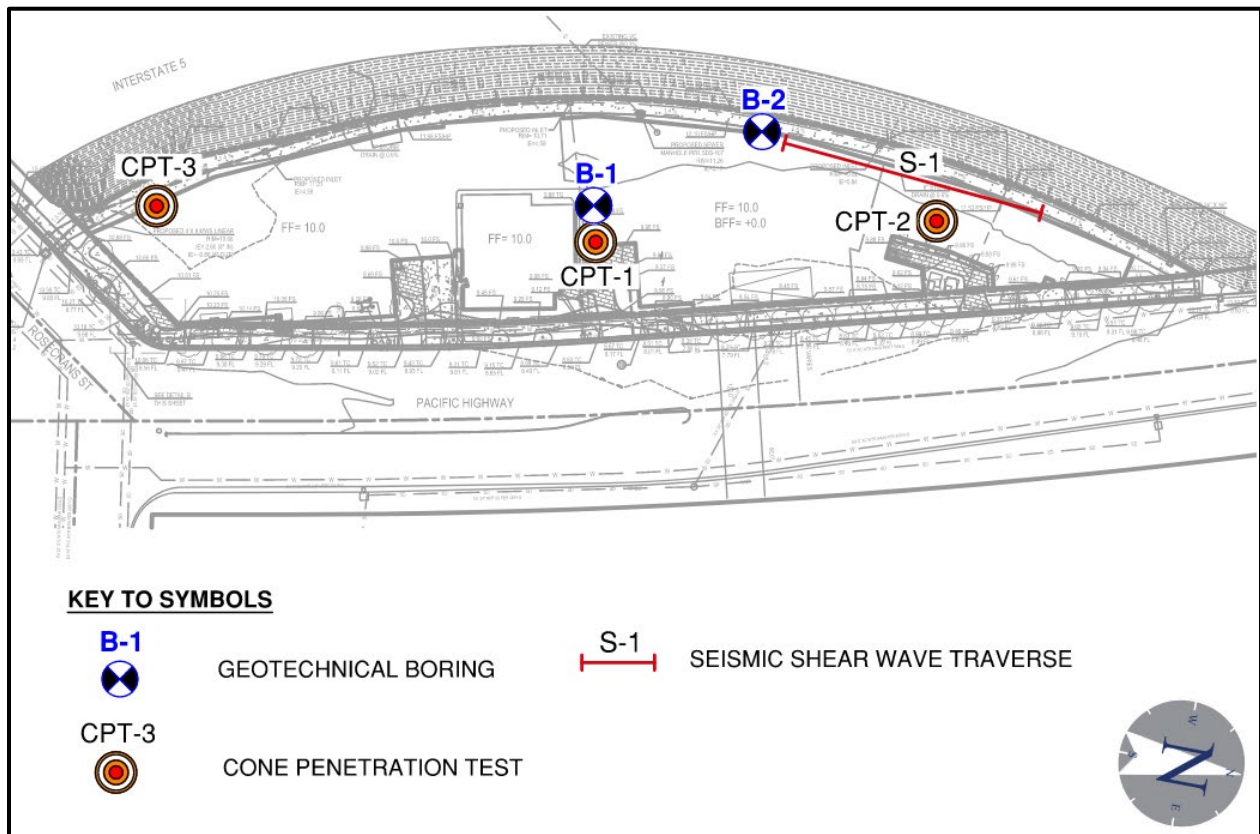

Figure 2-1. Location of Subsurface Explorations

### 2.1.2 Geotechnical Borings

A NOVA geologist logged the borings and collected samples of the materials encountered for laboratory testing. Relatively undisturbed samples were obtained using a modified California (CAL) sampler, a ring-lined split tube sampler with a 3-inch outer diameter and a 2½-inch inner diameter. Standard Penetration Tests (SPT) were performed in the borings using a 2-inch outer diameter and 1⅝-inch inner diameter split tube sampler. The CAL and SPT samplers were driven using automatic hammers with calibrated Energy Transfer Ratios (ETRs) of about 97%. The number of blows needed to drive the sampler the final 12 inches of an 18-inch drive is noted on the logs. The field blow counts,  $N$ , were corrected to a standard hammer (cathead and rope) with a 60% ETR. The corrected blow counts are noted on the boring logs as  $N_{60}$ . Disturbed bulk samples were obtained from the SPT sampler and the drill cuttings. Logs of the borings are presented in Appendix B. Soils are classified according to the Unified Soil Classification System.

### 2.1.3 CPT Soundings

Three CPT soundings in accordance with ASTM D5778 were advanced by a truck-mounted piezocone. Continuous measurements of resistance to penetration of the cone tip ( $q_c$ ) and the frictional resistance ( $f_s$ ) were used to evaluate the soil profile, the soil strength and compressibility, and liquefaction potential. Records of the CPT soundings are presented in Appendix C.

### 2.1.4 Geophysical

A shear wave traverse to estimate the shear wave velocities ( $V_{s100}$ ) of the subsurface materials was completed by a licensed geophysicist. Shear wave data was used to determine Site Class in accordance with ASCE 7-16 Table 20.3-1, and used in our site-specific ground motion hazard analysis. The shear wave traverse was about 180 feet in length. The approximate alignment of the survey line is shown on Figure 2-1 and Plate 1. Results are presented in Appendix D.

## 2.2. Laboratory Testing

The strength and compressibility of the dominantly cohesionless subsurface are adequately characterized by the CPT soundings. Accordingly, laboratory testing was limited to index, geochemical and R-Value testing to characterize the NOVA tested select samples to evaluate soil classification and for correlation with engineering properties. The results of the laboratory tests and brief explanations of the test procedures are presented in Appendix E.

## 2.3. Analysis and Report Preparation

The results of the field and laboratory testing were evaluated to develop conclusions and recommendations regarding the geotechnical aspects of the proposed construction. This report presents NOVA's findings, conclusions, and recommendations.

### 3. SITE AND PROJECT DESCRIPTION

#### 3.1. Site Description and Use

##### 3.1.1 Description

The approximately 1.75-acre site is comprised of APN's 442-740-03-00, 442-740-06-00, 442-740-07-00, nominally located 4620 Pacific Highway in San Diego. The site is bounded on the east by Pacific Highway. The arcuate-shaped connector between Interstate 5 North to Interstate 8 East bounds the site to the north and west, with Rosecrans Street to the south.

The site is level, ranging from an elevation of +10 feet mean sea level (msl) on the north side of the site to +11 feet msl on the southern portion of the site.

##### 3.1.2 Use

The site is currently occupied by the single-level Perry's Cafe and a surrounding asphalt parking lot. A 4-foot to 6-foot tall retaining wall bounds the site along the I-5/I-8 connector.

Available historic photography shows that the existing restaurant building was constructed between 1962 and 1964. The site is mapped on the regional geologic map as artificial fill. The 1902 historical topographic map, shows the site is in an area that connected Old Town to Point Loma and is therefore likely composed of alluvium from the San Diego River Delta.

#### 3.2. Proposed Development

##### 3.2.1 Design Basis

NOVA's understanding of current planning for the development is based upon review of permitting drawings (reference, *Site Development Plans, Viewpoint Old Town, 46220 Pacific Hwy, San Diego, CA 92110*, 38 Sheets, carrierjohnson + culture, plot date 3/31/2022, hereinafter 'CJC 2022').

##### 3.2.2 Architectural

Development will consist of constructing five stories of residential units over a podium with mixed uses, residential use, and above-grade parking. Design will provide for one partial level of below-grade parking. The existing Perry's Cafe (constructed in 1966) will be retained and the new structure developed around the restaurant.

The new structure will provide 221 dwelling units, with 32 affordable units. The podium level will include a pool and a variety of other amenities. Three levels of parking will provide 269 parking spaces.

Figure 3-1 reproduces a current architectural schematic.



**Figure 3-1. Architectural Schematic**  
(source: CJC 2022)

### 3.2.3 Structural

Design is in the preliminary stages. Figure 3-2 (following page) provides an elevation view of the proposed building. As may be seen by review of this graphic, the building will rise seven levels (about 80 feet) above surrounding ground.

By review of Figure 3-1 and Figure 3-2, it can be seen that most of the development will be developed with five levels of apartments and amenities set atop two podium levels of parking. A single level of parking will be developed below ground below a portion of the building, extending to 10 feet below the surrounding ground.

Structural information was not available for this report. However, based upon experience with similar structures, NOVA expects that the building will be developed with 'Type III over Type I' construction. NOVA expects that the below-ground parking and the first level of structure above ground will be constructed in reinforced concrete. The residential levels above the podium will be wood framed.

Preliminary planning indicates that column spacing at the garage level will range to about 30 feet x 40 feet. NOVA expects that column loads (DL+LL) at the garage level may range from about 400 kips to 900 kips.

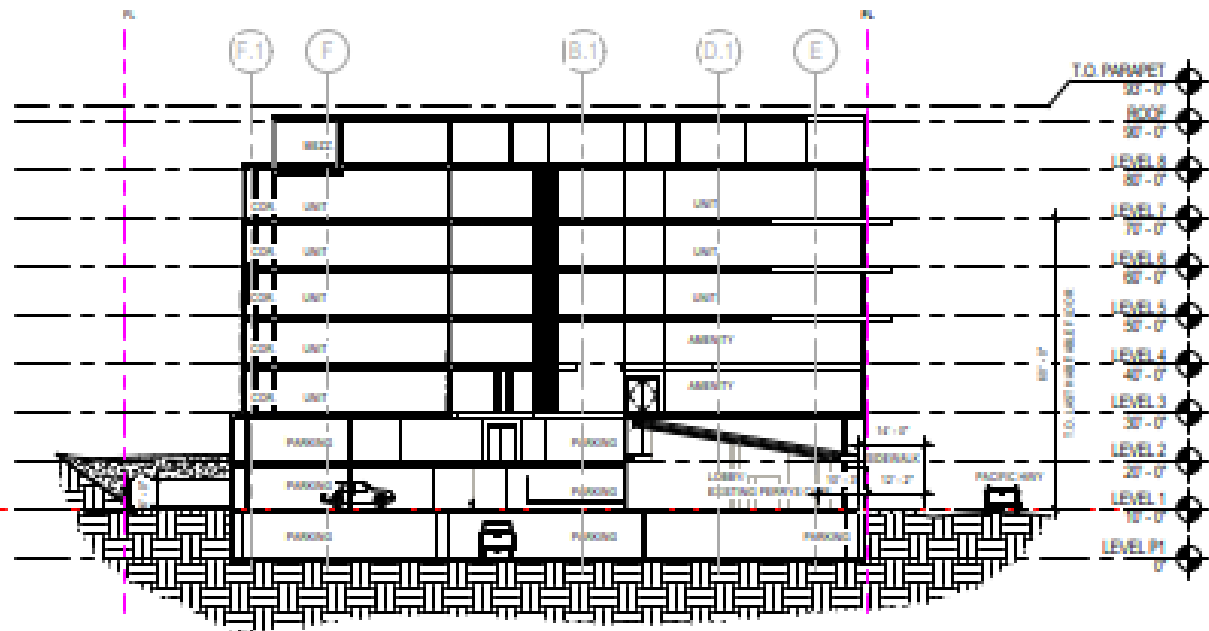

**Figure 3-2. West-East Elevation Schematic**  
(source: CJC 2022, Dwg. A-500, Detail 2)

### 3.2.4 Civil

Civil drawings are not yet available for review. However, as may be seen by review of Figures 3-1 and 3-2, it is expected that development will include minimal requirements for roadways.

Site improvements may include permanent stormwater Best Management Practices (BMPs) structures, though to NOVA's knowledge such structures have not yet been located.

### 3.2.5 Potential for Earthwork

With the exception of the partial subterranean garage, site grades will be adapted to the existing groundform, minimizing earthwork. The partial subterranean garage will extend across the west-east limits of the structure between about Column Line 11 and Column Line 19.2, enclosing about 18,500 square feet.

Anticipating soil removal of up to about 12 feet over this area, a neat (dimensional) volume of about 8,200 cy<sup>3</sup> (about 11,500 tons) would be excavated. The depth of this excavation will require temporary shoring. Temporary dewatering will also be required to allow construction in the dry.



## 4. GEOLOGY AND SUBSURFACE CONDITIONS

### 4.1. Regional Geology

The site is located within the Peninsular Ranges Geomorphic Province of California, which stretches from the Los Angeles basin to the tip of Baja California in Mexico. This province is characterized as a series of northwest-trending mountain ranges separated by subparallel fault zones and a coastal plain of subdued landforms. The mountain ranges are underlain primarily by Mesozoic metamorphic rocks that were intruded by plutonic rocks of the Southern California batholith, while the coastal plain is underlain by subsequently deposited marine and nonmarine sedimentary formations. The site is located within the coastal plain portion of the province and is underlain by a sequence of fill and/or young alluvial flood plain deposits, Quaternary bay deposits, and Quaternary old paralic deposits.

Figure 4-1 presents the regional geology in the vicinity of the site. Plate 1 following the text of this report presents the geologic cross-section across the site.

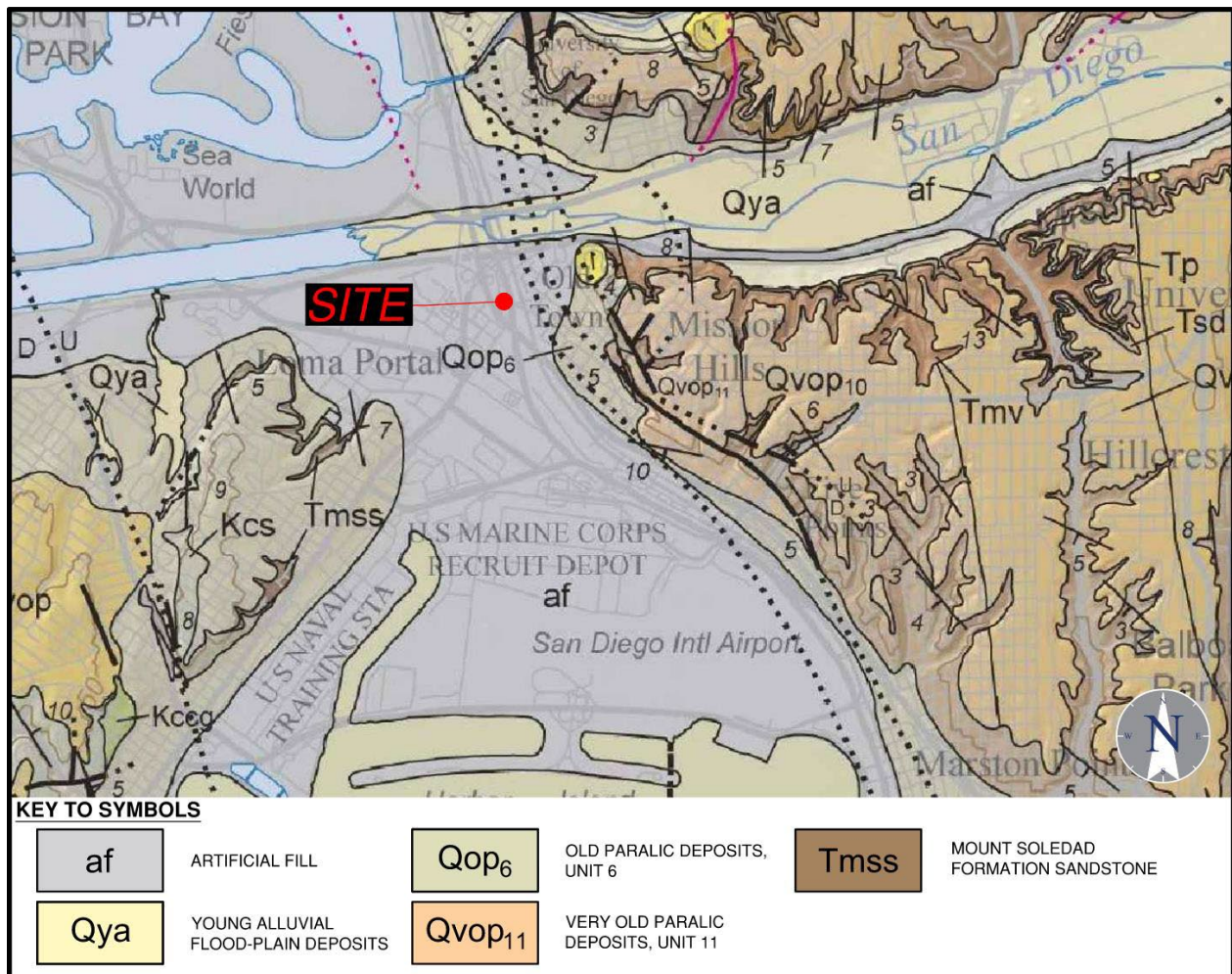

Figure 4-1. Regional Geology Map (Kennedy and Tan, 2008)

## 4.2. Site-Specific Geology

Descriptions of the materials encountered during the investigation are presented below.

**Fill/Quaternary young alluvial flood-plain deposits (af/Qya):** Fill/young alluvium was encountered in each of the borings to a depth of about 15 feet bgs. The fill/alluvium generally consisted of loose to medium dense sand with silt, silty sand, and clayey sand. The borings and CPT data indicate that the upper few feet are compacted. Figure 4-2 depicts the fill/alluvium.



Figure 4-2. Fill/Alluvial deposits in Boring B-1

**Quaternary bay sediments (Qmo):** The fill/alluvium is underlain by about 10 feet of bay sediments, soils that are common to areas of the San Diego shoreline that were developed by hydraulic filling. These soils consisted of medium dense to dense silty sand and medium stiff sandy clay/sandy silt. Figure 4-3 (following page) depicts the bay sediments.





Figure 4-3. Bay Sediments in Boring B-1

**Quaternary Old Paralic Deposits (Qop):** Late to middle Pleistocene old paralic deposits were encountered beneath the bay deposits at a depth of about 25 feet bgs to the maximum-explored depth. As encountered in Boring B-1, these deposits consisted of medium dense to dense sand with silt, silty sand, and clayey sand. Figure 4-4 depicts the old paralic deposits.

**Groundwater:** Groundwater was encountered in the borings at depths of about 9½ and 10 feet bgs, corresponding to elevations of about 0 and ½ feet msl. The need for temporary dewatering should be anticipated during construction, as the finished floor of the subsurface parking level is planned to be set at elevation 0 feet msl.



**Figure 4-4. Old Paralic deposits in Boring B-1**

---

## 5. GEOLOGIC, SOIL AND SITING HAZARDS

### 5.1. Faulting and Surface Rupture

#### 5.1.1 Regional

Major known active faults in the region generally consist of *en echelon*, northwest striking, right-lateral, strike-slip faults. These include the San Andreas, Elsinore, and San Jacinto Faults located northeast of the site, and the San Clemente, San Diego Trough, Agua Blanca-Coronado Bank Faults and Newport-Inglewood-Rose Canyon Fault Zone located to the west of the site.

Earthquake Fault Zones have been established along known active faults in California in accordance with the Alquist-Priolo Earthquake Fault Zoning Act. The State Geologist defines an “active” fault as one which has had surface rupture within recent geologic time (i.e., Holocene time, <11,700 years b.p.). Earthquake Fault Zones have been delineated to encompass traces of known Holocene-active faults to address hazards associated with fault surface rupture within California. Where developments for human occupancy are proposed within these zones, the state requires detailed fault evaluations be performed so that engineering geologists can identify the locations of active faults and recommend setbacks from locations of possible surface fault rupture.

#### 5.1.2 Faulting in the Site Vicinity

The site is not located in an Alquist-Priolo Earthquake Fault Zone. The nearest active fault is located about 1.5 miles south of the site within the Silver Strand section of the Newport-Inglewood-Rose Canyon Fault Zone (NIRC), which is recognized to have the potential for a Magnitude 6.99 seismic event. Evidence of active faulting was not observed at the site during the field investigation. The probability of fault rupture is considered very low.

Figure 5-1 (following page) shows the locations of known faults in the region of the site. Active faults are presented in orange, potentially active faults with displacement dating between 11,700 years and 700,000 years b.p. are presented in green, and undifferentiated Quaternary faults are presented in purple.

### 5.2. City of San Diego Seismic Safety Study

Figure 5-2 locates the site on the City of San Diego Seismic Safety Study map. The site is in Geologic Hazard Category 31, defined as high potential for liquefaction (City of San Diego, 2008).

NOVA performed a liquefaction analysis for this project, the results of which are discussed in the following section.



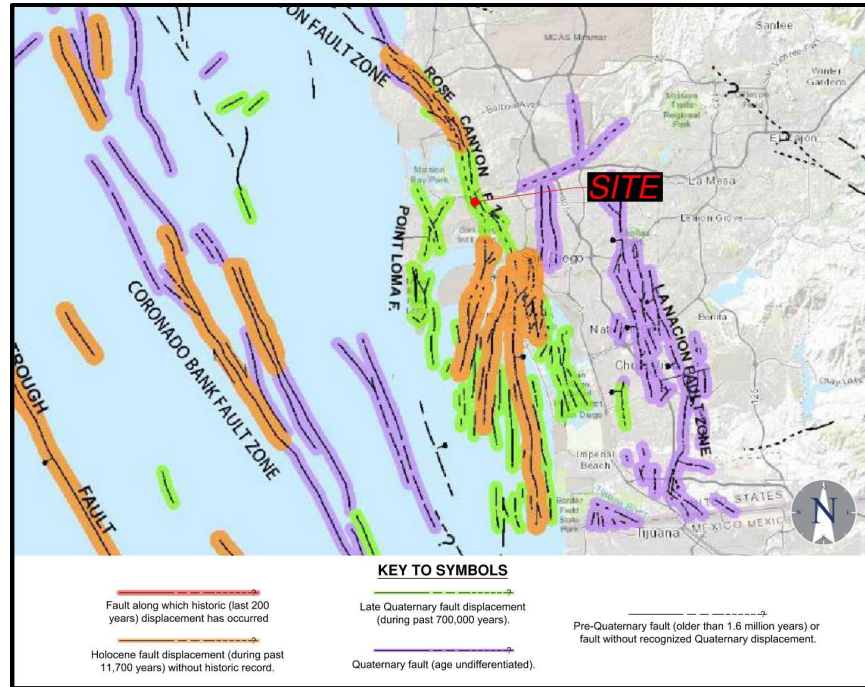

Figure 5-1. Fault Map (CGS, 2022)

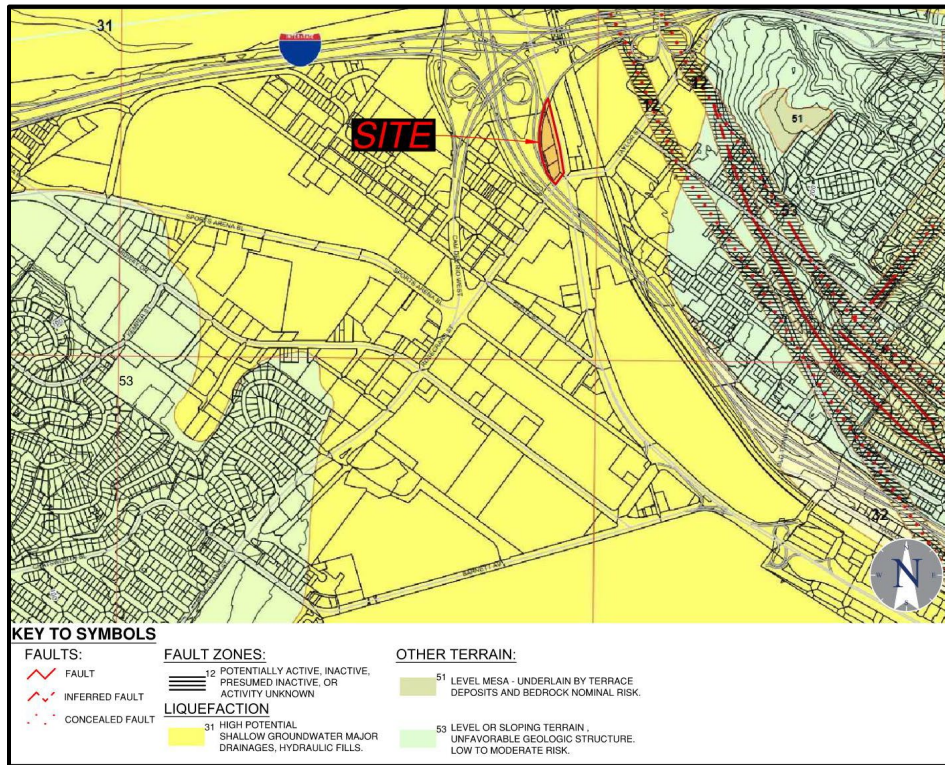

Figure 5-2. Site Location on City of San Diego Seismic Safety Study Map (source: City of San Diego, 2008)

### 5.3. Site Class

A geologic hazard likely to affect the project is ground shaking as a result of movement along an active fault zone in the vicinity of the subject site. Based on the shear wave traverse, the site may be classified as Site Class D. The site is subject to liquefaction (Site Class F); however, ground improvements will be performed, which will mitigate the liquefaction settlement, and therefore the site will be Site Class D. For a Site Class D, a site-specific ground motion hazard analysis (GMHA) is required to be performed in accordance with the requirements of 2019 CBC and ASCE 7-16.

A site-specific GMHA was performed as part of the investigation. As part of the analysis, base ground motions were evaluated in conjunction with both a Probabilistic Seismic Hazard Analysis (PSHA) and a Deterministic Seismic Hazard Analysis (DSHA) to characterize earthquake ground shaking that may occur at the site during future seismic events.

The PSHA is based on an assessment of the recurrence of earthquakes on potential seismic sources in the region and on ground motion prediction models of different seismic sources in the region. The United States Geological Survey (USGS) Unified Hazard Tool (USGS, 2022b) was used to develop seismic hazard curves for various periods and the USGS Risk-Targeted Ground Motion Calculator (USGS, 2022c) was used to analyze ground motions for each corresponding period. Maximum directional scale factors were applied to the results to develop the probabilistic ground motion response spectrum specific to this site.

The DSHA is represented by the 84<sup>th</sup> percentile of the spectral accelerations for different periods. The logarithmic means and standard deviations of various periods were calculated using the USGS Response Spectra Tool (USGS, 2022d) with the ground motion model "Combined: WUS 2018 (5.0, deep basins)." This combined model utilizes attenuation relationships of Abrahamson-et al (2014) NGA West 2, Boore-et al (2014) NGA West 2, Campbell & Bozorgnia (2014) NGA West 2, and Chiou & Youngs (2014) NGA West 2.

The deterministic ground motions are controlled by the Rose Canyon (Newport-Inglewood) Fault. Input parameters were obtained from the USGS Uniform California Earthquake Rupture Forecast, Version 3 (UCERF3) model, and USGS Earthquake Scenario Map (BSSC 2014) (USGS, 2022e), presented in Table 5-1.

The site-specific Risk-Targeted Maximum Considered Earthquake ( $MCE_R$ ) was taken as the lesser of the spectral response accelerations determined from the PSHA and DSHA for each period. The site-specific design response spectral accelerations were compared to the design response spectrum from ASCE 7-16, Section 11.4.6 (SEAOC, 2022) to verify that the values obtained from the site-specific analysis are not less than 80 percent of the accelerations obtained from Section 11.4.6. The site coefficients and maximum considered earthquake spectral response acceleration parameters are presented in Table 5-2.

Tabulated values and graphical plots are attached in Appendix D.

**Table 5-1. DSHA Input Parameters**

Fault: Rose Canyon	
Mw	6.99
Type	Strike-Slip
Dip (°)	90.0
Rake (°)	180
Width (km)	6.93
R <sub>x</sub> (km)	0.64
R <sub>RUP</sub> (km)	0.64
R <sub>JB</sub> (km)	0.64
V <sub>s30</sub> (m/s)	213*
Z <sub>1.0</sub> (km)	N/A
Z <sub>2.5</sub> (km)	N/A

\*Based on S-Wave Measurements Obtained from Seismic Traverse

**Table 5-2. 2019 California Building Code/ASCE 7-16 Site-Specific Parameters**

Site Coordinates	
Latitude: 32.75611	Longitude: -117.20161
Site Coefficients and Spectral Response Acceleration Parameters	Value
Site Class	D
Site Amplification Factor at 0.2 Second, F <sub>a</sub>	1.000
Site Amplification Factor at 1.0 Second, F <sub>v</sub>	2.500
Spectral Response Acceleration at Short Period, S <sub>s</sub>	1.519g
Spectral Response Acceleration at 1-Second Period, S <sub>1</sub>	0.530g
Spectral Response Acceleration at Short Period, Adjusted for Site Class, S <sub>MS</sub>	1.519g
Spectral Response Acceleration at 1-Second Period, Adjusted for Site Class, S <sub>M1</sub>	1.326g
Design Spectral Acceleration at Short Period, S <sub>DS</sub>	1.013g
Design Spectral Acceleration at 1-Second Period, S <sub>D1</sub>	0.884g
Peak Ground Acceleration, PGA <sub>M</sub>	0.693g

## 5.4. Liquefaction

'Liquefaction' refers to the loss of soil strength during a seismic event. The phenomenon is observed in areas that include geologically 'younger' soils (i.e., soils of Holocene age), shallow water table (less than about 60 feet depth), and cohesionless (i.e., sandy and silty) soils of looser consistency. The seismic ground motions increase soil water pressures, decreasing grain-to-grain contact among the soil particles, which causes the soils to lose strength.

Resistance of a soil mass to liquefaction increases with increasing density, plasticity (associated with clay-sized particles), geologic age, cementation, and stress history.

The CPT data was used in analyses of liquefaction potential using a peak ground acceleration (PGA) of 0.693g, an earthquake magnitude of 7.0, and groundwater depth of 9.7 feet bgs. The analyses indicate that liquefaction of the subsurface will occur in the event of a major earthquake. Appendix F presents the liquefaction analyses. Figure 5-3 depicts the evaluation of liquefaction potential at CPT-1, from which settlement on the order of 3 inches is expected at this location in the design-basis seismic event. Post-liquefaction ground settlement indicated by the three separate soundings range from 2 inches to 3 inches.

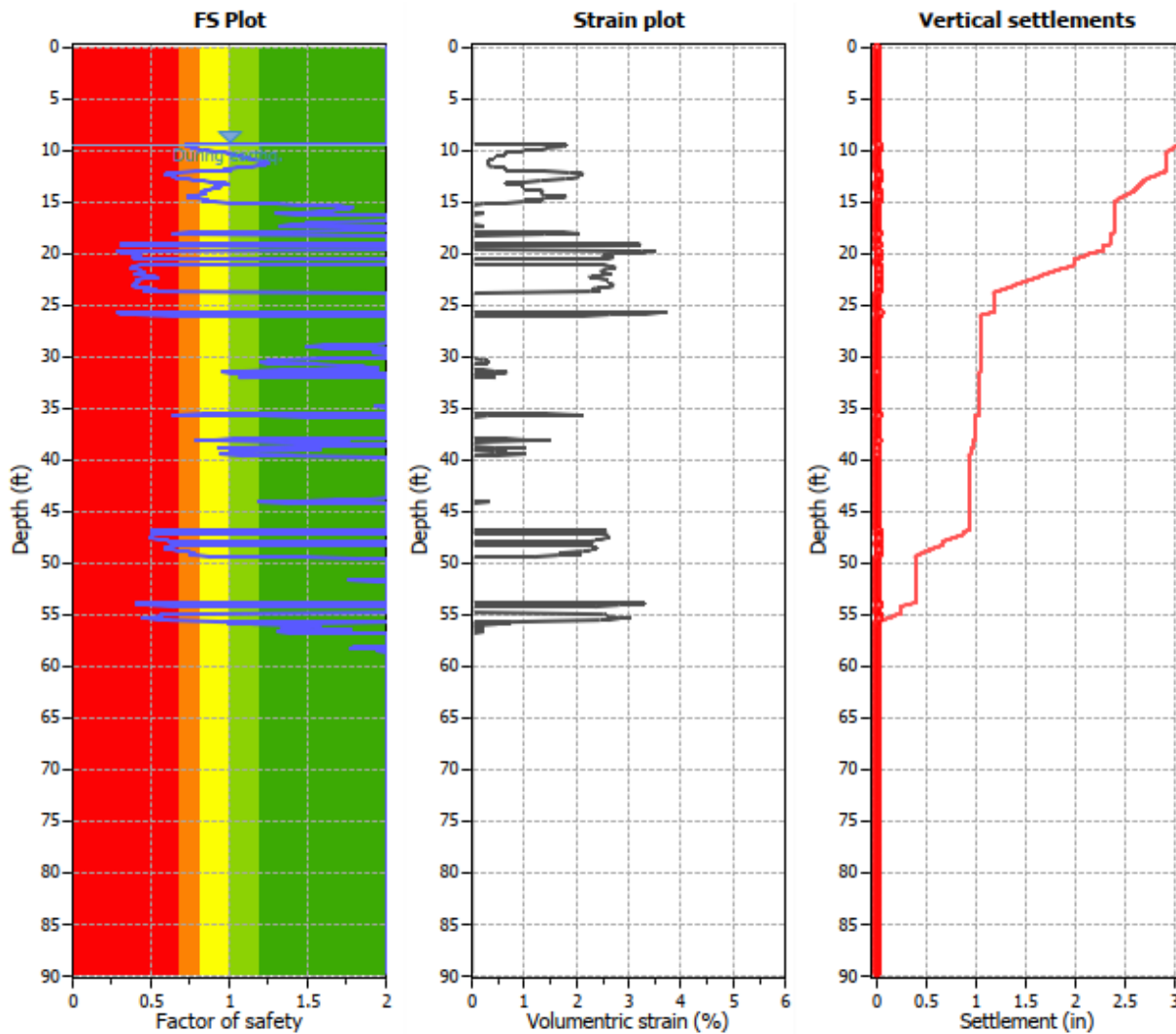
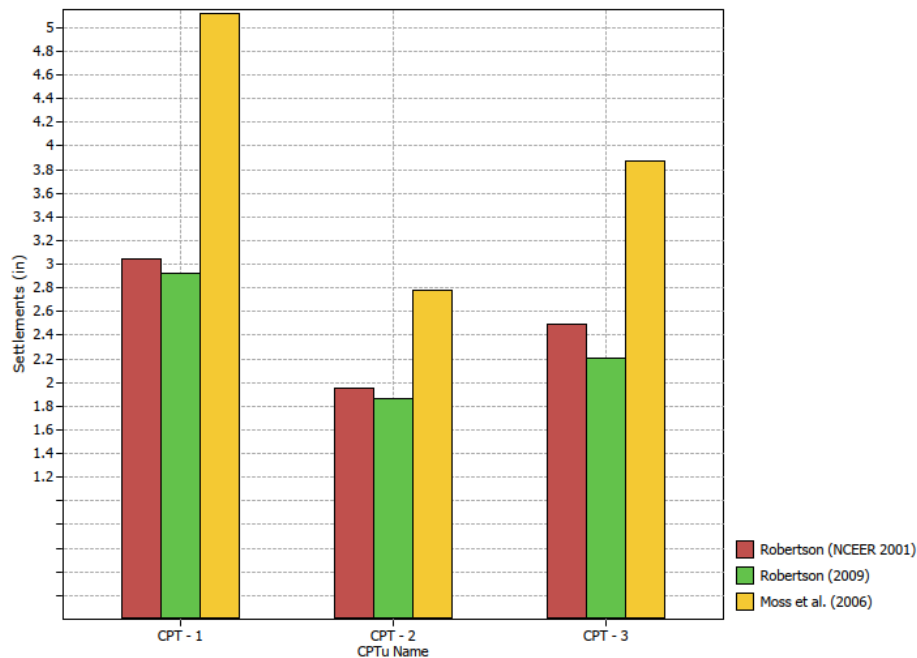

Figure 5-3. Estimate of Post-Liquefaction Settlement, CPT-1

As shown in the liquefaction-related settlement depicted on Figure 5-3, about  $\frac{2}{3}$  of the settlement occurs over the interval from the groundwater level (about 10 feet depth) to about 25 feet bgs. The remainder of the settlement occurs below this level, extending to about 55 feet bgs.



Estimating liquefaction-related ground settlement is complex and inexact. To address this uncertainty, data obtained from the CPT soundings considered estimates of liquefaction-related settlement using varying procedures. Figure 5-4 provides a graphic summarizing the results of these analyses, considering liquefaction as it could occur in subsurface conditions represented by each CPT sounding. As may be seen by review of this graphic, it is estimated that settlements in the range 2 inches to 5 inches could occur across the site. NOVA recommends an expected ground settlement of about 2 to 4 inches.

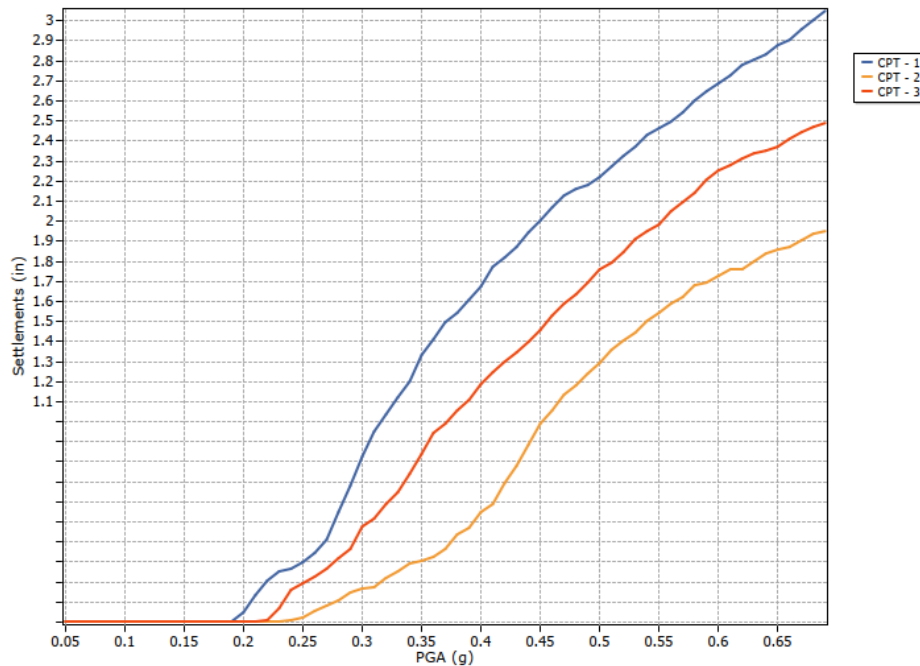

**Figure 5-4. Estimates of Liquefaction-Related Settlement,  $PGA_M = 0.69 g$**

The estimates provided in Figure 5-4 assume a ground surface acceleration ( $a$ ) of  $a = 0.69g$ . The potential for liquefaction-related settlement to occur at lower levels of ground surface acceleration was also considered. Figure 5-5 provides a summary of this evaluation, from which it can be seen that liquefaction-related settlement on the order of 1 inch will occur at  $PGA \sim 0.4g$

It is the judgment of NOVA that there is a potential for liquefaction to occur within the loose to medium dense alluvial sand and bay sediments underlying the site as a consequence of the design seismic event. Post-liquefaction settlements are estimated to be in range from about 2 inches to 5 inches. Because of the shallow-seated nature of the liquefaction, differential settlement at the ground surface may be high, on the order of 2 inches over a distance of 30 feet.

Despite the liquefaction seismic hazard there is no risk of related phenomena, to include Lateral spreading and seismic compression. Section 7 provides recommendations for ground improvement to mitigate this hazard.



**Figure 5-5. Estimates of Post Liquefaction-Related Settlement for Varying Ground Accelerations**

### 5.5. Landslides and Slope Stability

The potential for landslides or slope instabilities to occur at the site is considered negligible given the flat topography and flat-lying geological structure below the site.

### 5.6. Flooding, Tsunamis, and Seiches

The site is mapped within Zone X (FEMA, 2012), which are areas of minimal flood hazard. As such, the probability for a flood to affect the site is considered low.

The site is not located within a mapped area on the State of California Tsunami Inundation Maps (Cal EMA, 2009); therefore, damage due to tsunamis is considered negligible. Seiches are periodic oscillations in large bodies of water such as lakes, harbors, bays, or reservoirs.

The site is not located adjacent to any lakes or confined bodies of water; therefore, the potential for a seiche to affect the site is considered negligible.

### 5.7. Subsidence

The site is not located in an area of known subsidence associated with fluid withdrawal (groundwater or petroleum); therefore, the potential for subsidence due to the extraction of fluids is considered negligible.



## **5.8. Hydro-Consolidation**

Hydro-consolidation can occur in recently deposited sediments (less than 10,000 years old) that were deposited in a semi-arid environment. Examples of such sediments are eolian sands, alluvial fan deposits, and mudflow sediments deposited during flash floods. The pore spaces between the particle grains can re-adjust when inundated by groundwater, causing the material to consolidate. The fill/young alluvium unit is considered subject to hydro-consolidation unless it is improved per the ground improvement recommendations within Section 7 of this report.

## 6. CONCLUSIONS

Based on the results of this investigation, NOVA considers the proposed construction feasible from a geotechnical standpoint provided the recommendations contained in this report are followed. Geotechnical conditions exist that should be addressed prior to construction. Geotechnical design and construction considerations include those listed below.

- There are no known active or potentially active faults underlying the site. The primary seismic hazard at the site is the potential for moderate to severe ground shaking in response to large-magnitude earthquakes generated during the lifetime of the proposed construction. The risk of strong ground motion is common to all construction in southern California and is typically mitigated through building design in accordance with the CBC.
- The site is underlain by fill/young alluvial flood-plain deposits and saturated bay deposits to a depth of about 25 feet bgs. Old paralic deposits were encountered at 25 feet bgs to the maximum depth explored. The upper two units are potentially liquefiable should a significant seismic event occur. Liquefaction-related settlements on the order of 2 to 5 inches are estimated. Mitigation of potentially liquefiable soils typically consists of ground improvement or deep foundations. Ground improvement by means of aggregate piers or deep soil mixing may be used to mitigate this hazard. Section 7 addresses these considerations.
- The unsaturated soils above groundwater are potentially compressible. Ground improvement is recommended to improve subgrade support and reduce the potential for settlement. Section 7 addresses these considerations.
- The on-site soils are anticipated to have a very low to low expansion potential. These soils are suitable for reuse as compacted fill. Clays, if encountered, are not suitable for direct support of buildings or heave-sensitive improvements.
- Excavations should be achievable using standard heavy earthmoving equipment in good working order with experienced operators. Excavation bracing may be required.
- Following ground improvement to limit of both static and liquefaction-related settlements to acceptable levels, the proposed building can be supported on shallow foundations. Foundation recommendations are provided in Section 7.
- Groundwater was encountered at a depth of 9.7 feet bgs, corresponding to elevations of about +0.3 feet msl, and dewatering operations should be anticipated during construction.
- The infiltration feasibility condition category is “No Infiltration” within the fill/young alluvial flood-plain deposits due to increased risk of geotechnical hazards. Infiltration is discussed further in Section 8 of this report.



## 7. RECOMMENDATIONS

The remainder of this report presents recommendations regarding earthwork construction as well as preliminary geotechnical recommendations for the design of the proposed improvements. If these recommendations appear not to address a specific feature of the project, please contact NOVA for additions or revisions to the recommendations. The recommendations presented herein may need to be updated once final plans are developed.

### 7.1. Earthwork

#### 7.1.1 General

Grading and earthwork should be conducted in accordance with the CBC and the recommendations of this report. The following recommendations are provided regarding specific aspects of the proposed earthwork construction. These recommendations should be considered subject to revision based on field conditions observed by our offices during grading.

#### 7.1.2 Site Preparation

Site preparation should begin with the removal of existing improvements, vegetation, and debris. Subsurface improvements that are to be abandoned should be removed, and the resulting excavations should be backfilled and compacted in accordance with the criteria of this report. Pipeline abandonment can consist of capping or rerouting at the project perimeter and removal within the project perimeter. If appropriate, abandoned pipelines can be filled with grout or slurry as recommended and observed by the geotechnical consultant.

#### 7.1.3 Compacted Fill

Engineered fill/backfill should be a mineral soil free of organics, regulated chemicals, or otherwise toxic constituents, with the materials characteristics listed below:

- at least 40% by weight finer than ¼-inch;
- classified as GW, GM, GC, SW, SM, or SC after ASTM D2487;
- maximum particle size of 6 inches; and,
- expansion index (EI) of less than 20 (i.e.,  $EI < 20$ , after ASTM D4829).

Much of the existing fill and alluvium will conform to the above criteria.

Compacted fill beneath structures should be moisture conditioned to just above its optimum moisture content, placed in 6- to 8-inch-thick loose lifts, then densified to at least 95% relative compaction after ASTM D1557 (the 'modified Proctor'). Outside the structures, utility trench backfill and subgrade soils beneath pedestrian hardscape should be compacted to at least 90% relative compaction. The top 12 inches of subgrade soils beneath vehicular pavements should be compacted to at least 95% relative compaction.

#### *7.1.4 Imported Soil*

Any imported soil should conform to the criteria for engineered fill cited above. The source(s) of imported soil should be observed and, if appropriate, tested by NOVA prior to transport to the site to evaluate suitability for the intended use.

#### *7.1.5 Subgrade Stabilization*

Excavation bottoms should be firm and unyielding prior to placing fill. In areas of saturated or yielding subgrade, a reinforcing geogrid such as Tensar® Triax® TX-5 or equivalent can be placed on the excavation bottom, and then at least 12 inches of aggregate base placed and compacted. Once the surface of the aggregate base is firm enough to achieve compaction, then the remaining excavation should be filled to finished pad grade with suitable material.

#### *7.1.6 Excavation Characteristics*

It is anticipated that excavations can be achieved with conventional earthwork equipment in good working order.

#### *7.1.7 Oversized Material*

Excavations may generate oversized material. Oversized material is defined as rocks or cemented clasts greater than 6 inches in largest dimension. Oversized material should be broken down to no greater than 6 inches in largest dimension for use in fill, used as landscape material, or disposed of off-site.

#### *7.1.8 Grading Plan Review*

NOVA should review the grading plans and earthwork specifications to ascertain whether the intent of the recommendations contained in this report have been implemented and that no revised recommendations are needed due to changes in the development scheme.

## **7.2. Ground Improvement**

### *7.2.1 Potentially Applicable Ground Improvement Technologies*

Ground improvement to mitigate liquefaction risk and diminish compressibility of a soil mass is widely applied. In particular, the liquefaction hazard at hundreds of sites within the continental United States has been addressed by ground improvement.

A variety of ground improvement technologies can be applied to conditions comparable to those found at this site. Figure 7-1 depicts the variety of alternatives available for ground improvement, comparing the adaptability of these alternatives to dominantly sandy soils that underlie this site.

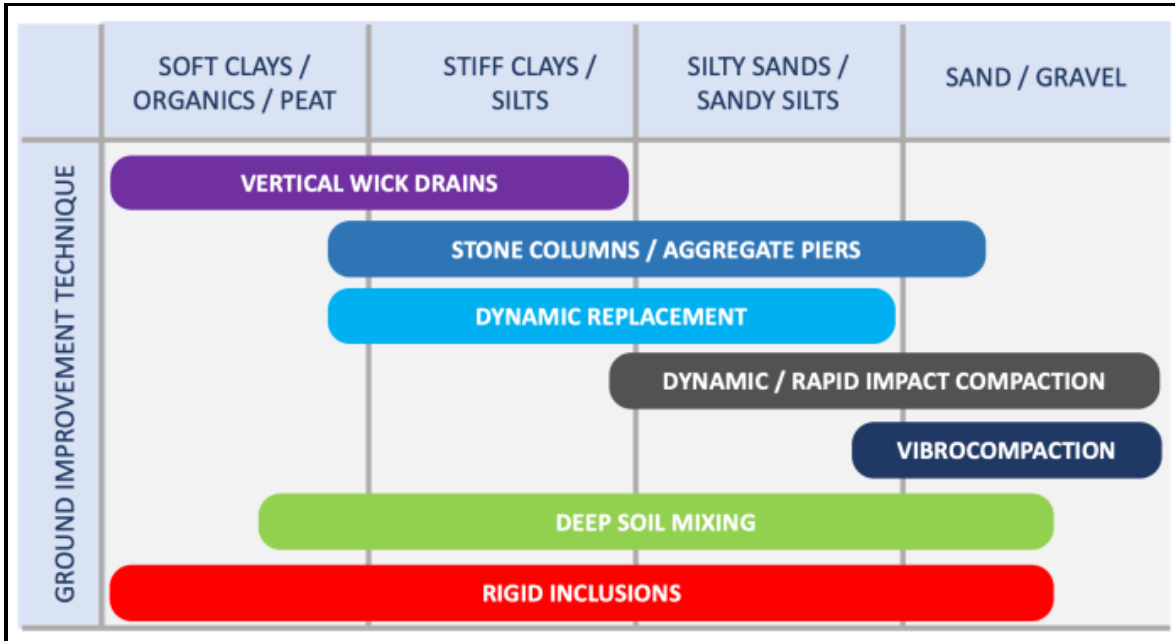

**Figure 7-1. Ground Improvement Techniques for Soils of Varying Gradation**  
(source: Civil + Structural Engineer, March 2021)

This evaluation considered both deep soil mixing ('DSM') and aggregate piers ('Vibro Piers') as alternatives for ground improvement. Both technologies are widely applied in this area of California.

1. Deep Soil Mixing. DSM is a ground improvement technology that employs *in-situ* mixing of soil with cementitious material (most commonly, cement) to harden and stiffen the ground. the technology is vended by a variety of specialty contractors, each with their own specialty equipment and means of soil mixing.

As applied in this instance, DSM would involve construction of an in-ground grid of soil cement shear walls. The grid constrains the enclosed soil against developing shear strains and related excess pore water pressures that can effect liquefaction. Figure 7-2 (following page) depicts the DSM grid enclosing a soil at risk for liquefaction.

The grid pattern for DSM is usually expressed in the form of an 'area replacement ratio' ( $A_r$ ). Initial evaluations for this site anticipate  $A_r$  in the range  $A_r = 30\% - 40\%$ . As applied in this instance, mixing would extend over a depth interval of about 20 feet, from about EI +5 feet msl to EI-15 feet msl. The DSM grid might be on the order of 15 feet x 15 feet in plan dimension across the limits of the planned building. Ground improved by DSM will support shallow foundations with net allowable bearing ( $q_a$ ) on the order of  $q_a \sim 6,000$  psf.

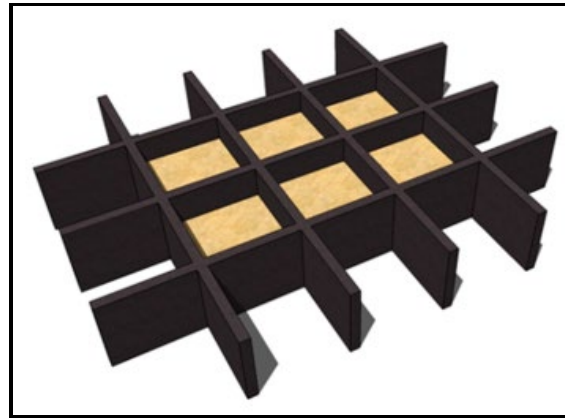

**Figure 7-2. Idealized DSM Grid Pattern**  
(source: Nguyen, *et al.*, 2013)

2. Aggregate Piers ('Vibro Piers'). The vibro-compaction technique utilizes a heavy, high-energy vibrator to penetrate the soil to the design depth. At sites such as this, with a relatively high groundwater level, penetration of the vibrator will be supported by displacement of the soil water jetting out the tip. Once the vibratory compactor reaches the design depth, crushed stone is added at the ground surface to the annular space around the vibrator. The stone falls through the space to the vibrator tip and fills the void created as the vibrator is lifted several feet. The vibrator is lowered, densifying and displacing the underlying stone. The vibro replacement process is repeated in lifts until a dense stone column is constructed to the ground surface.

The technology is reliant upon the ability of the soil mass to respond to the vibratory energy. Though several variables affect this response, the principal variable in this regard is the 'fines content' of the soil mass; that is the portion of the soil mass that is silt and clay-sized, as described by the fraction finer than the U.S. No. 200 sieve, 0.075 mm. Figure 7-3 depicts this relationship. The gradation of the soils at this site largely conforms to the gradation limits of the white-shaded area of Figure 7-3, suggesting that the technology would be successful at this site.

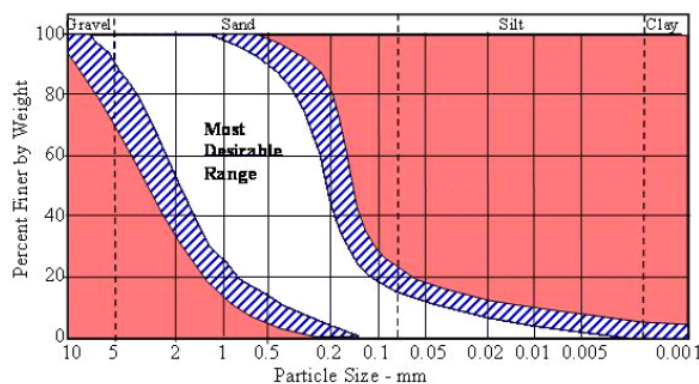

**Figure 7-3. Gradation of Soils Most Adaptable to Vibratory Compaction**



A field of aggregate piers can support shallow foundations with net allowable bearing on the order of  $q_a \sim 6,000$  psf. As employed in this instance, it is expected that a field of 36-inch diameter vibro piers placed on an 8' grid ( $A_r \sim 10\%$ ) would extend from the base of foundations to about El -20 feet msl.

### 7.2.2 Preferred Ground Improvement Technology

The aggregate pier ('vibro pier') alternative will likely offer a marginal cost savings over the DSM alternative for what will largely be similar foundation performance. However, several aspects of design and construction that will be particular to this site diminish this apparent advantage. These considerations are discussed below.

1. Site Limitations to Aggregate Piers. As is discussed in Section 3 (and evident by review of Figure 3-2), the east side of the building extends to the property line. It is normal that aggregate piers extend at least half their penetration depth beyond the limits of the structure for which ground treatment is undertaken. This requirement would complicate the use of aggregate piers, likely adding cost.
2. Savings On Dewatering. DSM creates a low permeability soil mass. As such, the technology can be used in the partial below-grade garage to limit (and practically eliminate) the need for dewatering. This action alone could lead to a consequential cost savings depending upon the efficiency with which the garage excavation and construction is completed and the efficiency of the dewatering system. Elimination of the risk of dewatering removes a considerable site development risk. Dewatering is among the most claims-prone elements of civil construction.
3. Savings on Excavation Bracing. If aggregate piers are employed, the excavation for the partial underground garage will be required to be shored with a 'soldier beam and lagging' system. If DSM is employed, the soil treatment can be adapted to eliminate the need for shoring, creating a stabilized wall that will allow an unbraced excavation.

In consideration of the foregoing, it is the judgment of NOVA that DSM is preferred over aggregate piers its expected superior performance.

Final design for implementation of either DSM or aggregate pier construction would be completed by a specialty contractor, providing ground improvement on a 'design-build' basis. NOVA will coordinate with you in identifying prospective contractors, obtaining rough-order-of-magnitude contractor's estimates, developing outline specifications for implementation, and developing bid requests. These activities should proceed as structural and civil-related designs become more developed.

## 7.3. Temporary Excavations

### 7.3.1 Responsibility

The recommendations provided in this section are intended to provide guidance for development of both unretained ('unbraced') and retained ('braced') excavations.

It is the sole responsibility of the contractor to provide an excavation that is safe, with deflections that do not damage nearby structures or utilities. If braced excavations are developed, this design of temporary shoring should be performed by a qualified shoring engineer. When excavations are active, the contractor should provide a properly trained and empowered Competent Person for temporary excavation safety.

### 7.3.2 *Unbraced Excavations*

Temporary excavations 3 feet deep or less can be made vertically. Deeper temporary excavations in fill should be laid back no steeper than 1:1 (horizontal:vertical). The faces of temporary slopes should be inspected daily by the contractor's Competent Person before personnel are allowed to enter the excavation. Corrective action should be implemented to address any zones of potential instability, sloughing, or raveling should be brought to the attention of the engineer and before personnel begin working in the excavation.

Excavated soils should not be stockpiled behind temporary excavations within a distance equal to the depth of the excavation. NOVA should be notified if other surcharge loads are anticipated so that lateral load criteria can be developed for the specific situation. If temporary slopes are to be maintained during the rainy season, berms are recommended along the tops of slopes to prevent runoff water from entering the excavation and eroding the slope faces.

Slopes steeper than those described above will require shoring. Additionally, temporary excavations that extend below a plane inclined at 1½:1 (h:v) downward from the outside bottom edge of existing structures or improvements will require shoring. Soldier piles and lagging, internally braced shoring, or trench boxes could be used. If trench boxes are used, the soil immediately adjacent to the trench box is not directly supported. Ground surface deformations immediately adjacent to the pit or trench could be greater where trench boxes are used compared to other methods of shoring.

### 7.3.3 *Braced Excavations*

For design of cantilevered shoring with level backfill, an active earth pressure equal to a fluid weighing 35 pounds per cubic foot (pcf) can be used. For design of tied-back shoring with level backfill, a rectangular earth pressure distribution with a maximum pressure of 23H pounds per square foot (psf), where H is the height of shoring in feet, can be used. Alternatively, a trapezoidal pressure distribution with a maximum pressure of 28H psf at 0.1H down from the top of shoring and 0.2H up from the base of shoring can be used. The surcharge loads from traffic and construction equipment adjacent to the shored excavation can be modeled by assuming an additional 2 feet of soil behind the shoring. An additional 20 pcf should be added for 2:1 (h:v) sloping ground.

For design of soldier piles, an allowable passive pressure of 350 pounds per square foot (psf) per foot of embedment above groundwater or 250 psf below groundwater can be used over two times the pile diameter up to a maximum of 2,000 psf. Soldier piles should be spaced at least three pile diameters, center to center. Continuous lagging will be required throughout. The soldier piles should be designed for the full anticipated lateral pressure; however, the pressure on the lagging

will be less due to arching in the soils. For design of lagging, the earth pressure can be limited to a maximum of 400 psf.

#### **7.4. Construction Dewatering**

Groundwater was encountered at an elevation of approximately +0.3 feet msl. If DSM is not undertaken, excavations below groundwater will require dewatering during the construction period. An experienced dewatering subcontractor should evaluate, design, and implement the dewatering system.

NOVA anticipates that a system of shallow wells and well points will be adequate to lower and maintain the groundwater level below the excavation to provide a stable excavation during construction. Dewatering rates, water volumes, drawdown time, radius of influence, and equipment requirements should be considered in the design. Pumping tests to evaluate the hydraulic parameters for the dewatering system design may be required. An NPDES permit from the Regional Water Quality Control Board will have to be obtained by the Contractor for discharge of the dewatering effluent.

Groundwater should be drawn down at least 5 feet below the bottom of the deepest planned excavation to reduce the possibility of wet, unstable soils. Groundwater must remain at this depressed level during construction until structure loads and uplift resistance are sufficient to counteract buoyant forces with groundwater at historic levels.

The Contractor should provide monitoring during construction (e.g., monitoring wells) to ensure that the design depressed groundwater level is maintained during construction. Nuisance groundwater that enters the excavation can typically be removed by a gravel sump pump collection system. The dewatering system should be integrated with the shoring system.

Dewatering will affect the water level outside the excavation. Lowering the water table will result in effective stress increases of the soil supporting nearby structures or improvements, which could result in ground settlement and distress to those structures or improvements. Adjacent structures and improvements should be surveyed by the contractor prior to dewatering and monitored during construction.

#### **7.5. Permanent Slopes and Surface Drainage**

##### *7.5.1 Permanent Slopes*

Permanent slopes should be constructed no steeper than 2:1 (h:v). Faces of fill slopes should be compacted either by rolling with a sheepsfoot roller or other suitable equipment, or by overfilling and cutting back to design grade. Fills should be benched into sloping ground inclined steeper than 5:1 (h:v). In our opinion, slopes constructed no steeper than 2:1 (h:v) will possess an adequate factor of safety. An engineering geologist should observe cut slopes during grading to ascertain that no unforeseen adverse geologic conditions are encountered that require revised recommendations.

Slopes are susceptible to surficial slope failure and erosion. Water should not be allowed to flow over the top of slope. Additionally, any slopes should be planted with vegetation that will reduce the potential for erosion.

### 7.5.2 *Surface Drainage*

Final surface grades around structures should be designed to collect and direct surface water away from structures, including retaining walls, and toward appropriate drainage facilities. The ground around the structure should be graded so that surface water flows rapidly away from the structure without ponding. In general, we recommend that the ground adjacent to the structure slope away at a gradient of at least 2%. Densely vegetated areas where runoff can be impaired should have a minimum gradient of at least 5% within the first 5 feet from the structure. Roof gutters with downspouts should discharge directly into a closed drainage system.

Drainage patterns established at the time of fine grading should be maintained throughout the life of the proposed structures. Site irrigation should be limited to the minimum necessary to sustain landscape growth. Should excessive irrigation, impaired drainage, or unusually high rainfall occur, saturated zones of perched groundwater can develop.

## 7.6. **Shallow Foundations**

### 7.6.1 *General*

If ground improvement by either DSM or vibro piers is undertaken, the building may be supported on shallow foundations in conformance with the geotechnical criteria provided in this section. Note that these recommendations are only minimum criteria based on geotechnical factors and should not be considered a structural design, or to preclude more restrictive criteria of governing agencies or by the structural engineer. The design of the foundation system should be performed by the structural engineer, incorporating the geotechnical parameters described herein and the requirements of applicable building codes.

### 7.6.2 *Spread Footings*

Following ground improvement, the proposed building can be supported on shallow spread footings with bottom levels bearing on the improved ground. Footings that are a minimum width of 12 inches set at least 24 inches below lowest adjacent finished grade may be designed for a net allowable bearing capacity of 6,000 psf can be used. This bearing value can be increased by  $\frac{1}{3}$  when considering the total of all loads, including wind or seismic forces.

Lateral loads will be resisted by friction between the bottoms of footings and passive pressure on the faces of footings and other structural elements below grade. An allowable coefficient of friction of 0.35 can be used. An allowable passive pressure of 350 psf per foot of depth below the ground surface can be used for level ground conditions. The passive pressure can be increased by  $\frac{1}{3}$  when considering the total of all loads, including wind or seismic forces. The upper 1 foot of soil should not be relied on for passive support unless the ground is covered with pavements or slabs.

### 7.6.3 Interior Slabs-On-Grade

The ground level of the building may be supported on conventionally reinforced on-grade concrete slabs founded atop at least 2 feet of fill compacted to at least 90% relative compaction after ASTM D1557. Conventional concrete slab-on-grade floors should be at least 5 inches thick and reinforced with at least No. 4 bars at 18 inches on center each way. Actual slab thickness and reinforcement should be designed by the structural engineer using a modulus of subgrade reaction ( $k$ ) of  $k = 100 \text{ lb/in}^3$ .

To reduce the potential for excessive cracking, concrete slabs-on-grade should be provided with construction or 'weakened plane' joints at frequent intervals

Moisture protection should be installed beneath slabs where moisture-sensitive floor coverings will be used. The project architect should review the tolerable moisture transmission rate of the proposed floor covering and specify an appropriate moisture protection system. Typically, a plastic vapor barrier is used. Minimum 15-mil plastic is recommended. The plastic should comply with ASTM E1745. The vapor barrier installation should comply with ASTM E1643. The slab can be placed directly on the vapor barrier.

### 7.6.4 Foundation Settlement

Supported on ground improved by either DSM or aggregate piers, foundations will settle on the order of 1 inch or less. This movement will be elastic- occurring approximately as load is applied- such that about 70% of the settlement will be complete during the construction period. Angular distortion due to differential settlement of adjacent, unevenly loaded footings will be less than 1 inch in 40 feet (i.e.,  $\Delta/L$  less than 1:480).

The above estimate is for the static case only. About 1 inch of settlement will occur following a liquefaction event related to the design basis earthquake. Differential movement of this deeper-seated settlement will effect only small (i.e.,  $\Delta/L$  less than 1:480) differential movement at the ground surface.

### 7.6.5 Foundation Plan Review

NOVA should review the foundation plans to ascertain that the intent of the recommendations in this report has been implemented and that revised recommendations are not necessary as a result of changes after this report was completed.

### 7.6.6 Foundation Excavation Observations

A representative from NOVA should observe the foundation excavations prior to forming or placing reinforcing steel.

## 7.7. Hardscape

### 7.7.1 Subgrade Preparation

The on-site soils beneath hardscape should be excavated to a depth of at least 2 feet below planned hardscape surface. Horizontally, excavations should extend at least 2 feet outside the



planned hardscape or up to existing improvements, whichever is less. NOVA should observe the conditions exposed at the bottom of excavations to evaluate whether additional excavation is recommended. The resulting surface should then be scarified to a depth of 6 to 8 inches, moisture conditioned to near optimum moisture content, and compacted to at least 90% relative compaction. The excavation should be backfilled with soil having an expansion index of 20 or less and compacted to at least 90% relative compaction after ASTM D1557.

### *7.7.2 Hardscape Section*

Exterior concrete slabs should be at least 4 inches thick and reinforced with at least No. 3 bars at 18 inches on center each way. Slabs should be provided with weakened plane joints. Joints should be placed in accordance with the American Concrete Institute (ACI) guidelines. The project architect should select the final joint patterns. A 1-inch maximum size aggregate mix is recommended for concrete for exterior slabs. The corrosion potential of on-site soils with respect to reinforced concrete will need to be taken into account in concrete mix design. Coarse and fine aggregate in concrete should conform to the “Greenbook” Standard Specifications for Public Works Construction.

## **7.8. Conventional Retaining Walls**

### *7.8.1 Foundation Preparation*

Conventional retaining walls founded on ground improved as described in Section 7.2 can be supported on shallow spread footings designed as described in Section 7.6.

The ground beneath site walls and retaining walls not connected to buildings, the existing soils should be excavated to a depth of at least 2 feet below bottom of footing. Horizontally, these excavation should extend at least 2 feet outside the planned wall footing, or up to existing improvements, whichever is less. If competent formational materials are exposed, excavation need not be performed. NOVA should observe the conditions exposed in the bottom of excavations to evaluate whether additional excavation is recommended. Any required fill or backfill should have an EI of 20 or less.

### *7.8.2 Wall Pressures*

The active earth pressure for the design of unrestrained retaining walls with level backfill can be taken as equivalent to the pressure of a fluid weighing 35 pcf. The at-rest earth pressure for the design of restrained retaining wall with level backfill can be taken as equivalent to the pressure of a fluid weighing 55 pcf. These values assume a granular and drained backfill condition. Higher lateral earth pressures would apply if walls retain clay soils. An additional 20 pcf should be added to these values for walls with 2:1 (h:v) sloping backfill. An increase in earth pressure equivalent to an additional 2 feet of retained soil can be used to account for surcharge loads from light traffic. The above values do not include a factor of safety. Appropriate factors of safety should be incorporated into the design. If any other surcharge loads are anticipated, NOVA should be contacted for the necessary increase in soil pressure.

If a wall extends below groundwater and cannot be drained, the wall should be designed to resist the incremental hydrostatic pressure. Consideration should also be given to positive side (i.e., the wet face) waterproofing to limit moisture accumulation inside the elevator pit, anticipating water level rise to perhaps El +6 feet msl.

### 7.8.3 Seismic Increment

Walls taller than 6 feet should include a seismic increment. The seismic load increment ( $\Delta P_E$ ) can be computed for the different conditions of wall yield that are described below.

- Basement wall (i.e., fixed), level backfill:  $\Delta P_E = \frac{1}{2} \gamma H^2$  (0.68) (PGA) (PGA = 0.69g)
- Cantilever wall, level backfill:  $\Delta P_E = \frac{1}{2} \gamma H^2$  (0.42) (PGA) (PGA = 0.69g)
- Cantilever wall with sloping backfill:  $\Delta P_E = \frac{1}{2} \gamma H^2$  (0.70) (PGA) (PGA = 0.69g)

In each of the above cases the resultant acts at 0.33H above the base of the wall.

### 7.8.4 Drainage

The recommendation for lateral wall loads assumes walls are provided with a backdrain to reduce the accumulation of hydrostatic pressures. Backdrains can consist of a 2-foot-wide zone of  $\frac{3}{4}$ -inch crushed rock. The crushed rock should be separated from the adjacent soils using a non-woven filter fabric, such as Mirafi 140N or equivalent. A perforated pipe should be installed at the base of the backdrain and sloped to discharge to a suitable storm drain facility, or weep holes should be provided. Alternatively, a geocomposite drainage system such as Miradrain® 6000 or equivalent placed behind the wall and connected to a suitable storm drain facility can be used. The project architect should provide dampproofing/waterproofing specifications and details. Figure 7-4 (following page) presents typical retaining wall backdrain details. Note that the guidance provided on Figure 7-4 is conceptual. Other options are available.

### 7.8.5 Backfill

Wall backfill should consist of granular, free-draining material having an expansion index of 20 or less. The backfill zone is defined by a 1:1 plane projected upward from the heel of the wall. Expansive or clayey soil should not be used. Additionally, backfill within 3 feet from the back of the wall should not contain rocks greater than 3 inches in dimension. Backfill should be compacted to at least 90% relative compaction. Backfill should not be placed until walls have achieved adequate structural strength.

Compaction of wall backfill will be necessary to minimize settlement of the backfill and overlying settlement-sensitive improvements. However, some settlement should still be anticipated. Provisions should be made for some settlement of concrete slabs and pavements supported on backfill. Additionally, any utilities supported on backfill should be designed to tolerate differential settlement.

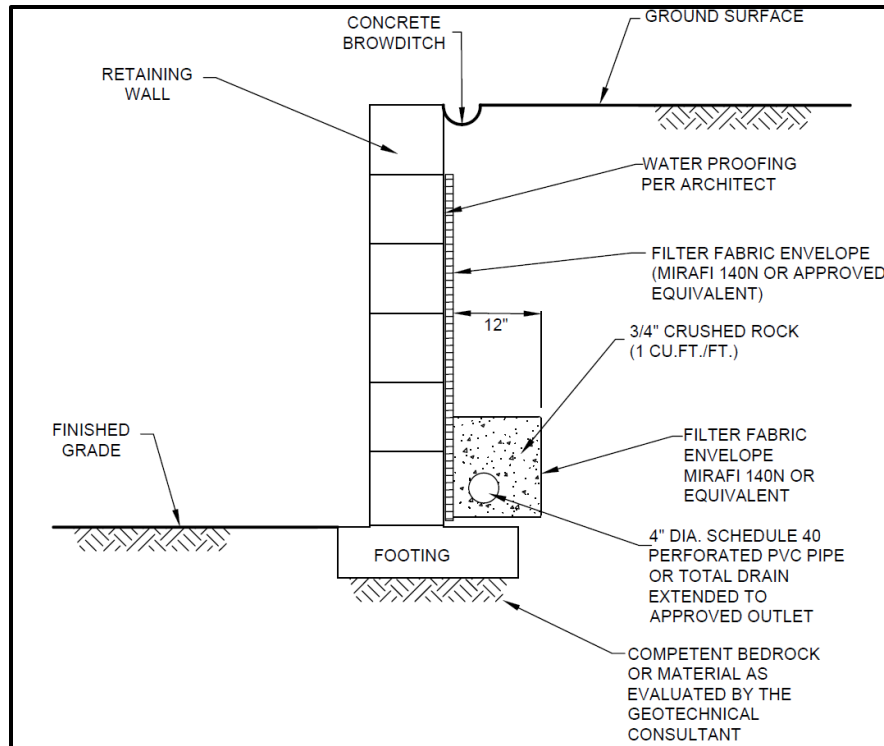

Figure 7-4. Typical Conventional Retaining Wall Backdrain Detail

### 7.8.6 Elevator Pits

It is expected that the building will include several elevator pits that will extend perhaps 6 feet deeper than the slab around it, bearing on a ground-supported slab.

An elevator pit slab and related retaining wall footings will derive suitable support from the sandy soils around it. Design for the elevator pit walls should consider the circumstances and conditions described below.

1. Wall Yield. NOVA expects that proper function of the elevator pit should not allow yielding of the elevator pit walls. As such, walls should be designed to resist 'at rest' lateral soil pressures and seismic pressures provided above, also allowing for any structural and hydrostatic surcharge.
2. Construction. It is common that construction of elevator walls precedes much of the construction around them. Design of the elevator pit walls should include consideration for surcharge conditions that will occur during construction. Such conditions may include, but not be limited to, surcharges from vehicle traffic, sloping ground above and around the walls, etc.
3. Moisture. Where applicable, consideration should be given to positive side (i.e., the wet face) waterproofing to limit moisture accumulation inside the elevator pit, anticipating water level rise to perhaps El +6 feet msl.

4. Piston. If the elevator pit includes a plunger-type elevator piston, a deeper drilled excavation may be required. NOVA should be consulted regarding recommendations for development of a plunger-type elevator piston.

## 7.9. Pipelines

For level ground conditions, a passive earth pressure of 350 psf per foot of depth below the lowest adjacent final grade can be used to compute allowable thrust block resistance. A value of 150 psf per foot should be used below groundwater level, if encountered.

A modulus of soil reaction ( $E'$ ) of 1,500 psi can be used to evaluate the deflection of buried flexible pipelines. This value assumes that granular bedding material is placed adjacent to the pipe and is compacted to at least 90% relative compaction.

Pipe bedding as specified in the "Greenbook" Standard Specifications for Public Works Construction can be used. Bedding material should consist of clean sand having a sand equivalent not less than 20 and should extend to at least 12 inches above the top of pipe. Alternative materials meeting the intent of the bedding specifications are also acceptable. Samples of materials proposed for use as bedding should be provided to the engineer for inspection and testing before the material is imported for use on the project. The on-site materials are not expected to meet "Greenbook" bedding specifications. The pipe bedding material should be placed over the full width of the trench. After placement of the pipe, the bedding should be brought up uniformly on both sides of the pipe to reduce the potential for unbalanced loads. No voids or uncompacted areas should be left beneath the pipe haunches. Ponding or jetting the pipe bedding should not be allowed.

Where pipeline inclinations exceed 15%, cutoff walls are recommended in trench excavations. Open graded rock should not be used for pipe bedding or backfill because of the potential for piping erosion. The recommended bedding is clean sand having a sand equivalent not less than 20 or 2-sack sand/cement slurry. If sand/cement slurry is used for pipe bedding to at least 1 foot over the top of the pipe, cutoff walls are not considered necessary. The need for cutoff walls should be further evaluated by the civil engineer designing the pipeline.

## 7.10. Pavements

### 7.10.1 Subgrade Preparation

Soils beneath proposed vehicular pavement areas should be excavated to a depth of at least 2 feet below the planned base course elevation. Horizontally, excavations should extend at least 2 feet outside the planned pavement or up to existing improvements, whichever is less.

NOVA should observe the conditions exposed in the bottom of excavations to evaluate whether additional excavation is necessary. The resulting surface should then be scarified to a depth of 6 to 8 inches, moisture conditioned to near optimum moisture content, and compacted to at least 90% relative compaction. All soft or yielding areas should be stabilized or removed and replaced with compacted fill or aggregate base.

The excavation should then be backfilled filled with material suitable for reuse as compacted fill.

### 7.10.2 Pavement Sections

Based upon the indications of laboratory testing, an R-value of 50 may be assumed for preliminary design of pavement sections. The actual R-value of the subgrade soils should be determined after grading, and the final pavement sections provided. Based on an R-value of 50, Table 7-1 provides preliminary pavement structural sections for the assumed Traffic Indexes.

**Table 7-1. AC and PCC Pavement Sections**

Traffic Type	Traffic Index	Asphalt Concrete (inches)	Portland Cement Concrete (inches)
Parking Stalls	4.5	3 AC / 4 AB	6 PCC
Driveways	6.0	4 AC / 4 AB	6½ PCC
Heavy Traffic Areas	7.5	5 AC / 6 AB	7 PCC

AC: Asphalt Concrete  
AB: Aggregate Base  
PCC: Portland Cement Concrete

Aggregate base and asphalt concrete should conform to the Caltrans Standard Specifications or the “Greenbook” and should be compacted to at least 95% relative compaction. Aggregate base should have an R-value of not less than 78. All materials and methods of construction should conform to good engineering practices and the minimum local standards.

### 7.11. Corrosivity

Representative samples of the on-site soils were tested to evaluate corrosion potential. The test results are presented in Appendix E.

The project design engineer can use the sulfate results in conjunction with ACI 318 to specify the water/cement ratio, compressive strength, and cementitious material types for concrete exposed to soil.

It should be noted that elevated levels of chloride (0.118% or 1180 parts per million) and low resistivity (240 Ohm-cm) were detected in one of the tested samples. The project architect and/or design engineer should review and consider the chloride content in the project design. A corrosion engineer should be contacted to provide specific corrosion control recommendations.





## **8. INFILTRATION FEASIBILITY**

Full or partial infiltration of stormwater is not recommended for this site, as the fill/young alluvial soils are hydro-collapsible, and the site is in an area designated by the City's Seismic Safety Study as having a high liquefaction potential, with high groundwater and deep hydraulic fill.

Appendix G provides the Infiltration Feasibility Condition Letter for the site.

---

## 9. CLOSURE

NOVA should review project plans and specifications prior to bidding and construction to check that the intent of the recommendations in this report has been incorporated. Observations and tests should be performed during construction. If the conditions encountered during construction differ from those anticipated based on the subsurface exploration program, the presence of personnel from our offices during construction will enable an evaluation of the exposed conditions and modifications of the recommendations in this report or development of additional recommendations in a timely manner.

NOVA should be advised of changes in the project scope so that the recommendations contained in this report can be evaluated with respect to the revised plans. Changes in recommendations will be verified in writing. The findings in this report are valid as of the date of this report. Changes in the condition of the site can, however, occur with the passage of time, whether they are due to natural processes or work on this or adjacent areas. In addition, changes in the standards of practice and government regulations can occur. Thus, the findings in this report may be invalidated wholly or in part by changes beyond our control. This report should not be relied upon after a period of two years without a review by us verifying the suitability of the conclusions and recommendations to site conditions at that time.

In the performance of our professional services, we comply with that level of care and skill ordinarily exercised by members of our profession currently practicing under similar conditions and in the same locality. The client recognizes that subsurface conditions may vary from those encountered at the boring locations and that our data, interpretations, and recommendations are based solely on the information obtained by us. NOVA will be responsible for those data, interpretations, and recommendations, but shall not be responsible for interpretations by others of the information developed. Our services consist of professional consultation and observation only, and no warranty whatsoever, express or implied, is made or intended in connection with the work performed or to be performed by us, or by our proposal for consulting or other services, or by our furnishing of oral or written reports or findings.

## 10. REFERENCES

### 10.1. Site Specific

carrierjohnson + culture (CJC), 2022, Viewpoint Old Town, 46220 Pacific Hwy, San Diego, CA 92110, 38 Sheets, Plot Date 3/31/2022.

### 10.2. Design

American Concrete Institute, 2014, *Building Code Requirements for Structural Concrete (ACI 318-14) and Commentary*, dated September.

American Concrete Institute, 2015, *Guide to Concrete Floor and Slab Construction*, ACI Publication 302.1R-15.

American Concrete Institute, 2016, *Guide for Concrete Slabs that Receive Moisture-Sensitive Flooring Materials (ACI 302.2R-06)*.

American Society of Civil Engineers, Minimum Design Load for Buildings and Other Structures, ASCE 7-16.

California Emergency Management Agency (Cal EMA), California Geological Survey, University of Southern California, 2009, *Tsunami Inundation Map for Emergency Planning, La Jolla Quadrangle, dated June 1*.

California Department of Transportation (Caltrans), 2018, Standard Specifications.

California Department of Transportation (Caltrans), 2003, *Corrosion Guidelines*, Version 1.0, found at: <http://www.dot.ca.gov/hq/esc/ttsb/corrosion/pdf/2012-11-19-Corrosion-Guidelines.pdf>.

California Geological Survey (CGS), 2022, Fault Activity Map of California Website, <https://maps.conservation.ca.gov/cgs/fam/>.

CGS, 2018 Revision, Earthquake Fault Zones, a Guide for Government Agencies, Property Owners/Developers, and Geoscience Practitioners for Assessing Fault Rupture Hazards in California, California Geological Survey Special Publication 42, found at <ftp://ftp.consrv.ca.gov/pub/dmg/pubs/sp/Sp42.pdf>.

City of San Diego. 2008, *Seismic Safety Study*, Grid 20, dated April 3.

City of San Diego, 2018, *Guidelines for Geotechnical Reports*, Development Services Department.

City San Diego, 2021, *Stormwater Standards Manual*, Effective Date: May 2021.

FHWA, 1983, Design and Construction of Stone Columns Vol. I, U.S. Department of Transportation, Federal Highway Administration, Report No. FHWA/RD-83/026, Dec 1983.

International Code Council, 2018, 2019 California Building Code, California Code of Regulations, Title 24, Part 2, Volume 2 of 2, Based on the 2018 International Building Code, Effective January 1, 2020.

OSHA Technical Manual, *Excavations: Hazard Recognition in Trenching and Shoring*, OSHA Instruction TED 01-00-015, Section V, Chapter 2. Found at:  
[https://www.osha.gov/dts/osta/otm/otm\\_v/otm\\_v\\_2.html#1](https://www.osha.gov/dts/osta/otm/otm_v/otm_v_2.html#1).

Public Works Standards, Inc., 2018, "Greenbook" Standard Specifications for Public Works Construction, 2020 Edition.

### 10.3. Site Setting

Federal Emergency Management Agency (FEMA), 2019, *Flood Insurance Rate Map (FIRM), City of San Diego, Firm Panel 06073C1614H*, <https://msc.fema.gov/portal/search>, dated December 20, accessed May 2022.

Google Earth, 2022, *Google*: found at <https://earth.google.com>.

Historic Aerials Website located at <https://www.historicaerials.com/>.

Kennedy, M.P. and Tan, S.S., 2008, *Geologic Map of the San Diego 30' x 60' Quadrangle, California*, California Geological Survey, Scale 1:100,000.

Structural Engineers Association of California (SEAOC), 2022, OSHPD Seismic Design Maps: found at <https://seismicmaps.org>, accessed July.

USGS, 2022a, USGS Historical Topographic Map Explorer, located at <https://livingatlas.arcgis.com/topoexplorer/index.html>.

USGS, 2022b, Unified Hazard Tool, <https://earthquake.usgs.gov/hazards/interactive/>, accessed April.

USGS, 2022c, Risk-Targeted Ground Motion Calculator, <https://earthquake.usgs.gov/designmaps/rtqm/>, accessed April.

USGS, 2022d, Response Spectra Tool, <https://earthquake.usgs.gov/nshmp-hazws/apps/spectra-plot.html>, accessed April.

USGS, 2022e, BSSC2014 (Scenario Catalog) <https://earthquake.usgs.gov/scenarios/catalog/bssc2014/>, accessed April.



# PLATES



**VIEWPOINT OLD TOWN**  
 4620 PACIFIC HIGHWAY  
 SAN DIEGO, CA

PROJECT NO.:	2021073
DATE:	JULY 2022
DRAWN BY:	DTJ
REVIEWED BY:	MS
SCALE:	1"=60'
DRAWING TITLE:	

SUBSURFACE INVESTIGATION MAP AND GEOLOGIC CROSS-SECTION A-A'

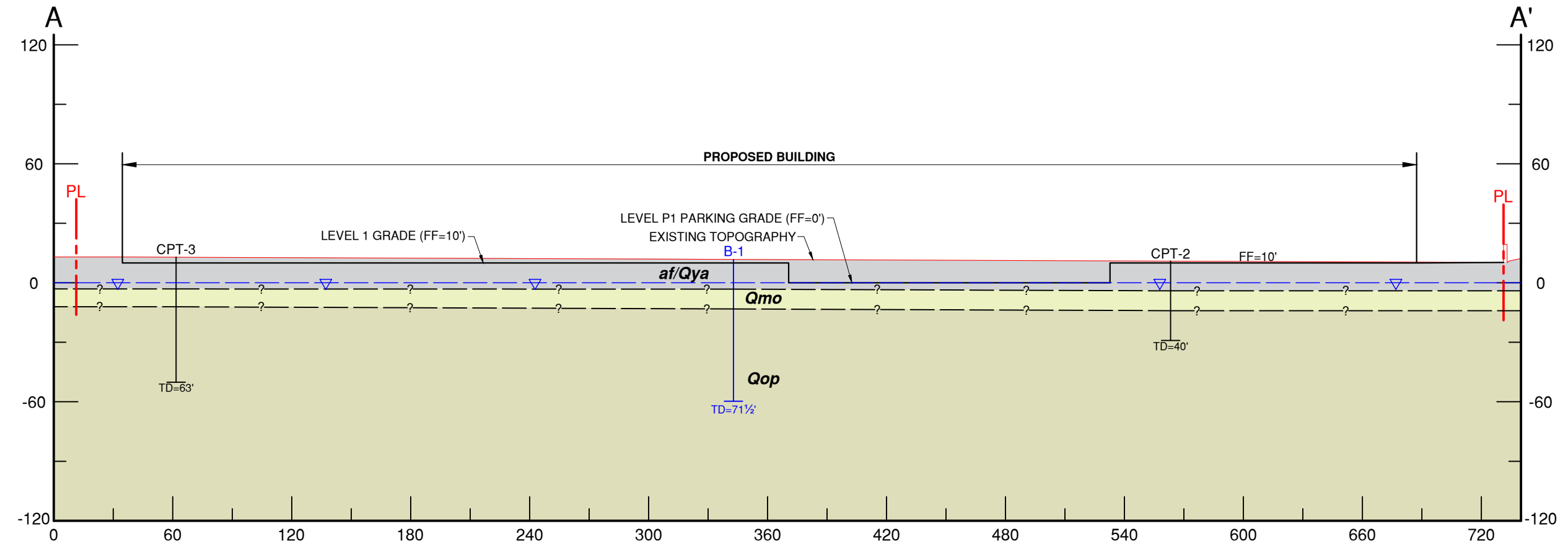
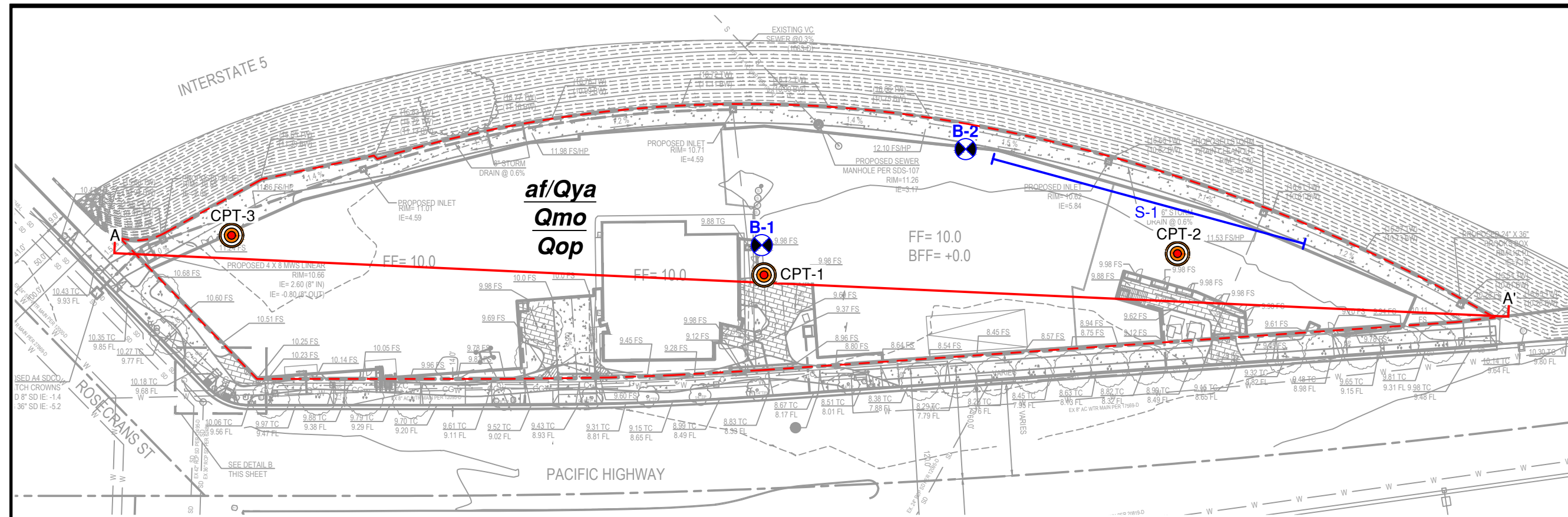

**KEY TO SYMBOLS**

- |               |  |              |                       |         |   |             |                             |
|---------------|--|--------------|-----------------------|---------|---|-------------|-----------------------------|
| <b>af/Qya</b> | FILL/YOUNG ALLUVIAL FLOOD-PLAIN DEPOSITS     | <b>B-2</b>   | GEOTECHNICAL BORING   | — ? —   | GEOLOGIC CONTACT, QUERIED WHERE UNCERTAIN | <b>S-1</b>  | SEISMIC SHEAR WAVE TRAVERSE |
| <b>Qmo</b>    | UNDIVIDED MARINE DEPOSITS IN OFFSHORE REGION | <b>CPT-3</b> | CONE PENETRATION TEST | — ∇ —   | GROUNDWATER                               | <b>A A'</b> | GEOLOGIC CROSS-SECTION      |
| <b>Qop</b>    | OLD PARALIC DEPOSITS                         |              |                       | - - - - | ANTICIPATED LIMITS OF GRADING             |             |                             |

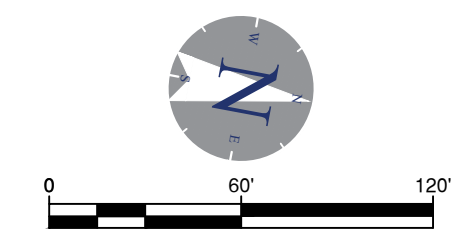



# **APPENDIX A**

## **USE OF THE GEOTECHNICAL REPORT**

# Important Information About Your Geotechnical Engineering Report

*Subsurface problems are a principal cause of construction delays, cost overruns, claims, and disputes.*

*The following information is provided to help you manage your risks.*

## Geotechnical Services Are Performed for Specific Purposes, Persons, and Projects

Geotechnical engineers structure their services to meet the specific needs of their clients. A geotechnical engineering study conducted for a civil engineer may not fulfill the needs of a construction contractor or even another civil engineer. Because each geotechnical engineering study is unique, each geotechnical engineering report is unique, prepared *solely* for the client. No one except you should rely on your geotechnical engineering report without first conferring with the geotechnical engineer who prepared it. *And no one — not even you — should apply the report for any purpose or project except the one originally contemplated.*

## Read the Full Report

Serious problems have occurred because those relying on a geotechnical engineering report did not read it all. Do not rely on an executive summary. Do not read selected elements only.

## A Geotechnical Engineering Report Is Based on A Unique Set of Project-Specific Factors

Geotechnical engineers consider a number of unique, project-specific factors when establishing the scope of a study. Typical factors include: the client's goals, objectives, and risk management preferences; the general nature of the structure involved, its size, and configuration; the location of the structure on the site; and other planned or existing site improvements, such as access roads, parking lots, and underground utilities. Unless the geotechnical engineer who conducted the study specifically indicates otherwise, do not rely on a geotechnical engineering report that was:

- not prepared for you,
- not prepared for your project,
- not prepared for the specific site explored, or
- completed before important project changes were made.

Typical changes that can erode the reliability of an existing geotechnical engineering report include those that affect:

- the function of the proposed structure, as when it's changed from a parking garage to an office building, or from a light industrial plant to a refrigerated warehouse,

- elevation, configuration, location, orientation, or weight of the proposed structure,
- composition of the design team, or
- project ownership.

As a general rule, *always* inform your geotechnical engineer of project changes—even minor ones—and request an assessment of their impact. *Geotechnical engineers cannot accept responsibility or liability for problems that occur because their reports do not consider developments of which they were not informed.*

## Subsurface Conditions Can Change

A geotechnical engineering report is based on conditions that existed at the time the study was performed. *Do not rely on a geotechnical engineering report* whose adequacy may have been affected by: the passage of time; by man-made events, such as construction on or adjacent to the site; or by natural events, such as floods, earthquakes, or groundwater fluctuations. *Always* contact the geotechnical engineer before applying the report to determine if it is still reliable. A minor amount of additional testing or analysis could prevent major problems.

## Most Geotechnical Findings Are Professional Opinions

Site exploration identifies subsurface conditions only at those points where subsurface tests are conducted or samples are taken. Geotechnical engineers review field and laboratory data and then apply their professional judgment to render an opinion about subsurface conditions throughout the site. Actual subsurface conditions may differ—sometimes significantly—from those indicated in your report. Retaining the geotechnical engineer who developed your report to provide construction observation is the most effective method of managing the risks associated with unanticipated conditions.

## A Report's Recommendations Are *Not* Final

Do not overrely on the construction recommendations included in your report. *Those recommendations are not final*, because geotechnical engineers develop them principally from judgment and opinion. Geotechnical engineers can finalize their recommendations only by observing actual

subsurface conditions revealed during construction. *The geotechnical engineer who developed your report cannot assume responsibility or liability for the report's recommendations if that engineer does not perform construction observation.*

## A Geotechnical Engineering Report Is Subject to Misinterpretation

Other design team members' misinterpretation of geotechnical engineering reports has resulted in costly problems. Lower that risk by having your geotechnical engineer confer with appropriate members of the design team after submitting the report. Also retain your geotechnical engineer to review pertinent elements of the design team's plans and specifications. Contractors can also misinterpret a geotechnical engineering report. Reduce that risk by having your geotechnical engineer participate in prebid and preconstruction conferences, and by providing construction observation.

## Do Not Redraw the Engineer's Logs

Geotechnical engineers prepare final boring and testing logs based upon their interpretation of field logs and laboratory data. To prevent errors or omissions, the logs included in a geotechnical engineering report should *never* be redrawn for inclusion in architectural or other design drawings. Only photographic or electronic reproduction is acceptable, *but recognize that separating logs from the report can elevate risk.*

## Give Contractors a Complete Report and Guidance

Some owners and design professionals mistakenly believe they can make contractors liable for unanticipated subsurface conditions by limiting what they provide for bid preparation. To help prevent costly problems, give contractors the complete geotechnical engineering report, *but* preface it with a clearly written letter of transmittal. In that letter, advise contractors that the report was not prepared for purposes of bid development and that the report's accuracy is limited; encourage them to confer with the geotechnical engineer who prepared the report (a modest fee may be required) and/or to conduct additional study to obtain the specific types of information they need or prefer. A prebid conference can also be valuable. *Be sure contractors have sufficient time* to perform additional study. Only then might you be in a position to give contractors the best information available to you, while requiring them to at least share some of the financial responsibilities stemming from unanticipated conditions.

## Read Responsibility Provisions Closely

Some clients, design professionals, and contractors do not recognize that geotechnical engineering is far less exact than other engineering disciplines. This lack of understanding has created unrealistic expectations that

have led to disappointments, claims, and disputes. To help reduce the risk of such outcomes, geotechnical engineers commonly include a variety of explanatory provisions in their reports. Sometimes labeled "limitations" many of these provisions indicate where geotechnical engineers' responsibilities begin and end, to help others recognize their own responsibilities and risks. *Read these provisions closely.* Ask questions. Your geotechnical engineer should respond fully and frankly.

## Geoenvironmental Concerns Are Not Covered

The equipment, techniques, and personnel used to perform a *geoenvironmental* study differ significantly from those used to perform a *geotechnical* study. For that reason, a geotechnical engineering report does not usually relate any geoenvironmental findings, conclusions, or recommendations; e.g., about the likelihood of encountering underground storage tanks or regulated contaminants. *Unanticipated environmental problems have led to numerous project failures.* If you have not yet obtained your own geoenvironmental information, ask your geotechnical consultant for risk management guidance. *Do not rely on an environmental report prepared for someone else.*

## Obtain Professional Assistance To Deal with Mold

Diverse strategies can be applied during building design, construction, operation, and maintenance to prevent significant amounts of mold from growing on indoor surfaces. To be effective, all such strategies should be devised for the *express purpose* of mold prevention, integrated into a comprehensive plan, and executed with diligent oversight by a professional mold prevention consultant. Because just a small amount of water or moisture can lead to the development of severe mold infestations, a number of mold prevention strategies focus on keeping building surfaces dry. While groundwater, water infiltration, and similar issues may have been addressed as part of the geotechnical engineering study whose findings are conveyed in this report, the geotechnical engineer in charge of this project is not a mold prevention consultant: ***none of the services performed in connection with the geotechnical engineer's study were designed or conducted for the purpose of mold prevention. Proper implementation of the recommendations conveyed in this report will not of itself be sufficient to prevent mold from growing in or on the structure involved.***

## Rely on Your ASFE-Member Geotechnical Engineer for Additional Assistance

Membership in ASFE/The Best People on Earth exposes geotechnical engineers to a wide array of risk management techniques that can be of genuine benefit for everyone involved with a construction project. Confer with you ASFE-member geotechnical engineer for more information.



8811 Colesville Road/Suite G106, Silver Spring, MD 20910  
Telephone: 301/565-2733 Facsimile: 301/589-2017  
e-mail: [info@asfe.org](mailto:info@asfe.org) [www.asfe.org](http://www.asfe.org)

*Copyright 2004 by ASFE, Inc. Duplication, reproduction, or copying of this document, in whole or in part, by any means whatsoever, is strictly prohibited, except with ASFE's specific written permission. Excerpting, quoting, or otherwise extracting wording from this document is permitted only with the express written permission of ASFE, and only for purposes of scholarly research or book review. Only members of ASFE may use this document as a complement to or as an element of a geotechnical engineering report. Any other firm, individual, or other entity that so uses this document without being an ASFE member could be committing negligent or intentional (fraudulent) misrepresentation.*



# **APPENDIX B**

# **BORING LOGS**



MAJOR DIVISIONS			TYPICAL NAMES		
COARSE-GRAINED SOILS MORE THAN HALF IS COARSER THAN NO. 200 SIEVE	GRAVEL MORE THAN HALF COARSE FRACTION IS LARGER THAN NO. 4 SIEVE	CLEAN GRAVEL WITH LESS THAN 15% FINES	GW	WELL-GRADED GRAVEL WITH OR WITHOUT SAND	
			GP	POORLY GRADED GRAVEL WITH OR WITHOUT SAND	
		GRAVEL WITH 15% OR MORE FINES	GM	SILTY GRAVEL WITH OR WITHOUT SAND	
			GC	CLAYEY GRAVEL WITH OR WITHOUT SAND	
	SAND MORE THAN HALF COARSE FRACTION IS FINER THAN NO. 4 SIEVE SIZE	CLEAN SAND WITH LESS THAN 15% FINES	SW	WELL-GRADED SAND WITH OR WITHOUT GRAVEL	
			SP	POORLY GRADED SAND WITH OR WITHOUT GRAVEL	
		SAND WITH 15% OR MORE FINES	SM	SILTY SAND WITH OR WITHOUT GRAVEL	
			SC	CLAYEY SAND WITH OR WITHOUT GRAVEL	
			SILTS AND CLAYS LIQUID LIMIT 50% OR LESS	ML	SILT WITH OR WITHOUT SAND OR GRAVEL
				CL	LEAN CLAY WITH OR WITHOUT SAND OR GRAVEL
OL	ORGANIC SILT OR CLAY OF LOW TO MEDIUM PLASTICITY WITH OR WITHOUT SAND OR GRAVEL				
SILTS AND CLAYS LIQUID LIMIT GREATER THAN 50%	MH	ELASTIC SILT WITH OR WITHOUT SAND OR GRAVEL			
	CH	FAT CLAY WITH OR WITHOUT SAND OR GRAVEL			
	OH	ORGANIC SILT OR CLAY OF HIGH PLASTICITY WITH OR WITHOUT SAND OR GRAVEL			
HIGHLY ORGANIC SOILS			PT	PEAT AND OTHER HIGHLY ORGANIC SOILS	

 GROUNDWATER / STABILIZED

 GROUNDWATER SEEPAGE

 BULK SAMPLE

 SPT SAMPLE (ASTM D1586)

 MOD. CAL. SAMPLE (ASTM D3550)

 UNRELIABLE BLOW COUNTS

 GEOLOGIC CONTACT

 SOIL TYPE CHANGE

#### LAB TEST ABBREVIATIONS

CR	CORROSIVITY
MD	MAXIMUM DENSITY
DS	DIRECT SHEAR
EI	EXPANSION INDEX
AL	ATTERBERG LIMITS
SA	SIEVE ANALYSIS
RV	RESISTANCE VALUE
CN	CONSOLIDATION
SE	SAND EQUIVALENT

#### RELATIVE DENSITY OF COHESIONLESS SOILS

RELATIVE DENSITY OF COHESIONLESS SOILS		CONSISTENCY OF COHESIVE SOILS		
RELATIVE DENSITY	SPT N60 BLOWS/FOOT	CONSISTENCY	SPT N60 BLOWS/FOOT	POCKET PENETROMETER MEASUREMENT (TSF)
VERY LOOSE	0 - 4	VERY SOFT	0 - 2	0 - 0.25
LOOSE	4 - 10	SOFT	2 - 4	0.25 - 0.50
MEDIUM DENSE	10 - 30	MEDIUM STIFF	4 - 8	0.50 - 1.0
DENSE	30 - 50	STIFF	8 - 15	1.0 - 2.0
VERY DENSE	OVER 50	VERY STIFF	15 - 30	2.0 - 4.0
		HARD	OVER 30	OVER 4.0

NUMBER OF BLOWS OF 140 LB HAMMER FALLING 30 INCHES TO DRIVE A 2 INCH O.D. (1-3/8 INCH I.D.) SPLIT-BARREL SAMPLER THE LAST 12 INCHES OF AN 18-INCH DRIVE (ASTM-1586 STANDARD PENETRATION TEST).  
IF THE SEATING INTERVAL (1st 6 INCH INTERVAL) IS NOT ACHIEVED, N IS REPORTED AS REF.



GEOTECHNICAL  
MATERIALS  
SPECIAL INSPECTION

4373 Viewridge Ave., Suite B  
San Diego, CA 92123  
P: 858.292.7575

www.usa-nova.com

944 Calle Amanecer, Suite F  
San Clemente, CA 92673  
P: 949.388.7710

## SUBSURFACE EXPLORATION LEGEND

# LOG OF BORING B-1

**DATE DRILLED:** MARCH 26, 2021      **DRILLING METHOD:** 6-INCH HOLLOW STEM AUGER/MUD ROTARY  
**ELEVATION:** ± 10 FT      **DRILLING EQUIP.:** YETI M10      **GROUNDWATER DEPTH:** 10 FT  
**SAMPLE METHOD:** HAMMER: 140 LBS., DROP: 30 IN (AUTOMATIC)      **NOTES:** ETR~96.5%, N<sub>60</sub> ~  $\frac{96.5}{60} \cdot N \sim 1.61 \cdot N$

DEPTH (FT)	BULK SAMPLE	CAL/SPT SAMPLE	BLOWS PER FOOT N	N <sub>60</sub>	MOISTURE (%)	DRY DENSITY (pcf)	SOIL CLASS. (USCS)	SOIL DESCRIPTION SUMMARY OF SUBSURFACE CONDITIONS (USCS; COLOR, MOISTURE, DENSITY, GRAIN SIZE, OTHER)	LAB TESTS
0								5½ IN OF ASPHALT CONCRETE OVER 4½ IN OF AGGREGATE BASE	
0 - 10	X	X	10	11	14.9	103.2	SM	<b>FILL/ QUATERNARY YOUNG ALLUVIAL FLOOD-PLAIN DEPOSITS (af/Qya): SILTY SAND; LIGHT BROWN TO BROWN, SLIGHTLY MOIST, LOOSE, FINE TO MEDIUM GRAINED, SCATTERED GRAVEL</b>  MEDIUM DENSE  LOOSE	MD SA RV CR
10 - 15	X	X	4	6					
10 - 15	X	X	3*	5*					
10 - 15	X	X	7	11			SP-SM	POORLY GRADED SAND WITH SILT; GRAYISH BROWN, WET, MEDIUM DENSE, FINE GRAINED, SWITCHED TO ROTARY DRILLING	SA
15 - 20	X	X	7	11			SM/SC	QUATERNARY BAY SEDIMENTS (Qmo): SILTY SAND/CLAYEY SAND; DARK GRAY, SATURATED, MEDIUM DENSE, FINE GRAINED	SA
20 - 25	X	X	5	8			CL/ML	SANDY CLAY/SANDY SILT; DARK GRAY/BLACK, WET, MEDIUM STIFF, FINE GRAINED, ABUNDANT MICA	SA
25 - 30	X	X	19	31			SP-SM	QUATERNARY OLD PARALIC DEPOSITS (Qop): POORLY GRADED SAND WITH SILT; DARK GRAY, WET, DENSE, FINE GRAINED	SA

**GEOTECHNICAL MATERIALS SPECIAL INSPECTION**

DVBE • SBE • SDVOSB • SLBE

[www.usa-nova.com](http://www.usa-nova.com)

4373 Viewridge Avenue, Suite B San Diego, CA 92123 P: 858.292.7575

944 Calle Amanecer, Suite F San Clemente, CA 92673 P: 949.388.7710

**VIEWPOINT OLD TOWN**

4609, 4610, 4620 PACIFIC HIGHWAY

SAN DIEGO, CALIFORNIA

BY: AR	REVIEWED BY: MS	PROJECT: 2021073	FIGURE: B.1
--------	-----------------	------------------	-------------

# CONTINUED LOG OF BORING B-1

**DATE DRILLED:** MARCH 26, 2021      **DRILLING METHOD:** 6-INCH HOLLOW STEM AUGER/MUD ROTARY  
**ELEVATION:** ± 10 FT      **DRILLING EQUIP.:** YETI M10      **GROUNDWATER DEPTH:** 10 FT  
**SAMPLE METHOD:** HAMMER: 140 LBS., DROP: 30 IN (AUTOMATIC)      **NOTES:** ETR~96.5%, N<sub>60</sub> ~  $\frac{96.5}{60} \cdot N \sim 1.61 \cdot N$

DEPTH (FT)	BULK SAMPLE	CAL/SPT SAMPLE	BLOWS PER FOOT N	N <sub>60</sub>	MOISTURE (%)	DRY DENSITY (pcf)	SOIL CLASS. (USCS)	SOIL DESCRIPTION <i>SUMMARY OF SUBSURFACE CONDITIONS (USCS; COLOR, MOISTURE, DENSITY, GRAIN SIZE, OTHER)</i>	LAB TESTS
30		/	16	26			SP-SM	<b>QUATERNARY OLD PARALIC DEPOSITS (Qop): POORLY GRADED SAND WITH SILT; DARK GRAY, WET, MEDIUM DENSE, FINE GRAINED</b>	SA
35		/	21	34			SM	<b>SILTY SAND; DARK GRAY, WET, DENSE, FINE GRAINED</b>	SA
40		/	19	31					SA
50		/	15	24			ML	<b>SANDY SILT; DARK GRAY, WET, MEDIUM DENSE, FINE GRAINED</b>	SA
55									
60									



**GEOTECHNICAL  
MATERIALS  
SPECIAL INSPECTION**

DVBE • SBE • SDVOSB • SLBE

[www.usa-nova.com](http://www.usa-nova.com)

4373 Viewridge Avenue, Suite B  
 San Diego, CA 92123  
 P: 858.292.7575

944 Calle Amanecer, Suite F  
 San Clemente, CA 92673  
 P: 949.388.7710

**VIEWPOINT OLD TOWN**

4609, 4610, 4620 PACIFIC HIGHWAY  
 SAN DIEGO, CALIFORNIA

BY: AR

REVIEWED BY: MS

PROJECT: 2021073

APPENDIX: B.2

# CONTINUED LOG OF BORING B-1

**DATE DRILLED:** MARCH 26, 2021      **DRILLING METHOD:** 6-INCH HOLLOW STEM AUGER/MUD ROTARY  
**ELEVATION:** ± 10 FT      **DRILLING EQUIP.:** YETI M10      **GROUNDWATER DEPTH:** 10 FT  
**SAMPLE METHOD:** HAMMER: 140 LBS., DROP: 30 IN (AUTOMATIC)      **NOTES:** ETR~96.5%, N<sub>60</sub> ~  $\frac{96.5}{60} \cdot N \sim 1.61 \cdot N$

DEPTH (FT)	BULK SAMPLE	CAL/SPT SAMPLE	BLOWS PER FOOT N	N <sub>60</sub>	MOISTURE (%)	DRY DENSITY (pcf)	SOIL CLASS. (USCS)	SOIL DESCRIPTION <i>SUMMARY OF SUBSURFACE CONDITIONS (USCS; COLOR, MOISTURE, DENSITY, GRAIN SIZE, OTHER)</i>	LAB TESTS
60		/	29	47			SP-SM	<b>QUATERNARY OLD PARALIC DEPOSITS (Qop): SAND WITH SILT; DARK GRAY, WET, DENSE, FINE TO MEDIUM GRAINED</b>	SA
65									
70		/	16	26			SM/SC	<b>SILTY SAND/CLAYEY SAND; DARK GRAY, WET, MEDIUM DENSE, FINE GRAINED</b>	SA
75								<i>BORING TERMINATED AT 71½ FT. GROUNDWATER ENCOUNTERED AT 10 FT.</i>	
80									
85									
90									



GEOTECHNICAL  
 MATERIALS  
 SPECIAL INSPECTION

DVBE • SBE • SDVOSB • SLBE

[www.usa-nova.com](http://www.usa-nova.com)

4373 Viewridge Avenue, Suite B  
 San Diego, CA 92123  
 P: 858.292.7575

944 Calle Amanecer, Suite F  
 San Clemente, CA 92673  
 P: 949.388.7710

**VIEWPOINT OLD TOWN**

4609, 4610, 4620 PACIFIC HIGHWAY  
 SAN DIEGO, CALIFORNIA

BY: AR

REVIEWED BY: MS

PROJECT: 2021073

APPENDIX: B.3

# LOG OF BORING B-2

**DATE DRILLED:** JULY 11, 2022      **DRILLING METHOD:** 6-INCH HOLLOW STEM AUGER/MUD ROTARY  
**ELEVATION:** ± 10 FT      **DRILLING EQUIP.:** CME 75      **GROUNDWATER DEPTH:** 9.7 FT  
**SAMPLE METHOD:** HAMMER: 140 LBS., DROP: 30 IN (AUTOMATIC)      **NOTES:** ETR~73.9%, N<sub>60</sub> ~  $\frac{73.9}{60} \times N \sim 1.23 \times N$

DEPTH (FT)	BULK SAMPLE	CAL/SPT SAMPLE	BLOWS PER FOOT N	N <sub>60</sub>	MOISTURE (%)	DRY DENSITY (pcf)	SOIL CLASS. (USCS)	SOIL DESCRIPTION <i>SUMMARY OF SUBSURFACE CONDITIONS (USCS; COLOR, MOISTURE, DENSITY, GRAIN SIZE, OTHER)</i>	LAB TESTS
0								3 IN OF ASPHALT CONCRETE OVER 6 IN OF AGGREGATE BASE	
0 - 3	X						SC	FILL/ QUATERNARY YOUNG ALLUVIAL FLOOD-PLAIN DEPOSITS (af/Qya): CLAYEY SAND; YELLOW BROWN, MOIST, LOOSE TO MEDIUM DENSE, FINE TO MEDIUM GRAINED, SOME CLAY BLEBS, FEW GRAVEL	
3 - 5		■	19	15			SM	SILTY SAND; YELLOW BROWN, MOIST, MEDIUM DENSE, MEDIUM TO COARSE GRAINED  DARK GRAY, FINE TO MEDIUM GRAINED, MICACEOUS	
5 - 10	X						SC	CLAYEY SAND; DARK GRAY, WET, LOOSE, FINE GRAINED, SOME INTERBEDDED CLAY LENSES	
10	▽		6	7					
10 - 15	X						SM	SILTY SAND; MOTTLED YELLOW BROWN AND DARK GRAY, WET, LOOSE, FINE TO MEDIUM GRAINED	CR
15 - 16.5		■	7	6			SM	QUATERNARY BAY SEDIMENTS (Qmo): SILTY SAND; GRAY, WET, DENSE, FINE GRAINED	
16.5 - 30			26	32				BORING TERMINATED AT 16½ FT. GROUNDWATER ENCOUNTERED AT 9 FT AND STABILIZED AT 9.7 FT. BACKFILLED WITH BENTONITE.	



GEOTECHNICAL  
 MATERIALS  
 SPECIAL INSPECTION

DVBE • SBE • SDVOSB • SLBE

www.usa-nova.com

4373 Viewridge Avenue, Suite B  
 San Diego, CA 92123  
 P: 858.292.7575

944 Calle Amanecer, Suite F  
 San Clemente, CA 92673  
 P: 949.388.7710

### VIEWPOINT OLD TOWN

4609, 4610, 4620 PACIFIC HIGHWAY  
 SAN DIEGO, CALIFORNIA

BY: SA

REVIEWED BY: MS

PROJECT: 2021073

APPENDIX: B.4





# **APPENDIX C**

## **LOGS OF CPT SOUNDINGS**

Cone no: 5238	Location:	Position: X: 0.00 ft Y: 0.00 ft	Ground level: 0.00	Test no: CPT 1
Tip/sleeve area [cm <sup>2</sup> ]: 10 / 150	Project ID:	Client: NOVA	Date: 3/26/2021	Standard / class: /
Area factor a/b: 838.000 / 0.000	Project: Perry's Cafe		Page: 1/1	Scale: 1:125
Pore pressure: U2			Coordinate system:	

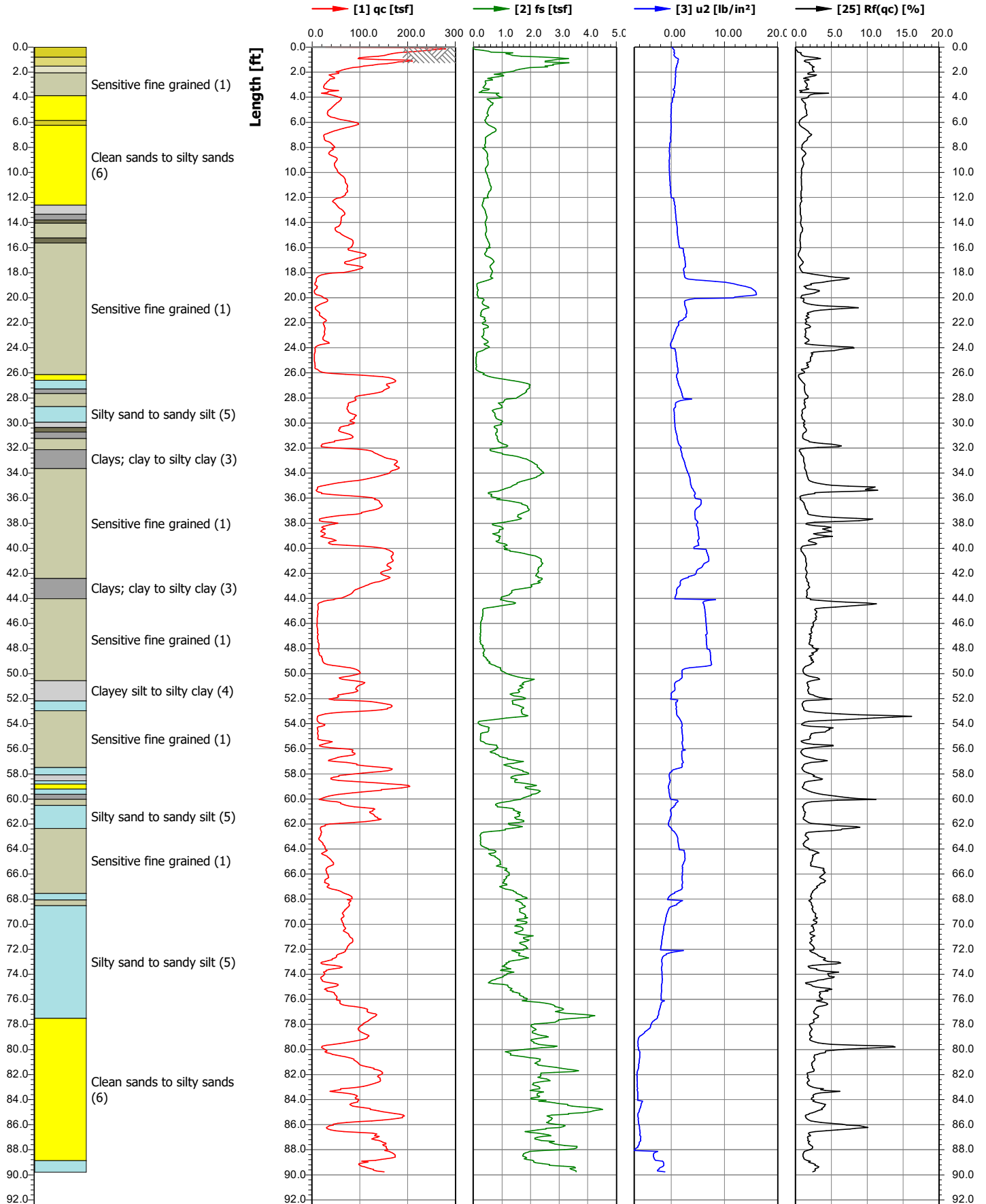

Cone no: 5238	Location:	Position: X: 0.00 ft Y: 0.00 ft	Ground level: 0.00	Test no: CPT #2
Tip/sleeve area [cm <sup>2</sup> ]: 10 / 150	Project ID:	Client: NOVA	Date: 3/26/2021	Standard / class: /
Area factor a/b: 838.000 / 0.000	Project: Perry's Cafe		Page: 1/1	Scale: 1:65
Pore pressure: U2			Coordinate system:	

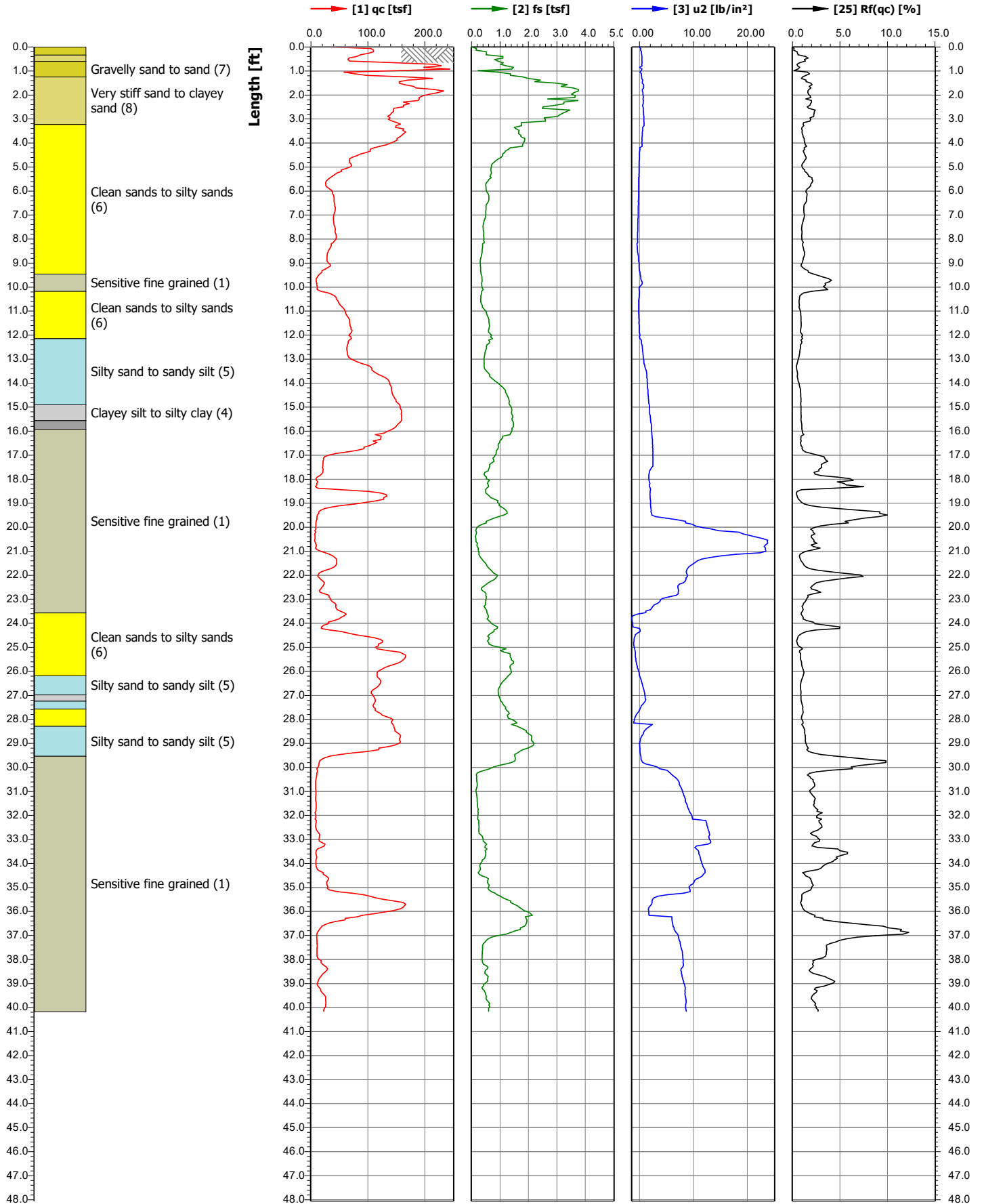

Cone no: 5238	Location:	Position: X: 0.00 ft Y: 0.00 ft	Ground level: 0.00	Test no: CPT #3
Tip/sleeve area [cm <sup>2</sup> ]: 10 / 150	Project ID:	Client: NOVA	Date: 3/26/2021	Standard / class: /
Area factor a/b: 838.000 / 0.000	Project: Perry's Cafe		Page: 1/1	Scale: 1:100
Pore pressure: U2			Coordinate system:	

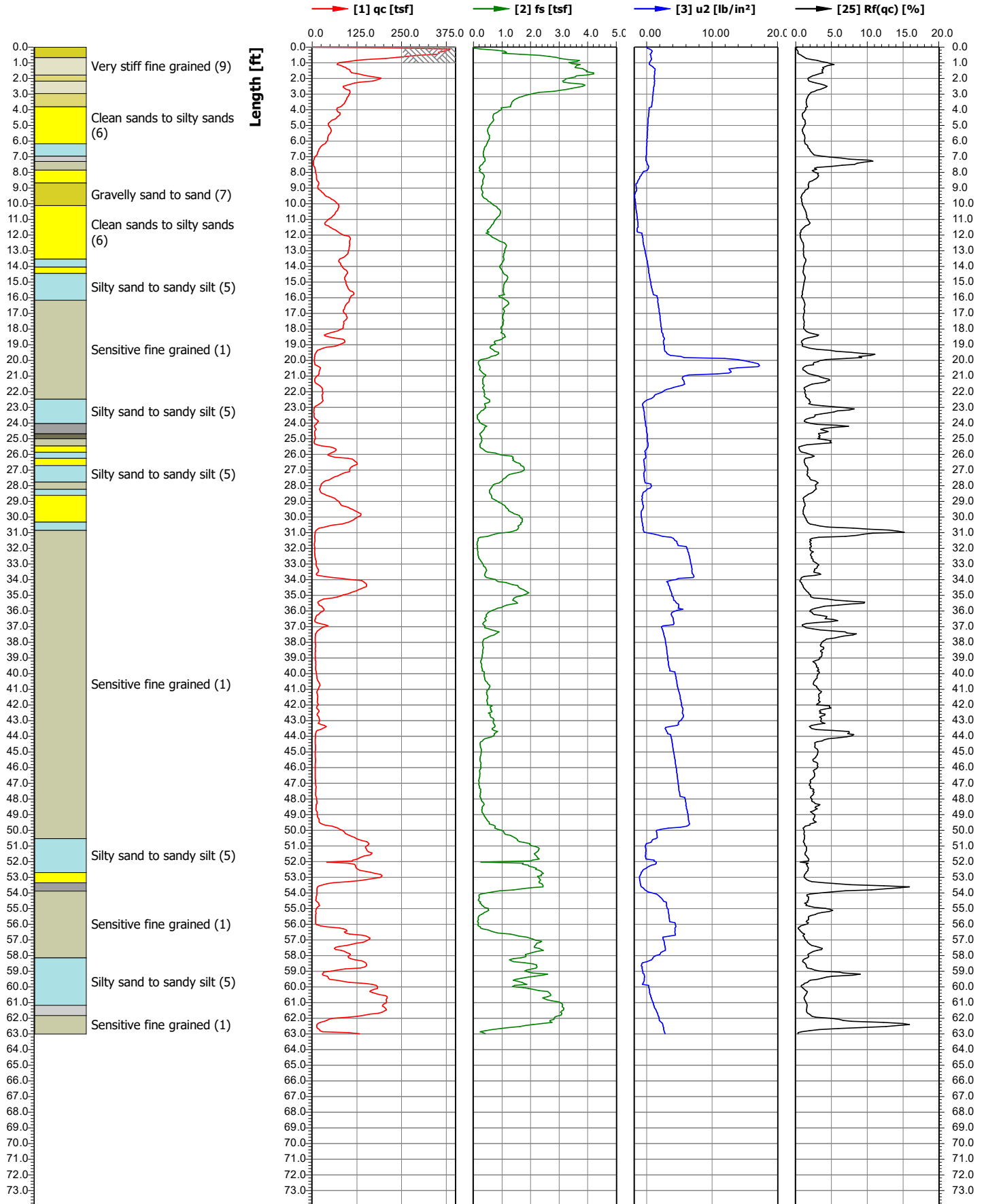



**APPENDIX D**  
**RESULTS OF SHEAR WAVE TRAVERSE**  
**AND SITE-SPECIFIC GROUND MOTION**  
**HAZARD ANALYSIS**



# SEISMIC LINE SW-1

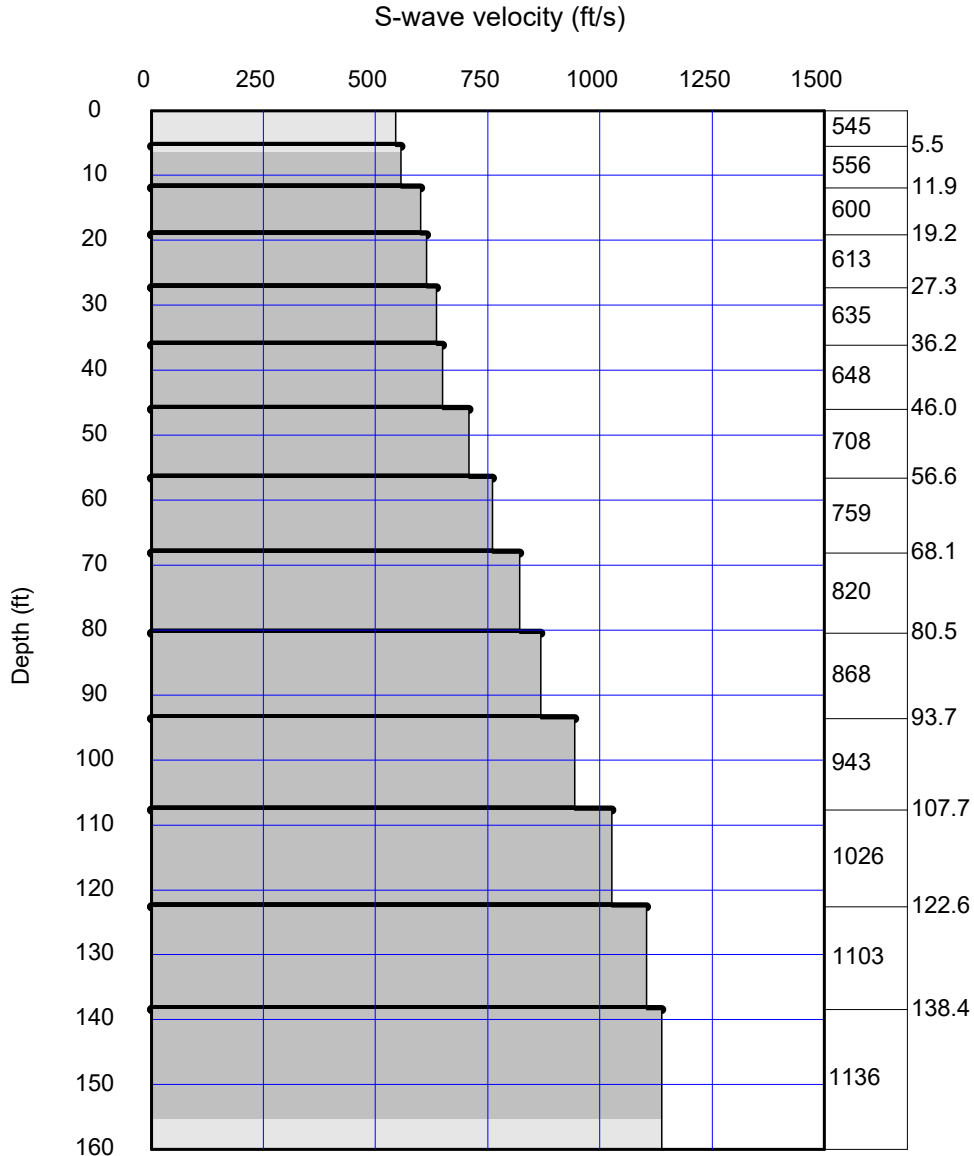

**SHEAR-WAVE VELOCITY MODEL: Average Vs 100ft = 698.6 ft/sec**

**Site Classification (ASCE 7-16 Ch. 20)- "D" (Stiff Soil profile)**

Client: Nova Services, Inc.

NOVA Project No. 2021073

Project Name: Viewpoint Old Town, San Diego, California

Survey Line End Coordinates: 32.757079, -117.201864 / 32.756578, -117.201939

Date: 7/3/22



TG Project No. 223847-1

**SITE-SPECIFIC GROUND MOTION ANALYSIS (ASCE 7-16)**

**Project:** Viewpoint Old Town  
**Client:** Viewpoint Development  
**Job No:** 2021073

**Latitude:** 32.75611 deg  
**Longitude:** -117.20161 deg  
**Vs<sub>30</sub>:** 213 m/s (Measured)

**Calculated By:** GLC  
**Date:** July 2022

Period T (sec)	PROBABILISTIC (RISK-TARGETED) GROUND MOTION ANALYSIS				DETERMINISTIC (84TH-PERCENTILE) GROUND MOTION ANALYSIS			CODE-BASED (LOWER LIMIT) ASCE 7-16 SECTION 11.4.6		SITE-SPECIFIC DESIGN RESPONSE		
	Uniform Hazard Ground Motion (g)	Risk Targeted Ground Motion (g)	Maximum Direction Scale Factor	Maximum Directional Probabilistic Sa (g)	84th Percentile Spectral Acceleration (g)	Maximum Direction Scale Factor	Maximum Directional Deterministic Sa (g)	Code Based Sa (g)	80% of Code Based Sa (g)	Design SaM (g)	Design Sa (g)	T x Sa (T>1s)
PGA	0.693	0.613	1.1	0.674	0.743	1.1	0.817	0.398	0.318	0.674	0.450	---
0.10	1.106	1.005	1.1	1.106	1.027	1.1	1.130	0.883	0.707	1.106	0.737	---
0.20	1.505	1.353	1.1	1.488	1.367	1.1	1.504	0.994	0.795	1.488	0.992	---
0.30	1.679	1.500	1.125	1.688	1.683	1.125	1.893	0.994	0.795	1.688	1.125	---
0.50	1.624	1.436	1.175	1.687	1.899	1.175	2.231	0.994	0.795	1.687	1.125	---
0.75	1.334	1.175	1.2375	1.454	1.747	1.2375	2.162	0.814	0.651	1.454	0.969	---
1.00	1.097	0.968	1.3	1.258	1.605	1.3	2.087	0.610	0.488	1.258	0.839	0.839
2.00	0.551	0.491	1.35	0.663	1.014	1.35	1.369	0.305	0.244	0.663	0.442	0.884
3.00	0.339	0.304	1.4	0.426	0.658	1.4	0.921	0.203	0.163	0.426	0.284	0.851
4.00	0.225	0.202	1.45	0.293	0.428	1.45	0.621	0.153	0.122	0.293	0.195	0.781
5.00	0.161	0.144	1.5	0.216	0.293	1.5	0.440	0.122	0.098	0.216	0.144	0.720

**INPUT PARAMETERS - SEAOC (<https://seismicmaps.org/>)**

Site Class=	D	
F <sub>a</sub> =	1.000	Short Period Site Coefficient
S <sub>5</sub> =	1.492	Mapped MCE <sub>R</sub> , 5% Damped at T=0.2s
S <sub>1</sub> =	0.512	Mapped MCE <sub>R</sub> , 5% Damped at T=1s
S <sub>0.5</sub> =	0.994	Design, 5% Damped at Short Periods
S <sub>M5</sub> =	1.492	The MCE <sub>R</sub> , 5% Damped at Short Periods
T <sub>1</sub> (sec)=	8.0	Long Period Transition (Sect 11.4.6)
F <sub>PGA</sub> (g)=	1.1	Site Coefficient for PGA
PGA <sub>M</sub> (g)=	0.750	
F <sub>v</sub> =	1.788	Used Only for Calculation of T <sub>0</sub> and T <sub>s</sub>
S <sub>M1</sub> =	0.915	
S <sub>D1</sub> =	0.610	Design, 5% Damped at T=1s
T <sub>0</sub> (sec)=	0.123	Defined in ASCE 7-16 Sect 11.4.6
T <sub>s</sub> (sec)=	0.614	Defined in ASCE 7-16 Sect 11.4.6

**SITE-SPECIFIC DESIGN PARAMETERS**

S <sub>D5</sub> =	1.013	90% of max S <sub>a</sub> (ASCE 7-16 Sect 21.4)
S <sub>M5</sub> =	1.519	MCE <sub>R</sub> , 5% Damped, adjusted for Site Class
S <sub>D1</sub> =	0.884	Design, 5% Damped, at T=1s (Sect 11.4.5)
S <sub>M1</sub> =	1.326	MCE <sub>R</sub> , 5% Damped, at T=1s, adjusted for Site
F <sub>a</sub> =	1.000	Short Period Site Coefficient
F <sub>v</sub> =	2.500	Long Period Site Coefficient (7-16 Sect 21.3)
S <sub>5</sub> =	1.519	MCE <sub>R</sub> , 5% Damped at T=0.2s
S <sub>1</sub> =	0.530	MCE <sub>R</sub> , 5% Damped at T=1s
PGA <sub>Probabilistic</sub> (g)=	0.693	Peak Ground Acceleration, Probabilistic
PGA <sub>Deterministic</sub> (g)=	0.743	Peak Ground Acceleration, Deterministic
F <sub>PGA</sub> (g)=	1.1	Site Coefficient for PGA
0.5 * F <sub>PGA</sub> (g)=	0.550	OK (Check PGA <sub>Deterministic</sub> > 0.5 x F <sub>PGA</sub> )
0.8 * PGA <sub>M</sub> (g)=	0.600	PGA <sub>M</sub> (g) (Determined from ASCE 7-16 Eq. 11.8-1)
Site Specific PGA <sub>M</sub> (g) =	0.693	(Check PGA <sub>Site Specific</sub> > 0.8 x PGA <sub>M</sub> )



Viewpoint Old Town  
San Diego, California

By:	GLC	Date:	July 2022
Job Number:	2021073	Figure:	D.2

Site-Specific Response Spectra per ASCE 7-16

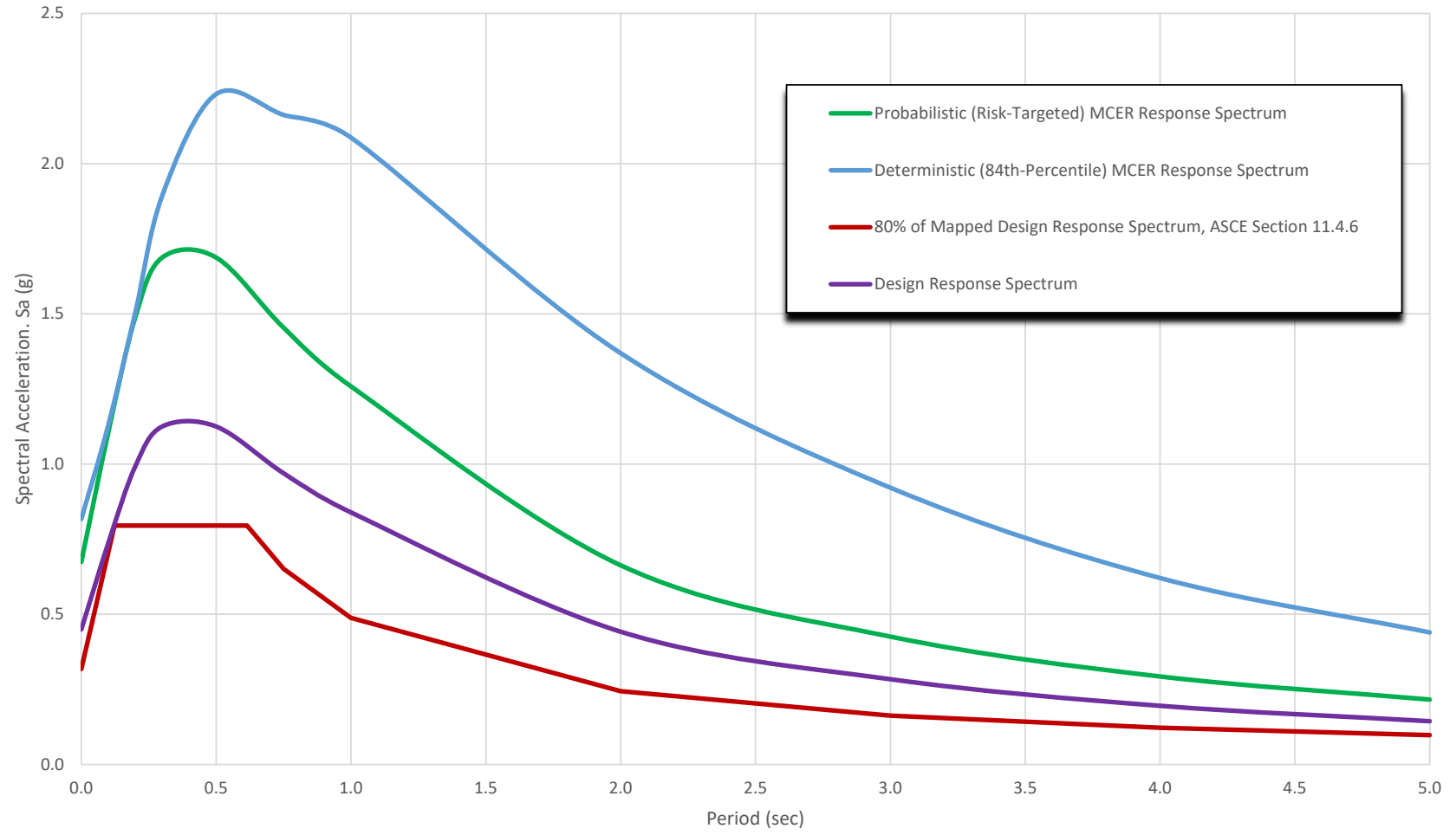



# **APPENDIX E**

## **LABORATORY TESTING**

Laboratory tests were performed in accordance with the generally accepted American Society for Testing and Materials (ASTM) test methods or suggested procedures. Brief descriptions of the tests performed are presented below:

- CLASSIFICATION:** Field classifications were verified in the laboratory by visual examination. The final soil classifications are in accordance with the Unified Soils Classification System and are presented on the exploration logs in Appendix B.
- MAXIMUM DENSITY AND OPTIMUM MOISTURE CONTENT (ASTM D 1557 METHOD A,B,C):** The maximum dry density and optimum moisture content of typical soils were determined in the laboratory in accordance with ASTM Standard Test D 1557, Method A, Method B, Method C.
- IN-PLACE MOISTURE AND DENSITY OF SOIL (ASTM D3550):** In-place moisture contents and dry densities were determined for representative soil samples. This information was an aid to classification and permitted recognition of variations in material consistency with depth. The dry unit weight is determined in pounds per cubic foot, and the in-place moisture content is determined as a percentage of the soil's dry weight. The results are summarized in the exploration logs presented in Appendix B.
- GRADATION ANALYSIS (ASTM D6913):** Tests were performed on selected representative soil samples in general accordance with ASTM D422. The grain size distributions of selected samples were determined in accordance with ASTM D6913.
- R-VALUE (CT 301 and ASTM D 2844):** The resistance Value, or R-Value, for near-surface site soils were evaluated in general accordance with California Test (CT) 301 and ASTM D 2844. The sample was prepared and evaluated for exudation pressure and expansion pressure. The equilibrium R-value is reported as the lesser or more conservative of the two calculated results.
- CORROSIVITY TEST (CAL. TEST METHOD 417, 422, 643):** Soil pH, and minimum resistivity tests were performed on representative soil samples in general accordance with test method CT 643. The sulfate and chloride content of the selected samples were evaluated in general accordance with CT 417 and CT 422, respectively.

Soil samples not tested are now stored in our laboratory for future reference and evaluation, if needed. Unless notified to the contrary, samples will be disposed of 90 days from the date of this report.



GEOTECHNICAL  
MATERIALS  
SPECIAL INSPECTION

DVBE • SBE • SDVOSB • SLBE

www.usa-nova.com

4373 Viewridge Avenue, Suite B  
San Diego, CA 92123  
P: 858.292.7575

944 Calle Amanecer, Suite F  
San Clemente, CA 92673  
P: 949.388.7710

## LAB TEST SUMMARY

**VIEWPOINT OLD TOWN**  
4620 PACIFIC HIGHWAY  
SAN DIEGO, CALIFORNIA

BY: GN

REVIEWED BY: MS

PROJECT: 2021073

FIGURE: E.1



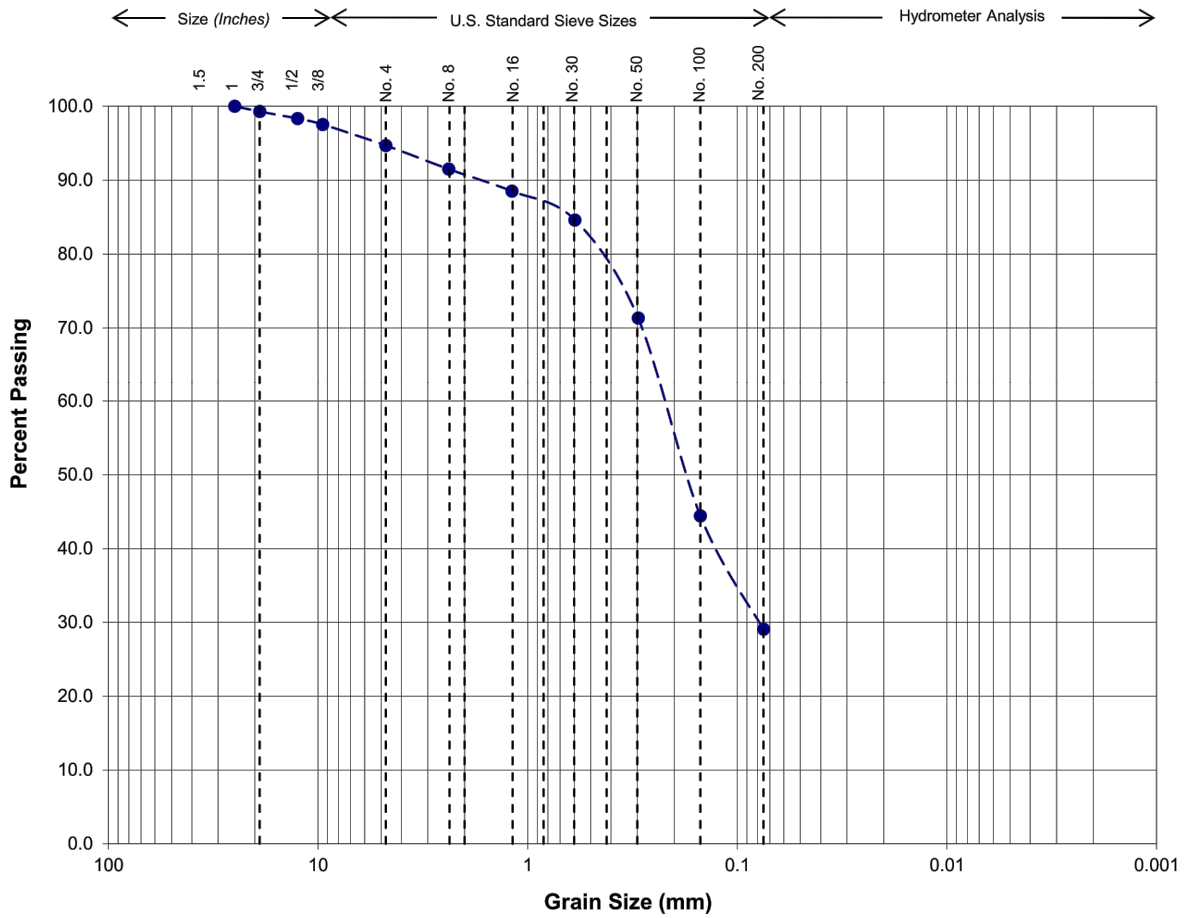

Gravel		Sand			Silt or Clay
Coarse	Fine	Coarse	Medium	Fine	

Sample Location: B - 1  
 Depth (ft): 0 - 8  
 USCS Soil Type: ML  
 Passing No. 200 (%): 29



GEOTECHNICAL  
 MATERIALS  
 SPECIAL INSPECTION

DVBE • SBE • SDVOSB • SLBE  
 www.usa-nova.com

4373 Viewridge Avenue, Suite B  
 San Diego, CA 92123  
 P: 858.292.7575

944 Calle Amanecer, Suite F  
 San Clemente, CA 92673  
 P: 949.388.7710

## GRADATION ANALYSIS TEST RESULTS

**VIEWPOINT OLD TOWN**  
 4620 PACIFIC HIGHWAY  
 SAN DIEGO, CALIFORNIA

BY: GN

REVIEWED BY: MS

PROJECT: 2021073

FIGURE: E.2

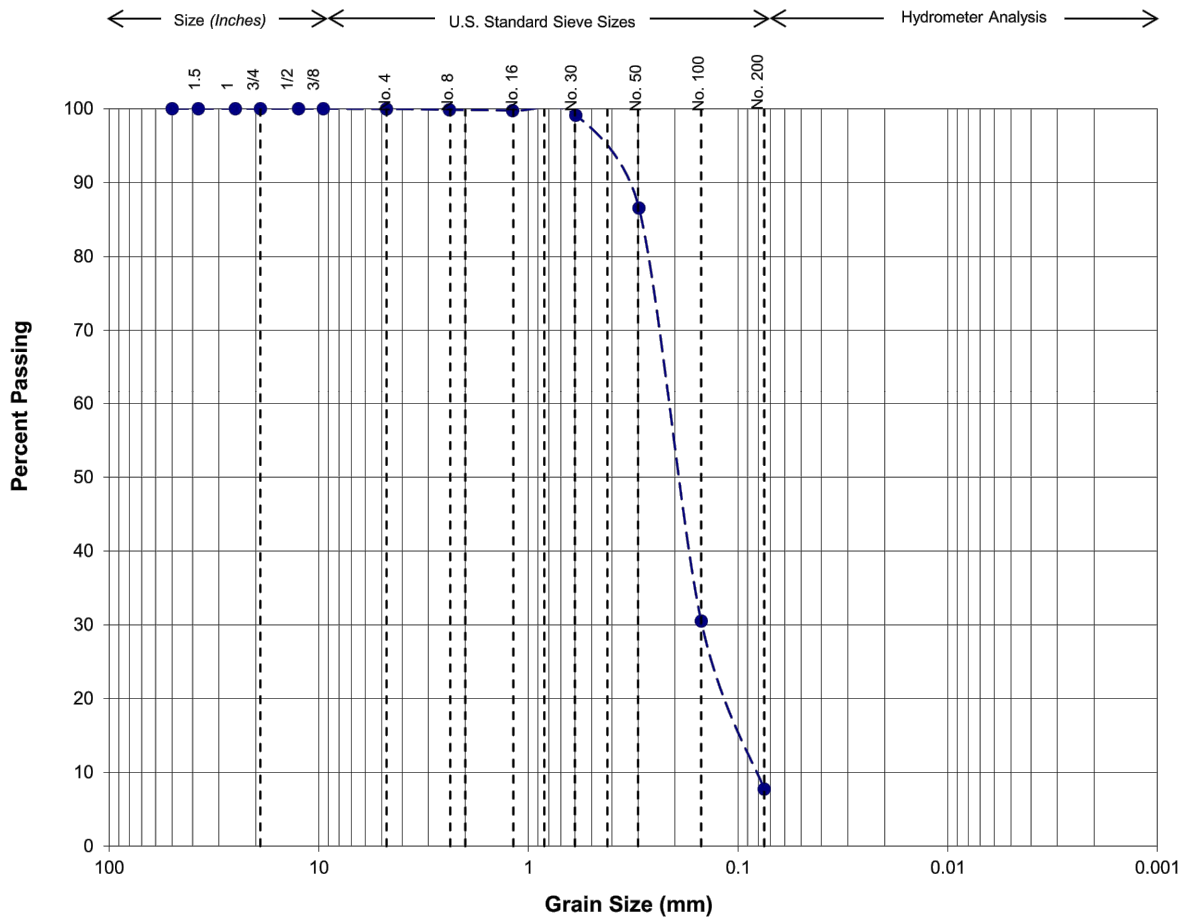

Gravel		Sand			Silt or Clay
Coarse	Fine	Coarse	Medium	Fine	

Sample Location: B - 1  
 Depth (ft): 10  
 USCS Soil Type: SP-SM  
 Passing No. 200 (%): 8



GEOTECHNICAL  
 MATERIALS  
 SPECIAL INSPECTION

DVBE • SBE • SDVOSB • SLBE  
 www.usa-nova.com

4373 Viewridge Avenue, Suite B  
 San Diego, CA 92123  
 P: 858.292.7575

944 Calle Amanecer, Suite F  
 San Clemente, CA 92673  
 P: 949.388.7710

## GRADATION ANALYSIS TEST RESULTS

**VIEWPOINT OLD TOWN**  
 4620 PACIFIC HIGHWAY  
 SAN DIEGO, CALIFORNIA

BY: GN

REVIEWED BY: MS

PROJECT: 2021073

FIGURE: E.3

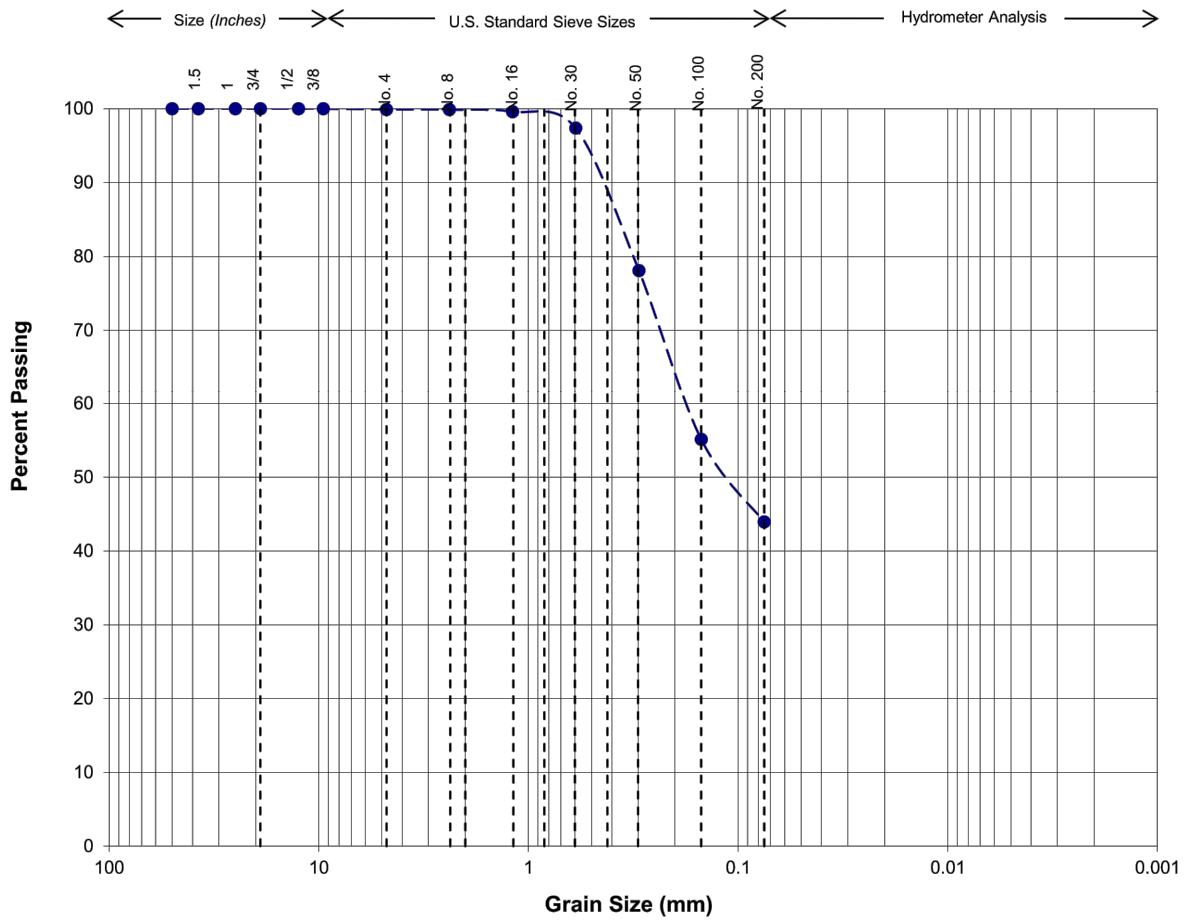

Gravel		Sand			Silt or Clay
Coarse	Fine	Coarse	Medium	Fine	

Sample Location: B - 1  
 Depth (ft): 15  
 USCS Soil Type: SM/SC  
 Passing No. 200 (%): 44



GEOTECHNICAL  
 MATERIALS  
 SPECIAL INSPECTION

DVBE • SBE • SDVOSB • SLBE  
 www.usa-nova.com

4373 Viewridge Avenue, Suite B  
 San Diego, CA 92123  
 P: 858.292.7575

944 Calle Amanecer, Suite F  
 San Clemente, CA 92673  
 P: 949.388.7710

## GRADATION ANALYSIS TEST RESULTS

**VIEWPOINT OLD TOWN**  
 4620 PACIFIC HIGHWAY  
 SAN DIEGO, CALIFORNIA

BY: GN

REVIEWED BY: MS

PROJECT: 2021073

FIGURE: E.4

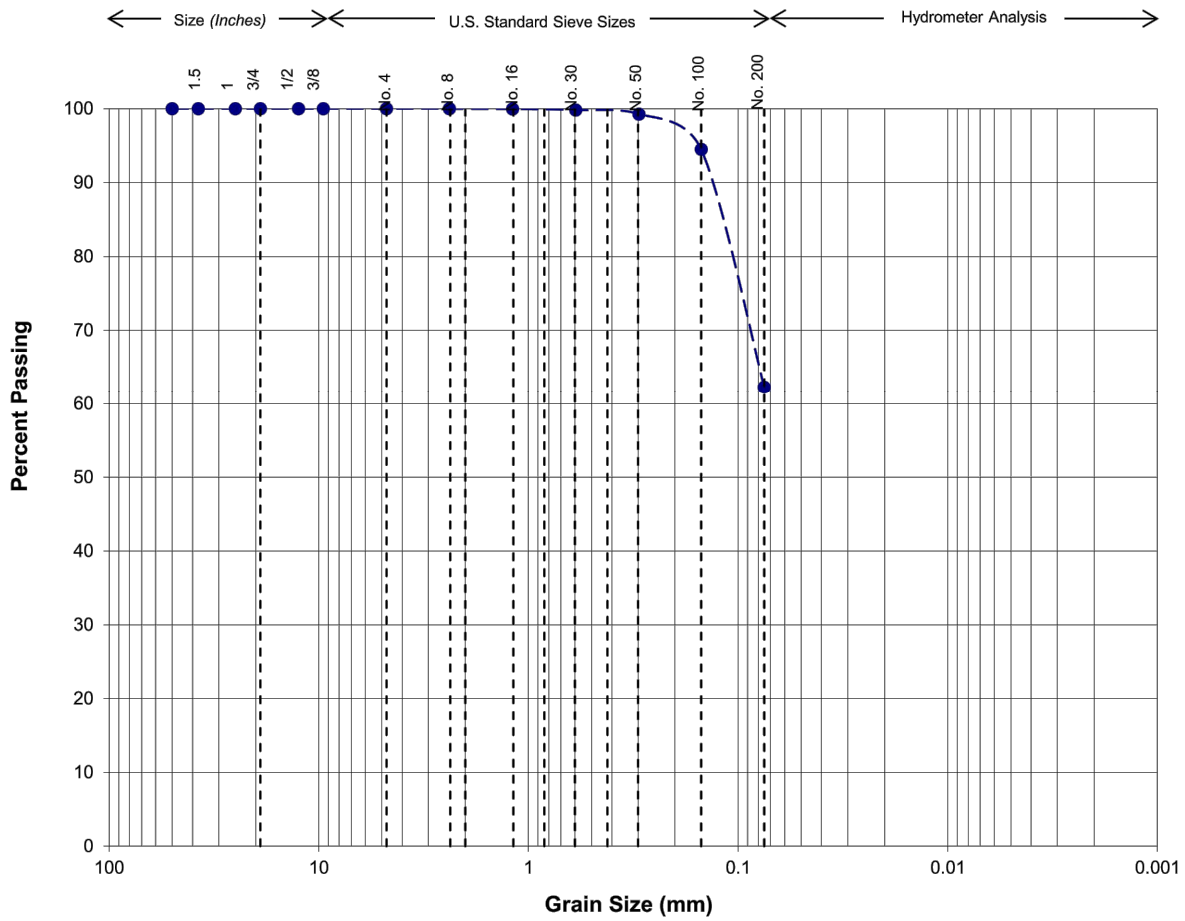

Gravel		Sand			Silt or Clay
Coarse	Fine	Coarse	Medium	Fine	

Sample Location: B - 1  
 Depth (ft): 20  
 USCS Soil Type: CL/ML  
 Passing No. 200 (%): 62



GEOTECHNICAL  
 MATERIALS  
 SPECIAL INSPECTION

DVBE • SBE • SDVOSB • SLBE  
 www.usa-nova.com

4373 Viewridge Avenue, Suite B  
 San Diego, CA 92123  
 P: 858.292.7575

944 Calle Amanecer, Suite F  
 San Clemente, CA 92673  
 P: 949.388.7710

## GRADATION ANALYSIS TEST RESULTS

**VIEWPOINT OLD TOWN**  
 4620 PACIFIC HIGHWAY  
 SAN DIEGO, CALIFORNIA

BY: GN

REVIEWED BY: MS

PROJECT: 2021073

FIGURE: E.5





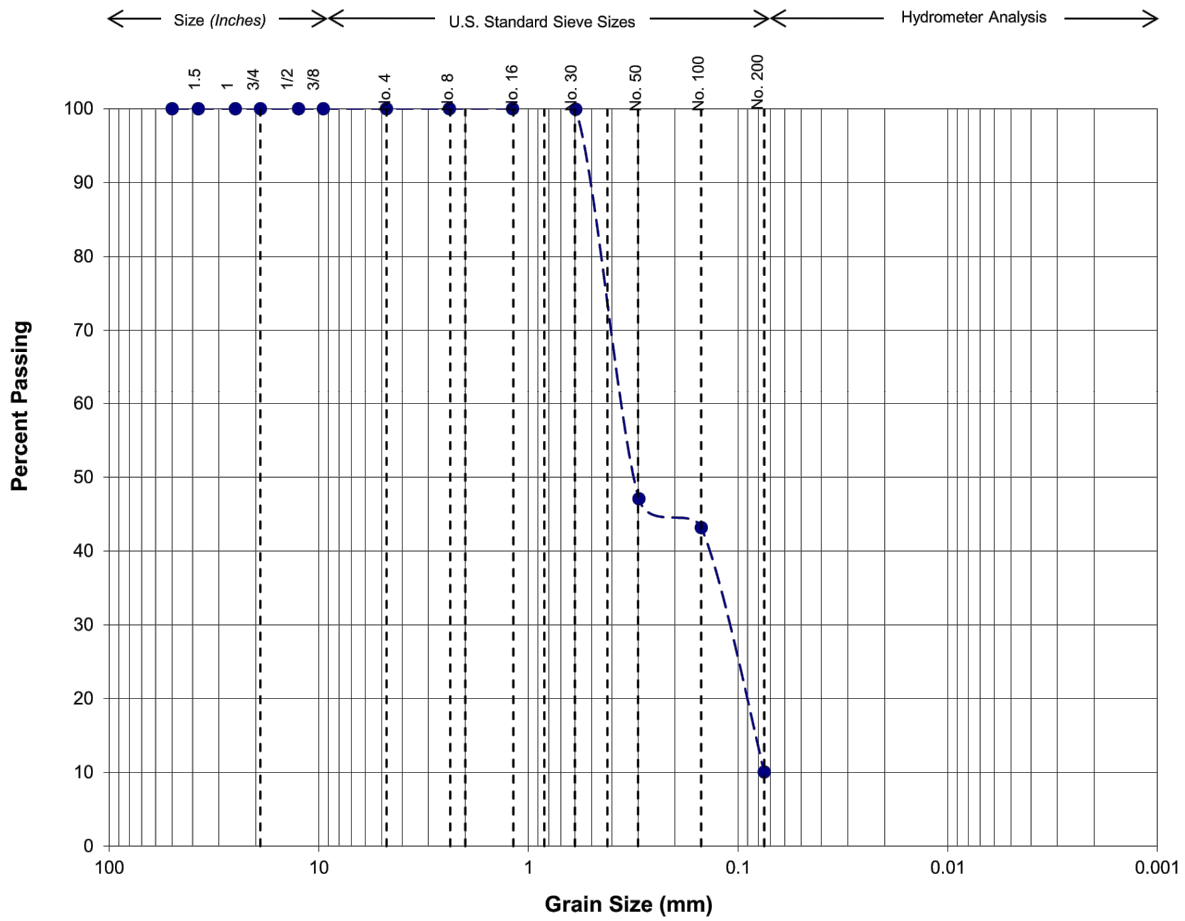

Gravel		Sand			Silt or Clay
Coarse	Fine	Coarse	Medium	Fine	

Sample Location: B - 1  
 Depth (ft): 30  
 USCS Soil Type: SP-SM  
 Passing No. 200 (%): 10



GEOTECHNICAL  
 MATERIALS  
 SPECIAL INSPECTION

DVBE • SBE • SDVOSB • SLBE  
 www.usa-nova.com

4373 Viewridge Avenue, Suite B  
 San Diego, CA 92123  
 P: 858.292.7575

944 Calle Amanecer, Suite F  
 San Clemente, CA 92673  
 P: 949.388.7710

## GRADATION ANALYSIS TEST RESULTS

**VIEWPOINT OLD TOWN**  
 4620 PACIFIC HIGHWAY  
 SAN DIEGO, CALIFORNIA

BY: GN

REVIEWED BY: MS

PROJECT: 2021073

FIGURE: E.7

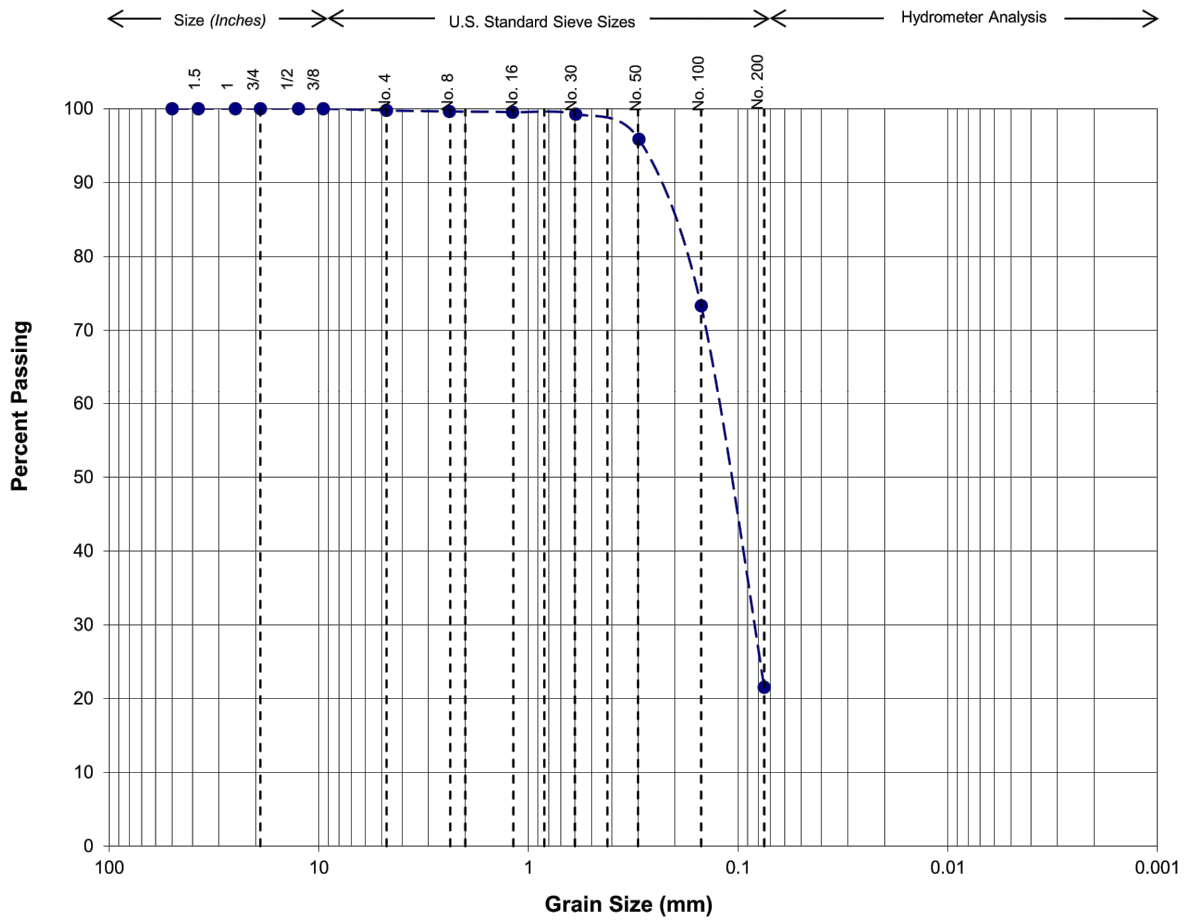

Gravel		Sand			Silt or Clay
Coarse	Fine	Coarse	Medium	Fine	

Sample Location: B - 1  
 Depth (ft): 35  
 USCS Soil Type: SM  
 Passing No. 200 (%): 22



GEOTECHNICAL  
 MATERIALS  
 SPECIAL INSPECTION

DVBE • SBE • SDVOSB • SLBE  
 www.usa-nova.com

4373 Viewridge Avenue, Suite B  
 San Diego, CA 92123  
 P: 858.292.7575

944 Calle Amanecer, Suite F  
 San Clemente, CA 92673  
 P: 949.388.7710

## GRADATION ANALYSIS TEST RESULTS

**VIEWPOINT OLD TOWN**  
 4620 PACIFIC HIGHWAY  
 SAN DIEGO, CALIFORNIA

BY: GN

REVIEWED BY: MS

PROJECT: 2021073

FIGURE: E.8

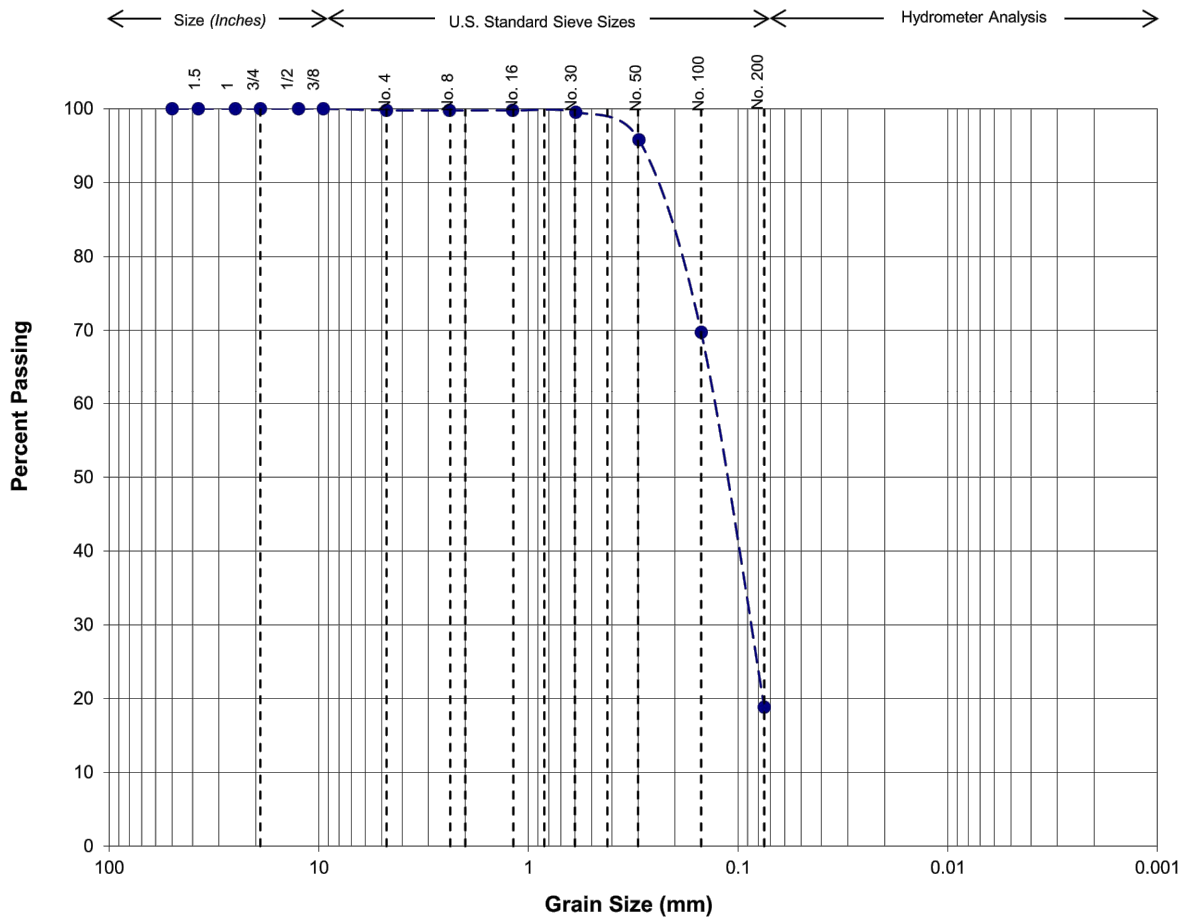

Gravel		Sand			Silt or Clay
Coarse	Fine	Coarse	Medium	Fine	

Sample Location: B - 1  
 Depth (ft): 40  
 USCS Soil Type: SM  
 Passing No. 200 (%): 19



GEOTECHNICAL  
 MATERIALS  
 SPECIAL INSPECTION

DVBE • SBE • SDVOSB • SLBE  
 www.usa-nova.com

4373 Viewridge Avenue, Suite B  
 San Diego, CA 92123  
 P: 858.292.7575

944 Calle Amanecer, Suite F  
 San Clemente, CA 92673  
 P: 949.388.7710

## GRADATION ANALYSIS TEST RESULTS

**VIEWPOINT OLD TOWN**  
 4620 PACIFIC HIGHWAY  
 SAN DIEGO, CALIFORNIA

BY: GN

REVIEWED BY: MS

PROJECT: 2021073

FIGURE: E.9

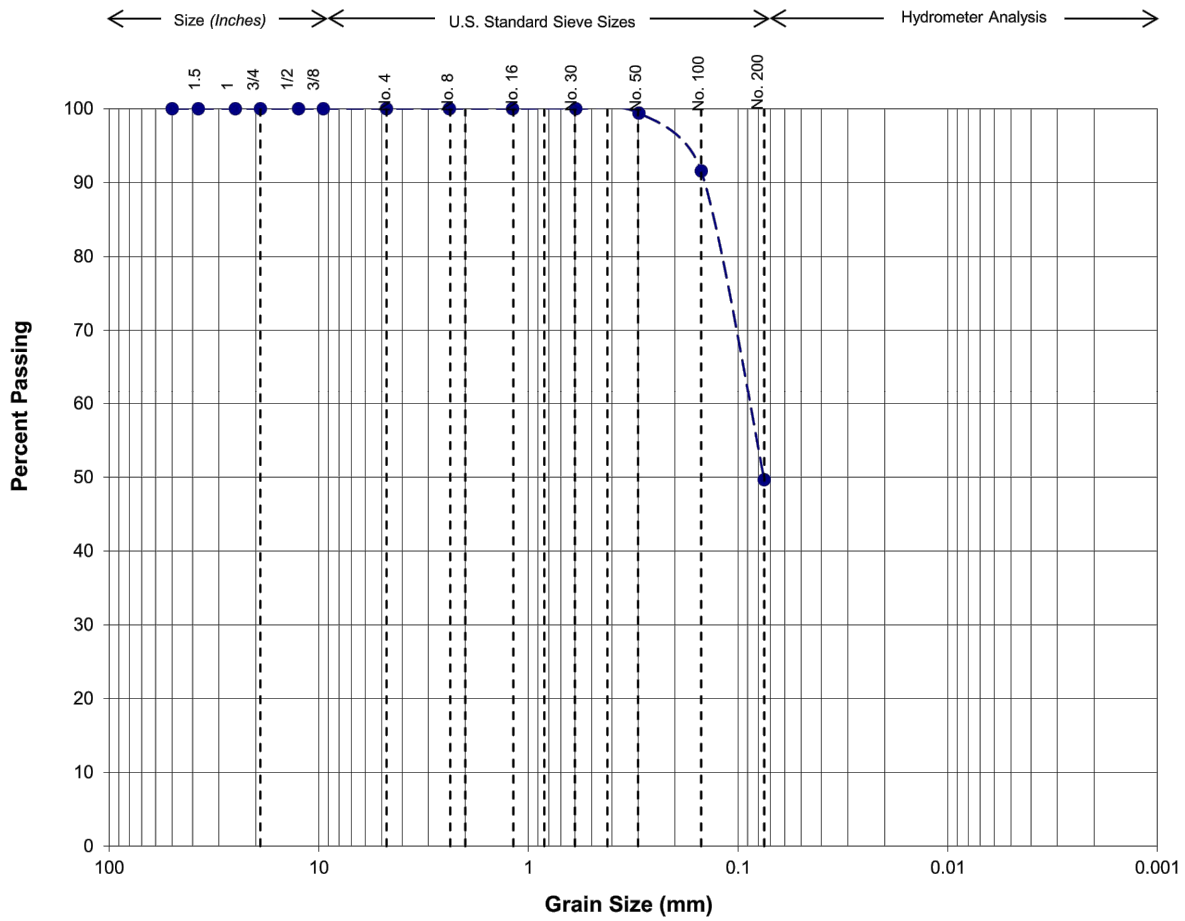

Gravel		Sand			Silt or Clay
Coarse	Fine	Coarse	Medium	Fine	

Sample Location: B - 1  
 Depth (ft): 50  
 USCS Soil Type: SM-ML  
 Passing No. 200 (%): 50



GEOTECHNICAL  
 MATERIALS  
 SPECIAL INSPECTION

DVBE • SBE • SDVOSB • SLBE  
 www.usa-nova.com

4373 Viewridge Avenue, Suite B  
 San Diego, CA 92123  
 P: 858.292.7575

944 Calle Amanecer, Suite F  
 San Clemente, CA 92673  
 P: 949.388.7710

## GRADATION ANALYSIS TEST RESULTS

**VIEWPOINT OLD TOWN**  
 4620 PACIFIC HIGHWAY  
 SAN DIEGO, CALIFORNIA

BY: GN

REVIEWED BY: MS

PROJECT: 2021073

FIGURE: E.10

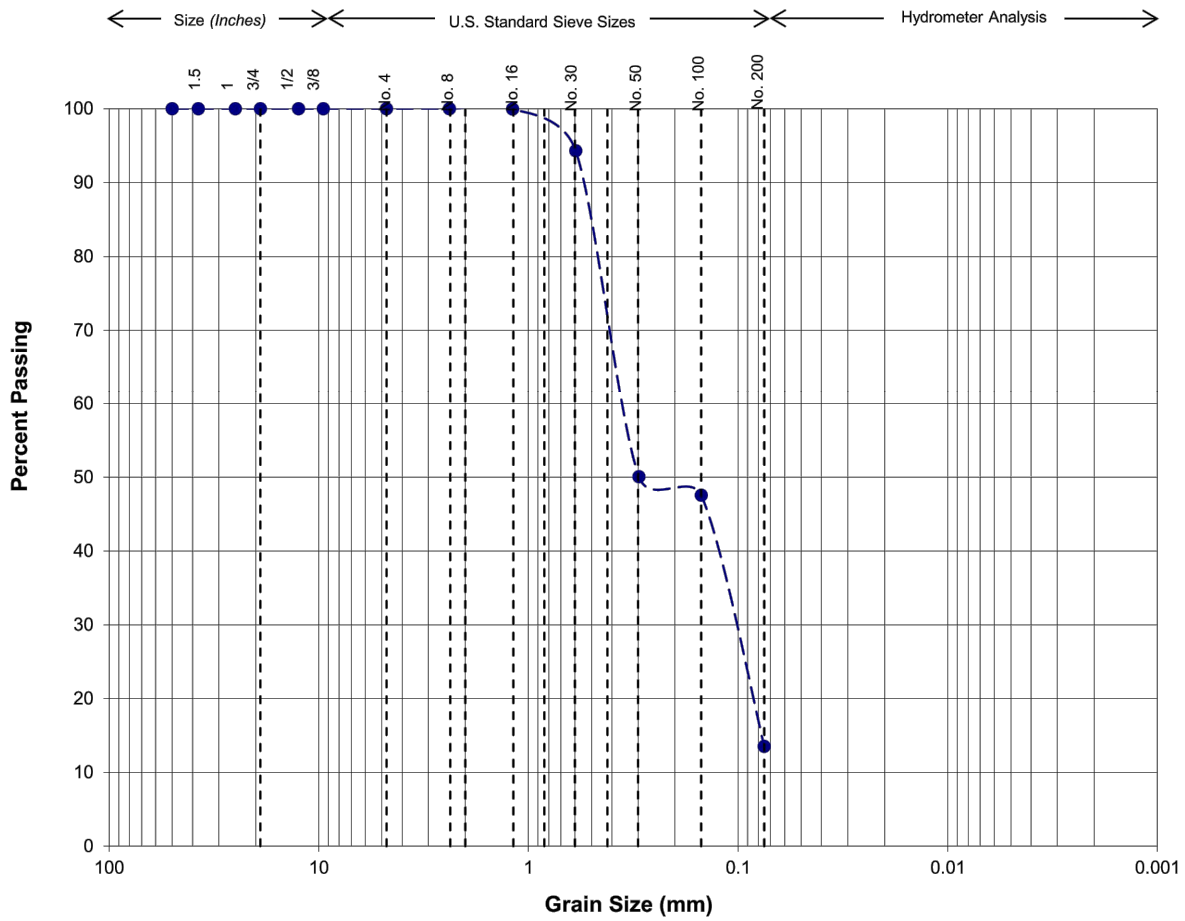

Gravel		Sand			Silt or Clay
Coarse	Fine	Coarse	Medium	Fine	

Sample Location: B - 1  
 Depth (ft): 60  
 USCS Soil Type: SP-SM  
 Passing No. 200 (%): 14



GEOTECHNICAL  
 MATERIALS  
 SPECIAL INSPECTION

DVBE • SBE • SDVOSB • SLBE  
 www.usa-nova.com

4373 Viewridge Avenue, Suite B  
 San Diego, CA 92123  
 P: 858.292.7575

944 Calle Amanecer, Suite F  
 San Clemente, CA 92673  
 P: 949.388.7710

## GRADATION ANALYSIS TEST RESULTS

**VIEWPOINT OLD TOWN**  
 4620 PACIFIC HIGHWAY  
 SAN DIEGO, CALIFORNIA

BY: GN

REVIEWED BY: MS

PROJECT: 2021073

FIGURE: E.11



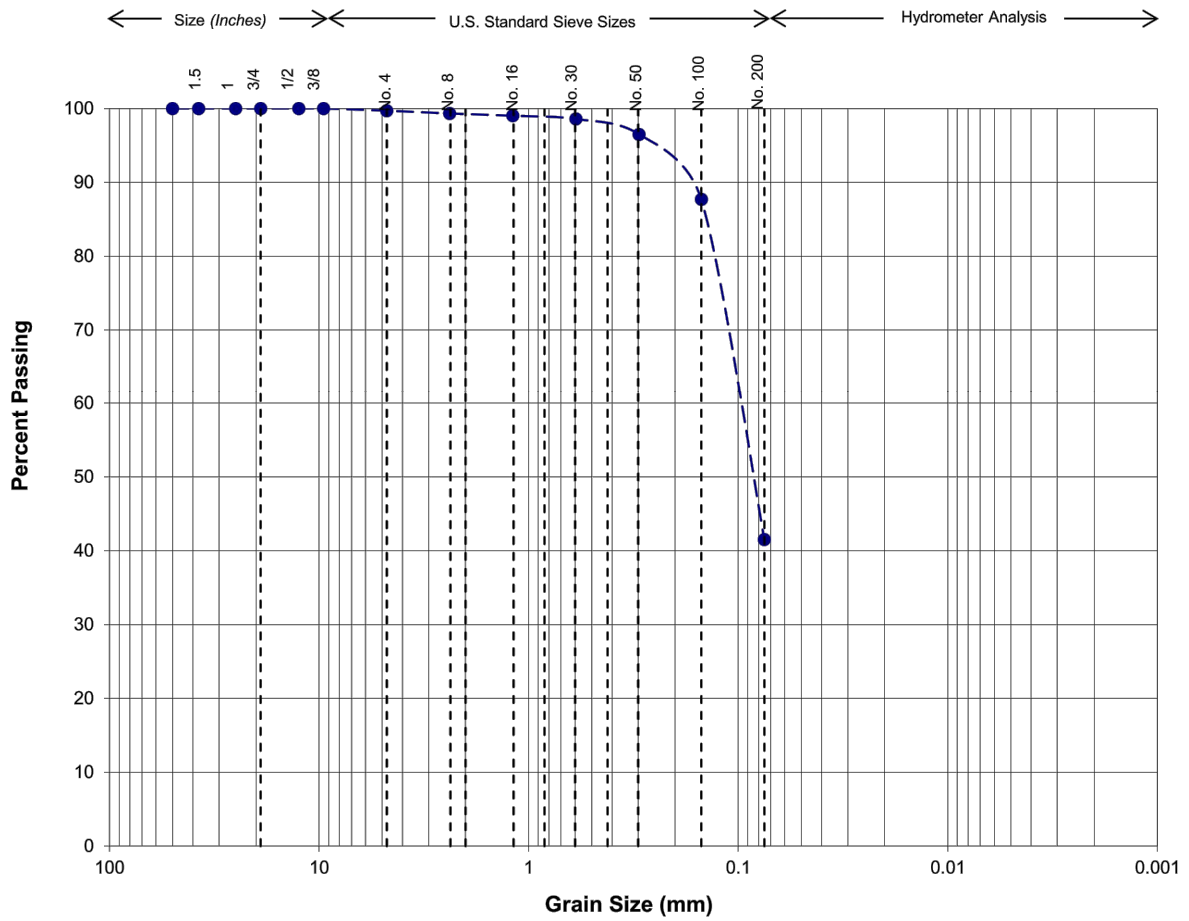

Gravel		Sand			Silt or Clay
Coarse	Fine	Coarse	Medium	Fine	

Sample Location: B - 1  
 Depth (ft): 70  
 USCS Soil Type: SM/SC  
 Passing No. 200 (%): 42



GEOTECHNICAL  
 MATERIALS  
 SPECIAL INSPECTION

DVBE • SBE • SDVOSB • SLBE  
 www.usa-nova.com

4373 Viewridge Avenue, Suite B  
 San Diego, CA 92123  
 P: 858.292.7575

944 Calle Amanecer, Suite F  
 San Clemente, CA 92673  
 P: 949.388.7710

## GRADATION ANALYSIS TEST RESULTS

**VIEWPOINT OLD TOWN**  
 4620 PACIFIC HIGHWAY  
 SAN DIEGO, CALIFORNIA

BY: GN

REVIEWED BY: MS

PROJECT: 2021073

FIGURE: E.12

### Maximum Dry Density and Optimum Moisture Content (ASTM D1557)

Sample Location	Sample Depth (ft.)	Maximum Dry Density (pcf)	Optimum Moisture Content (%)
B - 1	2 - 5	133.0	10.1

### R-Value (Cal. Test Method 301 & ASTM D2844)

Sample Location	Sample Depth (ft.)	R-Value
B - 1	0 - 8	60

### Corrosivity (Cal. Test Method 417,422,643)

Sample Location	Sample Depth (ft.)	pH	Resistivity (Ohm-cm)	Sulfate Content (ppm)	Sulfate Content (%)	Chloride Content (ppm)	Chloride Content (%)
B - 1	1 - 6	8.6	2400	84	0.008	53	0.005
B - 2	13½ - 15	8.2	1400	90	0.009	170	0.017

### Water-Soluble Sulfate Exposure (ACI 318 Table 19.3.1.1 and Table 19.3.2.1)

Water-Soluble Sulfate (SO <sub>4</sub> ) in Soil (% by Weight)	Exposure Severity	Exposure Class	Cement Type (ASTM C150)	Max. W/C	Min. f <sub>c</sub> ' (psi)
SO <sub>4</sub> < 0.10	N/A	S0	No type restriction	N/A	2,500
0.10 ≤ SO <sub>4</sub> < 0.20	Moderate	S1	II	0.50	4,000
0.20 ≤ SO <sub>4</sub> ≤ 0.20	Severe	S2	V	0.45	4,500
SO <sub>4</sub> > 2.00	Very Severe	S3	V plus pozzolan or slag cement	0.45	4,500

## LAB TEST RESULTS

VIEWPOINT OLD TOWN  
4620 PACIFIC HIGHWAY  
SAN DIEGO, CALIFORNIA

BY: GN

REVIEWED BY: MS

PROJECT: 2021073

FIGURE: E.13



GEOTECHNICAL  
MATERIALS  
SPECIAL INSPECTION

DVBE • SBE • SDVOSB • SLBE

www.usa-nova.com

4373 Viewridge Avenue, Suite B  
San Diego, CA 92123  
P: 858.292.7575

944 Calle Amanecer, Suite F  
San Clemente, CA 92673  
P: 949.388.7710



# **APPENDIX F**

## **LIQUEFACTION ANALYSES**

## TABLE OF CONTENTS

<b>CPT - 1 results</b>	
Summary data report	1
Transition layer algorithm summary report	8
Vertical settlements summary report	9
<b>CPT - 2 results</b>	
Summary data report	10
Transition layer algorithm summary report	17
Vertical settlements summary report	18
<b>CPT - 3 results</b>	
Summary data report	19
Transition layer algorithm summary report	26
Vertical settlements summary report	27



**LIQUEFACTION ANALYSIS REPORT**

**Project title : Old Town Viewpoint**

**Location : San Diego, California**

**CPT file : CPT - 1**

**Input parameters and analysis data**

Analysis method:	NCEER (1998)	G.W.T. (in-situ):	9.50 ft	Use fill:	No	Clay like behavior applied:	Sands only
Fines correction method:	NCEER (1998)	G.W.T. (earthq.):	9.50 ft	Fill height:	N/A	Limit depth applied:	Yes
Points to test:	Based on Ic value	Average results interval:	3	Fill weight:	N/A	Limit depth:	60.00 ft
Earthquake magnitude $M_w$ :	6.99	Ic cut-off value:	2.60	Trans. detect. applied:	Yes	MSF method:	Method based
Peak ground acceleration:	0.69	Unit weight calculation:	Based on SBT	$K_o$ applied:	Yes		

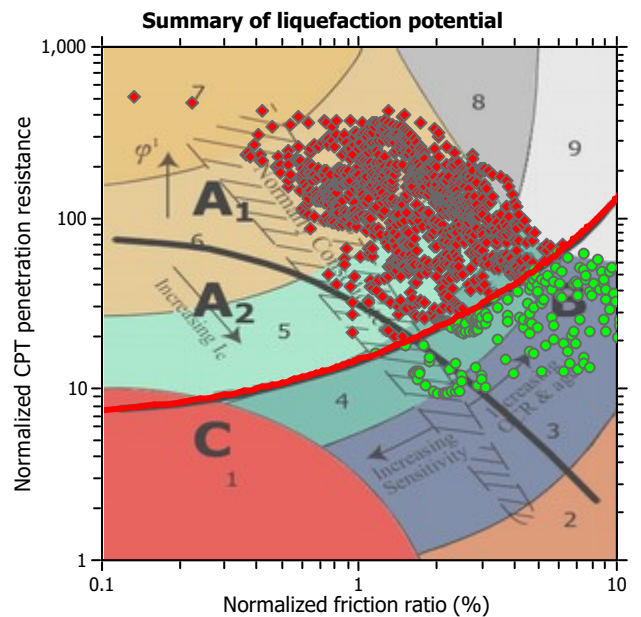
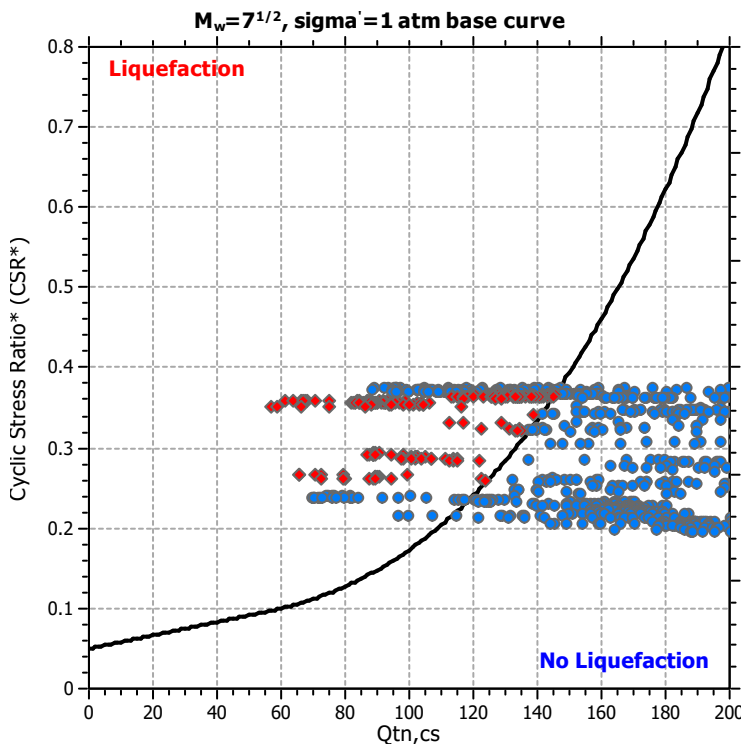
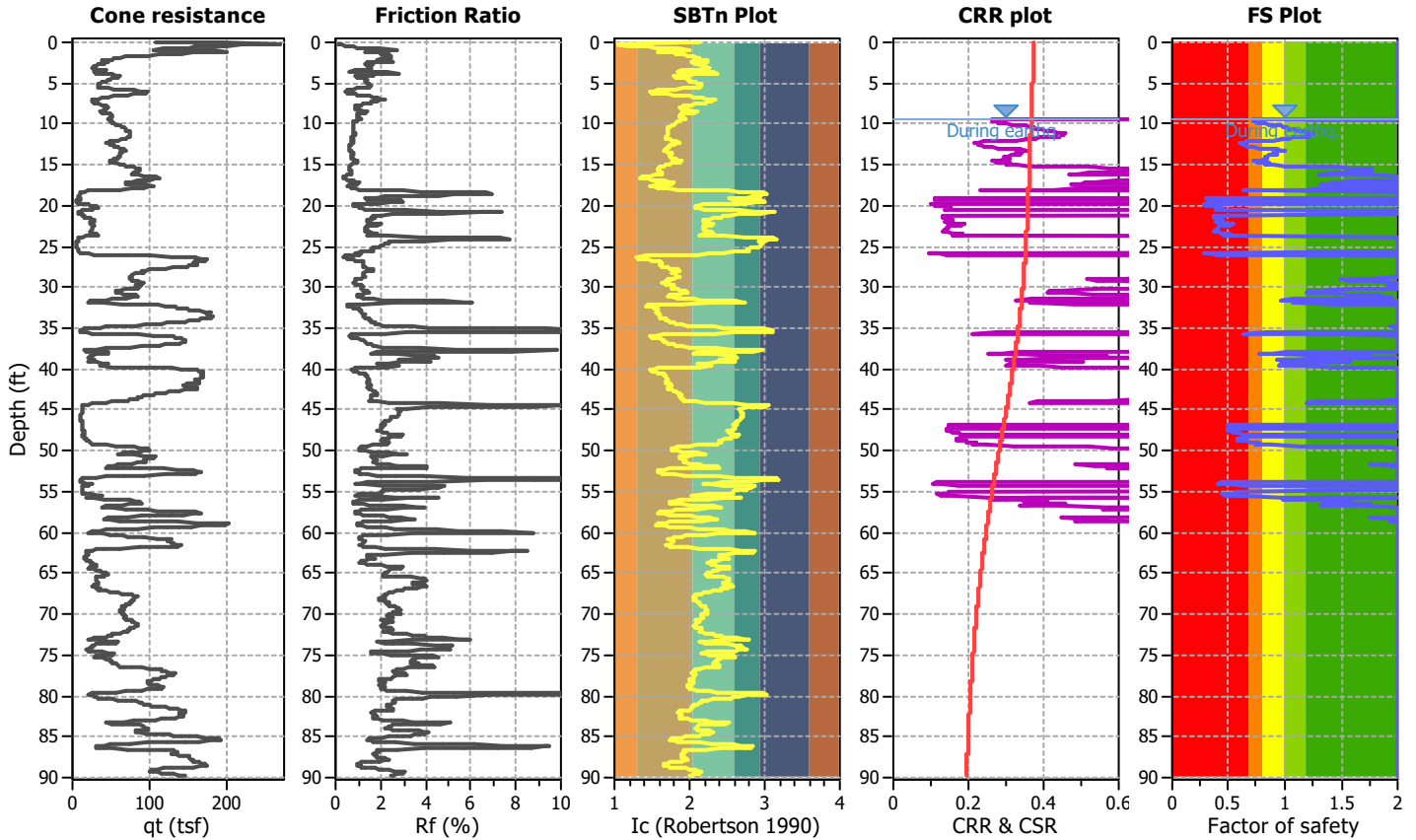

Zone A<sub>1</sub>: Cyclic liquefaction likely depending on size and duration of cyclic loading  
 Zone A<sub>2</sub>: Cyclic liquefaction and strength loss likely depending on loading and ground geometry  
 Zone B: Liquefaction and post-earthquake strength loss unlikely, check cyclic softening  
 Zone C: Cyclic liquefaction and strength loss possible depending on soil plasticity, brittleness/sensitivity, strain to peak undrained strength and ground geometry



### CPT basic interpretation plots

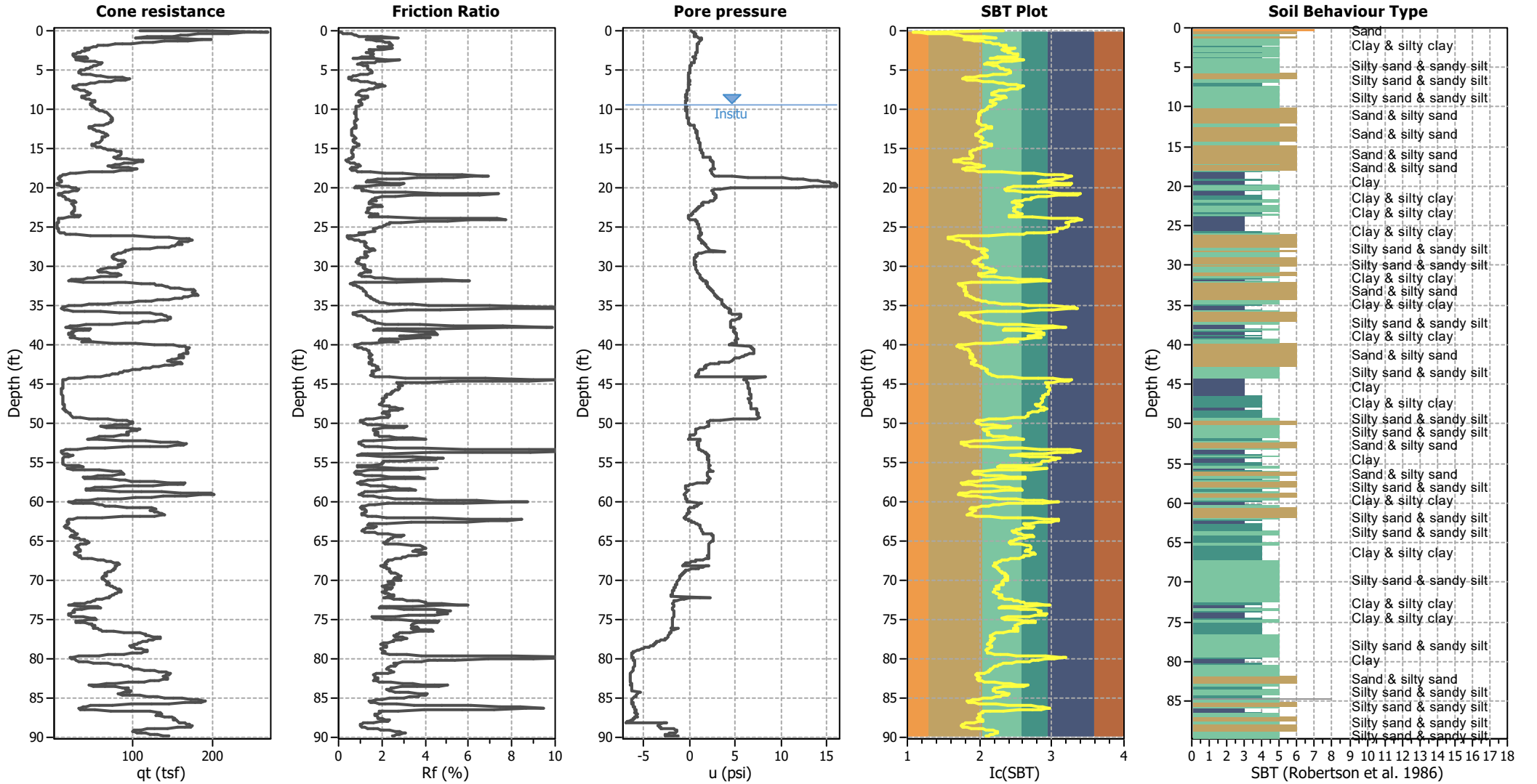

#### Input parameters and analysis data

Analysis method:	NCEER (1998)	Depth to water table (earthq.):	9.50 ft	Fill weight:	N/A
Fines correction method:	NCEER (1998)	Average results interval:	3	Transition detect. applied:	Yes
Points to test:	Based on Ic value	Ic cut-off value:	2.60	K <sub>o</sub> applied:	Yes
Earthquake magnitude M <sub>w</sub> :	6.99	Unit weight calculation:	Based on SBT	Clay like behavior applied:	Sands only
Peak ground acceleration:	0.69	Use fill:	No	Limit depth applied:	Yes
Depth to water table (insitu):	9.50 ft	Fill height:	N/A	Limit depth:	60.00 ft

#### SBT legend

1. Sensitive fine grained	4. Clayey silt to silty	7. Gravely sand to sand
2. Organic material	5. Silty sand to sandy silt	8. Very stiff sand to
3. Clay to silty clay	6. Clean sand to silty sand	9. Very stiff fine grained

### CPT basic interpretation plots (normalized)

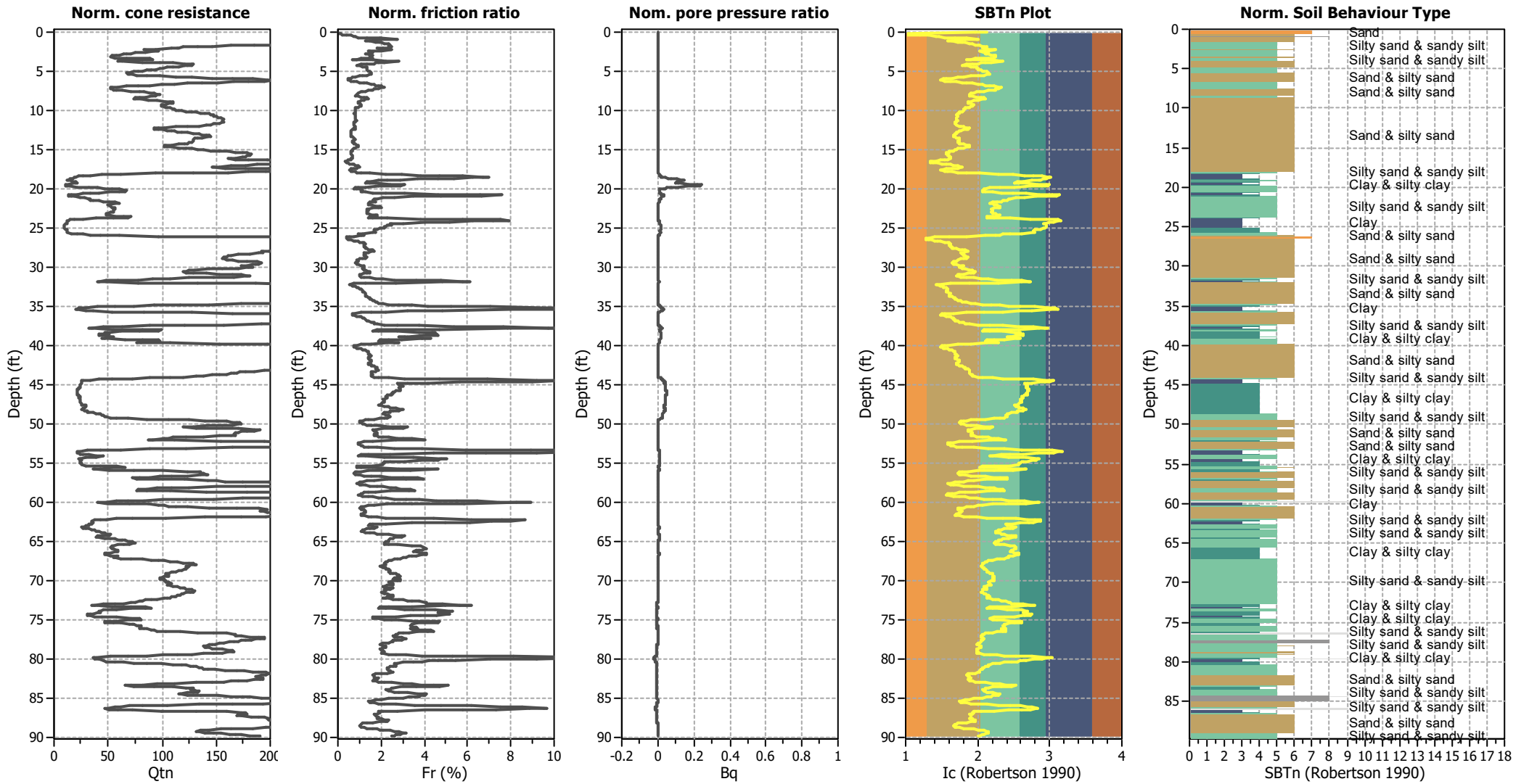

#### Input parameters and analysis data

Analysis method:	NCEER (1998)	Depth to water table (erthq.):	9.50 ft	Fill weight:	N/A
Fines correction method:	NCEER (1998)	Average results interval:	3	Transition detect. applied:	Yes
Points to test:	Based on Ic value	Ic cut-off value:	2.60	$K_o$ applied:	Yes
Earthquake magnitude $M_w$ :	6.99	Unit weight calculation:	Based on SBT	Clay like behavior applied:	Sands only
Peak ground acceleration:	0.69	Use fill:	No	Limit depth applied:	Yes
Depth to water table (insitu):	9.50 ft	Fill height:	N/A	Limit depth:	60.00 ft

#### SBTn legend

1. Sensitive fine grained	4. Clayey silt to silty	7. Gravely sand to sand
2. Organic material	5. Silty sand to sandy silt	8. Very stiff sand to
3. Clay to silty clay	6. Clean sand to silty sand	9. Very stiff fine grained

### Liquefaction analysis overall plots (intermediate results)

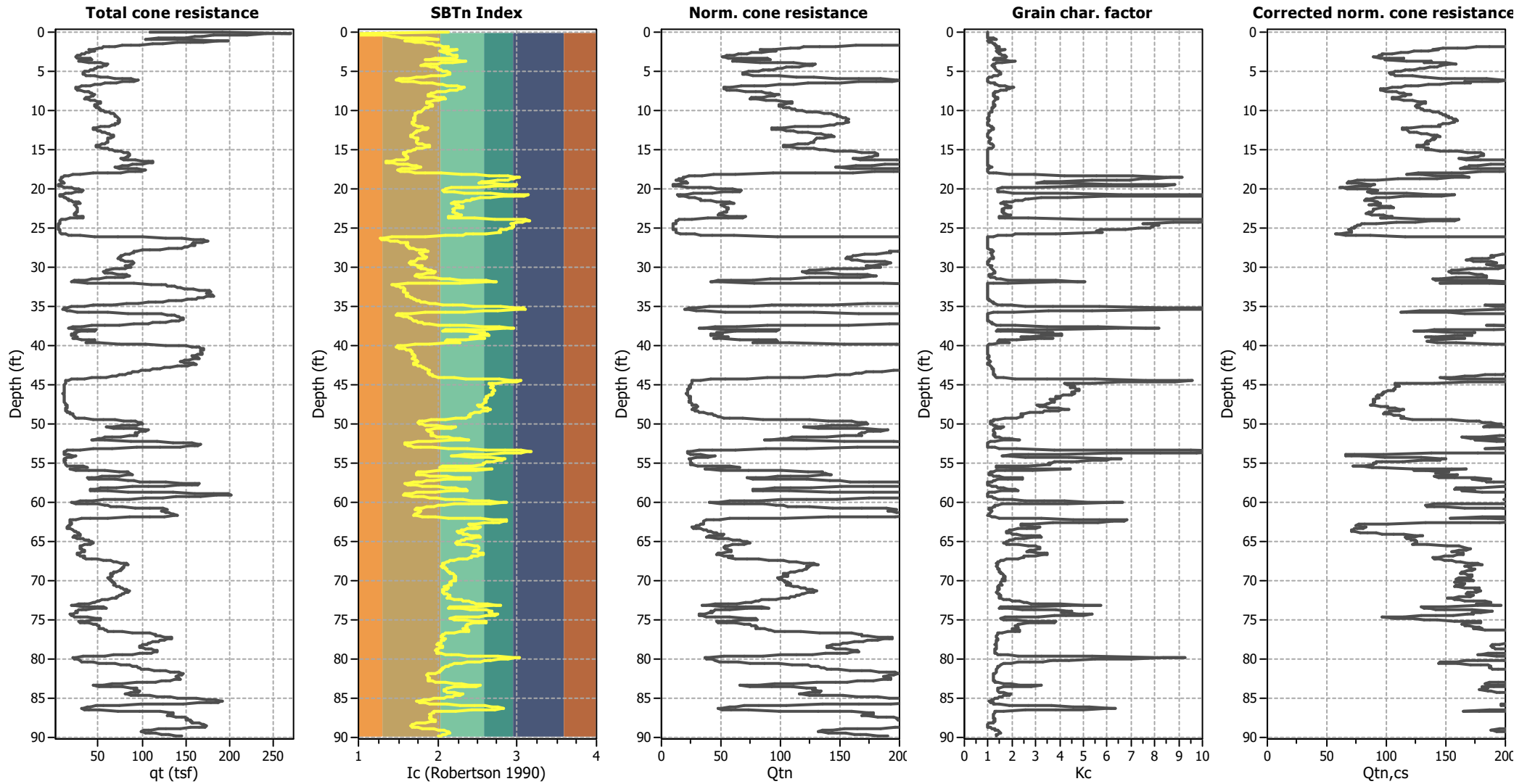

#### Input parameters and analysis data

Analysis method:	NCEER (1998)	Depth to water table (erthq.):	9.50 ft	Fill weight:	N/A
Fines correction method:	NCEER (1998)	Average results interval:	3	Transition detect. applied:	Yes
Points to test:	Based on Ic value	Ic cut-off value:	2.60	K <sub>o</sub> applied:	Yes
Earthquake magnitude M <sub>w</sub> :	6.99	Unit weight calculation:	Based on SBT	Clay like behavior applied:	Sands only
Peak ground acceleration:	0.69	Use fill:	No	Limit depth applied:	Yes
Depth to water table (insitu):	9.50 ft	Fill height:	N/A	Limit depth:	60.00 ft

### Liquefaction analysis overall plots

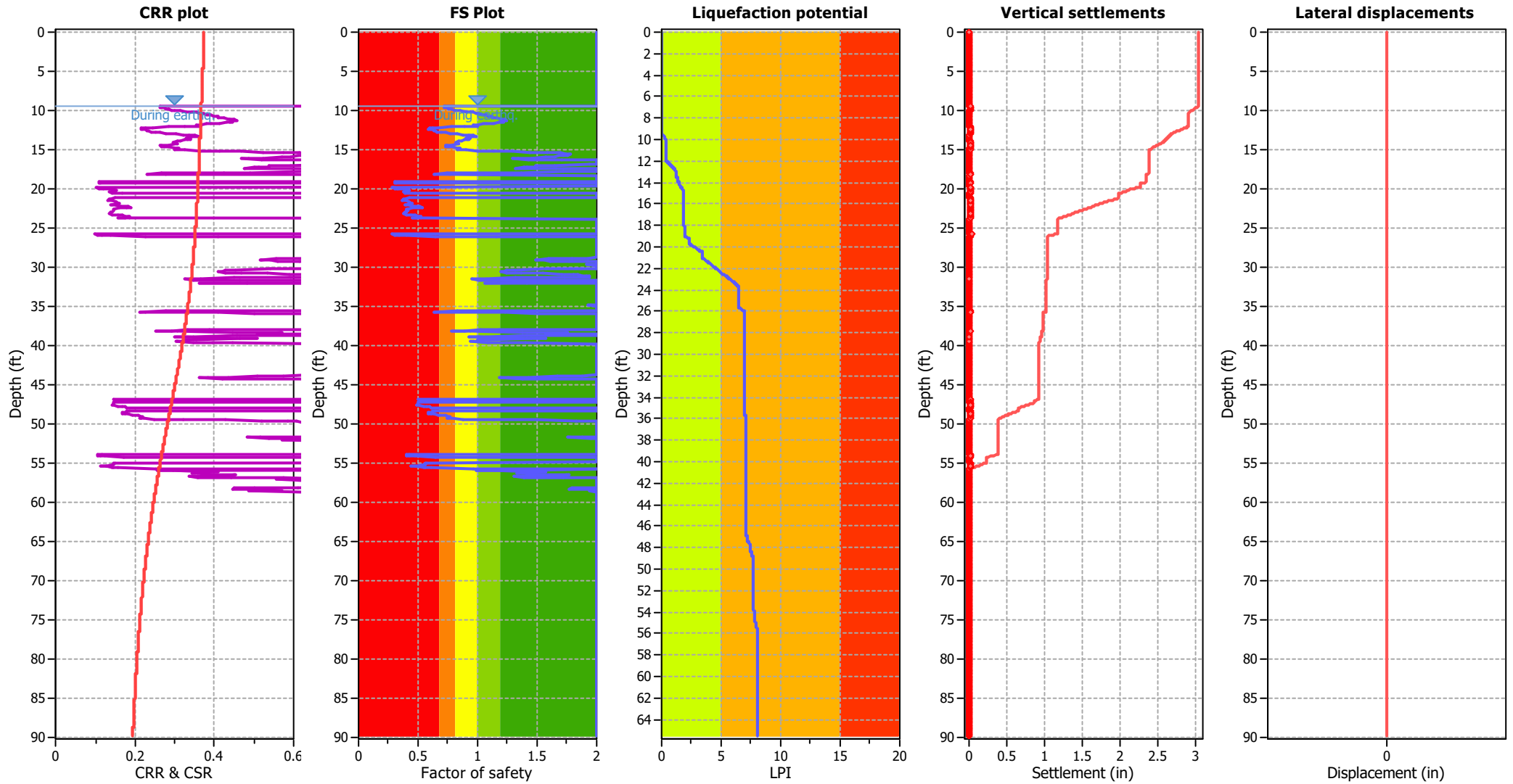

**Input parameters and analysis data**

Analysis method:	NCEER (1998)	Depth to water table (earthq.):	9.50 ft	Fill weight:	N/A
Fines correction method:	NCEER (1998)	Average results interval:	3	Transition detect. applied:	Yes
Points to test:	Based on Ic value	Ic cut-off value:	2.60	$K_0$ applied:	Yes
Earthquake magnitude $M_w$ :	6.99	Unit weight calculation:	Based on SBT	Clay like behavior applied:	Sands only
Peak ground acceleration:	0.69	Use fill:	No	Limit depth applied:	Yes
Depth to water table (insitu):	9.50 ft	Fill height:	N/A	Limit depth:	60.00 ft

**F.S. color scheme**

- Almost certain it will liquefy
- Very likely to liquefy
- Liquefaction and no liq. are equally likely
- Unlike to liquefy
- Almost certain it will not liquefy

**LPI color scheme**

- Very high risk
- High risk
- Low risk

### Liquefaction analysis summary plots

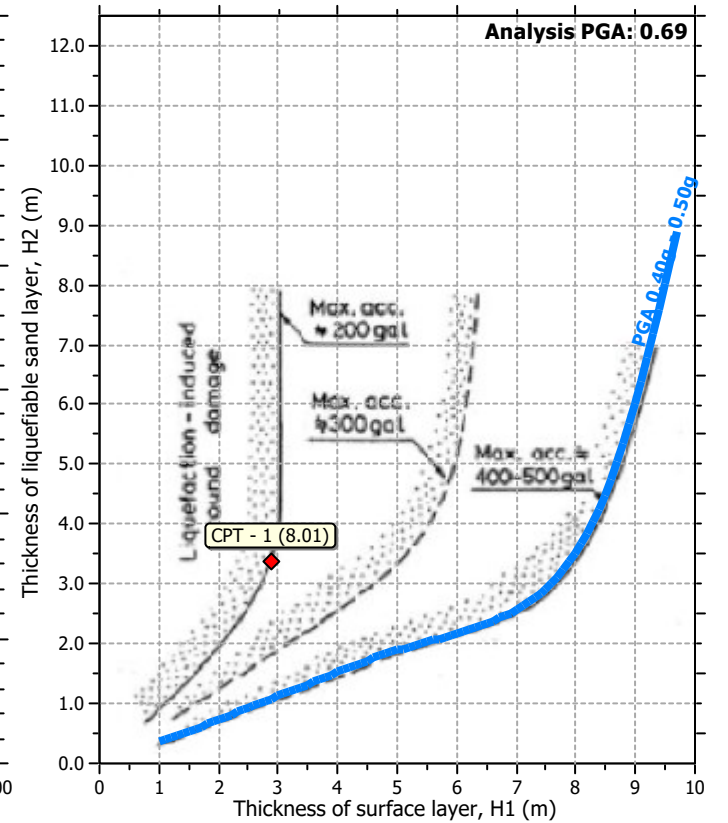
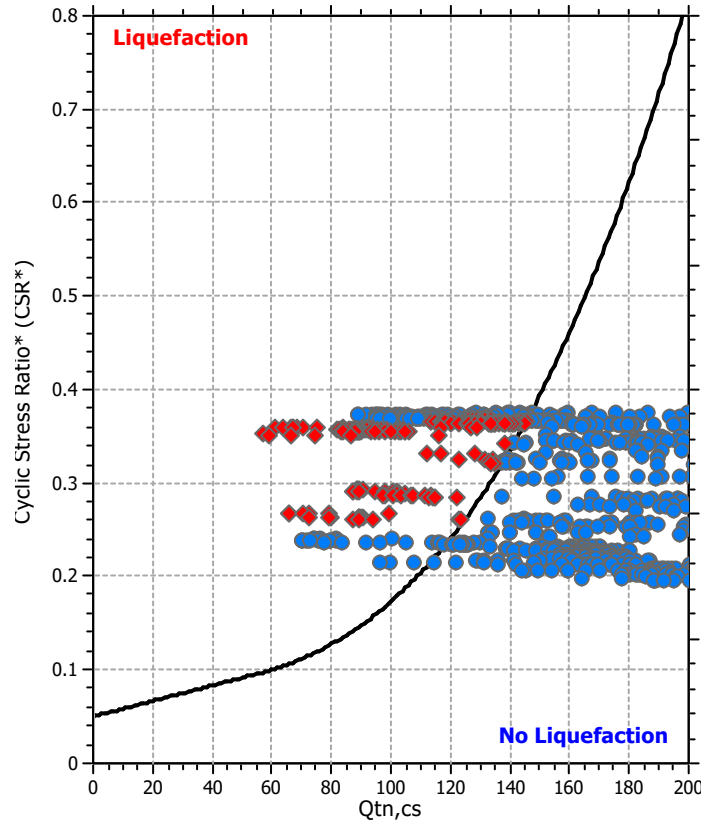
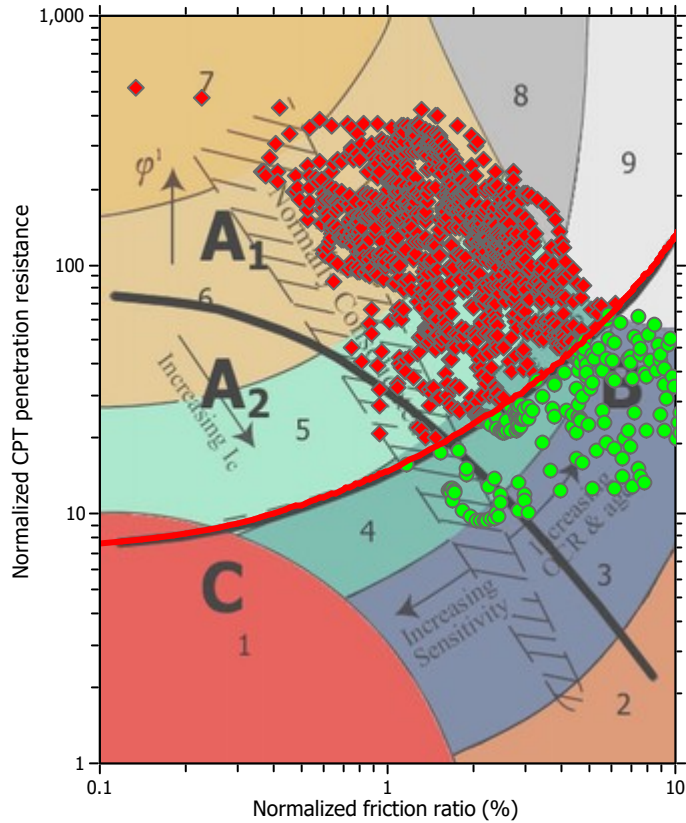

**Input parameters and analysis data**

Analysis method:	NCEER (1998)	Depth to water table (earthq.):	9.50 ft	Fill weight:	N/A
Fines correction method:	NCEER (1998)	Average results interval:	3	Transition detect. applied:	Yes
Points to test:	Based on Ic value	Ic cut-off value:	2.60	K <sub>o</sub> applied:	Yes
Earthquake magnitude M <sub>w</sub> :	6.99	Unit weight calculation:	Based on SBT	Clay like behavior applied:	Sands only
Peak ground acceleration:	0.69	Use fill:	No	Limit depth applied:	Yes
Depth to water table (insitu):	9.50 ft	Fill height:	N/A	Limit depth:	60.00 ft



### Check for strength loss plots (Robertson (2010))

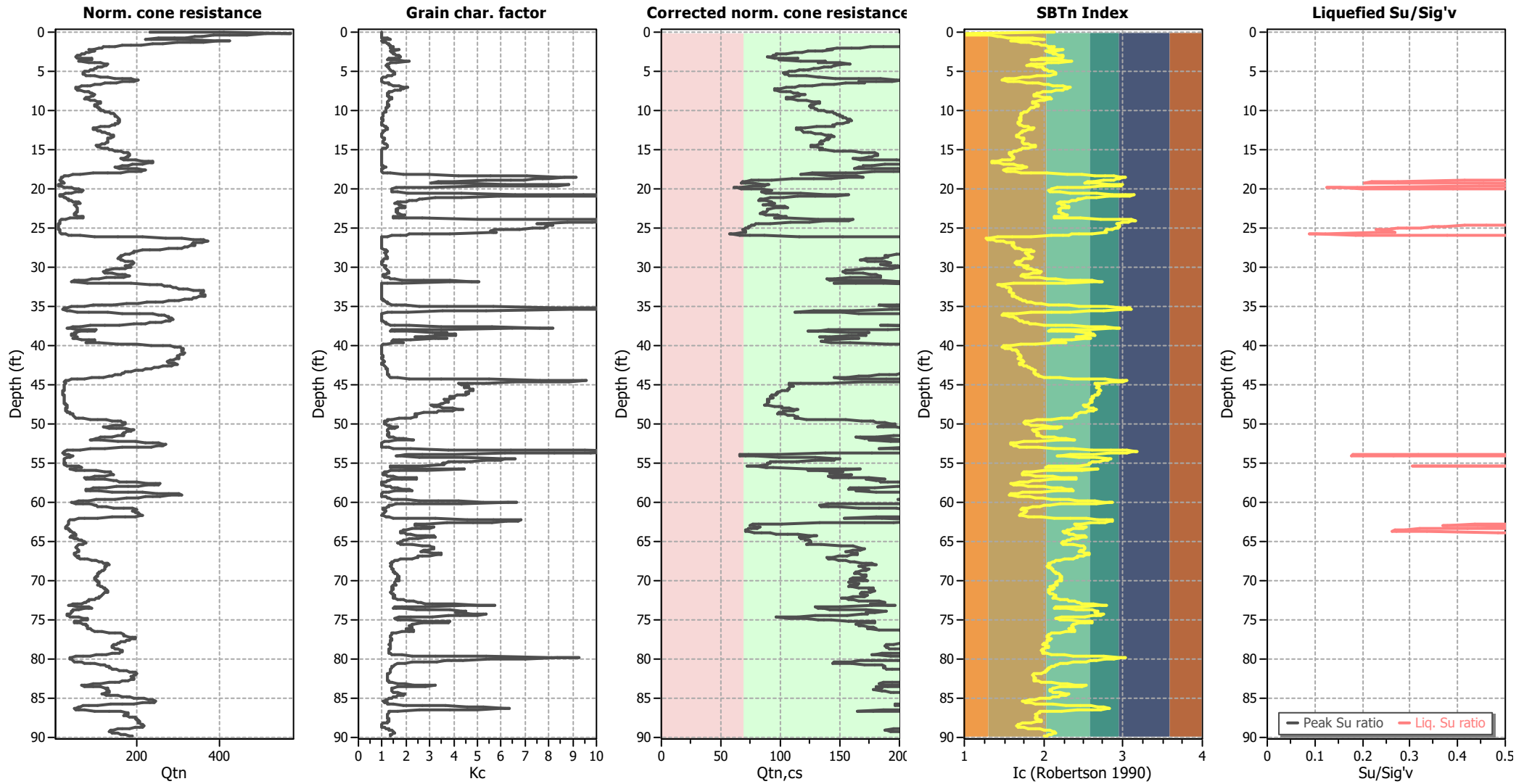

#### Input parameters and analysis data

Analysis method:	NCEER (1998)	Depth to water table (earthq.):	9.50 ft	Fill weight:	N/A
Fines correction method:	NCEER (1998)	Average results interval:	3	Transition detect. applied:	Yes
Points to test:	Based on Ic value	Ic cut-off value:	2.60	K <sub>o</sub> applied:	Yes
Earthquake magnitude M <sub>w</sub> :	6.99	Unit weight calculation:	Based on SBT	Clay like behavior applied:	Sands only
Peak ground acceleration:	0.69	Use fill:	No	Limit depth applied:	Yes
Depth to water table (insitu):	9.50 ft	Fill height:	N/A	Limit depth:	60.00 ft

## TRANSITION LAYER DETECTION ALGORITHM REPORT

### Summary Details & Plots

#### Short description

The software will delete data when the cone is in transition from either clay to sand or vice-versa. To do this the software requires a range of  $I_c$  values over which the transition will be defined (typically somewhere between  $1.80 < I_c < 3.0$ ) and a rate of change of  $I_c$ . Transitions typically occur when the rate of change of  $I_c$  is fast (i.e.  $\Delta I_c$  is small).

The  $SBT_n$  plot below, displays in red the detected transition layers based on the parameters listed below the graphs.

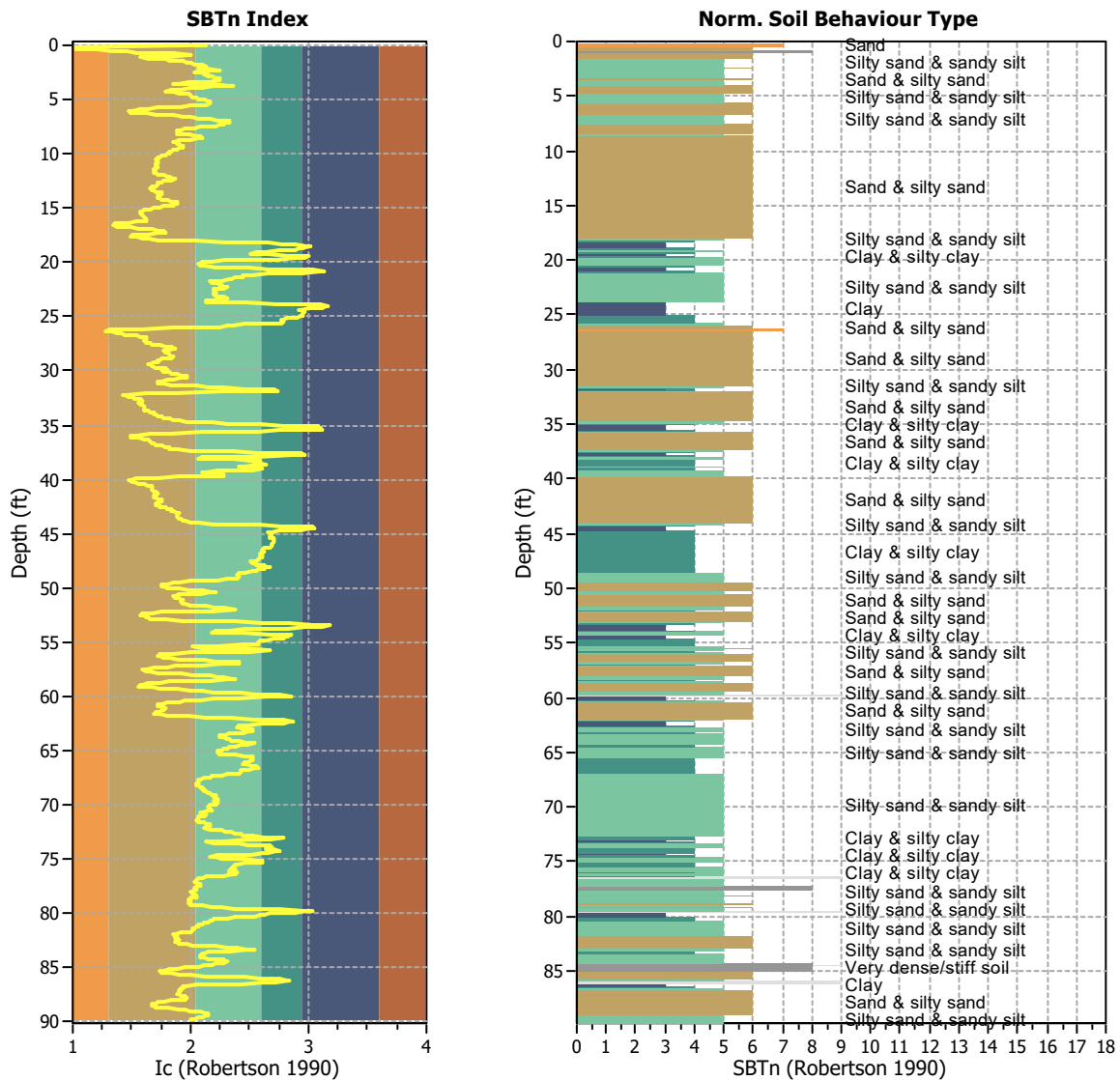

#### Transition layer algorithm properties

$I_c$  minimum check value: 1.70  
 $I_c$  maximum check value: 1.70  
 $I_c$  change ratio value: 3.0000  
 Minimum number of points in layer: -26215

#### General statistics

Total points in CPT file: 1369  
 Total points excluded: 0  
 Exclusion percentage: 0.00%  
 Number of layers detected: 0

### Estimation of post-earthquake settlements

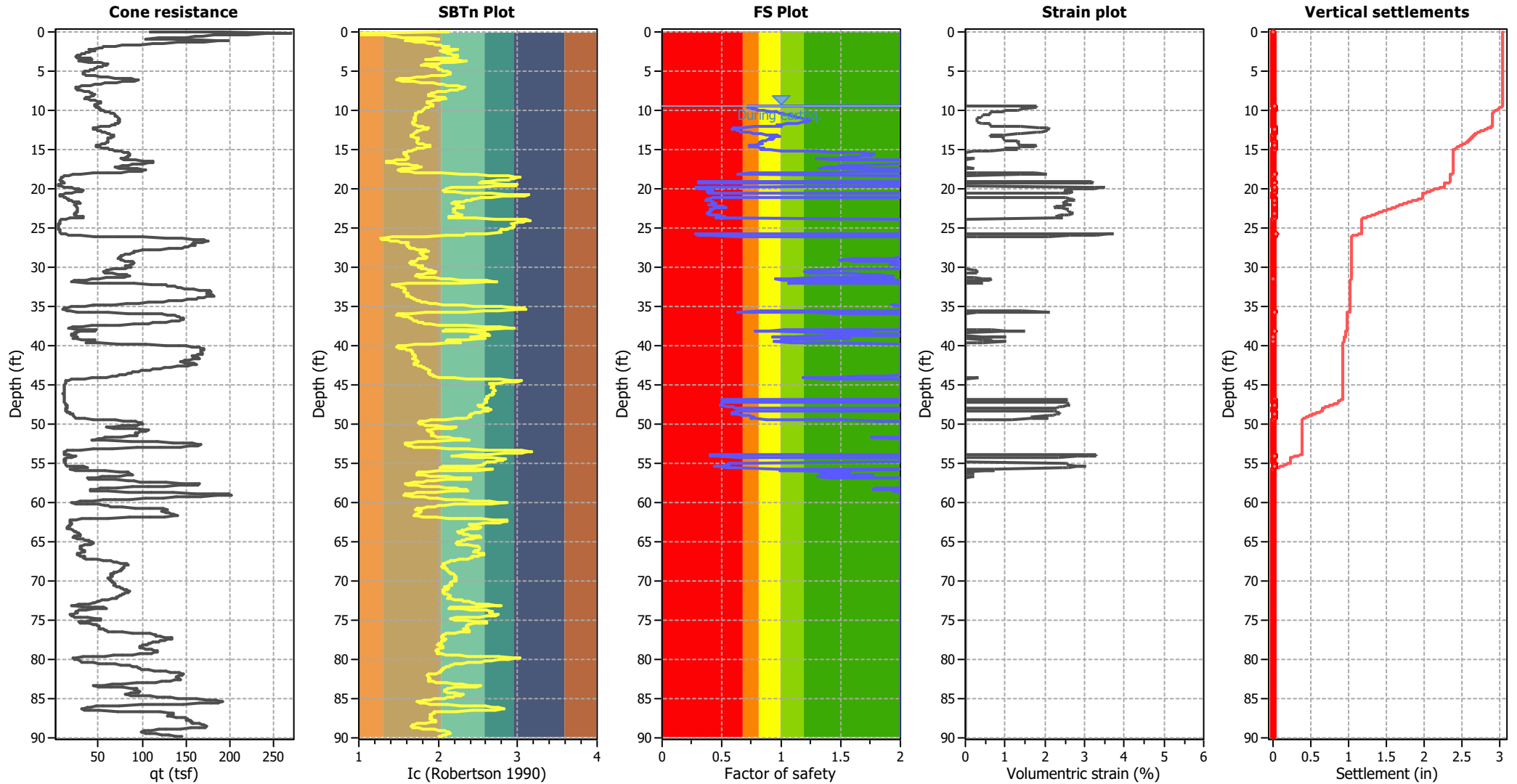

**Abbreviations**

- q<sub>c</sub>: Total cone resistance (cone resistance q<sub>c</sub> corrected for pore water effects)
- I<sub>c</sub>: Soil Behaviour Type Index
- FS: Calculated Factor of Safety against liquefaction
- Volumetric strain: Post-liquefaction volumetric strain



**LIQUEFACTION ANALYSIS REPORT**

**Project title : Old Town Viewpoint**

**Location : San Diego, California**

**CPT file : CPT - 2**

**Input parameters and analysis data**

Analysis method:	NCEER (1998)	G.W.T. (in-situ):	9.50 ft	Use fill:	No	Clay like behavior applied:	Sands only
Fines correction method:	NCEER (1998)	G.W.T. (earthq.):	9.50 ft	Fill height:	N/A	Limit depth applied:	Yes
Points to test:	Based on Ic value	Average results interval:	3	Fill weight:	N/A	Limit depth:	60.00 ft
Earthquake magnitude $M_w$ :	6.99	Ic cut-off value:	2.60	Trans. detect. applied:	Yes	MSF method:	Method based
Peak ground acceleration:	0.69	Unit weight calculation:	Based on SBT	$K_o$ applied:	Yes		

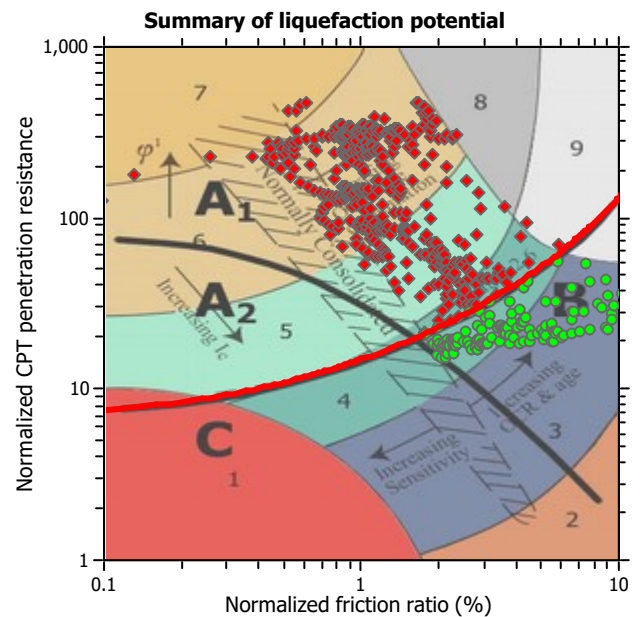
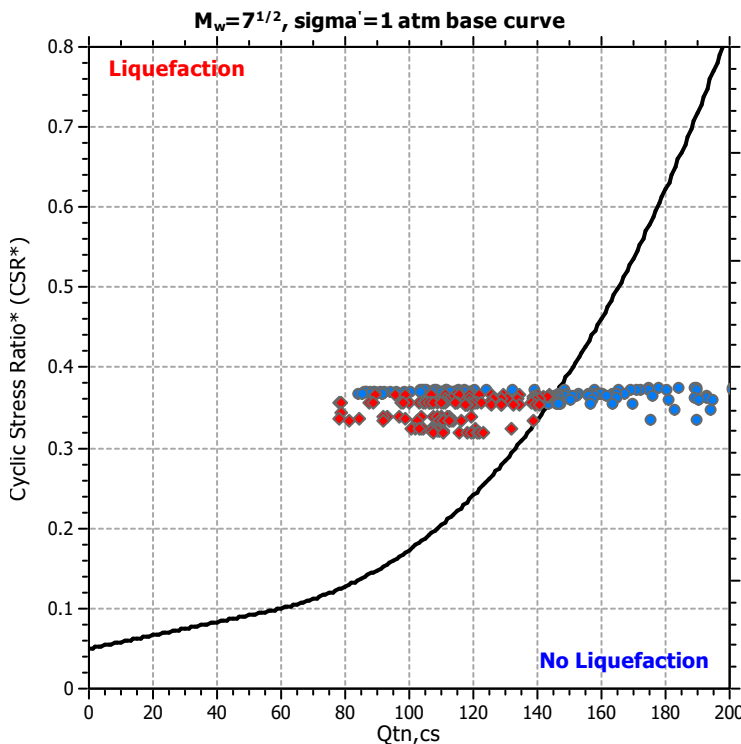
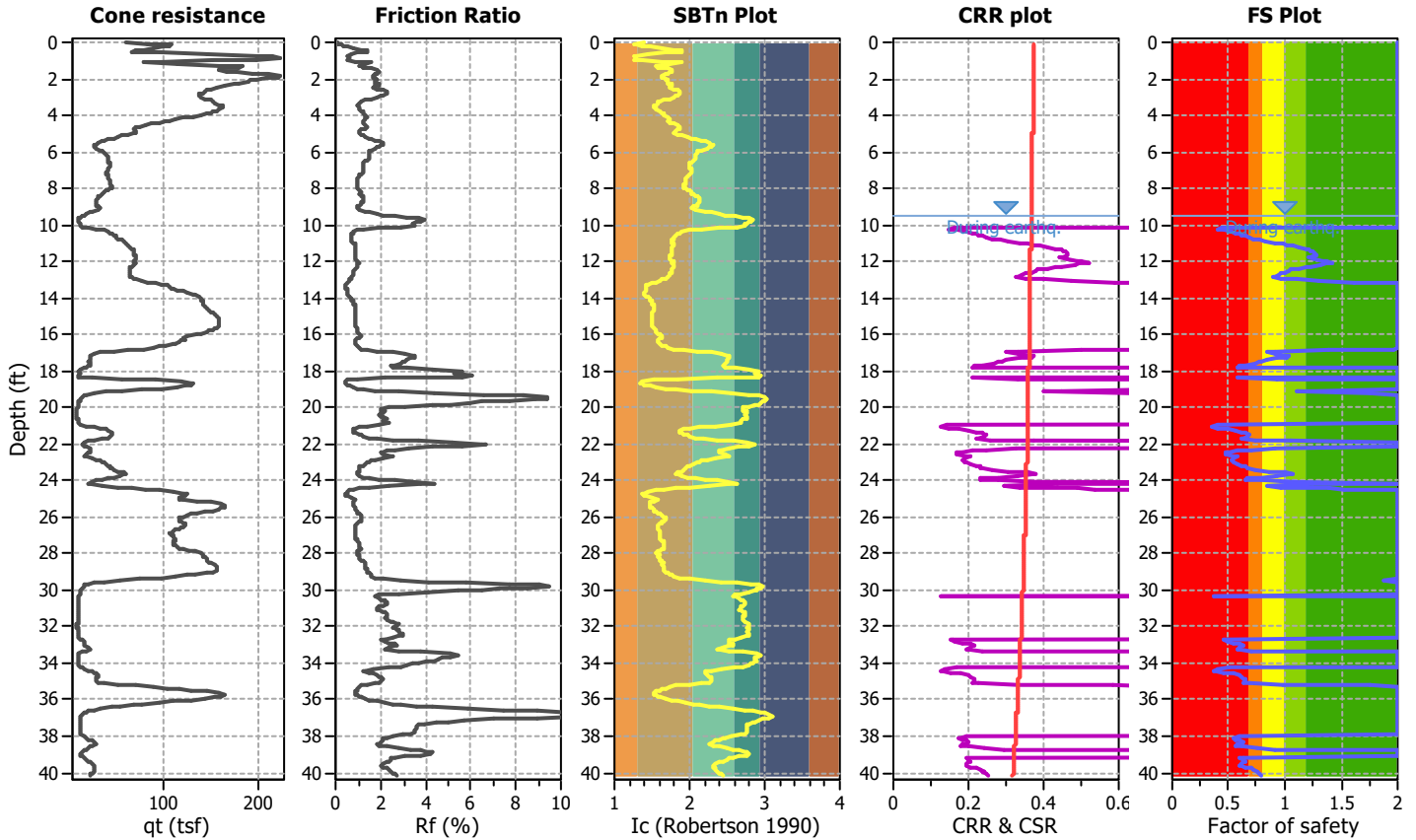

Zone A<sub>1</sub>: Cyclic liquefaction likely depending on size and duration of cyclic loading  
 Zone A<sub>2</sub>: Cyclic liquefaction and strength loss likely depending on loading and ground geometry  
 Zone B: Liquefaction and post-earthquake strength loss unlikely, check cyclic softening  
 Zone C: Cyclic liquefaction and strength loss possible depending on soil plasticity, brittleness/sensitivity, strain to peak undrained strength and ground geometry

### CPT basic interpretation plots

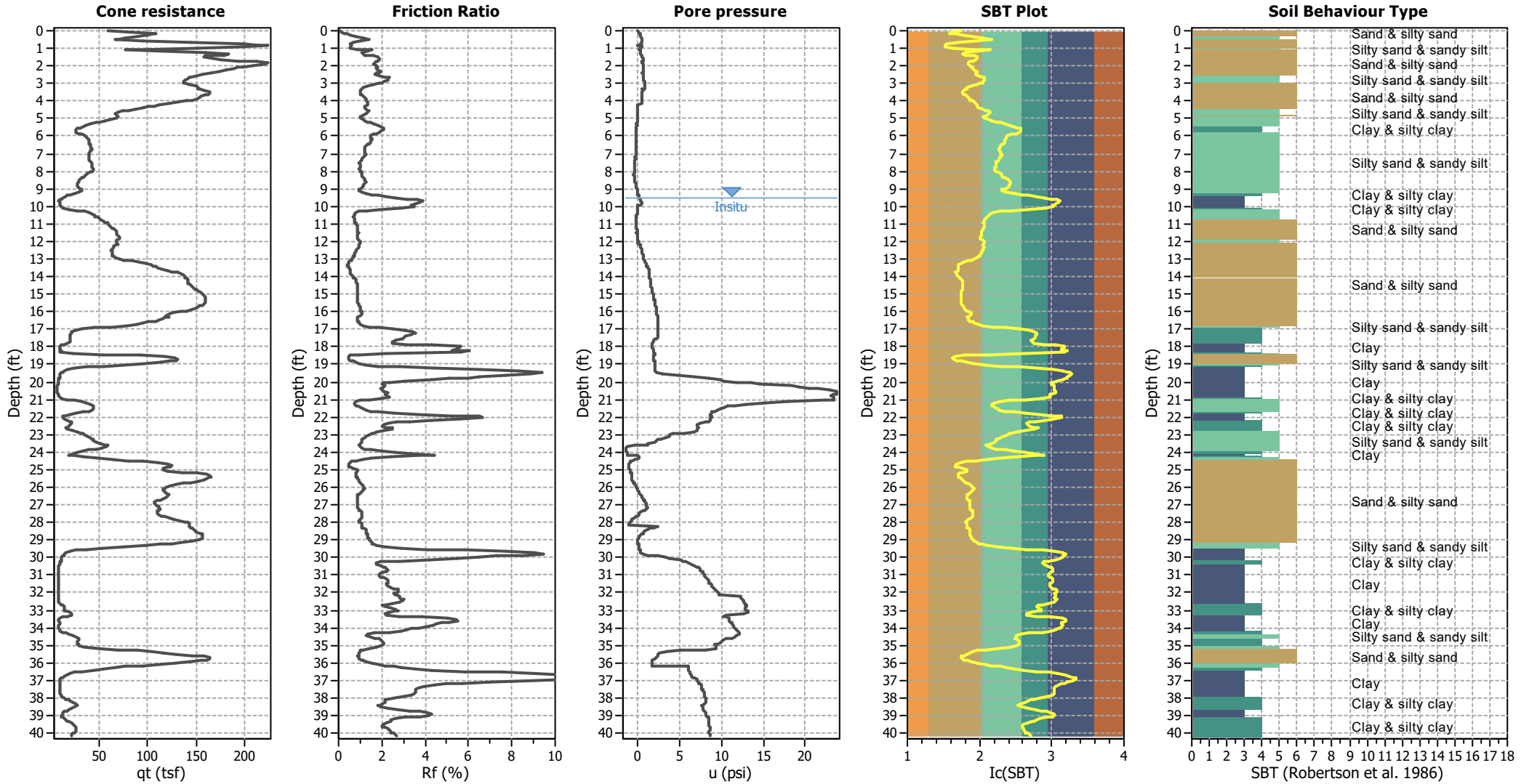

#### Input parameters and analysis data

Analysis method:	NCEER (1998)	Depth to water table (erthq.):	9.50 ft	Fill weight:	N/A
Fines correction method:	NCEER (1998)	Average results interval:	3	Transition detect. applied:	Yes
Points to test:	Based on Ic value	Ic cut-off value:	2.60	K <sub>o</sub> applied:	Yes
Earthquake magnitude M <sub>w</sub> :	6.99	Unit weight calculation:	Based on SBT	Clay like behavior applied:	Sands only
Peak ground acceleration:	0.69	Use fill:	No	Limit depth applied:	Yes
Depth to water table (insitu):	9.50 ft	Fill height:	N/A	Limit depth:	60.00 ft

#### SBT legend

1. Sensitive fine grained	4. Clayey silt to silty	7. Gravely sand to sand
2. Organic material	5. Silty sand to sandy silt	8. Very stiff sand to
3. Clay to silty clay	6. Clean sand to silty sand	9. Very stiff fine grained



### CPT basic interpretation plots (normalized)

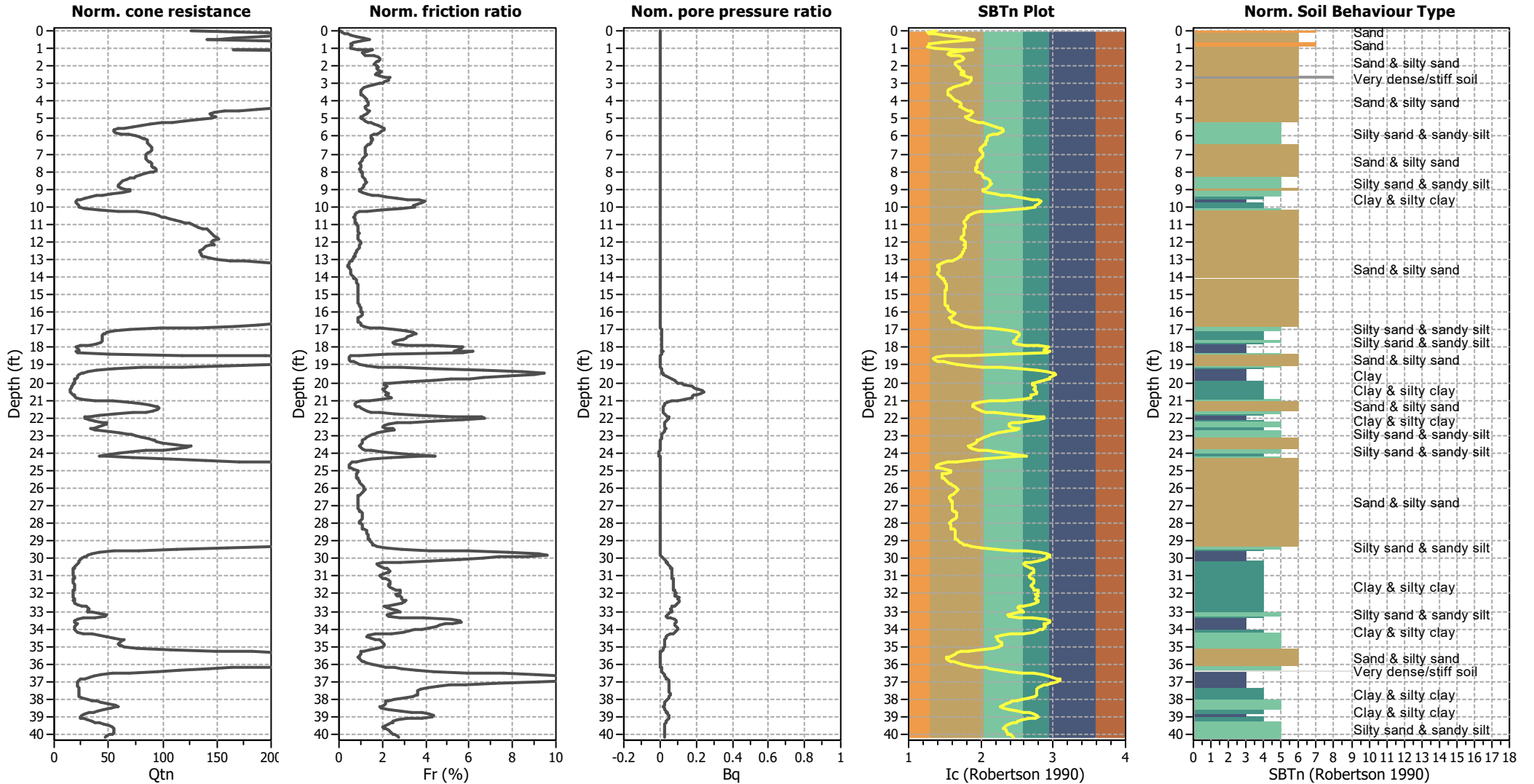

#### Input parameters and analysis data

Analysis method:	NCEER (1998)	Depth to water table (erthq.):	9.50 ft	Fill weight:	N/A
Fines correction method:	NCEER (1998)	Average results interval:	3	Transition detect. applied:	Yes
Points to test:	Based on Ic value	Ic cut-off value:	2.60	K <sub>o</sub> applied:	Yes
Earthquake magnitude M <sub>w</sub> :	6.99	Unit weight calculation:	Based on SBT	Clay like behavior applied:	Sands only
Peak ground acceleration:	0.69	Use fill:	No	Limit depth applied:	Yes
Depth to water table (insitu):	9.50 ft	Fill height:	N/A	Limit depth:	60.00 ft

#### SBTn legend

1. Sensitive fine grained	4. Clayey silt to silty	7. Gravely sand to sand
2. Organic material	5. Silty sand to sandy silt	8. Very stiff sand to
3. Clay to silty clay	6. Clean sand to silty sand	9. Very stiff fine grained

### Liquefaction analysis overall plots (intermediate results)

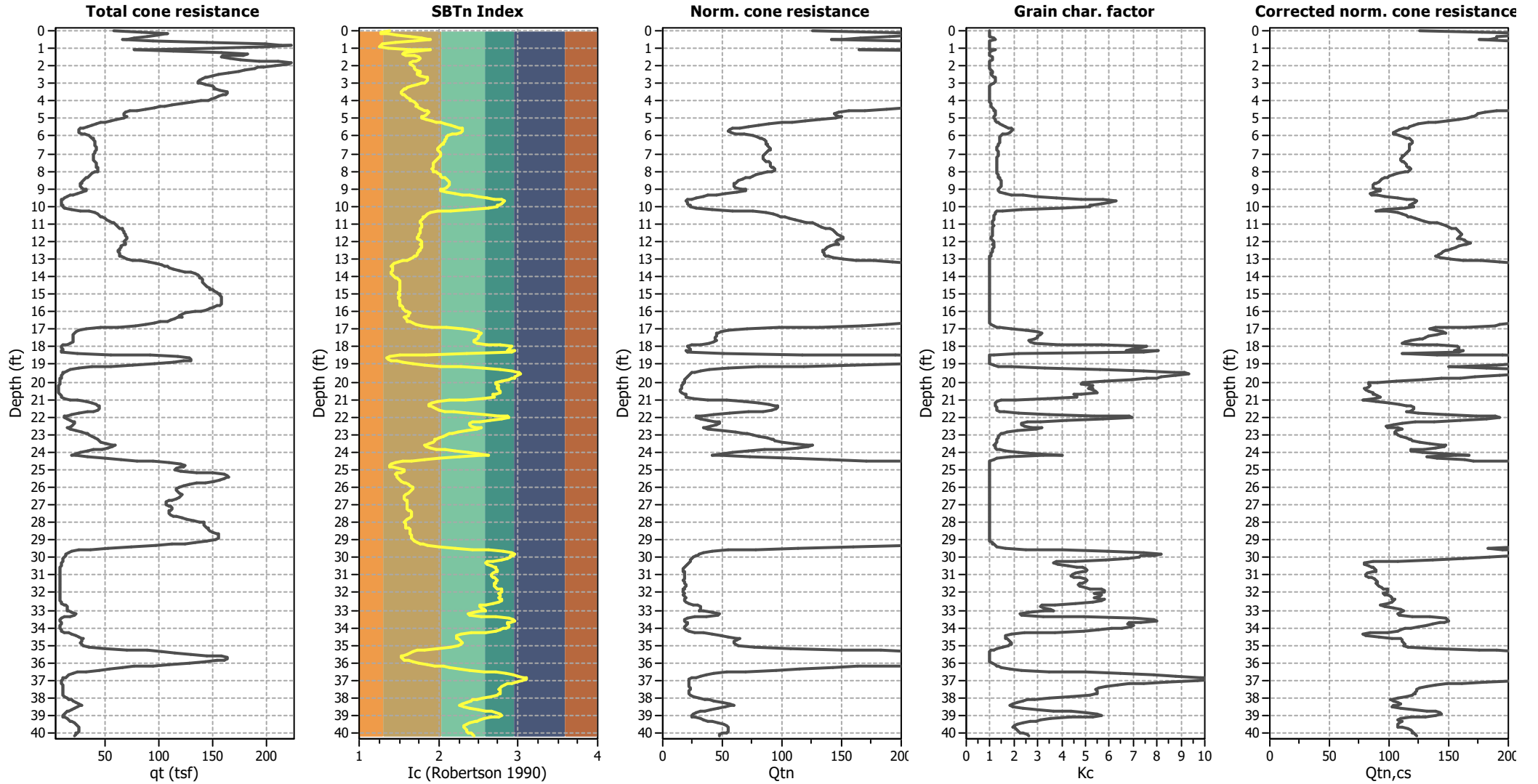

**Input parameters and analysis data**

Analysis method:	NCEER (1998)	Depth to water table (earthq.):	9.50 ft	Fill weight:	N/A
Fines correction method:	NCEER (1998)	Average results interval:	3	Transition detect. applied:	Yes
Points to test:	Based on Ic value	Ic cut-off value:	2.60	$K_{cs}$ applied:	Yes
Earthquake magnitude $M_w$ :	6.99	Unit weight calculation:	Based on SBT	Clay like behavior applied:	Sands only
Peak ground acceleration:	0.69	Use fill:	No	Limit depth applied:	Yes
Depth to water table (insitu):	9.50 ft	Fill height:	N/A	Limit depth:	60.00 ft

### Liquefaction analysis overall plots

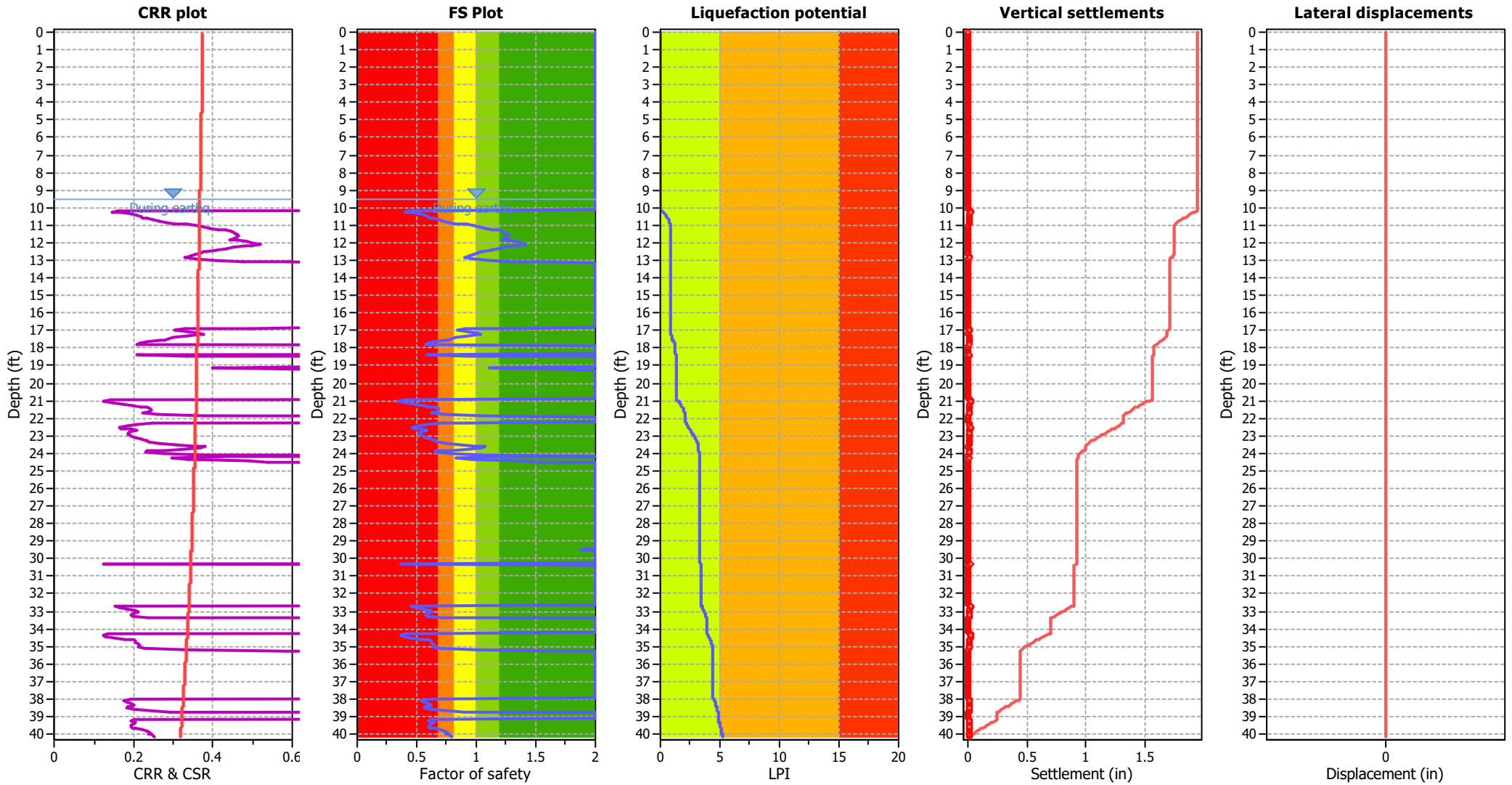

**Input parameters and analysis data**

Analysis method:	NCEER (1998)	Depth to water table (earthq.):	9.50 ft	Fill weight:	N/A
Fines correction method:	NCEER (1998)	Average results interval:	3	Transition detect. applied:	Yes
Points to test:	Based on Ic value	Ic cut-off value:	2.60	$K_0$ applied:	Yes
Earthquake magnitude $M_w$ :	6.99	Unit weight calculation:	Based on SBT	Clay like behavior applied:	Sands only
Peak ground acceleration:	0.69	Use fill:	No	Limit depth applied:	Yes
Depth to water table (insitu):	9.50 ft	Fill height:	N/A	Limit depth:	60.00 ft

**F.S. color scheme**

- Almost certain it will liquefy
- Very likely to liquefy
- Liquefaction and no liq. are equally likely
- Unlike to liquefy
- Almost certain it will not liquefy

**LPI color scheme**

- Very high risk
- High risk
- Low risk

### Liquefaction analysis summary plots

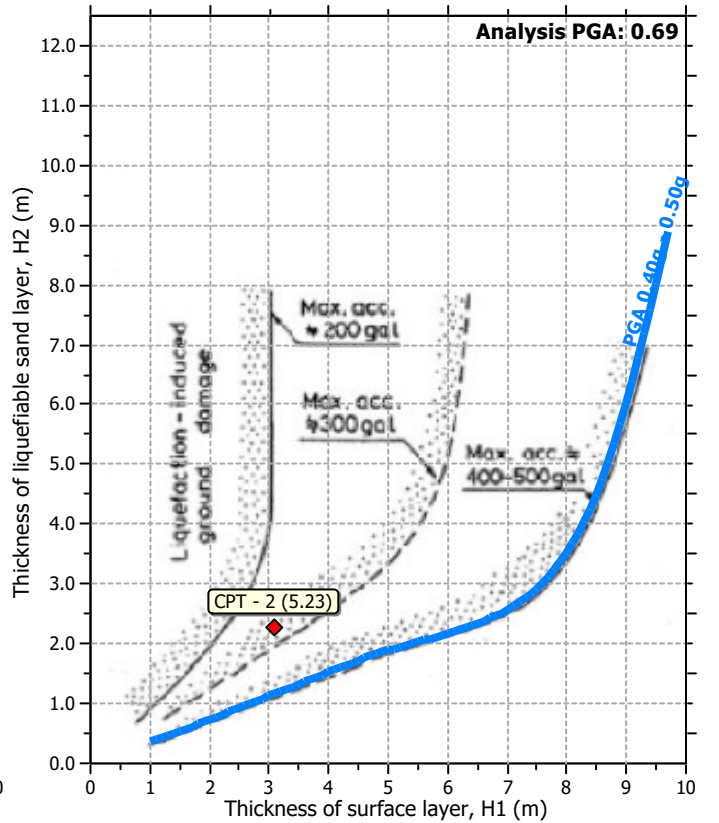
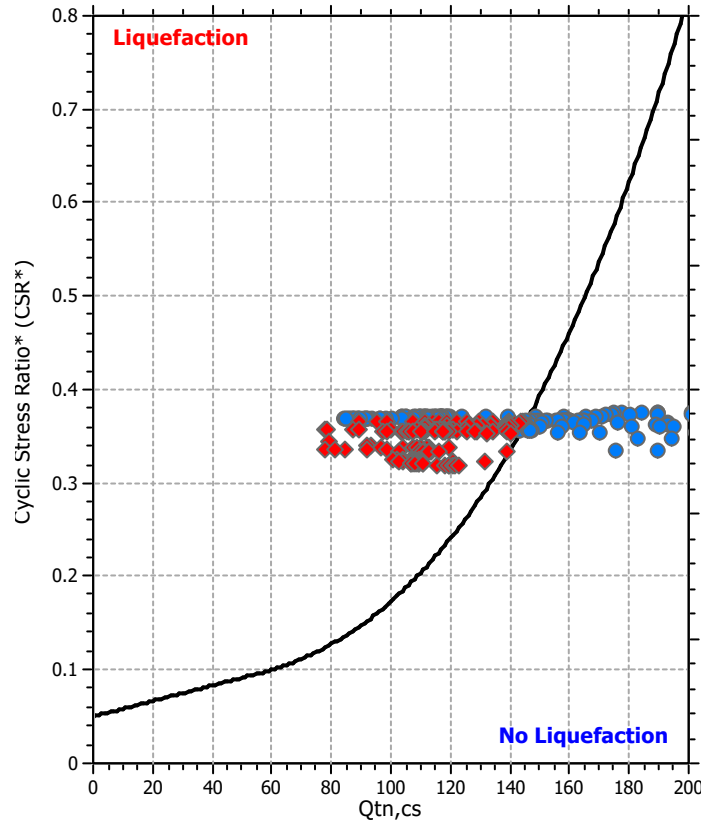
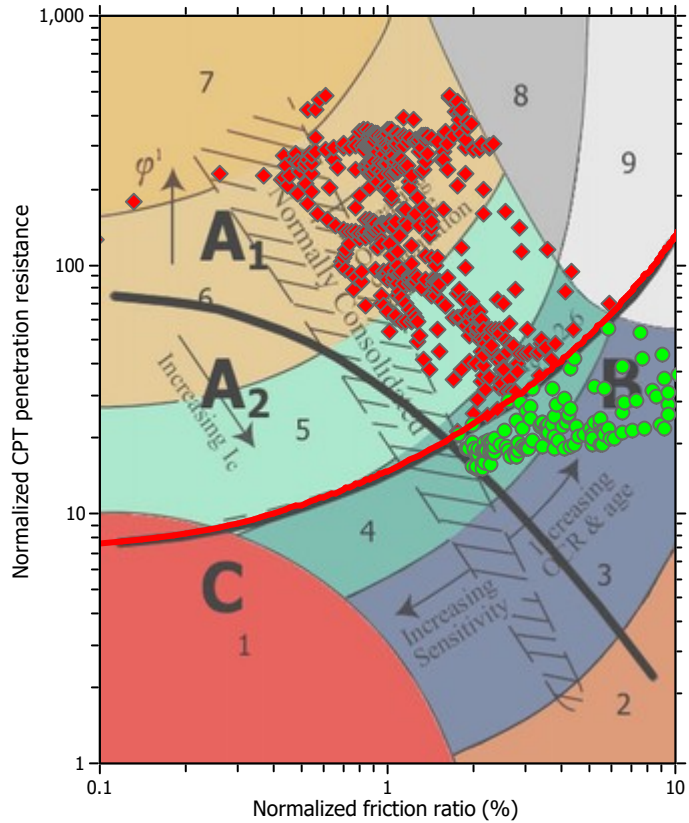

**Input parameters and analysis data**

Analysis method:	NCEER (1998)	Depth to water table (earthq.):	9.50 ft	Fill weight:	N/A
Fines correction method:	NCEER (1998)	Average results interval:	3	Transition detect. applied:	Yes
Points to test:	Based on Ic value	Ic cut-off value:	2.60	K <sub>o</sub> applied:	Yes
Earthquake magnitude M <sub>w</sub> :	6.99	Unit weight calculation:	Based on SBT	Clay like behavior applied:	Sands only
Peak ground acceleration:	0.69	Use fill:	No	Limit depth applied:	Yes
Depth to water table (insitu):	9.50 ft	Fill height:	N/A	Limit depth:	60.00 ft

### Check for strength loss plots (Robertson (2010))

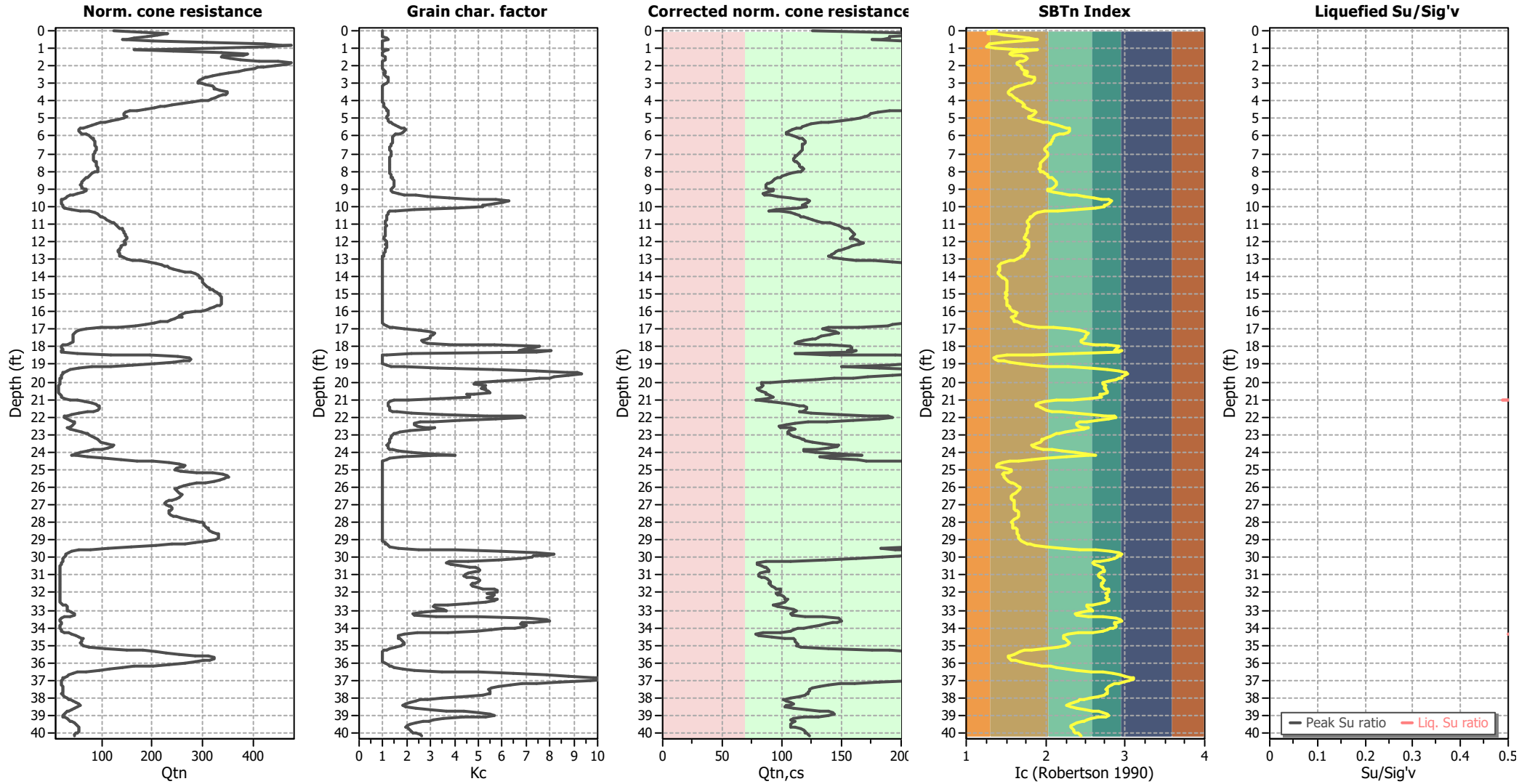

#### Input parameters and analysis data

Analysis method:	NCEER (1998)	Depth to water table (earthq.):	9.50 ft	Fill weight:	N/A
Fines correction method:	NCEER (1998)	Average results interval:	3	Transition detect. applied:	Yes
Points to test:	Based on Ic value	Ic cut-off value:	2.60	$K_o$ applied:	Yes
Earthquake magnitude $M_w$ :	6.99	Unit weight calculation:	Based on SBT	Clay like behavior applied:	Sands only
Peak ground acceleration:	0.69	Use fill:	No	Limit depth applied:	Yes
Depth to water table (insitu):	9.50 ft	Fill height:	N/A	Limit depth:	60.00 ft



## TRANSITION LAYER DETECTION ALGORITHM REPORT

### Summary Details & Plots

#### Short description

The software will delete data when the cone is in transition from either clay to sand or vice-versa. To do this the software requires a range of  $I_c$  values over which the transition will be defined (typically somewhere between  $1.80 < I_c < 3.0$ ) and a rate of change of  $I_c$ . Transitions typically occur when the rate of change of  $I_c$  is fast (i.e.  $\Delta I_c$  is small).

The  $SBT_n$  plot below, displays in red the detected transition layers based on the parameters listed below the graphs.

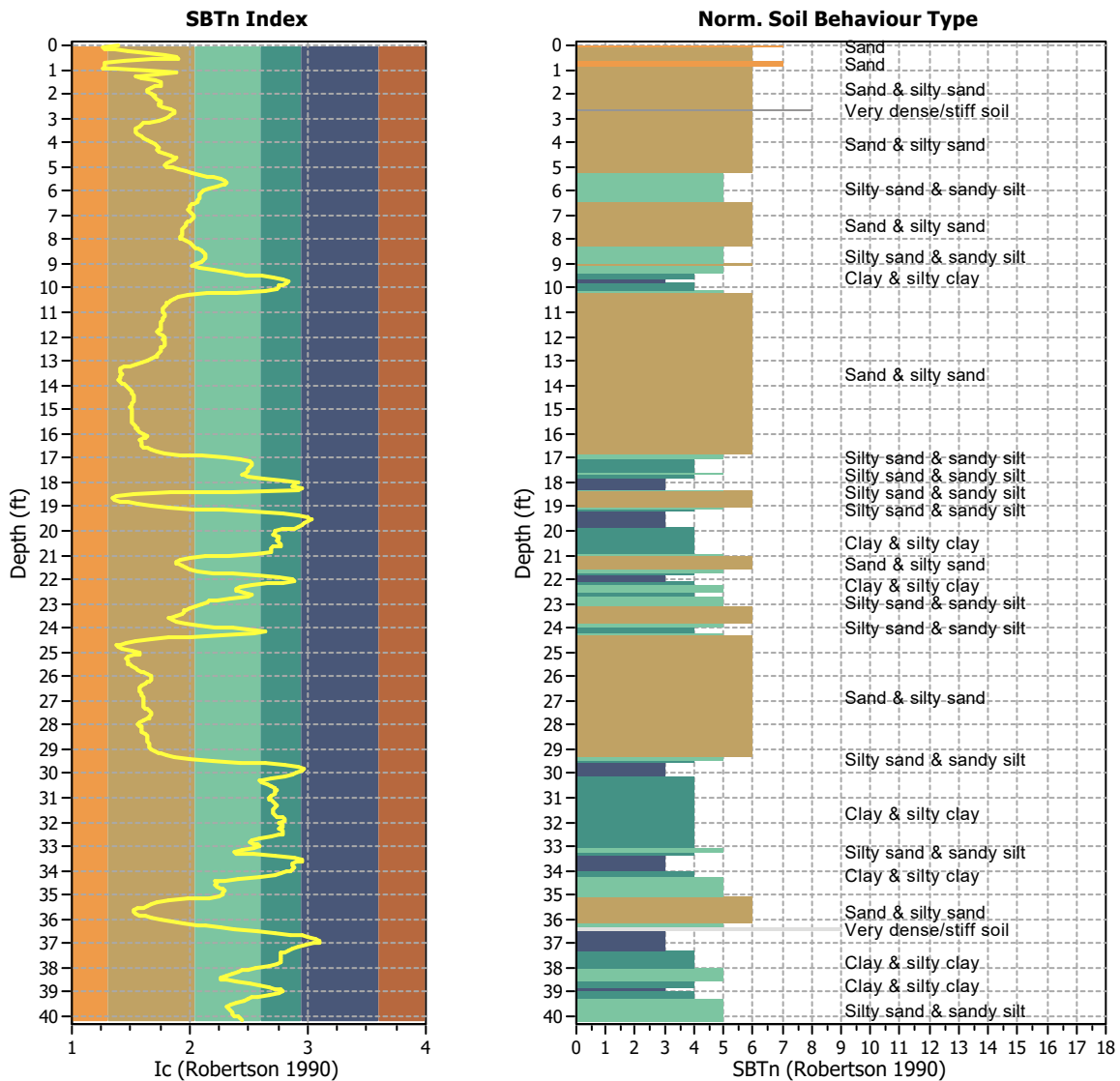

Transition layer algorithm properties		General statistics	
$I_c$ minimum check value:	1.70	Total points in CPT file:	613
$I_c$ maximum check value:	1.70	Total points excluded:	0
$I_c$ change ratio value:	3.0000	Exclusion percentage:	0.00%
Minimum number of points in layer:	-26215	Number of layers detected:	0

### Estimation of post-earthquake settlements

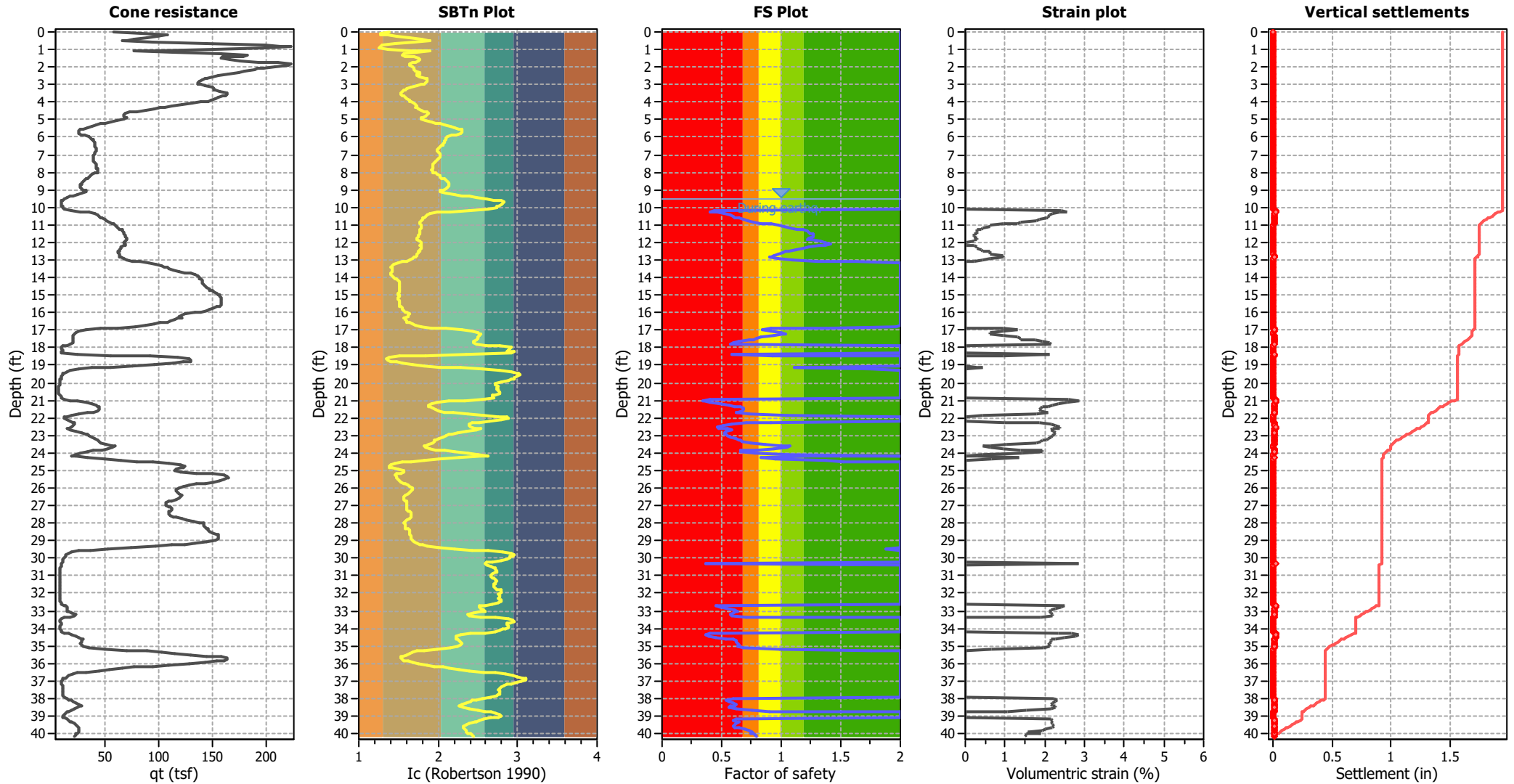

**Abbreviations**

- q<sub>c</sub>: Total cone resistance (cone resistance q<sub>c</sub> corrected for pore water effects)
- I<sub>c</sub>: Soil Behaviour Type Index
- FS: Calculated Factor of Safety against liquefaction
- Volumetric strain: Post-liquefaction volumetric strain



**LIQUEFACTION ANALYSIS REPORT**

**Project title : Old Town Viewpoint**  
**CPT file : CPT - 3**

**Location : San Diego, California**

**Input parameters and analysis data**

Analysis method:	NCEER (1998)	G.W.T. (in-situ):	9.50 ft	Use fill:	No	Clay like behavior applied:	Sands only
Fines correction method:	NCEER (1998)	G.W.T. (earthq.):	9.50 ft	Fill height:	N/A	Limit depth applied:	Yes
Points to test:	Based on Ic value	Average results interval:	3	Fill weight:	N/A	Limit depth:	60.00 ft
Earthquake magnitude $M_w$ :	6.99	Ic cut-off value:	2.60	Trans. detect. applied:	Yes	MSF method:	Method based
Peak ground acceleration:	0.69	Unit weight calculation:	Based on SBT	$K_o$ applied:	Yes		

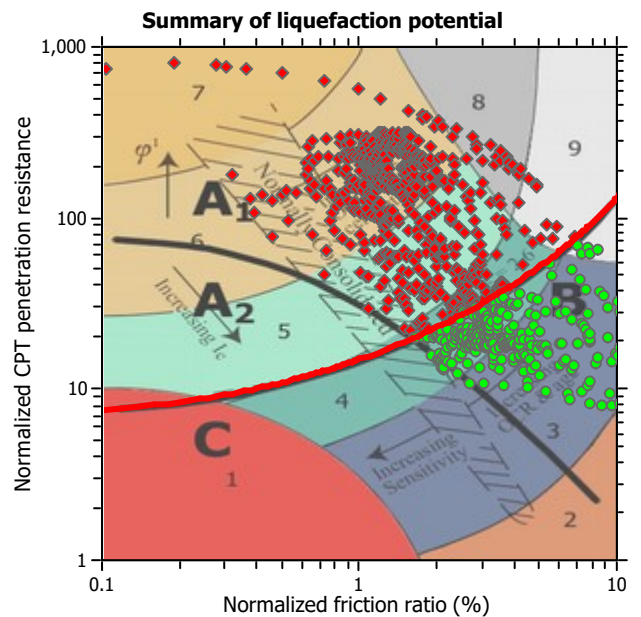
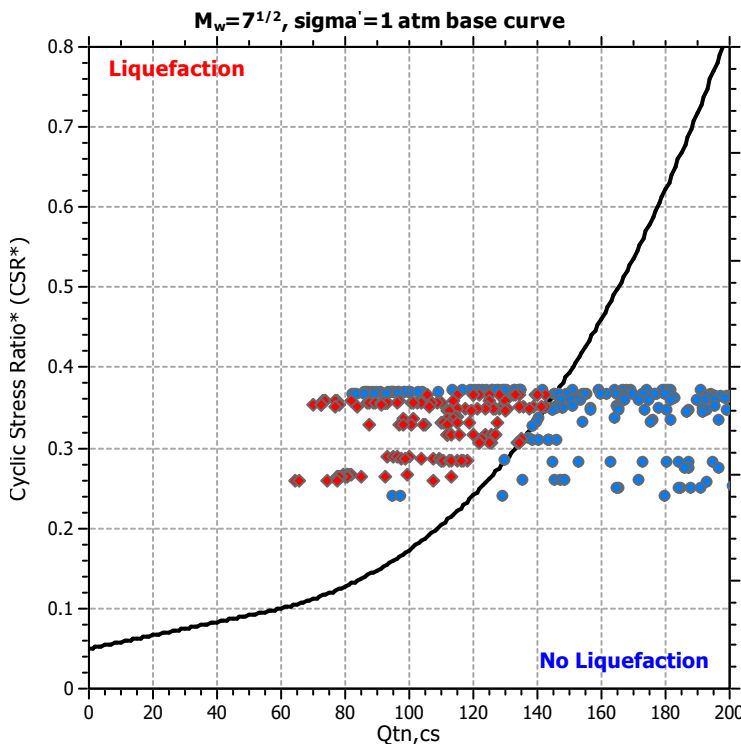
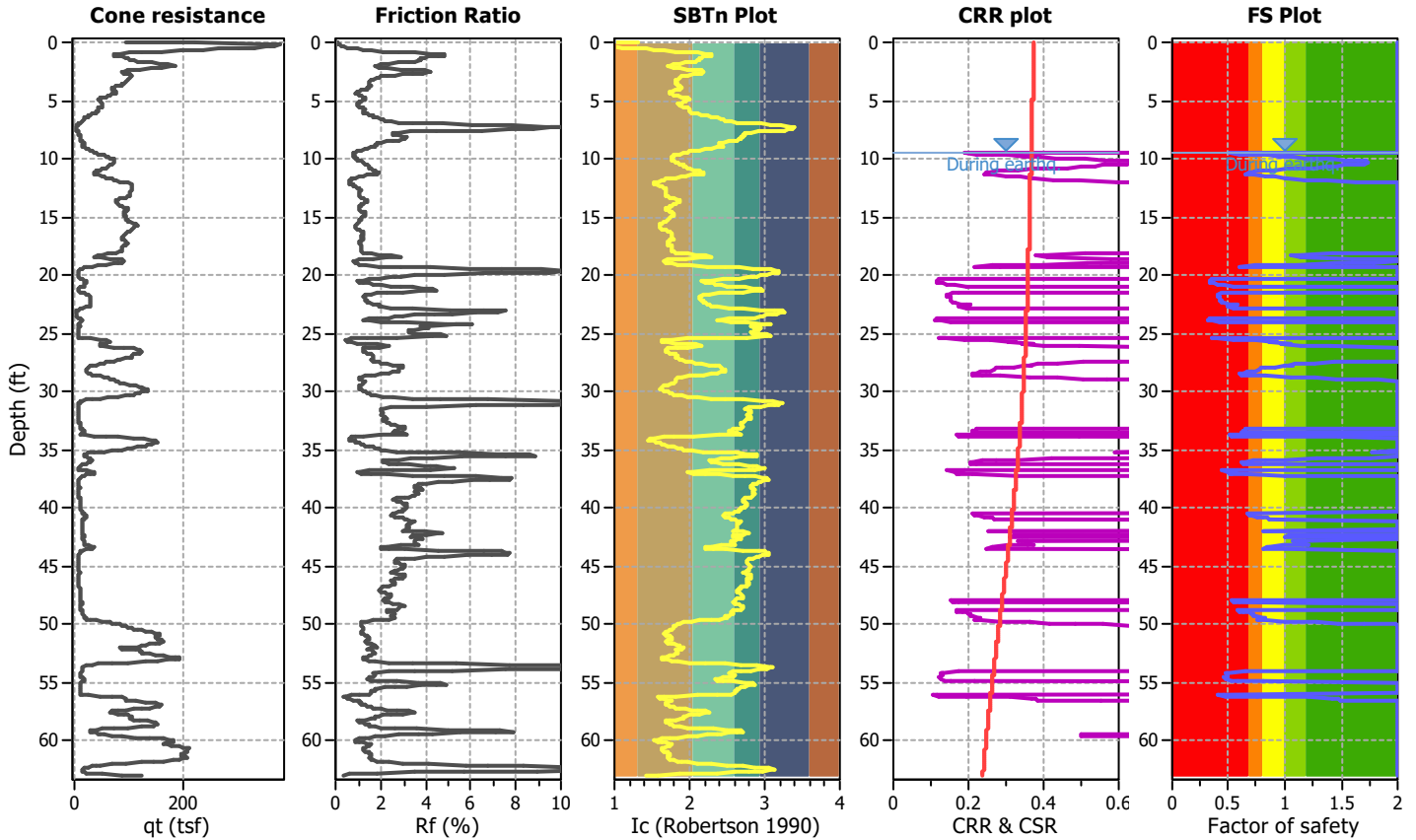

Zone A<sub>1</sub>: Cyclic liquefaction likely depending on size and duration of cyclic loading  
 Zone A<sub>2</sub>: Cyclic liquefaction and strength loss likely depending on loading and ground geometry  
 Zone B: Liquefaction and post-earthquake strength loss unlikely, check cyclic softening  
 Zone C: Cyclic liquefaction and strength loss possible depending on soil plasticity, brittleness/sensitivity, strain to peak undrained strength and ground geometry

### CPT basic interpretation plots

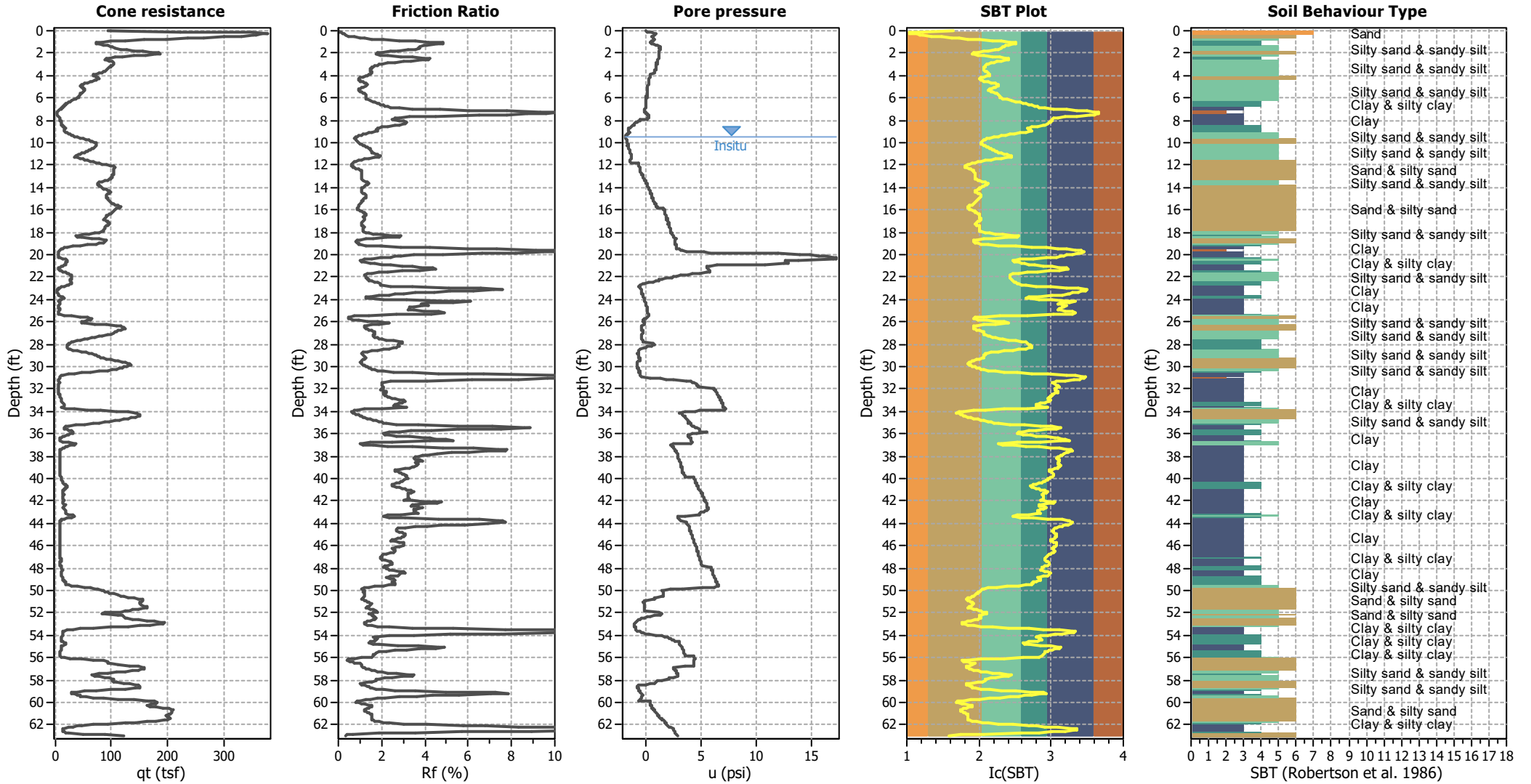

#### Input parameters and analysis data

Analysis method:	NCEER (1998)	Depth to water table (earthq.):	9.50 ft	Fill weight:	N/A
Fines correction method:	NCEER (1998)	Average results interval:	3	Transition detect. applied:	Yes
Points to test:	Based on Ic value	Ic cut-off value:	2.60	$K_o$ applied:	Yes
Earthquake magnitude $M_w$ :	6.99	Unit weight calculation:	Based on SBT	Clay like behavior applied:	Sands only
Peak ground acceleration:	0.69	Use fill:	No	Limit depth applied:	Yes
Depth to water table (insitu):	9.50 ft	Fill height:	N/A	Limit depth:	60.00 ft

#### SBT legend

1. Sensitive fine grained	4. Clayey silt to silty	7. Gravely sand to sand
2. Organic material	5. Silty sand to sandy silt	8. Very stiff sand to
3. Clay to silty clay	6. Clean sand to silty sand	9. Very stiff fine grained

### CPT basic interpretation plots (normalized)

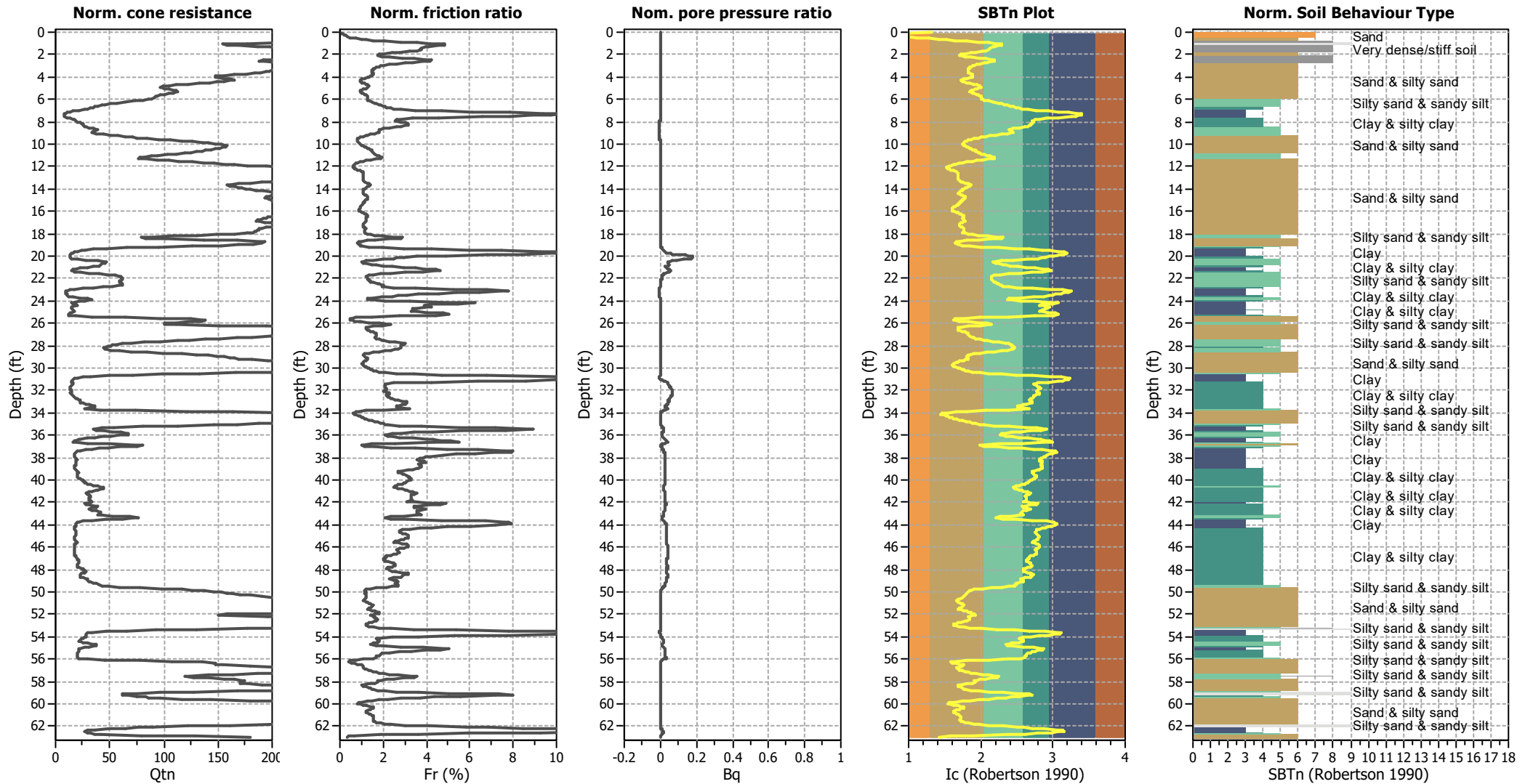

#### Input parameters and analysis data

Analysis method:	NCEER (1998)	Depth to water table (earthq.):	9.50 ft	Fill weight:	N/A
Fines correction method:	NCEER (1998)	Average results interval:	3	Transition detect. applied:	Yes
Points to test:	Based on Ic value	Ic cut-off value:	2.60	K <sub>o</sub> applied:	Yes
Earthquake magnitude M <sub>w</sub> :	6.99	Unit weight calculation:	Based on SBT	Clay like behavior applied:	Sands only
Peak ground acceleration:	0.69	Use fill:	No	Limit depth applied:	Yes
Depth to water table (insitu):	9.50 ft	Fill height:	N/A	Limit depth:	60.00 ft

#### SBTn legend

1. Sensitive fine grained	4. Clayey silt to silty	7. Gravely sand to sand
2. Organic material	5. Silty sand to sandy silt	8. Very stiff sand to
3. Clay to silty clay	6. Clean sand to silty sand	9. Very stiff fine grained



### Liquefaction analysis overall plots (intermediate results)

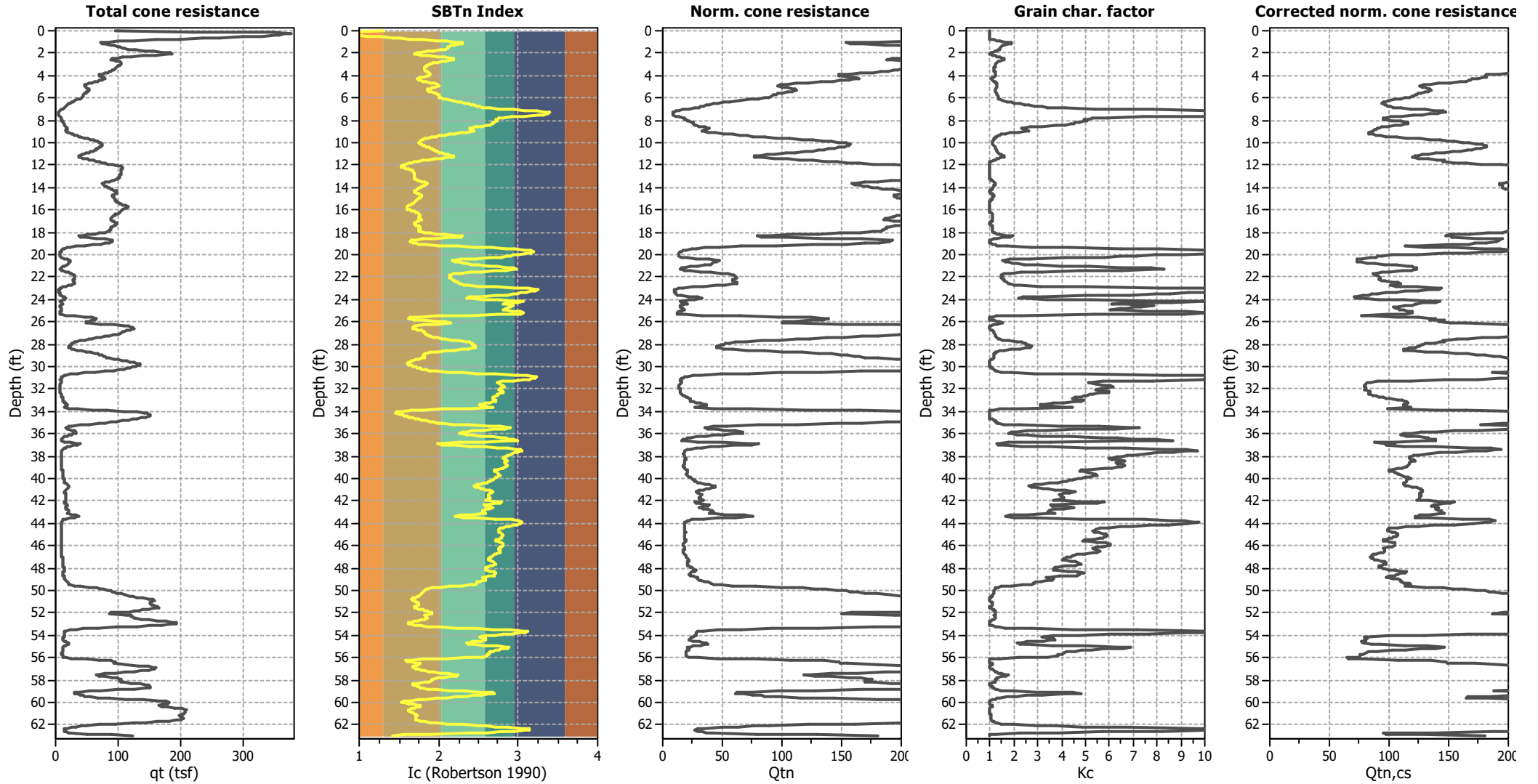

#### Input parameters and analysis data

Analysis method:	NCEER (1998)	Depth to water table (erthq.):	9.50 ft	Fill weight:	N/A
Fines correction method:	NCEER (1998)	Average results interval:	3	Transition detect. applied:	Yes
Points to test:	Based on Ic value	Ic cut-off value:	2.60	K <sub>o</sub> applied:	Yes
Earthquake magnitude M <sub>w</sub> :	6.99	Unit weight calculation:	Based on SBT	Clay like behavior applied:	Sands only
Peak ground acceleration:	0.69	Use fill:	No	Limit depth applied:	Yes
Depth to water table (insitu):	9.50 ft	Fill height:	N/A	Limit depth:	60.00 ft

### Liquefaction analysis overall plots

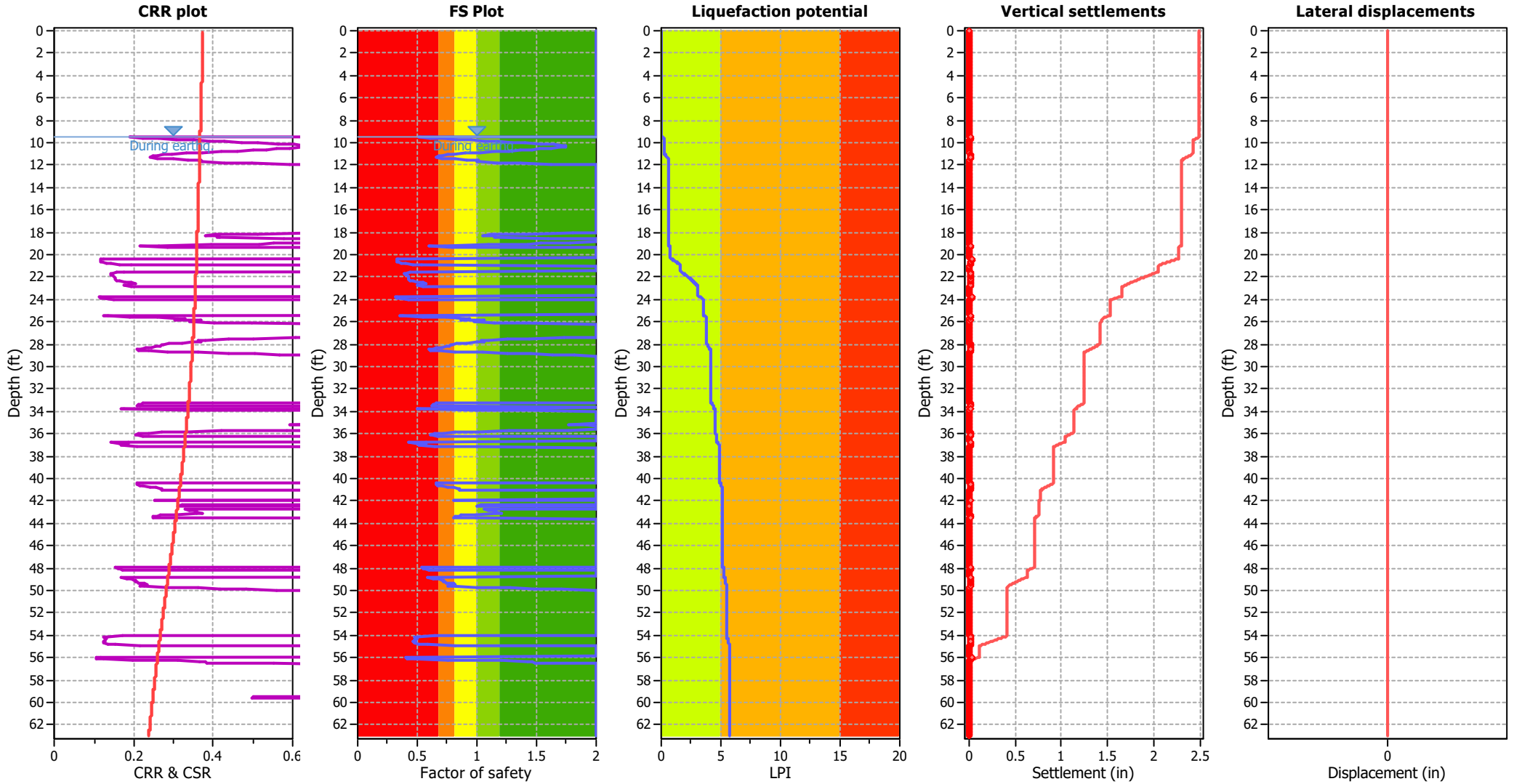

**Input parameters and analysis data**

Analysis method:	NCEER (1998)	Depth to water table (earthq.):	9.50 ft	Fill weight:	N/A
Fines correction method:	NCEER (1998)	Average results interval:	3	Transition detect. applied:	Yes
Points to test:	Based on Ic value	Ic cut-off value:	2.60	$K_0$ applied:	Yes
Earthquake magnitude $M_w$ :	6.99	Unit weight calculation:	Based on SBT	Clay like behavior applied:	Sands only
Peak ground acceleration:	0.69	Use fill:	No	Limit depth applied:	Yes
Depth to water table (insitu):	9.50 ft	Fill height:	N/A	Limit depth:	60.00 ft

**F.S. color scheme**

- Almost certain it will liquefy
- Very likely to liquefy
- Liquefaction and no liq. are equally likely
- Unlike to liquefy
- Almost certain it will not liquefy

**LPI color scheme**

- Very high risk
- High risk
- Low risk

### Liquefaction analysis summary plots

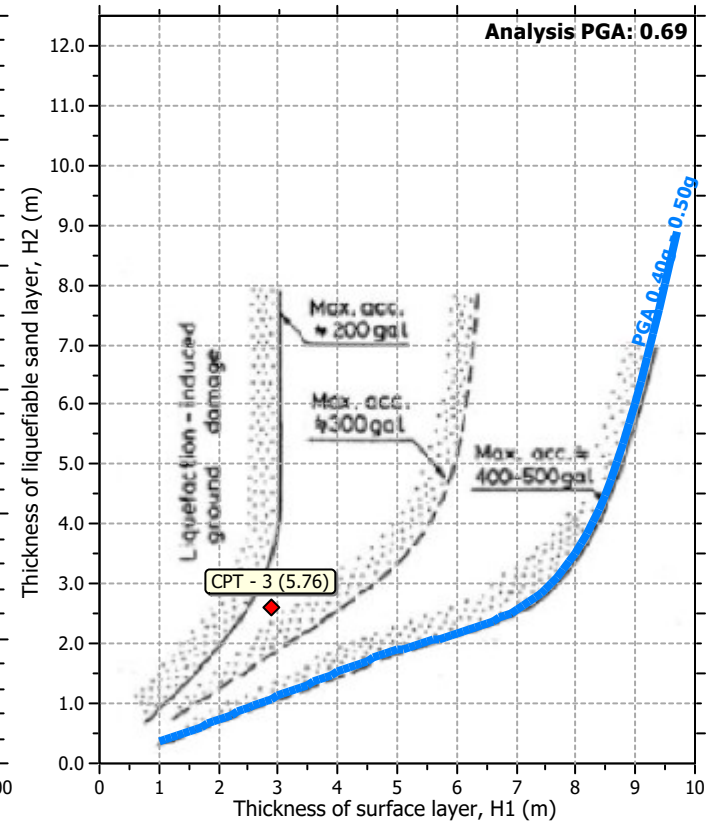
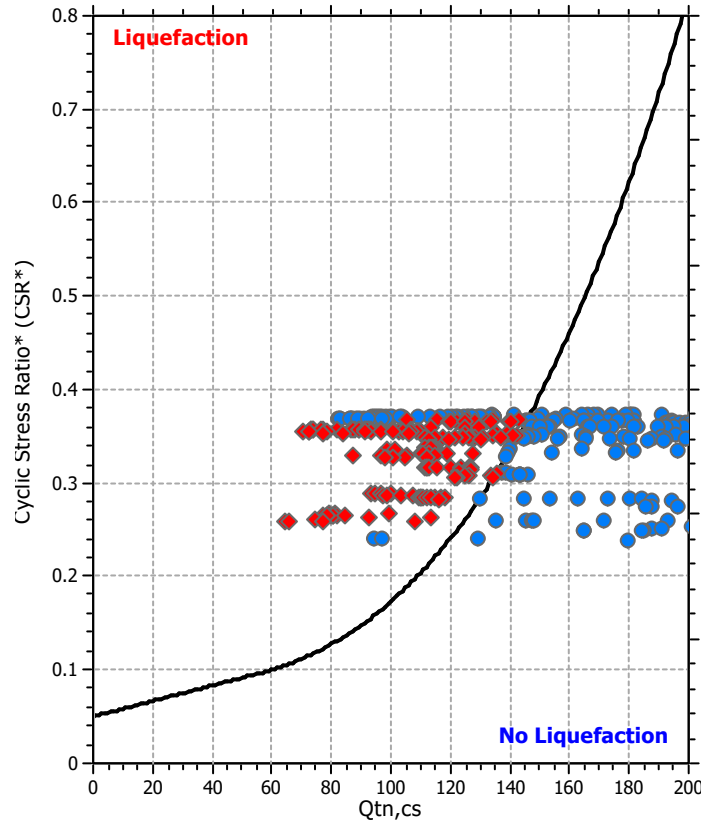
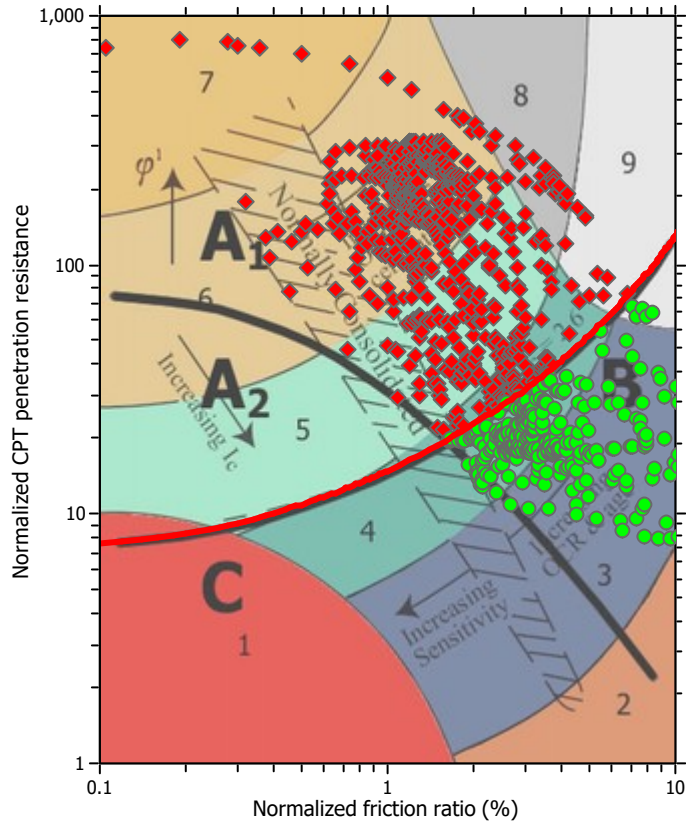

**Input parameters and analysis data**

Analysis method:	NCEER (1998)	Depth to water table (earthq.):	9.50 ft	Fill weight:	N/A
Fines correction method:	NCEER (1998)	Average results interval:	3	Transition detect. applied:	Yes
Points to test:	Based on Ic value	Ic cut-off value:	2.60	K <sub>0</sub> applied:	Yes
Earthquake magnitude M <sub>w</sub> :	6.99	Unit weight calculation:	Based on SBT	Clay like behavior applied:	Sands only
Peak ground acceleration:	0.69	Use fill:	No	Limit depth applied:	Yes
Depth to water table (insitu):	9.50 ft	Fill height:	N/A	Limit depth:	60.00 ft

### Check for strength loss plots (Robertson (2010))

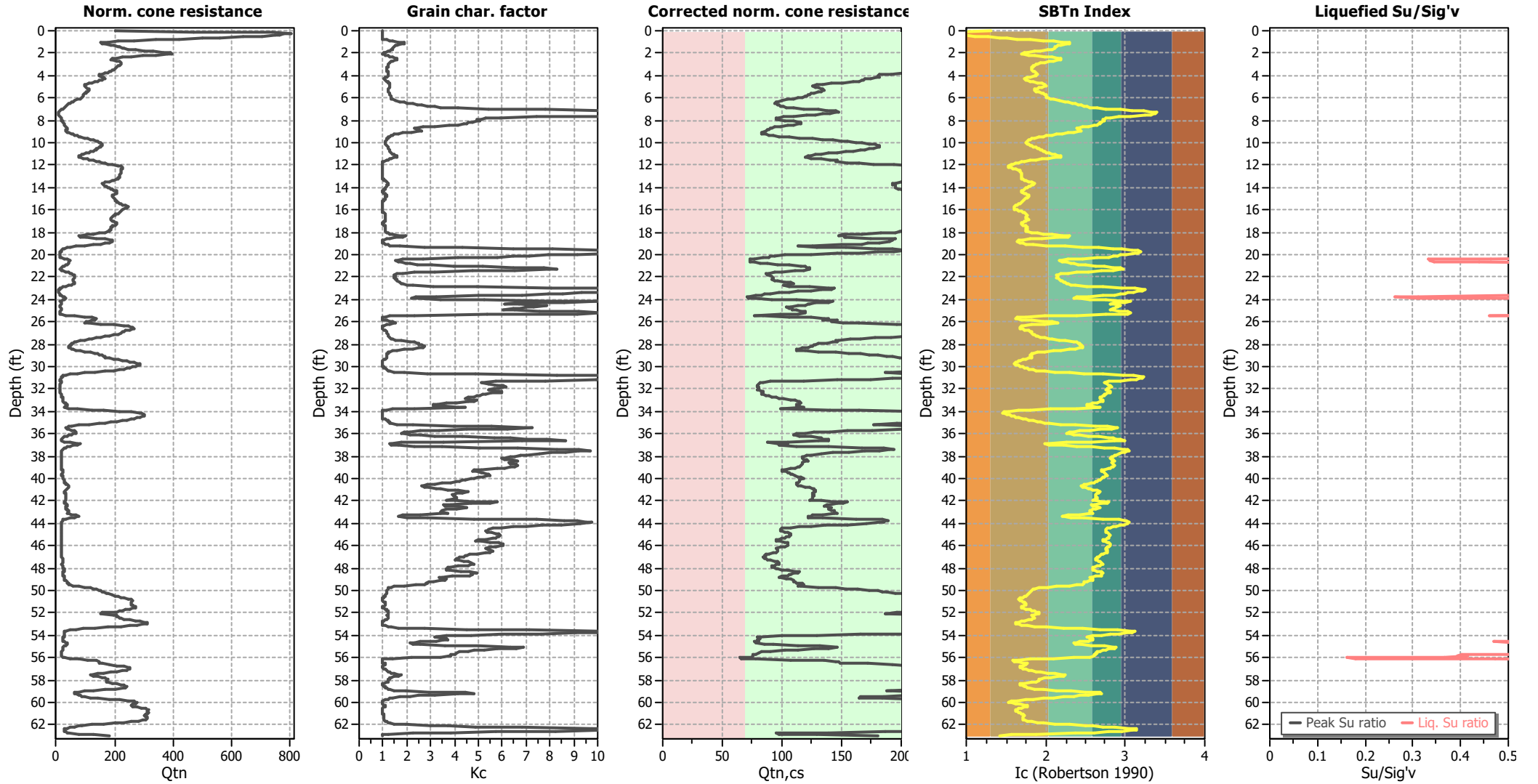

#### Input parameters and analysis data

Analysis method:	NCEER (1998)	Depth to water table (earthq.):	9.50 ft	Fill weight:	N/A
Fines correction method:	NCEER (1998)	Average results interval:	3	Transition detect. applied:	Yes
Points to test:	Based on Ic value	Ic cut-off value:	2.60	K <sub>o</sub> applied:	Yes
Earthquake magnitude M <sub>w</sub> :	6.99	Unit weight calculation:	Based on SBT	Clay like behavior applied:	Sands only
Peak ground acceleration:	0.69	Use fill:	No	Limit depth applied:	Yes
Depth to water table (insitu):	9.50 ft	Fill height:	N/A	Limit depth:	60.00 ft

## TRANSITION LAYER DETECTION ALGORITHM REPORT

### Summary Details & Plots

#### Short description

The software will delete data when the cone is in transition from either clay to sand or vice-versa. To do this the software requires a range of  $I_c$  values over which the transition will be defined (typically somewhere between  $1.80 < I_c < 3.0$ ) and a rate of change of  $I_c$ . Transitions typically occur when the rate of change of  $I_c$  is fast (i.e.  $\Delta I_c$  is small).

The  $SBT_n$  plot below, displays in red the detected transition layers based on the parameters listed below the graphs.

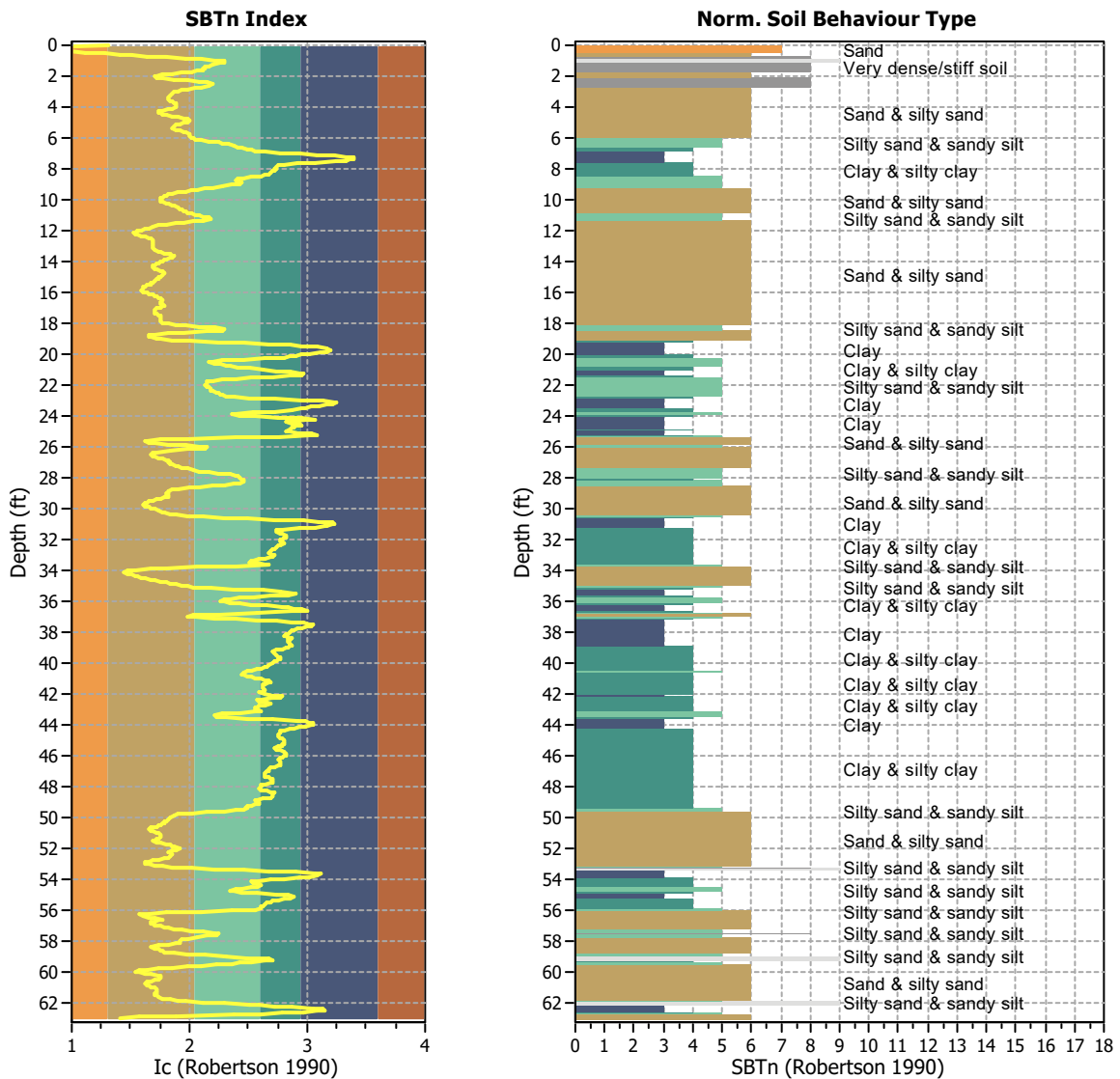

Transition layer algorithm properties		General statistics	
$I_c$ minimum check value:	1.70	Total points in CPT file:	961
$I_c$ maximum check value:	1.70	Total points excluded:	0
$I_c$ change ratio value:	3.0000	Exclusion percentage:	0.00%
Minimum number of points in layer:	-26215	Number of layers detected:	0



### Estimation of post-earthquake settlements

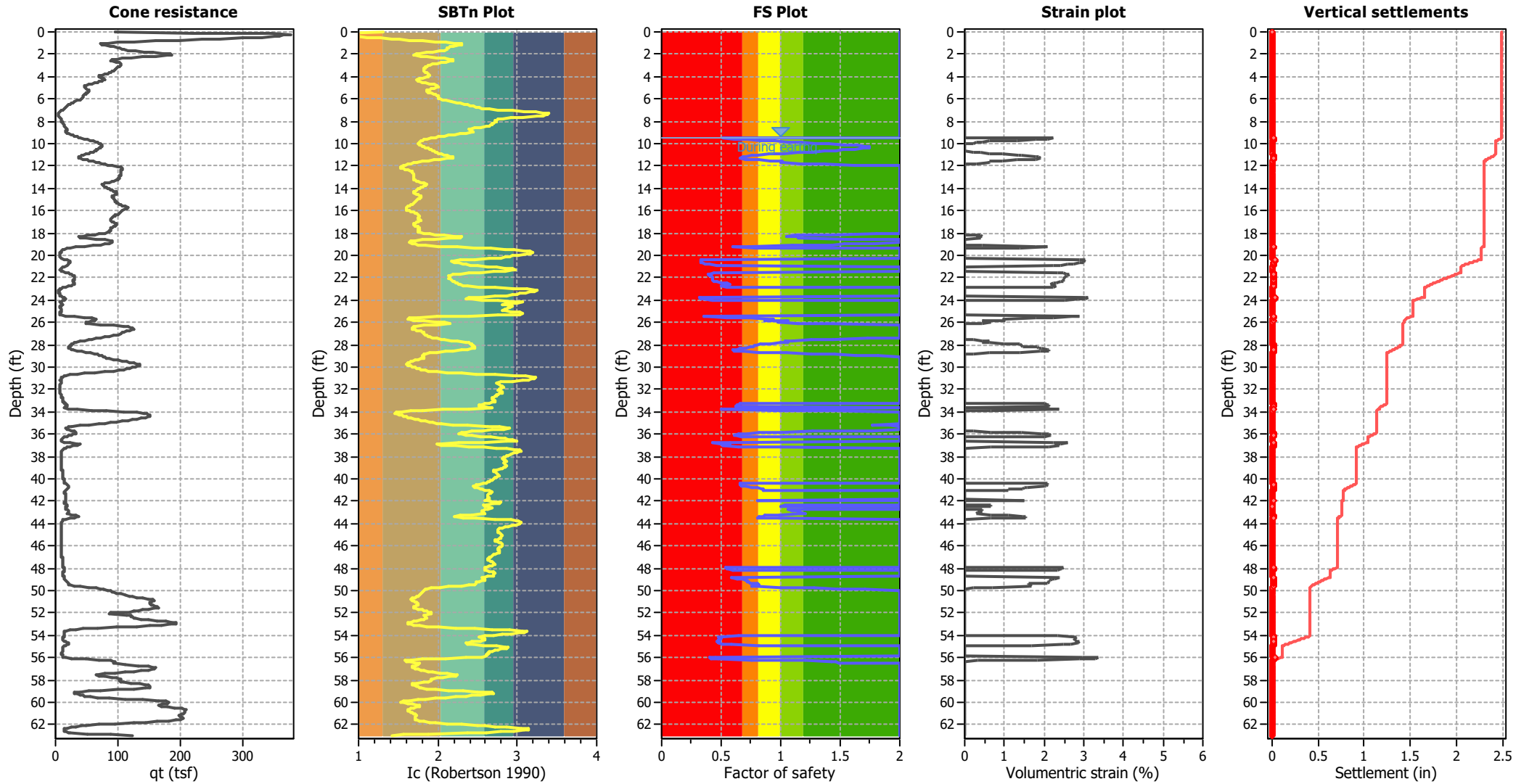

**Abbreviations**

- q<sub>c</sub>: Total cone resistance (cone resistance q<sub>c</sub> corrected for pore water effects)
- I<sub>c</sub>: Soil Behaviour Type Index
- FS: Calculated Factor of Safety against liquefaction
- Volumetric strain: Post-liquefaction volumetric strain

## Procedure for the evaluation of soil liquefaction resistance, NCEER (1998)

Calculation of soil resistance against liquefaction is performed according to the Robertson & Wride (1998) procedure. The procedure used in the software, slightly differs from the one originally published in NCEER-97-0022 (Proceedings of the NCEER Workshop on Evaluation of Liquefaction Resistance of Soils). The revised procedure is presented below in the form of a flowchart<sup>1</sup>:

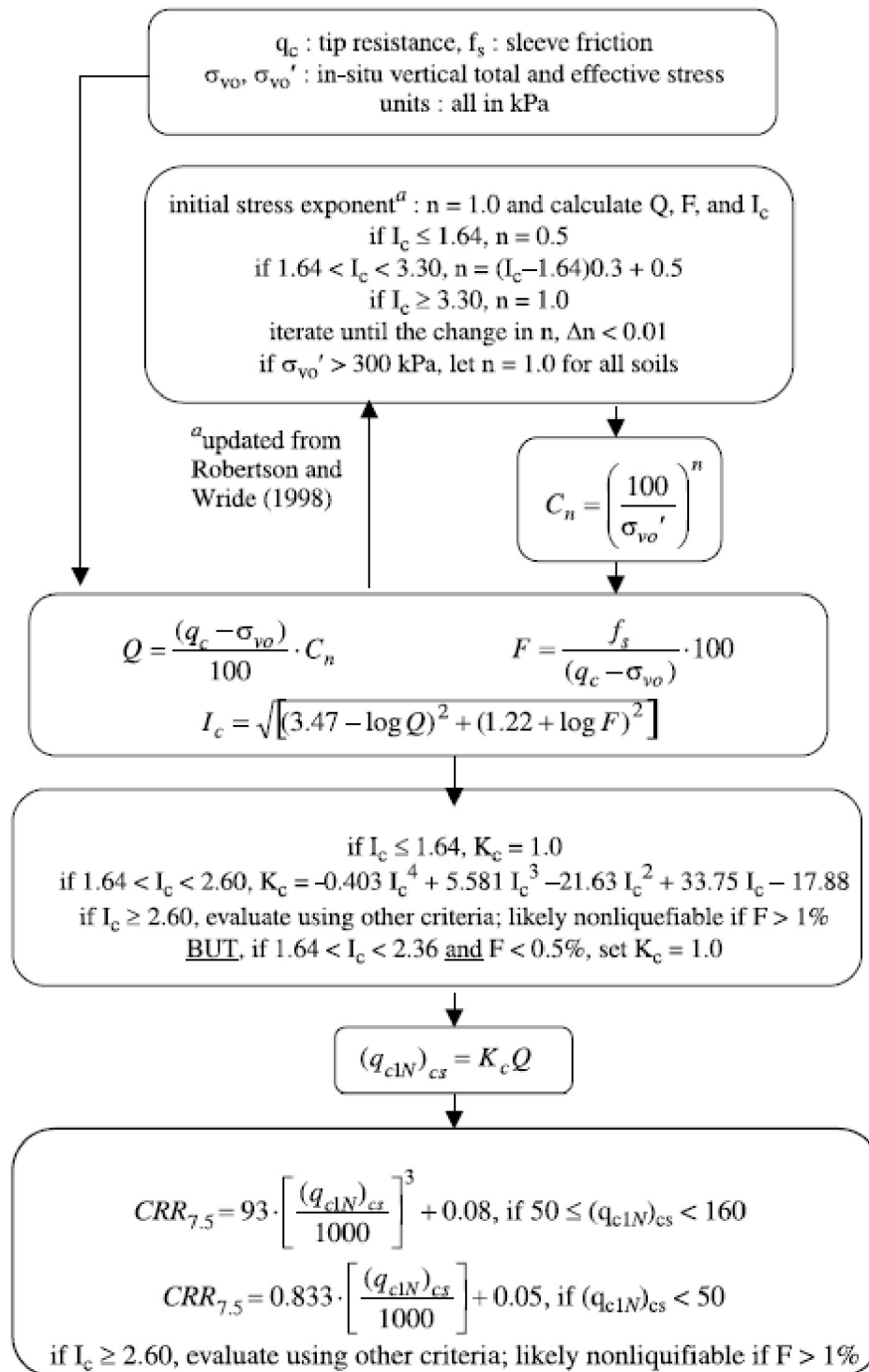

<sup>1</sup> "Estimating liquefaction-induced ground settlements from CPT for level ground", G. Zhang, P.K. Robertson, and R.W.I. Brachman

## Procedure for the evaluation of soil liquefaction resistance (all soils), Robertson (2010)

Calculation of soil resistance against liquefaction is performed according to the Robertson & Wride (1998) procedure. This procedure used in the software, slightly differs from the one originally published in NCEER-97-0022 (Proceedings of the NCEER Workshop on Evaluation of Liquefaction Resistance of Soils). The revised procedure is presented below in the form of a flowchart<sup>1</sup>:

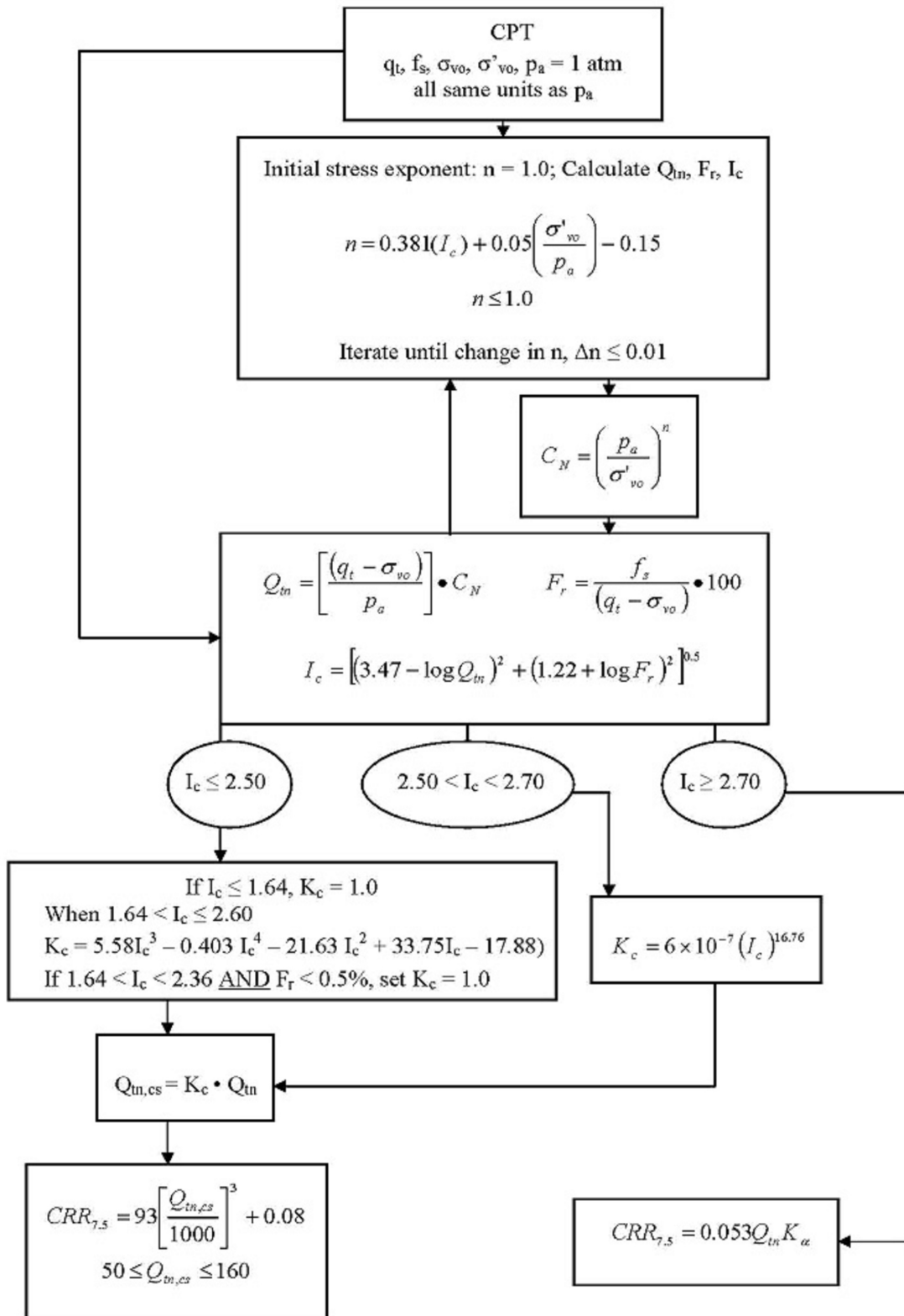

<sup>1</sup> P.K. Robertson, 2009. "Performance based earthquake design using the CPT", Keynote Lecture, International Conference on Performance-based Design in Earthquake Geotechnical Engineering – from case history to practice, IS-Tokyo, June 2009

**Procedure for the evaluation of soil liquefaction resistance, Idriss & Boulanger (2008)**

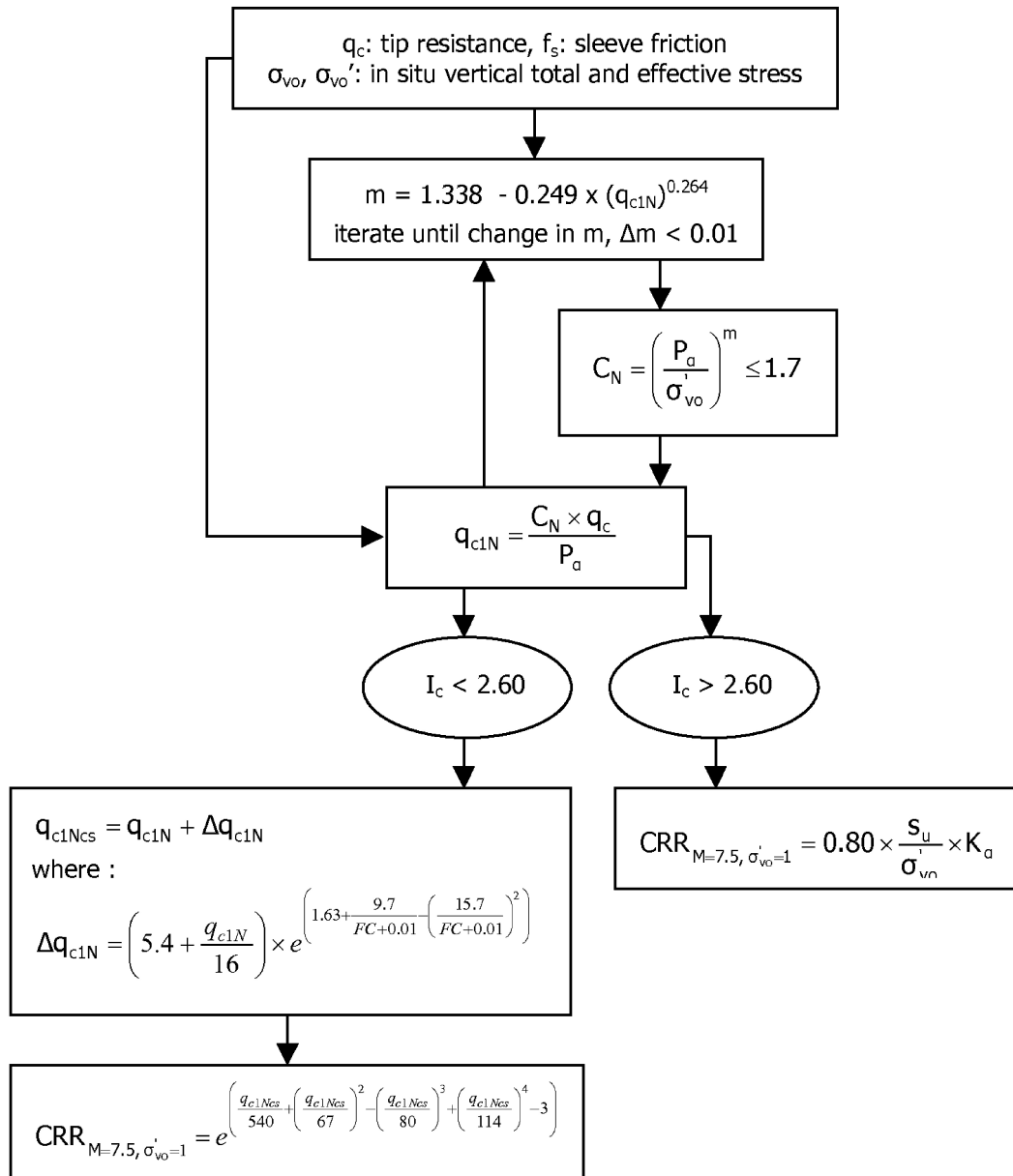

**Procedure for the evaluation of soil liquefaction resistance (sandy soils), Moss et al. (2006)**

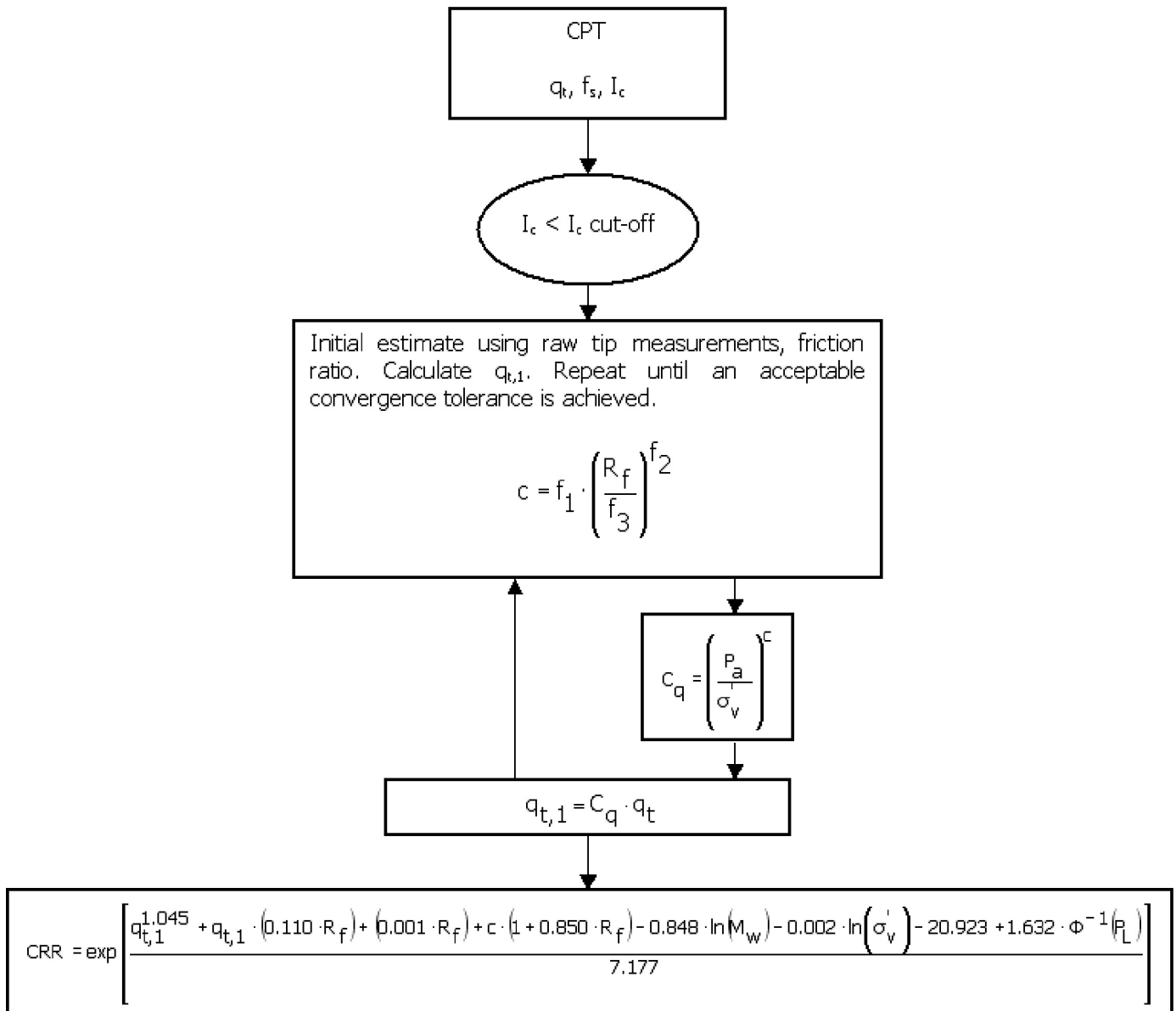



Procedure for the evaluation of soil liquefaction resistance, Boulanger & Idriss(2014)

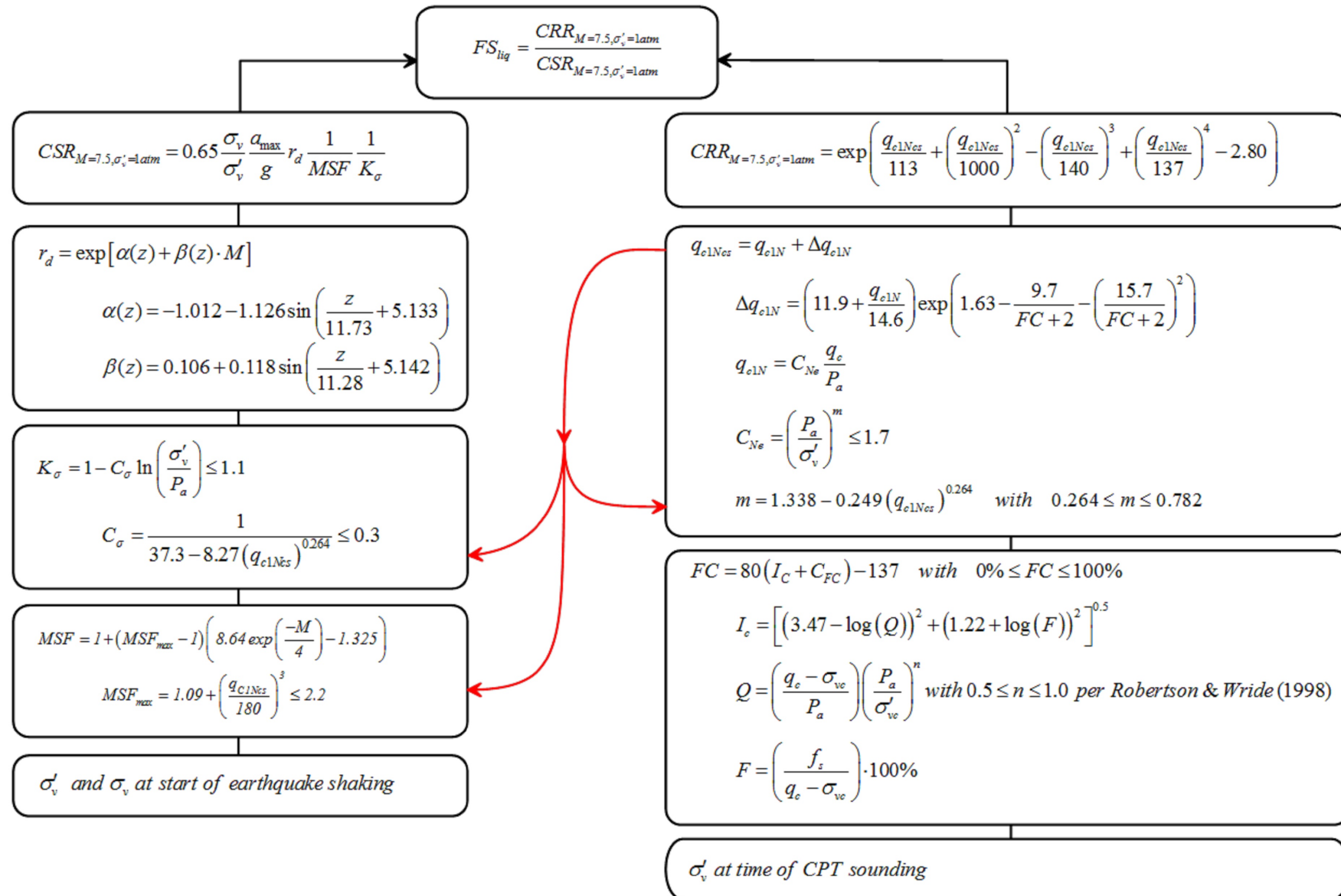

## Procedure for the evaluation of liquefaction-induced lateral spreading displacements

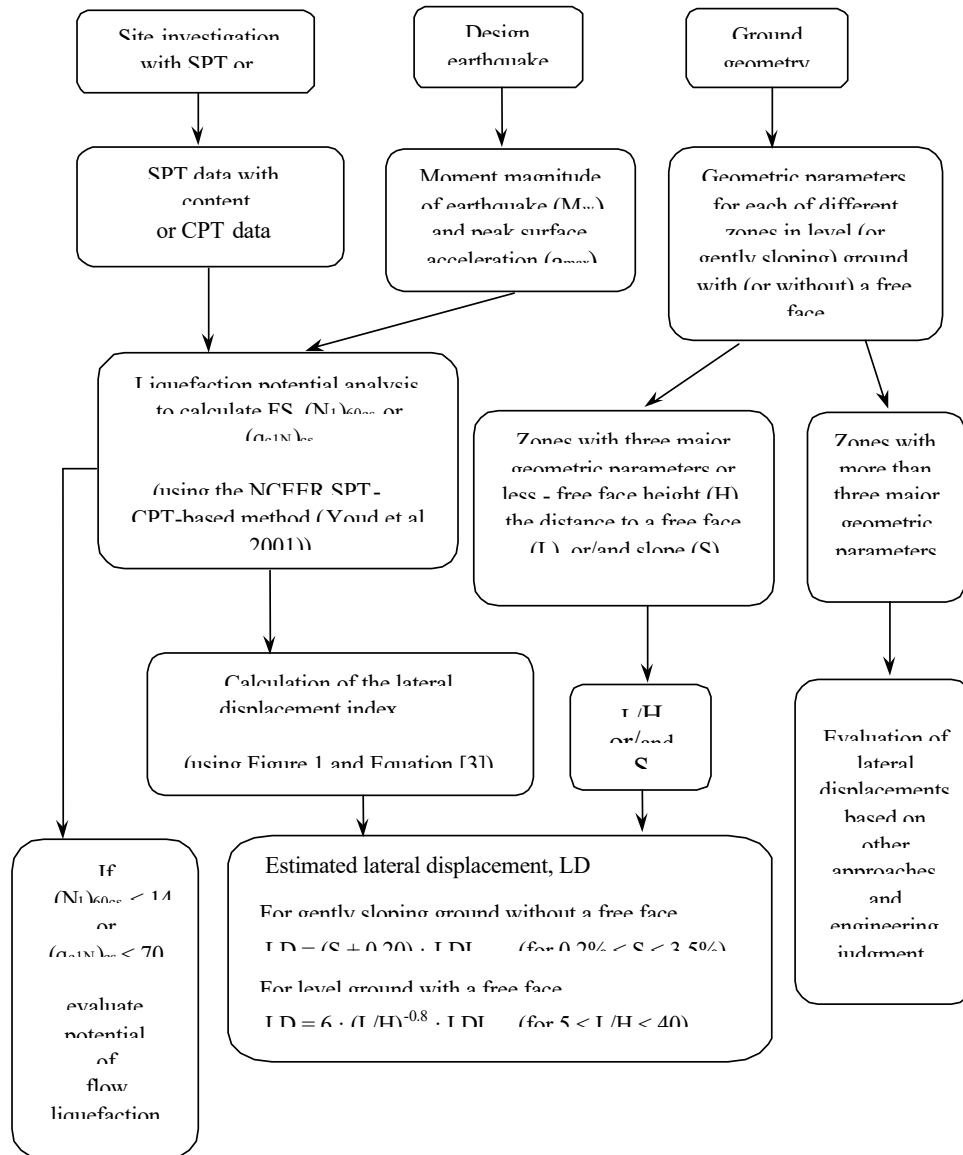

<sup>1</sup> Flow chart illustrating major steps in estimating liquefaction-induced lateral spreading displacements using the proposed approach

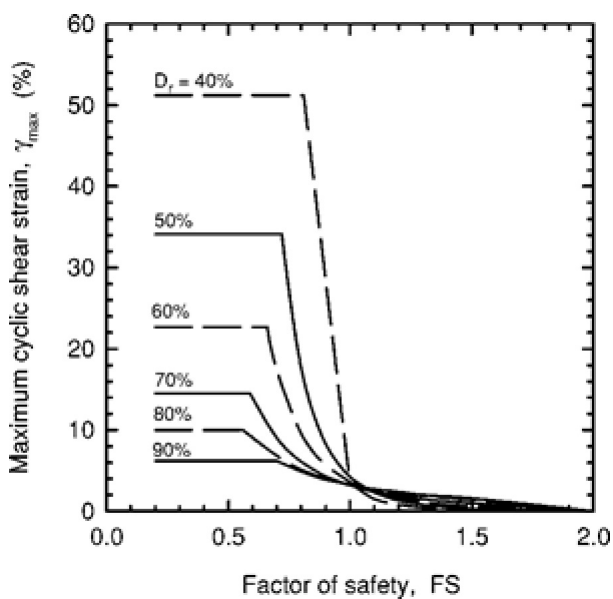

<sup>1</sup> Figure 1

$$LDI = \int_0^{Z_{max}} \gamma_{max} dz$$

<sup>1</sup> Equation [3]

<sup>1</sup> "Estimating liquefaction-induced ground settlements from CPT for level ground", G. Zhang, P.K. Robertson, and R.W.I. Brachman

## Procedure for the estimation of seismic induced settlements in dry sands

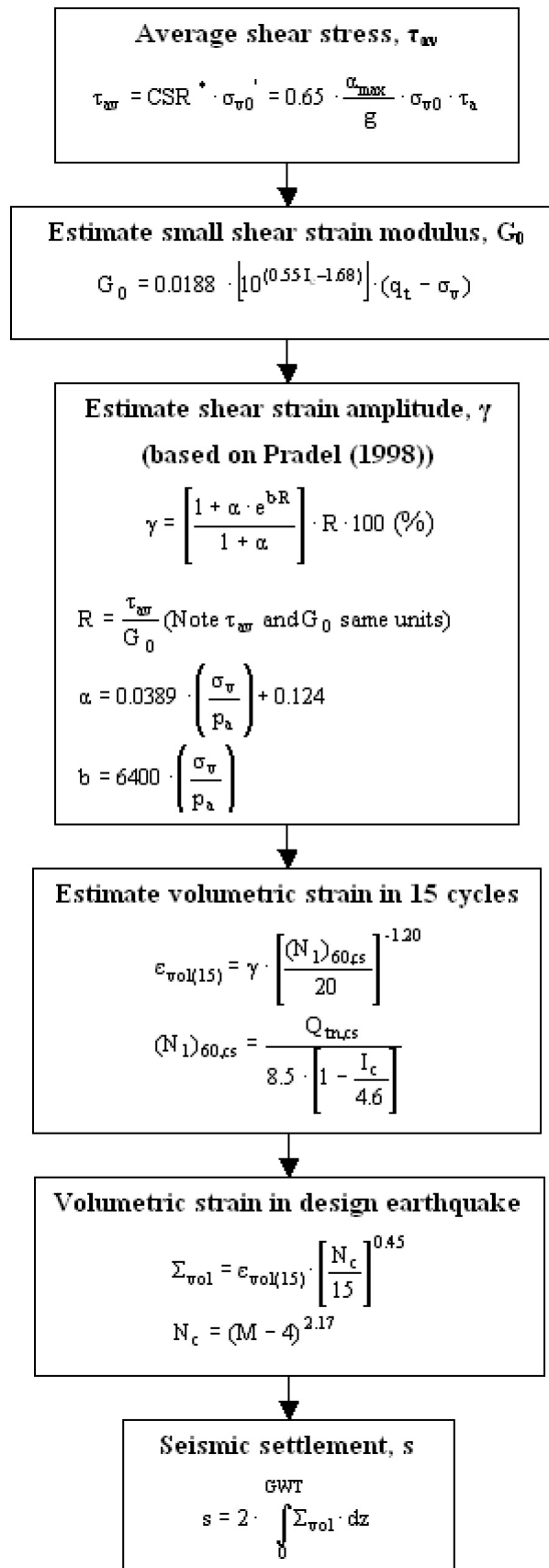

Robertson, P.K. and Lisheng, S., 2010, "Estimation of seismic compression in dry soils using the CPT" FIFTH INTERNATIONAL CONFERENCE ON RECENT ADVANCES IN GEOTECHNICAL EARTHQUAKE ENGINEERING AND SOIL DYNAMICS, Symposium in honor of professor I. M. Idriss, San Diego, CA

## Liquefaction Potential Index (LPI) calculation procedure

Calculation of the Liquefaction Potential Index (LPI) is used to interpret the liquefaction assessment calculations in terms of severity over depth. The calculation procedure is based on the methodology developed by Iwasaki (1982) and is adopted by AFPS.

To estimate the severity of liquefaction extent at a given site, LPI is calculated based on the following equation:

$$LPI = \int_0^{20} (10 - 0,5z) \times F_L \times dz$$

where:

$F_L = 1 - F.S.$  when F.S. less than 1

$F_L = 0$  when F.S. greater than 1

$z$  depth of measurement in meters

Values of LPI range between zero (0) when no test point is characterized as liquefiable and 100 when all points are characterized as susceptible to liquefaction. Iwasaki proposed four (4) discrete categories based on the numeric value of LPI:

- LPI = 0 : Liquefaction risk is very low
- $0 < LPI \leq 5$  : Liquefaction risk is low
- $5 < LPI \leq 15$  : Liquefaction risk is high
- LPI > 15 : Liquefaction risk is very high

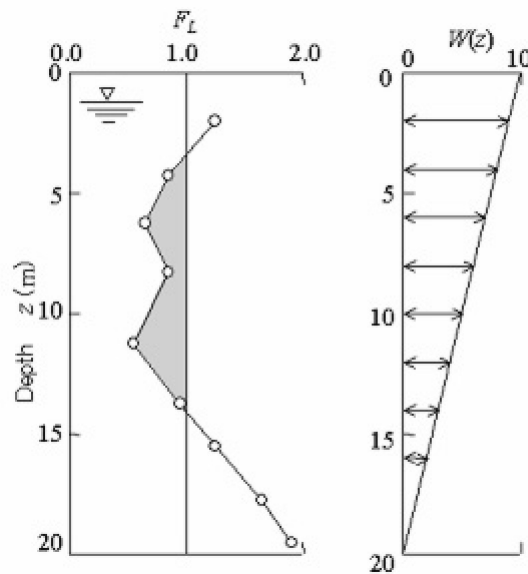

**Graphical presentation of the LPI calculation procedure**

## Shear-Induced Building Settlement (Ds) calculation procedure

The shear-induced building settlement (Ds) due to liquefaction below the building can be estimated using the relationship developed by Bray and Macedo (2017):

$$\begin{aligned} \ln(Ds) = & c1 + c2 * LBS + 0.58 * \ln\left(\tanh\left(\frac{HL}{6}\right)\right) + \\ & 4.59 * \ln(Q) - 0.42 * \ln(Q)^2 - 0.02 * B + \\ & 0.84 * \ln(CAVdp) + 0.41 * \ln(Sa1) + \varepsilon \end{aligned}$$

where Ds is in the units of mm, c1= -8.35 and c2= 0.072 for LBS ≤ 16, and c1= -7.48 and c2= 0.014 otherwise. Q is the building contact pressure in units of kPa, HL is the cumulative thickness of the liquefiable layers in the units of m, B is the building width in the units of m, CAVdp is a standardized version of the cumulative absolute velocity in the units of g-s, Sa1 is 5%-damped pseudo-acceleration response spectral value at a period of 1 s in the units of g, and ε is a normal random variable with zero mean and 0.50 standard deviation in Ln units. The liquefaction-induced building settlement index (LBS) is:

$$LBS = \sum W * \frac{\varepsilon_{shear}}{z} dz$$

where z (m) is the depth measured from the ground surface > 0, w is a foundation-weighting factor wherein W = 0.0 for z less than Df, which is the embedment depth of the foundation, and W = 1.0 otherwise. The shear strain parameter (ε<sub>shear</sub>) is the liquefaction-induced free-field shear strain (in %) estimated using Zhang et al. (2004). It is calculated based on the estimated Dr of the liquefied soil layer and the calculated safety factor against liquefaction triggering (FSL).



## References

- Lunne, T., Robertson, P.K., and Powell, J.J.M 1997. Cone penetration testing in geotechnical practice, E & FN Spon Routledge, 352 p, ISBN 0-7514-0393-8.
- Boulanger, R.W. and Idriss, I. M., 2007. Evaluation of Cyclic Softening in Silts and Clays. ASCE Journal of Geotechnical and Geoenvironmental Engineering June, Vol. 133, No. 6 pp 641 -652
- Boulanger, R.W. and Idriss, I. M., 2014. CPT AND SPT BASED LIQUEFACTION TRIGGERING PROCEDURES. DEPARTMENT OF CIVIL & ENVIRONMENTAL ENGINEERING COLLEGE OF ENGINEERING UNIVERSITY OF CALIFORNIA AT DAVIS
- Robertson, P.K. and Cabal, K.L., 2007, Guide to Cone Penetration Testing for Geotechnical Engineering. Available at no cost at <http://www.geologismiki.gr/>
- Robertson, P.K. 1990. Soil classification using the cone penetration test. Canadian Geotechnical Journal, 27 (1), 151 -8.
- Robertson, P.K. and Wride, C.E., 1998. Cyclic Liquefaction and its Evaluation based on the CPT Canadian Geotechnical Journal, 1998, Vol. 35, August.
- Youd, T.L., Idriss, I.M., Andrus, R.D., Arango, I., Castro, G., Christian, J.T., Dobry, R., Finn, W.D.L., Harder, L.F., Hynes, M.E., Ishihara, K., Koester, J., Liao, S., Marcuson III, W.F., Martin, G.R., Mitchell, J.K., Moriwaki, Y., Power, M.S., Robertson, P.K., Seed, R., and Stokoe, K.H., Liquefaction Resistance of Soils: Summary Report from the 1996 NCEER and 1998 NCEER/NSF Workshop on Evaluation of Liquefaction Resistance of Soils, ASCE, Journal of Geotechnical & Geoenvironmental Engineering, Vol. 127, October, pp 817-833
- Zhang, G., Robertson, P.K., Brachman, R., 2002, Estimating Liquefaction Induced Ground Settlements from the CPT, Canadian Geotechnical Journal, 39: pp 1168-1180
- Zhang, G., Robertson, P.K., Brachman, R., 2004, Estimating Liquefaction Induced Lateral Displacements using the SPT and CPT, ASCE, Journal of Geotechnical & Geoenvironmental Engineering, Vol. 130, No. 8, 861 -871
- Pradel, D., 1998, Procedure to Evaluate Earthquake -Induced Settlements in Dry Sandy Soils, ASCE, Journal of Geotechnical & Geoenvironmental Engineering, Vol. 124, No. 4, 364-368
- Iwasaki, T., 1986, Soil liquefaction studies in Japan: state -of-the-art, Soil Dynamics and Earthquake Engineering, Vol. 5, No. 1, 2-70
- Papathanassiou G., 2008, LPI-based approach for calibrating the severity of liquefaction -induced failures and for assessing the probability of liquefaction surface evidence, Eng. Geol. 96:94 -104
- P.K. Robertson, 2009, Interpretation of Cone Penetration Tests - a unified approach., Canadian Geotechnical Journal, Vol. 46, No. 11, pp 1337-1355
- P.K. Robertson, 2009. "Performance based earthquake design using the CPT", Keynote Lecture, International Conference on Performance-based Design in Earthquake Geotechnical Engineering - from case history to practice, IS-Tokyo, June 2009
- Robertson, P.K. and Lisheng, S., 2010, "Estimation of seismic compression in dry soils using the CPT" FIFTH INTERNATIONAL CONFERENCE ON RECENT ADVANCES IN GEOTECHNICAL EARTHQUAKE ENGINEERING AND SOIL DYNAMICS, *Symposium in honor of professor I. M. Idriss*, SAN diego, CA
- R. E. S. Moss, R. B. Seed, R. E. Kayen, J. P. Stewart, A. Der Kiureghian, K. O. Cetin, CPT -Based Probabilistic and Deterministic Assessment of In Situ Seismic Soil Liquefaction Potential, Journal of Geotechnical and Geoenvironmental Engineering, Vol. 132, No. 8, August 1, 2006
- I. M. Idriss and R. W. Boulanger, 2008. Soil liquefaction during earthquakes, Earthquake Engineering Research Institute MNO-12
- Jonathan D. Bray & Jorge Macedo, Department of Civil & Environmental Engineering, Univ. of California, Berkeley, CA, USA, Simplified procedure for estimating liquefaction -induced building settlement, *Proceedings of the 19th International Conference on Soil Mechanics and Geotechnical Engineering, Seoul 2011*



# **APPENDIX G**

## **INFILTRATION FEASIBILITY CONDITION LETTER**



**GEOTECHNICAL**  
**MATERIALS**  
**SPECIAL INSPECTION**

DVBE ♦ SBE ♦ SDVOSB ♦ SLBE

Viewpoint Development LLC  
Mr. Chris Livoni  
1635 Pacific Ranch Drive  
Encinitas, CA 92024

July 18, 2022  
NOVA Project No. 2021073

**Subject:** Infiltration Feasibility Condition Letter  
Viewpoint Old Town Apartments  
4620 Pacific Highway, San Diego, California

**References:** NOVA Services, Inc., 2022. *Report Geotechnical Investigation, Viewpoint Old Town Apartments, 4620 Pacific Highway, San Diego, California*, NOVA Project No. 2021069, July 18, 2022.  
carrierjohnson + culture (CJC), 2022, *Viewpoint Old Town, 46220 Pacific Hwy, San Diego, CA 92110*, 38 Sheets, Plot Date 3/31/2022.  
City San Diego, 2021, Stormwater Standards Manual, Effective Date: May 2021.  
City of San Diego. 2008, Seismic Safety Study, Grid 20, dated April 3.

Dear Mr. Livoni,

The intent of this letter is to provide the findings of an assessment by NOVA Services, Inc. (NOVA) of the infiltration conditions and related feasibility for permanent stormwater Best Management Practices ('stormwater BMPs') for drainage management areas (DMAs) at the above-referenced site.

The assessment has been prepared by NOVA for the Viewpoint Old Town Apartments. NOVA is retained by Viewpoint Development as Geotechnical Engineer-of-Record (GEOR) for the project.

The assessment provides an analysis of the infiltration feasibility in accordance with the criteria detailed in Section C.1.1 Simple Feasibility Criteria of the referenced City of San Diego BMP Design Manual (San Diego 2021). Based on these criteria, it is NOVA's opinion that this site should be considered to have a 'no-infiltration' condition.

## **EXISTING GEOLOGIC AND GEOTECHNICAL CONDITIONS**

Section C.1 of the BMP Manual states that if one of the standard setbacks listed cannot be achieved, the DMA may classify as a 'no infiltration condition'. Consideration of the existing fill thickness across the site and the location of the proposed BMPs, preclude the implementation of infiltration for the proposed BMPs.

As reported in NOVA 2022 and presented in Figure 1, the entire site is mapped on the regional geologic map as “af” a deep layer of undocumented artificial fill. Based on our subsurface investigation, this layer is approximately 15 feet deep. The BMP manual states that full and partial infiltration BMPs should not be placed within existing fill soils greater than 5 feet thick.

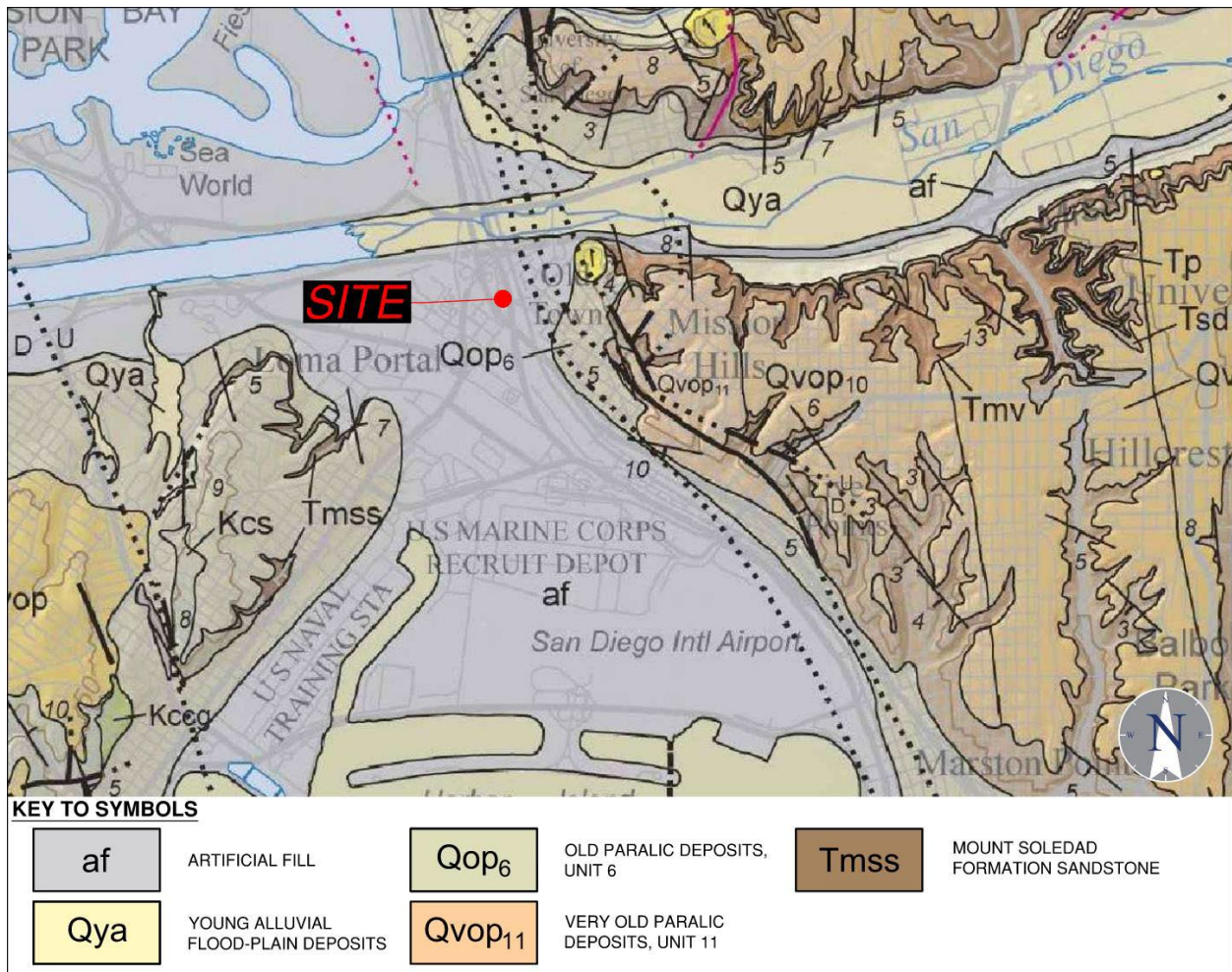
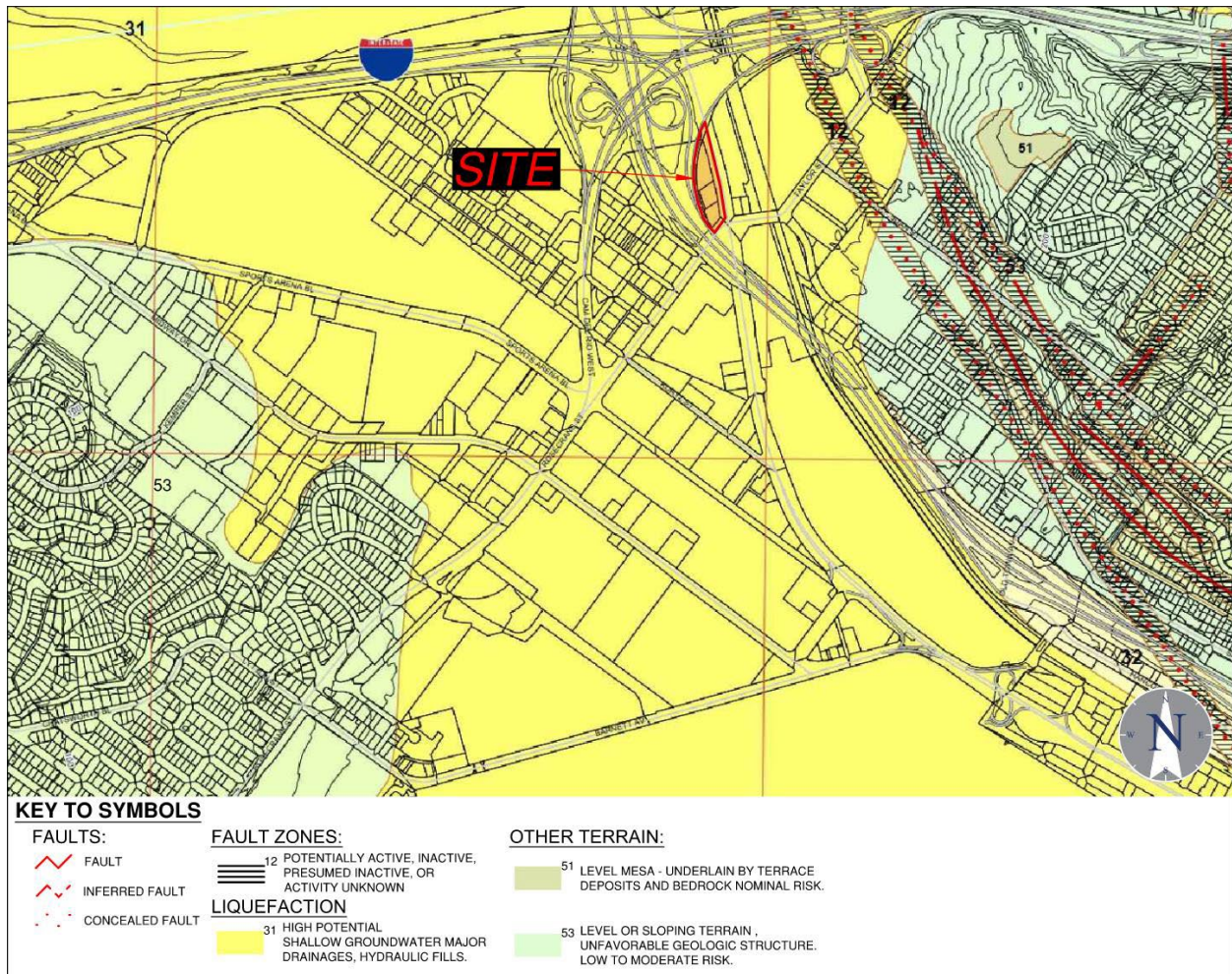

Figure 1. Regional Geology Map (Kennedy and Tan, 2008)

In addition, groundwater was measured at elevation +0.3 feet mean sea level- 9.7 feet below the existing ground surface. If infiltration were to be allowed, the infiltration surface would be far less than the recommended 10 feet of vertical separation between the infiltration surface and groundwater.

Finally, as shown in Figure 2, this site is mapped by the City of San Diego Seismic Safety Study as an area highly susceptible to liquefaction. NOVA has provided a liquefaction analysis on the site and determined that ground improvements or deep foundations are necessary to mitigate settlement caused by liquefaction.





**Figure 2. Site Location on City of San Diego Seismic Safety Study Map**  
 (source: City of San Diego, 2008)

## INFILTRATION FEASIBILITY CRITERIA FROM C.1.1

The following text reproduces the discussion points from Appendix C.1.1 in the referenced City of San Diego BMP Design Manual (San Diego 2021) for an infiltration feasibility condition letter. The discussion points from San Diego 2021 are reproduced below in italics, following which a response is provided by NOVA.

- *The phase of the project in which the geotechnical engineer first analyzed the site for infiltration feasibility.*

The project is currently in the planning phase of the site's development.

- *Results of previous geotechnical analyses conducted in the project area, if any.*

NOVA is not aware of previous geotechnical investigations at this site.



- *The development status of the site prior to the project application (i.e., new development with raw ungraded land, or redevelopment with existing graded conditions).*

The approximately 1.75-acre site is comprised of APN's 442-740-03-00, 442-740-06-00, 442-740-07-00, nominally located at 4620 Pacific Highway in San Diego. The site is bounded on the east by Pacific Highway. The arcuate-shaped connector between Interstate 5 North to Interstate 8 East bounds the site to the north and west, with Rosecrans Street to the south.

The site is level, ranging from an elevation of +10 feet mean sea level (msl) on the north side of the site to +11 feet msl on the southern portion of the site. The site is currently occupied by the single-level Perry's Cafe and a surrounding asphalt parking lot. A 4-foot to 6-foot tall retaining wall bounds the site along the Caltrans I-5/I-8 connector.

Available historic photography indicates that the grading for the existing restaurant building and parking lot was completed between 1962 and 1964.

- *The history of design discussions for the project footprint, resulting in the final design determination.*

NOVA has not been involved in design discussions pertaining to the project footprint. The footprint appears to maximize the available area for use as apartment units and the associated parking.

- *Full/partial infiltration BMP standard setbacks to underground utilities, structures, retaining walls, fill slopes, and natural slopes applicable to the DMA that prevent full/partial infiltration.*

As discussed previously, based on the BMP Manual, full and partial BMPs should not be sited within existing fill soils greater than 5 feet thick. As may be seen by a review of Figure 1 and boring logs in NOVA 2022, the site is covered by fill soils greater than 5 feet in thickness.

- *The physical impairments (i.e., fire road egress, public safety considerations, etc.) that prevent full/partial infiltration.*

The addition of stormwater into liquefiable soils is a risk to public safety.

- *The consideration of site design alternatives to achieve partial/full infiltration within the BMP.*

Based on high groundwater, deep fills, and liquefiable soils, stormwater infiltration should not be performed at this site. There are no viable design alternatives, as these conditions are uniform across the site.

- *The extent site design BMP requirements were included in the overall design.*

The Site Development Plan indicates that four DMAs are included in this project. Three are roof filtration systems and one is hardscape (CJC, 2022).



July 18, 2022

- *Conclusion of recommendation from the geotechnical engineer regarding the DMA's infiltration condition.*

In conclusion, given the deep fill condition, the shallow groundwater, and the liquefiable nature of the soils, it is NOVA's opinion that the risk of geologic or geotechnical hazards cannot be reasonably mitigated to an acceptable level at the site.

- *An Exhibit for all applicable DMAs that clearly labels:*
  - *Proposed development areas and development type.*
  - *All applicable features and setbacks that prevent partial or full infiltration, including underground utilities, structures, retaining walls, fill slopes, natural slopes, and existing fill materials greater than 5 feet.*
  - *Potential locations for structural BMPs.*
  - *Areas where full/partial infiltration BMPs cannot be proposed.*

See Plate 1 within NOVA 2022 for development areas and a cross-section of the proposed development. The development is five stories of residential apartments over one at-grade podium level with a partial subterranean parking level. Fill between 15 to 16 feet is mapped below the site, groundwater is located less than 10 feet below ground surface and the soils are liquefiable, therefore infiltration BMPs may not be proposed anywhere at this site.

## CLOSURE

NOVA appreciates the opportunity to be of service to Viewpoint Development on this project. Should you have any questions regarding this letter or other matters, please contact the undersigned at 858.292.7575 x 413.

Sincerely,  
**NOVA Services, Inc.**

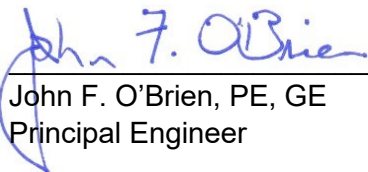
  
John F. O'Brien, PE, GE  
Principal Engineer

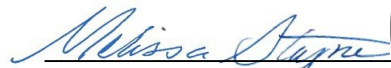

  
Melissa Stayner, PG, CEG  
Senior Engineering Geologist

