

## RESOLUTION NO. 23-074

### RESOLUTION OF THE MENDOCINO COUNTY BOARD OF SUPERVISORS ADOPTING AN ADDENDUM TO THE GARDEN'S GATE FINAL ENVIRONMENTAL IMPACT REPORT AND APPROVING AN AMENDED MITIGATION MONITORING & REPORTING PROGRAM FOR THE BELLA VISTA SUBDIVISION PROJECT

WHEREAS, on October 6, 2009, the Mendocino County Board of Supervisors adopted Resolution No. 09-230 certifying the Garden's Gate Subdivision Final Environmental Impact Report (State Clearinghouse No. 2007052006; "Garden's Gate Project EIR") which analyzed the environmental impacts of a 197-lot residential project located approximately one mile south of the Ukiah City limits ("Garden's Gate Project"), and adopted a Mitigation Monitoring and Reporting Program ("MMRP"), and a Statement of Overriding Considerations; and

WHEREAS, on October 6, 2009, the Board of Supervisors also approved a Vesting Tentative Subdivision Map for the Garden's Gate Project (S\_3-2005); and

WHEREAS, on October 20, 2009, the Board of Supervisors adopted Ordinance No. 4229 approving the Garden's Gate Development Agreement, and on July 13, 2010, the Board of Supervisors adopted Ordinance No. 4264 approving the First Amendment to the Garden's Gate Development Agreement; and

WHEREAS, the First Amendment to the Garden's Gate Development Agreement vests the project entitlements for the Garden's Gate Project for a period of 15 years, a term that remains valid until August 27, 2025; and

WHEREAS, subsequent to the approval of entitlements for the Garden's Gate Project, the project site was acquired by Rancho Yokayo, L.P. and the entitlements and Development Agreement were assumed by the new owner; and

WHEREAS, on July 23, 2020, Rancho Yokayo, L.P. ("Owner") and Guillon, Inc. ("Applicant") filed an application with the County of Mendocino requesting: (a) a subdivision modification (S\_2020-0001) to change the layout of the Garden's Gate Project (excluding the 1.68-acre portion known as Tract 261 for which a Final Map has been recorded), to reduce the number of lots, to modify the incentives and concessions that were granted under State Density Bonus Laws, to modify the Inclusionary Housing Plan and to modify the Phasing Plan; and (b) an amendment to the Garden's Gate Development Agreement (DEV\_2020-0001), collectively the "Bella Vista Subdivision Project" ("Project"); and

WHEREAS, at a properly noticed public hearing on March 9, 2023, the Planning Commission reviewed written and oral staff reports, conducted a public hearing on the Project and took testimony; and received into the record all pertinent documents related to the Project and adopted Resolution No. PC\_2023-0002 recommending, in part, that the Board of Supervisors adopt the Addendum to the Garden's Gate Environmental Impact Report ("EIR Addendum") which is attached to this Resolution as Exhibit A and incorporated herein by reference, and an amended Mitigation Monitoring & Reporting Program for the Project ("Amended MMRP") which is attached to this Resolution as Exhibit B and incorporated herein by reference; and

WHEREAS, in accordance with applicable provisions of law, the Board of Supervisors held a public hearing on April 11, 2023, at which time the Board of Supervisors heard and received all relevant testimony and evidence presented orally or in writing regarding EIR Addendum, Amended MMRP, and the Project and all interested persons were given an opportunity to hear and be heard regarding EIR Addendum, Amended MMRP, and the Project; and

NOW, THEREFORE BE IT RESOLVED that the Mendocino County Board of Supervisors hereby determines as follows:

1. The Board of Supervisors has independently reviewed, analyzed and considered the previously certified Garden's Gate Project EIR, the EIR Addendum, the staff report and all attachments thereto, as well as all written documentation and public comments thereto; and
2. The EIR Addendum was prepared and reviewed in compliance with the provisions of CEQA and the CEQA Guidelines; and
3. The information and analysis contained in the Garden's Gate Project EIR and the EIR Addendum reflects the County's independent judgment as to the environmental consequences of the Project; and
4. The Board of Supervisors affirms the findings for certification of the Garden's Gate Project EIR as made in Resolution No. 09-230, as approved on October 6, 2009; and
5. That, based upon substantial evidence demonstrated by the analysis included in the Garden's Gate Project EIR and EIR Addendum none of the conditions described in Sections 15162 or 15163 of the CEQA Guidelines calling for the preparation of a subsequent or supplemental EIR or negative declaration have occurred; specifically:
  - a. The proposed modifications to the approved Vesting Tentative Map would not result in any substantial changes from what was previously analyzed in the Garden's Gate Project EIR and would not involve new significant impacts or result in a substantial increase in the severity of previously identified significant impacts. The proposal, therefore, does not constitute a substantial change in the project.
  - b. No substantial changes have occurred in the site vicinity. Surrounding land uses have not changed from those evaluated in the Garden's Gate Project EIR and development in the region has occurred at a slower pace than anticipated in the Garden's Gate Project EIR. Based on the environmental baseline identified in the Garden's Gate Project EIR, the physical changes to the project site and vicinity that have occurred are consistent with the analysis of the Garden's Gate Project EIR and the cumulative projects considered in the Garden's Gate Project EIR. There have been no substantial changes in the circumstances of the project as considered in the certified Garden's Gate Project EIR.
  - c. The Project's consistency with the environmental resource analysis in the Garden's Gate Project EIR is summarized in Section 6 of the EIR Addendum. As discussed, the Project would not result in any new significant effects not discussed in the Garden's Gate Project EIR.
  - d. Based on the analysis presented in the EIR Addendum, no supplemental environmental review is required for the Project in accordance with Public Resources Code Section 21166, and CEQA Guidelines Sections 15162 and 15164.
  - e. To the extent that new or modified mitigations are identified in the EIR Addendum and the technical studies prepared in support of the Addendum, the Applicant has agreed to incorporate the mitigations into the Project and the modifications are incorporated into the Amended MMRP (Exhibit B).

BE IT FURTHER RESOLVED that the Board of Supervisors hereby adopts the EIR Addendum and the Amended MMRP for the Project; and

BE IT FURTHER RESOLVED that the Clerk of the Board is designated as the custodian of the documents and other materials that constitute the record of the proceedings upon which the Board's decisions herein are based. These documents may be found at the office of the Clerk of the Board of Supervisors, 501 Low Gap Road, Ukiah, California 95482.

The foregoing Resolution introduced by Supervisor Williams, seconded by Supervisor Mulheren, and carried this 11<sup>th</sup> day of April, 2023, by the following vote:

AYES: Supervisors McGourty, Mulheren, Haschak, Gjerde, and Williams  
NOES: None  
ABSENT: None

WHEREUPON, the Chair declared said Resolution adopted and SO ORDERED.

ATTEST: DARCIE ANTLE  
Clerk of the Board

  
\_\_\_\_\_  
Deputy

APPROVED AS TO FORM:  
CHRISTIAN M. CURTIS  
County Counsel

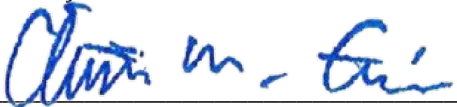
  
\_\_\_\_\_

  
\_\_\_\_\_  
GLENN MCGOURTY, Chair  
Mendocino County Board of Supervisors

I hereby certify that according to the provisions of Government Code Section 25103, delivery of this document has been made.

BY: DARCIE ANTLE  
Clerk of the Board

  
\_\_\_\_\_  
Deputy



# COUNTY OF MENDOCINO

## DEPARTMENT OF PLANNING AND BUILDING SERVICES

860 NORTH BUSH STREET • UKIAH, CALIFORNIA 95482  
120 WEST FIR STREET • FORT BRAGG, CALIFORNIA 95437

JULIA KROG, DIRECTOR  
PHONE: 707-234-6650  
FAX: 707-463-5709  
FB PHONE: 707-964-5379  
FB FAX: 707-961-2427  
[pbs@mendocinocounty.org](mailto:pbs@mendocinocounty.org)  
[www.mendocinocounty.org/pbs](http://www.mendocinocounty.org/pbs)

### ADDENDUM TO A CERTIFIED ENVIRONMENTAL IMPACT REPORT

The County of Mendocino, California, does hereby prepare, declare and publish this Addendum to a certified Environmental Impact Report (EIR) for the following described project:

**PROJECT NAME:** Bella Vista Subdivision (formerly known as "Garden's Gate Subdivision")  
**PROJECT NO.:** #S 2020-0001 (original file number: #S 3-2005)  
**SCH NO.:** 2007052006

This Addendum to the certified Final EIR for the Garden's Gate Subdivision evaluates a proposal to modify the approved and fully entitled Garden's Gate Subdivision project (approved by the Mendocino County Board of Supervisors on October 6, 2009, as amended on April 27, 2010). The current property owner (Rancho Yokayo, L.P.) and applicant (Guillon, Inc.) have filed an application to modify the project approvals. The revised project is known as the "Bella Vista Subdivision."

The requested modifications include amendments to the Garden's Gate Subdivision Vesting Tentative Map (Subdivision Modification #S\_2020-0001), Garden's Gate Development Agreement (DEV\_2020-0001), and Garden's Gate Inclusionary Housing Plan. As proposed, the site configuration is modified to include land immediately adjacent to South State Street, and to remove land in the northwest corner of the site (Tract 261) for which a Parcel Map has been recorded. Total acreage is increased from 46.1 acres to 48.8 acres (2.7-acre increase). The total number of residences is decreased from 197 to 171 (decrease of 26 units). The number of single-family lots is increased from 123 to 132 (increase of nine single family lots) and the project now includes 39 age-restricted lots. The circulation layout is modified to eliminate the proposed secondary access from Gobalet Lane and to add a new secondary access street to the south of the proposed roundabout at the main entry to the project. The total acreage of onsite parks is increased from 2.31 to 2.79 acres and the location/configuration of parks is modified. Rather than identifying 36 for-sale units for moderate-income households, the modified inclusionary housing plan provides a senior housing development of 39 age-restricted units and identifies 10% of the non-age-restricted units (13 units) to be sold to moderate-income households.

The County of Mendocino Department of Planning & Building Services has reviewed the proposed modifications to the project and, on the basis of the whole record before it, has determined that there is no substantial evidence that the Modified Project, as identified in the attached Addendum, would have a significant effect on the environment beyond that which was evaluated in the certified EIR. A supplemental or subsequent EIR is not required pursuant to the California Environmental Quality Act of 1970 (Section 21000, et seq., Public Resources Code of the State of California).

The Addendum to a certified EIR has been prepared pursuant to Title 14, Sections 15162 and 15164 of the California Code of Regulations. It may be reviewed at the offices of the Planning & Building Services Department, 860 North Bush St., Ukiah, California 95482 during public counter hours, or on the County's website at: <https://www.mendocinocounty.org/government/planning-building-services/plans-guidelines-and-eirs> or <https://www.mendocinocounty.org/government/planning-building-services/meeting-agendas/planning-commission>

Date: February 23, 2023

By: Julia Krog  
Julia Krog, Director of Planning & Building Services  
County of Mendocino, California

*This page is intentionally left blank*

# Addendum to Final Environmental Impact Report for the Garden's Gate Subdivision

(renamed "Bella Vista Subdivision")

SCH No. 2007052006

Mendocino County, California

## **Mendocino County**

Department of Planning & Building Services  
860 North Bush St.  
Ukiah, CA 95482  
(707)234-6650  
Contact: Julia Krog, Director

Prepared with assistance from:

## **North Coast Community Planning**

310 South Harold St.  
Fort Bragg, CA 95437  
(707) 272-2343  
Contact: Linda Ruffing

February 2023

*This page is intentionally left blank*

TABLE OF CONTENTS

**TABLE OF CONTENTS**.....

**1. FILE NUMBER/PROJECT NAME** ..... **1**

**2. PROJECT LOCATION**..... **1**

**3. EXISTING PLAN DESIGNATIONS AND ZONING** ..... **1**

**4. PROJECT DISCUSSION**..... **1**

**4.1 Garden's Gate Project - Background** ..... **1**

**4.2 Summary of Significant & Unavoidable Impacts identified in FEIR** ..... **2**

**4.3 Proposed Amendments to Project Approvals**..... **2**

**5. APPROACH TO CEQA ANALYSIS** ..... **4**

**5.1 "Substantial Changes in the Project" Standard**..... **5**

**5.2 "Substantial Changes in the Circumstances" Standard**..... **6**

**5.3 "New Information of Substantial Importance" Standard** ..... **6**

**6. ENVIRONMENTAL FACTORS** ..... **7**

**6.1 Geology, Seismicity and Soils (FEIR, Chapter 3.1)**..... **7**

**6.2 Hydrology and Water Quality (FEIR, Chapter 3.2)**..... **9**

**6.3 Biological Resources (FEIR, Chapter 3.3)**..... **14**

**6.4 Cultural Resources and Tribal Cultural Resources (FEIR, Chapter 3.4)**..... **18**

**6.5 Transportation (FEIR, Chapter 3.5)**..... **20**

**6.6 Air Quality (FEIR, Chapter 3.6)** ..... **22**

**6.7 Energy & Greenhouse Gas Emissions (FEIR, Chapter 3.6)** ..... **26**

**6.8 Noise (FEIR, Chapter 3.7)**..... **29**

**6.9 Aesthetics, Light and Glare (FEIR, Chapter 3.8)**..... **31**

**6.10 Utilities and Service Systems (FEIR, Chapter 3.9)** ..... **33**

**6.11 Public Services (FEIR, Chapter 3.9)** ..... **34**

**6.12 Recreation (addressed in FEIR, Chapter 3.9, Public Services and Infrastructure)** ..... **35**

**6.13 Hazards and Hazardous Materials (FEIR, Chapter 3.9)**..... **37**

**6.14 Wildfire (FEIR, Chapter 3.9)** ..... **39**

**6.15 Land Use and Planning (FEIR, Chapter 3.10)** ..... **40**

**Exhibits:**

- 1. Regional Location Map
- 2. Site Location Map



3. Zoning Designations Map
4. Airport Combining Zone Map
5. Garden's Gate Subdivision Vesting Tentative Map
6. Bella Vista Amended Vesting Tentative Map

**Appendices:**

- A. Bella Vista Drainage Report & Stormwater Control Plan (LACO Associates; March 2021)
- B. Will-Serve Letter for Water (Willow County Water District; September 2021)
- C. Biological Resources Assessment for the Bella Vista Subdivision Project (Gallaway Enterprises; July 2021)
- D. Technical Memorandum: Assessment of Biological Issues of the Bella Vista Subdivision Project in Relation to the Certified EIR for the Garden's Gate Project (Gallaway Enterprises; July 2021)
- E. Tree Inventory Report (Horticultural Associates; July 2021)
- F. Draft Delineation of Jurisdictional Waters of the United States (Gallaway Enterprises; June 2021)
- G. Traffic Analysis for the Bella Vista Housing Project (WTrans; March 2021)
- H. Air Quality and Greenhouse Gas Assessment (Illingworth & Rodkin, Inc.; January 2021)
- I. Bella Vista Development-Water Supply Verification (Luhdorff & Scalmanini, September 2021)
- J. UVSD Capacity to Serve Sewer for Bella Vista Subdivision (UVSD; March 2021)

**BELLA VISTA SUBDIVISION (#S 2020-0001)**  
**Addendum to the Garden's Gate Subdivision Environmental Impact Report**  
**SCH No. 2007052006**

## 1. FILE NUMBER/PROJECT NAME

Subdivision Modification (#S 2020-0001) - Bella Vista Subdivision  
 Development Agreement Amendment (#DEV\_2020-0001)  
 Administrative Permit (#AP 2022-0034)

## 2. PROJECT LOCATION

The project site is located at 3000 South State Street, in the unincorporated area of Mendocino County, California, just south of the Ukiah city limits ([Exhibit 1: Regional Location Map](#)). The site is bounded by South State Street (CR# 104A) and commercial and industrial uses to the east; Gobalet Lane (private road) and residential uses to the north; private lands and rural residential uses to the east; and agricultural, residential and institutional uses to the south. The project site is located on the *Elledge Peak, California* United States Geological Survey (USGS) 7.5-minute Quadrangle, (Latitude 39.112° N; Longitude -123.200° E).

The project site is assigned four Assessor's Parcel numbers: 184-110-28 (4.48± acres); 184-110-21 (0.67± acre); 184-110-29 (15.19± acres); 184-120-01 (29.18± acres) ([Exhibit 2: Site Location Map](#)).

The project site is currently undeveloped. The east end of the site is grassland that was previously used for agricultural purposes. West of this is a 28-acre fallow area that, until recently, was used as a vineyard that extended to the base of the western hills. The vineyard was removed in 2021. The west end of the site includes the lower portion of a wooded hillside. Cleland Mountain Creek, an intermittent tributary to the Russian River, traverses 280 feet of the site adjacent to the northwestern property boundary. The site is not under a Williamson Act contract.

## 3. EXISTING PLAN DESIGNATIONS AND ZONING

The Mendocino County General Plan and the Ukiah Valley Area Plan assign two separate land use classifications to the project site. The easternmost two-thirds of the property is classified Suburban Residential (SR) and the western third is classified Rural Residential (RR). The Mendocino County Inland Zoning Code assigns three zoning classifications to the property. A swath adjacent to South State Street is zoned Multiple-Family Residential (R-3), the central portion is zoned Suburban Residential (SR) and the westernmost portion is zoned Rural Residential (RR-5) ([Exhibit 3: Zoning Designations](#)). The property is within the Airport Zone combining district ([Exhibit 4: Airport Combining Zone Map](#)).

## 4. PROJECT DISCUSSION

### 4.1 Garden's Gate Project - Background

On November 14, 2006, the Board of Supervisors adopted Resolution No. 06-216 authorizing a density bonus application and concessions for the 197-unit Garden's Gate residential project. On October 6, 2009, the Board adopted Resolution No. 09-230 certifying the final Environmental Impact Report for the Garden's Gate Subdivision Project ("FEIR"). The Board also adopted Resolution No. 09-230 approving a Vesting Tentative Subdivision Map (#S 3-2005), Project Site Plan, Project Phasing Plan, Master Building Plan and Inclusionary Housing Agreement. On October 20, 2009, the Board adopted Ordinance 4229 approving the Garden's Gate Development Agreement. The Board subsequently amended the

Development Agreement on July 13, 2010 by adoption of Ordinance 4264. Collectively, these actions are referred to as the "Project Approvals." The Project Approvals are summarized in Table 1: Summary of Project Approvals and Requested Modifications.

The approved Vesting Tentative Subdivision Map is shown in Exhibit 5: Garden's Gate Subdivision Vesting Tentative Map. The Garden's Gate project includes 197 single family dwellings, two parks, and associated streets and infrastructure on a 46.1-acre site (including a 13.1-acre remainder parcel). The residential uses include 123 detached units and 74 attached townhouses in two- and four-unit structures. The project includes one- two- and three-story components.

#### 4.2 Summary of Significant & Unavoidable Impacts identified in FEIR

On October 6, 2009, the Mendocino County Board of Supervisors adopted Resolution No. 09-230 certifying the Final Environmental Impact Report for the Garden's Gate Subdivision Project ("FEIR"), making findings regarding project impacts, and adopting a Statement of Overriding Considerations. The resolution identifies the following significant, unavoidable adverse impacts:

- (a) Constructing the project will emit at least the equivalent of 7,388 tons of carbon dioxide into the atmosphere. Therefore, the project will be an increment of a significant and unavoidable cumulative impact on Global Climate Change (Impact 3.6-B).
- (b) Future residential use of the project will emit the equivalent of approximately 2,589 tons of carbon dioxide per year. The emissions can be reduced by recommended mitigation measures, but the emissions will remain above the zero net increase significance threshold. Therefore, the project will be an increment of a significant and unavoidable cumulative impact on Global Climate Change (Impact 3.6-F).
- (c) The project will convert 31 acres of Prime Farmland and 2 acres of Unique Farmland to non-agricultural use. (Impact 3.10-A).

The Statement of Overriding Considerations found that the benefits of the project outweigh the significant impacts due to the following considerations:

- (a) The benefits of the project in providing housing outweigh the impacts associated with the emission of greenhouse gases during project construction and during future residential use of the project site, since there is no way that any new development could feasibly occur in the County or the State if it was required to have no new emissions.
- (b) The benefits of the project in providing housing outweigh the impacts associated with the loss of Prime Farmland and Unique Farmland to non-agricultural use since the project site has been designated and zoned for residential use since 1981 and there is little developable land available for the development of new housing to meet demand that does not involve loss of agricultural land in the Ukiah Valley.

#### 4.3 Proposed Amendments to Project Approvals

The current property owner (Rancho Yokayo, L.P.) and applicant (Guillon, Inc.) have filed an application to modify the following components of the Project Approvals:

- Garden's Gate Subdivision Vesting Tentative Map (Subdivision Modification #S\_2020-0001) including the Project Site Plan, Master Building Plan and Project Phasing Plan
- Garden's Gate Development Agreement
- Garden's Gate Affordable Housing Agreement

The proposed modifications to the Project Approvals for the Garden's Gate project are referred to in this document as the "Modified Project" and are summarized in Table 1: Summary of Project Approvals and Requested Modifications.

Table 1 - Summary of Project Approvals and Requested Modifications

	Project Approvals (Garden's Gate)	Requested Modifications (Bella Vista)
Acreage	46.1 acres, includes: <ul style="list-style-type: none"> <li>▪ 4.48 acres along S. State Street is not included in the project</li> <li>▪ 13.1-acre remainder parcel</li> </ul>	48.8 acres, includes: <ul style="list-style-type: none"> <li>▪ 1.68 acres in Tract 261 has been removed from the map. A Final Map for 4 lots has been recorded for Tract 261.</li> <li>▪ The acreage along S. State Street is included in the project with the exception of 1.59-acre "Parcel A" at northeast corner which is not included in the project</li> <li>▪ 12.19-acre remainder parcel</li> </ul>
Number of residential lots	197 lots <ul style="list-style-type: none"> <li>▪ 123 single family lots</li> <li>▪ 74 townhome lots</li> </ul>	171 lots <ul style="list-style-type: none"> <li>▪ 132 single-family lots</li> <li>▪ 39 age-restricted lots</li> </ul>
Average Lot Size	<ul style="list-style-type: none"> <li>▪ Single-family: 3,774 SF</li> <li>▪ Townhomes: 2,125 SF</li> </ul>	<ul style="list-style-type: none"> <li>▪ Single-family: 6,219 SF</li> <li>▪ Age-restricted: 4,907 SF</li> </ul>
Circulation	Two access points to S. State Street: <ul style="list-style-type: none"> <li>▪ Roundabout at main entry</li> <li>▪ Connection to Gobalet Lane (200' north of roundabout)</li> </ul>	Two access points to S. State Street: <ul style="list-style-type: none"> <li>▪ Roundabout at main entry</li> <li>▪ New south entry street (600' south of roundabout)</li> <li>▪ Eliminated access via Gobalet Lane</li> </ul>
Parks	Total Park area: 2.31 acres <ul style="list-style-type: none"> <li>▪ Park A: 0.9 acres</li> <li>▪ Park B: 1.4 acres</li> </ul>	Total Park area: 2.81 acres <ul style="list-style-type: none"> <li>▪ Neighborhood Park: 1.99 acres (playground; stormwater detention)</li> <li>▪ Linear Park: 0.58 acres (930 linear feet of multi-use trail)</li> <li>▪ Cottage Park: 0.24 acre</li> </ul>
Phasing Plan	7 phases	7 phases

	Project Approvals (Garden's Gate)	Requested Modifications (Bella Vista)
Housing types	2,500 SF two-story units- 26 lots 760-1,370 SF one-story units (cottage) - 15 lots 1,400-1,900 SF two-story units (garden court) - 72 lots 944-1,300 SF units(duplex/fourplex) - 74 lots	1,200-2,200 SF one- and two-story units - 132 lots 900-1,400 SF one-story units (cottage) - 39 lots (age-restricted)
Affordable Housing	36 for-sale units targeted to moderate-income households	39 age-restricted units 10% of non-age restricted units (13 units) targeted to moderate-income households

The proposed modified Vesting Tentative Subdivision Map for the Bella Vista subdivision is shown in Exhibit 6: Bella Vista Amended Vesting Tentative Map. The Modified Project is a 171-lot multi-generational subdivision that consists of 132 single family residential lots and 39 age-restricted residential lots. All of the residential units will be single story. The project includes 2.79 acres of parkland. The development would be accessed via two new public streets entering from South State Street. A roundabout would be constructed at the northerly entrance which is aligned with Plant Road on the east side of South State Street.

## 5. APPROACH TO CEQA ANALYSIS

In the case of an application requiring discretionary approval on a project for which an EIR has been certified (as is the case for the requested modifications to the Garden's Gate project entitlements), the California Environmental Quality Act (CEQA) requires the lead agency to determine whether a supplemental or subsequent EIR is required. The requirement is codified in Public Resources Code section 21166 and CEQA Guidelines Section 15162. Section 15162 provides guidance in this process by requiring an examination of whether, since the certification of the EIR and approval of the project, changes in the project or conditions have been made to such an extent that the proposal may result in substantial changes in physical conditions that are considered significant under CEQA. If so, the County would be required to prepare a subsequent EIR or supplement to the EIR.

The following review examines the Modified Project in accordance with Section 15162. The evaluation concludes that the conditions set forth in Section 15162 are not present, and that an Addendum to the EIR is the appropriate CEQA document pursuant to CEQA Guidelines Section 15164.

Each of the following standards, as set forth in Section 15162(a), are addressed in this Addendum.

- 1) Are substantial changes proposed in the project which will require major revisions of the previous EIR or negative declaration due to the involvement of new significant environmental effects or a substantial increase in the severity of previously identified significant effects?
- 2) Have substantial changes occurred with respect to the circumstances under which the project is undertaken which will require major revisions of the previous EIR or negative declaration due to the involvement of new significant environmental effects or a substantial increase in the severity of previously identified significant effects?

- 3) Is there new information of substantial importance, which was not known and could not have been known with the exercise of reasonable diligence at the time the previous EIR was certified as complete or the negative declaration was adopted, that shows any of the following:
- (a) The project will have one or more significant effects not discussed in the previous EIR or negative declaration;
  - (b) Significant effects previously examined will be substantially more severe than shown in the previous EIR (or negative declaration);
  - (c) Mitigation measures or alternatives previously found not to be feasible would in fact be feasible, and would substantially reduce one or more significant effects of the project, but the project proponents decline to adopt the mitigation measure or alternative; or
  - (d) Mitigation measures or alternatives which are considerably different from those analyzed in the previous EIR would substantially reduce one or more significant effects on the environment, but the project proponents decline to adopt the mitigation measure or alternative.

Pursuant to CEQA, this Addendum evaluates the Modified Project to determine whether circumstances are present that could require a supplemental environmental document. Based on the Addendum, County staff recommends that: (a) the Modified Project's impacts are within the scope of those analyzed in the FEIR for the Garden's Gate Subdivision Project that was reviewed and certified by the County; (b) the FEIR requires only minor changes, and (c) the FEIR provides a sufficient and adequate analysis of the environmental impacts of the Modified Project.

#### 5.1 "Substantial Changes in the Project" Standard

The Modified Project would not alter the uses originally proposed for the site (residential uses, streets, parks). The Modified Project includes fewer residential units and an overall decrease in density as compared to the project evaluated in the FEIR. The Modified Project is consistent with the General Plan and zoning designations for the project site.

The Modified Project includes changes to the proposed internal street layout and improves the project's connection to the existing County-maintained street network by eliminating the secondary access on Gobalet Lane and replacing it with an access located south of the proposed roundabout at the main entry to the project site.

The Modified Project retains open space and provides parkland along the eastern frontage of the site along South State Street and establishes a Neighborhood Park in this area, just south of the main entry road.

The Modified Project does not include the portion of the site encompassed by Lots 194, 195, 196 and 197 in the northwest corner of the site, as identified on the approved Vesting Tentative Map. The County has approved a Final Map for four lots in this location ("Tract 261") consistent with the certified FEIR and Garden's Gate Vesting Tentative Map and, consequently, there is no need to include this area in the Modified Project.

One of the requirements of CEQA is the examination of whether a proposed project would conflict with existing plans and regulations, including the general plan, zoning regulations, and other planning documents. Inconsistencies may suggest that a project would have environmental effects that have not been identified in advance, and for which planning or analysis has not occurred. As discussed in this Addendum, the Modified Project would be consistent with the Mendocino County General Plan, zoning regulations, the Ukiah Municipal Airport Land Use Compatibility Plan, the Ukiah Valley Area Plan, and other planning documents.

The proposed modifications to the approved Vesting Tentative Map would not result in any substantial changes from what has been previously analyzed and would not involve new significant impacts not identified in the FEIR or result in a substantial increase in the severity of previously identified significant impacts. The proposal, therefore, does not constitute a substantial change in the project.

### 5.2 "Substantial Changes in the Circumstances" Standard

Pursuant to Section 15162(a)(2) of the CEQA Guidelines, this section presents a discussion of whether changes to the project site or the vicinity have occurred subsequent to the certification of the FEIR that would result in new significant impacts or a substantial increase in the severity of a previously identified significant impact.

The only physical change to the project site that has occurred since the FEIR was certified is the removal of an on-site vineyard in 2021. This change was contemplated and addressed in the FEIR. For this reason, the Modified Project would not result in any substantial physical changes to the project site that would constitute a change in circumstances from what was identified for the original project approval that would affect any issue of environmental significance.

No substantial changes have occurred on the site or in the site vicinity. Surrounding land uses have not changed from those evaluated in the FEIR and development in the region has occurred at a slower pace than anticipated in the FEIR. Based on the environmental baseline identified in the FEIR, the physical changes to the project site and vicinity that have occurred are consistent with the analysis of the FEIR and the cumulative projects considered in the FEIR. There have been no substantial changes in the circumstances of the project as considered in the FEIR.

### 5.3 "New Information of Substantial Importance" Standard

Pursuant to Section 15162(a)(3) of the CEQA Guidelines, this section includes a discussion of whether the Modified Project would result in new information of substantial importance which was not known and could not have been known with the exercise of reasonable diligence at the time the previous EIR was certified. New information of substantial importance includes: (1) one or more significant effects not discussed in the previous EIR; (2) significant effects previously examined that are substantially more severe than shown in the previous EIR; (3) mitigation measures or alternatives previously found not to be feasible would in fact be feasible, and would substantially reduce one or more significant effects of the project, but the project proponents decline to adopt the mitigation measure or alternative; or (4) mitigation measures or alternatives that are considerably different from those analyzed in the previous EIR and that would substantially reduce one or more significant effects on the environment, but the project proponents decline to adopt the mitigation measure or alternative.

Based on the passage of time since the FEIR was certified, the County of Mendocino required the project proponent to provide the following updated environmental analyses to determine whether there are significant effects not discussed in the FEIR or that are more severe than shown in the FEIR:

- Biological Resource Assessment (including wetlands delineation and tree inventory)
- Water Supply Verification
- Stormwater Control Plan
- Traffic Analysis
- Air Quality and Greenhouse Gas Assessment

The Modified Project's consistency with the environmental resource analysis in the FEIR is summarized in Section 6 "Environmental Factors," below. As discussed, the Modified Project would not result in any new significant effects not discussed in the FEIR. The project proponents have agreed to incorporate new or modified mitigations identified in these updated studies into the Modified Project and the mitigations are incorporated into an Amended Mitigation Monitoring and Reporting Program.

## 6. ENVIRONMENTAL FACTORS

### 6.1 Geology, Seismicity and Soils (FEIR, Chapter 3.1)

The FEIR determined that the plan area is in a seismically active region that includes major active fault systems capable of producing a maximum earthquake event of 6.7 or greater (Richter Magnitude) on the San Andreas fault. The EIR identifies mitigation measures to minimize seismic hazard risks and concludes that, if implemented, seismic hazards would be less than significant. The Modified Project would implement the same mitigation measures and federal and State requirements as those referenced in the FEIR to minimize seismic hazard risks (MM 3.1-A.1). There is no potential for new impacts associated with seismic hazards, beyond what was already evaluated and disclosed in FEIR. Therefore, implementation of the Modified Project would not introduce new impacts or create more severe impacts than those analyzed in the FEIR.

The FEIR determined that excavation and grading for development would require a combination of engineered fill slopes, fill and cut slopes restrained by retaining walls, and cut slopes exposing soils and bedrock. The alteration of topography, combined with the natural geologic and soils limitations of the site, represents a potentially significant impact. The Geology section of the FEIR identifies mitigation measures to minimize impacts associated with soil erosion (MM 3.1A-1 and MM 3.1-B.1) and concludes that, if implemented, impacts related to soil erosion would be less than significant. In addition, the Hydrology section of the EIR addresses impacts related to soil erosion and sedimentation and concludes that, with implementation of MM 3.2-C.1 and MM 3.2-C.2, impacts associated with soil erosion would be reduced to a less than significant level.

The FEIR determined that during and after construction, cut slopes could fail due to the removal of toe support, and engineered fills and/or retaining walls could fail if improperly designed or constructed. As a consequence, damage could be caused to structures and their occupants could be harmed which is a potentially significant impact. However, with the implementation of required mitigation measures (MM 3.1-C.1, MM 3.1-C.2, MM 3.1-C.3, MM 3.1-C.4) to reduce the potential for slope failure, general and differential settlement, lurch cracking, sloughing, and other forms of instability as identified in the FEIR, this impact would be reduced to a less than significant level.

The FEIR concludes that the project site has locally expansive soils which extend to a depth of about four feet below existing ground surface and that the presence of expansive soils on the site is a potentially significant impact. The FEIR identified a mitigation measure requiring excavation and replacement of expansive soils in accordance with recommendations of a geotechnical engineer (MM 3.1-D-1). Compliance with the mitigations in the FEIR would reduce impacts associated with expansive soils to a less than significant level.

The Modified Project would be subject to the same geologic risks as the project evaluated in the FEIR and, with the implementation of the required mitigation measures, risks associated with soil erosion, geologic hazards such as lateral spreading, liquefaction, and landslides, and potential impacts associated with expansive soils would be minimized. Implementation of the Modified Project would not introduce new impacts or create more severe impacts than those analyzed in the FEIR.

The Modified Project has a similar footprint and a lower intensity of development than the project analyzed in the FEIR. Applicable mitigation measures previously identified in the FEIR will be required as set forth in the MMRP and no considerably different mitigation measures that may substantially reduce impacts have been identified or rejected. The Modified Project does not propose substantial geological, seismic, or soils changes beyond those analyzed in the FEIR or require major revisions to the FEIR.

A minor modification to one mitigation measure is proposed to address the Modified Project. MM 3.1-C.2 is revised to eliminate the reference to the sidewalk extending to Oak Court Road as the connecting roadway was removed in the final approval of the Garden's Gate project. Furthermore, that portion of the site is not included in the Modified Project as a separate Final Map was recorded for the four parcels on



Tract 261. The reference to "10" hillside lots is removed as the configuration and number of the lots has changed in the Modified Project. These modifications do not alter the effectiveness of mitigation measure MM 3.1-C.2.

### Mitigation Measures - Geology, Seismicity and Soils

- MM 3.1-A.1** A final geotechnical report shall be prepared that incorporates the recommendations set forth in the 2005 RGH Report as modified by mitigation measures recommended in this EIR. The project applicant shall design project structures and foundations to withstand expected seismic forces in accordance with the California Building Code as adopted by the County of Mendocino. Since the project site is located within Seismic Zone 4, it is considered potentially seismically active. The County shall not issue building permits until seismic design criteria are reviewed and approved. During construction, adherence to design criteria shall be monitored, and a final report issued documenting conformance prior to occupancy.
- MM 3.1-B.1** Potentially unstable surface soils shall be remediated by strengthening the soils during site grading. The strengthening will be achieved by excavating the weak soils and replacing them as properly compacted engineered fill. All site grading and foundation construction shall follow the recommendations of the Geotechnical Engineer of Record for the project. The process will include excavation of surface soils and placement of all fill soils at a minimum of 90 percent compaction relative to the maximum dry density near the optimum moisture content as determined in accordance with ASTM D 1557. Site soils will be tested during construction by the Geotechnical Engineer of Record or by a Special Inspector to confirm that minimum standards are met. A final report documenting results of fill testing will be submitted to the County of Mendocino Department of Planning and Building Services and will be subject to the review of that department.
- MM 3.1-C.1** Cut and fill slopes should be designed and constructed as slope gradients of 2h:1v or flatter, unless otherwise approved by the Geotechnical Engineer-of-record in specified areas. The interior slopes of the retention basin should be inclined no steeper than 3h:1v. If steeper slopes are required, retaining walls shall be used. Fill slopes steeper than 2h:1v will require the use of a Geogrid reinforcing material to increase stability. Fill slopes shall be constructed by over-filling and cutting the slope to final grade. Graded slopes shall be planted with fast-growing, deep-rooted groundcover to reduce sloughing and erosion.
- Fills placed on terrain sloping at 5h:1v or steeper shall be continually keyed and benched into firm, undisturbed bedrock or firm soil. The benches shall allow space for the placement of select fill of even thickness under settlement sensitive structural elements supported directly on the fill.
- MM 3.1-C.2** Retaining walls shall be designed to retain planned cut slopes for the ~~40~~ hillside lots that exceed 2h:1v in slope steepness ~~and for the sidewalk between the project access and Oak Court Road~~. These cuts are planned to be as great as 13 feet in height. The Geotechnical Engineer-of-record shall provide revised recommendations for retaining walls if needed to meet current building code requirements. All retaining walls shall be designed by a State of California Registered Civil Engineer in accordance with requirements of the 2007 current edition of the California Building Code including seismic design considerations. Retaining wall design shall be reviewed by the County of Mendocino Department of Planning and Building Services to ensure conformance with state and local building code requirements.
- MM 3.1-C.3** Plan Review will be performed by the County of Mendocino Department of Planning and Building Services to ensure conformance with grading and drainage requirements. The

Geotechnical Engineer-of-Record shall prepare a geotechnical review letter documenting that the plans meet with the intent of geotechnical recommendations.

**MM 3.1-C.4** The Geotechnical Engineer of Record and/or Special Inspector shall perform construction observation and testing to ensure conformance with design requirements and geotechnical recommendations. Testing and monitoring shall include:

- Verification of compaction requirements for engineered fill and subgrade soils. Unless otherwise stated, all engineered fill shall be compacted to at least 90 percent of the maximum dry density at moisture contents above the optimum in accordance with ASTM D 1557 test method. Subgrade beneath foundations and pavement sections shall be additionally compacted to at least 95 percent of the maximum dry density at moisture contents near the optimum.
- Verification of the installation of subsurface drainage in accordance with project plans and specifications.
- Verification that footings are excavated into stable material and footing excavations are of sufficient depth and breadth to adequately support structures with minimal or no settlement.
- Materials Testing and Special Inspection of concrete, steel, asphalt, wood members and other structural elements to establish conformance with the design standards.
- Verification of correct installation of erosion control measures and adherence to the requirement of the approved Stormwater Pollution Prevention Plan (SWPPP) for the project.

**MM 3.1-D.1** Where spread footings are chosen for foundation support, weak, porous, compressible, and locally expansive surface soil shall be excavated to within 6 inches of their entire depth. Excavation of weak, compressible, and locally expansive soils shall extend a minimum of 12 inches below exterior concrete slabs and/or asphalt concrete pavement subgrade. These soils shall be replaced with select fill material. Additionally, excavation of weak, porous, compressible, expansive, creep-prone surface materials shall extend at least 5 feet beyond the outside edge of exterior footings of the proposed buildings and 3 feet beyond the edge of exterior slabs and/or pavements. These soils shall also be replaced with select fill material as described below.

Select fill material shall be free of organic matter, have a low expansion potential, and conform in general to the following requirements: 100% passing 6" sieve; 90-100% passing the 4" sieve; 10-60% passing the No. 200 sieve (all percentages by dry weight); LL-40 max; PI-15 max; R-value-20 min. The Geotechnical Engineer of Record shall approve imported material prior to use as compacted fill.

## 6.2 Hydrology and Water Quality (FEIR, Chapter 3.2)

The FEIR determined that development of the residential lots and accompanying streets and driveways in the Garden's Gate project would increase the amount of stormwater runoff into the existing drainage system which consists of an existing drainage ditch that runs along the southern boundary of the property and a stretch of Cleland Mountain Creek that runs through the northwestern corner of the property. The FEIR found that impacts related to sedimentation as a result of the development were potentially significant and identified MM 3.2-C-1 and MM 3.2-C.2 which, if implemented, would reduce potential impacts to a level of insignificance. The FEIR also found that episodic discharge of stormwater

contaminated with urban pollutants would be potentially significant and MM 3.2-D.1 and MM 3.2-D.2 were identified. The FEIR determined that, if implemented, these mitigation measures would reduce potential impacts on water quality to a level of insignificance.

The Modified Project includes an onsite stormwater system that relies on onsite detention, similar to the approved project, although the location of the stormwater detention facility has been modified. Whereas the approved project had stormwater detention facilities located in two onsite parks, the new plan relocates the detention basin to the new Neighborhood Park adjacent to South State Street between the two site access streets. The drainage system also collects stormwater along the southern boundary of the property and diverts it into the detention basin, rather than into the existing surface drainage ditch. An updated *Bella Vista Drainage Report & Stormwater Control Plan* (LACO Associates; March 2021) was prepared for the Modified Project ([Appendix A](#)). The *Stormwater Control Plan* describes and evaluates the drainage system, including the detention facilities, in the Modified Project to ensure that the project meets Mendocino County Standards for stormwater detention and the Mendocino County Low Impact Development Standards Manual.

The FEIR did not specifically address potential impacts of the project on groundwater supplies and/or groundwater recharge relative to groundwater management of the basin. The project would not directly impact groundwater supplies either through extraction (as no wells are proposed) or through reduced groundwater recharge as the stormwater management system would include facilities to recharge runoff back into the aquifer. The FEIR determined that Willow County Water District (WCWD) would provide potable water service to the project from its existing sources. WCWD has provided an updated will-serve letter for the Modified Project ([Appendix B](#)). WCWD's water sources include seasonal surface water rights and year-round rights to divert underflow from the Russian River as well as the contractual purchase of water from the Russian River Flood Control District.

The FEIR determined that during and after project construction, exposed slopes on site would be at increased risk of erosion and that such erosion could decrease the storage capacity of the onsite vault detention system. The FEIR also concluded that the proposed bridge crossing over Cleland Creek could result in the discharge of sediment into the creek. These impacts were deemed significant, however, with implementation of MM 3.2-C.1, MM 3.2-C.2, MM 3.2-D.1 and MM 3.2-D.2, the impacts would be less than significant. The Modified Project includes modifications to the stormwater collection and detention system. It would be required to comply with the mitigation measures presented in the FEIR and also with the recommendations presented in the *Bella Vista Drainage Report* ([Appendix A](#)). The Modified Project does not include the bridge crossing over Cleland Creek as the roadway extension to Oak Knoll Road was eliminated. Implementation of the Modified Project would not introduce new erosion impacts or create more severe impacts than those analyzed in the FEIR.

The FEIR determined that the project would create new impervious surfaces, increasing the rate and amount of stormwater runoff which could contribute to flooding in the vicinity of the project site. The FEIR found that less than 0.5 acres of impervious surface from the development would drain into Cleland Mountain Creek, an amount which would not perceptibly alter peak flow rates. The FEIR found that the increased runoff into Cleland Mountain Creek would not perceptibly affect peak flow rates. Flooding impacts to Cleland Mountain Creek, both within and downstream of the project, would be less than significant. For the remainder of the site, however, potential downstream flooding was identified as a potentially significant impact. The FEIR indicates that most of the stormwater runoff generated by the project would flow into an existing drainage ditch that runs along the southern boundary of the property. The FEIR found that the proposed onsite stormwater detention facilities would manage flows to the southern drainage ditch and concluded that, unless the stormwater retention/detention facilities are properly designed, constructed and maintained, the project could cause flooding along the southern drainage ditch, which would be a potentially significant impact. Implementation of MM 3.2-A.1 and MM 3.2-A.2 was determined to reduce potential impacts to a less than significant level.

The Modified Project includes modifications to the onsite stormwater management system. The updated system does not discharge into the southern ditch, but rather into two detention basins on the eastern portion of the site adjacent to South State Street. The updated *Bella Vista Drainage Report* (Appendix A) includes specifications and recommendations to ensure that the stormwater collection and detention facilities are sized appropriately to prevent runoff that exceeds the capacity of existing or planned drainage systems. Therefore, implementation of the Modified Project would not introduce new impacts or create more severe impacts than those analyzed in the FEIR.

The FEIR found that four of the proposed residential lots are located within the 100-year floodplain of Cleland Mountain Creek which crosses the northwest corner of the property (Lots 20, 21, 196 and 197). Flooding impacts were identified as a potentially significant impact and MM 3.2-B.1 identified two alternative means of reducing the impact to a less than significant level. The Modified Project does not include Lots 196 and 197 as they are part of Tract 261 (Oak Knoll, Unit One) for which a separate Parcel Map has been recorded. The lot configuration on the south side of the creek where Lots 20 and 21 were previously situated, is revised in the Modified Project. The new configuration includes four parcels (Lots 122, 123, 124 and 125) - however, per MM 3.2-D.2, these lots must be eliminated from the project and the project proponent has agreed to comply with that condition. Therefore, implementation of the Modified Project would not introduce new impacts or create more severe impacts than those analyzed in the FEIR.

The FEIR did not evaluate whether the project would result in impacts that would conflict with or obstruct implementation of a water quality control plan or sustainable groundwater management plan. The Modified Project would incorporate Best Management Practices (BMPs) from the updated Stormwater Control Plan. These standard measures would ensure, to the maximum extent practicable, that the Modified Project would not result in pollutants entering groundwater. Therefore, impacts would be less than significant, and no additional analysis is required.

In conclusion, the Modified Project does not change the type or extent of development analyzed in the FEIR. The Modified Project would be developed in compliance with the Mitigation Measures identified in the FEIR. The Modified Project does not propose substantial changes to the development that would affect hydrology and water quality beyond the effects analyzed in the FEIR or require major revisions to the FEIR.

Minor modifications are proposed for MM 3.2-A.1 and MM 3.2-A.2 to remove the references to maintenance of drainage vaults (as these features are replaced with detention basins in the Modified Project) and to remove the reference to Lots 20 and 21 and replace them with references to the analogous lots in the Modified Project. These modifications do not alter the effectiveness of the mitigation measures.

### Mitigation Measures - Hydrology and Water Quality

**MM 3.2-A.1** The project shall not cause flooding downstream of the project site, and post-development peak flows discharged to the 18-inch CMP storm drain beneath South State Street shall not exceed pre-development peak flows. At final project design, the applicant shall calculate the amount of runoff that will be generated by the developed, ~~southern~~ portions of ~~Lots 20 and 21~~, lots that drain into Cleland Mountain Creek and factor that increase into the analysis performed by Sandine and Associates to determine whether peak flow rates will remain below pre-development levels and the risk of flooding in the project site and off-site downstream will not be increased. If the post-project peak flow rates exceed the pre-development levels, the applicant shall increase the volume of the ~~vault system storage and/or~~ detention basin capacity to achieve the target peak flow discharge. The 18-inch storm drain facility beneath South State Street shall be located, inspected by video camera or other method, and a report submitted to the County Department of Transportation at the time of the final design of the subdivision storm drainage system,

substantiating the adequacy of the existing facility to accommodate the design runoff or recommending improvements necessary to the facility to adequately accommodate project runoff. Those recommendations shall be constructed.

**MM 3.2-A.2** As part of the Development Agreement, establish a Homeowners Association (HOA) maintenance agreement that details the provisions for regular monitoring of the ~~status of the vault and~~ detention pond storage capacities, as well as requirements for ~~vault and~~ detention pond cleanouts, when necessary, to maintain design stormwater storage levels. Establish a monitoring protocol that is acceptable to the County that monitors implementation of this maintenance, including a bond or other funding agreement that reimburses the County if the County is required to conduct required maintenance due to the HOA not implementing required maintenance.

**MM 3.2-B.1** The project shall not result in flooding of residences on the project site. To minimize the risk of flooding during the FEMA-designated 100-year base flood, the applicant shall implement one of the following alternatives:

A) Redesign the grading plan for Lots 21-22 and 196-197 in the vicinity of Cleland Mountain Creek so that building finished floor elevations are a minimum of one foot above the land surface elevations inferred by the FIRM Zone A SFHA mapping, or

B) Prepare a Letter of Map Revision (LOMR), accompanied by the appropriate technical documentation, and submit it to FEMA (or its sponsored contractor), to petition for a change in the FEMA SFHA designation for the project site. Required technical documentation would include an updated flood backwater profile modeling of Cleland Creek, including the proposed Plant Road bridge crossing, which was excluded from the original HEC-RAS analysis conducted by Sandine Associates. If the modeling results verify that the published FEMA mapping is inaccurate and that Lots 20-21 and 196-197 are outside of the redefined SFHA, then the lots could be developed as proposed, subject to possible regulatory restrictions or conditions imposed by the California Department of Fish and Game (CDFG) and the Mendocino County Water Agency (MCWA) for disturbance of the riparian corridor. If the modeling results verify that the published FEMA flood mapping was accurate, then Alternative A would be required for development of the lots. The same potential regulatory restriction or conditions imposed by CDFG or the MCWA would apply.

**MM 3.2-C.1** The project shall not cause significant erosion. The applicant shall submit a detailed Erosion Control Plan as part of the Stormwater Pollution Prevention Plan (SWPPP) to the Mendocino County Water Agency (MCWA) and to the State Water Resources Control Board (SWRCB), in conjunction with the filing of a Notice of Intent (NOI) with the SWRCB. The County shall not issue a Grading Permit until the County Water Agency agrees that the plan contains adequate Best Management Practices for controlling erosion.

At a minimum, the Erosion Control Plan shall include the following restrictions, guidelines, and measures: (1) grading and earthwork shall be prohibited during the wet season (typically October 15 through April 15) and such work shall be stopped before pending storm events during the spring-fall construction season; (2) erosion control/soil stabilization techniques such as straw or wood mulching, erosion control matting, and hydroseeding, or their functional equivalents shall be utilized in accordance with applicable manufacturers specifications and erosion control Best Management Practices (BMPs) published in the *California Stormwater BMP Handbook - Construction* (California Stormwater Quality Association, 2005) and/or similar proscriptions outlined in the *Erosion and Sediment Control Field Manual* (SF Bay RWQCB, 2002); (3) bales of hay or accepted

equivalent methods shall be installed in the flow path of graded areas receiving concentrated flows, as well as around storm drain inlets; (4) installation of silt fencing and other measures to segregate the active flow zone of Cleland Mountain Creek from the near overbank disturbance associated with bridge abutment construction; and (5) post-construction stormwater treatment measures.

These and other erosion control BMPs shall be monitored for effectiveness and shall be subject to inspection by the County. The applicant shall be responsible for implementing any remedial actions recommended by the County. After construction is completed, all drainage facilities shall be inspected for accumulated sediment, and these drainage structures shall be cleared of debris and sediment. Silt fence shall be left in place until the hydroseed has become established.

**MM 3.2-D.1** The project shall not cause substantial pollution of Cleland Mountain Creek or the Russian River. The applicant shall prepare an NOI and SWPPP for the project and incorporate the following additional site-appropriate BMPs or their equivalents for short- and long-term implementation by the Homeowners Association (HOA) and/or individual lot owners, in order to comply with the requirements of the NPDES General Permit and provisions of the Mendocino County Stormwater Management Program. The BMPs will result in stormwater leaving the site at least meeting the NCRWQCB water quality objectives for the Russian River. The SWPPP shall be approved by the Mendocino County Water Agency and the State prior to project construction.

- Impervious surfaces shall be minimized by using such techniques as driveway strips with bordering pervious pavement material (rather than a full paved driveway); using pervious materials for parking areas; directing runoff from rooftops and streets to landscaping buffers and/or recharge trenches.
- Install oil-grease separators at locations where street runoff enters the southern swale; or replace all or a portion of the detention pond outlet storm drain with a grass swale (i.e., bioswale) to enhance stormwater filtration of contaminants and increase local infiltration. The alignment of the drain-swale configuration could be adjusted to parallel the Plant Road entrance and then South State Street. The swale design should follow guidelines set forth by the North Coast RWQCB, or equivalent agencies (e.g., CA Stormwater Best Management Practice Handbooks, Construction Activity, Camp Dresser & McKee, et al., 1993). In particular, swale slopes and the swale base course material should be selected to allow adequate subsurface storage for the site soil characteristics.
- These and other BMPs shall be monitored for effectiveness and shall be subject to inspection by the County. The Homeowners Association shall be responsible for implementing any remedial actions recommended by the County. The applicant shall establish a monitoring protocol that is acceptable to the County that monitors implementation of these measures, including a bond or other funding agreement that reimburses the County if the County needs to conduct required maintenance due to the HOA not implementing required maintenance. The County can require that monitoring be done by a third party acceptable to the County; costs of all monitoring and any maintenance will be borne by the Homeowners Association.

Since the objective of erosion control and water quality treatment measures would be to reduce contaminant loading to the maximum extent practicable with implementation of the best available technologies, the recommended BMPs are not fixed. Other measures can

be applied as long as the applicant can demonstrate to the satisfaction of MCWA that those measures can provide equivalent levels of reduction in contaminant loading.

The applicant shall prepare a plan that describes the roles and responsibilities of the HOA, lot owners, and/or the County for implementing the BMPs and monitoring the results. If the County will be responsible for monitoring or implementing any actions, then a funding mechanism will be established. The County will review and approve this plan prior to the onset of construction.

- MM 3.2-D.2** Per the recommendations of the CDFG, Lots ~~21, 22~~, 121, 122, 123, 124 and ~~197~~ Lot 4 of Tract 261 shall be removed from the project in order to provide the minimum creekside buffer required to filter contaminants, including sediment, from stormwater runoff. These four lots may be relocated elsewhere in the subdivision in accordance with the Restated Development Agreement.

### 6.3 Biological Resources (FEIR, Chapter 3.3)

As part of the FEIR, the project study area was surveyed by the EIR botanist and the EIR wildlife biologist and four biological resource evaluations were prepared:

- Special Status Species Report-Botanical Survey (NCRM; September 14, 2005)
- Addendum to the Previously Submitted Botanical Report (NCRM; December 13, 2006)
- Biological Assessment of Garden's Gate Residential Subdivision (NCRM; November 15, 2005)
- Addendum to the Biological Assessment (NCRM; December 13, 2006)

In order to assess the biological resource impacts of the Modified Project, the following additional biological resource studies were prepared:

- *Biological Resource Assessment for the Bella Vista Subdivision Project* (Gallaway Enterprises; July 2021) (Appendix C, "BRA").
- *Technical Memorandum: Assessment of Biological Issues of the Bella Vista Subdivision Project in Relation to the Certified EIR for the Garden's Gate Project* (Gallaway Enterprises; July 2021) (Appendix D, "Technical Memo").
- *Tree Inventory Report* (Horticultural Associates; July 2021) (Appendix E; "Tree Inventory").
- *Draft Delineation of Jurisdictional Waters of the United States* (Gallaway Enterprises; June 2021) (Appendix F, Wetlands Delineation").

**Special Status Species.** The FEIR concludes that the project site does not contain any special status species of plants or animals. However, the FEIR noted that the stretch of Cleland Mountain Creek on the project site may support native steelhead trout when there is water in the creek. The FEIR includes a mitigation requiring establishment of a Riparian Enhancement Area (MM 3.3-A.1), a mitigation requiring establishment of building envelopes and deed-restricted riparian setbacks on portions of Lots 20, 21 and 197 (MM 3.3-B.1), and a mitigation measure (MM 3.2-D.2) requiring Lots 20, 21 and 197 to be removed from the project in order to provide the minimum creekside buffer required to filter contaminants, including sediment from stormwater runoff. The FEIR includes two additional mitigations to address potential water quality impacts (MM 3.2-C.1, MM 3.2-C.2). The FEIR concludes that implementation of these mitigation

measures would reduce impacts to water quality and, therefore, to listed salmonid species, to a less than significant level.

The *BRA* determined that the site does not contain any Sensitive Natural Communities and that there are no federally- or state-listed botanical species present within the project site. The habitat assessment identified a lack of necessary habitat elements for special status plant species. The *BRA* determined that there is a low potential for occurrence of California Coastal Chinook salmon and Central California Coast Steelhead on the site when Cleland Mountain Creek is flowing (because it is hydrologically connected to the Russian River) and there is no potential for occurrence when the creek is dry. The *BRA* also identified a low potential for occurrence for Western pond turtles, grasshopper sparrows, and Townsend big-eared bats, and a moderate possibility of occurrence for pallid bats.

As noted below, the applicant incorporated a number of additional mitigation measures into the Modified Project as recommended in the *BRA* to ensure that the Modified Project would not introduce new special-status species impacts or create more severe special-status species impacts than those analyzed in the FEIR. These mitigations include MM 3.3-A.5 requiring a pre-construction/demolition bat survey prior to removal of the existing outbuilding, and MM 3.3-A.3 requiring a survey for western pond turtles if work is performed in the vicinity of Cleland Mountain Creek when water is present.

**Oak Woodland Habitat.** The FEIR notes that project construction would potentially remove up to 25 oaks and convert oak woodland habitat to urban uses. This was identified as a potentially significant impact. MM 3.3-A.1 requires establishment of a Riparian Enhancement Area that includes Lots 20, 21 and 197 and calls for replacement tree plantings at a 3:1 ratio for trees that are removed. This is a higher replacement ratio than that specified in Action Item Resource Management (RM) 28.1 of the County General Plan which provides a 2:1 mitigation planting ratio. Further, MM 3.2-D.2 requires that Lots 20, 21 and 197 be removed from the project and that no development be permitted in order to provide the minimum creekside buffer required to filter contaminants, including sediment, from stormwater runoff. The FEIR notes that these lots contain 24 Oregon white oak along with two Oregon ash trees and one California bay tree. It concludes that:

"By preserving most of the remaining large oaks and Oregon ash on the site and by replanting the most biologically sensitive and valuable portion of the site, the project would reduce impacts to oak woodlands (as well as to woodlands and riparian habitat) to a less than significant level."

As presented in Appendix E, a *Tree Inventory Report* (Horticultural Associates, July 2021) was prepared to survey the trees in areas on the site that would be affected by construction, to provide information about expected impacts of the Modified Plan, and to present recommendations based on a general review of tree health and structural condition. The report notes that a total of 11 native oaks will be removed and that the Oregon Ash trees will remain. MM 3.3-B.1 requires the replacement of oak and hardwood trees that are removed at a 3:1 ratio. The *Tree Inventory Report* notes that the mitigation trees may be used to vegetate the riparian creek setback corridor, in the Linear Park, or as part of the park along South State Street (Neighborhood Park).

**Riparian and Wetland Habitat.** The FEIR notes that the project site is hydrologically dry with no significant seeps or springs and it does not contain any vernal pools or wetlands. Rainfall infiltrates the relatively course and well-drained soils and either continues downward or laterally into small adjoining ephemeral drainages. The FEIR notes that two drainage channels (Cleland Mountain Creek and a ditch along the southern edge of the site) are likely to qualify as waters of the U.S., but neither feature supports any significant wetland or riparian habitat on the project site.



The FEIR states that the reach of Cleland Mountain Creek on the site is largely devoid of riparian vegetation except for a few willow saplings on the east end of the creek. It notes that:

"The Cleland Mountain Creek creekbed has important generic values as a part of the local riparian corridor even though the on-site reach has already been severely compromised [...]. (Garden's Gate Draft EIR, p. 107)

The FEIR states that a proposed bridge across the creek would have abutments constructed 20 feet from the top of the banks and no construction activity would take place on the banks or in the creek channel. Therefore, the EIR concludes that bridge construction would have no impact on the creek channel and a less than significant impact on creek resources. It is also noted that MM 3.3-A.1 would ensure protection of the creek and foster the enhancement of riparian habitat in the area, thereby further reducing potential impacts on creek resources to a less than significant level.

The FEIR concludes that, because the creekbed and banks would not be directly affected by the development, and because the creek does not currently support riparian habitat, the project would have a less than significant impact on riparian habitat. It notes that MM 3.3-A.1 and MM 3.3-B-1 would ensure protection of the creek and foster the development of riparian habitat in the area, further reducing potential impacts to the resource.

MM 3.2-D.2 requires the removal of Lots 20, 21 and 197 (now identified as Lots 121, 122, 123, 124 and Lot 4 of Tract 261) from the subdivision and remains applicable to the Modified Project. This will ensure that at least a 100-foot creek setback is secured as recommended by the California Department of Fish and Wildlife (CDFW). The mitigation is modified to include language indicating that the four lots may be relocated elsewhere in the subdivision in accordance with the Restated Development Agreement.

In the Modified Project, the bridge across Cleland Mountain Creek is eliminated from the design. A 12" water main will be installed in an easement that traverses the creek to connect to the existing water main on Oak Knoll Road. The area of temporary impact in the creek bed associated with the new water main is estimated by the project engineers to be 62 square feet. The alignment of the easement was selected to minimize impacts to trees and vegetation in the Riparian Enhancement Area. In addition, a *Wetlands Delineation* was prepared for the project site in June 2021 ([Appendix F](#)). The study found that Cleland Mountain Creek functions as an intermittent Tributary to Traditional Navigable Waters (i.e., the Russian River). The survey identified a total area of 251.93 square feet (0.006 acres) on site that is associated with the Cleland Mountain Creek drainage and classified as "waters of the United States."

The applicant has incorporated two new mitigation measures into the project (MM 3.3-A.6 and MM 3.3-A.7) to ensure that any required permits from CDFW and the U.S. Army Corps of Engineers be obtained prior to work within the creek channel. In addition, the applicant has agreed to new MM 3.3-A.2 which establishes that construction activities within Cleland Mountain Creek shall be limited to the dry season when no flowing water is present in the channel and that channel disturbance shall be kept to a minimum.

**Nesting Habitat.** The FEIR indicates the large trees in the Riparian Enhancement Area provide important nesting habitat. The remainder of the project site is currently vineyard or non-native grassland which does not provide valuable habitat. The FEIR concludes that development of the area along the creek would have a potentially significant impact on nesting habitat. It notes that implementation of MM 3.3-A.1 would reduce impacts to nesting habitat to a less than significant level.

The applicant has agreed to a new mitigation measure (MM 3.3-A.4) recommended by the *BRA* which places limitations on the removal of nesting habitat to avoid impacts to nesting birds and requires nesting surveys and coordination with CDFW if work is performed during the nesting season.

The *Technical Memo* concluded that:

"Changes in project design and implementation of the current project as compared to the previous project are minor and in some instances superior to the previously approved project, and do not result in any new significant environmental effects or a substantial increase in the severity of previously identified resources."

In conclusion, the Modified Project does not change the type or extent of development as analyzed in the FEIR. Applicable mitigation measures previously identified in the FEIR and MMRP would continue to apply and additional measures as recommended in the *BRA* have been incorporated into the project. The Modified Project does not propose substantial biological resource changes beyond those analyzed in the Garden's Gate EIR or require major revisions to the FEIR. Therefore, the Modified Project would not involve new or more severe biological resource impacts than those previously identified and analyzed in the FEIR.

### Mitigation Measures - Biological Resources

- MM 3.3-A.1** The applicant shall preserve water quality in Cleland Mountain Creek. A Riparian Enhancement Area that includes Lots ~~21, 22,~~ 121, 122, 123, 124 and ~~497~~ Lot 4 of Tract 261 shall be established to include all areas within a setback of 20 feet from the top of bank of this creek and deed restricted to prohibit grading, tree cutting, trash deposition, landscaping other than natural habitat restoration, storage of materials, filling, structures, dumping of chemicals, or disruptive activities. The applicant shall replant the Riparian Enhancement Area. The planting and maintenance of the plantings shall be conducted per a plan prepared by a qualified biologist. The replanting shall include riparian species along the creek and oaks, bay, and buckeye further from the creek. The plan shall include the planting of at least three replacement trees (of the same species as the tree removed) for each oak, bay, buckeye, and Oregon ash that is removed. Within the 20-foot riparian habitat setback, appropriate native ground covers and shrubs will also be established to filter runoff from developed portions of nearby lots. All plantings established under this plan shall be irrigated and replaced as needed as well as monitored by the plan preparer for a period of no less than 3 years to ensure successful establishment. The Riparian Enhancement Area shall be maintained by the HOA pursuant to this plan.
- MM 3.3-B.1** An assessment shall be conducted that determines the area and number of oaks and other native hardwoods that would be removed or adversely impacted as a result of project development on Lots ~~21, 22,~~ 121, 122, 123, 124 and ~~497~~ Lot 4 of Tract 261. Building envelopes on Lots ~~21, 22,~~ 121, 122, 123, 124 and ~~497~~ Lot 4 of Tract 261, as well as driveway and utility connection locations, shall be adjusted if needed to avoid loss or both short-term and long-term adverse effects on native trees. The area outside of these building envelopes shall be deed restricted to require maintenance of existing native trees, and prohibition of lawns and landscaping incompatible with long-term survival of these trees, while allowing pruning and removal of any dead or dying trees, dead limbs and brush, and any clearances required as needed to reduce wildland fire hazard. All removed hardwoods shall be replaced with the same species at a minimum replacement ratio of 3:1 within the 20-foot riparian setback zone along the top of the bank of Cleland Mountain Creek. A minimum 3-year monitoring plan shall track planted trees and replace all that are dead or dying.

In addition to Biological Resources MM 3.3-A.1 and MM 3.3-B.1, the applicant has agreed to implement the following additional mitigation measures that were identified in the *BRA*. These measures are not recommended to address new or more severe impacts to biological resources associated with the Modified Project as the impacts of the Modified Project on biological resources are similar to those

identified in the Garden's Gate EIR. These additional mitigation measures are recommended to implement best management practices that have evolved since the Garden's Gate EIR was certified,

- \*MM 3.3-A.2** Construction activities within Cleland Mountain Creek shall be limited to the dry season when no flowing water is present in the channel. Channel disturbance shall be kept to a minimum during construction activities within the channel and only occur within designated areas.
- \*MM 3.3-A.3** When water is present within Cleland Mountain Creek, a qualified biologist shall conduct a clearance survey to determine the presence or absence of western pond turtle individuals immediately prior to the start of work. If western pond turtles are observed where they could be potentially impacted by Project activities, then work shall not be conducted within 100 feet of the turtle(s) until a qualified biologist has relocated the turtle(s) outside of the Project boundary. If turtle eggs are uncovered during construction activities, then all work shall stop within a 25-foot radius of the nest and CDFW shall be notified immediately. The 25-foot buffer shall be marked with identifiable markers that do not consist of fencing or materials that may block the migration of young turtles to the water or attract predators to the nest site. No work will be allowed within the 25-foot buffer until CDFW has been consulted.
- \*MM 3.3-A.4** Removal of nesting habitat (for grasshopper sparrows, migratory birds and raptors) from the work area shall only take place between September 1 and January 31 to avoid impacts to nesting birds. If removal of nesting habitat is required during the nesting season, a nesting bird survey shall be conducted by a qualified biologist no more than 5 calendar days prior to disturbance. If an active nest is located, the biologist will coordinate with CDFW to establish appropriate buffers and any monitoring requirements. Removal of existing vegetation shall not exceed the minimum necessary to complete operations.
- \*MM 3.3-A.5** A pre-construction/demolition bat survey shall be conducted by a qualified biologist within 5 days prior to the removal of suitable bat habitat (i.e., existing outbuilding). Mature trees and the existing outbuilding present on the project site should only be removed between September 16 and March 15, outside of the bat maternity season. Trees should be removed at dusk to minimize impacts to roosting bats.
- \*MM 3.3-A.6** Prior to any discharge or fill material into waters of the U.S., authorization under a Nationwide Permit shall be obtained from the U.S. Army Corps of Engineers, if necessary. For fill requiring a Corps permit, a water quality certification from the Regional Water Quality Control Board shall also be obtained.
- \*MM 3.3-A.7** Prior to any activities that would obstruct the flow of or alter the bed, channel, or bank of any perennial, intermittent, or ephemeral creeks, notification of streambed alteration shall be submitted to the CDFW, and, if required, a Lake and Streambed Alteration Agreement shall be obtained.

#### 6.4 Cultural Resources and Tribal Cultural Resources (FEIR, Chapter 3.4)

As described in the FEIR, a cultural resources survey was conducted for the project site by North Coast Resources Management. The survey found one small trash dump dating to the 1940s to 1950s and concluded that it was not a potentially significant historic resource. The Mendocino County Archaeological Commission reviewed the survey report and determined that no additional surveying or analysis of the site was required. The FEIR concludes that, although the site does not appear to contain important historical resources, there remains a chance that cultural resources may be unearthed and damaged or

destroyed during site development, resulting in a potentially significant impact on a historical resource. Implementation of MM 3.4-A-1 would reduce this impact to a less than significant level.

The cultural resources survey prepared for the FEIR found one "very sparse lithic scatter" consisting of five Franciscan chert flakes and three Konocti obsidian flakes in one location on the site. Trenching was conducted to determine whether there were any subsurface deposits in the area, and there were not. The Mendocino County Archaeological Commission reviewed the cultural resources survey report and determined that no additional surveying or analysis of the site was required. The FEIR concludes that, although the site does not appear to contain important cultural resources, there remains a chance that cultural resources may be unearthed and damaged or destroyed during site development, resulting in a potentially significant impact on an archaeological resource. Implementation of MM 3.4-A-1 would reduce this impact to a less than significant level.

The FEIR determined that no paleontological resources or unique geologic features are known to exist within or near the project site, however subsurface construction activity could uncover previously undiscovered paleontological resources (i.e., fossils) which could result in a potentially significant impact. The FEIR concluded that implementation of MM 3.4-B.1 would ensure that, if paleontological resources are discovered, impacts would be less than significant.

The FEIR determined that no human remains or cemeteries are known to exist within or near the project site but subsurface construction activity could uncover previously undiscovered human skeletal remains which could result in a potentially significant impact. The FEIR concluded that implementation of MM 3.4-A.2 would ensure that, if human remains are discovered, impacts would be less than significant.

Tribal consultation under Assembly Bill 52 (AB 52) was not required at the time the FEIR was certified and the project approved. As part of the development review process for the Modified Project, tribal consultation efforts were conducted by the County of Mendocino pursuant to AB 52. This effort did not identify any significant Tribal Cultural Resources ("TCRs") meeting the criteria set forth in subdivision (c) of Public Resources Code Section 5024.1. As a result, the Modified Project would not impact known TCRs. The Modified Project is on the same site and has a similar footprint to the approved project. The Modified Project with the incorporation of applicable mitigation measures identified in the FEIR and incorporated into the MMRP, would not impact known TCRs and would not involve new significant or more severe impacts to TCRs than those associated with the project analyzed in the FEIR.

The Modified Project would be within a similar development footprint as that addressed in the cultural resources survey. The Modified Project would not change the type or extent of development as analyzed in the FEIR. Applicable mitigation measures previously identified in the FEIR will be required as set forth in the MMRP and no considerably different mitigation measures that may substantially reduce impacts have been identified or rejected. The Modified Project would not involve new significant or more severe cultural or tribal cultural resource impacts than those previously identified and analyzed in the FEIR. Furthermore, implementation of MM 3.4-A.1, MM 3.4-A.2 and MM 3.4-B.1 would ensure that any potential impacts to undiscovered historic, archaeological, or paleontological resources would be less than significant. Therefore, implementation of the Modified Project would not introduce new cultural resource impacts or create more cultural resources impacts than those analyzed in the FEIR.

### **Mitigation Measures - Cultural Resources**

**MM 3.4-A.1** If cultural resources are discovered on the site during construction activities, all earthmoving activity in the area of impact shall be halted until the applicant retains the services of a qualified archaeological consultant. These archaeological sites will be documented (by a professional meeting the Secretary of the Interior qualification standards) on DPR (Department of Parks and Recreation) forms and evaluated for their eligibility for the California Register. The archaeological consultant shall identify specific measures to mitigate impacts to the resource if it is deemed eligible for the California

Register. Mitigation shall include data recover operations, protection in situ of deposits, and/or archival research, if appropriate. The applicant shall abide by the recommended proposals.

- MM 3.4-A.2** In the event that human skeletal remains are discovered, work shall be discontinued in the area of discovery and the County Coroner shall be contacted. If skeletal remains are found to be prehistoric Native American remains, the Coroner shall call the Native American Heritage Commission within 24 hours. The Commission will identify the person(s) it believes to be the "Most Likely Descendant" of the deceased Native American. The Most Likely Descendant would be responsible for recommending the disposition and treatment of the remains. The Most Likely Descendant may make recommendations to the landowner or the person responsible for the excavation/grading work for means of treating or disposing of the human remains and any associated grave goods as provided in Public Resources Code Section 5097.98.
- MM 3.4-B.1** During project grading operations, should any undiscovered evidence of paleontological resources be encountered, work at the place of discovery shall be halted, and a qualified paleontologist shall be consulted to assess the significance of the finds. Prompt evaluations can then be made regarding the finds, and a management plan consistent with CEQA cultural resources management requirements shall be adopted.

## 6.5 Transportation (FEIR, Chapter 3.5)

The FEIR determined that traffic generated by the project would have a less than significant impact on congestion at study area intersections and at the US 101/South State Street interchange. The FEIR also found that the proposed project access roadway connection to Oak Knoll Road would have acceptable sight lines and that the additional traffic on Oak Knoll Road and South Dora Street related to the project was less than significant and would pose no hazards for pedestrians. Prior to approval of the project and the Development Agreement, the site access road to Oak Knoll Road was eliminated from the project as requested by neighboring property owners.

An updated traffic study was prepared for the Modified Project (*Traffic Analysis for the Bella Vista Housing Project*; WTrans, March 2021; see [Appendix G](#)). The traffic study concludes that the Modified Project would have a net reduction in trip generation due to the reduction in housing units (from 197 to 171 homes) and the designation of 39 homes as age-restricted. The traffic study also evaluated potential impacts based on updated traffic volumes and found that impacts would be less than significant.

The traffic study evaluated the Modified Project's connections to Mendocino Transit Authority (MTA) transit stops and found that additional improvements should be constructed in conjunction with the roundabout at the project entry to ensure safe pedestrian access to the existing bus stop on Plant Road and that the applicant should work with MTA to investigate the feasibility of an additional southbound MTA stop in the site vicinity. MM 3.5-F.1 is revised to reflect the fact that an MTA bus stop on Plant Road now exists (it did not exist when the Garden's Gate EIR was certified). This bus stop provides both service to and from the site vicinity to locations to the north in the City of Ukiah and beyond. The modifications to this condition do not alter the effectiveness of the mitigation measure in addressing the need for safe and convenient connections to public transit for project residents. Implementation of the Modified Project would not introduce new circulation system impacts or create more severe impacts than those analyzed in the FEIR.

The FEIR does not evaluate the project's consistency with the guidance in CEQA Guidelines Section 15064.3(b) regarding significance thresholds for transportation impacts. This section, which requires lead agencies to base impact analyses on "vehicle miles travelled" (VMT) was added in 2018 to implement

Senate Bill (SB) 743. The FEIR determined that the project would not have any congestion-related impacts on streets and intersections in the study area.

The *Traffic Analysis for the Bella Vista Housing Project* includes an analysis of the Modified Project using the regional baseline VMT threshold adopted by the Mendocino Council of Governments (MCOG). The MCOG baseline study included a review of the approved Garden's Gate project as a test case for applying the recommended approach, which compares the VMT per service population (based on the number of residents and employees) in the project's traffic analysis zone (TAZ) to the VMT in the corresponding sub-regional area. The analysis determined that the Garden's Gate project is consistent with the General Plan and Regional Transportation Plan and with the Suburban Residential zoning designation in the Ukiah Valley Area Plan. Using MCOG's screening tool, it was determined that the Ukiah Adjacent sub-regional mean VMT was 27.2, and the recommended threshold was 23.3, 14.3 percent below the sub-regional mean. The VMT per service population for TAZ 770, which includes the project site, is 17.3, which is 25.8 percent below this threshold. Based on this analysis, the transportation impact of the project was determined to be less than significant. Since the Bella Vista project is located within the same footprint as the Garden's Gate project and has the same land use and a lower density, it would be expected to have a similar or lower VMT per service population. Therefore, the impact of the Modified Project would be less than significant.

The FEIR determined that the proposed roundabout at the project's entry could have a potentially significant impact unless designed to accommodate turning and through movements by large vehicles. MM 3.5-C.1 addresses the need for review and approval by the County Department of Transportation. The FEIR also indicates that the proposed bus pullout location on the project site poses safety concerns and MM 3.5-F.1 requires relocation of the internal bus stop. The Modified Project does not include an on-site transit stop but rather, relies upon the existing northbound bus stop on Plant Road that did not exist at the time the Garden's Gate EIR was certified.

The *Traffic Analysis for the Bella Vista Housing Project* recommends that a pedestrian walkway be constructed between the project entry/roundabout and the existing bus stop on Plant Road and that the applicant work with the MTA to investigate the feasibility of providing a bus stop for southbound bus service within walking distance of the project site. The traffic study concludes that, with the inclusion of pedestrian improvements and provision of access to a southbound bus stop near the site, the Modified Project would have a less than significant impact in terms of program, plan, ordinance or policy addressing the circulation system, including transit, roadway, bicycle, and pedestrian facilities. Implementation of the Modified Project would not introduce new traffic safety hazards impacts or create more severe impacts than those analyzed in the FEIR.

The FEIR determined that the emergency access to the project site, which included access via a roundabout to be constructed at the intersection of South State Street/ Plant Road, and a secondary access via a connection from an interior street to Gobalet Lane, just north of the project was sufficient. In the Modified Project, the primary access remains at the proposed roundabout, however the secondary access would be located approximately 500 feet south of the roundabout rather than via Gobalet Lane.

Resolution No. 09-230, adopted by the County Board of Supervisors on October 6, 2009, certified the FEIR and indicated that "an alternative mitigation has been proposed by the developer and has been approved by the Ukiah Valley Fire Protection District that such an alternative mitigation including fire sprinklers will adequately address fire protection." Further, the Conditions of Approval associated with the approved project indicated that "in lieu of an emergency evacuation access, the developer agrees to provide fire sprinklers in all structures and will continue to seek an alternative access to the south of the project." As required in the Conditions of Approval, the site plan identifies future connections along the south side of the project, providing stubs for roadway connections to future development on the adjoining parcels.

Since the Modified Project is consistent with the required mitigations in the FEIR and the physical distance between the two project access points is greater than in the previously approved project, the project is expected to have a less than significant impact related to emergency access. Therefore, implementation of the Modified Project would not introduce new emergency access impacts or create more severe impacts than those analyzed in the FEIR.

The Modified Project would generate less traffic than the approved project. A traffic analysis based on VMT concluded that the Modified Project would have a less than significant impact on regional traffic volumes. The project, with the implementation of applicable mitigation measures previously identified in the FEIR, as set forth in the MMRP, would have less than significant transportation impacts. The Modified Project does not propose substantial transportation changes beyond those analyzed in the FEIR or require major revisions to the FEIR. It would not involve new significant or more severe transportation impacts than those previously identified and analyzed in the FEIR.

### Mitigation Measures - Transportation

- MM 3.5-C.1** The project applicant shall design the proposed South State Street/Plant Road roundabout to accommodate all existing and anticipated buses and large trucks. Turning template diagrams shall be provided to the County Department of Transportation for the largest bus and trucks anticipated to be using the roundabout.
- MM 3.5-F.1** ~~The proposed bus stop internal to the project site shall be relocated to the outside of the Plant Road curve in order that all patrons will enter/exit by the bus via a sidewalk, and not the middle of the street. The bus stop shall be covered and protected from the wind. To provide access for project residents to the existing Mendocino Transit northbound bus stop on Plant Road across from the project site, a pedestrian walkway shall be constructed between the proposed roundabout at South State Street/ Plant Road-Charlie Barra Drive and the bus stop. The applicant shall also work with Mendocino Transit Authority to investigate the feasibility of providing a bus stop for southbound bus service within walking distance of the project site.~~
- MM 3.5-I.1** The applicant and/or future site developers shall pay the adopted Ukiah Valley Area Transportation Impact Fee at the time that building permits are issued.

### 6.6 Air Quality (FEIR, Chapter 3.6)

The Mendocino County Air Quality Management District (MCAQMD) is not required to prepare or implement an air quality plan, however, it is responsible for enforcing State and federal air quality regulations. Because the County does not have an air quality plan, no impacts would occur with regard to potential conflicts with an applicable air quality plan. The FEIR notes that the MCAQMD has prepared a PM<sub>10</sub> Attainment Plan and that implementation of the project would not obstruct or affect implementation of this plan. The Modified Project is on the same site, is the same use, and has a lower density than the project previously analyzed in the FEIR and, similarly, no impacts would occur with regard to potential conflicts with an applicable air quality plan.

The FEIR identifies Mendocino County as a federal attainment area or unclassified for all criteria pollutants and a State attainment area or unclassified for all pollutants, except for PM<sub>10</sub> for which the area is classified as nonattainment with respect to State standards. The FEIR analyzed emissions related to construction and found that maximum daily emissions from construction activities are lower than their respective significance thresholds for all pollutants except for PM<sub>10</sub>. Project generated construction-related emissions of PM<sub>10</sub> could cause local increases in dust generation that could exceed air quality standards, and adversely affect sensitive receptors if not mitigated. This impact was identified as potentially significant if not mitigated. Mitigation Measure 3.6-A.1 was proposed to require implementation

of a dust control program. The FEIR found that implementation of the mitigation measure would reduce the impact to a less than significant level.

An updated *Air Quality and Greenhouse Gas Assessment* ("AQ/GHG Assessment") was prepared for the Modified Project. It is included in Appendix H (Illingworth & Rodkin, Inc.; January 2021). The updated *AQ/GHG Assessment* prepared for the Modified Project evaluates construction-related emissions and operational emissions related to traffic and energy usage. The *AQ/GHG Assessment* compares the Modified Project with the previously approved project and evaluates consistency with current air quality standards. The *AQ/GHG Assessment* concludes that Maximum Daily Average Project Emissions for all pollutants, including PM<sub>10</sub>, are below the applicable MCAQMD thresholds. The Modified Project's emissions are significantly lower than those modeled for the previously approved subdivision for all pollutants except reactive organic gases (ROG), and ROG emissions remain substantially below current MCAQMD thresholds.

The *AQ/GHG Assessment* calculates daily and total annual emissions from the Modified Project and compares them to the emissions modeled for the previously approved project. In all cases, the operational emissions for the Modified Project are lower than those presented in the FEIR and well below the MCAQMD thresholds. Based on the updated analysis of air quality impacts presented in the *AQ/GHG Assessment*, the Modified Project would not introduce new environmental impacts or create more severe environmental impacts than those analyzed in the FEIR.

The FEIR indicates that the portion of the North Coast Air Basin within MCAQMD's jurisdiction is an attainment area for all federal and State standards for criteria pollutants and ozone precursors except for PM<sub>10</sub>. The FEIR found that, while exceedances of the PM<sub>10</sub> standard had not occurred over the prior three years in Ukiah, cumulative buildout under the Draft 2007 Ukiah Valley Area Plan is projected to result in exceedances of the significance threshold for PM<sub>10</sub>. However, the FEIR notes that the significance criterion applies to discrete projects and there is no criterion for groups of projects. The FEIR notes that the project's contribution to the cumulative impact is 1.8% and that the project is consistent with the MCAQMD's Particulate Matter Attainment Plan. Therefore, the FEIR concludes that the project's contribution to cumulative air quality impacts is less than significant. It is noteworthy that, when the Ukiah Valley Area Plan was adopted in 2011, the Board of Supervisors approved a Statement of Overriding Considerations related to the cumulative impacts of development in the Ukiah Valley on air quality.

The Modified Project is on the same site as the project previously analyzed in the FEIR and fewer residential lots are proposed. In addition, the Modified Project is being constructed at a later date than that which was assumed in the FEIR and improvements in technology and more stringent regulatory requirements will result in lower emission factors for construction equipment than previously identified. Therefore, construction impacts associated with the Modified Project would be similar or less than the FEIR construction analysis and the Modified Project would not result in construction-related cumulative impacts.

The Modified Project would result in lower emissions of each criteria air pollutant than the previously approved project except for ROG and would individually not exceed the applicable MCAQMD Thresholds of Significance. Therefore, the operational cumulative impact related to criteria pollutants and ambient air quality would be less than significant.

The FEIR assessed whether the project would expose sensitive receptors to substantial pollutant concentrations. It concluded that project-generated construction related emissions of PM<sub>10</sub> could cause local increases in dust generation that could exceed air quality standards and adversely affect sensitive receptors if not mitigated. The impact is reduced to a less than significant level with implementation of Mitigation Measure 3.6-A.1 which requires a dust control program to limit construction emissions of PM<sub>10</sub>.

The FEIR concluded that mobile source emissions generated by project traffic would increase carbon monoxide (CO) concentrations at intersections in the project vicinity, however since none of the



intersections affected by project-related traffic were operating at or were projected to operate at unacceptable Levels of Service (LOS E or F), CO concentrations are not expected to significantly increase as a result of project traffic. Therefore, the impacts of carbon monoxide hotspots on potential sensitive receptors were deemed less than significant.

The Modified Project is on the same site as the project previously analyzed in the FEIR and has a similar footprint and density. As with the previously approved project, the Modified Project would be a temporary source of air pollutant and Toxic Air Contaminant (TAC) emissions during construction. The *AQ/GHG Assessment* performed a health risk assessment of project construction activities to evaluate the potential health effects to nearby sensitive receptors from construction emissions. The modeling indicates that the unmitigated maximum increased cancer risks and maximum annual PM<sub>2.5</sub> concentrations from construction would not exceed the BAAQMD threshold that is used by the MCAQMD. Therefore, the Modified Project would not introduce new environmental impacts or create more severe environmental impacts than those analyzed in the FEIR.

The FEIR concluded that the project would not create objectionable odors affecting a substantial number of people. No impacts would occur. The Modified Project is on the same site and includes similar uses as the project previously analyzed in the FEIR. As such, the Modified Project would not create objectionable odors affecting a substantial number of people. No additional analysis is required.

Air quality impacts associated with the Modified Project would be consistent or lesser than those identified in the FEIR analysis. The Modified Project is on the same site and is substantially the same use and density as the project analyzed in the FEIR. Applicable mitigation measures previously identified in the FEIR and MMRP will be required and additional measures to further reduce air quality impacts have been incorporated into the Modified Project. The Modified Project would not result in substantial air quality changes beyond those analyzed in the FEIR or require major revisions to the FEIR.

### Mitigation Measures - Air Quality

- MM 3.6-A.1** The project applicant and construction contractor shall for all construction project phases prepare and implement a dust control program to limit construction emissions of PM<sub>10</sub>. The program shall include at least the following provisions from MCAQMD Rule 1-430 Fugitive Dust. Because the site is over one acre in size, a Grading Permit must be approved by MCAQMD, and MCAQMD may require additional mitigations.
- a. Covering open bodied trucks when used for transporting materials likely to give rise to airborne dust.
  - b. The use of water or chemicals for control of dust in the demolition of existing buildings or structures.
  - c. All visibly dry disturbed soil road surfaces shall be watered to minimize fugitive dust emissions.
  - d. All unpaved surfaces, unless otherwise treated with suitable chemicals or oils, shall have a posted speed limit of 10 miles per hour.
  - e. Earth or other material that has been transported by trucking or earth moving equipment, erosion by water, or other means onto paved streets shall be promptly removed.
  - f. Asphalt, oil, water or suitable chemicals shall be applied on materials stockpiles, and other surfaces that can give rise to dust emissions.
  - g. All earthmoving activities shall cease when sustained winds exceed 15 miles per hour.

- h. The operator shall take reasonable precautions to prevent the entry of unauthorized vehicles onto the site during non-work hours.
- i. The operator shall keep a daily log of activities to control fugitive dust.

The Modified Project would result in air quality impacts that are similar to or less than those evaluated in the FEIR and there have been no changed circumstances that would merit additional mitigations. However, the applicant has identified four additional measures that will be incorporated into the Modified Project to implement best management practices relating to dust control and construction impact mitigation as follows:

- \*MM 3.6-A.2** The proposed development will require the preparation of a detailed grading and erosion control plan subject to review and approval by the County prior to earth moving activities (Municipal Code section 18.70.060 – Grading Permit Requirements). Grading will be completed in compliance with County standards.
- \*MM 3.6-A.3** Dust control rules and regulations as required by the MCAQMD will be adhered to (Rule 1-200, 1-400(a), 1-410, 1-420, 1-430). These regulations minimize fugitive dust particle during construction. Measures imposed by the MCAQMD include, but not limited to:
  - All visibly dry disturbed soil surfaces shall be watered to minimize fugitive dust.
  - Installation of a “stabilized construction entrance/exit” as detailed in the Department of Transportation storm water handbook (TC-1) will be utilized.
  - Earth or other material tracked on to neighboring paved roads shall be removed promptly.
  - Dust generating activities will be limited during periods of high winds (over 15 mph).
  - Access of unauthorized vehicles onto the construction site during non-working hours shall be prevented.
  - A weekly log shall be kept of fugitive dust control measures that have been implemented.
  - Restrict idling of diesel engines on the site to less than 5 minutes.
  - All haul trucks transporting soil, sand or other loose materials off-site shall be covered.
  - All vehicle speeds on unpaved roads shall be limited to 15 mph.
  - Idling times shall be minimized either by shutting equipment off when not in use or reducing the maximum idling time to 5 minutes (as required by the California airborne toxics control measure title 13, Section 2485 of the California Code of Regulations). Clear signage shall be provided for construction workers at access points.
  - All construction equipment shall be maintained and properly tuned in accordance with manufacturer’s specifications. All equipment shall be checked by a certified mechanic and determined to be running in proper condition prior to operation.
  - Post a publicly visible sign with telephone number for the applicant’s representative regarding dust complaints. This person shall respond and take corrective action within 48 hours. The MCAQMD phone number shall also be visible to ensure compliance with applicable regulations.

- \*MM 3.6-A.4** All off road construction equipment with engines greater than 50 horsepower (hp) and operating on the site for more than two days or 20 hours shall meet, at a minimum, U.S. EPA particulate matter emission standards for Tier 4 engines or equivalent. In the event that such equipment is not available, the use of Tier 3 construction equipment is sufficient so long as it can be demonstrated to the County that similar Tier 4 construction equipment is not readily available.
- \*MM 3.6-A.5** The applicant shall submit a Construction and Demolition Waste Management Plan (CWM) to the Mendocino Solid Waste Management Authority prior to the start of construction-related activities in accordance with Mendocino Solid Waste Management Authority requirements (Ordinance 4301). The CWM will outline measure to capture and recycle materials that would otherwise end up in the waste stream.

### 6.7 Energy & Greenhouse Gas Emissions (FEIR, Chapter 3.6)

The FEIR describes the types of energy consumption that would result from the project during construction and operation and concludes that there is no evidence that the proposed project would cause wasteful or inefficient use of energy. It also concludes that the proposed project is not of sufficient size to generate a substantial increase in energy use. Nevertheless, the FEIR identifies the GHG increase related to the project, albeit a relatively small increase, as a potentially significant cumulative impact because "any increase in emissions from today's levels makes achievement of statewide GHG reduction goals by Mendocino County difficult to impossible to attain." MM 3.6-F-1 requires the project to implement a variety of energy efficient design measures including compliance with energy performance standards for Title 24, and installation of a solar system to offset electrical use by facilities owned or managed by the Homeowner's Association. The FEIR concluded that, even with implementation of mitigation, the project's GHG emissions would result in a significant and unavoidable cumulative impact on the global climate. When it certified the FEIR and approved the Garden's Gate subdivision project, the Board of Supervisors adopted a Statement of Overriding Considerations finding that "the benefits of the project in providing housing outweigh the impacts associated with the emission of greenhouse gases."

The FEIR determined that development of the project would comply with California's "Energy Efficiency Standards for Residential and Nonresidential Buildings" and would not result in the wasteful use of energy. The Modified Project will also be required to comply with State regulations which limit idling from both on-road and off-road diesel-powered equipment during construction and the State's Title 24 energy efficiency standards for residential buildings.

At the time the FEIR was prepared, the State of California had not prepared GHG significance thresholds, therefore the FEIR adopted the conservative significance threshold of zero new GHG emissions based on the belief that: (1) all GHG emissions contribute to global climate change and could be considered significant, and (2) not controlling emissions from smaller sources would be neglecting a major portion of the GHG inventory. The FEIR found that construction-related GHG emissions would be potentially significant with the concrete alone resulting in direct emission of 7,388 tons of CO<sub>2</sub>e. Construction-related GHG emissions are identified as a significant and unavoidable impact. Additionally, the FEIR found that project operation would use energy and thereby generate GHG emissions that would adversely affect the global climate. With implementation of MM 3.6-F.1, the FEIR found that the project's overall GHG emissions would be approximately 2,114 tons of CO<sub>2</sub>e per year (GHG emissions expressed as equivalent to carbon dioxide). While the FEIR found that the project itself is too small to have a significant impact on global climate change, it found the project's incremental impact on GHG emissions to be a significant and unavoidable cumulative impact on the global climate.

An updated *Air Quality and Greenhouse Gas Assessment* (Illingworth & Rodkin, Inc.; 1/19/21) was prepared for the Modified Project and is included in Appendix H. The updated study ("AQ/GHG

*Assessment*") found that GHG emissions associated with the Modified Project would occur over the short-term from construction activities, consisting primarily of emissions from equipment exhaust and worker and vendor trips. There would also be long-term operational emissions associated with vehicular traffic within the project vicinity, energy and water usage, and solid waste disposal. Emissions for the Modified Project were predicted in the *AQ/GHG Assessment* using the methodology recommended in the BAAQMD CEQA Air Quality Guidelines that MCAQMD recommends. The CalEEMod model (version 2016.3.2) was used to model GHG emissions associated with electricity usage that are based on the expected electricity consumption of the new residences combined with the anticipated emissions rate reported for the utility company providing the electricity.

GHG emissions associated with construction of the proposed land uses were computed to range from about 400 to 600 metric tons of CO<sub>2</sub>e per year under the modeled construction scenario. The total construction period emissions were computed as 1,019 metric tons. These are the emissions from on-site operation of construction equipment, vendor and hauling truck trips, and worker trips. Neither the County nor MCAQMD have an adopted threshold of significance for construction-related GHG.

Following construction, emissions would occur on a nearly continuous basis as the project operates through traffic generation, energy usage, water usage, and waste generation. The CalEEMod model was used to predict annual emissions associated with operation of the fully-developed project, both for the approved project and for the Modified Project. The operational emissions were assumed to be at the highest levels in 2026 if built out and fully occupied by that time. The Modified Project emissions are reflective of the GHG reduction features that the applicant has incorporated into the Modified Project. Modified Project emissions would be over 450 metric tons per year lower than the approved project.

Since the Modified Project would have fewer residential units and would cause less traffic, the *AQ/GHG Assessment* found that GHG emissions would be less than those identified in the FEIR for the Garden's Gate Subdivision. Furthermore, the Modified Project would include additional features to reduce GHG emissions that were not included in the Garden's Gate project. The Modified Project would not introduce new environmental impacts or create more severe environmental impacts related to GHG emissions than those analyzed in the FEIR.

As noted above, at the time the FEIR was prepared and certified, there were no adopted plans, policies and regulations for GHGs. Nevertheless, the FEIR conservatively established a "net zero" threshold whereby any increase in GHG emissions was deemed to be a significant and adverse impact. In approving the project, the Mendocino County Board of Supervisors adopted a Statement of Overriding Considerations relating to GHG emissions.

The *AQ/GHG Assessment* found that GHG emissions for the Modified Project would be less than those identified in the FEIR for the Garden's Gate Subdivision. Furthermore, the Modified Project would include additional features to reduce GHG emissions that were not included in the Garden's Gate project. The Modified Project would not introduce new environmental impacts or create more severe environmental impacts related to GHG emissions than those analyzed in the FEIR.

The Modified Project would have fewer residential units than the project analyzed in the FEIR. The Modified Project would have lower GHG emissions than those analyzed in the FEIR and therefore, the Modified Project would not involve new significant or more severe energy or GHG emission impacts than those previously identified and analyzed in the FEIR.

Applicable mitigation measures previously identified in the FEIR will be required as set forth in the MMRP. MM 3.6-F.1 is modified to eliminate the requirements for solar hot water heaters and a photovoltaic solar electric system to be owned and operated by the HOA. The intended benefits of these components would be addressed by two new mitigation measures proposed by the applicant for the Modified Project. New mitigation measure MM 3.6-F.2 requires compliance with standards of Title 24 of the California Building Code (CBC). The CBC has been updated substantially with regard to energy conservation since the FEIR

was certified. All new single-family residences are now required to have solar panels. In addition, the Modified Project would be an all-electric project and, per MM 3.6-F.3, it would have no natural gas hook-ups. The proposed revisions to MM 3.6-F.1 would not result in any change in the effectiveness of the mitigations for the project, but rather the revisions, coupled with new mitigation measures MM 3.6-F.2 and MM 3.6-F.3 reflect the updated approach to energy conservation that is incorporated into the Modified Project.

### Mitigation Measures - Energy & Greenhouse Gas Emissions

**MM 3.6-F.1.** The project shall minimize the emission of greenhouse gases by including at least the following:

- ~~▪ Install solar hot water heaters with a back-up electric water heater.~~
- The project shall be constructed to incorporate the 2010 Title 24 building standards (or whatever standards have been adopted at the time that building permits are issued).
- ~~▪ The project shall include a photovoltaic (PV) solar electricity system that will be owned and operated by the Homeowner's Association for the benefit of the future residents. The system will be sized sufficiently so that it totally offsets electrical use from project parks, recreational facilities, and other facilities owned or managed by the Homeowner's Association.~~
- Project residential units shall be oriented for maximum solar access. Roofs shall be constructed to allow easy and efficient retrofitting with roof-top solar panels.
- The project applicant shall ensure that the CC&Rs of the Homeowner's Association develops and maintains energy- and water-efficient practices for the common areas of the subdivision and follows a landscaping plan that does not impair the efficient operation of the solar collection facilities.

In addition to the above mitigation measure from the FEIR, the applicant for the Modified Project has identified the following measures that will be incorporated into the Modified Project to further reduce Energy and GHG-related impacts:

**\*MM 3.6-F.2** All residences would be constructed in accordance with the most recent edition of Title 24 of the California Building Code (CBC). The CBC contains mandatory requirements that apply to residential buildings that will be a part of the project which include high performance attics insulation and walls, high efficacy lighting, windows, water heating and HVAC systems. Specific energy conservation features include:

- Structures will incorporate natural cooling by utilizing window overhangs, awnings, front and rear patios, shade from neighboring structures, radiant heat-reflective barriers in the attic and appropriate tree plantings or a combination thereof.
- Structures will be constructed in compliance with solar requirements found in Title 24 of the California Building Code.
- Project will incorporate Energy Star Certified Appliances. At a minimum, the following appliances are recommended to be Energy Star rated: dishwasher and water heater.
- Natural lighting may be incorporated into the home through solar tubes and sky lights.
- Windows, sky lights and other fenestration will meet energy code requirements and will be Energy Star certified. These elements will have low U-factor (U-value)

rating. U-factors is a rate of non-solar heat loss or gain through a while window assembling. The lower the U-factor, the greater a window's resistance to heat flow and the better its insulating value.

- Project will incorporate the use of low flow toilets and faucets that meet the standards as set forth by the California Energy Commission.
- All landscaping will be installed to AB 1881 (The Water Conservation in Landscaping Act of 2006) standards, which promotes water efficiency and conservation, using mulch, bubblers, and timed sprinkler systems.

**\*MM 3.6-F.3** The following features shall be included in the Modified Project to reduce GHG emissions:

- No fireplaces;
- Include solar power for each of the residential lots;
- No natural gas hook-ups;
- Include infrastructure to promote electric car charging (i.e., provide 220VAC outlets);
- Meet latest CalGreen Title 24 standards);
- Include energy-efficient appliances;
- Include low-flow water fixtures; and
- Include water-efficient irrigation systems (drip systems).

## 6.8 Noise (FEIR, Chapter 3.7)

The FEIR determined that the easternmost residential units in the project could be exposed to future exterior noise levels of up to 62 Ldn due to motor vehicle traffic on South State Street. The FEIR found that, further west, sound levels would comply with the 60 Ldn exterior noise standard due to shielding from intervening structures and noise reduction with increasing distances. MM 3.7-A.1 requires project-specific acoustical analysis to ensure that measures are incorporated, if necessary, to ensure that indoor and outdoor noise levels do not exceed standards for residential uses. This mitigation would apply to the Modified Project and ensure that impacts are reduced to a less than significant level. Therefore, implementation of the Modified Project would not introduce substantial temporary or permanent noise impacts beyond those analyzed in the FEIR.

The FEIR found that construction of project improvements would generate construction noise over a period exceeding one year and that such impacts would be potentially significant. MM 3.7-C-1 was identified to reduce construction-related noise impacts to a less than significant level. This mitigation would apply to the Modified Project and ensure that impacts are reduced to a less than significant level. Therefore, implementation of the Modified Project would not introduce construction-related noise impacts beyond those analyzed in the FEIR.

The FEIR determined that the project would not be expected to generate groundborne vibration or noise and, thus, would not generate any vibration-based impacts. Similarly, the Modified Project would have no groundborne vibration or noise impacts.

The FEIR determined that the project site is outside of the 55 CNEL contours associated with the existing and future operations of the Ukiah Municipal Airport. The FEIR concluded that airport noise alone would be compatible with the planned residential uses, according to the County's noise standards, however, when combined with motor vehicle noise from South State Street, the FEIR concluded that aircraft noise

could increase the margin by which noise compatibility levels are exceeded. MM 3.7-A.1 requires project-specific acoustical analysis to ensure that measures are incorporated, if necessary, to ensure that indoor and outdoor noise levels do not exceed standards for residential uses. This mitigation would apply to the Modified Project and ensure that impacts are reduced to a less than significant level. Therefore, implementation of the Modified Project would not introduce substantial temporary or permanent noise impacts beyond those analyzed in the FEIR.

The Modified Project does not include changes in use or density beyond those analyzed in the FEIR. Applicable mitigation measures identified in the FEIR will be required as set forth in the MMRP and no considerably different mitigation measures that may substantially reduce impacts have been identified or rejected. The Modified Project would not result in substantial noise and vibration impact changes beyond those analyzed in the FEIR and major revisions to the FEIR would not be required.

### **Mitigation Measures - Noise**

**MM 3.7-A.1** Project-specific acoustical analyses shall be required to confirm that outdoor activity areas are provided with Ldn values at or below 60 dBA, and interior Ldn values will not exceed 45 dBA. Sound insulation measures, including any mechanical ventilation systems needed to permit closed windows, should be designed by an experienced acoustical consultant and incorporated into construction documents submitted for permits.

**MM 3.7-C.1** Project construction shall not cause excessive noise. To accomplish this standard, the following measures are required:

- Noise-generating activities at the construction site or in areas adjacent to the construction site associated with the project in any way should be restricted to the hours of 7:00 a.m. to 6:00 p.m., Monday through Friday. No construction activities should occur on weekends or holidays.
- Equip all internal combustion engine driven equipment with intake and exhaust mufflers that are in good condition and appropriate for the equipment.
- Unnecessary idling of internal combustion engines should be strictly prohibited.
- Locate stationary noise generating equipment such as air compressors or portable power generators as far as possible from sensitive receptors. Construct temporary noise barriers to screen stationary noise generating equipment when located near adjoining sensitive land uses.
- Utilize "quiet" air compressors and other stationary noise sources where technology exists.
- Control noise from construction workers' radios, CD players, etc. to a point that they are not audible at existing residences bordering the project site.
- Designate a "disturbance coordinator" who would be responsible for responding to any local complaints about construction noise. The disturbance coordinator will determine the cause of the noise complaint (e.g., starting too early, bad muffler, etc.) and will require that reasonable measures warranted to correct the problem be implemented. Conspicuously post a telephone number for the disturbance coordinator at the construction site and include it in the notice sent to neighbors regarding the construction schedule.
- Notify existing residents when especially noisy operations are scheduled near their property, allowing the residents to plan activities accordingly. Examples of especially noisy sources: heavy earth moving equipment, jack hammers, pile drivers.

### 6.9 Aesthetics, Light and Glare (FEIR, Chapter 3.8)

The FEIR determined that, while the vineyard and open space on the project site are scenic, such views are common visual resources in the Ukiah Valley and the County has not defined the site as having identified scenic vistas. Therefore, the FEIR concluded that the project would not adversely affect a scenic vista. The Modified Project has a similar footprint to the previously approved project.

U.S. 101 to the east of the project site is not a designated State Scenic Highway and, therefore, the FEIR concluded that the potential for damage to scenic resources within the viewshed of a State Scenic Highway would be less than significant. Additionally, there are no rock outcroppings or historic buildings on the site. The Modified Project is similar to the previously approved project that was evaluated and disclosed in the FEIR.

The FEIR considered the change in public views across the site from South State Street and other vantage points to the east of the site. Existing views of open space and vineyards would be replaced with views of residential development. The FEIR concluded that the project would change the visual character of the area by extending the developed area of Ukiah onto the project site and would have a potentially significant impact on views from the east due to the fact that the project site serves as a southern "gateway" to the City. The FEIR found that adherence to the proposed design guidelines and proposed landscaping plans would reduce the impact on views from the east to a less than significant level. However, since the County does not have a design review process or landscaping standards, the FEIR identified two mitigation measures (MM 3.8-A.1 and MM 3.8-A.2) to establish design and landscaping requirements. The FEIR also evaluated the project's impact on views from locations to the south, east and north of the site. It concluded that development of the subdivision would have a less than significant impact on views from the south (i.e., residences along Stipp Lane and other residences to the south), views from the east, and views from upper elevations to the northwest (i.e., residences along Oak Knoll Road and possibly residences at upper elevations to the northwest). The FEIR found that the impacts on these views were acceptable as the County has long designated the site for residential development, thereby accepting that there would be an eventual loss of open space views on the project site. The FEIR found that the change in views from Gobalet Lane immediately north of the project site would be potentially significant because the proposed residential structures adjacent to Gobalet would include three-story buildings. The FEIR concluded that, with implementation of the two mitigation measures, that impact would be less than significant. The Modified Project would have similar impacts on views from the east as the previously approved project, although the frontage on South State Street would be enhanced by the relocation of the neighborhood park to an area along South State Street immediately south of the main entry road. Views from the south and the northwest would be similar to those evaluated in the FEIR. The Modified Project would not include the three-story buildings next to Gobalet Lane, so the visual impact from that vantage point would be less than significant. Implementation of the Modified Project would not introduce new visual impacts or create more severe visual impacts than those analyzed in the FEIR.

The FEIR concluded that the project would introduce new sources of nighttime lighting that would be noticeable to residents living near the site and to drivers along South State Street. This was identified as a potentially significant impact. MM 3.8-F.1 requires a lighting plan that minimizes light escape from the site and the lighting plan is required to be included in the Declaration of Covenants, Conditions and Restrictions (CC&Rs) for the Homeowners Association. The Modified Project would produce sources of nighttime lighting similar to those analyzed in the FEIR. Therefore, implementation of the Modified Project would not introduce new nighttime lighting or create more severe nighttime lighting impacts than those analyzed in the FEIR.

The Modified Project does not propose a change in use, an increase in density, or a change in the extent of development as analyzed in the FEIR. The Modified Project does not propose substantial visual



changes beyond those analyzed in the FEIR or require major revisions to the FEIR. Therefore, the Modified Project would not involve new significant aesthetic impacts or more severe aesthetic impacts than those previously identified and analyzed in the FEIR. No additional analysis of Aesthetics is required.

### **EIR Mitigation Measures - Aesthetics, Light and Glare**

- MM 3.8-A.1** Final project design and landscape plan shall undergo design review by the County Department of Planning and Building Services and/or the County Planning Commission to ensure consistency with the design guidelines adopted for this project. The final project shall be revised, if requested, to comply with the County's review recommendations.
- MM 3.8-A.2** Landscaping will be mature within 15 years of initial project construction (Phase 1). Mature means that perimeter trees shall be at least 20 feet tall. The final landscape plan shall include tree landscaping along the north and east sides of the site using species that fully screen views from the east and screens at least half of the buildings on the north side. The plan shall include specifications for planting, irrigating, fertilizing, and replacing dead trees so that the landscaping will be mature within 15 years.
- MM 3.8-F.1** The final design shall include a lighting plan that minimizes light escape from the site. The final plan shall become part of the CC&Rs for the Homeowners Association. This plan shall include the following:
1. *Light shielding is required.* Except as otherwise, exempt, all outdoor lighting fixtures shall be constructed with full shielding. Shielding shall prevent the light source from being visible to adjacent residential properties.
  2. *Minimum/Maximum Level of Illumination.* The minimum and maximum levels of illumination permitted are listed below. A photometric study listing the number type, height, and level of illumination of all outdoor lighting fixtures shall be required prior to issuance of a building permit or site improvement plans to ensure compliance with these provisions.
    - a. Minimum security lighting for sidewalks, walkways, parking areas, and similar areas shall be 1.0 foot-candles, measured at ground level, not to exceed 4.0 foot-candles on average.
    - b. In order to minimize light trespass on abutting property, illumination measured on the property line of a subject parcel shall not exceed 0.5 foot-candles, measured on a vertical plane along the property line.
    - c. Building-mounted decorative or security lights shall not exceed 5.0 foot-candles, measured a distance of five feet from the light source. All building lighting shall be reviewed and authorized by Mendocino County prior to the initiation of lighting installation.
  3. *Maximum Height of Outdoor Light Fixtures.* The maximum height of freestanding outdoor light fixtures for multi-family residential development and non-residential development abutting a single-family residential zoning district or use shall be 20 feet. Otherwise, the maximum height for freestanding outdoor light fixtures shall be 25 feet.
  4. *Type of illumination.* All outdoor lighting fixtures shall be energy efficient. Energy efficient lights include all high-intensity discharge lamps (mercury vapor, high-pressure sodium, low-pressure sodium, and metal halide). The concentrated and/or exclusive use of either low-pressure sodium or metal halide lighting is prohibited.
  5. *Hours of illumination.* Automatic timing devices shall be required for all outdoor light fixtures on multi-family residential and no-residential development (e.g., parks) with off

hours (exterior lights turned off) between 11:00 p.m. and 6:00 a.m. Exceptions are that outdoor lights may remain on in conjunction with the hours of operation of the corresponding use, for security purposes, or to illuminate walkways, roadways, equipment yards, and parking lots.

6. *Prohibited Lighting.* The following outdoor light fixtures shall be prohibited as specified below.
  - a. Lighting of parks for active nighttime recreation.
  - b. Up-lighting/back-lit canopies or awnings.
  - c. The concentrated and/or exclusive use of either low-pressure sodium or metal halide lighting.
  - d. Neon tubing or band lighting along building structures.
  - e. Searchlights.
  - f. Flashing lights.
  - g. Illumination of entire buildings. Building illumination shall be limited to security lighting and lighting of architectural features authorized by the designated Approving Authority in conjunction with required development permit(s).
  - h. Roof-mounted lights except for security purposes with motion detection and full shielding so that the glare of the light source is not visible from any public right-of-way.

#### 6.10 Utilities and Service Systems (FEIR, Chapter 3.9)

The FEIR determined that the project would contribute to the need for the Willow County Water District (WCWD) to replace and expand an existing water storage tank located on Fircrest Drive. The FEIR indicated that the storage tank project was underway and included MM 3.9-H.1 requiring the developer to pay a capital improvement fee to WCWD to fund the project's share of the expanded water storage tank. The mitigation would reduce the impact to a less than significant level. The FEIR identified the proposed installation of a water line connecting the existing water main in South State Street with the water main in Oak Knoll Road which would provide a more reliable looped water system for the surrounding area as well as the project site.

A Water Supply Verification for the Modified Project prepared for WCWD (Appendix I; *Bella Vista Development - Water Supply Verification*; Luhdorff & Scalmanini; 09/09/21) found that the District currently has adequate water storage capacity to provide for operational storage, fire safety, and emergency storage.

The FEIR determined that the project would increase the demands for water by approximately 100,000 gallons of water per day, but it would not result in a need for new water entitlements. The WCWD approved a "will serve" letter for the project (dated June 7, 2005) indicating that it will supply water to a 210-unit subdivision on the project site. WCWD's conclusions regarding the adequacy of water supplies were confirmed by the State Department of Health Services in 2007.

The WCWD provided an updated "will serve" letter stating that it can and will supply water for the Modified Project (Appendix B; *09/14/21 letter from J. Walker; Willow County Water District*). The updated "will serve" letter was issued based on a Water Supply Verification for the project that was prepared for WCWD (Appendix I; *Bella Vista Development - Water Supply Verification*). The *Water Supply Verification* concluded that, even with water supply reductions such as those implemented in 2021 due to the drought, WCWD has sufficient water supply to serve the Modified Project. Therefore, implementation of the

Modified Project would not introduce new water demand impacts or create more severe impacts that would prevent WCWD from providing sufficient water supplies beyond those analyzed in the FEIR.

The FEIR determined that the project would have a less than significant impact on the Ukiah Valley Sanitation District (UVSD) treatment and disposal system. The UVSD had issued a will-serve letter to the project and no mitigation was required beyond the payment of UVSD connection fees. The UVSD issued an updated "Capacity to Serve" letter for the Modified Project (Appendix J; UVSD Capacity to Serve Sewer for Bella Vista Subdivision; 03/11/21). Implementation of the Modified Project would not introduce new wastewater treatment capacity impacts or create more severe impacts than those analyzed in the FEIR.

The applicable natural gas, electrical power, and telecommunications providers would serve the Modified Project, similar to the project analyzed in the FEIR. Therefore, implementation of the Modified Project would not result in the need for relocation or construction of new or expanded water, wastewater treatment or stormwater drainage, electric power, natural gas, or telecommunications facilities or create more severe impacts than those analyzed in the FEIR.

The FEIR indicated that the Ukiah Valley Transfer Station had a permitted capacity of 400 tons per day, but currently received an average of 120 to 130 tons of solid waste per day. The amount of household waste generated by the project was estimated to represent an approximately 0.7% increase in the average that was handled at the Ukiah Valley Transfer Station. The projects impact on solid waste facilities was determined to be less than significant. Implementation of the Modified Project would not increase the amount of solid waste entering the waste stream or create more severe impacts than those analyzed in the FEIR.

The FEIR indicated that the project and other new development in the project vicinity would be required to comply with applicable, federal, State, and local regulations related to solid waste and future development would not impede the ability of the Ukiah Valley Transfer Station to meet waste diversion requirements or violate other applicable regulations related to solid waste and no impact would occur. Implementation of the Modified Project would not introduce new solid waste impacts or create more severe impacts beyond those analyzed in the FEIR.

The Modified Project would not change the type or extent of development allowed under the approved project as analyzed in the FEIR. Development of the Modified Project would be in accordance with the mitigation measures identified and analyzed in the FEIR. The Modified Project does not include substantial changes to utilities beyond those analyzed in the FEIR or require major revisions to the FEIR.

### **Mitigation Measures - Utilities and Service Systems**

**MM 3.9-H.1** The applicant shall enter into an agreement with the Willow County Water District to pay a capital improvement fee (estimated at \$400,000) to fund the project's share of the replacement and expansion of the Fircrest Drive water storage tank.

### **6.11 Public Services (FEIR, Chapter 3.9)**

The FEIR determined that fire protection services for the project would be provided by the Ukiah Valley Fire District (UVFD) and that the project would increase demands on the UVFD but would not require the construction of new facilities. The FEIR further concludes that, if a new fire station is needed in the future, it could be constructed without having significant and unavoidable impacts and no mitigation is required. The Modified Project would place similar demands on the UVFD as the approved project. Therefore, implementation of the Modified Project would not introduce new fire protection service impacts or create more severe fire protection service impacts than those analyzed in the FEIR.

The FEIR concluded that the addition of 197 new residential units would increase the demand for police response from the County Sheriff's Office and from the Ukiah Police Department if mutual aid is required. The FEIR concluded that this impact was less than significant and that the project would not require new police facilities or the expansion of existing police facilities and police service impacts would be less than significant. The FEIR identified MM 3.9-C.1 which required review of the final project design by the Sheriff's Office to ensure adequate security measures are incorporated. The Modified Project would not result in an increase in demand for police protection services beyond that previously analyzed in the FEIR.

The FEIR determined that the project, at buildout, would generate approximately 85 new school-aged students, most of whom would attend schools within the Ukiah Unified School District. The FEIR indicates that there is sufficient excess capacity and new school facilities would not be needed to accommodate project-generated students. The FEIR determined that school service impacts were determined to be less than significant. The Modified Project has fewer residences than the approved project and 29 of those residences are age-restricted, thus the impact of the Modified Project on schools would likely be less than that of the approved project. Therefore, implementation of the proposed project would not introduce new school service impacts or create more severe school service impacts than those analyzed in the FEIR. No additional analysis is required.

The FEIR determined that the project, plus other potential development would increase demands on the Emergency Medical Service (EMS) system in the Ukiah Valley and that, absent funding solutions to ensure the continuation and growth of a quality EMS system, the project could have a potentially significant impact on the EMS system. MM 3.9-F.1 was identified to address short-term funding shortfalls. The FEIR indicates the mitigation reduces the impact to a less than significant level. The Modified Project would not increase demands on the EMS system beyond those evaluated in the FEIR for the approved project. It would not introduce new impacts or create more impacts to EMS system than those analyzed in the FEIR. No additional analysis is required.

The Modified Project does not change or intensify the land use analyzed in the FEIR. Development of the Modified Project would be in subject to the mitigation measures identified in the FEIR and the approved MMRP. The Modified Project does not pose substantial public service impacts beyond those analyzed in the FEIR or require major revisions to the FEIR. Therefore, the proposed project would not involve new significant or more severe public service impacts than those previously identified and analyzed in the FEIR. No additional analysis is required.

### **Mitigation Measures - Public Services**

- MM 3.9-C.1** The final project design shall be reviewed by the Sheriff's Office to determine if it provides adequate access, security lighting, and other factors affecting police response. The final map shall incorporate security measures required by the Sheriff's Office.
- MM 3.9-F.1** If the County has not adopted additional funding for the EMS system at the time of approval of the Development Agreement, then the applicant shall agree within the Development Agreement to pay any fees that the County adopts for EMS funding prior to and/or within five years of approval of the Development Agreement.

### **6.12 Recreation (FEIR, Chapter 3.9)**

The approved project includes a 1.4-acre park near the main entrance that would be open to the public. The park would have open areas and landscaping for passive recreation activities and small gatherings. In addition, a 0.9-acre park located in the interior of the site would provide open space and seating areas. The FEIR found that the proposed facilities do not meet the active recreational needs of the new residents and that increased use of existing parks and recreation facilities could lead to overuse and deterioration of these

facilities which is a potentially significant impact. The FEIR includes MM 3.9-M.1 and MM 3.9-M.2 which require inclusion of playground equipment and payment of a County park "in-lieu fee" which would reduce the impacts on recreation facilities to a less than significant level.

The Modified Project includes a revised layout for on-site recreation facilities, however it would be subject to the Mitigation Measures identified in the FEIR and the adopted MMRP. The Modified Project does not include a change in use or an increase in residential densities that could increase demands and result in deterioration of parks and recreation facilities. Therefore, implementation of the Modified Project would not introduce new impacts to park or recreational facilities or create more impacts than those analyzed in the FEIR. The FEIR concluded that the project's increased demand on recreation facilities would not have an adverse physical effect on the environment and no impacts would occur.

The Modified Project does not include a change in use or increase in development intensity that potentially could result in a significant increase in recreational facility use or demand that would necessitate the need for new or expanded facilities not previously contemplated in the FEIR. Therefore, implementation of the Modified Project would not introduce new impacts or create more impacts than those analyzed in the FEIR.

The Modified Project would not increase demands for recreational facilities beyond that analyzed in the FEIR. Development of the Modified Project would be in accordance with the Mitigation Measures identified in the FEIR and incorporated into the MMRP. The Modified Project does not propose substantial development changes beyond those analyzed in the FEIR or require major revisions to the FEIR. It would not involve new significant or more severe recreation impacts than those previously identified and analyzed in the FEIR.

The Modified Project does not propose changes in land use or development intensity that could potentially result in an increase in park demand not previously contemplated in the FEIR. This precludes the potential for the proposed project to introduce new or more severe impacts than those evaluated in the FEIR. Therefore, implementation of the proposed project would not introduce new park service impacts or create more severe park service impacts than those analyzed in the FEIR.

As noted below, MM 3.9-M.2 allows the developer to pay a "park in lieu fee" to address recreation impacts if such a fee was established by 2012. It is recommended that this mitigation be revised to eliminate the reference to payment of in lieu fees as the County has not established a park in lieu fee program. Additional text is incorporated into MM 3.9-M.2 to ensure that the playing area within the proposed Neighborhood Park is of a sufficient size and dimensions for use as a youth soccer field. The requirement to notify future homebuyers that the park may be developed with an active playfield is eliminated because the Modified Project includes development of the Neighborhood Park in the first phase of the project. The revisions to MM 3.9-M.2 do not reduce the effectiveness of the mitigation measure in offsetting impacts identified in the FEIR. As noted above, the impacts of the Modified Project on recreation are similar to those of the project analyzed in the FEIR and, in fact, elimination of the option to pay an in lieu park fee ensures that recreational facilities will be developed onsite in the Modified Project.

### **Mitigation Measures - Recreation**

**MM 3.9-M.1** Construct and maintain a "tot lot" with playground equipment on one of the two project parks. The tot lot will be maintained by the Homeowner's Association.

**MM 3.9-M.2** ~~The project applicant will agree to pay the County's park in lieu fee when the County adopts the fee program. If the County has not adopted such a fee by 2012, then the applicant will be required to construct the soccer field or ballfields. The applicant shall notify in writing all future homebuyers on the project that the park may be developed with an active playfield at some point in the future. The Neighborhood Park and the contours of the detention basin shall be modified to establish suitable terrain for a multi-purpose playing field that provides a minimum of 100' x 200' of level playing area.~~

### 6.13 Hazards and Hazardous Materials (FEIR, Chapter 3.9)

The FEIR determined the residential uses proposed in the project would not involve routine use, storage, transport, or disposal of the types or amounts of materials considered hazardous. Typical residential uses would consist of commonly used household cleaners, pesticides, solvents and petrochemicals. However, the use would not occur in significant amounts and no impacts are anticipated. The Modified Project has the same uses as those evaluated in the FEIR and would be anticipated to also result in no impacts related to the use, storage, transport or disposal of hazardous materials.

The FEIR indicates that a Phase I Environmental Site Assessment was prepared for the project. The report describes potential hazards associated with former fuel storage facilities on the site, old septic systems and unused water wells. The Phase I Environmental Site Assessment contains recommendations to address potential toxic materials on the site. The FEIR identifies the risk of exposure to toxic materials as a potentially significant impact that, with implementation of MM 3.9-R.1, would be reduced to a less than significant level. The Modified Project has the same uses as those evaluated in the FEIR and would be anticipated to have the same level of impact.

The FEIR concludes that, because the project would not include the use, transport, or storage of hazardous materials, there would not be a release of such material near a school. Therefore, the FEIR determined no impact would occur. The Modified Project would not introduce new impacts or create more severe impacts than those analyzed in the FEIR.

The FEIR indicates that the project site is located in an area that is designated Zone C, "Common Traffic Pattern" by the Mendocino County Airport Comprehensive Land Use Plan (CLUP) which addresses airport safety and viability as well as community safety and compatibility. The CLUP allows residential development up to 15 units per acre in this zone and determined that residential uses would not face significant hazards from aircraft use at the airport. The impact was deemed less than significant in the FEIR and no mitigation was required.

An updated CLUP was adopted in May 2021 ("UKIALUCP"). As shown on Exhibit 4 - Airport Combining Zones, the UKIALUCP designates a sliver of land adjacent to State Street (where the Neighborhood Park is situated in the Modified Project) as Zone 2 "Inner Approach/Departure Zone." To the west of that, a swath of the project site is designated Zone 3 "Inner Turning Zone"/Urban Overlay, and to the west of that, the site is designated Zone 6 "Traffic Pattern Zone." The Risk Level in Zone 2 is high. In Zone 3, it is moderate to high. In Zone 6, it is low.

On December 16, 2021, the Airport Land Use Commission evaluated the consistency of the Modified Project with the UKIALUCP. Policy 2.3.5(b) of the UKIALUCP addresses the ALUC's review of revisions to previously authorized projects and identifies the following types of changes that could raise questions as to the validity of earlier findings of consistency:

- (1) For residential uses, any increase in the number of dwelling units to a level exceeding the criteria set forth in this UKIALUCP unless the increase is a development by right. The Modified Project proposes to decrease the number of units from 197 units in the previously approved project to 171 units.
- (2) Any increase in the height of structures or other design features such that the height limits established herein would be exceeded or exceeded by a greater amount. The Modified Project would have all one- and two-story residences. The previously approved project had residences that ranged from one to three stories in height.
- (3) Major site design changes (such as incorporation of clustering or modifications to the configuration of open land areas proposed for the site) if site design was a factor in the initial review of the project. The Modified Project incorporates lands along the South State Street frontage of the site into the

project. This frontage area was previously not a part of the project. The Modified Project identifies two large parcels along the frontage: Parcel A (68,219 SF) and Parcel B (86,549 SF). Under the Modified Project, no development is proposed on Parcel A. Parcel B would be developed with a Neighborhood Park that would also function as a stormwater detention basin. This use would comply with both the sitewide and single-acre Intensity limitations.

- (4) Any new design features that would create visual hazards (e.g., certain types of lights, sources of glare, and sources of dust, steam, or smoke). The Modified Project does not include features that would create visual hazards.
- (5) Any new equipment or features that would create electronic hazards or cause interference with aircraft communications or navigation. The Modified Project does not include new equipment or features that would create electronic hazards or interference with aircraft communications or navigation.
- (6) Addition of features that could attract wildlife that is potentially hazardous to aircraft operations. The Modified Project does not include new features that could attract wildlife that is potentially hazardous to aircraft operations. The ALUC considered the possibility of the detention basin attracting birds and determined that the facility would only hold standing water for short periods of time during and following rain events.

The ALUC determined that the Modified Project is consistent with the UKIALUCP based on the purpose and intent of the Airport Compatibility Zones 2, 3, and 6, as well as the information presented to the ALUC. Per the recommendation of the ALUC, a condition will be added to the project approvals requiring recordation of an avigation easement on all parcels located in zones 2 and 3.

The FEIR indicated that the project site, adjacent to South State Street and near Highway 101 ramps, has good access for emergency response and evacuation. The FEIR notes that the project's street system extends to Oak Knoll Road which would provide an additional emergency response and evacuation route. The FEIR concluded that the project's impact on emergency response and evacuation is less than significant and no mitigation is required. When the project was approved by the County Board of Supervisors, the internal street connection to Oak Knoll Road was eliminated in lieu of a requirement that all of the residences have automatic fire sprinklers. The Modified Project includes enhanced access to South State Street by relocating the secondary access to the south end of the site (instead of utilizing Gobalet Lane). The primary access would be through a new roundabout aligned with the Plant Road intersection, similar to the site access for the approved project. Implementation of the Modified Project would not introduce new impacts or create more severe impacts than those analyzed in the FEIR.

The Modified Project would not change the type or extent of development analyzed in the FEIR. Applicable mitigation measures previously identified in the FEIR will be required as set forth in the MMRP and no considerably different mitigation measures that may substantially reduce impacts have been identified or rejected. Development of the Modified Project does not pose substantial hazards beyond those analyzed in the FEIR or require major revisions to the FEIR.

### **Mitigation Measures - Hazards and Hazardous Materials**

- MM 3.9-R.1** All potential toxic wastes and materials shall be removed and/or remediated prior to site grading. The applicant shall do the following as recommended in the Phase I Environmental Site Assessment:
- Abandon any inoperable water supply wells on the site following all the requirements of the Mendocino County Division of Environmental Health.
  - Collect soil samples in the area of the former underground storage tank and the aboveground fuel storage tank. The soil samples shall be tested for Total Petroleum Hydrocarbons (as gasoline) and the constituents benzene, toluene, ethylbenzene,

xylene, fuel oxygenates, lead scavengers, and total lead. Results of the testing shall be provided to the Mendocino County Division of Environmental Health. If the Division determines that additional testing or remediation is required, the applicant shall fulfill all County requirements.

- If volatile organic compounds are discovered on the site, a human health risk assessment will be performed per requirements of the County Division of Environmental Health. That assessment will identify measures needed to ensure that workers and future residents are not exposed to County- and State-defined harmful levels of these compounds.
- Dispose of any waste oil, lubricants, paints, or other liquids in accordance with all applicable regulatory requirements.
- Investigate the fuel source for the prune dryer that formerly was located on the west side of the site to determine its fuel sources. If it was gasoline, then conduct soil tests at that site as describe above.
- Assess whether the workshop/storage building has the potential for lead paint or asbestos. If so, then demolition shall follow all requirements established by the Mendocino County Division of Environmental Health.

#### 6.14 Wildfire (FEIR, Chapter 3.9)

The FEIR determined that the project site has good access for emergency response and evacuation due to its adjacency to South State Street and proximity to US 101. The FEIR found that the project's impact on emergency response and evacuation plans was less than significant and no mitigation was required. The Modified Project is on the same site and has a lower density and intensity of development than the project analyzed in the FEIR. Therefore, implementation of the Modified Project would not introduce new impacts or create more severe impacts than those analyzed in the FEIR.

The FEIR identified the portion of the project site on the hillsides to the west of the area to be developed as a high fire hazard area. While the project evaluated in the FEIR did not encroach upon the high fire hazard area, the FEIR identified its adjacency as a potentially significant fire risk. With implementation of MM 3.9-O.1 which requires the project to be designed and constructed to comply with Ukiah Valley Fire District requirements, the FEIR concluded that impacts related to wildfires would be reduced to a less than significant level. The Modified Project is on the same site and has a lower density and intensity of development than the project analyzed in the FEIR. The Modified Project would be required to implement MM 3.9-O.1 thus lowering the risk of loss, death, or injury because of wildfire. Therefore, implementation of the Modified Project would not introduce new impacts or create more severe impacts than those analyzed in the FEIR.

The FEIR determined that emergency access to the site is sufficient and that the project would not require emergency water sources because sufficient water supplies would be provided by WCWD. New electrical power and other utility lines would be installed in accordance with required codes and utility regulations. Therefore, the Modified Project would not increase fire risk due to installation or maintenance of associated infrastructure and impacts would be less than significant.

The Modified Project does not include a change in the type or increase in the intensity of development on the site as analyzed in the FEIR. Applicable mitigation measures previously identified in the FEIR will be required as set forth in the MMRP and no considerably different mitigation measures that may substantially reduce impacts have been identified or rejected. The Modified Project would not involve new significant wildfire hazard impacts and no additional analysis is needed.



**Mitigation Measures - Wildfires**

**MM 3.9-O.1** The project shall be designed and constructed to minimize risk of wildfire destroying residences. The Ukiah Valley Fire District shall review project plans and determine in writing that adequate access, emergency response, and fire flow are available, and that the project complies with the most current state requirements for development in the wildland/urban interface. Final project design shall conform with any changes that the District requires.

**6.15 Land Use and Planning (FEIR, Chapter 3.10)**

The FEIR determined that the project would not create any type of barrier that would physically divide the existing community and there would be no impacts. The Modified Project, similarly, would not divide an established community. It would not introduce new impacts or create more severe impacts that would divide an established community than those analyzed in the FEIR. No additional analysis is required.

Neither the approved project nor the Modified Project would induce population growth beyond that anticipated by the Mendocino County General Plan and the Ukiah Valley Area Plan, both of which designate the project site for residential development. The project would have no impacts related to unplanned population growth.

The project site is currently undeveloped. Neither the approved project nor the Modified Project would result in the displacement of any existing people or housing. The project would have no impacts related to residential displacement.

The Modified Project would not result in unplanned population growth or displacement of existing people or housing. While this impact was not addressed in the FEIR, there is no need for further analysis of impacts relating to population and housing.

The FEIR determined that the conversion of 31 acres of Prime Farmland and two acres of Unique Farmland to residential uses would be a significant and unavoidable adverse impact. There is no mitigation for this impact short of not developing all or part of the site. The FEIR notes that the project site has long been slated for residential development. The Board of Supervisors, when approving the project, adopted a Statement of Overriding Considerations for this impact. The Modified Project would not introduce new impacts or create more severe impacts related to the conversion of Prime Farmland, Unique Farmland, or Farmland of Statewide Importance to non-agricultural uses than those analyzed in the FEIR.

The Modified Project does not change the type or extent of development or propose substantial land use or development changes beyond those analyzed in the FEIR or require major revisions to the FEIR.

**Mitigation Measures - Land Use and Planning**

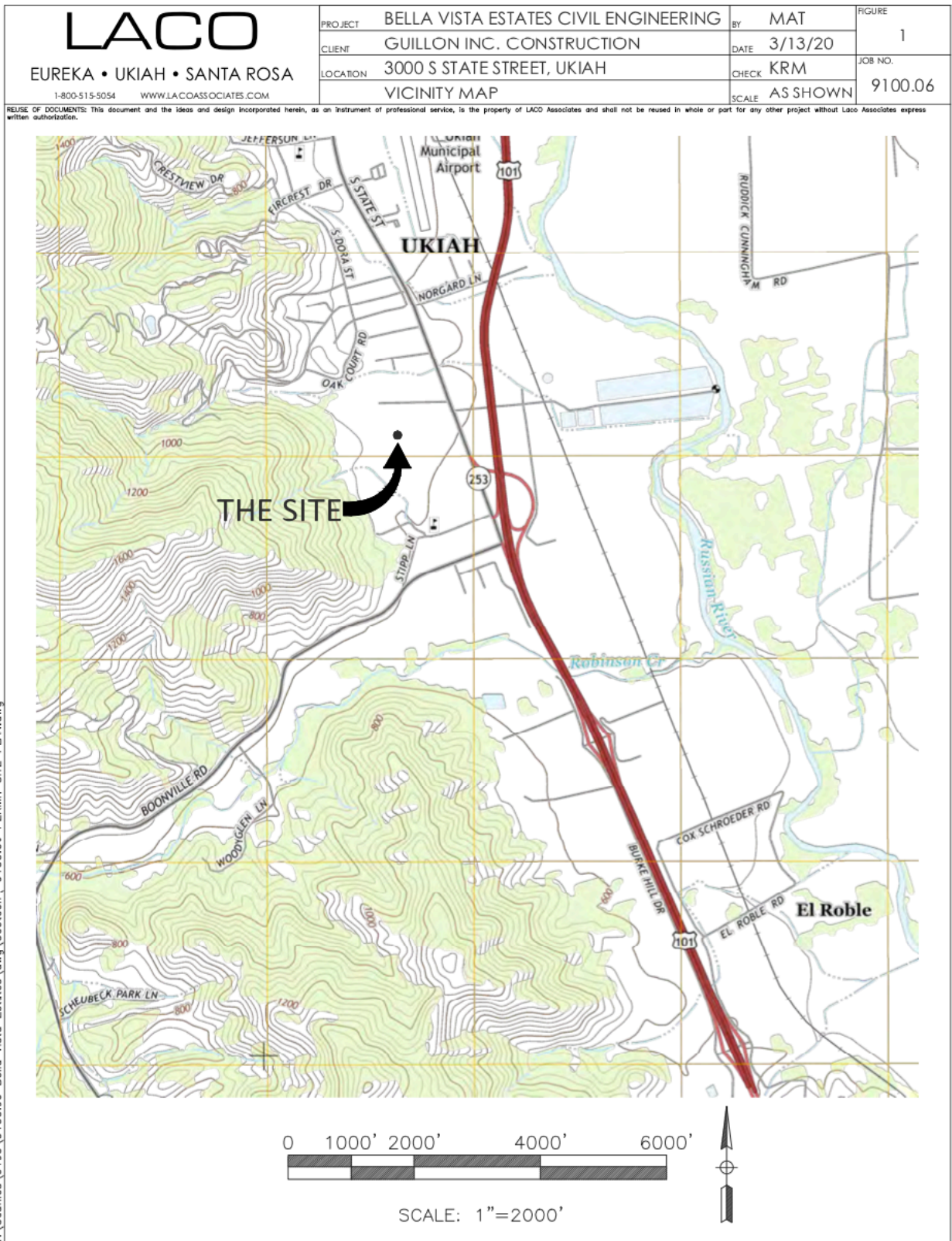

None.

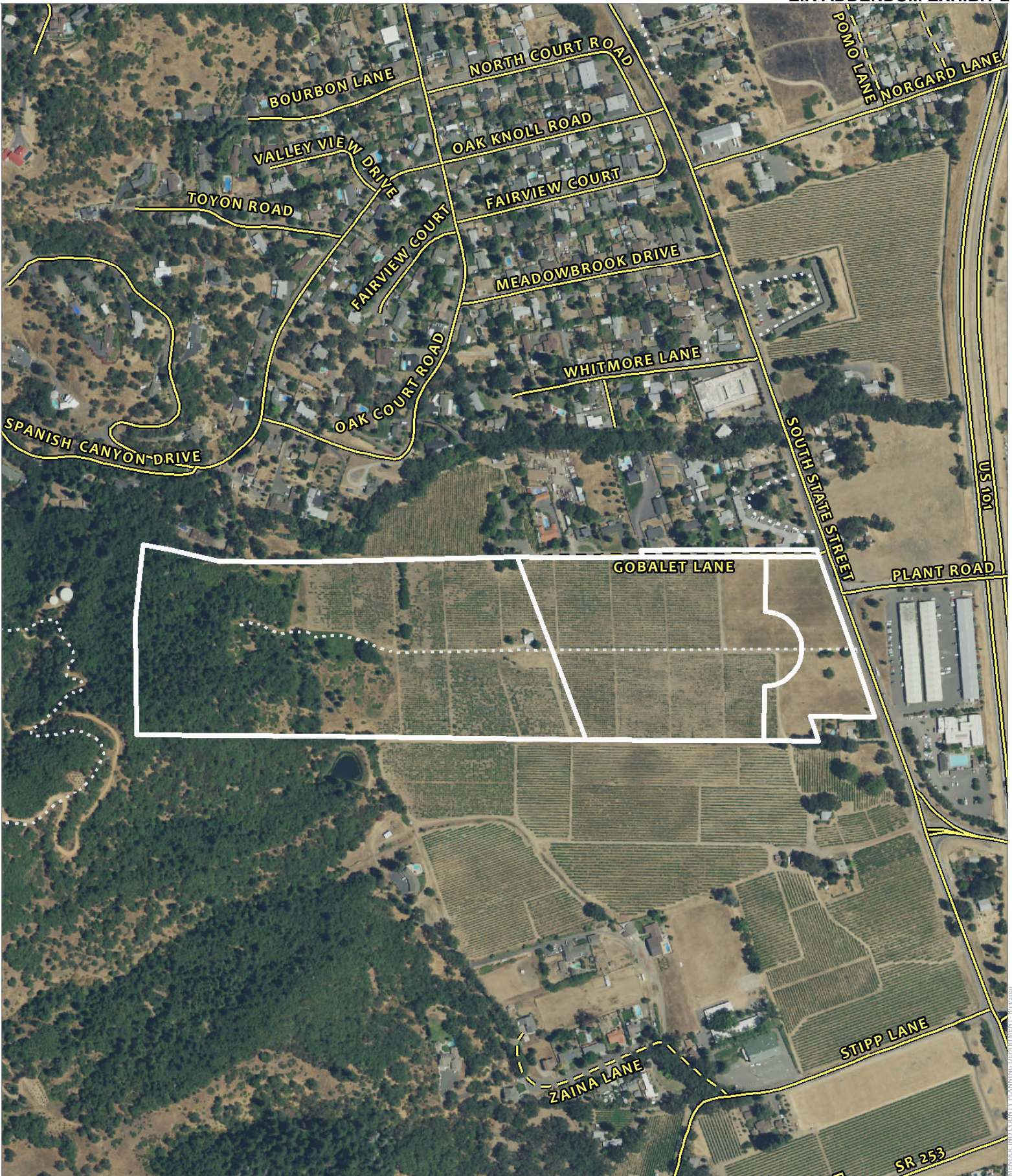

Mar: 3, 2020 - 11:27 am  
 T:\Caddfiles\9100\9100.06 Bella Vista Estates\dwg\Geotech\ 9100.06 PERMIT SITE PLAN.dwg



CASE: S 2020-0001  
 OWNER: Rancho Yokayo LP  
 APN: 184-110-28, 29, 184-120-01, 21  
 APLCT: Guillon, Inc.  
 AGENT: Jake Morley  
 ADDRESS: 3000 S. State Street, Ukiah

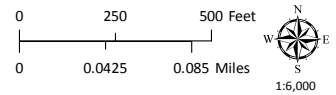

-  Public Roads
-  Private Roads
-  Driveways/Unnamed Roads

 Railroads

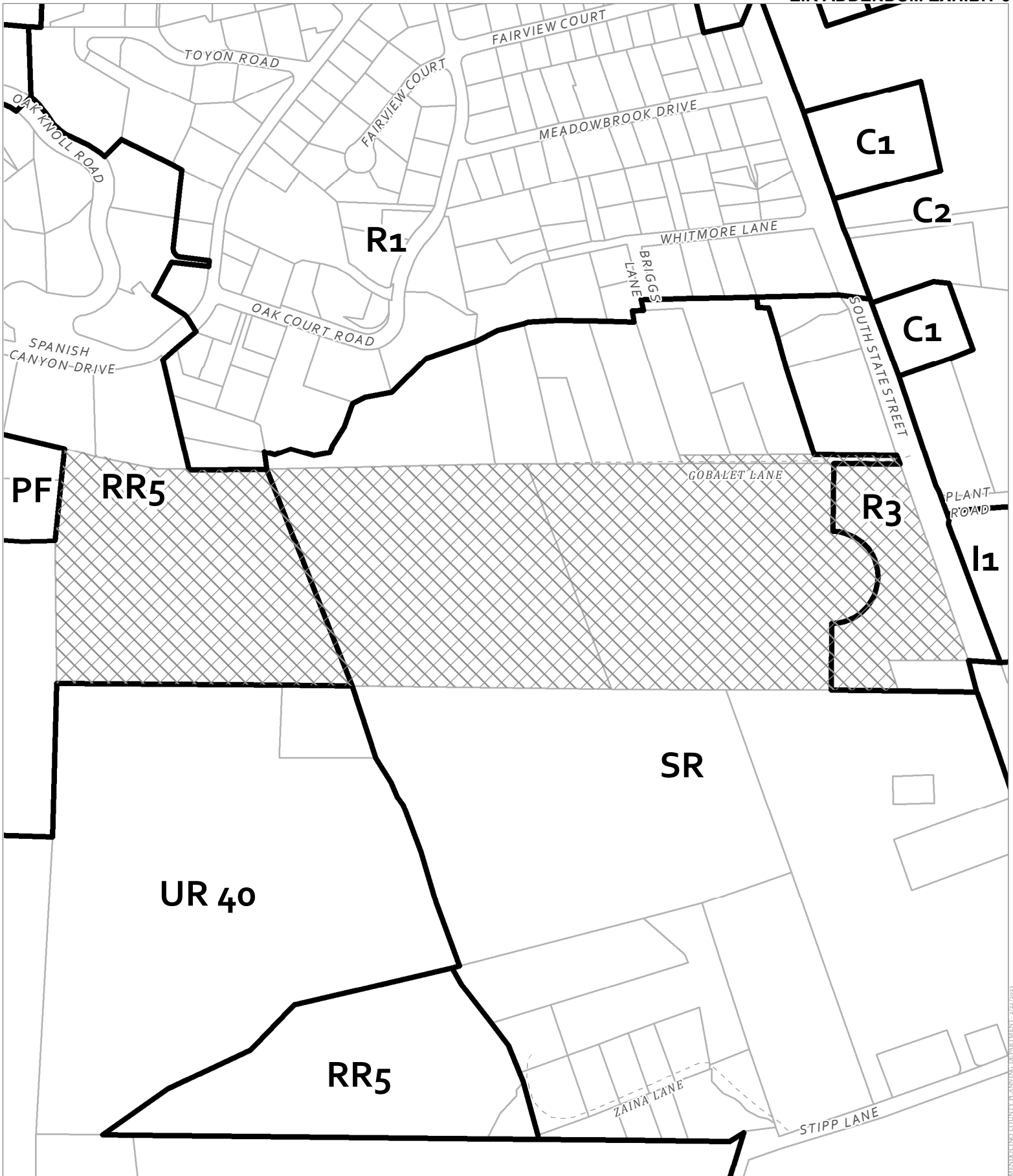



CASE: **S 2020-0001**  
 OWNER: **Rancho Yokayo LP**  
 APN: **184-110-28, 29, 184-120-01, 21**  
 APLCT: **Guillon, Inc.**  
 AGENT: **Jake Morley**  
 ADDRESS: **3000 S. State Street, Ukiah**

 Zoning Districts  
 Cannabis Prohibition (CP) Districts  
 Public Roads

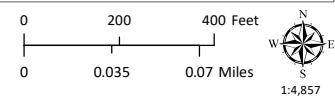

MENDOCINO COUNTY PLANNING DEPARTMENT - 2/12/2023

# Bella Vista Airport Zones

EIR ADDENDUM EXHIBIT 4

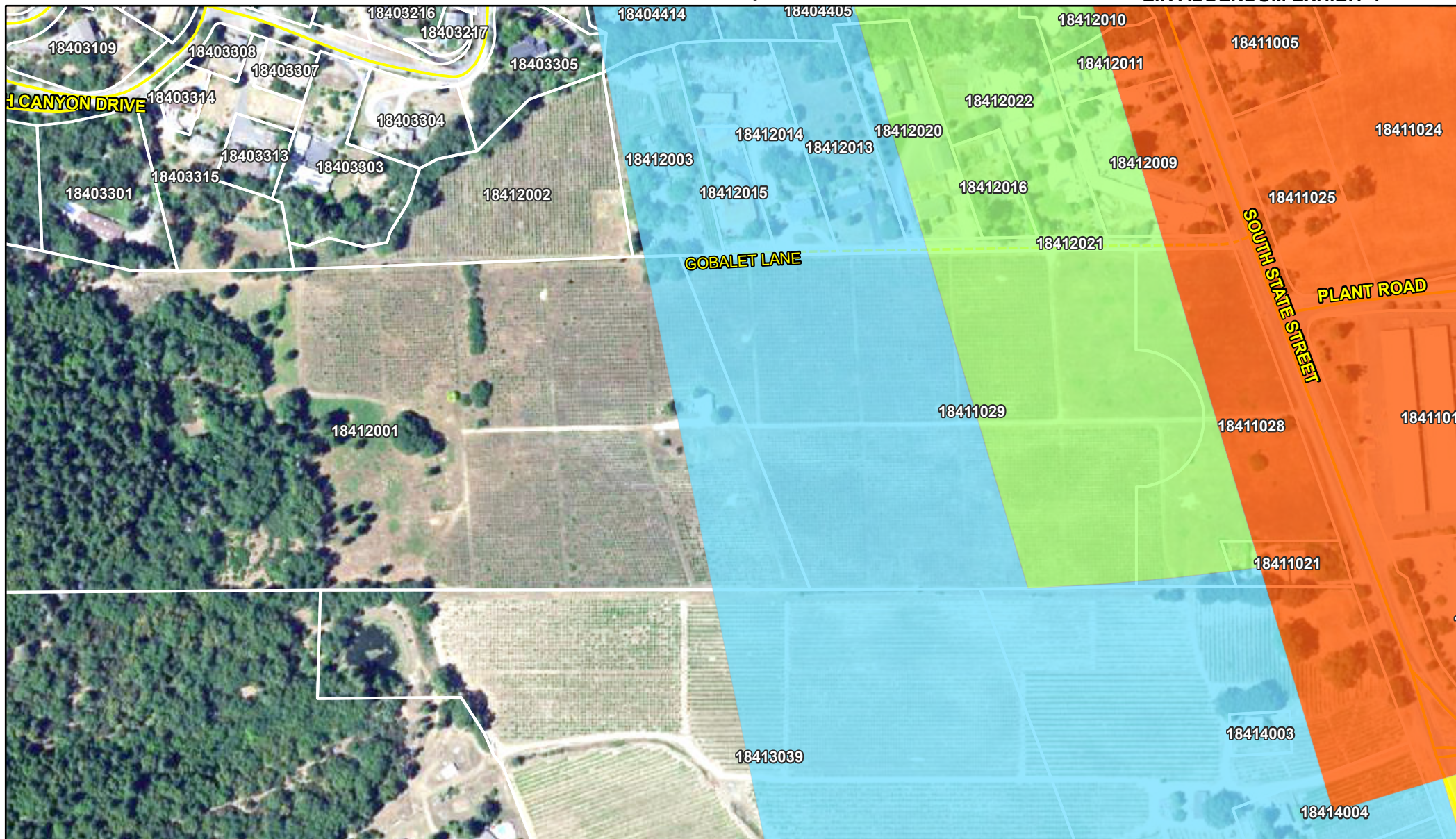

11/5/2021, 8:55:30 AM

- Assessor's Parcels  4
- Private Roads
- Public Roads
- NAIP 2020 Imagery
- Band\_3  Blue: Band\_3
- Band\_1  Red: Band\_1
- Band\_2  Green: Band\_2
- Airport Zones  6
- Band\_3  3
- Band\_2  2

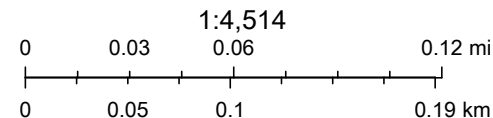

# VESTING TENTATIVE MAP GARDENS GATE SUBDIVISION

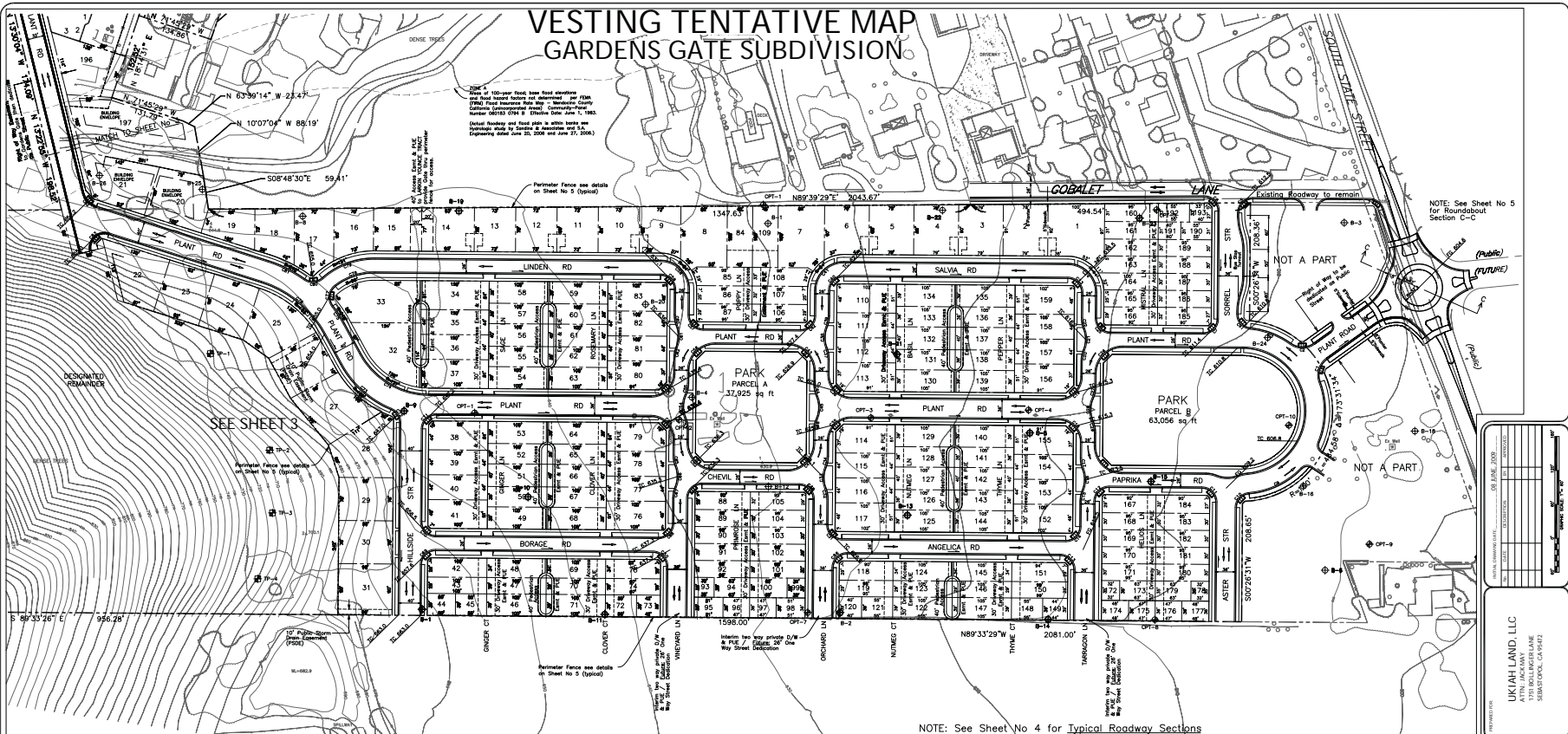

NOTE: See Sheet No 5 for Roundabout Section C-C  
 (Public)  
 (Future)  
 (Other)

NOTE: See Sheet No 4 for Typical Roadway Sections

SEE SHEET 3

**SHEET INDEX**

- 1 EASTERLY SITE PLAN
- 2 WESTERLY SITE PLAN
- 3 VESTING TENTATIVE MAP PHASING
- 4 DETAILS, SECTIONS & MISC.
- 5 CONCEPTUAL DRAINAGE PLAN
- 6 ZONING MAP
- 7 PRELIMINARY HILLSIDE GRADING PLAN

**PROJECT INFORMATION**

**OWNER:** Ukiah Land LLC - Jack May  
 1751 Bollinger Lane Sebastopol, Ca 95472  
 1-850-464-6700

**AGENT:** Ukiah Land LLC - Jack May  
 1751 Bollinger Lane Sebastopol, Ca 95472  
 1-850-464-6700

**ENGINEER/SURVEYOR:** DobleThomas and Associates, Inc.  
 216 West Perkins Street, Suite 201 Ukiah, Ca 95482  
 707-472-0541 Fax 707-472-0543

**PLANNER:** LANDMARK PLANNING AND PERMIT SERVICE  
 Andy Gutavson  
 2300 Mendocino Ave #A-2280 Santa Rosa, California 95403  
 707-546-2800 Fax 707-546-2802

**TOTAL PROJECT ACREAGE:** 46.1 Acres (Includes Designated Remainder (13.1 acres))  
**ASSESSOR PARCEL NUMBER:** 184-120-01, 184-110-29 & 184-033-15  
**NUMBER OF LOTS:**

**SINGLE FAMILY DETACHED LOTS**

10 Hillside Houses	Parcels	22 thru 31
08 Vineyard Houses	Parcels	1 thru 18, 20, 21, 32, 33, 194 thru 197
72 Garden Court Houses	Parcels	34 thru 41, 49 thru 68, 76 thru 83, 110 thru 117, 125 thru 144, 152 thru 159
15 Cottages	Parcels	19, 46, 71, 84, 87, 88, 105, 106, 109, 122, 147, 166, 167, 184 and 185

**TOWNHOUSE LOTS**

54 Two Unit Structures	Parcels	42 thru 45, 47, 48, 69, 70, 72 thru 75, 85, 86, 89 thru 92, 101 thru 104, 107, 108, 118 thru 121, 123, 124, 145, 146, 148 thru 151, 160 thru 165, 168 thru 171, 180 thru 183, 186 thru 189, 93 thru 100, 172 thru 179, 190 thru 193
------------------------	---------	---

**TOTAL NUMBER OF LOTS:** 197 Total  
**WATER:** Willow County Water District  
**SEWER:** Ukiah Valley Sanitation District

**NOTE:** Soils Condition: There are no known expansive soils on this site, however a soils report shall be required prior to filing the final map.  
 Hazardous Materials: There are no known hazardous materials on this site.  
 All on-site roads shall be (Public).  
 There shall be no parking in curves at curb returns. Hold parking back 10' from curb returns.

**LEGEND**

○ LIGHTPOLE	○ MANHOLE
○ UTILITY POLE W/ANCHOR	○ MISC. UTILITY
○ TRAFFIC SIGNAL	○ WATER VALVE
○ CURB, GUTTER, SIDEWALK & DRAIN ALLEY	○ FIRE HYDRANT
○ PAVED ROAD	○ UNPAVED ROAD
○ FENCE	○ CONTOURS
○ DRAINAGE	○ 1045.5 ELEVATION
○ TREE	○ 2 & 1000.0 CONTOUR POINT
○ BRUSH	○ GLEAVET
○ RETAINING WALL	○ GUARD RAIL
	○ SIGN

**LEGEND**

○ WATER (W)
○ SEWER (SS)
○ STORM DRAIN (SD)
○ MANHOLE - SEWER (SMH)
○ MANHOLE - STORM DRAIN (SMH)
○ DROP INLET (DI)
○ CATCH BASIN (CB)
○ STREET NAME & STOP SIGN
○ FIRE HYDRANT ASSEMBLY (FHA)
○ BLOWOFF (BO)
○ WATER SURFACE (WS)
○ DATE VALUE (DV)
○ SEWER LINES WITH CLEANOUT
○ CITY or COUNTY MONUMENT (CM)
○ HANGOVER SIGN
○ STREET LIGHT
○ SIGN
○ PROPERTY LINE (PL)
○ CENTRELINE (CL)
○ FENCE (F) (as noted on plan)
○ GASLINE
○ ELECTRIC (Underground)
○ FACE OF CURB (FC)
○ FINISH GRADE (FG)
○ BEIGN CURVE (BC)
○ DIP CURVE (DC)
○ POINT ON CURVE (POC)
○ CURVE RETURN (CR)
○ TOP OF CURB (TC)
○ POINT OF TANGENT (PT)
○ SECONDARY EXCUREMENT (SEC)
○ PRIVATE STORM DRAIN EXCUREMENT (PRSD)
○ PUBLIC STORM DRAIN EXCUREMENT (PRSD)

**NOTES:**  
 1 IN AREAS UNDER TREES WHERE GROUND IS NOT VISIBLE, CONTOURS ARE APPROXIMATE AND CONFORM TO NATIONAL MAP STANDARDS, ONE HALF THE HEIGHT OF THE TREE.  
 2 THIS MAPPING IS BASED ON SURVEY CONTROL PROVIDED BY THE ENGINEER & APPROXIMATE. SURVEY CONTROL DATA HAS BEEN VERIFIED TO ANY PARTIALS TO THE SURVEY. PROPERTY BOUNDARIES # SHOWN ON THIS MAP ARE APPROXIMATE, UNLESS CERTIFIED BY ABOVE-NOTED SURVEYOR.  
 3 ORITICAL ELEVATIONS SHOULD BE FIELD VERIFIED.

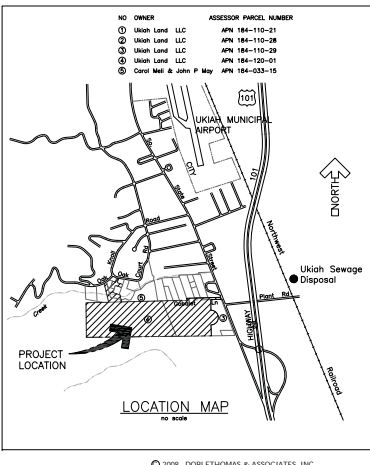

**UKIAH LAND, LLC**  
 1751 BOLLINGER LANE  
 SEBASTOPOLE, CA 95472

**ASSASSOR PARCEL NUMBER**

○ Ukiah Land LLC	APN 184-110-21
○ Ukiah Land LLC	APN 184-110-28
○ Ukiah Land LLC	APN 184-110-29
○ Ukiah Land LLC	APN 184-120-01
○ Carol Hill & John P. May	APN 184-033-15

**EASTERLY SITE PLAN**



DATE	1-1-07
APPROVED	WJ
CHECKED BY	BAT
FILE NO.	2008-063-1
SHEET NO.	1
TOTAL SHEETS	7

VESTING TENTATIVE MAP  
GARDENS GATE SUBDIVISION

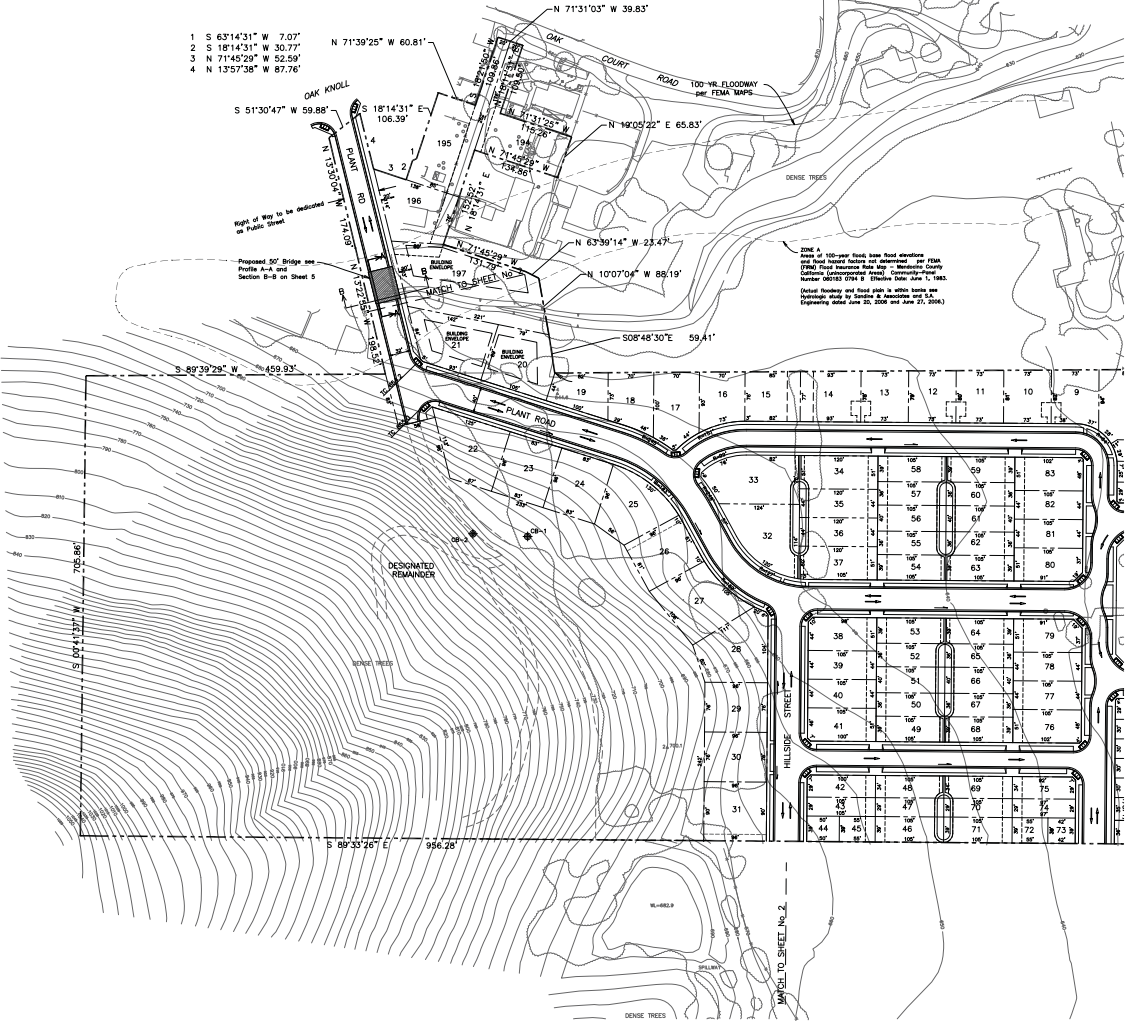

NOTE: See Sheet No 4 for Typical Roadway Sections

SEE SHEET 1

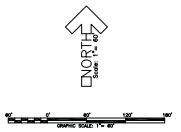

INITIAL DRAWING DATE: 08 JUNE 2009		
NO.	DATE	DESCRIPTION

PREPARED FOR:  
**UKIAH LAND, LLC**  
ATTN: JACK MAY  
1751 BOLLINGER LANE  
SEBASTOPOL, CA 95472

PROJECT DESCRIPTION:  
GARDENS GATE SUBDIVISION  
3000 SOUTH STATE STREET  
APNs 184-110-21, 28 & 29  
184-126-01

SHEET DESCRIPTION:  
**WESTERLY SITE PLAN**

Prepared under the supervision of:

**Bradley Thomas, PLS 5210**  
222 West Coast Center  
Folsom, CA 95630  
Tel: (916) 434-5392  
www.doblethomas.com

**DobleThomas & Associates, Inc.**  
Professional Engineer  
No. 5200  
Date: 06/08/09



SCALE:	1"=60'
DRAWN BY:	VR
CHECKED BY:	BAT
FILE No.:	2004-068.1
SHEET No.:	OF
<b>2</b>	<b>7</b>

# VESTING TENTATIVE MAP PHASING GARDENS GATE SUBDIVISION

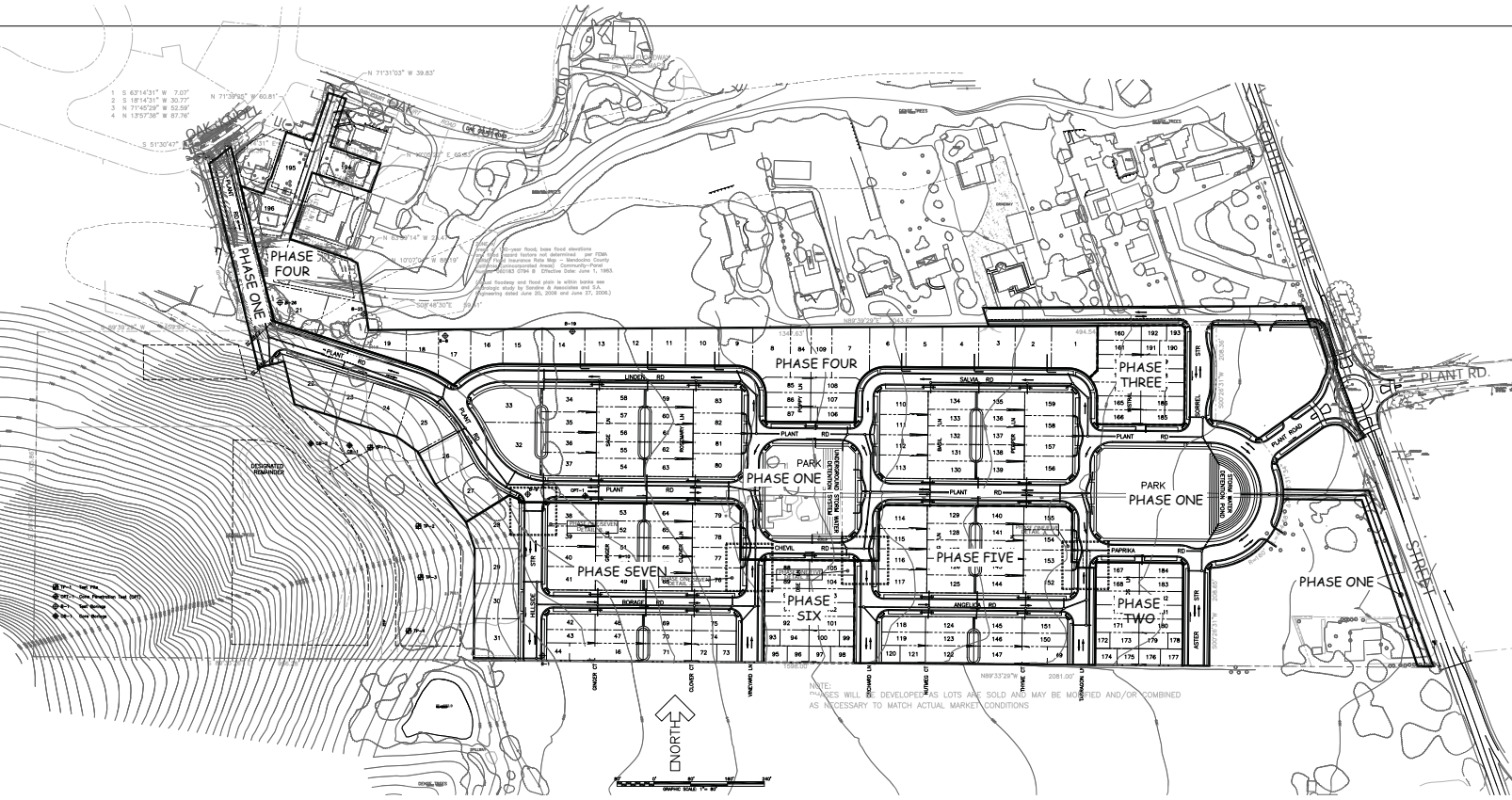

1. S 63°14'31" W 71.07'
2. S 16°14'31" W 30.77'
3. N 71°45'30" W 33.56'
4. N 15°57'30" W 87.76'

The owner of this tentative map subdivision is responsible for providing all information and data used in the preparation of this map. The engineer and the surveyor are not responsible for the accuracy of the information provided by the owner. The engineer and the surveyor are not responsible for the accuracy of the information provided by the owner. The engineer and the surveyor are not responsible for the accuracy of the information provided by the owner.

NOTE: PHASING WILL BE DEVELOPED AS LOTS ARE SOLD AND MAY BE INSERTED AND/OR COMBINED AS NECESSARY TO MATCH ACTUAL MARKET CONDITIONS.

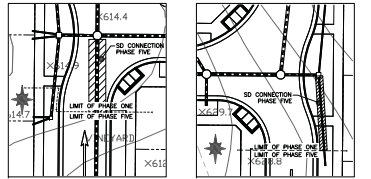

PHASE ONE/FIVE DETAIL .A. SCALE: 1"=20'  
PHASE ONE/FIVE DETAIL .B. SCALE: 1"=20'

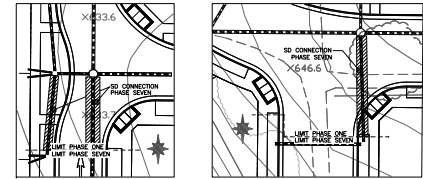

PHASE ONE/SEVEN DETAIL .A. SCALE: 1"=20'  
PHASE ONE/SEVEN DETAIL .B. SCALE: 1"=20'

NO.	DATE	DESCRIPTION	BY	APPROVED

PREPARED FOR:  
**UKIAH LAND, LLC**  
ATTN: JACK MAY  
1751 BOLLINGER LANE  
SEBASTOPOL, CA 95472

PROJECT DESCRIPTION:  
GARDENS GATE SUBDIVISION  
3000 SOUTH STATE STREET  
APNS 184-110-21, 28 & 29  
184-120-01

SHEET DESCRIPTION:  
VESTING TENTATIVE MAP  
PHASING

Prepared under the supervision of:  
**Bredley Thomas, PLS 5270**  
222 2nd Street, Suite 200  
P.O. Box 1000  
Petaluma, CA 94954  
Tel: (707) 433-5292  
www.bredleythomas.com  
Professional Seal: Bredley Thomas, PLS 5270, No. 5200, State of California, Surveyor

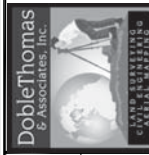

SCALE:	1"=80'
DRAWN BY:	KDOBLE
CHECKED BY:	BAT
FILE No.:	2004-068.1
SHEET No.:	OF
3	7



# VESTING TENTATIVE MAP GARDENS GATE SUBDIVISION

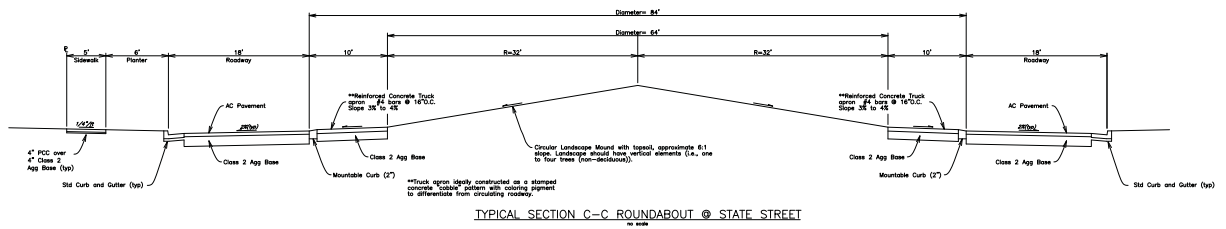
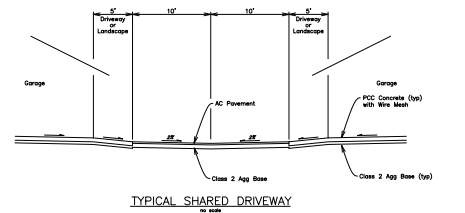
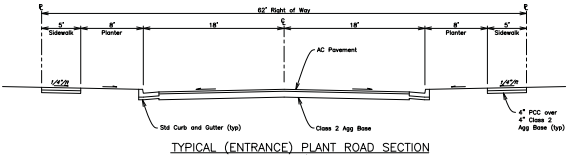
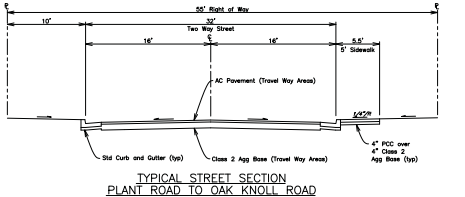
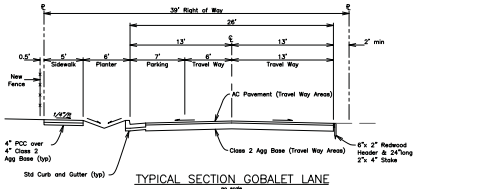
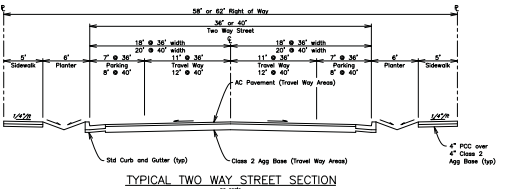
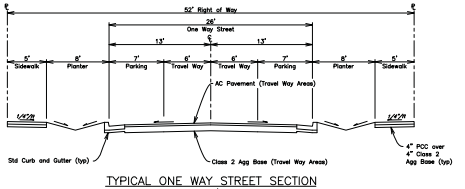
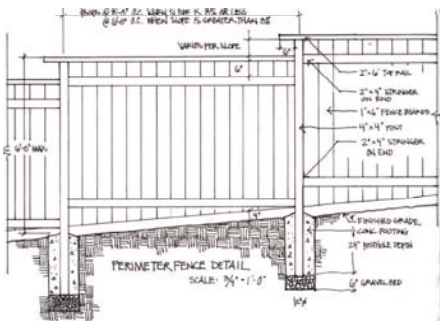
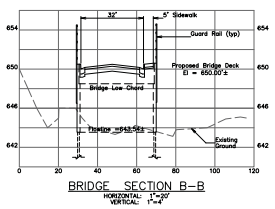
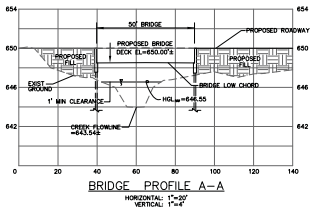

INITIAL DRAWING DATE	08 JUNE 2009
DATE	
DESCRIPTION	
NO.	
BY	
APPROVED	

PREPARED FOR:  
**UKIAH LAND, LLC**  
ATTN: JACK MAY  
1751 BOLLINGER LANE  
SEBASTOPOL, CA 95472

PROJECT DESCRIPTION:  
**GARDENS GATE SUBDIVISION**  
3000 SOUTH STATE STREET  
APNS 184-110-21, 28 & 29  
184-126-01

SHEET DESCRIPTION:  
**DETAILS, SECTIONS & MISC**

Prepared under the supervision of:  
**Ready Thomas, PLS 2920**  
220 West Coast Center  
Redwood City, CA 94066  
Tel: (650) 962-2926  
Fax: (650) 962-5292  
www.readythomas.com

Date: 08/11/09  
No. 500

**REGISTERED PROFESSIONAL ENGINEER**  
CALIFORNIA  
No. 500



SCALE:	AS SHOWN
DRAWN BY:	VR
CHECKED BY:	BAT
FILE No.:	2004-068.1
SHEET No.:	OF
4	7

VESTING TENTATIVE MAP  
GARDENS GATE SUBDIVISION

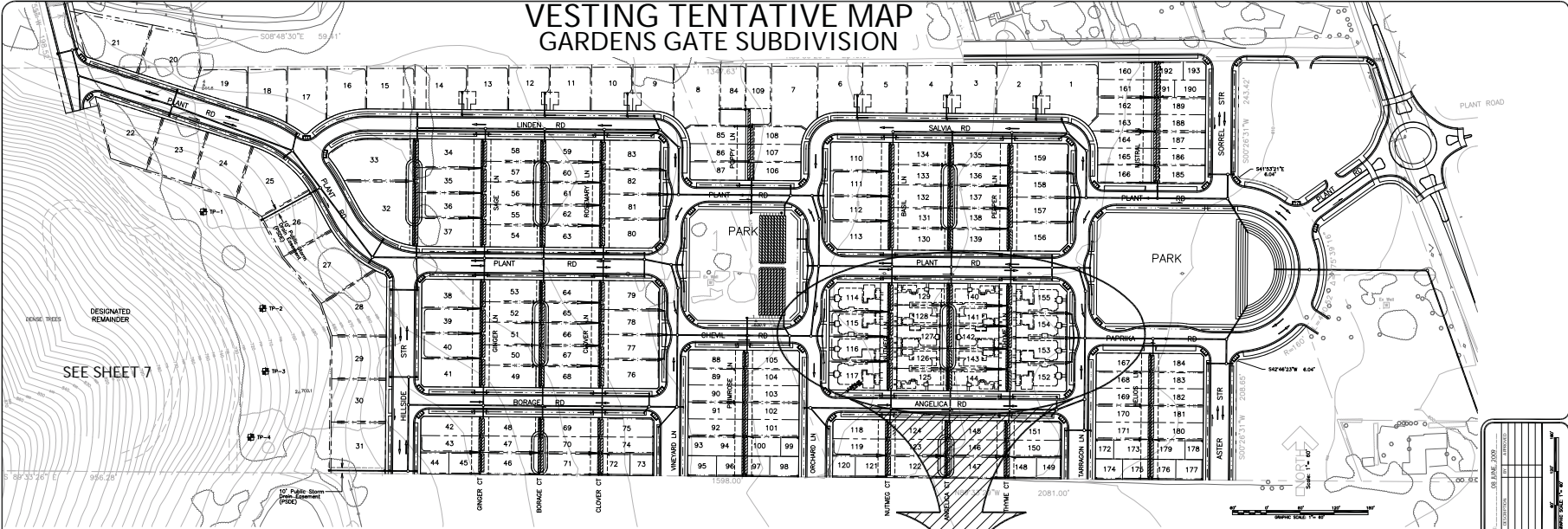

CONCEPTUAL SITE DRAINAGE  
SCALE: 1"=60'

LEGEND

- [Symbol] DETENTION POND
- [Symbol] UNDERGROUND DETENTION
- [Symbol] PROPOSED STORM DRAIN
- [Symbol] TYPICAL SWALE W/ FLOW DIRECTION
- [Symbol] STORM DRAIN MANHOLE
- [Symbol] DROPP INLET
- [Symbol] CATCH BASIN

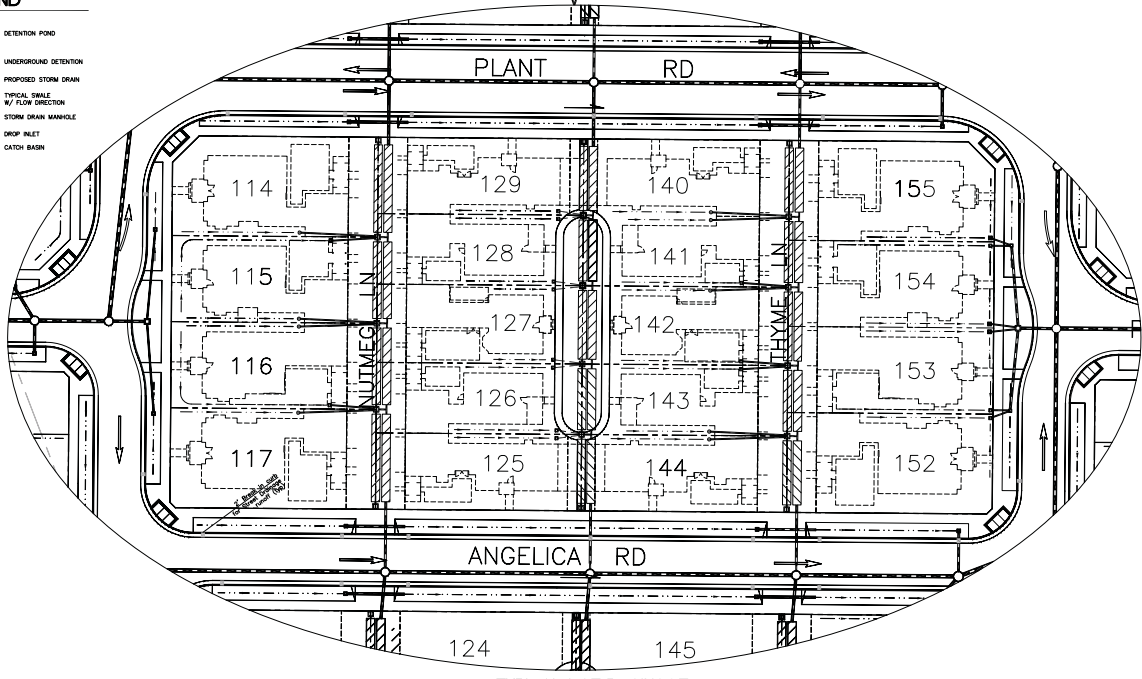

TYPICAL LOT DRAINAGE  
SCALE: 1"=50'

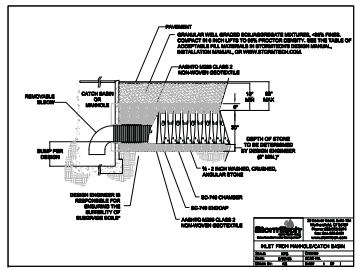
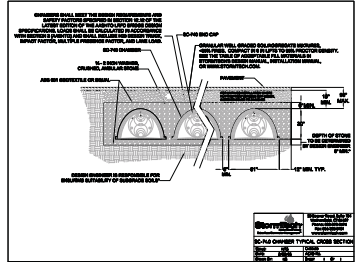

UKIAH LAND, LLC  
133 BOLLINGER LANE  
SEBASTOPOLE, CA 95972

CONCEPTUAL DRAINAGE PLAN

DATE: 08/11/2010  
SCALE: 1"=50'

DATE:	11-10'
DESIGNED BY:	VB
CHECKED BY:	BAT
FILE NO.:	2009-068-1
PROJECT NO.:	19
PAGE:	5
TOTAL PAGES:	7

VESTING TENTATIVE MAP  
GARDENS GATE SUBDIVISION

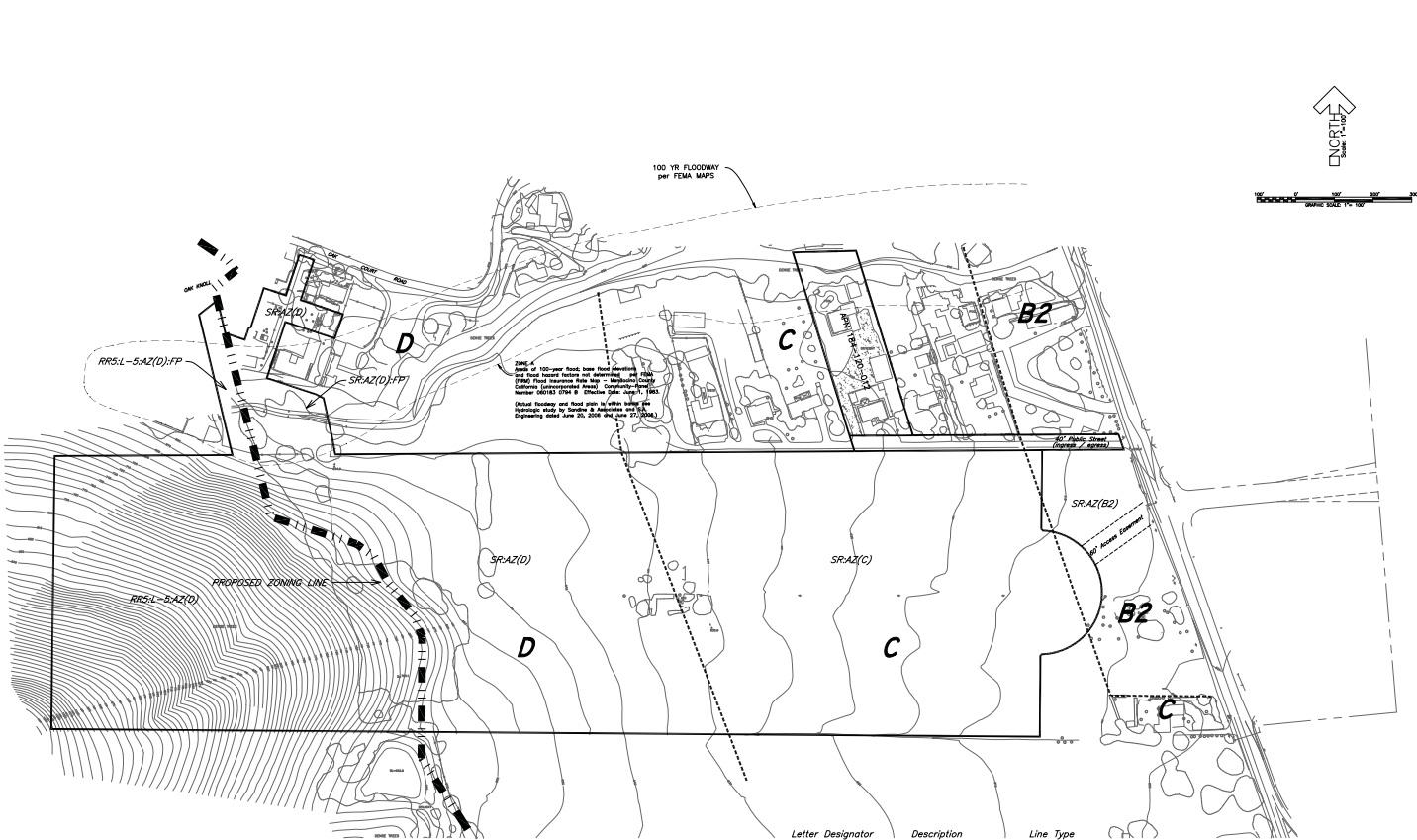

2006 is 100-year flood zone showing depth of flood hazard factors not shown and 1982 FEMA Flood Insurance Rate Map - Community Districts (Community District Number 00183 024 B Section 104-10-1, 104-10-2) (Official boundary and flood zone is within subject lot boundaries. Refer to number of annotations on drawing. Expenditure shall be \$10,000.00.

Letter Designator Description Line Type  
C - AIRPORT OVERLAY ZONING -----

ZONING	AREA	
	SQUARE FEET	ACRES
SR-AZ(B2)	27,576	0.63
SR-AZ(C)	733,894	16.85
SR-AZ(D)	599,709	13.77
SR-AZ(D)-FP	49,156	1.13
SR subtotal	1,410,337	32.38
RRS-L-5-AZ(D)	580,556	13.33
RRS-L-5-AZ(D)-FP	17,638	0.40
RRS-L-5 subtotal	598,194	13.73
<b>Total</b>	<b>2,008,531</b>	<b>46.11</b>

INITIAL DRAWING DATE: 08 JUNE 2009

No.	DATE	DESCRIPTION	BY	APPROVED

PREPARED FOR:  
**UKIAH LAND, LLC**  
ATTN: JACK MAY  
1751 BOLLINGER LANE  
SEBASTOPOL, CA 95472

PROJECT DESCRIPTION:  
GARDENS GATE SUBDIVISION  
3000 SOUTH STATE STREET  
APNs 184-110-21, 28 & 29  
184-120-01

SHEET DESCRIPTION:  
**ZONING MAP**

Prepared under the supervision of:

**Bradley Thomas, PLS 5710**  
222 West Coast Center  
Folsom, CA 95630  
Tel: (916) 433-5292  
www.doblethomas.com

Professional Seal: BRADLEY THOMAS, PLS No. 5710



SCALE:	1"=100'
DRAWN BY:	VR
CHECKED BY:	BAT
FILE No.:	2004-068.1
SHEET No.:	OF

# VESTING TENTATIVE MAP GARDENS GATE SUBDIVISION

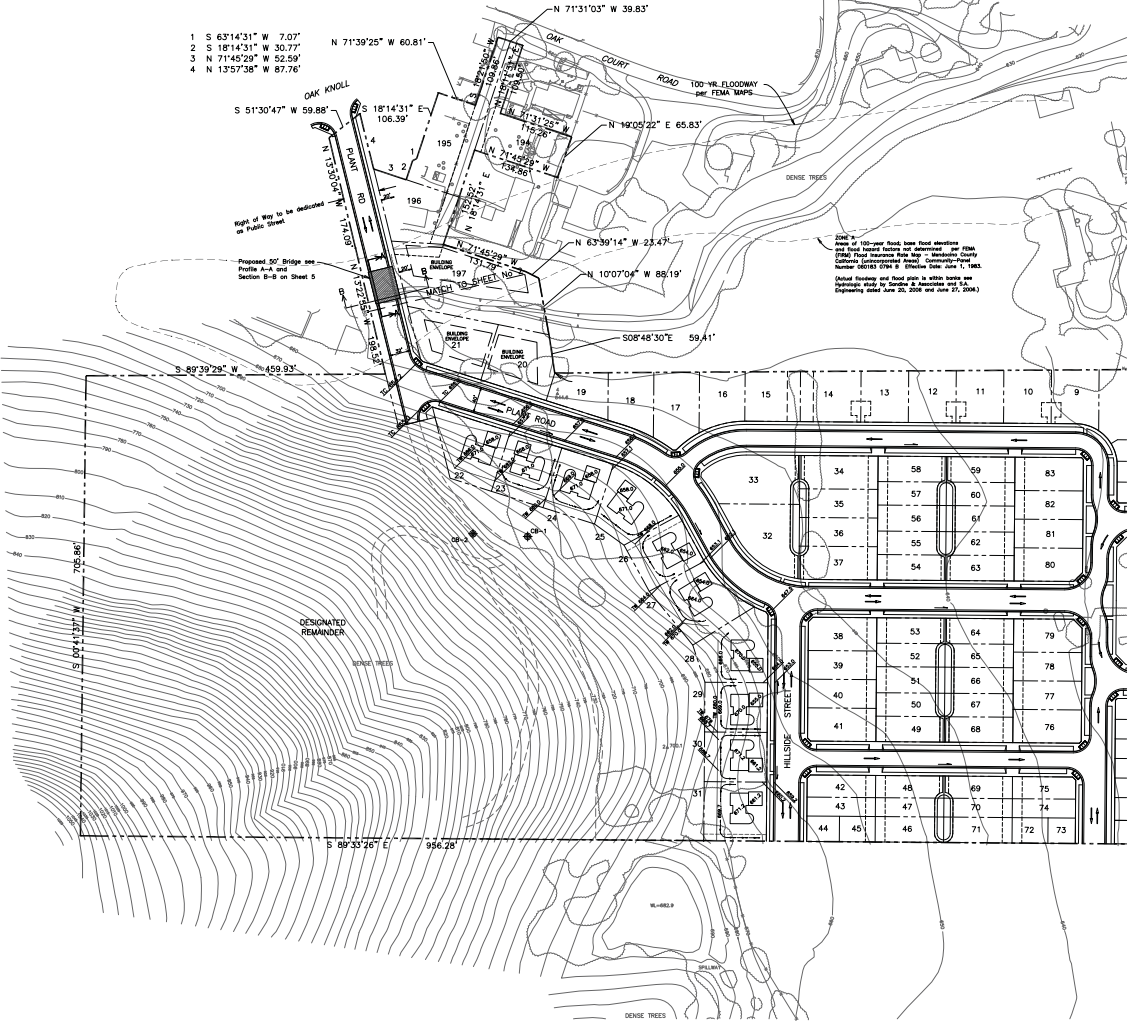

LOTS 22 thru 31 has an approximate 3500 cubic yards of CUT

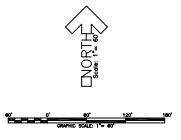

INITIAL DRAWING DATE: 08 JUNE 2009

NO.	DATE	DESCRIPTION	BY	APPROVED

PREPARED FOR:  
**UKIAH LAND, LLC**  
 ATTN: JACK MAY  
 1751 BOLLINGER LANE  
 SEBASTOPOL, CA 95472

PROJECT DESCRIPTION:  
 GARDENS GATE SUBDIVISION  
 3000 SOUTH STATE STREET  
 APPS 184-110-21, 28 & 29  
 184-126-01

SHEET DESCRIPTION:  
**PRELIMINARY HILLSIDE  
 GRADING PLAN**

Prepared under the supervision of:

**Bradley Thomas, PLS 2710**  
 222 West Coast Court  
 Redwood City, CA 94061  
 PH: (650) 684-2786  
 Fax: (650) 458-5282  
 www.doblethomas.com  
 BRADLEY THOMAS, PLS 2710

Date: \_\_\_\_\_  
 No. 5200  
 No. 5200



SCALE:	1"=60'
DRAWN BY:	BAT
CHECKED BY:	BAT
FILE No.:	2004-068.1
SHEET No.:	OF
7	7

# VESTING TENTATIVE MAP BELLA VISTA SUBDIVISION

## LYING WITHIN THE UNINCORPORATED AREA OF MENDOCINO COUNTY, CALIFORNIA

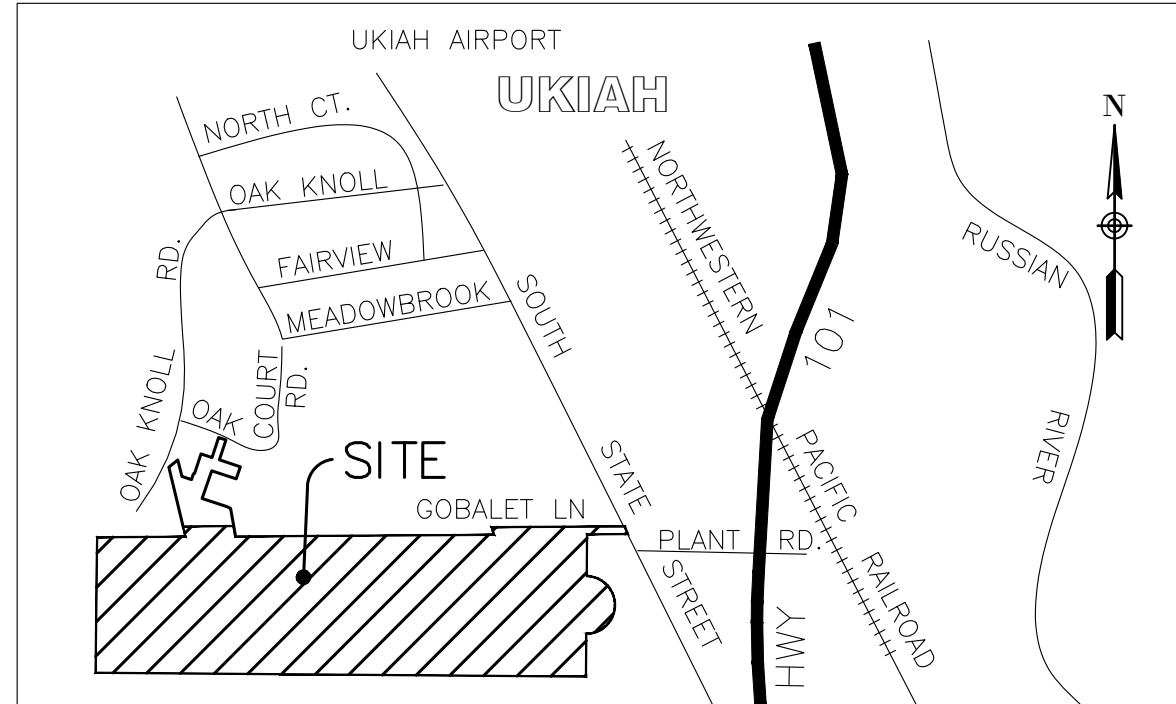

**VICINITY MAP**  
N.T.S

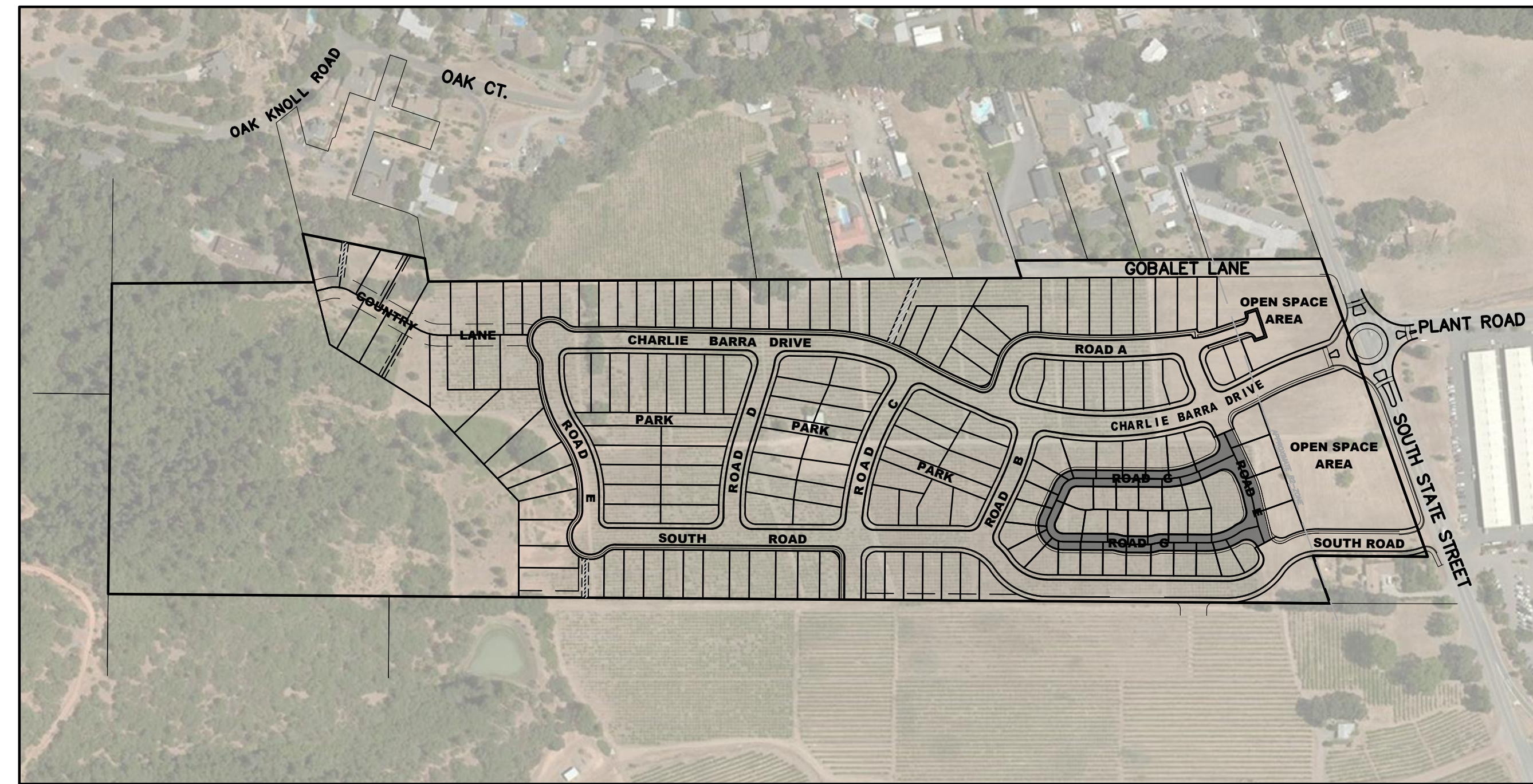

**PROJECT DATA**

PROPERTY ADDRESS: 3000 S STATE STREET,  
UKIAH, CA 95482

PROPERTY OWNER:  
YOKAYO RANCH LP.  
800 HENSLEY CREEK RD  
UKIAH, CA 95482

SURVEYOR/CIVIL ENGINEER:  
LACO ASSOCIATES  
776 S. STATE ST.,  
SUITE 102A  
UKIAH, CA 95482

EXISTING LAND USE: VINEYARD

EXISTING ZONING: SR, RR-5, AZ-B2,  
AZ-C, AZ-D

PROPOSED ZONING: SUBURBAN RESIDENTIAL

NUMBER OF LOTS: 171

PARKS & OPEN SPACE AREA SIZE: 4.39  
ACRES

MINIMUM GROSS LOT SIZE: 3,479  
SQUARE FEET

MAXIMUM GROSS LOT SIZE: 18,088  
SQUARE FEET

EXISTING ACREAGE: 48.8 ACRES

APN: 184-110-28, 184-110-29,  
148-120-21 & 184-120-01

**LEGEND/ABBREVIATIONS**

- PROPOSED PARCEL LINE
- EXISTING BOUNDARY LINE
- - - - PROPOSED WATER MAIN EASEMENT
- ROAD CENTERLINE
- PHASE LINE
- WV (in square) WATER VALVE
- (FH) FIRE HYDRANT
- (S) SANITARY SEWER MANHOLE
- STORM DRAIN
- DROP INLET
- JT— JOINT TRENCH
- ▭ CURB INLET
- - - - BUILDING SETBACK LINE (BSL)
- ⌚ PROPERTY LINE

**SHEET INDEX**

- 1 COVER SHEET
- 2 EXISTING PARCEL MAP
- 3 PHASING LAYOUT
- 4 PARCEL LAYOUT
- 5 PARCEL LAYOUT SENIOR AREA
- 6 GRADING & DRAINAGE
- 7 GRADING & DRAINAGE
- 8 UTILITIES AND IMPROVEMENTS
- 9 UTILITIES AND IMPROVEMENTS
- 10 ROAD SECTION DETAILS

**SURVEYOR**

PREPARED UNDER THE SUPERVISION OF:  
  
BRADLEY A. THOMAS PLS 5520 8/31/2020  
DATE DATE

**OWNER/SUBDIVIDER**

THIS MAP HAS BEEN APPROVED BY:  
  
DOUGLAS GULLON X/XX/XXXX  
OWNER/SUBDIVIDER DATE

**NOTES**

BOUNDARY LINES / LOT LINES SHOWN ON THIS  
MAP DERIVED FROM FOUND MONUMENTS AND  
RECORD DATA

**LACO**  
 EUREKA • UKIAH • SANTA ROSA • CHICO  
 1-800-515-5054 www.lacoassociates.com

NO.	HISTORY / REVISION	BY	CHK.	DATE
1	ADDRESS COUNTY COMMENTS	X	X	8/28/2020

VESTING TENTATIVE MAP  
 GULLON INC. CONSTRUCTION  
 3000 S STATE STREET, UKIAH, CA 95482  
**COVER SHEET**

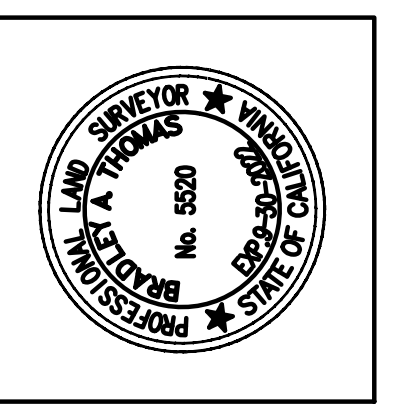

DRAWN	AR
CHECK	CCM
APPROVED	KD
DATE	August 30, 2022
JOB NUMBER	9100.06
DRAWING	1/10

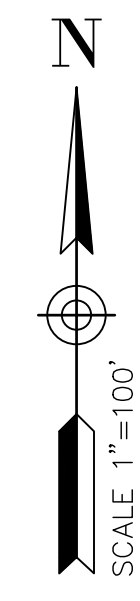
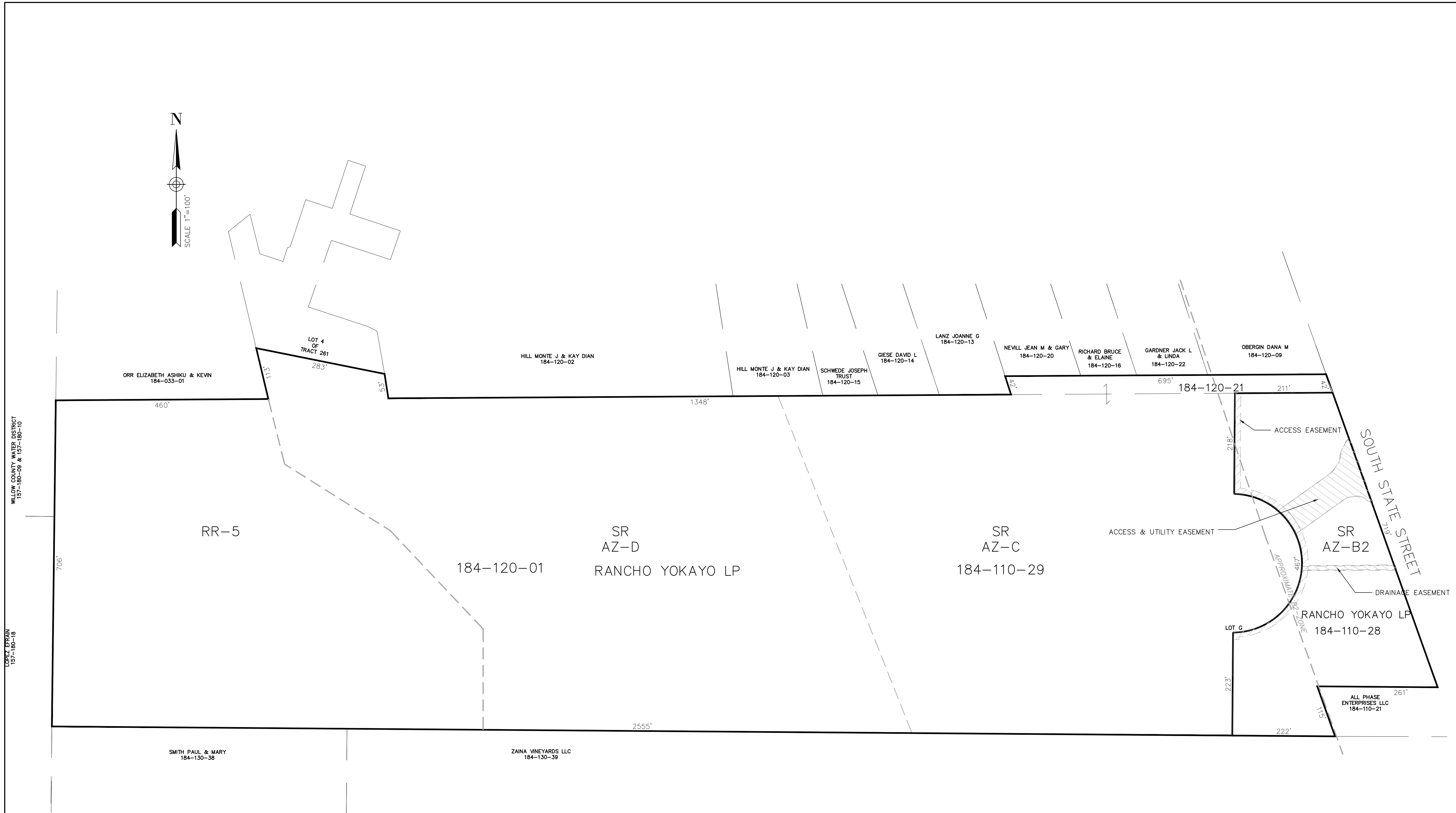

**LEGEND**

 EXISTING EASEMENT TO BE ABANDONED WITH THE RECORDATION OF PHASE 1.

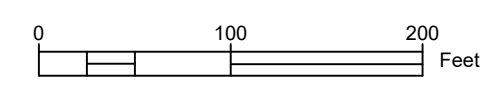

**LACO**  
 EUREKA • UKIAH • SANTA ROSA • CHICO  
 1-800-515-5054  
 www.lacoassociates.com

NO.	HISTORY / REVISION	BY / CHK	DATE
1	ADDRESS COUNTY COMMENTS	X	8/28/2020

VESTING TENTATIVE MAP  
 GULLON INC. CONSTRUCTION  
 3000 S STATE STREET, UKIAH, CA 95482

**EXISTING PARCEL MAP**

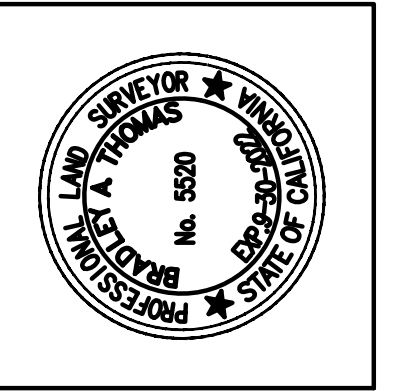

DRAWN	AR
CHECK	CCM
APPROVED	KD
DATE	August 31, 2022
JOB NUMBER	9100.06
DRAWING	2/10

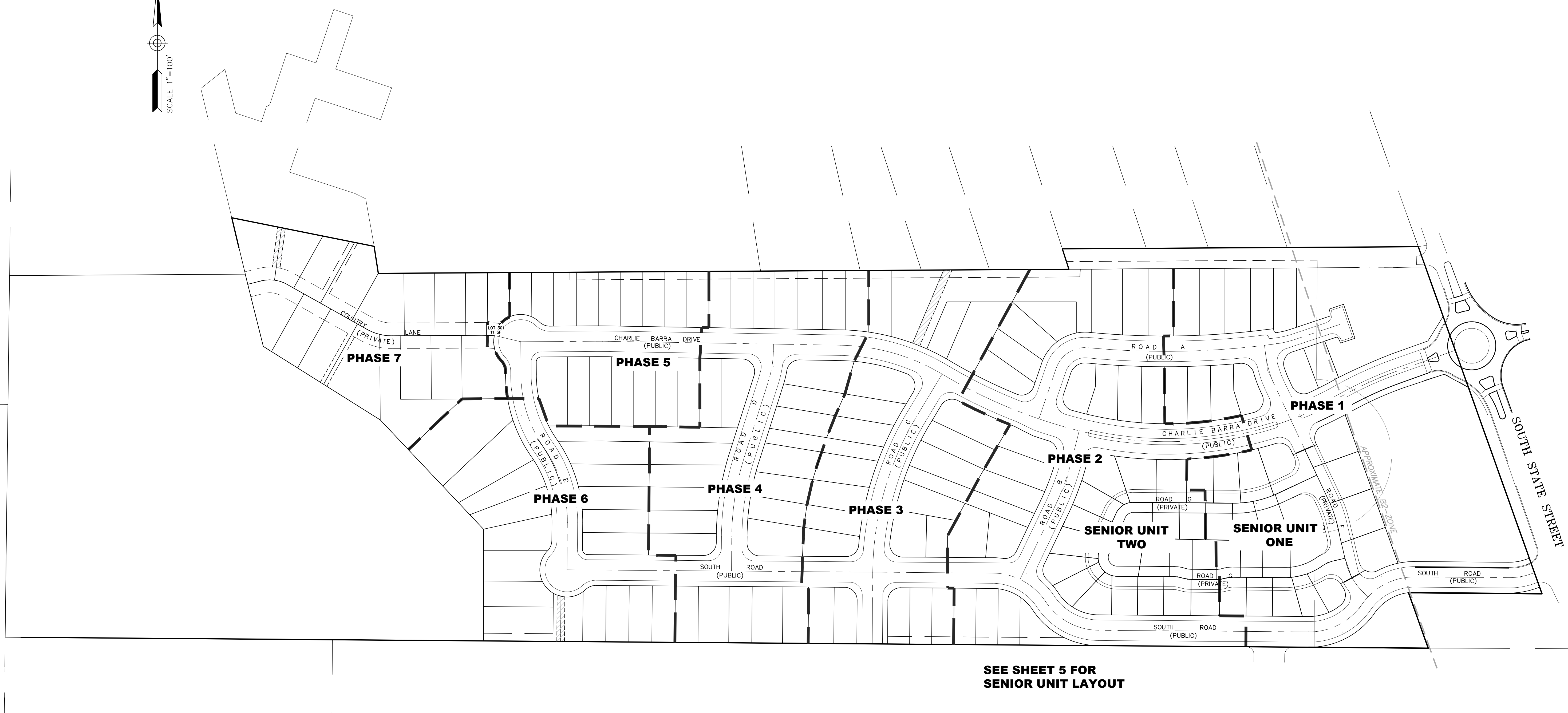
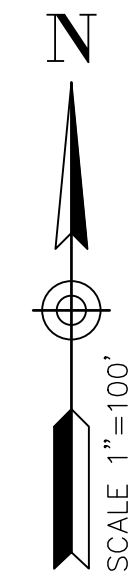

PHASING	
PHASE NUMBER	NUMBER OF LOTS
1	11
2	21
3	23
4	26
5	16
6	18
7	17

SENIOR AREA PHASING	
PHASE NUMBER	NUMBER OF LOTS
1	19
2	20

NOTE: PHASING LAYOUT MAY BE MODIFIED PURSUANT TO THE DEVELOPMENT AGREEMENT

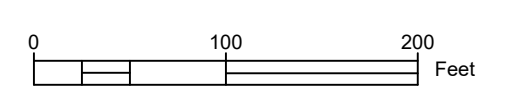

**LACO**  
 EUREKA • UKIAH • SANTA ROSA • CHICO  
 1-800-515-5054 www.lacoassociates.com

NO.	HISTORY / REVISION	BY	CHK.	DATE
1	ADDRESS COUNTY COMMENTS	X	X	8/28/2020

VESTING TENTATIVE MAP  
 GUILLON INC. CONSTRUCTION  
 3000 S STATE STREET, UKIAH, CA 95482

**SUBDIVISION PHASING**

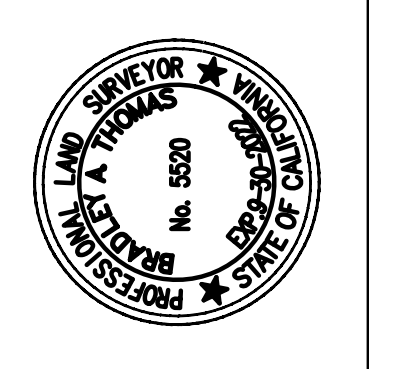

DRAWN	AR
CHECK	CCM
APPROVED	KD
DATE	August 31, 2022
JOB NUMBER	9100.06
DRAWING	3/10

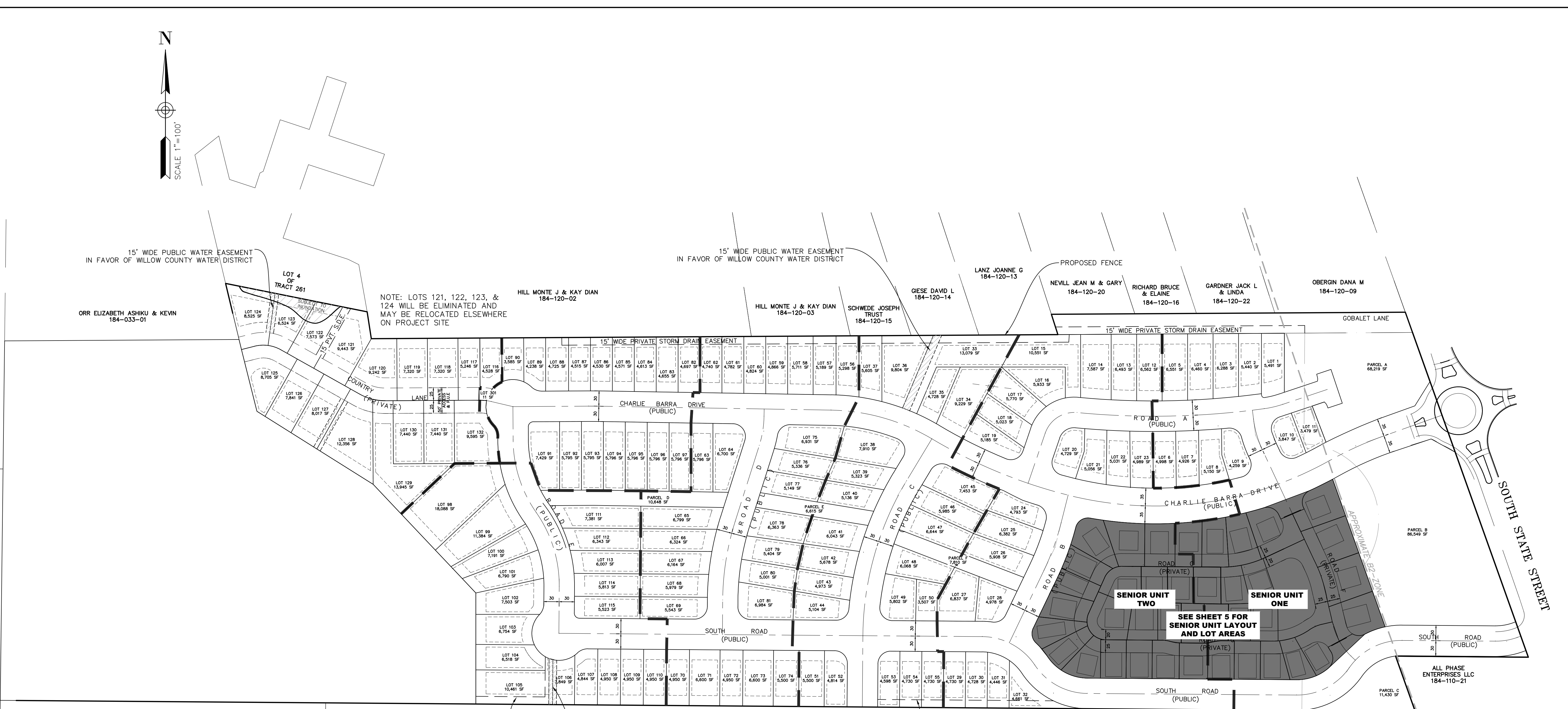
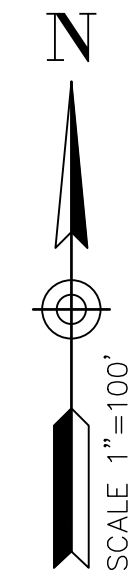

LOT NUMBER	AREA (GROSS)	AREA (NET)
LOT 1	5,491	5,491
LOT 2	5,440	5,440
LOT 3	6,288	6,288
LOT 4	6,460	6,460
LOT 5	6,551	6,551
LOT 6	4,998	4,998
LOT 7	4,926	4,926
LOT 8	5,150	5,150
LOT 9	4,259	4,259
LOT 10	3,847	3,847
LOT 11	3,479	3,479
LOT 12	6,562	6,562
LOT 13	6,493	6,493
LOT 14	7,587	7,587
LOT 15	10,551	9,019
LOT 16	5,933	5,933
LOT 17	5,770	5,770
LOT 18	5,023	5,023
LOT 19	5,185	5,185
LOT 20	4,729	4,729

LOT NUMBER	AREA (GROSS)	AREA (NET)
LOT 21	5,056	5,056
LOT 22	5,031	5,031
LOT 23	4,989	4,989
LOT 24	4,793	4,793
LOT 25	6,382	6,382
LOT 26	5,908	5,908
LOT 27	6,837	6,837
LOT 28	4,978	4,978
LOT 29	4,730	4,085
LOT 30	4,728	4,083
LOT 31	4,446	3,801
LOT 32	4,661	3,032
LOT 33	13,079	8,445
LOT 34	9,229	9,229
LOT 35	4,728	4,728
LOT 36	9,804	8,335
LOT 37	5,605	4,930
LOT 38	7,910	7,910
LOT 39	5,323	5,323
LOT 40	5,136	5,136

LOT NUMBER	AREA (GROSS)	AREA (NET)
LOT 41	6,043	6,043
LOT 42	5,678	5,678
LOT 43	4,973	4,973
LOT 44	5,104	5,104
LOT 45	7,453	7,453
LOT 46	5,985	5,985
LOT 47	6,644	6,644
LOT 48	6,068	6,068
LOT 49	5,802	5,802
LOT 50	3,507	3,507
LOT 51	5,500	5,500
LOT 52	4,814	4,814
LOT 53	4,598	3,952
LOT 54	4,730	4,085
LOT 55	4,730	4,085
LOT 56	5,298	4,623
LOT 57	5,189	4,514
LOT 58	5,711	4,961
LOT 59	4,866	4,221
LOT 60	4,824	4,179

LOT NUMBER	AREA (GROSS)	AREA (NET)
LOT 61	4,782	4,137
LOT 62	4,740	4,095
LOT 63	5,796	5,796
LOT 64	6,700	6,700
LOT 65	6,799	6,799
LOT 66	6,324	6,324
LOT 67	6,164	6,164
LOT 68	5,979	5,979
LOT 69	5,543	5,543
LOT 70	4,950	4,950
LOT 71	6,600	6,600
LOT 72	4,950	4,950
LOT 73	6,600	6,600
LOT 74	5,500	5,500
LOT 75	6,931	6,931
LOT 76	5,336	5,336
LOT 77	5,149	5,149
LOT 78	6,363	6,363
LOT 79	5,404	5,404
LOT 80	5,001	5,001

LOT NUMBER	AREA (GROSS)	AREA (NET)
LOT 81	6,984	6,984
LOT 82	4,697	4,052
LOT 83	4,655	4,010
LOT 84	4,613	3,968
LOT 85	4,571	3,926
LOT 86	4,530	3,885
LOT 87	4,515	3,870
LOT 88	4,725	4,527
LOT 89	4,238	4,238
LOT 90	3,585	3,585
LOT 91	7,429	7,429
LOT 92	5,795	5,795
LOT 93	5,795	5,795
LOT 94	5,796	5,796
LOT 95	5,796	5,796
LOT 96	5,796	5,796
LOT 97	5,796	5,796
LOT 98	18,088	18,088
LOT 99	11,384	11,384
LOT 100	7,191	7,191

LOT NUMBER	AREA (GROSS)	AREA (NET)
LOT 101	6,790	6,790
LOT 102	7,503	7,503
LOT 103	6,754	6,754
LOT 104	6,518	6,518
LOT 105	10,461	7,067
LOT 106	4,530	3,194
LOT 107	4,844	4,844
LOT 108	4,950	4,950
LOT 109	4,950	4,950
LOT 110	4,950	4,950
LOT 111	7,381	7,381
LOT 112	6,343	6,343
LOT 113	6,007	6,007
LOT 114	5,813	5,813
LOT 115	5,523	5,523
LOT 116	4,528	4,105
LOT 117	5,246	4,171
LOT 118	7,320	5,820
LOT 119	7,320	5,820
LOT 120	9,243	6,674

LOT NUMBER	AREA (GROSS)	AREA (NET)
LOT 121	9,443	7,032
LOT 122	7,573	5,079
LOT 123	6,524	4,801
LOT 124	8,525	6,491
LOT 125	8,705	6,020
LOT 126	7,841	6,341
LOT 127	8,017	6,517
LOT 128	12,356	10,994
LOT 129	13,945	12,940
LOT 130	7,440	5,940
LOT 131	7,440	5,940
LOT 132	9,595	8,019

PARCEL	AREA
PARCEL A	68,219
PARCEL B	86,549
PARCEL C	11,430
TOTAL	166,198
LINEAR PARK AREA	
PARCEL D	10,648
PARCEL E	6,615
PARCEL F	7,810
TOTAL	25,073
OTHER AREAS	
DESCRIPTION	AREA
PUBLIC ROW	390,450
SENIOR HOA	194,751
COMMON PARCEL G	9763
REMAINDER	531,242

VESTING TENTATIVE MAP  
 GUILLON INC. CONSTRUCTION  
 3000 S STATE STREET, UKIAH, CA 95482

LOT LAYOUT

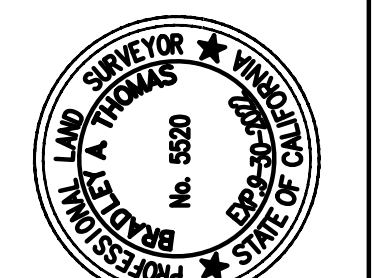

DRAWN	AR
CHECK	CCM
APPROVED	KD
DATE	August 31, 2022
JOB NUMBER	9100.06
DRAWING	4/10



NO.	HISTORY / REVISION	BY	CHK.	DATE
1	ADDRESS COUNTY COMMENTS	X	X	8/28/2020

VESTING TENTATIVE MAP  
 GUILLON INC. CONSTRUCTION  
 3000 S STATE STREET, UKIAH, CA 95482

**SENIOR LOT LAYOUT**

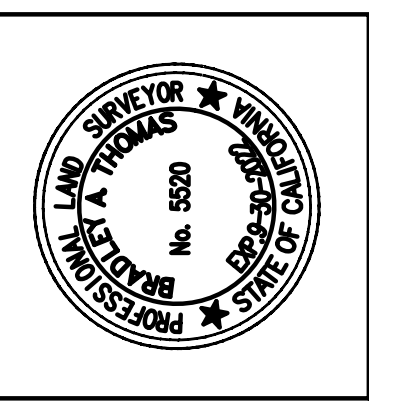

DRAWN	AR
CHECK	CCM
APPROVED	KD
DATE	August 31, 2022
JOB NUMBER	9100.06
DRAWING	5/10

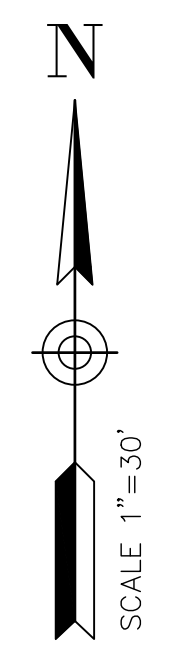

**LEGEND**

- RESTRICTED USE EASEMENT
- IE & PUE
- IE -INGRESS & EGRESS
- PUE -PUBLIC UTILITY EASEMENT
- EXCLUSIVE USE PARK EASEMENT

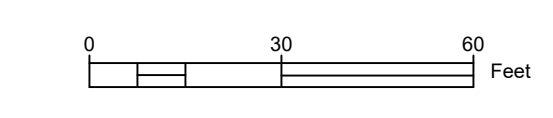
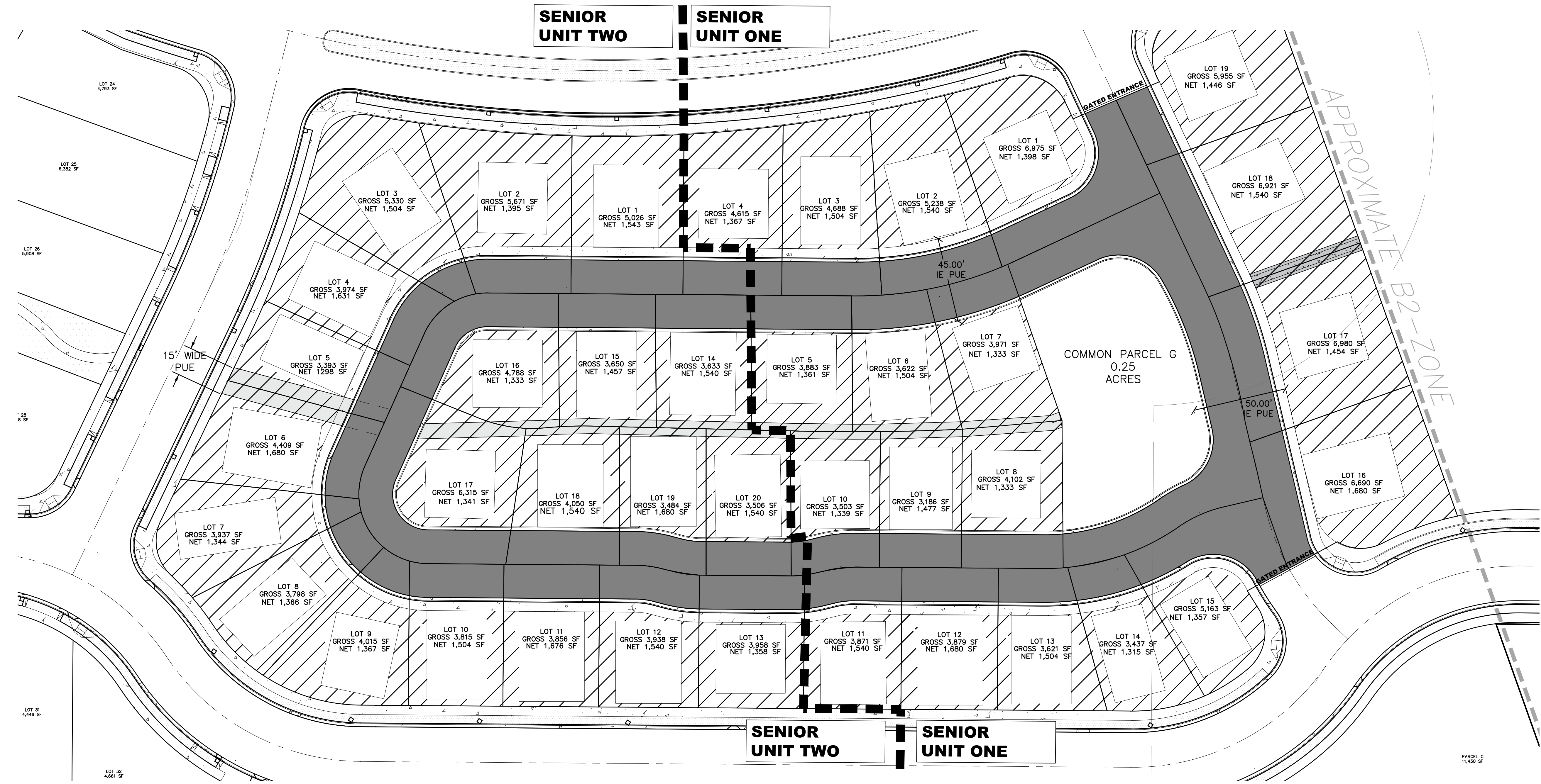



LACO

EUREKA • UKIAH • SANTA ROSA • CHICO

1-800-515-5054 www.lacoassociates.com

NO.	HISTORY / REVISION	BY	CHK.	DATE
1	ADDRESS COUNTY COMMENTS	X	X	8/28/2020

VESTING TENTATIVE MAP  
 GUILLON INC. CONSTRUCTION  
 3000 S STATE STREET, UKIAH, CA 95482

**GRADING & DRAINAGE**

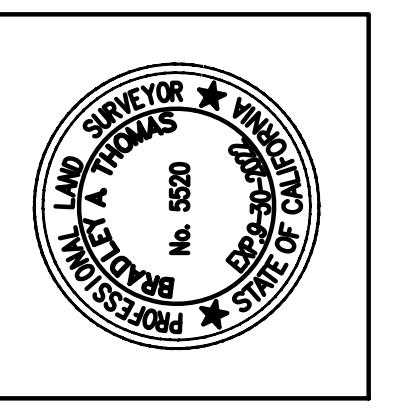

DRAWN	AR
CHECK	CCM
APPROVED	KD
DATE	August 31, 2022
JOB NUMBER	9100.06
DRAWING	6/10

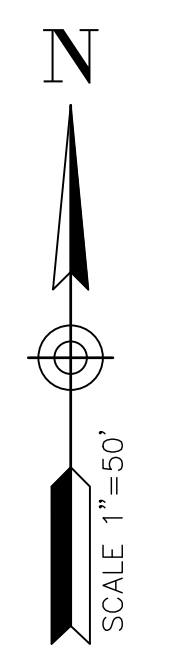
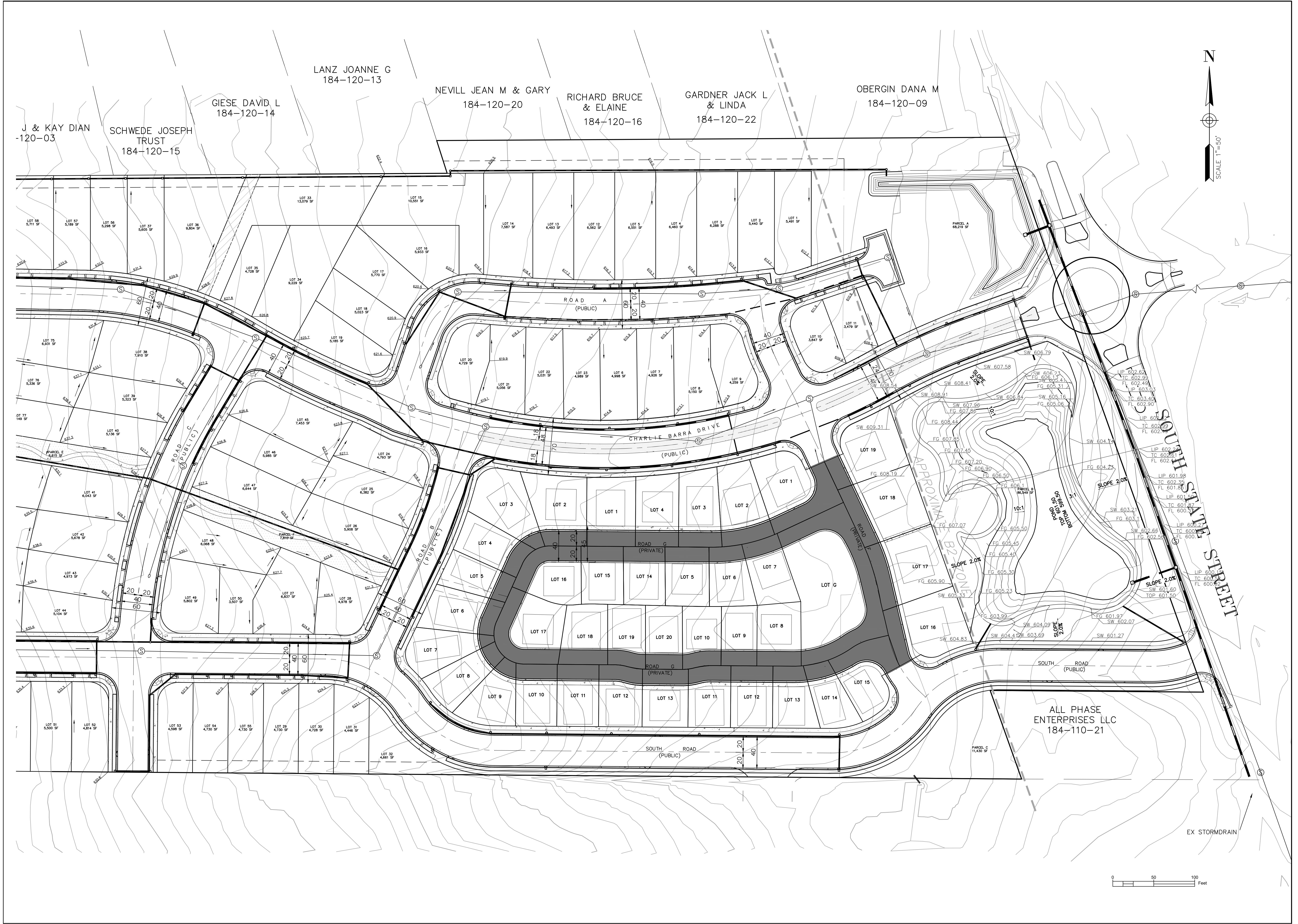

**LACO**  
 EUREKA • UKIAH • SANTA ROSA • CHICO  
 1-800-515-5054 www.lacoassociates.com

NO.	HISTORY / REVISION	BY	CHK.	DATE
1	ADDRESS COUNTY COMMENTS	X	X	8/28/2020

**VESTING TENTATIVE MAP**  
**GUILLON INC. CONSTRUCTION**  
 3000 S STATE STREET, UKIAH, CA 95482

**GRADING AND DRAINAGE**

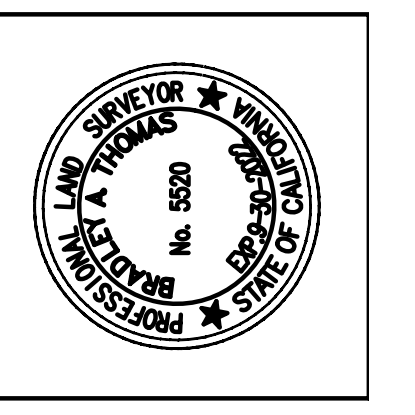

DRAWN	AR
CHECK	CCM
APPROVED	KD
DATE	August 31, 2022
JOB NUMBER	9100.06
DRAWING	7/10

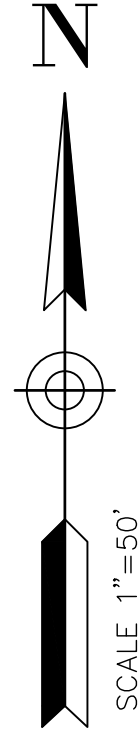
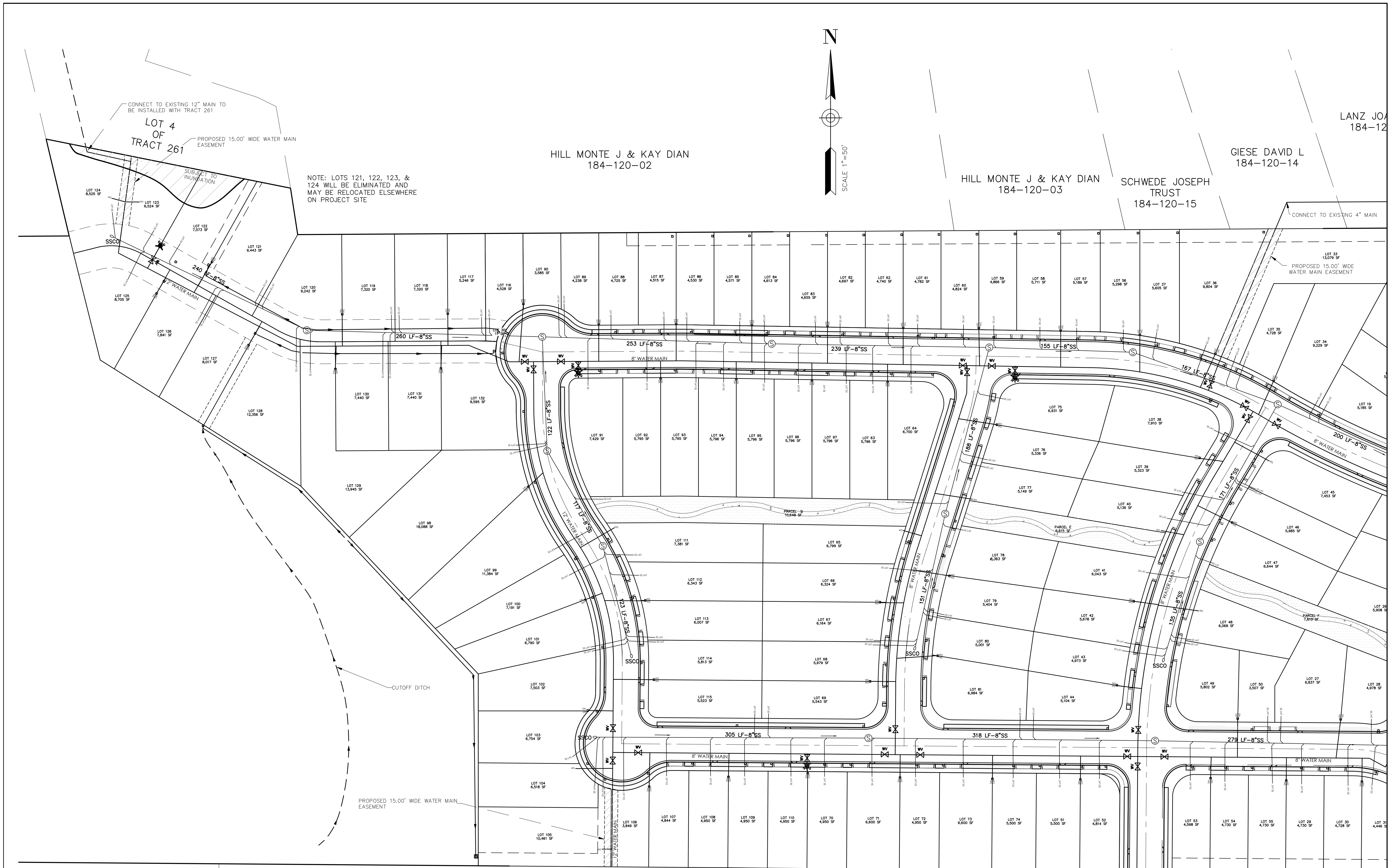

HILL MONTE J & KAY DIAN  
184-120-02

HILL MONTE J & KAY DIAN  
184-120-03

SCHWEDE JOSEPH  
TRUST  
184-120-15

GIESE DAVID L  
184-120-14

LANZ JO  
184-12

NOTE: LOTS 121, 122, 123, &  
124 WILL BE ELIMINATED AND  
MAY BE RELOCATED ELSEWHERE  
ON PROJECT SITE

CONNECT TO EXISTING 12" MAIN TO  
BE INSTALLED WITH TRACT 261  
LOT 4  
OF  
TRACT 261  
PROPOSED 15.00' WIDE WATER MAIN  
EASEMENT

CONNECT TO EXISTING 4" MAIN

PROPOSED 15.00' WIDE  
WATER MAIN EASEMENT

CUTOFF DITCH

PROPOSED 15.00' WIDE WATER MAIN  
EASEMENT

LACO  
EUREKA • UKIAH • SANTA ROSA • CHICO  
1-800-515-5054 www.lacoassociates.com

NO.	HISTORY / REVISION	BY	CHK.	DATE
1	ADDRESS COUNTY COMMENTS	X	X	8/28/2020

VESTING TENTATIVE MAP  
GUILLON INC. CONSTRUCTION  
3000 S STATE STREET, UKIAH, CA 95482

UTILITIES

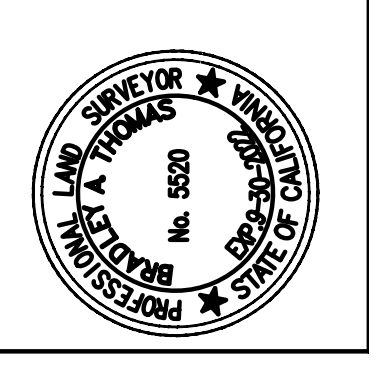

DRAWN	AR
CHECK	CCM
APPROVED	KD
DATE	August 31, 2022
JOB NUMBER	9100.06
DRAWING	8/10

ZAINA VINEYARDS LLC  
184-130-39

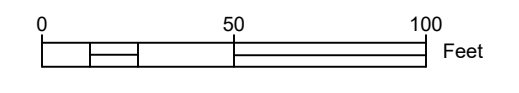

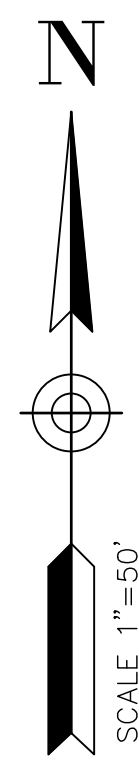
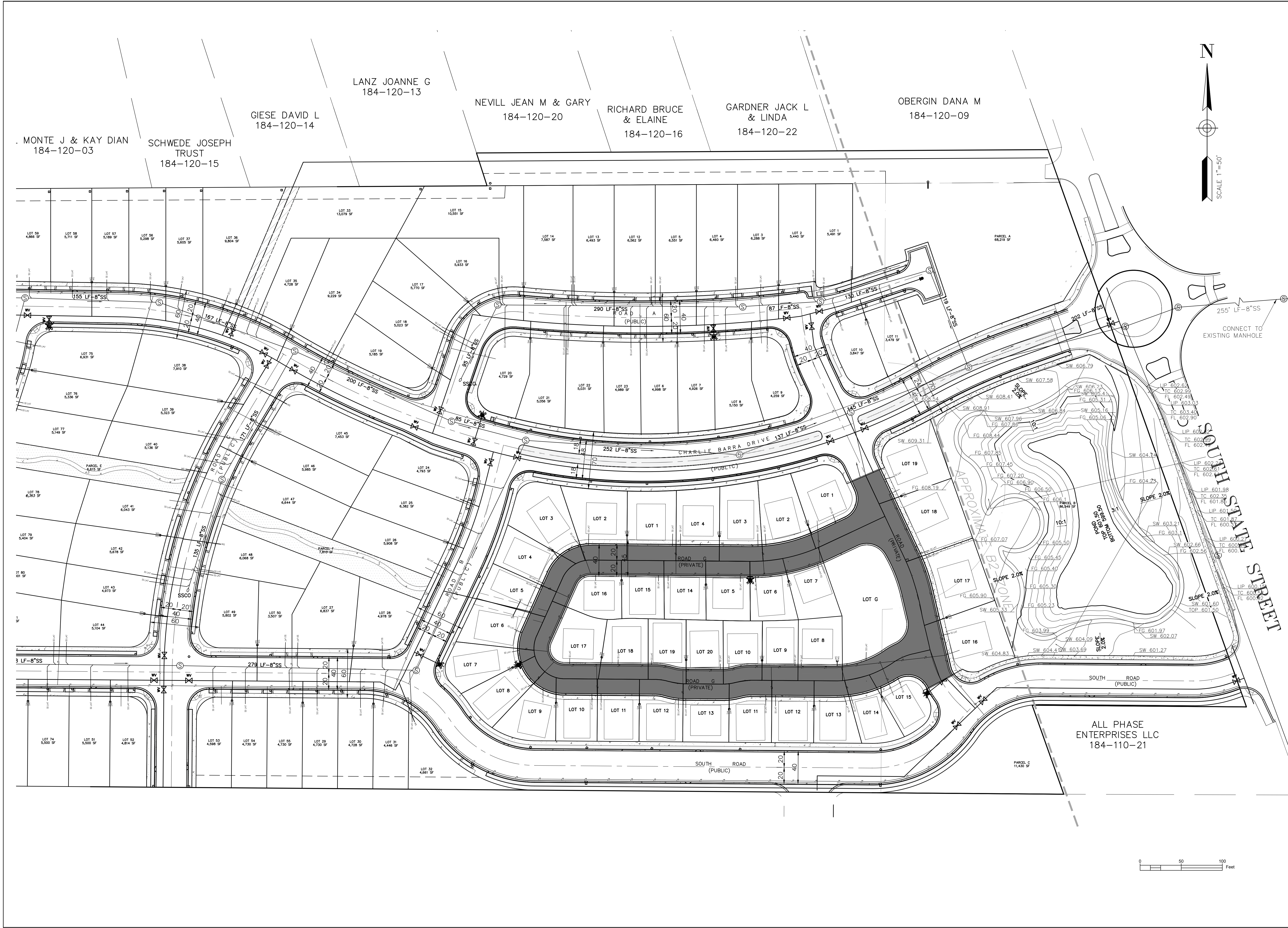

LACO  
 EUREKA • UKIAH • SANTA ROSA • CHICO  
 1-800-515-5054 www.lacoassociates.com

NO.	HISTORY / REVISION	BY	CHK.	DATE
1	ADDRESS COUNTY COMMENTS	X	X	8/28/2020

VESTING TENTATIVE MAP  
 GUILLON INC. CONSTRUCTION  
 3000 S STATE STREET, UKIAH, CA 95482

UTILITIES

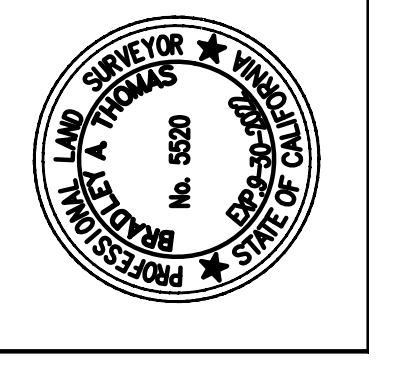

DRAWN	AR
CHECK	CCM
APPROVED	KD
DATE	August 31, 2022
JOB NUMBER	9100.06
DRAWING	9/10

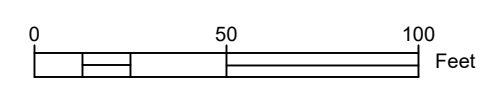

LACO  
 EUREKA • UKIAH • SANTA ROSA • CHICO  
 1-800-515-5054 www.lacocoassociates.com

NO.	HISTORY / REVISION	BY / CHK.	DATE
1	ADDRESS COUNTY COMMENTS	X	8/28/2020

VESTING TENTATIVE MAP  
 GUILLON INC. CONSTRUCTION  
 3000 S STATE STREET, UKIAH, CA 95482

TYPICAL SECTION DETAILS

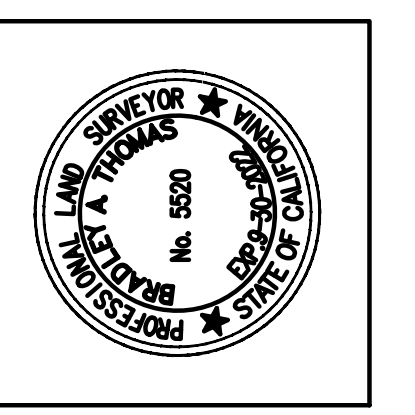

DRAWN	AR
CHECK	CCM
APPROVED	KD
DATE	August 31, 2022
JOB NUMBER	9100.06
DRAWING	10/10

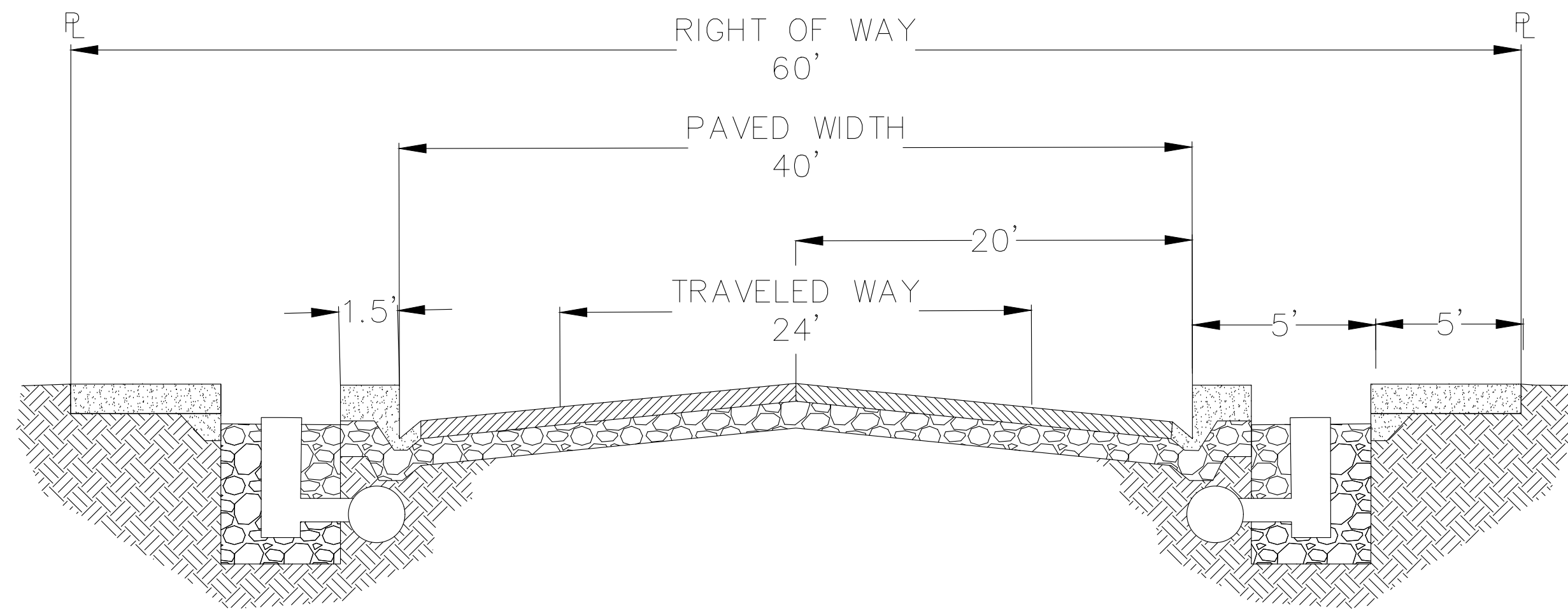

**1 TYPICAL ROAD SECTION DETAIL**  
 N.T.S.  
 ROAD A, B, C, D, & E, SOUTH ROAD,  
 CHARLIE BARRA DRIVE(27+50-38+50)

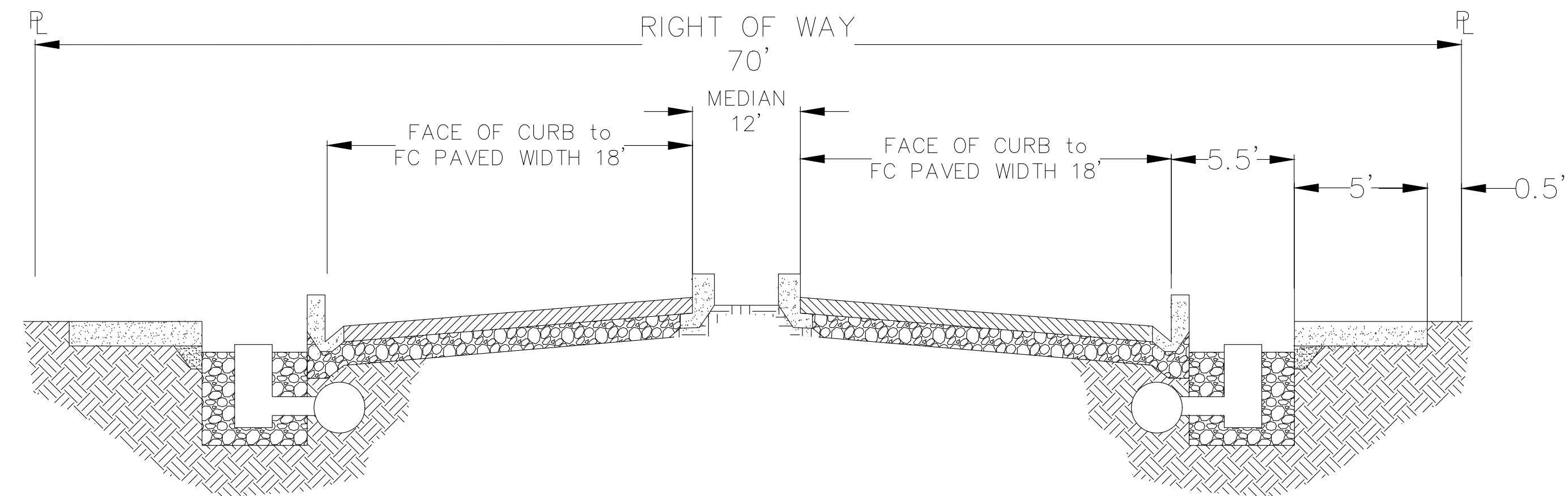

**2 LANDSCAPED ROAD SECTION DETAIL**  
 N.T.S.  
 CHARLIE BARRA DRIVE  
 STATION 20+00-27+50

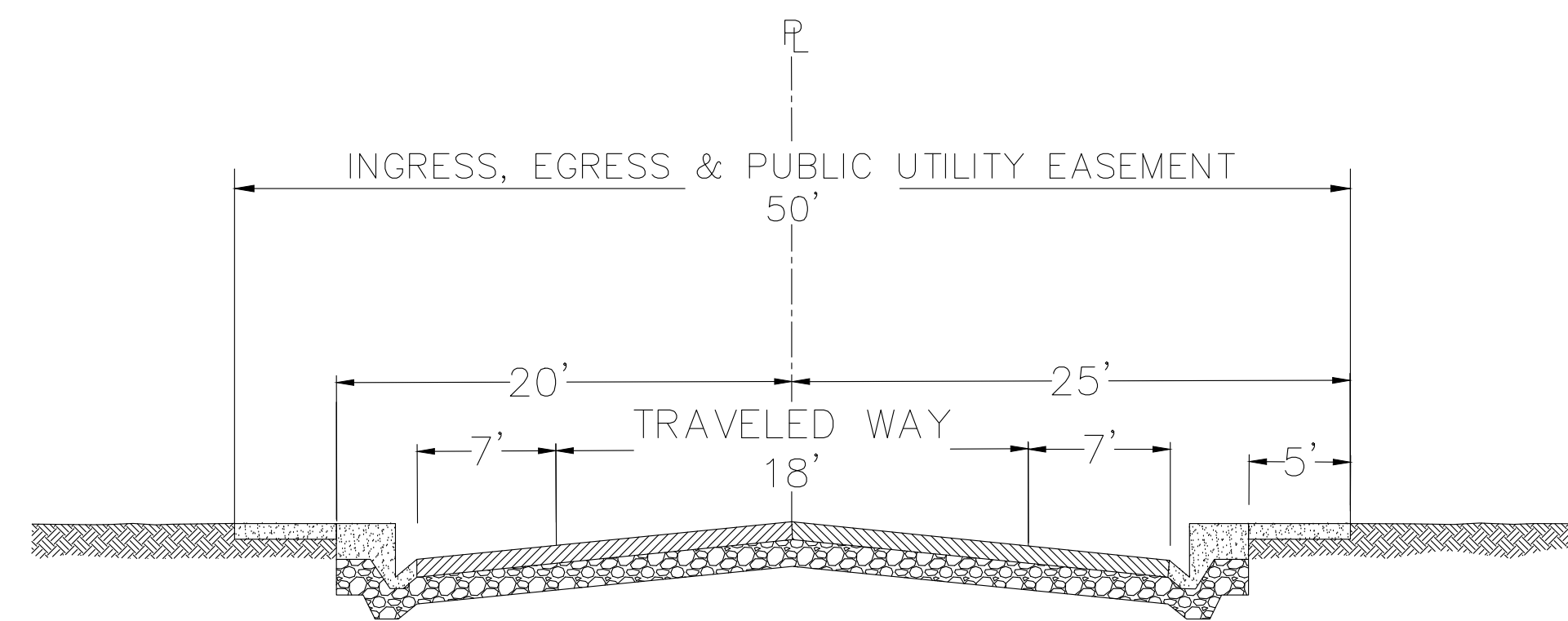

**3 REDUCED ROAD SECTION DETAIL**  
 N.T.S.  
 ROAD F & G

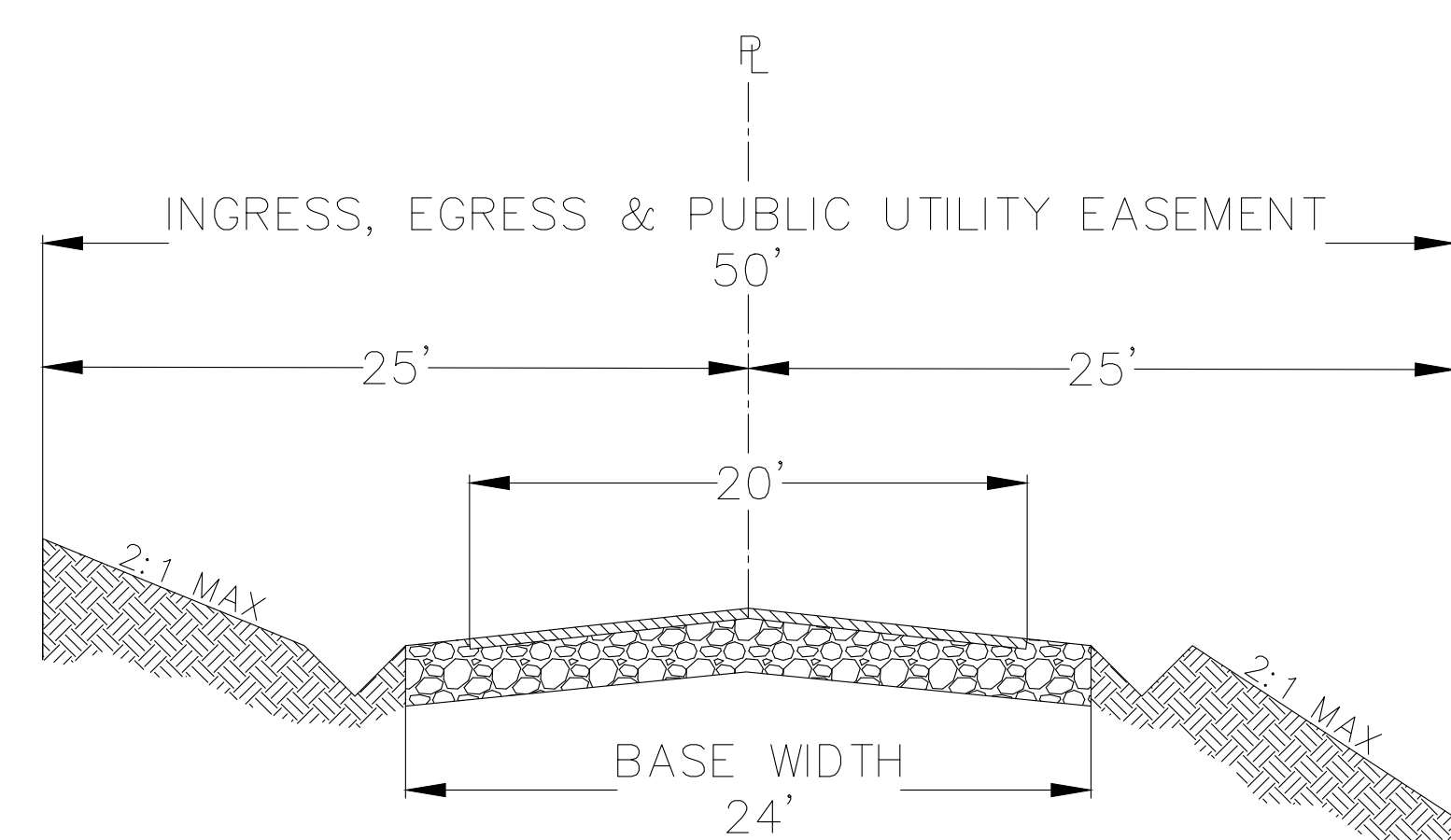

**4 PRIVATE ROAD SECTION DETAIL**  
 N.T.S.  
 COUNTRY LANE

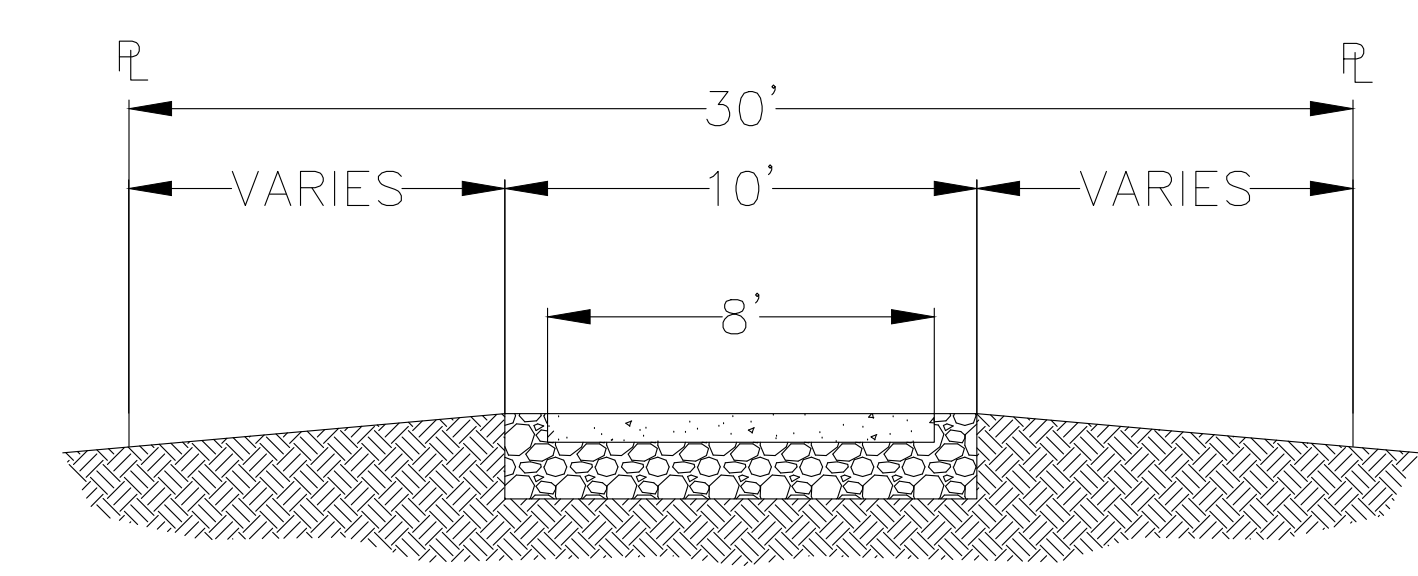

**5 PARKWAY PATH SECTION DETAIL**  
 N.T.S.  
 PARCELS D, E, F,  
 & NORTH SIDE OF LOT 17

**Stormwater Control Plan**  
Prepared For  
**Guillon Inc. Construction**  
Bella Vista Subdivision

**Project Location**  
3000 South State Street,  
Ukiah, CA 95482  
APN 184-110-28, 184-110-29, 184-120-01, & 184-120-21  
LACO Job #9100.06  
Owner: Guillon Inc. Construction  
Contact: (530) 879-4436



**PREPARED BY**  
LACO ASSOCIATES  
776 South State Street  
Ukiah, Ca 95482  
(707) 462-0222

March 2021

**Prepared under the supervision of**  
**Rodney L. Wilburn, Jr, RCE No.69388**



My License Expires 30, June 2022

## Introduction:

This report has been prepared for the purposes of evaluating the drainage conditions of the areas of the south terminus of South State Street surrounding the proposed Bella Vista Subdivision project. This report provides analysis of the existing drainage conditions and recommends improvements to the existing condition which would serve the proposed development.

Watershed boundaries were delineated by use of USGS topographic maps, aerial photo maps, and topographic surveys (Figures 1-4). Figures 1-4 also depict the watershed divided into Tributary Areas, Sub-Areas, and Drainage Management Areas (DMA's) for the purposes of estimating runoff to various points of concentration. All Figures are presented at a scale of 1-inch equals 180 feet the exception of Figure 1: Location Map that is 1-inch equals 2000 feet for clarity purposes. The total drainage areas delineated is approximately 75 acres draining to culverts along South State Street.

## Methodology:

The "Rational Method" is the most widely used method for determining runoff. The idea behind the rational method is that if rainfall of intensity "I" begins instantaneously and continues indefinitely, the rate of runoff will increase until the time of concentration, whereby, all the runoff in contributing to flow at the outlet. This method was used to develop the hydrology for this report. The determination of values for the variables in the rational formula was based on methods outlined in the County of Mendocino Road Standards, Tab-D. The determination of land use, necessary to choose a runoff coefficient, C, was based on the anticipated development. Appendices contains charts used in determining the standards used for this project and calculations using this described method.

Standards used are as follows:

Runoff Coefficient (C-Value)	C=0.31 (Vegetated); C=0.90 (Impervious)
Annual Precipitation (MENDOT STD. NO. D10)	35 Inches
Rainfall Intensity (MENDOT STD. NO. D11)	$i_{10} = 6.1567 (T_c)^{-0.5127}$ $i_{100} = 6.1567 (T_c)^{-0.5166}$
Design Storm Event	10 year
Initial Time of Concentration	15 minutes
K-Factor (MENDOT STD. NO. D10)	1

## Project Description:

The Bella Vista Subdivision project (hereinafter "Project") will consist of the development of 171 new homes, community streets and striping, asphalt pavement, self-retaining areas, bioretention areas and landscaped areas on a 48.8 acre property located at 3000 South State Street, Ukiah, California and identified by Assessor's Parcel Numbers (APN) 184-110-28, 184-110-29, 184-120-01, & 184-120-21 (hereinafter "Site"), See Figure 1: Location Map.

## Existing Topography and Drainage:

The existing site is a suburban residential zoned property. The location is at the south terminus of South State Street surrounded by properties that face onto South State Street. There are no wetlands or creek on site, trees within the buildable area are proposed to be removed. The general drainage pattern for the site is in a south-eastern direction. The hydrology for pre-development conditions has been broken up into tributaries based on watersheds and points of concentration; please refer to Figure 2: Pre-development Conditions. The pre-development Tributary 1 starts offsite and cuts across the west side of the property and outfalls offsite approximately 500 feet north of our project Site along North State Street. The flow for Tributary 1 is 13.1 cfs. The pre-development flow that contributes to our Site is 11.4 cfs (flow includes Tributaries 2 thru 7, and Tributary 9). There are two outfalls that are analyzed in this report. One outfalls at the end of Tributary 1 and the other at the end of Tributary 8.



Pre-development Flows	
Tributary	Flow (cfs)
<b>Trib 1 Outfall Total</b>	<b>13.1</b>
<b>Trib 8 Outfall Total</b>	<b>11.4</b>

**Proposed Drainage Description:**

This project is subject to maintain the 10-year pre-development flow conditions. Therefore, a detention pond will be designed to detain the difference in runoff due to an increase in impervious surfaces in post development conditions using the design 10-year storm event. Our proposed drainage design will intercept runoff and route to a detention pond located at the Eastern edge of the Site. The post development hydrology has been broken up into Drainage Management Areas (DMA); please refer to Figure 3: Post Development Conditions for exact locations. There are four proposed DMAs (Post Tributary 1, DMA 1, DMA 2 and DMA 3). Post Tributary 1 resulted in a decrease in flow due to a decrease in contributing area in post development conditions and having a longer time of concentration due to runoff being routed through a series of vegetated swales and storm drain pipe. The outfall of Tributary 1 is approximately 500 feet north of the project Site along North State Street. The flow for Post Tributary 1 is 12.4 cfs. Runoff from DMA 1 will connect directly to the county drainage system along South State Street. Runoff from DMA’s 2 and 3 will be routed through a proposed storm drain pipe along South State Street that outfalls at an existing culvert located at the southeastern terminus of the Site and crosses South State Street. The post development flow that contributes to our Site is 21.3 cfs (flow includes DMA’s 1 thru 3). Post development flows have been analyzed and calculated using the Storm Sewers application in AutoCAD software. Please refer to Figure 4: Flood Control Exhibit for delineation of drainage areas contributing to each drainage inlet. The post development flow calculation reports for the drainage inlets and storm drain pipes have been included in the appendices of this report.

Post Development Flows	
DMA	Flow (cfs)
<b>Trib 1 Outfall Total</b>	<b>12.4</b>
<b>Project Site Outfall Total</b>	<b>21.3</b>

**Post Development Runoff Increase Detention:**

There is an increase of 5.71 cfs that is designed to be detained and stored at the proposed detention pond located at the central eastern edge of the Site. In addition, a drainage inlet at the detention pond has been designed to allow pre-development flow to bypass detention, detain the increase runoff due to post development conditions, and allow any excessive runoff to enter the storm drain system using a weir drainage inlet design. The detention pond and drainage inlet has been sized accordingly using the Hydraflow Express application in AutoCAD software.

Post Development Runoff Increase	
Post Development Flow (cfs)	21.3
Pre-Development Flow (cfs)	11.4
<b>Increase Runoff (cfs)</b>	<b>9.9</b>
10-Year Volume Detention Sizing	
Volume Detention Required (cu.ft.)	16,685
<b>Detention Pond Capacity (cu.ft.)</b>	<b>24,750</b>

The proposed post-development drainage design will have DMA 1 and DMA 3 bypassing the volume detention. DMA 2 will detain the required flow and volume to maintain pre-development flow conditions. DMA 1 will allow 4.17 cfs to bypass volume detention and DMA 3 will allow 3.78 cfs to bypass volume detention. Since the Site pre-development flow is 11.4 cfs, DMA 2 can allow a maximum of 3.45 cfs to bypass detention using a weir drainage inlet design. Once the flow surpasses the Maximum Allowable DMA 2 Flow the weir drainage inlet will begin to back up runoff and detain runoff in the storage pond. In extreme rain events where the storage pond reaches

capacity, the weir drainage inlet will allow excessive runoff to enter the storm drain system via the top of grate inlet.

Detention Pond Outlet Structure Sizing	
Pre-development Flow (cfs)	11.4
DMA 1 Flow (cfs)	4.17
DMA 3 Flow (cfs)	3.78
<b>Max Allowable DMA 2 Flow (cfs)</b>	<b>3.45</b>

**100-Year Flood Control**

The detention pond will be designed to adequately detain the 100-year storm event and minimize the potential flood impacts. The detention pond has been sized accordingly using the Hydraflow Express application in AutoCAD software.

100-Year Volume Detention Sizing	
Volume Detention Required (cu.ft.)	23,940
<b>Detention Pond Capacity (cu.ft.)</b>	<b>24,750</b>

**Stormwater Control Plan (SCP) Requirements:**

The Mendocino County Low Impact Development Standards Manual, dated November 2018 (hereinafter "LID Manual") was utilized to develop a stormwater management plan to capture, treat, and infiltrate stormwater runoff to account for stormwater produced by an increase in impervious area. The LID Manual classifies all projects that create and/or replace greater than equal to 5,000 square feet of impervious surface as Regulated Projects. The LID Manual goes further and classifies all projects that create and/or replace one (1) acre of impervious surface as Hydromodification Projects, a specific type of Regulated Project. Under this classification the LID Manual requires a site assessment, delineation of drainage management areas (DMA) and a calculation quantifying the reduction in stormwater runoff by using site design measures. The findings must be delivered in a Stormwater Control Plan.

Site Design measures proposed to be used in this Project include planting trees and constructing self-retaining areas. In addition, the Project includes the construction of two (2) bioretention facilities proposed to be located along throughout the Site; please refer to Figure 3: Post Development Conditions for exact locations. Within the approximate 1,403,455 square-foot Site, an area totaling 638,506 square feet is proposed to be impervious surface and an area totaling 764,949 square feet is proposed to be comprised of pervious surfaces (including natural vegetation, landscape, self-retaining and bioretention areas). The BMPs have been sized to handle the projected runoff from the 85<sup>th</sup>-percentile, 24-hour storm event.

**Pollution Prevention Measures:**

Source control pollution prevention measures would include parking area sweeping, and all onsite Trash Enclosures shall be covered.

**Runoff Reduction Measures:**

Downspouts from roof gutters will be disconnected from the storm drain system and discharge into landscape areas and swales. Interceptor trees will be planted throughout the Site. The total tributary area used for delta volume and treatment calculations has been reduced by taking credit for these measures.

**Types of BMPs**

The selected BMPs for the developed site will include the following:

- Universal LID Features
  - Impervious area disconnection
  - Interceptor Trees

BMP LID Features

Bio-retention Areas

**Level of Treatment and Volume Capture**

Our proposed drainage design will intercept runoff and route to bioretention areas located throughout the Site in Drainage Management Areas (DMA); please refer to Figure 2: Post Development Conditions for exact locations. There are three proposed DMAs (DMA 1, DMA 2 and DMA 3). All three DMA’s will have self-retaining areas, DMA’s 2 and 3 will utilize the bioretention facilities located throughout the Site. The bioretention areas are best management practices (BMPs) that function as a soil and plant-based filtration and infiltration feature that remove pollutants through a variety of natural physical, biological, and chemical treatment process Self-retaining areas are concave, basin-like depressions that have vegetation that allow for efficient use of the water and can be enhanced by replacing native soils with amended soils that have high infiltration ratings.

The Hydromodification design goal has been achieved in DMAs 2 and 3 using bioretention areas. Runoff generated by DMA 1 will not be intercepted by a bioretention area. However, the total site achieves greater than the required Hydromodification design goal through the installation of an oversized bioretention area in DMA 2. See Table below and Calculations in appendices. In addition, the three DMA’s will provide treatment through the use of landscape areas, self-retaining areas and vegetated swales.

<b>Hydromodification Goals and Bioretention Sizing</b>		
DMA #	Required Bioretention Size (sf)	Proposed Bioretention Size (sf)
1	1,310	-
2	5,854	7,640
3	3,450	3,585
<b>Site Total</b>	<b>10,614</b>	<b>106%</b>

**Maintenance and Funding**

BMPs shall be inspected and maintained as described in the Mendocino County Low Impact Development Standards Manual, dated November 2018. All BMPs are located on private land throughout the entire property furthermore, BMPs will be the sole responsibility of and funded by Guillon Inc. Construction (owner).

**Maintenance of BMPs**

The maintenance of selected BMPs is recommended as follows:

Interceptor Trees

At a minimum inspection and maintenance shall include the following:

- Annual inspection prior to the rainy season.
- Annual proper watering and application of mulch.
- Routine pruning and weeding as needed.
- Replacement of trees as needed.

Impervious Area Disconnection

At a minimum inspection and maintenance shall include the following:

- Routinely inspect for ponding water near building foundation
- Annually inspect for undercutting/washouts at the outlet of pipe
- Annually inspect for splash blocks or rain chain damage
- Annually inspect for vegetation or debris blocking outlet of pipe

Bio-retention Areas

At a minimum maintenance shall include the following:

- Dry street sweeping upon completion of construction

- Dry street sweeping annually, and
  - When water is observed flowing in the gutter during a low intensity storm.
  - Algae is observed in the gutter.
  - Sediment/debris covers 1/3 of the gutter width or more.
- Inspect twice annually for sedimentation and trash accumulation in the gutter. Obstructions and trash shall be removed and properly disposed of.
- Inspect twice during the rainy season for ponded water.
- Pesticides and fertilizers shall not be used in the bioretention area.
- Plants should be pruned, weeds pulled and dead plants replaced as needed.

Appendices:

1. Figures
2. Final SCP
3. Source Control Worksheet
4. Bioretention Specifications and Checklist
5. Bioretention Plant List – Inland and Coastal
6. Operation and Maintenance Template
7. Pre-development 10-Year Frequency Calculations
8. Pre-development 100-Year Frequency Calculations
9. Post Development 10-Year Storm Sewer Storm Drain Reports
10. Post Development 100-Year Storm Sewer Storm Drain Reports
11. Hydraflow Pond Sizing
12. Hydraflow Outlet Structure Sizing
13. Mean Precipitation K-Value, Intensity Duration Curve, C-Value

# LACO

EUREKA • UKIAH • SANTA ROSA

1-800-515-5054 www.lacoassociates.com

PROJECT	BELLA VISTA SUBDIVISION	BY	GG	FIGURE	1
CLIENT	GUILLON INC. CONSTRUCTION	DATE	12-18-20		
LOCATION	3000 SOUTH STATE STREET, UKIAH, CA	CHECK	KD	JOB NO.	9100.06
	LOCATION MAP	SCALE	1" = 2000'		

REUSE OF DOCUMENTS: This document and the ideas and design incorporated herein, as an instrument of professional service, is the property of LACO Associates and shall not be reused in whole or part for any other project without LACO Associates express written authorization.

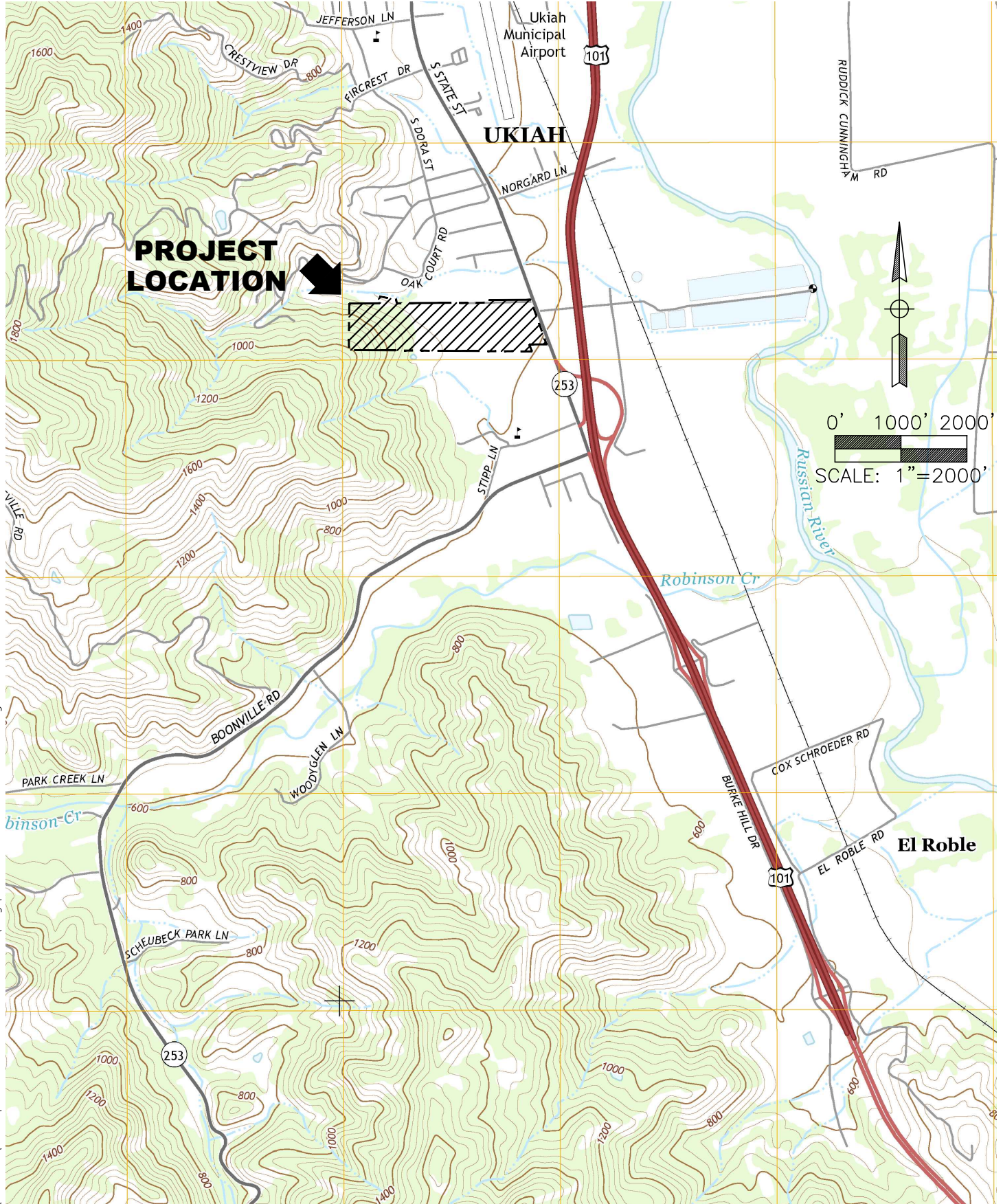

Dec 18, 2020 - 12:15pm  
T:\caddfiles\9100\9100.06 Bella Vista Estates\dwg\ 9100.06 PRE-DEV HYDRO.dwg

### LEGEND/ABBREVIATIONS

- PROPERTY LINE
- MAJOR TRIBUTARY BOUNDARY
- - - - - SUB-TRIBUTARY BOUNDARY
- FLOW DIRECTION
- TRIB 1A TRIBUTARY ID
- POC1 POINT OF CONNECTION (POC) ID

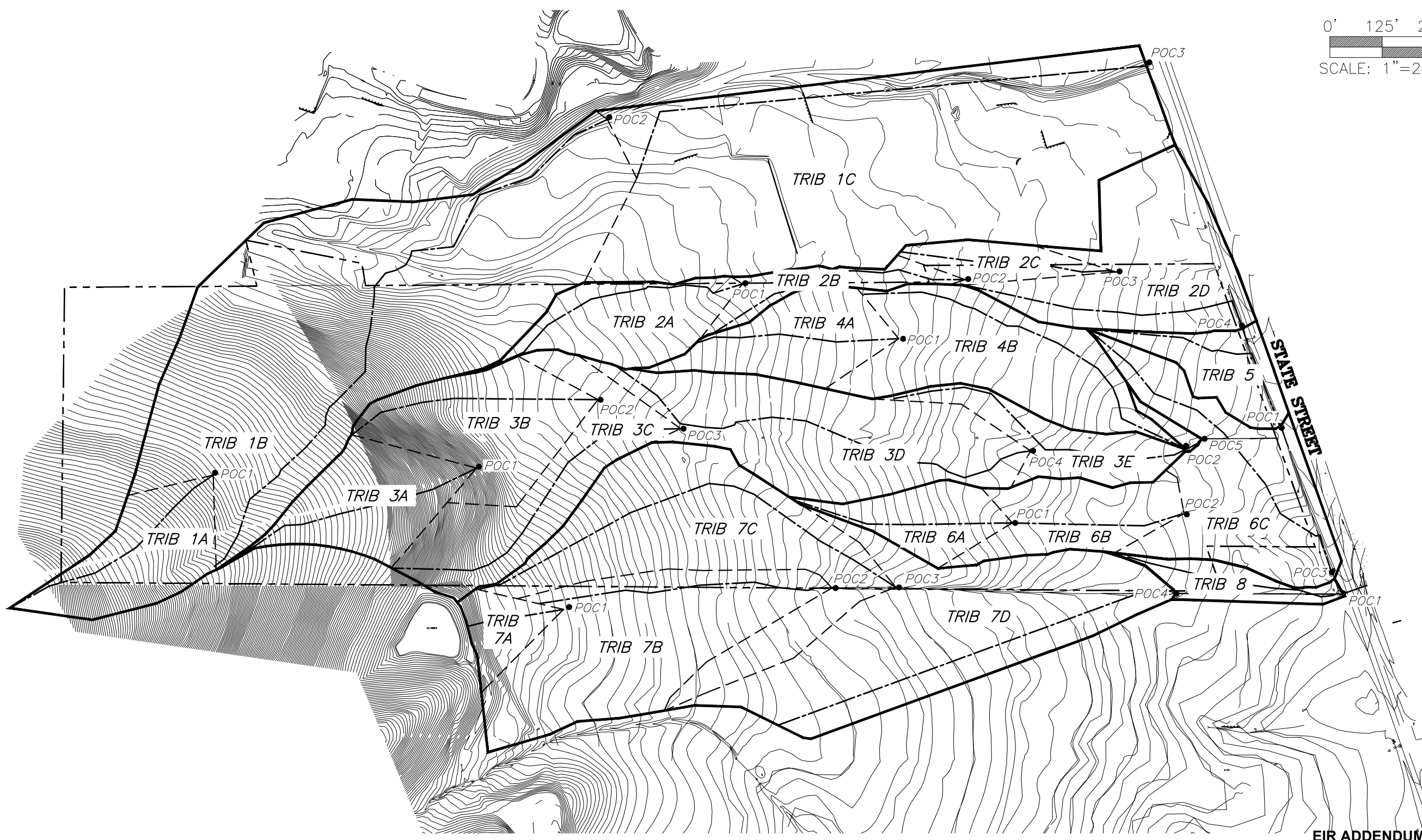
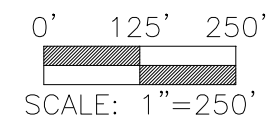
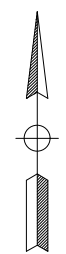

Dec 21, 2020 - 4:57pm  
T:\Cadfiles\9100\9100.06 Bella Vista Estates\dwg\ 9100.06 PRE-DEV HYDRO.dwg

NO.	HISTORY/ REVISION	BY	CHK.	DATE

BELLA VISTA SUBDIVISION  
PRE-DEVELOPMENT CONDITIONS

GUILLON INC. CONSTRUCTION  
2550 LAKEWEST DRIVE, STE. 50, CHICO, CA

DRAWN	GG
CHECK	KD
APPROVED	RLW
DATE	12-15-2020
JOB NUMBER	9100.06
SHEET	2 OF 4

**LACO**  
EUREKA • UKIAH • SANTA ROSA  
1-800-515-5054 www.lacoassociates.com

### LEGEND/ABBREVIATIONS

- PROPERTY LINE
- DRAINAGE MANAGEMENT AREA (DMA) BOUNDARY
- BRA 1 BIORETENTION AREA ID
- BIORETENTION AREA
- ↗ FLOW DIRECTION

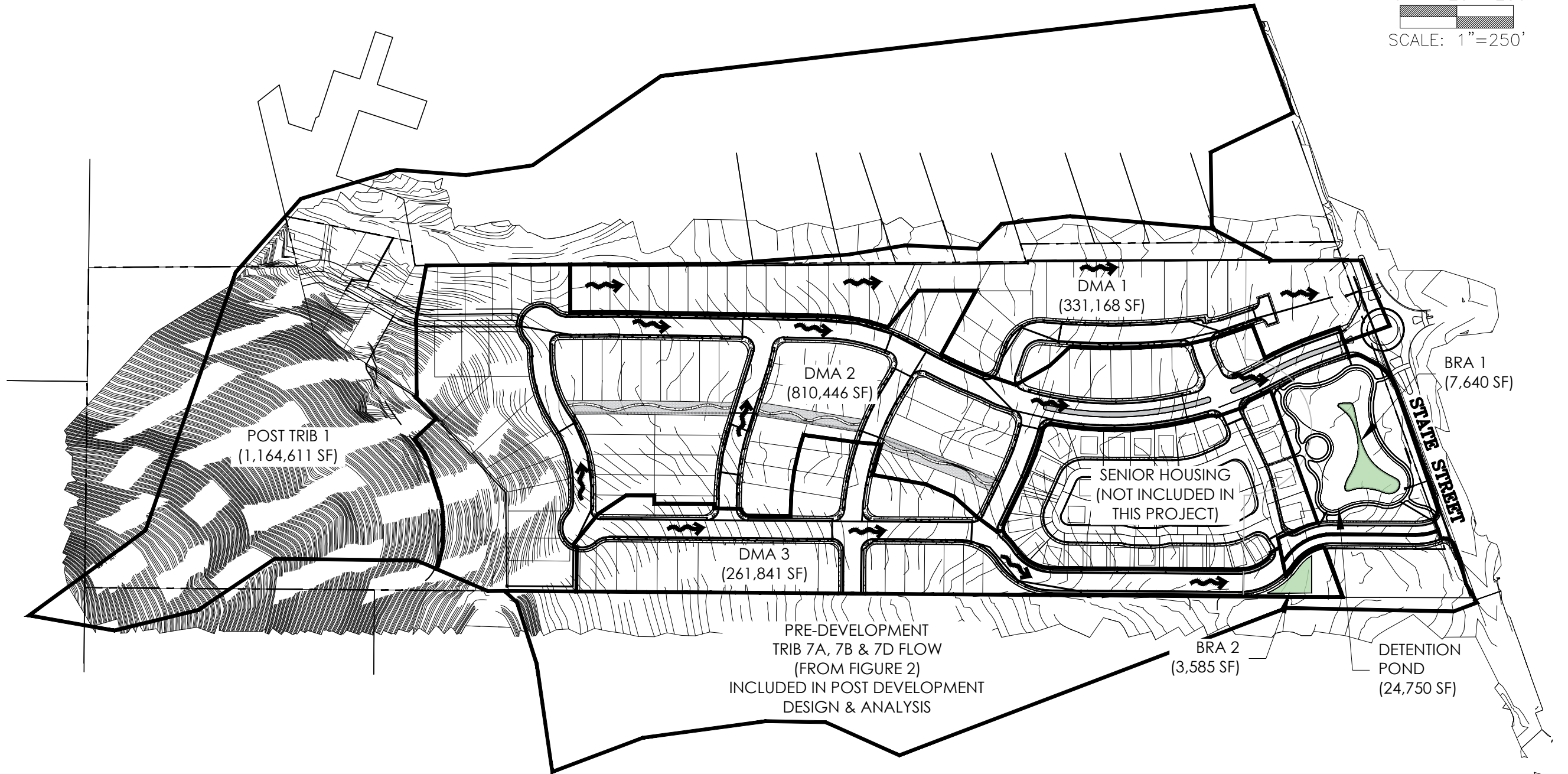
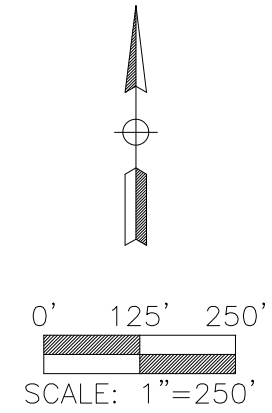

NO.	HISTORY/ REVISION	BY	CHK.	DATE

BELLA VISTA SUBDIVISION  
 POST DEVELOPMENT CONDITIONS

GUILLON INC. CONSTRUCTION  
 2550 LAKEWEST DRIVE, STE. 50, CHICO, CA

DRAWN	GG
CHECK	KD
APPROVED	RLW
DATE	12-15-2020
JOB NUMBER	9100.06
SHEET	OF
3	4

Dec 21, 2020 - 5:07pm  
 T:\Cadfiles\9100\9100.06 Bella Vista Estates\dwg\ 9100.06 POST-DEV HYDRO.dwg



**LEGEND/ABBREVIATIONS**

———— DRAINAGE MANAGEMENT AREA (DMA) BOUNDARY  
 DI 1 DRAINAGE INLET ID

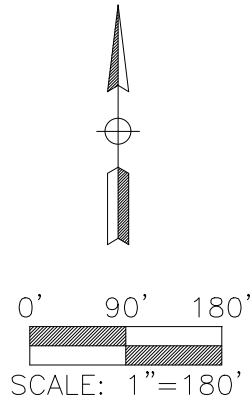

ADDITIONAL DRAINAGE INLET AREA (SHOWN HERE FOR CLARITY)					
DI #	SF	DI #	SF	DI #	SF
32	831	47	2,782	73	2,803
33	840	48	2,659	74	2,794
34	608	49	1,458	75	768
37	4,880	50	1,119	85	2,699
38	4,998	51	2,511	86	2,700
39	5,029	52	2,580	95	2,821
40	4,977	53	2,584	96	3,020
43	2,199	54	2,448	146	2,700
44	360	58	1,491	152	1,592
46	2,997	62	3,732	154	19,907

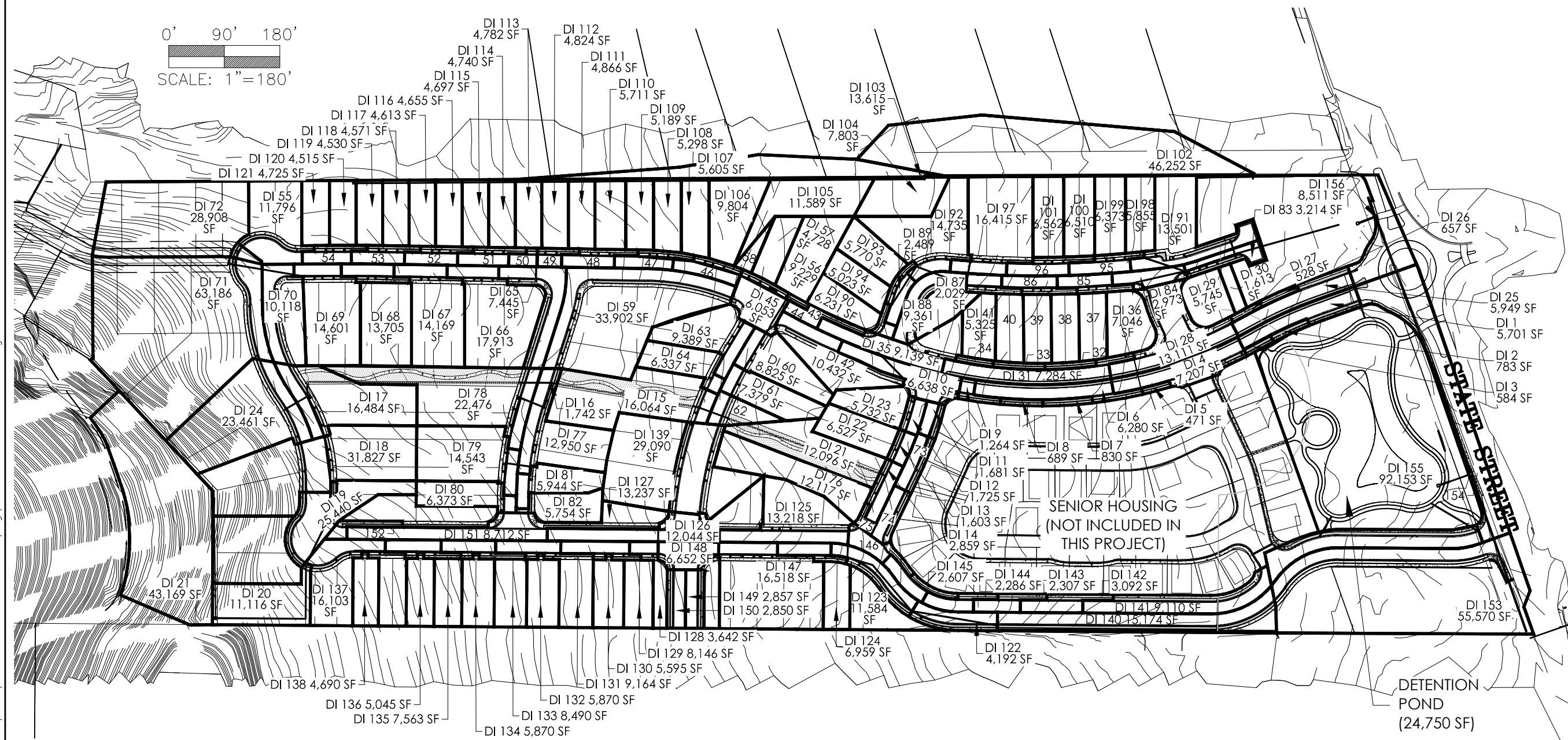

NO.	HISTORY/REVISION	BY	CHK.	DATE

BELLA VISTA SUBDIVISION  
 FLOOD CONTROL EXHIBIT

GUILLON INC. CONSTRUCTION  
 2550 LAKEWEST DRIVE, STE. 50, CHICO, CA

DRAWN	GG
CHECK	KD
APPROVED	RLW
DATE	12-15-2020
JOB NUMBER	9100.06
SHEET	OF
4	4

Dec 21, 2020 - 1:41pm  
 T:\Cadfiles\9100\9100.06 Bella Vista Estates\dwg\ 9100.06 POST-DEV HYDRO.dwg

**LACO**  
 EUREKA • UKIAH • SANTA ROSA  
 1-800-515-5054 www.lacoassociates.com

## APPENDIX 2

### **Final SCP**

All Regulated Projects



# Stormwater Control Plan for Regulated Projects

<p><b>For Office Use Only</b></p> <p>Application No. _____</p> <p>Received By: _____</p>
--

<p>Project Name: <u>Bella Vista Subdivision</u></p> <p>Physical Site Address/APN: <u>3000 South State Street, Ukiah, CA 95482</u></p> <p>Project Applicant: <u>Guillon Inc. Construction</u></p> <p>Mailing Address: <u>2550 Lakewest Drive, Suite 50, Chico, CA 95928</u></p> <p>Phone: <u>(530) 879-4436</u></p> <p><b>Consultant's Information</b></p> <p>Name: <u>Rodney L. Wilburn</u></p> <p>Firm: <u>LACO Associates</u> QSD certification#: <u>01320</u></p> <p>Address: <u>776 South State Street, Suite 103, Ukiah, CA 95482</u></p> <p>Email: <u>wilburnr@lacoassociates.com</u></p> <p>Phone: <u>(707) 462-0222</u></p>
---

**Instructions**

Based on the answers that you provided in the Construction and Post Construction Stormwater Runoff Control Checklist, you have determined that your project is classified as "regulated" for the purposes of the County of Mendocino MS4 Permit. Use this form to assist you in designing your project to comply with the County of Mendocino MS4 Permit design standards for regulated projects. The completed, signed SCP for Regulated Projects, plus any applicable, approved BMP Fact Sheets, must be submitted with your application to Mendocino County Planning and Building Services.

**Type of Application/Project:**

What type of application is this checklist accompanying?

- |   |   |
|---|---|
| <input checked="" type="checkbox"/> Subdivision | <input type="checkbox"/> Grading Permit               |
| <input type="checkbox"/> Building Permit        | <input type="checkbox"/> Design Review                |
| <input type="checkbox"/> Use Permit             | <input type="checkbox"/> Other (please specify) _____ |



# Stormwater Control Plan for Regulated Projects

## A. Project Description

<b>Project Type and Description:</b>	Compost Facility Improvement Plans - Phase I
<b>Total Pre-Project Impervious Surface Area (square feet)</b>	0 sq. ft.
<b>Total New or Replaced Impervious Surface Area (square feet)</b> <small>[Sum of impervious area that will be constructed as part of the project]</small>	638,506 sq. ft.
<b>Total Post-Project Impervious Surface Area (square feet)</b>	638,506 sq. ft.

If your project includes more than 5,000 square feet in new or replaced impervious area, is your project one of the following project types?

- Detached single family homes that create and/or replace 2,500 square feet or more and are not part of a larger plan of development
- Interior remodels
- Routine maintenance or repair, such as exterior wall surface replacement or pavement resurfacing within an existing footprint
- Linear Underground/Overhead Projects (LUPs) without a discrete location that has 5,000 square feet or more of newly constructed contiguous impervious surface.
- Sidewalks built as part of new streets or roads and built to direct stormwater runoff to adjacent vegetated areas
- Bicycle lanes that are built as part of new streets or roads that direct stormwater runoff to adjacent vegetated areas
- Impervious trails built to direct stormwater runoff to adjacent vegetated areas, or other non-erodible permeable areas
- Sidewalks, bicycle lanes, or trails constructed with permeable surfaces
- Trenching excavation and resurfacing associated with LUPs
- Grinding and resurfacing of existing roadways and parking lots
- Construction of new sidewalks, pedestrian ramps, or bike lanes on existing roadways
- Routine replacement of damaged pavement such as pothole repair, or replacement of short, non-contiguous sections of roadway

Yes

No

If you answered "Yes" above, your project is a non-regulated project under the definitions in the County of Mendocino MS4 Permit. Please use the Checklist for Non-Regulated Projects to assist you in your project design and application submittal.



# Stormwater Control Plan for Regulated Projects

## B. Site Assessment (Opportunities and Constraints)

### 1. Soil Characteristics

I. Soil characterization method Web Soil Survey

II. Were infiltration rates assessed for the site?  Yes  No

*If Yes, please attach soils testing report*

### 2. Depth to Groundwater

I. What is the depth (below ground surface) to groundwater (in feet)? 17.5 feet

II. How was this determined? Borings

### 3. Existing Vegetation and Natural Areas

I. Are there any key natural vegetation areas, sensitive habitats, or mature trees on the site?

Yes  No

If yes, please draw and label these features on the existing conditions site plan map and attach a description of them to this document.

### 4. Drainage and Hydrograph

I. Are there any natural drainage features or modified natural drainage features on the site or directly adjacent to the site?

Yes  No

### 5. Potential Contamination

I. Is the project site within or near a registered contaminated site, according to the State Water Resources Control Board Geotracker Website (<http://geotracker.waterboards.ca.gov/>)?

Yes  No

If yes, please attach the applicable contaminated site report from the Geotracker website and note the location of the contaminated site on the existing conditions site plan map. Please attach a description how this contamination will affect your project design.

## C. Project Layout Optimization



# Stormwater Control Plan for Regulated Projects

Optimizing the site layout can be done through the following methods:

1. Define the development envelope and protected areas, identifying areas that are most suitable for development and areas to be left undisturbed.
2. Concentrate development on portions of the site with less permeable soils and preserve areas that can promote infiltration.
3. Limit overall impervious coverage of the site from paving and roofs.
4. Set back development from creek, wetlands, and riparian habitats to maximize vegetative buffer widths.
5. Preserve significant trees.
6. Conform the site layout along natural landforms.
7. Avoid excessive grading and disturbance of vegetation and soils.
8. Replicate the site's natural drainage patterns.
9. Detain and retain runoff throughout the site.

Based on the features included in the existing conditions site plan, please ensure your project site plan applies project layout optimization measures to the greatest extent practicable, while still meeting the objectives of your project.

Have you attached a short description of how site optimization techniques have been integrated into the project design?

Yes       No

## D. Source Controls

Does your project contain potential pollutant-generating activities or sources?

Yes       No

If Yes, please complete the Source Control Worksheet, available at the County of Mendocino Stormwater website (<https://www.mendocinocounty.org/government/planning-building-services/stormwater>), and available as Appendix 4 of the County of Mendocino Low Impact Development Technical Design Manual; list and identify, using a simple table format, the source or treatment control measure and locations as an attachment to the SCP document.

## E. Drainage Management Areas

On the project site plan, please delineate and label all drainage management areas (refer to Sec. 6 of the manual). Record the DMA names and Areas in the table below.

**Table 1. DMAs**

DMA name	Area (square feet)
DMA 1	331,168 sq. ft.



# Stormwater Control Plan for Regulated Projects

DMA 2	810,446 sq. ft.
DMA 3	261,841 sq. ft.

**F. Site Design Measures**

Please identify the site design measures incorporated into the project design and attach the applicable, approved BMP Fact Sheet or equivalent to this checklist. These measures must be discussed in the SCP and shown on the site design map.

- Rooftop and Impervious Area Disconnection
- Tree Planting and Preservation
- Rain Barrels and Cisterns
- Porous Pavement
- Flow-Through Planter
- Bioretention



# Stormwater Control Plan for Regulated Projects

**Table 2. Area Calculations of Self-retaining Areas Used to Treat Impervious Areas**

<b>1</b> DMA Name	<b>2</b> Area (sq. ft.)
DMA 1	10,497
DMA 2	33,755
DMA 3	19,871

**Table 3. Runoff Factor (surface type)**

Roofs and Paving	1.0
Landscaped Area	0.1
Bricks or solid pavers- grouted	1.0
Bricks or solid Pavers-on sand base	0.5
Pervious Concrete Asphalt	0.1
Turfblock or gravel	0.1
Open or Porous pavers	0.1

Tables 4-6 below should be used to quantify the amount of runoff that is reduced by using site design measures. Using the tables in chronological order will calculate the minimum size for your bioretention facility in order to meet the MS4 permit requirements. Several iterations may be need to size facilities according to the site design.

**Table 4. Area draining to self-retaining areas**

<b>1</b> DMA Name  (must correspond to area on the site map and on Table 1)	<b>2</b> DMA Area (sq. ft.)  (Table 1)	<b>3</b> Type of Surface (Runoff Factor Table 3)	<b>4</b> Surface with Runoff Factor  Column 2 X Column 3	<b>5</b> Area of Self-retaining Area Receiving the Runoff (sq. ft.)  (Table 2, Col. 2)	<b>6</b> Ratio  Col. 4 : Col. 5  Not to exceed 2:1 ratio  (if number exceeds 2:1 use table 5 - 6 to reduce tributary area and recalculate or go directly to Table 7)
Example	700	Roof (1.0)	700	100	7:1 (must use site design measures, bioretention or both)
DMA 1	331,168	0.32	105,595	10,497	10.1 : 1
DMA 2	810,446	0.44	356,666	33,755	10.6 : 1
DMA 3	261,841	0.59	154,941	19,871	7.8 : 1





# Stormwater Control Plan for Regulated Projects

**Table 5. Tree Planting and Preservation (if not planting trees, go to Table 6)**

1 DMA Name (must correspond to area on the site map)	2 DMA sq. ft. (from Table 4, Col. 6)	3 Deciduous (Input 100 for each deciduous tree)	4 Evergreen (Input 200 for each evergreen tree)	5 Total Tree Credit (Col. 3 + Col. 4)  (DMA runoff reduction)	6 New DMA Area  Col. 2 – Col. 5  (for use in Table 6 - 8)
Example	700	-----	200	200	500 (new DMA size that must be treated with methods below Table 6-7)
DMA 1	105,595	2,900	-	2,900	102,695
DMA 2	356,666	24,100	-	24,100	332,566
DMA 3	154,941	9,200	-	9,200	145,741

**EIR Table 6. Rain Barrels and Cisterns (if not using site design measures, go to Table 8)**

1 DMA Name (must correspond to area on the site map)	2 New DMA sq. ft.  (Table 5, Col. 7 or, if no trees used, value from Table 4, Col. 2)	3 Number of Rain Barrels	4 Runoff Reduction from using a standard 55 gallon Rain Barrel = 88 sq. ft.  Use the following if size is other than the standard (for every gallon of storage, approx. 1.6 sq. ft. of reduction is achieved)	5 Col. 3 X Col. 4  (DMA runoff reduction)	6 New DMA Area  Col. 2 - Col. 5
Example	500	1	88	88	412 (go to Table 7 to recalculate Ratio)



# Stormwater Control Plan for Regulated Projects

**Table 6b. Infiltration Measures (Trenches and Dry Wells)**

1 DMA Name  (must correspond to area on the site map)	2 New DMA sq. ft.  (Table 5, Col. 7 or, if no trees used, value from Table 4, Col. 2)	3 Runoff Reduction Volume using guidance on Infiltration Site Design Sheet	4 New DMA Area Col. 2 – Col. 3
Example	500	200	300

**Table 7. New Tabulation of areas draining to self-retaining area after use of site design measures** (must achieve a 2:1 ratio; if not achievable, use table 8 to calculate the size of bioretention required)

1 DMA Name  (must correspond to area on the site map)	2 New Square footage of DMA  (Col 6, Table 4,5,6)	3 Area of Self-retaining Area Receiving the Runoff  (Table 2, Col. 2)	4 Ratio  Column 2 : Column 3 Not to exceed 2:1
Example	412 (Table 6)	100	4.12:1 (still exceeds 2:1 go back; add more trees, rain barrels, or use bioretention – example uses bioretention, Table 8)
DMA 1	102,695	10,497	9.8
DMA 2	332,566	33,755	9.9
DMA 3	145,741	19,871	7.3



# Stormwater Control Plan for Regulated Projects

**Table 8. Tabulation of areas draining to Bioretention Facility**

1	2	3	5	6	Minimum facility size	
DMA Name (must correspond to area on the site map)	DMA sq. ft. (Table 1, Col 2 or new DMA sq. ft. Table 7, Col. 2)	Runoff Factor Table 6a (skip if coming from Table 1)	DMA Area Col. 2 x Col. 3	Standard Sizing Factor	Col. 5 X Col. 6	If site does not allow for the minimum size, recalculate DMA using additional Site Design Measures to further reduce the tributary size
Example	300	1 (already calculated in steps above, for this example)	300	0.04	12 sq. ft.	(proposed facility size on site plans)
DMA 1	102,695	0.32	32,745	0.04	1,310	Accounted for in DMA 2 Bioretention Area
DMA 2	332,566	0.44	146,358	0.04	5,854	7,164 (Oversized to offset DMA 1)
DMA 3	145,741	0.59	86,240	0.04	3,450	3,585
				0.04		

**Table 9. Runoff Factors**

Roofs and Paving	1.0
Landscaped Area	0.1
Bricks or solid pavers- grouted	1.0
Bricks or solid Pavers-on sand base	0.5
Pervious Concrete Asphalt	0.1
Turfblock or gravel	0.1
Open or Porous pavers	0.1



# Stormwater Control Plan for Regulated Projects

## G. Operation and Maintenance in Perpetuity

Indicate whether an *Operation and Maintenance Plan* is accompanying this document (Appendix 9).

Yes  No

## H. Stormwater Control Plan

A Stormwater Control Plan is required for all Regulated Projects. This worksheet is designed to be the SCP if all requested descriptions and site plans have been attached. This document will be used by the plan checker to confirm that adequate stormwater control measures are being implemented on the project.

Indicate whether all supporting descriptions and worksheets are accompanying this document, Stormwater Control Plan

Yes  No

## I. Signature and Certification:

I, the below signed, confirm that I have accurately described my project to the best of my ability, and that I have not purposely omitted any detail affecting my project's classification for stormwater regulation. I hereby certify that the site design measures and stormwater flow treatment measures identified herein as being incorporated into my project have been designed in accordance with the approved BMP Fact Sheet or equivalent, which is attached to this checklist, and are included in the final site plans submitted to Mendocino County Planning and Building Services. I also hereby certify that my project meets the stormwater runoff reduction criteria identified in the County of Mendocino MS4 Post-Construction Stormwater Calculator, or as determined through other approved means.

Signature \_\_\_\_\_ Date \_\_\_\_\_

Print Name \_\_\_\_\_

I am the:  Property Owner  Contractor  Applicant

**Applicant Checklist for Regulated Projects; items that must be included in the Permit Packet**

<b>Items that must be on the Project Site Map</b>	
<input type="checkbox"/>	Existing natural hydrological features (depressions watercourses, wetlands, riparian areas, undisturbed natural areas, significant natural resource areas)
<input type="checkbox"/>	Existing and proposed site drainage network and connections to MS4 conveyances off-site
<input type="checkbox"/>	Proposed design features and surface treatments used to minimize imperviousness and reduce runoff
<input type="checkbox"/>	DMAs are delineated for the entire site and each is labeled with a unique identifier and is characterized as draining to self-retaining, self-treating, or draining to a bioretention facility
<input type="checkbox"/>	Proposed locations and footprints of bioretention facilities
<input type="checkbox"/>	Pollutant-generating source areas, including loading docks, food service areas, refuse areas, outdoor processes and storage, vehicle cleaning, repair or maintenance, fuel dispensing, equipment washing, etc. (Appendix 5)
<b>Contents of Stormwater Control Plan (SCP)</b>	
<input type="checkbox"/>	Narrative or description of site features and conditions that constrain or provide opportunities for stormwater control
<input type="checkbox"/>	Narrative of Site Design characteristics, building features, and pavement selections that reduce imperviousness of the site including the quantified runoff reduction.
<input type="checkbox"/>	Completed tables showing square footage of proposed pervious and impervious areas, self-treating areas, self-retaining areas, and areas draining to bioretention facilities
<input type="checkbox"/>	Preliminary designs, including calculations, for each bioretention facility. Elevations should show sufficient hydraulic head for each bioretention facility.
<input type="checkbox"/>	General Maintenance requirements for bioretention facilities
<input type="checkbox"/>	Statement accepting responsibility for interim operation and maintenance of facilities
<input type="checkbox"/>	Stormwater Construction Checklist
<input type="checkbox"/>	Certification by professional civil engineer, architect, landscape architect, or other approved professional

## APPENDIX 3

### Source Control Worksheet

**Storm water Pollutant Sources/Source Controls Checklist**

How to use this worksheet (also see instructions on Checklist for Regulated Projects):

- 1 Review Column 1 and identify which of these potential sources of storm water pollutants apply to your site. Check each box that applies.
- 2 Review Column 2 and incorporate all of the corresponding applicable Structural Source Control BMPs in your Storm water Control Plan drawings.
- 3 Review Columns 3 and 4 and incorporate all of the corresponding applicable Structural Source Control BMPs and Operational Source Control BMPs in a table in your Storm water Control Plan. Use this table and an accompanying narrative in the SCP, and explain any special conditions or situations that required omitting BMPs or substituting alternative BMPs.

IF THESE SOURCES WILL BE ON THE PROJECT SITE...	... THEN YOUR STORM WATER CONTROL PLAN (SCP) SHOULD INCLUDE THESE SOURCE CONTROL BMPS		
1 Potential Sources of Runoff Pollutants	2 Structural Source Controls – Show on SCP Drawings	3 Structural Source Control – List in SCP Table and Narrative	4 Operational Source Control BMPs – Include in SCP Table and Narrative
<input type="checkbox"/> <b>A.</b> On-site storm drain inlets (unauthorized non-storm water discharges and accidental spills or leaks)	<input type="checkbox"/> Location of inlets	<input type="checkbox"/> Mark all inlets with the words “No Dumping! Flows to River/Ocean” or similar.	<input type="checkbox"/> Maintain and periodically repaint or replace inlet markings.  <input type="checkbox"/> Provide storm water pollution prevention information to new site owners, lessees, or operators.  See applicable operational BMPs in Fact Sheet SC-44, “Drainage System Maintenance,” in the CASQA Storm water Quality Handbooks at <a href="http://www.casqa.org/resources/bmp-handbooks">www.casqa.org/resources/bmp-handbooks</a>  <input type="checkbox"/> Include the following in lease agreements: “Tenant shall not allow anyone to discharge anything to storm drains or to store or deposit materials so as to create a potential discharge to storm drains.”



IF THESE SOURCES WILL BE ON THE PROJECT SITE...	... THEN YOUR STORM WATER CONTROL PLAN (SCP) SHOULD INCLUDE THESE SOURCE CONTROL BMPs		
1 Potential Sources of Runoff Pollutants	2 Structural Source Controls – Show on SCP Drawings	3 Structural Source Control – List in SCP Table and Narrative	4 Operational Source Control BMPs – Include in SCP Table and Narrative
<input type="checkbox"/> B. Interior floor drains and elevator shaft sump pumps	<input type="checkbox"/> Show drain and pump locations	<input type="checkbox"/> State that interior floor drains and elevator shaft sump pumps will be plumbed to sanitary sewer	<input type="checkbox"/> Inspect and maintain drains to prevent blockages and overflow.
<input type="checkbox"/> C. Interior parking garages	<input type="checkbox"/> Show drain locations	<input type="checkbox"/> State that parking garage floor drains will be plumbed to the sanitary sewer	<input type="checkbox"/> Inspect and maintain drains to prevent blockages and overflow.
<input type="checkbox"/> D <sub>1</sub> . Need for future indoor & structural pest control		<input type="checkbox"/> Note building design features that discourage entry of pests	<input type="checkbox"/> Provide Integrated Pest Management information to owners, lessees, and operators.
<input type="checkbox"/> D <sub>2</sub> . Landscape/ Outdoor Pesticide Use/Building and Grounds Maintenance	<input type="checkbox"/> Show locations of native trees or areas of shrubs and ground cover to be undisturbed and retained.  <input type="checkbox"/> Show self-retaining landscape areas, if any.  <input type="checkbox"/> Show bioretention facilities. (See instructions in Chapter 4.)	State that final landscape plans will accomplish all of the following.  <input type="checkbox"/> Preserve existing native trees, shrubs, and ground cover to the maximum extent possible.  <input type="checkbox"/> Design landscaping to minimize irrigation and runoff, to promote surface infiltration where appropriate, and to minimize the use of fertilizers and pesticides that can contribute to storm water pollution.  <input type="checkbox"/> Where landscaped areas are used to retain or detain storm water, specify plants that are tolerant of saturated soil conditions.  <input type="checkbox"/> Consider using pest-resistant plants, especially adjacent to hardscape.  <input type="checkbox"/> To insure successful establishment, select plants appropriate to site soils, slopes, climate, sun, wind, rain, land use, air movement, ecological consistency, and plant interactions.	<input type="checkbox"/> Maintain landscaping using minimum or no pesticides.  <input type="checkbox"/> See applicable operational BMPs in Fact Sheet SC-41, “Building and Grounds Maintenance,” in the CASQA Storm water Quality Handbooks at <a href="http://www.casqa.org/resources/bmp-handbooks">www.casqa.org/resources/bmp-handbooks</a>  <input type="checkbox"/> Provide IPM information to new owners, lessees and operators.





IF THESE SOURCES WILL BE ON THE PROJECT SITE...	... THEN YOUR STORM WATER CONTROL PLAN (SCP) SHOULD INCLUDE THESE SOURCE CONTROL BMPs		
1 Potential Sources of Runoff Pollutants	2 Structural Source Controls – Show on SCP Drawings	3 Structural Source Control – List in SCP Table and Narrative	4 Operational Source Control BMPs – Include in SCP Table and Narrative
<input type="checkbox"/> E. Pools, spas, ponds, decorative fountains, and other water features	<input type="checkbox"/> Show location of water feature and a sanitary sewer cleanout in an accessible area within 10 feet.	<input type="checkbox"/> If the local municipality requires pools to be plumbed to the sanitary sewer, place a note on the plans and state in the narrative that this connection will be made according to local requirements.	<input type="checkbox"/> See applicable operational BMPs in Fact Sheet SC-72, “Fountain and Pool Maintenance,” in the CASQA Storm water Quality Handbooks at <a href="http://www.casqa.org/resources/bmp-handbooks">www.casqa.org/resources/bmp-handbooks</a>  <input type="checkbox"/> The sanitary sewer operator must be notified and a clean out identified when pools are to be drained to the sanitary sewer.
<input type="checkbox"/> F. Food Service	<input type="checkbox"/> For restaurants, grocery stores, and other food service operations, show location (indoors or in a covered area outdoors) of a floor sink or other area for cleaning floor mats, containers, and equipment.  <input type="checkbox"/> On the drawing, show a note that this drain will be connected to a grease interceptor before discharging to the sanitary sewer	<input type="checkbox"/> Describe the location and features of the designated cleaning area.  <input type="checkbox"/> Describe the items to be cleaned in this facility and how it has been sized to insure that the largest items can be accommodated.	<input type="checkbox"/> State maintenance schedule for grease interceptor
<input type="checkbox"/> G. Refuse areas	<input type="checkbox"/> Show where site refuse and recycled materials will be handled and stored for pickup. See local municipal requirements for sizes and other details of refuse areas.  <input type="checkbox"/> If dumpsters or other receptacles are outdoors, show how the designated area will be covered, graded, and paved to prevent run-on and show locations of berms to prevent runoff from the area.  <input type="checkbox"/> Any drains from dumpsters, compactors, and tallow bin areas shall be connected to a grease removal device before discharge to sanitary sewer.	<input type="checkbox"/> State how site refuse will be handled and provide supporting detail to what is shown on plans.  <input type="checkbox"/> State that signs will be posted on or near dumpsters with the words “Do not dump hazardous materials here” or similar.	<input type="checkbox"/> State how the following will be implemented:  Provide adequate number of receptacles. Inspect receptacles regularly; repair or replace leaky receptacles. Keep receptacles covered. Prohibit/prevent dumping of liquid or hazardous wastes. Post “no hazardous materials” signs. Inspect and pick up litter daily and clean up spills immediately. Keep spill control materials available on-site. See Fact Sheet SC-34, “Waste Handling and Disposal” in the CASQA Storm water Quality Handbooks at <a href="http://www.casqa.org/resources/bmp-handbooks">www.casqa.org/resources/bmp-handbooks</a>



IF THESE SOURCES WILL BE ON THE PROJECT SITE...	... THEN YOUR STORM WATER CONTROL PLAN (SCP) SHOULD INCLUDE THESE SOURCE CONTROL BMPS		
1 Potential Sources of Runoff Pollutants	2 Structural Source Controls – Show on SCP Drawings	3 Structural Source Control – List in SCP Table and Narrative	4 Operational Source Control BMPS – Include in SCP Table and Narrative
<input type="checkbox"/> H. Industrial Process area	<input type="checkbox"/> Show process area.	<input type="checkbox"/> If industrial processes are to be located on site, state: “All process activities to be performed indoors. No processes to drain to exterior or to storm drain system.”	<input type="checkbox"/> See Fact Sheet SC-10, “Non-Storm water Discharges” in the CASQA Storm water Quality Handbooks at <a href="http://www.casqa.org/resources/bmp-handbooks">www.casqa.org/resources/bmp-handbooks</a>
<input type="checkbox"/> I. Outdoor storage of wquipment or materials (See rows J and K for souce control measures for vehicle cleaning, repair, and maintenance.)	<input type="checkbox"/> Show any outdoor storage areas, including how materials will be covered. Show how areas will be graded and bermed to prevent run-on or run-off from area.  <input type="checkbox"/> Storage of non-hazardous liquids shall be covered by a roof and/or drain to the sanitary sewer system, and be contained by berms, dikes, liners, or vaults.  <input type="checkbox"/> Storage of hazardous materials and wastes must be in compliance with the local hazardous materials ordinance and a Hazardous Materials Management Plan for the site.	<input type="checkbox"/> Include a detailed description of materials to be stored, storage areas, and structural features to prevent pollutants from entering storm drains.  <input type="checkbox"/> Where appropriate, reference documentation of compliance with the requirements of programs for: <ul style="list-style-type: none"> <li>• Hazardous Waste Generation</li> <li>• Hazardous Materials Release Response and Inventory</li> <li>• California Accidental Release (CalARP)</li> <li>• Aboveground Storage Tank</li> <li>• Uniform Fire Code Article 80 Section 103(b) &amp; (c) 1991</li> <li>• Underground Storage Tank</li> </ul>	<input type="checkbox"/> See the Fact Sheets SC-31, “Outdoor Liquid Container Storage” and SC-33, “Outdoor Storage of Raw Materials ” in the CASQA Storm water Quality Handbooks at <a href="http://www.casqa.org/resources/bmp-handbooks">www.casqa.org/resources/bmp-handbooks</a>



IF THESE SOURCES WILL BE ON THE PROJECT SITE...	... THEN YOUR STORM WATER CONTROL PLAN (SCP) SHOULD INCLUDE THESE SOURCE CONTROL BMPs		
1 Potential Sources of Runoff Pollutants	2 Structural Source Controls – Show on SCP Drawings	3 Structural Source Control – List in SCP Table and Narrative	4 Operational Source Control BMPs – Include in SCP Table and Narrative
<input type="checkbox"/> J. Vehicle and Equipment Cleaning	<input type="checkbox"/> Show on drawings as appropriate:  (1) Commercial/industrial facilities having vehicle/ equipment cleaning needs shall either provide a covered, bermed area for washing activities or discourage vehicle/equipment washing by removing hose bibs and installing signs prohibiting such uses.  (2) Multi-dwelling complexes shall have a paved, bermed, and covered car wash area (unless car washing is prohibited on-site and hoses are provided with an automatic shut-off to discourage such use).  (3) Washing areas for cars, vehicles, and equipment shall be paved, designed to prevent run-on to or runoff from the area, and plumbed to drain to the sanitary sewer.  (4) Commercial car wash facilities shall be designed such that no runoff from the facility is discharged to the storm drain system. Wastewater from the facility shall discharge to the sanitary sewer, or a wastewater reclamation system shall be installed.	<input type="checkbox"/> If a car wash area is not provided, describe measures taken to discourage on-site car washing and explain how these will be enforced.	<input type="checkbox"/> Describe operational measures to implement the following (if applicable):  Wastewater from vehicle and equipment washing operations shall not be discharged to the storm drain system.  Car dealerships and similar may rinse cars with water only.  <input type="checkbox"/> See Fact Sheet SC-21, “Vehicle and Equipment Cleaning,” in the CASQA Storm water Quality Handbooks at <a href="http://www.casqa.org/resources/bmp-handbooks">www.casqa.org/resources/bmp-handbooks</a>



IF THESE SOURCES WILL BE ON THE PROJECT SITE...	... THEN YOUR STORM WATER CONTROL PLAN (SCP) SHOULD INCLUDE THESE SOURCE CONTROL BMPs		
1 Potential Sources of Runoff Pollutants	2 Structural Source Controls – Show on SCP Drawings	3 Structural Source Control – List in SCP Table and Narrative	4 Operational Source Control BMPs – Include in SCP Table and Narrative
<input type="checkbox"/> K. Vehicle and Equipment Repair and Maintenance	<input type="checkbox"/> Accommodate all vehicle equipment <input type="checkbox"/> repair and maintenance indoors. Or designate an outdoor work area and design the area to prevent run-on and runoff of storm water.  <input type="checkbox"/> Show secondary containment for exterior work areas where motor oil, brake fluid, gasoline, diesel fuel, radiator fluid, acid-containing batteries or other hazardous materials or hazardous wastes are used or stored. Drains shall not be installed within the secondary containment areas.  <input type="checkbox"/> Add a note on the plans that states either (1) there are no floor drains, or (2) floor drains are connected to wastewater pretreatment systems prior to discharge to the sanitary sewer and an industrial waste discharge permit will be obtained.	<input type="checkbox"/> State that no vehicle repair or maintenance will be done outdoors, or else describe the required features of the outdoor work area.  <input type="checkbox"/> State that there are no floor drains or if there are floor drains, note the agency from which an industrial waste discharge permit will be obtained and that the design meets that agency’s requirements.  <input type="checkbox"/> State that there are no tanks, containers or sinks to be used for parts cleaning or rinsing or, if there are, note the agency from which an industrial waste discharge permit will be obtained and that the design meets that agency’s requirements.	In the Storm water Control Plan, note that all of the following restrictions apply to use the site:  <input type="checkbox"/> No person shall dispose of, nor permit the disposal, directly or indirectly of vehicle fluids, hazardous materials, or rinsewater from parts cleaning into storm drains.  <input type="checkbox"/> No vehicle fluid removal shall be performed outside a building, nor on asphalt or ground surfaces, whether inside or outside a building, except in such a manner as to ensure that any spilled fluid will be in an area of secondary containment. Leaking vehicle fluids shall be contained or drained from the vehicle immediately.  <input type="checkbox"/> No person shall leave unattended parts or other open containers containing vehicle fluid, unless such containers are in use or in an area of secondary containment.



IF THESE SOURCES WILL BE ON THE PROJECT SITE...	... THEN YOUR STORM WATER CONTROL PLAN (SCP) SHOULD INCLUDE THESE SOURCE CONTROL BMPs		
1 Potential Sources of Runoff Pollutants	2 Structural Source Controls – Show on SCP Drawings	3 Structural Source Control – List in SCP Table and Narrative	4 Operational Source Control BMPs – Include in SCP Table and Narrative
<input type="checkbox"/> L. Fuel Dispensing Areas	<input type="checkbox"/> Fueling areas shall have impermeable floors (i.e., portland cement concrete or equivalent smooth impervious surface) that are: a) graded at the minimum slope necessary to prevent ponding; and b) separated from the rest of the site by a grade break that prevents run-on of storm water to the maximum extent practicable.  <input type="checkbox"/> Fueling areas shall be covered by a canopy that extends a minimum of ten feet in each direction from each pump. [Alternative: The fueling area must be covered and the cover’s minimum dimensions must be equal to or greater than the area within the grade break or fuel dispensing area1.] The canopy [or cover] shall not drain onto the fueling area	<input type="checkbox"/> State that no vehicle repair or maintenance will be done outdoors, or else describe the required features of the outdoor work area.  <input type="checkbox"/> State that there are no floor drains or if there are floor drains, note the agency from which an industrial waste discharge permit will be obtained and that the design meets that agency’s requirements.  <input type="checkbox"/> State that there are no tanks, containers or sinks to be used for parts cleaning or rinsing or, if there are, note the agency from which an industrial waste discharge permit will be obtained and that the design meets that agency’s requirements.	<input type="checkbox"/> The property owner shall dry sweep the fueling area routinely.  <input type="checkbox"/> See the Business Guide Sheet, “Automotive Service—Service Stations” in the CASQA Storm water Quality Handbooks at <a href="http://www.casqa.org/resources/bmp-handbooks">www.casqa.org/resources/bmp-handbooks</a>



IF THESE SOURCES WILL BE ON THE PROJECT SITE...	... THEN YOUR STORM WATER CONTROL PLAN (SCP) SHOULD INCLUDE THESE SOURCE CONTROL BMPs		
1 Potential Sources of Runoff Pollutants	2 Structural Source Controls – Show on SCP Drawings	3 Structural Source Control – List in SCP Table and Narrative	4 Operational Source Control BMPs – Include in SCP Table and Narrative
<input type="checkbox"/> <b>M. Loading Docks</b>	<input type="checkbox"/> Show the loading dock area, including roofing and drainage. Loading docks shall be covered and/or graded to minimize run-on to and runoff from the loading area. Roof downspouts shall be positioned to direct storm water away from the loading area. Water from loading dock areas shall be drained to the sanitary sewer, or diverted and collected for ultimate discharge to the sanitary sewer.  <input type="checkbox"/> Loading dock areas draining directly to the sanitary sewer shall be equipped with a spill control valve or equivalent device, which shall be kept closed during periods of operation.  <input type="checkbox"/> Provide a roof overhang over the loading area or install door skirts (cowling) at each bay that enclose the end of the trailer.		<input type="checkbox"/> Move loaded and unloaded items indoors as soon as possible.  <input type="checkbox"/> See Fact Sheet SC-30, “Outdoor Loading and Unloading,” in the CASQA Storm water Quality Handbooks at <a href="http://www.casqa.org/resources/bmp-handbooks">www.casqa.org/resources/bmp-handbooks</a>
<input type="checkbox"/> <b>N. Fire Sprinkler Test Water</b>		<input type="checkbox"/> Provide a means to drain fire sprinkler test water to the sanitary sewer	<input type="checkbox"/> See the note in Fact Sheet SC-41, “Building and Grounds Maintenance,” in the CASQA Storm water Quality Handbooks at <a href="http://www.casqa.org/resources/bmp-handbooks">www.casqa.org/resources/bmp-handbooks</a>



IF THESE SOURCES WILL BE ON THE PROJECT SITE...	... THEN YOUR STORM WATER CONTROL PLAN (SCP) SHOULD INCLUDE THESE SOURCE CONTROL BMPS		
1 Potential Sources of Runoff Pollutants	2 Structural Source Controls – Show on SCP Drawings	3 Structural Source Control – List in SCP Table and Narrative	4 Operational Source Control BMPS – Include in SCP Table and Narrative
<p><b>O. Miscellaneous Drain or Wash Water or Other Sources</b></p> <ul style="list-style-type: none"> <li><input type="checkbox"/> Boiler drain lines</li> <li><input type="checkbox"/> Condensate drain lines</li> <li><input type="checkbox"/> Rooftop equipment</li> <li><input type="checkbox"/> Drainage sumps</li> <li><input type="checkbox"/> Roofing, gutters, and trim</li> <li><input type="checkbox"/> Other sources</li> </ul>	<ul style="list-style-type: none"> <li><input type="checkbox"/> Show drain lines and drainage sumps</li> </ul>	<ul style="list-style-type: none"> <li><input type="checkbox"/> Boiler drain lines shall be directly or indirectly connected to the sanitary sewer system and may not discharge to the storm drain system.</li> <li><input type="checkbox"/> Condensate drain lines may discharge to landscaped areas if the flow is small enough that runoff will not occur. Condensate drain lines may not discharge to the storm drain system.</li> <li><input type="checkbox"/> Rooftop equipment with potential to produce pollutants shall be roofed and/or have secondary containment.</li> <li><input type="checkbox"/> Any drainage sumps on-site shall feature a sediment sump to reduce the quantity of sediment in pumped water.</li> <li><input type="checkbox"/> Include controls for other sources as specified by local reviewer.</li> </ul>	<p>If architectural copper is used, implement the following BMPS for management of rinse water during installation:</p> <ul style="list-style-type: none"> <li><input type="checkbox"/> If possible, purchase copper materials that have been pre-patinated at the factory.</li> <li><input type="checkbox"/> If patination is done on-site, prevent rinse water from entering storm drains by discharging to landscaping or by collecting in a tank and hauling off-site.</li> <li><input type="checkbox"/> Consider coating the copper materials with an impervious coating that prevents further corrosion and runoff.</li> </ul> <p>Implement the following BMPS during routine maintenance:</p> <ul style="list-style-type: none"> <li><input type="checkbox"/> Prevent rinse water from entering storm drains by discharging to landscaping or by collecting in a tank and hauling off-site.</li> </ul>
<ul style="list-style-type: none"> <li><input type="checkbox"/> <b>P. Plazas, sidewalks, and parking lots.</b></li> </ul>	<ul style="list-style-type: none"> <li><input type="checkbox"/> Show extent of permeable paving materials</li> </ul>		<ul style="list-style-type: none"> <li><input type="checkbox"/> Sweep plazas, sidewalks, and parking lots regularly to prevent accumulation of litter and debris.</li> <li><input type="checkbox"/> Collect debris from pressure washing to prevent entry into the storm drain system.</li> <li><input type="checkbox"/> Collect washwater containing any cleaning agent or degreaser and discharge to the sanitary sewer not to a storm drain.</li> </ul>



# Non-Stormwater Discharges

# SC-10



Graphic by: Margie Winter

### Description

Non-stormwater discharges are those flows that do not consist entirely of stormwater. For municipalities non-stormwater discharges present themselves in two situations. One is from fixed facilities owned and/or operated by the municipality. The other situation is non-stormwater discharges that are discovered during the normal operation of a field program. Some non-stormwater discharges do not include pollutants and may be discharged to the storm drain. These include uncontaminated groundwater and natural springs. There are also some non-stormwater discharges that typically do not contain pollutants and may be discharged to the storm drain with conditions. These include car washing, and surface cleaning. However, there are certain non-stormwater discharges that pose environmental concern. These discharges may originate from illegal dumping or from internal floor drains, appliances, industrial processes, sinks, and toilets that are connected to the nearby storm drainage system. These discharges (which may include: process waste waters, cooling waters, wash waters, and sanitary wastewater) can carry substances (such as paint, oil, fuel and other automotive fluids, chemicals and other pollutants) into storm drains. The ultimate goal is to effectively eliminate non-stormwater discharges to the stormwater drainage system through implementation of measures to detect, correct, and enforce against illicit connections and illegal discharges.

### Approach

The municipality must address non-stormwater discharges from its fixed facilities by assessing the types of non-stormwater discharges and implementing BMPs for the discharges determined to pose environmental concern. For field programs

### Objectives

- Contain
- Educate
- Reduce/Minimize

### Targeted Constituents

Sediment	<input checked="" type="checkbox"/>
Nutrients	<input checked="" type="checkbox"/>
Trash	<input checked="" type="checkbox"/>
Metals	<input checked="" type="checkbox"/>
Bacteria	<input checked="" type="checkbox"/>
Oil and Grease	<input checked="" type="checkbox"/>
Organics	<input checked="" type="checkbox"/>
Oxygen Demanding	<input checked="" type="checkbox"/>





## SC-10 **Non-Stormwater Discharges**

the field staff must be trained to now what to look for regarding non-stormwater discharges and the procedures to follow in investigating the detected discharges.

### ***Suggested Protocols***

#### **Fixed Facility**

##### *General*

- Post “No Dumping” signs with a phone number for reporting dumping and disposal. Signs should also indicate fines and penalties for illegal dumping.
- Stencil storm drains, where applicable, to prevent illegal disposal of pollutants. Storm drain inlets should have messages such as “Dump No Waste Drains to Stream” stenciled next to them to warn against ignorant or intentional dumping of pollutants into the storm drainage system.
- Landscaping and beautification efforts of hot spots might also discourage future dumping, as well as provide open space and increase property values.
- Lighting or barriers may also be needed to discourage future dumping.

##### *Illicit Connections*

- Locate discharges from the fixed facility drainage system to the municipal storm drain system through review of “as-built” piping schematics.
- Use techniques such as smoke testing, dye testing and television camera inspection (as noted below) to verify physical connections.
- Isolate problem areas and plug illicit discharge points.

##### *Visual Inspection and Inventory*

- Inventory and inspect each discharge point during dry weather.
- Keep in mind that drainage from a storm event can continue for several days following the end of a storm and groundwater may infiltrate the underground stormwater collection system. Also, non-stormwater discharges are often intermittent and may require periodic inspections.

##### *Review Infield Piping*

- Review the “as-built” piping schematic as a way to determine if there are any connections to the stormwater collection system.
- Inspect the path of floor drains in older buildings.

##### *Smoke Testing*

- Smoke testing of wastewater and stormwater collection systems is used to detect connections between the two systems.

# Non-Stormwater Discharges

# SC-10

- During dry weather the stormwater collection system is filled with smoke and then traced to sources. The appearance of smoke at the base of a toilet indicates that there may be a connection between the sanitary and the stormwater system.

### *Dye Testing*

- A dye test can be performed by simply releasing a dye into either your sanitary or process wastewater system and examining the discharge points from the stormwater collection system for discoloration.

### *TV Inspection of Storm Sewer*

- TV Cameras can be employed to visually identify illicit connections to the fixed facility storm drain system.

### *Illegal Dumping*

- Regularly inspect and clean up hot spots and other storm drainage areas where illegal dumping and disposal occurs.
- Clean up spills on paved surfaces with as little water as possible. Use a rag for small spills, a damp mop for general cleanup, and absorbent material for larger spills. If the spilled material is hazardous, then the used cleanup materials are also hazardous and must be sent to a certified laundry (rags) or disposed of as hazardous waste.
- Never hose down or bury dry material spills. Sweep up the material and dispose of properly.
- Use adsorbent materials on small spills rather than hosing down the spill. Remove the adsorbent materials promptly and dispose of properly.
- For larger spills, a private spill cleanup company or Hazmat team may be necessary.
- See fact sheet SC-11 Spill Prevention, Control, and Clean Up.

## **Field Program**

### *General*

- Develop clear protocols and lines of communication for effectively prohibiting non-stormwater discharges, especially ones that involve more than one jurisdiction and those that are not classified as hazardous, which are often not responded to as effectively as they need to be.
- Stencil storm drains, where applicable, to prevent illegal disposal of pollutants. Storm drain inlets should have messages such as “Dump No Waste Drains to Stream” stenciled next to them to warn against ignorant or intentional dumping of pollutants into the storm drainage system.
- See SC-74 Stormwater Drainage System Maintenance for additional information.

## SC-10 Non-Stormwater Discharges

---

### *Field Inspection*

- Regularly inspect and clean up hot spots and other storm drainage areas where illegal dumping and disposal occurs.
- During routine field program maintenance field staff should look for evidence of illegal discharges or illicit connection:
  - Is there evidence of spills such as paints, discoloring, etc.
  - Are there any odors associated with the drainage system
  - Record locations of apparent illegal discharges/illicit connections and notify appropriate investigating agency.
- If trained, conduct field investigation of non-stormwater discharges to determine whether they pose a threat to water quality.

### *Recommended Complaint Investigation Equipment*

- Field Screening Analysis
  - pH paper or meter
  - Commercial stormwater pollutant screening kit that can detect for reactive phosphorus, nitrate nitrogen, ammonium nitrogen, specific conductance, and turbidity
  - Sample jars
  - Sample collection pole
  - A tool to remove access hole covers
- Laboratory Analysis
  - Sample cooler
  - Ice
  - Sample jars and labels
  - Chain of custody forms.
- Documentation
  - Camera
  - Notebook
  - Pens
  - Notice of Violation forms

# Non-Stormwater Discharges

# SC-10

- Educational materials

## *Reporting*

- A database is useful for defining and tracking the magnitude and location of the problem.
- Report prohibited non-stormwater discharges observed during the course of normal daily activities so they can be investigated, contained and cleaned up or eliminated.
- Document that non-stormwater discharges have been eliminated by recording tests performed, methods used, dates of testing, and any onsite drainage points observed.
- Maintain documentation of illicit connection and illegal dumping incidents, including significant conditionally exempt discharges that are not properly managed.

## *Enforcement*

- Educate the responsible party if identified on the impacts of their actions, explain the stormwater requirements, and provide information regarding Best Management Practices (BMP), as appropriate. Initiate follow-up and/or enforcement procedures.
- If an illegal discharge is traced to a commercial, residential or industrial source, conduct the following activities or coordinate the following activities with the appropriate agency:
  - Contact the responsible party to discuss methods of eliminating the non-stormwater discharge, including disposal options, recycling, and possible discharge to the sanitary sewer (if within POTW limits).
  - Provide information regarding BMPs to the responsible party, where appropriate.
  - Begin enforcement procedures, if appropriate.
  - Continue inspection and follow-up activities until the illicit discharge activity has ceased.
- If an illegal discharge is traced to a commercial or industrial activity, coordinate information on the discharge with the jurisdiction's commercial and industrial facility inspection program.

## *Training*

- Train technical staff to identify and document illegal dumping incidents.
- Well-trained employees can reduce human errors that lead to accidental releases or spills. The employee should have the tools and knowledge to immediately begin cleaning up a spill if one should occur. Employees should be familiar with the Spill Prevention Control and Countermeasure Plan.
- Train employees to identify non-stormwater discharges and report them to the appropriate departments.
- Train staff who have the authority to conduct surveillance and inspections, and write citations for those caught illegally dumping.

## SC-10 Non-Stormwater Discharges

- Train municipal staff responsible for surveillance and inspection in the following:
  - OSHA-required Health and Safety Training (29 CFR 1910.120) plus annual refresher training (as needed).
  - OSHA Confined Space Entry training (Cal-OSHA Confined Space, Title 8 and federal OSHA 29 CFR 1910.146).
  - Procedural training (field screening, sampling, smoke/dye testing, TV inspection).
- Educate the identified responsible party on the impacts of his or her actions.

### ***Spill Response and Prevention***

- See SC-11 Spill Prevention Control and Clean Up

### ***Other Considerations***

- The elimination of illegal dumping is dependent on the availability, convenience, and cost of alternative means of disposal. The cost of fees for dumping at a proper waste disposal facility are often more than the fine for an illegal dumping offense, thereby discouraging people from complying with the law. The absence of routine or affordable pickup service for trash and recyclables in some communities also encourages illegal dumping. A lack of understanding regarding applicable laws or the inadequacy of existing laws may also contribute to the problem.
- Municipal codes should include sections prohibiting the discharge of soil, debris, refuse, hazardous wastes, and other pollutants into the storm drain system.
- Many facilities do not have accurate, up-to-date schematic drawings.
- Can be difficult to locate illicit connections especially if there is groundwater infiltration.

### **Requirements**

#### ***Costs***

- Eliminating illicit connections can be expensive especially if structural modifications are required such re-plumbing cross connections under an existing slab.
- Minor cost to train field crews regarding the identification of non-stormwater discharges. The primary cost is for a fully integrated program to identify and eliminate illicit connections and illegal dumping. However, by combining with other municipal programs (i.e. pretreatment program) cost may be lowered.
- Municipal cost for containment and disposal may be borne by the discharger.

#### ***Maintenance***

Not applicable

# Non-Stormwater Discharges

# SC-10

## Supplemental Information

### *Further Detail of the BMP*

*What constitutes a "non-stormwater" discharge?*

- Non-stormwater discharges are discharges not made up entirely of stormwater and include water used directly in the manufacturing process (process wastewater), air conditioning condensate and coolant, non-contact cooling water, cooling equipment condensate, outdoor secondary containment water, vehicle and equipment wash water, landscape irrigation, sink and drinking fountain wastewater, sanitary wastes, or other wastewaters.

### *Permit Requirements*

- Current municipal NPDES permits require municipalities to effectively prohibit non-stormwater discharges unless authorized by a separate NPDES permit or allowed in accordance with the current NPDES permit conditions. Typically the current permits allow certain non-stormwater discharges in the storm drain system as long as the discharges are not significant sources of pollutants. In this context the following non-stormwater discharges are typically allowed:
  - Diverted stream flows;
  - Rising found waters;
  - Uncontaminated ground water infiltration (as defined at 40 CFR 35.2005(20));
  - Uncontaminated pumped ground water;
  - Foundation drains;
  - Springs;
  - Water from crawl space pumps;
  - Footing drains;
  - Air conditioning condensation;
  - Flows from riparian habitats and wetlands;
  - Water line and hydrant flushing ;
  - Landscape irrigation;
  - Planned and unplanned discharges from potable water sources;
  - Irrigation water;
  - Individual residential car washing; and
  - Lawn watering.

## SC-10 **Non-Stormwater Discharges**

Municipal facilities subject to industrial general permit requirements must include a certification that the stormwater collection system has been tested or evaluated for the presence of non-stormwater discharges. The state's General Industrial Stormwater Permit requires that non-stormwater discharges be eliminated prior to implementation of the facility's SWPPP.

### *Illegal Dumping*

- Establish a system for tracking incidents. The system should be designed to identify the following:
  - Illegal dumping hot spots
  - Types and quantities (in some cases) of wastes
  - Patterns in time of occurrence (time of day/night, month, or year)
  - Mode of dumping (abandoned containers, "midnight dumping" from moving vehicles, direct dumping of materials, accidents/spills)
  - Responsible parties

### *Outreach*

One of the keys to success of reducing or eliminating illegal dumping is increasing the number of people on the street who are aware of the problem and who have the tools to at least identify the incident, if not correct it. There are a number of ways of accomplishing this:

- Train municipal staff from all departments (public works, utilities, street cleaning, parks and recreation, industrial waste inspection, hazardous waste inspection, sewer maintenance) to recognize and report the incidents.
- Deputize municipal staff who may come into contact with illegal dumping with the authority to write illegal dumping tickets for offenders caught in the act (see below).
- Educate the public. As many as 3 out of 4 people do not understand that in most communities the storm drain does not go to the wastewater treatment plant. Unfortunately, with the heavy emphasis in recent years on public education about solid waste management, including recycling and household hazardous waste, the sewer system (both storm and sanitary) has been the likely recipient of cross-media transfers of waste.
- Provide the public with a mechanism for reporting incidents such as a hot line and/or door hanger (see below).
- Help areas where incidents occur more frequently set up environmental watch programs (like crime watch programs).
- Train volunteers to notice and report the presence and suspected source of an observed pollutant to the appropriate public agency.

# Non-Stormwater Discharges

# SC-10

## *What constitutes a “non-stormwater” discharge?*

- Non-stormwater discharges are discharges not made up entirely of stormwater and include water used directly in the manufacturing process (process wastewater), air conditioning condensate and coolant, non-contact cooling water, cooling equipment condensate, outdoor secondary containment water, vehicle and equipment wash water, landscape irrigation, sink and drinking fountain wastewater, sanitary wastes, or other wastewaters.

## *Permit Requirements*

- Current municipal NPDES permits require municipalities to effectively prohibit non-stormwater discharges unless authorized by a separate NPDES permit or allowed in accordance with the current NPDES permit conditions. Typically the current permits allow certain non-stormwater discharges in the storm drain system as long as the discharges are not significant sources of pollutants. In this context the following non-stormwater discharges are typically allowed:
  - Diverted stream flows;
  - Rising found waters;
  - Uncontaminated ground water infiltration (as defined at 40 CFR 35.2005(20));
  - Uncontaminated pumped ground water;
  - Foundation drains;
  - Springs;
  - Water from crawl space pumps;
  - Footing drains;
  - Air conditioning condensation;
  - Flows from riparian habitats and wetlands;
  - Water line and hydrant flushing ;
  - Landscape irrigation;
  - Planned and unplanned discharges from potable water sources;
  - Irrigation water;
  - Individual residential car washing; and
  - Lawn watering.

Municipal facilities subject to industrial general permit requirements must include a certification that the stormwater collection system has been tested or evaluated for the presence



## SC-10 **Non-Stormwater Discharges**

of non-stormwater discharges. The state's General Industrial Stormwater Permit requires that non-stormwater discharges be eliminated prior to implementation of the facility's SWPPP.

### *Storm Drain Stenciling*

- Stencil storm drain inlets with a message to prohibit illegal dumpings, especially in areas with waste handling facilities.
- Encourage public reporting of improper waste disposal by a HOTLINE number stenciled onto the storm drain inlet.
- See Supplemental Information section of this fact sheet for further detail on stenciling program approach.

### *Oil Recycling*

- Contract collection and hauling of used oil to a private licensed used oil hauler/recycler.
- Comply with all applicable state and federal regulations regarding storage, handling, and transport of petroleum products.
- Create procedures for collection such as; collection locations and schedule, acceptable containers, and maximum amounts accepted.
- The California Integrated Waste Management Board has a Recycling Hotline, (800) 553-2962, that provides information and recycling locations for used oil.

### *Household Hazardous Waste*

- Provide household hazardous waste (HHW) collection facilities. Several types of collection approaches are available including permanent, periodic, or mobile centers, curbside collection, or a combination of these systems.

### *Training*

- Train municipal employees and contractors in proper and consistent methods for waste disposal.
- Train municipal employees to recognize and report illegal dumping.
- Train employees and subcontractors in proper hazardous waste management.

### *Spill Response and Prevention*

- Refer to SC-11, Spill Prevention, Control & Cleanup
- Have spill cleanup materials readily available and in a known location.
- Cleanup spills immediately and use dry methods if possible.
- Properly dispose of spill cleanup material.

# Non-Stormwater Discharges

# SC-10

## *Other Considerations*

- Federal Regulations (RCRA, SARA, CERCLA) and state regulations exist regarding the disposal of hazardous waste.
- Municipalities are required to have a used oil recycling element and a HHW element within their integrated waste management plan.
- Significant liability issues are involved with the collection, handling, and disposal of HHW.

## *Examples*

The City of Palo Alto has developed a public participation program for reporting dumping violations. When a concerned citizen or public employee encounters evidence of illegal dumping, a door hanger (similar in format to hotel "Do Not Disturb" signs) is placed on the front doors in the neighborhood. The door hanger notes that a violation has occurred in the neighborhood, informs the reader why illegal dumping is a problem, and notes that illegal dumping carries a significant financial penalty. Information is also provided on what citizens can do as well as contact numbers for more information or to report a violation.

The Port of Long Beach has a state of the art database incorporating storm drain infrastructure, potential pollutant sources, facility management practices, and a pollutant tracking system.

The State Department of Fish and Game has a hotline for reporting violations called CalTIP (1-800-952-5400). The phone number may be used to report any violation of a Fish and Game code (illegal dumping, poaching, etc.).

The California Department of Toxic Substances Control's Waste Alert Hotline, 1-800-69TOXIC, can be used to report hazardous waste violations.

## **References and Resources**

<http://www.stormwatercenter.net/>

California's Nonpoint Source Program Plan <http://www.co.clark.wa.us/pubworks/bmpman.pdf>

King County Stormwater Pollution Control Manual - <http://dnr.metrokc.gov/wlr/dss/spcm.htm>

Orange County Stormwater Program,  
[http://www.ocwatersheds.com/stormwater/swp\\_introduction.asp](http://www.ocwatersheds.com/stormwater/swp_introduction.asp)

San Diego Stormwater Co-permittees Jurisdictional Urban Runoff Management Program  
(<http://www.projectcleanwater.org>)

Santa Clara Valley Urban Runoff Pollution Prevention Program  
[http://www.sevurppp-w2k.com/pdf%20documents/PS\\_ICID.PDF](http://www.sevurppp-w2k.com/pdf%20documents/PS_ICID.PDF)

# Vehicle and Equipment Cleaning SC-21



Photo Credit: Geoff Brosseau

## Description

Wash water from vehicle and equipment cleaning activities performed outdoors or in areas where wash water flows onto the ground can contribute toxic hydrocarbons and other organic compounds, oils and greases, nutrients, phosphates, heavy metals, and suspended solids to stormwater runoff. Use of the procedures outlined below can prevent or reduce the discharge of pollutants to stormwater during vehicle and equipment cleaning.

## Approach

Reduce potential for pollutant discharge through source control pollution prevention and BMP implementation. Successful implementation depends on effective training of employees on applicable BMPs and general pollution prevention strategies and objectives

## Pollution Prevention

- If possible, use properly maintained off-site commercial washing and steam cleaning businesses whenever possible. These businesses are better equipped to handle and properly dispose of the wash waters.
- Good housekeeping practices can minimize the risk of contamination from wash water discharges.

## Objectives

- Cover
- Contain
- Educate
- Reduce/Minimize
- Product Substitution

## Targeted Constituents

Sediment	<input checked="" type="checkbox"/>
Nutrients	<input checked="" type="checkbox"/>
Trash	<input checked="" type="checkbox"/>
Metals	<input checked="" type="checkbox"/>
Bacteria	<input type="checkbox"/>
Oil and Grease	<input checked="" type="checkbox"/>
Organics	<input checked="" type="checkbox"/>
Oxygen Demanding	<input type="checkbox"/>



## **SC-21 Vehicle and Equipment Cleaning**

### ***Suggested Protocols***

#### *General*

- Use biodegradable, phosphate-free detergents for washing vehicles as appropriate.
- Mark the area clearly as a wash area.
- Post signs stating that only washing is allowed in wash area and that discharges to the storm drain are prohibited.
- Provide a trash container in wash area.
- Map on-site storm drain locations to avoid discharges to the storm drain system.
- Emphasize the connection between the storm drain system and runoff and help reinforce that car washing activities can have an affect on local water quality. This can be accomplished through storm drain stenciling programs.

#### *Vehicle and Equipment Cleaning*

- Design wash areas to properly collect and dispose of wash water when engine cleaning is conducted and when chemical additives, solvents, or degreasers are used. This may include installation of sumps or drain lines to collect wash water or construction of a berm around the designated area and grading of the area to collect wash water as well as prevent stormwater run-on.
- Consider washing vehicles and equipment inside the building if washing/cleaning must occur on-site. This will help to control the targeted constituents by directing them to the sanitary sewer.
- If washing must occur on-site and outdoor:
  - Use designated paved wash areas. Designated wash areas must be well marked with signs indicating where and how washing must be done. This area must be covered or bermed to collect the wash water and graded to direct the wash water to a treatment or disposal facility.
  - Oil changes and other engine maintenance cannot be conducted in the designated washing area. Perform these activities in a place designated for such activities.
  - Cover the wash area when not in use to prevent contact with rain water.
- Use hoses with nozzles that automatically turn off when left unattended.
- Perform pressure cleaning and steam cleaning off-site to avoid generating runoff with high pollutant concentrations. If done on-site, no pressure cleaning and steam cleaning should be done in areas designated as wellhead protection areas for public water supply.

#### *Disposal*

- Consider filtering and recycling wash water.

# Vehicle and Equipment Cleaning **SC-21**

- Discharge equipment wash water to the sanitary sewer, a holding tank, or a process treatment system, regardless of the washing method used.
- Discharge vehicle wash water to (1) the sanitary sewer, a holding tank, or process treatment system or (2) an enclosed recycling system.
- Discharge wash water to sanitary sewer only after contacting the local sewer authority to find out if pretreatment is required.

## ***Training***

- Train employees on proper cleaning and wash water disposal procedures and conduct “refresher” courses on a regular basis.
- Train staff on proper maintenance measures for the wash area.
- Train employees and contractors on proper spill containment and cleanup. The employee should have the tools and knowledge to immediately begin cleaning up a spill if one should occur.

## ***Spill Response and Prevention***

- Refer to SC-11, Spill Prevention, Control and Cleanup.
- Keep your Spill Prevention Control and Counter Measure (SPCC) Plan up-to-date, and implement accordingly.
- Have spill cleanup materials readily available and in a known location.
- Clean up spills immediately and use dry methods if possible.
- Properly dispose of spill cleanup material.

## ***Other Considerations (Limitations and Regulations)***

- Some municipalities may require pretreatment and monitoring of wash water discharges to the sanitary sewer.
- Steam cleaning can generate significant pollutant concentrations requiring that careful consideration be given to the environmental impacts and compliance issues related to steam cleaning.
- Most car washing best management practices are inexpensive, and rely more on good housekeeping practices (where vehicles are washed, planning for the collection of wash water) than on expensive technology. However, the construction of a specialized area for vehicle washing can be expensive for municipal facilities. Also, for facilities that cannot recycle their wash water the cost of pre-treating wash water through either structural practices or planning for collection and hauling of contaminated water to sewage treatment plants can represent a cost limitation.

## **Requirements**

### ***Costs***

- Capital costs vary depending on measures implemented

## **SC-21 Vehicle and Equipment Cleaning**

- Low cost (\$500-1,000) for berm construction,
  - Medium cost (\$5,000-20,000) for plumbing modifications (including re-routing discharge to sanitary sewer and installing simple sump).
  - High cost (\$30,000-150,000) for on-site treatment and recycling.
- O&M costs increase with increasing capital investment.

### ***Maintenance***

- Berm repair and patching.
- Sweep washing areas frequently to remove solid debris.
- Inspect and maintain sumps, oil/water separators, and on-site treatment/recycling units.

### **Supplemental Information**

#### ***Design Considerations***

##### ***Designated Cleaning Areas***

- Washing operations outside should be conducted in a designated wash area having the following characteristics:
  - Paved with Portland cement concrete,
  - Covered and bermed to prevent contact with stormwater and contain wash water,
  - Sloped for wash water collection,
  - Equipped with an oil/water separator, if necessary.

### ***Examples***

The City of Palo Alto has an effective program for commercial vehicle service facilities. Many of the program's elements, including specific BMP guidance and lists of equipment suppliers, are applicable to industrial vehicle service facilities.

The U.S. Postal Service in West Sacramento has a new vehicle wash system that collects, filters, and recycles the wash water.

### **References and Resources**

<http://www.stormwatercenter.net/>

King County - <ftp://dnr.metrokc.gov/wlr/dss/spcm/Chapter%203.PDF>

Orange County Stormwater Program

[http://www.ocwatersheds.com/StormWater/swp\\_introduction.asp](http://www.ocwatersheds.com/StormWater/swp_introduction.asp)

San Diego Stormwater Co-permittees Jurisdictional Urban Runoff Management Program (URMP)

<http://www.projectcleanwater.org/pdf/Model%20Program%20Municipal%20Facilities.pdf>

# Outdoor Loading/Unloading

## SC-30



### Objectives

- Cover
- Contain
- Educate
- Reduce/Minimize
- Product Substitution

### Description

The loading/unloading of materials usually takes place outside on docks or terminals; therefore, materials spilled, leaked, or lost during loading/unloading may collect in the soil or on other surfaces and have the potential to be carried away by stormwater runoff or when the area is cleaned. Additionally, rainfall may wash pollutants from machinery used to unload or move materials. Loading and unloading of material may include package products, barrels, and bulk products. Implementation of the following protocols will prevent or reduce the discharge of pollutants to stormwater from outdoor loading/unloading of materials.

### Approach

#### *Pollution Prevention*

- Keep accurate maintenance logs to evaluate materials removed and improvements made.
- Park tank trucks or delivery vehicles in designated areas so that spills or leaks can be contained.
- Limit exposure of materials with the potential to contaminate stormwater.
- Prevent stormwater runoff.
- Regularly check equipment for leaks.

### Targeted Constituents

Sediment	<input checked="" type="checkbox"/>
Nutrients	<input checked="" type="checkbox"/>
Trash	
Metals	<input checked="" type="checkbox"/>
Bacteria	
Oil and Grease	<input checked="" type="checkbox"/>
Organics	<input checked="" type="checkbox"/>
Oxygen Demanding	<input checked="" type="checkbox"/>



## **SC-30 Outdoor Loading/Unloading**

### ***Suggested Protocols***

#### ***Loading and Unloading – General Guidelines***

- Develop an operations plan that describes procedures for loading and/or unloading.
- Do not conduct loading and unloading during wet weather, whenever possible.
- Cover designated loading/unloading areas to reduce exposure of materials to rain.
- A seal or door skirt between delivery vehicles and building can reduce or prevent exposure to rain.
- Design loading/unloading area to prevent stormwater runoff which would include grading or berming the area, and positioning roof downspouts so they direct stormwater away from the loading/unloading areas.
- If feasible, load and unload all materials and equipment in covered areas such as building overhangs at loading docks.
- Load/unload only at designated loading areas.
- Use drip pans underneath hose and pipe connections and other leak-prone spots during liquid transfer operations, and when making and breaking connections. Several drip pans should be stored in a covered location near the liquid transfer area so that they are always available, yet protected from precipitation when not in use. Drip pans can be made specifically for railroad tracks. Drip pans must be cleaned periodically, and drip collected materials must be disposed of properly.
- Pave loading areas with concrete instead of asphalt.
- Avoid placing storm drains in the area.
- Grade and/or berm the loading/ unloading area to a drain that is connected to a dead-end sump.

#### ***Inspection***

- Check loading and unloading equipment regularly for leaks, including valves, pumps, flanges and connections.
- Look for dust or fumes during loading or unloading operations.

#### ***Training***

- Train employees (e.g. fork lift operators) and contractors on proper spill containment and cleanup.
- Employees trained in spill containment and cleanup should be present during the loading/unloading.
- Train employees in proper handling techniques during liquid transfers to avoid spills.



# Outdoor Loading/Unloading

# SC-30

- Make sure forklift operators are properly trained on loading and unloading procedures.

## ***Spill Response and Prevention***

- Refer to SC-11, Spill Prevention, Control & Cleanup
- Keep your spill prevention Control and countermeasure (SPCC) Plan up-to-date, and implement accordingly.
- Have spill cleanup materials readily available and in a known location.
- Cleanup spills immediately and use dry methods if possible.
- Properly dispose of spill cleanup material.

## ***Other Considerations***

- Space, material characteristics and/or time limitations may preclude all transfers from being performed indoors or under cover.

## **Requirements**

### ***Costs***

- Should be low except when covering a large loading/unloading area.

### ***Maintenance***

- Conduct regular inspections and make repairs as necessary. The frequency of repairs will depend on the age of the facility.
- Check loading and unloading equipment regularly for leaks.
- Regular broom dry-sweeping of area.
- Conduct major clean-out of loading and unloading area and sump prior to October 1 of each year.

## **Supplemental Information**

### ***Further Detail of the BMP***

#### ***Special Circumstances for Indoor Loading/Unloading of Materials***

As appropriate loading or unloading of liquids should occur indoors so that any spills that are not completely retained can be discharged to the sanitary sewer, treatment plant, or treated in a manner consistent with local sewer authorities and permit requirements.

- For loading and unloading tank trucks to above and below ground storage tanks, the following procedures should be used:
  - The area where the transfer takes place should be paved. If the liquid is reactive with the asphalt, Portland cement should be used to pave the area.
  - Transfer area should be designed to prevent runoff of stormwater from adjacent areas. Sloping the pad and using a curb, like a speed bump, around the uphill side of the transfer area should reduce run-on.

## **SC-30 Outdoor Loading/Unloading**

---

- Transfer area should be designed to prevent runoff of spilled liquids from the area. Sloping the area to a drain should prevent runoff. The drain should be connected to a dead-end sump or to the sanitary sewer (if allowed). A positive control valve should be installed on the drain.
- For transfer from rail cars to storage tanks that must occur outside, use the following procedures:
  - Drip pans should be placed at locations where spillage may occur, such as hose connections, hose reels, and filler nozzles, Use drip pans when making and breaking connections.
  - Drip pan systems should be installed between the rails to collect spillage from tank cars.

### **References and Resources**

<http://www.stormwatercenter.net/>

King County - <ftp://dnr.metrokc.gov/wlr/dss/spcm/Chapter%203.PDF>

Orange County Stormwater Program

[http://www.ocwatersheds.com/StormWater/swp\\_introduction.asp](http://www.ocwatersheds.com/StormWater/swp_introduction.asp)

San Diego Stormwater Co-permittees Jurisdictional Urban Runoff Management Program (URMP) -

<http://www.projectcleanwater.org/pdf/Model%20Program%20Municipal%20Facilities.pdf>

# Outdoor Container Storage

# SC-31



## Description

Accidental releases of materials from above ground liquid storage tanks, drums, and dumpsters present the potential for contaminating stormwaters with many different pollutants. Tanks may store many potential stormwater runoff pollutants, such as gasoline, aviation gas, diesel fuel, ammonia, solvents, syrups, etc. Materials spilled, leaked, or lost from storage tanks may accumulate in soils or on other surfaces and be carried away by rainfall runoff. These source controls apply to containers located outside of a building used to temporarily store liquid materials and include installing safeguards against accidental releases, installing secondary containment, conducting regular inspections, and training employees in standard operating procedures and spill cleanup techniques.

## Approach

### *Pollution Prevention*

- Educate employees about pollution prevention measures and goals
- Keep an accurate, up-to-date inventory of the materials delivered and stored on-site. Re-evaluate inventory needs and consider purchasing alternative products. Properly dispose of outdated products.
- Try to keep chemicals in their original containers, and keep them well labeled.

## Objectives

- Cover
- Contain
- Educate
- Reduce/Minimize
- Product Substitution

## Targeted Constituents

Sediment	
Nutrients	<input checked="" type="checkbox"/>
Trash	
Metals	<input checked="" type="checkbox"/>
Bacteria	
Oil and Grease	<input checked="" type="checkbox"/>
Organics	<input checked="" type="checkbox"/>
Oxygen Demanding	<input checked="" type="checkbox"/>



# SC-31 Outdoor Container Storage

---

## *Suggested Protocols*

### *General*

- Develop an operations plan that describes procedures for loading and/or unloading. Refer to SC-30 Outdoor Loading/Unloading for more detailed BMP information pertaining to loading and unloading of liquids.
- Protect materials from rainfall, runoff, and wind dispersal:
  - Cover the storage area with a roof.
  - Minimize stormwater runoff by enclosing the area or building a berm around it.
  - Use a “doghouse” structure for storage of liquid containers.
  - Use covered dumpsters for waste product containers.
- Employ safeguards against accidental releases:
  - Provide overflow protection devices to warn operator or automatic shut down transfer pumps.
  - Provide protection guards (bollards) around tanks and piping to prevent vehicle or forklift damage, and
  - Provide clear tagging or labeling, and restricting access to valves to reduce human error.
- Berm or surround tank or container with secondary containment system using dikes, liners, vaults, or double walled tanks.
- Contact the appropriate regulatory agency regarding environmental compliance for facilities with “spill ponds” designed to intercept, treat, and/or divert spills.
- Have registered and specifically trained professional engineers can identify and correct potential problems such as loose fittings, poor welding, and improper or poorly fitted gaskets for newly installed tank systems.

### *Storage Areas*

- Provide storage tank piping located below product level with a shut-off valve at the tank; ideally this valve should be an automatic shear valve with the shut-off located inside the tank.
- Provide barriers such as posts or guard rails, where tanks are exposed, to prevent collision damage with vehicles.
- Provide secure storage to prevent vandalism.
- Place tight-fitting lids on all containers.
- Enclose or cover the containers where they are stored.

# Outdoor Container Storage

# SC-31

- Raise the containers off the ground by use of pallet or similar method, with provisions for spill control and secondary containment.
- Contain the material in such a manner that if the container leaks or spills, the contents will not discharge, flow, or be washed into the storm drainage system, surface waters or groundwater.
- Place drip pans or absorbent materials beneath all mounted container taps, and at all potential drip and spill locations during filling and unloading of containers. Drip pans must be cleaned periodically, and all collected liquids and soiled absorbent materials must be reused/recycled or properly disposed.
- Ensure that any underground or aboveground storage tanks shall be designed and managed in accordance with applicable regulations, be identified as a potential pollution source, have secondary containment, such as a berm or dike with an impervious surface.
- Rainfall collected in secondary containment system must not contain pollutants for discharge to storm drain system.

## *Container Management*

- Keep containers in good condition without corrosion or leaky seams.
- Place containers in a lean-to structure or otherwise covered to keep rainfall from reaching the drums.
- Replace containers if they are deteriorating to the point where leakage is occurring. Keep all containers undercover to prevent the entry of stormwater. Employees should be made aware of the importance of keeping the containers free from leaks.
- Keep waste container drums in an area such as a service bay. Drums stored outside must be stored in a lean-to type structure, shed or walk-in container.

## *Storage of Hazardous Materials*

- Storage of reactive, ignitable, or flammable liquids must comply with the fire and hazardous waste codes.
- Place containers in a designated area that is paved, free of cracks and gaps, and impervious in order to contain leaks and spills. The area should also be covered.
- Surround stored hazardous materials and waste with a curb or dike to provide the volume to contain 10 percent of the volume of all of the containers or 110 percent of the volume of the largest container, whichever is greater. The area inside the curb should slope to a drain and a dead-end sump should be installed in the drain.

## *Inspection*

- Provide regular inspections:
  - Inspect storage areas regularly for leaks or spills.

## SC-31 Outdoor Container Storage

---

- Conduct routine inspections and check for external corrosion of material containers. Also check for structural failure, spills and overfills due to operator error, failure of piping system.
- Check for leaks or spills during pumping of liquids or gases from truck or rail car to a storage facility or vice versa.
- Visually inspect new tank or container installations for loose fittings, poor welding, and improper or poorly fitted gaskets.
- Inspect tank foundations, connections, coatings, and tank walls and piping system. Look for corrosion, leaks, cracks, scratches, and other physical damage that may weaken the tank or container system.
- Replace containers that are leaking, corroded, or otherwise deteriorating with ones in good condition. If the liquid chemicals are corrosive, containers made of compatible materials must be used instead of metal drums.
- Label new or secondary containers with the product name and hazards.

### ***Training***

- Train employees (e.g. fork lift operators) and contractors in proper spill containment and cleanup. The employee should have the tools and knowledge to immediately begin cleaning up a spill if one should occur.
- Train employees in proper storage measures.
- Use a training log or similar method to document training.

### ***Spill Response and Prevention***

- Keep your Spill Prevention Control and Countermeasure (SPCC) Plan up-to-date, and implement accordingly.
- Have an emergency plan, equipment and trained personnel ready at all times to deal immediately with major spills.
- Collect all spilled liquids and properly dispose of them.
- Employees trained in emergency spill cleanup procedures should be present when dangerous waste, liquid chemicals, or other wastes are delivered.
- Operator errors can be prevented by using engineering safe guards and thus reducing accidental releases of pollutant.
- Store and maintain appropriate spill cleanup materials in a location known to all near the tank storage area.
- See Aboveground Tank Leak and Spill Control section of the Spill Prevention, Control & Cleanup fact sheet (SC-11) for additional information.

# Outdoor Container Storage

# SC-31

## *Other Considerations*

- Storage sheds often must meet building and fire code requirements.
- The local fire district must be consulted for limitations on clearance of roof covers over containers used to store flammable materials.
- All specific standards set by federal and state laws concerning the storage of oil and hazardous materials must be met.
- Storage of reactive, ignitable, or flammable liquids should comply with the Uniform Fire Code and the National Electric Code.
- Storage of oil and hazardous materials must meet specific federal and state standards including:
  - Spill Prevention Control and Countermeasure Plan (SPCC) Plan
  - Secondary containment
  - Integrity and leak detection monitoring
  - Emergency preparedness plans

## **Requirements**

### *Costs*

- Will vary depending on the size of the facility and the necessary controls, such as berms or safeguards against accidental controls.

### *Maintenance*

- Conduct weekly inspection.
- Sweep and clean the storage area regularly if it is paved, do not hose down the area to a storm drain.

## **Supplemental Information**

- The most common causes of unintentional releases are:
  - Installation problems,
  - Failure of piping systems (pipes, pumps, flanges, couplings, hoses, and valves),
  - External corrosion and structural failure,
  - Spills and overfills due to operator error, and
  - Leaks during pumping of liquids or gases from truck or rail car to a storage tank or vice versa

# SC-31 Outdoor Container Storage

---

## *Further Detail of the BMP*

### *Dikes*

One of the best protective measures against contamination of stormwater is diking. Containment dikes are berms or retaining walls that are designed to hold spills. Diking is an effective pollution prevention measure for above ground storage tanks and railcar or tank truck loading and unloading areas. The dike surrounds the area of concern and holds the spill, keeping spill materials separated from the stormwater side of the dike area. Diking can be used in any industrial or municipal facility, but it is most commonly used for controlling large spills or releases from liquid storage areas and liquid transfer areas.

- For single-wall tanks, containment dikes should be large enough to hold the contents of the storage tank for the facility plus rain water.
- For trucks, diked areas should be capable of holding an amount equal to the volume of the tank truck compartment. Diked construction material should be strong enough to safely hold spilled materials.
- Dike materials can consist of earth, concrete, synthetic materials, metal, or other impervious materials.
- Strong acids or bases may react with metal containers, concrete, and some plastics.
- Where strong acids or bases are stored, alternative dike materials should be considered. More active organic chemicals may need certain special liners for dikes.
- Dikes may also be designed with impermeable materials to increase containment capabilities.
- Dikes should be inspected during or after significant storms or spills to check for washouts or overflows.
- Regular checks of containment dikes to insure the dikes are capable of holding spills should be conducted.
- Inability of a structure to retain stormwater, dike erosion, soggy areas, or changes in vegetation indicate problems with dike structures. Damaged areas should be patched and stabilized immediately.
- Accumulated stormwater in the containment area should be analyzed for pollutants before it is released to surface waters. If pollutants are found or if stormwater quality is not determined, then methods other than discharging to surface waters should be employed (e.g., discharge to sanitary sewer if allowed).
- Earthen dikes may require special maintenance of vegetation such as mulching and irrigation.



# Outdoor Container Storage

# SC-31

## *Curbing*

Curbing is a barrier that surrounds an area of concern. Curbing is similar to containment diking in the way that it prevents spills and leaks from being released into the environment. The curbing is usually small scaled and does not contain large spills like diking. Curbing is common at many facilities in small areas where handling and transfer liquid materials occur. Curbing can redirect stormwater away from the storage area. It is useful in areas where liquid materials are transferred from one container to another. Asphalt is a common material used for curbing; however, curbing materials include earth, concrete, synthetic materials, metal, or other impenetrable materials.

- Spilled materials should be removed immediately from curbed areas to allow space for future spills.
- Curbs should have manually-controlled pump systems rather than common drainage systems for collection of spilled materials.
- The curbed area should be inspected regularly to clear clogging debris.
- Maintenance should also be conducted frequently to prevent overflow of any spilled materials as curbed areas are designed only for smaller spills.
- Curbing has the following advantages:
  - Excellent runoff control,
  - Inexpensive,
  - Ease of installment,
  - Provides option to recycle materials spilled in curb areas, and
  - Common industry practice.

## **Examples**

The “doghouse” design has been used to store small liquid containers. The roof and flooring design prevent contact with direct rain or runoff. The doghouse has two solid structural walls and two canvas covered walls. The flooring is wire mesh about secondary containment. The unit has been used successfully at Lockheed Missile and Space Company in Sunnyvale.

## **References and Resources**

British Columbia Lake Stewardship Society. Best Management Practices to Protect Water Quality from Non-Point Source Pollution. March 2000  
<http://www.nalms.org/bclss/storage.html>

King County Stormwater Pollution Control Manual –  
<http://dnr.metrokc.gov/wlr/dss/spcm.htm>

# **SC-31 Outdoor Container Storage**

---

San Diego Stormwater Co-permittees Jurisdictional Urban Runoff Management Program  
(URMP) -

<http://www.projectcleanwater.org/pdf/Model%20Program%20Municipal%20Facilities.pdf>

# Outdoor Storage of Raw Materials SC-33



## Objectives

- Cover
- Contain
- Educate
- Reduce/Minimize

## Description

Raw materials, by-products, finished products, containers, and material storage areas exposed to rain and/or runoff can pollute stormwater. Stormwater can become contaminated when materials wash off or dissolve into water or are added to runoff by spills and leaks. Improper storage of these materials can result in accidental spills and the release of materials. To prevent or reduce the discharge of pollutants to stormwater from material delivery and storage, pollution prevention and source control measures, such as minimizing the storage of hazardous materials on-site, enclosing or covering materials, storing materials in a designated area, installing secondary containment, conducting regular inspections, preventing stormwater runoff and runoff, and training employees and subcontractors must be implemented.

## Approach

### *Pollution Prevention*

- Employee education is paramount for successful BMP implementation.
- Minimize inventory of raw materials.
- Keep an accurate, up-to-date inventory of the materials delivered and stored on-site.
- Try to keep chemicals in their original containers, and keep them well labeled.

## Targeted Constituents

Sediment	<input checked="" type="checkbox"/>
Nutrients	<input checked="" type="checkbox"/>
Trash	<input checked="" type="checkbox"/>
Metals	
Bacteria	
Oil and Grease	<input checked="" type="checkbox"/>
Organics	<input checked="" type="checkbox"/>
Oxygen Demanding	<input checked="" type="checkbox"/>



## **SC-33 Outdoor Storage of Raw Materials**

### ***Suggested Protocols***

#### *General*

- Store all materials inside. If this is not feasible, then all outside storage areas should be covered with a roof, and bermed, or enclosed to prevent stormwater contact. At the very minimum, a temporary waterproof covering made of polyethylene, polypropylene or hypalon should be used over all materials stored outside.
- Cover and contain the stockpiles of raw materials to prevent stormwater from running into the covered piles. The covers must be in place at all times when work with the stockpiles is not occurring. (applicable to small stockpiles only).
- If the stockpiles are so large that they cannot feasibly be covered and contained, implement erosion control practices at the perimeter of your site and at any catch basins to prevent erosion of the stockpiled material off site,
- Keep liquids in a designated area on a paved impervious surface within a secondary containment.
- Keep outdoor storage containers in good condition.
- Keep storage areas clean and dry.
- Design paved areas to be sloped in a manner that minimizes the pooling of water on the site, particularly with materials that may leach pollutants into stormwater and/or groundwater, such as compost, logs, and wood chips. A minimum slope of 1.5 percent is recommended.
- Secure drums stored in an area where unauthorized persons may gain access to prevent accidental spillage, pilferage, or any unauthorized use.
- Cover wood products treated with chromated copper arsenate, ammonical copper zinc arsenate, creosote, or pentachlorophenol with tarps or store indoors.

#### *Raw Material Containment*

- Do not store chemicals, drums, or bagged materials directly on the ground. Place these items in secondary containers if applicable.
- Prevent the run-on of uncontaminated stormwater from adjacent areas as well as runoff of stormwater from the stockpile areas, by placing a curb along the perimeter of the area. The area inside the curb should slope to a drain. Liquids should be drained to the sanitary sewer if allowed. The drain must have a positive control such as a lock, valve, or plug to prevent release of contaminated liquids.
- Tanks should be bermed or surrounded by a secondary containment system.
- Release accumulated stormwater in petroleum storage areas prior to the next storm. At a minimum, water should pass through an oil/water separator and, if allowed, discharged to a sanitary sewer.

## Outdoor Storage of Raw Materials SC-33

---

### *Inspection*

- Conduct regular inspections of storage areas so that leaks and spills are detected as soon as possible.
- Conduct routine inspections and check for external corrosion of material containers. Also check for structural failure, spills and overfills due to operator error, failure of piping system.
- Check for leaks or spills during pumping of liquids or gases from truck or rail car to a storage facility or vice versa.
- Visually inspect new tank or container installations for loose fittings, poor welding, and improper or poorly fitted gaskets.
- Inspect tank foundations, connections, coatings, and tank walls and piping system. Look for corrosion, leaks, cracks, scratches, and other physical damage that may weaken the tank or container system.

### *Training*

- Employees should be well trained in proper material storage.
- Train employees and contractors in proper techniques for spill containment and cleanup.

### *Spill Response and Prevention*

- Refer to SC-11, Spill Prevention, Control & Cleanup.
- Keep your Spill Prevention Control and countermeasure (SPCC) plan up-to-date, and implement accordingly.
- Have spill cleanup materials readily available and in a known location.
- Cleanup spills immediately and use dry methods if possible.
- Properly dispose of spill cleanup material.
- Have employees trained in spill containment and cleanup present during loading/unloading of dangerous waste, liquid chemicals and other potentially hazardous materials.

### *Other Considerations*

- Storage sheds often must meet building and fire code requirements. Storage of reactive, ignitable, or flammable liquids must comply with the Uniform Fire Code and the National Electric Code.
- Space limitations may preclude storing some materials indoors.
- Some municipalities require that secondary containment areas (regardless of size) be connected to the sanitary sewer, prohibiting any hard connections to the storm drain. Storage sheds often must meet building and fire code requirements.
- The local fire district must be consulted for limitations on clearance of roof covers over containers used to store flammable materials.

## **SC-33 Outdoor Storage of Raw Materials**

### **Requirements**

#### **Costs**

- Costs will vary depending on the size of the facility and the necessary controls. They should be low except where large areas may have to be covered.

#### **Maintenance**

- Accurate and up-to-date inventories should be kept of all stored materials.
- Berms and curbs may require periodic repair and patching.
- Parking lots or other surfaces near bulk materials storage areas should be swept periodically to remove debris blown or washed from storage area.
- Sweep paved storage areas regularly for collection and disposal of loose solid materials, do not hose down the area to a storm drain or conveyance ditch.
- Keep outdoor storage areas in good condition (e.g. repair roofs, floors, etc. to limit releases to runoff).

### **Supplemental Information**

#### **Further Detail of the BMP**

##### *Raw Material Containment*

Paved areas should be sloped in a manner that minimize the pooling of water on the site, particularly with materials that may leach pollutants into stormwater and/or groundwater, such as compost, logs, and wood chips. A minimum slope of 1.5 percent is recommended.

- Curbing should be placed along the perimeter of the area to prevent the runoff of uncontaminated stormwater from adjacent areas as well as runoff of stormwater from the stockpile areas.
- The storm drainage system should be designed to minimize the use of catch basins in the interior of the area as they tend to rapidly fill with manufacturing material.
- The area should be sloped to drain stormwater to the perimeter where it can be collected or to internal drainage alleyways where material is not stockpiled.
- If the raw material, by-product, or product is a liquid, more information for outside storage of liquids can be found under SC-31, Outdoor Container Storage.

#### **Examples**

The “doghouse” design has been used to store small liquid containers. The roof and flooring design prevent contact with direct rain or runoff. The doghouse has two solid structural walls and two canvas covered walls. The flooring is wire mesh about secondary containment. The unit has been used successively at Lockheed Missile and Space Company in Sunnyvale.

#### **References and Resources**

King County Stormwater Pollution Control Manual - <http://dnr.metrokc.gov/wlr/dss/spcm.htm>

## **Outdoor Storage of Raw Materials SC-33**

---

Model Urban Runoff Program: A How-To-Guide for Developing Urban Runoff Programs for Small Municipalities. Prepared by City of Monterey, City of Santa Cruz, California Coastal Commission, Monterey Bay National Marine Sanctuary, Association of Monterey Bay Area Governments, Woodward-Clyde, Central Coast Regional Water Quality Control Board. July 1998 (Revised February 2002 by the California Coastal Commission).

Orange County Stormwater Program

[http://www.ocwatersheds.com/StormWater/swp\\_introduction.asp](http://www.ocwatersheds.com/StormWater/swp_introduction.asp)

San Diego Stormwater Co-permittees Jurisdictional Urban Runoff Management Program (URMP)

<http://www.projectcleanwater.org/pdf/Model%20Program%20Municipal%20Facilities.pdf>

# Waste Handling & Disposal

# SC-34



## Objectives

- Cover
- Contain
- Educate
- Reduce/Minimize
- Product Substitution

## Description

Improper storage and handling of solid wastes can allow toxic compounds, oils and greases, heavy metals, nutrients, suspended solids, and other pollutants to enter stormwater runoff. The discharge of pollutants to stormwater from waste handling and disposal can be prevented and reduced by tracking waste generation, storage, and disposal; reducing waste generation and disposal through source reduction, re-use, and recycling; and preventing runoff and runoff.

## Approach

### Pollution Prevention

- Reduction in the amount of waste generated can be accomplished using the following source controls such as:
  - Production planning and sequencing
  - Process or equipment modification
  - Raw material substitution or elimination
  - Loss prevention and housekeeping
  - Waste segregation and separation
  - Close loop recycling
- Establish a material tracking system to increase awareness about material usage. This may reduce spills and minimize contamination, thus reducing the amount of waste produced.
- Recycle materials whenever possible.

## Targeted Constituents

Sediment	<input checked="" type="checkbox"/>
Nutrients	<input checked="" type="checkbox"/>
Trash	<input checked="" type="checkbox"/>
Metals	<input checked="" type="checkbox"/>
Bacteria	<input checked="" type="checkbox"/>
Oil and Grease	<input checked="" type="checkbox"/>
Organics	<input checked="" type="checkbox"/>
Oxygen Demanding	<input checked="" type="checkbox"/>





# SC-34 Waste Handling & Disposal

---

## *Suggested Protocols*

### *General*

- Cover storage containers with leak proof lids or some other means. If waste is not in containers, cover all waste piles (plastic tarps are acceptable coverage) and prevent stormwater runoff and runoff with a berm. The waste containers or piles must be covered except when in use.
- Use drip pans or absorbent materials whenever grease containers are emptied by vacuum trucks or other means. Grease cannot be left on the ground. Collected grease must be properly disposed of as garbage.
- Check storage containers weekly for leaks and to ensure that lids are on tightly. Replace any that are leaking, corroded, or otherwise deteriorating.
- Sweep and clean the storage area regularly. If it is paved, do not hose down the area to a storm drain.
- Dispose of rinse and wash water from cleaning waste containers into a sanitary sewer if allowed by the local sewer authority. Do not discharge wash water to the street or storm drain.
- Transfer waste from damaged containers into safe containers.
- Take special care when loading or unloading wastes to minimize losses. Loading systems can be used to minimize spills and fugitive emission losses such as dust or mist. Vacuum transfer systems can minimize waste loss.

### *Controlling Litter*

- Post "No Littering" signs and enforce anti-litter laws.
- Provide a sufficient number of litter receptacles for the facility.
- Clean out and cover litter receptacles frequently to prevent spillage.

### *Waste Collection*

- Keep waste collection areas clean.
- Inspect solid waste containers for structural damage or leaks regularly. Repair or replace damaged containers as necessary.
- Secure solid waste containers; containers must be closed tightly when not in use.
- Place waste containers under cover if possible.
- Do not fill waste containers with washout water or any other liquid.
- Ensure that only appropriate solid wastes are added to the solid waste container. Certain wastes such as hazardous wastes, appliances, fluorescent lamps, pesticides, etc. may not be

# Waste Handling & Disposal

# SC-34

disposed of in solid waste containers (see chemical/ hazardous waste collection section below).

- Do not mix wastes; this can cause chemical reactions, make recycling impossible, and complicate disposal.

## *Good Housekeeping*

- Use all of the product before disposing of the container.
- Keep the waste management area clean at all times by sweeping and cleaning up spills immediately.
- Use dry methods when possible (e.g. sweeping, use of absorbents) when cleaning around restaurant/food handling dumpster areas. If water must be used after sweeping/using absorbents, collect water and discharge through grease interceptor to the sewer.
- Stencil storm drains on the facility's property with prohibitive message regarding waste disposal.

## *Chemical/Hazardous Wastes*

- Select designated hazardous waste collection areas on-site.
- Store hazardous materials and wastes in covered containers protected from vandalism, and in compliance with fire and hazardous waste codes.
- Place hazardous waste containers in secondary containment.
- Make sure that hazardous waste is collected, removed, and disposed of only at authorized disposal areas.

## *Runon/Runoff Prevention*

- Prevent stormwater runon from entering the waste management area by enclosing the area or building a berm around the area.
- Prevent the waste materials from directly contacting rain.
- Cover waste piles with temporary covering material such as reinforced tarpaulin, polyethylene, polyurethane, polypropylene or hypalon.
- Cover the area with a permanent roof if feasible.
- Cover dumpsters to prevent rain from washing waste out of holes or cracks in the bottom of the dumpster.
- Move the activity indoor after ensuring all safety concerns such as fire hazard and ventilation are addressed.

## *Inspection*

## SC-34 **Waste Handling & Disposal**

---

- Inspect and replace faulty pumps or hoses regularly to minimize the potential of releases and spills.
- Check waste management areas for leaking containers or spills.
- Repair leaking equipment including valves, lines, seals, or pumps promptly.

### **Training**

- Train staff pollution prevention measures and proper disposal methods.
- Train employees and contractors proper spill containment and cleanup. The employee should have the tools and knowledge to immediately begin cleaning up a spill if one should occur.
- Train employees and subcontractors in proper hazardous waste management.

### **Spill Response and Prevention**

- Refer to SC-11, Spill Prevention, Control & Cleanup.
- Keep your Spill Prevention Control and countermeasure (SPCC) plan up-to-date, and implement accordingly.
- Have spill cleanup materials readily available and in a known location.
- Cleanup spills immediately and use dry methods if possible.
- Properly dispose of spill cleanup material.
- Vehicles transporting waste should have spill prevention equipment that can prevent spills during transport. The spill prevention equipment includes:
  - Vehicles equipped with baffles for liquid waste
  - Trucks with sealed gates and spill guards for solid waste

### **Other Considerations**

- Hazardous waste cannot be re-used or recycled; it must be disposed of by a licensed hazardous waste hauler.

### **Requirements**

#### **Costs**

- Capital and operation and maintenance costs will vary substantially depending on the size of the facility and the types of waste handled. Costs should be low if there is an inventory program in place.

#### **Maintenance**

- None except for maintaining equipment for material tracking program.

# Waste Handling & Disposal

**SC-34****Supplemental Information*****Further Detail of the BMP******Land Treatment System***

- Minimize the runoff of polluted stormwater from land application of municipal waste on-site by:
  - Choosing a site where slopes are under 6%, the soil is permeable, there is a low water table, it is located away from wetlands or marshes, there is a closed drainage system.
  - Avoiding application of waste to the site when it is raining or when the ground is saturated with water.
  - Growing vegetation on land disposal areas to stabilize soils and reduce the volume of surface water runoff from the site.
  - Maintaining adequate barriers between the land application site and the receiving waters. Planted strips are particularly good.
  - Using erosion control techniques such as mulching and matting, filter fences, straw bales, diversion terracing, and sediment basins.
  - Performing routine maintenance to ensure the erosion control or site stabilization measures are working.

**References and Resources**

King County Stormwater Pollution Control Manual - <http://dnr.metrokc.gov/wlr/dss/spcm.htm>

Orange County Stormwater Program

[http://www.ocwatersheds.com/StormWater/swp\\_introduction.asp](http://www.ocwatersheds.com/StormWater/swp_introduction.asp)

Pollution from Surface Cleaning Folder. 1996. Bay Area Stormwater Management Agencies Associations (BASMAA). On-line: <http://www.basmaa.org>

# Building & Grounds Maintenance SC-41



## Description

Stormwater runoff from building and grounds maintenance activities can be contaminated with toxic hydrocarbons in solvents, fertilizers and pesticides, suspended solids, heavy metals, and abnormal pH. Utilizing the following protocols will prevent or reduce the discharge of pollutants to stormwater from building and grounds maintenance activities by washing and cleaning up with as little water as possible, following good landscape management practices, preventing and cleaning up spills immediately, keeping debris from entering the storm drains, and maintaining the stormwater collection system.

## Approach

### Pollution Prevention

- Switch to non-toxic chemicals for maintenance when possible.
- Choose cleaning agents that can be recycled.
- Encourage proper lawn management and landscaping, including use of native vegetation.
- Encourage use of Integrated Pest Management techniques for pest control.
- Encourage proper onsite recycling of yard trimmings.
- Recycle residual paints, solvents, lumber, and other material as much as possible.

## Objectives

- Cover
- Contain
- Educate
- Reduce/Minimize
- Product Substitution

## Targeted Constituents

Sediment	<input checked="" type="checkbox"/>
Nutrients	<input checked="" type="checkbox"/>
Trash	<input checked="" type="checkbox"/>
Metals	<input checked="" type="checkbox"/>
Bacteria	<input checked="" type="checkbox"/>
Oil and Grease	<input checked="" type="checkbox"/>
Organics	<input checked="" type="checkbox"/>
Oxygen Demanding	<input checked="" type="checkbox"/>



## **SC-41 Building & Grounds Maintenance**

### ***Suggested Protocols***

#### *Pressure Washing of Buildings, Rooftops, and Other Large Objects*

- In situations where soaps or detergents are used and the surrounding area is paved, pressure washers must use a waste water collection device that enables collection of wash water and associated solids. A sump pump, wet vacuum or similarly effective device must be used to collect the runoff and loose materials. The collected runoff and solids must be disposed of properly.
- If soaps or detergents are not used, and the surrounding area is paved, wash water runoff does not have to be collected but must be screened. Pressure washers must use filter fabric or some other type of screen on the ground and/or in the catch basin to trap the particles in wash water runoff.
- If you are pressure washing on a grassed area (with or without soap), runoff must be dispersed as sheet flow as much as possible, rather than as a concentrated stream. The wash runoff must remain on the grass and not drain to pavement. Ensure that this practice does not kill grass.

#### *Landscaping Activities*

- Do not apply any chemicals (insecticide, herbicide, or fertilizer) directly to surface waters, unless the application is approved and permitted by the state.
- Dispose of grass clippings, leaves, sticks, or other collected vegetation as garbage, or by composting. Do not dispose of collected vegetation into waterways or storm drainage systems.
- Use mulch or other erosion control measures on exposed soils.
- Check irrigation schedules so pesticides will not be washed away and to minimize non-stormwater discharge.

#### *Building Repair, Remodeling, and Construction*

- Do not dump any toxic substance or liquid waste on the pavement, the ground, or toward a storm drain.
- Use ground or drop cloths underneath outdoor painting, scraping, and sandblasting work, and properly dispose of collected material daily.
- Use a ground cloth or oversized tub for activities such as paint mixing and tool cleaning.
- Clean paint brushes and tools covered with water-based paints in sinks connected to sanitary sewers or in portable containers that can be dumped into a sanitary sewer drain. Brushes and tools covered with non-water-based paints, finishes, or other materials must be cleaned in a manner that enables collection of used solvents (e.g., paint thinner, turpentine, etc.) for recycling or proper disposal.

## **Building & Grounds Maintenance SC-41**

- Use a storm drain cover, filter fabric, or similarly effective runoff control mechanism if dust, grit, wash water, or other pollutants may escape the work area and enter a catch basin. The containment device(s) must be in place at the beginning of the work day, and accumulated dirty runoff and solids must be collected and disposed of before removing the containment device(s) at the end of the work day.
- If you need to de-water an excavation site, you may need to filter the water before discharging to a catch basin or off-site. In which case you should direct the water through hay bales and filter fabric or use other sediment filters or traps.
- Store toxic material under cover with secondary containment during precipitation events and when not in use. A cover would include tarps or other temporary cover material.

### *Mowing, Trimming, and Planting*

- Dispose of leaves, sticks, or other collected vegetation as garbage, by composting or at a permitted landfill. Do not dispose of collected vegetation into waterways or storm drainage systems.
- Use mulch or other erosion control measures when soils are exposed.
- Place temporarily stockpiled material away from watercourses and drain inlets, and berm or cover stockpiles to prevent material releases to the storm drain system.
- Consider an alternative approach when bailing out muddy water; do not put it in the storm drain, pour over landscaped areas.
- Use hand or mechanical weeding where practical.

### *Fertilizer and Pesticide Management*

- Follow all federal, state, and local laws and regulations governing the use, storage, and disposal of fertilizers and pesticides and training of applicators and pest control advisors.
- Follow manufacturers' recommendations and label directions. Pesticides must never be applied if precipitation is occurring or predicted. Do not apply insecticides within 100 feet of surface waters such as lakes, ponds, wetlands, and streams.
- Use less toxic pesticides that will do the job, whenever possible. Avoid use of copper-based pesticides if possible.
- Do not use pesticides if rain is expected.
- Do not mix or prepare pesticides for application near storm drains.
- Use the minimum amount needed for the job.
- Calibrate fertilizer distributors to avoid excessive application.
- Employ techniques to minimize off-target application (e.g. spray drift) of pesticides, including consideration of alternative application techniques.

## **SC-41 Building & Grounds Maintenance**

---

- Apply pesticides only when wind speeds are low.
- Work fertilizers into the soil rather than dumping or broadcasting them onto the surface.
- Irrigate slowly to prevent runoff and then only as much as is needed.
- Clean pavement and sidewalk if fertilizer is spilled on these surfaces before applying irrigation water.
- Dispose of empty pesticide containers according to the instructions on the container label.
- Use up the pesticides. Rinse containers, and use rinse water as product. Dispose of unused pesticide as hazardous waste.
- Implement storage requirements for pesticide products with guidance from the local fire department and County Agricultural Commissioner. Provide secondary containment for pesticides.

### *Inspection*

- Inspect irrigation system periodically to ensure that the right amount of water is being applied and that excessive runoff is not occurring. Minimize excess watering, and repair leaks in the irrigation system as soon as they are observed.

### *Training*

- Educate and train employees on use of pesticides and in pesticide application techniques to prevent pollution.
- Train employees and contractors in proper techniques for spill containment and cleanup.
- Be sure the frequency of training takes into account the complexity of the operations and the nature of the staff.

### *Spill Response and Prevention*

- Refer to SC-11, Spill Prevention, Control & Cleanup
- Keep your Spill Prevention Control and countermeasure (SPCC) plan up-to-date, and implement accordingly.
- Have spill cleanup materials readily available and in a known location.
- Cleanup spills immediately and use dry methods if possible.
- Properly dispose of spill cleanup material.

### *Other Considerations*

- Alternative pest/weed controls may not be available, suitable, or effective in many cases.



# Building & Grounds Maintenance **SC-41**

## Requirements

### Costs

- Overall costs should be low in comparison to other BMPs.

### Maintenance

- Sweep paved areas regularly to collect loose particles, and wipe up spills with rags and other absorbent material immediately, do not hose down the area to a storm drain.

## Supplemental Information

### Further Detail of the BMP

#### *Fire Sprinkler Line Flushing*

Building fire sprinkler line flushing may be a source of non-stormwater runoff pollution. The water entering the system is usually potable water though in some areas it may be non-potable reclaimed wastewater. There are subsequent factors that may drastically reduce the quality of the water in such systems. Black iron pipe is usually used since it is cheaper than potable piping but it is subject to rusting and results in lower quality water. Initially the black iron pipe has an oil coating to protect it from rusting between manufacture and installation; this will contaminate the water from the first flush but not from subsequent flushes. Nitrates, polyphosphates and other corrosion inhibitors, as well as fire suppressants and antifreeze may be added to the sprinkler water system. Water generally remains in the sprinkler system a long time, typically a year, between flushes and may accumulate iron, manganese, lead, copper, nickel and zinc. The water generally becomes anoxic and contains living and dead bacteria and breakdown products from chlorination. This may result in a significant BOD problem and the water often smells. Consequently dispose fire sprinkler line flush water into the sanitary sewer. Do not allow discharge to storm drain or infiltration due to potential high levels of pollutants in fire sprinkler line water.

## References and Resources

California's Nonpoint Source Program Plan <http://www.swrcb.ca.gov/nps/index.html>

King County - <ftp://dnr.metrokc.gov/wlr/dss/spcm/Chapter%203.PDF>

Orange County Stormwater Program

[http://www.ocwatersheds.com/StormWater/swp\\_introduction.asp](http://www.ocwatersheds.com/StormWater/swp_introduction.asp)

Mobile Cleaners Pilot Program: Final Report. 1997. Bay Area Stormwater Management Agencies Association (BASSMA) <http://www.basmaa.org/>

Pollution from Surface Cleaning Folder. 1996. Bay Area Stormwater Management Agencies Association (BASMAA) <http://www.basmaa.org/>

San Diego Stormwater Co-permittees Jurisdictional Urban Runoff Management Program (URMP) -

<http://www.projectcleanwater.org/pdf/Model%20Program%20Municipal%20Facilities.pdf>

# Fountain & Pool Maintenance

# SC-72

## Description

The primary pollutant of concern in municipal swimming pool water is chlorine or chloramine used as a disinfectant. This water, if discharged to the storm drain system, can be toxic to aquatic life. In lakes, lagoons, and fountains, the pollutants of concern are chemical algaecides that are added to control algae mainly for aesthetic reasons (visual and odor). Following the procedures noted in this fact sheet will reduce the pollutants in this discharge.

## Approach

### Pollution Prevention

- Prevent algae problems with regular cleaning, consistent adequate chlorine levels, and well-maintained water filtration and circulation systems.
- Manage pH and water hardness to minimize corrosion of copper pipes.

### Suggested Protocols

#### Pools and Fountains

- Do not use copper-based algaecides. Control algae with chlorine or other alternatives, such as sodium bromide.
- Do not discharge water to a street or storm drain when draining pools or fountains; discharge to the sanitary sewer if permitted to do so. If water is dechlorinated with a neutralizing chemical or by allowing chlorine to dissipate for a few days (do not use the facility during this time), the water may be recycled/reused by draining it gradually onto a landscaped area. Water must be tested prior to discharge to ensure that chlorine is not present.
- Prevent backflow if draining a pool to the sanitary sewer by maintaining an "air gap" between the discharge line and the sewer line (do not seal the connection between the hose and sewer line). Be sure to call the local wastewater treatment plant for further guidance on flow rate restrictions, backflow prevention, and handling special cleaning waste (such as acid wash). Discharge flows should be kept to the low levels typically possible through a garden hose. Higher flow rates may be prohibited by local ordinance.
- Provide drip pans or buckets beneath drain pipe connections to catch leaks. This will be especially pertinent if pool or spa water that has not been dechlorinated is pumped through piping to a discharge location.

## Objectives

- Contain
- Educate
- Reduce/Minimize
- Product Substitution

## Targeted Constituents

Sediment	<input checked="" type="checkbox"/>
Nutrients	<input checked="" type="checkbox"/>
Trash	<input checked="" type="checkbox"/>
Metals	
Bacteria	<input checked="" type="checkbox"/>
Oil and Grease	
Organics	<input checked="" type="checkbox"/>
Oxygen Demanding	<input checked="" type="checkbox"/>



## SC-72 Fountains & Pools Maintenance

---

- Never clean a filter in the street or near a storm drain.
- Rinse cartridge filters onto a dirt area, and spade filter residue into soil.
- Backwash diatomaceous earth filters onto dirt. Dispose of spent diatomaceous earth in the garbage. Spent diatomaceous earth cannot be discharged to surface waters, storm drainage systems, septic systems, or on the ground.
- If there is not a suitable dirt area discharge filter backwash or rinsewater to the sanitary sewer if permitted to do so by the local sewerage agency.

### *Lakes and Lagoons*

- Reduce fertilizer use in areas around the water body. High nitrogen fertilizers can produce excess growth requiring more frequent mowing or trimming, and may contribute to excessive algae growth.
- To control bacteria, discourage the public from feeding birds and fish (i.e. place signs that prohibit feeding of waterfowl).
- Consider introducing fish species that consume algae. Contact the California Department of Fish and Game for more information on this issue.
- Mechanically remove pond scum (blue-green algae) using a 60 micron net.
- Educate the public on algae and that no controls are necessary for certain types of algae that are beneficial to the water body.
- Control erosion by doing the following:
  - Maintain vegetative cover on banks to prevent soil erosion. Apply mulch or leave clippings to serve as additional cover for soil stabilization and to reduce the velocity of stormwater runoff.
  - Areas should be designed (sloped) to prevent runoff and erosion and to promote better irrigation practices.
  - Provide energy dissipaters (e.g. riprap) along banks to minimize potential for erosion.
  - Confine excavated materials to surfaces away from lakes. Material must be covered if rain is expected.
- Conduct inspections to detect illegal dumping of clippings/cuttings in or near a lake. Materials found should be picked up and properly disposed of.
- Avoid landscape wastes in and around lakes should be avoided by either using bagging equipment or by manually picking up the material. Collect trash and debris from within water bodies where feasible
- Provide and maintain trash receptacles near recreational water bodies to hold refuse generated by the public.

# Fountain & Pool Maintenance

# SC-72

- Increase trash collection during peak visitation months (generally June, July and August).

## ***Training***

- Train maintenance personnel to test chlorine levels and to apply neutralizing chemicals.
- Train personnel regarding proper maintenance of pools, ponds and lakes.

## ***Spill Response and Prevention***

- Refer to SC-11, Spill Prevention, Control & Cleanup
- Have spill cleanup materials readily available and in a known location.
- Cleanup spills immediately and use dry methods if possible.
- Properly dispose of spill cleanup material.

## ***Other Considerations***

- Managers of pools located in sensitive areas or adjacent to shorelines should check with the appropriate authorities to determine if code requirements apply.
- Cleanup activities at lakes and lagoons may create a slight disturbance for local aquatic species. If the lake is recognized as a wetland, many activities, including maintenance, may be subject to regulation and permitting.

## **Requirements**

### ***Costs***

- The maintenance of pools and lakes is already a consideration of most municipal public works departments. Therefore the cost associated with this BMP is minimal and only reflects an increase in employee training and public outreach.

### ***Maintenance***

Not applicable

## **Supplemental Information**

### ***Further Detail of the BMP***

When dredging is conducted, adhere to the following:

- Dredge with shovels when laying/maintaining pipes.
- To determine amount to dredge, determine rate of volume loss due to sediments.
- For large lakes, dredge every 10 years.
- When dredging small lakes, drain lake.
- When dredging large lakes, use vacuum equipment.
- After dredging test sediment piles for proper disposal. Dredged sediment can be used as fill, or may have to be land filled.

## SC-72      Fountains & Pools Maintenance

---

### References and Resources

King County Stormwater Pollution Control Manual. Best Management Practices for Businesses. 1995. King County Surface Water Management. July. On-line:  
<http://dnr.metrokc.gov/wlr/dss/spcm.htm>

Los Angeles County Stormwater Quality. Public Agency Activities Model Program. On-line:  
[http://ladpw.org/wmd/npdes/public\\_TC.cfm](http://ladpw.org/wmd/npdes/public_TC.cfm)

Model Urban Runoff Program: A How-To Guide for Developing Urban Runoff Programs for Small Municipalities. Prepared by City of Monterey, City of Santa Cruz, California Coastal Commission, Monterey Bay National Marine Sanctuary, Association of Monterey Bay Area Governments, Woodward-Clyde, Central Coast Regional Water Quality Control Board. July. 1998.

Orange County Stormwater Program  
[http://www.ocwatersheds.com/StormWater/swp\\_introduction.asp](http://www.ocwatersheds.com/StormWater/swp_introduction.asp)

Santa Clara Valley Urban Runoff Pollution Prevention Program. Maintenance Best Management Practices for the Construction Industry. Brochures: Landscaping, Gardening, and Pool; Roadwork and Paving; and Fresh Concrete and Mortar Application. June 2001.

## APPENDIX 4

### **Bioretention Specifications and Checklist**

# Bioretention Facility

not to scale

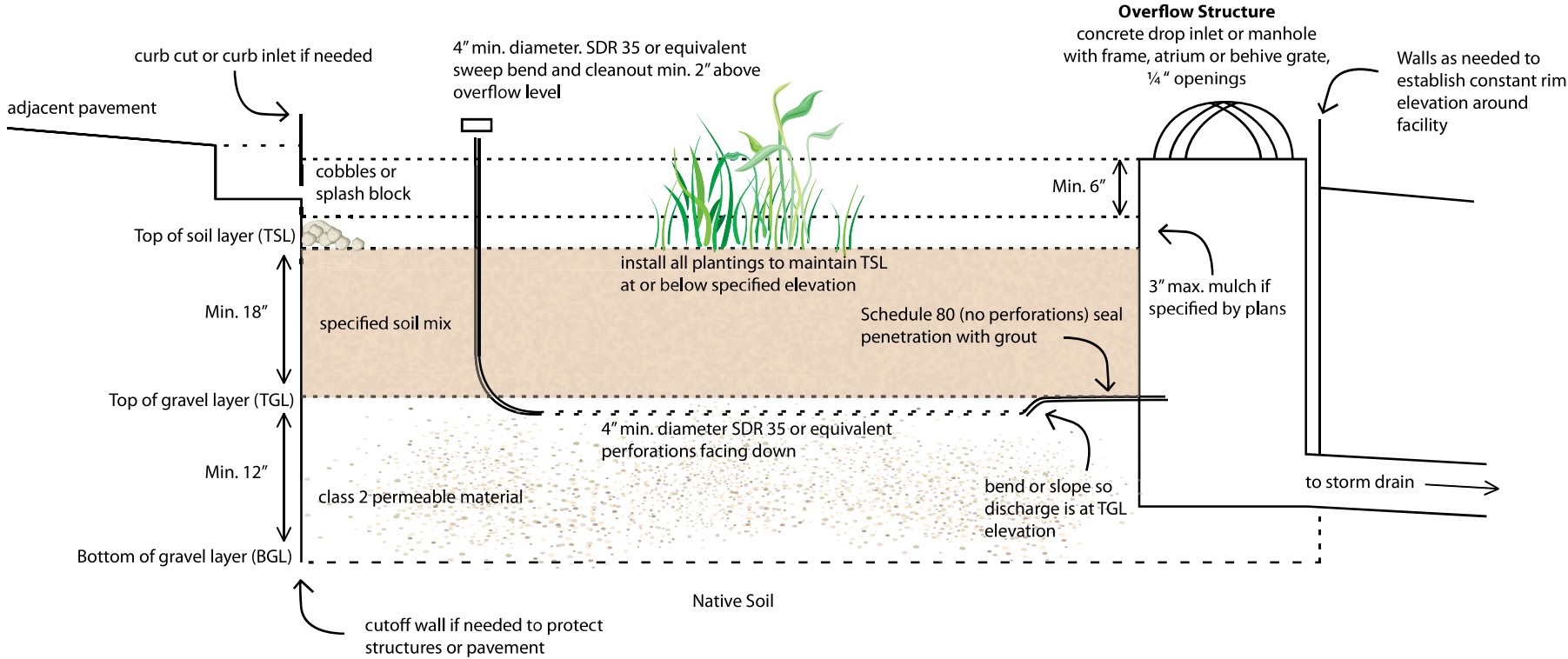

### Allowed variations for special site conditions:

- Facilities located within 10 feet of structures or other potential geotechnical hazards may incorporate an impervious cutoff wall
- Facilities with documented high concentrations of pollutants in underlying soil or groundwater, facilities where infiltration could contribute to a geotechnical hazard, and facilities located on elevated plazas or other structures may incorporate an impervious liner between the native soil and the BGL and locate the underdrain discharge at the BGL (flow-through planter configuration)
- Facilities located in areas of high groundwater, highly infiltrative soils, or where connection of the underdrain to a surface drain or subsurface storm drain are infeasible may omit the underdrain

### Notes:

- No liner, no filter fabric, no landscape cloth.
- Maintain BGL, TGL, TSL throughout facility area at elevations to be specified in plan.
- Class 7 permeable layer may extend below and underneath drop inlet.
- Elevation or underdrain discharge is at top of gravel layer.
- See Chapter X for instructions on facility sizing and additional specifications

# Bioretention Facility - Overview

not to scale

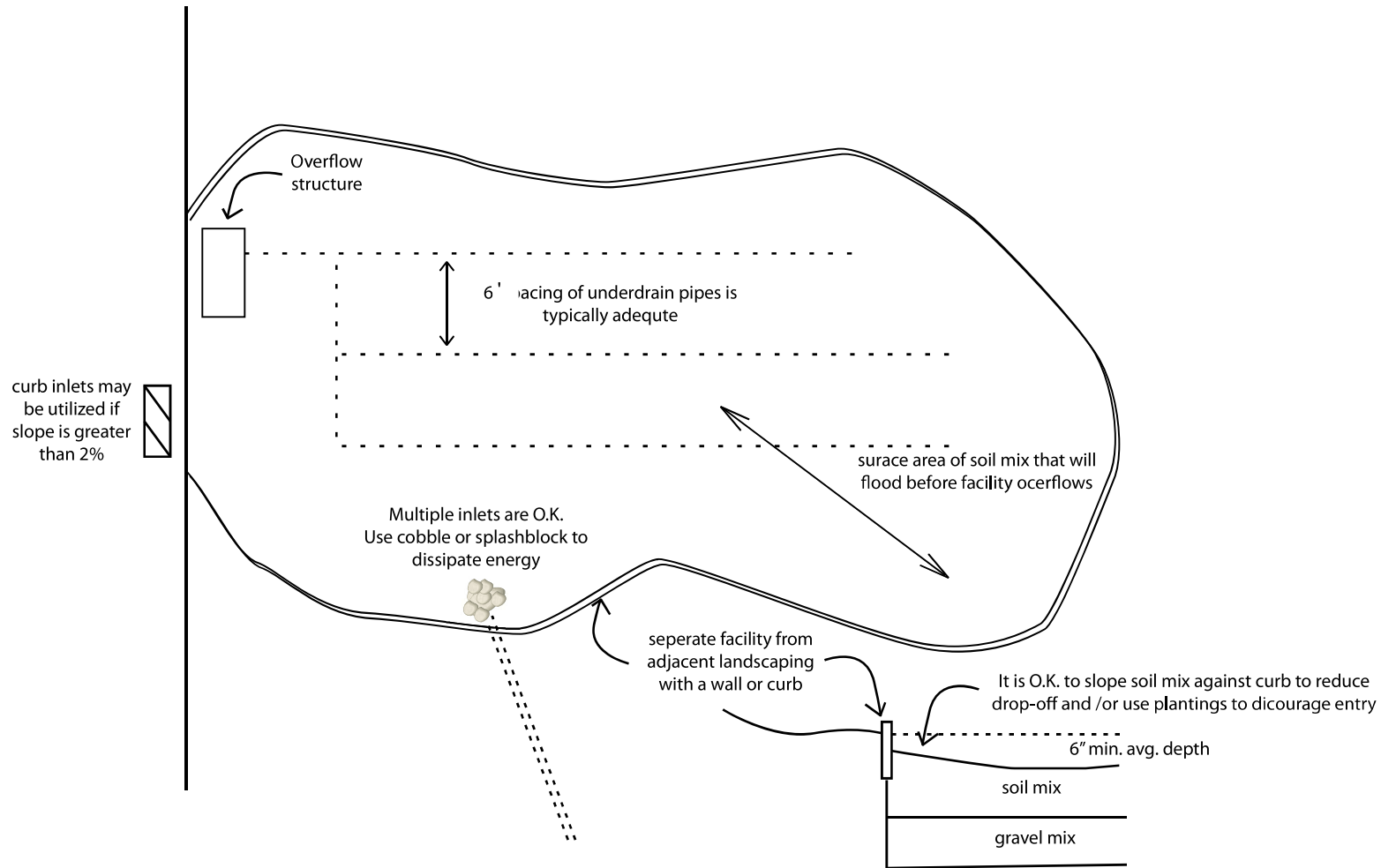

**Note:**

Show all elevations of curb, pavement, inlet, top of soil layer (TSL), top of gravel layer (TGL), and bottom of gravel layer (BGL) at all inlets and outlets and at key points along edge of facility.



Soil/Compost and Gravel Specifications for Bioretention Facility



Compost shall be a well-decomposed, stable, weed-free organic matter source derived from waste materials including yard debris, wood wastes or other organic materials not including manure or biosolids, and shall meet the standards developed by the US Composting Council (USCC). The product shall be certified through the USCC Seal of Testing Assurance (STA) Program (a compost testing and information disclosure program).

**Compost Quality Analysis:**

Before delivery of the soil, the supplier shall submit a copy of the lab analysis performed by a laboratory that is enrolled in the USCC's Compost Analysis Proficiency (CAP) program and using approved Test Methods for the Evaluation of Composting and Compost (TMECC). The lab report shall verify that the compost parameters are within the limits specified below.

Parameter	Range	Reported as (units)
Organic Matter Content	35-75	%, dry weight basis
Carbon to Nitrogen Ratio	15:1 to 25:1	ratio
Maturity (Seed Emergence and Seedling Vigor)	>80	average % of control
Stability (CO <sub>2</sub> Evolution Rate)	<8	mg CO <sub>2</sub> -C/g unit OM/day
Soluble Salts (Salinity)	<6.0	mmhos/cm
pH	6.5 - 8.0 May vary with plant species	units
Heavy Metals Content	PASS	PASS/FAIL: US EPA Class A standard, 40 CFR § 503.13, tables 1 and 3.
<b>Pathogens</b>		
Fecal coliform	PASS	PASS/FAIL: US EPA Class A standard, 40 CFR § 503.32(a) levels
Salmonella	PASS	PASS/FAIL: US EPA Class A standard, 40 CFR § 503.32(a) levels
<b>Nutrient Content (provide analysis, including):</b>		
Total Nitrogen (N)	≥0.9	%
Boron (Total B)	<80	ppm
Calcium (Ca)	For information only	%
Sodium (Na)	For information only	%
Magnesium (Mg)	For information only	%
Sulfur (S)	For information only	%

**Soil/Compost and Gravel Specifications for Bioretention Facility**



**Gravel Layer**

The gravel layer used in the bioretention facility must consist of *Class 2 Permeable Material* as specified in the State of California’s Business, Transportation and Housing Agency, Department of Transportation; Standard Specifications 2010, manual ([http://www.dot.ca.gov/hq/esc/oe/construction\\_contract\\_standards/std\\_specs/2010\\_StdSpecs/2010\\_StdSpecs.pdf](http://www.dot.ca.gov/hq/esc/oe/construction_contract_standards/std_specs/2010_StdSpecs/2010_StdSpecs.pdf)).

The specific section, Subsurface Drains, Sec. 68, of the manual is used because it offers specific specifications for subsurface drains. In addition to the standardized permeable layer, a membrane layer of pea gravel or other intermediate-sized material is recommended at the top of the gravel layer to prevent fines from the soil/compost layer from moving downward into the gravel layer.

**68-2.02F(1) General**

Permeable material for use in backfilling trenches under, around, and over underdrains must consist of hard, durable, clean sand, gravel, or crushed stone and must be free from organic material, clay balls, or other deleterious substances.

Permeable material must have a durability index of not less than 40.

**68-2.02F(3) Class 2 Permeable Material**

The percentage composition by weight of Class 2 permeable material in place must comply with the grading requirements shown in the following table:

**Class 2 Permeable Material Grading Requirements**

Sieve sizes	Percentage passing
1"	100
3/4"	90–100
3/8"	40–100
No. 4	25–40
No. 8	18–33
No. 30	5–15
No. 50	0–7
No. 200	0–3

Class 2 permeable material must have a sand equivalent value of not less than 75.

**Bioretention Facility Construction Checklist**



**Layout** (to be confirmed prior to beginning excavation permit approval stage)

<input type="checkbox"/>	Square footage of the facility meets or exceeds minimum shown in Stormwater Control Plan
<input type="checkbox"/>	Site grading and grade breaks are consistent with the boundaries of the tributary Drainage Management Area(s) (DMAs) shown in the Stormwater Control Plan
<input type="checkbox"/>	Inlet elevation of the facility is low enough to receive drainage from the entire tributary DMA
<input type="checkbox"/>	locations and elevations of overland flow or piping, including roof leaders, from impervious areas to the facility have been laid out and any conflicts resolved
<input type="checkbox"/>	Rim elevation of the facility is laid out to be level all the way around, or elevations are consistent with a detailed cross-section showing location and height of interior dams
<input type="checkbox"/>	Locations for vaults, utility boxes, and light standards have been identified so that they will not conflict with the facility
<input type="checkbox"/>	Facility is protected as needed from construction-phase runoff and sediment

**Excavation** (to be confirmed prior to backfilling or pipe installation)

<input type="checkbox"/>	Excavation conducted with materials and techniques to minimize compaction of soils within the facility area
<input type="checkbox"/>	Excavation is to accurate area and depth
<input type="checkbox"/>	Slopes or side walls protect from sloughing of native soils into the facility
<input type="checkbox"/>	Moisture barrier, if specified, has been added to protect adjacent pavement or structures.
<input type="checkbox"/>	Native soils at bottom of excavation are ripped or loosened to promote infiltration

**Overflow or Surface Connection to Storm Drainage** (to be confirmed prior to backfilling with any materials)

<input type="checkbox"/>	Grating excludes mulch and litter (beehive or atrium-style grates recommended)
<input type="checkbox"/>	Overflow is connected to storm drain via appropriately sized
<input type="checkbox"/>	No knockouts or side inlets are in overflow riser
<input type="checkbox"/>	Overflow is at specified elevation
<input type="checkbox"/>	Overflow location selected to minimize surface flow velocity (near, but offset from, inlet recommended)
<input type="checkbox"/>	Grating excludes mulch and litter (beehive or atrium-style grates recommended)
<input type="checkbox"/>	Overflow is connected to storm drain via appropriately sized

**Bioretention Facility Construction Checklist**



**Underground connection to storm drain/outlet orifice**

<input type="checkbox"/>	Perforated pipe underdrain (PVC SDR 35 or approved equivalent) is installed with holes facing down
<input type="checkbox"/>	Perforated pipe is connected to storm drain at specified elevation (typ. bottom of soil elevation)
<input type="checkbox"/>	Cleanouts are in accessible locations and connected via sweep

**Drain Rock/Subdrain** (to be confirmed prior to installation of soil mix)

<input type="checkbox"/>	Rock is installed as specified, 12" min. depth. Class 2 permeable, Caltrans specification 68-2.02F(3) recommended
<input type="checkbox"/>	Rock is smoothed to a consistent top elevation. Depth and top elevation are as shown in plans
<input type="checkbox"/>	Slopes or side walls protect from sloughing of native soils into the facility
<input type="checkbox"/>	No filter fabric is placed between the subdrain and soil mix layers

**Soil Mix**

<input type="checkbox"/>	Soil mix is as specified.
<input type="checkbox"/>	Mix installed in lifts not exceeding 12"
<input type="checkbox"/>	Mix is not compacted during installation but may be thoroughly wetted to encourage consolidation
<input type="checkbox"/>	Mix is smoothed to a consistent top elevation. Depth of mix (18" min.) and top elevation are as shown in plans, accounting for depth of mulch to follow and required reservoir depth

**Irrigation**

<input type="checkbox"/>	Irrigation system is installed so it can be controlled separately from other landscaped areas
<input type="checkbox"/>	Smart irrigation controllers and drip emitters are recommended and may be required by local code or ordinance.
<input type="checkbox"/>	Spray heads, if any, are positioned to avoid direct spray into outlet structures

**Bioretention Facility Construction Checklist****Planting**

<input type="checkbox"/>	Plants are installed consistent with approved planting plan, consistent with site water allowance
<input type="checkbox"/>	Any trees and large shrubs are staked securely
<input type="checkbox"/>	No fertilizer is added; compost tea may be used
<input type="checkbox"/>	No native soil or clayey material are imported into the facility with plantings
<input type="checkbox"/>	1"-2" mulch may be applied following planting; mulch selected to avoid floating
<input type="checkbox"/>	Final elevation of soil mix maintained following planting
<input type="checkbox"/>	Curb openings are free of obstructions

**Final Engineering Inspection**

<input type="checkbox"/>	Drainage Management Area(s) are free of construction sediment and landscaped areas are stabilized
<input type="checkbox"/>	Inlets are installed to provide smooth entry of runoff from adjoining pavement, have sufficient reveal (drop from the adjoining pavement to the top of the mulch or soil mix, and are not blocked)
<input type="checkbox"/>	Inflows from roof leaders and pipes are connected and operable
<input type="checkbox"/>	Temporary flow diversions are removed
<input type="checkbox"/>	Rock or other energy dissipation at piped or surface inlets is adequate
<input type="checkbox"/>	Overflow outlets are configured to allow the facility to flood and fill to near rim before overflow
<input type="checkbox"/>	Plantings are healthy and becoming established
<input type="checkbox"/>	Irrigation is operable
<input type="checkbox"/>	Facility drains rapidly; no surface ponding is evident
<input type="checkbox"/>	Any accumulated construction debris, trash, or sediment is removed from facility
<input type="checkbox"/>	Permanent signage is installed and is visible to site users and maintenance personnel

## APPENDIX 5

### **Bioretention Plant List – Inland and Coastal**

### Planting Zone Diagram

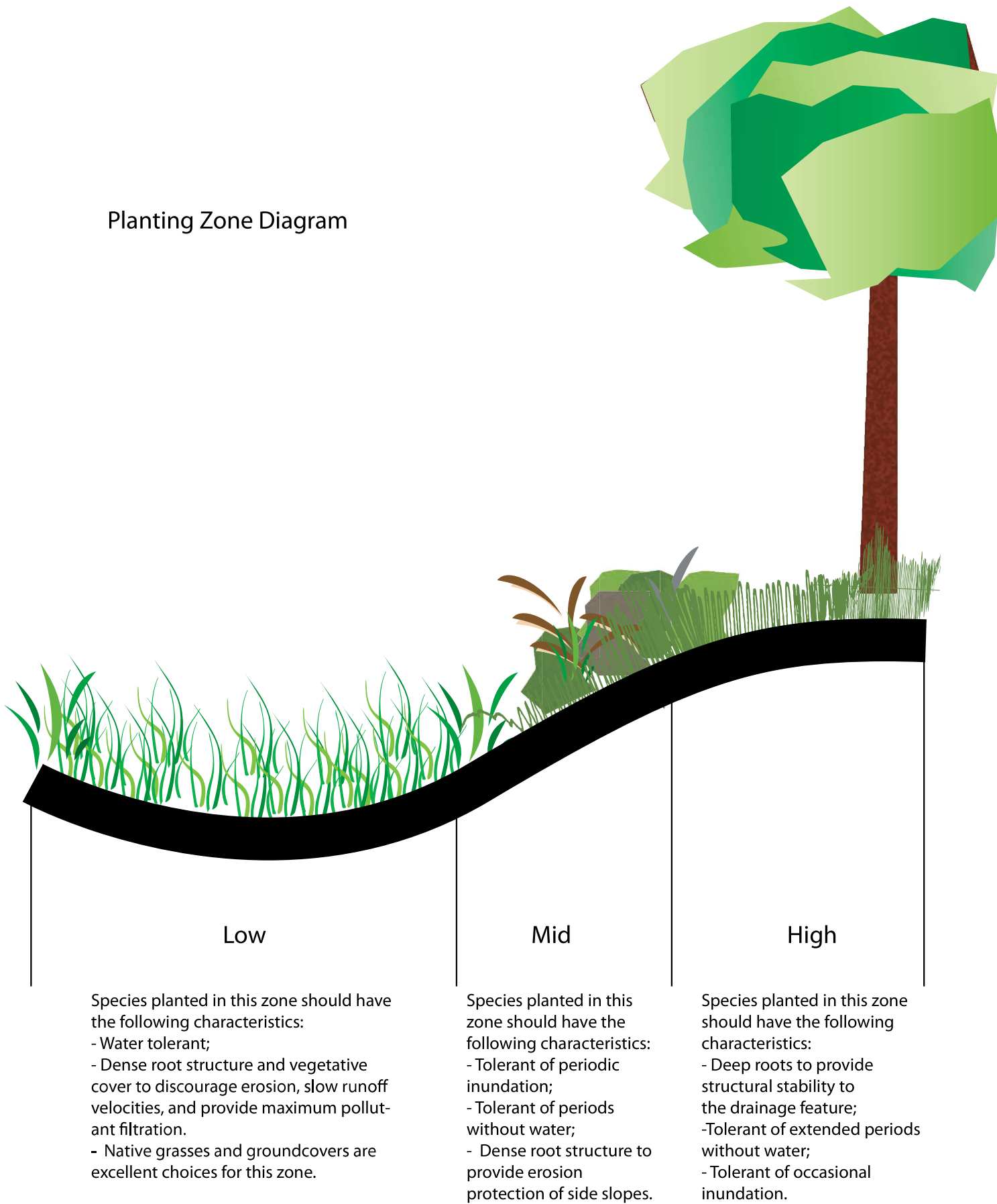

Plant List for Bioretention Facilities — Inland MS4 Area

Botanical Name	Common Name	Low	Mid	High	Low, Mid, and High refers to planting zones within the Bioretention Facility
<b>Grasses and Grass-like Plants</b>					
<i>Bromus carinatus</i>	California brome		X	X	
<i>Carex barbarae</i>	Santa Barbara sedge	X	X		Not for full sun
<i>Carex brevicaulis</i>	short stem sedge		X	X	Short turf-like growth habit
<i>Carex densa</i>	dense sedge	X	X		
<i>Carex deweyanna</i>	Dewey sedge	X	X		
<i>Carex divulsa</i>	Berkeley sedge	X	X		Not a native. Mistakenly sold as the native <i>C. tumulicola</i>
<i>Carex obnupta</i>	slough sedge	X	X		
<i>Carex pansa</i>	California meadow sedge	X	X		
<i>Carex rupestris</i>	curly sedge	X	X		
<i>Carex stipata</i>	sawbeak sedge	X	X		
<i>Carex subfusca</i>	rusty sedge	X	X		
<i>Carex testacea</i>	New Zealand orange sedge	X	X		
<i>Carex tumulicola</i>	foothill sedge	X	X	X	
<i>Carex vesicaria</i>	inflated sedge	X	X		
<i>Deschampsia danthonoides</i>	annual hairgrass		X	X	Can tolerate saturation if top soil layer drains
<i>Deschampsia cespitosa</i>	tufted hairgrass		X	X	Can tolerate saturation if top soil layer drains
<i>Eleocharis acicularis</i>	needle spike rush	X	X		
<i>Eleocharis macrostachya</i>	creeping spike rush	X	X		
<i>Eleocharis ovata</i>	ovate spike rush				
<i>Eleocharis palustris</i>	creeping spike rush				
<i>Elymus glaucus</i>	blue wild rye		X	X	
<i>Festuca californica</i>	California fescue			X	Can tolerate saturation if top soil layer drains
<i>Festuca idahoensis</i>	blue bunchgrass			X	Can tolerate saturation if top soil layer drains
<i>Festuca rubra</i>	red fescue			X	Can be mowed as turf alternative. Can tolerate saturation if top soil layer drains
<i>Glyceria occidentalis</i>	western mannagrass	X	X		



Plant List for Bioretention Facilities — Inland MS4 Area

Botanical Name	Common Name	Low	Mid	High	Low, Mid, and High refers to planting zones within the Bioretention Facility
<b>Grasses and Grass-like Plants</b>					
<i>Hordeum brachyantherum</i>	meadow barley		X	X	Can tolerate saturation if top soil drains
<i>Juncus balticus</i>	Baltic rush	X	X		
<i>Juncus bufonis</i>	toad rush	X	X		
<i>Juncus effusus</i>	Pacific rush	X	X		
<i>Juncus ensofolius</i>	dagger leaf rush	X	X		
<i>Juncus patens</i>	blue rush	X	X	X	May not need summer irrigation after establishment
<i>Juncus tenuis</i>	slender rush	X	X		
<i>Juncus xiphiodes</i>	iris-leaved rush	X	X		
<i>Leymus triticoides</i>	creeping wild rye		X	X	Can be mowed. Ideal plant for many uses.
<i>Melica californica</i>	California melic			X	Can tolerate saturation if top soil layer drains
<i>Melica imperfecta</i>	small flowered melic			X	Can tolerate saturation if top soil layer drains
<i>Muhlenbergia rigens</i>	deergass			X	
<b>Herbaceous Plants</b>					
<i>Achilea millefolium</i>	common yarrow			X	
<i>Aster sp.</i>	aster		X	X	
<i>Athyrium filix-femina</i>	lady fern		X	X	
<i>Blechnum spicant</i>	deer fern		X	X	
<i>Camassia leichtlinii</i>	camas lily	X	X		
<i>Camassia quamash</i>	common camas	X	X		
<i>Epilobium canum</i>	California fuschia			X	
<i>Eriogonum fasciculatum</i>	flattop buckwheat			X	
<i>Eschscholzia californica</i>	California poppy			X	

**Plant List for Bioretention Facilities — Inland MS4 Area**

Botanical Name	Common Name	Low	Mid	High	Low, Mid, and High refers to planting zones within the Bioretention Facility
<b>Herbaceous Plants</b>					
<i>Fragaria chiloensis</i>	beach strawberry			X	This species is adapted to low water conditions
<i>Iris douglasiana</i>	Douglas iris		X	X	
<i>Lupinus bicolor</i>	miniature lupine			X	Tolerates saturation in winter only
<i>Lupinus polyphyllus</i>	large leaf lupine		X	X	similar to Russell hybrids
<i>Mimulus guttatus</i>		X			
<i>Polypodium californicum</i>	California polypody		X	X	
<i>Polypodium glycyrrhiza</i>	licorice fern		X	X	
<i>Polystichum californicum</i>	California sword fern	X	X	X	
<i>Polystichum munitum</i>	western sword fern	X	X	X	
<i>Pteridium aquilinum</i>	bracken fern		X	X	
<i>Sisyrinchium bellum</i>	blue-eyed grass			X	
<i>Sisyrinchium californicum</i>	yellow-eyed grass		X	X	
<i>Veronica liwanensis</i>	speedwell			X	

Source: City of Santa Rosa, Storm Water Low Impact Development Technical Design Manual, August 2011

Plant List for Bioretention Facilities — Coastal MS4 Area

Botanical Name	Common Name	Low	Mid	High	Low, Mid, and High refers to planting zones within the Bioretention Facility
<b>Grasses and Grass-like Plants</b>					
<i>Carex ativulsa</i>	Berkeley Sedge, Grey Sedge	X	X	X	tolerates foot traffic, some drought and boggy soils
<i>Carex pansa</i>	California Meadow Sedge	X	X	X	good lawn substitute, tolerates wide range of growing conditions, seasonal inundation, drought, foot traffic and mowing
<i>Carex praegracilis</i>	Clustered Field Sedge	X	X		useful lawn substitute and bank stabilizer, good planted in masses, tolerates wide range of growing conditions, foot traffic and mowing, may look weedy when mixed with other plants
<i>Carex spissa</i>	San Diego Sedge	X			a large grass, tolerates alkaline soil, clay, serpentine, seasonal inundation, and deer
<i>Chondropetalum tectorum</i>	Small Cape Rush	X	X	X	A tough, attractive reed-like plant, tolerates boggy or clay soils and drought once established
<i>Festuca rubra</i>	Molate Red Fescue	X	X	X	a tufted, spreading bunchgrass, good lawn substitute, provides erosion control, tolerates wet conditions, but looks best with regular water, tolerates drought once established
<i>Juncus effusus</i>	Soft Rush	X			tolerates poor drainage, heavy soils, needs more supplemental water than <i>Juncus patens</i>
<i>Juncus patens</i>	Wire Grass, Blue Rush	X			strong performance in bioretention areas, tolerates poor drainage, seasonal inundation, drought, shade
<i>Leymus condensatus</i>	Canyon Prince Wild Rye			X	tolerates drought, wet, but not soggy soils, looks best with supplemental irrigation, spreads by rhizomes
<i>Muhlenbergia rigens</i>	Deer Grass			X	a large grass, tolerates sandy and clay soils, seasonal inundation, best when cut back annually to remove old thatch
<b>Perennials</b>					
<i>Achillea millefolium</i>	Yarrow			X	tolerates alkaline soil, sand, clay, seasonal wet conditions, foot traffic and deer, will self sow
<i>Fragaria chiloensis</i>	Beach Strawberry			X	vigorous spreading groundcover, tolerates sand, clay, wet conditions, prefers good drainage
<i>Iris douglasiana</i>	Douglas Iris			X	tolerates sand, clay and serpentine soils, seasonal wet (but not soggy) soils and drought
<i>Salvia uliginosa</i>	Bog Sage			X	low growing perennial, tolerates clay, winter wet, summer drought, prefers light shade, provides nectar for birds and insects, does well under oaks
<i>Sisyrinchium bellum</i>	Blue-eyed Grass			X	a semi-evergreen perennial, tolerates sand, clay, seasonal wet soils and deer, dormant in summer, but can be delayed with supplemental irrigation
<i>Solidago californica</i>	California Goldenrod			X	tolerates poor soils, seasonal wet and drought, can spread aggressively if over irrigated

Plant List for Bioretention Facilities — Coastal MS4 Area

Botanical Name	Common Name	Low	Mid	High	Low, Mid, and High refers to planting zones within the Bioretention Facility
<b>Shrubs and Subshrubs</b>					
<i>Baccharis pilularis</i>	California Wild Rose	X	X	X	tolerates a wide variety of soils, seasonal flooding and some drought, spreads aggressively, avoid edges of walkways because of thorns
<i>Coyote Brush</i>	Coyote Brush		X	X	adaptable evergreen shrub, provides quick cover and bank stabilization, tolerant of coastal conditions, alkaline soil, sand, clay and seasonal wet
<b>Large Shrubs</b>					
<i>Heteromeles arbutifolia</i>	Toyon			X	tolerates sand, clay and serpentine soils, seasonal water with good drainage
<i>Myrica californica</i>	Pacific Wax Myrtle			X	large shrub or small tree, tolerates coastal conditions, sand, clay and seasonal inundation
<i>Sambucus mexicana</i>	Western Elderberry			X	large shrub to tree, tolerates clay, seasonal flooding and drought, good wildlife food source
<b>Trees</b>					
<i>Chilopsis linearis</i>	Desert Willow			X	tolerates alkaline soil, sand, clay, seasonal flooding and drought, not coastal condition
<i>Platanus racemosa</i>	Western Sycamore			X	tolerates sand and clay soils, seasonal flooding, needs space to grow, avoid underground water/sewer pipes
<i>Quercus agrifolia</i>	Coast Live Oak			X	tolerates drought and winter wet conditions, mature trees produce significant litter limiting understory plantings, need space to grow

Source: Sunset Magazine

## APPENDIX 6

### **Operation and Maintenance Template**

**For Office Use Only**

Application No. \_\_\_\_\_

Received By: \_\_\_\_\_

**A. Responsible Individual (RI).**

The RI is the person that will have direct responsibility for the maintenance of stormwater controls, maintain self-inspection records, and sign any correspondence with the County of Mendocino.

Name of RI: Steve Honeycutt

Phone: 530-879-4436

Project Name: Bella Vista Subdivision

Physical Site Address and/or APN: 3000 South State Street, Ukiah, CA 95482

Include from the Stormwater Control Plan Worksheet the *Drainage Management Areas* tabulations (tables #1-4)

Include the site plan delineating the DMAs and the locations of the bioretention or equivalent facilities.

Include the final construction drawings of the stormwater facilities:

- Plans, elevations, and details of bioretention facilities.
- Construction details and specifications, including: depths of sand and soil, compaction, pipe materials, and bedding.
- Location and layouts of inflow piping and piping to off-site discharge
- Native soils (lenses beneath the facilities)

**B. Scheduled Maintenance Activities**

The following activities will need to occur on an annual basis. Frequency may need to be adjusted depending on facility.

- **Refuse removal:** remove trash that collects near the inlets or that is trapped by vegetation. Clean out soil and debris blocking inlets or overflows.
- **Control weeds:** manual methods and soil amendments; non-natural (synthetic) pesticides should not be used.
- **Add mulch:** add mulch to maintain a mulch layer thickness of ~ 3 inches.
- **Pruning and replanting vegetation:** it may be necessary to replace or remove vegetation to ensure the proper functioning of the facility.
- **Check irrigation:** if irrigation exists, check to make sure the system is working as intended.

An annual self-certification letter will be mailed to the RI. This letter will serve as verification that all the stormwater facilities on the property are being maintained and remain operational. The letter should be signed and returned within 30 days.

**C. Updates to the O & M Plan**

Contact information for the Responsible Individual should be current. If the RI changes, the County of Mendocino's Planning and Building Department should be notified with the appropriate revisions.

**D. O & M plans for other Facility Types**

If your project included a non-standard stormwater treatment facility that was approved by the Planning and Building Services Department, such as a tree-box type system, than the O & M should reflect the manufacturer's recommended maintenance scheduling.

**E. Signature and Certification:**

"I, the RI/applicant accept responsibility for operation and maintenance of stormwater treatment and flow-control facilities until such time as this responsibility is transferred to a subsequent owner. Furthermore, a condition on the property deed will be recorded with the County Recorder's office indicating that a stormwater facility is present on the property and that the maintenance responsibility will transfer with property ownership in perpetuity."

\_\_\_\_\_  
Signature of the RI

\_\_\_\_\_  
Date

\_\_\_\_\_  
Print Name

I am the:

Property Owner

Applicant

Contractor

Point of Conc.	Area	ΔEL	Distance	Slope	v	Time of Conc. (in minutes)		i	K	C	ΔA	A Total	KΔAC	ΣKΔAC	Q	Design
						Travel Time	Total Time									
<b>Tributary 2</b>																
1	A	17.5	701	0.025		10	10	1.89	1	0.32	0.44	0.44	0.14	0.14	0.26	
2	B	11.25	652	0.017		11.5	21.5	1.28	1	0.31	0.79	1.22	0.24	0.38	0.49	
3	C	7	521	0.013		10.5	32	1.04	1	0.30	0.75	1.98	0.23	0.61	0.63	
4	D	10.01	705	0.014		13	45	0.87	1	0.30	3.47	5.44	1.04	1.65	1.44	Outlets into 18" CPP to TRIB 5
<b>Tributary 3</b>																
1	A	234	678	0.345		15	15	1.54	1	0.45	2.01	2.01	0.90	0.90	1.39	
2	B	25.5	570	0.045		7	22	1.26	1	0.34	2.63	4.63	0.89	1.80	2.27	
3	C	5	814	0.006		19	41	0.92	1	0.30	2.70	7.33	0.81	2.61	2.39	
4	D	23	1092	0.021		15	56	0.78	1	0.31	4.34	11.67	1.35	3.95	3.09	
5	E	8.26	811	0.010		16	72	0.69	1	0.30	1.54	13.21	0.46	4.41	3.03	Outlets into 10" RCP to TRIB 6
								1.10			5.21	18.41	1.65	6.06	6.66	Tributary 4 added flow
<b>Tributary 4</b>																
1	A	17.5	489	0.036		15	15	1.54	1	0.33	1.79	1.79	0.59	0.59	0.91	
2	B	17	906	0.019		13.8	28.8	1.10	1	0.31	3.41	5.21	1.06	1.65	1.81	Overland flow to TRIB 3
<b>Tributary 5</b>																
1	A	13.43	585	0.023		15	15	1.89	1	0.32	1.19	1.19	0.38	0.38	0.72	Outlets into 18" CMP to TRIB 6
								0.87			5.44	6.63	1.65	2.03	1.77	Tributary 2 added flow
<b>Tributary 6 (MAIN)</b>																
1	A	17.25	531	0.032		15	30	1.08	1	0.33	1.19	1.19	0.39	0.39	0.42	
2	B	6.75	411	0.016		8.5	38.5	0.95	1	0.31	1.68	2.87	0.52	0.91	0.87	
3	C	10.2	852	0.012		15	53.5	0.80	1	0.30	3.54	6.41	1.06	1.97	1.58	Outlets into 18" CMP to TRIB 8
							72	0.69			25.04	31.45	8.09	10.07	6.92	TRIB 3 & TRIB 5 added flow
<b>Tributary 7</b>																
1	A	35.5	235	0.151		15	68.5	0.71	1	0.44	0.68	0.68	0.30	0.30	0.21	
2	B	32.5	708	0.046		9.6	78.1	0.66	1	0.34	4.40	5.08	1.50	1.80	1.18	
3	C	4.5	1130	0.004		29.5	107.6	0.56	1	0.30	5.11	10.19	1.53	3.33	1.86	
4	D	16.97	977	0.017		14.5	122.1	0.52	1	0.31	5.66	15.85	1.75	5.08	2.66	Outlets into 18" RCP to TRIB9



Point of Conc.	Area	ΔEL	Distance	Slope	v	Time of Conc. (in minutes)		i	K	C	ΔA	A Total	KΔAC	ΣKΔAC	Q	Design
						Travel Time	Total Time									
<b>Tributary 8</b>																
1	A	6	522	0.011		10	10	1.89	1	0.36	0.73	0.73	0.26	0.26	0.50	Outlets into 18" CMP
							122.1	0.52			47.30	48.03	15.15	15.41	8.08	TRIB 6 & TRIB 7 added flow

<b>Tributary 1</b>																
1	A	215	591	0.364		15	15	1.54	1	0.45	1.99	1.99	0.90	0.90	1.38	
2	B	205	1544	0.133		5	20	1.33	1	0.42	12.73	14.72	5.35	6.24	8.27	
3	C	30	1335	0.022		8.75	28.75	1.10	1	0.45	12.54	27.26	5.64	11.89	13.08	

Point of Conc.	Area	ΔEL	Distance	Slope	v	Time of Conc. (in minutes)		i	K	C	ΔA	A Total	KΔAC	ΣKΔAC	Q	Design	Remarks
						Travel Time	Total Time										
<b>Tributary 2</b>																	
1	A	17.5	701	0.025		10	10	2.69	1	0.32	0.44	0.44	0.14	0.14	0.38		
2	B	11.25	652	0.017		11.5	21.5	1.81	1	0.31	0.79	1.22	0.24	0.38	0.69		
3	C	7	521	0.013		10.5	32	1.48	1	0.30	0.75	1.98	0.23	0.61	0.90		
4	D	10.01	705	0.014		13	45	1.24	1	0.30	3.47	5.44	1.04	1.65	2.04		adds water to Trib 5 via 18" CPP
<b>Tributary 3</b>																	
1	A	234	678	0.345		15	15	2.18	1	0.45	2.01	2.01	0.90	0.90	1.97		
2	B	25.5	570	0.045		7	22	1.79	1	0.34	2.63	4.63	0.89	1.80	3.22		
3	C	5	814	0.006		19	41	1.30	1	0.30	2.70	7.33	0.81	2.61	3.38		
4	D	23	1092	0.021		15	56	1.11	1	0.31	4.34	11.67	1.35	3.95	4.37		
5	E	8.26	811	0.010		16	72	0.97	1	0.30	1.54	13.21	0.46	4.41	4.28		Adds water to Trib 6 via 10" RCP
						1.56		5.21		18.41	1.65	6.06	9.45	Tributary 4 added flow			
<b>Tributary 4</b>																	
1	A	17.5	489	0.036		15	15	2.18	1	0.33	1.79	1.79	0.59	0.59	1.29		
2	B	17	906	0.019		13.8	28.8	1.56	1	0.31	3.41	5.21	1.06	1.65	2.57		Adds water to Trib 3 surface flow
<b>Tributary 5</b>																	
1	A	13.43	585	0.023		15	15	2.69	1	0.32	1.19	1.19	0.38	0.38	1.02		Adds water to Trib 6 via 18" CMP
						1.24		5.44		6.63	1.65	2.03	2.51	Tributary 2 added flow			
<b>Tributary 6 (MAIN)</b>																	
2	A	17.25	531	0.032		15	30	1.53	1	0.33	1.19	1.19	0.39	0.39	0.60		
3	B	6.75	411	0.016		8.5	38.5	1.34	1	0.31	1.68	2.87	0.52	0.91	1.23		
4	C	10.2	852	0.012		15	53.5	1.13	1	0.30	3.54	6.41	1.06	1.97	2.23		Adds water to Trib 8 via 18" RCP
						72	0.97	25.04		31.45	8.09	10.07	9.77	Trib 3 added flow			
														Trib 5 added flow			
<b>Tributary 7</b>																	
5	A	35.5	235	0.151		15	68.5	1.00	1	0.44	0.68	0.68	0.30	0.30	0.30		
6	B	32.5	708	0.046		9.6	78.1	0.93	1	0.34	4.40	5.08	1.50	1.80	1.67		
7	C	4.5	1130	0.004		29.5	107.6	0.79	1	0.30	5.11	10.19	1.53	3.33	2.63		
7	D	16.97	977	0.017		14.5	122.1	0.74	1	0.31	5.66	15.85	1.75	5.08	3.76		Adds water to Trib 8 via 18" RCP

Point of Conc.	Area	ΔEL	Distance	Slope	v	Time of Conc. (in minutes)		i	K	C	ΔA	A Total	KΔAC	ΣKΔAC	Q	Design	Remarks
						Travel Time	Total Time										

Tributary 8																	
1	A	6	522	0.011		10	10	2.69	1	0.36	0.73	0.73	0.26	0.26	0.71		enters 18" CMP
							122.1	0.74			47.30	48.03	15.15	15.41	11.39		Trib 6 added flow
																	Trib 7 added flow

Tributary 1																	
1	A	215	591	0.364		15	15	2.18	1	0.45	1.99	1.99	0.90	0.90	1.96		
2	B	205	1544	0.133		5	20	1.88	1	0.42	12.73	14.72	5.35	6.24	11.75		
3	C	30	1335	0.022		8.75	28.75	1.56	1	0.45	12.54	27.26	5.64	11.89	18.54		

EIR ADDENDUM APPENDIX A

Line No.	Line ID	Flow Rate (cfs)	Line Length (ft)	Line Slope (%)	Line Size (in)	n-val Pipe	Capac Full (cfs)	Gnd/Rim EI Up (ft)	Invert Up (ft)	Gnd/Rim EI Dn (ft)	Invert Dn (ft)	HGL Up (ft)	HGL Dn (ft)	EGL Up (ft)	EGL Dn (ft)	Vel Up (ft/s)	Vel Dn (ft/s)
1	DI 1	3.89	28.461	1.19	12	0.010	5.06	606.34	603.34	606.00	603.00	604.18 j	603.84	604.65	604.32	5.54	5.52
2	DI 2	3.77	89.836	1.20	12	0.010	5.08	607.42	604.42	606.34	603.34	605.25 j	604.30	605.70	604.76	5.43	4.87
3	DI 3	3.76	65.340	1.19	12	0.010	5.06	608.20	605.20	607.42	604.42	606.03 j	605.35	606.48	605.81	5.43	4.95
4	DI 4	3.77	53.891	1.21	12	0.010	5.08	608.85	605.85	608.20	605.20	606.68 j	606.13	607.13	606.58	5.43	4.96
5	DI 5	3.60	125.811	1.20	12	0.010	5.07	610.36	607.36	608.85	605.85	608.17 j	606.81	608.60	607.24	5.29	4.66
6	DI 6	3.61	46.638	1.20	12	0.010	5.07	610.92	607.92	610.36	607.36	608.73 j	608.28	609.17	608.71	5.29	4.78
7	DI 7	3.46	81.666	2.00	12	0.010	6.54	612.55	609.55	610.92	607.92	610.34 j	608.86	610.76	609.28	5.17	4.51
8	DI 8	3.46	79.657	2.00	12	0.010	6.54	614.14	611.14	612.55	609.55	611.93 j	610.46	612.35	610.87	5.17	4.62
9	DI 9	3.46	68.037	2.00	12	0.010	6.55	615.50	612.50	614.14	611.14	613.29 j	612.05	613.71	612.46	5.17	4.61
10	DI 10	3.45	68.924	2.00	12	0.012	5.46	616.88	613.88	615.50	612.50	614.67 j	613.41	615.09	613.82	5.16	4.59
11	DI 11	3.27	36.620	1.91	12	0.010	6.40	617.58	614.58	616.88	613.88	615.35 j	614.82	615.74	615.21	5.02	4.28
12	DI 12	3.23	40.569	1.90	12	0.010	6.38	618.35	615.35	617.58	614.58	616.12 j	615.48	616.51	615.87	4.99	4.34
13	BEND	3.19	29.501	1.90	12	0.010	6.38	618.91	615.91	618.35	615.35	616.67 j	616.25	617.06	616.63	4.95	4.29
14	DI 13	3.11	26.580	1.92	12	0.010	6.41	619.42	616.42	618.91	615.91	617.18 j	616.81	617.55	617.18	4.89	4.18
15	BEND	3.07	27.313	1.90	12	0.010	6.39	619.94	616.94	619.42	616.42	617.69 j	617.31	618.06	617.68	4.86	4.16
16	DI 14	2.98	25.739	1.90	12	0.010	6.39	620.43	617.43	619.94	616.94	618.17 j	617.83	618.53	618.19	4.79	4.03
17	BEND	2.90	20.587	1.89	12	0.010	6.37	620.82	617.82	620.43	617.43	618.55 j	618.31	618.90	618.66	4.73	3.95
18	JUNCTION BOX	2.61	4.250	1.88	12	0.010	6.35	620.90	617.90	620.82	617.82	618.59 j	618.59	618.91	618.91	4.50	4.00
19	DI 15	2.71	323.631	2.50	12	0.010	7.32	628.99	625.99	620.90	617.90	626.69 j	618.72	627.02	619.05	4.58	3.92
20	DI 16	2.52	240.762	2.50	12	0.010	7.32	635.01	632.01	628.99	625.99	632.69 j	626.86	632.99	627.17	4.43	3.47
21	BEND	2.61	396.004	2.50	12	0.010	7.32	645.00	641.91	635.01	632.01	642.60 j	632.82	642.92	633.14	4.50	3.81
22	DI 17	2.61	23.755	2.48	12	0.010	7.30	645.00	642.50	645.00	641.91	643.19 j	642.74	643.51	643.06	4.51	3.74
23	DI 18	1.87	71.891	4.30	12	0.010	9.60	648.59	645.59	645.00	642.50	646.17 j	643.42	646.41	643.66	3.94	2.47

Project File: MIDDLE TRUNK.stm

Number of lines: 104

Date: 12/17/2020

NOTES: \*\* Critical depth

Line No.	Line ID	Flow Rate (cfs)	Line Length (ft)	Line Slope (%)	Line Size (in)	n-val Pipe	Capac Full (cfs)	Gnd/Rim EI Up (ft)	Invert Up (ft)	Gnd/Rim EI Dn (ft)	Invert Dn (ft)	HGL Up (ft)	HGL Dn (ft)	EGL Up (ft)	EGL Dn (ft)	Vel Up (ft/s)	Vel Dn (ft/s)
24	DI 19	1.26	74.359	4.30	12	0.010	9.60	651.79	648.79	648.59	645.59	649.26 j	646.37	649.45	646.56	3.44	1.90
25	BEND	0.70	51.000	4.29	12	0.010	9.59	653.98	650.98	651.79	648.79	651.33 j	649.43	651.46	649.56	2.87	1.30
26	DI 20	0.71	89.893	4.31	12	0.010	9.61	654.85	654.85	653.98	650.98	655.20 j	651.44	655.33	651.57	2.89	2.01
27	BEND	0.55	88.506	8.60	12	0.010	13.58	665.46	662.46	654.85	654.85	662.77 j	655.32	662.88	655.44	2.68	1.50
28	DI 21	0.58	144.504	8.60	12	0.010	13.58	678.00	674.89	665.46	662.46	675.21 j	662.87	675.32	662.99	2.72	1.90
29	DI 21	0.40	11.000	1.91	12	0.010	6.40	621.03	618.03	620.82	617.82	618.88	618.88	618.89	618.89	0.56	0.51
30	DI 22	0.13	11.500	1.91	12	0.010	6.40	620.16	617.16	619.94	616.94	618.05	618.05	618.05	618.05	0.18	0.17
31	DI 23	0.12	11.000	1.91	12	0.010	6.40	619.12	616.12	618.91	615.91	617.05	617.05	617.05	617.05	0.16	0.15
32	DI 24	0.52	40.000	2.50	12	0.010	7.32	646.50	643.50	645.00	642.50	643.80 j	643.50	643.91	643.51	2.64	0.66
33	DI 25	0.91	49.105	1.20	12	0.010	5.07	606.93	603.93	606.34	603.34	604.33 j	603.74	604.48	603.89	3.10	3.09
34	DI 26	0.71	86.846	1.20	12	0.010	5.07	607.97	604.97	606.93	603.93	605.32 j	604.47	605.45	604.60	2.88	1.65
35	DI 27	0.69	66.150	1.19	12	0.010	5.06	608.76	605.76	607.97	604.97	606.11 j	605.44	606.23	605.57	2.86	1.92
36	BEND	0.68	20.684	1.21	12	0.010	5.09	609.01	606.01	608.76	605.76	606.35 j	606.22	606.48	606.35	2.85	1.91
37	DI 28	0.64	31.532	1.21	12	0.012	4.24	609.39	606.39	609.01	606.01	606.72 j	606.47	606.84	606.59	2.80	1.82
38	BEND	0.14	12.530	1.20	12	0.010	5.06	609.54	606.54	609.39	606.39	606.69	606.83	606.75	606.88	1.84	0.42
39	DI 29	0.14	10.000	1.20	12	0.010	5.07	609.66	606.66	609.54	606.54	606.81 j	606.74	606.87	606.80	1.84	1.21
40	DI 30	0.05	11.000	1.18	12	0.010	5.03	609.14	606.14	609.01	606.01	606.23	606.47	606.26	606.50	1.39	0.13
41	DI 31	1.25	48.000	2.00	12	0.010	6.55	611.88	608.88	610.92	607.92	609.35	608.39	609.53	608.57	3.43	3.44
42	BEND	0.99	4.610	1.95	12	0.010	6.47	611.97	608.97	611.88	608.88	609.39	609.51	609.54	609.67	3.19	1.90
43	DI 32	0.86	57.959	2.00	12	0.010	6.55	613.13	610.13	611.97	608.97	610.52 j	609.53	610.66	609.67	3.06	1.92
44	BEND	0.83	4.008	2.00	12	0.010	6.54	613.21	610.21	613.13	610.13	610.59	610.65	610.73	610.79	3.02	2.03
45	BEND	0.74	45.200	1.99	12	0.010	6.53	614.11	611.11	613.21	610.21	611.47 j	610.72	611.60	610.85	2.92	1.85
46	DI 33	0.65	35.022	2.00	12	0.010	6.55	614.81	611.81	614.11	611.11	612.15 j	611.59	612.27	611.71	2.81	1.74

Project File: MIDDLE TRUNK.stm

Number of lines: 104

Date: 12/17/2020

NOTES: \*\* Critical depth

Line No.	Line ID	Flow Rate (cfs)	Line Length (ft)	Line Slope (%)	Line Size (in)	n-val Pipe	Capac Full (cfs)	Gnd/Rim El Up (ft)	Invert Up (ft)	Gnd/Rim El Dn (ft)	Invert Dn (ft)	HGL Up (ft)	HGL Dn (ft)	EGL Up (ft)	EGL Dn (ft)	Vel Up (ft/s)	Vel Dn (ft/s)
47	BEND	0.62	10.500	2.00	12	0.010	6.55	615.02	612.02	614.81	611.81	612.35 j	612.26	612.47	612.38	2.78	1.82
48	BEND	0.52	46.033	2.00	12	0.010	6.54	615.94	612.94	615.02	612.02	613.24 j	612.46	613.35	612.57	2.64	1.56
49	DI 34	0.42	28.609	1.99	12	0.010	6.53	616.51	613.51	615.94	612.94	613.78 j	613.34	613.88	613.44	2.49	1.43
50	BEND	0.41	20.224	1.98	12	0.010	6.51	616.91	613.91	616.51	613.51	614.17 j	613.87	614.27	613.97	2.47	1.61
51	DI 35	0.31	40.566	2.00	12	0.010	6.54	617.72	614.72	616.91	613.91	614.95 j	614.27	615.03	614.35	2.27	1.21
52	DI 36	0.16	12.000	2.00	12	0.010	6.55	612.21	609.21	611.97	608.97	609.37	609.53	609.43	609.58	1.90	0.35
53	DI 37	0.11	12.000	2.00	12	0.010	6.55	613.45	610.45	613.21	610.21	610.58	610.72	610.63	610.76	1.71	0.27
54	DI 38	0.11	12.000	2.00	12	0.010	6.55	614.35	611.35	614.11	611.11	611.48	611.58	611.53	611.63	1.71	0.29
55	DI 39	0.12	12.000	2.00	12	0.010	6.55	615.26	612.26	615.02	612.02	612.40	612.43	612.45	612.48	1.75	0.38
56	DI 40	0.11	12.000	2.00	12	0.010	6.55	616.18	613.18	615.94	612.94	613.31	613.35	613.36	613.39	1.71	0.35
57	DI 41	0.11	12.000	2.00	12	0.010	6.55	617.15	614.15	616.91	613.91	614.29 j	614.27	614.33	614.32	1.74	0.45
58	DI 42	2.44	90.356	2.80	12	0.010	7.75	619.41	616.41	0.00	613.88	617.08 j	614.55	617.38	614.85	4.37	4.36
59	DI 43	2.24	96.705	2.80	12	0.010	7.75	622.12	619.12	619.41	616.41	619.76 j	617.25	620.04	617.53	4.23	3.19
60	DI 44	2.21	101.447	2.80	12	0.010	7.75	624.96	621.96	622.12	619.12	622.59 j	619.91	622.87	620.19	4.20	3.30
61	BEND	2.19	4.589	2.83	12	0.010	7.79	625.09	622.09	624.96	621.96	622.72 j	622.75	623.00	623.02	4.19	3.31
62	DI 45	2.07	30.973	2.81	12	0.010	7.76	626.00	622.96	625.09	622.09	623.57 j	622.89	623.84	623.15	4.10	3.09
63	BEND	1.89	28.294	2.30	12	0.010	7.02	626.61	623.61	626.00	622.96	624.20 j	623.74	624.44	623.99	3.96	2.86
64	BEND	1.82	42.826	2.31	12	0.010	7.04	627.60	624.60	626.61	623.61	625.17 j	624.36	625.41	624.59	3.90	2.89
65	DI 46	1.81	14.648	2.32	12	0.010	7.05	627.94	624.94	627.60	624.60	625.51 j	625.33	625.75	625.56	3.89	2.95
66	DI 47	0.97	78.640	2.30	12	0.010	7.02	629.75	626.75	627.94	624.94	627.16 j	625.72	627.32	625.88	3.17	1.47
67	DI 48	0.91	89.857	2.30	12	0.010	7.03	628.82	628.82	629.75	626.75	629.22 j	627.30	629.37	627.45	3.11	2.05
68	DI 49	0.84	95.012	2.30	12	0.010	7.03	634.01	631.01	628.82	628.82	631.39 j	629.35	631.54	629.49	3.03	1.99
69	DI 50	0.81	68.516	2.31	12	0.010	7.03	635.59	632.59	634.01	631.01	632.97 j	631.52	633.11	631.66	3.00	2.01

Project File: MIDDLE TRUNK.stm

Number of lines: 104

Date: 12/17/2020

NOTES: \*\* Critical depth

Line No.	Line ID	Flow Rate (cfs)	Line Length (ft)	Line Slope (%)	Line Size (in)	n-val Pipe	Capac Full (cfs)	Gnd/Rim EI Up (ft)	Invert Up (ft)	Gnd/Rim EI Dn (ft)	Invert Dn (ft)	HGL Up (ft)	HGL Dn (ft)	EGL Up (ft)	EGL Dn (ft)	Vel Up (ft/s)	Vel Dn (ft/s)
70	DI 51	0.77	17.502	2.29	12	0.010	7.00	635.99	632.99	635.59	632.59	633.36 j	633.09	633.49	633.23	2.95	1.95
71	DI 52	0.70	86.009	2.30	12	0.010	7.02	637.97	634.97	635.99	632.99	635.32 j	633.48	635.45	633.61	2.87	1.82
72	DI 53	0.62	86.009	2.30	12	0.010	7.02	639.95	636.95	637.97	634.97	637.28 j	635.44	637.40	635.56	2.77	1.73
73	DI 54	0.54	86.018	2.30	12	0.010	7.02	641.93	638.93	639.95	636.95	639.24 j	637.39	639.35	637.50	2.67	1.63
74	DI 55	0.46	86.000	2.30	12	0.010	7.02	643.91	640.91	641.93	638.93	641.19 j	639.34	641.29	639.44	2.55	1.51
75	DI 56	0.17	12.000	2.83	12	0.010	7.79	625.43	622.43	625.09	622.09	622.60	622.99	622.66	623.04	1.93	0.22
76	DI 57	0.11	13.000	2.31	12	0.010	7.03	626.91	623.91	626.61	623.61	624.04	624.43	624.09	624.48	1.72	0.16
77	DI 58	0.02	13.000	2.31	12	0.010	7.03	627.90	624.90	627.60	624.60	624.95	625.40	624.97	625.42	1.08	0.03
78	DI 59	0.93	41.000	2.29	12	0.010	7.01	628.88	625.88	627.94	624.94	626.28 j	625.73	626.44	625.88	3.13	1.40
79	BEND	0.48	55.915	1.00	12	0.010	4.63	626.52	623.52	625.96	622.96	623.81 j	623.25	623.91	623.35	2.57	2.51
80	DI 60	0.48	8.062	0.99	12	0.010	4.61	626.60	623.60	626.52	623.52	623.89 j	623.90	623.99	624.01	2.57	1.73
81	DI 61	0.29	69.071	1.00	12	0.010	4.63	627.29	624.29	626.60	623.60	624.51 j	623.99	624.59	624.06	2.24	1.03
82	DI 62	0.12	47.183	1.00	12	0.010	4.62	627.76	624.76	627.29	624.29	624.90 j	624.59	624.95	624.64	1.76	0.60
83	DI 63	0.38	38.685	1.01	12	0.010	4.65	626.99	623.99	626.60	623.60	624.24	623.85	624.33	623.94	2.41	2.45
84	DI 64	0.15	64.873	1.00	12	0.010	4.63	627.64	624.64	626.99	623.99	624.80 j	624.33	624.85	624.39	1.88	0.63
85	DI 65	2.45	38.763	2.30	12	0.010	7.01	636.48	633.48	635.59	632.59	634.15	633.26	634.45	633.56	4.38	4.38
86	DI 66	2.21	47.006	2.30	12	0.010	7.02	637.56	634.56	636.48	633.48	635.20 j	634.32	635.47	634.60	4.20	3.13
87	DI 67	1.88	73.000	2.30	12	0.010	7.02	639.24	636.24	637.56	634.56	636.82 j	635.38	637.07	635.62	3.95	2.73
88	DI 68	1.60	86.009	2.30	12	0.010	7.02	641.22	638.22	639.24	636.24	638.76 j	637.00	638.97	637.22	3.73	2.49
89	DI 69	1.33	86.513	2.30	12	0.010	7.02	643.21	640.21	641.22	638.22	640.70 j	638.93	640.89	639.12	3.50	2.23
90	DI 70	1.03	86.001	2.30	12	0.010	7.02	645.19	642.19	643.21	640.21	642.62 j	640.86	642.78	641.02	3.23	1.91
91	DI 71	0.78	121.655	2.30	12	0.010	7.02	647.99	644.99	645.19	642.19	645.36 j	642.76	645.50	642.90	2.97	1.67
92	DI 72	0.59	21.101	2.32	12	0.010	7.05	648.48	645.48	647.99	644.99	645.80 j	645.49	645.91	645.60	2.73	1.51

Project File: MIDDLE TRUNK.stm

Number of lines: 104

Date: 12/17/2020

NOTES: \*\* Critical depth

Line No.	Line ID	Flow Rate (cfs)	Line Length (ft)	Line Slope (%)	Line Size (in)	n-val Pipe	Capac Full (cfs)	Gnd/Rim EI Up (ft)	Invert Up (ft)	Gnd/Rim EI Dn (ft)	Invert Dn (ft)	HGL Up (ft)	HGL Dn (ft)	EGL Up (ft)	EGL Dn (ft)	Vel Up (ft/s)	Vel Dn (ft/s)
93	DI 73	0.19	112.886	1.90	12	0.010	6.37	619.72	616.72	617.58	614.58	616.90	614.76	616.96	614.82	2.01	2.02
94	DI 74	0.10	74.250	1.90	12	0.010	6.38	621.13	618.13	619.72	616.72	618.26 j	616.96	618.31	617.01	1.70	0.69
95	BEND	0.27	29.300	1.91	12	0.010	6.40	621.46	618.46	620.90	617.90	618.68 j	618.12	618.75	618.20	2.21	2.14
96	DI 75	0.03	25.495	1.88	12	0.010	6.35	621.94	618.94	621.46	618.46	619.01 j	618.75	619.04	618.78	1.28	0.18
97	DI 76	0.25	12.500	1.92	12	0.010	6.41	621.70	618.70	621.46	618.46	618.90 j	618.75	618.98	618.82	2.15	1.32
98	DI 77	1.86	41.431	2.51	12	0.010	7.33	636.05	633.05	635.01	632.01	633.63	632.59	633.87	632.83	3.93	3.94
99	DI 78	1.54	40.482	2.49	12	0.010	7.31	637.06	634.06	636.05	633.05	634.59 j	633.81	634.80	634.02	3.68	2.40
100	DI 79	0.76	67.073	2.50	12	0.010	7.33	638.74	635.74	637.06	634.06	636.10 j	634.78	636.24	634.92	2.95	1.26
101	JUNCTION BOX	0.46	41.304	2.49	12	0.010	7.31	639.77	636.77	638.74	635.74	637.05 j	636.23	637.15	636.33	2.54	1.18
102	DI 80	0.16	34.297	2.51	12	0.010	7.33	640.63	637.63	639.77	636.77	637.79 j	637.15	637.85	637.21	1.91	0.58
103	DI 81	0.31	38.000	2.50	12	0.010	7.32	640.72	637.72	639.77	636.77	637.95 j	637.15	638.03	637.23	2.28	1.14
104	DI 82	0.11	43.000	2.51	12	0.010	7.34	641.80	638.80	640.72	637.72	638.93 j	638.03	638.98	638.08	1.72	0.52

Project File: MIDDLE TRUNK.stm

Number of lines: 104

Date: 12/17/2020

NOTES: \*\* Critical depth



Line No.	Line ID	Flow Rate (cfs)	Line Length (ft)	Line Slope (%)	Line Size (in)	n-val Pipe	Capac Full (cfs)	Gnd/Rim EI Up (ft)	Invert Up (ft)	Gnd/Rim EI Dn (ft)	Invert Dn (ft)	HGL Up (ft)	HGL Dn (ft)	EGL Up (ft)	EGL Dn (ft)	Vel Up (ft/s)	Vel Dn (ft/s)
1	DI 83	1.67	175.000	1.80	12	0.010	6.21	611.15	608.15	608.00	605.00	608.70 j	605.95	608.92	606.17	3.78	2.17
2	DI 84	1.28	86.000	1.80	12	0.010	6.22	612.70	609.70	611.15	608.15	610.18 j	608.88	610.36	609.07	3.46	2.08
3	DI 85	1.20	87.208	1.80	12	0.010	6.21	614.27	611.27	612.70	609.70	611.73 j	610.33	611.91	610.50	3.39	2.32
4	DI 86	1.14	90.699	1.80	12	0.010	6.21	615.90	612.90	614.27	611.27	613.35 j	611.88	613.52	612.05	3.33	2.27
5	DI 87	1.07	89.503	1.80	12	0.010	6.21	617.51	614.51	615.90	612.90	614.94 j	613.49	615.11	613.66	3.27	2.21
6	DI 88	1.02	89.589	1.80	12	0.010	6.21	619.12	616.12	617.51	614.51	616.54 j	615.08	616.70	615.25	3.21	2.18
7	DI 89	0.46	85.440	1.80	12	0.010	6.22	620.66	617.66	619.12	616.12	617.94 j	616.70	618.04	616.80	2.55	0.99
8	JUNCTION BOX	0.37	5.831	1.89	12	0.010	6.36	620.77	617.77	620.66	617.66	618.02 j	618.04	618.11	618.13	2.39	1.34
9	JUNCTION BOX	0.26	45.905	1.81	12	0.010	6.23	621.60	618.60	620.77	617.77	618.81 j	618.11	618.88	618.18	2.17	1.12
10	BEND	0.15	24.274	1.81	12	0.010	6.23	0.00	619.04	621.60	618.60	619.20 j	618.88	619.25	618.94	1.87	0.81
11	DI 90	0.15	1.250	1.60	12	0.010	5.86	622.06	619.06	0.00	619.04	619.22	619.25	619.27	619.31	1.87	1.23
12	DI 91	0.38	19.000	1.79	12	0.010	6.19	611.49	608.49	611.15	608.15	608.74	608.88	608.84	608.98	2.42	0.62
13	DI 92	0.32	41.000	1.80	12	0.010	6.22	619.86	616.86	619.12	616.12	617.09 j	616.70	617.18	616.78	2.30	0.68
14	DI 93	0.12	15.000	1.80	12	0.010	6.21	621.04	618.04	620.77	617.77	618.18 j	618.11	618.23	618.16	1.76	0.50
15	DI 94	0.12	18.000	1.78	12	0.010	6.17	621.92	618.92	621.60	618.60	619.06 j	618.88	619.11	618.93	1.75	0.63
16	DI 95	0.82	68.542	1.79	12	0.010	6.20	613.93	610.93	612.70	609.70	611.31 j	610.41	611.45	610.55	3.01	1.37
17	JUNCTION BOX	0.72	4.528	1.77	12	0.010	6.15	614.01	611.01	613.93	610.93	611.36	611.43	611.50	611.57	2.90	1.82
18	JUNCTION BOX	0.62	50.225	1.79	12	0.010	6.20	614.91	611.91	614.01	611.01	612.24 j	611.49	612.36	611.61	2.78	1.70
19	DI 96	0.50	27.115	1.81	12	0.010	6.22	615.40	612.40	614.91	611.91	612.69 j	612.35	612.80	612.46	2.61	1.50
20	JUNCTION BOX	0.39	23.505	1.79	12	0.010	6.19	615.82	612.82	615.40	612.40	613.08 j	612.80	613.17	612.89	2.44	1.36
21	JUNCTION BOX	0.28	51.000	1.78	12	0.010	6.18	616.73	613.73	615.82	612.82	613.95 j	613.17	614.02	613.25	2.21	1.13
22	JUNCTION BOX	0.15	26.000	1.81	12	0.010	6.22	617.20	614.20	616.73	613.73	614.36 j	614.02	614.41	614.08	1.88	0.79
23	DI 97	0.15	1.750	1.71	12	0.010	6.06	617.23	614.23	617.20	614.20	614.39	614.41	614.44	614.47	1.88	1.23

Project File: TRIB 2 - 2H.stm

Number of lines: 27

Date: 12/17/2020

NOTES: \*\* Critical depth

Line No.	Line ID	Flow Rate (cfs)	Line Length (ft)	Line Slope (%)	Line Size (in)	n-val Pipe	Capac Full (cfs)	Gnd/Rim El Up (ft)	Invert Up (ft)	Gnd/Rim El Dn (ft)	Invert Dn (ft)	HGL Up (ft)	HGL Dn (ft)	EGL Up (ft)	EGL Dn (ft)	Vel Up (ft/s)	Vel Dn (ft/s)
24	DI 98	0.12	11.000	1.82	12	0.010	6.24	614.21	611.21	614.01	611.01	611.35	611.48	611.40	611.53	1.76	0.33
25	DI 99	0.13	11.500	1.83	12	0.010	6.26	615.12	612.12	614.91	611.91	612.27	612.33	612.32	612.38	1.82	0.43
26	DI 100	0.13	12.000	1.83	12	0.010	6.27	616.04	613.04	615.82	612.82	613.19 j	613.17	613.24	613.22	1.81	0.53
27	DI 101	0.13	12.260	1.79	12	0.010	6.20	616.95	613.95	616.73	613.73	614.10 j	614.02	614.15	614.07	1.81	0.68

Project File: TRIB 2 - 2H.stm	Number of lines: 27	Date: 12/17/2020
-------------------------------	---------------------	------------------

NOTES: \*\* Critical depth

Line No.	Line ID	Flow Rate (cfs)	Line Length (ft)	Line Slope (%)	Line Size (in)	n-val Pipe	Capac Full (cfs)	Gnd/Rim El Up (ft)	Invert Up (ft)	Gnd/Rim El Dn (ft)	Invert Dn (ft)	HGL Up (ft)	HGL Dn (ft)	EGL Up (ft)	EGL Dn (ft)	Vel Up (ft/s)	Vel Dn (ft/s)
1	DI 102	2.50	7.750	2.06	12	0.010	6.65	611.16	608.16	609.00	608.00	608.84	608.62	609.14	608.92	4.42	4.88
2	DI 103	1.80	532.003	2.00	12	0.010	6.55	621.80	618.80	611.16	608.16	619.37 j	609.06	619.60	609.29	3.88	2.41
3	DI 104	1.66	6.500	2.00	12	0.010	6.55	621.93	618.93	621.80	618.80	619.48 j	619.53	619.70	619.76	3.77	2.68
4	DI 105	1.56	84.503	2.00	12	0.010	6.55	623.62	620.62	621.93	618.93	621.15 j	619.64	621.36	619.85	3.70	2.64
5	DI 106	1.45	169.003	2.00	12	0.010	6.55	627.00	624.00	623.62	620.62	624.51 j	621.31	624.71	621.51	3.60	2.50
6	DI 107	1.33	98.003	2.00	12	0.010	6.55	628.96	625.96	627.00	624.00	626.45 j	624.67	626.64	624.86	3.50	2.39
7	DI 108	1.24	45.003	2.00	12	0.010	6.55	629.86	626.86	628.96	625.96	627.33 j	626.60	627.51	626.78	3.43	2.35
8	DI 109	1.16	45.001	2.00	12	0.010	6.55	630.76	627.76	629.86	626.86	628.21 j	627.48	628.39	627.65	3.35	2.27
9	DI 110	1.08	45.001	2.00	12	0.010	6.55	631.66	628.66	630.76	627.76	629.10 j	628.36	629.26	628.53	3.27	2.19
10	DI 111	0.99	50.003	2.00	12	0.010	6.55	632.66	629.66	631.66	628.66	630.08 j	629.24	630.24	629.40	3.19	2.10
11	DI 112	0.91	43.001	2.00	12	0.010	6.55	633.52	630.52	632.66	629.66	630.92 j	630.21	631.07	630.36	3.11	2.03
12	DI 113	0.82	43.501	2.00	12	0.010	6.55	634.39	631.39	633.52	630.52	631.77 j	631.05	631.91	631.19	3.02	1.94
13	DI 114	0.74	42.003	2.00	12	0.010	6.55	635.23	632.23	634.39	631.39	632.59 j	631.90	632.72	632.03	2.92	1.85
14	DI 115	0.65	43.501	2.00	12	0.010	6.55	636.10	633.10	635.23	632.23	633.44 j	632.71	633.56	632.83	2.81	1.75
15	116	0.56	42.001	2.00	12	0.010	6.55	636.94	633.94	636.10	633.10	634.25 j	633.55	634.36	633.66	2.70	1.64
16	DI 117	0.47	44.001	2.00	12	0.010	6.55	637.82	634.82	636.94	633.94	635.10 j	634.36	635.21	634.46	2.57	1.52
17	DI 118	0.38	43.501	2.00	12	0.010	6.55	638.69	635.69	637.82	634.82	635.94 j	635.20	636.04	635.29	2.42	1.37
18	DI 119	0.29	42.003	2.00	12	0.010	6.55	639.53	636.53	638.69	635.69	636.75 j	636.03	636.83	636.11	2.25	1.23
19	DI 120	0.20	46.001	2.00	12	0.010	6.55	640.45	637.45	639.53	636.53	637.63 j	636.83	637.70	636.89	2.03	1.02
20	DI 121	0.11	41.507	2.00	12	0.010	6.55	642.00	638.28	640.45	637.45	638.41 j	637.70	638.46	637.74	1.72	0.71

Project File: TRIB 2 - NORTH.stm

Number of lines: 20

Date: 12/17/2020

NOTES: \*\* Critical depth

Line No.	Line ID	Flow Rate (cfs)	Line Length (ft)	Line Slope (%)	Line Size (in)	n-val Pipe	Capac Full (cfs)	Gnd/Rim El Up (ft)	Invert Up (ft)	Gnd/Rim El Dn (ft)	Invert Dn (ft)	HGL Up (ft)	HGL Dn (ft)	EGL Up (ft)	EGL Dn (ft)	Vel Up (ft/s)	Vel Dn (ft/s)
1	BEND	3.62	11.909	2.02	12	0.010	6.57	608.24	605.24	608.00	605.00	606.05	605.81	606.49	606.25	5.31	5.31
2	JUNCTION BOX	3.65	91.501	2.00	12	0.010	6.55	610.07	607.07	608.24	605.24	607.88 j	606.15	608.33	606.59	5.33	4.86
3	BEND	3.78	357.503	2.10	12	0.010	6.71	617.58	614.58	610.07	607.07	615.41 j	607.97	615.87	608.43	5.44	5.09
4	DI 122	3.78	7.000	2.14	12	0.010	6.78	617.73	614.73	617.58	614.58	615.56 j	615.51	616.02	615.97	5.45	4.98
5	DI 123	3.70	139.945	2.10	12	0.010	6.71	620.67	617.67	617.73	614.73	618.49 j	615.67	618.94	616.12	5.38	4.83
6	BEND	3.47	97.053	2.10	12	0.010	6.71	622.71	619.71	620.67	617.67	620.51 j	618.64	620.92	619.05	5.18	4.47
7	DI 124	3.49	43.342	2.10	12	0.010	6.71	623.62	620.62	622.71	619.71	621.42 j	620.62	621.84	621.04	5.19	4.66
8	DI 125	3.35	42.048	2.40	12	0.010	7.18	624.63	621.63	623.62	620.62	622.41 j	621.55	622.81	621.96	5.08	4.38
9	DI 126	3.09	143.504	2.40	12	0.010	7.17	628.07	625.07	624.63	621.63	625.82 j	622.57	626.19	622.94	4.87	4.03
10	JUNCTION BOX	2.78	99.503	2.40	12	0.010	7.18	630.46	627.46	628.07	625.07	628.17 j	626.00	628.51	626.33	4.63	3.66
11	DI 127	2.16	65.502	2.40	12	0.010	7.17	632.03	629.03	630.46	627.46	629.66 j	628.39	629.93	628.66	4.16	2.83
12	DI 128	1.76	39.000	4.31	12	0.010	9.61	633.71	630.71	632.03	629.03	631.27 j	629.85	631.51	630.08	3.86	2.56
13	DI 129	1.69	29.004	4.31	12	0.010	9.61	634.96	631.96	633.71	630.71	632.51 j	631.43	632.74	631.66	3.80	2.78
14	DI 130	1.51	47.003	4.30	12	0.010	9.60	636.98	633.98	634.96	631.96	634.50 j	632.68	634.71	632.89	3.65	2.49
15	DI 131	1.41	30.001	4.30	12	0.010	9.60	638.27	635.27	636.98	633.98	635.77 j	634.66	635.97	634.86	3.57	2.49
16	DI 132	1.22	80.006	4.30	12	0.010	9.60	641.71	638.71	638.27	635.27	639.18 j	635.93	639.36	636.11	3.40	2.20
17	DI 133	1.12	30.001	4.30	12	0.010	9.60	643.00	640.00	641.71	638.71	640.45 j	639.32	640.62	639.49	3.31	2.22
18	DI 134	0.94	75.007	4.31	12	0.010	9.61	646.23	643.23	643.00	640.00	643.64 j	640.59	643.79	640.75	3.14	1.93
19	DI 134	0.81	30.001	4.30	12	0.010	9.60	647.52	644.52	646.23	643.23	644.90 j	643.77	645.04	643.91	3.00	1.85
20	DI 136	0.63	60.005	4.30	12	0.010	9.60	650.10	647.10	647.52	644.52	647.43 j	645.03	647.55	645.15	2.79	1.58
21	DI 137	0.52	30.001	4.30	12	0.010	9.60	651.39	648.39	650.10	647.10	648.69 j	647.54	648.80	647.65	2.64	1.56
22	BEND	0.11	60.005	4.30	12	0.010	9.60	654.00	650.97	651.39	648.39	651.11 j	648.80	651.15	648.85	1.73	0.36
23	DI 138	0.11	2.500	4.40	12	0.010	9.71	654.08	651.08	654.00	650.97	651.22 j	651.15	651.26	651.20	1.73	1.13

Project File: SOUTH TRUNK.stm

Number of lines: 40

Date: 12/17/2020

NOTES: \*\* Critical depth

Line No.	Line ID	Flow Rate (cfs)	Line Length (ft)	Line Slope (%)	Line Size (in)	n-val Pipe	Capac Full (cfs)	Gnd/Rim EI Up (ft)	Invert Up (ft)	Gnd/Rim EI Dn (ft)	Invert Dn (ft)	HGL Up (ft)	HGL Dn (ft)	EGL Up (ft)	EGL Dn (ft)	Vel Up (ft/s)	Vel Dn (ft/s)
24	DI 139	0.77	29.000	2.41	12	0.010	7.19	631.16	628.16	630.46	627.46	628.53 j	628.49	628.66	628.51	2.96	0.98
25	DI 140	1.16	5.500	2.00	12	0.010	6.55	610.18	607.18	0.00	607.07	607.63	607.52	607.81	607.69	3.35	3.38
26	DI 141	0.69	41.262	2.01	12	0.010	6.57	611.01	608.01	610.18	607.18	608.36 j	607.80	608.48	607.92	2.86	1.36
27	DI 142	0.42	172.007	2.00	12	0.010	6.55	614.45	611.45	611.01	608.01	611.72 j	608.48	611.81	608.57	2.49	1.17
28	DI 143	0.33	107.005	2.00	12	0.010	6.55	616.59	613.59	614.45	611.45	613.83 j	611.81	613.91	611.90	2.33	1.30
29	DI 144	0.27	79.004	2.00	12	0.010	6.55	618.17	615.17	616.59	613.59	615.38 j	613.91	615.46	613.98	2.19	1.23
30	DI 145	0.19	67.502	2.00	12	0.010	6.55	619.52	616.52	618.17	615.17	616.70 j	615.46	616.76	615.52	2.01	1.05
31	BEND	0.10	16.867	2.02	12	0.010	6.57	619.86	616.86	619.52	616.52	616.99 j	616.76	617.03	616.81	1.68	0.66
32	BEND	0.10	46.519	2.00	12	0.010	6.55	620.79	617.79	619.86	616.86	617.92 j	617.03	617.96	617.08	1.69	1.13
33	DI 146	0.10	21.162	1.98	12	0.010	6.52	621.21	618.21	620.79	617.79	618.34 j	617.96	618.39	618.01	1.70	1.12
34	DI 147	0.80	55.595	1.91	12	0.010	6.39	624.68	621.68	0.00	620.62	622.05	620.99	622.19	621.13	2.99	3.03
35	DI 148	0.41	154.507	1.80	12	0.010	6.21	627.46	624.46	624.68	621.68	624.72 j	622.19	624.82	622.28	2.47	1.02
36	BEND	0.22	41.000	1.80	12	0.010	6.22	628.20	625.20	627.46	624.46	625.39 j	624.82	625.46	624.89	2.08	0.88
37	DI 149	0.23	93.005	1.80	12	0.010	6.20	629.87	626.87	628.20	625.20	627.07 j	625.46	627.14	625.53	2.11	1.43
38	DI 150	0.12	40.501	1.80	12	0.010	6.22	630.60	627.60	629.87	626.87	627.74 j	627.14	627.79	627.19	1.77	0.71
39	DI 151	0.24	276.511	4.30	12	0.010	9.60	643.92	640.92	632.03	629.03	641.12	629.23	641.19	629.30	2.12	2.11
40	DI 152	0.07	144.004	4.30	12	0.010	9.60	650.11	647.11	643.92	640.92	647.22 j	641.19	647.25	641.23	1.53	0.40

Project File: SOUTH TRUNK.stm

Number of lines: 40

Date: 12/17/2020

NOTES: \*\* Critical depth

Line No.	Line ID	Flow Rate (cfs)	Line Length (ft)	Line Slope (%)	Line Size (in)	n-val Pipe	Capac Full (cfs)	Gnd/Rim El Up (ft)	Invert Up (ft)	Gnd/Rim El Dn (ft)	Invert Dn (ft)	HGL Up (ft)	HGL Dn (ft)	EGL Up (ft)	EGL Dn (ft)	Vel Up (ft/s)	Vel Dn (ft/s)
1	DI 153	12.83	12.000	0.58	24	0.010	22.46	598.00	594.07	595.00	594.00	595.36	595.42	595.92	595.98	6.00	5.38
2	DI 154	6.33	220.202	1.60	24	0.010	37.18	600.00	597.59	598.00	594.07	598.48 j	595.85	598.82	596.20	4.69	2.14
3	DI 155	5.56	34.000	1.59	18	0.010	17.20	600.00	598.13	600.00	597.59	599.04 j	598.67	599.42	599.05	4.97	4.09

Project File: STATE STREET TRUNK.stm	Number of lines: 3	Date: 12/17/2020
--------------------------------------	--------------------	------------------

NOTES: \*\* Critical depth

Line No.	Line ID	Flow Rate (cfs)	Line Length (ft)	Line Slope (%)	Line Size (in)	n-val Pipe	Capac Full (cfs)	Gnd/Rim El Up (ft)	Invert Up (ft)	Gnd/Rim El Dn (ft)	Invert Dn (ft)	HGL Up (ft)	HGL Dn (ft)	EGL Up (ft)	EGL Dn (ft)	Vel Up (ft/s)	Vel Dn (ft/s)
1	DI 156	4.29	30.000	1.67	24	0.013	29.20	609.00	606.00	608.50	605.50	606.73	606.23	607.00	606.50	4.16	4.16

Project File: NORTH OUTFALL.stm	Number of lines: 1	Date: 12/21/2020
---------------------------------	--------------------	------------------

NOTES: \*\* Critical depth

Line No.	Line ID	Flow Rate (cfs)	Line Length (ft)	Line Slope (%)	Line Size (in)	n-val Pipe	Capac Full (cfs)	Gnd/Rim El Up (ft)	Invert Up (ft)	Gnd/Rim El Dn (ft)	Invert Dn (ft)	HGL Up (ft)	HGL Dn (ft)	EGL Up (ft)	EGL Dn (ft)	Vel Up (ft/s)	Vel Dn (ft/s)
1	Post Trib 1	12.39	30.000	2.00	24	0.012	34.65	609.00	606.00	608.40	605.40	607.26 j	606.96	607.81	607.50	5.92	4.71

Project File: New.stm	Number of lines: 1	Date: 12/21/2020
-----------------------	--------------------	------------------

NOTES: \*\* Critical depth



Line No.	Line ID	Flow Rate (cfs)	Line Length (ft)	Line Slope (%)	Line Size (in)	n-val Pipe	Capac Full (cfs)	Gnd/Rim El Up (ft)	Invert Up (ft)	Gnd/Rim El Dn (ft)	Invert Dn (ft)	HGL Up (ft)	HGL Dn (ft)	EGL Up (ft)	EGL Dn (ft)	Vel Up (ft/s)	Vel Dn (ft/s)
1	DI 1	5.82	28.461	1.19	12	0.010	5.06	606.34	603.34	606.00	603.00	604.40	603.95	605.26	604.84	7.42	7.56
2	DI 2	5.63	89.836	1.20	12	0.010	5.08	607.42	604.42	606.34	603.34	607.07	605.74	607.87	606.54	7.17	7.17
3	DI 3	5.62	65.340	1.19	12	0.010	5.06	608.20	605.20	607.42	604.42	608.44	607.47	609.23	608.27	7.15	7.15
4	DI 4	5.62	53.891	1.21	12	0.010	5.08	608.85	605.85	608.20	605.20	609.63	608.83	610.42	609.63	7.16	7.16
5	DI 5	5.36	125.811	1.20	12	0.010	5.07	610.36	607.36	608.85	605.85	611.79	610.10	612.51	610.82	6.83	6.83
6	DI 6	5.36	46.638	1.20	12	0.010	5.07	610.92	607.92	610.36	607.36	612.78	612.15	613.50	612.87	6.83	6.83
7	DI 7	5.14	81.666	2.00	12	0.010	6.54	612.55	609.55	610.92	607.92	614.20	613.20	614.87	613.86	6.55	6.55
8	DI 8	5.14	79.657	2.00	12	0.010	6.54	614.14	611.14	612.55	609.55	615.52	614.54	616.19	615.20	6.54	6.54
9	DI 9	5.13	68.037	2.00	12	0.010	6.55	615.50	612.50	614.14	611.14	616.69	615.85	617.35	616.52	6.53	6.53
10	DI 10	5.10	68.924	2.00	12	0.012	5.46	616.88	613.88	615.50	612.50	618.23	617.03	618.89	617.68	6.49	6.49
11	DI 11	4.84	36.620	1.91	12	0.010	6.40	617.58	614.58	616.88	613.88	619.43	619.03	620.02	619.62	6.16	6.16
12	DI 12	4.78	40.569	1.90	12	0.010	6.38	618.35	615.35	617.58	614.58	620.57	620.14	621.14	620.71	6.09	6.09
13	BEND	4.72	29.501	1.90	12	0.010	6.38	618.91	615.91	618.35	615.35	621.75	621.45	622.31	622.01	6.01	6.01
14	DI 13	4.60	26.580	1.92	12	0.010	6.41	619.42	616.42	618.91	615.91	622.60	622.34	623.14	622.88	5.86	5.86
15	BEND	4.54	27.313	1.90	12	0.010	6.39	619.94	616.94	619.42	616.42	623.15	622.89	623.67	623.40	5.78	5.78
16	DI 14	4.40	25.739	1.90	12	0.010	6.39	620.43	617.43	619.94	616.94	623.93	623.70	624.42	624.19	5.61	5.61
17	BEND	4.28	20.587	1.89	12	0.010	6.37	620.82	617.82	620.43	617.43	624.38	624.20	624.84	624.66	5.45	5.45
18	JUNCTION BOX	3.84	4.250	1.88	12	0.010	6.35	620.90	617.90	620.82	617.82	624.96	624.93	625.33	625.30	4.89	4.90
19	DI 15	3.98	323.631	2.50	12	0.010	7.32	628.99	625.99	620.90	617.90	627.90	625.51	628.30	625.91	5.07	5.07
20	DI 16	3.68	240.762	2.50	12	0.010	7.32	635.01	632.01	628.99	625.99	632.83 j	628.16	633.27	628.50	5.36	4.69
21	BEND	3.77	396.004	2.50	12	0.010	7.32	645.00	641.91	635.01	632.01	642.74 j	632.91	643.20	633.37	5.44	5.05
22	DI 17	3.78	23.755	2.48	12	0.010	7.30	645.00	642.50	645.00	641.91	643.33 j	642.83	643.79	643.30	5.45	4.99
23	DI 18	2.69	71.891	4.30	12	0.010	9.60	648.59	645.59	645.00	642.50	646.29 j	643.61	646.62	643.79	4.57	3.43

Project File: MIDDLE TRUNK.stm

Number of lines: 104

Date: 12/18/2020

NOTES: \*\* Critical depth

Line No.	Line ID	Flow Rate (cfs)	Line Length (ft)	Line Slope (%)	Line Size (in)	n-val Pipe	Capac Full (cfs)	Gnd/Rim El Up (ft)	Invert Up (ft)	Gnd/Rim El Dn (ft)	Invert Dn (ft)	HGL Up (ft)	HGL Dn (ft)	EGL Up (ft)	EGL Dn (ft)	Vel Up (ft/s)	Vel Dn (ft/s)
24	DI 19	1.81	74.359	4.30	12	0.010	9.60	651.79	648.79	648.59	645.59	649.36 j	646.53	649.60	646.77	3.89	2.35
25	BEND	1.00	51.000	4.29	12	0.010	9.59	653.98	650.98	651.79	648.79	651.40 j	649.57	651.56	649.73	3.20	1.52
26	DI 20	1.03	89.893	4.31	12	0.010	9.61	654.85	654.85	653.98	650.98	655.28 j	651.53	655.44	651.69	3.22	2.30
27	BEND	0.79	88.506	8.60	12	0.010	13.58	665.46	662.46	654.85	654.85	662.83 j	655.42	662.97	655.56	2.98	1.70
28	DI 21	0.83	144.504	8.60	12	0.010	13.58	678.00	674.89	665.46	662.46	675.27 j	662.95	675.41	663.09	3.02	2.15
29	DI 21	0.57	11.000	1.91	12	0.010	6.40	621.03	618.03	620.82	617.82	625.29	625.29	625.30	625.30	0.72	0.72
30	DI 22	0.19	11.500	1.91	12	0.010	6.40	620.16	617.16	619.94	616.94	624.18	624.18	624.19	624.19	0.24	0.24
31	DI 23	0.17	11.000	1.91	12	0.010	6.40	619.12	616.12	618.91	615.91	622.88	622.87	622.88	622.88	0.21	0.21
32	DI 24	0.74	40.000	2.50	12	0.010	7.32	646.50	643.50	645.00	642.50	643.86 j	643.77	643.99	643.79	2.92	0.94
33	DI 25	1.30	49.105	1.20	12	0.010	5.07	606.93	603.93	606.34	603.34	604.41	603.74	604.60	603.93	3.48	4.44
34	DI 26	1.01	86.846	1.20	12	0.010	5.07	607.97	604.97	606.93	603.93	605.39 j	604.57	605.55	604.73	3.21	1.90
35	DI 27	0.99	66.150	1.19	12	0.010	5.06	608.76	605.76	607.97	604.97	606.18 j	605.53	606.33	605.69	3.19	2.19
36	BEND	0.97	20.684	1.21	12	0.010	5.09	609.01	606.01	608.76	605.76	606.42 j	606.31	606.58	606.47	3.17	2.19
37	DI 28	0.91	31.532	1.21	12	0.012	4.24	609.39	606.39	609.01	606.01	606.79 j	606.56	606.94	606.71	3.11	2.07
38	BEND	0.20	12.530	1.20	12	0.010	5.06	609.54	606.54	609.39	606.39	606.72	606.92	606.79	606.99	2.02	0.46
39	DI 29	0.20	10.000	1.20	12	0.010	5.07	609.66	606.66	609.54	606.54	606.84 j	606.79	606.91	606.85	2.03	1.34
40	DI 30	0.07	11.000	1.18	12	0.010	5.03	609.14	606.14	609.01	606.01	606.25	606.57	606.28	606.61	1.52	0.15
41	DI 31	1.79	48.000	2.00	12	0.010	6.55	611.88	608.88	610.92	607.92	609.45	608.39	609.68	608.62	3.88	4.94
42	BEND	1.42	4.610	1.95	12	0.010	6.47	611.97	608.97	611.88	608.88	609.47 j	609.49	609.67	609.69	3.58	2.84
43	DI 32	1.23	57.959	2.00	12	0.010	6.55	613.13	610.13	611.97	608.97	610.60 j	609.63	610.78	609.82	3.42	2.23
44	BEND	1.19	4.008	2.00	12	0.010	6.54	613.21	610.21	613.13	610.13	610.67	610.74	610.85	610.92	3.38	2.35
45	BEND	1.06	45.200	1.99	12	0.010	6.53	614.11	611.11	613.21	610.21	611.54 j	610.82	611.71	610.98	3.26	2.13
46	DI 33	0.93	35.022	2.00	12	0.010	6.55	614.81	611.81	614.11	611.11	612.21 j	611.69	612.37	611.84	3.13	1.99

Project File: MIDDLE TRUNK.stm

Number of lines: 104

Date: 12/18/2020

NOTES: \*\* Critical depth

Line No.	Line ID	Flow Rate (cfs)	Line Length (ft)	Line Slope (%)	Line Size (in)	n-val Pipe	Capac Full (cfs)	Gnd/Rim El Up (ft)	Invert Up (ft)	Gnd/Rim El Dn (ft)	Invert Dn (ft)	HGL Up (ft)	HGL Dn (ft)	EGL Up (ft)	EGL Dn (ft)	Vel Up (ft/s)	Vel Dn (ft/s)
47	BEND	0.89	10.500	2.00	12	0.010	6.55	615.02	612.02	614.81	611.81	612.41 j	612.35	612.56	612.50	3.09	2.07
48	BEND	0.74	46.033	2.00	12	0.010	6.54	615.94	612.94	615.02	612.02	613.30 j	612.55	613.43	612.68	2.93	1.77
49	DI 34	0.61	28.609	1.99	12	0.010	6.53	616.51	613.51	615.94	612.94	613.83 j	613.42	613.95	613.54	2.75	1.61
50	BEND	0.59	20.224	1.98	12	0.010	6.51	616.91	613.91	616.51	613.51	614.23 j	613.94	614.34	614.06	2.73	1.80
51	DI 35	0.44	40.566	2.00	12	0.010	6.54	617.72	614.72	616.91	613.91	614.99 j	614.34	615.09	614.44	2.51	1.35
52	DI 36	0.22	12.000	2.00	12	0.010	6.55	612.21	609.21	611.97	608.97	609.40	609.66	609.47	609.73	2.09	0.39
53	DI 37	0.15	12.000	2.00	12	0.010	6.55	613.45	610.45	613.21	610.21	610.61	610.83	610.66	610.89	1.88	0.29
54	DI 38	0.15	12.000	2.00	12	0.010	6.55	614.35	611.35	614.11	611.11	611.51	611.69	611.56	611.75	1.88	0.32
55	DI 39	0.16	12.000	2.00	12	0.010	6.55	615.26	612.26	615.02	612.02	612.43	612.54	612.48	612.60	1.92	0.40
56	DI 40	0.15	12.000	2.00	12	0.010	6.55	616.18	613.18	615.94	612.94	613.34	613.40	613.39	613.46	1.88	0.42
57	DI 41	0.16	12.000	2.00	12	0.010	6.55	617.15	614.15	616.91	613.91	614.31 j	614.34	614.37	614.40	1.91	0.50
58	DI 42	3.56	90.356	2.80	12	0.010	7.75	619.41	616.41	0.00	613.88	617.22	614.55	617.64	614.98	5.25	6.37
59	DI 43	3.27	96.705	2.80	12	0.010	7.75	622.12	619.12	619.41	616.41	619.89 j	617.38	620.28	617.77	5.01	4.20
60	DI 44	3.21	101.447	2.80	12	0.010	7.75	624.96	621.96	622.12	619.12	622.73 j	620.02	623.11	620.41	4.97	4.30
61	BEND	3.19	4.589	2.83	12	0.010	7.79	625.09	622.09	624.96	621.96	622.85 j	622.85	623.24	623.24	4.95	4.31
62	DI 45	3.01	30.973	2.81	12	0.010	7.76	626.00	622.96	625.09	622.09	623.70 j	623.01	624.06	623.37	4.81	3.99
63	BEND	2.75	28.294	2.30	12	0.010	7.02	626.61	623.61	626.00	622.96	624.32 j	623.87	624.65	624.20	4.61	3.65
64	BEND	2.64	42.826	2.31	12	0.010	7.04	627.60	624.60	626.61	623.61	625.30 j	624.47	625.61	624.79	4.52	3.65
65	DI 46	2.62	14.648	2.32	12	0.010	7.05	627.94	624.94	627.60	624.60	625.63 j	625.44	625.95	625.76	4.51	3.72
66	DI 47	1.41	78.640	2.30	12	0.010	7.02	629.75	626.75	627.94	624.94	627.25 j	625.90	627.45	626.10	3.57	1.82
67	DI 48	1.31	89.857	2.30	12	0.010	7.03	628.82	628.82	629.75	626.75	629.30 j	627.41	629.49	627.60	3.49	2.40
68	DI 49	1.21	95.012	2.30	12	0.010	7.03	634.01	631.01	628.82	628.82	631.47 j	629.46	631.65	629.64	3.40	2.30
69	DI 50	1.17	68.516	2.31	12	0.010	7.03	635.59	632.59	634.01	631.01	633.05 j	631.62	633.22	631.79	3.36	2.33

Project File: MIDDLE TRUNK.stm

Number of lines: 104

Date: 12/18/2020

NOTES: \*\* Critical depth

Line No.	Line ID	Flow Rate (cfs)	Line Length (ft)	Line Slope (%)	Line Size (in)	n-val Pipe	Capac Full (cfs)	Gnd/Rim El Up (ft)	Invert Up (ft)	Gnd/Rim El Dn (ft)	Invert Dn (ft)	HGL Up (ft)	HGL Dn (ft)	EGL Up (ft)	EGL Dn (ft)	Vel Up (ft/s)	Vel Dn (ft/s)
70	DI 51	1.11	17.502	2.29	12	0.010	7.00	635.99	632.99	635.59	632.59	633.43 j	633.19	633.60	633.36	3.30	2.25
71	DI 52	1.00	86.009	2.30	12	0.010	7.02	637.97	634.97	635.99	632.99	635.39 j	633.58	635.55	633.74	3.20	2.09
72	DI 53	0.89	86.009	2.30	12	0.010	7.02	639.95	636.95	637.97	634.97	637.34 j	635.53	637.49	635.68	3.09	1.97
73	DI 54	0.77	86.018	2.30	12	0.010	7.02	641.93	638.93	639.95	636.95	639.30 j	637.48	639.43	637.61	2.96	1.84
74	DI 55	0.65	86.000	2.30	12	0.010	7.02	643.91	640.91	641.93	638.93	641.25 j	639.42	641.37	639.55	2.82	1.70
75	DI 56	0.24	12.000	2.83	12	0.010	7.79	625.43	622.43	625.09	622.09	623.23	623.23	623.23	623.23	0.35	0.30
76	DI 57	0.15	13.000	2.31	12	0.010	7.03	626.91	623.91	626.61	623.61	624.64	624.64	624.64	624.64	0.25	0.20
77	DI 58	0.03	13.000	2.31	12	0.010	7.03	627.90	624.90	627.60	624.60	625.60	625.60	625.60	625.60	0.04	0.03
78	DI 59	1.32	41.000	2.29	12	0.010	7.01	628.88	625.88	627.94	624.94	626.37 j	625.91	626.56	626.10	3.50	1.70
79	BEND	0.68	55.915	1.00	12	0.010	4.63	626.52	623.52	625.96	622.96	623.86	623.25	623.99	623.38	2.85	3.60
80	DI 60	0.68	8.062	0.99	12	0.010	4.61	626.60	623.60	626.52	623.52	623.94 j	623.98	624.07	624.10	2.85	1.94
81	DI 61	0.41	69.071	1.00	12	0.010	4.63	627.29	624.29	626.60	623.60	624.55 j	624.07	624.65	624.16	2.47	1.14
82	DI 62	0.17	47.183	1.00	12	0.010	4.62	627.76	624.76	627.29	624.29	624.93 j	624.65	624.99	624.71	1.93	0.66
83	DI 63	0.54	38.685	1.01	12	0.010	4.65	626.99	623.99	626.60	623.60	624.29	623.85	624.40	623.96	2.66	3.50
84	DI 64	0.21	64.873	1.00	12	0.010	4.63	627.64	624.64	626.99	623.99	624.83 j	624.40	624.90	624.47	2.07	0.70
85	DI 65	3.54	38.763	2.30	12	0.010	7.01	636.48	633.48	635.59	632.59	634.28	633.26	634.71	633.69	5.24	6.34
86	DI 66	3.20	47.006	2.30	12	0.010	7.02	637.56	634.56	636.48	633.48	635.33 j	634.45	635.71	634.83	4.96	4.11
87	DI 67	2.72	73.000	2.30	12	0.010	7.02	639.24	636.24	637.56	634.56	636.95 j	635.52	637.27	635.85	4.58	3.50
88	DI 68	2.31	86.009	2.30	12	0.010	7.02	641.22	638.22	639.24	636.24	638.87 j	637.14	639.15	637.42	4.27	3.10
89	DI 69	1.91	86.513	2.30	12	0.010	7.02	643.21	640.21	641.22	638.22	640.80 j	639.06	641.04	639.31	3.97	2.70
90	DI 70	1.48	86.001	2.30	12	0.010	7.02	645.19	642.19	643.21	640.21	642.70 j	640.99	642.91	641.19	3.63	2.25
91	DI 71	1.11	121.655	2.30	12	0.010	7.02	647.99	644.99	645.19	642.19	645.43 j	642.88	645.60	643.05	3.30	1.93
92	DI 72	0.83	21.101	2.32	12	0.010	7.05	648.48	645.48	647.99	644.99	645.86 j	645.59	646.00	645.73	3.03	1.71

Project File: MIDDLE TRUNK.stm

Number of lines: 104

Date: 12/18/2020

NOTES: \*\* Critical depth

Line No.	Line ID	Flow Rate (cfs)	Line Length (ft)	Line Slope (%)	Line Size (in)	n-val Pipe	Capac Full (cfs)	Gnd/Rim El Up (ft)	Invert Up (ft)	Gnd/Rim El Dn (ft)	Invert Dn (ft)	HGL Up (ft)	HGL Dn (ft)	EGL Up (ft)	EGL Dn (ft)	Vel Up (ft/s)	Vel Dn (ft/s)
93	DI 73	0.28	112.886	1.90	12	0.010	6.37	619.72	616.72	617.58	614.58	616.94	614.76	617.01	614.84	2.21	2.89
94	DI 74	0.15	74.250	1.90	12	0.010	6.38	621.13	618.13	619.72	616.72	618.29 j	617.01	618.34	617.07	1.86	0.76
95	BEND	0.39	29.300	1.91	12	0.010	6.40	621.46	618.46	620.90	617.90	618.72	618.12	618.81	618.21	2.44	3.06
96	DI 75	0.05	25.495	1.88	12	0.010	6.35	621.94	618.94	621.46	618.46	619.03 j	618.81	619.06	618.84	1.40	0.20
97	DI 76	0.35	12.500	1.92	12	0.010	6.41	621.70	618.70	621.46	618.46	618.95 j	618.81	619.03	618.89	2.37	1.46
98	DI 77	2.68	41.431	2.51	12	0.010	7.33	636.05	633.05	635.01	632.01	633.75	632.59	634.07	632.91	4.55	5.67
99	DI 78	2.21	40.482	2.49	12	0.010	7.31	637.06	634.06	636.05	633.05	634.69 j	633.95	634.97	634.22	4.20	2.97
100	DI 79	1.09	67.073	2.50	12	0.010	7.33	638.74	635.74	637.06	634.06	636.18 j	634.94	636.35	635.11	3.29	1.49
101	JUNCTION BOX	0.65	41.304	2.49	12	0.010	7.31	639.77	636.77	638.74	635.74	637.11 j	636.34	637.23	636.46	2.81	1.33
102	DI 80	0.23	34.297	2.51	12	0.010	7.33	640.63	637.63	639.77	636.77	637.83 j	637.23	637.89	637.30	2.09	0.65
103	DI 81	0.44	38.000	2.50	12	0.010	7.32	640.72	637.72	639.77	636.77	637.99 j	637.22	638.09	637.32	2.52	1.28
104	DI 82	0.15	43.000	2.51	12	0.010	7.34	641.80	638.80	640.72	637.72	638.96 j	638.09	639.02	638.15	1.89	0.58

Project File: MIDDLE TRUNK.stm

Number of lines: 104

Date: 12/18/2020

NOTES: \*\* Critical depth

Line No.	Line ID	Flow Rate (cfs)	Line Length (ft)	Line Slope (%)	Line Size (in)	n-val Pipe	Capac Full (cfs)	Gnd/Rim El Up (ft)	Invert Up (ft)	Gnd/Rim El Dn (ft)	Invert Dn (ft)	HGL Up (ft)	HGL Dn (ft)	EGL Up (ft)	EGL Dn (ft)	Vel Up (ft/s)	Vel Dn (ft/s)
1	DI 83	2.42	175.000	1.80	12	0.010	6.21	611.15	608.15	608.00	605.00	608.82 j	605.95	609.11	606.25	4.36	3.14
2	DI 84	1.85	86.000	1.80	12	0.010	6.22	612.70	609.70	611.15	608.15	610.28 j	609.03	610.52	609.26	3.93	2.54
3	DI 85	1.73	87.208	1.80	12	0.010	6.21	614.27	611.27	612.70	609.70	611.83 j	610.44	612.06	610.67	3.83	2.77
4	DI 86	1.64	90.699	1.80	12	0.010	6.21	615.90	612.90	614.27	611.27	613.44 j	611.99	613.66	612.21	3.76	2.70
5	DI 87	1.54	89.503	1.80	12	0.010	6.21	617.51	614.51	615.90	612.90	615.04 j	613.60	615.25	613.81	3.68	2.61
6	DI 88	1.46	89.589	1.80	12	0.010	6.21	619.12	616.12	617.51	614.51	616.63 j	615.19	616.83	615.39	3.61	2.55
7	DI 89	0.66	85.440	1.80	12	0.010	6.22	620.66	617.66	619.12	616.12	618.00 j	616.82	618.12	616.95	2.83	1.13
8	JUNCTION BOX	0.52	5.831	1.89	12	0.010	6.36	620.77	617.77	620.66	617.66	618.07 j	618.12	618.18	618.23	2.64	1.50
9	JUNCTION BOX	0.37	45.905	1.81	12	0.010	6.23	621.60	618.60	620.77	617.77	618.85 j	618.18	618.94	618.27	2.40	1.24
10	BEND	0.21	24.274	1.81	12	0.010	6.23	0.00	619.04	621.60	618.60	619.23 j	618.94	619.29	619.01	2.06	0.90
11	DI 90	0.21	1.250	1.60	12	0.010	5.86	622.06	619.06	0.00	619.04	619.25	619.29	619.31	619.36	2.06	1.35
12	DI 91	0.54	19.000	1.79	12	0.010	6.19	611.49	608.49	611.15	608.15	608.80	609.08	608.91	609.19	2.67	0.71
13	DI 92	0.46	41.000	1.80	12	0.010	6.22	619.86	616.86	619.12	616.12	617.14 j	616.83	617.24	616.93	2.54	0.77
14	DI 93	0.17	15.000	1.80	12	0.010	6.21	621.04	618.04	620.77	617.77	618.21 j	618.18	618.27	618.24	1.94	0.56
15	DI 94	0.16	18.000	1.78	12	0.010	6.17	621.92	618.92	621.60	618.60	619.09 j	618.94	619.14	619.00	1.92	0.70
16	DI 95	1.17	68.542	1.79	12	0.010	6.20	613.93	610.93	612.70	609.70	611.39 j	610.41	611.56	610.59	3.36	1.96
17	JUNCTION BOX	1.04	4.528	1.77	12	0.010	6.15	614.01	611.01	613.93	610.93	611.44	611.53	611.60	611.70	3.23	2.09
18	JUNCTION BOX	0.89	50.225	1.79	12	0.010	6.20	614.91	611.91	614.01	611.01	612.31 j	611.58	612.45	611.73	3.09	1.93
19	DI 96	0.72	27.115	1.81	12	0.010	6.22	615.40	612.40	614.91	611.91	612.75 j	612.44	612.88	612.57	2.90	1.70
20	JUNCTION BOX	0.56	23.505	1.79	12	0.010	6.19	615.82	612.82	615.40	612.40	613.13 j	612.88	613.24	612.99	2.70	1.53
21	JUNCTION BOX	0.39	51.000	1.78	12	0.010	6.18	616.73	613.73	615.82	612.82	613.99 j	613.24	614.08	613.33	2.44	1.25
22	JUNCTION BOX	0.21	26.000	1.81	12	0.010	6.22	617.20	614.20	616.73	613.73	614.39 j	614.08	614.46	614.15	2.06	0.87
23	DI 97	0.21	1.750	1.71	12	0.010	6.06	617.23	614.23	617.20	614.20	614.42	614.45	614.49	614.52	2.07	1.36

Project File: TRIB 2 - 2H.stm

Number of lines: 27

Date: 12/18/2020

NOTES: \*\* Critical depth

Line No.	Line ID	Flow Rate (cfs)	Line Length (ft)	Line Slope (%)	Line Size (in)	n-val Pipe	Capac Full (cfs)	Gnd/Rim El Up (ft)	Invert Up (ft)	Gnd/Rim El Dn (ft)	Invert Dn (ft)	HGL Up (ft)	HGL Dn (ft)	EGL Up (ft)	EGL Dn (ft)	Vel Up (ft/s)	Vel Dn (ft/s)
24	DI 98	0.17	11.000	1.82	12	0.010	6.24	614.21	611.21	614.01	611.01	611.38	611.59	611.44	611.64	1.94	0.36
25	DI 99	0.19	11.500	1.83	12	0.010	6.26	615.12	612.12	614.91	611.91	612.30	612.43	612.36	612.50	2.00	0.46
26	DI 100	0.19	12.000	1.83	12	0.010	6.27	616.04	613.04	615.82	612.82	613.22 j	613.24	613.28	613.31	1.99	0.59
27	DI 101	0.19	12.260	1.79	12	0.010	6.20	616.95	613.95	616.73	613.73	614.13 j	614.08	614.19	614.14	1.99	0.76

Project File: TRIB 2 - 2H.stm	Number of lines: 27	Date: 12/18/2020
-------------------------------	---------------------	------------------

NOTES: \*\* Critical depth

Line No.	Line ID	Flow Rate (cfs)	Line Length (ft)	Line Slope (%)	Line Size (in)	n-val Pipe	Capac Full (cfs)	Gnd/Rim El Up (ft)	Invert Up (ft)	Gnd/Rim El Dn (ft)	Invert Dn (ft)	HGL Up (ft)	HGL Dn (ft)	EGL Up (ft)	EGL Dn (ft)	Vel Up (ft/s)	Vel Dn (ft/s)
1	DI 102	3.68	7.750	2.06	12	0.010	6.65	611.16	608.16	609.00	608.00	608.98	608.62	609.42	609.07	5.36	7.20
2	DI 103	2.62	532.003	2.00	12	0.010	6.55	621.80	618.80	611.16	608.16	619.49 j	609.25	619.81	609.42	4.51	3.34
3	DI 104	2.42	6.500	2.00	12	0.010	6.55	621.93	618.93	621.80	618.80	619.60	619.66	619.89	619.96	4.36	3.36
4	DI 105	2.28	84.503	2.00	12	0.010	6.55	623.62	620.62	621.93	618.93	621.27 j	619.76	621.55	620.04	4.25	3.27
5	DI 106	2.10	169.003	2.00	12	0.010	6.55	627.00	624.00	623.62	620.62	624.62 j	621.43	624.88	621.70	4.12	3.07
6	DI 107	1.93	98.003	2.00	12	0.010	6.55	628.96	625.96	627.00	624.00	626.55 j	624.79	626.80	625.04	3.99	2.90
7	DI 108	1.80	45.003	2.00	12	0.010	6.55	629.86	626.86	628.96	625.96	627.43 j	626.72	627.67	626.95	3.89	2.82
8	DI 109	1.68	45.001	2.00	12	0.010	6.55	630.76	627.76	629.86	626.86	628.31 j	627.59	628.53	627.82	3.79	2.72
9	DI 110	1.56	45.001	2.00	12	0.010	6.55	631.66	628.66	630.76	627.76	629.19 j	628.47	629.40	628.68	3.69	2.60
10	DI 111	1.43	50.003	2.00	12	0.010	6.55	632.66	629.66	631.66	628.66	630.17 j	629.35	630.37	629.55	3.58	2.47
11	DI 112	1.31	43.001	2.00	12	0.010	6.55	633.52	630.52	632.66	629.66	631.00 j	630.32	631.19	630.51	3.48	2.37
12	DI 113	1.19	43.501	2.00	12	0.010	6.55	634.39	631.39	633.52	630.52	631.85 j	631.16	632.03	631.33	3.38	2.25
13	DI 114	1.06	42.003	2.00	12	0.010	6.55	635.23	632.23	634.39	631.39	632.66 j	632.00	632.83	632.16	3.26	2.13
14	DI 115	0.94	43.501	2.00	12	0.010	6.55	636.10	633.10	635.23	632.23	633.51 j	632.81	633.66	632.96	3.14	2.00
15	116	0.81	42.001	2.00	12	0.010	6.55	636.94	633.94	636.10	633.10	634.32 j	633.64	634.46	633.78	3.00	1.86
16	DI 117	0.68	44.001	2.00	12	0.010	6.55	637.82	634.82	636.94	633.94	635.16 j	634.44	635.29	634.57	2.85	1.71
17	DI 118	0.55	43.501	2.00	12	0.010	6.55	638.69	635.69	637.82	634.82	636.00 j	635.28	636.11	635.39	2.67	1.54
18	DI 119	0.42	42.003	2.00	12	0.010	6.55	639.53	636.53	638.69	635.69	636.80 j	636.10	636.89	636.20	2.48	1.37
19	DI 120	0.29	46.001	2.00	12	0.010	6.55	640.45	637.45	639.53	636.53	637.67 j	636.89	637.75	636.97	2.24	1.13
20	DI 121	0.15	41.507	2.00	12	0.010	6.55	642.00	638.28	640.45	637.45	638.44 j	637.75	638.50	637.80	1.89	0.78

Project File: TRIB 2 - NORTH.stm

Number of lines: 20

Date: 12/18/2020

NOTES: \*\* Critical depth



Line No.	Line ID	Flow Rate (cfs)	Line Length (ft)	Line Slope (%)	Line Size (in)	n-val Pipe	Capac Full (cfs)	Gnd/Rim El Up (ft)	Invert Up (ft)	Gnd/Rim El Dn (ft)	Invert Dn (ft)	HGL Up (ft)	HGL Dn (ft)	EGL Up (ft)	EGL Dn (ft)	Vel Up (ft/s)	Vel Dn (ft/s)
1	BEND	5.38	11.909	2.02	12	0.010	6.57	608.24	605.24	608.00	605.00	606.17	605.81	606.95	606.58	7.05	7.89
2	JUNCTION BOX	5.42	91.501	2.00	12	0.010	6.55	610.07	607.07	608.24	605.24	608.01 j	606.21	608.79	606.99	7.09	6.97
3	BEND	5.56	357.503	2.10	12	0.010	6.71	617.58	614.58	610.07	607.07	615.52	608.01	616.34	608.82	7.26	7.28
4	DI 122	5.57	7.000	2.14	12	0.010	6.78	617.73	614.73	617.58	614.58	615.67 j	615.56	616.49	616.38	7.26	7.13
5	DI 123	5.43	139.945	2.10	12	0.010	6.71	620.67	617.67	617.73	614.73	618.61 j	615.75	619.39	616.49	7.11	6.92
6	BEND	5.08	97.053	2.10	12	0.010	6.71	622.71	619.71	620.67	617.67	620.63 j	618.74	621.33	619.39	6.72	6.47
7	DI 124	5.10	43.342	2.10	12	0.010	6.71	623.62	620.62	622.71	619.71	621.54 j	620.68	622.25	621.38	6.74	6.56
8	DI 125	4.89	42.048	2.40	12	0.010	7.18	624.63	621.63	623.62	620.62	622.54 j	621.65	623.20	622.25	6.51	6.22
9	DI 126	4.50	143.504	2.40	12	0.010	7.17	628.07	625.07	624.63	621.63	625.96 j	622.69	626.54	623.20	6.11	5.73
10	JUNCTION BOX	4.03	99.503	2.40	12	0.010	7.18	630.46	627.46	628.07	625.07	628.31 j	626.13	628.81	626.54	5.67	5.14
11	DI 127	3.12	65.502	2.40	12	0.010	7.17	632.03	629.03	630.46	627.46	629.79 j	628.56	630.16	628.81	4.90	3.98
12	DI 128	2.55	39.000	4.31	12	0.010	9.61	633.71	630.71	632.03	629.03	631.39 j	630.00	631.70	630.31	4.46	3.28
13	DI 129	2.44	29.004	4.31	12	0.010	9.61	634.96	631.96	633.71	630.71	632.63 j	631.55	632.93	631.85	4.38	3.46
14	DI 130	2.18	47.003	4.30	12	0.010	9.60	636.98	633.98	634.96	631.96	634.61 j	632.81	634.88	633.08	4.17	3.07
15	DI 131	2.03	30.001	4.30	12	0.010	9.60	638.27	635.27	636.98	633.98	635.88 j	634.78	636.14	635.03	4.07	3.03
16	DI 132	1.75	80.006	4.30	12	0.010	9.60	641.71	638.71	638.27	635.27	639.27 j	636.06	639.50	636.29	3.85	2.64
17	DI 133	1.61	30.001	4.30	12	0.010	9.60	643.00	640.00	641.71	638.71	640.54 j	639.44	640.76	639.66	3.74	2.63
18	DI 134	1.35	75.007	4.31	12	0.010	9.61	646.23	643.23	643.00	640.00	643.72 j	640.71	643.91	640.90	3.52	2.26
19	DI 134	1.16	30.001	4.30	12	0.010	9.60	647.52	644.52	646.23	643.23	644.97 j	643.88	645.15	644.05	3.35	2.15
20	DI 136	0.90	60.005	4.30	12	0.010	9.60	650.10	647.10	647.52	644.52	647.50 j	645.13	647.65	645.28	3.10	1.81
21	DI 137	0.75	30.001	4.30	12	0.010	9.60	651.39	648.39	650.10	647.10	648.75 j	647.63	648.89	647.77	2.93	1.76
22	BEND	0.16	60.005	4.30	12	0.010	9.60	654.00	650.97	651.39	648.39	651.13 j	648.88	651.19	648.94	1.90	0.40
23	DI 138	0.16	2.500	4.40	12	0.010	9.71	654.08	651.08	654.00	650.97	651.24 j	651.19	651.30	651.24	1.90	1.25

Project File: SOUTH TRUNK.stm

Number of lines: 40

Date: 12/18/2020

NOTES: \*\* Critical depth

Line No.	Line ID	Flow Rate (cfs)	Line Length (ft)	Line Slope (%)	Line Size (in)	n-val Pipe	Capac Full (cfs)	Gnd/Rim El Up (ft)	Invert Up (ft)	Gnd/Rim El Dn (ft)	Invert Dn (ft)	HGL Up (ft)	HGL Dn (ft)	EGL Up (ft)	EGL Dn (ft)	Vel Up (ft/s)	Vel Dn (ft/s)
24	DI 139	1.10	29.000	2.41	12	0.010	7.19	631.16	628.16	630.46	627.46	628.64	628.70	628.78	628.73	2.93	1.40
25	DI 140	1.68	5.500	2.00	12	0.010	6.55	610.18	607.18	0.00	607.07	607.73	607.52	607.95	607.74	3.79	4.89
26	DI 141	1.00	41.262	2.01	12	0.010	6.57	611.01	608.01	610.18	607.18	608.43 j	607.93	608.59	608.09	3.19	1.58
27	DI 142	0.61	172.007	2.00	12	0.010	6.55	614.45	611.45	611.01	608.01	611.77 j	608.58	611.89	608.70	2.76	1.32
28	DI 143	0.48	107.005	2.00	12	0.010	6.55	616.59	613.59	614.45	611.45	613.88 j	611.89	613.98	611.99	2.58	1.45
29	DI 144	0.38	79.004	2.00	12	0.010	6.55	618.17	615.17	616.59	613.59	615.42 j	613.98	615.52	614.07	2.41	1.36
30	DI 145	0.28	67.502	2.00	12	0.010	6.55	619.52	616.52	618.17	615.17	616.74 j	615.51	616.81	615.59	2.21	1.16
31	BEND	0.14	16.867	2.02	12	0.010	6.57	619.86	616.86	619.52	616.52	617.01 j	616.81	617.07	616.87	1.85	0.73
32	BEND	0.14	46.519	2.00	12	0.010	6.55	620.79	617.79	619.86	616.86	617.94 j	617.07	618.00	617.12	1.86	1.24
33	DI 146	0.15	21.162	1.98	12	0.010	6.52	621.21	618.21	620.79	617.79	618.37 j	618.00	618.42	618.05	1.86	1.23
34	DI 147	1.15	55.595	1.91	12	0.010	6.39	624.68	621.68	0.00	620.62	622.13	620.99	622.31	621.16	3.35	4.37
35	DI 148	0.59	154.507	1.80	12	0.010	6.21	627.46	624.46	624.68	621.68	624.78 j	622.30	624.89	622.41	2.73	1.16
36	BEND	0.32	41.000	1.80	12	0.010	6.22	628.20	625.20	627.46	624.46	625.43 j	624.89	625.51	624.97	2.30	0.98
37	DI 149	0.33	93.005	1.80	12	0.010	6.20	629.87	626.87	628.20	625.20	627.11 j	625.51	627.19	625.60	2.33	1.58
38	DI 150	0.17	40.501	1.80	12	0.010	6.22	630.60	627.60	629.87	626.87	627.77 j	627.19	627.83	627.25	1.94	0.78
39	DI 151	0.34	276.511	4.30	12	0.010	9.60	643.92	640.92	632.03	629.03	641.16	629.23	641.25	629.32	2.34	3.03
40	DI 152	0.10	144.004	4.30	12	0.010	9.60	650.11	647.11	643.92	640.92	647.24 j	641.24	647.28	641.29	1.68	0.44

Project File: SOUTH TRUNK.stm

Number of lines: 40

Date: 12/18/2020

NOTES: \*\* Critical depth

Line No.	Line ID	Flow Rate (cfs)	Line Length (ft)	Line Slope (%)	Line Size (in)	n-val Pipe	Capac Full (cfs)	Gnd/Rim El Up (ft)	Invert Up (ft)	Gnd/Rim El Dn (ft)	Invert Dn (ft)	HGL Up (ft)	HGL Dn (ft)	EGL Up (ft)	EGL Dn (ft)	Vel Up (ft/s)	Vel Dn (ft/s)
1	DI 153	4.14	12.000	0.58	24	0.010	22.46	598.00	594.07	595.00	594.00	594.78	595.42	595.05	595.68	4.12	1.74
2	DI 154	2.85	220.202	1.60	24	0.010	37.18	600.00	597.59	598.00	594.07	598.18 j	595.03	598.39	595.25	3.70	1.90
3	DI 155	1.77	34.000	1.59	18	0.010	17.20	600.00	598.13	600.00	597.59	598.63 j	598.38	598.81	598.56	3.43	1.89

Project File: STATE STREET TRUNK.stm      Number of lines: 3      Date: 12/18/2020

NOTES: \*\* Critical depth

Line No.	Line ID	Flow Rate (cfs)	Line Length (ft)	Line Slope (%)	Line Size (in)	n-val Pipe	Capac Full (cfs)	Gnd/Rim El Up (ft)	Invert Up (ft)	Gnd/Rim El Dn (ft)	Invert Dn (ft)	HGL Up (ft)	HGL Dn (ft)	EGL Up (ft)	EGL Dn (ft)	Vel Up (ft/s)	Vel Dn (ft/s)
1	DI 156	4.34	30.000	1.67	24	0.013	29.20	609.00	606.00	608.50	605.50	606.73	606.23	607.00	606.50	4.17	4.18

Project File: NORTH OUTFALL.stm	Number of lines: 1	Date: 12/21/2020
---------------------------------	--------------------	------------------

NOTES: \*\* Critical depth

Line No.	Line ID	Flow Rate (cfs)	Line Length (ft)	Line Slope (%)	Line Size (in)	n-val Pipe	Capac Full (cfs)	Gnd/Rim El Up (ft)	Invert Up (ft)	Gnd/Rim El Dn (ft)	Invert Dn (ft)	HGL Up (ft)	HGL Dn (ft)	EGL Up (ft)	EGL Dn (ft)	Vel Up (ft/s)	Vel Dn (ft/s)
1	Post Trib 1	17.56	30.000	2.00	24	0.012	34.65	609.00	606.00	608.40	605.40	607.51 j	606.96	608.25	607.70	6.91	6.68

Project File: New.stm	Number of lines: 1	Date: 12/21/2020
-----------------------	--------------------	------------------

NOTES: \*\* Critical depth

## Required Detention Volume

Hydrograph type	= Rational	Peak discharge (cfs)	= 21.34
Storm frequency (yrs)	= 10	Time interval (min)	= 1
Drainage area (ac)	= 34.200	Runoff coeff. (C)	= 0.56
Rainfall Inten (in/hr)	= 1.114	Tc by User (min)	= 28
IDF Curve	= Ukiah-Lake Mendocino IDF Curve	Reflimb factor	= 1.00

Hydrograph Volume = 35,851 (cuft); 0.823 (acft)

### Runoff Hydrograph

10-yr frequency

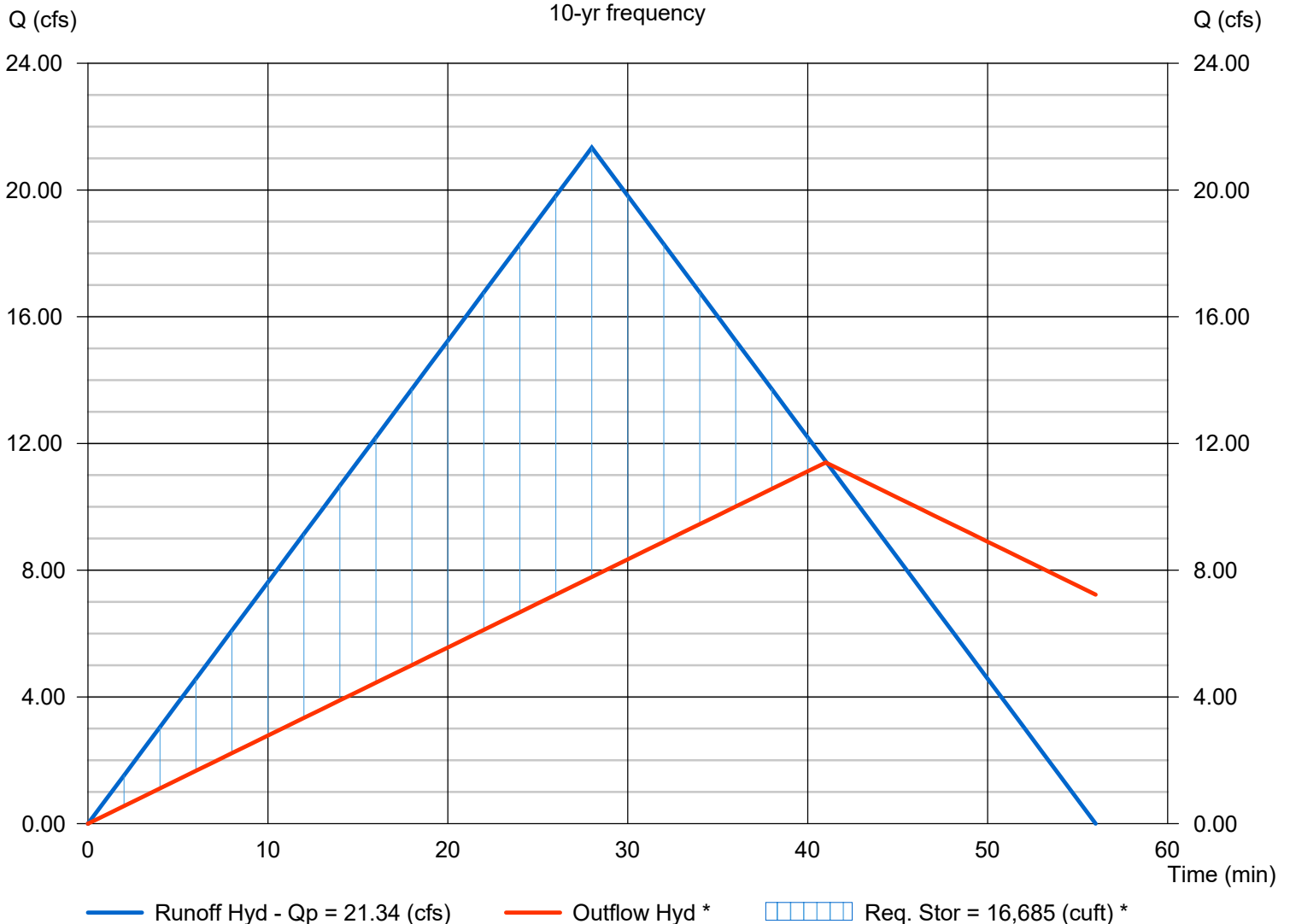

\* Estimated

Runoff Hydrograph		
Time	Q	Volume
(min)	(cfs)	(cuft)
0	0.000	0.00
1	0.762	22.86
2	1.524	91.46
3	2.286	205.78
4	3.049	365.83
5	3.811	571.60
6	4.573	823.11
7	5.335	1,120
8	6.097	1,463
9	6.859	1,852
10	7.621	2,286
11	8.384	2,767
12	9.146	3,292
13	9.908	3,864
14	10.67	4,481
15	11.43	5,144
16	12.19	5,853
17	12.96	6,608
18	13.72	7,408
19	14.48	8,254
20	15.24	9,146

Runoff Hydrograph		
Time	Q	Volume
(min)	(cfs)	(cuft)
21	16.00	10,083
22	16.77	11,066
23	17.53	12,095
24	18.29	13,170
25	19.05	14,290
26	19.82	15,456
27	20.58	16,668
<b>28</b>	<b>21.34</b>	<b>17,925</b>
29	20.58	19,183
30	19.82	20,395
31	19.05	21,561
32	18.29	22,681
33	17.53	23,756
34	16.77	24,785
35	16.00	25,768
36	15.24	26,705
37	14.48	27,597
38	13.72	28,443
39	12.96	29,243
40	12.19	29,998
41	11.43	30,707



Runoff Hydrograph		
Time	Q	Volume
(min)	(cfs)	(cuft)
42	10.67	31,370
43	9.908	31,987
44	9.146	32,559
45	8.384	33,084
46	7.621	33,565
47	6.859	33,999
48	6.097	34,388
49	5.335	34,731
50	4.573	35,028
51	3.811	35,279
52	3.049	35,485
53	2.286	35,645
54	1.524	35,759
55	0.762	35,828
56	0.000	35,851

Outflow Hydrograph		Detention
Q	Volume	Required Storage
(cfs)	(cuft)	(cuft)
0.000	0.00	0.00
0.278	16.68	29.05
0.556	50.05	87.14
0.834	100.10	174.27
1.112	166.83	290.45
1.390	250.24	435.68
1.668	350.34	609.95
1.946	467.12	813.27
2.224	600.59	1,046
2.502	750.73	1,307
2.780	917.56	1,597
3.059	1,101	1,917
3.337	1,301	2,266
3.615	1,518	2,643
3.893	1,752	3,050
4.171	2,002	3,485
4.449	2,269	3,950
4.727	2,552	4,444
5.005	2,853	4,967
5.283	3,170	5,519
5.561	3,503	6,100

Outflow Hydrograph		Detention
Q	Volume	Required Storage
(cfs)	(cuft)	(cuft)
5.839	3,854	6,709
6.117	4,221	7,348
6.395	4,604	8,017
6.673	5,005	8,714
6.951	5,422	9,440
7.229	5,856	10,195
7.507	6,306	10,979
7.785	6,773	11,792
8.063	7,257	12,543
8.341	7,758	13,232
8.620	8,275	13,858
8.898	8,809	14,421
9.176	9,359	14,923
9.454	9,926	15,361
9.732	10,510	15,738
10.01	11,111	16,052
10.29	11,728	16,303
10.57	12,362	16,492
10.84	13,013	16,619
11.12	13,680	16,684
<b>11.40</b>	<b>14,364</b>	<b>16,685</b>

Outflow Hydrograph		Detention
Q	Volume	Required Storage
(cfs)	(cuft)	(cuft)
11.12	15,031	0.00
10.84	15,682	0.00
10.57	16,316	0.00
10.29	16,933	0.00
10.01	17,534	0.00
9.732	18,118	0.00
9.454	18,685	0.00
9.176	19,235	0.00
8.898	19,769	0.00
8.620	20,286	0.00
8.341	20,787	0.00
8.063	21,271	0.00
7.785	21,738	0.00
7.507	22,188	0.00
7.229	22,622	0.00

## 100-Year Detention Volume

Hydrograph type	= Rational	Peak discharge (cfs)	= 30.28
Storm frequency (yrs)	= 100	Time interval (min)	= 1
Drainage area (ac)	= 34.200	Runoff coeff. (C)	= 0.56
Rainfall Inten (in/hr)	= 1.581	Tc by User (min)	= 28
IDF Curve	= Ukiah-Lake Mendocino IDF Curve	Reflimb factor	= 1.00

Hydrograph Volume = 50,876 (cuft); 1.168 (acft)

### Runoff Hydrograph

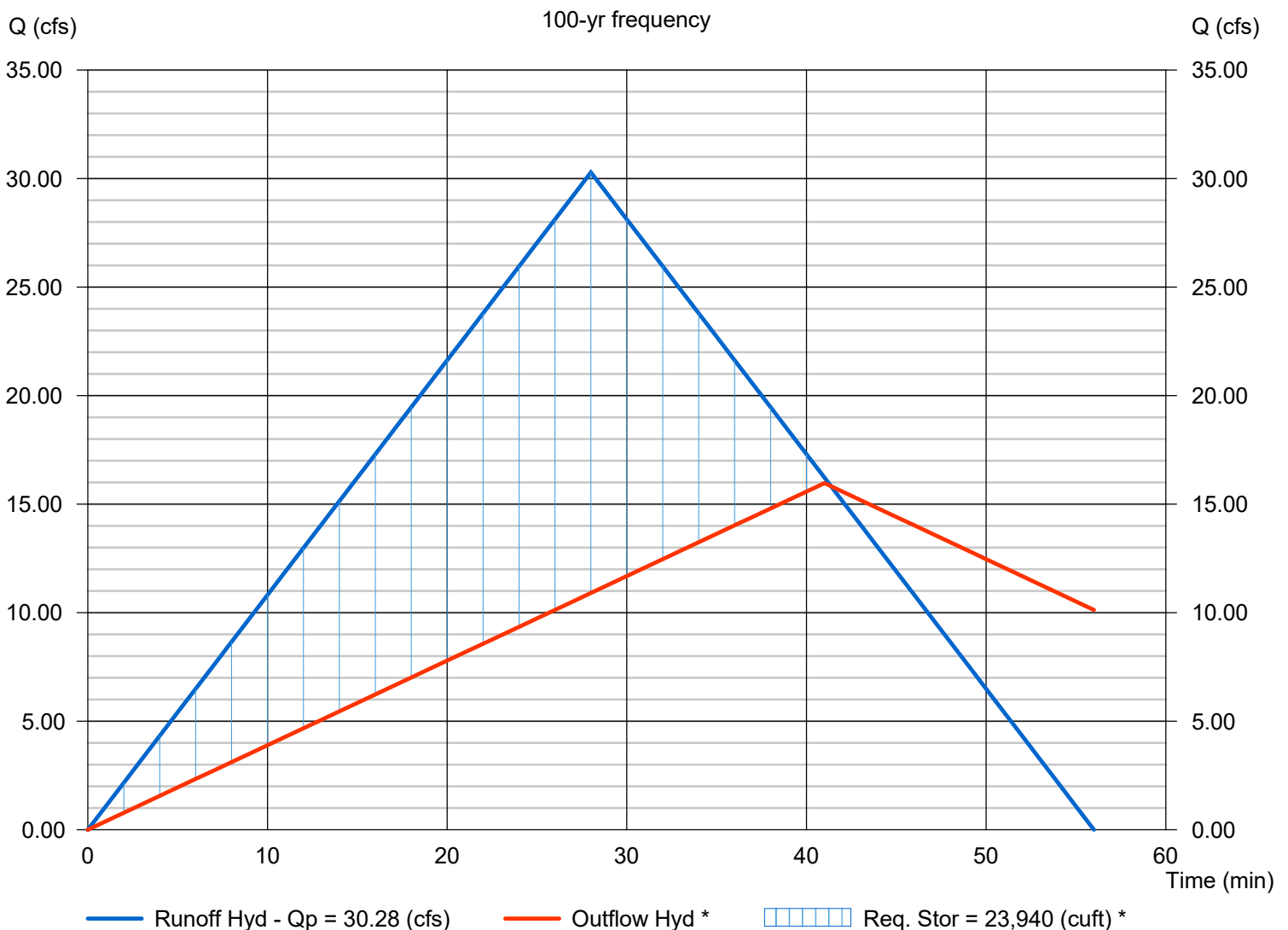

\* Estimated

Runoff Hydrograph		
Time	Q	Volume
(min)	(cfs)	(cuft)
0	0.000	0.00
1	1.082	32.45
2	2.163	129.79
3	3.245	292.02
4	4.326	519.14
5	5.408	811.16
6	6.489	1,168
7	7.571	1,590
8	8.652	2,077
9	9.734	2,628
10	10.82	3,245
11	11.90	3,926
12	12.98	4,672
13	14.06	5,483
14	15.14	6,359
15	16.22	7,300
16	17.30	8,306
17	18.39	9,377
18	19.47	10,513
19	20.55	11,713
20	21.63	12,979

Runoff Hydrograph		
Time	Q	Volume
(min)	(cfs)	(cuft)
21	22.71	14,309
22	23.79	15,704
23	24.88	17,164
24	25.96	18,689
25	27.04	20,279
26	28.12	21,934
27	29.20	23,653
<b>28</b>	<b>30.28</b>	<b>25,438</b>
29	29.20	27,222
30	28.12	28,942
31	27.04	30,597
32	25.96	32,187
33	24.88	33,712
34	23.79	35,172
35	22.71	36,567
36	21.63	37,897
37	20.55	39,163
38	19.47	40,363
39	18.39	41,499
40	17.30	42,570
41	16.22	43,575

Runoff Hydrograph		
Time	Q	Volume
(min)	(cfs)	(cuft)
42	15.14	44,516
43	14.06	45,392
44	12.98	46,204
45	11.90	46,950
46	10.82	47,631
47	9.734	48,248
48	8.652	48,799
49	7.571	49,286
50	6.489	49,708
51	5.408	50,065
52	4.326	50,357
53	3.245	50,584
54	2.163	50,746
55	1.082	50,843
56	0.000	50,876



Outflow Hydrograph		Detention
Q	Volume	Required Storage
(cfs)	(cuft)	(cuft)
0.000	0.00	0.00
0.390	23.37	41.52
0.779	70.11	124.57
1.169	140.22	249.13
1.558	233.71	415.22
1.948	350.56	622.83
2.337	490.79	871.96
2.727	654.38	1,163
3.116	841.35	1,495
3.506	1,052	1,868
3.895	1,285	2,284
4.285	1,542	2,740
4.674	1,823	3,239
5.064	2,127	3,778
5.453	2,454	4,360
5.843	2,804	4,983
6.232	3,178	5,647
6.622	3,576	6,353
7.011	3,996	7,100
7.401	4,440	7,889
7.790	4,908	8,720

Outflow Hydrograph		Detention
Q	Volume	Required Storage
(cfs)	(cuft)	(cuft)
8.180	5,399	9,592
8.569	5,913	10,505
8.959	6,450	11,460
9.348	7,011	12,457
9.738	7,595	13,495
10.13	8,203	14,574
10.52	8,834	15,695
10.91	9,489	16,858
11.30	10,166	17,932
11.69	10,867	18,918
12.07	11,592	19,816
12.46	12,340	20,626
12.85	13,111	21,347
13.24	13,906	21,980
13.63	14,724	22,525
14.02	15,565	22,981
14.41	16,430	23,350
14.80	17,318	23,630
15.19	18,229	23,821
15.58	19,164	23,925
<b>15.97</b>	<b>20,122</b>	<b>23,940</b>

Outflow Hydrograph		Detention
Q	Volume	Required Storage
(cfs)	(cuft)	(cuft)
15.58	21,057	0.00
15.19	21,968	0.00
14.80	22,857	0.00
14.41	23,721	0.00
14.02	24,563	0.00
13.63	25,381	0.00
13.24	26,175	0.00
12.85	26,946	0.00
12.46	27,694	0.00
12.07	28,419	0.00
11.69	29,120	0.00
11.30	29,798	0.00
10.91	30,452	0.00
10.52	31,083	0.00
10.13	31,691	0.00

## 10-Year Weir Pond Outfall

### Rectangular Weir

Crest = Sharp  
 Bottom Length (ft) = 1.50  
 Total Depth (ft) = 0.80

### Highlighted

Depth (ft) = 0.78  
 Q (cfs) = 3.450  
 Area (sqft) = 1.17  
 Velocity (ft/s) = 2.94  
 Top Width (ft) = 1.50

### Calculations

Weir Coeff. Cw = 3.33  
 Compute by: Known Q  
 Known Q (cfs) = 3.45

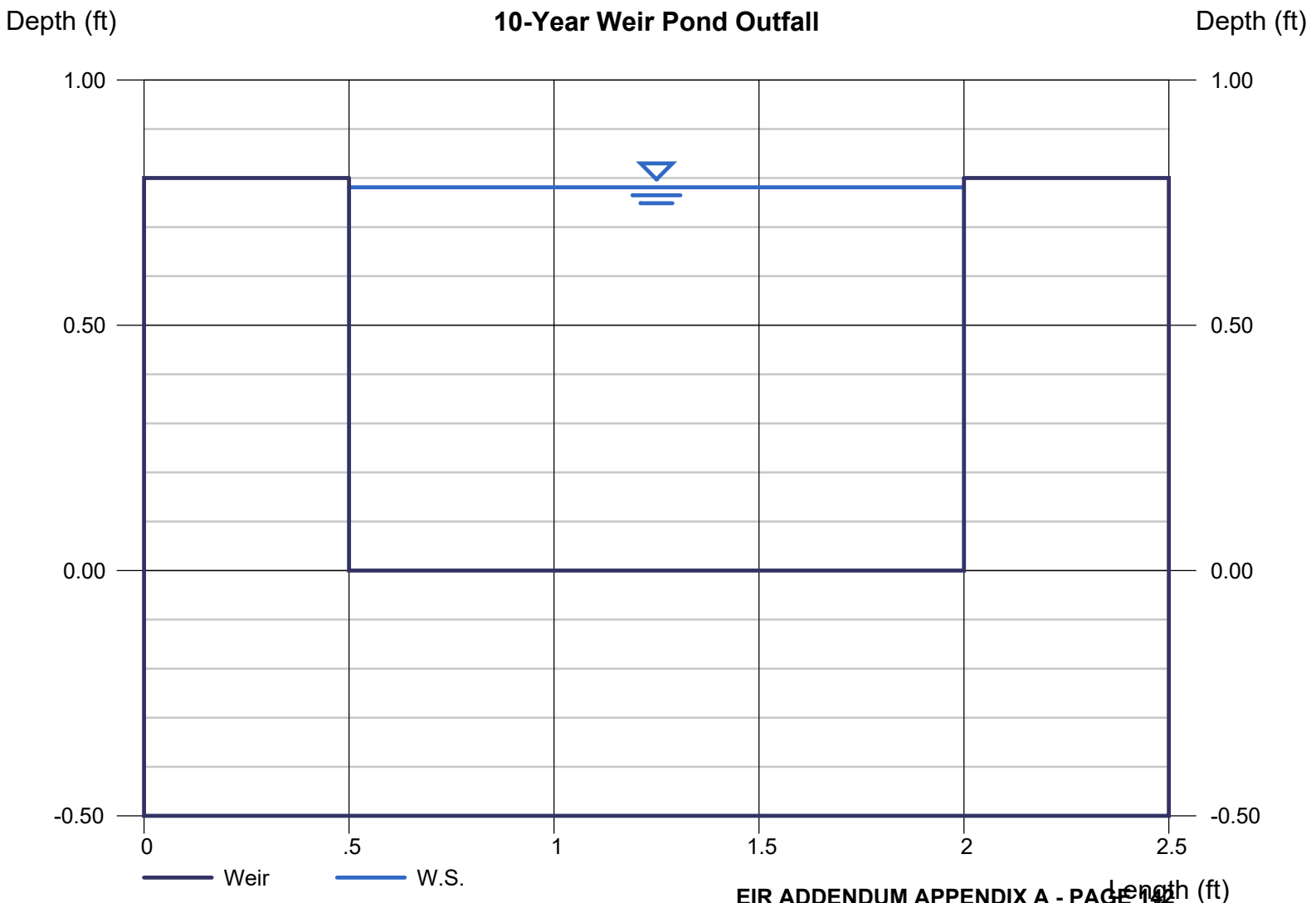

PLOT DATE: 23-AUG-00

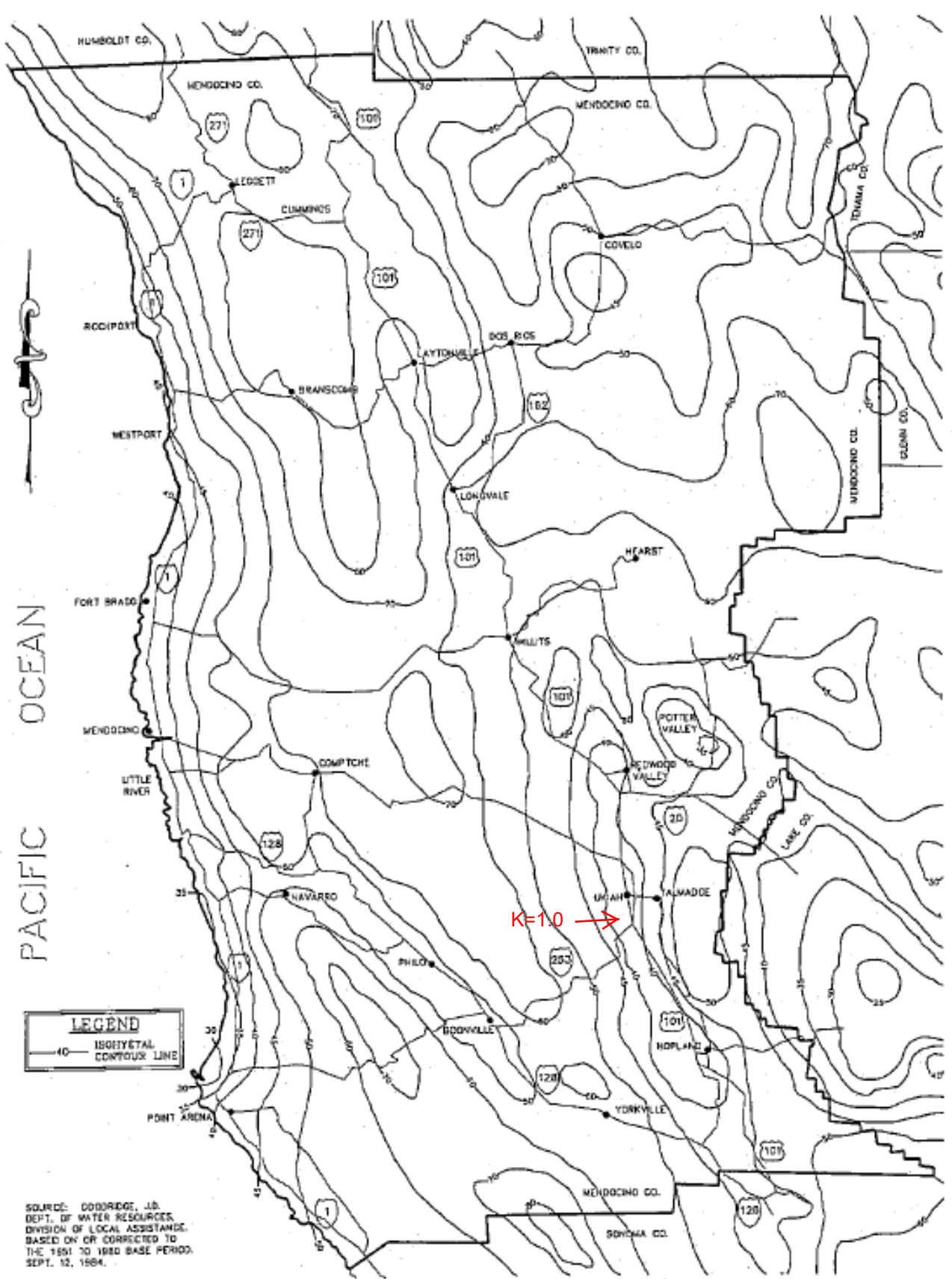

PACIFIC OCEAN

**LEGEND**  
 40 — ISOTHERMAL  
 CONTOUR LINE

SOURCE: DOBSON, J.D.  
 DEPT. OF WATER RESOURCES,  
 DIVISION OF LOCAL ASSISTANCE,  
 BASED ON OR CORRECTED TO  
 THE 1951 TO 1980 BASE PERIOD.  
 SEPT. 12, 1984.



# MEAN SEASONAL PRECIPITATION IN INCHES

MENDOT  
 STD. NO.  
 D10

FILE: CLFS1:\LDD PROJECTS\22301\MEN-D10.DWG XREF: MENDOCO.DWG

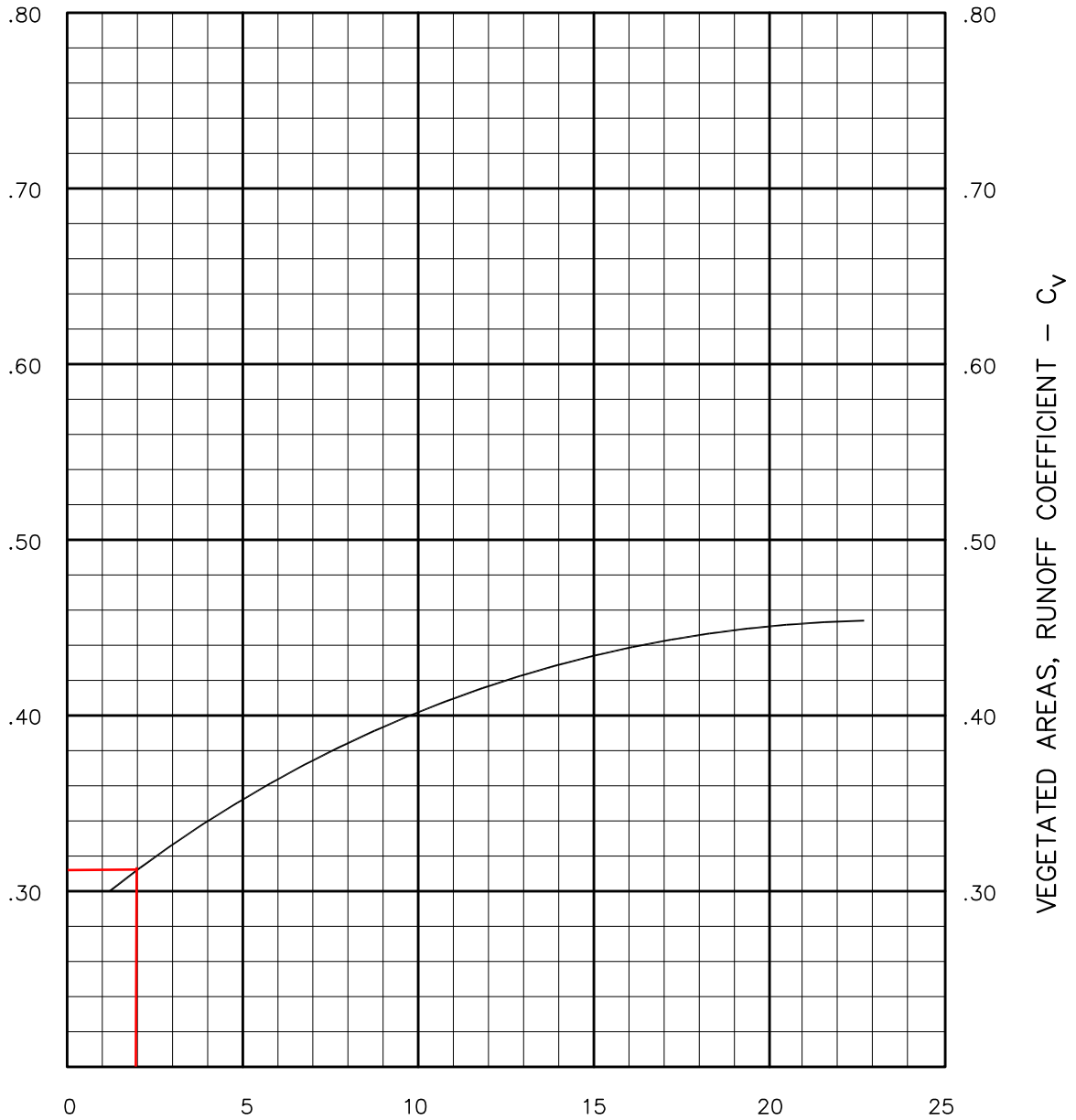

Cv=0.31 (Vegetated Areas)  
 Cp=0.9 (Impervious Areas)

AVERAGE GROUND SLOPE %  
 (NOT SLOPE OF CHANNEL OR STORM DRAIN)



**RUNOFF COEFFICIENTS  
 FOR RATIONAL FORMULA,  
 VEGETATED AREAS**

MENDOT  
 STD. NO.  
**D12**

INTENSITY-DURATION-FREQUENCY CHART

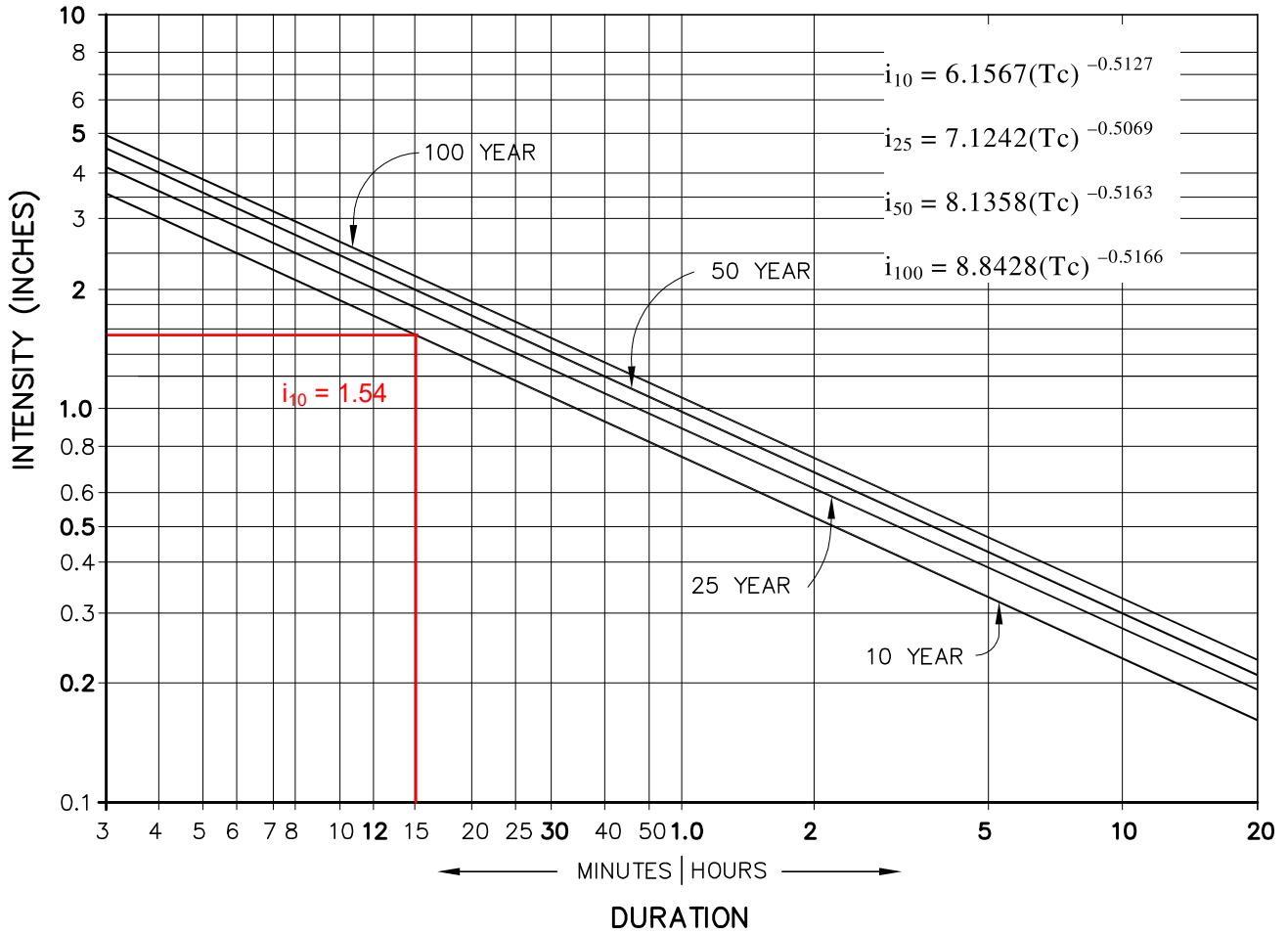

STATION DATA	
LONGITUDE:	123.183
LATITUDE:	39.233
ALTITUDE:	670
YEARS OF DATA:	1972-1986



INTENSITY/DURATION/FREQUENCY CHART  
UKIAH-LAKE MENDOCINO DAM

MENDOT  
STD. NO.  
**D11G**

# Willow County Water District

151 Laws Avenue  
Ukiah, California 95482-6655  
707-462-2666  
FAX 707-462-2687

September 14, 2021

Jake Morley, Project Manager  
Guillon Inc. Construction  
2550 Lakewest Drive #50  
Chico, CA 95928

RE: Will Serve Letter for Bella Vista Tentative Subdivision Map, Ukiah, CA

Dear Mr. Morley,

This letter is in response for your request for a Will Serve Letter from the Willow County Water District to provide water to the Bella Vista Subdivision located at 3000 South State Street. The project, as we know it, is the development of 171 single-family residential lots on approximately 48.8 acres, the project includes outdoor areas and landscaped areas as well.

The Willow County Water District has the capacity and ability to serve the above referenced project. We will work in concert with Guillon Inc. Construction in reviewing construction plans and sizing requirements to adequately serve the project.

Sincerely,



Jared Walker  
General Manager  
Willow County Water District  
151 Laws Avenue  
Ukiah, CA 95482

"A California Special District"  
An efficient and responsive form of local government.



# BIOLOGICAL RESOURCE ASSESSMENT

Terrestrial and Aquatic Wildlife, and Botanical Resources

## Bella Vista Subdivision Project

Mendocino County, California

July 2021



Prepared for:

**Guillon, Inc.**

Jake Morley

2550 Lakewest Drive, Suite 50

Chico, CA 95928

(530) 513-3626

Prepared by:

**Gallaway Enterprises**

117 Meyers Street, Suite 120

Chico CA 95928

(530) 332-9909

Contact: Kevin Sevier

[www.gallawayenterprises.com](http://www.gallawayenterprises.com)

**CONTENTS**

INTRODUCTION ..... 1

    Purpose and Overview ..... 1

    Project Location and Environmental Setting ..... 1

    Project Description..... 5

METHODS..... 5

    References Consulted ..... 5

    Special-Status Species ..... 5

    Critical Habitat ..... 7

    Sensitive Natural Communities..... 7

    Waters of the United States ..... 7

    Habitat Assessments ..... 7

    Rare Plant Survey ..... 9

RESULTS ..... 9

    Habitats ..... 9

        Montane Hardwood-Conifer..... 9

        Vineyard ..... 9

        Riverine ..... 10

        Annual Grassland ..... 10

        Urban ..... 10

        Barren..... 10

    Critical Habitat ..... 11

    Sensitive Natural Communities..... 11

    Special-Status Species ..... 11

        Endangered, Threatened and Rare Plants ..... 18

        Endangered, Threatened, and Special-status Wildlife..... 18

            California Coastal Chinook salmon and Central California Coast steelhead..... 18

            Western pond turtle ..... 19

            Grasshopper sparrow..... 20

            Pallid bat ..... 21

            Townsend’s big-eared bat..... 21

Migratory birds and raptors..... 22

REGULATORY FRAMEWORK..... 22

    Federal ..... 22

        Federal Endangered Species Act..... 22

        Migratory Bird Treaty Act ..... 23

    State of California ..... 23

        California Endangered Species Act ..... 23

        California Fish and Game Code (§3503.5)..... 23

        California Migratory Bird Protection Act ..... 24

        Rare and Endangered Plants ..... 24

        California Environmental Quality Act Guidelines §15380..... 24

CONCLUSIONS AND RECOMMENDATIONS..... 25

    Endangered, Threatened, and Rare Plants ..... 25

    Endangered, Threatened, and Special-status Wildlife..... 25

    Other Natural Resources..... 26

REFERENCES ..... 28

LIST OF PREPARERS ..... 30

**FIGURES**

Figure 1. Regional Location..... 3

Figure 2. Biological Survey Area..... 4

Figure 3. CNDDDB Occurrences..... 6

Figure 4. Habitat Types ..... 8

**TABLES**

Table 1. Special-status species and Sensitive Natural Communities and their potential to occur in the BSA of the Bella Vista Subdivision Project, Mendocino County, CA ..... 11

**APPENDICES**

Appendix A.....Species Lists

Appendix B.....Observed Species Lists

Appendix C.....Draft Delineation of Waters of the U.S. Map

Appendix D.....Tree Inventory Report  
Appendix E.....Project Site Photos

# BIOLOGICAL RESOURCE ASSESSMENT

## Bella Vista Subdivision Project

### Project Location:

Mendocino County, California  
Rancho Yokaya Land Grant

## INTRODUCTION

### Purpose and Overview

The purpose of this biological resource assessment (BRA) is to document the endangered, threatened, sensitive, and rare species and their habitats that occur or may occur in the biological survey area (BSA) of the Bella Vista Subdivision Project (Project) boundary, located within unincorporated Mendocino County, California (**Figure 1**) adjacent to the City of Ukiah. The Project boundary is located at the southwest corner of the intersection of Gobalet Lane and South State Street and is approximately 36.8 acres in size.

The BSA is the area where biological surveys are conducted, which encompasses the entire area where development and construction activities are proposed to take place (**Figure 2**). Gallaway Enterprises conducted biological and botanical habitat assessments in the BSA to evaluate site conditions and potential for biological and botanical species to occur, as well as a protocol-level rare plant survey. Other primary references consulted include species lists and information gathered using the United States Fish and Wildlife Service (USFWS) Information for Planning and Consultation (IPaC), California Department of Fish and Wildlife's (CDFW) California Natural Diversity Database (CNDDDB), the California Native Plant Society's (CNPS) inventory of rare and endangered plants, and literature review. The results of the BRA are the findings of habitat assessments and surveys and the recommendations for avoidance and minimization of impacts to resources.

### Project Location and Environmental Setting

The BSA is located within the County of Mendocino, located near the southern edge of the City of Ukiah. The BSA falls within the Rancho Yokaya Land Grant, Section 32, Township 15N, Range 12W, and is located at latitude 39.1115, longitude -123.2009. The site is characterized by relatively flat terrain that has been utilized for agriculture, primarily vineyards. The western edge of the BSA is located at the base of a large, steep foothill, known locally as Cleland Mountain, that is dominated by mixed hardwood conifer vegetation. Scattered mature trees, including white oak (*Quercus garryana*) and Douglas fir (*Pseudotsuga menziesii*) occur near the base of Cleland Mountain in the northwest corner of the BSA. These mature trees likely represent the remnants of riparian and mixed conifer hardwood forest that

historically existed; however, most vegetation was previously cleared in this area and the mature trees are now generally isolated within annual grassland habitat.

There is a small intermittent drainage, Cleland Mountain Creek, that passes through a narrow portion of the northwestern section of the BSA. The BSA is surrounded by existing residential development and undeveloped mixed hardwood conifer woodland to the west. East of the BSA, on the other side of Highway 101, is a wastewater treatment plant and the Russian River.

The BSA is located at approximately 615 feet in elevation. Soils within the BSA are primarily Pinole gravelly loam, 2 to 8 percent slopes; well drained with a deep restrictive layer of more than 80 inches in depth. Soils in the western section of the BSA near the base of the foothill are Kekawaka-Casabonne-Wohly complex, 30 to 50 percent slopes; well drained with a deep restrictive layer of more than 80 inches in depth. The average annual precipitation for the area is 37.26 inches and the average temperature is 58.6° F (WRCC 2021).

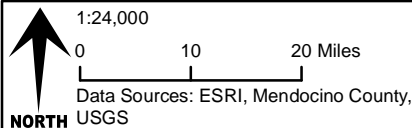
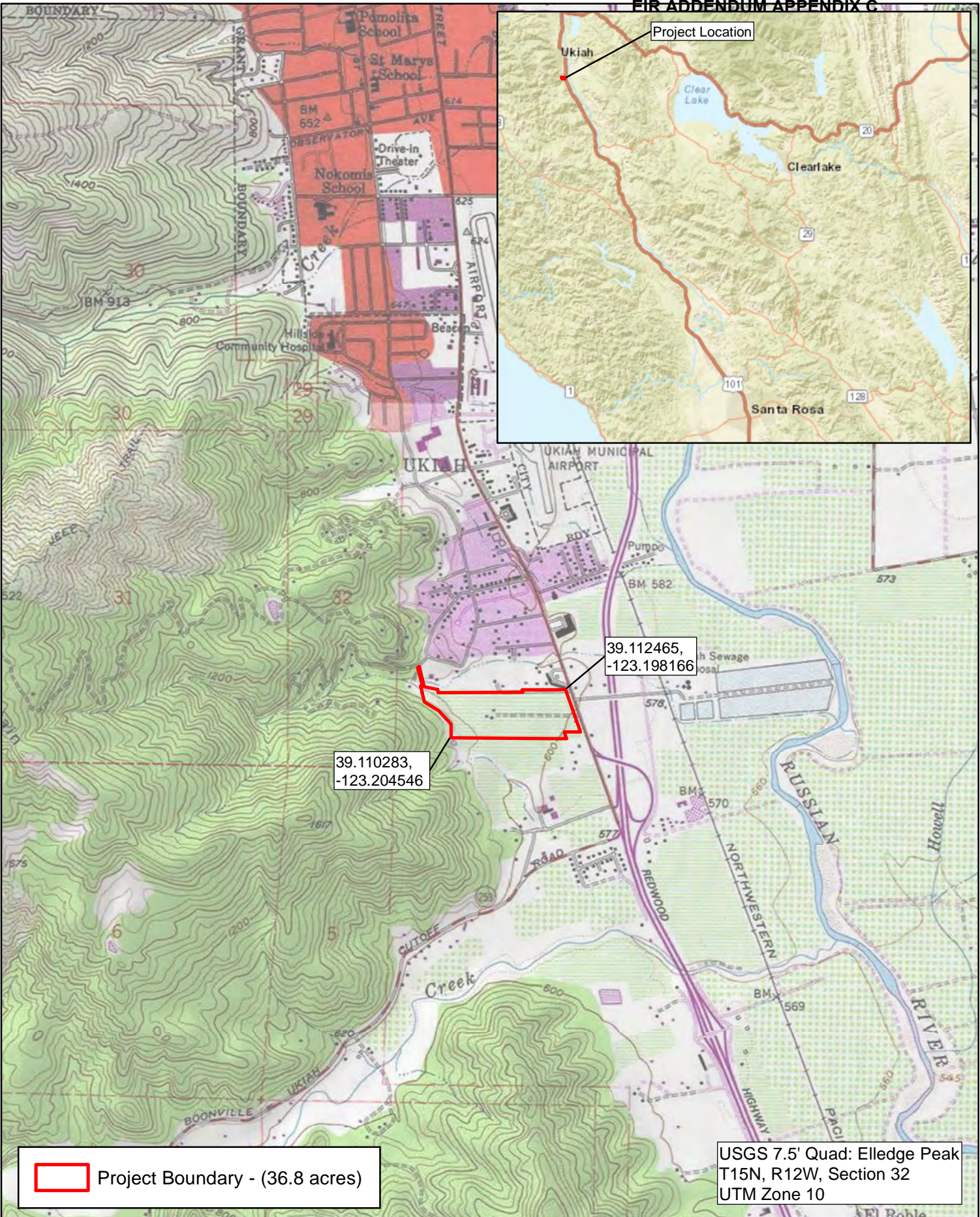
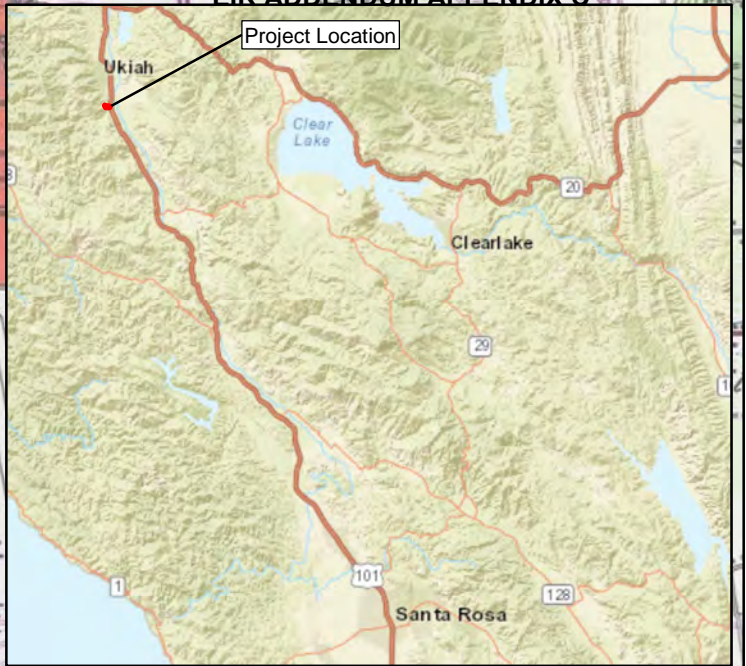



Bella Vista  
Regional Location Map  
Figure 1



39.112465,  
-123.198166

39.110283,  
-123.204546

S State St

 Biological Survey Area - (36.8 acres)  
 Project Boundary - (36.8 acres)

 1:4,400  
 0 290 580 Feet  
 Data Sources: ESRI, Mendocino County,  
 Maxar 6/08/2020

Bella Vista  
 Biological Survey Area  
 Figure 2



## Project Description

The proposed Project consists of the construction of a residential subdivision development. The site will be developed with the construction of residential homes, open space parks, a water detention basin, and associated structures. The project is accessible through two new vehicle connections from South State Street. A new water line connection will be established at the northeast corner of the site and will cross Cleland Creek. The expected method of water line installation is to jack-and-bore under the creek.

## METHODS

### References Consulted

Gallaway Enterprises obtained lists of special-status species that occur in the vicinity of the BSA. The CNDDDB, Rarefind 5, was also consulted and showed special-status species occurrences within a 5-mile radius of the BSA (**Figure 3**). Other primary sources of information regarding the potential occurrence of threatened, endangered, proposed, and candidate species and their habitats within the BSA used in the preparation of this BRA are:

- The USFWS IPaC Official Species List for the Project area, March 24, 2021, Consultation Code 08EACT00-2021-SLI-0297 (**Appendix A: Species Lists**);
- The NOAA-NMFS Official Species List for the 7.5-minute United States Geological Survey (USGS) “Elledge Peak” quadrangle (**Appendix A: Species Lists**);
- The results of a species record search of the CDFW CNDDDB, RareFind 5, for the 7.5-minute United States Geological Survey (USGS) “Orrs Springs,” “Ukiah,” “Cow Mountain,” and “Boonville,” “Elledge Peak,” and “Purdys Gardens” quadrangles (**Appendix A: Species Lists**);
- The review of the CNPS Inventory of Rare and Endangered Plants of California for the 7.5 minute USGS “Orrs Springs,” “Ukiah,” “Cow Mountain,” and “Boonville,” “Elledge Peak,” and “Purdys Gardens” quadrangles (**Appendix A: Species Lists**);
- USFWS Critical Habitat Portal, March 24, 2021;
- Results from the habitats assessments, protocol-level rare plant survey, and delineation of waters of the United States conducted by Gallaway Enterprises on April 13 and May 3, 2021 (**Appendix B; Observed Species Lists and Appendix C; Draft Delineation of Waters of the U.S.**);
- The *Garden’s Gate Subdivision Draft Environmental Impact Report* prepared by Leonard Charles and Associates, 2008; and
- The “*Biological Assessment*” for the Bella Vista Subdivision prepared by NCRM, Inc., 2021.

### Special-Status Species

Special-status species that have potential to occur in the BSA are those that fall into one of the following categories:

- Listed as threatened or endangered, or are proposed or candidates for listing under the California Endangered Species Act (CESA, 14 California Code of Regulations 670.5) or the Federal Endangered Species Act (ESA, 50 Code of Federal Regulations 17.12);

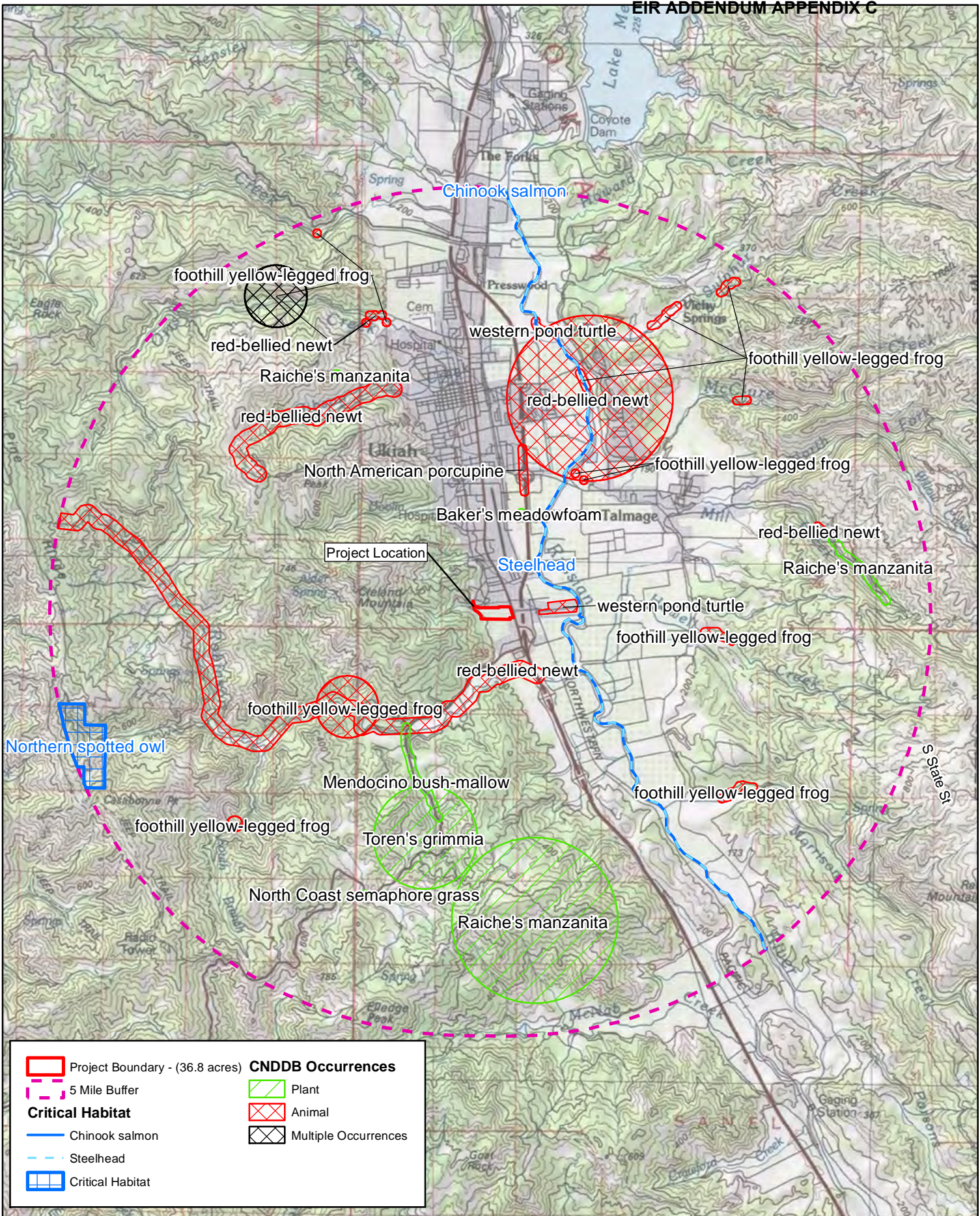

	Project Boundary - (36.8 acres)	<b>CNDDB Occurrences</b>	
	5 Mile Buffer		Plant
<b>Critical Habitat</b>			Animal
	Chinook salmon		Multiple Occurrences
	Steelhead		
	Critical Habitat		

1:95,000  
 0 5,000 10,000 Feet  
 Data Sources: ESRI, Mendocino County, USGS  
 NORTH

Bella Vista  
 CNDDB Occurrences and Critical Habitat  
 Figure 3

- Listed as a Species of Special Concern (SSC) by CDFW or protected under the California Fish and Game Code (CFG) (i.e., Fully Protected species);
- Ranked by the CNPS as 1A, 1B, or 2;
- Protected under the Migratory Bird Treaty Act (MBTA);
- Protected under the Bald and Golden Eagle Protection Act; or
- Species that are otherwise protected under policies or ordinances at the local or regional level as required by the California Environmental Quality Act (CEQA §15380).

### **Critical Habitat**

The ESA requires that critical habitat be designated for all species listed under the ESA. Critical habitat is designated for areas that provide essential habitat elements that enable a species' survival, and which are occupied by the species during the species listing under the ESA. Areas outside of the species' range of occupancy during the time of its listing can also be determined as critical habitat if the agency decides that the area is essential to the conservation of the species.

The USFWS Critical Habitat Portal was accessed on March 24, 2021 to determine if critical habitat occurs within the BSA. Appropriate Federal Registers were also used to confirm the presence or absence of critical habitat.

### **Sensitive Natural Communities**

Sensitive Natural Communities (SNCs) are monitored by CDFW with the goal of preserving these areas of habitat that are rare or ecologically important. Many SNCs are designated as such because they represent a historical landscape and are typically preserved as valued components of California's diverse habitat assemblage.

### **Waters of the United States**

A formal delineation of waters of the United States (WOTUS) was conducted by senior botanist Elena Gregg within the Project site on May 3, 2021 (**Appendix C**). An intermittent drainage runs roughly west to east through the northernmost portion of the BSA. The one (1) drainage identified within the Project is an intermittent feature that meets the current definition of jurisdictional WOTUS. There are no other aquatic features present within the BSA.

### **Habitat Assessments**

Habitat assessments were conducted by Gallaway Enterprises staff on April 13 and May 3, 2021 (**Figure 4**). A wildlife habitat assessment was conducted by biologist Brittany Reaves. Senior botanist Elena Gregg conducted a botanical habitat assessment and protocol-level rare plant survey within the BSA.

Habitat assessments for botanical and wildlife species were conducted to determine the suitable habitat elements for special-status species within the BSA. The habitat assessment was conducted by walking the entire BSA, where accessible, and recording specific habitat types and elements. If potentially suitable habitat was observed for special-status species, it was then evaluated for quality based on



**Legend**

- Project Boundary - (36.8 acres)
- Biological Survey Area - (36.8 acres)

**Habitat Types**

- Annual Grassland - (8.42 acres)
- Barren - (0.62 acres)
- Montane Hardwood Conifer - (0.92 acres)
- Riverine - (0.006 acres)
- Urban - (1.24 acres)
- Vineyard - (25.59 acres)

1:4,500  
 0 300 600 Feet  
 Data Sources: ESRI, Mendocino County, Maxar 6/08/2020  
 NORTH

Bella Vista  
 Habitat Types  
 Figure 4

vegetation composition and structure, physical features (e.g., soils, elevation), micro-climate, surrounding area, presence of predatory species and available resources (e.g., prey items, nesting substrates), and land-use patterns.

### Rare Plant Survey

A protocol-level rare plant survey and habitat evaluation for rare plants was conducted by Mrs. Gregg on May 3, 2021. The survey and evaluation were conducted by walking all areas of the BSA and taking inventory of observed botanical species (**Appendix B**). The protocol-level survey was conducted for species with blooming periods that overlapped the survey date.

## RESULTS

### Habitats

#### Montane Hardwood-Conifer

Montane hardwood-conifer woodland occurs along the western edges of the BSA. This habitat type is typically diverse in structure, with a mix of hardwoods, conifers, and shrubs. The tree layer present in the BSA is composed of oracle oak (*Quercus x morehus*), Garry oak (*Quercus garryana* var. *garryana*), douglas-fir (*Pseudotsuga menziesii* var. *menziesii*), bay laurel (*Umbellularia californica*) and pacific madrone (*Arbutus menziesii*). The shrub component is composed of Himalayan blackberry (*Rubus armeniacus*) and poison oak (*Toxicodendron diversilobum*). Bird and animal species characteristic of the Montane Hardwood habitat include disseminators of acorns (e.g., acorn woodpecker [*Melanerpes formicivorus*], western gray squirrel [*Sciurus griseus*]) and those that utilize acorns as a major food source (e.g., wild turkey [*Meleagris gallopavo*], mountain quail [*Oreortyx pictus*], California ground squirrel [*Otospermophilus beecheyi*]). Deer also use the foliage of several hardwoods to a moderate extent. Many amphibians and reptiles are found on the forest floor; among them are western fence lizard (*Sceloporus occidentalis*) and western rattlesnake (*Crotalus viridis*) (Mayer and Laudenslayer 1988).

#### Vineyard

A large portion of the BSA is comprised of vineyard. Vineyards are irrigated vine orchards can be found on flat alluvial soils in the valley floors, in rolling foothill areas, or on relatively steep slopes. Vineyards have been planted on deep, fertile soils which once supported productive and diverse natural habitats. Some species of birds and mammals have adapted to the vineyard habitats, and many have become "agricultural pests" which has resulted in intensive efforts to reduce crop losses through fencing and other various wildlife management techniques. Wildlife such as deer, rabbit, squirrel, and birds browse on the vines and feed on fruit. Some wildlife use vineyard habitat for cover and nesting sites. Vineyards can be especially beneficial to wildlife during hot summer periods; however, because they are deciduous and relatively short, they do not provide significant cover during cold and wet winter months. The literature is generally lacking on wildlife associated with these habitats, except as it relates to pests and pest control (Mayer and Laudenslayer 1988). The understory of the vineyard was dominated by annual

grasses and snow white meadowfoam (*Limnanthes douglasii* ssp. *nivea*), which persists in the vineyards due to regular irrigation.

### **Riverine**

Riverine habitat is characterized by intermittent or continually running water. There is an intermittent drainage, known locally as Cleland Mountain Creek, present that runs west to east in the northwest corner of the BSA. This drainage flows during wet winter and early spring months and dries every year by June at the latest (RTA 2003). Its substrate is composed primarily of large cobble. Vegetation present in association with this drainage included perennial ryegrass (*Festuca perennis*), curly dock (*Rumex crispus*), watercress (*Nasturtium officinale*), seep monkeyflower (*Erythranthe guttata*), and cut-leaf geranium (*Geranium dissectum*). The portion of Cleland Mountain Creek within the BSA notably lacked associated riparian vegetation due to past human management of the area. Typical riverine habitat functions as habitat for fishes and other aquatic species, and provides food for waterfowl, herons (*Ardeidae* sp.), and many species of insectivorous birds, hawks, and their prey. The drainage present has a hydrological connection to the Russian River and may support special-status fishes when flows are sufficient.

### **Annual Grassland**

Annual grasslands make up the portions of the BSA that have not been cultivated for agriculture. Annual grassland habitats and species composition depend largely on annual precipitation, fire regimes, and grazing practices (Mayer and Laudenslayer 1988). Species observed in the annual grasslands in the BSA include rattlesnake grass (*Briza maxima*), wild oats (*Avena barbata*), foothill filaree (*Erodium brachycarpum*), Mediterranean barley (*Hordeum marinum* ssp. *gussoneanum*), soft chess (*Bromus hordeaceus*), winter vetch (*Vicia villosa*), field bindweed (*Convolvulus arvensis*), and smooth cat's ear (*Hypochaeris glabra*). Most wildlife species use grassland habitat for foraging, but generally require some other habitat characteristic such as rocky outcrops, cliffs, caves, or ponds in order to find shelter and cover for escapement. Some rodents, such as ground squirrel (*Otospermophilus beecheyi*), utilize annual grasslands for burrowing.

### **Urban**

Urban habitat is present at the northern edges of BSA, which is composed of residential homes, paved roads, and associated landscaping. The agricultural outbuilding and paved area present in the middle of the BSA are also considered urban habitat. This environment can present a mosaic of vegetation, including primarily ornamental landscaping, but can also incorporate native tree species. Generalist and invasive species often occupy urban habitat, such as common raven (*Corvus corax*), house sparrow (*Passer domesticus*), scrub-jay (*Aphelocoma californica*) and Brewer's blackbird (*Euphagus cyanocephalus*), as well as small to medium mammals (e.g., raccoon [*Procyon lotor*], opossum [*Didelphis virginiana*]) (Mayer and Laudenslayer 1988). Abandoned buildings can sometimes provide suitable habitat for bat species.

### **Barren**

Barren habitat is typified by less than 2 percent vegetative cover. Within the BSA, the paved roads, unpaved access roads, and patches of bare soils are classified as barren. While barren habitat generally

does not provide high quality habitat to wildlife, some native reptiles and migratory birds such as killdeer (*Charadrius vociferous*) may utilize these areas for breeding (Mayer and Laudenslayer 1988).

**Critical Habitat**

There is no designated critical habitat within the BSA. Cleland Mountain Creek, which occurs in the BSA, is tributary to the Russian River approximately 1 mile east of the BSA. The Russian River is designated as critical habitat for California Coastal (CC) Chinook salmon Evolutionarily Significant Unit (ESU) (*Oncorhynchus tshawytscha*) and Central California Coast (CCC) steelhead Distinct Population Segment (DPS) (*Oncorhynchus mykiss irideus*) by NMFS.

**Sensitive Natural Communities**

No SNCs occur within the BSA. The BSA has been extensively modified from the natural condition and the site does not currently or historically support characteristics of high quality habitat that have been designated as SNCs.

**Special-Status Species**

A summary of special-status species assessed for potential occurrence within the BSA based on the USFWS IPaC, CDFW CNDDDB, and CNPS species lists are described in **Table 1**. Potential for occurrence was determined by reviewing database queries from federal and State agencies, performing surveys, and evaluating habitat characteristics.

**Table 1. Special-status species and Sensitive Natural Communities and their potential to occur in the BSA of the Bella Vista Subdivision Project, Mendocino County, CA**

Common Name (Scientific Name)	Status Fed/State/CNPS	Associated Habitats	Potential for Occurrence
<b>SENSITIVE NATURAL COMMUNITIES</b>			
Northern Interior Cypress Forest	_/_SNC/_	Cypress forest.	<u>None</u> . There is no Northern Interior Cypress Forest within the BSA.
Serpentine Bunchgrass	_/_SNC/_	Grassland community.	<u>None</u> . There is no Serpentine Bunchgrass within the BSA.
<b>PLANTS</b>			
Baker’s meadowfoam ( <i>Limnanthes bakeri</i> )	_/_/1B.1	Seasonally moist or saturated sites within grassland; also in swales, roadside ditches, and margins of freshwater marshy areas. (Blooming Period [BP]: Apr – May)	<u>None</u> . Not observed during protocol-level survey.

Common Name (Scientific Name)	Status Fed/State/CNPS	Associated Habitats	Potential for Occurrence
<b>PLANTS</b>			
<b>Baker's navarretia</b> ( <i>Navarretia leucocephala</i> ssp. <i>bakeri</i> )	_/_/1B.1	Vernal pools and swales; adobe or alkaline soils. (BP: Apr – Jul)	<u>None</u> . No suitable vernal habitat present within the BSA and not observed during protocol-level survey.
<b>Beaked tracyina</b> ( <i>Tracyina rostrata</i> )	_/_/1B.2	Open, grassy meadows; usually within oak woodland and grassland habitats. (BP: May – Jun)	<u>None</u> . No suitable meadow habitat present within the BSA and not observed during protocol-level survey.
<b>Boggs Lake hedge-hyssop</b> ( <i>Gratiola heterosepala</i> )	_/SE/1B.2	Lake margins and vernal pools. (BP: Apr – Aug)	<u>None</u> . There is no suitable wetland habitat present within the BSA.
<b>Bolander's horkelia</b> ( <i>Horkelia bolanderi</i> )	_/_/1B.2	Edges of vernal mesic areas in valley/foothill grassland, and meadows and seeps in chaparral and lower montane coniferous forest. (BP: May – Aug)	<u>None</u> . No suitable mesic habitat present within the BSA and not observed during protocol-level survey.
<b>Bristly sedge</b> ( <i>Carex comosa</i> )	_/_/2B.1	Lake margins, wet places in marshes and swamps, coastal prairie, valley and foothill grassland. (BP: May – Sep)	<u>None</u> . No suitable habitat present within the BSA.
<b>Burke's goldfields</b> ( <i>Lasthenia burkei</i> )	FE/SE/1B.1	Vernal pools and swales. (BP: Apr – Jun)	<u>None</u> . No suitable vernal habitat present within the BSA and not observed during protocol-level survey.
<b>Colusa layia</b> ( <i>Layia septentrionalis</i> )	_/_/1B.2	Fields and grassy slopes in sandy or serpentine soil. (BP: Apr – May)	<u>None</u> . No suitable habitat present within the BSA and not observed during protocol-level survey.
<b>Contra Costa goldfields</b> ( <i>Lasthenia conjugens</i> )	FE/_/1B.1	Vernal pools. (BP: Mar – June)	<u>None</u> . No suitable habitat present within the BSA and not observed during protocol-level survey.
<b>Glandular western flax</b> ( <i>Hesperolinon adenophyllum</i> )	_/_/1B.2	Serpentinite substrates in annual grassland, cismontane woodland and chaparral. (BP: May – Aug)	<u>None</u> . No suitable habitat present within the BSA and not observed during protocol-level survey.



Common Name (Scientific Name)	Status Fed/State/CNPS	Associated Habitats	Potential for Occurrence
<b>PLANTS</b>			
<b>Great burnet</b> ( <i>Sanguisorba officinalis</i> )	_/_/2B.2	Rocky, serpentine seepage areas and along streams. (BP: Jul – Oct)	<u>None</u> . No suitable habitat present within the BSA.
<b>Hoffman's bristly jewelflower</b> ( <i>Streptanthus glandulosus</i> ssp. <i>hoffmanii</i> )	_/_/1B.3	Moist, steep rocky banks, in chaparral, cismontane woodland, valley and foothill grassland. (BP: Mar – Jul)	<u>None</u> . No suitable habitat present within the BSA and not observed during protocol-level survey.
<b>Koch's cord moss</b> ( <i>Entosthodon kochii</i> )	_/_/1B.3	Moss growing on soil on riverbanks in cismontane woodland.	<u>None</u> . No suitable habitat present within the BSA and not observed during protocol-level survey.
<b>Mendocino bush-mallow</b> ( <i>Malacothamnus mendocinensis</i> )	_/_/1A	Open, roadside banks; chaparral. (BP: May – Jun)	<u>None</u> . No suitable habitat present within the BSA and not observed during protocol-level survey
<b>Minute pocket moss</b> ( <i>Fissidens pauperculus</i> )	_/_/1B.2	Moss growing on damp soil along the coast, in dry streambeds and on stream banks.	<u>None</u> . No suitable habitat present within the BSA and not observed during protocol-level survey.
<b>North Coast semaphore grass</b> ( <i>Pleuropogon hooverianus</i> )	_/_/ST/1B.1	Shady, wet grassy areas and freshwater marshes on forest floor. (BP: Apr – Jun)	<u>None</u> . No suitable habitat present within the BSA and not observed during protocol-level survey.
<b>Oval-leaved viburnum</b> ( <i>Viburnum ellipticum</i> )	_/_/2B.3	Chaparral, cismontane woodland, lower montane coniferous forest, generally on north-facing slopes. (BP: May – Jun)	<u>None</u> . No suitable habitat present within the BSA and perennial shrub not observed during protocol-level survey.
<b>Raiche's manzanita</b> ( <i>Arctostaphylos stanfordiana</i> ssp. <i>raichei</i> )	_/_/1B.1	Rocky, often serpentinite openings in chaparral and lower montane coniferous forests. (BP: Feb – Apr)	<u>None</u> . Suitable habitat not present within the BSA and not observed during protocol-level survey.
<b>Rincon Ridge ceanothus</b> ( <i>Ceanothus confusus</i> )	_/_/1B.1	Serpentinite substrate in chaparral habitat. (BP: Feb – Jun)	<u>None</u> . Suitable habitat not present within the BSA and not observed during protocol-level survey.

<b>Common Name</b> ( <i>Scientific Name</i> )	<b>Status</b> Fed/State/CNPS	<b>Associated Habitats</b>	<b>Potential for Occurrence</b>
<b>PLANTS</b>			
<b>Roderick's fritillary</b> ( <i>Fritillaria roderickii</i> )	_/_/1B.1	Shady, wet grassy areas and freshwater marshes on forest floor. (BP: Mar – May)	<u>None</u> . No suitable wet habitat present within the BSA and not observed during protocol-level survey.
<b>Showy Indian clover</b> ( <i>Trifolium amoenum</i> )	FE/_/1B.1	Usually occurs in wetlands within valley grassland and wetland-riparian communities. (BP: Apr – Jun)	<u>None</u> . Not observed within the BSA during protocol-level survey.
<b>Small groundcone</b> ( <i>Kopsiopsis hookeri</i> )	_/_/2B.3	Open woods, shrubby places, generally on <i>Gaultheria shallon</i> in north coast coniferous forest. (BP: Apr – Aug)	<u>None</u> . Suitable habitat not present and not observed within the BSA.
<b>Toren's grimmia</b> ( <i>Grimmia torenii</i> )	_/_/1B.3	Openings, rocky, boulder and rock walls, serpentine, volcanic in cismontane woodland, lower montane coniferous forest, chaparral.	<u>None</u> . Suitable habitat not present and not observed within the BSA.
<b>White-flowered rein orchid</b> ( <i>Piperia candida</i> )	_/_/1B.2	Sometimes serpentinite soils; forest duff, mossy banks, and rock outcrops. (BP: [Mar]May – Sep)	<u>None</u> . Suitable habitat not present within the BSA.
<b>FISH</b>			
<b>Chinook salmon</b> California Coastal Evolutionarily Significant Unit (ESU) ( <i>Oncorhynchus tshawytscha</i> )	FT/_/_	Rivers and streams south of the Klamath River in Humboldt County to the Russian River in Sonoma County.	<u>Low when creek is flowing.</u> <u>None when creek is dry.</u> Cleland Mountain Creek is hydrologically connected to the Russian River, which supports this species.
<b>Clear Lake tule perch</b> ( <i>Hysteroecarpus traskii lagunae</i> )	_/SSC/_	Confined to Clear Lake, Lower Blue Lake, and Upper Blue Lake in Lake County, California.	<u>None</u> . The BSA is located outside of this species' range.

Common Name (Scientific Name)	Status Fed/State/CNPS	Associated Habitats	Potential for Occurrence
<b>FISH</b>			
<b>Coho salmon</b> Central California Coast ESU <i>(Oncorhynchus kisutch)</i>	FE/SE/_	Rivers and streams from Punta Gorda (southern coastal Humboldt County) south to Aptos Creek in Santa Cruz County.	<u>None.</u> The BSA is located outside of this species' range.
<b>Steelhead</b> Central California Coast Distinct Population Segment (DPS) <i>(Oncorhynchus mykiss irideus)</i>	FT/_/_	Russian River to Aptos Creek and the drainages of San Francisco, San Pablo, and Suisun Bays eastward to Chipps Island at the confluence of the Sacramento and San Joaquin Rivers.	<u>Low when creek is flowing.</u> <u>None when creek is dry.</u> Cleland Mountain Creek is hydrologically connected to the Russian River, which supports this species.
<b>HERPTILES</b>			
<b>California red-legged frog</b> <i>(Rana draytonii)</i>	FT/SSC/_	Lowlands and foothills in or near permanent sources of deep water with dense, shrubby, or emergent riparian vegetation.	<u>None.</u> There is no suitable habitat present within the BSA. The intermittent drainage does not contain ponded water for long enough duration to support this species.
<b>Foothill yellow-legged frog</b> Northwest/North Coast Clade <i>(Rana boylei)</i>	_/SSC/_	Perennial, shallow streams and riffles with rocky substrates and partial shade; commonly found in canyons and narrow streams.	<u>None.</u> The intermittent drainage present does not contain suitable aquatic habitat during the FYLF breeding period (April – July) or tadpole development period (3-4 months after breeding) (Zeiner et al. 1990).
<b>Red-bellied newt</b> <i>(Taricha rivularis)</i>	_/SSC/_	Rapid-flowing, permanent streams with rocky substrate in coastal woodlands and redwood forests.	<u>None.</u> The intermittent drainage present does not contain suitable aquatic habitat during the red-bellied newt larval development period (late summer – early fall) (Zeiner et al. 1990).

Common Name (Scientific Name)	Status Fed/State/CNPS	Associated Habitats	Potential for Occurrence
<b>HERPTILES</b>			
<b>Western pond turtle</b> ( <i>Emys marmorata</i> )	_ /SSC/ _	Bodies of water with deep pools, emergent vegetation for foraging and cover, and locations for basking and nesting.	<b>Low.</b> There are no perennial aquatic features within the BSA; however, western pond turtles can be found aestivating along intermittent drainages (Belli 2015). The BSA does not contain suitable aquatic habitat for western pond turtle during their nesting season (typically June and July).
<b>BIRDS</b>			
<b>Grasshopper sparrow</b> ( <i>Ammodramus savannarum</i> )	_ /SSC/ _	Dense grasslands on rolling hills, lowland plains, in valleys and on hillsides on lower mountain slopes. Favors native grasslands with a mix of grasses, forbs, and scattered shrubs. Loosely colonial when nesting.	<b>Low.</b> The fragmented grasslands present within the BSA provide marginal potential habitat for this species.
<b>Northern spotted owl</b> ( <i>Strix occidentalis caurina</i> )	FT/ST/ _	Forests characterized by dense canopy closure of mature and old-growth trees, abundant logs, standing snags, and live trees with broken tops.	<b>None.</b> There is no suitable habitat within the BSA.
<b>Western snowy plover</b> ( <i>Charadrius nivosus nivosus</i> )	FT/SSC/ _	Sandy beaches, salt pond levees, and shores of large alkali lakes. Needs sandy, gravelly, or friable soils for nesting.	<b>None.</b> There is no suitable habitat within the BSA.
<b>Yellow-billed cuckoo</b> Western U.S. DPS ( <i>Coccyzus americanus occidentalis</i> )	FT/SE/ _	Nests in dense riparian forests that occur in patch sizes of 25 acres or greater with a width of at least 330 feet.	<b>None.</b> There is no suitable habitat within the BSA.

Common Name (Scientific Name)	Status Fed/State/CNPS	Associated Habitats	Potential for Occurrence
<b>MAMMALS</b>			
<b>Fisher</b> West Coast DPS ( <i>Pekania pennanti</i> )	FC/SSC/_	Intermediate to large tree stages of coniferous forests and deciduous-riparian areas with high percent canopy closure. Uses cavities, snags, logs and rocky areas for cover and denning. Needs large areas of mature, dense forest.	<u>None</u> . There is no suitable habitat within the BSA.
<b>Sonoma tree vole</b> ( <i>Arborimus pomo</i> )	_/SSC/_	Douglas-fir and grand fir trees in dense, old-growth forests.	<u>None</u> . There is no suitable habitat within the BSA.
<b>Pallid bat</b> ( <i>Antrozous pallidus</i> )	_/SSC/_	Rocky outcroppings to open, sparsely vegetated grasslands with nearby water source. Day and night roosts include crevices in rocky outcrops and cliffs, caves, mines, trees (e.g., cavities and exfoliating bark), and various human structures (i.e., bridges).	<b>Moderate</b> . Mature trees and the existing outbuilding could provide suitable roosting habitat within the BSA. There is only one (1) CNDDDB occurrence of this species within 15 miles of the BSA.
<b>Townsend's big-eared bat</b> ( <i>Corynorhinus townsendii</i> )	_/SSC/_	Roost in caves and cave-like cavities; occasionally in bridges and abandoned buildings.	<b>Low</b> . The existing outbuilding could potentially provide suitable roosting habitat within the BSA. There are no CNDDDB occurrences of this species within 15 miles of the BSA.

<b>CODE DESIGNATIONS</b>	
<p><b>FE or FT</b> = Federally listed as Endangered or Threatened  <b>FC</b> = Federal Candidate Species</p> <p><b>SE or ST</b> = State Listed as Endangered or Threatened  <b>SC</b> = State Candidate Species  <b>SSC</b> = State Species of Special Concern  <b>FP</b> = State Fully Protected Species  <b>SNC</b> = CDFW Sensitive Natural Community</p>	<p><b>CNPS California Rare Plant Rank (CRPR):</b>  <b>CRPR 1B</b> = Rare or Endangered in California or elsewhere  <b>CRPR 2</b> = Rare or Endangered in California, more common elsewhere  <b>CRPR 3</b> = More information is needed  <b>CRPR 4</b> = Plants with limited distribution</p> <p><b>0.1</b> = Seriously Threatened  <b>0.2</b> = Fairly Threatened  <b>0.3</b> = Not very Threatened</p>

**Potential for Occurrence:** for plants it is considered the potential to occur during the survey period; for birds and bats it is considered the potential to breed, forage, roost, or over-winter in the BSA during migration. Any bird or bat species could fly over the BSA, but this is not considered a potential occurrence. The categories for the potential for occurrence include:

**None:** The species or natural community is known not to occur and has no potential to occur in the BSA based on sufficient surveys, the lack suitable habitat, and/or the BSA is well outside of the known distribution of the species.

**Low:** Potential habitat in the BSA is sub-marginal and/or the species is known to occur in the vicinity of the BSA.

**Moderate:** Suitable habitat is present in the BSA and/or the species is known to occur in the vicinity of the BSA. Pre-construction surveys may be required.

**High:** Habitat in the BSA is highly suitable for the species and there are reliable records close to the BSA, but the species was not observed. Pre-construction surveys required, with the exception of indicators for foraging habitat.

**Known:** Species was detected in the BSA or a recent reliable record exists for the BSA.

The following special-status species have potential to occur within the BSA based on the presence of suitable habitat and/or known records of species occurrence within the vicinity of the BSA.

### **Endangered, Threatened and Rare Plants**

There were no endangered, threatened, or rare plants observed within the BSA during the protocol-level rare plant survey conducted on May 3, 2021. A complete list of plant species observed within the BSA can be found in **Appendix B**.

During the field visit, a number of manzanita shrubs were observed; however, based on the few flowers observed, these manzanita shrubs were able to be identified as the common species of manzanita (*Arctostaphylos manzanita* ssp. *manzanita*). Since the field visit was conducted prior to the blooming period for many of the species listed in **Table 1**, a habitat assessment was conducted to determine the potential for these special-status plants to occur within the BSA. The BSA was determined to lack the necessary habitat elements for these species and, therefore, no special-status plant species were determined to have potential to occur within the BSA.

### **Endangered, Threatened, and Special-status Wildlife**

A wildlife habitat assessment was conducted within the BSA on April 13, 2021. Potential habitat was identified for California Coastal (CC) Chinook salmon, Central California Coast (CCC) steelhead, western pond turtle, grasshopper sparrow, pallid bat, Townsend's big-eared bat, and several avian species protected under the MBTA. A complete list of wildlife species observed within the BSA can be found in **Appendix B**.

### **California Coastal Chinook salmon and Central California Coast steelhead**

Chinook salmon and steelhead are anadromous fish and return from the ocean to the streams where they were born to spawn and die. This cycle of life takes them from freshwater to tidal zones to the ocean and back again in as few as 3 years. Each transition into a new habitat is associated with a different life stage. Salmon and steelhead begin as eggs in stream gravels where their parents spawned, they then emerge from the gravels up into the stream flow as juveniles where they will stay for a few months (some Chinook salmon) or a few years (steelhead) before beginning their downstream migration

to the ocean as smolts. As adults, 1 to 3 years usually are spent in the ocean (depending on the species) before they return to the stream where they were born to spawn. Unlike Chinook salmon (and coho salmon), steelhead are iteroparous, meaning some adults do not die after spawning but instead return to the ocean and repeat the adult portion of their lifecycle one or more times (NMFS 2016).

The Russian River, which is hydrologically connected to Cleland Mountain Creek, is utilized by adult anadromous salmonids (CC Chinook salmon and CCC steelhead) for migration and spawning and is designated as critical habitat for these species by NMFS. Adult salmon and steelhead enter the Russian River in the late-summer and early fall, prior to the onset of the rainy season. The upstream migration of these fish does not occur until enough rain has fallen to raise water levels and to also establish a winter baseflow that is higher than the summer baseflow level. Sufficient migration conditions usually do not occur until mid-November, or later.

#### **Status of CC Chinook salmon and CCC steelhead occurring in the BSA**

During the proposed construction period for the installation of the water main under Cleland Mountain Creek (June 15 to October 15), the creek does not sustain sufficient flows or suitable temperatures to support salmonids. At the time of the site visits on April 13 and May 3, Cleland Mountain Creek was not flowing and no salmonids were observed.

Whether or not CC Chinook salmon and CCC steelhead spawn in Cleland Mountain Creek during the winter when flows are sufficient is unconfirmed. A fish passage study conducted by Ross Taylor and Associates in 2003 found no barrier for adult salmonids between Cleland Mountain Creek and the Russian River; however, fish passage criteria flows for juvenile salmonids were found to be only 40% passable at the culvert under South State Street. Additionally, Cleland Mountain Creek within the BSA lacks many essential habitat components for juvenile rearing and survival, such as natural cover and shade, submerged and overhanging large wood, log jams and beaver dams, aquatic vegetation, large rocks and boulders, side channels, and undercut banks. These features are essential to conservation because without them juveniles cannot access and use the areas needed to forage, grow, and develop behaviors (e.g., predator avoidance, competition), nor allow them to avoid high flows, begin the behavioral and physiological changes needed for life in the ocean, or reach the ocean in a timely manner (70 FR 52488-52627). Further, there is no riparian vegetation present at the creek within the BSA due to past human management. Due to the lack of preferred habitat components, there is low potential for these species to occur when the creek is flowing and no potential for these species to occur during the summer months when the creek is dry.

#### **Western pond turtle**

The western pond turtle is a SSC in California. Western pond turtles are drab, darkish-colored turtles with a yellowish to cream colored head. They range from the Washington Puget Sound to the California Sacramento Valley. Suitable aquatic habitats include slow moving to stagnant water, such as back waters and ponded areas of rivers and creeks, semi-permanent to permanent ponds and irrigation ditches. Preferred habitats include features such as hydrophytic vegetation, for foraging and cover, and basking areas to regulate body temperature. In early spring through early summer, female turtles begin

to move over land in search for nesting sites. Eggs are laid on the banks of slow-moving streams. The female digs a hole approximately 4 inches deep and lays up to eleven eggs. Afterwards, the eggs are covered with sediment and are left to incubate under the warm soils. Eggs are laid between March and August (Zeiner et al. 1990), typically June and July. Current threats facing the western pond turtle include loss of suitable aquatic habitats due to rapid changes in water regimes and removal of hydrophytic vegetation.

#### **CNDDB Occurrences**

The nearest CNDDB occurrence (#612) is located immediately east of the BSA at the Ukiah Sewage Treatment Plant, where it was noted in 2004 that western pond turtles frequent the percolation ponds present there.

#### **Status of western pond turtle occurring in the BSA**

The BSA does not contain suitable aquatic habitat for western pond turtle during their nesting season (typically June and July). Cleland Mountain Creek contains marginally suitable aquatic habitat for western pond turtle when there is water present. The stretch of Cleland Mountain Creek that occurs within the BSA lacks emergent rocks and logs on which western pond turtles bask for thermoregulation and deep pools and fresh emergent vegetation for foraging and cover; however, there are some open banks for basking. Western pond turtles are known to travel up to 400 meters from aquatic habitat into upland areas to nest (Reese and Welsh 1997), and they may aestivate in upland areas along intermittent drainages for several months during dry periods (Belli 2015). Due to the intermittent nature of Cleland Mountain Creek and lack of suitable habitat components, there is low potential for western pond turtle to occur within the BSA.

#### **Grasshopper sparrow**

Grasshopper sparrows are a SSC in California. Adults have upperparts streaked with brown, grey, black, and white; they have a light brown breast, a white belly, and a short brown tail. Their face is light brown with an eye ring and a dark brown crown with a central narrow light stripe. There are regional variations in the appearance of this bird. Grasshopper sparrows prefer open grasslands with bare ground for foraging. In western arid grasslands and prairies, grasshopper sparrows tend to be found in areas with shrub cover and more vegetation. Grasshopper sparrows seem to prefer areas with broad expanses of unfragmented suitable habitat. They nest in small colonies, and their nests are built on the ground, very well hidden at base of weed, shrub, or clump of grass. Their nests are often placed in slight depression, so that rim of nest is even with level of ground (Audubon 2021).

#### **CNDDB Occurrences**

The nearest CNDDB occurrence (#2) is located approximately 8.5 miles southeast of the BSA, where a breeding colony was found in moderately grazed grassland in 1991.

#### **Status of grasshopper sparrow occurring in the BSA**

There is open grassland present in the BSA, with some interspersed remnant montane hardwood conifer vegetation at the base of Cleland Mountain that could provide suitable foraging and nesting habitat for



grasshopper sparrow. Due to the fragmented, anthropogenically modified habitat present, general lack of shrubby vegetation, and lack of nearby occurrences, there is low potential for grasshopper sparrow to occur within the BSA.

### **Pallid bat**

Pallid bat is designated as a SSC. Pallid bats roost alone, in small groups (2 to 20 bats), or gregariously (hundreds of individuals). Day and night roosts include crevices in rocky outcrops and cliffs, caves, mines, trees (e.g., basal hollows of coast redwoods and giant sequoias, bole cavities of oaks, exfoliating Ponderosa pine and valley oak bark, deciduous trees in riparian areas, and fruit trees in orchards), and various human structures such as bridges (especially wooden and concrete girder designs), barns, porches, bat boxes, and human-occupied as well as vacant buildings. Roosts generally have unobstructed entrances/exits, are high above the ground, warm, and inaccessible to terrestrial predators. However, this species has also been found roosting on or near the ground under burlap sacks, stone piles, rags, and baseboards. Lewis 1996 found that pallid bats have low roost fidelity and both pregnant and lactating pallid bats changed roosts an average of once every 1.4 days throughout the summer. Overwintering roosts have relatively cool, stable temperatures and are located in protected structures beneath the forest canopy or on the ground, out of direct sunlight. In other parts of the species' range, males and females have been found hibernating alone or in small groups, wedged deeply into narrow fissures in mines, caves, and buildings. At low latitudes, outdoor winter activity has been reported at temperatures between -5 and 10 °C (Western Bat Working Group 2021).

### **CNDDB Occurrences**

There is only one CNDDB occurrence of pallid bat within 15 miles of the BSA (#207) dated from 1947. This occurrence was found approximately 8 miles northeast of Ukiah at Cold Creek.

### **Status of pallid bat occurring in the BSA**

There are a few mature trees within the BSA that contain suitable habitat elements (e.g., cavities, peeling bark), as well as an existing agricultural outbuilding near the center of the BSA that may provide suitable roosting habitat. No evidence of roosting, such as guano or urine stains, was observed during the habitat assessment. There is **moderate** potential for pallid bats to occur within the BSA.

### **Townsend's big-eared bat**

Townsend's big-eared bat is designated as a SSC. This bat is distinguished by its bilateral nose bumps and large ears (WBWG 2021). This bat requires large cavities for roosting; these may include abandoned buildings and mines, caves, and basal cavities of trees. During the summer, males and females occupy separate roosting sites; males are typically solitary, while females form maternity colonies, where they raise their pups. Maternity colonies form between March and June (based on local climactic factors), with a single pup born between May and July (WBWG 2021). A maternity colony may range in size from 12 bats to 200, although in the eastern United States, colonies of 1,000 or more have been formed. During the winter, these bats hibernate, often when temperatures are around 32 to 53°F. Hibernation occurs in tightly packed clusters, which could possibly help stabilize body temperatures against the cold. Males often hibernate in warmer places than females and are more easily aroused and active in winter

than females. This species has 2-3 feeding periods between dark and dawn, with periods of rest in between. They rest in areas different from where they roost during the day (Schwartz et al. 2016).

#### **CNDDDB Occurrences**

There is only one CNDDDB occurrence of pallid bat within 9 miles of the BSA (#136) dated from 1963 and 1987. This occurrence is located approximately 3 miles northeast of Hopland.

#### **Status of Townsend's big-eared bat occurring in the BSA**

The existing agricultural outbuilding near the center of the BSA could provide suitable roosting habitat for this species; however, no evidence of roosting, such as guano or urine stains, was identified during the habitat assessment. There is low potential for Townsend's big-eared bat to occur within the BSA.

#### **Migratory birds and raptors**

Nesting birds are protected under the MBTA (16 USC 703) and the CFGC (§3503). The MBTA (16 USC §703) prohibits the killing of migratory birds or the destruction of their occupied nests and eggs except in accordance with regulations prescribed by the USFWS. The bird species covered by the MBTA includes nearly all of those that breed in North America, excluding introduced (i.e., exotic) species (50 Code of Federal Regulations §10.13). Activities that involve the removal of vegetation including trees, shrubs, grasses, and forbs or ground disturbance has the potential to affect bird species protected by the MBTA.

The CFGC (§3503.5) states that it is "unlawful to take, possess, or destroy any birds in the order Falconiformes (hawks, eagles, and falcons) or Strigiformes (owls) or to take, possess, or destroy the nest or eggs of any such bird except as otherwise provided by this code or any regulation adopted pursuant thereto." Take includes the disturbance of an active nest resulting in the abandonment or loss of young. The CFGC (§3503) also states that "it is unlawful to take, possess, or needlessly destroy the nest or eggs of any bird, except as otherwise provided by this code or any regulation made pursuant thereto."

#### **CNDDDB Occurrences**

The majority of migratory birds and raptors protected under the MBTA and CFGC are not recorded on the CNDDDB because they are abundant and widespread.

#### **Status of migratory birds and raptors occurring in the BSA**

There is suitable nesting habitat for avian species within and adjacent to the BSA.

## **REGULATORY FRAMEWORK**

The following describes federal, state, and local environmental laws and policies that may be relevant if the BSA were to be developed or modified.

### **Federal**

#### **Federal Endangered Species Act**

The United States Congress passed the ESA in 1973 to protect species that are endangered or threatened with extinction. The ESA is intended to operate in conjunction with the National

Environmental Policy Act (NEPA) to help protect the ecosystems upon which endangered and threatened species depend.

Under the ESA, species may be listed as either “endangered” or “threatened.” Endangered means a species is in danger of extinction throughout all or a significant portion of its range. Threatened means a species is likely to become endangered within the foreseeable future throughout all or a significant portion of its range. All species of plants and animals, except non-native species and pest insects, are eligible for listing as endangered or threatened. The USFWS also maintains a list of “candidate” species. Candidate species are species for which there is enough information to warrant proposing them for listing, but that have not yet been proposed. “Proposed” species are those that have been proposed for listing but have not yet been listed.

The ESA makes it unlawful to “take” a listed animal without a permit. Take is defined as “to harass, harm, pursue, hunt, shoot, wound, kill, trap, capture, or collect or attempt to engage in any such conduct.” Through regulations, the term “harm” is defined as “an act which actually kills or injures wildlife. Such an act may include significant habitat modification or degradation where it actually kills or injures wildlife by significantly impairing essential behavioral patterns, including breeding, feeding, or sheltering.”

### **Migratory Bird Treaty Act**

The MBTA (16 USC §703) prohibits the killing of migratory birds or the destruction of their occupied nests and eggs except in accordance with regulations prescribed by the USFWS. The bird species covered by the MBTA includes nearly all of those that breed in North America, excluding introduced (i.e., exotic) species (50 Code of Federal Regulations §10.13).

## **State of California**

### **California Endangered Species Act**

The CESA is similar to the ESA but pertains to state-listed endangered and threatened species. The CESA requires state agencies to consult with the CDFW when preparing documents to comply with the California Environmental Quality Act (CEQA). The purpose is to ensure that the actions of the lead agency do not jeopardize the continued existence of a listed species or result in the destruction, or adverse modification of habitat essential to the continued existence of those species. In addition to formal listing under the federal and state endangered species acts, “species of special concern” receive consideration by CDFW. Species of special concern are those whose numbers, reproductive success, or habitat may be threatened.

### **California Fish and Game Code (§3503.5)**

The CFGC (§3503.5) states that it is “unlawful to take, possess, or destroy any birds in the order Falconiformes (hawks, eagles, and falcons) or Strigiformes (all owls except barn owls) or to take, possess, or destroy the nest or eggs of any such bird except as otherwise provided by this code or any regulation adopted pursuant thereto.” Take includes the disturbance of an active nest resulting in the abandonment or loss of young. The CFGC (§3503) also states that “it is unlawful to take, possess, or

needlessly destroy the nest or eggs of any bird, except as otherwise provided by this code or any regulation made pursuant thereto.”

### **California Migratory Bird Protection Act**

The CMBPA amends the CFGC (§3513) to mirror the provisions of the MBTA and allow the State of California to enforce the prohibition of take or possession of any migratory nongame bird as designated in the federal MBTA, including incidental take.

Activities that involve the removal of vegetation including trees, shrubs, grasses, and forbs or ground disturbance have the potential to affect bird species protected by the MBTA and CFGC. Thus, vegetation removal and ground disturbance in areas with breeding birds should be conducted outside of the breeding season (approximately March 1 through August 31). If vegetation removal or ground-disturbing activities are conducted during the breeding season, then a qualified biologist must determine if there are any nests of bird species protected under the MBTA and CFGC present in the Project area prior to commencement of vegetation removal or ground-disturbing activities. If active nests are located or presumed present, then appropriate avoidance measures (e.g., spatial or temporal buffers) must be implemented.

### **Rare and Endangered Plants**

The CNPS maintains a list of plant species native to California with low population numbers, limited distribution, or otherwise threatened with extinction. This information is published in the Inventory of Rare and Endangered Vascular Plants of California. Potential impacts to populations of CNPS California Rare Plant Rank (CRPR) plants receive consideration under CEQA review. The CNPS CRPR categorizes plants as follows:

- Rank 1A: Plants presumed extinct in California;
- Rank 1B: Plants rare, threatened, or endangered in California or elsewhere;
- Rank 2A: Plants presumed extirpated or extinct in California, but not elsewhere;
- Rank 2B: Plants rare, threatened, or endangered in California, but more numerous elsewhere;
- Rank 3: Plants about which we need more information; and
- Rank 4: Plants of limited distribution.

The California Native Plant Protection Act (CFGC §1900-1913) prohibits the taking, possessing, or sale within the state of any plants with a state designation of rare, threatened, or endangered as defined by CDFW. An exception to this prohibition allows landowners, under specific circumstances, to take listed plant species, provided that the owners first notify CDFW and give the agency at least 10 days to retrieve (and presumably replant) the plants before they are destroyed. Fish and Game Code §1913 exempts from the ‘take’ prohibition “the removal of endangered or rare native plants from a canal, lateral channel, building site, or road, or other right of way.”

### **California Environmental Quality Act Guidelines §15380**

Although threatened and endangered species are protected by specific federal and state statutes, CEQA Guidelines §15380(d) provides that a species not listed on the federal or state list of protected species

may be considered rare or endangered if the species can be shown to meet certain specified criteria. These criteria have been modeled based on the definition in the ESA and the section of the CFGC dealing with rare, threatened, and endangered plants and animals. The CEQA Guidelines (§15380) allows a public agency to undertake a review to determine if a significant effect on species that have not yet been listed by either the USFWS or CDFW (e.g., candidate species, species of concern) would occur. Thus, CEQA provides an agency with the ability to protect a species from a project's potential impacts until the respective government agencies have an opportunity to designate the species as protected, if warranted.

## CONCLUSIONS AND RECOMMENDATIONS

### Endangered, Threatened, and Rare Plants

There are no federally or state listed botanical species present within the BSA; therefore, there will be no effects to federally or state listed botanical species or their habitats. No special-status plants were observed within the BSA during the protocol-level botanical survey. Further, the habitat assessment conducted identified a lack of necessary habitat elements for special-status plant species and therefore there is no potential for special-status plants to occur within the BSA.

### Endangered, Threatened, and Special-status Wildlife

The following are the recommended minimization and mitigation measures further reduce or eliminate Project-associated impacts to special-status wildlife species. These proposed measures may be amended or superseded by the Project-specific permits issued by the regulatory agencies.

#### *Anadromous fishes*

- Construction activities within Cleland Mountain Creek shall be limited to the dry season when no flowing water is present in the channel.
- Channel disturbance shall be kept to a minimum during construction activities within the channel and only occur within designated areas.
- Per Mitigation Measure (MM) 3.3-A.1 of the Garden's Gate Environmental Impact Report (EIR) Mitigation, Monitoring, and Reporting Program (MMRP), the Riparian Restoration Plan shall be implemented and monitored for a period of no less than 3 years to ensure successful establishment.
- Per MM 3.2-C.1, the applicant shall submit a detailed Erosion Control Plan as part of the Stormwater Pollution Prevention Plan (SWPPP) to the Mendocino County Water Agency (MCWA) and to the State Water Resource Control Board (SWRCB), in conjunction with the filing of the Notice of Intent (NOI) with the SWRCB. The County shall not issue a grading permit until the County Water Agency agrees that the plan contains adequate Best Management Practices (BMPs) for controlling erosion. Applicable BMPs will include erosion control and soil stabilization techniques such as straw and wood mulching, erosion control matting, and hydroseeding, or their functional equivalents. The Erosion Control Plan that incorporates erosion BMPs shall be created and implemented prior to the wet season (October 15 – April 15) in order to avoid sediment from entering Cleland Mountain Creek.

***Western pond turtle***

- When water is present within Cleland Mountain Creek, a qualified biologist shall conduct a clearance survey to determine the presence or absence of western pond turtle individuals immediately prior to the start of work. If western pond turtles are observed where they could be potentially impacted by Project activities, then work shall not be conducted within 100 feet of the turtle(s) until a qualified biologist has relocated the turtle(s) outside of the Project boundary.
- If turtle eggs are uncovered during construction activities, then all work shall stop within a 25-foot radius of the nest and CDFW shall be notified immediately. The 25-foot buffer shall be marked with identifiable markers that do not consist of fencing or materials that may block the migration of young turtles to the water or attract predators to the nest site. No work will be allowed within the 25-foot buffer until CDFW has been consulted.
- The previously described MMs 3.3-A.1 and 3.2-C.1 require that a Riparian Restoration Plan and Erosion Control Plan shall be implemented.

***Grasshopper Sparrow and Migratory Birds and Raptors***

Nesting or attempted nesting by resident or migratory birds within and near the Project area is anticipated to occur between, but is not limited to, February 1 and August 31. The Permittee shall protect migratory birds, active nests, and their eggs as specified by Fish and Game Code sections 3503 and 3513 by implementing the following measures:

- Removal of nesting habitat from the work area shall only take place between September 1 and January 31 to avoid impacts to nesting birds.
- If removal of nesting habitat is required during the nesting season, a nesting bird survey shall be conducted by a qualified biologist no more than 5 calendar days prior to disturbance. If an active nest is located, the biologist will coordinate with CDFW to establish appropriate buffers and any monitoring requirements. Removal of existing vegetation shall not exceed the minimum necessary to complete operations.

***Pallid bat and Townsend's big-eared bat***

- A bat pre-construction/demolition survey shall be conducted by a qualified biologist within 5 days prior to the removal of suitable bat habitat (i.e. existing building).
- Mature trees and the existing outbuilding present in the BSA should only be removed between September 16 and March 15, outside of the bat maternity season. Trees should be removed at dusk to minimize impacts to roosting bats.

**Other Natural Resources*****Waters of the United States***

If activities occur within the ordinary high water mark and/or result in fill or discharge to any waters of the U.S which include but are not limited to, intrastate lakes, rivers, streams (including intermittent streams), mudflats, sandflats, "wetlands," sloughs, prairie potholes, wet meadows, playa lakes, vernal pools or natural ponds, then the following will need to be obtained:

- Prior to any discharge or fill material into Waters of the U.S, authorization under a Nationwide Permit shall be obtained from the Corps, if necessary. For fill requiring a Corps permit, a water quality certification from the Regional Water Quality Board (Clean Water Act §401) shall also be obtained prior to discharge of dredged or fill material.
- Prior to any activities that would obstruct the flow of or alter the bed, channel, or bank of any perennial, intermittent, or ephemeral creeks, notification of streambed alteration shall be submitted to the CDFW, and, if required, a Lake and Streambed Alteration Agreement (LSAA, §1602) shall be obtained, if necessary.

Mitigation requirements for the fill of waters of the U.S will be implemented through an onsite restoration plan, and/or an In Lieu Fund and/or a certified mitigation bank with a Service Area that covers the Project area.

#### ***Oak Woodlands and Riparian Vegetation***

Per MM 3.3-B.1, an assessment shall be conducted that determines the area and number of oaks and other native hardwoods that would be removed or adversely impacted as a result of the project. A Tree Inventory Report was prepared by Horticultural Associates in July 2021 which assessed potential construction impacts on trees (**Appendix D**). A total of 63 trees are proposed for conservation, 30 trees are proposed for removal, and four (4) trees are in poor health or potentially hazardous condition and are recommended for removal regardless of Project activities. Modification to the earlier plan has included the elimination of four lots along the creek corridor and this is allowing the preservation of a greater number of native trees in that area.

Mitigation for impacts to trees will be addressed in the Riparian Restoration Plan and Oak Mitigation and Tree Protection Plan that shall be prepared and implemented in compliance with MMs 3.3-A.1 and 3.3-B1 of the MMRP. Mitigation trees could be used to vegetate the riparian creek setback corridor on the north and south banks, in the linear interior park, or as part of the Open Space Area along South State Street.

## REFERENCES

- Audubon: Guide to North American Birds. 2021. Grasshopper Sparrow. Available: <http://www.audubon.org/field-guide/bird/grasshopper-sparrow> [accessed 24 March 2021]. National Audubon Society.
- Baldwin, B. G., D. H. Goldman, D. J. Keil, R. Patterson, T. J. Rosatti, and D. H. Wilken, editors. 2012. The Jepson Manual: vascular plants of California, second edition. University of California Press, Berkeley.
- Belli, Joseph Paul, "Movements, Habitat Use, and Demography of Western Pond Turtles in an Intermittent Central California Stream" (2015). Master's Theses. 4624. DOI: <https://doi.org/10.31979/etd.b9sq-ak47>; [https://scholarworks.sjsu.edu/etd\\_theses/4624](https://scholarworks.sjsu.edu/etd_theses/4624)
- California Native Plant Society, Rare Plant Program. 2021. Inventory of Rare and Endangered Plants of California (online edition, v8-03 0.39). Website <http://www.rareplants.cnps.org> [accessed 24 March 2021].
- California Natural Diversity Database (CNDDDB). 2021. Rarefind 5 version 5.2.14. California Department of Fish and Wildlife. Sacramento, California.
- Lewis, Susan. 1996. Low Roost-Site Fidelity in Pallid Bats: Associated Factors and Effect on Group Stability. Behavioral Ecology and Sociobiology Vol. 39, No. 5, pp. 335-344.
- Mayer, K.E and Laudenslayer, W.F. 1988. A guide to Wildlife Habitats of California. California Department of Forestry and Fire Protection. Sacramento, California.
- Moyle, P.B. 2002. Inland fishes of California. University of California Press, Berkeley, CA. 502 pp.
- Reese, D.A. and Welsh, H.H. 1997. Use of Terrestrial Habitat by Western Pond Turtles, *Clemmys marmorata*: Implications for Management. USDA Forest Service. PSW Redwood Science Laboratory, Arcata, California.
- Ross Taylor and Associates (RTA). 2003. Russian River Stream Crossing Inventory and Fish Passage Evaluation: Final Report. California Department of Fish and Game.
- Boze, Jeanne. 1987. Limnanthaceae of Butte County, California. Studies from the Herbarium. California State University, Chico. January 1987.
- Schwartz, Charles W., et al. The Wild Mammals of Missouri. University of Missouri Press and Department of Conservation, 2016.
- Western Bat Working Group. 2021. Western Bat Species Accounts. Available: <http://wbwg.org/western-bat-species> [accessed 11 February 2021].



Western Regional Climate Center (WRCC). 2021. Period of Record Monthly Climate Summary for Ukiah, California (049122). Online access. Available: <https://wrcc.dri.edu> [accessed 17 May 2021].

Zeiner, D.C., W.F. Laudenslayer, Jr., K.E. Mayer, and M. White, eds. 1990. California's Wildlife. Vol. I-III. California Department of Fish and Game, Sacramento, California.

#### **FEDERAL REGISTER**

70 FR 52488-52627. Endangered and Threatened Species; Designation of Critical Habitat for Seven Evolutionary Significant Units of Pacific Salmon and Steelhead in California. NMFS, NOAA and Commerce. (September 2, 2005) Volume 70.

## LIST OF PREPARERS

**Brittany Reaves.** Biologist and GIS Analyst. B.S. in Parks and Natural Resources Management, California State University, Chico. Mrs. Reaves has over 4 years of experience conducting wildlife surveys and habitat assessments, collecting field data, and preparing technical documents, maps, and reports.

**Elena Gregg.** Senior Botanist. B.S. in Environmental Biology and Management, University of California, Davis. Mrs. Gregg has more than 15 years' experience conducting rare plant surveys, habitat assessments, wetland delineations, and preparing reports.

**Trevor Morgan.** GIS Analyst. B.A. in Physical and Environmental Geography and Certificate in Geospatial Technology, California State University, Chico. Mr. Morgan has 5 professional years' experience working with spatial data while utilizing GIS software, collecting field data, processing field data, developing technical reports, and running QC/QA processes.

# Appendix A

---

Species Lists



## United States Department of the Interior

FISH AND WILDLIFE SERVICE  
 Arcata Fish And Wildlife Office  
 1655 Heindon Road  
 Arcata, CA 95521-4573  
 Phone: (707) 822-7201 Fax: (707) 822-8411



In Reply Refer To:

July 26, 2021

Consultation Code: 08EACT00-2021-SLI-0297

Event Code: 08EACT00-2021-E-00971

Project Name: Bella Vista Ukiah

Subject: Updated list of threatened and endangered species that may occur in your proposed project location or may be affected by your proposed project

To Whom It May Concern:

The enclosed species list identifies threatened, endangered, proposed and candidate species, as well as proposed and final designated critical habitat, that may occur within the boundary of your proposed project and/or may be affected by your proposed project. The species list fulfills the requirements of the U.S. Fish and Wildlife Service (Service) under section 7(c) of the Endangered Species Act (Act) of 1973, as amended (16 U.S.C. 1531 *et seq.*).

New information based on updated surveys, changes in the abundance and distribution of species, changed habitat conditions, or other factors could change this list. Please feel free to contact us if you need more current information or assistance regarding the potential impacts to federally proposed, listed, and candidate species and federally designated and proposed critical habitat. Please note that under 50 CFR 402.12(e) of the regulations implementing section 7 of the Act, the accuracy of this species list should be verified after 90 days. This verification can be completed formally or informally as desired. The Service recommends that verification be completed by visiting the ECOS-IPaC website at regular intervals during project planning and implementation for updates to species lists and information. An updated list may be requested through the ECOS-IPaC system by completing the same process used to receive the enclosed list.

The purpose of the Act is to provide a means whereby threatened and endangered species and the ecosystems upon which they depend may be conserved. Under sections 7(a)(1) and 7(a)(2) of the Act and its implementing regulations (50 CFR 402 *et seq.*), Federal agencies are required to utilize their authorities to carry out programs for the conservation of threatened and endangered species and to determine whether projects may affect threatened and endangered species and/or designated critical habitat.

A Biological Assessment is required for construction projects (or other undertakings having similar physical impacts) that are major Federal actions significantly affecting the quality of the human environment as defined in the National Environmental Policy Act (42 U.S.C. 4332(2))

(c)). For projects other than major construction activities, the Service suggests that a biological evaluation similar to a Biological Assessment be prepared to determine whether the project may affect listed or proposed species and/or designated or proposed critical habitat. Recommended contents of a Biological Assessment are described at 50 CFR 402.12.

If a Federal agency determines, based on the Biological Assessment or biological evaluation, that listed species and/or designated critical habitat may be affected by the proposed project, the agency is required to consult with the Service pursuant to 50 CFR 402. In addition, the Service recommends that candidate species, proposed species and proposed critical habitat be addressed within the consultation. More information on the regulations and procedures for section 7 consultation, including the role of permit or license applicants, can be found in the "Endangered Species Consultation Handbook" at:

<http://www.fws.gov/endangered/esa-library/pdf/TOC-GLOS.PDF>

Please be aware that bald and golden eagles are protected under the Bald and Golden Eagle Protection Act (16 U.S.C. 668 *et seq.*), and projects affecting these species may require development of an eagle conservation plan ([http://www.fws.gov/windenergy/eagle\\_guidance.html](http://www.fws.gov/windenergy/eagle_guidance.html)). Additionally, wind energy projects should follow the wind energy guidelines (<http://www.fws.gov/windenergy/>) for minimizing impacts to migratory birds and bats.

Guidance for minimizing impacts to migratory birds for projects including communications towers (e.g., cellular, digital television, radio, and emergency broadcast) can be found at: <http://www.fws.gov/migratorybirds/CurrentBirdIssues/Hazards/towers/towers.htm>; <http://www.towerkill.com>; and <http://www.fws.gov/migratorybirds/CurrentBirdIssues/Hazards/towers/comtow.html>.

We appreciate your concern for threatened and endangered species. The Service encourages Federal agencies to include conservation of threatened and endangered species into their project planning to further the purposes of the Act. Please include the Consultation Tracking Number in the header of this letter with any request for consultation or correspondence about your project that you submit to our office.

Attachment(s):

- Official Species List

## Official Species List

This list is provided pursuant to Section 7 of the Endangered Species Act, and fulfills the requirement for Federal agencies to "request of the Secretary of the Interior information whether any species which is listed or proposed to be listed may be present in the area of a proposed action".

This species list is provided by:

**Arcata Fish And Wildlife Office**

1655 Heindon Road

Arcata, CA 95521-4573

(707) 822-7201

## Project Summary

Consultation Code: 08EACT00-2021-SLI-0297

Event Code: 08EACT00-2021-E-00971

Project Name: Bella Vista Ukiah

Project Type: DEVELOPMENT

Project Description: subdivision

Project Location:

Approximate location of the project can be viewed in Google Maps: <https://www.google.com/maps/@39.111828349999996,-123.20197643757425,14z>



Counties: Mendocino County, California

## Endangered Species Act Species

There is a total of 7 threatened, endangered, or candidate species on this species list.

Species on this list should be considered in an effects analysis for your project and could include species that exist in another geographic area. For example, certain fish may appear on the species list because a project could affect downstream species.

IPaC does not display listed species or critical habitats under the sole jurisdiction of NOAA Fisheries<sup>1</sup>, as USFWS does not have the authority to speak on behalf of NOAA and the Department of Commerce.

See the "Critical habitats" section below for those critical habitats that lie wholly or partially within your project area under this office's jurisdiction. Please contact the designated FWS office if you have questions.

1. [NOAA Fisheries](#), also known as the National Marine Fisheries Service (NMFS), is an office of the National Oceanic and Atmospheric Administration within the Department of Commerce.

## Birds

NAME	STATUS
Northern Spotted Owl <i>Strix occidentalis caurina</i> There is <b>final</b> critical habitat for this species. The location of the critical habitat is not available. Species profile: <a href="https://ecos.fws.gov/ecp/species/1123">https://ecos.fws.gov/ecp/species/1123</a>	Threatened
Western Snowy Plover <i>Charadrius nivosus nivosus</i> Population: Pacific Coast population DPS-U.S.A. (CA, OR, WA), Mexico (within 50 miles of Pacific coast) There is <b>final</b> critical habitat for this species. The location of the critical habitat is not available. Species profile: <a href="https://ecos.fws.gov/ecp/species/8035">https://ecos.fws.gov/ecp/species/8035</a>	Threatened
Yellow-billed Cuckoo <i>Coccyzus americanus</i> Population: Western U.S. DPS There is <b>final</b> critical habitat for this species. The location of the critical habitat is not available. Species profile: <a href="https://ecos.fws.gov/ecp/species/3911">https://ecos.fws.gov/ecp/species/3911</a>	Threatened

## Amphibians

NAME	STATUS
California Red-legged Frog <i>Rana draytonii</i> There is <b>final</b> critical habitat for this species. The location of the critical habitat is not available. Species profile: <a href="https://ecos.fws.gov/ecp/species/2891">https://ecos.fws.gov/ecp/species/2891</a>	Threatened



## Flowering Plants

NAME	STATUS
Burke's Goldfields <i>Lasthenia burkei</i> No critical habitat has been designated for this species. Species profile: <a href="https://ecos.fws.gov/ecp/species/4338">https://ecos.fws.gov/ecp/species/4338</a>	Endangered
Contra Costa Goldfields <i>Lasthenia conjugens</i> There is <b>final</b> critical habitat for this species. The location of the critical habitat is not available. Species profile: <a href="https://ecos.fws.gov/ecp/species/7058">https://ecos.fws.gov/ecp/species/7058</a>	Endangered
Showy Indian Clover <i>Trifolium amoenum</i> No critical habitat has been designated for this species. Species profile: <a href="https://ecos.fws.gov/ecp/species/6459">https://ecos.fws.gov/ecp/species/6459</a>	Endangered

## Critical habitats

THERE ARE NO CRITICAL HABITATS WITHIN YOUR PROJECT AREA UNDER THIS OFFICE'S JURISDICTION.

From: [Brittany Reaves](#)  
 To: ["nmfs.wcrca.specieslist@noaa.gov"](mailto:nmfs.wcrca.specieslist@noaa.gov)  
 Subject: Bella Vista Subdivision Project  
 Date: Friday, May 21, 2021 3:30:19 PM

---

Bella Vista Subdivision Project

Quad Name **Elledge Peak**

Quad Number **39123-A2**

**ESA Anadromous Fish**

SONCC Coho ESU (T) -

CCC Coho ESU (E) - **X**

CC Chinook Salmon ESU (T) - **X**

CVSR Chinook Salmon ESU (T) -

SRWR Chinook Salmon ESU (E) -

NC Steelhead DPS (T) -

CCC Steelhead DPS (T) - **X**

SCCC Steelhead DPS (T) -

SC Steelhead DPS (E) -

CCV Steelhead DPS (T) -

Eulachon (T) -

sDPS Green Sturgeon (T) -

**ESA Anadromous Fish Critical Habitat**

SONCC Coho Critical Habitat -

CCC Coho Critical Habitat - **X**

CC Chinook Salmon Critical Habitat - **X**

CVSR Chinook Salmon Critical Habitat -

SRWR Chinook Salmon Critical Habitat -

NC Steelhead Critical Habitat -

CCC Steelhead Critical Habitat - **X**

SCCC Steelhead Critical Habitat -

SC Steelhead Critical Habitat -

CCV Steelhead Critical Habitat -

Eulachon Critical Habitat -

sDPS Green Sturgeon Critical Habitat -

**ESA Marine Invertebrates**

Range Black Abalone (E) -

Range White Abalone (E) -

**ESA Marine Invertebrates Critical Habitat**

Black Abalone Critical Habitat -

**ESA Sea Turtles**

- East Pacific Green Sea Turtle (T) -
- Olive Ridley Sea Turtle (T/E) -
- Leatherback Sea Turtle (E) -
- North Pacific Loggerhead Sea Turtle (E) -

**ESA Whales**

- Blue Whale (E) -
- Fin Whale (E) -
- Humpback Whale (E) -
- Southern Resident Killer Whale (E) -
- North Pacific Right Whale (E) -
- Sei Whale (E) -
- Sperm Whale (E) -

**ESA Pinnipeds**

- Guadalupe Fur Seal (T) -
- Steller Sea Lion Critical Habitat -

**Essential Fish Habitat**

- Coho EFH - **X**
- Chinook Salmon EFH - **X**
- Groundfish EFH -
- Coastal Pelagics EFH -
- Highly Migratory Species EFH -

**MMPA Species (See list at left)**

**ESA and MMPA Cetaceans/Pinnipeds**

**See list at left and consult the NMFS Long Beach office  
562-980-4000**

- MMPA Cetaceans -
- MMPA Pinnipeds -

Guillon, Inc.  
Jake Morley  
2550 Lakewest Drive, Suite 50  
Chico, CA 95928  
(530) 513-3626

**Brittany Reaves**

**Biologist**

Gallaway Enterprises  
(530) 332-9909

**From:** [NMFS SpeciesList - NOAA Service Account](#)  
**To:** [Brittany Reaves](#)  
**Subject:** Federal ESA - - NOAA Fisheries Species List Re: Bella Vista Subdivision Project  
**Date:** Friday, May 21, 2021 3:30:33 PM

---

Please retain a copy of each email request that you send to NOAA at [nmfs.wcra.specieslist@noaa.gov](mailto:nmfs.wcra.specieslist@noaa.gov) as proof of your official Endangered Species Act SPECIES LIST. The email you send to NOAA should include the following information: your first and last name; email address; phone number; federal agency name (or delegated state agency such as Caltrans); mailing address; project title; brief description of the project; and a copy of a list of threatened or endangered species identified within specified geographic areas derived from the NOAA Fisheries, West Coast Region, California Species List Tool. You may only receive this instruction once per week. If you have questions, contact your local NOAA Fisheries liaison.



EIR ADDENDUM APPENDIX C

## Selected Elements by Common Name

California Department of Fish and Wildlife  
California Natural Diversity Database



**Query Criteria:** Quad<span style='color: Red'> IS </span>(Orrs Springs (3912323)<span style='color: Red'> OR </span><span style='color: Red'> Ukiah (3912322)<span style='color: Red'> OR </span><span style='color: Red'> Cow Mountain (3912321)<span style='color: Red'> OR </span><span style='color: Red'> Boonville (3912313)<span style='color: Red'> OR </span><span style='color: Red'> Elledge Peak (3912312)<span style='color: Red'> OR </span><span style='color: Red'> Purdys Gardens (3912311))

Species	Element Code	Federal Status	State Status	Global Rank	State Rank	Rare Plant Rank/CDFW SSC or FP
<b>Baker's meadowfoam</b> <i>Limnanthes bakeri</i>	PDLIM02020	None	Rare	G1	S1	1B.1
<b>Baker's navarretia</b> <i>Navarretia leucocephala ssp. bakeri</i>	PDPLM0C0E1	None	None	G4T2	S2	1B.1
<b>beaked tracyina</b> <i>Tracyina rostrata</i>	PDAST9D010	None	None	G2	S2	1B.2
<b>Boggs Lake hedge-hyssop</b> <i>Gnaphalium heterosepala</i>	PDSCR0R060	None	Endangered	G2	S2	1B.2
<b>Bolander's horkelia</b> <i>Horkelia bolanderi</i>	PDROS0W011	None	None	G1	S1	1B.2
<b>bristly sedge</b> <i>Carex comosa</i>	PMCYP032Y0	None	None	G5	S2	2B.1
<b>Burke's goldfields</b> <i>Lasthenia burkei</i>	PDAST5L010	Endangered	Endangered	G1	S1	1B.1
<b>Clear Lake tule perch</b> <i>Hysterolepis traskii lagunae</i>	AFCQK02013	None	None	G5T2T3	S2S3	SSC
<b>Colusa layia</b> <i>Layia septentrionalis</i>	PDAST5N0F0	None	None	G2	S2	1B.2
<b>Fisher</b> <i>Pekania pennanti</i>	AMAJF01020	None	None	G5	S2S3	SSC
<b>foothill yellow-legged frog</b> <i>Rana boylei</i>	AAABH01050	None	Endangered	G3	S3	SSC
<b>glandular western flax</b> <i>Hesperolinon adenophyllum</i>	PDLIN01010	None	None	G2G3	S2S3	1B.2
<b>grasshopper sparrow</b> <i>Ammodramus savannarum</i>	ABPBXA0020	None	None	G5	S3	SSC
<b>Hoffman's bristly jewelflower</b> <i>Streptanthus glandulosus ssp. hoffmanii</i>	PDBRA2G0J4	None	None	G4T2	S2	1B.3
<b>Koch's cord moss</b> <i>Entosthodon kochii</i>	NBMUS2P050	None	None	G1	S1	1B.3
<b>Mendocino bush-mallow</b> <i>Malacothamnus mendocinensis</i>	PDMAL0Q0D0	None	None	GXQ	SX	1A
<b>Methuselah's beard lichen</b> <i>Usnea longissima</i>	NLLEC5P420	None	None	G4	S4	4.2
<b>North American porcupine</b> <i>Erethizon dorsatum</i>	AMAFJ01010	None	None	G5	S3	
<b>North Coast semaphore grass</b> <i>Pleuropogon hooverianus</i>	PMPOA4Y070	None	Threatened	G2	S2	1B.1



EIR ADDENDUM APPENDIX C

## Selected Elements by Common Name

California Department of Fish and Wildlife  
California Natural Diversity Database



Species	Element Code	Federal Status	State Status	Global Rank	State Rank	Rare Plant Rank/CDFW SSC or FP
<b>Northern Interior Cypress Forest</b> <i>Northern Interior Cypress Forest</i>	CTT83220CA	None	None	G2	S2.2	
<b>obscure bumble bee</b> <i>Bombus caliginosus</i>	IIHYM24380	None	None	G4?	S1S2	
<b>osprey</b> <i>Pandion haliaetus</i>	ABNKC01010	None	None	G5	S4	WL
<b>oval-leaved viburnum</b> <i>Viburnum ellipticum</i>	PDCPR07080	None	None	G4G5	S3?	2B.3
<b>pallid bat</b> <i>Antrozous pallidus</i>	AMACC10010	None	None	G4	S3	SSC
<b>Raiche's manzanita</b> <i>Arctostaphylos stanfordiana ssp. raichei</i>	PDERI041G2	None	None	G3T2	S2	1B.1
<b>red-bellied newt</b> <i>Taricha rivularis</i>	AAAAF02020	None	None	G2	S2	SSC
<b>Rincon Ridge ceanothus</b> <i>Ceanothus confusus</i>	PDRHA04220	None	None	G1	S1	1B.1
<b>Serpentine Bunchgrass</b> <i>Serpentine Bunchgrass</i>	CTT42130CA	None	None	G2	S2.2	
<b>small groundcone</b> <i>Kopsiopsis hookeri</i>	PDORO01010	None	None	G4?	S1S2	2B.3
<b>Sonoma tree vole</b> <i>Arborimus pomo</i>	AMAFF23030	None	None	G3	S3	SSC
<b>Toren's grimmia</b> <i>Grimmia torenii</i>	NBMUS32330	None	None	G2	S2	1B.3
<b>Townsend's big-eared bat</b> <i>Corynorhinus townsendii</i>	AMACC08010	None	None	G4	S2	SSC
<b>western bumble bee</b> <i>Bombus occidentalis</i>	IIHYM24250	None	Candidate Endangered	G2G3	S1	
<b>western pond turtle</b> <i>Emys marmorata</i>	ARAAD02030	None	None	G3G4	S3	SSC
<b>western ridged mussel</b> <i>Gonidea angulata</i>	IMBIV19010	None	None	G3	S1S2	
<b>white-flowered rein orchid</b> <i>Piperia candida</i>	PMORC1X050	None	None	G3	S3	1B.2

Record Count: 36

Inventory of Rare and Endangered Plants of California



[HOME](#) [ABOUT](#) [CHANGES](#) [REVIEW](#) [HELP](#)

Search:

Search for species and

Search Results

33 matches found. Click on scientific name for details

Search Criteria: Quad is one of [3912323,3912322,3912321,3912313,3912312,3912311]

Search:

SCIENTIFIC NAME	▲ COMMON NAME	FAMILY	LIFEFORM	BLOOMING PERIOD	FED LIST	STATE LIST	GLOBAL RANK	STATE RANK	CA RARE PLANT RANK
<a href="#">Limnanthes bakeri</a>	Baker's meadowfoam	Limnanthaceae	annual herb	Apr-May	None	CR	G1	S1	1B.1
<a href="#">Navarretia leucocephala ssp. bakeri</a>	Baker's navarretia	Polemoniaceae	annual herb	Apr-Jul	None	None	G4T2	S2	1B.1
<a href="#">Tracyina rostrata</a>	beaked tracyina	Asteraceae	annual herb	May-Jun	None	None	G2	S2	1B.2
<a href="#">Gratiola heterosepala</a>	Boggs Lake hedge-hyssop	Plantaginaceae	annual herb	Apr-Aug	None	CE	G2	S2	1B.2
<a href="#">Horkelia bolanderi</a>	Bolander's horkelia	Rosaceae	perennial herb	(May)Jun-Aug	None	None	G1	S1	1B.2
<a href="#">Leptosiphon acicularis</a>	bristly leptosiphon	Polemoniaceae	annual herb	Apr-Jul	None	None	G4?	S4?	4.2
<a href="#">Carex comosa</a>	bristly sedge	Cyperaceae	perennial rhizomatous herb	May-Sep	None	None	G5	S2	2B.1
<a href="#">Leptosiphon latisectus</a>	broad-lobed leptosiphon	Polemoniaceae	annual herb	Apr-Jun	None	None	G4	S4	4.3
<a href="#">Lasthenia burkei</a>	Burke's goldfields	Asteraceae	annual herb	Apr-Jun	FE	CE	G1	S1	1B.1
<a href="#">Cypripedium californicum</a>	California lady's-slipper	Orchidaceae	perennial rhizomatous herb	Apr-Aug(Sep)	None	None	G4	S4	4.2
<a href="#">Layia septentrionalis</a>	Colusa layia	Asteraceae	annual herb	Apr-May	None	None	G2	S2	1B.2
<a href="#">Perideridia gairdneri ssp. gairdneri</a>	Gairdner's yampah	Apiaceae	perennial herb	Jun-Oct	None	None	G5T3T4	S3S4	4.2
<a href="#">Hesperolinon adenophyllum</a>	glandular western flax	Linaceae	annual herb	May-Aug	None	None	G2G3	S2S3	1B.2
<a href="#">Monardella viridis</a>	green monardella	Lamiaceae	perennial rhizomatous herb	Jun-Sep	None	None	G3	S3	4.3
<a href="#">Streptanthus glandulosus ssp. hoffmanii</a>	Hoffman's bristly jewelflower	Brassicaceae	annual herb	Mar-Jul	None	None	G4T2	S2	1B.3

no/rare

SCIENTIFIC NAME	NAME	FAMILY	LIFEFORM	PERIOD	LIST	LIST	RANK	RANK	RANK
<i>Entosthodon kochii</i>	Koch's moss	Funariaceae	moss	BLOOMING	None	None	G1	S1	1B.3
<i>Ranunculus lobbii</i>	Lobb's aquatic buttercup	Ranunculaceae	annual herb (aquatic)	Feb-May	None	None	G4	S3	4.2
<i>Malacothamnus mendocinensis</i>	Mendocino bush- mallow	Malvaceae	perennial deciduous shrub	May-Jun	None	None	GXQ	SX	1A
<i>Hemizonia congesta ssp. calyculata</i>	Mendocino tarplant	Asteraceae	annual herb	Jul-Nov	None	None	G5T4	S4	4.3
<i>Usnea longissima</i>	Methuselah's beard lichen	Parmeliaceae	fruticose lichen (epiphytic)		None	None	G4	S4	4.2
<i>Cypripedium montanum</i>	mountain lady's- slipper	Orchidaceae	perennial rhizomatous herb	Mar-Aug	None	None	G4	S4	4.2
<i>Pleuropogon hooverianus</i>	North Coast semaphore grass	Poaceae	perennial rhizomatous herb	Apr-Jun	None	CT	G2	S2	1B.1
<i>Viburnum ellipticum</i>	oval-leaved viburnum	Adoxaceae	perennial deciduous shrub	May-Jun	None	None	G4G5	S3?	2B.3
<i>Fritillaria purdyi</i>	Purdy's fritillary	Liliaceae	perennial bulbiferous herb	Mar-Jun	None	None	G4	S4	4.3
<i>Arctostaphylos stanfordiana ssp. raichei</i>	Raiche's manzanita	Ericaceae	perennial evergreen shrub	Feb-Apr	None	None	G3T2	S2	1B.1
<i>Lilium rubescens</i>	redwood lily	Liliaceae	perennial bulbiferous herb	Apr- Aug(Sep)	None	None	G3	S3	4.2
<i>Ceanothus confusus</i>	Rincon Ridge ceanothus	Rhamnaceae	perennial evergreen shrub	Feb-Jun	None	None	G1	S1	1B.1
<i>Kopsiopsis hookeri</i>	small groundcone	Orobanchaceae	perennial rhizomatous herb (parasitic)	Apr-Aug	None	None	G4?	S1S2	2B.3
<i>Fritillaria agrestis</i>	stinkbells	Liliaceae	perennial bulbiferous herb	Mar-Jun	None	None	G3	S3	4.2
<i>Grimmia torenii</i>	Toren's grimmia	Grimmiaceae	moss		None	None	G2	S2	1B.3
<i>Hemizonia congesta ssp. tracyi</i>	Tracy's tarplant	Asteraceae	annual herb	May-Oct	None	None	G5T4	S4	4.3
<i>Piperia candida</i>	white-flowered rein orchid	Orchidaceae	perennial herb	(Mar)May- Sep	None	None	G3	S3	1B.2
<i>Lessingia hololeuca</i>	woolly-headed lessingia	Asteraceae	annual herb	Jun-Oct	None	None	G2G3	S2S3	3

Showing 1 to 33 of 33 entries

## CONTACT US

Send questions and comments  
to [rareplants@cnps.org](mailto:rareplants@cnps.org).

## ABOUT THIS WEBSITE

[About the Inventory](#)  
[Release Notes](#)  
[Advanced Search](#)  
[Glossary](#)

## ABOUT CNPS

[About the Rare Plant Program](#)  
[CNPS Home Page](#)  
[About CNPS](#)  
[Join CNPS](#)

## CONTRIBUTORS

[The Calflora Database](#)  
[The California Lichen Society](#)  
[California Natural Diversity  
Database](#)



# Appendix B

---

Observed Species Lists

Plant Species Observed within the Bella Vista BRA on May 3, 2021	
Scientific Name	Common Name
<i>Achyrachaena mollis</i>	Blow-wives
<i>Acmispon brachycarpus</i>	Foothill lotus
<i>Ailanthus altissima</i>	Tree-of-heaven
<i>Aira caryophyllea</i>	Silver hairgrass
<i>Amsinckia intermedia</i>	Common fiddleneck
<i>Arbutus menziesii</i>	Pacific madrone
<i>Asclepias fascicularis</i>	Narrow leaf milkweed
<i>Avena barbata</i>	Wild oats
<i>Baccharis pilularis</i>	Coyote brush
<i>Brachypodium distachyon</i>	False brome
<i>Brassica nigra</i>	Black mustard
<i>Briza maxima</i>	Greater quaking-grass
<i>Briza minor</i>	Lesser quaking-grass
<i>Bromus diandrus</i>	Rip-gut brome
<i>Bromus hordeaceus</i>	Soft chess
<i>Calochortus amabilis</i>	Diogenes' lantern
<i>Calystegia spp.</i>	Morning glory
<i>Cardamine oligosperma</i>	Western bittercress
<i>Carduus pycnocephalus</i>	Italian thistle
<i>Cerastium glomeratum</i>	Mouse-eared chickweed
<i>Chlorogalum pomeridianum var. pomeridianum</i>	Wavyleaf soap-plant
<i>Convolvulus arvensis</i>	Bindweed
<i>Crassula tillaea</i>	Moss pygmyweed
<i>Cynodon dactylon</i>	Bermuda grass
<i>Cynosurus echinatus</i>	Hedgehog dogtail
<i>Dactylis glomerata</i>	Orchardgrass
<i>Dichelostemma congestum</i>	Fork toothed ookow
<i>Drymocallis glandulosa var. glandulosa</i>	Sticky cinquefoil
<i>Elymus glaucus</i>	Blue wildrye
<i>Erodium botrys</i>	Long-beaked stork's-bill
<i>Erodium brachycarpum</i>	Foothill filaree
<i>Erythranthe guttata</i>	Seep monkeyflower
<i>Eschscholzia californica</i>	California poppy
<i>Festuca myuros</i>	Rattail fescue
<i>Festuca perennis</i>	Rye-grass
<i>Fraxinus latifolia</i>	Oregon ash
<i>Galium aparine</i>	Bedstraw
<i>Genista monspessulana</i>	French broom
<i>Geranium dissectum</i>	Cut-leaved geranium
<i>Gnaphalium palustre</i>	Western marsh cudweed
<i>Heteromeles arbutifolia</i>	Toyon
<i>Hordeum marinum ssp. gussoneanum</i>	Mediterranean barley
<i>Hordeum murinum</i>	Wall hare barley

Scientific Name	Common Name
<i>Hypericum perforatum</i>	Klamathweed
<i>Hypochaeris radica</i>	Hairy cats ear
<i>Iris macrosiphon</i>	Long tubed iris
<i>Juglans regia</i>	English walnut
<i>Juncus spp.</i>	Rush
<i>Juncus bufonius</i>	Toadrush
<i>Lactuca serriola</i>	Prickly lettuce
<i>Limnanthes douglasii ssp. nivea</i>	Snow white meadowfoam
<i>Lupinus nanus</i>	Sky lupine
<i>Lysimachia arvensis</i>	Scarlet pimpernel
<i>Matricaria discoidea</i>	Common pineapple weed
<i>Medicago polymorpha</i>	Common bur-clover
<i>Mentha pulegium</i>	Pennyroyal
<i>Morus sp.</i>	Mulberry
<i>Nasturtium officinale</i>	Watercress
<i>Oxalis corniculata</i>	Creeping wood-sorrel
<i>Phalaris lemmonii</i>	Lemmon's canarygrass
<i>Pistacia chinensis</i>	Chinese pistache
<i>Plantago lanceolata</i>	English plantain
<i>Poa spp.</i>	Bluegrass
<i>Poa annua</i>	Annual bluegrass
<i>Poterium sanguisorba</i>	Garden burnet
<i>Prunus sp.</i>	Cherry/plum
<i>Pseudotsuga menziesii var. menziesii</i>	Douglas-fir
<i>Quercus garryana</i>	Oregon oak
<i>Quercus x morehus</i>	Oracle oak
<i>Ranunculus orthorhynchus</i>	Bloomer's buttercup
<i>Rosa sp.</i>	Wild rose
<i>Rubus armeniacus</i>	Himalayan blackberry
<i>Rumex acetosella</i>	Sheep sorrel
<i>Rumex crispus</i>	Curly dock
<i>Sanicula crassicaulis</i>	Pacific sanicle
<i>Sequoia sempervirens</i>	Coast redwood
<i>Sherardia arvensis</i>	Field-madder
<i>Sisymbrium officinale</i>	Hedge mustard
<i>Sisyrinchium bellum</i>	Blue-eyed grass
<i>Spergularia bocconi</i>	Sandspurry
<i>Stachys rigida</i>	Rigid hedge nettle
<i>Syringa spp.</i>	Lilac
<i>Torilis arvensis</i>	Hedge parsley
<i>Toxicodendron diversilobum</i>	Poison oak
<i>Tragopogon porrifolius</i>	Purple salsify
<i>Trifolium dubium</i>	Shamrock clover
<i>Trifolium glomeratum</i>	Sessile-headed clover
<i>Trifolium hirtum</i>	Rose clover

Scientific Name	Common Name
<i>Trifolium incarnatum</i>	Crimson clover
<i>Trifolium microcephalum</i>	Maiden clover
<i>Trifolium subterraneum</i>	Sub clover
<i>Triteleia hyacinthina</i>	Wild hyacinth
<i>Umbellularia californica</i>	California bay laurel
<i>Verbascum blattaria</i>	Moth mullein
<i>Verbena lasiostachys var. lasiostachys</i>	Western vervain
<i>Vicia sativa</i>	Garden vetch
<i>Vicia villosa</i>	Winter vetch
<i>Vinca sp.</i>	Periwinkle
<i>Viola ocellata</i>	Western heart's-ease
<i>Vitis spp.</i>	Cultivated grape
<i>Wyethia glabra</i>	Coast Range mule ears

Wildlife Species Observed within the Bella Vista Subdivision Project BSA on April 13, 2021	
Scientific Name	Common Name
<i>Accipiter cooperii</i>	Cooper's hawk
<i>Aimophila ruficeps</i>	Rufous-crowned sparrow
<i>Aphelocoma californica</i>	California scrub-jay
<i>Cyanocitta stelleri</i>	Steller's jay
<i>Cathartes aura</i>	Turkey vulture
<i>Corvus corax</i>	Common raven
<i>Odocoileus hemionus columbianus</i>	Columbian black-tailed deer
<i>Pipilo maculatus</i>	Spotted towhee
<i>Sciurus griseus</i>	Western gray squirrel

# Appendix C

---

Draft Delineation of Waters of the U.S. Map

**EIR ADDENDUM APPENDIX C**

Coordinate System: NAD1983 California State Plane II (Feet)  
 Projection: Lambert Conformal Conic  
 Datum: North American 1983  
 Vertical Datum: NAVD 88

Made in accordance with the Updated Map & Drawing Standards  
 for the South Pacific Division Regulatory Program

The features represented on this graphic are  
 considered preliminary until written verification by the USACE

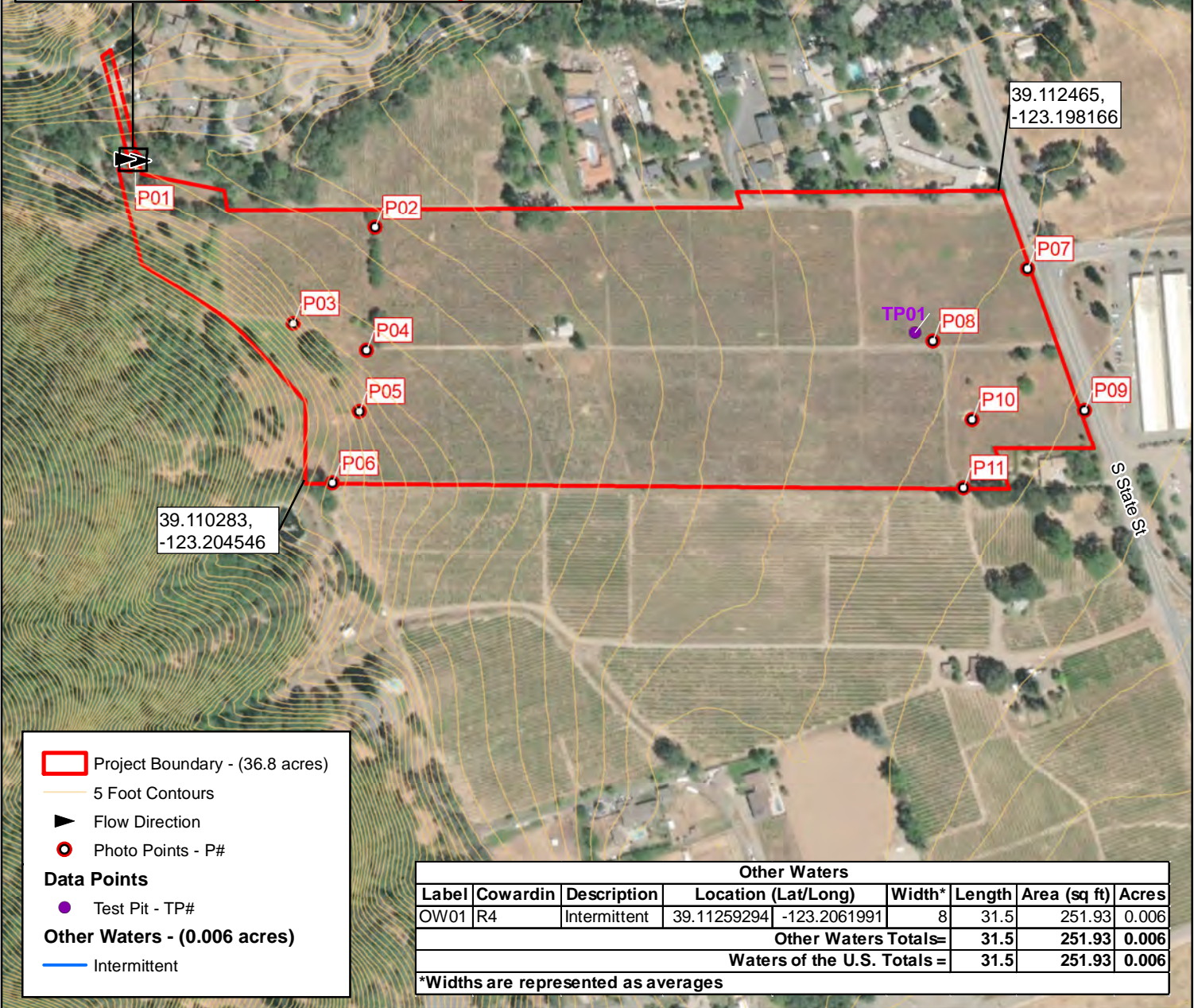

**Legend**

- Project Boundary - (36.8 acres)
- 5 Foot Contours
- Flow Direction
- Photo Points - P#

**Data Points**

- Test Pit - TP#

**Other Waters - (0.006 acres)**

- Intermittent

Other Waters								
Label	Cowardin	Description	Location (Lat/Long)		Width*	Length	Area (sq ft)	Acres
OW01	R4	Intermittent	39.11259294	-123.2061991	8	31.5	251.93	0.006
<b>Other Waters Totals =</b>						<b>31.5</b>	<b>251.93</b>	<b>0.006</b>
<b>Waters of the U.S. Totals =</b>						<b>31.5</b>	<b>251.93</b>	<b>0.006</b>

\*Widths are represented as averages

1:4,800  
 0 320 640 Feet  
 1 inch = 400 feet  
 Data Sources: ESRI, Mendocino County, Maxar 6/08/2020  
 NORTH

**Bella Vista Subdivision  
 Delineation of Waters of the U.S.**



# Appendix D

---

Tree Inventory Report

---

# HORTICULTURAL *Associates*

---

*Consultants in Horticulture and Arboriculture*

## TREE INVENTORY REPORT

3000 State Street  
Ukiah, CA

**Prepared for:**

Guillon Inc.  
2550 Lakewest Drive, Suite 50  
Chico, CA 95928

**Prepared by:**

John C. Meserve  
ISA Certified Arborist, WE #0478A  
ISA Qualified Tree Risk Assessor/TRAQ  
ASCA Qualified Tree and Plant Appraiser/TPAQ

July 14, 2021





Consultants in Horticulture and Arboriculture  
P.O. Box 1261, Glen Ellen, CA 95442

July 14, 2021

Jake Morley  
Project Manager  
Guillon, Inc  
2550 Lakewest Drive, Suite 50  
Chico, CA 95928

Re: Completed and Updated *Tree Inventory Report*, 3000 State Street in Ukiah, California

Jake,

Attached you will find our completed *Tree Inventory Report* for the above noted site in Windsor. A total of 97 trees were surveyed and this includes all trees that were present in the vicinity of proposed construction that were 5 inches or greater in trunk diameter in most areas of the site and 2 inches or greater in the creek area.

All trees in this report was evaluated and documented for species, size, health, and structural condition. The *Tree Inventory Chart* also includes information about expected impacts of the proposed development plan and recommendations for action based on the plan reviewed. The *Tree Location Plan* shows the location and numbering sequence of all evaluated trees. No topo map was provided and tree trunk locations are approximate. Also included are *Pruning Guidelines*, *Tree Preservation Guidelines*, and a *Fencing Detail*.

This report is intended to be a basic inventory of trees present at this site, which includes a general review of tree health and structural condition. No in-depth evaluation has occurred on any tree, and assessment has included only external visual examination without probing, drilling, coring, root collar examination, root excavation, or dissecting any tree part. Failures, deficiencies, and problems may occur in these trees in the future, and this inventory in no way guarantees or provides a warranty for their health or structural condition. No other trees beyond those listed have been included in this report. If other trees need to be included it is the responsibility of the client to provide that direction.

#### EXISTING SITE CONDITION SUMMARY

The project site consists of a combination of open land, existing vineyards, a farming outbuilding, and a creek drainage.

## EXISTING TREE SUMMARY

Species native to the site include Coast Live Oak, Valley Oak, Douglas Fir, Black Oak, Bay Laurel, Incense Cedar, Oregon Ash, Cottonwood, Sandbar Willow, and a Willow species.

Ornamental species that are present include English Walnut, Black Walnut, Coast Redwood, and Persimmon.

There are two dense clumps of willows in the western pocket of the site where a shallow creek swale is present. These each are referenced in the *Tree Inventory Chart* by a single tree reference number. Tree #91 has many stems ranging from 1 inch up to 3 inches in diameter. Tree #97 also has many small stems including a single 14" diameter trunk. I have addressed each group with a single reference number due to the many stems that are present.

## CONSTRUCTION IMPACT SUMMARY

The following is a summary of the initial expected impacts on trees:

- (63) Trees that can be preserved
- (30) Trees that will require removal due to the expected impacts of proposed development
- (4) Trees that are in poor health or hazardous structure that should be removed regardless of proposed development

Of the 30 trees that will require removal for this project it appears that only 11 are native Oaks. Based on a draft version of the Mendocino County Tree Ordinance the removal of 11 Oaks would require replacement at a ratio of 8:1 generating 88 mitigation replacement trees. In a revegetation/restoration approach these trees would most likely be small Valley Oaks grown in revegetation specific containers like 'D' pots, they would be staked and screened for rodent protection, and they would be irrigated for up to 3 years to reach establishment.

Mitigation trees could be used to vegetate the riparian creek setback corridor on the north and south banks, in the linear interior park, or as part of the Open Space Area along South State Street.

Modification to the earlier plan has included the elimination of four lots along the creek corridor and this is allowing the preservation of a greater number of native trees in that area.

In addition to the removal of these lots a 12" water main is being shown to traverse the creek area where an impact may occur on some trees. The water line should be located in the field in a manner to minimize impacts to any nearby trees and temporary protection fencing should be put into place during the trenching and construction process.

Jake Morley  
7-14-21  
Page 3 of 3

Please feel free to contact me if you have questions regarding this report, or if further discussion would be helpful.

Regards,



John C. Meserve  
ISA Certified Arborist, WE #0478A  
ISA Qualified Tree Risk Assessor/TRAQ  
ASCA Qualified Tree and Plant Appraiser/TPAQ



TREE INVENTORY CHART

TREE INVENTORY  
Bella Vista Subdivision  
Ukiah, CA

July 14, 2021

Tree #	Species	Common Name	Trunk (dbh ± inches)	Height (± feet)	Radius (± feet)	Health 1 - 5	Structure 1 - 4	Expected Impact	Recommendations
1	<i>Juglans regia</i>	English Walnut	25	22	15	3	3	0	1, 6, 9
2	<i>Morus alba</i>	Mulberry	16	18	18	4	3	0	1, 6, 9
3	<i>Pistache chinensis</i>	Chinese Pistache	6	14	10	4	3	0	1, 6, 9
4	<i>Morus alba</i>	Mulberry	11	18	12	4	3	0	1, 6, 9
5	<i>Sequoia sempervirens</i>	Coast Redwood	24	50	14	4	3	0	1, 6, 9
6	<i>Salix matsudana 'Tortuosa'</i>	Curley Willow	27	30	15	1	1	0	3
7	<i>Sequoia sempervirens</i>	Coast Redwood	27	40	1	3	3	2	1, 6, 7, 8, 9
8	<i>Sequoia sempervirens</i>	Coast Redwood	42	50	18	4	3	2	1, 6, 7, 8, 9
9	<i>Prunus cerasifera</i>	Purple Leaf Plum	14	20	16	2	2	3	2
10	<i>Quercus lobata</i>	Valley Oak	18+18	40	20	4	3	2	1, 6, 7, 8, 9
11	<i>Quercus lobata</i>	Valley Oak	36	40	30	4	3	2	1, 6, 7, 8, 9
12	<i>Quercus kelloggii</i>	Black Oak	15	35	30	4	3	2	1, 6, 7, 8, 9
13	<i>Quercus lobata</i>	Valley Oak	18	40	20	4	3	2	1, 6, 7, 8, 9
14	<i>Quercus lobata</i>	Valley Oak	17	22	30	4	3	2	1, 6, 7, 8, 9
15	<i>Quercus lobata</i>	Valley Oak	25	40	30	4	3	2	1, 6, 7, 8, 9
16	<i>Quercus kelloggii</i>	Black Oak	6+6+7+7+12	25	16	4	3	3	2

HORTICULTURAL ASSOCIATES  
P.O. Box 1261, Glen Ellen, CA 95442  
707.935.3911

TREE INVENTORY  
Bella Vista Subdivision  
Ukiah, CA

July 14, 2021

Tree #	Species	Common Name	Trunk (dbh ± inches)	Height (± feet)	Radius (± feet)	Health 1 - 5	Structure 1 - 4	Expected Impact	Recommendations
17	<i>Juglans regia</i>	English Walnut	12+14+15	20	12	1	1	3	2
18	<i>Juglans nigra</i>	Black Walnut	12+15+16	25	15	1.5	2	2	1, 6, 7, 8, 9
19	<i>Juglans regia</i>	English Walnut	7+8+12+14+15	35	18	2	3	3	2
20	<i>Diospyros kaki</i>	Persimmon	3+3+3+4+6	15	15	4	3	3	2
21	<i>Diospyros kaki</i>	Persimmon	6+5+5	15	15	4	3	3	2
22	<i>Juglans regia</i>	English Walnut	18	18	20	2	2	3	2
23	<i>Juglans regia</i>	English Walnut	18	18	20	2	2	3	2
24	<i>Juglans regia</i>	English Walnut	32	22	18	2	2	3	2
25	<i>Juglans regia</i>	English Walnut	11+13+13	25	16	2	2	3	2
26	<i>Juglans regia</i>	English Walnut	12+14	25	15	2	2	3	2
27	<i>Juglans regia</i>	English Walnut	20	22	15	2	1	3	3
28	<i>Juglans regia</i>	English Walnut	10+10+10	25	16	2	2	3	2
29	<i>Juglans regia</i>	English Walnut	24	30	18	2	2	3	2
30	<i>Quercus kelloggii</i>	Black Oak	12+14+16	40	24	4	2	3	2
31	<i>Quercus kelloggii</i>	Black Oak	14+20	40	28	4	2	3	2
32	<i>Quercus kelloggii</i>	Black Oak	12	35	21	4	3	3	2

HORTICULTURAL ASSOCIATES  
P.O. Box 1261, Glen Ellen, CA 95442  
707.935.3911

TREE INVENTORY  
Bella Vista Subdivision  
Ukiah, CA

July 14, 2021

Tree #	Species	Common Name	Trunk (dbh ± inches)	Height (± feet)	Radius (± feet)	Health 1 - 5	Structure 1 - 4	Expected Impact	Recommendations
33	<i>Quercus kelloggii</i>	Black Oak	14+18	40	25	4	3	3	2
34	<i>Quercus kelloggii</i>	Black Oak	28	40	24	4	3	3	2
35	<i>Quercus kelloggii</i>	Black Oak	14+14	40	24	4	3	3	2
36	<i>Quercus kelloggii</i>	Black Oak	1414	35	20	4	3	3	2
37	<i>Juglans regia</i>	English Walnut	24	25	18	3	3	3	2
38	<i>Juglans regia</i>	English Walnut	16	25	22	3	2	3	2
39	<i>Pseudotsuga menziesii</i>	Douglas Fir	16	40	12	4	3	3	2
40	<i>Pseudotsuga menziesii</i>	Douglas Fir	14	40	12	4	3	0	1, 6, 7
41	<i>Pseudotsuga menziesii</i>	Douglas Fir	15	40	12	4	3	0	1, 6, 7
42	<i>Pseudotsuga menziesii</i>	Douglas Fir	17	50	14	4	3	0	1, 6, 7
43	<i>Pseudotsuga menziesii</i>	Douglas Fir	16	50	14	4	3	0	1, 6, 7
44	<i>Pseudotsuga menziesii</i>	Douglas Fir	16	50	14	4	3	0	1, 6, 7
45	<i>Pseudotsuga menziesii</i>	Douglas Fir	19	50	14	4	3	0	1, 6, 7
46	<i>Pseudotsuga menziesii</i>	Douglas Fir	17	50	14	4	3	0	1, 6, 7
47	<i>Pseudotsuga menziesii</i>	Douglas Fir	32	60	15	4	3	0	1, 6, 7
48	<i>Pseudotsuga menziesii</i>	Douglas Fir	24	60	16	4	3	0	1, 6, 7

HORTICULTURAL ASSOCIATES  
P.O. Box 1261, Glen Ellen, CA 95442  
707.935.3911

TREE INVENTORY  
Bella Vista Subdivision  
Ukiah, CA

July 14, 2021

Tree #	Species	Common Name	Trunk (dbh ± inches)	Height (± feet)	Radius (± feet)	Health 1 - 5	Structure 1 - 4	Expected Impact	Recommendations
49	<i>Pseudotsuga menziesii</i>	Douglas Fir	36	70	25	4	3	0	1, 6, 7
50	<i>Quercus kelloggii</i>	Black Oak	8+8+10+10	35	25	4	3	0	1, 6, 7
51	<i>Pseudotsuga menziesii</i>	Douglas Fir	6	25	8	4	3	0	1, 6, 7
52	<i>Pseudotsuga menziesii</i>	Douglas Fir	13	45	12	4	3	0	1, 6, 7
53	<i>Pseudotsuga menziesii</i>	Douglas Fir	8	25	12	4	3	0	1, 6, 7
54	<i>Umbellularia californica</i>	Bay Laurel	14	40	12	4	3	0	1, 6, 7
55	<i>Quercus kelloggii</i>	Black Oak	12+13+13	40	18	4	3	0	1, 6, 7
56	<i>Quercus kelloggii</i>	Black Oak	9+10+12	40	18	4	3	0	1, 6, 7
57	<i>Pseudotsuga menziesii</i>	Douglas Fir	13	30	14	4	3	3	2
58	<i>Calocedrus decurrens</i>	Incense Cedar	15	25	12	4	3	3	2
59	<i>Pseudotsuga menziesii</i>	Douglas Fir	15	60	15	4	3	3	2
60	<i>Pseudotsuga menziesii</i>	Douglas Fir	17	60	15	4	3	3	2
61	<i>Pseudotsuga menziesii</i>	Douglas Fir	16	50	15	4	3	3	2
62	<i>Quercus kelloggii</i>	Black Oak	13	40	20	4	3	3	2
63	<i>Quercus kelloggii</i>	Black Oak	13	35	16	4	3	2	1, 6, 7
64	<i>Quercus lobata</i>	Valley Oak	11	35	18	4	3	3	2

HORTICULTURAL ASSOCIATES  
P.O. Box 1261, Glen Ellen, CA 95442  
707.935.3911



TREE INVENTORY  
Bella Vista Subdivision  
Ukiah, CA

July 14, 2021

Tree #	Species	Common Name	Trunk (dbh ± inches)	Height (± feet)	Radius (± feet)	Health 1 - 5	Structure 1 - 4	Expected Impact	Recommendations
65	<i>Quercus kelloggii</i>	Black Oak	15	40	20	4	3	1	1, 6, 7
66	<i>Pseudotsuga menziesii</i>	Douglas Fir	12	30	10	4	3	3	2
67	<i>Quercus kelloggii</i>	Black Oak	20	40	25	4	3	0	1, 6, 7
68	<i>Quercus kelloggii</i>	Black Oak	21+25	40	30	4	3	0	1, 6, 7
69	<i>Quercus kelloggii</i>	Black Oak	26	40	30	4	3	0	1, 6, 7
70	<i>Quercus lobata</i>	Valley Oak	32	45	30	4	3	3	2
71	<i>Quercus lobata</i>	Valley Oak	28	45	30	4	3	0	1, 6, 7
72	<i>Fraxinus latifolia</i>	Oregon Ash	12	35	14	3	3	0	1, 6, 7
73	<i>Populus fremontii</i>	Cottonwood	30	45	36	3	3	0	1, 6, 7
74	<i>Juglans nigra</i>	Black Walnut	4	14	8	4	3	0	1, 6, 7
75	<i>Quercus kelloggii</i>	<i>Quercus kelloggii</i>	24	40	20	4	3	0	1, 6, 7
76	<i>Quercus kelloggii</i>	Black Oak	13+14	40	30	4	3	0	1, 6, 7
77	<i>Quercus kelloggii</i>	Black Oak	25	45	30	4	3	0	1, 6, 7
78	<i>Fraxinus latifolia</i>	Oregon Ash	10	40	15	4	3	0	1, 6, 7
79	<i>Quercus lobata</i>	Valley Oak	22	45	30	4	3	0	1, 6, 7
80	<i>Quercus lobata</i>	Valley Oak	30	45	30	4	3	0	1, 6, 7

HORTICULTURAL ASSOCIATES  
P.O. Box 1261, Glen Ellen, CA 95442  
707.935.3911

TREE INVENTORY  
 Bella Vista Subdivision  
 Ukiah, CA

July 14, 2021

Tree #	Species	Common Name	Trunk (dbh ± inches)	Height (± feet)	Radius (± feet)	Health 1 - 5	Structure 1 - 4	Expected Impact	Recommendations
81	<i>Umbellularia californica</i>	Bay Laurel	22	40	18	4	3	0	1, 6, 7
82	<i>Quercus lobata</i>	Valley Oak	24	40	25	3	3	0	1, 6, 7
83	<i>Quercus lobata</i>	Valley Oak	29	40	30	4	3	0	1, 6, 7
84	<i>Quercus lobata</i>	Valley Oak	28	40	25	2	3	0	1, 6, 7
85	<i>Quercus lobata</i>	Valley Oak	48	45	30	3	3	0	1, 6, 7
86	<i>Fraxinus latifolia</i>	Oregon Ash	11	35	112	4	3	0	1, 6, 7
87	<i>Fraxinus latifolia</i>	Oregon Ash	6+5	20	10	4	3	0	1, 6, 7
88	<i>Fraxinus latifolia</i>	Oregon Ash	2+4+4+5+56	35	14	4	3	0	1, 6, 7
89	<i>Fraxinus latifolia</i>	Oregon Ash	4+5+5+6+6	35	16	4	3	0	1, 6, 7
90	<i>Fraxinus latifolia</i>	Oregon Ash	5+6+8	35	30	4	3	0	1, 6, 7
91	<i>Salix exigua</i>	Sandbar Willow	1" to 4"	18	12	4	3	0	1, 6, 7
92	<i>Fraxinus latifolia</i>	Oregon Ash	12	40	18	3	3	0	1, 6, 7
93	<i>Fraxinus latifolia</i>	Oregon Ash	6	25	18	3	3	0	1, 6, 7
94	<i>Fraxinus latifolia</i>	Oregon Ash	6	25	18	3	3	0	1, 6, 7
95	<i>Quercus lobata</i>	Valley Oak	6	40	18	4	3	0	1, 6, 7
96	<i>Quercus lobata</i>	Valley Oak	12	40	18	4	3	0	1, 6, 7

HORTICULTURAL ASSOCIATES  
 P.O. Box 1261, Glen Ellen, CA 95442  
 707.935.3911

TREE INVENTORY  
 Bella Vista Subdivision  
 Ukiah, CA  
 July 14, 2021

Tree #	Species	Common Name	Trunk (dbh ± inches)	Height (± feet)	Radius (± feet)	Health 1 - 5	Structure 1 - 4	Expected Impact	Recommendations
97	<i>Salix species</i>	Native Willow	14	25	12	4	3	0	1, 6, 7

HORTICULTURAL ASSOCIATES  
 P.O. Box 1261, Glen Ellen, CA 95442  
 707.935.3911

KEY TO TREE  
INVENTORY CHART

## KEY TO TREE INVENTORY CHART

### Tree Number

Each tree has been identified in the field with an aluminum tag and reference number. Tags are attached to the trunk at approximately eye level and the *Tree Location Plan* illustrates the location of each numbered tree.

### Species

Each tree has been identified by genus, species and common name. Many species have more than one common name.

### Trunk

Each trunk has been measured, to the nearest one half inch, to document its diameter at 4 feet above adjacent grade. Trunk diameter is a good indicator of age, and is commonly used to determine mitigation replacement requirements.

### Height

Height is estimated in feet, using visual assessment.

### Radius

Radius is estimated in feet, using visual assessment. Since many canopies are asymmetrical, it is not uncommon for a radius estimate to be an average of the canopy size.

### Health

The following descriptions are used to rate the health of a tree. Trees with a rating of 4 or 5 are very good candidates for preservation and will tolerate more construction impacts than trees in poorer condition. Trees with a rating of 3 may or may not be good candidates for preservation, depending on the species and expected construction impacts. Trees with a rating of 1 or 2 are generally poor candidates for preservation.

- (5) Excellent - health and vigor are exceptional, no pest, disease, or distress symptoms.
- (4) Good - health and vigor are average, no significant or specific distress symptoms, no significant pest or disease.
- (3) Fair - health and vigor are somewhat compromised, distress is visible, pest or disease may be present and affecting health, problems are generally correctable.
- (2) Marginal - health and vigor are significantly compromised, distress is highly visible and present to the degree that survivability is in question.
- (1) Poor - decline has progressed beyond the point of being able to return to a healthy condition again. Long-term survival is not expected. This designation includes dead trees.

**Structure**

The following descriptions are used to rate the structural integrity of a tree. Trees with a rating of 3 or 4 are generally stable, sound trees which do not require significant pruning, although cleaning, thinning, or raising the canopy might be desirable. Trees with a rating of 2 are generally poor candidates for preservation unless they are preserved well away from improvements or active use areas. Significant time and effort would be required to reconstruct the canopy and improve structural integrity. Trees with a rating of 1 are hazardous and should be removed.

- (4) Good structure - minor structural problems may be present which do not require corrective action.
- (3) Moderate structure - normal, typical structural issues which can be corrected with pruning.
- (2) Marginal structure - serious structural problems are present which may or may not be correctable with pruning, cabling, bracing, etc.
- (1) Poor structure - hazardous structural condition which cannot be effectively corrected with pruning or other measures, may require removal depending on location and the presence of targets.

**Tree Protection Zone (TPZ)**

The area to be protected by temporary fencing during construction. Represented by 1 foot of radius for each inch of trunk diameter measured at 4.5 feet above adjacent grade.

**Development Impacts**

Considering the proximity of construction activities, type of activities, tree species, and tree condition - the following ratings are used to estimate the amount of impact on tree health and stability. Most trees will tolerate a (1) rating, many trees could tolerate a (2) rating with careful consideration and mitigation, but trees with a (3) rating are poor candidates for preservation due to their very close proximity to construction or because they are located within the footprint of construction and cannot be preserved.

- (3) A significant impact on long term tree integrity can be expected as a result of proposed development.
- (2) A moderate impact on long term tree integrity can be expected as a result of proposed development.
- (1) A minor impact on long term tree integrity can be expected as a result of proposed development.
- (0) No impact is expected based on distance away from proposed construction activity.

**Recommendations**

Recommendations are provided for removal or preservation. For those being preserved, protection measures and mitigation procedures to offset impacts and improve tree health are provided.

- (1) Preservation appears to be possible.
- (2) Removal is required due to significant development impacts.
- (3) Removal is recommended due to poor health or hazardous structure.
- (4) Removal is required due to significant development impacts and poor existing health or structure.
- (5) Removal is recommended due to poor species characteristics.
- (6) Install temporary protective fencing at the edge of the Tree Protection Zone (TPZ), or edge of approved construction, prior to beginning grading or construction. Maintain fencing in place for duration of all construction activity in the area.
- (7) Maintain existing grade within the fenced portion of the TPZ. Route drainage swales and all underground work outside the dripline.
- (8) Place a 4" layer of chipped bark mulch over the soil surface within the fenced TPZ prior to installing temporary fencing. Maintain this layer of mulch throughout construction.
- (9) Prune to clean, raise, or provide necessary clearance. Prune to reduce branches that are over-loaded, over-extended, largely horizontal, arching, or have foliage concentrated near the branch ends, per International Society of Arboriculture Pruning Standards.

Pruning to occur by, or under the supervision of, an Arborist certified by the International Society of Arboriculture. Pruning Standards are attached to this report.

- (10) This is an off-site tree that overhangs the project site and must be protected and preserved
- (11) Excavation may be required within the TPZ and the dripline for development. Excavation within the TPZ of any type must adhere to the following guidelines:

All roots encountered that are 2 inches or larger in diameter must be cleanly cut as they are encountered by excavating equipment.

Roots may not be ripped from the ground and then trimmed. They must be trimmed as encountered and this will require the use of a ground man working with a suitable power tool.

Pruned and exposed roots greater than 2 inches in diameter must be protected from desiccation if left exposed for more than 24 hours. Cover cut roots with heavy cloth, burlap, used carpeting, or similar material that has been soaked in water, until trench or excavation has been backfilled.

If excavation impacts more than 20% of the defined TPZ then supplemental irrigation may be required to offset loss of roots. Excavation in this case should be directed by the project arborist who will determine whether excavation is required, when, and how.

Any excavation within the defined TPZ will require that the tree be monitored on a monthly basis by the project arborist for the duration of construction and for one year beyond completion of construction. Monitoring may determine other mitigation measures that may be required to offset root loss or damage.

TREE LOCATION PLAN



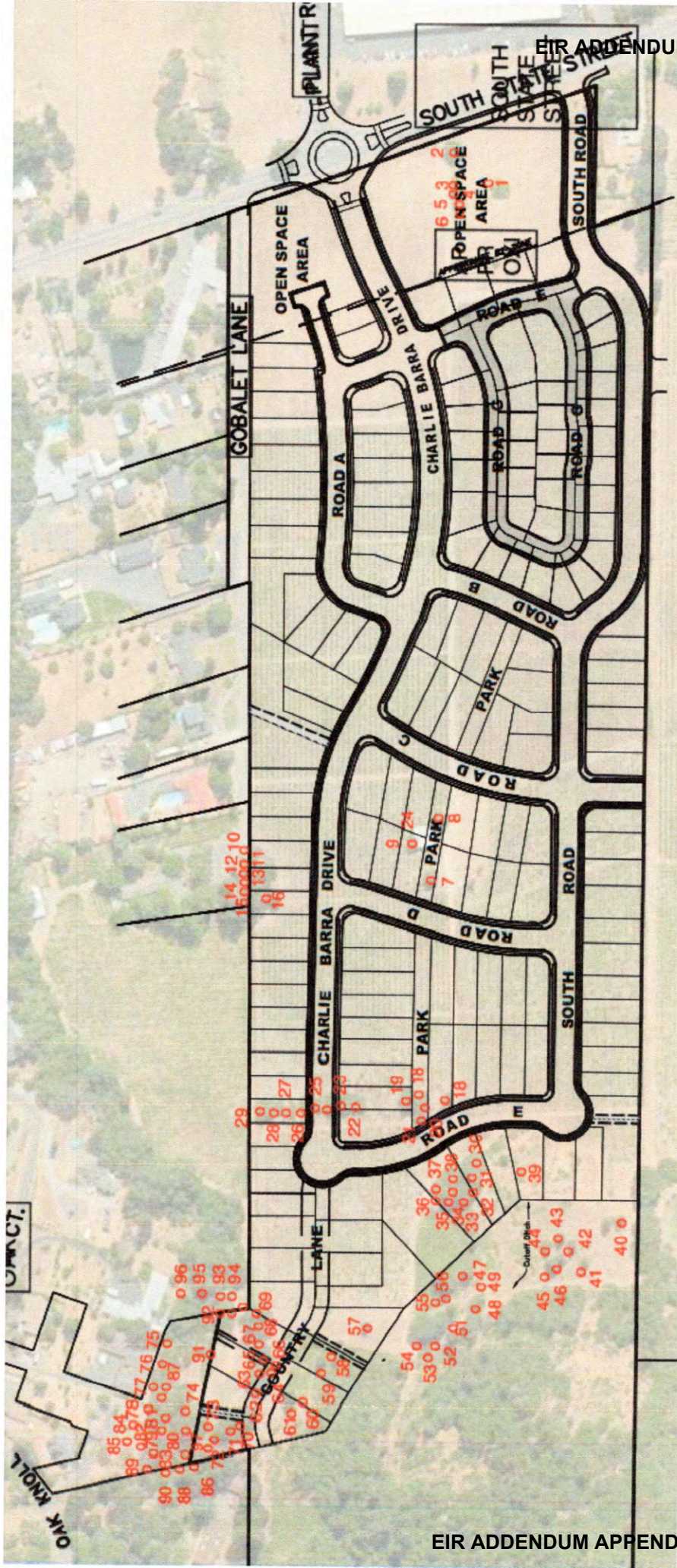

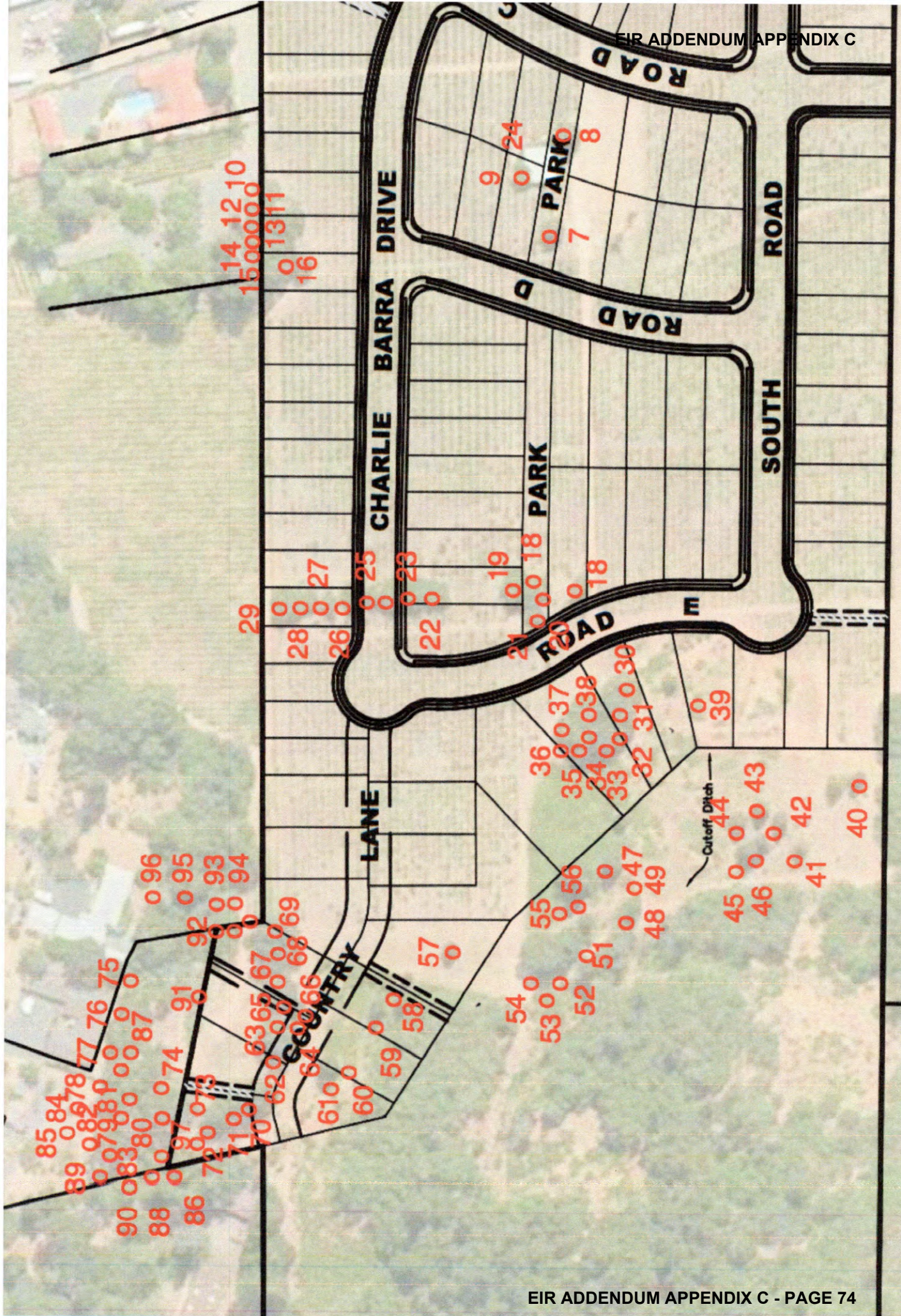

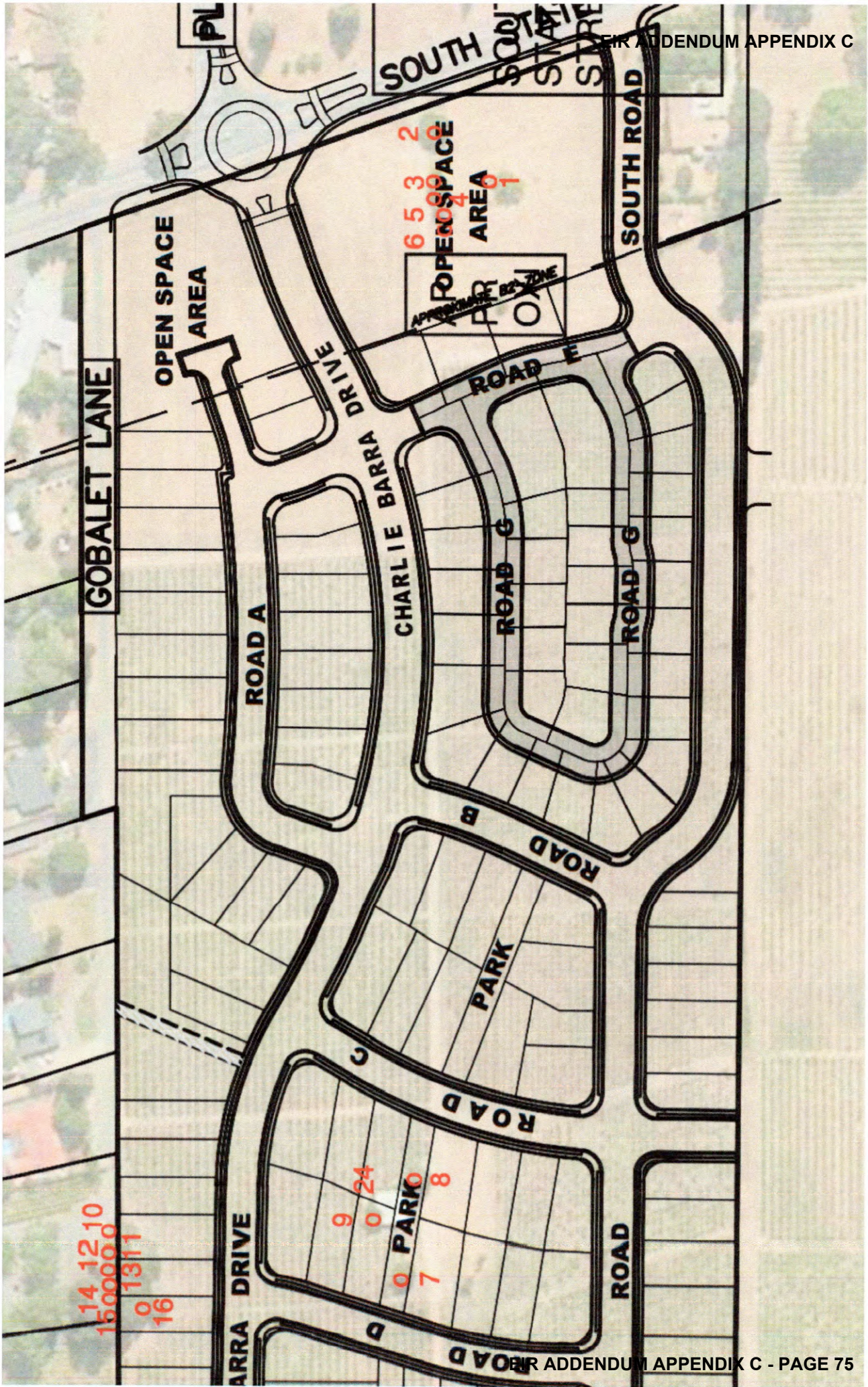

CURRENT SITE PLAN WITH 4 LOTS DELETED  
Deleted lots in yellow

NO.	BY	CHKD.	DATE

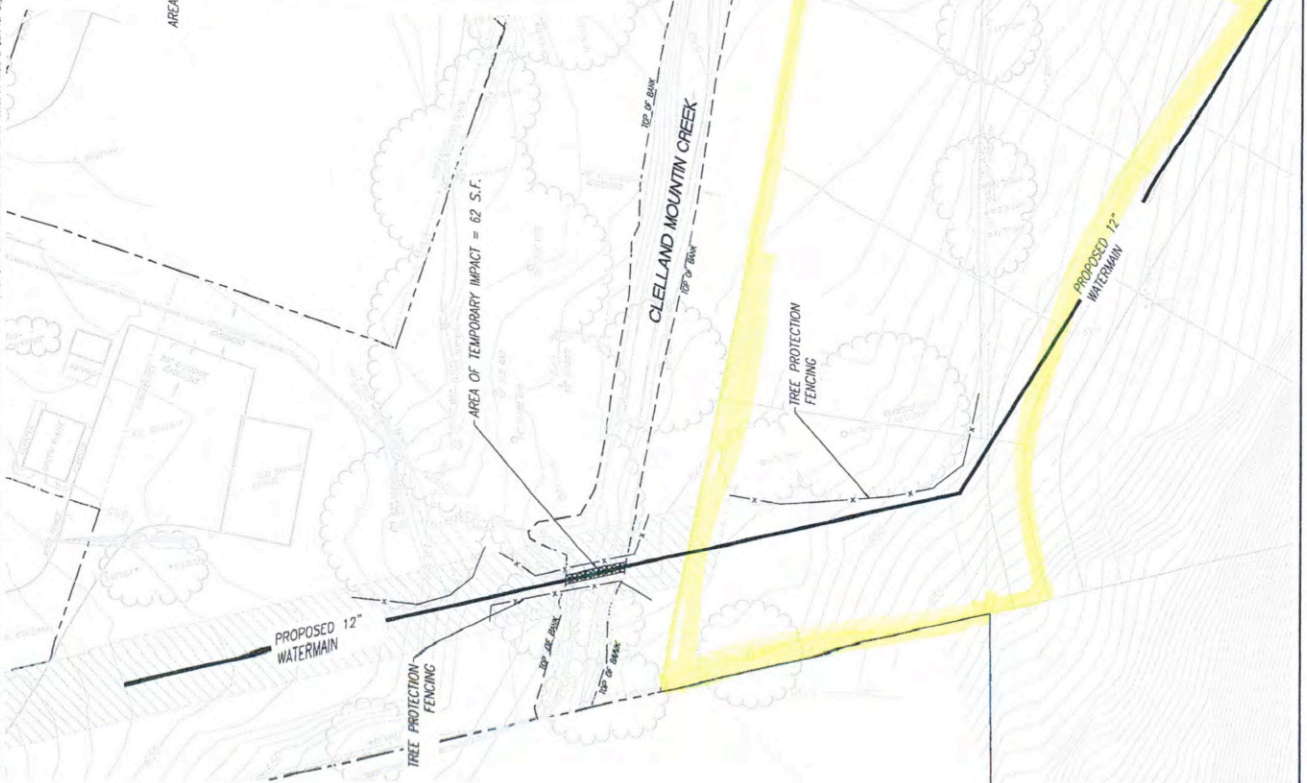

DOCUMENTS THE EXISTENCE AND THE SIZE AND SHAPE, INTERFERED WITH, IN AN EXHIBIT OF PROPOSED WORK, IS THE PROPERTY OF LASCO ASSOCIATES AND SHALL BE REPRODUCED IN WHOLE OR PART FOR ANY OTHER PROJECT WITHOUT LASCO ASSOCIATES' WRITTEN AUTHORIZATION.

TREE FENCING DETAIL

TREE PROTECTION FENCING DETAIL

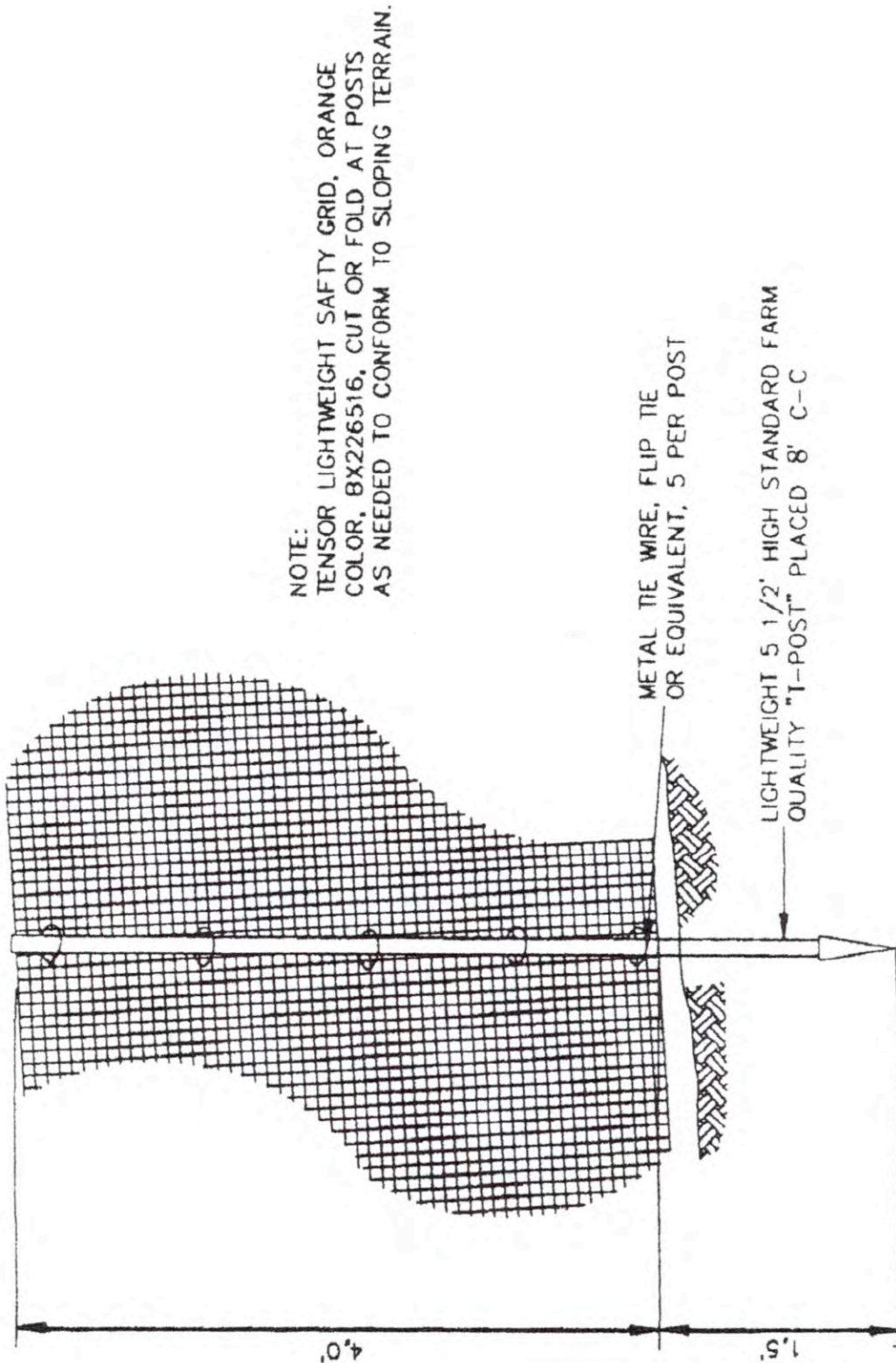

TREE PRESERVATION GUIDELINES



## TREE PRESERVATION GUIDELINES

### INTRODUCTION

Great care must be exercised when development is proposed in the vicinity of established trees of any type. The trees present at this site require specialized protection techniques during all construction activities to minimize negative impact on their long term health and vigor. The area immediately beneath and around canopy driplines is especially critical, and the specifications that follow are established to protect short and long term tree integrity. The purpose of this specification is therefore to define the procedures that must be followed during any and all phases of development in the immediate vicinity of designated protected trees.

Established, mature trees respond in a number of different ways to the disruption of their natural conditions. Change of grade within the root system area or near the root collar, damage to the bark of the trunk, soil compaction above the root system, root system reduction or damage, or alteration of summer soil moisture levels may individually or collectively cause physiological stress leading to tree decline and death. The individual impacts of these activities may cause trees to immediately exhibit symptoms and begin to decline, but more commonly the decline process takes many years, with symptoms appearing slowly and over a period of time. Trees may not begin to show obvious signs of decline from the negative impacts of construction until many years after construction is completed. It is not appropriate to wait for symptoms to appear, as this may be too late to correct the conditions at fault and to halt decline.

It is therefore critical to the long-term health of all protected trees that a defined protection program be established before beginning any construction activity where protected trees are found. Once incorporated at the design level, it is mandatory that developers, contractors, and construction personnel understand the critical importance of these guidelines, and the potential penalties that will be levied if they are not fully incorporated at every stage of development.

The following specifications are meant to be utilized by project managers and those supervising any construction in the vicinity of protected trees including grading contractors, underground contractors, all equipment operators, construction personnel, and landscape contractors. Questions which arise, or interpretation of specifications as they apply to specific site activities, must be referred to the project arborist as they occur.

Horticultural Associates  
P.O. Box 1261  
Glen Ellen, CA 95442  
707-935-3911

## TREE PROTECTION ZONE

1. The canopy dripline is illustrated on the Improvement Plans and represents the area around each tree, or group of trees, which must be protected at all times with tree protection fencing.
2. No encroachment into the dripline is allowed at any time without approval from the project arborist, and unauthorized entry may be subject to civil action and penalties.
3. The dripline will be designated by the project arborist at a location determined to be adequate to ensure long term tree viability and health. This is to occur prior to installation of fencing and in conjunction with the fencing contractor

## TREE PROTECTION FENCING

1. Prior to initiating any construction activity on a construction project, including demolition or grading, temporary protective fencing shall be installed at each site tree, or group of trees. Fencing shall be located at the dripline designated by the project arborist and generally illustrated on the Improvement Plans.
2. Fencing shall be minimum 4' height at all locations, and shall form a continuous barrier without entry points around all individual trees, or groups of trees. Barrier type fencing such as *Tensar* plastic fencing is recommended, but any fencing system that adequately prevents entry will be considered for approval by the project arborist. The use of post and cable fencing is not acceptable, however.
3. Fencing shall be installed tightly between steel fence posts (standard quality farm 'T' posts work well) placed no more than 8 feet on center. Fencing shall be attached to each post at 5 locations with plastic electrical ties, metal tie wire, or flip ties. See attached fencing detail.
4. Fencing shall serve as a barrier to prevent encroachment of any type by construction activities, equipment, materials storage, or personnel.
5. All encroachment into the fenced dripline must be approved and supervised by the project arborist. Approved dripline encroachment may require

Horticultural Associates  
P.O. Box 1261  
Glen Ellen, CA 95442  
707-935-3911

additional mitigation or protection measures that will be determined by the project arborist at the time of the request.

6. Contractors and subcontractors shall direct all equipment and personnel to remain outside the fenced area at all times until project is complete, and shall instruct personnel and sub-contractors as to the purpose and importance of fencing and preservation.
7. Fencing shall be upright and functional at all times from start to completion of project. Fencing shall remain in place and not be moved or removed until all construction activities at the site are completed.

#### TREE PRUNING AND TREATMENTS

1. All recommendations for pruning or other treatments must be completed prior to acceptance of the project. It is strongly recommended that pruning be completed prior to the start of grading to facilitate optimum logistics and access.
2. All pruning shall be conducted in conformance with International Society of Arboriculture pruning standards, and all pruning must occur by, or under the direct supervision of, an arborist certified by the International Society of Arboriculture.

#### GRADING AND TRENCHING

1. Any construction activity that necessitates soil excavation in the vicinity of preserved trees shall be avoided where possible, or be appropriately mitigated under the guidance of the project arborist. All contractors must be aware at all times that specific protection measures are defined, and non conformance may generate stop-work orders.
2. The designated dripline is defined around all site trees to be preserved. Fences protect the designated areas. No grading or trenching is to occur within this defined area unless so designated by the Improvement Plan, and where designated shall occur under the direct supervision of the project arborist.
3. Trenching should be routed around the dripline. Where trenching has been designated within the dripline, utilization of underground technology to bore, tunnel or excavate with high-pressure air or water will be specified. Hand digging will be generally discouraged unless site conditions restrict the use of alternate technology.

Horticultural Associates  
P.O. Box 1261  
Glen Ellen, CA 95442  
707-935-3911

4. All roots greater than one inch in diameter shall be cleanly hand-cut as they are encountered in any trench or during any grading activity. The tearing of roots by equipment shall not be allowed. Mitigation treatment of pruned roots shall be specified by the project arborist as determined by the degree of root pruning, location of root pruning, and potential exposure to desiccation. No pruning paints or sealants shall be used on cut roots.
5. Where significant roots are encountered mitigation measures such as supplemental irrigation and/or organic mulches may be specified by the project arborist to offset the reduction of root system capacity.
6. Retaining walls are effective at holding grade changes outside the area of the dripline and are recommended where necessary. Retaining walls shall be constructed in post and beam or drilled pier construction styles where they are necessary near or within a dripline.
7. Grade changes outside the dripline, or those necessary in conjunction with retaining walls, shall be designed so that drainage water of any type or source is not diverted toward or around the root crown in any manner. Grade shall drain away from root crown at a minimum of 2%. If grading toward the root collar is unavoidable, appropriate surface and/or subsurface drain facilities shall be installed so that water is effectively diverted away from root collar area.
8. Grade reduction within the designated dripline shall be generally discouraged, and where approved, shall be conducted only after careful consideration and coordination with the project arborist.
9. Foundations of all types within the dripline shall be constructed using design techniques that eliminate the need for trenching into natural grade. These techniques might include drilled piers, grade beams, bridges, or cantilevered structures. Building footprints should generally be outside the dripline whenever possible.

## DRAINAGE

The location and density of native trees may be directly associated with the presence of naturally occurring water, especially ephemeral waterways. Project design, especially drainage components, should take into consideration that these trees may begin a slow decline if this naturally present association with water is changed or eliminated.

Horticultural Associates  
P.O. Box 1261  
Glen Ellen, CA 95442  
707-935-3911

## TREE DAMAGE

1. Any form of tree damage which occurs during the demolition, grading, or construction process shall be evaluated by the project arborist. Specific mitigation measures will be developed to compensate for or correct the damage. Fines and penalties may also be levied.

2. Measures may include, but are not limited to, the following:

- pruning to remove damaged limbs or wood
- bark scoring to remove damaged bark and promote callous formation
- alleviation of compaction by lightly scarifying the soil surface
- installation of a specific mulching material
- supplemental irrigation during the growing season for up to 5 years
- treatment with specific amendments intended to promote health, vigor, or root growth
- vertical mulching or soil fracturing to promote root growth
- periodic post-construction monitoring at the developer's expense
- tree replacement, or payment of the established appraised value, if the damage is so severe that long term survival is not expected.

3. Any tree that is significantly damaged and whose survivability is threatened, due to negligence by any contractor, shall be appraised using the Trunk Formula Method provided in the 9th Edition of the Guide For Plant Appraisal. This appraisal value will be the basis for any fines levied on the offending contractor.

## MULCHING

1. Trees will benefit from the application of a 4 inch layer of chipped bark mulch over the soil surface within the Tree Protection Zone. Ideal mulch material is a chipped bark containing a wide range of particle sizes. Bark mulches composed of shredded redwood, bark screened for uniformity of size, dyed bark, or chipped lumber will not function as beneficially. All trees that are expected to be

Horticultural Associates  
P.O. Box 1261  
Glen Ellen, CA 95442  
707-935-3911

impacted in any way by project activities shall have mulch placed prior to the installation of protection fencing.

2. Mulch should be generated from existing site trees that are removed or pruned as part of the project. Much brought onto the site from an outside source must be from trees that are verified to be free of the Sudden Oak Death pathogen *Phytophthora ramorum*.

Horticultural Associates  
P.O. Box 1261  
Glen Ellen, CA 95442  
707-935-3911

Appendix C  
List of Abbreviations

Table 1. List of Abbreviations

Table with multiple columns and rows of abbreviations and their corresponding full names. The text is extremely faint and largely illegible.

PRUNING STANDARDS



WESTERN CHAPTER  
**ISA**

## **PRUNING STANDARDS**

### **Purpose:**

Trees and other woody plants respond in specific and predictable ways to pruning and other maintenance practices. Careful study of these responses has led to pruning practices which best preserve and enhance the beauty, structural integrity, and functional value of trees.

In an effort to promote practices which encourage the preservation of tree structure and health, the W.C. ISA Certification Committee has established the following Standards of Pruning for Certified Arborists. The Standards are presented as working guidelines, recognizing that trees are individually unique in form and structure, and that their pruning needs may not always fit strict rules. The Certified Arborist must take responsibility for special pruning practices that vary greatly from these Standards.

### **I. Pruning Techniques**

- A. A thinning cut removes a branch at its point of attachment or shortens it to a lateral large enough to assume the terminal role. Thinning opens up a tree, reduces weight on heavy limbs, can reduce a tree's height, distributes ensuing invigoration throughout a tree and helps retain the tree's natural shape. Thinning cuts are therefore preferred in tree pruning.

When shortening a branch or leader, the lateral to which it is cut should be at least one-half the diameter of the cut being made. Removal of a branch or leader back to a sufficiently large lateral is often called "drop crotching."

- B. A heading cut removes a branch to a stub, a bud or a lateral branch not large enough to assume the terminal role. Heading cuts should seldom be used because vigorous, weakly attached upright sprouts are forced just below such cuts, and the tree's natural form is altered. In some situations, branch stubs die or produce only weak sprouts.

- C. When removing a live branch, pruning cuts should be made in branch tissue just outside the branch bark ridge and collar, which are trunk tissue. *(Figure 1)* If no collar is visible, the angle of the cut should approximate the angle formed by the branch bark ridge and the trunk. *(Figure 2)*
- D. When removing a dead branch, the final cut should be made outside the collar of live callus tissue. If the collar has grown out along the branch stub, only the dead stub should be removed, the live collar should remain intact, and uninjured. *(Figure 3)*
- E. When reducing the length of a branch or the height of a leader, the final cut should be made just beyond (without violating) the branch bark ridge of the branch being cut to. The cut should approximately bisect the angle formed by the branch bark ridge and an imaginary line perpendicular to the trunk or branch cut. *(Figure 4)*
- F. A goal of structural pruning is to maintain the size of lateral branches to less than three-fourths the diameter of the parent branch or trunk. If the branch is codominant or close to the size of the parent branch, thin the branch's foliage by 15% to 25%, particularly near the terminal. Thin the parent branch less, if at all. This will allow the parent branch to grow at a faster rate, will reduce the weight of the lateral branch, slow its total growth, and develop a stronger branch attachment. If this does not appear appropriate, the branch should be completely removed or shortened to a large lateral. *(Figure 5)*
- G. On large-growing trees, except whorl-branching conifers, branches that are more than one-third the diameter of the trunk should be spaced along the trunk at least 18 inches apart, on center. If this is not possible because of the present size of the tree, such branches should have their foliage thinned 15% to 25%, particularly near their terminals. *(Figure 6)*
- H. Pruning cuts should be clean and smooth with the bark at the edge of the cut firmly attached to the wood.
- I. Large or heavy branches that cannot be thrown clear, should be lowered on ropes to prevent injury to the tree or other property.
- J. Wound dressings and tree paints have not been shown to be effective in preventing or reducing decay. They are therefore not recommended for routine use when pruning.

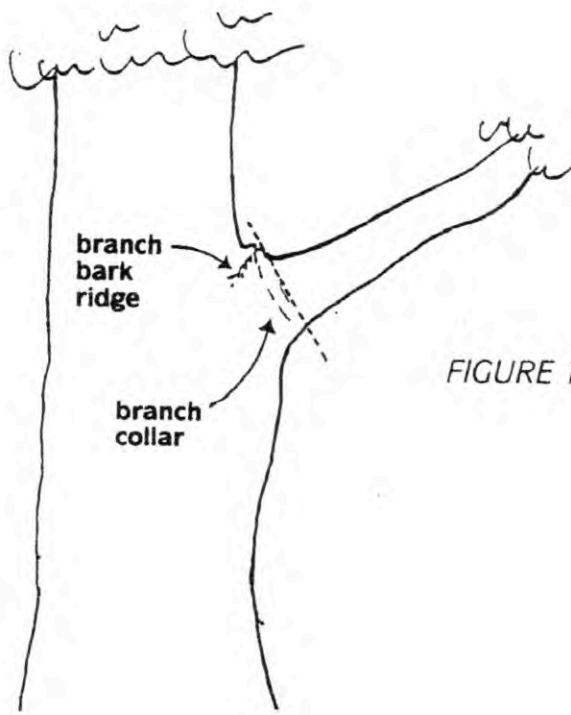

FIGURE 1. When removing a branch, the final cut should be just outside the branch bark ridge and collar.

FIGURE 2. In removing a limb without a branch collar, the angle of the final cut to the branch bark ridge should approximate the angle the branch bark ridge forms with the limb. Angle AB should equal Angle BC.

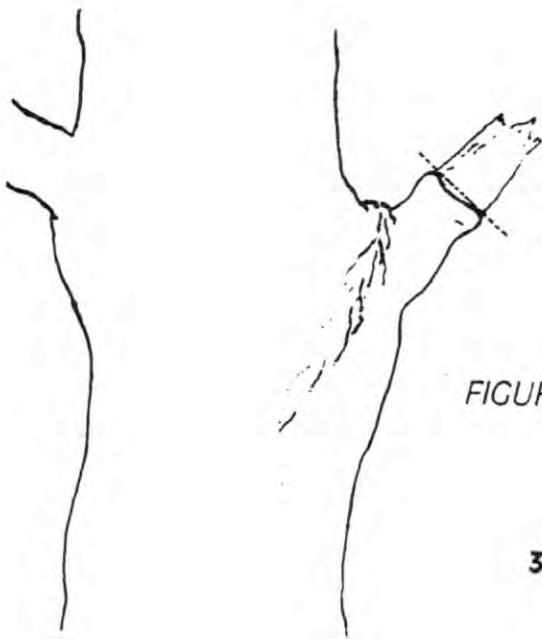
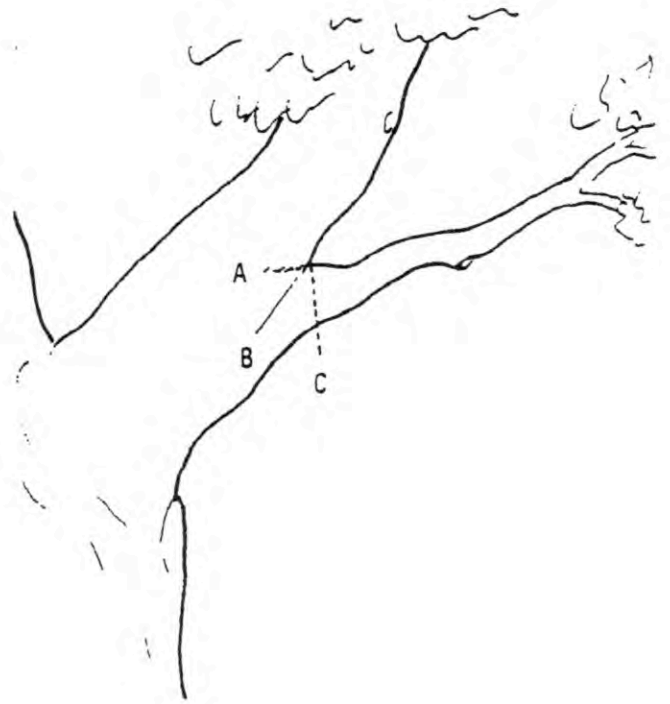

FIGURE 3. When removing a dead branch, cut outside the callus tissue that has begun to form around the branch.

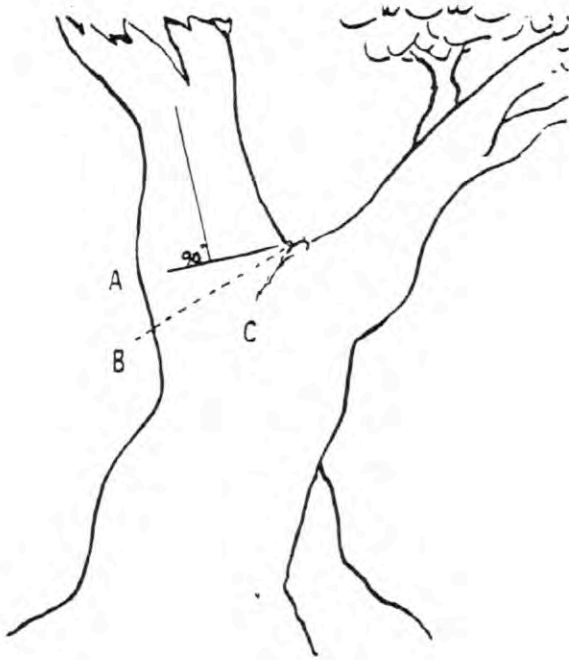
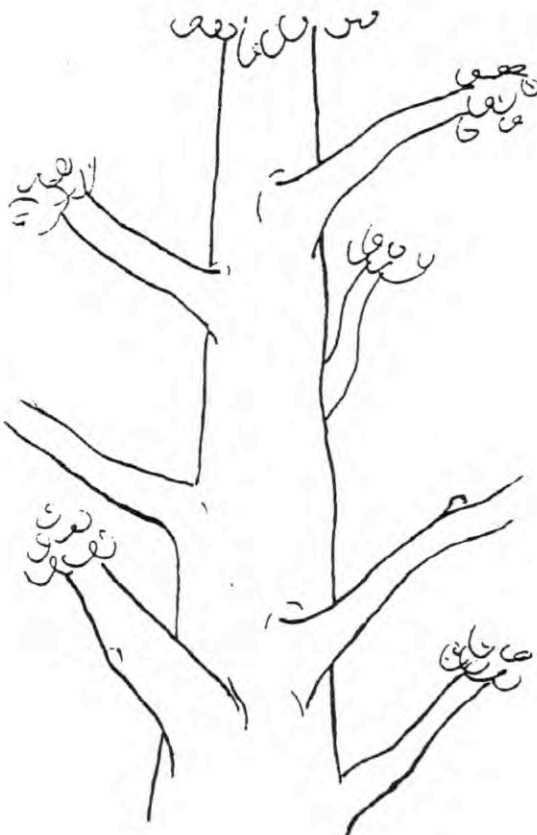

FIGURE 4. In removing the end of a limb to a large lateral branch, the final cut is made along a line that bisects the angle between the branch bark ridge and a line perpendicular to the limb being removed. Angle AB is equal to Angle BC.

FIGURE 5. A tree with limbs tending to be equal-sized, or codominant. Limbs marked B are greater than  $\frac{3}{4}$  the size of the parent limb A. Thin the foliage of branch B more than branch A to slow its growth and develop a stronger branch attachment.



FIGURE 6. Major branches should be well spaced both along and around the stem.



## II. Types of Pruning — Mature Trees

### A. CROWN CLEANING

Crown cleaning or cleaning out is the removal of dead, dying, diseased, crowded, weakly attached, and low-vigor branches and watersprouts from a tree crown.

### B. CROWN THINNING

Crown thinning includes crown cleaning and the selective removal of branches to increase light penetration and air movement into the crown. Increased light and air stimulates and maintains interior foliage, which in turn improves branch taper and strength. Thinning reduces the wind-sail effect of the crown and the weight of heavy limbs. Thinning the crown can emphasize the structural beauty of trunk and branches as well as improve the growth of plants beneath the tree by increasing light penetration. When thinning the crown of mature trees, seldom should more than one-third of the live foliage be removed.

At least one-half of the foliage should be on branches that arise in the lower two-thirds of the trees. Likewise, when thinning laterals from a limb, an effort should be made to retain inner lateral branches and leave the same distribution of foliage along the branch. Trees and branches so pruned will have stress more evenly distributed throughout the tree or along a branch.

An effect known as "lion's-tailing" results from pruning out the inside lateral branches. Lion's-tailing, by removing all the inner foliage, displaces the weight to the ends of the branches and may result in sunburned branches, watersprouts, weakened branch structure and limb breakage.

### C. CROWN REDUCTION

Crown reduction is used to reduce the height and/or spread of a tree. Thinning cuts are most effective in maintaining the structural integrity and natural form of a tree and in delaying the time when it will need to be pruned again. The lateral to which a branch or trunk is cut should be at least one-half the diameter of the cut being made.

### D. CROWN RESTORATION

Crown restoration can improve the structure and appearance of trees that have been topped or severely pruned using heading cuts. One to three sprouts on main branch stubs should be selected to reform a more natural appearing crown. Selected vigorous sprouts may need to be thinned to a lateral, or even headed, to control length growth in order to ensure adequate attachment for the size of the sprout. Restoration may require several prunings over a number of years.

## II. Types of Pruning – Mature Trees *(continued)*

### E. CROWN RAISING

Crown raising removes the lower branches of a tree in order to provide clearance for buildings, vehicles, pedestrians, and vistas. It is important that a tree have at least one-half of its foliage on branches that originate in the lower two-thirds of its crown to ensure a well-formed, tapered structure and to uniformly distribute stress within a tree.

When pruning for view, it is preferable to develop “windows” through the foliage of the tree, rather than to severely raise or reduce the crown.

## III. Size of Pruning Cuts

Each of the Pruning Techniques (Section I) and Types of Pruning (Section II) can be done to different levels of detail or refinement. The removal of many small branches rather than a few large branches will require more time, but will produce a less-pruned appearance, will force fewer watersprouts and will help to maintain the vitality and structure of the tree. Designating the maximum size (base diameter) that any occasional undesirable branch may be left within the tree crown, such as ½', 1' or 2' branch diameter, will establish the degree of pruning desired.

## IV. Climbing Techniques

- A. Climbing and pruning practices should not injure the tree except for the pruning cuts.
- B. Climbing spurs or gaffs should not be used when pruning a tree, unless the branches are more than throw-line distance apart. In such cases, the spurs should be removed once the climber is tied in.
- C. Spurs may be used to reach an injured climber and when removing a tree.
- D. Rope injury to thin barked trees from loading out heavy limbs should be avoided by installing a block in the tree to carry the load. This technique may also be used to reduce injury to a crotch from the climber's line.

# Appendix E

---

Project Site Photos

**Project Site Photos**  
Taken April 13, 2021



Looking south at the site from Gobalet Lane.



Looking west toward Cleland Mountain within the BSA.



Looking south at annual grassland and adjacent residential development.



Looking east at abandoned agricultural outbuilding.



Looking north at Cleland Mountain Creek.



Vineyards and barren habitat, looking west.





117 Meyers Street • Suite 120 • Chico CA 95928 • 530-332-9909

---

**Technical Memorandum:  
Assessment of Biological Issues of the Bella Vista Subdivision Project in Relation  
to the Certified Environmental Impact Report for the Garden Gate Project  
July 2021**

This memo is being provided to provide an assessment of the biological conditions of currently proposed Bella Vista project compared to the mitigation measures pertaining to biological resources of the previously certified Environmental Impact Report (EIR) for the Garden Gate project from 2006. This memo is not intended to make a determination on the validity of the current project in light of the existing EIR, but rather to provide guidance to the applicant and County in support of their decision making processes.

The subsequent Biological Resource Assessment produced by Gallaway Enterprises (July 26, 2021) and its recommendations and conclusions supports the conclusions that existing certified EIR's mitigation measures, existing regulations and applicant's incorporation of their Good Neighbor Policies are consistent. Changes in project design and implementation of the current project compares to the previous project are minor, and in some instances superior to the previously approved project, and do not result in any new significant environmental effects or a substantial increase in the severity of previously identified resources.

The Bella Vista Subdivision project area contains multiple biological communities including annual grassland, montane hardwood conifer, riverine, vineyard, urban and barren. Cleland Mountain Creek is a water of the U.S. tributary to the Russian River that contains suitable habitat for Northern California steelhead trout and Chinook salmon. The Project, with the incorporation of the mitigation measures from the previous certified EIR will not affect FESA-listed Central California Coast steelhead trout or Chinook salmon. The Project may adversely affect state candidate (SC) species western bumble bee and species of special concern (SSC) western pond turtle and pallid bat.

Mitigation measures included in Conclusions and Recommendations section of the Biological Resource Assessment produced by Gallaway Enterprises are proposed to reduce potential impacts to the federally threatened (FT), federally protected (FP), state candidate (SC), and state species of concern (SSC) to a level that is considered less than significant.

The project site was previously surveyed by North Coast Resource Management in the mid-2000s as part of the Garden Gate Tentative Subdivision Map, a 199-lot subdivision. As part of that project an Environmental Impact Report (EIR) was certified by Mendocino County. That EIR contain biological mitigation measures to reduce impacts associated with the proposed project. A subsequent Biological Resource Assessment was conducted by Gallaway Enterprises in 2021 to evaluate and document the current biological conditions at the site.

Outlined below, are the mitigation measures that pertain to the biological resources from that EIR and an evaluation of their applicability based on current circumstances.

*Mitigation Measure 3.2-D.1: The project shall not cause substantial pollution of Cleland Mountain Creek or the Russian River. The applicant shall prepare an NOI and SWPPP for the project, and incorporate the following additional site-appropriate BMPS or their equivalents for short- and long-term implementation by the Homeowners Associations (HOA) and/or individual lot owners, in order to comply with the requirements of the NPDES General Permit and provisions of the Mendocino County Storm Water Management Program. The BMPS will result in stormwater leaving the site at least meeting the NCRWQCB water quality objectives for the Russian River. The SWPP shall be approved by the Mendocino County Water Agency and the State prior to project construction.*

*Mitigation Measure 3.2-D-2: Per the recommendation of the CDFG, Lots 20, 21 and 197 shall be removed from the project in order to provide the minimum Creekside buffer required to filter contaminations including sediments, from stormwater runoff.*

The above Mitigation Measures are still applicable to the project, in that a project of this size is required to submit a Notice of Intent (NOI) and develop a Stormwater Pollution Prevention Plan (SWPPP). In addition to the County, SWPPPs are plans, submitted to and approved by the State Water Resource Control Board, that identify opportunities to reduce or eliminate stormwater runoff and contain standardized Best Management Practices (BMPs) such as; utilization of silt fences, erosion control blankets and waddles, watering exposed soil, sweeping sidewalks and streets, maintaining equipment and training site staff on erosion and sediment control practices, to name a few.

Further, the removal of three lots (Mitigation Measure 3.2-D-2) from the design is still applicable to the project and ensures that at least a 100-foot setback is secured as recommended by the California Department of Fish and Game (now Fish and Wildlife). These lots have been redesigned under the new proposal into 4 lots and are identified as Lot 122, 123, 124 and 125 the Bella Vista Map. In order to ensure appropriate retention of the approximately 13 mature true oak trees, comprising the riparian shade trees on the south side of the creek, retention tree root zones shall be protected as described in the Bella Vista project description Tree Protection Zones BMPs.

*Mitigation Measure: 3.3-A.1: The applicant shall preserve water quality in Cleland Mountain Creek. A Riparian Enhancement Area that includes Lots 20, 21 and 197 shall be established to include all areas within a setback of 20 feet from the top of bank of this creek and deed restricted to prohibit grading, tree cuttings, trash depositions, landscaping other than natural habitat restoration, storage of materials, fillings, structures, dumping of chemicals, or disruptive activities. The applicant shall replant the Riparian Enhancement Area. The replanting shall include riparian species along the creek and oaks, bay and buckeye further from the creek. The plan shall include the planting of at least three replacement trees of the same species as the tree removed) for each oak, bay and buckeye and Oregon ash that is removed. With the 20-foot riparian habitat setback, appropriate native ground covers and shrubs will also be established to filter runoff from development portions of nearby lots. All plantings established under this plan shall be irrigated and replaced as needed as well as monitored by the plan prepare for a period of no less than 3 years to ensure successful establishment. The Riparian Enhancement Area shall be maintained by the HOA pursuant to this plan.*

A Riparian Enhancement Area Plan is still appropriate for Lots 20 and 21 (now Lots 122, 123, 124 and 125 on the Bella Vista Tentative Subdivision Map), which lay on the south side of Cleland Mountain Creek.

With the incorporation of Mitigation Measure 3.2-D.2, the Riparian Enhancement Area will have setback between 110 to 130-linear feet from the top of bank of Cleland Creek.

*Mitigation Measure 3.3-B.1: An assessment shall be conducted that determines the area and number of oaks and other native hardwoods that would be removed or adversely impacted as a result of project development on Lots 20, 21, and 197. Building envelopes on Lots 20, 21 and 197, as well as driveway and utility connections locations shall be adjusted if needed to avoid loss or both short-term and long-term adverse effects on native trees. The area outside of these building envelopes shall be deed restricted to require maintenance of existing native trees, and prohibit of lawns and landscaping incompatible with long-term survival of these trees while allowing pruning and removal of any dead or dying trees, dead limbs and brush, and any clearance required as needed to reduce wildland fires hazard. All removed hardwoods shall be replaced with the same species at minimum replacement ration of 3:1 within the 20-foot riparian setback zone along the top of the bank of Cleland Mountain Creek. A minimum 3-year monitoring plan shall track planted trees and replace all that are dead or dying.*

The above mitigation measure is still applicable to the project. The setback is incorrect, as noted above, but the deed protection of the native trees, is appropriate. The developer's removal of the four lots near the creek were implemented to meet the greatest setback identified in the Mitigation Measure. The applicant also notes in their project description that a tree survey, identifying native trees within the entire area of the development will be conducted prior to any tree removal. The survey results will also note a 3 to 1 replacement for any oak tree removed from the project, monitoring, and replacement plantings.

The Biological Section of the EIR also references other Mitigation Measure that are located in another section of the report (Hydrology and Water Quality. The report notes that if the mitigation measured are implemented, it would reduce impacts upon the Biological environment. These Mitigations Measures are listed as 3.2-C.1, 3.2-C.2, 3.2-D.1 and 3.3-A.1 respectively.

*Mitigation Measure 3.2-C.1: The project shall not cause significant erosion. The applicant shall submit a detailed Erosion Control Plan as part of the Stormwater Pollution Prevention Plan (SWPPP to the Mendocino County Water Agency (MCWA) and to the State Water Resource Control Board (SWRCB), in conjunction with the filing of the Notice of Intent (NOI) with the SWRCB. The County shall not issue a Grading Permit until the County Water Agency agrees that the plan contains adequate Best Management Practices for controlling erosion. At a minimum, the Erosion Control Plan shall include the following restrictions, guidelines, and measures: (1) grading and earthwork shall be prohibited during the wet season (typically October 15 through April 15) and such work shall be stopped before pending storm events during the spring-fall construction season; (2) erosion control/soil stabilization techniques such as straw and wood mulching, erosion control matting, and hydroseeding, or their functional equivalents shall be utilized in accordance with applicable manufacturers specifications and erosion control Best Management Practices (BMPs) published in the California Stormwater BMP Handbook – Construction (California Stormwater Quality Association 2005) and/or similar proscriptions outlined in the Erosion and Sediment Control Field Manual (SF Bay RWQCB 2002); (3) bales of hay or accepted equivalent methods shall be installed in the flow path of graded areas receiving concentrated flows, as well as around storm drain inlets; (4) installation of silt fencing and other measures to segregate the active flow zone of Cleland*

*Mountain Creek from the near overbank disturbance associated with bridge abutment construction; and (5) post-construction stormwater treatment measures.*

*These and other erosion control BMPs shall be monitored for effectiveness and shall be subject to inspection by the County. The applicant shall be responsible for implementing any remedial actions recommended by the County. After construction is completed, all drainage facilities shall be inspected for accumulated sediment, and these drainage structures shall be cleared of debris and sediment. Silt fencing shall be left in place until the hydroseed has become established.*

The above mitigation measure is still applicable to the Project. The applicant also notes in the project description that they will follow all existing rules and regulations when it comes to a project this size, which includes obtaining necessary permits from local and state agencies, such as NOIs and SWPPPs. NOIs and SWPPPs, which are approved at local and State levels, identify opportunities to reduce or eliminate stormwater runoff and contain standardize Best Management Practices (BMPs) such as; utilization of silt fences, erosion control blankets and wattles, watering exposed soil, sweeping sidewalks and streets, maintaining equipment and training site staff on erosion and sediment control practices, to name a few. The project description also notes installation of BMPs that would reduce unnecessary runoff and drainage into Cleland Mountain Creek, reducing sedimentation into the storm water collection system.

*Mitigation Measure 3.2.-C.2: riprap sections of the drainage ditch bank at both the detention pond and underground storage vault outlets to dissipate the erosive energy of the discharges. Stabilize the southern drainage ditch by grading its bank to slopes of 3:1 and establish riparian vegetative cover using biotechnical techniques and native erosion control mix and native tree and shrub plantings.*

The project has been redesigned to avoid all potential impacts to the ditch. The above mitigation measure is no longer applicable to the Project.

*Mitigation Measure 3.2-D.1: The project shall not cause substantial pollution of Cleland Mountain Creek or the Russian River. The applicant shall prepare and NOI and SWPPP for the project, and incorporate the following additional site-appropriate BMPs or their equivalents for short- and long-term implementation by the Homeowners Association (HOA) and/or individual lot owners, in order to comply with the requirements of the NPDES General Permit and provisions of the Mendocino County Storm Water Management Program. The BMPs will result in stormwater leaving the site at least meeting the NCRWQCB water quality objectives for the Russian River. The SWPPP shall be approved by the Mendocino County Water Agency and State prior to project construction.*

- *Impervious surfaces shall be minimized by using such techniques as driveway strips with bordering pervious pavement materials (rather than a full paved driveway): using pervious materials for parking areas; directing runoff from rooftops and streets to landscape buffers and/or recharge trenches.*
- *Install oil-grease separators at locations where street runoff enters the southern swale; or replace all or a portion of the detention pond outlet storm drain with a grass swale (i.e. bioswale) to enhance stormwater filtration on contaminants and increase local infiltration. The alignment of drain-swale configuration could be*

*adjusted to parallel the Plant Road entrance and then South State Street. The swale designed should follow guidelines set forth by the North Coast RWQCB, or equivalent agencies (e.g. CA. Storm Water Best Management Practices Handbooks, Construction Activity, Camp Dresser & McKee et al. 1993). In particular, swale slopes and the swale base course materials should be selected to allow adequate subsurface storage for the site soil characteristics.*

- *These and other BMPs shall be monitored for effectiveness and shall be subject to inspection by the County. The Homeowners Association shall be responsible for implementing any remedial actions recommended by the County. The applicant shall establish a monitoring protocol that is acceptable to the County that monitors implementation of these measures, including a bond or other funding agreement that reimburses the County if the County needs to conduct required maintenance due to the HOA not implementing required maintenance. The County can require that monitoring be done by a third party acceptable to the County; cost of all monitoring and any maintenance will be borne by the Homeowners Association. Since the objective of erosion control and water quality treatment measures would be to reduce contaminant loading to the maximum extent practicable with implementation of the best available technologies, the recommended BMPs are not fixed. Other measures can be applied as long as the applicant can demonstrate to the satisfaction of MCWA that those measures can provide equivalent levels of reduction in contaminant loading. The applicant shall prepare a plan that describes the roles and responsibilities of the HOA, lot owners, and/or the County for implementing the BMPs and monitoring the results. If the County will be responsible for monitoring or implementing any actions, then a funding mechanism will be established. The County will review and approve this plan prior to the onset of construction.*

The above mitigation measure is still applicable to the project.

## **Conclusion**

Based on Gallaway Enterprises understanding of the previously certified EIR for the Garden Gate project and the proposed Bella Vista project, the biological conditions and potential impacts to biological resources of the two proposals are consistent. No new significant environmental effects or a substantial increase in the severity of previously identified significant effects; or new information of substantial importance in regards to biological resources have been identified.

Prepared by,



Kevin Sevier  
Vice President  
Gallaway Enterprises

---

# HORTICULTURAL

---

## *Associates*

*Consultants in Horticulture and Arboriculture*

### TREE INVENTORY REPORT

3000 State Street  
Ukiah, CA

**Prepared for:**

Guillon Inc.  
2550 Lakewest Drive, Suite 50  
Chico, CA 95928

**Prepared by:**

John C. Meserve  
ISA Certified Arborist, WE #0478A  
ISA Qualified Tree Risk Assessor/TRAQ  
ASCA Qualified Tree and Plant Appraiser/TPAQ

July 14, 2021



*Consultants in Horticulture and Arboriculture*  
P.O Box 1261, Glen Ellen, CA 95442

July 14, 2021

Jake Morley  
Project Manager  
Guillon, Inc  
2550 Lakewest Drive, Suite 50  
Chico, CA 95928

Re: Completed and Updated *Tree Inventory Report*, 3000 State Street in Ukiah, California

Jake,

Attached you will find our completed *Tree Inventory Report* for the above noted site in Ukiah. A total of 97 trees were surveyed and this includes all trees that were present in the vicinity of proposed construction that were 5 inches or greater in trunk diameter in most areas of the site and 2 inches or greater in the creek area.

All trees in this report was evaluated and documented for species, size, health, and structural condition. The *Tree Inventory Chart* also includes information about expected impacts of the proposed development plan and recommendations for action based on the plan reviewed. The *Tree Location Plan* shows the location and numbering sequence of all evaluated trees. No topo map was provided and tree trunk locations are approximate. Also included are *Pruning Guidelines*, *Tree Preservation Guidelines*, and a *Fencing Detail*.

This report is intended to be a basic inventory of trees present at this site, which includes a general review of tree health and structural condition. No in-depth evaluation has occurred on any tree, and assessment has included only external visual examination without probing, drilling, coring, root collar examination, root excavation, or dissecting any tree part. Failures, deficiencies, and problems may occur in these trees in the future, and this inventory in no way guarantees or provides a warranty for their health or structural condition. No other trees beyond those listed have been included in this report. If other trees need to be included it is the responsibility of the client to provide that direction.

#### EXISTING SITE CONDITION SUMMARY

The project site consists of a combination of open land, existing vineyards, a farming outbuilding, and a creek drainage.

## EXISTING TREE SUMMARY

Species native to the site include Coast Live Oak, Valley Oak, Douglas Fir, Black Oak, Bay Laurel, Incense Cedar, Oregon Ash, Cottonwood, Sandbar Willow, and a Willow species.

Ornamental species that are present include English Walnut, Black Walnut, Coast Redwood, and Persimmon.

There are two dense clumps of willows in the western pocket of the site where a shallow creek swale is present. These each are referenced in the *Tree Inventory Chart* by a single tree reference number. Tree #91 has many stems ranging from 1 inch up to 3 inches in diameter. Tree #97 also has many small stems including a single 14" diameter trunk. I have addressed each group with a single reference number due to the many stems that are present.

## CONSTRUCTION IMPACT SUMMARY

The following is a summary of the initial expected impacts on trees:

- (63) Trees that can be preserved
- (30) Trees that will require removal due to the expected impacts of proposed development
- (4) Trees that are in poor health or hazardous structure that should be removed regardless of proposed development

Of the 30 trees that will require removal for this project it appears that only 11 are native Oaks. Based on a draft version of the Mendocino County Tree Ordinance the removal of 11 Oaks would require replacement at a ratio of 8:1 generating 88 mitigation replacement trees. In a revegetation/restoration approach these trees would most likely be small Valley Oaks grown in revegetation specific containers like 'D' pots, they would be staked and screened for rodent protection, and they would be irrigated for up to 3 years to reach establishment.

Mitigation trees could be used to vegetate the riparian creek setback corridor on the north and south banks, in the linear interior park, or as part of the Open Space Area along South State Street.

Modification to the earlier plan has included the elimination of four lots along the creek corridor and this is allowing the preservation of a greater number of native trees in that area.

In addition to the removal of these lots a 12" water main is being shown to traverse the creek area where an impact may occur on some trees. The water line should be located in the field in a manner to minimize impacts to any nearby trees and temporary protection fencing should be put into place during the trenching and construction process.



Please feel free to contact me if you have questions regarding this report, or if further discussion would be helpful.

Regards,



John C. Meserve  
ISA Certified Arborist, WE #0478A  
ISA Qualified Tree Risk Assessor/TRAQ  
ASCA Qualified Tree and Plant Appraiser/TPAQ

TREE INVENTORY CHART

TREE INVENTORY  
Bella Vista Subdivision  
Ukiah, CA

July 14, 2021

Tree #	Species	Common Name	Trunk (dbh ± inches)	Height (± feet)	Radius (± feet)	Health 1 - 5	Structure 1 - 4	Expected Impact	Recommendations
1	<i>Juglans regia</i>	English Walnut	25	22	15	3	3	0	1, 6, 9
2	<i>Morus alba</i>	Mulberry	16	18	18	4	3	0	1, 6, 9
3	<i>Pistache chinensis</i>	Chinese Pistache	6	14	10	4	3	0	1, 6, 9
4	<i>Morus alba</i>	Mulberry	11	18	12	4	3	0	1, 6, 9
5	<i>Sequoia sempereirens</i>	Coast Redwood	24	50	14	4	3	0	1, 6, 9
6	<i>Salix matsudana 'Tortuosa'</i>	Curley Willow	27	30	15	1	1	0	3
7	<i>Sequoia sempereirens</i>	Coast Redwood	27	40	1	3	3	2	1, 6, 7, 8, 9
8	<i>Sequoia sempereirens</i>	Coast Redwood	42	50	18	4	3	2	1, 6, 7, 8, 9
9	<i>Prunus cerasifera</i>	Purple Leaf Plum	14	20	16	2	2	3	2
10	<i>Quercus lobata</i>	Valley Oak	18+18	40	20	4	3	2	1, 6, 7, 8, 9
11	<i>Quercus lobata</i>	Valley Oak	36	40	30	4	3	2	1, 6, 7, 8, 9
12	<i>Quercus kelloggii</i>	Black Oak	15	35	30	4	3	2	1, 6, 7, 8, 9
13	<i>Quercus lobata</i>	Valley Oak	18	40	20	4	3	2	1, 6, 7, 8, 9
14	<i>Quercus lobata</i>	Valley Oak	17	22	30	4	3	2	1, 6, 7, 8, 9
15	<i>Quercus lobata</i>	Valley Oak	25	40	30	4	3	2	1, 6, 7, 8, 9
16	<i>Quercus kelloggii</i>	Black Oak	6+6+7+7+12	25	16	4	3	3	2

TREE INVENTORY  
Bella Vista Subdivision  
Ukiah, CA

July 14, 2021

Tree #	Species	Common Name	Trunk (dbh ± inches)	Height (± feet)	Radius (± feet)	Health 1 - 5	Structure 1 - 4	Expected Impact	Recommendations
17	<i>Juglans regia</i>	English Walnut	12+14+15	20	12	1	1	3	2
18	<i>Juglans nigra</i>	Black Walnut	12+15+16	25	15	1.5	2	2	1, 6, 7, 8, 9
19	<i>Juglans regia</i>	English Walnut	7+8+12+14+15	35	18	2	3	3	2
20	<i>Diospyros kaki</i>	Persimmon	3+3+3+4+6	15	15	4	3	3	2
21	<i>Diospyros kaki</i>	Persimmon	6+5+5	15	15	4	3	3	2
22	<i>Juglans regia</i>	English Walnut	18	18	20	2	2	3	2
23	<i>Juglans regia</i>	English Walnut	18	18	20	2	2	3	2
24	<i>Juglans regia</i>	English Walnut	32	22	18	2	2	3	2
25	<i>Juglans regia</i>	English Walnut	11+13+13	25	16	2	2	3	2
26	<i>Juglans regia</i>	English Walnut	12+14	25	15	2	2	3	2
27	<i>Juglans regia</i>	English Walnut	20	22	15	2	1	3	3
28	<i>Juglans regia</i>	English Walnut	10+10+10	25	16	2	2	3	2
29	<i>Juglans regia</i>	English Walnut	24	30	18	2	2	3	2
30	<i>Quercus kelloggii</i>	Black Oak	12+14+16	40	24	4	2	3	2
31	<i>Quercus kelloggii</i>	Black Oak	14+20	40	28	4	2	3	2
32	<i>Quercus kelloggii</i>	Black Oak	12	35	21	4	3	3	2

TREE INVENTORY  
Bella Vista Subdivision  
Ukiah, CA

July 14, 2021

Tree #	Species	Common Name	Trunk (dbh ± inches)	Height (± feet)	Radius (± feet)	Health 1 - 5	Structure 1 - 4	Expected Impact	Recommendations
33	<i>Quercus kelloggii</i>	Black Oak	14+18	40	25	4	3	3	2
34	<i>Quercus kelloggii</i>	Black Oak	28	40	24	4	3	3	2
35	<i>Quercus kelloggii</i>	Black Oak	14+14	40	24	4	3	3	2
36	<i>Quercus kelloggii</i>	Black Oak	1414	35	20	4	3	3	2
37	<i>Juglans regia</i>	English Walnut	24	25	18	3	3	3	2
38	<i>Juglans regia</i>	English Walnut	16	25	22	3	2	3	2
39	<i>Pseudotsuga menziesii</i>	Douglas Fir	16	40	12	4	3	3	2
40	<i>Pseudotsuga menziesii</i>	Douglas Fir	14	40	12	4	3	0	1, 6, 7
41	<i>Pseudotsuga menziesii</i>	Douglas Fir	15	40	12	4	3	0	1, 6, 7
42	<i>Pseudotsuga menziesii</i>	Douglas Fir	17	50	14	4	3	0	1, 6, 7
43	<i>Pseudotsuga menziesii</i>	Douglas Fir	16	50	14	4	3	0	1, 6, 7
44	<i>Pseudotsuga menziesii</i>	Douglas Fir	16	50	14	4	3	0	1, 6, 7
45	<i>Pseudotsuga menziesii</i>	Douglas Fir	19	50	14	4	3	0	1, 6, 7
46	<i>Pseudotsuga menziesii</i>	Douglas Fir	17	50	14	4	3	0	1, 6, 7
47	<i>Pseudotsuga menziesii</i>	Douglas Fir	32	60	15	4	3	0	1, 6, 7
48	<i>Pseudotsuga menziesii</i>	Douglas Fir	24	60	16	4	3	0	1, 6, 7

HORTICULTURAL ASSOCIATES  
P.O. Box 1261, Glen Ellen, CA 95442  
707.935.3911

TREE INVENTORY  
Bella Vista Subdivision  
Ukiah, CA

July 14, 2021

Tree #	Species	Common Name	Trunk (dbh ± inches)	Height (± feet)	Radius (± feet)	Health 1 - 5	Structure 1 - 4	Expected Impact	Recommendations
49	<i>Pseudotsuga menziesii</i>	Douglas Fir	36	70	25	4	3	0	1, 6, 7
50	<i>Quercus kelloggii</i>	Black Oak	8+8+10+10	35	25	4	3	0	1, 6, 7
51	<i>Pseudotsuga menziesii</i>	Douglas Fir	6	25	8	4	3	0	1, 6, 7
52	<i>Pseudotsuga menziesii</i>	Douglas Fir	13	45	12	4	3	0	1, 6, 7
53	<i>Pseudotsuga menziesii</i>	Douglas Fir	8	25	12	4	3	0	1, 6, 7
54	<i>Umbellularia californica</i>	Bay Laurel	14	40	12	4	3	0	1, 6, 7
55	<i>Quercus kelloggii</i>	Black Oak	12+13+13	40	18	4	3	0	1, 6, 7
56	<i>Quercus kelloggii</i>	Black Oak	9+10+12	40	18	4	3	0	1, 6, 7
57	<i>Pseudotsuga menziesii</i>	Douglas Fir	13	30	14	4	3	3	2
58	<i>Calocedrus decurrens</i>	Incense Cedar	15	25	12	4	3	3	2
59	<i>Pseudotsuga menziesii</i>	Douglas Fir	15	60	15	4	3	3	2
60	<i>Pseudotsuga menziesii</i>	Douglas Fir	17	60	15	4	3	3	2
61	<i>Pseudotsuga menziesii</i>	Douglas Fir	16	50	15	4	3	3	2
62	<i>Quercus kelloggii</i>	Black Oak	13	40	20	4	3	3	2
63	<i>Quercus kelloggii</i>	Black Oak	13	35	16	4	3	2	1, 6, 7
64	<i>Quercus lobata</i>	Valley Oak	11	35	18	4	3	3	2

TREE INVENTORY  
Bella Vista Subdivision  
Ukiah, CA

July 14, 2021

Tree #	Species	Common Name	Trunk (dbh ± inches)	Height (± feet)	Radius (± feet)	Health 1 - 5	Structure 1 - 4	Expected Impact	Recommendations
65	<i>Quercus kelloggii</i>	Black Oak	15	40	20	4	3	1	1, 6, 7
66	<i>Pseudotsuga menziesii</i>	Douglas Fir	12	30	10	4	3	3	2
67	<i>Quercus kelloggii</i>	Black Oak	20	40	25	4	3	0	1, 6, 7
68	<i>Quercus kelloggii</i>	Black Oak	21+25	40	30	4	3	0	1, 6, 7
69	<i>Quercus kelloggii</i>	Black Oak	26	40	30	4	3	0	1, 6, 7
70	<i>Quercus lobata</i>	Valley Oak	32	45	30	4	3	3	2
71	<i>Quercus lobata</i>	Valley Oak	28	45	30	4	3	0	1, 6, 7
72	<i>Fraxinus latifolia</i>	Oregon Ash	12	35	14	3	3	0	1, 6, 7
73	<i>Populus fremontii</i>	Cottonwood	30	45	36	3	3	0	1, 6, 7
74	<i>Juglans nigra</i>	Black Walnut	4	14	8	4	3	0	1, 6, 7
75	<i>Quercus kelloggii</i>	<i>Quercus kelloggii</i>	24	40	20	4	3	0	1, 6, 7
76	<i>Quercus kelloggii</i>	Black Oak	13+14	40	30	4	3	0	1, 6, 7
77	<i>Quercus kelloggii</i>	Black Oak	25	45	30	4	3	0	1, 6, 7
78	<i>Fraxinus latifolia</i>	Oregon Ash	10	40	15	4	3	0	1, 6, 7
79	<i>Quercus lobata</i>	Valley Oak	22	45	30	4	3	0	1, 6, 7
80	<i>Quercus lobata</i>	Valley Oak	30	45	30	4	3	0	1, 6, 7

HORTICULTURAL ASSOCIATES  
P.O. Box 1261, Glen Ellen, CA 95442  
707.935.3911

TREE INVENTORY  
Bella Vista Subdivision  
Ukiah, CA

July 14, 2021

Tree #	Species	Common Name	Trunk (dbh ± inches)	Height (± feet)	Radius (± feet)	Health 1 - 5	Structure 1 - 4	Expected Impact	Recommendations
81	<i>Umbellularia californica</i>	Bay Laurel	22	40	18	4	3	0	1, 6, 7
82	<i>Quercus lobata</i>	Valley Oak	24	40	25	3	3	0	1, 6, 7
83	<i>Quercus lobata</i>	Valley Oak	29	40	30	4	3	0	1, 6, 7
84	<i>Quercus lobata</i>	Valley Oak	28	40	25	2	3	0	1, 6, 7
85	<i>Quercus lobata</i>	Valley Oak	48	45	30	3	3	0	1, 6, 7
86	<i>Fraxinus latifolia</i>	Oregon Ash	11	35	112	4	3	0	1, 6, 7
87	<i>Fraxinus latifolia</i>	Oregon Ash	6+5	20	10	4	3	0	1, 6, 7
88	<i>Fraxinus latifolia</i>	Oregon Ash	2+4+4+5+56	35	14	4	3	0	1, 6, 7
89	<i>Fraxinus latifolia</i>	Oregon Ash	4+5+5+6+6	35	16	4	3	0	1, 6, 7
90	<i>Fraxinus latifolia</i>	Oregon Ash	5+6+8	35	30	4	3	0	1, 6, 7
91	<i>Salix exigua</i>	Sandbar Willow	1" to 4"	18	12	4	3	0	1, 6, 7
92	<i>Fraxinus latifolia</i>	Oregon Ash	12	40	18	3	3	0	1, 6, 7
93	<i>Fraxinus latifolia</i>	Oregon Ash	6	25	18	3	3	0	1, 6, 7
94	<i>Fraxinus latifolia</i>	Oregon Ash	6	25	18	3	3	0	1, 6, 7
95	<i>Quercus lobata</i>	Valley Oak	6	40	18	4	3	0	1, 6, 7
96	<i>Quercus lobata</i>	Valley Oak	12	40	18	4	3	0	1, 6, 7



TREE INVENTORY  
 Bella Vista Subdivision  
 Ukiah, CA  
 July 14, 2021

Tree #	Species	Common Name	Trunk (dbh ± inches)	Height (± feet)	Radius (± feet)	Health 1 - 5	Structure 1 - 4	Expected Impact	Recommendations
97	<i>Salix species</i>	Native Willow	14	25	12	4	3	0	1, 6, 7

KEY TO TREE  
INVENTORY CHART

## KEY TO TREE INVENTORY CHART

### Tree Number

Each tree has been identified in the field with an aluminum tag and reference number. Tags are attached to the trunk at approximately eye level and the *Tree Location Plan* illustrates the location of each numbered tree.

### Species

Each tree has been identified by genus, species and common name. Many species have more than one common name.

### Trunk

Each trunk has been measured, to the nearest one half inch, to document its diameter at 4 feet above adjacent grade. Trunk diameter is a good indicator of age, and is commonly used to determine mitigation replacement requirements.

### Height

Height is estimated in feet, using visual assessment.

### Radius

Radius is estimated in feet, using visual assessment. Since many canopies are asymmetrical, it is not uncommon for a radius estimate to be an average of the canopy size.

### Health

The following descriptions are used to rate the health of a tree. Trees with a rating of 4 or 5 are very good candidates for preservation and will tolerate more construction impacts than trees in poorer condition. Trees with a rating of 3 may or may not be good candidates for preservation, depending on the species and expected construction impacts. Trees with a rating of 1 or 2 are generally poor candidates for preservation.

- (5) Excellent - health and vigor are exceptional, no pest, disease, or distress symptoms.
- (4) Good - health and vigor are average, no significant or specific distress symptoms, no significant pest or disease.
- (3) Fair - health and vigor are somewhat compromised, distress is visible, pest or disease may be present and affecting health, problems are generally correctable.
- (2) Marginal - health and vigor are significantly compromised, distress is highly visible and present to the degree that survivability is in question.
- (1) Poor - decline has progressed beyond the point of being able to return to a healthy condition again. Long-term survival is not expected. This designation includes dead trees.

**Structure**

The following descriptions are used to rate the structural integrity of a tree. Trees with a rating of 3 or 4 are generally stable, sound trees which do not require significant pruning, although cleaning, thinning, or raising the canopy might be desirable. Trees with a rating of 2 are generally poor candidates for preservation unless they are preserved well away from improvements or active use areas. Significant time and effort would be required to reconstruct the canopy and improve structural integrity. Trees with a rating of 1 are hazardous and should be removed.

- (4) Good structure - minor structural problems may be present which do not require corrective action.
- (3) Moderate structure - normal, typical structural issues which can be corrected with pruning.
- (2) Marginal structure - serious structural problems are present which may or may not be correctable with pruning, cabling, bracing, etc.
- (1) Poor structure - hazardous structural condition which cannot be effectively corrected with pruning or other measures, may require removal depending on location and the presence of targets.

**Tree Protection Zone (TPZ)**

The area to be protected by temporary fencing during construction. Represented by 1 foot of radius for each inch of trunk diameter measured at 4.5 feet above adjacent grade.

**Development Impacts**

Considering the proximity of construction activities, type of activities, tree species, and tree condition - the following ratings are used to estimate the amount of impact on tree health and stability. Most trees will tolerate a (1) rating, many trees could tolerate a (2) rating with careful consideration and mitigation, but trees with a (3) rating are poor candidates for preservation due to their very close proximity to construction or because they are located within the footprint of construction and cannot be preserved.

- (3) A significant impact on long term tree integrity can be expected as a result of proposed development.
- (2) A moderate impact on long term tree integrity can be expected as a result of proposed development.
- (1) A minor impact on long term tree integrity can be expected as a result of proposed development.
- (0) No impact is expected based on distance away from proposed construction activity.

**Recommendations**

Recommendations are provided for removal or preservation. For those being preserved, protection measures and mitigation procedures to offset impacts and improve tree health are provided.

- (1) Preservation appears to be possible.
- (2) Removal is required due to significant development impacts.
- (3) Removal is recommended due to poor health or hazardous structure.
- (4) Removal is required due to significant development impacts and poor existing health or structure.
- (5) Removal is recommended due to poor species characteristics.
- (6) Install temporary protective fencing at the edge of the Tree Protection Zone (TPZ), or edge of approved construction, prior to beginning grading or construction. Maintain fencing in place for duration of all construction activity in the area.
- (7) Maintain existing grade within the fenced portion of the TPZ. Route drainage swales and all underground work outside the dripline.
- (8) Place a 4" layer of chipped bark mulch over the soil surface within the fenced TPZ prior to installing temporary fencing. Maintain this layer of mulch throughout construction.
- (9) Prune to clean, raise, or provide necessary clearance. Prune to reduce branches that are over-loaded, over-extended, largely horizontal, arching, or have foliage concentrated near the branch ends, per International Society of Arboriculture Pruning Standards.

Pruning to occur by, or under the supervision of, an Arborist certified by the International Society of Arboriculture. Pruning Standards are attached to this report.

- (10) This is an off-site tree that overhangs the project site and must be protected and preserved
- (11) Excavation may be required within the TPZ and the dripline for development. Excavation within the TPZ of any type must adhere to the following guidelines:

All roots encountered that are 2 inches or larger in diameter must be cleanly cut as they are encountered by excavating equipment.

Roots may not be ripped from the ground and then trimmed. They must be trimmed as encountered and this will require the use of a ground man working with a suitable power tool.

Pruned and exposed roots greater than 2 inches in diameter must be protected from desiccation if left exposed for more than 24 hours. Cover cut roots with heavy cloth, burlap, used carpeting, or similar material that has been soaked in water, until trench or excavation has been backfilled.

If excavation impacts more than 20% of the defined TPZ then supplemental irrigation may be required to offset loss of roots. Excavation in this case should be directed by the project arborist who will determine whether excavation is required, when, and how.

Any excavation within the defined TPZ will require that the tree be monitored on a monthly basis by the project arborist for the duration of construction and for one year beyond completion of construction. Monitoring may determine other mitigation measures that may be required to offset root loss or damage.

TREE LOCATION PLAN

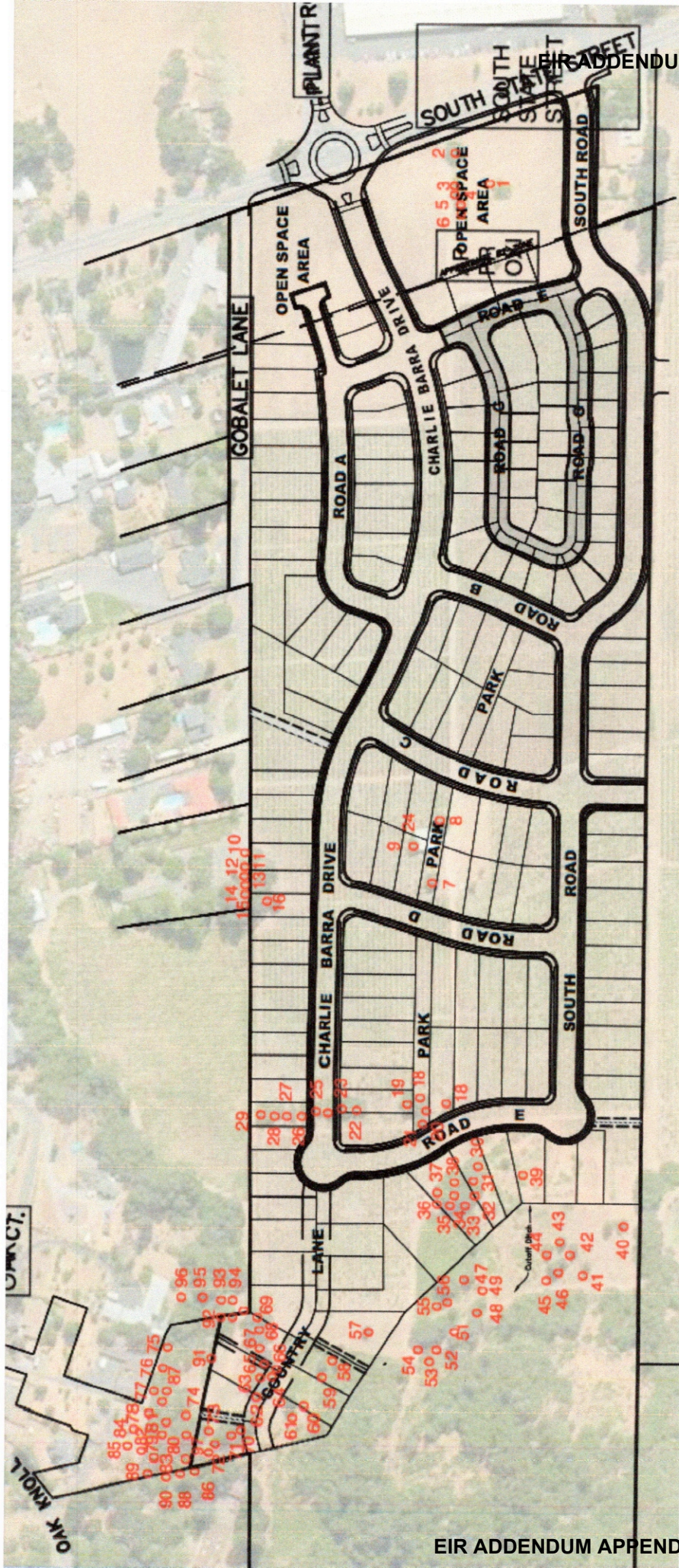

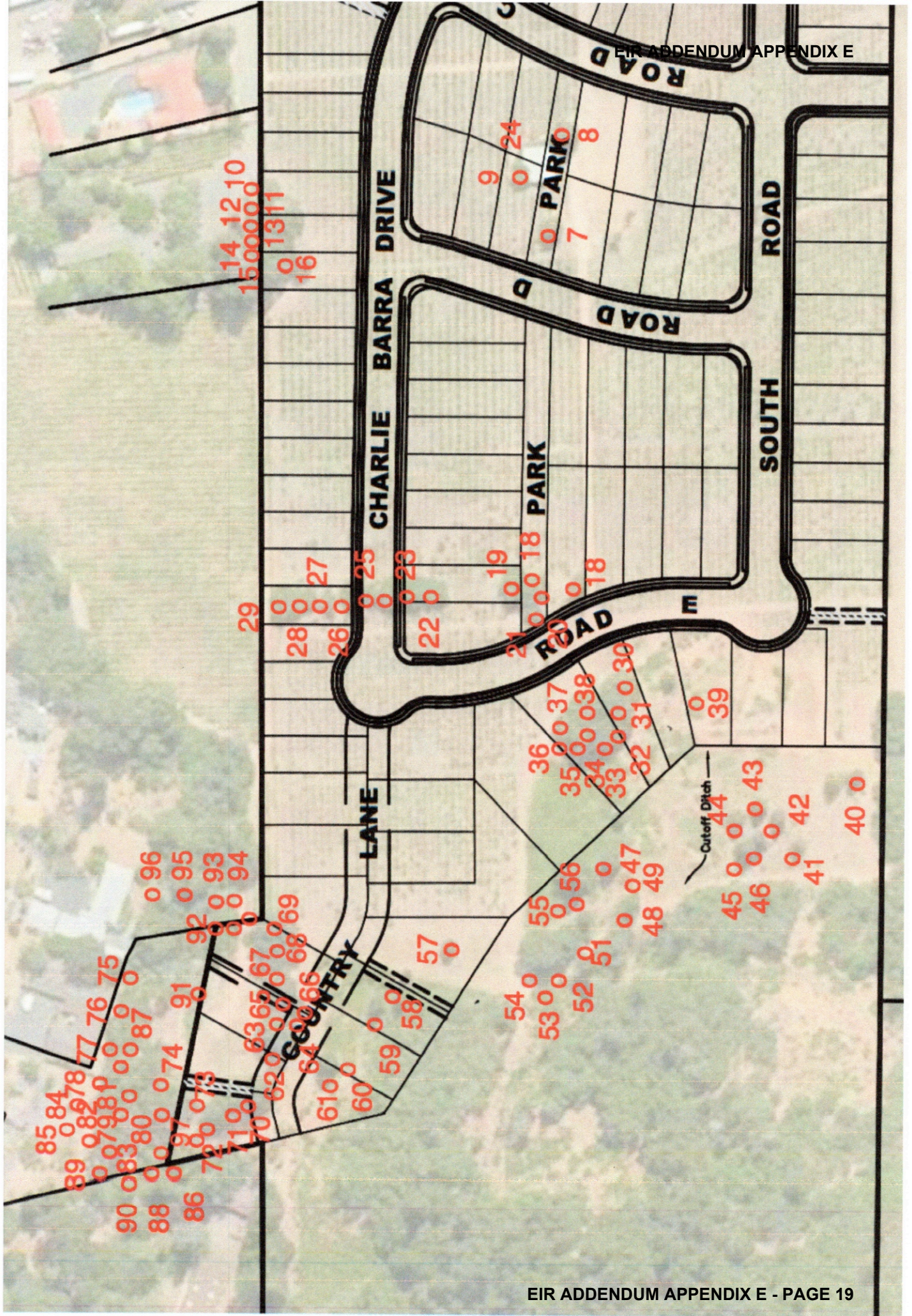



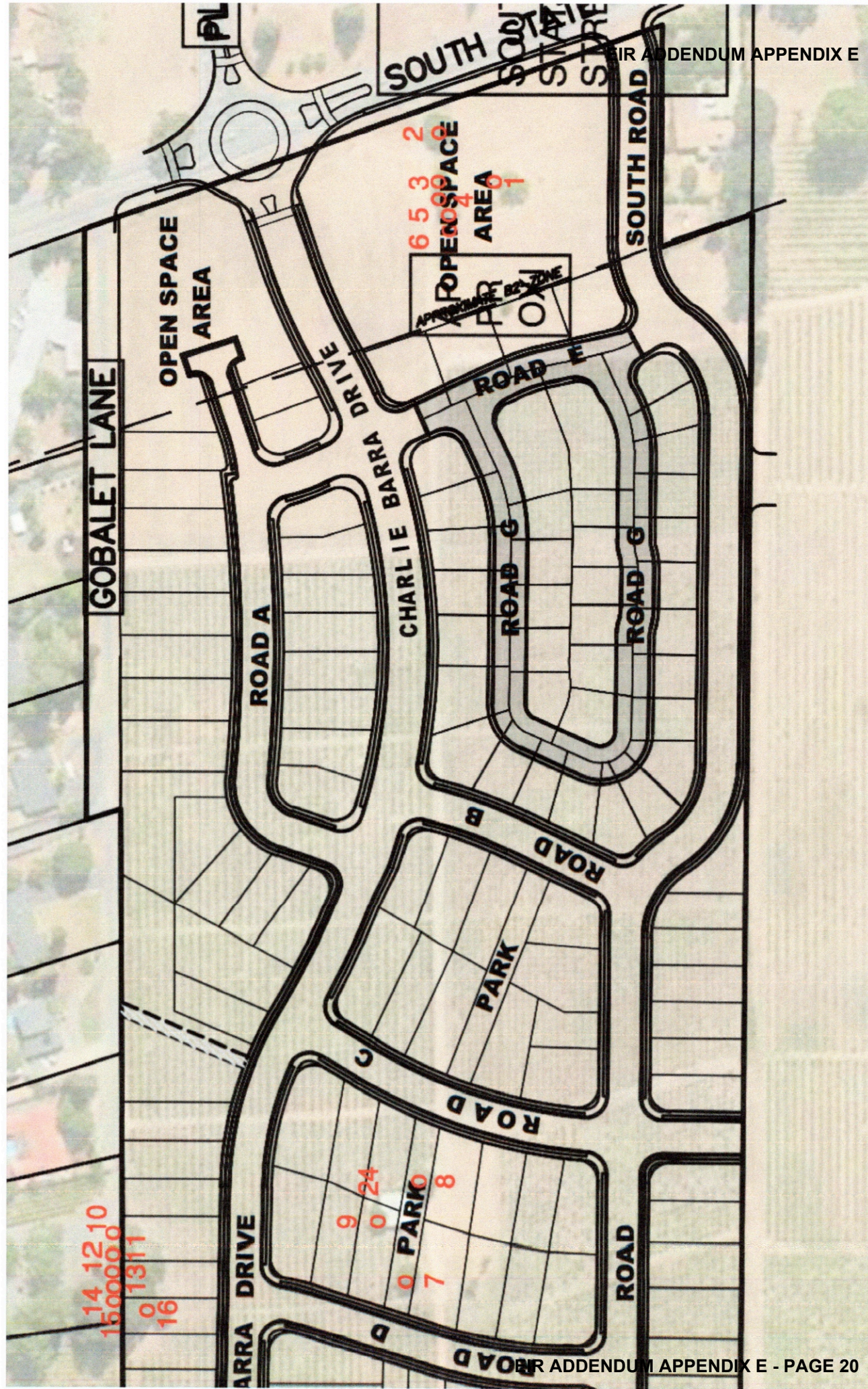

CURRENT SITE PLAN WITH 4 LOTS DELETED  
Deleted lots in yellow

NO.	BY	CHKD	DATE

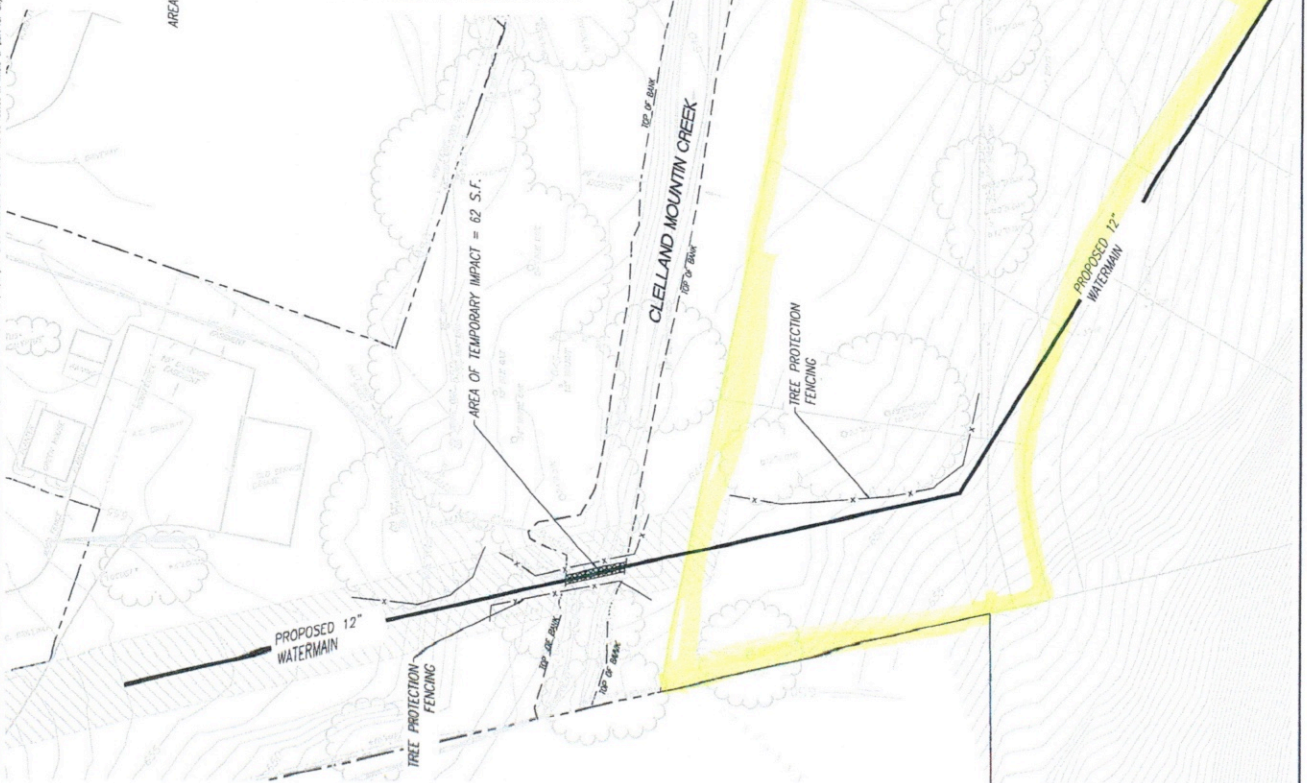

DOCUMENTS THIS EXHIBIT AND THE DATA AND DESIGN INFORMATION HEREIN IS AN INSTRUMENT OF PROFESSIONAL SERVICE IN THE INTEREST OF PROFESSIONAL SERVICE. IT IS THE PROPERTY OF LSCD ASSOCIATES AND SHALL NOT BE REPRODUCED OR TRANSMITTED IN ANY FORM OR BY ANY MEANS, ELECTRONIC OR MECHANICAL, INCLUDING PHOTOCOPYING, RECORDING, OR BY ANY INFORMATION STORAGE AND RETRIEVAL SYSTEM, WITHOUT THE WRITTEN PERMISSION OF LSCD ASSOCIATES.

TREE FENCING DETAIL

TREE PROTECTION FENCING DETAIL

NOTE:  
TENSOR LIGHTWEIGHT SAFETY GRID, ORANGE  
COLOR, BX226516, CUT OR FOLD AT POSTS  
AS NEEDED TO CONFORM TO SLOPING TERRAIN.

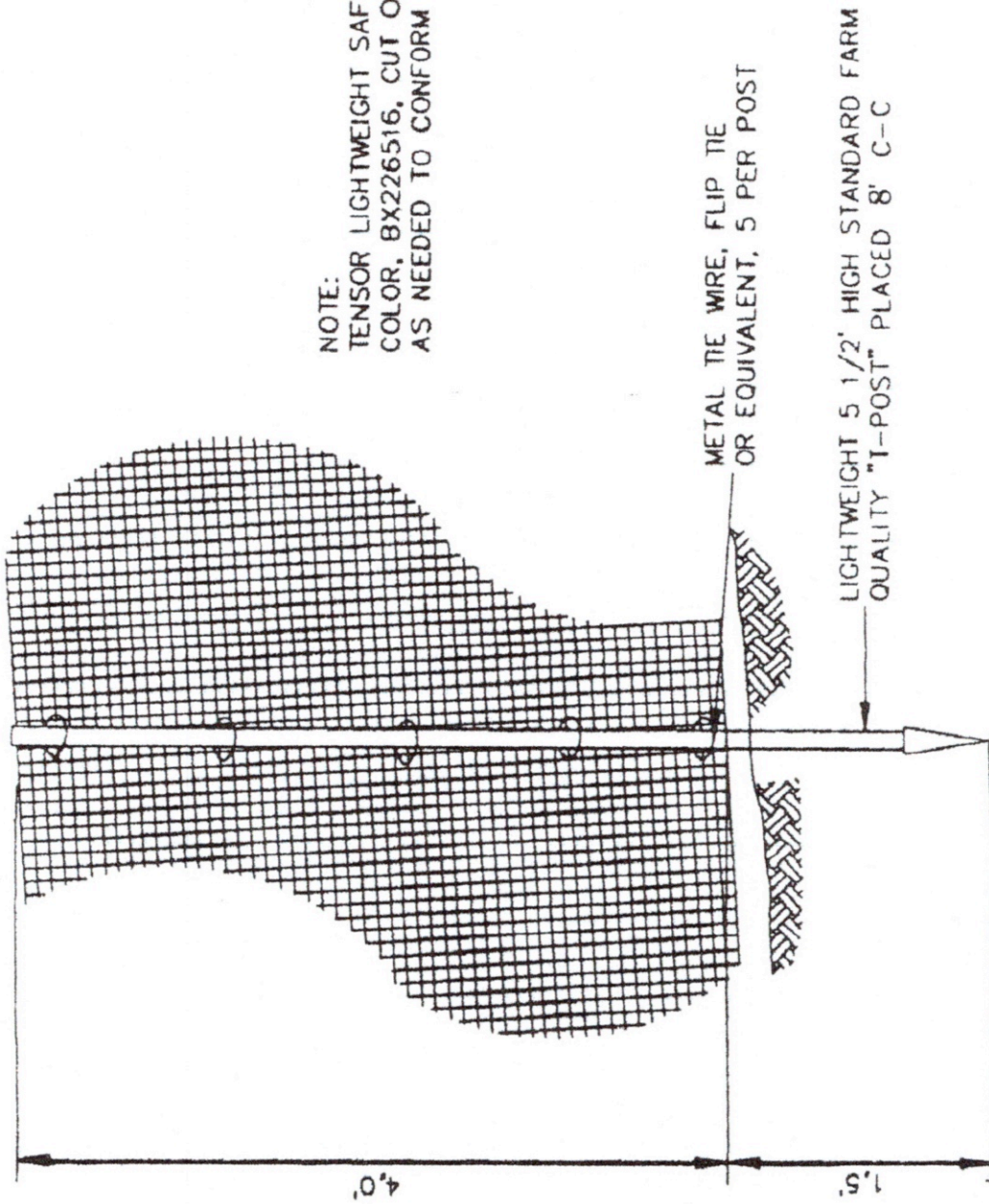

TREE PRESERVATION GUIDELINES

## TREE PRESERVATION GUIDELINES

### INTRODUCTION

Great care must be exercised when development is proposed in the vicinity of established trees of any type. The trees present at this site require specialized protection techniques during all construction activities to minimize negative impact on their long term health and vigor. The area immediately beneath and around canopy driplines is especially critical, and the specifications that follow are established to protect short and long term tree integrity. The purpose of this specification is therefore to define the procedures that must be followed during any and all phases of development in the immediate vicinity of designated protected trees.

Established, mature trees respond in a number of different ways to the disruption of their natural conditions. Change of grade within the root system area or near the root collar, damage to the bark of the trunk, soil compaction above the root system, root system reduction or damage, or alteration of summer soil moisture levels may individually or collectively cause physiological stress leading to tree decline and death. The individual impacts of these activities may cause trees to immediately exhibit symptoms and begin to decline, but more commonly the decline process takes many years, with symptoms appearing slowly and over a period of time. Trees may not begin to show obvious signs of decline from the negative impacts of construction until many years after construction is completed. It is not appropriate to wait for symptoms to appear, as this may be too late to correct the conditions at fault and to halt decline.

It is therefore critical to the long-term health of all protected trees that a defined protection program be established before beginning any construction activity where protected trees are found. Once incorporated at the design level, it is mandatory that developers, contractors, and construction personnel understand the critical importance of these guidelines, and the potential penalties that will be levied if they are not fully incorporated at every stage of development.

The following specifications are meant to be utilized by project managers and those supervising any construction in the vicinity of protected trees including grading contractors, underground contractors, all equipment operators, construction personnel, and landscape contractors. Questions which arise, or interpretation of specifications as they apply to specific site activities, must be referred to the project arborist as they occur.

Horticultural Associates  
P.O. Box 1261  
Glen Ellen, CA 95442  
707-935-3911

### TREE PROTECTION ZONE

1. The canopy dripline is illustrated on the Improvement Plans and represents the area around each tree, or group of trees, which must be protected at all times with tree protection fencing.
2. No encroachment into the dripline is allowed at any time without approval from the project arborist, and unauthorized entry may be subject to civil action and penalties.
3. The dripline will be designated by the project arborist at a location determined to be adequate to ensure long term tree viability and health. This is to occur prior to installation of fencing and in conjunction with the fencing contractor

### TREE PROTECTION FENCING

1. Prior to initiating any construction activity on a construction project, including demolition or grading, temporary protective fencing shall be installed at each site tree, or group of trees. Fencing shall be located at the dripline designated by the project arborist and generally illustrated on the Improvement Plans.
2. Fencing shall be minimum 4' height at all locations, and shall form a continuous barrier without entry points around all individual trees, or groups of trees. Barrier type fencing such as *Tensar* plastic fencing is recommended, but any fencing system that adequately prevents entry will be considered for approval by the project arborist. The use of post and cable fencing is not acceptable, however.
3. Fencing shall be installed tightly between steel fence posts (standard quality farm 'T' posts work well) placed no more than 8 feet on center. Fencing shall be attached to each post at 5 locations with plastic electrical ties, metal tie wire, or flip ties. See attached fencing detail.
4. Fencing shall serve as a barrier to prevent encroachment of any type by construction activities, equipment, materials storage, or personnel.
5. All encroachment into the fenced dripline must be approved and supervised by the project arborist. Approved dripline encroachment may require

Horticultural Associates  
P.O. Box 1261  
Glen Ellen, CA 95442  
707-935-3911



additional mitigation or protection measures that will be determined by the project arborist at the time of the request.

6. Contractors and subcontractors shall direct all equipment and personnel to remain outside the fenced area at all times until project is complete, and shall instruct personnel and sub-contractors as to the purpose and importance of fencing and preservation.
7. Fencing shall be upright and functional at all times from start to completion of project. Fencing shall remain in place and not be moved or removed until all construction activities at the site are completed.

#### TREE PRUNING AND TREATMENTS

1. All recommendations for pruning or other treatments must be completed prior to acceptance of the project. It is strongly recommended that pruning be completed prior to the start of grading to facilitate optimum logistics and access.
2. All pruning shall be conducted in conformance with International Society of Arboriculture pruning standards, and all pruning must occur by, or under the direct supervision of, an arborist certified by the International Society of Arboriculture.

#### GRADING AND TRENCHING

1. Any construction activity that necessitates soil excavation in the vicinity of preserved trees shall be avoided where possible, or be appropriately mitigated under the guidance of the project arborist. All contractors must be aware at all times that specific protection measures are defined, and non conformance may generate stop-work orders.
2. The designated dripline is defined around all site trees to be preserved. Fences protect the designated areas. No grading or trenching is to occur within this defined area unless so designated by the Improvement Plan, and where designated shall occur under the direct supervision of the project arborist.
3. Trenching should be routed around the dripline. Where trenching has been designated within the dripline, utilization of underground technology to bore, tunnel or excavate with high-pressure air or water will be specified. Hand digging will be generally discouraged unless site conditions restrict the use of alternate technology.

Horticultural Associates  
P.O. Box 1261  
Glen Ellen, CA 95442  
707-935-3911

4. All roots greater than one inch in diameter shall be cleanly hand-cut as they are encountered in any trench or during any grading activity. The tearing of roots by equipment shall not be allowed. Mitigation treatment of pruned roots shall be specified by the project arborist as determined by the degree of root pruning, location of root pruning, and potential exposure to desiccation. No pruning paints or sealants shall be used on cut roots.
5. Where significant roots are encountered mitigation measures such as supplemental irrigation and/or organic mulches may be specified by the project arborist to offset the reduction of root system capacity.
6. Retaining walls are effective at holding grade changes outside the area of the dripline and are recommended where necessary. Retaining walls shall be constructed in post and beam or drilled pier construction styles where they are necessary near or within a dripline.
7. Grade changes outside the dripline, or those necessary in conjunction with retaining walls, shall be designed so that drainage water of any type or source is not diverted toward or around the root crown in any manner. Grade shall drain away from root crown at a minimum of 2%. If grading toward the root collar is unavoidable, appropriate surface and/or subsurface drain facilities shall be installed so that water is effectively diverted away from root collar area.
8. Grade reduction within the designated dripline shall be generally discouraged, and where approved, shall be conducted only after careful consideration and coordination with the project arborist.
9. Foundations of all types within the dripline shall be constructed using design techniques that eliminate the need for trenching into natural grade. These techniques might include drilled piers, grade beams, bridges, or cantilevered structures. Building footprints should generally be outside the dripline whenever possible.

## DRAINAGE

The location and density of native trees may be directly associated with the presence of naturally occurring water, especially ephemeral waterways. Project design, especially drainage components, should take into consideration that these trees may begin a slow decline if this naturally present association with water is changed or eliminated.

Horticultural Associates  
P.O. Box 1261  
Glen Ellen, CA 95442  
707-935-3911

## TREE DAMAGE

1. Any form of tree damage which occurs during the demolition, grading, or construction process shall be evaluated by the project arborist. Specific mitigation measures will be developed to compensate for or correct the damage. Fines and penalties may also be levied.

2. Measures may include, but are not limited to, the following:

- pruning to remove damaged limbs or wood
- bark scoring to remove damaged bark and promote callous formation
- alleviation of compaction by lightly scarifying the soil surface
- installation of a specific mulching material
- supplemental irrigation during the growing season for up to 5 years
- treatment with specific amendments intended to promote health, vigor, or root growth
- vertical mulching or soil fracturing to promote root growth
- periodic post-construction monitoring at the developer's expense
- tree replacement, or payment of the established appraised value, if the damage is so severe that long term survival is not expected.

3. Any tree that is significantly damaged and whose survivability is threatened, due to negligence by any contractor, shall be appraised using the Trunk Formula Method provided in the 9th Edition of the Guide For Plant Appraisal. This appraisal value will be the basis for any fines levied on the offending contractor.

## MULCHING

1. Trees will benefit from the application of a 4 inch layer of chipped bark mulch over the soil surface within the Tree Protection Zone. Ideal mulch material is a chipped bark containing a wide range of particle sizes. Bark mulches composed of shredded redwood, bark screened for uniformity of size, dyed bark, or chipped lumber will not function as beneficially. All trees that are expected to be

Horticultural Associates  
P.O. Box 1261  
Glen Ellen, CA 95442  
707-935-3911

impacted in any way by project activities shall have mulch placed prior to the installation of protection fencing.

2. Mulch should be generated from existing site trees that are removed or pruned as part of the project. Much brought onto the site from an outside source must be from trees that are verified to be free of the Sudden Oak Death pathogen *Phytophthora ramorum*.

Horticultural Associates  
P.O. Box 1261  
Glen Ellen, CA 95442  
707-935-3911

SECTION 15.00  
GENERAL NOTES

1. The contractor shall be responsible for obtaining all necessary permits and approvals from the appropriate authorities. The contractor shall also be responsible for obtaining all necessary insurance and bonding.

SECTION 16.00

1. The contractor shall be responsible for obtaining all necessary permits and approvals from the appropriate authorities. The contractor shall also be responsible for obtaining all necessary insurance and bonding.

2. The contractor shall be responsible for obtaining all necessary permits and approvals from the appropriate authorities. The contractor shall also be responsible for obtaining all necessary insurance and bonding.

3. The contractor shall be responsible for obtaining all necessary permits and approvals from the appropriate authorities. The contractor shall also be responsible for obtaining all necessary insurance and bonding.

4. The contractor shall be responsible for obtaining all necessary permits and approvals from the appropriate authorities. The contractor shall also be responsible for obtaining all necessary insurance and bonding.

5. The contractor shall be responsible for obtaining all necessary permits and approvals from the appropriate authorities. The contractor shall also be responsible for obtaining all necessary insurance and bonding.

6. The contractor shall be responsible for obtaining all necessary permits and approvals from the appropriate authorities. The contractor shall also be responsible for obtaining all necessary insurance and bonding.

PRUNING STANDARDS

WESTERN CHAPTER  
**ISA**

## **PRUNING STANDARDS**

### **Purpose:**

Trees and other woody plants respond in specific and predictable ways to pruning and other maintenance practices. Careful study of these responses has led to pruning practices which best preserve and enhance the beauty, structural integrity, and functional value of trees.

In an effort to promote practices which encourage the preservation of tree structure and health, the W.C. ISA Certification Committee has established the following Standards of Pruning for Certified Arborists. The Standards are presented as working guidelines, recognizing that trees are individually unique in form and structure, and that their pruning needs may not always fit strict rules. The Certified Arborist must take responsibility for special pruning practices that vary greatly from these Standards.

### **I. Pruning Techniques**

- A. A thinning cut removes a branch at its point of attachment or shortens it to a lateral large enough to assume the terminal role. Thinning opens up a tree, reduces weight on heavy limbs, can reduce a tree's height, distributes ensuing invigoration throughout a tree and helps retain the tree's natural shape. Thinning cuts are therefore preferred in tree pruning.

When shortening a branch or leader, the lateral to which it is cut should be at least one-half the diameter of the cut being made. Removal of a branch or leader back to a sufficiently large lateral is often called "drop crotching."

- B. A heading cut removes a branch to a stub, a bud or a lateral branch not large enough to assume the terminal role. Heading cuts should seldom be used because vigorous, weakly attached upright sprouts are forced just below such cuts, and the tree's natural form is altered. In some situations, branch stubs die or produce only weak sprouts.

- C. When removing a live branch, pruning cuts should be made in branch tissue just outside the branch bark ridge and collar, which are trunk tissue. *(Figure 1)* If no collar is visible, the angle of the cut should approximate the angle formed by the branch bark ridge and the trunk. *(Figure 2)*
- D. When removing a dead branch, the final cut should be made outside the collar of live callus tissue. If the collar has grown out along the branch stub, only the dead stub should be removed, the live collar should remain intact, and uninjured. *(Figure 3)*
- E. When reducing the length of a branch or the height of a leader, the final cut should be made just beyond (without violating) the branch bark ridge of the branch being cut to. The cut should approximately bisect the angle formed by the branch bark ridge and an imaginary line perpendicular to the trunk or branch cut. *(Figure 4)*
- F. A goal of structural pruning is to maintain the size of lateral branches to less than three-fourths the diameter of the parent branch or trunk. If the branch is codominant or close to the size of the parent branch, thin the branch's foliage by 15% to 25%, particularly near the terminal. Thin the parent branch less, if at all. This will allow the parent branch to grow at a faster rate, will reduce the weight of the lateral branch, slow its total growth, and develop a stronger branch attachment. If this does not appear appropriate, the branch should be completely removed or shortened to a large lateral. *(Figure 5)*
- G. On large-growing trees, except whorl-branching conifers, branches that are more than one-third the diameter of the trunk should be spaced along the trunk at least 18 inches apart, on center. If this is not possible because of the present size of the tree, such branches should have their foliage thinned 15% to 25%, particularly near their terminals. *(Figure 6)*
- H. Pruning cuts should be clean and smooth with the bark at the edge of the cut firmly attached to the wood.
- I. Large or heavy branches that cannot be thrown clear, should be lowered on ropes to prevent injury to the tree or other property.
- J. Wound dressings and tree paints have not been shown to be effective in preventing or reducing decay. They are therefore not recommended for routine use when pruning.



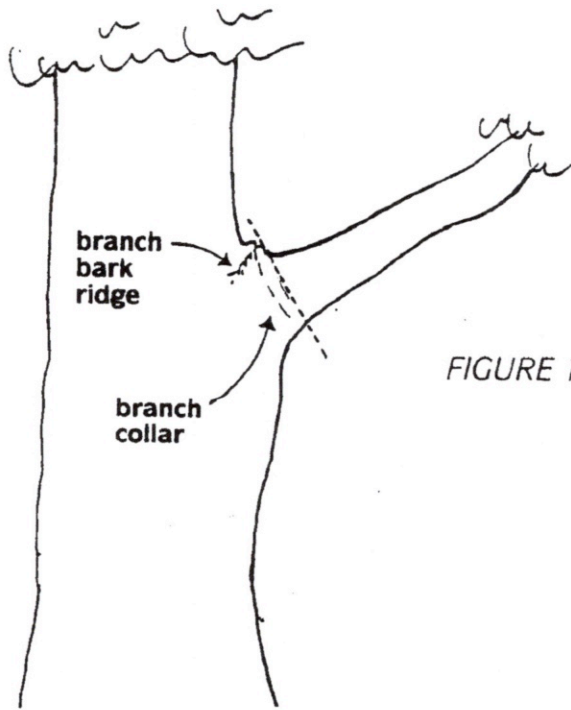

FIGURE 1. When removing a branch, the final cut should be just outside the branch bark ridge and collar.

FIGURE 2. In removing a limb without a branch collar, the angle of the final cut to the branch bark ridge should approximate the angle the branch bark ridge forms with the limb. Angle AB should equal Angle BC.

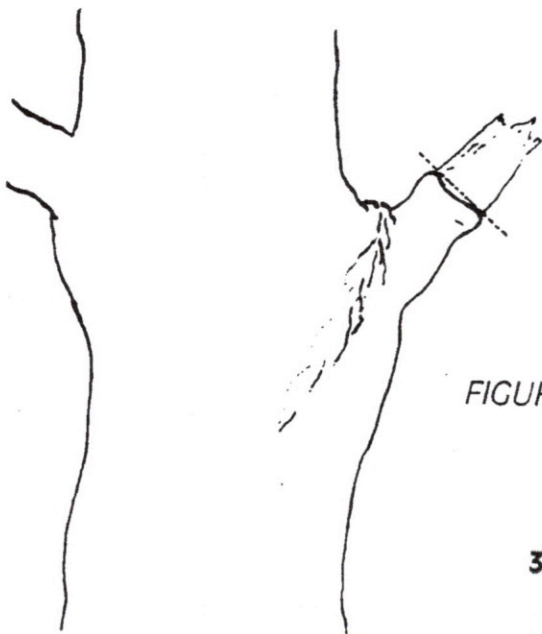
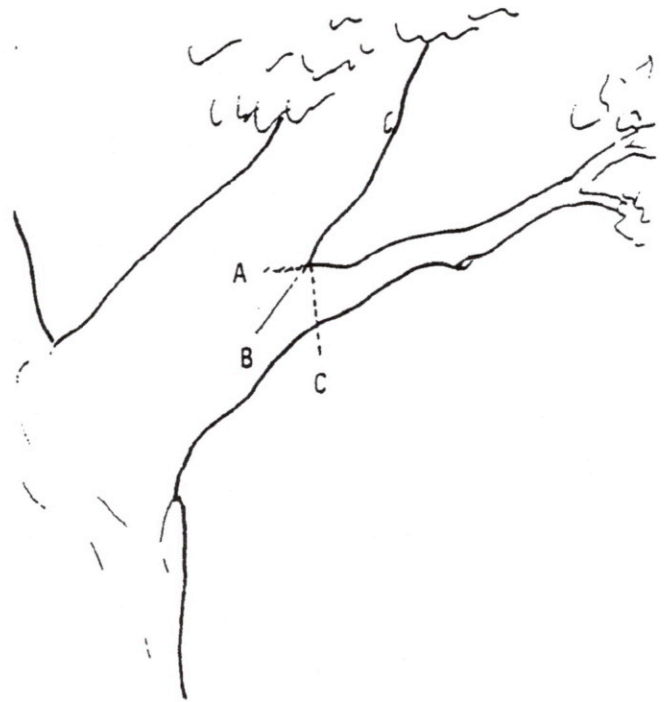

FIGURE 3. When removing a dead branch, cut outside the callus tissue that has begun to form around the branch.

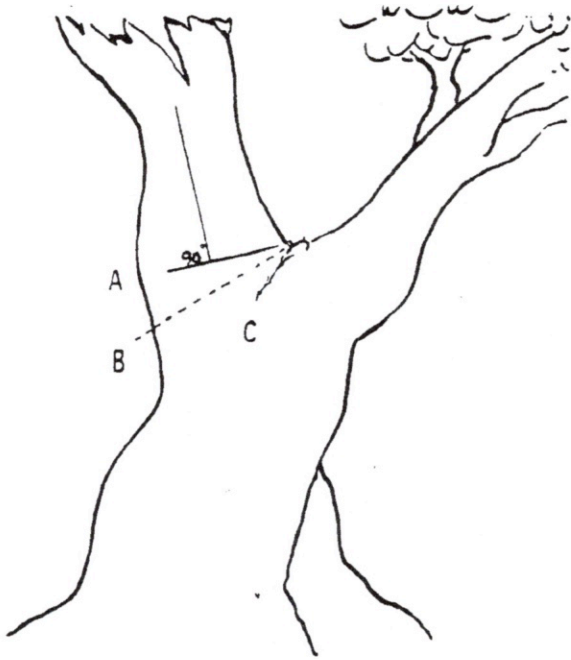
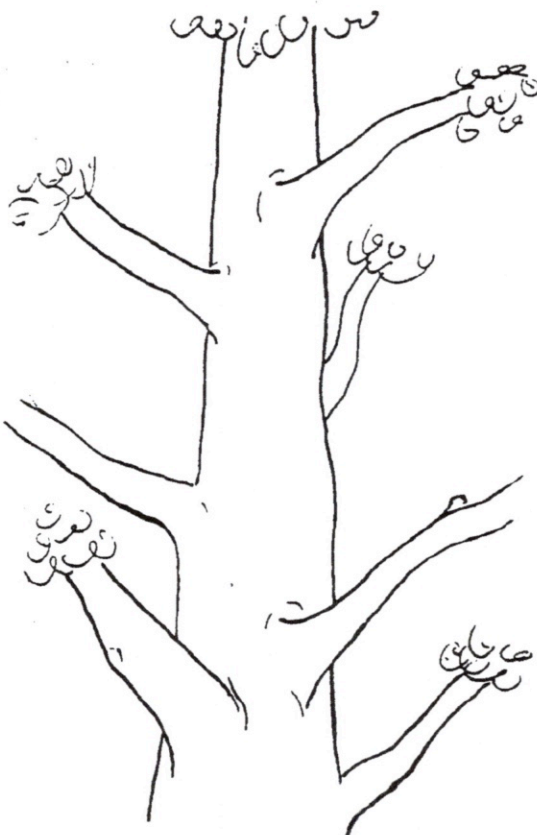

FIGURE 4. In removing the end of a limb to a large lateral branch, the final cut is made along a line that bisects the angle between the branch bark ridge and a line perpendicular to the limb being removed. Angle AB is equal to Angle BC.

FIGURE 5. A tree with limbs tending to be equal-sized, or codominant. Limbs marked B are greater than  $\frac{3}{4}$  the size of the parent limb A. Thin the foliage of branch B more than branch A to slow its growth and develop a stronger branch attachment.



FIGURE 6. Major branches should be well spaced both along and around the stem.



## II. Types of Pruning — Mature Trees

### A. CROWN CLEANING

Crown cleaning or cleaning out is the removal of dead, dying, diseased, crowded, weakly attached, and low-vigor branches and watersprouts from a tree crown.

### B. CROWN THINNING

Crown thinning includes crown cleaning and the selective removal of branches to increase light penetration and air movement into the crown. Increased light and air stimulates and maintains interior foliage, which in turn improves branch taper and strength. Thinning reduces the wind-sail effect of the crown and the weight of heavy limbs. Thinning the crown can emphasize the structural beauty of trunk and branches as well as improve the growth of plants beneath the tree by increasing light penetration. When thinning the crown of mature trees, seldom should more than one-third of the live foliage be removed.

At least one-half of the foliage should be on branches that arise in the lower two-thirds of the trees. Likewise, when thinning laterals from a limb, an effort should be made to retain inner lateral branches and leave the same distribution of foliage along the branch. Trees and branches so pruned will have stress more evenly distributed throughout the tree or along a branch.

An effect known as "lion's-tailing" results from pruning out the inside lateral branches. Lion's-tailing, by removing all the inner foliage, displaces the weight to the ends of the branches and may result in sunburned branches, watersprouts, weakened branch structure and limb breakage.

### C. CROWN REDUCTION

Crown reduction is used to reduce the height and/or spread of a tree. Thinning cuts are most effective in maintaining the structural integrity and natural form of a tree and in delaying the time when it will need to be pruned again. The lateral to which a branch or trunk is cut should be at least one-half the diameter of the cut being made.

### D. CROWN RESTORATION

Crown restoration can improve the structure and appearance of trees that have been topped or severely pruned using heading cuts. One to three sprouts on main branch stubs should be selected to reform a more natural appearing crown. Selected vigorous sprouts may need to be thinned to a lateral, or even headed, to control length growth in order to ensure adequate attachment for the size of the sprout. Restoration may require several prunings over a number of years.

## II. Types of Pruning — Mature Trees *(continued)*

### E. CROWN RAISING

Crown raising removes the lower branches of a tree in order to provide clearance for buildings, vehicles, pedestrians, and vistas. It is important that a tree have at least one-half of its foliage on branches that originate in the lower two-thirds of its crown to ensure a well-formed, tapered structure and to uniformly distribute stress within a tree.

When pruning for view, it is preferable to develop "windows" through the foliage of the tree, rather than to severely raise or reduce the crown.

## III. Size of Pruning Cuts

Each of the Pruning Techniques (Section I) and Types of Pruning (Section II) can be done to different levels of detail or refinement. The removal of many small branches rather than a few large branches will require more time, but will produce a less-pruned appearance, will force fewer watersprouts and will help to maintain the vitality and structure of the tree. Designating the maximum size (base diameter) that any occasional undesirable branch may be left within the tree crown, such as ½', 1' or 2' branch diameter, will establish the degree of pruning desired.

## IV. Climbing Techniques

- A. Climbing and pruning practices should not injure the tree except for the pruning cuts.
- B. Climbing spurs or gaffs should not be used when pruning a tree, unless the branches are more than throw-line distance apart. In such cases, the spurs should be removed once the climber is tied in.
- C. Spurs may be used to reach an injured climber and when removing a tree.
- D. Rope injury to thin barked trees from loading out heavy limbs should be avoided by installing a block in the tree to carry the load. This technique may also be used to reduce injury to a crotch from the climber's line.

**DRAFT DELINEATION OF JURISDICTIONAL WATERS  
OF THE UNITED STATES**

**Bella Vista Subdivision Project**

Mendocino County, California

June 2021



Prepared for:

**Guillon, Inc.**

C/O: Jake Morley

2550 Lakewest Drive, Suite 50

Chico, CA 95928

(530) 513-3626

Prepared by:

**Gallaway Enterprises**

117 Meyers Street, Suite 120

Chico CA 95928

(530) 332-9909

[www.gallawayenterprises.com](http://www.gallawayenterprises.com)

**Contents**

Introduction and Project Location ..... 1  
     Environmental Setting and Site Conditions ..... 1  
 Survey Methodology ..... 4  
     Determination of Hydrophytic Vegetation ..... 4  
     Determination of Hydric Soils ..... 6  
     Determination of Wetland Hydrology ..... 6  
     Determination of Ordinary High Water Mark ..... 6  
     Jurisdictional Boundary Determination and Acreage Calculation ..... 7  
     Determination of Wetland Boundaries in Difficult Wetland Situations ..... 7  
     Non-wetland Boundary Determination ..... 7  
 Results ..... 9  
     Waters of the United States: Tributaries ..... 9  
     Waters of the United States: Adjacent Wetlands ..... 9  
     Soils ..... 9  
     Vegetation ..... 10  
     Hydrology ..... 10  
     Site Photos Taken on May 3, 2021 ..... 11  
 Glossary ..... 14  
 References ..... 18

**List of Tables and Figures**

Table 1. Waters of the United States Acreage Table for the Bella Vista Subdivision Project..... 9

Table 2. Soil Map Units, NRCS hydric soil designation, and approximate totals for Bella Vista Subdivision Project. .... 10

Figure 1 - Regional Location Map ..... 2

Figure 2 - Project Location Map..... 3

Figure 3 - Photo Point Location Map ..... 5

Figure 4 - Draft Delineation of Waters of the United States Map ..... 8

**List of Appendices**

- Appendix A: Wetland Delineation Data Sheets
- Appendix B: NRCS Soil Map and Soil Series Descriptions

## DRAFT DELINEATION OF JURISDICTIONAL WATERS OF THE UNITED STATES,

### Bella Vista Subdivision Project Location:

Mendocino, California

Rancho Yokaya Land Grant

### Introduction and Project Location

Gallaway Enterprises conducted a delineation of waters of the United States (WOTUS) and aquatic resources for the Bella Vista Subdivision project (Project) site consisting of approximately 36.8-acres of land located immediately south of the city limits of Ukiah in Mendocino County, California. The Project site is located on the west side of South State Street and Hwy 101 and south of Gobalet Lane (**Figure 1 and 2**). The Project site is located within the United States Geological Survey (USGS) Rancho Yokaya Land Grant quadrangle, within Section 32, Township 15N, Range 12W.

To access the site from Hwy 101 N, take exit 546 for State Street. Yield right onto South State Street heading north towards Ukiah. Continue on South State Street for approximately 1,000 feet and the Project site will be on the left side of the road.

A survey of WOTUS was conducted on May 3, 2021, by senior botanist Elena Gregg. Data regarding the location and extent of wetlands and other waters of the United States were collected using a Trimble Geo Explorer 6000 Series GPS Receiver. The survey involved an examination of botanical resources, soils, hydrological features, and determination of wetland characteristics based on the *United States Army Corps of Engineers Wetlands Delineation Manual* (1987) (1987 Delineation Manual); the *Regional Supplement to the Corps of Engineers Wetland Delineation Manual: Arid West Region* (2008) (Arid West Manual); the *Field Guide to the Identification of the Ordinary High Water Mark (OHWM) in the Arid West Region of the Western United States* (2008); the *State of California 2016 Wetland Plant List and 2019 National Wetland Plant List updated information*; and the *Clean Water Act Final Rule, Federal Register Volume 85, No-77* (Final Rule), April 21, 2020. Gallaway Enterprises have prepared this report in compliance with the Minimum Standards for Acceptance of Aquatic Resources Delineation Reports (January 2016).

### Environmental Setting and Site Conditions

The Project site is composed largely of a mix of annual grassland and vineyards with small areas of urban habitat and mixed montane hardwood conifer vegetation. A number of barren dirt/gravel access roads occur throughout the site. One small intermittent drainage, Cleland Mountain Creek, flows roughly west to east through the northernmost part of the Project site. Gobalet Lane, residential homes and a small vineyard occur adjacent to the Project site to the north, a large established vineyard to the south, South State Street and an industrial area to the east, and open montane hardwood conifer woodland associated with Cleland Mountain to the west.

The average annual precipitation is 37.26 inches and the average annual temperature is 58.6° F (WRCC 2021) in the region where the Project is located. The elevation of the Project site ranges from 600 to 695 feet above sea level. The Project site is relatively flat in the eastern portion of the site and becomes steeper with rolling terrain in the western portion of the site. Slopes on site range from 2 to 50 percent. Soils within the site were well draining loams and gravelly loams with a deep restrictive layer typically found more than 80 inches in depth.



Project Location

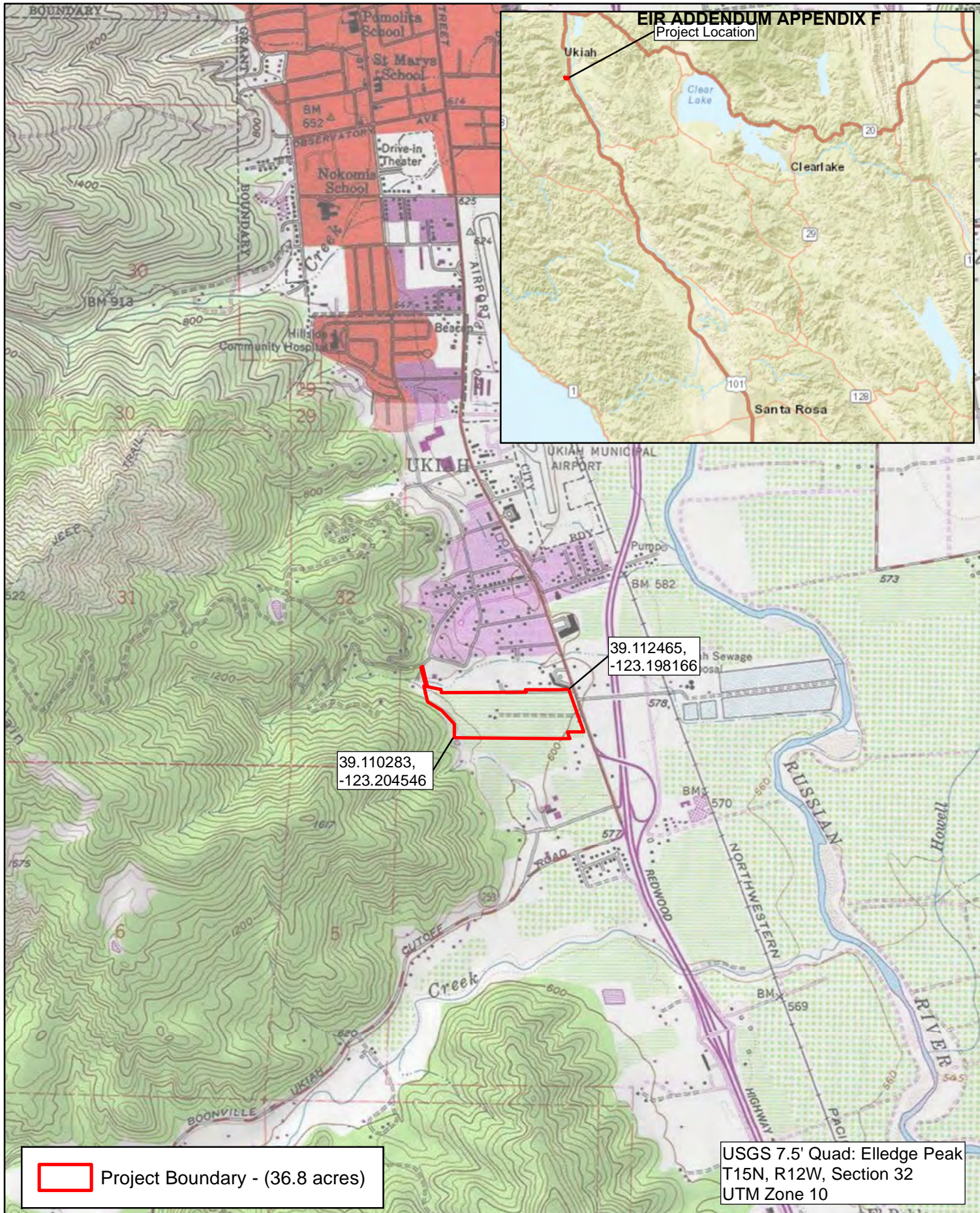
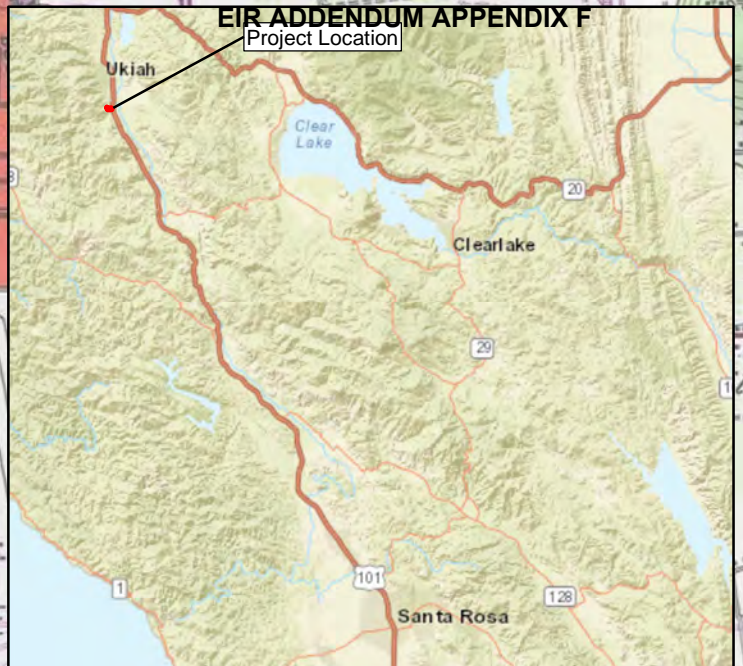

39.110283, -123.204546

39.112465, -123.198166

Project Boundary - (36.8 acres)

USGS 7.5' Quad: Elledge Peak T15N, R12W, Section 32 UTM Zone 10

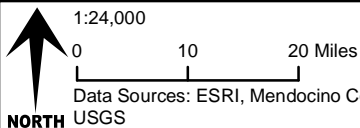

Bella Vista Subdivision Regional Location Map

Figure 1





39.112465,  
-123.198166

39.110283,  
-123.204546

S State St

 Project Boundary - (36.8 acres)

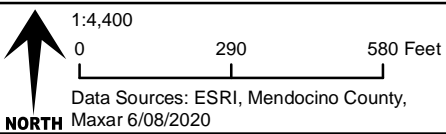

Bella Vista Subdivision  
Project Location Map

Figure 2

## Survey Methodology

The entire Project site was traversed on foot by Gallaway Enterprises staff on May 3, 2021 to identify any potentially jurisdictional features. The survey, mapping efforts, and report production were performed according to the current valid legal definitions of WOTUS that went into effect starting June 22, 2020. The boundaries of non-tidal, non-wetland waters, when present, were delineated at the ordinary high water mark (OHWM) as defined in 33 Code of Federal Regulations (CFR) 328.3. The OHWM represents the limit of United States Army Corps of Engineers (Corps) jurisdiction over non-tidal waters (e.g., streams and ponds) in the absence of adjacent wetlands (33 CFR 328.04) (Curtis, et. al. 2011). Historic aerial photographs available on Google Earth were analyzed prior to conducting the field visit. Areas identified as having potential wetland or unusual signatures on historical aerial photos were assessed in the field to determine the current conditions.

Field data was entered onto data sheets using the most current format (**Appendix A**). The 1987 Delineation Manual and the Arid West Manual were used to identify the presence of wetlands, when present, and record and define the wetland perimeters according to their topographic and hydrologic orientation. Test pit sampling was performed and/or photographs were taken in areas displaying potential wetland signatures on aerial photographs and problem areas. At each sampling point data collected involved physical sampling of soils and vegetation, and investigation regarding hydrological connectivity. Only areas exhibiting the necessary wetland parameters according to the 1987 Delineation Manual and Arid West Manual on the date surveyed were mapped as wetlands. Photographs were taken to show test pit locations, features and/or areas identified as having unusual aerial signatures. The locations of the photo points are depicted in **Figure 3** and the associated photographs are provided at the end of the report.

Many of the terms used throughout this report have specific meanings relating to the federal wetland delineation process. Term definitions are based on the Corps 1987 Delineation Manual; the Arid West Manual; *Field Guide to the Identification of the Ordinary High Water Mark (OHWM) in the Arid West Region of the Western United States*, (Lichvar and McColley 2008) and the Final Rule. The terms defined below have specific meaning relating to the delineation of WOTUS as prescribed by §404 of the Clean Water Act (CWA) and described in 33 CFR Part 328 and 40 CFR Parts 110, 112, and 116, and 122.

### Determination of Hydrophytic Vegetation

The presence of hydrophytic vegetation was determined using the methods outlined in the 1987 Delineation Manual and the Arid West Manual. Areas were considered to have positive indicators of hydrophytic vegetation if they pass the dominance test, meaning more than 50 percent of the dominant species are obligate wetland, facultative wetland and facultative plants. Plant species were identified to the lowest taxonomy possible. Plant indicator status was determined by reviewing the State of California 2016 Wetland Plant List for the Arid West Region and the National Wetland Plant List 2019 updated information. In situations where dominance can be misleading due to seasonality, the prevalence index will be used to determine hydrophytic status of the community surrounding sample sites.

#### ***Plant indicator status categories:***

*Obligate wetland plants* (OBL) – plants that occur almost always (estimated probability 99%) in wetlands under normal conditions, but which may also occur rarely (estimated probability 1%) in non-wetlands.

*Facultative wetland plants* (FACW) - plants that usually occur (estimated probability 67% to 99%) in wetlands under normal conditions, but also occur (estimated probability 1% to 33%) in non-wetlands.

*Facultative plants* (FAC) – Plants with a similar likelihood (estimated probability 33% to 67%) of occurring in both wetlands and non-wetlands.

Ground Photographs Table				
label	Direction	Latitude	Longitude	Comment
P01	W	39.11259927	-123.2061748	intermittent drainage
P02	E + S + W	39.11212711	-123.2039491	upland overview
P03	SW	39.11143009	-123.2046945	upland hillside
P04	W + SW	39.1112425	-123.2040152	toe of slope
P05	W	39.11080542	-123.2040761	eroded/slide
P06	NE	39.11028211	-123.204313	overview
P07	W	39.11188901	-123.1979218	upland with signature
P08	NW	39.11136321	-123.1987893	TP01
P09	N + S	39.11088329	-123.1973779	upland ditch
P10	NE + W + N	39.11080615	-123.1984151	upland / upland depression
P11	W + E	39.11030819	-123.1984876	upland ditch

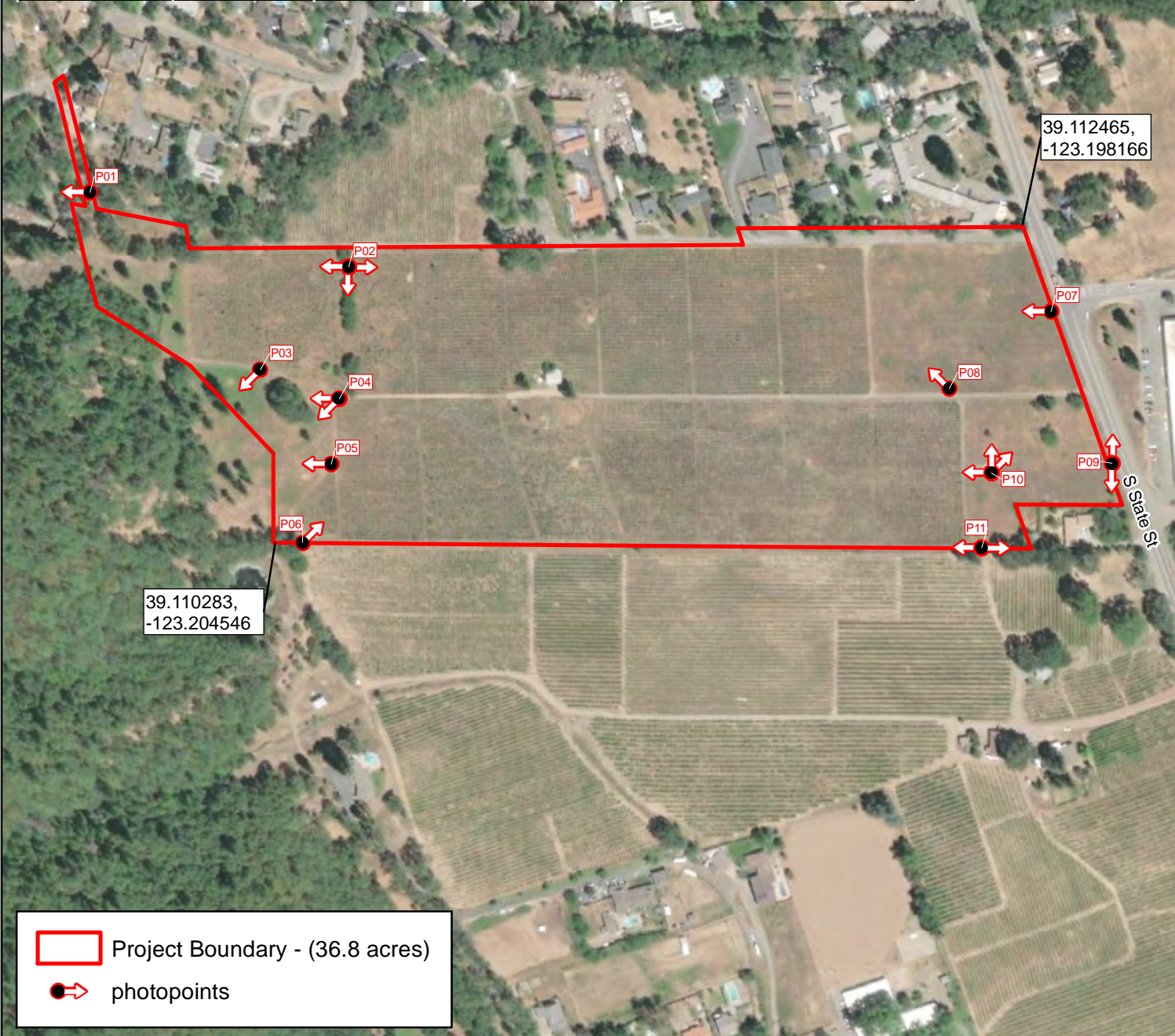

Project Boundary - (36.8 acres)  
● ➔ photopoints

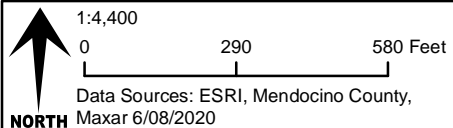

Bella Vista Subdivision  
 Ground Photographs Map  
 Figure 3

*Facultative upland plants* (FACU) – Plants that occur sometimes (estimated probability 1% to 33%) in wetlands, but occur more often (estimated probability 67% to 99%) in non-wetlands.

*Obligate upland plants* (UPL) – Plants that occur rarely (estimated probability 1%) in wetlands, but occur almost always (estimated probability 99%) in non-wetlands under natural conditions.

### Determination of Hydric Soils

Soil survey information was reviewed for the current site condition. Field samples were evaluated by using the Munsell soil color chart (2009 Edition), hand texturing, and assessing soil features (e.g. oxidized root channels, evidence of hardpan, Mn and Fe concretions). Information regarding local soil and series descriptions is provided in **Appendix B**. The current Natural Resources Conservation Service (NRCS) *Field Indicators of Hydric Soils in the United States, Version 8.2* (NRCS 2018) was used in conjunction with the Arid West Manual to determine the presence of hydric soil indicators.

### Determination of Wetland Hydrology

Wetland hydrology was determined to be present if a site supported one or more of the following characteristics:

- Landscape position and surface topography (e.g. position of the site relative to an up-slope water source, location within a distinct wetland drainage pattern, and concave surface topography),
- Inundation or saturation for a long duration either inferred based on field indicators or observed during repeated site visits, and
- Residual evidence of ponding or flooding resulting in field indicators such as scour marks, sediment deposits, algal matting, surface soil cracks and drift lines.

The presence of water or saturated soil for approximately 12% or 14 consecutive days during the growing season typically creates anaerobic conditions in the soil, and these conditions affect the types of plants that can grow and the types of soils that develop (Wetland Training Institute 1995).

Historic aerial photographs were analyzed to look for primary and secondary wetland hydrology indicators of inundation or saturation. The historic aerial imagery reviewed was the public, readily available imagery provided on Google Earth (1998-2018). If aerial signatures demonstrated the presence of surface water on 5 or more of the historic aerial photographs viewed, inundation and a primary indicator of wetland hydrology was determined to be present. Saturation, a secondary indicator of wetland hydrology, was determined to be present if saturation, “darker patches within the field,” were observed on 5 or more of the 9 historic aerial photographs viewed.

### Determination of Ordinary High Water Mark

Gallaway Enterprises utilized methods consistent with the Arid West Manual and *Field Guide to the Identification of the Ordinary High Water Mark (OHWM) in the Arid West Region of the Western United States*, (Lichvar and McColley 2008) to determine the OHWM. The lateral extents of non-tidal water bodies (e.g. intermittent and ephemeral streams) were based on the OHWM, which is “the line on the shore established by the fluctuations of water” (Corps 2005). The OHWM was determined based on multiple observed physical characteristics of the area, which can include scour, multiple observed flow events (from current and historical aerial photos), shelving, and changes in the character of soil, presence of mature vegetation, deposition, and topography. Due to the wide extent of some floodplains, adjacent riparian scrub areas characterized by hydric soils, hydrophytic vegetation, and

hydrology may be included within the OHWM of a non-tidal water body (Curtis, et. al. 2011). Inclusion of minor special aquatic areas is an acceptable practice as outlined in the Arid West Manual.

#### **OHWM Transects:**

Representative OHWM widths measured in the field in feet as required by the Corps *Updated Map and Drawing Standards for the South Pacific Division Regulatory Program (2016)* and presented as an average for the entire drainage. These transect measurements are used to ensure that the other waters of the United States identified within the area surveyed are mapped and calculated at the appropriate average width for each channel segment based on the Corps definition of OHWM as defined in the Arid West OHWM Field Guide and the Ordinary High Water Mark Identification RGL 05-05 (2005) (RGL 05-05). At the transect line Gallaway Enterprises used multiple observed physical indicators in determining the OHWM. The lateral extents of the transect lines identify the location of the OHWM where benches, drift, exposed root hairs, changes in substrate/particle size, and, if appropriate, changes in vegetation were observed.

#### **Jurisdictional Boundary Determination and Acreage Calculation**

The wetland-upland boundary was determined based on the presence or inference of positive indicators of all mandatory criteria. Soil samples were taken, as needed, within wetland and upland areas. The site was traversed on foot to identify wetland features and boundaries. The spatial data obtained during the preparation of this wetland delineation was collected using a Trimble Geo Explorer 6000 Series GPS Receiver. No readings were taken with fewer than 5 satellites. Point data locations were recorded for at least 25 seconds at a rate of 1 position per second. Area and line data were recorded at a rate of 1 position per second while walking at a slow pace. All GPS data were differentially corrected for maximum accuracy. In some cases, when visual errors and degrees of precision are identified due to environmental factors negatively influencing the precision of the GPS instrument (i.e. dense tree cover, steep topography, and other factors affecting satellite connection) mapping procedures utilized available topographic and aerial imagery datasets in order to improve accuracy in feature alignment and location.

#### **Determination of Wetland Boundaries in Difficult Wetland Situations**

In California, the winter of 2020/2021 was considered a below average rainfall year (NOAA 2021). As such, the guidelines provided in the Arid West Manual for making wetland determinations in atypical, difficult wetland situations was used. To aid in the determination, spatial patterns, analysis of aerial photographs, topography, and landscape position were used in conjunction with vegetation data to determine the wetland boundary. Areas where wetland vegetation or wetland hydrology was lacking but where the landscape position was likely to concentrate water were closely inspected. Gallaway Enterprises mapped these areas as wetlands if hydric soil indicators were detected and at least one other hydric indicator was present (i.e. wetland hydrology or hydrophytic vegetation).

#### **Non-wetland Boundary Determination**

Areas were determined to be non-wetlands if they did not meet the necessary wetland test parameters (hydrophytic vegetation, hydric soil, and wetland hydrology) (33 CFR 328.4). One test pit (TP01) was taken at a minute depression in the annual grassland portion of the Project site (**Figure 4**). This test pit location lacked the necessary wetland parameters to be considered a wetland and was, thus, determined to be upland/non-wetland (**Appendix A**). Further, the southeast block of vineyard within the Project site was observed to be dominated by an understory of snow white meadowfoam (*Limnanthes douglasii ssp. nivea*) (OBL). However, this area lacked suitable ponding landscape position, was being actively irrigated and lacked wetland hydrology indicators so the area was considered upland.

**EIR ADDENDUM APPENDIX F**

Coordinate System: NAD1983 California State Plane II (Feet)  
 Projection: Lambert Conformal Conic  
 Datum: North American 1983  
 Vertical Datum: NAVD 88

Made in accordance with the Updated Map & Drawing Standards  
 for the South Pacific Division Regulatory Program

The features represented on this graphic are  
 considered preliminary until written verification by the USACE

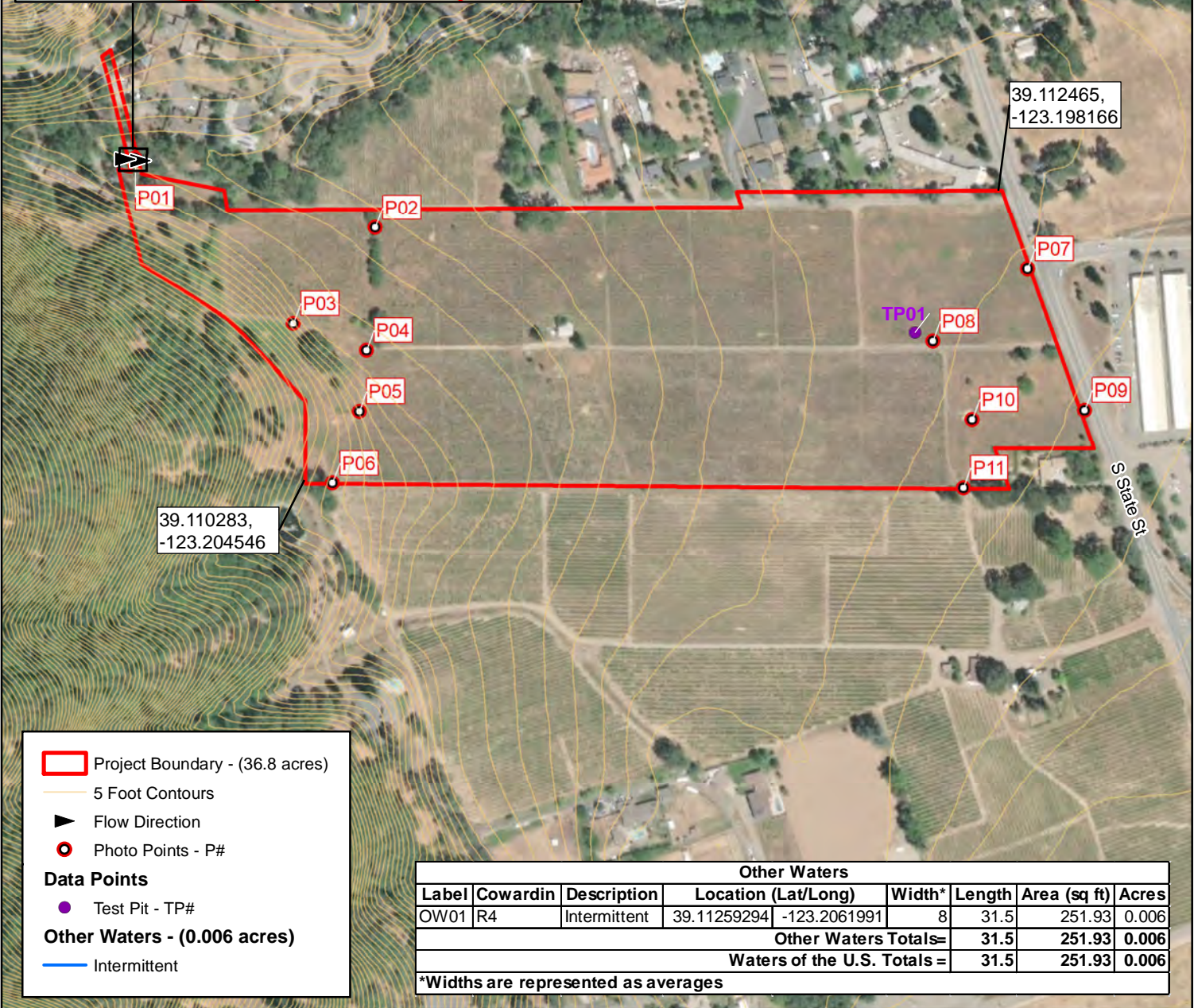

**Legend**

- Project Boundary - (36.8 acres)
- 5 Foot Contours
- Flow Direction
- Photo Points - P#

**Data Points**

- Test Pit - TP#

**Other Waters - (0.006 acres)**

- Intermittent

Other Waters								
Label	Cowardin	Description	Location (Lat/Long)		Width*	Length	Area (sq ft)	Acres
OW01	R4	Intermittent	39.11259294	-123.2061991	8	31.5	251.93	0.006
<b>Other Waters Totals =</b>						<b>31.5</b>	<b>251.93</b>	<b>0.006</b>
<b>Waters of the U.S. Totals =</b>						<b>31.5</b>	<b>251.93</b>	<b>0.006</b>

\*Widths are represented as averages

1:4,800  
 0 320 640 Feet  
 1 inch = 400 feet

Data Sources: ESRI, Mendocino County, Maxar 6/08/2020

**NORTH**

Bella Vista Subdivision  
 Delineation of Waters of the U.S.



## Results

A complete Draft Delineation of WOTUS map, utilizing a 1" to 400' scale, is included as **Figure 4**. **Table 1** details the area calculations for the pre-jurisdictional features within the Project site.

**Table 1. Waters of the United States Acreage Table for the Bella Vista Subdivision Project.**

Waters of the United States						
Label	Cowardin	Description	Avg Width	Length	Area (sq ft)	Acres
OW01	R4	Intermittent	8	31.5	251.93	0.006
<b>Other Waters Totals=</b>				<b>31.5</b>	<b>251.93</b>	<b>0.006</b>
<b>Waters of the U.S. Totals =</b>				<b>31.5</b>	<b>251.93</b>	<b>0.006</b>

### Waters of the United States: Tributaries

There is one feature that functions as a Tributary (Tributary) to a TNW per the Final Rule within the Project site. Tributaries are intermittent or perennial water bodies in a typical year, including lakes, stream channels, and other similar surface water features that exhibit an OHWM, but lack positive indicators for one or more of the three wetland parameters (hydrophytic vegetation, hydric soil, and wetland hydrology) (33 CFR 328.4).

The one drainage identified within the Project is an intermittent drainage that demonstrated an OHWM and is locally referred to as Cleland Mountain Creek (OW01, **Figure 4**). No water was observed flowing within the intermittent drainage during the May field visit, but the streambed substrate was saturated (see picture associated with photo point P01, **Figure 3**).

### Waters of the United States: Adjacent Wetlands

No potentially adjacent wetlands were found to occur within the Project site.

Photo points were taken throughout the Project site to depict the current site conditions (**Figure 3**).

### Soils

Gallaway Enterprises' field observations of soil characteristics included soil color, texture, structure, and the visual assessment of soil features (e.g. the presence, or absence of redoximorphic features and the depth of restrictive layers such as hardpans). Gallaway Enterprises' soil texture evaluations rendered silty and gravelly loams. Iron concentrations and depletions were found primarily in pore spaces and as soft masses in the soil matrix at varying depths within the surface horizons. Field observations of soil characteristics at the test pit site are included in the data sheet form presented in **Appendix A**.

The geographic region in which the Project site is found is often characterized as having a deep naturally occurring restrictive layer. Within the Project site, the restrictive layer is typically found at a depth of more than 80 inches. The depth of the hand dug soil pits were dug deep enough to determine or rule out the presence/absence of hydric soil indicators.

Gallaway Enterprises queried the National Cooperative Soil Survey database to further evaluate the soil conditions. A copy of the soil survey map and a description of mapped soil units for the Project site are included as **Appendix B**. Two soil map units occur within the Project site. These map units are listed below in **Table 2**. Based on Gallaway Enterprises' review of the soil map units identified within the Project site, no hydric components occur. A copy of the soil survey map and a description of mapped soil units for the Project site are included as **Appendix B**.



**Table 2. Soil Map Units, NRCS hydric soil designation, and approximate totals for Bella Vista Subdivision Project.**

Map Unit Symbol	Map Unit Name	% Hydric Component	Hydric Component Landform	% Map Unit in Project Site
155	Kekawaka-Casabonne-Wohly complex, 30 to 50 percent slopes	N/A	N/A	13.8%
178	Pinole gravelly loam, 2 to 8 percent slopes	N/A	N/A	86.2%

### Vegetation

The central portion of the Project site was dominated by vineyard (*Vitis* sp.) (FACU) with scattered English walnuts (*Juglans regia*) (UPL) along the periphery of the blocks of vineyard and an understory of weedy annual vegetation. Only the southeast block of vineyard was observed to have a dense understory dominated by snow white meadowfoam. The annual grassland habitat present was dominated primarily by rattlesnake grass (*Briza maxima*) (UPL), wild oats (*Avena barbata*) (UPL), foothill filaree (*Erodium brachycarpum*) (NL), Mediterranean barley (*Hordeum marinum ssp. gussoneanum*) (FAC), soft chess (*Bromus hordeaceus*) (FACU), winter vetch (*Vicia villosa*) (NL), field bindweed (*Convolvulus arvensis*) (NL), and smooth cat's ear (*Hypochaeris glabra*) (NL). The montane hardwood conifer habitat was dominated by a tree canopy of oracle oak (*Quercus x morehus*) (NL), Garry oak (*Quercus garryana* var. *garryana*) (UPL), douglas-fir (*Pseudotsuga menziesii* var. *menziesii*) (FACU), bay laurel (*Umbellularia californica*) (FAC) and pacific madrone (*Arbutus menziesii*) (NL) with a shrub layer dominated by Himalayan blackberry (*Rubus armeniacus*) (FAC) and poison oak (*Toxicodendron diversilobum*) (FACU). The bed of the intermittent drainage was largely void of vegetation but within the active floodplain the vegetation was composed of perennial ryegrass (*Festuca perennis*) (FAC), curly dock (*Rumex crispus*) (FAC), watercress (*Nasturtium officinale*) (OBL), and seep monkeyflower (*Erythranthe guttata*) (OBL) with a few sporadic willows (*Salix* sp.) (FACW).

### Hydrology

Hydrology within the Project site is influenced primarily by irrigation practices of the vineyard, precipitation and localized runoff. No wetlands were observed within the Project site. One small intermittent Tributary, as defined by the Final Rule, occurs within the northernmost portion of the Project site (OW01). This Tributary, Cleland Mountain Creek, is a direct tributary of the Russian River, a TNW.

Site Photos Taken on May 3, 2021



P01 – OW01 looking west



P02 – Upland overview looking east



P03 – upland with dark aerial signature looking southwest



P02 – Upland overview looking west



P04 – Upland at the toe of the hillslope looking west



P02 – Upland overview looking south



P04 – Upland at the toe of the hillslope looking southwest



P07 – Upland grassland overview looking west



P05 – Erosion/hill slump looking west



P08 – TP01 looking northwest



P06 – Site overview looking slightly northeast



P09 – upland roadside swale looking north



P09 – Upland roadside swale looking south



P10 – Upland overview looking northeast



P10 – Upland overview looking west



P11 – Upland agricultural ditch looking west



P10 – Upland depression looking north



P11 – End of upland ditch looking east

## Glossary

**Abutting:** When referring to wetlands that are adjacent to a tributary, abutting defines those wetlands that are not separated from the tributary by an upland feature, such as a berm or dike.

**Adjacent:** Adjacent wetlands are defined in Corps and EPA regulations as wetlands that abut, or touch at least at one point or side, a tributary or other jurisdictional feature. Wetlands separated from other waters of the U.S. by man-made/artificial dikes or barriers, natural river berms, beach dunes and the like are 'adjacent wetlands' so long as the artificial structure allows for a direct hydrologic surface connection. The entirety of wetlands are considered adjacent if the wetland has a road or similar artificial structure dividing it as long as the road/structure allows for a direct hydrologic surface connection through or over that structure in a typical year.

The regulations define "adjacent wetlands" as wetlands that meet at least one of following criteria:

- (1) There is an unbroken surface hydrologic connection between the wetland and jurisdictional waters;
- (2) The wetland is inundated by flooding from a jurisdictional sea, tributary or lake/pond;
- (3) The wetlands are physically separated from jurisdictional sea, tributary or lake/pond only by a natural berm, bank, dune, or similar natural feature; or
- (4) The wetlands are physically separated from jurisdictional sea, tributary or lake/pond only by an artificial dike, barrier or similar artificial structure and the artificial structure allows for a direct connection between the wetland and jurisdictional water in a typical year.

The agencies will also continue to assert jurisdiction over wetlands "adjacent" to traditional navigable waters as defined in the agencies' regulations. The Rapanos decision does not affect the scope of jurisdiction over wetlands that are adjacent to traditional navigable waters. The agencies will assert jurisdiction over those adjacent wetlands that have a continuous surface connection with a relatively permanent, non-navigable tributary, without the legal obligation to make a significant nexus finding.

**Atypical situation (significantly disturbed):** In an atypical (significantly disturbed) situation, recent human activities or natural events have created conditions where positive indicators for hydrophytic vegetation, hydric soil, or wetland hydrology are not present or observable.

**Channel.** "An open conduit either naturally or artificially created which periodically or continuously contains moving water, or which forms a connecting link between two bodies of standing water" (Langbein and Iseri 1960:5).

**Channel bank.** The sloping land bordering a channel. The bank has steeper slope than the bottom of the channel and is usually steeper than the land surrounding the channel.

**Cobbles.** Rock fragments 7.6 cm (3 inches) to 25.4 cm (10 inches) in diameter.

**Debris flow.** A moving mass of rock fragments, soil, and mud where more than 50% of the particles are larger than sand-sized.

**Ditch.** A constructed or excavated channel used to convey water.

**Drift.** Organic debris oriented to flow direction(s) (larger than small twigs).

**Ephemeral stream.** An ephemeral stream has flowing water only in direct response to precipitation events in a typical year. Ephemeral streambeds are located above the water table year-round. Groundwater is not a source of water for the stream. Runoff from rainfall is the primary source of water for stream flow.

**Facultative wetland (FACW).** Wetland indicator category; species usually occurs in wetlands (estimated probability 67–99%) but occasionally found in non-wetlands.

**Flat.** A level landform composed of unconsolidated sediments usually mud or sand. Flats may be irregularly shaped or elongate and continuous with the shore, whereas bars are generally elongate, parallel to the shore, and separated from the shore by water.

**Gravel.** A mixture composed primarily of rock fragments 2mm (0 .08 inch) to 7.6 cm (3 inches) in diameter. Usually contains much sand.

**Growing season** The frost-free period of the year (see U.S. Department of Interior, National Atlas 1970:110-111 for generalized regional delineation).

**Herbaceous.** With the characteristics of an herb; a plant with no persistent woody stem above ground.

**Hydric soil.** Soil is hydric that is saturated, flooded, or ponded long enough during the growing season to develop anaerobic (oxygen-depleted) conditions in its upper part (i.e., within the shallow rooting zone of herbaceous plants).

**Hydrophyte, hydrophytic.** Any plant growing in water or on a substrate that is at least periodically deficient in oxygen as a result of excessive water content.

**Intermittent stream.** An intermittent stream has flowing water during certain times of the year and more than in direct response from precipitation, when elevated groundwater provides water for stream flow. During dry periods, intermittent streams may not have flowing water.

**Jurisdictional Waters.** Features that meet the definition of waters of the United States provided below and that fall under Corps regulations pursuant to Section 404 of the CWA are considered jurisdictional features. These include territorial seas; tributaries; lakes and ponds and impoundments of jurisdictional waters; and adjacent wetlands.

**Litter.** Organic debris oriented to flow direction(s) (small twigs and leaves).

**Man-induced wetlands.** A man-induced wetland is an area that has developed at least some characteristics of naturally occurring wetlands due to either intentional or incidental human activities.

**Normal circumstances.** This term refers to the soil and hydrologic conditions that are normally present, without regard to whether the vegetation has been removed.

**Obligate hydrophytes.** Species that are found only in wetlands e.g., cattail (*Typha latifolia*) as opposed to ubiquitous species that grow either in wetland or on upland-e .g., red maple (*Acer rubrum*).

**Obligate wetland (OBL).** Wetland indicator category; species occurs almost always (estimated probability 99%) under natural conditions in wetlands.

**Palustrine** the Palustrine System includes all nontidal wetlands dominated by trees, shrubs, persistent emergents, emergent mosses or lichens, and all such wetlands that occur in tidal areas where salinity due to ocean derived salts is below 0.5 parts per thousand. It also includes wetlands lacking such vegetation, but with all of the following four characteristics: (1) area less than 8 ha (20 acres); (2) active wave-formed or bedrock shoreline features lacking; (3) water depth in the deepest part of basin less than 2 m (6.6 feet) at low water; and (4) salinity due to ocean-derived salts is less than 0.5 parts per thousand.

**Perennial stream.** A perennial stream has flowing water year-round during atypical year. The water table is located above the stream bed for most of the year. Groundwater is the primary source of water for stream flow. Runoff from rainfall is a supplemental source of water for stream flow.

**Ponded.** Ponding is a condition in which free water covers the soil surface (e.g., in a closed depression) and is removed only by percolation, evaporation, or transpiration.

**Problem area.** Problem areas are those where one or more wetland parameters may be lacking because of normal seasonal or annual variations in environmental conditions that result from causes other than human activities or catastrophic natural events.

**Scour.** Soil and debris movement.

**Sheetflow.** Overland flow occurring in a continuous sheet; a relatively high-frequency, low-magnitude event.

**Shrub.** A woody plant which at maturity is usually less than 6 meters (20 feet) tall and generally exhibits several erect, spreading, or prostrate stems and has a bushy appearance; e.g., speckled alder (*Alnus rugosa*) or buttonbush (*Cephalanthus occidentalis*).

**Succession.** Changes in the composition or structure of an ecological community.

**Traditional Navigable Waters (TNWs).** “[a]ll waters which are currently used, or were used in the past, or may be susceptible to use in interstate or foreign commerce, including all waters which are subject to the ebb and flow of the tide.” These waters are referred to in this guidance as traditional navigable waters. The traditional navigable waters include all of the “navigable waters of the United States,” as defined in 33 C.F.R. Part 329 and by numerous decisions of the federal courts, plus all other waters that are navigable-in-fact (for example, the Great Salt Lake, UT, and Lake Minnetonka, MN). Thus, the traditional navigable waters include, but are not limited to, the “navigable waters of the United States” within the meaning of Section 10 of the Rivers and Harbors Act of 1899 (also known as “Section 10 waters”).

**Tree.** A woody plant which at maturity is usually 6 m (20 feet) or more in height and generally has a single trunk, unbranched for 1 m or more above the ground, and a more or less definite crown; e.g., red maple (*Acer rubrum*), northern white cedar (*Thuja occidentalis*).

**Tributary.** Tributaries are defined by regulation as a “river, stream or similar naturally occurring surface water channel that contributes surface water flow to a [jurisdictional water] in a typical year either directly or through one or more [jurisdictional water]. A tributary must be perennial or intermittent in a typical year.” Tributaries include natural perennial or intermittent drainages that have been realigned or relocated.

**Typical Year.** Defined by the EPA and Corps as meaning when precipitation and other climactic variables are within the normal periodic range for the geographic area based on a rolling thirty-year period.

**Water table.** The upper surface of a zone of saturation. No water table exists where that surface is formed by an impermeable body.

**Waters of the United States (WOTUS).** This is the encompassing term for areas under federal jurisdiction pursuant to Section 404 of the CWA. Waters of the United States are divided into “adjacent wetlands” and “tributaries”.

**Watershed (drainage basin).** An area of land that drains to a single outlet and is separated from other watersheds by a divide.

**Wetland.** Wetlands are defined as “areas that are inundated or saturated by surface or ground water at a frequency and duration sufficient to support, and that under normal circumstances do support, a prevalence of vegetation typically adapted for life in saturated soil conditions” (33 CFR 328.3 [b], 40 CFR

230.3). To be considered under potential federal jurisdiction, a wetland must support positive indicators for hydrophytic vegetation, hydric soil, and wetland hydrology.

**Woody plant.** A seed plant (gymnosperm or angiosperm) that develops persistent, hard, fibrous tissues, basically xylem; e.g., trees and shrubs.

**Xeric.** Relating or adapted to an extremely dry habitat



## References

- Cheatham, N.H., and J.R. Haller. 1975. An annotated list of California habitat types. Univ. of California Natural Land and Water Reserve System, unpubl. manuscript.
- Cowardin, Lewis M., Virginia Carter, Francis C. Golet and Edward T. LaRoe. 1979. Classification of Wetlands and Deepwater Habitats of the United States. U.S. Department of the Interior, Fish and Wildlife Service, Washington D.C.
- Curtis, Katherine E., Robert W. Lichvar. 2010. Updated Datasheet for the Identification of the Ordinary High Water Mark (OHWM) in the Arid West Region of the Western United States. ERDC/CRREL TN-10-1. U.S. Army Engineer Research and Development Center, Cold Regions Research and Engineering Laboratory, Hanover, NH
- Curtis, Katherine E., Robert W. Lichvar, Lindsey E. Dixon. 2011. Ordinary High Flows and the Stage-Discharge Relationship in the Arid West Region (Technical Report). U.S. Army Engineer Research and Development Center, Cold Regions Research and Engineering Laboratory, Hanover, NH
- Environmental Laboratory 1987. U.S. Army Corps of Engineers wetlands delineation manual. (Technical Report Y-87-1). U.S. Army Waterways Experiment Station. Vicksburg, MS.
- Environmental Protection Agency and Department of Defense. 2020. Federal Register, Vol. 85, No. 77, The Navigable Waters Protection Rule: Definition of “Waters of the United States”; Final Rule. April 21, 2020. 22250- 22342. Washington, DC.
- Lichvar, R.W., and J.S. Wakeley, ed. 2004. Review of Ordinary High Water Mark indicators for delineating arid streams in the southwestern United States. ERDC/CRREL TR-04-1. Hanover, NH: U.S. Army Engineer Research and Development Center, Cold Regions Research and Engineering Laboratory. ([http://www.crrel.usace.army.mil/techpub/CRREL\\_Reports/reports/TR04-21.pdf](http://www.crrel.usace.army.mil/techpub/CRREL_Reports/reports/TR04-21.pdf)).
- Lichvar, R.W., D. Finnegan, M. Ericsson, and W. Ochs. 2006. Distribution of Ordinary High Water Mark (OHWM) indicators and their reliability in identifying the limits of “Waters of the United States” in arid southwestern channels. ERDC/CRREL TR-06-5. Hanover, NH: U.S. Army Engineer Research and Development Center, Cold Regions Research and Engineering Laboratory. ([http://www.crrel.usace.army.mil/techpub/CRREL\\_Reports/reports/TR06-5.pdf](http://www.crrel.usace.army.mil/techpub/CRREL_Reports/reports/TR06-5.pdf)).
- Lichvar, R.W. and S.M. McColley. 2008. A Field Guide to the Identification of the Ordinary High Water Mark (OHWM) in the Western Region of the Western United States. ERDC/CRREL TR-08-12. Hanover, NH: U.S. Army Engineer Research and Development Center, Cold Regions Research and Engineering Laboratory.
- Lichvar, R.W., D.L. Banks, W.N. Kirchner, and N.C. Melvin. 2016. State of California 2016 Wetland Plant List: The National Wetland Plant List: 2016 wetland ratings. Phytoneuron 2016-30: 1-17. U.S. Army Corps of Engineers. ISSN 2153 733X.
- Mayer, K.E. and W.F. Laudenslayer. 1988. A Guide to Wildlife Habitats of California. California Department of Forestry and Fire Protection. Sacramento, CA.
- National Oceanic and Atmospheric Administration (NOAA). 2019. National Integrated Drought Information System. U.S. Drought Monitor. Accessed online through the U.S. Drought Portal ([www.drought.gov](http://www.drought.gov)).

- Natural Resources Conservation Service (NRCS). 2021. Custom Soil Resource Report for Mendocino County, Eastern Part and Southwestern Part of Trinity County, California. Accessed through the NRCS Web Soil Survey website (<http://websoilsurvey.sc.egov.usda.gov/App/HomePage.htm>).
- Soil Survey Staff. 2010. Keys to Soil Taxonomy, 11th ed. USDA-Natural Resources Conservation Service, Washington, DC.
- U.S. Army Corps of Engineers (Corps). 2008. Regional supplement to the Corps of Engineers Wetland Delineation Manual: Arid West Region. J.S. Wakeley, R.W. Lichvar, and C.V. Noble, ed. ERDC/EL TR-06-16. Vicksburg, MS: U.S. Army Engineer Research and Development Center, Environmental Laboratory.
- U.S. Army Corps of Engineers, South Pacific Division. 2001. Final summary report: Guidelines for jurisdictional determinations for water of the United States in the arid Southwest. San Francisco, CA: U.S. Army Corps of Engineers, South Pacific Division. (<http://www.spl.usace.army.mil/regulatory/lad.htm>).
- United States Department of Agriculture, Natural Resources Conservation Service. National soil survey handbook, title 430-VI. <http://soils.usda.gov/>
- United States Department of Agriculture, Natural Resources Conservation Service. 2018. Field Indicators of Hydric Soils in the United States, Version 8.2. L.M. Vasilas, G.W. Hurt, and J.F. Berkowitz (eds.). USDA, NRCS, in cooperation with the National Technical Committee for Hydric Soils.
- Western Regional Climate Center (WRCC). 2021. Period of Record Monthly Climate Summary for Ukiah, California (049122). Online access. Available: <https://wrcc.dri.edu> [accessed 17 May 2021].
- Wetland Training Institute. 1995. Field guide for wetland delineation: 1987 Corps of Engineers manual. (WTI 95-3). Poolsville, MD.

**Appendix A: Wetland Delineation Data Sheets**

**EIR ADDENDUM APPENDIX F  
WETLAND DETERMINATION DATA FORM - Arid West Region**

Project/Site: Bella Vista Subdivision City/County: Ukiah, Mendocino County Sampling Date: 5-3-2021  
 Applicant/Owner: Guillon, Inc. State: CA Sampling Point: TP01  
 Investigator(s): E. Gregg Section, Township, Range: Section 32, Township 15N, Range 12W  
 Landform (hillslope, terrace, etc.): Valley flat Local relief (concave, convex, none): none Slope (%): 0.5  
 Subregion (LRR): C - Mediterranean California Lat: 39.111424 Long: -123.198952 Datum: NAD 83  
 Soil Map Unit Name: Pinole gravelly loam, 2 to 8 percent slopes NWI classification: N/A

Are climatic / hydrologic conditions on the site typical for this time of year? Yes  No  (If no, explain in Remarks.)  
 Are Vegetation  Soil  or Hydrology  significantly disturbed? Are "Normal Circumstances" present? Yes  No   
 Are Vegetation  Soil  or Hydrology  naturally problematic? (If needed, explain any answers in Remarks.)

**SUMMARY OF FINDINGS - Attach site map showing sampling point locations, transects, important features, etc.**

Hydrophytic Vegetation Present? Yes <input type="radio"/> No <input checked="" type="radio"/> Hydric Soil Present? Yes <input checked="" type="radio"/> No <input type="radio"/> Wetland Hydrology Present? Yes <input type="radio"/> No <input checked="" type="radio"/>	<b>Is the Sampled Area within a Wetland?</b> Yes <input type="radio"/> No <input checked="" type="radio"/>
Remarks: <u>Low rainfall year. Area was relatively flat to minutely concave.</u>	

**VEGETATION**

Tree Stratum (Use scientific names.)	Absolute % Cover	Dominant Species?	Indicator Status	
1. _____				
2. _____				
3. _____				
4. _____				
Total Cover: _____ %				
Sapling/Shrub Stratum				
1. _____				
2. _____				
3. _____				
4. _____				
5. _____				
Total Cover: _____ %				
Herb Stratum				
1. <u>Hordeum marinum ssp. gussoneanum</u>	50	Yes	FAC	
2. <u>Convolvulus arvensis</u>	20	Yes	Not Listed	
3. <u>Festuca myuros</u>	10	No	FACU	
4. <u>Avena barbata</u>	10	No	UPL	
5. <u>Plantago lanceolata</u>	5	No	FAC	
6. <u>Mentha pulegium</u>	5	No	OBL	
7. _____				
8. _____				
Total Cover: <u>100%</u>				
Woody Vine Stratum				
1. _____				
2. _____				
Total Cover: _____ %				
% Bare Ground in Herb Stratum <u>0 %</u>	%		% Cover of Biotic Crust <u>0 %</u>	%

**Dominance Test worksheet:**  
 Number of Dominant Species That Are OBL, FACW, or FAC: 1 (A)  
 Total Number of Dominant Species Across All Strata: 2 (B)  
 Percent of Dominant Species That Are OBL, FACW, or FAC: 50.0 % (A/B)

**Prevalence Index worksheet:**  
 Total % Cover of: \_\_\_\_\_ Multiply by: \_\_\_\_\_  
 OBL species 5 x 1 = 5  
 FACW species \_\_\_\_\_ x 2 = 0  
 FAC species 55 x 3 = 165  
 FACU species 10 x 4 = 40  
 UPL species 30 x 5 = 150  
 Column Totals: 100 (A) 360 (B)  
 Prevalence Index = B/A = 3.60

**Hydrophytic Vegetation Indicators:**  
 Dominance Test is >50%  
 Prevalence Index is ≤3.0<sup>1</sup>  
 Morphological Adaptations<sup>1</sup> (Provide supporting data in Remarks or on a separate sheet)  
 Problematic Hydrophytic Vegetation<sup>1</sup> (Explain)

<sup>1</sup>Indicators of hydric soil and wetland hydrology must be present.

**Hydrophytic Vegetation Present?** Yes  No

Remarks:

**SOIL**

**Profile Description: (Describe to the depth needed to document the indicator or confirm the absence of indicators.)**

Depth (inches)	Matrix		Redox Features				Texture	Remarks
	Color (moist)	%	Color (moist)	%	Type <sup>1</sup>	Loc <sup>2</sup>		
0-2	10YR 4/3	99	2.5YR 4/6	1	C	PL	silty loam	
2-9	10YR 5/3	95	5YR 4/6	10	C	PL	gravelly loam	

<sup>1</sup>Type: C=Concentration, D=Depletion, RM=Reduced Matrix. CS=Covered or Coated Sand Grains      <sup>2</sup> Location: PL=Pore Lining, M=Matrix.

**Hydric Soil Indicators: (Applicable to all LRRs, unless otherwise noted.)**

- |  |  |
|--|--|
| <input type="checkbox"/> Histosol (A1)                     | <input type="checkbox"/> Sandy Redox (S5)                  |
| <input type="checkbox"/> Histic Epipedon (A2)              | <input type="checkbox"/> Stripped Matrix (S6)              |
| <input type="checkbox"/> Black Histic (A3)                 | <input type="checkbox"/> Loamy Mucky Mineral (F1)          |
| <input type="checkbox"/> Hydrogen Sulfide (A4)             | <input type="checkbox"/> Loamy Gleyed Matrix (F2)          |
| <input type="checkbox"/> Stratified Layers (A5) (LRR C)    | <input type="checkbox"/> Depleted Matrix (F3)              |
| <input type="checkbox"/> 1 cm Muck (A9) (LRR D)            | <input type="checkbox"/> Redox Dark Surface (F6)           |
| <input type="checkbox"/> Depleted Below Dark Surface (A11) | <input type="checkbox"/> Depleted Dark Surface (F7)        |
| <input type="checkbox"/> Thick Dark Surface (A12)          | <input checked="" type="checkbox"/> Redox Depressions (F8) |
| <input type="checkbox"/> Sandy Mucky Mineral (S1)          | <input type="checkbox"/> Vernal Pools (F9)                 |
| <input type="checkbox"/> Sandy Gleyed Matrix (S4)          |  |

**Indicators for Problematic Hydric Soils: <sup>3</sup>**

- 1 cm Muck (A9) (LRR C)
- 2 cm Muck (A10) (LRR B)
- Reduced Vertic (F18)
- Red Parent Material (TF2)
- Other (Explain in Remarks)

<sup>3</sup> Indicators of hydrophytic vegetation and wetland hydrology must be present unless distributed or problematic

**Restrictive Layer (if present):**

Type: none  
 Depth (inches): N/A

**Hydric Soil Present?** Yes  No

Remarks: Area was very minutely concave, therefore, it could be considered to be a closed depression and meet the criteria for indicator F8.

**HYDROLOGY**

**Wetland Hydrology Indicators:**

Primary Indicators (minimum of one required; check all that apply)

- |  |  |
|--|--|
| <input type="checkbox"/> Surface Water (A1)                        | <input type="checkbox"/> Salt Crust (B11)                              |
| <input type="checkbox"/> High Water Table (A2)                     | <input type="checkbox"/> Biotic Crust (B12)                            |
| <input type="checkbox"/> Saturation (A3)                           | <input type="checkbox"/> Aquatic Invertebrates (B13)                   |
| <input type="checkbox"/> Water Marks (B1) (Nonriverine)            | <input type="checkbox"/> Hydrogen Sulfide Odor (C1)                    |
| <input type="checkbox"/> Sediment Deposits (B2) (Nonriverine)      | <input type="checkbox"/> Oxidized Rhizospheres along Living Roots (C3) |
| <input type="checkbox"/> Drift Deposits (B3) (Nonriverine)         | <input type="checkbox"/> Presence of Reduced Iron (C4)                 |
| <input type="checkbox"/> Surface Soil Cracks (B6)                  | <input type="checkbox"/> Recent Iron Reduction in Plowed Soils (C6)    |
| <input type="checkbox"/> Inundation Visible on Aerial Imagery (B7) | <input type="checkbox"/> Thin Muck Surface (C7)                        |
| <input type="checkbox"/> Water-Stained Leaves (B9)                 | <input type="checkbox"/> Other (Explain in Remarks)                    |

Secondary Indicators (2 or more required)

- Water Marks (B1) (Riverine)
- Sediment Deposits (B2) (Riverine)
- Drift Deposits (B3) (Riverine)
- Drainage Patterns (B10)
- Dry-Season Water Table (C2)
- Crayfish Burrows (C8)
- Saturation Visible on Aerial Imagery (C9)
- Shallow Aquitard (D3)
- FAC-Neutral Test (D5)

**Field Observations:**

Surface Water Present? Yes  No  Depth (inches): \_\_\_\_\_  
 Water Table Present? Yes  No  Depth (inches): \_\_\_\_\_  
 Saturation Present? (includes capillary fringe) Yes  No  Depth (inches): \_\_\_\_\_

**Wetland Hydrology Present?** Yes  No

Describe Recorded Data (stream gauge, monitoring well, aerial photos, previous inspections), if available:

Remarks: No wetland hydrology indicators observed.

**Appendix B: NRCS Soils Map and Soil Series Description**

# Custom Soil Resource Report for Mendocino County, Eastern Part and Southwestern Part of Trinity County, California

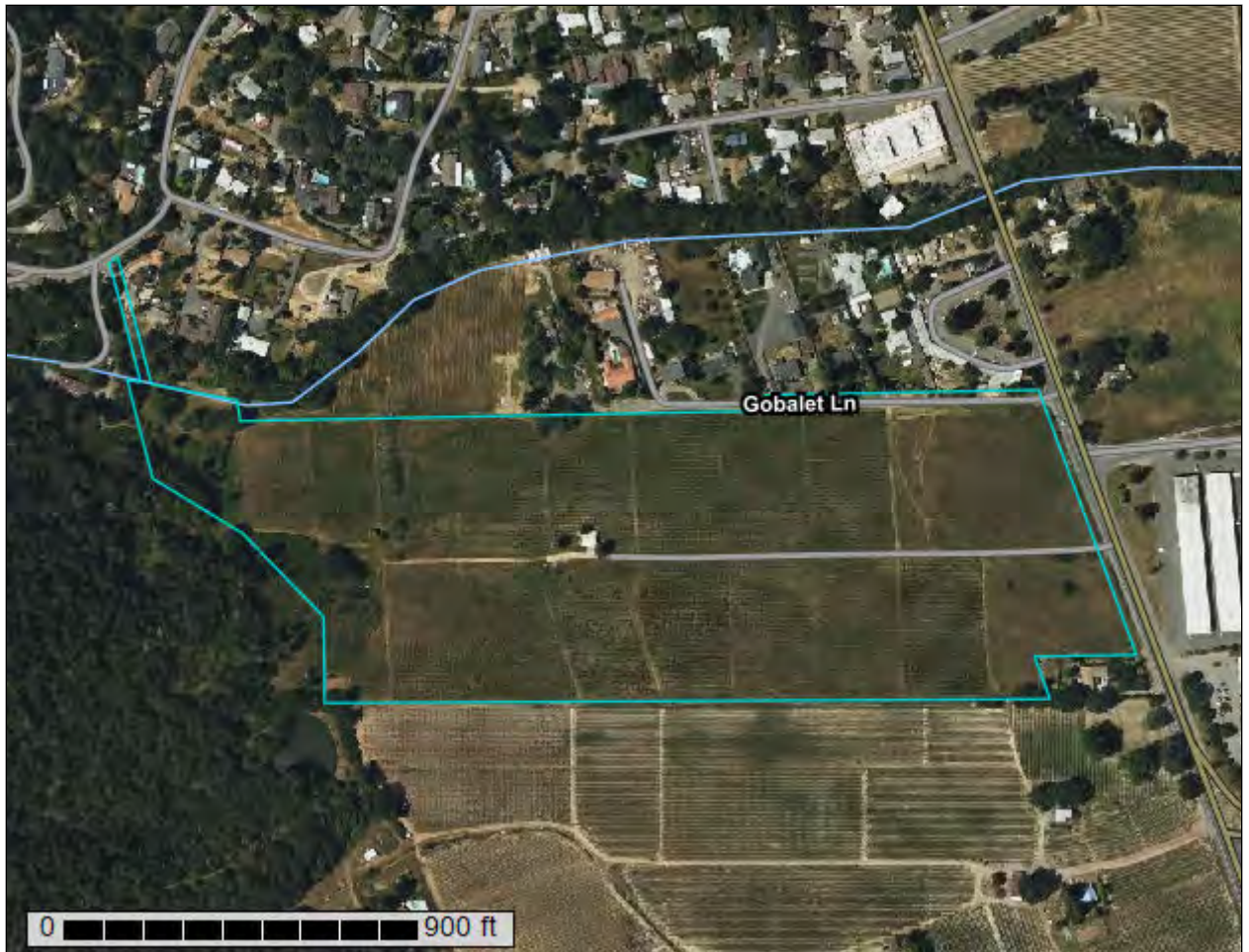

# Preface

---

Soil surveys contain information that affects land use planning in survey areas. They highlight soil limitations that affect various land uses and provide information about the properties of the soils in the survey areas. Soil surveys are designed for many different users, including farmers, ranchers, foresters, agronomists, urban planners, community officials, engineers, developers, builders, and home buyers. Also, conservationists, teachers, students, and specialists in recreation, waste disposal, and pollution control can use the surveys to help them understand, protect, or enhance the environment.

Various land use regulations of Federal, State, and local governments may impose special restrictions on land use or land treatment. Soil surveys identify soil properties that are used in making various land use or land treatment decisions. The information is intended to help the land users identify and reduce the effects of soil limitations on various land uses. The landowner or user is responsible for identifying and complying with existing laws and regulations.

Although soil survey information can be used for general farm, local, and wider area planning, onsite investigation is needed to supplement this information in some cases. Examples include soil quality assessments (<http://www.nrcs.usda.gov/wps/portal/nrcs/main/soils/health/>) and certain conservation and engineering applications. For more detailed information, contact your local USDA Service Center (<https://offices.sc.egov.usda.gov/locator/app?agency=nrcs>) or your NRCS State Soil Scientist ([http://www.nrcs.usda.gov/wps/portal/nrcs/detail/soils/contactus/?cid=nrcs142p2\\_053951](http://www.nrcs.usda.gov/wps/portal/nrcs/detail/soils/contactus/?cid=nrcs142p2_053951)).

Great differences in soil properties can occur within short distances. Some soils are seasonally wet or subject to flooding. Some are too unstable to be used as a foundation for buildings or roads. Clayey or wet soils are poorly suited to use as septic tank absorption fields. A high water table makes a soil poorly suited to basements or underground installations.

The National Cooperative Soil Survey is a joint effort of the United States Department of Agriculture and other Federal agencies, State agencies including the Agricultural Experiment Stations, and local agencies. The Natural Resources Conservation Service (NRCS) has leadership for the Federal part of the National Cooperative Soil Survey.

Information about soils is updated periodically. Updated information is available through the NRCS Web Soil Survey, the site for official soil survey information.

The U.S. Department of Agriculture (USDA) prohibits discrimination in all its programs and activities on the basis of race, color, national origin, age, disability, and where applicable, sex, marital status, familial status, parental status, religion, sexual orientation, genetic information, political beliefs, reprisal, or because all or a part of an individual's income is derived from any public assistance program. (Not all prohibited bases apply to all programs.) Persons with disabilities who require



alternative means for communication of program information (Braille, large print, audiotape, etc.) should contact USDA's TARGET Center at (202) 720-2600 (voice and TDD). To file a complaint of discrimination, write to USDA, Director, Office of Civil Rights, 1400 Independence Avenue, S.W., Washington, D.C. 20250-9410 or call (800) 795-3272 (voice) or (202) 720-6382 (TDD). USDA is an equal opportunity provider and employer.

# Contents

---

**Preface**..... 2

**How Soil Surveys Are Made**..... 5

**Soil Map**..... 8

    Soil Map..... 9

    Legend..... 10

    Map Unit Legend..... 12

    Map Unit Descriptions..... 12

        Mendocino County, Eastern Part and Southwestern Part of Trinity  
            County, California..... 14

            155—Kekawaka-Casabonne-Wohly complex, 30 to 50 percent slopes..... 14

            178—Pinole gravelly loam, 2 to 8 percent slopes..... 16

**Soil Information for All Uses**..... 19

    Soil Reports..... 19

    Land Classifications..... 19

    Hydric Soil List - All Components..... 19

**References**..... 22

## How Soil Surveys Are Made

---

Soil surveys are made to provide information about the soils and miscellaneous areas in a specific area. They include a description of the soils and miscellaneous areas and their location on the landscape and tables that show soil properties and limitations affecting various uses. Soil scientists observed the steepness, length, and shape of the slopes; the general pattern of drainage; the kinds of crops and native plants; and the kinds of bedrock. They observed and described many soil profiles. A soil profile is the sequence of natural layers, or horizons, in a soil. The profile extends from the surface down into the unconsolidated material in which the soil formed or from the surface down to bedrock. The unconsolidated material is devoid of roots and other living organisms and has not been changed by other biological activity.

Currently, soils are mapped according to the boundaries of major land resource areas (MLRAs). MLRAs are geographically associated land resource units that share common characteristics related to physiography, geology, climate, water resources, soils, biological resources, and land uses (USDA, 2006). Soil survey areas typically consist of parts of one or more MLRA.

The soils and miscellaneous areas in a survey area occur in an orderly pattern that is related to the geology, landforms, relief, climate, and natural vegetation of the area. Each kind of soil and miscellaneous area is associated with a particular kind of landform or with a segment of the landform. By observing the soils and miscellaneous areas in the survey area and relating their position to specific segments of the landform, a soil scientist develops a concept, or model, of how they were formed. Thus, during mapping, this model enables the soil scientist to predict with a considerable degree of accuracy the kind of soil or miscellaneous area at a specific location on the landscape.

Commonly, individual soils on the landscape merge into one another as their characteristics gradually change. To construct an accurate soil map, however, soil scientists must determine the boundaries between the soils. They can observe only a limited number of soil profiles. Nevertheless, these observations, supplemented by an understanding of the soil-vegetation-landscape relationship, are sufficient to verify predictions of the kinds of soil in an area and to determine the boundaries.

Soil scientists recorded the characteristics of the soil profiles that they studied. They noted soil color, texture, size and shape of soil aggregates, kind and amount of rock fragments, distribution of plant roots, reaction, and other features that enable them to identify soils. After describing the soils in the survey area and determining their properties, the soil scientists assigned the soils to taxonomic classes (units). Taxonomic classes are concepts. Each taxonomic class has a set of soil characteristics with precisely defined limits. The classes are used as a basis for comparison to classify soils systematically. Soil taxonomy, the system of taxonomic classification used in the United States, is based mainly on the kind and character of soil properties and the arrangement of horizons within the profile. After the soil

## Custom Soil Resource Report

scientists classified and named the soils in the survey area, they compared the individual soils with similar soils in the same taxonomic class in other areas so that they could confirm data and assemble additional data based on experience and research.

The objective of soil mapping is not to delineate pure map unit components; the objective is to separate the landscape into landforms or landform segments that have similar use and management requirements. Each map unit is defined by a unique combination of soil components and/or miscellaneous areas in predictable proportions. Some components may be highly contrasting to the other components of the map unit. The presence of minor components in a map unit in no way diminishes the usefulness or accuracy of the data. The delineation of such landforms and landform segments on the map provides sufficient information for the development of resource plans. If intensive use of small areas is planned, onsite investigation is needed to define and locate the soils and miscellaneous areas.

Soil scientists make many field observations in the process of producing a soil map. The frequency of observation is dependent upon several factors, including scale of mapping, intensity of mapping, design of map units, complexity of the landscape, and experience of the soil scientist. Observations are made to test and refine the soil-landscape model and predictions and to verify the classification of the soils at specific locations. Once the soil-landscape model is refined, a significantly smaller number of measurements of individual soil properties are made and recorded. These measurements may include field measurements, such as those for color, depth to bedrock, and texture, and laboratory measurements, such as those for content of sand, silt, clay, salt, and other components. Properties of each soil typically vary from one point to another across the landscape.

Observations for map unit components are aggregated to develop ranges of characteristics for the components. The aggregated values are presented. Direct measurements do not exist for every property presented for every map unit component. Values for some properties are estimated from combinations of other properties.

While a soil survey is in progress, samples of some of the soils in the area generally are collected for laboratory analyses and for engineering tests. Soil scientists interpret the data from these analyses and tests as well as the field-observed characteristics and the soil properties to determine the expected behavior of the soils under different uses. Interpretations for all of the soils are field tested through observation of the soils in different uses and under different levels of management. Some interpretations are modified to fit local conditions, and some new interpretations are developed to meet local needs. Data are assembled from other sources, such as research information, production records, and field experience of specialists. For example, data on crop yields under defined levels of management are assembled from farm records and from field or plot experiments on the same kinds of soil.

Predictions about soil behavior are based not only on soil properties but also on such variables as climate and biological activity. Soil conditions are predictable over long periods of time, but they are not predictable from year to year. For example, soil scientists can predict with a fairly high degree of accuracy that a given soil will have a high water table within certain depths in most years, but they cannot predict that a high water table will always be at a specific level in the soil on a specific date.

After soil scientists located and identified the significant natural bodies of soil in the survey area, they drew the boundaries of these bodies on aerial photographs and

identified each as a specific map unit. Aerial photographs show trees, buildings, fields, roads, and rivers, all of which help in locating boundaries accurately.

## Soil Map

---

The soil map section includes the soil map for the defined area of interest, a list of soil map units on the map and extent of each map unit, and cartographic symbols displayed on the map. Also presented are various metadata about data used to produce the map, and a description of each soil map unit.

Custom Soil Resource Report  
Soil Map



Map Scale: 1:4,370 if printed on A landscape (11" x 8.5") sheet.

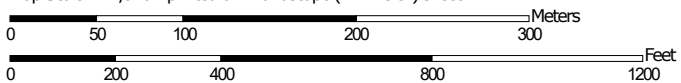

Map projection: Web Mercator Corner coordinates: WGS84 Edge tics: UTM Zone 10N WGS84

### MAP LEGEND

**Area of Interest (AOI)**

 Area of Interest (AOI)



















**Soils**







 Soil Map Unit Polygons

 Soil Map Unit Lines

 Soil Map Unit Points

**Special Point Features**





-  Blowout
-  Borrow Pit
-  Clay Spot
-  Closed Depression
-  Gravel Pit
-  Gravelly Spot
-  Landfill
-  Lava Flow
-  Marsh or swamp
-  Mine or Quarry
-  Miscellaneous Water
-  Perennial Water
-  Rock Outcrop
-  Saline Spot
-  Sandy Spot
-  Severely Eroded Spot
-  Sinkhole
-  Slide or Slip
-  Sodic Spot

-  Spoil Area
-  Stony Spot
-  Very Stony Spot
-  Wet Spot
-  Other
-  Special Line Features

**Water Features**

 Streams and Canals

**Transportation**

-  Rails
-  Interstate Highways
-  US Routes
-  Major Roads
-  Local Roads

**Background**

 Aerial Photography

### MAP INFORMATION

The soil surveys that comprise your AOI were mapped at 1:24,000.

Warning: Soil Map may not be valid at this scale.

Enlargement of maps beyond the scale of mapping can cause misunderstanding of the detail of mapping and accuracy of soil line placement. The maps do not show the small areas of contrasting soils that could have been shown at a more detailed scale.

Please rely on the bar scale on each map sheet for map measurements.

Source of Map: Natural Resources Conservation Service  
 Web Soil Survey URL:  
 Coordinate System: Web Mercator (EPSG:3857)

Maps from the Web Soil Survey are based on the Web Mercator projection, which preserves direction and shape but distorts distance and area. A projection that preserves area, such as the Albers equal-area conic projection, should be used if more accurate calculations of distance or area are required.

This product is generated from the USDA-NRCS certified data as of the version date(s) listed below.

Soil Survey Area: Mendocino County, Eastern Part and Southwestern Part of Trinity County, California  
 Survey Area Data: Version 15, Jun 1, 2020

Soil map units are labeled (as space allows) for map scales 1:50,000 or larger.

Date(s) aerial images were photographed: May 5, 2019—Jun 3, 2019

The orthophoto or other base map on which the soil lines were compiled and digitized probably differs from the background



**MAP LEGEND**

**MAP INFORMATION**

imagery displayed on these maps. As a result, some minor shifting of map unit boundaries may be evident.

## Map Unit Legend

Map Unit Symbol	Map Unit Name	Acres in AOI	Percent of AOI
155	Kekawaka-Casabonne-Wohly complex, 30 to 50 percent slopes	5.1	13.8%
178	Pinole gravelly loam, 2 to 8 percent slopes	31.7	86.2%
<b>Totals for Area of Interest</b>		<b>36.8</b>	<b>100.0%</b>

## Map Unit Descriptions

The map units delineated on the detailed soil maps in a soil survey represent the soils or miscellaneous areas in the survey area. The map unit descriptions, along with the maps, can be used to determine the composition and properties of a unit.

A map unit delineation on a soil map represents an area dominated by one or more major kinds of soil or miscellaneous areas. A map unit is identified and named according to the taxonomic classification of the dominant soils. Within a taxonomic class there are precisely defined limits for the properties of the soils. On the landscape, however, the soils are natural phenomena, and they have the characteristic variability of all natural phenomena. Thus, the range of some observed properties may extend beyond the limits defined for a taxonomic class. Areas of soils of a single taxonomic class rarely, if ever, can be mapped without including areas of other taxonomic classes. Consequently, every map unit is made up of the soils or miscellaneous areas for which it is named and some minor components that belong to taxonomic classes other than those of the major soils.

Most minor soils have properties similar to those of the dominant soil or soils in the map unit, and thus they do not affect use and management. These are called noncontrasting, or similar, components. They may or may not be mentioned in a particular map unit description. Other minor components, however, have properties and behavioral characteristics divergent enough to affect use or to require different management. These are called contrasting, or dissimilar, components. They generally are in small areas and could not be mapped separately because of the scale used. Some small areas of strongly contrasting soils or miscellaneous areas are identified by a special symbol on the maps. If included in the database for a given area, the contrasting minor components are identified in the map unit descriptions along with some characteristics of each. A few areas of minor components may not have been observed, and consequently they are not mentioned in the descriptions, especially where the pattern was so complex that it was impractical to make enough observations to identify all the soils and miscellaneous areas on the landscape.

The presence of minor components in a map unit in no way diminishes the usefulness or accuracy of the data. The objective of mapping is not to delineate pure taxonomic classes but rather to separate the landscape into landforms or landform segments that have similar use and management requirements. The delineation of such segments on the map provides sufficient information for the

## Custom Soil Resource Report

development of resource plans. If intensive use of small areas is planned, however, onsite investigation is needed to define and locate the soils and miscellaneous areas.

An identifying symbol precedes the map unit name in the map unit descriptions. Each description includes general facts about the unit and gives important soil properties and qualities.

Soils that have profiles that are almost alike make up a *soil series*. Except for differences in texture of the surface layer, all the soils of a series have major horizons that are similar in composition, thickness, and arrangement.

Soils of one series can differ in texture of the surface layer, slope, stoniness, salinity, degree of erosion, and other characteristics that affect their use. On the basis of such differences, a soil series is divided into *soil phases*. Most of the areas shown on the detailed soil maps are phases of soil series. The name of a soil phase commonly indicates a feature that affects use or management. For example, Alpha silt loam, 0 to 2 percent slopes, is a phase of the Alpha series.

Some map units are made up of two or more major soils or miscellaneous areas. These map units are complexes, associations, or undifferentiated groups.

A *complex* consists of two or more soils or miscellaneous areas in such an intricate pattern or in such small areas that they cannot be shown separately on the maps. The pattern and proportion of the soils or miscellaneous areas are somewhat similar in all areas. Alpha-Beta complex, 0 to 6 percent slopes, is an example.

An *association* is made up of two or more geographically associated soils or miscellaneous areas that are shown as one unit on the maps. Because of present or anticipated uses of the map units in the survey area, it was not considered practical or necessary to map the soils or miscellaneous areas separately. The pattern and relative proportion of the soils or miscellaneous areas are somewhat similar. Alpha-Beta association, 0 to 2 percent slopes, is an example.

An *undifferentiated group* is made up of two or more soils or miscellaneous areas that could be mapped individually but are mapped as one unit because similar interpretations can be made for use and management. The pattern and proportion of the soils or miscellaneous areas in a mapped area are not uniform. An area can be made up of only one of the major soils or miscellaneous areas, or it can be made up of all of them. Alpha and Beta soils, 0 to 2 percent slopes, is an example.

Some surveys include *miscellaneous areas*. Such areas have little or no soil material and support little or no vegetation. Rock outcrop is an example.

## Mendocino County, Eastern Part and Southwestern Part of Trinity County, California

### 155—Kekawaka-Casabonne-Wohly complex, 30 to 50 percent slopes

#### Map Unit Setting

*National map unit symbol:* hgr8  
*Elevation:* 500 to 4,800 feet  
*Mean annual precipitation:* 35 to 80 inches  
*Mean annual air temperature:* 54 to 57 degrees F  
*Frost-free period:* 150 to 290 days  
*Farmland classification:* Not prime farmland

#### Map Unit Composition

*Kekawaka and similar soils:* 35 percent  
*Casabonne and similar soils:* 20 percent  
*Wohly and similar soils:* 20 percent  
*Minor components:* 25 percent  
*Estimates are based on observations, descriptions, and transects of the mapunit.*

#### Description of Kekawaka

##### Setting

*Landform:* Hills, mountains  
*Landform position (two-dimensional):* Backslope  
*Landform position (three-dimensional):* Mountainflank, side slope  
*Down-slope shape:* Concave  
*Across-slope shape:* Concave  
*Parent material:* Residuum weathered from sandstone and siltstone

##### Typical profile

*H1 - 0 to 4 inches:* loam  
*H2 - 4 to 35 inches:* clay loam  
*H3 - 35 to 61 inches:* clay

##### Properties and qualities

*Slope:* 30 to 50 percent  
*Depth to restrictive feature:* More than 80 inches  
*Drainage class:* Well drained  
*Runoff class:* Very high  
*Capacity of the most limiting layer to transmit water (Ksat):* Moderately high (0.20 to 0.57 in/hr)  
*Depth to water table:* More than 80 inches  
*Frequency of flooding:* None  
*Frequency of ponding:* None  
*Available water capacity:* High (about 9.6 inches)

##### Interpretive groups

*Land capability classification (irrigated):* None specified  
*Land capability classification (nonirrigated):* 6e  
*Hydrologic Soil Group:* C  
*Hydric soil rating:* No

**Description of Casabonne****Setting**

*Landform:* Hills, mountains  
*Landform position (two-dimensional):* Backslope  
*Landform position (three-dimensional):* Mountainflank, side slope  
*Down-slope shape:* Concave  
*Across-slope shape:* Convex  
*Parent material:* Residuum weathered from sandstone and shale

**Typical profile**

*A1 - 0 to 7 inches:* gravelly loam  
*A2 - 7 to 15 inches:* loam  
*Bt1 - 15 to 24 inches:* clay loam  
*Bt2 - 24 to 43 inches:* clay loam  
*Bt3 - 43 to 53 inches:* gravelly clay loam  
*CB - 53 to 58 inches:* gravelly clay loam  
*Ct - 58 to 71 inches:* gravel

**Properties and qualities**

*Slope:* 30 to 50 percent  
*Depth to restrictive feature:* 58 to 62 inches to strongly contrasting textural stratification  
*Drainage class:* Well drained  
*Runoff class:* High  
*Capacity of the most limiting layer to transmit water (Ksat):* Moderately low to moderately high (0.06 to 0.60 in/hr)  
*Depth to water table:* More than 80 inches  
*Frequency of flooding:* None  
*Frequency of ponding:* None  
*Maximum salinity:* Nonsaline to very slightly saline (0.0 to 2.0 mmhos/cm)  
*Available water capacity:* High (about 9.0 inches)

**Interpretive groups**

*Land capability classification (irrigated):* None specified  
*Land capability classification (nonirrigated):* 6e  
*Hydrologic Soil Group:* C  
*Hydric soil rating:* No

**Description of Wohly****Setting**

*Landform:* Mountains, hills  
*Landform position (two-dimensional):* Backslope  
*Landform position (three-dimensional):* Mountainflank, side slope  
*Down-slope shape:* Convex  
*Across-slope shape:* Convex  
*Parent material:* Residuum weathered from sandstone and shale

**Typical profile**

*A1 - 0 to 5 inches:* loam  
*A2 - 5 to 11 inches:* loam  
*Bt1 - 11 to 17 inches:* gravelly clay loam  
*Bt2 - 17 to 24 inches:* gravelly clay loam  
*Ct - 24 to 71 inches:* gravel

## Custom Soil Resource Report

**Properties and qualities***Slope: 30 to 50 percent**Depth to restrictive feature: 24 to 28 inches to paralithic bedrock**Drainage class: Well drained**Runoff class: High**Capacity of the most limiting layer to transmit water (Ksat): Moderately high to high  
(0.20 to 2.00 in/hr)**Depth to water table: More than 80 inches**Frequency of flooding: None**Frequency of ponding: None**Maximum salinity: Nonsaline to very slightly saline (0.0 to 2.0 mmhos/cm)**Available water capacity: Low (about 3.7 inches)***Interpretive groups***Land capability classification (irrigated): None specified**Land capability classification (nonirrigated): 6e**Hydrologic Soil Group: C**Hydric soil rating: No***Minor Components****Cummiskey***Percent of map unit: 5 percent**Hydric soil rating: No***Woodin***Percent of map unit: 4 percent**Hydric soil rating: No***Rock outcrop***Percent of map unit: 4 percent**Hydric soil rating: No***Sanhedrin***Percent of map unit: 4 percent**Hydric soil rating: No***Pardaloe***Percent of map unit: 4 percent**Hydric soil rating: No***Unnamed***Percent of map unit: 4 percent**Hydric soil rating: No***178—Pinole gravelly loam, 2 to 8 percent slopes****Map Unit Setting***National map unit symbol: hgs0*

## Custom Soil Resource Report

*Elevation:* 500 to 1,500 feet  
*Mean annual precipitation:* 37 inches  
*Mean annual air temperature:* 57 degrees F  
*Frost-free period:* 200 to 250 days  
*Farmland classification:* Prime farmland if irrigated

**Map Unit Composition**

*Pinole and similar soils:* 85 percent  
*Minor components:* 15 percent  
*Estimates are based on observations, descriptions, and transects of the mapunit.*

**Description of Pinole****Setting**

*Landform:* Terraces  
*Landform position (two-dimensional):* Backslope  
*Landform position (three-dimensional):* Tread  
*Down-slope shape:* Linear  
*Across-slope shape:* Linear  
*Parent material:* Alluvium derived from sedimentary rock

**Typical profile**

*H1 - 0 to 10 inches:* gravelly loam  
*H2 - 10 to 37 inches:* gravelly clay loam, clay loam  
*H2 - 10 to 37 inches:* sandy clay loam, gravelly sandy clay loam  
*H3 - 37 to 61 inches:*  
*H3 - 37 to 61 inches:*

**Properties and qualities**

*Slope:* 2 to 8 percent  
*Depth to restrictive feature:* More than 80 inches  
*Drainage class:* Well drained  
*Runoff class:* High  
*Capacity of the most limiting layer to transmit water (Ksat):* Moderately high (0.20 to 0.57 in/hr)  
*Depth to water table:* More than 80 inches  
*Frequency of flooding:* None  
*Frequency of ponding:* None  
*Available water capacity:* Very high (about 15.8 inches)

**Interpretive groups**

*Land capability classification (irrigated):* 2e  
*Land capability classification (nonirrigated):* 3e  
*Hydrologic Soil Group:* C  
*Hydric soil rating:* No

**Minor Components****Yokayo**

*Percent of map unit:* 5 percent  
*Landform:* Terraces  
*Hydric soil rating:* No

**Unnamed**

*Percent of map unit:* 5 percent  
*Hydric soil rating:* No

**Pinnobie**

*Percent of map unit: 5 percent*

*Landform: Terraces*

*Hydric soil rating: No*



# Soil Information for All Uses

---

## Soil Reports

The Soil Reports section includes various formatted tabular and narrative reports (tables) containing data for each selected soil map unit and each component of each unit. No aggregation of data has occurred as is done in reports in the Soil Properties and Qualities and Suitabilities and Limitations sections.

The reports contain soil interpretive information as well as basic soil properties and qualities. A description of each report (table) is included.

## Land Classifications

This folder contains a collection of tabular reports that present a variety of soil groupings. The reports (tables) include all selected map units and components for each map unit. Land classifications are specified land use and management groupings that are assigned to soil areas because combinations of soil have similar behavior for specified practices. Most are based on soil properties and other factors that directly influence the specific use of the soil. Example classifications include ecological site classification, farmland classification, irrigated and nonirrigated land capability classification, and hydric rating.

## Hydric Soil List - All Components

This table lists the map unit components and their hydric status in the survey area. This list can help in planning land uses; however, onsite investigation is recommended to determine the hydric soils on a specific site (National Research Council, 1995; Hurt and others, 2002).

The three essential characteristics of wetlands are hydrophytic vegetation, hydric soils, and wetland hydrology (Cowardin and others, 1979; U.S. Army Corps of Engineers, 1987; National Research Council, 1995; Tiner, 1985). Criteria for all of the characteristics must be met for areas to be identified as wetlands. Undrained hydric soils that have natural vegetation should support a dominant population of ecological wetland plant species. Hydric soils that have been converted to other uses should be capable of being restored to wetlands.

Hydric soils are defined by the National Technical Committee for Hydric Soils (NTCHS) as soils that formed under conditions of saturation, flooding, or ponding long enough during the growing season to develop anaerobic conditions in the

## Custom Soil Resource Report

upper part (Federal Register, 1994). These soils, under natural conditions, are either saturated or inundated long enough during the growing season to support the growth and reproduction of hydrophytic vegetation.

The NTCHS definition identifies general soil properties that are associated with wetness. In order to determine whether a specific soil is a hydric soil or nonhydric soil, however, more specific information, such as information about the depth and duration of the water table, is needed. Thus, criteria that identify those estimated soil properties unique to hydric soils have been established (Federal Register, 2002). These criteria are used to identify map unit components that normally are associated with wetlands. The criteria used are selected estimated soil properties that are described in "Soil Taxonomy" (Soil Survey Staff, 1999) and "Keys to Soil Taxonomy" (Soil Survey Staff, 2006) and in the "Soil Survey Manual" (Soil Survey Division Staff, 1993).

If soils are wet enough for a long enough period of time to be considered hydric, they should exhibit certain properties that can be easily observed in the field. These visible properties are indicators of hydric soils. The indicators used to make onsite determinations of hydric soils are specified in "Field Indicators of Hydric Soils in the United States" (Hurt and Vasilas, 2006).

Hydric soils are identified by examining and describing the soil to a depth of about 20 inches. This depth may be greater if determination of an appropriate indicator so requires. It is always recommended that soils be excavated and described to the depth necessary for an understanding of the redoximorphic processes. Then, using the completed soil descriptions, soil scientists can compare the soil features required by each indicator and specify which indicators have been matched with the conditions observed in the soil. The soil can be identified as a hydric soil if at least one of the approved indicators is present.

Map units that are dominantly made up of hydric soils may have small areas, or inclusions, of nonhydric soils in the higher positions on the landform, and map units dominantly made up of nonhydric soils may have inclusions of hydric soils in the lower positions on the landform.

The criteria for hydric soils are represented by codes in the table (for example, 2). Definitions for the codes are as follows:

1. All Histels except for Folistels, and Histosols except for Folists.
2. Soils in Aquic suborders, great groups, or subgroups, Albolls suborder, Historthels great group, Histoturbels great group, Pachic subgroups, or Cumulic subgroups that:
  - A. Based on the range of characteristics for the soil series, will at least in part meet one or more Field Indicators of Hydric Soils in the United States, or
  - B. Show evidence that the soil meets the definition of a hydric soil;
3. Soils that are frequently ponded for long or very long duration during the growing season.
  - A. Based on the range of characteristics for the soil series, will at least in part meet one or more Field Indicators of Hydric Soils in the United States, or
  - B. Show evidence that the soil meets the definition of a hydric soil;
4. Map unit components that are frequently flooded for long duration or very long duration during the growing season that:
  - A. Based on the range of characteristics for the soil series, will at least in part meet one or more Field Indicators of Hydric Soils in the United States, or

## Custom Soil Resource Report

B. Show evidence that the soil meets the definition of a hydric soil;

Hydric Condition: Food Security Act information regarding the ability to grow a commodity crop without removing woody vegetation or manipulating hydrology.

## References:

- Federal Register. July 13, 1994. Changes in hydric soils of the United States.  
 Federal Register. Doc. 2012-4733 Filed 2-28-12. February, 28, 2012. Hydric soils of the United States.  
 Soil Survey Division Staff. 1993. Soil survey manual. Soil Conservation Service. U.S. Department of Agriculture Handbook 18.  
 Soil Survey Staff. 1999. Soil taxonomy: A basic system of soil classification for making and interpreting soil surveys. 2nd edition. Natural Resources Conservation Service. U.S. Department of Agriculture Handbook 436.  
 Soil Survey Staff. 2010. Keys to soil taxonomy. 11th edition. U.S. Department of Agriculture, Natural Resources Conservation Service.  
 Vasilas, L.M., G.W. Hurt, and C.V. Noble, editors. Version 7.0, 2010. Field indicators of hydric soils in the United States.

### Report—Hydric Soil List - All Components

Hydric Soil List - All Components—CA687-Mendocino County, Eastern Part and Southwestern Part of Trinity County, California					
Map symbol and map unit name	Component/Local Phase	Comp. pct.	Landform	Hydric status	Hydric criteria met (code)
155: Kekawaka-Casabonne-Wohly complex, 30 to 50 percent slopes	Kekawaka	35	Hills,mountains	No	—
	Casabonne	20	Hills,mountains	No	—
	Wohly	20	Mountains,hills	No	—
	Cumiskey	5	—	No	—
	Woodin	4	—	No	—
	Rock outcrop	4	—	No	—
	Sanhedrin	4	—	No	—
	Pardaloe	4	—	No	—
	Unnamed	4	—	No	—
178: Pinole gravelly loam, 2 to 8 percent slopes	Pinole	85	Terraces	No	—
	Yokayo	5	Terraces	No	—
	Unnamed	5	—	No	—
	Pinnobie	5	Terraces	No	—

## References

---

- American Association of State Highway and Transportation Officials (AASHTO). 2004. Standard specifications for transportation materials and methods of sampling and testing. 24th edition.
- American Society for Testing and Materials (ASTM). 2005. Standard classification of soils for engineering purposes. ASTM Standard D2487-00.
- Cowardin, L.M., V. Carter, F.C. Golet, and E.T. LaRoe. 1979. Classification of wetlands and deep-water habitats of the United States. U.S. Fish and Wildlife Service FWS/OBS-79/31.
- Federal Register. July 13, 1994. Changes in hydric soils of the United States.
- Federal Register. September 18, 2002. Hydric soils of the United States.
- Hurt, G.W., and L.M. Vasilas, editors. Version 6.0, 2006. Field indicators of hydric soils in the United States.
- National Research Council. 1995. Wetlands: Characteristics and boundaries.
- Soil Survey Division Staff. 1993. Soil survey manual. Soil Conservation Service. U.S. Department of Agriculture Handbook 18. [http://www.nrcs.usda.gov/wps/portal/nrcs/detail/national/soils/?cid=nrcs142p2\\_054262](http://www.nrcs.usda.gov/wps/portal/nrcs/detail/national/soils/?cid=nrcs142p2_054262)
- Soil Survey Staff. 1999. Soil taxonomy: A basic system of soil classification for making and interpreting soil surveys. 2nd edition. Natural Resources Conservation Service, U.S. Department of Agriculture Handbook 436. [http://www.nrcs.usda.gov/wps/portal/nrcs/detail/national/soils/?cid=nrcs142p2\\_053577](http://www.nrcs.usda.gov/wps/portal/nrcs/detail/national/soils/?cid=nrcs142p2_053577)
- Soil Survey Staff. 2010. Keys to soil taxonomy. 11th edition. U.S. Department of Agriculture, Natural Resources Conservation Service. [http://www.nrcs.usda.gov/wps/portal/nrcs/detail/national/soils/?cid=nrcs142p2\\_053580](http://www.nrcs.usda.gov/wps/portal/nrcs/detail/national/soils/?cid=nrcs142p2_053580)
- Tiner, R.W., Jr. 1985. Wetlands of Delaware. U.S. Fish and Wildlife Service and Delaware Department of Natural Resources and Environmental Control, Wetlands Section.
- United States Army Corps of Engineers, Environmental Laboratory. 1987. Corps of Engineers wetlands delineation manual. Waterways Experiment Station Technical Report Y-87-1.
- United States Department of Agriculture, Natural Resources Conservation Service. National forestry manual. [http://www.nrcs.usda.gov/wps/portal/nrcs/detail/soils/home/?cid=nrcs142p2\\_053374](http://www.nrcs.usda.gov/wps/portal/nrcs/detail/soils/home/?cid=nrcs142p2_053374)
- United States Department of Agriculture, Natural Resources Conservation Service. National range and pasture handbook. <http://www.nrcs.usda.gov/wps/portal/nrcs/detail/national/landuse/rangepasture/?cid=stelprdb1043084>

## Custom Soil Resource Report

United States Department of Agriculture, Natural Resources Conservation Service. National soil survey handbook, title 430-VI. [http://www.nrcs.usda.gov/wps/portal/nrcs/detail/soils/scientists/?cid=nrcs142p2\\_054242](http://www.nrcs.usda.gov/wps/portal/nrcs/detail/soils/scientists/?cid=nrcs142p2_054242)

United States Department of Agriculture, Natural Resources Conservation Service. 2006. Land resource regions and major land resource areas of the United States, the Caribbean, and the Pacific Basin. U.S. Department of Agriculture Handbook 296. [http://www.nrcs.usda.gov/wps/portal/nrcs/detail/national/soils/?cid=nrcs142p2\\_053624](http://www.nrcs.usda.gov/wps/portal/nrcs/detail/national/soils/?cid=nrcs142p2_053624)

United States Department of Agriculture, Soil Conservation Service. 1961. Land capability classification. U.S. Department of Agriculture Handbook 210. [http://www.nrcs.usda.gov/Internet/FSE\\_DOCUMENTS/nrcs142p2\\_052290.pdf](http://www.nrcs.usda.gov/Internet/FSE_DOCUMENTS/nrcs142p2_052290.pdf)



March 11, 2021

Mr. Jake Morley  
Guillon Inc.  
2550 Lakehurst Drive, Suite 50  
Chico, CA 95928

## **Traffic Analysis for the Bella Vista (formerly Garden's Gate) Housing Project**

Dear Mr. Morley;

As requested, W-Trans has prepared traffic-related analysis for the Bella Vista Subdivision Project, which is a modification to the Garden's Gate Subdivision in which an Environmental Impact Report (EIR) was certified. The purpose of this analysis is to evaluate any changes to the transportation impacts of the Bella Vista project, based on the modifications to the previously approved Garden's Gate project as studied in the EIR.

### **Project Description**

The Bella Vista project is a modification of the Garden's Gate project, for which there is a certified EIR. The modified project includes 171 homes, 39 of which would be age-restricted. The project would therefore result in fewer lots than the Garden's Gate project, which included 197 homes. The site circulation has been modified as well. Garden's Gate included access points to South State Street, where the project access would have been located directly across South State Street from the existing Plant Road, and to Gobalet Lane, which also connects to South State Street. The Bella Vista project would also have two access points, both onto South State Street. As with Garden's Gate, the Bella Vista project proposes to reconfigure the existing T-intersection of South State Street/Plant Road as a roundabout with the addition of Charlie Barra Drive as a new west leg that would serve the project. The project's second access point would be South Road, a new street to be constructed as part of the project that would connect to South State Street approximately 500 feet to the south of the roundabout.

### **Trip Generation**

The anticipated trip generation for the Garden's Gate project was estimated using standard rates published by the Institute of Transportation Engineers (ITE) in *Trip Generation*, 7<sup>th</sup> Edition. For the currently proposed Bella Vista project a more recent version of the ITE *Trip Generation Manual* (10<sup>th</sup> Edition, 2017) was used. The land use categories of Single-Family Detached Housing (Land Use #210) and Senior Adult Housing – Detached (Land Use #251) were determined to most closely match the proposed project.

Based on application of these assumptions, the proposed Bella Vista project is expected to generate an average of 1,413 trips per day, including 107 a.m. peak hour trips and 143 trips during the p.m. peak hour. Compared to the Garden's Gate project, this represents a decrease of 199 trips per day, including a reduction of 17 trips during the a.m. peak hour and 21 during the p.m. peak hour. These results are summarized in Table 1.

**Table 1 – Trip Generation Summary**

Land Use	Units	Daily		AM Peak Hour				PM Peak Hour			
		Rate	Trips	Rate	Trips	In	Out	Rate	Trips	In	Out
<b>Approved (Garden’s Gate)</b>											
Single-Family Housing	123 du	9.57	1178	0.75	92	23	69	1.01	125	79	46
Multifamily Housing	74 du	5.86	434	0.44	32	5	27	0.52	39	26	13
<b>Subtotal</b>			<b>1612</b>		<b>124</b>	<b>28</b>	<b>96</b>		<b>164</b>	<b>105</b>	<b>59</b>
<b>Proposed (Bella Vista)</b>											
Single-Family Housing	132 du	9.44	1246	0.74	98	24	74	0.99	131	82	49
Senior Adult Housing	39 du	4.27	167	0.24	9	3	6	0.30	12	7	5
<b>Subtotal</b>			<b>1413</b>		<b>107</b>	<b>27</b>	<b>80</b>		<b>143</b>	<b>89</b>	<b>54</b>
<b>Net Change</b>			<b>-199</b>		<b>-17</b>	<b>-1</b>	<b>-16</b>		<b>-21</b>	<b>-16</b>	<b>-5</b>

Note: du = dwelling unit

### Trip Distribution

The pattern used to allocate new project trips to the street network was based on the assumptions applied in the EIR, which were derived from the UVAP traffic model. The trip distribution assumptions are shown in Table 2.

**Table 2 – Trip Distribution Assumptions**

Route	AM Peak Hour		PM Peak Hour	
	Inbound	Outbound	Inbound	Outbound
S State St North of Project Access	52%	40%	27%	46%
S State St South of Project Access	48%	60%	73%	54%
<b>TOTAL</b>	<b>100%</b>	<b>100%</b>	<b>100%</b>	<b>100%</b>

### Study Area and Scope of Analysis

The study area includes the project frontage along South State Street and the proposed intersections of South State Street with South Road and Charlie Barra Drive. South State Street includes two travel lanes and has a posted speed of 45 mph. Five intersections that do not provide direct access to the project were evaluated as part of the EIR. These five intersections were South State Street/Talmadge Road, South State Street/Washington Avenue-Hastings Avenue, South State Street/Plant Road, South State Street/US 101 North Ramps, South State Street/US 101 South Off-Ramp-Stipp Lane, and South State Street/US 101 South On-Ramp-CA 253.

As noted above, the Bella Vista subdivision would generate fewer trips per day and during peak hours than Garden’s Gate project. Assuming the same trip distribution, the study intersections evaluated in the EIR that would not provide direct access to the project would therefore receive fewer project trips. As the analysis contained in the EIR is based on a higher number of added trips from the project, this analysis would remain valid for the project as currently proposed so operation of these intersections was not analyzed.

Conversely, the number and location of the project access points was changed as part of the redesign of the project, so operations of both proposed Bella Vista access points – South State Street/ Plant Road-Charlie Barra

Drive and South State Street/South Road – were evaluated. The locations of the access points are indicated in the Bella Vista site plan, which is enclosed.

**Existing and Existing Plus Project Conditions**

The project trips were distributed to the two project access points. The Garden’s Gate project was expected to add 124 trips to the South State Street/Plant Road intersection during the a.m. peak hour and 145 trips during the p.m. peak hour. The Bella Vista project would be expected to add 77 trips to the South State Street/Plant Road intersection during the a.m. peak hour and 98 trips during the p.m. peak hour. Since the impact of the project would be less than what was analyzed in the Garden’s Gate EIR, an operational analysis of this intersection was not performed as the results presented in the EIR remain valid. An operational analysis was conducted for the proposed South State Street/South Road intersection since it was not included in the Garden’s Gate project.

Due to impacts of Covid-19 restrictions on 2020 traffic volumes, traffic volumes under non-pandemic conditions were estimated. The nearest location for which recent pre-pandemic counts were available was South State Street/Talmadge Road, where peak period turning movement counts were collected in May 2018. Turning movement counts were also collected in the a.m. and p.m. peak periods in November 2020 for the South State Street/Talmadge Road and South State Street/Plan Road intersections. The 2018 counts were then used to develop a factor indicating the difference between 2018 volumes and 2020 volumes that was then applied to estimate what current volumes at South State Street/Plant Road would now be under typical conditions.

The estimated project traffic was added to the Existing volumes to generate the Existing plus Project Conditions scenario. This scenario also accounted for the conversion of South State Street/Plant Road from a tee intersection to a four-legged roundabout and the addition of the South State Street/South Road intersection. The new project intersection of South State Street/South Road intersection would be expected to operate at LOS B during both the a.m. and p.m. peak hours. A summary of the intersection level of service calculations for the Existing plus Project Conditions scenario is contained in Table 3. A copy of the level of service calculations is enclosed.

**Table 3 – Plus Project Conditions**

Study Intersection <i>Approach</i>	Existing plus Project				Future plus Project			
	AM Peak		PM Peak		AM Peak		PM Peak	
	Delay	LOS	Delay	LOS	Delay	LOS	Delay	LOS
S State St/South Rd <i>Eastbound Approach</i>	12.3	B	13.6	B	13.8	B	14.8	B

Notes: Delay is in average number of seconds per vehicle, LOS = Level of Service; results for stop-controlled minor street approach are shown in *italics*

**Future and Future Plus Project Conditions**

Future traffic volumes for the horizon year 2040 were estimated using the Caltrans District 1 20-year growth factor of 1.30 for US 101 in the Ukiah area. The calculated 2040 volumes were used to estimate the Future volumes at the proposed South State Street/South Road intersection. The estimated project traffic was added to the Future volumes to generate the Future plus Project Conditions scenario. With the addition of project traffic, the South State Street/South Road intersection is expected to continue operating at LOS B during the a.m. and p.m. peak hours. A summary of the intersection level of service calculations for the Future plus Project Conditions scenario is contained in Table 3. A copy of the level of service calculations is enclosed.



**CEQA Checklist**

The change in the project’s potential impacts from what was evaluated in the EIR based on the project as now proposed as well as the current CEQA Checklist are summarized in Table 4.

<b>Table 4 – XVII. TRANSPORTATION/TRAFFIC</b>				
<b>Would the Project:</b>	<b>Potentially Significant Impact</b>	<b>Less than Significant Impact with Mitigation</b>	<b>Less than Significant Impact</b>	<b>No Impact</b>
a) Conflict with a program, plan, ordinance, or policy addressing the circulation system, including transit, roadway, bicycle, and pedestrian facilities?		X		
b) Conflict or be inconsistent with CEQA Guidelines § 15064.3, subdivision (b)?			X	
c) Substantially increase hazards due to a geometric design feature (e.g., sharp curves or dangerous intersections) or incompatible uses (e.g., farm equipment)?			X	
d) Result in inadequate emergency access?			X	

The project was evaluated based on conformity with CEQA requirements and consistency with the Mendocino County General Plan as well as other relevant plans.

**Would the project:**

- a) *Conflict with a program, plan, ordinance, or policy addressing the circulation system, including transit, roadway, bicycle, and pedestrian facilities?*

There are several plans that address the need to provide improvements to support all modes of transportation, but specific improvements in the project area are not identified.

**Mendocino County General Plan, 2009**

The Mendocino County General Plan includes the following policies regarding the provision of pedestrian and bicycle accommodations that are relevant to the proposed project:

- **Policy DE-153:** Provide pedestrian and bicycle ways along public roadway systems consistent with community area goals and policies and where sufficient right of way is available.
- **Policy DE-155:** Connect pedestrian, bicycle, and trail routes to form local and regional networks. Link pedestrian, bicycle, and trail routes with other transportation modes to maximize local and regional non-motorized transportation.
- **Policy DE-156:** Concentrate pedestrian improvements along school and transit routes, in areas of established pedestrian activity, and adjacent to sites serving senior citizen and/or persons with disabilities.
- **Policy DE-157:** When development occurs, require installation of pedestrian and bicycle systems or, if infeasible, the payment of in-lieu fees to fund improvements to bicycle and pedestrian facilities.

### Ukiah Valley Area Plan

The Ukiah Valley Area Plan includes the following policies related to the provision of facilities for pedestrians, bicyclists, and transit users.

- **GOAL CT2.** Enhance pedestrian, bicycle, and transit connectivity between land use types.
- **CT2.1b Pedestrian Walkways.** To the extent allowed under state law, require private development projects to provide pedestrian walkways that provide direct access between key destinations.
- **Policy CT2.2.** Develop a safe and integrated bicycle transportation system in order to promote the use of bicycles as a viable and attractive alternative to the automobile.

### Mendocino County Regional Transportation Plan

- **Non-Motorized Transportation Goal:** Provide a safe and useable network of bicycle and pedestrian facilities throughout the region as a means to lessen dependence on vehicular travel and improve the health of Mendocino County's residents.
  - *Objective:* Provide a nonmotorized transportation network that offers a feasible alternative to vehicular travel.
- **Policy:** Consider the needs of the transit system (bus stops and bike/pedestrian access) when planning roadway improvements.

### Existing and Proposed Facilities Serving the Project Site

There are currently no sidewalks along South State Street, which is typical of development where density is relatively low. Pedestrians and bicyclists may use the shoulders, which are generally at least eight feet wide.

Mendocino Transit Routes 7 (Ukiah Jitney) and 9 (Ukiah Local) provide service to central Ukiah from the bus stop on Plant Road, approximately 250 feet east of the project, an acceptable walking distance. The nearest bus stop to the project for service heading south from Ukiah is located approximately 900 feet north of the South State Street/Plant Road intersection. While this is within a reasonable walking distance, bus riders would be required to walk along the shoulder of the roadway to travel between the stop and Bella Vista.

The project includes conversion of the South State Street/Plant Road intersection to a roundabout, including a marked crosswalk to support pedestrian access to Plant Road. Currently there is a narrow shoulder along westbound Plant Road approaching South State Street. Additional improvements should be constructed to provide an adequate connection for pedestrians between the intersection and the bus stop. This walkway should be addressed as part of the roundabout design, which will identify the right-of-way required for the necessary improvements.

There are no designated bicycle facilities on South State Street, but bicyclists may use the shoulders along the roadway as well as local streets where they can mix with vehicle traffic. To access central Ukiah, bicyclists could use South Dora Street, which is parallel to South State Street and has lower traffic volumes. South Dora Street includes bike lanes within the City limits, approximately 1.5 miles north of the project.

**Less than significant impact with mitigation.** The inclusion of a marked crosswalk as part of the roundabout that would be constructed as part of the project would enhance pedestrian access between the project and the northbound bus stop on Plant Road. To complete this connection, a pedestrian walkway should be included as part of the project to improve access from the east side of the crosswalk to the bus stop. To provide adequate pedestrian access between the project site and transit facilities for service from central Ukiah to the project, the applicant should work with the Mendocino Transit Authority to investigate the feasibility of adding a southbound stop near the South State Street/Plant Road-Charlie Barra Drive intersection on South State Street or across from the existing northbound stop on Plant Road. Alternatively, pedestrian improvements could be provided along

South State Street to provide access between the project site and the existing southbound bus stop at Whitmore Lane. Such improvements would consist of a pedestrian path, designed to be consistent with adopted plans. The inclusion of these enhancements to pedestrian facilities and the provision of access to a southbound bus stop within walking distance of the project site would reduce the impact of the project to less than significant.

**Would the project:**

***b) Conflict or be inconsistent with CEQA Guidelines §15064.3, subdivision (b)?***

**Less than significant impact.** Senate Bill (SB) 743 established a change in the metric to be applied for determining traffic impacts associated with development projects. Rather than the delay-based criteria associated with a Level of Service analysis, the increase in Vehicle Miles Traveled (VMT) as a result of a project is now the basis for determining impacts. The Mendocino Council of Governments (MCOG) has adopted a regional baseline VMT study based on the guidance provided by the California Governor’s Office of Planning and Research (OPR) in the publication *Transportation Impacts (SB 743) CEQA Guidelines Update and Technical Advisory*, 2018. This document indicates that a residential project generating vehicle travel that is 15 percent or more below the existing citywide residential VMT per capita may be an appropriate VMT threshold.

In June 2020, MCOG accepted the *Senate Bill 743 Vehicle Miles Traveled Baseline Study*, which includes a recommended methodology and thresholds for VMT analysis for use in Mendocino County. Since Mendocino County has not yet adopted VMT thresholds, the MCOG methodology was used to analyze the potential impacts of the Bella Vista project.

The MCOG baseline study included a review of the proposed Garden’s Gate project as a test case for applying the recommended approach, which compares the VMT per service population (based on the number of residents and employees) in the project’s traffic analysis zone (TAZ) to the VMT in the corresponding sub-regional area. The analysis determined that the project is consistent with the General Plan and Regional Transportation Plan and with the Suburban Residential zoning designation in the Ukiah Valley Area Plan. Using MCOG’s screening tool, it was determined that the Ukiah Adjacent sub-regional mean VMT was 27.2, and the recommended threshold was 23.3, 14.3 percent below the sub-regional mean. The VMT per service population for TAZ 770, where the project is located, is 17.3, which is 25.8 percent below this threshold. Based on this analysis, the transportation impact of the project was determined to be less than significant. Since the Bella Vista project is located within the same footprint as the Garden’s Gate project and has the same land use, it would be expected to have the same VMT per service population. Therefore, the impact of the project would be less than significant. A summary of the project’s VMT findings is provided in Table 5 and the section of the MCOG baseline study summarizing the Garden’s Gate VMT analysis is enclosed.

**Table 5 – Vehicle Miles Traveled Analysis Summary**

<b>VMT Metric</b>	<b>Ukiah Adjacent Sub-regional Mean VMT</b>	<b>Significance Threshold</b>	<b>Project VMT Rate</b>	<b>Resulting Significance</b>
VMT per Service Population (sub-regional baseline)	27.2	23.3	17.3	Less than significant

**Would the project:**

***c) Substantially increase hazards due to a geometric design feature (e.g., sharp curves or dangerous intersections) or incompatible uses (e.g., farm equipment)?***

**Less than significant impact.** Access to the project site would be via two access roads from South State Street, one at the intersection of South State Street/ Plant Road, which is proposed to be converted to a roundabout with

Charlie Barra Drive connecting as the west leg, and the second at South Road, approximately 500 feet south of this intersection. South State Street is straight and flat through the project area. The roundabout, the South State Street/South Road intersection and the interior project streets and intersections would be designed and constructed to meet currently applicable codes and requirements, so would not be expected to result in any increased hazards. The project is therefore expected to have a less-than-significant impact regarding geometric design features or incompatible uses.

**Would the project:**

**d) Result in inadequate emergency access?**

**Less than significant impact.** Emergency access to the project site was evaluated relative to the previously approved Garden's Gate project. Garden's Gate included access at the intersection of South State Street/ Plant Road, to be reconstructed as a roundabout. The roundabout would also provide the primary access for Bella Vista, connecting to Charlie Barra Drive within the project. Secondary access for Garden's Gate was via a connection from an interior street to Gobalet Lane, just north of the project, which in turn would provide a connection to South State Street, approximately 150 feet north of the proposed roundabout. As indicated in the site plan, the secondary access to Bella Vista would be directly onto South State Street, approximately 500 feet south of the roundabout; the secondary access is therefore 350 feet further from the primary access than was proposed for Garden's Gate. Neither Garden's Gate nor Bella Vista included access via Oak Knoll Road.

Resolution No. 09-230, adopted by the County Board of Supervisors on October 6, 2009 certified the EIR and indicated that "an alternative mitigation has been proposed by the developer and has been approved by the Ukiah Valley Fire Protection District that such an alternative mitigation including fire sprinklers will adequately address fire protection." Further, the Conditions of Approval associated with the approved project (Case # S 3-2005) indicated that "in lieu of an emergency evacuation access, the developer agrees to provide fire sprinklers in all structures and will continue to seek an alternative access to the south of the project." As required in the Conditions of Approval, the site plan identifies future connections along the south side of the project, providing stubs for roadway connections to future development on the adjoining parcels.

Since Bella Vista is consistent with the required mitigations in the Garden's Gate EIR and the physical distance between the two project access points is greater than in the previously approved project, the project is expected to have a less-than-significant impact related to emergency access.

## Conclusions and Recommendations

- The Bella Vista project would be expected to generate an average of 1,413 trips per day, including 107 during the a.m. peak hour and 143 during the p.m. peak hour. This is 199 fewer daily trips than the previous version of the project – known as Garden's Gate – which was proposed for the same site and for which there is a certified EIR.
- Based on the estimated trip generation for the Bella Vista project and using the same trip distribution assumptions, all intersections that were previously analyzed in the Garden's Gate EIR, including the proposed roundabout at South State Street/Plant Road-Charlie Barra Drive, would receive fewer project-related trips from the Bella Vista project. The analysis as presented in the EIR therefore remains valid to address potential impacts at these locations.
- The proposed intersection of South State Street/South Road would be expected to operate at LOS B under Existing plus Project and Future plus Project volumes, which is considered to be acceptable.

Mr. Jake Morley

Page 8

March 11, 2021

- To provide access for project residents to the existing Mendocino Transit northbound bus stop on Plant Road across from the project site, a pedestrian walkway should be constructed between the proposed roundabout at South State Street/ Plant Road-Charlie Barra Drive and the bus stop. The applicant should also work with Mendocino Transit Authority to investigate the feasibility of providing a bus stop for southbound bus service within walking distance of the project site; alternatively, pedestrian improvements could be provided along South State Street between the project site and the existing bus stop at Whitmore Lane. With the inclusion of pedestrian improvements and provision of access to a southbound bus stop near the site, the project would have a less-than-significant impact in terms of program, plan, ordinance or policy addressing the circulation system, including transit, roadway, bicycle, and pedestrian facilities.
- The project would have a less-than-significant impact in terms of VMT based on the thresholds and methodology recommended in the SB 743 VMT Baseline Study that has been accepted by the Mendocino County Council of Governments.
- The project would be designed in accordance with current standards and code requirements and would therefore have a less-than-significant impact regarding geometric design features or incompatible uses.
- The project would comply with the emergency access-related mitigations identified in the Garden's Gate EIR and would increase the distance between the two project access points. Therefore, the project would have a less-than-significant impact regarding emergency access.

Thank you for giving W-Trans the opportunity to provide these services. Please call if you have any questions.

Sincerely,

Kim Tellez  
Assistant Engineer

Barry Bergman, AICP  
Senior Planner

Dalene J. Whitlock, PE, PTOE  
Senior Principal



DJW/bdb/kt/MEX050.L1

Enclosures: Bella Vista Site Plan; Level of Service Calculations; Garden's Gate VMT Test Case Summary

**LACO**  
 EUREKA • UKIAH • SANTA ROSA • CHICO  
 1-800-515-5054 www.laco.com

NO.	DESCRIPTION / REVISION	BY	CHK	DATE

VESTING TENTATIVE MAP  
 GULLION INC. CONSTRUCTION  
 3000 S STATE STREET, UKIAH, CA 95422  
 SUBDIVISION PHASING

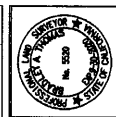

3/10  
 DRAWN: [ ]  
 CHECKED: [ ]  
 DATE: [ ]  
 LAYOUT DATE: 12/2009  
 SHEET NUMBER: [ ]  
 DRAWINGS: [ ]

Bella Vista Site Plan

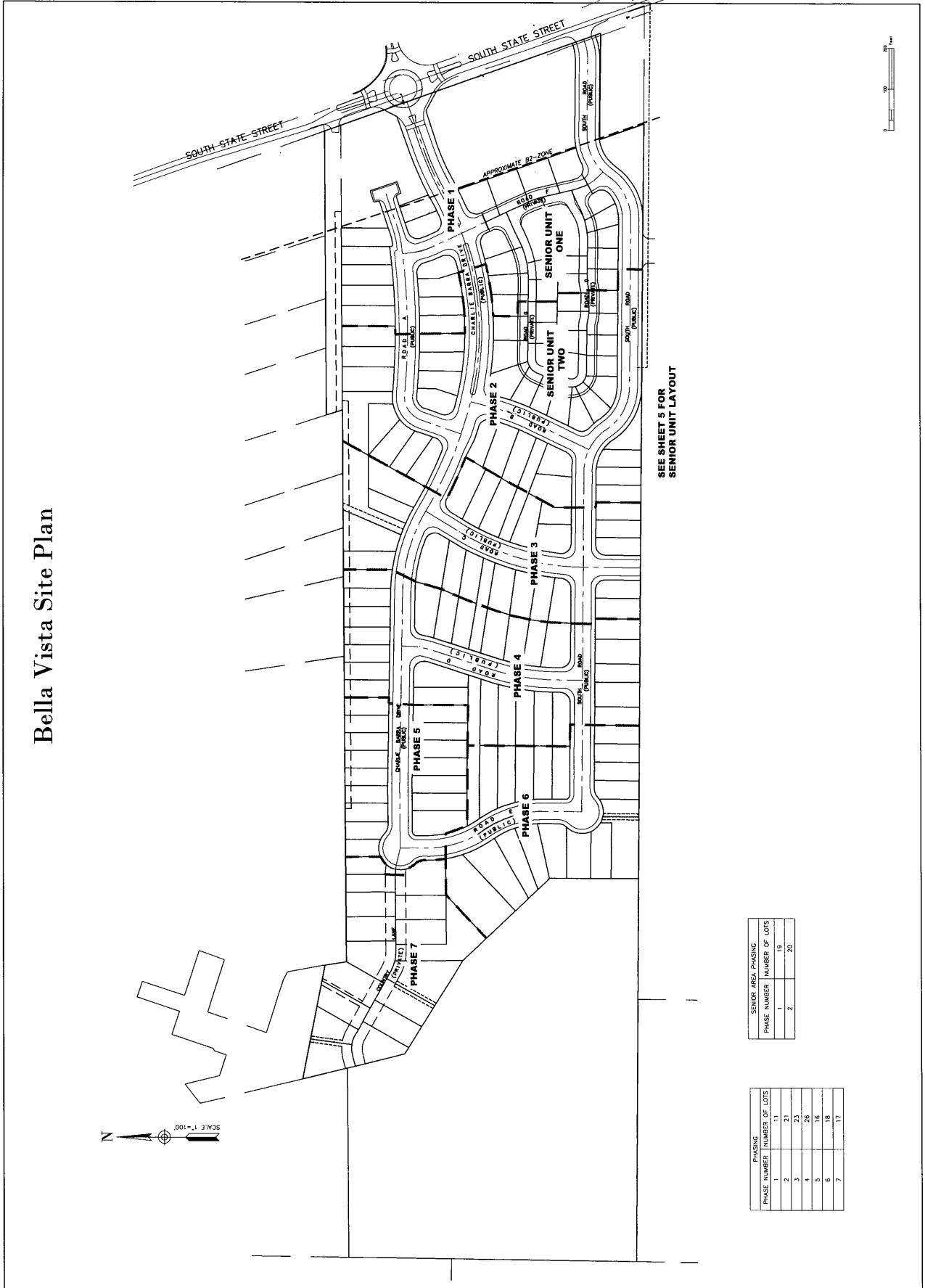

SEE SHEET 5 FOR SENIOR UNIT LAYOUT

SENIOR AREA PHASING		
PHASE NUMBER	NUMBER OF LOTS	
1	19	
2	20	

PHASING		
PHASE NUMBER	NUMBER OF LOTS	
1	11	
2	21	
3	23	
4	26	
5	17	
6	18	
7	17	

Intersection Level Of Service Report

Intersection 2: South State St/South Rd

Two-way stop  
HCM 2010  
15 minutes

Delay (sec / veh): 14.6  
Level Of Service: B  
Volume to Capacity (v/c): 0.040

Intersection Setup

Name	Northbound	Southbound	South State St	South Rd
Approach	Northbound	Southbound	Southbound	Eastbound
Lane Configuration	Left 12.00 0 100.00	Thru 12.00 0 106.00	Right 12.00 0 100.00	Right 12.00 0 100.00
Turning Movement				
Lane Width [ft]	12.00	12.00	12.00	12.00
No. of Lanes in Pocket	0	0	0	0
Pocket Length [ft]	100.00	106.00	100.00	100.00
Speed [mph]	45.00	45.00	45.00	30.00
Grade [%]	0.00	0.00	0.00	0.00
Crosswalk	Yes	Yes	Yes	Yes

Volumes

Name	Northbound	Southbound	South State St	South Rd
Base Volume Input [veh/h]	0	330	311	0
Base Volume Adjustment Factor	1.0000	1.0000	1.0000	1.0000
Heavy Vehicles Percentage [%]	2.00	2.00	2.00	2.00
Growth Factor	1.0000	1.0000	1.0000	1.0000
In-Process Volume [veh/h]	0	0	0	0
Site-Generated Trips [veh/h]	7	7	24	16
Diverter Trips [veh/h]	0	0	0	0
Pass-by Trips [veh/h]	0	0	0	0
Existing Site Adjustment Volume [veh/h]	0	0	0	0
Other Volume [veh/h]	0	0	0	0
Total Hourly Volume [veh/h]	7	337	335	24
Peak Hour Factor	0.9700	0.9700	0.9700	0.9700
Other Adjustment Factor	1.0000	1.0000	1.0000	1.0000
Total 15-Minute Volume [veh/h]	2	87	86	4
Total Analysis Volume [veh/h]	7	347	345	16
Pedestrian Volume [ped/h]	0	0	0	0

Intersection Settings

Priority Scheme	Free	Free	Stop
Flared Lane			No
Storage Area [veh]	0	0	0
Two-Stage Gap Acceptance	0	0	No
Number of Storage Spaces in Median	0	0	0

Movement, Approach, & Intersection Results

V/C, Movement V/C Ratio	0.01	0.00	0.00	0.00	0.04	0.04
d_L, Delay for Movement [s/veh]	8.00	0.00	0.00	0.00	14.61	10.73
Movement LOS	A	A	A	A	B	B
95th-Percentile Queue Length [veh/m]	0.02	0.02	0.00	0.00	0.25	0.25
95th-Percentile Queue Length [ft/m]	0.44	0.44	0.00	0.00	6.17	6.17
d_A, Approach Delay [s/veh]	0.16				12.25	
Approach LOS	A				B	
d_L, Intersection Delay [s/veh]					0.75	
Intersection LOS					B	

**Intersection Level of Service Report**  
**Intersection 2: South State St/South Rd**  
 Control Type: Two-way stop  
 Analysis Method: HCM 2010  
 Analysis Period: 15 minutes  
 Delay (sec / veh): 16.9  
 Level Of Service: C  
 Volume to Capacity (v/c): 0.044

**Intersection Setup**

Name	Approach	Northbound	South State St	Southbound	South Rd	Eastbound
Lane Configuration		←	←	←	←	←
Turning Movement		Left	Thru	Right	Left	Right
Lane Width [ft]		12.00	12.00	12.00	12.00	12.00
No. of Lanes in Pocket		0	0	0	0	0
Pocket Length [ft]		533.00	499.00	500.00	600.00	483.00
Speed [mph]		45.00	45.00	45.00	30.00	30.00
Grade [%]		0.00	0.00	0.00	0.00	0.00
Crosswalk		Yes	Yes	Yes	Yes	Yes

**Volumes**

Name	South State St	Southbound	South Rd	Eastbound
Base Volume Input [veh/h]	0	292	0	0
Base Volume Adjustment Factor	1.0000	1.0000	1.0000	1.0000
Heavy Vehicles Percentage [%]	2.00	2.00	2.00	2.00
Growth Factor	1.0000	1.0000	1.0000	1.0000
In-Process Volume [veh/h]	0	0	0	0
Site-Generated Trips [veh/h]	33	15	12	13
Diversified Trips [veh/h]	0	0	0	0
Pass-by Trips [veh/h]	0	0	0	0
Existing Site Adjustment Volume [veh/h]	0	0	0	0
Other Volume [veh/h]	0	0	0	0
Total Hourly Volume [veh/h]	33	307	12	13
Peak Hour Factor	0.9000	0.9000	0.9000	0.9000
Other Adjustment Factor	1.0000	1.0000	1.0000	1.0000
Total 15-Minute Volume [veh/h]	9	107	3	4
Total Analysis Volume [veh/h]	37	429	13	14
Pedestrian Volume [ped/h]	0	0	0	0

**Intersection Settings**

Priority Scheme	Free	Free	Stop
Flared Lane			No
Storage Area [veh]	0	0	0
Two-Stage Gap Acceptance	C	C	No
Number of Storage Spaces in Median			0

**Movement, Approach, & Intersection Results**

V/C, Movement V/C Ratio	d_M, Delay for Movement [s/veh]	d_A, Approach Delay [s/veh]	d_J, Intersection Delay [s/veh]
0.03	0.03	0.00	0.04
8.08	0.00	0.00	16.93
A	A	A	C
0.09	0.09	0.00	0.22
2.37	2.37	0.00	5.50
0.64	0.64	0.00	13.55
A	A	A	B
0.84	0.84	0.84	C



**Intersection Level Of Service Report**  
**Intersection 2: South State St/South Rd**  
 Control Type: Two-way stop  
 Analysis Method: HCM 2010  
 Analysis Period: 15 minutes  
 Delay (sec / veh): 17.2  
 Level Of Service: C  
 Volume to Capacity (V/C): 0.051

**Intersection Setup**

Name	Northbound	South State St	South Rd
Approach	Northbound	Southbound	Eastbound
Lane Configuration	Left Thru Right	Thru Right Left	Left Right
Turning Movement	12.00 0 0	12.00 0 0	12.00 0 0
Lane Width [ft]	12.00	12.00	12.00
No. of Lanes in Pocket	0	0	0
Pocket Length [ft]	100.00	100.00	100.00
Speed [mph]	45.00	45.00	30.00
Grade [%]	0.00	0.00	0.00
Crosswalk	Yes	Yes	Yes

**Volumes**

Name	South State St	South Rd
Base Volume Input [veh/h]	404	0
Base Volume Adjustment Factor	1.0000	1.0000
Heavy Vehicles Percentage [%]	2.00	2.00
Growth Factor	1.0000	1.0000
In-Process Volume [veh/h]	0	0
Site-Generated Trips [veh/h]	7	24
Diverter Trips [veh/h]	0	0
Pass-by Trips [veh/h]	0	0
Existing Site Adjustment Volume [veh/h]	0	0
Other Volume [veh/h]	0	0
Total Hourly Volume [veh/h]	7	24
Peak Hour Factor	1.0000	1.0000
Other Adjustment Factor	1.0000	1.0000
Total 15-Minute Volume [veh/h]	2	6
Total Analysis Volume [veh/h]	7	24
Pedestrian Volume [ped/h]	0	0

**Intersection Settings**

Priority Scheme	Free	Free	Stop
Flared Lane			No
Storage Area [veh]	0	0	0
Two-Stage Gap Acceptance			No
Number of Storage Spaces in Median	0	0	0

**Movement, Approach, & Intersection Results**

V/C, Movement V/C Ratio	0.01	0.00	0.00	0.00	0.05	0.04
d_M, Delay for Movement [s/veh]	8.22	0.00	0.00	0.00	17.24	11.56
Movement LOS	A	A	A	A	C	B
95th-Percentile Queue Length [veh/ln]	0.02	0.02	0.00	0.00	0.29	0.29
95th-Percentile Queue Length [ft/ln]	0.47	0.47	0.00	0.00	7.32	7.32
d_A, Approach Delay [s/veh]		0.13				13.83
Approach LOS		A				B
d_I, Intersection Delay [s/veh]					0.67	
Intersection LOS					C	

Control Type: Two-way stop  
Analysis Method: HCM 2010  
Analysis Period: 15 minutes

Intersection Level Of Service Report  
Intersection 2: South State St/South Rd  
Delay (sec / veh): 18.8  
Level Of Service: C  
Volume to Capacity (v/c): 0.047

**Intersection Setup**

Name	Approach	Northbound	South State St	Southbound	South Rd	Eastbound
Lane Configuration		←	←	←	←	←
Turning Movement		Left 12.00	Thru 12.00	Right 12.00	Left 12.00	Right 12.00
Lane Width [ft]		0	0	0	0	0
No. of Lanes in Pocket		0	0	0	0	0
Pocket Length [ft]		100.00	100.00	100.00	100.00	100.00
Speed [mph]		45.00	45.00	30.00	30.00	30.00
Grade [%]		0.00	0.00	0.00	0.00	0.00
Crosswalk		Yes	Yes	Yes	Yes	Yes

**Volumes**

Name	South State St	Southbound	South Rd	Eastbound
Base Volume Input [veh/h]	0	459	380	0
Base Volume Adjustment Factor	1.0000	1.0000	1.0000	1.0000
Heavy Vehicles Percentage [%]	2.00	2.00	2.00	2.00
Growth Factor	1.0000	1.0000	1.0000	1.0000
In-Process Volume [veh/h]	0	0	0	0
Site-Generated Trips [veh/h]	33	33	15	12
Diverted Trips [veh/h]	0	0	0	0
Pass-by Trips [veh/h]	0	0	0	0
Existing Site Adjustment Volume [veh/h]	0	0	0	0
Other Volume [veh/h]	0	0	0	0
Total Hourly Volume [veh/h]	33	492	395	12
Peak Hour Factor	1.0000	1.0000	1.0000	1.0000
Other Adjustment Factor	1.0000	1.0000	1.0000	1.0000
Total 15-Minute Volume [veh/h]	8	123	99	3
Total Analysis Volume [veh/h]	33	492	395	12
Pedestrian Volume [ped/h]	0	0	0	0

**Intersection Settings**

Priority Scheme	Free	Free	Stop
Planned Lane			No
Storage Area [veh]	0	0	0
Two-Stage Gap Acceptance	0	0	No
Number of Storage Spaces in Median	0	0	0

**Movement, Approach, & Intersection Results**

VIC Movement	VIC Ratio	d_M Delay [s/veh]	d_L Delay [s/veh]	d_A Approach Delay [s/veh]	d_J Intersection Delay [s/veh]	Intersection LOS
d_M, Delay for Movement [s/veh]	0.03	8.22	0.00	0.00	0.00	0.05
Movement LOS	A	A	A	A	A	C
95th-Percentile Queue Length [veh]	0.09	0.09	0.00	0.00	0.00	0.23
95th-Percentile Queue Length [ft]	2.21	2.21	0.00	0.00	0.00	5.67
d_A, Approach Delay [s/veh]	0.52					14.76
Approach LOS	A					B
d_J, Intersection Delay [s/veh]					0.71	C
Intersection LOS						



## 4. Test Cases for VMT Analysis

This section uses recent projects in Mendocino County as test cases for the proposed VMT analysis methodologies and thresholds. For each test case, the project was assessed to determine if the methodology was appropriate or if more detailed analysis was required. If the methodology was determined to be appropriate, the flowchart above was used to analyze the test case.

Each test case is discussed below. Analysis results are shown in italics.

### 4.1 Garden’s Gate Subdivision

This proposed project consists of 123 detached homes and 74 townhouses just south of the Ukiah city limit, in the Ukiah Adjacent subregion.

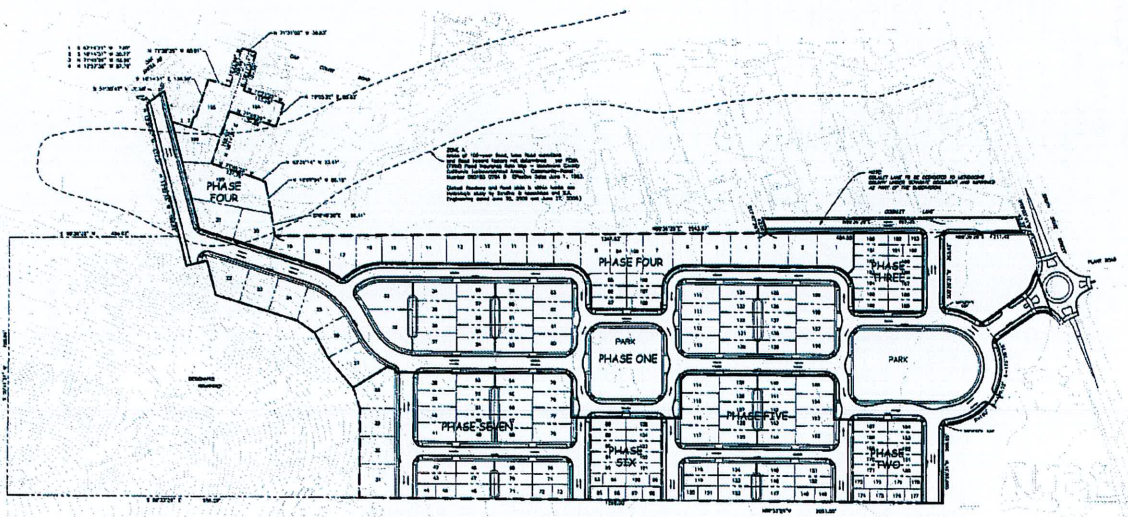

Garden’s Gate Tentative Map 1 (Garden’s Gate Subdivision Draft Environmental Impact Report, September 2008)

#### 4.1.1 Analysis

The project was assessed to determine if the methodology is appropriate, including:

- Does the project change the assumptions in the model?
- Does the project have specific impacts outside the model area?
- Does the project have specific impacts that will not be captured by the model?

*The methodology is appropriate: the project does not change the assumptions in the model, nor have specific impacts outside the model area, nor have specific impacts that will not be captured by the model.*

The questions in the flowchart were evaluated:



- Is the project/plan consistent with the General Plan and Regional Transportation Plan (RTP)?

*Yes: The project is consistent with the suburban residential designation in the Ukiah Valley Area Plan. The project is consistent with the land use in the model TAZ used to evaluate the RTP.*

- Is the project a local-serving retail project, 50,000 square feet or less?

*No.*

- Is the project/plan residential or work-related land use located in a TAZ with similar land uses?

*Yes, the project is residential and there is existing residential land use in the TAZ.*

- Is the project/plan located in a TAZ with total VMT per service population x% less than the subregional mean?

*Yes. For this analysis, X was assumed to be 14.3 percent in accordance with the reduction in total VMT per capita recommended in the California Air Resource Board 2017 Scoping Plan-Identified VMT Reductions and Relationship to State Climate Goals. The base year was assumed to be 2019. The screening tool showed that the total VMT per service population for the TAZ is 36 percent less than Ukiah Adjacent subregional mean. Figure 4 shows the screening tool inputs and Figure 5 shows the screening tool results*



Senate Bill 743 Vehicle Miles Traveled Regional Baseline Study  
 May 20, 2020

Figure 4: Screening tool inputs

**MCOG SB 743 VMT Screening Tool** Powered by FEHR & PEERS

**CRITERIA >**

Select Project Inputs  
 Use tools below to draw on the map and select the parcels you wish to screen.

Select parcels that represent your project

Add Remove

Enrich your map with layers  
 Turn layers on and off and adjust visibility to aide in parcel selection.

<input checked="" type="checkbox"/>	Traffic Analysis Zones	100%
<input checked="" type="checkbox"/>	Parcels (Zoom in to view)	100%
<input checked="" type="checkbox"/>	Subregions	75%
<input checked="" type="checkbox"/>	Project Area	100%

CONTINUE TO CRITERIA

Map showing a highlighted parcel in a green area. Includes zoom controls (+, -).

Esri, NASA, NGA, USGS, FEMA | Esri Community Maps Contrib... Powered by Esri

Figure 5: Screening tool results

**Screening Results** EDIT INPUTS NEW ANALYSIS EXPORT

**Screening Inputs**

Criteria	Input
VMT Metric	Total VMT per Service Population
Baseline Year	2019
Threshold (% reduction from Baseline Year)	Subregion Benchmark (-14.3%)

**Legend**

Category	Color
Salmon Project Area	[Salmon Box]

**Project Location**

Map showing project location with a salmon-colored area. Includes zoom controls.

**Project Proximity to Output Low VMT Generating TAZs**

Map showing project proximity to low VMT generating TAZs with a salmon-colored area. Includes zoom controls.

**Passed**

Screening Questions Results

Within a low VMT generating TAZ? Yes (Pass)

Screening results are based on location of parcel centroids. If results are desired considering the full parcel, please refer to the associated map layers to visually review parcel and TAZ boundary relationship.

**Traffic Analysis Zone (TAZ) Details**

TAZ Questions	TAZ ID: 770
Subarea	Ukiah Adjacent
TAZ VMT	17.3
Subarea VMT	27.2
% Difference	-36.31%
VMT Metric	Total VMT per Service Population
Threshold	23.3

**Threshold Evaluation**

Bar chart showing VMT Metric for TAZ 770 (17.3) compared to Threshold (23.3).

TAZ	VMT Metric	Threshold
TAZ 770	17.3	23.3



Senate Bill 743 Vehicle Miles Traveled Regional Baseline Study  
May 20, 2020

*Conclusion: Project passes screening and supports the presumption that VMT impact is less than significant.*

This evidence supports a conclusion that the project would have a less than significant VMT impact under baseline plus project conditions. This conclusion would also apply under cumulative conditions presuming no substantial changes to the subregion land use and transportation context.

## 4.2 Willits Sphere of Influence Expansion

This proposal is to expand the City of Willits sphere of influence to the southwest. The area would be rezoned for a mix of residential types, including single family dwelling units, duplexes, apartments, and senior housing. A minimum of 1,932 dwelling units would be planned.

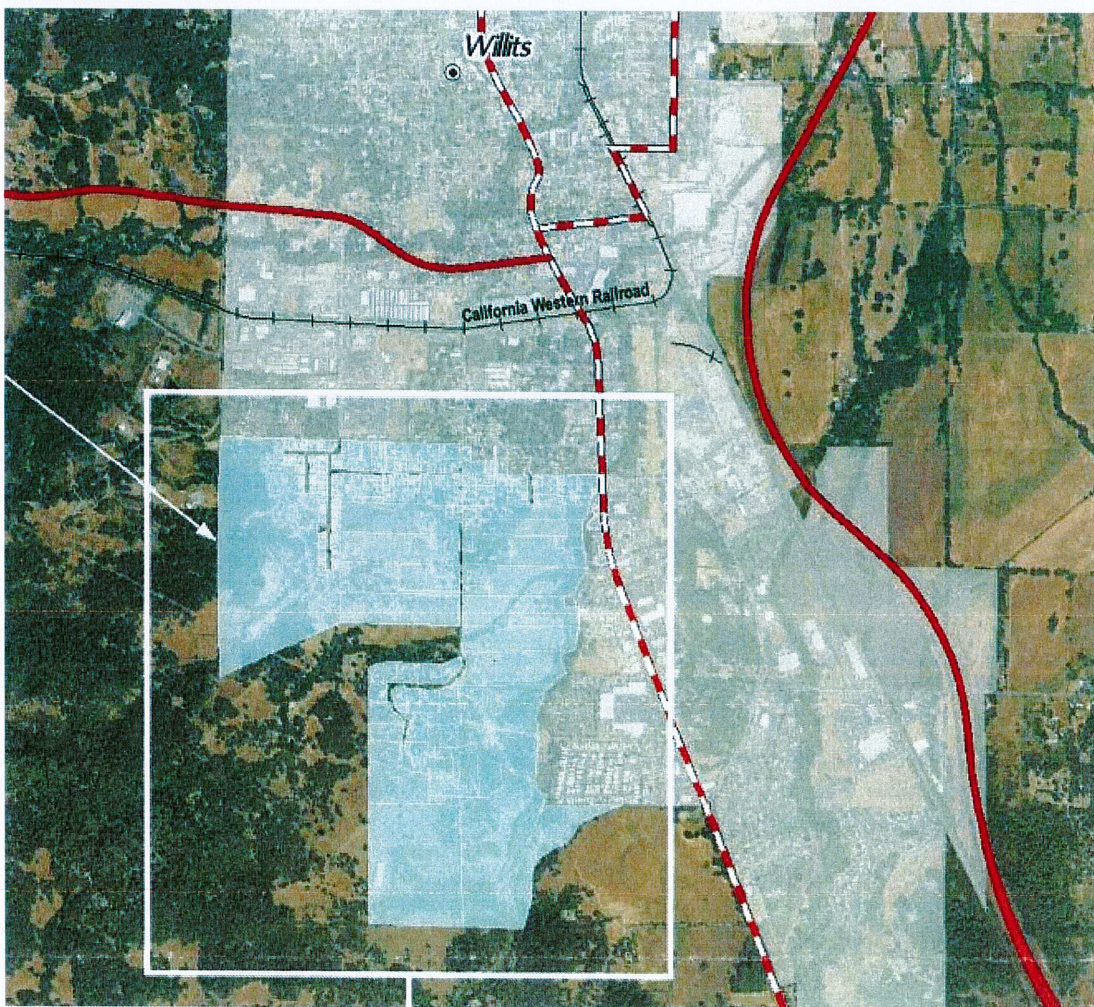

Excerpt from Draft City SOI Update figure, Mendocino County, July 2019

### 4.2.1 Analysis

The project was assessed to determine if the methodology is appropriate, including:



# ***BELLA VISTA RESIDENTIAL PROJECT***

## ***AIR QUALITY AND GREENHOUSE GAS ASSESSMENT***

***Mendocino County, California***

**January 19, 2021**

**Prepared for:**

**Jake Morley**  
Project Manager



2550 Lakewest Drive, Suite 50  
Chico, CA 95928

**Prepared by:**

**James Reyff**

**ILLINGWORTH & RODKIN, INC.**  
/// Acoustics • Air Quality ///

429 East Cotati Avenue  
Cotati, CA 94931  
(707) 794-0400

Project: 20-186

## Introduction

The purpose of this report is to evaluate the air quality and greenhouse gas impacts associated with the proposed residential development at 3000 South State Street, which is approximately 0.45 miles from the City of Ukiah limits. The project proposes to develop 171 residences along with parks, landscaped areas, and a water detention basin. The site includes approximately 48.8 acres of land that are mostly undeveloped, containing out of production grape vines, vegetation, and a wooded hillside at the west end. The proposed project represents a modification to the approved Garden's Gate residential project, a 199 lot and subdivision that includes 2.3 acres of open space and park area divided between a Neighborhood Park and a Community Park.

## Project Description

In 2006 a residential project, known as Garden's Gate, was approved at the project site. The approval consisted of a 199-lot Vested Tentative Subdivision Map, Development Agreement, Phasing Plan, Affordable Housing Agreement, and the certification of an Environmental Impact Report (EIR) pursuant to the California Environmental Quality Act (CEQA). The EIR included an air quality analysis and greenhouse gas (GHG) emissions assessment.

The EIR found air quality impacts to be less than significant if Mitigation Measure 3.6-A.1 is implemented to control construction period emissions. Project impacts in terms of GHG emissions were found to be significant and unavoidable because the project would use more energy and thereby generate GHG emissions that would adversely affect the global climate. Mitigation measure 3.6-F.1 was identified to reduce GHG emissions. With this measure, annual GHG emissions from the project were estimated at 2,114 tons of CO<sub>2e</sub> per year (GHG emissions expressed as equivalent to carbon dioxide). Mitigation measures addressing air quality and GHG emissions identified in the EIR that would apply to the project include the following:

***MM 3.6-A.1*** *The project applicant and construction contractor shall for all construction project phases prepare and implement a dust control program to limit construction emissions of PM<sub>10</sub>. The program shall include at least the following provisions from MCAQMD Rule 1-430 Fugitive Dust. Because the site is over one acre in size, a Grading Permit must be approved by MCAQMD, and MCAQMD may require additional mitigations.*

- *Covering open bodied trucks when used for transporting materials likely to give rise to airborne dust.*
- *The use of water or chemicals for control of dust in the demolition of existing buildings or structures.*
- *All visibly dry disturbed soil road surfaces shall be watered to minimize fugitive dust emissions.*
- *All unpaved surfaces, unless otherwise treated with suitable chemicals or oils, shall have a posted speed limit of 10 miles per hour.*



- *Earth or other material that has been transported by trucking or earth moving equipment, erosion by water, or other means onto paved streets shall be promptly removed.*
- *Asphalt, oil, water, or suitable chemicals shall be applied on materials stockpiles, and other surfaces that can give rise to dust emissions.*
- *All earthmoving activities shall cease when sustained winds exceed 15 miles per hour.*
- *The operator shall take reasonable precautions to prevent the entry of unauthorized vehicles onto the site during non-work hours.*
- *The operator shall keep a daily log of activities to control fugitive dust.*

**MM 3.6-F.1** *The project shall minimize the emission of greenhouse gases by including at least the following:*

- *Install solar hot water heaters with a back-up electric water heater.*
- *The project shall be constructed to incorporate the 2010 Title 24 building standards (or whatever standards have been adopted at the time that building permits are issued).*
- *The project shall include a photovoltaic (PV) solar electricity system that will be owned and operated by the Homeowner's Association for the benefit of the future residents. The system will be sized sufficiently so that it totally offsets electrical use from project parks, recreational facilities, and other facilities owned or managed by the Homeowners Association.*
- *Project residential units shall be oriented for maximum solar access. Roofs shall be constructed to allow easy and efficient retrofitting with roof- top solar panels.*

The applicant, Guillon Inc., proposes to modify the subdivision into a diverse range of detached age-restricted cottage units and single-family homes, public right-of-way, parkland, and open space. The project site is designated as Suburban Residential (SR) in the County's General Plan and is zoned Suburban Residential and Rural Residential. The subdivision, totaling 48.8 acres on four existing parcels, proposes to create the following:

- 171 Total Residential Lots:
  - Single Family Residential: 132 (average lot size 6,219 square feet)
  - Age Restricted Residential: 39 (average lot size 4,907 square feet)
- Neighborhood Park: 1.96 acres
  - Linear Park: 0.57 Acres
  - Cottage Park: 0.24 Acres

In addition to roadways and sidewalks, the project would also include an approximately 930 linear feet (0.18 of a mile) Class I Bicycle Lane. The subdivision would also result in a 12.19-acre Remainder Parcel at the west end of the site that encompasses the portion of the site that is zoned Rural Residential (RRS). No development is currently proposed for that parcel, and it is not part of the proposed project.

*Energy Efficiency and Conservation*

All residences would be constructed in accordance with the most recent edition of Title 24 of the California Building Code (CBC). The CBC contains mandatory requirements that apply to residential buildings that will be a part of the project which include; high performance attics insulation and walls, high efficacy lighting, windows, water heating and HVAC systems. Specific energy conservation features include:

- Structures will incorporate natural cooling by utilizing window overhangs, awnings, front and rear patios, shade from neighboring structures, radiant heat-reflective barriers in the attic and appropriate tree plantings or a combination thereof.
- Structures will be constructed in compliance with solar requirements found in Title 24 of the California Building Code.
- Project will incorporate Energy Star Certified Appliances. At a minimum, the following appliances are recommended to be Energy Star rated: dishwasher and water heater.
- Natural lighting may be incorporated into the home through solar tubes and sky lights.
- Windows, sky lights and other fenestration will meet energy code requirements and will be Energy Star certified. These elements will have low U-factor (U-value) rating. U-factors is a rate of non-solar heat loss or gain through a while window assembling. The lower the U-factor, the greater a window's resistance to heat flow and the better its insulating value.
- Project will incorporate the use of low flow toilets and faucets that meet the standards as set forth by the California Energy Commission.
- All landscaping will be installed to AB 1881 (The Water Conservation in Landscaping Act of 2006) standards, which promotes water efficiency and conservation, using mulch, bubblers, and timed sprinkler systems.

#### *Construction Grading and Dust*

The proposed development will require the preparation of a detailed grading and erosion control plan subject to review and approval by the County prior to earth moving activities (Municipal Code section 18.70.060 – Grading Permit Requirements). Grading will be completed in compliance with County standards. Dust control rules and regulations as required by the Mendocino County Air Quality Management District (MCAQMD) will be adhered to (Rule 1-200, 1-400(a), 1-410, 1-420, 1-430). These regulations minimize fugitive dust particle during construction. Measures imposed by the District include, but not limited to:

1. All visibly dry disturbed soil surfaces shall be watered to minimize fugitive dust.
2. Installation of a “stabilized construction entrance/exit” as detailed in the Department of Transportation storm water handbook (TC-1) will be utilized.
3. Earth or other material tracked on to neighboring paved roads shall be removed promptly.
4. Dust generating activities will be limited during periods of high winds (over 15 mph).
5. Access of unauthorized vehicles onto the construction site during non-working hours shall be prevented.
6. A weekly log shall be kept of fugitive dust control measures that have been implemented.
7. Restrict idling of diesel engines on the site to less than 5 minutes.
8. All haul trucks transporting soil, sand or other loose materials off-site shall be covered.
9. All vehicle speeds on unpaved roads shall be limited to 15 mph.

10. Idling times shall be minimized either by shutting equipment off when not in use or reducing the maximum idling time to 5 minutes (as required by the California airborne toxics control measure title 13, Section 2485 of the California Code of Regulations). Clear signage shall be provided for construction workers at access points.
11. All construction equipment shall be maintained and properly tuned in accordance with manufacturer's specifications. All equipment shall be checked by a certified mechanic and determined to be running in proper condition prior to operation.
12. Post a publicly visible sign with telephone number for the applicant's representative regarding dust complaints. This person shall respond and take corrective action within 48 hours. The Air District's phone number shall also be visible to ensure compliance with applicable regulations.

Additionally, measures to reduced diesel particulate matter emissions that could affect local receptors are incorporated into the project as follows:

All off road construction equipment with engines greater than 50 horsepower (hp) and operating on the site for more than two days or 20 hours shall meet, at a minimum, U.S. EPA particulate matter emission standards for Tier 4 engines or equivalent. In the event that such equipment is not available, the use of Tier 3 construction equipment is sufficient so long as it can be demonstrated to the County that similar Tier 4 construction equipment is not readily available.

In accordance with requirements from the Mendocino Solid Waste Authority, a Construction and Demolition Waste Management Plan (CWM) will be provided at the time the permit is issued by the Waste Authority (Ordinance 4301). The CWM will be submitted to the Solid Waste Authority prior to the start of construction related activities. The CWM will outline measure to capture and recycle materials that would otherwise end up in the waste stream.

#### *GHG Reduction Measures*

GHG emissions would be reduced based on the following features:

- No fireplaces;
- Include solar power for each of the residential lots (not quantified);
- No natural gas hookups;
- Include infrastructure to promote electric car charging (i.e., provide 220VAC outlets);
- Meet latest CalGreen Title 24 standards);
- Include energy efficient appliances;
- Include low-flow water fixtures; and
- Include water-efficient irrigation systems (drip systems).

#### **Purpose of this Air Quality/GHG Study**

In this analysis, the impacts from the proposed Bella Vista residential project are compared to the previously entitled Garden's Gate Subdivision project. Any new significant or significant impacts that are substantially worsened under the currently proposed project are identified. Mitigation measures to reduce impacts are updated in this analysis.

## **Air Quality Setting**

### Air Quality Regulatory Framework

Air quality and air pollution sources are regulated by Federal, State, regional, and local regulatory agencies. Air quality regulations provide the standards by which air quality is determined and institute controls on air pollution sources to improve air quality. The Federal Clean Air Act established the national ambient air quality standards and delegated the enforcement of air pollution control regulations to the states. In California, the California Air Resources Board (CARB) develops and enforces air regulations, but delegates the responsibility of stationary emission source regulation to local air pollution control agencies. In the project area, the Mendocino County Air Quality Management District (MCAQMD) is responsible for air pollution source regulation. Mobile sources of air pollutant emissions are regulated on a state-wide basis by the CARB. The air pollutants of concern and the roles of the agencies primarily responsible for managing the air quality within the project area and relevant air quality regulations are further discussed below.

### Federal Air Quality Regulations

The Federal Clean Air Act (Federal Act) was established in an effort to assure that acceptable levels of air quality are maintained in all areas of the United States. Air quality is characterized by the presence of pollutants that fall into two basic categories; criteria air pollutants and toxic or hazardous air contaminants. Criteria air pollutants refer to a group of pollutants that the regulatory agencies have adopted ambient air quality standards and pollution management and control strategies. Toxic or hazardous air contaminants refer to a category of air pollutants that have potential adverse health effects but do not have an associated ambient air quality standard. These pollutants are called hazardous air pollutants (HAPs) in Federal law and toxic air pollutants (TACs) in California law.

Each state is divided into air basins based on topographic, geographic, and meteorological conditions. Each air basin is then assessed to determine if the area meets the National Ambient Air Quality Standards (NAAQS). Air basins or portions thereof have been classified as either “attainment” or “nonattainment” for each criteria air pollutant based on whether or not compliance with the standards has been achieved.

If an area does not meet the NAAQS over a set period of time, the United States Environmental Protection Agency (U.S. EPA) designates the area as a “nonattainment” area for that particular pollutant and sets deadlines for bringing the area into compliance with the standards. These deadlines vary by pollutant, the current level of air pollution in the air basin, and the ability of each region to meet the deadline. The U.S. EPA requires states that have areas that are not in compliance with the national standards to prepare and submit air quality plans showing how and when the standards will be met. These plans are referred to as State Implementation Plans (SIPs). If the states cannot show how the standards will be met, then they must show progress toward meeting the standards. Under severe cases, the U.S. EPA may impose a Federal plan to show progress in meeting the Federal standards. Since, as discussed below, the area meets all NAAQS, there is no SIP imposed on the North Coast Air Basin.

### State Air Quality Regulations

Air pollution in California is regulated under the provisions of the California Clean Air Act (State Act). These statutes provide the basis for implementing the Federal Act. The CARB is responsible for establishing and reviewing the State standards, compiling the California SIP, securing approval of that plan from the U.S. EPA, and identifying toxic air contaminants. CARB also regulates mobile emission sources in California, such as construction equipment, trucks, and automobiles. The State Act divides implementation responsibility between the CARB and local or regional agencies called air quality management districts or air pollution control districts. The MCAQMD is the local air quality district for the project. The MCAQMD is responsible for bringing and/or maintaining air quality within Federal and State air quality standards. This includes the responsibility to monitor ambient air pollutant levels and to develop and implement attainment strategies to ensure that future emissions will be within standards.

The air districts are primarily responsible for implementing and enforcing Federal and State regulations for stationary sources at industrial and commercial facilities within their jurisdictions and for preparing the regional air quality plans that are required under the Federal Clean Air Act and California Clean Air Act. These regional air quality plans prepared by districts throughout the State are compiled by the CARB to form the California SIP. The local air districts also have the responsibility and authority to adopt transportation control measures and emission reduction programs for indirect and area-wide emission sources.

The CARB oversees air district regulation of stationary sources and is the agency primarily responsible for controlling air pollution from mobile sources in California. Regulations have been adopted at both U.S. EPA and CARB levels that set specific emission standards for vehicles. As older vehicles are retired and replaced with newer, cleaner vehicles (called “fleet turnover”), it is expected that the air quality will improve. Consistent with this notion, most air quality planning documents project reduced vehicle emissions in the future.

### *Criteria Air Pollutants*

The California Clean Air Act outlines a program for areas in the State to attain the California Air Quality Standards (CAAQS) by the earliest practical date. The California Clean Air Act set more stringent air quality standards, as shown in Table 1, for most of the pollutants covered under the Federal standards. Additionally, California has adopted ambient air quality standards for vinyl chloride, hydrogen sulfide, sulfates, and visibility-reducing particulates.

In a manner similar to the Federal requirements, the California Clean Air Act requires designation of attainment and nonattainment areas with respect to CAAQS. The California Clean Air Act also requires that local and regional air districts prepare a Clean Air Plan (CAP) if the State air quality standards for carbon monoxide (CO), sulfur dioxide (SO<sub>2</sub>), nitrogen dioxide (NO<sub>2</sub>), or ozone (O<sub>3</sub>) are violated in their district. These CAPs include information on existing air quality in the region, an inventory of current and forecasted future emissions, emission reductions required to meet the standards, and the control measures required to achieve the emission reduction. The CAP must show satisfactory progress in attaining the State air quality standards. The California Clean

Air Act requires that the State air quality standards be met as expeditiously as practicable but unlike the Federal Clean Air Act, does not set precise attainment date deadlines. Instead, the act established increasingly stringent requirements for areas that will require more time to achieve the standards.

Unlike for other pollutants an attainment plan is not required for areas that violate the State respirable particulate matter or particulates with an aerodynamic diameter of 10 micrometers ( $\mu\text{m}$ ) or less ( $\text{PM}_{10}$ ) standards. As discussed below, the State  $\text{PM}_{10}$  standards are exceeded in Mendocino County. While the MCAQMD is not required to prepare a  $\text{PM}_{10}$  attainment plan, the District is required to prevent significant deterioration of local air quality and make reasonable efforts toward achieving attainment status for all pollutants. However, the MCAQMD has prepared a Particulate Matter Attainment Plan, which lists  $\text{PM}_{10}$  control measures it considers cost-effective and developed a schedule for implementation of the plan. There are also standards for fine particulate matter, or particulates with an aerodynamic diameter of 2.5  $\mu\text{m}$  or less ( $\text{PM}_{2.5}$ )

### *Toxic Air Contaminants*

Toxic Air Contaminants (TACs) are a broad class of compounds known to cause morbidity or mortality (usually because they cause cancer or serious illness) and include, but are not limited to, the criteria air pollutants listed in Section 2.3.2.2. TACs are found in ambient air, especially in urban areas, and are caused by industry, agriculture, fuel combustion, and commercial operations (e.g., dry cleaners). TACs are typically found in low concentrations, even near their source (e.g., diesel particulate matter near a freeway). Because chronic exposure can result in adverse health effects, TACs are regulated at the regional, state, and federal level. The identification, regulation, and monitoring of TACs is relatively new compared to that for criteria air pollutants that have established ambient air quality standards. TACs are regulated or evaluated on the basis of risk to human health rather than comparison to an ambient air quality standard or emission-based threshold.

Diesel exhaust is the predominant cancer-causing TAC in California. CARB estimates that about 70 percent of total known cancer risk related to air toxics in California is attributable to DPM.<sup>1</sup> According to CARB, diesel exhaust is a complex mixture of gases, vapors, and fine particles. This complexity makes the evaluation of health effects of diesel exhaust a complex scientific issue. Some of the chemicals in diesel exhaust, such as benzene and formaldehyde, have been previously identified as TACs by the CARB, and are listed as carcinogens either under the state's Proposition 65 or under the Federal Hazardous Air Pollutants programs.

To address the issue of diesel emissions in the state, CARB developed the Risk Reduction Plan to Reduce Particulate Matter Emissions from Diesel-Fueled Engines and Vehicles.<sup>2</sup> In addition to requiring more stringent emission standards for new on-road and off-road mobile sources and stationary diesel-fueled engines to reduce particulate matter emissions by 90 percent, a significant

---

<sup>1</sup> CARB. *Summary: Diesel Particulate Matter Health Impacts*. [https://www.arb.ca.gov/research/diesel/diesel-health\\_summ.htm](https://www.arb.ca.gov/research/diesel/diesel-health_summ.htm)

<sup>2</sup> California Air Resources Board. *Risk Reduction Plan to Reduce Particulate Matter Emissions from Diesel-Fueled Engines and Vehicles*. October 2000.

component of the plan involves application of emission control strategies to existing diesel vehicles and equipment. Many of the measures of the Diesel Risk Reduction Plan have been approved and adopted, including the Federal on-road and non-road diesel engine emission standards for new engines, as well as adoption of regulations for low sulfur fuel in California.

CARB has adopted and implemented a number of regulations for stationary and mobile sources to reduce emissions of diesel particulate matter (DPM). Several of these regulatory programs affect medium and heavy-duty diesel trucks that represent the bulk of DPM emissions from California highways. CARB regulations adopted in 2014 require on-road diesel trucks to be retrofitted with particulate matter controls or replaced to meet 2010 or later engine standards that have much lower DPM and PM<sub>2.5</sub> emissions.<sup>3</sup> This regulation will substantially reduce these emissions between 2013 and 2023. While new trucks and buses will meet strict federal standards, this measure is intended to accelerate the rate at which the fleet either turns over so there are more cleaner vehicles on the road, or is retrofitted to meet similar standards. With this regulation, older, more polluting trucks would be removed from the roads sooner.

CARB has also adopted and implemented regulations to reduce DPM and nitrogen oxides (NOx) emissions from in-use (existing) and new off-road heavy-duty diesel vehicles (e.g., loaders, tractors, bulldozers, backhoes, off-highway trucks, etc.). The regulations apply to diesel-powered off-road vehicles with engines 25 horsepower (hp) or greater. The regulations are intended to reduce particulate matter and NOx exhaust emissions by requiring owners to turn over their fleet (replace older equipment with newer equipment) or retrofit existing equipment in order to achieve specified fleet-averaged emission rates. Implementation of this regulation, in conjunction with stringent Federal off-road equipment engine emission limits for new vehicles, will significantly reduce emissions of DPM and NOx. *Attachment 1* includes detailed community risk modeling methodology.

#### *Naturally Occurring Asbestos*

Naturally occurring asbestos (NOA) was identified as a TAC in 1986 by CARB. NOA is located in many parts of California and is commonly associated with ultramafic rocks. Asbestos is the common name for a group of naturally occurring fibrous silicate minerals that can separate into thin but strong and durable fibers. Ultramafic rocks form in high-temperature environments well below the surface of the earth. When exposed at the surface by geologic uplift and erosion, ultramafic rocks may be partially to completely altered into a type of rock called serpentinite. Sometimes the metamorphic conditions are right for the formation of chrysotile asbestos or tremolite-actinolite asbestos in the bodies of these rocks, along their boundaries, or in the soil. For individuals living in areas of NOA, there are many potential pathways for airborne exposure. Exposures to soil dust containing asbestos can occur under a variety of scenarios, including children playing in the dirt; dust raised from unpaved roads and driveways covered with crushed serpentinite; grading and earth disturbance associated with construction activity; quarrying; gardening; and other human activities. For homes built on asbestos outcroppings, asbestos can be tracked into the home and can also enter as fibers suspended in the air. People exposed to low levels of asbestos may be at elevated risk (e.g., above background rates) of lung cancer and

---

<sup>3</sup> Title 13, California Code of Regulations Division 3: Air Resources Board Chapter 1: Motor Vehicle Pollution Control Devices

mesothelioma. The risk is proportional to the cumulative inhaled quantity of fibers, and also increases with the time since first exposure. Although there are a number of factors that influence the disease-causing potency of any given asbestos (such as fiber length and width, fiber type, and fiber chemistry), all forms are carcinogens.

### Local Air Quality Policies and Regulations

#### *Mendocino County General Plan Goals and Policies*

The Mendocino County General Plan contains goals, policies, standards, and implementation programs pertinent to air quality. The following general plan policies regarding air quality are considered relevant to the proposed project:

- Policy RM-37: Public and private development shall not exceed Mendocino County Air Quality Management District emissions standards.
- Policy RM-38: The County shall work to reduce or mitigate particulate matter emissions resulting from development, including emissions from wood-burning devices.
- Policy RM-43: Reduce the effects of earth-moving, grading, clearing and construction activities on air quality.
- Policy RM-44: New development should be focused within and around community areas to reduce vehicle travel.
- Policy RM-45: Encourage the use of alternative fuels, energy sources and advanced technologies that result in fewer airborne pollutants.
- Policy RM-46: Reduce or eliminate exposure of persons, especially sensitive populations, to air toxics.
- Policy RM-47: Minimize the exposure of sensitive uses, such as residences, schools, day care, group homes or medical facilities to industrial uses, transportation facilities, or other sources of air toxics.

#### *Mendocino County Air Quality Management District (MCAQMD) Regulations*

The MCAQMD is responsible for permitting and inspection of stationary sources; enforcement of regulations, including setting fees, levying fines, and enforcement actions; and ensuring that public nuisances are minimized.

Regulation 4 *Particulate Matter Reduction Measures* would apply to construction of the project. This Regulation contains general limitations associated with air emission source operations including those relating to public nuisance, visible emissions, particulate matter emissions, and fugitive dust.

Rule 1-400(a) Public Nuisance – This is a general requirement that is applicable to odors, as well as other air contaminants. Specifically, the rule states that a person shall not discharge from any source whatsoever such quantities of air contaminants or other material which cause injury, detriment, nuisance or annoyance to any considerable number of persons or to the public or which endanger the comfort, repose, health or safety of any such persons or the public or that cause or have a natural tendency to cause injury or damage to business or property.



Rule 1-410 Visible Emissions – This applies to any source at the facility and limits visible emissions to no more than 20 percent opacity for more than a 3-minute period in any one hour.

Rule 1-420 Particulate Matter – This rule imposes particulate matter emission rate limitations and is applicable to combustion and non-combustion sources. Combustion sources do not include mobile sources. The proposed project will have both combustion and non-combustion sources that would be subject to these requirements.

Rule 1-430 Fugitive Dust Emissions – This rule requires that (a) all reasonable precautions be taken to prevent particulate matter from becoming airborne and (b) specifies airborne dust control measures that would be required. The project would be subject to these requirements.

In addition, there are other MCAQMD rules and regulations, not detailed here, which may apply to the proposed project but are administrative or descriptive in nature. These include rules associated with fees, enforcement and penalty actions, and variance procedures.

#### Existing Ambient Air Quality

Table 1 summarizes air quality data for monitoring stations in Ukiah, California. Data from 2017-2019 are the most recent available. The data reported in Table 1 show that the ambient air quality standards for PM<sub>2.5</sub> were exceeded in 2017 and 2018. These high levels were the result of Northern California wildfires. Ozone concentrations measured in Ukiah were below the ambient air quality standards. Carbon monoxide, nitrogen dioxide, sulphur dioxide, and lead are not measured in the county due to the lack of emission sources. These pollutants have been measured at very low levels in the past.

**Table 1. Maximum Measured Air Pollutant Concentrations Closest to the Project Site**

Pollutant & Location	Averaging Period	Air Quality Standard		2017	2018	2019
		National	State			
Fine Particulate Matter (PM <sub>2.5</sub> )	24-Hour (µg/m <sup>3</sup> )	35	-	<b>127*</b>	<b>263*</b>	<b>21</b>
	Annual (µg/m <sup>3</sup> )	15	12	9.4	11.4	6.0
Ozone (O <sub>3</sub> )	1-Hour (ppm)	-	0.09	0.085	0.075	0.062
	8-Hour (ppm)	0.075	0.070	0.064	0.060	0.054

\*Affected by wild fires

Notes: ppm = parts per million

µg/m<sup>3</sup> = micrograms per cubic meter

Values reported in bold exceed ambient air quality standard

There are no nearby stations measuring other pollutants (i.e., NO<sub>2</sub>, CO, SO<sub>2</sub>, or Lead).

#### Attainment Status

Areas that do not violate ambient air quality standards are considered to have attained the standard. Violations of ambient air quality standards are based on air pollutant monitoring data and are judged for each air pollutant, using the most recent three years of monitoring data. The Mendocino County as a whole does not meet State standards for PM<sub>10</sub>, as designated by CARB.<sup>4</sup> The air basin and County is considered attainment or unclassified for all other air pollutants. Unclassified typically means the region does not have concentrations of that pollutant that exceed ambient air quality standards.

#### Sensitive Receptors

Sensitive receptors are people who are particularly susceptible to the adverse effects of air pollution. The CARB has identified the following people who are most likely to be affected by air pollution: children, the elderly, the acutely ill and the chronically ill, especially those with cardio-respiratory diseases. Residential areas are also considered sensitive receptors to air pollution because residents (including children and the elderly) tend to be at home for extended periods of time, resulting in sustained exposure to any pollutants present. The closest sensitive receptors to the project site are single family residences along the north side of Cobalt Lane and some rural residences to the west along S. State Street.

#### **Greenhouse Gas Emissions and Global Climate Change**

Climate change is caused by greenhouse gases (GHGs) emitted into the atmosphere around the world from a variety of sources, including the combustion of fuel for energy and transportation, cement manufacturing, and refrigerant emissions. GHGs are those gases that have the ability to trap heat in the atmosphere, a process that is analogous to the way a greenhouse traps heat. GHGs may be emitted as a result of human activities, as well as through natural processes. GHGs have been accumulating in the earth's atmosphere at a faster rate than has occurred historically. Increasing GHG concentrations in the atmosphere are leading to global climate change.

Carbon dioxide (CO<sub>2</sub>) is the most important anthropogenic GHG because it comprises the majority of total GHG emissions emitted per year and it is very long-lived in the atmosphere. Common GHGs include carbon dioxide, methane, nitrous oxides, and halocarbons (a group of gases containing fluorine, chlorine, or bromine). Typically, when evaluating GHG emissions they are expressed as carbon dioxide equivalents, or CO<sub>2</sub>e, which is a means of weighting the global warming potential (GWP) of the different gases relative to the global warming effect of CO<sub>2</sub>, which has a GWP value of one. Other GHGs, such as methane and nitrous oxide which are commonly found in the atmosphere, but at much lower concentrations, have a GWP of 21 and 310, respectively. In the United States, CO<sub>2</sub> emissions account for about 85 percent of the CO<sub>2</sub>e emissions, followed by methane at about eight percent and nitrous oxide at about five percent.

---

<sup>4</sup> CARB. See <http://www.arb.ca.gov/desig/adm/adm.htm>, accessed August 24, 2016.

### Federal Regulations

The United States participates in the United Nations Framework Convention on Climate Change (UNFCCC). In 2007, the U.S. EPA identified CO<sub>2</sub> as an air pollutant as defined under the Clean Air Act, and that the U.S. EPA has the authority to regulate emissions of GHGs. The U.S. EPA has promulgated several GHG regulations, which for the most part, apply to larger facilities that emit large amounts of CO<sub>2</sub> or its equivalent in other regulated GHGs. These regulations include the Federal Mandatory Reporting of Greenhouse Gases (Mandatory Reporting Rule) and the Tailoring Rule. The Mandatory Reporting Rule, which requires reporting of CO<sub>2</sub> and other GHG emissions, applies to particular facility types. Land use projects are not identified as facilities that are subject to this rule.

### State Regulations

In response to the increasing body of evidence that GHGs will continue to affect the global climate, the State has enacted key legislation and implemented regulations in an effort to reduce the State's contribution to climate change.

California Assembly Bill 1493 (Pavley), enacted on July 22, 2002, required the CARB to develop and adopt regulations that reduce GHGs emitted by passenger vehicles and light duty trucks. Regulations adopted by the CARB will apply to 2009 and later model year vehicles. The CARB estimates that the regulation will reduce GHG emissions from light duty passenger vehicles in California by an estimated 18 percent in 2020 and by 27 percent in 2030.

In 2006, AB 32, the *California Global Warming Solutions Act of 2006* was adopted. AB 32 focuses on reducing GHG emissions in California. GHGs as defined under AB 32 include: carbon dioxide, methane, nitrous oxide, hydrofluorocarbons, perfluorocarbons, and sulfur hexafluoride. AB 32 requires the CARB to adopt rules and regulations that would achieve GHG emissions equivalent to statewide levels in 1990 by 2020. CARB approved the Climate Change Scoping Plan (Scoping Plan) in December 2008. The Scoping Plan outlines actions to obtain the goal set out in AB 32 of reducing emissions to 1990 levels by 2020. The Scoping Plan “proposes a comprehensive set of actions designed to reduce overall greenhouse gas emissions in California, improve our environment, reduce our dependence on oil, diversify our energy sources, save energy, create new jobs, and enhance public health”. Most of the measures in the Scoping Plan were in place by 2012. The Scoping Plan's recommendations for reducing greenhouse gas emissions to 1990 levels by 2020 provide for emission reduction measures, including a cap-and-trade program linked to Western Climate Initiative partner jurisdictions, green building strategies, recycling and waste-related measures, and Voluntary Early Actions and Reductions. CARB has also developed and approved a 1990 State GHG emissions inventory of 427 million metric tons of carbon dioxide equivalent (MMTCO<sub>2</sub>e) in December 2007. In 2020, GHG emissions in California are required to be at or below 427 MMTCO<sub>2</sub>e.

In 2014, CARB approved the first update to the AB 32 Scoping Plan that was adopted in late 2008. The Update describes California's progress toward meeting the “near-term” 2020 GHG emission reduction goals defined in the initial Scoping Plan and identifies opportunities to leverage existing and new funds to further drive GHG emission reductions through strategic planning and targeted

low carbon investments. Furthermore, this update defines CARB's climate change priorities for the next five years, and also sets the groundwork to reach the long-term GHG reduction goals.

Executive Order S-01-07, enacted in 2007, mandated a Low Carbon Fuel Standard for transportation fuels sold in California.

California Senate Bill 375, adopted in 2008, requires: (1) metropolitan planning organizations to include sustainable community strategies in their regional transportation plans for reducing GHG emissions, (2) aligns planning for transportation and housing, and (3) creates specified incentives for the implementation of the strategies.

Executive Order B-30-15, which was signed by the Governor in 2015, established a California GHG reduction target of 40 percent below 1990 levels by 2030. On September 8, 2016, the California legislature passed SB 32 which requires CARB to ensure that statewide GHG emissions are reduced to 40 percent below the 1990 level by 2030. The bill noted that it would become operative only if AB 197 is enacted and becomes effective on or before January 1, 2017. AB 197 was enacted the same day.

#### Mendocino County General Plan Goals and Policies

Policy RM-50: Mendocino County acknowledges the real challenge of climate change and will implement existing strategies to reduce greenhouse gas emissions and incorporate future measures that the State adopts in the coming years.

## Impact Assessment

### Evaluation Criteria and Significance Thresholds

The project would cause a significant impact related to odor and air quality, as defined by the CEQA Guidelines (Appendix G), if it would:

1. Conflict with or obstruct implementation of the applicable air quality plan;
2. Violate any air quality standard or contribute substantially to an existing or projected air quality violation;
3. Result in a cumulatively considerable net increase of any criteria pollutant for which the project region is non-attainment under an applicable federal or state ambient air quality standard (including releasing emissions which exceed quantitative thresholds for ozone precursors);
4. Expose sensitive receptors to substantial pollutant concentrations; or
5. Create objectionable odors affecting a substantial number of people.

For GHG emissions, the project would have a significant effect if it would:

6. Generate greenhouse gas emissions, either directly or indirectly, that may have a significant impact on the environment ; or
7. Conflict with an applicable plan, policy, or regulation adopted for the purpose of reducing the emissions of greenhouse gases.

### *Criteria Pollutant and GHG Significance Thresholds*

The Garden's Gate Subdivision Draft EIR used significant thresholds recommended by MCAQMD at the time of the analysis in 2008. These were identified as shown in Table 2.

**Table 2. Thresholds Used for Approved Project**

<b>Pollutant</b>	<b>MCAQMD Significant Impact Threshold for Stationary Sources (lb/day)</b>	<b>MCAQMD Significant Impact Threshold for Indirect Sources (lb/day)</b>
ROG	110	180
NO <sub>x</sub>	110	42
CO	225	690
PM <sub>10</sub>	40	80
PM <sub>2.5</sub>	No threshold	

Subsequently, MCAQMD has identified significance thresholds for use in evaluating project impacts under CEQA.<sup>5</sup> The approach to MCAQMD thresholds for projects in Mendocino County is based on the Bay Area Air Quality Management District's (BAAQMD) Air Quality CEQA

<sup>5</sup> MCAQMD. 2013. Advisory – District Interim CEQA Criteria and GHG Pollutant Thresholds. See [http://www.co.mendocino.ca.us/aqmd/pdf\\_files/ceqa-criteria-and-ghg.pdf](http://www.co.mendocino.ca.us/aqmd/pdf_files/ceqa-criteria-and-ghg.pdf) and [http://www.co.mendocino.ca.us/aqmd/pdf\\_files/MCAQMDCEQARecomendations.pdf](http://www.co.mendocino.ca.us/aqmd/pdf_files/MCAQMDCEQARecomendations.pdf), accessed on August 24, 2016.

Guideline thresholds adopted in 2010. Significance thresholds used to evaluate air quality and GHG impacts from this project are described in Table 3. The District was contacted to confirm and clarify the thresholds and their application to this project, noting that the project includes indirect sources. For this project, which does not contain stationary sources, criteria pollutants and GHGs are compared against the *Indirect Source* thresholds.

**Table 3. Current MCAQMD Significant Impact Thresholds**

Criteria Pollutant and Precursors	Construction	Indirect Source	Project/Stationary Source
	Average Daily Emissions (lb/day)	Average Daily Emissions (lb/day)	Maximum Annual Emissions (tons/year)
ROG	54	180	40
NO <sub>x</sub>	54	42	40
PM <sub>10</sub>	82	82	15
PM <sub>2.5</sub>	54	54	10
Fugitive Dust (PM <sub>10</sub> /PM <sub>2.5</sub> )	Best Management Practices	same as above	
Local CO <sup>a</sup>	None	125 tons/year	
<b>Greenhouse Gas Emissions</b>		<b>Projects Other than Stationary Sources</b>	<b>Stationary Sources</b>
GHGs	None	1,100 MT of CO <sub>2</sub> e/year <b>OR</b> 4.6 MT of CO <sub>2</sub> e/Service Population/year <sup>b</sup>	10,000 MT of CO <sub>2</sub> e/year

Notes: MT = metric tons, CO<sub>2</sub>e = CO<sub>2</sub> equivalents. <sup>a</sup> MCAQMD's indirect permitting rules allow 125 ton/year of CO. <sup>b</sup> Service population = number of new residents + workers.

### *Toxic Air Contaminant Significance Thresholds*

The operation of any project with the potential to expose sensitive receptors to substantial levels of TACs would have a potentially significant impact. MCAQMD recommends that health effects be evaluated for proposed projects that emit TACs where sensitive receptors are within a 1,000-foot radius from the project boundary (Zone of Influence). The following MCAQMD-recommended CEQA thresholds should be considered to have a significant impact.<sup>6</sup>

- An increase in cancer risk of greater than 10.0 cases in a million people
- An increase in the exposure to non-carcinogenic TACs that would result in a Hazard Index (Chronic or Acute) of greater than 1.0

Non-cancer health risk is usually determined by comparing the predicted level of exposure to a chemical to the level of exposure that is not expected to cause any adverse effects (reference exposure level), even to the most susceptible people. This ratio of predicted exposure level to the reference exposure level is called the Hazard Index. This value represents the maximum concentration at which no adverse health effects to the respiratory system are anticipated to occur.

<sup>6</sup> MCAQMD. 2010. *Adopted Air Quality CEQA Thresholds of Significance – June 2, 2010*. See [http://www.co.mendocino.ca.us/aqmd/pdf\\_files/MCAQMDCEQARecomendations.pdf](http://www.co.mendocino.ca.us/aqmd/pdf_files/MCAQMDCEQARecomendations.pdf), accessed on August 24, 2016.

### Greenhouse Gas Emissions

Note that the MCAQMD threshold for GHG is based upon BAAQMD's recommended GHG threshold of 1,100 metric tons or 4.6 metric tons per capita. This threshold was developed based on meeting the 2020 GHG targets set in the scoping plan that addressed AB 32 goals.

**Impact: Result in a cumulatively considerable net increase of any criteria pollutant for which the project region is non-attainment under an applicable federal or State ambient air quality standard (including releasing emissions which exceed quantitative thresholds for ozone precursors)?**

MBAQMD has established thresholds of significance for air pollutants. These thresholds are for ozone precursor pollutants (ROG and NO<sub>x</sub>), PM<sub>10</sub> and PM<sub>2.5</sub> and were applied to both construction period and operational period emissions.

Both construction and operational emissions were computed using the California Emissions Estimator Model, Version 2016.3.2 (CalEEMod). The project is planned to be constructed over several years, with the earliest construction start date of 2021. Construction impacts were modeled using CalEEMod default assumptions. The model output from CalEEMod along with construction inputs are included as *Attachment 2*.

#### CalEEMod Modeling Assumptions

The land uses inputs and construction schedule for the construction phasing was input to CalEEMod as shown in Table 4.

**Table 4. CalEEMod Construction Modeling Assumptions**

Land Uses	Size	Metric	Lot Acreage	Floor Surface Area	Population
City Park	2.77	Acre	0.00	120,661.20	0
Retirement Community	39.00	Dwelling Unit	0.00	43,200.00	112
Single Family Housing	132.00	Dwelling Unit	36.60	210,600.00	378

#### *Construction Period Emissions*

Under a worst-case condition where construction is assumed to occur all at once, construction would begin in 2021 and be completed in early 2025, a total of 45 months or 1,000 workdays. This schedule assumed that the entire project was constructed all at once in 6 phases: Demolition, Site Preparation, Grading, Trenching, Exterior Building Construction, Paving, and Interior Building Construction. The schedule assumed 22 workdays per month or 260 days per year. Architectural coatings were assumed to be applied during the last building construction phase of 310 days, as not all homes would be constructed and painted during one period. Equipment type, quantity, number of days in use, average hours of use per day (of use) were based on CalEEMod default assumptions.

Construction worker and vendor travel is based on the CalEEMod default values, which assign a daily rate for each phase. CalEEMod also computes the number of haul trips that are based on the

amount of soil material to be imported or exported from the site. Since this is anticipated to be a balanced or nearly balanced site, no soil haul truck trips were included in the modeling. Note that since this is residential development in a built-out area, there would be very little unpaved roadway travel for workers and vendors. The inputs to CalEEMod were adjusted to represent 100 percent travel on paved roadways.

### *Emissions Controls*

The project description for the updated project includes diesel powered construction equipment that would meet U.S. EPA Tier 4 engines standards for particulate matter emissions. Where that equipment is not available, equipment meeting Tier 3 standards would be used. Since Tier 4 equipment has been available since about 2012 or earlier (depending on size based on horsepower), construction equipment assumed in the modeling would meet Tier 4 standards for particulate matter emissions.

### *Construction Fugitive Dust*

During grading and construction activities, dust would be generated. Most of the dust would result during grading activities. The amount of dust generated would be highly variable and is dependent on the size of the area disturbed at any given time, amount of activity, soil conditions and meteorological conditions. Nearby areas could be adversely affected by dust generated during construction activities.

The project description for the updated Project includes control measures to reduce fugitive dust from construction activities. The Project would be subject to requirements of MCAQMD Regulation 1, Rule 1-430. Projects requiring grading of more than 1 acre, such as this project, will require an application for a Large Grading Operation Permit from the District in accordance with District Regulation 1, Rule 1-200.

CalEEMod provided construction emissions in tons per year. Average daily emissions for each year were computed by dividing the total emissions by the number of workdays for each year. Construction emissions from full build out of the project are shown in Table 5.

**Table 5. Construction Period Emissions Modeled Using CalEEMod**

<b>Description</b>	<b>ROG Emissions</b>	<b>NO<sub>x</sub> Emissions</b>	<b>CO Emissions</b>	<b>PM<sub>10</sub> Emissions</b>	<b>PM<sub>2.5</sub> Emissions</b>
Maximum Daily Average Project Emissions	26.85 lbs/day*	16.73 lbs/day	31.17 lbs/day	12.65 lbs/day	1.91 lbs/day
Approved Garden's Gate Subdivision	15.29 lbs/day	51.38 lbs/day	76.92 lbs/day	59.96 lbs/day	14.54 lbs/day
MCAQMD Thresholds used in Garden's Gate Subdivision DEIR	110 lbs/day	110lbs/day	225lbs/day	40lbs/day	54lbs/day
Current MCAQAMD Thresholds	180 lbs/day	42lbs/day	680lbs/day	82lbs/day	54lbs/day
<b>Significant?</b>	<b>No</b>	<b>No</b>	<b>No</b>	<b>No</b>	<b>No</b>

Note: \*Average daily emissions were computed for ROG since homes would be painted over several years and not all at one time. Total building construction emissions were divided by 310 building construction workdays.



According to maps provided by MCAQMD, the project site is not in an area identified as possibly containing naturally occurring asbestos; therefore, no additional dust control measures or special permits would be required during project grading activities.<sup>7</sup>

This impact is considered less-than-significant with activities carried out in conformance with MCAQMD rules and regulations. In addition, the project would incorporate specific controls to reduce construction period emissions, required by the Garden's Gate Subdivision EIR (MM 3.6-A.1), along with updated measures to further reductions. implementation of *Mitigation Measures AQ-1* to ensure dust emissions are properly controlled. In addition, exhaust control measures are included in the project to reduce NO<sub>x</sub> and particulate matter (i.e., PM<sub>10</sub> and PM<sub>2.5</sub> exhaust) emissions.

### *Operational Emissions*

CalEEMod provided emissions for operation that primarily includes traffic and energy usage (i.e., natural gas usage). Some adjustments to the model were made to represent this particular project:

1. Trip generation rates used in the traffic analysis were used for each different type of residential land use. The trip generation rates were assumed to represent weekday trips. CalEEMod predicts annual emissions using Saturday and Sunday trips. So, the Saturday and Sunday trip rates were computed by applying a ratio of the CalEEMod default Saturday to Weekday and Sunday to Weekday rates to the weekday rates. The total trips predicted by CalEEMod are similar to those predicted by W-Trans for the project on weekdays and slight higher on Saturdays and lower on Sundays.
2. Vehicle Fleet Mix assumed by CalEEMod was modified to be more representative of residential land uses. The default trip generation assigned by CalEEMod is reflective of all travel in Mendocino County and includes a relatively high percentage of truck traffic (i.e., 13.7 percent heavy-duty trucks). The fleet mix was adjusted to reflect that of a more urban fleet mix that would reflect the residential nature of the project. The default vehicle mix for the Bay Area air basin was used to be reflective of a residential development. This fleet mix is comprised of 6.5 percent heavy-duty trucks.
3. The CalEEMod default assumptions for wood burning was adjusted to reflect that there would be no woodstoves or fireplaces for the proposed project.
4. The proposed project will not include natural gas appliances

Table 6 provides a summary of the operational emissions. Since the site is undeveloped, there are no existing emissions from the project site. Therefore, the modeled emissions shown in Table 6 represent net-new emissions caused by the project when compared to existing conditions. Project emissions are compared to the approved project emissions reported in the 2006 EIR to identify and substantial increase over the proposed project. The 2006 project was modeled with CalEEMod to provide an appropriate comparison. Total daily and annual emissions from operation of the project

---

<sup>7</sup> MCAQMD. 2013. Maps – Areas that may contain Naturally Occurring Asbestos in the Ukiah Valley. Accessed August 4, 2017. See <http://www.co.mendocino.ca.us/aqmd/natural-occurring-asbestos.html>

would not exceed any of the significance thresholds and the difference between the proposed project and the previously approved project is not substantial. The proposed project would have lower emissions than the previously approved project. The impact is considered a *less-than-significant*.

**Table 6. Operation Period Emissions**

<b>Description</b>	<b>ROG Emissions</b>	<b>NOx Emissions</b>	<b>CO Emissions</b>	<b>PM<sub>10</sub> Emissions</b>	<b>PM<sub>2.5</sub> Emissions</b>
Project Build Out	1.94 tons/yr.	2.04 tons/yr.	7.11 tons/yr.	1.49 tons/yr.	0.42 tons/yr.
Bella Vista Average Daily Emissions	10.64 lbs/day	11.20 lbs/day	38.97 lbs/day	8.18 lbs/day	2.27 lbs/day
Bella Vista Maximum Daily Emissions	11.08 lbs/day	11.55 lbs/day	47.08 lbs/day	9.11 lbs/day	2.55 lbs/day
<i>Approved Garden's Gate Subdivision</i>	<i>31.44 lbs/day</i>	<i>23.19 lbs/day</i>	<i>204.8 lbs/day</i>	<i>23.87 lbs/day</i>	<i>4.70 lbs/day</i>
<i>Project Difference</i>	<i>-20 lbs/day</i>	<i>-11 lbs/day</i>	<i>-155 lbs/day</i>	<i>-15 lbs/day</i>	<i>-2 lbs/day</i>
<i>MCQMD Thresholds</i>	<i>180 lbs/day</i>	<i>42 lbs/day</i>	<i>680 lbs/day</i>	<i>82 lbs/day</i>	<i>54 lbs/day</i>
<b>Significant?</b>	<i>No</i>	<i>No</i>	<i>No</i>	<i>No</i>	<i>No</i>

Note: Average daily emissions assume 365 days operation per year.

**Impact: Violate any air quality standard or contribute substantially to an existing or projected air quality violation?**

As described above, emissions of air pollutants or their precursors associated with the project were computed and compared to relevant significance thresholds. These include precursors to ozone, carbon monoxide (or CO), and particulate matter in the form of PM<sub>10</sub> and PM<sub>2.5</sub>. Emissions of these pollutants or precursors that would exceed the thresholds are considered to contribute substantially to an existing or projected air quality violation.

As described above, emissions of ozone precursors, CO, and particulate matter would not exceed the significance thresholds. Increased intersection congestion can lead to increased localized CO concentrations (hot spots) in the vicinity of the intersection. Typically there needs to be a substantial increase in the number of vehicles accessing an intersection and a decrease in the intersection level of service (LOS) in order for there to be elevated CO concentrations of concern. The project would not cause or contribute to CO exceedances since the traffic at affected intersections would be well below the BAAQMD screening criteria of 44,000 vehicles per hour per intersection.<sup>8</sup> Note that the North Coast Air Basin, as a whole, is considered attainment for CO and has not recorded an exceedance of a standard.

Since the project would have emissions that do not exceed the significance thresholds and traffic would not cause or contribute to exceedances of the CO ambient air quality standards, this impact is considered *less-than-significant*.

<sup>8</sup> BAAQMD. 2017. BAAQMD CEQA Air Quality Guidelines. May.

**Impact: Expose sensitive receptors to substantial pollutant concentrations from construction activities?**

The proposed project would be a temporary source of air pollutant and TAC emissions during construction. The project would be subject to MCAQMD rules and regulations pertaining to construction and construction contractors would be subject to CARB requirements regarding emissions from construction fleets. All off-road vehicles used for the construction, regardless of time spent on site, must be registered with CARB and portable diesel-powered equipment that is 50 horsepower or greater used during the construction must be either registered with the CARB Portable Equipment Registration Program (PERP). In addition, the project description for the updated project would include newer, Tier 4 construction equipment, that has the lowest diesel particulate matter emissions. These measures are meant to reduce PM<sub>2.5</sub> and TAC emissions associated with diesel exhaust.

Construction equipment and associated heavy-duty truck traffic generates diesel exhaust, which is a known TAC. Although it was concluded in the previous sections (see Table 5) that construction exhaust air pollutant emissions would not contribute substantially to existing or projected air quality violations, construction exhaust emissions may still pose health risks for sensitive receptors such as surrounding residents. The primary community risks associated with construction emissions are cancer risk and exposure to PM<sub>2.5</sub>. A health risk assessment of the project construction activities was conducted to evaluate the potential health effects to nearby sensitive receptors from construction emissions of DPM and PM<sub>2.5</sub>.<sup>9</sup> Thresholds recommended by BAAQMD and used by MCAQMD were used to judge impacts.

*Construction Period Emissions*

The CalEEMod model provided total annual PM<sub>10</sub> exhaust emissions (assumed to be DPM) for the off-road construction equipment and EMFAC2017 was used to estimate exhaust emissions from on-road vehicles. Total DPM emissions from the construction site over the 5-year construction period was estimated to be 0.041 tons (81 pounds). The on-road emissions are a result of haul truck travel during grading activities, worker travel, and vendor deliveries during construction. A trip length of a one mile was used to represent vehicle travel while at or near the construction site. It was assumed emissions from on-road vehicles traveling at or near the site would occur at the construction site. Controlled fugitive PM<sub>2.5</sub> dust emissions were estimated to be 0.184 tons (369 pounds) using the same methods and assumptions used to estimate site DPM emissions.

*Dispersion Modeling*

The U.S. EPA AERMOD dispersion model was used to predict DPM and PM<sub>2.5</sub> concentrations at sensitive receptors (i.e., residents) in the vicinity of the project construction area. A single area source encompassing the entire project site was used for the modeling. DPM and PM<sub>2.5</sub> concentrations were computed at nearby sensitive receptors (residential) at receptor heights of 1.5 meters. To represent the construction equipment exhaust emissions, an emission release height of 19.7 feet (6 meters) was used. The elevated source height reflects the height of the equipment

---

<sup>9</sup> DPM is identified by California as a toxic air contaminant due to the potential to cause cancer.

exhaust pipes plus an additional distance for the height of the exhaust plume above the exhaust pipes to account for plume rise of the exhaust gases. For modeling fugitive PM<sub>2.5</sub> emissions, a near-ground level release height of 6.6 feet (2 meters) was used. Emissions from the construction equipment and on-site vehicle travel were distributed throughout the modeled area sources. Construction emissions were modeled as occurring daily between 7:00 a.m. to 4:00 p.m., when most construction activity is expected.

The modeling used a five-year data set (2009-2013) of hourly meteorological data from the Ukiah Airport that was prepared for use with the AERMOD model by CARB. Annual DPM and PM<sub>2.5</sub> concentrations from construction activities during the construction period (2021 through 2025) were calculated using the model. DPM and PM<sub>2.5</sub> concentrations were calculated at nearby sensitive receptors. Due to the topography of the surrounding area, terrain elevations were used in the modeling. Digital elevation data from the United States Geological Survey (USGS) were used to obtain the terrain elevations for the modeling. The maximum cancer risks and PM<sub>2.5</sub> impacts occurred at residences just southeast of the project site.

### Project Construction Community Risk Impacts

The maximum modeled annual DPM and PM<sub>2.5</sub> concentrations, and thus the maximally exposed individuals (MEIs), were identified as those at a residence adjacent to the southeast corner of the project site (as shown in Figure 1). Using the maximum annual modeled DPM concentrations, the maximum increased cancer risks were calculated using BAAQMD recommended methods and exposure parameters described in *Attachment 1*. Non-cancer health hazards and maximum annual PM<sub>2.5</sub> concentrations were also calculated and identified. *Attachment 3* to this report includes the emission calculations used for the construction area source modeling and the construction cancer risk calculations.

Results indicate the unmitigated maximum increased cancer risks and maximum annual PM<sub>2.5</sub> concentrations from construction would not exceed the BAAQMD-recommended single-source thresholds of greater than 10.0 per million for cancer risk, greater than 0.3 µg/m<sup>3</sup> for annual PM<sub>2.5</sub> concentrations and a Hazard Index (HI) greater than 1.0. Table 7 summarizes the maximum cancer risks, PM<sub>2.5</sub> concentrations, and HIs for project related construction activities affecting the off-site residential MEI.

**Table 7. Construction Risk Impacts at the Off-site Residential MEI**

Source	Cancer Risk (per million)	Annual PM <sub>2.5</sub> (µg/m <sup>3</sup> )	Hazard Index
Project Construction	1.6 (infant/child exposure)	0.08	0.01
<b><i>BAAQMD Recommended Single-Source Threshold</i></b>	<b><i>&gt;10.0</i></b>	<b><i>&gt;0.3</i></b>	<b><i>&gt;1.0</i></b>
<i>Exceed Threshold?</i>	<i>No</i>	<i>No</i>	<i>No</i>

**Figure 1. Project Site, Modeled Sensitive Receptors, and Location of Maximum TAC Impact**



Since construction equipment is a source of TAC emissions that can be reduced substantially through the use best management practices and newer diesel equipment, the impact is considered *potentially significant*. Compliance with District and CARB requirements, along with implementation of project measures intended to reduce construction period emissions is expected to result in *less-than-significant* impacts with respect to health risks. Operation of the project would not be expected to cause long-term emissions of TACs or PM<sub>2.5</sub> that would be localized and cause health risk impacts.

## GHG EMISSIONS

GHG emissions associated with the project would occur over the short-term from construction activities, consisting primarily of emissions from equipment exhaust and worker and vendor trips. There would also be long-term operational emissions associated with vehicular traffic within the project vicinity, energy and water usage, and solid waste disposal. Emissions for the proposed project were predicted using the methodology recommended in the BAAQMD CEQA Air Quality Guidelines that MCAQMD recommends.<sup>10</sup>

### CalEEMod Modeling

The CalEEMod model (version 2016.3.2) was used to predict air pollutant emissions associated with the project, as described under *Air Quality Impact 1*. The CalEEMod modeling is described in the discussion associated with *Impact 1*.

#### *Indirect Emissions from Electricity*

For GHG emissions, CalEEMod predicts emissions associated with electricity usage that are based on the expected electricity consumption of the new residences combined with the anticipated emissions rate reported for the utility company providing the electricity.

CalEEMod defaults for energy use were used, which include the 2016 Title 24 Building Standards.<sup>11</sup> GHG emissions modeling includes those indirect emissions from electricity consumption. The electricity produced emission rate was modified in CalEEMod. CalEEMod has a default emission factor of 641.3 pounds of CO<sub>2</sub> per megawatt of electricity produced, which is based on PG&E's 2008 emissions rate. PG&E published in 2019 emissions rates for 2010 through 2017, which showed the emission rate for delivered electricity had been reduced to 210 pounds CO<sub>2</sub> per megawatt of electricity delivered in the year 2017.<sup>12</sup>

#### *Water and Wastewater*

The CalEEMod default rates were used for water consumption. The project is anticipated to provide low-flow water fixtures, drought-tolerant landscape, and drip irrigation systems.

#### *Solid Waste*

The CalEEMod default rates were used for residential solid waste production. The project is anticipated to be subject to local recycling programs that would reduce waste.

---

<sup>10</sup> BAAQMD, 2011. *Op cit*. BAAQMD updated these guidelines in May 2017 and these can be found at this website: [http://www.baaqmd.gov/~media/files/planning-and-research/ceqa/ceqa\\_guidelines\\_may2017-pdf.pdf?la=en](http://www.baaqmd.gov/~media/files/planning-and-research/ceqa/ceqa_guidelines_may2017-pdf.pdf?la=en), Accessed on August 11, 2017.

<sup>11</sup> An update to CalEEMod to include new 2019 Title 24 standards that include more energy efficient buildings has not been completed at the time of this analysis.

<sup>12</sup> PG&E, 2019. *Corporate Responsibility and Sustainability Report*. Web: [http://www.pgecorp.com/corp\\_responsibility/reports/2019/assets/PGE\\_CRSR\\_2019.pdf](http://www.pgecorp.com/corp_responsibility/reports/2019/assets/PGE_CRSR_2019.pdf)

### Construction Emissions

GHG emissions associated with construction of the maximum land uses under rezoning were computed to range from about 400 to 600 metric tons of CO<sub>2</sub>e per year under the modeled construction scenario. The total construction period emissions were computed as 1,019 metric tons. These are the emissions from on-site operation of construction equipment, vendor and hauling truck trips, and worker trips. Neither the City nor MCAQMD have an adopted threshold of significance for construction-related GHG. Best management practices assumed to be incorporated into construction of the proposed rezoning project include, but are not limited to: using local building materials of at least 10 percent and recycling or reusing at least 50 percent of construction waste or demolition materials.

### Operational Emissions

Following construction, emissions would occur on a nearly continuous basis as the project operates through traffic generation, energy usage, water usage, and waste generation. The CalEEMod model was used to predict annual emissions associated with operation of the fully-developed project. The operational emissions were assumed to be at the highest levels in 2026 if built out and fully occupied by that time.<sup>13</sup> Table 8 reports the annual emissions resulting from operation of the project and compares these emissions to the approved project. The proposed project emissions are reflective of the GHG reduction features that the project would include. Proposed project emissions would be over 450 metric tons per year lower than the approved project. The effectiveness of these measures is included in the CalEEMod modeling as “Mitigated” model output and are included in Table 8.

Since the Proposed Project would have fewer residential units, causing less traffic, GHG emissions would be less than those identified for the Garden’s Gate Subdivision. In addition, the Proposed Project would include addition features to reduced GHG emissions that were not included in the Garden’s Gate project.

**Table 8. Annual Project GHG Emissions (CO<sub>2</sub>e) in Metric Tons**

<b>Source Category</b>	<b>Approved Garden’s Gate Subdivision</b>	<b>2026 Proposed Project Emissions</b>
Area	--	2
Energy Consumption	--	108
Mobile	--	1,447
Solid Waste Generation	--	93
Water Usage	--	13
Total Emissions	2,114	1,663
Difference		-451
<i>MCAQMD Threshold</i>		<i>1,100</i>
<i>Significant?</i>		<i>No</i>

<sup>13</sup> Note that the provided construction schedule indicates that the project would not be completed until mid-2025 at the earliest.

## Supporting Documentation

*Attachment 1* is the methodology used to compute community risk impacts, including the methods to compute increased cancer risk from exposure to project emissions.

*Attachment 2* includes the CalEEMod modeling assumptions and output for project construction and operational criteria air pollutant and GHG emissions.

*Attachment 3* is the construction health risk assessment. This includes the summary of the dispersion modeling and the cancer risk calculations for construction and operation. AERMOD dispersion modeling files for this assessment, which are quite voluminous, are available upon request and would be provided in digital format.



## Attachment 1: Health Risk Calculation Methodology

### Health Risk Assessment Methodology

A health risk assessment (HRA) for exposure to Toxic Air Contaminates (TACs) requires the application of a risk characterization model to the results from the air dispersion model to estimate potential health risk at each sensitive receptor location. The State of California Office of Environmental Health Hazard Assessment (OEHHA) and California Air Resources Board (CARB) develop recommended methods for conducting health risk assessments. The most recent OEHHA risk assessment guidelines were published in February of 2015.<sup>14</sup> These guidelines incorporate substantial changes designed to provide for enhanced protection of children, as required by State law, compared to previous published risk assessment guidelines. CARB has provided additional guidance on implementing OEHHA's recommended methods.<sup>15</sup> This HRA used the 2015 OEHHA risk assessment guidelines and CARB guidance. For CEQA assessments, MCAQMD follows procedures used by the Bay Area Air Quality Management District (BAAQMD). The BAAQMD has adopted recommended procedures for applying the newest OEHHA guidelines as part of Regulation 2, Rule 5: New Source Review of Toxic Air Contaminants.<sup>16</sup> Exposure parameters from the OEHHA guidelines and the recent BAAQMD HRA Guidelines were used in this evaluation.

### Cancer Risk

Potential increased cancer risk from inhalation of TACs is calculated based on the TAC concentration over the period of exposure, inhalation dose, the TAC cancer potency factor, and an age sensitivity factor to reflect the greater sensitivity of infants and children to cancer causing TACs. The inhalation dose depends on a person's breathing rate, exposure time and frequency and duration of exposure. These parameters vary depending on the age, or age range, of the persons being exposed and whether the exposure is considered to occur at a residential location or other sensitive receptor location.

The current OEHHA guidance recommends that cancer risk be calculated by age groups to account for different breathing rates and sensitivity to TACs. Specifically, they recommend evaluating risks for the third trimester of pregnancy to age zero, ages zero to less than two (infant exposure), ages two to less than 16 (child exposure), and ages 16 to 70 (adult exposure). Age sensitivity factors (ASFs) associated with the different types of exposure are an ASF of 10 for the third trimester and infant exposures, an ASF of 3 for a child exposure, and an ASF of 1 for an adult exposure. Also associated with each exposure type are different breathing rates, expressed as liters per kilogram of body weight per day (L/kg-day) or liters per kilogram of body weight per 8-hour period for the case of worker or school child exposures. As recommended by the BAAQMD for residential exposures, 95<sup>th</sup> percentile breathing rates are used for the third trimester and infant exposures, and 80<sup>th</sup> percentile breathing rates for child and adult exposures. For children at schools

---

<sup>14</sup> OEHHA, 2015. *Air Toxics Hot Spots Program Risk Assessment Guidelines, The Air Toxics Hot Spots Program Guidance Manual for Preparation of Health Risk Assessments*. Office of Environmental Health Hazard Assessment. February.

<sup>15</sup> CARB, 2015. *Risk Management Guidance for Stationary Sources of Air Toxics*. July 23.

<sup>16</sup> BAAQMD, 2016. *BAAQMD Air Toxics NSR Program Health Risk Assessment (HRA) Guidelines*. December 2016.

and daycare facilities, BAAQMD recommends using the 95<sup>th</sup> percentile 8-hour breathing rates. Additionally, CARB and the BAAQMD recommend the use of a residential exposure duration of 30 years for sources with long-term emissions (e.g., roadways). For workers, assumed to be adults, a 25-year exposure period is recommended by the BAAQMD. For school children a 9-year exposure period is recommended by the BAAQMD.

Under previous OEHHA and BAAQMD HRA guidance, residential receptors are assumed to be at their home 24 hours a day, or 100 percent of the time. In the 2015 Risk Assessment Guidance, OEHHA includes adjustments to exposure duration to account for the fraction of time at home (FAH), which can be less than 100 percent of the time, based on updated population and activity statistics. The FAH factors are age-specific and are: 0.85 for third trimester of pregnancy to less than 2 years old, 0.72 for ages 2 to less than 16 years, and 0.73 for ages 16 to 70 years. Use of the FAH factors is allowed by the BAAQMD if there are no schools in the project vicinity have a cancer risk of one in a million or greater assuming 100 percent exposure (FAH = 1.0).

Functionally, cancer risk is calculated using the following parameters and formulas:

$$\text{Cancer Risk (per million)} = \text{CPF} \times \text{Inhalation Dose} \times \text{ASF} \times \text{ED/AT} \times \text{FAH} \times 10^6$$

Where:

- CPF = Cancer potency factor (mg/kg-day)<sup>-1</sup>
- ASF = Age sensitivity factor for specified age group
- ED = Exposure duration (years)
- AT = Averaging time for lifetime cancer risk (years)
- FAH = Fraction of time spent at home (unitless)

$$\text{Inhalation Dose} = C_{\text{air}} \times \text{DBR}^* \times A \times (\text{EF}/365) \times 10^{-6}$$

Where:

- C<sub>air</sub> = concentration in air (µg/m<sup>3</sup>)
- DBR = daily breathing rate (L/kg body weight-day)
- 8HrBR = 8-hour breathing rate (L/kg body weight-8 hours)
- A = Inhalation absorption factor
- EF = Exposure frequency (days/year)
- 10<sup>-6</sup> = Conversion factor

\* An 8-hour breathing rate (8HrBR) is used for worker and school child exposures.

The health risk parameters used in this evaluation are summarized as follows:

Parameter	Exposure Type →	Infant		Child	Adult
	Age Range →	3 <sup>rd</sup> Trimester	0<2	2 < 16	16 - 30
DPM Cancer Potency Factor (mg/kg-day) <sup>-1</sup>		1.10E+00	1.10E+00	1.10E+00	1.10E+00
Daily Breathing Rate (L/kg-day) 80 <sup>th</sup> Percentile Rate		273	758	572	261
Daily Breathing Rate (L/kg-day) 95 <sup>th</sup> Percentile Rate		361	1,090	745	335
8-hour Breathing Rate (L/kg-8 hours) 95 <sup>th</sup> Percentile Rate		-	1,200	520	240
Inhalation Absorption Factor		1	1	1	1
Averaging Time (years)		70	70	70	70
Exposure Duration (years)		0.25	2	14	14*
Exposure Frequency (days/year)		350	350	350	350*
Age Sensitivity Factor		10	10	3	1
Fraction of Time at Home (FAH)		0.85-1.0	0.85-1.0	0.72-1.0	0.73*

### Non-Cancer Hazards

Non-cancer health risk is usually determined by comparing the predicted level of exposure to a chemical to the level of exposure that is not expected to cause any adverse effects (reference exposure level), even to the most susceptible people. Potential non-cancer health hazards from TAC exposure are expressed in terms of a hazard index (HI), which is the ratio of the TAC concentration to a reference exposure level (REL). OEHHA has defined acceptable concentration levels for contaminants that pose non-cancer health hazards. TAC concentrations below the REL are not expected to cause adverse health impacts, even for sensitive individuals. The total HI is calculated as the sum of the HIs for each TAC evaluated and the total HI is compared to the BAAQMD significance thresholds to determine whether a significant non-cancer health impact from a project would occur.

Typically, for residential projects located near roadways with substantial TAC emissions, the primary TAC of concern with non-cancer health effects is diesel particulate matter (DPM). For DPM, the chronic inhalation REL is 5 micrograms per cubic meter ( $\mu\text{g}/\text{m}^3$ ).

### Annual PM<sub>2.5</sub> Concentrations

While not a TAC, fine particulate matter (PM<sub>2.5</sub>) has been identified by the BAAQMD as a pollutant with potential non-cancer health effects that should be included when evaluating potential community health impacts under the California Environmental Quality Act (CEQA). The thresholds of significance for PM<sub>2.5</sub> (project level and cumulative) are in terms of an increase in the annual average concentration. When considering PM<sub>2.5</sub> impacts, the contribution from all sources of PM<sub>2.5</sub> emissions should be included. For projects with potential impacts from nearby local roadways, the PM<sub>2.5</sub> impacts should include those from vehicle exhaust emissions, PM<sub>2.5</sub> generated from vehicle tire and brake wear, and fugitive emissions from re-suspended dust on the roads.

**Attachment 2: CalEEMod Output and Assumptions**

Summary of CalEEMod Output – Criteria Pollutants and GHG

Bella Vista							
<i>Unmitigated</i>	ROG	NOX	CO	PM10	PM2.5	CO2e	
Year	Annual Emissions (Tons)					MT	
Construction							
2021	0.1024	1.4724	2.7428	0.5252	0.1681	402	
2022	0.2477	2.0667	3.3739	1.6439	0.2059	548	
2023	0.2317	1.923	3.2312	1.639	0.2029	539	
2024	0.6893	1.7445	2.9258	1.3023	0.1612	470	
2025	3.4729	0.0302	0.066	0.0505	0.00695	10	
Total Construction Emissions							
Tons	4.74	7.24	12.34	5.16	0.75	1019	
Average Daily Emissions (lbs)							
Pounds/Workdays	Average Daily Emissions (lbs)					Workdays	
2021	1.16	16.73	31.17	5.97	1.91		176
2022	1.91	15.90	25.95	12.65	1.58		260
2023	1.78	14.79	24.86	12.61	1.56		260
2024	5.30	13.42	22.51	10.02	1.24		260
2025	138.92	1.21	2.64	2.02	0.28		50
ROG	26.85						1006
Bella Vista							
<i>Unmitigated</i>	ROG	NOX		Total PM10	Total PM2.5		
Operational Emissions (Tons)							
Tons/year	1.94	2.04	7.11	1.49	0.42		
Average Daily Emissions (Pounds Per Day)							
Scenario	Pounds Per Day						
Project Average Daily	10.64	11.20	38.97	8.18	2.27		
Project Max. Day	11.08	12.38	49.56	9.11	2.55		
Approved Daily	31.44	23.19	204.80	23.87	4.70		
Difference	-20.36	-10.81	-155.24	-14.76	-2.15		

Category	CO2e				
	Project 2026	Approved Project			
Area	2	--			
Energy	108	--			
Mobile	1,447	--			
Waste	93	--			
Water	13	--			
TOTAL	1,663	2,114			
Net GHG Emissions		-451			0

Bella Vista, Ukiah - Mendocino County AQMD Air District, Annual

**Bella Vista, Ukiah  
Mendocino County AQMD Air District, Annual**

**1.0 Project Characteristics**

**1.1 Land Usage**

Land Uses	Size	Metric	Lot Acreage	Floor Surface Area	Population
City Park	2.77	Acre	0.00	120,661.20	0
Retirement Community	39.00	Dwelling Unit	0.00	43,200.00	112
Single Family Housing	132.00	Dwelling Unit	36.60	210,600.00	378

**1.2 Other Project Characteristics**

<b>Urbanization</b>	Urban	<b>Wind Speed (m/s)</b>	2.2	<b>Precipitation Freq (Days)</b>	86
<b>Climate Zone</b>	1			<b>Operational Year</b>	2026
<b>Utility Company</b>	Pacific Gas & Electric Company				
<b>CO2 Intensity (lb/MW hr)</b>	210	<b>CH4 Intensity (lb/MW hr)</b>	0.029	<b>N2O Intensity (lb/MW hr)</b>	0.006

**1.3 User Entered Comments & Non-Default Data**

Project Characteristics - PG&E 2017 CO2 Factor Rate

Land Use - Provided project description land uses. 36.6 acres to be disturbed. Square footage estimated 12/10/20 email

Construction Phase - Default Const schedule. Added trenching

Off-road Equipment -

Off-road Equipment -

Off-road Equipment - Equipment quantities provided

Off-road Equipment -

- Off-road Equipment -
- Off-road Equipment - Equipment quantities provided
- Off-road Equipment - Trenching added
- Off-road Equipment - added this equipment
- Trips and VMT - added asphalt trips assuming 10cy/load 2,780 cy. Cement part fo vendor trips
- On-road Fugitive Dust - Assum mostly paved travel
- Demolition - provided information
- Grading - Default values
- Vehicle Trips - Trip gen from traffic 12/3/2020 email (W-Trans)
- Road Dust - Assumed paved travel
- Woodstoves - No fireplaces
- Energy Use - No natural gas
- Water And Wastewater - all WTP
- Energy Mitigation -
- Water Mitigation -
- Construction Off-road Equipment Mitigation - BMPs and Tier 4i (>50hp)

Table Name	Column Name	Default Value	New Value
tblConstDustMitigation	WaterUnpavedRoadMoistureContent	0	0.5
tblConstDustMitigation	WaterUnpavedRoadVehicleSpeed	0	15
tblConstEquipMitigation	NumberOfEquipmentMitigated	0.00	1.00
tblConstEquipMitigation	NumberOfEquipmentMitigated	0.00	6.00
tblConstEquipMitigation	NumberOfEquipmentMitigated	0.00	3.00
tblConstEquipMitigation	NumberOfEquipmentMitigated	0.00	1.00
tblConstEquipMitigation	NumberOfEquipmentMitigated	0.00	1.00
tblConstEquipMitigation	NumberOfEquipmentMitigated	0.00	2.00
tblConstEquipMitigation	NumberOfEquipmentMitigated	0.00	2.00
tblConstEquipMitigation	NumberOfEquipmentMitigated	0.00	2.00
tblConstEquipMitigation	NumberOfEquipmentMitigated	0.00	2.00
tblConstEquipMitigation	NumberOfEquipmentMitigated	0.00	6.00
tblConstEquipMitigation	NumberOfEquipmentMitigated	0.00	2.00
tblConstEquipMitigation	NumberOfEquipmentMitigated	0.00	10.00



tblConstEquipMitigation	Tier	No Change	Tier 4 Interim
tblConstEquipMitigation	Tier	No Change	Tier 4 Interim
tblConstEquipMitigation	Tier	No Change	Tier 4 Interim
tblConstEquipMitigation	Tier	No Change	Tier 4 Interim
tblConstEquipMitigation	Tier	No Change	Tier 4 Interim
tblConstEquipMitigation	Tier	No Change	Tier 4 Interim
tblConstEquipMitigation	Tier	No Change	Tier 4 Interim
tblConstEquipMitigation	Tier	No Change	Tier 4 Interim
tblConstEquipMitigation	Tier	No Change	Tier 4 Interim
tblConstEquipMitigation	Tier	No Change	Tier 4 Interim
tblConstEquipMitigation	Tier	No Change	Tier 4 Interim
tblEnergyUse	NT24NG	1,599.00	0.00
tblEnergyUse	NT24NG	1,599.00	0.00
tblEnergyUse	T24NG	9,200.58	0.00
tblEnergyUse	T24NG	10,517.50	0.00
tblFireplaces	FireplaceWoodMass	4,992.00	0.00
tblFireplaces	FireplaceWoodMass	4,992.00	0.00
tblFireplaces	NumberGas	1.95	0.00
tblFireplaces	NumberGas	39.60	0.00
tblFireplaces	NumberWood	1.95	0.00
tblFireplaces	NumberWood	46.20	0.00
tblFleetMix	HHD	0.07	0.03
tblFleetMix	HHD	0.07	0.03
tblFleetMix	HHD	0.07	0.03
tblFleetMix	LDA	0.52	0.58
tblFleetMix	LDA	0.52	0.58
tblFleetMix	LDA	0.52	0.58
tblFleetMix	LDT1	0.04	0.04
tblFleetMix	LDT1	0.04	0.04
tblFleetMix	LDT1	0.04	0.04

tbIFleetMix	LDT2	0.20	0.19
tbIFleetMix	LDT2	0.20	0.19
tbIFleetMix	LDT2	0.20	0.19
tbIFleetMix	LHD1	0.03	0.01
tbIFleetMix	LHD1	0.03	0.01
tbIFleetMix	LHD1	0.03	0.01
tbIFleetMix	LHD2	4.4860e-003	5.3010e-003
tbIFleetMix	LHD2	4.4860e-003	5.3010e-003
tbIFleetMix	LHD2	4.4860e-003	5.3010e-003
tbIFleetMix	MCY	4.6960e-003	5.7320e-003
tbIFleetMix	MCY	4.6960e-003	5.7320e-003
tbIFleetMix	MCY	4.6960e-003	5.7320e-003
tbIFleetMix	MDV	0.12	0.11
tbIFleetMix	MDV	0.12	0.11
tbIFleetMix	MDV	0.12	0.11
tbIFleetMix	MH	7.1700e-004	7.0800e-004
tbIFleetMix	MH	7.1700e-004	7.0800e-004
tbIFleetMix	MH	7.1700e-004	7.0800e-004
tbIFleetMix	MHD	0.02	0.02
tbIFleetMix	MHD	0.02	0.02
tbIFleetMix	MHD	0.02	0.02
tbIFleetMix	OBUS	1.7520e-003	2.6690e-003
tbIFleetMix	OBUS	1.7520e-003	2.6690e-003
tbIFleetMix	OBUS	1.7520e-003	2.6690e-003
tbIFleetMix	SBUS	1.0590e-003	9.0600e-004
tbIFleetMix	SBUS	1.0590e-003	9.0600e-004
tbIFleetMix	SBUS	1.0590e-003	9.0600e-004
tbIFleetMix	UBUS	1.1270e-003	2.0110e-003
tbIFleetMix	UBUS	1.1270e-003	2.0110e-003
tbIFleetMix	UBUS	1.1270e-003	2.0110e-003

tblLandUse	LandUseSquareFeet	39,000.00	43,200.00
tblLandUse	LandUseSquareFeet	237,600.00	210,600.00
tblLandUse	LotAcreage	2.77	0.00
tblLandUse	LotAcreage	7.80	0.00
tblLandUse	LotAcreage	42.86	36.60
tblOnRoadDust	HaulingPercentPave	55.00	99.00
tblOnRoadDust	HaulingPercentPave	55.00	99.00
tblOnRoadDust	HaulingPercentPave	55.00	99.00
tblOnRoadDust	HaulingPercentPave	55.00	99.00
tblOnRoadDust	HaulingPercentPave	55.00	99.00
tblOnRoadDust	HaulingPercentPave	55.00	99.00
tblOnRoadDust	HaulingPercentPave	55.00	99.00
tblOnRoadDust	VendorPercentPave	55.00	99.00
tblOnRoadDust	VendorPercentPave	55.00	99.00
tblOnRoadDust	VendorPercentPave	55.00	99.00
tblOnRoadDust	VendorPercentPave	55.00	99.00
tblOnRoadDust	VendorPercentPave	55.00	99.00
tblOnRoadDust	VendorPercentPave	55.00	99.00
tblOnRoadDust	VendorPercentPave	55.00	99.00
tblOnRoadDust	WorkerPercentPave	55.00	99.00
tblOnRoadDust	WorkerPercentPave	55.00	99.00
tblOnRoadDust	WorkerPercentPave	55.00	99.00
tblOnRoadDust	WorkerPercentPave	55.00	99.00
tblOnRoadDust	WorkerPercentPave	55.00	99.00
tblOnRoadDust	WorkerPercentPave	55.00	99.00
tblOnRoadDust	WorkerPercentPave	55.00	99.00
tblProjectCharacteristics	CO2IntensityFactor	641.35	210
tblRoadDust	RoadPercentPave	55	100
tblVehicleTrips	ST_TR	22.75	0.00
tblVehicleTrips	ST_TR	2.03	4.00

tblVehicleTrips	SU_TR	16.74	0.00
tblVehicleTrips	SU_TR	1.95	4.00
tblVehicleTrips	WD_TR	1.89	0.00
tblVehicleTrips	WD_TR	2.40	4.27
tblVehicleTrips	WD_TR	9.52	9.44
tblWater	AerobicPercent	87.46	100.00
tblWater	AerobicPercent	87.46	100.00
tblWater	AerobicPercent	87.46	100.00
tblWater	AnaerobicandFacultativeLagoonsPercent	2.21	0.00
tblWater	AnaerobicandFacultativeLagoonsPercent	2.21	0.00
tblWater	AnaerobicandFacultativeLagoonsPercent	2.21	0.00
tblWater	SepticTankPercent	10.33	0.00
tblWater	SepticTankPercent	10.33	0.00
tblWater	SepticTankPercent	10.33	0.00
tblWoodstoves	WoodstoveWoodMass	4,896.00	0.00
tblWoodstoves	WoodstoveWoodMass	4,896.00	0.00

## 2.0 Emissions Summary

### 2.1 Overall Construction Unmitigated Construction

	ROG	NOx	CO	SO2	Fugitive PM10	Exhaust PM10	PM10 Total	Fugitive PM2.5	Exhaust PM2.5	PM2.5 Total	Bio- CO2	NBio- CO2	Total CO2	CH4	N2O	CO2e
Year	tons/yr										MT/yr					
2021	0.3413	3.4126	2.4009	4.5400e-003	0.9815	0.1561	1.1376	0.3263	0.1441	0.4704	0.0000	399.0840	399.0840	0.1160	0.0000	401.9827
2022	0.3711	2.7031	3.1479	6.1500e-003	2.5573	0.1094	2.6668	0.2824	0.1030	0.3853	0.0000	545.7423	545.7423	0.0862	0.0000	547.8984
2023	0.3394	2.4057	2.9958	6.0500e-003	2.5541	0.0928	2.6469	0.2820	0.0873	0.3693	0.0000	536.6487	536.6487	0.0821	0.0000	538.7018

2024	0.7819	2.0115	2.6650	5.2800e-003	2.0293	0.0758	2.1051	0.2240	0.0710	0.2950	0.0000	468.4641	468.4641	0.0803	0.0000	470.4703
2025	3.4729	0.0302	0.0660	1.1000e-004	0.0775	1.2700e-003	0.0788	8.5100e-003	1.2700e-003	9.7800e-003	0.0000	9.7386	9.7386	5.2000e-004	0.0000	9.7515
<b>Maximum</b>	<b>3.4729</b>	<b>3.4126</b>	<b>3.1479</b>	<b>6.1500e-003</b>	<b>2.5573</b>	<b>0.1561</b>	<b>2.6668</b>	<b>0.3263</b>	<b>0.1441</b>	<b>0.4704</b>	<b>0.0000</b>	<b>545.7423</b>	<b>545.7423</b>	<b>0.1160</b>	<b>0.0000</b>	<b>547.8984</b>

**Mitigated Construction**

	ROG	NOx	CO	SO2	Fugitive PM10	Exhaust PM10	PM10 Total	Fugitive PM2.5	Exhaust PM2.5	PM2.5 Total	Bio- CO2	NBio- CO2	Total CO2	CH4	N2O	CO2e
Year	tons/yr										MT/yr					
2021	0.1024	1.4724	2.7428	4.5400e-003	0.5131	0.0121	0.5252	0.1561	0.0120	0.1681	0.0000	399.0836	399.0836	0.1160	0.0000	401.9822
2022	0.2477	2.0667	3.3739	6.1500e-003	1.6272	0.0167	1.6439	0.1894	0.0165	0.2059	0.0000	545.7419	545.7419	0.0862	0.0000	547.8980
2023	0.2317	1.9230	3.2312	6.0500e-003	1.6252	0.0139	1.6390	0.1891	0.0138	0.2029	0.0000	536.6483	536.6483	0.0821	0.0000	538.7014
2024	0.6893	1.7445	2.9258	5.2800e-003	1.2912	0.0111	1.3023	0.1502	0.0110	0.1612	0.0000	468.4638	468.4638	0.0803	0.0000	470.4700
2025	3.4729	0.0302	0.0660	1.1000e-004	0.0493	1.2700e-003	0.0505	5.6800e-003	1.2700e-003	6.9500e-003	0.0000	9.7386	9.7386	5.2000e-004	0.0000	9.7515
<b>Maximum</b>	<b>3.4729</b>	<b>2.0667</b>	<b>3.3739</b>	<b>6.1500e-003</b>	<b>1.6272</b>	<b>0.0167</b>	<b>1.6439</b>	<b>0.1894</b>	<b>0.0165</b>	<b>0.2059</b>	<b>0.0000</b>	<b>545.7419</b>	<b>545.7419</b>	<b>0.1160</b>	<b>0.0000</b>	<b>547.8980</b>

	ROG	NOx	CO	SO2	Fugitive PM10	Exhaust PM10	PM10 Total	Fugitive PM2.5	Exhaust PM2.5	PM2.5 Total	Bio- CO2	NBio-CO2	Total CO2	CH4	N2O	CO2e
<b>Percent Reduction</b>	<b>10.60</b>	<b>31.49</b>	<b>-9.44</b>	<b>0.00</b>	<b>37.73</b>	<b>87.36</b>	<b>40.23</b>	<b>38.53</b>	<b>86.58</b>	<b>51.30</b>	<b>0.00</b>	<b>0.00</b>	<b>0.00</b>	<b>0.00</b>	<b>0.00</b>	<b>0.00</b>

Quarter	Start Date	End Date	Maximum Unmitigated ROG + NOX (tons/quarter)	Maximum Mitigated ROG + NOX (tons/quarter)
1	5-1-2021	7-31-2021	1.2221	0.4897
2	8-1-2021	10-31-2021	1.6272	0.6226
3	11-1-2021	1-31-2022	1.1889	0.6819
4	2-1-2022	4-30-2022	0.7501	0.5644
5	5-1-2022	7-31-2022	0.7673	0.5753
6	8-1-2022	10-31-2022	0.7714	0.5795

7	11-1-2022	1-31-2023	0.7529	0.5753
8	2-1-2023	4-30-2023	0.6741	0.5297
9	5-1-2023	7-31-2023	0.6895	0.5402
10	8-1-2023	10-31-2023	0.6932	0.5440
11	11-1-2023	1-31-2024	0.6867	0.5484
12	2-1-2024	4-30-2024	0.6418	0.5275
13	5-1-2024	7-31-2024	0.6492	0.5323
14	8-1-2024	10-31-2024	0.5624	0.4785
15	11-1-2024	1-31-2025	2.3815	2.3790
16	2-1-2025	4-30-2025	1.8249	1.8249
		Highest	2.3815	2.3790

**2.2 Overall Operational  
Unmitigated Operational**

	ROG	NOx	CO	SO2	Fugitive PM10	Exhaust PM10	PM10 Total	Fugitive PM2.5	Exhaust PM2.5	PM2.5 Total	Bio- CO2	NBio- CO2	Total CO2	CH4	N2O	CO2e
Category	tons/yr										MT/yr					
Area	1.4275	0.0146	1.2685	7.0000e-005		7.0400e-003	7.0400e-003		7.0400e-003	7.0400e-003	0.0000	2.0741	2.0741	1.9900e-003	0.0000	2.1237
Energy	0.0000	0.0000	0.0000	0.0000		0.0000	0.0000		0.0000	0.0000	0.0000	127.4918	127.4918	0.0176	3.6400e-003	129.0175
Mobile	0.5149	2.0302	5.8486	0.0158	1.4722	0.0137	1.4859	0.3952	0.0128	0.4080	0.0000	1,445.9873	1,445.9873	0.0593	0.0000	1,447.4694
Waste						0.0000	0.0000		0.0000	0.0000	37.4518	0.0000	37.4518	2.2133	0.0000	92.7853
Water						0.0000	0.0000		0.0000	0.0000	3.9418	9.1845	13.1263	0.0148	8.8300e-003	16.1299
<b>Total</b>	<b>1.9423</b>	<b>2.0448</b>	<b>7.1172</b>	<b>0.0159</b>	<b>1.4722</b>	<b>0.0207</b>	<b>1.4929</b>	<b>0.3952</b>	<b>0.0198</b>	<b>0.4150</b>	<b>41.3937</b>	<b>1,584.7377</b>	<b>1,626.1314</b>	<b>2.3071</b>	<b>0.0125</b>	<b>1,687.5258</b>

**Mitigated Operational**

	ROG	NOx	CO	SO2	Fugitive PM10	Exhaust PM10	PM10 Total	Fugitive PM2.5	Exhaust PM2.5	PM2.5 Total	Bio- CO2	NBio- CO2	Total CO2	CH4	N2O	CO2e
Category	tons/yr										MT/yr					
Area	1.4275	0.0146	1.2685	7.0000e-005		7.0400e-003	7.0400e-003		7.0400e-003	7.0400e-003	0.0000	2.0741	2.0741	1.9900e-003	0.0000	2.1237
Energy	0.0000	0.0000	0.0000	0.0000		0.0000	0.0000		0.0000	0.0000	0.0000	106.2267	106.2267	0.0147	3.0400e-003	107.4979
Mobile	0.5149	2.0302	5.8486	0.0158	1.4722	0.0137	1.4859	0.3952	0.0128	0.4080	0.0000	1,445.9873	1,445.9873	0.0593	0.0000	1,447.4694
Waste						0.0000	0.0000		0.0000	0.0000	37.4518	0.0000	37.4518	2.2133	0.0000	92.7853
Water						0.0000	0.0000		0.0000	0.0000	3.1535	7.8260	10.9795	0.0119	7.0800e-003	13.3881
<b>Total</b>	<b>1.9423</b>	<b>2.0448</b>	<b>7.1172</b>	<b>0.0159</b>	<b>1.4722</b>	<b>0.0207</b>	<b>1.4929</b>	<b>0.3952</b>	<b>0.0198</b>	<b>0.4150</b>	<b>40.6053</b>	<b>1,562.1142</b>	<b>1,602.7195</b>	<b>2.3012</b>	<b>0.0101</b>	<b>1,663.2644</b>

	ROG	NOx	CO	SO2	Fugitive PM10	Exhaust PM10	PM10 Total	Fugitive PM2.5	Exhaust PM2.5	PM2.5 Total	Bio- CO2	NBio-CO2	Total CO2	CH4	N2O	CO2e
<b>Percent Reduction</b>	<b>0.00</b>	<b>0.00</b>	<b>0.00</b>	<b>0.00</b>	<b>0.00</b>	<b>0.00</b>	<b>0.00</b>	<b>0.00</b>	<b>0.00</b>	<b>0.00</b>	<b>1.90</b>	<b>1.43</b>	<b>1.44</b>	<b>0.25</b>	<b>18.85</b>	<b>1.44</b>

**3.0 Construction Detail**

**Construction Phase**

Phase Number	Phase Name	Phase Type	Start Date	End Date	Num Days Week	Num Days	Phase Description
1	Demolition	Demolition	5/1/2021	7/9/2021	5	50	
2	Site Preparation	Site Preparation	7/10/2021	8/20/2021	5	30	
3	Grading	Grading	8/21/2021	12/3/2021	5	75	
4	Trenching/Utilities	Trenching	12/4/2021	1/14/2022	5	30	Overlaps
5	Building Construction	Building Construction	12/4/2021	10/4/2024	5	740	
6	Paving	Paving	10/5/2024	12/20/2024	5	55	
7	Architectural Coating	Architectural Coating	12/21/2024	3/7/2025	5	55	

Acres of Grading (Site Preparation Phase): 0

Acres of Grading (Grading Phase): 187.5

Acres of Paving: 0

Residential Indoor: 513,945; Residential Outdoor: 171,315; Non-Residential Indoor: 0; Non-Residential Outdoor: 0; Striped Parking Area:

**OffRoad Equipment**

Phase Name	Offroad Equipment Type	Amount	Usage Hours	Horse Power	Load Factor
Demolition		0		97	0.37
Demolition	Concrete/Industrial Saws	1	8.00	81	0.73
Demolition	Excavators	3	8.00	158	0.38
Demolition	Rubber Tired Dozers	2	8.00	247	0.40
Site Preparation		0		187	0.41
Site Preparation	Rubber Tired Dozers	3	8.00	247	0.40
Site Preparation	Tractors/Loaders/Backhoes	4	8.00	97	0.37
Grading	Excavators	2	8.00	158	0.38
Grading	Graders	1	8.00	187	0.41
Grading	Rubber Tired Dozers	1	8.00	247	0.40
Grading	Scrapers	2	8.00	367	0.48
Grading	Tractors/Loaders/Backhoes	2	8.00	97	0.37
Trenching/Utilities	Excavators	1	8.00	158	0.38
Trenching/Utilities	Tractors/Loaders/Backhoes	1	8.00	97	0.37
Building Construction	Cranes	1	7.00	231	0.29
Building Construction	Forklifts	3	8.00	89	0.20
Building Construction	Generator Sets	1	8.00	84	0.74
Building Construction	Tractors/Loaders/Backhoes	3	7.00	97	0.37
Building Construction	Welders	1	8.00	46	0.45
Paving	Pavers	2	8.00	130	0.42
Paving	Paving Equipment	2	8.00	132	0.36
Paving	Rollers	2	8.00	80	0.38
Architectural Coating	Air Compressors	1	6.00	78	0.48

**Trips and VMT**



Phase Name	Offroad Equipment Count	Worker Trip Number	Vendor Trip Number	Hauling Trip Number	Worker Trip Length	Vendor Trip Length	Hauling Trip Length	Worker Vehicle Class	Vendor Vehicle Class	Hauling Vehicle Class
Demolition	6	15.00	0.00	9.00	10.80	7.30	20.00	LD_Mix	HDT_Mix	HHDT
Site Preparation	7	18.00	0.00	0.00	10.80	7.30	20.00	LD_Mix	HDT_Mix	HHDT
Grading	8	20.00	0.00	0.00	10.80	7.30	20.00	LD_Mix	HDT_Mix	HHDT
Trenching/Utilities	2	5.00	0.00	0.00	10.80	7.30	20.00	LD_Mix	HDT_Mix	HHDT
Building Construction	9	126.00	38.00	0.00	10.80	7.30	20.00	LD_Mix	HDT_Mix	HHDT
Paving	6	15.00	0.00	0.00	10.80	7.30	20.00	LD_Mix	HDT_Mix	HHDT
Architectural Coating	1	25.00	0.00	0.00	10.80	7.30	20.00	LD_Mix	HDT_Mix	HHDT

**3.1 Mitigation Measures Construction**

- Use Cleaner Engines for Construction Equipment
- Water Exposed Area
- Reduce Vehicle Speed on Unpaved Roads

**3.2 Demolition - 2021**

Unmitigated Construction On-Site

	ROG	NOx	CO	SO2	Fugitive PM10	Exhaust PM10	PM10 Total	Fugitive PM2.5	Exhaust PM2.5	PM2.5 Total	Bio- CO2	NBio- CO2	Total CO2	CH4	N2O	CO2e
Category	tons/yr										MT/yr					
Fugitive Dust					9.8000e-004	0.0000	9.8000e-004	1.5000e-004	0.0000	1.5000e-004	0.0000	0.0000	0.0000	0.0000	0.0000	0.0000
Off-Road	0.0791	0.7860	0.5391	9.7000e-004		0.0388	0.0388		0.0360	0.0360	0.0000	85.0020	85.0020	0.0239	0.0000	85.6001
<b>Total</b>	<b>0.0791</b>	<b>0.7860</b>	<b>0.5391</b>	<b>9.7000e-004</b>	<b>9.8000e-004</b>	<b>0.0388</b>	<b>0.0398</b>	<b>1.5000e-004</b>	<b>0.0360</b>	<b>0.0362</b>	<b>0.0000</b>	<b>85.0020</b>	<b>85.0020</b>	<b>0.0239</b>	<b>0.0000</b>	<b>85.6001</b>

Unmitigated Construction Off-Site

	ROG	NOx	CO	SO2	Fugitive PM10	Exhaust PM10	PM10 Total	Fugitive PM2.5	Exhaust PM2.5	PM2.5 Total	Bio- CO2	NBio- CO2	Total CO2	CH4	N2O	CO2e
Category	tons/yr										MT/yr					
Hauling	4.0000e-005	1.2500e-003	2.3000e-004	0.0000	1.0900e-003	1.0000e-005	1.0900e-003	1.2000e-004	1.0000e-005	1.3000e-004	0.0000	0.3393	0.3393	1.0000e-005	0.0000	0.3395
Vendor	0.0000	0.0000	0.0000	0.0000	0.0000	0.0000	0.0000	0.0000	0.0000	0.0000	0.0000	0.0000	0.0000	0.0000	0.0000	0.0000
Worker	2.9700e-003	2.4700e-003	0.0209	3.0000e-005	0.0485	3.0000e-005	0.0485	5.3200e-003	3.0000e-005	5.3400e-003	0.0000	2.5805	2.5805	1.8000e-004	0.0000	2.5849
<b>Total</b>	<b>3.0100e-003</b>	<b>3.7200e-003</b>	<b>0.0212</b>	<b>3.0000e-005</b>	<b>0.0496</b>	<b>4.0000e-005</b>	<b>0.0496</b>	<b>5.4400e-003</b>	<b>4.0000e-005</b>	<b>5.4700e-003</b>	<b>0.0000</b>	<b>2.9198</b>	<b>2.9198</b>	<b>1.9000e-004</b>	<b>0.0000</b>	<b>2.9245</b>

**Mitigated Construction On-Site**

	ROG	NOx	CO	SO2	Fugitive PM10	Exhaust PM10	PM10 Total	Fugitive PM2.5	Exhaust PM2.5	PM2.5 Total	Bio- CO2	NBio- CO2	Total CO2	CH4	N2O	CO2e
Category	tons/yr										MT/yr					
Fugitive Dust					4.4000e-004	0.0000	4.4000e-004	7.0000e-005	0.0000	7.0000e-005	0.0000	0.0000	0.0000	0.0000	0.0000	0.0000
Off-Road	0.0214	0.3591	0.6122	9.7000e-004		5.6600e-003	5.6600e-003		5.6600e-003	5.6600e-003	0.0000	85.0019	85.0019	0.0239	0.0000	85.6000
<b>Total</b>	<b>0.0214</b>	<b>0.3591</b>	<b>0.6122</b>	<b>9.7000e-004</b>	<b>4.4000e-004</b>	<b>5.6600e-003</b>	<b>6.1000e-003</b>	<b>7.0000e-005</b>	<b>5.6600e-003</b>	<b>5.7300e-003</b>	<b>0.0000</b>	<b>85.0019</b>	<b>85.0019</b>	<b>0.0239</b>	<b>0.0000</b>	<b>85.6000</b>

**Mitigated Construction Off-Site**

	ROG	NOx	CO	SO2	Fugitive PM10	Exhaust PM10	PM10 Total	Fugitive PM2.5	Exhaust PM2.5	PM2.5 Total	Bio- CO2	NBio- CO2	Total CO2	CH4	N2O	CO2e
Category	tons/yr										MT/yr					

Hauling	4.0000e-005	1.2500e-003	2.3000e-004	0.0000	6.9000e-004	1.0000e-005	7.0000e-004	8.0000e-005	1.0000e-005	9.0000e-005	0.0000	0.3393	0.3393	1.0000e-005	0.0000	0.3395
Vendor	0.0000	0.0000	0.0000	0.0000	0.0000	0.0000	0.0000	0.0000	0.0000	0.0000	0.0000	0.0000	0.0000	0.0000	0.0000	0.0000
Worker	2.9700e-003	2.4700e-003	0.0209	3.0000e-005	0.0308	3.0000e-005	0.0308	3.5500e-003	3.0000e-005	3.5800e-003	0.0000	2.5805	2.5805	1.8000e-004	0.0000	2.5849
<b>Total</b>	<b>3.0100e-003</b>	<b>3.7200e-003</b>	<b>0.0212</b>	<b>3.0000e-005</b>	<b>0.0315</b>	<b>4.0000e-005</b>	<b>0.0315</b>	<b>3.6300e-003</b>	<b>4.0000e-005</b>	<b>3.6700e-003</b>	<b>0.0000</b>	<b>2.9198</b>	<b>2.9198</b>	<b>1.9000e-004</b>	<b>0.0000</b>	<b>2.9245</b>

**3.3 Site Preparation - 2021**

**Unmitigated Construction On-Site**

	ROG	NOx	CO	SO2	Fugitive PM10	Exhaust PM10	PM10 Total	Fugitive PM2.5	Exhaust PM2.5	PM2.5 Total	Bio- CO2	NBio- CO2	Total CO2	CH4	N2O	CO2e
Category	tons/yr										MT/yr					
Fugitive Dust					0.2710	0.0000	0.2710	0.1490	0.0000	0.1490	0.0000	0.0000	0.0000	0.0000	0.0000	0.0000
Off-Road	0.0583	0.6075	0.3173	5.7000e-004		0.0307	0.0307		0.0282	0.0282	0.0000	50.1536	50.1536	0.0162	0.0000	50.5591
<b>Total</b>	<b>0.0583</b>	<b>0.6075</b>	<b>0.3173</b>	<b>5.7000e-004</b>	<b>0.2710</b>	<b>0.0307</b>	<b>0.3017</b>	<b>0.1490</b>	<b>0.0282</b>	<b>0.1772</b>	<b>0.0000</b>	<b>50.1536</b>	<b>50.1536</b>	<b>0.0162</b>	<b>0.0000</b>	<b>50.5591</b>

**Unmitigated Construction Off-Site**

	ROG	NOx	CO	SO2	Fugitive PM10	Exhaust PM10	PM10 Total	Fugitive PM2.5	Exhaust PM2.5	PM2.5 Total	Bio- CO2	NBio- CO2	Total CO2	CH4	N2O	CO2e
Category	tons/yr										MT/yr					
Hauling	0.0000	0.0000	0.0000	0.0000	0.0000	0.0000	0.0000	0.0000	0.0000	0.0000	0.0000	0.0000	0.0000	0.0000	0.0000	0.0000
Vendor	0.0000	0.0000	0.0000	0.0000	0.0000	0.0000	0.0000	0.0000	0.0000	0.0000	0.0000	0.0000	0.0000	0.0000	0.0000	0.0000
Worker	2.1400e-003	1.7800e-003	0.0151	2.0000e-005	0.0349	2.0000e-005	0.0349	3.8300e-003	2.0000e-005	3.8500e-003	0.0000	1.8580	1.8580	1.3000e-004	0.0000	1.8612
<b>Total</b>	<b>2.1400e-003</b>	<b>1.7800e-003</b>	<b>0.0151</b>	<b>2.0000e-005</b>	<b>0.0349</b>	<b>2.0000e-005</b>	<b>0.0349</b>	<b>3.8300e-003</b>	<b>2.0000e-005</b>	<b>3.8500e-003</b>	<b>0.0000</b>	<b>1.8580</b>	<b>1.8580</b>	<b>1.3000e-004</b>	<b>0.0000</b>	<b>1.8612</b>

**Mitigated Construction On-Site**

	ROG	NOx	CO	SO2	Fugitive PM10	Exhaust PM10	PM10 Total	Fugitive PM2.5	Exhaust PM2.5	PM2.5 Total	Bio- CO2	NBio- CO2	Total CO2	CH4	N2O	CO2e
Category	tons/yr										MT/yr					
Fugitive Dust					0.1220	0.0000	0.1220	0.0670	0.0000	0.0670	0.0000	0.0000	0.0000	0.0000	0.0000	0.0000
Off-Road	0.0105	0.1824	0.3444	5.7000e-004		9.3000e-004	9.3000e-004		9.3000e-004	9.3000e-004	0.0000	50.1535	50.1535	0.0162	0.0000	50.5590
<b>Total</b>	<b>0.0105</b>	<b>0.1824</b>	<b>0.3444</b>	<b>5.7000e-004</b>	<b>0.1220</b>	<b>9.3000e-004</b>	<b>0.1229</b>	<b>0.0670</b>	<b>9.3000e-004</b>	<b>0.0680</b>	<b>0.0000</b>	<b>50.1535</b>	<b>50.1535</b>	<b>0.0162</b>	<b>0.0000</b>	<b>50.5590</b>

**Mitigated Construction Off-Site**

	ROG	NOx	CO	SO2	Fugitive PM10	Exhaust PM10	PM10 Total	Fugitive PM2.5	Exhaust PM2.5	PM2.5 Total	Bio- CO2	NBio- CO2	Total CO2	CH4	N2O	CO2e
Category	tons/yr										MT/yr					
Hauling	0.0000	0.0000	0.0000	0.0000	0.0000	0.0000	0.0000	0.0000	0.0000	0.0000	0.0000	0.0000	0.0000	0.0000	0.0000	0.0000
Vendor	0.0000	0.0000	0.0000	0.0000	0.0000	0.0000	0.0000	0.0000	0.0000	0.0000	0.0000	0.0000	0.0000	0.0000	0.0000	0.0000
Worker	2.1400e-003	1.7800e-003	0.0151	2.0000e-005	0.0222	2.0000e-005	0.0222	2.5600e-003	2.0000e-005	2.5800e-003	0.0000	1.8580	1.8580	1.3000e-004	0.0000	1.8612
<b>Total</b>	<b>2.1400e-003</b>	<b>1.7800e-003</b>	<b>0.0151</b>	<b>2.0000e-005</b>	<b>0.0222</b>	<b>2.0000e-005</b>	<b>0.0222</b>	<b>2.5600e-003</b>	<b>2.0000e-005</b>	<b>2.5800e-003</b>	<b>0.0000</b>	<b>1.8580</b>	<b>1.8580</b>	<b>1.3000e-004</b>	<b>0.0000</b>	<b>1.8612</b>

**3.4 Grading - 2021**

**Unmitigated Construction On-Site**

	ROG	NOx	CO	SO2	Fugitive PM10	Exhaust PM10	PM10 Total	Fugitive PM2.5	Exhaust PM2.5	PM2.5 Total	Bio- CO2	NBio- CO2	Total CO2	CH4	N2O	CO2e
Category	tons/yr										MT/yr					
Fugitive Dust					0.3253	0.0000	0.3253	0.1349	0.0000	0.1349	0.0000	0.0000	0.0000	0.0000	0.0000	0.0000
Off-Road	0.1572	1.7400	1.1579	2.3300e-003		0.0745	0.0745		0.0685	0.0685	0.0000	204.3562	204.3562	0.0661	0.0000	206.0085
<b>Total</b>	<b>0.1572</b>	<b>1.7400</b>	<b>1.1579</b>	<b>2.3300e-003</b>	<b>0.3253</b>	<b>0.0745</b>	<b>0.3997</b>	<b>0.1349</b>	<b>0.0685</b>	<b>0.2034</b>	<b>0.0000</b>	<b>204.3562</b>	<b>204.3562</b>	<b>0.0661</b>	<b>0.0000</b>	<b>206.0085</b>

**Unmitigated Construction Off-Site**

	ROG	NOx	CO	SO2	Fugitive PM10	Exhaust PM10	PM10 Total	Fugitive PM2.5	Exhaust PM2.5	PM2.5 Total	Bio- CO2	NBio- CO2	Total CO2	CH4	N2O	CO2e
Category	tons/yr										MT/yr					
Hauling	0.0000	0.0000	0.0000	0.0000	0.0000	0.0000	0.0000	0.0000	0.0000	0.0000	0.0000	0.0000	0.0000	0.0000	0.0000	0.0000
Vendor	0.0000	0.0000	0.0000	0.0000	0.0000	0.0000	0.0000	0.0000	0.0000	0.0000	0.0000	0.0000	0.0000	0.0000	0.0000	0.0000
Worker	5.9500e-003	4.9500e-003	0.0419	6.0000e-005	0.0969	6.0000e-005	0.0970	0.0106	5.0000e-005	0.0107	0.0000	5.1610	5.1610	3.5000e-004	0.0000	5.1699
<b>Total</b>	<b>5.9500e-003</b>	<b>4.9500e-003</b>	<b>0.0419</b>	<b>6.0000e-005</b>	<b>0.0969</b>	<b>6.0000e-005</b>	<b>0.0970</b>	<b>0.0106</b>	<b>5.0000e-005</b>	<b>0.0107</b>	<b>0.0000</b>	<b>5.1610</b>	<b>5.1610</b>	<b>3.5000e-004</b>	<b>0.0000</b>	<b>5.1699</b>

**Mitigated Construction On-Site**

	ROG	NOx	CO	SO2	Fugitive PM10	Exhaust PM10	PM10 Total	Fugitive PM2.5	Exhaust PM2.5	PM2.5 Total	Bio- CO2	NBio- CO2	Total CO2	CH4	N2O	CO2e
Category	tons/yr										MT/yr					
Fugitive Dust					0.1464	0.0000	0.1464	0.0607	0.0000	0.0607	0.0000	0.0000	0.0000	0.0000	0.0000	0.0000

Off-Road	0.0379	0.7227	1.3771	2.3300e-003		3.8100e-003	3.8100e-003		3.8100e-003	3.8100e-003	0.0000	204.3559	204.3559	0.0661	0.0000	206.0083
<b>Total</b>	<b>0.0379</b>	<b>0.7227</b>	<b>1.3771</b>	<b>2.3300e-003</b>	<b>0.1464</b>	<b>3.8100e-003</b>	<b>0.1502</b>	<b>0.0607</b>	<b>3.8100e-003</b>	<b>0.0645</b>	<b>0.0000</b>	<b>204.3559</b>	<b>204.3559</b>	<b>0.0661</b>	<b>0.0000</b>	<b>206.0083</b>

**Mitigated Construction Off-Site**

	ROG	NOx	CO	SO2	Fugitive PM10	Exhaust PM10	PM10 Total	Fugitive PM2.5	Exhaust PM2.5	PM2.5 Total	Bio- CO2	NBio- CO2	Total CO2	CH4	N2O	CO2e
Category	tons/yr										MT/yr					
Hauling	0.0000	0.0000	0.0000	0.0000	0.0000	0.0000	0.0000	0.0000	0.0000	0.0000	0.0000	0.0000	0.0000	0.0000	0.0000	0.0000
Vendor	0.0000	0.0000	0.0000	0.0000	0.0000	0.0000	0.0000	0.0000	0.0000	0.0000	0.0000	0.0000	0.0000	0.0000	0.0000	0.0000
Worker	5.9500e-003	4.9500e-003	0.0419	6.0000e-005	0.0616	6.0000e-005	0.0616	7.1000e-003	5.0000e-005	7.1600e-003	0.0000	5.1610	5.1610	3.5000e-004	0.0000	5.1699
<b>Total</b>	<b>5.9500e-003</b>	<b>4.9500e-003</b>	<b>0.0419</b>	<b>6.0000e-005</b>	<b>0.0616</b>	<b>6.0000e-005</b>	<b>0.0616</b>	<b>7.1000e-003</b>	<b>5.0000e-005</b>	<b>7.1600e-003</b>	<b>0.0000</b>	<b>5.1610</b>	<b>5.1610</b>	<b>3.5000e-004</b>	<b>0.0000</b>	<b>5.1699</b>

**3.5 Trenching/Utilities - 2021**

**Unmitigated Construction On-Site**

	ROG	NOx	CO	SO2	Fugitive PM10	Exhaust PM10	PM10 Total	Fugitive PM2.5	Exhaust PM2.5	PM2.5 Total	Bio- CO2	NBio- CO2	Total CO2	CH4	N2O	CO2e
Category	tons/yr										MT/yr					
Off-Road	4.1600e-003	0.0405	0.0553	8.0000e-005		2.1600e-003	2.1600e-003		1.9900e-003	1.9900e-003	0.0000	7.2674	7.2674	2.3500e-003	0.0000	7.3262
<b>Total</b>	<b>4.1600e-003</b>	<b>0.0405</b>	<b>0.0553</b>	<b>8.0000e-005</b>		<b>2.1600e-003</b>	<b>2.1600e-003</b>		<b>1.9900e-003</b>	<b>1.9900e-003</b>	<b>0.0000</b>	<b>7.2674</b>	<b>7.2674</b>	<b>2.3500e-003</b>	<b>0.0000</b>	<b>7.3262</b>

**Unmitigated Construction Off-Site**

	ROG	NOx	CO	SO2	Fugitive PM10	Exhaust PM10	PM10 Total	Fugitive PM2.5	Exhaust PM2.5	PM2.5 Total	Bio- CO2	NBio- CO2	Total CO2	CH4	N2O	CO2e
Category	tons/yr										MT/yr					
Hauling	0.0000	0.0000	0.0000	0.0000	0.0000	0.0000	0.0000	0.0000	0.0000	0.0000	0.0000	0.0000	0.0000	0.0000	0.0000	0.0000
Vendor	0.0000	0.0000	0.0000	0.0000	0.0000	0.0000	0.0000	0.0000	0.0000	0.0000	0.0000	0.0000	0.0000	0.0000	0.0000	0.0000
Worker	4.0000e-004	3.3000e-004	2.7900e-003	0.0000	6.4600e-003	0.0000	6.4600e-003	7.1000e-004	0.0000	7.1000e-004	0.0000	0.3441	0.3441	2.0000e-005	0.0000	0.3447
<b>Total</b>	<b>4.0000e-004</b>	<b>3.3000e-004</b>	<b>2.7900e-003</b>	<b>0.0000</b>	<b>6.4600e-003</b>	<b>0.0000</b>	<b>6.4600e-003</b>	<b>7.1000e-004</b>	<b>0.0000</b>	<b>7.1000e-004</b>	<b>0.0000</b>	<b>0.3441</b>	<b>0.3441</b>	<b>2.0000e-005</b>	<b>0.0000</b>	<b>0.3447</b>

**Mitigated Construction On-Site**

	ROG	NOx	CO	SO2	Fugitive PM10	Exhaust PM10	PM10 Total	Fugitive PM2.5	Exhaust PM2.5	PM2.5 Total	Bio- CO2	NBio- CO2	Total CO2	CH4	N2O	CO2e
Category	tons/yr										MT/yr					
Off-Road	1.3300e-003	0.0363	0.0626	8.0000e-005		1.4000e-004	1.4000e-004		1.4000e-004	1.4000e-004	0.0000	7.2674	7.2674	2.3500e-003	0.0000	7.3261
<b>Total</b>	<b>1.3300e-003</b>	<b>0.0363</b>	<b>0.0626</b>	<b>8.0000e-005</b>		<b>1.4000e-004</b>	<b>1.4000e-004</b>		<b>1.4000e-004</b>	<b>1.4000e-004</b>	<b>0.0000</b>	<b>7.2674</b>	<b>7.2674</b>	<b>2.3500e-003</b>	<b>0.0000</b>	<b>7.3261</b>

**Mitigated Construction Off-Site**

	ROG	NOx	CO	SO2	Fugitive PM10	Exhaust PM10	PM10 Total	Fugitive PM2.5	Exhaust PM2.5	PM2.5 Total	Bio- CO2	NBio- CO2	Total CO2	CH4	N2O	CO2e
Category	tons/yr										MT/yr					

Hauling	0.0000	0.0000	0.0000	0.0000	0.0000	0.0000	0.0000	0.0000	0.0000	0.0000	0.0000	0.0000	0.0000	0.0000	0.0000	0.0000
Vendor	0.0000	0.0000	0.0000	0.0000	0.0000	0.0000	0.0000	0.0000	0.0000	0.0000	0.0000	0.0000	0.0000	0.0000	0.0000	0.0000
Worker	4.0000e-004	3.3000e-004	2.7900e-003	0.0000	4.1100e-003	0.0000	4.1100e-003	4.7000e-004	0.0000	4.8000e-004	0.0000	0.3441	0.3441	2.0000e-005	0.0000	0.3447
<b>Total</b>	<b>4.0000e-004</b>	<b>3.3000e-004</b>	<b>2.7900e-003</b>	<b>0.0000</b>	<b>4.1100e-003</b>	<b>0.0000</b>	<b>4.1100e-003</b>	<b>4.7000e-004</b>	<b>0.0000</b>	<b>4.8000e-004</b>	<b>0.0000</b>	<b>0.3441</b>	<b>0.3441</b>	<b>2.0000e-005</b>	<b>0.0000</b>	<b>0.3447</b>

**3.5 Trenching/Utilities - 2022**

**Unmitigated Construction On-Site**

	ROG	NOx	CO	SO2	Fugitive PM10	Exhaust PM10	PM10 Total	Fugitive PM2.5	Exhaust PM2.5	PM2.5 Total	Bio- CO2	NBio- CO2	Total CO2	CH4	N2O	CO2e
Category	tons/yr										MT/yr					
Off-Road	1.8400e-003	0.0173	0.0275	4.0000e-005		8.8000e-004	8.8000e-004		8.1000e-004	8.1000e-004	0.0000	3.6344	3.6344	1.1800e-003	0.0000	3.6638
<b>Total</b>	<b>1.8400e-003</b>	<b>0.0173</b>	<b>0.0275</b>	<b>4.0000e-005</b>		<b>8.8000e-004</b>	<b>8.8000e-004</b>		<b>8.1000e-004</b>	<b>8.1000e-004</b>	<b>0.0000</b>	<b>3.6344</b>	<b>3.6344</b>	<b>1.1800e-003</b>	<b>0.0000</b>	<b>3.6638</b>

**Unmitigated Construction Off-Site**

	ROG	NOx	CO	SO2	Fugitive PM10	Exhaust PM10	PM10 Total	Fugitive PM2.5	Exhaust PM2.5	PM2.5 Total	Bio- CO2	NBio- CO2	Total CO2	CH4	N2O	CO2e
Category	tons/yr										MT/yr					
Hauling	0.0000	0.0000	0.0000	0.0000	0.0000	0.0000	0.0000	0.0000	0.0000	0.0000	0.0000	0.0000	0.0000	0.0000	0.0000	0.0000
Vendor	0.0000	0.0000	0.0000	0.0000	0.0000	0.0000	0.0000	0.0000	0.0000	0.0000	0.0000	0.0000	0.0000	0.0000	0.0000	0.0000
Worker	1.9000e-004	1.5000e-004	1.2600e-003	0.0000	3.2300e-003	0.0000	3.2300e-003	3.5000e-004	0.0000	3.6000e-004	0.0000	0.1668	0.1668	1.0000e-005	0.0000	0.1671
<b>Total</b>	<b>1.9000e-004</b>	<b>1.5000e-004</b>	<b>1.2600e-003</b>	<b>0.0000</b>	<b>3.2300e-003</b>	<b>0.0000</b>	<b>3.2300e-003</b>	<b>3.5000e-004</b>	<b>0.0000</b>	<b>3.6000e-004</b>	<b>0.0000</b>	<b>0.1668</b>	<b>0.1668</b>	<b>1.0000e-005</b>	<b>0.0000</b>	<b>0.1671</b>



**Mitigated Construction On-Site**

	ROG	NOx	CO	SO2	Fugitive PM10	Exhaust PM10	PM10 Total	Fugitive PM2.5	Exhaust PM2.5	PM2.5 Total	Bio- CO2	NBio- CO2	Total CO2	CH4	N2O	CO2e
Category	tons/yr										MT/yr					
Off-Road	6.7000e-004	0.0182	0.0313	4.0000e-005		7.0000e-005	7.0000e-005		7.0000e-005	7.0000e-005	0.0000	3.6344	3.6344	1.1800e-003	0.0000	3.6638
<b>Total</b>	<b>6.7000e-004</b>	<b>0.0182</b>	<b>0.0313</b>	<b>4.0000e-005</b>		<b>7.0000e-005</b>	<b>7.0000e-005</b>		<b>7.0000e-005</b>	<b>7.0000e-005</b>	<b>0.0000</b>	<b>3.6344</b>	<b>3.6344</b>	<b>1.1800e-003</b>	<b>0.0000</b>	<b>3.6638</b>

**Mitigated Construction Off-Site**

	ROG	NOx	CO	SO2	Fugitive PM10	Exhaust PM10	PM10 Total	Fugitive PM2.5	Exhaust PM2.5	PM2.5 Total	Bio- CO2	NBio- CO2	Total CO2	CH4	N2O	CO2e
Category	tons/yr										MT/yr					
Hauling	0.0000	0.0000	0.0000	0.0000	0.0000	0.0000	0.0000	0.0000	0.0000	0.0000	0.0000	0.0000	0.0000	0.0000	0.0000	0.0000
Vendor	0.0000	0.0000	0.0000	0.0000	0.0000	0.0000	0.0000	0.0000	0.0000	0.0000	0.0000	0.0000	0.0000	0.0000	0.0000	0.0000
Worker	1.9000e-004	1.5000e-004	1.2600e-003	0.0000	2.0500e-003	0.0000	2.0500e-003	2.4000e-004	0.0000	2.4000e-004	0.0000	0.1668	0.1668	1.0000e-005	0.0000	0.1671
<b>Total</b>	<b>1.9000e-004</b>	<b>1.5000e-004</b>	<b>1.2600e-003</b>	<b>0.0000</b>	<b>2.0500e-003</b>	<b>0.0000</b>	<b>2.0500e-003</b>	<b>2.4000e-004</b>	<b>0.0000</b>	<b>2.4000e-004</b>	<b>0.0000</b>	<b>0.1668</b>	<b>0.1668</b>	<b>1.0000e-005</b>	<b>0.0000</b>	<b>0.1671</b>

**3.6 Building Construction - 2021**

**Unmitigated Construction On-Site**

	ROG	NOx	CO	SO2	Fugitive PM10	Exhaust PM10	PM10 Total	Fugitive PM2.5	Exhaust PM2.5	PM2.5 Total	Bio- CO2	NBio- CO2	Total CO2	CH4	N2O	CO2e
Category	tons/yr										MT/yr					
Off-Road	0.0190	0.1743	0.1658	2.7000e-004		9.5900e-003	9.5900e-003		9.0100e-003	9.0100e-003	0.0000	23.1637	23.1637	5.5900e-003	0.0000	23.3034
<b>Total</b>	<b>0.0190</b>	<b>0.1743</b>	<b>0.1658</b>	<b>2.7000e-004</b>		<b>9.5900e-003</b>	<b>9.5900e-003</b>		<b>9.0100e-003</b>	<b>9.0100e-003</b>	<b>0.0000</b>	<b>23.1637</b>	<b>23.1637</b>	<b>5.5900e-003</b>	<b>0.0000</b>	<b>23.3034</b>

**Unmitigated Construction Off-Site**

	ROG	NOx	CO	SO2	Fugitive PM10	Exhaust PM10	PM10 Total	Fugitive PM2.5	Exhaust PM2.5	PM2.5 Total	Bio- CO2	NBio- CO2	Total CO2	CH4	N2O	CO2e
Category	tons/yr										MT/yr					
Hauling	0.0000	0.0000	0.0000	0.0000	0.0000	0.0000	0.0000	0.0000	0.0000	0.0000	0.0000	0.0000	0.0000	0.0000	0.0000	0.0000
Vendor	1.9800e-003	0.0452	0.0143	1.1000e-004	0.0337	1.9000e-004	0.0338	3.8200e-003	1.8000e-004	4.0100e-003	0.0000	10.1879	10.1879	4.8000e-004	0.0000	10.1999
Worker	9.9900e-003	8.3100e-003	0.0703	1.0000e-004	0.1628	1.0000e-004	0.1629	0.0179	9.0000e-005	0.0180	0.0000	8.6705	8.6705	5.9000e-004	0.0000	8.6854
<b>Total</b>	<b>0.0120</b>	<b>0.0535</b>	<b>0.0846</b>	<b>2.1000e-004</b>	<b>0.1965</b>	<b>2.9000e-004</b>	<b>0.1968</b>	<b>0.0217</b>	<b>2.7000e-004</b>	<b>0.0220</b>	<b>0.0000</b>	<b>18.8584</b>	<b>18.8584</b>	<b>1.0700e-003</b>	<b>0.0000</b>	<b>18.8853</b>

**Mitigated Construction On-Site**

	ROG	NOx	CO	SO2	Fugitive PM10	Exhaust PM10	PM10 Total	Fugitive PM2.5	Exhaust PM2.5	PM2.5 Total	Bio- CO2	NBio- CO2	Total CO2	CH4	N2O	CO2e
Category	tons/yr										MT/yr					
Off-Road	7.9200e-003	0.1076	0.1810	2.7000e-004		1.1200e-003	1.1200e-003		1.1200e-003	1.1200e-003	0.0000	23.1637	23.1637	5.5900e-003	0.0000	23.3034

Total	7.9200e-003	0.1076	0.1810	2.7000e-004		1.1200e-003	1.1200e-003		1.1200e-003	1.1200e-003	0.0000	23.1637	23.1637	5.5900e-003	0.0000	23.3034
-------	-------------	--------	--------	-------------	--	-------------	-------------	--	-------------	-------------	--------	---------	---------	-------------	--------	---------

**Mitigated Construction Off-Site**

	ROG	NOx	CO	SO2	Fugitive PM10	Exhaust PM10	PM10 Total	Fugitive PM2.5	Exhaust PM2.5	PM2.5 Total	Bio- CO2	NBio- CO2	Total CO2	CH4	N2O	CO2e
Category	tons/yr										MT/yr					
Hauling	0.0000	0.0000	0.0000	0.0000	0.0000	0.0000	0.0000	0.0000	0.0000	0.0000	0.0000	0.0000	0.0000	0.0000	0.0000	0.0000
Vendor	1.9800e-003	0.0452	0.0143	1.1000e-004	0.0216	1.9000e-004	0.0217	2.6100e-003	1.8000e-004	2.8000e-003	0.0000	10.1879	10.1879	4.8000e-004	0.0000	10.1999
Worker	9.9900e-003	8.3100e-003	0.0703	1.0000e-004	0.1035	1.0000e-004	0.1036	0.0119	9.0000e-005	0.0120	0.0000	8.6705	8.6705	5.9000e-004	0.0000	8.6854
<b>Total</b>	<b>0.0120</b>	<b>0.0535</b>	<b>0.0846</b>	<b>2.1000e-004</b>	<b>0.1250</b>	<b>2.9000e-004</b>	<b>0.1253</b>	<b>0.0145</b>	<b>2.7000e-004</b>	<b>0.0148</b>	<b>0.0000</b>	<b>18.8584</b>	<b>18.8584</b>	<b>1.0700e-003</b>	<b>0.0000</b>	<b>18.8853</b>

**3.6 Building Construction - 2022**

**Unmitigated Construction On-Site**

	ROG	NOx	CO	SO2	Fugitive PM10	Exhaust PM10	PM10 Total	Fugitive PM2.5	Exhaust PM2.5	PM2.5 Total	Bio- CO2	NBio- CO2	Total CO2	CH4	N2O	CO2e
Category	tons/yr										MT/yr					
Off-Road	0.2218	2.0300	2.1272	3.5000e-003		0.1052	0.1052		0.0990	0.0990	0.0000	301.2428	301.2428	0.0722	0.0000	303.0471
<b>Total</b>	<b>0.2218</b>	<b>2.0300</b>	<b>2.1272</b>	<b>3.5000e-003</b>		<b>0.1052</b>	<b>0.1052</b>		<b>0.0990</b>	<b>0.0990</b>	<b>0.0000</b>	<b>301.2428</b>	<b>301.2428</b>	<b>0.0722</b>	<b>0.0000</b>	<b>303.0471</b>

**Unmitigated Construction Off-Site**

	ROG	NOx	CO	SO2	Fugitive PM10	Exhaust PM10	PM10 Total	Fugitive PM2.5	Exhaust PM2.5	PM2.5 Total	Bio- CO2	NBio- CO2	Total CO2	CH4	N2O	CO2e
Category	tons/yr										MT/yr					
Hauling	0.0000	0.0000	0.0000	0.0000	0.0000	0.0000	0.0000	0.0000	0.0000	0.0000	0.0000	0.0000	0.0000	0.0000	0.0000	0.0000
Vendor	0.0238	0.5577	0.1694	1.3900e-003	0.4375	2.2100e-003	0.4397	0.0497	2.1200e-003	0.0518	0.0000	131.4122	131.4122	5.9600e-003	0.0000	131.5611
Worker	0.1234	0.0979	0.8225	1.2200e-003	2.1166	1.1700e-003	2.1178	0.2323	1.0800e-003	0.2334	0.0000	109.2861	109.2861	6.9300e-003	0.0000	109.4593
<b>Total</b>	<b>0.1472</b>	<b>0.6556</b>	<b>0.9919</b>	<b>2.6100e-003</b>	<b>2.5541</b>	<b>3.3800e-003</b>	<b>2.5575</b>	<b>0.2820</b>	<b>3.2000e-003</b>	<b>0.2852</b>	<b>0.0000</b>	<b>240.6982</b>	<b>240.6982</b>	<b>0.0129</b>	<b>0.0000</b>	<b>241.0204</b>

**Mitigated Construction On-Site**

	ROG	NOx	CO	SO2	Fugitive PM10	Exhaust PM10	PM10 Total	Fugitive PM2.5	Exhaust PM2.5	PM2.5 Total	Bio- CO2	NBio- CO2	Total CO2	CH4	N2O	CO2e
Category	tons/yr										MT/yr					
Off-Road	0.0996	1.3928	2.3495	3.5000e-003		0.0132	0.0132		0.0132	0.0132	0.0000	301.2425	301.2425	0.0722	0.0000	303.0467
<b>Total</b>	<b>0.0996</b>	<b>1.3928</b>	<b>2.3495</b>	<b>3.5000e-003</b>		<b>0.0132</b>	<b>0.0132</b>		<b>0.0132</b>	<b>0.0132</b>	<b>0.0000</b>	<b>301.2425</b>	<b>301.2425</b>	<b>0.0722</b>	<b>0.0000</b>	<b>303.0467</b>

**Mitigated Construction Off-Site**

	ROG	NOx	CO	SO2	Fugitive PM10	Exhaust PM10	PM10 Total	Fugitive PM2.5	Exhaust PM2.5	PM2.5 Total	Bio- CO2	NBio- CO2	Total CO2	CH4	N2O	CO2e
Category	tons/yr										MT/yr					

Hauling	0.0000	0.0000	0.0000	0.0000	0.0000	0.0000	0.0000	0.0000	0.0000	0.0000	0.0000	0.0000	0.0000	0.0000	0.0000	0.0000
Vendor	0.0238	0.5577	0.1694	1.3900e-003	0.2802	2.2100e-003	0.2824	0.0340	2.1200e-003	0.0361	0.0000	131.4122	131.4122	5.9600e-003	0.0000	131.5611
Worker	0.1234	0.0979	0.8225	1.2200e-003	1.3450	1.1700e-003	1.3461	0.1552	1.0800e-003	0.1562	0.0000	109.2861	109.2861	6.9300e-003	0.0000	109.4593
<b>Total</b>	<b>0.1472</b>	<b>0.6556</b>	<b>0.9919</b>	<b>2.6100e-003</b>	<b>1.6252</b>	<b>3.3800e-003</b>	<b>1.6285</b>	<b>0.1891</b>	<b>3.2000e-003</b>	<b>0.1923</b>	<b>0.0000</b>	<b>240.6982</b>	<b>240.6982</b>	<b>0.0129</b>	<b>0.0000</b>	<b>241.0204</b>

**3.6 Building Construction - 2023**

**Unmitigated Construction On-Site**

	ROG	NOx	CO	SO2	Fugitive PM10	Exhaust PM10	PM10 Total	Fugitive PM2.5	Exhaust PM2.5	PM2.5 Total	Bio- CO2	NBio- CO2	Total CO2	CH4	N2O	CO2e
Category	tons/yr										MT/yr					
Off-Road	0.2045	1.8700	2.1117	3.5000e-003		0.0910	0.0910		0.0856	0.0856	0.0000	301.3462	301.3462	0.0717	0.0000	303.1383
<b>Total</b>	<b>0.2045</b>	<b>1.8700</b>	<b>2.1117</b>	<b>3.5000e-003</b>		<b>0.0910</b>	<b>0.0910</b>		<b>0.0856</b>	<b>0.0856</b>	<b>0.0000</b>	<b>301.3462</b>	<b>301.3462</b>	<b>0.0717</b>	<b>0.0000</b>	<b>303.1383</b>

**Unmitigated Construction Off-Site**

	ROG	NOx	CO	SO2	Fugitive PM10	Exhaust PM10	PM10 Total	Fugitive PM2.5	Exhaust PM2.5	PM2.5 Total	Bio- CO2	NBio- CO2	Total CO2	CH4	N2O	CO2e
Category	tons/yr										MT/yr					
Hauling	0.0000	0.0000	0.0000	0.0000	0.0000	0.0000	0.0000	0.0000	0.0000	0.0000	0.0000	0.0000	0.0000	0.0000	0.0000	0.0000
Vendor	0.0178	0.4470	0.1467	1.3700e-003	0.4375	7.1000e-004	0.4382	0.0497	6.7000e-004	0.0504	0.0000	129.5422	129.5422	4.2500e-003	0.0000	129.6484
Worker	0.1172	0.0886	0.7374	1.1800e-003	2.1166	1.0900e-003	2.1177	0.2323	1.0100e-003	0.2333	0.0000	105.7603	105.7603	6.1900e-003	0.0000	105.9150
<b>Total</b>	<b>0.1350</b>	<b>0.5357</b>	<b>0.8841</b>	<b>2.5500e-003</b>	<b>2.5541</b>	<b>1.8000e-003</b>	<b>2.5559</b>	<b>0.2820</b>	<b>1.6800e-003</b>	<b>0.2837</b>	<b>0.0000</b>	<b>235.3025</b>	<b>235.3025</b>	<b>0.0104</b>	<b>0.0000</b>	<b>235.5634</b>

**Mitigated Construction On-Site**

	ROG	NOx	CO	SO2	Fugitive PM10	Exhaust PM10	PM10 Total	Fugitive PM2.5	Exhaust PM2.5	PM2.5 Total	Bio- CO2	NBio- CO2	Total CO2	CH4	N2O	CO2e
Category	tons/yr										MT/yr					
Off-Road	0.0967	1.3873	2.3471	3.5000e-003		0.0121	0.0121		0.0121	0.0121	0.0000	301.3458	301.3458	0.0717	0.0000	303.1380
<b>Total</b>	<b>0.0967</b>	<b>1.3873</b>	<b>2.3471</b>	<b>3.5000e-003</b>		<b>0.0121</b>	<b>0.0121</b>		<b>0.0121</b>	<b>0.0121</b>	<b>0.0000</b>	<b>301.3458</b>	<b>301.3458</b>	<b>0.0717</b>	<b>0.0000</b>	<b>303.1380</b>

**Mitigated Construction Off-Site**

	ROG	NOx	CO	SO2	Fugitive PM10	Exhaust PM10	PM10 Total	Fugitive PM2.5	Exhaust PM2.5	PM2.5 Total	Bio- CO2	NBio- CO2	Total CO2	CH4	N2O	CO2e
Category	tons/yr										MT/yr					
Hauling	0.0000	0.0000	0.0000	0.0000	0.0000	0.0000	0.0000	0.0000	0.0000	0.0000	0.0000	0.0000	0.0000	0.0000	0.0000	0.0000
Vendor	0.0178	0.4470	0.1467	1.3700e-003	0.2802	7.1000e-004	0.2809	0.0340	6.7000e-004	0.0347	0.0000	129.5422	129.5422	4.2500e-003	0.0000	129.6484
Worker	0.1172	0.0886	0.7374	1.1800e-003	1.3450	1.0900e-003	1.3461	0.1552	1.0100e-003	0.1562	0.0000	105.7603	105.7603	6.1900e-003	0.0000	105.9150
<b>Total</b>	<b>0.1350</b>	<b>0.5357</b>	<b>0.8841</b>	<b>2.5500e-003</b>	<b>1.6252</b>	<b>1.8000e-003</b>	<b>1.6270</b>	<b>0.1891</b>	<b>1.6800e-003</b>	<b>0.1908</b>	<b>0.0000</b>	<b>235.3025</b>	<b>235.3025</b>	<b>0.0104</b>	<b>0.0000</b>	<b>235.5634</b>

**3.6 Building Construction - 2024**

**Unmitigated Construction On-Site**

	ROG	NOx	CO	SO2	Fugitive PM10	Exhaust PM10	PM10 Total	Fugitive PM2.5	Exhaust PM2.5	PM2.5 Total	Bio- CO2	NBio- CO2	Total CO2	CH4	N2O	CO2e
Category	tons/yr										MT/yr					
Off-Road	0.1472	1.3444	1.6167	2.7000e-003		0.0613	0.0613		0.0577	0.0577	0.0000	231.8491	231.8491	0.0548	0.0000	233.2198
<b>Total</b>	<b>0.1472</b>	<b>1.3444</b>	<b>1.6167</b>	<b>2.7000e-003</b>		<b>0.0613</b>	<b>0.0613</b>		<b>0.0577</b>	<b>0.0577</b>	<b>0.0000</b>	<b>231.8491</b>	<b>231.8491</b>	<b>0.0548</b>	<b>0.0000</b>	<b>233.2198</b>

**Unmitigated Construction Off-Site**

	ROG	NOx	CO	SO2	Fugitive PM10	Exhaust PM10	PM10 Total	Fugitive PM2.5	Exhaust PM2.5	PM2.5 Total	Bio- CO2	NBio- CO2	Total CO2	CH4	N2O	CO2e
Category	tons/yr										MT/yr					
Hauling	0.0000	0.0000	0.0000	0.0000	0.0000	0.0000	0.0000	0.0000	0.0000	0.0000	0.0000	0.0000	0.0000	0.0000	0.0000	0.0000
Vendor	0.0130	0.3367	0.1048	1.0400e-003	0.3365	5.1000e-004	0.3370	0.0382	4.9000e-004	0.0387	0.0000	98.9397	98.9397	3.1700e-003	0.0000	99.0191
Worker	0.0853	0.0618	0.5145	8.7000e-004	1.6282	7.9000e-004	1.6290	0.1787	7.3000e-004	0.1794	0.0000	78.5900	78.5900	4.2200e-003	0.0000	78.6955
<b>Total</b>	<b>0.0983</b>	<b>0.3985</b>	<b>0.6194</b>	<b>1.9100e-003</b>	<b>1.9647</b>	<b>1.3000e-003</b>	<b>1.9660</b>	<b>0.2169</b>	<b>1.2200e-003</b>	<b>0.2182</b>	<b>0.0000</b>	<b>177.5298</b>	<b>177.5298</b>	<b>7.3900e-003</b>	<b>0.0000</b>	<b>177.7146</b>

**Mitigated Construction On-Site**

	ROG	NOx	CO	SO2	Fugitive PM10	Exhaust PM10	PM10 Total	Fugitive PM2.5	Exhaust PM2.5	PM2.5 Total	Bio- CO2	NBio- CO2	Total CO2	CH4	N2O	CO2e
Category	tons/yr										MT/yr					
Off-Road	0.0726	1.0632	1.8041	2.7000e-003		8.5300e-003	8.5300e-003		8.5300e-003	8.5300e-003	0.0000	231.8488	231.8488	0.0548	0.0000	233.2195

Total	0.0726	1.0632	1.8041	2.7000e-003		8.5300e-003	8.5300e-003		8.5300e-003	8.5300e-003	0.0000	231.8488	231.8488	0.0548	0.0000	233.2195
-------	--------	--------	--------	-------------	--	-------------	-------------	--	-------------	-------------	--------	----------	----------	--------	--------	----------

**Mitigated Construction Off-Site**

	ROG	NOx	CO	SO2	Fugitive PM10	Exhaust PM10	PM10 Total	Fugitive PM2.5	Exhaust PM2.5	PM2.5 Total	Bio- CO2	NBio- CO2	Total CO2	CH4	N2O	CO2e
Category	tons/yr										MT/yr					
Hauling	0.0000	0.0000	0.0000	0.0000	0.0000	0.0000	0.0000	0.0000	0.0000	0.0000	0.0000	0.0000	0.0000	0.0000	0.0000	0.0000
Vendor	0.0130	0.3367	0.1048	1.0400e-003	0.2155	5.1000e-004	0.2160	0.0261	4.9000e-004	0.0266	0.0000	98.9397	98.9397	3.1700e-003	0.0000	99.0191
Worker	0.0853	0.0618	0.5145	8.7000e-004	1.0346	7.9000e-004	1.0354	0.1193	7.3000e-004	0.1201	0.0000	78.5900	78.5900	4.2200e-003	0.0000	78.6955
<b>Total</b>	<b>0.0983</b>	<b>0.3985</b>	<b>0.6194</b>	<b>1.9100e-003</b>	<b>1.2501</b>	<b>1.3000e-003</b>	<b>1.2514</b>	<b>0.1455</b>	<b>1.2200e-003</b>	<b>0.1467</b>	<b>0.0000</b>	<b>177.5298</b>	<b>177.5298</b>	<b>7.3900e-003</b>	<b>0.0000</b>	<b>177.7146</b>

**3.7 Paving - 2024**

**Unmitigated Construction On-Site**

	ROG	NOx	CO	SO2	Fugitive PM10	Exhaust PM10	PM10 Total	Fugitive PM2.5	Exhaust PM2.5	PM2.5 Total	Bio- CO2	NBio- CO2	Total CO2	CH4	N2O	CO2e
Category	tons/yr										MT/yr					
Off-Road	0.0272	0.2619	0.4022	6.3000e-004		0.0129	0.0129		0.0119	0.0119	0.0000	55.0730	55.0730	0.0178	0.0000	55.5183
Paving	0.0000					0.0000	0.0000		0.0000	0.0000	0.0000	0.0000	0.0000	0.0000	0.0000	0.0000
<b>Total</b>	<b>0.0272</b>	<b>0.2619</b>	<b>0.4022</b>	<b>6.3000e-004</b>		<b>0.0129</b>	<b>0.0129</b>		<b>0.0119</b>	<b>0.0119</b>	<b>0.0000</b>	<b>55.0730</b>	<b>55.0730</b>	<b>0.0178</b>	<b>0.0000</b>	<b>55.5183</b>

**Unmitigated Construction Off-Site**



	ROG	NOx	CO	SO2	Fugitive PM10	Exhaust PM10	PM10 Total	Fugitive PM2.5	Exhaust PM2.5	PM2.5 Total	Bio- CO2	NBio- CO2	Total CO2	CH4	N2O	CO2e
Category	tons/yr										MT/yr					
Hauling	0.0000	0.0000	0.0000	0.0000	0.0000	0.0000	0.0000	0.0000	0.0000	0.0000	0.0000	0.0000	0.0000	0.0000	0.0000	0.0000
Vendor	0.0000	0.0000	0.0000	0.0000	0.0000	0.0000	0.0000	0.0000	0.0000	0.0000	0.0000	0.0000	0.0000	0.0000	0.0000	0.0000
Worker	2.7900e-003	2.0200e-003	0.0168	3.0000e-005	0.0533	3.0000e-005	0.0533	5.8500e-003	2.0000e-005	5.8700e-003	0.0000	2.5729	2.5729	1.4000e-004	0.0000	2.5763
<b>Total</b>	<b>2.7900e-003</b>	<b>2.0200e-003</b>	<b>0.0168</b>	<b>3.0000e-005</b>	<b>0.0533</b>	<b>3.0000e-005</b>	<b>0.0533</b>	<b>5.8500e-003</b>	<b>2.0000e-005</b>	<b>5.8700e-003</b>	<b>0.0000</b>	<b>2.5729</b>	<b>2.5729</b>	<b>1.4000e-004</b>	<b>0.0000</b>	<b>2.5763</b>

**Mitigated Construction On-Site**

	ROG	NOx	CO	SO2	Fugitive PM10	Exhaust PM10	PM10 Total	Fugitive PM2.5	Exhaust PM2.5	PM2.5 Total	Bio- CO2	NBio- CO2	Total CO2	CH4	N2O	CO2e
Category	tons/yr										MT/yr					
Off-Road	9.1900e-003	0.2761	0.4756	6.3000e-004		1.0300e-003	1.0300e-003		1.0300e-003	1.0300e-003	0.0000	55.0729	55.0729	0.0178	0.0000	55.5182
Paving	0.0000					0.0000	0.0000		0.0000	0.0000	0.0000	0.0000	0.0000	0.0000	0.0000	0.0000
<b>Total</b>	<b>9.1900e-003</b>	<b>0.2761</b>	<b>0.4756</b>	<b>6.3000e-004</b>		<b>1.0300e-003</b>	<b>1.0300e-003</b>		<b>1.0300e-003</b>	<b>1.0300e-003</b>	<b>0.0000</b>	<b>55.0729</b>	<b>55.0729</b>	<b>0.0178</b>	<b>0.0000</b>	<b>55.5182</b>

**Mitigated Construction Off-Site**

	ROG	NOx	CO	SO2	Fugitive PM10	Exhaust PM10	PM10 Total	Fugitive PM2.5	Exhaust PM2.5	PM2.5 Total	Bio- CO2	NBio- CO2	Total CO2	CH4	N2O	CO2e
Category	tons/yr										MT/yr					

Hauling	0.0000	0.0000	0.0000	0.0000	0.0000	0.0000	0.0000	0.0000	0.0000	0.0000	0.0000	0.0000	0.0000	0.0000	0.0000	0.0000
Vendor	0.0000	0.0000	0.0000	0.0000	0.0000	0.0000	0.0000	0.0000	0.0000	0.0000	0.0000	0.0000	0.0000	0.0000	0.0000	0.0000
Worker	2.7900e-003	2.0200e-003	0.0168	3.0000e-005	0.0339	3.0000e-005	0.0339	3.9100e-003	2.0000e-005	3.9300e-003	0.0000	2.5729	2.5729	1.4000e-004	0.0000	2.5763
<b>Total</b>	<b>2.7900e-003</b>	<b>2.0200e-003</b>	<b>0.0168</b>	<b>3.0000e-005</b>	<b>0.0339</b>	<b>3.0000e-005</b>	<b>0.0339</b>	<b>3.9100e-003</b>	<b>2.0000e-005</b>	<b>3.9300e-003</b>	<b>0.0000</b>	<b>2.5729</b>	<b>2.5729</b>	<b>1.4000e-004</b>	<b>0.0000</b>	<b>2.5763</b>

**3.8 Architectural Coating - 2024**

**Unmitigated Construction On-Site**

	ROG	NOx	CO	SO2	Fugitive PM10	Exhaust PM10	PM10 Total	Fugitive PM2.5	Exhaust PM2.5	PM2.5 Total	Bio- CO2	NBio- CO2	Total CO2	CH4	N2O	CO2e
Category	tons/yr										MT/yr					
Archit. Coating	0.5053					0.0000	0.0000		0.0000	0.0000	0.0000	0.0000	0.0000	0.0000	0.0000	0.0000
Off-Road	6.3000e-004	4.2700e-003	6.3400e-003	1.0000e-005		2.1000e-004	2.1000e-004		2.1000e-004	2.1000e-004	0.0000	0.8936	0.8936	5.0000e-005	0.0000	0.8949
<b>Total</b>	<b>0.5059</b>	<b>4.2700e-003</b>	<b>6.3400e-003</b>	<b>1.0000e-005</b>		<b>2.1000e-004</b>	<b>2.1000e-004</b>		<b>2.1000e-004</b>	<b>2.1000e-004</b>	<b>0.0000</b>	<b>0.8936</b>	<b>0.8936</b>	<b>5.0000e-005</b>	<b>0.0000</b>	<b>0.8949</b>

**Unmitigated Construction Off-Site**

	ROG	NOx	CO	SO2	Fugitive PM10	Exhaust PM10	PM10 Total	Fugitive PM2.5	Exhaust PM2.5	PM2.5 Total	Bio- CO2	NBio- CO2	Total CO2	CH4	N2O	CO2e
Category	tons/yr										MT/yr					
Hauling	0.0000	0.0000	0.0000	0.0000	0.0000	0.0000	0.0000	0.0000	0.0000	0.0000	0.0000	0.0000	0.0000	0.0000	0.0000	0.0000
Vendor	0.0000	0.0000	0.0000	0.0000	0.0000	0.0000	0.0000	0.0000	0.0000	0.0000	0.0000	0.0000	0.0000	0.0000	0.0000	0.0000
Worker	5.9000e-004	4.3000e-004	3.5700e-003	1.0000e-005	0.0113	1.0000e-005	0.0113	1.2400e-003	1.0000e-005	1.2500e-003	0.0000	0.5458	0.5458	3.0000e-005	0.0000	0.5465
<b>Total</b>	<b>5.9000e-004</b>	<b>4.3000e-004</b>	<b>3.5700e-003</b>	<b>1.0000e-005</b>	<b>0.0113</b>	<b>1.0000e-005</b>	<b>0.0113</b>	<b>1.2400e-003</b>	<b>1.0000e-005</b>	<b>1.2500e-003</b>	<b>0.0000</b>	<b>0.5458</b>	<b>0.5458</b>	<b>3.0000e-005</b>	<b>0.0000</b>	<b>0.5465</b>

**Mitigated Construction On-Site**

	ROG	NOx	CO	SO2	Fugitive PM10	Exhaust PM10	PM10 Total	Fugitive PM2.5	Exhaust PM2.5	PM2.5 Total	Bio- CO2	NBio- CO2	Total CO2	CH4	N2O	CO2e
Category	tons/yr										MT/yr					
Archit. Coating	0.5053					0.0000	0.0000		0.0000	0.0000	0.0000	0.0000	0.0000	0.0000	0.0000	0.0000
Off-Road	6.3000e-004	4.2700e-003	6.3400e-003	1.0000e-005		2.1000e-004	2.1000e-004		2.1000e-004	2.1000e-004	0.0000	0.8936	0.8936	5.0000e-005	0.0000	0.8949
<b>Total</b>	<b>0.5059</b>	<b>4.2700e-003</b>	<b>6.3400e-003</b>	<b>1.0000e-005</b>		<b>2.1000e-004</b>	<b>2.1000e-004</b>		<b>2.1000e-004</b>	<b>2.1000e-004</b>	<b>0.0000</b>	<b>0.8936</b>	<b>0.8936</b>	<b>5.0000e-005</b>	<b>0.0000</b>	<b>0.8949</b>

**Mitigated Construction Off-Site**

	ROG	NOx	CO	SO2	Fugitive PM10	Exhaust PM10	PM10 Total	Fugitive PM2.5	Exhaust PM2.5	PM2.5 Total	Bio- CO2	NBio- CO2	Total CO2	CH4	N2O	CO2e
Category	tons/yr										MT/yr					
Hauling	0.0000	0.0000	0.0000	0.0000	0.0000	0.0000	0.0000	0.0000	0.0000	0.0000	0.0000	0.0000	0.0000	0.0000	0.0000	0.0000
Vendor	0.0000	0.0000	0.0000	0.0000	0.0000	0.0000	0.0000	0.0000	0.0000	0.0000	0.0000	0.0000	0.0000	0.0000	0.0000	0.0000
Worker	5.9000e-004	4.3000e-004	3.5700e-003	1.0000e-005	7.1800e-003	1.0000e-005	7.1900e-003	8.3000e-004	1.0000e-005	8.3000e-004	0.0000	0.5458	0.5458	3.0000e-005	0.0000	0.5465
<b>Total</b>	<b>5.9000e-004</b>	<b>4.3000e-004</b>	<b>3.5700e-003</b>	<b>1.0000e-005</b>	<b>7.1800e-003</b>	<b>1.0000e-005</b>	<b>7.1900e-003</b>	<b>8.3000e-004</b>	<b>1.0000e-005</b>	<b>8.3000e-004</b>	<b>0.0000</b>	<b>0.5458</b>	<b>0.5458</b>	<b>3.0000e-005</b>	<b>0.0000</b>	<b>0.5465</b>

**3.8 Architectural Coating - 2025**

**Unmitigated Construction On-Site**

	ROG	NOx	CO	SO2	Fugitive PM10	Exhaust PM10	PM10 Total	Fugitive PM2.5	Exhaust PM2.5	PM2.5 Total	Bio- CO2	NBio- CO2	Total CO2	CH4	N2O	CO2e
Category	tons/yr										MT/yr					
Archit. Coating	3.4649					0.0000	0.0000		0.0000	0.0000	0.0000	0.0000	0.0000	0.0000	0.0000	0.0000
Off-Road	4.1000e-003	0.0275	0.0434	7.0000e-005		1.2400e-003	1.2400e-003		1.2400e-003	1.2400e-003	0.0000	6.1278	6.1278	3.3000e-004	0.0000	6.1362
<b>Total</b>	<b>3.4690</b>	<b>0.0275</b>	<b>0.0434</b>	<b>7.0000e-005</b>		<b>1.2400e-003</b>	<b>1.2400e-003</b>		<b>1.2400e-003</b>	<b>1.2400e-003</b>	<b>0.0000</b>	<b>6.1278</b>	<b>6.1278</b>	<b>3.3000e-004</b>	<b>0.0000</b>	<b>6.1362</b>

**Unmitigated Construction Off-Site**

	ROG	NOx	CO	SO2	Fugitive PM10	Exhaust PM10	PM10 Total	Fugitive PM2.5	Exhaust PM2.5	PM2.5 Total	Bio- CO2	NBio- CO2	Total CO2	CH4	N2O	CO2e
Category	tons/yr										MT/yr					
Hauling	0.0000	0.0000	0.0000	0.0000	0.0000	0.0000	0.0000	0.0000	0.0000	0.0000	0.0000	0.0000	0.0000	0.0000	0.0000	0.0000
Vendor	0.0000	0.0000	0.0000	0.0000	0.0000	0.0000	0.0000	0.0000	0.0000	0.0000	0.0000	0.0000	0.0000	0.0000	0.0000	0.0000
Worker	3.8400e-003	2.6900e-003	0.0226	4.0000e-005	0.0775	4.0000e-005	0.0776	8.5100e-003	3.0000e-005	8.5400e-003	0.0000	3.6108	3.6108	1.8000e-004	0.0000	3.6154
<b>Total</b>	<b>3.8400e-003</b>	<b>2.6900e-003</b>	<b>0.0226</b>	<b>4.0000e-005</b>	<b>0.0775</b>	<b>4.0000e-005</b>	<b>0.0776</b>	<b>8.5100e-003</b>	<b>3.0000e-005</b>	<b>8.5400e-003</b>	<b>0.0000</b>	<b>3.6108</b>	<b>3.6108</b>	<b>1.8000e-004</b>	<b>0.0000</b>	<b>3.6154</b>

**Mitigated Construction On-Site**

	ROG	NOx	CO	SO2	Fugitive PM10	Exhaust PM10	PM10 Total	Fugitive PM2.5	Exhaust PM2.5	PM2.5 Total	Bio- CO2	NBio- CO2	Total CO2	CH4	N2O	CO2e
Category	tons/yr										MT/yr					
Archit. Coating	3.4649					0.0000	0.0000		0.0000	0.0000	0.0000	0.0000	0.0000	0.0000	0.0000	0.0000

Off-Road	4.1000e-003	0.0275	0.0434	7.0000e-005		1.2400e-003	1.2400e-003		1.2400e-003	1.2400e-003	0.0000	6.1278	6.1278	3.3000e-004	0.0000	6.1362
<b>Total</b>	<b>3.4690</b>	<b>0.0275</b>	<b>0.0434</b>	<b>7.0000e-005</b>		<b>1.2400e-003</b>	<b>1.2400e-003</b>		<b>1.2400e-003</b>	<b>1.2400e-003</b>	<b>0.0000</b>	<b>6.1278</b>	<b>6.1278</b>	<b>3.3000e-004</b>	<b>0.0000</b>	<b>6.1362</b>

**Mitigated Construction Off-Site**

	ROG	NOx	CO	SO2	Fugitive PM10	Exhaust PM10	PM10 Total	Fugitive PM2.5	Exhaust PM2.5	PM2.5 Total	Bio- CO2	NBio- CO2	Total CO2	CH4	N2O	CO2e
Category	tons/yr										MT/yr					
Hauling	0.0000	0.0000	0.0000	0.0000	0.0000	0.0000	0.0000	0.0000	0.0000	0.0000	0.0000	0.0000	0.0000	0.0000	0.0000	0.0000
Vendor	0.0000	0.0000	0.0000	0.0000	0.0000	0.0000	0.0000	0.0000	0.0000	0.0000	0.0000	0.0000	0.0000	0.0000	0.0000	0.0000
Worker	3.8400e-003	2.6900e-003	0.0226	4.0000e-005	0.0493	4.0000e-005	0.0493	5.6800e-003	3.0000e-005	5.7200e-003	0.0000	3.6108	3.6108	1.8000e-004	0.0000	3.6154
<b>Total</b>	<b>3.8400e-003</b>	<b>2.6900e-003</b>	<b>0.0226</b>	<b>4.0000e-005</b>	<b>0.0493</b>	<b>4.0000e-005</b>	<b>0.0493</b>	<b>5.6800e-003</b>	<b>3.0000e-005</b>	<b>5.7200e-003</b>	<b>0.0000</b>	<b>3.6108</b>	<b>3.6108</b>	<b>1.8000e-004</b>	<b>0.0000</b>	<b>3.6154</b>

**4.0 Operational Detail - Mobile**

**4.1 Mitigation Measures Mobile**

	ROG	NOx	CO	SO2	Fugitive PM10	Exhaust PM10	PM10 Total	Fugitive PM2.5	Exhaust PM2.5	PM2.5 Total	Bio- CO2	NBio- CO2	Total CO2	CH4	N2O	CO2e
Category	tons/yr										MT/yr					
Mitigated	0.5149	2.0302	5.8486	0.0158	1.4722	0.0137	1.4859	0.3952	0.0128	0.4080	0.0000	1,445.9873	1,445.9873	0.0593	0.0000	1,447.4694
Unmitigated	0.5149	2.0302	5.8486	0.0158	1.4722	0.0137	1.4859	0.3952	0.0128	0.4080	0.0000	1,445.9873	1,445.9873	0.0593	0.0000	1,447.4694

**4.2 Trip Summary Information**

Land Use	Average Daily Trip Rate			Unmitigated	Mitigated
	Weekday	Saturday	Sunday	Annual VMT	Annual VMT
City Park	0.00	0.00	0.00		
Retirement Community	166.53	156.00	156.00	468,039	468,039
Single Family Housing	1,246.08	1,308.12	1,137.84	3,547,700	3,547,700
<b>Total</b>	<b>1,412.61</b>	<b>1,464.12</b>	<b>1,293.84</b>	<b>4,015,739</b>	<b>4,015,739</b>

**4.3 Trip Type Information**

Land Use	Miles			Trip %			Trip Purpose %		
	H-W or C-W	H-S or C-C	H-O or C-NW	H-W or C-W	H-S or C-C	H-O or C-NW	Primary	Diverted	Pass-by
City Park	9.50	7.30	7.30	33.00	48.00	19.00	66	28	6
Retirement Community	10.80	7.30	7.50	42.30	19.60	38.10	86	11	3
Single Family Housing	10.80	7.30	7.50	42.30	19.60	38.10	86	11	3

**4.4 Fleet Mix**

Land Use	LDA	LDT1	LDT2	MDV	LHD1	LHD2	MHD	HHD	OBUS	UBUS	MCY	SBUS	MH
City Park	0.582811	0.037485	0.193775	0.108307	0.014136	0.005301	0.018855	0.027301	0.002669	0.002011	0.005732	0.000906	0.000708
Retirement Community	0.582811	0.037485	0.193775	0.108307	0.014136	0.005301	0.018855	0.027301	0.002669	0.002011	0.005732	0.000906	0.000708
Single Family Housing	0.582811	0.037485	0.193775	0.108307	0.014136	0.005301	0.018855	0.027301	0.002669	0.002011	0.005732	0.000906	0.000708

**5.0 Energy Detail**

Historical Energy Use: N

**5.1 Mitigation Measures Energy**

- Exceed Title 24
- Install High Efficiency Lighting
- Install Energy Efficient Appliances

	ROG	NOx	CO	SO2	Fugitive PM10	Exhaust PM10	PM10 Total	Fugitive PM2.5	Exhaust PM2.5	PM2.5 Total	Bio- CO2	NBio- CO2	Total CO2	CH4	N2O	CO2e
Category	tons/yr										MT/yr					
Electricity Mitigated						0.0000	0.0000		0.0000	0.0000	0.0000	106.2267	106.2267	0.0147	3.0400e-003	107.4979
Electricity Unmitigated						0.0000	0.0000		0.0000	0.0000	0.0000	127.4918	127.4918	0.0176	3.6400e-003	129.0175
NaturalGas Mitigated	0.0000	0.0000	0.0000	0.0000		0.0000	0.0000		0.0000	0.0000	0.0000	0.0000	0.0000	0.0000	0.0000	0.0000
NaturalGas Unmitigated	0.0000	0.0000	0.0000	0.0000		0.0000	0.0000		0.0000	0.0000	0.0000	0.0000	0.0000	0.0000	0.0000	0.0000

**5.2 Energy by Land Use - NaturalGas**  
**Unmitigated**

	NaturalGas Use	ROG	NOx	CO	SO2	Fugitive PM10	Exhaust PM10	PM10 Total	Fugitive PM2.5	Exhaust PM2.5	PM2.5 Total	Bio- CO2	NBio- CO2	Total CO2	CH4	N2O	CO2e
Land Use	kBTU/yr	tons/yr										MT/yr					
City Park	0	0.0000	0.0000	0.0000	0.0000		0.0000	0.0000		0.0000	0.0000	0.0000	0.0000	0.0000	0.0000	0.0000	0.0000
Retirement Community	0	0.0000	0.0000	0.0000	0.0000		0.0000	0.0000		0.0000	0.0000	0.0000	0.0000	0.0000	0.0000	0.0000	0.0000
Single Family Housing	0	0.0000	0.0000	0.0000	0.0000		0.0000	0.0000		0.0000	0.0000	0.0000	0.0000	0.0000	0.0000	0.0000	0.0000
<b>Total</b>		<b>0.0000</b>	<b>0.0000</b>	<b>0.0000</b>	<b>0.0000</b>		<b>0.0000</b>	<b>0.0000</b>		<b>0.0000</b>	<b>0.0000</b>	<b>0.0000</b>	<b>0.0000</b>	<b>0.0000</b>	<b>0.0000</b>	<b>0.0000</b>	<b>0.0000</b>

**Mitigated**

	NaturalGas Use	ROG	NOx	CO	SO2	Fugitive PM10	Exhaust PM10	PM10 Total	Fugitive PM2.5	Exhaust PM2.5	PM2.5 Total	Bio- CO2	NBio- CO2	Total CO2	CH4	N2O	CO2e
--	----------------	-----	-----	----	-----	---------------	--------------	------------	----------------	---------------	-------------	----------	-----------	-----------	-----	-----	------

Land Use	kBTU/yr	tons/yr										MT/yr					
City Park	0	0.0000	0.0000	0.0000	0.0000	0.0000	0.0000	0.0000	0.0000	0.0000	0.0000	0.0000	0.0000	0.0000	0.0000	0.0000	
Retirement Community	0	0.0000	0.0000	0.0000	0.0000	0.0000	0.0000	0.0000	0.0000	0.0000	0.0000	0.0000	0.0000	0.0000	0.0000	0.0000	
Single Family Housing	0	0.0000	0.0000	0.0000	0.0000	0.0000	0.0000	0.0000	0.0000	0.0000	0.0000	0.0000	0.0000	0.0000	0.0000	0.0000	
<b>Total</b>		<b>0.0000</b>	<b>0.0000</b>	<b>0.0000</b>	<b>0.0000</b>	<b>0.0000</b>	<b>0.0000</b>	<b>0.0000</b>	<b>0.0000</b>	<b>0.0000</b>	<b>0.0000</b>	<b>0.0000</b>	<b>0.0000</b>	<b>0.0000</b>	<b>0.0000</b>	<b>0.0000</b>	

**5.3 Energy by Land Use - Electricity**

**Unmitigated**

	Electricity Use	Total CO2	CH4	N2O	CO2e
Land Use	kWh/yr	MT/yr			
City Park	0	0.0000	0.0000	0.0000	0.0000
Retirement Community	193042	18.3881	2.5400e-003	5.3000e-004	18.6081
Single Family Housing	1.14539e+006	109.1037	0.0151	3.1200e-003	110.4093
<b>Total</b>		<b>127.4918</b>	<b>0.0176</b>	<b>3.6500e-003</b>	<b>129.0175</b>

**Mitigated**

	Electricity Use	Total CO2	CH4	N2O	CO2e
Land Use	kWh/yr	MT/yr			
City Park	0	0.0000	0.0000	0.0000	0.0000
Retirement Community	158390	15.0873	2.0800e-003	4.3000e-004	15.2679



Single Family Housing	956800	91.1394	0.0126	2.6000e-003	92.2300
<b>Total</b>		<b>106.2267</b>	<b>0.0147</b>	<b>3.0300e-003</b>	<b>107.4979</b>

**6.0 Area Detail**

**6.1 Mitigation Measures Area**

	ROG	NOx	CO	SO2	Fugitive PM10	Exhaust PM10	PM10 Total	Fugitive PM2.5	Exhaust PM2.5	PM2.5 Total	Bio- CO2	NBio- CO2	Total CO2	CH4	N2O	CO2e
Category	tons/yr										MT/yr					
Mitigated	1.4275	0.0146	1.2685	7.0000e-005		7.0400e-003	7.0400e-003		7.0400e-003	7.0400e-003	0.0000	2.0741	2.0741	1.9900e-003	0.0000	2.1237
Unmitigated	1.4275	0.0146	1.2685	7.0000e-005		7.0400e-003	7.0400e-003		7.0400e-003	7.0400e-003	0.0000	2.0741	2.0741	1.9900e-003	0.0000	2.1237

**6.2 Area by SubCategory**

Unmitigated

	ROG	NOx	CO	SO2	Fugitive PM10	Exhaust PM10	PM10 Total	Fugitive PM2.5	Exhaust PM2.5	PM2.5 Total	Bio- CO2	NBio- CO2	Total CO2	CH4	N2O	CO2e
SubCategory	tons/yr										MT/yr					
Architectural Coating	0.3970					0.0000	0.0000		0.0000	0.0000	0.0000	0.0000	0.0000	0.0000	0.0000	0.0000
Consumer Products	0.9924					0.0000	0.0000		0.0000	0.0000	0.0000	0.0000	0.0000	0.0000	0.0000	0.0000
Hearth	0.0000	0.0000	0.0000	0.0000		0.0000	0.0000		0.0000	0.0000	0.0000	0.0000	0.0000	0.0000	0.0000	0.0000

Landscaping	0.0381	0.0146	1.2685	7.0000e-005		7.0400e-003	7.0400e-003		7.0400e-003	7.0400e-003	0.0000	2.0741	2.0741	1.9900e-003	0.0000	2.1237
<b>Total</b>	<b>1.4275</b>	<b>0.0146</b>	<b>1.2685</b>	<b>7.0000e-005</b>		<b>7.0400e-003</b>	<b>7.0400e-003</b>		<b>7.0400e-003</b>	<b>7.0400e-003</b>	<b>0.0000</b>	<b>2.0741</b>	<b>2.0741</b>	<b>1.9900e-003</b>	<b>0.0000</b>	<b>2.1237</b>

**Mitigated**

	ROG	NOx	CO	SO2	Fugitive PM10	Exhaust PM10	PM10 Total	Fugitive PM2.5	Exhaust PM2.5	PM2.5 Total	Bio- CO2	NBio- CO2	Total CO2	CH4	N2O	CO2e
SubCategory	tons/yr										MT/yr					
Architectural Coating	0.3970						0.0000	0.0000		0.0000	0.0000	0.0000	0.0000	0.0000	0.0000	0.0000
Consumer Products	0.9924						0.0000	0.0000		0.0000	0.0000	0.0000	0.0000	0.0000	0.0000	0.0000
Hearth	0.0000	0.0000	0.0000	0.0000			0.0000	0.0000		0.0000	0.0000	0.0000	0.0000	0.0000	0.0000	0.0000
Landscaping	0.0381	0.0146	1.2685	7.0000e-005			7.0400e-003	7.0400e-003		7.0400e-003	7.0400e-003	0.0000	2.0741	2.0741	1.9900e-003	0.0000
<b>Total</b>	<b>1.4275</b>	<b>0.0146</b>	<b>1.2685</b>	<b>7.0000e-005</b>			<b>7.0400e-003</b>	<b>7.0400e-003</b>		<b>7.0400e-003</b>	<b>7.0400e-003</b>	<b>0.0000</b>	<b>2.0741</b>	<b>2.0741</b>	<b>1.9900e-003</b>	<b>0.0000</b>

**7.0 Water Detail**

**7.1 Mitigation Measures Water**

- Install Low Flow Bathroom Faucet
- Install Low Flow Kitchen Faucet
- Install Low Flow Toilet
- Install Low Flow Shower
- Use Water Efficient Irrigation System

	Total CO2	CH4	N2O	CO2e
Category	MT/yr			
Mitigated	10.9795	0.0119	7.0800e-003	13.3881
Unmitigated	13.1263	0.0148	8.8300e-003	16.1299

## 7.2 Water by Land Use

### Unmitigated

	Indoor/Outdoor Use	Total CO2	CH4	N2O	CO2e
Land Use	Mgal	MT/yr			
City Park	0 / 3.3004	1.1003	1.5000e-004	3.0000e-005	1.1135
Retirement Community	2.54101 / 1.60194	2.7428	3.3500e-003	2.0100e-003	3.4248
Single Family Housing	8.60033 / 5.42195	9.2832	0.0113	6.8000e-003	11.5916
<b>Total</b>		<b>13.1263</b>	<b>0.0148</b>	<b>8.8400e-003</b>	<b>16.1299</b>

### Mitigated

	Indoor/Outdoor Use	Total CO2	CH4	N2O	CO2e
Land Use	Mgal	MT/yr			
City Park	0 / 3.09908	1.0332	1.4000e-004	3.0000e-005	1.0456
Retirement Community	2.03281 / 1.50422	2.2685	2.6900e-003	1.6100e-003	2.8150

Single Family Housing	6.88027 / 5.09121	7.6779	9.1000e-003	5.4400e-003	9.5276
<b>Total</b>		<b>10.9795</b>	<b>0.0119</b>	<b>7.0800e-003</b>	<b>13.3881</b>

**8.0 Waste Detail**

**8.1 Mitigation Measures Waste**

Category/Year

	Total CO2	CH4	N2O	CO2e
	MT/yr			
Mitigated	37.4518	2.2133	0.0000	92.7853
Unmitigated	37.4518	2.2133	0.0000	92.7853

**8.2 Waste by Land Use**

Unmitigated

	Waste Disposed	Total CO2	CH4	N2O	CO2e
Land Use	tons	MT/yr			
City Park	0.24	0.0487	2.8800e-003	0.0000	0.1207
Retirement Community	17.94	3.6417	0.2152	0.0000	9.0221
Single Family Housing	166.32	33.7615	1.9952	0.0000	83.6426

Total		37.4518	2.2133	0.0000	92.7853
-------	--	---------	--------	--------	---------

**Mitigated**

Land Use	Waste Disposed tons	Total CO2	CH4	N2O	CO2e
		MT/yr			
City Park	0.24	0.0487	2.8800e-003	0.0000	0.1207
Retirement Community	17.94	3.6417	0.2152	0.0000	9.0221
Single Family Housing	166.32	33.7615	1.9952	0.0000	83.6426
<b>Total</b>		<b>37.4518</b>	<b>2.2133</b>	<b>0.0000</b>	<b>92.7853</b>

**9.0 Operational Offroad**

Equipment Type	Number	Hours/Day	Days/Year	Horse Power	Load Factor	Fuel Type
----------------	--------	-----------	-----------	-------------	-------------	-----------

**10.0 Stationary Equipment**

**Fire Pumps and Emergency Generators**

Equipment Type	Number	Hours/Day	Hours/Year	Horse Power	Load Factor	Fuel Type
----------------	--------	-----------	------------	-------------	-------------	-----------

**Boilers**

Equipment Type	Number	Heat Input/Day	Heat Input/Year	Boiler Rating	Fuel Type
----------------	--------	----------------	-----------------	---------------	-----------

**User Defined Equipment**

Equipment Type	Number
----------------	--------

**11.0 Vegetation**

### Attachment 3. Construction Health Risk Assessment

#### CalEEMod Emissions Modeling

The health risk assessment used the on-site construction emissions produced by CalEEMod. Since localized emissions are used in the health risk assessment, the worker and truck trip travel lengths for construction activity were set to one mile. Otherwise, annual emissions used in this modeling are the same as those contained in Attachment 2.

#### Construction HRA

Uncontrolled		Controlled	
PM10 Exhaust	PM2.5 fug	PM10 Exhaust	PM2.5 fug
Annual Emissions (Tons)			
Construction			
0.1557	0.2881	0.0074	0.1305
0.1069	0.0285	0.0119	0.0191
0.0913	0.0284	0.0114	0.0191
0.0747	0.0225	0.0098	0.0152
0.0012	0.0008	0.0001	0.0005

Total (tons)	0.0405	0.1844
Total (pounds)	81.04	368.86

#### Health Risk Results

#### Maximum Impacts at Construction MEI Location - With Controls

Emissions Year	Maximum Concentrations		Cancer Risk (per million)		Hazard Index (-)	Maximum Annual PM2.5 Concentration (µg/m³)
	Exhaust PM10/DPM (µg/m³)	Fugitive PM2.5 (µg/m³)	Child	Adult		
	2021	0.0031	0.0731	0.55	0.01	0.001
2022	0.0050	0.0107	0.83	0.01	0.001	0.02
2023	0.0048	0.0107	0.14	0.01	0.001	0.02
2024	0.0041	0.0085	0.12	0.01	0.001	0.01
2025	0.0000	0.0003	0.00	0.00	0.000	0.00
<b>Total</b>	-	-	<b>1.6</b>	<b>0.05</b>	-	-
<b>Maximum</b>	0.0050	0.0731	-	-	<b>0.001</b>	<b>0.08</b>

Bella Vista Ukiah, CA

**DPM Construction Emissions and Modeling Emission Rates - With Controls**

Emissions Model	Activity	DPM (ton/year)	Area Source	DPM Emissions			Modeled Area (m <sup>2</sup> )	DPM Emission Rate (g/s/m <sup>2</sup> )
				(lb/yr)	(lb/hr)	(g/s)		
2021	Construction	0.0074	DPM	14.7	0.00447	5.64E-04	146,136	<b>3.86E-09</b>
2022	Construction	0.0119	DPM	23.8	0.00725	9.13E-04	146,136	<b>6.25E-09</b>
2023	Construction	0.0114	DPM	22.8	0.00694	8.75E-04	146,136	<b>5.98E-09</b>
2024	Construction	0.0098	DPM	19.5	0.00595	7.49E-04	146,136	<b>5.13E-09</b>
2025	Construction	0.0001	DPM	0.2	0.00006	7.67E-06	146,136	<b>5.25E-11</b>
<b>Total</b>		<b>0.0405</b>		<b>81.0</b>	<b>0.0247</b>	<b>0.0031</b>		

*Modeled Operation Hours*

hr/day = 9 (7am - 4pm)  
 days/yr = 365  
 hours/year = 3285

**PM2.5 Fugitive Dust Construction Emissions for Modeling - With Controls**

Construction Year	Activity	Area Source	PM2.5 Emissions (ton/year)	PM2.5 Emissions			Modeled Area (m <sup>2</sup> )	PM2.5 Emission Rate (g/s/m <sup>2</sup> )
				(lb/yr)	(lb/hr)	(g/s)		
2021	Construction	FUG	0.1305	261.0	0.07945	1.00E-02	146,136	<b>6.85E-08</b>
2022	Construction	FUG	0.0191	38.2	0.01163	1.47E-03	146,136	<b>1.00E-08</b>
2023	Construction	FUG	0.0191	38.2	0.01163	1.47E-03	146,136	<b>1.00E-08</b>
2024	Construction	FUG	0.0152	30.4	0.00925	1.17E-03	146,136	<b>7.98E-09</b>
2025	Construction	FUG	0.0005	1.1	0.00032	4.07E-05	146,136	<b>2.78E-10</b>
<b>Total</b>			<b>0.1844</b>	<b>368.9</b>	<b>0.1123</b>	<b>0.0141</b>		

*Modeled Operation Hours*

hr/day = 9 (7am - 4pm)  
 days/yr = 365  
 hours/year = 3285

Bella Vista Ukiah, CA

**Construction Health Impacts Summary**

**Maximum Impacts at Construction MEI Location - With Controls**

Emissions Year	Maximum Concentrations		Cancer Risk (per million)		Hazard Index (-)	Maximum Annual PM2.5 Concentration (µg/m <sup>3</sup> )
	Exhaust PM10/DPM (µg/m <sup>3</sup> )	Fugitive PM2.5 (µg/m <sup>3</sup> )	Child	Adult		
	2021	0.0031	0.0731	0.55	0.01	0.001
2022	0.0050	0.0107	0.83	0.01	0.001	0.02
2023	0.0048	0.0107	0.14	0.01	0.001	0.02
2024	0.0041	0.0085	0.12	0.01	0.001	0.01
2025	0.0000	0.0003	0.00	0.00	0.000	0.00
<b>Total</b>	-	-	<b>1.6</b>	<b>0.05</b>	-	-
<b>Maximum</b>	0.0050	0.0731	-	-	<b>0.001</b>	<b>0.08</b>

**Bella Vista Ukiah, CA - Controlled Emissions**  
**Maximum DPM Cancer Risk Calculations From Construction**  
**Impacts at Off-Site Receptors-1.5 meter receptor height**

Cancer Risk (per million) = CPF x Inhalation Dose x ASF x ED/AT x FAH x 1.0E6

Where: CPF = Cancer potency factor (mg/kg-day)<sup>-1</sup>  
 ASF = Age sensitivity factor for specified age group  
 ED = Exposure duration (years)  
 AT = Averaging time for lifetime cancer risk (years)  
 FAH = Fraction of time spent at home (unitless)

Inhalation Dose = C<sub>air</sub> x DBR x A x (EF/365) x 10<sup>-6</sup>

Where: C<sub>air</sub> = concentration in air (µg/m<sup>3</sup>)  
 DBR = daily breathing rate (L/kg body weight-day)  
 A = Inhalation absorption factor  
 EF = Exposure frequency (days/year)  
 10<sup>-6</sup> = Conversion factor

**Values**

Age --> Parameter	Infant/Child				Adult
	3rd Trimester	0 - 2	2 - 9	2 - 16	16 - 30
ASF =	10	10	3	3	1
CPF =	1.10E+00	1.10E+00	1.10E+00	1.10E+00	1.10E+00
DBR* =	361	1090	631	572	261
A =	1	1	1	1	1
EF =	350	350	350	350	350
AT =	70	70	70	70	70
FAH =	1.00	1.00	1.00	1.00	0.73

\* 95th percentile breathing rates for infants and 80th percentile for children and adults

**Construction Cancer Risk by Year - Maximum Impact Receptor Location**

Exposure Year	Exposure Duration (years)	Age	Infant/Child - Exposure Information			Infant/Child Cancer Risk (per million)	Adult - Exposure Information			Adult Cancer Risk (per million)	Fugitive PM2.5	Total PM2.5
			DPM Conc (ug/m3)		Age Sensitivity Factor		Modeled		Age Sensitivity Factor			
			Year	Annual			Year	Annual				
0	0.25	-0.25 - 0*	2021	0.0031	10	0.04	2021	-	-	-		
1	1	0 - 1	2021	0.0031	10	0.51	2021	0.0031	1	0.01	0.0731	0.076
2	1	1 - 2	2022	0.0050	10	0.83	2022	0.0050	1	0.01	0.0107	0.016
3	1	2 - 3	2023	0.0048	3	0.14	2023	0.0048	1	0.01	0.0107	0.015
4	1	3 - 4	2024	0.0041	3	0.12	2024	0.0041	1	0.01	0.0085	0.013
5	1	4 - 5	2025	0.00004	3	0.00	2025	0.00004	1	0.00	0.0003	0.000
6	1	5 - 6		0.0000	3	0.00		0.0000	1	0.00		
7	1	6 - 7		0.0000	3	0.00		0.0000	1	0.00		
8	1	7 - 8		0.0000	3	0.00		0.0000	1	0.00		
9	1	8 - 9		0.0000	3	0.00		0.0000	1	0.00		
10	1	9 - 10		0.0000	3	0.00		0.0000	1	0.00		
11	1	10 - 11		0.0000	3	0.00		0.0000	1	0.00		
12	1	11 - 12		0.0000	3	0.00		0.0000	1	0.00		
13	1	12 - 13		0.0000	3	0.00		0.0000	1	0.00		
14	1	13 - 14		0.0000	3	0.00		0.0000	1	0.00		
15	1	14 - 15		0.0000	3	0.00		0.0000	1	0.00		
16	1	15 - 16		0.0000	3	0.00		0.0000	1	0.00		
17	1	16-17		0.0000	1	0.00		0.0000	1	0.00		
18	1	17-18		0.0000	1	0.00		0.0000	1	0.00		
19	1	18-19		0.0000	1	0.00		0.0000	1	0.00		
20	1	19-20		0.0000	1	0.00		0.0000	1	0.00		
21	1	20-21		0.0000	1	0.00		0.0000	1	0.00		
22	1	21-22		0.0000	1	0.00		0.0000	1	0.00		
23	1	22-23		0.0000	1	0.00		0.0000	1	0.00		
24	1	23-24		0.0000	1	0.00		0.0000	1	0.00		
25	1	24-25		0.0000	1	0.00		0.0000	1	0.00		
26	1	25-26		0.0000	1	0.00		0.0000	1	0.00		
27	1	26-27		0.0000	1	0.00		0.0000	1	0.00		
28	1	27-28		0.0000	1	0.00		0.0000	1	0.00		
29	1	28-29		0.0000	1	0.00		0.0000	1	0.00		
30	1	29-30		0.0000	1	0.00		0.0000	1	0.00		
<b>Total Increased Cancer Risk</b>						<b>1.6</b>				<b>0.05</b>		

\* Third trimester of pregnancy



Bella Vista, Ukiah - construction HRA - Mendocino County AQMD Air District, Annual

**Bella Vista, Ukiah - construction HRA  
Mendocino County AQMD Air District, Annual**

Used for construction HRA with 1 mile worker and truck travel lengths

**1.0 Project Characteristics**

**1.1 Land Usage**

Land Uses	Size	Metric	Lot Acreage	Floor Surface Area	Population
City Park	2.77	Acre	0.00	120,661.20	0
Retirement Community	39.00	Dwelling Unit	0.00	43,200.00	112
Single Family Housing	132.00	Dwelling Unit	36.60	210,600.00	378

**1.2 Other Project Characteristics**

<b>Urbanization</b>	Urban	<b>Wind Speed (m/s)</b>	2.2	<b>Precipitation Freq (Days)</b>	86
<b>Climate Zone</b>	1			<b>Operational Year</b>	2026
<b>Utility Company</b>	Pacific Gas & Electric Company				
<b>CO2 Intensity (lb/MW hr)</b>	210	<b>CH4 Intensity (lb/MW hr)</b>	0.029	<b>N2O Intensity (lb/MW hr)</b>	0.006

**1.3 User Entered Comments & Non-Default Data**

Project Characteristics - PG&E 2017 CO2 Factor Rate

Land Use - Provided project description land uses. 36.6 acres to be disturbed. Square footage estimated 12/10/20 email

Construction Phase - Default Const schedule. Added trenching

Off-road Equipment -

Off-road Equipment -

Off-road Equipment - Equipment quantities provided

Off-road Equipment -

- Off-road Equipment -
- Off-road Equipment - Equipment quantities provided
- Off-road Equipment - Trenching added
- Off-road Equipment - added this equipment
- Trips and VMT - added asphalt trips assuming 10cy/load 2,780 cy. Cement part of vendor trips
- On-road Fugitive Dust - Assum mostly paved travel
- Demolition - provided information
- Grading - Default values
- Vehicle Trips - Trip gen from traffic 12/3/2020 email (W-Trans)
- Road Dust - Assumed paved travel
- Woodstoves - No fireplaces
- Energy Use - No natural gas
- Water And Wastewater - all WTP
- Energy Mitigation -
- Water Mitigation -
- Construction Off-road Equipment Mitigation - BMPs and Tier 4i

Table Name	Column Name	Default Value	New Value
tblConstDustMitigation	WaterUnpavedRoadMoistureContent	0	0.5
tblConstDustMitigation	WaterUnpavedRoadVehicleSpeed	0	15
tblConstEquipMitigation	NumberOfEquipmentMitigated	0.00	1.00
tblConstEquipMitigation	NumberOfEquipmentMitigated	0.00	1.00
tblConstEquipMitigation	NumberOfEquipmentMitigated	0.00	1.00
tblConstEquipMitigation	NumberOfEquipmentMitigated	0.00	6.00
tblConstEquipMitigation	NumberOfEquipmentMitigated	0.00	3.00
tblConstEquipMitigation	NumberOfEquipmentMitigated	0.00	1.00
tblConstEquipMitigation	NumberOfEquipmentMitigated	0.00	1.00
tblConstEquipMitigation	NumberOfEquipmentMitigated	0.00	2.00
tblConstEquipMitigation	NumberOfEquipmentMitigated	0.00	2.00
tblConstEquipMitigation	NumberOfEquipmentMitigated	0.00	2.00
tblConstEquipMitigation	NumberOfEquipmentMitigated	0.00	6.00

tblConstEquipMitigation	NumberOfEquipmentMitigated	0.00	2.00
tblConstEquipMitigation	NumberOfEquipmentMitigated	0.00	10.00
tblConstEquipMitigation	NumberOfEquipmentMitigated	0.00	1.00
tblConstEquipMitigation	Tier	No Change	Tier 4 Interim
tblConstEquipMitigation	Tier	No Change	Tier 4 Interim
tblConstEquipMitigation	Tier	No Change	Tier 4 Interim
tblConstEquipMitigation	Tier	No Change	Tier 4 Interim
tblConstEquipMitigation	Tier	No Change	Tier 4 Interim
tblConstEquipMitigation	Tier	No Change	Tier 4 Interim
tblConstEquipMitigation	Tier	No Change	Tier 4 Interim
tblConstEquipMitigation	Tier	No Change	Tier 4 Interim
tblConstEquipMitigation	Tier	No Change	Tier 4 Interim
tblConstEquipMitigation	Tier	No Change	Tier 4 Interim
tblConstEquipMitigation	Tier	No Change	Tier 4 Interim
tblConstEquipMitigation	Tier	No Change	Tier 4 Interim
tblConstEquipMitigation	Tier	No Change	Tier 4 Interim
tblEnergyUse	NT24NG	1,599.00	0.00
tblEnergyUse	NT24NG	1,599.00	0.00
tblEnergyUse	T24NG	9,200.58	0.00
tblEnergyUse	T24NG	10,517.50	0.00
tblFireplaces	FireplaceWoodMass	4,992.00	0.00
tblFireplaces	FireplaceWoodMass	4,992.00	0.00
tblFireplaces	NumberGas	1.95	0.00
tblFireplaces	NumberGas	39.60	0.00
tblFireplaces	NumberWood	1.95	0.00
tblFireplaces	NumberWood	46.20	0.00
tblFleetMix	HHD	0.07	0.03
tblFleetMix	HHD	0.07	0.03
tblFleetMix	HHD	0.07	0.03

tbIFleetMix	LDA	0.52	0.58
tbIFleetMix	LDA	0.52	0.58
tbIFleetMix	LDA	0.52	0.58
tbIFleetMix	LDT1	0.04	0.04
tbIFleetMix	LDT1	0.04	0.04
tbIFleetMix	LDT1	0.04	0.04
tbIFleetMix	LDT2	0.20	0.19
tbIFleetMix	LDT2	0.20	0.19
tbIFleetMix	LDT2	0.20	0.19
tbIFleetMix	LHD1	0.03	0.01
tbIFleetMix	LHD1	0.03	0.01
tbIFleetMix	LHD1	0.03	0.01
tbIFleetMix	LHD2	4.4860e-003	5.3010e-003
tbIFleetMix	LHD2	4.4860e-003	5.3010e-003
tbIFleetMix	LHD2	4.4860e-003	5.3010e-003
tbIFleetMix	MCY	4.6960e-003	5.7320e-003
tbIFleetMix	MCY	4.6960e-003	5.7320e-003
tbIFleetMix	MCY	4.6960e-003	5.7320e-003
tbIFleetMix	MDV	0.12	0.11
tbIFleetMix	MDV	0.12	0.11
tbIFleetMix	MDV	0.12	0.11
tbIFleetMix	MH	7.1700e-004	7.0800e-004
tbIFleetMix	MH	7.1700e-004	7.0800e-004
tbIFleetMix	MH	7.1700e-004	7.0800e-004
tbIFleetMix	MHD	0.02	0.02
tbIFleetMix	MHD	0.02	0.02
tbIFleetMix	MHD	0.02	0.02
tbIFleetMix	OBUS	1.7520e-003	2.6690e-003
tbIFleetMix	OBUS	1.7520e-003	2.6690e-003
tbIFleetMix	OBUS	1.7520e-003	2.6690e-003

tblFleetMix	SBUS	1.0590e-003	9.0600e-004
tblFleetMix	SBUS	1.0590e-003	9.0600e-004
tblFleetMix	SBUS	1.0590e-003	9.0600e-004
tblFleetMix	UBUS	1.1270e-003	2.0110e-003
tblFleetMix	UBUS	1.1270e-003	2.0110e-003
tblFleetMix	UBUS	1.1270e-003	2.0110e-003
tblLandUse	LandUseSquareFeet	39,000.00	43,200.00
tblLandUse	LandUseSquareFeet	237,600.00	210,600.00
tblLandUse	LotAcreage	2.77	0.00
tblLandUse	LotAcreage	7.80	0.00
tblLandUse	LotAcreage	42.86	36.60
tblOnRoadDust	HaulingPercentPave	55.00	99.00
tblOnRoadDust	HaulingPercentPave	55.00	99.00
tblOnRoadDust	HaulingPercentPave	55.00	99.00
tblOnRoadDust	HaulingPercentPave	55.00	99.00
tblOnRoadDust	HaulingPercentPave	55.00	99.00
tblOnRoadDust	HaulingPercentPave	55.00	99.00
tblOnRoadDust	HaulingPercentPave	55.00	99.00
tblOnRoadDust	VendorPercentPave	55.00	99.00
tblOnRoadDust	VendorPercentPave	55.00	99.00
tblOnRoadDust	VendorPercentPave	55.00	99.00
tblOnRoadDust	VendorPercentPave	55.00	99.00
tblOnRoadDust	VendorPercentPave	55.00	99.00
tblOnRoadDust	VendorPercentPave	55.00	99.00
tblOnRoadDust	VendorPercentPave	55.00	99.00
tblOnRoadDust	WorkerPercentPave	55.00	99.00
tblOnRoadDust	WorkerPercentPave	55.00	99.00
tblOnRoadDust	WorkerPercentPave	55.00	99.00
tblOnRoadDust	WorkerPercentPave	55.00	99.00
tblOnRoadDust	WorkerPercentPave	55.00	99.00

tblOnRoadDust	WorkerPercentPave	55.00	99.00
tblOnRoadDust	WorkerPercentPave	55.00	99.00
tblProjectCharacteristics	CO2IntensityFactor	641.35	210
tblRoadDust	RoadPercentPave	55	100
tblTripsAndVMT	HaulingTripLength	20.00	1.00
tblTripsAndVMT	HaulingTripLength	20.00	1.00
tblTripsAndVMT	HaulingTripLength	20.00	1.00
tblTripsAndVMT	HaulingTripLength	20.00	1.00
tblTripsAndVMT	HaulingTripLength	20.00	1.00
tblTripsAndVMT	HaulingTripLength	20.00	1.00
tblTripsAndVMT	HaulingTripLength	20.00	1.00
tblTripsAndVMT	VendorTripLength	7.30	1.00
tblTripsAndVMT	VendorTripLength	7.30	1.00
tblTripsAndVMT	VendorTripLength	7.30	1.00
tblTripsAndVMT	VendorTripLength	7.30	1.00
tblTripsAndVMT	VendorTripLength	7.30	1.00
tblTripsAndVMT	VendorTripLength	7.30	1.00
tblTripsAndVMT	VendorTripLength	7.30	1.00
tblTripsAndVMT	WorkerTripLength	10.80	1.00
tblTripsAndVMT	WorkerTripLength	10.80	1.00
tblTripsAndVMT	WorkerTripLength	10.80	1.00
tblTripsAndVMT	WorkerTripLength	10.80	1.00
tblTripsAndVMT	WorkerTripLength	10.80	1.00
tblTripsAndVMT	WorkerTripLength	10.80	1.00
tblTripsAndVMT	WorkerTripLength	10.80	1.00
tblVehicleTrips	ST_TR	22.75	0.00
tblVehicleTrips	ST_TR	2.03	4.00
tblVehicleTrips	SU_TR	16.74	0.00
tblVehicleTrips	SU_TR	1.95	4.00
tblVehicleTrips	WD_TR	1.89	0.00

tblVehicleTrips	WD_TR	2.40	4.27
tblVehicleTrips	WD_TR	9.52	9.44
tblWater	AerobicPercent	87.46	100.00
tblWater	AerobicPercent	87.46	100.00
tblWater	AerobicPercent	87.46	100.00
tblWater	AnaerobicandFacultativeLagoonsPerce nt	2.21	0.00
tblWater	AnaerobicandFacultativeLagoonsPerce nt	2.21	0.00
tblWater	AnaerobicandFacultativeLagoonsPerce nt	2.21	0.00
tblWater	SepticTankPercent	10.33	0.00
tblWater	SepticTankPercent	10.33	0.00
tblWater	SepticTankPercent	10.33	0.00
tblWoodstoves	WoodstoveWoodMass	4,896.00	0.00
tblWoodstoves	WoodstoveWoodMass	4,896.00	0.00

## 2.0 Emissions Summary

### 2.1 Overall Construction

#### Unmitigated Construction

	ROG	NOx	CO	SO2	Fugitive PM10	Exhaust PM10	PM10 Total	Fugitive PM2.5	Exhaust PM2.5	PM2.5 Total	Bio- CO2	NBio- CO2	Total CO2	CH4	N2O	CO2e
Year	tons/yr										MT/yr					
2021	0.3255	3.3797	2.2871	4.2800e-003	0.6343	0.1557	0.7900	0.2881	0.1438	0.4319	0.0000	375.6855	375.6855	0.1149	0.0000	378.5571
2022	0.2741	2.4137	2.4981	4.1600e-003	0.2565	0.1069	0.3634	0.0285	0.1006	0.1290	0.0000	362.5199	362.5199	0.0800	0.0000	364.5202
2023	0.2496	2.1914	2.4188	4.1200e-003	0.2562	0.0913	0.3475	0.0284	0.0859	0.1144	0.0000	358.4586	358.4586	0.0767	0.0000	360.3753
2024	0.7137	1.8549	2.2468	3.8000e-003	0.2030	0.0747	0.2777	0.0225	0.0700	0.0925	0.0000	331.4527	331.4527	0.0764	0.0000	333.3624
2025	3.4702	0.0280	0.0498	8.0000e-005	7.1800e-003	1.2400e-003	8.4300e-003	7.9000e-004	1.2400e-003	2.0300e-003	0.0000	6.5613	6.5613	3.7000e-004	0.0000	6.5706

Maximum	3.4702	3.3797	2.4981	4.2800e-003	0.6343	0.1557	0.7900	0.2881	0.1438	0.4319	0.0000	375.6855	375.6855	0.1149	0.0000	378.5571
---------	--------	--------	--------	-------------	--------	--------	--------	--------	--------	--------	--------	----------	----------	--------	--------	----------

**Mitigated Construction**

	ROG	NOx	CO	SO2	Fugitive PM10	Exhaust PM10	PM10 Total	Fugitive PM2.5	Exhaust PM2.5	PM2.5 Total	Bio- CO2	NBio- CO2	Total CO2	CH4	N2O	CO2e
Year	tons/yr										MT/yr					
2021	0.0774	1.4209	2.6313	4.2800e-003	0.2923	7.3500e-003	0.2997	0.1305	7.3500e-003	0.1379	0.0000	375.6851	375.6851	0.1149	0.0000	378.5566
2022	0.1205	1.8031	2.6983	4.1600e-003	0.1634	0.0119	0.1753	0.0191	0.0119	0.0310	0.0000	362.5195	362.5195	0.0800	0.0000	364.5198
2023	0.1145	1.7400	2.6307	4.1200e-003	0.1632	0.0114	0.1745	0.0191	0.0113	0.0305	0.0000	358.4583	358.4583	0.0767	0.0000	360.3749
2024	0.6015	1.6154	2.4910	3.8000e-003	0.1293	9.7700e-003	0.1391	0.0152	9.7600e-003	0.0249	0.0000	331.4524	331.4524	0.0764	0.0000	333.3621
2025	3.4674	0.0260	0.0503	8.0000e-005	4.5700e-003	1.0000e-004	4.6700e-003	5.3000e-004	1.0000e-004	6.3000e-004	0.0000	6.5613	6.5613	3.7000e-004	0.0000	6.5706
Maximum	3.4674	1.8031	2.6983	4.2800e-003	0.2923	0.0119	0.2997	0.1305	0.0119	0.1379	0.0000	375.6851	375.6851	0.1149	0.0000	378.5566

	ROG	NOx	CO	SO2	Fugitive PM10	Exhaust PM10	PM10 Total	Fugitive PM2.5	Exhaust PM2.5	PM2.5 Total	Bio- CO2	NBio-CO2	Total CO2	CH4	N2O	CO2e
Percent Reduction	12.95	33.06	-10.54	0.00	44.53	90.58	55.61	49.90	89.94	70.79	0.00	0.00	0.00	0.00	0.00	0.00

Quarter	Start Date	End Date	Maximum Unmitigated ROG + NOX (tons/quarter)	Maximum Mitigated ROG + NOX (tons/quarter)
1	5-1-2021	7-31-2021	1.2163	0.4570
2	8-1-2021	10-31-2021	1.6204	0.6158
3	11-1-2021	1-31-2022	1.1149	0.6065
4	2-1-2022	4-30-2022	0.6525	0.4657
5	5-1-2022	7-31-2022	0.6748	0.4818
6	8-1-2022	10-31-2022	0.6746	0.4816
7	11-1-2022	1-31-2023	0.6549	0.4769
8	2-1-2023	4-30-2023	0.5968	0.4534



9	5-1-2023	7-31-2023	0.6172	0.4690
10	8-1-2023	10-31-2023	0.6171	0.4688
11	11-1-2023	1-31-2024	0.6046	0.4679
12	2-1-2024	4-30-2024	0.5682	0.4567
13	5-1-2024	7-31-2024	0.5812	0.4672
14	8-1-2024	10-31-2024	0.5124	0.4305
15	11-1-2024	1-31-2025	2.3753	2.3695
16	2-1-2025	4-30-2025	1.8220	1.8195
		Highest	2.3753	2.3695

### 3.0 Construction Detail

#### Construction Phase

Phase Number	Phase Name	Phase Type	Start Date	End Date	Num Days Week	Num Days	Phase Description
1	Demolition	Demolition	5/1/2021	7/9/2021	5	50	
2	Site Preparation	Site Preparation	7/10/2021	8/20/2021	5	30	
3	Grading	Grading	8/21/2021	12/3/2021	5	75	
4	Trenching/Utilities	Trenching	12/4/2021	1/14/2022	5	30	Overlaps
5	Building Construction	Building Construction	12/4/2021	10/4/2024	5	740	
6	Paving	Paving	10/5/2024	12/20/2024	5	55	
7	Architectural Coating	Architectural Coating	12/21/2024	3/7/2025	5	55	

Acres of Grading (Site Preparation Phase): 0

Acres of Grading (Grading Phase): 187.5

Acres of Paving: 0

Residential Indoor: 513,945; Residential Outdoor: 171,315; Non-Residential Indoor: 0; Non-Residential Outdoor: 0; Striped Parking Area:

#### OffRoad Equipment

Phase Name	Offroad Equipment Type	Amount	Usage Hours	Horse Power	Load Factor
------------	------------------------	--------	-------------	-------------	-------------

Demolition		0		97	0.37
Demolition	Concrete/Industrial Saws	1	8.00	81	0.73
Demolition	Excavators	3	8.00	158	0.38
Demolition	Rubber Tired Dozers	2	8.00	247	0.40
Site Preparation		0		187	0.41
Site Preparation	Rubber Tired Dozers	3	8.00	247	0.40
Site Preparation	Tractors/Loaders/Backhoes	4	8.00	97	0.37
Grading	Excavators	2	8.00	158	0.38
Grading	Graders	1	8.00	187	0.41
Grading	Rubber Tired Dozers	1	8.00	247	0.40
Grading	Scrapers	2	8.00	367	0.48
Grading	Tractors/Loaders/Backhoes	2	8.00	97	0.37
Trenching/Utilities	Excavators	1	8.00	158	0.38
Trenching/Utilities	Tractors/Loaders/Backhoes	1	8.00	97	0.37
Building Construction	Cranes	1	7.00	231	0.29
Building Construction	Forklifts	3	8.00	89	0.20
Building Construction	Generator Sets	1	8.00	84	0.74
Building Construction	Tractors/Loaders/Backhoes	3	7.00	97	0.37
Building Construction	Welders	1	8.00	46	0.45
Paving	Pavers	2	8.00	130	0.42
Paving	Paving Equipment	2	8.00	132	0.36
Paving	Rollers	2	8.00	80	0.38
Architectural Coating	Air Compressors	1	6.00	78	0.48

**Trips and VMT**

Phase Name	Offroad Equipment Count	Worker Trip Number	Vendor Trip Number	Hauling Trip Number	Worker Trip Length	Vendor Trip Length	Hauling Trip Length	Worker Vehicle Class	Vendor Vehicle Class	Hauling Vehicle Class
Demolition	6	15.00	0.00	9.00	1.00	1.00	1.00	LD_Mix	HDT_Mix	HHDT
Site Preparation	7	18.00	0.00	0.00	1.00	1.00	1.00	LD_Mix	HDT_Mix	HHDT
Grading	8	20.00	0.00	0.00	1.00	1.00	1.00	LD_Mix	HDT_Mix	HHDT

Trenching/Utilities	2	5.00	0.00	0.00	1.00	1.00	1.00	LD_Mix	HDT_Mix	HHDT
Building Construction	9	126.00	38.00	0.00	1.00	1.00	1.00	LD_Mix	HDT_Mix	HHDT
Paving	6	15.00	0.00	0.00	1.00	1.00	1.00	LD_Mix	HDT_Mix	HHDT
Architectural Coating	1	25.00	0.00	0.00	1.00	1.00	1.00	LD_Mix	HDT_Mix	HHDT

**3.1 Mitigation Measures Construction**

- Use Cleaner Engines for Construction Equipment
- Water Exposed Area
- Reduce Vehicle Speed on Unpaved Roads

**3.2 Demolition - 2021**

**Unmitigated Construction On-Site**

	ROG	NOx	CO	SO2	Fugitive PM10	Exhaust PM10	PM10 Total	Fugitive PM2.5	Exhaust PM2.5	PM2.5 Total	Bio- CO2	NBio- CO2	Total CO2	CH4	N2O	CO2e
Category	tons/yr										MT/yr					
Fugitive Dust					9.8000e-004	0.0000	9.8000e-004	1.5000e-004	0.0000	1.5000e-004	0.0000	0.0000	0.0000	0.0000	0.0000	0.0000
Off-Road	0.0791	0.7860	0.5391	9.7000e-004		0.0388	0.0388		0.0360	0.0360	0.0000	85.0020	85.0020	0.0239	0.0000	85.6001
<b>Total</b>	<b>0.0791</b>	<b>0.7860</b>	<b>0.5391</b>	<b>9.7000e-004</b>	<b>9.8000e-004</b>	<b>0.0388</b>	<b>0.0398</b>	<b>1.5000e-004</b>	<b>0.0360</b>	<b>0.0362</b>	<b>0.0000</b>	<b>85.0020</b>	<b>85.0020</b>	<b>0.0239</b>	<b>0.0000</b>	<b>85.6001</b>

**Unmitigated Construction Off-Site**

	ROG	NOx	CO	SO2	Fugitive PM10	Exhaust PM10	PM10 Total	Fugitive PM2.5	Exhaust PM2.5	PM2.5 Total	Bio- CO2	NBio- CO2	Total CO2	CH4	N2O	CO2e
Category	tons/yr										MT/yr					
Hauling	1.0000e-005	4.9000e-004	8.0000e-005	0.0000	5.0000e-005	0.0000	6.0000e-005	1.0000e-005	0.0000	1.0000e-005	0.0000	0.0676	0.0676	1.0000e-005	0.0000	0.0679

Vendor	0.0000	0.0000	0.0000	0.0000	0.0000	0.0000	0.0000	0.0000	0.0000	0.0000	0.0000	0.0000	0.0000	0.0000	0.0000	0.0000
Worker	9.3000e-004	5.0000e-004	5.8300e-003	0.0000	4.4900e-003	1.0000e-005	4.5000e-003	4.9000e-004	1.0000e-005	5.0000e-004	0.0000	0.3088	0.3088	3.0000e-005	0.0000	0.3097
<b>Total</b>	<b>9.4000e-004</b>	<b>9.9000e-004</b>	<b>5.9100e-003</b>	<b>0.0000</b>	<b>4.5400e-003</b>	<b>1.0000e-005</b>	<b>4.5600e-003</b>	<b>5.0000e-004</b>	<b>1.0000e-005</b>	<b>5.1000e-004</b>	<b>0.0000</b>	<b>0.3764</b>	<b>0.3764</b>	<b>4.0000e-005</b>	<b>0.0000</b>	<b>0.3775</b>

**Mitigated Construction On-Site**

	ROG	NOx	CO	SO2	Fugitive PM10	Exhaust PM10	PM10 Total	Fugitive PM2.5	Exhaust PM2.5	PM2.5 Total	Bio- CO2	NBio- CO2	Total CO2	CH4	N2O	CO2e
Category	tons/yr										MT/yr					
Fugitive Dust					4.4000e-004	0.0000	4.4000e-004	7.0000e-005	0.0000	7.0000e-005	0.0000	0.0000	0.0000	0.0000	0.0000	0.0000
Off-Road	0.0146	0.3389	0.6169	9.7000e-004		1.5400e-003	1.5400e-003		1.5400e-003	1.5400e-003	0.0000	85.0019	85.0019	0.0239	0.0000	85.6000
<b>Total</b>	<b>0.0146</b>	<b>0.3389</b>	<b>0.6169</b>	<b>9.7000e-004</b>	<b>4.4000e-004</b>	<b>1.5400e-003</b>	<b>1.9800e-003</b>	<b>7.0000e-005</b>	<b>1.5400e-003</b>	<b>1.6100e-003</b>	<b>0.0000</b>	<b>85.0019</b>	<b>85.0019</b>	<b>0.0239</b>	<b>0.0000</b>	<b>85.6000</b>

**Mitigated Construction Off-Site**

	ROG	NOx	CO	SO2	Fugitive PM10	Exhaust PM10	PM10 Total	Fugitive PM2.5	Exhaust PM2.5	PM2.5 Total	Bio- CO2	NBio- CO2	Total CO2	CH4	N2O	CO2e
Category	tons/yr										MT/yr					
Hauling	1.0000e-005	4.9000e-004	8.0000e-005	0.0000	3.0000e-005	0.0000	4.0000e-005	0.0000	0.0000	0.0000	0.0000	0.0676	0.0676	1.0000e-005	0.0000	0.0679
Vendor	0.0000	0.0000	0.0000	0.0000	0.0000	0.0000	0.0000	0.0000	0.0000	0.0000	0.0000	0.0000	0.0000	0.0000	0.0000	0.0000
Worker	9.3000e-004	5.0000e-004	5.8300e-003	0.0000	2.8500e-003	1.0000e-005	2.8600e-003	3.3000e-004	1.0000e-005	3.4000e-004	0.0000	0.3088	0.3088	3.0000e-005	0.0000	0.3097
<b>Total</b>	<b>9.4000e-004</b>	<b>9.9000e-004</b>	<b>5.9100e-003</b>	<b>0.0000</b>	<b>2.8800e-003</b>	<b>1.0000e-005</b>	<b>2.9000e-003</b>	<b>3.3000e-004</b>	<b>1.0000e-005</b>	<b>3.4000e-004</b>	<b>0.0000</b>	<b>0.3764</b>	<b>0.3764</b>	<b>4.0000e-005</b>	<b>0.0000</b>	<b>0.3775</b>

**3.3 Site Preparation - 2021**

**Unmitigated Construction On-Site**

	ROG	NOx	CO	SO2	Fugitive PM10	Exhaust PM10	PM10 Total	Fugitive PM2.5	Exhaust PM2.5	PM2.5 Total	Bio- CO2	NBio- CO2	Total CO2	CH4	N2O	CO2e
Category	tons/yr										MT/yr					
Fugitive Dust					0.2710	0.0000	0.2710	0.1490	0.0000	0.1490	0.0000	0.0000	0.0000	0.0000	0.0000	0.0000
Off-Road	0.0583	0.6075	0.3173	5.7000e-004		0.0307	0.0307		0.0282	0.0282	0.0000	50.1536	50.1536	0.0162	0.0000	50.5591
<b>Total</b>	<b>0.0583</b>	<b>0.6075</b>	<b>0.3173</b>	<b>5.7000e-004</b>	<b>0.2710</b>	<b>0.0307</b>	<b>0.3017</b>	<b>0.1490</b>	<b>0.0282</b>	<b>0.1772</b>	<b>0.0000</b>	<b>50.1536</b>	<b>50.1536</b>	<b>0.0162</b>	<b>0.0000</b>	<b>50.5591</b>

**Unmitigated Construction Off-Site**

	ROG	NOx	CO	SO2	Fugitive PM10	Exhaust PM10	PM10 Total	Fugitive PM2.5	Exhaust PM2.5	PM2.5 Total	Bio- CO2	NBio- CO2	Total CO2	CH4	N2O	CO2e
Category	tons/yr										MT/yr					
Hauling	0.0000	0.0000	0.0000	0.0000	0.0000	0.0000	0.0000	0.0000	0.0000	0.0000	0.0000	0.0000	0.0000	0.0000	0.0000	0.0000
Vendor	0.0000	0.0000	0.0000	0.0000	0.0000	0.0000	0.0000	0.0000	0.0000	0.0000	0.0000	0.0000	0.0000	0.0000	0.0000	0.0000
Worker	6.7000e-004	3.6000e-004	4.1900e-003	0.0000	3.2300e-003	0.0000	3.2400e-003	3.6000e-004	0.0000	3.6000e-004	0.0000	0.2223	0.2223	3.0000e-005	0.0000	0.2230
<b>Total</b>	<b>6.7000e-004</b>	<b>3.6000e-004</b>	<b>4.1900e-003</b>	<b>0.0000</b>	<b>3.2300e-003</b>	<b>0.0000</b>	<b>3.2400e-003</b>	<b>3.6000e-004</b>	<b>0.0000</b>	<b>3.6000e-004</b>	<b>0.0000</b>	<b>0.2223</b>	<b>0.2223</b>	<b>3.0000e-005</b>	<b>0.0000</b>	<b>0.2230</b>

**Mitigated Construction On-Site**

	ROG	NOx	CO	SO2	Fugitive PM10	Exhaust PM10	PM10 Total	Fugitive PM2.5	Exhaust PM2.5	PM2.5 Total	Bio- CO2	NBio- CO2	Total CO2	CH4	N2O	CO2e
--	-----	-----	----	-----	---------------	--------------	------------	----------------	---------------	-------------	----------	-----------	-----------	-----	-----	------

Category	tons/yr										MT/yr					
	Fugitive Dust					0.1220	0.0000	0.1220	0.0670	0.0000	0.0670	0.0000	0.0000	0.0000	0.0000	0.0000
Off-Road	0.0105	0.1824	0.3444	5.7000e-004		9.3000e-004	9.3000e-004		9.3000e-004	9.3000e-004	0.0000	50.1535	50.1535	0.0162	0.0000	50.5590
<b>Total</b>	<b>0.0105</b>	<b>0.1824</b>	<b>0.3444</b>	<b>5.7000e-004</b>	<b>0.1220</b>	<b>9.3000e-004</b>	<b>0.1229</b>	<b>0.0670</b>	<b>9.3000e-004</b>	<b>0.0680</b>	<b>0.0000</b>	<b>50.1535</b>	<b>50.1535</b>	<b>0.0162</b>	<b>0.0000</b>	<b>50.5590</b>

**Mitigated Construction Off-Site**

Category	ROG	NOx	CO	SO2	Fugitive PM10	Exhaust PM10	PM10 Total	Fugitive PM2.5	Exhaust PM2.5	PM2.5 Total	MT/yr					
	Hauling	0.0000	0.0000	0.0000	0.0000	0.0000	0.0000	0.0000	0.0000	0.0000	0.0000	0.0000	0.0000	0.0000	0.0000	0.0000
Vendor	0.0000	0.0000	0.0000	0.0000	0.0000	0.0000	0.0000	0.0000	0.0000	0.0000	0.0000	0.0000	0.0000	0.0000	0.0000	0.0000
Worker	6.7000e-004	3.6000e-004	4.1900e-003	0.0000	2.0600e-003	0.0000	2.0600e-003	2.4000e-004	0.0000	2.4000e-004	0.0000	0.2223	0.2223	3.0000e-005	0.0000	0.2230
<b>Total</b>	<b>6.7000e-004</b>	<b>3.6000e-004</b>	<b>4.1900e-003</b>	<b>0.0000</b>	<b>2.0600e-003</b>	<b>0.0000</b>	<b>2.0600e-003</b>	<b>2.4000e-004</b>	<b>0.0000</b>	<b>2.4000e-004</b>	<b>0.0000</b>	<b>0.2223</b>	<b>0.2223</b>	<b>3.0000e-005</b>	<b>0.0000</b>	<b>0.2230</b>

**3.4 Grading - 2021**

**Unmitigated Construction On-Site**

Category	ROG	NOx	CO	SO2	Fugitive PM10	Exhaust PM10	PM10 Total	Fugitive PM2.5	Exhaust PM2.5	PM2.5 Total	MT/yr					
	Fugitive Dust					0.3253	0.0000	0.3253	0.1349	0.0000	0.1349	0.0000	0.0000	0.0000	0.0000	0.0000
Off-Road	0.1572	1.7400	1.1579	2.3300e-003		0.0745	0.0745		0.0685	0.0685	0.0000	204.3562	204.3562	0.0661	0.0000	206.0085

<b>Total</b>	<b>0.1572</b>	<b>1.7400</b>	<b>1.1579</b>	<b>2.3300e-003</b>	<b>0.3253</b>	<b>0.0745</b>	<b>0.3997</b>	<b>0.1349</b>	<b>0.0685</b>	<b>0.2034</b>	<b>0.0000</b>	<b>204.3562</b>	<b>204.3562</b>	<b>0.0661</b>	<b>0.0000</b>	<b>206.0085</b>
--------------	---------------	---------------	---------------	--------------------	---------------	---------------	---------------	---------------	---------------	---------------	---------------	-----------------	-----------------	---------------	---------------	-----------------

**Unmitigated Construction Off-Site**

	ROG	NOx	CO	SO2	Fugitive PM10	Exhaust PM10	PM10 Total	Fugitive PM2.5	Exhaust PM2.5	PM2.5 Total	Bio- CO2	NBio- CO2	Total CO2	CH4	N2O	CO2e
Category	tons/yr										MT/yr					
Hauling	0.0000	0.0000	0.0000	0.0000	0.0000	0.0000	0.0000	0.0000	0.0000	0.0000	0.0000	0.0000	0.0000	0.0000	0.0000	0.0000
Vendor	0.0000	0.0000	0.0000	0.0000	0.0000	0.0000	0.0000	0.0000	0.0000	0.0000	0.0000	0.0000	0.0000	0.0000	0.0000	0.0000
Worker	1.8500e-003	9.9000e-004	0.0117	1.0000e-005	8.9800e-003	1.0000e-005	8.9900e-003	9.9000e-004	1.0000e-005	1.0000e-003	0.0000	0.6176	0.6176	7.0000e-005	0.0000	0.6193
<b>Total</b>	<b>1.8500e-003</b>	<b>9.9000e-004</b>	<b>0.0117</b>	<b>1.0000e-005</b>	<b>8.9800e-003</b>	<b>1.0000e-005</b>	<b>8.9900e-003</b>	<b>9.9000e-004</b>	<b>1.0000e-005</b>	<b>1.0000e-003</b>	<b>0.0000</b>	<b>0.6176</b>	<b>0.6176</b>	<b>7.0000e-005</b>	<b>0.0000</b>	<b>0.6193</b>

**Mitigated Construction On-Site**

	ROG	NOx	CO	SO2	Fugitive PM10	Exhaust PM10	PM10 Total	Fugitive PM2.5	Exhaust PM2.5	PM2.5 Total	Bio- CO2	NBio- CO2	Total CO2	CH4	N2O	CO2e
Category	tons/yr										MT/yr					
Fugitive Dust					0.1464	0.0000	0.1464	0.0607	0.0000	0.0607	0.0000	0.0000	0.0000	0.0000	0.0000	0.0000
Off-Road	0.0379	0.7227	1.3771	2.3300e-003		3.8100e-003	3.8100e-003		3.8100e-003	3.8100e-003	0.0000	204.3559	204.3559	0.0661	0.0000	206.0083
<b>Total</b>	<b>0.0379</b>	<b>0.7227</b>	<b>1.3771</b>	<b>2.3300e-003</b>	<b>0.1464</b>	<b>3.8100e-003</b>	<b>0.1502</b>	<b>0.0607</b>	<b>3.8100e-003</b>	<b>0.0645</b>	<b>0.0000</b>	<b>204.3559</b>	<b>204.3559</b>	<b>0.0661</b>	<b>0.0000</b>	<b>206.0083</b>

**Mitigated Construction Off-Site**

	ROG	NOx	CO	SO2	Fugitive PM10	Exhaust PM10	PM10 Total	Fugitive PM2.5	Exhaust PM2.5	PM2.5 Total	Bio- CO2	NBio- CO2	Total CO2	CH4	N2O	CO2e
Category	tons/yr										MT/yr					
Hauling	0.0000	0.0000	0.0000	0.0000	0.0000	0.0000	0.0000	0.0000	0.0000	0.0000	0.0000	0.0000	0.0000	0.0000	0.0000	0.0000
Vendor	0.0000	0.0000	0.0000	0.0000	0.0000	0.0000	0.0000	0.0000	0.0000	0.0000	0.0000	0.0000	0.0000	0.0000	0.0000	0.0000
Worker	1.8500e-003	9.9000e-004	0.0117	1.0000e-005	5.7100e-003	1.0000e-005	5.7200e-003	6.6000e-004	1.0000e-005	6.7000e-004	0.0000	0.6176	0.6176	7.0000e-005	0.0000	0.6193
<b>Total</b>	<b>1.8500e-003</b>	<b>9.9000e-004</b>	<b>0.0117</b>	<b>1.0000e-005</b>	<b>5.7100e-003</b>	<b>1.0000e-005</b>	<b>5.7200e-003</b>	<b>6.6000e-004</b>	<b>1.0000e-005</b>	<b>6.7000e-004</b>	<b>0.0000</b>	<b>0.6176</b>	<b>0.6176</b>	<b>7.0000e-005</b>	<b>0.0000</b>	<b>0.6193</b>

**3.5 Trenching/Utilities - 2021**  
**Unmitigated Construction On-Site**

	ROG	NOx	CO	SO2	Fugitive PM10	Exhaust PM10	PM10 Total	Fugitive PM2.5	Exhaust PM2.5	PM2.5 Total	Bio- CO2	NBio- CO2	Total CO2	CH4	N2O	CO2e
Category	tons/yr										MT/yr					
Off-Road	4.1600e-003	0.0405	0.0553	8.0000e-005		2.1600e-003	2.1600e-003		1.9900e-003	1.9900e-003	0.0000	7.2674	7.2674	2.3500e-003	0.0000	7.3262
<b>Total</b>	<b>4.1600e-003</b>	<b>0.0405</b>	<b>0.0553</b>	<b>8.0000e-005</b>		<b>2.1600e-003</b>	<b>2.1600e-003</b>		<b>1.9900e-003</b>	<b>1.9900e-003</b>	<b>0.0000</b>	<b>7.2674</b>	<b>7.2674</b>	<b>2.3500e-003</b>	<b>0.0000</b>	<b>7.3262</b>

**Unmitigated Construction Off-Site**

	ROG	NOx	CO	SO2	Fugitive PM10	Exhaust PM10	PM10 Total	Fugitive PM2.5	Exhaust PM2.5	PM2.5 Total	Bio- CO2	NBio- CO2	Total CO2	CH4	N2O	CO2e
Category	tons/yr										MT/yr					



Hauling	0.0000	0.0000	0.0000	0.0000	0.0000	0.0000	0.0000	0.0000	0.0000	0.0000	0.0000	0.0000	0.0000	0.0000	0.0000	0.0000
Vendor	0.0000	0.0000	0.0000	0.0000	0.0000	0.0000	0.0000	0.0000	0.0000	0.0000	0.0000	0.0000	0.0000	0.0000	0.0000	0.0000
Worker	1.2000e-004	7.0000e-005	7.8000e-004	0.0000	6.0000e-004	0.0000	6.0000e-004	7.0000e-005	0.0000	7.0000e-005	0.0000	0.0412	0.0412	0.0000	0.0000	0.0413
<b>Total</b>	<b>1.2000e-004</b>	<b>7.0000e-005</b>	<b>7.8000e-004</b>	<b>0.0000</b>	<b>6.0000e-004</b>	<b>0.0000</b>	<b>6.0000e-004</b>	<b>7.0000e-005</b>	<b>0.0000</b>	<b>7.0000e-005</b>	<b>0.0000</b>	<b>0.0412</b>	<b>0.0412</b>	<b>0.0000</b>	<b>0.0000</b>	<b>0.0413</b>

**Mitigated Construction On-Site**

	ROG	NOx	CO	SO2	Fugitive PM10	Exhaust PM10	PM10 Total	Fugitive PM2.5	Exhaust PM2.5	PM2.5 Total	Bio- CO2	NBio- CO2	Total CO2	CH4	N2O	CO2e
Category	tons/yr										MT/yr					
Off-Road	1.3300e-003	0.0363	0.0626	8.0000e-005		1.4000e-004	1.4000e-004		1.4000e-004	1.4000e-004	0.0000	7.2674	7.2674	2.3500e-003	0.0000	7.3261
<b>Total</b>	<b>1.3300e-003</b>	<b>0.0363</b>	<b>0.0626</b>	<b>8.0000e-005</b>		<b>1.4000e-004</b>	<b>1.4000e-004</b>		<b>1.4000e-004</b>	<b>1.4000e-004</b>	<b>0.0000</b>	<b>7.2674</b>	<b>7.2674</b>	<b>2.3500e-003</b>	<b>0.0000</b>	<b>7.3261</b>

**Mitigated Construction Off-Site**

	ROG	NOx	CO	SO2	Fugitive PM10	Exhaust PM10	PM10 Total	Fugitive PM2.5	Exhaust PM2.5	PM2.5 Total	Bio- CO2	NBio- CO2	Total CO2	CH4	N2O	CO2e
Category	tons/yr										MT/yr					
Hauling	0.0000	0.0000	0.0000	0.0000	0.0000	0.0000	0.0000	0.0000	0.0000	0.0000	0.0000	0.0000	0.0000	0.0000	0.0000	0.0000
Vendor	0.0000	0.0000	0.0000	0.0000	0.0000	0.0000	0.0000	0.0000	0.0000	0.0000	0.0000	0.0000	0.0000	0.0000	0.0000	0.0000
Worker	1.2000e-004	7.0000e-005	7.8000e-004	0.0000	3.8000e-004	0.0000	3.8000e-004	4.0000e-005	0.0000	4.0000e-005	0.0000	0.0412	0.0412	0.0000	0.0000	0.0413
<b>Total</b>	<b>1.2000e-004</b>	<b>7.0000e-005</b>	<b>7.8000e-004</b>	<b>0.0000</b>	<b>3.8000e-004</b>	<b>0.0000</b>	<b>3.8000e-004</b>	<b>4.0000e-005</b>	<b>0.0000</b>	<b>4.0000e-005</b>	<b>0.0000</b>	<b>0.0412</b>	<b>0.0412</b>	<b>0.0000</b>	<b>0.0000</b>	<b>0.0413</b>

**3.5 Trenching/Utilities - 2022**  
**Unmitigated Construction On-Site**

	ROG	NOx	CO	SO2	Fugitive PM10	Exhaust PM10	PM10 Total	Fugitive PM2.5	Exhaust PM2.5	PM2.5 Total	Bio- CO2	NBio- CO2	Total CO2	CH4	N2O	CO2e
Category	tons/yr										MT/yr					
Off-Road	1.8400e-003	0.0173	0.0275	4.0000e-005		8.8000e-004	8.8000e-004		8.1000e-004	8.1000e-004	0.0000	3.6344	3.6344	1.1800e-003	0.0000	3.6638
<b>Total</b>	<b>1.8400e-003</b>	<b>0.0173</b>	<b>0.0275</b>	<b>4.0000e-005</b>		<b>8.8000e-004</b>	<b>8.8000e-004</b>		<b>8.1000e-004</b>	<b>8.1000e-004</b>	<b>0.0000</b>	<b>3.6344</b>	<b>3.6344</b>	<b>1.1800e-003</b>	<b>0.0000</b>	<b>3.6638</b>

**Unmitigated Construction Off-Site**

	ROG	NOx	CO	SO2	Fugitive PM10	Exhaust PM10	PM10 Total	Fugitive PM2.5	Exhaust PM2.5	PM2.5 Total	Bio- CO2	NBio- CO2	Total CO2	CH4	N2O	CO2e
Category	tons/yr										MT/yr					
Hauling	0.0000	0.0000	0.0000	0.0000	0.0000	0.0000	0.0000	0.0000	0.0000	0.0000	0.0000	0.0000	0.0000	0.0000	0.0000	0.0000
Vendor	0.0000	0.0000	0.0000	0.0000	0.0000	0.0000	0.0000	0.0000	0.0000	0.0000	0.0000	0.0000	0.0000	0.0000	0.0000	0.0000
Worker	6.0000e-005	3.0000e-005	3.5000e-004	0.0000	3.0000e-004	0.0000	3.0000e-004	3.0000e-005	0.0000	3.0000e-005	0.0000	0.0200	0.0200	0.0000	0.0000	0.0200
<b>Total</b>	<b>6.0000e-005</b>	<b>3.0000e-005</b>	<b>3.5000e-004</b>	<b>0.0000</b>	<b>3.0000e-004</b>	<b>0.0000</b>	<b>3.0000e-004</b>	<b>3.0000e-005</b>	<b>0.0000</b>	<b>3.0000e-005</b>	<b>0.0000</b>	<b>0.0200</b>	<b>0.0200</b>	<b>0.0000</b>	<b>0.0000</b>	<b>0.0200</b>

**Mitigated Construction On-Site**

	ROG	NOx	CO	SO2	Fugitive PM10	Exhaust PM10	PM10 Total	Fugitive PM2.5	Exhaust PM2.5	PM2.5 Total	Bio- CO2	NBio- CO2	Total CO2	CH4	N2O	CO2e
Category	tons/yr										MT/yr					
Off-Road	6.7000e-004	0.0182	0.0313	4.0000e-005		7.0000e-005	7.0000e-005		7.0000e-005	7.0000e-005	0.0000	3.6344	3.6344	1.1800e-003	0.0000	3.6638
<b>Total</b>	<b>6.7000e-004</b>	<b>0.0182</b>	<b>0.0313</b>	<b>4.0000e-005</b>		<b>7.0000e-005</b>	<b>7.0000e-005</b>		<b>7.0000e-005</b>	<b>7.0000e-005</b>	<b>0.0000</b>	<b>3.6344</b>	<b>3.6344</b>	<b>1.1800e-003</b>	<b>0.0000</b>	<b>3.6638</b>

**Mitigated Construction Off-Site**

	ROG	NOx	CO	SO2	Fugitive PM10	Exhaust PM10	PM10 Total	Fugitive PM2.5	Exhaust PM2.5	PM2.5 Total	Bio- CO2	NBio- CO2	Total CO2	CH4	N2O	CO2e
Category	tons/yr										MT/yr					
Hauling	0.0000	0.0000	0.0000	0.0000	0.0000	0.0000	0.0000	0.0000	0.0000	0.0000	0.0000	0.0000	0.0000	0.0000	0.0000	0.0000
Vendor	0.0000	0.0000	0.0000	0.0000	0.0000	0.0000	0.0000	0.0000	0.0000	0.0000	0.0000	0.0000	0.0000	0.0000	0.0000	0.0000
Worker	6.0000e-005	3.0000e-005	3.5000e-004	0.0000	1.9000e-004	0.0000	1.9000e-004	2.0000e-005	0.0000	2.0000e-005	0.0000	0.0200	0.0200	0.0000	0.0000	0.0200
<b>Total</b>	<b>6.0000e-005</b>	<b>3.0000e-005</b>	<b>3.5000e-004</b>	<b>0.0000</b>	<b>1.9000e-004</b>	<b>0.0000</b>	<b>1.9000e-004</b>	<b>2.0000e-005</b>	<b>0.0000</b>	<b>2.0000e-005</b>	<b>0.0000</b>	<b>0.0200</b>	<b>0.0200</b>	<b>0.0000</b>	<b>0.0000</b>	<b>0.0200</b>

**3.6 Building Construction - 2021**

**Unmitigated Construction On-Site**

	ROG	NOx	CO	SO2	Fugitive PM10	Exhaust PM10	PM10 Total	Fugitive PM2.5	Exhaust PM2.5	PM2.5 Total	Bio- CO2	NBio- CO2	Total CO2	CH4	N2O	CO2e
Category	tons/yr										MT/yr					
Off-Road	0.0190	0.1743	0.1658	2.7000e-004		9.5900e-003	9.5900e-003		9.0100e-003	9.0100e-003	0.0000	23.1637	23.1637	5.5900e-003	0.0000	23.3034

Total	0.0190	0.1743	0.1658	2.7000e-004		9.5900e-003	9.5900e-003		9.0100e-003	9.0100e-003	0.0000	23.1637	23.1637	5.5900e-003	0.0000	23.3034
-------	--------	--------	--------	-------------	--	-------------	-------------	--	-------------	-------------	--------	---------	---------	-------------	--------	---------

**Unmitigated Construction Off-Site**

	ROG	NOx	CO	SO2	Fugitive PM10	Exhaust PM10	PM10 Total	Fugitive PM2.5	Exhaust PM2.5	PM2.5 Total	Bio- CO2	NBio- CO2	Total CO2	CH4	N2O	CO2e
Category	tons/yr										MT/yr					
Hauling	0.0000	0.0000	0.0000	0.0000	0.0000	0.0000	0.0000	0.0000	0.0000	0.0000	0.0000	0.0000	0.0000	0.0000	0.0000	0.0000
Vendor	1.0500e-003	0.0274	9.5400e-003	4.0000e-005	4.6200e-003	5.0000e-005	4.6700e-003	5.3000e-004	5.0000e-005	5.8000e-004	0.0000	3.4477	3.4477	4.2000e-004	0.0000	3.4583
Worker	3.1100e-003	1.6700e-003	0.0196	1.0000e-005	0.0151	2.0000e-005	0.0151	1.6600e-003	2.0000e-005	1.6800e-003	0.0000	1.0375	1.0375	1.2000e-004	0.0000	1.0404
<b>Total</b>	<b>4.1600e-003</b>	<b>0.0291</b>	<b>0.0291</b>	<b>5.0000e-005</b>	<b>0.0197</b>	<b>7.0000e-005</b>	<b>0.0198</b>	<b>2.1900e-003</b>	<b>7.0000e-005</b>	<b>2.2600e-003</b>	<b>0.0000</b>	<b>4.4852</b>	<b>4.4852</b>	<b>5.4000e-004</b>	<b>0.0000</b>	<b>4.4988</b>

**Mitigated Construction On-Site**

	ROG	NOx	CO	SO2	Fugitive PM10	Exhaust PM10	PM10 Total	Fugitive PM2.5	Exhaust PM2.5	PM2.5 Total	Bio- CO2	NBio- CO2	Total CO2	CH4	N2O	CO2e
Category	tons/yr										MT/yr					
Off-Road	5.3300e-003	0.1091	0.1787	2.7000e-004		8.5000e-004	8.5000e-004		8.5000e-004	8.5000e-004	0.0000	23.1637	23.1637	5.5900e-003	0.0000	23.3034
<b>Total</b>	<b>5.3300e-003</b>	<b>0.1091</b>	<b>0.1787</b>	<b>2.7000e-004</b>		<b>8.5000e-004</b>	<b>8.5000e-004</b>		<b>8.5000e-004</b>	<b>8.5000e-004</b>	<b>0.0000</b>	<b>23.1637</b>	<b>23.1637</b>	<b>5.5900e-003</b>	<b>0.0000</b>	<b>23.3034</b>

**Mitigated Construction Off-Site**

	ROG	NOx	CO	SO2	Fugitive PM10	Exhaust PM10	PM10 Total	Fugitive PM2.5	Exhaust PM2.5	PM2.5 Total	Bio- CO2	NBio- CO2	Total CO2	CH4	N2O	CO2e
Category	tons/yr										MT/yr					
Hauling	0.0000	0.0000	0.0000	0.0000	0.0000	0.0000	0.0000	0.0000	0.0000	0.0000	0.0000	0.0000	0.0000	0.0000	0.0000	0.0000
Vendor	1.0500e-003	0.0274	9.5400e-003	4.0000e-005	2.9600e-003	5.0000e-005	3.0100e-003	3.6000e-004	5.0000e-005	4.1000e-004	0.0000	3.4477	3.4477	4.2000e-004	0.0000	3.4583
Worker	3.1100e-003	1.6700e-003	0.0196	1.0000e-005	9.5900e-003	2.0000e-005	9.6100e-003	1.1100e-003	2.0000e-005	1.1300e-003	0.0000	1.0375	1.0375	1.2000e-004	0.0000	1.0404
<b>Total</b>	<b>4.1600e-003</b>	<b>0.0291</b>	<b>0.0291</b>	<b>5.0000e-005</b>	<b>0.0126</b>	<b>7.0000e-005</b>	<b>0.0126</b>	<b>1.4700e-003</b>	<b>7.0000e-005</b>	<b>1.5400e-003</b>	<b>0.0000</b>	<b>4.4852</b>	<b>4.4852</b>	<b>5.4000e-004</b>	<b>0.0000</b>	<b>4.4988</b>

**3.6 Building Construction - 2022**

**Unmitigated Construction On-Site**

	ROG	NOx	CO	SO2	Fugitive PM10	Exhaust PM10	PM10 Total	Fugitive PM2.5	Exhaust PM2.5	PM2.5 Total	Bio- CO2	NBio- CO2	Total CO2	CH4	N2O	CO2e
Category	tons/yr										MT/yr					
Off-Road	0.2218	2.0300	2.1272	3.5000e-003		0.1052	0.1052		0.0990	0.0990	0.0000	301.2428	301.2428	0.0722	0.0000	303.0471
<b>Total</b>	<b>0.2218</b>	<b>2.0300</b>	<b>2.1272</b>	<b>3.5000e-003</b>		<b>0.1052</b>	<b>0.1052</b>		<b>0.0990</b>	<b>0.0990</b>	<b>0.0000</b>	<b>301.2428</b>	<b>301.2428</b>	<b>0.0722</b>	<b>0.0000</b>	<b>303.0471</b>

**Unmitigated Construction Off-Site**

	ROG	NOx	CO	SO2	Fugitive PM10	Exhaust PM10	PM10 Total	Fugitive PM2.5	Exhaust PM2.5	PM2.5 Total	Bio- CO2	NBio- CO2	Total CO2	CH4	N2O	CO2e
Category	tons/yr										MT/yr					

Hauling	0.0000	0.0000	0.0000	0.0000	0.0000	0.0000	0.0000	0.0000	0.0000	0.0000	0.0000	0.0000	0.0000	0.0000	0.0000	0.0000
Vendor	0.0126	0.3467	0.1132	4.7000e-004	0.0600	6.1000e-004	0.0607	6.8500e-003	5.8000e-004	7.4300e-003	0.0000	44.5345	44.5345	5.3000e-003	0.0000	44.6669
Worker	0.0379	0.0197	0.2298	1.5000e-004	0.1961	2.2000e-004	0.1964	0.0216	2.1000e-004	0.0218	0.0000	13.0882	13.0882	1.3700e-003	0.0000	13.1224
<b>Total</b>	<b>0.0504</b>	<b>0.3664</b>	<b>0.3430</b>	<b>6.2000e-004</b>	<b>0.2562</b>	<b>8.3000e-004</b>	<b>0.2570</b>	<b>0.0284</b>	<b>7.9000e-004</b>	<b>0.0292</b>	<b>0.0000</b>	<b>57.6226</b>	<b>57.6226</b>	<b>6.6700e-003</b>	<b>0.0000</b>	<b>57.7893</b>

**Mitigated Construction On-Site**

	ROG	NOx	CO	SO2	Fugitive PM10	Exhaust PM10	PM10 Total	Fugitive PM2.5	Exhaust PM2.5	PM2.5 Total	Bio- CO2	NBio- CO2	Total CO2	CH4	N2O	CO2e
Category	tons/yr										MT/yr					
Off-Road	0.0694	1.4186	2.3236	3.5000e-003		0.0110	0.0110		0.0110	0.0110	0.0000	301.2425	301.2425	0.0722	0.0000	303.0467
<b>Total</b>	<b>0.0694</b>	<b>1.4186</b>	<b>2.3236</b>	<b>3.5000e-003</b>		<b>0.0110</b>	<b>0.0110</b>		<b>0.0110</b>	<b>0.0110</b>	<b>0.0000</b>	<b>301.2425</b>	<b>301.2425</b>	<b>0.0722</b>	<b>0.0000</b>	<b>303.0467</b>

**Mitigated Construction Off-Site**

	ROG	NOx	CO	SO2	Fugitive PM10	Exhaust PM10	PM10 Total	Fugitive PM2.5	Exhaust PM2.5	PM2.5 Total	Bio- CO2	NBio- CO2	Total CO2	CH4	N2O	CO2e
Category	tons/yr										MT/yr					
Hauling	0.0000	0.0000	0.0000	0.0000	0.0000	0.0000	0.0000	0.0000	0.0000	0.0000	0.0000	0.0000	0.0000	0.0000	0.0000	0.0000
Vendor	0.0126	0.3467	0.1132	4.7000e-004	0.0385	6.1000e-004	0.0391	4.7000e-003	5.8000e-004	5.2800e-003	0.0000	44.5345	44.5345	5.3000e-003	0.0000	44.6669
Worker	0.0379	0.0197	0.2298	1.5000e-004	0.1247	2.2000e-004	0.1249	0.0144	2.1000e-004	0.0146	0.0000	13.0882	13.0882	1.3700e-003	0.0000	13.1224
<b>Total</b>	<b>0.0504</b>	<b>0.3664</b>	<b>0.3430</b>	<b>6.2000e-004</b>	<b>0.1632</b>	<b>8.3000e-004</b>	<b>0.1640</b>	<b>0.0191</b>	<b>7.9000e-004</b>	<b>0.0199</b>	<b>0.0000</b>	<b>57.6226</b>	<b>57.6226</b>	<b>6.6700e-003</b>	<b>0.0000</b>	<b>57.7893</b>

**3.6 Building Construction - 2023**  
**Unmitigated Construction On-Site**

	ROG	NOx	CO	SO2	Fugitive PM10	Exhaust PM10	PM10 Total	Fugitive PM2.5	Exhaust PM2.5	PM2.5 Total	Bio- CO2	NBio- CO2	Total CO2	CH4	N2O	CO2e
Category	tons/yr										MT/yr					
Off-Road	0.2045	1.8700	2.1117	3.5000e-003		0.0910	0.0910		0.0856	0.0856	0.0000	301.3462	301.3462	0.0717	0.0000	303.1383
<b>Total</b>	<b>0.2045</b>	<b>1.8700</b>	<b>2.1117</b>	<b>3.5000e-003</b>		<b>0.0910</b>	<b>0.0910</b>		<b>0.0856</b>	<b>0.0856</b>	<b>0.0000</b>	<b>301.3462</b>	<b>301.3462</b>	<b>0.0717</b>	<b>0.0000</b>	<b>303.1383</b>

**Unmitigated Construction Off-Site**

	ROG	NOx	CO	SO2	Fugitive PM10	Exhaust PM10	PM10 Total	Fugitive PM2.5	Exhaust PM2.5	PM2.5 Total	Bio- CO2	NBio- CO2	Total CO2	CH4	N2O	CO2e
Category	tons/yr										MT/yr					
Hauling	0.0000	0.0000	0.0000	0.0000	0.0000	0.0000	0.0000	0.0000	0.0000	0.0000	0.0000	0.0000	0.0000	0.0000	0.0000	0.0000
Vendor	9.6800e-003	0.3035	0.0999	4.7000e-004	0.0600	1.6000e-004	0.0602	6.8500e-003	1.5000e-004	7.0000e-003	0.0000	44.4357	44.4357	3.7600e-003	0.0000	44.5296
Worker	0.0355	0.0179	0.2071	1.4000e-004	0.1961	2.1000e-004	0.1963	0.0216	2.0000e-004	0.0218	0.0000	12.6767	12.6767	1.2300e-003	0.0000	12.7074
<b>Total</b>	<b>0.0452</b>	<b>0.3214</b>	<b>0.3071</b>	<b>6.1000e-004</b>	<b>0.2562</b>	<b>3.7000e-004</b>	<b>0.2565</b>	<b>0.0284</b>	<b>3.5000e-004</b>	<b>0.0288</b>	<b>0.0000</b>	<b>57.1125</b>	<b>57.1125</b>	<b>4.9900e-003</b>	<b>0.0000</b>	<b>57.2370</b>

**Mitigated Construction On-Site**

	ROG	NOx	CO	SO2	Fugitive PM10	Exhaust PM10	PM10 Total	Fugitive PM2.5	Exhaust PM2.5	PM2.5 Total	Bio- CO2	NBio- CO2	Total CO2	CH4	N2O	CO2e
Category	tons/yr										MT/yr					
Off-Road	0.0694	1.4186	2.3236	3.5000e-003		0.0110	0.0110		0.0110	0.0110	0.0000	301.3458	301.3458	0.0717	0.0000	303.1380
<b>Total</b>	<b>0.0694</b>	<b>1.4186</b>	<b>2.3236</b>	<b>3.5000e-003</b>		<b>0.0110</b>	<b>0.0110</b>		<b>0.0110</b>	<b>0.0110</b>	<b>0.0000</b>	<b>301.3458</b>	<b>301.3458</b>	<b>0.0717</b>	<b>0.0000</b>	<b>303.1380</b>

**Mitigated Construction Off-Site**

	ROG	NOx	CO	SO2	Fugitive PM10	Exhaust PM10	PM10 Total	Fugitive PM2.5	Exhaust PM2.5	PM2.5 Total	Bio- CO2	NBio- CO2	Total CO2	CH4	N2O	CO2e
Category	tons/yr										MT/yr					
Hauling	0.0000	0.0000	0.0000	0.0000	0.0000	0.0000	0.0000	0.0000	0.0000	0.0000	0.0000	0.0000	0.0000	0.0000	0.0000	0.0000
Vendor	9.6800e-003	0.3035	0.0999	4.7000e-004	0.0385	1.6000e-004	0.0387	4.7000e-003	1.5000e-004	4.8500e-003	0.0000	44.4357	44.4357	3.7600e-003	0.0000	44.5296
Worker	0.0355	0.0179	0.2071	1.4000e-004	0.1247	2.1000e-004	0.1249	0.0144	2.0000e-004	0.0146	0.0000	12.6767	12.6767	1.2300e-003	0.0000	12.7074
<b>Total</b>	<b>0.0452</b>	<b>0.3214</b>	<b>0.3071</b>	<b>6.1000e-004</b>	<b>0.1632</b>	<b>3.7000e-004</b>	<b>0.1635</b>	<b>0.0191</b>	<b>3.5000e-004</b>	<b>0.0195</b>	<b>0.0000</b>	<b>57.1125</b>	<b>57.1125</b>	<b>4.9900e-003</b>	<b>0.0000</b>	<b>57.2370</b>

**3.6 Building Construction - 2024**

**Unmitigated Construction On-Site**

	ROG	NOx	CO	SO2	Fugitive PM10	Exhaust PM10	PM10 Total	Fugitive PM2.5	Exhaust PM2.5	PM2.5 Total	Bio- CO2	NBio- CO2	Total CO2	CH4	N2O	CO2e
Category	tons/yr										MT/yr					
Off-Road	0.1472	1.3444	1.6167	2.7000e-003		0.0613	0.0613		0.0577	0.0577	0.0000	231.8491	231.8491	0.0548	0.0000	233.2198



Total	0.1472	1.3444	1.6167	2.7000e-003		0.0613	0.0613		0.0577	0.0577	0.0000	231.8491	231.8491	0.0548	0.0000	233.2198
-------	--------	--------	--------	-------------	--	--------	--------	--	--------	--------	--------	----------	----------	--------	--------	----------

**Unmitigated Construction Off-Site**

	ROG	NOx	CO	SO2	Fugitive PM10	Exhaust PM10	PM10 Total	Fugitive PM2.5	Exhaust PM2.5	PM2.5 Total	Bio- CO2	NBio- CO2	Total CO2	CH4	N2O	CO2e
Category	tons/yr										MT/yr					
Hauling	0.0000	0.0000	0.0000	0.0000	0.0000	0.0000	0.0000	0.0000	0.0000	0.0000	0.0000	0.0000	0.0000	0.0000	0.0000	0.0000
Vendor	6.9800e-003	0.2314	0.0710	3.6000e-004	0.0462	1.1000e-004	0.0463	5.2700e-003	1.1000e-004	5.3800e-003	0.0000	33.8354	33.8354	2.8300e-003	0.0000	33.9062
Worker	0.0255	0.0125	0.1449	1.1000e-004	0.1509	1.5000e-004	0.1510	0.0166	1.4000e-004	0.0167	0.0000	9.4275	9.4275	8.4000e-004	0.0000	9.4484
<b>Total</b>	<b>0.0324</b>	<b>0.2439</b>	<b>0.2159</b>	<b>4.7000e-004</b>	<b>0.1971</b>	<b>2.6000e-004</b>	<b>0.1973</b>	<b>0.0219</b>	<b>2.5000e-004</b>	<b>0.0221</b>	<b>0.0000</b>	<b>43.2629</b>	<b>43.2629</b>	<b>3.6700e-003</b>	<b>0.0000</b>	<b>43.3546</b>

**Mitigated Construction On-Site**

	ROG	NOx	CO	SO2	Fugitive PM10	Exhaust PM10	PM10 Total	Fugitive PM2.5	Exhaust PM2.5	PM2.5 Total	Bio- CO2	NBio- CO2	Total CO2	CH4	N2O	CO2e
Category	tons/yr										MT/yr					
Off-Road	0.0534	1.0912	1.7874	2.7000e-003		8.4600e-003	8.4600e-003		8.4600e-003	8.4600e-003	0.0000	231.8488	231.8488	0.0548	0.0000	233.2195
<b>Total</b>	<b>0.0534</b>	<b>1.0912</b>	<b>1.7874</b>	<b>2.7000e-003</b>		<b>8.4600e-003</b>	<b>8.4600e-003</b>		<b>8.4600e-003</b>	<b>8.4600e-003</b>	<b>0.0000</b>	<b>231.8488</b>	<b>231.8488</b>	<b>0.0548</b>	<b>0.0000</b>	<b>233.2195</b>

**Mitigated Construction Off-Site**

	ROG	NOx	CO	SO2	Fugitive PM10	Exhaust PM10	PM10 Total	Fugitive PM2.5	Exhaust PM2.5	PM2.5 Total	Bio- CO2	NBio- CO2	Total CO2	CH4	N2O	CO2e
Category	tons/yr										MT/yr					
Hauling	0.0000	0.0000	0.0000	0.0000	0.0000	0.0000	0.0000	0.0000	0.0000	0.0000	0.0000	0.0000	0.0000	0.0000	0.0000	0.0000
Vendor	6.9800e-003	0.2314	0.0710	3.6000e-004	0.0296	1.1000e-004	0.0297	3.6100e-003	1.1000e-004	3.7200e-003	0.0000	33.8354	33.8354	2.8300e-003	0.0000	33.9062
Worker	0.0255	0.0125	0.1449	1.1000e-004	0.0959	1.5000e-004	0.0961	0.0111	1.4000e-004	0.0112	0.0000	9.4275	9.4275	8.4000e-004	0.0000	9.4484
<b>Total</b>	<b>0.0324</b>	<b>0.2439</b>	<b>0.2159</b>	<b>4.7000e-004</b>	<b>0.1255</b>	<b>2.6000e-004</b>	<b>0.1258</b>	<b>0.0147</b>	<b>2.5000e-004</b>	<b>0.0150</b>	<b>0.0000</b>	<b>43.2629</b>	<b>43.2629</b>	<b>3.6700e-003</b>	<b>0.0000</b>	<b>43.3546</b>

**3.7 Paving - 2024**

**Unmitigated Construction On-Site**

	ROG	NOx	CO	SO2	Fugitive PM10	Exhaust PM10	PM10 Total	Fugitive PM2.5	Exhaust PM2.5	PM2.5 Total	Bio- CO2	NBio- CO2	Total CO2	CH4	N2O	CO2e
Category	tons/yr										MT/yr					
Off-Road	0.0272	0.2619	0.4022	6.3000e-004		0.0129	0.0129		0.0119	0.0119	0.0000	55.0730	55.0730	0.0178	0.0000	55.5183
Paving	0.0000					0.0000	0.0000		0.0000	0.0000	0.0000	0.0000	0.0000	0.0000	0.0000	0.0000
<b>Total</b>	<b>0.0272</b>	<b>0.2619</b>	<b>0.4022</b>	<b>6.3000e-004</b>		<b>0.0129</b>	<b>0.0129</b>		<b>0.0119</b>	<b>0.0119</b>	<b>0.0000</b>	<b>55.0730</b>	<b>55.0730</b>	<b>0.0178</b>	<b>0.0000</b>	<b>55.5183</b>

**Unmitigated Construction Off-Site**

	ROG	NOx	CO	SO2	Fugitive PM10	Exhaust PM10	PM10 Total	Fugitive PM2.5	Exhaust PM2.5	PM2.5 Total	Bio- CO2	NBio- CO2	Total CO2	CH4	N2O	CO2e
Category	tons/yr										MT/yr					

Hauling	0.0000	0.0000	0.0000	0.0000	0.0000	0.0000	0.0000	0.0000	0.0000	0.0000	0.0000	0.0000	0.0000	0.0000	0.0000	0.0000
Vendor	0.0000	0.0000	0.0000	0.0000	0.0000	0.0000	0.0000	0.0000	0.0000	0.0000	0.0000	0.0000	0.0000	0.0000	0.0000	0.0000
Worker	8.3000e-004	4.1000e-004	4.7400e-003	0.0000	4.9400e-003	1.0000e-005	4.9400e-003	5.4000e-004	0.0000	5.5000e-004	0.0000	0.3086	0.3086	3.0000e-005	0.0000	0.3093
<b>Total</b>	<b>8.3000e-004</b>	<b>4.1000e-004</b>	<b>4.7400e-003</b>	<b>0.0000</b>	<b>4.9400e-003</b>	<b>1.0000e-005</b>	<b>4.9400e-003</b>	<b>5.4000e-004</b>	<b>0.0000</b>	<b>5.5000e-004</b>	<b>0.0000</b>	<b>0.3086</b>	<b>0.3086</b>	<b>3.0000e-005</b>	<b>0.0000</b>	<b>0.3093</b>

**Mitigated Construction On-Site**

	ROG	NOx	CO	SO2	Fugitive PM10	Exhaust PM10	PM10 Total	Fugitive PM2.5	Exhaust PM2.5	PM2.5 Total	Bio- CO2	NBio- CO2	Total CO2	CH4	N2O	CO2e
Category	tons/yr										MT/yr					
Off-Road	9.1900e-003	0.2761	0.4756	6.3000e-004		1.0300e-003	1.0300e-003		1.0300e-003	1.0300e-003	0.0000	55.0729	55.0729	0.0178	0.0000	55.5182
Paving	0.0000					0.0000	0.0000		0.0000	0.0000	0.0000	0.0000	0.0000	0.0000	0.0000	0.0000
<b>Total</b>	<b>9.1900e-003</b>	<b>0.2761</b>	<b>0.4756</b>	<b>6.3000e-004</b>		<b>1.0300e-003</b>	<b>1.0300e-003</b>		<b>1.0300e-003</b>	<b>1.0300e-003</b>	<b>0.0000</b>	<b>55.0729</b>	<b>55.0729</b>	<b>0.0178</b>	<b>0.0000</b>	<b>55.5182</b>

**Mitigated Construction Off-Site**

	ROG	NOx	CO	SO2	Fugitive PM10	Exhaust PM10	PM10 Total	Fugitive PM2.5	Exhaust PM2.5	PM2.5 Total	Bio- CO2	NBio- CO2	Total CO2	CH4	N2O	CO2e
Category	tons/yr										MT/yr					
Hauling	0.0000	0.0000	0.0000	0.0000	0.0000	0.0000	0.0000	0.0000	0.0000	0.0000	0.0000	0.0000	0.0000	0.0000	0.0000	0.0000
Vendor	0.0000	0.0000	0.0000	0.0000	0.0000	0.0000	0.0000	0.0000	0.0000	0.0000	0.0000	0.0000	0.0000	0.0000	0.0000	0.0000
Worker	8.3000e-004	4.1000e-004	4.7400e-003	0.0000	3.1400e-003	1.0000e-005	3.1400e-003	3.6000e-004	0.0000	3.7000e-004	0.0000	0.3086	0.3086	3.0000e-005	0.0000	0.3093
<b>Total</b>	<b>8.3000e-004</b>	<b>4.1000e-004</b>	<b>4.7400e-003</b>	<b>0.0000</b>	<b>3.1400e-003</b>	<b>1.0000e-005</b>	<b>3.1400e-003</b>	<b>3.6000e-004</b>	<b>0.0000</b>	<b>3.7000e-004</b>	<b>0.0000</b>	<b>0.3086</b>	<b>0.3086</b>	<b>3.0000e-005</b>	<b>0.0000</b>	<b>0.3093</b>

**3.8 Architectural Coating - 2024**  
**Unmitigated Construction On-Site**

	ROG	NOx	CO	SO2	Fugitive PM10	Exhaust PM10	PM10 Total	Fugitive PM2.5	Exhaust PM2.5	PM2.5 Total	Bio- CO2	NBio- CO2	Total CO2	CH4	N2O	CO2e
Category	tons/yr										MT/yr					
Archit. Coating	0.5053					0.0000	0.0000		0.0000	0.0000	0.0000	0.0000	0.0000	0.0000	0.0000	0.0000
Off-Road	6.3000e-004	4.2700e-003	6.3400e-003	1.0000e-005		2.1000e-004	2.1000e-004		2.1000e-004	2.1000e-004	0.0000	0.8936	0.8936	5.0000e-005	0.0000	0.8949
<b>Total</b>	<b>0.5059</b>	<b>4.2700e-003</b>	<b>6.3400e-003</b>	<b>1.0000e-005</b>		<b>2.1000e-004</b>	<b>2.1000e-004</b>		<b>2.1000e-004</b>	<b>2.1000e-004</b>	<b>0.0000</b>	<b>0.8936</b>	<b>0.8936</b>	<b>5.0000e-005</b>	<b>0.0000</b>	<b>0.8949</b>

**Unmitigated Construction Off-Site**

	ROG	NOx	CO	SO2	Fugitive PM10	Exhaust PM10	PM10 Total	Fugitive PM2.5	Exhaust PM2.5	PM2.5 Total	Bio- CO2	NBio- CO2	Total CO2	CH4	N2O	CO2e
Category	tons/yr										MT/yr					
Hauling	0.0000	0.0000	0.0000	0.0000	0.0000	0.0000	0.0000	0.0000	0.0000	0.0000	0.0000	0.0000	0.0000	0.0000	0.0000	0.0000
Vendor	0.0000	0.0000	0.0000	0.0000	0.0000	0.0000	0.0000	0.0000	0.0000	0.0000	0.0000	0.0000	0.0000	0.0000	0.0000	0.0000
Worker	1.8000e-004	9.0000e-005	1.0100e-003	0.0000	1.0500e-003	0.0000	1.0500e-003	1.2000e-004	0.0000	1.2000e-004	0.0000	0.0655	0.0655	1.0000e-005	0.0000	0.0656
<b>Total</b>	<b>1.8000e-004</b>	<b>9.0000e-005</b>	<b>1.0100e-003</b>	<b>0.0000</b>	<b>1.0500e-003</b>	<b>0.0000</b>	<b>1.0500e-003</b>	<b>1.2000e-004</b>	<b>0.0000</b>	<b>1.2000e-004</b>	<b>0.0000</b>	<b>0.0655</b>	<b>0.0655</b>	<b>1.0000e-005</b>	<b>0.0000</b>	<b>0.0656</b>

**Mitigated Construction On-Site**

	ROG	NOx	CO	SO2	Fugitive PM10	Exhaust PM10	PM10 Total	Fugitive PM2.5	Exhaust PM2.5	PM2.5 Total	Bio- CO2	NBio- CO2	Total CO2	CH4	N2O	CO2e	
Category	tons/yr										MT/yr						
Archit. Coating	0.5053						0.0000	0.0000		0.0000	0.0000	0.0000	0.0000	0.0000	0.0000	0.0000	
Off-Road	1.9000e-004	3.7100e-003	6.4100e-003	1.0000e-005			1.0000e-005	1.0000e-005		1.0000e-005	1.0000e-005	0.0000	0.8936	0.8936	5.0000e-005	0.0000	0.8949
<b>Total</b>	<b>0.5055</b>	<b>3.7100e-003</b>	<b>6.4100e-003</b>	<b>1.0000e-005</b>			<b>1.0000e-005</b>	<b>1.0000e-005</b>		<b>1.0000e-005</b>	<b>1.0000e-005</b>	<b>0.0000</b>	<b>0.8936</b>	<b>0.8936</b>	<b>5.0000e-005</b>	<b>0.0000</b>	<b>0.8949</b>

**Mitigated Construction Off-Site**

	ROG	NOx	CO	SO2	Fugitive PM10	Exhaust PM10	PM10 Total	Fugitive PM2.5	Exhaust PM2.5	PM2.5 Total	Bio- CO2	NBio- CO2	Total CO2	CH4	N2O	CO2e
Category	tons/yr										MT/yr					
Hauling	0.0000	0.0000	0.0000	0.0000	0.0000	0.0000	0.0000	0.0000	0.0000	0.0000	0.0000	0.0000	0.0000	0.0000	0.0000	0.0000
Vendor	0.0000	0.0000	0.0000	0.0000	0.0000	0.0000	0.0000	0.0000	0.0000	0.0000	0.0000	0.0000	0.0000	0.0000	0.0000	0.0000
Worker	1.8000e-004	9.0000e-005	1.0100e-003	0.0000	6.7000e-004	0.0000	6.7000e-004	8.0000e-005	0.0000	8.0000e-005	0.0000	0.0655	0.0655	1.0000e-005	0.0000	0.0656
<b>Total</b>	<b>1.8000e-004</b>	<b>9.0000e-005</b>	<b>1.0100e-003</b>	<b>0.0000</b>	<b>6.7000e-004</b>	<b>0.0000</b>	<b>6.7000e-004</b>	<b>8.0000e-005</b>	<b>0.0000</b>	<b>8.0000e-005</b>	<b>0.0000</b>	<b>0.0655</b>	<b>0.0655</b>	<b>1.0000e-005</b>	<b>0.0000</b>	<b>0.0656</b>

**3.8 Architectural Coating - 2025**

**Unmitigated Construction On-Site**

	ROG	NOx	CO	SO2	Fugitive PM10	Exhaust PM10	PM10 Total	Fugitive PM2.5	Exhaust PM2.5	PM2.5 Total	Bio- CO2	NBio- CO2	Total CO2	CH4	N2O	CO2e
Category	tons/yr										MT/yr					
Archit. Coating	3.4649						0.0000	0.0000		0.0000	0.0000	0.0000	0.0000	0.0000	0.0000	0.0000

Off-Road	4.1000e-003	0.0275	0.0434	7.0000e-005		1.2400e-003	1.2400e-003		1.2400e-003	1.2400e-003	0.0000	6.1278	6.1278	3.3000e-004	0.0000	6.1362
<b>Total</b>	<b>3.4690</b>	<b>0.0275</b>	<b>0.0434</b>	<b>7.0000e-005</b>		<b>1.2400e-003</b>	<b>1.2400e-003</b>		<b>1.2400e-003</b>	<b>1.2400e-003</b>	<b>0.0000</b>	<b>6.1278</b>	<b>6.1278</b>	<b>3.3000e-004</b>	<b>0.0000</b>	<b>6.1362</b>

**Unmitigated Construction Off-Site**

	ROG	NOx	CO	SO2	Fugitive PM10	Exhaust PM10	PM10 Total	Fugitive PM2.5	Exhaust PM2.5	PM2.5 Total	Bio- CO2	NBio- CO2	Total CO2	CH4	N2O	CO2e
Category	tons/yr										MT/yr					
Hauling	0.0000	0.0000	0.0000	0.0000	0.0000	0.0000	0.0000	0.0000	0.0000	0.0000	0.0000	0.0000	0.0000	0.0000	0.0000	0.0000
Vendor	0.0000	0.0000	0.0000	0.0000	0.0000	0.0000	0.0000	0.0000	0.0000	0.0000	0.0000	0.0000	0.0000	0.0000	0.0000	0.0000
Worker	1.1400e-003	5.4000e-004	6.3500e-003	0.0000	7.1800e-003	1.0000e-005	7.1900e-003	7.9000e-004	1.0000e-005	8.0000e-004	0.0000	0.4335	0.4335	4.0000e-005	0.0000	0.4344
<b>Total</b>	<b>1.1400e-003</b>	<b>5.4000e-004</b>	<b>6.3500e-003</b>	<b>0.0000</b>	<b>7.1800e-003</b>	<b>1.0000e-005</b>	<b>7.1900e-003</b>	<b>7.9000e-004</b>	<b>1.0000e-005</b>	<b>8.0000e-004</b>	<b>0.0000</b>	<b>0.4335</b>	<b>0.4335</b>	<b>4.0000e-005</b>	<b>0.0000</b>	<b>0.4344</b>

**Mitigated Construction On-Site**

	ROG	NOx	CO	SO2	Fugitive PM10	Exhaust PM10	PM10 Total	Fugitive PM2.5	Exhaust PM2.5	PM2.5 Total	Bio- CO2	NBio- CO2	Total CO2	CH4	N2O	CO2e
Category	tons/yr										MT/yr					
Archit. Coating	3.4649					0.0000	0.0000		0.0000	0.0000	0.0000	0.0000	0.0000	0.0000	0.0000	0.0000
Off-Road	1.3100e-003	0.0254	0.0440	7.0000e-005		1.0000e-004	1.0000e-004		1.0000e-004	1.0000e-004	0.0000	6.1278	6.1278	3.3000e-004	0.0000	6.1362
<b>Total</b>	<b>3.4662</b>	<b>0.0254</b>	<b>0.0440</b>	<b>7.0000e-005</b>		<b>1.0000e-004</b>	<b>1.0000e-004</b>		<b>1.0000e-004</b>	<b>1.0000e-004</b>	<b>0.0000</b>	<b>6.1278</b>	<b>6.1278</b>	<b>3.3000e-004</b>	<b>0.0000</b>	<b>6.1362</b>

**Mitigated Construction Off-Site**

	ROG	NOx	CO	SO2	Fugitive PM10	Exhaust PM10	PM10 Total	Fugitive PM2.5	Exhaust PM2.5	PM2.5 Total	Bio- CO2	NBio- CO2	Total CO2	CH4	N2O	CO2e
Category	tons/yr										MT/yr					
Hauling	0.0000	0.0000	0.0000	0.0000	0.0000	0.0000	0.0000	0.0000	0.0000	0.0000	0.0000	0.0000	0.0000	0.0000	0.0000	0.0000
Vendor	0.0000	0.0000	0.0000	0.0000	0.0000	0.0000	0.0000	0.0000	0.0000	0.0000	0.0000	0.0000	0.0000	0.0000	0.0000	0.0000
Worker	1.1400e-003	5.4000e-004	6.3500e-003	0.0000	4.5700e-003	1.0000e-005	4.5700e-003	5.3000e-004	1.0000e-005	5.3000e-004	0.0000	0.4335	0.4335	4.0000e-005	0.0000	0.4344
<b>Total</b>	<b>1.1400e-003</b>	<b>5.4000e-004</b>	<b>6.3500e-003</b>	<b>0.0000</b>	<b>4.5700e-003</b>	<b>1.0000e-005</b>	<b>4.5700e-003</b>	<b>5.3000e-004</b>	<b>1.0000e-005</b>	<b>5.3000e-004</b>	<b>0.0000</b>	<b>0.4335</b>	<b>0.4335</b>	<b>4.0000e-005</b>	<b>0.0000</b>	<b>0.4344</b>



## TECHNICAL MEMORANDUM

DATE: September 9, 2021 Project No.: 21-5-034

TO: Jared Walker, General Manager, Willow County Water District

FROM: Oscar Serrano, PE, Senior Engineer  
 Lucy Li, Ph.D., PE, Project Engineer  
 Jason Coleman, PE, Supervising Engineer  
 William Gustavson, Principal Project Manager

SUBJECT: **Bella Vista Development – Water Supply Verification**

### 1. INTRODUCTION

The Bella Vista development is a proposed subdivision within the Willow County Water District (District) located in Mendocino County. The development is located at 3000 South State Street. It is approximately 0.45 miles south of the City of Ukiah limits. This technical memorandum (TM), prepared by Luhdorff and Scalmanini Consulting Engineers (LSCE), presents a Water Supply Verification for Bella Vista subdivision.

The proposed subdivision is presented on a conceptual plan dated August 31, 2020, by Guillon Inc. Construction titled Vesting Tentative Map, Bella Vista Subdivision <sup>[1]</sup>. The developer is seeking a determination of Water Supply Verification in accordance with Senate Bill 221 to confirm the District has available water supply to serve the proposed subdivision. The conceptual plan with 48.8 acres of land shows 132 single-family residential units, 39 age-restricted residential (senior housing) units, and 2.62 acres of park spaces <sup>[2]</sup>. The detailed land usage is listed in **Table 1-1**.

Table 1-1. Bella Vista Development Plan <sup>[2]</sup>		
Customer Class		Lots
Residential	Single Family	132
	Senior Lot	39
<b>Total</b>		<b>171</b>
		Area (Acres)
Irrigation	Neighborhood Park	1.96
	Linear Park	0.57
	Cottage Park	0.24
	Class I Bicycle Lane (Paved)*	0.15
<b>Total</b>		<b>2.62</b>
Total Net Density		3.5 (Units Per Acres)
Average Lot Size	Single Family	6,219 Square Feet
	Age Restricted (Senior Lot)	4,907 Square Feet

\* Paved Class I Bicycle Lane (7-foot wide and 930-foot long) is part of the Linear Park.



Jared Walker, Willow County Water District

September 9, 2021

Page 2

Water use factors within and around the District's service area were evaluated to estimate the potential water requirements of the Bella Vista development. The combined water demand of the development and the District's existing service area is presented herein, and is compared to the available water supplies during a normal, single-dry, and multiple-dry year period. Prior studies serving as a basis for available water supplies include the *Preliminary Water Demand Assessment* by Doble Thomas & Associates, Inc. dated January 2010, and the *Water Supply Assessment for the Ukiah Valley Area Plan* (UVAP) dated October 20, 2010. Updates are made to the available water supply characterized in those studies based on actual record of deliveries through years of recent drought that have occurred since the date of those studies.

## 2. EXISTING SYSTEM

The District (System No. CA2310005) serves 3,797 people with 1,070 service connections per the CA Drinking Water Watch website <sup>[3]</sup>. Per information provided by the District, a population of 4,000 people and 1,064 total service connections were used in this analysis. Of the total of 1,064 connections, 17 are irrigation services. According to the Estimates of the Resident Population by the U.S. Census Bureau, the percentage of population change over the last 10 years is -0.5% for the City of Ukiah, and -1.3% for the Mendocino County <sup>[4]</sup>; the US Census does not have specific information for Willow County Water District. For this analysis, the service connections and population were considered unchanged during the past 10 years. The District's boundary is shown in **Attachment A**.

## 3. WATER SUPPLY

The District's raw water supply is obtained from the Russian River pursuant to water rights held by the District, and a water supply contract with the Russian River Flood Control District (RRFCD). Limited emergency water supplies are available via an intertie with City of Ukiah (UVAP, 2010).

The District has water rights and contracts totaling 2,199 acre-feet (AF) per year, equal to 716.6 million-gallon (MG) per year (**Table 3-1**). The District holds two water right licenses from the CA State Water Resources Control Board, AA015721 and A017232, with face values of 724.5 AF and 884.8 AF, respectively (California Waterboard eWRIMS). Water right license A015721 is a year-round water right with a flow rate of 1 cubic foot per second (CFS), while water right license A017232 is a permitted flow rate of 3 CFS and can be used from November 1<sup>st</sup> of each year to July 1<sup>st</sup> of the succeeding year. The District's contract with RRFCD is up to 590 AF of purchased water, which can be used throughout the year.

Table 3-1. Water Supply Summary	
Application #	Water Right Details
A015721:	Maximum diversion rate of 1 CFS (449 Gallon Per Minute (GPM)) for year round use with a Face Value of 724 AF (235.9 MG) for Municipal Use with 2 points of diversion. Source: Russian River Underflow <sup>[5]</sup> .
A017232:	Maximum diversion rate of 3 CFS (1,346 GPM) from November 1 to July 1 with a Face Value of 884.8 AF (469.2 MG) for Municipal Use with 2 points of diversion. Source: Russian River Underflow <sup>[5]</sup> .
Contract Details	
RRFCD Contract:	590 AF (192.2 MG) under contract with 2 points of diversion.

The water right allocations over the course of a year are cited in the UVAP <sup>[5]</sup>. The water rights can be used, as needed, within the allowable constraints noted in Table 3-1 in terms of period of use, diversion flow rate, and total diversion. The face value for license A017232 is evenly distributed from November to June which results in a diversion factor of 1.84 CFS which meets the maximum 3 CFS requirement. RRFCD contract fills in the water supply from July to September with a diversion factor of 2.41 CFS. An example of the allocation of water rights and RRFCD contract water is shown in **Figure 3-1** demonstrating water supply availability throughout the year to maximize all water supplies. However, if for example the RRFCD water were to be curtailed, the District has the option to use more of the year-round right (A015721) during summer months July-October than in the winter months.

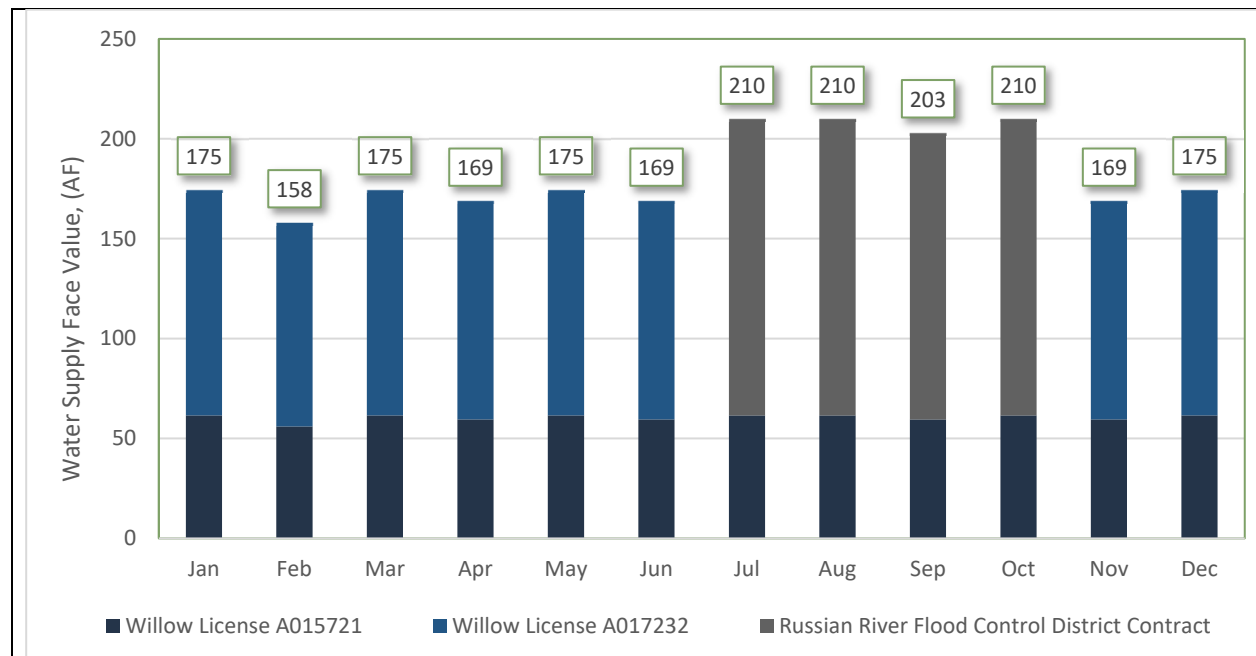

Figure 3-1. District Available Water Supply

## 4. WATER DEMAND ESTIMATES

Several methods are available and commonly applied to estimating water demand requirements, usually for the purpose of projecting increases in water demands over time. Among a broader range of methods, those with potential applicability to the District include the *Per-Capita Method*, the *Disaggregate Method*, the *Land Use Method*, and the *Regression Method*. For the development of this TM, LSCE employed the *Disaggregate Method* to calculate the residential water demand, as the available customer metering data was most conducive to this method.

In the *Disaggregate Method*, historical water metering records are subdivided, or disaggregated, into several significant use classes, e.g., residential, commercial/institutional, irrigation, and other. Based on disaggregated water use in each sector, unitized water consumptions are determined for each year of record, which is then used to develop a base water use for each customer class, e.g., gallons per day per residential service connection, commercial connection, and irrigation connection.

Once the unitized water consumption is determined per connection for each customer class, the service connections can be represented as an equivalent dwelling unit (EDU), which is the amount of water used by a typical single-family residential house. The water system size can be expressed as a total EDU for the existing system and at build-out.

For landscaping water demand, due to the unavailability of the planned connection services in this preliminary analysis, a water budget tool from EPA was used to estimate the maximum monthly landscape water allowance. Meanwhile, the method of *Maximum Applied Water Allowance (MAWA)* was conducted to cross-compare the estimate.

Finally, based on the projected population for the Bella Vista development, the *Per-Capita Method* was used to compare to the yearly water demand analysis above.

### 4.1 Water Production and Consumption

Historical water production was provided by the District and is depicted in **Figure 4-1** for the period of 2010 to 2020. The production growth generally coincides with the population growth in District. In the past 10 years, the production rate has been relatively constant with an average of 254.8 million gallons per year (MGY). The lowest production rates were in 2014 and 2015 during the drought where water rights were curtailed by 25% in 2014.

Jared Walker, Willow County Water District

September 9, 2021

Page 5

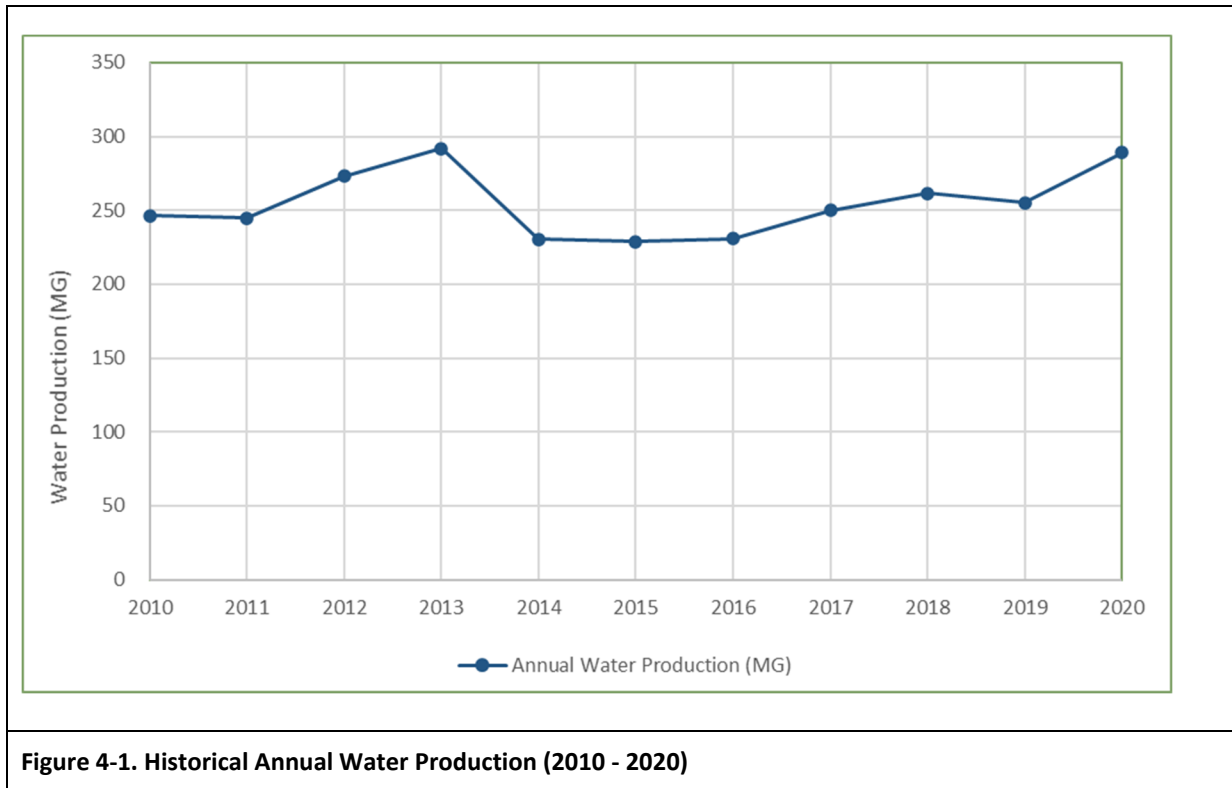

The water meter usage data from 2016 to 2020 was provided by the District. The average annual consumption with estimated losses is shown in **Figure 4-2**. Water consumption is comprised of approximately 62 % residential usage, 9 % irrigation usage, 12 % commercial/institutional usage, and 17 % system losses.

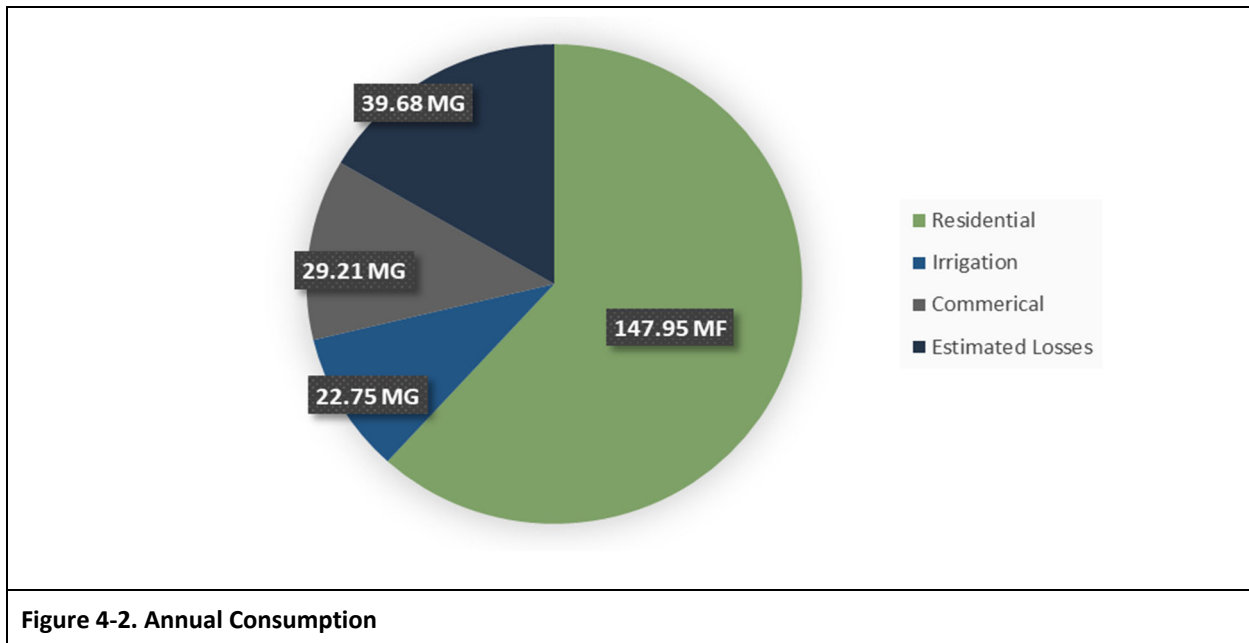

Jared Walker, Willow County Water District  
 September 9, 2021  
 Page 6

The metering data records (2016-2020) were plotted to show the average total consumption by month, average total production (2010-2020) by month, and available water supply (Figure 3-1) by month, as shown in **Figure 4-3**. The total available water supply is 716.6 MGY. The average total production is 254.8 MGY which is 35.6% of the available water supply. The average total consumption is 199.9 MGY.

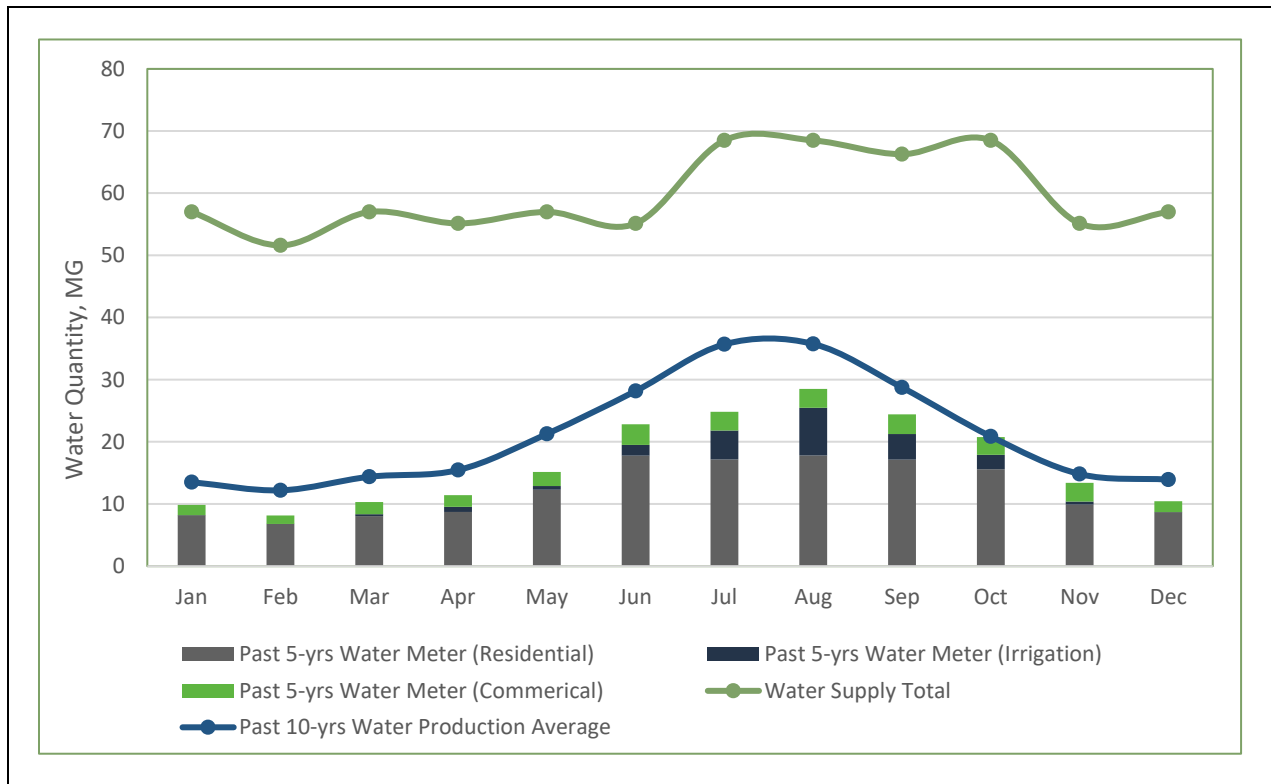

**Figure 4-3 Historical Average Annual Consumption, Average Annual Production, and Available Water Supply by Month**

As seen in Figure 4-3, the minimum water usage occurs in the winter (December – February) and is approximately 9.5 MG per month with zero irrigation use. Water usage increases with drier and warmer weather primarily from outdoor usage. On this basis, the estimated annual indoor consumption is 114 MGY, and outdoor consumption is 86 MGY.

## 4.2 Water Service Connections

The District has a total of 1,064 accounts of which 17 are irrigation services and the remaining are residential and commercial connections. The District could not distinguish the residential and commercial total accounts therefore the remaining 1,047 accounts were all counted as residential connections for this analysis.

The Bella Vista subdivision includes 171 units of residential houses with 132 being single-family residences and 39 senior homes. The irrigation services were not provided by the developer, Guillon Inc. Construction. Irrigation water demand is evaluated based on irrigation acres rather than services, which is most accurate. With the addition of the Bella Vista subdivision, the District's residential connections increase from 1,064 to 1,235 plus the Bella Vista landscape usage estimates. Of this total, the residential connections increase from 1,047 to 1,218, which is a 16% increase (**Table 4-1**).

Table 4-1. Service Connections (SC)			
Customer Class	Existing Willow	Bella Vista	Total
Total Residential	1,047	171	1,218
Irrigation	17	0	17
Commercial*	N/A	N/A	N/A
<b>Total</b>	<b>1,064</b>	<b>171</b>	<b>1,235</b>

\*Existing commercial service connection totals were not available (N/A) from the District and none are included for the proposed development.

## 4.3 Water Use Factors

A review of meter data and service connection data from 2016 - 2020 (**Table 4-2**) was used to estimate water use factors for each customer class. Annual consumption for each customer class is presented as an average flow rate (GPM) and divided by the total connections to determine the flow rate per service connection (GPM/SC) for each customer class, respectively. Several months of meter data were missing for 2016, 2017, and 2019, so the years 2018 and 2020 were selected to conduct the analysis, and the data in 2020 was used for further analysis.

Table 4-2. District's Meter Data (MG), Service Connections (SC), and Equivalent Dwelling Unit (EDU)								
Customer Class	2018				2020			
	MG	SC	GPM / SC	EDU	MG	SC	GPM / SC	EDU
Total Residential	162.8	1,047	0.30	1.0	185.7	1,047	0.34	1.0
Irrigation	24.0	17	2.68	9.1	29.1	17	3.25	9.7
Commercial	40.5	N/A	N/A	N/A	29.7	N/A	N/A	N/A
<b>Total</b>	<b>227.3</b>	<b>1,064</b>			<b>244.5</b>	<b>1,064</b>		

Jared Walker, Willow County Water District

September 9, 2021

Page 8

As **Table 4-2** shows, residential and irrigation annual water usage was relatively the same in 2018 and 2020. These findings are consistent with the water production and population trends that demonstrate a stable water system for the District.

Based on a comparison of the water production and water meter usage, water loss for the District's water system was determined to be 44 MG or 16.8% in 2020. These losses change year-to-year due to varying operational practices (e.g., hydrant flushing), leakage, and meter reading inaccuracies. With the count of system water loss, one EDU (or one typical single-family household) is estimated to require on average approximately 0.40 GPM as shown in **Table 4-3**, it is equal to 582 gallons per day, 18,000 gallons per month, and 217,000 gallons per year in 2020. Comparing with the single residential usage of 0.4 GPM/SC as one EDU, each irrigation connection consumed 9.7 equivalent EDU units of water in 2020.

Based on the EDU analysis, the total current average annual water requirements and total EDUs in the system are presented in **Table 4-3**.

<b>Table 4-3. Existing Willow County EDU and Usage (2020)</b>					
Customer Class	Existing Connections	Average Usage Per Connection	EDU Factor	Equivalent EDU	Water Usage
	SC	GPM			MGY
Total Residential	1,047	0.40	1.0	1,047	223
Irrigation	17	3.91	9.7	164	35
Commercial					
<b>Total</b>	<b>1,064</b>	<b>4.31</b>	<b>10.7</b>	<b>1,211</b>	<b>257</b>

By utilizing the future connections in the system (Table 4-1), with the Bella Vista residential water demand, the average annual water requirements at build-out and the total EDUs at build-out are presented in **Table 4-4**.

<b>Table 4-4. Future Willow County &amp; Bella Vista's Residential EDU and Usage</b>					
Customer Class	Future Connections	Average Usage Per Connection	EDU Factor	Equivalent EDU	Water Use
	SC	GPM			MGY
Total Residential	1,218	0.40	1.0	1,218	259
Irrigation	17*	3.91	9.7	164	35
Commercial					
<b>Total</b>	<b>1,235</b>	<b>4.31</b>	<b>10.7</b>	<b>1,382</b>	<b>294</b>

\* 17 connections represent current Willow County Water District irrigation system. The Bella Vista irrigation demand will be analyzed separately.

#### 4.4 Bella Vista Landscaping Water Demand

The Bella Vista development has a planned 2.77-acre park area (Table 1-1) with 0.15 acres paved class I bicycle lane, which gives the potential irrigation area of 2.62 acres (114,151 square feet). The Bella Vista project description <sup>[2]</sup> states that landscaping shall be installed per AB 1881 Water Usage Requirements (Water Conservation in Landscaping Act of 2006) with drought-tolerant plants and a drip irrigation system on a timer. Applying these criteria to the WaterSense New Home Specification: Water Budget Tool (V 1.04) from EPA <sup>[6]</sup>, the Monthly Landscape Water Allowance (LWA) is 324,369 gallons per month (0.32 MG/month) for the 2.62 acres of proposed irrigation area within the development. Although the highest production month is August in the District's records, EPA Water Budget Tool used the peak watering month of July decided by the zip code of the Bella Vista development in the model.

Factors of average irrigation usage between each month to July were calculated according to the monthly usage data in the District from 2016-2020. Applying the factors to the EPA LWA of 0.32 MG/month (in July) results in a 1.58 MGY landscape water allowance for Bella Vista.

For comparison, a second analysis was done utilizing the Maximum Applied Water Allowance (MAWA) for landscaping as shown in **Table 4-5**. The reference evapotranspiration data was obtained from the Irrigation Training & Research Center (ITRC) California Polytechnic State University database <sup>[7]</sup>. The selection was for Zone 4 (Mendocino County) for a typical year with drip/micro-irrigation system and grass surface.

**Table 4-5. Maximum Applied Water Allowance (MAWA) for Landscape with ITRC Data**

Month	Reference Evapotranspiration (ET <sub>o</sub> )	Conversion Factor	ET Adjustment Factor (ETAF)	Landscape Area including SLA	Additional Water Allowance Factor for SLA	Special Landscape Area	MAW
	Inches/Month	To Gallons		SQFT		SQFT	Gallons
Jan	1.53	0.62	0.70	114,151	0.30	0.0	75,799
Feb	2.43	0.62	0.70	114,151	0.30	0.0	120,386
Mar	3.44	0.62	0.70	114,151	0.30	0.0	170,423
Apr	4.82	0.62	0.70	114,151	0.30	0.0	238,791
May	5.74	0.62	0.70	114,151	0.30	0.0	284,369
Jun	5.79	0.62	0.70	114,151	0.30	0.0	286,846
Jul	5.92	0.62	0.70	114,151	0.30	0.0	293,286
Aug	5.70	0.62	0.70	114,151	0.30	0.0	282,387
Sep	4.78	0.62	0.70	114,151	0.30	0.0	236,809
Oct	3.58	0.62	0.70	114,151	0.30	0.0	177,359
Nov	1.56	0.62	0.70	114,151	0.30	0.0	77,285
Dec	1.74	0.62	0.70	114,151	0.30	0.0	86,202
<b>Total</b>	<b>47.03</b>	<b>0.62</b>	<b>0.70</b>	<b>114,151.2</b>	<b>0.30</b>	<b>0.0</b>	<b>2,329,942</b>

\* SQFT: Square Feet



The Equation used for the MAWA method in Table 4-5 is presented in **Equation 4-1**.

$$MAWA = (ET_o) \times (0.62) \times [(0.7 \times LA) + (0.3 \times SLA)] \quad \text{Equation 4-1}$$

Where:

MAWA = Maximum Applied Water Allowance (gallons per year)

ET<sub>o</sub> = Reference Evapotranspiration (inches per year)

0.62 = Conversion Factor (to gallons)

0.7 = ET Adjustment Factor (ETAF)

LA = Landscape Area including SLA (square feet)

0.3 = Additional Water Allowance Factor for SLA

SLA = Special Landscape Area (square feet) (areas dedicated to edible plants, areas irrigated with recycled water, water features using recycled water, and areas dedicated to active play)

The resultant water demand utilizing the MAWA method is 2.33 MGY and exceeds the EPA water budget method result of 1.58 MGY. To be conservative, the 2.33 MGY of landscape water demand will be used.

#### 4.5 District Build-out Demand with Bella Vista

Summarizing the analysis above, the proposed Bella Vista subdivision will add 171 residential connections to the current District's water system. The Bella Vista development will increase the District's water demand from 257 MGY (Table 4-3) to 294 MGY (Table 4-4). The planned 2.62 acres of irrigatable parks will introduce a 2.33 MGY water demand to the District, which results in a total 296 MGY build-out demand for the District with the Bella Vista Development.

As shown in **Figure 4-4**, a set of monthly distribution factors were calculated utilizing the past ten years of production records and were utilized to estimate the proposed Bella Vista developments water demand. The figure demonstrates that the future water demand still meets the water right summarized in Section 3 and Figure 3-1.

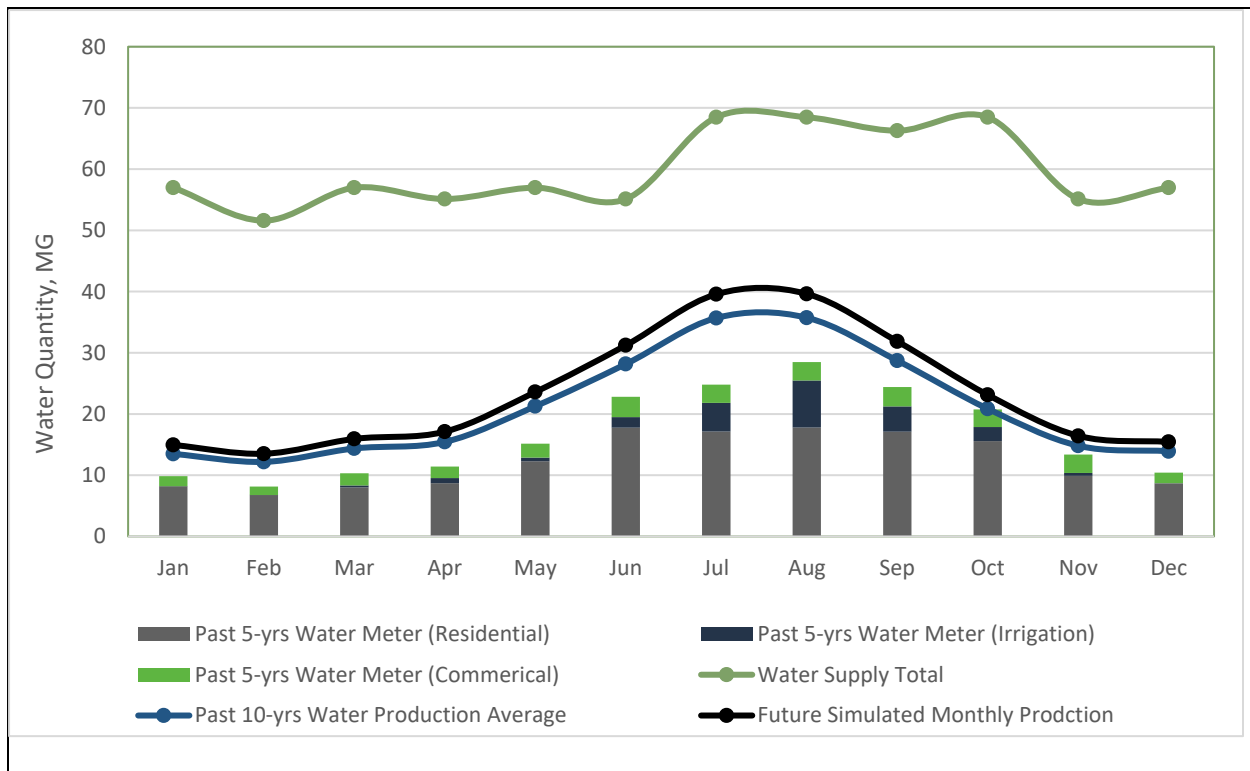

**Figure 4-4 Future Average Annual Consumption, Average Annual Consumption, and Water Supply by Month, with Bella Vista Development**

To examine the above conclusions, the *Per-Capita Method* was employed on this estimate. From the U.S. Census Bureau estimate, there are 2.55 people per household in Ukiah City [4]. The proposed 171 residential accounts for the Bella Vista subdivision projects to 436 people (Table 4-6). The build-out demand for the District and Bella Vista is 283 MGY, which is smaller than the *Disaggregate Method* result of 296 MGY. So, 296 MGY of future demand (Figure 4-4) is used to estimate water supplies.

Table 4-6. Bella Vista Water Usage Projection		
		Unit
Willow County Past 10-yrs, GPCD	63,696	Gallon Per Person per Year
Bella Vista Projection Population	436	People
Bella Vista Water Usage Projection	27.77	MG per Year
Future Willow County Annually Water Demand w/ Bella Vista	282.56	MGY

## 5. INFRASTRUCTURE SOURCE CAPACITY

The standards governing any proposed facilities discussed in this Technical Memorandum conform with the standards set forth (and not limited to) those listed below. These apply to all municipal drinking water systems in California, be they private (or investor-owned) and governmental entities:

1. Environmental Protection Agency of the Federal Government
2. California Code of Regulations, Title 22, Chapter 16 “California Waterworks Standards”
3. American Water Works Standards – current edition
4. Local county requirements
5. California Fire Code for fire flow requirements

### 5.1 Daily Water Demand and Peaking Factors

This section develops the daily water use and peaking factors that are needed to evaluate the adequacy of source and storage capacity in subsequent tasks.

Average Day Demand (ADD): The ADD is determined by dividing the annual water requirements by 365 days. The current annual water requirement in the District’s system is 257 MGY, as determined in Table 4-3. This equates to an ADD of 0.71 million gallons per day (MGD), or an average flow of 490 GPM. The annual water requirement at build-out is 296 MGY, as determined in Section 4.3 and Table 4-4. This equates to an ADD of 0.81 MGD or an average flow of 563 GPM.

Maximum Day Demand (MDD): In accordance with the California Waterworks Standards (Title 22), a public water system shall determine the MDD using the most recent ten years of data using daily production records, if available. When daily production data is not available, the MDD can be determined using the maximum month of production over the most recent ten years of operation and multiplying a factor of 1.5 times the average daily consumption in the maximum month.

Daily production records were not available and the multiplier of 1.5 times the average flow for the maximum month was used as allowed in Title 22. **Table 5-1** summarizes the historic production since 2010 including the maximum month of each year. The maximum day demand (MDD) was calculated using the maximum month production with the 1.5 multiplier.

The ratio of the MDD to ADD (referred to as the MDD peaking factor) is used for projecting future demands based on the future ADD estimates. From the current MDD of 1.96 MGD (1,363 GPM) and the current ADD of 0.71 MG, the MDD peaking factor is 2.78.

Jared Walker, Willow County Water District

September 9, 2021

Page 13

<b>Table 5-1. District Maximum Day Demand (MDD) (2010 - 2020)</b>			
Year	Annual Production	Max. Month Production	MDD using Title 22
	(MG)	(MG)	(MGD)
2010	247	37	1.77
2011	245	36	1.76
2012	273	40	1.92
2013	292	41	1.96
2014	230	32	1.53
2015	229	29	1.39
2016	231	34	1.63
2017	250	37	1.80
2018	262	39	1.90
2019	255	36	1.75
2020	289	40	1.96
<b>Maximum</b>	<b>292</b>	<b>41</b>	<b>1.96</b>

Peak Hour Demand (PHD): The peak hour demand (PHD) is the peak flow rate that occurs over a period of several hours on the day of maximum use. Certain factors specific to each system affect the peak hour demand, such as irrigation timers and residential use patterns, which can be measured and represented by a system's diurnal curve if hourly data is available. In the absence of that information, Title 22 permits the use of a factor of 1.5 multiplied by the MDD. Diurnal curves were not evaluated in this study. The PHD of 2,044 GPM is calculated by multiplying 1.5 times the MDD of 1,363 GPM. The ratio of PHD to ADD (or the PHD peaking factor) is 4.17.

For the Bella Vista development, the estimated residential ADD is 69 GPM using 0.40 GPM/EDU (Section 4.3). The MDD is 192 GPM using the peaking factor of 2.78, and the PHD is 289 GPM using the peaking factor of 4.17. The estimated landscaping ADD is 4 GPM converting the 2.33 MGY determined in Section 4.4. The MDD is 12 GPM using the peaking factor of 2.78, and the PHD is 18 GPM using the peaking factor of 4.17. The estimated current and future water demands at build-out are shown in **Table 5-2**.

<b>Table 5-2. Willow County Water District and Bella Vista – Water Demand (ADD, MDD, PHD)</b>						
	Equivalent EDU	ADD		MDD		PHD
		GPM	MGD	GPM	MGD	GPM
Existing Willow District	1,211	490	0.71	1,363	1.96	2,044
Bella Vista Residential	171	69	0.10	192	0.28	289
Bella Vista Landscaping	2.62 Acres	4	0.01	12	0.03	18
<b>Total</b>	<b>1,382</b>	<b>563</b>	<b>0.81</b>	<b>1,567</b>	<b>2.27</b>	<b>2,351</b>

## 5.2 District Existing Water Infrastructure Capacity

The District currently serves potable drinking water to an estimated 4,000 people via approximately 1,064 service connections. Supplies are obtained from two Well Fields, referred to as the Burke Hill Well Field and the Norgard Well Field. There are five underflow supply wells. Two wells are dedicated to Burke Hill Well Field and three wells are dedicated to Norgard Well Field. Storage tanks are located in two pressure zones. The main pressure zone has a 1.55 MG storage capacity, while the upper pressure zone holds 0.048 MG capacity. The details of the existing water supply infrastructures are listed in **Table 5-3**.

Table 5-3. Water Intake and Supply Infrastructures							
Water Wells						Storage Tanks	
Well Field	Well Name	Production Rate	Function	Function	Water Source	Zone	Storage Size
		GPM					Gallon
Burke Hill Well Field	Well 7	1,000	Primary	Mostly only use one well at a time	Underflow Wells	Main Pressure	1,550,000
	Well 8	1,000	Backup			Upper Pressure	48,000
Norgard Well Field	Well 3	300	Combine Production Rate	Operation from May 1 to Sep. 30			
	Well 5						
	Well 6						

## 5.3 Water Supply Analysis

As shown in Table 5-3, Well 7 is the primary well with a pumping capacity of 1,000 GPM and Well 8 serves as the backup well with a capacity of 1,000 GPM. In the summer, the District has an additional 300 GPM available from Well's 3, 5 and 6. However, the District does not typically operate Well 7 and Well 8 at the same time since they are located in the same well field, so the District's pumping capacity is 1,300 GPM from May to September and 1,000 GPM beside the summer period. The District has approximately 1.6 MG of storage capacity.

**Well Capacity**, as required in the California Waterworks Standards (Title 22), must always meet the MDD of the system. The District's current MDD is 1,363 GPM and the build-out MDD is 1,567 GPM. Meanwhile, the well production rate is 1,000 GPM. In the summer with high water demand, the available well capacity is 1,300 GPM. Thus, with only 1,000 GPM from Well 7 (or Well 8) plus the additional 300 GPM capacity available in the summer, the District cannot meet the current MDD of 1,363 GPM and the build-out MDD of 1,567 GPM. If the District has all wells available, Wells 3, 5, 6, 7, and 8 the total pumping capacity is 2,300 GPM in summer and 2,000 GPM in the other seasons, the District could meet the MDD.

From the District's 10-year historical production, the maximum production 908 GPM, which is less than the available well supply (1,300 GPM). We assume the District does not pump Well 7 and Well 8 together since the system does not have the demand to do so.

**Storage Capacity** is sized for the instantaneous peak flows (operational storage), fire safety, emergency, and unusable storage volumes. Storage requirements are unique to each storage site because of the hydraulic demands specific to each WTP during peak instantaneous and fire flows. Storage capacity requirements are summarized in **Table 5-4** and described below. The District has a 1.6 MG storage capacity which is sufficient for the 0.95 MG storage requirement.

- **Operational Storage:** Per regulations (Title 22), storage tanks are sized to meet 4 hours of Peak Hour Demand (PHD).
- **Fire Storage:** Fire flows in the distribution system are sized for the suppression of residential or commercial fires. There must be enough volume held in storage to fight the larger requirement, which is a commercial fire flow of 3,000 GPM, for a three-hour duration.
- **Emergency Storage:** Emergency storage is the volume held in residence for periods where there are interruptions in the water supplies from the wells. Industry practice is to maintain an emergency volume of one MDD to protect against prolonged power outages. Alternatively, standby emergency generators can be equipped to ensure there are uninterrupted power supplies to the water supply facilities.
- **Unusable Storage:** Unusable storage is the volume of water that is not available from a nominal tank volume due to inlet and outlet pipe configurations. The unusable volume is assumed to be ten percent of the nominal volume of storage required.

Operation Storage	Fire Storage	Unusable Storage	Total
MG	MG	MG	MG
0.32	0.54	0.09	0.95

## 6. WATER SUPPLY RISK DURING DROUGHT

The District uses the Russian River Underflow for their water supply. Based on the historical records, an average of 35.6% of the appropriative water rights have been used during the last 10 years, and an estimated 41.3% of the water rights will be used in the future with the Bella Vista development.

The UVAP assessment report shows that from 2007 to 2009, the Ukiah Valley Area (UVA) experienced severe drought conditions, and well below average precipitation in 2002. Especially in 2009, Lake Mendocino water levels receded to record lows, and the Mendocino County Board of Supervisors issued a mandatory 50% reduction in water use. Comparing with this critically dry year, with the Bella Vista development, Willow County Water District uses 41.3% of the regular water rights and still could meet the 50% reduction requirement. UVAP also mentions the District's current water supplies are sufficient to meet the existing and projected future water demands, in normal, critically dry, and extended dry years<sup>[5]</sup>.

The District's water rights were curtailed by a mandatory reduction of 25% in 2014 and 2021. The District met the reduction in 2014. In 2021, purchased water from RRFC was also cut by 20% due to the water shortage caused by the current drought. As shown in **Figure 6-1**, with a 25% reduction on the two Willow licenses, the total water right reduces to 82% of the regular years. And with an additional 20% reduction

Jared Walker, Willow County Water District

September 9, 2021

Page 16

on the purchased RRFC water, the water availability for the District is 76% compared to a normal-year. Under restrictions like 2021, the estimated water consumption of 909 AF per year (296 MGY) is 41% of the available water supply and can still be met when the water supply is curtailed.

### **Water Shortage Contingency Plan**

In 1983 the state passed the California Urban Water Management Act (Act) which requires all urban water suppliers who serve 3,000 or more customers or who provide 3,000 or more-acre feet of water per year to prepare an Urban Water Management Plan (UWMP) every 5 years and submit the UWMP to the California Department of Water Resources (DWR). The purpose of the Act is to ensure that water suppliers plan for the long-term conservation and efficient use of the State's water supplies.

The District is not required to prepare an UWMP or a Water Shortage Contingency Plan as they do not have over 3,000 customers (i.e. service connections) or supply over 3,000 acre-feet of water. However, earlier this year in 2021, the District did approve a new water shortage contingency resolution asking for 25% mandatory water use conservation during periods of drought.

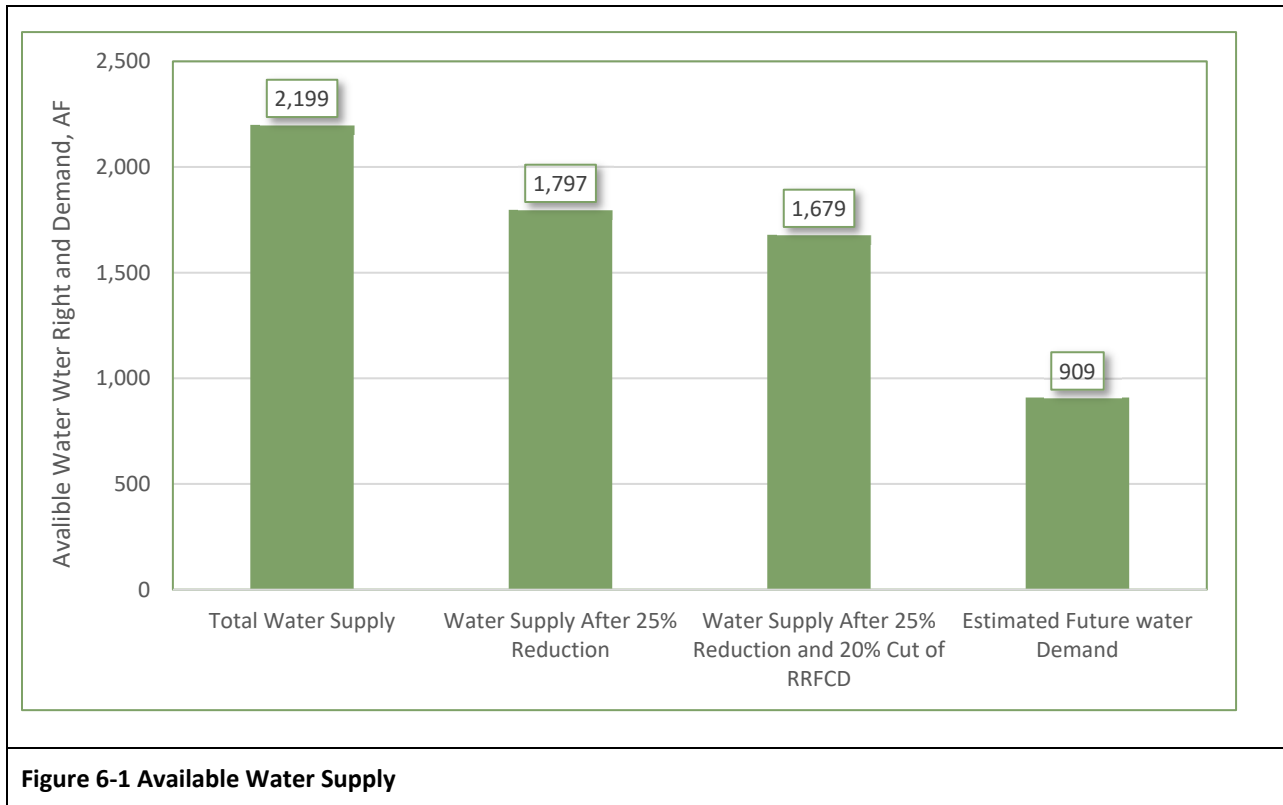

## 7. SUMMARY

The District has approximately a total of 2,199 AF (717 MG) water to use yearly under the two water right licenses and a purchased water contract. Historical records show the District uses an average of 255 MGY, approximately 35.6% of the available 717 MG water supply. With the Bella Vista subdivision development, the District will consume 296 MGY, which occupies 41.3% of the available water supply.

Well 7 is the District’s primary well with a pumping capacity of 1,000 gallons per minute (gpm) and Well 8 serves as the backup well with a capacity of 1,000 gpm. In the summer, the District has an additional 300 gpm available from Well’s 3, 5 and 6. Historically, the District has not utilized Well 7 and Well 8 together since the system does not have the demand to do so but the District could operate both wells concurrently if needed. From the District’s 10-year historical production data, the maximum production is close to 1,000 gpm.

The District’s calculated Maximum Day Demand (MDD) is 1,363 gpm and the build-out MDD is 1,567 gpm. Thus, with only 1,000 gpm from Well 7 (or Well 8) plus the additional 300 gpm capacity available in the summer, the District has a well capacity of 1,300 gpm and cannot meet the MDD of 1,363 gpm. If the District has all wells available, Wells: 3, 5, 6, 7, and 8 the total pumping capacity is 2,300 gpm and the District could meet the MDD.

The District has 1.6 MG storage capacity which is sufficient to meet the estimated 0.95 MG storage requirement.



Jared Walker, Willow County Water District

September 9, 2021

Page 18

The District's water rights were curtailed to 1,679 AF by a mandatory reduction of 25% on the water rights and a 20% reduction on the purchased water from RRFC in 2021. In dry years like 2021, the District has sufficient water supply availability to meet the estimated future water demand of 909 AF, with the Bella Vista development.

In conclusion, this technical memorandum provides verification that the District has sufficient water supply for the proposed Bella Vista development.

Jared Walker, Willow County Water District  
September 9, 2021  
Page 19

## REFERENCES:

- [1] Guillon Inc. Construction, August 31, 2020, Vesting Tentative Map, Bella Vista Subdivision
- [2] Guillon Inc. Construction, August 27, 2020, Bella Vista Project Description
- [3] CA Drinking Water Watch,  
[https://sdwis.waterboards.ca.gov/PDWW/JSP/WaterSystemDetail.jsp?tinwsys\\_is\\_number=3014&tinwsys\\_st\\_code=CA&wsnumber=CA2310005](https://sdwis.waterboards.ca.gov/PDWW/JSP/WaterSystemDetail.jsp?tinwsys_is_number=3014&tinwsys_st_code=CA&wsnumber=CA2310005)
- [4] U.S. Census Bureau, Population Division, May 2020, Annual Estimates of the Resident Population for Incorporated Places in California: April 1, 2010 to July 1, 2019 (SUB-IP-EST2019-ANNRES-06)
- [5] Mendocino County Water Agency, October 20, 2010, Water Supply Assessment for the Ukiah Valley Area Plan
- [6] U.S. Environmental Protection Agency, <https://www.epa.gov/watersense/water-budget-tool>
- [7] California Polytechnic State University, Irrigation Training & Research Center (ITRC),  
<http://www.itrc.org/etdata/>

## ATTACHMENT(S):

Attachment A - Map of Willow County Water District and Bella Vista Development

# ATTACHMENT A

## Map of Willow County Water District and Bella Vista Development

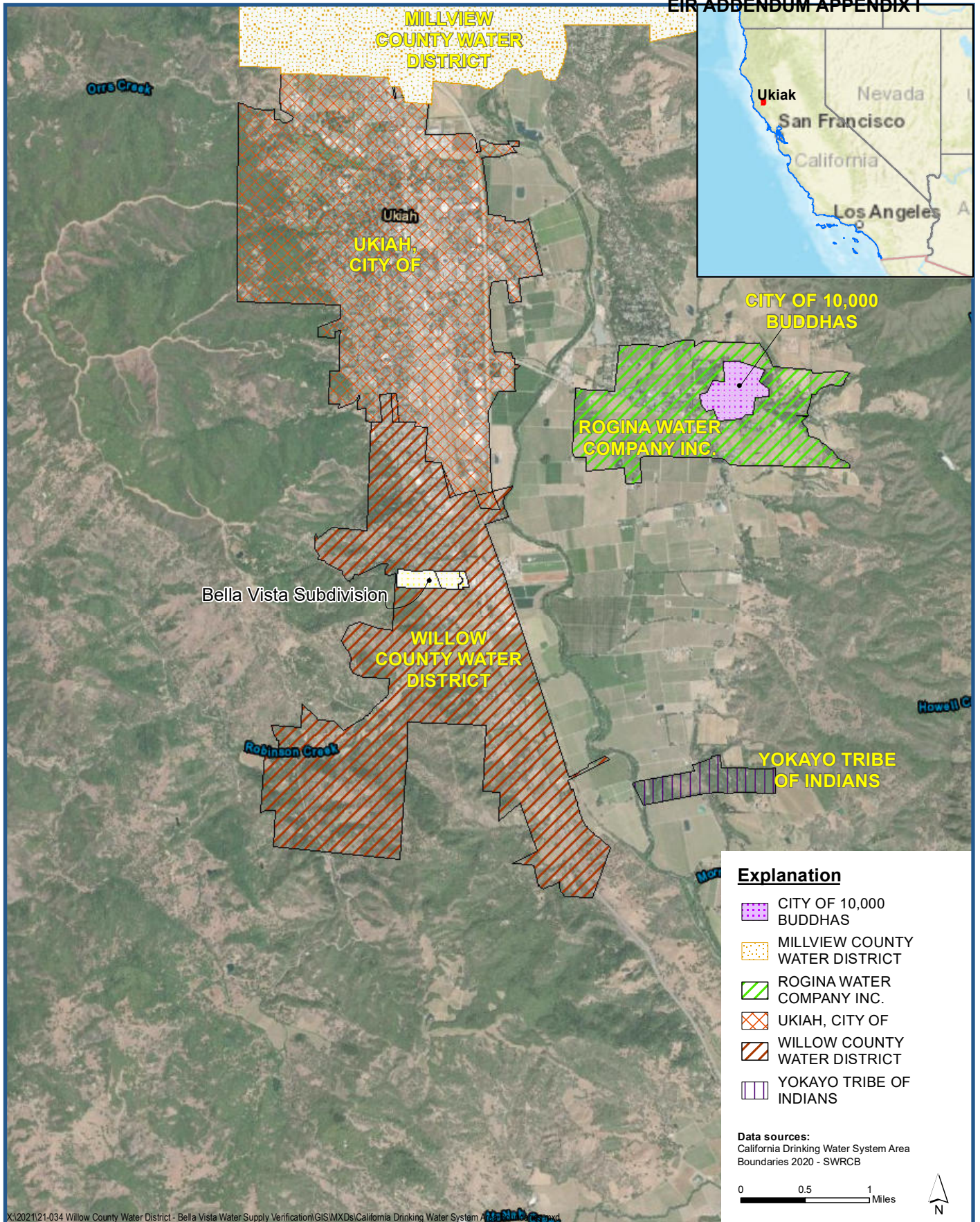

**Willow County Water District Boundary Map**

*Bella Vista Development Water Supply Verification  
Willow County Water District/Mendocino County*

**Attachment A**

UKIAH VALLEY SANITATION DISTRICT

WING-SEE FOX  
Interim District Manager  
wingseef@urbanfuturesinc.com

151 Laws Avenue STE B  
Ukiah, CA 95482  
(707) 462-4429

WEB SITE  
www.uvsd.org

March 11, 2021

Guillon Inc. Construction  
Attn: Jake Morley, Project Manager  
2550 Lakewest Drive #50  
Chico, CA 95928

Re: Ukiah Valley Sanitation District (UVSD) Capacity to Serve Sewer for Bella Vista Tentative Subdivision Map, Ukiah, CA

Ms. Morley,

The UVSD received your request for a Capacity to Serve Letter for a new development. Bella Vista is a 171-lot subdivision, made up to 39 age restricted lots and 132 single family lots (Major Subdivision No. s\_2020-0001). The project will be constructed over 9 phases and is located at 3000 South State Street in Ukiah, CA (APN: 184-110-28, 184-110-29, 184-120-21 and 184-120-01) and consists of approximately 48.8 acres.

The UVSD at this time has the Capacity to Serve this project with sewer services. Upon submittal and review of your project plans, the UVSD will determine sewer connection fees that will be due and payable prior to the issuance of a building permit for your project.

Sincerely,



Wing-See Fox  
Interim General Manager

**EXHIBIT "B"**  
**AMENDED MITIGATION MONITORING & REPORTING PROGRAM**  
**for the Bella Vista Subdivision**

Impact	Mitigation Measure	Implemented by	Implemented when	Monitored by	Verified by and date
<b>GEOLOGY</b>					
<p><b>3.1-A:</b> Improvements built on the site would be subject to seismic ground shaking, which could cause the failure of those improvements and risk to human health.</p>	<p><b>3.1-A.1:</b> A final geotechnical report shall be prepared that incorporates the recommendations set forth in the 2005 RGH Report as modified by mitigation measures recommended in this EIR. The project applicant shall design project structures and foundations to withstand expected seismic forces in accordance with the California Building Code as adopted by the County of Mendocino. Since the project site is located within Seismic Zone 4 it is considered potentially seismically active. The County shall not issue building permits until seismic design criteria are reviewed and approved. During construction adherence to design criteria shall be monitored, and a final report issued documenting conformance prior to occupancy.</p>	<p>Project Engineer  Project Geotechnical Consultant</p>	<p>Issuance of Building, Grading or Other Permits</p>	<p>Mendocino County Dept. of Planning &amp; Building Services (Planning Dept.)</p>	<p>Planning Dept.  Approval of Final Map</p>
<p><b>3.1-B:</b> Seismically induced ground failure, including liquefaction and densification, would cause improvements to fail and risk to human health.</p>	<p><b>3.1-B.1:</b> Potentially unstable surface soils shall be remediated by strengthening the soils during site grading. The strengthening will be achieved by excavating the weak soils and replacing them as properly compacted engineered fill. All site grading and foundation construction shall follow the recommendations of the Geotechnical Engineer of record for the project. The process will include excavation of surface soils and placement of all fill soils at a minimum of 90 percent compaction relative to the maximum dry density near the optimum moisture content as determined in accordance with ASTM D 1557.</p>	<p>Project Engineer</p>	<p>Issuance of Building, Grading or Other Permits</p>	<p>Planning Dept.</p>	<p>Planning Dept.  Prior to building construction</p>

**EXHIBIT "B"**  
**AMENDED MITIGATION MONITORING & REPORTING PROGRAM**  
**for the Bella Vista Subdivision**

Impact	Mitigation Measure	Implemented by	Implemented when	Monitored by	Verified by and date
	<p>Site soils will be tested during construction by the Geotechnical Engineer-of-Record or by a Special Inspector to confirm that minimum standards are met. A final report documenting results of fill testing will be submitted to the County of Mendocino Department of Planning and Building Services and will be subject to the review of that department.</p>				
<p><b>3.1-C:</b> Potentially unstable slopes or underlying soils could cause the failure of improvements and risk to human health.</p>	<p><b>3.1-C.1:</b> Cut and fill slopes should be designed and constructed as slope gradients of 2h:1v or flatter, unless otherwise approved by the Geotechnical Engineer-of-record in specified areas. The interior slopes of the retention basin should be inclined no steeper than 3h:1v. If steeper slopes are required, retaining walls shall be used. Fill slopes steeper than 2h: 1v will require the use of a Geogrid reinforcing material to increase stability. Fill slopes shall be constructed by over-filling and cutting the slope to final grade. Graded slopes shall be planted with fast-growing, deep-rooted groundcover to reduce sloughing and erosion.</p> <p>Fills placed on terrain sloping at 5h:1v or steeper shall be continually keyed and benched into firm, undisturbed bedrock or firm soil. The benches shall allow space for the placement of select fill of even thickness under settlement sensitive structural elements supported directly on the fill.</p>	<p>Project Engineer</p> <p>Project Geotechnical Consultant</p>	<p>Issuance of Building, Grading or Other Permits</p>	<p>Planning Dept.</p>	<p>Planning Dept.</p> <p>Prior to building construction</p>

**EXHIBIT "B"**  
**AMENDED MITIGATION MONITORING & REPORTING PROGRAM**  
**for the Bella Vista Subdivision**

Impact	Mitigation Measure	Implemented by	Implemented when	Monitored by	Verified by and date
	<p><b>3.1-C.2</b> Retaining walls shall be designed to retain planned cut slopes for the hillside lots that exceed 2h:1v in slope steepness. These cuts are planned to be as great as 13 feet in height. The Geotechnical Engineer-of-record shall provide revised recommendations for retaining walls if needed to meet current building code requirements. All retaining walls shall be designed by a State of California Registered Civil Engineer in accordance with requirements of the current edition of the California Building Code including seismic design considerations. Retaining wall design shall be reviewed by the County of Mendocino Department of Planning and Building Services to ensure conformance with state and local building code requirements.</p>	<p>Project Engineer  Project Geotechnical Consultant</p>	<p>Issuance of Building, Grading or Other Permits</p>	<p>Planning Dept.</p>	<p>Planning Dept.  Prior to building construction</p>
	<p><b>3.1-C.3:</b> Plan Review will be performed by the County of Mendocino Department of Planning and Building Services to ensure conformance with grading and drainage requirements. The Geotechnical Engineer-of-Record shall prepare a geotechnical review letter documenting that plans meet with the intent of geotechnical recommendations.</p>	<p>Project Geotechnical Consultant</p>	<p>During Construction</p>	<p>Planning Dept.</p>	<p>Planning Dept.  Prior to building construction</p>
	<p><b>3.1-C.4:</b> The Geotechnical Engineer-of-Record and/or Special Inspector shall perform construction observation and testing to ensure conformance with design requirements and geotechnical</p>	<p>Project Geotechnical Consultant</p>	<p>During Construction</p>	<p>Planning Dept.</p>	<p>Planning Dept.  Completion of building construction</p>



**EXHIBIT "B"**  
**AMENDED MITIGATION MONITORING & REPORTING PROGRAM**  
**for the Bella Vista Subdivision**

Impact	Mitigation Measure	Implemented by	Implemented when	Monitored by	Verified by and date
	<p>recommendations. Testing and monitoring shall include:</p> <ul style="list-style-type: none"> <li>● Verification of compaction requirements for engineered fill and subgrade soils. Unless otherwise stated all engineered fill shall be compacted to at least 90 percent of the maximum dry density at moisture contents above the optimum in accordance with ASTM D 1557 test method. Subgrade beneath foundations and pavement sections shall be additionally compacted to at least 95 percent of the maximum dry density at moisture contents near the optimum.</li> <li>● Verification of the installation of subsurface drainage in accordance with project plans and specifications.</li> <li>● Verification that footings are excavated into stable material and footing excavations are of sufficient depth and breadth to adequately support structures with minimal or no settlement.</li> <li>● Materials Testing and Special Inspection of concrete, steel, asphalt, wood members and other structural elements to establish conformance with the design standards.</li> <li>● Verification of correct installation of erosion control measures and adherence to the requirements of the approved Stormwater Pollution Plan (SWPPP) for the project.</li> </ul>				

**EXHIBIT "B"**  
**AMENDED MITIGATION MONITORING & REPORTING PROGRAM**  
**for the Bella Vista Subdivision**

Impact	Mitigation Measure	Implemented by	Implemented when	Monitored by	Verified by and date
<p><b>3.1-D:</b>  Expansive soils on the site could cause the failure of improvements and risk to human health.</p>	<p><b>3.1-D.1:</b> Where spread footings are chosen for foundation support, weak, porous, compressible and locally expansive surface soil shall be excavated to within 6 inches of their entire depth. Excavation of weak, compressible, and locally expansive soils shall extend a minimum of 12 inches below exterior concrete slabs and/or asphalt concrete pavement subgrade. These soils shall be replaced with select fill material. Additionally, excavation of weak, porous, compressible, expansive, creep-prone surface materials shall extend at least 5 feet beyond the outside edge of exterior footings of the proposed buildings and 3 feet beyond the edge of exterior slabs and or pavements. These soils shall also be replaced with select fill material as described below. Select fill material shall be free of organic matter, have a low expansion potential, and conform in general to the following requirements: 100% passing 6" sieve; 90-100 % passing the 4" sieve; 10-60% passing the No. 200 sieve (all percentages by dry weight); LL - 40 max; PI - 15 max; R-value - 20 min. The Geotechnical Engineer - of - Record shall approve imported material prior to use as compacted fill.</p>	<p>Project Engineer  Project Geotechnical Consultant</p>	<p>Issuance of Building, Grading or Other Permits</p>	<p>Planning Dept.</p>	<p>Planning Dept.  Completion of building construction</p>
<b>HYDROLOGY &amp; WATER QUALITY</b>					
<p><b>3.2-A:</b>  Development of the project would create new impervious</p>	<p><b>3.2-A.1:</b> The project shall not cause flooding downstream of the project site, and post-development peak flows discharged to the 18-inch CMP storm drain beneath South State Street shall</p>	<p>Project Engineer</p>	<p>Final Map approval</p>	<p>Mendocino Water Agency</p>	<p>Mendocino Water Agency and Planning Dept.</p>

**EXHIBIT "B"**  
**AMENDED MITIGATION MONITORING & REPORTING PROGRAM**  
**for the Bella Vista Subdivision**

Impact	Mitigation Measure	Implemented by	Implemented when	Monitored by	Verified by and date
<p>surfaces, increasing the rate and amount of stormwater runoff. This runoff could contribute to flooding in the vicinity of the project site.</p>	<p>not exceed pre-development peak flows. At final project design, the applicant shall calculate the amount of runoff that will be generated by the developed portions of lots that drain into Cleland Mountain Creek and factor that increase into the analysis performed by Sandine and Associates to determine whether peak flow rates will remain below pre-development levels and the risk of flooding in the project site and off-site downstream will not be increased. If the post-project peak flow rates exceed the pre-development levels, the applicant shall increase the volume of the detention basin capacity to achieve the target peak flow discharge. The 18-inch storm drain facility beneath South State Street shall be located, inspected by video camera or other method, and a report submitted to the County Department of Transportation at the time of the final design of the subdivision storm drainage system, substantiating the adequacy of the existing facility to accommodate the design runoff or recommending improvements necessary to the facility to adequately accommodate project runoff. Those recommendations shall be constructed.</p>			<p>(Water Agency)  Mendocino County Department of Transportation</p>	<p>Mendocino County Department of Transportation  Final Map approval</p>
	<p><b>3.2-A.2:</b> As part of the Development Agreement, establish a Homeowners Association (HOA) maintenance agreement that details the provisions for regular monitoring of the detention pond storage capacities, as well as requirements for detention pond cleanouts, when necessary, to maintain design stormwater storage levels.</p>	<p>Project Engineer</p>	<p>Approval of Development Agreement</p>	<p>Planning Dept.</p>	<p>Planning Dept. Prior to construction</p>

**EXHIBIT "B"**  
**AMENDED MITIGATION MONITORING & REPORTING PROGRAM**  
**for the Bella Vista Subdivision**

Impact	Mitigation Measure	Implemented by	Implemented when	Monitored by	Verified by and date
	<p>Establish a monitoring protocol that is acceptable to the County that monitors implementation of this maintenance, including a bond or other funding agreement that reimburses the County if the County is required to conduct required maintenance due to the HOA not implementing required maintenance.</p>				
<p><b>3.2-B:</b>            Project development would result in the construction of four residential lots in the FEMA- designated 100- year floodplain of Cleland Mountain Creek.</p>	<p><b>3.2-B.1:</b> The project shall not result in flooding of residences on the project site. To minimize the risk of flooding during the FEMA-designated 100-year base flood, the applicant shall implement one of the following alternatives:</p> <p>A) Re-design the grading plan for Lots 20-21 and 196-197 in the vicinity of Cleland Mountain Creek so that building finished floor elevations are a minimum of one foot above the land surface elevations inferred by the FIRM Zone A SFHA mapping,</p> <p>or</p> <p>B) Prepare a Letter of Map Revision (LOMR), accompanied by the appropriate technical documentation, and submit it to FEMA (or its sponsored contractor), to petition for a change in the FEMA SFHA designation for the project site. Required technical documentation would include an updated flood backwater profile modeling of Cleland. Creek, including the proposed Plant Road bridge crossing, which was excluded from</p>	<p>Project Engineer</p>	<p>Final Map approval</p>	<p>Planning Dept.  Water Agency</p>	<p>Planning Dept.  Prior to Final Map</p>

**EXHIBIT "B"**  
**AMENDED MITIGATION MONITORING & REPORTING PROGRAM**  
**for the Bella Vista Subdivision**

Impact	Mitigation Measure	Implemented by	Implemented when	Monitored by	Verified by and date
	<p>the original HEC-RAS analysis conducted for the project by Sandine Associates.</p> <p>If the modeling results verify that the published FEMA mapping is inaccurate and that Lots 20-21 and 196-197 are outside of the redefined SFHA, then the lots could be developed as proposed, subject to possible regulatory restrictions or conditions imposed by the California Department of Fish and Game (CDFG) and the Mendocino County Water Agency (MCWA) for disturbance of the riparian corridor. If the modeling results verify that the published FEMA flood mapping was accurate, then Alternative A would be required for development of the lots.</p> <p>The same potential regulatory restriction or conditions imposed by CDFG or the MCWA would apply.</p>				
<p><b>3.2-C:</b>  Project development would result in the clearing of land for the proposed site improvements. During and after project construction exposed slopes will be at increased risk of erosion. Site erosion could</p>	<p><b>3.2-C.1:</b> The project shall not cause significant erosion. The applicant shall submit a detailed Erosion Control Plan as part of the Stormwater Pollution Prevention Plan (SWPPP) to the Mendocino County Water Agency (MCWA) and to the State Water Resources Control Board (SWRCB), in conjunction with the filing of a Notice of Intent (NOI) with the SWRCB. The County shall not issue a Grading Permit until the County Water Agency agrees that the plan contains adequate Best Management Practices for controlling</p>	<p>Project Engineer</p>	<p>Issuance of Building, Grading or Other Permits</p>	<p>Water Agency  SWRCB</p>	<p>Water Agency  SWRCB  Plan verified at approval of Grading Permit  Implementation verified at completion of construction</p>

**EXHIBIT "B"**  
**AMENDED MITIGATION MONITORING & REPORTING PROGRAM**  
**for the Bella Vista Subdivision**

Impact	Mitigation Measure	Implemented by	Implemented when	Monitored by	Verified by and date
<p>prematurely decrease the storage capacity of the vault detention system. The construction of the proposed bridge crossing over Cleland Mountain Creek would also create conditions for the discharge of fill into Waters of the United States.</p>	<p>erosion. At a minimum, the Erosion Control Plan shall include the following restrictions, guidelines, and measures:</p> <p>(1) grading and earthwork shall be prohibited during the wet season (typically October 15 through April 15) and such work shall be stopped before pending storm events during the spring fall construction season; (2) erosion control/soil stabilization techniques such as straw or wood mulching, erosion control matting, and hydroseeding, or their functional equivalents shall be utilized in accordance with applicable manufacturers specifications and erosion control Best Management Practices (BMPs) published in the California Stormwater BMP Handbook - Construction (California Stormwater Quality Association 2005) and/or similar proscriptions outlined in the Erosion and Sediment Control Field Manual (SF Bay RWQCB 2002); (3) bales of hay or accepted equivalent methods shall be installed in the flow path of graded areas receiving concentrated flows, as well as around storm drain inlets; (4) installation of silt fencing and other measures to segregate the active flow zone of Cleland Mountain Creek from the near overbank disturbance associated with bridge abutment construction; and (5) post-construction stormwater treatment measures.</p> <p>These and other erosion control BMPs shall be monitored for effectiveness and shall be subject to inspection by the County. The applicant shall be</p>				

**EXHIBIT "B"**  
**AMENDED MITIGATION MONITORING & REPORTING PROGRAM**  
**for the Bella Vista Subdivision**

Impact	Mitigation Measure	Implemented by	Implemented when	Monitored by	Verified by and date
	responsible for implementing any remedial actions recommended by the County. After construction is completed, all drainage facilities shall be inspected for accumulated sediment, and these drainage structures shall be cleared of debris and sediment. Silt fence shall be left in place until the hydroseed has become established.				
<p><b>3.2-D:</b>            Project implementation would increase the area devoted to both paved (roadway and driveway) surfaces and maintained landscaping. Episodic discharge of stormwater contaminated with heavy metals could detrimentally affect downstream water quality. Residential lot development would be accompanied by increased application of fertilizers and chemicals (such as herbicides and pesticides).</p>	<p><b>3.2-D.1:</b> The project shall not cause substantial pollution of Cleland Mountain Creek or the Russian River. The applicant shall prepare an NOI and SWPPP for the project, and incorporate the following additional site-appropriate BMPs or their equivalents for short- and long-term implementation by the Homeowners Association (HOA) and/or individual lot owners, in order to comply with the requirements of the NPDES General Permit and provisions of the Mendocino County Storm Water Management Program. The BMPs will result in stormwater leaving the site at least meeting the NCRWQCB water quality objectives for the Russian River. The SWPPP shall be approved by the Mendocino County Water Agency and the State prior to project construction. Impervious surfaces shall be minimized by using such techniques as driveway strips with bordering pervious pavement material (rather than a full paved driveway); using pervious materials for parking areas; directing runoff from rooftops and</p>	Project Engineer	Issuance of Building, Grading or Other Permits	Water Agency  Planning Dept.  SWRCB	Water Agency  SWRCB  Plan verified at approval of Grading Permit Implementation verified at completion of construction

**EXHIBIT "B"**  
**AMENDED MITIGATION MONITORING & REPORTING PROGRAM**  
**for the Bella Vista Subdivision**

Impact	Mitigation Measure	Implemented by	Implemented when	Monitored by	Verified by and date
	<p>streets to landscaping buffers and/or recharge trenches.</p> <p>These and other BMPs shall be monitored for effectiveness and shall be subject to inspection by the County. The Homeowners Association shall be responsible for implementing any remedial actions recommended by the County. The applicant shall establish a monitoring protocol that is acceptable to the County that monitors implementation of these measures, including a bond or other funding agreement that reimburses the County if the County needs to conduct required maintenance due to the HOA not implementing required maintenance. The County can require that monitoring be done by a third party acceptable to the County; costs of all monitoring and any maintenance will be borne by the Homeowners Association.</p> <p>Since the objective of erosion control and water quality treatment measures would be to reduce contaminant loading to the maximum extent practicable with implementation of the best available technologies, the recommended BMPs are not fixed. Other measures can be applied as long as the applicant can demonstrate to the satisfaction of MCWA that those measures can provide equivalent levels of reduction in contaminant loading.</p> <p>The applicant shall prepare a plan that describes the roles and responsibilities of the HOA, lot</p>				



**EXHIBIT "B"**  
**AMENDED MITIGATION MONITORING & REPORTING PROGRAM**  
**for the Bella Vista Subdivision**

Impact	Mitigation Measure	Implemented by	Implemented when	Monitored by	Verified by and date
	owners, and/or the County for implementing the BMPs and monitoring the results. If the County will be responsible for monitoring or implementing any actions, then a funding mechanism will be established. The County will review and approve this plan prior to the onset of construction.				
	<b>3.2-D.2:</b> Per the recommendations of the CDFG, Lots 121, 122, 123, 124 and Lot 4 of Tract 261 shall be removed from the project in order to provide the minimum creekside buffer required to filter contaminants, including sediment, from stormwater runoff. These four lots may be relocated elsewhere in the subdivision in accordance with the Restated Development Agreement.	Project Engineer	Prior to issuance of first Final Map	Planning Dept.	Planning Dept.  Prior to issuance of first Final Map
<b>3.2-E:</b> The project plus other cumulative development could adversely affect the water quality of the Russian River.	Mitigation Measures for Impacts 3.2-C and 3.2-D also apply to this impact.	See the cited measures.			
<b>BIOLOGICAL RESOURCES</b>					
<b>3.3-A:</b> Project development could adversely	<b>3.3-A.1:</b> The applicant shall preserve water quality in Cleland Mountain Creek. A Riparian Enhancement Area that includes Lots 21, 22, and	Project Applicant	Final	Planning Dept.	Planning Dept.

**EXHIBIT "B"**  
**AMENDED MITIGATION MONITORING & REPORTING PROGRAM**  
**for the Bella Vista Subdivision**

Impact	Mitigation Measure	Implemented by	Implemented when	Monitored by	Verified by and date
affect water quality thereby indirectly affecting listed salmonid species.	197 121, 122, 123, 124 shall be established to include all areas within a setback of 20 feet from the top of bank of this creek and deed restricted to prohibit grading, tree cutting, trash deposition, landscaping other than natural habitat restoration, storage of materials, filling, structures, dumping of chemicals, or disruptive activities. The applicant shall replant the Riparian Enhancement Area. The planting and maintenance of the plantings shall be conducted per a plan prepared by a qualified biologist. The replanting shall include riparian species along the creek and oaks, bay, and buckeye further from the creek. The plan shall include the planting of at least three replacement trees (of the same species as the tree removed) for each oak, bay, buckeye, and Oregon ash that is removed. Within the 20-foot riparian habitat setback, appropriate native ground covers and shrubs will also be established to filter runoff from developed portions of nearby lots. All plantings established under this plan shall be irrigated and replaced as needed as well as monitored by the plan preparer for a period of no less than 3 years to ensure successful establishment. The Riparian Enhancement Area shall be maintained by the HOA pursuant to this plan.		Map for Phase in which lots are located		Approval of Final Map for Phase in which lots are located
	<b>3.3-A.2:</b> Construction activities within Cleland Mountain Creek shall be limited to the dry season when no flowing water is present in the channel. Channel disturbance shall be kept to a minimum	Project Applicant	Prior to initiation of construction within	Planning Dept.	Planning Dept.

**EXHIBIT "B"**  
**AMENDED MITIGATION MONITORING & REPORTING PROGRAM**  
**for the Bella Vista Subdivision**

Impact	Mitigation Measure	Implemented by	Implemented when	Monitored by	Verified by and date
	during construction activities within the channel and only occur within designated areas.		Cleland Mountain Creek channel		During construction activities
	<b>3.3-A.3:</b> When water is present within Cleland Mountain Creek, a qualified biologist shall conduct a clearance survey to determine the presence or absence of western pond turtle individuals immediately prior to the start of work. If western pond turtles are observed where they could be potentially impacted by Project activities, then work shall not be conducted within 100 feet of the turtle(s) until a qualified biologist has relocated the turtle(s) outside of the Project boundary. If turtle eggs are uncovered during construction activities, then all work shall stop within a 25-foot radius of the nest and CDFW shall be notified immediately. The 25-foot buffer shall be marked with identifiable markers that do not consist of fencing or materials that may block the migration of young turtles to the water or attract predators to the nest site. No work will be allowed within the 25-foot buffer until CDFW has been consulted.	Project Applicant  Project Biologist	Prior to initiation of construction within Cleland Mountain Creek channel	Planning Dept.  CDFW	Planning Dept.  Prior to issuance of construction permits
	<b>3.3-A.4:</b> Removal of nesting habitat (for grasshopper sparrows, migratory birds and raptors) from the work area shall only take place between September 1 and January 31 to avoid impacts to nesting birds. If removal of nesting habitat is required during the nesting season, a nesting bird survey shall be conducted by a	Project Applicant  Project Biologist	Prior to tree removal and/or grading activities between February 1	Planning Dept.  CDFW	Planning Dept.  Prior to removal of nesting habitat during

**EXHIBIT "B"**  
**AMENDED MITIGATION MONITORING & REPORTING PROGRAM**  
**for the Bella Vista Subdivision**

Impact	Mitigation Measure	Implemented by	Implemented when	Monitored by	Verified by and date
	qualified biologist no more than 5 calendar days prior to disturbance. If an active nest is located, the biologist will coordinate with CDFW to establish appropriate buffers and any monitoring requirements. Removal of existing vegetation shall not exceed the minimum necessary to complete operations.		and August 31.		nesting season.
	<b>3.3-A.5:</b> A pre-construction/demolition bat survey shall be conducted by a qualified biologist within 5 days prior to the removal of suitable bat habitat (i.e., existing building). Mature trees and the existing outbuilding present on the project site should only be removed between September 16 and March 15, outside of the bat maternity season. Trees should be removed at dusk to minimize impacts to roosting bats.	Project Applicant  Project Biologist	Prior to removal of outbuilding and/or tree removal	Planning Dept.	Planning Dept.  Prior to removal of outbuilding and/or tree removal
	<b>3.3-A.6:</b> Prior to any discharge or fill material into waters of the U.S., authorization under a Nationwide Permit shall be obtained from the U.S. Army Corps of Engineers, if necessary. For fill requiring a Corps permit, a water quality certification from the Regional Water Quality Control Board shall also be obtained	Project Applicant	Prior to activities requiring said permits	Planning Dept.  CDFW  ACOE  RWQCB	Planning Dept.  Prior to approval of any work within Cleland Mountain Creek corridor
	<b>3.3-A.7:</b> Prior to any activities that would obstruct the flow of or alter the bed, channel, or bank of any perennial, intermittent, or ephemeral creeks, notification of streambed alteration shall	Project Applicant	Prior to activities requiring said permits	Planning Dept.  CDFW	Planning Dept.

**EXHIBIT "B"**  
**AMENDED MITIGATION MONITORING & REPORTING PROGRAM**  
**for the Bella Vista Subdivision**

Impact	Mitigation Measure	Implemented by	Implemented when	Monitored by	Verified by and date
	be submitted to the CDFW, and, if required, a Lake and Streambed Alteration Agreement shall be obtained.				Prior to approval of any work within Cleland Mountain Creek corridor
<b>3.3-B:</b> Project construction would remove up to 25 oaks.	Mitigation Measure 3.3-A.1 also applies to this impact.	See the cited measure.			
	<b>3.3-B.1:</b> An assessment shall be conducted that determines the area and number of oaks and other native hardwoods that would be removed or adversely impacted as a result of project development on Lots 121, 122, 123, 124 and Lot 4 of Tract 261. Building envelopes on Lots 121, 122, 123, 124 and Lot 4 of Tract 261, as well as driveway and utility connection locations, shall be adjusted if needed to avoid loss or both short-term and long-term adverse effects on native trees. The area outside of these building envelopes shall be deed restricted to require maintenance of existing native trees, and prohibition of lawns and landscaping incompatible with long-term survival of these trees, while allowing pruning and removal of any dead or dying trees, dead limbs and brush, and any clearances required as needed to reduce wildland fire hazard. All removed hardwoods shall be replaced with the same species at a	Project Applicant  Project Construction Manager during construction	Issuance of Building, Grading or Other Permits	Planning Dept.	Planning Dept.  Completion of construction implementation

**EXHIBIT "B"**  
**AMENDED MITIGATION MONITORING & REPORTING PROGRAM**  
**for the Bella Vista Subdivision**

Impact	Mitigation Measure	Implemented by	Implemented when	Monitored by	Verified by and date
	<p>minimum replacement ratio of 3:1 within the 20-foot riparian setback zone along the top of the bank of Cleland Mountain Creek. A minimum 3-year monitoring plan shall track planted trees and replace all that are dead or dying.</p>				
	<p><b>3.3-B.2:</b> If any of the 11 oak trees are removed, they shall be replaced at a mitigation ratio of 8:1. Trees shall be staked and screened for rodent protection and shall be irrigated for at least 3 years. The mitigation trees shall be located on properties that will be managed and maintained by the HOA.</p>	<p>Project Applicant  Project Construction Manager during construction</p>	<p>Issuance of Building, Grading or Other Permits</p>	<p>Planning Dept.</p>	<p>Planning Dept.  Completion of construction implementation</p>
<p><b>3.3-D:</b> Project construction would restrict wildlife movement and displace nesting sites.</p>	<p>Mitigation Measure 3.3-A.1 also applies to this impact.</p>	<p>See the cited measure.</p>			
<p><b>3.3-E:</b> The project plus other proposed new development in the area could have a cumulative impact on Russian River water quality and oak woodlands.</p>	<p>Mitigation Measures 3.2-C.1, 3.2-C.2, 3.2-D.1, 3.2-D.2, and 3.3-A.1 also apply to this impact.</p>	<p>See the cited measure.</p>			

**EXHIBIT "B"**  
**AMENDED MITIGATION MONITORING & REPORTING PROGRAM**  
**for the Bella Vista Subdivision**

Impact	Mitigation Measure	Implemented by	Implemented when	Monitored by	Verified by and date
<b>CULTURAL RESOURCES</b>					
<p><b>3.4-A:</b> Cultural resources could be damaged or destroyed by project construction.</p>	<p><b>3.4-A.1:</b> If cultural resources are discovered on the site during construction activities, all earthmoving activity in the area of impact shall be halted until the applicant retains the services of a qualified archaeological consultant. These archaeological sites will be documented (by a professional meeting the Secretary of the Interior qualification standards) on DPR forms and evaluated for their eligibility for the California Register. The archaeological consultant shall identify specific measures to mitigate impacts to the resource if it is deemed eligible for the California Register. Mitigation shall include data recovery operations, protection in situ of deposits, and/or archival research, if appropriate. The applicant shall abide by the recommended proposals.</p>	<p>Project Applicant  Project Construction Manager during construction</p>	<p>Issuance of Building, Grading or Other Permits</p>	<p>Planning Dept.</p>	<p>Planning Dept.  Completion of construction for implementation</p>
	<p><b>3.4-A.2:</b> In the event that human skeletal remains are discovered, work shall be discontinued in the area of the discovery and the County Coroner shall be contacted. If skeletal remains are found to be prehistoric Native American remains, the Coroner shall call the Native American Heritage Commission within 24 hours. The Commission will identify the person(s) it believes to be the "Most Likely Descendant" of the deceased Native American. The Most Likely Descendant would be</p>	<p>Project Applicant  Project Construction Manager during construction</p>	<p>Issuance of Building, Grading or Other Permits</p>	<p>Planning Dept.</p>	<p>Planning Dept.  County Coroner  Completion of construction for implementation</p>

**EXHIBIT "B"**  
**AMENDED MITIGATION MONITORING & REPORTING PROGRAM**  
**for the Bella Vista Subdivision**

Impact	Mitigation Measure	Implemented by	Implemented when	Monitored by	Verified by and date
	responsible for recommending the disposition and treatment of the remains. The Most Likely Descendant may make recommendations to the landowner or the person responsible for the excavation/grading work for means of treating or disposing of the human remains and any associated grave goods as provided in Public Resources Code Section 5097.98.				
<b>3.4-B:</b> Paleontological resources could be damaged or destroyed by project construction.	<b>3.4-B.1:</b> During project grading operations, should any undiscovered evidence of paleontological resources be encountered, work at the place of discovery shall be halted, and a qualified paleontologist shall be consulted to assess the significance of the finds. Prompt evaluations can then be made regarding the finds, and a management plan consistent with CEQA. cultural resources management requirements shall be adopted.	Project Applicant  Project Construction Manager during construction	Issuance of Building, Grading or Other Permits	Planning Dept.	Planning Dept.  Completion of construction for implementation
<b>TRAFFIC AND CIRCULATION</b>					
<b>3.5-C:</b> The proposed roundabout may not be able to accommodate truck and bus traffic.	<b>3.5-C.1:</b> The project applicant shall design the proposed South State Street/Plant Road roundabout to accommodate all existing and anticipated buses and large trucks.  Turning template diagrams shall be provided to the County Department of Transportation for the largest bus and trucks anticipated to be using the roundabout.	Project Applicant	Final Subdivision Map or Issuance of Building, Grading or Other Permits	Mendocino County Department of Transportation (DOT)	DOT  Approval of Final Subdivision Map



**EXHIBIT "B"**  
**AMENDED MITIGATION MONITORING & REPORTING PROGRAM**  
**for the Bella Vista Subdivision**

Impact	Mitigation Measure	Implemented by	Implemented when	Monitored by	Verified by and date
<p><b>3.5-F:</b> The project design does not adequately provide for mass transit access.</p>	<p><b>3.5-F.1</b> To provide access for project residents to the existing Mendocino Transit northbound bus stop on Plant Road across from the project site, a pedestrian walkway shall be constructed between the proposed roundabout at South State Street/ Plant Road-Charlie Barra Drive and the bus stop. The applicant shall also work with Mendocino Transit Authority to investigate the feasibility of providing a bus stop for southbound bus service within walking distance of the project site.</p>	Project Applicant	Final Subdivision Map or Issuance of Building, Grading or Other Permits	Mendocino County Department of Transportation (DOT)	DOT  Approval of Final Subdivision Map
<p><b>3.5-I:</b> The project plus other new development would generate new traffic that would add congestion to study area intersections.</p>	<p><b>3.5-I.1:</b> The applicant and/or future site developers shall pay the adopted Ukiah Valley Area Transportation Impact Fee at the time that building permits are issued.</p>	Project Applicant	Building Permits	Planning Dept.  Mendocino Council of Governments	Planning Dept.  Issuance of Building Permits
<b>AIR QUALITY</b>					
<p><b>3.6-A:</b> Construction activities associated with development of the project would generate short-term emissions of criteria</p>	<p><b>3.6-A.1:</b> The project applicant and construction contractor shall for all construction project phases prepare and implement a dust control program to limit construction emissions of PM<sub>10</sub>  The program shall include at least the following provisions from MCAQMD Rule 1-430 Fugitive Dust. Because the site is over one acre in size, a</p>	Project Construction Manager	Issuance of Building, Grading or Other Permits	Planning Dept.	Planning Dept.  During and at Completion of construction

**EXHIBIT "B"**  
**AMENDED MITIGATION MONITORING & REPORTING PROGRAM**  
**for the Bella Vista Subdivision**

Impact	Mitigation Measure	Implemented by	Implemented when	Monitored by	Verified by and date
<p>pollutants, including fine and respirable particulate matter and equipment exhaust emissions.</p>	<p>Grading Permit must be approved by MCAQMD. and MCAQMD may require additional mitigations.</p> <ul style="list-style-type: none"> <li>a. Covering open bodied trucks when used for transporting materials likely to give rise to airborne dust.</li> <li>b. The use of water or chemicals for control of dust in the demolition of existing buildings or structures.</li> <li>c. All visibly dry disturbed soil road surfaces shall be watered to minimize fugitive dust emissions.</li> <li>d. All unpaved surfaces, unless otherwise treated with suitable chemicals or oils, shall have a posted speed limit of 10 miles per hour.</li> <li>e. Earth or other material. that has been transported by trucking or earth moving equipment, erosion by water, or other means onto paved streets shall be promptly removed.</li> <li>f. Asphalt, oil, water or suitable chemicals shall be applied on materials stockpiles, and other surfaces that can give rise to dust emissions.</li> <li>g. All earthmoving activities shall cease when sustained winds exceed 15 miles per hour.</li> <li>h. The operator shall take reasonable precautions to prevent the entry of unauthorized vehicles onto the site during non-work hours.</li> <li>i. The operator shall keep a daily log of activities to control fugitive dust.</li> </ul>				

**EXHIBIT “B”  
 AMENDED MITIGATION MONITORING & REPORTING PROGRAM  
 for the Bella Vista Subdivision**

Impact	Mitigation Measure	Implemented by	Implemented when	Monitored by	Verified by and date
	<p><b>3.6-A.2</b> The proposed development will require the preparation of a detailed grading and erosion control plan subject to review and approval by the County prior to earth moving activities (Municipal Code section 18.70.060 – Grading Permit Requirements). Grading will be completed in compliance with County standards.</p>	Project Construction Manager	Issuance of Building, Grading or Other Permits	Planning Dept.	Planning Dept.  During and at Completion of construction
	<p><b>3.6-A.3</b> Dust control rules and regulations as required by the MCAQMD will be adhered to (Rule 1-200, 1-400(a), 1-410, 1-420, 1-430). These regulations minimize fugitive dust particle during construction. Measures imposed by the MCAQMD include, but not limited to:</p> <ul style="list-style-type: none"> <li>• All visibly dry disturbed soil surfaces shall be watered to minimize fugitive dust.</li> <li>• Installation of a “stabilized construction entrance/exit” as detailed in the Department of Transportation storm water handbook (TC-1) will be utilized.</li> <li>• Earth or other material tracked on to neighboring paved roads shall be removed promptly.</li> <li>• Dust generating activities will be limited during periods of high winds (over 15 mph).</li> <li>• Access of unauthorized vehicles onto the construction site during non-working hours shall be prevented.</li> </ul>	Project Construction Manager	Issuance of Building, Grading or Other Permits	Planning Dept.	Planning Dept.  During and at Completion of construction

**EXHIBIT "B"**  
**AMENDED MITIGATION MONITORING & REPORTING PROGRAM**  
**for the Bella Vista Subdivision**

Impact	Mitigation Measure	Implemented by	Implemented when	Monitored by	Verified by and date
	<ul style="list-style-type: none"> <li>● A weekly log shall be kept of fugitive dust control measures that have been implemented.</li> <li>● Restrict idling of diesel engines on the site to less than 5 minutes.</li> <li>● All haul trucks transporting soil, sand or other loose materials off-site shall be covered.</li> <li>● All vehicle speeds on unpaved roads shall be limited to 15 mph.</li> <li>● Idling times shall be minimized either by shutting equipment off when not in use or reducing the maximum idling time to 5 minutes (as required by the California airborne toxics control measure title 13, Section 2485 of the California Code of Regulations). Clear signage shall be provided for construction workers at access points.</li> <li>● All construction equipment shall be maintained and properly tuned in accordance with manufacturer's specifications. All equipment shall be checked by a certified mechanic and determined to be running in proper condition prior to operation.</li> <li>● Post a publicly visible sign with telephone number for the applicant's representative regarding dust complaints. This person shall respond and take corrective action within 48 hours. The MCAQMD phone number shall</li> </ul>				

**EXHIBIT "B"**  
**AMENDED MITIGATION MONITORING & REPORTING PROGRAM**  
**for the Bella Vista Subdivision**

Impact	Mitigation Measure	Implemented by	Implemented when	Monitored by	Verified by and date
	also be visible to ensure compliance with applicable regulations.				
	<p><b>3.6-A.4</b> All off road construction equipment with engines greater than 50 horsepower (hp) and operating on the site for more than two days or 20 hours shall meet, at a minimum, U.S. EPA particulate matter emission standards for Tier 4 engines or equivalent. In the event that such equipment is not available, the use of Tier 3 construction equipment is sufficient so long as it can be demonstrated to the County that similar Tier 4 construction equipment is not readily available</p>	Project Construction Manager	Issuance of Building, Grading or Other Permits	Planning Dept.	Planning Dept.  During and at Completion of construction
	<p><b>3.6-A.5</b> The applicant shall submit a Construction and Demolition Waste Management Plan (CWMP) to the Mendocino Solid Waste Management Authority prior to the start of construction-related activities in accordance with Mendocino Solid Waste Management Authority requirements (Ordinance 4301). The CWMP will outline measure to capture and recycle materials that would otherwise end up in the waste stream.</p>	Project Construction Manager	Issuance of Building, Grading or Other Permits	Planning Dept.  MSWMA	Planning Dept.  During and at Completion of construction
<p><b>3.6-F:</b> The project will use more energy and thereby generate greenhouse gas emissions that would</p>	<p><b>3.6-F.1</b> The project shall minimize the emission of greenhouse gases by including at least the following:</p> <ul style="list-style-type: none"> <li>• The project shall be constructed to incorporate the 2010 Title 24 building standards (or</li> </ul>	Project Applicant	Issuance of Building, Grading or Other Permits	Planning Dept.	Planning Dept.  Completion of construction

**EXHIBIT "B"**  
**AMENDED MITIGATION MONITORING & REPORTING PROGRAM**  
**for the Bella Vista Subdivision**

Impact	Mitigation Measure	Implemented by	Implemented when	Monitored by	Verified by and date
adversely affect the global climate.	<p>whatever standards have been adopted at the time that building permits are issued).</p> <ul style="list-style-type: none"> <li>• Project residential units shall be oriented for maximum solar access. Roofs shall be constructed to allow easy and efficient retrofitting with roof-top solar panels.</li> <li>• The project applicant shall ensure that the CC&amp;Rs of the Homeowner's Association develops and maintains energy- and water-efficient practices for the common areas of the subdivision and follows a landscaping plan that does not impair the efficient operation of the solar collection facilities.</li> </ul>				
	<p><b>3.6-F.2</b> All residences would be constructed in accordance with the most recent edition of Title 24 of the California Building Code (CBC). The CBC contains mandatory requirements that apply to residential buildings that will be a part of the project which include: high performance attics insulation and walls, high efficacy lighting, windows, water heating and HVAC systems. Specific energy conservation features include:</p> <ul style="list-style-type: none"> <li>• Structures will incorporate natural cooling by utilizing window overhangs, awnings, front and rear patios, shade from neighboring structures, radiant heat-reflective barriers in the attic and appropriate tree plantings or a combination thereof.</li> </ul>	Project Applicant	Issuance of Building, Grading or Other Permits	Planning Dept.	Planning Dept.  Completion of construction

**EXHIBIT "B"**  
**AMENDED MITIGATION MONITORING & REPORTING PROGRAM**  
**for the Bella Vista Subdivision**

Impact	Mitigation Measure	Implemented by	Implemented when	Monitored by	Verified by and date
	<ul style="list-style-type: none"> <li>● Structures will be constructed in compliance with solar requirements found in Title 24 of the California Building Code.</li> <li>● Project will incorporate Energy Star Certified Appliances. At a minimum, the following appliances are recommended to be Energy Star rated: dishwasher and water heater.</li> <li>● Natural lighting may be incorporated into the home through solar tubes and sky lights.</li> <li>● Windows, sky lights and other fenestration will meet energy code requirements and will be Energy Star certified. These elements will have low U-factor (U-value) rating. U-factors is a rate of non-solar heat loss or gain through a while window assembling. The lower the U-factor, the greater a window's resistance to heat flow and the better its insulating value.</li> <li>● Project will incorporate the use of low flow toilets and faucets that meet the standards as set forth by the California Energy Commission.</li> <li>● All landscaping will be installed to AB 1881 (The Water Conservation in Landscaping Act of 2006) standards, which promotes water efficiency and conservation, using mulch, bubblers, and timed sprinkler systems.</li> </ul>				

**EXHIBIT "B"**  
**AMENDED MITIGATION MONITORING & REPORTING PROGRAM**  
**for the Bella Vista Subdivision**

Impact	Mitigation Measure	Implemented by	Implemented when	Monitored by	Verified by and date
	<p><b>3.6-F.3</b> The following features shall be included in the Modified Project to reduce GHG emissions:</p> <ul style="list-style-type: none"> <li>• No fireplaces;</li> <li>• Include solar power for each of the residential lots (not quantified);</li> <li>• No natural gas hookups;</li> <li>• Include infrastructure to promote electric car charging (i.e., provide 220VAC outlets);</li> <li>• Meet latest CalGreen Title 24 standards);</li> <li>• Include energy efficient appliances;</li> <li>• Include low-flow water fixtures; and</li> <li>• Include water-efficient irrigation systems (drip systems).</li> </ul>	Project Applicant	Issuance of Building, Grading or Other Permits	Planning Dept.	Planning Dept.  Completion of construction
<b>NOISE</b>					
<p><b>3.7-A:</b> The east end of the project could be exposed to excessive noise.</p>	<p><b>3.7-A.1:</b> Project-specific acoustical analyses shall be required to confirm that outdoor activity areas are provided with Ldn values at or below 60 dBA, and interior Ldn values will not exceed 45 dBA. Sound insulation measures, including any mechanical ventilation systems needed to permit closed windows, should be designed by an experienced acoustical consultant and incorporated into construction documents submitted for permits.</p>	Project Applicant	Prior to approval of final map for Phases 1 and 2 (east end of project site)	Planning Dept.	Planning Dept.  Issuance of Building Permits



**EXHIBIT "B"**  
**AMENDED MITIGATION MONITORING & REPORTING PROGRAM**  
**for the Bella Vista Subdivision**

Impact	Mitigation Measure	Implemented by	Implemented when	Monitored by	Verified by and date
<p><b>3.7-C:</b> Construction of project improvements would generate construction noise over a period exceeding one year.</p>	<p><b>3.7-C.1:</b> Project construction shall not cause excessive noise. To accomplish this standard, the following measures are required:</p> <ul style="list-style-type: none"> <li>● Noise-generating activities at the construction site or in areas adjacent to the construction site associated with the project in any way should be restricted to the hours of 7:00 a.m. to 6:00 p.m., Monday through Friday. No construction activities should occur on weekends or holidays.</li> <li>● Equip all internal combustion engine driven equipment with intake and exhaust mufflers that are in good condition and appropriate for the equipment.</li> <li>● Unnecessary idling of internal combustion engines should be strictly prohibited.</li> <li>● Locate stationary noise generating equipment such as air compressors or portable power generators as far as possible from sensitive receptors. Construct temporary noise barriers to screen stationary noise generating equipment when located near adjoining sensitive land uses.</li> <li>● Utilize "quiet" air compressors and other stationery noise sources where technology exists.</li> <li>● Control noise from construction workers' radios, CD players, etc. to a point that they are</li> </ul>	Project Applicant	During construction of all phases of the project.	Planning Dept.	Planning Dept.  Completion of construction

**EXHIBIT "B"**  
**AMENDED MITIGATION MONITORING & REPORTING PROGRAM**  
**for the Bella Vista Subdivision**

Impact	Mitigation Measure	Implemented by	Implemented when	Monitored by	Verified by and date
	<p>not audible at existing residences bordering the project site.</p> <ul style="list-style-type: none"> <li>• Designate a "disturbance coordinator" who would be responsible for responding to any local complaints about construction noise. The disturbance coordinator will determine the cause of the noise complaint (e.g., starting too early, bad muffler, etc.) and will require that reasonable measures warranted to correct the problem be implemented. Conspicuously post a telephone number for the disturbance coordinator at the construction site and include it in the notice sent to neighbors regarding the construction schedule.</li> <li>• Notify existing residents when especially noisy operations are scheduled near their property, allowing the residents to plan activities accordingly. Examples of especially noisy sources: heavy earth moving equipment, jack hammers, pile drivers.</li> </ul>				
<b>AESTHETICS</b>					
<p><b>3.8-A:</b> The project would replace views from South State Street and other vantage points east of the site</p>	<p><b>3.8-A.1:</b> Final project design and landscape plan shall undergo design review by the County Department of Planning and Building Services and/or the County Planning Commission to ensure consistency with the design guidelines adopted for this project. The final project shall be</p>	<p>Project Applicant</p>	<p>Upon submittal of project site and landscaping, park, and</p>	<p>Planning Dept.</p>	<p>Planning Dept.  Prior to issuance of building permits</p>

**EXHIBIT "B"**  
**AMENDED MITIGATION MONITORING & REPORTING PROGRAM**  
**for the Bella Vista Subdivision**

Impact	Mitigation Measure	Implemented by	Implemented when	Monitored by	Verified by and date
of open space with views of residential development.	revised, if requested, to comply with the County's review recommendations.		initial building plans,		
	<b>3.8-A.2:</b> Landscaping will be mature within 15 years of initial project construction (Phase 1). Mature means that perimeter trees shall be at least 20 feet tall. The final landscape plan shall include tree landscaping along the north and east sides of the site using species that fully screen views from the east and screens at least half of the buildings on the north side. The plan shall include specifications for planting, irrigating, fertilizing, and replacing dead trees so that the landscaping will be mature within 15 years.	Project Applicant	Development Agreement	Planning Dept.  Mendocino County Water Agency	Planning Dept.  Mendocino County Water Agency  15 years after project completion
<b>3.8-C:</b> The project would replace views from Gobalet Lane, residences north of Gobalet Lane, and residences south of Oak Knoll Road of open space with views of residential development.	Mitigation Measures 3.8-A.1 and 3.8-A.2 apply to this impact.	See the cited mitigation measures			
<b>3.8-F:</b> New lighting on the project site will	<b>3.8-F.1:</b> The final design shall include a lighting plan that minimizes light escape from the site. The final plan shall become part of the CC&Rs for the	Project Applicant	Development Agreement	Planning Dept.	Planning Dept.

**EXHIBIT "B"**  
**AMENDED MITIGATION MONITORING & REPORTING PROGRAM**  
**for the Bella Vista Subdivision**

Impact	Mitigation Measure	Implemented by	Implemented when	Monitored by	Verified by and date
change nighttime views in the area.	<p>Homeowners Association. This plan shall include the following:</p> <ol style="list-style-type: none"> <li>1. Light shielding is required. Except as otherwise exempt, all outdoor lighting fixtures shall be constructed with full shielding. Shielding shall prevent the light source from being visible to adjacent residential properties.</li> <li>2. Minimum/Maximum Level of Illumination. The minimum and maximum levels of illumination permitted are listed below. A photometric study listing the number; type, height, and level of illumination of all outdoor lighting fixtures shall be required prior to issuance of a building permit or site improvement plans to ensure compliance with these provisions.               <ol style="list-style-type: none"> <li>a. Minimum security lighting for sidewalks, walkways, parking areas, and similar areas shall be 1.0 foot-candles, measured at ground level, not to exceed 3.0 foot-candles on average.</li> <li>b. In order to minimize light trespass on abutting property, illumination measured on the property line of a subject parcel shall not exceed 0.5 foot-candies, measured on a vertical plane along the property line.</li> <li>c. Building-mounted decorative or security lights shall not exceed 5.0 foot-candles, measured a distance of five feet from the light source. All buildings lighting shall be reviewed and</li> </ol> </li> </ol>				Issuance of Building Permits

**EXHIBIT "B"**  
**AMENDED MITIGATION MONITORING & REPORTING PROGRAM**  
**for the Bella Vista Subdivision**

Impact	Mitigation Measure	Implemented by	Implemented when	Monitored by	Verified by and date
	<p>authorized by Mendocino County prior to the initiation of lighting installation.</p> <p>3. Maximum Height of Outdoor Light Fixtures. The maximum height of freestanding outdoor light fixtures for multi-family residential development and non-residential development abutting a single-family residential zoning district or use shall be 20 feet. Otherwise, the maximum height for freestanding outdoor light fixtures shall be 25 feet.</p> <p>4. Type of illumination. All outdoor lighting fixtures shall be energy efficient. Energy efficient lights include all high-intensity discharge lamps (mercury vapor, high-pressure sodium, low-pressure sodium, and metal halide). The concentrated and/or exclusive use of either low-pressure sodium or metal halide lighting is prohibited.</p> <p>5. Hours of illumination. Automatic timing devices shall be required for all outdoor light fixtures on multi-family residential and non-residential development (e.g., parks) with off hours (exterior lights turned off) between 11:00 p.m. and 6:00 a.m. Exceptions are that outdoor lights may remain on in conjunction with the hours of operation of the corresponding use, for security purposes, or to illuminate walkways, roadways, equipment yards, and parking lots.</p> <p>6. Prohibited Lighting. The following outdoor light fixtures shall be prohibited as specified below.</p>				

**EXHIBIT "B"**  
**AMENDED MITIGATION MONITORING & REPORTING PROGRAM**  
**for the Bella Vista Subdivision**

Impact	Mitigation Measure	Implemented by	Implemented when	Monitored by	Verified by and date
	<ul style="list-style-type: none"> <li>a. Lighting of parks for active nighttime recreation.</li> <li>b. Uplighting/back-lit canopies or awnings.</li> <li>c. The concentrated and/or exclusive use of either low- pressure sodium or metal halide lighting</li> <li>d. Neon tubing or band lighting along building structures</li> <li>e. Searchlights.</li> <li>f. Flashing lights.</li> <li>g. Illumination of entire buildings. Building illumination shall be limited to security lighting and lighting of architectural features authorized by the designated Approving Authority in conjunction with the required development permit(s).</li> <li>h. Roof mounted lights except for security purposes with motion detection and full shielding so that the glare of the light source is not visible from any public right- of-way.</li> </ul>				
<b>PUBLIC SERVICES AND INFRASTRUCTURE</b>					
<b>3.9-C:</b> Development of the project would increase the demand for police response	<b>3.9-C.1:</b> The final project design shall be reviewed by the Sheriff's Office to determine if it provides adequate access, security lighting, and other factors affecting police response. The final map	Project Applicant	Final Subdivision Map	Mendocino County Sheriff's Office	Sheriff's Office Planning Dept.

**EXHIBIT "B"**  
**AMENDED MITIGATION MONITORING & REPORTING PROGRAM**  
**for the Bella Vista Subdivision**

Impact	Mitigation Measure	Implemented by	Implemented when	Monitored by	Verified by and date
by the Mendocino County Sheriff's Office and by the Ukiah Police Department and would increase demand on other portions of the criminal justice system.	shall incorporate security measures required by the Sheriff's Office.				Issuance of Building Permits
<b>3.9-F:</b> New development resulting from the project and other new development in the area would increase the demands on the Ukiah Valley Fire District and the emergency medical response system possibly require the construction of new facilities.	<b>3.9-F.1:</b> If the County has not adopted additional funding for the EMS system at the time of approval of the Development Agreement, then the applicant shall agree within the Development Agreement to pay any fees that the County adopts for EMS funding prior to and/or within five years of approval of the Development Agreement.	Project Applicant	Development Agreement	Planning Dept.	Planning Dept.  Issuance of Building Permits
<b>3.9-H:</b> The project would contribute to the need for a new water	<b>3.9-H.1:</b> The applicant shall enter into an agreement with the Willow County Water District to pay a capital improvement fee (estimated at	Project Applicant	Development Agreement	Planning Dept.	Planning Dept.  Willow CWD

**EXHIBIT "B"**  
**AMENDED MITIGATION MONITORING & REPORTING PROGRAM**  
**for the Bella Vista Subdivision**

Impact	Mitigation Measure	Implemented by	Implemented when	Monitored by	Verified by and date
storage facility.	\$400,000) to fund the project's share of the replacement and expansion of the Fircrest Drive water storage tank.			Willow CWD	Issuance of Building Permits
<b>3.9-M:</b> The project would increase the plan area population, thereby increasing the demand for parks and recreational facilities. This increased demand could result in significant deterioration of existing facilities and the need for new or expanded facilities.	<b>3.9-M.1:</b> Construct and maintain a "tot lot" with playground equipment on one of the two project parks. The tot lot will be maintained by the Homeowner's Association.	Project Applicant	Development Agreement	Planning Dept.	Planning Dept.  Issuance of Building Permits
	<b>3.9-M.2</b> The Neighborhood Park and the contours of the detention basin shall be modified to establish suitable terrain for a multi-purpose playing field that provides a minimum of 100' x 200' of level playing area.	Project Applicant	Development Agreement	Planning Dept.	Planning Dept.  Issuance of Building Permits
<b>3.9-O:</b> Future development could be placed in locations where people and structures would be exposed to potential wildland fires.	<b>3.9-O.1:</b> The project shall be designed and constructed to minimize risk of wildfire destroying residences. The Ukiah Valley Fire District shall review project plans and determine in writing that adequate access, emergency response, and fire flow are available, and that the project complies with the most current State requirements for development in the wildland/urban interface. Final	Project Applicant	Conditions of Approval	Ukiah Valley Fire District  Planning Dept.	Ukiah Valley Fire District  Planning Dept.  Issuance of Building Permits



**EXHIBIT "B"**  
**AMENDED MITIGATION MONITORING & REPORTING PROGRAM**  
**for the Bella Vista Subdivision**

Impact	Mitigation Measure	Implemented by	Implemented when	Monitored by	Verified by and date
	project design shall conform with any changes that the District requires.				
<p><b>3.9-R:</b> Toxic materials and wastes on the site could pose a risk to human health.</p>	<p><b>3.9-R.1:</b> All potential toxic wastes and materials shall be removed and/or remediated prior to site grading. The applicant shall do the following, as recommended in the Phase I Environmental Site Assessment:</p> <ul style="list-style-type: none"> <li>● Abandon any inoperable water supply wells on the site following all the requirements of the Mendocino County Division of Environmental Health.</li> <li>● Collect soil samples in the area of the former underground storage tank and the aboveground fuel storage tank. The soil samples shall be tested for Total Petroleum Hydrocarbons as gasoline and the constituents benzene, toluene, ethylbenzene; xylenes, fuel oxygenates, lead scavengers, and total lead. Results of the testing shall be provided to the Mendocino County Division of Environmental Health. If the Division determines that additional testing or remediation is required, the applicant shall fulfill all County requirements.</li> <li>● If volatile organic compounds are discovered on the site, a human health risk</li> </ul>	Project Applicant	Conditions of Approval	Mendocino County Division of Environmental Health	<p>Mendocino County Division of Environmental Health            Planning Dept.            Prior to issuance of Grading Permit</p>

**EXHIBIT "B"**  
**AMENDED MITIGATION MONITORING & REPORTING PROGRAM**  
**for the Bella Vista Subdivision**

Impact	Mitigation Measure	Implemented by	Implemented when	Monitored by	Verified by and date
	<p>assessment will be performed per requirements of the County Division of Environmental Health. That assessment will identify measures needed to ensure that workers and future residents are not exposed to County- and State- defined harmful levels of these compounds.</p> <ul style="list-style-type: none"> <li>● Dispose of any waste oil, lubricants, paints, or other liquids in accordance with all applicable regulatory requirements.</li> <li>● Investigate the fuel source for the prune dryer that formerly was located on the west side of the site to determine its fuel source. If it was gasoline, then conduct soil tests at that site as described above.</li> <li>● Assess whether the workshop/storage building has the potential for lead paint or asbestos. If so, then demolition shall follow all requirements established by the Mendocino County Division of Environmental Health.</li> </ul>				