

## Appendix G: Hydrological Report

# PRELIMINARY PRIORITY PROJECT **HYDROLOGY STUDY**

**FOR:**

*NUTMEG HOMES  
ESCONDIDO, CA*

**PREPARED FOR:**

*ADJ HOLDINGS, LLC*

**PREPARED BY:**

*EXCEL ENGINEERING*

*440 State Place*

*Escondido, CA 92029*

*Tel: (760) 745-8118*

*Project No: 16-038*

**DATE PREPARED:**

*JUNE 14, 2018*

**DATE REVISED:**

*September 26, 2018*

# **TABLE OF CONTENTS**

<b>1.0</b>	<b>Project Description</b>
1.1	Project Purpose
1.2	Project Proposed facilities
<b>2.0</b>	<b>Vicinity Map</b>
<b>3.0</b>	<b>Site Map</b>
<b>4.0</b>	<b>Description of Watershed</b>
4.1	Existing Conditions Topography
4.2	Existing Conditions + Project Conditions Topography
4.3	Hydrologic Unit Contribution
<b>5.0</b>	<b>Methodology</b>
5.1	Hydrology Software
5.2	Routing Software
5.3	Hydraulics Software
<b>6.0</b>	<b>Calculations</b>
6.1	Determine the Watershed that affects the project
6.2	Calculate Runoff Coefficient
6.3	Calculate Storm Flows using the Rational Method
6.4	Design / Analyze proposed Storm Drain Facilities
<b>7.0</b>	<b>Mitigation Measures</b>
7.1	Mitigation of Increased Runoff
7.2	Check Capacity of Existing Downstream Storm Drain Facilities
<b>8.0</b>	<b>Summary</b>
<b>9.0</b>	<b>References</b>
<b>10.0</b>	<b>Declaration Of Responsible Charge</b>
<b>11.0</b>	<b>Attachments</b>
	Attachment A – Site Map
	Attachment B – Figures & Tables from the SD Hydrology Manual 2003
	Attachment C – Watershed Information
	Watershed Map
	Soils Index Map
	Rainfall Isopluvial Maps
	Attachment D –50 Year Pre Development Calculations
	Attachment E – 50 Year Post Developed Q Calculations
	Attachment F –100 Year Pre Development Map and Calculations
	Attachment G –100 Year Post Developed Q Calculations
	Attachment H – Post Developed Hydrology Map
	Attachment I – Hydraulic Calculations

---

## **1.0 PROJECT DESCRIPTION**

### **1.1 Project Purpose**

The purpose of this project is to receive approval from the City of Escondido to construct high density residential units and their associated infrastructure and improvements on an existing 7.45 acre parcel.

### **1.2 Project Proposed Facilities**

The project is 137 residential homes which range in square foot from 1,104 square feet to 1,950 square feet; and an overall density of 18 DU/AC. As part of the new construction, associated improvements will include walkways, grass and landscaped areas, parking spaces, landscaping throughout the parking areas and frontages, and all necessary utilities (storm, sewer, water, dry, etc.).

Normal uses of such a development will generate storm water runoff with the potential to carry pollutants to off-site tributaries. Biofiltration ponds are planned to be incorporated throughout the site to treat and detain runoff from impervious and landscaped areas.

ADJ Holdings, LLC is the recorded owner of the project site.

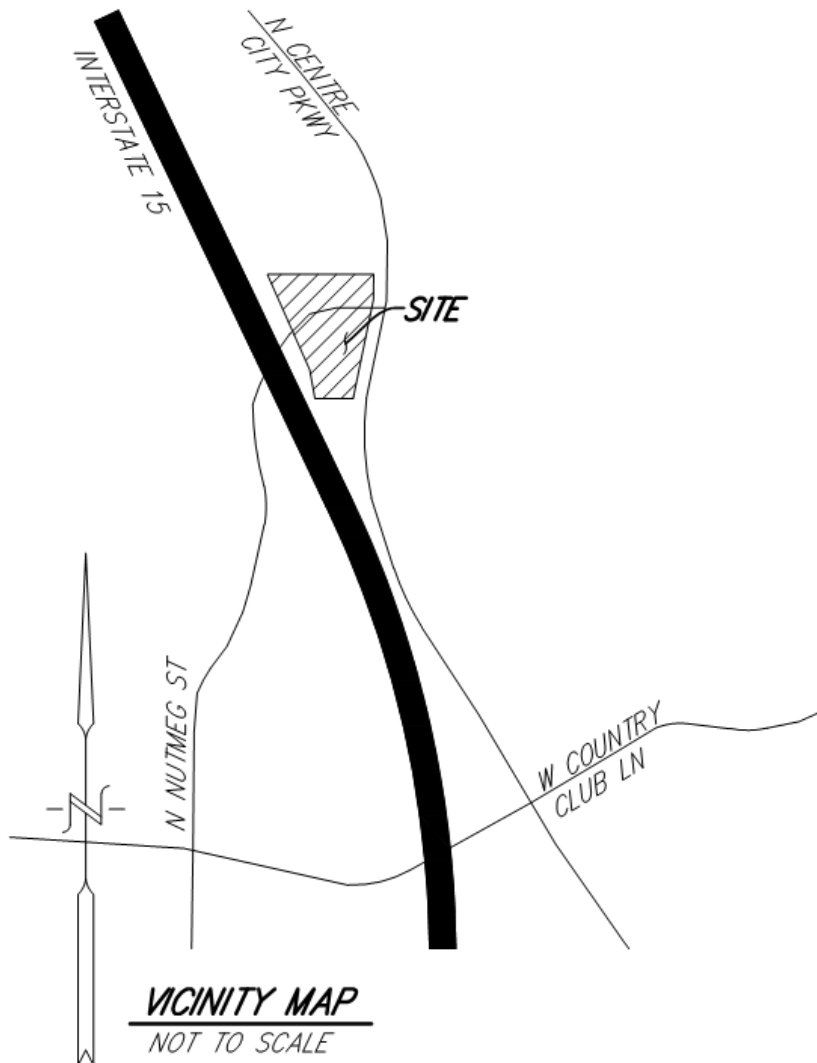

---

**2.0 VICINITY MAP****3.0 SITE MAP**

Please see Attachment A – Site map

**4.0 DESCRIPTION OF WATERSHED****4.1 Existing Conditions Topography**

The site is currently an undeveloped area adjacent to the I-15 freeway and Center City Parkway; on the North end of Escondido. It is served by utilities (water, sewer, and storm drain (on the south westerly portion of the site connecting to an existing cal trans line)).

Existing residential developments exist on the East side of Center City Parkway, and West of the I-15. This site has three POCs; the first draining the proposed onsite which is private, the Third POC drains a quarter of Nutmeg street and a portion of

---

Center City Parkway to an open pervious area that flows southwesterly to an existing Caltrans pipeline. A second area north of Nutmeg Street drains south westerly along Nutmeg Street with a Half the flow of Nutmeg Street around to a natural channel to meet with the Caltrans pipeline. The second POC is the north eastern corner of the site that drains along with the remaining of Nutmeg Street and Center City Street North to enter the Escondido sub area.

After drainage leaves the site, it flows in two directions to the north where the water circles back on itself and travels through the Escondido sub Hydrologic area southward to Escondido Creek. Once in Escondido creek flows continue until they reach the Pacific Ocean at San Elijo Lagoon. The second flow travels South westerly to travel to San Marcos Creek which flows to the Pacific Ocean and discharges at Batiquitos Lagoon.

Please see Attachment C – Watershed Map.

#### **4.2 Existing Conditions + Project Conditions Topography**

The Nutmeg Street Development project layout proposes to place multiple residential housing units in place to cover a majority of the site. Fill soil will be brought in to level the site and bring the current surface up to allow a gentler slope. The finish floor elevations of the building pads is a relatively flat plane through the the site to drain in the direction of the existing flows away from the buildings towards water quality treatment basins. Once within the water quality treatment systems, the stormwater infiltrates through the treatment medium into underdrains that route the flows to the private on site storm drainage system. This system uses new piping to direct the flows to the existing Caltrans pipe that travels under the I-15 Freeway. The northflow discharges through a water quality treatment basin then travels to an infiltration basin before being released back the natural channel going offsite.

As calculated below, and summarized further in Section 8, the proposed site is expected to discharge peak 100-year flows at less than those shown on the existing site conditions. The pre development calculations standards set forth by the 2003 San Diego County Hydrology Manual, the resultant peak storm water discharge has been decreased by the incorporation of the landscaping (higher pervious footprint) and several confluences of lines.

#### **4.3 Hydrologic Unit Contribution**

The project site is within the Carlsbad Hydrologic Unit, San Marcos HA, Escondido HA (904.52, 904.62). After drainage leaves the site, it flows in two directions to the north where the water circles back on itself and travels through the Escondido sub Hydrologic area southward to Escondido Creek. Once in Escondido creek flows continue until they reach the Pacific Ocean at San Elijo Lagoon. The second flow travels South westerly to travel to San Marcos Creek which flows to the Pacific Ocean and discharges at Batiquitos Lagoon.

## 5.0 METHODOLOGY

This study complies with the 2003 San Diego Hydrology Manual. The rational method as presented in Section 3 of that manual and workbook examples were followed.

### 5.1 Hydrology Software

The “Rational Hydrology Method, San Diego County (2003 Manual)” module of the CIVILCADD/CIVIL DESIGN Engineering software version 7.9 is used in this study. This software was also used to developed hydrographs from the rational method results. This procedure also complies with the 2003 San Diego Hydrology Manual as presented in Section 6.

### 5.2 Routing Software

No routing calculations were performed for this site at this time. Should further routing be required upon further development of the site and possible site plan changes causing discharge rates to increase above the predeveloped rates, the existing hydromodification/water quality treatment ponds can be used as flow control facilities. In order to show this is the case, Hydraflow Hydrographs 2004 by Intelisolve would then be used in this step. The hydrograph developed from the rational method is then manually entered into this software and routed into each detention pond.

### 5.3 Hydraulics Software

The hydraulics calculations were performed on the Hydraflow Storm Sewers Extension v.10.4, and Hydraflow Hydrographs Extension v. 10.4 by Autodesk, Inc. <http://www.autodesk.com/civil3d-stormwater>.

## 6.0 CALCULATIONS

The calculations to be done are determining the flows that will discharge offsite and both POC 1 and POC 2 for the pre and post develop conditions. These values will then be used to size appropriate piping for HGL and travel flow, detention and detention facilitates if appropriate. The areas of the site are broken in the following table. The following calculations are provided 50-year, 100 year

Table 1

Area (Acres)	Pre-Development (Acres)	Post-Development (Acres)
POC-1	7.16	7.08
POC-2	6.35	5.84
POC-3	1.49	2.32
Total	15	15.24

Flow (cfs)	Pre-Development (cfs)	Post-Development (cfs)	Post-Development Det (CFS)
POC-1	12.02	32.89	11.69
POC-2	8.43	13.02	3.52
POC-3	7.12	7.06	7.06 (no det)
Total	25.55	52.97	22.27

Table 2 100 Year

Flow (cfs)	Pre-Development (cfs)	Post-Development (cfs)	Post-Development Det (CFS)
POC-1	10.24	23.92	7.076
POC-2	7.12	11.01	3.36
POC-3	4.334	6.037	2.32
Total	24.19	46.34	12.76

Table 3 50 Year

These numbers will be used to size the proposed storm drain pipes and to doublecheck if the existing storm drain outlet facilities are adequate. Since these pipes are private, the hydrology software’s selected pipe sizes have been used to size the pipe sizes themselves. No hydraulic system runs have been performed for the private system.

**6.1 Determine the Watershed that affects the project**

Please see the “Watershed Map” in Attachment C

**6.2 Calculate Runoff Coefficient**

The whole project site is in type “C” and “D” soils. Therefore, we are going to use all coefficients for that type of soil. As stated in section 3.1.2 of the San Diego Hydrology Manual on the second paragraph, “impervious percentage (% Impervious) as given in Table 3-1 for any area, shall govern the selected value for C.”

For all areas to remain pervious post-construction a “c” factor of c=0.35 is used. The remainder of the site’s “c” factors will be based on the percentage of impervious within that subarea (for the 100-year calculations, pervious concrete is assumed to be 25% impervious to provide a conservative estimate of its infiltration capabilities during heavy flows.

**6.3 Calculate Storm Flows using the Rational Method**

The 100-year post developed storm flows were calculated for this project to be 32.89cfs, 13.02cfs and 7.06 respectively. The discharge is higher than predevelop conditions and mitigations will need to occur to keep within compliance. Mitigation results and calculations to follow.

Please see “Post Developed Q Calculations” in Attachment E for the developed conditions.

---

#### **6.4 Design / Analyze Proposed Storm Drain Facilities**

In this stage of the project, we will not get into detailed calculations for the proposed storm drain systems since they are private.

### **7.0 MITIGATION MEASURES**

A Storm Water Management Plan (SWQMP) has been prepared for this project to discuss treatment and flow control of the lower flows (2-year and 10-year). This Hydrology study analyzes the higher 100-year flows.

#### **7.1 Mitigate Increase Runoff**

As discussed above, the postdeveloped runoff rates are 32.89cfs, 13.02cfs and 7.06 for the proposed outfalls respectfully (see Attachment D and E). The proposed site development has higher than anticipated flows and mitigation will need to occur in order to decrease the expected peak flows at each connection point. Detention flows calculated are as follows 11.69, 3.52, and 7.06 cfs respectfully, lower than the predevelopment values of 12.02, 8.43, and 7.12 cfs.

#### **7.2 Check Capacity of Existing Downstream Storm Drain Facilities**

Since peak flows will be anticipated to be mitigated and reduced, no further capacity analysis of downstream storm drain facilities is necessary.

### **8.0 SUMMARY**

This project will need to have a mitigation study to show that the proposed site does not negatively impact the existing downstream storm drain facilities. The resulting 100-year flowrates from the proposed development are higher than those calculated and accounted for as part of the pre-development area of the Nutmeg Development where pads are to be graded out and infrastructure installed to account for the expected development type that this site conforms to.

### **9.0 REFERENCES**

County of San Diego, Department of Public Works, Flood Control Section, June 2003  
San Diego County Hydrology Manual

---

**10.0 DECLARATION OF RESPONSIBLE CHARGE**

I hereby declare that I am the engineer of work for this project. That I have exercised responsible charge over the design of the project as defined in section 6703 of the business and professions codes, and that the design is consistent with current design.

I understand that the check of the project drawings and specifications by the City of Oceanside is confined to a review only and does not relieve me, as engineer of work, of my responsibilities for project design.

**ENGINEER OF WORK**

Excel Engineering  
440 State Place  
Escondido, CA 92029  
Tel – (760)745-8118  
Fax – (760)745-1890

Project Number: 17-046

---

Robert D. Dentino, RCE 45629  
Registration Expire: December 31, 2018

09/26/2018  
Date

**ATTACHMENT A**  
**SITE MAP**

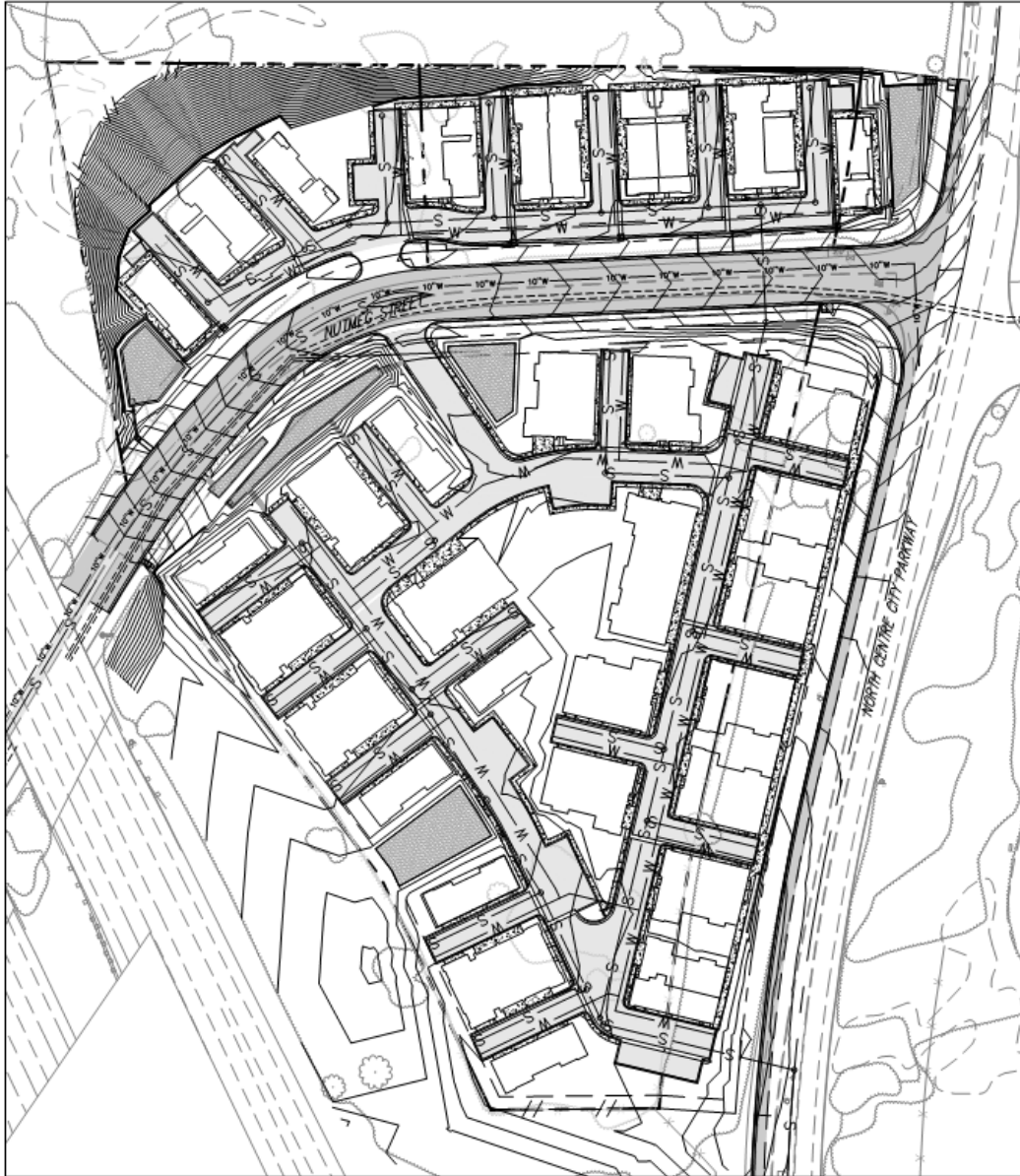

**ATTACHMENT B**  
**FIGURES & TABLES FROM THE SD HYDROLOGY MANUAL 2003**



**Table 3-1  
RUNOFF COEFFICIENTS FOR URBAN AREAS**

Land Use		Runoff Coefficient "C"				
		% IMPER.	Soil Type			
NRCS Elements	County Elements		A	B	C	D
Undisturbed Natural Terrain (Natural)	Permanent Open Space	0*	0.20	0.25	0.30	0.35
Low Density Residential (LDR)	Residential, 1.0 DU/A or less	10	0.27	0.32	0.36	0.41
Low Density Residential (LDR)	Residential, 2.0 DU/A or less	20	0.34	0.38	0.42	0.46
Low Density Residential (LDR)	Residential, 2.9 DU/A or less	25	0.38	0.41	0.45	0.49
Medium Density Residential (MDR)	Residential, 4.3 DU/A or less	30	0.41	0.45	0.48	0.52
Medium Density Residential (MDR)	Residential, 7.3 DU/A or less	40	0.48	0.51	0.54	0.57
Medium Density Residential (MDR)	Residential, 10.9 DU/A or less	45	0.52	0.54	0.57	0.60
Medium Density Residential (MDR)	Residential, 14.5 DU/A or less	50	0.55	0.58	0.60	0.63
High Density Residential (HDR)	Residential, 24.0 DU/A or less	65	0.66	0.67	0.69	0.71
High Density Residential (HDR)	Residential, 43.0 DU/A or less	80	0.76	0.77	0.78	0.79
Commercial/Industrial (N. Com)	Neighborhood Commercial	80	0.76	0.77	0.78	0.79
Commercial/Industrial (G. Com)	General Commercial	85	0.80	0.80	0.81	0.82
Commercial/Industrial (O.P. Com)	Office Professional/Commercial	90	0.83	0.84	0.84	0.85
Commercial/Industrial (Limited I.)	Limited Industrial	90	0.83	0.84	0.84	0.85
Commercial/Industrial (General I.)	General Industrial	95	0.87	0.87	0.87	0.87

\*The values associated with 0% impervious may be used for direct calculation of the runoff coefficient as described in Section 3.1.2 (representing the pervious runoff coefficient, Cp, for the soil type), or for areas that will remain undisturbed in perpetuity. Justification must be given that the area will remain natural forever (e.g., the area is located in Cleveland National Forest).

DU/A = dwelling units per acre

NRCS = National Resources Conservation Service

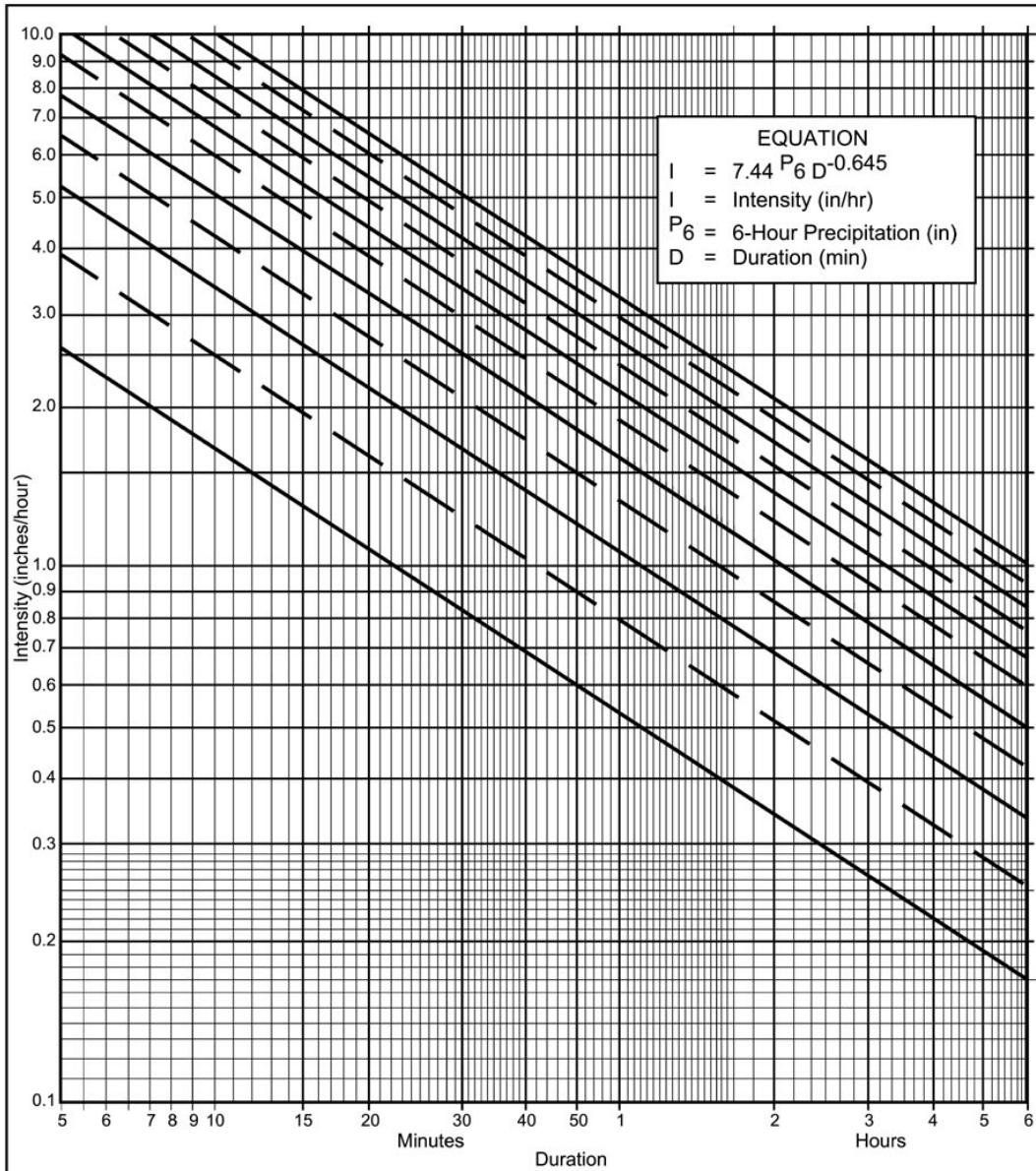

**Directions for Application:**

- (1) From precipitation maps determine 6 hr and 24 hr amounts for the selected frequency. These maps are included in the County Hydrology Manual (10, 50, and 100 yr maps included in the Design and Procedure Manual).
- (2) Adjust 6 hr precipitation (if necessary) so that it is within the range of 45% to 65% of the 24 hr precipitation (not applicable to Desert).
- (3) Plot 6 hr precipitation on the right side of the chart.
- (4) Draw a line through the point parallel to the plotted lines.
- (5) This line is the intensity-duration curve for the location being analyzed.

**Application Form:**

- (a) Selected frequency \_\_\_\_\_ year
- (b)  $P_6 =$  \_\_\_\_\_ in.,  $P_{24} =$  \_\_\_\_\_,  $\frac{P_6}{P_{24}} =$  \_\_\_\_\_ %<sup>(2)</sup>
- (c) Adjusted  $P_6^{(2)} =$  \_\_\_\_\_ in.
- (d)  $t_x =$  \_\_\_\_\_ min.
- (e)  $I =$  \_\_\_\_\_ in./hr.

Note: This chart replaces the Intensity-Duration-Frequency curves used since 1965.

P6	1	1.5	2	2.5	3	3.5	4	4.5	5	5.5	6
Duration	I	I	I	I	I	I	I	I	I	I	I
5	2.63	3.95	5.27	6.59	7.90	9.22	10.54	11.86	13.17	14.49	15.81
7	2.12	3.18	4.24	5.30	6.36	7.42	8.48	9.54	10.60	11.66	12.72
10	1.68	2.53	3.37	4.21	5.05	5.90	6.74	7.58	8.42	9.27	10.11
15	1.30	1.95	2.59	3.24	3.89	4.54	5.19	5.84	6.49	7.13	7.78
20	1.08	1.62	2.15	2.69	3.23	3.77	4.31	4.85	5.39	5.93	6.46
25	0.93	1.40	1.87	2.33	2.80	3.27	3.73	4.20	4.67	5.13	5.60
30	0.83	1.24	1.66	2.07	2.49	2.90	3.32	3.73	4.15	4.56	4.98
40	0.69	1.03	1.38	1.72	2.07	2.41	2.76	3.10	3.45	3.79	4.13
50	0.60	0.90	1.19	1.49	1.79	2.09	2.39	2.69	2.98	3.28	3.58
60	0.53	0.80	1.06	1.33	1.59	1.86	2.12	2.39	2.65	2.92	3.18
90	0.41	0.61	0.82	1.02	1.23	1.43	1.63	1.84	2.04	2.25	2.45
120	0.34	0.51	0.68	0.85	1.02	1.19	1.36	1.53	1.70	1.87	2.04
150	0.29	0.44	0.59	0.73	0.88	1.03	1.18	1.32	1.47	1.62	1.76
180	0.26	0.39	0.52	0.65	0.78	0.91	1.04	1.18	1.31	1.44	1.57
240	0.22	0.33	0.43	0.54	0.65	0.76	0.87	0.98	1.08	1.19	1.30
300	0.19	0.28	0.38	0.47	0.56	0.66	0.75	0.85	0.94	1.03	1.13
360	0.17	0.25	0.33	0.42	0.50	0.58	0.67	0.75	0.84	0.92	1.00

Intensity-Duration Design Chart - Template

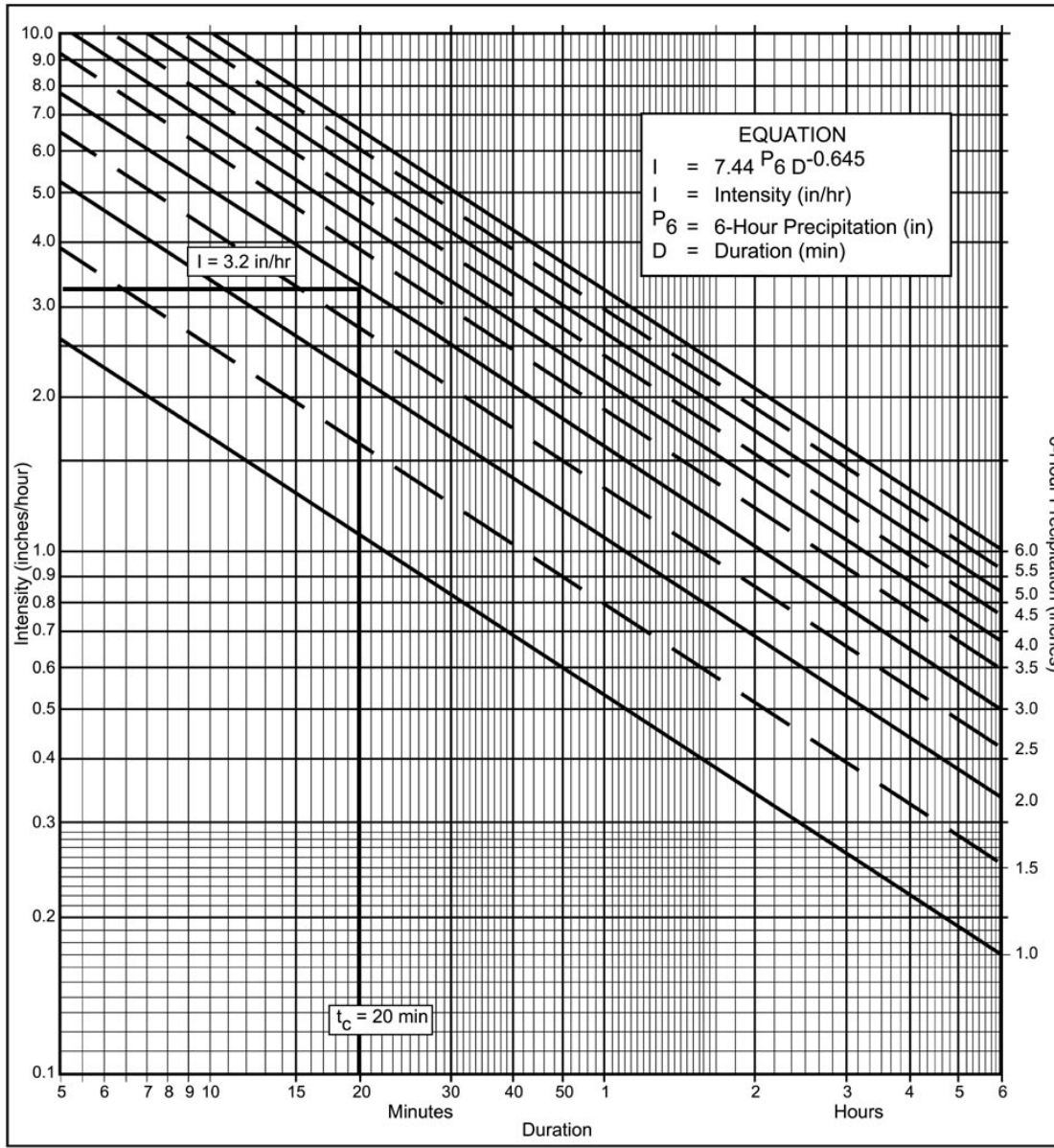

**Directions for Application:**

- (1) From precipitation maps determine 6 hr and 24 hr amounts for the selected frequency. These maps are included in the County Hydrology Manual (10, 50, and 100 yr maps included in the Design and Procedure Manual).
- (2) Adjust 6 hr precipitation (if necessary) so that it is within the range of 45% to 65% of the 24 hr precipitation (not applicable to Desert).
- (3) Plot 6 hr precipitation on the right side of the chart.
- (4) Draw a line through the point parallel to the plotted lines.
- (5) This line is the intensity-duration curve for the location being analyzed.

**Application Form:**

- (a) Selected frequency 50 year
- (b)  $P_6 = \underline{3}$  in.,  $P_{24} = \underline{5.5}$  in.,  $\frac{P_6}{P_{24}} = \underline{54.5} \%$ (<sup>2</sup>)
- (c) Adjusted  $P_6$ (<sup>2</sup>) = 3 in.
- (d)  $t_x = \underline{20}$  min.
- (e)  $I = \underline{3.2}$  in./hr.

Note: This chart replaces the Intensity-Duration-Frequency curves used since 1965.

P6	1	1.5	2	2.5	3	3.5	4	4.5	5	5.5	6
Duration											
5	2.63	3.95	5.27	6.59	7.90	9.22	10.54	11.86	13.17	14.49	15.81
7	2.12	3.18	4.24	5.30	6.36	7.42	8.48	9.54	10.60	11.66	12.72
10	1.68	2.53	3.37	4.21	5.05	5.90	6.74	7.58	8.42	9.27	10.11
15	1.30	1.95	2.59	3.24	3.89	4.54	5.19	5.84	6.49	7.13	7.78
20	1.08	1.62	2.15	2.69	3.23	3.77	4.31	4.85	5.39	5.93	6.46
25	0.93	1.40	1.87	2.33	2.80	3.27	3.73	4.20	4.67	5.13	5.60
30	0.83	1.24	1.66	2.07	2.49	2.90	3.32	3.73	4.15	4.56	4.98
40	0.69	1.03	1.38	1.72	2.07	2.41	2.76	3.10	3.45	3.79	4.13
50	0.60	0.90	1.19	1.49	1.79	2.09	2.39	2.69	2.98	3.28	3.58
60	0.53	0.80	1.06	1.33	1.59	1.86	2.12	2.39	2.65	2.92	3.18
90	0.41	0.61	0.82	1.02	1.23	1.43	1.63	1.84	2.04	2.25	2.45
120	0.34	0.51	0.68	0.85	1.02	1.19	1.36	1.53	1.70	1.87	2.04
150	0.29	0.44	0.59	0.73	0.88	1.03	1.18	1.32	1.47	1.62	1.76
180	0.26	0.39	0.52	0.65	0.78	0.91	1.04	1.18	1.31	1.44	1.57
240	0.22	0.33	0.43	0.54	0.65	0.76	0.87	0.98	1.08	1.19	1.30
300	0.19	0.28	0.38	0.47	0.56	0.66	0.75	0.85	0.94	1.03	1.13
360	0.17	0.25	0.33	0.42	0.50	0.58	0.67	0.75	0.84	0.92	1.00

Intensity-Duration Design Chart - Example

Note that the Initial Time of Concentration should be reflective of the general land-use at the upstream end of a drainage basin. A single lot with an area of two or less acres does not have a significant effect where the drainage basin area is 20 to 600 acres.

Table 3-2 provides limits of the length (Maximum Length ( $L_M$ )) of sheet flow to be used in hydrology studies. Initial  $T_i$  values based on average C values for the Land Use Element are also included. These values can be used in planning and design applications as described below. Exceptions may be approved by the “Regulating Agency” when submitted with a detailed study.

**Table 3-2**

**MAXIMUM OVERLAND FLOW LENGTH ( $L_M$ )  
 & INITIAL TIME OF CONCENTRATION ( $T_i$ )**

Element*	DU/ Acre	.5%		1%		2%		3%		5%		10%	
		$L_M$	$T_i$	$L_M$	$T_i$	$L_M$	$T_i$	$L_M$	$T_i$	$L_M$	$T_i$	$L_M$	$T_i$
Natural		50	13.2	70	12.5	85	10.9	100	10.3	100	8.7	100	6.9
LDR	1	50	12.2	70	11.5	85	10.0	100	9.5	100	8.0	100	6.4
LDR	2	50	11.3	70	10.5	85	9.2	100	8.8	100	7.4	100	5.8
LDR	2.9	50	10.7	70	10.0	85	8.8	95	8.1	100	7.0	100	5.6
MDR	4.3	50	10.2	70	9.6	80	8.1	95	7.8	100	6.7	100	5.3
MDR	7.3	50	9.2	65	8.4	80	7.4	95	7.0	100	6.0	100	4.8
MDR	10.9	50	8.7	65	7.9	80	6.9	90	6.4	100	5.7	100	4.5
MDR	14.5	50	8.2	65	7.4	80	6.5	90	6.0	100	5.4	100	4.3
HDR	24	50	6.7	65	6.1	75	5.1	90	4.9	95	4.3	100	3.5
HDR	43	50	5.3	65	4.7	75	4.0	85	3.8	95	3.4	100	2.7
N. Com		50	5.3	60	4.5	75	4.0	85	3.8	95	3.4	100	2.7
G. Com		50	4.7	60	4.1	75	3.6	85	3.4	90	2.9	100	2.4
O.P./Com		50	4.2	60	3.7	70	3.1	80	2.9	90	2.6	100	2.2
Limited I.		50	4.2	60	3.7	70	3.1	80	2.9	90	2.6	100	2.2
General I.		50	3.7	60	3.2	70	2.7	80	2.6	90	2.3	100	1.9

\*See Table 3-1 for more detailed description

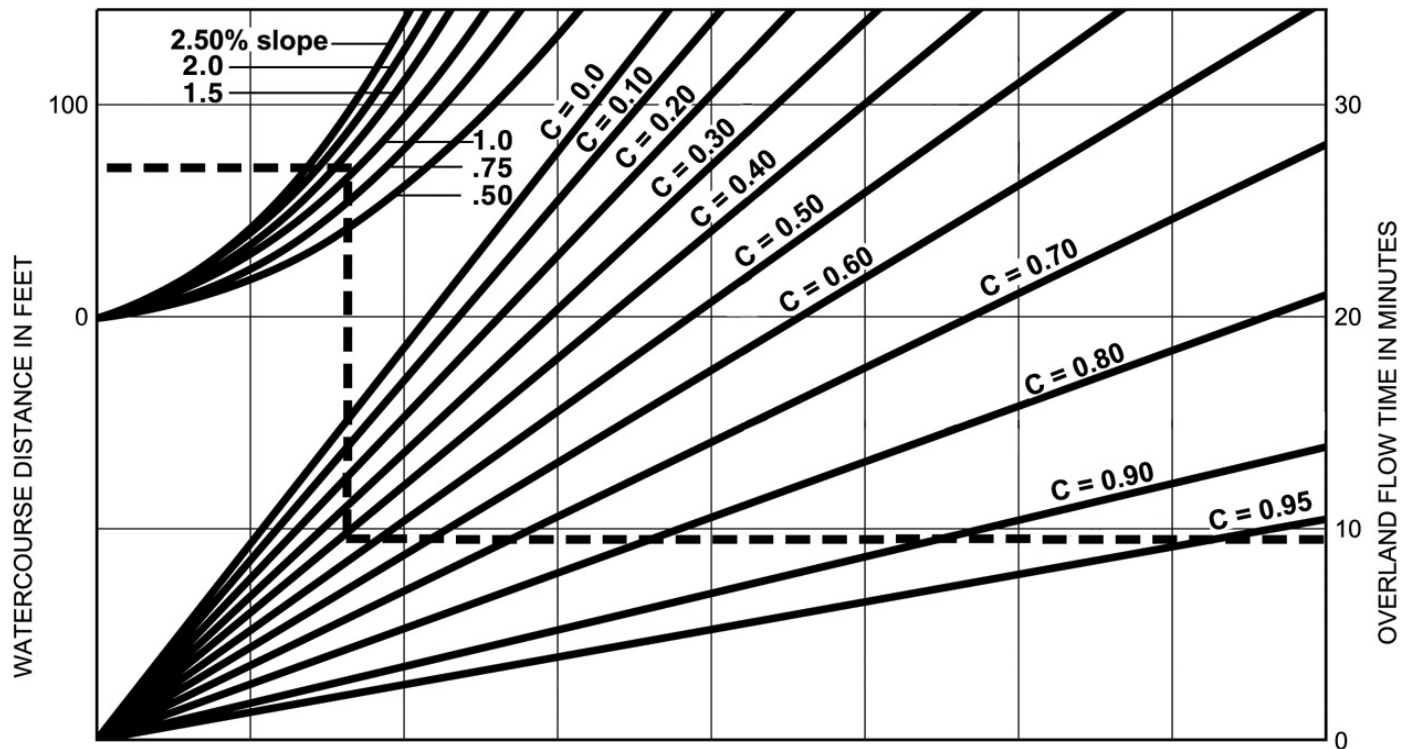

EXAMPLE:

Given: Watercourse Distance (D) = 70 Feet  
 Slope (s) = 1.3%  
 Runoff Coefficient (C) = 0.41  
 Overland Flow Time (T) = 9.5 Minutes

$$T = \frac{1.8 (1.1-C) \sqrt{D}}{\sqrt[3]{s}}$$

SOURCE: Airport Drainage, Federal Aviation Administration, 1965

**F I G U R E**

**Rational Formula - Overland Time of Flow Nomograph**

**3-3**

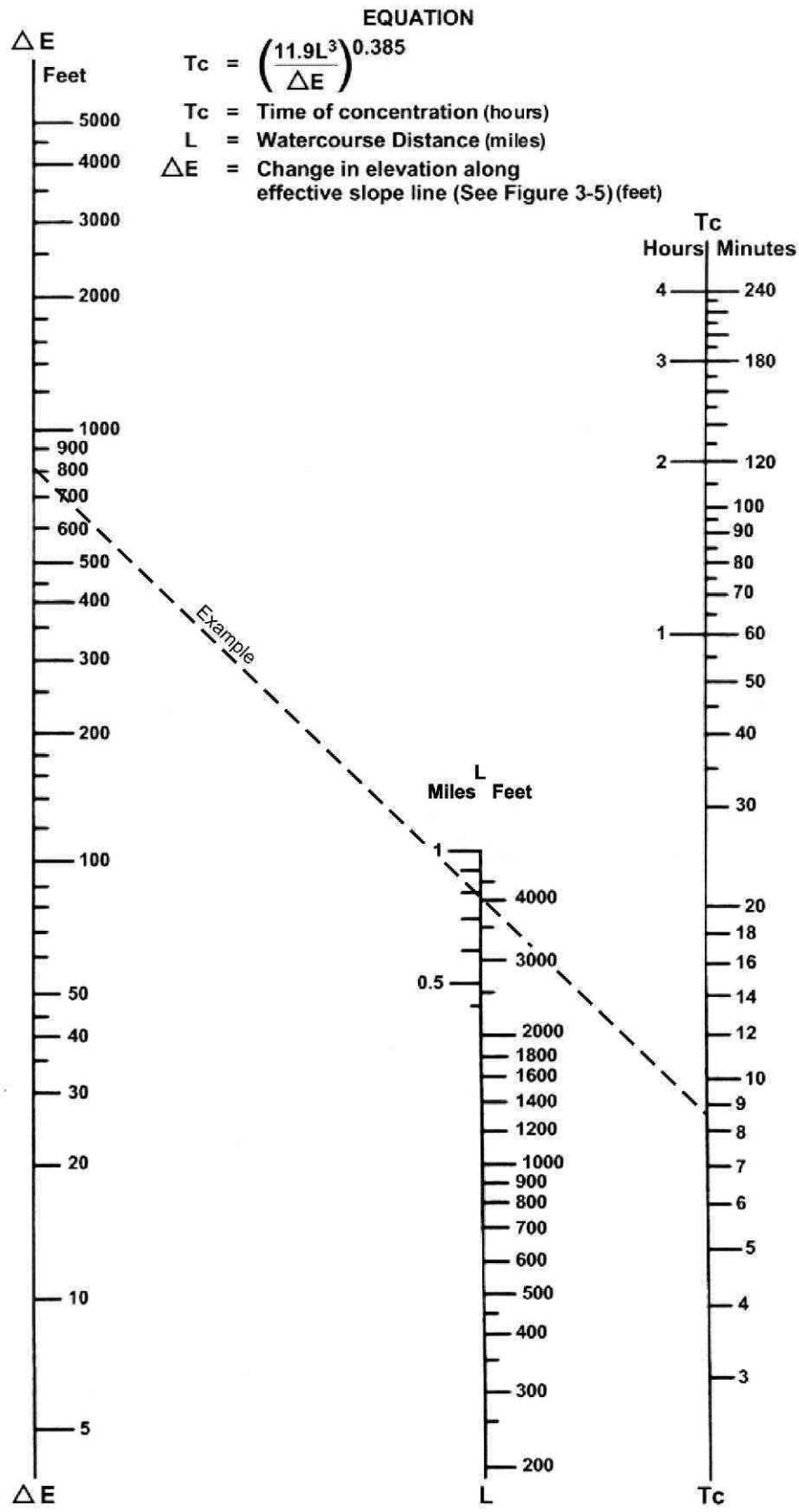

SOURCE: California Division of Highways (1941) and Kirpich (1940)

Nomograph for Determination of  
Time of Concentration ( $T_c$ ) or Travel Time ( $T_t$ ) for Natural Watersheds

FIGURE

3-4

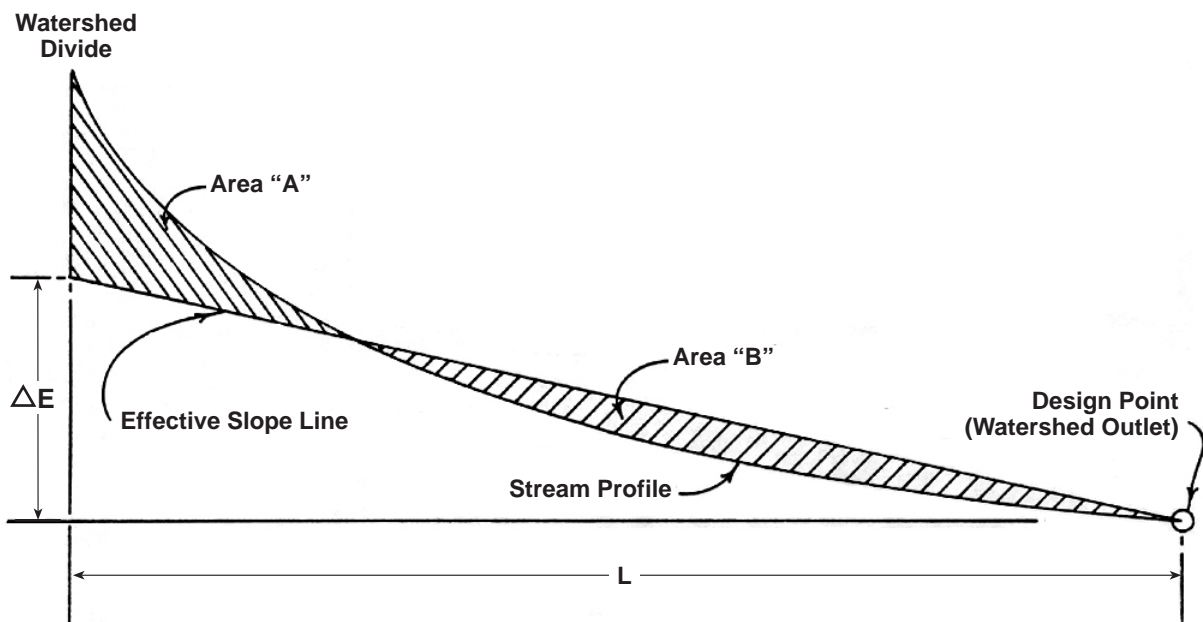
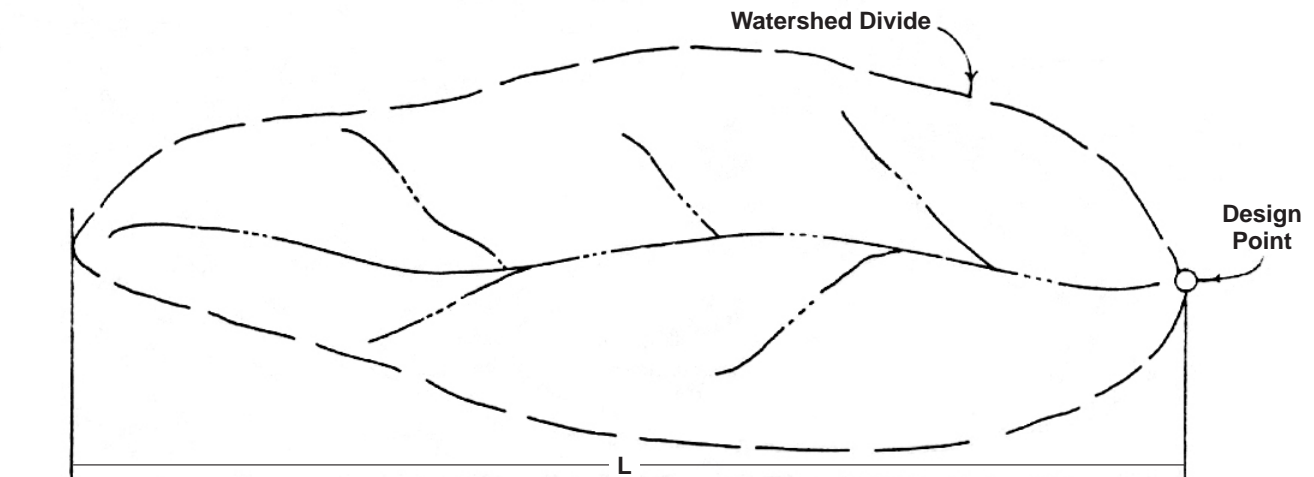

Area "A" = Area "B"

SOURCE: California Division of Highways (1941) and Kirpich (1940)

FIGURE

Computation of Effective Slope for Natural Watersheds

3-5

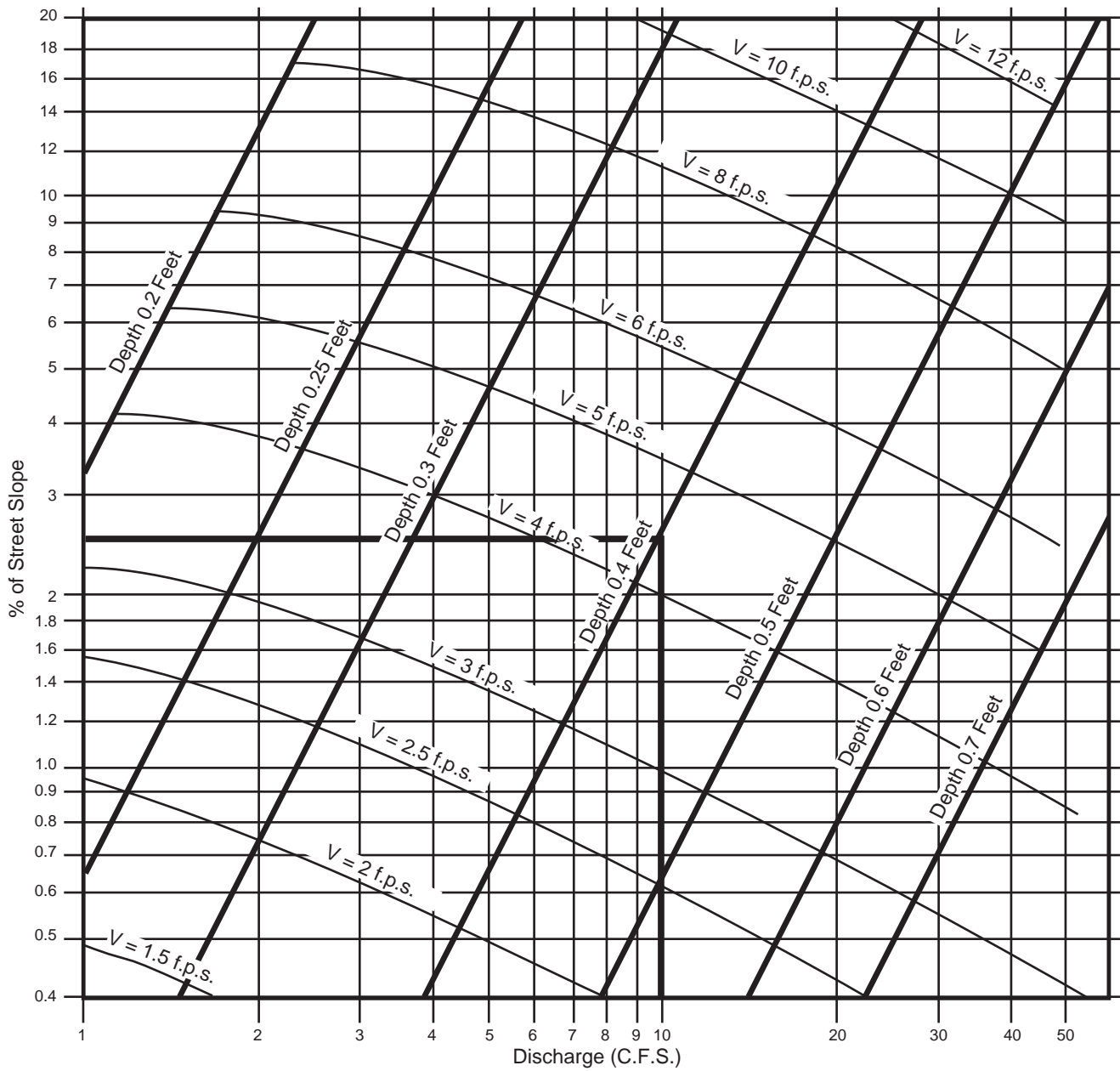
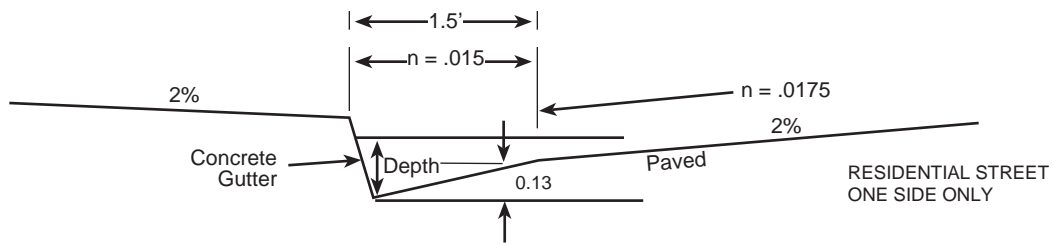

**EXAMPLE:**  
 Given:  $Q = 10$   $S = 2.5\%$   
 Chart gives: Depth = 0.4, Velocity = 4.4 f.p.s.

SOURCE: San Diego County Department of Special District Services Design Manual

**Gutter and Roadway Discharge - Velocity Chart**

**FIGURE**

**3-6**



EQUATION:  $V = \frac{1.49}{n} R^{2/3} s^{1/2}$

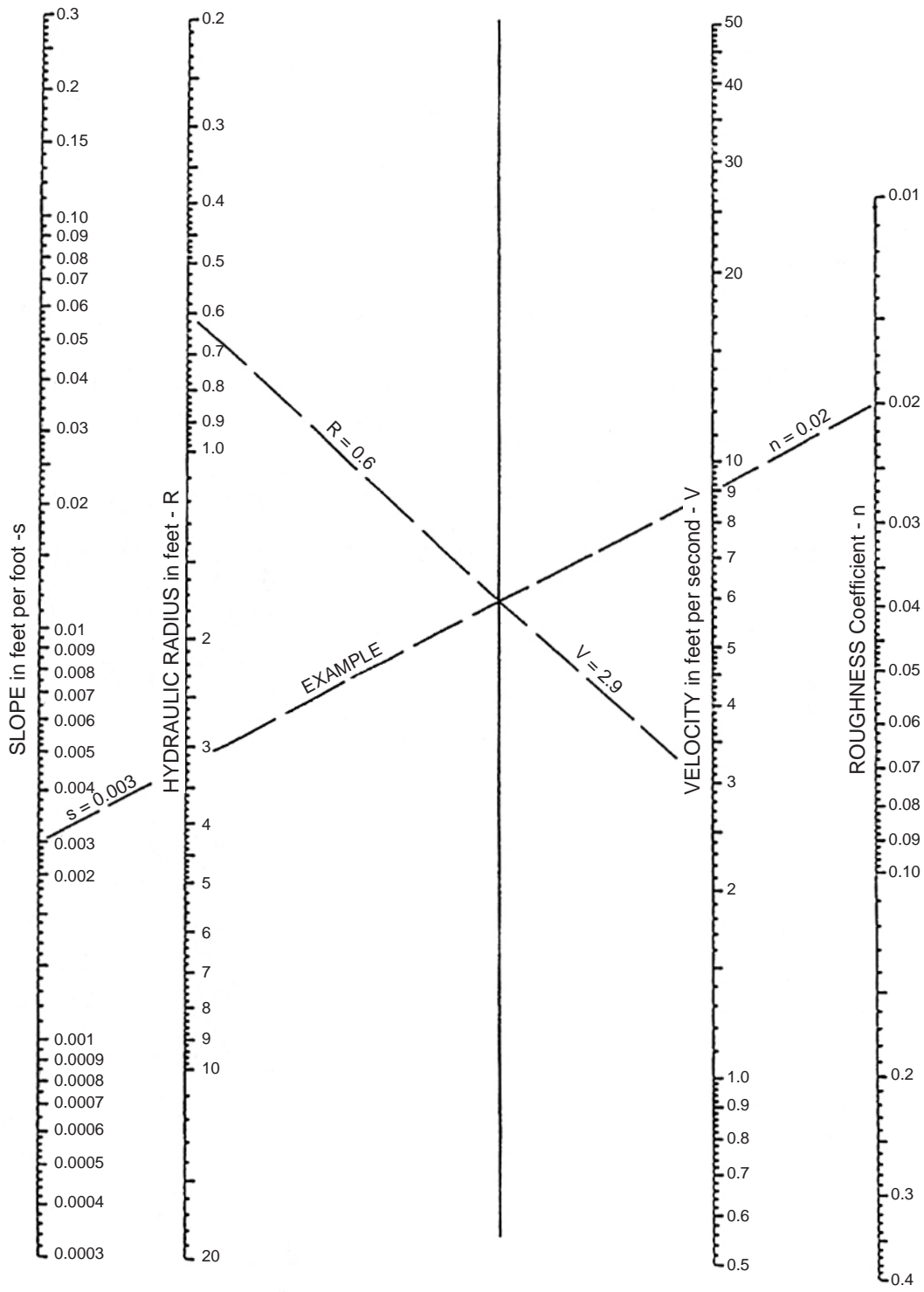

SOURCE: USDOT, FHWA, HDS-3 (1961)

Manning's Equation Nomograph

FIGURE

3-7

**ATTACHMENT C**  
**WATERSHED INFORMATION**  
Soils Index Map  
Point Rainfall Isopluvial maps

# County of San Diego Hydrology Manual



## Soil Hydrologic Groups

### Legend

Soil Groups	
	Group A
	Group B
	Group C
	Group D
	Undetermined
	Data Unavailable



THIS MAP IS PROVIDED WITHOUT WARRANTY OF ANY KIND, EITHER EXPRESS OR IMPLIED, INCLUDING, BUT NOT LIMITED TO, THE IMPLIED WARRANTIES OF MERCHANTABILITY AND FITNESS FOR A PARTICULAR PURPOSE. Copyright SanGIS. All Rights Reserved.

This product may contain information from the SANDAG Regional Information System which cannot be reproduced without the written permission of SANDAG.

This product may contain information which has been reproduced with permission granted by Thomas Brothers Maps.

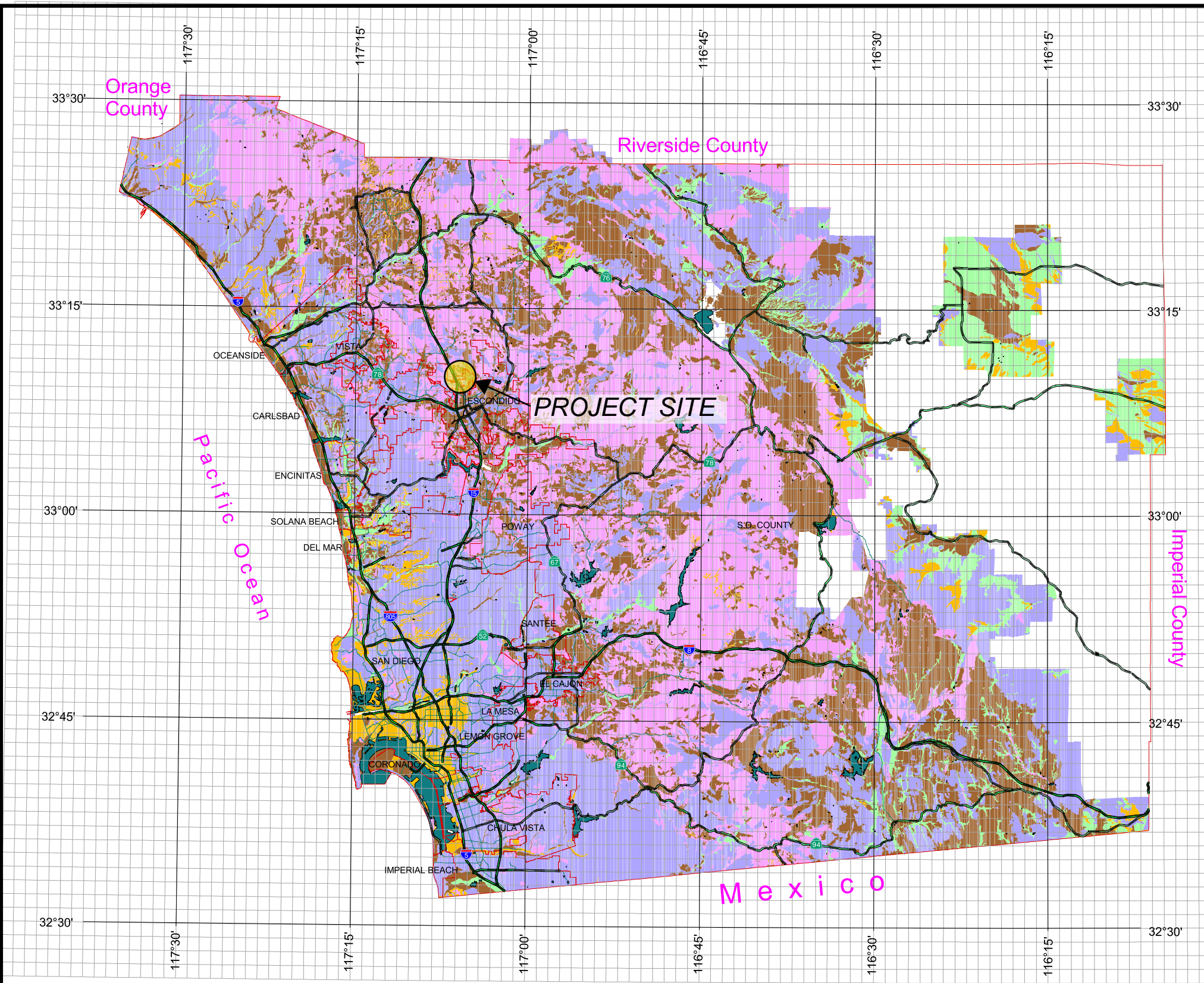
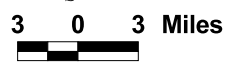

PROJECT SOIL MAP



# County of San Diego Hydrology Manual



## Rainfall Isopluvials

### 100 Year Rainfall Event - 6 Hours

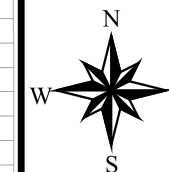
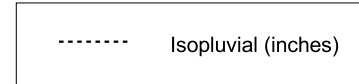

3 0 3 Miles

THIS MAP IS PROVIDED WITHOUT WARRANTY OF ANY KIND, EITHER EXPRESS OR IMPLIED, INCLUDING, BUT NOT LIMITED TO, THE IMPLIED WARRANTIES OF MERCHANTABILITY AND FITNESS FOR A PARTICULAR PURPOSE. Copyright SanGIS. All Rights Reserved.

This product may contain information from the SANDAG Regional Information System which cannot be reproduced without the written permission of SANDAG.

This product may contain information which has been reproduced with permission granted by Thomas Brothers Maps.

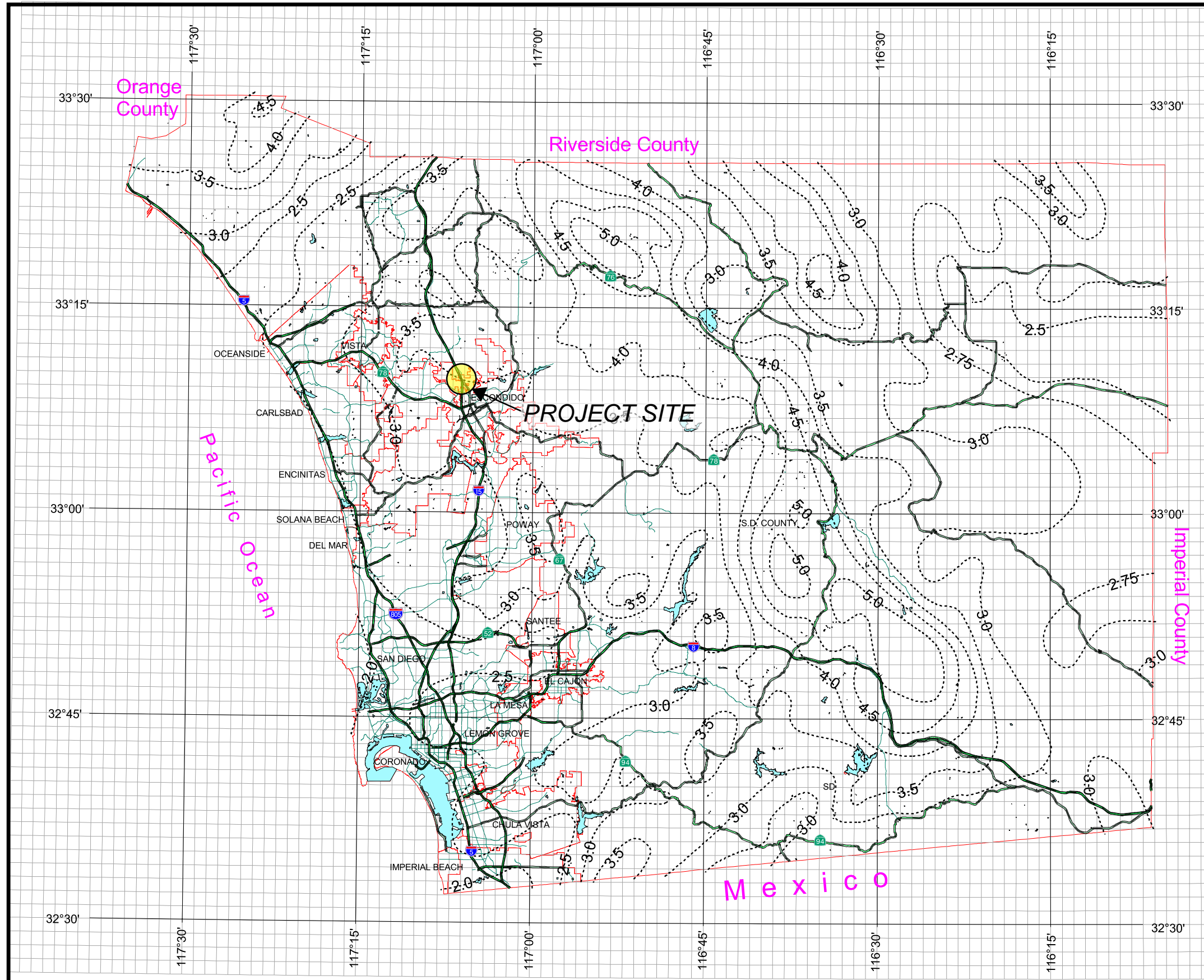

# County of San Diego Hydrology Manual



## Rainfall Isopluvials

### 100 Year Rainfall Event - 24 Hours

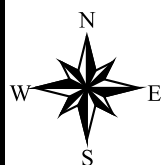
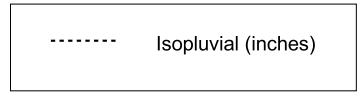

THIS MAP IS PROVIDED WITHOUT WARRANTY OF ANY KIND, EITHER EXPRESS OR IMPLIED, INCLUDING, BUT NOT LIMITED TO, THE IMPLIED WARRANTIES OF MERCHANTABILITY AND FITNESS FOR A PARTICULAR PURPOSE. Copyright SanGIS. All Rights Reserved.

This product may contain information from the SANDAG Regional Information System which cannot be reproduced without the written permission of SANDAG.

This product may contain information which has been reproduced with permission granted by Thomas Brothers Maps.

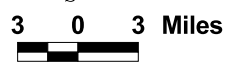

## PROJECT ISOPULIVIAL MAP

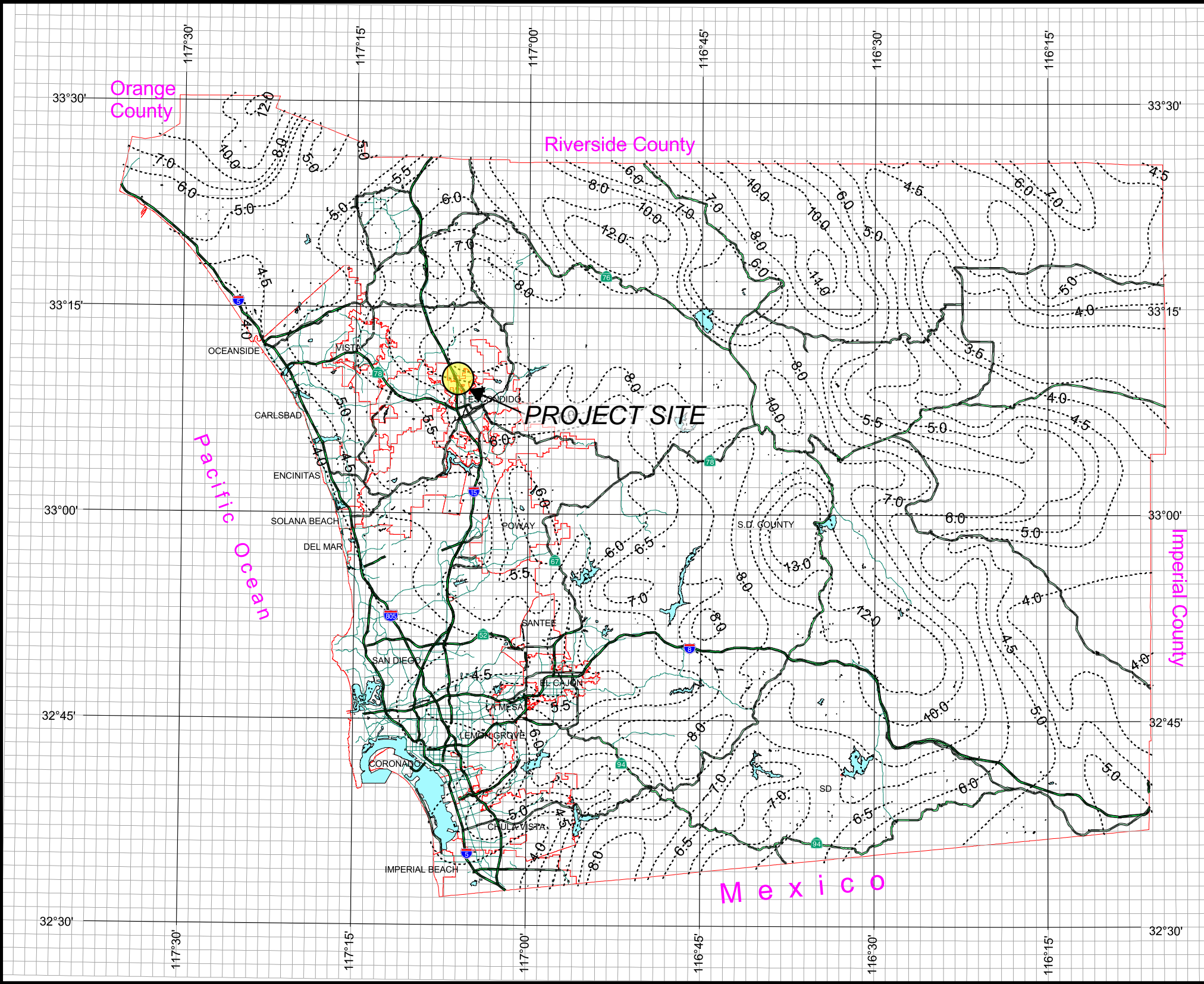

---

**WATERSHED MAP**



# Watershed Map

## Legend



Project Site



Carlsbad Watershed,  
San Marcos 904.52

 NUTMEG

Google Earth

© 2018 Google



800 ft



## **ATTACHMENT D**

### **50 Year Pre Development Calculations**

#### ***Steps Taken To Analyze This Condition***

The Rational Method as outlined in section 3 of the June 2003 San Diego County Hydrology Manual is followed here. The software that we are using is the “*Rational Hydrology Method, San Diego County (2003 Manual)*” module of the CIVILCADD/CIVIL DESIGN Engineering software version 7.9.

Please see the subsequent pages for the calculations. These calculations are for the Q100. The results are outlined/summarized in Section 8.



San Diego County Rational Hydrology Program

CIVILCADD/CIVILDESIGN Engineering Software,(c)1991-2014 Version 9.0

Rational method hydrology program based on  
San Diego County Flood Control Division 2003 hydrology manual  
Rational Hydrology Study Date: 09/24/18

-----  
17046 Nutmeg Development  
Pre-Development Poc1 50 Year  
17046predevpoc1.rd3

-----  
\*\*\*\*\* Hydrology Study Control Information \*\*\*\*\*  
-----

Program License Serial Number 6332

-----  
Rational hydrology study storm event year is 50.0  
English (in-lb) input data Units used

Map data precipitation entered:  
6 hour, precipitation(inches) = 3.000  
24 hour precipitation(inches) = 6.000  
P6/P24 = 50.0%  
San Diego hydrology manual 'C' values used

+++++  
Process from Point/Station 401.000 to Point/Station 402.000  
\*\*\*\* INITIAL AREA EVALUATION \*\*\*\*

---

Decimal fraction soil group A = 0.000  
Decimal fraction soil group B = 0.000  
Decimal fraction soil group C = 1.000  
Decimal fraction soil group D = 0.000  
[UNDISTURBED NATURAL TERRAIN ]  
(Permanent Open Space )  
Impervious value, Ai = 0.000  
Sub-Area C Value = 0.300  
Initial subarea total flow distance = 201.000(Ft.)  
Highest elevation = 889.120(Ft.)  
Lowest elevation = 881.370(Ft.)  
Elevation difference = 7.750(Ft.) Slope = 3.856 %  
INITIAL AREA TIME OF CONCENTRATION CALCULATIONS:  
The maximum overland flow distance is 100.00 (Ft)  
for the top area slope value of 3.86 %, in a development type of  
Permanent Open Space  
In Accordance With Figure 3-3  
Initial Area Time of Concentration = 9.18 minutes  
 $TC = [1.8*(1.1-C)*distance(Ft.)^0.5]/(slope^{1/3})$   
 $TC = [1.8*(1.1-0.3000)*(100.000^0.5)]/(3.856^{1/3}) = 9.18$   
The initial area total distance of 201.00 (Ft.) entered leaves a  
remaining distance of 101.00 (Ft.)  
Using Figure 3-4, the travel time for this distance is 0.96 minutes  
for a distance of 101.00 (Ft.) and a slope of 3.86 %  
with an elevation difference of 3.89(Ft.) from the end of the top area  
 $Tt = [11.9*length(Mi)^3]/(elevation\ change(Ft.))^{0.385} *60(\text{min/hr})$   
= 0.956 Minutes  
 $Tt = [(11.9*0.0191^3)/(3.89)]^{0.385} = 0.96$   
Total initial area Ti = 9.18 minutes from Figure 3-3 formula plus  
0.96 minutes from the Figure 3-4 formula = 10.14 minutes

Rainfall intensity (I) = 5.010(In/Hr) for a 50.0 year storm  
Effective runoff coefficient used for area (Q=KCIA) is C = 0.300  
Subarea runoff = 0.977(CFS)  
Total initial stream area = 0.650(Ac.)

++++  
Process from Point/Station 402.000 to Point/Station 402.000  
\*\*\*\* SUBAREA FLOW ADDITION \*\*\*\*

---

Rainfall intensity (I) = 5.010(In/Hr) for a 50.0 year storm  
Decimal fraction soil group A = 0.000  
Decimal fraction soil group B = 0.000  
Decimal fraction soil group C = 1.000  
Decimal fraction soil group D = 0.000  
[HIGH DENSITY RESIDENTIAL ]  
(43.0 DU/A or Less )  
Impervious value, Ai = 0.800  
Sub-Area C Value = 0.780  
Time of concentration = 10.14 min.  
Rainfall intensity = 5.010(In/Hr) for a 50.0 year storm  
Effective runoff coefficient used for total area  
(Q=KCIA) is C = 0.441 CA = 0.406  
Subarea runoff = 1.055(CFS) for 0.270(Ac.)  
Total runoff = 2.032(CFS) Total area = 0.920(Ac.)

++++  
Process from Point/Station 402.000 to Point/Station 402.000  
\*\*\*\* SUBAREA FLOW ADDITION \*\*\*\*

---

Rainfall intensity (I) = 5.010(In/Hr) for a 50.0 year storm  
Decimal fraction soil group A = 0.000  
Decimal fraction soil group B = 0.000  
Decimal fraction soil group C = 1.000  
Decimal fraction soil group D = 0.000  
[HIGH DENSITY RESIDENTIAL ]  
(43.0 DU/A or Less )  
Impervious value, Ai = 0.800  
Sub-Area C Value = 0.780  
Time of concentration = 10.14 min.  
Rainfall intensity = 5.010(In/Hr) for a 50.0 year storm  
Effective runoff coefficient used for total area  
(Q=KCIA) is C = 0.474 CA = 0.484  
Subarea runoff = 0.391(CFS) for 0.100(Ac.)  
Total runoff = 2.423(CFS) Total area = 1.020(Ac.)

++++  
Process from Point/Station 402.000 to Point/Station 402.000  
\*\*\*\* SUBAREA FLOW ADDITION \*\*\*\*

---

Rainfall intensity (I) = 5.010(In/Hr) for a 50.0 year storm  
Decimal fraction soil group A = 0.000  
Decimal fraction soil group B = 0.000  
Decimal fraction soil group C = 0.000  
Decimal fraction soil group D = 1.000  
[LOW DENSITY RESIDENTIAL ]  
(1.0 DU/A or Less )  
Impervious value, Ai = 0.100  
Sub-Area C Value = 0.410  
Time of concentration = 10.14 min.  
Rainfall intensity = 5.010(In/Hr) for a 50.0 year storm  
Effective runoff coefficient used for total area  
(Q=KCIA) is C = 0.463 CA = 0.573  
Subarea runoff = 0.448(CFS) for 0.218(Ac.)

Total runoff = 2.871(CFS) Total area = 1.238(Ac.)

++++  
Process from Point/Station 402.000 to Point/Station 403.000  
\*\*\*\* IRREGULAR CHANNEL FLOW TRAVEL TIME \*\*\*\*

-----  
Estimated mean flow rate at midpoint of channel = 5.594(CFS)  
Depth of flow = 0.474(Ft.), Average velocity = 2.487(Ft/s)  
\*\*\*\*\* Irregular Channel Data \*\*\*\*\*

-----  
Information entered for subchannel number 1 :  
Point number 'X' coordinate 'Y' coordinate  
1 0.00 3.00  
2 30.00 0.00  
3 60.00 3.00  
Manning's 'N' friction factor = 0.045  
-----

Sub-Channel flow = 5.594(CFS)  
' ' flow top width = 9.485(Ft.)  
' ' velocity = 2.487(Ft/s)  
' ' area = 2.249(Sq.Ft)  
' ' Froude number = 0.900

Upstream point elevation = 881.370(Ft.)  
Downstream point elevation = 864.410(Ft.)  
Flow length = 436.000(Ft.)  
Travel time = 2.92 min.  
Time of concentration = 13.06 min.  
Depth of flow = 0.474(Ft.)  
Average velocity = 2.487(Ft/s)  
Total irregular channel flow = 5.594(CFS)  
Irregular channel normal depth above invert elev. = 0.474(Ft.)  
Average velocity of channel(s) = 2.487(Ft/s)  
Adding area flow to channel  
Rainfall intensity (I) = 4.255(In/Hr) for a 50.0 year storm  
Decimal fraction soil group A = 0.000  
Decimal fraction soil group B = 0.000  
Decimal fraction soil group C = 0.840  
Decimal fraction soil group D = 0.160  
[UNDISTURBED NATURAL TERRAIN ]  
(Permanent Open Space )  
Impervious value, Ai = 0.000  
Sub-Area C Value = 0.308  
Rainfall intensity = 4.255(In/Hr) for a 50.0 year storm  
Effective runoff coefficient used for total area  
(Q=KCIA) is C = 0.342 CA = 1.934  
Subarea runoff = 5.360(CFS) for 4.420(Ac.)  
Total runoff = 8.231(CFS) Total area = 5.658(Ac.)  
Depth of flow = 0.548(Ft.), Average velocity = 2.739(Ft/s)

++++  
Process from Point/Station 403.000 to Point/Station 403.000  
\*\*\*\* SUBAREA FLOW ADDITION \*\*\*\*

-----  
Rainfall intensity (I) = 4.255(In/Hr) for a 50.0 year storm  
Decimal fraction soil group A = 0.000  
Decimal fraction soil group B = 0.000  
Decimal fraction soil group C = 0.700  
Decimal fraction soil group D = 0.300  
[UNDISTURBED NATURAL TERRAIN ]  
(Permanent Open Space )  
Impervious value, Ai = 0.000  
Sub-Area C Value = 0.315  
Time of concentration = 13.06 min.

Rainfall intensity = 4.255(In/Hr) for a 50.0 year storm  
Effective runoff coefficient used for total area  
(Q=KCIA) is C = 0.336 CA = 2.407  
Subarea runoff = 2.010(CFS) for 1.500(Ac.)  
Total runoff = 10.241(CFS) Total area = 7.158(Ac.)

++++  
Process from Point/Station 403.000 to Point/Station 305.000  
\*\*\*\* PIPEFLOW TRAVEL TIME (User specified size) \*\*\*\*

---

Upstream point/station elevation = 864.410(Ft.)  
Downstream point/station elevation = 855.620(Ft.)  
Pipe length = 444.00(Ft.) Slope = 0.0198 Manning's N = 0.013  
No. of pipes = 1 Required pipe flow = 10.241(CFS)  
Given pipe size = 36.00(In.)  
Calculated individual pipe flow = 10.241(CFS)  
Normal flow depth in pipe = 8.03(In.)  
Flow top width inside pipe = 29.97(In.)  
Critical Depth = 12.15(In.)  
Pipe flow velocity = 8.71(Ft/s)  
Travel time through pipe = 0.85 min.  
Time of concentration (TC) = 13.91 min.  
End of computations, total study area = 7.158 (Ac.)

San Diego County Rational Hydrology Program

CIVILCADD/CIVILDESIGN Engineering Software,(c)1991-2014 Version 9.0

Rational method hydrology program based on  
San Diego County Flood Control Division 2003 hydrology manual  
Rational Hydrology Study Date: 09/25/18

-----  
17046 Nutmeg Development  
Pre-Development Poc2 50 Year  
17046predevpoc250.rd3

-----  
\*\*\*\*\* Hydrology Study Control Information \*\*\*\*\*  
-----

Program License Serial Number 6332

-----  
Rational hydrology study storm event year is 50.0  
English (in-lb) input data Units used

Map data precipitation entered:  
6 hour, precipitation(inches) = 3.000  
24 hour precipitation(inches) = 6.000  
P6/P24 = 50.0%  
San Diego hydrology manual 'C' values used

+++++  
Process from Point/Station 101.000 to Point/Station 102.000  
\*\*\*\* INITIAL AREA EVALUATION \*\*\*\*

---

Decimal fraction soil group A = 0.000  
Decimal fraction soil group B = 0.000  
Decimal fraction soil group C = 0.000  
Decimal fraction soil group D = 1.000  
[UNDISTURBED NATURAL TERRAIN ]  
(Permanent Open Space )  
Impervious value, Ai = 0.000  
Sub-Area C Value = 0.350  
Initial subarea total flow distance = 157.000(Ft.)  
Highest elevation = 1080.000(Ft.)  
Lowest elevation = 1070.000(Ft.)  
Elevation difference = 10.000(Ft.) Slope = 6.369 %  
INITIAL AREA TIME OF CONCENTRATION CALCULATIONS:  
The maximum overland flow distance is 100.00 (Ft)  
for the top area slope value of 6.37 %, in a development type of  
Permanent Open Space  
In Accordance With Figure 3-3  
Initial Area Time of Concentration = 7.28 minutes  
 $TC = [1.8 * (1.1 - C) * distance(Ft.)^{.5}] / (\% slope^{(1/3)})$   
 $TC = [1.8 * (1.1 - 0.3500) * (100.000^{.5})] / (6.369^{(1/3)}) = 7.28$   
The initial area total distance of 157.00 (Ft.) entered leaves a  
remaining distance of 57.00 (Ft.)  
Using Figure 3-4, the travel time for this distance is 0.51 minutes  
for a distance of 57.00 (Ft.) and a slope of 6.37 %  
with an elevation difference of 3.63(Ft.) from the end of the top area  
 $Tt = [11.9 * length(Mi)^3] / (elevation\ change(Ft.))^{.385} * 60(\text{min/hr})$   
= 0.507 Minutes  
 $Tt = [(11.9 * 0.0108^3) / (3.63)]^{.385} = 0.51$   
Total initial area Ti = 7.28 minutes from Figure 3-3 formula plus  
0.51 minutes from the Figure 3-4 formula = 7.79 minutes

Rainfall intensity (I) = 5.938(In/Hr) for a 50.0 year storm  
Effective runoff coefficient used for area (Q=KCIA) is C = 0.350  
Subarea runoff = 0.769(CFS)  
Total initial stream area = 0.370(Ac.)

+++++

Process from Point/Station 102.000 to Point/Station 103.000  
\*\*\*\* IRREGULAR CHANNEL FLOW TRAVEL TIME \*\*\*\*

---

Estimated mean flow rate at midpoint of channel = 2.954(CFS)  
Depth of flow = 0.142(Ft.), Average velocity = 2.019(Ft/s)  
\*\*\*\*\* Irregular Channel Data \*\*\*\*\*

-----  
Information entered for subchannel number 1 :

Point number	'X' coordinate	'Y' coordinate
1	0.00	1.00
2	12.00	0.00
3	21.00	0.00
4	27.00	1.00

Manning's 'N' friction factor = 0.090  
-----

Sub-Channel flow = 2.954(CFS)  
' ' flow top width = 11.562(Ft.)  
' ' velocity = 2.019(Ft/s)  
' ' area = 1.463(Sq.Ft)  
' ' Froude number = 1.000

Upstream point elevation = 1070.000(Ft.)  
Downstream point elevation = 884.150(Ft.)  
Flow length = 788.000(Ft.)  
Travel time = 6.50 min.  
Time of concentration = 14.29 min.  
Depth of flow = 0.142(Ft.)  
Average velocity = 2.019(Ft/s)  
Total irregular channel flow = 2.954(CFS)  
Irregular channel normal depth above invert elev. = 0.142(Ft.)  
Average velocity of channel(s) = 2.019(Ft/s)  
Adding area flow to channel

Rainfall intensity (I) = 4.014(In/Hr) for a 50.0 year storm  
Decimal fraction soil group A = 0.000  
Decimal fraction soil group B = 0.000  
Decimal fraction soil group C = 0.200  
Decimal fraction soil group D = 0.800  
[UNDISTURBED NATURAL TERRAIN ]  
(Permanent Open Space )  
Impervious value, Ai = 0.000  
Sub-Area C Value = 0.340

Rainfall intensity = 4.014(In/Hr) for a 50.0 year storm  
Effective runoff coefficient used for total area  
(Q=KCIA) is C = 0.341 CA = 1.265  
Subarea runoff = 4.309(CFS) for 3.340(Ac.)  
Total runoff = 5.078(CFS) Total area = 3.710(Ac.)  
Depth of flow = 0.194(Ft.), Average velocity = 2.430(Ft/s)

+++++

Process from Point/Station 103.000 to Point/Station 103.000  
\*\*\*\* CONFLUENCE OF MINOR STREAMS \*\*\*\*

---

Along Main Stream number: 1 in normal stream number 1  
Stream flow area = 3.710(Ac.)  
Runoff from this stream = 5.078(CFS)  
Time of concentration = 14.29 min.  
Rainfall intensity = 4.014(In/Hr)

\*\*\*\*\*  
 Process from Point/Station 201.000 to Point/Station 202.000  
 \*\*\*\* INITIAL AREA EVALUATION \*\*\*\*

---

Decimal fraction soil group A = 0.000  
 Decimal fraction soil group B = 0.000  
 Decimal fraction soil group C = 0.000  
 Decimal fraction soil group D = 1.000  
 [UNDISTURBED NATURAL TERRAIN ]  
 (Permanent Open Space )  
 Impervious value, Ai = 0.000  
 Sub-Area C Value = 0.350  
 Initial subarea total flow distance = 788.000(Ft.)  
 Highest elevation = 974.970(Ft.)  
 Lowest elevation = 925.370(Ft.)  
 Elevation difference = 49.600(Ft.) Slope = 6.294 %  
 INITIAL AREA TIME OF CONCENTRATION CALCULATIONS:  
 The maximum overland flow distance is 100.00 (Ft)  
 for the top area slope value of 6.29 %, in a development type of  
 Permanent Open Space  
 In Accordance With Figure 3-3  
 Initial Area Time of Concentration = 7.31 minutes  
 $TC = [1.8 * (1.1 - C) * distance(Ft.)^{1.5}] / (\% slope^{1/3})$   
 $TC = [1.8 * (1.1 - 0.3500) * (100.000^{1.5})] / (6.294^{1/3}) = 7.31$   
 The initial area total distance of 788.00 (Ft.) entered leaves a  
 remaining distance of 688.00 (Ft.)  
 Using Figure 3-4, the travel time for this distance is 3.47 minutes  
 for a distance of 688.00 (Ft.) and a slope of 6.29 %  
 with an elevation difference of 43.30(Ft.) from the end of the top area  
 $Tt = [11.9 * length(Mi)^3] / (elevation\ change(Ft.))^{0.385} * 60(\text{min/hr})$   
 $= 3.467 \text{ Minutes}$   
 $Tt = [(11.9 * 0.1303^3) / (43.30)]^{0.385} = 3.47$   
 Total initial area Ti = 7.31 minutes from Figure 3-3 formula plus  
 3.47 minutes from the Figure 3-4 formula = 10.78 minutes  
 Rainfall intensity (I) = 4.816(In/Hr) for a 50.0 year storm  
 Effective runoff coefficient used for area (Q=KCIA) is C = 0.350  
 Subarea runoff = 0.337(CFS)  
 Total initial stream area = 0.200(Ac.)

\*\*\*\*\*  
 Process from Point/Station 202.000 to Point/Station 103.000  
 \*\*\*\* IRREGULAR CHANNEL FLOW TRAVEL TIME \*\*\*\*

---

Estimated mean flow rate at midpoint of channel = 1.044(CFS)  
 Depth of flow = 0.134(Ft.), Average velocity = 0.722(Ft/s)  
 \*\*\*\*\* Irregular Channel Data \*\*\*\*\*

-----  
 Information entered for subchannel number 1 :

Point number	'X' coordinate	'Y' coordinate
1	0.00	1.00
2	80.00	0.00
3	160.00	1.00

Manning's 'N' friction factor = 0.090  
 -----

Sub-Channel flow = 1.044(CFS)  
 ' ' flow top width = 21.500(Ft.)  
 ' ' velocity = 0.722(Ft/s)  
 ' ' area = 1.445(Sq.Ft)  
 ' ' Froude number = 0.491

Upstream point elevation = 925.370(Ft.)  
 Downstream point elevation = 884.150(Ft.)  
 Flow length = 588.000(Ft.)  
 Travel time = 13.56 min.

Time of concentration = 24.34 min.  
Depth of flow = 0.134(Ft.)  
Average velocity = 0.722(Ft/s)  
Total irregular channel flow = 1.044(CFS)  
Irregular channel normal depth above invert elev. = 0.134(Ft.)  
Average velocity of channel(s) = 0.722(Ft/s)  
Adding area flow to channel  
Rainfall intensity (I) = 2.848(In/Hr) for a 50.0 year storm  
Decimal fraction soil group A = 0.000  
Decimal fraction soil group B = 0.000  
Decimal fraction soil group C = 0.600  
Decimal fraction soil group D = 0.400  
[UNDISTURBED NATURAL TERRAIN ]  
(Permanent Open Space )  
Impervious value, Ai = 0.000  
Sub-Area C Value = 0.320  
Rainfall intensity = 2.848(In/Hr) for a 50.0 year storm  
Effective runoff coefficient used for total area  
(Q=KCIA) is C = 0.323 CA = 0.595  
Subarea runoff = 1.357(CFS) for 1.640(Ac.)  
Total runoff = 1.694(CFS) Total area = 1.840(Ac.)  
Depth of flow = 0.161(Ft.), Average velocity = 0.815(Ft/s)

++++  
Process from Point/Station 103.000 to Point/Station 103.000  
\*\*\*\* SUBAREA FLOW ADDITION \*\*\*\*

---

Rainfall intensity (I) = 2.848(In/Hr) for a 50.0 year storm  
Decimal fraction soil group A = 0.000  
Decimal fraction soil group B = 0.000  
Decimal fraction soil group C = 1.000  
Decimal fraction soil group D = 0.000  
[HIGH DENSITY RESIDENTIAL ]  
(43.0 DU/A or Less )  
Impervious value, Ai = 0.800  
Sub-Area C Value = 0.780  
Time of concentration = 24.34 min.  
Rainfall intensity = 2.848(In/Hr) for a 50.0 year storm  
Effective runoff coefficient used for total area  
(Q=KCIA) is C = 0.403 CA = 0.899  
Subarea runoff = 0.866(CFS) for 0.390(Ac.)  
Total runoff = 2.560(CFS) Total area = 2.230(Ac.)

++++  
Process from Point/Station 103.000 to Point/Station 103.000  
\*\*\*\* SUBAREA FLOW ADDITION \*\*\*\*

---

Rainfall intensity (I) = 2.848(In/Hr) for a 50.0 year storm  
Decimal fraction soil group A = 0.000  
Decimal fraction soil group B = 0.000  
Decimal fraction soil group C = 1.000  
Decimal fraction soil group D = 0.000  
[HIGH DENSITY RESIDENTIAL ]  
(43.0 DU/A or Less )  
Impervious value, Ai = 0.800  
Sub-Area C Value = 0.780  
Time of concentration = 24.34 min.  
Rainfall intensity = 2.848(In/Hr) for a 50.0 year storm  
Effective runoff coefficient used for total area  
(Q=KCIA) is C = 0.450 CA = 1.149  
Subarea runoff = 0.711(CFS) for 0.320(Ac.)  
Total runoff = 3.271(CFS) Total area = 2.550(Ac.)



++++  
 Process from Point/Station 103.000 to Point/Station 103.000  
 \*\*\*\* SUBAREA FLOW ADDITION \*\*\*\*

---

Rainfall intensity (I) = 2.848(In/Hr) for a 50.0 year storm  
 Decimal fraction soil group A = 0.000  
 Decimal fraction soil group B = 0.000  
 Decimal fraction soil group C = 1.000  
 Decimal fraction soil group D = 0.000  
 [HIGH DENSITY RESIDENTIAL ]  
 (43.0 DU/A or Less )  
 Impervious value, Ai = 0.800  
 Sub-Area C Value = 0.780  
 Time of concentration = 24.34 min.  
 Rainfall intensity = 2.848(In/Hr) for a 50.0 year storm  
 Effective runoff coefficient used for total area  
 (Q=KCIA) is C = 0.462 CA = 1.219  
 Subarea runoff = 0.200(CFS) for 0.090(Ac.)  
 Total runoff = 3.471(CFS) Total area = 2.640(Ac.)

++++  
 Process from Point/Station 103.000 to Point/Station 103.000  
 \*\*\*\* CONFLUENCE OF MINOR STREAMS \*\*\*\*

---

Along Main Stream number: 1 in normal stream number 2  
 Stream flow area = 2.640(Ac.)  
 Runoff from this stream = 3.471(CFS)  
 Time of concentration = 24.34 min.  
 Rainfall intensity = 2.848(In/Hr)  
 Summary of stream data:

Stream No.	Flow rate (CFS)	TC (min)	Rainfall Intensity (In/Hr)
1	5.078	14.29	4.014
2	3.471	24.34	2.848

Qmax(1) =  
 $1.000 * 1.000 * 5.078) +$   
 $1.000 * 0.587 * 3.471) += 7.116$

Qmax(2) =  
 $0.709 * 1.000 * 5.078) +$   
 $1.000 * 1.000 * 3.471) += 7.073$

Total of 2 streams to confluence:  
 Flow rates before confluence point:  
 5.078 3.471  
 Maximum flow rates at confluence using above data:  
 7.116 7.073  
 Area of streams before confluence:  
 3.710 2.640  
 Results of confluence:  
 Total flow rate = 7.116(CFS)  
 Time of concentration = 14.295 min.  
 Effective stream area after confluence = 6.350(Ac.)  
 End of computations, total study area = 6.350 (Ac.)

San Diego County Rational Hydrology Program

CIVILCADD/CIVILDESIGN Engineering Software,(c)1991-2014 Version 9.0

Rational method hydrology program based on  
San Diego County Flood Control Division 2003 hydrology manual  
Rational Hydrology Study Date: 09/25/18

-----  
17046 Nutmeg Development  
Pre-Development Poc3 50 Year  
17046predevpoc350.rd3

-----  
\*\*\*\*\* Hydrology Study Control Information \*\*\*\*\*  
-----

Program License Serial Number 6332

-----  
Rational hydrology study storm event year is 50.0  
English (in-lb) input data Units used

Map data precipitation entered:  
6 hour, precipitation(inches) = 3.000  
24 hour precipitation(inches) = 6.000  
P6/P24 = 50.0%  
San Diego hydrology manual 'C' values used

+++++  
Process from Point/Station 301.000 to Point/Station 302.000  
\*\*\*\* INITIAL AREA EVALUATION \*\*\*\*

---

Decimal fraction soil group A = 0.000  
Decimal fraction soil group B = 0.000  
Decimal fraction soil group C = 0.000  
Decimal fraction soil group D = 1.000  
[UNDISTURBED NATURAL TERRAIN ]  
(Permanent Open Space )  
Impervious value, Ai = 0.000  
Sub-Area C Value = 0.350  
Initial subarea total flow distance = 170.000(Ft.)  
Highest elevation = 974.970(Ft.)  
Lowest elevation = 919.930(Ft.)  
Elevation difference = 55.040(Ft.) Slope = 32.376 %  
INITIAL AREA TIME OF CONCENTRATION CALCULATIONS:  
The maximum overland flow distance is 100.00 (Ft)  
for the top area slope value of 32.38 %, in a development type of  
Permanent Open Space  
In Accordance With Figure 3-3  
Initial Area Time of Concentration = 4.24 minutes  
 $TC = [1.8 * (1.1 - C) * distance(Ft.)^{.5}] / (\% slope^{(1/3)})$   
 $TC = [1.8 * (1.1 - 0.3500) * (100.000^{.5})] / (32.376^{(1/3)}) = 4.24$   
The initial area total distance of 170.00 (Ft.) entered leaves a  
remaining distance of 70.00 (Ft.)  
Using Figure 3-4, the travel time for this distance is 0.32 minutes  
for a distance of 70.00 (Ft.) and a slope of 32.38 %  
with an elevation difference of 22.66(Ft.) from the end of the top area  
 $Tt = [11.9 * length(Mi)^3] / (elevation\ change(Ft.))^{.385} * 60(\text{min/hr})$   
= 0.318 Minutes  
 $Tt = [(11.9 * 0.0133^3) / (22.66)]^{.385} = 0.32$   
Total initial area Ti = 4.24 minutes from Figure 3-3 formula plus  
0.32 minutes from the Figure 3-4 formula = 4.55 minutes

Calculated TC of 4.553 minutes is less than 5 minutes,  
 resetting TC to 5.0 minutes for rainfall intensity calculations  
 Rainfall intensity (I) = 7.904(In/Hr) for a 50.0 year storm  
 Effective runoff coefficient used for area (Q=KCIA) is C = 0.350  
 Subarea runoff = 1.273(CFS)  
 Total initial stream area = 0.460(Ac.)

+++++  
 Process from Point/Station 302.000 to Point/Station 303.000  
 \*\*\*\* IRREGULAR CHANNEL FLOW TRAVEL TIME \*\*\*\*

-----  
 Estimated mean flow rate at midpoint of channel = 1.745(CFS)  
 Depth of flow = 0.143(Ft.), Average velocity = 0.970(Ft/s)  
 \*\*\*\*\* Irregular Channel Data \*\*\*\*\*

-----  
 Information entered for subchannel number 1 :  
 Point number 'X' coordinate 'Y' coordinate  
 1 0.00 1.00  
 2 80.00 0.00  
 3 175.00 1.00  
 Manning's 'N' friction factor = 0.090

-----  
 Sub-Channel flow = 1.745(CFS)  
 ' ' flow top width = 25.088(Ft.)  
 ' ' velocity = 0.970(Ft/s)  
 ' ' area = 1.798(Sq.Ft)  
 ' ' Froude number = 0.639

Upstream point elevation = 919.930(Ft.)  
 Downstream point elevation = 903.230(Ft.)  
 Flow length = 144.000(Ft.)  
 Travel time = 2.47 min.  
 Time of concentration = 7.03 min.  
 Depth of flow = 0.143(Ft.)  
 Average velocity = 0.970(Ft/s)  
 Total irregular channel flow = 1.745(CFS)  
 Irregular channel normal depth above invert elev. = 0.143(Ft.)  
 Average velocity of channel(s) = 0.970(Ft/s)  
 Adding area flow to channel  
 Rainfall intensity (I) = 6.346(In/Hr) for a 50.0 year storm  
 Decimal fraction soil group A = 0.000  
 Decimal fraction soil group B = 0.000  
 Decimal fraction soil group C = 0.800  
 Decimal fraction soil group D = 0.200  
 [UNDISTURBED NATURAL TERRAIN ]  
 (Permanent Open Space )  
 Impervious value, Ai = 0.000  
 Sub-Area C Value = 0.310  
 Rainfall intensity = 6.346(In/Hr) for a 50.0 year storm  
 Effective runoff coefficient used for total area  
 (Q=KCIA) is C = 0.328 CA = 0.335  
 Subarea runoff = 0.851(CFS) for 0.560(Ac.)  
 Total runoff = 2.123(CFS) Total area = 1.020(Ac.)  
 Depth of flow = 0.154(Ft.), Average velocity = 1.019(Ft/s)

+++++  
 Process from Point/Station 303.000 to Point/Station 304.000  
 \*\*\*\* IRREGULAR CHANNEL FLOW TRAVEL TIME \*\*\*\*

-----  
 Estimated mean flow rate at midpoint of channel = 2.748(CFS)  
 Depth of flow = 0.335(Ft.), Average velocity = 8.165(Ft/s)  
 \*\*\*\*\* Irregular Channel Data \*\*\*\*\*

-----  
 Information entered for subchannel number 1 :

Point number 'X' coordinate 'Y' coordinate  
 1 0.00 0.50  
 2 0.00 0.00  
 3 3.00 0.50  
 Manning's 'N' friction factor = 0.013

-----  
 Sub-Channel flow = 2.748(CFS)  
 ' ' flow top width = 2.010(Ft.)  
 ' ' velocity= 8.165(Ft/s)  
 ' ' area = 0.337(Sq.Ft)  
 ' ' Froude number = 3.516

Upstream point elevation = 903.230(Ft.)  
 Downstream point elevation = 893.300(Ft.)  
 Flow length = 144.000(Ft.)  
 Travel time = 0.29 min.  
 Time of concentration = 7.32 min.  
 Depth of flow = 0.335(Ft.)  
 Average velocity = 8.165(Ft/s)  
 Total irregular channel flow = 2.748(CFS)  
 Irregular channel normal depth above invert elev. = 0.335(Ft.)  
 Average velocity of channel(s) = 8.165(Ft/s)  
 Adding area flow to channel  
 Rainfall intensity (I) = 6.181(In/Hr) for a 50.0 year storm  
 Decimal fraction soil group A = 0.000  
 Decimal fraction soil group B = 0.000  
 Decimal fraction soil group C = 1.000  
 Decimal fraction soil group D = 0.000  
 [HIGH DENSITY RESIDENTIAL ]  
 (43.0 DU/A or Less )  
 Impervious value, Ai = 0.800  
 Sub-Area C Value = 0.780  
 Rainfall intensity = 6.181(In/Hr) for a 50.0 year storm  
 Effective runoff coefficient used for total area  
 (Q=KCIA) is C = 0.428 CA = 0.561  
 Subarea runoff = 1.343(CFS) for 0.290(Ac.)  
 Total runoff = 3.466(CFS) Total area = 1.310(Ac.)  
 Depth of flow = 0.365(Ft.), Average velocity = 8.653(Ft/s)

++++  
 Process from Point/Station 304.000 to Point/Station 304.000  
 \*\*\*\* SUBAREA FLOW ADDITION \*\*\*\*

-----  
 Rainfall intensity (I) = 6.181(In/Hr) for a 50.0 year storm  
 Decimal fraction soil group A = 0.000  
 Decimal fraction soil group B = 0.000  
 Decimal fraction soil group C = 1.000  
 Decimal fraction soil group D = 0.000  
 [HIGH DENSITY RESIDENTIAL ]  
 (43.0 DU/A or Less )  
 Impervious value, Ai = 0.800  
 Sub-Area C Value = 0.780  
 Time of concentration = 7.32 min.  
 Rainfall intensity = 6.181(In/Hr) for a 50.0 year storm  
 Effective runoff coefficient used for total area  
 (Q=KCIA) is C = 0.471 CA = 0.701  
 Subarea runoff = 0.868(CFS) for 0.180(Ac.)  
 Total runoff = 4.334(CFS) Total area = 1.490(Ac.)  
 End of computations, total study area = 1.490 (Ac.)

San Diego County Rational Hydrology Program

CIVILCADD/CIVILDESIGN Engineering Software,(c)1991-2014 Version 9.0

Rational method hydrology program based on  
San Diego County Flood Control Division 2003 hydrology manual  
Rational Hydrology Study Date: 09/25/18

-----  
1746 Nutmeg Development  
Post-Development Detention Poc 1 50 Year  
17046postdevpoc13det.rd3

-----  
\*\*\*\*\* Hydrology Study Control Information \*\*\*\*\*  
-----

Program License Serial Number 6332

-----  
Rational hydrology study storm event year is 50.0  
English (in-lb) input data Units used

Map data precipitation entered:  
6 hour, precipitation(inches) = 3.000  
24 hour precipitation(inches) = 6.000  
P6/P24 = 50.0%  
San Diego hydrology manual 'C' values used

++++  
Process from Point/Station 606.000 to Point/Station 606.000  
\*\*\*\* USER DEFINED FLOW INFORMATION AT A POINT \*\*\*\*

-----  
User specified 'C' value of 0.760 given for subarea  
Rainfall intensity (I) = 0.618(In/Hr) for a 50.0 year storm  
User specified values are as follows:  
TC = 259.80 min. Rain intensity = 0.62(In/Hr)  
Total area = 7.076(Ac.) Total runoff = 6.035(CFS)  
End of computations, total study area = 7.076 (Ac.)

San Diego County Rational Hydrology Program

CIVILCADD/CIVILDESIGN Engineering Software,(c)1991-2014 Version 9.0

Rational method hydrology program based on  
San Diego County Flood Control Division 2003 hydrology manual  
Rational Hydrology Study Date: 09/25/18

-----  
17046 Nutmeg Development  
Post-Development Poc2 50 Year  
17046postpoc250.rd3

-----  
\*\*\*\*\* Hydrology Study Control Information \*\*\*\*\*  
-----

Program License Serial Number 6332

-----  
Rational hydrology study storm event year is 50.0  
English (in-lb) input data Units used

Map data precipitation entered:  
6 hour, precipitation(inches) = 3.000  
24 hour precipitation(inches) = 6.000  
P6/P24 = 50.0%  
San Diego hydrology manual 'C' values used

+++++  
Process from Point/Station 101.000 to Point/Station 102.000  
\*\*\*\* INITIAL AREA EVALUATION \*\*\*\*

---

Decimal fraction soil group A = 0.000  
Decimal fraction soil group B = 0.000  
Decimal fraction soil group C = 0.000  
Decimal fraction soil group D = 1.000  
[UNDISTURBED NATURAL TERRAIN ]  
(Permanent Open Space )  
Impervious value, Ai = 0.000  
Sub-Area C Value = 0.350  
Initial subarea total flow distance = 157.000(Ft.)  
Highest elevation = 1080.000(Ft.)  
Lowest elevation = 1070.000(Ft.)  
Elevation difference = 10.000(Ft.) Slope = 6.369 %  
INITIAL AREA TIME OF CONCENTRATION CALCULATIONS:  
The maximum overland flow distance is 100.00 (Ft)  
for the top area slope value of 6.37 %, in a development type of  
Permanent Open Space  
In Accordance With Figure 3-3  
Initial Area Time of Concentration = 7.28 minutes  
 $TC = [1.8 * (1.1 - C) * distance(Ft.)^{.5}] / (\% slope^{(1/3)})$   
 $TC = [1.8 * (1.1 - 0.3500) * (100.000^{.5})] / (6.369^{(1/3)}) = 7.28$   
The initial area total distance of 157.00 (Ft.) entered leaves a  
remaining distance of 57.00 (Ft.)  
Using Figure 3-4, the travel time for this distance is 0.51 minutes  
for a distance of 57.00 (Ft.) and a slope of 6.37 %  
with an elevation difference of 3.63(Ft.) from the end of the top area  
 $Tt = [11.9 * length(Mi)^3] / (elevation\ change(Ft.))^{.385} * 60(\text{min/hr})$   
= 0.507 Minutes  
 $Tt = [(11.9 * 0.0108^3) / (3.63)]^{.385} = 0.51$   
Total initial area Ti = 7.28 minutes from Figure 3-3 formula plus  
0.51 minutes from the Figure 3-4 formula = 7.79 minutes

Rainfall intensity (I) = 5.938(In/Hr) for a 50.0 year storm  
Effective runoff coefficient used for area (Q=KCIA) is C = 0.350  
Subarea runoff = 0.769(CFS)  
Total initial stream area = 0.370(Ac.)

\*\*\*\*\*  
Process from Point/Station 102.000 to Point/Station 103.000  
\*\*\*\* IRREGULAR CHANNEL FLOW TRAVEL TIME \*\*\*\*

---

Estimated mean flow rate at midpoint of channel = 2.953(CFS)  
Depth of flow = 0.142(Ft.), Average velocity = 2.016(Ft/s)  
\*\*\*\*\* Irregular Channel Data \*\*\*\*\*

-----  
Information entered for subchannel number 1 :

Point number	'X' coordinate	'Y' coordinate
1	0.00	1.00
2	12.00	0.00
3	21.00	0.00
4	27.00	1.00

Manning's 'N' friction factor = 0.090  
-----

Sub-Channel flow = 2.953(CFS)  
' ' flow top width = 11.564(Ft.)  
' ' velocity = 2.016(Ft/s)  
' ' area = 1.464(Sq.Ft)  
' ' Froude number = 0.999

Upstream point elevation = 1070.000(Ft.)  
Downstream point elevation = 884.810(Ft.)  
Flow length = 788.000(Ft.)  
Travel time = 6.51 min.  
Time of concentration = 14.30 min.  
Depth of flow = 0.142(Ft.)  
Average velocity = 2.016(Ft/s)  
Total irregular channel flow = 2.953(CFS)  
Irregular channel normal depth above invert elev. = 0.142(Ft.)  
Average velocity of channel(s) = 2.016(Ft/s)  
Adding area flow to channel

Rainfall intensity (I) = 4.013(In/Hr) for a 50.0 year storm  
Decimal fraction soil group A = 0.000  
Decimal fraction soil group B = 0.000  
Decimal fraction soil group C = 0.200  
Decimal fraction soil group D = 0.800  
[UNDISTURBED NATURAL TERRAIN ]  
(Permanent Open Space )  
Impervious value, Ai = 0.000  
Sub-Area C Value = 0.340

Rainfall intensity = 4.013(In/Hr) for a 50.0 year storm  
Effective runoff coefficient used for total area  
(Q=KCIA) is C = 0.341 CA = 1.265  
Subarea runoff = 4.308(CFS) for 3.340(Ac.)  
Total runoff = 5.077(CFS) Total area = 3.710(Ac.)  
Depth of flow = 0.195(Ft.), Average velocity = 2.427(Ft/s)

\*\*\*\*\*  
Process from Point/Station 103.000 to Point/Station 103.000  
\*\*\*\* SUBAREA FLOW ADDITION \*\*\*\*

---

Rainfall intensity (I) = 4.013(In/Hr) for a 50.0 year storm  
Decimal fraction soil group A = 0.000  
Decimal fraction soil group B = 0.000  
Decimal fraction soil group C = 0.000  
Decimal fraction soil group D = 1.000  
[UNDISTURBED NATURAL TERRAIN ]

(Permanent Open Space )  
Impervious value, Ai = 0.000  
Sub-Area C Value = 0.350  
Time of concentration = 14.30 min.  
Rainfall intensity = 4.013(In/Hr) for a 50.0 year storm  
Effective runoff coefficient used for total area  
(Q=KCIA) is C = 0.342 CA = 1.342  
Subarea runoff = 0.309(CFS) for 0.220(Ac.)  
Total runoff = 5.385(CFS) Total area = 3.930(Ac.)

\*\*\*\*\*  
Process from Point/Station 103.000 to Point/Station 103.000  
\*\*\*\* CONFLUENCE OF MINOR STREAMS \*\*\*\*

---

Along Main Stream number: 1 in normal stream number 1  
Stream flow area = 3.930(Ac.)  
Runoff from this stream = 5.385(CFS)  
Time of concentration = 14.30 min.  
Rainfall intensity = 4.013(In/Hr)

\*\*\*\*\*  
Process from Point/Station 201.000 to Point/Station 202.000  
\*\*\*\* INITIAL AREA EVALUATION \*\*\*\*

---

Decimal fraction soil group A = 0.000  
Decimal fraction soil group B = 0.000  
Decimal fraction soil group C = 1.000  
Decimal fraction soil group D = 0.000  
[HIGH DENSITY RESIDENTIAL ]  
(24.0 DU/A or Less )  
Impervious value, Ai = 0.650  
Sub-Area C Value = 0.690  
Initial subarea total flow distance = 107.000(Ft.)  
Highest elevation = 906.050(Ft.)  
Lowest elevation = 905.330(Ft.)  
Elevation difference = 0.720(Ft.) Slope = 0.673 %  
Top of Initial Area Slope adjusted by User to 1.364 %  
Bottom of Initial Area Slope adjusted by User to 1.364 %  
INITIAL AREA TIME OF CONCENTRATION CALCULATIONS:  
The maximum overland flow distance is 65.00 (Ft)  
for the top area slope value of 1.36 %, in a development type of  
24.0 DU/A or Less  
In Accordance With Figure 3-3  
Initial Area Time of Concentration = 5.37 minutes  
 $TC = [1.8 * (1.1 - C) * distance(Ft.)^{.5}] / (% slope^{(1/3)})$   
 $TC = [1.8 * (1.1 - 0.6900) * (65.000^{.5})] / (1.364^{(1/3)}) = 5.37$   
The initial area total distance of 107.00 (Ft.) entered leaves a  
remaining distance of 42.00 (Ft.)  
Using Figure 3-4, the travel time for this distance is 0.73 minutes  
for a distance of 42.00 (Ft.) and a slope of 1.36 %  
with an elevation difference of 0.57(Ft.) from the end of the top area  
 $Tt = [11.9 * length(Mi)^3] / (elevation change(Ft.))^{.385} * 60(min/hr)$   
= 0.725 Minutes  
 $Tt = [(11.9 * 0.0080^3) / (0.57)]^{.385} = 0.73$   
Total initial area Ti = 5.37 minutes from Figure 3-3 formula plus  
0.73 minutes from the Figure 3-4 formula = 6.09 minutes  
Rainfall intensity (I) = 6.960(In/Hr) for a 50.0 year storm  
Effective runoff coefficient used for area (Q=KCIA) is C = 0.690  
Subarea runoff = 1.297(CFS)  
Total initial stream area = 0.270(Ac.)

\*\*\*\*\*  
Process from Point/Station 202.000 to Point/Station 203.000



\*\*\*\* PIPEFLOW TRAVEL TIME (Program estimated size) \*\*\*\*

---

Upstream point/station elevation = 892.900(Ft.)  
Downstream point/station elevation = 892.300(Ft.)  
Pipe length = 157.00(Ft.) Slope = 0.0038 Manning's N = 0.013  
No. of pipes = 1 Required pipe flow = 1.297(CFS)  
Nearest computed pipe diameter = 12.00(In.)  
Calculated individual pipe flow = 1.297(CFS)  
Normal flow depth in pipe = 6.62(In.)  
Flow top width inside pipe = 11.94(In.)  
Critical Depth = 5.77(In.)  
Pipe flow velocity = 2.92(Ft/s)  
Travel time through pipe = 0.90 min.  
Time of concentration (TC) = 6.99 min.

++++  
Process from Point/Station 203.000 to Point/Station 203.000  
\*\*\*\* SUBAREA FLOW ADDITION \*\*\*\*

---

Rainfall intensity (I) = 6.370(In/Hr) for a 50.0 year storm  
Decimal fraction soil group A = 0.000  
Decimal fraction soil group B = 0.000  
Decimal fraction soil group C = 1.000  
Decimal fraction soil group D = 0.000  
[HIGH DENSITY RESIDENTIAL ]  
(24.0 DU/A or Less )  
Impervious value, Ai = 0.650  
Sub-Area C Value = 0.690  
Time of concentration = 6.99 min.  
Rainfall intensity = 6.370(In/Hr) for a 50.0 year storm  
Effective runoff coefficient used for total area  
(Q=K CIA) is C = 0.690 CA = 0.359  
Subarea runoff = 0.989(CFS) for 0.250(Ac.)  
Total runoff = 2.285(CFS) Total area = 0.520(Ac.)

++++  
Process from Point/Station 203.000 to Point/Station 204.000  
\*\*\*\* PIPEFLOW TRAVEL TIME (User specified size) \*\*\*\*

---

Upstream point/station elevation = 892.300(Ft.)  
Downstream point/station elevation = 891.500(Ft.)  
Pipe length = 166.00(Ft.) Slope = 0.0048 Manning's N = 0.013  
No. of pipes = 1 Required pipe flow = 2.285(CFS)  
Given pipe size = 18.00(In.)  
Calculated individual pipe flow = 2.285(CFS)  
Normal flow depth in pipe = 6.92(In.)  
Flow top width inside pipe = 17.51(In.)  
Critical Depth = 6.85(In.)  
Pipe flow velocity = 3.65(Ft/s)  
Travel time through pipe = 0.76 min.  
Time of concentration (TC) = 7.75 min.

++++  
Process from Point/Station 204.000 to Point/Station 204.000  
\*\*\*\* SUBAREA FLOW ADDITION \*\*\*\*

---

Rainfall intensity (I) = 5.960(In/Hr) for a 50.0 year storm  
Decimal fraction soil group A = 0.000  
Decimal fraction soil group B = 0.000  
Decimal fraction soil group C = 1.000  
Decimal fraction soil group D = 0.000  
[HIGH DENSITY RESIDENTIAL ]  
(24.0 DU/A or Less )

Impervious value, Ai = 0.650  
Sub-Area C Value = 0.690  
Time of concentration = 7.75 min.  
Rainfall intensity = 5.960(In/Hr) for a 50.0 year storm  
Effective runoff coefficient used for total area  
(Q=KCIA) is C = 0.690 CA = 0.690  
Subarea runoff = 1.827(CFS) for 0.480(Ac.)  
Total runoff = 4.113(CFS) Total area = 1.000(Ac.)

\*\*\*\*\*  
Process from Point/Station 204.000 to Point/Station 205.000  
\*\*\*\* PIPEFLOW TRAVEL TIME (User specified size) \*\*\*\*

---

Upstream point/station elevation = 891.500(Ft.)  
Downstream point/station elevation = 891.200(Ft.)  
Pipe length = 46.00(Ft.) Slope = 0.0065 Manning's N = 0.013  
No. of pipes = 1 Required pipe flow = 4.113(CFS)  
Given pipe size = 18.00(In.)  
Calculated individual pipe flow = 4.113(CFS)  
Normal flow depth in pipe = 8.84(In.)  
Flow top width inside pipe = 18.00(In.)  
Critical Depth = 9.32(In.)  
Pipe flow velocity = 4.76(Ft/s)  
Travel time through pipe = 0.16 min.  
Time of concentration (TC) = 7.91 min.

\*\*\*\*\*  
Process from Point/Station 205.000 to Point/Station 206.000  
\*\*\*\* SUBAREA FLOW ADDITION \*\*\*\*

---

Rainfall intensity (I) = 5.882(In/Hr) for a 50.0 year storm  
Decimal fraction soil group A = 0.000  
Decimal fraction soil group B = 0.000  
Decimal fraction soil group C = 1.000  
Decimal fraction soil group D = 0.000  
[MEDIUM DENSITY RESIDENTIAL ]  
(14.5 DU/A or Less )  
Impervious value, Ai = 0.500  
Sub-Area C Value = 0.600  
Time of concentration = 7.91 min.  
Rainfall intensity = 5.882(In/Hr) for a 50.0 year storm  
Effective runoff coefficient used for total area  
(Q=KCIA) is C = 0.676 CA = 0.803  
Subarea runoff = 0.613(CFS) for 0.189(Ac.)  
Total runoff = 4.725(CFS) Total area = 1.189(Ac.)

\*\*\*\*\*  
Process from Point/Station 206.000 to Point/Station 206.000  
\*\*\*\* SUBAREA FLOW ADDITION \*\*\*\*

---

Rainfall intensity (I) = 5.882(In/Hr) for a 50.0 year storm  
Decimal fraction soil group A = 0.000  
Decimal fraction soil group B = 0.000  
Decimal fraction soil group C = 1.000  
Decimal fraction soil group D = 0.000  
[HIGH DENSITY RESIDENTIAL ]  
(43.0 DU/A or Less )  
Impervious value, Ai = 0.800  
Sub-Area C Value = 0.780  
Time of concentration = 7.91 min.  
Rainfall intensity = 5.882(In/Hr) for a 50.0 year storm  
Effective runoff coefficient used for total area  
(Q=KCIA) is C = 0.702 CA = 1.115

Subarea runoff = 1.835(CFS) for 0.400(Ac.)  
Total runoff = 6.561(CFS) Total area = 1.589(Ac.)

\*\*\*\*\*  
Process from Point/Station 206.000 to Point/Station 103.000  
\*\*\*\* PIPEFLOW TRAVEL TIME (User specified size) \*\*\*\*

---

Upstream point/station elevation = 891.200(Ft.)  
Downstream point/station elevation = 884.810(Ft.)  
Pipe length = 10.00(Ft.) Slope = 0.6390 Manning's N = 0.013  
No. of pipes = 1 Required pipe flow = 6.561(CFS)  
Given pipe size = 24.00(In.)  
Calculated individual pipe flow = 6.561(CFS)  
Normal flow depth in pipe = 3.13(In.)  
Flow top width inside pipe = 16.16(In.)  
Critical Depth = 10.89(In.)  
Pipe flow velocity = 27.26(Ft/s)  
Travel time through pipe = 0.01 min.  
Time of concentration (TC) = 7.91 min.

\*\*\*\*\*  
Process from Point/Station 103.000 to Point/Station 103.000  
\*\*\*\* SUBAREA FLOW ADDITION \*\*\*\*

---

Rainfall intensity (I) = 5.879(In/Hr) for a 50.0 year storm  
Decimal fraction soil group A = 0.000  
Decimal fraction soil group B = 0.000  
Decimal fraction soil group C = 1.000  
Decimal fraction soil group D = 0.000  
[HIGH DENSITY RESIDENTIAL ]  
(43.0 DU/A or Less )  
Impervious value, Ai = 0.800  
Sub-Area C Value = 0.780  
Time of concentration = 7.91 min.  
Rainfall intensity = 5.879(In/Hr) for a 50.0 year storm  
Effective runoff coefficient used for total area  
(Q=K CIA) is C = 0.715 CA = 1.367  
Subarea runoff = 1.473(CFS) for 0.322(Ac.)  
Total runoff = 8.034(CFS) Total area = 1.911(Ac.)

\*\*\*\*\*  
Process from Point/Station 103.000 to Point/Station 103.000  
\*\*\*\* CONFLUENCE OF MINOR STREAMS \*\*\*\*

---

Along Main Stream number: 1 in normal stream number 2  
Stream flow area = 1.911(Ac.)  
Runoff from this stream = 8.034(CFS)  
Time of concentration = 7.91 min.  
Rainfall intensity = 5.879(In/Hr)  
Summary of stream data:

Stream No.	Flow rate (CFS)	TC (min)	Rainfall Intensity (In/Hr)
1	5.385	14.30	4.013
2	8.034	7.91	5.879

Qmax(1) =  
1.000 \* 1.000 \* 5.385 +  
0.683 \* 1.000 \* 8.034) += 10.869

Qmax(2) =  
1.000 \* 0.553 \* 5.385 +  
1.000 \* 1.000 \* 8.034) += 11.013

Total of 2 streams to confluence:  
Flow rates before confluence point:  
5.385 8.034  
Maximum flow rates at confluence using above data:  
10.869 11.013  
Area of streams before confluence:  
3.930 1.911  
Results of confluence:  
Total flow rate = 11.013(CFS)  
Time of concentration = 7.912 min.  
Effective stream area after confluence = 5.841(Ac.)  
End of computations, total study area = 5.841 (Ac.)

**ATTACHMENT E**  
**50 Year POST DEVELOPED Q CALCULATIONS**

***Steps Taken To Analyze This Condition***

The Rational Method as outlined in section 3 of the June 2003 San Diego County Hydrology Manual is followed here. The software that we are using is the “*Rational Hydrology Method, San Diego County (2003 Manual)*” module of the CIVILCADD/CIVIL DESIGN Engineering software version 7.9.

Please see the subsequent pages for the calculations. These calculations are for the Q100. The results are outlined/summarized in Section 8.

San Diego County Rational Hydrology Program

CIVILCADD/CIVILDESIGN Engineering Software,(c)1991-2014 Version 9.0

Rational method hydrology program based on  
San Diego County Flood Control Division 2003 hydrology manual  
Rational Hydrology Study Date: 09/25/18

-----  
1746 Nutmeg Development  
Post-Development Poc 1 50 Year  
17046postdevpoc1.rd3

-----  
\*\*\*\*\* Hydrology Study Control Information \*\*\*\*\*  
-----

Program License Serial Number 6332

-----  
Rational hydrology study storm event year is 50.0  
English (in-lb) input data Units used

Map data precipitation entered:  
6 hour, precipitation(inches) = 3.000  
24 hour precipitation(inches) = 6.000  
P6/P24 = 50.0%  
San Diego hydrology manual 'C' values used

+++++  
Process from Point/Station 601.000 to Point/Station 602.000  
\*\*\*\* INITIAL AREA EVALUATION \*\*\*\*

---

Decimal fraction soil group A = 0.000  
Decimal fraction soil group B = 0.000  
Decimal fraction soil group C = 1.000  
Decimal fraction soil group D = 0.000  
[HIGH DENSITY RESIDENTIAL ]  
(24.0 DU/A or Less )  
Impervious value, Ai = 0.650  
Sub-Area C Value = 0.690  
Initial subarea total flow distance = 105.000(Ft.)  
Highest elevation = 905.220(Ft.)  
Lowest elevation = 903.290(Ft.)  
Elevation difference = 1.930(Ft.) Slope = 1.838 %  
Top of Initial Area Slope adjusted by User to 1.619 %  
Bottom of Initial Area Slope adjusted by User to 1.619 %  
INITIAL AREA TIME OF CONCENTRATION CALCULATIONS:  
The maximum overland flow distance is 75.00 (Ft)  
for the top area slope value of 1.62 %, in a development type of  
24.0 DU/A or Less  
In Accordance With Figure 3-3  
Initial Area Time of Concentration = 5.44 minutes  
TC =  $[1.8*(1.1-C)*distance(Ft.)^{.5}/(%\ slope^{(1/3)})]$   
TC =  $[1.8*(1.1-0.6900)*( 75.000^{.5})/( 1.619^{(1/3)})]= 5.44$   
The initial area total distance of 105.00 (Ft.) entered leaves a  
remaining distance of 30.00 (Ft.)  
Using Figure 3-4, the travel time for this distance is 0.52 minutes  
for a distance of 30.00 (Ft.) and a slope of 1.62 %  
with an elevation difference of 0.49(Ft.) from the end of the top area  
Tt =  $[11.9*length(Mi)^3/(elevation\ change(Ft.))]^{.385} *60(\text{min/hr})$   
= 0.524 Minutes  
Tt= $[(11.9*0.0057^3)/( 0.49)]^{.385}= 0.52$

Total initial area  $T_i = 5.44$  minutes from Figure 3-3 formula plus  
 0.52 minutes from the Figure 3-4 formula = 5.97 minutes  
 Rainfall intensity (I) = 7.052(In/Hr) for a 50.0 year storm  
 Effective runoff coefficient used for area (Q=KCIA) is  $C = 0.690$   
 Subarea runoff = 1.168(CFS)  
 Total initial stream area = 0.240(Ac.)

++++  
 Process from Point/Station 602.000 to Point/Station 603.000  
 \*\*\*\* IRREGULAR CHANNEL FLOW TRAVEL TIME \*\*\*\*

---

Estimated mean flow rate at midpoint of channel = 4.246(CFS)  
 Depth of flow = 0.334(Ft.), Average velocity = 2.518(Ft/s)  
 \*\*\*\*\* Irregular Channel Data \*\*\*\*\*

-----  
 Information entered for subchannel number 1 :

Point number	'X' coordinate	'Y' coordinate
1	0.00	0.50
2	0.00	0.00
3	1.50	0.13
4	23.50	0.50

Manning's 'N' friction factor = 0.013  
 -----

Sub-Channel flow = 4.246(CFS)  
 ' ' flow top width = 13.752(Ft.)  
 ' ' velocity = 2.518(Ft/s)  
 ' ' area = 1.686(Sq.Ft)  
 ' ' Froude number = 1.267

Upstream point elevation = 903.290(Ft.)  
 Downstream point elevation = 899.990(Ft.)  
 Flow length = 401.000(Ft.)  
 Travel time = 2.65 min.  
 Time of concentration = 8.62 min.  
 Depth of flow = 0.334(Ft.)  
 Average velocity = 2.518(Ft/s)  
 Total irregular channel flow = 4.246(CFS)  
 Irregular channel normal depth above invert elev. = 0.334(Ft.)  
 Average velocity of channel(s) = 2.518(Ft/s)  
 Adding area flow to channel  
 Rainfall intensity (I) = 5.562(In/Hr) for a 50.0 year storm  
 Decimal fraction soil group A = 0.000  
 Decimal fraction soil group B = 0.000  
 Decimal fraction soil group C = 1.000  
 Decimal fraction soil group D = 0.000  
 [HIGH DENSITY RESIDENTIAL ]  
 (24.0 DU/A or Less )  
 Impervious value,  $A_i = 0.650$   
 Sub-Area C Value = 0.690  
 Rainfall intensity = 5.562(In/Hr) for a 50.0 year storm  
 Effective runoff coefficient used for total area  
 (Q=KCIA) is  $C = 0.690$   $CA = 1.304$   
 Subarea runoff = 6.086(CFS) for 1.650(Ac.)  
 Total runoff = 7.254(CFS) Total area = 1.890(Ac.)  
 Depth of flow = 0.389(Ft.), Average velocity = 2.870(Ft/s)

++++  
 Process from Point/Station 603.000 to Point/Station 603.000  
 \*\*\*\* SUBAREA FLOW ADDITION \*\*\*\*

---

Rainfall intensity (I) = 5.562(In/Hr) for a 50.0 year storm  
 Decimal fraction soil group A = 0.000  
 Decimal fraction soil group B = 0.000  
 Decimal fraction soil group C = 1.000

Decimal fraction soil group D = 0.000  
[HIGH DENSITY RESIDENTIAL ]  
(24.0 DU/A or Less )  
Impervious value, Ai = 0.650  
Sub-Area C Value = 0.690  
Time of concentration = 8.62 min.  
Rainfall intensity = 5.562(In/Hr) for a 50.0 year storm  
Effective runoff coefficient used for total area  
(Q=KCIA) is C = 0.690 CA = 1.525  
Subarea runoff = 1.228(CFS) for 0.320(Ac.)  
Total runoff = 8.482(CFS) Total area = 2.210(Ac.)

++++  
Process from Point/Station 603.000 to Point/Station 603.000  
\*\*\*\* SUBAREA FLOW ADDITION \*\*\*\*

---

Rainfall intensity (I) = 5.562(In/Hr) for a 50.0 year storm  
Decimal fraction soil group A = 0.000  
Decimal fraction soil group B = 0.000  
Decimal fraction soil group C = 1.000  
Decimal fraction soil group D = 0.000  
[HIGH DENSITY RESIDENTIAL ]  
(24.0 DU/A or Less )  
Impervious value, Ai = 0.650  
Sub-Area C Value = 0.690  
Time of concentration = 8.62 min.  
Rainfall intensity = 5.562(In/Hr) for a 50.0 year storm  
Effective runoff coefficient used for total area  
(Q=KCIA) is C = 0.690 CA = 1.863  
Subarea runoff = 1.881(CFS) for 0.490(Ac.)  
Total runoff = 10.362(CFS) Total area = 2.700(Ac.)

++++  
Process from Point/Station 603.000 to Point/Station 604.000  
\*\*\*\* PIPEFLOW TRAVEL TIME (User specified size) \*\*\*\*

---

Upstream point/station elevation = 892.500(Ft.)  
Downstream point/station elevation = 891.600(Ft.)  
Pipe length = 185.00(Ft.) Slope = 0.0049 Manning's N = 0.013  
No. of pipes = 1 Required pipe flow = 10.362(CFS)  
Given pipe size = 18.00(In.)  
NOTE: Normal flow is pressure flow in user selected pipe size.  
The approximate hydraulic grade line above the pipe invert is  
1.701(Ft.) at the headworks or inlet of the pipe(s)  
Pipe friction loss = 1.800(Ft.)  
Minor friction loss = 0.801(Ft.) K-factor = 1.50  
Pipe flow velocity = 5.86(Ft/s)  
Travel time through pipe = 0.53 min.  
Time of concentration (TC) = 9.15 min.

++++  
Process from Point/Station 604.000 to Point/Station 604.000  
\*\*\*\* CONFLUENCE OF MINOR STREAMS \*\*\*\*

---

Along Main Stream number: 1 in normal stream number 1  
Stream flow area = 2.700(Ac.)  
Runoff from this stream = 10.362(CFS)  
Time of concentration = 9.15 min.  
Rainfall intensity = 5.354(In/Hr)

++++  
Process from Point/Station 701.000 to Point/Station 702.000



\*\*\*\* INITIAL AREA EVALUATION \*\*\*\*

---

Decimal fraction soil group A = 0.000  
Decimal fraction soil group B = 0.000  
Decimal fraction soil group C = 1.000  
Decimal fraction soil group D = 0.000  
[HIGH DENSITY RESIDENTIAL ]  
(24.0 DU/A or Less )  
Impervious value, Ai = 0.650  
Sub-Area C Value = 0.690  
Initial subarea total flow distance = 36.000(Ft.)  
Highest elevation = 902.120(Ft.)  
Lowest elevation = 901.580(Ft.)  
Elevation difference = 0.540(Ft.) Slope = 1.500 %  
Top of Initial Area Slope adjusted by User to 1.472 %  
INITIAL AREA TIME OF CONCENTRATION CALCULATIONS:  
The maximum overland flow distance is 65.00 (Ft)  
for the top area slope value of 1.47 %, in a development type of  
24.0 DU/A or Less  
In Accordance With Figure 3-3  
Initial Area Time of Concentration = 5.23 minutes  
 $TC = [1.8 * (1.1 - C) * distance(Ft.)^{.5}] / (\% slope^{(1/3)})$   
 $TC = [1.8 * (1.1 - 0.6900) * (65.000^{.5})] / (1.472^{(1/3)}) = 5.23$   
Rainfall intensity (I) = 7.678(In/Hr) for a 50.0 year storm  
Effective runoff coefficient used for area (Q=KCIA) is C = 0.690  
Subarea runoff = 0.424(CFS)  
Total initial stream area = 0.080(Ac.)

+++++  
Process from Point/Station 702.000 to Point/Station 703.000  
\*\*\*\* IRREGULAR CHANNEL FLOW TRAVEL TIME \*\*\*\*

---

Estimated mean flow rate at midpoint of channel = 2.863(CFS)  
Depth of flow = 0.247(Ft.), Average velocity = 4.003(Ft/s)  
\*\*\*\*\* Irregular Channel Data \*\*\*\*\*

-----  
Information entered for subchannel number 1 :  
Point number 'X' coordinate 'Y' coordinate  
1 0.00 0.50  
2 0.00 0.00  
3 1.50 0.13  
4 23.50 0.50  
Manning's 'N' friction factor = 0.013  
-----

Sub-Channel flow = 2.863(CFS)  
' ' flow top width = 8.670(Ft.)  
' ' velocity = 4.003(Ft/s)  
' ' area = 0.715(Sq.Ft)  
' ' Froude number = 2.456

Upstream point elevation = 901.580(Ft.)  
Downstream point elevation = 896.860(Ft.)  
Flow length = 133.000(Ft.)  
Travel time = 0.55 min.  
Time of concentration = 5.78 min.  
Depth of flow = 0.247(Ft.)  
Average velocity = 4.003(Ft/s)  
Total irregular channel flow = 2.863(CFS)  
Irregular channel normal depth above invert elev. = 0.247(Ft.)  
Average velocity of channel(s) = 4.003(Ft/s)  
Adding area flow to channel  
Rainfall intensity (I) = 7.195(In/Hr) for a 50.0 year storm  
Decimal fraction soil group A = 0.000  
Decimal fraction soil group B = 0.000  
Decimal fraction soil group C = 1.000

Decimal fraction soil group D = 0.000  
 [HIGH DENSITY RESIDENTIAL ]  
 (24.0 DU/A or Less )  
 Impervious value, Ai = 0.650  
 Sub-Area C Value = 0.690  
 Rainfall intensity = 7.195(In/Hr) for a 50.0 year storm  
 Effective runoff coefficient used for total area  
 (Q=KCIA) is C = 0.690 CA = 0.724  
 Subarea runoff = 4.789(CFS) for 0.970(Ac.)  
 Total runoff = 5.213(CFS) Total area = 1.050(Ac.)  
 Depth of flow = 0.289(Ft.), Average velocity = 4.607(Ft/s)

++++++  
 Process from Point/Station 703.000 to Point/Station 604.000  
 \*\*\*\* CONFLUENCE OF MINOR STREAMS \*\*\*\*

Along Main Stream number: 1 in normal stream number 2  
 Stream flow area = 1.050(Ac.)  
 Runoff from this stream = 5.213(CFS)  
 Time of concentration = 5.78 min.  
 Rainfall intensity = 7.195(In/Hr)  
 Summary of stream data:

Stream No.	Flow rate (CFS)	TC (min)	Rainfall Intensity (In/Hr)
------------	-----------------	----------	----------------------------

1	10.362	9.15	5.354
2	5.213	5.78	7.195

Qmax(1) =  
 $1.000 * 10.362 + 0.744 * 5.213 = 14.241$   
 Qmax(2) =  
 $1.000 * 10.362 + 1.000 * 5.213 = 11.766$

Total of 2 streams to confluence:  
 Flow rates before confluence point:  
 10.362 5.213  
 Maximum flow rates at confluence using above data:  
 14.241 11.766  
 Area of streams before confluence:  
 2.700 1.050  
 Results of confluence:  
 Total flow rate = 14.241(CFS)  
 Time of concentration = 9.147 min.  
 Effective stream area after confluence = 3.750(Ac.)

++++++  
 Process from Point/Station 604.000 to Point/Station 605.000  
 \*\*\*\* PIPEFLOW TRAVEL TIME (User specified size) \*\*\*\*

Upstream point/station elevation = 891.600(Ft.)  
 Downstream point/station elevation = 890.300(Ft.)  
 Pipe length = 267.00(Ft.) Slope = 0.0049 Manning's N = 0.013  
 No. of pipes = 1 Required pipe flow = 14.241(CFS)  
 Given pipe size = 24.00(In.)  
 Calculated individual pipe flow = 14.241(CFS)  
 Normal flow depth in pipe = 17.84(In.)  
 Flow top width inside pipe = 20.97(In.)  
 Critical Depth = 16.31(In.)  
 Pipe flow velocity = 5.69(Ft/s)  
 Travel time through pipe = 0.78 min.  
 Time of concentration (TC) = 9.93 min.

Process from Point/Station 605.000 to Point/Station 605.000  
\*\*\*\* CONFLUENCE OF MINOR STREAMS \*\*\*\*

Along Main Stream number: 1 in normal stream number 1  
Stream flow area = 3.750(Ac.)  
Runoff from this stream = 14.241(CFS)  
Time of concentration = 9.93 min.  
Rainfall intensity = 5.078(In/Hr)

Process from Point/Station 801.000 to Point/Station 802.000  
\*\*\*\* INITIAL AREA EVALUATION \*\*\*\*

Decimal fraction soil group A = 0.000  
Decimal fraction soil group B = 0.000  
Decimal fraction soil group C = 0.000  
Decimal fraction soil group D = 1.000  
[HIGH DENSITY RESIDENTIAL ]  
(24.0 DU/A or Less )  
Impervious value, Ai = 0.650  
Sub-Area C Value = 0.710  
Initial subarea total flow distance = 144.000(Ft.)  
Highest elevation = 906.460(Ft.)  
Lowest elevation = 902.870(Ft.)  
Elevation difference = 3.590(Ft.) Slope = 2.493 %  
Top of Initial Area Slope adjusted by User to 2.451 %  
Bottom of Initial Area Slope adjusted by User to 2.451 %  
INITIAL AREA TIME OF CONCENTRATION CALCULATIONS:  
The maximum overland flow distance is 75.00 (Ft)  
for the top area slope value of 2.45 %, in a development type of  
24.0 DU/A or Less  
In Accordance With Figure 3-3  
Initial Area Time of Concentration = 4.51 minutes  
 $TC = [1.8 * (1.1 - C) * distance(Ft.)^{.5}] / (\% slope^{(1/3)})$   
 $TC = [1.8 * (1.1 - 0.7100) * (75.000^{.5})] / (2.451^{(1/3)}) = 4.51$   
The initial area total distance of 144.00 (Ft.) entered leaves a  
remaining distance of 69.00 (Ft.)  
Using Figure 3-4, the travel time for this distance is 0.85 minutes  
for a distance of 69.00 (Ft.) and a slope of 2.45 %  
with an elevation difference of 1.69(Ft.) from the end of the top area  
 $Tt = [11.9 * length(Mi)^3] / (elevation change(Ft.))^{.385} * 60(\text{min/hr})$   
= 0.848 Minutes  
 $Tt = [(11.9 * 0.0131^3) / (1.69)]^{.385} = 0.85$   
Total initial area Ti = 4.51 minutes from Figure 3-3 formula plus  
0.85 minutes from the Figure 3-4 formula = 5.36 minutes  
Rainfall intensity (I) = 7.560(In/Hr) for a 50.0 year storm  
Effective runoff coefficient used for area (Q=KCIA) is C = 0.710  
Subarea runoff = 1.557(CFS)  
Total initial stream area = 0.290(Ac.)

Process from Point/Station 802.000 to Point/Station 803.000  
\*\*\*\* IRREGULAR CHANNEL FLOW TRAVEL TIME \*\*\*\*

Estimated mean flow rate at midpoint of channel = 5.796(CFS)  
Depth of flow = 0.317(Ft.), Average velocity = 3.979(Ft/s)  
\*\*\*\*\* Irregular Channel Data \*\*\*\*\*

Information entered for subchannel number 1 :  
Point number 'X' coordinate 'Y' coordinate  
1 0.00 0.50

2 0.00 0.00  
3 1.50 0.13  
4 23.50 0.50

Manning's 'N' friction factor = 0.013

-----  
Sub-Channel flow = 5.796(CFS)  
' ' flow top width = 12.735(Ft.)  
' ' velocity= 3.979(Ft/s)  
' ' area = 1.457(Sq.Ft)  
' ' Froude number = 2.073

Upstream point elevation = 902.870(Ft.)  
Downstream point elevation = 898.990(Ft.)  
Flow length = 172.000(Ft.)  
Travel time = 0.72 min.  
Time of concentration = 6.08 min.  
Depth of flow = 0.317(Ft.)  
Average velocity = 3.979(Ft/s)  
Total irregular channel flow = 5.796(CFS)  
Irregular channel normal depth above invert elev. = 0.317(Ft.)  
Average velocity of channel(s) = 3.979(Ft/s)  
Adding area flow to channel  
Rainfall intensity (I) = 6.969(In/Hr) for a 50.0 year storm  
Decimal fraction soil group A = 0.000  
Decimal fraction soil group B = 0.000  
Decimal fraction soil group C = 0.500  
Decimal fraction soil group D = 0.500  
[HIGH DENSITY RESIDENTIAL ]  
(24.0 DU/A or Less )  
Impervious value, Ai = 0.650  
Sub-Area C Value = 0.700  
Rainfall intensity = 6.969(In/Hr) for a 50.0 year storm  
Effective runoff coefficient used for total area  
(Q=KCIA) is C = 0.701 CA = 1.431  
Subarea runoff = 8.415(CFS) for 1.750(Ac.)  
Total runoff = 9.972(CFS) Total area = 2.040(Ac.)  
Depth of flow = 0.368(Ft.), Average velocity = 4.540(Ft/s)

++++  
Process from Point/Station 803.000 to Point/Station 803.000  
\*\*\*\* SUBAREA FLOW ADDITION \*\*\*\*

-----  
Rainfall intensity (I) = 6.969(In/Hr) for a 50.0 year storm  
Decimal fraction soil group A = 0.000  
Decimal fraction soil group B = 0.000  
Decimal fraction soil group C = 0.800  
Decimal fraction soil group D = 0.200  
[LOW DENSITY RESIDENTIAL ]  
(1.0 DU/A or Less )  
Impervious value, Ai = 0.100  
Sub-Area C Value = 0.370  
Time of concentration = 6.08 min.  
Rainfall intensity = 6.969(In/Hr) for a 50.0 year storm  
Effective runoff coefficient used for total area  
(Q=KCIA) is C = 0.573 CA = 1.907  
Subarea runoff = 3.316(CFS) for 1.286(Ac.)  
Total runoff = 13.288(CFS) Total area = 3.326(Ac.)

++++  
Process from Point/Station 803.000 to Point/Station 605.000  
\*\*\*\* CONFLUENCE OF MINOR STREAMS \*\*\*\*

-----  
Along Main Stream number: 1 in normal stream number 2  
Stream flow area = 3.326(Ac.)

Runoff from this stream = 13.288(CFS)  
 Time of concentration = 6.08 min.  
 Rainfall intensity = 6.969(In/Hr)  
 Summary of stream data:

Stream No.	Flow rate (CFS)	TC (min)	Rainfall Intensity (In/Hr)
------------	-----------------	----------	----------------------------

1	14.241	9.93	5.078
2	13.288	6.08	6.969

Qmax(1) =  
 $1.000 * 1.000 * 14.241 + 0.729 * 1.000 * 13.288) += 23.923$

Qmax(2) =  
 $1.000 * 0.612 * 14.241 + 1.000 * 1.000 * 13.288) += 22.005$

Total of 2 streams to confluence:  
 Flow rates before confluence point:  
 14.241 13.288

Maximum flow rates at confluence using above data:  
 23.923 22.005

Area of streams before confluence:  
 3.750 3.326

Results of confluence:  
 Total flow rate = 23.923(CFS)  
 Time of concentration = 9.929 min.  
 Effective stream area after confluence = 7.076(Ac.)  
 End of computations, total study area = 7.076 (Ac.)

San Diego County Rational Hydrology Program

CIVILCADD/CIVILDESIGN Engineering Software,(c)1991-2014 Version 9.0

Rational method hydrology program based on  
San Diego County Flood Control Division 2003 hydrology manual  
Rational Hydrology Study Date: 09/25/18

-----  
17046 Nutmeg Development  
Post-Development Poc2 50 Year  
17046postpoc2det50.rd3

-----  
\*\*\*\*\* Hydrology Study Control Information \*\*\*\*\*  
-----

Program License Serial Number 6332

-----  
Rational hydrology study storm event year is 50.0  
English (in-lb) input data Units used

Map data precipitation entered:  
6 hour, precipitation(inches) = 3.000  
24 hour precipitation(inches) = 6.000  
P6/P24 = 50.0%  
San Diego hydrology manual 'C' values used

++++  
Process from Point/Station 103.000 to Point/Station 103.000  
\*\*\*\* USER DEFINED FLOW INFORMATION AT A POINT \*\*\*\*

-----  
User specified 'C' value of 0.700 given for subarea  
Rainfall intensity (I) = 0.624(In/Hr) for a 50.0 year storm  
User specified values are as follows:  
TC = 256.20 min. Rain intensity = 0.62(In/Hr)  
Total area = 6.350(Ac.) Total runoff = 3.364(CFS)  
End of computations, total study area = 6.350 (Ac.)

San Diego County Rational Hydrology Program

CIVILCADD/CIVILDESIGN Engineering Software,(c)1991-2014 Version 9.0

Rational method hydrology program based on  
San Diego County Flood Control Division 2003 hydrology manual  
Rational Hydrology Study Date: 09/25/18

-----  
17046 Nutmeg Development  
Post-Development Poc 3 50 Year  
postdevpoc1350.rd3

-----  
\*\*\*\*\* Hydrology Study Control Information \*\*\*\*\*

-----  
Program License Serial Number 6332

-----  
Rational hydrology study storm event year is 50.0  
English (in-lb) input data Units used

Map data precipitation entered:  
6 hour, precipitation(inches) = 3.000  
24 hour precipitation(inches) = 6.000  
P6/P24 = 50.0%  
San Diego hydrology manual 'C' values used

+++++  
Process from Point/Station 301.000 to Point/Station 302.000  
\*\*\*\* INITIAL AREA EVALUATION \*\*\*\*

---

Decimal fraction soil group A = 0.000  
Decimal fraction soil group B = 0.000  
Decimal fraction soil group C = 1.000  
Decimal fraction soil group D = 0.000  
[HIGH DENSITY RESIDENTIAL ]  
(24.0 DU/A or Less )  
Impervious value, Ai = 0.650  
Sub-Area C Value = 0.690  
Initial subarea total flow distance = 122.000(Ft.)  
Highest elevation = 903.520(Ft.)  
Lowest elevation = 903.220(Ft.)  
Elevation difference = 0.300(Ft.) Slope = 0.246 %  
INITIAL AREA TIME OF CONCENTRATION CALCULATIONS:  
The maximum overland flow distance is 50.00 (Ft)  
for the top area slope value of 0.25 %, in a development type of  
24.0 DU/A or Less  
In Accordance With Figure 3-3  
Initial Area Time of Concentration = 8.33 minutes  
 $TC = [1.8 * (1.1 - C) * distance(Ft.)^{.5}] / (\% slope^{(1/3)})$   
 $TC = [1.8 * (1.1 - 0.6900) * (50.000^{.5})] / (0.246^{(1/3)}) = 8.33$   
The initial area total distance of 122.00 (Ft.) entered leaves a  
remaining distance of 72.00 (Ft.)  
Using Figure 3-4, the travel time for this distance is 2.12 minutes  
for a distance of 72.00 (Ft.) and a slope of 0.25 %  
with an elevation difference of 0.18(Ft.) from the end of the top area  
 $Tt = [11.9 * length(Mi)^3] / (elevation\ change(Ft.))^{.385} * 60(\text{min/hr})$   
= 2.124 Minutes  
 $Tt = [(11.9 * 0.0136^3) / (0.18)]^{.385} = 2.12$   
Total initial area Ti = 8.33 minutes from Figure 3-3 formula plus  
2.12 minutes from the Figure 3-4 formula = 10.45 minutes

Rainfall intensity (I) = 4.912(In/Hr) for a 50.0 year storm  
Effective runoff coefficient used for area (Q=KCIA) is C = 0.690  
Subarea runoff = 0.746(CFS)  
Total initial stream area = 0.220(Ac.)

\*\*\*\*\*  
Process from Point/Station 302.000 to Point/Station 303.000  
\*\*\*\* IRREGULAR CHANNEL FLOW TRAVEL TIME \*\*\*\*

-----  
Estimated mean flow rate at midpoint of channel = 1.631(CFS)  
Depth of flow = 0.149(Ft.), Average velocity = 3.129(Ft/s)  
\*\*\*\*\* Irregular Channel Data \*\*\*\*\*

-----  
Information entered for subchannel number 1 :

Point number	'X' coordinate	'Y' coordinate
1	0.00	0.50
2	0.00	0.00
3	23.50	0.50

Manning's 'N' friction factor = 0.013

-----  
Sub-Channel flow = 1.631(CFS)  
' ' flow top width = 6.999(Ft.)  
' ' velocity = 3.129(Ft/s)  
' ' area = 0.521(Sq.Ft)  
' ' Froude number = 2.021

Upstream point elevation = 903.220(Ft.)  
Downstream point elevation = 899.480(Ft.)  
Flow length = 152.000(Ft.)  
Travel time = 0.81 min.  
Time of concentration = 11.26 min.  
Depth of flow = 0.149(Ft.)  
Average velocity = 3.129(Ft/s)  
Total irregular channel flow = 1.631(CFS)  
Irregular channel normal depth above invert elev. = 0.149(Ft.)  
Average velocity of channel(s) = 3.129(Ft/s)  
Adding area flow to channel  
Rainfall intensity (I) = 4.682(In/Hr) for a 50.0 year storm  
Decimal fraction soil group A = 0.000  
Decimal fraction soil group B = 0.000  
Decimal fraction soil group C = 1.000  
Decimal fraction soil group D = 0.000  
[HIGH DENSITY RESIDENTIAL ]  
(24.0 DU/A or Less )  
Impervious value, Ai = 0.650  
Sub-Area C Value = 0.690  
Rainfall intensity = 4.682(In/Hr) for a 50.0 year storm  
Effective runoff coefficient used for total area  
(Q=KCIA) is C = 0.690 CA = 0.524  
Subarea runoff = 1.709(CFS) for 0.540(Ac.)  
Total runoff = 2.455(CFS) Total area = 0.760(Ac.)  
Depth of flow = 0.174(Ft.), Average velocity = 3.466(Ft/s)

\*\*\*\*\*  
Process from Point/Station 303.000 to Point/Station 304.000  
\*\*\*\* PIPEFLOW TRAVEL TIME (User specified size) \*\*\*\*

-----  
Upstream point/station elevation = 895.700(Ft.)  
Downstream point/station elevation = 895.600(Ft.)  
Pipe length = 41.00(Ft.) Slope = 0.0024 Manning's N = 0.013  
No. of pipes = 1 Required pipe flow = 2.455(CFS)  
Given pipe size = 18.00(In.)  
Calculated individual pipe flow = 2.455(CFS)  
Normal flow depth in pipe = 8.72(In.)



Flow top width inside pipe = 17.99(In.)  
Critical Depth = 7.12(In.)  
Pipe flow velocity = 2.90(Ft/s)  
Travel time through pipe = 0.24 min.  
Time of concentration (TC) = 11.50 min.

++++  
Process from Point/Station 304.000 to Point/Station 305.000  
\*\*\*\* IRREGULAR CHANNEL FLOW TRAVEL TIME \*\*\*\*

-----  
Estimated mean flow rate at midpoint of channel = 3.294(CFS)  
Depth of flow = 0.229(Ft.), Average velocity = 3.930(Ft/s)  
\*\*\*\*\* Irregular Channel Data \*\*\*\*\*

-----  
Information entered for subchannel number 1 :  
Point number 'X' coordinate 'Y' coordinate  
1 0.00 0.50  
2 0.00 0.00  
3 1.50 0.13  
4 42.00 0.50  
Manning's 'N' friction factor = 0.013

-----  
Sub-Channel flow = 3.294(CFS)  
' ' flow top width = 12.768(Ft.)  
' ' velocity = 3.930(Ft/s)  
' ' area = 0.838(Sq.Ft)  
' ' Froude number = 2.703

Upstream point elevation = 895.600(Ft.)  
Downstream point elevation = 891.940(Ft.)  
Flow length = 80.000(Ft.)  
Travel time = 0.34 min.  
Time of concentration = 11.84 min.  
Depth of flow = 0.229(Ft.)  
Average velocity = 3.930(Ft/s)  
Total irregular channel flow = 3.294(CFS)  
Irregular channel normal depth above invert elev. = 0.229(Ft.)  
Average velocity of channel(s) = 3.930(Ft/s)  
Adding area flow to channel  
Rainfall intensity (I) = 4.534(In/Hr) for a 50.0 year storm  
Decimal fraction soil group A = 0.000  
Decimal fraction soil group B = 0.000  
Decimal fraction soil group C = 1.000  
Decimal fraction soil group D = 0.000  
[HIGH DENSITY RESIDENTIAL ]  
(24.0 DU/A or Less )  
Impervious value, Ai = 0.650  
Sub-Area C Value = 0.690  
Rainfall intensity = 4.534(In/Hr) for a 50.0 year storm  
Effective runoff coefficient used for total area  
(Q=KCIA) is C = 0.690 CA = 0.897  
Subarea runoff = 1.612(CFS) for 0.540(Ac.)  
Total runoff = 4.067(CFS) Total area = 1.300(Ac.)  
Depth of flow = 0.240(Ft.), Average velocity = 4.128(Ft/s)

++++  
Process from Point/Station 305.000 to Point/Station 305.000  
\*\*\*\* SUBAREA FLOW ADDITION \*\*\*\*

-----  
Rainfall intensity (I) = 4.534(In/Hr) for a 50.0 year storm  
Decimal fraction soil group A = 0.000  
Decimal fraction soil group B = 0.000  
Decimal fraction soil group C = 1.000  
Decimal fraction soil group D = 0.000

[HIGH DENSITY RESIDENTIAL ]  
(24.0 DU/A or Less )  
Impervious value, Ai = 0.650  
Sub-Area C Value = 0.690  
Time of concentration = 11.84 min.  
Rainfall intensity = 4.534(In/Hr) for a 50.0 year storm  
Effective runoff coefficient used for total area  
(Q=KCIA) is C = 0.690 CA = 0.959  
Subarea runoff = 0.282(CFS) for 0.090(Ac.)  
Total runoff = 4.348(CFS) Total area = 1.390(Ac.)

\*\*\*\*\*  
Process from Point/Station 305.000 to Point/Station 305.000  
\*\*\*\* SUBAREA FLOW ADDITION \*\*\*\*

---

Rainfall intensity (I) = 4.534(In/Hr) for a 50.0 year storm  
Decimal fraction soil group A = 0.000  
Decimal fraction soil group B = 0.000  
Decimal fraction soil group C = 1.000  
Decimal fraction soil group D = 0.000  
[HIGH DENSITY RESIDENTIAL ]  
(24.0 DU/A or Less )  
Impervious value, Ai = 0.650  
Sub-Area C Value = 0.690  
Time of concentration = 11.84 min.  
Rainfall intensity = 4.534(In/Hr) for a 50.0 year storm  
Effective runoff coefficient used for total area  
(Q=KCIA) is C = 0.690 CA = 1.063  
Subarea runoff = 0.469(CFS) for 0.150(Ac.)  
Total runoff = 4.817(CFS) Total area = 1.540(Ac.)

\*\*\*\*\*  
Process from Point/Station 305.000 to Point/Station 305.000  
\*\*\*\* SUBAREA FLOW ADDITION \*\*\*\*

---

Rainfall intensity (I) = 4.534(In/Hr) for a 50.0 year storm  
Decimal fraction soil group A = 0.000  
Decimal fraction soil group B = 0.000  
Decimal fraction soil group C = 0.100  
Decimal fraction soil group D = 0.900  
[UNDISTURBED NATURAL TERRAIN ]  
(Permanent Open Space )  
Impervious value, Ai = 0.000  
Sub-Area C Value = 0.345  
Time of concentration = 11.84 min.  
Rainfall intensity = 4.534(In/Hr) for a 50.0 year storm  
Effective runoff coefficient used for total area  
(Q=KCIA) is C = 0.574 CA = 1.332  
Subarea runoff = 1.220(CFS) for 0.780(Ac.)  
Total runoff = 6.037(CFS) Total area = 2.320(Ac.)  
End of computations, total study area = 2.320 (Ac.)

San Diego County Rational Hydrology Program

CIVILCADD/CIVILDESIGN Engineering Software,(c)1991-2014 Version 9.0

Rational method hydrology program based on  
San Diego County Flood Control Division 2003 hydrology manual  
Rational Hydrology Study Date: 09/25/18

-----  
17046 Nutmeg Development  
Post-Development Poc 3 50 Year  
postdevpoc1350det.rd3

-----  
\*\*\*\*\* Hydrology Study Control Information \*\*\*\*\*  
-----

Program License Serial Number 6332

-----  
Rational hydrology study storm event year is 50.0  
English (in-lb) input data Units used

Map data precipitation entered:  
6 hour, precipitation(inches) = 3.000  
24 hour precipitation(inches) = 6.000  
P6/P24 = 50.0%  
San Diego hydrology manual 'C' values used

++++  
Process from Point/Station 305.000 to Point/Station 305.000  
\*\*\*\* USER DEFINED FLOW INFORMATION AT A POINT \*\*\*\*

-----  
User specified 'C' value of 0.760 given for subarea  
Rainfall intensity (I) = 0.612(In/Hr) for a 50.0 year storm  
User specified values are as follows:  
TC = 264.00 min. Rain intensity = 0.61(In/Hr)  
Total area = 2.320(Ac.) Total runoff = 2.033(CFS)  
End of computations, total study area = 2.320 (Ac.)

## **ATTACHMENT F**

### **100 Year Pre Development Calculations and Map**

#### ***Steps Taken To Analyze This Condition***

The Rational Method as outlined in section 3 of the June 2003 San Diego County Hydrology Manual is followed here. The software that we are using is the “*Rational Hydrology Method, San Diego County (2003 Manual)*” module of the CIVILCADD/CIVIL DESIGN Engineering software version 7.9.

Please see the subsequent pages for the calculations. These calculations are for the Q100. The results are outlined/summarized in Section 8.

San Diego County Rational Hydrology Program

CIVILCADD/CIVILDESIGN Engineering Software,(c)1991-2014 Version 9.0

Rational method hydrology program based on  
San Diego County Flood Control Division 2003 hydrology manual  
Rational Hydrology Study Date: 09/24/18

-----  
17046 Nutmeg Development  
Pre-Development Poc1 100 Year  
17046predevpoc1.rd3

-----  
\*\*\*\*\* Hydrology Study Control Information \*\*\*\*\*  
-----

Program License Serial Number 6332

-----  
Rational hydrology study storm event year is 100.0  
English (in-lb) input data Units used

Map data precipitation entered:  
6 hour, precipitation(inches) = 3.500  
24 hour precipitation(inches) = 7.000  
P6/P24 = 50.0%  
San Diego hydrology manual 'C' values used

+++++  
Process from Point/Station 401.000 to Point/Station 402.000  
\*\*\*\* INITIAL AREA EVALUATION \*\*\*\*

---

Decimal fraction soil group A = 0.000  
Decimal fraction soil group B = 0.000  
Decimal fraction soil group C = 1.000  
Decimal fraction soil group D = 0.000  
[UNDISTURBED NATURAL TERRAIN ]  
(Permanent Open Space )  
Impervious value, Ai = 0.000  
Sub-Area C Value = 0.300  
Initial subarea total flow distance = 201.000(Ft.)  
Highest elevation = 889.120(Ft.)  
Lowest elevation = 881.370(Ft.)  
Elevation difference = 7.750(Ft.) Slope = 3.856 %  
INITIAL AREA TIME OF CONCENTRATION CALCULATIONS:  
The maximum overland flow distance is 100.00 (Ft)  
for the top area slope value of 3.86 %, in a development type of  
Permanent Open Space  
In Accordance With Figure 3-3  
Initial Area Time of Concentration = 9.18 minutes  
 $TC = [1.8*(1.1-C)*distance(Ft.)^{.5}/(\% slope^{(1/3)})]$   
 $TC = [1.8*(1.1-0.3000)*(100.000^{.5})/(3.856^{(1/3)})] = 9.18$   
The initial area total distance of 201.00 (Ft.) entered leaves a  
remaining distance of 101.00 (Ft.)  
Using Figure 3-4, the travel time for this distance is 0.96 minutes  
for a distance of 101.00 (Ft.) and a slope of 3.86 %  
with an elevation difference of 3.89(Ft.) from the end of the top area  
 $Tt = [11.9*length(Mi)^3/(elevation\ change(Ft.))]^{.385} *60(\text{min/hr})$   
= 0.956 Minutes  
 $Tt = [(11.9*0.0191^3)/(3.89)]^{.385} = 0.96$   
Total initial area Ti = 9.18 minutes from Figure 3-3 formula plus  
0.96 minutes from the Figure 3-4 formula = 10.14 minutes

Rainfall intensity (I) = 5.845(In/Hr) for a 100.0 year storm  
Effective runoff coefficient used for area (Q=KCIA) is C = 0.300  
Subarea runoff = 1.140(CFS)  
Total initial stream area = 0.650(Ac.)

++++  
Process from Point/Station 402.000 to Point/Station 402.000  
\*\*\*\* SUBAREA FLOW ADDITION \*\*\*\*

---

Rainfall intensity (I) = 5.845(In/Hr) for a 100.0 year storm  
Decimal fraction soil group A = 0.000  
Decimal fraction soil group B = 0.000  
Decimal fraction soil group C = 1.000  
Decimal fraction soil group D = 0.000  
[HIGH DENSITY RESIDENTIAL ]  
(43.0 DU/A or Less )  
Impervious value, Ai = 0.800  
Sub-Area C Value = 0.780  
Time of concentration = 10.14 min.  
Rainfall intensity = 5.845(In/Hr) for a 100.0 year storm  
Effective runoff coefficient used for total area  
(Q=KCIA) is C = 0.441 CA = 0.406  
Subarea runoff = 1.231(CFS) for 0.270(Ac.)  
Total runoff = 2.371(CFS) Total area = 0.920(Ac.)

++++  
Process from Point/Station 402.000 to Point/Station 402.000  
\*\*\*\* SUBAREA FLOW ADDITION \*\*\*\*

---

Rainfall intensity (I) = 5.845(In/Hr) for a 100.0 year storm  
Decimal fraction soil group A = 0.000  
Decimal fraction soil group B = 0.000  
Decimal fraction soil group C = 1.000  
Decimal fraction soil group D = 0.000  
[HIGH DENSITY RESIDENTIAL ]  
(43.0 DU/A or Less )  
Impervious value, Ai = 0.800  
Sub-Area C Value = 0.780  
Time of concentration = 10.14 min.  
Rainfall intensity = 5.845(In/Hr) for a 100.0 year storm  
Effective runoff coefficient used for total area  
(Q=KCIA) is C = 0.474 CA = 0.484  
Subarea runoff = 0.456(CFS) for 0.100(Ac.)  
Total runoff = 2.827(CFS) Total area = 1.020(Ac.)

++++  
Process from Point/Station 402.000 to Point/Station 402.000  
\*\*\*\* SUBAREA FLOW ADDITION \*\*\*\*

---

Rainfall intensity (I) = 5.845(In/Hr) for a 100.0 year storm  
Decimal fraction soil group A = 0.000  
Decimal fraction soil group B = 0.000  
Decimal fraction soil group C = 0.000  
Decimal fraction soil group D = 1.000  
[LOW DENSITY RESIDENTIAL ]  
(1.0 DU/A or Less )  
Impervious value, Ai = 0.100  
Sub-Area C Value = 0.410  
Time of concentration = 10.14 min.  
Rainfall intensity = 5.845(In/Hr) for a 100.0 year storm  
Effective runoff coefficient used for total area  
(Q=KCIA) is C = 0.463 CA = 0.573  
Subarea runoff = 0.522(CFS) for 0.218(Ac.)

Total runoff = 3.349(CFS) Total area = 1.238(Ac.)

+++++  
Process from Point/Station 402.000 to Point/Station 403.000  
\*\*\*\* IRREGULAR CHANNEL FLOW TRAVEL TIME \*\*\*\*

-----  
Estimated mean flow rate at midpoint of channel = 6.552(CFS)  
Depth of flow = 0.503(Ft.), Average velocity = 2.587(Ft/s)  
\*\*\*\*\* Irregular Channel Data \*\*\*\*\*

-----  
Information entered for subchannel number 1 :  
Point number 'X' coordinate 'Y' coordinate  
1 0.00 3.00  
2 30.00 0.00  
3 60.00 3.00  
Manning's 'N' friction factor = 0.045  
-----

Sub-Channel flow = 6.552(CFS)  
' ' flow top width = 10.065(Ft.)  
' ' velocity = 2.587(Ft/s)  
' ' area = 2.533(Sq.Ft)  
' ' Froude number = 0.909

Upstream point elevation = 881.370(Ft.)  
Downstream point elevation = 864.410(Ft.)  
Flow length = 436.000(Ft.)  
Travel time = 2.81 min.  
Time of concentration = 12.95 min.  
Depth of flow = 0.503(Ft.)  
Average velocity = 2.587(Ft/s)  
Total irregular channel flow = 6.552(CFS)  
Irregular channel normal depth above invert elev. = 0.503(Ft.)  
Average velocity of channel(s) = 2.587(Ft/s)  
Adding area flow to channel  
Rainfall intensity (I) = 4.992(In/Hr) for a 100.0 year storm  
Decimal fraction soil group A = 0.000  
Decimal fraction soil group B = 0.000  
Decimal fraction soil group C = 0.840  
Decimal fraction soil group D = 0.160  
[UNDISTURBED NATURAL TERRAIN ]  
(Permanent Open Space )  
Impervious value, Ai = 0.000  
Sub-Area C Value = 0.308  
Rainfall intensity = 4.992(In/Hr) for a 100.0 year storm  
Effective runoff coefficient used for total area  
(Q=KCIA) is C = 0.342 CA = 1.934  
Subarea runoff = 6.307(CFS) for 4.420(Ac.)  
Total runoff = 9.657(CFS) Total area = 5.658(Ac.)  
Depth of flow = 0.582(Ft.), Average velocity = 2.851(Ft/s)

+++++  
Process from Point/Station 403.000 to Point/Station 403.000  
\*\*\*\* SUBAREA FLOW ADDITION \*\*\*\*

-----  
Rainfall intensity (I) = 4.992(In/Hr) for a 100.0 year storm  
Decimal fraction soil group A = 0.000  
Decimal fraction soil group B = 0.000  
Decimal fraction soil group C = 0.700  
Decimal fraction soil group D = 0.300  
[UNDISTURBED NATURAL TERRAIN ]  
(Permanent Open Space )  
Impervious value, Ai = 0.000  
Sub-Area C Value = 0.315  
Time of concentration = 12.95 min.

Rainfall intensity = 4.992(In/Hr) for a 100.0 year storm  
Effective runoff coefficient used for total area  
(Q=KCIA) is C = 0.336 CA = 2.407  
Subarea runoff = 2.359(CFS) for 1.500(Ac.)  
Total runoff = 12.015(CFS) Total area = 7.158(Ac.)

\*\*\*\*\*  
Process from Point/Station 403.000 to Point/Station 305.000  
\*\*\*\* PIPEFLOW TRAVEL TIME (User specified size) \*\*\*\*

---

Upstream point/station elevation = 864.410(Ft.)  
Downstream point/station elevation = 855.620(Ft.)  
Pipe length = 444.00(Ft.) Slope = 0.0198 Manning's N = 0.013  
No. of pipes = 1 Required pipe flow = 12.015(CFS)  
Given pipe size = 36.00(In.)  
Calculated individual pipe flow = 12.015(CFS)  
Normal flow depth in pipe = 8.70(In.)  
Flow top width inside pipe = 30.82(In.)  
Critical Depth = 13.19(In.)  
Pipe flow velocity = 9.12(Ft/s)  
Travel time through pipe = 0.81 min.  
Time of concentration (TC) = 13.76 min.  
End of computations, total study area = 7.158 (Ac.)



San Diego County Rational Hydrology Program

CIVILCADD/CIVILDESIGN Engineering Software,(c)1991-2012 Version 7.9

Rational method hydrology program based on  
San Diego County Flood Control Division 2003 hydrology manual  
Rational Hydrology Study Date: 06/10/18

-----  
17046 Nutmeg Development  
Pre-Development Poc2 100 Year  
17046predevpoc2.rd3

-----  
\*\*\*\*\* Hydrology Study Control Information \*\*\*\*\*  
-----

Program License Serial Number 6312

-----  
Rational hydrology study storm event year is 100.0  
English (in-lb) input data Units used

Map data precipitation entered:  
6 hour, precipitation(inches) = 3.500  
24 hour precipitation(inches) = 7.000  
P6/P24 = 50.0%  
San Diego hydrology manual 'C' values used

+++++  
Process from Point/Station 101.000 to Point/Station 102.000  
\*\*\*\* INITIAL AREA EVALUATION \*\*\*\*

---

Decimal fraction soil group A = 0.000  
Decimal fraction soil group B = 0.000  
Decimal fraction soil group C = 0.000  
Decimal fraction soil group D = 1.000  
[UNDISTURBED NATURAL TERRAIN ]  
(Permanent Open Space )  
Impervious value, Ai = 0.000  
Sub-Area C Value = 0.350  
Initial subarea total flow distance = 157.000(Ft.)  
Highest elevation = 1080.000(Ft.)  
Lowest elevation = 1070.000(Ft.)  
Elevation difference = 10.000(Ft.) Slope = 6.369 %  
INITIAL AREA TIME OF CONCENTRATION CALCULATIONS:  
The maximum overland flow distance is 100.00 (Ft)  
for the top area slope value of 6.37 %, in a development type of  
Permanent Open Space  
In Accordance With Figure 3-3  
Initial Area Time of Concentration = 7.28 minutes  
 $TC = [1.8*(1.1-C)*distance(Ft.)^0.5]/(slope^{1/3})$   
 $TC = [1.8*(1.1-0.3500)*(100.000^0.5)]/(6.369^{1/3}) = 7.28$   
The initial area total distance of 157.00 (Ft.) entered leaves a  
remaining distance of 57.00 (Ft.)  
Using Figure 3-4, the travel time for this distance is 0.51 minutes  
for a distance of 57.00 (Ft.) and a slope of 6.37 %  
with an elevation difference of 3.63(Ft.) from the end of the top area  
 $Tt = [11.9*length(Mi)^3]/(elevation\ change(Ft.))^{0.385} *60(\text{min/hr})$   
= 0.507 Minutes  
 $Tt = [(11.9*0.0108^3)/(3.63)]^{0.385} = 0.51$   
Total initial area Ti = 7.28 minutes from Figure 3-3 formula plus  
0.51 minutes from the Figure 3-4 formula = 7.79 minutes

Rainfall intensity (I) = 6.928(In/Hr) for a 100.0 year storm  
Effective runoff coefficient used for area (Q=KCIA) is C = 0.350  
Subarea runoff = 0.897(CFS)  
Total initial stream area = 0.370(Ac.)

+++++

Process from Point/Station 102.000 to Point/Station 103.000  
\*\*\*\* IRREGULAR CHANNEL FLOW TRAVEL TIME \*\*\*\*

---

Estimated mean flow rate at midpoint of channel = 3.495(CFS)  
Depth of flow = 0.157(Ft.), Average velocity = 2.140(Ft/s)  
\*\*\*\*\* Irregular Channel Data \*\*\*\*\*

-----  
Information entered for subchannel number 1 :

Point number	'X' coordinate	'Y' coordinate
1	0.00	1.00
2	12.00	0.00
3	21.00	0.00
4	27.00	1.00

Manning's 'N' friction factor = 0.090  
-----

Sub-Channel flow = 3.495(CFS)  
' ' flow top width = 11.823(Ft.)  
' ' velocity = 2.140(Ft/s)  
' ' area = 1.633(Sq.Ft)  
' ' Froude number = 1.015

Upstream point elevation = 1070.000(Ft.)  
Downstream point elevation = 884.150(Ft.)  
Flow length = 788.000(Ft.)  
Travel time = 6.14 min.  
Time of concentration = 13.93 min.  
Depth of flow = 0.157(Ft.)  
Average velocity = 2.140(Ft/s)  
Total irregular channel flow = 3.495(CFS)  
Irregular channel normal depth above invert elev. = 0.157(Ft.)  
Average velocity of channel(s) = 2.140(Ft/s)  
Adding area flow to channel

Rainfall intensity (I) = 4.763(In/Hr) for a 100.0 year storm  
Decimal fraction soil group A = 0.000  
Decimal fraction soil group B = 0.000  
Decimal fraction soil group C = 0.200  
Decimal fraction soil group D = 0.800  
[UNDISTURBED NATURAL TERRAIN ]  
(Permanent Open Space )  
Impervious value, Ai = 0.000  
Sub-Area C Value = 0.340  
Rainfall intensity = 4.763(In/Hr) for a 100.0 year storm  
Effective runoff coefficient used for total area  
(Q=KCIA) is C = 0.341 CA = 1.265  
Subarea runoff = 5.128(CFS) for 3.340(Ac.)  
Total runoff = 6.025(CFS) Total area = 3.710(Ac.)  
Depth of flow = 0.214(Ft.), Average velocity = 2.573(Ft/s)

+++++

Process from Point/Station 103.000 to Point/Station 103.000  
\*\*\*\* CONFLUENCE OF MINOR STREAMS \*\*\*\*

---

Along Main Stream number: 1 in normal stream number 1  
Stream flow area = 3.710(Ac.)  
Runoff from this stream = 6.025(CFS)  
Time of concentration = 13.93 min.  
Rainfall intensity = 4.763(In/Hr)

\*\*\*\*\*  
 Process from Point/Station 201.000 to Point/Station 202.000  
 \*\*\*\* INITIAL AREA EVALUATION \*\*\*\*

---

Decimal fraction soil group A = 0.000  
 Decimal fraction soil group B = 0.000  
 Decimal fraction soil group C = 0.000  
 Decimal fraction soil group D = 1.000  
 [UNDISTURBED NATURAL TERRAIN ]  
 (Permanent Open Space )  
 Impervious value, Ai = 0.000  
 Sub-Area C Value = 0.350  
 Initial subarea total flow distance = 788.000(Ft.)  
 Highest elevation = 974.970(Ft.)  
 Lowest elevation = 925.370(Ft.)  
 Elevation difference = 49.600(Ft.) Slope = 6.294 %  
 INITIAL AREA TIME OF CONCENTRATION CALCULATIONS:  
 The maximum overland flow distance is 100.00 (Ft)  
 for the top area slope value of 6.29 %, in a development type of  
 Permanent Open Space  
 In Accordance With Figure 3-3  
 Initial Area Time of Concentration = 7.31 minutes  
 $TC = [1.8 * (1.1 - C) * distance(Ft.)^{1.5}] / (\% slope^{1/3})$   
 $TC = [1.8 * (1.1 - 0.3500) * (100.000^{1.5})] / (6.294^{1/3}) = 7.31$   
 The initial area total distance of 788.00 (Ft.) entered leaves a  
 remaining distance of 688.00 (Ft.)  
 Using Figure 3-4, the travel time for this distance is 3.47 minutes  
 for a distance of 688.00 (Ft.) and a slope of 6.29 %  
 with an elevation difference of 43.30(Ft.) from the end of the top area  
 $Tt = [11.9 * length(Mi)^3] / (elevation\ change(Ft.))^{0.385} * 60(\text{min/hr})$   
 $= 3.467\ \text{Minutes}$   
 $Tt = [(11.9 * 0.1303^3) / (43.30)]^{0.385} = 3.47$   
 Total initial area Ti = 7.31 minutes from Figure 3-3 formula plus  
 3.47 minutes from the Figure 3-4 formula = 10.78 minutes  
 Rainfall intensity (I) = 5.619(In/Hr) for a 100.0 year storm  
 Effective runoff coefficient used for area (Q=KCIA) is C = 0.350  
 Subarea runoff = 0.393(CFS)  
 Total initial stream area = 0.200(Ac.)

\*\*\*\*\*  
 Process from Point/Station 202.000 to Point/Station 103.000  
 \*\*\*\* IRREGULAR CHANNEL FLOW TRAVEL TIME \*\*\*\*

---

Estimated mean flow rate at midpoint of channel = 1.232(CFS)  
 Depth of flow = 0.143(Ft.), Average velocity = 0.753(Ft/s)  
 \*\*\*\*\* Irregular Channel Data \*\*\*\*\*

-----  
 Information entered for subchannel number 1 :

Point number	'X' coordinate	'Y' coordinate
1	0.00	1.00
2	80.00	0.00
3	160.00	1.00

Manning's 'N' friction factor = 0.090  
 -----

Sub-Channel flow = 1.232(CFS)  
 ' ' flow top width = 22.878(Ft.)  
 ' ' velocity = 0.753(Ft/s)  
 ' ' area = 1.636(Sq.Ft)  
 ' ' Froude number = 0.496

Upstream point elevation = 925.370(Ft.)  
 Downstream point elevation = 884.150(Ft.)  
 Flow length = 588.000(Ft.)  
 Travel time = 13.02 min.

Time of concentration = 23.79 min.  
Depth of flow = 0.143(Ft.)  
Average velocity = 0.753(Ft/s)  
Total irregular channel flow = 1.232(CFS)  
Irregular channel normal depth above invert elev. = 0.143(Ft.)  
Average velocity of channel(s) = 0.753(Ft/s)  
Adding area flow to channel  
Rainfall intensity (I) = 3.371(In/Hr) for a 100.0 year storm  
Decimal fraction soil group A = 0.000  
Decimal fraction soil group B = 0.000  
Decimal fraction soil group C = 0.600  
Decimal fraction soil group D = 0.400  
[UNDISTURBED NATURAL TERRAIN ]  
(Permanent Open Space )  
Impervious value, Ai = 0.000  
Sub-Area C Value = 0.320  
Rainfall intensity = 3.371(In/Hr) for a 100.0 year storm  
Effective runoff coefficient used for total area  
(Q=KCIA) is C = 0.323 CA = 0.595  
Subarea runoff = 1.612(CFS) for 1.640(Ac.)  
Total runoff = 2.005(CFS) Total area = 1.840(Ac.)  
Depth of flow = 0.172(Ft.), Average velocity = 0.851(Ft/s)

++++  
Process from Point/Station 103.000 to Point/Station 103.000  
\*\*\*\* SUBAREA FLOW ADDITION \*\*\*\*

---

Rainfall intensity (I) = 3.371(In/Hr) for a 100.0 year storm  
Decimal fraction soil group A = 0.000  
Decimal fraction soil group B = 0.000  
Decimal fraction soil group C = 1.000  
Decimal fraction soil group D = 0.000  
[HIGH DENSITY RESIDENTIAL ]  
(43.0 DU/A or Less )  
Impervious value, Ai = 0.800  
Sub-Area C Value = 0.780  
Time of concentration = 23.79 min.  
Rainfall intensity = 3.371(In/Hr) for a 100.0 year storm  
Effective runoff coefficient used for total area  
(Q=KCIA) is C = 0.403 CA = 0.899  
Subarea runoff = 1.026(CFS) for 0.390(Ac.)  
Total runoff = 3.031(CFS) Total area = 2.230(Ac.)

++++  
Process from Point/Station 103.000 to Point/Station 103.000  
\*\*\*\* SUBAREA FLOW ADDITION \*\*\*\*

---

Rainfall intensity (I) = 3.371(In/Hr) for a 100.0 year storm  
Decimal fraction soil group A = 0.000  
Decimal fraction soil group B = 0.000  
Decimal fraction soil group C = 1.000  
Decimal fraction soil group D = 0.000  
[HIGH DENSITY RESIDENTIAL ]  
(43.0 DU/A or Less )  
Impervious value, Ai = 0.800  
Sub-Area C Value = 0.780  
Time of concentration = 23.79 min.  
Rainfall intensity = 3.371(In/Hr) for a 100.0 year storm  
Effective runoff coefficient used for total area  
(Q=KCIA) is C = 0.450 CA = 1.149  
Subarea runoff = 0.842(CFS) for 0.320(Ac.)  
Total runoff = 3.872(CFS) Total area = 2.550(Ac.)

++++  
 Process from Point/Station 103.000 to Point/Station 103.000  
 \*\*\*\* SUBAREA FLOW ADDITION \*\*\*\*

---

Rainfall intensity (I) = 3.371(In/Hr) for a 100.0 year storm  
 Decimal fraction soil group A = 0.000  
 Decimal fraction soil group B = 0.000  
 Decimal fraction soil group C = 1.000  
 Decimal fraction soil group D = 0.000  
 [HIGH DENSITY RESIDENTIAL ]  
 (43.0 DU/A or Less )  
 Impervious value, Ai = 0.800  
 Sub-Area C Value = 0.780  
 Time of concentration = 23.79 min.  
 Rainfall intensity = 3.371(In/Hr) for a 100.0 year storm  
 Effective runoff coefficient used for total area  
 (Q=KCIA) is C = 0.462 CA = 1.219  
 Subarea runoff = 0.237(CFS) for 0.090(Ac.)  
 Total runoff = 4.109(CFS) Total area = 2.640(Ac.)

++++  
 Process from Point/Station 103.000 to Point/Station 103.000  
 \*\*\*\* CONFLUENCE OF MINOR STREAMS \*\*\*\*

---

Along Main Stream number: 1 in normal stream number 2  
 Stream flow area = 2.640(Ac.)  
 Runoff from this stream = 4.109(CFS)  
 Time of concentration = 23.79 min.  
 Rainfall intensity = 3.371(In/Hr)  
 Summary of stream data:

Stream No.	Flow rate (CFS)	TC (min)	Rainfall Intensity (In/Hr)
1	6.025	13.93	4.763
2	4.109	23.79	3.371

Qmax(1) =  
 $1.000 * 1.000 * 6.025 + 1.000 * 0.585 * 4.109 = 8.431$

Qmax(2) =  
 $0.708 * 1.000 * 6.025 + 1.000 * 1.000 * 4.109 = 8.374$

Total of 2 streams to confluence:  
 Flow rates before confluence point:  
 6.025 4.109  
 Maximum flow rates at confluence using above data:  
 8.431 8.374  
 Area of streams before confluence:  
 3.710 2.640  
 Results of confluence:  
 Total flow rate = 8.431(CFS)  
 Time of concentration = 13.927 min.  
 Effective stream area after confluence = 6.350(Ac.)  
 End of computations, total study area = 6.350 (Ac.)

San Diego County Rational Hydrology Program

CIVILCADD/CIVILDESIGN Engineering Software,(c)1991-2014 Version 9.0

Rational method hydrology program based on  
San Diego County Flood Control Division 2003 hydrology manual  
Rational Hydrology Study Date: 09/24/18

-----  
17046 Nutmeg Development  
Pre-Development Poc3 100 Year  
17046predevpoc3.rd3

-----  
\*\*\*\*\* Hydrology Study Control Information \*\*\*\*\*  
-----

Program License Serial Number 6332

-----  
Rational hydrology study storm event year is 100.0  
English (in-lb) input data Units used

Map data precipitation entered:  
6 hour, precipitation(inches) = 3.500  
24 hour precipitation(inches) = 7.000  
P6/P24 = 50.0%  
San Diego hydrology manual 'C' values used

+++++  
Process from Point/Station 301.000 to Point/Station 302.000  
\*\*\*\* INITIAL AREA EVALUATION \*\*\*\*

---

Decimal fraction soil group A = 0.000  
Decimal fraction soil group B = 0.000  
Decimal fraction soil group C = 0.000  
Decimal fraction soil group D = 1.000  
[UNDISTURBED NATURAL TERRAIN ]  
(Permanent Open Space )  
Impervious value, Ai = 0.000  
Sub-Area C Value = 0.350  
Initial subarea total flow distance = 170.000(Ft.)  
Highest elevation = 974.970(Ft.)  
Lowest elevation = 919.930(Ft.)  
Elevation difference = 55.040(Ft.) Slope = 32.376 %  
INITIAL AREA TIME OF CONCENTRATION CALCULATIONS:  
The maximum overland flow distance is 100.00 (Ft)  
for the top area slope value of 32.38 %, in a development type of  
Permanent Open Space  
In Accordance With Figure 3-3  
Initial Area Time of Concentration = 4.24 minutes  
 $TC = [1.8 * (1.1 - C) * distance(Ft.)^{.5}] / (\% slope^{(1/3)})$   
 $TC = [1.8 * (1.1 - 0.3500) * (100.000^{.5})] / (32.376^{(1/3)}) = 4.24$   
The initial area total distance of 170.00 (Ft.) entered leaves a  
remaining distance of 70.00 (Ft.)  
Using Figure 3-4, the travel time for this distance is 0.32 minutes  
for a distance of 70.00 (Ft.) and a slope of 32.38 %  
with an elevation difference of 22.66(Ft.) from the end of the top area  
 $Tt = [11.9 * length(Mi)^3] / (elevation\ change(Ft.))^{.385} * 60(\text{min/hr})$   
= 0.318 Minutes  
 $Tt = [(11.9 * 0.0133^3) / (22.66)]^{.385} = 0.32$   
Total initial area Ti = 4.24 minutes from Figure 3-3 formula plus  
0.32 minutes from the Figure 3-4 formula = 4.55 minutes

Calculated TC of 4.553 minutes is less than 5 minutes,  
resetting TC to 5.0 minutes for rainfall intensity calculations  
Rainfall intensity (I) = 9.222(In/Hr) for a 100.0 year storm  
Effective runoff coefficient used for area (Q=KCIA) is C = 0.350  
Subarea runoff = 1.485(CFS)  
Total initial stream area = 0.460(Ac.)

++++  
Process from Point/Station 302.000 to Point/Station 303.000  
\*\*\*\* IRREGULAR CHANNEL FLOW TRAVEL TIME \*\*\*\*

-----  
Estimated mean flow rate at midpoint of channel = 2.019(CFS)  
Depth of flow = 0.151(Ft.), Average velocity = 1.006(Ft/s)  
\*\*\*\*\* Irregular Channel Data \*\*\*\*\*

-----  
Information entered for subchannel number 1 :  
Point number 'X' coordinate 'Y' coordinate  
1 0.00 1.00  
2 80.00 0.00  
3 175.00 1.00  
Manning's 'N' friction factor = 0.090

-----  
Sub-Channel flow = 2.019(CFS)  
' ' flow top width = 26.498(Ft.)  
' ' velocity = 1.006(Ft/s)  
' ' area = 2.006(Sq.Ft)  
' ' Froude number = 0.644

Upstream point elevation = 919.930(Ft.)  
Downstream point elevation = 903.230(Ft.)  
Flow length = 144.000(Ft.)  
Travel time = 2.39 min.  
Time of concentration = 6.94 min.  
Depth of flow = 0.151(Ft.)  
Average velocity = 1.006(Ft/s)  
Total irregular channel flow = 2.019(CFS)  
Irregular channel normal depth above invert elev. = 0.151(Ft.)  
Average velocity of channel(s) = 1.006(Ft/s)  
Adding area flow to channel  
Rainfall intensity (I) = 7.465(In/Hr) for a 100.0 year storm  
Decimal fraction soil group A = 0.000  
Decimal fraction soil group B = 0.000  
Decimal fraction soil group C = 0.800  
Decimal fraction soil group D = 0.200  
[UNDISTURBED NATURAL TERRAIN ]  
(Permanent Open Space )  
Impervious value, Ai = 0.000  
Sub-Area C Value = 0.310  
Rainfall intensity = 7.465(In/Hr) for a 100.0 year storm  
Effective runoff coefficient used for total area  
(Q=KCIA) is C = 0.328 CA = 0.335  
Subarea runoff = 1.013(CFS) for 0.560(Ac.)  
Total runoff = 2.498(CFS) Total area = 1.020(Ac.)  
Depth of flow = 0.164(Ft.), Average velocity = 1.061(Ft/s)

++++  
Process from Point/Station 303.000 to Point/Station 304.000  
\*\*\*\* IRREGULAR CHANNEL FLOW TRAVEL TIME \*\*\*\*

-----  
Estimated mean flow rate at midpoint of channel = 3.261(CFS)  
Depth of flow = 0.357(Ft.), Average velocity = 8.522(Ft/s)  
\*\*\*\*\* Irregular Channel Data \*\*\*\*\*

-----  
Information entered for subchannel number 1 :

Point number 'X' coordinate 'Y' coordinate  
 1 0.00 0.50  
 2 0.00 0.00  
 3 3.00 0.50  
 Manning's 'N' friction factor = 0.013

-----  
 Sub-Channel flow = 3.261(CFS)  
 ' ' flow top width = 2.143(Ft.)  
 ' ' velocity= 8.522(Ft/s)  
 ' ' area = 0.383(Sq.Ft)  
 ' ' Froude number = 3.554

Upstream point elevation = 903.230(Ft.)  
 Downstream point elevation = 893.300(Ft.)  
 Flow length = 144.000(Ft.)  
 Travel time = 0.28 min.  
 Time of concentration = 7.22 min.  
 Depth of flow = 0.357(Ft.)  
 Average velocity = 8.522(Ft/s)  
 Total irregular channel flow = 3.261(CFS)  
 Irregular channel normal depth above invert elev. = 0.357(Ft.)  
 Average velocity of channel(s) = 8.522(Ft/s)  
 Adding area flow to channel  
 Rainfall intensity (I) = 7.276(In/Hr) for a 100.0 year storm  
 Decimal fraction soil group A = 0.000  
 Decimal fraction soil group B = 0.000  
 Decimal fraction soil group C = 1.000  
 Decimal fraction soil group D = 0.000  
 [HIGH DENSITY RESIDENTIAL ]  
 (43.0 DU/A or Less )  
 Impervious value, Ai = 0.800  
 Sub-Area C Value = 0.780  
 Rainfall intensity = 7.276(In/Hr) for a 100.0 year storm  
 Effective runoff coefficient used for total area  
 (Q=KCIA) is C = 0.428 CA = 0.561  
 Subarea runoff = 1.583(CFS) for 0.290(Ac.)  
 Total runoff = 4.080(CFS) Total area = 1.310(Ac.)  
 Depth of flow = 0.388(Ft.), Average velocity = 9.013(Ft/s)

++++  
 Process from Point/Station 304.000 to Point/Station 304.000  
 \*\*\*\* SUBAREA FLOW ADDITION \*\*\*\*

-----  
 Rainfall intensity (I) = 7.276(In/Hr) for a 100.0 year storm  
 Decimal fraction soil group A = 0.000  
 Decimal fraction soil group B = 0.000  
 Decimal fraction soil group C = 1.000  
 Decimal fraction soil group D = 0.000  
 [HIGH DENSITY RESIDENTIAL ]  
 (43.0 DU/A or Less )  
 Impervious value, Ai = 0.800  
 Sub-Area C Value = 0.780  
 Time of concentration = 7.22 min.  
 Rainfall intensity = 7.276(In/Hr) for a 100.0 year storm  
 Effective runoff coefficient used for total area  
 (Q=KCIA) is C = 0.471 CA = 0.701  
 Subarea runoff = 1.022(CFS) for 0.180(Ac.)  
 Total runoff = 5.102(CFS) Total area = 1.490(Ac.)  
 End of computations, total study area = 1.490 (Ac.)



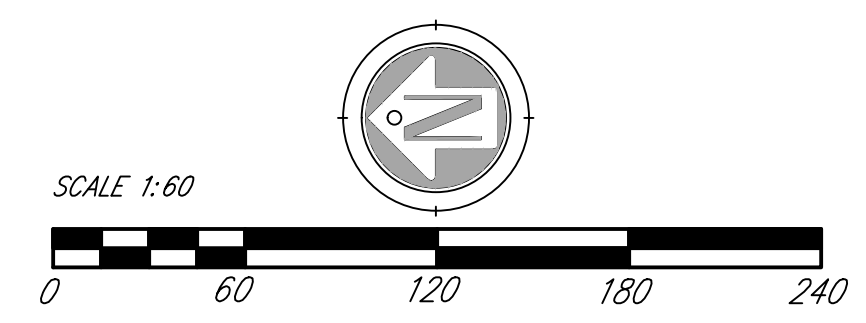
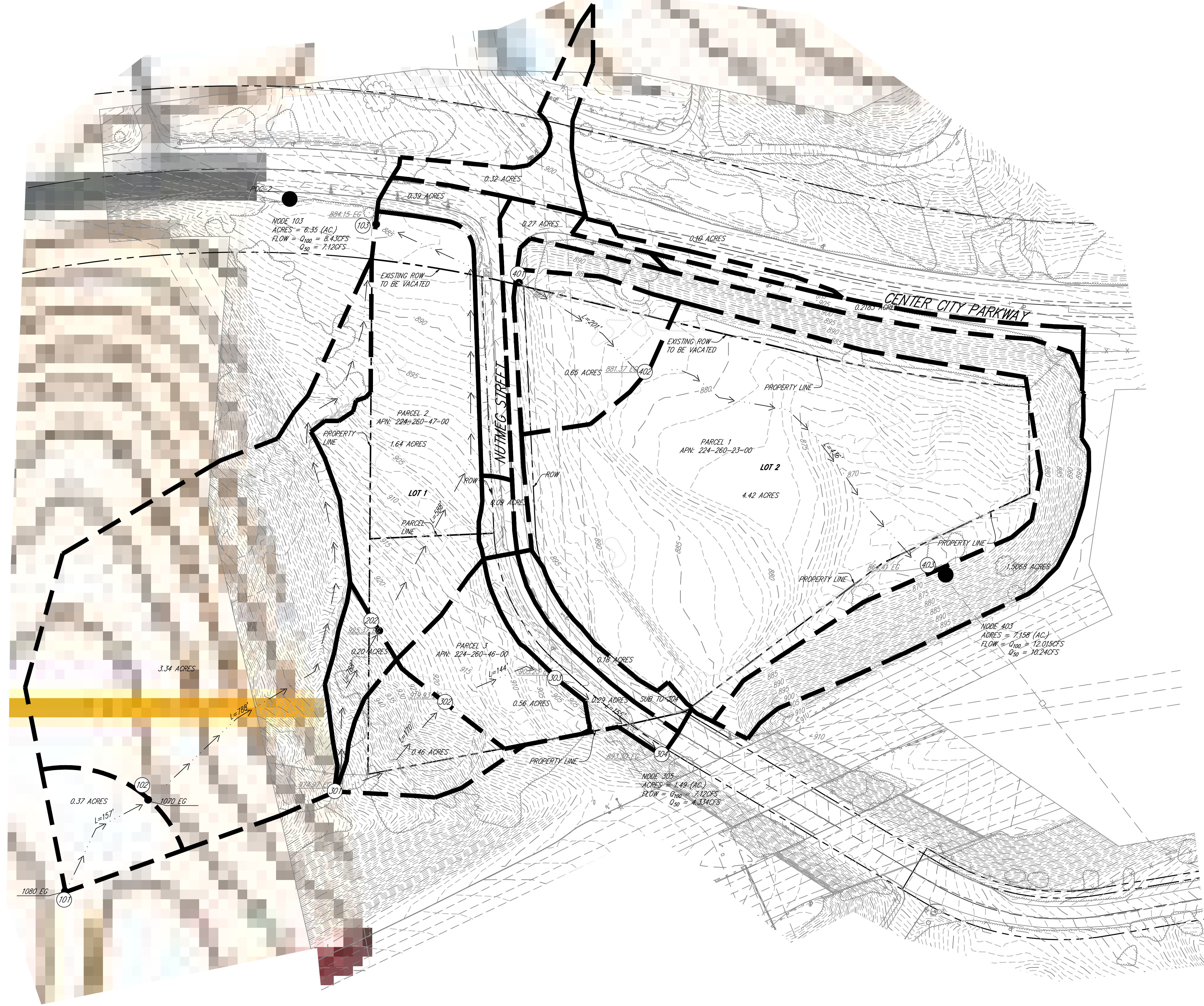

**NUTMEG DEVELOPMENT  
 PRE-DEVELOPMENT EXHIBIT**



  
 LAND PLANNING • ENGINEERING • SURVEYING  
 440 STATE PLACE, ESCONDIDO, CA 92029  
 PH (760)745-8118 FX (760)745-1890



## **ATTACHMENT G**

### **100 Year POST DEVELOPED Q CALCULATIONS**

#### ***Steps Taken To Analyze This Condition***

The Rational Method as outlined in section 3 of the June 2003 San Diego County Hydrology Manual is followed here. The software that we are using is the “*Rational Hydrology Method, San Diego County (2003 Manual)*” module of the CIVILCADD/CIVIL DESIGN Engineering software version 7.9.

Please see the subsequent pages for the calculations. These calculations are for the Q100. The results are outlined/summarized in Section 8.

San Diego County Rational Hydrology Program

CIVILCADD/CIVILDESIGN Engineering Software,(c)1991-2014 Version 9.0

Rational method hydrology program based on  
San Diego County Flood Control Division 2003 hydrology manual  
Rational Hydrology Study Date: 09/24/18

-----  
1746 Nutmeg Development  
Post-Development Poc 1 100 Year  
17046postdevpoc1.rd3

-----  
\*\*\*\*\* Hydrology Study Control Information \*\*\*\*\*  
-----

Program License Serial Number 6332

-----  
Rational hydrology study storm event year is 50.0  
English (in-lb) input data Units used

Map data precipitation entered:  
6 hour, precipitation(inches) = 3.000  
24 hour precipitation(inches) = 6.000  
P6/P24 = 50.0%  
San Diego hydrology manual 'C' values used

+++++  
Process from Point/Station 601.000 to Point/Station 602.000  
\*\*\*\* INITIAL AREA EVALUATION \*\*\*\*

---

Decimal fraction soil group A = 0.000  
Decimal fraction soil group B = 0.000  
Decimal fraction soil group C = 1.000  
Decimal fraction soil group D = 0.000  
[HIGH DENSITY RESIDENTIAL ]  
(24.0 DU/A or Less )  
Impervious value, Ai = 0.650  
Sub-Area C Value = 0.690  
Initial subarea total flow distance = 105.000(Ft.)  
Highest elevation = 905.220(Ft.)  
Lowest elevation = 903.290(Ft.)  
Elevation difference = 1.930(Ft.) Slope = 1.838 %  
Top of Initial Area Slope adjusted by User to 1.619 %  
Bottom of Initial Area Slope adjusted by User to 1.619 %  
INITIAL AREA TIME OF CONCENTRATION CALCULATIONS:  
The maximum overland flow distance is 75.00 (Ft)  
for the top area slope value of 1.62 %, in a development type of  
24.0 DU/A or Less  
In Accordance With Figure 3-3  
Initial Area Time of Concentration = 5.44 minutes  
TC = [1.8\*(1.1-C)\*distance(Ft.)^0.5]/(% slope^(1/3))  
TC = [1.8\*(1.1-0.6900)\*( 75.000^0.5)]/( 1.619^(1/3))= 5.44  
The initial area total distance of 105.00 (Ft.) entered leaves a  
remaining distance of 30.00 (Ft.)  
Using Figure 3-4, the travel time for this distance is 0.52 minutes  
for a distance of 30.00 (Ft.) and a slope of 1.62 %  
with an elevation difference of 0.49(Ft.) from the end of the top area  
Tt = [11.9\*length(Mi)^3]/(elevation change(Ft.))^.385 \*60(min/hr)  
= 0.524 Minutes  
Tt=[(11.9\*0.0057^3)]/( 0.49)]^.385= 0.52

Total initial area  $T_i = 5.44$  minutes from Figure 3-3 formula plus  
 0.52 minutes from the Figure 3-4 formula = 5.97 minutes  
 Rainfall intensity (I) = 7.052(In/Hr) for a 50.0 year storm  
 Effective runoff coefficient used for area (Q=KCIA) is  $C = 0.690$   
 Subarea runoff = 1.168(CFS)  
 Total initial stream area = 0.240(Ac.)

++++  
 Process from Point/Station 602.000 to Point/Station 603.000  
 \*\*\*\* IRREGULAR CHANNEL FLOW TRAVEL TIME \*\*\*\*

---

Estimated mean flow rate at midpoint of channel = 4.246(CFS)  
 Depth of flow = 0.334(Ft.), Average velocity = 2.518(Ft/s)  
 \*\*\*\*\* Irregular Channel Data \*\*\*\*\*

-----  
 Information entered for subchannel number 1 :

Point number	'X' coordinate	'Y' coordinate
1	0.00	0.50
2	0.00	0.00
3	1.50	0.13
4	23.50	0.50

Manning's 'N' friction factor = 0.013  
 -----

Sub-Channel flow = 4.246(CFS)  
 ' ' flow top width = 13.752(Ft.)  
 ' ' velocity = 2.518(Ft/s)  
 ' ' area = 1.686(Sq.Ft)  
 ' ' Froude number = 1.267

Upstream point elevation = 903.290(Ft.)  
 Downstream point elevation = 899.990(Ft.)  
 Flow length = 401.000(Ft.)  
 Travel time = 2.65 min.  
 Time of concentration = 8.62 min.  
 Depth of flow = 0.334(Ft.)  
 Average velocity = 2.518(Ft/s)  
 Total irregular channel flow = 4.246(CFS)  
 Irregular channel normal depth above invert elev. = 0.334(Ft.)  
 Average velocity of channel(s) = 2.518(Ft/s)  
 Adding area flow to channel  
 Rainfall intensity (I) = 5.562(In/Hr) for a 50.0 year storm  
 Decimal fraction soil group A = 0.000  
 Decimal fraction soil group B = 0.000  
 Decimal fraction soil group C = 1.000  
 Decimal fraction soil group D = 0.000  
 [HIGH DENSITY RESIDENTIAL ]  
 (24.0 DU/A or Less )  
 Impervious value,  $A_i = 0.650$   
 Sub-Area C Value = 0.690  
 Rainfall intensity = 5.562(In/Hr) for a 50.0 year storm  
 Effective runoff coefficient used for total area  
 (Q=KCIA) is  $C = 0.690$   $CA = 1.304$   
 Subarea runoff = 6.086(CFS) for 1.650(Ac.)  
 Total runoff = 7.254(CFS) Total area = 1.890(Ac.)  
 Depth of flow = 0.389(Ft.), Average velocity = 2.870(Ft/s)

++++  
 Process from Point/Station 603.000 to Point/Station 603.000  
 \*\*\*\* SUBAREA FLOW ADDITION \*\*\*\*

---

Rainfall intensity (I) = 5.562(In/Hr) for a 50.0 year storm  
 Decimal fraction soil group A = 0.000  
 Decimal fraction soil group B = 0.000  
 Decimal fraction soil group C = 1.000

Decimal fraction soil group D = 0.000  
[HIGH DENSITY RESIDENTIAL ]  
(24.0 DU/A or Less )  
Impervious value, Ai = 0.650  
Sub-Area C Value = 0.690  
Time of concentration = 8.62 min.  
Rainfall intensity = 5.562(In/Hr) for a 50.0 year storm  
Effective runoff coefficient used for total area  
(Q=KCIA) is C = 0.690 CA = 1.525  
Subarea runoff = 1.228(CFS) for 0.320(Ac.)  
Total runoff = 8.482(CFS) Total area = 2.210(Ac.)

++++  
Process from Point/Station 603.000 to Point/Station 603.000  
\*\*\*\* SUBAREA FLOW ADDITION \*\*\*\*

---

Rainfall intensity (I) = 5.562(In/Hr) for a 50.0 year storm  
Decimal fraction soil group A = 0.000  
Decimal fraction soil group B = 0.000  
Decimal fraction soil group C = 1.000  
Decimal fraction soil group D = 0.000  
[HIGH DENSITY RESIDENTIAL ]  
(24.0 DU/A or Less )  
Impervious value, Ai = 0.650  
Sub-Area C Value = 0.690  
Time of concentration = 8.62 min.  
Rainfall intensity = 5.562(In/Hr) for a 50.0 year storm  
Effective runoff coefficient used for total area  
(Q=KCIA) is C = 0.690 CA = 1.863  
Subarea runoff = 1.881(CFS) for 0.490(Ac.)  
Total runoff = 10.362(CFS) Total area = 2.700(Ac.)

++++  
Process from Point/Station 603.000 to Point/Station 604.000  
\*\*\*\* PIPEFLOW TRAVEL TIME (User specified size) \*\*\*\*

---

Upstream point/station elevation = 892.500(Ft.)  
Downstream point/station elevation = 891.600(Ft.)  
Pipe length = 185.00(Ft.) Slope = 0.0049 Manning's N = 0.013  
No. of pipes = 1 Required pipe flow = 10.362(CFS)  
Given pipe size = 18.00(In.)  
NOTE: Normal flow is pressure flow in user selected pipe size.  
The approximate hydraulic grade line above the pipe invert is  
1.701(Ft.) at the headworks or inlet of the pipe(s)  
Pipe friction loss = 1.800(Ft.)  
Minor friction loss = 0.801(Ft.) K-factor = 1.50  
Pipe flow velocity = 5.86(Ft/s)  
Travel time through pipe = 0.53 min.  
Time of concentration (TC) = 9.15 min.

++++  
Process from Point/Station 604.000 to Point/Station 604.000  
\*\*\*\* CONFLUENCE OF MINOR STREAMS \*\*\*\*

---

Along Main Stream number: 1 in normal stream number 1  
Stream flow area = 2.700(Ac.)  
Runoff from this stream = 10.362(CFS)  
Time of concentration = 9.15 min.  
Rainfall intensity = 5.354(In/Hr)

++++  
Process from Point/Station 701.000 to Point/Station 702.000

\*\*\*\* INITIAL AREA EVALUATION \*\*\*\*

---

Decimal fraction soil group A = 0.000  
Decimal fraction soil group B = 0.000  
Decimal fraction soil group C = 1.000  
Decimal fraction soil group D = 0.000  
[HIGH DENSITY RESIDENTIAL ]  
(24.0 DU/A or Less )  
Impervious value, Ai = 0.650  
Sub-Area C Value = 0.690  
Initial subarea total flow distance = 36.000(Ft.)  
Highest elevation = 902.120(Ft.)  
Lowest elevation = 901.580(Ft.)  
Elevation difference = 0.540(Ft.) Slope = 1.500 %  
Top of Initial Area Slope adjusted by User to 1.472 %  
INITIAL AREA TIME OF CONCENTRATION CALCULATIONS:  
The maximum overland flow distance is 65.00 (Ft)  
for the top area slope value of 1.47 %, in a development type of  
24.0 DU/A or Less  
In Accordance With Figure 3-3  
Initial Area Time of Concentration = 5.23 minutes  
 $TC = [1.8 * (1.1 - C) * distance(Ft.)^0.5] / (\% slope^{1/3})$   
 $TC = [1.8 * (1.1 - 0.6900) * (65.000^0.5)] / (1.472^{1/3}) = 5.23$   
Rainfall intensity (I) = 7.678(In/Hr) for a 50.0 year storm  
Effective runoff coefficient used for area (Q=KCIA) is C = 0.690  
Subarea runoff = 0.424(CFS)  
Total initial stream area = 0.080(Ac.)

+++++  
Process from Point/Station 702.000 to Point/Station 703.000  
\*\*\*\* IRREGULAR CHANNEL FLOW TRAVEL TIME \*\*\*\*

---

Estimated mean flow rate at midpoint of channel = 2.863(CFS)  
Depth of flow = 0.247(Ft.), Average velocity = 4.003(Ft/s)  
\*\*\*\*\* Irregular Channel Data \*\*\*\*\*

-----  
Information entered for subchannel number 1 :

Point number	'X' coordinate	'Y' coordinate
1	0.00	0.50
2	0.00	0.00
3	1.50	0.13
4	23.50	0.50

Manning's 'N' friction factor = 0.013  
-----

Sub-Channel flow = 2.863(CFS)  
' ' flow top width = 8.670(Ft.)  
' ' velocity = 4.003(Ft/s)  
' ' area = 0.715(Sq.Ft)  
' ' Froude number = 2.456

Upstream point elevation = 901.580(Ft.)  
Downstream point elevation = 896.860(Ft.)  
Flow length = 133.000(Ft.)  
Travel time = 0.55 min.  
Time of concentration = 5.78 min.  
Depth of flow = 0.247(Ft.)  
Average velocity = 4.003(Ft/s)  
Total irregular channel flow = 2.863(CFS)  
Irregular channel normal depth above invert elev. = 0.247(Ft.)  
Average velocity of channel(s) = 4.003(Ft/s)  
Adding area flow to channel  
Rainfall intensity (I) = 7.195(In/Hr) for a 50.0 year storm  
Decimal fraction soil group A = 0.000  
Decimal fraction soil group B = 0.000  
Decimal fraction soil group C = 1.000

Decimal fraction soil group D = 0.000  
 [HIGH DENSITY RESIDENTIAL ]  
 (24.0 DU/A or Less )  
 Impervious value, Ai = 0.650  
 Sub-Area C Value = 0.690  
 Rainfall intensity = 7.195(In/Hr) for a 50.0 year storm  
 Effective runoff coefficient used for total area  
 (Q=KCIA) is C = 0.690 CA = 0.724  
 Subarea runoff = 4.789(CFS) for 0.970(Ac.)  
 Total runoff = 5.213(CFS) Total area = 1.050(Ac.)  
 Depth of flow = 0.289(Ft.), Average velocity = 4.607(Ft/s)

++++  
 Process from Point/Station 703.000 to Point/Station 604.000  
 \*\*\*\* CONFLUENCE OF MINOR STREAMS \*\*\*\*

Along Main Stream number: 1 in normal stream number 2  
 Stream flow area = 1.050(Ac.)  
 Runoff from this stream = 5.213(CFS)  
 Time of concentration = 5.78 min.  
 Rainfall intensity = 7.195(In/Hr)  
 Summary of stream data:

Stream No.	Flow rate (CFS)	TC (min)	Rainfall Intensity (In/Hr)
------------	-----------------	----------	----------------------------

1	10.362	9.15	5.354
2	5.213	5.78	7.195

Qmax(1) =  
 $1.000 * 1.000 * 10.362) + 0.744 * 1.000 * 5.213) += 14.241$   
 Qmax(2) =  
 $1.000 * 0.632 * 10.362) + 1.000 * 1.000 * 5.213) += 11.766$

Total of 2 streams to confluence:  
 Flow rates before confluence point:  
 10.362 5.213  
 Maximum flow rates at confluence using above data:  
 14.241 11.766  
 Area of streams before confluence:  
 2.700 1.050  
 Results of confluence:  
 Total flow rate = 14.241(CFS)  
 Time of concentration = 9.147 min.  
 Effective stream area after confluence = 3.750(Ac.)

++++  
 Process from Point/Station 604.000 to Point/Station 605.000  
 \*\*\*\* PIPEFLOW TRAVEL TIME (User specified size) \*\*\*\*

Upstream point/station elevation = 891.600(Ft.)  
 Downstream point/station elevation = 890.300(Ft.)  
 Pipe length = 267.00(Ft.) Slope = 0.0049 Manning's N = 0.013  
 No. of pipes = 1 Required pipe flow = 14.241(CFS)  
 Given pipe size = 24.00(In.)  
 Calculated individual pipe flow = 14.241(CFS)  
 Normal flow depth in pipe = 17.84(In.)  
 Flow top width inside pipe = 20.97(In.)  
 Critical Depth = 16.31(In.)  
 Pipe flow velocity = 5.69(Ft/s)  
 Travel time through pipe = 0.78 min.  
 Time of concentration (TC) = 9.93 min.

\*\*\*\*\*  
Process from Point/Station 605.000 to Point/Station 605.000  
\*\*\*\* CONFLUENCE OF MINOR STREAMS \*\*\*\*

---

Along Main Stream number: 1 in normal stream number 1  
Stream flow area = 3.750(Ac.)  
Runoff from this stream = 14.241(CFS)  
Time of concentration = 9.93 min.  
Rainfall intensity = 5.078(In/Hr)

\*\*\*\*\*  
Process from Point/Station 801.000 to Point/Station 802.000  
\*\*\*\* INITIAL AREA EVALUATION \*\*\*\*

---

Decimal fraction soil group A = 0.000  
Decimal fraction soil group B = 0.000  
Decimal fraction soil group C = 0.000  
Decimal fraction soil group D = 1.000  
[HIGH DENSITY RESIDENTIAL ]  
(24.0 DU/A or Less )  
Impervious value, Ai = 0.650  
Sub-Area C Value = 0.710  
Initial subarea total flow distance = 144.000(Ft.)  
Highest elevation = 906.460(Ft.)  
Lowest elevation = 902.870(Ft.)  
Elevation difference = 3.590(Ft.) Slope = 2.493 %  
Top of Initial Area Slope adjusted by User to 2.451 %  
Bottom of Initial Area Slope adjusted by User to 2.451 %  
INITIAL AREA TIME OF CONCENTRATION CALCULATIONS:  
The maximum overland flow distance is 75.00 (Ft)  
for the top area slope value of 2.45 %, in a development type of  
24.0 DU/A or Less  
In Accordance With Figure 3-3  
Initial Area Time of Concentration = 4.51 minutes  
 $TC = [1.8 * (1.1 - C) * distance(Ft.)^{.5}] / (\% slope^{(1/3)})$   
 $TC = [1.8 * (1.1 - 0.7100) * (75.000^{.5})] / (2.451^{(1/3)}) = 4.51$   
The initial area total distance of 144.00 (Ft.) entered leaves a  
remaining distance of 69.00 (Ft.)  
Using Figure 3-4, the travel time for this distance is 0.85 minutes  
for a distance of 69.00 (Ft.) and a slope of 2.45 %  
with an elevation difference of 1.69(Ft.) from the end of the top area  
 $Tt = [11.9 * length(Mi)^3] / (elevation change(Ft.))^{.385} * 60(\text{min/hr})$   
= 0.848 Minutes  
 $Tt = [(11.9 * 0.0131^3) / (1.69)]^{.385} = 0.85$   
Total initial area Ti = 4.51 minutes from Figure 3-3 formula plus  
0.85 minutes from the Figure 3-4 formula = 5.36 minutes  
Rainfall intensity (I) = 7.560(In/Hr) for a 50.0 year storm  
Effective runoff coefficient used for area (Q=KCIA) is C = 0.710  
Subarea runoff = 1.557(CFS)  
Total initial stream area = 0.290(Ac.)

\*\*\*\*\*  
Process from Point/Station 802.000 to Point/Station 803.000  
\*\*\*\* IRREGULAR CHANNEL FLOW TRAVEL TIME \*\*\*\*

---

Estimated mean flow rate at midpoint of channel = 5.796(CFS)  
Depth of flow = 0.317(Ft.), Average velocity = 3.979(Ft/s)  
\*\*\*\*\* Irregular Channel Data \*\*\*\*\*

-----  
Information entered for subchannel number 1 :  
Point number 'X' coordinate 'Y' coordinate  
1 0.00 0.50



2 0.00 0.00  
3 1.50 0.13  
4 23.50 0.50

Manning's 'N' friction factor = 0.013

-----  
Sub-Channel flow = 5.796(CFS)  
' ' flow top width = 12.735(Ft.)  
' ' velocity= 3.979(Ft/s)  
' ' area = 1.457(Sq.Ft)  
' ' Froude number = 2.073

Upstream point elevation = 902.870(Ft.)  
Downstream point elevation = 898.990(Ft.)  
Flow length = 172.000(Ft.)  
Travel time = 0.72 min.  
Time of concentration = 6.08 min.  
Depth of flow = 0.317(Ft.)  
Average velocity = 3.979(Ft/s)  
Total irregular channel flow = 5.796(CFS)  
Irregular channel normal depth above invert elev. = 0.317(Ft.)  
Average velocity of channel(s) = 3.979(Ft/s)  
Adding area flow to channel  
Rainfall intensity (I) = 6.969(In/Hr) for a 50.0 year storm  
Decimal fraction soil group A = 0.000  
Decimal fraction soil group B = 0.000  
Decimal fraction soil group C = 0.500  
Decimal fraction soil group D = 0.500  
[HIGH DENSITY RESIDENTIAL ]  
(24.0 DU/A or Less )  
Impervious value, Ai = 0.650  
Sub-Area C Value = 0.700  
Rainfall intensity = 6.969(In/Hr) for a 50.0 year storm  
Effective runoff coefficient used for total area  
(Q=KCIA) is C = 0.701 CA = 1.431  
Subarea runoff = 8.415(CFS) for 1.750(Ac.)  
Total runoff = 9.972(CFS) Total area = 2.040(Ac.)  
Depth of flow = 0.368(Ft.), Average velocity = 4.540(Ft/s)

\*\*\*\*\*  
Process from Point/Station 803.000 to Point/Station 803.000  
\*\*\*\* SUBAREA FLOW ADDITION \*\*\*\*

-----  
Rainfall intensity (I) = 6.969(In/Hr) for a 50.0 year storm  
Decimal fraction soil group A = 0.000  
Decimal fraction soil group B = 0.000  
Decimal fraction soil group C = 0.800  
Decimal fraction soil group D = 0.200  
[LOW DENSITY RESIDENTIAL ]  
(1.0 DU/A or Less )  
Impervious value, Ai = 0.100  
Sub-Area C Value = 0.370  
Time of concentration = 6.08 min.  
Rainfall intensity = 6.969(In/Hr) for a 50.0 year storm  
Effective runoff coefficient used for total area  
(Q=KCIA) is C = 0.573 CA = 1.907  
Subarea runoff = 3.316(CFS) for 1.286(Ac.)  
Total runoff = 13.288(CFS) Total area = 3.326(Ac.)

\*\*\*\*\*  
Process from Point/Station 803.000 to Point/Station 605.000  
\*\*\*\* CONFLUENCE OF MINOR STREAMS \*\*\*\*

-----  
Along Main Stream number: 1 in normal stream number 2  
Stream flow area = 3.326(Ac.)

Runoff from this stream = 13.288(CFS)  
 Time of concentration = 6.08 min.  
 Rainfall intensity = 6.969(In/Hr)  
 Summary of stream data:

Stream No.	Flow rate (CFS)	TC (min)	Rainfall Intensity (In/Hr)
------------	-----------------	----------	----------------------------

1	14.241	9.93	5.078
2	13.288	6.08	6.969

Qmax(1) =  
 $1.000 * 1.000 * 14.241 + 0.729 * 1.000 * 13.288 = 23.923$

Qmax(2) =  
 $1.000 * 0.612 * 14.241 + 1.000 * 1.000 * 13.288 = 22.005$

Total of 2 streams to confluence:  
 Flow rates before confluence point:  
 14.241 13.288

Maximum flow rates at confluence using above data:  
 23.923 22.005

Area of streams before confluence:  
 3.750 3.326

Results of confluence:  
 Total flow rate = 23.923(CFS)  
 Time of concentration = 9.929 min.  
 Effective stream area after confluence = 7.076(Ac.)  
 End of computations, total study area = 7.076 (Ac.)

San Diego County Rational Hydrology Program

CIVILCADD/CIVILDESIGN Engineering Software,(c)1991-2014 Version 9.0

Rational method hydrology program based on  
San Diego County Flood Control Division 2003 hydrology manual  
Rational Hydrology Study Date: 09/24/18

-----  
1746 Nutmeg Development  
Post-Development Detention Poc 1 100 Year  
17046postdevpoc13det.rd3

-----  
\*\*\*\*\* Hydrology Study Control Information \*\*\*\*\*  
-----

Program License Serial Number 6332

-----  
Rational hydrology study storm event year is 50.0  
English (in-lb) input data Units used

Map data precipitation entered:  
6 hour, precipitation(inches) = 3.000  
24 hour precipitation(inches) = 7.000  
P6/P24 = 42.9%  
Adjusted 6 hour precipitation (inches) = 3.150  
Adjusted P6/P24 = 45.0%  
San Diego hydrology manual 'C' values used

++++  
Process from Point/Station 606.000 to Point/Station 606.000  
\*\*\*\* USER DEFINED FLOW INFORMATION AT A POINT \*\*\*\*

-----  
User specified 'C' value of 0.760 given for subarea  
Rainfall intensity (I) = 0.649(In/Hr) for a 50.0 year storm  
User specified values are as follows:  
TC = 259.80 min. Rain intensity = 0.65(In/Hr)  
Total area = 7.076(Ac.) Total runoff = 11.690(CFS)  
End of computations, total study area = 7.076 (Ac.)

San Diego County Rational Hydrology Program

CIVILCADD/CIVILDESIGN Engineering Software,(c)1991-2014 Version 9.0

Rational method hydrology program based on  
San Diego County Flood Control Division 2003 hydrology manual  
Rational Hydrology Study Date: 09/24/18

-----  
17046 Nutmeg Development  
Post-Development Poc2 100 Year  
17046postpoc2.rd3

-----  
\*\*\*\*\* Hydrology Study Control Information \*\*\*\*\*  
-----

Program License Serial Number 6332

-----  
Rational hydrology study storm event year is 100.0  
English (in-lb) input data Units used

Map data precipitation entered:  
6 hour, precipitation(inches) = 3.500  
24 hour precipitation(inches) = 7.000  
P6/P24 = 50.0%  
San Diego hydrology manual 'C' values used

+++++  
Process from Point/Station 101.000 to Point/Station 102.000  
\*\*\*\* INITIAL AREA EVALUATION \*\*\*\*

---

Decimal fraction soil group A = 0.000  
Decimal fraction soil group B = 0.000  
Decimal fraction soil group C = 0.000  
Decimal fraction soil group D = 1.000  
[UNDISTURBED NATURAL TERRAIN ]  
(Permanent Open Space )  
Impervious value, Ai = 0.000  
Sub-Area C Value = 0.350  
Initial subarea total flow distance = 157.000(Ft.)  
Highest elevation = 1080.000(Ft.)  
Lowest elevation = 1070.000(Ft.)  
Elevation difference = 10.000(Ft.) Slope = 6.369 %  
INITIAL AREA TIME OF CONCENTRATION CALCULATIONS:  
The maximum overland flow distance is 100.00 (Ft)  
for the top area slope value of 6.37 %, in a development type of  
Permanent Open Space  
In Accordance With Figure 3-3  
Initial Area Time of Concentration = 7.28 minutes  
 $TC = [1.8 * (1.1 - C) * distance(Ft.)^{.5}] / (\% slope^{(1/3)})$   
 $TC = [1.8 * (1.1 - 0.3500) * (100.000^{.5})] / (6.369^{(1/3)}) = 7.28$   
The initial area total distance of 157.00 (Ft.) entered leaves a  
remaining distance of 57.00 (Ft.)  
Using Figure 3-4, the travel time for this distance is 0.51 minutes  
for a distance of 57.00 (Ft.) and a slope of 6.37 %  
with an elevation difference of 3.63(Ft.) from the end of the top area  
 $Tt = [11.9 * length(Mi)^3] / (elevation\ change(Ft.))^{.385} * 60(\text{min/hr})$   
= 0.507 Minutes  
 $Tt = [(11.9 * 0.0108^3) / (3.63)]^{.385} = 0.51$   
Total initial area Ti = 7.28 minutes from Figure 3-3 formula plus  
0.51 minutes from the Figure 3-4 formula = 7.79 minutes

Rainfall intensity (I) = 6.928(In/Hr) for a 100.0 year storm  
Effective runoff coefficient used for area (Q=KCIA) is C = 0.350  
Subarea runoff = 0.897(CFS)  
Total initial stream area = 0.370(Ac.)

\*\*\*\*\*  
Process from Point/Station 102.000 to Point/Station 103.000  
\*\*\*\* IRREGULAR CHANNEL FLOW TRAVEL TIME \*\*\*\*

-----  
Estimated mean flow rate at midpoint of channel = 3.494(CFS)  
Depth of flow = 0.157(Ft.), Average velocity = 2.137(Ft/s)  
\*\*\*\*\* Irregular Channel Data \*\*\*\*\*

-----  
Information entered for subchannel number 1 :

Point number	'X' coordinate	'Y' coordinate
1	0.00	1.00
2	12.00	0.00
3	21.00	0.00
4	27.00	1.00

Manning's 'N' friction factor = 0.090

-----  
Sub-Channel flow = 3.494(CFS)  
' ' flow top width = 11.826(Ft.)  
' ' velocity = 2.137(Ft/s)  
' ' area = 1.635(Sq.Ft)  
' ' Froude number = 1.013

Upstream point elevation = 1070.000(Ft.)  
Downstream point elevation = 884.810(Ft.)  
Flow length = 788.000(Ft.)  
Travel time = 6.14 min.  
Time of concentration = 13.93 min.  
Depth of flow = 0.157(Ft.)  
Average velocity = 2.137(Ft/s)  
Total irregular channel flow = 3.494(CFS)  
Irregular channel normal depth above invert elev. = 0.157(Ft.)  
Average velocity of channel(s) = 2.137(Ft/s)  
Adding area flow to channel

Rainfall intensity (I) = 4.761(In/Hr) for a 100.0 year storm  
Decimal fraction soil group A = 0.000  
Decimal fraction soil group B = 0.000  
Decimal fraction soil group C = 0.200  
Decimal fraction soil group D = 0.800  
[UNDISTURBED NATURAL TERRAIN ]  
(Permanent Open Space )  
Impervious value, Ai = 0.000  
Sub-Area C Value = 0.340  
Rainfall intensity = 4.761(In/Hr) for a 100.0 year storm  
Effective runoff coefficient used for total area  
(Q=KCIA) is C = 0.341 CA = 1.265  
Subarea runoff = 5.126(CFS) for 3.340(Ac.)  
Total runoff = 6.023(CFS) Total area = 3.710(Ac.)  
Depth of flow = 0.214(Ft.), Average velocity = 2.570(Ft/s)

\*\*\*\*\*  
Process from Point/Station 103.000 to Point/Station 103.000  
\*\*\*\* SUBAREA FLOW ADDITION \*\*\*\*

-----  
Rainfall intensity (I) = 4.761(In/Hr) for a 100.0 year storm  
Decimal fraction soil group A = 0.000  
Decimal fraction soil group B = 0.000  
Decimal fraction soil group C = 0.000  
Decimal fraction soil group D = 1.000  
[UNDISTURBED NATURAL TERRAIN ]

(Permanent Open Space )  
Impervious value, Ai = 0.000  
Sub-Area C Value = 0.350  
Time of concentration = 13.93 min.  
Rainfall intensity = 4.761(In/Hr) for a 100.0 year storm  
Effective runoff coefficient used for total area  
(Q=KCIA) is C = 0.342 CA = 1.342  
Subarea runoff = 0.367(CFS) for 0.220(Ac.)  
Total runoff = 6.390(CFS) Total area = 3.930(Ac.)

++++  
Process from Point/Station 103.000 to Point/Station 103.000  
\*\*\*\* CONFLUENCE OF MINOR STREAMS \*\*\*\*

---

Along Main Stream number: 1 in normal stream number 1  
Stream flow area = 3.930(Ac.)  
Runoff from this stream = 6.390(CFS)  
Time of concentration = 13.93 min.  
Rainfall intensity = 4.761(In/Hr)

++++  
Process from Point/Station 201.000 to Point/Station 202.000  
\*\*\*\* INITIAL AREA EVALUATION \*\*\*\*

---

Decimal fraction soil group A = 0.000  
Decimal fraction soil group B = 0.000  
Decimal fraction soil group C = 1.000  
Decimal fraction soil group D = 0.000  
[HIGH DENSITY RESIDENTIAL ]  
(24.0 DU/A or Less )  
Impervious value, Ai = 0.650  
Sub-Area C Value = 0.690  
Initial subarea total flow distance = 107.000(Ft.)  
Highest elevation = 906.050(Ft.)  
Lowest elevation = 905.330(Ft.)  
Elevation difference = 0.720(Ft.) Slope = 0.673 %  
Top of Initial Area Slope adjusted by User to 1.364 %  
Bottom of Initial Area Slope adjusted by User to 1.364 %  
INITIAL AREA TIME OF CONCENTRATION CALCULATIONS:  
The maximum overland flow distance is 65.00 (Ft)  
for the top area slope value of 1.36 %, in a development type of  
24.0 DU/A or Less  
In Accordance With Figure 3-3  
Initial Area Time of Concentration = 5.37 minutes  
 $TC = [1.8 * (1.1 - C) * distance(Ft.)^{.5}] / (\% slope^{(1/3)})$   
 $TC = [1.8 * (1.1 - 0.6900) * (65.000^{.5})] / (1.364^{(1/3)}) = 5.37$   
The initial area total distance of 107.00 (Ft.) entered leaves a  
remaining distance of 42.00 (Ft.)  
Using Figure 3-4, the travel time for this distance is 0.73 minutes  
for a distance of 42.00 (Ft.) and a slope of 1.36 %  
with an elevation difference of 0.57(Ft.) from the end of the top area  
 $Tt = [11.9 * length(Mi)^3] / (elevation change(Ft.))^{.385} * 60(\text{min/hr})$   
= 0.725 Minutes  
 $Tt = [(11.9 * 0.0080^3) / (0.57)]^{.385} = 0.73$   
Total initial area Ti = 5.37 minutes from Figure 3-3 formula plus  
0.73 minutes from the Figure 3-4 formula = 6.09 minutes  
Rainfall intensity (I) = 8.120(In/Hr) for a 100.0 year storm  
Effective runoff coefficient used for area (Q=KCIA) is C = 0.690  
Subarea runoff = 1.513(CFS)  
Total initial stream area = 0.270(Ac.)

++++  
Process from Point/Station 202.000 to Point/Station 203.000

\*\*\*\* PIPEFLOW TRAVEL TIME (Program estimated size) \*\*\*\*

---

Upstream point/station elevation = 892.900(Ft.)  
Downstream point/station elevation = 892.300(Ft.)  
Pipe length = 157.00(Ft.) Slope = 0.0038 Manning's N = 0.013  
No. of pipes = 1 Required pipe flow = 1.513(CFS)  
Nearest computed pipe diameter = 12.00(In.)  
Calculated individual pipe flow = 1.513(CFS)  
Normal flow depth in pipe = 7.30(In.)  
Flow top width inside pipe = 11.71(In.)  
Critical Depth = 6.25(In.)  
Pipe flow velocity = 3.02(Ft/s)  
Travel time through pipe = 0.87 min.  
Time of concentration (TC) = 6.96 min.

++++  
Process from Point/Station 203.000 to Point/Station 203.000  
\*\*\*\* SUBAREA FLOW ADDITION \*\*\*\*

---

Rainfall intensity (I) = 7.452(In/Hr) for a 100.0 year storm  
Decimal fraction soil group A = 0.000  
Decimal fraction soil group B = 0.000  
Decimal fraction soil group C = 1.000  
Decimal fraction soil group D = 0.000  
[HIGH DENSITY RESIDENTIAL ]  
(24.0 DU/A or Less )  
Impervious value, Ai = 0.650  
Sub-Area C Value = 0.690  
Time of concentration = 6.96 min.  
Rainfall intensity = 7.452(In/Hr) for a 100.0 year storm  
Effective runoff coefficient used for total area  
(Q=K CIA) is C = 0.690 CA = 0.359  
Subarea runoff = 1.161(CFS) for 0.250(Ac.)  
Total runoff = 2.674(CFS) Total area = 0.520(Ac.)

++++  
Process from Point/Station 203.000 to Point/Station 204.000  
\*\*\*\* PIPEFLOW TRAVEL TIME (User specified size) \*\*\*\*

---

Upstream point/station elevation = 892.300(Ft.)  
Downstream point/station elevation = 891.500(Ft.)  
Pipe length = 166.00(Ft.) Slope = 0.0048 Manning's N = 0.013  
No. of pipes = 1 Required pipe flow = 2.674(CFS)  
Given pipe size = 18.00(In.)  
Calculated individual pipe flow = 2.674(CFS)  
Normal flow depth in pipe = 7.54(In.)  
Flow top width inside pipe = 17.76(In.)  
Critical Depth = 7.44(In.)  
Pipe flow velocity = 3.81(Ft/s)  
Travel time through pipe = 0.73 min.  
Time of concentration (TC) = 7.68 min.

++++  
Process from Point/Station 204.000 to Point/Station 204.000  
\*\*\*\* SUBAREA FLOW ADDITION \*\*\*\*

---

Rainfall intensity (I) = 6.990(In/Hr) for a 100.0 year storm  
Decimal fraction soil group A = 0.000  
Decimal fraction soil group B = 0.000  
Decimal fraction soil group C = 1.000  
Decimal fraction soil group D = 0.000  
[HIGH DENSITY RESIDENTIAL ]  
(24.0 DU/A or Less )

Impervious value, Ai = 0.650  
Sub-Area C Value = 0.690  
Time of concentration = 7.68 min.  
Rainfall intensity = 6.990(In/Hr) for a 100.0 year storm  
Effective runoff coefficient used for total area  
(Q=KCIA) is C = 0.690 CA = 0.690  
Subarea runoff = 2.149(CFS) for 0.480(Ac.)  
Total runoff = 4.823(CFS) Total area = 1.000(Ac.)

\*\*\*\*\*  
Process from Point/Station 204.000 to Point/Station 205.000  
\*\*\*\* PIPEFLOW TRAVEL TIME (User specified size) \*\*\*\*

---

Upstream point/station elevation = 891.500(Ft.)  
Downstream point/station elevation = 891.200(Ft.)  
Pipe length = 46.00(Ft.) Slope = 0.0065 Manning's N = 0.013  
No. of pipes = 1 Required pipe flow = 4.823(CFS)  
Given pipe size = 18.00(In.)  
Calculated individual pipe flow = 4.823(CFS)  
Normal flow depth in pipe = 9.73(In.)  
Flow top width inside pipe = 17.94(In.)  
Critical Depth = 10.14(In.)  
Pipe flow velocity = 4.96(Ft/s)  
Travel time through pipe = 0.15 min.  
Time of concentration (TC) = 7.84 min.

\*\*\*\*\*  
Process from Point/Station 205.000 to Point/Station 206.000  
\*\*\*\* SUBAREA FLOW ADDITION \*\*\*\*

---

Rainfall intensity (I) = 6.901(In/Hr) for a 100.0 year storm  
Decimal fraction soil group A = 0.000  
Decimal fraction soil group B = 0.000  
Decimal fraction soil group C = 1.000  
Decimal fraction soil group D = 0.000  
[MEDIUM DENSITY RESIDENTIAL ]  
(14.5 DU/A or Less )  
Impervious value, Ai = 0.500  
Sub-Area C Value = 0.600  
Time of concentration = 7.84 min.  
Rainfall intensity = 6.901(In/Hr) for a 100.0 year storm  
Effective runoff coefficient used for total area  
(Q=KCIA) is C = 0.676 CA = 0.803  
Subarea runoff = 0.721(CFS) for 0.189(Ac.)  
Total runoff = 5.544(CFS) Total area = 1.189(Ac.)

\*\*\*\*\*  
Process from Point/Station 206.000 to Point/Station 206.000  
\*\*\*\* SUBAREA FLOW ADDITION \*\*\*\*

---

Rainfall intensity (I) = 6.901(In/Hr) for a 100.0 year storm  
Decimal fraction soil group A = 0.000  
Decimal fraction soil group B = 0.000  
Decimal fraction soil group C = 1.000  
Decimal fraction soil group D = 0.000  
[HIGH DENSITY RESIDENTIAL ]  
(43.0 DU/A or Less )  
Impervious value, Ai = 0.800  
Sub-Area C Value = 0.780  
Time of concentration = 7.84 min.  
Rainfall intensity = 6.901(In/Hr) for a 100.0 year storm  
Effective runoff coefficient used for total area  
(Q=KCIA) is C = 0.702 CA = 1.115



Subarea runoff = 2.153(CFS) for 0.400(Ac.)  
Total runoff = 7.697(CFS) Total area = 1.589(Ac.)

\*\*\*\*\*  
Process from Point/Station 206.000 to Point/Station 103.000  
\*\*\*\* PIPEFLOW TRAVEL TIME (User specified size) \*\*\*\*

---

Upstream point/station elevation = 891.200(Ft.)  
Downstream point/station elevation = 884.810(Ft.)  
Pipe length = 10.00(Ft.) Slope = 0.6390 Manning's N = 0.013  
No. of pipes = 1 Required pipe flow = 7.697(CFS)  
Given pipe size = 24.00(In.)  
Calculated individual pipe flow = 7.697(CFS)  
Normal flow depth in pipe = 3.38(In.)  
Flow top width inside pipe = 16.69(In.)  
Critical Depth = 11.83(In.)  
Pipe flow velocity = 28.59(Ft/s)  
Travel time through pipe = 0.01 min.  
Time of concentration (TC) = 7.84 min.

\*\*\*\*\*  
Process from Point/Station 103.000 to Point/Station 103.000  
\*\*\*\* SUBAREA FLOW ADDITION \*\*\*\*

---

Rainfall intensity (I) = 6.897(In/Hr) for a 100.0 year storm  
Decimal fraction soil group A = 0.000  
Decimal fraction soil group B = 0.000  
Decimal fraction soil group C = 1.000  
Decimal fraction soil group D = 0.000  
[HIGH DENSITY RESIDENTIAL ]  
(43.0 DU/A or Less )  
Impervious value, Ai = 0.800  
Sub-Area C Value = 0.780  
Time of concentration = 7.84 min.  
Rainfall intensity = 6.897(In/Hr) for a 100.0 year storm  
Effective runoff coefficient used for total area  
(Q=KCIA) is C = 0.715 CA = 1.367  
Subarea runoff = 1.729(CFS) for 0.322(Ac.)  
Total runoff = 9.425(CFS) Total area = 1.911(Ac.)

\*\*\*\*\*  
Process from Point/Station 103.000 to Point/Station 103.000  
\*\*\*\* CONFLUENCE OF MINOR STREAMS \*\*\*\*

---

Along Main Stream number: 1 in normal stream number 2  
Stream flow area = 1.911(Ac.)  
Runoff from this stream = 9.425(CFS)  
Time of concentration = 7.84 min.  
Rainfall intensity = 6.897(In/Hr)  
Summary of stream data:

Stream No.	Flow rate (CFS)	TC (min)	Rainfall Intensity (In/Hr)
1	6.390	13.93	4.761
2	9.425	7.84	6.897

Qmax(1) =  
1.000 \* 1.000 \* 6.390) +  
0.690 \* 1.000 \* 9.425) += 12.896

Qmax(2) =  
1.000 \* 0.563 \* 6.390) +  
1.000 \* 1.000 \* 9.425) += 13.022

Total of 2 streams to confluence:  
Flow rates before confluence point:  
6.390 9.425  
Maximum flow rates at confluence using above data:  
12.896 13.022  
Area of streams before confluence:  
3.930 1.911  
Results of confluence:  
Total flow rate = 13.022(CFS)  
Time of concentration = 7.844 min.  
Effective stream area after confluence = 5.841(Ac.)  
End of computations, total study area = 5.841 (Ac.)

San Diego County Rational Hydrology Program

CIVILCADD/CIVILDESIGN Engineering Software,(c)1991-2014 Version 9.0

Rational method hydrology program based on  
San Diego County Flood Control Division 2003 hydrology manual  
Rational Hydrology Study Date: 09/25/18

-----  
17046 Nutmeg Development  
Post-Development Poc2 100 Year  
17046postpoc2det.rd3

-----  
\*\*\*\*\* Hydrology Study Control Information \*\*\*\*\*  
-----

Program License Serial Number 6332

-----  
Rational hydrology study storm event year is 100.0  
English (in-lb) input data Units used

Map data precipitation entered:  
6 hour, precipitation(inches) = 3.500  
24 hour precipitation(inches) = 7.000  
P6/P24 = 50.0%  
San Diego hydrology manual 'C' values used

++++  
Process from Point/Station 103.000 to Point/Station 103.000  
\*\*\*\* USER DEFINED FLOW INFORMATION AT A POINT \*\*\*\*

-----  
User specified 'C' value of 0.700 given for subarea  
Rainfall intensity (I) = 0.728(In/Hr) for a 100.0 year storm  
User specified values are as follows:  
TC = 256.20 min. Rain intensity = 0.73(In/Hr)  
Total area = 6.350(Ac.) Total runoff = 3.521(CFS)  
End of computations, total study area = 6.350 (Ac.)

San Diego County Rational Hydrology Program

CIVILCADD/CIVILDESIGN Engineering Software,(c)1991-2014 Version 9.0

Rational method hydrology program based on  
San Diego County Flood Control Division 2003 hydrology manual  
Rational Hydrology Study Date: 09/24/18

-----  
17046 Nutmeg Development  
Post-Development Poc 3 100 Year  
postdevpoc13.rd3

-----  
\*\*\*\*\* Hydrology Study Control Information \*\*\*\*\*  
-----

Program License Serial Number 6332

-----  
Rational hydrology study storm event year is 100.0  
English (in-lb) input data Units used

Map data precipitation entered:  
6 hour, precipitation(inches) = 3.500  
24 hour precipitation(inches) = 7.000  
P6/P24 = 50.0%  
San Diego hydrology manual 'C' values used

+++++  
Process from Point/Station 301.000 to Point/Station 302.000  
\*\*\*\* INITIAL AREA EVALUATION \*\*\*\*

---

Decimal fraction soil group A = 0.000  
Decimal fraction soil group B = 0.000  
Decimal fraction soil group C = 1.000  
Decimal fraction soil group D = 0.000  
[HIGH DENSITY RESIDENTIAL ]  
(24.0 DU/A or Less )  
Impervious value, Ai = 0.650  
Sub-Area C Value = 0.690  
Initial subarea total flow distance = 122.000(Ft.)  
Highest elevation = 903.520(Ft.)  
Lowest elevation = 903.220(Ft.)  
Elevation difference = 0.300(Ft.) Slope = 0.246 %  
INITIAL AREA TIME OF CONCENTRATION CALCULATIONS:  
The maximum overland flow distance is 50.00 (Ft)  
for the top area slope value of 0.25 %, in a development type of  
24.0 DU/A or Less  
In Accordance With Figure 3-3  
Initial Area Time of Concentration = 8.33 minutes  
 $TC = [1.8 * (1.1 - C) * distance(Ft.)^{.5}] / (\% slope^{(1/3)})$   
 $TC = [1.8 * (1.1 - 0.6900) * (50.000^{.5})] / (0.246^{(1/3)}) = 8.33$   
The initial area total distance of 122.00 (Ft.) entered leaves a  
remaining distance of 72.00 (Ft.)  
Using Figure 3-4, the travel time for this distance is 2.12 minutes  
for a distance of 72.00 (Ft.) and a slope of 0.25 %  
with an elevation difference of 0.18(Ft.) from the end of the top area  
 $Tt = [11.9 * length(Mi)^3] / (elevation\ change(Ft.))^{.385} * 60(\text{min/hr})$   
= 2.124 Minutes  
 $Tt = [(11.9 * 0.0136^3) / (0.18)]^{.385} = 2.12$   
Total initial area Ti = 8.33 minutes from Figure 3-3 formula plus  
2.12 minutes from the Figure 3-4 formula = 10.45 minutes

Rainfall intensity (I) = 5.731(In/Hr) for a 100.0 year storm  
Effective runoff coefficient used for area (Q=KCIA) is C = 0.690  
Subarea runoff = 0.870(CFS)  
Total initial stream area = 0.220(Ac.)

\*\*\*\*\*

Process from Point/Station 302.000 to Point/Station 303.000  
\*\*\*\* IRREGULAR CHANNEL FLOW TRAVEL TIME \*\*\*\*

-----  
Estimated mean flow rate at midpoint of channel = 1.904(CFS)  
Depth of flow = 0.158(Ft.), Average velocity = 3.252(Ft/s)  
\*\*\*\*\* Irregular Channel Data \*\*\*\*\*

-----  
Information entered for subchannel number 1 :

Point number	'X' coordinate	'Y' coordinate
1	0.00	0.50
2	0.00	0.00
3	23.50	0.50

Manning's 'N' friction factor = 0.013

-----  
Sub-Channel flow = 1.904(CFS)  
' ' flow top width = 7.418(Ft.)  
' ' velocity = 3.252(Ft/s)  
' ' area = 0.585(Sq.Ft)  
' ' Froude number = 2.040

Upstream point elevation = 903.220(Ft.)  
Downstream point elevation = 899.480(Ft.)  
Flow length = 152.000(Ft.)  
Travel time = 0.78 min.  
Time of concentration = 11.23 min.  
Depth of flow = 0.158(Ft.)  
Average velocity = 3.252(Ft/s)  
Total irregular channel flow = 1.904(CFS)  
Irregular channel normal depth above invert elev. = 0.158(Ft.)  
Average velocity of channel(s) = 3.252(Ft/s)  
Adding area flow to channel  
Rainfall intensity (I) = 5.471(In/Hr) for a 100.0 year storm  
Decimal fraction soil group A = 0.000  
Decimal fraction soil group B = 0.000  
Decimal fraction soil group C = 1.000  
Decimal fraction soil group D = 0.000  
[HIGH DENSITY RESIDENTIAL ]  
(24.0 DU/A or Less )  
Impervious value, Ai = 0.650  
Sub-Area C Value = 0.690  
Rainfall intensity = 5.471(In/Hr) for a 100.0 year storm  
Effective runoff coefficient used for total area  
(Q=KCIA) is C = 0.690 CA = 0.524  
Subarea runoff = 1.999(CFS) for 0.540(Ac.)  
Total runoff = 2.869(CFS) Total area = 0.760(Ac.)  
Depth of flow = 0.184(Ft.), Average velocity = 3.604(Ft/s)

\*\*\*\*\*

Process from Point/Station 303.000 to Point/Station 304.000  
\*\*\*\* PIPEFLOW TRAVEL TIME (User specified size) \*\*\*\*

-----  
Upstream point/station elevation = 895.700(Ft.)  
Downstream point/station elevation = 895.600(Ft.)  
Pipe length = 41.00(Ft.) Slope = 0.0024 Manning's N = 0.013  
No. of pipes = 1 Required pipe flow = 2.869(CFS)  
Given pipe size = 18.00(In.)  
Calculated individual pipe flow = 2.869(CFS)  
Normal flow depth in pipe = 9.56(In.)

Flow top width inside pipe = 17.96(In.)  
Critical Depth = 7.72(In.)  
Pipe flow velocity = 3.01(Ft/s)  
Travel time through pipe = 0.23 min.  
Time of concentration (TC) = 11.46 min.

++++  
Process from Point/Station 304.000 to Point/Station 305.000  
\*\*\*\* IRREGULAR CHANNEL FLOW TRAVEL TIME \*\*\*\*

-----  
Estimated mean flow rate at midpoint of channel = 3.851(CFS)  
Depth of flow = 0.237(Ft.), Average velocity = 4.075(Ft/s)  
\*\*\*\*\* Irregular Channel Data \*\*\*\*\*

-----  
Information entered for subchannel number 1 :  
Point number 'X' coordinate 'Y' coordinate  
1 0.00 0.50  
2 0.00 0.00  
3 1.50 0.13  
4 42.00 0.50  
Manning's 'N' friction factor = 0.013

-----  
Sub-Channel flow = 3.851(CFS)  
' ' flow top width = 13.642(Ft.)  
' ' velocity = 4.075(Ft/s)  
' ' area = 0.945(Sq.Ft)  
' ' Froude number = 2.729

Upstream point elevation = 895.600(Ft.)  
Downstream point elevation = 891.940(Ft.)  
Flow length = 80.000(Ft.)  
Travel time = 0.33 min.  
Time of concentration = 11.79 min.  
Depth of flow = 0.237(Ft.)  
Average velocity = 4.075(Ft/s)  
Total irregular channel flow = 3.851(CFS)  
Irregular channel normal depth above invert elev. = 0.237(Ft.)  
Average velocity of channel(s) = 4.075(Ft/s)  
Adding area flow to channel  
Rainfall intensity (I) = 5.304(In/Hr) for a 100.0 year storm  
Decimal fraction soil group A = 0.000  
Decimal fraction soil group B = 0.000  
Decimal fraction soil group C = 1.000  
Decimal fraction soil group D = 0.000  
[HIGH DENSITY RESIDENTIAL ]  
(24.0 DU/A or Less )  
Impervious value, Ai = 0.650  
Sub-Area C Value = 0.690  
Rainfall intensity = 5.304(In/Hr) for a 100.0 year storm  
Effective runoff coefficient used for total area  
(Q=KCIA) is C = 0.690 CA = 0.897  
Subarea runoff = 1.889(CFS) for 0.540(Ac.)  
Total runoff = 4.758(CFS) Total area = 1.300(Ac.)  
Depth of flow = 0.249(Ft.), Average velocity = 4.283(Ft/s)

++++  
Process from Point/Station 305.000 to Point/Station 305.000  
\*\*\*\* SUBAREA FLOW ADDITION \*\*\*\*

-----  
Rainfall intensity (I) = 5.304(In/Hr) for a 100.0 year storm  
Decimal fraction soil group A = 0.000  
Decimal fraction soil group B = 0.000  
Decimal fraction soil group C = 1.000  
Decimal fraction soil group D = 0.000

[HIGH DENSITY RESIDENTIAL ]  
(24.0 DU/A or Less )  
Impervious value, Ai = 0.650  
Sub-Area C Value = 0.690  
Time of concentration = 11.79 min.  
Rainfall intensity = 5.304(In/Hr) for a 100.0 year storm  
Effective runoff coefficient used for total area  
(Q=KCIA) is C = 0.690 CA = 0.959  
Subarea runoff = 0.329(CFS) for 0.090(Ac.)  
Total runoff = 5.087(CFS) Total area = 1.390(Ac.)

\*\*\*\*\*  
Process from Point/Station 305.000 to Point/Station 305.000  
\*\*\*\* SUBAREA FLOW ADDITION \*\*\*\*

---

Rainfall intensity (I) = 5.304(In/Hr) for a 100.0 year storm  
Decimal fraction soil group A = 0.000  
Decimal fraction soil group B = 0.000  
Decimal fraction soil group C = 1.000  
Decimal fraction soil group D = 0.000  
[HIGH DENSITY RESIDENTIAL ]  
(24.0 DU/A or Less )  
Impervious value, Ai = 0.650  
Sub-Area C Value = 0.690  
Time of concentration = 11.79 min.  
Rainfall intensity = 5.304(In/Hr) for a 100.0 year storm  
Effective runoff coefficient used for total area  
(Q=KCIA) is C = 0.690 CA = 1.063  
Subarea runoff = 0.549(CFS) for 0.150(Ac.)  
Total runoff = 5.636(CFS) Total area = 1.540(Ac.)

\*\*\*\*\*  
Process from Point/Station 305.000 to Point/Station 305.000  
\*\*\*\* SUBAREA FLOW ADDITION \*\*\*\*

---

Rainfall intensity (I) = 5.304(In/Hr) for a 100.0 year storm  
Decimal fraction soil group A = 0.000  
Decimal fraction soil group B = 0.000  
Decimal fraction soil group C = 0.100  
Decimal fraction soil group D = 0.900  
[UNDISTURBED NATURAL TERRAIN ]  
(Permanent Open Space )  
Impervious value, Ai = 0.000  
Sub-Area C Value = 0.345  
Time of concentration = 11.79 min.  
Rainfall intensity = 5.304(In/Hr) for a 100.0 year storm  
Effective runoff coefficient used for total area  
(Q=KCIA) is C = 0.574 CA = 1.332  
Subarea runoff = 1.427(CFS) for 0.780(Ac.)  
Total runoff = 7.063(CFS) Total area = 2.320(Ac.)  
End of computations, total study area = 2.320 (Ac.)

**ATTACHMENT H**  
**POST DEVELOPED HYDROLOGY MAP**



K:\171\17046\Engineering\Current\17046\Storm\17046-HID-POST.dwg 9/25/2018 3:56 PM ORIGINAL PLOT SIZE: -----

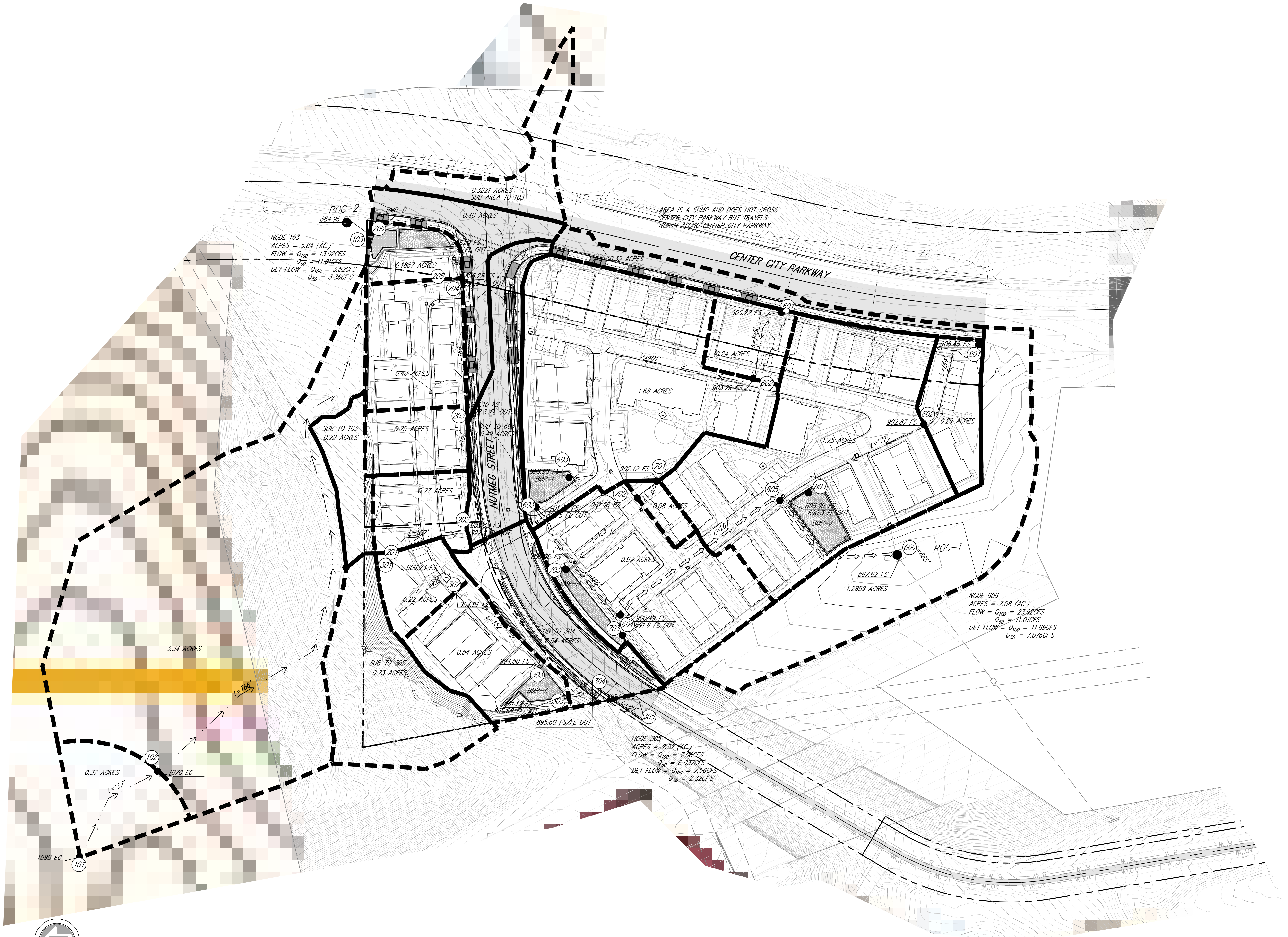

POC-2  
884.96  
NODE 103  
ACRES = 5.84 (AC.)  
FLOW =  $Q_{100} = 13.02\text{CFS}$   
 $Q_{50} = 11.81\text{CFS}$   
DET FLOW =  $Q_{100} = 3.52\text{CFS}$   
 $Q_{50} = 3.36\text{CFS}$

POC-1  
887.62  
NODE 606  
ACRES = 7.08 (AC.)  
FLOW =  $Q_{100} = 23.82\text{CFS}$   
 $Q_{50} = 11.01\text{CFS}$   
DET FLOW =  $Q_{100} = 11.69\text{CFS}$   
 $Q_{50} = 7.07\text{CFS}$

POC-3  
895.60  
NODE 300  
ACRES = 2.32 (AC.)  
FLOW =  $Q_{100} = 7.06\text{CFS}$   
 $Q_{50} = 6.03\text{CFS}$   
DET FLOW =  $Q_{100} = 7.06\text{CFS}$   
 $Q_{50} = 2.32\text{CFS}$

AREA IS A SUMP AND DOES NOT CROSS CENTER CITY PARKWAY BUT TRAVELS NORTH ALONG CENTER CITY PARKWAY

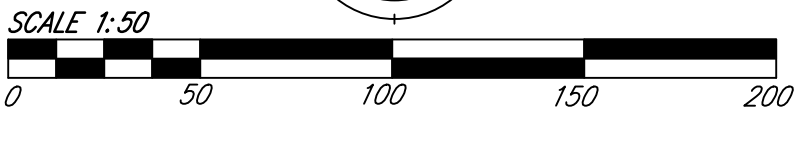

NUTMEG DEVELOPMENT  
POST-DEVELOPMENT EXHIBIT



440 STATE PLACE, ESCONDO, CA 92029  
PH (760)745-8118 FX (760)745-1890



**ATTACHMENT I**  
**HYDRAULIC CALCULATIONS**

---

## I1. Purpose of Hydraulic Calculations

The purpose of the Hydraulic calculations in this section is to show the HGL and flowlines of the proposed storm drain pipes and structures falls within tolerance of the available Q100 flows and adequately sized.

## I2. Methodology of Hydraulic Calculation

### ▪ Pipe Flow

- Hydraflow Storm Sewers Extension computes the hydraulic grade line using a method that is similar to the method used for computing open channels. The application begins computing at the most downstream line and works in a standard step procedure in an upstream direction. This method assumes the starting hydraulic grade line elevation, HGL, is known. For more information, see Computing the System. Hydraflow Storm Sewers Extension assumes an upstream HGL for a given line and then checks the energy equation. If the energy equation does not balance, another HGL is assumed and the iterative process continues until the assumed HGL equals the computed HGL. The starting downstream HGL for the next upstream line is based on the computed HGL plus any junction (minor) loss.
- If the starting HGL at the downstream end of any line (except outfalls) is below the Minimum Starting Depth that was set in the Design Codes, Hydraflow Storm Sewers Extension automatically change the HGL to the Minimum Starting Depth.
- Hydraflow Storm Sewers Extension computes the HGL for any given line at three places:

HGL Down Represents the downstream end of the line. At the beginning of an outfall there is a user-defined elevation which can be a known elevation, Crown, Normal Depth  $(dc + D)/2$ , or Critical Depth. At all other lines it is equal to the HGL Junct of its downstream line. However, if the energy grade line (EGL Dn) is less than the energy grade line (EGL) in the downstream junction (EGL Junct), the HGL Down is reset to the EGL Junct minus the velocity head. This prevents an increase of energy in the downstream direction if you have selected Correct EGL Discrepancies in the [Design Codes dialog box](#). If the starting HGL is below the Minimum Starting Depth that you specified in the Design Codes, Hydraflow Storm Sewers Extension automatically changes the HGL to the Minimum Starting Depth.

---

HGL Up	Represents the upstream end of the pipe and is computed using the Standard Step Method. If you select the option Check For Inlet Control on the Calculations tab in the Design Codes dialog box, and the line is flowing under inlet control, the HGL Up is equal to the HGL Junct minus the upstream velocity head.
HGL Junct	Represents the junction at the upstream end of each Line, and is equal to the HGL Up plus any minor or junction loss. If you select the option Check For Inlet Control on the Calculations tab in the Design Codes dialog box, and the line is flowing under inlet control, the HGL Junct is equal to the depth determined by the Inlet Control procedure.

The energy grade line (EGL) is computed as the HGL plus velocity head. If the line is flowing under inlet control, velocity at this point is zero and the EGL equals HGL.

- **Critical Depth**

Critical depth is computed using the following equation:

$$Dc = \left( \frac{1.01}{D^{.26}} \right) \times \left( \frac{Q^2}{g} \right)^{.25}$$

Where:

Dc = Critical depth

D = Pipe diameter

Q = Flow rate

Note

If Dc is greater than 85% of D, then a trial-and-error method is used to find the minimum specific energy, for example the critical depth. For more information please refer to Open Channel Hydraulics, McGraw - Hill, 1985, by Richard H. French.

- **Junction Losses**

Junction losses are computed using the following equation:

$$Junctionloss = k \left( \frac{v^2}{2g} \right)$$

Where:

---

k = Coefficient

V = Velocity of flow exiting the junction

Junction losses are not computed for lines at critical depth or lines that flow under inlet control.

- **Junction Loss Coefficients**

Hydraflow Storm Sewers Extension automatically computes and assigns junction loss coefficients based on the junction configuration when you specify Automatic in the Design Codes - Calculations tab. Coefficients are selected based on data adapted from FHWA HEC No. 22. These selected coefficients are based on the angle of the lines entering the junction at its upstream end.

For angles less than 90 degrees, Hydraflow Storm Sewers Extension uses the following equation to compute junction loss coefficients K:

$$K = \left[ 1 - \left( \frac{90 - \text{DeflectionAngle}}{90} \right)^2 \right]$$

If the junction is an inlet, K is multiplied by 1.5. K is never less than 0.15 for Manholes, or 0.50 for Inlets. For angles greater than or equal to 90, Inlets K = 1.5, and Manholes K = 1.00. For Lines at ends of a branch, K = 1.00

A conservative value for this coefficient is 1.0, which assumes all of the velocity head is lost at the manhole, and the junction is simply a reservoir being fed by any incoming lines. The incoming velocity is lost and converted to static head.

- **Supercritical Flow**

Hydraflow Storm Sewers Extension can automatically compute supercritical flow profiles with hydraulic jumps. If the energy equation does not balance, Hydraflow Storm Sewers Extension initially assumes critical depth and proceeds to the next upstream line. When the subcritical profile is finished, the calculation procedure is reversed for any lines with critical depth assumed at their upstream ends, (from upstream to downstream), and computes the supercritical profile.

- **Hydraulic Jump**

The Momentum Principle is used to determine the depths and locations of hydraulic jumps. At each step (one tenth of the line length) during supercritical flow calculations, the momentum is computed and compared

---

to the momentum developed during the subcritical profile calculations. If the two momentums are equal, then a hydraulic jump must occur.

Note:

There are some situations when a hydraulic jump does not exist or when it is submerged.

The following condition must be satisfied to determine a hydraulic jump:

Momentum ( $M$ ) of the subcritical profile equals the momentum of the supercritical profile.

$$M1 = M2$$

Where:

$Q$  = Flow rate

$A$  = Cross-sectional area of flow

$Y$  = Distance from the water surface to the centroid of  $A$

The location of the jump is the point along the line when  $M1 = M2$ , and is reported as the distance from the downstream end of the line. The length of the jump is difficult to determine, especially in circular sections. A generally acceptable jump length is between 4 and 6 times the sequent depth. Hydraflow Storm Sewers Extension assumes 5 for the jump length.

The following illustration shows the computation of supercritical flow profiles with hydraulic jumps. The dotted line represents the energy grade line (EGL).

- **Inlet Control**

Inlet and outlet control is often a misunderstood concept in storm sewer hydraulics. Inlet control occurs when it is more difficult for the flow to enter the pipe than to move through the pipe. The critical factors during inlet control are the cross-sectional area of the pipe and the inlet geometry. The roughness coefficient, pipe length, and slope are not necessary.

Outlet control occurs when it is more difficult for the flow to move through the pipe than to enter the pipe. The solution is to compute the HGL assuming both exist, and then selecting the larger of the two.

You can check HGL calculations for inlet control on all junctions except for No Junction types. One calculation method is derived from HDS-5 Hydraulic design of Highway Culverts, and the other is the standard

---

orifice equation. If the computed HGL for inlet control is greater than the computed HGL (outlet control), then the HGL Junct is set equal to the inlet control value. When inlet control is used, the minor loss (junction loss) is not computed.

The standard orifice equation used is:

$$Q = CoA\sqrt{2gh}$$

Where:

Co = Orifice coefficient = 0.62

A = Cross-sectional area of flow in sqft (sqm)

h = Headwater depth to the center of A in ft (m)

Note

This is the default equation used when working in SI units.

- **Flow Under Inlet Control**

The HDS-5 method uses the following inlet control equation:

$$Hdi = D \times \left[ c \times \left( \frac{Q}{A\sqrt{D}} \right)^2 + Y - .5S \right]$$

Where:

Hdi = Headwater depth above invert

D = Line Rise, ft

c = 0.0398 (Coeff. for square edged circular section)

Q = Flow rate, cfs

A = Full cross-sectional area of pipe, sqft

Y = Coeff. 0.67

S = Line slope, ft/ft

This equation only applies when  $Q/AD^{0.5}$  is greater than or equal to 4.0.

Note

---

Inlet control is only considered when you select the Check for Inlet Control option on the Calculations tab in the Design Codes dialog box. If this option is not selected then inlet control is not evaluated.



### **I3. Calculations from Hydraulics Software**

# Hydrograph Report

Hydraflow Hydrographs Extension for Autodesk® Civil 3D® 2019 by Autodesk, Inc. v2020

Tuesday, 09 / 25 / 2018

## Hyd. No. 1

Basin H

Hydrograph type	= Manual	Peak discharge	= 23.92 cfs
Storm frequency	= 100 yrs	Time to peak	= 4.17 hrs
Time interval	= 10 min	Hyd. volume	= 58,152 cuft

## Hydrograph Discharge Table

(Printed values &gt;= 1.00% of Qp.)

Time -- Outflow (hrs cfs)	Time -- Outflow (hrs cfs)
0.17 1.000	3.67 3.700
0.33 1.000	3.83 5.400
0.50 1.000	4.00 10.80
0.67 1.000	4.17 23.92
0.83 1.100	4.33 4.300
1.00 1.100	4.50 2.900
1.17 1.200	4.67 2.300
1.33 1.200	4.83 1.900
1.50 1.300	5.00 1.600
1.67 1.300	5.17 1.500
1.83 1.400	5.33 1.300
2.00 1.400	5.50 1.200
2.17 1.500	5.67 1.100
2.33 1.600	5.83 1.100
2.50 1.700	6.00 1.000
2.67 1.800	...End
2.83 2.000	
3.00 2.100	
3.17 2.400	
3.33 2.600	
3.50 3.200	

# Hydrograph Report

Hydraflow Hydrographs Extension for Autodesk® Civil 3D® 2019 by Autodesk, Inc. v2020

Tuesday, 09 / 25 / 2018

## Hyd. No. 2

<no description>

Hydrograph type	= Reservoir	Peak discharge	= 6.035 cfs
Storm frequency	= 100 yrs	Time to peak	= 4.33 hrs
Time interval	= 10 min	Hyd. volume	= 58,143 cuft
Inflow hyd. No.	= 1 - Basin H	Reservoir name	= BMP-H
Max. Elevation	= 899.79 ft	Max. Storage	= 25,105 cuft

Storage Indication method used.

### Hydrograph Discharge Table

(Printed values >= 1.00% of Qp.)

Time (hrs)	Inflow cfs	Elevation ft	Clv A cfs	Clv B cfs	Clv C cfs	PfRsr cfs	Wr A cfs	Wr B cfs	Wr C cfs	Wr D cfs	Exfil cfs	Outflow cfs
0.17	1.000	890.11	37.33	0.069	----	----	----	----	----	----	----	0.069
0.33	1.000	890.28	37.33	0.403	----	----	----	----	----	----	----	0.403
0.50	1.000	890.38	37.33	0.677	----	----	----	----	----	----	----	0.677
0.67	1.000	890.44	37.33	0.822	----	----	----	----	----	----	----	0.822
0.83	1.100	890.47	37.33	0.888	----	----	----	----	----	----	----	0.888
1.00	1.100	890.49	37.33	0.936	----	----	----	----	----	----	----	0.936
1.17	1.200	890.33	37.33	0.544	----	----	----	----	----	----	----	0.544
1.33	1.200	890.45	37.33	0.848	----	----	----	----	----	----	----	0.848
1.50	1.300	890.66	37.33	0.998	----	----	----	----	----	----	----	0.998
1.67	1.300	890.69	37.33	1.100	----	----	----	----	----	----	----	1.100
1.83	1.400	890.72	37.33	1.179	----	----	----	----	----	----	----	1.179
2.00	1.400	890.74	37.33	1.243	----	----	----	----	----	----	----	1.243
2.17	1.500	890.76	37.33	1.303	----	----	----	----	----	----	----	1.303
2.33	1.600	890.79	37.33	1.370	----	----	----	----	----	----	----	1.369
2.50	1.700	890.82	37.33	1.431	----	----	----	----	----	----	----	1.431
2.67	1.800	890.86	37.33	1.479	----	----	----	----	----	----	----	1.479
2.83	2.000	890.91	37.33	1.537	----	----	----	----	----	----	----	1.537
3.00	2.100	890.96	37.33	1.596	----	----	----	----	----	----	----	1.596
3.17	2.400	891.03	37.33	1.669	----	----	----	----	----	----	----	1.669
3.33	2.600	891.11	37.33	1.757	----	----	----	----	----	----	----	1.757

Continues on next page...

<no description>

**Hydrograph Discharge Table**

Time (hrs)	Inflow cfs	Elevation ft	Clv A cfs	Clv B cfs	Clv C cfs	PfRsr cfs	Wr A cfs	Wr B cfs	Wr C cfs	Wr D cfs	Exfil cfs	Outflow cfs
3.50	3.200	891.23	37.33	1.871	----	----	----	----	----	----	----	1.871
3.67	3.700	891.39	37.33	2.016	----	----	----	----	----	----	----	2.016
3.83	5.400	891.62	37.33	2.216	----	----	----	----	----	----	----	2.216
4.00	10.80	892.16	37.33	2.614	----	----	----	----	----	----	----	2.614
4.17	23.92 <<	893.57	37.33	3.445	----	----	----	----	----	----	----	3.445
<< 4.33	4.300	898.78 <<	37.33	5.518	0.517	----	----	----	----	----	----	6.035
4.50	2.900	896.67	37.33	4.782	----	----	----	----	----	----	----	4.782
4.67	2.300	894.61	37.33	3.944	----	----	----	----	----	----	----	3.944
4.83	1.900	894.13	37.33	3.723	----	----	----	----	----	----	----	3.723
5.00	1.600	893.85	37.33	3.585	----	----	----	----	----	----	----	3.585
5.17	1.500	893.59	37.33	3.456	----	----	----	----	----	----	----	3.456
5.33	1.300	893.38	37.33	3.343	----	----	----	----	----	----	----	3.343
5.50	1.200	893.16	37.33	3.224	----	----	----	----	----	----	----	3.224
5.67	1.100	892.96	37.33	3.113	----	----	----	----	----	----	----	3.113
5.83	1.100	892.77	37.33	3.002	----	----	----	----	----	----	----	3.002
6.00	1.000	892.59	37.33	2.893	----	----	----	----	----	----	----	2.893
6.17	0.000	892.37	37.33	2.756	----	----	----	----	----	----	----	2.756
6.33	0.000	892.13	37.33	2.589	----	----	----	----	----	----	----	2.589
6.50	0.000	891.89	37.33	2.423	----	----	----	----	----	----	----	2.423
6.67	0.000	891.67	37.33	2.252	----	----	----	----	----	----	----	2.252
6.83	0.000	891.46	37.33	2.078	----	----	----	----	----	----	----	2.078
7.00	0.000	891.26	37.33	1.896	----	----	----	----	----	----	----	1.896
7.17	0.000	891.06	37.33	1.705	----	----	----	----	----	----	----	1.705
7.33	0.000	890.89	37.33	1.511	----	----	----	----	----	----	----	1.511
7.50	0.000	890.71	37.33	1.173	----	----	----	----	----	----	----	1.173
7.67	0.000	890.41	37.33	0.753	----	----	----	----	----	----	----	0.753
7.83	0.000	890.48	37.33	0.909	----	----	----	----	----	----	----	0.909

*Continues on next page...*

<no description>

### Hydrograph Discharge Table

Time (hrs)	Inflow cfs	Elevation ft	Clv A cfs	Clv B cfs	Clv C cfs	PfRsr cfs	Wr A cfs	Wr B cfs	Wr C cfs	Wr D cfs	Exfil cfs	Outflow cfs
8.00	0.000	890.34	37.33	0.555	----	----	----	----	----	----	----	0.554
8.17	0.000	890.24	37.33	0.309	----	----	----	----	----	----	----	0.309
8.33	0.000	890.18	37.33	0.189	----	----	----	----	----	----	----	0.189
8.50	0.000	890.15	37.33	0.127	----	----	----	----	----	----	----	0.127
8.67	0.000	890.12	37.33	0.090	----	----	----	----	----	----	----	0.090
8.83	0.000	890.10	37.33	0.067	----	----	----	----	----	----	----	0.067

...End

## Pond No. 1 - BMP-H

### Pond Data

**UG Chambers** -Invert elev. = 890.00 ft, Rise x Span = 4.50 x 4.50 ft, Barrel Len = 360.00 ft, No. Barrels = 4, Slope = 0.00%, Headers = No  
**Contours** -User-defined contour areas. Conic method used for volume calculation. Begining Elevation = 899.99 ft

### Stage / Storage Table

Stage (ft)	Elevation (ft)	Contour area (sqft)	Incr. Storage (cuft)	Total storage (cuft)
0.00	890.00	n/a	0	0
0.45	890.45	n/a	1,195	1,195
0.90	890.90	n/a	2,069	3,263
1.35	891.35	n/a	2,519	5,783
1.80	891.80	n/a	2,775	8,557
2.25	892.25	n/a	2,899	11,456
2.70	892.70	n/a	2,899	14,355
3.15	893.15	n/a	2,774	17,129
3.60	893.60	n/a	2,518	19,647
4.05	894.05	n/a	2,070	21,716
4.50	894.50	n/a	1,190	22,907
17.99	899.99	1,543	6,935	29,842
18.49	900.49	1,799	834	30,677
18.99	900.99	2,364	1,037	31,714

### Culvert / Orifice Structures

	[A]	[B]	[C]	[PrfRsr]
Rise (in)	= 18.00	6.00	6.00	0.00
Span (in)	= 18.00	6.00	6.00	0.00
No. Barrels	= 1	2	4	0
Invert El. (ft)	= 870.00	890.00	899.00	0.00
Length (ft)	= 18.00	0.50	0.50	0.00
Slope (%)	= 0.50	0.00	0.00	n/a
N-Value	= .013	.013	.013	n/a
Orifice Coeff.	= 0.60	0.60	0.60	0.60
Multi-Stage	= n/a	No	No	No

### Weir Structures

	[A]	[B]	[C]	[D]
Crest Len (ft)	= 12.00	0.00	0.00	0.00
Crest El. (ft)	= 901.00	0.00	0.00	0.00
Weir Coeff.	= 3.33	3.33	3.33	3.33
Weir Type	= 1	---	---	---
Multi-Stage	= Yes	No	No	No
Exfil.(in/hr)	= 0.000 (by Contour)			
TW Elev. (ft)	= 0.00			

Note: Culvert/Orifice outflows are analyzed under inlet (ic) and outlet (oc) control. Weir risers checked for orifice conditions (ic) and submergence (s).

### Stage / Storage / Discharge Table

Stage ft	Storage cuft	Elevation ft	Clv A cfs	Clv B cfs	Clv C cfs	PrfRsr cfs	Wr A cfs	Wr B cfs	Wr C cfs	Wr D cfs	Exfil cfs	User cfs	Total cfs
0.00	0	890.00	0.00	0.00	0.00	---	0.00	---	---	---	---	---	0.000
0.05	119	890.04	37.33 ic	0.01 ic	0.00	---	0.00	---	---	---	---	---	0.013
0.09	239	890.09	37.33 ic	0.05 ic	0.00	---	0.00	---	---	---	---	---	0.049
0.14	358	890.13	37.33 ic	0.11 ic	0.00	---	0.00	---	---	---	---	---	0.107
0.18	478	890.18	37.33 ic	0.18 ic	0.00	---	0.00	---	---	---	---	---	0.184
0.22	597	890.22	37.33 ic	0.28 ic	0.00	---	0.00	---	---	---	---	---	0.277
0.27	717	890.27	37.33 ic	0.38 ic	0.00	---	0.00	---	---	---	---	---	0.383
0.31	836	890.31	37.33 ic	0.50 ic	0.00	---	0.00	---	---	---	---	---	0.498
0.36	956	890.36	37.33 ic	0.62 ic	0.00	---	0.00	---	---	---	---	---	0.618
0.40	1,075	890.40	37.33 ic	0.74 ic	0.00	---	0.00	---	---	---	---	---	0.738
0.45	1,195	890.45	37.33 ic	0.85 ic	0.00	---	0.00	---	---	---	---	---	0.850
0.50	1,402	890.49	37.33 ic	0.94 ic	0.00	---	0.00	---	---	---	---	---	0.939
0.54	1,609	890.54	37.33 ic	0.51 oc	0.00	---	0.00	---	---	---	---	---	0.508
0.58	1,815	890.59	37.33 ic	0.74 oc	0.00	---	0.00	---	---	---	---	---	0.740
0.63	2,022	890.63	37.33 ic	0.92 oc	0.00	---	0.00	---	---	---	---	---	0.916
0.68	2,229	890.67	37.33 ic	1.06 oc	0.00	---	0.00	---	---	---	---	---	1.062
0.72	2,436	890.72	37.33 ic	1.19 oc	0.00	---	0.00	---	---	---	---	---	1.191
0.76	2,643	890.76	37.33 ic	1.31 oc	0.00	---	0.00	---	---	---	---	---	1.307
0.81	2,850	890.81	37.33 ic	1.41 oc	0.00	---	0.00	---	---	---	---	---	1.414
0.86	3,057	890.85	37.33 ic	1.47 ic	0.00	---	0.00	---	---	---	---	---	1.470
0.90	3,263	890.90	37.33 ic	1.52 ic	0.00	---	0.00	---	---	---	---	---	1.524
0.94	3,515	890.95	37.33 ic	1.58 ic	0.00	---	0.00	---	---	---	---	---	1.576
0.99	3,767	890.99	37.33 ic	1.63 ic	0.00	---	0.00	---	---	---	---	---	1.626
1.03	4,019	891.03	37.33 ic	1.68 ic	0.00	---	0.00	---	---	---	---	---	1.675
1.08	4,271	891.08	37.33 ic	1.72 ic	0.00	---	0.00	---	---	---	---	---	1.722
1.13	4,523	891.12	37.33 ic	1.77 ic	0.00	---	0.00	---	---	---	---	---	1.768
1.17	4,775	891.17	37.33 ic	1.81 ic	0.00	---	0.00	---	---	---	---	---	1.813
1.22	5,027	891.21	37.33 ic	1.86 ic	0.00	---	0.00	---	---	---	---	---	1.857

Continues on next page...

BMP-H

**Stage / Storage / Discharge Table**

Stage ft	Storage cuft	Elevation ft	Clv A cfs	Clv B cfs	Clv C cfs	PrfRsr cfs	Wr A cfs	Wr B cfs	Wr C cfs	Wr D cfs	Exfil cfs	User cfs	Total cfs
1.26	5,279	891.26	37.33 ic	1.90 ic	0.00	---	0.00	---	---	---	---	---	1.900
1.30	5,531	891.30	37.33 ic	1.94 ic	0.00	---	0.00	---	---	---	---	---	1.942
1.35	5,783	891.35	37.33 ic	1.98 ic	0.00	---	0.00	---	---	---	---	---	1.983
1.39	6,060	891.40	37.33 ic	2.02 ic	0.00	---	0.00	---	---	---	---	---	2.023
1.44	6,337	891.44	37.33 ic	2.06 ic	0.00	---	0.00	---	---	---	---	---	2.062
1.49	6,615	891.48	37.33 ic	2.10 ic	0.00	---	0.00	---	---	---	---	---	2.101
1.53	6,892	891.53	37.33 ic	2.14 ic	0.00	---	0.00	---	---	---	---	---	2.139
1.58	7,170	891.57	37.33 ic	2.18 ic	0.00	---	0.00	---	---	---	---	---	2.176
1.62	7,447	891.62	37.33 ic	2.21 ic	0.00	---	0.00	---	---	---	---	---	2.213
1.66	7,725	891.66	37.33 ic	2.25 ic	0.00	---	0.00	---	---	---	---	---	2.249
1.71	8,002	891.71	37.33 ic	2.28 ic	0.00	---	0.00	---	---	---	---	---	2.284
1.75	8,280	891.75	37.33 ic	2.32 ic	0.00	---	0.00	---	---	---	---	---	2.319
1.80	8,557	891.80	37.33 ic	2.35 ic	0.00	---	0.00	---	---	---	---	---	2.354
1.85	8,847	891.84	37.33 ic	2.39 ic	0.00	---	0.00	---	---	---	---	---	2.388
1.89	9,137	891.89	37.33 ic	2.42 ic	0.00	---	0.00	---	---	---	---	---	2.421
1.93	9,427	891.93	37.33 ic	2.45 ic	0.00	---	0.00	---	---	---	---	---	2.454
1.98	9,717	891.98	37.33 ic	2.49 ic	0.00	---	0.00	---	---	---	---	---	2.487
2.03	10,007	892.02	37.33 ic	2.52 ic	0.00	---	0.00	---	---	---	---	---	2.519
2.07	10,296	892.07	37.33 ic	2.55 ic	0.00	---	0.00	---	---	---	---	---	2.550
2.12	10,586	892.11	37.33 ic	2.58 ic	0.00	---	0.00	---	---	---	---	---	2.582
2.16	10,876	892.16	37.33 ic	2.61 ic	0.00	---	0.00	---	---	---	---	---	2.613
2.20	11,166	892.20	37.33 ic	2.64 ic	0.00	---	0.00	---	---	---	---	---	2.643
2.25	11,456	892.25	37.33 ic	2.67 ic	0.00	---	0.00	---	---	---	---	---	2.674
2.30	11,746	892.29	37.33 ic	2.70 ic	0.00	---	0.00	---	---	---	---	---	2.704
2.34	12,036	892.34	37.33 ic	2.73 ic	0.00	---	0.00	---	---	---	---	---	2.733
2.38	12,326	892.38	37.33 ic	2.76 ic	0.00	---	0.00	---	---	---	---	---	2.762
2.43	12,616	892.43	37.33 ic	2.79 ic	0.00	---	0.00	---	---	---	---	---	2.791
2.47	12,905	892.47	37.33 ic	2.82 ic	0.00	---	0.00	---	---	---	---	---	2.820
2.52	13,195	892.52	37.33 ic	2.85 ic	0.00	---	0.00	---	---	---	---	---	2.848
2.57	13,485	892.56	37.33 ic	2.88 ic	0.00	---	0.00	---	---	---	---	---	2.876
2.61	13,775	892.61	37.33 ic	2.90 ic	0.00	---	0.00	---	---	---	---	---	2.904
2.66	14,065	892.65	37.33 ic	2.93 ic	0.00	---	0.00	---	---	---	---	---	2.932
2.70	14,355	892.70	37.33 ic	2.96 ic	0.00	---	0.00	---	---	---	---	---	2.959
2.74	14,632	892.74	37.33 ic	2.99 ic	0.00	---	0.00	---	---	---	---	---	2.986
2.79	14,910	892.79	37.33 ic	3.01 ic	0.00	---	0.00	---	---	---	---	---	3.013
2.84	15,187	892.84	37.33 ic	3.04 ic	0.00	---	0.00	---	---	---	---	---	3.040
2.88	15,464	892.88	37.33 ic	3.07 ic	0.00	---	0.00	---	---	---	---	---	3.066
2.92	15,742	892.92	37.33 ic	3.09 ic	0.00	---	0.00	---	---	---	---	---	3.092
2.97	16,019	892.97	37.33 ic	3.12 ic	0.00	---	0.00	---	---	---	---	---	3.118
3.02	16,297	893.01	37.33 ic	3.14 ic	0.00	---	0.00	---	---	---	---	---	3.144
3.06	16,574	893.06	37.33 ic	3.17 ic	0.00	---	0.00	---	---	---	---	---	3.169
3.11	16,851	893.10	37.33 ic	3.19 ic	0.00	---	0.00	---	---	---	---	---	3.194
3.15	17,129	893.15	37.33 ic	3.22 ic	0.00	---	0.00	---	---	---	---	---	3.220
3.19	17,380	893.20	37.33 ic	3.24 ic	0.00	---	0.00	---	---	---	---	---	3.244
3.24	17,632	893.24	37.33 ic	3.27 ic	0.00	---	0.00	---	---	---	---	---	3.269
3.29	17,884	893.28	37.33 ic	3.29 ic	0.00	---	0.00	---	---	---	---	---	3.294
3.33	18,136	893.33	37.33 ic	3.32 ic	0.00	---	0.00	---	---	---	---	---	3.318
3.38	18,388	893.37	37.33 ic	3.34 ic	0.00	---	0.00	---	---	---	---	---	3.342
3.42	18,639	893.42	37.33 ic	3.37 ic	0.00	---	0.00	---	---	---	---	---	3.366
3.47	18,891	893.46	37.33 ic	3.39 ic	0.00	---	0.00	---	---	---	---	---	3.390
3.51	19,143	893.51	37.33 ic	3.41 ic	0.00	---	0.00	---	---	---	---	---	3.414
3.56	19,395	893.55	37.33 ic	3.44 ic	0.00	---	0.00	---	---	---	---	---	3.437
3.60	19,647	893.60	37.33 ic	3.46 ic	0.00	---	0.00	---	---	---	---	---	3.460
3.64	19,854	893.65	37.33 ic	3.48 ic	0.00	---	0.00	---	---	---	---	---	3.484
3.69	20,061	893.69	37.33 ic	3.51 ic	0.00	---	0.00	---	---	---	---	---	3.507
3.73	20,268	893.73	37.33 ic	3.53 ic	0.00	---	0.00	---	---	---	---	---	3.529
3.78	20,474	893.78	37.33 ic	3.55 ic	0.00	---	0.00	---	---	---	---	---	3.552
3.83	20,681	893.82	37.33 ic	3.57 ic	0.00	---	0.00	---	---	---	---	---	3.575
3.87	20,888	893.87	37.33 ic	3.60 ic	0.00	---	0.00	---	---	---	---	---	3.597
3.92	21,095	893.91	37.33 ic	3.62 ic	0.00	---	0.00	---	---	---	---	---	3.619
3.96	21,302	893.96	37.33 ic	3.64 ic	0.00	---	0.00	---	---	---	---	---	3.641
4.01	21,509	894.00	37.33 ic	3.66 ic	0.00	---	0.00	---	---	---	---	---	3.663
4.05	21,716	894.05	37.33 ic	3.69 ic	0.00	---	0.00	---	---	---	---	---	3.685
4.09	21,835	894.09	37.33 ic	3.71 ic	0.00	---	0.00	---	---	---	---	---	3.707
4.14	21,954	894.14	37.33 ic	3.73 ic	0.00	---	0.00	---	---	---	---	---	3.729
4.18	22,073	894.18	37.33 ic	3.75 ic	0.00	---	0.00	---	---	---	---	---	3.750
4.23	22,193	894.23	37.33 ic	3.77 ic	0.00	---	0.00	---	---	---	---	---	3.772
4.28	22,312	894.27	37.33 ic	3.79 ic	0.00	---	0.00	---	---	---	---	---	3.793
4.32	22,431	894.32	37.33 ic	3.81 ic	0.00	---	0.00	---	---	---	---	---	3.814
4.37	22,550	894.36	37.33 ic	3.84 ic	0.00	---	0.00	---	---	---	---	---	3.835
4.41	22,669	894.41	37.33 ic	3.86 ic	0.00	---	0.00	---	---	---	---	---	3.856
4.46	22,788	894.45	37.33 ic	3.88 ic	0.00	---	0.00	---	---	---	---	---	3.877

Continues on next page...

BMP-H

**Stage / Storage / Discharge Table**

Stage ft	Storage cuft	Elevation ft	Clv A cfs	Clv B cfs	Clv C cfs	PrfRsr cfs	Wr A cfs	Wr B cfs	Wr C cfs	Wr D cfs	Exfil cfs	User cfs	Total cfs
4.50	22,907	894.50	37.33 ic	3.90 ic	0.00	---	0.00	---	---	---	---	---	3.898
5.85	23,600	895.85	37.33 ic	4.47 ic	0.00	---	0.00	---	---	---	---	---	4.474
7.20	24,294	897.20	37.33 ic	4.98 ic	0.00	---	0.00	---	---	---	---	---	4.983
8.55	24,987	898.55	37.33 ic	5.45 ic	0.00	---	0.00	---	---	---	---	---	5.446
9.90	25,681	899.90	37.33 ic	5.87 ic	3.04 ic	---	0.00	---	---	---	---	---	8.911
11.24	26,375	901.24	37.33 ic	6.27 ic	5.34 ic	---	4.85	---	---	---	---	---	16.46
12.59	27,068	902.59	47.79 ic	6.64 ic	6.91 ic	---	47.79 s	---	---	---	---	---	61.34
13.94	27,762	903.94	48.98 ic	7.00 ic	8.19 ic	---	48.96 s	---	---	---	---	---	64.14
15.29	28,455	905.29	49.99 ic	7.33 ic	9.29 ic	---	49.92 s	---	---	---	---	---	66.55
16.64	29,149	906.64	50.96 ic	7.65 ic	10.28 ic	---	50.89 s	---	---	---	---	---	68.82
17.99	29,842	899.99	0.00	5.90 ic	3.25 ic	---	0.00	---	---	---	---	---	9.153
18.04	29,926	900.04	0.00	5.92 ic	3.36 ic	---	0.00	---	---	---	---	---	9.276
18.09	30,009	900.09	0.00	5.93 ic	3.47 ic	---	0.00	---	---	---	---	---	9.396
18.14	30,093	900.14	0.00	5.95 ic	3.57 ic	---	0.00	---	---	---	---	---	9.513
18.19	30,176	900.19	0.00	5.96 ic	3.67 ic	---	0.00	---	---	---	---	---	9.627
18.24	30,259	900.24	0.00	5.98 ic	3.76 ic	---	0.00	---	---	---	---	---	9.738
18.29	30,343	900.29	0.00	5.99 ic	3.86 ic	---	0.00	---	---	---	---	---	9.846
18.34	30,426	900.34	0.00	6.01 ic	3.95 ic	---	0.00	---	---	---	---	---	9.953
18.39	30,510	900.39	0.00	6.02 ic	4.04 ic	---	0.00	---	---	---	---	---	10.06
18.44	30,593	900.44	0.00	6.04 ic	4.12 ic	---	0.00	---	---	---	---	---	10.16
18.49	30,677	900.49	0.00	6.05 ic	4.21 ic	---	0.00	---	---	---	---	---	10.26
18.54	30,780	900.54	0.00	6.06 ic	4.29 ic	---	0.00	---	---	---	---	---	10.36
18.59	30,884	900.59	0.00	6.08 ic	4.38 ic	---	0.00	---	---	---	---	---	10.46
18.64	30,988	900.64	0.00	6.09 ic	4.46 ic	---	0.00	---	---	---	---	---	10.55
18.69	31,092	900.69	0.00	6.11 ic	4.54 ic	---	0.00	---	---	---	---	---	10.65
18.74	31,195	900.74	0.00	6.12 ic	4.62 ic	---	0.00	---	---	---	---	---	10.74
18.79	31,299	900.79	0.00	6.14 ic	4.69 ic	---	0.00	---	---	---	---	---	10.83
18.84	31,403	900.84	0.00	6.15 ic	4.77 ic	---	0.00	---	---	---	---	---	10.92
18.89	31,507	900.89	0.00	6.17 ic	4.84 ic	---	0.00	---	---	---	---	---	11.01
18.94	31,610	900.94	0.00	6.18 ic	4.92 ic	---	0.00	---	---	---	---	---	11.10
18.99	31,714	900.99	0.00	6.20 ic	4.99 ic	---	0.00	---	---	---	---	---	11.18

...End



# Hydrograph Report

Hydraflow Hydrographs Extension for Autodesk® Civil 3D® 2019 by Autodesk, Inc. v2020

Monday, 09 / 24 / 2018

## Hyd. No. 1

Basin H

Hydrograph type	= Manual	Peak discharge	= 28.16 cfs
Storm frequency	= 100 yrs	Time to peak	= 4.17 hrs
Time interval	= 10 min	Hyd. volume	= 62,556 cuft

## Hydrograph Discharge Table

(Printed values &gt;= 1.00% of Qp.)

Time -- Outflow (hrs      cfs)	Time -- Outflow (hrs      cfs)
0.17      1.000	3.67      3.900
0.33      1.100	3.83      5.800
0.50      1.100	4.00      9.300
0.67      1.100	4.17      28.16
0.83      1.200	4.33      4.600
1.00      1.200	4.50      3.100
1.17      1.300	4.67      2.400
1.33      1.300	4.83      2.000
1.50      1.400	5.00      1.800
1.67      1.400	5.17      1.600
1.83      1.500	5.33      1.400
2.00      1.500	5.50      1.300
2.17      1.600	5.67      1.200
2.33      1.700	5.83      1.100
2.50      1.900	6.00      1.100
2.67      1.900	...End
2.83      2.100	
3.00      2.300	
3.17      2.600	
3.33      2.800	
3.50      3.500	

# Hydrograph Report

Hydraflow Hydrographs Extension for Autodesk® Civil 3D® 2019 by Autodesk, Inc. v2020

Monday, 09 / 24 / 2018

## Hyd. No. 2

<no description>

Hydrograph type	= Reservoir	Peak discharge	= 11.69 cfs
Storm frequency	= 100 yrs	Time to peak	= 4.33 hrs
Time interval	= 10 min	Hyd. volume	= 62,547 cuft
Inflow hyd. No.	= 1 - Basin H	Reservoir name	= BMP-H
Max. Elevation	= 904.53 ft	Max. Storage	= 25,936 cuft

Storage Indication method used.

### Hydrograph Discharge Table

(Printed values >= 1.00% of Qp.)

Time (hrs)	Inflow cfs	Elevation ft	Clv A cfs	Clv B cfs	Clv C cfs	PfRsr cfs	Wr A cfs	Wr B cfs	Wr C cfs	Wr D cfs	Exfil cfs	Outflow cfs
0.33	1.100	890.29	37.33	0.425	----	----	----	----	----	----	----	0.425
0.50	1.100	890.40	37.33	0.736	----	----	----	----	----	----	----	0.736
0.67	1.100	890.46	37.33	0.874	----	----	----	----	----	----	----	0.874
0.83	1.200	890.49	37.33	0.937	----	----	----	----	----	----	----	0.937
1.00	1.200	890.34	37.33	0.571	----	----	----	----	----	----	----	0.571
1.17	1.300	890.46	37.33	0.879	----	----	----	----	----	----	----	0.879
1.33	1.300	890.67	37.33	1.032	----	----	----	----	----	----	----	1.032
1.50	1.400	890.70	37.33	1.135	----	----	----	----	----	----	----	1.135
1.67	1.400	890.73	37.33	1.216	----	----	----	----	----	----	----	1.216
1.83	1.500	890.76	37.33	1.284	----	----	----	----	----	----	----	1.284
2.00	1.500	890.78	37.33	1.343	----	----	----	----	----	----	----	1.343
2.17	1.600	890.80	37.33	1.399	----	----	----	----	----	----	----	1.399
2.33	1.700	890.83	37.33	1.443	----	----	----	----	----	----	----	1.443
2.50	1.900	890.88	37.33	1.496	----	----	----	----	----	----	----	1.496
2.67	1.900	890.92	37.33	1.549	----	----	----	----	----	----	----	1.549
2.83	2.100	890.97	37.33	1.600	----	----	----	----	----	----	----	1.600
3.00	2.300	891.03	37.33	1.667	----	----	----	----	----	----	----	1.667
3.17	2.600	891.11	37.33	1.750	----	----	----	----	----	----	----	1.750
3.33	2.800	891.20	37.33	1.846	----	----	----	----	----	----	----	1.846
3.50	3.500	891.34	37.33	1.971	----	----	----	----	----	----	----	1.971

Continues on next page...

<no description>

**Hydrograph Discharge Table**

Time (hrs)	Inflow cfs	Elevation ft	Clv A cfs	Clv B cfs	Clv C cfs	PfRsr cfs	Wr A cfs	Wr B cfs	Wr C cfs	Wr D cfs	Exfil cfs	Outflow cfs
3.67	3.900	891.50	37.33	2.113	----	----	----	----	----	----	----	2.113
3.83	5.800	891.76	37.33	2.320	----	----	----	----	----	----	----	2.320
4.00	9.300	892.23	37.33	2.659	----	----	----	----	----	----	----	2.659
4.17	28.16 <<	893.83	37.33	3.575	----	----	----	----	----	----	----	3.575
<< 4.33	4.600	900.39 <<	37.33	6.018	3.886	----	1.784	----	----	----	----	11.69
4.50	3.100	895.53	37.33	4.339	----	----	----	----	----	----	----	4.339
4.67	2.400	894.40	37.33	3.850	----	----	----	----	----	----	----	3.850
4.83	2.000	894.04	37.33	3.683	----	----	----	----	----	----	----	3.683
5.00	1.800	893.82	37.33	3.572	----	----	----	----	----	----	----	3.572
5.17	1.600	893.59	37.33	3.453	----	----	----	----	----	----	----	3.453
5.33	1.400	893.38	37.33	3.346	----	----	----	----	----	----	----	3.346
5.50	1.300	893.17	37.33	3.233	----	----	----	----	----	----	----	3.233
5.67	1.200	892.98	37.33	3.126	----	----	----	----	----	----	----	3.126
5.83	1.100	892.80	37.33	3.017	----	----	----	----	----	----	----	3.017
6.00	1.100	892.62	37.33	2.910	----	----	----	----	----	----	----	2.910
6.17	0.000	892.41	37.33	2.776	----	----	----	----	----	----	----	2.776
6.33	0.000	892.15	37.33	2.609	----	----	----	----	----	----	----	2.609
6.50	0.000	891.92	37.33	2.443	----	----	----	----	----	----	----	2.443
6.67	0.000	891.70	37.33	2.273	----	----	----	----	----	----	----	2.273
6.83	0.000	891.48	37.33	2.099	----	----	----	----	----	----	----	2.099
7.00	0.000	891.28	37.33	1.920	----	----	----	----	----	----	----	1.920
7.17	0.000	891.09	37.33	1.728	----	----	----	----	----	----	----	1.728
7.33	0.000	890.91	37.33	1.537	----	----	----	----	----	----	----	1.537
7.50	0.000	890.73	37.33	1.224	----	----	----	----	----	----	----	1.224
7.67	0.000	890.43	37.33	0.801	----	----	----	----	----	----	----	0.801
7.83	0.000	890.49	37.33	0.925	----	----	----	----	----	----	----	0.925
8.00	0.000	890.35	37.33	0.580	----	----	----	----	----	----	----	0.580

*Continues on next page...*

<no description>

### Hydrograph Discharge Table

Time (hrs)	Inflow cfs	Elevation ft	Clv A cfs	Clv B cfs	Clv C cfs	PfRsr cfs	Wr A cfs	Wr B cfs	Wr C cfs	Wr D cfs	Exfil cfs	Outflow cfs
8.17	0.000	890.24	37.33	0.321	----	----	----	----	----	----	----	0.321
8.33	0.000	890.19	37.33	0.195	----	----	----	----	----	----	----	0.195
8.50	0.000	890.15	37.33	0.130	----	----	----	----	----	----	----	0.130

...End

## Pond No. 1 - BMP-H

### Pond Data

**UG Chambers** -Invert elev. = 890.00 ft, Rise x Span = 4.50 x 4.50 ft, Barrel Len = 360.00 ft, No. Barrels = 4, Slope = 0.00%, Headers = No  
**Contours** -User-defined contour areas. Conic method used for volume calculation. Begining Elevation = 899.99 ft

### Stage / Storage Table

Stage (ft)	Elevation (ft)	Contour area (sqft)	Incr. Storage (cuft)	Total storage (cuft)
0.00	890.00	n/a	0	0
0.45	890.45	n/a	1,195	1,195
0.90	890.90	n/a	2,069	3,263
1.35	891.35	n/a	2,519	5,783
1.80	891.80	n/a	2,775	8,557
2.25	892.25	n/a	2,899	11,456
2.70	892.70	n/a	2,899	14,355
3.15	893.15	n/a	2,774	17,129
3.60	893.60	n/a	2,518	19,647
4.05	894.05	n/a	2,070	21,716
4.50	894.50	n/a	1,190	22,907
17.99	899.99	1,543	6,935	29,842
18.49	900.49	1,799	834	30,677
18.99	900.99	2,364	1,037	31,714

### Culvert / Orifice Structures

	[A]	[B]	[C]	[PrfRsr]
Rise (in)	= 18.00	6.00	6.00	0.00
Span (in)	= 18.00	6.00	6.00	0.00
No. Barrels	= 1	2	4	0
Invert El. (ft)	= 870.00	890.00	899.00	0.00
Length (ft)	= 18.00	0.50	0.50	0.00
Slope (%)	= 0.50	0.00	0.00	n/a
N-Value	= .013	.013	.013	n/a
Orifice Coeff.	= 0.60	0.60	0.60	0.60
Multi-Stage	= n/a	No	No	No

### Weir Structures

	[A]	[B]	[C]	[D]
Crest Len (ft)	= 12.00	0.00	0.00	0.00
Crest El. (ft)	= 901.00	0.00	0.00	0.00
Weir Coeff.	= 3.33	3.33	3.33	3.33
Weir Type	= 1	---	---	---
Multi-Stage	= Yes	No	No	No
Exfil.(in/hr)	= 0.000 (by Contour)			
TW Elev. (ft)	= 0.00			

Note: Culvert/Orifice outflows are analyzed under inlet (ic) and outlet (oc) control. Weir risers checked for orifice conditions (ic) and submergence (s).

### Stage / Storage / Discharge Table

Stage ft	Storage cuft	Elevation ft	Clv A cfs	Clv B cfs	Clv C cfs	PrfRsr cfs	Wr A cfs	Wr B cfs	Wr C cfs	Wr D cfs	Exfil cfs	User cfs	Total cfs
0.00	0	890.00	0.00	0.00	0.00	---	0.00	---	---	---	---	---	0.000
0.04	119	890.04	37.33 ic	0.01 ic	0.00	---	0.00	---	---	---	---	---	0.013
0.09	239	890.09	37.33 ic	0.05 ic	0.00	---	0.00	---	---	---	---	---	0.049
0.13	358	890.13	37.33 ic	0.11 ic	0.00	---	0.00	---	---	---	---	---	0.107
0.18	478	890.18	37.33 ic	0.18 ic	0.00	---	0.00	---	---	---	---	---	0.184
0.22	597	890.22	37.33 ic	0.28 ic	0.00	---	0.00	---	---	---	---	---	0.277
0.27	717	890.27	37.33 ic	0.38 ic	0.00	---	0.00	---	---	---	---	---	0.383
0.31	836	890.31	37.33 ic	0.50 ic	0.00	---	0.00	---	---	---	---	---	0.498
0.36	956	890.36	37.33 ic	0.62 ic	0.00	---	0.00	---	---	---	---	---	0.618
0.40	1,075	890.40	37.33 ic	0.74 ic	0.00	---	0.00	---	---	---	---	---	0.738
0.45	1,195	890.45	37.33 ic	0.85 ic	0.00	---	0.00	---	---	---	---	---	0.850
0.49	1,402	890.49	37.33 ic	0.94 ic	0.00	---	0.00	---	---	---	---	---	0.939
0.54	1,609	890.54	37.33 ic	0.51 oc	0.00	---	0.00	---	---	---	---	---	0.508
0.58	1,815	890.58	37.33 ic	0.74 oc	0.00	---	0.00	---	---	---	---	---	0.740
0.63	2,022	890.63	37.33 ic	0.92 oc	0.00	---	0.00	---	---	---	---	---	0.916
0.68	2,229	890.67	37.33 ic	1.06 oc	0.00	---	0.00	---	---	---	---	---	1.062
0.72	2,436	890.72	37.33 ic	1.19 oc	0.00	---	0.00	---	---	---	---	---	1.191
0.77	2,643	890.76	37.33 ic	1.31 oc	0.00	---	0.00	---	---	---	---	---	1.307
0.81	2,850	890.81	37.33 ic	1.41 oc	0.00	---	0.00	---	---	---	---	---	1.414
0.86	3,057	890.85	37.33 ic	1.47 ic	0.00	---	0.00	---	---	---	---	---	1.470
0.90	3,263	890.90	37.33 ic	1.52 ic	0.00	---	0.00	---	---	---	---	---	1.524
0.94	3,515	890.95	37.33 ic	1.58 ic	0.00	---	0.00	---	---	---	---	---	1.576
0.99	3,767	890.99	37.33 ic	1.63 ic	0.00	---	0.00	---	---	---	---	---	1.626
1.03	4,019	891.03	37.33 ic	1.68 ic	0.00	---	0.00	---	---	---	---	---	1.675
1.08	4,271	891.08	37.33 ic	1.72 ic	0.00	---	0.00	---	---	---	---	---	1.722
1.12	4,523	891.12	37.33 ic	1.77 ic	0.00	---	0.00	---	---	---	---	---	1.768
1.17	4,775	891.17	37.33 ic	1.81 ic	0.00	---	0.00	---	---	---	---	---	1.813
1.21	5,027	891.21	37.33 ic	1.86 ic	0.00	---	0.00	---	---	---	---	---	1.857

Continues on next page...

BMP-H

**Stage / Storage / Discharge Table**

Stage ft	Storage cuft	Elevation ft	Clv A cfs	Clv B cfs	Clv C cfs	PrfRsr cfs	Wr A cfs	Wr B cfs	Wr C cfs	Wr D cfs	Exfil cfs	User cfs	Total cfs
1.26	5,279	891.26	37.33 ic	1.90 ic	0.00	---	0.00	---	---	---	---	---	1.900
1.30	5,531	891.30	37.33 ic	1.94 ic	0.00	---	0.00	---	---	---	---	---	1.942
1.35	5,783	891.35	37.33 ic	1.98 ic	0.00	---	0.00	---	---	---	---	---	1.983
1.39	6,060	891.39	37.33 ic	2.02 ic	0.00	---	0.00	---	---	---	---	---	2.023
1.44	6,337	891.44	37.33 ic	2.06 ic	0.00	---	0.00	---	---	---	---	---	2.062
1.48	6,615	891.48	37.33 ic	2.10 ic	0.00	---	0.00	---	---	---	---	---	2.101
1.53	6,892	891.53	37.33 ic	2.14 ic	0.00	---	0.00	---	---	---	---	---	2.139
1.57	7,170	891.57	37.33 ic	2.18 ic	0.00	---	0.00	---	---	---	---	---	2.176
1.62	7,447	891.62	37.33 ic	2.21 ic	0.00	---	0.00	---	---	---	---	---	2.213
1.66	7,725	891.66	37.33 ic	2.25 ic	0.00	---	0.00	---	---	---	---	---	2.249
1.71	8,002	891.71	37.33 ic	2.28 ic	0.00	---	0.00	---	---	---	---	---	2.284
1.75	8,280	891.75	37.33 ic	2.32 ic	0.00	---	0.00	---	---	---	---	---	2.319
1.80	8,557	891.80	37.33 ic	2.35 ic	0.00	---	0.00	---	---	---	---	---	2.354
1.85	8,847	891.84	37.33 ic	2.39 ic	0.00	---	0.00	---	---	---	---	---	2.388
1.89	9,137	891.89	37.33 ic	2.42 ic	0.00	---	0.00	---	---	---	---	---	2.421
1.93	9,427	891.93	37.33 ic	2.45 ic	0.00	---	0.00	---	---	---	---	---	2.454
1.98	9,717	891.98	37.33 ic	2.49 ic	0.00	---	0.00	---	---	---	---	---	2.487
2.02	10,007	892.02	37.33 ic	2.52 ic	0.00	---	0.00	---	---	---	---	---	2.519
2.07	10,296	892.07	37.33 ic	2.55 ic	0.00	---	0.00	---	---	---	---	---	2.550
2.12	10,586	892.11	37.33 ic	2.58 ic	0.00	---	0.00	---	---	---	---	---	2.582
2.16	10,876	892.16	37.33 ic	2.61 ic	0.00	---	0.00	---	---	---	---	---	2.613
2.21	11,166	892.20	37.33 ic	2.64 ic	0.00	---	0.00	---	---	---	---	---	2.643
2.25	11,456	892.25	37.33 ic	2.67 ic	0.00	---	0.00	---	---	---	---	---	2.674
2.30	11,746	892.29	37.33 ic	2.70 ic	0.00	---	0.00	---	---	---	---	---	2.704
2.34	12,036	892.34	37.33 ic	2.73 ic	0.00	---	0.00	---	---	---	---	---	2.733
2.39	12,326	892.38	37.33 ic	2.76 ic	0.00	---	0.00	---	---	---	---	---	2.762
2.43	12,616	892.43	37.33 ic	2.79 ic	0.00	---	0.00	---	---	---	---	---	2.791
2.48	12,905	892.47	37.33 ic	2.82 ic	0.00	---	0.00	---	---	---	---	---	2.820
2.52	13,195	892.52	37.33 ic	2.85 ic	0.00	---	0.00	---	---	---	---	---	2.848
2.57	13,485	892.56	37.33 ic	2.88 ic	0.00	---	0.00	---	---	---	---	---	2.876
2.61	13,775	892.61	37.33 ic	2.90 ic	0.00	---	0.00	---	---	---	---	---	2.904
2.66	14,065	892.65	37.33 ic	2.93 ic	0.00	---	0.00	---	---	---	---	---	2.932
2.70	14,355	892.70	37.33 ic	2.96 ic	0.00	---	0.00	---	---	---	---	---	2.959
2.75	14,632	892.74	37.33 ic	2.99 ic	0.00	---	0.00	---	---	---	---	---	2.986
2.79	14,910	892.79	37.33 ic	3.01 ic	0.00	---	0.00	---	---	---	---	---	3.013
2.84	15,187	892.83	37.33 ic	3.04 ic	0.00	---	0.00	---	---	---	---	---	3.040
2.88	15,464	892.88	37.33 ic	3.07 ic	0.00	---	0.00	---	---	---	---	---	3.066
2.93	15,742	892.92	37.33 ic	3.09 ic	0.00	---	0.00	---	---	---	---	---	3.092
2.97	16,019	892.97	37.33 ic	3.12 ic	0.00	---	0.00	---	---	---	---	---	3.118
3.02	16,297	893.01	37.33 ic	3.14 ic	0.00	---	0.00	---	---	---	---	---	3.144
3.06	16,574	893.06	37.33 ic	3.17 ic	0.00	---	0.00	---	---	---	---	---	3.169
3.11	16,851	893.10	37.33 ic	3.19 ic	0.00	---	0.00	---	---	---	---	---	3.194
3.15	17,129	893.15	37.33 ic	3.22 ic	0.00	---	0.00	---	---	---	---	---	3.220
3.20	17,380	893.20	37.33 ic	3.24 ic	0.00	---	0.00	---	---	---	---	---	3.244
3.24	17,632	893.24	37.33 ic	3.27 ic	0.00	---	0.00	---	---	---	---	---	3.269
3.29	17,884	893.28	37.33 ic	3.29 ic	0.00	---	0.00	---	---	---	---	---	3.294
3.33	18,136	893.33	37.33 ic	3.32 ic	0.00	---	0.00	---	---	---	---	---	3.318
3.38	18,388	893.37	37.33 ic	3.34 ic	0.00	---	0.00	---	---	---	---	---	3.342
3.42	18,639	893.42	37.33 ic	3.37 ic	0.00	---	0.00	---	---	---	---	---	3.366
3.47	18,891	893.46	37.33 ic	3.39 ic	0.00	---	0.00	---	---	---	---	---	3.390
3.51	19,143	893.51	37.33 ic	3.41 ic	0.00	---	0.00	---	---	---	---	---	3.414
3.56	19,395	893.55	37.33 ic	3.44 ic	0.00	---	0.00	---	---	---	---	---	3.437
3.60	19,647	893.60	37.33 ic	3.46 ic	0.00	---	0.00	---	---	---	---	---	3.460
3.65	19,854	893.64	37.33 ic	3.48 ic	0.00	---	0.00	---	---	---	---	---	3.484
3.69	20,061	893.69	37.33 ic	3.51 ic	0.00	---	0.00	---	---	---	---	---	3.507
3.74	20,268	893.73	37.33 ic	3.53 ic	0.00	---	0.00	---	---	---	---	---	3.529
3.78	20,474	893.78	37.33 ic	3.55 ic	0.00	---	0.00	---	---	---	---	---	3.552
3.83	20,681	893.82	37.33 ic	3.57 ic	0.00	---	0.00	---	---	---	---	---	3.575
3.87	20,888	893.87	37.33 ic	3.60 ic	0.00	---	0.00	---	---	---	---	---	3.597
3.92	21,095	893.91	37.33 ic	3.62 ic	0.00	---	0.00	---	---	---	---	---	3.619
3.96	21,302	893.96	37.33 ic	3.64 ic	0.00	---	0.00	---	---	---	---	---	3.641
4.01	21,509	894.00	37.33 ic	3.66 ic	0.00	---	0.00	---	---	---	---	---	3.663
4.05	21,716	894.05	37.33 ic	3.69 ic	0.00	---	0.00	---	---	---	---	---	3.685
4.10	21,835	894.09	37.33 ic	3.71 ic	0.00	---	0.00	---	---	---	---	---	3.707
4.14	21,954	894.14	37.33 ic	3.73 ic	0.00	---	0.00	---	---	---	---	---	3.729
4.19	22,073	894.18	37.33 ic	3.75 ic	0.00	---	0.00	---	---	---	---	---	3.750
4.23	22,192	894.23	37.33 ic	3.77 ic	0.00	---	0.00	---	---	---	---	---	3.772
4.28	22,312	894.27	37.33 ic	3.79 ic	0.00	---	0.00	---	---	---	---	---	3.793
4.32	22,431	894.32	37.33 ic	3.81 ic	0.00	---	0.00	---	---	---	---	---	3.814
4.37	22,550	894.36	37.33 ic	3.84 ic	0.00	---	0.00	---	---	---	---	---	3.835
4.41	22,669	894.41	37.33 ic	3.86 ic	0.00	---	0.00	---	---	---	---	---	3.856
4.46	22,788	894.45	37.33 ic	3.88 ic	0.00	---	0.00	---	---	---	---	---	3.877

Continues on next page...

BMP-H

**Stage / Storage / Discharge Table**

Stage ft	Storage cuft	Elevation ft	Clv A cfs	Clv B cfs	Clv C cfs	PrfRsr cfs	Wr A cfs	Wr B cfs	Wr C cfs	Wr D cfs	Exfil cfs	User cfs	Total cfs
4.50	22,907	894.50	37.33 ic	3.90 ic	0.00	---	0.00	---	---	---	---	---	3.898
5.85	23,600	895.85	37.33 ic	4.47 ic	0.00	---	0.00	---	---	---	---	---	4.474
7.20	24,294	897.20	37.33 ic	4.98 ic	0.00	---	0.00	---	---	---	---	---	4.983
8.55	24,987	898.55	37.33 ic	5.45 ic	0.00	---	0.00	---	---	---	---	---	5.446
9.90	25,681	899.90	37.33 ic	5.87 ic	3.04 ic	---	0.00	---	---	---	---	---	8.911
11.24	26,375	901.24	37.33 ic	6.27 ic	5.34 ic	---	4.85	---	---	---	---	---	16.46
12.59	27,068	902.59	47.79 ic	6.64 ic	6.91 ic	---	47.79 s	---	---	---	---	---	61.34
13.94	27,762	903.94	48.98 ic	7.00 ic	8.19 ic	---	48.96 s	---	---	---	---	---	64.14
15.29	28,455	905.29	49.99 ic	7.33 ic	9.29 ic	---	49.92 s	---	---	---	---	---	66.55
16.64	29,149	906.64	50.96 ic	7.65 ic	10.28 ic	---	50.89 s	---	---	---	---	---	68.82
17.99	29,842	899.99	0.00	5.90 ic	3.25 ic	---	0.00	---	---	---	---	---	9.153
18.04	29,926	900.04	0.00	5.92 ic	3.36 ic	---	0.00	---	---	---	---	---	9.276
18.09	30,009	900.09	0.00	5.93 ic	3.47 ic	---	0.00	---	---	---	---	---	9.396
18.14	30,093	900.14	0.00	5.95 ic	3.57 ic	---	0.00	---	---	---	---	---	9.513
18.19	30,176	900.19	0.00	5.96 ic	3.67 ic	---	0.00	---	---	---	---	---	9.627
18.24	30,259	900.24	0.00	5.98 ic	3.76 ic	---	0.00	---	---	---	---	---	9.738
18.29	30,343	900.29	0.00	5.99 ic	3.86 ic	---	0.00	---	---	---	---	---	9.846
18.34	30,426	900.34	0.00	6.01 ic	3.95 ic	---	0.00	---	---	---	---	---	9.953
18.39	30,510	900.39	0.00	6.02 ic	4.04 ic	---	0.00	---	---	---	---	---	10.06
18.44	30,593	900.44	0.00	6.04 ic	4.12 ic	---	0.00	---	---	---	---	---	10.16
18.49	30,677	900.49	0.00	6.05 ic	4.21 ic	---	0.00	---	---	---	---	---	10.26
18.54	30,780	900.54	0.00	6.06 ic	4.29 ic	---	0.00	---	---	---	---	---	10.36
18.59	30,884	900.59	0.00	6.08 ic	4.38 ic	---	0.00	---	---	---	---	---	10.46
18.64	30,988	900.64	0.00	6.09 ic	4.46 ic	---	0.00	---	---	---	---	---	10.55
18.69	31,092	900.69	0.00	6.11 ic	4.54 ic	---	0.00	---	---	---	---	---	10.65
18.74	31,195	900.74	0.00	6.12 ic	4.62 ic	---	0.00	---	---	---	---	---	10.74
18.79	31,299	900.79	0.00	6.14 ic	4.69 ic	---	0.00	---	---	---	---	---	10.83
18.84	31,403	900.84	0.00	6.15 ic	4.77 ic	---	0.00	---	---	---	---	---	10.92
18.89	31,507	900.89	0.00	6.17 ic	4.84 ic	---	0.00	---	---	---	---	---	11.01
18.94	31,610	900.94	0.00	6.18 ic	4.92 ic	---	0.00	---	---	---	---	---	11.10
18.99	31,714	900.99	0.00	6.20 ic	4.99 ic	---	0.00	---	---	---	---	---	11.18

...End

# Hydrograph Report

Hydraflow Hydrographs Extension for Autodesk® Civil 3D® 2019 by Autodesk, Inc. v2020

Tuesday, 09 / 25 / 2018

## Hyd. No. 1

Basin H

Hydrograph type	= Manual	Peak discharge	= 20.10 cfs
Storm frequency	= 100 yrs	Time to peak	= 4.00 hrs
Time interval	= 8 min	Hyd. volume	= 48,058 cuft

## Hydrograph Discharge Table

(Printed values &gt;= 1.00% of Qp.)

Time -- Outflow (hrs cfs)	Time -- Outflow (hrs cfs)	Time -- Outflow (hrs cfs)
0.13 0.800	2.93 1.700	5.73 0.900
0.27 0.800	3.07 1.900	5.87 0.900
0.40 0.800	3.20 2.000	6.00 0.800
0.53 0.800	3.33 2.300	...End
0.67 0.900	3.47 2.500	
0.80 0.900	3.60 3.100	
0.93 0.900	3.73 3.500	
1.07 0.900	3.87 5.100	
1.20 1.000	4.00 20.10	
1.33 1.000	4.13 13.02	
1.47 1.000	4.27 4.100	
1.60 1.100	4.40 2.800	
1.73 1.100	4.53 2.200	
1.87 1.100	4.67 1.800	
2.00 1.200	4.80 1.600	
2.13 1.200	4.93 1.400	
2.27 1.300	5.07 1.300	
2.40 1.400	5.20 1.200	
2.53 1.500	5.33 1.100	
2.67 1.500	5.47 1.000	
2.80 1.600	5.60 1.000	

&lt;&lt;



# Hydrograph Report

## Hyd. No. 2

<no description>

Hydrograph type	= Reservoir	Peak discharge	= 3.521 cfs
Storm frequency	= 100 yrs	Time to peak	= 4.27 hrs
Time interval	= 8 min	Hyd. volume	= 48,048 cuft
Inflow hyd. No.	= 1 - Basin H	Reservoir name	= BMP-H
Max. Elevation	= 893.75 ft	Max. Storage	= 20,189 cuft

Storage Indication method used.

### Hydrograph Discharge Table

(Printed values >= 1.00% of Qp.)

Time (hrs)	Inflow cfs	Elevation ft	Clv A cfs	Clv B cfs	Clv C cfs	PfRsr cfs	Wr A cfs	Wr B cfs	Wr C cfs	Wr D cfs	Exfil cfs	Outflow cfs
0.27	0.800	890.19	37.33	0.209	----	----	----	----	----	----	----	0.209
0.40	0.800	890.28	37.33	0.410	----	----	----	----	----	----	----	0.410
0.53	0.800	890.34	37.33	0.559	----	----	----	----	----	----	----	0.559
0.67	0.900	890.38	37.33	0.672	----	----	----	----	----	----	----	0.672
0.80	0.900	890.41	37.33	0.759	----	----	----	----	----	----	----	0.759
0.93	0.900	890.43	37.33	0.811	----	----	----	----	----	----	----	0.811
1.07	0.900	890.45	37.33	0.844	----	----	----	----	----	----	----	0.844
1.20	1.000	890.46	37.33	0.867	----	----	----	----	----	----	----	0.867
1.33	1.000	890.47	37.33	0.892	----	----	----	----	----	----	----	0.892
1.47	1.000	890.48	37.33	0.912	----	----	----	----	----	----	----	0.912
1.60	1.100	890.49	37.33	0.938	----	----	----	----	----	----	----	0.938
1.73	1.100	890.36	37.33	0.629	----	----	----	----	----	----	----	0.629
1.87	1.100	890.38	37.33	0.682	----	----	----	----	----	----	----	0.682
2.00	1.200	890.45	37.33	0.852	----	----	----	----	----	----	----	0.852
2.13	1.200	890.64	37.33	0.962	----	----	----	----	----	----	----	0.962
2.27	1.300	890.67	37.33	1.046	----	----	----	----	----	----	----	1.046
2.40	1.400	890.70	37.33	1.127	----	----	----	----	----	----	----	1.127
2.53	1.500	890.73	37.33	1.209	----	----	----	----	----	----	----	1.209
2.67	1.500	890.75	37.33	1.278	----	----	----	----	----	----	----	1.278
2.80	1.600	890.78	37.33	1.340	----	----	----	----	----	----	----	1.340

Continues on next page...

&lt;no description&gt;

**Hydrograph Discharge Table**

Time (hrs)	Inflow cfs	Elevation ft	Clv A cfs	Clv B cfs	Clv C cfs	PfRsr cfs	Wr A cfs	Wr B cfs	Wr C cfs	Wr D cfs	Exfil cfs	Outflow cfs
2.93	1.700	890.81	37.33	1.408	----	----	----	----	----	----	----	1.408
3.07	1.900	890.85	37.33	1.459	----	----	----	----	----	----	----	1.459
3.20	2.000	890.89	37.33	1.517	----	----	----	----	----	----	----	1.517
3.33	2.300	890.95	37.33	1.578	----	----	----	----	----	----	----	1.578
3.47	2.500	891.01	37.33	1.652	----	----	----	----	----	----	----	1.652
3.60	3.100	891.11	37.33	1.751	----	----	----	----	----	----	----	1.751
3.73	3.500	891.24	37.33	1.877	----	----	----	----	----	----	----	1.877
3.87	5.100	891.43	37.33	2.052	----	----	----	----	----	----	----	2.052
4.00	20.10 <<	892.21	37.33	2.645	----	----	----	----	----	----	----	2.645
4.13	13.02	893.25	37.33	3.277	----	----	----	----	----	----	----	3.277
4.27	4.100	893.72 <<	37.33	3.521	----	----	----	----	----	----	----	3.521
4.40	2.800	893.71	37.33	3.517	----	----	----	----	----	----	----	3.517
4.53	2.200	893.61	37.33	3.464	----	----	----	----	----	----	----	3.464
4.67	1.800	893.48	37.33	3.399	----	----	----	----	----	----	----	3.399
4.80	1.600	893.34	37.33	3.324	----	----	----	----	----	----	----	3.324
4.93	1.400	893.19	37.33	3.241	----	----	----	----	----	----	----	3.241
5.07	1.300	893.04	37.33	3.158	----	----	----	----	----	----	----	3.158
5.20	1.200	892.89	37.33	3.075	----	----	----	----	----	----	----	3.075
5.33	1.100	892.75	37.33	2.988	----	----	----	----	----	----	----	2.988
5.47	1.000	892.61	37.33	2.901	----	----	----	----	----	----	----	2.901
5.60	1.000	892.47	37.33	2.815	----	----	----	----	----	----	----	2.815
5.73	0.900	892.33	37.33	2.727	----	----	----	----	----	----	----	2.727
5.87	0.900	892.20	37.33	2.639	----	----	----	----	----	----	----	2.639
6.00	0.800	892.07	37.33	2.549	----	----	----	----	----	----	----	2.549
6.13	0.000	891.91	37.33	2.437	----	----	----	----	----	----	----	2.437
6.27	0.000	891.73	37.33	2.302	----	----	----	----	----	----	----	2.302
6.40	0.000	891.56	37.33	2.163	----	----	----	----	----	----	----	2.163

*Continues on next page...*

&lt;no description&gt;

**Hydrograph Discharge Table**

<b>Time (hrs)</b>	<b>Inflow cfs</b>	<b>Elevation ft</b>	<b>Clv A cfs</b>	<b>Clv B cfs</b>	<b>Clv C cfs</b>	<b>PfRsr cfs</b>	<b>Wr A cfs</b>	<b>Wr B cfs</b>	<b>Wr C cfs</b>	<b>Wr D cfs</b>	<b>Exfil cfs</b>	<b>Outflow cfs</b>
6.53	0.000	891.40	37.33	2.024	----	----	----	----	----	----	----	2.024
6.67	0.000	891.23	37.33	1.875	----	----	----	----	----	----	----	1.875
6.80	0.000	891.08	37.33	1.722	----	----	----	----	----	----	----	1.722
6.93	0.000	890.94	37.33	1.568	----	----	----	----	----	----	----	1.568
7.07	0.000	890.79	37.33	1.374	----	----	----	----	----	----	----	1.374
7.20	0.000	890.67	37.33	1.037	----	----	----	----	----	----	----	1.037
7.33	0.000	890.39	37.33	0.697	----	----	----	----	----	----	----	0.697
7.47	0.000	890.49	37.33	0.932	----	----	----	----	----	----	----	0.932
7.60	0.000	890.38	37.33	0.665	----	----	----	----	----	----	----	0.665
7.73	0.000	890.28	37.33	0.409	----	----	----	----	----	----	----	0.410
7.87	0.000	890.22	37.33	0.266	----	----	----	----	----	----	----	0.266
8.00	0.000	890.18	37.33	0.182	----	----	----	----	----	----	----	0.182
8.13	0.000	890.15	37.33	0.133	----	----	----	----	----	----	----	0.133
8.27	0.000	890.13	37.33	0.100	----	----	----	----	----	----	----	0.100
8.40	0.000	890.11	37.33	0.079	----	----	----	----	----	----	----	0.079
8.53	0.000	890.10	37.33	0.062	----	----	----	----	----	----	----	0.062
8.67	0.000	890.09	37.33	0.049	----	----	----	----	----	----	----	0.049
8.80	0.000	890.08	37.33	0.043	----	----	----	----	----	----	----	0.043
8.93	0.000	890.07	37.33	0.037	----	----	----	----	----	----	----	0.037

...End

# Hydrograph Report

Hydraflow Hydrographs Extension for Autodesk® Civil 3D® 2019 by Autodesk, Inc. v2020

Tuesday, 09 / 25 / 2018

## Hyd. No. 1

Basin H

Hydrograph type	= Manual	Peak discharge	= 19.90 cfs
Storm frequency	= 50 yrs	Time to peak	= 4.00 hrs
Time interval	= 8 min	Hyd. volume	= 44,933 cuft

## Hydrograph Discharge Table

(Printed values &gt;= 1.00% of Qp.)

Time -- Outflow (hrs      cfs)	Time -- Outflow (hrs      cfs)	Time -- Outflow (hrs      cfs)
0.13      0.700	2.93      1.600	5.73      0.800
0.27      0.800	3.07      1.800	5.87      0.800
0.40      0.800	3.20      1.900	6.00      0.800
0.53      0.800	3.33      2.200	<i>...End</i>
0.67      0.800	3.47      2.300	
0.80      0.800	3.60      2.900	
0.93      0.900	3.73      3.300	
1.07      0.900	3.87      4.800	
1.20      0.900	4.00      19.90	
1.33      0.900	4.13      11.01	
1.47      1.000	4.27      3.800	
1.60      1.000	4.40      2.600	
1.73      1.000	4.53      2.000	
1.87      1.100	4.67      1.700	
2.00      1.100	4.80      1.500	
2.13      1.200	4.93      1.300	
2.27      1.200	5.07      1.200	
2.40      1.300	5.20      1.100	
2.53      1.400	5.33      1.000	
2.67      1.400	5.47      0.900	
2.80      1.500	5.60      0.900	

&lt;&lt;

# Hydrograph Report

Hydraflow Hydrographs Extension for Autodesk® Civil 3D® 2019 by Autodesk, Inc. v2020

Tuesday, 09 / 25 / 2018

## Hyd. No. 2

<no description>

Hydrograph type	= Reservoir	Peak discharge	= 3.364 cfs
Storm frequency	= 50 yrs	Time to peak	= 4.27 hrs
Time interval	= 8 min	Hyd. volume	= 44,924 cuft
Inflow hyd. No.	= 1 - Basin H	Reservoir name	= BMP-H
Max. Elevation	= 893.44 ft	Max. Storage	= 18,621 cuft

Storage Indication method used.

### Hydrograph Discharge Table

(Printed values >= 1.00% of Qp.)

Time (hrs)	Inflow cfs	Elevation ft	Clv A cfs	Clv B cfs	Clv C cfs	PfRsr cfs	Wr A cfs	Wr B cfs	Wr C cfs	Wr D cfs	Exfil cfs	Outflow cfs
0.27	0.800	890.18	37.33	0.181	----	----	----	----	----	----	----	0.181
0.40	0.800	890.27	37.33	0.386	----	----	----	----	----	----	----	0.386
0.53	0.800	890.33	37.33	0.543	----	----	----	----	----	----	----	0.543
0.67	0.800	890.37	37.33	0.643	----	----	----	----	----	----	----	0.643
0.80	0.800	890.39	37.33	0.704	----	----	----	----	----	----	----	0.704
0.93	0.900	890.41	37.33	0.760	----	----	----	----	----	----	----	0.760
1.07	0.900	890.43	37.33	0.811	----	----	----	----	----	----	----	0.811
1.20	0.900	890.45	37.33	0.844	----	----	----	----	----	----	----	0.844
1.33	0.900	890.45	37.33	0.858	----	----	----	----	----	----	----	0.858
1.47	1.000	890.46	37.33	0.875	----	----	----	----	----	----	----	0.875
1.60	1.000	890.47	37.33	0.898	----	----	----	----	----	----	----	0.898
1.73	1.000	890.48	37.33	0.917	----	----	----	----	----	----	----	0.917
1.87	1.100	890.48	37.33	0.909	----	----	----	----	----	----	----	0.909
2.00	1.100	890.33	37.33	0.526	----	----	----	----	----	----	----	0.526
2.13	1.200	890.41	37.33	0.763	----	----	----	----	----	----	----	0.763
2.27	1.200	890.48	37.33	0.911	----	----	----	----	----	----	----	0.911
2.40	1.300	890.66	37.33	1.010	----	----	----	----	----	----	----	1.010
2.53	1.400	890.69	37.33	1.104	----	----	----	----	----	----	----	1.104
2.67	1.400	890.72	37.33	1.181	----	----	----	----	----	----	----	1.181
2.80	1.500	890.74	37.33	1.246	----	----	----	----	----	----	----	1.246

Continues on next page...

<no description>

**Hydrograph Discharge Table**

Time (hrs)	Inflow cfs	Elevation ft	Clv A cfs	Clv B cfs	Clv C cfs	PfRsr cfs	Wr A cfs	Wr B cfs	Wr C cfs	Wr D cfs	Exfil cfs	Outflow cfs
2.93	1.600	890.77	37.33	1.317	----	----	----	----	----	----	----	1.317
3.07	1.800	890.80	37.33	1.401	----	----	----	----	----	----	----	1.402
3.20	1.900	890.85	37.33	1.462	----	----	----	----	----	----	----	1.462
3.33	2.200	890.91	37.33	1.530	----	----	----	----	----	----	----	1.530
3.47	2.300	890.96	37.33	1.597	----	----	----	----	----	----	----	1.597
3.60	2.900	891.05	37.33	1.687	----	----	----	----	----	----	----	1.687
3.73	3.300	891.16	37.33	1.806	----	----	----	----	----	----	----	1.806
3.87	4.800	891.35	37.33	1.980	----	----	----	----	----	----	----	1.980
4.00	19.90 <<	892.12	37.33	2.583	----	----	----	----	----	----	----	2.583
4.13	11.01	893.07	37.33	3.175	----	----	----	----	----	----	----	3.175
4.27	3.800	893.42 <<	37.33	3.364	----	----	----	----	----	----	----	3.364
4.40	2.600	893.40	37.33	3.357	----	----	----	----	----	----	----	3.357
4.53	2.000	893.31	37.33	3.309	----	----	----	----	----	----	----	3.309
4.67	1.700	893.19	37.33	3.243	----	----	----	----	----	----	----	3.243
4.80	1.500	893.06	37.33	3.171	----	----	----	----	----	----	----	3.171
4.93	1.300	892.93	37.33	3.094	----	----	----	----	----	----	----	3.094
5.07	1.200	892.79	37.33	3.012	----	----	----	----	----	----	----	3.012
5.20	1.100	892.65	37.33	2.928	----	----	----	----	----	----	----	2.928
5.33	1.000	892.51	37.33	2.843	----	----	----	----	----	----	----	2.843
5.47	0.900	892.37	37.33	2.755	----	----	----	----	----	----	----	2.755
5.60	0.900	892.24	37.33	2.666	----	----	----	----	----	----	----	2.666
5.73	0.800	892.11	37.33	2.576	----	----	----	----	----	----	----	2.576
5.87	0.800	891.98	37.33	2.485	----	----	----	----	----	----	----	2.485
6.00	0.800	891.86	37.33	2.396	----	----	----	----	----	----	----	2.396
6.13	0.000	891.71	37.33	2.282	----	----	----	----	----	----	----	2.282
6.27	0.000	891.53	37.33	2.143	----	----	----	----	----	----	----	2.143
6.40	0.000	891.37	37.33	2.004	----	----	----	----	----	----	----	2.004

Continues on next page...

&lt;no description&gt;

**Hydrograph Discharge Table**

<b>Time (hrs)</b>	<b>Inflow cfs</b>	<b>Elevation ft</b>	<b>Clv A cfs</b>	<b>Clv B cfs</b>	<b>Clv C cfs</b>	<b>PfRsr cfs</b>	<b>Wr A cfs</b>	<b>Wr B cfs</b>	<b>Wr C cfs</b>	<b>Wr D cfs</b>	<b>Exfil cfs</b>	<b>Outflow cfs</b>
6.53	0.000	891.21	37.33	1.853	----	----	----	----	----	----	----	1.853
6.67	0.000	891.06	37.33	1.700	----	----	----	----	----	----	----	1.700
6.80	0.000	890.92	37.33	1.546	----	----	----	----	----	----	----	1.546
6.93	0.000	890.77	37.33	1.327	----	----	----	----	----	----	----	1.327
7.07	0.000	890.65	37.33	0.989	----	----	----	----	----	----	----	0.989
7.20	0.000	890.37	37.33	0.647	----	----	----	----	----	----	----	0.647
7.33	0.000	890.49	37.33	0.920	----	----	----	----	----	----	----	0.920
7.47	0.000	890.37	37.33	0.644	----	----	----	----	----	----	----	0.644
7.60	0.000	890.28	37.33	0.397	----	----	----	----	----	----	----	0.397
7.73	0.000	890.22	37.33	0.259	----	----	----	----	----	----	----	0.259
7.87	0.000	890.18	37.33	0.179	----	----	----	----	----	----	----	0.178
8.00	0.000	890.15	37.33	0.131	----	----	----	----	----	----	----	0.131
8.13	0.000	890.13	37.33	0.098	----	----	----	----	----	----	----	0.098
8.27	0.000	890.11	37.33	0.078	----	----	----	----	----	----	----	0.078
8.40	0.000	890.10	37.33	0.062	----	----	----	----	----	----	----	0.061
8.53	0.000	890.09	37.33	0.049	----	----	----	----	----	----	----	0.049
8.67	0.000	890.08	37.33	0.042	----	----	----	----	----	----	----	0.042
8.80	0.000	890.07	37.33	0.036	----	----	----	----	----	----	----	0.036

...End

## Pond No. 1 - BMP-H

### Pond Data

**UG Chambers** -Invert elev. = 890.00 ft, Rise x Span = 4.50 x 4.50 ft, Barrel Len = 360.00 ft, No. Barrels = 4, Slope = 0.00%, Headers = No  
**Contours** -User-defined contour areas. Conic method used for volume calculation. Begining Elevation = 899.99 ft

### Stage / Storage Table

Stage (ft)	Elevation (ft)	Contour area (sqft)	Incr. Storage (cuft)	Total storage (cuft)
0.00	890.00	n/a	0	0
0.45	890.45	n/a	1,195	1,195
0.90	890.90	n/a	2,069	3,263
1.35	891.35	n/a	2,519	5,783
1.80	891.80	n/a	2,775	8,557
2.25	892.25	n/a	2,899	11,456
2.70	892.70	n/a	2,899	14,355
3.15	893.15	n/a	2,774	17,129
3.60	893.60	n/a	2,518	19,647
4.05	894.05	n/a	2,070	21,716
4.50	894.50	n/a	1,190	22,907
17.99	899.99	1,543	6,935	29,842
18.49	900.49	1,799	834	30,677
18.99	900.99	2,364	1,037	31,714

### Culvert / Orifice Structures

	[A]	[B]	[C]	[PrfRsr]
Rise (in)	= 18.00	6.00	6.00	0.00
Span (in)	= 18.00	6.00	6.00	0.00
No. Barrels	= 1	2	4	0
Invert El. (ft)	= 870.00	890.00	899.00	0.00
Length (ft)	= 18.00	0.50	0.50	0.00
Slope (%)	= 0.50	0.00	0.00	n/a
N-Value	= .013	.013	.013	n/a
Orifice Coeff.	= 0.60	0.60	0.60	0.60
Multi-Stage	= n/a	No	No	No

### Weir Structures

	[A]	[B]	[C]	[D]
Crest Len (ft)	= 12.00	0.00	0.00	0.00
Crest El. (ft)	= 901.00	0.00	0.00	0.00
Weir Coeff.	= 3.33	3.33	3.33	3.33
Weir Type	= 1	---	---	---
Multi-Stage	= Yes	No	No	No
Exfil.(in/hr)	= 0.000 (by Contour)			
TW Elev. (ft)	= 0.00			

Note: Culvert/Orifice outflows are analyzed under inlet (ic) and outlet (oc) control. Weir risers checked for orifice conditions (ic) and submergence (s).

### Stage / Storage / Discharge Table

Stage ft	Storage cuft	Elevation ft	Clv A cfs	Clv B cfs	Clv C cfs	PrfRsr cfs	Wr A cfs	Wr B cfs	Wr C cfs	Wr D cfs	Exfil cfs	User cfs	Total cfs
0.00	0	890.00	0.00	0.00	0.00	---	0.00	---	---	---	---	---	0.000
0.05	119	890.04	37.33 ic	0.01 ic	0.00	---	0.00	---	---	---	---	---	0.013
0.09	239	890.09	37.33 ic	0.05 ic	0.00	---	0.00	---	---	---	---	---	0.049
0.14	358	890.13	37.33 ic	0.11 ic	0.00	---	0.00	---	---	---	---	---	0.107
0.18	478	890.18	37.33 ic	0.18 ic	0.00	---	0.00	---	---	---	---	---	0.184
0.22	597	890.22	37.33 ic	0.28 ic	0.00	---	0.00	---	---	---	---	---	0.277
0.27	717	890.27	37.33 ic	0.38 ic	0.00	---	0.00	---	---	---	---	---	0.383
0.31	836	890.31	37.33 ic	0.50 ic	0.00	---	0.00	---	---	---	---	---	0.498
0.36	956	890.36	37.33 ic	0.62 ic	0.00	---	0.00	---	---	---	---	---	0.618
0.40	1,075	890.40	37.33 ic	0.74 ic	0.00	---	0.00	---	---	---	---	---	0.738
0.45	1,195	890.45	37.33 ic	0.85 ic	0.00	---	0.00	---	---	---	---	---	0.850
0.50	1,402	890.49	37.33 ic	0.94 ic	0.00	---	0.00	---	---	---	---	---	0.939
0.54	1,609	890.54	37.33 ic	0.51 oc	0.00	---	0.00	---	---	---	---	---	0.508
0.58	1,815	890.59	37.33 ic	0.74 oc	0.00	---	0.00	---	---	---	---	---	0.740
0.63	2,022	890.63	37.33 ic	0.92 oc	0.00	---	0.00	---	---	---	---	---	0.916
0.68	2,229	890.67	37.33 ic	1.06 oc	0.00	---	0.00	---	---	---	---	---	1.062
0.72	2,436	890.72	37.33 ic	1.19 oc	0.00	---	0.00	---	---	---	---	---	1.191
0.76	2,643	890.76	37.33 ic	1.31 oc	0.00	---	0.00	---	---	---	---	---	1.307
0.81	2,850	890.81	37.33 ic	1.41 oc	0.00	---	0.00	---	---	---	---	---	1.414
0.86	3,057	890.85	37.33 ic	1.47 ic	0.00	---	0.00	---	---	---	---	---	1.470
0.90	3,263	890.90	37.33 ic	1.52 ic	0.00	---	0.00	---	---	---	---	---	1.524
0.94	3,515	890.95	37.33 ic	1.58 ic	0.00	---	0.00	---	---	---	---	---	1.576
0.99	3,767	890.99	37.33 ic	1.63 ic	0.00	---	0.00	---	---	---	---	---	1.626
1.03	4,019	891.03	37.33 ic	1.68 ic	0.00	---	0.00	---	---	---	---	---	1.675
1.08	4,271	891.08	37.33 ic	1.72 ic	0.00	---	0.00	---	---	---	---	---	1.722
1.13	4,523	891.12	37.33 ic	1.77 ic	0.00	---	0.00	---	---	---	---	---	1.768
1.17	4,775	891.17	37.33 ic	1.81 ic	0.00	---	0.00	---	---	---	---	---	1.813
1.22	5,027	891.21	37.33 ic	1.86 ic	0.00	---	0.00	---	---	---	---	---	1.857

Continues on next page...



BMP-H

**Stage / Storage / Discharge Table**

Stage ft	Storage cuft	Elevation ft	Clv A cfs	Clv B cfs	Clv C cfs	PrfRsr cfs	Wr A cfs	Wr B cfs	Wr C cfs	Wr D cfs	Exfil cfs	User cfs	Total cfs
1.26	5,279	891.26	37.33 ic	1.90 ic	0.00	---	0.00	---	---	---	---	---	1.900
1.30	5,531	891.30	37.33 ic	1.94 ic	0.00	---	0.00	---	---	---	---	---	1.942
1.35	5,783	891.35	37.33 ic	1.98 ic	0.00	---	0.00	---	---	---	---	---	1.983
1.39	6,060	891.40	37.33 ic	2.02 ic	0.00	---	0.00	---	---	---	---	---	2.023
1.44	6,337	891.44	37.33 ic	2.06 ic	0.00	---	0.00	---	---	---	---	---	2.062
1.49	6,615	891.48	37.33 ic	2.10 ic	0.00	---	0.00	---	---	---	---	---	2.101
1.53	6,892	891.53	37.33 ic	2.14 ic	0.00	---	0.00	---	---	---	---	---	2.139
1.58	7,170	891.57	37.33 ic	2.18 ic	0.00	---	0.00	---	---	---	---	---	2.176
1.62	7,447	891.62	37.33 ic	2.21 ic	0.00	---	0.00	---	---	---	---	---	2.213
1.66	7,725	891.66	37.33 ic	2.25 ic	0.00	---	0.00	---	---	---	---	---	2.249
1.71	8,002	891.71	37.33 ic	2.28 ic	0.00	---	0.00	---	---	---	---	---	2.284
1.75	8,280	891.75	37.33 ic	2.32 ic	0.00	---	0.00	---	---	---	---	---	2.319
1.80	8,557	891.80	37.33 ic	2.35 ic	0.00	---	0.00	---	---	---	---	---	2.354
1.85	8,847	891.84	37.33 ic	2.39 ic	0.00	---	0.00	---	---	---	---	---	2.388
1.89	9,137	891.89	37.33 ic	2.42 ic	0.00	---	0.00	---	---	---	---	---	2.421
1.93	9,427	891.93	37.33 ic	2.45 ic	0.00	---	0.00	---	---	---	---	---	2.454
1.98	9,717	891.98	37.33 ic	2.49 ic	0.00	---	0.00	---	---	---	---	---	2.487
2.03	10,007	892.02	37.33 ic	2.52 ic	0.00	---	0.00	---	---	---	---	---	2.519
2.07	10,296	892.07	37.33 ic	2.55 ic	0.00	---	0.00	---	---	---	---	---	2.550
2.12	10,586	892.11	37.33 ic	2.58 ic	0.00	---	0.00	---	---	---	---	---	2.582
2.16	10,876	892.16	37.33 ic	2.61 ic	0.00	---	0.00	---	---	---	---	---	2.613
2.20	11,166	892.20	37.33 ic	2.64 ic	0.00	---	0.00	---	---	---	---	---	2.643
2.25	11,456	892.25	37.33 ic	2.67 ic	0.00	---	0.00	---	---	---	---	---	2.674
2.30	11,746	892.29	37.33 ic	2.70 ic	0.00	---	0.00	---	---	---	---	---	2.704
2.34	12,036	892.34	37.33 ic	2.73 ic	0.00	---	0.00	---	---	---	---	---	2.733
2.38	12,326	892.38	37.33 ic	2.76 ic	0.00	---	0.00	---	---	---	---	---	2.762
2.43	12,616	892.43	37.33 ic	2.79 ic	0.00	---	0.00	---	---	---	---	---	2.791
2.47	12,905	892.47	37.33 ic	2.82 ic	0.00	---	0.00	---	---	---	---	---	2.820
2.52	13,195	892.52	37.33 ic	2.85 ic	0.00	---	0.00	---	---	---	---	---	2.848
2.57	13,485	892.56	37.33 ic	2.88 ic	0.00	---	0.00	---	---	---	---	---	2.876
2.61	13,775	892.61	37.33 ic	2.90 ic	0.00	---	0.00	---	---	---	---	---	2.904
2.66	14,065	892.65	37.33 ic	2.93 ic	0.00	---	0.00	---	---	---	---	---	2.932
2.70	14,355	892.70	37.33 ic	2.96 ic	0.00	---	0.00	---	---	---	---	---	2.959
2.74	14,632	892.74	37.33 ic	2.99 ic	0.00	---	0.00	---	---	---	---	---	2.986
2.79	14,910	892.79	37.33 ic	3.01 ic	0.00	---	0.00	---	---	---	---	---	3.013
2.84	15,187	892.84	37.33 ic	3.04 ic	0.00	---	0.00	---	---	---	---	---	3.040
2.88	15,464	892.88	37.33 ic	3.07 ic	0.00	---	0.00	---	---	---	---	---	3.066
2.92	15,742	892.92	37.33 ic	3.09 ic	0.00	---	0.00	---	---	---	---	---	3.092
2.97	16,019	892.97	37.33 ic	3.12 ic	0.00	---	0.00	---	---	---	---	---	3.118
3.02	16,297	893.01	37.33 ic	3.14 ic	0.00	---	0.00	---	---	---	---	---	3.144
3.06	16,574	893.06	37.33 ic	3.17 ic	0.00	---	0.00	---	---	---	---	---	3.169
3.11	16,851	893.10	37.33 ic	3.19 ic	0.00	---	0.00	---	---	---	---	---	3.194
3.15	17,129	893.15	37.33 ic	3.22 ic	0.00	---	0.00	---	---	---	---	---	3.220
3.19	17,380	893.20	37.33 ic	3.24 ic	0.00	---	0.00	---	---	---	---	---	3.244
3.24	17,632	893.24	37.33 ic	3.27 ic	0.00	---	0.00	---	---	---	---	---	3.269
3.29	17,884	893.28	37.33 ic	3.29 ic	0.00	---	0.00	---	---	---	---	---	3.294
3.33	18,136	893.33	37.33 ic	3.32 ic	0.00	---	0.00	---	---	---	---	---	3.318
3.38	18,388	893.37	37.33 ic	3.34 ic	0.00	---	0.00	---	---	---	---	---	3.342
3.42	18,639	893.42	37.33 ic	3.37 ic	0.00	---	0.00	---	---	---	---	---	3.366
3.47	18,891	893.46	37.33 ic	3.39 ic	0.00	---	0.00	---	---	---	---	---	3.390
3.51	19,143	893.51	37.33 ic	3.41 ic	0.00	---	0.00	---	---	---	---	---	3.414
3.56	19,395	893.55	37.33 ic	3.44 ic	0.00	---	0.00	---	---	---	---	---	3.437
3.60	19,647	893.60	37.33 ic	3.46 ic	0.00	---	0.00	---	---	---	---	---	3.460
3.64	19,854	893.65	37.33 ic	3.48 ic	0.00	---	0.00	---	---	---	---	---	3.484
3.69	20,061	893.69	37.33 ic	3.51 ic	0.00	---	0.00	---	---	---	---	---	3.507
3.73	20,268	893.73	37.33 ic	3.53 ic	0.00	---	0.00	---	---	---	---	---	3.529
3.78	20,474	893.78	37.33 ic	3.55 ic	0.00	---	0.00	---	---	---	---	---	3.552
3.83	20,681	893.82	37.33 ic	3.57 ic	0.00	---	0.00	---	---	---	---	---	3.575
3.87	20,888	893.87	37.33 ic	3.60 ic	0.00	---	0.00	---	---	---	---	---	3.597
3.92	21,095	893.91	37.33 ic	3.62 ic	0.00	---	0.00	---	---	---	---	---	3.619
3.96	21,302	893.96	37.33 ic	3.64 ic	0.00	---	0.00	---	---	---	---	---	3.641
4.01	21,509	894.00	37.33 ic	3.66 ic	0.00	---	0.00	---	---	---	---	---	3.663
4.05	21,716	894.05	37.33 ic	3.69 ic	0.00	---	0.00	---	---	---	---	---	3.685
4.09	21,835	894.09	37.33 ic	3.71 ic	0.00	---	0.00	---	---	---	---	---	3.707
4.14	21,954	894.14	37.33 ic	3.73 ic	0.00	---	0.00	---	---	---	---	---	3.729
4.18	22,073	894.18	37.33 ic	3.75 ic	0.00	---	0.00	---	---	---	---	---	3.750
4.23	22,193	894.23	37.33 ic	3.77 ic	0.00	---	0.00	---	---	---	---	---	3.772
4.28	22,312	894.27	37.33 ic	3.79 ic	0.00	---	0.00	---	---	---	---	---	3.793
4.32	22,431	894.32	37.33 ic	3.81 ic	0.00	---	0.00	---	---	---	---	---	3.814
4.37	22,550	894.36	37.33 ic	3.84 ic	0.00	---	0.00	---	---	---	---	---	3.835
4.41	22,669	894.41	37.33 ic	3.86 ic	0.00	---	0.00	---	---	---	---	---	3.856
4.46	22,788	894.45	37.33 ic	3.88 ic	0.00	---	0.00	---	---	---	---	---	3.877

Continues on next page...

BMP-H

**Stage / Storage / Discharge Table**

Stage ft	Storage cuft	Elevation ft	Clv A cfs	Clv B cfs	Clv C cfs	PrfRsr cfs	Wr A cfs	Wr B cfs	Wr C cfs	Wr D cfs	Exfil cfs	User cfs	Total cfs
4.50	22,907	894.50	37.33 ic	3.90 ic	0.00	---	0.00	---	---	---	---	---	3.898
5.85	23,600	895.85	37.33 ic	4.47 ic	0.00	---	0.00	---	---	---	---	---	4.474
7.20	24,294	897.20	37.33 ic	4.98 ic	0.00	---	0.00	---	---	---	---	---	4.983
8.55	24,987	898.55	37.33 ic	5.45 ic	0.00	---	0.00	---	---	---	---	---	5.446
9.90	25,681	899.90	37.33 ic	5.87 ic	3.04 ic	---	0.00	---	---	---	---	---	8.911
11.24	26,375	901.24	37.33 ic	6.27 ic	5.34 ic	---	4.85	---	---	---	---	---	16.46
12.59	27,068	902.59	47.79 ic	6.64 ic	6.91 ic	---	47.79 s	---	---	---	---	---	61.34
13.94	27,762	903.94	48.98 ic	7.00 ic	8.19 ic	---	48.96 s	---	---	---	---	---	64.14
15.29	28,455	905.29	49.99 ic	7.33 ic	9.29 ic	---	49.92 s	---	---	---	---	---	66.55
16.64	29,149	906.64	50.96 ic	7.65 ic	10.28 ic	---	50.89 s	---	---	---	---	---	68.82
17.99	29,842	899.99	0.00	5.90 ic	3.25 ic	---	0.00	---	---	---	---	---	9.153
18.04	29,926	900.04	0.00	5.92 ic	3.36 ic	---	0.00	---	---	---	---	---	9.276
18.09	30,009	900.09	0.00	5.93 ic	3.47 ic	---	0.00	---	---	---	---	---	9.396
18.14	30,093	900.14	0.00	5.95 ic	3.57 ic	---	0.00	---	---	---	---	---	9.513
18.19	30,176	900.19	0.00	5.96 ic	3.67 ic	---	0.00	---	---	---	---	---	9.627
18.24	30,259	900.24	0.00	5.98 ic	3.76 ic	---	0.00	---	---	---	---	---	9.738
18.29	30,343	900.29	0.00	5.99 ic	3.86 ic	---	0.00	---	---	---	---	---	9.846
18.34	30,426	900.34	0.00	6.01 ic	3.95 ic	---	0.00	---	---	---	---	---	9.953
18.39	30,510	900.39	0.00	6.02 ic	4.04 ic	---	0.00	---	---	---	---	---	10.06
18.44	30,593	900.44	0.00	6.04 ic	4.12 ic	---	0.00	---	---	---	---	---	10.16
18.49	30,677	900.49	0.00	6.05 ic	4.21 ic	---	0.00	---	---	---	---	---	10.26
18.54	30,780	900.54	0.00	6.06 ic	4.29 ic	---	0.00	---	---	---	---	---	10.36
18.59	30,884	900.59	0.00	6.08 ic	4.38 ic	---	0.00	---	---	---	---	---	10.46
18.64	30,988	900.64	0.00	6.09 ic	4.46 ic	---	0.00	---	---	---	---	---	10.55
18.69	31,092	900.69	0.00	6.11 ic	4.54 ic	---	0.00	---	---	---	---	---	10.65
18.74	31,195	900.74	0.00	6.12 ic	4.62 ic	---	0.00	---	---	---	---	---	10.74
18.79	31,299	900.79	0.00	6.14 ic	4.69 ic	---	0.00	---	---	---	---	---	10.83
18.84	31,403	900.84	0.00	6.15 ic	4.77 ic	---	0.00	---	---	---	---	---	10.92
18.89	31,507	900.89	0.00	6.17 ic	4.84 ic	---	0.00	---	---	---	---	---	11.01
18.94	31,610	900.94	0.00	6.18 ic	4.92 ic	---	0.00	---	---	---	---	---	11.10
18.99	31,714	900.99	0.00	6.20 ic	4.99 ic	---	0.00	---	---	---	---	---	11.18

...End

## Pond No. 1 - BMP-H

### Pond Data

**UG Chambers** -Invert elev. = 890.00 ft, Rise x Span = 4.50 x 4.50 ft, Barrel Len = 360.00 ft, No. Barrels = 4, Slope = 0.00%, Headers = No  
**Contours** -User-defined contour areas. Conic method used for volume calculation. Begining Elevation = 899.99 ft

### Stage / Storage Table

Stage (ft)	Elevation (ft)	Contour area (sqft)	Incr. Storage (cuft)	Total storage (cuft)
0.00	890.00	n/a	0	0
0.45	890.45	n/a	1,195	1,195
0.90	890.90	n/a	2,069	3,263
1.35	891.35	n/a	2,519	5,783
1.80	891.80	n/a	2,775	8,557
2.25	892.25	n/a	2,899	11,456
2.70	892.70	n/a	2,899	14,355
3.15	893.15	n/a	2,774	17,129
3.60	893.60	n/a	2,518	19,647
4.05	894.05	n/a	2,070	21,716
4.50	894.50	n/a	1,190	22,907
17.99	899.99	1,543	6,935	29,842
18.49	900.49	1,799	834	30,677
18.99	900.99	2,364	1,037	31,714

### Culvert / Orifice Structures

	[A]	[B]	[C]	[PrfRsr]
Rise (in)	= 18.00	6.00	6.00	0.00
Span (in)	= 18.00	6.00	6.00	0.00
No. Barrels	= 1	2	4	0
Invert El. (ft)	= 870.00	890.00	899.00	0.00
Length (ft)	= 18.00	0.50	0.50	0.00
Slope (%)	= 0.50	0.00	0.00	n/a
N-Value	= .013	.013	.013	n/a
Orifice Coeff.	= 0.60	0.60	0.60	0.60
Multi-Stage	= n/a	No	No	No

### Weir Structures

	[A]	[B]	[C]	[D]
Crest Len (ft)	= 12.00	0.00	0.00	0.00
Crest El. (ft)	= 901.00	0.00	0.00	0.00
Weir Coeff.	= 3.33	3.33	3.33	3.33
Weir Type	= 1	---	---	---
Multi-Stage	= Yes	No	No	No
Exfil.(in/hr)	= 0.000 (by Contour)			
TW Elev. (ft)	= 0.00			

Note: Culvert/Orifice outflows are analyzed under inlet (ic) and outlet (oc) control. Weir risers checked for orifice conditions (ic) and submergence (s).

### Stage / Storage / Discharge Table

Stage ft	Storage cuft	Elevation ft	Clv A cfs	Clv B cfs	Clv C cfs	PrfRsr cfs	Wr A cfs	Wr B cfs	Wr C cfs	Wr D cfs	Exfil cfs	User cfs	Total cfs
0.00	0	890.00	0.00	0.00	0.00	---	0.00	---	---	---	---	---	0.000
0.05	119	890.04	37.33 ic	0.01 ic	0.00	---	0.00	---	---	---	---	---	0.013
0.09	239	890.09	37.33 ic	0.05 ic	0.00	---	0.00	---	---	---	---	---	0.049
0.14	358	890.13	37.33 ic	0.11 ic	0.00	---	0.00	---	---	---	---	---	0.107
0.18	478	890.18	37.33 ic	0.18 ic	0.00	---	0.00	---	---	---	---	---	0.184
0.22	597	890.22	37.33 ic	0.28 ic	0.00	---	0.00	---	---	---	---	---	0.277
0.27	717	890.27	37.33 ic	0.38 ic	0.00	---	0.00	---	---	---	---	---	0.383
0.31	836	890.31	37.33 ic	0.50 ic	0.00	---	0.00	---	---	---	---	---	0.498
0.36	956	890.36	37.33 ic	0.62 ic	0.00	---	0.00	---	---	---	---	---	0.618
0.40	1,075	890.40	37.33 ic	0.74 ic	0.00	---	0.00	---	---	---	---	---	0.738
0.45	1,195	890.45	37.33 ic	0.85 ic	0.00	---	0.00	---	---	---	---	---	0.850
0.50	1,402	890.49	37.33 ic	0.94 ic	0.00	---	0.00	---	---	---	---	---	0.939
0.54	1,609	890.54	37.33 ic	0.51 oc	0.00	---	0.00	---	---	---	---	---	0.508
0.58	1,815	890.59	37.33 ic	0.74 oc	0.00	---	0.00	---	---	---	---	---	0.740
0.63	2,022	890.63	37.33 ic	0.92 oc	0.00	---	0.00	---	---	---	---	---	0.916
0.68	2,229	890.67	37.33 ic	1.06 oc	0.00	---	0.00	---	---	---	---	---	1.062
0.72	2,436	890.72	37.33 ic	1.19 oc	0.00	---	0.00	---	---	---	---	---	1.191
0.76	2,643	890.76	37.33 ic	1.31 oc	0.00	---	0.00	---	---	---	---	---	1.307
0.81	2,850	890.81	37.33 ic	1.41 oc	0.00	---	0.00	---	---	---	---	---	1.414
0.86	3,057	890.85	37.33 ic	1.47 ic	0.00	---	0.00	---	---	---	---	---	1.470
0.90	3,263	890.90	37.33 ic	1.52 ic	0.00	---	0.00	---	---	---	---	---	1.524
0.94	3,515	890.95	37.33 ic	1.58 ic	0.00	---	0.00	---	---	---	---	---	1.576
0.99	3,767	890.99	37.33 ic	1.63 ic	0.00	---	0.00	---	---	---	---	---	1.626
1.03	4,019	891.03	37.33 ic	1.68 ic	0.00	---	0.00	---	---	---	---	---	1.675
1.08	4,271	891.08	37.33 ic	1.72 ic	0.00	---	0.00	---	---	---	---	---	1.722
1.13	4,523	891.12	37.33 ic	1.77 ic	0.00	---	0.00	---	---	---	---	---	1.768
1.17	4,775	891.17	37.33 ic	1.81 ic	0.00	---	0.00	---	---	---	---	---	1.813
1.22	5,027	891.21	37.33 ic	1.86 ic	0.00	---	0.00	---	---	---	---	---	1.857

Continues on next page...

BMP-H

**Stage / Storage / Discharge Table**

Stage ft	Storage cuft	Elevation ft	Civ A cfs	Civ B cfs	Civ C cfs	PrfRsr cfs	Wr A cfs	Wr B cfs	Wr C cfs	Wr D cfs	Exfil cfs	User cfs	Total cfs
1.26	5,279	891.26	37.33 ic	1.90 ic	0.00	---	0.00	---	---	---	---	---	1.900
1.30	5,531	891.30	37.33 ic	1.94 ic	0.00	---	0.00	---	---	---	---	---	1.942
1.35	5,783	891.35	37.33 ic	1.98 ic	0.00	---	0.00	---	---	---	---	---	1.983
1.39	6,060	891.40	37.33 ic	2.02 ic	0.00	---	0.00	---	---	---	---	---	2.023
1.44	6,337	891.44	37.33 ic	2.06 ic	0.00	---	0.00	---	---	---	---	---	2.062
1.49	6,615	891.48	37.33 ic	2.10 ic	0.00	---	0.00	---	---	---	---	---	2.101
1.53	6,892	891.53	37.33 ic	2.14 ic	0.00	---	0.00	---	---	---	---	---	2.139
1.58	7,170	891.57	37.33 ic	2.18 ic	0.00	---	0.00	---	---	---	---	---	2.176
1.62	7,447	891.62	37.33 ic	2.21 ic	0.00	---	0.00	---	---	---	---	---	2.213
1.66	7,725	891.66	37.33 ic	2.25 ic	0.00	---	0.00	---	---	---	---	---	2.249
1.71	8,002	891.71	37.33 ic	2.28 ic	0.00	---	0.00	---	---	---	---	---	2.284
1.75	8,280	891.75	37.33 ic	2.32 ic	0.00	---	0.00	---	---	---	---	---	2.319
1.80	8,557	891.80	37.33 ic	2.35 ic	0.00	---	0.00	---	---	---	---	---	2.354
1.85	8,847	891.84	37.33 ic	2.39 ic	0.00	---	0.00	---	---	---	---	---	2.388
1.89	9,137	891.89	37.33 ic	2.42 ic	0.00	---	0.00	---	---	---	---	---	2.421
1.93	9,427	891.93	37.33 ic	2.45 ic	0.00	---	0.00	---	---	---	---	---	2.454
1.98	9,717	891.98	37.33 ic	2.49 ic	0.00	---	0.00	---	---	---	---	---	2.487
2.03	10,007	892.02	37.33 ic	2.52 ic	0.00	---	0.00	---	---	---	---	---	2.519
2.07	10,296	892.07	37.33 ic	2.55 ic	0.00	---	0.00	---	---	---	---	---	2.550
2.12	10,586	892.11	37.33 ic	2.58 ic	0.00	---	0.00	---	---	---	---	---	2.582
2.16	10,876	892.16	37.33 ic	2.61 ic	0.00	---	0.00	---	---	---	---	---	2.613
2.20	11,166	892.20	37.33 ic	2.64 ic	0.00	---	0.00	---	---	---	---	---	2.643
2.25	11,456	892.25	37.33 ic	2.67 ic	0.00	---	0.00	---	---	---	---	---	2.674
2.30	11,746	892.29	37.33 ic	2.70 ic	0.00	---	0.00	---	---	---	---	---	2.704
2.34	12,036	892.34	37.33 ic	2.73 ic	0.00	---	0.00	---	---	---	---	---	2.733
2.38	12,326	892.38	37.33 ic	2.76 ic	0.00	---	0.00	---	---	---	---	---	2.762
2.43	12,616	892.43	37.33 ic	2.79 ic	0.00	---	0.00	---	---	---	---	---	2.791
2.47	12,905	892.47	37.33 ic	2.82 ic	0.00	---	0.00	---	---	---	---	---	2.820
2.52	13,195	892.52	37.33 ic	2.85 ic	0.00	---	0.00	---	---	---	---	---	2.848
2.57	13,485	892.56	37.33 ic	2.88 ic	0.00	---	0.00	---	---	---	---	---	2.876
2.61	13,775	892.61	37.33 ic	2.90 ic	0.00	---	0.00	---	---	---	---	---	2.904
2.66	14,065	892.65	37.33 ic	2.93 ic	0.00	---	0.00	---	---	---	---	---	2.932
2.70	14,355	892.70	37.33 ic	2.96 ic	0.00	---	0.00	---	---	---	---	---	2.959
2.74	14,632	892.74	37.33 ic	2.99 ic	0.00	---	0.00	---	---	---	---	---	2.986
2.79	14,910	892.79	37.33 ic	3.01 ic	0.00	---	0.00	---	---	---	---	---	3.013
2.84	15,187	892.84	37.33 ic	3.04 ic	0.00	---	0.00	---	---	---	---	---	3.040
2.88	15,464	892.88	37.33 ic	3.07 ic	0.00	---	0.00	---	---	---	---	---	3.066
2.92	15,742	892.92	37.33 ic	3.09 ic	0.00	---	0.00	---	---	---	---	---	3.092
2.97	16,019	892.97	37.33 ic	3.12 ic	0.00	---	0.00	---	---	---	---	---	3.118
3.02	16,297	893.01	37.33 ic	3.14 ic	0.00	---	0.00	---	---	---	---	---	3.144
3.06	16,574	893.06	37.33 ic	3.17 ic	0.00	---	0.00	---	---	---	---	---	3.169
3.11	16,851	893.10	37.33 ic	3.19 ic	0.00	---	0.00	---	---	---	---	---	3.194
3.15	17,129	893.15	37.33 ic	3.22 ic	0.00	---	0.00	---	---	---	---	---	3.220
3.19	17,380	893.20	37.33 ic	3.24 ic	0.00	---	0.00	---	---	---	---	---	3.244
3.24	17,632	893.24	37.33 ic	3.27 ic	0.00	---	0.00	---	---	---	---	---	3.269
3.29	17,884	893.28	37.33 ic	3.29 ic	0.00	---	0.00	---	---	---	---	---	3.294
3.33	18,136	893.33	37.33 ic	3.32 ic	0.00	---	0.00	---	---	---	---	---	3.318
3.38	18,388	893.37	37.33 ic	3.34 ic	0.00	---	0.00	---	---	---	---	---	3.342
3.42	18,639	893.42	37.33 ic	3.37 ic	0.00	---	0.00	---	---	---	---	---	3.366
3.47	18,891	893.46	37.33 ic	3.39 ic	0.00	---	0.00	---	---	---	---	---	3.390
3.51	19,143	893.51	37.33 ic	3.41 ic	0.00	---	0.00	---	---	---	---	---	3.414
3.56	19,395	893.55	37.33 ic	3.44 ic	0.00	---	0.00	---	---	---	---	---	3.437
3.60	19,647	893.60	37.33 ic	3.46 ic	0.00	---	0.00	---	---	---	---	---	3.460
3.64	19,854	893.65	37.33 ic	3.48 ic	0.00	---	0.00	---	---	---	---	---	3.484
3.69	20,061	893.69	37.33 ic	3.51 ic	0.00	---	0.00	---	---	---	---	---	3.507
3.73	20,268	893.73	37.33 ic	3.53 ic	0.00	---	0.00	---	---	---	---	---	3.529
3.78	20,474	893.78	37.33 ic	3.55 ic	0.00	---	0.00	---	---	---	---	---	3.552
3.83	20,681	893.82	37.33 ic	3.57 ic	0.00	---	0.00	---	---	---	---	---	3.575
3.87	20,888	893.87	37.33 ic	3.60 ic	0.00	---	0.00	---	---	---	---	---	3.597
3.92	21,095	893.91	37.33 ic	3.62 ic	0.00	---	0.00	---	---	---	---	---	3.619
3.96	21,302	893.96	37.33 ic	3.64 ic	0.00	---	0.00	---	---	---	---	---	3.641
4.01	21,509	894.00	37.33 ic	3.66 ic	0.00	---	0.00	---	---	---	---	---	3.663
4.05	21,716	894.05	37.33 ic	3.69 ic	0.00	---	0.00	---	---	---	---	---	3.685
4.09	21,835	894.09	37.33 ic	3.71 ic	0.00	---	0.00	---	---	---	---	---	3.707
4.14	21,954	894.14	37.33 ic	3.73 ic	0.00	---	0.00	---	---	---	---	---	3.729
4.18	22,073	894.18	37.33 ic	3.75 ic	0.00	---	0.00	---	---	---	---	---	3.750
4.23	22,193	894.23	37.33 ic	3.77 ic	0.00	---	0.00	---	---	---	---	---	3.772
4.28	22,312	894.27	37.33 ic	3.79 ic	0.00	---	0.00	---	---	---	---	---	3.793
4.32	22,431	894.32	37.33 ic	3.81 ic	0.00	---	0.00	---	---	---	---	---	3.814
4.37	22,550	894.36	37.33 ic	3.84 ic	0.00	---	0.00	---	---	---	---	---	3.835
4.41	22,669	894.41	37.33 ic	3.86 ic	0.00	---	0.00	---	---	---	---	---	3.856
4.46	22,788	894.45	37.33 ic	3.88 ic	0.00	---	0.00	---	---	---	---	---	3.877

Continues on next page...

BMP-H

**Stage / Storage / Discharge Table**

Stage ft	Storage cuft	Elevation ft	Clv A cfs	Clv B cfs	Clv C cfs	PrfRsr cfs	Wr A cfs	Wr B cfs	Wr C cfs	Wr D cfs	Exfil cfs	User cfs	Total cfs
4.50	22,907	894.50	37.33 ic	3.90 ic	0.00	---	0.00	---	---	---	---	---	3.898
5.85	23,600	895.85	37.33 ic	4.47 ic	0.00	---	0.00	---	---	---	---	---	4.474
7.20	24,294	897.20	37.33 ic	4.98 ic	0.00	---	0.00	---	---	---	---	---	4.983
8.55	24,987	898.55	37.33 ic	5.45 ic	0.00	---	0.00	---	---	---	---	---	5.446
9.90	25,681	899.90	37.33 ic	5.87 ic	3.04 ic	---	0.00	---	---	---	---	---	8.911
11.24	26,375	901.24	37.33 ic	6.27 ic	5.34 ic	---	4.85	---	---	---	---	---	16.46
12.59	27,068	902.59	47.79 ic	6.64 ic	6.91 ic	---	47.79 s	---	---	---	---	---	61.34
13.94	27,762	903.94	48.98 ic	7.00 ic	8.19 ic	---	48.96 s	---	---	---	---	---	64.14
15.29	28,455	905.29	49.99 ic	7.33 ic	9.29 ic	---	49.92 s	---	---	---	---	---	66.55
16.64	29,149	906.64	50.96 ic	7.65 ic	10.28 ic	---	50.89 s	---	---	---	---	---	68.82
17.99	29,842	899.99	0.00	5.90 ic	3.25 ic	---	0.00	---	---	---	---	---	9.153
18.04	29,926	900.04	0.00	5.92 ic	3.36 ic	---	0.00	---	---	---	---	---	9.276
18.09	30,009	900.09	0.00	5.93 ic	3.47 ic	---	0.00	---	---	---	---	---	9.396
18.14	30,093	900.14	0.00	5.95 ic	3.57 ic	---	0.00	---	---	---	---	---	9.513
18.19	30,176	900.19	0.00	5.96 ic	3.67 ic	---	0.00	---	---	---	---	---	9.627
18.24	30,259	900.24	0.00	5.98 ic	3.76 ic	---	0.00	---	---	---	---	---	9.738
18.29	30,343	900.29	0.00	5.99 ic	3.86 ic	---	0.00	---	---	---	---	---	9.846
18.34	30,426	900.34	0.00	6.01 ic	3.95 ic	---	0.00	---	---	---	---	---	9.953
18.39	30,510	900.39	0.00	6.02 ic	4.04 ic	---	0.00	---	---	---	---	---	10.06
18.44	30,593	900.44	0.00	6.04 ic	4.12 ic	---	0.00	---	---	---	---	---	10.16
18.49	30,677	900.49	0.00	6.05 ic	4.21 ic	---	0.00	---	---	---	---	---	10.26
18.54	30,780	900.54	0.00	6.06 ic	4.29 ic	---	0.00	---	---	---	---	---	10.36
18.59	30,884	900.59	0.00	6.08 ic	4.38 ic	---	0.00	---	---	---	---	---	10.46
18.64	30,988	900.64	0.00	6.09 ic	4.46 ic	---	0.00	---	---	---	---	---	10.55
18.69	31,092	900.69	0.00	6.11 ic	4.54 ic	---	0.00	---	---	---	---	---	10.65
18.74	31,195	900.74	0.00	6.12 ic	4.62 ic	---	0.00	---	---	---	---	---	10.74
18.79	31,299	900.79	0.00	6.14 ic	4.69 ic	---	0.00	---	---	---	---	---	10.83
18.84	31,403	900.84	0.00	6.15 ic	4.77 ic	---	0.00	---	---	---	---	---	10.92
18.89	31,507	900.89	0.00	6.17 ic	4.84 ic	---	0.00	---	---	---	---	---	11.01
18.94	31,610	900.94	0.00	6.18 ic	4.92 ic	---	0.00	---	---	---	---	---	11.10
18.99	31,714	900.99	0.00	6.20 ic	4.99 ic	---	0.00	---	---	---	---	---	11.18

...End

# Hydrograph Report

Hydraflow Hydrographs Extension for Autodesk® Civil 3D® 2019 by Autodesk, Inc. v2020

Tuesday, 09 / 25 / 2018

## Hyd. No. 1

Basin H

Hydrograph type	= Manual	Peak discharge	= 6.040 cfs
Storm frequency	= 50 yrs	Time to peak	= 4.20 hrs
Time interval	= 12 min	Hyd. volume	= 17,813 cuft

## Hydrograph Discharge Table

(Printed values &gt;= 1.00% of Qp.)

Time -- Outflow (hrs      cfs)	Time -- Outflow (hrs      cfs)
0.20      0.300	4.40      1.200
0.40      0.300	4.60      0.800
0.60      0.300	4.80      0.600
0.80      0.300	5.00      0.500
1.00      0.300	5.20      0.400
1.20      0.400	5.40      0.400
1.40      0.400	5.60      0.400
1.60      0.400	5.80      0.300
1.80      0.400	6.00      0.300
2.00      0.400	<i>...End</i>
2.20      0.500	
2.40      0.500	
2.60      0.500	
2.80      0.600	
3.00      0.700	
3.20      0.700	
3.40      0.900	
3.60      1.000	
3.80      1.500	
4.00      3.400	
4.20      6.040	

# Hydrograph Report

Hydraflow Hydrographs Extension for Autodesk® Civil 3D® 2019 by Autodesk, Inc. v2020

Tuesday, 09 / 25 / 2018

## Hyd. No. 2

<no description>

Hydrograph type	= Reservoir	Peak discharge	= 2.033 cfs
Storm frequency	= 50 yrs	Time to peak	= 4.40 hrs
Time interval	= 12 min	Hyd. volume	= 17,803 cuft
Inflow hyd. No.	= 1 - Basin H	Reservoir name	= BMP-H
Max. Elevation	= 891.45 ft	Max. Storage	= 6,129 cuft

Storage Indication method used.

### Hydrograph Discharge Table

(Printed values >= 1.00% of Qp.)

Time (hrs)	Inflow cfs	Elevation ft	Clv A cfs	Clv B cfs	Clv C cfs	PfRsr cfs	Wr A cfs	Wr B cfs	Wr C cfs	Wr D cfs	Exfil cfs	Outflow cfs
0.40	0.300	890.11	37.33	0.074	----	----	----	----	----	----	----	0.074
0.60	0.300	890.16	37.33	0.150	----	----	----	----	----	----	----	0.150
0.80	0.300	890.19	37.33	0.210	----	----	----	----	----	----	----	0.210
1.00	0.300	890.21	37.33	0.249	----	----	----	----	----	----	----	0.250
1.20	0.400	890.23	37.33	0.295	----	----	----	----	----	----	----	0.295
1.40	0.400	890.25	37.33	0.346	----	----	----	----	----	----	----	0.346
1.60	0.400	890.27	37.33	0.372	----	----	----	----	----	----	----	0.372
1.80	0.400	890.27	37.33	0.386	----	----	----	----	----	----	----	0.386
2.00	0.400	890.27	37.33	0.393	----	----	----	----	----	----	----	0.393
2.20	0.500	890.29	37.33	0.423	----	----	----	----	----	----	----	0.422
2.40	0.500	890.30	37.33	0.463	----	----	----	----	----	----	----	0.463
2.60	0.500	890.31	37.33	0.482	----	----	----	----	----	----	----	0.482
2.80	0.600	890.32	37.33	0.518	----	----	----	----	----	----	----	0.518
3.00	0.700	890.35	37.33	0.588	----	----	----	----	----	----	----	0.588
3.20	0.700	890.37	37.33	0.647	----	----	----	----	----	----	----	0.647
3.40	0.900	890.40	37.33	0.729	----	----	----	----	----	----	----	0.729
3.60	1.000	890.45	37.33	0.841	----	----	----	----	----	----	----	0.841
3.80	1.500	890.35	37.33	0.587	----	----	----	----	----	----	----	0.587
4.00	3.400	890.77	37.33	1.311	----	----	----	----	----	----	----	1.311
4.20	6.040 <<	891.20	37.33	1.838	----	----	----	----	----	----	----	1.838

Continues on next page...

&lt;no description&gt;

**Hydrograph Discharge Table**

Time (hrs)	Inflow cfs	Elevation ft	Clv A cfs	Clv B cfs	Clv C cfs	PfRsr cfs	Wr A cfs	Wr B cfs	Wr C cfs	Wr D cfs	Exfil cfs	Outflow cfs
4.40	1.200	891.41 <<	37.33	2.033	----	----	----	----	----	----	----	2.033
4.60	0.800	891.29	37.33	1.924	----	----	----	----	----	----	----	1.924
4.80	0.600	891.14	37.33	1.781	----	----	----	----	----	----	----	1.781
5.00	0.500	890.99	37.33	1.626	----	----	----	----	----	----	----	1.626
5.20	0.400	890.84	37.33	1.450	----	----	----	----	----	----	----	1.450
5.40	0.400	890.70	37.33	1.131	----	----	----	----	----	----	----	1.131
5.60	0.400	890.44	37.33	0.830	----	----	----	----	----	----	----	0.830
5.80	0.300	890.34	37.33	0.574	----	----	----	----	----	----	----	0.575
6.00	0.300	890.48	37.33	0.916	----	----	----	----	----	----	----	0.916
6.20	0.000	890.35	37.33	0.579	----	----	----	----	----	----	----	0.579
6.40	0.000	890.23	37.33	0.285	----	----	----	----	----	----	----	0.285
6.60	0.000	890.17	37.33	0.163	----	----	----	----	----	----	----	0.163
6.80	0.000	890.13	37.33	0.103	----	----	----	----	----	----	----	0.103
7.00	0.000	890.11	37.33	0.072	----	----	----	----	----	----	----	0.072
7.20	0.000	890.09	37.33	0.051	----	----	----	----	----	----	----	0.051
7.40	0.000	890.08	37.33	0.040	----	----	----	----	----	----	----	0.040
7.60	0.000	890.07	37.33	0.032	----	----	----	----	----	----	----	0.032
7.80	0.000	890.06	37.33	0.026	----	----	----	----	----	----	----	0.026
8.00	0.000	890.05	37.33	0.021	----	----	----	----	----	----	----	0.021

...End



## Pond No. 1 - BMP-H

### Pond Data

**UG Chambers** -Invert elev. = 890.00 ft, Rise x Span = 4.50 x 4.50 ft, Barrel Len = 360.00 ft, No. Barrels = 4, Slope = 0.00%, Headers = No  
**Contours** -User-defined contour areas. Conic method used for volume calculation. Begining Elevation = 899.99 ft

### Stage / Storage Table

Stage (ft)	Elevation (ft)	Contour area (sqft)	Incr. Storage (cuft)	Total storage (cuft)
0.00	890.00	n/a	0	0
0.45	890.45	n/a	1,195	1,195
0.90	890.90	n/a	2,069	3,263
1.35	891.35	n/a	2,519	5,783
1.80	891.80	n/a	2,775	8,557
2.25	892.25	n/a	2,899	11,456
2.70	892.70	n/a	2,899	14,355
3.15	893.15	n/a	2,774	17,129
3.60	893.60	n/a	2,518	19,647
4.05	894.05	n/a	2,070	21,716
4.50	894.50	n/a	1,190	22,907
17.99	899.99	1,543	6,935	29,842
18.49	900.49	1,799	834	30,677
18.99	900.99	2,364	1,037	31,714

### Culvert / Orifice Structures

	[A]	[B]	[C]	[PrfRsr]
Rise (in)	= 18.00	6.00	6.00	0.00
Span (in)	= 18.00	6.00	6.00	0.00
No. Barrels	= 1	2	4	0
Invert El. (ft)	= 870.00	890.00	899.00	0.00
Length (ft)	= 18.00	0.50	0.50	0.00
Slope (%)	= 0.50	0.00	0.00	n/a
N-Value	= .013	.013	.013	n/a
Orifice Coeff.	= 0.60	0.60	0.60	0.60
Multi-Stage	= n/a	No	No	No

### Weir Structures

	[A]	[B]	[C]	[D]
Crest Len (ft)	= 12.00	0.00	0.00	0.00
Crest El. (ft)	= 901.00	0.00	0.00	0.00
Weir Coeff.	= 3.33	3.33	3.33	3.33
Weir Type	= 1	---	---	---
Multi-Stage	= Yes	No	No	No
Exfil.(in/hr)	= 0.000 (by Contour)			
TW Elev. (ft)	= 0.00			

Note: Culvert/Orifice outflows are analyzed under inlet (ic) and outlet (oc) control. Weir risers checked for orifice conditions (ic) and submergence (s).

### Stage / Storage / Discharge Table

Stage ft	Storage cuft	Elevation ft	Clv A cfs	Clv B cfs	Clv C cfs	PrfRsr cfs	Wr A cfs	Wr B cfs	Wr C cfs	Wr D cfs	Exfil cfs	User cfs	Total cfs
0.00	0	890.00	0.00	0.00	0.00	---	0.00	---	---	---	---	---	0.000
0.05	119	890.04	37.33 ic	0.01 ic	0.00	---	0.00	---	---	---	---	---	0.013
0.09	239	890.09	37.33 ic	0.05 ic	0.00	---	0.00	---	---	---	---	---	0.049
0.14	358	890.13	37.33 ic	0.11 ic	0.00	---	0.00	---	---	---	---	---	0.107
0.18	478	890.18	37.33 ic	0.18 ic	0.00	---	0.00	---	---	---	---	---	0.184
0.22	597	890.22	37.33 ic	0.28 ic	0.00	---	0.00	---	---	---	---	---	0.277
0.27	717	890.27	37.33 ic	0.38 ic	0.00	---	0.00	---	---	---	---	---	0.383
0.31	836	890.31	37.33 ic	0.50 ic	0.00	---	0.00	---	---	---	---	---	0.498
0.36	956	890.36	37.33 ic	0.62 ic	0.00	---	0.00	---	---	---	---	---	0.618
0.40	1,075	890.40	37.33 ic	0.74 ic	0.00	---	0.00	---	---	---	---	---	0.738
0.45	1,195	890.45	37.33 ic	0.85 ic	0.00	---	0.00	---	---	---	---	---	0.850
0.50	1,402	890.49	37.33 ic	0.94 ic	0.00	---	0.00	---	---	---	---	---	0.939
0.54	1,609	890.54	37.33 ic	0.51 oc	0.00	---	0.00	---	---	---	---	---	0.508
0.58	1,815	890.59	37.33 ic	0.74 oc	0.00	---	0.00	---	---	---	---	---	0.740
0.63	2,022	890.63	37.33 ic	0.92 oc	0.00	---	0.00	---	---	---	---	---	0.916
0.68	2,229	890.67	37.33 ic	1.06 oc	0.00	---	0.00	---	---	---	---	---	1.062
0.72	2,436	890.72	37.33 ic	1.19 oc	0.00	---	0.00	---	---	---	---	---	1.191
0.76	2,643	890.76	37.33 ic	1.31 oc	0.00	---	0.00	---	---	---	---	---	1.307
0.81	2,850	890.81	37.33 ic	1.41 oc	0.00	---	0.00	---	---	---	---	---	1.414
0.86	3,057	890.85	37.33 ic	1.47 ic	0.00	---	0.00	---	---	---	---	---	1.470
0.90	3,263	890.90	37.33 ic	1.52 ic	0.00	---	0.00	---	---	---	---	---	1.524
0.94	3,515	890.95	37.33 ic	1.58 ic	0.00	---	0.00	---	---	---	---	---	1.576
0.99	3,767	890.99	37.33 ic	1.63 ic	0.00	---	0.00	---	---	---	---	---	1.626
1.03	4,019	891.03	37.33 ic	1.68 ic	0.00	---	0.00	---	---	---	---	---	1.675
1.08	4,271	891.08	37.33 ic	1.72 ic	0.00	---	0.00	---	---	---	---	---	1.722
1.13	4,523	891.12	37.33 ic	1.77 ic	0.00	---	0.00	---	---	---	---	---	1.768
1.17	4,775	891.17	37.33 ic	1.81 ic	0.00	---	0.00	---	---	---	---	---	1.813
1.22	5,027	891.21	37.33 ic	1.86 ic	0.00	---	0.00	---	---	---	---	---	1.857

Continues on next page...

BMP-H

**Stage / Storage / Discharge Table**

Stage ft	Storage cuft	Elevation ft	Clv A cfs	Clv B cfs	Clv C cfs	PrfRsr cfs	Wr A cfs	Wr B cfs	Wr C cfs	Wr D cfs	Exfil cfs	User cfs	Total cfs
1.26	5,279	891.26	37.33 ic	1.90 ic	0.00	---	0.00	---	---	---	---	---	1.900
1.30	5,531	891.30	37.33 ic	1.94 ic	0.00	---	0.00	---	---	---	---	---	1.942
1.35	5,783	891.35	37.33 ic	1.98 ic	0.00	---	0.00	---	---	---	---	---	1.983
1.39	6,060	891.40	37.33 ic	2.02 ic	0.00	---	0.00	---	---	---	---	---	2.023
1.44	6,337	891.44	37.33 ic	2.06 ic	0.00	---	0.00	---	---	---	---	---	2.062
1.49	6,615	891.48	37.33 ic	2.10 ic	0.00	---	0.00	---	---	---	---	---	2.101
1.53	6,892	891.53	37.33 ic	2.14 ic	0.00	---	0.00	---	---	---	---	---	2.139
1.58	7,170	891.57	37.33 ic	2.18 ic	0.00	---	0.00	---	---	---	---	---	2.176
1.62	7,447	891.62	37.33 ic	2.21 ic	0.00	---	0.00	---	---	---	---	---	2.213
1.66	7,725	891.66	37.33 ic	2.25 ic	0.00	---	0.00	---	---	---	---	---	2.249
1.71	8,002	891.71	37.33 ic	2.28 ic	0.00	---	0.00	---	---	---	---	---	2.284
1.75	8,280	891.75	37.33 ic	2.32 ic	0.00	---	0.00	---	---	---	---	---	2.319
1.80	8,557	891.80	37.33 ic	2.35 ic	0.00	---	0.00	---	---	---	---	---	2.354
1.85	8,847	891.84	37.33 ic	2.39 ic	0.00	---	0.00	---	---	---	---	---	2.388
1.89	9,137	891.89	37.33 ic	2.42 ic	0.00	---	0.00	---	---	---	---	---	2.421
1.93	9,427	891.93	37.33 ic	2.45 ic	0.00	---	0.00	---	---	---	---	---	2.454
1.98	9,717	891.98	37.33 ic	2.49 ic	0.00	---	0.00	---	---	---	---	---	2.487
2.03	10,007	892.02	37.33 ic	2.52 ic	0.00	---	0.00	---	---	---	---	---	2.519
2.07	10,296	892.07	37.33 ic	2.55 ic	0.00	---	0.00	---	---	---	---	---	2.550
2.12	10,586	892.11	37.33 ic	2.58 ic	0.00	---	0.00	---	---	---	---	---	2.582
2.16	10,876	892.16	37.33 ic	2.61 ic	0.00	---	0.00	---	---	---	---	---	2.613
2.20	11,166	892.20	37.33 ic	2.64 ic	0.00	---	0.00	---	---	---	---	---	2.643
2.25	11,456	892.25	37.33 ic	2.67 ic	0.00	---	0.00	---	---	---	---	---	2.674
2.30	11,746	892.29	37.33 ic	2.70 ic	0.00	---	0.00	---	---	---	---	---	2.704
2.34	12,036	892.34	37.33 ic	2.73 ic	0.00	---	0.00	---	---	---	---	---	2.733
2.38	12,326	892.38	37.33 ic	2.76 ic	0.00	---	0.00	---	---	---	---	---	2.762
2.43	12,616	892.43	37.33 ic	2.79 ic	0.00	---	0.00	---	---	---	---	---	2.791
2.47	12,905	892.47	37.33 ic	2.82 ic	0.00	---	0.00	---	---	---	---	---	2.820
2.52	13,195	892.52	37.33 ic	2.85 ic	0.00	---	0.00	---	---	---	---	---	2.848
2.57	13,485	892.56	37.33 ic	2.88 ic	0.00	---	0.00	---	---	---	---	---	2.876
2.61	13,775	892.61	37.33 ic	2.90 ic	0.00	---	0.00	---	---	---	---	---	2.904
2.66	14,065	892.65	37.33 ic	2.93 ic	0.00	---	0.00	---	---	---	---	---	2.932
2.70	14,355	892.70	37.33 ic	2.96 ic	0.00	---	0.00	---	---	---	---	---	2.959
2.74	14,632	892.74	37.33 ic	2.99 ic	0.00	---	0.00	---	---	---	---	---	2.986
2.79	14,910	892.79	37.33 ic	3.01 ic	0.00	---	0.00	---	---	---	---	---	3.013
2.84	15,187	892.84	37.33 ic	3.04 ic	0.00	---	0.00	---	---	---	---	---	3.040
2.88	15,464	892.88	37.33 ic	3.07 ic	0.00	---	0.00	---	---	---	---	---	3.066
2.92	15,742	892.92	37.33 ic	3.09 ic	0.00	---	0.00	---	---	---	---	---	3.092
2.97	16,019	892.97	37.33 ic	3.12 ic	0.00	---	0.00	---	---	---	---	---	3.118
3.02	16,297	893.01	37.33 ic	3.14 ic	0.00	---	0.00	---	---	---	---	---	3.144
3.06	16,574	893.06	37.33 ic	3.17 ic	0.00	---	0.00	---	---	---	---	---	3.169
3.11	16,851	893.10	37.33 ic	3.19 ic	0.00	---	0.00	---	---	---	---	---	3.194
3.15	17,129	893.15	37.33 ic	3.22 ic	0.00	---	0.00	---	---	---	---	---	3.220
3.19	17,380	893.20	37.33 ic	3.24 ic	0.00	---	0.00	---	---	---	---	---	3.244
3.24	17,632	893.24	37.33 ic	3.27 ic	0.00	---	0.00	---	---	---	---	---	3.269
3.29	17,884	893.28	37.33 ic	3.29 ic	0.00	---	0.00	---	---	---	---	---	3.294
3.33	18,136	893.33	37.33 ic	3.32 ic	0.00	---	0.00	---	---	---	---	---	3.318
3.38	18,388	893.37	37.33 ic	3.34 ic	0.00	---	0.00	---	---	---	---	---	3.342
3.42	18,639	893.42	37.33 ic	3.37 ic	0.00	---	0.00	---	---	---	---	---	3.366
3.47	18,891	893.46	37.33 ic	3.39 ic	0.00	---	0.00	---	---	---	---	---	3.390
3.51	19,143	893.51	37.33 ic	3.41 ic	0.00	---	0.00	---	---	---	---	---	3.414
3.56	19,395	893.55	37.33 ic	3.44 ic	0.00	---	0.00	---	---	---	---	---	3.437
3.60	19,647	893.60	37.33 ic	3.46 ic	0.00	---	0.00	---	---	---	---	---	3.460
3.64	19,854	893.65	37.33 ic	3.48 ic	0.00	---	0.00	---	---	---	---	---	3.484
3.69	20,061	893.69	37.33 ic	3.51 ic	0.00	---	0.00	---	---	---	---	---	3.507
3.73	20,268	893.73	37.33 ic	3.53 ic	0.00	---	0.00	---	---	---	---	---	3.529
3.78	20,474	893.78	37.33 ic	3.55 ic	0.00	---	0.00	---	---	---	---	---	3.552
3.83	20,681	893.82	37.33 ic	3.57 ic	0.00	---	0.00	---	---	---	---	---	3.575
3.87	20,888	893.87	37.33 ic	3.60 ic	0.00	---	0.00	---	---	---	---	---	3.597
3.92	21,095	893.91	37.33 ic	3.62 ic	0.00	---	0.00	---	---	---	---	---	3.619
3.96	21,302	893.96	37.33 ic	3.64 ic	0.00	---	0.00	---	---	---	---	---	3.641
4.01	21,509	894.00	37.33 ic	3.66 ic	0.00	---	0.00	---	---	---	---	---	3.663
4.05	21,716	894.05	37.33 ic	3.69 ic	0.00	---	0.00	---	---	---	---	---	3.685
4.09	21,835	894.09	37.33 ic	3.71 ic	0.00	---	0.00	---	---	---	---	---	3.707
4.14	21,954	894.14	37.33 ic	3.73 ic	0.00	---	0.00	---	---	---	---	---	3.729
4.18	22,073	894.18	37.33 ic	3.75 ic	0.00	---	0.00	---	---	---	---	---	3.750
4.23	22,193	894.23	37.33 ic	3.77 ic	0.00	---	0.00	---	---	---	---	---	3.772
4.28	22,312	894.27	37.33 ic	3.79 ic	0.00	---	0.00	---	---	---	---	---	3.793
4.32	22,431	894.32	37.33 ic	3.81 ic	0.00	---	0.00	---	---	---	---	---	3.814
4.37	22,550	894.36	37.33 ic	3.84 ic	0.00	---	0.00	---	---	---	---	---	3.835
4.41	22,669	894.41	37.33 ic	3.86 ic	0.00	---	0.00	---	---	---	---	---	3.856
4.46	22,788	894.45	37.33 ic	3.88 ic	0.00	---	0.00	---	---	---	---	---	3.877

Continues on next page...

BMP-H

**Stage / Storage / Discharge Table**

Stage ft	Storage cuft	Elevation ft	Clv A cfs	Clv B cfs	Clv C cfs	PrfRsr cfs	Wr A cfs	Wr B cfs	Wr C cfs	Wr D cfs	Exfil cfs	User cfs	Total cfs
4.50	22,907	894.50	37.33 ic	3.90 ic	0.00	---	0.00	---	---	---	---	---	3.898
5.85	23,600	895.85	37.33 ic	4.47 ic	0.00	---	0.00	---	---	---	---	---	4.474
7.20	24,294	897.20	37.33 ic	4.98 ic	0.00	---	0.00	---	---	---	---	---	4.983
8.55	24,987	898.55	37.33 ic	5.45 ic	0.00	---	0.00	---	---	---	---	---	5.446
9.90	25,681	899.90	37.33 ic	5.87 ic	3.04 ic	---	0.00	---	---	---	---	---	8.911
11.24	26,375	901.24	37.33 ic	6.27 ic	5.34 ic	---	4.85	---	---	---	---	---	16.46
12.59	27,068	902.59	47.79 ic	6.64 ic	6.91 ic	---	47.79 s	---	---	---	---	---	61.34
13.94	27,762	903.94	48.98 ic	7.00 ic	8.19 ic	---	48.96 s	---	---	---	---	---	64.14
15.29	28,455	905.29	49.99 ic	7.33 ic	9.29 ic	---	49.92 s	---	---	---	---	---	66.55
16.64	29,149	906.64	50.96 ic	7.65 ic	10.28 ic	---	50.89 s	---	---	---	---	---	68.82
17.99	29,842	899.99	0.00	5.90 ic	3.25 ic	---	0.00	---	---	---	---	---	9.153
18.04	29,926	900.04	0.00	5.92 ic	3.36 ic	---	0.00	---	---	---	---	---	9.276
18.09	30,009	900.09	0.00	5.93 ic	3.47 ic	---	0.00	---	---	---	---	---	9.396
18.14	30,093	900.14	0.00	5.95 ic	3.57 ic	---	0.00	---	---	---	---	---	9.513
18.19	30,176	900.19	0.00	5.96 ic	3.67 ic	---	0.00	---	---	---	---	---	9.627
18.24	30,259	900.24	0.00	5.98 ic	3.76 ic	---	0.00	---	---	---	---	---	9.738
18.29	30,343	900.29	0.00	5.99 ic	3.86 ic	---	0.00	---	---	---	---	---	9.846
18.34	30,426	900.34	0.00	6.01 ic	3.95 ic	---	0.00	---	---	---	---	---	9.953
18.39	30,510	900.39	0.00	6.02 ic	4.04 ic	---	0.00	---	---	---	---	---	10.06
18.44	30,593	900.44	0.00	6.04 ic	4.12 ic	---	0.00	---	---	---	---	---	10.16
18.49	30,677	900.49	0.00	6.05 ic	4.21 ic	---	0.00	---	---	---	---	---	10.26
18.54	30,780	900.54	0.00	6.06 ic	4.29 ic	---	0.00	---	---	---	---	---	10.36
18.59	30,884	900.59	0.00	6.08 ic	4.38 ic	---	0.00	---	---	---	---	---	10.46
18.64	30,988	900.64	0.00	6.09 ic	4.46 ic	---	0.00	---	---	---	---	---	10.55
18.69	31,092	900.69	0.00	6.11 ic	4.54 ic	---	0.00	---	---	---	---	---	10.65
18.74	31,195	900.74	0.00	6.12 ic	4.62 ic	---	0.00	---	---	---	---	---	10.74
18.79	31,299	900.79	0.00	6.14 ic	4.69 ic	---	0.00	---	---	---	---	---	10.83
18.84	31,403	900.84	0.00	6.15 ic	4.77 ic	---	0.00	---	---	---	---	---	10.92
18.89	31,507	900.89	0.00	6.17 ic	4.84 ic	---	0.00	---	---	---	---	---	11.01
18.94	31,610	900.94	0.00	6.18 ic	4.92 ic	---	0.00	---	---	---	---	---	11.10
18.99	31,714	900.99	0.00	6.20 ic	4.99 ic	---	0.00	---	---	---	---	---	11.18

...End

---

**I4. Summary of results**

The results of the analysis show that for the given Pipe sizes and given flows calculated from the Civil D program that pipe size are adequate for the conditions set and should not cause a backup of flows.