

## APPENDIX C: GEOTECHNICAL INVESTIGATION

*This page intentionally left blank.*

**GEOTECHNICAL INVESTIGATION  
PROPOSED COMMERCIAL/INDUSTRIAL  
BUILDING**

11115 Hemlock Avenue  
Fontana, California  
for  
ProLogis



**SOUTHERN  
CALIFORNIA  
GEOTECHNICAL**  
*A California Corporation*

September 4, 2015

ProLogis  
2817 East Cedar Street, Suite 200  
Ontario, California 91761



SOUTHERN  
CALIFORNIA  
GEOTECHNICAL  
*A California Corporation*

Attention: Mr. Scott Mulkey

Project No.: **15G177-1**

Subject: **Geotechnical Investigation**  
Proposed Commercial/Industrial Building  
11115 Hemlock Avenue  
Fontana, California

Gentlemen:

In accordance with your request, we have conducted a geotechnical investigation at the subject site. We are pleased to present this report summarizing the conclusions and recommendations developed from our investigation.

We sincerely appreciate the opportunity to be of service on this project. We look forward to providing additional consulting services during the course of the project. If we may be of further assistance in any manner, please contact our office.

Respectfully Submitted,

SOUTHERN CALIFORNIA GEOTECHNICAL, INC.

A handwritten signature in blue ink, appearing to read "Daniel W. Nielsen".

Daniel W. Nielsen, RCE 77915  
Project Engineer



A handwritten signature in blue ink, appearing to read "John A. Seminara".

John A. Seminara, GE 2294  
Principal Engineer



Distribution: (2) Addressee



# TABLE OF CONTENTS

<b>1.0 EXECUTIVE SUMMARY</b>	<b>1</b>
<b>2.0 SCOPE OF SERVICES</b>	<b>3</b>
<b>3.0 SITE AND PROJECT DESCRIPTION</b>	<b>4</b>
3.1 Site Conditions	4
3.2 Proposed Development	4
<b>4.0 SUBSURFACE EXPLORATION</b>	<b>6</b>
4.1 Scope of Exploration/Sampling Methods	6
4.2 Geotechnical Conditions	6
<b>5.0 LABORATORY TESTING</b>	<b>8</b>
<b>6.0 CONCLUSIONS AND RECOMMENDATIONS</b>	<b>10</b>
6.1 Seismic Design Considerations	10
6.2 Geotechnical Design Considerations	11
6.3 Site Grading Recommendations	13
6.4 Construction Considerations	16
6.5 Foundation Design and Construction	16
6.6 Floor Slab Design and Construction	18
6.7 Retaining Wall Design and Construction	19
6.8 Pavement Design Parameters	21
<b>7.0 GENERAL COMMENTS</b>	<b>24</b>
<b>APPENDICES</b>	
A Plate 1: Site Location Map Plate 2: Boring Location Plan	
B Boring Logs	
C Laboratory Test Results	
D Grading Guide Specifications	
E Seismic Design Parameters	

# 1.0 EXECUTIVE SUMMARY

---

Presented below is a brief summary of the conclusions and recommendations of this investigation. Since this summary is not all inclusive, it should be read in complete context with the entire report.

## Site Preparation

- Demolition of the existing structures and pavements will be required. Demolition of these structures and associated improvements should include all foundations, floor slabs, utilities, and any other subsurface improvements that will not remain in place for use with the new development. Concrete and asphalt debris may be crushed to a maximum 2-inch particle size, mixed well with the on-site soils, and incorporated into structural fills if desired. Alternatively, concrete and asphalt may be crushed into miscellaneous base (CMB).
- Stripping of the existing landscaped areas should include the removal of all vegetation, organic soils, and root masses.
- Undocumented fill soils were encountered at several of the boring locations, extending to depths of  $2\frac{1}{2}\pm$  feet below the existing site grades.
- The near-surface native alluvial soils generally consist of variable strength silty sands and fine to medium sands. Laboratory testing indicates that some of the near surface soils possess a minor potential for collapse.
- Based on these conditions, remedial grading is recommended within the proposed building and improvement areas in order to remove all of the artificial fill materials and the upper portion of the near surface native alluvial soils. The existing soils within the proposed building area should be overexcavated to a depth of at least 3 feet below existing grade and to a depth of at least 3 feet below proposed pad grade. Within the building area, the proposed foundation influence zones should be overexcavated to a depth of 2 feet below proposed foundation bearing grade.
- After overexcavation has been completed, the resulting subgrade soils should be evaluated by the geotechnical engineer to identify any additional soils that should be overexcavated. The resulting subgrade should then be scarified to a depth of 12 inches. The overexcavation subgrade should be moisture conditioned to 2 to 4 percent above the optimum moisture content and recompacted. The previously excavated soils may then be replaced as compacted structural fill.
- The new parking area subgrade soils are recommended to be scarified to a depth of  $12\pm$  inches, thoroughly moisture conditioned and recompacted to at least 90 percent of the ASTM D-1557 maximum dry density.

## Building Foundations

- Conventional shallow foundations, supported in newly placed compacted fill.
- 3,000 lbs/ft<sup>2</sup> maximum allowable soil bearing pressure.
- Reinforcement consisting of at least two (2) No. 5 rebars (1 top and 1 bottom) in strip footings. Additional reinforcement may be necessary for structural considerations.

### Building Floor Slabs

- Conventional slab-on-grade, at least 5 inches thick.
- Reinforcement is not required for geotechnical considerations. The actual floor slab reinforcement to be determined by the structural engineer, based on the proposed loading.

### Pavements

<b>ASPHALT PAVEMENTS (R = 50)</b>					
<b>Materials</b>	<b>Thickness (inches)</b>				
	Parking Stalls (TI = 4.0)	Auto Drive Lanes (TI = 5.0)	Light Truck Traffic (TI = 6.0)	Moderate Truck Traffic (TI = 7.0)	Heavy Truck Traffic (TI = 8.0)
Asphalt Concrete	3	3	3½	4	5
Aggregate Base	3	3	4	5	5
Compacted Subgrade	12	12	12	12	12

<b>PORTLAND CEMENT CONCRETE PAVEMENTS (R=50)</b>				
<b>Materials</b>	<b>Thickness (inches)</b>			
	Automobile Parking and Drive Areas	Light Truck Traffic Areas (TI =6.0)	Moderate Truck Traffic Areas (TI =7.0)	Heavy Truck Traffic Areas (TI =8.0)
PCC	5	5	6	7
Compacted Subgrade (95% minimum compaction)	12	12	12	12

## **2.0 SCOPE OF SERVICES**

---

The scope of services performed for this project was in accordance with our Proposal No. 15P322, dated July 23, 2015. The scope of services included a visual site reconnaissance, subsurface exploration, field and laboratory testing, and geotechnical engineering analysis to provide criteria for preparing the design of the building foundations, building floor slab, and parking lot pavements along with site preparation recommendations and construction considerations for the proposed development. The evaluation of the environmental aspects of this site was beyond the scope of services for this geotechnical investigation.

## **3.0 SITE AND PROJECT DESCRIPTION**

---

### **3.1 Site Conditions**

The subject site is located on the east side of Hemlock Avenue, approximately 750 feet north of the intersection of Hemlock Avenue and Jurupa Avenue, at the street address of 11115 Hemlock Avenue in Fontana, California. The site is bounded to the north by existing commercial/industrial development, to the east by Beech Avenue, to the south by an existing commercial/industrial building, and to the west by Hemlock Avenue. The general location of the site is illustrated on the Site Location Map, included as Plate 1 in Appendix A of this report.

The site consists of a rectangular shaped parcel, 37.21± acres in size. The site is currently utilized as a mobile trailer storage yard, occupied by Modular Space Corporation. Two buildings are present in the west-central area of the site. These buildings are single-story structures, which are assumed to be supported on shallow foundations with concrete slab-on-grade floors. Ground surface cover throughout the majority of the site consists of crushed miscellaneous base (CMB) with areas of asphaltic concrete pavements surrounding the buildings and near the northwest corner of the site. The easternmost of the two buildings is immediately surrounded by Portland cement concrete. Landscape planters are present along the northern side of the westernmost building, and along the east and west property lines.

Detailed topographic information was not available at the time of this report. Based on visual observations, site grades appear to dip downwards toward the southwest at an estimated gradient of approximately 1 to 2± percent.

### **3.2 Proposed Development**

A preliminary site plan, prepared by RGA, was provided to our office. Based on this plan, the site will be developed with one (1) commercial/industrial building. The proposed building will be located in the central portion of the site and will possess a footprint area of 775,200± ft<sup>2</sup>. The building will be constructed in a cross-deck configuration with dock high doors on the east and west sides. We expect that the building will be surrounded by asphaltic concrete pavements in parking and drive areas and Portland cement concrete pavements in the truck court and loading dock areas. It is assumed that several landscape planters and concrete flatwork will be included throughout the site.

Detailed structural information has not been provided. It is assumed that the new building will be a single-story structure of tilt-up concrete construction, typically supported on a conventional shallow foundation system with a concrete slab-on-grade floor. The proposed construction may include second floor mezzanine office areas. Based on the assumed construction, maximum column and wall loads are expected to be on the order of 80 kips and 3 to 5 kips per linear foot, respectively.

No significant amounts of below grade construction, such as basements or crawl spaces, are expected to be included in the proposed development. Based on the assumed topography, cuts and fills of 3 to 4± feet are expected to be necessary to achieve the proposed site grades.

## **4.0 SUBSURFACE EXPLORATION**

---

### **4.1 Scope of Exploration/Sampling Methods**

The subsurface exploration conducted for this project consisted of ten (10) borings advanced to depths of 5 to 30± feet below existing site grades. All of the borings were logged during drilling by a member of our staff.

The borings were advanced with hollow-stem augers, by a conventional truck-mounted drilling rig. Representative bulk and relatively undisturbed soil samples were taken during drilling. Relatively undisturbed samples were taken with a split barrel "California Sampler" containing a series of one inch long, 2.416± inch diameter brass rings. This sampling method is described in ASTM Test Method D-3550. Samples were also taken using a 1.4± inch inside diameter split spoon sampler, in general accordance with ASTM D-1586. Both of these samplers are driven into the ground with successive blows of a 140-pound weight falling 30 inches. The blow counts obtained during driving are recorded for further analysis. Bulk samples were collected in plastic bags to retain their original moisture content. The relatively undisturbed ring samples were placed in molded plastic sleeves that were then sealed and transported to our laboratory.

The approximate locations of the borings are indicated on the Boring Location Plan, included as Plate 2 in Appendix A of this report. The Boring Logs, which illustrate the conditions encountered at the boring locations, as well as the results of some of the laboratory testing, are included in Appendix B.

### **4.2 Geotechnical Conditions**

#### Pavements

Boring No. B-1 was drilled through existing asphaltic concrete pavements. The pavement section at Boring No. B-1 consists of 6½± inches of asphaltic concrete with no discernable underlying layer of aggregate base. The remaining borings were drilled in areas paved with crushed miscellaneous base (CMB). At Boring Nos. B-2 through B-10, the ground surface cover consists of a 3 to 4-inch thick CMB layer.

#### Artificial Fill

Artificial fill soils were encountered beneath the pavements at Boring No. B-1, and beneath the CMB layer at Boring Nos. B-2 and B-8. The artificial fill soils extend to depths of 2½ ± feet below the existing site grades and generally consist of medium dense to dense fine sands with varying amounts of fine to coarse gravel, medium to coarse sand, and silt. The fill soils possess a disturbed appearance, resulting in their classification as fill.

## Alluvium

Native alluvium was encountered beneath pavements and/or the artificial fill soils at all of the boring locations, extending to at least the maximum depth explored of 30± feet below existing site grades. The alluvium generally consists of medium dense to very dense fine sands, silty fine sands, fine to coarse sands and fine sandy silts with varying amounts of silt, fine to coarse gravel and cobbles. Boring No. B-7 also encountered a layer of very dense gravelly fine to coarse sands between depths of 17 and 25± feet.

## Groundwater

Groundwater was not encountered at any of the borings. Based on the lack of any water within the borings, and the moisture contents of the recovered soil samples, the static groundwater table is considered to have existed at a depth in excess of 30± feet below existing site grades, at the time of the subsurface investigation.



## **5.0 LABORATORY TESTING**

---

The soil samples recovered from the subsurface exploration were returned to our laboratory for further testing to determine selected physical and engineering properties of the soils. The tests are briefly discussed below. It should be noted that the test results are specific to the actual samples tested, and variations could be expected at other locations and depths.

### Classification

All recovered soil samples were classified using the Unified Soil Classification System (USCS), in accordance with ASTM D-2488. The field identifications were then supplemented with additional visual classifications and/or by laboratory testing. The USCS classifications are shown on the Boring Logs and are periodically referenced throughout this report.

### Dry Density and Moisture Content

The density has been determined for selected relatively undisturbed ring samples. These densities were determined in general accordance with the method presented in ASTM D-2937. The results are recorded as dry unit weight in pounds per cubic foot. The moisture contents are determined in accordance with ASTM D-2216, and are expressed as a percentage of the dry weight. These test results are presented on the Boring Logs.

### Consolidation

Selected soil samples were tested to determine their consolidation potential, in accordance with ASTM D-2435. The testing apparatus is designed to accept either natural or remolded samples in a one-inch high ring, approximately 2.416 inches in diameter. Each sample is then loaded incrementally in a geometric progression and the resulting deflection is recorded at selected time intervals. Porous stones are in contact with the top and bottom of the sample to permit the addition or release of pore water. The samples are typically inundated with water at an intermediate load to determine their potential for collapse or heave. The results of the consolidation testing are plotted on Plates C-1 through C-8 in Appendix C of this report.

### Maximum Dry Density and Optimum Moisture Content

A representative bulk sample was tested for its maximum dry density and optimum moisture content. The results have been obtained using the Modified Proctor procedure, per ASTM D-1557. These tests are generally used to compare the in-situ densities of undisturbed field samples, and for later compaction testing. Additional testing of other soil type or soil mixes may be necessary at a later date. The results of the testing are plotted on Plate C-9 in Appendix C of this report.

## Soluble Sulfates

Representative samples of the near-surface soils were submitted to a subcontracted analytical laboratory for determination of soluble sulfate content. Soluble sulfates are naturally present in soils, and if the concentration is high enough, can result in degradation of concrete which comes into contact with these soils. The results of the soluble sulfate testing are presented below, and are discussed further in a subsequent section of this report.

<b><u>Sample Identification</u></b>	<b><u>Soluble Sulfates (%)</u></b>	<b><u>ACI 318 Classification</u></b>
B-1 @ 0 to 5 feet	0.015	Negligible
B-8 @ 0 to 5 feet	0.012	Negligible

## **6.0 CONCLUSIONS AND RECOMMENDATIONS**

---

Based on the results of our review, field exploration, laboratory testing and geotechnical analysis, the proposed development is considered feasible from a geotechnical standpoint. The recommendations contained in this report should be taken into the design, construction, and grading considerations. The recommendations are contingent upon all grading and foundation construction activities being monitored by the geotechnical engineer of record. The Grading Guide Specifications, included as Appendix D, should be considered part of this report, and should be incorporated into the project specifications. The contractor and/or owner of the development should bring to the attention of the geotechnical engineer any conditions that differ from those stated in this report, or which may be detrimental for the development.

### **6.1 Seismic Design Considerations**

The subject site is located in an area which is subject to strong ground motions due to earthquakes. The performance of a site specific seismic hazards analysis was beyond the scope of this investigation. However, numerous faults capable of producing significant ground motions are located near the subject site. Due to economic considerations, it is not generally considered reasonable to design a structure that is not susceptible to earthquake damage. Therefore, significant damage to structures may be unavoidable during large earthquakes. The proposed structures should, however, be designed to resist structural collapse and thereby provide reasonable protection from serious injury, catastrophic property damage and loss of life.

#### Faulting and Seismicity

Research of available maps indicates that the subject site is not located within an Alquist-Priolo Earthquake Fault Zone. Therefore, the possibility of significant fault rupture on the site is considered to be low.

#### Seismic Design Parameters

Beginning January 1, 2014, the 2013 CBC was adopted by all municipalities within Southern California. The CBC provides procedures for earthquake resistant structural design that include considerations for on-site soil conditions, occupancy, and the configuration of the structure including the structural system and height. The seismic design parameters presented below are based on the soil profile and the proximity of known faults with respect to the subject site.

The 2013 CBC Seismic Design Parameters have been generated using U.S. Seismic Design Maps, a web-based software application developed by the United States Geological Survey. This software application, available at the USGS web site, calculates seismic design parameters in accordance with the 2013 CBC, utilizing a database of deterministic site accelerations at 0.01 degree intervals. The table below is a compilation of the data provided by the USGS application. A copy of the output generated from this program is included in Appendix E of this report. A copy of the Design Response Spectrum, as generated by the USGS application is also included

in Appendix E. Based on this output, the following parameters may be utilized for the subject site:

### **2013 CBC SEISMIC DESIGN PARAMETERS**

<b>Parameter</b>		<b>Value</b>
Mapped Spectral Acceleration at 0.2 sec Period	$S_S$	1.500
Mapped Spectral Acceleration at 1.0 sec Period	$S_1$	0.600
Site Class	---	D
Site Modified Spectral Acceleration at 0.2 sec Period	$S_{MS}$	1.500
Site Modified Spectral Acceleration at 1.0 sec Period	$S_{M1}$	0.900
Design Spectral Acceleration at 0.2 sec Period	$S_{DS}$	1.000
Design Spectral Acceleration at 1.0 sec Period	$S_{D1}$	0.600

#### Liquefaction

Liquefaction is the loss of strength in generally cohesionless, saturated soils when the pore-water pressure induced in the soil by a seismic event becomes equal to or exceeds the overburden pressure. The primary factors which influence the potential for liquefaction include groundwater table elevation, soil type and grain size characteristics, relative density of the soil, initial confining pressure, and intensity and duration of ground shaking. The depth within which the occurrence of liquefaction may impact surface improvements is generally identified as the upper 50 feet below the existing ground surface. Liquefaction potential is greater in saturated, loose, poorly graded fine sands with a mean ( $d_{50}$ ) grain size in the range of 0.075 to 0.2 mm (Seed and Idriss, 1971). Clayey (cohesive) soils or soils which possess clay particles ( $d < 0.005\text{mm}$ ) in excess of 20 percent (Seed and Idriss, 1982) are generally not considered to be susceptible to liquefaction, nor are those soils which are above the historic static groundwater table.

The California Geological Survey (CGS) has not yet conducted detailed seismic hazards mapping in the area of the subject site. The general liquefaction susceptibility of the site was determined by research of the San Bernardino County Official Land Use Plan, General Plan, Geologic Hazard Overlay map for the Fontana Quadrangle, which is identified as Map No. FH29. This map indicates that the subject site is not located within a liquefaction hazard zone. Based on the mapping performed by the county of San Bernardino and the subsurface conditions encountered at the boring locations, liquefaction is not considered to be a design concern for this project.

## **6.2 Geotechnical Design Considerations**

### General

Artificial fill soils were encountered at some of the boring locations extending to depths of  $2\frac{1}{2} \pm$  feet below the existing site grades. These fill soils possess variable strengths and compositions,

and no documentation of the placement and compaction of these fill soils has been provided. The near-surface alluvium encountered at the boring locations generally possesses variable strengths and densities. Laboratory testing indicates that some of the near-surface alluvial soils possess a minor potential for collapse when inundated with water. The fill soils and near surface alluvium, in their present condition, are not considered suitable for the support of the new site improvements.

Based on these conditions, remedial grading is considered warranted within the proposed building area in order to remove all of the undocumented fill soils and the upper portion of the near surface, native alluvium.

### Settlement

The proposed remedial grading will remove the existing undocumented fill soils and a portion of the near surface native alluvium from within the proposed building area. The native soils that will remain in place below the recommended depth of overexcavation will not be subject to significant load increases from the foundations of the new structure. Therefore, following completion of the recommended remedial grading, post-construction settlements are expected to be within tolerable limits.

### Expansion

The on-site soils consist of fine to medium sands and silty sands, with varying gravel content. These materials have been visually classified as very low to non-expansive. Therefore, no design considerations related to expansive soils are considered warranted for this site.

### Soluble Sulfates

The results of the soluble sulfate testing indicate that the selected samples of the on-site soils contain levels of soluble sulfates that are classified as having a negligible potential to attack concrete, in accordance with the American Concrete Institute (ACI) Publication 318-05 Building Code Requirements for Structural Concrete and Commentary, Section 4.3. Therefore, no specialized concrete mix designs are considered warranted, with regard to sulfate protection. We do, however, recommend that additional sulfate testing be conducted after the completion of rough grading.

### Shrinkage/Subsidence

Based on the results of the laboratory testing, removal and recompaction of the near surface fill soils and native alluvium is estimated to result in an average shrinkage of 10 to 15 percent. Minor ground subsidence is expected to occur in the soils below the zone of removal, due to settlement and machinery working. The subsidence is estimated to be  $0.1\pm$  feet. This estimate may be used for grading in areas that are underlain by native alluvial soils.

These estimates are based on previous experience with projects in the vicinity of the subject site and the subsurface conditions encountered at the boring locations. The actual amount of subsidence is expected to be variable and will be dependent on the type of machinery used, repetitions of use, and dynamic effects, all of which are difficult to assess precisely.

## Foundation and Grading Plan Review

Foundation and grading plans were not available at the time of this report. It is therefore recommended that we be provided with copies of all future foundation and grading plans, when they become available, for review with regard to the conclusions, recommendations, and assumptions contained within this report.

### **6.3 Site Grading Recommendations**

The grading recommendations presented below are based on the subsurface conditions encountered at the boring and trench locations and our understanding of the proposed development. We recommend that all grading activities be completed in accordance with the Grading Guide Specifications included as Appendix D of this report, unless superseded by site-specific recommendations presented below.

#### Site Stripping and Demolition

Demolition of two structures and pavements present in the western portion of the site will be required. Demolition should include all foundations, floor slabs, utilities and any other subsurface improvements that will not remain in place with the new development. Concrete and asphalt debris may be crushed to a maximum 2-inch particle size, mixed with the on-site soils, and reused as compacted structural fill. It may also be feasible to crush these materials for use as crushed miscellaneous base (CMB).

Some small areas of landscaping are present in the northwest portion of the site and along the east and west property lines. Site stripping should include the removal of all vegetation and organic materials. These materials should be disposed of offsite. Where trees are removed, the removal should include any associated root masses. The actual extent of site stripping should be determined in the field by the geotechnical engineer, based on the organic content and stability of the materials encountered.

#### Treatment of Existing Soils: Building Pad

Overexcavation should be performed within the proposed building area to remove all of the existing undocumented fill soils and a portion of the near-surface native alluvial soils. The fill soils were determined to extend to a depth of  $2\frac{1}{2}\pm$  feet below existing site grades at the boring locations. The building pad overexcavation should also extend to a depth of at least 3 feet below existing grade and to a depth of at least 3 feet below proposed pad grade throughout the building areas. Within the foundation influence zones, the overexcavation should extend to depths of at least 2 feet below proposed foundation bearing grade.

The overexcavation areas should extend at least 5 feet beyond the building and foundation perimeters, and to an extent equal to the depth of fill below the new foundations. If the proposed structure incorporates any exterior columns (such as for a canopy or overhang) the overexcavations should also encompass these areas.

Following completion of the overexcavation, the subgrade soils within the building area should be evaluated by the geotechnical engineer to verify their suitability to serve as the structural fill subgrade, as well as to support the foundation loads of the new structure. This evaluation should include proofrolling with a heavy rubber-tired vehicle to identify any soft, loose or otherwise unstable soils that must be removed. Some localized areas of deeper excavation may be required if dry, loose, porous, low density or otherwise unsuitable materials are encountered at the base of the overexcavation.

After a suitable overexcavation subgrade has been achieved, the exposed soils should be scarified to a depth of at least 12 inches, moisture treated to 2 to 4 percent above the optimum moisture content, and compacted. The previously excavated soils may then be replaced as compacted structural fill.

#### Treatment of Existing Soils: Retaining Walls and Site Walls

The existing soils within the areas of any proposed retaining and site walls should be overexcavated to a depth of 2 feet below foundation bearing grade and replaced as compacted structural fill as discussed above for the proposed building pad. Any undocumented fill soils within any of these foundation areas should be removed in their entirety. The overexcavation subgrade soils should be evaluated by the geotechnical engineer prior to scarifying, moisture conditioning, and recompacting the upper 12 inches of exposed subgrade soils, as discussed for the building areas. The previously excavated soils may then be replaced as compacted structural fill.

#### Treatment of Existing Soils: Parking Areas

Based on economic considerations, removal and replacement of the undocumented fill and collapsible alluvium is not considered warranted within the proposed parking areas. Subgrade preparation in the new parking and drive areas should initially consist of removal of all soils disturbed during site stripping. The geotechnical engineer should then evaluate the subgrade to identify any areas of additional unsuitable soils. Based on the presence of undocumented fill soils at several boring locations, it is expected that some isolated areas of additional overexcavation may be required to remove zones of lower strength, unsuitable soils. The subgrade soils should then be scarified to a depth of 12± inches, moisture conditioned to 2 to 4 percent above optimum moisture content (to a depth of at least 24 inches) and recompacted to at least 90 percent of the ASTM D-1557 maximum dry density.

The grading recommendations presented above for the proposed parking and drive areas assume that the owner and/or developer can tolerate minor amounts of settlement within the proposed parking areas. The grading recommendations presented above do not completely mitigate the extent of collapsible native soils and undocumented fill in the parking areas. As such, settlement and associated pavement distress could occur. Typically, repair of such distressed areas involves significantly lower costs than completely mitigating these soils at the time of construction.



## Fill Placement

- Fill soils should be placed in thin ( $6\pm$  inches), near-horizontal lifts, moisture conditioned to 2 to 4 percent above the optimum moisture content, and compacted.
- On-site soils may be used for fill provided they are cleaned of any debris to the satisfaction of the geotechnical engineer. The on-site soils, especially below depths of  $8\pm$  feet, possess occasional quantities of oversized material, including cobbles. Some sorting and/or crushing of these materials may be required to generate soils that are suitable for reuse as compacted structural fill.
- All grading and fill placement activities should be completed in accordance with the requirements of the CBC and the grading code of the city of Fontana.
- All fill soils should be compacted to at least 90 percent of the ASTM D-1557 maximum dry density. Fill soils should be well mixed.
- Compaction tests should be performed periodically by the geotechnical engineer as random verification of compaction and moisture content. These tests are intended to aid the contractor. Since the tests are taken at discrete locations and depths, they may not be indicative of the entire fill and therefore should not relieve the contractor of his responsibility to meet the job specifications.

## Selective Grading and Oversized Material Placement

Some of the soils encountered at the boring locations possess occasional cobble content, especially at depths greater than  $8\pm$  feet below the existing site grades. If the proposed grading requires excavation of cobble containing soils, it may be desirable to selectively grade the proposed building pad area. The presence of particles greater than 3 inches in diameter within the upper 1 to 3 feet of the building pad subgrade will impact the utility and foundation excavations. Depending on the depths of fills required within the proposed parking areas, it may be feasible to sort the on-site soils, placing the materials greater than 3 inches in diameter within the lower depths of the fills, and limiting the upper 1 to 3 feet of soils to materials less than 3 inches in size. Oversized materials could also be placed within the lower depths of the recommended overexcavations. In order to achieve this grading, it would likely be necessary to use rock buckets and/or rock sieves to separate the oversized materials from the remaining soil. Although such selective grading will facilitate further construction activities, it is not considered mandatory and a suitable subgrade could be achieved without such extensive sorting. However, in any case, it is recommended that all materials greater than 6 inches in size be excluded from the upper 1 foot of the surface of any compacted fills.

Consideration should also be given to using a thin clean sand layer on the finished building pad and paved areas. During completion of fine grading of the building pad, any exposed cobbles could be hand-picked and replaced with clean sand in order to provide a level cobble free finished building pad. **The placement of any oversized materials should be performed in accordance with the Grading Guide Specifications included in Appendix D of this report.** If disposal of oversized materials is required, rock blankets or windrows should be used and such areas should be observed during construction and placement by a representative of the geotechnical engineer



### Imported Structural Fill

All imported structural fill should consist of very low expansive ( $EI < 20$ ), well graded soils possessing at least 10 percent fines (that portion of the sample passing the No. 200 sieve). As discussed previously, imported fill for use below new flatwork should consist of very low expansive ( $EI < 20$ ) material. Additional specifications for structural fill are presented in the Grading Guide Specifications, included as Appendix D.

### Utility Trench Backfill

In general, all utility trench backfill should be compacted to at least 90 percent of the ASTM D-1557 maximum dry density. Compacted trench backfill should conform to the requirements of the local grading code, and more restrictive requirements may be indicated by the city of Fontana. All utility trench backfills should be witnessed by the geotechnical engineer. The trench backfill soils should be compaction tested where possible; probed and visually evaluated elsewhere.

Utility trenches which parallel a footing, and extending below a 1h:1v plane projected from the outside edge of the footing should be backfilled with structural fill soils, compacted to at least 90 percent of the ASTM D-1557 standard. Pea gravel backfill should not be used for these trenches.

## **6.4 Construction Considerations**

### Excavation Considerations

The near surface soils generally consist of silty sands and fine to coarse sands with varying gravel content and occasional cobbles. Based on their composition, minor to moderate caving of shallow excavations may occur. Where caving occurs within shallow excavations, flattened excavation slopes may be sufficient to provide excavation stability. On a preliminary basis, temporary excavations should be laid back at a slope no steeper than 2h:1v. Deeper excavations may require some form of external stabilization such as shoring or bracing. Maintaining adequate moisture content within the near surface soils will improve excavation stability. All excavation activities on this site should be conducted in accordance with Cal-OSHA regulations.

### Groundwater

The static groundwater table at this site is considered to exist at a depth in excess of 30± feet. Therefore, groundwater is not expected to impact the grading or foundation construction activities.

## **6.5 Foundation Design and Construction**

Based on the preceding grading recommendations, it is assumed that the new building pad will be underlain by structural fill soils used to replace existing undocumented fill and variable

strength, collapsible native soils. The new structural fill soils are expected to extend to a depth of at least 2 feet below foundation bearing grade underlain by existing native soils that have been densified in place. Based on this subsurface profile, the proposed structure may be supported on shallow foundations.

### Foundation Design Parameters

New square and rectangular footings may be designed as follows:

- Maximum, net allowable soil bearing pressure: 3,000 lbs/ft<sup>2</sup>.
- Minimum wall/column footing width: 14 inches/24 inches.
- Minimum longitudinal steel reinforcement within strip footings: Two (2) No. 5 rebars (1 top and 1 bottom).
- Minimum foundation embedment: 12 inches into suitable structural fill soils, and at least 18 inches below adjacent exterior grade. Interior column footings may be placed immediately beneath the floor slab.
- It is recommended that the perimeter building foundations be continuous across all exterior doorways. Any flatwork adjacent to the exterior doors should be doweled into the perimeter foundations in a manner determined by the structural engineer.

The allowable bearing pressures presented above may be increased by one-third when considering short duration wind or seismic loads. The minimum steel reinforcement recommended above is based on standard geotechnical practice. The actual design of the foundations should be determined by the structural engineer.

### Foundation Construction

The foundation subgrade soils should be evaluated at the time of overexcavation, as discussed in Section 6.3 of this report. It is further recommended that the foundation subgrade soils be evaluated by the geotechnical engineer immediately prior to steel or concrete placement. Soils suitable for direct foundation support should consist of newly placed structural fill, compacted to at least 90 percent of the ASTM D-1557 maximum dry density. Any unsuitable materials should be removed to a depth of suitable bearing compacted structural fill, with the resulting excavations backfilled with compacted fill soils. As an alternative, lean concrete slurry (500 to 1,500 psi) may be used to backfill such isolated overexcavations.

The foundation subgrade soils should also be properly moisture conditioned to 2 to 4 percent above the Modified Proctor optimum, to a depth of at least 12 inches below bearing grade. Since it is typically not feasible to increase the moisture content of the floor slab and foundation subgrade soils once rough grading has been completed, care should be taken to maintain the moisture content of the building pad subgrade soils throughout the construction process.

### Estimated Foundation Settlements

Post-construction total and differential settlements of shallow foundations designed and constructed in accordance with the previously presented recommendations are estimated to be less than 1.0 and 0.5 inches, respectively, under static conditions. Differential movements are expected to occur over a 30-foot span, thereby resulting in an angular distortion of less than 0.002 inches per inch.

### Lateral Load Resistance

Lateral load resistance will be developed by a combination of friction acting at the base of foundations and slabs and the passive earth pressure developed by footings below grade. The following friction and passive pressure may be used to resist lateral forces:

- Passive Earth Pressure: 300 lbs/ft<sup>3</sup>
- Friction Coefficient: 0.30

These are allowable values, and include a factor of safety. When combining friction and passive resistance, the passive pressure component should be reduced by one-third. These values assume that footings will be poured directly against compacted structural fill. The maximum allowable passive pressure is 3000 lbs/ft<sup>2</sup>.

## **6.6 Floor Slab Design and Construction**

Subgrades which will support new floor slabs should be prepared in accordance with the recommendations contained in the ***Site Grading Recommendations*** section of this report. Based on the anticipated grading which will occur at this site, the floors of the proposed structures may be constructed as conventional slabs on grade supported on newly placed structural fill, extending to a depth of at least 3 feet below finished pad grade. Based on geotechnical considerations, the floor slabs may be designed as follows:

- Minimum slab thickness: 5 inches
- Minimum slab reinforcement: Not required for geotechnical considerations. The actual floor slab reinforcement should be determined by the structural engineer, based on the imposed loading.
- Modulus of subgrade reaction: 150 psi/inch
- Slab underlayment: If moisture sensitive floor coverings will be used, the minimum slab underlayment should consist of a moisture vapor barrier constructed below the entire area of the proposed slab where such moisture sensitive floor coverings are anticipated. The moisture vapor barrier should meet or exceed the Class A rating as defined by ASTM E 1745-97 and have a permeance rating less than 0.01 perms as described in ASTM E 96-95 and ASTM E 154-88. The moisture vapor barrier should be properly constructed in accordance with all applicable manufacturer specifications. Given that a rock free subgrade is anticipated and that a capillary break is not required, sand below

the barrier is not required. The need for sand and/or the amount of sand above the moisture vapor barrier should be specified by the structural engineer or concrete contractor. The selection of sand above the barrier is not a geotechnical engineering issue and hence outside our purview. Where moisture sensitive floor coverings are not anticipated, the vapor barrier may be eliminated.

- Moisture condition the floor slab subgrade soils to 2 to 4 percent above the Modified Proctor optimum moisture content, to a depth of 24 inches. The moisture content of the floor slab subgrade soils should be verified by the geotechnical engineer within 24 hours prior to concrete placement.
- Proper concrete curing techniques should be utilized to reduce the potential for slab curling or the formation of excessive shrinkage cracks.

The actual design of the floor slab should be completed by the structural engineer to verify adequate thickness and reinforcement.

## **6.7 Retaining Wall Design and Construction**

Although not indicated on the site plan, some small (less than 3 to 5± feet in height) retaining walls may be required to facilitate the new site grades. It is also expected that some retaining walls will be required in the new loading dock areas. The parameters recommended for use in the design of these walls are presented below.

### Retaining Wall Design Parameters

Based on the soil conditions encountered at the boring locations, the following parameters may be used in the design of new retaining walls for this site. We have provided parameters assuming the use of on-site soils for retaining wall backfill. The on-site soils generally consist of silty sands and fine to coarse sands with varying gravel content. Based on their classification, these materials are expected to possess a friction angle of at least 32 degrees.

If desired, SCG could provide design parameters for an alternative select backfill material behind the retaining walls. The use of select backfill material could result in lower lateral earth pressures. In order to use the design parameters for the imported select fill, this material must be placed within the entire active failure wedge. This wedge is defined as extending from the heel of the retaining wall upwards at an angle of approximately 60° from horizontal. If select backfill material behind the retaining wall is desired, SCG should be contacted for supplementary recommendations.

### RETAINING WALL DESIGN PARAMETERS

Design Parameter		Soil Type
		On-site Sandy Soils
Internal Friction Angle ( $\phi$ )		32°
Unit Weight		125 lbs/ft <sup>3</sup>
Equivalent Fluid Pressure:	Active Condition (level backfill)	35 lbs/ft <sup>3</sup>
	Active Condition (2h:1v backfill)	59 lbs/ft <sup>3</sup>
	At-Rest Condition (level backfill)	59 lbs/ft <sup>3</sup>

The walls should be designed using a soil-footing coefficient of friction of 0.30 and an equivalent passive pressure of 300 lbs/ft<sup>3</sup>. The structural engineer should incorporate appropriate factors of safety in the design of the retaining walls.

The active earth pressure may be used for the design of retaining walls that do not directly support structures or support soils that in turn support structures and which will be allowed to deflect. The at-rest earth pressure should be used for walls that will not be allowed to deflect such as those which will support foundation bearing soils, or which will support foundation loads directly.

Where the soils on the toe side of the retaining wall are not covered by a "hard" surface such as a structure or pavement, the upper 1 foot of soil should be neglected when calculating passive resistance due to the potential for the material to become disturbed or degraded during the life of the structure.

#### Seismic Lateral Earth Pressures

In accordance with the 2013 CBC, any retaining walls more than 6 feet in height must be designed for seismic lateral earth pressures. If walls 6 feet or more are required for this site, the geotechnical engineer should be contacted for supplementary seismic lateral earth pressure recommendations.

#### Retaining Wall Foundation Design

The foundation subgrade soils for the new retaining should be prepared in accordance with the grading recommendations presented in Section 6.3 of this report.

#### Backfill Material

On-site soils may be used to backfill the retaining walls. However, all backfill material placed within 3 feet of the back wall face should have a particle size no greater than 3 inches. The retaining wall backfill materials should be well graded.

It is recommended that a properly installed prefabricated drainage composite such as the MiraDRAIN 6000XL (or approved equivalent), which is specifically designed for use behind retaining walls be used. If the drainage composite material is not covered by an impermeable surface, such as a structure or pavement, a 12-inch thick layer of a low permeability soil should be placed over the backfill to reduce surface water migration to the underlying soils. The drainage composite should be separated from the backfill soils by a suitable geotextile, approved by the geotechnical engineer.

All retaining wall backfill should be placed and compacted under engineering controlled conditions in the necessary layer thicknesses to ensure an in-place density between 90 and 93 percent of the maximum dry density as determined by the Modified Proctor test (ASTM D1557). Care should be taken to avoid over-compaction of the soils behind the retaining walls, and the use of heavy compaction equipment should be avoided.

### Subsurface Drainage

As previously indicated, the retaining wall design parameters are based upon drained backfill conditions. Consequently, some form of permanent drainage system will be necessary in conjunction with the appropriate backfill material. Subsurface drainage may consist of either:

- A weep hole drainage system typically consisting of a series of 4-inch diameter holes in the wall situated slightly above the ground surface elevation on the exposed side of the wall and at an approximate 8-foot on-center spacing. The weep holes should include a 2 cubic foot pocket of open graded gravel, surrounded by an approved geotextile fabric, at each weep hole location.
- A 4-inch diameter perforated pipe surrounded by 2 cubic feet of gravel per linear foot of drain placed behind the wall, above the retaining wall footing. The gravel layer should be wrapped in a suitable geotextile fabric to reduce the potential for migration of fines. The footing drain should be extended to daylight or tied into a storm drainage system.

## **6.8 Pavement Design Parameters**

Site preparation in the pavement area should be completed as previously recommended in the ***Site Grading Recommendations*** section of this report. The subsequent pavement recommendations assume proper drainage and construction monitoring, and are based on either PCA or CALTRANS design parameters for a twenty (20) year design period. However, these designs also assume a routine pavement maintenance program to obtain the anticipated 20-year pavement service life.

### Pavement Subgrades

It is anticipated that the new pavements will be primarily supported on a layer of compacted structural fill, consisting of scarified, thoroughly moisture conditioned and recompacted existing soils. The on-site soils generally consist of silty sands and sands with varying gravel content. Based on the results of R-value testing, these materials to possess an R-value of 58. The

subsequent pavement design is based upon an R-value of 50. Any fill material imported to the site should have support characteristics equal to or greater than that of the on-site soils and be placed and compacted under engineering controlled conditions. It is recommended that additional R-value testing be performed after completion of rough grading to verify the pavement support characteristics of the pavement subgrades following site grading.

Asphaltic Concrete

Presented below are the recommended thicknesses for new flexible pavement structures consisting of asphaltic concrete over a granular base. The pavement designs are based on the traffic indices (TI's) indicated. The client and/or civil engineer should verify that these TI's are representative of the anticipated traffic volumes. If the client and/or civil engineer determine that the expected traffic volume will exceed the applicable traffic index, we should be contacted for supplementary recommendations. The design traffic indices equate to the following approximate daily traffic volumes over a 20 year design life, assuming six operational traffic days per week.

Traffic Index	No. of Heavy Trucks per Day
4.0	0
5.0	1
6.0	3
7.0	11
8.0	35

For the purpose of the traffic volumes indicated above, a truck is defined as a 5-axle tractor trailer unit with one 8-kip axle and two 32-kip tandem axles. All of the traffic indices allow for 1,000 automobiles per day.

ASPHALT PAVEMENTS (R = 50)					
Materials	Thickness (inches)				
	Parking Stalls (TI = 4.0)	Auto Drive Lanes (TI = 5.0)	Light Truck Traffic (TI = 6.0)	Moderate Truck Traffic (TI = 7.0)	Heavy Truck Traffic (TI = 8.0)
Asphalt Concrete	3	3	3½	4	5
Aggregate Base	3	3	4	5	5
Compacted Subgrade	12	12	12	12	12

The aggregate base course should be compacted to at least 95 percent of the ASTM D-1557 maximum dry density. The asphaltic concrete should be compacted to at least 95 percent of the Marshall maximum density, as determined by ASTM D-2726. The aggregate base course may consist of crushed aggregate base (CAB) or crushed miscellaneous base (CMB), which is a recycled gravel, asphalt and concrete material. The gradation, R-Value, Sand Equivalent, and Percentage Wear of the CAB or CMB should comply with appropriate specifications contained in the current edition of the "Greenbook" Standard Specifications for Public Works Construction.

Portland Cement Concrete

The preparation of the subgrade soils within Portland cement concrete pavement areas should be performed as previously described for proposed asphalt pavement areas. The minimum recommended thicknesses for the Portland Cement Concrete pavement sections are as follows:

<b>PORTLAND CEMENT CONCRETE PAVEMENTS (R = 50)</b>				
<b>Materials</b>	<b>Thickness (inches)</b>			
	Automobile Parking and Drive Areas	Light Truck Traffic Areas (TI =6.0)	Moderate Truck Traffic Areas (TI =7.0)	Heavy Truck Traffic Areas (TI =8.0)
PCC	5	5	6	7
Compacted Subgrade (95% minimum compaction)	12	12	12	12

The concrete should have a 28-day compressive strength of at least 3,000 psi. Reinforcing within all pavements should be designed by the structural engineer. The maximum joint spacing within all of the PCC pavements is recommended to be equal to or less than 30 times the pavement thickness. The actual joint spacing and reinforcing of the Portland cement concrete pavements should be determined by the structural engineer.



## 7.0 GENERAL COMMENTS

---

This report has been prepared as an instrument of service for use by the client, in order to aid in the evaluation of this property and to assist the architects and engineers in the design and preparation of the project plans and specifications. This report may be provided to the contractor(s) and other design consultants to disclose information relative to the project. However, this report is not intended to be utilized as a specification in and of itself, without appropriate interpretation by the project architect, civil engineer, and/or structural engineer. The reproduction and distribution of this report must be authorized by the client and Southern California Geotechnical, Inc. Furthermore, any reliance on this report by an unauthorized third party is at such party's sole risk, and we accept no responsibility for damage or loss which may occur. The client(s)' reliance upon this report is subject to the Engineering Services Agreement, incorporated into our proposal for this project.

The analysis of this site was based on a subsurface profile interpolated from limited discrete soil samples. While the materials encountered in the project area are considered to be representative of the total area, some variations should be expected between boring locations and sample depths. If the conditions encountered during construction vary significantly from those detailed herein, we should be contacted immediately to determine if the conditions alter the recommendations contained herein.

This report has been based on assumed or provided characteristics of the proposed development. It is recommended that the owner, client, architect, structural engineer, and civil engineer carefully review these assumptions to ensure that they are consistent with the characteristics of the proposed development. If discrepancies exist, they should be brought to our attention to verify that they do not affect the conclusions and recommendations contained herein. We also recommend that the project plans and specifications be submitted to our office for review to verify that our recommendations have been correctly interpreted.

The analysis, conclusions, and recommendations contained within this report have been promulgated in accordance with generally accepted professional geotechnical engineering practice. No other warranty is implied or expressed.

# APPENDIX A



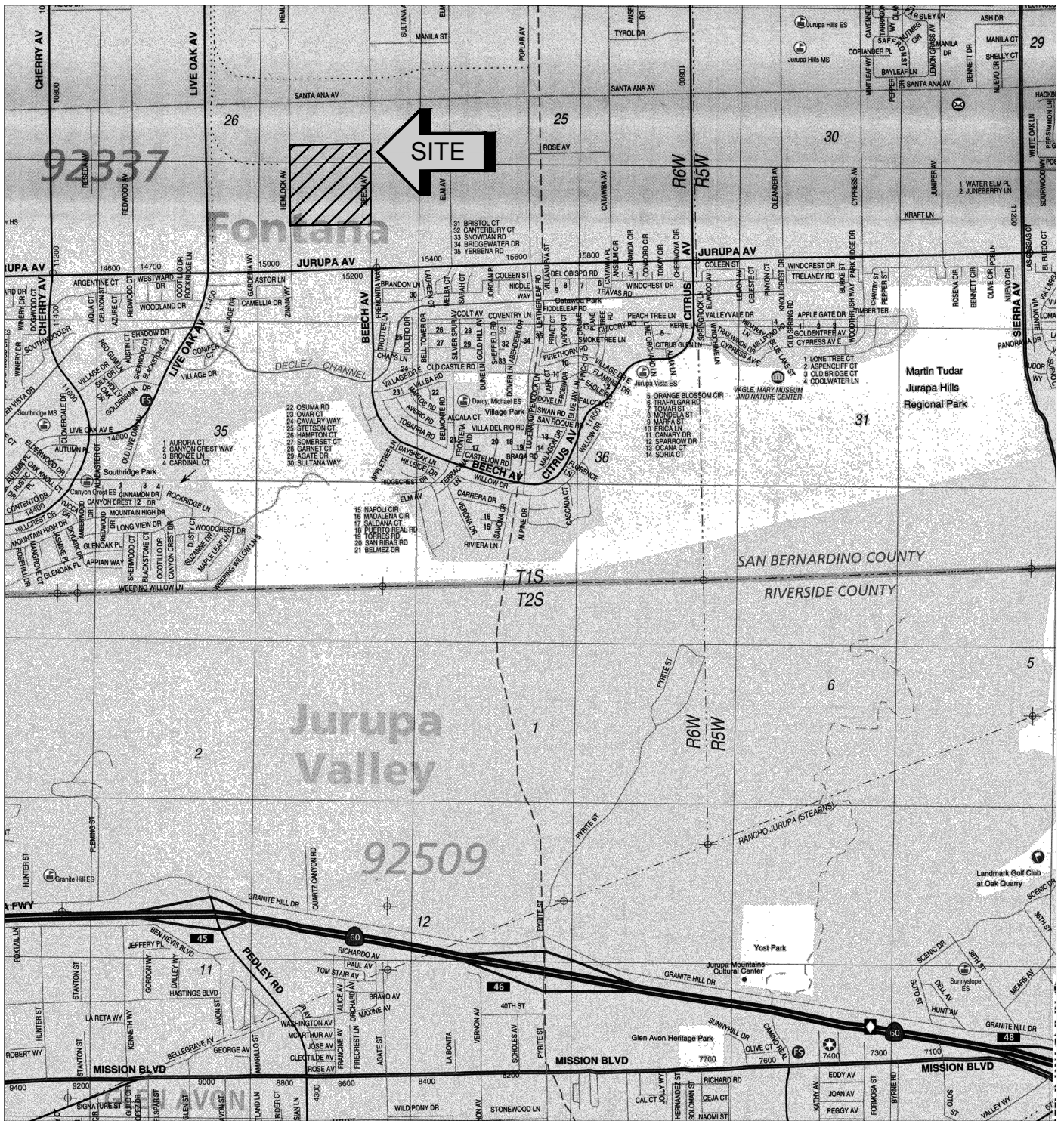

SOURCE: SAN BERNARDINO COUNTY  
THOMAS GUIDE, 2013



**SITE LOCATION MAP**  
**PROPOSED COMMERCIAL/INDUSTRIAL BUILDING**  
**FONTANA, CALIFORNIA**

SCALE: 1" = 2400'  
 DRAWN: JL  
 CHKD: JAS  
 SCG PROJECT  
 15G177-1  
**PLATE 1**





**SOUTHERN  
CALIFORNIA  
GEOTECHNICAL**

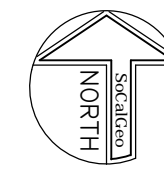
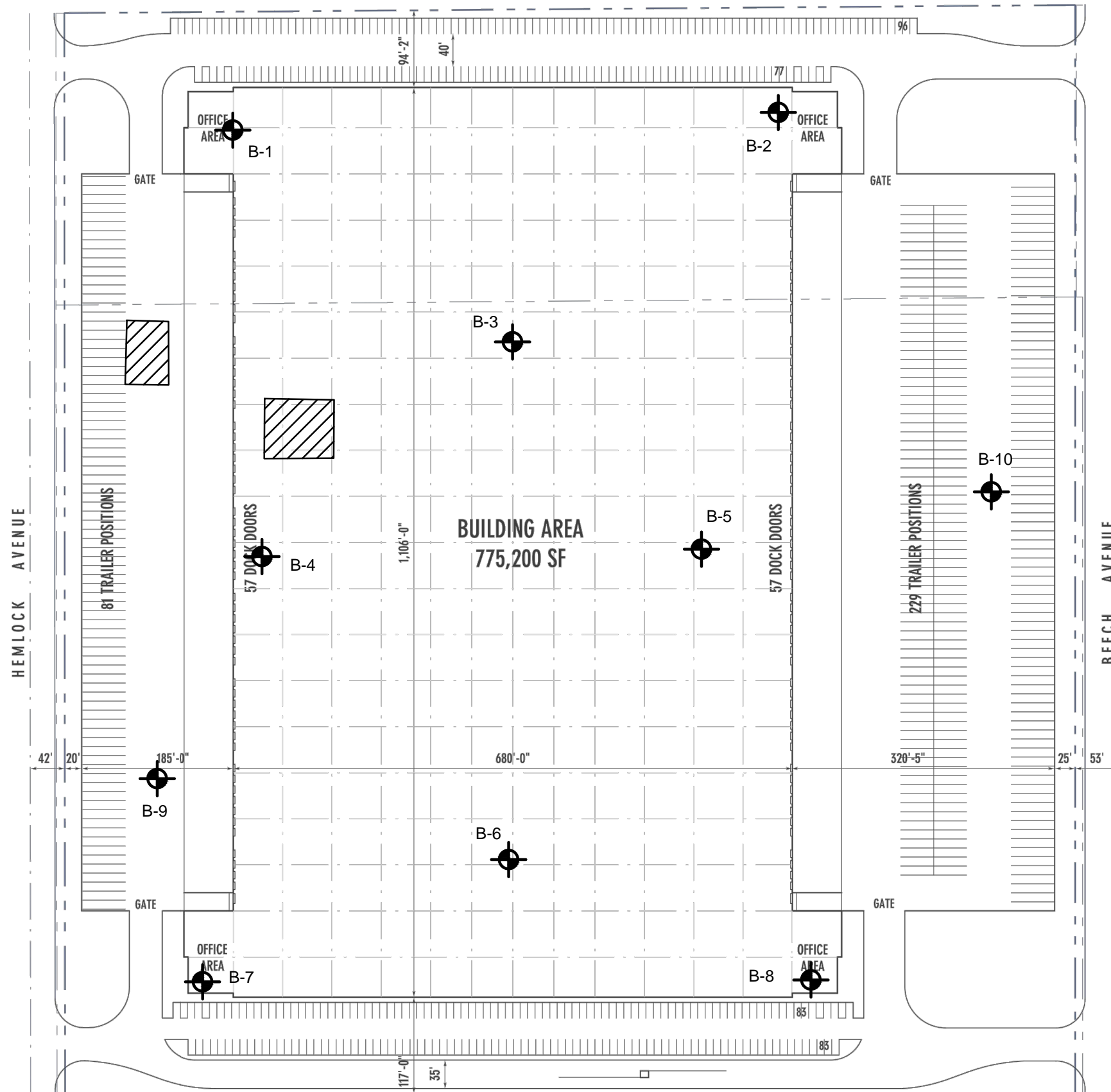



**GEOTECHNICAL LEGEND**







-  APPROXIMATE BORING LOCATION
-  EXISTING BUILDING TO BE DEMOLISHED

NOTE: BASE MAP PREPARED BY RGA

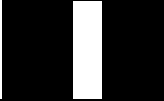
<b>BORING LOCATION PLAN</b>	
PROPOSED COMMERCIAL/INDUSTRIAL BUILDING	
FONTANA, CALIFORNIA	
SCALE: 1" = 150'	
DRAWN: JL CHKD: JAS	
SCG PROJECT 15G177-1	
<b>PLATE 2</b>	
<b>SOUTHERN CALIFORNIA GEOTECHNICAL</b>	

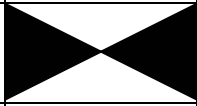
# APPENDIX B

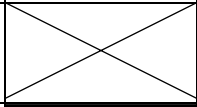
# BORING LOG LEGEND

SAMPLE TYPE	GRAPHICAL SYMBOL	SAMPLE DESCRIPTION
AUGER		SAMPLE COLLECTED FROM AUGER CUTTINGS, NO FIELD MEASUREMENT OF SOIL STRENGTH. (DISTURBED)
CORE		ROCK CORE SAMPLE: TYPICALLY TAKEN WITH A DIAMOND-TIPPED CORE BARREL. TYPICALLY USED ONLY IN HIGHLY CONSOLIDATED BEDROCK.
GRAB		SOIL SAMPLE TAKEN WITH NO SPECIALIZED EQUIPMENT, SUCH AS FROM A STOCKPILE OR THE GROUND SURFACE. (DISTURBED)
CS		CALIFORNIA SAMPLER: 2-1/2 INCH I.D. SPLIT BARREL SAMPLER, LINED WITH 1-INCH HIGH BRASS RINGS. DRIVEN WITH SPT HAMMER. (RELATIVELY UNDISTURBED)
NSR		NO RECOVERY: THE SAMPLING ATTEMPT DID NOT RESULT IN RECOVERY OF ANY SIGNIFICANT SOIL OR ROCK MATERIAL.
SPT		STANDARD PENETRATION TEST: SAMPLER IS A 1.4 INCH INSIDE DIAMETER SPLIT BARREL, DRIVEN 18 INCHES WITH THE SPT HAMMER. (DISTURBED)
SH		SHELBY TUBE: TAKEN WITH A THIN WALL SAMPLE TUBE, PUSHED INTO THE SOIL AND THEN EXTRACTED. (UNDISTURBED)
VANE		VANE SHEAR TEST: SOIL STRENGTH OBTAINED USING A 4 BLADED SHEAR DEVICE. TYPICALLY USED IN SOFT CLAYS-NO SAMPLE RECOVERED.

## COLUMN DESCRIPTIONS

### DEPTH:

Distance in feet below the ground surface.

### SAMPLE:

Sample Type as depicted above.

### BLOW COUNT:

Number of blows required to advance the sampler 12 inches using a 140 lb hammer with a 30-inch drop. 50/3" indicates penetration refusal (>50 blows) at 3 inches. WH indicates that the weight of the hammer was sufficient to push the sampler 6 inches or more.

### POCKET PEN.:

Approximate shear strength of a cohesive soil sample as measured by pocket penetrometer.

### GRAPHIC LOG:

Graphic Soil Symbol as depicted on the following page.

### DRY DENSITY:

Dry density of an undisturbed or relatively undisturbed sample in lbs/ft<sup>3</sup>.

### MOISTURE CONTENT:

Moisture content of a soil sample, expressed as a percentage of the dry weight.

### LIQUID LIMIT:

The moisture content above which a soil behaves as a liquid.

### PLASTIC LIMIT:

The moisture content above which a soil behaves as a plastic.

### PASSING #200 SIEVE:

The percentage of the sample finer than the #200 standard sieve.

### UNCONFINED SHEAR:

The shear strength of a cohesive soil sample, as measured in the unconfined state.

# SOIL CLASSIFICATION CHART

MAJOR DIVISIONS			SYMBOLS		TYPICAL DESCRIPTIONS	
			GRAPH	LETTER		
<p><b>COARSE GRAINED SOILS</b></p> <p>MORE THAN 50% OF MATERIAL IS LARGER THAN NO. 200 SIEVE SIZE</p>	<p><b>GRAVEL AND GRAVELLY SOILS</b></p>	<p>CLEAN GRAVELS</p> <p>(LITTLE OR NO FINES)</p>		<b>GW</b>	WELL-GRADED GRAVELS, GRAVEL - SAND MIXTURES, LITTLE OR NO FINES	
		<p>GRAVELS WITH FINES</p> <p>(APPRECIABLE AMOUNT OF FINES)</p>		<b>GP</b>	POORLY-GRADED GRAVELS, GRAVEL - SAND MIXTURES, LITTLE OR NO FINES	
		<p>MORE THAN 50% OF COARSE FRACTION RETAINED ON NO. 4 SIEVE</p>	<p>CLEAN SANDS</p> <p>(LITTLE OR NO FINES)</p>		<b>SW</b>	WELL-GRADED SANDS, GRAVELLY SANDS, LITTLE OR NO FINES
			<p>SANDS WITH FINES</p> <p>(APPRECIABLE AMOUNT OF FINES)</p>		<b>SP</b>	POORLY-GRADED SANDS, GRAVELLY SAND, LITTLE OR NO FINES
	<p>MORE THAN 50% OF COARSE FRACTION PASSING ON NO. 4 SIEVE</p>	<p><b>SAND AND SANDY SOILS</b></p>	<p>CLEAN SANDS</p> <p>(LITTLE OR NO FINES)</p>		<b>SM</b>	SILTY SANDS, SAND - SILT MIXTURES
			<p>SANDS WITH FINES</p> <p>(APPRECIABLE AMOUNT OF FINES)</p>		<b>SC</b>	CLAYEY SANDS, SAND - CLAY MIXTURES
	<p><b>FINE GRAINED SOILS</b></p> <p>MORE THAN 50% OF MATERIAL IS SMALLER THAN NO. 200 SIEVE SIZE</p>	<p><b>SILTS AND CLAYS</b></p>	<p>LIQUID LIMIT LESS THAN 50</p>		<b>ML</b>	INORGANIC SILTS AND VERY FINE SANDS, ROCK FLOUR, SILTY OR CLAYEY FINE SANDS OR CLAYEY SILTS WITH SLIGHT PLASTICITY
					<b>CL</b>	INORGANIC CLAYS OF LOW TO MEDIUM PLASTICITY, GRAVELLY CLAYS, SANDY CLAYS, SILTY CLAYS, LEAN CLAYS
					<b>OL</b>	ORGANIC SILTS AND ORGANIC SILTY CLAYS OF LOW PLASTICITY
		<p><b>SILTS AND CLAYS</b></p>	<p>LIQUID LIMIT GREATER THAN 50</p>		<b>MH</b>	INORGANIC SILTS, MICACEOUS OR DIATOMACEOUS FINE SAND OR SILTY SOILS
				<b>CH</b>	INORGANIC CLAYS OF HIGH PLASTICITY	
				<b>OH</b>	ORGANIC CLAYS OF MEDIUM TO HIGH PLASTICITY, ORGANIC SILTS	
<p><b>HIGHLY ORGANIC SOILS</b></p>				<b>PT</b>	PEAT, HUMUS, SWAMP SOILS WITH HIGH ORGANIC CONTENTS	

NOTE: DUAL SYMBOLS ARE USED TO INDICATE BORDERLINE SOIL CLASSIFICATIONS



JOB NO.: 15G177      DRILLING DATE: 8/6/15      WATER DEPTH: Dry  
 PROJECT: Proposed Comm/Industrial Bldg      DRILLING METHOD: Hollow Stem Auger      CAVE DEPTH: 15 feet  
 LOCATION: Fontana, California      LOGGED BY: Matt Manni      READING TAKEN: At Completion

FIELD RESULTS				DESCRIPTION	LABORATORY RESULTS						COMMENTS	
DEPTH (FEET)	SAMPLE	BLOW COUNT	POCKET PEN. (TSF)		GRAPHIC LOG	DRY DENSITY (PCF)	MOISTURE CONTENT (%)	LIQUID LIMIT	PLASTIC LIMIT	PASSING #200 SIEVE (%)		UNCONFINED SHEAR (TSF)
SURFACE ELEVATION: --- MSL												
					6½ inches Asphaltic concrete, no discernible Aggregate base							
					FILL: Light Gray Brown fine Sand, trace Silt, trace fine Gravel, trace medium to coarse Sand, mottled, medium dense-damp	112	6					
					ALLUVIUM: Brown Silty fine Sand, trace medium to coarse Sand, trace fine to coarse Gravel, occasional Cobbles, dense-damp		6					Disturbed Sample
5					Gray Silty fine Sand, trace medium to coarse Sand, dense-moist	112	8					
					Light Gray fine to coarse Sand, trace Silt, trace fine Gravel, dense-dry to damp	101	2					
						100	2					
10					Gray Brown Silty fine Sand, trace medium Sand, abundant Iron oxide staining, medium dense-moist	98	10					
					@ 13½ to 15 feet, slightly porous, very moist		16					
					Gray fine to coarse Sand, trace Silt, little fine to coarse Gravel, occasional Cobbles, dense-damp		3					
					Gray Brown fine Sandy Silt, trace Clay, trace Iron oxide staining, dense-very moist		23					
					Gray Brown fine Sand, trace medium to coarse Sand, trace fine Gravel, trace Silt, very dense-damp		4					
30			70/10"									
Boring Terminated at 30'												

TBL\_15G177.GPJ\_SOCALGEO.GDT 9/4/15





JOB NO.: 15G177      DRILLING DATE: 8/6/15      WATER DEPTH: Dry  
 PROJECT: Proposed Comm/Industrial Bldg      DRILLING METHOD: Hollow Stem Auger      CAVE DEPTH: 11 feet  
 LOCATION: Fontana, California      LOGGED BY: Matt Manni      READING TAKEN: At Completion

FIELD RESULTS				DESCRIPTION	LABORATORY RESULTS					COMMENTS	
DEPTH (FEET)	SAMPLE	BLOW COUNT	POCKET PEN. (TSF)		GRAPHIC LOG	DRY DENSITY (PCF)	MOISTURE CONTENT (%)	LIQUID LIMIT	PLASTIC LIMIT		PASSING #200 SIEVE (%)
SURFACE ELEVATION: --- MSL											
				3 inches Crushed Miscellaneous base							
		62		FILL: Light Gray fine Sand, little Silt, trace medium to coarse Sand, trace fine Gravel, mottled, dense-dry to damp	110	2					
		42		ALLUVIUM: Gray Brown Silty fine Sand, trace medium to coarse Sand, trace Iron oxide staining, medium dense-damp	113	5					
5		54		Gray Silty fine Sand, trace medium to coarse Sand, dense-moist	108	7					
		76		Gray Brown Silty fine Sand, little medium to coarse Sand, trace fine Gravel, occasional Cobbles, very dense-damp to moist	121	5					
10		50		@ 9 to 9½ feet, dense	107	7					
				Brown fine to medium Sand, trace coarse Sand, trace fine Gravel, dense-damp	111	5					
15		45		Light Gray fine to coarse Sand, trace fine to coarse Gravel, trace Silt, dense-dry		1					
20		15		Gray Brown fine Sandy Silt, trace calcareous veining, trace Iron oxide staining, medium dense-moist		13					
25		18		Brown Silty fine Sand, trace medium to coarse Sand, abundant Iron oxide staining, medium dense-moist		8					
				Boring Terminated at 25'							

TBL\_15G177.GPJ\_SOCALGEO.GDT 9/4/15



JOB NO.: 15G177	DRILLING DATE: 8/6/15	WATER DEPTH: Dry
PROJECT: Proposed Comm/Industrial Bldg	DRILLING METHOD: Hollow Stem Auger	CAVE DEPTH: 6 feet
LOCATION: Fontana, California	LOGGED BY: Matt Manni	READING TAKEN: At Completion

FIELD RESULTS				DESCRIPTION	LABORATORY RESULTS						COMMENTS
DEPTH (FEET)	SAMPLE	BLOW COUNT	POCKET PEN. (TSF)		GRAPHIC LOG	DRY DENSITY (PCF)	MOISTURE CONTENT (%)	LIQUID LIMIT	PLASTIC LIMIT	PASSING #200 SIEVE (%)	
SURFACE ELEVATION: --- MSL											
				4 inches Crushed Miscellaneous base							
		50			<u>ALLUVIUM:</u> Light Gray Gravelly fine to coarse Sand, trace Silt, occasional Cobbles, dense-dry to damp		2				
		47			Gray fine to coarse Sand, trace Silt, trace fine to coarse Gravel, medium dense to dense-dry to damp		3				
5		45					2				
		25					2				
10		25			Gray Brown Silty fine Sand, trace calcareous veining, medium dense-moist		7				
		44			Gray fine to coarse Sand, trace calcareous veining, occasional Cobbles, medium dense-dry to damp		2				
15					Boring Terminated at 15'						

TBL\_15G177.GPJ\_SOCALGEO.GDT\_9/4/15



JOB NO.: 15G177	DRILLING DATE: 8/6/15	WATER DEPTH: Dry
PROJECT: Proposed Comm/Industrial Bldg	DRILLING METHOD: Hollow Stem Auger	CAVE DEPTH: 6 feet
LOCATION: Fontana, California	LOGGED BY: Matt Manni	READING TAKEN: At Completion

FIELD RESULTS				GRAPHIC LOG	DESCRIPTION	LABORATORY RESULTS					COMMENTS	
DEPTH (FEET)	SAMPLE	BLOW COUNT	POCKET PEN. (TSF)			DRY DENSITY (PCF)	MOISTURE CONTENT (%)	LIQUID LIMIT	PLASTIC LIMIT	PASSING #200 SIEVE (%)		UNCONFINED SHEAR (TSF)
SURFACE ELEVATION: --- MSL												
				4 inches Crushed Miscellaneous base								
		49		ALLUVIUM: Light Gray fine to medium Sand, little coarse Sand little fine to coarse Gravel, trace Silt, dense-dry to damp	2							
5		26		Light Gray Brown fine to coarse Sand, little fine to coarse Gravel, medium dense-dry	2							
		17		Gray Brown fine Sand, trace Silt, medium dense-damp	4							
10		34		Gray fine to medium Sand, little coarse Sand, trace Silt, trace fine to coarse Gravel, occasional Cobbles, dense-dry to damp	2							
15		16		Gray Brown fine Sandy Silt, abundant Iron oxide staining, medium dense-moist to very moist	14							
20		27		Gray Brown Silty fine Sand, abundant Iron oxide staining, medium dense-moist	28 7							
Boring Terminated at 20'												

TBL\_15G177.GPJ\_SOCALGEO.GDT\_9/4/15



JOB NO.: 15G177	DRILLING DATE: 8/6/15	WATER DEPTH: Dry
PROJECT: Proposed Comm/Industrial Bldg	DRILLING METHOD: Hollow Stem Auger	CAVE DEPTH: 8 feet
LOCATION: Fontana, California	LOGGED BY: Matt Manni	READING TAKEN: At Completion

FIELD RESULTS				DESCRIPTION	LABORATORY RESULTS					COMMENTS	
DEPTH (FEET)	SAMPLE	BLOW COUNT	POCKET PEN. (TSF)		GRAPHIC LOG	DRY DENSITY (PCF)	MOISTURE CONTENT (%)	LIQUID LIMIT	PLASTIC LIMIT		PASSING #200 SIEVE (%)
SURFACE ELEVATION: --- MSL											
				3 inches Crushed Miscellaneous base							
		36		ALLUVIUM: Gray fine Sand, little Silt, trace medium to coarse Sand, dense-damp	5						
		13		Gray Brown Silty fine Sand, medium dense-very moist	17						
5				Gray fine Sand, trace Silt, medium dense-damp	4						
		12		Gray Brown Silty fine Sand, trace Iron oxide staining, medium dense-moist	9						
		14			8						
10											
		16									
15											
		29		Light Gray Brown Silty fine to medium Sand, little coarse Sand, trace fine to coarse Gravel, medium dense-damp to moist	6						
20											
Boring Terminated at 20'											

TBL\_15G177.GPJ\_SOCALGEO.GDT\_9/4/15



JOB NO.: 15G177	DRILLING DATE: 8/6/15	WATER DEPTH: Dry
PROJECT: Proposed Comm/Industrial Bldg	DRILLING METHOD: Hollow Stem Auger	CAVE DEPTH: 5 feet
LOCATION: Fontana, California	LOGGED BY: Matt Manni	READING TAKEN: At Completion

FIELD RESULTS					DESCRIPTION	LABORATORY RESULTS						COMMENTS
DEPTH (FEET)	SAMPLE	BLOW COUNT	POCKET PEN. (TSF)	GRAPHIC LOG		DRY DENSITY (PCF)	MOISTURE CONTENT (%)	LIQUID LIMIT	PLASTIC LIMIT	PASSING #200 SIEVE (%)	UNCONFINED SHEAR (TSF)	
					SURFACE ELEVATION: --- MSL							
				3 inches Crushed Miscellaneous base								
		32		ALLUVIUM: Light Gray fine to medium Sand, little coarse Sand, trace fine to coarse Gravel, trace Silt, dense-dry		1						
		24		Gray Brown fine to medium Sand, trace coarse Sand, trace fine Gravel, medium dense-dry to damp		2						
5				@ 6 to 12 feet, little coarse Sand, trace fine to coarse Gravel		2						
		25		@ 8½ to 10 feet, occasional Cobbles		2						
		47										
10												
		19		Gray Brown fine Sand, little medium to coarse Sand, trace fine to coarse Gravel, trace Silt, medium dense-damp		4						
15												
					Boring Terminated at 15'							

TBL\_15G177.GPJ\_SOCALGEO.GDT 9/4/15



JOB NO.: 15G177	DRILLING DATE: 8/6/15	WATER DEPTH: Dry
PROJECT: Proposed Comm/Industrial Bldg	DRILLING METHOD: Hollow Stem Auger	CAVE DEPTH: 12 feet
LOCATION: Fontana, California	LOGGED BY: Matt Manni	READING TAKEN: At Completion

FIELD RESULTS				GRAPHIC LOG	DESCRIPTION	LABORATORY RESULTS						COMMENTS
DEPTH (FEET)	SAMPLE	BLOW COUNT	POCKET PEN. (TSF)			DRY DENSITY (PCF)	MOISTURE CONTENT (%)	LIQUID LIMIT	PLASTIC LIMIT	PASSING #200 SIEVE (%)	UNCONFINED SHEAR (TSF)	
SURFACE ELEVATION: --- MSL												
				4 inches Crushed Miscellaneous base								
		18		ALLUVIUM: Light Brown Silty fine Sand, medium dense-moist	100	7						
		22		Light Gray Brown fine Sand, trace Silt, medium dense-damp	110	4						
5		27		@ 5 to 6 feet, trace medium Sand	102	3						
		39		Gray fine to medium Sand, little coarse Sand, trace fine to coarse Gravel, trace Silt, occasional Cobbles, dense-damp	114	5						
10		20		Light Gray fine Sand, trace Silt, medium dense-damp to moist	94	6						
		28		Gray Brown fine to coarse Sand, trace Silt, little fine Gravel, medium dense-damp		3						
15				Gray Brown Silty fine Sand, trace Iron oxide staining, trace medium Sand, medium dense-moist		9						
		81		Light Gray Brown Gravelly fine to coarse Sand, trace Silt, occasional Cobbles, very dense-dry to damp		2						
20												
		57				3						
25												
Boring Terminated at 25'												

TBL\_15G177.GPJ\_SOCALGEO.GDT 9/4/15



JOB NO.: 15G177      DRILLING DATE: 8/6/15      WATER DEPTH: Dry  
 PROJECT: Proposed Comm/Industrial Bldg      DRILLING METHOD: Hollow Stem Auger      CAVE DEPTH: 12 feet  
 LOCATION: Fontana, California      LOGGED BY: Matt Manni      READING TAKEN: At Completion

FIELD RESULTS				GRAPHIC LOG	DESCRIPTION	LABORATORY RESULTS					COMMENTS	
DEPTH (FEET)	SAMPLE	BLOW COUNT	POCKET PEN. (TSF)			DRY DENSITY (PCF)	MOISTURE CONTENT (%)	LIQUID LIMIT	PLASTIC LIMIT	PASSING #200 SIEVE (%)		UNCONFINED SHEAR (TSF)
SURFACE ELEVATION: --- MSL												
					3 inches Crushed Miscellaneous base							
		35			FILL: Gray Brown fine Sand, little Silt, trace medium to coarse Sand, trace fine to coarse Gravel, trace Iron oxide staining, mottled, medium dense-damp	108	5					
		29			ALLUVIUM: Gray Brown Silty fine Sand, trace medium to coarse Sand, abundant Iron oxide staining, medium dense-moist	119	9					
5		20			Gray Silty fine Sand, trace medium to coarse Sand, trace Iron oxide staining, medium dense-damp to moist	111	6					
		25				113	4					
						106	7					
10		44			Light Gray fine to coarse Sand, trace fine to coarse Gravel, trace Silt, occasional Cobbles, medium dense-dry to damp		2					
					Gray Brown fine to medium Sand, trace fine Gravel, trace coarse Sand, dense-dry to damp							
15		49					2					
					Light Gray Gravelly fine to coarse Sand, trace Silt, occasional Cobbles, very dense-damp							
20		84/10"					3					
25		79/11"					3					
					Light Gray Brown fine to coarse Sandy Gravel, trace Silt, occasional Cobbles, very dense-damp							
30		70/11"					4					
Boring Terminated at 30'												

TBL\_15G177.GPJ\_SOCALGEO.GDT 9/4/15



JOB NO.: 15G177	DRILLING DATE: 8/6/15	WATER DEPTH: Dry
PROJECT: Proposed Comm/Industrial Bldg	DRILLING METHOD: Hollow Stem Auger	CAVE DEPTH: 2 feet
LOCATION: Fontana, California	LOGGED BY: Matt Manni	READING TAKEN: At Completion

FIELD RESULTS					DESCRIPTION	LABORATORY RESULTS						COMMENTS
DEPTH (FEET)	SAMPLE	BLOW COUNT	POCKET PEN. (TSF)	GRAPHIC LOG		DRY DENSITY (PCF)	MOISTURE CONTENT (%)	LIQUID LIMIT	PLASTIC LIMIT	PASSING #200 SIEVE (%)	UNCONFINED SHEAR (TSF)	
SURFACE ELEVATION: --- MSL												
	X	41			4 inches Crushed Miscellaneous base		2					
	X	87/11			ALLUVIUM: Light Gray Gravelly fine to coarse Sand, trace Silt, dense-dry to damp		2					
5					Boring Terminated at 5'							

TBL\_15G177.GPJ\_SOCALGEO.GDT\_9/4/15





JOB NO.: 15G177	DRILLING DATE: 8/6/15	WATER DEPTH: Dry
PROJECT: Proposed Comm/Industrial Bldg	DRILLING METHOD: Hollow Stem Auger	CAVE DEPTH: 2 feet
LOCATION: Fontana, California	LOGGED BY: Matt Manni	READING TAKEN: At Completion

FIELD RESULTS				DESCRIPTION	LABORATORY RESULTS						COMMENTS
DEPTH (FEET)	SAMPLE	BLOW COUNT	POCKET PEN. (TSF)		GRAPHIC LOG	DRY DENSITY (PCF)	MOISTURE CONTENT (%)	LIQUID LIMIT	PLASTIC LIMIT	PASSING #200 SIEVE (%)	
SURFACE ELEVATION: --- MSL											
	X	26		[Symbol]	4 inches Crushed Miscellaneous base		7				
	X	11		[Symbol]	ALLUVIUM: Gray Brown Silty fine Sand, trace medium to coarse Sand, trace Iron oxide staining, medium dense-damp to moist		6				
5					Boring Terminated at 5'						

TBL\_15G177.GPJ\_SOCALGEO.GDT\_9/4/15

# APPENDIX C

### Consolidation/Collapse Test Results

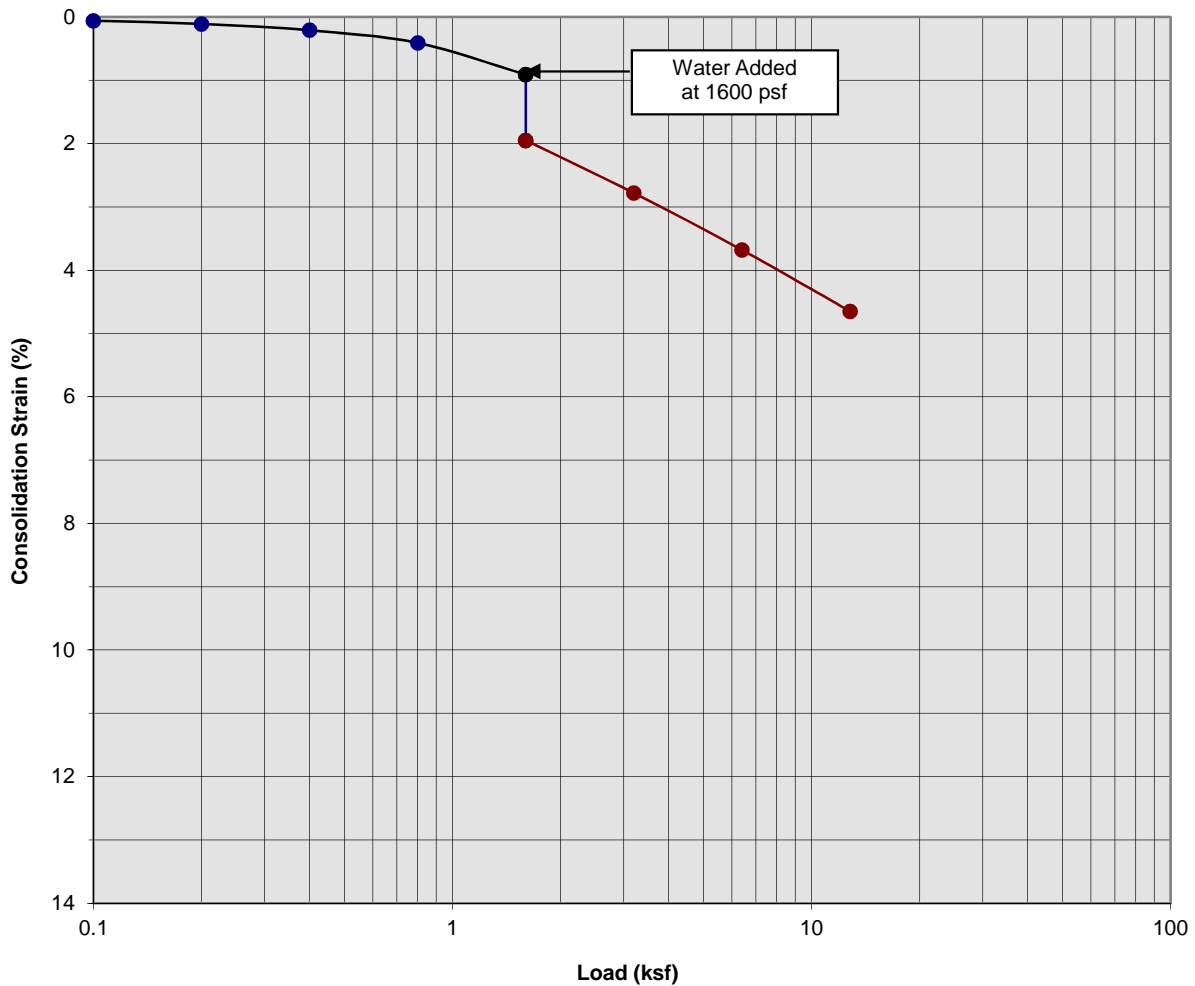

Classification: Gray Brown Silty fine Sand, trace medium to coarse Sand

Boring Number:	B-2	Initial Moisture Content (%)	5
Sample Number:	---	Final Moisture Content (%)	12
Depth (ft)	3 to 4	Initial Dry Density (pcf)	113.8
Specimen Diameter (in)	2.4	Final Dry Density (pcf)	118.4
Specimen Thickness (in)	1.0	Percent Collapse (%)	1.04

Proposed Comm/Industrial Bldg  
 Fontana, California  
 Project No. 15G177  
**PLATE C- 1**



**SOUTHERN  
 CALIFORNIA  
 GEOTECHNICAL**  
*A California Corporation*

### Consolidation/Collapse Test Results

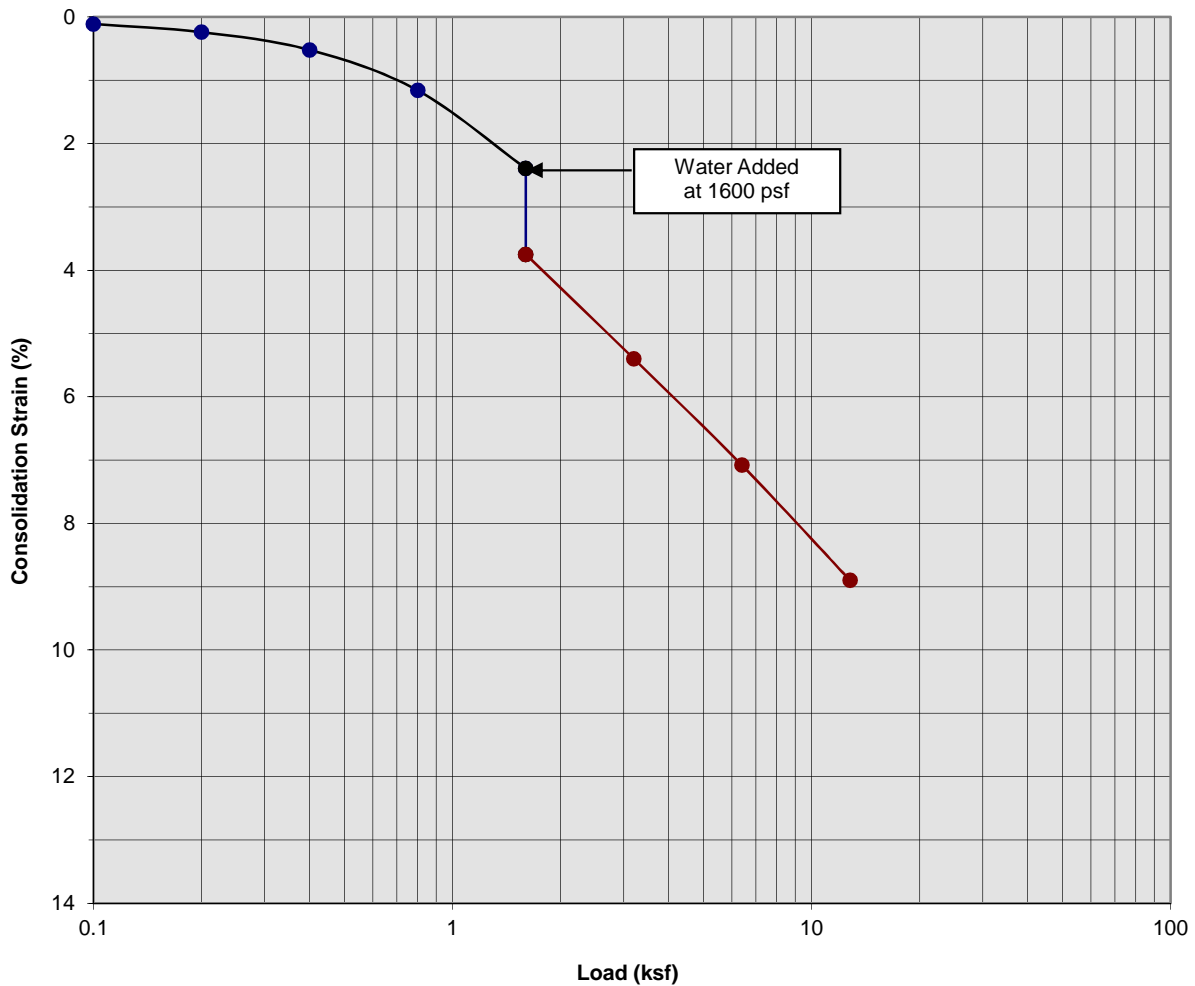

Classification: Gray Silty fine Sand, trace medium to coarse Sand

Boring Number:	B-2	Initial Moisture Content (%)	7
Sample Number:	---	Final Moisture Content (%)	14
Depth (ft)	5 to 6	Initial Dry Density (pcf)	108.0
Specimen Diameter (in)	2.4	Final Dry Density (pcf)	119.5
Specimen Thickness (in)	1.0	Percent Collapse (%)	1.36

Proposed Comm/Industrial Bldg  
 Fontana, California  
 Project No. 15G177  
**PLATE C- 2**



**SOUTHERN  
 CALIFORNIA  
 GEOTECHNICAL**  
*A California Corporation*

### Consolidation/Collapse Test Results

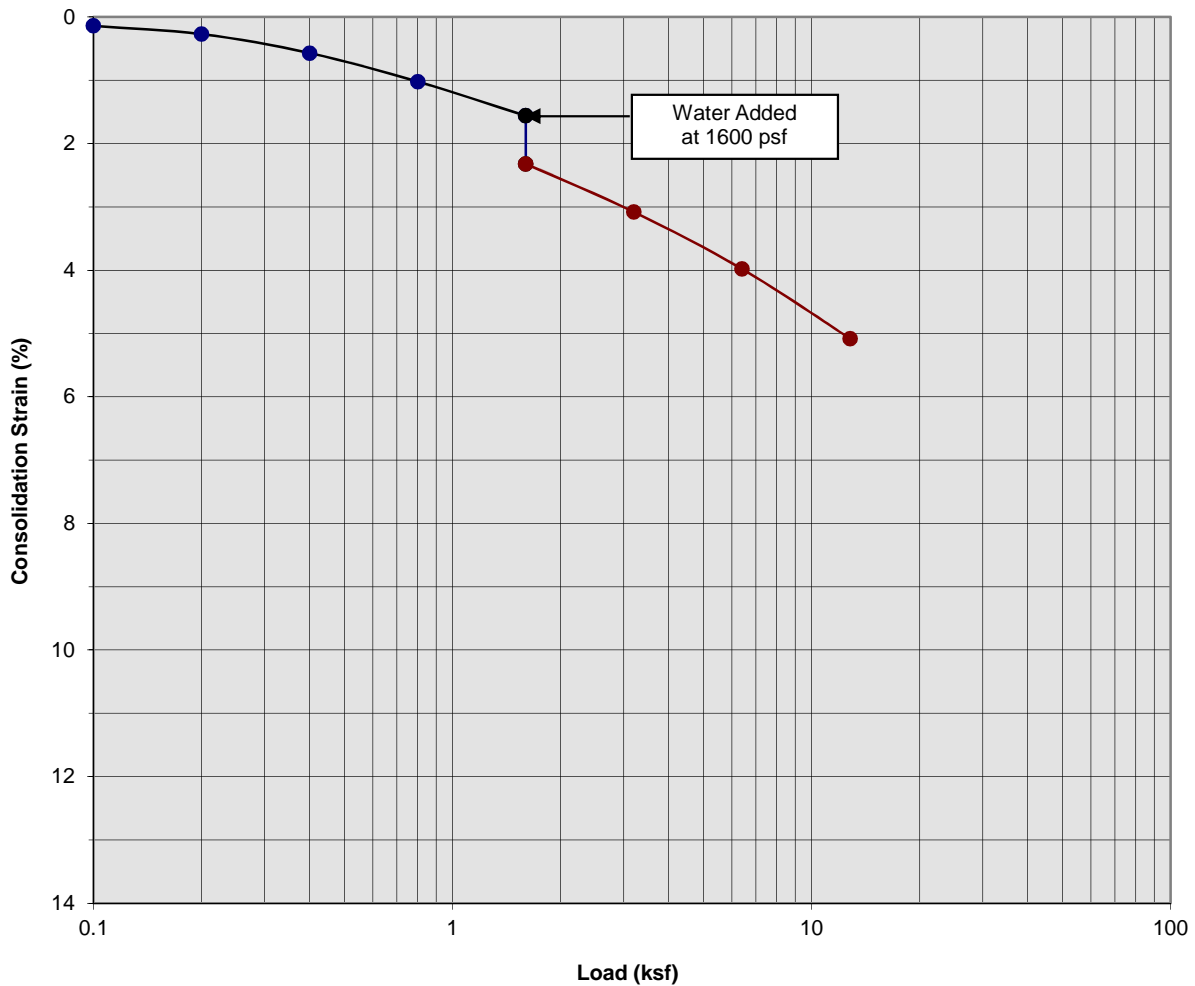

Classification: Gray Brown Silty fine Sand, little medium to coarse Sand

Boring Number:	B-2	Initial Moisture Content (%)	5
Sample Number:	---	Final Moisture Content (%)	11
Depth (ft)	7 to 8	Initial Dry Density (pcf)	121.3
Specimen Diameter (in)	2.4	Final Dry Density (pcf)	127.1
Specimen Thickness (in)	1.0	Percent Collapse (%)	0.76

Proposed Comm/Industrial Bldg  
 Fontana, California  
 Project No. 15G177  
**PLATE C- 3**



**SOUTHERN  
 CALIFORNIA  
 GEOTECHNICAL**  
*A California Corporation*

### Consolidation/Collapse Test Results

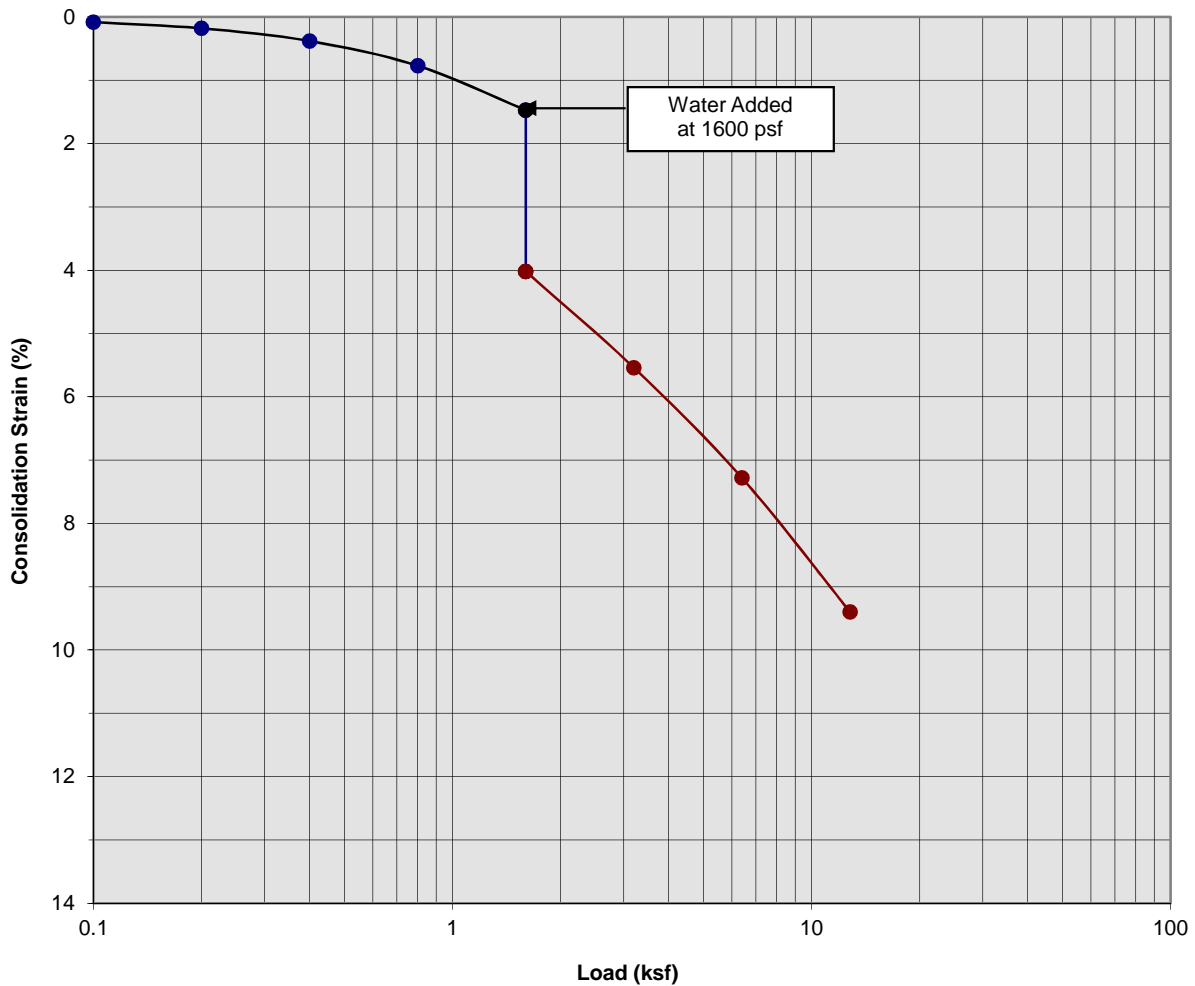

Classification: Brown fine to medium Sand, trace coarse Sand, trace fine Gravel

Boring Number:	B-2	Initial Moisture Content (%)	5
Sample Number:	---	Final Moisture Content (%)	14
Depth (ft)	9 to 10	Initial Dry Density (pcf)	111.5
Specimen Diameter (in)	2.4	Final Dry Density (pcf)	122.2
Specimen Thickness (in)	1.0	Percent Collapse (%)	2.55

Proposed Comm/Industrial Bldg  
 Fontana, California  
 Project No. 15G177  
**PLATE C- 4**



**SOUTHERN CALIFORNIA GEOTECHNICAL**  
*A California Corporation*

### Consolidation/Collapse Test Results

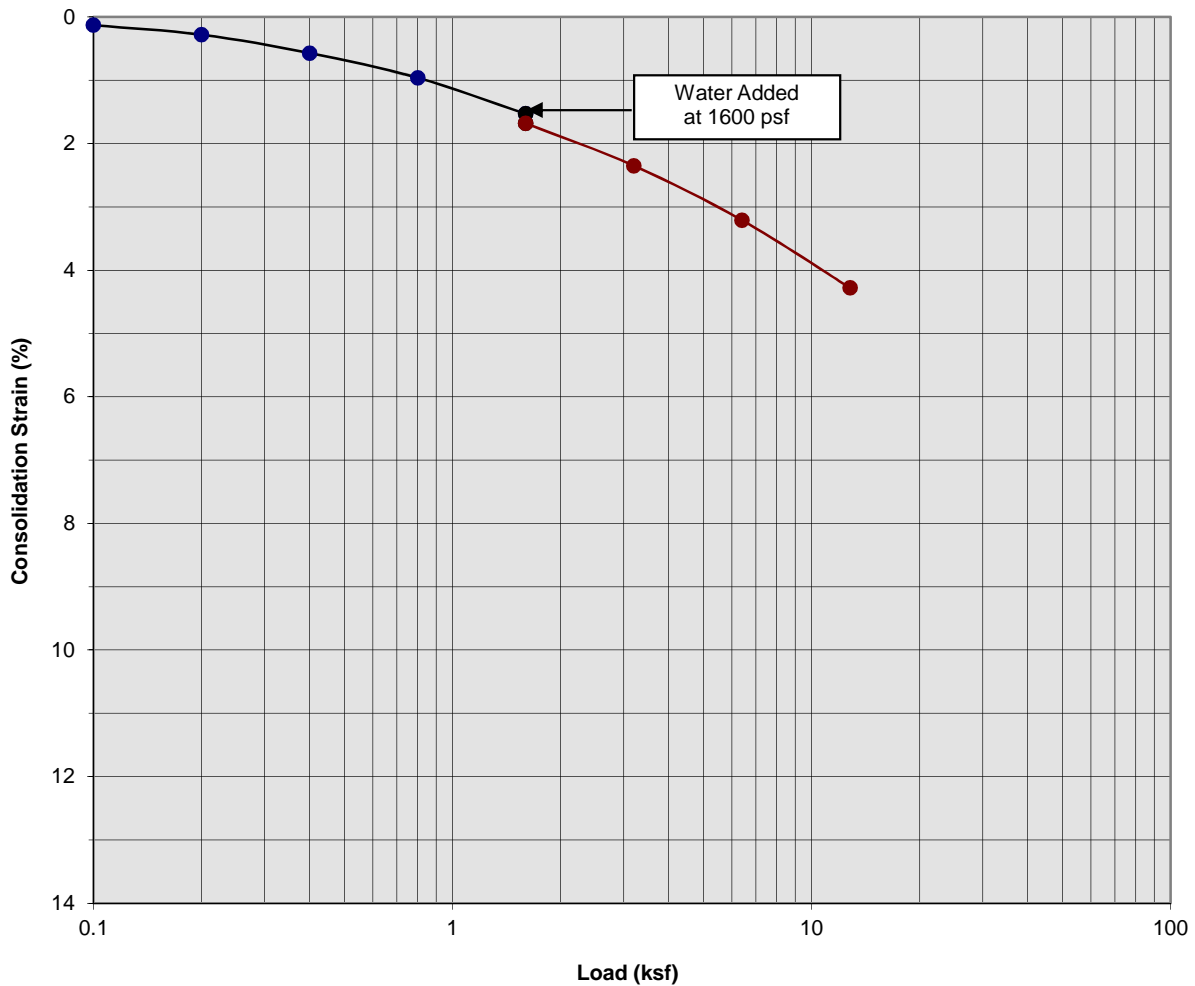

Classification: Light Gray Brown fine Sand, trace Silt

Boring Number:	B-7	Initial Moisture Content (%)	5
Sample Number:	---	Final Moisture Content (%)	19
Depth (ft)	3 to 4	Initial Dry Density (pcf)	110.7
Specimen Diameter (in)	2.4	Final Dry Density (pcf)	116.0
Specimen Thickness (in)	1.0	Percent Collapse (%)	0.15

Proposed Comm/Industrial Bldg  
 Fontana, California  
 Project No. 15G177  
**PLATE C- 5**



**SOUTHERN  
 CALIFORNIA  
 GEOTECHNICAL**  
*A California Corporation*

### Consolidation/Collapse Test Results

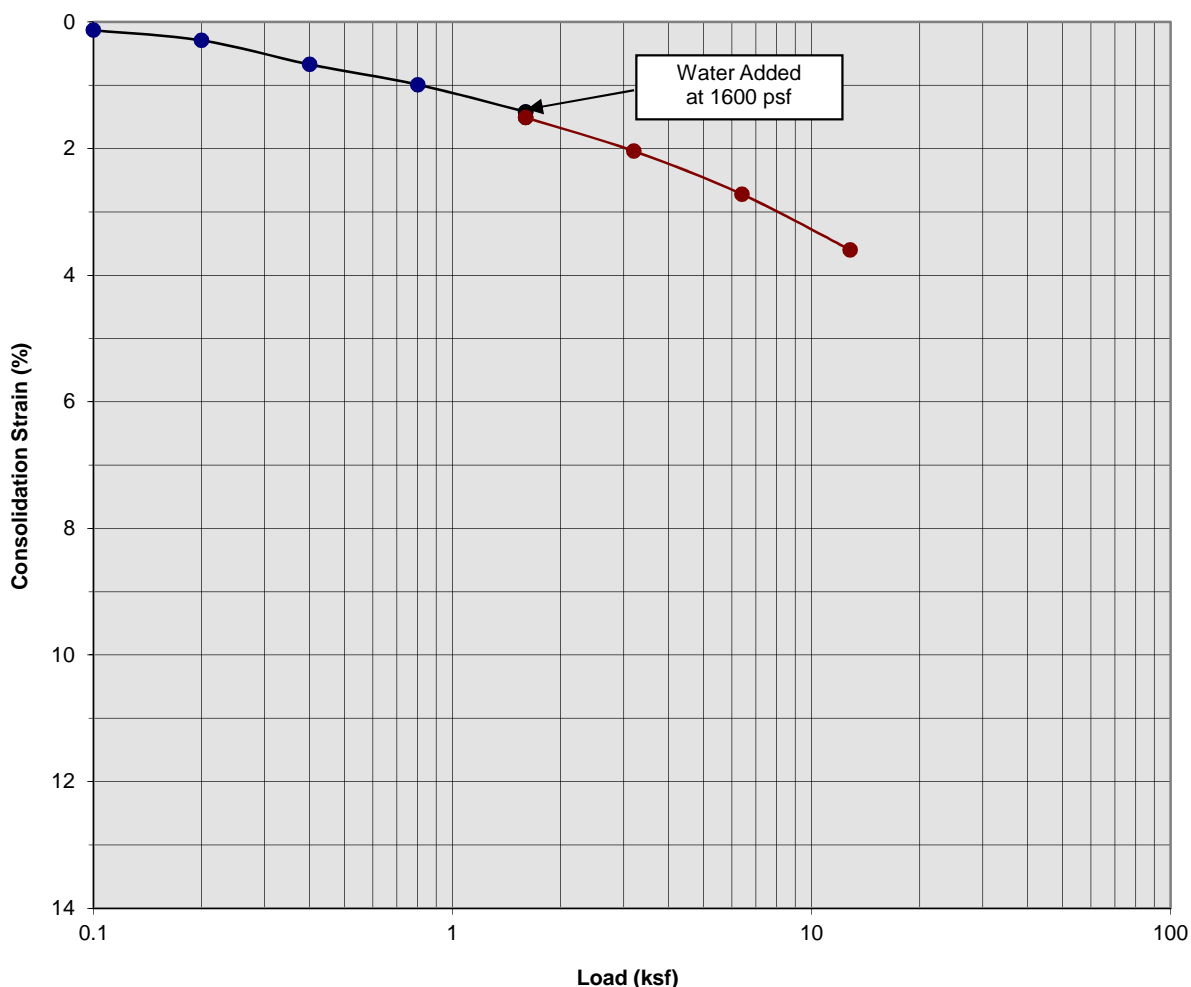

Classification: Light Gray Brown fine Sand, trace Silt

Boring Number:	B-7	Initial Moisture Content (%)	3
Sample Number:	---	Final Moisture Content (%)	19
Depth (ft)	5 to 6	Initial Dry Density (pcf)	102.7
Specimen Diameter (in)	2.4	Final Dry Density (pcf)	106.5
Specimen Thickness (in)	1.0	Percent Collapse (%)	0.09

Proposed Comm/Industrial Bldg  
 Fontana, California  
 Project No. 15G177  
**PLATE C- 6**



**SOUTHERN  
 CALIFORNIA  
 GEOTECHNICAL**  
*A California Corporation*



### Consolidation/Collapse Test Results

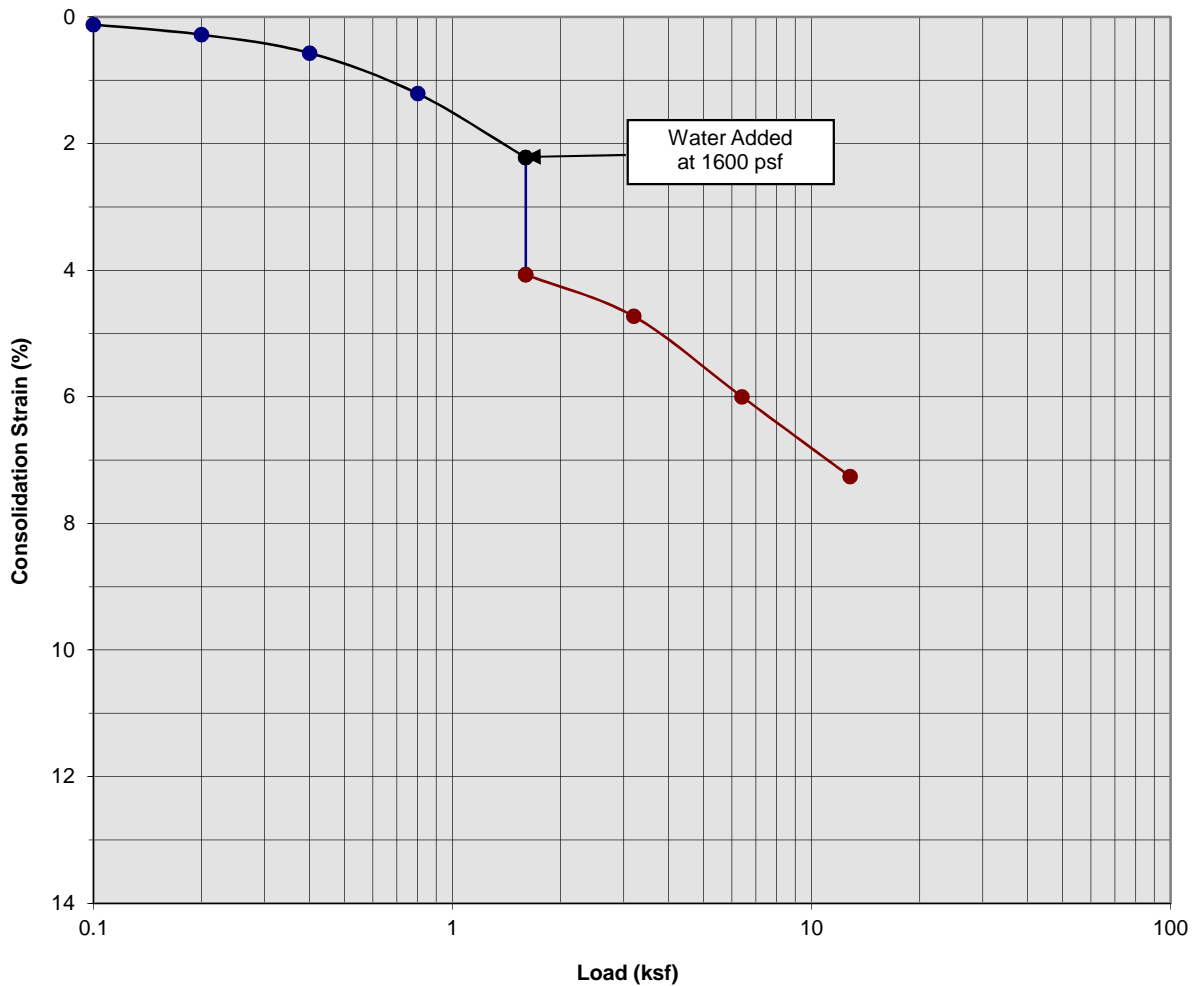

Classification: Gray fine to medium Sand, little coarse Sand

Boring Number:	B-7	Initial Moisture Content (%)	3
Sample Number:	---	Final Moisture Content (%)	15
Depth (ft)	7 to 8	Initial Dry Density (pcf)	101.5
Specimen Diameter (in)	2.4	Final Dry Density (pcf)	110.0
Specimen Thickness (in)	1.0	Percent Collapse (%)	1.85

Proposed Comm/Industrial Bldg  
 Fontana, California  
 Project No. 15G177  
**PLATE C- 7**



**SOUTHERN CALIFORNIA GEOTECHNICAL**  
 A California Corporation

### Consolidation/Collapse Test Results

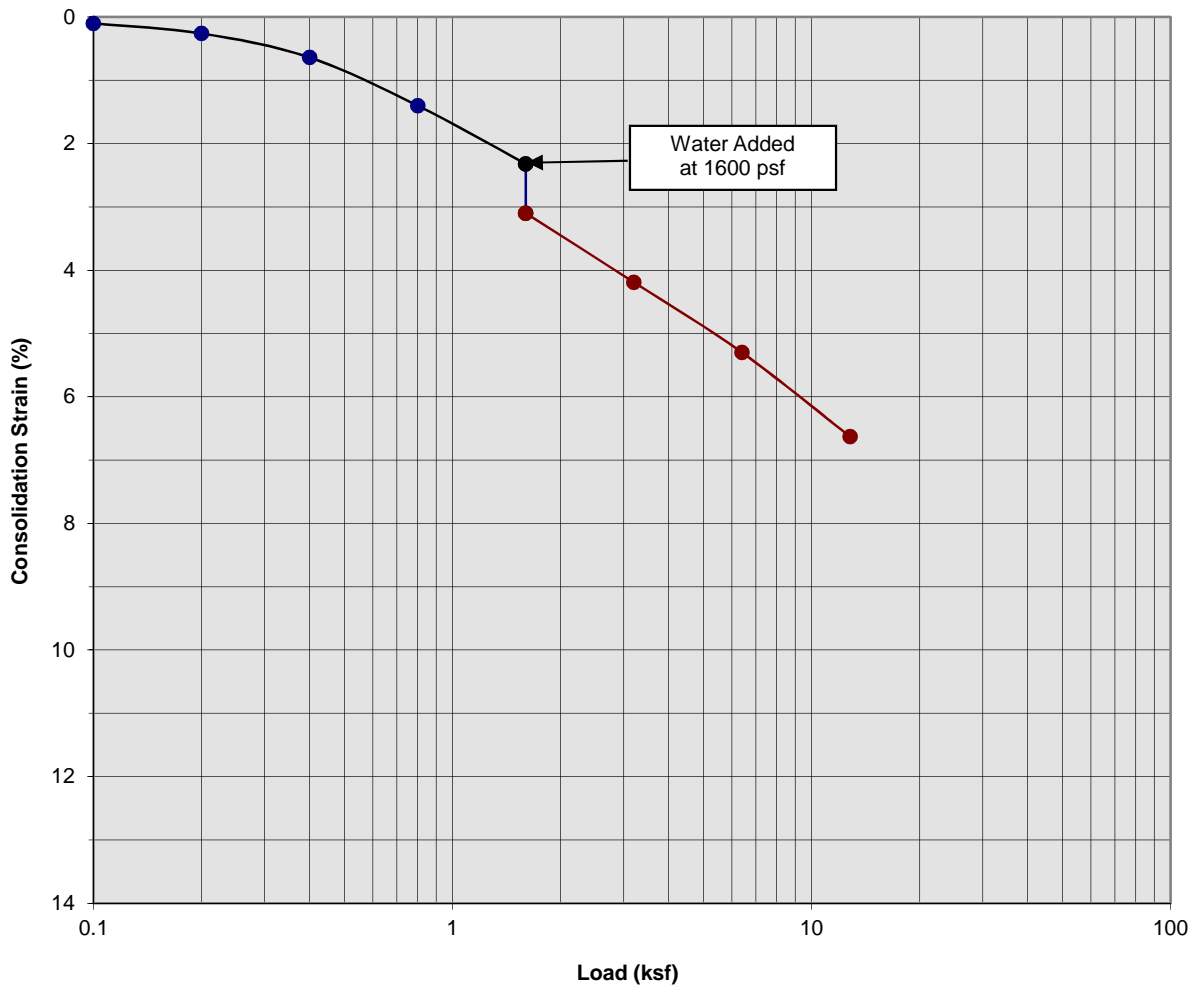

Classification: Light Gray fine Sand, trace Silt

Boring Number:	B-7	Initial Moisture Content (%)	6
Sample Number:	---	Final Moisture Content (%)	20
Depth (ft)	9 to 10	Initial Dry Density (pcf)	93.9
Specimen Diameter (in)	2.4	Final Dry Density (pcf)	100.6
Specimen Thickness (in)	1.0	Percent Collapse (%)	0.78

Proposed Comm/Industrial Bldg  
 Fontana, California  
 Project No. 15G177  
**PLATE C- 8**



**SOUTHERN  
 CALIFORNIA  
 GEOTECHNICAL**  
*A California Corporation*

### Moisture/Density Relationship ASTM D-1557

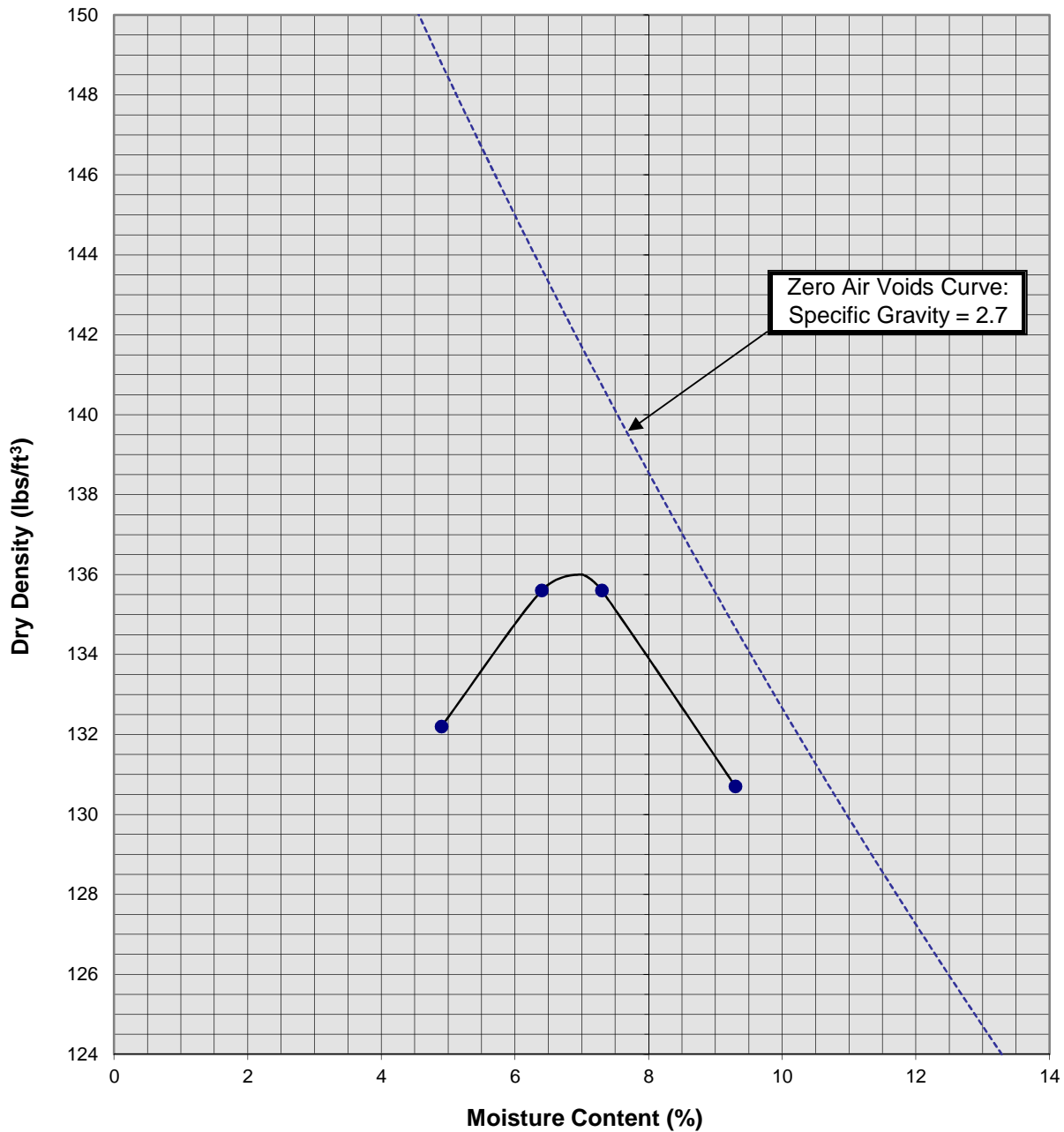

Soil ID Number		B-1 @ 0 to 5'
Optimum Moisture (%)		7
Maximum Dry Density (pcf)		136
Soil Classification	Light Brown Silty fine to medium Sand, little fine to coarse Gravel	

Proposed Comm/Industrial Bldg  
 Fontana, California  
 Project No. 15G177  
**PLATE C-9**



**SOUTHERN CALIFORNIA GEOTECHNICAL**  
*A California Corporation*

# APPENDIX D

## **GRADING GUIDE SPECIFICATIONS**

These grading guide specifications are intended to provide typical procedures for grading operations. They are intended to supplement the recommendations contained in the geotechnical investigation report for this project. Should the recommendations in the geotechnical investigation report conflict with the grading guide specifications, the more site specific recommendations in the geotechnical investigation report will govern.

### General

- The Earthwork Contractor is responsible for the satisfactory completion of all earthwork in accordance with the plans and geotechnical reports, and in accordance with city, county, and applicable building codes.
- The Geotechnical Engineer is the representative of the Owner/Builder for the purpose of implementing the report recommendations and guidelines. These duties are not intended to relieve the Earthwork Contractor of any responsibility to perform in a workman-like manner, nor is the Geotechnical Engineer to direct the grading equipment or personnel employed by the Contractor.
- The Earthwork Contractor is required to notify the Geotechnical Engineer of the anticipated work and schedule so that testing and inspections can be provided. If necessary, work may be stopped and redone if personnel have not been scheduled in advance.
- The Earthwork Contractor is required to have suitable and sufficient equipment on the job-site to process, moisture condition, mix and compact the amount of fill being placed to the approved compaction. In addition, suitable support equipment should be available to conform with recommendations and guidelines in this report.
- Canyon cleanouts, overexcavation areas, processed ground to receive fill, key excavations, subdrains and benches should be observed by the Geotechnical Engineer prior to placement of any fill. It is the Earthwork Contractor's responsibility to notify the Geotechnical Engineer of areas that are ready for inspection.
- Excavation, filling, and subgrade preparation should be performed in a manner and sequence that will provide drainage at all times and proper control of erosion. Precipitation, springs, and seepage water encountered shall be pumped or drained to provide a suitable working surface. The Geotechnical Engineer must be informed of springs or water seepage encountered during grading or foundation construction for possible revision to the recommended construction procedures and/or installation of subdrains.

### Site Preparation

- The Earthwork Contractor is responsible for all clearing, grubbing, stripping and site preparation for the project in accordance with the recommendations of the Geotechnical Engineer.
- If any materials or areas are encountered by the Earthwork Contractor which are suspected of having toxic or environmentally sensitive contamination, the Geotechnical Engineer and Owner/Builder should be notified immediately.

- Major vegetation should be stripped and disposed of off-site. This includes trees, brush, heavy grasses and any materials considered unsuitable by the Geotechnical Engineer.
- Underground structures such as basements, cesspools or septic disposal systems, mining shafts, tunnels, wells and pipelines should be removed under the inspection of the Geotechnical Engineer and recommendations provided by the Geotechnical Engineer and/or city, county or state agencies. If such structures are known or found, the Geotechnical Engineer should be notified as soon as possible so that recommendations can be formulated.
- Any topsoil, slopewash, colluvium, alluvium and rock materials which are considered unsuitable by the Geotechnical Engineer should be removed prior to fill placement.
- Remaining voids created during site clearing caused by removal of trees, foundations basements, irrigation facilities, etc., should be excavated and filled with compacted fill.
- Subsequent to clearing and removals, areas to receive fill should be scarified to a depth of 10 to 12 inches, moisture conditioned and compacted
- The moisture condition of the processed ground should be at or slightly above the optimum moisture content as determined by the Geotechnical Engineer. Depending upon field conditions, this may require air drying or watering together with mixing and/or discing.

#### Compacted Fills

- Soil materials imported to or excavated on the property may be utilized in the fill, provided each material has been determined to be suitable in the opinion of the Geotechnical Engineer. Unless otherwise approved by the Geotechnical Engineer, all fill materials shall be free of deleterious, organic, or frozen matter, shall contain no chemicals that may result in the material being classified as "contaminated," and shall be very low to non-expansive with a maximum expansion index (EI) of 50. The top 12 inches of the compacted fill should have a maximum particle size of 3 inches, and all underlying compacted fill material a maximum 6-inch particle size, except as noted below.
- All soils should be evaluated and tested by the Geotechnical Engineer. Materials with high expansion potential, low strength, poor gradation or containing organic materials may require removal from the site or selective placement and/or mixing to the satisfaction of the Geotechnical Engineer.
- Rock fragments or rocks less than 6 inches in their largest dimensions, or as otherwise determined by the Geotechnical Engineer, may be used in compacted fill, provided the distribution and placement is satisfactory in the opinion of the Geotechnical Engineer.
- Rock fragments or rocks greater than 12 inches should be taken off-site or placed in accordance with recommendations and in areas designated as suitable by the Geotechnical Engineer. These materials should be placed in accordance with Plate D-8 of these Grading Guide Specifications and in accordance with the following recommendations:
  - Rocks 12 inches or more in diameter should be placed in rows at least 15 feet apart, 15 feet from the edge of the fill, and 10 feet or more below subgrade. Spaces should be left between each rock fragment to provide for placement and compaction of soil around the fragments.
  - Fill materials consisting of soil meeting the minimum moisture content requirements and free of oversize material should be placed between and over the rows of rock or

concrete. Ample water and compactive effort should be applied to the fill materials as they are placed in order that all of the voids between each of the fragments are filled and compacted to the specified density.

- Subsequent rows of rocks should be placed such that they are not directly above a row placed in the previous lift of fill. A minimum 5-foot offset between rows is recommended.
- To facilitate future trenching, oversized material should not be placed within the range of foundation excavations, future utilities or other underground construction unless specifically approved by the soil engineer and the developer/owner representative.
- Fill materials approved by the Geotechnical Engineer should be placed in areas previously prepared to receive fill and in evenly placed, near horizontal layers at about 6 to 8 inches in loose thickness, or as otherwise determined by the Geotechnical Engineer for the project.
- Each layer should be moisture conditioned to optimum moisture content, or slightly above, as directed by the Geotechnical Engineer. After proper mixing and/or drying, to evenly distribute the moisture, the layers should be compacted to at least 90 percent of the maximum dry density in compliance with ASTM D-1557-78 unless otherwise indicated.
- Density and moisture content testing should be performed by the Geotechnical Engineer at random intervals and locations as determined by the Geotechnical Engineer. These tests are intended as an aid to the Earthwork Contractor, so he can evaluate his workmanship, equipment effectiveness and site conditions. The Earthwork Contractor is responsible for compaction as required by the Geotechnical Report(s) and governmental agencies.
- Fill areas unused for a period of time may require moisture conditioning, processing and recompaction prior to the start of additional filling. The Earthwork Contractor should notify the Geotechnical Engineer of his intent so that an evaluation can be made.
- Fill placed on ground sloping at a 5-to-1 inclination (horizontal-to-vertical) or steeper should be benched into bedrock or other suitable materials, as directed by the Geotechnical Engineer. Typical details of benching are illustrated on Plates D-2, D-4, and D-5.
- Cut/fill transition lots should have the cut portion overexcavated to a depth of at least 3 feet and rebuilt with fill (see Plate D-1), as determined by the Geotechnical Engineer.
- All cut lots should be inspected by the Geotechnical Engineer for fracturing and other bedrock conditions. If necessary, the pads should be overexcavated to a depth of 3 feet and rebuilt with a uniform, more cohesive soil type to impede moisture penetration.
- Cut portions of pad areas above buttresses or stabilizations should be overexcavated to a depth of 3 feet and rebuilt with uniform, more cohesive compacted fill to impede moisture penetration.
- Non-structural fill adjacent to structural fill should typically be placed in unison to provide lateral support. Backfill along walls must be placed and compacted with care to ensure that excessive unbalanced lateral pressures do not develop. The type of fill material placed adjacent to below grade walls must be properly tested and approved by the Geotechnical Engineer with consideration of the lateral earth pressure used in the design.

### Foundations

- The foundation influence zone is defined as extending one foot horizontally from the outside edge of a footing, and proceeding downward at a ½ horizontal to 1 vertical (0.5:1) inclination.
- Where overexcavation beneath a footing subgrade is necessary, it should be conducted so as to encompass the entire foundation influence zone, as described above.
- Compacted fill adjacent to exterior footings should extend at least 12 inches above foundation bearing grade. Compacted fill within the interior of structures should extend to the floor subgrade elevation.

### Fill Slopes

- The placement and compaction of fill described above applies to all fill slopes. Slope compaction should be accomplished by overfilling the slope, adequately compacting the fill in even layers, including the overfilled zone and cutting the slope back to expose the compacted core
- Slope compaction may also be achieved by backrolling the slope adequately every 2 to 4 vertical feet during the filling process as well as requiring the earth moving and compaction equipment to work close to the top of the slope. Upon completion of slope construction, the slope face should be compacted with a sheepsfoot connected to a sideboom and then grid rolled. This method of slope compaction should only be used if approved by the Geotechnical Engineer.
- Sandy soils lacking in adequate cohesion may be unstable for a finished slope condition and therefore should not be placed within 15 horizontal feet of the slope face.
- All fill slopes should be keyed into bedrock or other suitable material. Fill keys should be at least 15 feet wide and inclined at 2 percent into the slope. For slopes higher than 30 feet, the fill key width should be equal to one-half the height of the slope (see Plate D-5).
- All fill keys should be cleared of loose slough material prior to geotechnical inspection and should be approved by the Geotechnical Engineer and governmental agencies prior to filling.
- The cut portion of fill over cut slopes should be made first and inspected by the Geotechnical Engineer for possible stabilization requirements. The fill portion should be adequately keyed through all surficial soils and into bedrock or suitable material. Soils should be removed from the transition zone between the cut and fill portions (see Plate D-2).

### Cut Slopes

- All cut slopes should be inspected by the Geotechnical Engineer to determine the need for stabilization. The Earthwork Contractor should notify the Geotechnical Engineer when slope cutting is in progress at intervals of 10 vertical feet. Failure to notify may result in a delay in recommendations.
- Cut slopes exposing loose, cohesionless sands should be reported to the Geotechnical Engineer for possible stabilization recommendations.
- All stabilization excavations should be cleared of loose slough material prior to geotechnical inspection. Stakes should be provided by the Civil Engineer to verify the location and dimensions of the key. A typical stabilization fill detail is shown on Plate D-5.



- Stabilization key excavations should be provided with subdrains. Typical subdrain details are shown on Plates D-6.

#### Subdrains

- Subdrains may be required in canyons and swales where fill placement is proposed. Typical subdrain details for canyons are shown on Plate D-3. Subdrains should be installed after approval of removals and before filling, as determined by the Soils Engineer.
- Plastic pipe may be used for subdrains provided it is Schedule 40 or SDR 35 or equivalent. Pipe should be protected against breakage, typically by placement in a square-cut (backhoe) trench or as recommended by the manufacturer.
- Filter material for subdrains should conform to CALTRANS Specification 68-1.025 or as approved by the Geotechnical Engineer for the specific site conditions. Clean  $\frac{3}{4}$ -inch crushed rock may be used provided it is wrapped in an acceptable filter cloth and approved by the Geotechnical Engineer. Pipe diameters should be 6 inches for runs up to 500 feet and 8 inches for the downstream continuations of longer runs. Four-inch diameter pipe may be used in buttress and stabilization fills.

CUT LOT

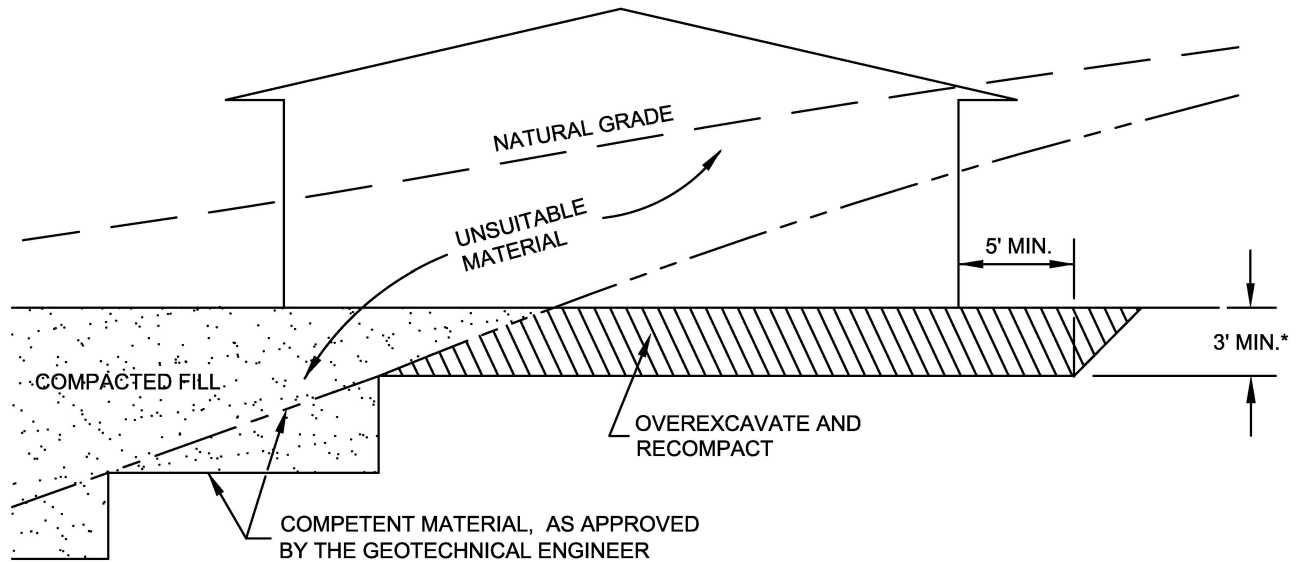

CUT/FILL LOT (TRANSITION)

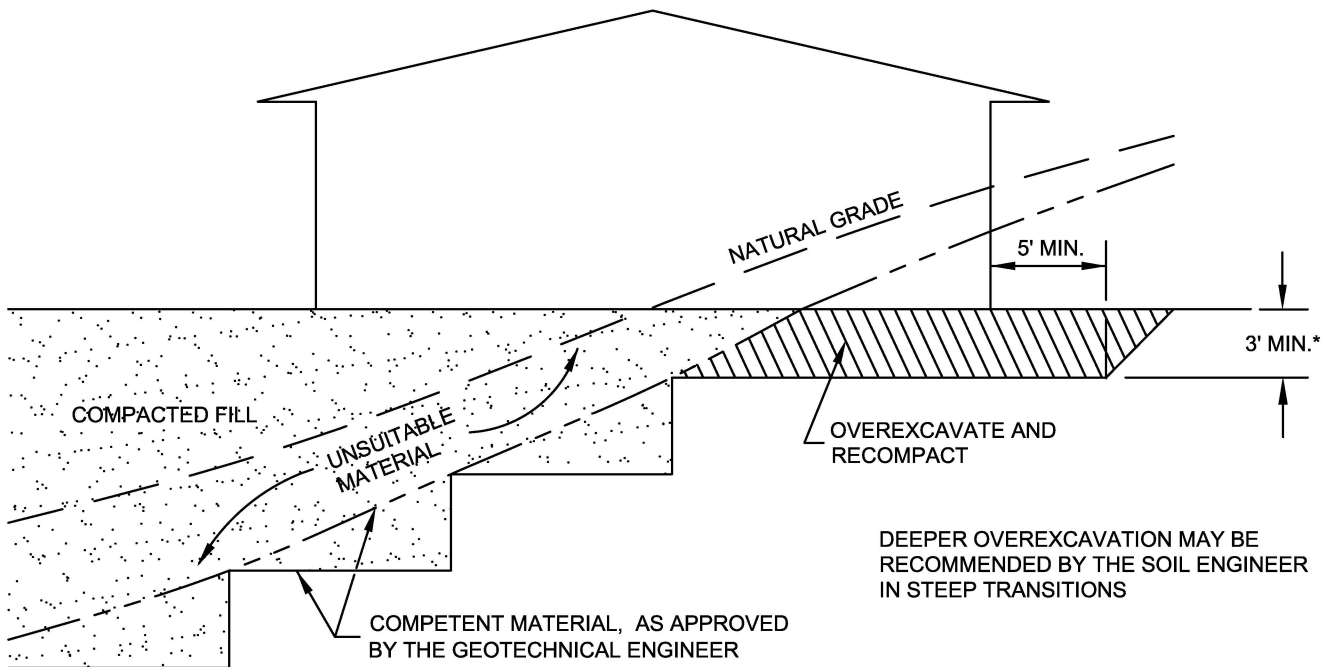

\*SEE TEXT OF REPORT FOR SPECIFIC RECOMMENDATION.  
ACTUAL DEPTH OF OVEREXCAVATION MAY BE GREATER.

<b>TRANSITION LOT DETAIL</b>	
<b>GRADING GUIDE SPECIFICATIONS</b>	
NOT TO SCALE	 <b>SOUTHERN CALIFORNIA GEOTECHNICAL</b>
DRAWN: JAS CHKD: GKM	
<b>PLATE D-1</b>	

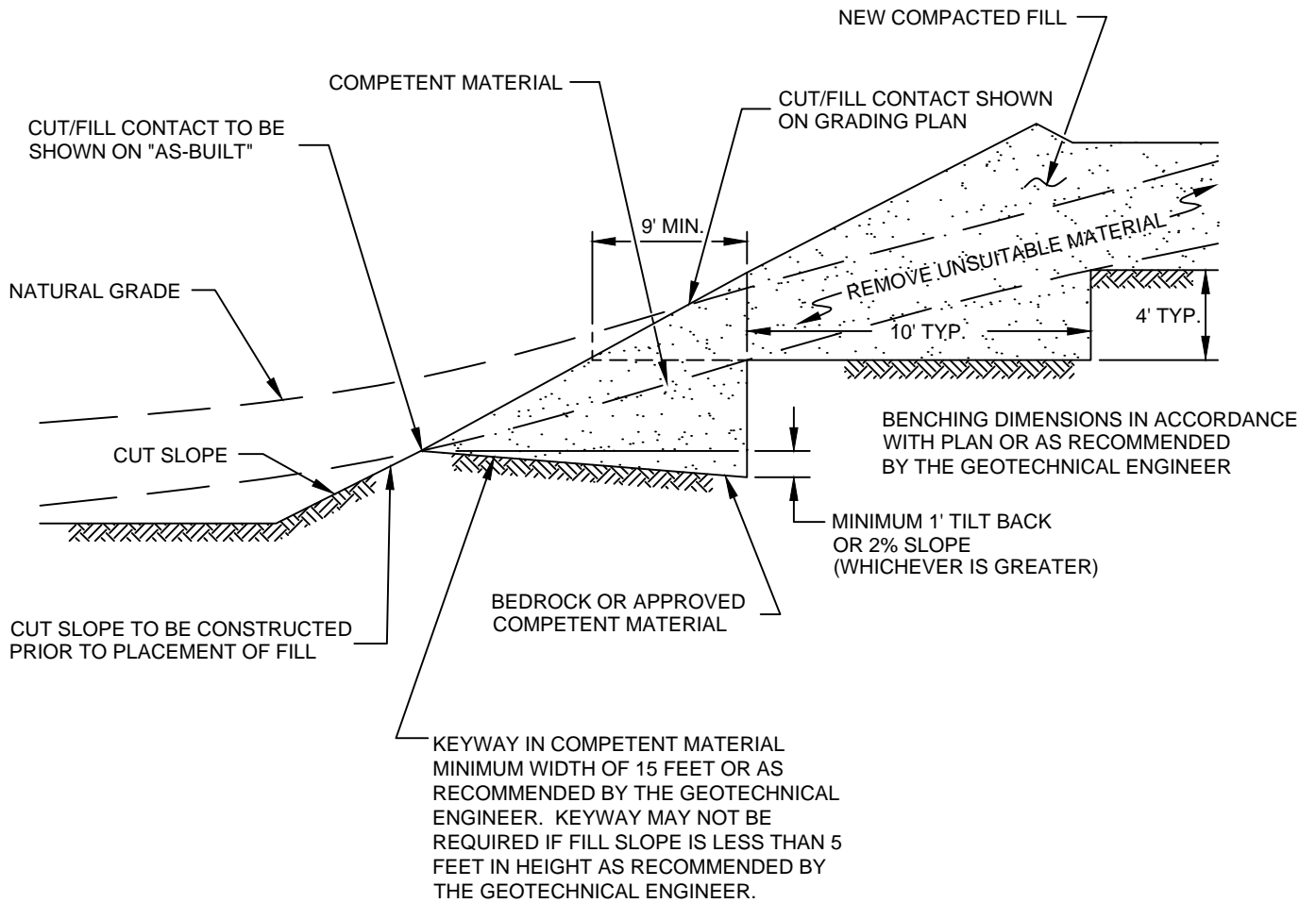

<b>FILL ABOVE CUT SLOPE DETAIL</b>	
<b>GRADING GUIDE SPECIFICATIONS</b>	
NOT TO SCALE	 <b>SOUTHERN CALIFORNIA GEOTECHNICAL</b>
DRAWN: JAS CHKD: GKM	
<b>PLATE D-2</b>	

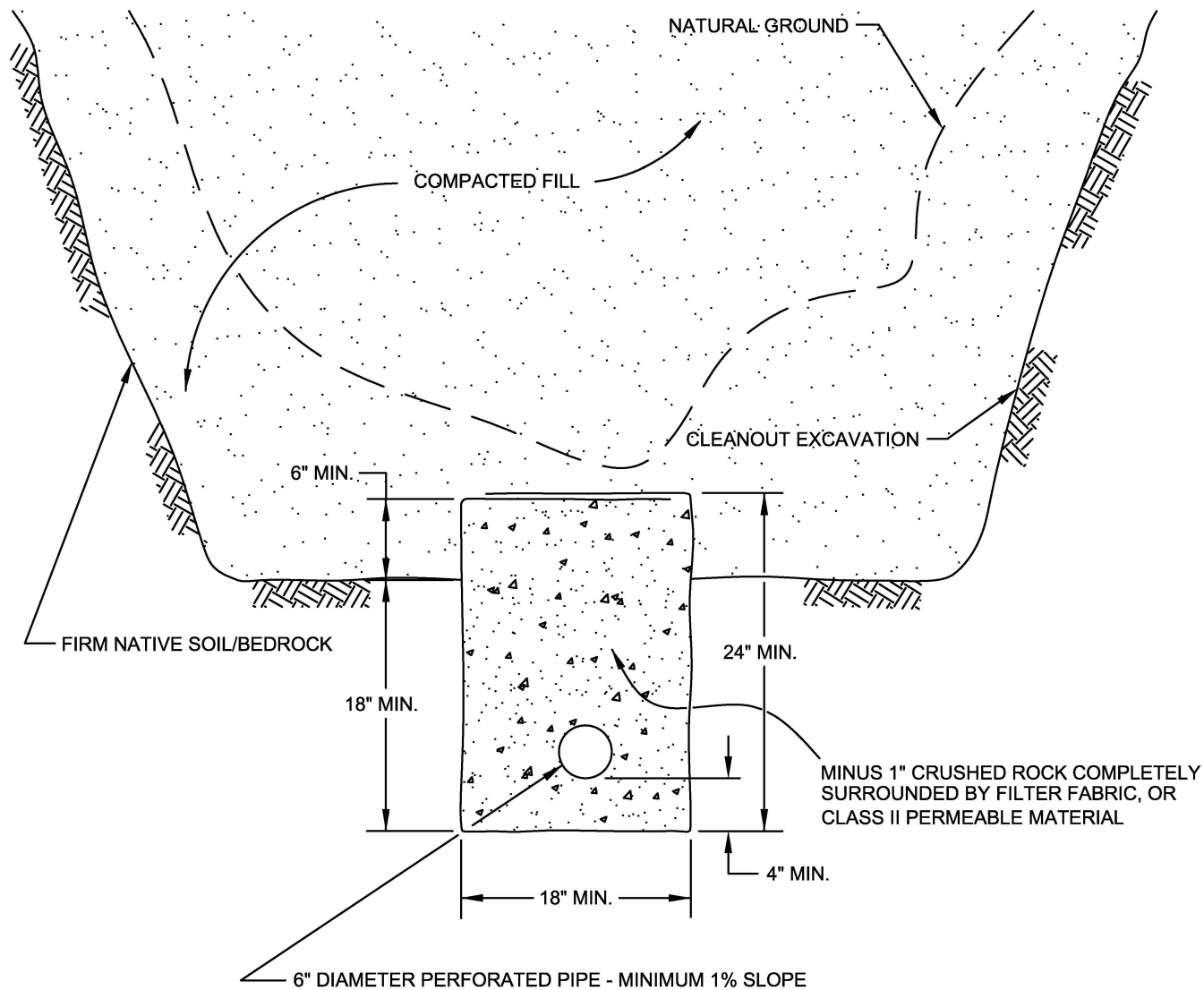

PIPE MATERIAL	DEPTH OF FILL OVER SUBDRAIN
ADS (CORRUGATED POLETHYLENE)	8
TRANSITE UNDERDRAIN	20
PVC OR ABS: SDR 35	35
SDR 21	100

**SCHEMATIC ONLY  
NOT TO SCALE**

<b>CANYON SUBDRAIN DETAIL</b>	
<b>GRADING GUIDE SPECIFICATIONS</b>	
NOT TO SCALE	
DRAWN: JAS CHKD: GKM	
<b>PLATE D-3</b>	



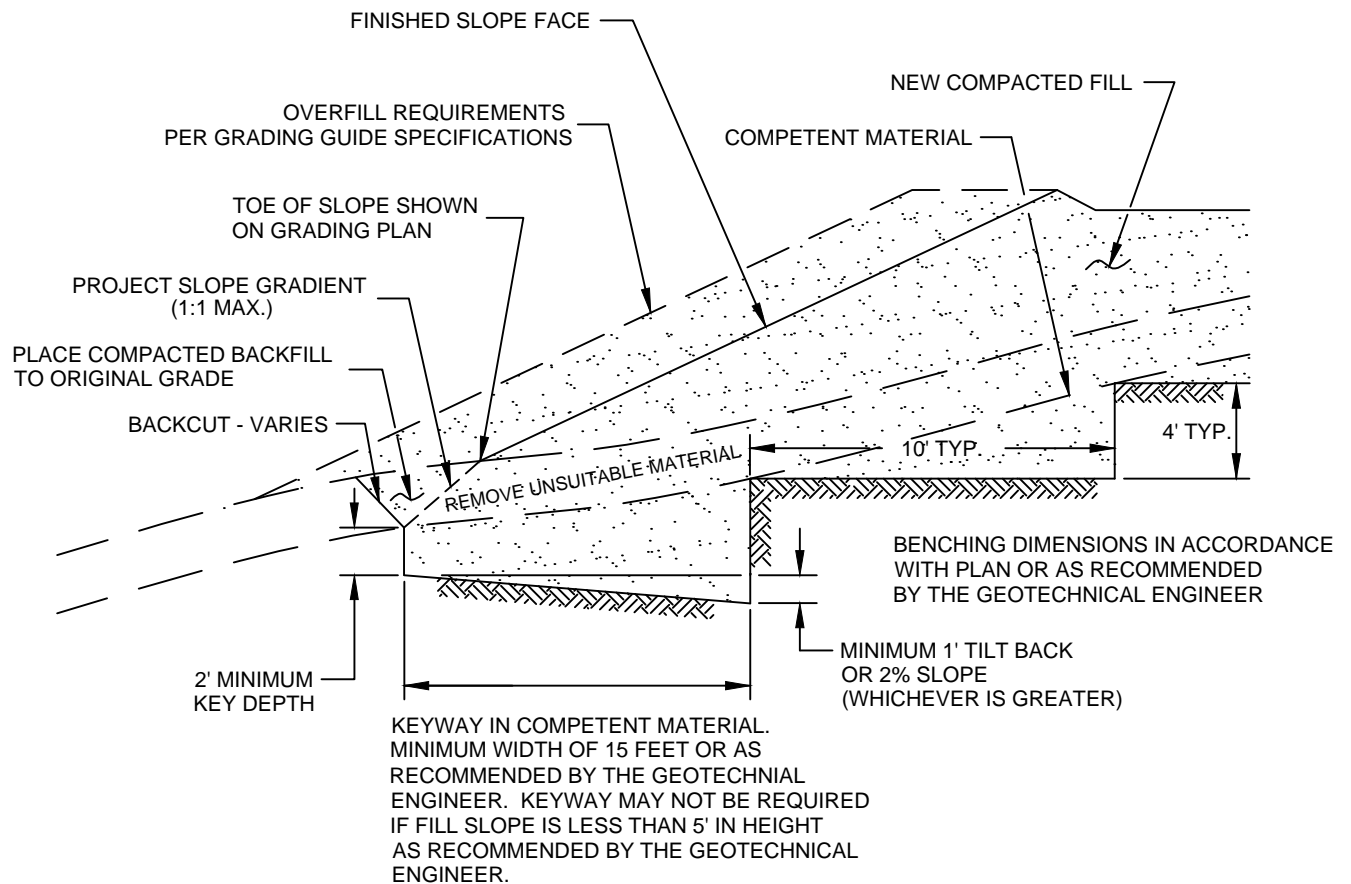

SOUTHERN  
CALIFORNIA  
GEOTECHNICAL

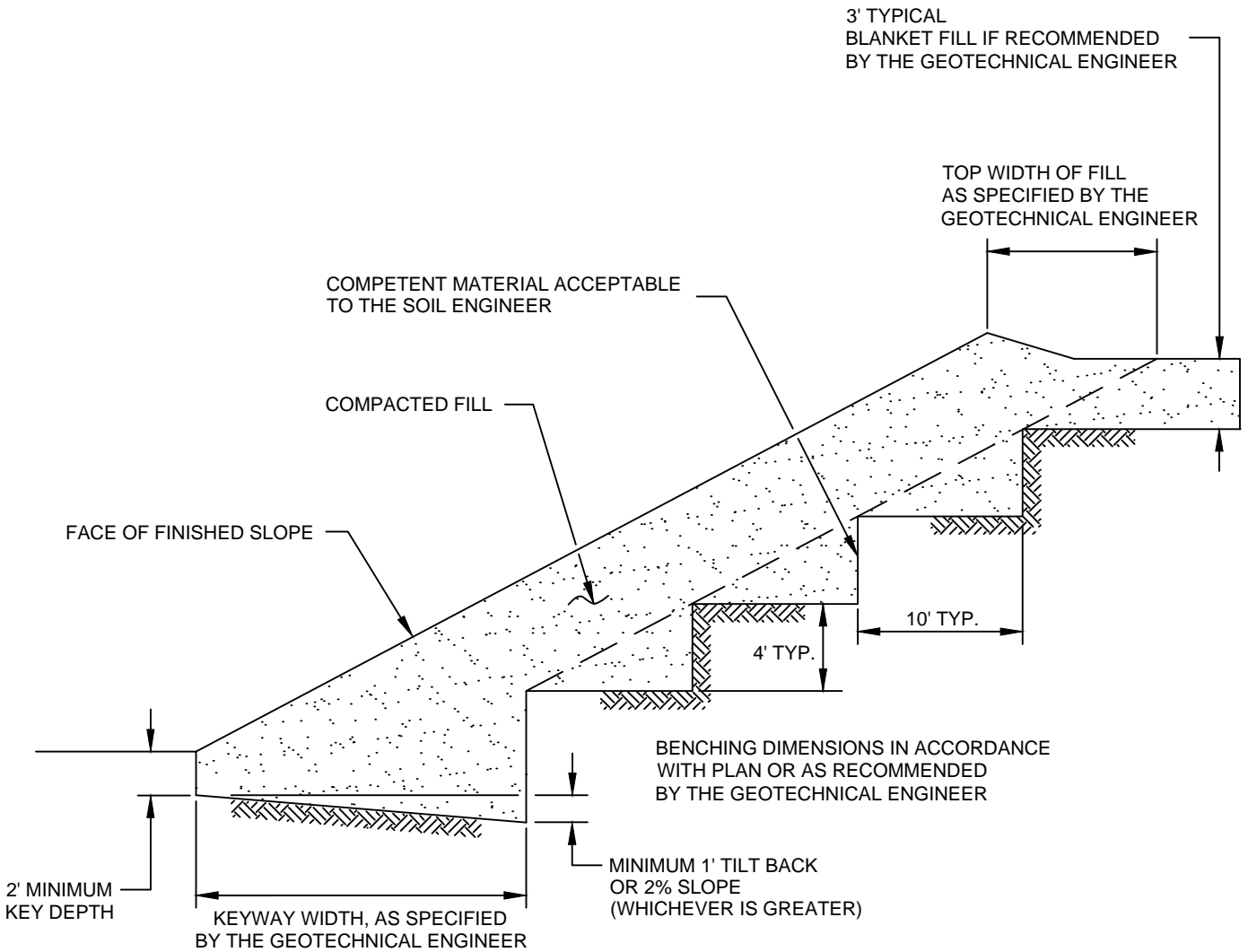

NOTE:  
 BENCHING SHALL BE REQUIRED WHEN NATURAL SLOPES ARE EQUAL TO OR STEEPER THAN 5:1 OR WHEN RECOMMENDED BY THE GEOTECHNICAL ENGINEER.

<b>FILL ABOVE NATURAL SLOPE DETAIL</b>	
<b>GRADING GUIDE SPECIFICATIONS</b>	
NOT TO SCALE	
DRAWN: JAS CHKD: GKM	
	
<b>SOUTHERN CALIFORNIA GEOTECHNICAL</b>	
PLATE D-4	



<b>STABILIZATION FILL DETAIL</b>	
GRADING GUIDE SPECIFICATIONS	
NOT TO SCALE	 <b>SOUTHERN CALIFORNIA GEOTECHNICAL</b>
DRAWN: JAS CHKD: GKM	
<b>PLATE D-5</b>	

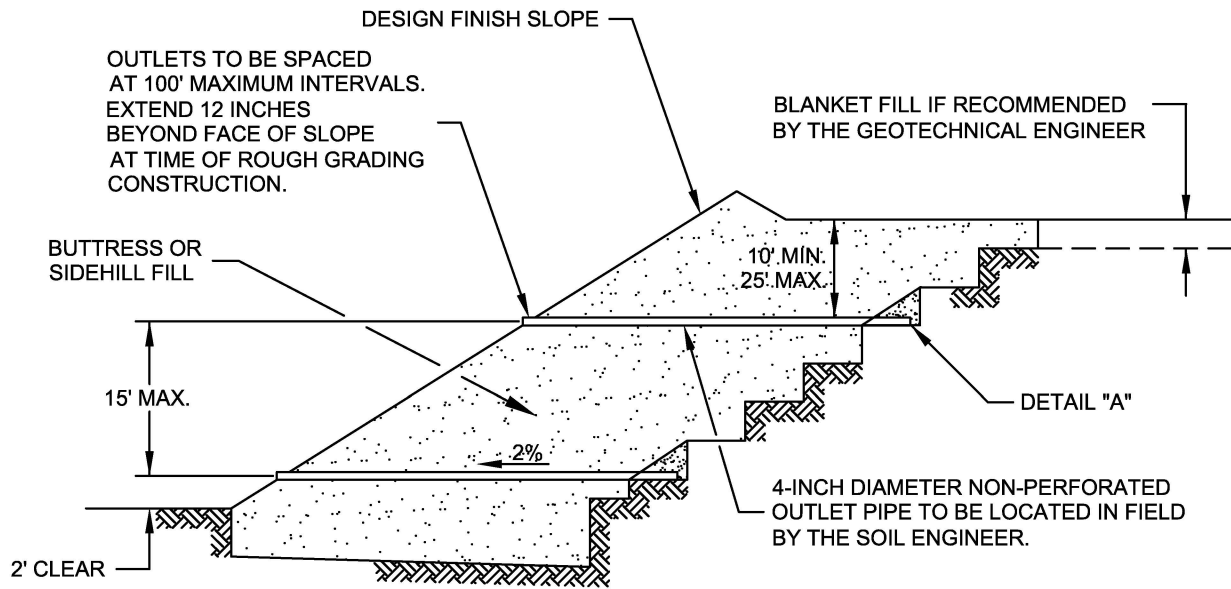

"FILTER MATERIAL" TO MEET FOLLOWING SPECIFICATION OR APPROVED EQUIVALENT: (CONFORMS TO EMA STD. PLAN 323)

SIEVE SIZE	PERCENTAGE PASSING
1"	100
3/4"	90-100
3/8"	40-100
NO. 4	25-40
NO. 8	18-33
NO. 30	5-15
NO. 50	0-7
NO. 200	0-3

"GRAVEL" TO MEET FOLLOWING SPECIFICATION OR APPROVED EQUIVALENT:

SIEVE SIZE	MAXIMUM PERCENTAGE PASSING
1 1/2"	100
NO. 4	50
NO. 200	8
SAND EQUIVALENT = MINIMUM OF 50	

OUTLET PIPE TO BE CONNECTED TO SUBDRAIN PIPE WITH TEE OR ELBOW

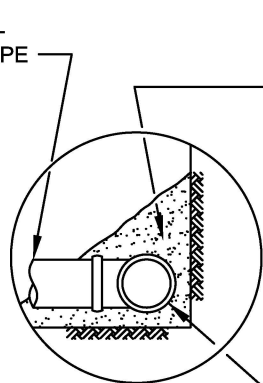

DETAIL "A"

FILTER MATERIAL - MINIMUM OF FIVE CUBIC FEET PER FOOT OF PIPE. SEE ABOVE FOR FILTER MATERIAL SPECIFICATION.

ALTERNATIVE: IN LIEU OF FILTER MATERIAL FIVE CUBIC FEET OF GRAVEL PER FOOT OF PIPE MAY BE ENCASED IN FILTER FABRIC. SEE ABOVE FOR GRAVEL SPECIFICATION.

FILTER FABRIC SHALL BE MIRAFI 140 OR EQUIVALENT. FILTER FABRIC SHALL BE LAPPED A MINIMUM OF 12 INCHES ON ALL JOINTS.

MINIMUM 4-INCH DIAMETER PVC SCH 40 OR ABS CLASS SDR 35 WITH A CRUSHING STRENGTH OF AT LEAST 1,000 POUNDS, WITH A MINIMUM OF 8 UNIFORMLY SPACED PERFORATIONS PER FOOT OF PIPE INSTALLED WITH PERFORATIONS ON BOTTOM OF PIPE. PROVIDE CAP AT UPSTREAM END OF PIPE. SLOPE AT 2 PERCENT TO OUTLET PIPE.

NOTES:

1. TRENCH FOR OUTLET PIPES TO BE BACKFILLED WITH ON-SITE SOIL.

SLOPE FILL SUBDRAINS	
GRADING GUIDE SPECIFICATIONS	
NOT TO SCALE	 <b>SOUTHERN CALIFORNIA GEOTECHNICAL</b>
DRAWN: JAS CHKD: GKM	
PLATE D-6	

MINIMUM ONE FOOT THICK LAYER OF LOW PERMEABILITY SOIL IF NOT COVERED WITH AN IMPERMEABLE SURFACE

MINIMUM ONE FOOT WIDE LAYER OF FREE DRAINING MATERIAL (LESS THAN 5% PASSING THE #200 SIEVE) OR PROPERLY INSTALLED PREFABRICATED DRAINAGE COMPOSITE (MiraDRAIN 6000 OR APPROVED EQUIVALENT).

FILTER MATERIAL - MINIMUM OF TWO CUBIC FEET PER FOOT OF PIPE. SEE BELOW FOR FILTER MATERIAL SPECIFICATION.

ALTERNATIVE: IN LIEU OF FILTER MATERIAL TWO CUBIC FEET OF GRAVEL PER FOOT OF PIPE MAY BE ENCASED IN FILTER FABRIC. SEE BELOW FOR GRAVEL SPECIFICATION.

FILTER FABRIC SHALL BE MIRAFAI 140 OR EQUIVALENT. FILTER FABRIC SHALL BE LAPPED A MINIMUM OF 6 INCHES ON ALL JOINTS.

MINIMUM 4-INCH DIAMETER PVC SCH 40 OR ABS CLASS SDR 35 WITH A CRUSHING STRENGTH OF AT LEAST 1,000 POUNDS, WITH A MINIMUM OF 8 UNIFORMLY SPACED PERFORATIONS PER FOOT OF PIPE INSTALLED WITH PERFORATIONS ON BOTTOM OF PIPE. PROVIDE CAP AT UPSTREAM END OF PIPE. SLOPE AT 2 PERCENT TO OUTLET PIPE.

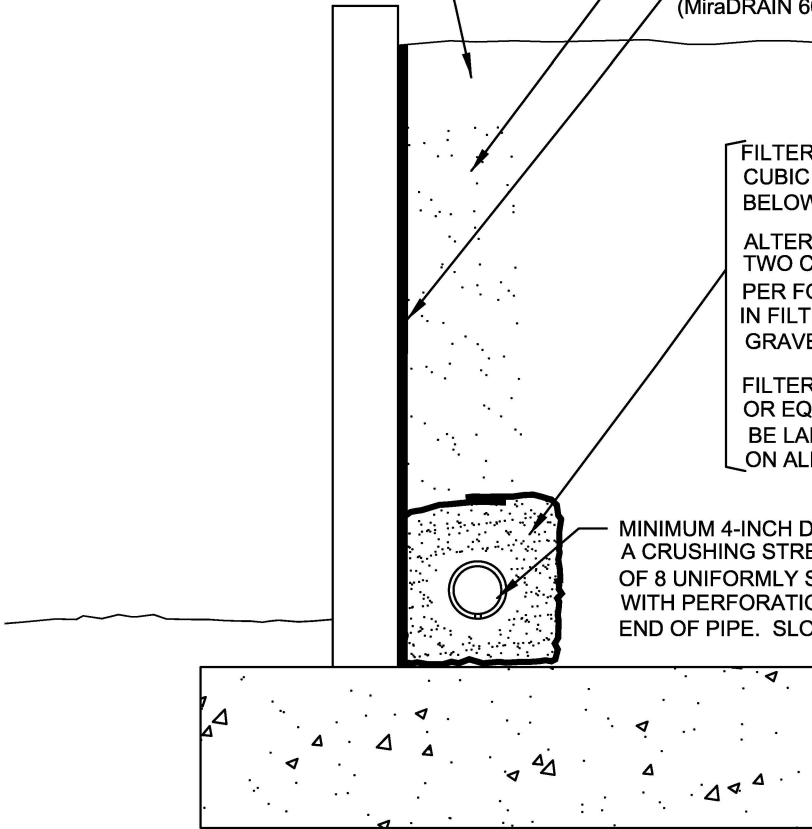

"FILTER MATERIAL" TO MEET FOLLOWING SPECIFICATION OR APPROVED EQUIVALENT: (CONFORMS TO EMA STD. PLAN 323)

SIEVE SIZE	PERCENTAGE PASSING
1"	100
3/4"	90-100
3/8"	40-100
NO. 4	25-40
NO. 8	18-33
NO. 30	5-15
NO. 50	0-7
NO. 200	0-3

"GRAVEL" TO MEET FOLLOWING SPECIFICATION OR APPROVED EQUIVALENT:

SIEVE SIZE	MAXIMUM PERCENTAGE PASSING
1 1/2"	100
NO. 4	50
NO. 200	8
SAND EQUIVALENT = MINIMUM OF 50	

<b>RETAINING WALL BACKDRAINS</b>	
<b>GRADING GUIDE SPECIFICATIONS</b>	
NOT TO SCALE	
DRAWN: JAS CHKD: GKM	
<b>PLATE D-7</b>	
<b>SOUTHERN CALIFORNIA GEOTECHNICAL</b>	



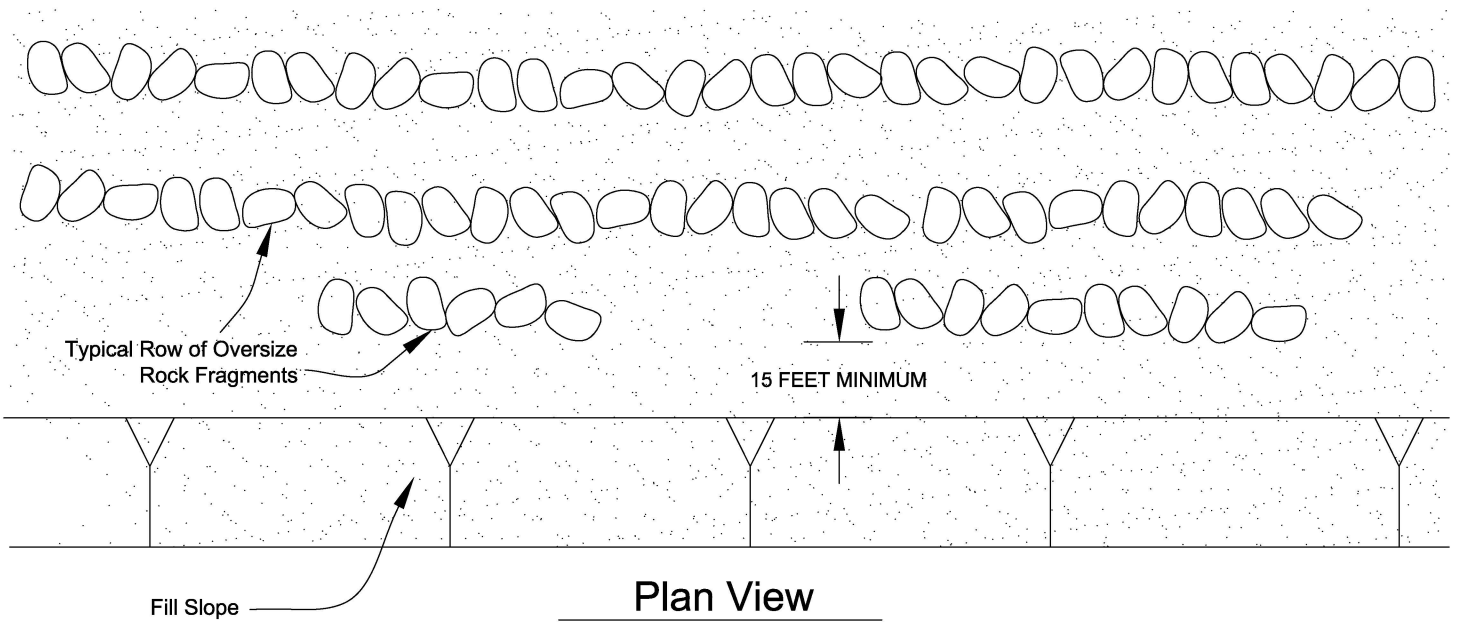
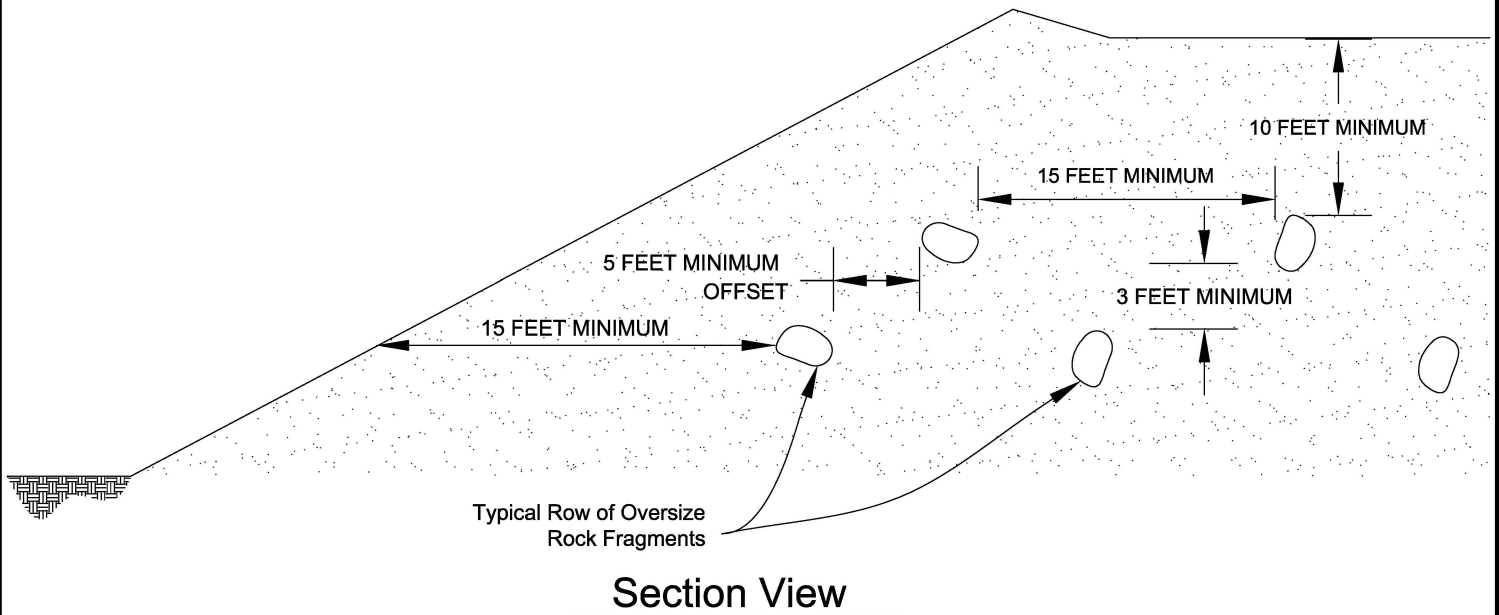

**PLACEMENT OF OVERSIZED MATERIAL  
GRADING GUIDE SPECIFICATIONS**

NOT TO SCALE

DRAWN: PM  
CHKD: GKM

PLATE D-8



**SOUTHERN  
CALIFORNIA  
GEOTECHNICAL**

# APPENDIX E

# USGS Design Maps Summary Report

## User-Specified Input

**Building Code Reference Document** ASCE 7-10 Standard  
(which utilizes USGS hazard data available in 2008)

**Site Coordinates** 34.05222°N, 117.47341°W

**Site Soil Classification** Site Class D – “Stiff Soil”

**Risk Category** I/II/III



## USGS-Provided Output

$S_S = 1.500\text{ g}$	$S_{MS} = 1.500\text{ g}$	$S_{DS} = 1.000\text{ g}$
$S_1 = 0.600\text{ g}$	$S_{M1} = 0.900\text{ g}$	$S_{D1} = 0.600\text{ g}$

For information on how the  $S_S$  and  $S_1$  values above have been calculated from probabilistic (risk-targeted) and deterministic ground motions in the direction of maximum horizontal response, please return to the application and select the “2009 NEHRP” building code reference document.

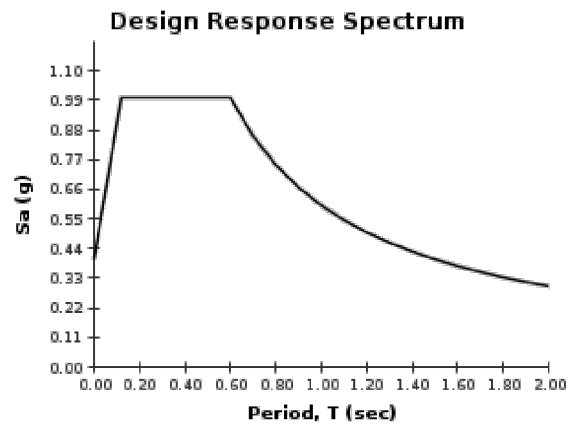
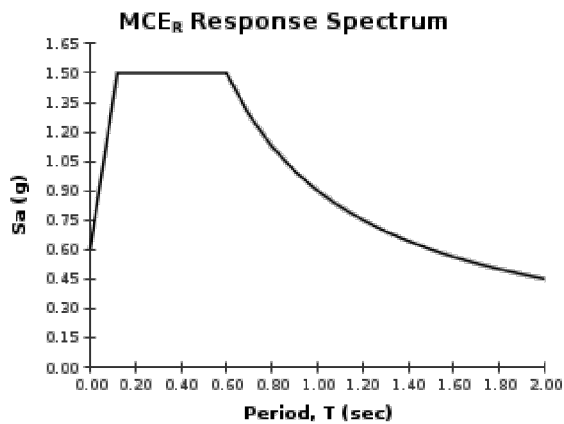

SOURCE: U.S. GEOLOGICAL SURVEY (USGS)  
<<http://geohazards.usgs.gov/designmaps/us/application.php>>



<b>SEISMIC DESIGN PARAMETERS</b>	
PROPOSED COMMERCIAL/INDUSTRIAL BUILDING	
FONTANA, CALIFORNIA	
DRAWN: JL CHKD: JAS SCG PROJECT 15G177-1 PLATE E-1	 SOUTHERN CALIFORNIA GEOTECHNICAL