

Appendix 2C Construction Means, Methods, and Assumptions

Table of Contents

1	Introduction	1
1.1	Overview of Alternatives	1
2	Construction Assumptions	3
2.1	Construction Timing and Sequencing	3
2.2	Construction Utilities	5
2.3	Borrow Areas and Quarries	7
2.4	Batch Plants	10
2.5	Construction Traffic and Personnel	11
2.6	Construction Tables	13
3	Construction Means and Methods	14
3.1	Site Preparation for Construction.....	14
3.2	Existing Facilities Common to Alternatives 1, 2, and 3	17
3.3	Proposed Facilities Common to Alternatives 1 and 3.....	25
3.4	Alternative 2 Specific Elements.....	61
3.5	Construction Schedule	75

List of Tables

Table 2C-1. Summary of Facilities Proposed for Each Alternative.....	2
Table 2C-2. Estimated Temporary Construction Power Requirements	6
Table 2C-3. Summary of Active Mines	8
Table 2C-4. Expected Construction Access Routes to Project Facilities.....	11
Table 2C-5. Construction Personnel and Highway Truck Trips.....	13
Table 2C-6. Inlet/Outlet Works Quantity Estimates for Earthwork and Concrete	31
Table 2C-7. Sites Dam Diversion/Outlet Quantity Estimates for Earthwork, Concrete and Riprap	34

Table 2C-8. Golden Gate Dam Diversion Quantity Estimates for Earthwork, Concrete, and Riprap.....	35
Table 2C-9. Estimated Material Quantities and Disturbance Areas for Earth and Rockfill Dams	37
Table 2C-10. Estimated Borrow, Stockpile, Disposal, Staging, Processing, and Haul Road Areas for Dams	44
Table 2C-11. Estimated Construction Disturbance Areas for Road and Bridges	46
Table 2C-12. Sites Lodoga Road Realignment Bridge.....	54
Table 2C-13. Preliminary Quantities for Roads.....	55
Table 2C-13. Preliminary Quantities for Roads (Continued)	56
Table 2C-14. Preliminary Quantities for County Road Bridge Improvements.....	57
Table 2C-15. Recreational Facility Construction Equipment Requirements	60
Table 2C-16. Summary of Reservoir Characteristics	61
Table 2C-17. Alternative 2 Key Similarities and Differences	62
Table 2C-18. Key Scheduling Assumptions Leading to Construction	63
Table 2C-19. Expected Construction Access Routes to Sites Lodoga Road (South Road).....	63
Table 2C-20. Project-Related Construction Personnel and Highway Truck Trips	64
Table 2C-21. TRR West Reservoir Quantities.....	65
Table 2C-22. Estimated Material Quantities and Disturbance Areas for Earth and Rockfill Dams (Alternative 2).....	67
Table 2C-23. Estimated Borrow, Stockpile, Disposal, Staging, Processing, and Haul Road Areas for Dams (Alternative 2).....	68
Table 2C-24. Summary of Differences in Roadway Characteristics	69
Table 2C-25. Estimated Construction Disturbance Areas for Alternative 2 Roads.....	70
Table 2C-26. Preliminary Quantities for Alternative 2 Roads.....	71

Attachments

Attachment 1 – Figures

Attachment 2 – Construction Schedules

Appendix 3C Construction Means, Methods, and Assumptions

1 Introduction

This appendix describes current assumptions and the means and methods that will be utilized to construct proposed project facilities. It is intended to augment the physical description of the proposed project and alternatives found in Chapter 2, *Project Description and Alternatives* (Chapter 2) of the Sites Reservoir Project (Project) Revised Draft Environmental Impacts Report/Supplemental Draft Environmental Impact Statement (RDEIR/DSEIS). The preparers of the RDEIR/DSEIS have relied upon the detail below in the analysis of the potential environmental effects related to construction of the Project.

1.1 Overview of Alternatives

As noted in Chapter 2 of the RDEIR/SDEIS, the Project would utilize existing infrastructure to divert unregulated and unappropriated flow from the Sacramento River at Red Bluff and Hamilton City and convey water to a new off-stream reservoir west of Maxwell, California (See Figure 2C-1). New and existing facilities would move water into and out of the reservoir, with ultimate release back to the Sacramento River system via existing canals and a new pipeline located near Dunnigan. Construction of the reservoir would necessitate construction of either a bridge or bypass road to connect Maxwell with the community of Lodoga. Additional components would include future development of new recreation facilities at the reservoir. The RDEIR/SDEIS presents the three proposed alternatives to implement the Project. The key differences related to design include:

- Alternative 1: 1.5 million acre foot (MAF) reservoir, Terminal Regulating Reservoir (TRR) East, bridge, release to the Colusa Basin Drain (CBD)
- Alternative 2: 1.3 MAF reservoir, TRR West, South Road, partial release to the CBD and the Sacramento River
- Alternative 3: 1.5 MAF reservoir, bridge, TRR East, release to the CBD

Project facilities for Alternatives 1 and 3 are the same and are shown in Figure 2C-2 and 2C-3. Project facilities for Alternative 2 are shown in Figures 2C-4 and 2C-5. Table 2C-1 provides a summary of facilities proposed under each action alternative. Chapter 2 of the RDEIR/SDEIS provides a more detailed description of the alternatives and addresses future operations and maintenance of the facilities.

Table 2C-1. Summary of Facilities Proposed for Each Alternative

Facilities	Alternative 1	Alternative 2	Alternative 3
Diversion/Reservoir Infrastructure Details			
Diversions(s) (existing)	Diversion from Sacramento River into existing TC Canal at Red Bluff Pumping Plant requires installation of 2 new pumps in an existing bay; diversion into the GCID Main Canal at Hamilton City would require improvements to GCID Main Canal, including a new head gate structure	Same as Alternative 1	Same as Alternative 1
Reservoir Size	1.5 MAF	1.3 MAF	Same as Alternative 1
Dams [Scaled to the size of the reservoir]	Golden Gate and Sites Dams; 7 saddle dams; 2 saddle dikes	Golden Gate and Sites Dams; 4 saddle dams; 3 saddle dikes	Same as Alternative 1
Spillway	One spillway on Saddle Dam 8B; Weir crest length of 85.5 feet and crest elevation of 504 feet	Similar to Alternative 1, but weir crest length of 200 feet and crest elevation of 487 feet	Same as Alternative 1
Funks Reservoir (existing)	Pumping from Tehama-Colusa Canal (TC Canal) via Funks Reservoir to Sites Reservoir requires the existing Funks Reservoir to be excavated to original capacity (same footprint); a new Funks Pump Generating Plant (PGP); and, a new Funks pipeline alignment with 2 pipelines	Similar to Alternative 1 but minor variations due to reservoir size.	Same as Alternative 1
Terminal Regulating Reservoir (TRR)	Pumping from the GCID Main Canal to Sites Reservoir requires construction of the TRR East; a TRR East PGP; and a new TRR East pipeline alignment with 2 pipelines	Pumping from the GCID Main Canal to Sites Reservoir requires construction of the TRR West; a TRR West PGP; and a new TRR West pipeline alignment with 2 pipelines	Same as Alternative 1
Hydropower	Incidental power generation up to 40 megawatts at each Funks PGP and TRR (East or West) PGP	Same as Alternative 1	Same as Alternative 1
Emergency Release Flow	Releases into Funks Creek and Stone Corral Creek via Inlet/Outlet Works and Sites Dam Outlet; release from spillway on Saddle Dam 8B north to Hunters Creek Watershed; emergency release structures in Saddle Dams 3 and 5 to release north to Hunters Creek watershed (may be eliminated)	Similar releases via Inlet/Outlet Works, Sites Dam, and spillway on Saddle Dam 8B; no emergency release structures on Saddle Dams 3 and 5	Same as Alternative 1
Electrical Facilities (some existing)	Transmission lines, substations, switchyards; interconnection with WAPA or PG&E	Similar to Alternative 1 but minor variations due to reservoir size.	Same as Alternative 1
Dunnigan Release	Release 1,000 cfs into new pipeline to CBD	Release into new pipeline to Sacramento River, partial release to the CBD	Same as Alternative 1

Facilities	Alternative 1	Alternative 2	Alternative 3
Recreation			
Multiple Facilities Consistent with WSIP Application	Two primary areas with infrastructure: 1. Peninsula Hills Recreation Area 2. Stone Corral Creek Recreation Area An additional day-use boat ramp w/parking located on the west side of the reservoir and south of the bridge	Same as Alternative 1	Same as Alternative 1
Transportation/Circulation			
Provide Route to West Side of Reservoir	Permanent bridge crossing the reservoir on Sites Lodoga Road realignment, and realignment of Huffmaster Road, with gravel road to residents at the south end of the reservoir; temporary detour from Sites Lodoga Road to Peterson Road for public access during construction while the bridge and roads are under construction	Paved roadway including the realigned segment of Huffmaster Road and a new South Road on the west side of the reservoir; temporary detour from Sites Lodoga Rd to Peterson Road for public access during construction while the new road to Lodoga is under construction	Same as Alternative 1
Multiple Maintenance and Local Access Roads	Approximately 46 miles of new paved and unpaved roads would provide construction and maintenance access to the proposed facilities, as well as provide public access to the proposed recreation areas	Similar to Alternative 1 but minor variations due to reservoir size and configuration as well as access to west side of the reservoir	Same as Alternative 1

2 Construction Assumptions

The following provides an overview of general construction assumptions applicable to all three proposed project alternatives.

2.1 Construction Timing and Sequencing

Construction may start as early as spring 2024, depending on the timing of funding, design, and permitting. The construction start date is based on several assumptions, including real estate access and acquisition. Construction of the Project components would generally be expected to occur in the sequence shown in the chart below. Initial activities would include developing the Sites Reservoir inundation area, constructing the access roads, and realigning/constructing the Sites Lodoga Road or South Road.

Durations of construction were based on production rates associated with the anticipated equipment types needed for construction. Some construction activities would be concurrent with the road relocations, but the existing Sites Lodoga Road and Huffmaster Road would not be closed until the road realignments were completed. Overall, the construction of all necessary facilities associated with Alternatives 1 and 3 are expected to last for approximately 6 years.

	Description	2024				2025				2026				2027				2028				2029			
		Q1	Q2	Q3	Q4	Q1	Q2	Q3	Q4	Q1	Q2	Q3	Q4	Q1	Q2	Q3	Q4	Q1	Q2	Q3	Q4	Q1	Q2	Q3	Q4
Roads and Bridges	Northern Construction Access Roads																								
	Southern Construction Access Roads																								
	Sites Lodoga Road Realignment and Bridge																								
	Huffmaster Road Alignment																								
	Process and Haul Filter Materials to Project																								
Dams and Dikes	Golden Gate Dam																								
	Sites Dam																								
	Saddle Dam 3																								
	Saddle Dam 5																								
	Minor Saddle Dams (1,2,6,8A)																								
	Inlet Outlet Facilities																								
Reservoir Site Development	Reservoir Footprint Mitigation Actions																								
	Site Access and Staging Development																								
	Demolition and Clearing																								
Conveyance to Sacramento River	Dunnigan Pipeline – Alt 1,3																								
	Dunnigan Pipeline – Alt 2																								
Regulating Reservoirs and Conveyance	Funks/TRR East Pipelines – Alt 1,3																								
	Funks/TRR West Pipelines – Alt 2																								
	Funks Reservoir Improvements																								
	Funks Pumping Generating Plant																								
	TRR East Reservoir – Alt 1,3																								
	TRR West Reservoir – Alt 2																								
	TRR Pumping Generating Plant																								
	TRR East Transmission Powerlines – Alt 1,3																								
	TRR West Transmission Powerlines – Alt 2																								
	Substations																								
Sacramento River Div./Conv.	Red Bluff Pumping Plant Improvements																								
	GCID Improvements																								

Several factors could affect this anticipated schedule, including funding, environmental compliance and permits, contracting methods and strategies, material and construction equipment availability, lead time for fabrication of major pumping and generating equipment, labor force constraints, weather, and access road capacity limitations. Additional adjustments to the schedule would be addressed as required during Project development and implementation.

A logical sequence of construction activities was assumed and represents a reasonable order for construction activities to occur; however, the Contractors may significantly modify the actual sequence of activities. The durations of construction activities are based on production rates associated with the anticipated equipment types needed for construction. For a project of this magnitude, Contractors are likely to purchase new equipment in addition to using the equipment they already own.

Successful sequencing of all Dam and I/O Facilities relies on several key strategies and milestones:

- The construction schedule relies on construction of site access for the haul of aggregates.
- The demand for filter, drain, transition, and concrete aggregates from offsite sources is high. This activity should begin early so as not to become critical. Haul over public roads will have limitations and daily demand for filter, drain, and concrete aggregates would likely exceed the capacity of public roads. Multiple dam contracts would effectively compete with each other for filter, drain, and concrete aggregates and would need to be coordinated so as not to prohibit delivery to one or more projects.
- The project will rely on early development of construction water sources.
- Some double-shift work should be anticipated, particularly in tunnel construction. Additional consideration for double-shift work would be foundation grouting, quarry drilling, foundation excavation, and dam embankment. This will depend on the contractor's approach to equipment labor resources. Multiple shift use of a significant equipment fleet would have economic advantages.
- Procurement packages should divide the work in a manner that considers market conditions, resource availability, and is conducive to concurrent construction of dam packages.
- Golden Gate Dam requires the longest duration for construction of any of the dam facilities and should be the first dam to begin construction once access to the construction site is established.

2.2 Construction Utilities

2.2.1 Water

Water for construction use would be obtained from numerous sources due to the size of the project footprint. This would include existing surface water from the Sites Storage Partners pursuant to existing water rights agreements; existing groundwater wells in the Sites Reservoir inundation area; and new groundwater wells in the Sites Reservoir inundation area. The Authority would seek to acquire water from nearby local water purveyors (ditches, canals, and

wells) and possibly local landowners (wells) for use in the construction of roads. Excavation dewatering operations would also provide a source of construction water.

Approximately 750,000 to one million gallons/day (500 to 700 gallons per minute) would be needed for constructing the Golden Gate Dam, Sites Dam, saddle dams, saddle dikes, and I/O Works over a period of 4 years. As such, a total of approximately 3,360 acre-feet per year (AFY) to 4,480 AFY would be required over the 4 years. It is assumed for the purposes of this analysis that more water may be used from existing or new groundwater wells than surface water for the reservoir facilities located within Antelope Valley. Because the groundwater quality within Antelope Valley is variable, it may not be fully suitable for use in some construction activities (e.g., mixing concrete). Therefore, it is anticipated that onsite water treatment plants would be required adjacent to the three batch plants for the reservoir facilities.

For the conveyance facilities, approximately 200,000 gallons per day would be required for GCID system upgrades and the regulating reservoirs and conveyance complex over a period of 4 years. An additional 20,000 to 30,000 gallons per day will be needed during construction of the Dunnigan Pipeline over a period of 2 years. During construction of the Dunnigan Pipeline, water captured during dewatering may be reused. Batch water treatment plants would be used to treat water, as necessary, for the intended use. Construction water would be reused to the extent possible. Average construction water use is expected to be approximately 75,000 gallons per day, primarily related to the pipelines for compaction and dust control. Total water use for the project associated with the conveyance facilities is roughly calculated to be approximately 175 to 200 million gallons.

The Funks PGP and TRR PGP and associated facilities would obtain water from the GCID Canal. Water used for construction would be transferred to the facility footprints from the GCID Main Canal, by trucks and/or pipes. The pipes are not expected to be buried except at crossings of heavily trafficked areas, where they may be installed several feet below ground surface.

Construction water uses include moisture conditioning of fill materials, batching concrete, grouting, and dust suppression for haul roads, stockpiles, disposal areas, quarries, and borrow areas.

2.2.2 Energy

Anticipated construction energy needs are shown in Table 2C-2.

Table 2C-2. Estimated Temporary Construction Power Requirements

Location/Facility	Required Load, 3-Phase, KVA	Annual Use (hours/year)
Golden Gate and Sites Dams		
Contractor's and Owner's Office Complex	300	2,100
GG Quarry Feeder/Jaw for Rockfill	1000	1,500
Sites Quarry Feeder/Jaw for Rockfill	1000	1500
GG Concrete Batch Plant	600	1,500
Sites Concrete Batch Plant	600	1,500
Contractor's Shop Complex	300	1,500

Location/Facility	Required Load, 3-Phase, KVA	Annual Use (hours/year)
Saddle Dams		
Contractor's and Owner's Office Complex	300	2,100
Saddle Dams Quarry Feeder/Jaw for Rockfill	1000	1,500
Concrete Batch Plant	600	1,500
Contractor's Shop Complex	300	1,500
Inlet-Outlet Facilities		
Contractor's and Owner's Office Complex	300	2,100
Concrete Batch Plant	600	1,500
Contractor's Shop Complex	200	1,500
Roads		
Contractor's and Owner's Office Complex	300	2,100
Asphalt Batch Plant	600	1,500
Contractor's Shop Complex	200	1,500
Conveyance		
Contractor's and Owner's Office Complex (3)	300 each	2,100
Concrete Batch Plant & CDSM Batch Plant	600 each	1,500

2.3 Borrow Areas and Quarries

It is anticipated that all earth and rockfill for the reservoir facilities (approximately 80 percent of the required materials) would come from onsite sources, and all aggregate—which includes filter, drain, transition materials, and concrete aggregate (approximately 20 percent of the required materials)—would be obtained from offsite commercial sources.

2.3.1 Onsite Borrow Areas, Quarries, and Rock Processing

The onsite borrow areas and quarries include alluvial materials for the earthfill portion of the dams and rock quarries for the rockfill portion of the dams. Approximate locations of the borrow areas and quarries are shown in Figure 2C-6. There are four alluvial borrow areas identified within the reservoir, two rock quarries and rock processing areas identified within the reservoir, and three rock quarries and rock processing areas identified outside the reservoir inundation area.

It is assumed all riprap materials and rockfill materials would be sourced from the following quarries:

- Saddle Dam Rockfill Quarry. There are two rockfill quarries for Saddle Dams. SD 3,5,6,8A-Z3 Quarry 1 located inside the reservoir and SD1,2,3-Z3 Quarry 2 located outside the reservoir. Neither of these are existing quarries and would be developed by the Contractor.
- Golden Gate Alternative Rockfill Quarry. There are two rockfill quarries for Golden Gate Dam. GG-Z3 Quarry 1 located inside the reservoir and GG-Z3 Quarry 2 located outside

the reservoir. Neither of these are existing quarries and would be developed by the Contractor. (HR Road Meeting 7/17 and Roads & Bridge Draft TM_HR2.96)

- Sites Dam Rockfill Quarry. There is one rockfill quarry for Sites Dam. Sites-Z3 Quarry located outside the reservoir. This is not an existing quarry and would be developed by the Contractor. (HR Road Meeting 7/17 and Roads & Bridge Draft TM_HR2.96)

Figure 2C-6 also shows the details associated with the types of borrow areas within the inundation area. Rock processing areas will be required adjacent to each onsite quarry to process the materials.

After the completion of project construction, these three quarries outside the inundation area would be decommissioned and regraded, including installing perimeter fences and grading slopes to promote positive drainage to the quarry bottoms. Revegetation would occur at the bottom of the quarries and not along the slopes because of the steepness and substrate (i.e., rock) of the quarry slopes. The three quarries would be visible after construction of Alternatives 1 and 3.

2.3.2 Offsite Quarries

Aggregate (i.e., high quality sand and gravel and concrete aggregate) would be needed for filter, drain, and transition materials in all dam structures and for concrete structures (e.g., spillway on Saddle Dam 8B, I/O Works). The primary sources of aggregate in the region are alluvial deposits associated with historical/abandoned river channels and rock outcrops. The Contractor(s) would have discretion over the source locations of the aggregate and for the purposes of this analysis it is assumed that all aggregate would come from existing active locations. There are multiple potential offsite sources of aggregate.

As part of the feasibility-level cost estimate, Project engineers looked at a variety of sources of sand and gravel in the Project region. Due to the large quantities of required materials, sources of materials were considered within a distance of 50 miles from the site. Figure 2C-7, from the California Department of Conservation, Division of Mine Reclamation, shows the locations of active mines in the project vicinity. The active mines shown on the figure are summarized in Table 2C-3. The primary source of material for these quarries are alluvial deposits or rock outcrops of various quality. Most of the larger quarries for sand and aggregate are located east and north of the project site.

Table 2C-3. Summary of Active Mines

Mine Name	Primary Product	Owner	Area Disturbed (acres)	Area Permitted (acres)
Almond Avenue Mine	Sand and Gravel	Franklin Construction Company, Inc.	12	44
Bangor Rock Quarry-Site A	Stone	Bangor Rock LLC	41	28
Brownstone Quarry	Dimension Stone	Brownstone Quarry	5	Unknown
Butte Sand & Gravel	Sand and Gravel	Butte Sand And Gravel	268	481
Cal Sierra Development, Inc.	Gold (Placer)	Cal Sierra Development, Inc.	7	704
Clearlake Lava	Cinders	Clearlake Lava, Inc.	44	50
Clearlake Lava Rock	Sand and Gravel	Clearlake Lava, Inc.	7	11

Appendix 2C
Construction Means, Methods, and Assumptions

Mine Name	Primary Product	Owner	Area Disturbed (acres)	Area Permitted (acres)
Dantoni Pit	Sand and Gravel	Noble (Bud) Plant And Eleanor Plant	0	200
Davis Pit, Blue Rock	Sand and Gravel	Thorn	0	10
DNA Ridge Rock	Sand and Gravel	Epidendio	20	20
Dry Creek Plant	Sand and Gravel	Franklin Construction Company, Inc.	2	11
Dunstone Rock Quarry	Sand and Gravel	Hammett	40	120
DWR/Palm Avenue Gravel Pit	Sand and Gravel	DWR Flood Management	10	Unknown
Finch Ranch	Sand and Gravel	Graham	14	313
Hallwood Plant	Sand and Gravel	Baldwin Contracting Company, Inc.	393	688
Kaiser Pit	Sand and Gravel	Glenn Cty., Dept. of Public Works	21	31
Keithly Ranch	Stone	Granite Construction Company	52	200
Little Chico Creek	Sand and Gravel	Franklin Construction Company, Inc.	8	5
Long Bar Property	Sand and Gravel	Silica Resources, Inc.	62	120
Lovelady Ranch, LLC	Sand and Gravel	Lovelady Ranch, LLC & Little Stony, LLC	2	8
Lucky 7	Sand and Gravel	Duke Sherwood Contracting, Inc.	0	10
Marysville Property	Sand and Gravel	Teichert Aggregates	283	590
Middle Creek Terrace Pond Project	Sand and Gravel	Clearlake Redi-Mix, Inc.	2	31
Morris Ravine Mine	Silica	Mineral Resources, LLC	76	520
Orland Plant	Sand and Gravel	Baldwin Contracting Company, Inc.	60	85
Orland/Hambright	Sand and Gravel	Baldwin Contracting Company, Inc.	18	150
Parks Bar Quarry	Rock	Nordic Industries, Inc.	44	234
Patterson Sand And Gravel	Sand and Gravel	Cemex	375	326
Pentz Pit	Sand and Gravel	Baldwin Contracting Company, Inc.	0	362
Point Lake View	Cinders	Clearlake Lava, Inc.	43	150
Robinson Pit	Sand and Gravel	Granite Construction Company	75	130
Ron Harmon Mine	Fill Dirt	Harmon	0	27
Sperbeck Quarry	Rock	Nordic Industries, Inc.	28	28
S-Bar-S Quarry	Not Reported	Rich-Ted Trucking, Inc.	14	Unknown
Stony Creek	Sand and Gravel	North Valley Rock, LLC	4	80
Stony Creek	Sand and Gravel	Baldwin Contracting Company, Inc.	37	192
Stony Creek Pit	Sand and Gravel	Bogart Construction	1	117
Table Mountain Quarry	Sand and Gravel	Florida Rock Industries, Inc	105	320
Watts Pit	Sand and Gravel	Glenn Cty., Dept. of Public Works	21	58
West Butte Quarry	Sand and Gravel	Butte Sand And Gravel	18	36
Western Aggregates	Sand and Gravel	Western Aggregates, Inc.	407	0
Wheatland Pit	Clay	Gladding Mc Bean	2	114
Wildlife Area	Sand and Gravel	Granite Construction Company	72	115

Information in table is based on information from the California Department of Conservation, Division of Mine Reclamation in 2019 (downloaded April 14, 2021)

2.4 Batch Plants

Three concrete batch plants are anticipated for the construction of reservoir facilities:

- **Inlet/Outlet Facilities** – This plant will produce the approximately 110,000 cubic yards of concrete required for the inlet/outlet facilities, including intake/outlet tower and the concrete lined tunnel. Hours of operation would likely be daytime hours from 7AM to 7PM. A likely location for this batch plant would be at the Golden Gate Staging Area, located near the Intake Tower. This location may take advantage of permanent power associated with long-term operations of the Intake and Outlet Facilities. This would facilitate concrete construction at the Intake Tower, and likely with a significant portion of the concrete tunnel lining. Tunneling generally is done from the downstream end of tunnels; however, the Sites Intake and Outlet Facilities, with twin tunnels and this work on the critical path, provide an opportunity for tunnel lining from the upstream end.
- **Golden Gate Dam, Sites Dam, Diversions** – This plant will produce the approximately 221,000 cubic yards of concrete required for Golden Gate Dam and Sites Dam grout caps, the Golden Gate Diversion at Funks Creek and the Sites Diversion Outlet at Stone Corral Creek. Hours of operation would likely be daytime hours from 7AM to 7PM. Depending in part on the contracting packages for the project, a concrete batch plant could be located at either the Sites Staging Area or the Golden Gate Staging Area. The concrete needs for these facilities is primarily associated with the Grout Caps, Golden Gate Diversion encasement, and the Sites Diversion structures and tunnel lining. Most of this work can be easily serviced from the staging areas conveniently located within the reservoir pool limits. One exception to this would be the Sites Dam Diversion Facilities, where the tunnel lining would likely be installed from the downstream end. The Energy Dissipation Structure is also at the downstream end. In this case, ready-mix trucks would need to haul concrete from the batch plant to the downstream end of the diversion via construction access roads.
- **Saddle Dams, ERS-1, ERS-2** – This plant would produce the approximately 126,000 cubic yards of concrete required for Saddle Dam 8B Spillway, Saddle Dams 1,2,3,5,6, and 8A grout caps, and ERS-1 and ERS-2. Hours of operation would likely be daytime hours from 7AM to 7PM. Depending on contracting packaging for the Saddle Dams, a single batch plant, located at the Saddle Dam 3, 5 Staging Area. This staging area is somewhat central to the concrete needs of the Saddle Dams as a group. Concrete needs are associated with grout caps, ERS-1, ERS-2, and Saddle Dam 8B, which is a concrete gravity dam, serving as the spillway for the reservoir. The farthest concrete need from this plant location is approximately 2 miles.

In addition, each batch plant would likely be capable of producing between 100 and 400 CY per hour. Plants would be large, portable plants, powered by either generator or line power, depending on availability. Generation typically would be approximately 350 HP at each plant. Aggregate for batching concrete would be imported from offsite sources and hauled to the site by conventional highway trucks, including belly dump, side dump, or truck and pup, with capacities of between 23 and 25 tons.

Onsite aggregate plants would likely be limited to processing for rockfill and riprap. These would be large vibrating grizzly type plants, with belt feeders. Operating horsepower (HP) would be approximately 750 HP at each plant location.

For conveyance facilities, the following batch plants are anticipated:

- Concrete plant associated with the large volumes of concrete for the two PGPs. Smaller volumes of concrete would be required for the transmission tower foundations.
- Ground improvement plant associated with the large volume (900,000 cubic yards) of cement deep soil mixing (CDSM) material required for the TRR East.
- A traveling batch plant is anticipated to produce controlled low strength material using native soils combined with cement and water. This material would be discharged to the trench to provide uniform and stable foundation for the pipes.

2.5 Construction Traffic and Personnel

Traffic-generating construction activities associated with the Project would include trucks hauling equipment and materials to and from the worksites and the daily arrival and departure of the construction workers. Construction traffic on local roadways would include dump trucks (end-dump, bottom-dump and side-dump), concrete mixer trucks, flatbed trucks for delivering construction equipment and permanent Project equipment, pickups, water trucks, equipment maintenance vehicles, and other delivery trucks. Dump trucks would be used for earth-moving and clearing, removal of excavated material, and import of other structural and paving materials. Other delivery trucks would deliver construction equipment, job trailer items, concrete forming materials, reinforcing steel and structural steel, piping materials, foundation piles and sheet piling, sand and gravel from offsite sources, new facility equipment, and other miscellaneous construction-related deliveries.

Table 2C-4 presents the anticipated typical construction access routes to be used for access in the construction to some of the major Project features; the existing construction access routes are shown in Figure 2C-8.

Table 2C-4. Expected Construction Access Routes to Project Facilities

Project Feature	Access Route
Sites Reservoir Inundation Area, Including Borrow Areas for Dam Embankment Zones.	Access on 5.5 miles of narrow (+/- 24 feet wide) paved road from I-5, west along Road 68, south on Road D, and west on Road 69 to just west of the Tehama-Colusa Canal, where the road reverts to a single-lane (+/- 12 feet wide) gravel road, referred to as the North Road (Access Road), continuing for approximately 5 miles to the northern end of the reservoir at the saddle dams. From this location, the Contractor would establish their own “onsite” access roads within the limits of the reservoir.
Sites Dam and Stone Corral Creek Diversion Outlet (East Side)	To the extent practical, Sites Dam activities will be accessed from the west using the Sites Reservoir Inundation Area route described above. Where access to the east side of the dam is required, it will be through the 12 miles of narrow (+/- 24 feet wide) paved road from I-5, along Delevan Road, south along McDermott Road to Maxwell Sites Road, and then west to the Sites Dam location.

Project Feature	Access Route
Golden Gate Dam and I/O Tunnel (East Side)	To the extent practical, Golden Gate Dam activities will be accessed from the west using the Sites Reservoir Inundation Area route described above. Where access to the east side of the dam is required, it will use the 12 miles of narrow (+/- 24 feet wide) paved road from I-5, along Delevan Road, south along McDermott Road to Maxwell Sites Road, and then west to the existing gravel access road to Funks Reservoir. The first mile of this gravel road is the initial segment of Alternatives 1 and 3 of the realigned Sites Lodoga Road.
Saddle Dams	Access on 5.5 miles of narrow (+/- 24 feet wide) paved road from I-5, west along Road 68, south on Road D, and west on Road 69 to just west of the Tehama-Colusa Canal, where the road reverts to a single-lane (+/- 12 feet wide) gravel road, referred to as the North Road (Access Road), continuing for approximately 5 miles to the northern end of the reservoir at the saddle dams. From this location, the Contractor would establish the permanent Saddle Dams maintenance roads.
Bridge	Accessed from the east side of the Sites Reservoir will be through the 12 miles of narrow (+/- 24 feet wide) paved road from I-5, along Delevan Road, south along McDermott Road to Maxwell Sites Road, and then west to the easterly bridge location.
Com Road	From I-5, travel west on Maxwell Sites Road, turn left on Huffmaster Road Realignment (new permanent), and turn right on Com Road (new permanent)

Notes:

I = Interstate Freeway

O&M = Operations and maintenance

SR = State Route

Under Alternatives 1 and 3, up to 1,657 construction personnel would be working at the peak of construction. Approximately 847 of these personnel would be involved with reservoir facilities and 810 would be working on conveyance facilities. Expected highway truck trips per day associated with construction will range from 4 for installation of the new pump at the RBPP to 330 estimated trips (each) for the construction of dams, dikes, and other reservoir-related components. Similarly, personnel vehicle trips associated with the same facilities will range from 2 to over 1,600 per day. Trips associated with Alternative 2 would be slightly less for reservoir facilities.

Project-related construction personnel and highway truck trips are identified in Table 2C-5. Of the Project construction related trips, construction worker trips would compose the majority. Construction workers would likely commute daily to construction sites from regional population centers, including Sacramento, Woodland, Maxwell, Willows, Orland, Williams, and Colusa, and from other northern California counties when specialty trades or skillsets are not available locally. The number of construction workers required during peak construction of Project facilities varies by alternative, resulting in different trip distributions for each alternative.

Table 2C-5. Construction Personnel and Highway Truck Trips

Facility	Total Highway Truck Trips	Construction Days	Highway Truck Trips per Day ^a	Total Personnel Trips ^b	Personnel Trips per Day ^b
Sites Reservoir Inundation Area and Dams	280,800	1,200	360	496,860	637
Sites Lodoga Road Bridge Causeway, Gravel Roads, and Paved Roads	24,986	980	26	297,910	310
Inlet/Outlet Structure, Tunnel	59,885	1,015	59	50,750	50
Dunnigan Pipeline Alt 1	18,460	355	52	51,830	146
Funks/TRR Pipelines	187,210	505	194	413,020	428
Funks Reservoir	7,322	680	14	41,840	80
Funks PGP	25,488	880	24	91,332	86
TRR East Reservoir	3,120	780	4	37,440	48
TRR East PGP	24,240	880	24	88,880	88
Transmission Powerlines	875	765	1	64,750	74
Substations	1,510	645	2	12,080	16
Red Bluff Pumping Plant	280	560	0.5	1,120	2
GCID Improvements	7,480	680	11	29,920	44

Notes:

^aOne-way truck trips.

^bAssumes one incoming and one outgoing trip per worker

2.6 Construction Tables

Tables have been developed to describe the heavy equipment, employee trips, batch plants, and water conveyance that would be used in the construction of the project. This information was used for various resource analyses, including the modeling of the air quality and greenhouse gas analysis. Tables are on file with the Authority and available upon request.

3 Construction Means and Methods

The following describes proposed means and methods for the construction of proposed project facilities. All alternatives will use existing facilities to divert water from the Sacramento River and convey water to and from the reservoir to existing facilities. Alternatives 1 and 3 propose the same facilities and means and methods for construction are addressed together in Section 3.3. The different facilities proposed under Alternative 2 are addressed in Section 3.4.

3.1 Site Preparation for Construction

The following section describes all the activities required for site preparation for the various facilities. It is organized by reservoir facilities and then conveyance-related facilities.

3.1.1 Reservoir Construction Site Preparation

This section describes the construction means, methods, and assumptions regarding typical activities that would be needed to prepare the various facilities for construction within the reservoir, including establishing staging areas and access, performing demolition, clearing and grubbing, and handling of construction spoils (e.g., from tunneling). The site preparation information described below would generally be applicable to all facilities.

Staging Areas and Access

Staging areas for construction would be located within the footprint of the reservoir as shown in Figure 2C-6, which shows potential staging areas near each of the facilities. The space required for staging areas is anticipated for staging of equipment and materials needed at each location, such as concrete formwork, rock anchors, geotextiles, and foundation drainage pipe materials.

There would be overland travel within the inundation area and no restoration would occur in this area because it would be inundated. Off-road travel would be limited on the exterior of the reservoir to the extent feasible.

The Authority has already identified several construction routes that would avoid the community of Maxwell (Table 2C-4, above). Generally, access to the site during dam construction will be from the north using County Road 69 to the North Road (access road) and Saddle Dam Access Road. The roadway improvements along the construction access routes are anticipated to occur within the existing right-of-way. New or realigned roadways would require new right-of-way in accordance with the applicable county standards. The amount of right-of-way acquired would be based on the minimal need to accommodate the roadbed and any adjacent roadside ditches. Where fill or cut slopes are required, the right-of-way would be widened to accommodate them and to preserve the area for future slope maintenance. Fences would be placed along all new right-of-way as necessary to keep livestock from entering the right-of-way.

Sites Reservoir construction would require relocating existing county roads (Maxwell Sites Road, Sites Lodoga Road, and Huffmaster Road). Other new paved or unpaved roads would also be provided to access project facilities from existing roads and to improve operation and maintenance access between the main dams and saddle dams.

Demolition

Within the Sites Reservoir Inundation Area, approximately 24 houses, 29 barns, and 50 other structures (combination of sheds, silos, and a pump houses) would be demolished once all property owner negotiations were completed. Existing septic tanks and other underground storage tanks would also be removed. All gas wells and water wells would be abandoned in accordance with regulatory requirements. In addition, many miles of fencing and asphalt would be removed as necessary. Demolition debris would be transported and disposed of at an approved landfills. In addition, two private cemeteries would be relocated.

- Removal of 28 existing septic tanks and systems and other underground storage tanks; approximately 3.2 miles of fencing and asphalt.
- Asphalt roads would be removed and existing asphalt would be pulverized and used to build new roads. The pulverizing and reuse of road materials is described in Section 2C.2.15, Roads and Bridge.
- Demolition debris would be transported and disposed of at an approved landfill(s).

Two private cemeteries within the inundation area would be relocated to a site approved for interment of human remains per requirements of the California Health and Safety Code (HSC § 7500-7527). The code requires a written order from the local health department or county superior court before human remains in a cemetery may be moved. The disinterment, transportation, and removal of human remains is subject to reasonable rules and regulations relative to the manner of disinterring, transporting or removing such remains as are adopted by the board of health or health officer of the county.

The construction equipment that is anticipated to be used for demolition within the reservoir footprint is to be developed.

Clearing and Grubbing

Approximately 92 percent of the reservoir inundation area footprint is composed of annual grasslands. As a result, clearing and grubbing would not be needed in this area. The remaining 8 percent consists of blue oak woodland and other vegetation, which would be cleared. To provide for unobstructed flow through the reservoir inlet/outlet works, selected larger vegetation would need to be removed from the inundation area prior to first filling. Reservoir clearing would consist predominantly of the removal of blue oak woodland, for a total cleared area of roughly 1,050 acres. Cleared vegetation materials would be disposed of at an appropriate landfill/green waste facility or onsite as appropriate and necessary.

- Work sites would be cleared to the areas required for earthwork operations. Vegetative material from clearing operations at work sites would be chipped, stockpiled, and disposed of either onsite or offsite
- If disposed of offsite, cleared vegetation materials would be disposed of at an appropriate landfill/green waste facility that has already gone through environmental review.
- Clearing and grubbing timing is estimated to be approximately 410 days for the reservoir.

Construction Spoils

Nonhazardous materials within the inundation area and adjacent to the inundation area may be disposed of within the deadpool area for Sites Reservoir. Collectively, non-suitable materials, or spoils, will be disposed in designated disposal areas shown in Figure 2C-6. The approximate size of the disposal area within the reservoir is 165 acres. Additionally, some spoil materials, borrow and quarry overburden, and waste products from rock processing, will be disposed of as part of borrow area and quarry reclamation.

Construction spoils, comprised of unsuitable materials, will generally be of the following categories and handled as follows:

- **Excess materials produced from road construction activities.** These materials would be disposed of in borrow areas as part of the borrow area restoration efforts.
- **Organic laden or otherwise unsuitable or excess materials from dam foundation excavation.** Dam foundation excavation materials are generally thought to be usable as Zone 4 Random Embankment. Excess material could be used in borrow area and quarry restoration. Organic laden or otherwise unsuitable material would be hauled to disposal areas or potentially used for topsoil or quarry restoration.
- **Quarry and Borrow Area stripping and unsuitable materials.** Some quarry and borrow area material could be stockpiled, contoured, and left in place. Other materials generated in the quarry and borrow operations would be used to restore the borrow areas as needed to avoid ponding.

Construction spoils that cannot be disposed of onsite will be trucked to the nearest landfill. These materials would be construction and demolition derived materials such as wood, concrete, metals, septic tanks, and other construction and demolition debris.

3.1.2 Conveyance Site Preparation

This section describes the construction means, methods, and assumptions regarding typical activities that would be needed to prepare the various conveyance facilities for construction including establishing staging areas and access, performing demolition, clearing and grubbing, and handling of construction spoils (e.g., from tunneling).

Staging Areas and Access

Staging areas for the various facilities are shown in Figures 2C-9 through 16, The space required for staging areas is anticipated for staging of equipment and materials needed at each location, such as concrete formwork, pipe, equipment, and excavated materials

Overland travel for regulating reservoirs, the conveyance complex, and the conveyance to the Sacramento River would be within construction easements. Temporary roads may remain within construction corridors (e.g., along power lines) or may be restored after use.

The roadway improvements along the construction access routes are anticipated to occur within the existing right-of-way. New or realigned roadways would require new right-of-way in accordance with the applicable county standards. The amount of right-of-way acquired would be

based on the minimal need to accommodate the roadbed and any adjacent roadside ditches. Where fill or cut slopes are required, the right-of-way would be widened to accommodate them and to preserve the area for future slope maintenance. Fences would be placed along all new right-of-way as necessary to keep livestock from entering the right-of-way.

Demolition

Demolition of existing structures would be required for the Willow Creek and Walker Creek Siphon replacements on the GCID Main Canal. No demolition or relocation would be required for the TC Canal Diversion, TRR-related facilities, Funks-related facilities, GCID Main Canal railroad siphon, or facilities associated with conveyance to the Sacramento River (i.e., TC Canal intake, Dunnigan Pipeline, and Colusa Basin Drain outlet)

Clearing and Grubbing

Clearing and grubbing along the pipelines and the TRR East reservoir site makes up a majority of the total clearing and grubbing requirements. There will also be a small amount (relative) for the PGP sites and associated staging areas. Cleared vegetation materials would be disposed of at an appropriate landfill/green waste facility or onsite as appropriate and necessary.

- Work sites would be cleared to the areas required for earthwork operations. Vegetative material from clearing operations at work sites would be chipped, stockpiled, and disposed of either onsite or offsite
- Clearing and grubbing of the Funks, TRR, and Dunnigan pipelines will occur throughout the pipeline construction activity. Contractor will only clear and grub approximately a month ahead of the pipe laying crew
- Clearing and grubbing for the Funks and TRR PGPs will occur early in the construction activity and take approximately 14 days to complete.
- Clearing and grubbing of the TRR East reservoir site will occur early in the construction activity and take approximately 30 days to complete.

Construction Spoils

Spoils will largely come from the pipelines where the pipeline displaces native soils. These spoils are anticipated to be hauled to the TRR East reservoir site for use in construction the embankments.

Spoils will also come from the dredging of Funks Reservoir. The areas of dredging and placement of construction spoils is provided in Figure 2C-17.

3.2 Existing Facilities Common to Alternatives 1, 2, and 3

The Project will utilize existing facilities The project will utilize certain existing water supply infrastructure. This includes the following existing Bureau of Reclamation infrastructure operated by the Tehama-Colusa Canal Authority (TCCA):

- Red Bluff Pumping Plant

- Tehama-Colusa Canal
- Funks Reservoir

The Project will also utilize the following existing Glenn Colusa Irrigations (GCID) facilities:

- Hamilton City Diversion
- GCID Main Canal

Reclamation owns the RBPP (including the intake, fish passage facilities, and settling basin), TC Canal, and Corning Canal, and the facilities are operated by TCCA. The RBPP is on the Sacramento River approximately 2 miles southeast of Red Bluff (River Mile 243) and has been operating since 2012. The facility was constructed adjacent to Reclamation's Red Bluff Diversion Dam (RBDD) and includes a fish screen, canal, siphon, forebay, switchyard, and a bridge across Red Bank Creek. The 1,118-foot-long, flat-plate fish screen was designed to meet the criteria of the National Marine Fisheries Service (NMFS) and California Department of Fish and Wildlife (CDFW) for diversion flows of 80 to 2,500 cfs.

The RBPP is a 2,500-cfs full operating capacity pumping plant and contains an intake structure and discharge conduit to divert water from the Sacramento River into the TC Canal and Corning Canal. There are bays for 11 vertical axial-flow pumps at the RBPP. Nine of these bays have pumps (seven 250-cfs pumps and two 125-cfs pumps) and have a combined total rated capacity of 2,000 cfs. The RBPP also contains two additional pump bays designed for the future installation of two 250-cfs vertical axial-flow pumps, which would increase the capacity to the maximum 2,500 cfs.

The TC Canal delivers water to areas in Tehama, Glenn, Colusa, and northern Yolo Counties. The TC Canal is also the water source for 20,000 acres of wildlife preserves in the Sacramento Valley. The canal is approximately 111 miles long and extends from Red Bluff in Tehama County to south of Dunnigan in Yolo County. The TC Canal is a concrete-lined channel with a regulating reservoir (Funks Reservoir) at its midpoint approximately 66 canal miles downstream of the intake. The canal's capacity is 2,500 cfs at its start, 2,100 cfs at Funks Reservoir, and 1,700 cfs at its terminus.

Funks Reservoir regulates flows on the TC Canal and automated check structures control the water surface elevation (WSE) where the canal enters and exits the reservoir. The initial capacity of the Funks Reservoir was approximately 2,200 acre-feet, but sediment deposition has reduced the capacity of usable storage in the canal's operating range to approximately 1,100 acre-feet.

The existing GCID facilities include the Hamilton City Pump Station and forebay, Main Canal, intake and bypass channels, fish screens, head gates, gradient facility, and three siphons on the Main Canal (i.e., Walker Creek, Willow Creek, and the railroad siphon). GCID's system of canals, including the Main Canal, was largely constructed in the early 1900s and conveys water to over 140,000 acres of irrigated lands in the GCID service area along with the Sacramento, Colusa, and Delevan National Wildlife Refuges.

The Hamilton City Pump Station is on the Sacramento River approximately 5 miles northwest of Hamilton City (River Mile 205) and pumps water into the GCID Main Canal intake. GCID

completed an expansion of the fish screen on the canal intake in 2001. Existing facilities at the GCID diversion site include a 1,090-ft-long flat plate fish screen designed to meet NMFS and CDFW fish screen criteria. GCID operates 10 pumps with a total capacity of 3,000 cfs diversion.

The approximately 65-mile-long GCID Main Canal is an unlined, earthen channel that delivers water between the intake at the pump station and its terminus at the CBD to the southeast near the city of Williams. The canal's capacity varies from 3,000 cfs at the upstream end to 300 cfs at the CBD. The GCID Main Canal is typically out of service approximately 6 weeks each year between early January and late February for maintenance.

Improvements to existing TCCA and GCID facilities will be required and the means and methods for construction of improvements are described below.

3.2.1 Sacramento River Diversion and Conveyance Facility Improvements

The Red Bluff Diversion improvements include the addition of two pumps and motors at the RBPP (see Figures 2C-1 and 2C-18 for location) and electrical equipment to increase capacity of the facility. These improvements will require only a few months of onsite construction, so there is flexibility on the timing of construction. The improvements are best completed during the winter, when there is less pumping and potential impact to existing operations.

Installation of the pump units (see Figures 2C-19 and 2C-20 for plan and profile) would be conducted in accordance with the pump manufacturer's installation instructions as well as the following general procedures. This work would likely be done during the non-irrigation season (e.g., fall/winter) because of the need to dewater in order to perform the installation.

Construction would require the following:

- Dewater the afterbay
- Remove existing blind flange on the afterbay side of the pumping plant and replace it with an 84-inch-diameter butterfly valve. A new 84 inch-diameter flanged steel pipe spool (approximately 3 feet long) would be connected to the butterfly valve. Permanent supports would be required beneath the butterfly valve and flap gate.
- Installation of pumping plant unit bay stoplogs and use of a mobile crane if afterbay dewatering was necessary
- Inspect the pump bays and removing all sediment. Access to the bottom floor of the pumping plant would be provided at each bay through 4.5-foot × 7-foot access hatches and ladders
- Temporarily remove roof hatches over the pump bays using a mobile crane
- Install the pump in accordance with the manufacturer's instructions, including constructing the pump pedestal and connecting the pump discharge nozzle to the discharge pipe with a flexible coupling.
- Install motor control centers, electrical equipment, electrical conductors, and SCADA system to integrate the pumps into plant operation.

The following equipment would be required over a two week period assuming 10 hour days.

- A mobile crane would be required to install the piping and appurtenances (40 hours)
- Forklift (40 hours)
- Generator (80 hours)
- Utility Trucks (30 hours)
- Misc. Equipment (dewatering pumps, 30 hours)

GCID Main Canal Diversion and System Upgrades

The GCID Main Canal needs improvements to some of its existing infrastructure (shown in Figure 2C-21 and Figure 2C-22) in order to reliably convey 1,800 cubic feet per second to TRR East in the November to May time frame. Improvements include replacing the Headgate Structure (also shown in Figures 2C-23 and Figure 2C-24), the Walker Creek Siphon (also shown in Figure 2C-25), and the Willow Creek Siphon (also shown in Figure 2C-26), modifications to the Railroad Siphon, raising the canal banks to provide necessary freeboard, and improving canal bank roads to all weather status. These project components are explained below. All Main Canal upgrades are located off the Sacramento River and behind the fish screens. Construction activities would be scheduled to occur from early January to late February when the GCID Main Canal is typically out of service for maintenance. If construction activities are required outside of the maintenance period, then temporary facilities will be needed to maintain regular canal operation.

The new Headgate structure would be placed just upstream of the existing structure, and the existing structure would be left in place, as it also serves as a Glenn County maintained bridge.

Construction would include the following and occur between November 2025 and October 2027.

- Construct a staging area and provide site access.
- Place construction materials at staging areas.
- Transport materials to the Project Site.
- Build a pumping bypass around the proposed facility to allow the flow of water in the canal during the low flow winter while the new Head Gate Structure is built in the dry.
- Build the new Headgate Structure in phases over various low flow winter seasons.
- Remove only the gates at the old Headgate Structure, but leave the structure.
- Perform site restoration once construction is completed.

The Walker Creek Siphon and Willow Creek Siphon construction would include the following:

- Construct a staging area and provide site access.
- Place construction materials at staging areas.
- Transport materials to the Project Site
- Build a bypass around the existing siphon to allow the flow of water in the canal while the new siphon is built in the dry. This may involve sheet pile cut off walls.

- Build the new siphon.
- Demolish the old siphon.
- Cut through the bypass to allow water flow through the GCID Main Canal through the new siphon.
- Remove the bypass and bring the site to pre-construction conditions.
- Perform site restoration once construction is completed.

Railroad siphon modification construction would include the following:

- Construct a staging area and provide site access.
- Place construction materials at staging areas.
- Transport materials to the Project Site
- A portion of the canal around the north side of the structure would be dewatered, using an earth cofferdam lined with geomembrane and sump pumps.
- Install a new barrel using a bore and jack procedure a new barrel; new headwalls on the upstream and downstream end would be installed to approximately match the existing headwall.
- Perform site restoration once construction is completed.

Canal Bank Improvements and Canal Road Improvements. The canal bank improvements are in designated areas of the main canal generally between the Willows Check and TRR East where there may need to be material added to keep the design freeboard in the canal when conveying 1,800 cubic feet per second. This would involve placing approximately 5,000 cubic yards of material along the canal banks. The canal road improvements are to provide all-weather access from the Willow Creek Siphon to the Funks Creek Siphon along approximately 16.6 miles of left canal bank road. It would involve approximately 6 inches of aggregate base material that would involve approximately 27,000 cubic yards of material.

Canal bank and canal road construction would include the following:

- Transport earth materials to the Project Site.
- Raise the canal banks by laying down 3 inches to 12 inches of material. Material would be placed on the canal banks, water added for compaction, graded and roller compacted.
- Top the left bank canal road with 6 inches of aggregate base material. Material would be placed on the canal road; water would be added for compaction, and then would be graded and roller compacted.

3.2.2 Regulating Reservoirs – Funks Reservoir

All alternatives will utilize the existing Funks Reservoir as well as a new Terminal Regulating Reservoir (TRR) to fill Sites Reservoir (see Figures 2C-2 and 2C-4). Both regulating reservoirs would have two 12-foot-diameter pipelines extending to and from Sites Reservoir just below Golden Gate Dam. At each regulating reservoir, the pipelines would be connected to a pumping generating plant that pumps water from the regulating reservoir to Sites Reservoir, as well as

turbines that would generate power when flows were released from Sites Reservoir. There would also be energy dissipation equipment adjacent to each PGP (e.g., fixed cone valve[s]) to throttle the flow of water into each regulating reservoir when the turbines are not being used.

Improvements to the existing Funks Reservoir are described below. The proposed TRR East and West facilities are addressed in Sections 3.3 and 3.4, below.

Funks Reservoir

Anticipated construction activities for the Funks Reservoir (see Figure 2C-27) include the following:

- Construct access roads and stockpile areas required for construction activities.
- Dredging and excavation of sediments, inlet channels to pumping generating plant (PGP), and required cofferdam foundations for PGP and TRR pipeline construction across Funks Reservoir.
- Cofferdam construction
- Construction of pipeline through Funks Reservoir
- Removal of pipeline and PGP cofferdams

The first two activities are expected to be completed in one year, with the third activity taking approximately three months; the pipeline construction would take approximately nine months, and the final two activities would take another year with starts and stops. Total construction time for Funks Reservoir is estimated to be approximately three years.

The modifications at Funks Reservoir consist of dredging and excavating material out of the reservoir footprint to gain back the original capacity of the reservoir when it was built in the late 1970s, to provide a channel to the Funks PGP, building cofferdams to support pipeline and PGP construction, and removing the cofferdams to restore the reservoir. The dredging/excavating involves removing approximately 600,000 cubic yards of material from the reservoir and stockpiling onsite and/or hauling it offsite. It will necessitate building access roads to stockpile areas where dredged/excavated materials can be processed for construction of other project features or hauled offsite for disposal.

Temporary cofferdams will be constructed to support construction for the TRR East pipelines that run through the northern portion of Funks Reservoir and for construction of the Funks PGP. After construction of the TRR East pipeline, the pipeline cofferdam would be removed; after construction of the Funks PGP, the PGP cofferdam would be removed. Construction would include the following:

- Build access roads from Funks Reservoir to dredged/excavated material stockpile areas.
- Dredge/excavate material from Funks Reservoir.
- Transport dredged/excavated materials to the stockpile areas and offsite.
- Manage the materials at the stockpile area.

- Haul materials from the stockpile areas to re-use areas (e.g., Golden Gate Dam area) and/or to offsite for disposal.
- Construct the cofferdams to support construction of the TRR East pipelines and Funks PGP.
- Subsequently remove the cofferdams.
- Revegetate the stockpile areas once completed.

Funks Pumping Generating Plant

Construction of the Funks PGP (see Figures 2C-28A and 2C-28B) would include the Funks substation and coincide with the Funks Pipelines, a portion of the TRR East pipelines, and Funks Reservoir dredging. Construction of the Funks PGP would include the following:

- Clear and grub the site.
- Rough grade excavate the location of the PGP.
- Place construction materials at staging areas.
- Transport materials to the Project Site. Materials would consist of concrete, rebar, yard piping, pumps, motors, energy dissipation valves, hydropower equipment, and electrical equipment.
- Build the PGP, which would consist of excavating the ground to accommodate placement of structure structural concrete and rebar.
- Connect the PGP to the Funks Pipelines.
- Connect the PGP to the substation.
- Test the facility.

Funks Electrical Substation

The Funks substations will be located adjacent to the PGP (see Figure 2C-27). Anticipated construction activities for the substation include the following:

- Clear and grub the substation area.
- Construct the substation.
- Perform testing.
- Connect to PGP's main load and other loads.

Funks Pipelines

The Funks Pipelines consist of two 12-foot diameter pipes (see Figure 2C-27) that would go from the Funks PGP to the Inlet/Outlet Tunnel manifold south of Golden Gate Dam.

Construction of the Funks pipelines would include the following:

- Clearing and grading the pipeline alignment.
- Provide a dewatering system near Funks Reservoir and potentially along Funks Creek so that installation of the pipelines can be done in the dry.

- Dig pipeline trench and provide shoring. It is anticipated that several hundred feet of open trench would occur at one time.
- Install and weld up the pipeline and backfill with a combination of controlled low strength material (CLSM) and native material.
- Install surge tanks, flow meters and valving, air valves, blowoffs, and access manways.
- Install a cathodic protection system consisting of rectifiers attached to pipe.
- Revegetate and restore the pipeline route, and construct a gravel maintenance road along the pipeline route.

Transition Manifold

A transition manifold (Figure 2C-29) would be constructed south of Golden Gate Dam to connect pipelines from Sites Reservoir to Funks Reservoir. The Transition Manifold area will first be used on the east side as the portal for the inlet/outlet tunnel. Once the tunnel is completed, then the transition manifold construction will be done. The staging area footprint will be used first by the tunneling Contractor and then used by the transition manifold Contractor.

- Clear and grub the work and staging area of the transition manifold between reservoir tunnels and Funks pipelines.
- Deliver pipe materials to the area.
- Install piping and valves, and weld them together.
- Backfill with combination of CLSM and native material.
- Regrade the area to smooth surface.

3.2.3 TCCA TC Canal Intake Structure

Water released from Sites Reservoir would be discharged into Funks Reservoir and then conveyed south of Funks Reservoir using the existing TC Canal and a new Dunnigan Pipeline, discussed further in Section 3.3. The water would flow south about 40 miles to near the end of the TC Canal, where it would be diverted into the Dunnigan pipeline via a new intake shown in Figure C2-30 and Figure C2-31).

The construction means and methods for the TC Canal intake structure include:

- Clear and grub the area along TC Canal for the intake structure.
- Place the cofferdam in the TC Canal and bypass pumping around the intake site to provide limited flow to end of canal and downstream users (less than 0.25 mile from end of canal)
- Transport materials including concrete, rebar, yard piping, control gates, and electrical equipment to the project site.
- Place construction materials at staging areas.

- Build the intake structure, which would consist of excavating the ground to accommodate placement of structural concrete and rebar.
- Connect the intake structure to the Dunnigan Pipeline.
- Test the facility

3.3 Proposed Facilities Common to Alternatives 1 and 3

As outlined in Table 2C-1, Alternatives 1 and 3 propose the construction of the same facilities. These alternatives differ only due to operations and maintenance, as described in Chapter 2 of the RDEIR/SDEIS. The following provides a description of the construction means and methods for the facilities that are common to Alternatives 1 and 3.

3.3.1 TRR East and Conveyance Complex

Pumping from the GCID Main Canal to Sites Reservoir would require construction of the TRR facilities. There would be four primary facilities: the TRR, the TRR PGP, an electrical substation, and TRR pipelines. Anticipated construction activities for the Terminal Regulating Reservoir (TRR) East include the following:

- Construct access roads required for construction activities.
- Perform ground improvement for the containment berm areas using deep soil cement mixing with an onsite batch plant.
- Construct TRR embankments, new control structures, and spillway.
- Prepare the reservoir subgrade and install a liner.
- Finalize construction of the GCID Canal plug as part of commissioning.

The first two activities are expected to be completed in one year, with the third of the activity taking approximately 15 months, and the final two activities taking another nine months. Total construction time for the TRR is estimated to be approximately three years.

TRR East consists of the reservoir footprint and an access bridge over the GCID Main Canal (see Figure 2C-32). The TRR East PGP (Figures 2C-33A and 2C-33B), a portion of the TRR East Pipelines (Figure 2C-34), and the substation (Figure 2C-35) are within the reservoir footprint but are described separately for construction means and methods. There are three phases of construction for TRR East, which are shown in the construction schedule.

Phase 1 consists of building access roads to the site, installing a bridge across GCID Main Canal, and constructing staging/laydown/stockpile areas (including the area within the TRR East footprint and a 20-acre stockpile area west of the GCID Main Canal). Construction would include the following:

- Clear and grub for access and haul roads.
- Build the access roads.

- Construct the bridge across the GCID Main Canal (such that flows in the GCID Main Canal are not interrupted).
- Construct the additional stockpile area west of the GCID Main Canal.
- Place construction materials at staging areas.
- Transport materials to the Project Site.

Phase 2 consists of conducting ground improvement within the reservoir footprint. Construction would include the following:

- Clear and grub trees and brush in the reservoir footprint.
- Transport materials to the Project Site.
- Place construction materials at the stockpile/staging area.
- Conduct ground improvement in designated areas. Ground improvement would be implemented by the cement deep soil mixing (CDSM) method to an approximate depth of 40 to 50 feet under the area of the TRR East embankment, PGP, and substation at an approximate replacement ratio of 30 percent. This would involve approximately 900,000 cubic yards of material.

Phase 3 consists of building the reservoir and check structures in the dry and then connecting the GCID Main Canal to TRR East. Construction would include the following:

- Transport materials to the Project Site.
- Place construction materials at stockpile/staging areas.
- Grade the reservoir to final elevation including deeper intake channel to TRR East PGP.
- Build the reservoir and install a liner.
- Build the check structures.
- Install the perimeter fencing.
- Once the TRR East pipelines, PGP, and substation have been installed and the facility is ready for testing with water, modify the GCID Main Canal right bank to allow water to go into the reservoir.
- Perform site restoration once construction is completed.

TRR Pumping Generating Plant

Anticipated construction activities for the Funks and TRR PGPs are essentially the same and include the following:

- Procure large equipment with long lead times.
- Construct access roads and staging areas.
- Coordinate with reservoir cofferdam construction for Funks and ground improvement for TRR to begin excavation for the foundation.

- Construct the facility.
- Coordinate to remove cofferdams and have water in reservoirs available for testing.
- Coordinate with construction of pipelines to ensure they are completed to begin PGP testing.
- Complete testing and commissioning of pumps.

Construction of the TRR East PGP would not start until after ground improvement is finished at the TRR East site as described above. Construction would include the following:

- Place construction materials at staging areas.
- Transport materials to the Project Site. Materials would consist of concrete, rebar, yard piping, pumps, motors, energy dissipation valves, hydropower equipment, and electrical equipment.
- Build the PGP, which would consist of excavating the ground to accommodate placement of structure, structural concrete, and rebar.
- Connect the PGP to the TRR East Pipelines.
- Connect the PGP to the substation.
- Test the facility.

3.3.2 Electrical Transmission Connections

Electrical transmission connections consist of substations and high voltage transmission towers/lines. The staging areas for this activity will utilize the same easement areas and staging areas as the pipeline Contractor for the Funks and TRR pipelines. It is unknown at this time if the power interconnection will be from Pacific Gas and Electric (PG&E) or from Western Area Power Authority (WAPA). Both power entities have high voltage transmission lines that run north/south between Funks Reservoir and the GCID Main Canal. While the exact location of the interconnection is unknown, the facilities will be similar for both PG&E and WAPA. The selection of the transmission line conductors for intertie to the PG&E or WAPA 230-kilovolt line would be based on matching the rating of the existing circuits of these lines.

Substations

There will be three substations: a primary substation at the point of interconnection, with either PG&E or WAPA, and two secondary substations—one at the TRR East PGP (Figure 2C-32) and one at the Funks PGP (Figure 2C-27). The location of the primary substation would be somewhere within the right-of-way corridor shown on Figures 2C-2 and 2C-4).

Construction of the substations would include the following:

- Transport materials to the Project Site.
- Clear and grade the primary substation site for construction. The secondary substations would not require clearing and gradings as that would be done prior with the construction of the two PGPs.

- Place construction materials at staging areas.
- Construct the substations and perimeter fencing.
- Perform site restoration after construction is complete.

High voltage transmission towers/lines

It is anticipated that the foundations for the transmission line structures (towers) would consist of single concrete piers reinforced as necessary to withstand design loads (Figure 2C-36). These would be formed by auguring a hole of appropriate depth and diameter, placing a cage of reinforcing steel in the hole, and filling the hole with high-strength concrete. These facilities would be constructed after the TRR East pipelines are installed, as it is assumed this would be the utility corridor for the project. Construction of the transmission towers/lines would include the following:

- Transport materials to the Project Site.
- Place construction materials at staging areas.
- Construct the transmission towers and stringing the lines.
- Test and hook up the system to either PG&E or WAPA and to each of the PGP's.
- Perform site restoration after construction is complete.

Clearing and grubbing would not be required as this would already have been done for the TRR East pipelines. Minor grading would be required at each tower site.

Substation – Point of Interconnection

There will be a point of interconnection substation either for WAPA or for PG&E. The point of interconnection substation will be located adjacent to their respective transmission lines (see Figure 2C-37). Anticipated construction activities for this substation will include the following:

- Clear and grub the substation area.
- Construct the substation.
- Perform testing.
- Connect the substation to the Funks Substation and the TRR substation.

The anticipated construction time for the substation is anticipated to be approximately one year.

Transmission Lines

The transmission lines are composed of the 230-kilovolt lines from the point of interconnection substation (either PG&E or WAPA) to either TRR substation or Funks substation. See Figure 2C-38 and Figures 2C-39 for schematics. Then a secondary line will connect between the Funks and TRR substations. The transmission lines consist of towers and stringing conductors. The line connecting between TRR and Funks will be within and parallel to the TRR pipeline for most of the corridor. Anticipated construction activities for the transmission lines include the following:

- Clear and grub the easement area (for interconnection line).

- Form and pour tower foundations.
- Erect towers.
- Install conductors between towers between the interconnection point and Funks/TRR substations.
- Energize lines and test.

The anticipated construction time to complete the transmission lines is approximately 18 months.

3.3.3 Administration, Operations and Maintenance, and Storage Buildings

Two proposed buildings would be located next to the Funks PGP. The Administration and Operations Building (see Figure 2C-40) would be approximately 3,400 square feet and the Maintenance and Storage Building (see Figure 2C-41) would be approximately 2,800 square feet. The two buildings would be located within the disturbance area of the Funks PGP site.

The buildings would require a potable water source, most likely supplied by a groundwater well, a septic system, and aboveground fuel and waste oil storage tanks. Oil/water separators would be provided in maintenance areas, as necessary. Construction of the proposed buildings would include the following:

- Transport materials to the Project Site.
- Clear and grade the site for construction.
- Place construction materials at staging areas.
- Construct the administrative/operations building and the maintenance/storage building.
- Construct ancillary facilities (e.g., potable water source, septic system, lighting, concrete pad for refueling island, aboveground fuel tanks, perimeter fencing).
- Perform site restoration after construction is complete.

3.3.4 Sites Reservoir and Related Facilities

Under all Action Alternatives, water would be impounded by the Golden Gate Dam on Funks Creek and the Sites Dam on Stone Corral Creek; a series of saddle dams along the eastern and northern rims of reservoir would close off topographic saddles in the surrounding ridges to form Sites Reservoir. See Figures C2-2 for the location of the Sites Reservoir, Golden Gate Dam, saddle dams, and I/O Works under Alternative 1 and 3.

Inlet/Outlet Works

The proposed I/O works are located to the south of Golden Gate Dam. Figures C2-42 and C2-43 provide plan and profile views of the I/O Works site. Figures 2C-44 and 2C-45 provide schematics for the I/O Tower. They would be used both to fill the reservoir through conveyance facilities situated to the east and to make releases from Sites Reservoir. The I/O works include the following:

- a multi-level intake tower, including a low-level intake

- two 23-foot-inside-diameter I/O tunnels through the ridge on the right abutment of Golden Gate Dam.

Construction of the I/O works would disturb approximately 30 acres in the reservoir inundation area, and another 30-acre area outside of it at the downstream (eastern) tunnel portal. The construction disturbance would consist of the footprint of the two intake structures, the tunnel portals, the materials, spoils and equipment staging areas, and access roads. A portion of the footprint outside of the reservoir inundation area would overlap with the disturbance area for the conveyance system to Funks Reservoir. Construction activities associated with the I/O works would consist of the following:

- Survey and set the work in the construction area.
- Clear, grub, and prepare materials laydown and equipment staging areas.
- Build access roads, install temporary infrastructure, and transport construction materials and equipment to the site.
- Excavate the hillside for the downstream and upstream tunnel portals 80 feet and 180 feet deep, respectively.
- Dewater the construction site with an onsite treatment facility that will likely include settling basins with treatment for oil/grease, settleable solids, pH and turbidity. Treated water from the settling basins would be used for onsite dust suppression or discharged to Funks creek.
- Tunnel and haul tunnel muck to a disposal area.
- Construct the multi-level tower of reinforced concrete.
- Construct the access bridge to the multi-level tower.
- Finish grading and site clean-up.

The disturbance area within the inundation area would include the footprint of the proposed facilities, the materials and equipment staging area, the area needed to construct the facilities, and access roads.

The construction of the I/O works would require excavation of the tunnel, installation of tunnel support systems, and control of groundwater. A combination of drill-and-blast and roadheader excavation is assumed to be the construction method for the two I/O tunnels. Drill-and-blast would be used in areas where the rock strength is higher and the use of a roadheader is inefficient. Roadheader excavation would be used in soft to moderately strong rock. In both cases, the excavated tunnel muck would be loaded into mining cars by underground loaders for transportation to the portals and then for final disposal in disposal areas.

The I/O tunnels are assumed to be constructed using pre-excavation grouting to reduce groundwater inflow, and help stabilize the ground, followed by a two-pass lining system. The first pass (initial support) would be installed as part of the excavation process to support the ground and provide a safe work environment. The second pass—or final support—would be installed once the tunnel excavation is complete and would accommodate all designs loads while serving as the water conveyance line.

Batch plants would be on site to produce the concrete needed for the I/O tower and tunnel lining. The quantity estimates for the I/O works are listed in Table 2C-6.

Table 2C-6. Inlet/Outlet Works Quantity Estimates for Earthwork and Concrete

Item	Quantity	Unit	Factor of Safety/ Bulking	Rounded Quantity	Notes
Excavation Volumes					
Upstream portal and intake channel excavation Volume	474,300	yd ³	1.7	806,400	
Tunnel excavation volume	185,200	yd ³	1.3	240,700	2 tunnels, 3,110 ft long
Downstream portal excavation volume	63,300	yd ³	1.7	107,600	
Total		yd ³		1,154,700	Bulking factor for excavated materials is 1.7
Facility Footprints					
Upstream portal and intake channel excavation Footprint	7.1	acres	2	15	Inside the reservoir footprint. Multi-level tower included in footprint
Downstream portal excavation footprint	1.2	acres	2	3	Downstream of the reservoir. Outlet structure included in footprint
Disposal area for excavated materials	29	acres	2	58	Materials disposed in creek, inside the reservoir footprint
Total		acres		76	76 acres in the reservoir footprint, 3 acres downstream
Concrete Volumes					
Multi-level tower concrete aggregate	20,000	yd ³	1.2	24,100	
Tunnel lining (shotcrete and concrete) aggregate	76,500	yd ³	1.2	91,800	2 tunnels, 3,110 ft long
Total		yd ³		115,900	Assuming 90% aggregate in the concrete

Notes:

- 1 All excavated materials would be disposed of in the upstream thalweg (below El. 300) or potentially used for GG dam.
- 2 Tunnel spoils and excavated material from the downstream portal would be stockpiled at portal or near GG dam for use as Zone 4 material or access road fill.
- 3 Access roads during construction included in the GG Dam and Jacobs pipeline estimates.
- 4 Stockpile and staging areas included in Golden Gate dam footprint.

Creek Diversions

Funks and Stone Corral creeks would need to be diverted for construction of Golden Gate Dam (Figure 2C-46) and Sites Dam (Figure 2C-47), respectively. The design storm event for both temporary diversions would be a 100-year storm event in accordance with the Reclamation Flood Hydrology Manual (Reclamation 1989).

Coffer dams at both Golden Gate Dam and Sites Dam sites at the upstream toes would be used to store portions of the creek flows to reduce peak flows to be diverted during construction. (Design Criteria TM HR2.6 June 29) and would protect the work areas from flows diverted as described below.

Construction of the Golden Gate Dam diversion and the Sites Dam diversion/outlet would disturb approximately 5 acres in the reservoir inundation area and a similar area outside of it at the downstream tunnel portal. The construction disturbance would consist of the footprints of the intake structure; energy-dissipation measures on the downstream side; the tunnel portals at Sites; the materials, spoils, and equipment staging areas; and access roads. Excavation for the diversion pipe at Golden Gate dam should be covered by the dam's footprint.

- **Funks Creek – Golden Gate Dam:** A 48-inch diameter diversion pipe on the order of 2,000 feet long would be trenched in the bedrock under the foundation of Golden Gate Dam using an alignment that minimizes excavation and interference with the dam foundation. The steel pipe would be encased in reinforced concrete. The pipe would be backfilled with concrete grout when decommissioned at the end of construction. There would be a short riser (5 to 10 feet tall) with a trashrack on the upstream end of the pipe. The riser would prevent sediment from the construction site being transported downstream. On the downstream end, a flow control valve would be installed along with riprap to provide energy dissipation to diverted flows.
- **Stone Corral Creek – Sites Dam:** The diversion for Sites Dam would consist of a 1,600-foot-long tunnel in the left abutment of the dam. The upstream 1,100 feet of the tunnel would be concrete lined with a 12-foot inside diameter and the downstream 500 feet would be steel lined with a 12-foot inside diameter due to the small amount of rock cover above the tunnel crown. The excavation would be a 16-foot-diameter horseshoe-shaped tunnel.

A combination of drill-and-blast and roadheader excavation is assumed to be the construction method for the Sites outlet. Drill-and-blast would be used in areas where the rock strength is higher and the use of a roadheader is inefficient. Roadheader excavation would be used in soft to moderately strong rock. In both cases, the excavated tunnel muck would be loaded into mining cars by underground loaders for transportation to the portals and then for final disposal in disposal areas.

The intake system for the Sites Dam piping system is expected to include a bar trashrack, a 14-foot × 14-foot slide gate, a separate fish screen and inlet valve to support Stone Corral Creek release flows, a stoplog bulkhead, and permanent air vent assembly. The intake system would be

well above the creek thalweg, preventing sediment from the construction site being washed downstream.

The outlet works system at the tunnel outlet would include guard valves, combination air release and vacuum valves, two 84-inch diameter flow control valves for drawdown, and one flow control valve for creek release.

The upstream random zone of Golden Gate and Sites dams would function as the cofferdam and upstream toe berm, provides a convenient place to put waste materials from foundation excavation work during the initial stages of construction, and would be used to divert Funks and Stone Corral creeks from the dam footprint. Construction activities related to the creek diversions would consist of the following:

- Dewater the construction site and an onsite water treatment facility; in general, dewatering would either consist of installing dewatering wells around the perimeter of an excavation or installing sumps within an excavation.
- Cofferdam construction and placement would be constructed of Zone 4 material likely derived from the excavation of the dam foundations. The crest of the cofferdams would be at an elevation of 310 feet, 5 feet above high-water during construction. Batch plants are not required for cofferdam construction.
 - The cofferdams would be constructed out of soil/weathered rock removed during dam excavations; the construction procedures and process would be similar to the other dams.
 - Depth of cofferdam excavation is approximately 15 feet below ground surface.
 - The area behind the cofferdam would retain the stormwater and the sediments and uncton like a sedimentation basin. Very fine sediments typically go through sedimentation basins.
 - Several large culverts will be incorporated into the temporary cofferdam within Funks Reservoir to allow the creek to flow while building the TRR pipeline downstream across Funks Creek.
- Conduct trenching concurrently with dam foundation excavation for the diversion pipeline at Golden Gate Dam.
- Conduct hillside excavation for the downstream and upstream tunnel portals for Sites Dam.
- Excavate for tunnel and haul tunnel muck to a disposal area for Sites Dam following tunnel portal construction.
- Conduct excavation for the intake structures and downstream energy dissipation structures, 40 feet and 30 feet deep, respectively.
- Construct the structures from reinforced concrete.
- Manage groundwater.
- Finish grading and site clean-up.

The quantity estimates for the Sites Dam Diversion/Outlet are listed in Table 2C-7.

Table 2C-7. Sites Dam Diversion/Outlet Quantity Estimates for Earthwork, Concrete and Riprap

Item	Quantity	Unit	Factor of Safety/ Bulking	Rounded Quantity	Notes
Excavation volumes					
Upstream portal excavation volume	15,700	yd3	1.7	26,800	
Tunnel excavation volume	15,200	yd3	1.7	25,900	Tunnel is 1,590 ft long
Downstream portal excavation volume	12,400	yd3	1.7	21,200	
Total		yd3		75,490	Bulking factor for excavated materials is 1.7
Facility Footprints					
Upstream portal excavation footprint	0.5	acres	2	1	Inside the reservoir footprint. Intake structure included in footprint
Downstream portal excavation footprint	0.6	acres	2	2	Downstream of the reservoir. Outlet structure included in footprint
Disposal area for excavated materials	2	acres	2	4	Materials disposed in creek, inside the reservoir footprint.
Total		acres		7	5 acres in the reservoir footprint, 2 acres downstream
Concrete Volumes					
Intake structure concrete aggregate	900	yd3	1.2	1,100	
Tunnel lining (shotcrete and concrete) aggregate	6800	yd3	1.2	8,200	
Outlet structure concrete aggregate	900	yd3	1.2	1,100	
Total		yd3		10,400	Assuming 90% aggregate in the concrete
Riprap Volume					
Riprap Volume	1	yd3	1.2	230	Assuming 1000 sq. ft with 5 ft thick riprap at outlet structure

Table Assumptions/Notes:

All excavated materials would be disposed of in the reservoir footprint (below elevation of 300 feet).

Tunnel spoils and excavated material from the outlet structure would be hauled to the upstream thalweg via the tunnel.

Access roads during construction included in the Sites Dam estimates.

Stockpile and staging areas included in Sites Dam footprint.

Table 2C-8. Golden Gate Dam Diversion Quantity Estimates for Earthwork, Concrete, and Riprap

Item	Quantity	Unit	Factor of Safety/ Bulking	Rounded Quantity	Notes
Excavation Volumes					
Diversion pipe trench	2,800	yd ³	1.7	4,900	Pipe is 2,100 ft long
Upstream and downstream structures	1,000	yd ³	1.7	1,700	
Total		yd³		6,600	Bulking factor for excavated materials is 1.7
Concrete Volumes					
Intake structure concrete aggregate	180	yd ³	1.2	300	
Pipe trench and pipe backfill aggregate	2550	yd ³	1.2	3,100	
Outlet structure concrete aggregate	450	yd ³	1.2	600	
Total		yd³		4,000	Assuming 90% aggregate in the concrete
Riprap Volume	185	yd³	1.2	230	Assuming 1,000 sq. ft with 5 ft thick riprap at outlet structure

Table Assumptions/Notes:

All excavated materials would be incorporated in dam or disposed of in the reservoir footprint (below elevation of 300 feet).

Footprint of diversion pipe included in Golden Gate Dam footprint.

Access roads during construction included in the Golden Gate Dam estimate.

Stockpile and staging areas included in Golden Gate Dam footprint.

Dam Construction

All proposed dams comprising the Sites Reservoir would be constructed as zoned earth and rockfill embankment dams and would be constructed using four types of fill materials. The impervious core materials include finer material known as Zone 1, Zone 2 materials (filter, drain, and transition), Zone 3 materials (rockfill) and riprap, and Zone 4 materials (random materials). A typical section of dam embankment is provided in Figure 2C-48 that shows the zones proposed for Sites Dam. Figure 2C-49 provides a cross section for Golden Gate Dam.

Zone 1, 3, and 4 materials will be obtained from onsite borrow areas and quarries. Zone 2 materials would be imported from offsite commercial sources.

Embankment materials would be designed and suitable to construct earth and rockfill embankment dams. Material quantities and disturbance areas associated with each of the dams are provided in Table 2C-9.

Anticipated ground-disturbing activities during construction include the following:

- Survey.
- Set up staging areas within the Sites Reservoir footprint.
- Construct access roads.
- Transport equipment to the Project Site and set up offices and batch plants.
- Clear, including demolition of existing structures, and grub dam area.
- Construct stream diversions at Sites and Golden Gate dams.
- Perform dewatering at dam foundations.
- Excavate dam foundations and perform stockpiling activities.
- Grout dam foundations and portions of the reservoir rim.
- Develop borrow areas, quarries, and rock processing areas.
- Construct dam embankments.
- Construct Spillway (Saddle Dam 8B) and Emergency Release Structures.
- Install monitoring instrumentation.
- Construct roads and buildings for facility operation and maintenance.
- Clean up Project area, remove equipment, and restore the area.

Table 2C-9. Estimated Material Quantities and Disturbance Areas for Earth and Rockfill Dams

Dam	Length, ft	Maximum Height, ft	Footprint Disturbance Areas (acres)			Dam Embankment Volume										Excavation Volume (CY)
			Total Area	Area within Reservoir	Area outside Reservoir	Zone 1 (Core), CY	Zone 2A (Filter), Tons	Zone 2A (Drain), Tons	Zone 2A (Transition), Tons	Zone 2B (Filter), Tons	Zone 2B (Transition), Tons	Zone 3 (Rockfill), CY	Zone 4 (Random), CY	Riprap, CY	Concrete Aggregate, CY	Foundation Excavation (CY)
Golden Gate	2,200	287	38	17	21	2,400,000	660,000	730,000	98,000	410,000	430,000	2,600,000	2,200,000	98,000	35,000	1,600,000
Sites	780	267	18	9	8	710,000	220,000	270,000	39,000	135,000	145,000	1,050,000	660,000	40,000	11,000	570,000
Saddle Dam 1	310	27	2	1	1	20,000	7,300	6,600	1,500	-	-	17,000	16,000	3,100	1,300	25,000
Saddle Dam 2	240	57	2	1	1	20,000	7,300	6,600	1,500	-	-	17,000	16,000	4,400	1,100	25,000
Saddle Dam 3	3,400	107	33	11	22	900,000	290,000	290,000	84,000	-	-	610,000	1,600,000	130,000	19,000	670,000
Saddle Dam 5	1,900	77	18	6	12	310,000	110,000	115,000	33,000	-	-	190,000	470,000	47,000	9,300	260,000
Saddle Dam 6	360	47	3	1	2	30,000	13,000	13,000	3,700	-	-	15,000	34,000	4,500	1,600	32,000
Saddle Dam 8A	1,300	82	13	4	9	360,000	130,000	135,000	37,000	-	-	175,000	530,000	43,000	5,500	280,000
Saddle Dam 8B (Spillway)	470	37	2	1	1	20,000	-	540	-	-	-	-	-	2,400	19,500	40,000
Saddle Dike 1	120	12	1	-	1	-	-	-	-	-	-	-	3,900	-	-	3,300
Saddle Dike 2	200	12	1	-	1	-	-	-	-	-	-	-	6,300	-	-	5,400
Rim Grouting															10,500	
Emergency Release Structure, ERS -1	-	-	4	-	4			170					63,000	4,500	2,000	81,000
Emergency Release Structure, ERS -2			3	-	3	59,000		190						4,200	2,000	77,000
Total Quantities						4,800,000	1,450,000	1,550,000	300,000	550,000	580,000	4,700,000	5,600,000	380,000	118,000	3,700,000

Key activities are discussed in greater detail below.

Developing Borrow Areas and Quarries.

Borrow areas will first be developed by clearing, stripping, and grubbing the surface materials. The borrow areas for Zone 1 will be excavated with equipment consisting of excavators and loaded into dump trucks or excavated with scrapers and hauled directly to the dams. Moisture would be added in the borrow areas for both dust control and to adjust moisture for compaction.

The quarries would be developed by first clearing, stripping and grubbing. The quarries will then be stripped of weathered rock using bulldozers. This weathered rock would be used for Zone 4 within the dams. Moisture would be added to the material within the quarry for dust control and to adjust moisture for compaction. Benches would then be created from which a drilling and blasting operation would proceed. This operation would produce Zone 3 material, riprap, and additional Zone 4 material. The materials from a blast would be separated within the quarry and rock processing area into the different Zone materials and would be transported to the dams.

The rock-processing operation would consist of sorting rock for either Zone 3, Riprap, or Zone 4 materials. Stockpiled materials would be loaded by large excavators, loaders, and possibly conveyors into large dump trucks and transported to the dam construction sites. Material excavation, processing, and stockpiling are anticipated to occur throughout the dam construction period.

Foundation Excavation.

Recent and older alluvium and decomposed and intensely weathered bedrock would be excavated from the entire footprint of the main dam sites to reach a moderately weathered bedrock surface. In addition, moderately weathered bedrock would be excavated from the impervious core footprint down to the top of slightly weathered and/or fresh bedrock surface.

For the saddle dams, the foundation objectives are intensely weathered rock for the shell and moderately weathered rock for the core. Additional shaping of the foundations would be done after each of these foundation objectives is achieved. Excavation depths are estimated to average approximately 15 feet, excluding the core foundation. It is anticipated to reach the core foundation at approximately 40 feet depth.

Excavation would be performed by heavy equipment, but limited controlled blasting may be required in the harder sandstone. For Golden Gate and Sites Dams, approximately 25 percent of the rock in the core foundation may require controlled blasting.

The current estimated quantity of rock in the dam foundations is about 206,000 CY. This material would be drilled and shot in a controlled manner in order to shape the foundation to meet foundation objectives. Blasting plans and resulting shots would vary in size, depth, and overall shape. However, it is envisioned that the average shot size would be between 2,000 and 4,000 CY. Blasting of the core trench would be ongoing, as the dam foundation is exposed from the abutments down to the central part or maximum section area of the dam, dependent on excavation of overlying materials and rock formations within the dam footprint. Overall blasting operations would likely last the duration of the dam foundation excavation, but would not occur

on a daily basis. Given the overall quantity of 206,000 CY of material and an average blast size of 3,000 CY, this would involve approximately 70 shots.

A minimum bottom core trench width of 20 feet has been incorporated into the saddle dam foundation design. The average depth to intensely weathered bedrock for the saddle dams was estimated at 12 feet below ground surface and average depth to moderately weathered bedrock is 25 feet. In addition, the average depth to slightly weathered bedrock for the saddle dams would be 35 feet.

No significant landslides have been mapped within the dam footprints. However, if any landslides are encountered, they will be removed within the dam foundation excavation.

Groundwater is present at the main and saddle dam sites and dewatering would be required during excavations (DWR, 2003b). For Golden Gate Dam, the groundwater is approximately 13 feet to 25 feet below ground surface along the dam channel area and about 40 feet to 75 feet below ground surface along the dam abutments. For Sites Dam, the groundwater is approximately 10 to 20 feet below ground surface along the dam channel area, and for the most part reflects the groundwater elevation associated with the creek channel. The depth to water at the abutments averaged about 80 feet below ground surface. For the saddle dams, the groundwater depth is shallow (less than 10 feet) along the channel areas and varies between 20 feet and 90 feet along the abutments.

Dewatering would occur within the dam footprints to get to the foundation level; the water generated through this dewatering would be kept on site and would be used within the reservoir footprint or other construction locations. The water would be stored in sedimentation ponds upstream of the dam.

Foundation Grouting

The foundation grouting for the proposed Golden Gate and Sites dams would consist of a two-row grout curtain, with one row of consolidation holes upstream and one row downstream of the curtain holes. The rows would parallel the dam centerline and would be spaced 10 feet apart. In addition, a 40-foot-wide \times 3-foot-thick grout cap is included in the design to prevent grout surface leakage during grouting of the upper stage. Foundation grouting for the proposed saddle dams would consist of a two-row vertical grout curtain spaced 10 feet apart parallel to the dam centerline.

The saddle dam foundation grouting would also include a 20-foot-wide \times 3-foot-thick grout cap to prevent surface leakage of grout during grouting of the upper stage. Each row of consolidation and curtain grout holes for all dams would consist of mandatory primary and secondary holes spaced at 10-foot centers. The grout curtains would be constructed by drilling holes into the bedrock and filling the holes with grout pumped in under pressure.

The configuration and depth of the grout curtain under the dam and spillway sections would be determined based on geologic conditions and the results of permeability testing performed as part of the site investigation work.

Additional Grouting at Eastern Rim

Additional grouting will be performed along the eastern rim of the reservoir north of Golden Gate Dam. Grouting will be in narrow rim areas and is intended to minimize seepage through the rim when the reservoir is full. Grouting would extend from the ground surface down into fresh rock.

Dam Embankment Construction

As mentioned above, all proposed dams composing the Sites Reservoir would be constructed as zoned earth rockfill embankment dams and would be constructed of four types of fill materials. The impervious core materials (finer material known as Zone 1), Zone 3 materials (rockfill) and riprap, and Zone 4 materials (random materials). These materials would be hauled in large dump trucks from the borrow areas and quarries, spread by graders or bulldozers, moisture-conditioned with water trucks, and compacted with sheepsfoot rollers and vibratory compactors. Zone 2 materials (filter, drain, and transition materials) would potentially be hauled in highway-legal large dump trucks from offsite commercial sources approximately 40 miles from the reservoir site, and then be spread, watered, and compacted.

Monitoring Instrumentation Installation

Monitoring instrumentation, including seismic accelerographs, piezometers, settlement monuments, inclinometers and seepage weirs would be installed at the proposed dam sites to monitor the long-term performance of the dams. Piezometers and inclinometers would be installed in deep drill holes; settlement monuments would be installed in shallow (about 6 feet) drill holes.

Dams Construction Disturbance Areas

A conceptual layout of expected borrow areas, haul routes, disposal, staging, stockpile, and rock processing areas are shown in Figure 2C-6. Summarized below is the approximate disturbance areas for each of the features (the total dam construction disturbance areas are summarized in Table 2C-9):

- **Onsite Materials (Zone 1 borrow areas and dam foundation excavations)** – The locations of the onsite borrow areas are shown in Figure 2C-6. These areas comprise approximately 440 acres. The actual required borrow areas and disturbance limits will depend largely on the quality of each borrow area, including overburden depth, the usable depth of the underlying materials, and the expected consolidation of these materials in the embankment. Another significant factor will be the useable portion of material from the excavation of dam foundations and other facilities. The onsite borrow sources are expected to provide materials for both Zone 1 – Core, and Zone 4 – Random. The total required in-place volume of these materials is about 4.8 million CY for Zone 1 and 5.6 million CY for Zone 4. Total foundation excavation quantity is about 3.7 million CY of which approximately 1.9 million CY could be used for Zone 4, leaving a minimum borrow requirement of approximately 3.7 million CY of Zone 4 material. The Zone 1 borrow areas are permanent disturbance areas because they are within the reservoir inundation area. This Zone 4 material will be obtained from the quarries described below.

- **Quarried Materials (Zone 3 and 4)** – Figure 2C-6 shows approximately 970 acres of quarries. The actual required quarry area and disturbance limits will depend largely on the quality and depth of material to be quarried, as well as inclusion of non-suitable stratum of mudstone that must be extracted separately from the usable sandstone for Zone 3. The mudstones will be used for Zone 4. Also of significance is the potential waste material produced from blasting and processing operations. Quarried material sources are expected to provide materials for Zone 3 – Rockfill, Riprap, and Zone 4 Random. The total required in-place volume of these materials is approximately 8.8 million CY. Quarried material source plans include approximately twice the anticipated volume to account for suitability of materials. Minimum expected area of disturbance is approximately 970 acres. The quarries are permanent disturbance areas.

Significant quarry blasts and operations would be required during dam construction, particularly during the embankment operations involving rockfill. Blasts would be done during mid-day or afternoon hours. Quarry locations are shown on Figure 2C-6. The current estimated quantity of Zone 3 Rockfill to be produced is about 4.7 million CY. To process this material, significant sandstone and mudstone deposits would need to be drilled and shot, with multiple quarries in operation nearly every day of rockfill embankment. Quarried materials would be drilled and shot in fairly large blasts, likely sized according to processing and placing demands. It is expected that, in order to supply Golden Gate Dam, Sites Dam, and the Saddle Dams, there would be blasts at three quarries every day for the duration of Zone 3 Rockfill processing and placement. Currently expected to last approximately 3 years. Depending on the actual size of individual shots, as well as the amount of mudstone that requires drilling and shooting, the number of individual shots is likely to be in the range of 800 to 1,200.

This material would be drilled and shot in a controlled manner in order to shape the foundation to meet Project objectives. Blasting plans and resulting shots would vary in size, depth, and overall shape. However, it is envisioned that the average shot size would be between 2,000 and 4,000 CY. Blasting of the core trench would be ongoing, as the dam foundation is exposed from the abutments down to the central part or maximum section area of the dam, dependent on excavation of overlying materials and rock formations within the dam footprint. Overall blasting operations would likely last the duration of the dam foundation excavation, but would not occur on a daily basis. Given the overall quantity of 206,000 CY of material and an average blast size of 3,000 CY, this would involve approximately 70 shots.

- **Processing Areas** – Figure 2C-6 shows processing areas for Golden Gate Dam, Sites Dam, and for the Saddle Dams. The space required for processing areas will be dependent on the Contractor's operation, including processing approach, waste materials generated, and stockpiled material. The processing areas are approximately 130 acres. The rock processing areas are temporary disturbance areas.
- **Disposal Areas** – Figure 2C-6 indicates three disposal areas, primarily near Golden Gate Dam and Sites Dam. The space required for disposal areas will be largely dependent on the suitability of materials and the ability to dispose of borrow and quarry overburden and

unsuitable materials within those areas. Actual disposal depth and contouring requirements will also influence the required size of disposal areas. The disposal areas are approximately 165 acres. The disposal areas are permanent disturbance areas.

- **Contractor's Office and Shop Facilities** – The Contractor's office and shop facilities will be dependent on the procurement strategy and outcomes. If more than one Contractor is employed for the construction of the dams and I/O facilities, then each Contractor will require independent office and shop areas. Regardless, it is expected that office facilities would be required near Golden Gate Dam and Sites Dam, with office facilities separately near the saddle dams, since these facilities are approximately 5 miles apart. Generally, for a project of this size, the Contractor's office and yard facilities would require approximately 6 to 10 acres for each Contractor. Shop facilities for equipment maintenance for each Contractor would require approximately 10 to 15 acres. Minimum expected area of temporary disturbance, assuming 3 contracts total, should be approximately 75 acres.
- **Staging and Stockpile Areas** – Figure 2C-6 indicates approximate location of staging and stockpile areas near each of the facilities. Stockpile areas would be needed primarily for dam foundation excavation and imported filter and drain materials. The filter and drain materials would come from offsite commercial or other sources at distances upwards of 40 miles. This would require that these materials be imported over a longer duration than is required for their installation, creating the need for onsite stockpiling near their final embankment location. The space required for staging areas is anticipated for staging of equipment and materials needed at each location, such as concrete formwork, rock anchors, geotextiles, and foundation drainage pipe materials. The staging and stockpile areas are approximately 290 acres. The staging and stockpile areas are permanent within the reservoir inundation area and temporary outside the reservoir inundation area.
- **Haul Roads** – Figure 2C-6 identifies anticipated major haul routes. Additional haul roads and ramps will be needed near each of the facilities for localized access. Minimum expected area of disturbance should be approximately 270 acres. Haul roads are permanent within the reservoir inundation area and temporary outside the reservoir inundation area.
- **Batch Plant Facilities Areas** – It is anticipated that batch plants would be located at staging and stockpile areas near each of the facilities. The greatest needs for concrete materials are at the I/O structure, Golden Gate Dam, Sites Dam, Saddle Dam 3, Saddle Dam 6, and Saddle Dam 8B Spillway, with a total site concrete requirement in excess of 390,000 CY. The number of batch plants will be somewhat influenced by the number of contracts, but there are practical minimums associated with the various facilities, construction schedule, and concrete demands. Saddle Dam 8B and the I/O structure would likely require independent plants. Saddle Dams 3 and 5 include the work associated with ERS-1 and ERS-2, which are primary concrete demand at those locations, but could potentially be serviced by the Saddle Dam 8B plant if all saddle dams are under the same contract. Golden Gate Dam and Sites Dam each require concrete for the grout

cap. However, the greatest need for concrete at these locations is at the Stone Corral Creek and Funks Creek Diversions. The Inlet/Outlet Facilities as a separate contract would require a separate batch plant. Each batch plant would require approximately 5 acres, including space needed for aggregate storage. Anticipated batch plants would be as follows, with minimum expected area of disturbance of approximately 15 acres.

Estimated borrow, stockpile, disposal, staging, processing, and haul road areas are provided in Table 2C-10.

Table 2C-10. Estimated Borrow, Stockpile, Disposal, Staging, Processing, and Haul Road Areas for Dams

	Golden Gate			Sites Dam			Saddle Dams 1 and 2			Saddle Dam 3			Saddle Dams 5, 6, 8A, 8B, Saddle Dikes 1 and 2, ERS 1 and 2			Total (acres)
	ID #	Required Volume, CY	Footprint Area (acres)	ID #	Required Volume, CY	Footprint Area (acres)	ID #	Required Volume, CY	Footprint Area (acres)	ID #	Required Volume, CY	Footprint Area (acres)	ID #	Required Volume, CY	Footprint Area (acres)	
Total Dam Footprint/Construction Area, acres	-	-	76	-	-	36	-	-	7	-	-	66	-	-	89	274
Dam Footprint/Construction Area Inside Reservoir, acres	-	-	34	-	-	19	-	-	3	-	-	21	-	-	24	101
Dam Footprint/Construction Area Outside Reservoir, acres	-	-	42	-	-	17	-	-	5	-	-	45	-	-	65	173
Borrow Areas (permanent)																
Impervious Area (Zone 1) Inside Reservoir	GG-Z1 Borrow	4,800,000	150	Sites-Z1 Borrow	1,420,000	44	SD 1, 2-Z1 Borrow	80,000	3	SD3-Z1 Borrow	1,800,000	56	SD5,6,8-Z1 Borrow	1,558,000	48	300
Rockfill (Zone 3) and Riprap Inside Reservoir	GG- Z3 Quarry 1	10,800,000	37	-	4,360,000	-	-	166,000	-	SD3,5,6,8A-Z3 Quarry 1	2,960,000	51	SD3,5,6,8A-Z3 Quarry 1	1,942,400	60	150
Rockfill (Zone 3) and Riprap Outside Reservoir	GG- Z3 Quarry 2		300	Sites- Z3 Quarry		135	SD1,2,3-Z3 Quarry 2		5	SD1,2,3-Z3 Quarry 2		-	-		41	-
Random (Zone 4) - Inside Reservoir	GG- Z3 Quarry 1	4,400,000	10	-	1,320,000	-	-	64,000	-	SD3,5,6,8A-Z3 Quarry 1	3,200,000	10	SD3,5,6,8A-Z3 Quarry 1	2,088,400	20	40
Random (Zone 4) - Outside Reservoir	GG- Z3 Quarry 2		125	Sites- Z3 Quarry		41	SD1,2,3-Z3 Quarry 2		2	SD1,2,3-Z3 Quarry 2		20	GG- Z3 Quarry 2		69	45
Other Areas (temporary/permanent)																
Stockpile Area Inside the Reservoir (temporary)	GG-Stockpile	-	41	Sites-Stockpile	-	19	SD1,2-Stockpile	-	13	SD3-Stockpile	-	32	SD5,6,8A-Stockpile	-	40	145
Disposal Areas Inside the Reservoir (permanent)	GG-Disposal Area	-	132	SITES-Disposal Area	-	32	-	-	-	-	-	-	-	-	-	164
Staging Areas Inside the Reservoir (temporary)	GG-Staging	-	56	Sites-Staging	-	33	SD1,2-Staging	-	5	SD3,5-Staging	-	23	SD 6,8A Staging	-	5	145
													SD3,5-Staging	-	23	
Rock Processing Area Inside Reservoir (permanent)	GG_Rock Processing 1	-	14	-	-	-	-	-	-	SD3,5,6,8A-Rock Processing	-	7	SD3,5,6,8A-Rock Processing	-	7	29
Rock Processing Area Outside Reservoir (temporary)	GG_Rock Processing 2	-	49	Sites_Rock Processing	-	30	SD1,2,3-Rock Processing	-	10	SD1,2,3-Rock Processing	-	10	-	-	-	99
Haul Routes Inside Reservoir (permanent)	-	-	12	-	-	22	-	-	35	-	-	51	-	-	45	166
Haul Routes Outside Reservoir (temporary)	-	-	25	-	-	15	-	-	31	-	-	12	-	-	22	104
Total Area (acres) 2,400																
Offsite Borrow (Tons)																
Offsite Borrow (Zone 2)	-	2,560,000	-	-	890,000	-	-	34,000	-	-	730,000	-	-	650,000	-	4,860,000
Cement (Tons)		13,200	-	-	4,000	-	-	1,000	-	-	6,500	-	-	9,500	-	34,200
Concrete Aggregate (CY)		38,500	-	-	12,000	-	-	2,600	-	-	21,000	-	-	55,500	-	130,000

Notes: Plan view showing the locations of the areas presented in Figures 2C-48 and 2C-49; Dam footprint areas are doubled to account for the dam construction disturbance area; Required volume of borrow is doubled from the estimated volume for all Zones, except for Zone 3. The required volume for Zone 3 is increased by four times.; Disturbance areas inside the reservoir are considered permanent; Zone1 borrow is approximately 25 feet deep and yields 20 feet of Zone 1, remainder to disposal; Haul routes assumed to be 50 feet wide and length of the haul routes are doubled; Areas within the reservoir having elevations lower than 290 feet are considered disposal areas.

3.3.5 Roads and Bridges

In addition to modifying existing roads for construction access, the project will require up to 53 miles of new paved and unpaved roads to provide construction and maintenance access to the proposed facilities, as well as public access to the proposed recreation areas. Figures 2C-53 and 2C-54 provide new and relocated road locations. Figures 2C-55 through 2C-58 provide typical cross sections for new or improved roadways. Sites Lodoga Road provides access to and from the town of Maxwell, which is adjacent to Interstate 5 (I-5). Sites Lodoga Road becomes Maxwell Sites Road east of the rural community of Sites that is within the inundation area.

The reservoir would eliminate east-west access to I-5 (east of the reservoir) from the rural communities of Stonyford and Lodoga (west of the reservoir) because it would inundate the current route of Sites Lodoga Road. The current Sites Lodoga Road is an east-west, two-lane rural collector road and provides an emergency and evacuation route to and from these rural communities. Because construction of the Sites Dam would eliminate access on the Sites Lodoga Road, this collector road would need to be relocated/realigned prior to project construction.

Under Alternatives 1 and 3, the realigned Sites Lodoga Road would include the construction of the bridge causeway across the reservoir and the realignment of the existing Huffmaster Road to provide access to properties otherwise inaccessible due to reservoir construction.

Roads

The construction disturbance area would include the footprints of the proposed bridge(s) and roadway fill prisms within the planned reservoir, the proposed access, construction, and maintenance roads outside the limits of the reservoir, the materials and equipment staging areas, borrow area, and the perimeter space needed to construct these facilities.

The area planned to be inundated by the reservoir would be used as a materials and construction equipment staging area for the Sites Lodoga Road/Maxwell Sites Road and bridge(s). Temporary construction easements (TCE) would likely be needed to construct access roads that are noted above. Some TCEs may be needed for constructing the Sites Lodoga Road/Maxwell Sites Road and would be explored with further project development.

For the portion of proposed roadway and bridges across the reservoir, the total construction permanent disturbance area would be approximately 442 acres. This area would incorporate the roadway fill prism, bridges, equipment and materials staging area, borrow areas, stockpile areas, site access and perimeter space to construct these facilities, refer to Table 2C-11 for additional information. This acreage for the facility across the reservoir would be completely within the construction disturbance area for the Sites Reservoir inundation area itself. More information regarding this facility can be found in Section 2.

For the access, construction, and maintenance roads beyond the Sites Reservoir inundation area, the total construction permanent disturbance area would be approximately 1,107 acres. This area would incorporate a realigned roadway (assumed balanced cut and fill—no borrow or stockpiling), widening of roadways, equipment and materials staging area, site access, and perimeter space to construct these facilities; refer to Table 2C-11 for additional information. The disturbance area is caused by construction activities involving roadway excavation, rock cutting,

clearing and grubbing, grading, construction equipment circulation, drainage system construction, ditch excavation, fence placement, and roadside sign placement. Acreage for these facilities is beyond the Sites Reservoir inundation disturbance area and is thus additive to the construction disturbance area for the inundation area. More information regarding these facilities can be found in Section 2.

Table 2C-11. Estimated Construction Disturbance Areas for Road and Bridges

Inside the Reservoir Inundation Area			
Type/Description	Location	Permanent Disturbance Area (Acres)	
Borrow Area	LR Bridge - Borrow 1	68.7	
Borrow Area	LR Bridge - Borrow 2	97.4	
Borrow Area	LR Bridge - Borrow 3	126.7	
Fill Prism Area	West Bridge - Abut 1	15.7	
Fill Prism Area/Roadway	West Bridge - Abut 7 & East Bridge - Abut 1	98.2	
Fill Prism Area	East Bridge - Abut 8	20.5	
Construction/Staging/Bridge	West Bridge	7.3	
Construction/Staging/Bridge	East Bridge	7.4	
	Total	442	
Outside the Reservoir Inundation Area			
Type/Description	Location	Permanent Disturbance Area (Acres)	Temporary Disturbance Area (Acres)
Site Access/Roadway	Saddle Dike 2	2.6	2.4
Site Access/Roadway	Saddle Dam 8A & 8B	3.2	3.4
Site Access/Roadway	Saddle Dike 1	2.2	2.3
Site Access/Roadway	Saddle Dam 6	8.6	7.9
Site Access/Roadway	Saddle Dam 5 & ERF	9.9	6.1
Site Access/Roadway	Saddle Dam 3 & ERF	8.7	6.4
Site Access/Roadway	Saddle Dam 3	3.0	1.8
Site Access/Roadway	Saddle Dam 2	27.9	17.0
Site Access/Roadway	Saddle Dam 1	12.8	12.7
Site Access/Roadway	Access Road A1	34.0	32.6
Site Access/Roadway	Access Road B1 & B2	15.1	9.0
Site Access/Roadway	Sites Lodoga Road Realigned (east portion)	115.6	-
Construction/Roadway	Comm Rd - South	19.9	20.5
Construction/Roadway	Huffmaster Rd Realigned	368.0	-
Construction/Roadway	Sites Lodoga Road Realigned (west portion)	114.1	-

Outside the Reservoir Inundation Area			
Type/Description	Location	Permanent Disturbance Area (Acres)	Temporary Disturbance Area (Acres)
Construction/Roadway	Sites Lodoga Road Temporary Detour	18	18
Construction/Roadway	Day Use Boat Ramp	6.4	7.5
Site Access/Roadway	Peninsula Hills Recreational Area	29.2	27.0
Site Access/Roadway	North Access Road	173.7	-
Construction/Roadway	County Road 69	25.9	-
Construction/Roadway	County Road D	6.0	-
Construction/Roadway	County Road 68	33.3	-
Construction/Roadway	County Road F/McDermott Rd	50.8	-
Site Access/Roadway	McDermott Rd	-	35.2
Construction/Roadway	Maxwell Sites Rd/McDermott Rd	1.6	-
Total		1107	227

An asphalt batch plant for road construction may be set up onsite and outside of the Sites Reservoir footprint. One possible location could be adjacent to the footprint of the proposed Field Office Maintenance Yard. This location would be centrally located to the Project’s paving needs, is relatively flat, and has shallow soils and impervious subsoil that should facilitate spill containment and site cleanup. Alternatively, the construction Contractor may obtain asphalt from regional commercial sources. Anticipated ground-disturbing activities during construction include the following:

- Survey.
- Set up staging areas within the Sites Reservoir footprint.
- Construct access roads involving grading.
- Transport materials and equipment to the Project Site, and set up offices and batch plants.
- Clear and grub.
- Excavate and stockpile.
- Construct roadway fill prisms for the reservoir crossing.
- Construct bridge pier and abutment foundations, piers and abutments, and superstructures.
- Relocate utilities, if necessary.
- Construct roadway embankments and cuts.
- Widen roadways and intersections.

- Construct temporary and permanent fencing.
- Construct temporary and permanent roadway drainage conveyance systems.
- Extend, improve, or replace bridges and box culverts.
- Extend or replace pipe culverts.
- Clean up the Project area, remove equipment, and restore the area.

Quantities for the primary roadway items and County Road bridge improvements are presented in Tables 2C-13 and 2C-14. Key roadway construction activities are summarized below.

Sites Lodoga Road Temporary Detour

A detour road would be constructed to expedite construction. This detour road would convey local traffic for a period of approximately one year and would be aligned around the Sites Dam site partially on the Sites Lodoga realignment from Maxwell Sites Road to near the easterly bridge at the top of the mountain ridge where it would depart on its own alignment and turn south away from Sites Lodoga Road realignment and traverse partially steep terrain and rejoin Sites Lodoga Road near the intersection of Peterson Road. This temporary road would permit traffic to be maintained through the reservoir site at-grade while the reservoir crossing of fill prisms and bridges are construction during the same time that Sites Dam is constructed on top of the existing Sites Lodoga Road.

Realigning Sites Lodoga Road

This roadway would be realigned through undeveloped mountainous terrain on the west side of Sites Reservoir, and the hilly terrain on the east side of the reservoir, which will involve substantive cuts and fills. The cuts and fills are proposed to be sloped at approximately 1.5:1 (H:V) to 2:1 (H:V) and are anticipated to involve some rock cutting and blasting. The roadway shoulders will be flanked with earthen ditches to convey stormwater off the roadbed to pipe culverts. Crossing pipe culverts will be placed in fill sections to convey stormwater beneath the roadway at various locations. The roadbed will be constructed as a two-lane road with 12-foot lanes and 5-foot shoulders and is assumed to consist of 4 inches of asphalt pavement on 6 inches of aggregate base and 6 inches of aggregate subbase. Excavation may involve rock cutting and blasting in some areas. As the surrounding land is used for cattle grazing, this roadway will be aligned with fencing to restrict cattle access to the roadway.

The segment of this road that is proposed to cross the Sites Reservoir would involve earthfill prisms (embankments) to support the roadway approach to two bridges. Four prisms are proposed that range in length from approximately 800 to 3,200 feet. The height of these fill prisms will vary up to approximately 125 feet. These fill prisms would support the bridge abutments. Material for these fill prisms would be sourced onsite from various borrow sites and from the roadway excavation and rock cutting/blasting activities.

CIP P/S is the most common bridge structure type in California. Many local bridge contractors are familiar with this type of construction and are equipped with the needed falsework. Low initial construction and maintenance costs, high torsional rigidity, and good resistance to seismic loads are advantages of this structure type.

The CIP P/S structure type is a feasible option for span lengths up to several hundred feet. This structure type also provides more deflection control than other available types. Due to the high-water surface elevation of the reservoir, a very tall bridge is required to elevate the bridge deck above the water with column heights ranging up to 200 feet, which can make typical falsework for this type of construction infeasible. For falsework to be feasible, the technique of using temporary fill placed beneath the bridge to reduce the height of the falsework towers will be considered. The fill would subsequently be removed after construction of the bridge superstructure and the original groundline would be restored.

Because the Project would involve mining a fair amount of material for the dams and some of the dams are very tall earthen dam, a fill prism would be extended from a narrow peninsula, and only the deeper portions of the reservoir would be spanned by bridges. Causeways would be used for the remaining parts.

The existing Sites Lodoga Road roadbed material would be pulverized, excavated and used as aggregate base for the realigned Sites Lodoga Road to save on materials costs and need for disposal.

Drilled piers would be used for bridge foundations. The portion of the existing road that would be realigned would also be obliterated and the existing roadbed involving asphalt and aggregate base could be repurposed as aggregate base or asphalt for new roadways.

Realigning Huffmaster Road

Huffmaster Road Realignment is the easterly segment of Sites Lodoga Road Realignment from existing Huffmaster Road to Maxwell Sites Road. This road would be a gravel road to serve the residences at the end of Huffmaster Road. Similarly to realigning Sites Lodoga Road, it will be realigned through a combination of underdeveloped mountainous and rolling hills terrain.

The roadbed will be constructed as a two-lane gravel road with 12-foot lanes and shoulders, and is assumed to consist of 12 inches of compacted aggregate base on top of 6 inches of compacted aggregate subbase. Some areas of excavation may also involve rock cutting and blasting, with proposed slope cuts and fills to be approximately 1.5: 1 (H:V) to 2:1 (H:V). Earthen roadside ditches would be constructed adjacent to the shoulders, connecting to crossing pipe culverts, which will convey stormwater runoff. This road will also be aligned with fencing to restrict livestock from the roadway.

Construction Roads

These roadways involve existing rural public roads in Glenn and Colusa counties. As these roads convey low average daily traffic (ADT) volumes, the construction of Sites Reservoir facilities will increase the ADT to the extent that improvements to the existing roadway will be necessary to adequately convey a larger volume of large and small construction equipment along with the existing ADT.

Existing local roads are proposed to be widened to add paved shoulders resulting in two 12-foot lanes with 2-foot shoulders. The existing roadside ditches will be maintained. The existing roadbed structural section is anticipated to be inadequate for the increased ADT and is proposed

to either receive an overlay of asphalt paving to increase the integrity of the roadbed to accommodate the increase in ADT and resulting cyclical loading, or the roadbed could be reconstructed.

This reconstruction could occur through two means: 1) Removing the existing structural section, performing roadway excavation, grading, and compaction, then assume placing approximately 4 inches of asphalt paving on 6 inches of aggregate base on top of aggregate subbase on compacted subgrade; or 2) Excavating for shoulders and compacting the subgrade, performing full-depth reclamation of the existing roadbed by in-place pulverization (assumed 14 inches deep), grading, compaction, and assume placing approximately 6 inches of asphalt paving. Existing roadside fencing, signs and utilities would be protected in place. Existing box and pipe culverts would be extended or replaced as needed. Existing box culverts could require temporary supports to accommodate increased vehicular loading from transporting construction equipment.

Some construction access roads will need to be constructed for this Project. These roads would be preserved in perpetuity as maintenance roads to various Sites Reservoir facilities. These roads are proposed to be 24 feet wide and constructed of 12 inches of aggregate base on 6 inches of aggregate subbase on compacted subgrade. Some excavation would be required to establish minor cuts and fills to support the roadbed. Pipe drainage culverts and box culverts would be placed as needed beneath the roadbed in embankment areas.

Maintenance Roads

These roadways provide access to various Sites Reservoir facilities that will need to be maintained in perpetuity. These roads are proposed to be typically 15 feet wide and constructed of 18 inches of aggregate base on compacted subgrade. One maintenance road that is anticipated to be traveled more frequently than normal is the maintenance road to Funks Switchyard. This road is proposed to be 30 feet wide to accommodate two 15-foot wide paved lanes with unmarked shoulders and assumed constructed of approximately 4 inches of asphalt on 6 inches of aggregate base on 6 inches of aggregate subbase on compacted subgrade. Some excavation would be required to establish minor cuts and fills to support the roadbed. Pipe drainage culverts would be placed as needed beneath the roadbed in embankment areas.

Perpetual operations and maintenance of roads would involve the following activities:

- Blade roadside drainage ditches and earthen shoulders
- Brush removal and mowing
- Clean/repair drainage systems
- Clean/repair structures – grates, cattleguards
- Hazardous tree removal
- Dust abatement
- Debris removal
- Repaint pavement markings
- Asphalt repair – patch, pothole, crack seal

- Resurface asphalt – overlay or chip seal
- Sign maintenance/replacement
- Spot surfacing

As mentioned above, if necessary for maintenance roads, an asphalt batch plant would be set up onsite and outside of the Sites Reservoir footprint. One possible location could be adjacent to the footprint of the proposed Field Office Maintenance Yard. This location would be centrally located to the Project's paving needs, is relatively flat, and has shallow soils and impervious subsoil that should facilitate spill containment and site cleanup. Alternatively, the construction Contractor may obtain asphalt from regional commercial sources. The roadway is designed to current AASHTO and County Adopted Standard.

Roadway Design Considerations

The general design standards that would govern roadway design would be based on the American Association of State Highway and Transportation Officials (AASHTO) A Policy on Geometric Design of Highways and Streets (2018), California Department of Transportation Highway Design Manual (2020), and Colusa and Glenn County standards.

The design of the roadways would require determining future Average Daily Traffic (ADT) based on a full functioning reservoir and associated facilities. The future ADT would establish the Traffic Index (TI) for appropriate geometric and structural section design and would provide for a 40-year minimum design service life of the roadways. Where non-standard features were necessary and agreed to, a Design Exception from the County would be issued to document the need, justification, and concurrence on any non-standard features.

Typical road sections for County roads are illustrated in Figure 2C-55. Maintenance and access road typical sections are shown in Figures 2C-56 and 2C-57. Current design considerations include:

Cross Sections

- 12-foot-wide lanes and turning lanes
- 5-foot-wide shoulders (paved and unpaved) to accommodate bicycles
- Asphalt-concrete pavement
- 2 percent cross slopes
- Passing lanes on uphill slopes (as needed)
- Super elevations/rates of change of up to 8 percent (as needed)
- Fill and cut slopes
 - Fill slopes – generally 2:1 (H:V); 1.5:1 (H:V) maximum with soil reinforcement where needed
 - Cut slopes – would be determined based on the results of geotechnical investigations; 1.5:1 (H:V) maximum; benches for debris as needed
- 20-foot-long clear recovery zone for errant vehicles to regain control

- Horizontal clearance to roadside objects would be equal to the shoulder width but not less than 4 feet
- Roadway drainage facilities that do not contain high density polyurethane (HDPE)
- Consideration would be given to existing utilities for potential relocation, protecting in place, and/or accounting for future facilities

Ditches

- Side slopes – 4:1 (H:V) on foreslopes; 3:1 (H:V) on backslopes; steeper slopes may be required in steep terrain and may involve barrier installation.
- Slope treatments would be determined based on soil materials investigations.

Alignments

- Speed advisories and limits would be designed based on terrain (i.e., from 30 miles per hour [mph] advisory to 65 mph limit).
- To facilitate alignment consistency, the following would be considered on a case-by-case basis upon further evaluation of terrain:
 - Advisory curves for curves less than design speed—20 mph and 25 mph—occur on the west near Lodoga
 - The design speeds for consecutive curves should not vary by more than 10 mph
 - Compound curves where the shorter radius would not be less than two-thirds of the larger radius
 - Reversing curves
 - Broken back curves with short tangent between the curves
 - Superimposed horizontal and vertical curves
- Grade limitations (i.e., 8 percent maximum)

Other considerations

- Reservoir overlook
- Causeway (fill prism) in reservoir
 - Static (including reservoir drawdown) and seismic stability
 - Settlement and its duration
- Upgrading existing roadway facilities

Bridges

This section discusses the bridge, which includes two bridge segments. The design and construction of the bridge would also comply with all applicable federal, State, and local requirements. The bridge would be designed in accordance with the latest version of the AASHTO Load and Resistance Factor Design (LRFD) Bridge Design Specifications with California Department of Transportation California Amendments. The bridge would also be designed using the California Department of Transportation' Seismic Design Criteria (SDC) 2.0

acceleration response spectral curve to determine the seismic loading by soil profile and earthquake magnitude.

Concrete bridge construction in general would include excavation for pier foundations and abutments; construction of the cast-in-place drilled holed piles (CIDH piles), installation of concrete formwork for pier footings, columns, and abutments; placement of reinforcing steel and concrete in abutments, columns, and pier footings; installation of bridge deck expansion joints and hinges; construction of the bridge superstructure including the bridge deck, installation of bridge barriers, bridge lighting, signs, and reflectors; and painting approach and bridge deck striping and approach slabs. Figure 2C-58 provides typical sections for the Sites Lodaga Road realignment and bridge.

Anticipated ground-disturbing and related activities during bridge construction include the following:

- Survey and set markers
- Implement BMPs
- Clear and grade the construction workspace
- Prepare the construction materials laydown and equipment staging areas
- Transport materials and equipment to the project site
- Build concrete and/or portable concrete batch plant
- Create road cuts and fills; haul excess cut materials
- Construct bridge foundation, including drilled pier installation for foundations
- Construct bridge columns
- Construct bridge spans
- Install barriers
- Install roadway striping and reflectors
- Perform erosion and stormwater management
- Perform site restoration and cleanup

It is assumed that the bridge type would be a CIP P/S discussed previously. The substructure elements include pile installation, shoring, construction of the pile caps, footings, abutments, wingwall/retaining walls, and the pier columns. The construction of the CIP P/S girder bridge would require placement of the concrete in the tall formwork for the superstructure. The entire system would have to be supported from the ground level using falsework during its construction.

The use of falsework for the heights being planned for this structure would be extensive and costly. The use of temporary fill to support the falsework during construction of the bridge would provide a more cost-effective way of building this bridge. Other construction methods, such as incremental launching or movable scaffolding system, may reduce the cost. Once the concrete

attains the desired strength, post-tensioning would be applied; and subsequently falsework (and temporary fill used to support the falsework) would be removed.

Table 2C-12 provides specifications for the Sites Lodoga Road Realignment Bridge. Table 2C-13 shows preliminary materials quantities required for public road construction on the Project and Table 2C-14 shows preliminary quantities for county road bridge improvements.

Table 2C-12. Sites Lodoga Road Realignment Bridge

West-side Bridge Segment Length (feet)	1,400
East-side Bridge Segment Length (feet)	1,633
Bridge Width (feet)	35.5
Footprint Area (acres)	2.5
Structure Excavation (Bridge) (CY)	24,360
48" Cast-In-Drilled-Hole Concrete Piling (LF)	23,760
Structural Concrete, Bridge Footing (CY)	19,040
Structural Concrete, Bridge (CY)	20,650
Concrete Barrier (Type 842) (LF)	6,150
24" Cast-In-Drilled-Hole Concrete Piling (LF)	2,880
Structure Backfill (Bridge) (CY)	5,030
Structural Concrete, Approach Slab (CY)	60
Structural Concrete, Bridge (Polymer Fiber) (CY)	10,920
Prestressing Cast-In-Place Concrete (LB)	493,520
Bar Reinforcing Steel (LB)	16,897,800

Table 2C-13. Preliminary Quantities for Roads

Type	Road Name	Approx. Road Length	Roadway Width	Roadway Excavation (Excess Suitable Material to be Stockpiled)	Roadway Excavation (Cut to Haul/Waste)	Roadway Excavation (Rock Cut)	Roadway Embankment (From Excavated Suitable Material)	Class 4 Aggregate Subbase	Class 2 Aggregate Base	Hot Mix Asphalt (Type A)	Tack Coat
		(lf)	(lf)	(cy)	(cy)	(cy)	(cy)	(cy)	(cy)	(ton)	(ton)
Public Roadway	Sites Lodoga Road Realignment and Bridge	28,980	34	2,601,000	248,800	113,100	11,382,000	25,800	25,800	34,420	26
Public Roadway	Huffmaster Road Realignment	47,200	32	13,994,000	1,346,900	524,800	3,145,000	42,000	42,000	56,640	42
Maintenance/ Construction	North Road (Access Road - Road 69)	27,200	24	262,200	25,400	7,900	92,100	18,100	36,300	0	0
Local/ Construction	County Road 69	11,230	28	26,200	2,600	0	600	8,700	8,700	11,790	9
Local/ Construction	County Road D	2,700	28	6,100	600	0	100	2,100	2,100	2,810	2
Local/ Construction	County Road 68	14,250	28	33,200	3,300	0	700	11,100	11,100	14,930	11
Local/ Construction	County Road F/McDermott Road	21,240	28	49,600	4,960	0	1,090	16,600	16,600	22,300	17
Maintenance	Saddle Dam Road - North	11,200	15	314,600	30,300	11,800	110,500	0	14,000	0	0
Maintenance	Saddle Dam Road - South	18,250	15	558,700	52,500	33,500	196,300	0	22,800	0	0
Maintenance	Access Road A1	7,640	15	144,900	14,400	1,100	50,900	0	9,500	0	0
Maintenance	Access Road B1	2,080	15	65,600	6,100	4,900	23,100	0	2,600	0	0
Maintenance	Access Road B2	3,790	15	105,100	9,700	7,900	36,900	0	4,700	0	0
Maintenance	Access Road C1	5,190	15	333,500	33,300	0	117,200	4,300	4,300	5,800	5
Maintenance	Access Road C2	3,540	15	227,300	22,700	0	79,900	0	4,400	0	0
Maintenance	Comm Road South	4,550	15	89,500	9,000	0	31,500	0	5,700	0	0
Recreation	Day Use Boat Ramp (From Sites Lodoga Rd - Westside)	1,950	30	143,500	14,300	0	50,400	1,860	1,860	2,510	2
Recreation	Peninsula Hills Recreation Area	19,700	30	552,900	54,500	8,300	194,300	16,400	16,400	22,170	17
Recreation	Stone Corral Recreation Area/Sites Dam	13,320	30	323,000	32,100	2,400	113,500	11,100	11,100	14,800	11
Public Roadway	Existing Sites Lodoga Road	19,980	22	0	0	0	0	0	0	0	0
Public Roadway	Existing Maxwell Sites Road	9,400	24	0	0	0	0	0	0	0	0

Table 2C-13. Preliminary Quantities for Roads (Continued)

Type	Road Name	Clearing and Grubbing	Temporary Silt Fence	24" pipe culvert (galvanized corrugated metal)	Box Culvert Single Cell	Permanent Blanket Erosion Control (hydroseed)	Rock pad Energy Dissipator (18" d x 2' w x 6' l)	Temporary Inlet/Outlet Protection	Fiber Roll	Remove AC Surfacing
		(acre)	(lf)	(lf)	(ea)	(sq ft)	(ea)	(ea)	(ft)	(cy)
Public Roadway	Sites Lodoga Road Realignment and Bridge	109	32,400	4,290	0	847,600	75	150	0	0
Public/ Construction	Sites Lodoga Road Detour	6,500	30	749,392	103,465	40,311	181,793	5,778	5,778	7,800
Public Roadway	Huffmaster Road Realignment	117	8,400	8,330	0	781,700	147	294	0	0
Maintenance/ Construction	North Road (Access Road - Road 69)	78	14,400	1,500	3	124,500	33	132	0	0
Local/ Construction	County Road 69	8	7,200	160	3	0	12	24	66,600	0
Local/ Construction	County Road D	1	3,600	125	5	0	9	18	15,400	0
Local/ Construction	County Road 68	7	2,400	0	3	0	6	12	85,330	0
Local/ Construction	County Road F/McDermott Road	11	3,600	9	0	0	9	18	99,500	0
Maintenance	Saddle Dam Road - North	14	2,400	620	0	51,200	12	12	0	0
Maintenance	Saddle Dam Road - South	22	4,200	1,010	0	83,500	21	21	0	0
Maintenance	Access Road A1	9	1,800	420	0	35,000	9	9	0	0
Maintenance	Access Road B1	3	600	120	0	9,500	3	3	0	0
Maintenance	Access Road B2	5	1,200	185	0	15,300	6	6	0	0
Maintenance	Access Road C1	9	1,200	290	0	23,800	6	6	0	0
Maintenance	Access Road C2	5	1,200	0	0	16,200	6	6	0	0
Maintenance	Comm Road North	9	1,800	410	0	34,300	6	6	0	0
Maintenance	Comm Road South	6	1,200	250	0	20,700	6	6	0	0
Recreation	Day Use Boat Ramp (From Sites Lodoga Rd - Westside)	4	600	120	0	10,200	3	3	0	0
Recreation	Peninsula Hills Recreation Area	27	4,800	1,090	0	90,200	24	24	0	0
Recreation	Stone Corral Recreation Area/Sites Dam	17	3,000	660	0	56,000	15	15	0	0
Public Roadway	Existing Sites Lodoga Road	0	0	0	0	0	0	0	0	12,300
Public Roadway	Existing Maxwell Sites Road	0	0	0	0	0	0	0	0	6,300

Notes:
Preliminary quantity values have a 1.5 safety factor applied

Table 2C-14. Preliminary Quantities for County Road Bridge Improvements

Road	Bridge No.	PC/PS Slab	Concrete Barrier	Tubular Railing
		Replacement	(TYPE 842)	
		(sqft)	(lf)	(lf)
County Road 69	Br. No. 11C0257 - Bridge Replacement	2,520	220	220
County Road 69	Br. No. 11C0001 - Bridge Replacement	2,020	192	192
County Road F	Br. No. 11C0174 - Bridge Replacement	1,750	146	146
McDermott Rd	Br. No. 15C0122 – Bridge Replacement	1,151	100	100
McDermott Rd	Br. No. 15C0196 – Bridge Replacement	1,932	140	140
McDermott Rd	Br. No. 15C0003 – Bridge Replacement	1,467	120	120
McDermott Rd	Br. No. 15C0204 – Bridge Replacement	966	80	80
Maxwell Sites Rd	Br. No. 15C0065 – Bridge Replacement	2,180	160	160
Maxwell Sites Rd	Br. No. 15C0017 – Bridge Replacement	1,610	140	140

Notes:

Preliminary quantity values have a 1.5 safety factor applied.

3.3.6 Conveyance to Sacramento River Dunnigan Pipeline to CBD

The Dunnigan Pipeline (see Figures C2-59 and C2-60) would consist of one 9-foot diameter pipe that will go from the inlet structure to the Colusa Basin Drain, a distance of roughly 4 miles. Construction of the Dunnigan Pipeline would include the following:

- Clear and grade the pipeline alignment.
- Excavate pipeline trench and provide shoring. It is anticipated that several hundred feet of open trench would occur at one time.
- Install and weld up the pipeline and backfill with a combination of CLSM and native material.
- Tunneling under Interstate-5, Highway 99, and the railroad, as follows:
 - Construct jacking pit and receiving pit. Provide shoring to support these pits that are anticipated to be about 25 feet in depth +/- . Remove and stockpile excavated material.
 - Assemble large boring machine sized to provide a roughly 128-inch to 144-inch casing pipe bore. Final diameter will be determined during design.
 - Obtain steel casing pipe
 - Lower tunneling machine into jacking pit after setting up guide rails to provide correct tunnel alignment.
 - Begin tunneling from jacking pit to receiving pit. Remove and dispose of excavated material offsite.

- Weld the steel casing segments together as tunneling progresses.
 - Continue tunneling, welding and removing excess material until tunneling machine reaches receiving pit.
 - Removing tunneling machine from receiving pit.
 - Install main carrier pipe in casing pipe and weld joints as pipe segments are lowered into jacking pit. Carrier pipe will have piping supports attached to help center in casing pipe and to keep from resting on casing pipe.
 - Depending on requirements of County and Caltrans, likely will fill annulus space between casing and carrier pipes with sand or lightweight grout. Ends of casing pipe will be plugged using boots or other methods to prevent grout or sand from running into pits.
 - Add cathodic protection requirements to casing and carrier pipes.
 - Connect extensions of carrier pipes in each pit to return to open cut methods for normal pipe installation.
 - Backfill the jacking and receiving pits with material removed during step 1. In some instances, slurry will be used around the pipes, followed by backfill with native excavated material.
- Install flow meters, valving, air valves, blowoffs, and access manways.
 - Install a cathodic protection system consisting of rectifiers attached to pipe.
 - Revegetate and restore the pipeline route, and constructing a gravel maintenance road along the pipeline route
 - Construct the CBD Outlet Structure
 - Clear and grub area along CBD for the outlet structure.
 - Transport materials to the Project Site. Materials would consist of concrete, rebar, yard piping, energy dissipation valves, and electrical equipment.
 - Place construction materials at staging areas.
 - Build the outlet structure, which would consist of excavating the ground to accommodate placement of structure structural concrete and rebar.
 - Connect the outlet structure to the Dunnigan Pipeline.
 - Test the facility.

3.3.7 Recreation Areas

The total construction disturbance area of the recreation areas would be within the acreage of the recreation areas themselves, approximately 618 acres (see Figure C2-61). Construction disturbance may be much less if recreational facilities are designed and constructed to minimize vegetative disturbance, including tree removal. Anticipated ground-disturbing and related activities during construction include the following:

- Surveying
- Clearing and grubbing
- Excavating
- Backfilling
- Constructing road and parking lot
- Installing potable water and power connections where they are planned to be provided
- Installing amenities
- Constructing boat ramp
- Performing site revegetation

The construction equipment that is anticipated to be used for the recreation areas is listed in Table 2C-15, which is from *Reclamation's North-of-the Delta Offstream Storage Investigation Feasibility Report*.

Table 2C-1. Recreational Facility Construction Equipment Requirements

Equipment	Count	Grading & Paving Days	Equip Days	Count	Concrete Work Days	Equip Days	Count	Miscellaneous Days	Equip Days	Total Equip Days
Bobcat	2	158								
Bulldozer	1	116	116							116
Concrete Trucks			-	2	33	66				66
Concrete Material Trucks				4	44					
Dump Truck	3	158	474							474
Fork Lift - Yard			-			-	1	121	121	121
Fuel Truck	1	158	158	1	33	33	1	121	121	312
Generator			-	1	33	33				33
Grader	1	28	28							28
Highway Trucks	4	10	40			-	2	121	242	282
Loader	1	158	158							158
Paving Machine	1	22	22							22
Roller	1	50	50							50
Water Trucks	1	144	144							144
Staff Max	24			18			14			

3.4 Alternative 2 Specific Elements

Alternative 2 facilities are shown on Figures 2C-4 and 2C-5. The information provided below is intended to highlight the differences in construction means, methods, and assumptions for Alternative 2. The unique features of Alternative 2 include the following:

- TRR East would be replaced with TRR West;
- Reservoir capacity would be 1.3 MAF;
- A local access road around the southern end of the reservoir would provide access to the west of the Project; and
- Dunnigan Pipeline would extend to and discharge at the Sacramento River with a partial discharge at the CBD.

Table 2C-16 summarizes the differences in the reservoir characteristics between Alternatives 1 and 2.

Table 2C-16. Summary of Reservoir Characteristics

	Alternatives 1 and 3	Alternative 2
Alternative Reservoir Storage Capacity	1.5 MAF	1.3 MAF
Reservoir Elevation at full pool (feet)	498.0	482.0
Dam Crest Elevation (feet)	517.0	500.0
Reservoir Area at full pool (acres)	13,200	12,600

Table 2C-17 summarizes the key features for Alternative 2 and whether they are similar or different from Alternatives 1 and 3.

Table 2C-17. Alternative 2 Key Similarities and Differences

Section number, Title	Facility	Same As Alternative 1 and 3
Tehama-Colusa Canal Diversion	Tehama Colusa Canal Diversion and Red Bluff Pumping Plant	Yes
GCID Main Canal Diversion and System Upgrades	GCID Main Canal Diversion	Yes
Regulating Reservoirs and Conveyance Complex	Funks Reservoir and Funks PGP	Yes
	TRR West	No
	TRR PGP	Yes
	Dunnigan Pipeline from TC Canal to CBD	Yes
	Dunnigan Pipeline from TC Canal to Sacramento River	No
Inlet/Outlet Works	Inlet/Outlet Works and I/O Tunnels	Yes
Creek Diversions		Yes
Dam Construction	Saddle Dam 1	No (changed to Saddle Dike 1)
	Saddle Dam 2	No (changed to Saddle Dike 2)
	Saddle Dam 6	No (changed to Saddle Dike 3)
	Emergency Release Structures (ERS-1 and ERS-2)	No (ERS-1 and ERS-2 have been deleted)
Roads and Bridge	Access varies due to footprint	No
	Sites Lodoga Road (South Road)	No Bridge

*As the Alternative 2 dams have a reduced height by 17 feet from Alternatives 1 and 3, the footprint areas and embankment quantities have also been reduced (see Section 3.4.8, below)

3.4.1 Construction Timing and Sequencing

The Alternative 2 construction duration would be the similar to Alternatives 1 and 3 (i.e., approximately 6 years). As for Alternatives 1 and 3, the construction start date is based on several assumptions, including real estate access and acquisition. Delays in the start date could affect the sequencing of activities. Table 2C-18 provides the key assumptions regarding the start of construction. This table (first row) shows that there is no bridge for Alternative 2. Otherwise, it is the same as for Alternatives 1 and 3.

Table 2C-18. Key Scheduling Assumptions Leading to Construction

Activity	Start	Finish	Duration
Real Estate Access and Permitting for Geotechnical Investigation for Road, Dams, and I/O Facilities	7/5/2021	7/1/2022	260 days
CWC Award of Funds	6/1/2023	6/1/2023	0
Board Approval/NTP for Phase 3 to Begin	6/1/2022	7/1/2022	15 days
Obtain Environmental Compliance Permits	11/2/2020	8/11/2023	XXX days
Initial Geotechnical Investigation and Surveying	7/4/2022	12/30/2022	130 days
Preliminary Engineering	12/5/2022	9/1/2023	195 days
Final Geotechnical Investigation	1/2/2023	6/30/2023	130 days
Final Engineering	9/4/2023	6/21/2024	210 days
Contract Award	6/24/2024	9/20/2024	65 days

3.4.2 Borrow Areas and Quarries

Figure 2C-6 shows the Alternative 2 Reservoir with borrow areas, quarries, disposal areas, staging areas, and stockpile areas. Borrow, quarries, rock processing areas, stockpile, disposal, staging, and haul routes disturbance areas are would be similar to Alternative 1. However, the depth of excavations in the borrow areas and quarries would be less than for Alternative 1, and would vary based on the embankment quantities. Offsite quarry locations are the same for Alternative 2 as for Alternatives 1 and 3.

3.4.3 Batch Plants

The batch plants for Alternative 2 would be similar to Alternatives 1 and 3; however, it is noted that there will be no concrete batch plant for the Sites-Lodoga Bridge.

3.4.4 Construction Traffic and Personnel

The anticipated typical construction routes to be used for access in the construction to the major Project features for Alternative 2 would be similar to Alternatives 1 and 3. However, access for the Sites Lodoga Road (South Road) is described in Table 2C-19.

Table 2C-19. Expected Construction Access Routes to Sites Lodoga Road (South Road)

Project Feature	Access Route
Sites Lodoga Road (South Road)	From I-5, along Delevan Road, south along McDermott Road to Maxwell Sites Road, and then west to Sites Lodoga Road (South Road)

Project-related construction personnel and highway truck trips are identified in Table 2C-20. Of the Project construction related trips, construction worker trips would compose the majority. Construction workers would likely commute daily to construction sites from regional population centers, including Sacramento, Woodland, Maxwell, Willows, Orland, Williams, and Colusa,

and from other northern California counties when specialty trades or skillsets are not available regionally. The number of construction workers required during peak construction of Project facilities varies by alternative, resulting in different trip distributions for each alternative.

Table 2C-20. Project-Related Construction Personnel and Highway Truck Trips

Facility	Total Highway Truck Trips	Construction Days	Highway Truck Trips per Day ^a	Total Personnel Trips ^b	Personnel Trips per Day ^b
Sites Reservoir Inundation Area and Dams	280,800	780	360	496,860	637
South Road, Gravel Roads, and Paved Roads	24,986	961	26	297,910	310
Inlet/Outlet Structure, Tunnel	59,885	1,015	59	50,750	50
Dunnigan Pipeline Alt 2	18,460	505	52	51,830	146
Funks/TRR Pipelines	187,210	505	194	413,020	428
Funks Reservoir	7,322	680	14	41,840	80
Funks PGP	25,488	880	24	91,332	86
TRR West Reservoir	3,120	780	4	37,440	48
TRR West PGP	24,240	880	24	88,880	88
Transmission Powerlines	875	765	1	64,750	74
Substations	1,510	645	2	12,080	16
Red Bluff Pumping Plant	280	560	0.5	1,120	2
GCID Improvements	7,480	680	11	29,920	44

3.4.5 TRR West

The TRR-West facilities would be located west of the GCID Main Canal and east of Funks Reservoir. The approximately 150-acre site would be accessed by an all-weather gravel road from the Funks Dam/Tehama Colusa Canal area. Asphalt concrete paved roads would provide onsite vehicle access between the PGP and electrical substation, with facility spacing to accommodate a mobile crane. Paved parking would be provided near the PGP. Access roads will also be constructed surrounding and in between the Main and Extension reservoirs of TRR-West. The proposed PGP and electrical substation would encompass approximately 7 acres and would

be enclosed with security fencing with access gates. See Figure 2C-62 for the locations of the proposed facilities.

The TRR-West PGP is the same as the TRR-East PGP except the orientation and location has been changed. The dual 12-foot diameter TRR-West pipelines are approximately 10,300 feet shorter than the TRR-East pipelines. The TRR-West electrical transmission lines are approximately 8,000 feet shorter than TRR-East. All other facilities are the same except the reservoirs themselves and the configuration of the tie-in to GCID Main Canal.

The new reservoir has a storage capacity of approximately 600 acre-feet. It would encompass approximately 100 acres between the GCID Main Canal and the Tehama Colusa Canal. The new reservoir would be split between a main and extension reservoir (see Figures 2C-62A through 2C-62B) to mitigate impact to an existing PG&E transmission right-of-way, which contain a pair of underground natural gas pipelines and overhead transmission lines running north to south through the site.

The reservoirs would be hydraulically connected through a tunnel corridor (four 12-foot diameter pipes) passing under the PG&E transmission right-of-way. TRR-West would be developed primarily via excavation and have an impermeable lining consisting of a geomembrane overlying geocomposite placed over prepared subgrade. The subsurface materials in this area are assumed to consist primarily of fine-grained deposits and Pleistocene clays, where it is likely that extensive ground improvement would not be required as compared to TRR-East.

The TRR-West Reservoir will be connected hydraulically to the existing GCID Canal and constructed via primarily mass excavation. This connection occurs through the inlet/outlet canal facilities located adjacent and west of the GCID Canal. The inlet/out canal facilitates flow through several check structures into the Main and Extension reservoirs to the west.

Table 2C-21 provides TRR-West Reservoir construction quantities based on conceptual design.

Table 2C-21. TRR West Reservoir Quantities

Item	Quantity
Cement Deep Soil Mixing (CDSM)	0 cy
Total Excavation	9,300,000 cy
Construction of Embankment	0 cy
Liner Area	5,000,000 sf

3.4.6 Inlet/Outlet Works

The Alternative 2 tunnels are nearly the same as for Alternatives 1 and 3. However, the I/O tower for Alternatives 1 and 3 would have a top elevation of 558 feet and a height of 258 feet, with seven elevations to draw water from reservoir. Since the reservoir water surface elevation is lower in Alternative 2, the I/O tower would have a top elevation of 543 feet and a height of 243 feet, with six elevations to draw water from reservoir. The concrete volume for the Alternative 2

I/O tower is estimated at 23,500 cy (as compared to 24,100 cy for the Alternatives 1 and 3 tower).

3.4.7 Creek Diversions

For Alternative 2, there would be no change from Alternatives 1 and 3.

3.4.8 Dam Construction

The Alternative 2 dam designs are the same as for Alternatives 1 and 3, in that they would be earthfill and rockfill embankment dams. Figures 2C-64 and Figure 2C-65 illustrate the different footprints for Sites Dam and Golden Gate Dams, respectively. Different saddle dam and saddle dike configurations are shown in Figure 2C-4 and Figures 2C-66A through 2C-66C. Alternative 2 would not include Emergency Release Structures at the saddle dams. In addition, Saddle Dams 1, 2 and 6 from Alternatives 1 and 3 would become Saddle Dikes 1, 2, and 3. Material quantities and disturbance areas associated with each of the dams are provided in Table 2C-22.

Estimated borrow, stockpile, disposal, staging, processing, and haul road areas for the dams are presented in Table 2C-23. These areas would be similar to Alternatives 1 and 3; however, the depth of excavation would vary based on the embankment quantities.

Table 2C-22. Estimated Material Quantities and Disturbance Areas for Earth and Rockfill Dams (Alternative 2)

Dam	Length, ft	Maximum Height, ft	Permanent Footprint Disturbance Areas (acres)			Dam Embankment Volume										Excavation Volume (CY)	
			Total Area	Area within Reservoir	Area outside Reservoir	Zone 1 (Core), CY	Zone 2A (Filter), Tons	Zone 2A (Drain), Tons	Zone 2A (Transition), Tons	Zone 2B (Filter), Tons	Zone 2B (Transition), Tons	Zone 3 (Rockfill), CY	Zone 4 (Random), CY	Riprap, CY	Cement (Tons)	Concrete Aggregate, CY	Foundation Excavation (CY)
Golden Gate	2,050	270	35	18	17	2,030,000	560,000	620,000	83,000	350,000	370,000	2,170,000	1,850,000	84,000	10,000	31,000	1,350,000
Sites	730	250	16	8	7	640,000	200,000	240,000	35,000	120,000	130,000	950,000	600,000	36,000	3,500	10,600	510,000
Saddle Dam 3	2,700	90	27	10	17	480,000	150,000	150,000	44,000	-	-	320,000	845,000	70,000	4,000	13,000	350,000
Saddle Dam 5	1,750	60	13	4	9	250,000	90,000	95,000	27,000	-	-	155,000	380,000	38,000	2,500	8,000	210,000
Saddle Dam 8A	1,140	62	10	3	7	190,000	69,500	72,500	19,600	-	-	92,000	283,000	22,900	1,500	4,000	151,000
Saddle Dam 8B (Spillway)	300	20	3	0	3	11,000	-	300	-	-	-	-	-	1,500	-	10,000	21,000
Saddle Dike 1	150	10	1	0	1	-	-	-	-	-	-	-	4,000	-	-	-	4,000
Saddle Dike 2	80	20	1	0	1	-	-	-	-	-	-	-	2,500	-	-	-	2,200
Saddle Dike 3	245	30	1	0	1	-	-	-	-	-	-	-	16,500	-	-	-	10,100
Rim Grouting	-	-	-	-	-	-	-	-	-	-	-	-	-	-	3,300	10,500	-
Total Quantities						3,600,000	1,070,000	1,180,000	210,000	470,000	500,000	3,700,000	4,000,000	250,000	25,000	87,000	2,610,000

Table 2C-23. Estimated Borrow, Stockpile, Disposal, Staging, Processing, and Haul Road Areas for Dams (Alternative 2)

	Golden Gate			Sites Dam			Saddle Dikes 1,2			Saddle Dam 3			Saddle Dams 5, 8A, 8B, Saddle Dike 3			Total (acres)
	ID #	Required Volume, CY	Footprint Area (acres)	ID #	Required Volume, CY		ID #	Required Volume, CY	Footprint Area (acres)	ID #	Required Volume, CY		ID #	Required Volume, CY	Footprint Area (acres)	
Total Dam Footprint/ Construction Area, acres	-	-	70	-	-	31	-	-	3	-	-	54	-	-	54	212
Dam Footprint/ Construction Area Inside Reservoir, acres	-	-	35	-	-	16	-	-	1	-	-	21	-	-	14	87
Dam Footprint/ Construction Area Outside Reservoir, acres	-	-	35	-	-	15	-	-	2	-	-	33	-	-	40	125
Borrow Areas (permanent)																
Impervious Area (Zone 1) Inside Reservoir	GG-Z1 Borrow	4,060,000	150	Sites-Z1 Borrow	1,280,000	44	-	-	-	SD3-Z1 Borrow	960,000	56	SD5,6,8-Z1 Borrow	900,000	48	298
Rockfill (Zone 3) and Riprap Inside Reservoir	GG- Z3 Quarry 1	9,015,000	37	-	3,944,000	-	-	-	-	SD3,5,6,8A-Z3 Quarry 1	1,560,000	51	SD3,5,6,8A-Z3 Quarry 1	1,238,000	60	148
Rockfill (Zone 3) and Riprap Outside Reservoir	GG- Z3 Quarry 2		300	Sites- Z3 Quarry		135	-	-	-	SD1,2,3-Z3 Quarry 2		46	-		-	-
Random (Zone 4) - Inside Reservoir	GG- Z3 Quarry 1	3,700,000	10	-	1,200,000	-	-	-	-	SD3,5,6,8A-Z3 Quarry 1	1,690,000	10	SD3,5,6,8A-Z3 Quarry 1	1,359,000	20	40
Random (Zone 4) - Outside Reservoir	GG- Z3 Quarry 2		125	Sites- Z3 Quarry		41	13,000	-	-	SD1,2,3-Z3 Quarry 2		20	-		-	GG- Z3 Quarry 2
Other Areas (temporary/permanent)																
Stockpile Area Inside the Reservoir (temporary)	GG- Stockpile	-	41	Sites- Stockpile	-	19	SD1,2- Stockpile	-	13	SD3-Stockpile	-	32	SD5,6,8A- Stockpile	-	40	144
Disposal Areas Inside the Reservoir (permanent)	GG-Disposal Area	-	132	Sites-Disposal Area	-	32	-	-	-	-	-	-	-	-	-	164
Staging Areas Inside the Reservoir (temporary)	GG-Staging	-	56	Sites-Staging	-	33	SD1,2-Staging	-	5	SD3,5-Staging	-	23	SD 6,8A Staging	-	5	145
													SD3,5-Staging	-	23	
Rock Processing Area Inside Reservoir (permanent)	GG-Rock Processing 1	-	14	-	-	-	-	-	-	SD3,5,6,8A-Rock Processing	-	7	SD3,5,6,8A-Rock Processing	-	7	29
Rock Processing Area Outside Reservoir (temporary)	GG_Rock Processing 2	-	49	Sites-Rock Processing	-	30	SD1,2,3-Rock Processing	-	10	SD1,2,3-Rock Processing	-	10	-	-	-	99
Haul Routes Inside Reservoir (permanent)	-	-	12	-	-	22	-	-	35	-	-	51	-	-	45	166
Haul Routes Outside Reservoir (temporary)	-	-	25	-	-	15	-	-	31	-	-	12	-	-	22	104
Total Area (acres) 2,330																
Offsite Borrow (Zone 2)	-	2,200,000	-	-	800,000	-	-	-	-	-	400,000	-	-	400,000	-	3,800,000
Cement (Tons)	-	11,000	-	-	3,900	-	-	-	-	-	4,400	-	-	8,000	-	27,000
Concrete Aggregate (CY)	-	34,000	-	-	12,100	-	-	-	-	-	14,300	-	-	36,000	-	96,000

Notes: Plan view showing the locations of the areas presented in Figures 2C-48 and 2C-49; Dam footprint areas are doubled to account for the dam construction disturbance area; Required volume of borrow is doubled from the estimated volume for all Zones, except for Zone 3; The required volume for Zone 3 is increased by 4 times; Disturbance areas inside the reservoir are considered permanent; Haul routes assumed to be 50 feet wide and length of the haul routes are doubled; Areas within the reservoir having elevations lower than 290 feet are considered disposal areas.

3.4.9 Roads

Table 2C-24 summarizes the differences in the roadway characteristics between reservoir Alternatives 1 and 3 and Alternative 2.

Table 2C-24. Summary of Differences in Roadway Characteristics

	Alternatives 1 and 3	Alternative 2
Sites Lodoga Road Realignment	Causeway across reservoir – 5.5 miles in length	South Road around southerly reservoir tip – 18.9 miles in length
Huffmaster Road Realignment	Provided as gravel road – 8.9 miles in length	Provided as part of Sites Lodoga Road Realignment

The construction disturbance area would include the footprints of the proposed roadway cuts and fills, the proposed access, construction, and maintenance roads outside the limits of the reservoir, the materials and equipment staging areas, borrow area, and the perimeter space needed to construct these facilities.

The area planned to be inundated by the reservoir would be used as a materials and construction equipment staging area for the Sites Lodoga Road/Maxwell Sites Road relocation. This roadway will be realigned through undeveloped mountainous terrain around the south tip of Sites Reservoir, which will involve substantive cuts and fills (see Figure 2C-67). The cuts and fills are proposed to be sloped at approximately 1.5:1 (H:V) to 2:1 (H:V) and is anticipated to involve some rock cutting and blasting. The roadway shoulders will be flanked with earthen ditches to convey stormwater off the roadbed to pipe culverts. Crossing pipe culverts will be placed in fill sections to convey stormwater beneath the roadway at various locations.

The roadbed will be constructed as a two-lane road with 12-foot lanes and 5-foot shoulders and is assumed to consist of 4 inches of asphalt pavement on 6 inches of aggregate base and 6 inches of aggregate subbase. Excavation may involve rock cutting and blasting in some areas. As the surrounding land is used for cattle grazing, this road will be aligned with fencing to restrict cattle access to the roadway.

For the temporary access, construction and maintenance roads beyond the Sites Reservoir inundation area, the total construction permanent disturbance area would be approximately 1,653 acres, and the temporary disturbance area would be approximately 675 acres. Table 2C-25 summarizes the estimated construction disturbance areas for Alternative 2 road construction. Table 2C-26 shows preliminary estimates for construction quantities for Alternative 2 roads.

Table 2C-25. Estimated Construction Disturbance Areas for Alternative 2 Roads

Inside the Reservoir Inundation Area			
Type/Description	Location	Permanent Disturbance Area (Acres)	
Borrow Area	LR Bridge - Borrow 1	68.7	
Borrow Area	LR Bridge - Borrow 2	97.4	
Borrow Area	LR Bridge - Borrow 3	126.7	
Fill Prism Area	West Bridge - Abut 1	15.7	
Total		442	
Outside the Reservoir Inundation Area			
Type/Description	Location	Permanent Disturbance Area (Acres)	Temporary Disturbance Area (Acres)
Site Access/Roadway	Saddle Dike 2	3	3
Site Access/Roadway	Saddle Dam 8A & 8B	3	4
Site Access/Roadway	Saddle Dike 1	2	2
Site Access/Roadway	Saddle Dam 6	9	8
Site Access/Roadway	Saddle Dam 5 & ERF	10	6
Site Access/Roadway	Saddle Dam 3 & ERF	9	7
Site Access/Roadway	Saddle Dam 3	3	2
Site Access/Roadway	Saddle Dam 2	28	17
Site Access/Roadway	Saddle Dam 1	13	13
Site Access/Roadway	Access Road A1	34	33
Site Access/Roadway	Access Road B1 & B2	15	9
Site Access/Roadway	Sites Lodoga Road Realigned (South Road)	950	472
Construction/Roadway	Comm Rd - South	20	21
Construction/Roadway	Sites Lodoga Road Detour	18	8
Construction/Roadway	Day Use Boat Ramp	6	8
Site Access/Roadway	Peninsula Hills Recreational Area	30	27
Site Access/Roadway	North Access Road	174	NA
Construction/Roadway	County Road 69	26	NA
Construction/Roadway	County Road D	6	NA-
Construction/Roadway	County Road 68	33	NA-
Construction/Roadway	County Road F/McDermott Rd	110	NA-
Site Access/Roadway	Delevan Rd	21	NA
Construction/Roadway	Maxwell Sites Rd	95	NA
Total		1,653	675

Table 2C-26. Preliminary Quantities for Alternative 2 Roads

Type	Road Name	Approx. Road Length	Roadway Width	Roadway Excavation (Excess Suitable Material to be Stockpiled)	Roadway Excavation (Cut to Haul/Waste)	Roadway Excavation (Rock Cut)	Roadway Embankment (From Excavated Suitable Material)	Class 4 Aggregate Subbase	Class 2 Aggregate Base	Hot Mix Asphalt (Type A)	Tack Coat
		(lf)	(lf)	(cy)	(cy)	(cy)	(cy)	(cy)	(cy)	(ton)	(ton)
Public Roadway	Sites Lodoga Road Realignment (South Road)	99,800	34	0	1,842,600	897,400	3,043,700	89,000	89,000	120,000	90
Public/ Construction	Sites Lodoga Road Detour	6,500	30	749,392	202,702	85,442	181,793	16,674	16,674	22,510	17
Maintenance/ Construction	North Road (Access Road - Road 69)	27,200	24	136,700	25,400	7,900	92,100	18,100	36,300	0	0
Local/ Construction	County Road 69	11,230	28	23,000	2,600	0	600	8,700	8,700	11,790	9
Local/ Construction	County Road D	2,700	28	5,400	600	0	100	2,100	2,100	2,810	2
Local/ Construction	County Road 68	14,250	28	29,100	3,300	0	700	11,100	11,100	14,930	11
Local/ Construction	County Road F/McDermott Road	21,240	28	43,500	4,960	0	1,090	16,600	16,600	22,300	17
Maintenance	Saddle Dam Road - North	11,200	15	162,000	30,300	11,800	110,500	0	14,000	0	0
Maintenance	Saddle Dam Road - South	18,250	15	276,300	52,500	33,500	196,300	0	22,800	0	0
Maintenance	Access Road A1	7,640	15	78,500	14,400	1,100	50,900	0	9,500	0	0
Maintenance	Access Road B1	2,080	15	31,600	6,100	4,900	23,100	0	2,600	0	0
Maintenance	Access Road B2	3,790	15	50,600	9,700	7,900	36,900	0	4,700	0	0
Maintenance	Access Road C1	5,190	15	183,000	33,300	0	117,200	4,300	4,300	5,800	5
Maintenance	Access Road C2	3,540	15	124,700	22,700	0	79,900	0	4,400	0	0
Maintenance	Comm Road North	7,500	15	81,300	9,000	0	31,500	0	5,700	0	0
Maintenance	Comm Road South	4,550	15	49,100	9,000	0	31,500	0	5,700	0	0
Recreation	Day Use Boat Ramp (From Sites Lodoga Rd - Westside)	1,950	30	78,700	14,300	0	50,400	1,860	1,860	2,510	2
Recreation	Peninsula Hills Recreation Area	19,700	30	295,800	54,500	8,300	194,300	16,400	16,400	22,170	17
Recreation	Stone Corral Recreation Area/Sites Dam	13,320	30	175,000	32,100	2,400	113,500	11,100	11,100	14,800	11
Public Roadway	Existing Sites Lodoga Road	19,980	22	0	0	0	0	0	0	0	0
Public Roadway	Existing Maxwell Sites Road	9,400	24	0	0	0	0	0	0	0	0

Table 2C-26. Preliminary Quantities for Roads (Continued)

Type	Road Name	Clearing and Grubbing	Temporary Silt Fence	24" pipe culvert (galvanized corrugated metal)	Box Culvert Single Cell	Permanent Blanket Erosion Control (hydroseed)	Rock pad Energy Dissipator (18" d x 2' w x 6' l)	Temporary Inlet/Outlet Protection	Fiber Roll	Remove AC Surfacing
		(acre)	(lf)	(lf)	(ea)	(sqft)	(ea)	(ea)	(ft)	(cy)
Public Roadway	Sites Lodoga Road Realignment (South Road)	109	32,400	4,290	0	847,600	75	150	0	0
Maintenance/ Construction	North Road (Access Road - Road 69)	78	14,400	1,500	3	124,500	33	132	0	0
Local/ Construction	County Road 69	8	7,200	160	3	0	12	24	66,600	0
Local/ Construction	County Road D	1	3,600	125	5	0	9	18	15,400	0
Local/ Construction	County Road 68	7	2,400	0	3	0	6	12	85,330	0
Local/ Construction	County Road F/McDermott Road	11	3,600	9	0	0	9	18	99,500	0
Maintenance	Saddle Dam Road - North	14	2,400	620	0	51,200	12	12	0	0
Maintenance	Saddle Dam Road - South	22	4,200	1,010	0	83,500	21	21	0	0
Maintenance	Access Road A1	9	1,800	420	0	35,000	9	9	0	0
Maintenance	Access Road B1	3	600	120	0	9,500	3	3	0	0
Maintenance	Access Road B2	5	1,200	185	0	15,300	6	6	0	0
Maintenance	Access Road C1	9	1,200	290	0	23,800	6	6	0	0
Maintenance	Access Road C2	5	1,200	0	0	16,200	6	6	0	0
Maintenance	Comm Road North	9	1,800	410	0	34,300	6	6	0	0
Maintenance	Comm Road South	6	1,200	250	0	20,700	6	6	0	0
Recreation	Day Use Boat Ramp (From Sites Lodoga Rd - Westside)	4	600	120	0	10,200	3	3	0	0
Recreation	Peninsula Hills Recreation Area	27	4,800	1,090	0	90,200	24	24	0	0
Recreation	Stone Corral Recreation Area/Sites Dam	17	3,000	660	0	56,000	15	15	0	0
Public Roadway	Existing Sites Lodoga Road	0	0	0	0	0	0	0	0	12,300
Public Roadway	Existing Maxwell Sites Road	0	0	0	0	0	0	0	0	6,300
Public Roadway	Sites Lodoga Road Realignment and Bridge	247	17,797	17,650	8	1,656,238	311	623	0	0
Public/ Construction	Sites Lodoga Road Detour	16	1,157	1,147	0	107,655	20	40	0	0

Notes:
Preliminary quantity values have a 1.5 safety factor applied

3.4.10 Conveyance to Sacramento River

Similar to Alternatives 1 and 3, water released from Sites Reservoir would be conveyed south of Sites Reservoir using the existing Tehama-Colusa Canal and a new Dunnigan pipeline. The water would flow south about 40 miles to the end of the Tehama-Colusa Canal, where it would be diverted into the proposed Dunnigan Pipeline. However, under Alternative 2 water would flow south to the end of the Tehama-Colusa Canal but would be diverted into an extended Dunnigan Pipeline, with release directly to the Sacramento River with some flows released to the CBD to flow into the Yolo Bypass/Cache Slough complex through the Knights Landing Ridge Cut

Dunnigan Pipeline

The Dunnigan Pipeline under Alternative 2 is from TCC to the Sacramento River. Figure 2C-5 shows the pipeline alignment while Figure 2C-16 illustrates access to the pipeline. The proposed Sacramento Discharge is shown in Figure 2C-68. Activities are roughly the same, but the durations would be different, with Alternative 2 taking longer due to its longer length. Anticipated construction activities for the Dunnigan Pipeline include the following:

- Clear and grub the pipeline easement areas.
- Construct temporary access roads and staging areas.
- Construct coffer dam.
- String pipe, excavate trench, lay pipe, weld, backfill trench, and restore surface.
- Utilize native material to make CLSM for pipe trench backfill. This will require a moving batch plant that moves long trench after pipe is laid.
- Install appurtenances.
- Test the pipeline.

The following construction means and methods are required for the construction of the Dunnigan Pipeline and the outlet structure for release to the CBD and to the Sacramento River:

- Pipeline consists of one 10.5-foot diameter pipe that would go from the inlet structure to the Sacramento River, a distance of approximately 10 miles.
- Construction of the Dunnigan Pipeline would include:
 - Clear and grade the pipeline alignment.
 - Provide a dewatering system along the pipeline alignment once you parallel Bird Creek all the way to the Sacramento River so that installation of the pipelines can be done in the dry.
 - Excavate pipeline trench and provide shoring. It is anticipated that several hundred feet of open trench would occur at one time.
 - Tunneling under Interstate-5, Highway 99, the railroad and the CBD.
 - Install and weld up the pipeline and backfill with a combination of CLSM and native material.

- Install flow meters, valving, air valves, blowoffs, and access manways.
- Install a cathodic protection system consisting of rectifiers attached to pipe.
- Replace topsoil where the pipeline is going through agricultural land and restore the pipeline route to its pre-construction condition.
- Construct the CBD Outlet Structure.
 - Clear and grub the area along CBD for the outlet structure.
 - Transport materials to the Project Site. Materials would consist of concrete, rebar, yard piping, energy dissipation valves, and electrical equipment
 - Place construction materials at staging areas.
 - Build the outlet structure, which would consist of excavating the ground to accommodate placement of structure structural concrete and rebar.
 - Connect the outlet structure to the Dunnigan Pipeline.
 - Test the facility.
- Construct the Sacramento River Outlet Structure.
 - Clear and grub the area along Sacramento River for the outlet structure.
 - Transport materials to the Project Site. Materials would consist of concrete, rebar, yard piping, energy dissipation valves, and electrical equipment
 - Place construction materials at staging areas.
 - Construct cofferdam; the length would be between 200 to 250 feet and it would take approximately four to six weeks to construct, concurrent with other Sacramento Discharge activities. The number of steel sheet piles is expected to be approximately 45 to 55 sheet piles.

A temporary work bridge with pipe piles and timbers would form a work platform for a crane to be able to install the cofferdam from the land side. There may be two temporary work platforms (one on the upstream side and one on the downstream side of the structure. The work bridge(s) would extend from the top of the levee (given the distances they won't be able to reach the river from the levee road itself) out toward the river but not in the river. There would be approximately 12 to 15 pipe piles per work platform. The pipe piles would all be on land and either vibrated in or hammer driven. The work platform would be constructed in about 2 weeks. The crane would reach out over all the area to put the coffer dam around the discharge location.

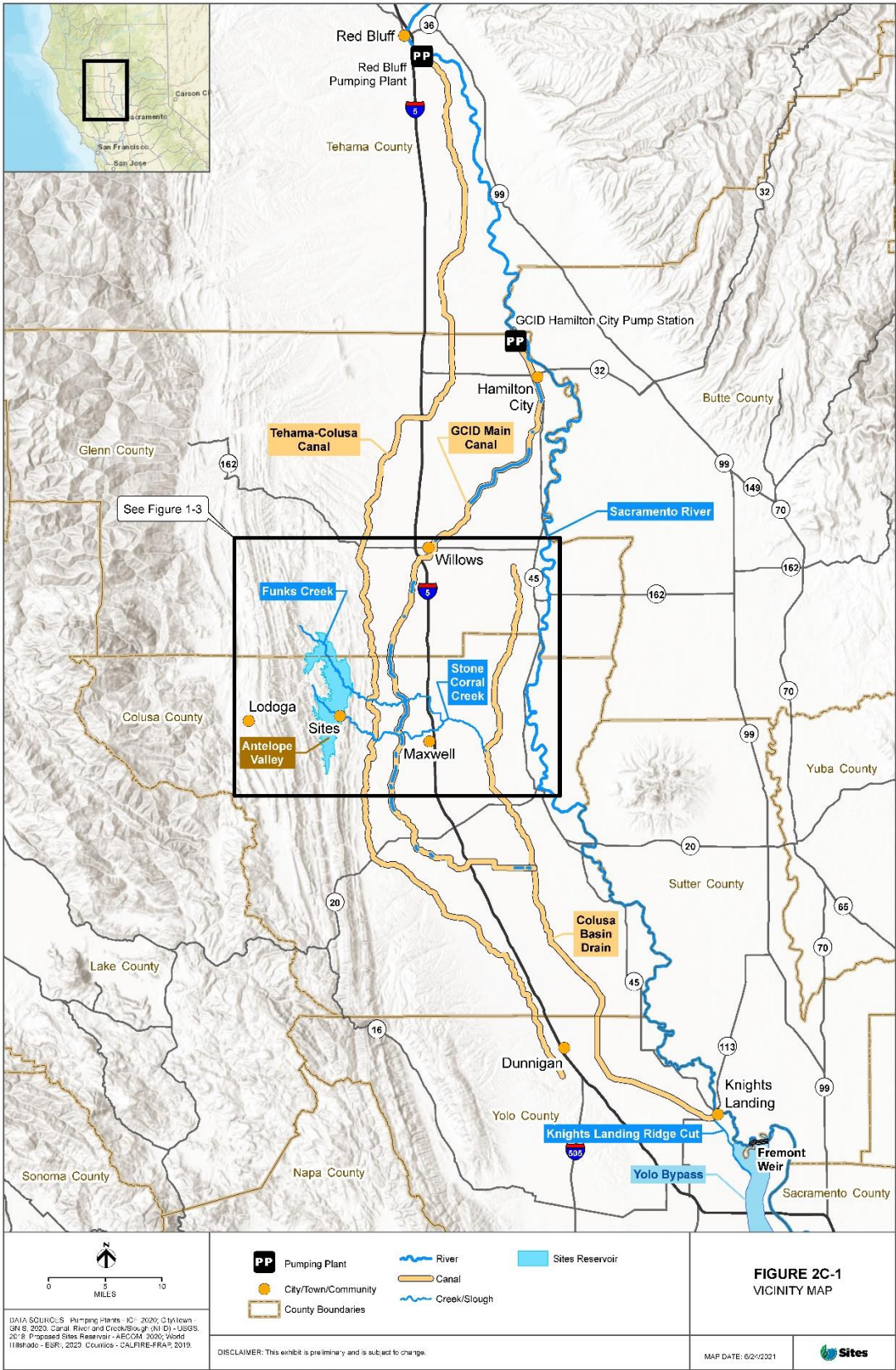
- The location is at a bend so this is the deep side of the river.
- Barges would not be used.
- Pile driving will be needed if planning to vibrate the steel sheets in, although encountering of rock riprap on the banks may require pounding the sheets in.
- Sheet piles would be installed on the very edge of the shoreline

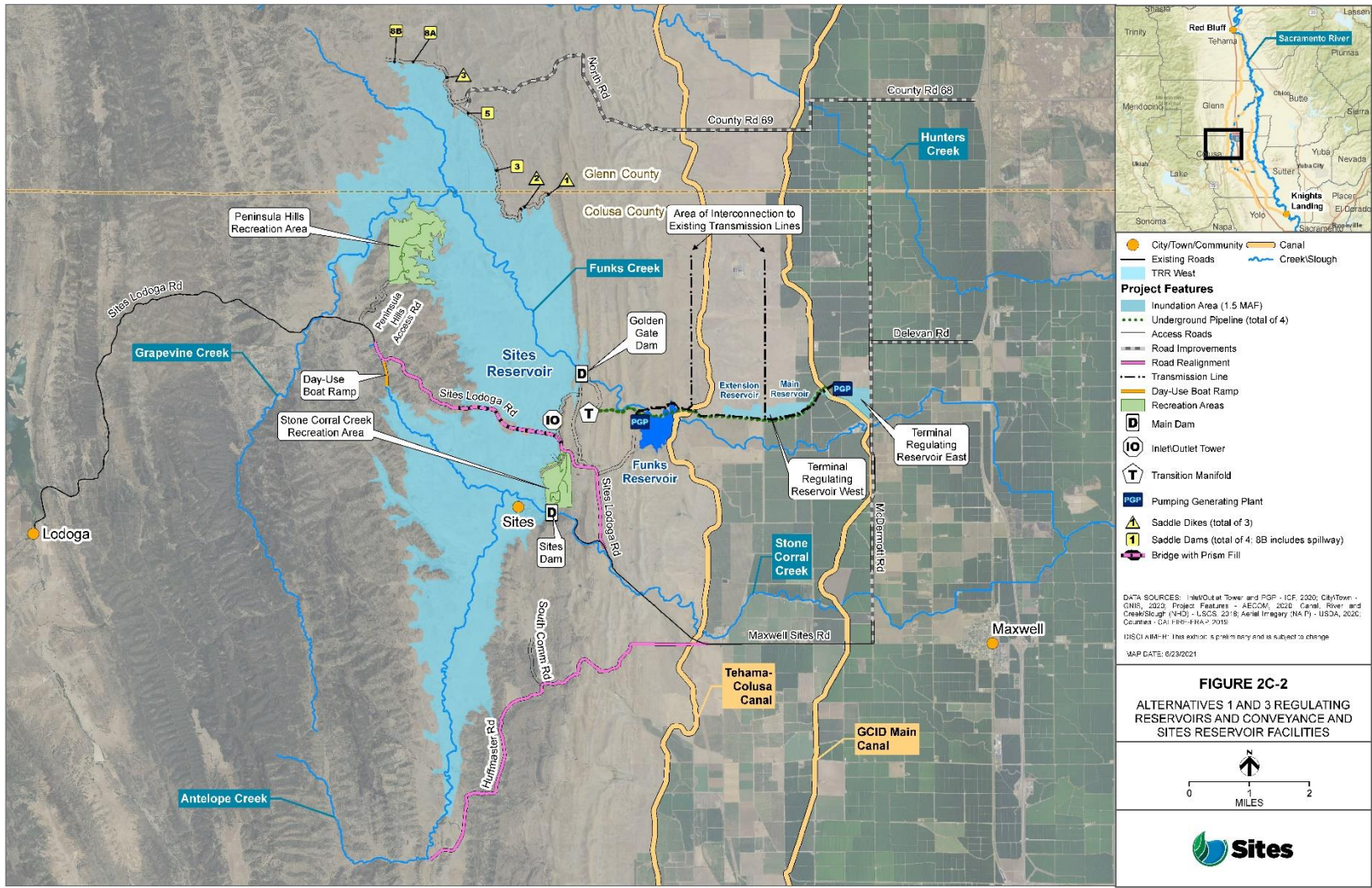
- Pipe Piles for the work platform would be installed on dry land, not in the river, and therefore do not need to meet any fishery criteria for installation.
- Best Management Practices would include:
 - Work to be conducted during NMFS approved work window in the fall. If possible, ask for more time as we want to give the Contractor as much of a window as possible.
 - Silt curtains would be used when installing the sheet piles
 - Dewatered water from behind the coffer dam would be conducted after a fish rescue is done by fishery biologists with a sein net. Once the area has been cleared of fish, then the dewatering can occur using a sump pump that is in a gravel envelop (which would trap the silt) and the water is then pumped right back into the river. If the water is too deep for an effective fish rescue then the sump pump or area surrounding sump pump would need to be screened to meet CDFW and NMFS criteria.
 - A silt sock would also be used on the discharge end and water would be discharged on the landward side of silt curtains
 - Fish rescue would be required during dewatering behind the coffer dam and repeated if high flows fill the area behind the coffer dam
- Build the outlet structure, which would consist of excavating the ground to accommodate placement of structure structural concrete and rebar.
- Connect the outlet structure to the Dunnigan Pipeline.

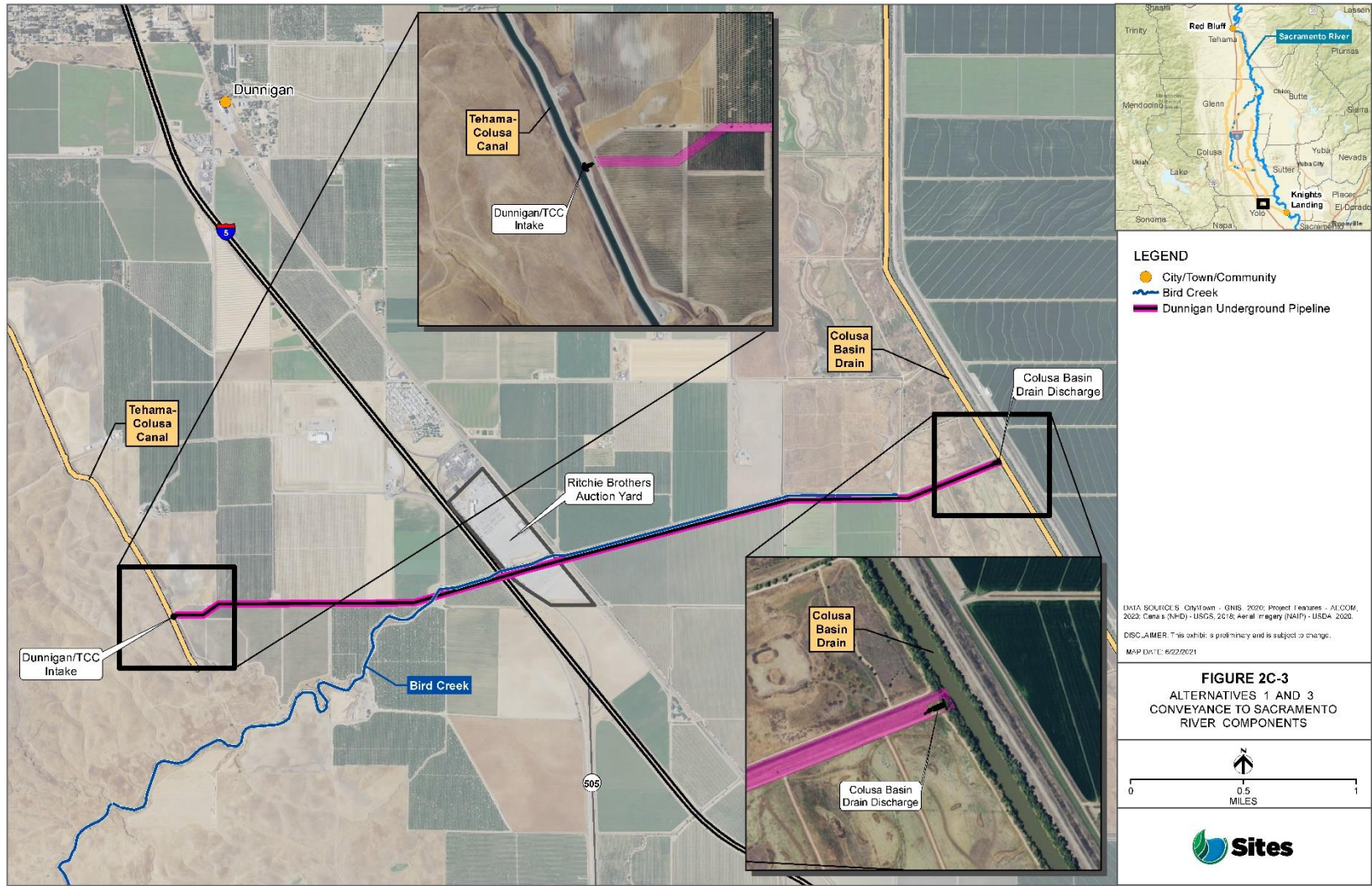
3.5 Construction Schedule

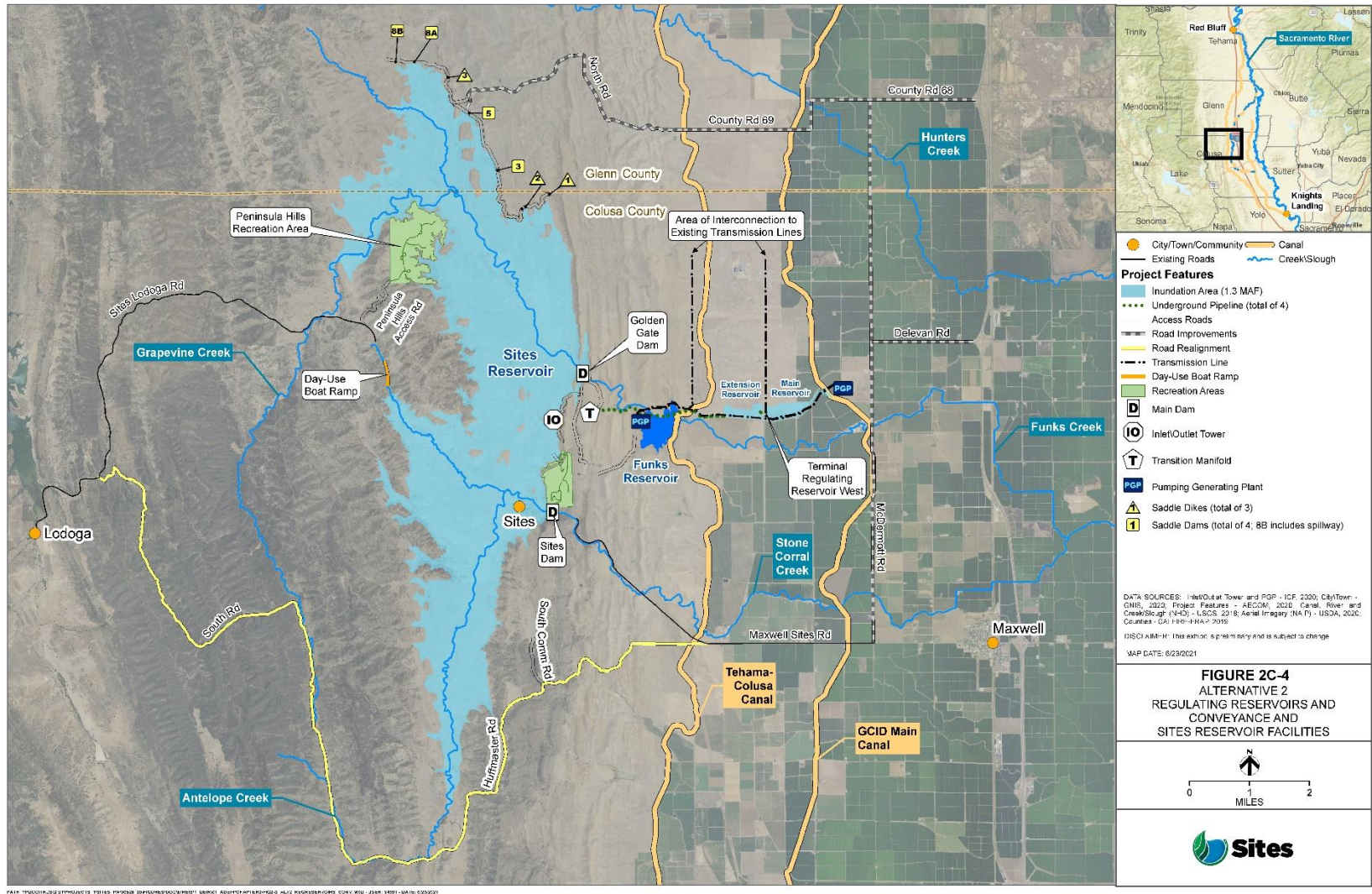
Preliminary construction schedules are included as Attachment 2; however, these schedules are subject to change. As noted in Section 2.1, construction may start as early as spring 2024, depending on the timing of funding, design, and permitting. The schedule is also based on conceptual design. Further design refinements due to value engineering and ongoing engineering will also result in changes in the construction schedule for various facilities.

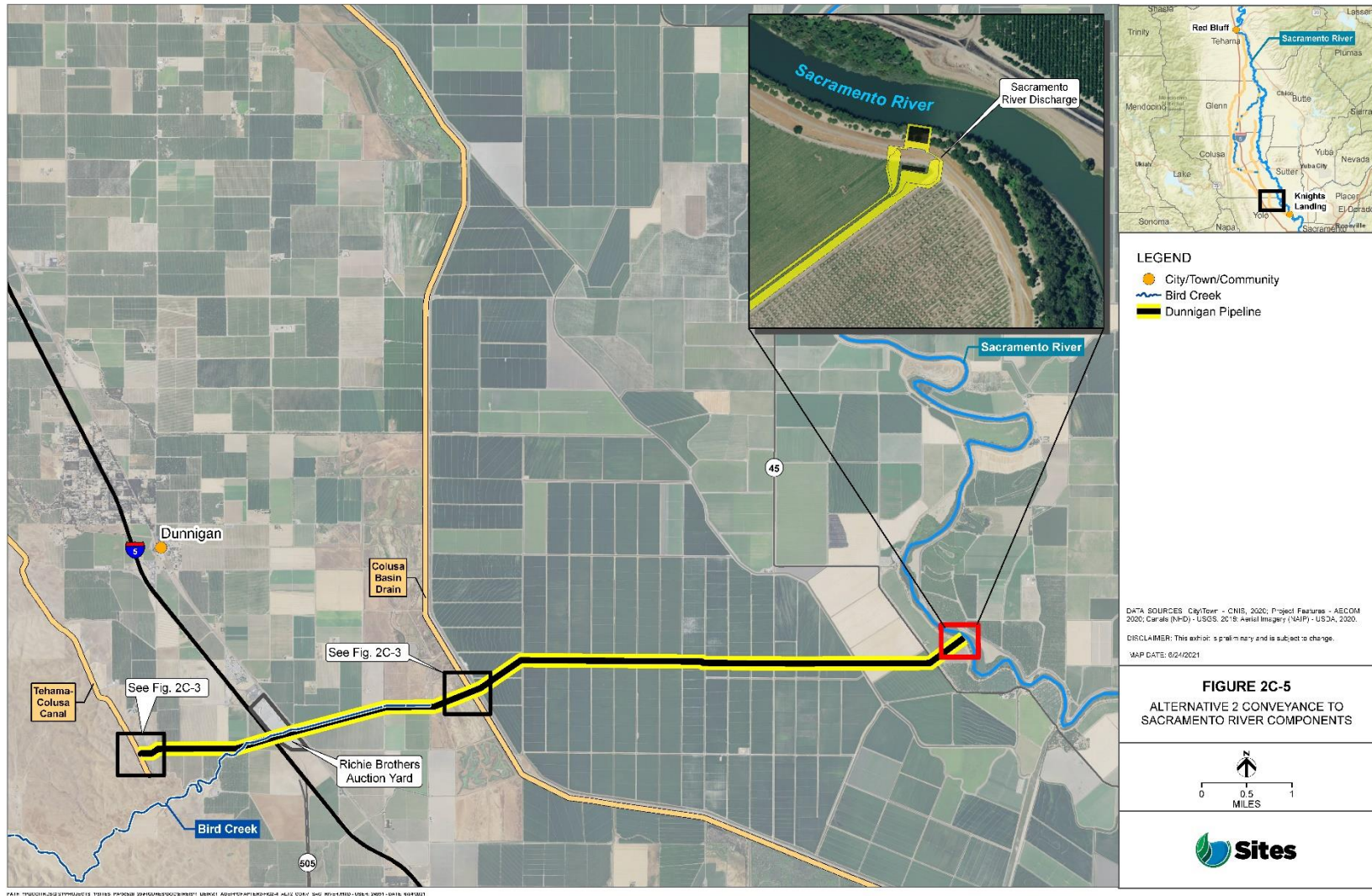
Attachment 1 – Figures











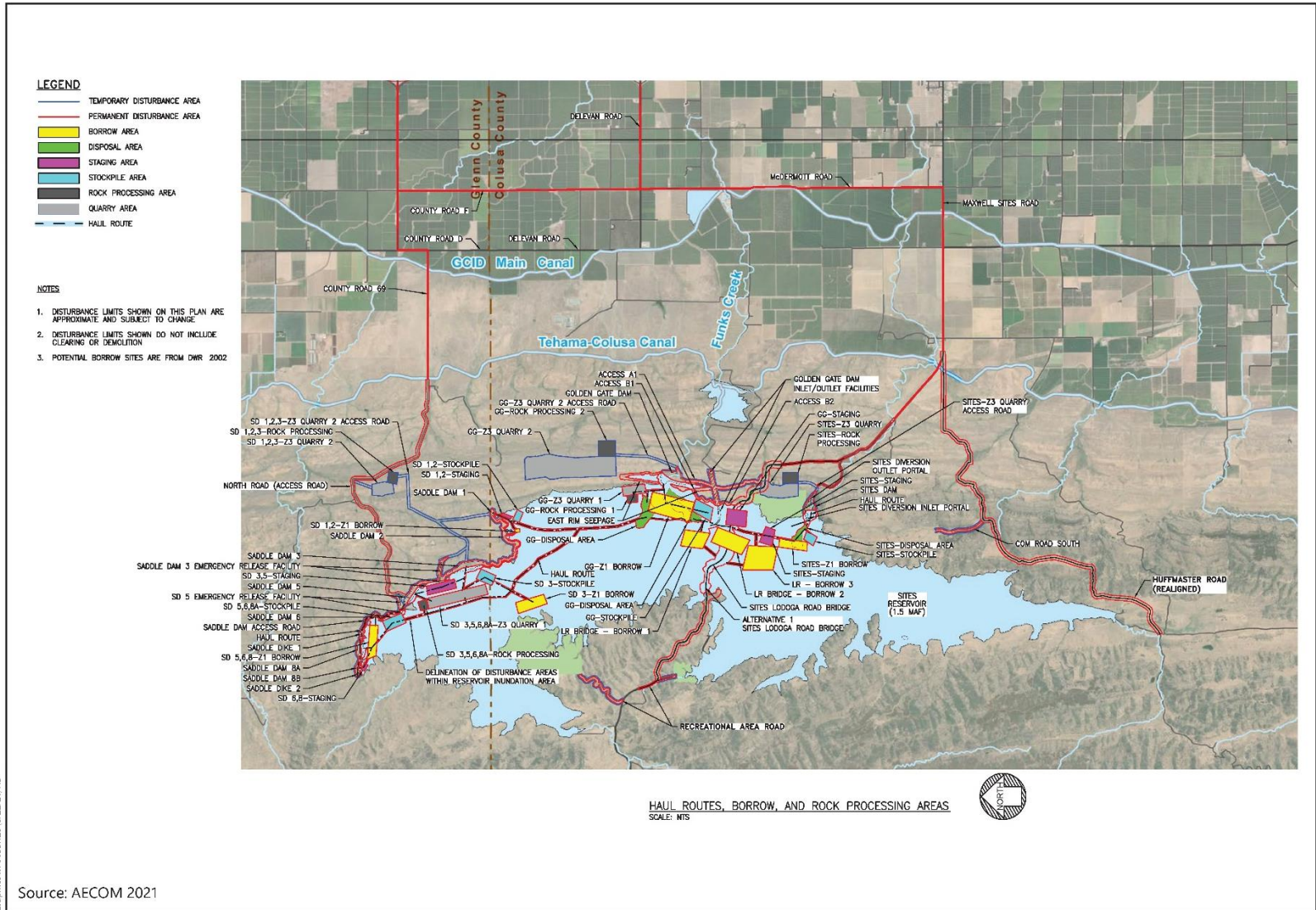


Figure 2C-6
Onsite Borrow Area Details

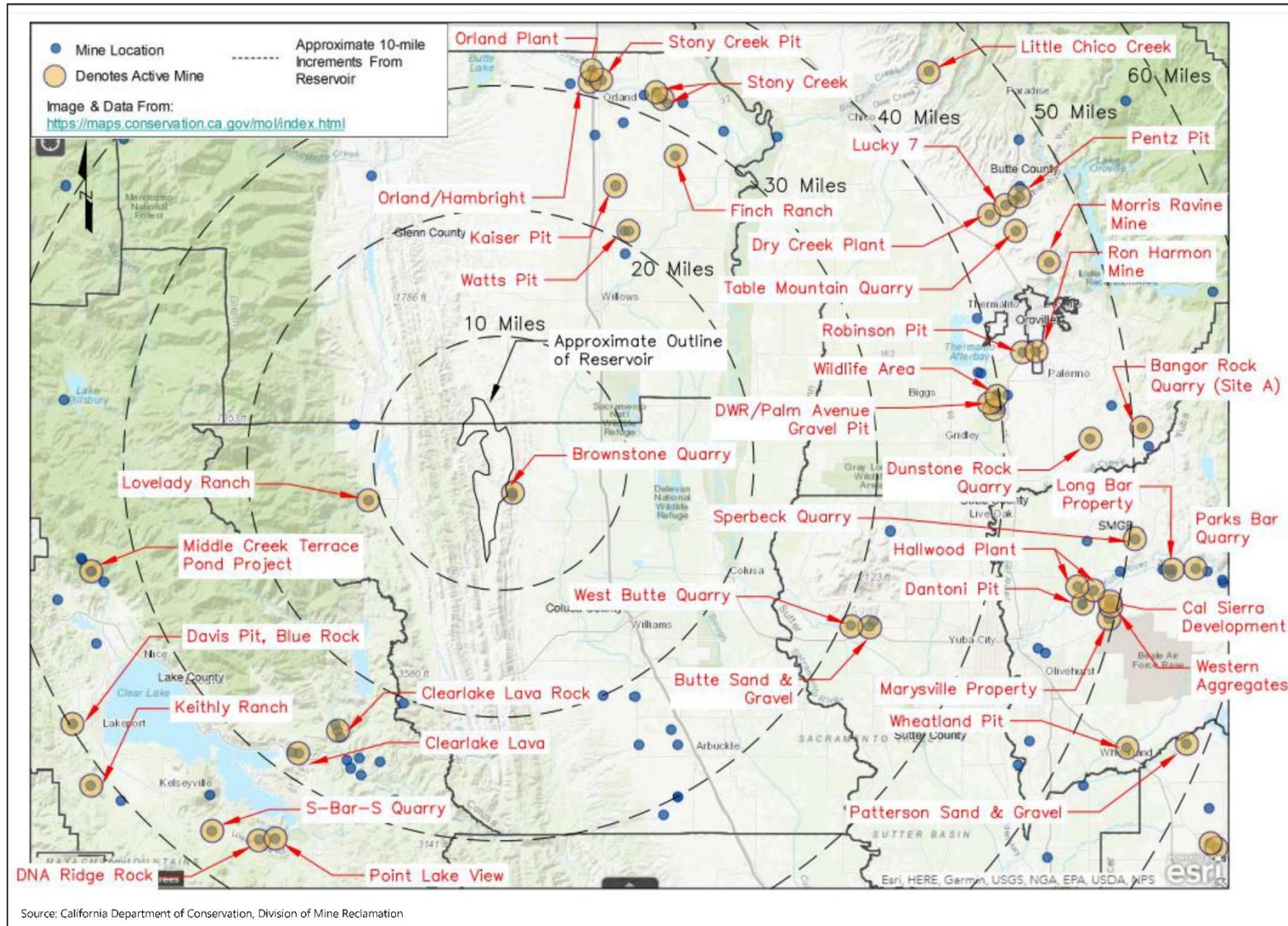


Figure 2C-7
Active and Inactive Mines In Project Vicinity

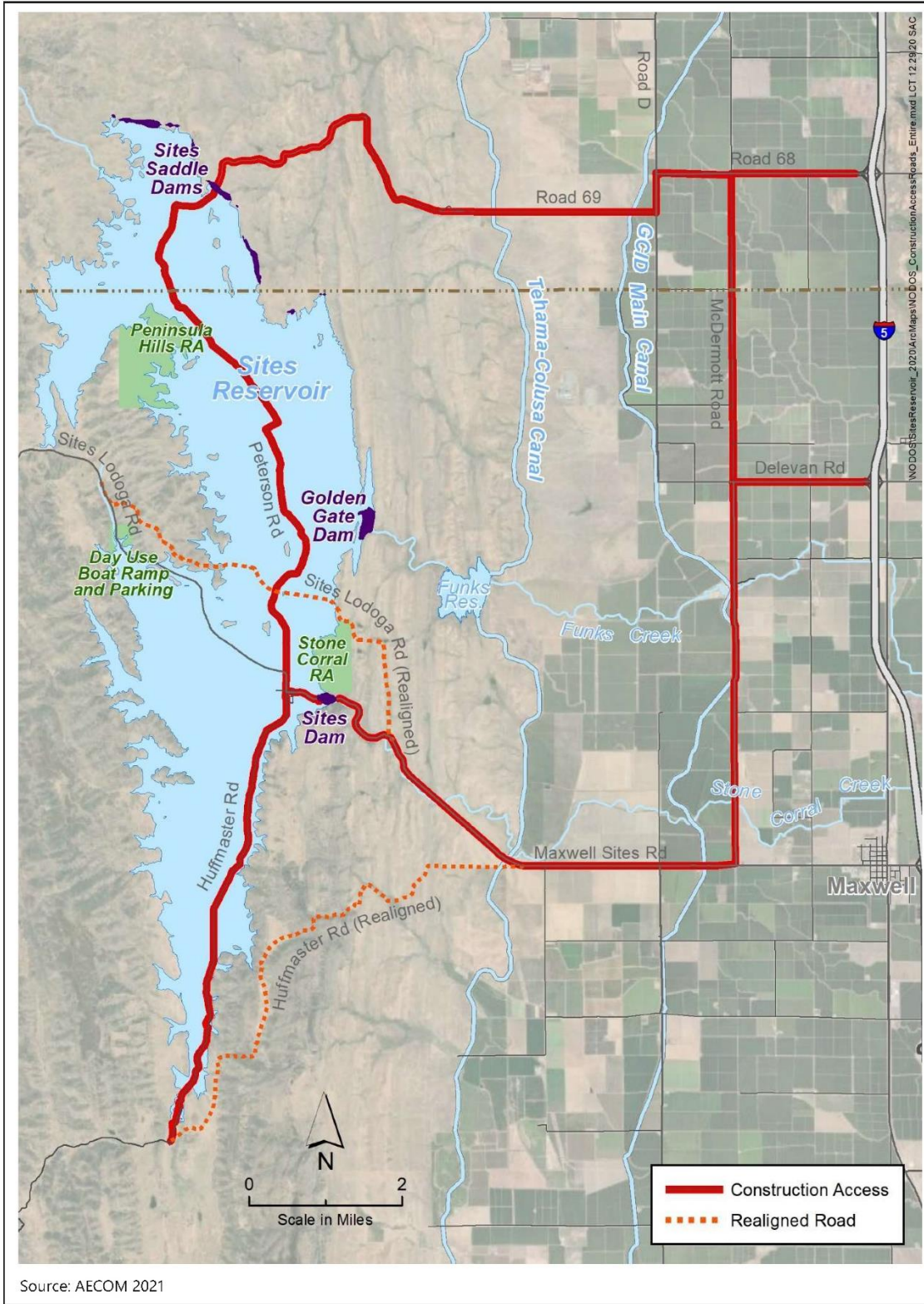
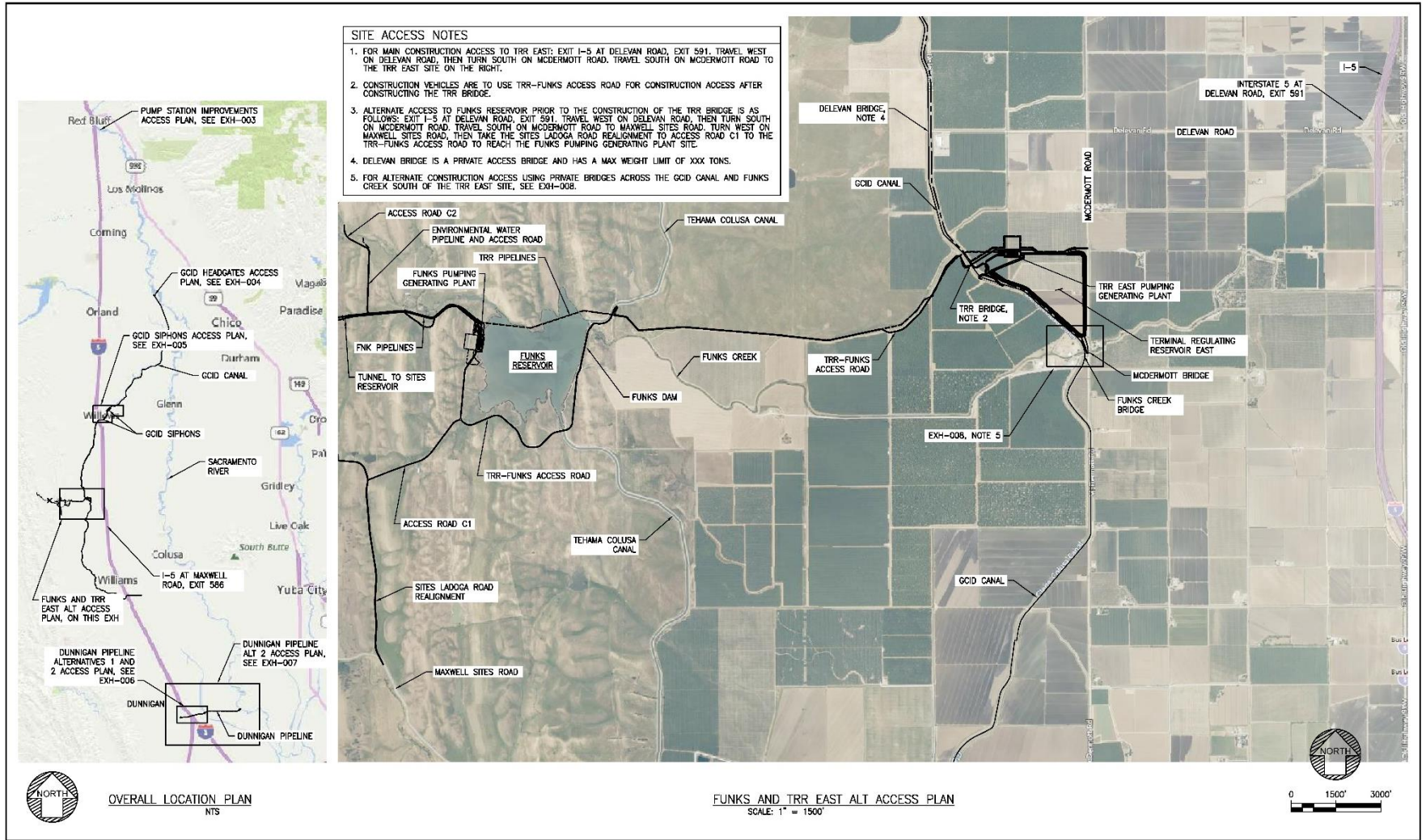
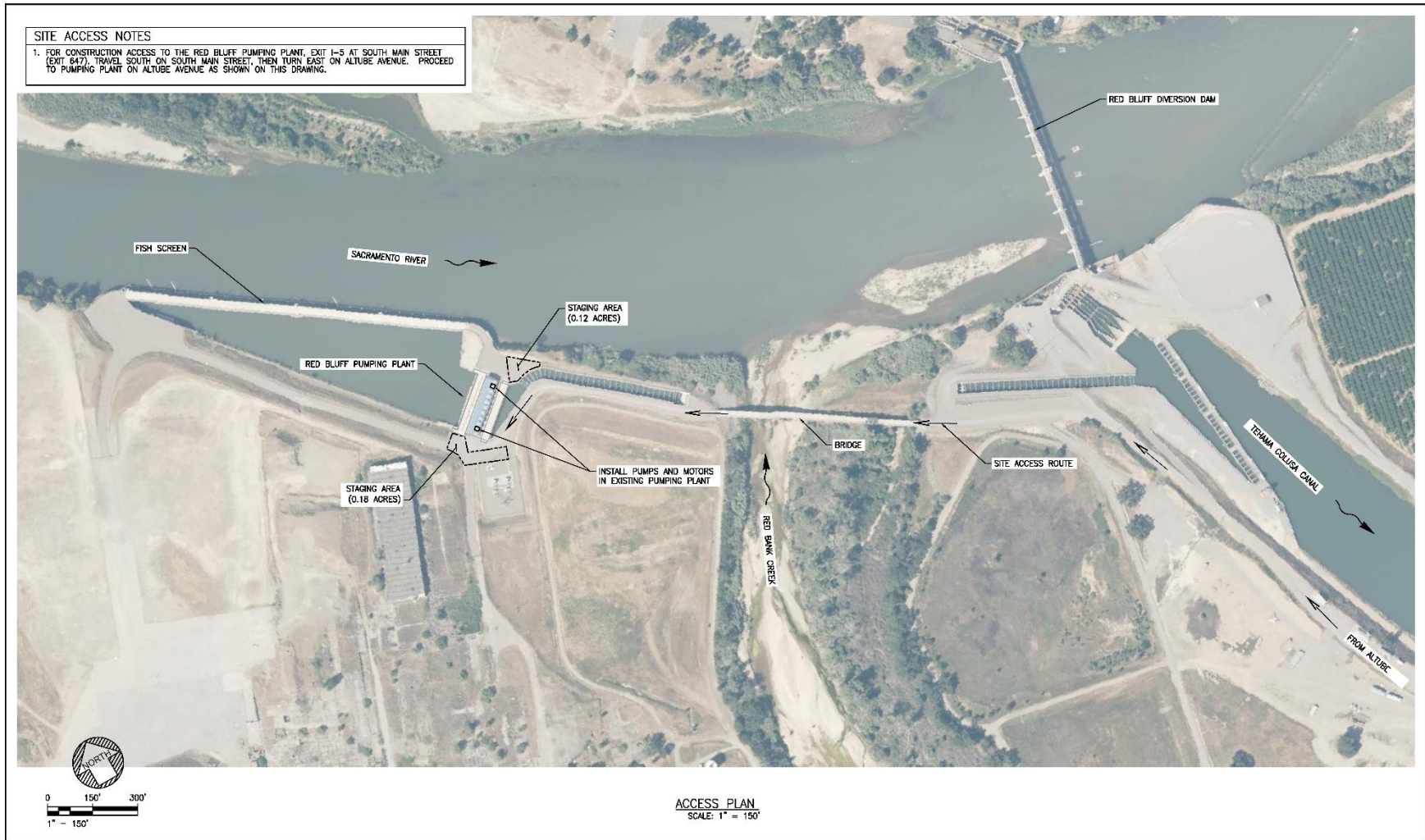


Figure 2C-8
Existing Roadways



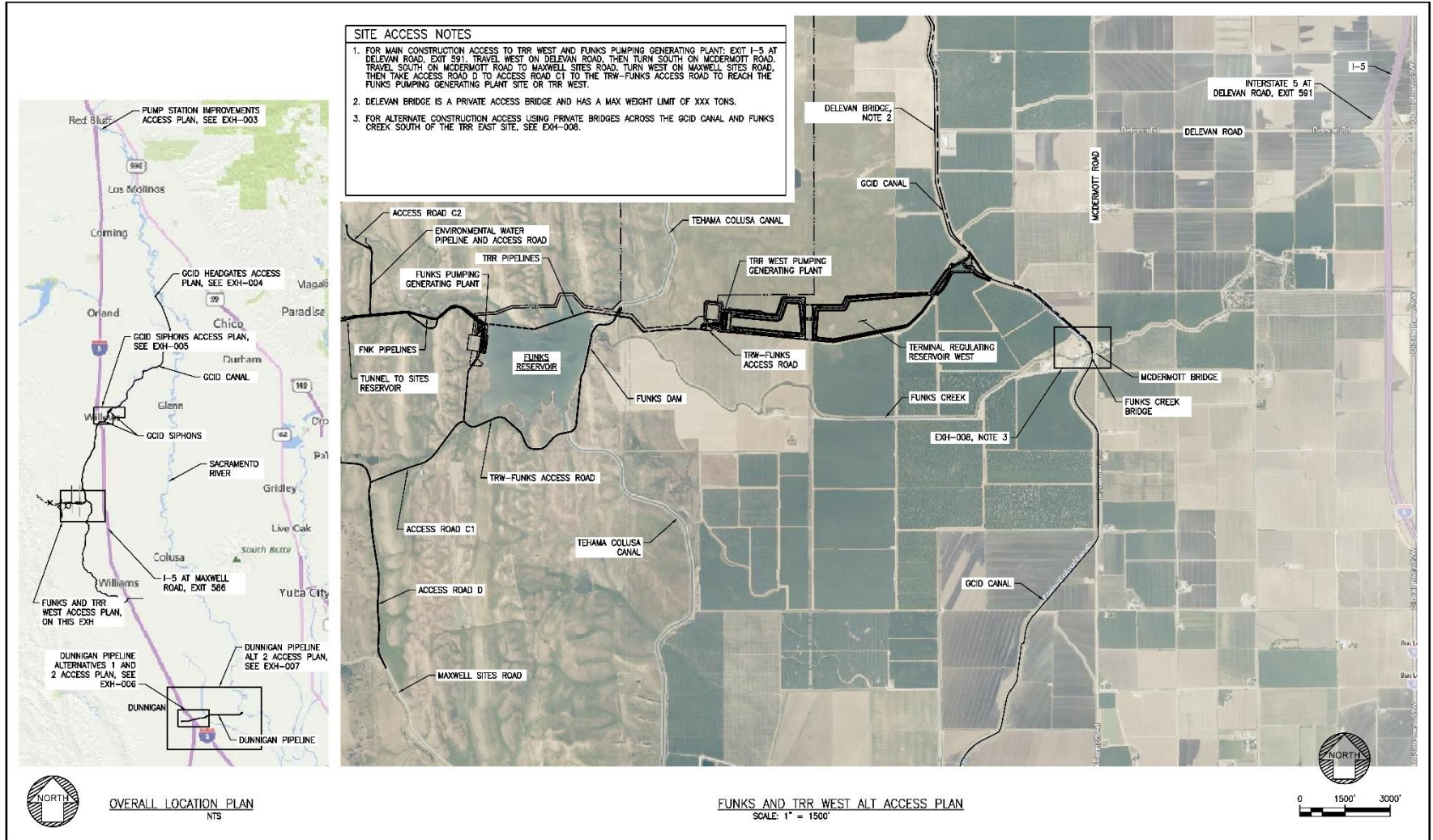
Source: Jacobs, 2021

Figure 2C-9
Overall Location and Access Plan - Terminal Regulating Reservoir East Alt



Source: Jacobs, 2021

Figure 2C-10
Red Bluff Pumping Plant Access Plan



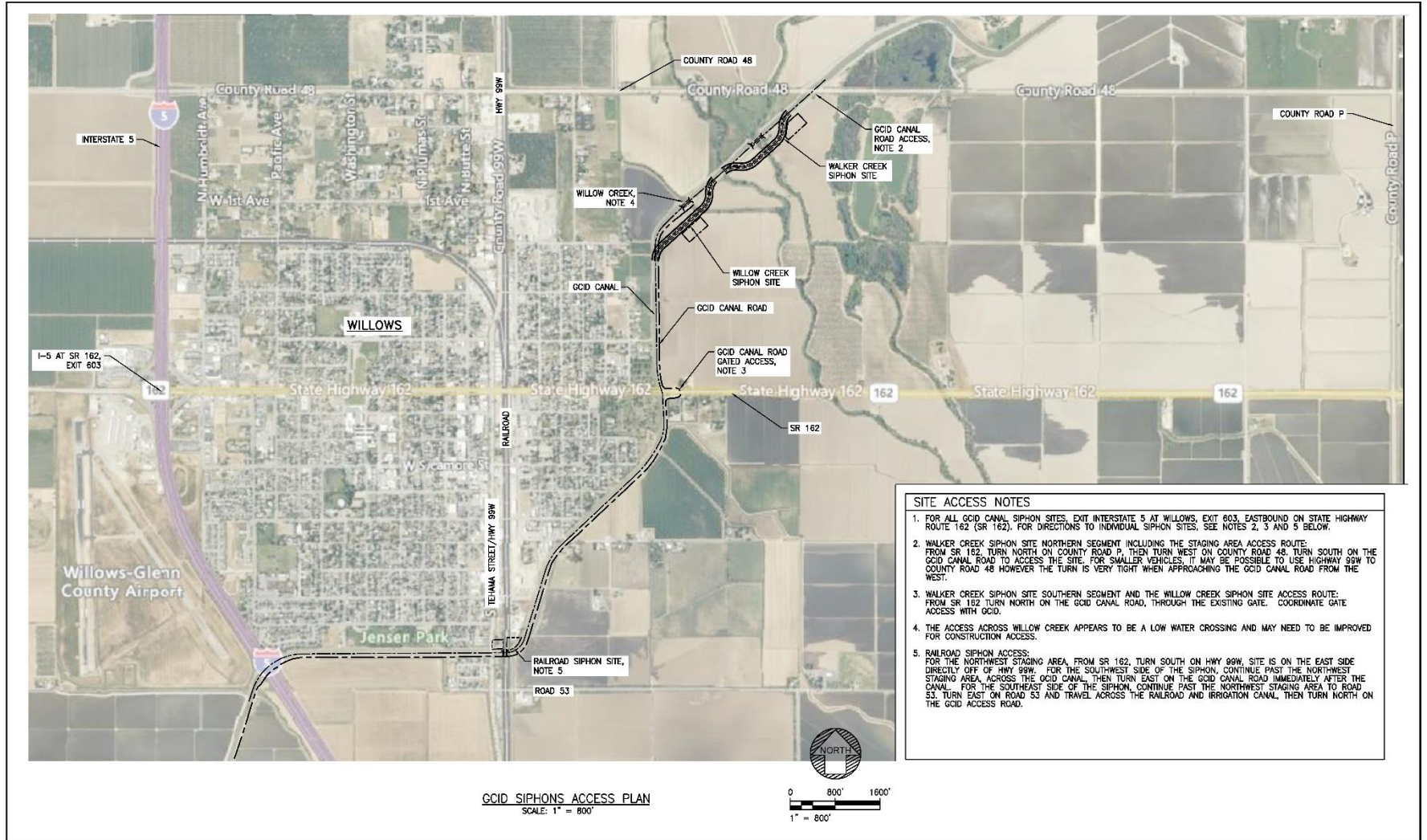
Source: Jacobs, 2021

Figure 2C-11
Overall Location and Access Plan - Terminal Regulating Reservoir West Alt



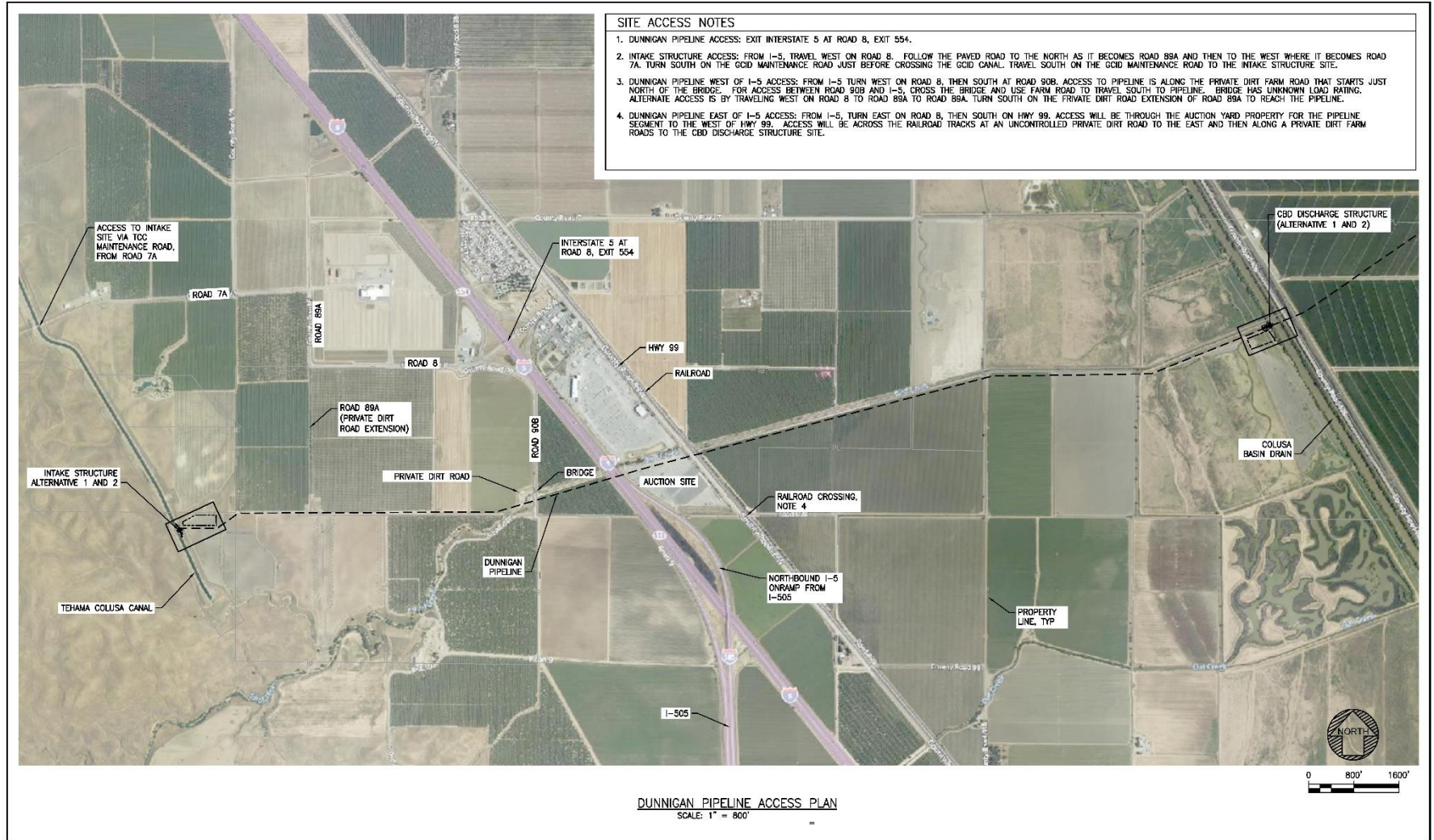
Source: Jacobs, 2021

Figure 2C-12
GCID Main Canal Headgates Access Plan



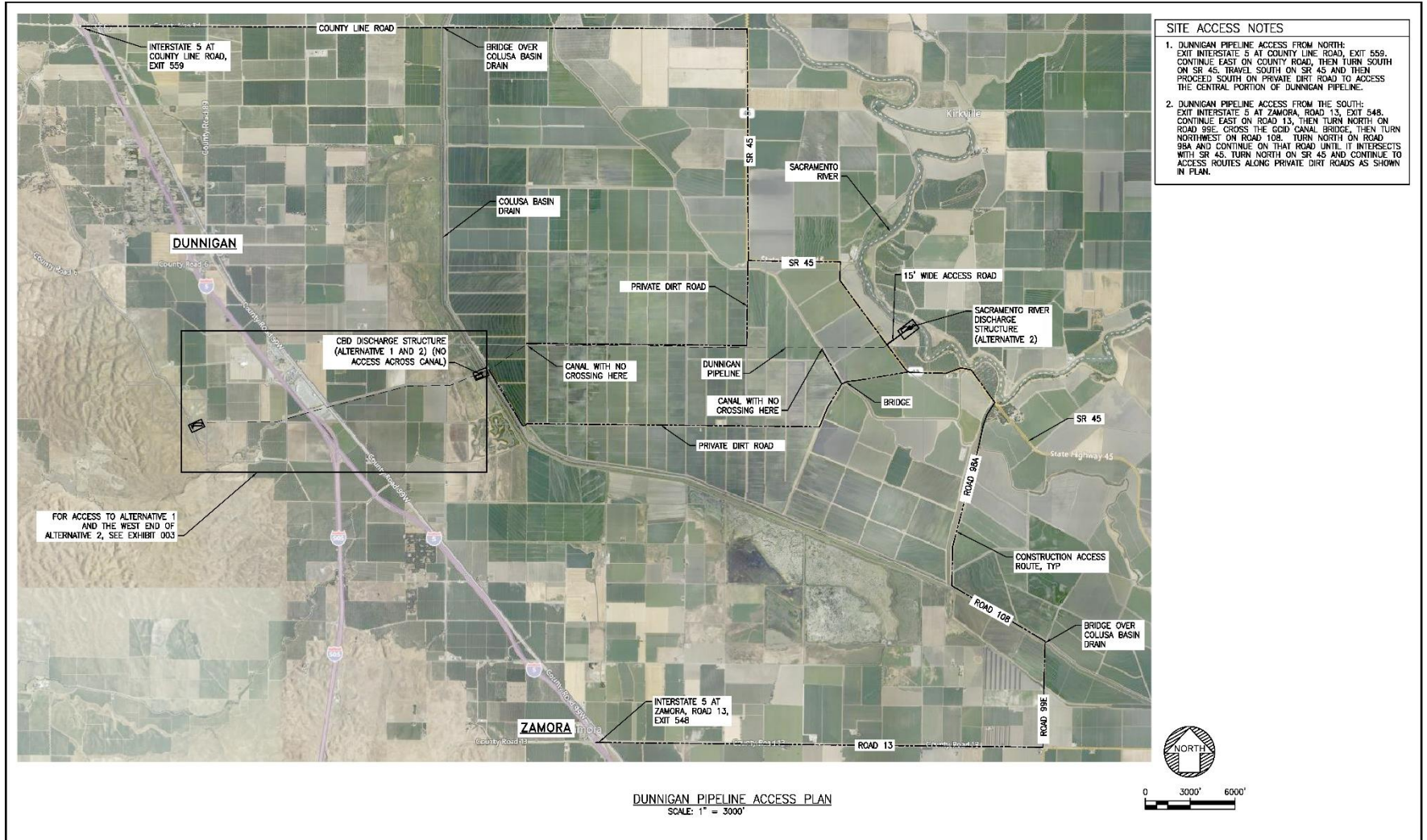
Source: Jacobs, 2021

Figure 2C-13
GCID Siphons Access Plan



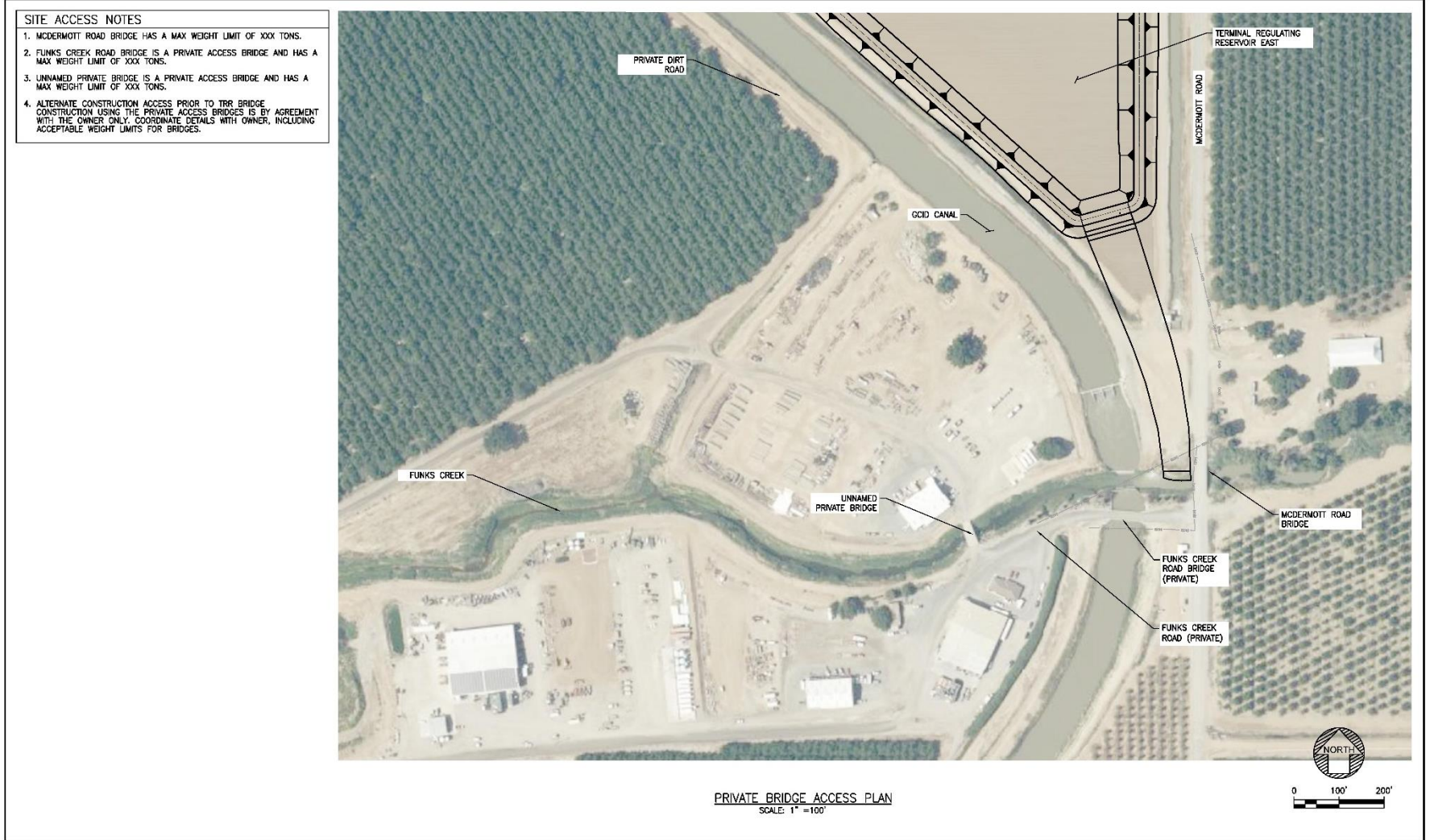
Source: Jacobs, 2021

Figure 2C-14
Dunnigan Pipeline Alts 1 and 2 Access Plan



Source: Jacobs, 2021

Figure 2C-15
Dunnigan Pipeline Alt 2 Access Plan



Source: Jacobs, 2021

Figure 2C-16
Private Bridge Access Plan

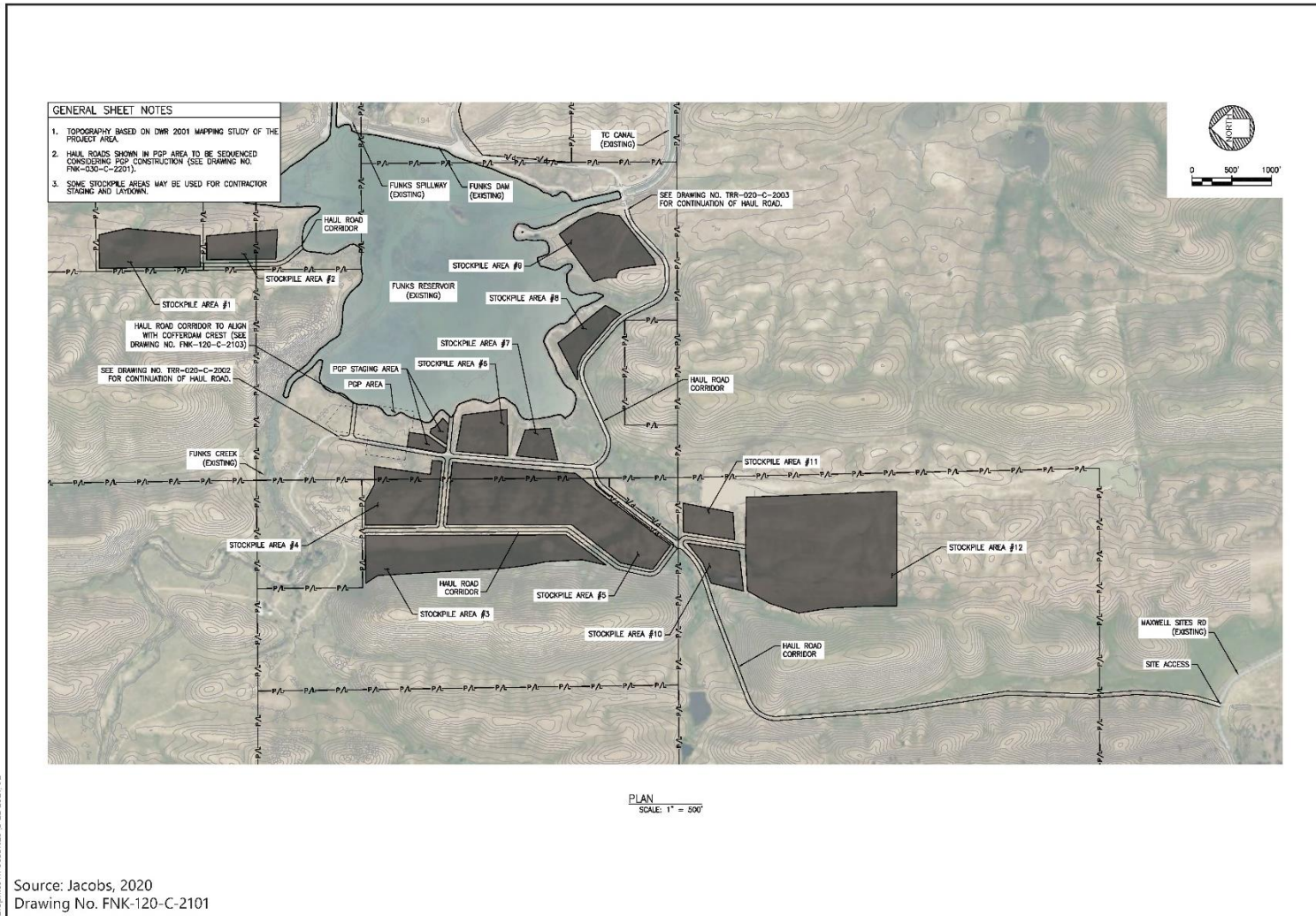
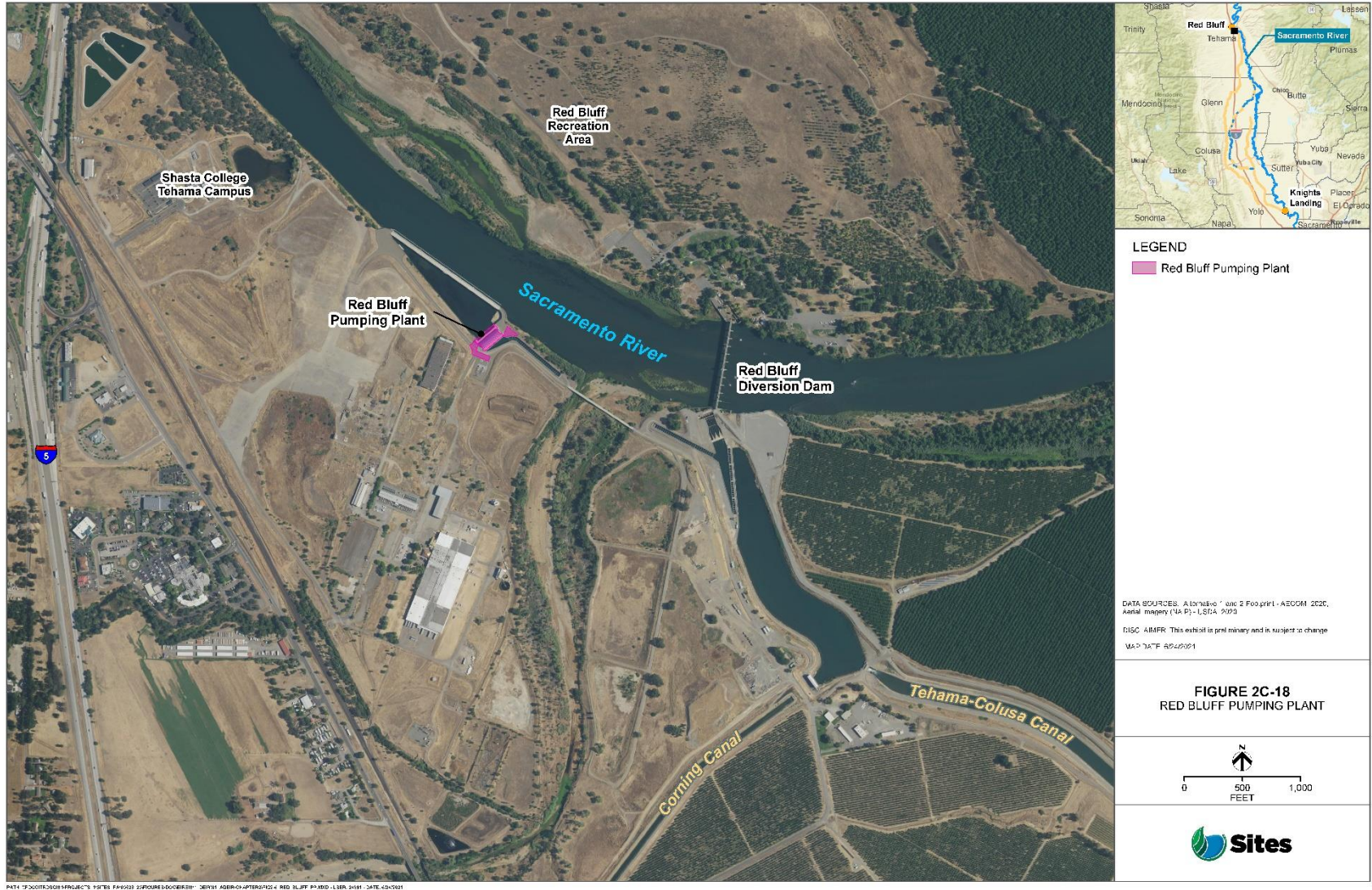


Figure 2C-17
Funks Reservoir Stockpile and Haul Route Plan



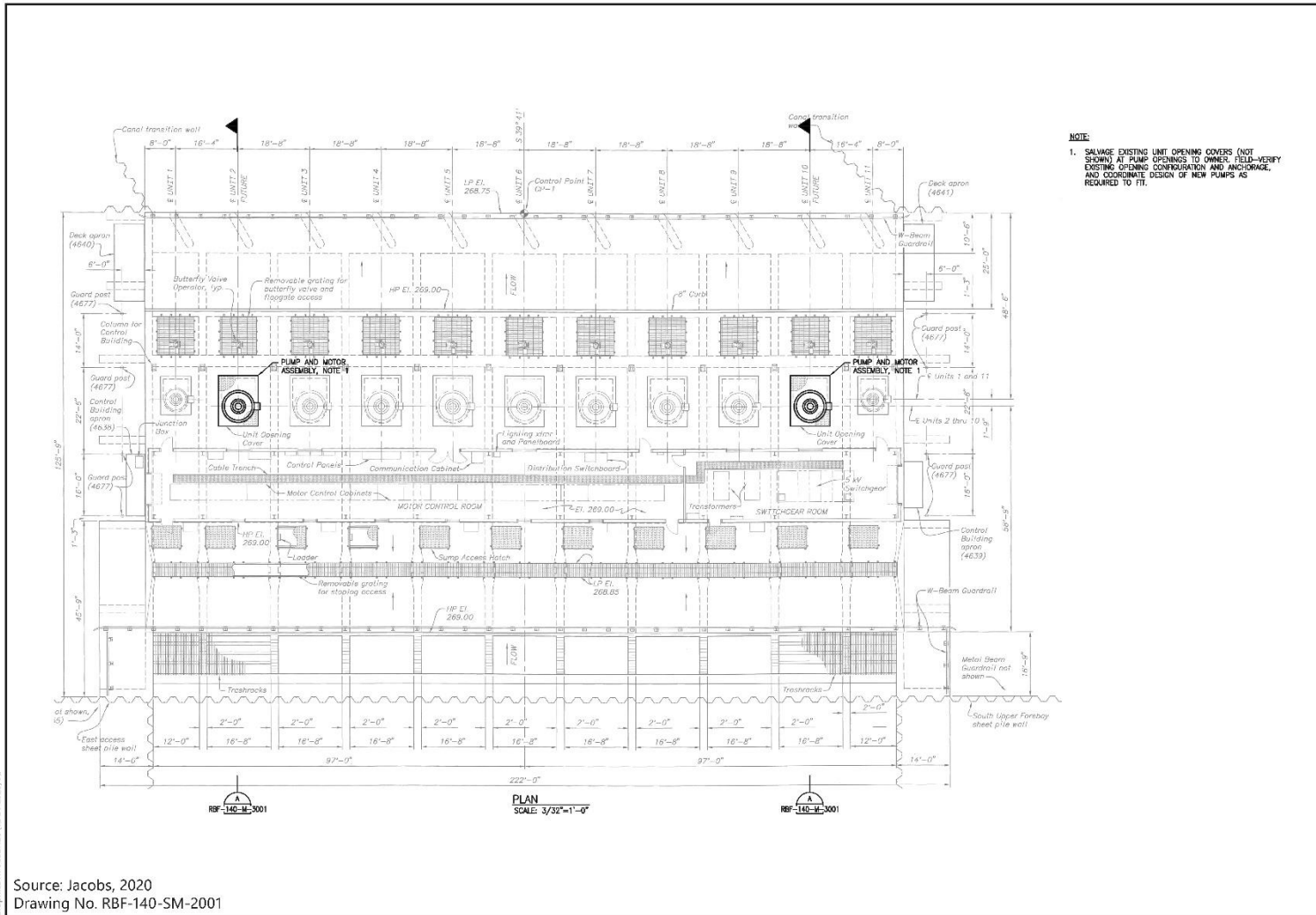


Figure 2C-19
Tehama-Colusa Canal Diversion at Red Bluff Pumping Plant - Plan View

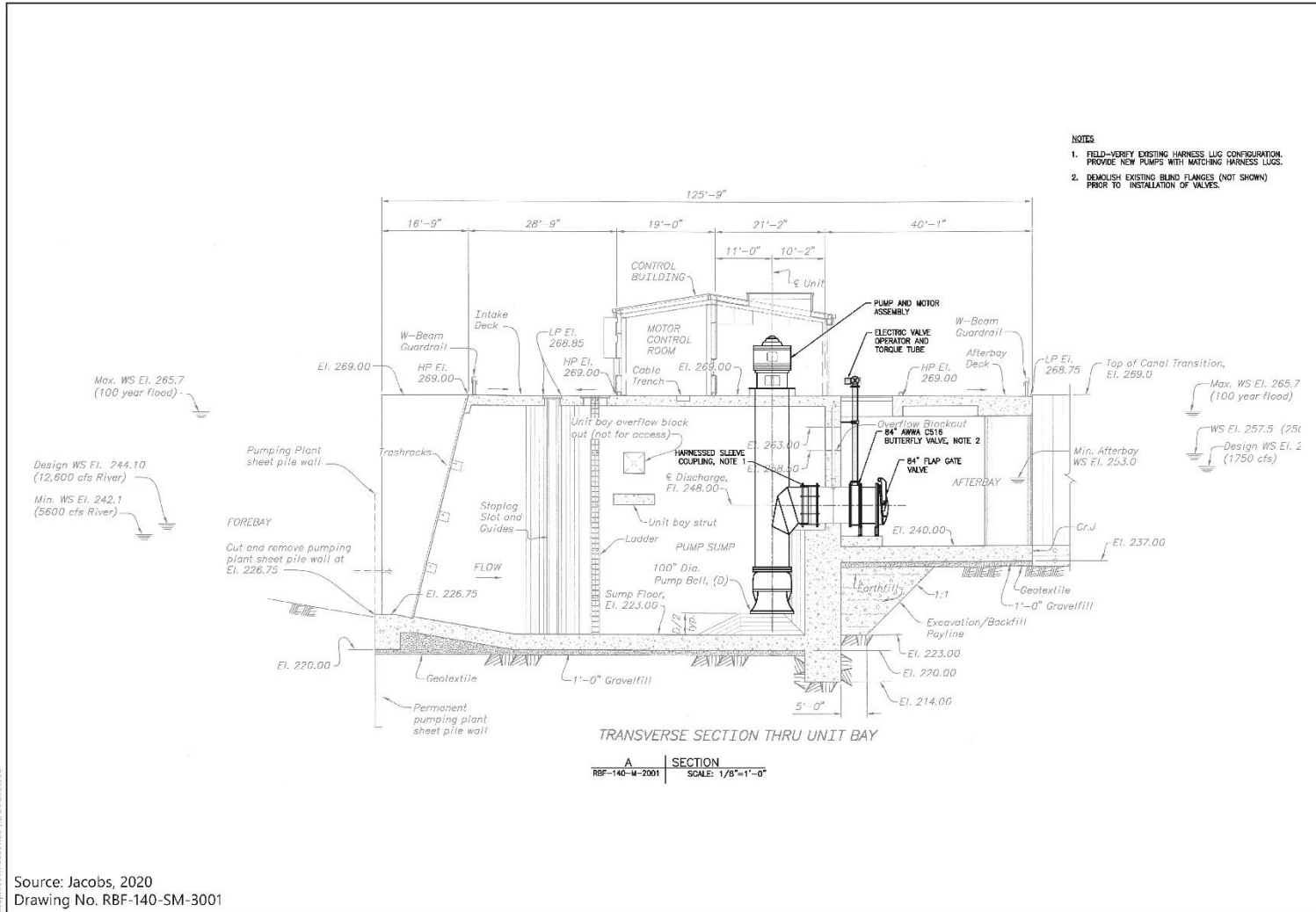


Figure 2C-20
Tehama-Colusa Canal Diversion at Red Bluff Pumping Plant- Profile View

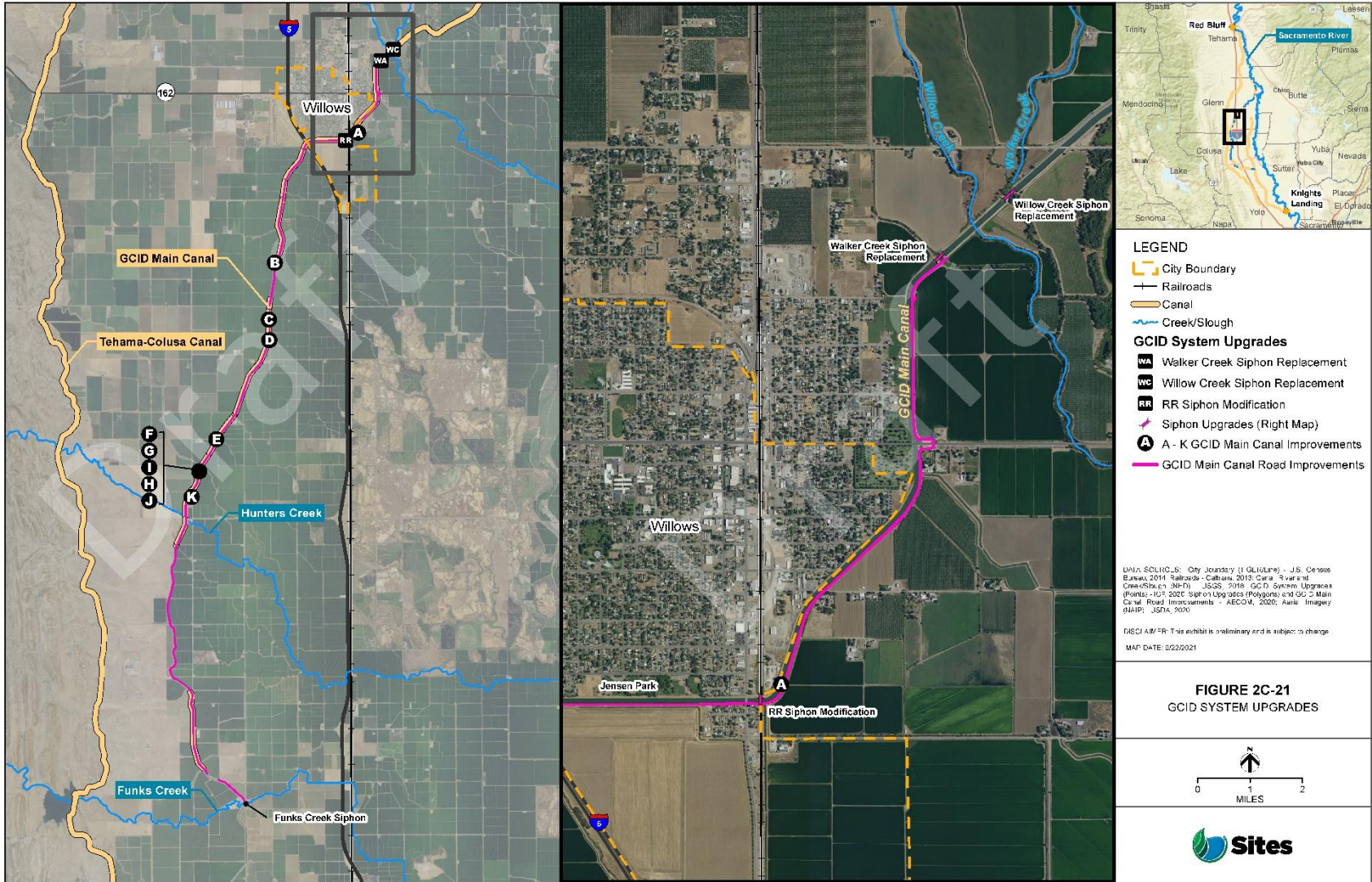




Figure 2C-24
GCID Canal New Head Gate Site Plan

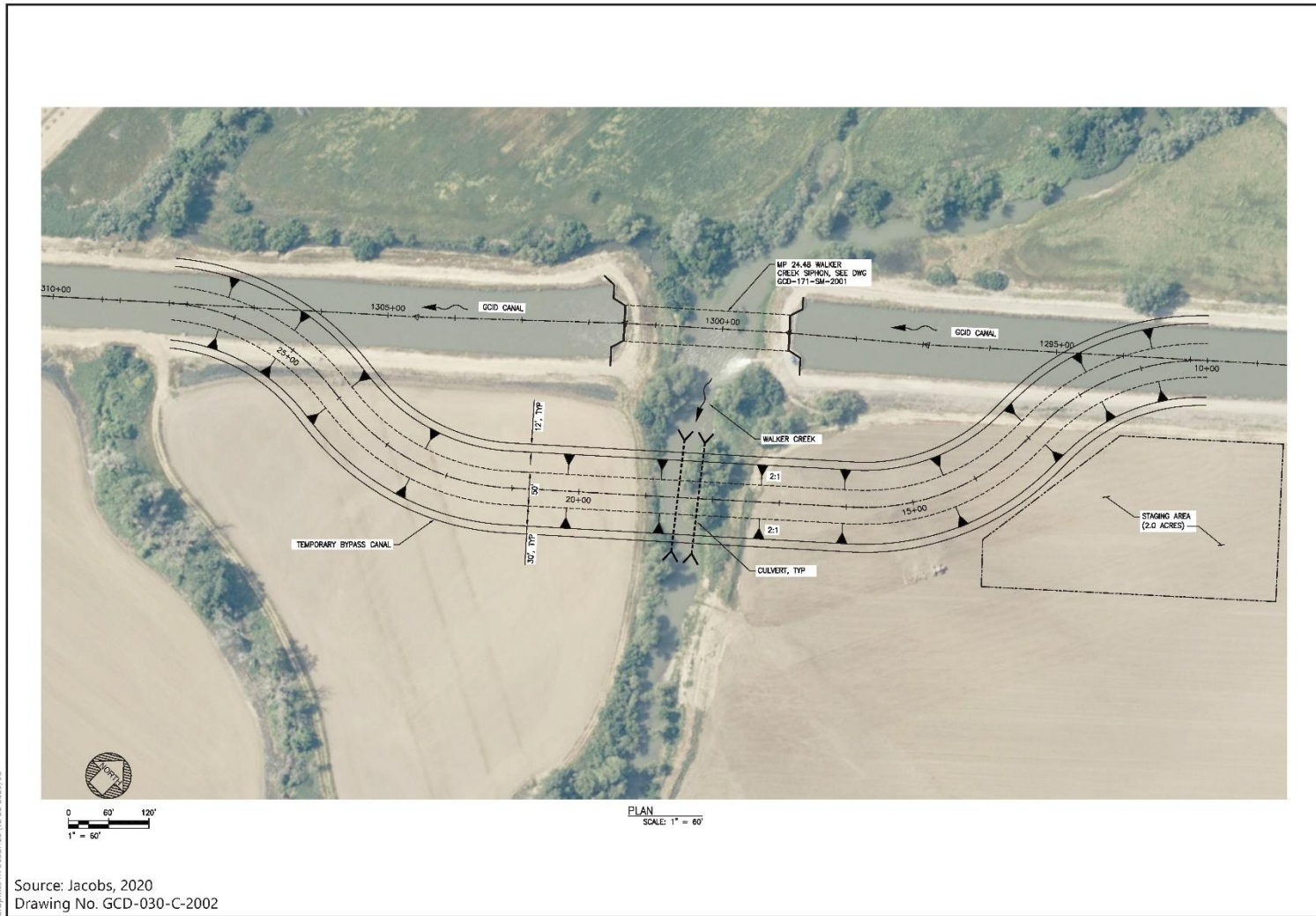


Figure 2C-25
GCID Main Canal Walker Creek Siphon Site Plan



Figure 2C-26
GCID Main Canal Willow Creek Siphon Site Plan

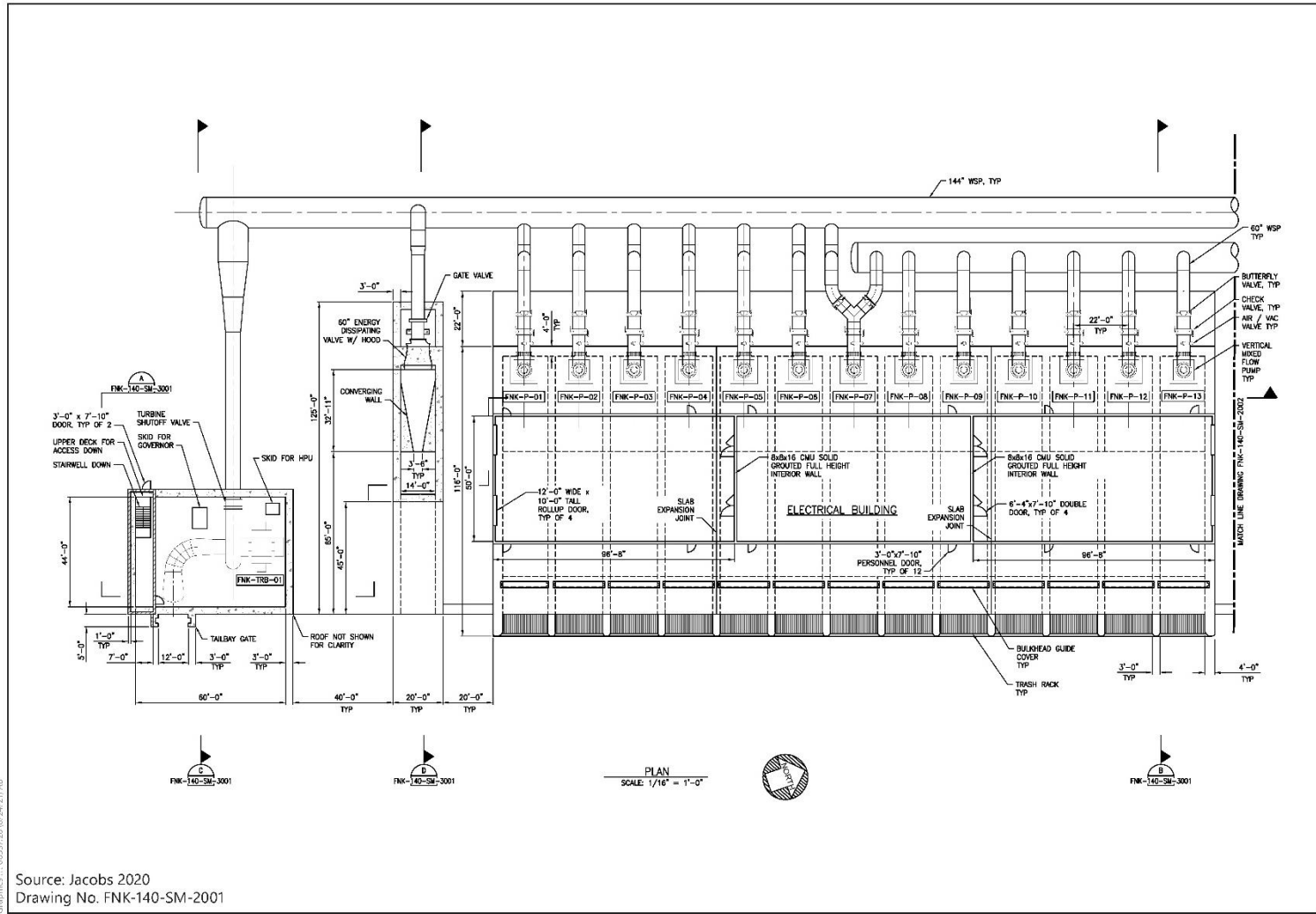
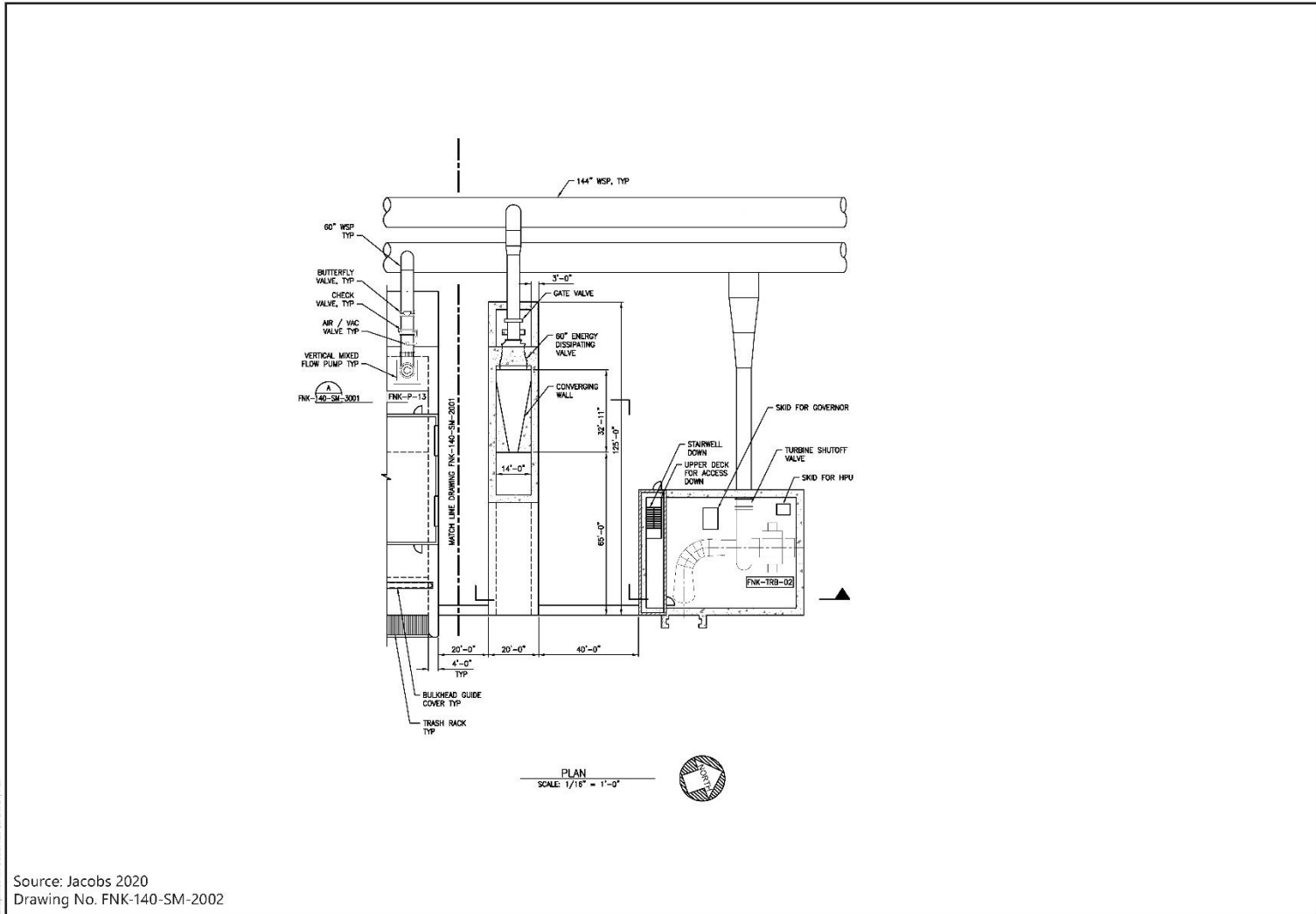


Figure 2C-28A
Funks Pumping Generating Plant Facilities



Source: Jacobs 2020
Drawing No. FNK-140-SM-2002

Figure 2C-28B
Funks Pumping Generating Plant Facilities

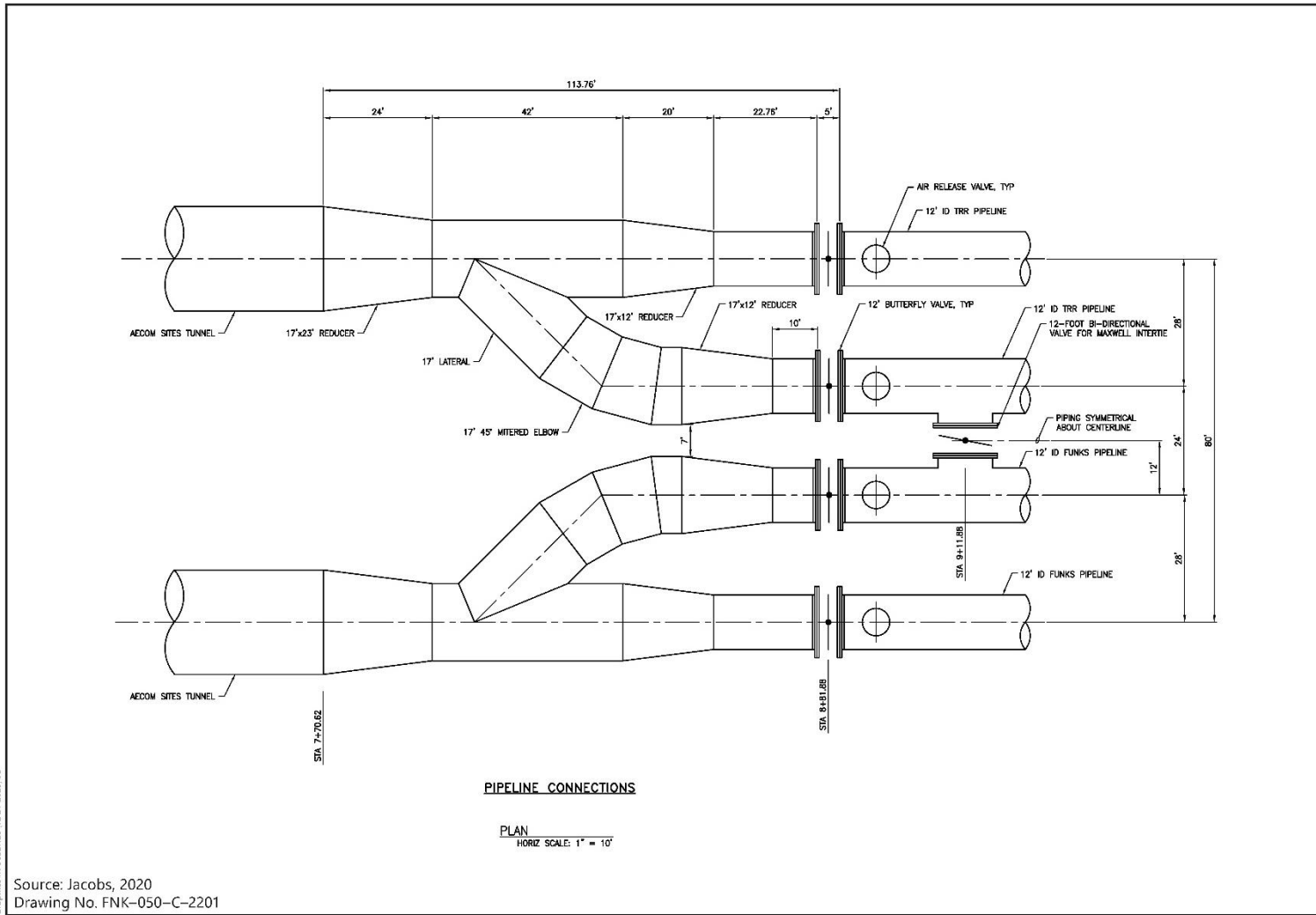


Figure 2C-29
Transition Manifold

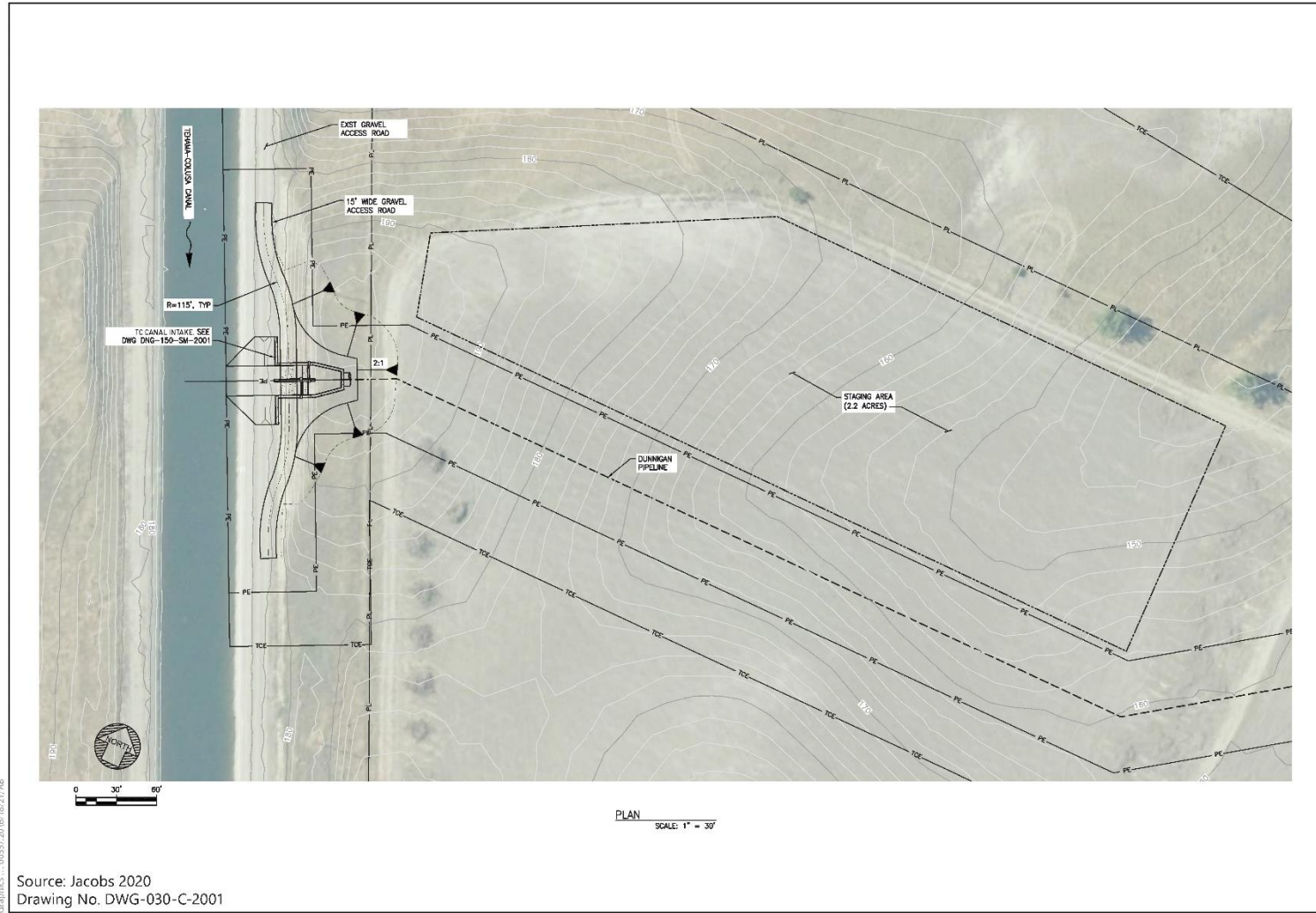


Figure 2C-30
TC Canal Intake Site Plan

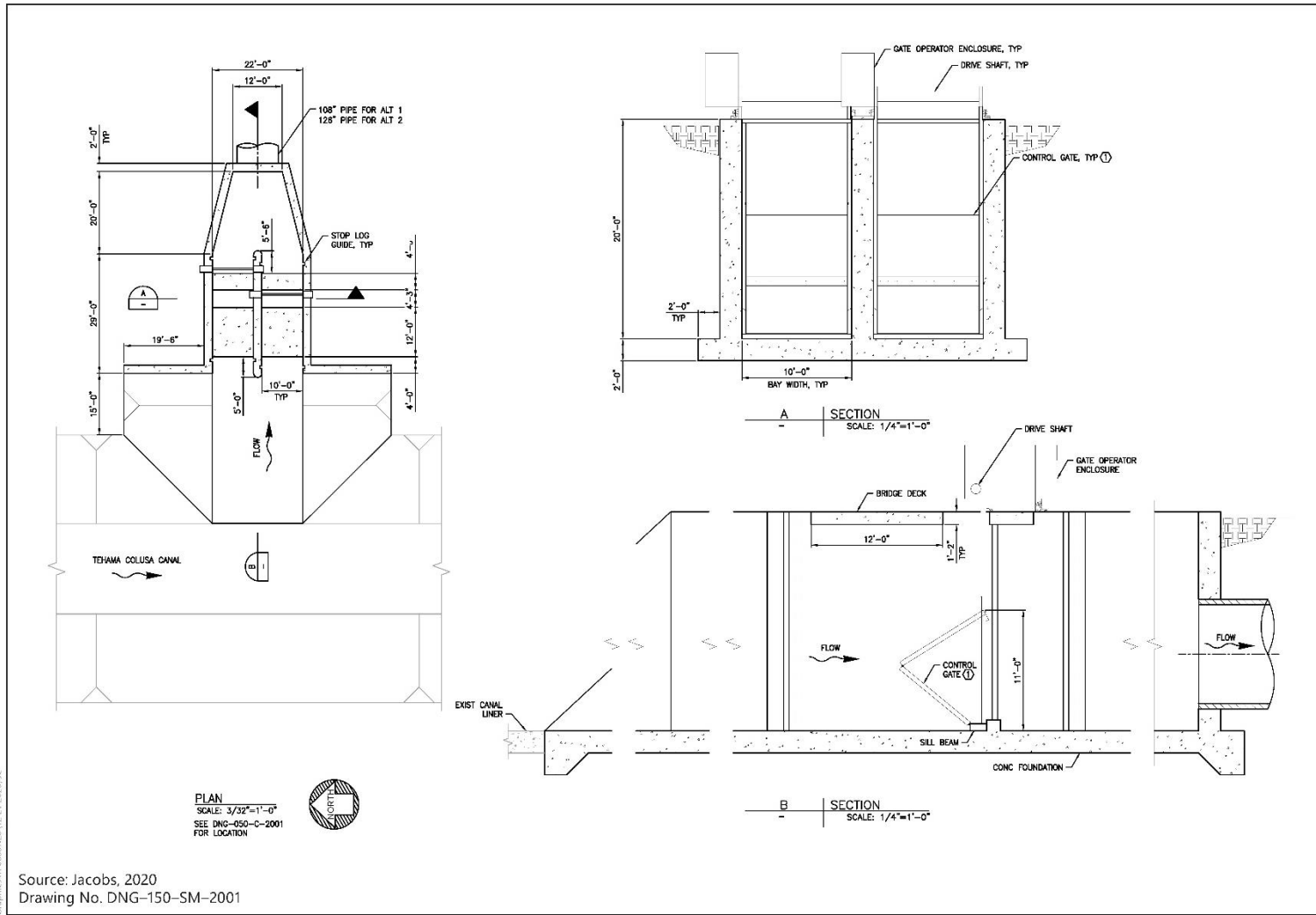


Figure 2C-31
TC Canal Dissipation Structure

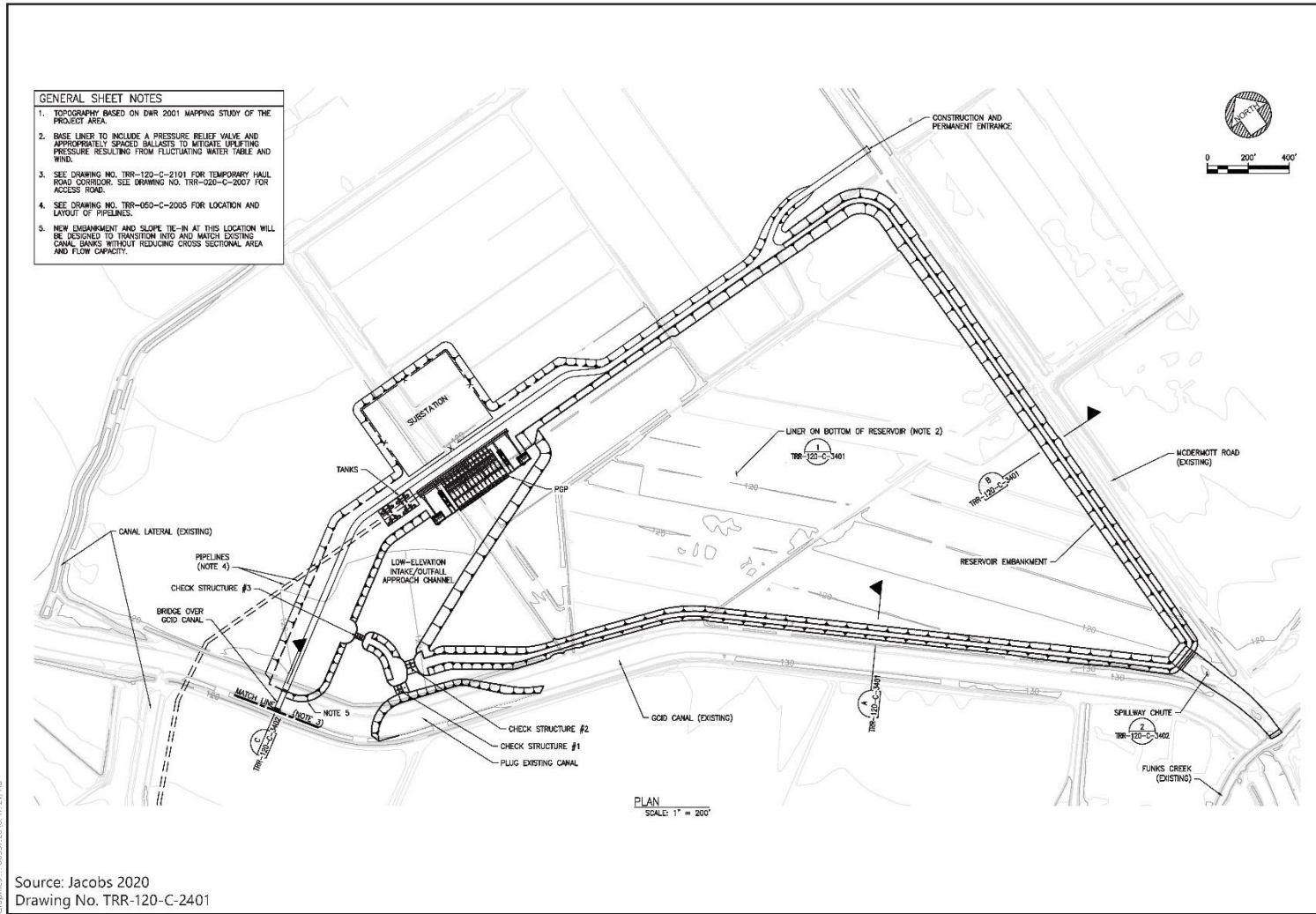


Figure 2C-32
Terminal Regulating Reservoir East Facilities Site Plan

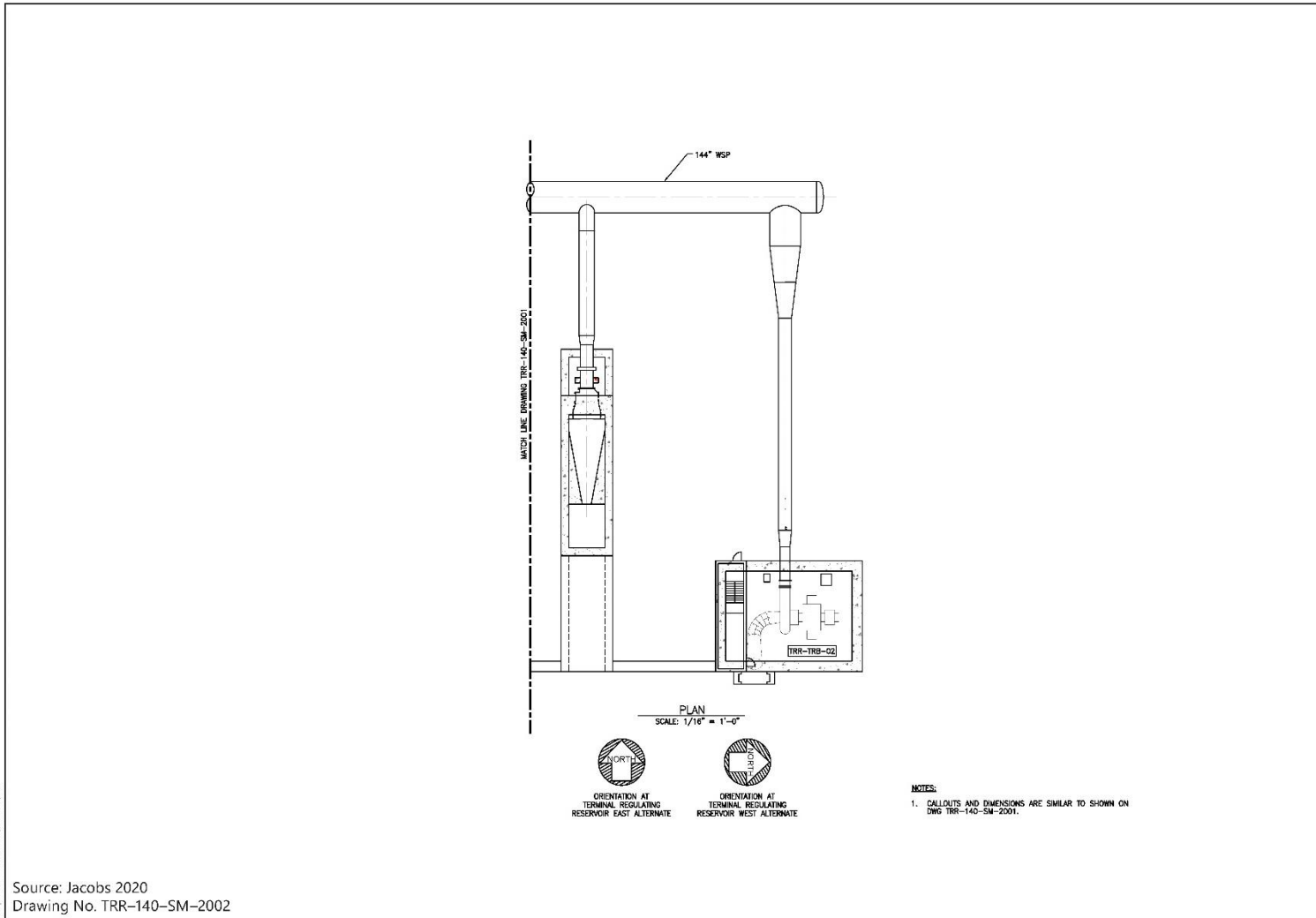
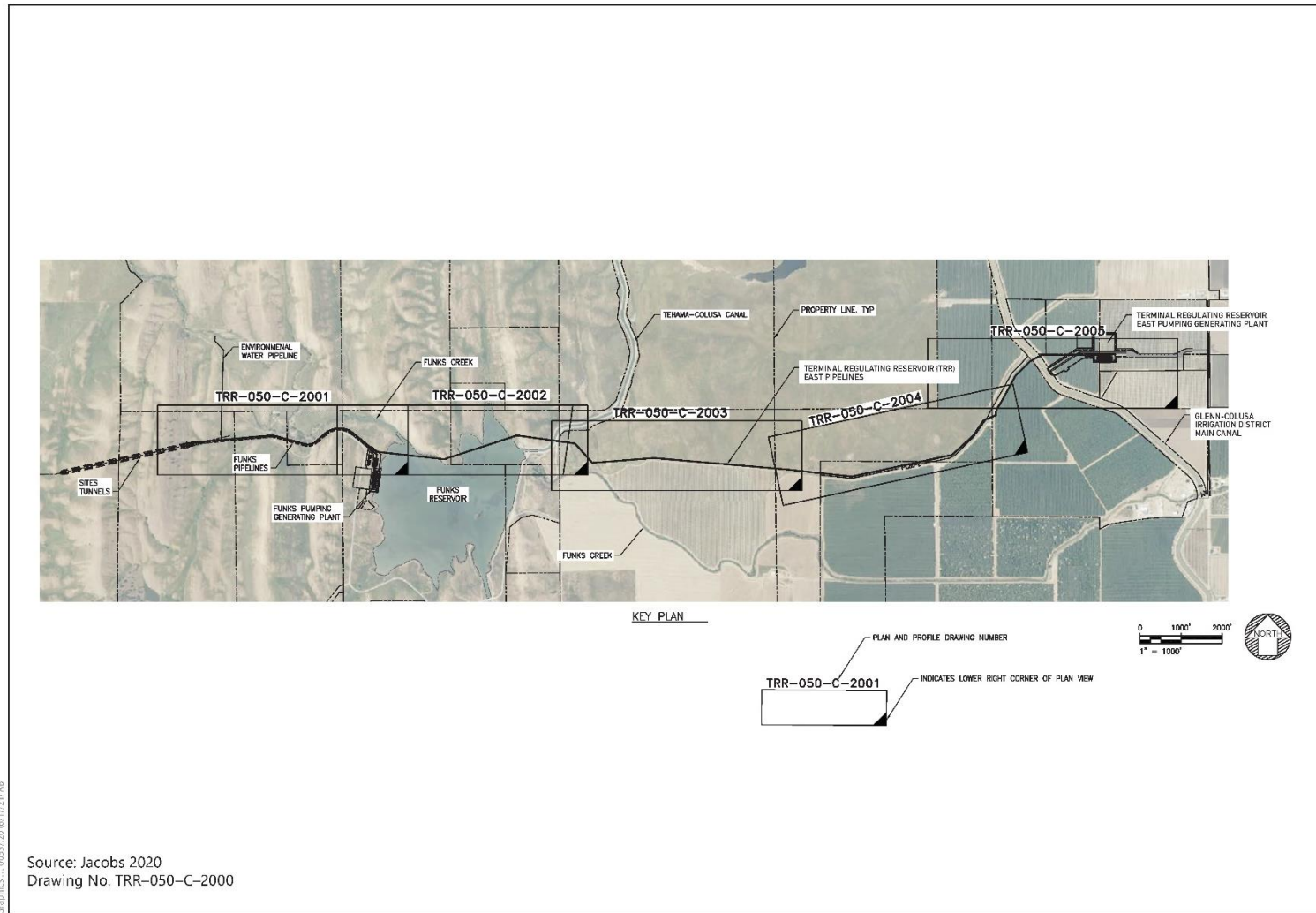


Figure 2C-33B
Terminal Regulating Reservoir East and West Alts Pumping Generating Plant



Source: Jacobs 2020
 Drawing No. TRR-050-C-2000

Figure 2C-34
Terminal Regulating Reservoir East Pipelines

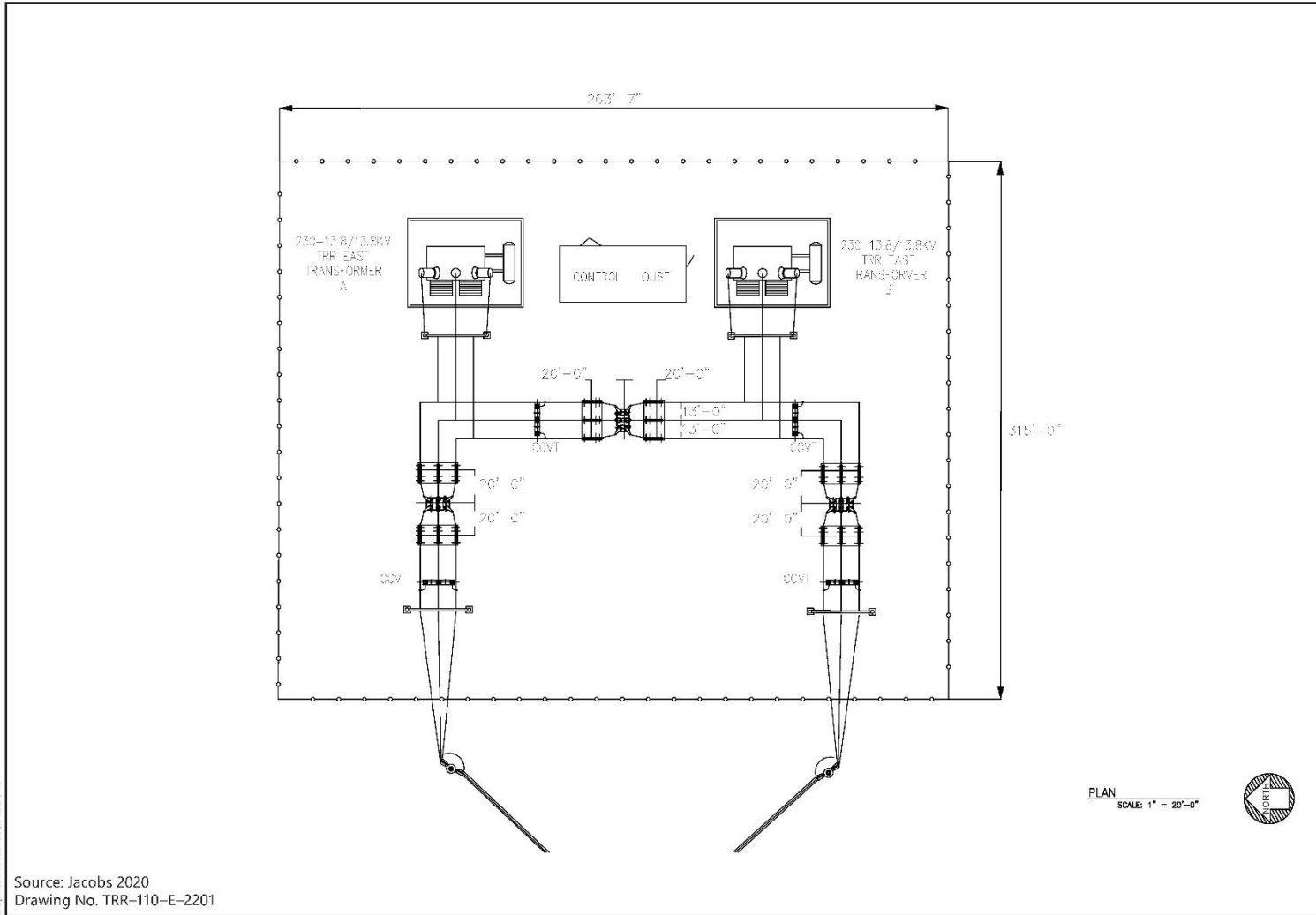
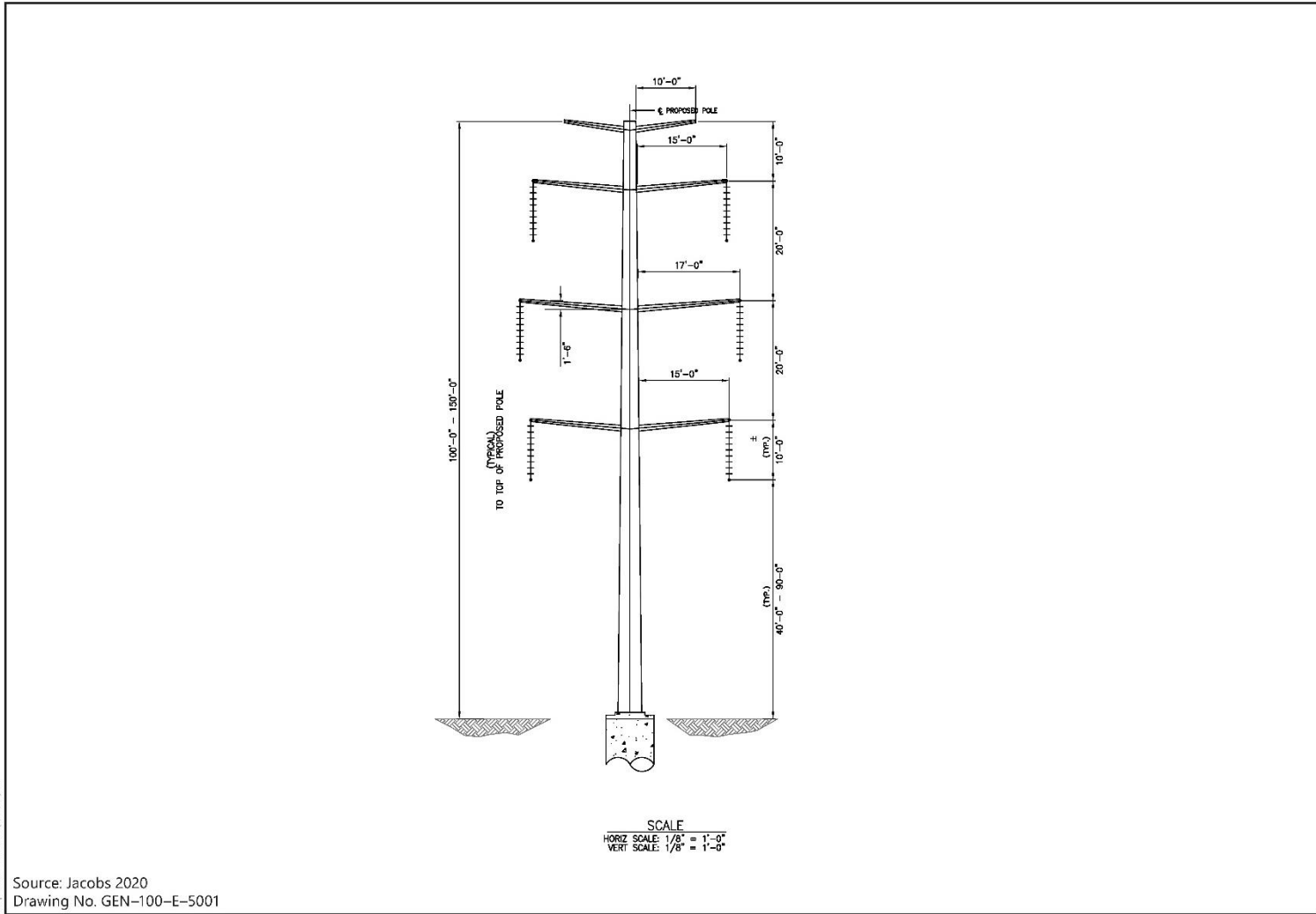


Figure 2C-35
Terminal Regulating Reservoir East or West Substation



Graphics: 00337.20/06/16/21/AB

Source: Jacobs 2020
Drawing No. GEN-100-E-5001

Figure 2C-36
Double-Circuit Source Transmission Poles

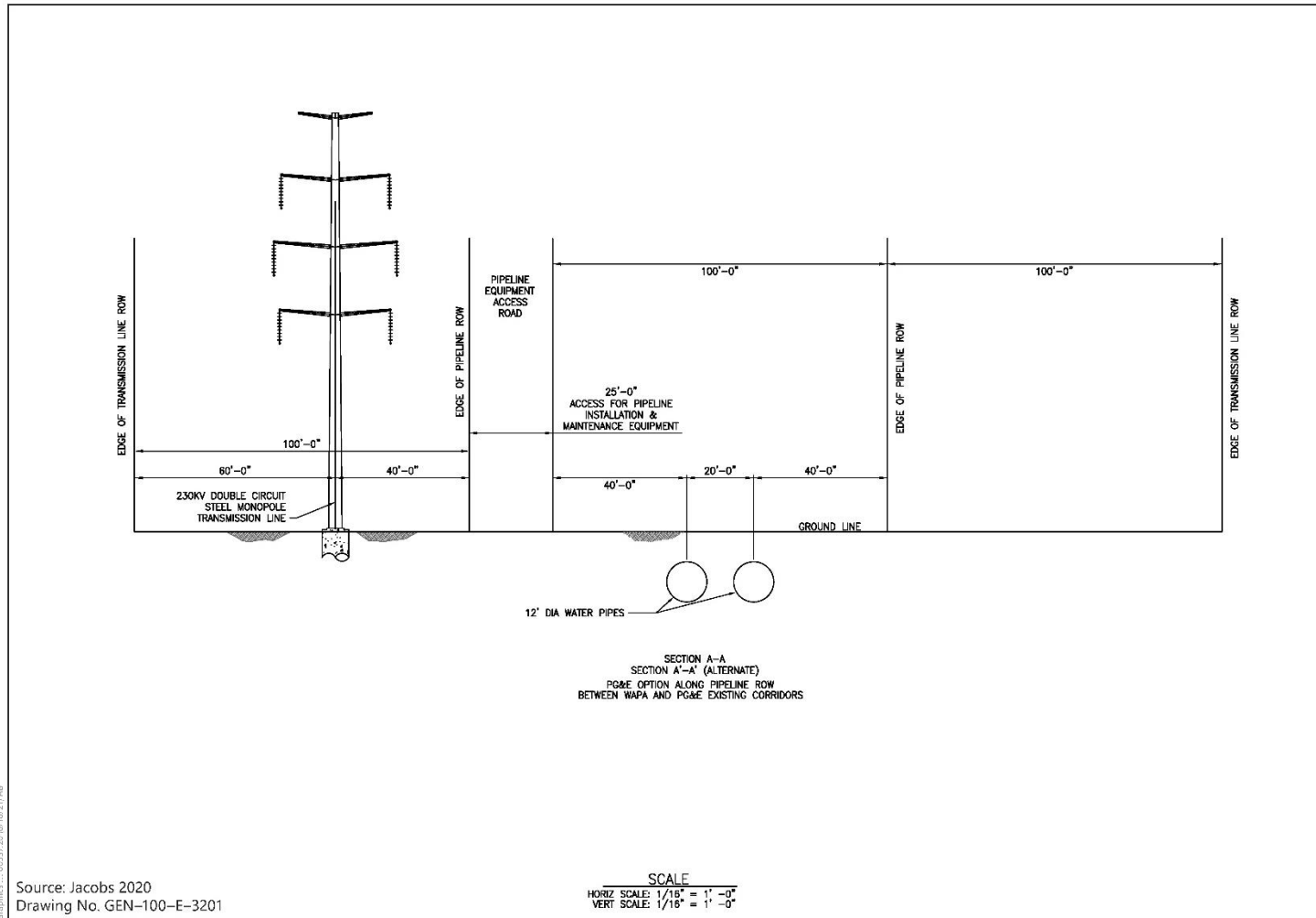
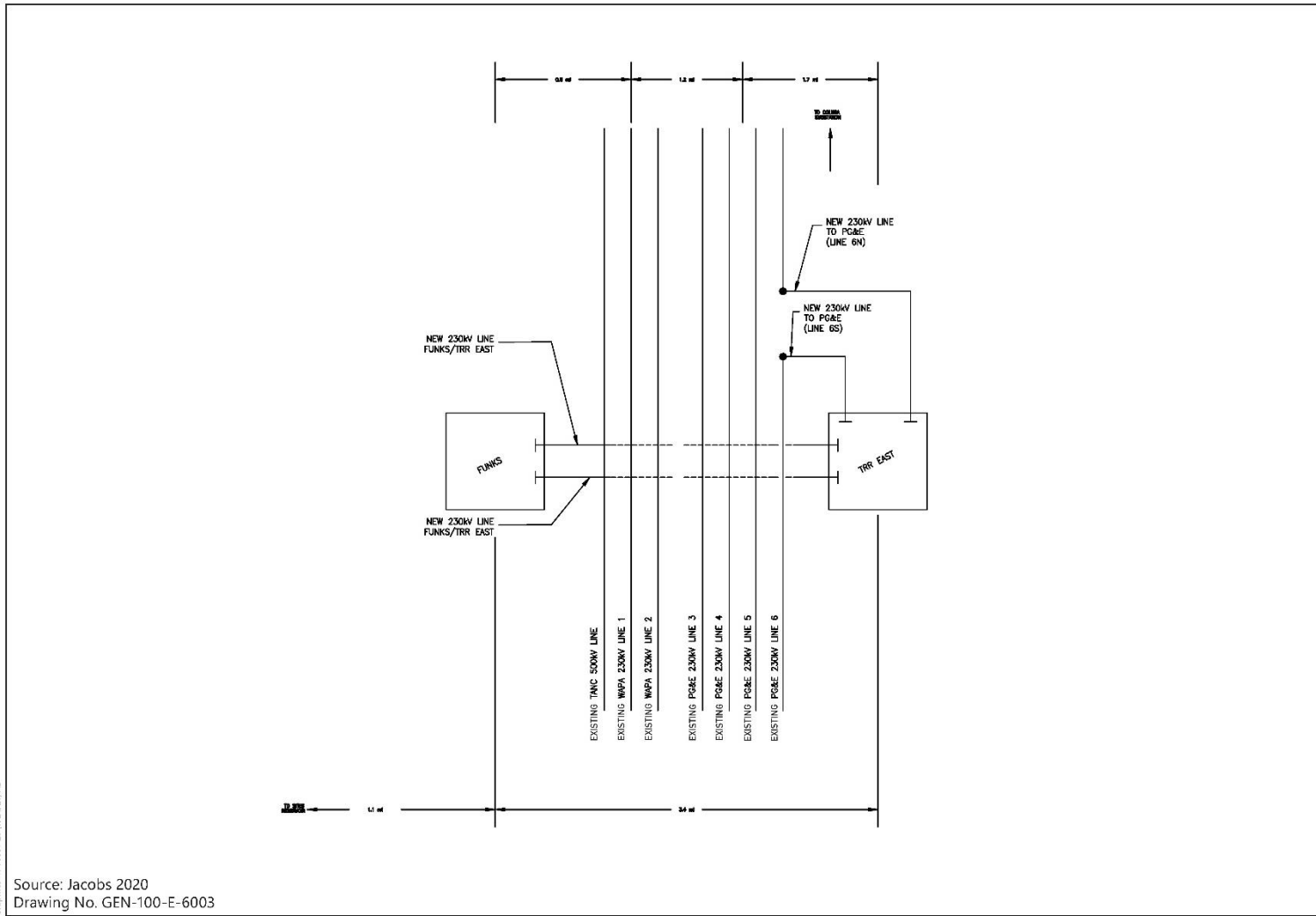


Figure 2C-37
Alternatives 1 and 3 Funks Reservoir to
Terminal Regulating Reservoir East or West Electrical Interconnection



Graphics: ...0653720 (6/24/21) AB

Source: Jacobs 2020
Drawing No. GEN-100-E-6003

Figure 2C-38
PG&E Schematic Sketch

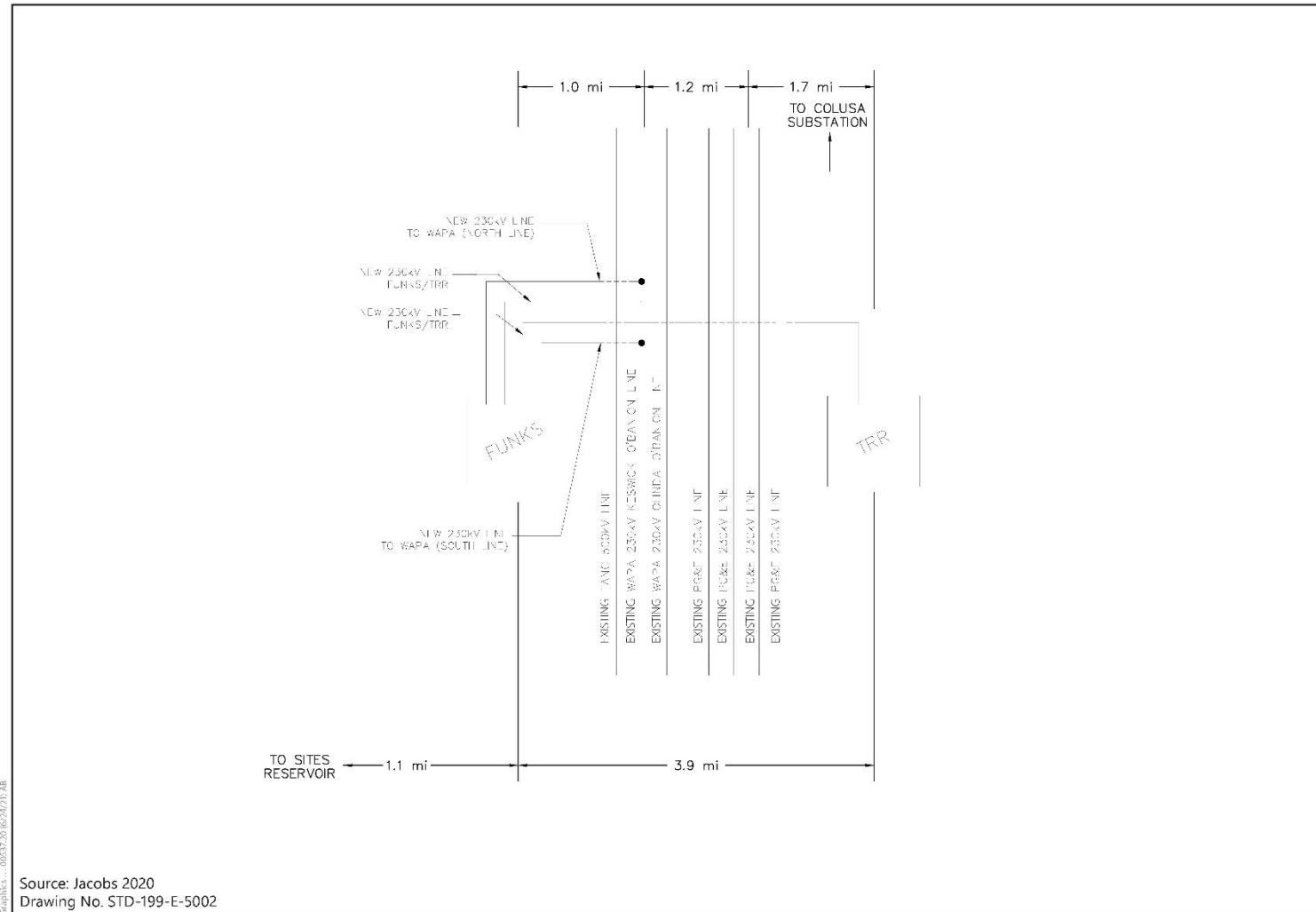
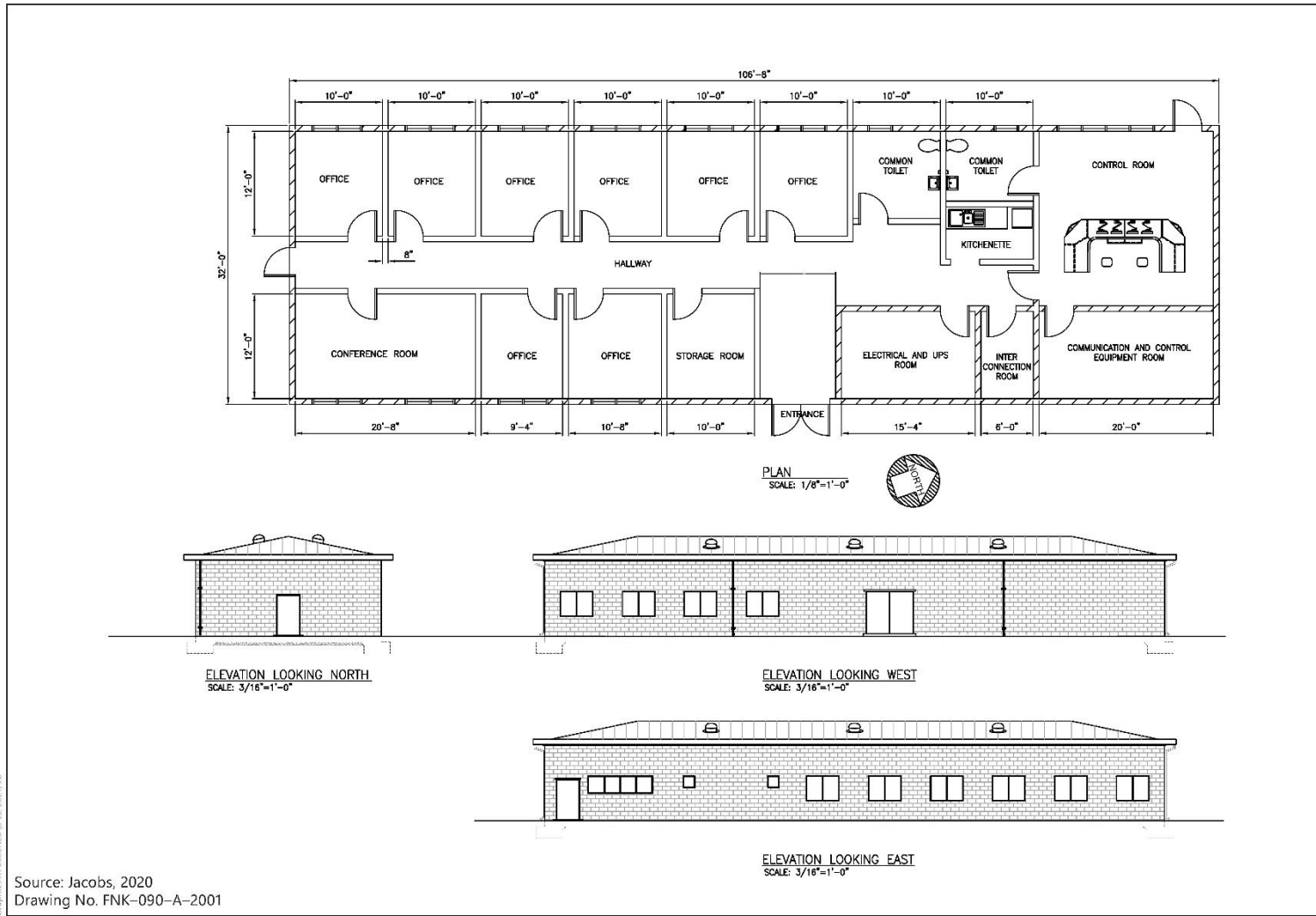


Figure 2C-39
WAPA Schematic Sketch



Graphics: 065372019-22-2021)JC

Source: Jacobs, 2020
Drawing No. FNK-090-A-2001

Figure 2C-40
Administration and Operations Building

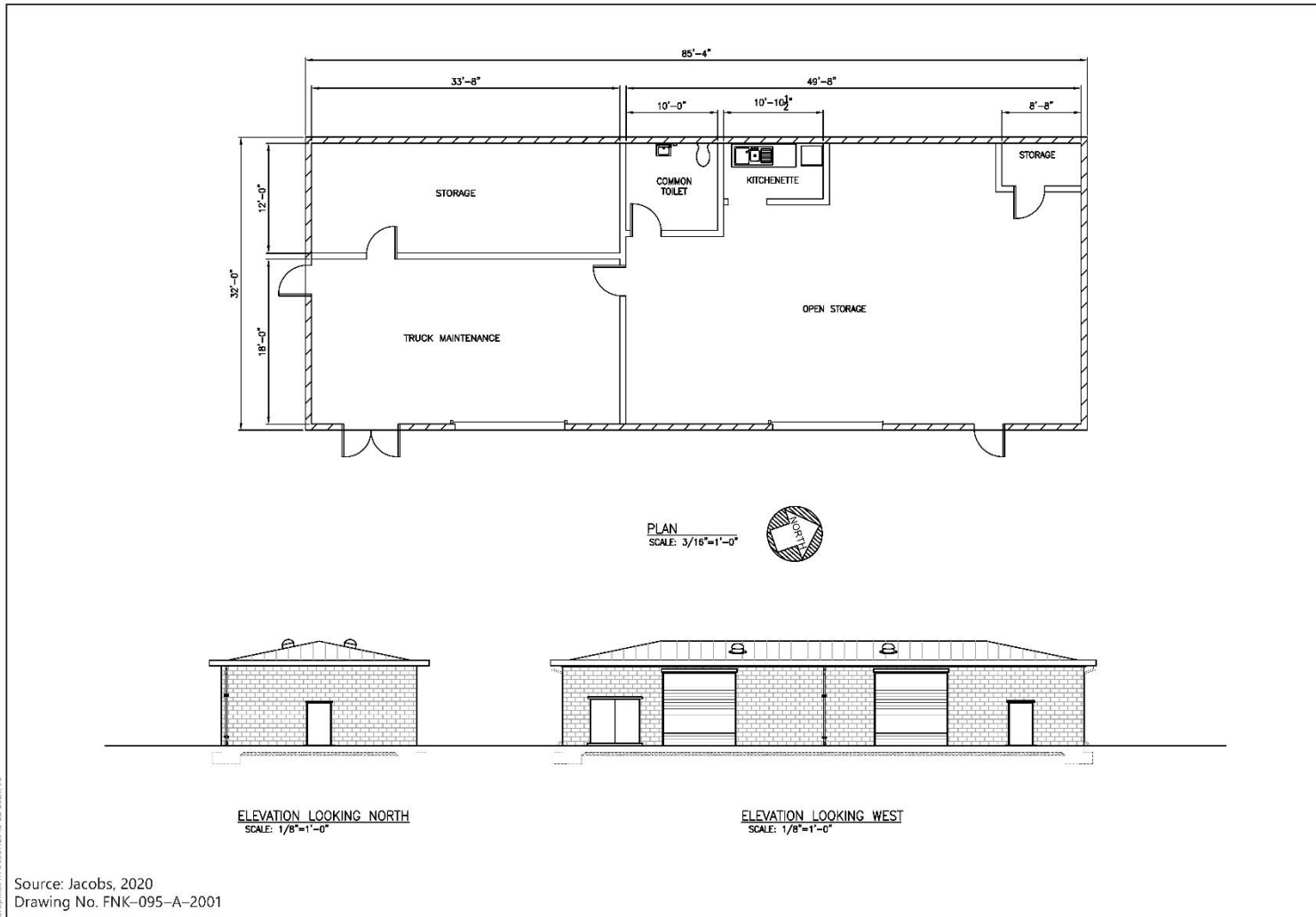


Figure 2C-41
Maintenance and Storage Building

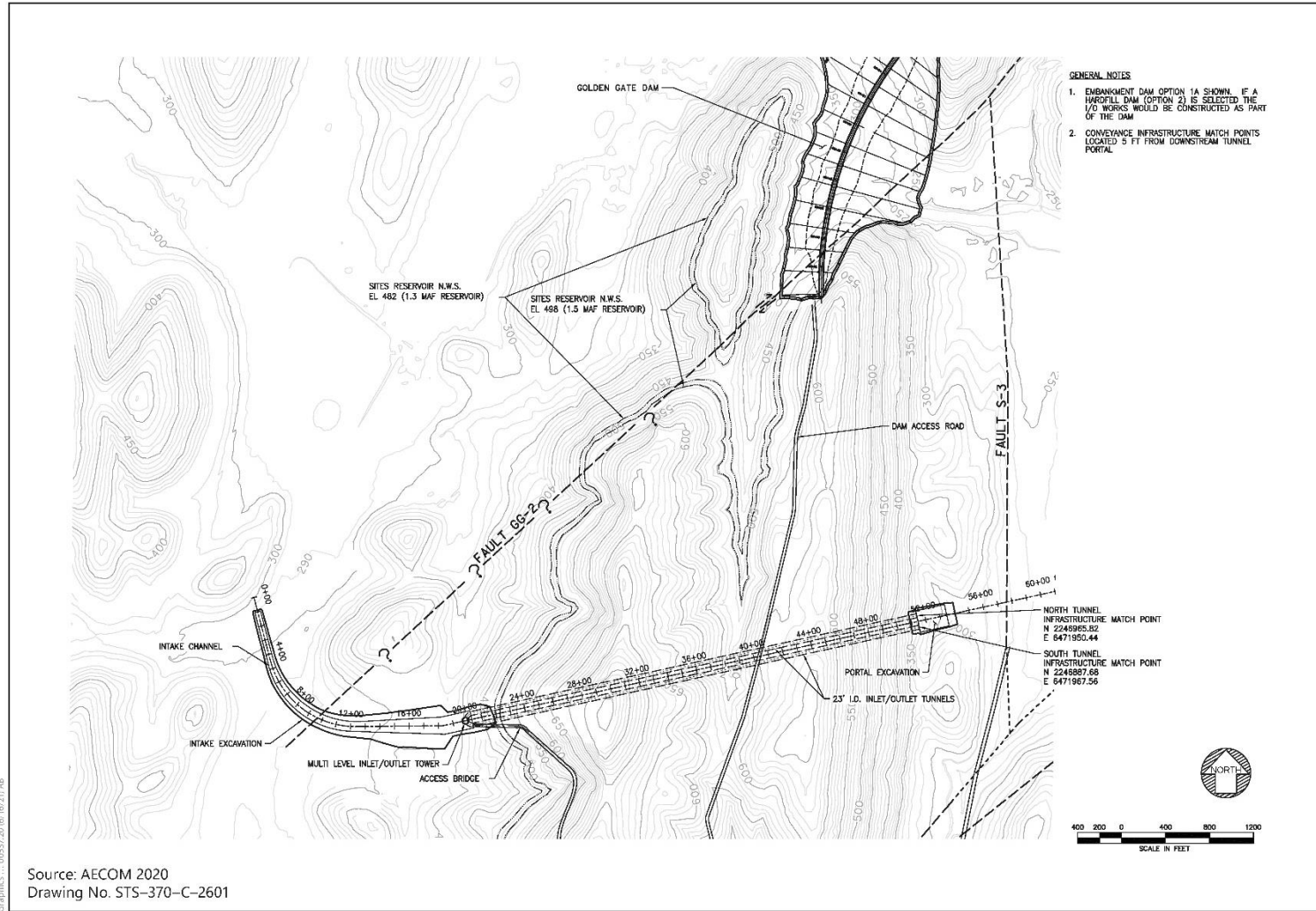
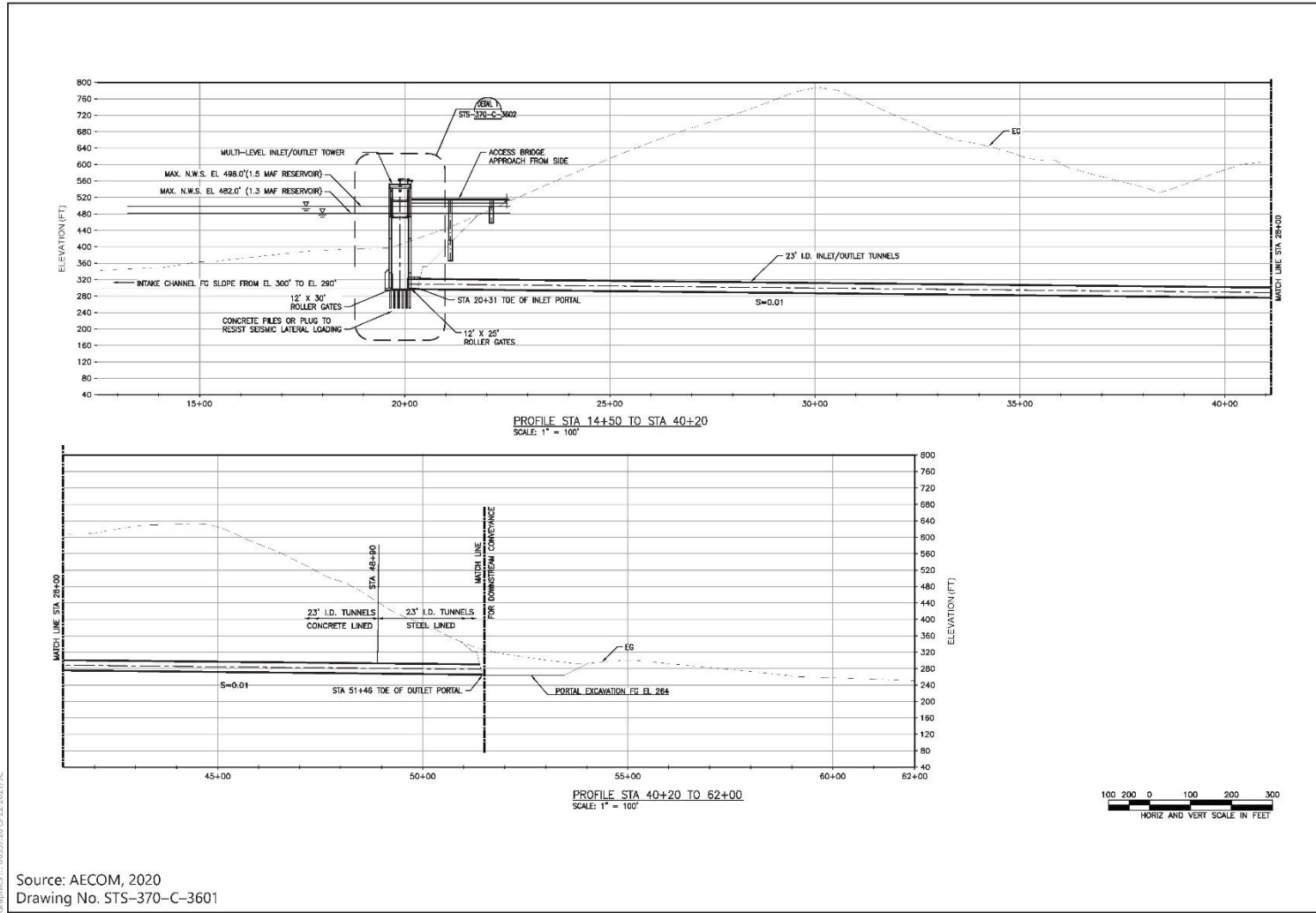
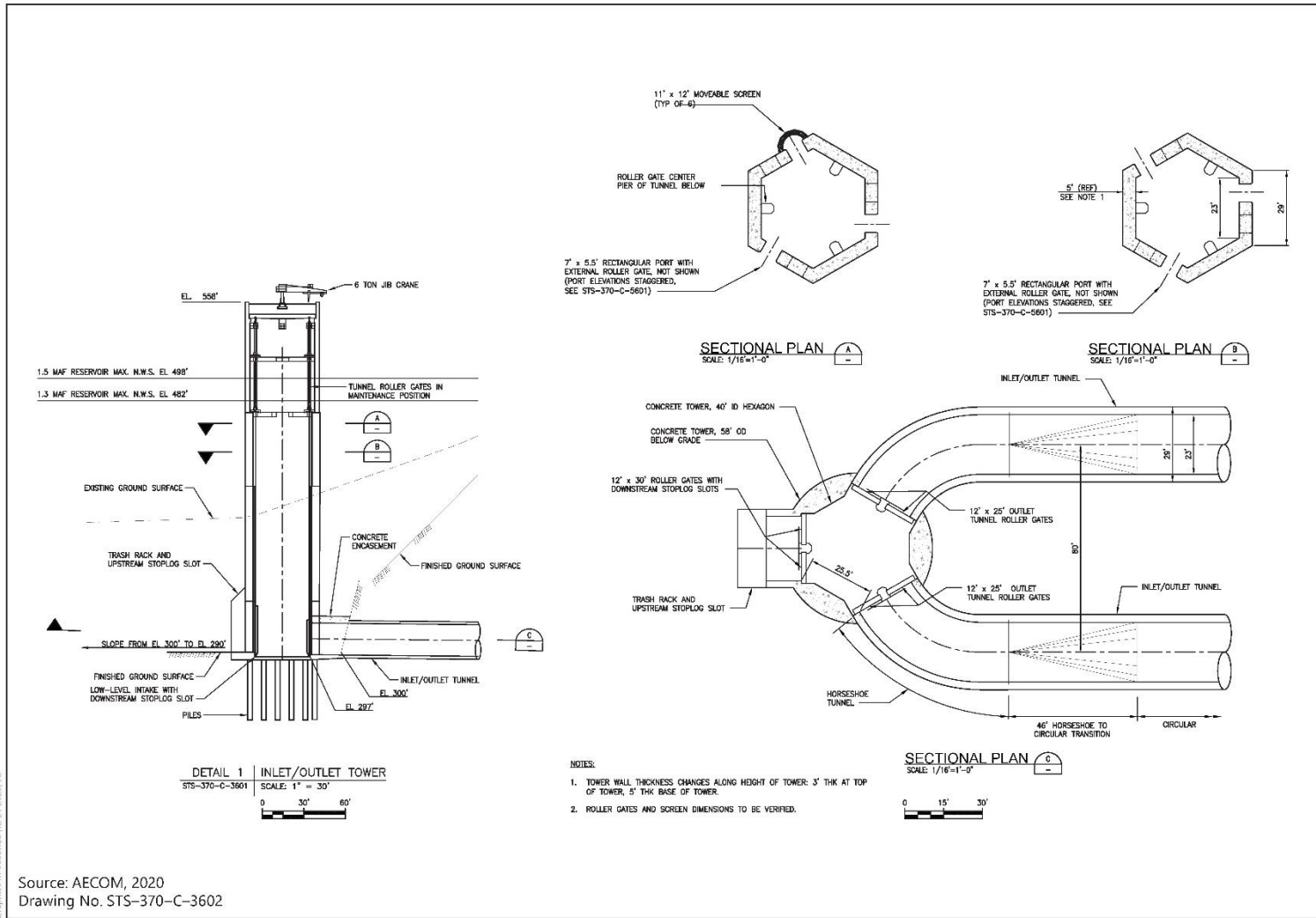


Figure 2C-42
Plan of Inlet/Outlet Works Site



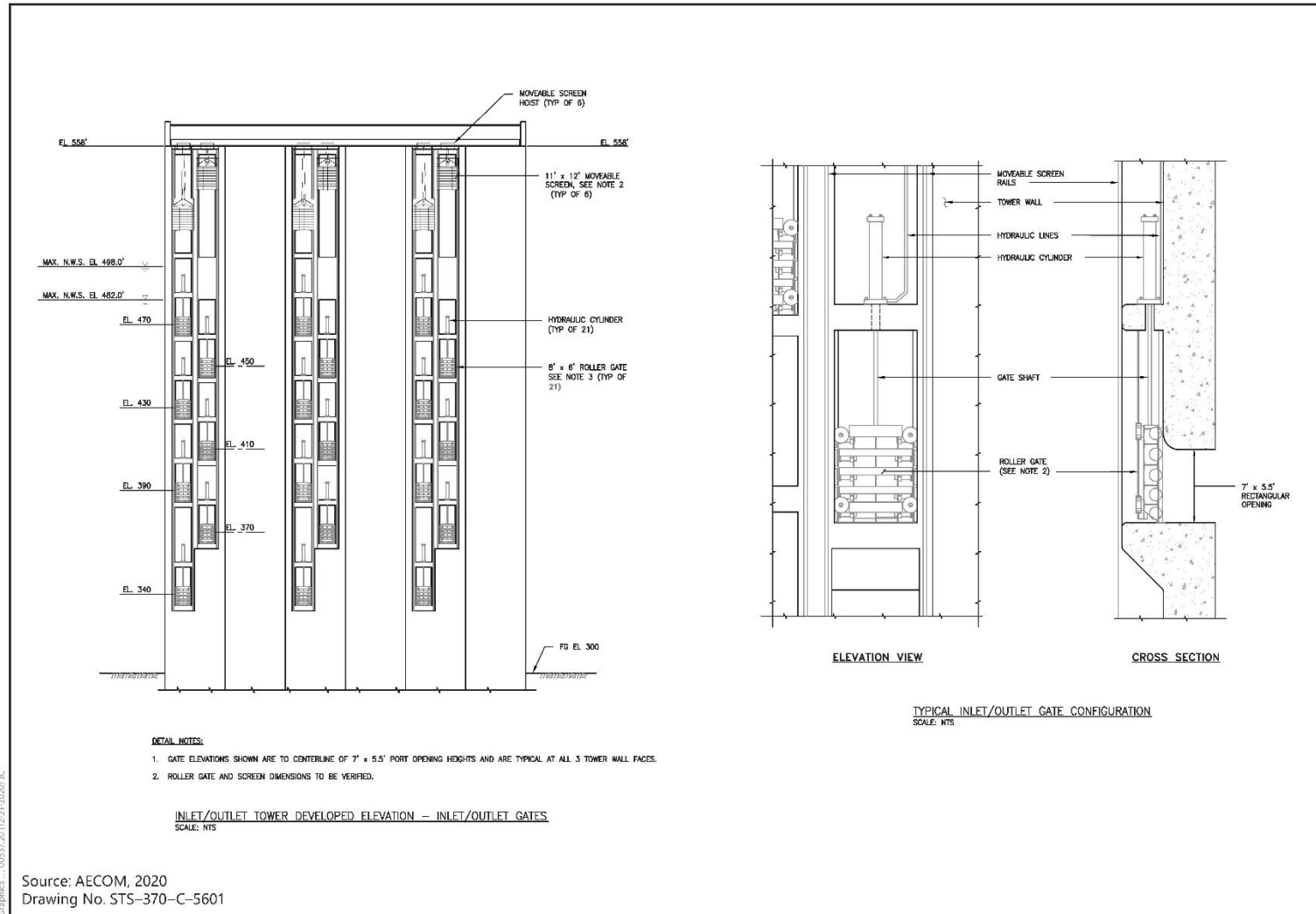
Source: AECOM, 2020
Drawing No. STS-370-C-3601

Figure 2C-43
Profile of Inlet/Outlet Works Site



Source: AECOM, 2020
Drawing No. STS-370-C-3602

Figure 2C-44
Inlet/Outlet Works Schematic



Source: AECOM, 2020
Drawing No. STS-370-C-5601

Figure 2C-45
Inlet/Outlet Works Schematic

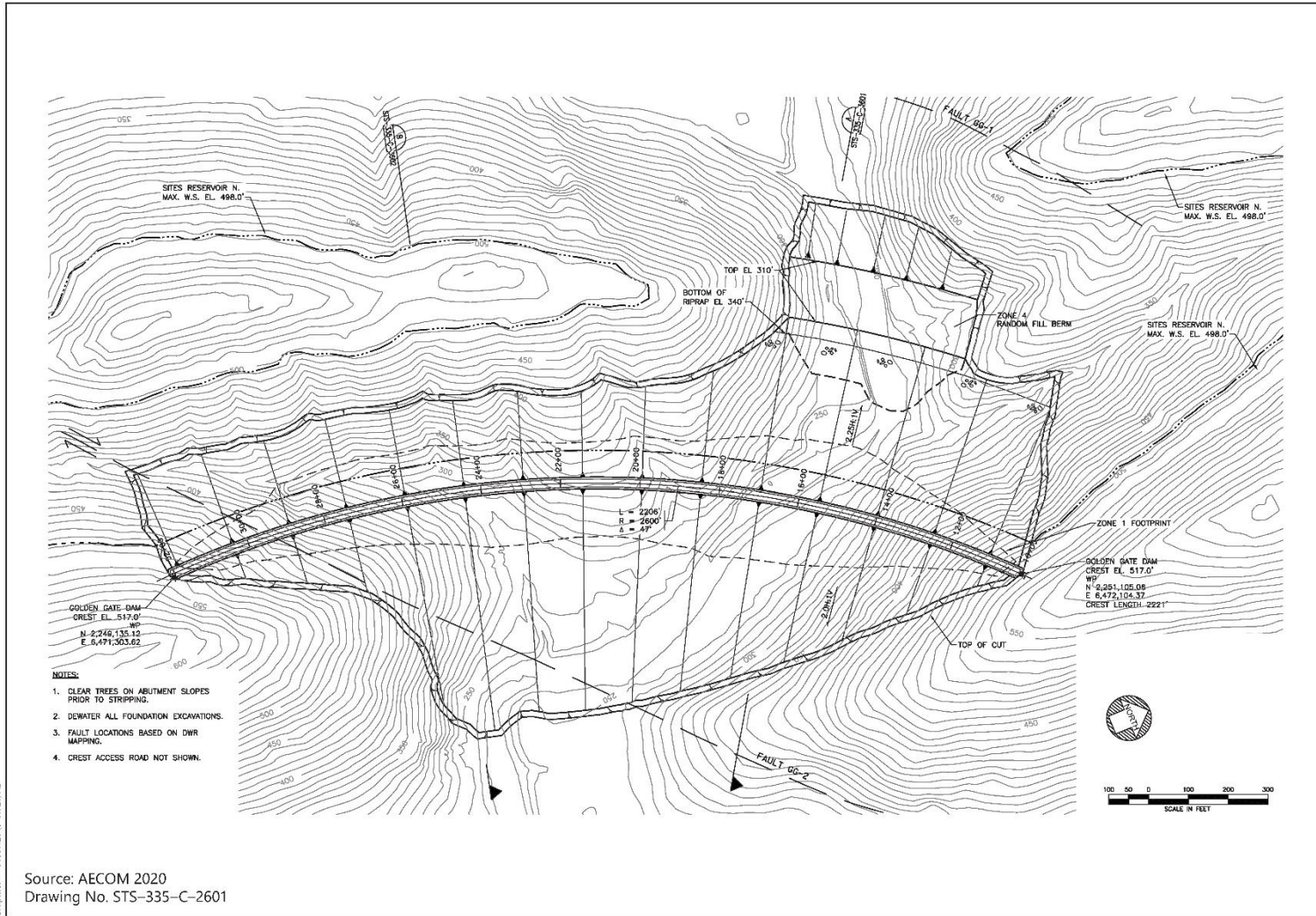


Figure 2C-46
Golden Gate Dam Plan

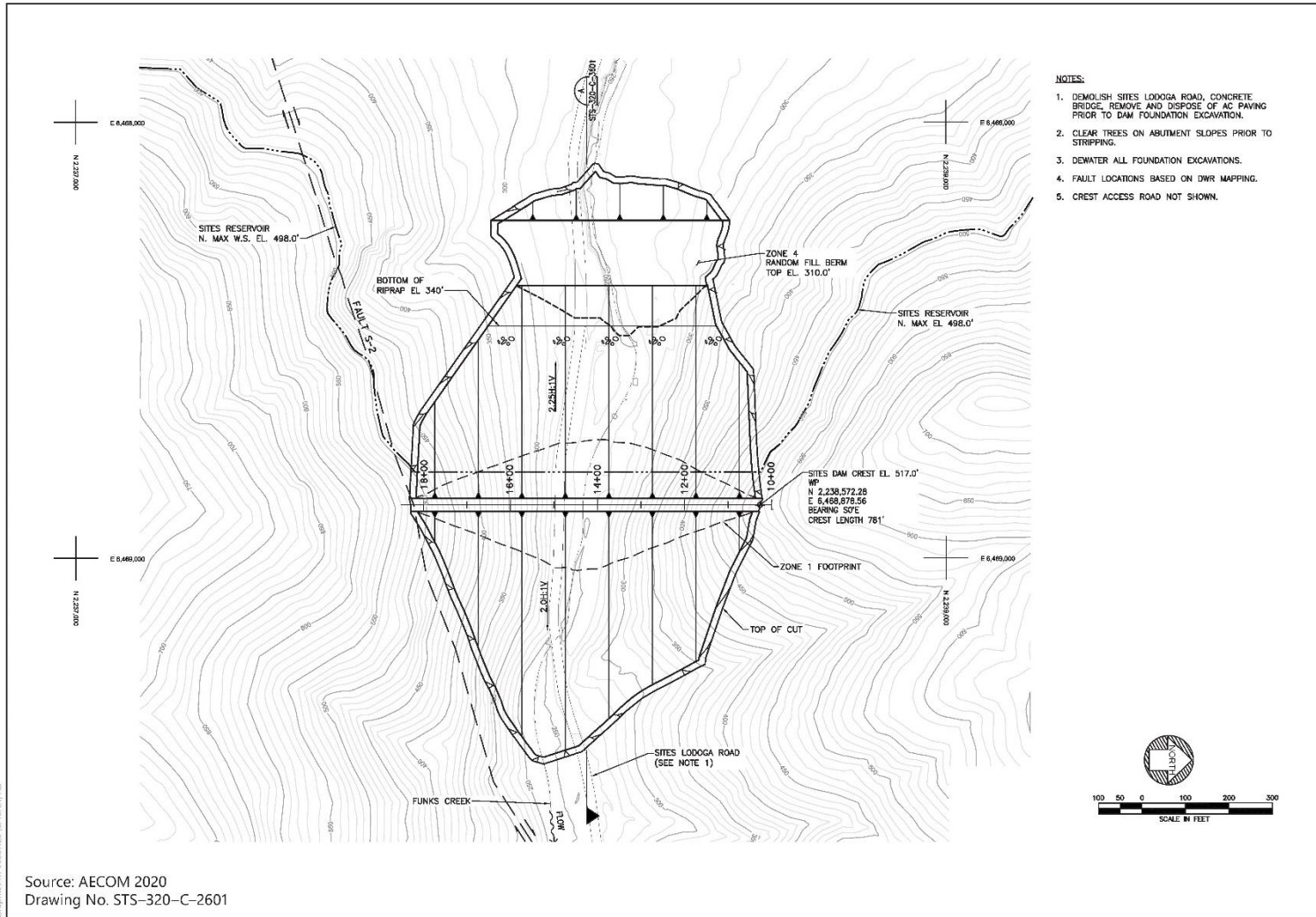
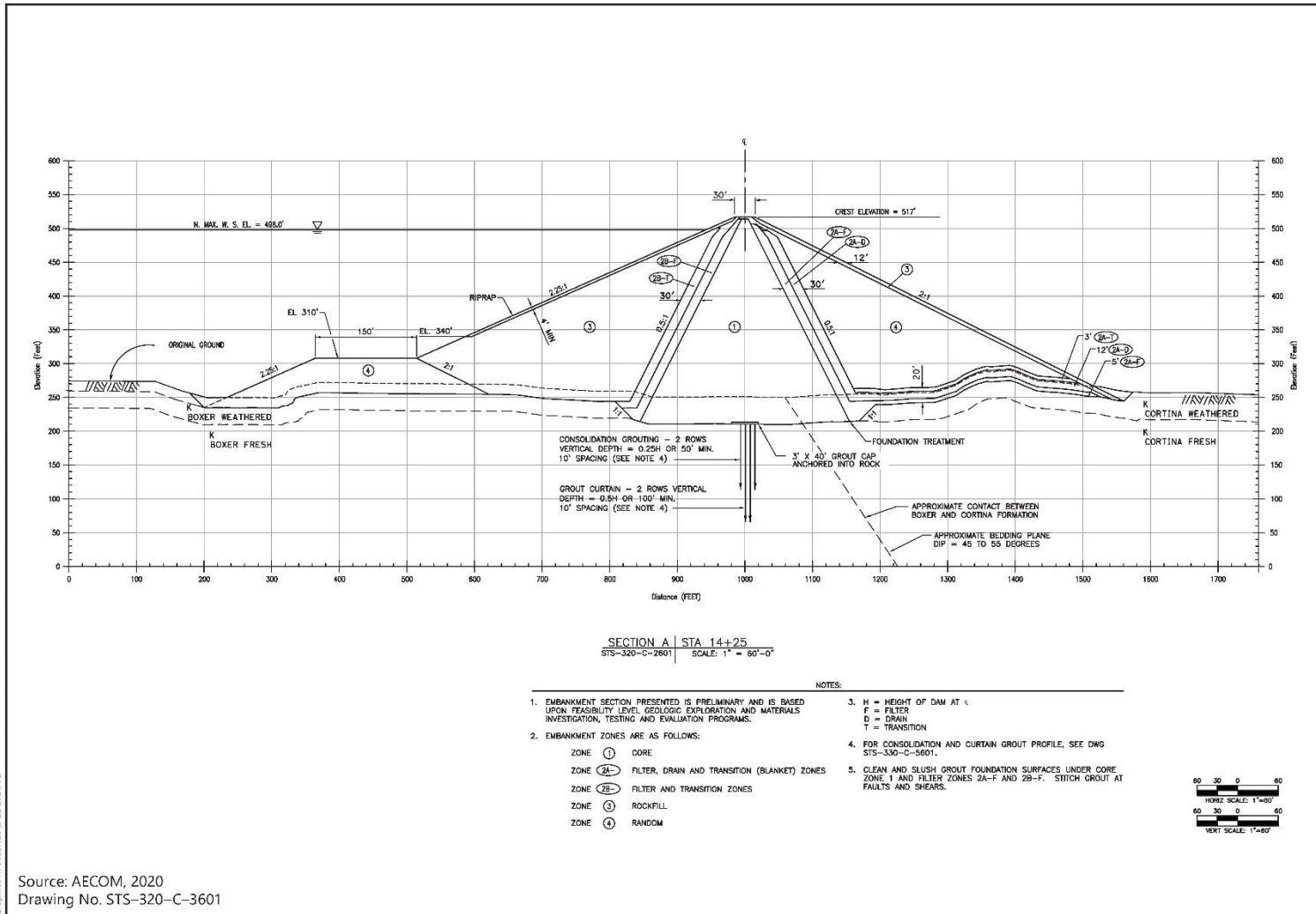


Figure 2C-47
Sites Dam Plan



Source: AECOM, 2020
Drawing No. STS-320-C-3601

Figure 2C-48
Sites Dam Section

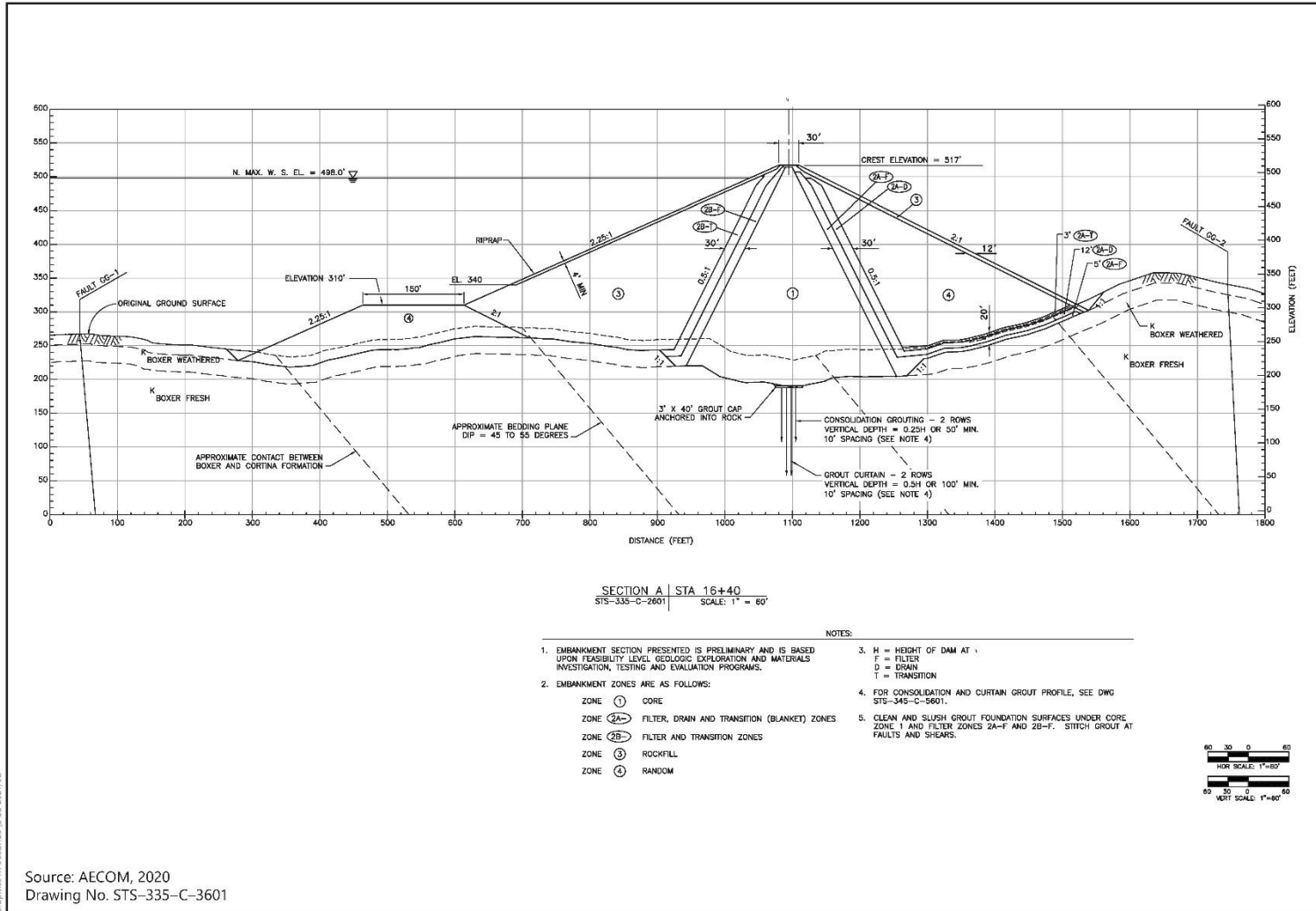
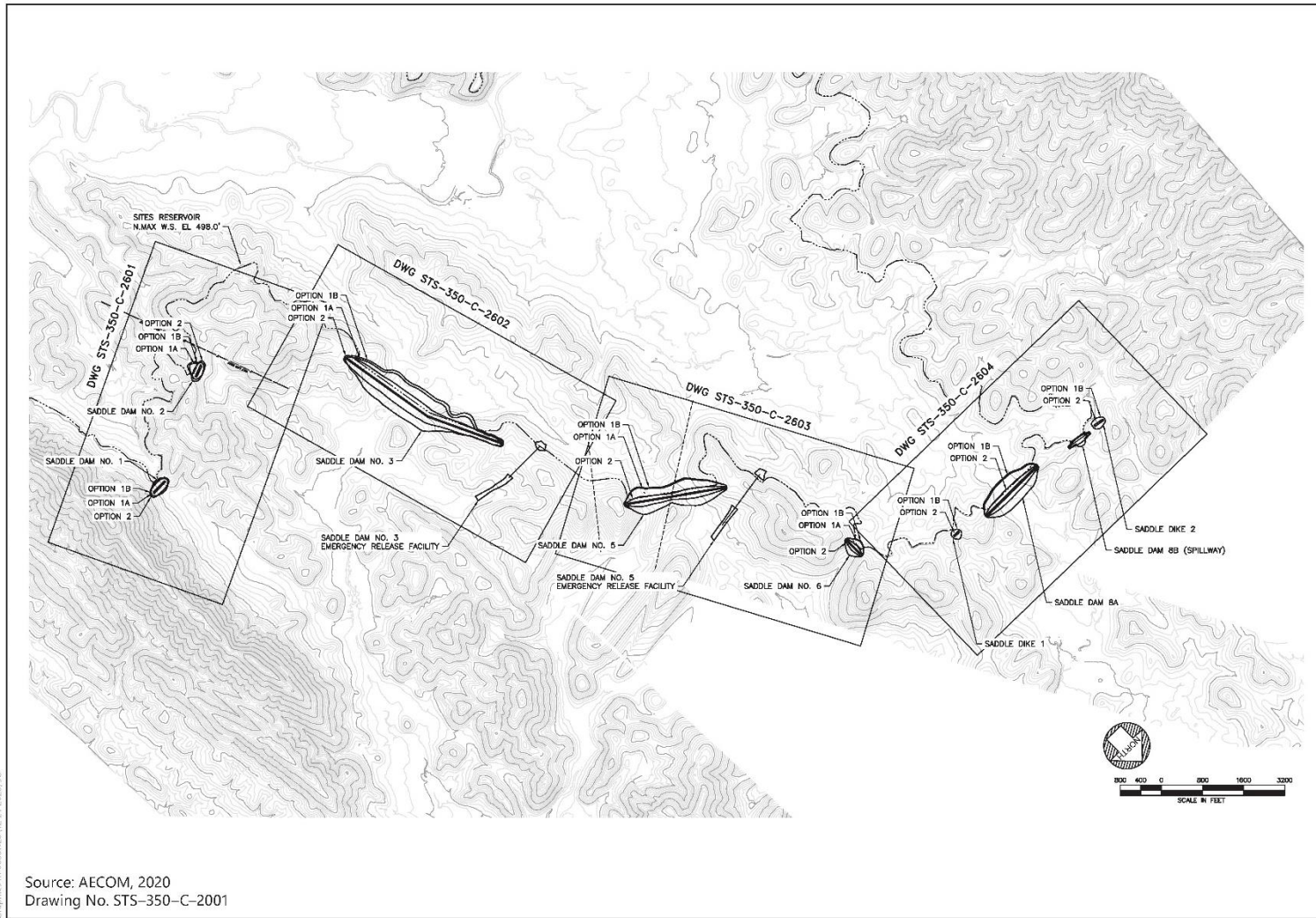


Figure 2C-49
Golden Gate Dam Section



Source: AECOM, 2020
Drawing No. STS-350-C-2001

Figure 2C-50
Location of Saddle Dams and Saddle Dikes

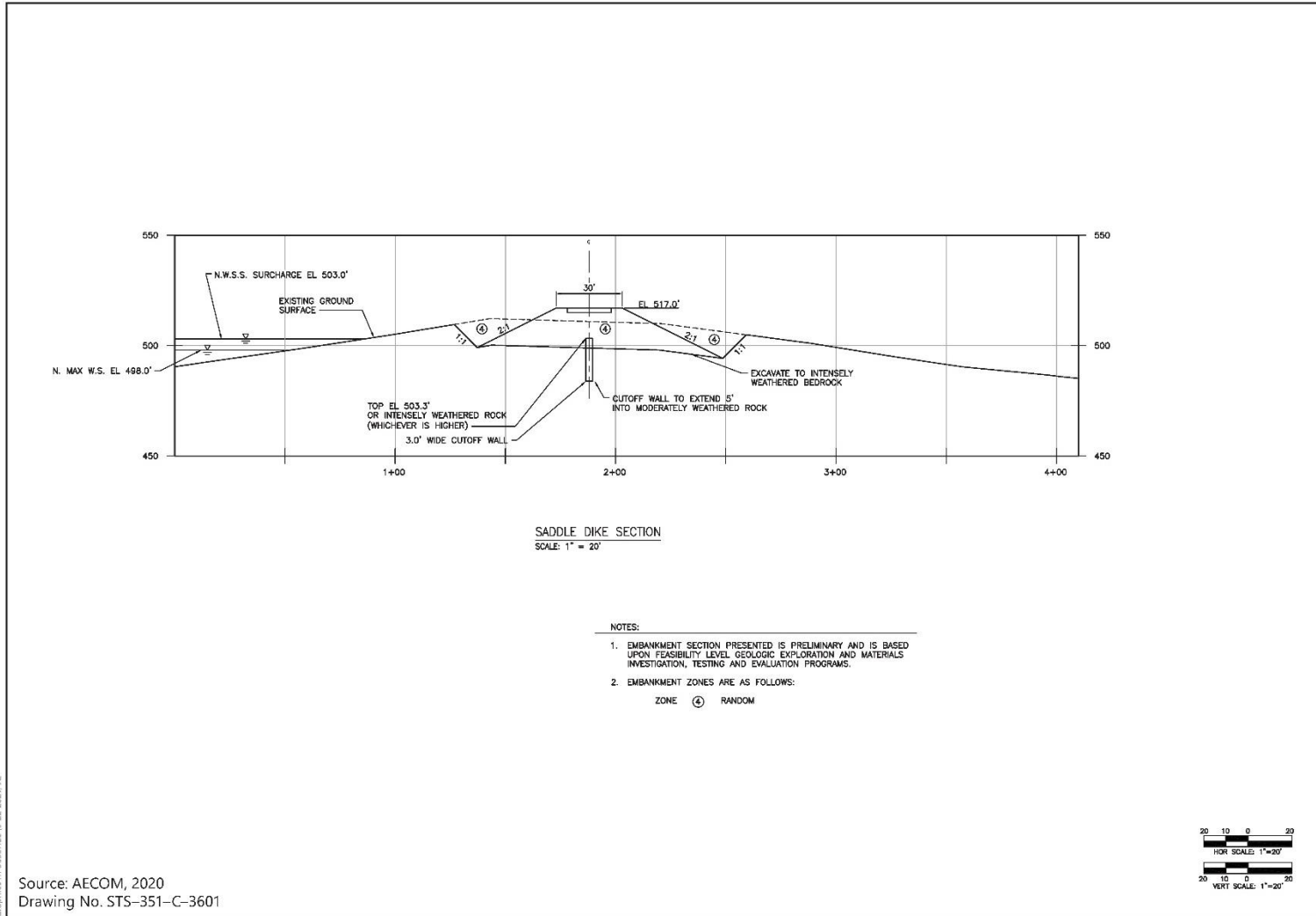


Figure 2C-51
Saddle Dike Section

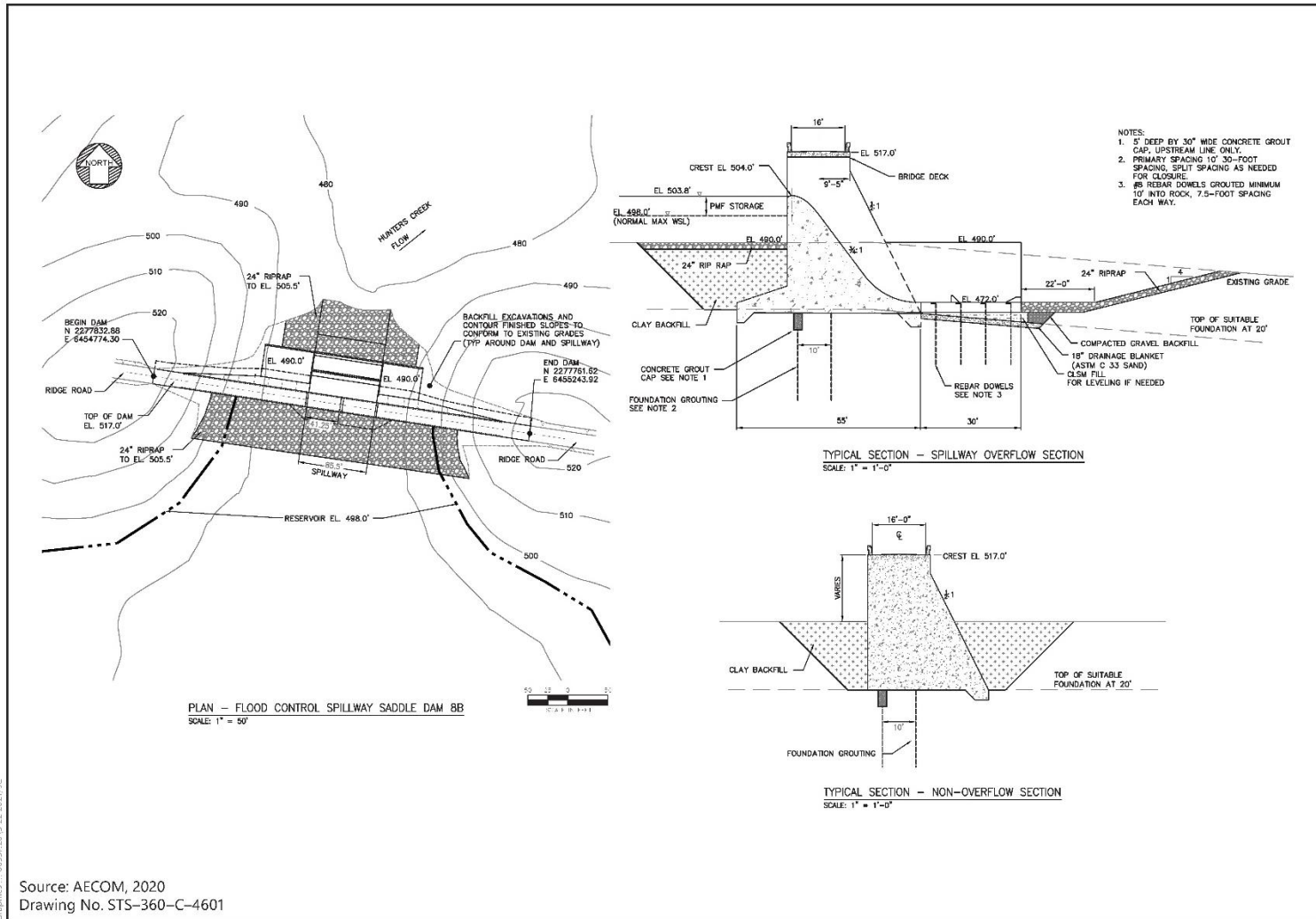


Figure 2C-52
Saddle Dam 8B Spillway

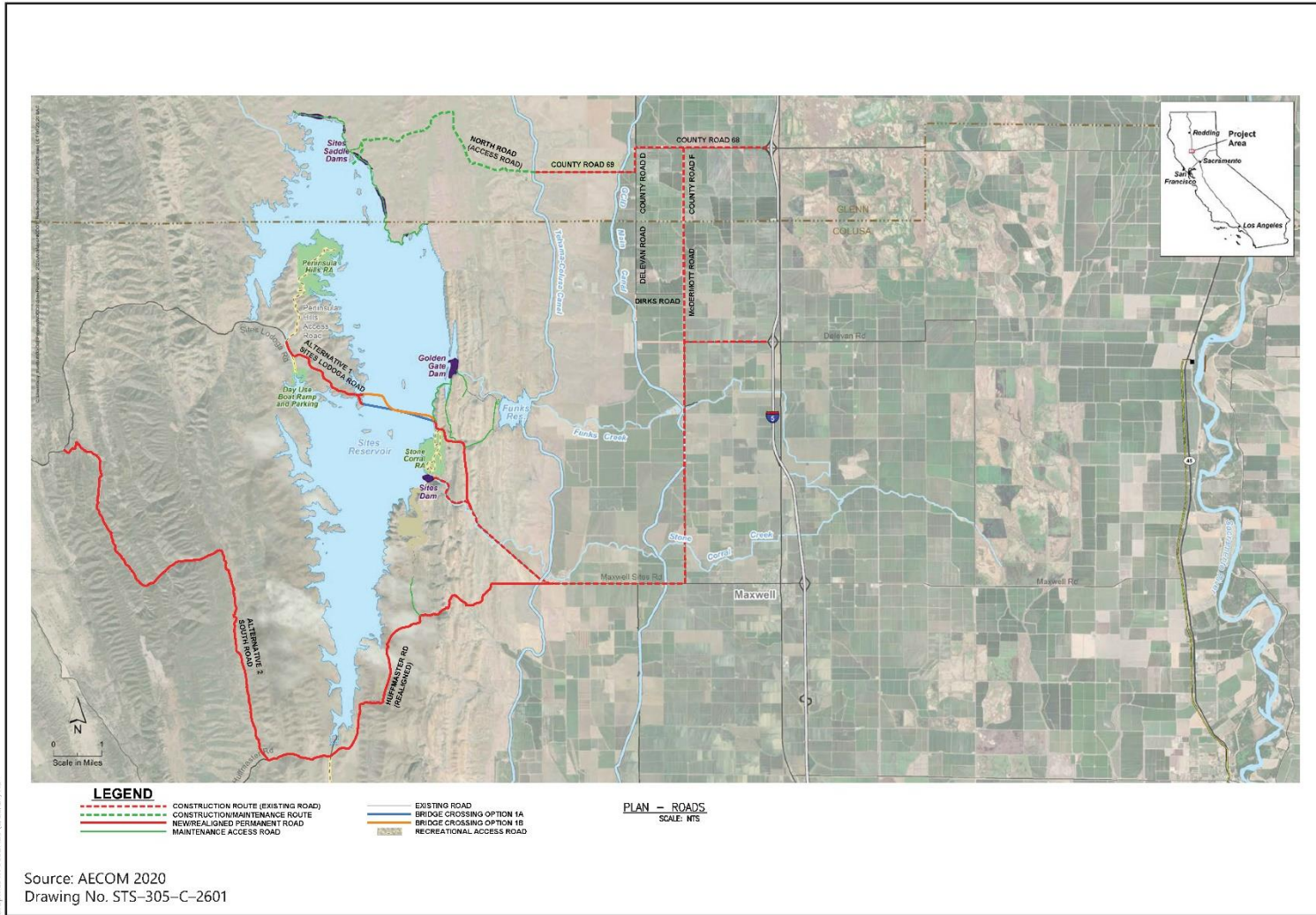


Figure 2C-53
Local Access, Construction Access, and Maintenance Access Roads

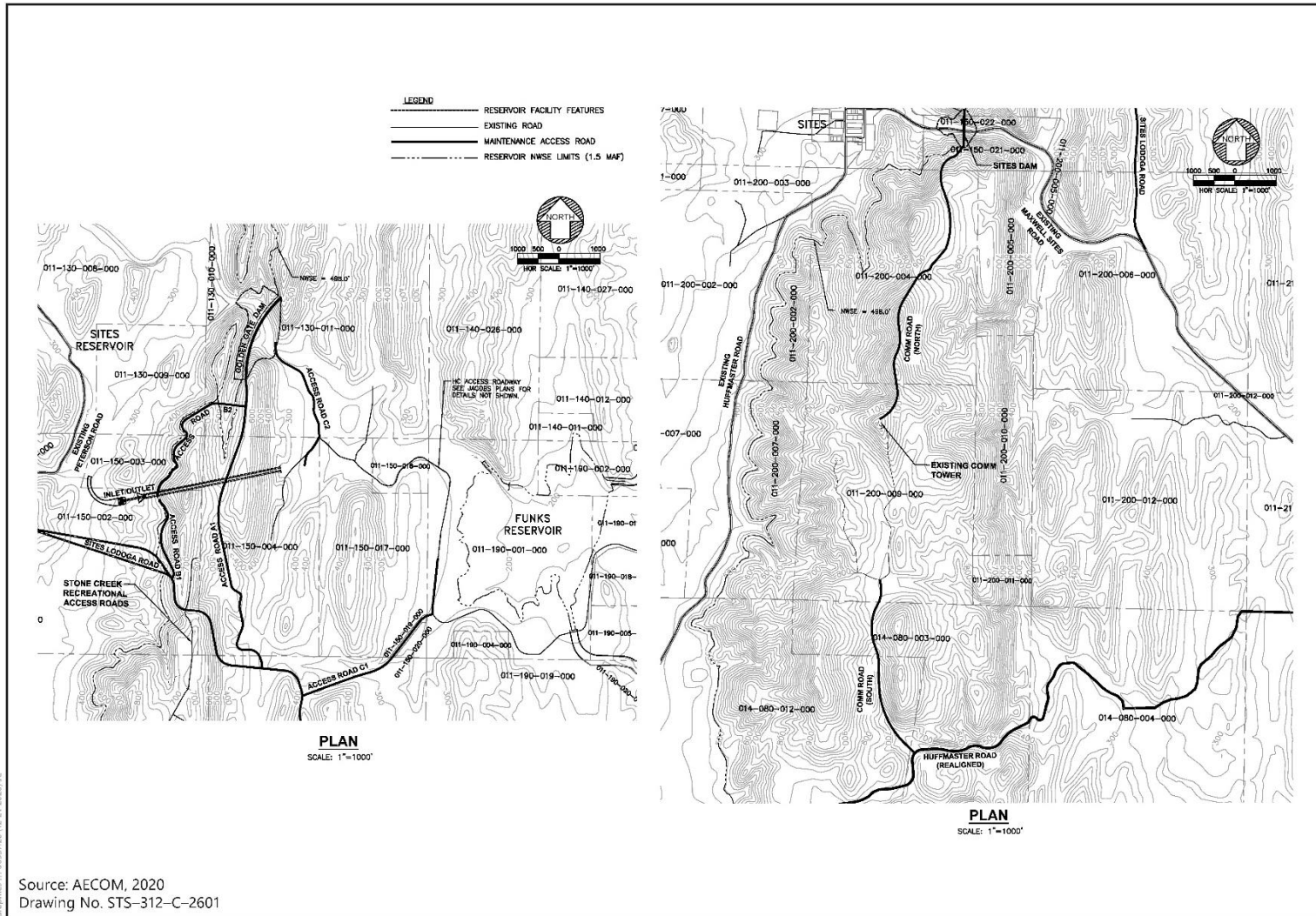


Figure 2C-54
Maintenance and Access Roads

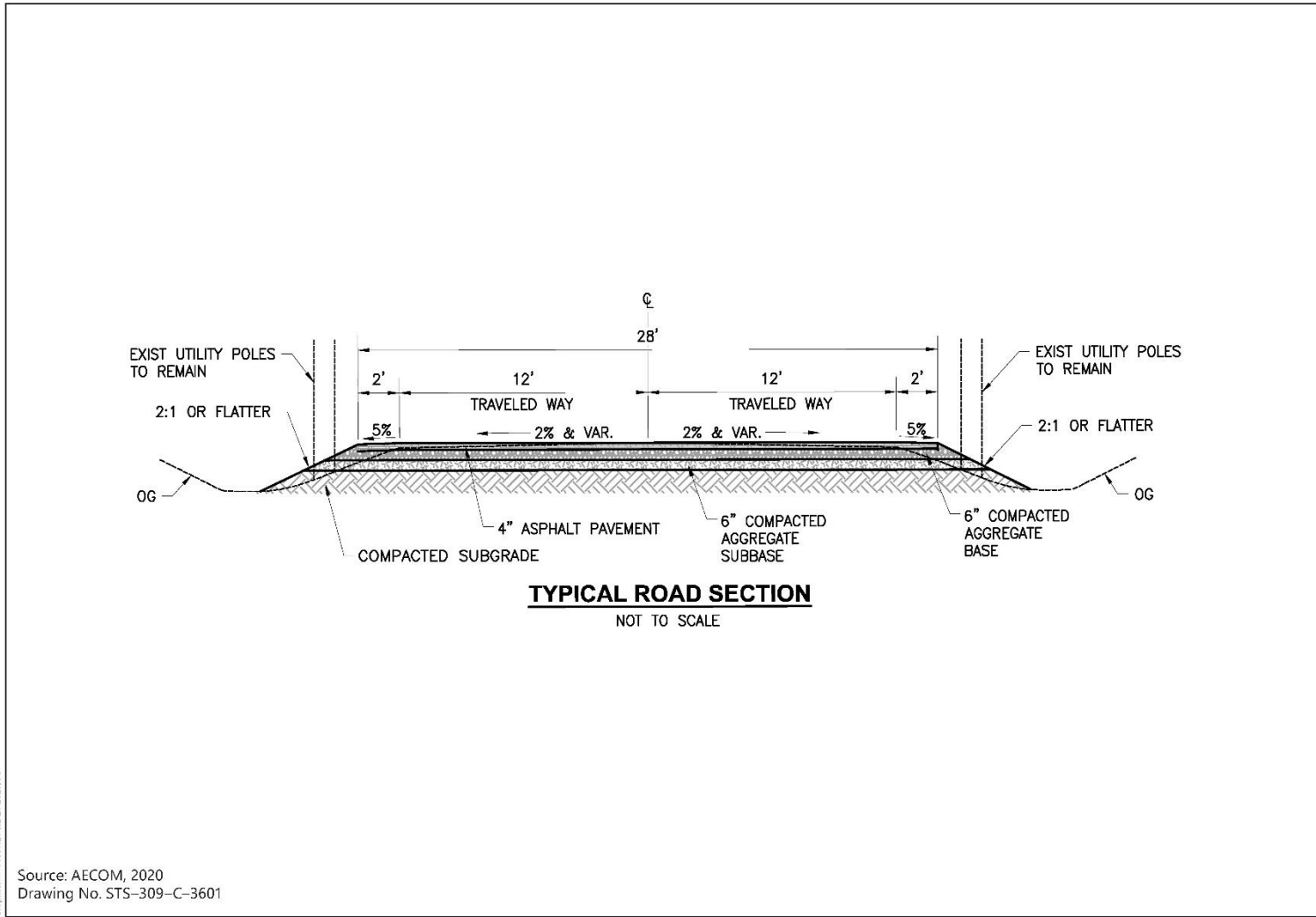


Figure 2C-55
County Road Improvement

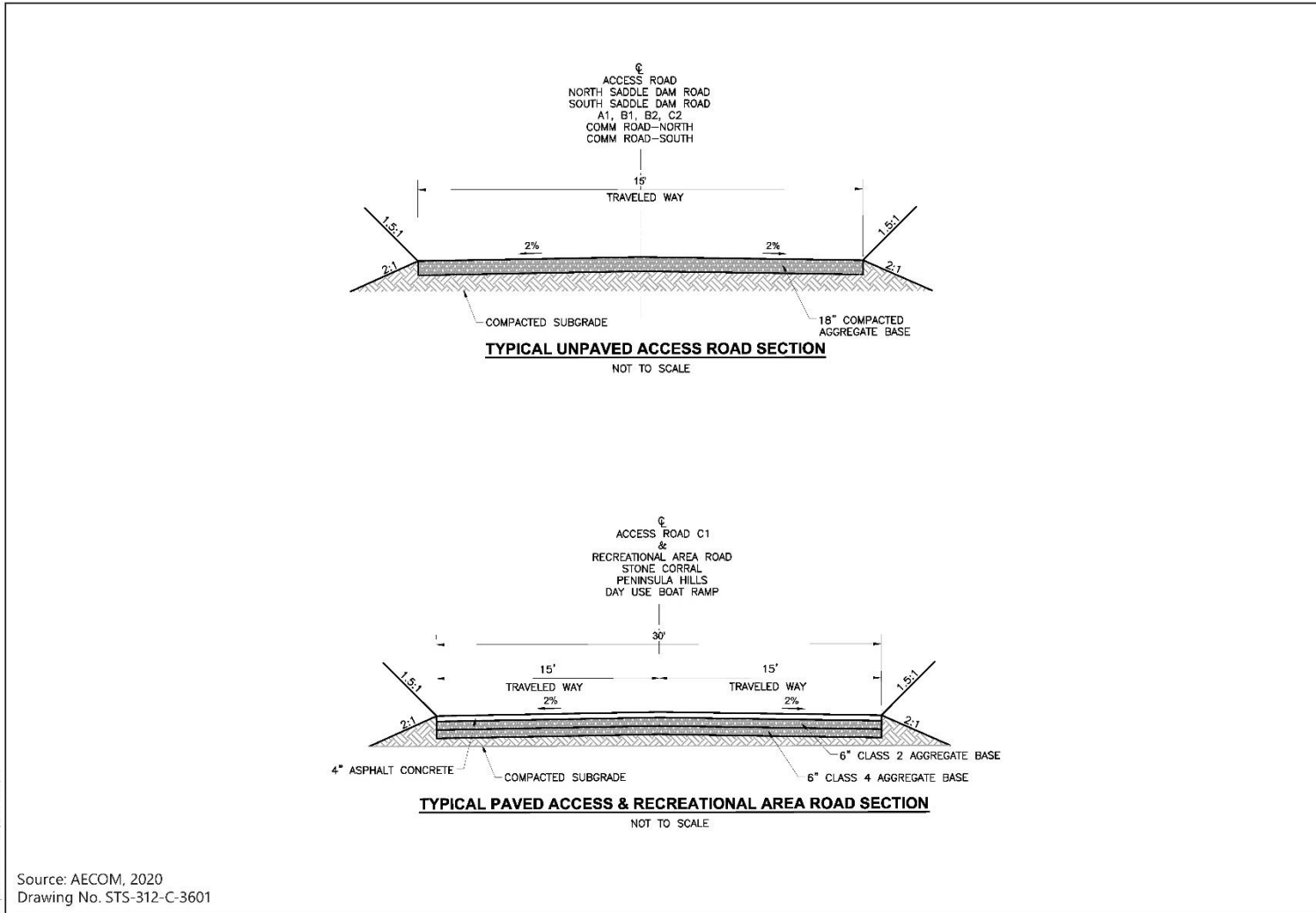


Figure 2C-56
Maintenance Access Road Typical - Paved and Unpaved

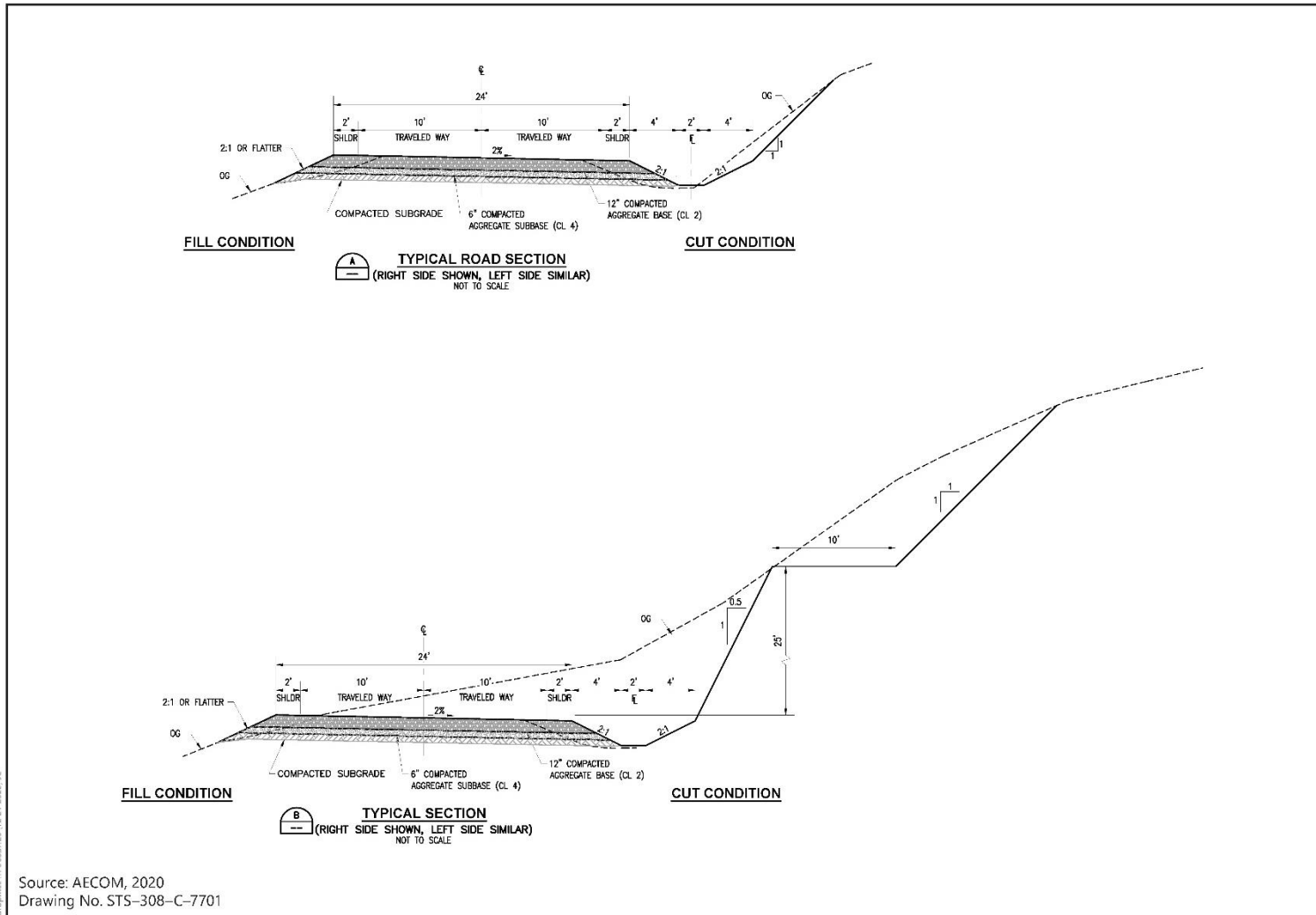
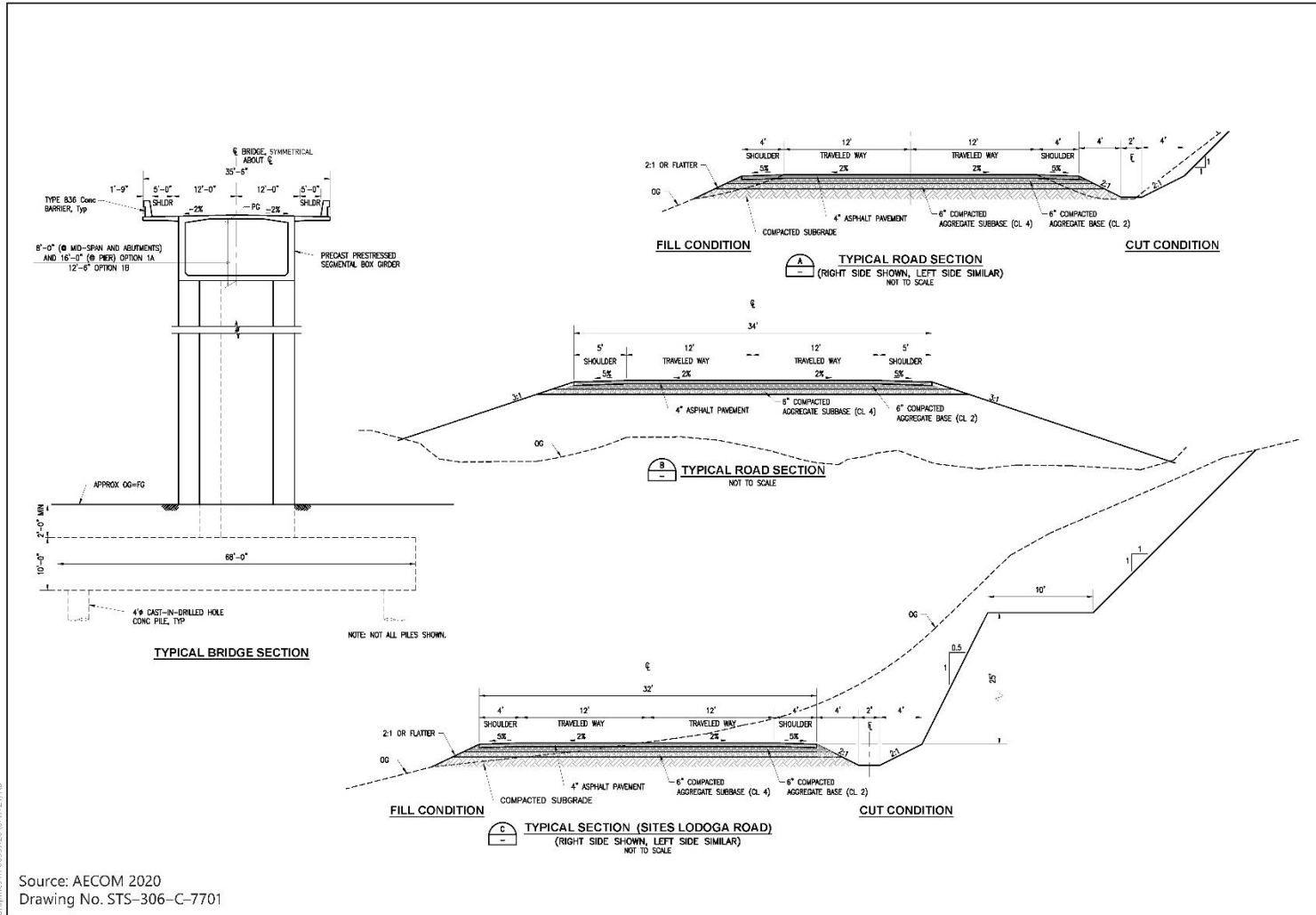


Figure 2C-57
North Access Road



Source: AECOM 2020
Drawing No. STS-306-C-7701

Figure 2C-58
Sites Lodoga Road Realignment and Bridge



Figure 2C-59
Dunnigan CBD Discharge Site Plan

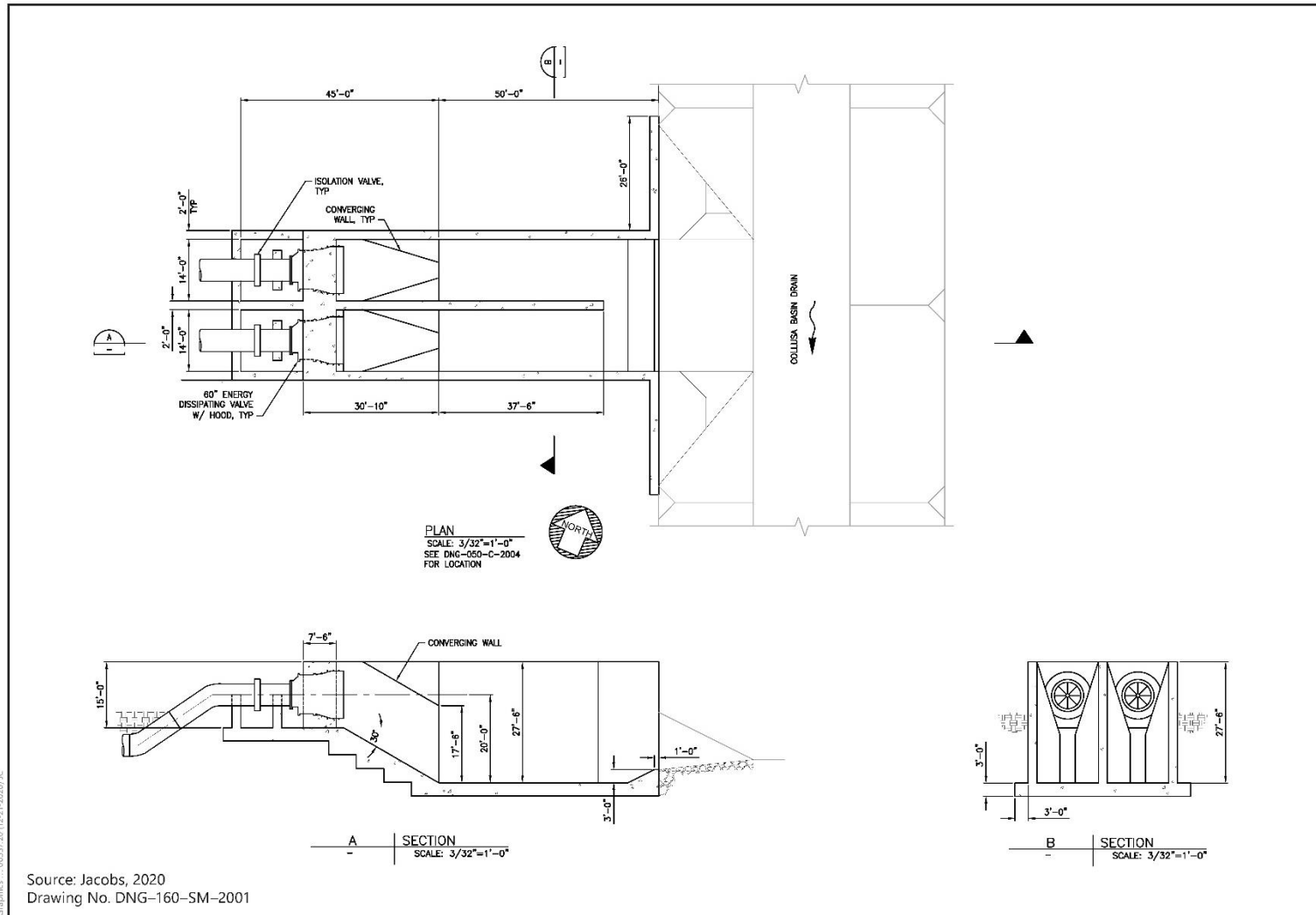


Figure 2C-60
CBD Outlet

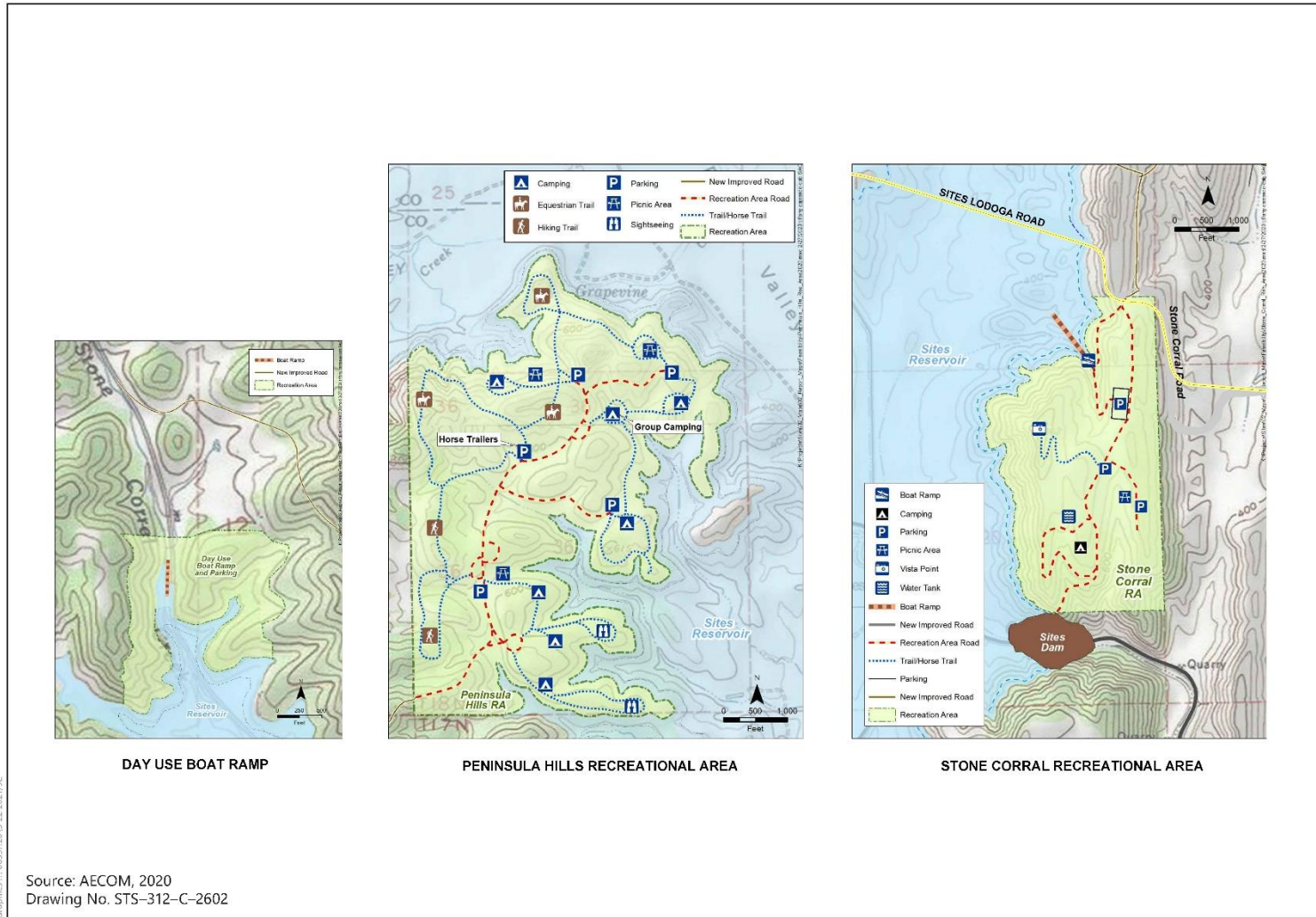


Figure 2C-61
Recreation Areas

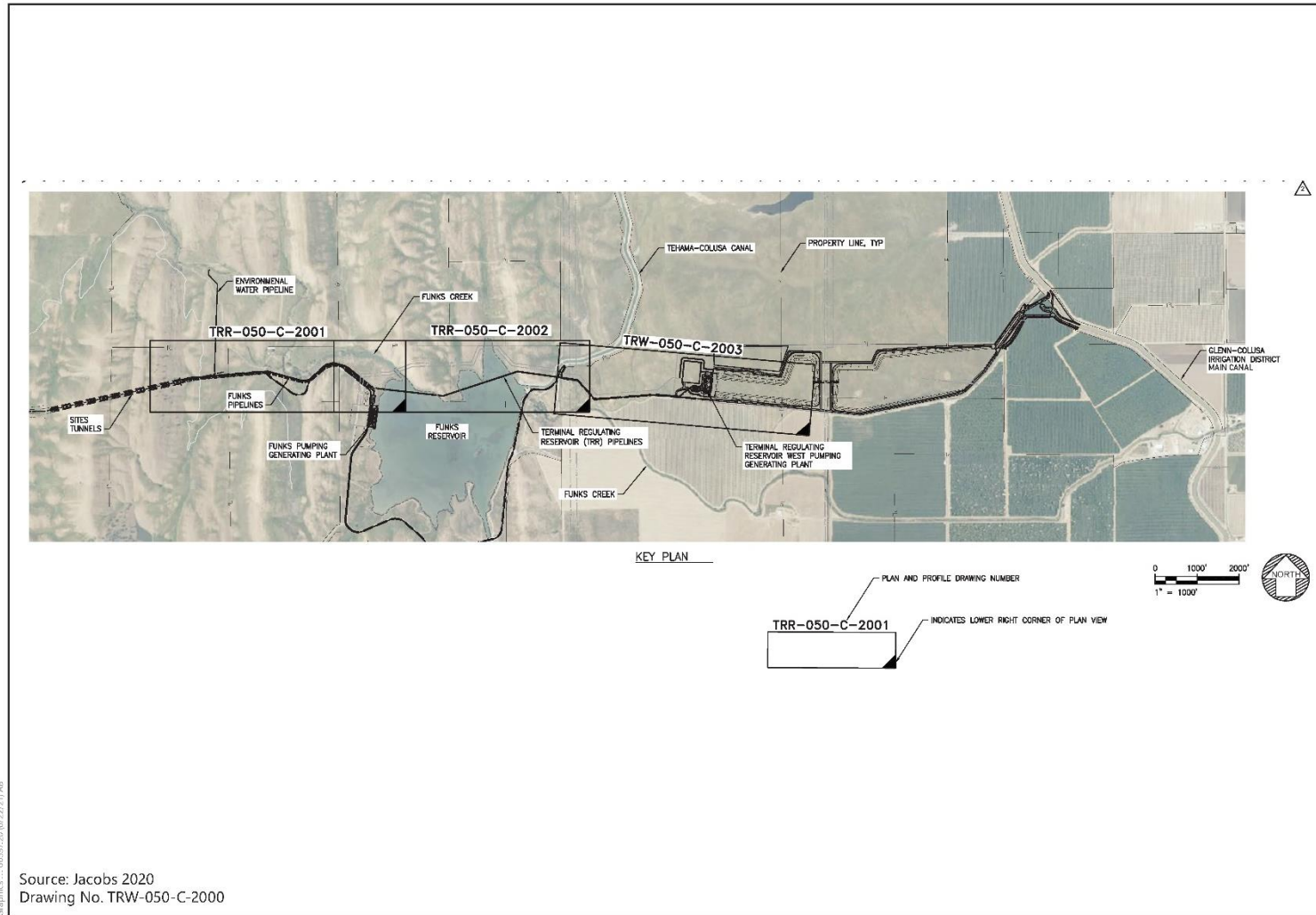


Figure 2C-62
Terminal Regulating Reservoir West Pipelines

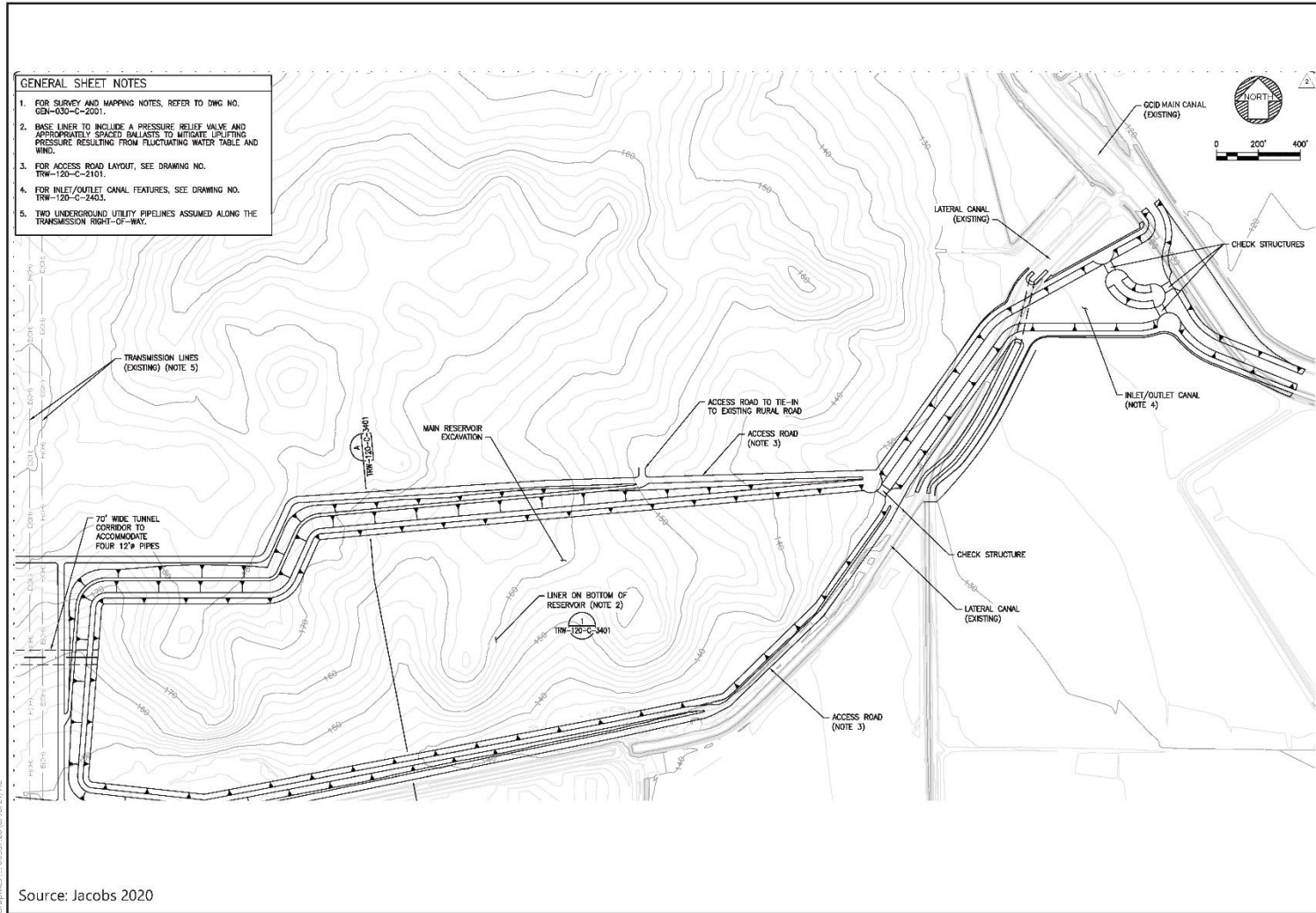


Figure 2C-63A
Terminal Regulating Reservoir West Main Reservoir Plan

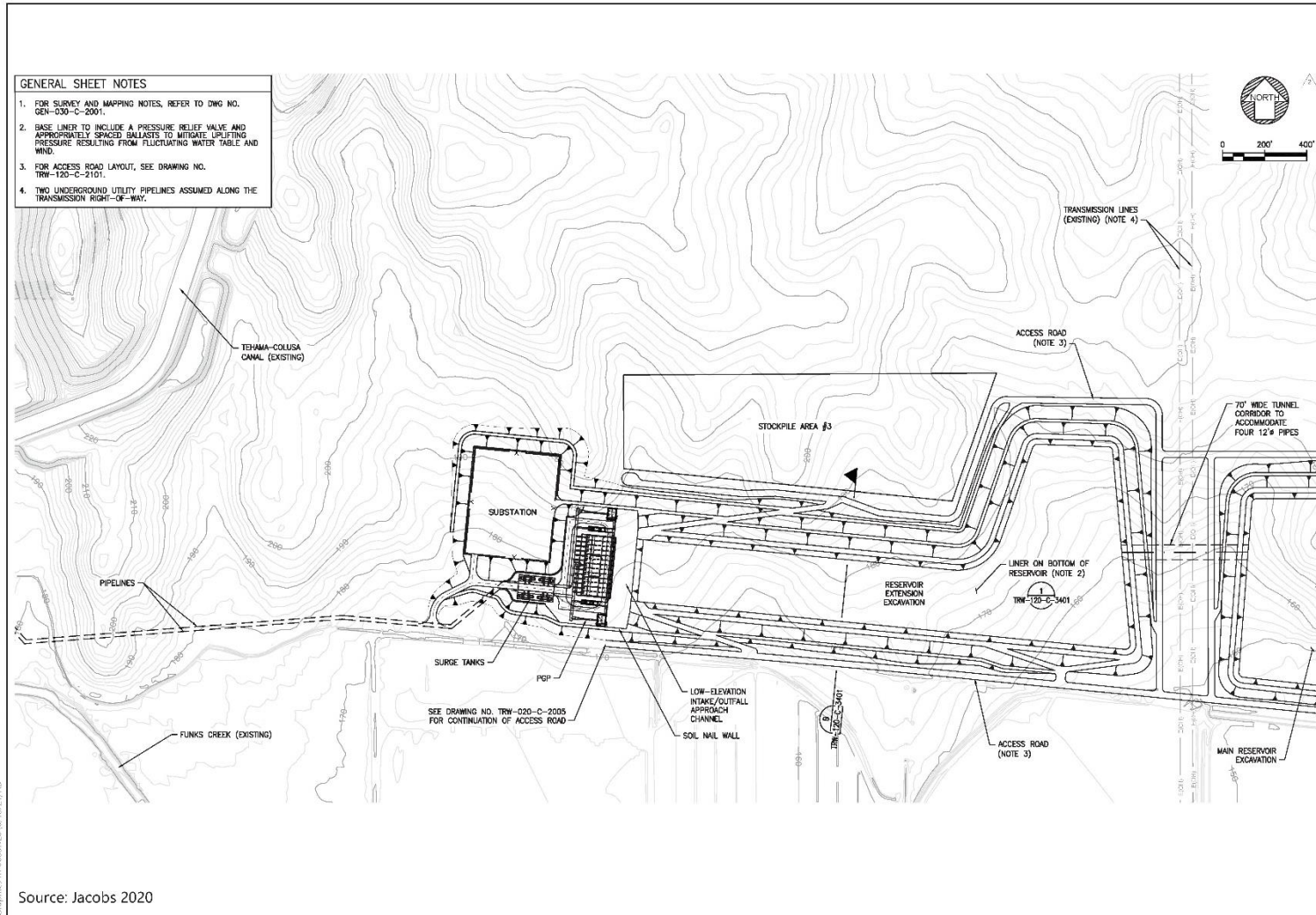


Figure 2C-63B
Terminal Regulating Reservoir West Reservoir Extension Plan

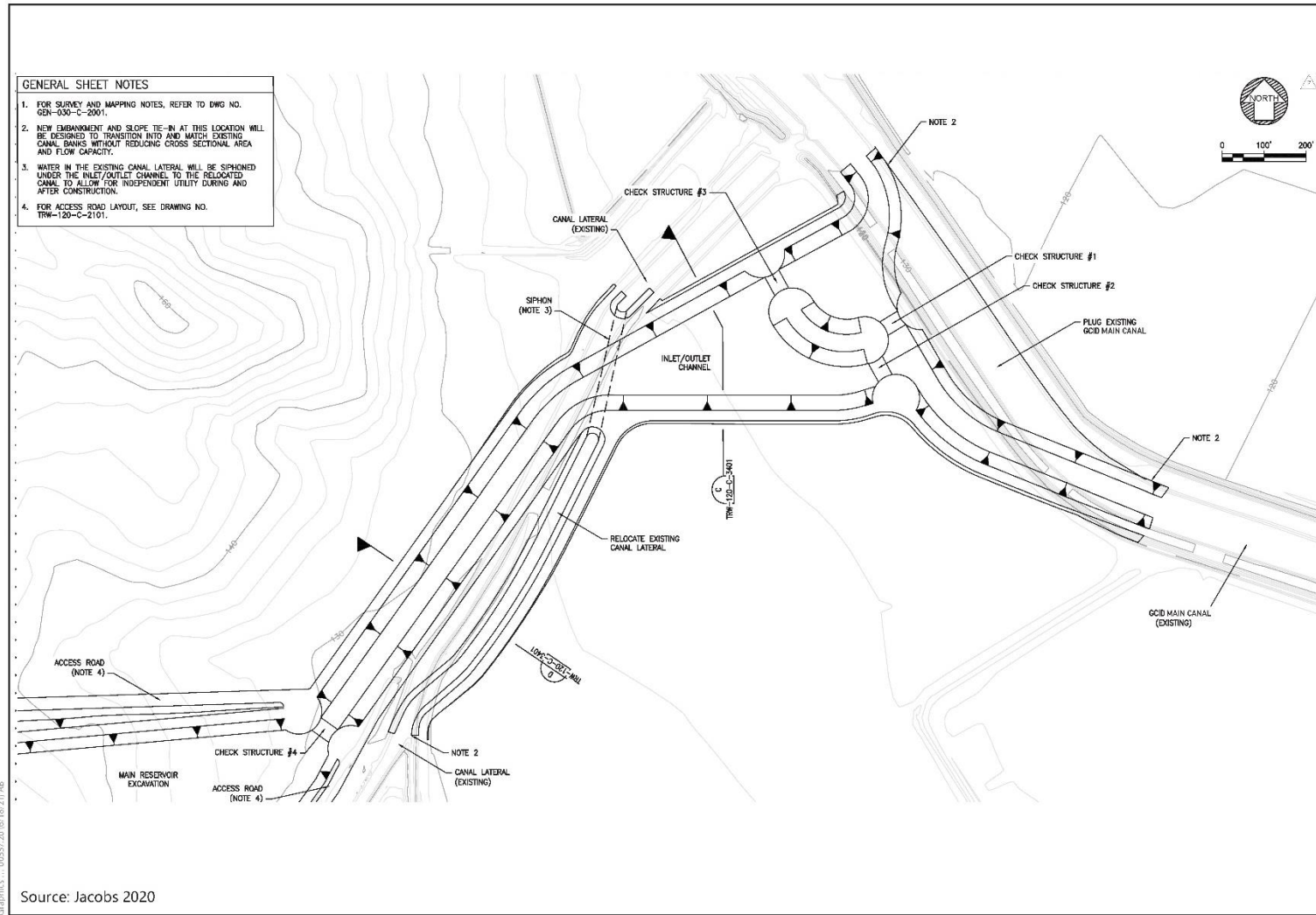


Figure 2C-63C
Terminal Regulating Reservoir West Inlet/Outlet Canal Plan

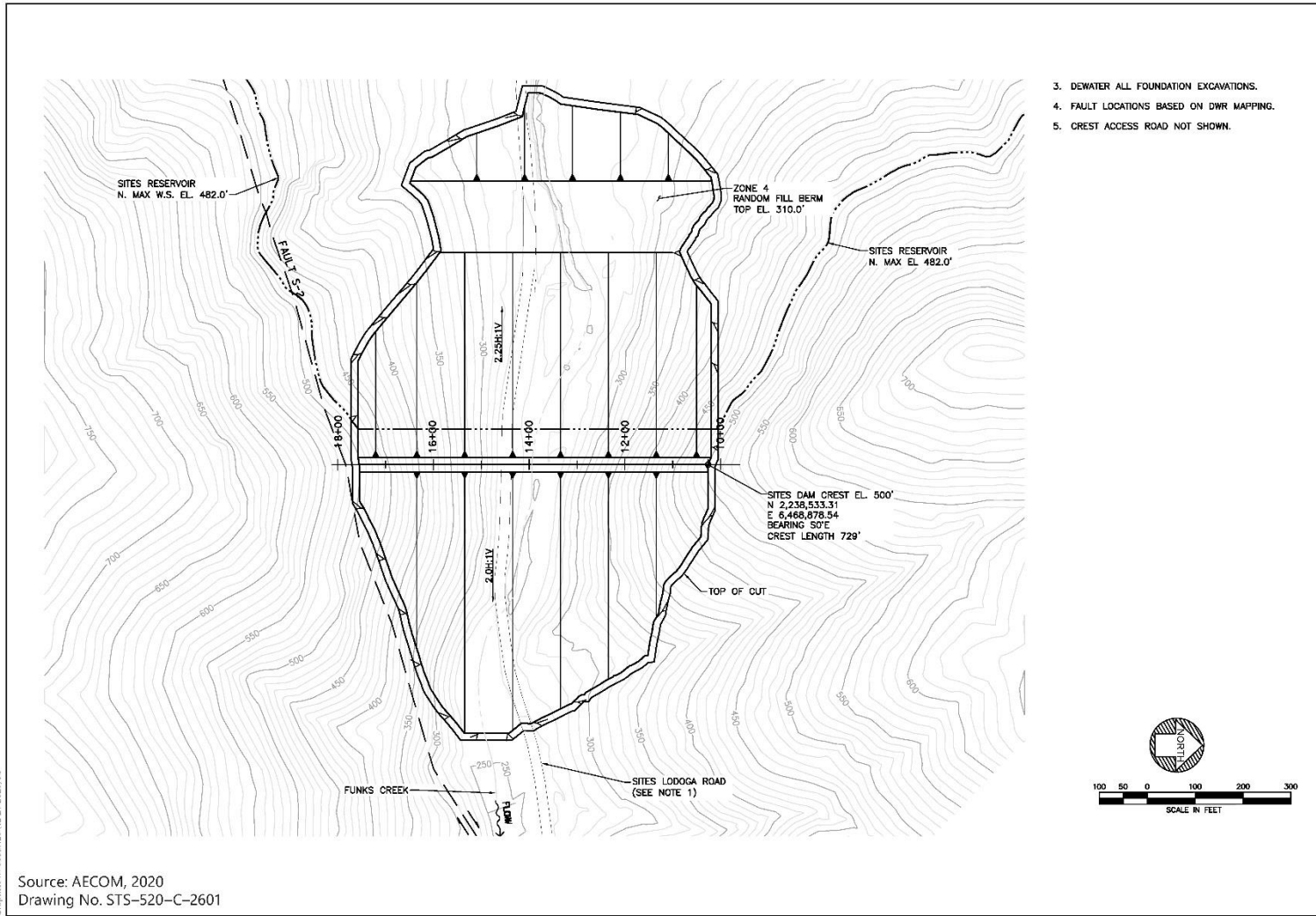


Figure 2C-64
Alternative 2, Sites Dam Location

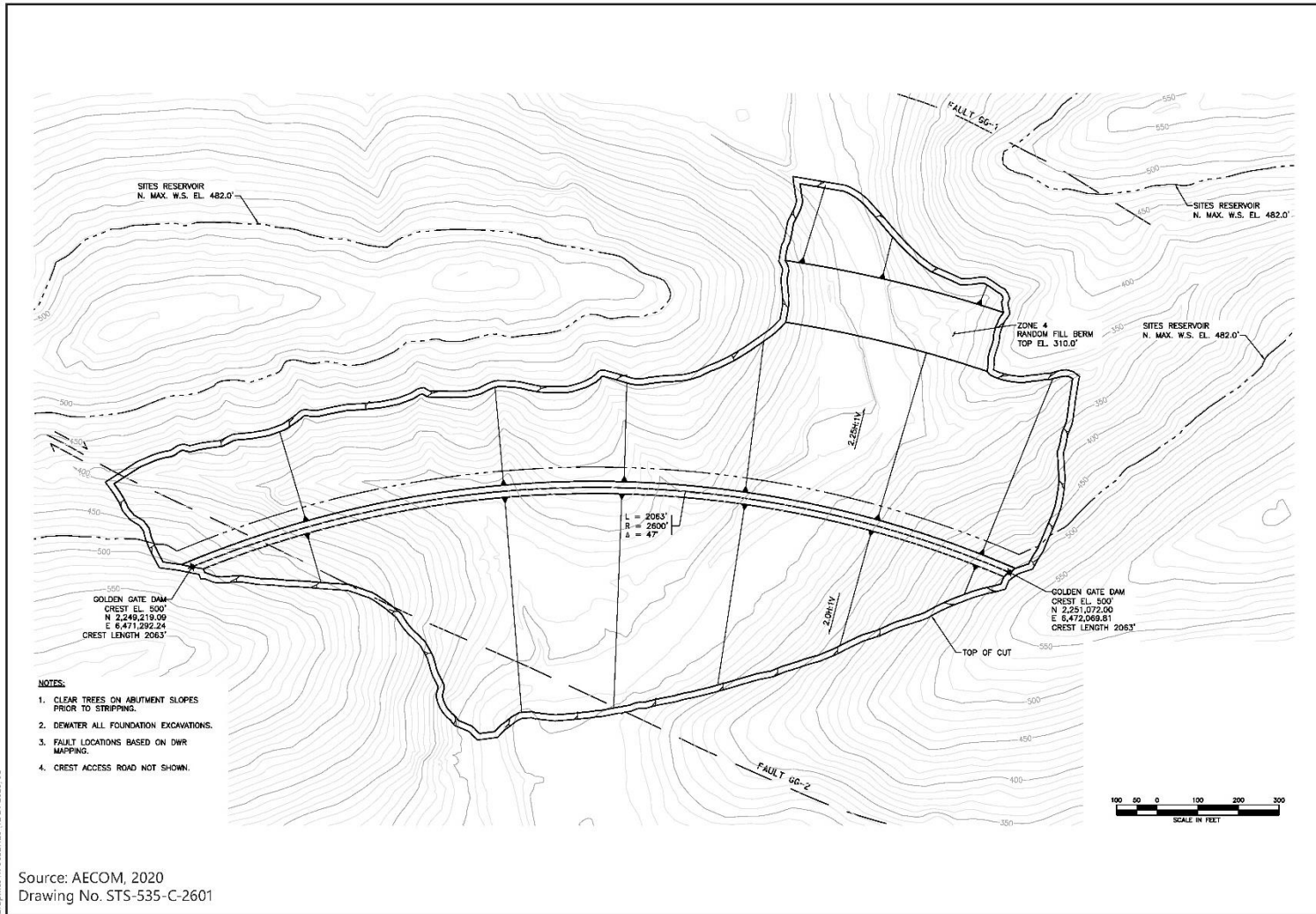
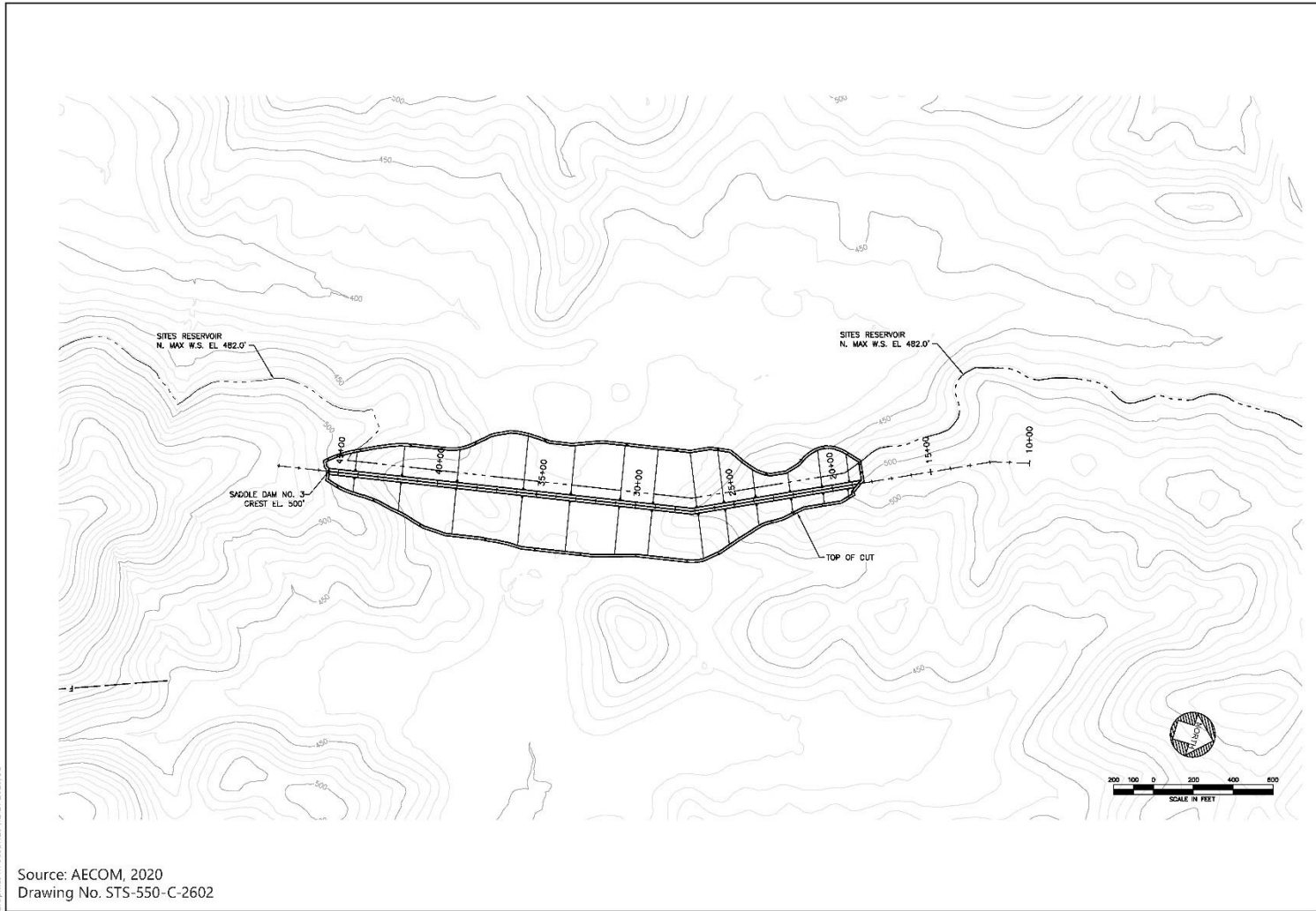


Figure 2C-65
Alternative 2, Golden Gate Dam Location



Source: AECOM, 2020
Drawing No. STS-550-C-2602

Figure 2C-66A
Alternative 2, Saddle Dams and Saddle Dike 3 Locations

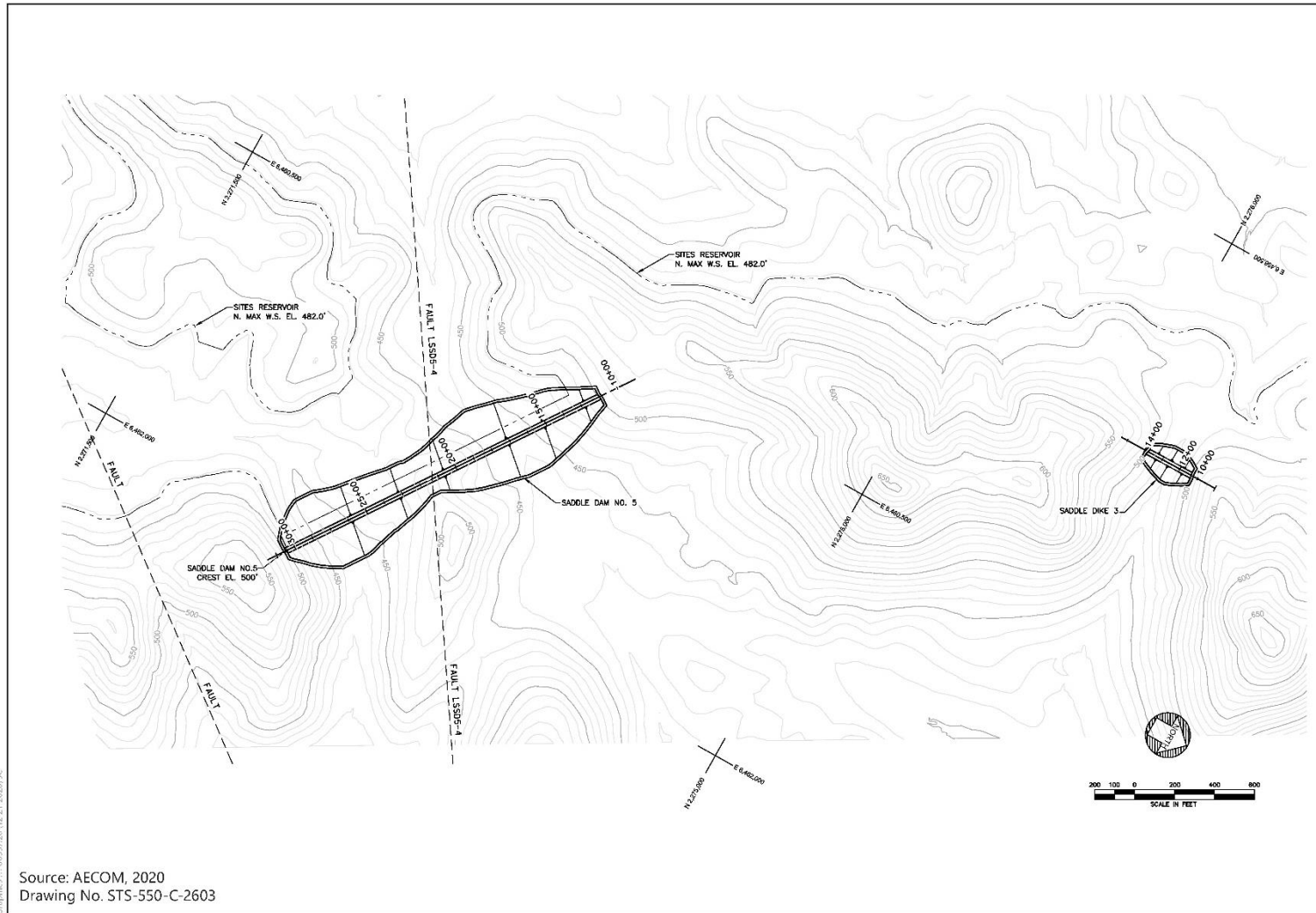


Figure 2C-66B
Alternative 2, Saddle Dams and Saddle Dike 3 Locations

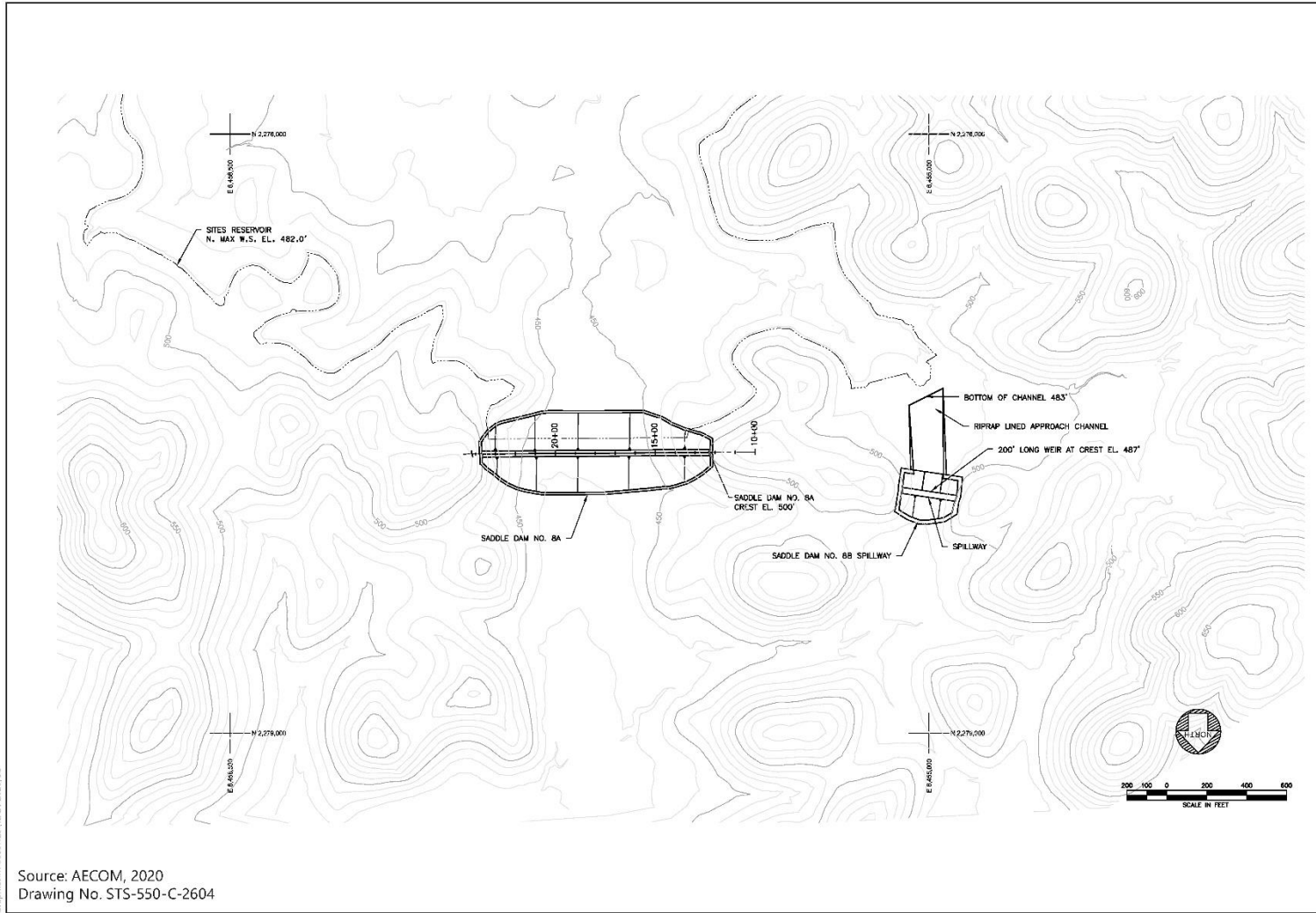


Figure 2C-66C
Alternative 2, Saddle Dams and Saddle Dike 3 Locations

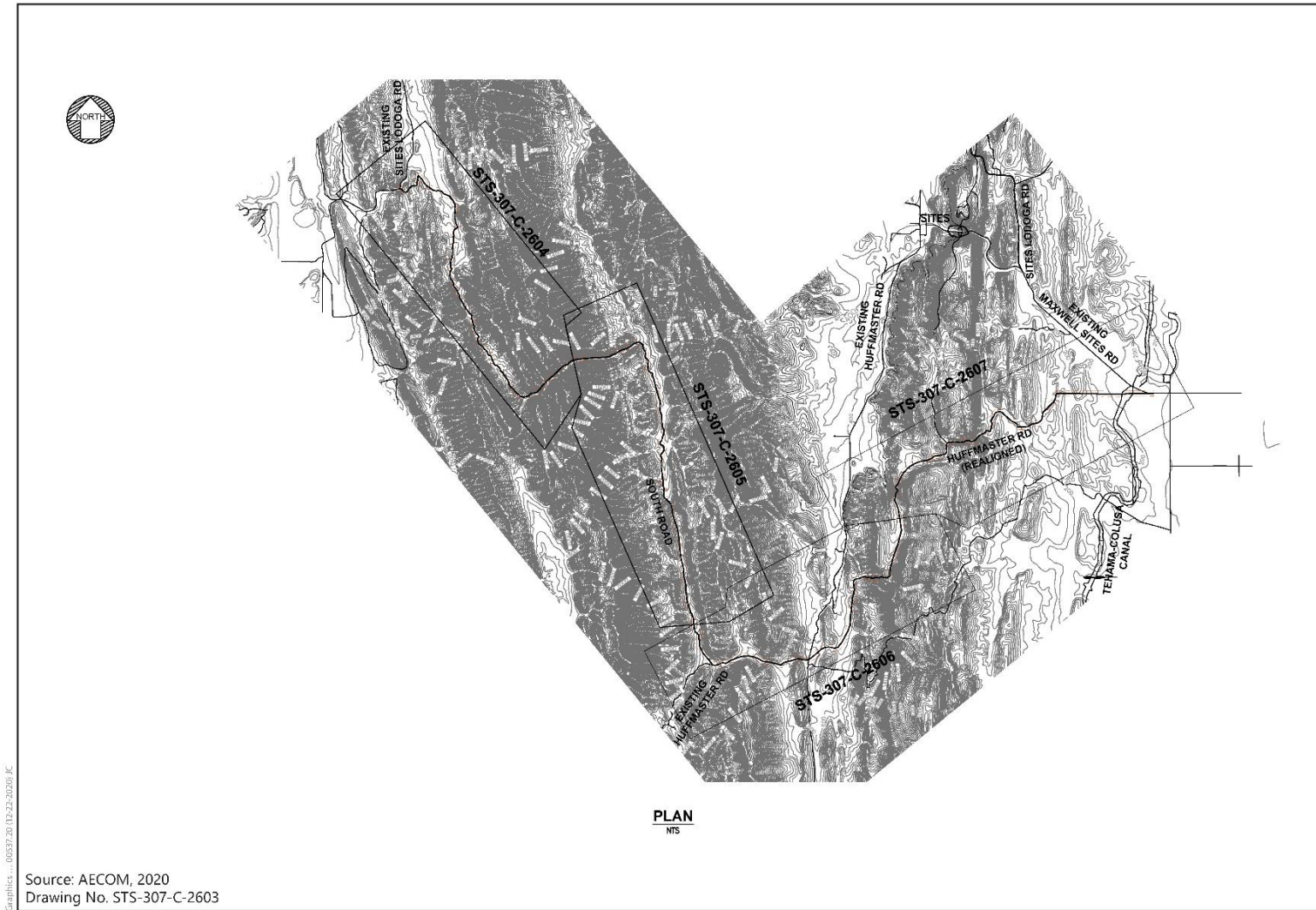
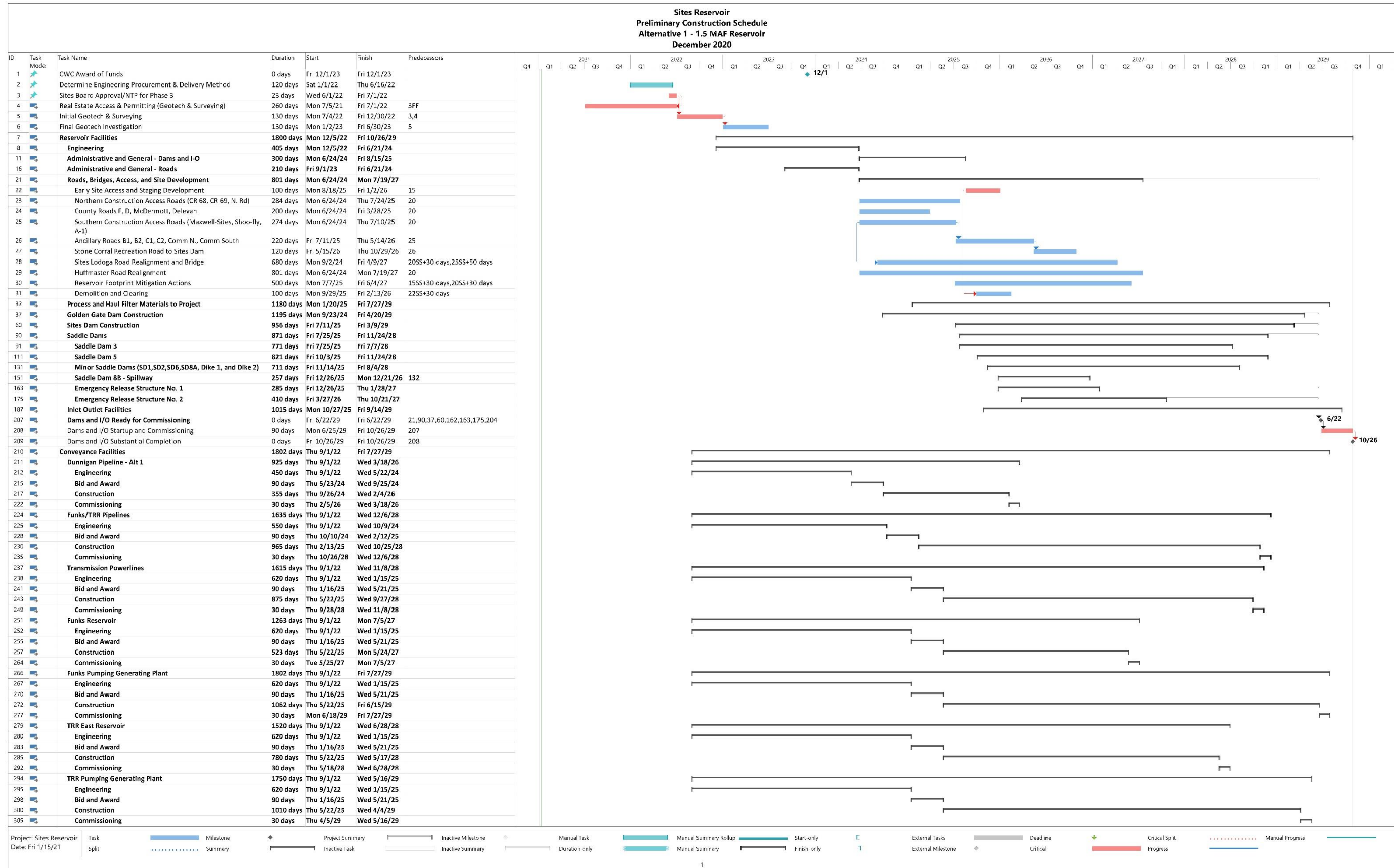


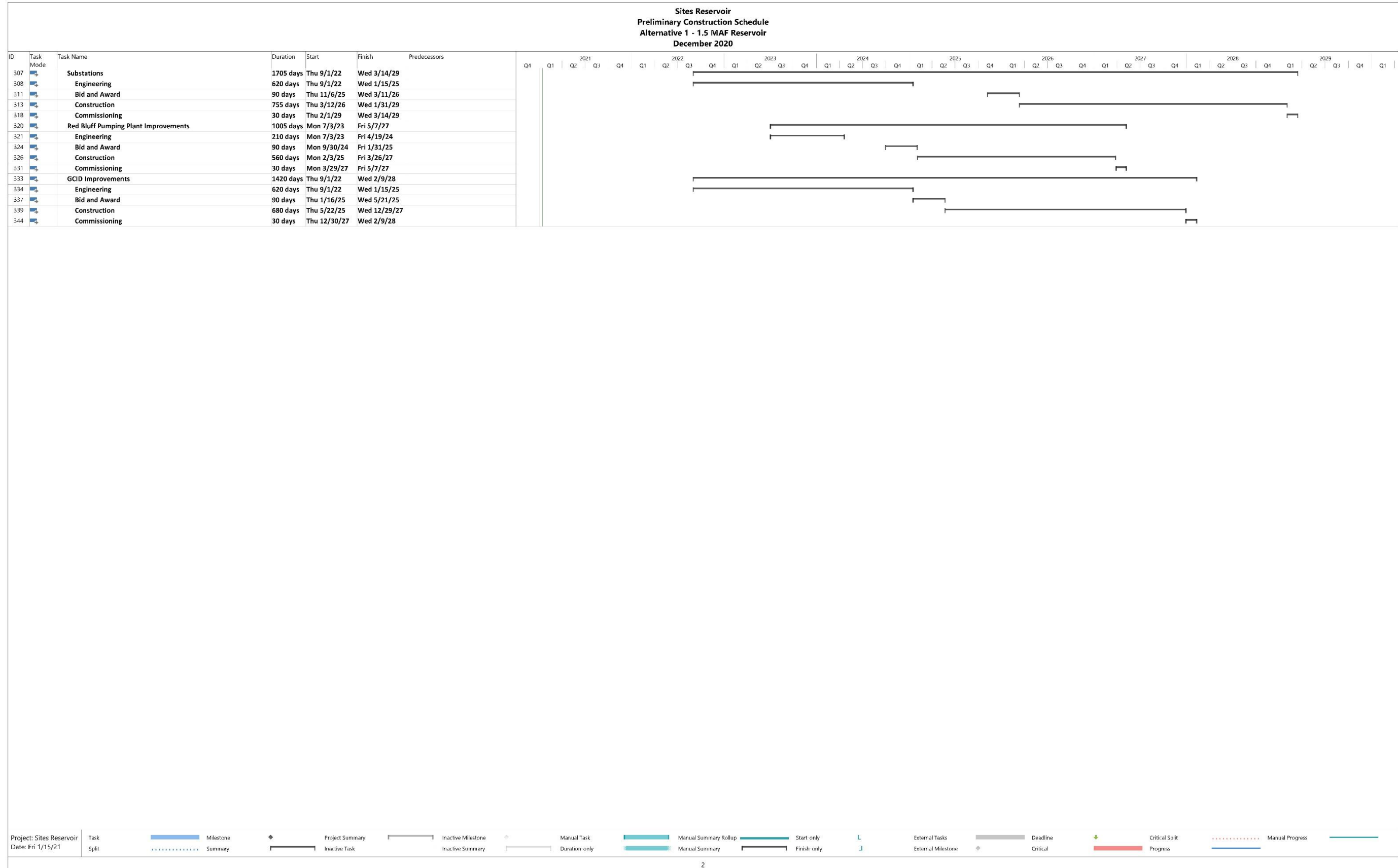
Figure 2C-67
Alternative 2 Huffmaster Road Realignment and South Road

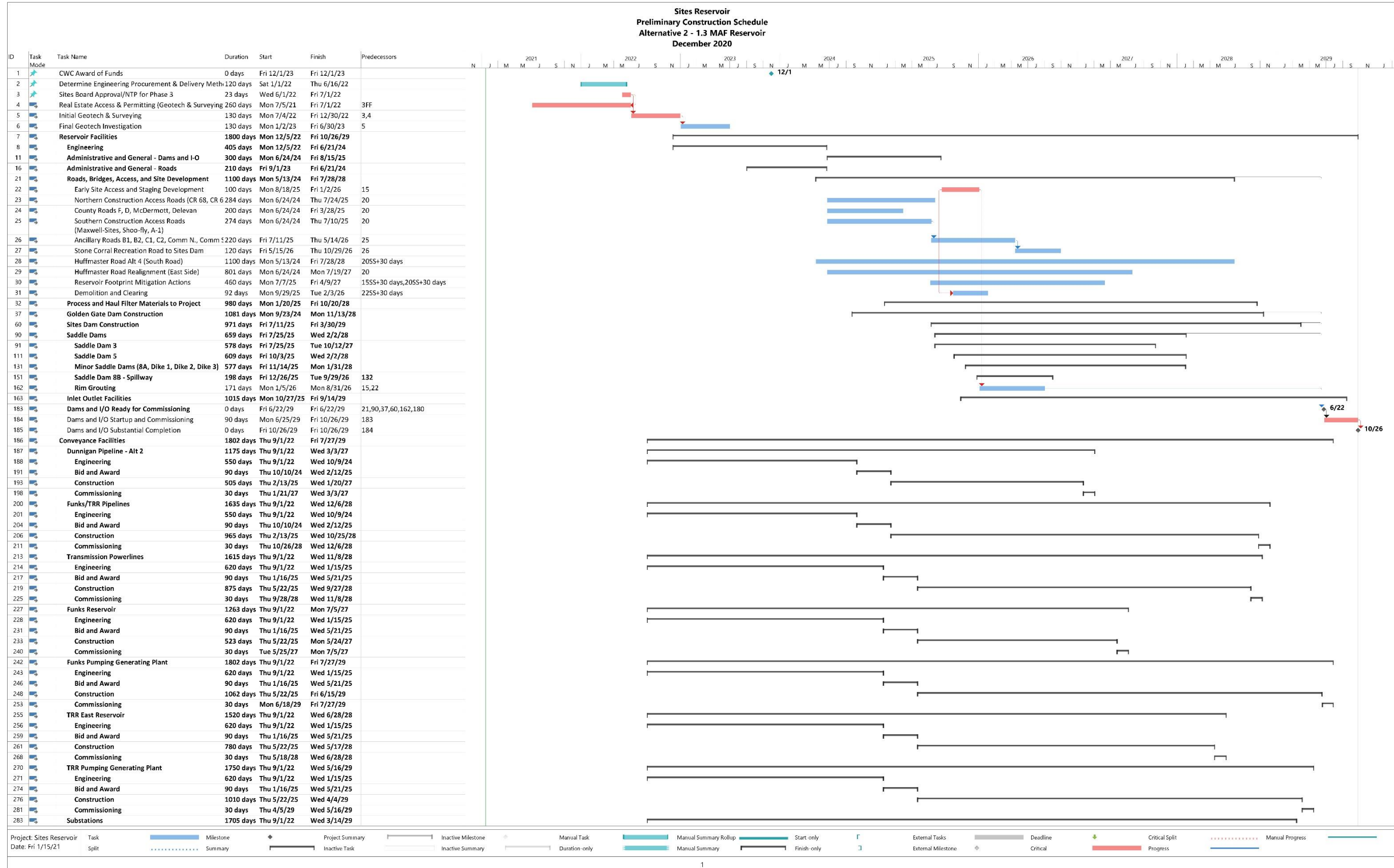


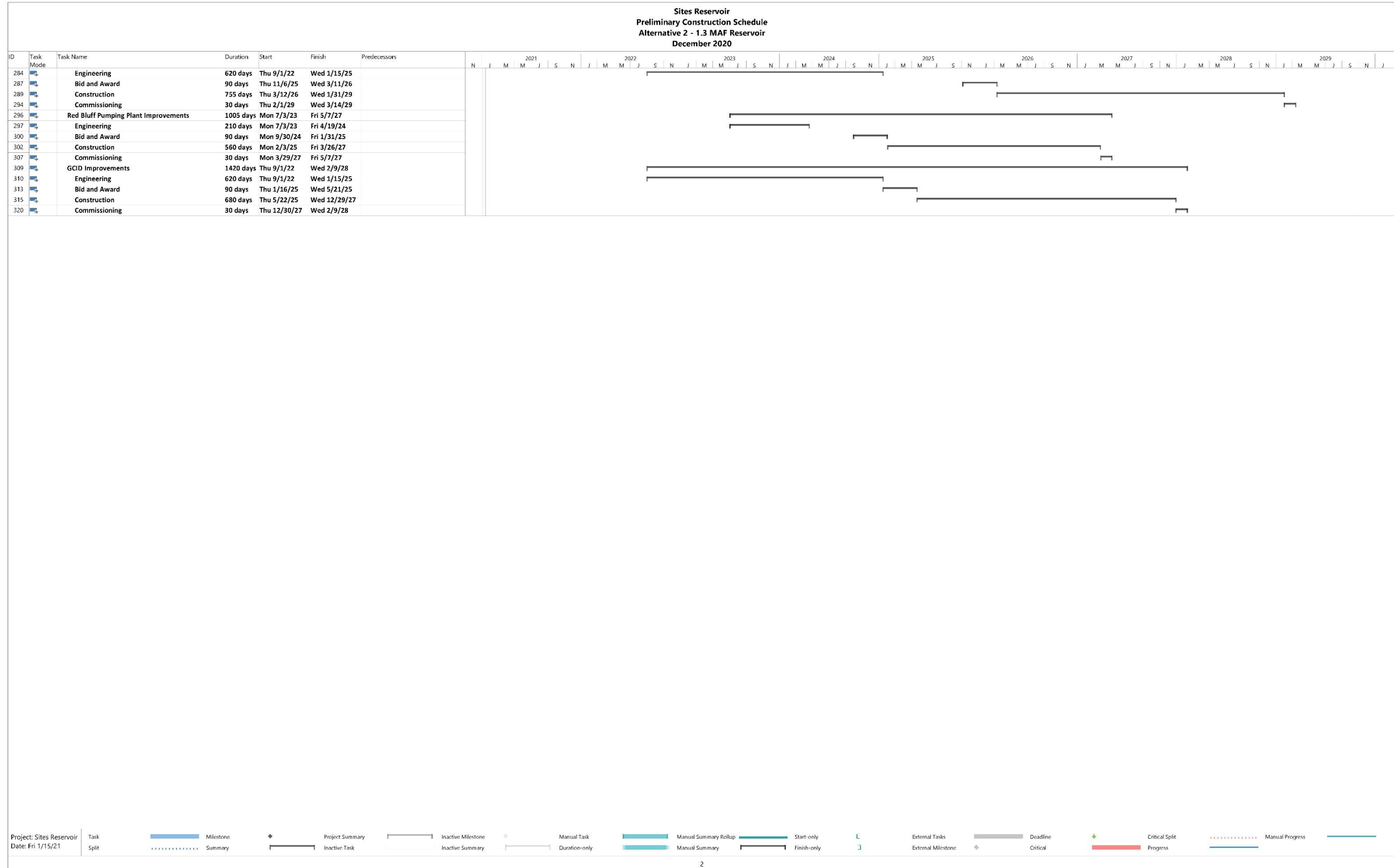
Figure 2C-68
Dunnigan Sacramento River Discharge Site Plan

Attachment 2 – Construction Schedules









Attachment 3 – Alternative Text for Appendix 2C Figures

Figure Number	Figure Title	Alternative Text (ADA Compliance)
2C-1	Vicinity Map	Vicinity Map
2C-2	Alternatives 1 and 3 Regulating Reservoirs and Conveyance and Sites Reservoir Facilities	Alternatives 1 and 3 Regulating Reservoirs and Conveyance and Sites Reservoir Facilities
2C-3	Alternatives 1 and 3 Conveyance to Sacramento River Components	Alternatives 1 and 3 Conveyance to Sacramento River Components
2C-4	Alternative 2 Regulating Reservoirs and Conveyance and Sites Reservoir Facilities	Alternative 2 Regulating Reservoirs and Conveyance and Sites Reservoir Facilities
2C-5	Alternative 2 Conveyance to Sacramento River Components	Alternative 2 Conveyance to Sacramento River Components
2C-6	Onsite Borrow Area Details	Onsite Borrow Area Details
2C-7	Active and Inactive Mines in Project Vicinity	Active and Inactive Mines in Project Vicinity
2C-8	Existing Roadways	Existing Roadways
2C-9	Overall Location and Access Plan - Terminal Regulating Reservoir East Alt	Overall Location and Access Plan - Terminal Regulating Reservoir East Alt
2C-10	Red Bluff Pumping Plant Access Plan	Red Bluff Pumping Plant Access Plan
2C-11	Overall Location and Access Plan - Terminal Regulating Reservoir West Alt	Overall Location and Access Plan - Terminal Regulating Reservoir West Alt
2C-12	GCID Main Canal Headgates Access Plan	GCID Main Canal Headgates Access Plan
2C-13	GCID Siphons Access Plan	GCID Siphons Access Plan
2C-14	Dunnigan Pipeline Alts 1 and 2 Access Plan	Dunnigan Pipeline Alts 1 and 2 Access Plan
2C-15	Dunnigan Pipeline Alt 2 Access Plan	Dunnigan Pipeline Alt 2 Access Plan
2C-16	Private Bridge Access Plan	Private Bridge Access Plan
2C-17	Funks Reservoir Stockpile and Haul Route Plan	Funks Reservoir Stockpile and Haul Route Plan
2C-18	Red Bluff Pumping Plant	Red Bluff Pumping Plant
2C-19	Tehama-Colusa Canal Diversion at Red Bluff Pumping Plant - Plan View	Tehama-Colusa Canal Diversion at Red Bluff Pumping Plant - Plan View
2C-20	Tehama-Colusa Canal Diversion at Red Bluff Pumping Plant- Profile View	Tehama-Colusa Canal Diversion at Red Bluff Pumping Plant- Profile View
2C-21	GCID System Upgrades	GCID System Upgrades
2C-22	GCID System Upgrades Continued	GCID System Upgrades Continued
2C-23	GCID Main Canal Head Gate Structure	GCID Main Canal Head Gate Structure
2C-24	GCID Canal New Head Gate Site Plan	GCID Canal New Head Gate Site Plan
2C-25	GCID Main Canal Walker Creek Siphon Site Plan	GCID Main Canal Walker Creek Siphon Site Plan

Attachment 3 – Alternative Text for Appendix 2C

Figure Number	Figure Title	Alternative Text (ADA Compliance)
2C-26	GCID Main Canal Willow Creek Siphon Site Plan	GCID Main Canal Willow Creek Siphon Site Plan
2C-27	Funks Reservoir Facilities Site Plan	Funks Reservoir Facilities Site Plan
2C-28A	Funks Pumping Generating Plant Facilities	Funks Pumping Generating Plant Facilities
2C-28B	Funks Pumping Generating Plant Facilities	Funks Pumping Generating Plant Facilities
2C-29	Transition Manifold	Transition Manifold
2C-30	TC Canal Intake Site Plan	TC Canal Intake Site Plan
2C-31	TC Canal Dissipation Structure	TC Canal Dissipation Structure
2C-32	Terminal Regulating Reservoir East Facilities Site Plan	Terminal Regulating Reservoir East Facilities Site Plan
2C-33A	Terminal Regulating Reservoir East and West Alts Pumping Generating Plant	Terminal Regulating Reservoir East and West Alts Pumping Generating Plant
2C-33B	Terminal Regulating Reservoir East and West Alts Pumping Generating Plant	Terminal Regulating Reservoir East and West Alts Pumping Generating Plant
2C-34	Terminal Regulating Reservoir East Pipelines	Terminal Regulating Reservoir East Pipelines
2C-35	Terminal Regulating Reservoir East or West Substation	Terminal Regulating Reservoir East or West Substation
2C-36	Double-Circuit Source Transmission Poles	Double-Circuit Source Transmission Poles
2C-37	Alternatives 1 and 3 Funks Reservoir to Terminal Regulating Reservoir East or West Electrical Interconnection	Alternatives 1 and 3 Funks Reservoir to Terminal Regulating Reservoir East or West Electrical Interconnection
2C-38	PG&E Schematic Sketch	PG&E Schematic Sketch
2C-39	WAPA Schematic Sketch	WAPA Schematic Sketch
2C-40	Administration and Operations Building	Administration and Operations Building
2C-41	Maintenance and Storage Building	Maintenance and Storage Building
2C-42	Plan of Inlet/Outlet Works Site	Plan of Inlet/Outlet Works Site
2C-43	Profile of Inlet/Outlet Works Site	Profile of Inlet/Outlet Works Site
2C-44	Inlet/Outlet Works Schematic	Inlet/Outlet Works Schematic
2C-45	Inlet/Outlet Works Schematic	Inlet/Outlet Works Schematic
2C-46	Golden Gate Dam Plan	Golden Gate Dam Plan
2C-47	Sites Dam Plan	Sites Dam Plan
2C-48	Sites Dam Section	Sites Dam Section
2C-49	Golden Gate Dam Section	Golden Gate Dam Section
2C-50	Location of Saddle Dams and Saddle Dikes	Location of Saddle Dams and Saddle Dikes
2C-51	Saddle Dike Section	Saddle Dike Section
2C-52	Saddle Dam 8B Spillway	Saddle Dam 8B Spillway
2C-53	Local Access, Construction Access, and Maintenance Access Roads	Local Access, Construction Access, and Maintenance Access Roads

Attachment 3 – Alternative Text for Appendix 2C

Figure Number	Figure Title	Alternative Text (ADA Compliance)
2C-54	Maintenance Access Roads	Maintenance Access Roads
2C-55	County Road Improvement	County Road Improvement
2C-56	Maintenance Access Road Typical - Paved and Unpaved	Maintenance Access Road Typical - Paved and Unpaved
2C-57	North Access Road	North Access Road
2C-58	Sites Lodoga Road Realignment and Bridge	Sites Lodoga Road Realignment and Bridge
2C-59	Dunnigan CBD Discharge Site Plan	Dunnigan CBD Discharge Site Plan
2C-60	CBD Outlet	CBD Outlet
2C-61	Recreation Access	Recreation Access
2C-62	Terminal Regulating Reservoir West Pipelines	Terminal Regulating Reservoir West Pipelines
2C-63A	Terminal Regulating Reservoir West Main Reservoir Plan	Terminal Regulating Reservoir West Main Reservoir Plan
2C-63B	Terminal Regulating Reservoir West Reservoir Extension Plan	Terminal Regulating Reservoir West Reservoir Extension Plan
2C-63C	Terminal Regulating Reservoir West Inlet/Outlet Canal Plan	Terminal Regulating Reservoir West Inlet/Outlet Canal Plan
2C-64	Alternative 2, Sites Dam Location	Alternative 2, Sites Dam Location
2C-65	Alternative 2, Golden Gate Dam Location	Alternative 2, Golden Gate Dam Location
2C-66A	Alternative 2, Saddle Dams and Saddle Dike 3 Location	Alternative 2, Saddle Dams and Saddle Dike 3 Location
2C-66B	Alternative 2, Saddle Dams and Saddle Dike 3 Location	Alternative 2, Saddle Dams and Saddle Dike 3 Location
2C-66C	Alternative 2, Saddle Dams and Saddle Dike 3 Location	Alternative 2, Saddle Dams and Saddle Dike 3 Location
2C-67	Alternative 2 Huffmaster Road Realignment and South Road	Alternative 2 Huffmaster Road Realignment and South Road
2C-68	Dunnigan Sacramento River Discharge Site Plan	Dunnigan Sacramento River Discharge Site Plan