

City of Escondido PRIORITY DEVELOPMENT PROJECT (PDP) SWQMP

Quince Street Senior Housing

220-240 QUINCE STREET, ESCONDIDO, CA

ASSESSOR'S PARCEL NUMBER(S):
229-331-10

ENGINEER OF WORK:

Michael D. Schweitzer, 59658

PREPARED FOR:
Interfaith Housing Dev. Corp.
7956 Lester Avenue
Lemon Grove, CA 91945

PDP SWQMP PREPARED BY:



SWS Engineering, Inc.
261 Autumn Drive, Suite 115
San Marcos, CA 92069

DATE OF SWQMP:
February 1, 2019

PLANS PREPARED BY:
SWS Engineering, Inc.
261 Autumn Dr., Suite 115
San Marcos, CA 92069
760-744-0011

SWQMP APPROVED BY:

APPROVAL DATE:



PRIORITY DEVELOPMENT PROJECT (PDP) SWQMP

This page was left intentionally blank.

PRIORITY DEVELOPMENT PROJECT (PDP) SWQMP

TABLE OF CONTENTS

TABLE OF CONTENTS	iii
ATTACHMENTS	iv
ACRONYMS	iv
PDP SWQMP PREPARER'S CERTIFICATION PAGE	v
SUBMITTAL RECORD	vii
PROJECT VICINITY MAP.....	viii
Step 1: Project type determination (Standard or Priority Development Project) (Form I-2a)..	1
Step 1.1: Storm Water Quality Management Plan requirements.....	4
Step 1.2: Exception to PDP definitions	4
Step 2: Construction Storm Water BMPs.....	5
Step 3: City of Escondido PDP SWQMP Site Information Checklist (Form I-2a).....	6
Step 3.1: Description of Existing Site Condition.....	6
Step 3.2: Description of Existing Site Drainage Patterns	7
Step 3.3: Description of Proposed Site Development	8
Step 3.4: Description of Proposed Site Drainage Patterns.....	9
Step 3.5: Potential Pollutant Source Areas	10
Step 3.6: Identification and Narrative of Receiving Water and Pollutants of Concern	11
Step 3.7: Hydromodification Management Requirements	12
Step 3.7.1: Critical Coarse Sediment Yield Areas*	13
Step 3.7.2: Flow Control for Post-Project Runoff*	14
Step 3.8: Other Site Requirements and Constraints	15
Step 4: Source Control BMP Checklist (Form I-2b).....	16
Step 5: Site Design BMP Checklist (Form I-2c)	18
Step 6: PDP Structural BMPs (Form I-3)	20
Step 6.1: Description of structural BMP strategy.....	20
Step 6.2: Structural BMP Checklist.....	22
Step 6.3: Offsite Alternative Compliance Participation Form.....	23

PRIORITY DEVELOPMENT PROJECT (PDP) SWQMP

ATTACHMENTS

Attachment 1: Backup for PDP Pollutant Control BMPs

Attachment 1a: Storm Water Pollutant Control Worksheet Calculations (Worksheet B.2-1 DCV, Form I-4)

Attachment 1b: Form I-5, Categorization of Infiltration Feasibility Condition

Attachment 1c: Form I-6, Factor of Safety and Design Infiltration Rate Worksheet

Attachment 1d: Drainage Management Area (DMA) Exhibit

Attachment 1e: Individual Structural BMP DMA Mapbook

Attachment 2: Backup for PDP Hydromodification Control Measures

Attachment 2a: Flow Control Facility Design

Attachment 2b: Hydromodification Management Exhibit

Attachment 2c: Management of Critical Coarse Sediment Yield Areas

Attachment 2d: Geomorphic Assessment of Receiving Channels (optional)

Attachment 2e: Vector Control Plan (if applicable)

Attachment 3: Structural BMP Maintenance Plan

Attachment 3a: Structural BMP Maintenance Thresholds and Actions

Attachment 3b: Draft Maintenance Agreements / Notifications (when applicable)

Attachment 4: City of Escondido PDP Structural BMP Verification

Attachment 5: Copy of Plan Sheets Showing Permanent Storm Water BMPs

ACRONYMS

ACP	Alternative Compliance Project
APN	Assessor's Parcel Number
BMP	Best Management Practice
DMA	Drainage Management Area
EOW	Engineer of Work
HMP	Hydromodification Management Plan
HSG	Hydrologic Soil Group
MS4	Municipal Separate Storm Sewer System
N/A	Not Applicable
PDP	Priority Development Project
PE	Professional Engineer
SC	Source Control
SD	Site Design
SDRWQCB	San Diego Regional Water Quality Control Board
SIC	Standard Industrial Classification
SWDM	Storm Water Design Manual
SWQMP	Storm Water Quality Management Plan
WMAA	Watershed Management Area Analysis
WQIP	Water Quality Improvement Plan

PRIORITY DEVELOPMENT PROJECT (PDP) SWQMP

PDP SWQMP PREPARER'S CERTIFICATION PAGE

Project Name: [Insert Project Name]

Permit Application Number: [Insert Permit Application Number]

PREPARER'S CERTIFICATION

I hereby declare that I am the Engineer in Responsible Charge of design of storm water best management practices (BMPs) for this project, and that I have exercised responsible charge over the design of the BMPs as defined in Section 6703 of the Business and Professions Code, and that the design is consistent with the PDP requirements of the City of Escondido Storm Water Design Manual, which is a design manual for compliance with the City of Escondido Municipal Code (Chapter 22, Article 2) and regional MS4 Permit (California Regional Water Quality Control Board San Diego Region Order No. R9-2013-0001 as amended by R9-2015-0001 and R9-2015-0100) requirements for storm water management.

I have read and understand that the City of Escondido has adopted minimum requirements for managing urban runoff, including storm water, from land development activities, as described in the Storm Water Design Manual. I certify that this PDP SWQMP has been completed to the best of my ability and accurately reflects the project being proposed and the applicable BMPs proposed to minimize the potentially negative impacts of this project's land development activities on water quality. I understand and acknowledge that the plan check review of this PDP SWQMP by City staff is confined to a review and does not relieve me, as the Engineer in Responsible Charge of design of storm water BMPs for this project, of my responsibilities for project design.

Engineer of Work's Signature, PE Number & Expiration Date

Michael D. Schweitzer

SWS Engineering, Inc.
Company

Date

Engineer's Seal:

PRIORITY DEVELOPMENT PROJECT (PDP) SWQMP

PRIORITY DEVELOPMENT PROJECT (PDP) SWQMP

SUBMITTAL RECORD

Use this Table to keep a record of submittals of this PDP SWQMP. Each time the PDP SWQMP is re-submitted, provide the date and status of the project. In column 4 summarize the changes that have been made or indicate if response to plancheck comments is included. When applicable, insert response to plancheck comments behind this page.

Preliminary Design / Planning / CEQA

Submittal Number	Date	Summary of Changes
1	9/7/17	Initial Submittal
2	11/15/18	2 nd Submittal
3	2/5/19	3 rd Submittal
4	4/22/19	4 th Submittal

Final Design

Submittal Number	Date	Summary of Changes
1		Initial Submittal
2		
3		
4		

Plan Changes

Submittal Number	Date	Summary of Changes
1		Initial Submittal
2		
3		
4		

PRIORITY DEVELOPMENT PROJECT (PDP) SWQMP

PROJECT VICINITY MAP

Project Name: Quince Senior Housing
Record ID:

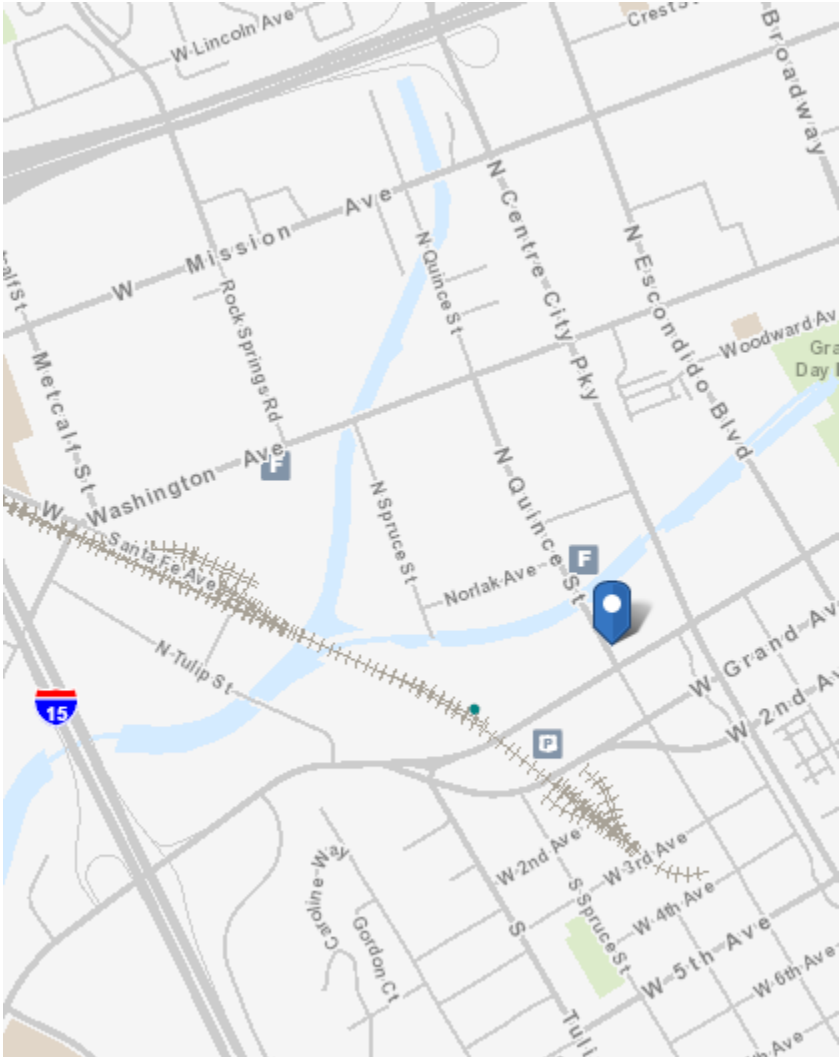

PRIORITY DEVELOPMENT PROJECT (PDP) SWQMP

Step 1: Project type determination (Standard or Priority Development Project) (Form I-2a)

Project Summary Information	
Project Name	Quince Senior Housing
Project Address	220-240 QUINCE STREET, ESCONDIDO, CA
Assessor's Parcel Number(s)	229-331-10
Permit Application Number	
Project Watershed (Hydrologic Unit)	Select One: Carlsbad 904 San Dieguito 905
Parcel Area (total area of Assessor's Parcel(s) associated with the project)	<u>1.488</u> Acres (<u>64,832</u> Square Feet)
Area to be disturbed by the project (Project Area)	<u>1.488</u> Acres (<u>64,832</u> Square Feet)
Project Proposed Impervious Area (subset of Project Area)	<u>1.28</u> Acres (<u>55,755</u> Square Feet)
Project Proposed Pervious Area (subset of Project Area)	<u>0.208</u> Acres (<u>9,077</u> Square Feet)
Note: Proposed Impervious Area + Proposed Pervious Area = Area to be Disturbed by the Project. This may be less than the Parcel Area.	
Confirmation of Priority Development Project Determination	
The project is (select one): <input type="checkbox"/> New Development <input checked="" type="checkbox"/> Redevelopment ¹	
The total proposed newly created or replaced impervious area is: 55,755 ft ²	

¹ Redevelopment is defined as: The creation and/or replacement of impervious surface on an already developed site. Examples include the expansion of a building footprint, road widening, the addition to or replacement of a structure, and creation or addition of impervious surfaces. Replacement of impervious surfaces includes any activity that is not part of a routine maintenance activity where impervious material(s) are removed, exposing underlying soil during construction. Redevelopment does not include routine maintenance activities, such as trenching and resurfacing associated with utility work; pavement grinding; resurfacing existing roadways; new sidewalks construction; pedestrian ramps; or bike lanes on existing roads; and routine replacement of damaged pavement, such as pothole repair.

Solar energy farms that are not also one of the categories listed in Step 2b of Table 1-1. City staff must also determine that appropriate BMPs are provided to mitigate for downstream impacts due to significant changes to the existing hydrology

PRIORITY DEVELOPMENT PROJECT (PDP) SWQMP

Is the project in any of the following categories, (a) through (f)?			
Yes x	No <input type="checkbox"/>	(a)	New development projects that create 10,000 square feet or more of impervious surfaces (collectively over the entire project site). This includes commercial, industrial, residential, mixed-use, and public development projects on public or private land.
Yes x	No <input type="checkbox"/>	(b)	Redevelopment projects that create and/or replace 5,000 square feet or more of impervious surface (collectively over the entire project site on an existing site of 10,000 square feet or more of impervious surfaces). This includes commercial, industrial, residential, mixed-use, and public development projects on public or private land.
Yes <input type="checkbox"/>	No x	(c)	<p>New and redevelopment projects that create and/or replace 5,000 square feet or more of impervious surface (collectively over the entire project site), and support one or more of the following uses:</p> <ul style="list-style-type: none"> (i) Restaurants. This category is defined as a facility that sells prepared foods and drinks for consumption, including stationary lunch counters and refreshment stands selling prepared foods and drinks for immediate consumption (Standard Industrial Classification (SIC) code 5812). (ii) Hillside development projects. This category includes development on any natural slope that is twenty-five percent or greater. (iii) Parking lots. This category is defined as a land area or facility for the temporary parking or storage of motor vehicles used personally, for business, or for commerce. (iv) Streets, roads, highways, freeways, and driveways. This category is defined as any paved impervious surface used for the transportation of automobiles, trucks, motorcycles, and other vehicles.
Yes <input type="checkbox"/>	No x	(d)	<p>New or redevelopment projects that create and/or replace 2,500 square feet or more of impervious surface (collectively over the entire project site), and discharging directly to an Environmentally Sensitive Area (ESA). "Discharging directly to" includes flow that is conveyed overland a distance of 200 feet or less from the project to the ESA, or conveyed in a pipe or open channel any distance as an isolated flow from the project to the ESA (i.e. not commingled with flows from adjacent lands).</p> <p><i>Note: ESAs are areas that include but are not limited to all Clean Water Act Section 303(d) impaired water bodies; areas designated as Areas of Special Biological Significance by the State Water Board and San Diego Water Board; State Water Quality Protected Areas; water bodies designated with the RARE beneficial use by the State Water Board and San Diego Water Board; and any other equivalent environmentally sensitive areas which have been identified by the Copermittees.</i></p>
Yes <input type="checkbox"/>	No x	(e)	<p>New development projects, or redevelopment projects that create and/or replace 5,000 square feet or more of impervious surface, that support one or more of the following uses:</p> <ul style="list-style-type: none"> (i) Automotive repair shops. This category is defined as a facility that is categorized in any one of the following SIC codes: 5013, 5014, 5541, 7532-7534, or 7536-7539. (ii) Retail gasoline outlets (RGOs). This category includes RGOs that meet the following criteria: (a) 5,000 square feet or more or (b) a projected Average Daily Traffic (ADT) of 100 or more vehicles per day.

PRIORITY DEVELOPMENT PROJECT (PDP) SWQMP

Yes <input type="checkbox"/>	No x	(e)	New development projects, or redevelopment projects that create and/or replace 5,000 square feet or more of impervious surface, that support one or more of the following uses: (iii) Automotive repair shops. This category is defined as a facility that is categorized in any one of the following SIC codes: 5013, 5014, 5541, 7532-7534, or 7536-7539. (iv) Retail gasoline outlets (RGOs). This category includes RGOs that meet the following criteria: (a) 5,000 square feet or more or (b) a projected Average Daily Traffic (ADT) of 100 or more vehicles per day.
Yes x	No <input type="checkbox"/>	(f)	New or redevelopment projects that result in the disturbance of one or more acres of land and are expected to generate pollutants post construction. <i>Note: See Storm Water Design Manual Section 1.4.2 for additional guidance.</i>

Does the project meet the definition of one or more of the Priority Development Project categories (a) through (f) listed above?

- No – the project is not a Priority Development Project (Standard Project).
 x Yes – the project is a Priority Development Project (PDP).

Further guidance may be found in Chapter 1 and Table 1-2 of the Storm Water Design Manual.

The following is for **redevelopment PDPs only**:

The area of existing (pre-project) impervious area at the project site is: 64,904 ft² (A)
 The total proposed newly created or replaced impervious area is 47,916 ft² (B)
 Percent impervious surface created or replaced (B/A)*100: 73%

The percent impervious surface created or replaced is (select one based on the above calculation):

- less than or equal to fifty percent (50%) – **only newly created or replaced impervious areas are considered a PDP and subject to stormwater requirements**
 OR
 x greater than fifty percent (50%) – **the entire project site is considered a PDP and subject to stormwater requirements**

PRIORITY DEVELOPMENT PROJECT (PDP) SWQMP

Step 1.1: Storm Water Quality Management Plan requirements

Step	Answer	Progression
<p>Is the project a Standard Project, Priority Development Project (PDP), or exception to PDP definitions?</p> <p>To answer this item, complete Step 1 Project Type Determination Checklist on Pages 1 and 2, and see PDP exemption information below. For further guidance, see Section 1.4 of the Storm Water Design Manual <i>in its entirety</i>.</p>	<input type="checkbox"/> Standard Project	<u>Standard Project</u> requirements apply, including <u>Standard Project SWQMP</u> . Complete Form I-1.
	<input checked="" type="checkbox"/> PDP	<u>Standard and PDP</u> requirements apply, including <u>PDP SWQMP</u> . SWQMP Required.
	<input type="checkbox"/> PDP with ACP	If participating in offsite alternative compliance, complete Step 6.3 and an ACP SWQMP.
	<input type="checkbox"/> PDP Exemption	Go to Step 1.2 below.

Step 1.2: Exemption to PDP definitions

<p>Is the project exempt from PDP definitions based on either of the following:</p> <ul style="list-style-type: none"> <input type="checkbox"/> Projects that are only new or retrofit paved sidewalks, bicycle lanes, or trails that meet the following criteria: <ul style="list-style-type: none"> (i) Designed and constructed to direct storm water runoff to adjacent vegetated areas, or other non-erodible permeable areas; OR (ii) Designed and constructed to be hydraulically disconnected from paved streets or roads [i.e., runoff from the new improvement does not drain directly onto paved streets or roads]; OR (iii) Designed and constructed with permeable pavements or surfaces in accordance with County of San Diego Green Streets Infrastructure; <input type="checkbox"/> Projects that are only retrofitting or redeveloping existing paved alleys, streets or roads that are designed and constructed in accordance with the City of Escondido Guidance on Green Infrastructure. 	<p>If so:</p> <p><u>Standard Project</u> requirements apply, AND <u>any additional requirements specific to the type of project</u>. <u>City concurrence</u> with the exemption is required. <i>Provide discussion and list any additional requirements below in this form.</i></p>
<p>PDP Exempt.</p>	
<p><i>Discussion / justification, and additional requirements for exceptions to PDP definitions, if applicable:</i></p>	

Step 2: Construction Storm Water BMPs

Construction storm water BMPs shall be shown on the Grading Plan and (if applicable) included in the Storm Water Pollution Prevention Plan (SWPPP).

PRIORITY DEVELOPMENT PROJECT (PDP) SWQMP

Step 3: City of Escondido PDP SWQMP Site Information Checklist (Form I-2a)

Step 3.1: Description of Existing Site Condition

<p>Current Status of the Site (select all that apply):</p> <p><input checked="" type="checkbox"/> Existing development</p> <p><input type="checkbox"/> Previously graded but not built out</p> <p><input type="checkbox"/> Demolition completed without new construction</p> <p><input type="checkbox"/> Agricultural or other non-impervious use</p> <p><input type="checkbox"/> Vacant, undeveloped/natural</p> <p><i>Description / Additional Information:</i></p>
<p>Existing Land Cover Includes (select all that apply and provide each area on site):</p> <p><input type="checkbox"/> Vegetative Cover _____ Acres (_____ Square Feet)</p> <p><input type="checkbox"/> Non-Vegetated Pervious Areas _____ Acres (_____ Square Feet)</p> <p><input checked="" type="checkbox"/> Impervious Areas <u>1.488</u> Acres (<u>64,832</u> Square Feet)</p> <p><i>Description / Additional Information:</i></p>
<p>Underlying Soil belongs to Hydrologic Soil Group (select all that apply):</p> <p><input checked="" type="checkbox"/> NRCS Type A</p> <p><input type="checkbox"/> NRCS Type B</p> <p><input type="checkbox"/> NRCS Type C</p> <p><input type="checkbox"/> NRCS Type D</p>
<p>Approximate Depth to Groundwater (GW) (or N/A for no infiltration BMPs):</p> <p><input type="checkbox"/> GW Depth < 5 feet</p> <p><input type="checkbox"/> 5 feet < GW Depth < 10 feet</p> <p><input checked="" type="checkbox"/> 10 feet < GW Depth < 20 feet</p> <p><input type="checkbox"/> GW Depth > 20 feet</p>
<p>Existing Natural Hydrologic Features (select all that apply):</p> <p><input type="checkbox"/> Watercourses</p> <p><input type="checkbox"/> Seeps</p> <p><input type="checkbox"/> Springs</p> <p><input type="checkbox"/> Wetlands</p> <p><input checked="" type="checkbox"/> None</p> <p><input type="checkbox"/> Other</p> <p><i>Description / Additional Information:</i></p>

PRIORITY DEVELOPMENT PROJECT (PDP) SWQMP

Step 3.2: Description of Existing Site Drainage Patterns

How is storm water runoff conveyed from the site? At a minimum, this description should answer:

- (1) Whether existing drainage conveyance is natural or urban;
- (2) Is runoff from offsite conveyed through the site? if yes, quantify all offsite drainage areas, design flows, and locations where offsite flows enter the project site, and summarize how such flows are conveyed through the site;
- (3) Provide details regarding existing project site drainage conveyance network, including any existing storm drains, concrete channels, swales, detention facilities, storm water treatment facilities, natural or constructed channels; and
- (4) Identify all discharge locations from the existing project site along with a summary of conveyance system size and capacity for each of the discharge locations. Provide summary of the pre-project drainage areas and design flows to each of the existing runoff discharge locations.

The existing site sheet flows out to Quince Street and is 100% impervious.

PRIORITY DEVELOPMENT PROJECT (PDP) SWQMP

Step 3.3: Description of Proposed Site Development

<p><i>Project proposes to construct a podium apartment project for low income senior housing.</i></p>
<p><i>List/describe proposed impervious features of the project:</i></p> <p><i>The project will have a concrete podium structure on which the apartment units will be constructed. The project will also include a fire lane on the north side of the building. The fire lane will drain to a self-retaining landscape area adjacent to it.</i></p>
<p><i>List/describe proposed pervious features of the project (e.g., landscape areas):</i></p> <p><i>The project will have several landscaped areas on the podium above the garage area. These areas along with the landscape areas within the garage will be utilized to provide the storm water treatment for the project.</i></p>
<p>Does the project include grading and changes to site topography?</p> <p><input checked="" type="checkbox"/> Yes</p> <p><input type="checkbox"/> No</p> <p><i>Description / Additional Information: The site will be leveled out for the parking garage under the podium.</i></p>

Insert acreage or square feet for the different land cover types in the table below:

Change in Land Cover Type Summary			
Land Cover Type	Existing (acres or ft ²)	Proposed (acres or ft ²)	Percent Change
Vegetation	0	9077	+100%
Pervious (non-vegetated)	0	0	
Impervious	64,832	55,755	-14%

PRIORITY DEVELOPMENT PROJECT (PDP) SWQMP

Step 3.4: Description of Proposed Site Drainage Patterns

Does the project include changes to site drainage (e.g., installation of new storm water conveyance systems)?

Yes

No

If yes, provide details regarding the proposed project site drainage conveyance network, including storm drains, concrete channels, swales, detention facilities, storm water treatment facilities, natural or constructed channels, and the method for conveying offsite flows through or around the proposed project site. Identify all discharge locations from the proposed project site along with a summary of the conveyance system size and capacity for each of the discharge locations. Provide a summary of pre- and post-project drainage areas and design flows to each of the runoff discharge locations. Reference the drainage study for detailed calculations.

Describe proposed site drainage patterns:

The overall drainage patterns will remain the same with the storm water flows being directed out to Quince Street. Due to the construction of the project and the storm water treatment areas a private storm drain system will be constructed onsite that will tie into the public MS4 system in Quince. DMA-7 is a PDP exempt area as the paving for fire access is an extension of the existing bike path and is designated and constructed to direct storm water runoff to adjacent vegetated areas.

PRIORITY DEVELOPMENT PROJECT (PDP) SWQMP

Step 3.5: Potential Pollutant Source Areas

Identify whether any of the following features, activities, and/or pollutant source areas will be present (select all that apply).

- On-site storm drain inlets
- Interior floor drains and elevator shaft sump pumps
- Interior parking garages
- Need for future indoor & structural pest control
- Landscape/Outdoor Pesticide Use
- Pools, spas, ponds, decorative fountains, and other water features
- Food service
- Refuse areas
- Industrial processes
- Outdoor storage of equipment or materials
- Vehicle and Equipment Cleaning
- Vehicle/Equipment Repair and Maintenance
- Fuel Dispensing Areas
- Loading Docks
- Fire Sprinkler Test Water
- Miscellaneous Drain or Wash Water
- Plazas, sidewalks, and parking lots
- Other (provide description)

Description / Additional Information:

PRIORITY DEVELOPMENT PROJECT (PDP) SWQMP

Step 3.6: Identification and Narrative of Receiving Water and Pollutants of Concern

<p><i>Describe flow path of storm water from the project site discharge location(s), through urban storm conveyance systems as applicable, to receiving creeks, rivers, and lagoons as applicable, and ultimate discharge to the Pacific Ocean (or bay, lagoon, lake or reservoir, as applicable):</i></p> <p>Discharges to public storm drain which drains to Escondido Creek which flows out the San Elijo Lagoon to the Pacific Ocean</p>			
<p>List any 303(d) impaired water bodies² within the path of storm water from the project site to the Pacific Ocean (or bay, lagoon, lake or reservoir, as applicable), identify the pollutant(s)/stressor(s) causing impairment, and identify any TMDLs and/or Highest Priority Pollutants from the WQIP for the impaired water bodies:</p>			
303(d) Impaired Water Body	Pollutant(s)/Stressor(s)	TMDLs / WQIP Highest Priority Pollutant	
Escondido Creek	Indicator Bacteria, TDS, Toxicity	Total Dissolved Solids (TDS)	
San Elijo Lagoon	Sedimentation/Siltation, Toxicity	Sedimentation/Siltation	
Pacific Ocean	Indicator Bacteria	Bacteria	
<p align="center">Identification of Project Site Pollutants*</p> <p>*Identification of project site pollutants below is only required if flow-thru treatment BMPs are implemented onsite in lieu of retention or biofiltration BMPs. Note the project must also participate in an alternative compliance program (unless prior lawful approval to meet earlier PDP requirements is demonstrated).</p>			
<p>Identify pollutants expected from the project site based on all proposed use(s) of the site (see Storm Water Design Manual Appendix B.6):</p>			
Pollutant	Not Applicable to the Project Site	Anticipated from the Project Site	Also a Receiving Water Pollutant of Concern
Sediment		x	
Nutrients		x	
Heavy Metals		x	
Organic Compounds		x	
Trash & Debris		x	
Oxygen Demanding Substances		x	
Oil & Grease		x	
Bacteria & Viruses		x	
Pesticides		x	

² The current list of Section 303(d) impaired water bodies can be found at http://www.waterboards.ca.gov/water_issues/programs/water_quality_assessment/#impaired

PRIORITY DEVELOPMENT PROJECT (PDP) SWQMP

Step 3.7: Hydromodification Management Requirements

Do hydromodification management requirements apply (see Section 1.6 of the Storm Water Design Manual)?

- Yes, hydromodification management requirements for flow control and preservation of critical coarse sediment yield areas are applicable.
- No, the project will discharge runoff directly to existing underground storm drains discharging directly to water storage reservoirs, lakes, enclosed embayments, or the Pacific Ocean.
- No, the project will discharge runoff directly to conveyance channels whose bed and bank are concrete-lined all the way from the point of discharge to water storage reservoirs, lakes, enclosed embayments, or the Pacific Ocean.
- No, the project will discharge runoff directly to an area identified as appropriate for an exemption by the WMAA³ for the watershed in which the project resides.

Description / Additional Information (to be provided if a 'No' answer has been selected above):

³The Watershed Management Area Analysis (WMAA) is an optional element for inclusion in the Water Quality Improvement Plans (WQIPs) described in the 2013 MS4 Permit [Provision B.3.b.(4)]. It is available online at the Project Clean Water website:

http://www.projectcleanwater.org/index.php?option=com_content&view=article&id=248

PRIORITY DEVELOPMENT PROJECT (PDP) SWQMP

Step 3.7.1: Critical Coarse Sediment Yield Areas*

***This Section only required if hydromodification management requirements apply**

Based on the maps provided within the WMAA, do potential critical coarse sediment yield areas exist within the project drainage boundaries?

If yes, have any of the optional analyses presented in Section 6.2 of the manual been performed?

6.2.1 Verification of GLUs (classification that provides an estimate of sediment yield based on geology, hillslope, and land cover) Onsite

6.2.2 Downstream Systems Sensitivity to Coarse Sediment

6.2.3 Optional Additional Analysis of Potential Critical Coarse Sediment Yield Areas Onsite

No optional analyses performed, the project will avoid critical coarse sediment yield areas identified based on WMAA maps

If optional analyses were performed, what is the final result?

No critical coarse sediment yield areas to be protected based on verification of GLUs onsite. Critical coarse sediment yield areas exist but additional analysis has determined that protection is not required. Documentation attached in Attachment 8 of the SWQMP.

Critical coarse sediment yield areas exist and require protection. The project will implement management measures described in Sections 6.2.4 and 6.2.5 as applicable, and the areas are identified on the SWQMP Exhibit.

Discussion / Additional Information:

PRIORITY DEVELOPMENT PROJECT (PDP) SWQMP

Flow Control for Post-Project Runoff*

***This Section only required if hydromodification management requirements apply**

List and describe point(s) of compliance (POCs) for flow control for hydromodification management (see Section 6.3.1). For each POC, provide a POC identification name or number correlating to the project's HMP Exhibit and a receiving channel identification name or number correlating to the project's HMP Exhibit.

Has a geomorphic assessment been performed for the receiving channel(s)?

- No, the low flow threshold is 0.1Q2 (default low flow threshold)
- Yes, the result is the low flow threshold is 0.1Q2
- Yes, the result is the low flow threshold is 0.3Q2
- Yes, the result is the low flow threshold is 0.5Q2

If a geomorphic assessment has been performed, provide title, date, and preparer:

Discussion / Additional Information: (optional)

PRIORITY DEVELOPMENT PROJECT (PDP) SWQMP

Step 3.8: Other Site Requirements and Constraints

When applicable, list other site requirements or constraints that will influence storm water management design, such as zoning requirements including setbacks and open space, or local codes governing minimum street width, sidewalk construction, allowable pavement types, and drainage requirements.

Optional Additional Information or Continuation of Previous Sections As Needed

This space provided for additional information or continuation of information from previous sections as needed.

PRIORITY DEVELOPMENT PROJECT (PDP) SWQMP

Step 4: Source Control BMP Checklist (Form I-2b)

Source Control BMPs			
<p>All development projects must implement source control BMPs 4.2.1 through 4.2.6 where applicable and feasible. See Chapter 4.2 and Appendix E of the City Storm Water Design Manual for information to implement source control BMPs shown in this checklist. The following checklists serve as guides only. Mark what elements are included in your project. See Storm Water Design Manual Chapter 4 and Appendix E for more information on determining appropriate BMPs for your project.</p> <p>Answer each category below pursuant to the following:</p> <ul style="list-style-type: none"> • "Yes" means the project will implement the source control BMP as described in Chapter 4.2 and/or Appendix E of the City Storm Water Design Manual. Discussion / justification is not required. • "No" means the BMP is applicable to the project but it is not feasible to implement. Discussion / justification must be provided. • "N/A" means the BMP is not applicable at the project site because the project does not include the feature that is addressed by the BMP (e.g., the project has no outdoor materials storage areas). Discussion / justification must be provided. 			
Source Control Requirement	Applied?		
SC-1 Prevention of Illicit Discharges into the MS4	xYes	<input type="checkbox"/> No	<input type="checkbox"/> N/A
<input type="checkbox"/> Direct irrigation water away from impervious surfaces <input type="checkbox"/> Direct vehicle wash water away from impervious surfaces <input type="checkbox"/> Other: _____			
<i>Discussion / justification if SC-1 not implemented:</i>			
SC-2 Storm Drain Stenciling or Signage	xYes	<input type="checkbox"/> No	<input type="checkbox"/> N/A
<input type="checkbox"/> Stencil or stamp storm drains with anti-dumping message <input type="checkbox"/> Post signs prohibiting illegal dumping <input type="checkbox"/> Other			
<i>Discussion / justification if SC-2 not implemented:</i>			
SC-3 Protect Outdoor Materials Storage Areas from Rainfall, Run-On, Runoff, and Wind Dispersal	xYes	<input type="checkbox"/> No	<input type="checkbox"/> N/A
<input type="checkbox"/> Store materials inside a covered enclosure <input type="checkbox"/> Direct runoff from downspouts and roofs away from storage areas <input type="checkbox"/> Other			
<i>Discussion / justification if SC-3 not implemented:</i>			

PRIORITY DEVELOPMENT PROJECT (PDP) SWQMP

SC-4 Protect Materials Stored in Outdoor Work Areas from Rainfall, Run-On, Runoff, and Wind Dispersal	<input type="checkbox"/> Yes	<input type="checkbox"/> No	<input checked="" type="checkbox"/> N/A
<input type="checkbox"/> Locate work area away from storm drains or catch basins Work over impermeable surfaces where spills and pollutants can be captured and removed <input type="checkbox"/> removed <i>Discussion / justification if SC-4 not implemented:</i>			
SC-5 Protect Trash Storage Areas from Rainfall, Run-On, Runoff, and Wind Dispersal	<input checked="" type="checkbox"/> Yes	<input type="checkbox"/> No	<input type="checkbox"/> N/A
<input type="checkbox"/> Locate trash containers in a roofed, walled enclosure <input type="checkbox"/> Locate trash containers away from storm drains <i>Discussion / justification if SC-5 not implemented:</i>			
SC-6 Additional BMPs Based on Potential Sources of Runoff Pollutants (must answer for each source listed below):			
<input type="checkbox"/> A. On-site storm drain inlets	<input checked="" type="checkbox"/> Yes	<input type="checkbox"/> No	<input type="checkbox"/> N/A
<input type="checkbox"/> B. Interior floor drains and elevator shaft sump pumps	<input checked="" type="checkbox"/> Yes	<input type="checkbox"/> No	<input type="checkbox"/> N/A
<input type="checkbox"/> C. Interior parking garages	<input checked="" type="checkbox"/> Yes	<input type="checkbox"/> No	<input type="checkbox"/> N/A
<input type="checkbox"/> D. Need for future indoor & structural pest control	<input checked="" type="checkbox"/> Yes	<input type="checkbox"/> No	<input type="checkbox"/> N/A
<input type="checkbox"/> E. Landscape/outdoor pesticide use	<input checked="" type="checkbox"/> Yes	<input type="checkbox"/> No	<input type="checkbox"/> N/A
<input type="checkbox"/> F. Pools, spas, ponds, fountains, and other water features	<input type="checkbox"/> Yes	<input type="checkbox"/> No	<input checked="" type="checkbox"/> N/A
<input type="checkbox"/> G. Food service	<input type="checkbox"/> Yes	<input type="checkbox"/> No	<input checked="" type="checkbox"/> N/A
<input type="checkbox"/> H. Refuse areas	<input checked="" type="checkbox"/> Yes	<input type="checkbox"/> No	<input type="checkbox"/> N/A
<input type="checkbox"/> I. Industrial processes	<input type="checkbox"/> Yes	<input type="checkbox"/> No	<input checked="" type="checkbox"/> N/A
<input type="checkbox"/> J. Outdoor storage of equipment or materials	<input type="checkbox"/> Yes	<input type="checkbox"/> No	<input checked="" type="checkbox"/> N/A
<input type="checkbox"/> K. Vehicle and equipment cleaning	<input type="checkbox"/> Yes	<input type="checkbox"/> No	<input checked="" type="checkbox"/> N/A
<input type="checkbox"/> L. Vehicle/equipment repair and maintenance	<input type="checkbox"/> Yes	<input type="checkbox"/> No	<input checked="" type="checkbox"/> N/A
<input type="checkbox"/> M. Fuel dispensing areas	<input type="checkbox"/> Yes	<input type="checkbox"/> No	<input checked="" type="checkbox"/> N/A
<input type="checkbox"/> N. Loading docks	<input type="checkbox"/> Yes	<input type="checkbox"/> No	<input checked="" type="checkbox"/> N/A
<input type="checkbox"/> O. Fire sprinkler test water	<input checked="" type="checkbox"/> Yes	<input type="checkbox"/> No	<input type="checkbox"/> N/A
<input type="checkbox"/> P. Miscellaneous drain or wash water	<input checked="" type="checkbox"/> Yes	<input type="checkbox"/> No	<input type="checkbox"/> N/A
<input type="checkbox"/> Q. Plazas, sidewalks, and parking lots	<input checked="" type="checkbox"/> Yes	<input type="checkbox"/> No	<input checked="" type="checkbox"/> N/A
<i>Discussion / justification if SC-6 not implemented. Clearly identify which sources of runoff pollutants are discussed. Justification must be provided for <u>all</u> "No" answers shown above.</i>			

Note: Show all source control measures described above that are included in design capture volume calculations in the plan sheets of Attachment 5.

PRIORITY DEVELOPMENT PROJECT (PDP) SWQMP

Step 5: Site Design BMP Checklist (Form I-2c)

Site Design BMPs			
<p>All development projects must implement site design BMPs SD-A through SD-H where applicable and feasible. See Chapter 4.3 and Appendix E of the City Storm Water Design Manual for information to implement site design BMPs shown in this checklist. The following checklists serve as guides only. Mark what elements are included in your project. See Storm Water Design Manual Chapter 4 and Appendix E for more information on determining appropriate BMPs for your project.</p> <p>Answer each category below pursuant to the following:</p> <ul style="list-style-type: none"> • "Yes" means the project will implement the site design BMP as described in Chapter 4.3 and/or Appendix E of the City Storm Water Design Manual. Discussion / justification is not required. • "No" means the BMP is applicable to the project but it is not feasible to implement. Discussion / justification must be provided. • "N/A" means the BMP is not applicable at the project site because the project does not include the feature that is addressed by the BMP (e.g., the project site has no existing natural areas to conserve). Discussion / justification must be provided. 			
Site Design Requirement	Applied?		
SD-1 Maintain Natural Drainage Pathways and Hydrologic Features	<input type="checkbox"/> Yes	<input type="checkbox"/> No	<input checked="" type="checkbox"/> N/A
<input type="checkbox"/> Maintain existing drainage patterns <i>Discussion / justification if SD-1 not implemented:</i>			
SD-2 Conserve Natural Areas, Soils, and Vegetation	<input type="checkbox"/> Yes	<input type="checkbox"/> No	<input checked="" type="checkbox"/> N/A
<input type="checkbox"/> Preserve trees (see Zoning Code Art. 55 Grading & Erosion Control; Art. 62 Landscape Regulations) <input type="checkbox"/> Avoid sensitive areas such as wetlands and waterways <i>Discussion / justification if SD-2 not implemented:</i>			
SD-3 Minimize Impervious Area	<input checked="" type="checkbox"/> Yes	<input type="checkbox"/> No	<input type="checkbox"/> N/A
<input type="checkbox"/> Install parking and driving aisles to minimum width required to meet standards <i>Discussion / justification if SD-3 not implemented:</i>			

PRIORITY DEVELOPMENT PROJECT (PDP) SWQMP

SD-4 Minimize Soil Compaction	<input checked="" type="checkbox"/> Yes	<input type="checkbox"/> No	<input type="checkbox"/> N/A
<input type="checkbox"/> Avoid compaction in planned landscaped spaces <input type="checkbox"/> Till and amend soil for improved infiltration capacity <i>Discussion / justification if SD-4 not implemented:</i>			
SD-5 Impervious Area Dispersion	<input checked="" type="checkbox"/> Yes	<input type="checkbox"/> No	<input type="checkbox"/> N/A
<input type="checkbox"/> Drain rooftops, roads or sidewalks into adjacent landscape areas <input type="checkbox"/> Drain impervious surfaces through pervious areas <i>Discussion / justification if SD-5 not implemented:</i>			
SD-6 Runoff Collection	<input type="checkbox"/> Yes		
<i>Discussion / justification if SD-6 not implemented:</i>	<input checked="" type="checkbox"/> Yes	<input type="checkbox"/> No	<input type="checkbox"/> N/A
SD-7 Landscaping with Native or Drought Tolerant Species			
<i>Discussion / justification if SD-7 not implemented:</i>	<input checked="" type="checkbox"/> Yes	<input type="checkbox"/> No	<input type="checkbox"/> N/A
SD-8 Harvesting and Using Precipitation			
<i>Discussion / justification if SD-8 not implemented:</i>	<input type="checkbox"/> Yes	<input type="checkbox"/> No	<input checked="" type="checkbox"/> N/A

Note: Show all site design measures described above that are included in design capture volume calculations in the plan sheets of Attachment 5.

PRIORITY DEVELOPMENT PROJECT (PDP) SWQMP

Step 6: PDP Structural BMPs (Form I-3)

All PDPs must implement structural BMPs for storm water pollutant control (see Chapter 5 of the Storm Water Design Manual). Selection of PDP structural BMPs for storm water pollutant control must be based on the selection process described in Chapter 5. PDPs subject to hydromodification management requirements must also implement structural BMPs for flow control for hydromodification management (see Chapter 6 of the Storm Water Design Manual). Both storm water pollutant control and flow control for hydromodification management can be achieved within the same structural BMP(s).

PDP structural BMPs must be verified by the City at the completion of construction. This may include requiring the project owner or project owner's representative and engineer of record to certify construction of the structural BMPs (see Section 8.2.3.2 of the Storm Water Design Manual). PDP structural BMPs must be maintained into perpetuity, and the City must confirm the maintenance (see Section 7 of the Storm Water Design Manual).

Use this section to provide narrative description of the general strategy for structural BMP implementation at the project site in the box below. Then complete the PDP structural BMP summary information sheet (Step 6.2) for each structural BMP within the project (copy the BMP summary information sheet [Step 6.2] as many times as needed to provide summary information for each individual structural BMP).

Step 6.1: Description of structural BMP strategy

Describe the general strategy for structural BMP implementation at the site. This information must describe how the steps for selecting and designing storm water pollutant control BMPs presented in Section 5.1 of the Storm Water Design Manual were followed, and the results (type of BMPs selected). For projects requiring hydromodification flow control BMPs, indicate whether pollutant control and flow control BMPs are integrated or separate. At the end of this discussion provide a summary of all the structural BMPs within the project including the type and number.

The project will construct a series of biofiltration basins both on the podium structure and along the sides of the parking garage in order to provide for the storm water treatment requirements. DMA-7 is a PDP exempt area as the paving for fire access is an extension of the existing bike path and is designated and constructed to direct storm water runoff to adjacent vegetated areas. The project is hydromodification flow control exempt.

(Continue on following page as necessary.)

PRIORITY DEVELOPMENT PROJECT (PDP) SWQMP

Description of structural **BMP** strategy continued
(Page reserved for continuation of description of general strategy for structural **BMP** implementation at the site)

(Continued from previous page)

PRIORITY DEVELOPMENT PROJECT (PDP) SWQMP

Step 6.2: Structural BMP Checklist

(Copy this page as needed to provide information for each individual proposed structural BMP)	
Structural BMP ID No. BMP 1	
Construction Plan Sheet No.	
Type of structural BMP: <input type="checkbox"/> Retention by harvest and use (HU-1) <input type="checkbox"/> Retention by infiltration basin (INF-1) <input type="checkbox"/> Retention by bioretention (INF-2) <input type="checkbox"/> Retention by permeable pavement (INF-3) <input type="checkbox"/> Partial retention by biofiltration with partial retention (PR-1) <input checked="" type="checkbox"/> Biofiltration (BF-1) <input type="checkbox"/> Biofiltration with Nutrient Sensitive Media Design (BF-2) <input type="checkbox"/> Proprietary Biofiltration (BF-3) meeting all requirements of Appendix F <input type="checkbox"/> Flow-thru treatment control with prior lawful approval to meet earlier PDP requirements (provide BMP type/description in discussion section below) <input type="checkbox"/> Flow-thru treatment control included as pre-treatment/forebay for an onsite retention or biofiltration BMP (provide BMP type/description and indicate which onsite retention or biofiltration BMP it serves in discussion section below) <input type="checkbox"/> Flow-thru treatment control with alternative compliance (provide BMP type/description in discussion section below) <input type="checkbox"/> Detention pond or vault for hydromodification management <input type="checkbox"/> Other (describe in discussion section below)	
Purpose: <input type="checkbox"/> Pollutant control only <input type="checkbox"/> Hydromodification control only <input checked="" type="checkbox"/> Combined pollutant control and hydromodification control <input type="checkbox"/> Pre-treatment/forebay for another structural BMP <input type="checkbox"/> Other (describe in discussion section below)	
Who will certify construction of this BMP? Provide name and contact information for the party responsible to sign BMP verification forms (See Section 8.2.3.2 of the Storm Water Design Manual)	Michael D. Schweitzer SWS Engineering 760-744-0011
Who will be the final owner of this BMP?	<input type="checkbox"/> HOA <input checked="" type="checkbox"/> Property Owner <input type="checkbox"/> City <input type="checkbox"/> Other (describe)
Who will maintain this BMP into perpetuity?	<input type="checkbox"/> HOA <input checked="" type="checkbox"/> Property Owner <input type="checkbox"/> City <input type="checkbox"/> Other (describe)
<i>Discussion (as needed):</i>	
<i>(Continue on subsequent pages as necessary)</i>	

PRIORITY DEVELOPMENT PROJECT (PDP) SWQMP

Step 6.2: Structural BMP Checklist

(Copy this page as needed to provide information for each individual proposed structural BMP)	
Structural BMP ID No. BMP 2	
Construction Plan Sheet No.	
Type of structural BMP: <input type="checkbox"/> Retention by harvest and use (HU-1) <input type="checkbox"/> Retention by infiltration basin (INF-1) <input type="checkbox"/> Retention by bioretention (INF-2) <input type="checkbox"/> Retention by permeable pavement (INF-3) <input type="checkbox"/> Partial retention by biofiltration with partial retention (PR-1) <input checked="" type="checkbox"/> Biofiltration (BF-1) <input type="checkbox"/> Biofiltration with Nutrient Sensitive Media Design (BF-2) <input type="checkbox"/> Proprietary Biofiltration (BF-3) meeting all requirements of Appendix F <input type="checkbox"/> Flow-thru treatment control with prior lawful approval to meet earlier PDP requirements (provide BMP type/description in discussion section below) <input type="checkbox"/> Flow-thru treatment control included as pre-treatment/forebay for an onsite retention or biofiltration BMP (provide BMP type/description and indicate which onsite retention or biofiltration BMP it serves in discussion section below) <input type="checkbox"/> Flow-thru treatment control with alternative compliance (provide BMP type/description in discussion section below) <input type="checkbox"/> Detention pond or vault for hydromodification management <input type="checkbox"/> Other (describe in discussion section below)	
Purpose: <input type="checkbox"/> Pollutant control only <input type="checkbox"/> Hydromodification control only <input checked="" type="checkbox"/> Combined pollutant control and hydromodification control <input type="checkbox"/> Pre-treatment/forebay for another structural BMP <input type="checkbox"/> Other (describe in discussion section below)	
Who will certify construction of this BMP? Provide name and contact information for the party responsible to sign BMP verification forms (See Section 8.2.3.2 of the Storm Water Design Manual)	Michael D. Schweitzer SWS Engineering 760-744-0011
Who will be the final owner of this BMP?	<input type="checkbox"/> HOA <input checked="" type="checkbox"/> Property Owner <input type="checkbox"/> City <input type="checkbox"/> Other (describe)
Who will maintain this BMP into perpetuity?	<input type="checkbox"/> HOA <input checked="" type="checkbox"/> Property Owner <input type="checkbox"/> City <input type="checkbox"/> Other (describe)
<i>Discussion (as needed):</i>	
<i>(Continue on subsequent pages as necessary)</i>	

PRIORITY DEVELOPMENT PROJECT (PDP) SWQMP

Step 6.2: Structural BMP Checklist

(Copy this page as needed to provide information for each individual proposed structural BMP)	
Structural BMP ID No. BMP 3	
Construction Plan Sheet No.	
Type of structural BMP: <input type="checkbox"/> Retention by harvest and use (HU-1) <input type="checkbox"/> Retention by infiltration basin (INF-1) <input type="checkbox"/> Retention by bioretention (INF-2) <input type="checkbox"/> Retention by permeable pavement (INF-3) <input type="checkbox"/> Partial retention by biofiltration with partial retention (PR-1) <input checked="" type="checkbox"/> Biofiltration (BF-1) <input type="checkbox"/> Biofiltration with Nutrient Sensitive Media Design (BF-2) <input type="checkbox"/> Proprietary Biofiltration (BF-3) meeting all requirements of Appendix F <input type="checkbox"/> Flow-thru treatment control with prior lawful approval to meet earlier PDP requirements (provide BMP type/description in discussion section below) <input type="checkbox"/> Flow-thru treatment control included as pre-treatment/forebay for an onsite retention or biofiltration BMP (provide BMP type/description and indicate which onsite retention or biofiltration BMP it serves in discussion section below) <input type="checkbox"/> Flow-thru treatment control with alternative compliance (provide BMP type/description in discussion section below) <input type="checkbox"/> Detention pond or vault for hydromodification management <input type="checkbox"/> Other (describe in discussion section below)	
Purpose: <input type="checkbox"/> Pollutant control only <input type="checkbox"/> Hydromodification control only <input checked="" type="checkbox"/> Combined pollutant control and hydromodification control <input type="checkbox"/> Pre-treatment/forebay for another structural BMP <input type="checkbox"/> Other (describe in discussion section below)	
Who will certify construction of this BMP? Provide name and contact information for the party responsible to sign BMP verification forms (See Section 8.2.3.2 of the Storm Water Design Manual)	Michael D. Schweitzer SWS Engineering 760-744-0011
Who will be the final owner of this BMP?	<input type="checkbox"/> HOA <input checked="" type="checkbox"/> Property Owner <input type="checkbox"/> City <input type="checkbox"/> Other (describe)
Who will maintain this BMP into perpetuity?	<input type="checkbox"/> HOA <input checked="" type="checkbox"/> Property Owner <input type="checkbox"/> City <input type="checkbox"/> Other (describe)
<i>Discussion (as needed):</i> <i>(Continue on subsequent pages as necessary)</i>	

PRIORITY DEVELOPMENT PROJECT (PDP) SWQMP

Step 6.2: Structural BMP Checklist

(Copy this page as needed to provide information for each individual proposed structural BMP)	
Structural BMP ID No. BMP 4	
Construction Plan Sheet No.	
Type of structural BMP: <input type="checkbox"/> Retention by harvest and use (HU-1) <input type="checkbox"/> Retention by infiltration basin (INF-1) <input type="checkbox"/> Retention by bioretention (INF-2) <input type="checkbox"/> Retention by permeable pavement (INF-3) <input type="checkbox"/> Partial retention by biofiltration with partial retention (PR-1) <input checked="" type="checkbox"/> Biofiltration (BF-1) <input type="checkbox"/> Biofiltration with Nutrient Sensitive Media Design (BF-2) <input type="checkbox"/> Proprietary Biofiltration (BF-3) meeting all requirements of Appendix F <input type="checkbox"/> Flow-thru treatment control with prior lawful approval to meet earlier PDP requirements (provide BMP type/description in discussion section below) <input type="checkbox"/> Flow-thru treatment control included as pre-treatment/forebay for an onsite retention or biofiltration BMP (provide BMP type/description and indicate which onsite retention or biofiltration BMP it serves in discussion section below) <input type="checkbox"/> Flow-thru treatment control with alternative compliance (provide BMP type/description in discussion section below) <input type="checkbox"/> Detention pond or vault for hydromodification management <input type="checkbox"/> Other (describe in discussion section below)	
Purpose: <input type="checkbox"/> Pollutant control only <input type="checkbox"/> Hydromodification control only <input checked="" type="checkbox"/> Combined pollutant control and hydromodification control <input type="checkbox"/> Pre-treatment/forebay for another structural BMP <input type="checkbox"/> Other (describe in discussion section below)	
Who will certify construction of this BMP? Provide name and contact information for the party responsible to sign BMP verification forms (See Section 8.2.3.2 of the Storm Water Design Manual)	Michael D. Schweitzer SWS Engineering 760-744-0011
Who will be the final owner of this BMP?	<input type="checkbox"/> HOA <input checked="" type="checkbox"/> Property Owner <input type="checkbox"/> City <input type="checkbox"/> Other (describe)
Who will maintain this BMP into perpetuity?	<input type="checkbox"/> HOA <input checked="" type="checkbox"/> Property Owner <input type="checkbox"/> City <input type="checkbox"/> Other (describe)
<i>Discussion (as needed):</i>	
<i>(Continue on subsequent pages as necessary)</i>	

PRIORITY DEVELOPMENT PROJECT (PDP) SWQMP

Step 6.2: Structural BMP Checklist

(Copy this page as needed to provide information for each individual proposed structural BMP)	
Structural BMP ID No. BMP 5	
Construction Plan Sheet No.	
Type of structural BMP: <input type="checkbox"/> Retention by harvest and use (HU-1) <input type="checkbox"/> Retention by infiltration basin (INF-1) <input type="checkbox"/> Retention by bioretention (INF-2) <input type="checkbox"/> Retention by permeable pavement (INF-3) <input type="checkbox"/> Partial retention by biofiltration with partial retention (PR-1) <input checked="" type="checkbox"/> Biofiltration (BF-1) <input type="checkbox"/> Biofiltration with Nutrient Sensitive Media Design (BF-2) <input type="checkbox"/> Proprietary Biofiltration (BF-3) meeting all requirements of Appendix F <input type="checkbox"/> Flow-thru treatment control with prior lawful approval to meet earlier PDP requirements (provide BMP type/description in discussion section below) <input type="checkbox"/> Flow-thru treatment control included as pre-treatment/forebay for an onsite retention or biofiltration BMP (provide BMP type/description and indicate which onsite retention or biofiltration BMP it serves in discussion section below) <input type="checkbox"/> Flow-thru treatment control with alternative compliance (provide BMP type/description in discussion section below) <input type="checkbox"/> Detention pond or vault for hydromodification management <input type="checkbox"/> Other (describe in discussion section below)	
Purpose: <input type="checkbox"/> Pollutant control only <input type="checkbox"/> Hydromodification control only <input checked="" type="checkbox"/> Combined pollutant control and hydromodification control <input type="checkbox"/> Pre-treatment/forebay for another structural BMP <input type="checkbox"/> Other (describe in discussion section below)	
Who will certify construction of this BMP? Provide name and contact information for the party responsible to sign BMP verification forms (See Section 8.2.3.2 of the Storm Water Design Manual)	Michael D. Schweitzer SWS Engineering 760-744-0011
Who will be the final owner of this BMP?	<input type="checkbox"/> HOA <input checked="" type="checkbox"/> Property Owner <input type="checkbox"/> City <input type="checkbox"/> Other (describe)
Who will maintain this BMP into perpetuity?	<input type="checkbox"/> HOA <input checked="" type="checkbox"/> Property Owner <input type="checkbox"/> City <input type="checkbox"/> Other (describe)
<i>Discussion (as needed):</i> <i>(Continue on subsequent pages as necessary)</i>	

PRIORITY DEVELOPMENT PROJECT (PDP) SWQMP

Step 6.2: Structural BMP Checklist

(Copy this page as needed to provide information for each individual proposed structural BMP)	
Structural BMP ID No. BMP 6	
Construction Plan Sheet No.	
Type of structural BMP: <input type="checkbox"/> Retention by harvest and use (HU-1) <input type="checkbox"/> Retention by infiltration basin (INF-1) <input type="checkbox"/> Retention by bioretention (INF-2) <input type="checkbox"/> Retention by permeable pavement (INF-3) <input type="checkbox"/> Partial retention by biofiltration with partial retention (PR-1) <input checked="" type="checkbox"/> Biofiltration (BF-1) <input type="checkbox"/> Biofiltration with Nutrient Sensitive Media Design (BF-2) <input type="checkbox"/> Proprietary Biofiltration (BF-3) meeting all requirements of Appendix F <input type="checkbox"/> Flow-thru treatment control with prior lawful approval to meet earlier PDP requirements (provide BMP type/description in discussion section below) <input type="checkbox"/> Flow-thru treatment control included as pre-treatment/forebay for an onsite retention or biofiltration BMP (provide BMP type/description and indicate which onsite retention or biofiltration BMP it serves in discussion section below) <input type="checkbox"/> Flow-thru treatment control with alternative compliance (provide BMP type/description in discussion section below) <input type="checkbox"/> Detention pond or vault for hydromodification management <input type="checkbox"/> Other (describe in discussion section below)	
Purpose: <input type="checkbox"/> Pollutant control only <input type="checkbox"/> Hydromodification control only <input checked="" type="checkbox"/> Combined pollutant control and hydromodification control <input type="checkbox"/> Pre-treatment/forebay for another structural BMP <input type="checkbox"/> Other (describe in discussion section below)	
Who will certify construction of this BMP? Provide name and contact information for the party responsible to sign BMP verification forms (See Section 8.2.3.2 of the Storm Water Design Manual)	Michael D. Schweitzer SWS Engineering 760-744-0011
Who will be the final owner of this BMP?	<input type="checkbox"/> HOA <input checked="" type="checkbox"/> Property Owner <input type="checkbox"/> City <input type="checkbox"/> Other (describe)
Who will maintain this BMP into perpetuity?	<input type="checkbox"/> HOA <input checked="" type="checkbox"/> Property Owner <input type="checkbox"/> City <input type="checkbox"/> Other (describe)
<i>Discussion (as needed):</i> <i>(Continue on subsequent pages as necessary)</i>	

PRIORITY DEVELOPMENT PROJECT (PDP) SWQMP

Step 6.3: Offsite Alternative Compliance Participation Form

THIS FORM IS NOT APPLICABLE AT THIS TIME: An Alternative Compliance Program is under consideration by the City of Escondido.	
PDP INFORMATION	
Record ID:	
Assessor's Parcel Number(s) [APN(s)]	
What are your PDP Pollutant Control Debits? *See Attachment 1 of the PDP SWQMP	
What are your PDP HMP Debits? (if applicable) *See Attachment 2 of the PDP SWQMP	
ACP Information	
Record ID:	
Assessor's Parcel Number(s) [APN(s)]	
Project Owner/Address	
What are your ACP Pollutant Control Credits? *See Attachment 1 of the ACP SWQMP	
What are your ACP HMP Debits? (if applicable) *See Attachment 2 of the ACP SWQMP	
Is your ACP in the same watershed as your PDP? <input type="checkbox"/> Yes <input type="checkbox"/> No	Will your ACP project be completed prior to the completion of the PDP? <input type="checkbox"/> Yes <input type="checkbox"/> No
Does your ACP account for all Deficits generated by the PDP? <input type="checkbox"/> Yes <input type="checkbox"/> No (PDP and/or ACP must be redesigned to account for all deficits generated by the PDP.)	What is the difference between your PDP debits and ACP Credits? *(ACP Credits - Total PDP Debits = Total Earned Credits) _____

PRIORITY DEVELOPMENT PROJECT (PDP) SWQMP

PRIORITY DEVELOPMENT PROJECT (PDP) SWQMP

ATTACHMENT 1

BACKUP FOR PDP POLLUTANT CONTROL BMPS

This is the cover sheet for Attachment 1.

Indicate which Items are Included behind this cover sheet:

Attachment Sequence	Contents	Checklist
Attachment 1a	Storm Water Pollutant Control Worksheet Calculations -Worksheet B.2-1 (Required) -Worksheet B.3-1 (Form I-4; Required) -Worksheet B.4-1 (if applicable) -Worksheet B.5-1 (if applicable) -Worksheet B.5-2 (if applicable) -Worksheet B.5-3 (if applicable) -Worksheet B.6-1 (if applicable) -Summary Worksheet (optional)	<input checked="" type="checkbox"/> Included
Attachment 1b	Form I-5, Categorization of Infiltration Feasibility Condition (Required unless the project will use harvest and use BMPs) Refer to Appendices C and D of the Storm Water Design Manual to complete Form I-5.	<input type="checkbox"/> Included <input type="checkbox"/> Not included because the entire project will use harvest and use BMPs
Attachment 1c	Form I-6, Factor of Safety and Design Infiltration Rate Worksheet (Required unless the project will use harvest and use BMPs) Refer to Appendices C and D of the Storm Water Design Manual to complete Form I-6.	<input type="checkbox"/> Included <input type="checkbox"/> Not included because the entire project will use harvest and use BMPs
Attachment 1d	DMA Exhibit (Required) See DMA Exhibit Checklist on the back of this Attachment cover sheet.	<input checked="" type="checkbox"/> Included
Attachment 1e	Individual Structural BMP DMA Mapbook (Required) -Place each map on 8.5"x11" paper. -Show at a minimum the DMA, Structural BMP, and any existing hydrologic features within the DMA.	<input type="checkbox"/> Included

PRIORITY DEVELOPMENT PROJECT (PDP) SWQMP

This page was left intentionally blank.

**Quince St
DCV Summary
11/13/2018**

		DMA					
		1	2	3	4	5	6
<i>d (in)</i>		0.53	0.53	0.53	0.53	0.53	0.53
<i>A (ac)</i>		0.30	0.19	0.07	0.18	0.11	0.65
Area Weighted Runoff Factor							
<i>Surface Type</i>	<i>Runoff Factor</i>	<i>Area (sf)</i>	<i>Area (sf)</i>	<i>Area (sf)</i>	<i>Area (sf)</i>	<i>Area (sf)</i>	<i>Area (sf)</i>
Concrete/ Asphalt/ Roofs	0.90	11184	6983	2528	6648	4248	24163
Unit Pavers (grouted)	0.90						
Decomposed Granite Cobbles or Crushed Aggregate	0.30						
Amended, Mulched Soils or Landscape	0.10	1821	1137	412	1082	692	3934
Permeable Pavement (Per B.2.1.3)	0.10						
Compacted Soil (e.g., unpaved parking)	0.30						
Natural (A Soil)	0.10						
Natural (B Soil)	0.14						
Natural (C Soil)	0.23						
Natural (D Soil)	0.30						
<i>Total Area (sf)</i>		13005	8120	2940	7730	4940	28097
<i>Calculated C</i>		0.79	0.79	0.79	0.79	0.79	0.79
DCV (cu ft)		454	283	103	270	172	980

Automated Worksheet B.1-1: Calculation of Design Capture Volume (V1.3)

Category	#	Description	<i>i</i>	<i>ii</i>	<i>iii</i>	<i>iv</i>	<i>v</i>	<i>vi</i>	Units
Standard Drainage Basin Inputs	0	Drainage Basin ID or Name	BMP-1	BMP-2	BMP-3	BMP-4	BMP-5	BMP-6	unitless
	1	Basin Drains to the Following BMP Type	Biofiltration	Biofiltration	Biofiltration	Biofiltration	Biofiltration	Biofiltration	unitless
	2	85th Percentile 24-hr Storm Depth	0.53	0.53	0.53	0.53	0.53	0.53	inches
	3	Design Infiltration Rate Recommended by Geotechnical Engineer	0.000	0.000	0.000	0.000	0.000	0.000	in/hr
	4	Impervious Surfaces <u>Not Directed to Dispersion Area</u> (C=0.90)	11,184	6,983	2,528	6,648	4,248	24,163	sq-ft
	5	Semi-Pervious Surfaces <u>Not Serving as Dispersion Area</u> (C=0.30)							sq-ft
	6	Engineered Pervious Surfaces <u>Not Serving as Dispersion Area</u> (C=0.10)	1,821	1,137	412	1,082	692	3,934	sq-ft
	7	Natural Type A Soil <u>Not Serving as Dispersion Area</u> (C=0.10)							sq-ft
	8	Natural Type B Soil <u>Not Serving as Dispersion Area</u> (C=0.14)							sq-ft
	9	Natural Type C Soil <u>Not Serving as Dispersion Area</u> (C=0.23)							sq-ft
	10	Natural Type D Soil <u>Not Serving as Dispersion Area</u> (C=0.30)							sq-ft
Dispersion Area, Tree Well & Rain Barrel Inputs (Optional)	11	Does Tributary Incorporate Dispersion, Tree Wells, and/or Rain Barrels?	No	No	No	No	No	No	yes/no
	12	Impervious Surfaces Directed to Dispersion Area per SD-B (Ci=0.90)							sq-ft
	13	Semi-Pervious Surfaces Serving as Dispersion Area per SD-B (Ci=0.30)							sq-ft
	14	Engineered Pervious Surfaces Serving as Dispersion Area per SD-B (Ci=0.10)							sq-ft
	15	Natural Type A Soil Serving as Dispersion Area per SD-B (Ci=0.10)							sq-ft
	16	Natural Type B Soil Serving as Dispersion Area per SD-B (Ci=0.14)							sq-ft
	17	Natural Type C Soil Serving as Dispersion Area per SD-B (Ci=0.23)							sq-ft
	18	Natural Type D Soil Serving as Dispersion Area per SD-B (Ci=0.30)							sq-ft
	19	Number of Tree Wells Proposed per SD-A							#
	20	Average Mature Tree Canopy Diameter							ft
	21	Number of Rain Barrels Proposed per SD-E							#
	22	Average Rain Barrel Size							gal
Treatment Train Inputs & Calculations	23	Does BMP Overflow to Stormwater Features in <u>Downstream</u> Drainage?	No	No	No	No	No	No	unitless
	24	Identify Downstream Drainage Basin Providing Treatment in Series							unitless
	25	Percent of Upstream Flows Directed to Downstream Dispersion Areas							percent
	26	Upstream Impervious Surfaces Directed to Dispersion Area (Ci=0.90)	0	0	0	0	0	0	cubic-feet
	27	Upstream Impervious Surfaces Not Directed to Dispersion Area (C=0.90)	0	0	0	0	0	0	cubic-feet
Initial Runoff Factor Calculation	28	Total Tributary Area	13,005	8,120	2,940	7,730	4,940	28,097	sq-ft
	29	Initial Runoff Factor for Standard Drainage Areas	0.79	0.79	0.79	0.79	0.79	0.79	unitless
	30	Initial Runoff Factor for Dispersed & Dispersion Areas	0.00	0.00	0.00	0.00	0.00	0.00	unitless
	31	Initial Weighted Runoff Factor	0.79	0.79	0.79	0.79	0.79	0.79	unitless
Dispersion Area Adjustments	32	Initial Design Capture Volume	454	283	103	270	172	980	cubic-feet
	33	Total Impervious Area Dispersed to Pervious Surface	0	0	0	0	0	0	sq-ft
	34	Total Pervious Dispersion Area	0	0	0	0	0	0	sq-ft
	35	Ratio of Dispersed Impervious Area to Pervious Dispersion Area	n/a	n/a	n/a	n/a	n/a	n/a	ratio
	36	Adjustment Factor for Dispersed & Dispersion Areas	1.00	1.00	1.00	1.00	1.00	1.00	ratio
	37	Runoff Factor After Dispersion Techniques	0.79	0.79	0.79	0.79	0.79	0.79	unitless
Tree & Barrel Adjustments	38	Design Capture Volume After Dispersion Techniques	454	283	103	270	172	980	cubic-feet
	39	Total Tree Well Volume Reduction	0	0	0	0	0	0	cubic-feet
Results	40	Total Rain Barrel Volume Reduction	0	0	0	0	0	0	cubic-feet
	41	Final Adjusted Runoff Factor	0.79	0.79	0.79	0.79	0.79	0.79	unitless
	42	Final Effective Tributary Area	10,274	6,415	2,323	6,107	3,903	22,197	sq-ft
	43	Initial Design Capture Volume Retained by Site Design Elements	0	0	0	0	0	0	cubic-feet
	44	Final Design Capture Volume Tributary to BMP	454	283	103	270	172	980	cubic-feet

Worksheet B.1-1 General Notes:

A. Applicants may use this worksheet to calculate design capture volumes for up to 10 drainage areas. User input must be provided for yellow shaded cells; values for all other cells will be automatically generated, errors/notifications will be highlighted in red and summarized below. Upon completion of this worksheet, proceed to the appropriate BMP Sizing worksheet(s).

Automated Worksheet B.3-1: Project-Scale BMP Feasibility Analysis (V1.3)

Category	#	Description	Value	Units
Capture & Use Inputs	0	Design Capture Volume for Entire Project Site	2,262	cubic-feet
	1	Proposed Development Type	Residential	unitless
	2	Number of Residents or Employees at Proposed Development	250	#
	3	Total Planted Area within Development	9,077	sq-ft
	4	Water Use Category for Proposed Planted Areas	Low	unitless
Infiltration Inputs	5	Is Average Site Design Infiltration Rate ≤ 0.500 Inches per Hour?	Yes	yes/no
	6	Is Average Site Design Infiltration Rate ≤ 0.010 Inches per Hour?	Yes	yes/no
	7	Is Infiltration of the Full DCV Anticipated to Produce Negative Impacts?	Yes	yes/no
	8	Is Infiltration of Any Volume Anticipated to Produce Negative Impacts?	Yes	yes/no
Calculations	9	36-Hour Toilet Use Per Resident or Employee	1.86	cubic-feet
	10	Subtotal: Anticipated 36 Hour Toilet Use	466	cubic-feet
	11	Anticipated 1 Acre Landscape Use Over 36 Hours	52.14	cubic-feet
	12	Subtotal: Anticipated Landscape Use Over 36 Hours	11	cubic-feet
	13	Total Anticipated Use Over 36 Hours	477	cubic-feet
	14	Total Anticipated Use / Design Capture Volume	0.21	cubic-feet
	15	Are Full Capture and Use Techniques Feasible for this Project?	No	unitless
	16	Is Full Retention Feasible for this Project?	No	yes/no
17	Is Partial Retention Feasible for this Project?	No	yes/no	
Result	18	Feasibility Category	5	1, 2, 3, 4, 5

Worksheet B.3-1 General Notes:

- A. Applicants may use this worksheet to determine the types of structural BMPs that are acceptable for implementation at their project site (as required in Section 5 of the BMPDM). User input should be provided for yellow shaded cells, values for all other cells will be automatically generated. Projects demonstrating feasibility or potential feasibility via this worksheet are encouraged to incorporate capture and use features in their project.
- B. Negative impacts associated with retention may include geotechnical, groundwater, water balance, or other issues identified by a geotechnical engineer and substantiated through completion of Form I-8.
- C. Feasibility Category 1: Applicant must implement capture & use, retention, and/or infiltration elements for the entire DCV.
- D. Feasibility Category 2: Applicant must implement capture & use elements for the entire DCV.
- E. Feasibility Category 3: Applicant must implement retention and/or infiltration elements for all DMAs with Design Infiltration Rates greater than 0.50 in/hr.
- F. Feasibility Category 4: Applicant must implement standard unlined biofiltration BMPs sized at $\geq 3\%$ of the effective impervious tributary area for all DMAs with Design Infiltration Rates of 0.011 to 0.50 in/hr. Applicants may be permitted to implement lined BMPs, reduced size BMPs, and/or specialized biofiltration BMPs provided additional criteria identified in "Supplemental Retention Criteria for Non-Standard Biofiltration BMPs" are satisfied.
- G. Feasibility Category 5: Applicant must implement standard lined biofiltration BMPs sized at $\geq 3\%$ of the effective impervious tributary area for all DMAs with Design Infiltration Rates of 0.010 in/hr or less. Applicants may also be permitted to implement reduced size and/or specialized biofiltration BMPs provided additional criteria identified in "Supplemental Retention Criteria for Non-Standard Biofiltration BMPs" are satisfied.
- H. PDPs participating in an offsite alternative compliance program are not held to the feasibility categories presented herein.

Automated Worksheet B.5-1: Sizing Lined or Unlined Biofiltration BMPs (V1.3)

Category	#	Description	<i>i</i>	<i>ii</i>	<i>iii</i>	<i>iv</i>	<i>v</i>	<i>vi</i>	Units
BMP Inputs	0	Drainage Basin ID or Name	BMP-1	BMP-2	BMP-3	BMP-4	BMP-5	BMP-6	sq-ft
	1	Design Infiltration Rate Recommended by Geotechnical Engineer	0.000	0.000	0.000	0.000	0.000	0.000	in/hr
	2	Effective Tributary Area	10,274	6,415	2,323	6,107	3,903	22,197	sq-ft
	3	Minimum Biofiltration Footprint Sizing Factor	0.030	0.030	0.030	0.030	0.030	0.030	ratio
	4	Design Capture Volume Tributary to BMP	454	283	103	270	172	980	cubic-feet
	5	Is Biofiltration Basin Impermeably Lined or Unlined?	Lined	Lined	Lined	Lined	Lined	Lined	unitless
	6	Provided Biofiltration BMP Surface Area	407	268	97	255	163	905	sq-ft
	7	Provided Surface Ponding Depth	12	12	12	12	12	12	inches
	8	Provided Soil Media Thickness	18	18	18	18	18	18	inches
	9	Provided Depth of Gravel Above Underdrain Invert	8	8	8	8	8	8	inches
	10	Diameter of Underdrain or Hydromod Orifice (Select Smallest)	0.38	0.38	0.25	0.25	0.25	0.50	inches
11	Provided Depth of Gravel Below the Underdrain	4	4	4	4	4	4	inches	
Retention Calculations	12	Volume Infiltrated Over 6 Hour Storm	0	0	0	0	0	0	cubic-feet
	13	Soil Media Pore Space Available for Retention	0.05	0.05	0.05	0.05	0.05	0.05	unitless
	14	Gravel Pore Space Available for Retention	0.00	0.00	0.00	0.00	0.00	0.00	unitless
	15	Effective Retention Depth	0.90	0.90	0.90	0.90	0.90	0.90	inches
	16	Calculated Retention Storage Drawdown (Including 6 Hr Storm)	120	120	120	120	120	120	hours
	17	Volume Retained by BMP	31	20	7	19	12	68	cubic-feet
	18	Fraction of DCV Retained	0.07	0.07	0.07	0.07	0.07	0.07	ratio
	19	Portion of Retention Performance Standard Satisfied	0.08	0.08	0.08	0.08	0.08	0.08	ratio
	20	Fraction of DCV Retained (normalized to 36-hr drawdown)	0.04	0.04	0.04	0.04	0.04	0.04	ratio
	21	Design Capture Volume Remaining for Biofiltration	436	272	99	259	165	941	cubic-feet
Biofiltration Calculations	22	Max Hydromod Flow Rate through Underdrain	0.0066	0.0066	0.0029	0.0029	0.0029	0.0116	CFS
	23	Max Soil Filtration Rate Allowed by Underdrain Orifice	0.70	1.06	1.30	0.49	0.77	0.56	in/hr
	24	Soil Media Filtration Rate per Specifications	5.00	5.00	5.00	5.00	5.00	5.00	in/hr
	25	Soil Media Filtration Rate to be used for Sizing	0.70	1.06	1.30	0.49	0.77	0.56	in/hr
	26	Depth Biofiltered Over 6 Hour Storm	4.17	6.34	7.79	2.96	4.64	3.34	inches
	27	Soil Media Pore Space Available for Biofiltration	0.20	0.20	0.20	0.20	0.20	0.20	unitless
	28	Effective Depth of Biofiltration Storage	18.80	18.80	18.80	18.80	18.80	18.80	inches
	29	Drawdown Time for Surface Ponding	17	11	9	24	16	22	hours
	30	Drawdown Time for Effective Biofiltration Depth	27	18	14	38	24	34	hours
	31	Total Depth Biofiltered	22.97	25.14	26.59	21.76	23.44	22.14	inches
	32	Option 1 - Biofilter 1.50 DCV: Target Volume	654	408	149	389	248	1,412	cubic-feet
	33	Option 1 - Provided Biofiltration Volume	654	408	149	389	248	1,412	cubic-feet
	34	Option 2 - Store 0.75 DCV: Target Volume	327	204	74	194	124	706	cubic-feet
	35	Option 2 - Provided Storage Volume	327	204	74	194	124	706	cubic-feet
	36	Portion of Biofiltration Performance Standard Satisfied	1.00	1.00	1.00	1.00	1.00	1.00	ratio
Result	37	Do Site Design Elements and BMPs Satisfy Annual Retention Requirements?	Yes	Yes	Yes	Yes	Yes	Yes	yes/no
	38	Overall Portion of Performance Standard Satisfied	1.00	1.00	1.00	1.00	1.00	1.00	ratio
	39	This BMP Overflows to the Following Drainage Basin	-	-	-	-	-	-	unitless
	40	Deficit of Effectively Treated Stormwater	0	0	0	0	0	0	cubic-feet

Worksheet B.5-1 General Notes:

A. Applicants may use this worksheet to size Lined or Unlined Biofiltration BMPs (BF-1, PR-1) for up to 10 basins. User input must be provided for yellow shaded cells, values for blue cells are automatically populated based on user inputs from previous worksheets, values for all other cells will be automatically generated, errors/notifications will be highlighted in red/orange and summarized below. BMPs fully satisfying the pollutant control performance standards will have a deficit treated volume of zero and be highlighted in green.

Summary of Stormwater Pollutant Control Calculations (V1.3)

Category	#	Description	<i>i</i>	<i>ii</i>	<i>iii</i>	<i>iv</i>	<i>v</i>	<i>vi</i>	Units
General Info	0	Drainage Basin ID or Name	BMP-1	BMP-2	BMP-3	BMP-4	BMP-5	BMP-6	unitless
	1	85th Percentile Storm Depth	0.53	0.53	0.53	0.53	0.53	0.53	inches
	2	Design Infiltration Rate Recommended by Geotechnical Engineer	0.000	0.000	0.000	0.000	0.000	0.000	in/hr
	3	Total Tributary Area	13,005	8,120	2,940	7,730	4,940	28,097	sq-ft
	4	85th Percentile Storm Volume (Rainfall Volume)	574	359	130	341	218	1,241	cubic-feet
Initial DCV	5	Initial Weighted Runoff Factor	0.79	0.79	0.79	0.79	0.79	0.79	unitless
	6	Initial Design Capture Volume	454	283	103	270	172	980	cubic-feet
Site Design Volume Reductions	7	Dispersion Area Reductions	0	0	0	0	0	0	cubic-feet
	8	Tree Well and Rain Barrel Reductions	0	0	0	0	0	0	cubic-feet
BMP Volume Reductions	9	Effective Area Tributary to BMP	10,274	6,415	2,323	6,107	3,903	22,197	square feet
	10	Final Design Capture Volume Tributary to BMP	454	283	103	270	172	980	cubic-feet
	11	Basin Drains to the Following BMP Type	Biofiltration	Biofiltration	Biofiltration	Biofiltration	Biofiltration	Biofiltration	unitless
	12	Volume Retained by BMP (normalized to 36 hour drawdown)	18	11	4	11	7	39	cubic-feet
Total Volume Reductions	13	Total Fraction of Initial DCV Retained within DMA	0.04	0.04	0.04	0.04	0.04	0.04	fraction
	14	Percent of Average Annual Runoff Retention Provided	6.1%	6.1%	6.1%	6.1%	6.1%	6.1%	%
	15	Percent of Average Annual Runoff Retention Required	4.5%	4.5%	4.5%	4.5%	4.5%	4.5%	%
Performance Standard	16	Percent of Pollution Control Standard Satisfied	100.0%	100.0%	100.0%	100.0%	100.0%	100.0%	%
Treatment Train	17	Discharges to Secondary Treatment in Drainage Basin	-	-	-	-	-	-	unitless
	18	Impervious Surface Area Still Requiring Treatment	0	0	0	0	0	0	square feet
	19	Impervious Surfaces Directed to Downstream Dispersion Area	-	-	-	-	-	-	square feet
	20	Impervious Surfaces Not Directed to Downstream Dispersion Area	-	-	-	-	-	-	square feet
Result	21	Deficit of Effectively Treated Stormwater	0	0	0	0	0	0	cubic-feet

Summary Notes:

All fields in this summary worksheet are populated based on previous user inputs. If applicable, drainage basin elements that require revisions and/or supplemental information outside the scope of these worksheets are highlighted in orange and summarized in the red text below. If all drainage basins achieve full compliance without a need for supplemental information, a green message will

-Congratulations, all specified drainage basins and BMPs are in compliance with stormwater pollutant control requirements. Include 11x17 color prints of this summary sheet and supporting worksheet calculations as part of the SWQMP submittal package.

False

Hydrologic Soil Group—San Diego County Area, California
(220 Quince)

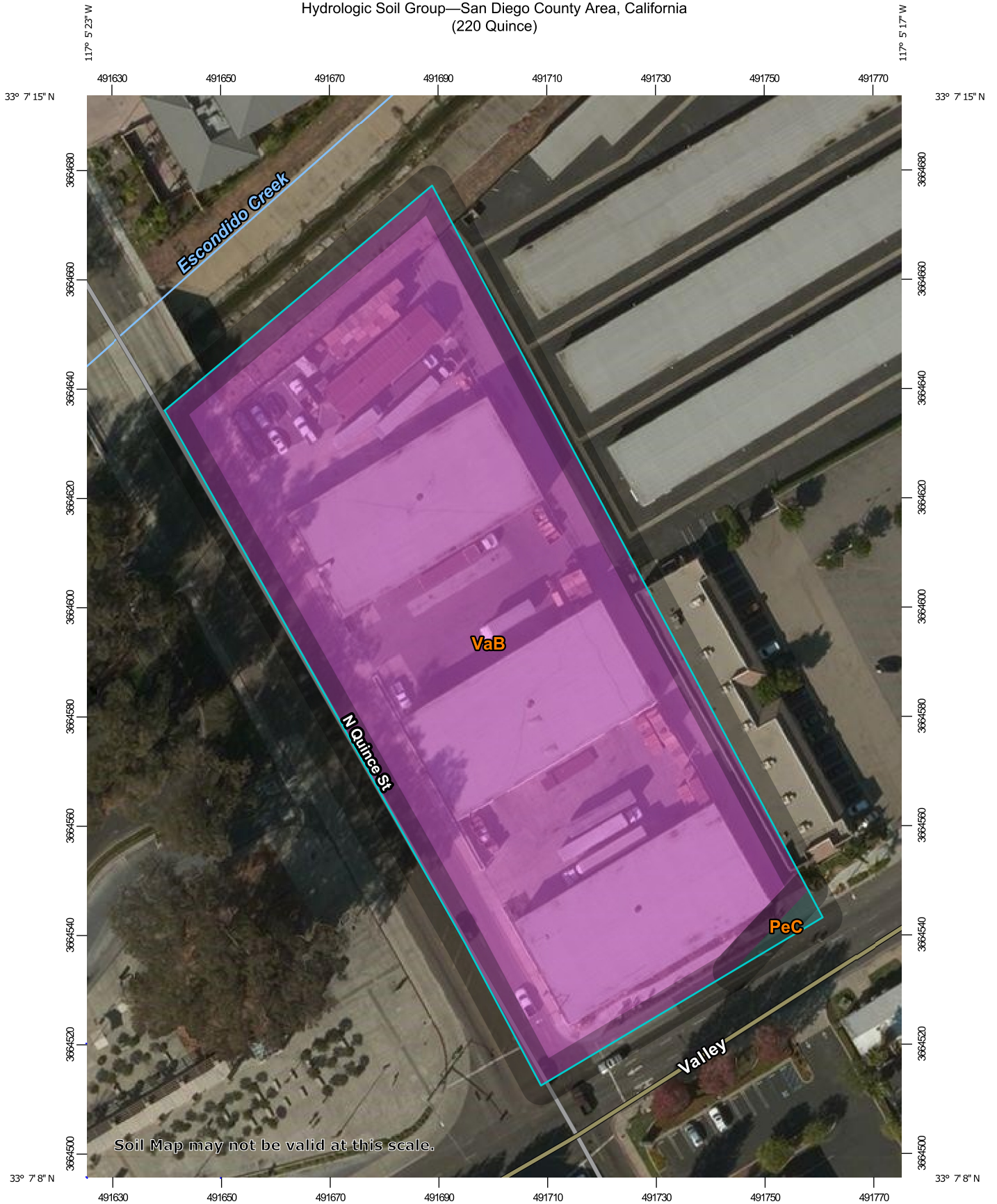

Map Scale: 1:966 if printed on A portrait (8.5" x 11") sheet.

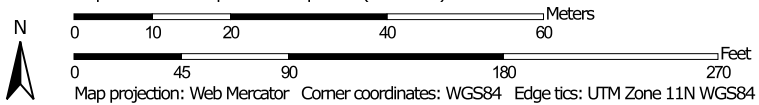

MAP LEGEND

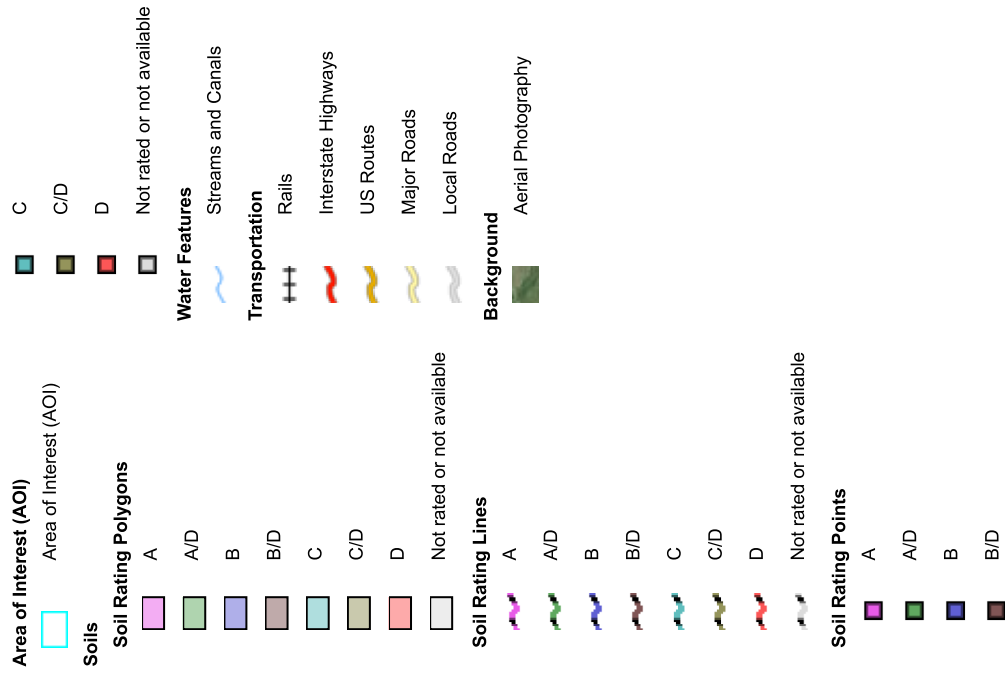

MAP INFORMATION

The soil surveys that comprise your AOI were mapped at 1:24,000.

Warning: Soil Map may not be valid at this scale.

Enlargement of maps beyond the scale of mapping can cause misunderstanding of the detail of mapping and accuracy of soil line placement. The maps do not show the small areas of contrasting soils that could have been shown at a more detailed scale.

Please rely on the bar scale on each map sheet for map measurements.

Source of Map: Natural Resources Conservation Service
 Web Soil Survey URL:
 Coordinate System: Web Mercator (EPSG:3857)

Maps from the Web Soil Survey are based on the Web Mercator projection, which preserves direction and shape but distorts distance and area. A projection that preserves area, such as the Albers equal-area conic projection, should be used if more accurate calculations of distance or area are required.

This product is generated from the USDA-NRCS certified data as of the version date(s) listed below.

Soil Survey Area: San Diego County Area, California
 Survey Area Data: Version 13, Sep 12, 2018

Soil map units are labeled (as space allows) for map scales 1:50,000 or larger.

Date(s) aerial images were photographed: Nov 3, 2014—Nov 22, 2014

The orthophoto or other base map on which the soil lines were compiled and digitized probably differs from the background imagery displayed on these maps. As a result, some minor shifting of map unit boundaries may be evident.

Hydrologic Soil Group

Map unit symbol	Map unit name	Rating	Acres in AOI	Percent of AOI
PeC	Placentia sandy loam, 2 to 9 percent slopes, warm MAAT, MLRA 19	C	0.0	0.6%
VaB	Visalia sandy loam, 2 to 5 percent slopes	A	2.2	99.4%
Totals for Area of Interest			2.2	100.0%

Description

Hydrologic soil groups are based on estimates of runoff potential. Soils are assigned to one of four groups according to the rate of water infiltration when the soils are not protected by vegetation, are thoroughly wet, and receive precipitation from long-duration storms.

The soils in the United States are assigned to four groups (A, B, C, and D) and three dual classes (A/D, B/D, and C/D). The groups are defined as follows:

Group A. Soils having a high infiltration rate (low runoff potential) when thoroughly wet. These consist mainly of deep, well drained to excessively drained sands or gravelly sands. These soils have a high rate of water transmission.

Group B. Soils having a moderate infiltration rate when thoroughly wet. These consist chiefly of moderately deep or deep, moderately well drained or well drained soils that have moderately fine texture to moderately coarse texture. These soils have a moderate rate of water transmission.

Group C. Soils having a slow infiltration rate when thoroughly wet. These consist chiefly of soils having a layer that impedes the downward movement of water or soils of moderately fine texture or fine texture. These soils have a slow rate of water transmission.

Group D. Soils having a very slow infiltration rate (high runoff potential) when thoroughly wet. These consist chiefly of clays that have a high shrink-swell potential, soils that have a high water table, soils that have a claypan or clay layer at or near the surface, and soils that are shallow over nearly impervious material. These soils have a very slow rate of water transmission.

If a soil is assigned to a dual hydrologic group (A/D, B/D, or C/D), the first letter is for drained areas and the second is for undrained areas. Only the soils that in their natural condition are in group D are assigned to dual classes.

Rating Options

Aggregation Method: Dominant Condition

Component Percent Cutoff: None Specified

Tie-break Rule: Higher

PRIORITY DEVELOPMENT PROJECT (PDP) SWQMP

Categorization of Infiltration Feasibility Condition		Form I-5	
Part 1 - Full Infiltration Feasibility Screening Criteria Would infiltration of the full design volume be feasible from a physical perspective without any undesirable consequences that cannot be reasonably mitigated?			
Criteria	Screening Question	Yes	No
1	Is the estimated reliable infiltration rate below proposed facility locations greater than 0.5 inches per hour? The response to this Screening Question shall be based on a comprehensive evaluation of the factors presented in Appendix C.2 and Appendix D.		
Provide basis: Summarize findings of studies; provide reference to studies, calculations, maps, data sources, etc. Provide narrative discussion of study/data source applicability.			
2	Can infiltration greater than 0.5 inches per hour be allowed without increasing risk of geotechnical hazards (slope stability, groundwater mounding, utilities, or other factors) that cannot be mitigated to an acceptable level? The response to this Screening Question shall be based on a comprehensive evaluation of the factors presented in Appendix C.2.		
Provide basis: Summarize findings of studies; provide reference to studies, calculations, maps, data sources, etc. Provide narrative discussion of study/data source applicability.			

PRIORITY DEVELOPMENT PROJECT (PDP) SWQMP

Form I-5			
Criteria	Screening Question	Yes	No
3	Can infiltration greater than 0.5 inches per hour be allowed without increasing risk of groundwater contamination (shallow water table, storm water pollutants or other factors) that cannot be mitigated to an acceptable level? The response to this Screening Question shall be based on a comprehensive evaluation of the factors presented in Appendix C.3.		
<p>Provide basis:</p> <p>Summarize findings of studies; provide reference to studies, calculations, maps, data sources, etc. Provide narrative discussion of study/data source applicability.</p>			
4	Can infiltration greater than 0.5 inches per hour be allowed without causing potential water balance issues such as change of seasonality of ephemeral streams or increased discharge of contaminated groundwater to surface waters? The response to this Screening Question shall be based on a comprehensive evaluation of the factors presented in Appendix C.3.		
<p>Provide basis:</p> <p>Summarize findings of studies; provide reference to studies, calculations, maps, data sources, etc. Provide narrative discussion of study/data source applicability.</p>			
Part 1 Result*	<p>If all answers to rows 1 - 4 are “Yes” a full infiltration design is potentially feasible. The feasibility screening category is Full Infiltration</p> <p>If any answer from row 1-4 is “No”, infiltration may be possible to some extent but would not generally be feasible or desirable to achieve a “full infiltration” design. Proceed to Part 2</p>		

PRIORITY DEVELOPMENT PROJECT (PDP) SWQMP

Form I-5			
Part 2 – Partial Infiltration vs. No Infiltration Feasibility Screening Criteria			
Would infiltration of water in any appreciable amount be physically feasible without any negative consequences that cannot be reasonably mitigated?			
Criteria	Screening Question	Yes	No
5	Do soil and geologic conditions allow for infiltration in any appreciable rate or volume? The response to this Screening Question shall be based on a comprehensive evaluation of the factors presented in Appendix C.2 and Appendix D.		
Provide basis: Summarize findings of studies; provide reference to studies, calculations, maps, data sources, etc. Provide narrative discussion of study/data source applicability and why it was not feasible to mitigate low infiltration rates.			
6	Can Infiltration in any appreciable quantity be allowed without increasing risk of geotechnical hazards (slope stability, groundwater mounding, utilities, or other factors) that cannot be mitigated to an acceptable level? The response to this Screening Question shall be based on a comprehensive evaluation of the factors presented in Appendix C.2.		
Provide basis: Summarize findings of studies; provide reference to studies, calculations, maps, data sources, etc. Provide narrative discussion of study/data source applicability and why it was not feasible to mitigate low infiltration rates.			

PRIORITY DEVELOPMENT PROJECT (PDP) SWQMP

Form I-5 Certification

The Geotechnical Engineer certifies they completed Form I-5 except Criteria 4 & 8 (see Appendix C.4.3).

Professional Geotechnical Engineer's Printed Name:

Professional Geotechnical Engineer's Signed Name:

Date: _____

[SEAL]

The Project Design Engineer certifies they completed Criteria 4 & 8 (see Appendix C.4.4).

Professional Project Design Engineer's Printed Name:

Professional Project Design Engineer's Signed Name:

Date: _____

[SEAL]

PRIORITY DEVELOPMENT PROJECT (PDP) SWQMP

This page was left intentionally blank.

PRIORITY DEVELOPMENT PROJECT (PDP) SWQMP

Factor of Safety and Design Infiltration Rate Worksheet			Form I-6	
Factor Category	Factor Description	Assigned Weight (w)	Factor Value (v)	Product (p) $p = w \times v$
A	Suitability Assessment	Soil assessment methods	0.25	
		Predominant soil texture	0.25	
		Site soil variability	0.25	
		Depth to groundwater / impervious layer	0.25	
		Suitability Assessment Safety Factor, $S_A = \sum p$		
B	Design	Level of pretreatment/ expected sediment loads	0.5	
		Redundancy/resiliency	0.25	
		Compaction during construction	0.25	
		Design Safety Factor, $S_B = \sum p$		
Combined Safety Factor, $S_{total} = S_A \times S_B$				
Observed Infiltration Rate, inch/hr, $K_{observed}$ (corrected for test-specific bias)				
Design Infiltration Rate, in/hr, $K_{design} = K_{observed} / S_{total}$				
Supporting Data				
Briefly describe infiltration test and provide reference to test forms:				

PRIORITY DEVELOPMENT PROJECT (PDP) SWQMP



The Geotechnical Engineer certifies they completed Form I-6 (see Appendix C.4.3).

Professional Geotechnical Engineer's Printed Name:

Professional Geotechnical Engineer's Signed Name:

Date: _____

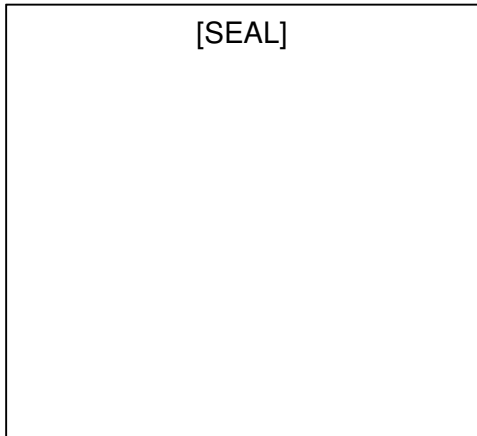

PRIORITY DEVELOPMENT PROJECT (PDP) SWQMP

Use this checklist to ensure the required information has been included on the DMA Exhibit:

The DMA Exhibit must identify:

- Underlying hydrologic soil group
- Approximate depth to groundwater
- Existing natural hydrologic features (watercourses, seeps, springs, wetlands)
- Critical coarse sediment yield areas to be protected
- Existing topography and impervious areas
- Existing and proposed site drainage network and connections to drainage offsite
- Proposed demolition
- Proposed grading
- Proposed impervious features
- Proposed design features and surface treatments used to minimize imperviousness
- Drainage management area (DMA) boundaries, DMA ID numbers, and DMA areas (square footage or acreage), and DMA type (i.e., drains to BMP, self-retaining, or self-mitigating)
- Potential pollutant source areas and corresponding required source controls (see Chapter 4, Appendix E.1, and Step 3.5)
- Structural BMPs (identify location, structural BMP ID#, type of BMP, and size/detail)

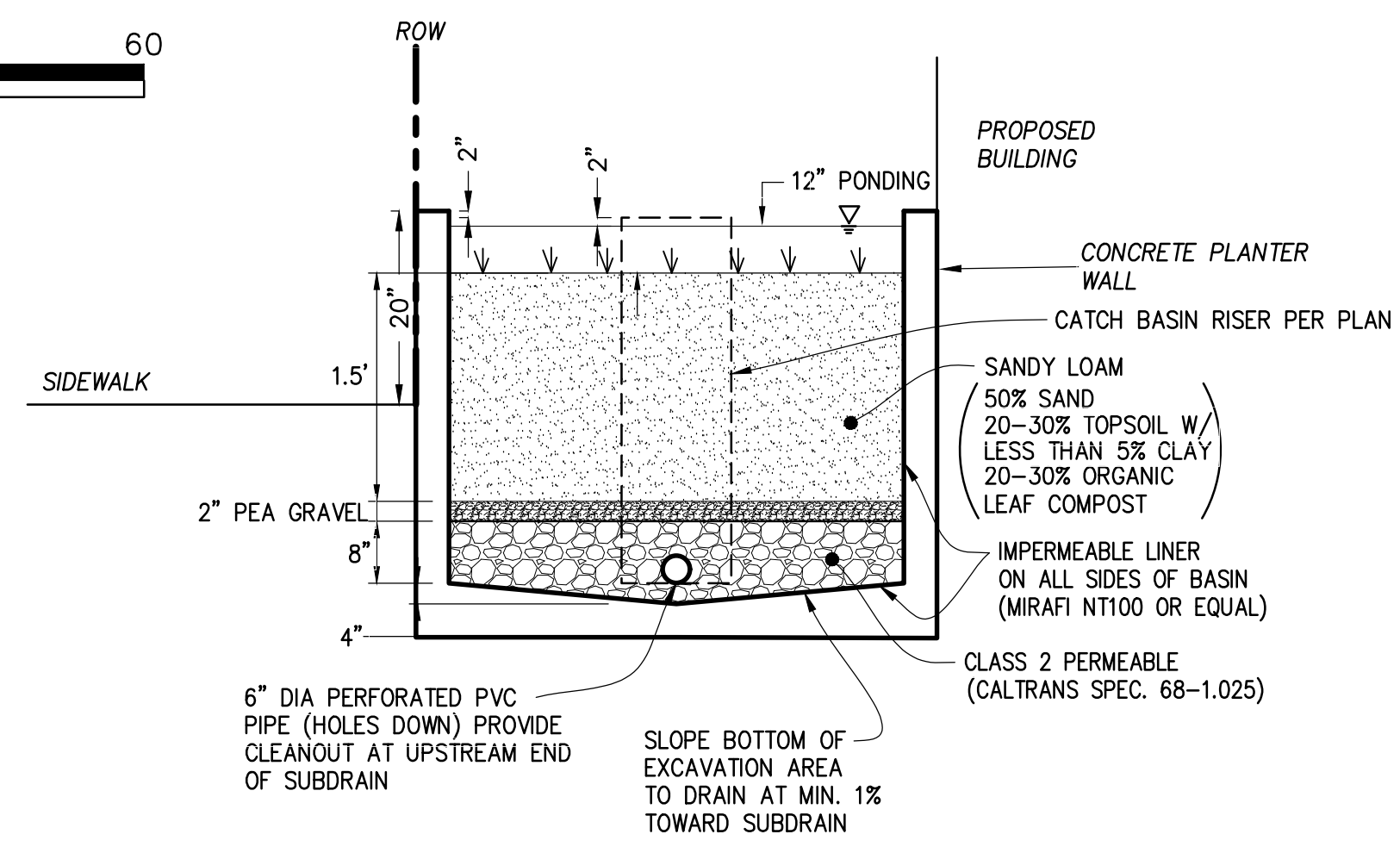
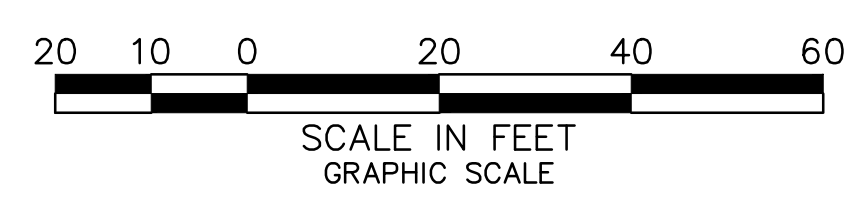
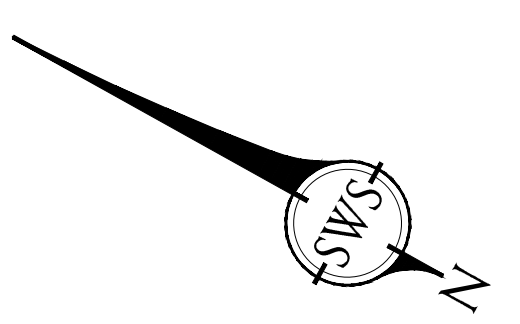
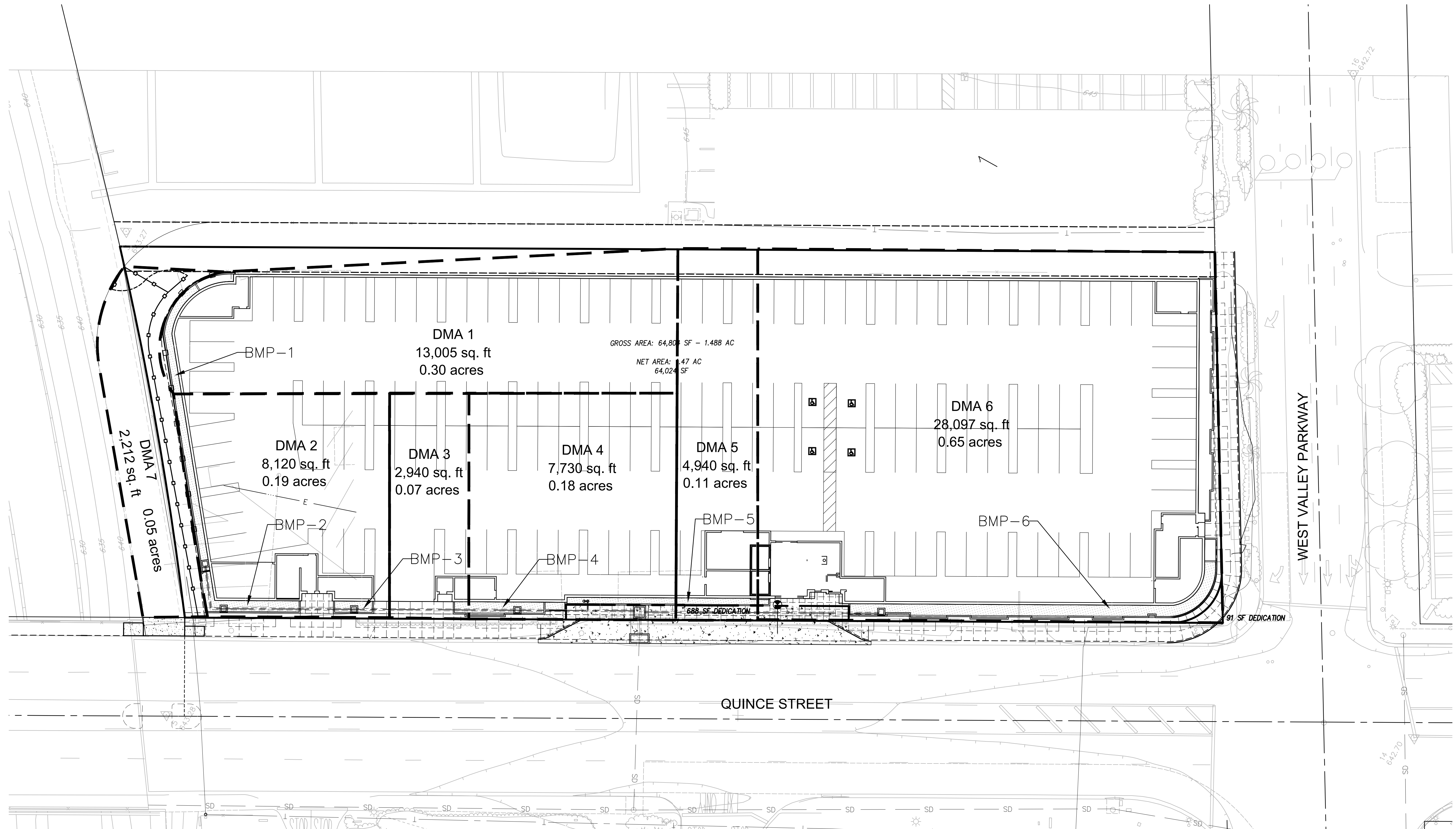

BIOFILTRATION RAISED PLANTER DETAIL
N.T.S.

NOTE: ALL DMA AREAS SOILS GROUP - A

SUMMARY

SYMBOL	DESCRIPTION	DMA 1	DMA 2	DMA 3	DMA 4	DMA 5	DMA 6	DMA 7
[Symbol]	POST - PERVIOUS	1,821 SF	1,137 SF	412 SF	1,082 SF	692 SF	3,934 SF	2,212 SF
[Symbol]	POST - IMPERVIOUS	11,184 SF	6,983 SF	2,528 SF	6,648 SF	4,248 SF	24,163 SF	1,029 SF
	TOTAL =	13,005 SF	8,120 SF	2,940 SF	7,730 SF	4,940 SF	28,097 SF	3,241 SF
	BMP 1 (BF-1)		BMP 2 (BF-1)	BMP 3 (BF-1)	BMP 4 (BF-1)	BMP 5 (BF-1)	BMP 6 (BF-1)	PDP EXEMPT
	BMP AREA =	407 SF	268 SF	97 SF	255 SF	163 SF	905 SF	1,029 SF

220 QUINCE
DMA EXHIBIT

PRIORITY DEVELOPMENT PROJECT (PDP) SWQMP

ATTACHMENT 2

BACKUP FOR PDP HYDROMODIFICATION CONTROL MEASURES

This is the cover sheet for Attachment 2.

Mark this box if this attachment is empty because the project is exempt from PDP hydromodification management requirements.

Indicate which Items are Included behind this cover sheet:

Attachment Sequence	Contents	Checklist
Attachment 2a	Flow Control Facility Design, including Structural BMP Drawdown Calculations and Overflow Design Summary (Required) See Chapter 6 and Appendix G of the Storm Water Design Manual	<input type="checkbox"/> Included <input type="checkbox"/> Submitted as separate stand-alone document
Attachment 2b	Hydromodification Management Exhibit (Required)	<input type="checkbox"/> Included See Hydromodification Management Exhibit Checklist on the back of this Attachment cover sheet.
Attachment 2c	Management of Critical Coarse Sediment Yield Areas See Section 6.2 and Appendix H of the Storm Water Design Manual.	<input type="checkbox"/> Exhibit depicting onsite and/or upstream sources of critical coarse sediment as mapped in the WMAA AND, <input type="checkbox"/> Demonstration that the project effectively avoids and bypasses sources of mapped critical coarse sediment OR, <input type="checkbox"/> Demonstration that project does not generate a net impact on the receiving water.
Attachment 2d	Geomorphic Assessment of Receiving Channels (Optional) See Section 6.3.4 of the Storm Water Design Manual.	<input type="checkbox"/> Not performed <input type="checkbox"/> Included <input type="checkbox"/> Submitted as separate stand-alone document
Attachment 2e	Vector Control Plan (Required when structural BMPs will not drain in 96 hours)	<input type="checkbox"/> Included <input type="checkbox"/> Not required because BMPs will drain in less than 96 hours

PRIORITY DEVELOPMENT PROJECT (PDP) SWQMP

This page was left intentionally blank.

PRIORITY DEVELOPMENT PROJECT (PDP) SWQMP

ATTACHMENT 3

Structural BMP Maintenance Information

This is the cover sheet for Attachment 3.

Indicate which Items are Included behind this cover sheet:

Attachment Sequence	Contents	Checklist
Attachment 3a	Structural BMP Maintenance Plan (Required)	<input type="checkbox"/> Included See Structural BMP Maintenance Information Checklist on the back of this Attachment cover sheet.
Attachment 3b	Draft Storm Water Control Facilities Maintenance Agreement (SWCFMA) (when applicable)	<input type="checkbox"/> Included <input type="checkbox"/> Not Applicable

PRIORITY DEVELOPMENT PROJECT (PDP) SWQMP

This page was left intentionally blank.

PRIORITY DEVELOPMENT PROJECT (PDP) SWQMP

Use this checklist to ensure the required information has been included in the Structural BMP Maintenance Information Attachment:

Attachment 3a must identify:

- Specific maintenance indicators and actions for proposed structural BMP(s). This must be based on Section 7.7 of the Storm Water Design Manual and enhanced to reflect actual proposed components of the structural BMP(s)
- How to access the structural BMP(s) to inspect and perform maintenance
- Features that are provided to facilitate inspection (e.g., observation ports, cleanouts, silt posts, or other features that allow the inspector to view necessary components of the structural BMP and compare to maintenance thresholds)
- Manufacturer and part number for proprietary parts of structural BMP(s) when applicable
- Maintenance thresholds specific to the structural BMP(s), with a location-specific frame of reference (e.g., level of accumulated materials that triggers removal of the materials, to be identified based on viewing marks on silt posts or measured with a survey rod with respect to a fixed benchmark within the BMP)
- Recommended equipment to perform maintenance
- When applicable, necessary special training or certification requirements for inspection and maintenance personnel such as confined space entry or hazardous waste management

Attachment 3b: For all Structural BMPs, Attachment 3b must include a draft maintenance agreement in the City's standard format (PDP applicant to contact City staff to obtain the current maintenance agreement forms or download from City's website).

PRIORITY DEVELOPMENT PROJECT (PDP) SWQMP

This page was left intentionally blank.

ATTACHMENT 3

Structural BMP Maintenance Information

1. Maintenance Timing – The bioretention basin shall be visually inspected before and after all storm events in excess of 0.5 inches. Any debris and dead vegetation shall be removed. The orifice at the subdrain connection to the catch basin shall be inspected and cleaned out if clogged. The bioretention basin shall also be included in the normal landscape maintenance schedule for the project.
 - a. Maintenance Indicators –
 - i. Accumulation of Sediment and Debris – Remove and properly dispose of accumulated materials, without damage to the vegetation.
 - ii. Poor vegetation establishment – Re-seed, re-plant or re-establish vegetation per original plans.
 - iii. Overgrown vegetation – Mow or trim as appropriate, but not less than the design height of the vegetation per original plans when applicable.
 - iv. Standing water in Bioretention Basin – Remove and replace clogged surface soils. Clean out orifice at subdrain connection to catch basin if necessary.
2. Access – The bioretention basin can be accessed on foot. No special equipment will be required.
3. Proprietary Equipment – No proprietary equipment is proposed within the bioretention basin.
4. Maintenance Equipment – Normal landscape maintenance equipment can be used for the maintenance of the bioretention basin.
5. Training – No special training is required for the maintenance of the bioretention basin.

PRIORITY DEVELOPMENT PROJECT (PDP) SWQMP

ATTACHMENT 4

City of Escondido PDP Structural BMP Verification for Permitted Land
Development Projects

PRIORITY DEVELOPMENT PROJECT (PDP) SWQMP

This page was left intentionally blank.

PRIORITY DEVELOPMENT PROJECT (PDP) SWQMP

City of Escondido Storm Water Structural BMP Verification Form Page 1 of 4	
Project Summary Information	
Project Name	Quince Senior Housing
Record ID (e.g., grading/improvement plan number)	
Project Address	220 N Quince St, Escondido, CA
Assessor's Parcel Number(s) (APN(s))	
Project Watershed (Complete Hydrologic Unit, Area, and Subarea Name with Numeric Identifier)	
Maintenance Notification / Agreement No.	
Responsible Party for Construction Phase	
Developer's Name	
Address	
Email Address	
Phone Number	
Engineer of Work	
Engineer's Phone Number	
Responsible Party for Ongoing Maintenance	
Owner's Name(s)*	
Address	
Email Address	
Phone Number	
*Note: If a corporation or LLC, provide information for principal partner or Agent for Service of Process. If an HOA, provide information for the Board or property manager at time of project closeout.	

PRIORITY DEVELOPMENT PROJECT (PDP) SWQMP

Checklist for Engineer of Work (EOW) to submit to Field Engineering:

- Copy of the final accepted SWQMP and any accepted addendum.
- Copy of the most current plan showing the Storm Water Structural BMP Table, plans/cross-section sheets of the Structural BMPs and the location of each verified as-built Structural BMP.
- Photograph of each Structural BMP.
- Photograph(s) of each Structural BMP during the construction process to illustrate proper construction.
- Copy of the approved Structural BMP maintenance agreement and associated security

By signing below, I certify that the Structural BMP(s) for this project have been constructed and all BMPs are in substantial conformance with the approved plans and applicable regulations. I understand the City reserves the right to inspect the above BMPs to verify compliance with the approved plans and Storm Water Ordinance. Should it be determined that the BMPs were not constructed to plan or code, corrective actions may be necessary before permits can be closed.

Please sign your name and seal.

Professional Engineer's Printed Name:

Professional Engineer's Signed Name:

Date: _____

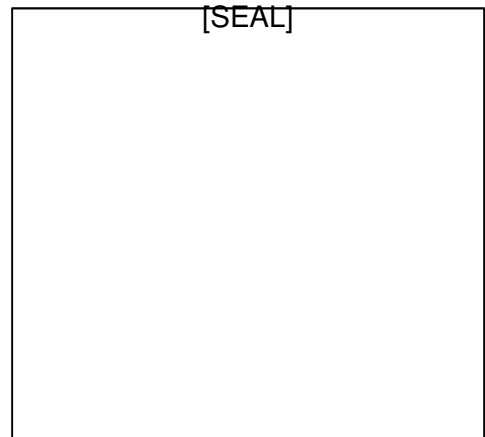

PRIORITY DEVELOPMENT PROJECT (PDP) SWQMP

CITY - OFFICIAL USE ONLY:

Permit #: _____

City Inspector: _____

Date Project has/expects to close: _____

Date verification received from Engineer of Work (EOW): _____

By signing below, City Inspector concurs that every noted Structural BMP has been installed per plan.

City Inspector's Signature: _____ Date: _____

FOR Environmental Programs:

Date Received from Field Engineering: _____

Environmental Programs Submittal Reviewer: _____

Environmental Programs Reviewer concurs that the information provided for the following Structural BMPs is acceptable to enter into the Structural BMP Maintenance verification inventory:

List acceptable Structural BMPs:

Environmental Programs Reviewer's Signature: _____

Date: _____

PRIORITY DEVELOPMENT PROJECT (PDP) SWQMP

ATTACHMENT 5

Copy of Plan Sheets Showing Permanent Storm Water BMPs, Source Control, and Site Design

This is the cover sheet for Attachment 5.

Use this checklist to ensure the required information has been included on the plans:

The plans must identify:

- Structural BMP(s) with ID numbers matching Step 6 Summary of PDP Structural BMPs
- The grading and drainage design shown on the plans must be consistent with the delineation of DMAs shown on the DMA exhibit
- Details and specifications for construction of structural BMP(s)
- Signage indicating the location and boundary of structural BMP(s) as required by City staff
- How to access the structural BMP(s) to inspect and perform maintenance
- Features that are provided to facilitate inspection (e.g., observation ports, cleanouts, silt posts, or other features that allow the inspector to view necessary components of the structural BMP and compare to maintenance thresholds)
- Manufacturer and part number for proprietary parts of structural BMP(s) when applicable
- Maintenance thresholds specific to the structural BMP(s), with a location-specific frame of reference (e.g., level of accumulated materials that triggers removal of the materials, to be identified based on viewing marks on silt posts or measured with a survey rod with respect to a fixed benchmark within the BMP)
- Recommended equipment to perform maintenance
- When applicable, necessary special training or certification requirements for inspection and maintenance personnel such as confined space entry or hazardous waste management
- Include landscaping plan sheets showing vegetation requirements for vegetated structural BMP(s)
- All BMPs must be fully dimensioned on the plans
- When proprietary BMPs are used, site-specific cross section with outflow, inflow, and model number must be provided. Photocopies of general brochures are not acceptable.
- Include all source control and site design measures described in Steps 4 and 5 of the SWQMP. Can be included as a separate exhibit as necessary.

***Note: Plan sheets included in this attachment can be full size or half size.**

PARCEL 1 PM 3800

POR. LOT 1, BLOCK 11
MAP NO. 527

PROPOSED BUILDING
GARAGE F.F. 642.10

GROSS AREA: 64,804 SF - 1.488 AC
NET AREA: 1.47 AC
64,024 SF

PUBLIC METERS
2" DOM SERVICE W/ 2" WM AND 2" BFP
1.5" IRR SERVICE W/ 1.5" WM AND 1.5" BFP

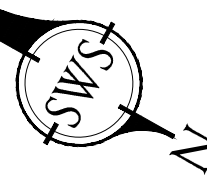
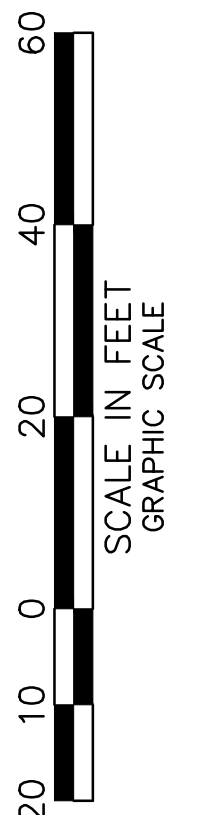

EARTHWORK QUANTITIES
1,000 CY OFFHAUL

LEGEND

- FIRE ACCESS ROAD
- RAISED BIOFILTRATION
- ROW
- CENTERLINE
- CURB AND GUTTER
- WATER MAIN
- WROUGHT IRON FENCE
- FIRE HYDRANT
- GATE VALVE
- PUBLIC SIDEWALK
- DCDA, FDC AND PIV
- SEWER LATERAL

EASEMENT NOTES

- 1) EXISTING ROAD AND PUBLIC UTILITY EASEMENT GRANTED IN A DOCUMENT GRANTED TO: LAWRENCE W. WEIR AND MARIE A. WIER RECORDED ON NOVEMBER 1, 1965 AS DOC. NO. 1965-0197793 OF OFFICIAL RECORDS.
- 2) PROPOSED FIRE ACCESS EASEMENT.

PRELIMINARY GRADING AND UTILITY PLAN

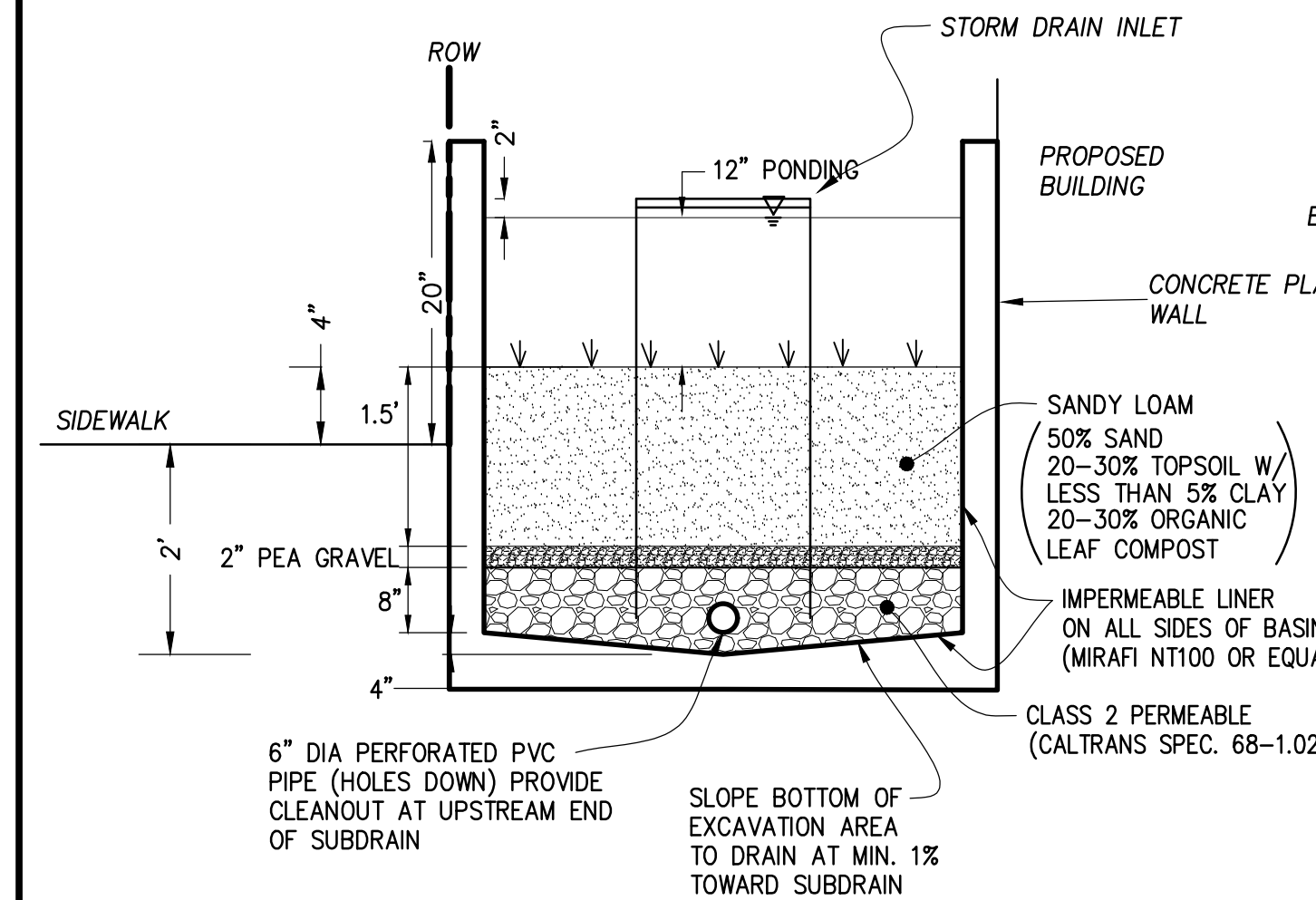
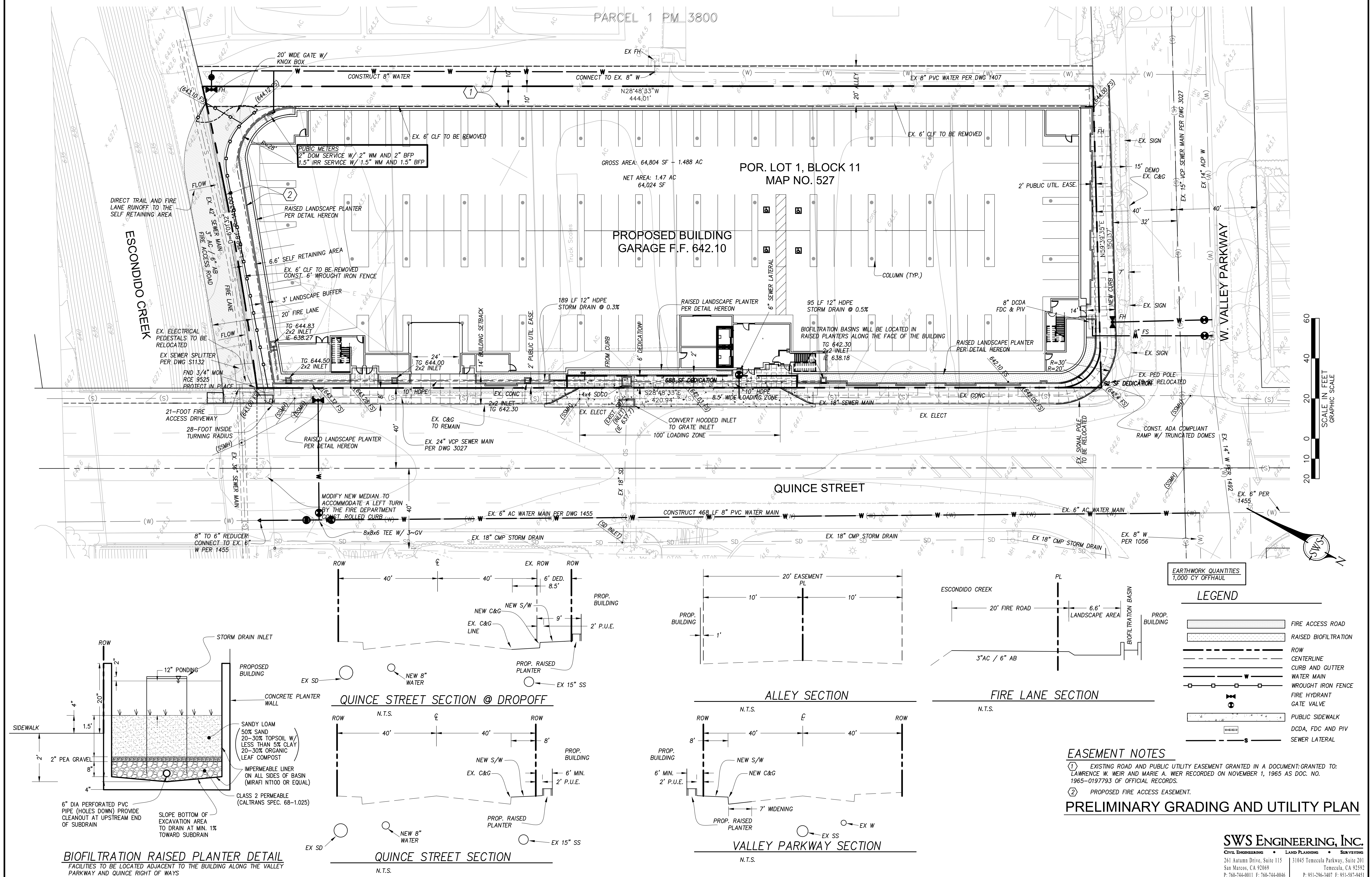

QUINCE STREET SECTION @ DROPOFF

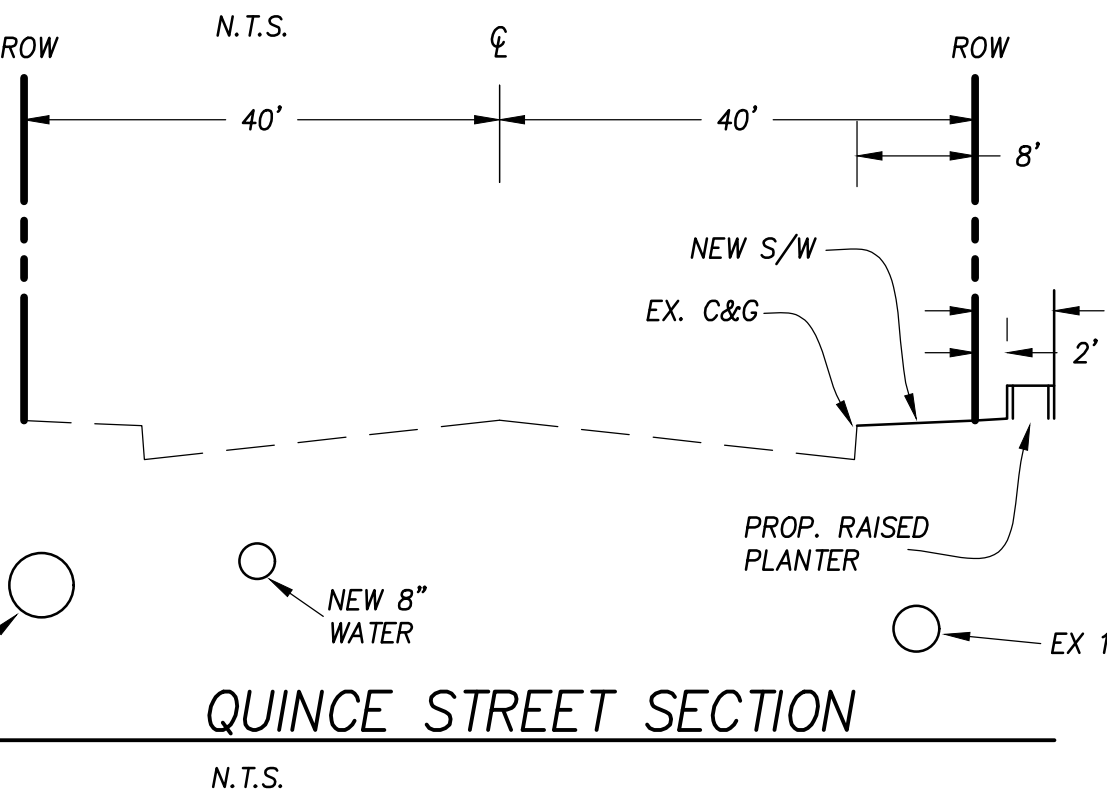

ALLEY SECTION

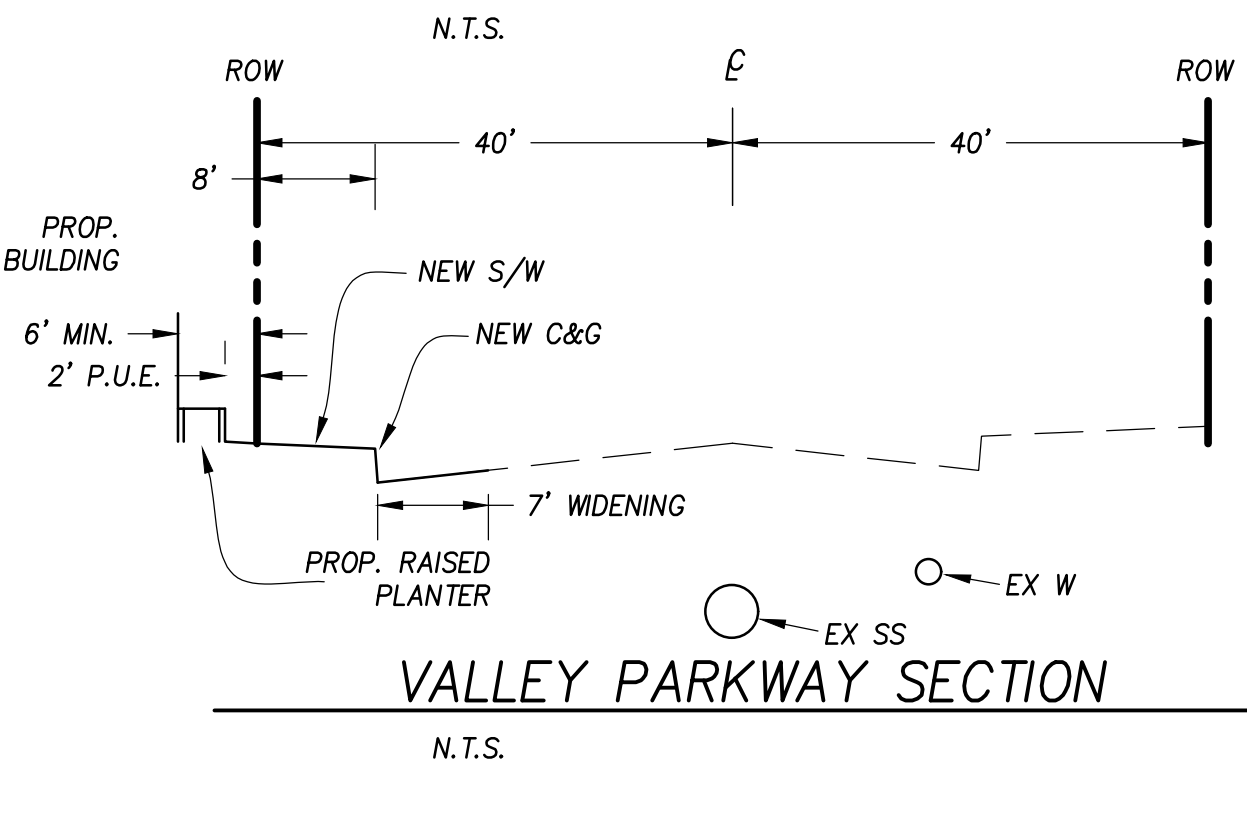

FIRE LANE SECTION

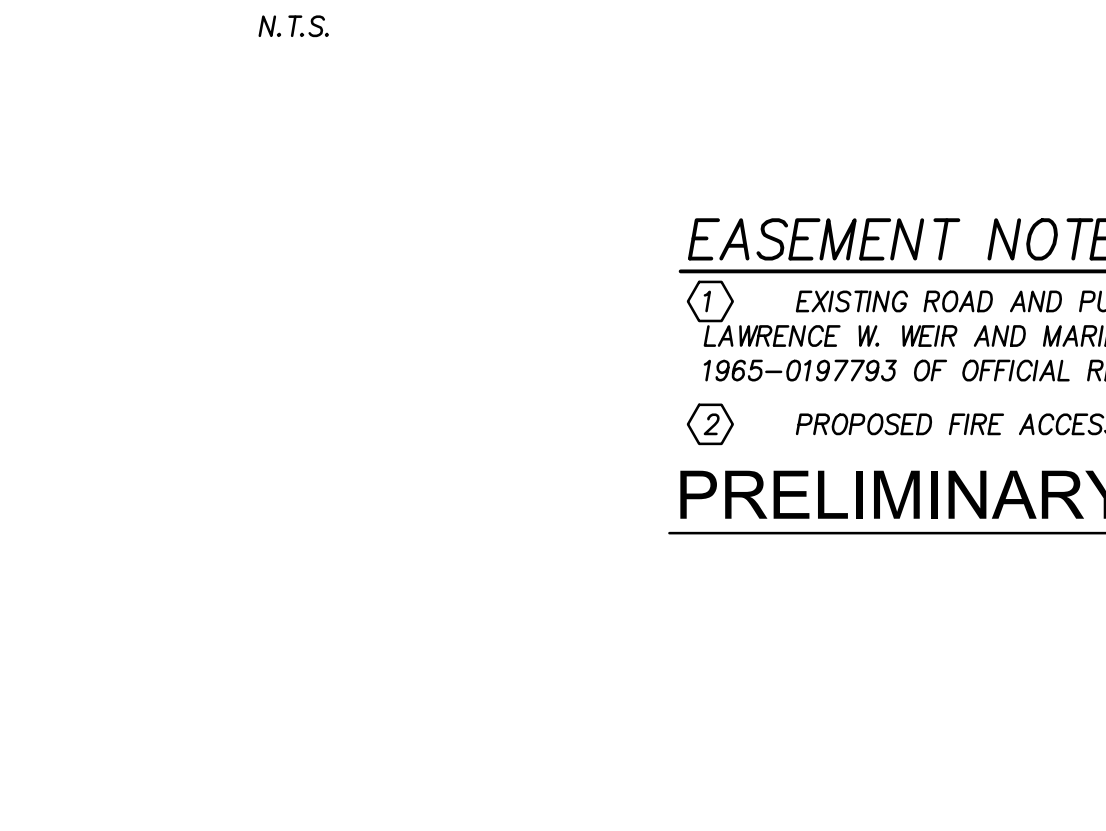

BIOFILTRATION RAISED PLANTER DETAIL
FACILITIES TO BE LOCATED ADJACENT TO THE BUILDING ALONG THE VALLEY PARKWAY AND QUINCE RIGHT OF WAYS