

HYDROLOGY/HYDRAULIC STUDY

DATED: 4/6/18

RESQUE RANCH

LOCATION: North of Highland Valley Road, Escondido, CA 92025
APN: 276-030-48 & 49

OWNER:
4030 Goldfinch Investment, LLC
c/o Phil Pace
15635 Paseo Penasco
Escondido CA 92025
(619) 814-0050
phil@Philsbbq.net

BY: SPEAR & ASSOCIATES, INC.
CIVIL ENGINEERING AND LAND SURVEYING
475 Production Street
San Marcos, CA 92078
PHONE: (760) 736-2040

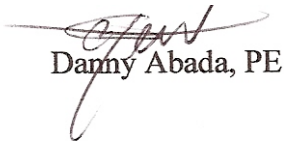
Danny Abada, PE



DECLARATION OF RESPONSIBLE CHARGE

I, HEREBY DECLARE THAT I AM THE CIVIL ENGINEER OF WORK FOR THIS PROJECT, THAT I HAVE EXERCISED RESPONSIBLE CHARGE OVER THE DESIGN OF THIS PROJECT AS DEFINED IN SECTION 6703 OF THE BUSINESS AND PROFESSIONAL CODE AND THAT THE DESIGN IS CONSISTENT WITH CURRENT DESIGN STANDARDS.

I UNDERSTAND THAT THE CHECK OF PROJECT DRAWINGS AND SPECIFICATIONS BY THE COUNTY OF SAN DIEGO IS CONFINED TO A REVIEW ONLY AND DOES NOT RELIEVE ME, AS ENGINEER OF WORK, OF MY RESPONSIBILITIES FOR PROJECT DESIGN.



4/6/18

Danny Abada
REGISTERED CIVIL ENGINEER

DATE



TABLE OF CONTENTS

I. INTRODUCTION	1
II. DISCUSSION/CONCLUSION	1
SUMMARY OF FLOW RATES	2
<u>ATTACHMENTS</u>	
A. LOCATION MAP	3
B. HYDROLOGY CALCULATIONS	6
C. HYDRAULICS PIPI & RSP SIZING	30
D. DRAINAGE AREA MAP	41

I. INTRODUCTION

This hydrology report is prepared for Resque Ranch located north of Highland Valley Road, Escondido, CA 92025. The site encompasses approximately 5.13 acres and is zoned agricultural and the proposed use is commercial. APN: 276-030-48 & 49

The project will disturb most of the site and consists developing a horse stable, with a driveway and hardscape surfaces. Construction will include associated utilities, landscaping and an onsite bioretention facility for stormwater treatment.

The onsite topography slopes in a northwesterly direction with elevations approximately ranging from 1079' to 955'. The site is mostly bare and the drainage includes offsite areas sloping into the easterly side of the property and an offsite access easement from the southwest portion of the site.

The site drainage sheet flows in a northwesterly direction, continuing approximately 0.5 miles north towards the San Dieguito River, then 5 miles through Lake Hodges, and 18 miles west to the Pacific Ocean.

The development utilizes low impact development strategies that mimic the site's pre-development hydrology by using design techniques that infiltrate, store, evaporate and detain runoff close to its source. Pervious surfaces were minimized by maximizing landscaping and a bioretention facility.

We have used the County of San Diego Hydrology Manual for this report to calculate the 100-year flow generated from the site. Based on the soil hydrologic group map in Appendix A of the County Hydrology Manual, onsite subareas consist of 14% Type B, 70% type C and 16% type D soils.

II. DISCUSSION/CONCLUSION

This project will maintain existing drainage patterns along the site and will not alter the course of a stream or river and therefore will not contribute to substantial erosion or siltation onsite or offsite.

Post development peak flows, flow volumes and velocities will be maintained lower than from pre-development rates by maximizing pervious surfaces, onsite times of concentration and with the use of low impact strategies as shown on the project's Stormwater Management Plan. Therefore the project will not create or contribute runoff which will exceed the capacity of existing or planned storm water drainage systems.

100-yr Hydrology Results Summary							
	P_6	C	I	Area (acres)	TC	Q (cfs)	Outlet V (ft/s)
Pre-Dev. Onsite	2.88	0.3	5.52	5.13	8.2	8.5	
Post-Dev. Onsite	2.88	0.38	3.35	5.13	17.8	6.5	
Pre Dev Total Onsite & Offsite @ NW Confluence	2.88	0.25 & 0.3 & 0.33	5.05	21.71	9.4	28.7	6.7
Post Dev Total Onsite & Offsite @ NW Confluence	2.88	0.25 & 0.32 & 0.38 & 0.82	3.61	21.71	15.8	22.2	6.4
Pre & Post Dev Offsite C1 to Exist/Extended 30" CMP	2.88	0.33	6.11	3.5	7	7.1	9.3

ATTACHMENT A

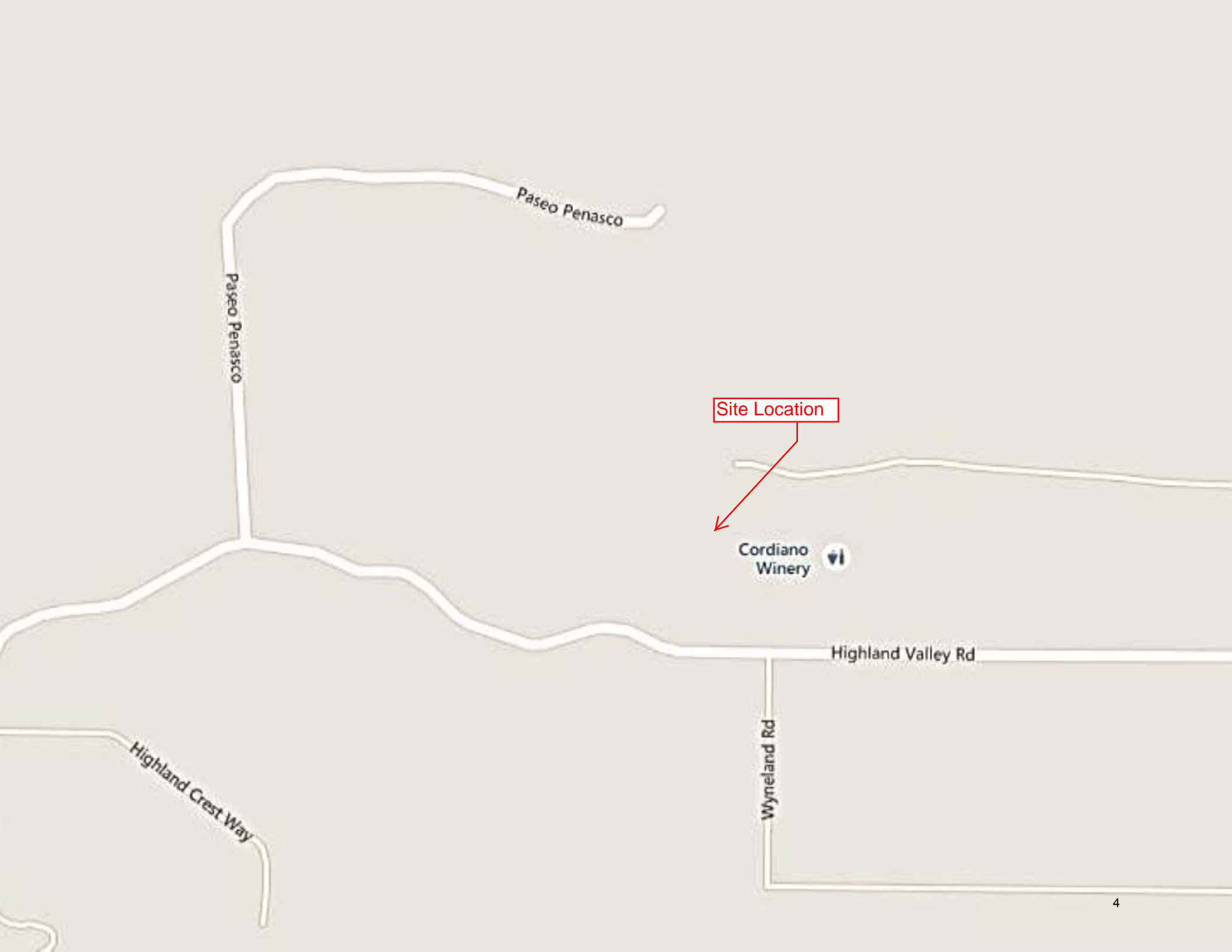

Site Location

Cordiano Winery

Highland Valley Rd

Wymeland Rd

Highland Crest Way

Paseo Penasco

Paseo Penasco



Site

Paseo Penasco

ATTACHMENT B

Developed Conditions 100-yr Event

***Rational Method**

REACH	TC	C	A	CA	ΣCA	P ₆	I	Q cfs
Offsite A1	5.7	0.25	3.5	0.87	0.87	2.88	6.97	6.1
Offsite B1	9.4	0.25	12.9	3.23	3.23	2.88	5.05	16.3
Offsite C1	7	0.33	3.5	1.16	1.16	2.88	6.11	7.1
Offsite O	5	0.82	0.12	0.10	0.10	2.88	7.59	0.7
Offsite B1 To NW outlet confluence point, through brow ditch 315' @ 6.5%								
Total Travel Time =		0.33			ΣTC 9.73			
Onsite								
Area A	7.9	0.38	0.53	0.20	0.20	2.88	5.65	1.1
Area B	14.8	0.38	2.14	0.81	0.81	2.88	3.77	3.1
Area C	15.8	0.38	1.18	0.45	0.45	2.88	3.61	1.6
Area D	8.7	0.38	0.91	0.35	0.35	2.88	5.31	1.8
Area E	5	0.38	0.28	0.11	0.11	2.88	7.59	0.8
Area AO	5	0.38	0.08	0.03	0.03	2.88	7.59	0.2
Total Onsite Flow	15.8				1.95	2.88	3.61	7.0
Total Onsite & Offsite A1 & B1 & O @ NW Confluence	15.8		21.71		6.14	2.88	3.61	22.2

Pre-Development Conditions 100-yr Event

REACH	TC	C	A	CA	ΣCA	P ₆	I	Q cfs
Offsite A1	6.9	0.25	3.5	0.87	0.87	2.88	6.16	5.4
Offsite B1	9.4	0.25	12.9	3.23	3.23	2.88	5.05	16.3
Offsite C1	7.4	0.33	3.5	1.16	1.16	2.88	5.89	6.9
Offsite O	7.2	0.3	0.12	0.04	0.04	2.88	6.00	0.2
Site Area	8.2	0.3	5.13	1.54	1.54	2.88	5.52	8.5
Total Onsite & Offsite A1 & B1 & O @ NW Confluence	9.4		21.71		5.68	2.88	5.05	28.7

County of San Diego Hydrology Manual



Rainfall Isopleths

100 Year Rainfall Event - 24 Hours

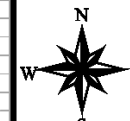
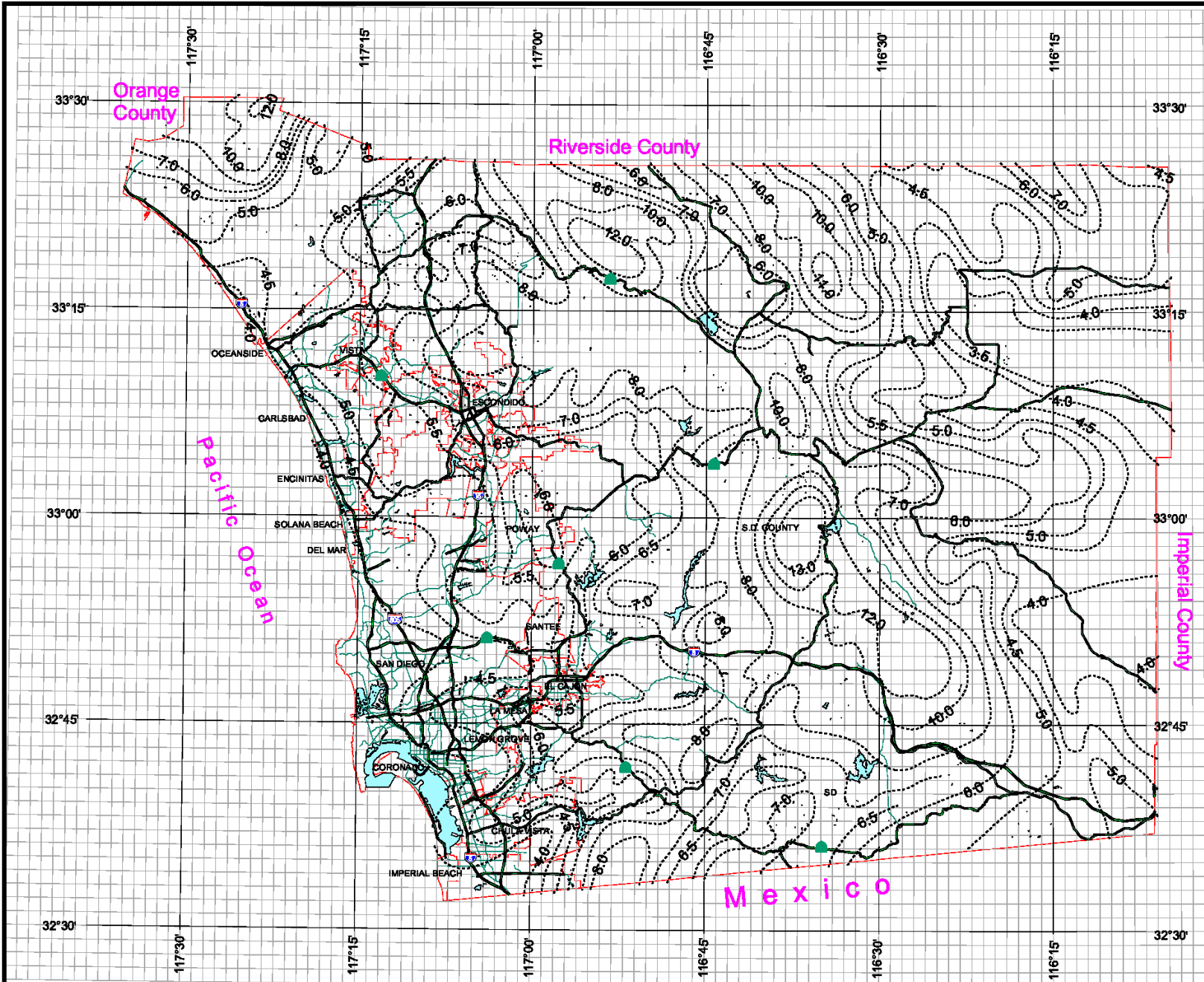

3 0 3 Miles

THIS MAP IS PROVIDED WITHOUT WARRANTY OF ANY KIND, EITHER EXPRESS OR IMPLIED, INCLUDING, BUT NOT LIMITED TO, THE IMPLIED WARRANTIES OF MERCHANTABILITY AND FITNESS FOR A PARTICULAR PURPOSE. Copyright 2018. All Rights Reserved.

This product may contain information from the SANDAG Regional Information System which cannot be reproduced without the written permission of SANDAG.

This product may contain information which has been reproduced with permission granted by Thomas Brothers Maps.

County of San Diego Hydrology Manual



Rainfall Isopluvials

100 Year Rainfall Event - 6 Hours

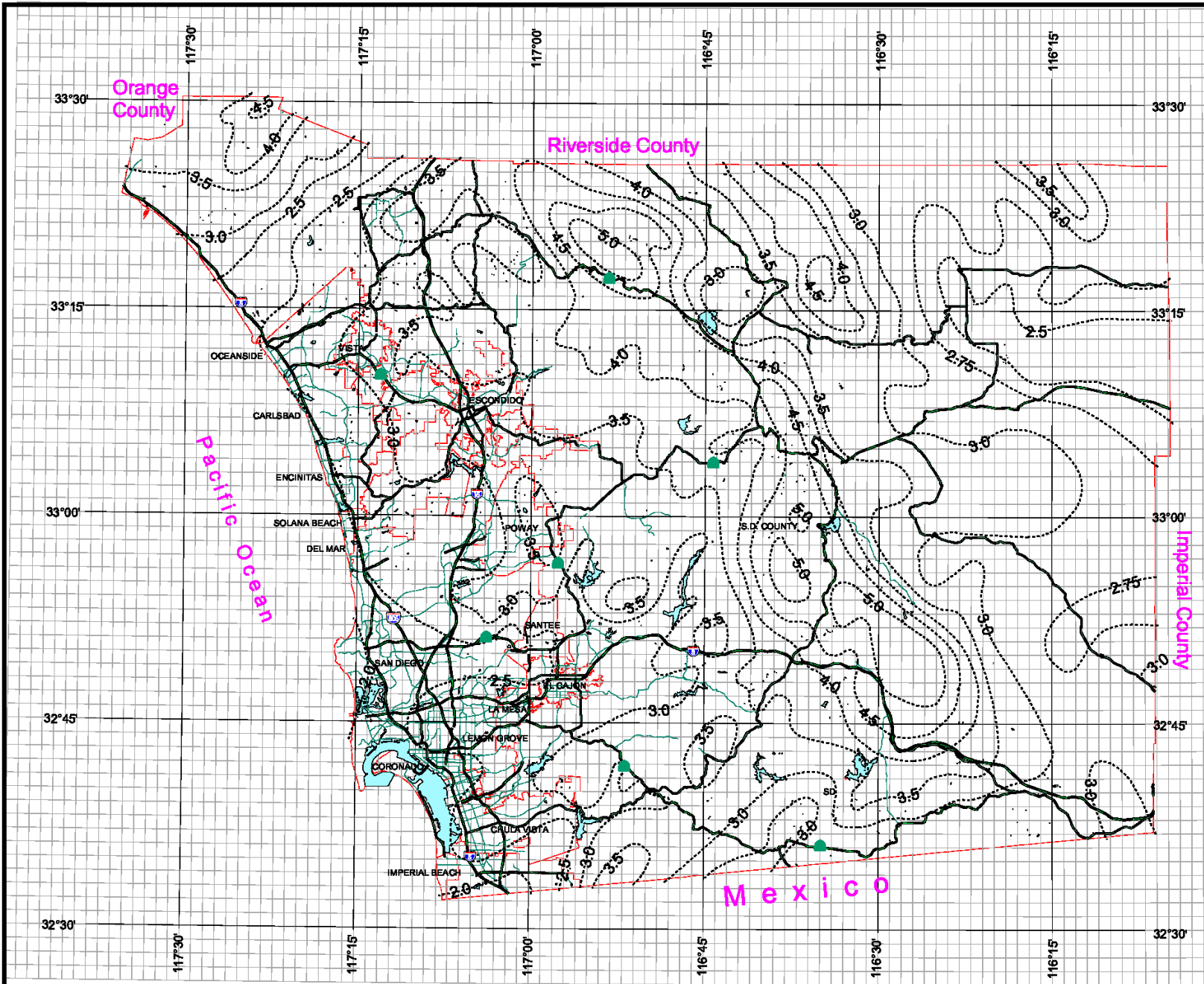

3 0 3 Miles

THIS MAP IS PROVIDED WITHOUT WARRANTY OF ANY KIND, EITHER EXPRESS OR IMPLIED, INCLUDING, BUT NOT LIMITED TO, THE IMPLIED WARRANTIES OF MERCHANTABILITY AND FITNESS FOR A PARTICULAR PURPOSE. Copyright 2008. All Rights Reserved.

This product may contain information from the SANDAG Regional Information System which cannot be reproduced without the written permission of SANDAG.

This product may contain information which has been reproduced with permission granted by Thomas Brothers Maps.



POINT PRECIPITATION FREQUENCY ESTIMATES

Sanja Perica, Sarah Dietz, Sarah Heim, Lillian Hiner, Kazungu Maitaria, Deborah Martin, Sandra Pavlovic, Ishani Roy, Carl Trypaluk, Dale Unruh, Fenglin Yan, Michael Yekta, Tan Zhao, Geoffrey Bonnin, Daniel Brewer, Li-Chuan Chen, Tye Parzybok, John Yarchoan

NOAA, National Weather Service, Silver Spring, Maryland

[PF_tabular](#) | [PF_graphical](#) | [Maps & aeriels](#)

PF tabular

PDS-based point precipitation frequency estimates with 90% confidence intervals (in inches)¹										
Duration	Average recurrence interval (years)									
	1	2	5	10	25	50	100	200	500	1000
5-min	0.112 (0.095-0.135)	0.142 (0.120-0.171)	0.183 (0.153-0.220)	0.217 (0.180-0.263)	0.264 (0.212-0.332)	0.301 (0.237-0.388)	0.341 (0.260-0.450)	0.382 (0.283-0.520)	0.440 (0.312-0.626)	0.485 (0.332-0.717)
10-min	0.161 (0.136-0.193)	0.204 (0.172-0.245)	0.262 (0.220-0.315)	0.310 (0.258-0.377)	0.378 (0.304-0.476)	0.432 (0.339-0.556)	0.488 (0.373-0.645)	0.547 (0.406-0.745)	0.630 (0.447-0.897)	0.696 (0.476-1.03)
15-min	0.195 (0.164-0.234)	0.247 (0.208-0.296)	0.317 (0.266-0.381)	0.375 (0.312-0.456)	0.457 (0.367-0.576)	0.523 (0.410-0.673)	0.590 (0.451-0.780)	0.662 (0.491-0.902)	0.762 (0.541-1.08)	0.842 (0.575-1.24)
30-min	0.275 (0.231-0.329)	0.348 (0.293-0.417)	0.446 (0.375-0.537)	0.529 (0.440-0.642)	0.645 (0.517-0.811)	0.736 (0.578-0.948)	0.832 (0.636-1.10)	0.933 (0.692-1.27)	1.07 (0.762-1.53)	1.19 (0.811-1.75)
60-min	0.410 (0.345-0.491)	0.519 (0.437-0.622)	0.666 (0.559-0.801)	0.789 (0.656-0.958)	0.962 (0.772-1.21)	1.10 (0.862-1.41)	1.24 (0.949-1.64)	1.39 (1.03-1.90)	1.60 (1.14-2.28)	1.77 (1.21-2.61)
2-hr	0.574 (0.484-0.688)	0.725 (0.611-0.870)	0.930 (0.781-1.12)	1.10 (0.917-1.34)	1.34 (1.08-1.69)	1.54 (1.21-1.98)	1.74 (1.33-2.30)	1.95 (1.45-2.66)	2.25 (1.60-3.21)	2.49 (1.71-3.68)
3-hr	0.693 (0.584-0.831)	0.875 (0.737-1.05)	1.12 (0.942-1.35)	1.33 (1.11-1.61)	1.62 (1.30-2.04)	1.86 (1.46-2.39)	2.10 (1.61-2.78)	2.36 (1.75-3.22)	2.73 (1.94-3.88)	3.02 (2.07-4.46)
6-hr	0.948 (0.799-1.14)	1.20 (1.01-1.44)	1.54 (1.29-1.85)	1.82 (1.52-2.21)	2.23 (1.79-2.80)	2.55 (2.00-3.28)	2.88 (2.20-3.81)	3.24 (2.40-4.42)	3.75 (2.66-5.33)	4.15 (2.84-6.13)
12-hr	1.29 (1.09-1.55)	1.64 (1.38-1.97)	2.11 (1.77-2.54)	2.50 (2.08-3.04)	3.06 (2.46-3.85)	3.50 (2.75-4.51)	3.97 (3.03-5.24)	4.46 (3.31-6.07)	5.14 (3.65-7.32)	5.70 (3.90-8.41)
24-hr	1.66 (1.46-1.92)	2.11 (1.86-2.45)	2.73 (2.40-3.17)	3.25 (2.84-3.80)	3.98 (3.37-4.80)	4.56 (3.78-5.61)	5.16 (4.18-6.50)	5.80 (4.58-7.49)	6.69 (5.08-8.99)	7.41 (5.44-10.3)
2-day	2.06 (1.82-2.38)	2.65 (2.34-3.07)	3.46 (3.04-4.01)	4.13 (3.60-4.83)	5.08 (4.30-6.13)	5.84 (4.85-7.19)	6.64 (5.38-8.36)	7.49 (5.91-9.68)	8.68 (6.59-11.7)	9.64 (7.08-13.4)
3-day	2.33 (2.05-2.69)	3.01 (2.66-3.49)	3.96 (3.48-4.59)	4.76 (4.15-5.56)	5.89 (4.99-7.11)	6.81 (5.65-8.38)	7.77 (6.30-9.78)	8.80 (6.95-11.4)	10.3 (7.79-13.8)	11.4 (8.41-15.9)
4-day	2.55 (2.25-2.95)	3.32 (2.92-3.84)	4.38 (3.85-5.08)	5.28 (4.61-6.17)	6.56 (5.55-7.92)	7.60 (6.30-9.35)	8.70 (7.05-11.0)	9.88 (7.80-12.8)	11.6 (8.78-15.5)	12.9 (9.50-18.0)
7-day	2.99 (2.64-3.46)	3.90 (3.44-4.52)	5.17 (4.54-6.00)	6.24 (5.45-7.30)	7.78 (6.58-9.39)	9.03 (7.49-11.1)	10.3 (8.39-13.0)	11.8 (9.29-15.2)	13.8 (10.5-18.5)	15.5 (11.4-21.5)
10-day	3.30 (2.91-3.81)	4.32 (3.80-5.00)	5.72 (5.03-6.64)	6.93 (6.05-8.10)	8.66 (7.32-10.4)	10.1 (8.34-12.4)	11.5 (9.36-14.5)	13.1 (10.4-17.0)	15.4 (11.7-20.8)	17.3 (12.7-24.0)
20-day	4.02 (3.54-4.64)	5.30 (4.67-6.13)	7.08 (6.22-8.21)	8.61 (7.51-10.1)	10.8 (9.15-13.1)	12.6 (10.5-15.5)	14.6 (11.8-18.3)	16.6 (13.1-21.5)	19.6 (14.9-26.4)	22.1 (16.2-30.7)
30-day	4.90 (4.32-5.67)	6.49 (5.72-7.51)	8.71 (7.66-10.1)	10.6 (9.27-12.4)	13.4 (11.3-16.2)	15.7 (13.0-19.3)	18.1 (14.7-22.8)	20.8 (16.4-26.9)	24.6 (18.7-33.1)	27.8 (20.4-38.6)
45-day	5.74 (5.07-6.64)	7.63 (6.72-8.83)	10.3 (9.04-11.9)	12.6 (11.0-14.7)	15.9 (13.5-19.2)	18.7 (15.5-23.0)	21.6 (17.5-27.2)	24.9 (19.6-32.1)	29.5 (22.4-39.7)	33.4 (24.6-46.4)
60-day	6.65 (5.87-7.69)	8.84 (7.79-10.2)	11.9 (10.5-13.8)	14.6 (12.7-17.1)	18.5 (15.6-22.3)	21.7 (18.0-26.7)	25.2 (20.4-31.7)	29.0 (22.9-37.5)	34.5 (26.2-46.3)	39.0 (28.7-54.2)

¹ Precipitation frequency (PF) estimates in this table are based on frequency analysis of partial duration series (PDS). Numbers in parenthesis are PF estimates at lower and upper bounds of the 90% confidence interval. The probability that precipitation frequency estimates (for a given duration and average recurrence interval) will be greater than the upper bound (or less than the lower bound) is 5%. Estimates at upper bounds are not checked against probable maximum precipitation (PMP) estimates and may be higher than currently valid PMP values. Please refer to NOAA Atlas 14 document for more information.

PF graphical

PDS-based depth-duration-frequency (DDF) curves
 Latitude: 33.0681°, Longitude: -116.9917°

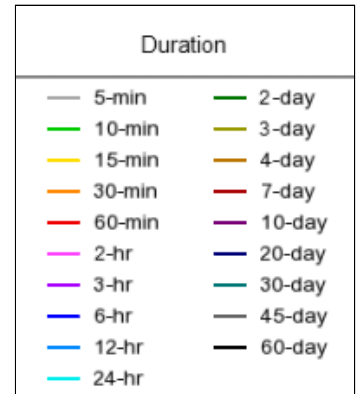
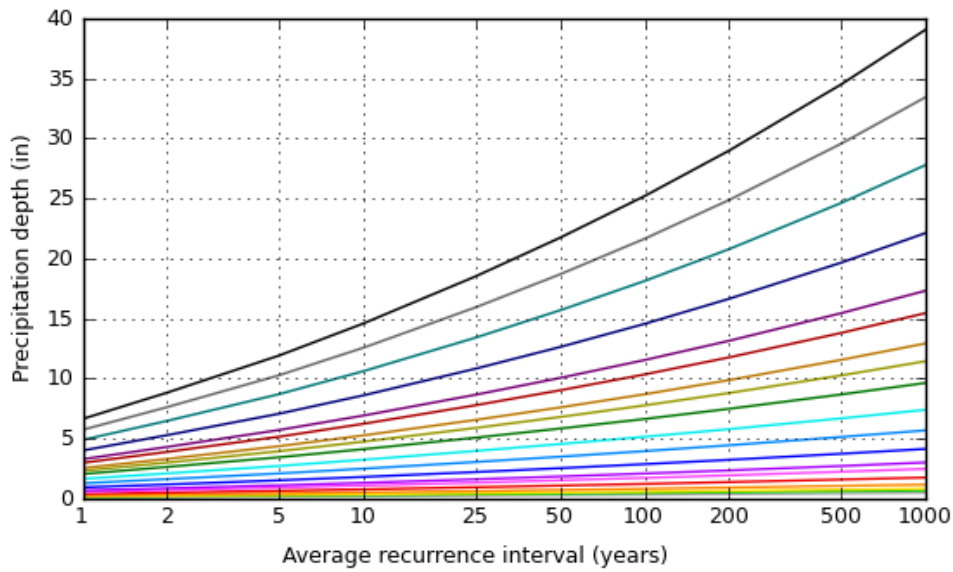
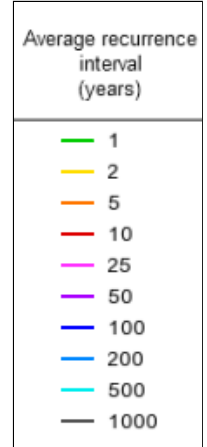
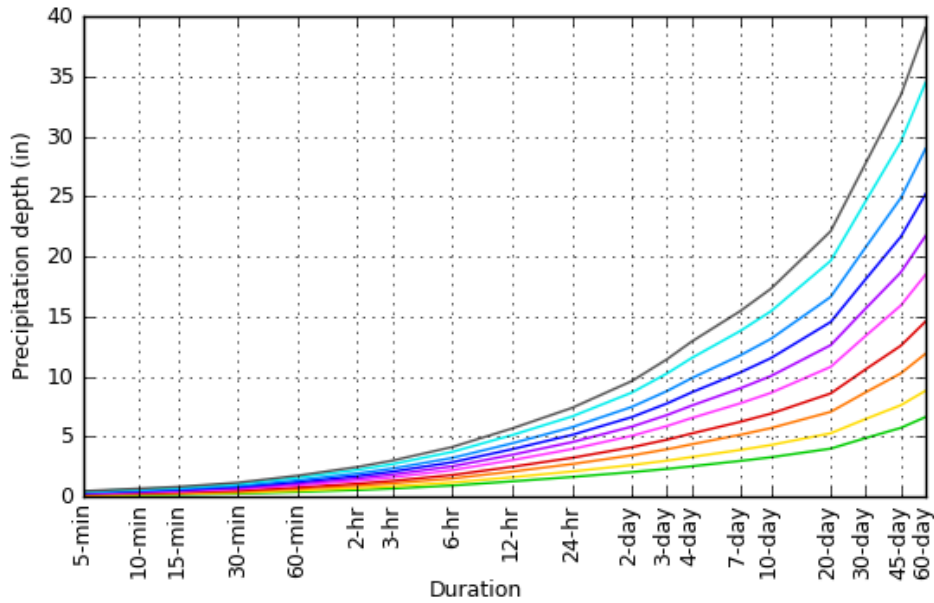

[Back to Top](#)

Maps & aerials

Small scale terrain



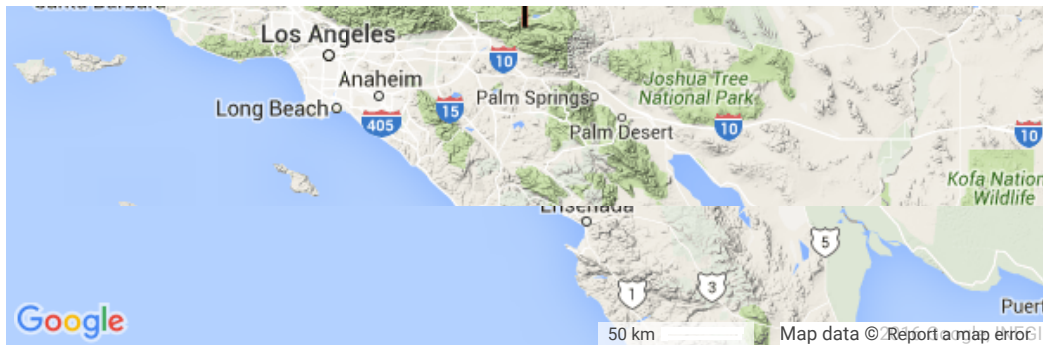

Large scale terrain



Large scale map



Large scale aerial





[Back to Top](#)

[US Department of Commerce](#)
[National Oceanic and Atmospheric Administration](#)
[National Weather Service](#)
[National Water Center](#)
1325 East West Highway
Silver Spring, MD 20910
Questions?: HDSC.Questions@noaa.gov

[Disclaimer](#)

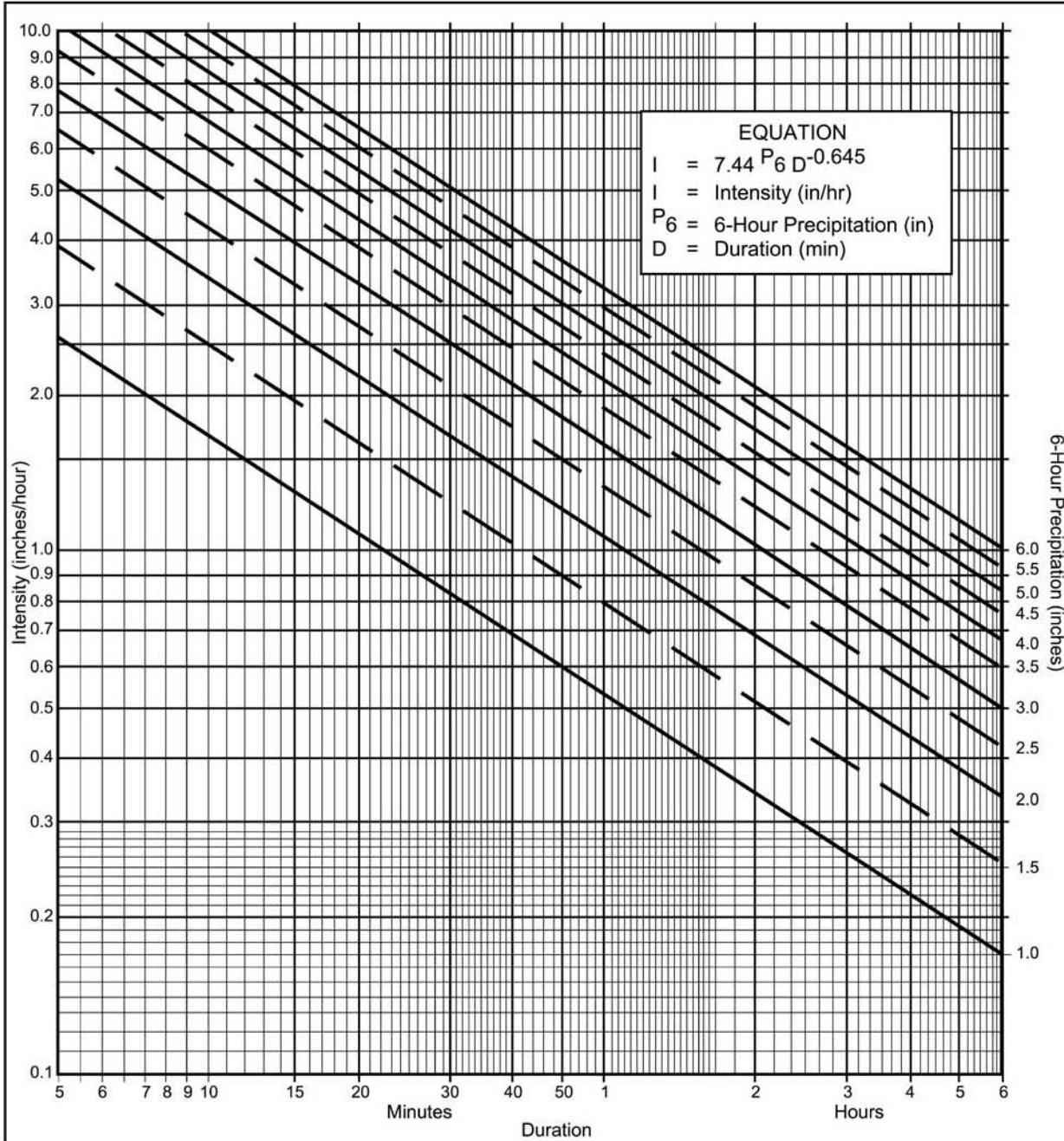

Directions for Application:

- (1) From precipitation maps determine 6 hr and 24 hr amounts for the selected frequency. These maps are included in the County Hydrology Manual (10, 50, and 100 yr maps included in the Design and Procedure Manual).
- (2) Adjust 6 hr precipitation (if necessary) so that it is within the range of 45% to 65% of the 24 hr precipitation (not applicable to Desert).
- (3) Plot 6 hr precipitation on the right side of the chart.
- (4) Draw a line through the point parallel to the plotted lines.
- (5) This line is the intensity-duration curve for the location being analyzed.

Application Form:

- (a) Selected frequency $\frac{100}{}$ year
- (b) $P_6 = \frac{2.88}{}$ in., $P_{24} = \frac{5.16}{}$ $\frac{P_6}{P_{24}} = \frac{56}{}$ %⁽²⁾
- (c) Adjusted $P_6^{(2)} = \frac{2.88}{}$ in.
- (d) $t_x = \frac{ }{}$ min.
- (e) $I = \frac{ }{}$ in./hr.

Note: This chart replaces the Intensity-Duration-Frequency curves used since 1965.

P6	1	1.5	2	2.5	3	3.5	4	4.5	5	5.5	6
5	2.63	3.95	5.27	6.59	7.90	9.22	10.54	11.86	13.17	14.49	15.81
7	2.12	3.18	4.24	5.30	6.36	7.42	8.48	9.54	10.60	11.66	12.72
10	1.68	2.53	3.37	4.21	5.05	5.90	6.74	7.58	8.42	9.27	10.11
15	1.30	1.95	2.59	3.24	3.89	4.54	5.19	5.84	6.49	7.13	7.78
20	1.08	1.62	2.15	2.69	3.23	3.77	4.31	4.85	5.39	5.93	6.46
25	0.93	1.40	1.87	2.33	2.80	3.27	3.73	4.20	4.67	5.13	5.60
30	0.83	1.24	1.66	2.07	2.49	2.90	3.32	3.73	4.15	4.56	4.98
40	0.69	1.03	1.38	1.72	2.07	2.41	2.76	3.10	3.45	3.79	4.13
50	0.60	0.90	1.19	1.49	1.79	2.09	2.39	2.69	2.98	3.28	3.58
60	0.53	0.80	1.06	1.33	1.59	1.86	2.12	2.39	2.65	2.92	3.18
90	0.41	0.61	0.82	1.02	1.23	1.43	1.63	1.84	2.04	2.25	2.45
120	0.34	0.51	0.68	0.85	1.02	1.19	1.36	1.53	1.70	1.87	2.04
150	0.29	0.44	0.59	0.73	0.88	1.03	1.18	1.32	1.47	1.62	1.76
180	0.26	0.39	0.52	0.65	0.78	0.91	1.04	1.18	1.31	1.44	1.57
240	0.22	0.33	0.43	0.54	0.65	0.76	0.87	0.98	1.08	1.19	1.30
300	0.19	0.28	0.38	0.47	0.56	0.66	0.75	0.85	0.94	1.03	1.13
360	0.17	0.25	0.33	0.42	0.50	0.58	0.67	0.75	0.84	0.92	1.00

Intensity-Duration Design Chart - Template

FIGURE

3-1

**Table 3-1
RUNOFF COEFFICIENTS FOR URBAN AREAS**

Land Use		Runoff Coefficient "C"				
NRCS Elements	County Elements	% IMPER.	Soil Type			
			A	B	C	D
Undisturbed Natural Terrain (Natural)	Permanent Open Space	0*	0.20	0.25	0.30	0.35
Low Density Residential (LDR)	Residential, 1.0 DU/A or less	10	0.27	0.32	0.36	0.41
Low Density Residential (LDR)	Residential, 2.0 DU/A or less	20	0.34	0.38	0.42	0.46
Low Density Residential (LDR)	Residential, 2.9 DU/A or less	25	0.38	0.41	0.45	0.49
Medium Density Residential (MDR)	Residential, 4.3 DU/A or less	30	0.41	0.45	0.48	0.52
Medium Density Residential (MDR)	Residential, 7.3 DU/A or less	40	0.48	0.51	0.54	0.57
Medium Density Residential (MDR)	Residential, 10.9 DU/A or less	45	0.52	0.54	0.57	0.60
Medium Density Residential (MDR)	Residential, 14.5 DU/A or less	50	0.55	0.58	0.60	0.63
High Density Residential (HDR)	Residential, 24.0 DU/A or less	65	0.66	0.67	0.69	0.71
High Density Residential (HDR)	Residential, 43.0 DU/A or less	80	0.76	0.77	0.78	0.79
Commercial/Industrial (N. Com)	Neighborhood Commercial	80	0.76	0.77	0.78	0.79
Commercial/Industrial (G. Com)	General Commercial	85	0.80	0.80	0.81	0.82
Commercial/Industrial (O.P. Com)	Office Professional/Commercial	90	0.83	0.84	0.84	0.85
Commercial/Industrial (Limited I.)	Limited Industrial	90	0.83	0.84	0.84	0.85
Commercial/Industrial (General I.)	General Industrial	95	0.87	0.87	0.87	0.87

*The values associated with 0% impervious may be used for direct calculation of the runoff coefficient as described in Section 3.1.2 (representing the pervious runoff coefficient, C_p , for the soil type), or for areas that will remain undisturbed in perpetuity. Justification must be given that the area will remain natural forever (e.g., the area is located in Cleveland National Forest).

DU/A = dwelling units per acre

NRCS = National Resources Conservation Service

Custom Soil Resource Report
Map—Hydrologic Soil Group



Map Scale: 1:897 if printed on A landscape (11" x 8.5") sheet.

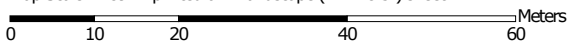

Map projection: Web Mercator Corner coordinates: WGS84 Edge tics: UTM Zone 11N WGS84



Table—Hydrologic Soil Group

Hydrologic Soil Group— Summary by Map Unit — San Diego County Area, California (CA638)				
Map unit symbol	Map unit name	Rating	Acres in AOI	Percent of AOI
AvC	Arlington coarse sandy loam, 2 to 9 percent slopes	C	3.1	75.3%
CnG2	Cieneba-Fallbrook rocky sandy loams, 30 to 65 percent slopes, eroded	D	0.6	13.3%
VsE2	Vista coarse sandy loam, 15 to 30 percent slopes, eroded	B	0.5	11.4%
Totals for Area of Interest			4.2	100.0%

Rating Options—Hydrologic Soil Group

Aggregation Method: Dominant Condition

Component Percent Cutoff: None Specified

Tie-break Rule: Higher

Runoff Coefficient Adjustment

Post Development Area

Total Area	5.13	proposed impervious	0.69
	Area	% of total	
Total Area B soils =	0.7	13.65%	
Total Area C soils =	3.61	70.37%	
Total Area D Soils =	0.82	15.98%	
Total	5.13		

B soils Runoff Adjustment

$$C = 0.90 \times (\% \text{ Impervious}) + C_p \times (1 - \% \text{ Impervious})$$

$$\% \text{ impervious} = 0.13$$

$$C_p = 0.25 \quad (\text{Table 3.1, soil type B, 0\% impervious, County Hydrology Manual})$$

$$C = 0.33$$

C Soils Runoff Adjustment

$$C = 0.90 \times (\% \text{ Impervious}) + C_p \times (1 - \% \text{ Impervious})$$

$$\% \text{ impervious} = 0.13$$

$$C_p = 0.3 \quad (\text{Table 3.1, soil type B, 0\% impervious, County Hydrology Manual})$$

$$C = 0.38$$

D Soils Runoff Adjustment

$$C = 0.90 \times (\% \text{ Impervious}) + C_p \times (1 - \% \text{ Impervious})$$

$$\% \text{ impervious} = 0.13$$

$$C_p = 0.35 \quad (\text{Table 3.1, soil type B, 0\% impervious, County Hydrology Manual})$$

$$C = 0.42$$

$$\text{Total Composit Runoff} = (0.7 \times 0.33 + 3.61 \times 0.38 + 0.82 \times 0.42)/5.13 = 0.38$$

Pre Development Area

Total Area	5.13		
	Area	% of total	Runoff
Total Area B soils =	0.7	13.65%	0.25
Total Area C soils =	3.61	70.37%	0.3
Total Area D Soils =	0.82	15.98%	0.35
Total	5.13		

$$\text{Total Composit Runoff} = (0.7 \times 0.25 + 3.61 \times 0.30 + 0.82 \times 0.35)/5.13 = 0.30$$

Offsite A1 & B1, Soil Type B Runoff = 0.25

Offsite C1, 50% Soil Type D & 50% Soil Type C Composite Runoff = 0.33

Offsite O Soil Type C Runoff = 0.30

Note that the Initial Time of Concentration should be reflective of the general land-use at the upstream end of a drainage basin. A single lot with an area of two or less acres does not have a significant effect where the drainage basin area is 20 to 600 acres.

Table 3-2 provides limits of the length (Maximum Length (L_M)) of sheet flow to be used in hydrology studies. Initial T_i values based on average C values for the Land Use Element are also included. These values can be used in planning and design applications as described below. Exceptions may be approved by the "Regulating Agency" when submitted with a detailed study.

Table 3-2

**MAXIMUM OVERLAND FLOW LENGTH (L_M)
& INITIAL TIME OF CONCENTRATION (T_i)**

Element*	DU/ Acre	.5%		1%		2%		3%		5%		10%	
		L_M	T_i	L_M	T_i	L_M	T_i	L_M	T_i	L_M	T_i	L_M	T_i
Natural		50	13.2	70	12.5	85	10.9	100	10.3	100	8.7	100	6.9
LDR	1	50	12.2	70	11.5	85	10.0	100	9.5	100	8.0	100	6.4
LDR	2	50	11.3	70	10.5	85	9.2	100	8.8	100	7.4	100	5.8
LDR	2.9	50	10.7	70	10.0	85	8.8	95	8.1	100	7.0	100	5.6
MDR	4.3	50	10.2	70	9.6	80	8.1	95	7.8	100	6.7	100	5.3
MDR	7.3	50	9.2	65	8.4	80	7.4	95	7.0	100	6.0	100	4.8
MDR	10.9	50	8.7	65	7.9	80	6.9	90	6.4	100	5.7	100	4.5
MDR	14.5	50	8.2	65	7.4	80	6.5	90	6.0	100	5.4	100	4.3
HDR	24	50	6.7	65	6.1	75	5.1	90	4.9	95	4.3	100	3.5
HDR	43	50	5.3	65	4.7	75	4.0	85	3.8	95	3.4	100	2.7
N. Com		50	5.3	60	4.5	75	4.0	85	3.8	95	3.4	100	2.7
G. Com		50	4.7	60	4.1	75	3.6	85	3.4	90	2.9	100	2.4
O.P./Com		50	4.2	60	3.7	70	3.1	80	2.9	90	2.6	100	2.2
Limited I.		50	4.2	60	3.7	70	3.1	80	2.9	90	2.6	100	2.2
General I.		50	3.7	60	3.2	70	2.7	80	2.6	90	2.3	100	1.9

*See Table 3-1 for more detailed description

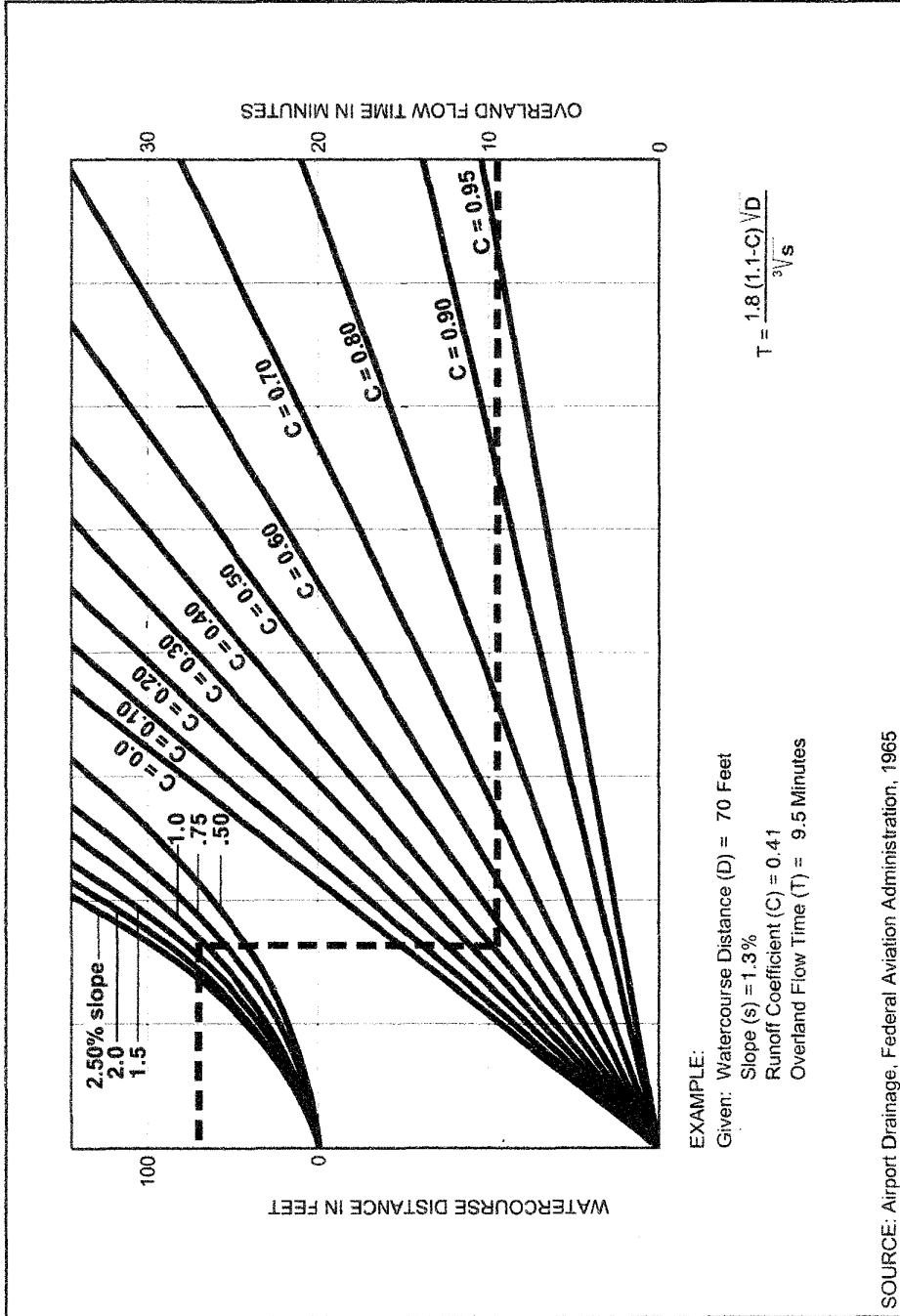

FIGURE

3-3

Rational Formula - Overland Time of Flow Nomograph

Time of Concentration

Location	Initial Average		Initial TC		Average		Q (cfs)	Mannings V (ft/s)	Additional TC (travel time)	
	slope %	Initial L (ft)	Initial T (min)	Add'l L (ft)	slope %	area (ac)			Inc. T (min)	total T (min)
							* Est. Average Q			(5 minutes min)
Offsite										
A1	50	100	4.15	460	24	(Kirpich Formula)			1.52	5.7
B1	32	100	4.82	1670	18	(Kirpich Formula)			4.58	9.4
C1	30	100	4.46	670	14	(Kirpich Formula)			2.49	7.0
O	13	100	6.12	220	13	(Kirpich Formula)			1.1	7.2
Pre Dev.										
onsite	15	100	5.84	500		(Kirpich Formula)			2.0	7.8
Post Dev.										
Offsite B1 through brow ditch 315' @ 6.5%								15.6	0.3	9.7
Area A	6.5	100	6.94	320	6.5			5.2	1.0	7.9
Area B	3.4	100	8.62	780	1.6			2.1	6.2	14.8
Area C	0.9	70	11.23	195	0.5			0.7	4.6	15.8
Area D	13.5	100	5.44	430	13.5			2.2	3.3	8.7
Area E	50	50	2.5	220	8			5.2	0.7	5.0
Offsite O	13	100	2.1	220						5.0

Initial TC (Figure 3-3)

$$T_{min} = \frac{1.8(1.1-C)D^{1/2}}{S^{1/3}}$$

Initial TC	Pre-Dev Onsite	Post-Dev Area A	Post-Dev Area B	Post-Dev Area C	Post-Dev Area D	Post-Dev Area E	Offsite A1	Offsite B1	Offsite C1	Offsite O	Offsite O
C =	0.3	0.38	0.38	0.38	0.38	0.38	0.25	0.25	0.33	0.3	0.82
D ft =	100	100	100	70	100	50	100	100	100	100	100
S % =	15	6.5	3.4	0.9	13.5	50	50	32	30	13	13
T =	5.84	6.94	8.62	11.23	5.44	2.49	4.15	4.82	4.46	6.12	2.14

Overland Flow (Offsite & Pre-Development)

Kirpich Formula

$$T_c \text{ min} = (11.9L^3/\Delta E)^{0.385}$$

	Onsite Pre-Dev	Offsite A1	Offsite B1	Offsite C1	Offsite O
ΔE ft =	70	110	300	94	28
L Feet =	500	460	1670	670	220
L miles =	0.094697	0.08712	0.31628788	0.126894	0.04166667
T hours =	0.033219	0.02535	0.07638169	0.041582	0.01831411
T min =	1.99	1.52	4.58	2.49	1.10

Channel Report

Post Dev Area A TC Average Q

Circular

Diameter (ft) = 3.00

Invert Elev (ft) = 100.00

Slope (%) = 6.50

N-Value = 0.013

Calculations

Compute by: Known Q

Known Q (cfs) = 0.50

Highlighted

Depth (ft) = 0.12

Q (cfs) = 0.500

Area (sqft) = 0.10

Velocity (ft/s) = 5.19

Wetted Perim (ft) = 1.21

Crit Depth, Y_c (ft) = 0.22

Top Width (ft) = 1.18

EGL (ft) = 0.54

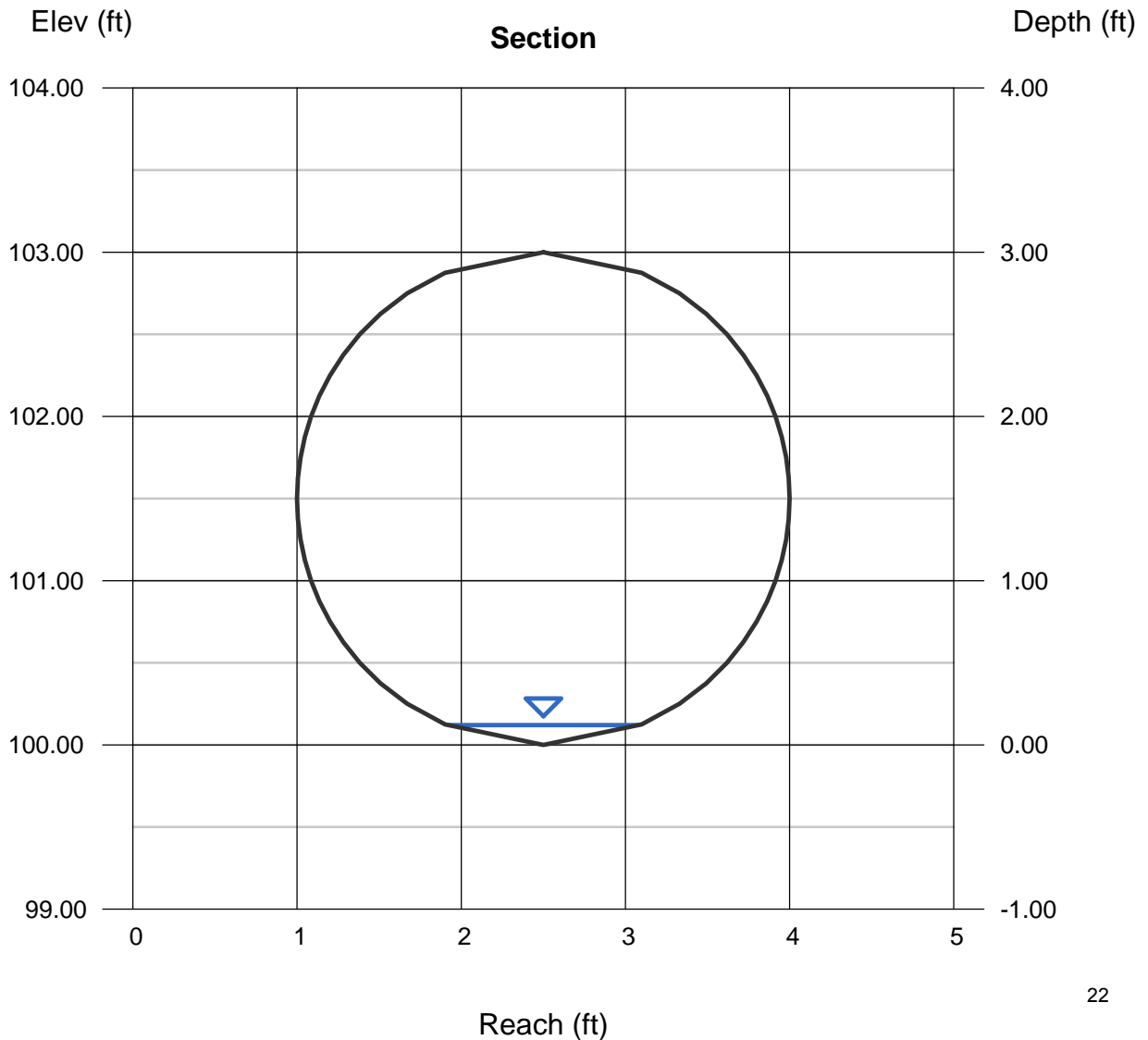

Channel Report

Post Dev Area B TC Average Q

Gutter

Cross Sl, Sx (ft/ft) = 0.02
Cross Sl, Sw (ft/ft) = 0.02
Gutter Width (ft) = 1.50
Invert Elev (ft) = 100.00
Slope (%) = 1.60
N-Value = 0.016

Highlighted

Depth (ft) = 0.16
Q (cfs) = 1.350
Area (sqft) = 0.64
Velocity (ft/s) = 2.11
Wetted Perim (ft) = 8.16
Crit Depth, Yc (ft) = 0.18
Spread Width (ft) = 8.00
EGL (ft) = 0.23

Calculations

Compute by: Known Q
Known Q (cfs) = 1.35

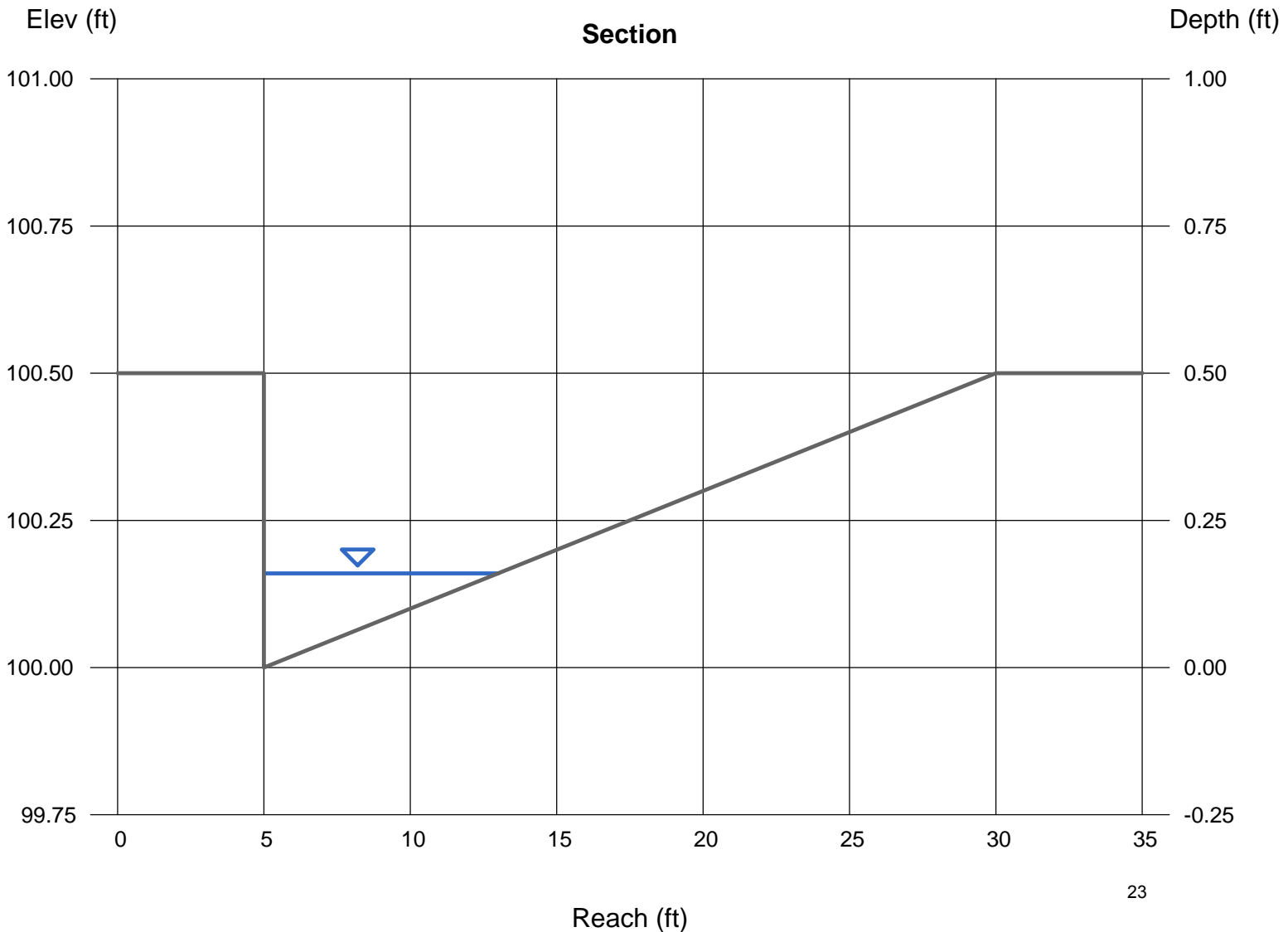

Channel Report

Post Dev Area C TC Average Q

Triangular

Side Slopes (z:1) = 100.00, 100.00
Total Depth (ft) = 0.20

Invert Elev (ft) = 100.00
Slope (%) = 0.50
N-Value = 0.020

Calculations

Compute by: Known Q
Known Q (cfs) = 0.80

Highlighted

Depth (ft) = 0.11
Q (cfs) = 0.800
Area (sqft) = 1.21
Velocity (ft/s) = 0.66
Wetted Perim (ft) = 22.00
Crit Depth, Yc (ft) = 0.09
Top Width (ft) = 22.00
EGL (ft) = 0.12

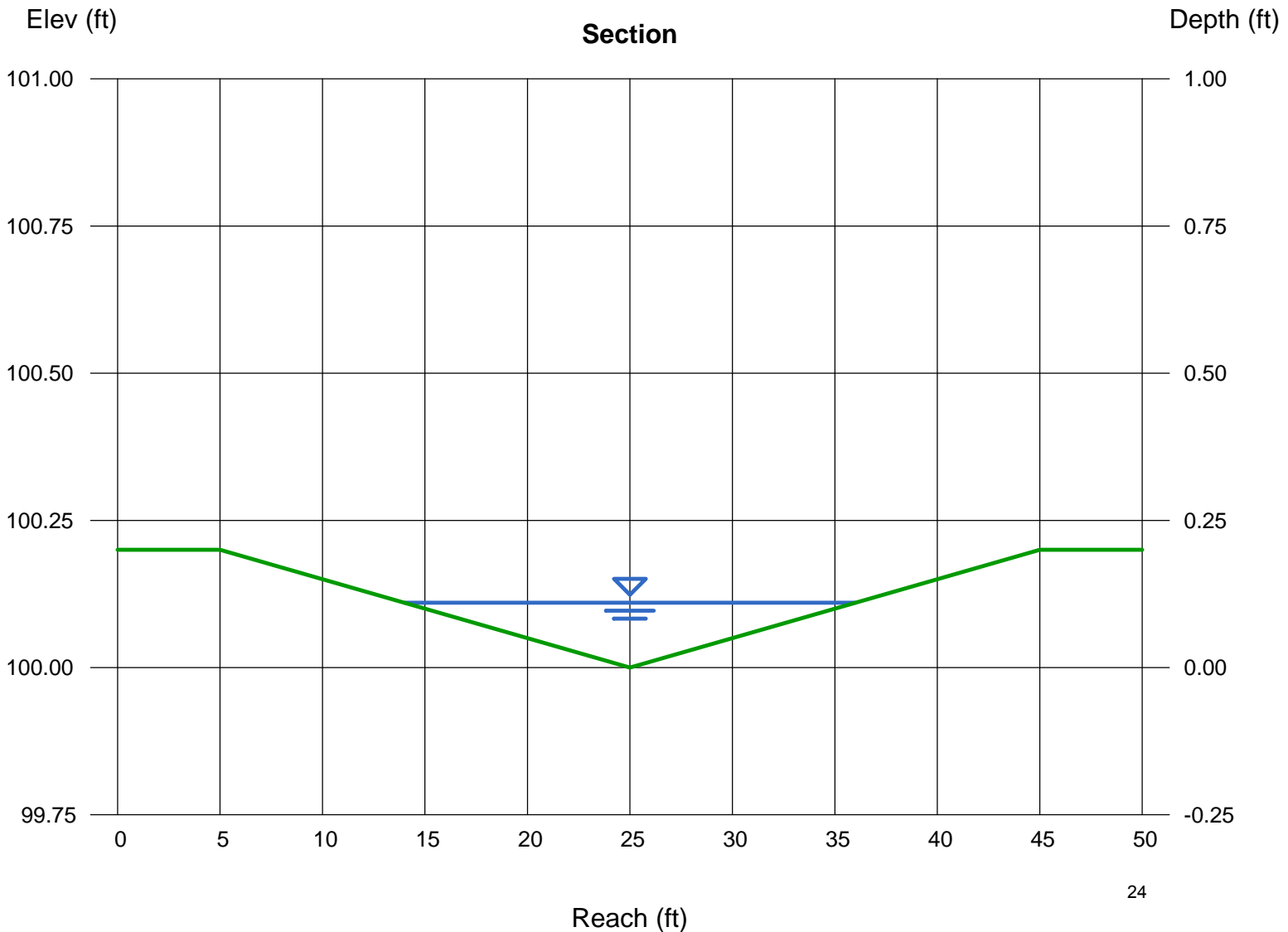

Channel Report

Post Dev Area D TC Average Q

Triangular

Side Slopes (z:1) = 100.00, 100.00
Total Depth (ft) = 0.30

Invert Elev (ft) = 100.00
Slope (%) = 13.50
N-Value = 0.020

Calculations

Compute by: Known Q
Known Q (cfs) = 0.80

Highlighted

Depth (ft) = 0.06
Q (cfs) = 0.800
Area (sqft) = 0.36
Velocity (ft/s) = 2.22
Wetted Perim (ft) = 12.00
Crit Depth, Yc (ft) = 0.09
Top Width (ft) = 12.00
EGL (ft) = 0.14

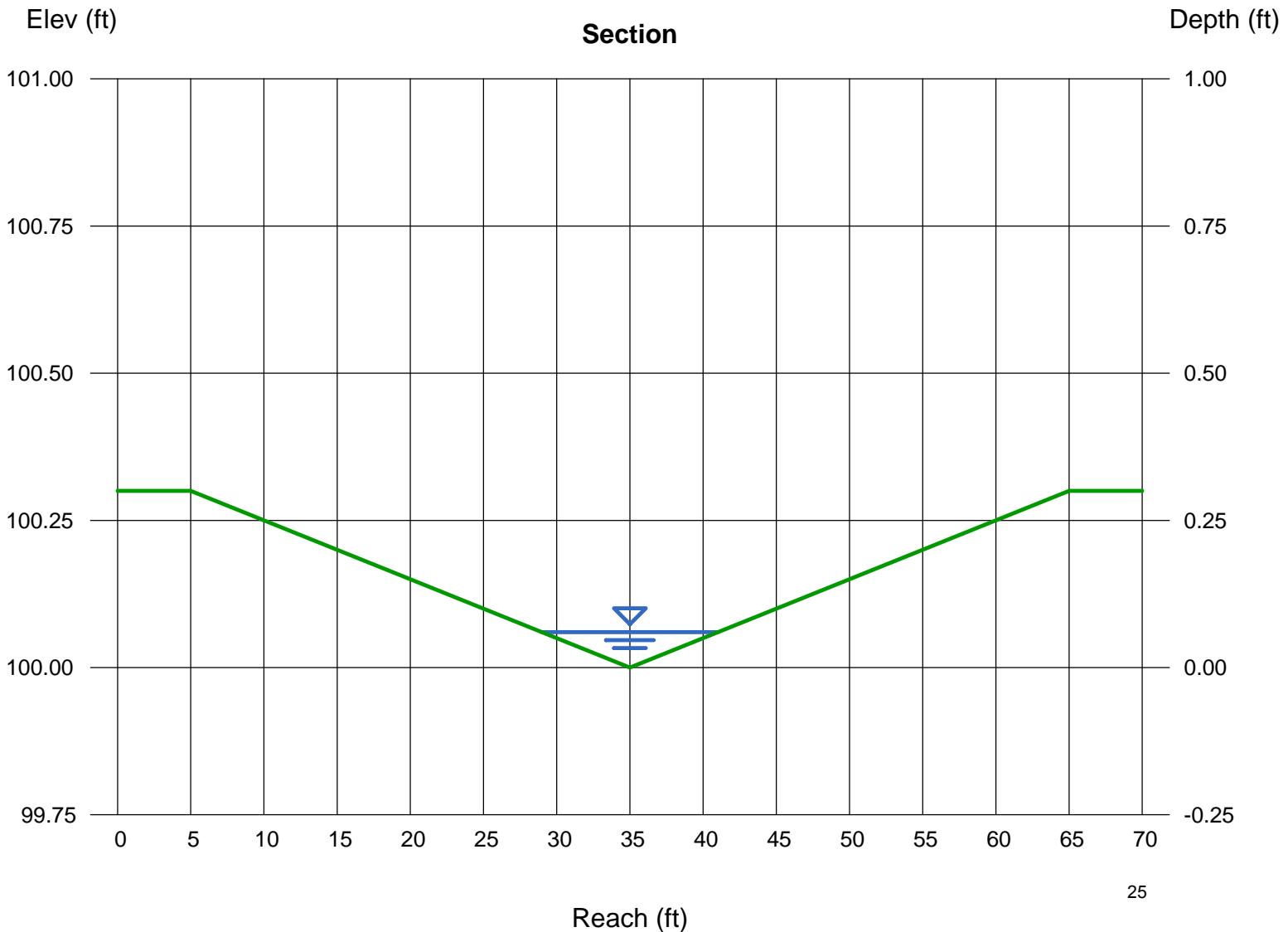

Channel Report

Post Dev Area E TC Average Q

Circular

Diameter (ft) = 2.00

Invert Elev (ft) = 100.00
Slope (%) = 8.00
N-Value = 0.013

Highlighted

Depth (ft) = 0.12
Q (cfs) = 0.400
Area (sqft) = 0.08
Velocity (ft/s) = 5.20
Wetted Perim (ft) = 0.99
Crit Depth, Yc (ft) = 0.22
Top Width (ft) = 0.95
EGL (ft) = 0.54

Calculations

Compute by: Known Q
Known Q (cfs) = 0.40

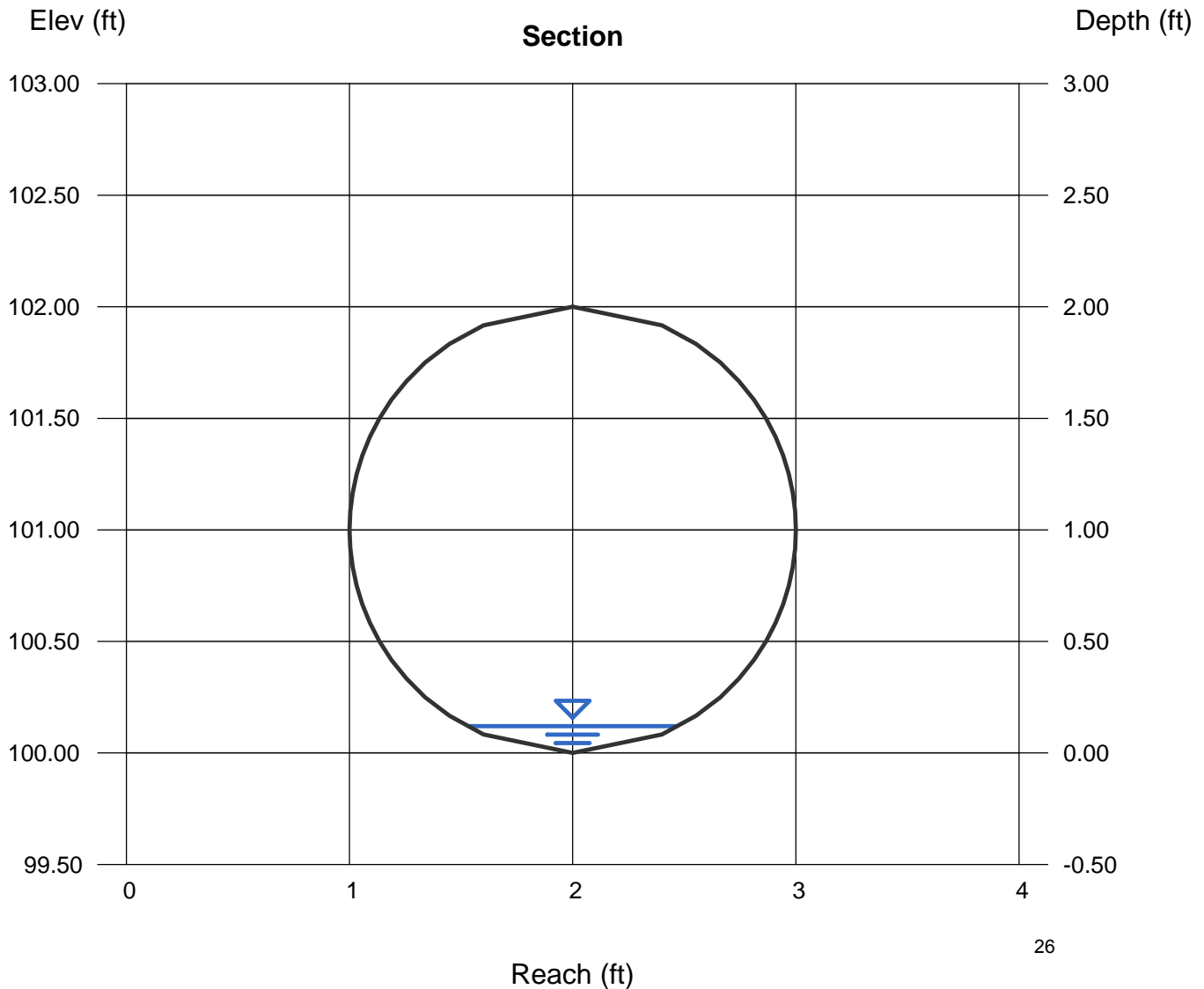

Channel Report

Pre-Dev Total Onsite & Offsite Q100 @ NW Confluence

Triangular

Side Slopes (z:1) = 30.00, 30.00
Total Depth (ft) = 0.50

Invert Elev (ft) = 100.00
Slope (%) = 9.70
N-Value = 0.022

Calculations

Compute by: Known Q
Known Q (cfs) = 28.80

Highlighted

Depth (ft) = 0.38
Q (cfs) = 28.80
Area (sqft) = 4.33
Velocity (ft/s) = 6.65
Wetted Perim (ft) = 22.81
Crit Depth, Yc (ft) = 0.50
Top Width (ft) = 22.80
EGL (ft) = 1.07

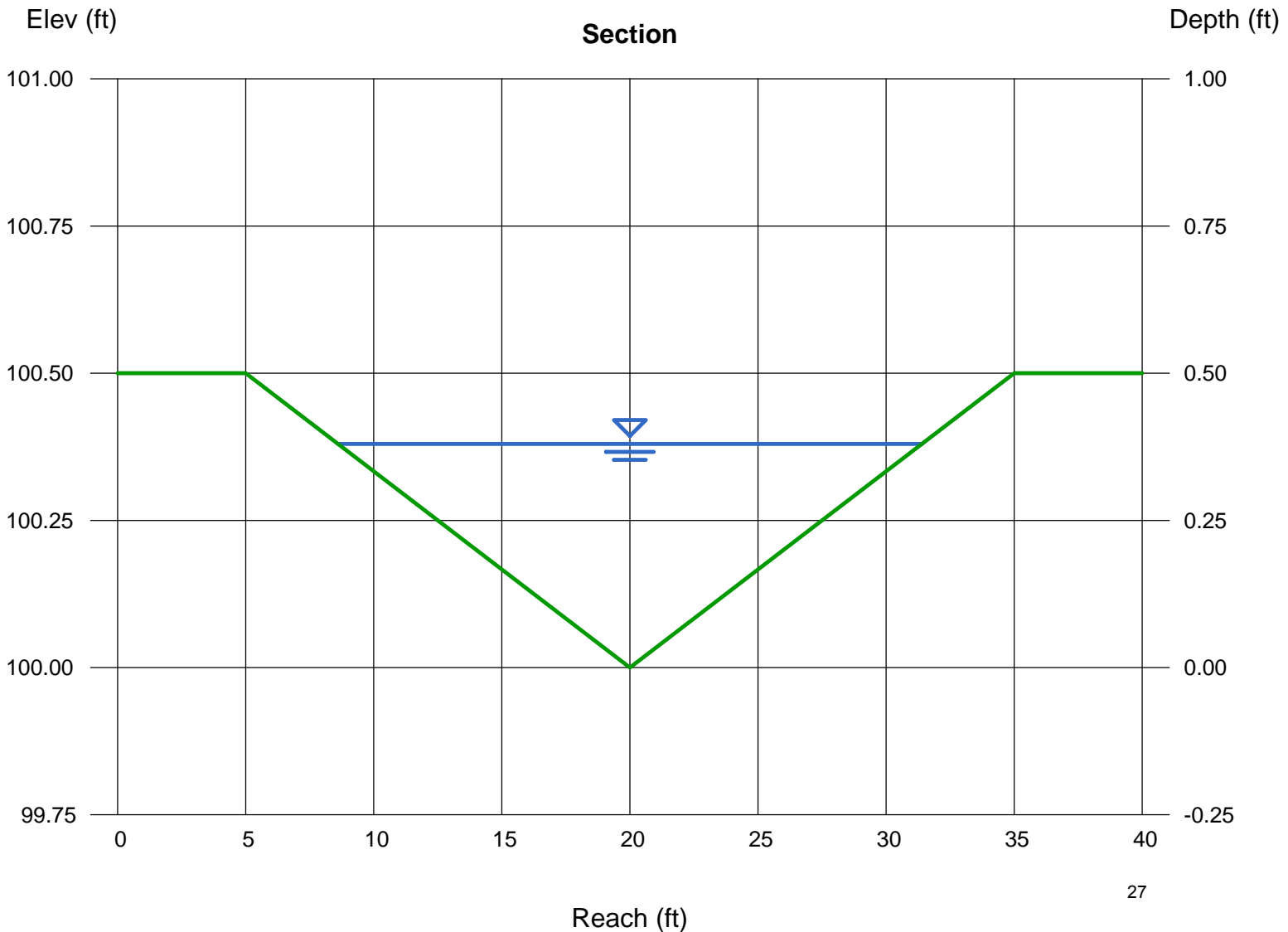

Channel Report

Post-Dev Total Onsite & Offsite Q100 @ NW Confluence

Triangular

Side Slopes (z:1) = 30.00, 30.00
Total Depth (ft) = 0.50

Invert Elev (ft) = 100.00
Slope (%) = 9.70
N-Value = 0.022

Calculations

Compute by: Known Q
Known Q (cfs) = 22.20

Highlighted

Depth (ft) = 0.34
Q (cfs) = 22.20
Area (sqft) = 3.47
Velocity (ft/s) = 6.40
Wetted Perim (ft) = 20.41
Crit Depth, Yc (ft) = 0.50
Top Width (ft) = 20.40
EGL (ft) = 0.98

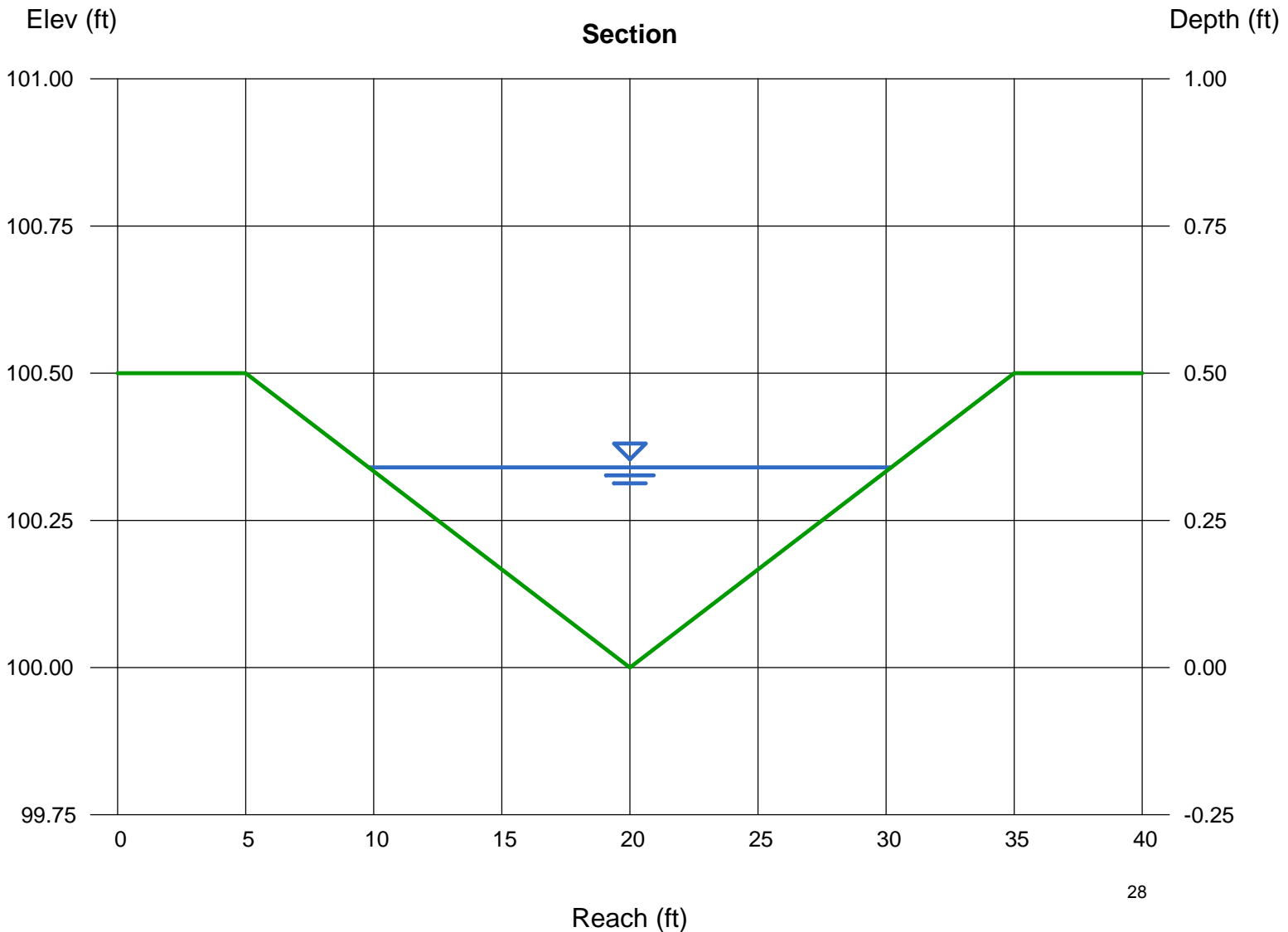

Channel Report

Offsite C1 Q100 to exist/proposed extended 30in CMP

Circular

Diameter (ft) = 2.50

Invert Elev (ft) = 100.00
Slope (%) = 11.00
N-Value = 0.024

Highlighted

Depth (ft) = 0.53
Q (cfs) = 7.100
Area (sqft) = 0.77
Velocity (ft/s) = 9.27
Wetted Perim (ft) = 2.40
Crit Depth, Yc (ft) = 0.88
Top Width (ft) = 2.05
EGL (ft) = 1.87

Calculations

Compute by: Known Q
Known Q (cfs) = 7.10

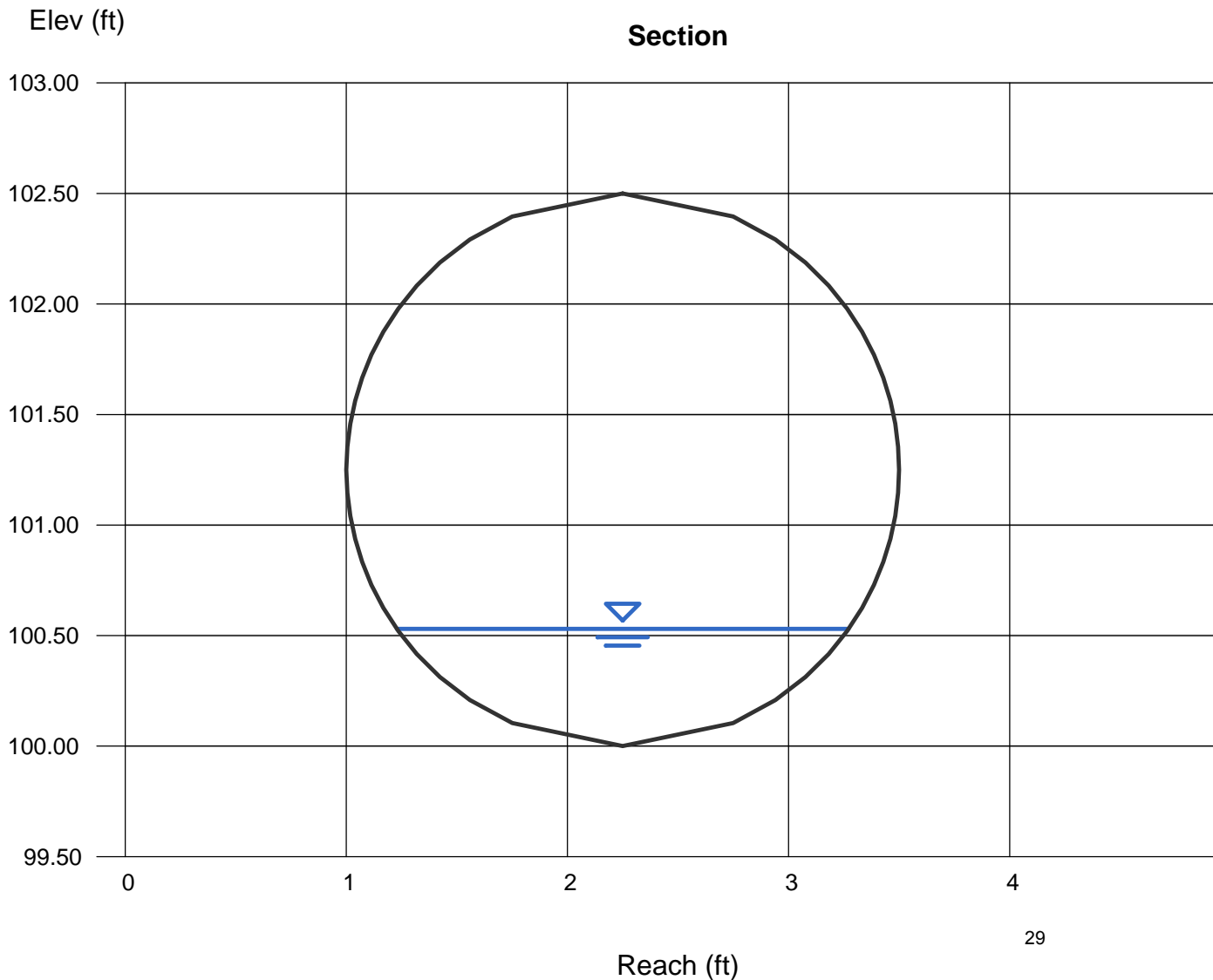

ATTACHMENT C

Developed Conditions 100-yr Event

RSP Sizing @ Brow Ditch Outlets

REACH	TC	C	A	CA	ΣCA	P ₆	I	Q cfs	V ft/s	Rock Size
East Brow Ditch 3' Type D S = 18%										
Offsite A1	5.7	0.25	3.5	0.87	0.87	2.88	6.97	6.1	15.8	2 Ton
Area D to 24" HDPE @ 10%										
Offsite B1	9.4	0.25	12.9	3.23	3.23	2.88	5.05	16.3		
Area D	8.7	0.38	0.91	0.35	0.35	2.88	5.31	1.8		
Total Flow	9.4				3.58	2.88	5.05	18.1	24.3	2 Ton
West Brow Ditch Type D 3' @ 6.3 %										
Offsite B1	9.4	0.25	12.9	3.23	3.23	2.88	5.05	16.3		
Area D	8.7	0.38	0.91	0.35	0.35	2.88	5.31	1.8		
Area E	5	0.38	0.28	0.11	0.11	2.88	7.59	0.8		
Area A	7.9	0.38	0.53	0.20	0.20	2.88	5.65	1.1		
Area AO	5	0.38	0.06	0.02	0.02	2.88	7.59	0.2		
Offsite O	5	0.82	0.12	0.10	0.10	2.88	7.59	0.7		
Total Flow	9.4				4.00	2.88	5.05	20.2	15.9	2 Ton
Area B East Brow Ditch Type B @ 8% to pipe 12" HDPE @ 3.4%										
	5	0.38	0.23	0.09	0.09	2.88	7.59	0.7	6.7	No. 2 Backing
Area D South Brow Ditch Type B @ 11%										
	8.7	0.38	0.92	0.35	0.35	2.88	5.31	1.9	9.9	1/4 Ton
Area C Brow Ditch Type B @ 21%										
Area C	15.8	0.38	1.18	0.45	0.45	2.88	3.61	1.6	11.4	1/4 Ton
Offsite O to bioretention AO to 12" HDPE @ 3.6 %										
Offsite O	5	0.82	0.12	0.10	0.10	2.88	7.59	0.75	7.20	No. 2 Backing
Offsite O & Area AO to 12" HDPE @ 0.5%										
Offsite O	5	0.82	0.12	0.10	0.10	2.88	7.59	0.75		
Area AO	5	0.38	0.08	0.03	0.03	2.88	7.59	0.23		
Total Flow	5				0.13	2.88	7.59	0.98	4.10	
Driveway Crossing North Boundary Offsite A1 & Area C to new 18" HDPE @ 14.3%										
Offsite A1	5.7	0.25	3.50	0.88	0.88	2.88	6.97	6.10		
Area C	15.8	0.38	1.18	0.45	0.45	2.88	3.61	1.62		
Total Flow	15.8				1.32	2.88	3.61	6.10	4.10	

Channel Report

West Brow Ditch RSP Sizing Velocity

Circular

Diameter (ft) = 3.00

Invert Elev (ft) = 100.00
Slope (%) = 6.30
N-Value = 0.013

Highlighted

Depth (ft) = 0.70
Q (cfs) = 20.00
Area (sqft) = 1.26
Velocity (ft/s) = 15.88
Wetted Perim (ft) = 3.03
Crit Depth, Yc (ft) = 1.44
Top Width (ft) = 2.54
EGL (ft) = 4.62

Calculations

Compute by: Known Q
Known Q (cfs) = 20.00

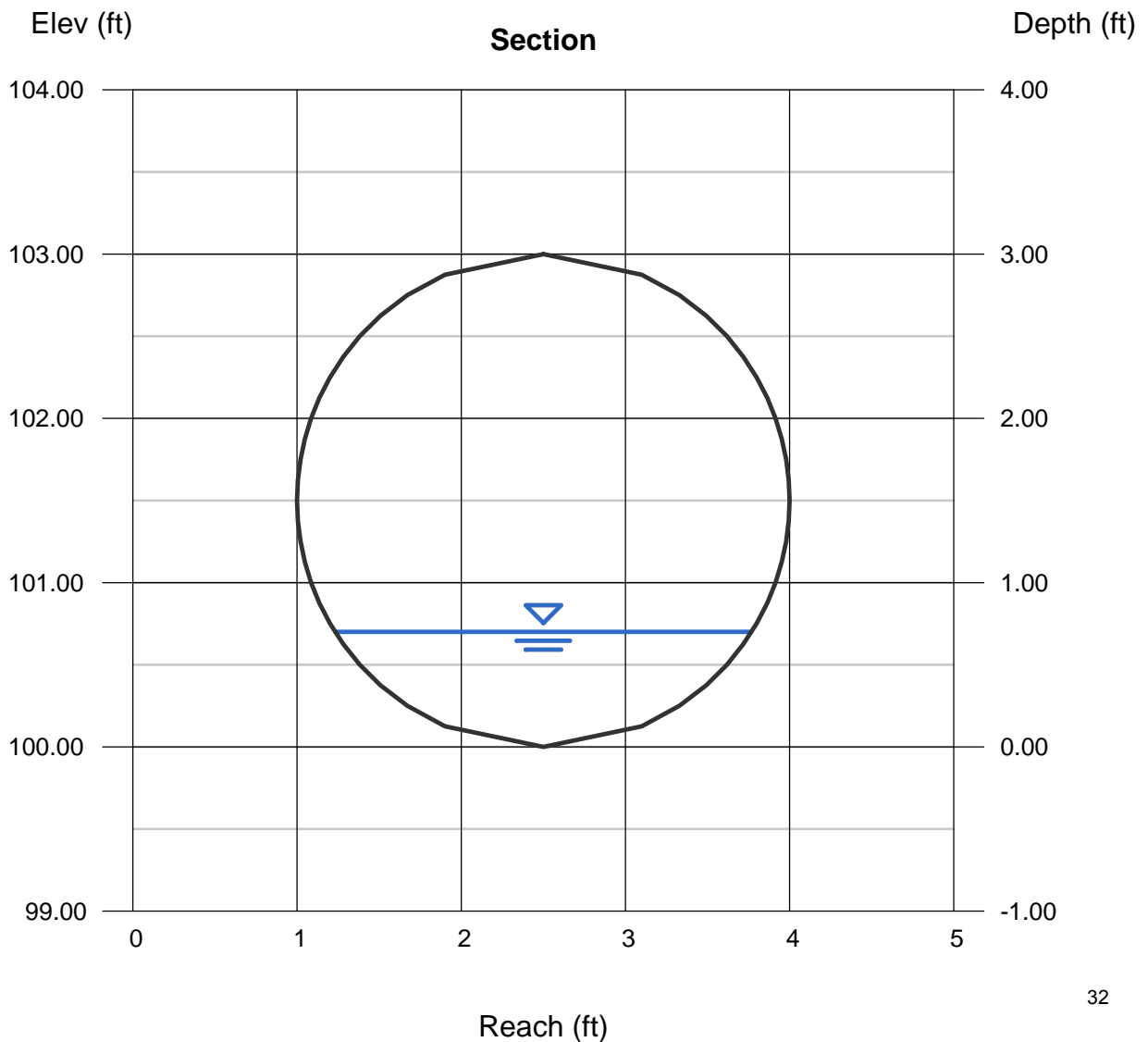

Channel Report

Offsite O to Bioretention AO RSP Sizing Velocity

Circular

Diameter (ft) = 1.00

Invert Elev (ft) = 100.00
Slope (%) = 3.60
N-Value = 0.009

Highlighted

Depth (ft) = 0.19
Q (cfs) = 0.750
Area (sqft) = 0.10
Velocity (ft/s) = 7.16
Wetted Perim (ft) = 0.90
Crit Depth, Y_c (ft) = 0.37
Top Width (ft) = 0.79
EGL (ft) = 0.99

Calculations

Compute by: Known Q
Known Q (cfs) = 0.75

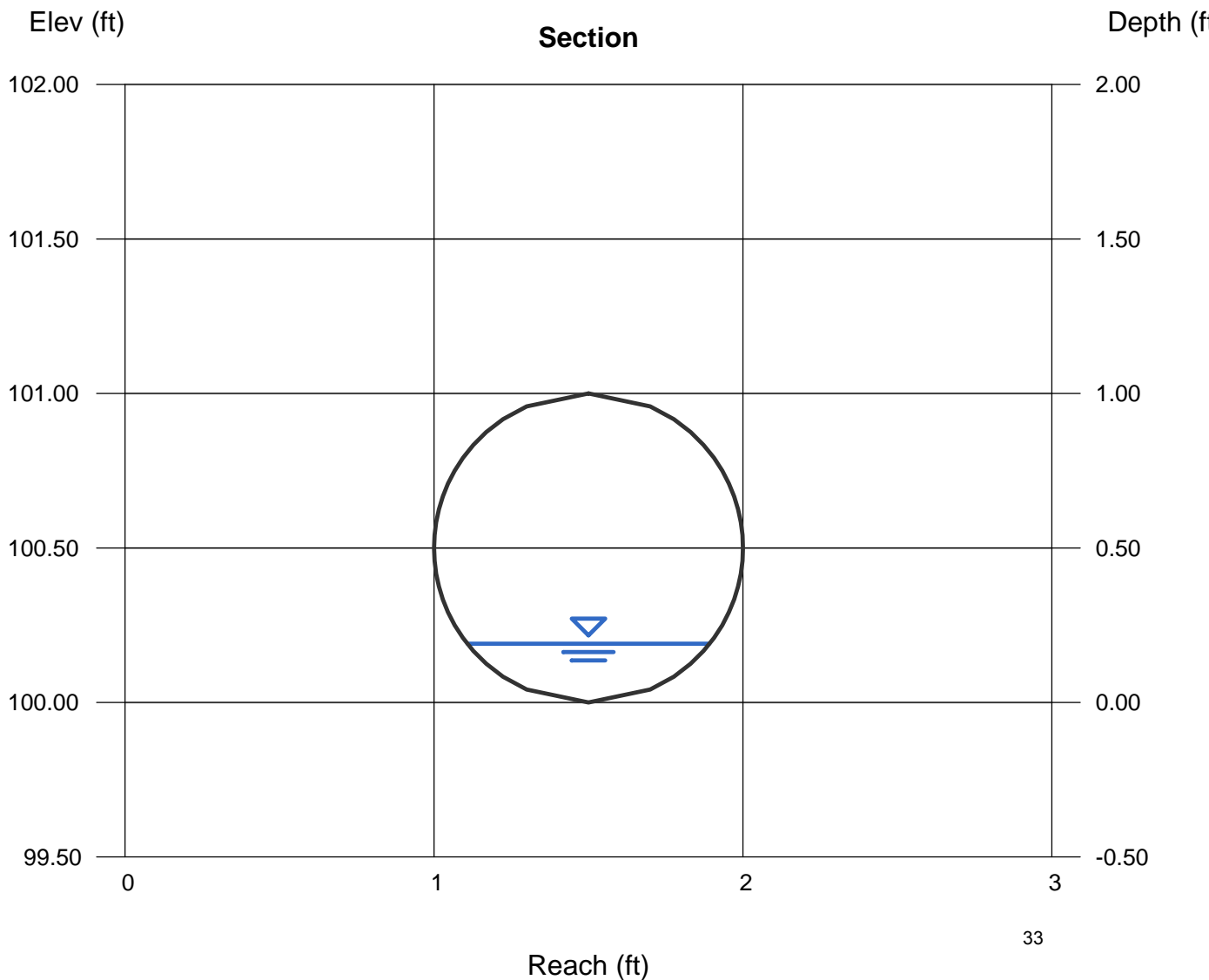

Channel Report

Offsite O & Area AO Pipe Velocity

Circular

Diameter (ft) = 1.00

Invert Elev (ft) = 100.00
Slope (%) = 0.50
N-Value = 0.009

Highlighted

Depth (ft) = 0.42
Q (cfs) = 1.300
Area (sqft) = 0.32
Velocity (ft/s) = 4.12
Wetted Perim (ft) = 1.41
Crit Depth, Yc (ft) = 0.48
Top Width (ft) = 0.99
EGL (ft) = 0.68

Calculations

Compute by: Known Q
Known Q (cfs) = 1.30

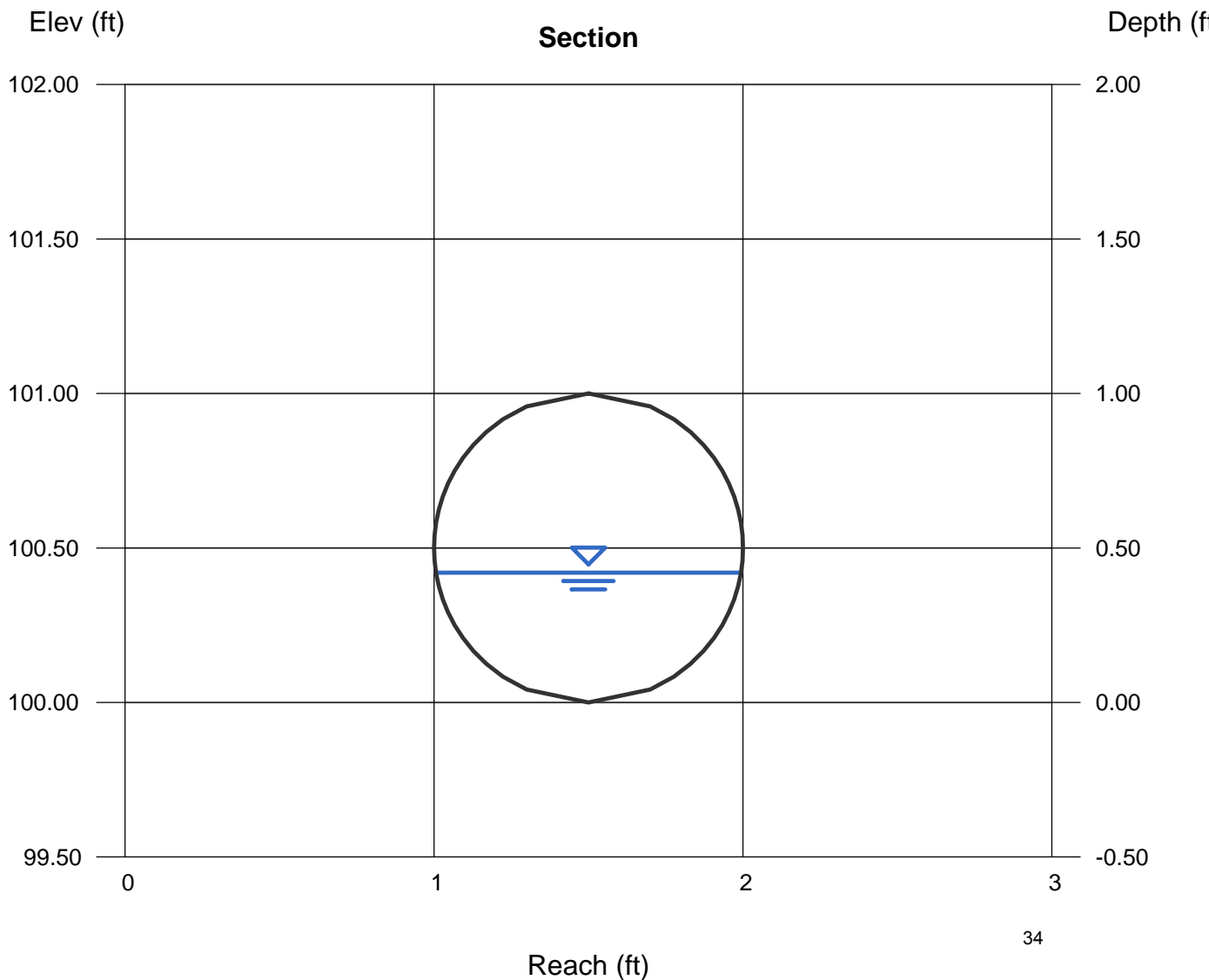

Channel Report

Driveway Crossing North Bountrary Offsite A1 & Area C to new 18in HDPE

Circular

Diameter (ft) = 1.50

Invert Elev (ft) = 100.00
Slope (%) = 14.30
N-Value = 0.009

Highlighted

Depth (ft) = 0.27
Q (cfs) = 4.100
Area (sqft) = 0.22
Velocity (ft/s) = 18.74
Wetted Perim (ft) = 1.32
Crit Depth, Yc (ft) = 0.78
Top Width (ft) = 1.16
EGL (ft) = 5.73

Calculations

Compute by: Known Q
Known Q (cfs) = 4.10

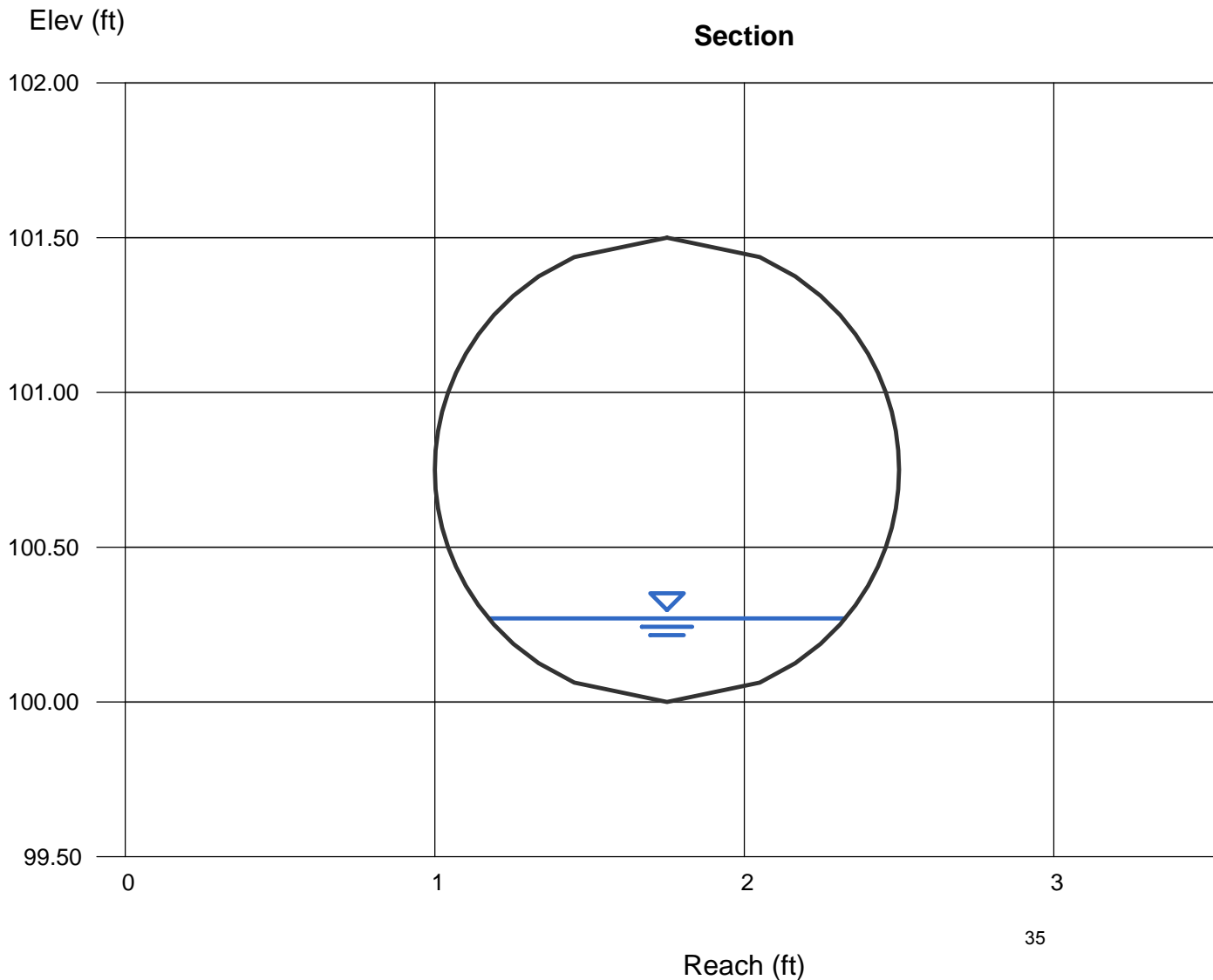

Channel Report

East Brow Ditch RSP Sizing Velocity

Circular

Diameter (ft) = 3.00

Invert Elev (ft) = 100.00

Slope (%) = 18.00

N-Value = 0.013

Calculations

Compute by: Known Q

Known Q (cfs) = 6.10

Highlighted

Depth (ft) = 0.31

Q (cfs) = 6.100

Area (sqft) = 0.39

Velocity (ft/s) = 15.77

Wetted Perim (ft) = 1.96

Crit Depth, Y_c (ft) = 0.78

Top Width (ft) = 1.83

EGL (ft) = 4.18

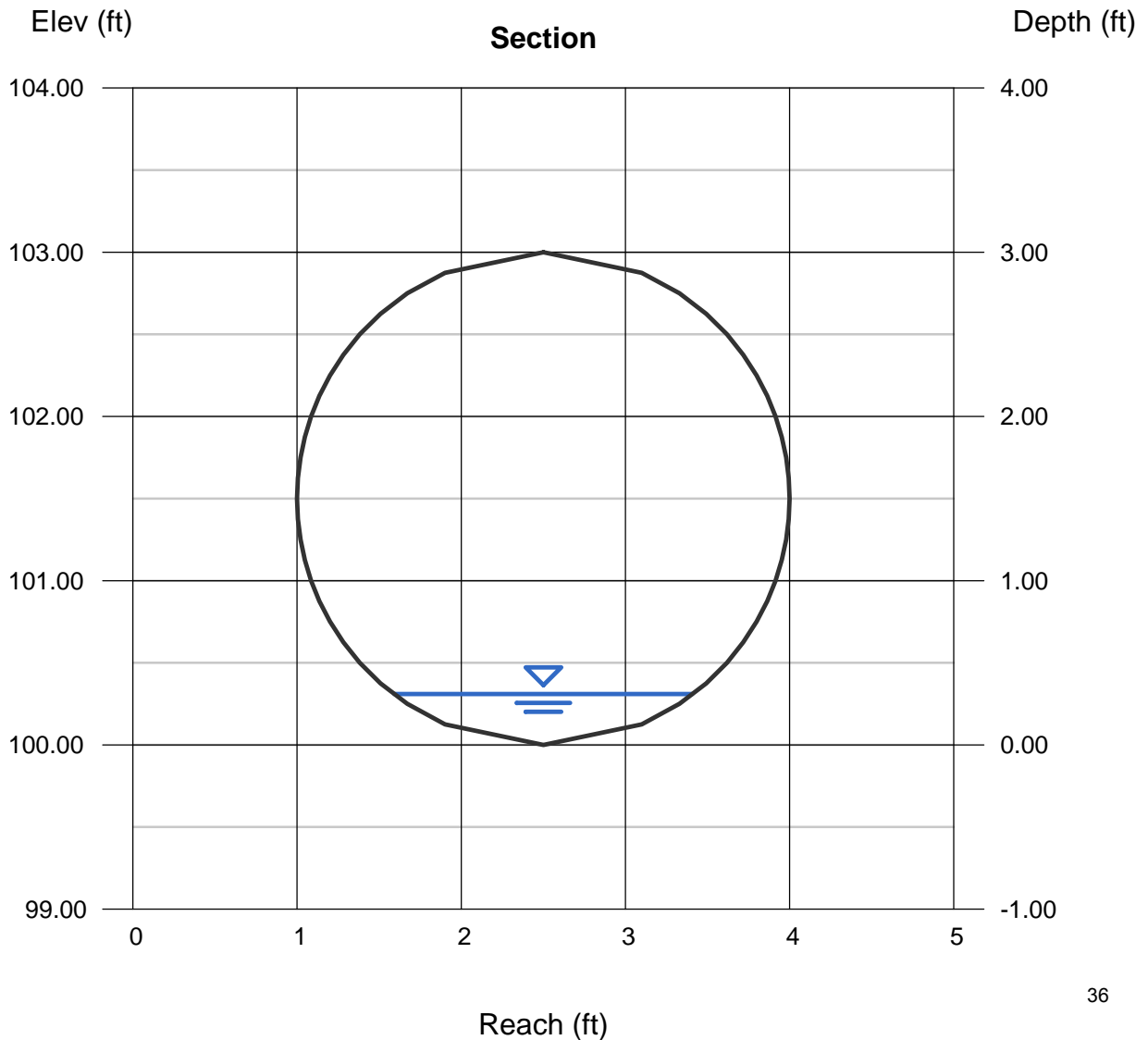

Channel Report

Area D South Brow Ditch RSP Sizing Velocity

Circular

Diameter (ft) = 2.00

Invert Elev (ft) = 100.00

Slope (%) = 11.00

N-Value = 0.013

Calculations

Compute by: Known Q

Known Q (cfs) = 1.90

Highlighted

Depth (ft) = 0.22

Q (cfs) = 1.900

Area (sqft) = 0.19

Velocity (ft/s) = 9.94

Wetted Perim (ft) = 1.36

Crit Depth, Yc (ft) = 0.48

Top Width (ft) = 1.26

EGL (ft) = 1.76

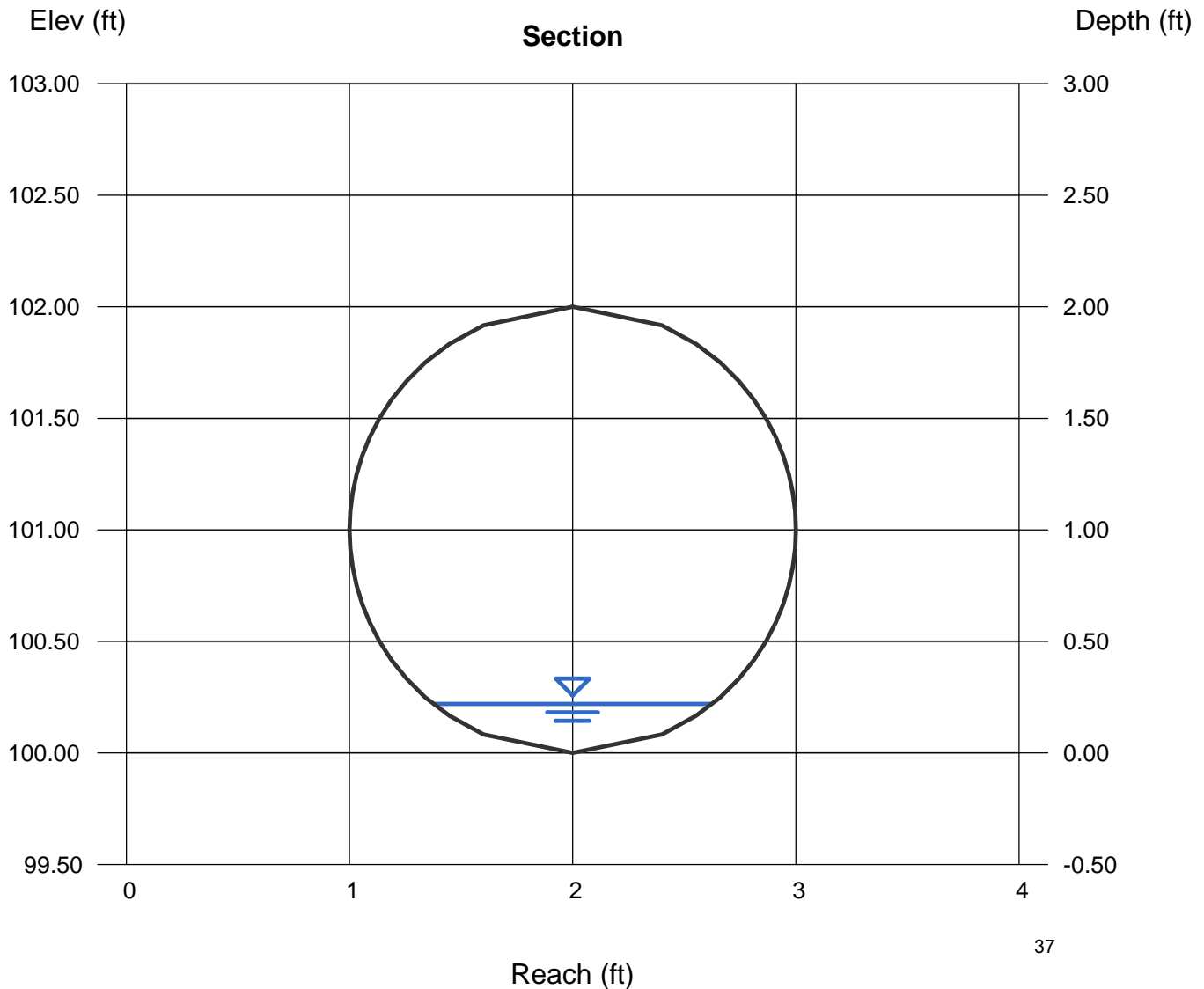

Channel Report

Area B East Brow Ditch to 12in HDPE RSP Sizing Velocity

Circular

Diameter (ft) = 1.00
Invert Elev (ft) = 100.00
Slope (%) = 3.40
N-Value = 0.009

Highlighted

Depth (ft) = 0.19
Q (cfs) = 0.700
Area (sqft) = 0.10
Velocity (ft/s) = 6.68
Wetted Perim (ft) = 0.90
Crit Depth, Y_c (ft) = 0.35
Top Width (ft) = 0.79
EGL (ft) = 0.88

Calculations

Compute by: Known Q
Known Q (cfs) = 0.70

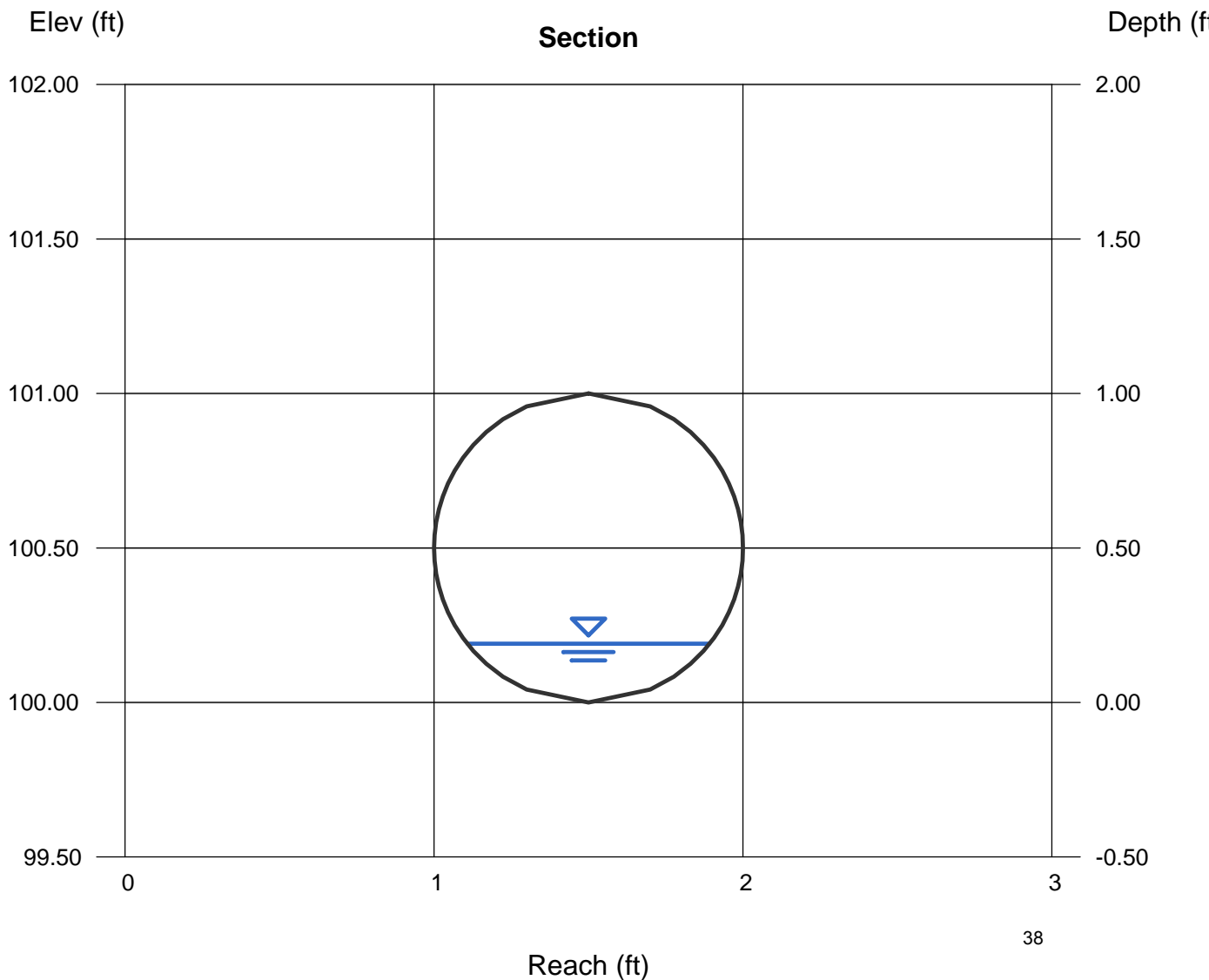

Channel Report

Area D to A 24in HDPE @ 10%

Circular

Diameter (ft) = 2.00

Invert Elev (ft) = 100.00
Slope (%) = 10.00
N-Value = 0.009

Highlighted

Depth (ft) = 0.57
Q (cfs) = 18.10
Area (sqft) = 0.74
Velocity (ft/s) = 24.32
Wetted Perim (ft) = 2.26
Crit Depth, Yc (ft) = 1.54
Top Width (ft) = 1.81
EGL (ft) = 9.77

Calculations

Compute by: Known Q
Known Q (cfs) = 18.10

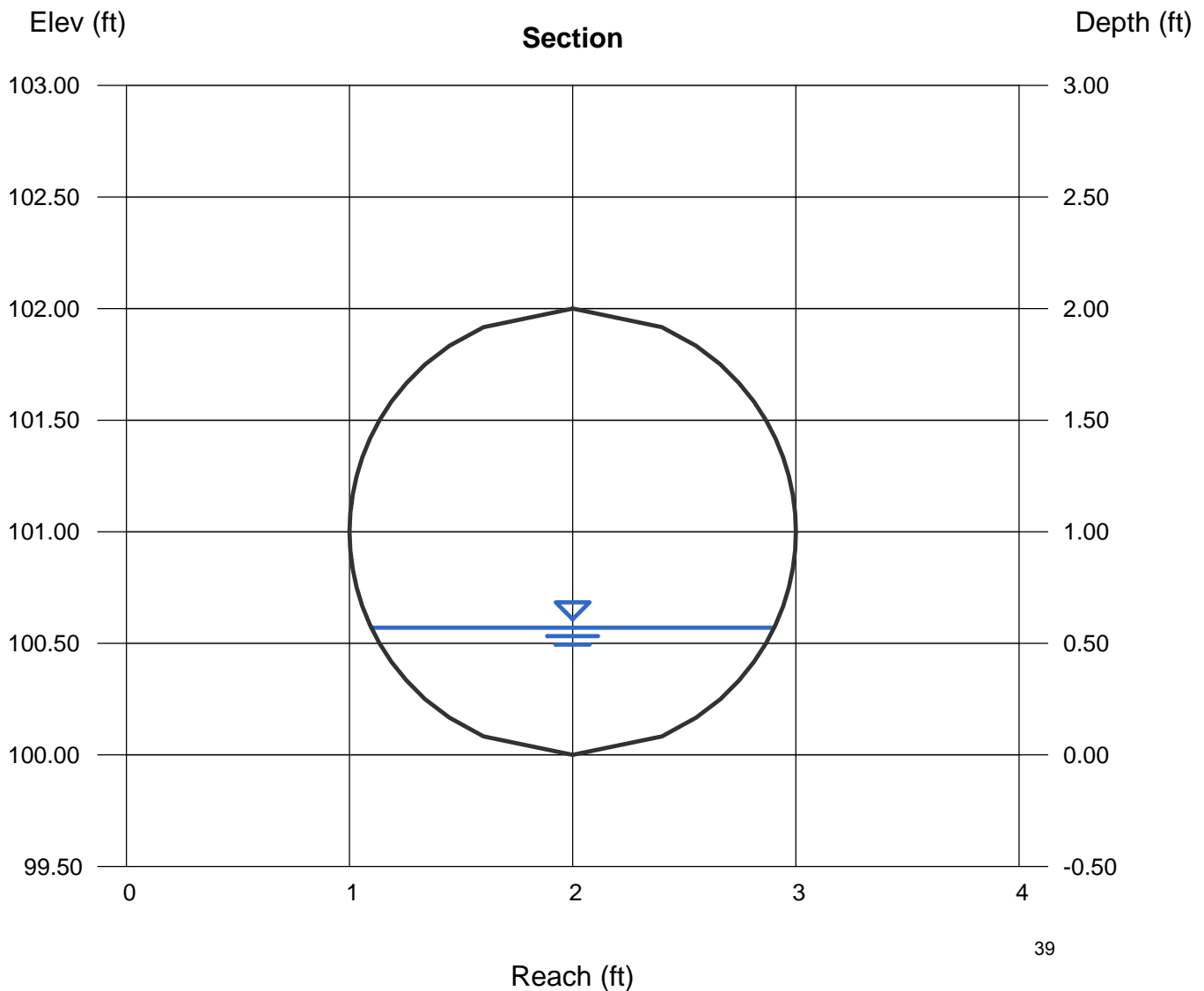

Channel Report

Area C Brow Ditch RSP Sizing Velocity

Circular

Diameter (ft) = 2.00

Invert Elev (ft) = 100.00
Slope (%) = 21.00
N-Value = 0.013

Highlighted

Depth (ft) = 0.18
Q (cfs) = 1.600
Area (sqft) = 0.14
Velocity (ft/s) = 11.39
Wetted Perim (ft) = 1.22
Crit Depth, Yc (ft) = 0.44
Top Width (ft) = 1.15
EGL (ft) = 2.20

Calculations

Compute by: Known Q
Known Q (cfs) = 1.60

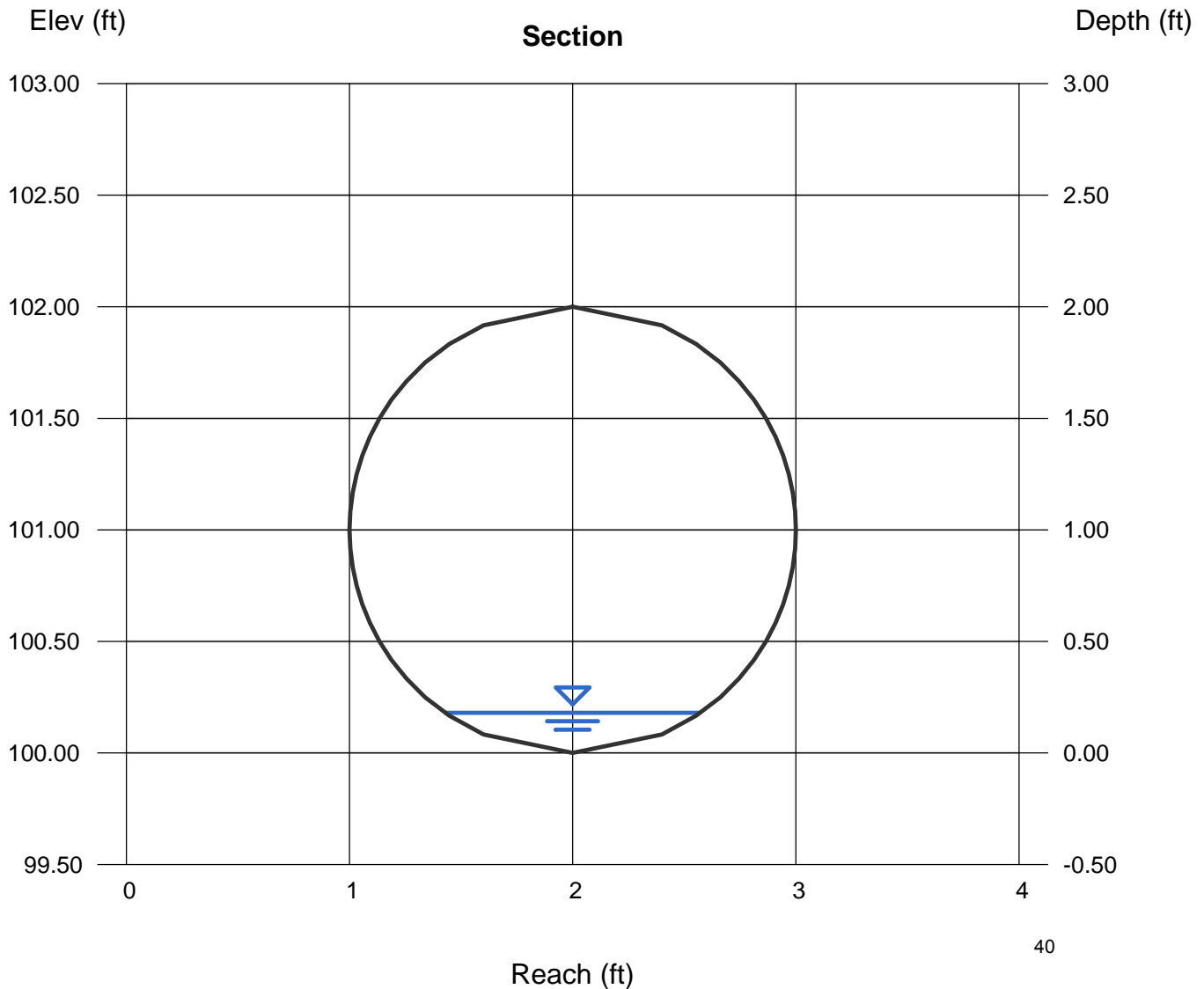

ATTACHMENT D

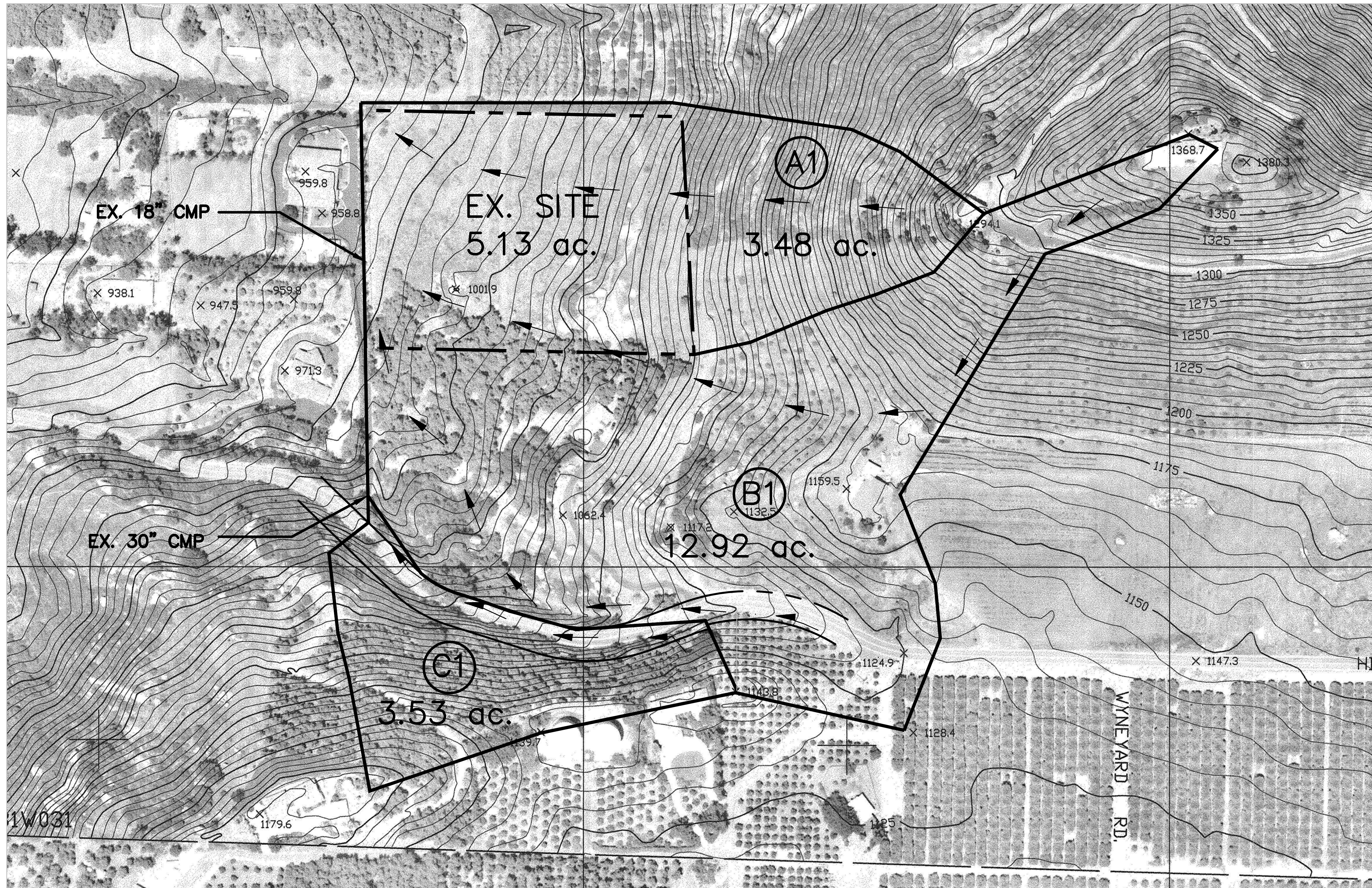

LEGEND

- PROJECT BOUNDARY
- PROP. CONCENTRATED FLOW
- DRAINAGE AREA BOUNDARY
- DRAINAGE AREA DESIGNATION

SITE ADDRESS:

HIGHLAND VALLEY ROAD
 ESCONDIDO, CA 92025

OWNER/APPLICANT:

4030 GOLDFINCH INVESTMENT, LLC
 C/O PHILS PACE
 15635 PASEO PENASCO
 ESCONDIDO CA 92025
 (619) 814-0050

APN:

276-030-48 & 49

PRIVATE CONTRACT

SHEET 1	COUNTY OF SAN DIEGO DEPARTMENT OF PUBLIC WORKS	1 SHEETS
PRE DEVELOPMENT DRAINAGE AREA PLAN FOR: RESQUE RANCH HIGHLAND VALLEY ROAD "VIOLATION"		
CALIFORNIA COORDINATE INDEX		
APPROVED FOR: SIRIOUS DEYLANIAN COUNTY ENGINEER	ENGINEER OF WORK: DANNY ABADA R.C.E. NO. 45381 EXP. 9-30-16	
BY: _____	GRADING PERMIT NO. PD82016-	
DATE _____		

PLANS PREPARED BY:
SPEAR & ASSOCIATES, INC.
 CIVIL ENGINEERING & LAND SURVEYING
 475 PRODUCTION STREET, SAN MARCOS, CA 92078
 PHONE (760) 736-2040 FAX (760) 736-4866
 WWW.SPEARINC.NET

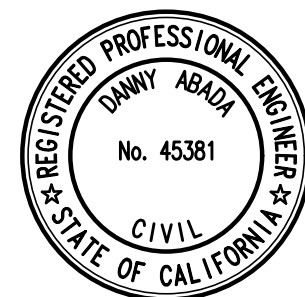

PLOT DATE: 4/26/2011 10:04 AM

ENGINEER'S NAME: SPEAR & ASSOCIATES, INC
 PHONE NO. 1-760-736-2040

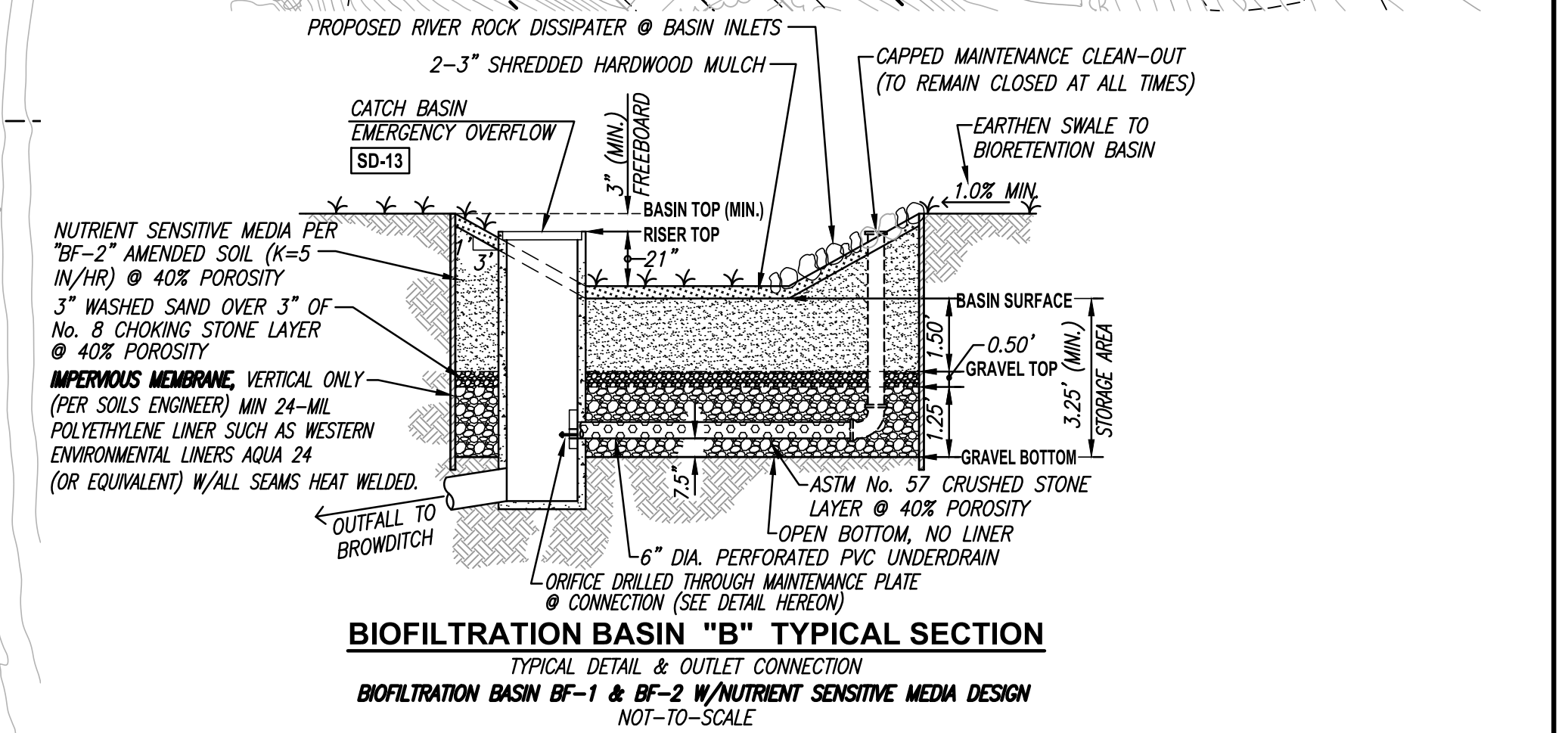
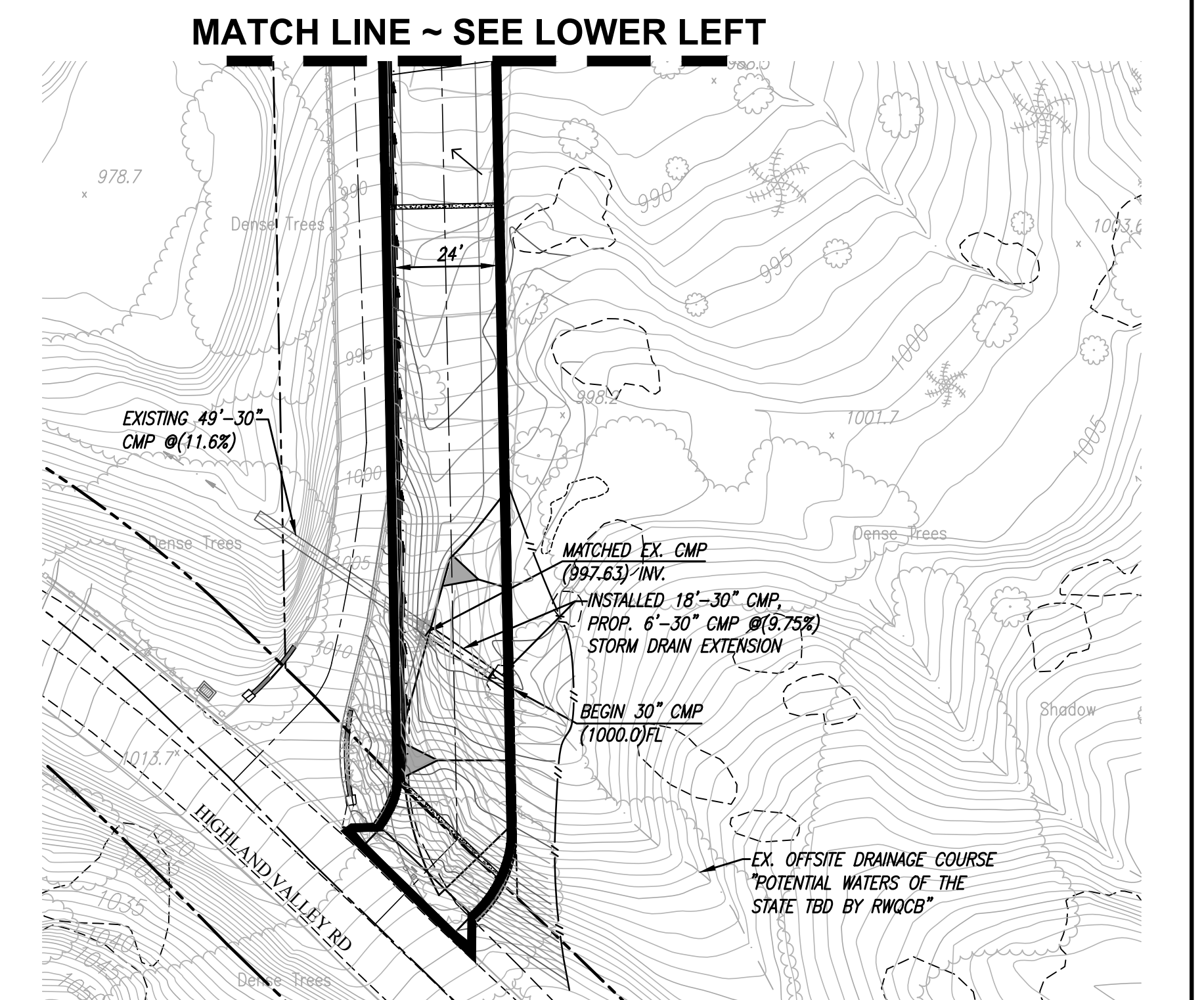
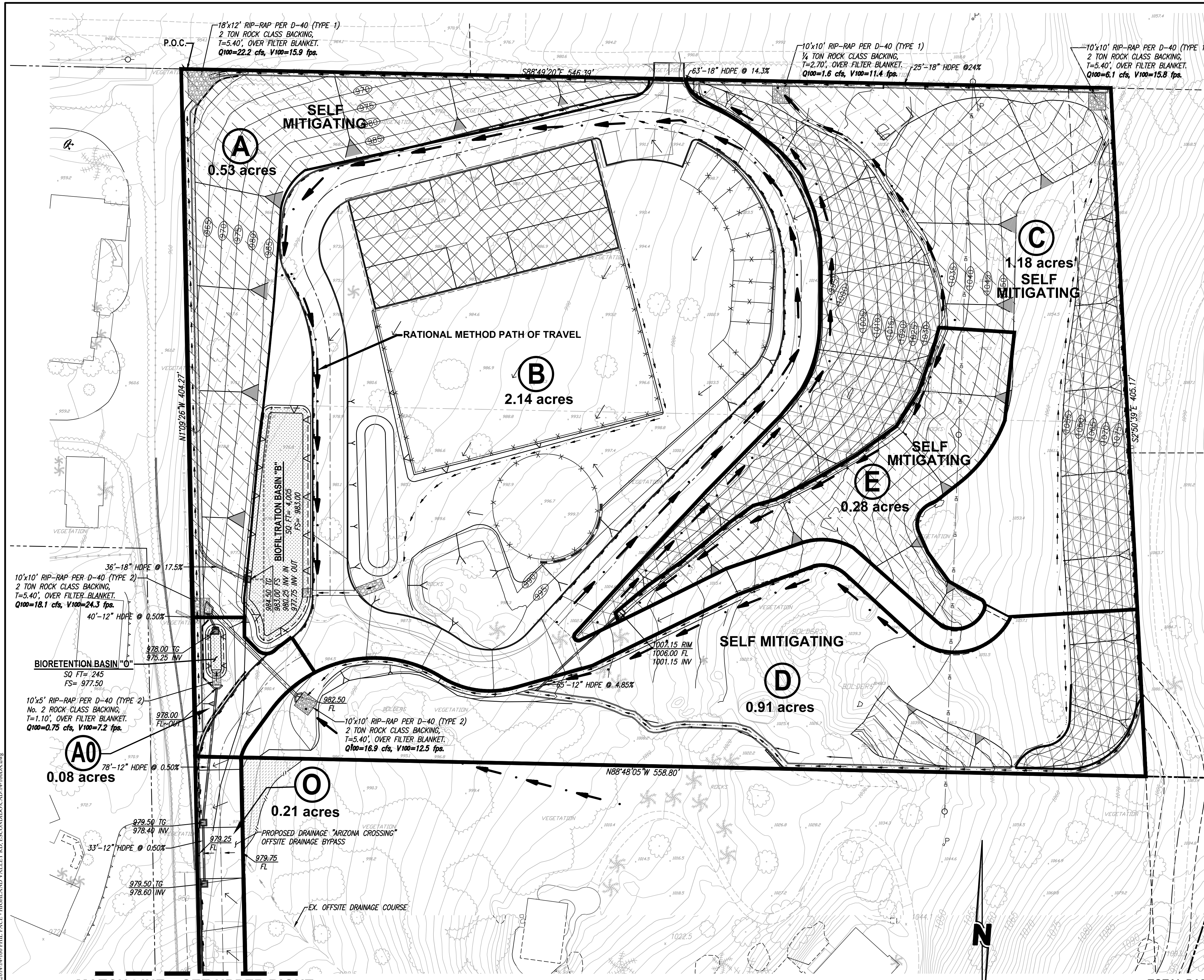

BIOFILTRATION BASIN MEDIA
 PER COUNTY OF SAN DIEGO 2014 LID HANDBOOK, APPENDIX C - FACT SHEETS.

3" MULCH LAYER (MANDATORY)
 A MINIMUM OF 3 INCHES OF WELL-AGED, SHREDDED HARDWOOD MULCH THAT HAS BEEN STOCKPILED OR STORED FOR AT LEAST 12 MONTHS IS PROVIDED. MULCH MUST BE NON-FLOATING TO AVOID CLOGGING OF OVERFLOW STRUCTURE.

18" AMENDED SOIL LAYER
 COMPOSITION AND TEXTURE:
 65% SAND, 20% SANDY LOAM, & 15% COMPOST (FROM VEGETATION-BASED FEEDSTOCK). ANIMAL WASTES OR BY-PRODUCTS SHOULD NOT BE APPLIED.

PERMEABILITY:
 5 IN/HR INFILTRATION RATE FOR THE FLOW-BASED SUSMP METHOD (1-6IN/HR FOR ALTERNATIVE DESIGNS, AS APPROVED BY LOCAL JURISDICTION).

CHEMICAL COMPOSITION: TOTAL PHOSPHORUS < 15 PARTS PER MILLION (PPM); PH 6-8; CATION EXCHANGE CAPACITY > 5 MILLIEQUIVALENTS PER 100 GRAMS (MEQ/100 G) OF SOIL; ORGANIC MATTER CONTENT < 5 PERCENT BY WEIGHT.

DRAINAGE LAYER
 SEPARATE SOIL MEDIA FROM UNDERDRAIN LAYER WITH 3 INCHES OF WASHED SAND (ASTM NO. 33), FOLLOWED BY 3 INCHES OF CHOKING STONE (ASTM NO. 8), OVER A 1.25'-FOOT ENVELOPE OF ASTM NO. 57 STONE.

SURFACE VEGETATION
 AS SPECIFIED BY THE LANDSCAPE ARCHITECT PLANS.

SELF-MITIGATING DMAS
 SELF-MITIGATING DMAS CONSIST OF NATURAL OR LANDSCAPED AREAS THAT DRAIN DIRECTLY OFFSITE OR TO THE PUBLIC STORM DRAIN SYSTEM. SELF-MITIGATING DMAS MUST MEET ALL OF THE FOLLOWING TO BE ELIGIBLE FOR EXCLUSION:

- VEGETATION IN THE NATURAL OR LANDSCAPED AREA IS NATIVE AND/OR NON-NATIVE/NON-INVASIVE DROUGHT TOLERANT SPECIES THAT DO NOT REQUIRE REGULAR APPLICATION OF FERTILIZERS AND PESTICIDES.
- SOILS ARE UNDISTURBED NATIVE TOPSOIL, OR DISTURBED SOILS THAT HAVE BEEN AMENDED AND AERATED TO PROMOTE WATER RETENTION CHARACTERISTICS EQUIVALENT TO UNDISTURBED NATIVE TOPSOIL.
- THE INCIDENTAL IMPERVIOUS AREAS ARE LESS THAN 5 PERCENT OF THE SELF-MITIGATING AREA.
- IMPERVIOUS AREA WITHIN THE SELF-MITIGATED AREA SHOULD NOT BE HYDRAULICALLY CONNECTED TO OTHER IMPERVIOUS AREAS UNLESS IT IS A STORM WATER CONVEYANCE SYSTEM (SUCH AS A BROW DITCH).
- THE SELF-MITIGATING AREA IS HYDRAULICALLY SEPARATE FROM DMAS THAT CONTAIN PERMANENT STORM WATER POLLUTANT CONTROL BMPs.

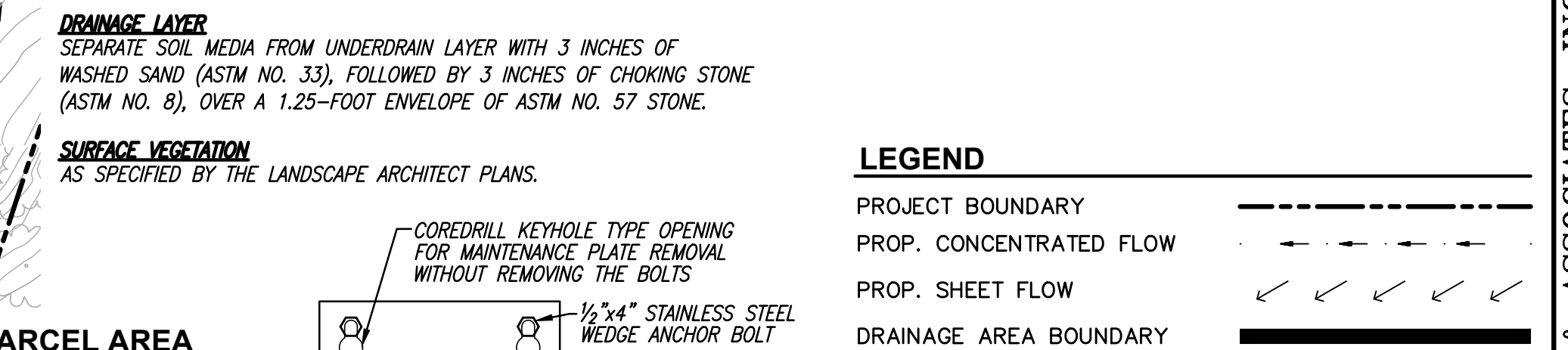

TOTAL PARCEL AREA
 223,264 SQUARE FEET

SITE ADDRESS:
 HIGHLAND VALLEY ROAD
 ESCONDIDO, CA 92025

OWNER/APPLICANT:
 4030 GOLDFINCH INVESTMENT, LLC
 C/O PHILS PACE
 15635 PASO PENASCO
 ESCONDIDO CA 92025
 (619) 814-0050

APN:
 276-030-48 & 49

LEGEND

PROJECT BOUNDARY
 PROP. CONCENTRATED FLOW
 PROP. SHEET FLOW
 DRAINAGE AREA BOUNDARY
 DRAINAGE AREA DESIGNATION (E)

PRIVATE CONTRACT

SHEET 1 COUNTY OF SAN DIEGO DEPARTMENT OF PUBLIC WORKS 1 SHEETS

BMP PLAN FOR:
RESQUE RANCH
HIGHLAND VALLEY ROAD "VIOLATION"
 CALIFORNIA COORDINATE INDEX 326-1767

SYMBOL	PROPOSED SURFACE	DRAINAGE AREA TABLE						OFFSITE	
		AREA A	AREA B	AREA C	AREA D	AREA E	AREA AO	AREA O	
	ROOFTOPS	0 SF	9,753 SF	0 SF	0 SF	0 SF	0 SF	0 SF	
	AC PAVING, WALKWAYS, HARDSCAPE, ETC.	0 SF	18,907 SF	0 SF	0 SF	0 SF	1,843 SF	5,345 SF	
	STABILIZED PERVIOUS AREA	23,097 SF	64,491 SF	51,512 SF	39,562 SF	12,253 SF	1,846 SF	0 SF	

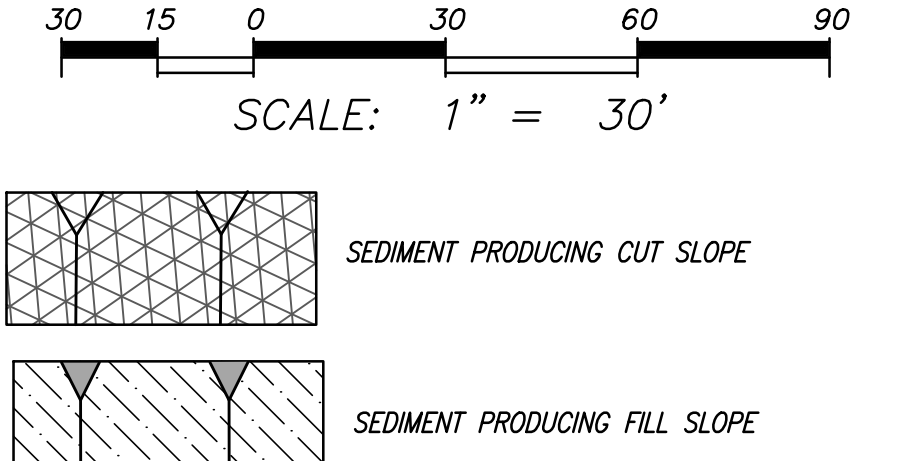

PLANS PREPARED BY:
SPEAR & ASSOCIATES, INC.
 CIVIL ENGINEERING & LAND SURVEYING
 475 PRODUCTION STREET, SAN MARCOS, CA 92078
 PHONE (760) 736-2040 FAX (760) 736-4866
 WWW.SPEARINC.NET

REGISTERED PROFESSIONAL ENGINEER
 ARIZONA R. TEJER
 No. 85413
 CIVIL
 STATE OF CALIFORNIA

PLANT DATE: 11/27/2018 6:55 AM
 S:\Spec\Projects\2014\14-160 PHIL PACE - HIGHLAND VALLEY RD. ESCONDIDO\CAD\4-600.dwg
 SPEAR & ASSOCIATES PROJECT NO. 14-160 ARN

ENGINEER'S NAME: SPEAR & ASSOCIATES, INC.
 PHONE NO. 1-760-736-2040