

# LAURELWOOD DATA CENTER

## Initial Study and

## Proposed Mitigated Negative Declaration

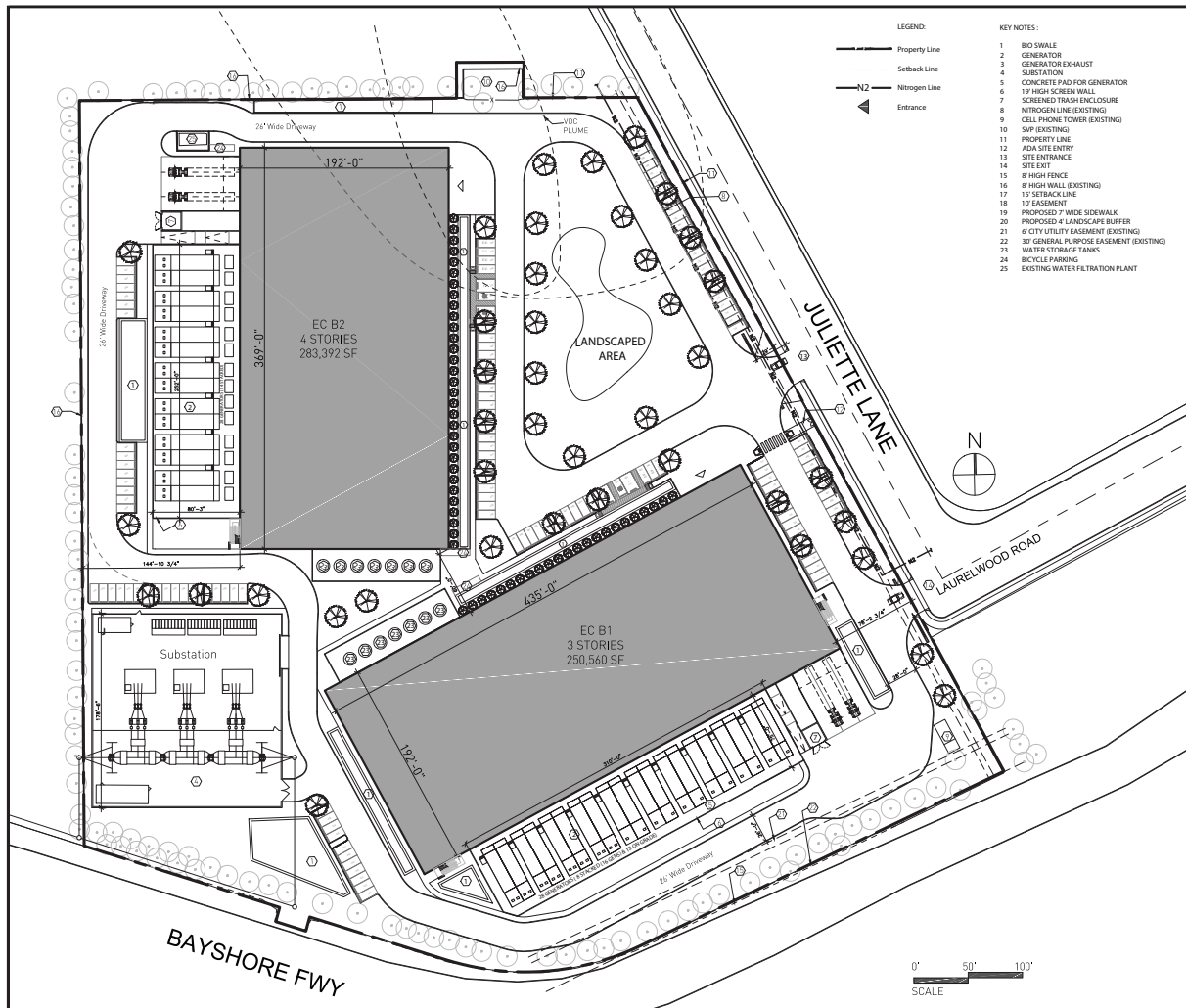

CALIFORNIA  
ENERGY COMMISSION  
Gavin Newsom, Governor

August 2019  
CEC-700-2019-002

DOCKET NUMBER 19-SPPE-01

# **Initial Study and Proposed Mitigated Negative Declaration**

## **Laurelwood Data Center**

(19-SPPE-01)

Lead Agency

**California Energy Commission**



August 2019



**CALIFORNIA ENERGY COMMISSION**

1516 NINTH STREET  
SACRAMENTO, CA 95814-5512  
www.energy.ca.gov



## **NOTICE OF INTENT TO ADOPT A PROPOSED MITIGATED NEGATIVE DECLARATION**

Laurelwood Data Center  
(19-SPPE-01)

MECP1 Santa Clara 1, LLC (Applicant) filed an application with the California Energy Commission on March 5, 2019 (TN 227273-1 and associated documents) requesting a Small Power Plant Exemption (SPPE) for the Laurelwood Data Center (LDC or project) in Santa Clara, California. The project description was subsequently revised via a new filing on June 13, 2019 (TN 228748), stemming from refinements to the site plan and incorporation of data responses, and again on June 21, 2019 (TN 228823) with an updated discussion of the building's cooling system.

The Energy Commission is responsible for reviewing, and ultimately approving or denying, all thermal electric power plants, 50 megawatts (MW) and greater, proposed for construction in California. The SPPE process allows applicants with projects between 50 and 100 MW to obtain an exemption from the Energy Commission's jurisdiction and proceed with local approval rather than requiring certification by the Energy Commission. The Energy Commission can grant an exemption if it finds that the proposed project would not create a substantial adverse impact on the environment or energy resources. Section 25519(c) of the Public Resources Code designates the Energy Commission as the California Environmental Quality Act (CEQA) lead agency, as provided in section 21165 of the Public Resources Code, for all projects that seek an exemption from the Energy Commission's power plant certification process.

This Notice of Intent is provided to inform parties, responsible agencies, and members of the public that Energy Commission staff has proposed for adoption a Mitigated Negative Declaration (MND) for this project. Staff has prepared a proposed MND based upon the assessment of potential environmental impacts outlined in staff's Initial Study (IS). As discussed below, both of these documents are now available for public review.

### **PROJECT DESCRIPTION**

The applicant proposes to construct and operate the LDC at 2201 Laurelwood Road in Santa Clara, California. The LDC would consist of two multi-storied data center buildings and 56 3.0-MW standby backup diesel-fired generators capable of providing electrical power during utility outages or certain onsite electrical equipment interruption or failure. The maximum electrical load of the LDC would be 99 MW, inclusive of tenant-installed information technology (IT) equipment in the LDC and cooling and ancillary electrical and telecommunications equipment operating to support IT equipment. The LDC would also include an onsite 60-kilovolt substation with an electrical supply line that would connect to a Silicon Valley Power distribution line located 0.1 mile west of the LDC. To make way for the project, demolition and removal of asphalt/foundations and underground utilities would be necessary, prior to construction.

### **HAZARDOUS WASTE SITES**

The location of the LDC is a listed site on the California Hazardous Waste and Substances Sites List (also known as the Cortese List), published under Government Code section 65962.5. The listing is due to a cleanup order of the San Francisco Bay Regional Water Quality Control Board in response to volatile

organic compounds detected in groundwater and a trichloroethylene plume associated with the previous owner Siliconix, Inc. More information about the listing, including site maps and regulatory activities, is available on the State Water Resources Control Board GeoTracker listing for the LDC site: [https://geotracker.waterboards.ca.gov/profile\\_report?global\\_id=SL20230848](https://geotracker.waterboards.ca.gov/profile_report?global_id=SL20230848).

## **STAFF CONCLUSIONS**

Energy Commission staff has completed an independent review of the LDC. Staff concludes that the project, as mitigated, would not have a significant effect on the environment. Staff concludes that compliance with the mitigation measures detailed in the Initial Study would be sufficient to ensure there would be no significant impacts from the demolition and construction or operation of the LDC.

## **AVAILABILITY OF DOCUMENTS**

The Proposed IS/MND for the LDC have been filed in the Energy Commission's docket for this project, which can be found on the Commission's Laurelwood Data Center webpage at the following link: <https://ww2.energy.ca.gov/sitingcases/laurelwood/> (Click "Documents for this Proceeding" to find the Proposed IS/MND and all other documents filed in the proceeding).

In addition, the Commission's Docket Unit has all documents filed in this proceeding. If you would like to obtain a physical copy of a document or documents, please contact the Docket Unit and specify you are looking for documents associated with proceeding 19-SPPE-01:

Docket Unit  
California Energy Commission  
1516 9th Street, MS-4  
Sacramento, CA 95814  
(916) 654-5076  
[docket@energy.ca.gov](mailto:docket@energy.ca.gov)

A copy of the Proposed IS/MND is available for review at the following additional locations:

Northside Branch Library  
695 Moreland Way  
Santa Clara, CA 95054

City of Santa Clara Planning Division, Community  
Development Department  
1501 Warburton Avenue  
Santa Clara, CA 95050

This Notice of Intent has been mailed to a list of nearby property owners compiled in accordance with CEQA Guidelines section 15072(b). Additionally, this Notice of Intent has been provided to responsible agencies, trustee agencies, the Santa Clara County Clerk, and organizations and individuals who have previously requested such notice. The Proposed IS/MND was submitted to the State Clearinghouse for review by state agencies.

## **PUBLIC COMMENTS**

The public review period for the Proposed IS/MND begins on August 29, 2019. Written comments will be accepted until 5:00 p.m. on October 3, 2019. The preferred method for submitting comments is via the Energy Commission's Laurelwood Data Center webpage: <https://ww2.energy.ca.gov/sitingcases/laurelwood/>.

Click on the "Comment on this Proceeding" link. Please provide your full name, any organization name, an email address, a reference to Docket No. 19-SPPE-01, and preferably put your comment in an attached document (.doc, .docx, or .pdf format). After checking the box to ensure that responses are generated by

a human user and not a computer, click on the "Agree & Submit Your Comment" button to submit the comment to the Energy Commission Docket Unit.

If you wish to mail written comments on the project, please submit them to the Energy Commission's Docket Unit. Please include the docket number (19-SPPE-01) for the Laurelwood Data Center project in the subject line or first paragraph of your comments and mail or hand-deliver them to the address listed above.

All written comments and materials filed with the Docket Unit will become a part of the public record of the proceeding. Additionally, comments may be posted on the Laurelwood Data Center webpage of the Energy Commission's website.

**Please note that the IS and Proposed MND are not decision documents for the proceeding, nor do they contain final findings of the Energy Commission related to environmental impacts.** Staff's recommendation, along with any other recommendations and materials presented by the applicant, interveners, government agencies, and the public, will be considered by the assigned Committee at an evidentiary hearing to be scheduled and conducted by the assigned Hearing Officer.<sup>1</sup> Following this hearing, the Committee will issue its proposed decision. In the last step, the full Energy Commission will hold a public hearing to consider the Committee's proposed decision and issue a final decision on the SPPE application.<sup>2</sup> Should an exemption be granted, any further CEQA analysis and permitting decisions would become the responsibility of local permitting authorities, in this case primarily the City of Santa Clara and Bay Area Air Quality Management District.

Please direct technical or project schedule questions to Lisa Worrall, CEQA Lead Project Manager, at (916) 654-4545, or by email at [lisa.worrall@energy.ca.gov](mailto:lisa.worrall@energy.ca.gov). If you desire information on participating in the Energy Commission's review of the project, please contact the Energy Commission's Public Adviser's Office, at (916) 654-4489 or toll free in California, at (800) 822-6228. The Public Adviser's Office can also be contacted via email at [publicadviser@energy.ca.gov](mailto:publicadviser@energy.ca.gov).

---

<sup>1</sup> Currently, the Committee's Evidentiary Hearing for this proceeding is scheduled for October 25, 2019. Time and location details will be available in the LDC docket as this date nears, and this date is subject to change upon the Committee's order.

<sup>2</sup> A hearing of the Energy Commission to consider whether to adopt the Committee's proposed decision is scheduled for the Commission's regular business meeting at 10:00 am on December 11, 2019 in the Art Rosenfeld Hearing Room, First Floor, California Energy Commission, 1516 9th Street, Sacramento, CA 95814. This date is subject to change upon the Committee's order.

## Table of Contents

<b>1</b>	<b>Proposed Mitigated Negative Declaration .....</b>	<b>1-1</b>
<b>2</b>	<b>Environmental Determination.....</b>	<b>2-1</b>
<b>3</b>	<b>Introduction to the Initial Study .....</b>	<b>3-1</b>
<b>4</b>	<b>Project Description .....</b>	<b>4-1</b>
<b>5</b>	<b>Environmental Setting and Environmental Impacts .....</b>	<b>5-1</b>
5.1	Aesthetics.....	5.1-1
5.2	Agriculture and Forestry Resources .....	5.2-1
5.3	Air Quality .....	5.3-1
5.4	Biological Resources .....	5.4-1
5.5	Cultural and Tribal Cultural Resources .....	5.5-1
5.6	Energy and Energy Resources .....	5.6-1
5.7	Geology and Soils .....	5.7-1
5.8	Greenhouse Gas Emissions .....	5.8-1
5.9	Hazards and Hazardous Materials.....	5.9-1
5.10	Hydrology and Water Quality.....	5.10-1
5.11	Land Use and Planning .....	5.11-1
5.12	Mineral Resources.....	5.12-1
5.13	Noise.....	5.13-1
5.14	Population and Housing .....	5.14-1
5.15	Public Services.....	5.15-1
5.16	Recreation.....	5.16-1
5.17	Transportation .....	5.17-1
5.18	Utilities and Service Systems .....	5.18-1
5.19	Wildfire .....	5.19-1
5.20	Mandatory Findings of Significance .....	5.20-1
5.21	Environmental Justice .....	5.21-1
<b>6</b>	<b>Authors and Reviewers .....</b>	<b>6-1</b>

## Appendices

Appendix A: Project’s Jurisdictional and Generating Capacity Determination

Appendix B: Silicon Valley Power System Details

# **Section 1**

---

Proposed Mitigated Negative  
Declaration

**CALIFORNIA ENERGY COMMISSION**

1516 NINTH STREET  
SACRAMENTO, CA 95814-5512  
www.energy.ca.gov



# Proposed Mitigated Negative Declaration

## Laurelwood Data Center

### 19-SPPE-01

## 1 Proposed Mitigated Negative Declaration

### 1.1 Project Description

Project: Laurelwood Data Center  
2201 Laurelwood Road  
Santa Clara, California

Applicant: MECP1 Santa Clara 1, LLC  
Represented by JACOBS  
80 Promenade Circle  
Sacramento, CA 95834

MECP1 Santa Clara 1, LLC proposes to construct the Laurelwood Data Center (LDC or project), which would include two multi-storied data center buildings, and a series of standby backup generators capable of providing a maximum of 99 megawatts (MW) of electrical power during utility outages or certain onsite electrical equipment interruption or failure. The LDC would also include an onsite 60 kilovolt (kV) substation with an electrical supply line that would connect to a Silicon Valley Power (SVP) distribution line located 0.1 mile west of the LDC. To make way for the project, demolition of asphalt/foundations and underground utilities would be necessary, prior to construction.

The California Energy Commission is responsible for reviewing, and ultimately approving or denying, all thermal electric power plants, 50 MW and greater, proposed for construction in California. The Energy Commission has a regulatory process, referred to as the Small Power Plant Exemption (SPPE) process, which allows applicants with projects between 50 and 100 MW to obtain an exemption from the Energy Commission's jurisdiction and proceed with local approval rather than requiring an Energy Commission certificate. The Energy Commission can grant an exemption if it finds that the proposed project would not create a substantial adverse impact on the environment or energy resources.

### 1.2 Introduction

Pursuant to the California Environmental Quality Act (CEQA), the Energy Commission prepared an Initial Study (IS) for the proposed project to determine if any significant adverse effects on the environment would result from project implementation. The IS utilizes the environmental checklist outlined in Appendix G of the CEQA Guidelines. If an IS for a project indicates that a significant adverse impact could occur, a public agency shall prepare an Environmental Impact Report.

According to Article 6 (Negative Declaration Process) and Section 15070 (Decision to Prepare a Negative Declaration or Mitigated Negative Declaration) of the CEQA Guidelines, a public agency shall prepare or

have prepared a proposed negative declaration or mitigated negative declaration for a project subject to CEQA when:

- (a) The initial study shows that there is no substantial evidence, in light of the whole record before the agency, that the project may have a significant effect on the environment, or*
- (b) The initial study identifies potentially significant effects, but:*
  - (1) Revisions in the project plans or proposals made by, or agreed to by, the applicant before a proposed mitigated negative declaration and initial study are released for public review would avoid the effects or mitigate the effects to a point where clearly no significant effects would occur, and*
  - (2) There is no substantial evidence, in light of the whole record before the agency, that the project as revised may have a significant effect on the environment.*

### **1.3 Environmental Determination**

The IS was prepared to identify the potential environmental effects resulting from proposed project implementation, and to evaluate the level of significance of these effects. The IS is based on information from the applicant's SPPE application, twice-revised project description and associated submittals, site visits, data requests and responses, and additional staff research.

Based on the analysis in the IS, it has been determined that all project-related environmental impacts could be reduced to a less than significant level with the incorporation of feasible mitigation measures. Energy Commission staff held a public workshop on August 26, 2019 to reach an agreement on proposed mitigation with the applicant, as required in Section 15070 (b) (1) of the CEQA Guidelines. An agreement was reached with the applicant. Mitigation measures are proposed in the technical areas of Biological Resources and Cultural and Tribal Cultural Resources. See the respective technical area for the full text of the mitigation measures.

Therefore, adoption of a Mitigated Negative Declaration (MND) will satisfy the requirements of CEQA. The project's mitigation measures included are designed to reduce or eliminate the potentially significant environmental impacts. Mitigation measures are structured in accordance with the criteria in Section 15370 of the CEQA Guidelines.



## **Section 2**

---

### Environmental Determination and Environmental Checklist

## 2 Environmental Determination

### 2.1 Environmental Factors Potentially Affected

The environmental factors checked below would be potentially affected by this project, involving at least one impact that is a "Potentially Significant Impact" and requiring implementation of mitigation as indicated by the checklist on the following pages.

- |  |  |  |
|--|--|--|
| <input type="checkbox"/> Aesthetics                      | <input type="checkbox"/> Agriculture & Forestry Resources                  | <input type="checkbox"/> Air Quality                   |
| <input checked="" type="checkbox"/> Biological Resources | <input checked="" type="checkbox"/> Cultural and Tribal Cultural Resources | <input type="checkbox"/> Energy                        |
| <input type="checkbox"/> Geology/Soils                   | <input type="checkbox"/> Greenhouse Gas Emissions                          | <input type="checkbox"/> Hazards & Hazardous Materials |
| <input type="checkbox"/> Hydrology/Water Quality         | <input type="checkbox"/> Land Use/Planning                                 | <input type="checkbox"/> Mineral Resources             |
| <input type="checkbox"/> Noise                           | <input type="checkbox"/> Population/Housing                                | <input type="checkbox"/> Public Services               |
| <input type="checkbox"/> Recreation                      | <input type="checkbox"/> Transportation                                    | <input type="checkbox"/> Utilities/Service Systems     |
| <input type="checkbox"/> Wildfire                        | <input type="checkbox"/> Mandatory Findings of Significance                |  |

### 2.2 Environmental Determination

On the basis of this initial evaluation:

- I find that the Proposed Project COULD NOT have a significant effect on the environment, and a **NEGATIVE DECLARATION** will be prepared.
- I find that although the Proposed Project could have a significant effect on the environment, there will not be a significant effect in this case because revisions in the project have been made by or agreed to by the project proponent. A **MITIGATED NEGATIVE DECLARATION** will be prepared.
- I find that the Proposed Project MAY have a significant effect on the environment, and an **ENVIRONMENTAL IMPACT REPORT** is required.
- I find that the Proposed Project may have a "potentially significant impact" or "potentially significant unless mitigated" impact on the environment, but at least one effect (1) has been adequately analyzed in an earlier document pursuant to applicable legal standards, and (2) has been addressed by mitigation measures based on the earlier analysis as described on attached sheets. An **ENVIRONMENTAL IMPACT REPORT** is required, but it must analyze only the effects that remain to be addressed.
- I find that although the Proposed Project could have a significant effect on the environment, because all potentially significant effects (a) have been analyzed adequately in an earlier EIR pursuant to applicable standards, and (b) have been avoided or mitigated pursuant to that earlier EIR, including revisions or mitigation measures that are imposed upon the Proposed Project, nothing further is required.



Shawn Pittard, Deputy Director  
Siting, Transmission and Environmental Protection Division  
California Energy Commission

8-28-19

Date

## **Section 3**

---

### Introduction to the Initial Study

## 3 Introduction to the Initial Study

### 3.1 Energy Commission Jurisdiction and the Small Power Plant Exemption (SPPE) Process

The California Energy Commission is responsible for reviewing, and ultimately approving or denying, all applications for thermal electric power plants, 50 megawatts (MW) and greater, proposed for construction in California. The Energy Commission has a regulatory process, referred to as the Small Power Plant Exemption (SPPE) process, which allows applicants with projects between 50 and 100 MW to obtain an exemption from the Energy Commission's jurisdiction and proceed with local approval rather than requiring certification by the Energy Commission. The Energy Commission can grant an exemption if it finds that the proposed project would not create a substantial adverse impact on the environment or energy resources. (See Pub. Resources Code, § 25541.) For more information about the Energy Commission's jurisdiction and generating capacity determination, see **Appendix A**.

### 3.2 CEQA Lead Agency

In accordance with section 25519(c) of the Public Resources Code and the California Environmental Quality Act (CEQA), the Energy Commission serves as the lead agency to review an SPPE application and perform an environmental analysis of the project. If the Energy Commission grants the exemption, the local permitting authority, in this case the City of Santa Clara, will impose mitigation, as necessary, and has authority to approve the project.

### 3.3 Assembly Bill 52 and Tribal Consultation

CEQA requires lead agencies to consult with all California Native American tribes (tribe) that have traditional and cultural affiliation with the geographic area of a project, and that have previously requested consultation. To invoke an agency's requirement to consult under CEQA, a tribe must first send the lead agency a written request for formal notification of any projects within the geographic area with which they are traditionally and culturally affiliated. (Pub. Resources Code, § 21080.3.1(b).)

The Energy Commission has not received any requests for formal notification from tribes that have traditional and cultural affiliation with the geographic area of the proposed project. Therefore, the Energy Commission has no obligations under CEQA's formal tribal notification or consultation requirements.

However, consistent with the Energy Commission's tribal consultation policy, Energy Commission staff contacted the Native American Heritage Commission (NAHC) on March 6, 2019, to request a search of the Sacred Lands File and a list of California Native American tribes that might be interested in the proposed project. The NAHC responded on March 7, 2019, and provided a list of six California Native American tribes to contact. Energy Commission staff mailed initial consultation letters to these six tribes on March 26, 2019. For more information and results of project tribal consultation, see **Section 5.5, Cultural and Tribal Cultural Resources**.

### 3.4 Purpose of the Analysis

The purpose of this document is to provide objective information regarding potential adverse environmental impacts of the proposed project to the Commissioners who will be reviewing and considering applicant MECP1 Santa Clara 1, LLC's request for an SPPE.

### 3.5 CEQA Analysis Format

The environmental analysis of an SPPE typically takes the form of an Initial Study (IS), which is prepared to conform to the requirements of CEQA (Pub. Resources Code, § 21000 et seq.), the CEQA Guidelines (Cal. Code Regs, tit. 14, § 15000 et. seq.), and the regulations and policies of the Energy Commission. The IS is based on information from the applicant’s SPPE application and associated submittals, site visits, data requests and responses, and additional staff research.

The Laurelwood Data Center (LDC or project) consists of two data center buildings, and a series of backup generators capable of providing power in the case of a break in service from the local power-providing authority, and associated connections to utility services. For a more complete project description, please see **Chapter 4, Project Description**.

This IS evaluates the potential environmental impacts that might reasonably be anticipated to result from the construction and operation of the project. Staff’s analysis is broken down into issue areas derived from Appendix G to the CEQA Guidelines and the Warren-Alquist Act:

- Aesthetics
- Agricultural and Forestry Resources
- Air Quality
- Biological Resources
- Cultural and Tribal Cultural Resources
- Energy and Energy Resources
- Geology and Soils
- Greenhouse Gas Emissions
- Hazards and Hazardous Materials
- Hydrology and Water Quality
- Land Use and Planning
- Mineral Resources
- Noise
- Population and Housing
- Public Services
- Recreation
- Transportation
- Utilities and Service Systems
- Wildfire
- Mandatory Findings of Significance
- Environmental Justice

In addition, Energy Commission CEQA analysis documents include an analysis of Environmental Justice.

For each subject area, the analysis includes a description of the existing conditions and setting related to the subject area, an analysis of the proposed project’s potential environmental impacts, and a discussion of mitigation measures, if necessary, to reduce potentially significant impacts to less than significant levels.

## **Section 4**

---

### Project Description

## 4. Project Description

MECP1 Santa Clara 1, LLC (Applicant) is seeking an exemption from the Energy Commission’s jurisdiction (Small Power Plant Exemption, or SPPE) and proceed with local approval rather than requiring requiring certification by the Energy Commission. In reviewing an SPPE application the Energy Commission acts as the lead agency under section 25519(c) of the Public Resources Code and, in accordance with CEQA, will perform any required environmental analysis.

The applicant proposes to construct and operate the Laurelwood Data Center (LDC or project) in Santa Clara, California. The LDC would consist of two multi-storied data center buildings, and a series of standby backup generators capable of providing electrical power during utility outages or certain onsite electrical equipment interruption or failure. The maximum electrical load of the LDC would be 99 megawatts (MW), inclusive of tenant-installed information technology (IT) equipment in the LDC and cooling and ancillary electrical and telecommunications equipment operating to support IT equipment. To make way for the project, demolition of asphalt/foundations and underground utilities would be necessary, prior to construction.

### 4.1 Project Title

Laurelwood Data Center

### 4.2 Lead Agency Name and Address

California Energy Commission  
1516 Ninth Street  
Sacramento, California 95814

### 4.3 Lead Agency Contact Person and Phone Number

Lisa Worrall, CEQA Lead Project Manager  
Siting, Transmission and Environmental Protection Division  
California Energy Commission  
(916) 654-4545

### 4.4 Project Location

Figure 4-1 shows the regional location and Figure 4-2 identifies the project location.

### 4.5 Project Overview

The LDC is proposed at 2201 Laurelwood Road in the City of Santa Clara on an approximately 12 acre industrial site. The project site was previously developed with industrial warehouse, manufacturing and office facility with parking. The buildings have been removed by the previous owner. The remaining asphalt, foundations, and underground utilities would be demolished before construction of the LDC would begin.



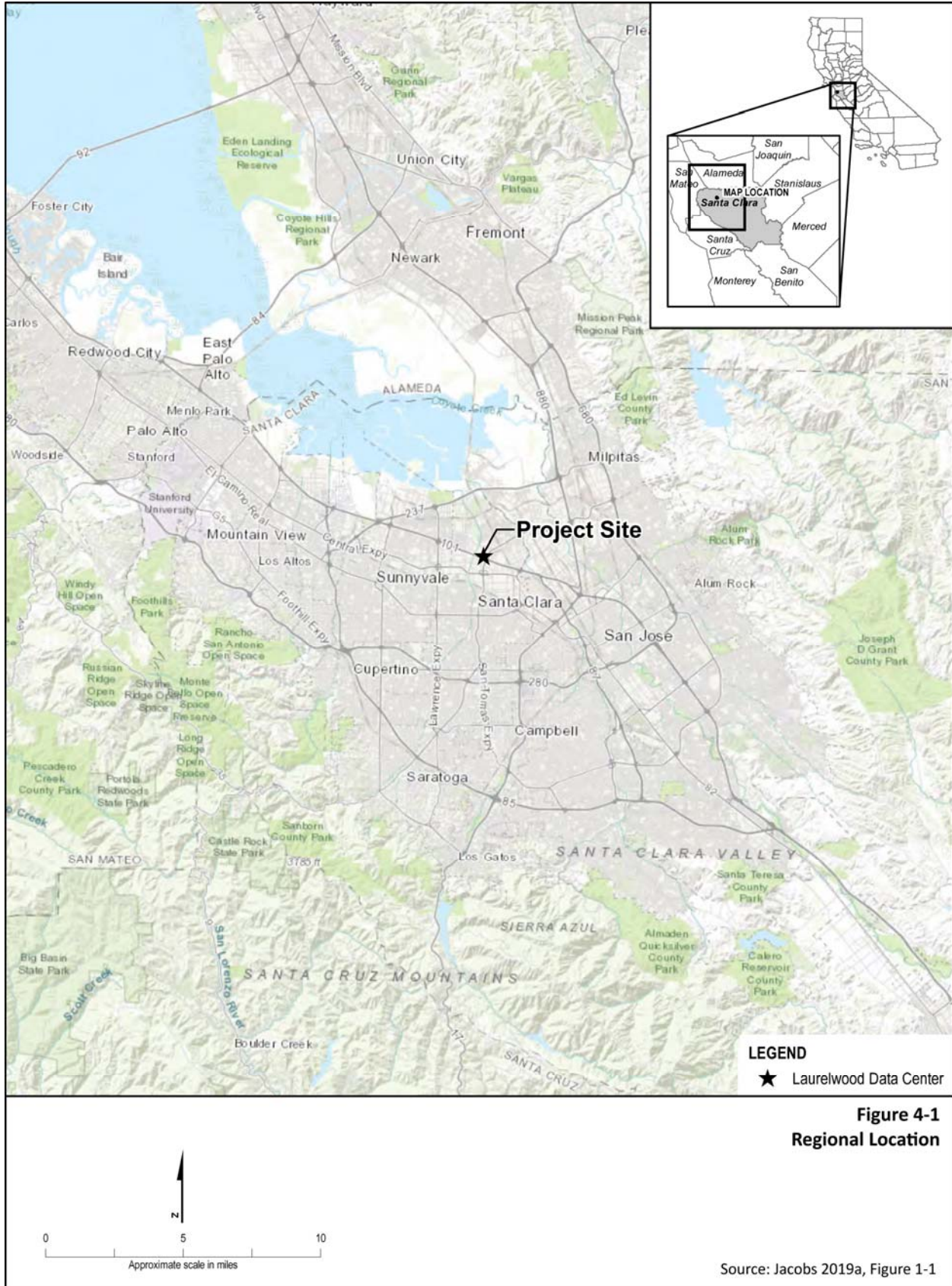



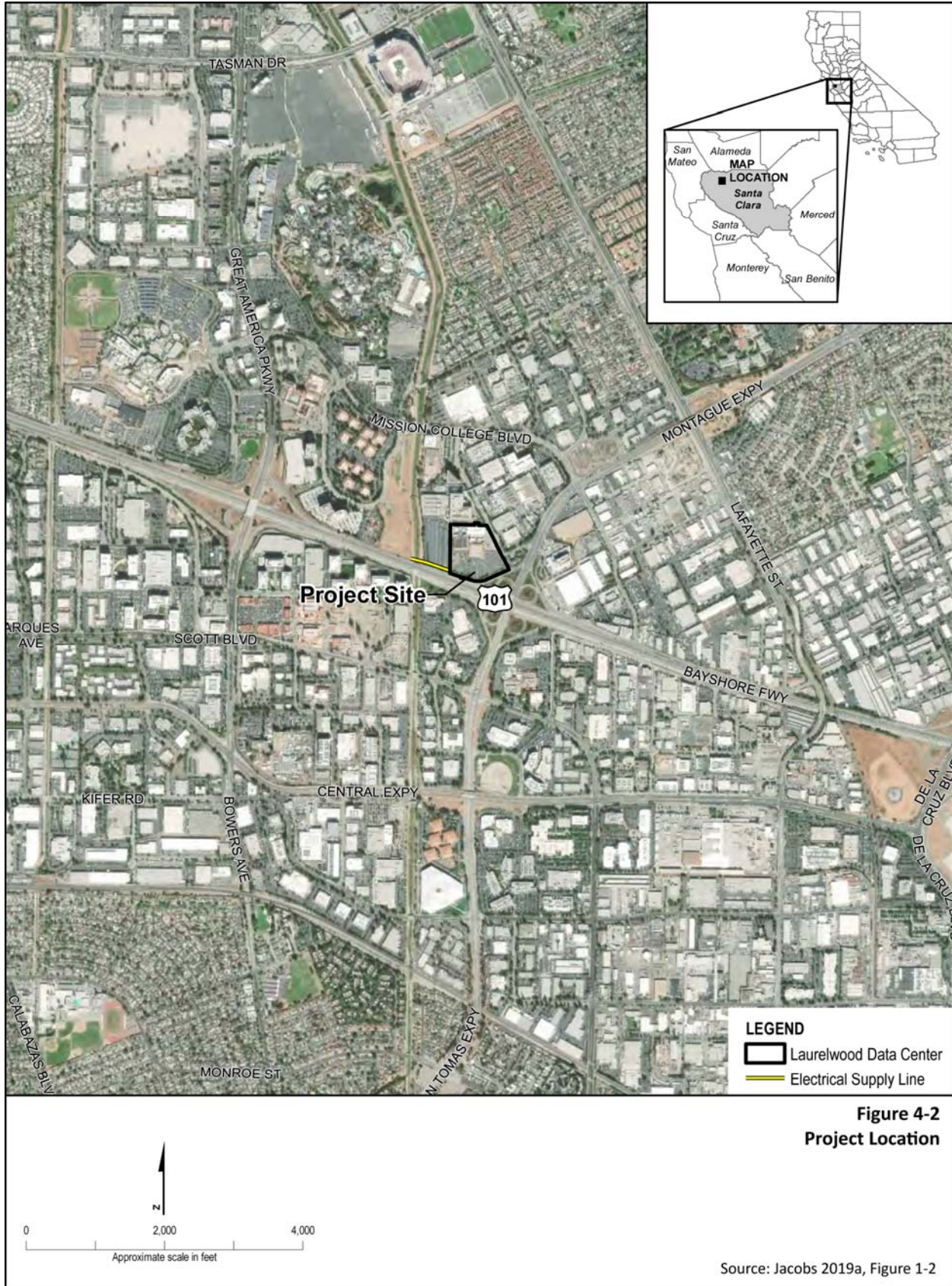

The LDC would include two buildings. Building 1 would be an approximately 250,560-square-foot, three-story structure with supporting amenities including elevators, restrooms, lobby, staging, and storage. Building 2 would be an approximately 283,392-square-foot, four-story structure with supporting amenities including elevators, restrooms, lobby, staging, and storage. Both buildings would include loading docks, backup generator yards, stormwater bio-swales, paved surface parking lots, and landscaping features. The LDC would also include an onsite 60 kilovolt (kV) substation with an electrical supply line that would connect to a Silicon Valley Power (SVP) distribution line located 0.1 miles west of the LDC. The approximately 12-acre LDC site is zoned Planned Industrial with an Assessor's Parcel Number of 104-39-023.

The standby generation system for the LDC would consist of 56 3.0-MW diesel-fired generators, each with a peak output capacity of 3.0 MW and a continuous steady state output capacity of 2.725 MW to support the need for the LDC to provide an uninterruptible power supply. Additional project features include electrical switchgear and distribution lines between the substation and buildings, as well as from the backup generator yards and each respective building. The approximately 31,150-square-foot substation would be located in the southwest corner of the project site, adjacent to a public easement located along the southern edge of the project parcel. The approximately 600-foot-long electrical supply line would be located within this public easement and head west from the LDC to tie into SVP's existing 60 kV distribution line located on the western side of the San Tomas Aquino Creek. This distribution line would consist of three distribution poles located within the existing easement. A site plan is provided in **Figure 4-3**.

The backup generation system would be located in equipment yards along the outside of each building. Each building would include 28 standby generators. One generator would provide continuous power to the essential systems (fire monitoring and other emergency operations) for both buildings during electrical outages. At no time would the total LDC electrical demand exceed 99 MWs. Therefore, at no time would the standby generators generate more than 99 MWs of electricity for onsite consumption.

Each backup generator is a fully independent package system with dedicated fuel tanks located on a skid below the generator. The generators would be supported in a stacked configuration. Each backup generation yard would be electrically interconnected to the building it serves through a combination of underground and aboveground conduit/cabling to a location within the building that houses electrical distribution equipment.

### **Data Center Design**

Buildings 1 and 2 would be constructed of steel structural components with metal framed and insulated exterior walls with stucco or metal panel façade containing accent fields and reveals. The entries would include curtain wall glazing and an aluminum canopy. Heating/ventilation and air conditioning equipment, including chiller units (adiabatic condenser cooling system), would be located on the roof of each building and screened using perforated corrugated steel panels. The exterior of the building would conform to City of Santa Clara design standards. Elevation drawings are presented on **Figures 4-4 and 4-5**.

### **Electrical Supply**

Electricity for the LDC would be supplied via a new San Tomas Junction (STJ) substation constructed on the project site, connecting through SVP's 60 kV Northwest Loop. The substation would include three 50 MVA (60/12.47kV) transformers, only two are required to supply the loads at the LDC. The four circuit breakers proposed in the STJ substation would allow one of the transformers be taken out of service for

repairs or maintenance while the other two can fully support customer load. The 60 kV Northwest Loop is fed from Northern Receiving Station (NRS) and Scott Receiving Station (SRS). Both NRS and SRS are 115/60 kV receiving stations. Both NRS and SRS have two 115/60 kV transformers for redundancy and reliability. The loads on the Northwest Loop can be fully supplied through either of the receiving stations.

### ***Silicon Valley Power System Reliability***

The SVP 60 kV loop systems are designed to provide reliable electric service to customers. The looped interconnection allows SVP to provide continuous electricity to customers even under contingency conditions, when one part of the electric network is not functioning. The interconnections for data centers, like the LDC, on the SVP 60 kV system are designed with redundant equipment throughout such that there is no single point of failure. It takes at least two contingencies before customers on the 60 kV system lose power and, in the case of data centers, would instead rely on back-up generators. According to SVP, double outages on the 60 kV loop systems are extremely rare, and the data supports this (see **Appendix B**) (CEC 2019e).

SVP provided a list of all of the outages on its 60 kV system over the last ten-years. There were thirty-one outages, only four of which resulted in customers being without power. This means that in twenty-seven of these outages the redundant design of the system prevented customers from being without power; data centers would not have isolated from the grid and would not have relied on their back-up generators. Of the remaining four outages, three were on 60 kV loops. One approximately 7.5 hour outage was on Center Loop and two outages (one approximately 4 hours and the other 3.5 hours) were on the South Loop. Even then, only a limited number of data centers were affected by these outages. Thus, customers on two of the loops each experienced a total of 7.5 hours of outages over 10-years due to faults on the 60 kV system while the three other loops experienced no outages due to faults on the 60 kV system. Either 7.5 hours or 0 hours would be extremely rare, and the consequences or effects on the fleet of data centers, almost negligible.

Wildfire policies could impact SVP's ability to supply power to customers if curtailments on the Pacific Gas and Electric (PG&E) system interrupt SVP's electricity supplies. A Public Safety Power Shutoff (PSPS) could indirectly limit electricity supplies to SVP. A PSPS essentially de-energizes power lines in order to prevent the lines from causing wildfires. The PSPSs are generally limited to high fire risk zones and only implemented under special conditions. While the SVP service territory is not in a high risk zone, a line de-energization in one of PG&E's high risk zones to reduce the risk of lines causing a wildfire could reduce the electricity supplied to SVP through PG&E lines. Electricity supplies to SVP through PG&E could also be reduced if transmission lines were de-energized to avoid damage from a wildfire. The potential impact of safety shutoffs on the PG&E system are not currently known or well defined by SVP or PG&E. SVP has the ability to produce about 200 MW through generators connected to its system but severe outages on the PG&E system could require curtailments to SVP customers.

### **Electrical System Engineering**

If electricity were curtailed to the data center, a standby generator would take up the electrical load. The standby generator system includes a 5-to-make-4 design topology, meaning that for every four standby generators that would support load in the event of a utility failure, there is one standby generator (i.e. the fifth generator in that lineup would begin operating only if one of the four generators running in the event of a utility service disruption were to fail).



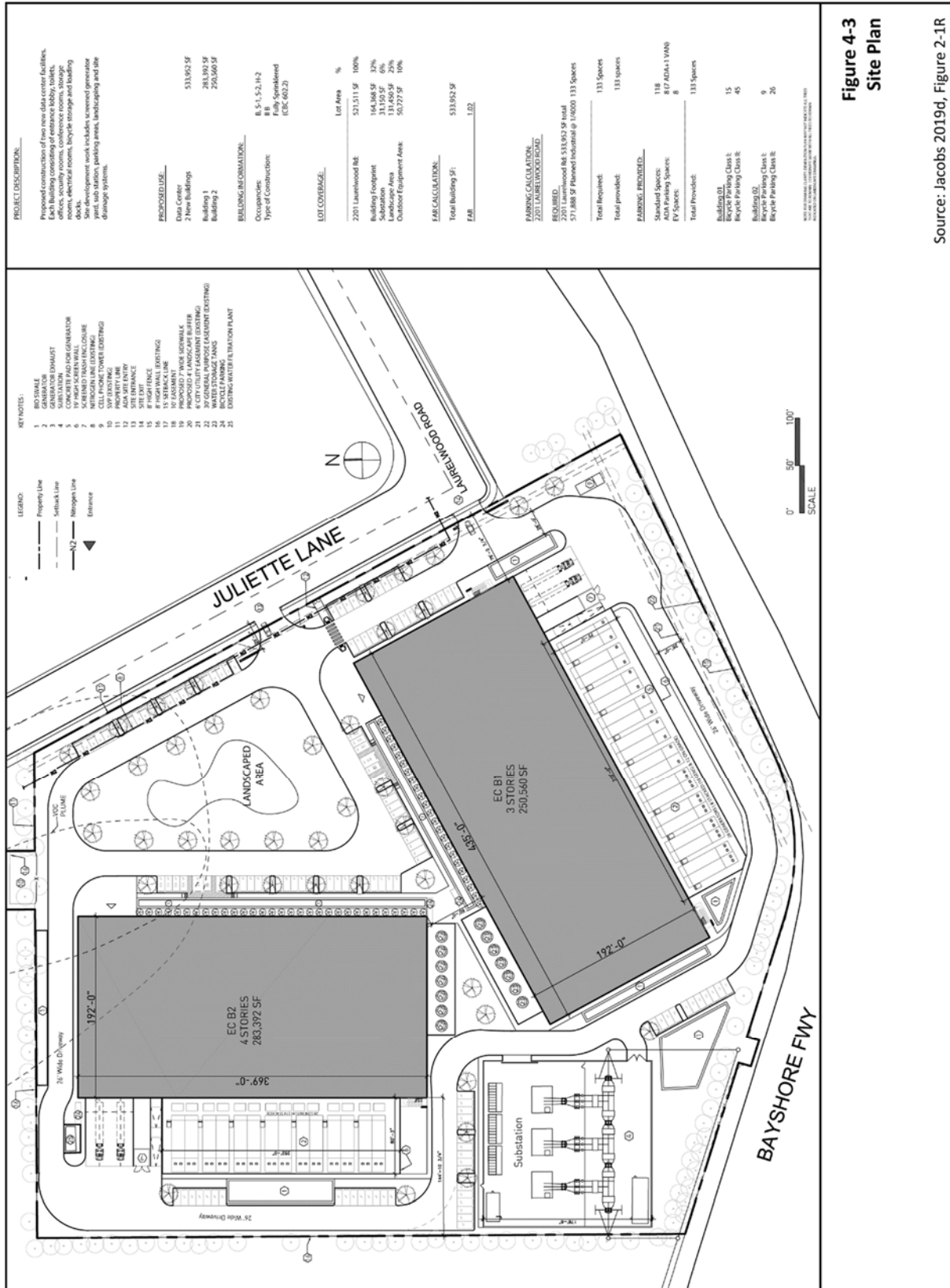
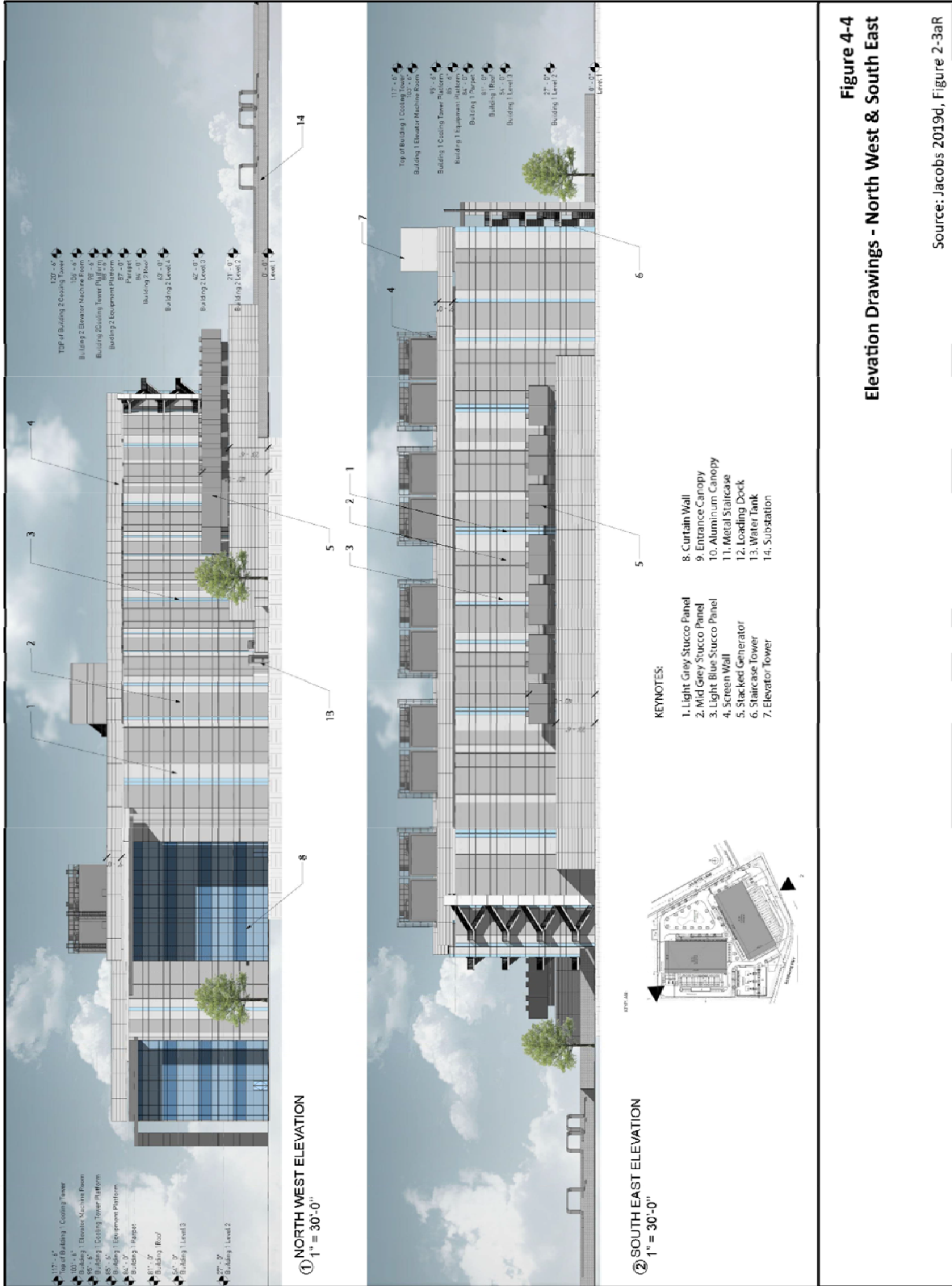
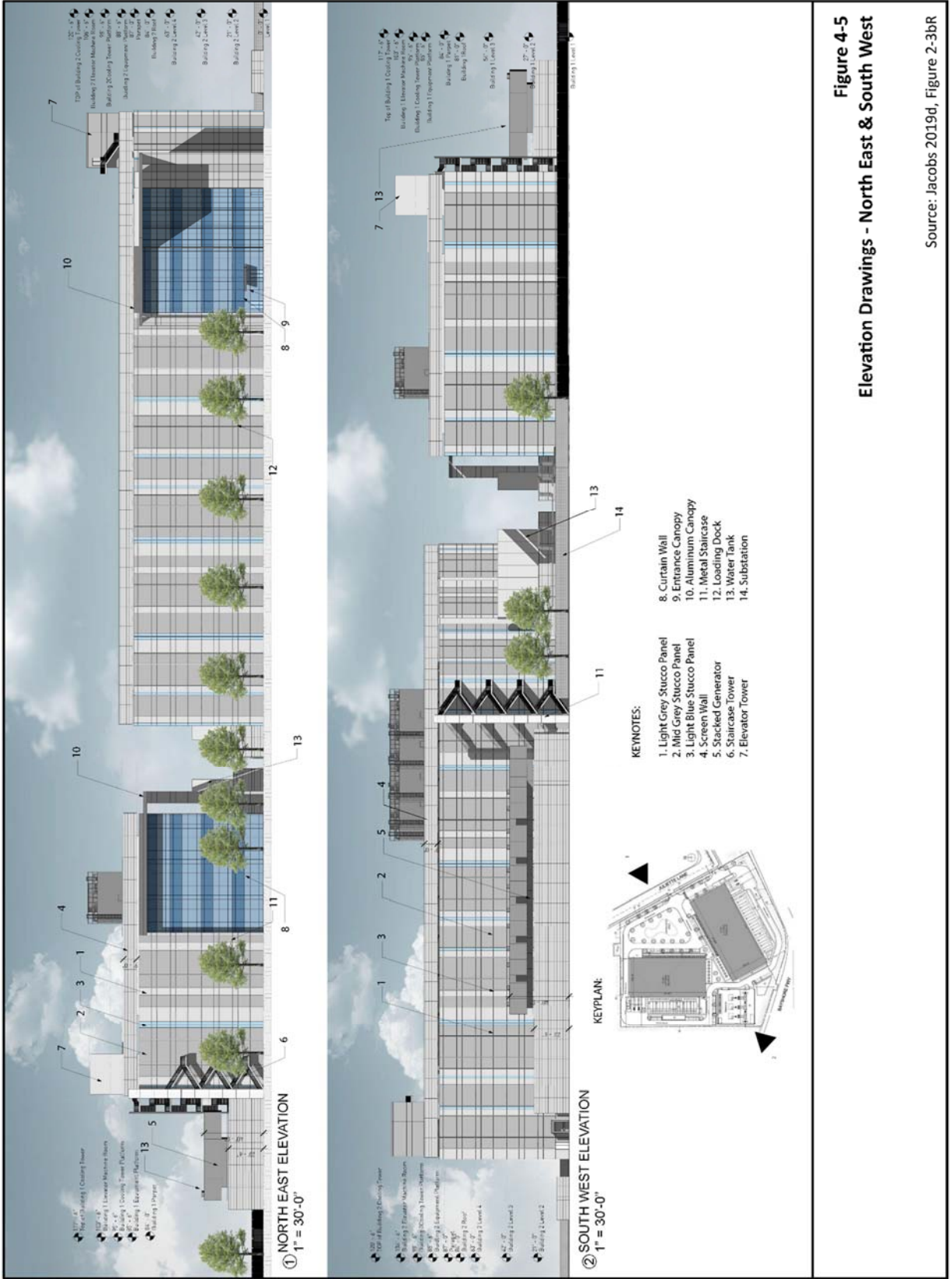

Figure 4-3  
Site Plan

Source: Jacobs 2019d, Figure 2-1R







This means that of the 55 standby generators (note, the 56<sup>th</sup> generator provides fire/life safety services), a maximum of 33 generators operating at 100 percent of their maximum rated output are required to support the operation of LDC under peak summer-time ambient conditions (99 MW of backup generator output). Each building's standby generators would be supported by an Uninterruptible Power Supply (UPS) system consisting of batteries, an inverter, and switches.

The UPS system would facilitate the uninterrupted transfer of electrical power supply from the SVP substation to the onsite standby generators in the event of an undefined number of potential events that could impact SVP's service (resulting in a loss of power or degradation in power quality) which would trigger the starting of the standby generators. The UPS system would include valve-regulated battery banks, with each bank capable of providing up to 10 minutes of backup at 100 percent load. The UPS system would have a rectifier and inverter to condition electricity and is sized to deliver power to support 100 percent of the server bay demand for up to 10 minutes. However, when the electrical service is outside of pre-determined tolerances (+10 percent or 15 percent of AC nominal voltages or a frequency range of 60 hertz +/- 5 percent), the UPS facilitates the transfer from utility power to generator produced power. The UPS transfer load from SVP to UPS battery power would occur within 0.1 seconds, which would trigger the start of the generators. Load would then transfer from the UPS battery system to the standby generators within 90 seconds of generator start. The UPS would direct standby generator load based on the building load demand. The UPS system would provide "clean" utility power for critical loads (fire/security and building management systems, and some small 120-volt circuits). The major mechanical systems, lighting, and general receptacles would not be powered from the UPS sources.

The SVP distribution line would be connected to SVP's Northwest Loop, which includes 115 kV receiving stations that would connect to SVP's electrical system. The LDC distribution line would include a 715 double-bundle ACCR conductor with a current carrying capacity of 310 MVS. The receiving stations step voltage down to 60 kV for distribution along the Northwest Loop, which can then provide electricity to facilities interconnected to the loop from either end, making electrical service reliable. SVP has indicated they expect a zero-outage frequency on the 60 kV Northwest Loop. There has been one system-wide outage on the SRS-Central 60 kV system within the past 5 years due to a bird coming in contact with the 60 kV line. The duration of the outage was approximately 40 minutes due to SVP maintenance staff inspecting the line in order to locate the fault and determine whether it was safe to re-energize the line. However, because SVP's grid is a looped system and not a radial system, no customers lost power during this outage.

The project would have a single electrical system consisting of a 12.47-kV to 480-volt substation transformer feeding the 480-volt critical bus that would feed two independent UPS modules. The UPS modules would be electrically independent of one another for the purposes of loading. The critical bus would be supported by its own standby generator and each standby generator would operate independent of one another. A utility main breaker and a generator main breaker would be included in the critical bus 480-volt switchgear, which would be controlled by an automatic transfer controller that would transfer the electricity generated by the dedicated standby generator in the event of a power outage.

The SVP distribution line supplying electricity to the onsite substation would be located within an existing 30-foot public easement along the southern portion of the project parcel. This distribution line would interconnect to SVP's existing 60-kV distribution line located on the west side of the San Tomas Aquino Creek. Three power poles would be installed within the existing public easement for the distribution line. No power poles would be located within the bed or banks of the San Tomas Aquino Creek.

## Electrical Generation Equipment

Each of the 56 standby generators would be an Environmental Protection Agency (EPA) Tier-2 diesel fired generator equipped with diesel particulate filters (DPF). The generators would be Caterpillar Model C175 16 with a maximum generating capacity of 3.0 MW and a continuous generating capacity of 2.725 MW.

Each standby generator would include an engine, alternator, and sound-attenuated enclosure. Each generator could be independently operated based on signals from the UPS system programmable logic controllers. The standby generators would be optimized for rapid start, with redundant starters, redundant batteries, redundant battery chargers, and a best battery selector switch. The standby generators would be designed to minimize space requirements by stacking one generator on top of another generator. Building 1 would have 16 stacked generators and 12 unstacked generators. Building 2 would have 28 stacked generators and no unstacked generators. Each generator would be approximately 9.5 feet wide, 26 feet long, and 14 feet tall. The stacked generators would be approximately 36 feet tall when installed and the unstacked generators would be approximately 14 feet tall. The backup generator yards would include an approximately 19-foot-high sound-attenuated screen wall to minimize visual and noise impacts from the equipment. Each standby generator would include a separate exhaust stack with stacked generator stacks being enclosed in a separate space or plenum to enhance the appearance of these industrial components. The exhaust stacks would be approximately 40 feet above grade for the stacked generators and 18 feet above grade for the unstacked generators.

Based on building demand estimates at full capacity, approximately 21 generators for each building would be expected to operate at approximately 78 percent load to support the full building load demand, including roof top mechanical systems and house loads (21 units at 78 percent of 3 MWs is approximately 49 MWs per building).

## Fuel System

Each standby generator would include an approximately 10,300-gallon diesel fuel tank with polishing filtration. The tank would be located underneath each standby generator and provide sufficient fuel storage to operate the generator at steady state continuous load for at least 48 hours.

The LDC would contract with multiple fuel suppliers to provide delivery within 48 hours of a request to ensure fuel availability.

## Cooling System

Each generator would be self-contained within an enclosure with its own radiator for cooling. The heating, ventilation, and air conditioning (HVAC) equipment proposed for LDC would use a refrigerant (R-134A) to cool the electronic equipment housed in the two buildings. The HVAC system will include 72, 4-cell adiabatic condensers installed on the roof of each LDC building (for a total of 144) to condense the refrigerant. The adiabatic condenser uses both evaporative and aircooling to remove heat from the refrigerant.

## Water Supply and Use

Potable water would be provided to LDC by the City of Santa Clara. If available, recycled water would be used onsite for landscaping purposes. The standby generators would require water during the initial filling of the closed-loop radiator system and periodically during maintenance events. After the initial fill, no further consumption of water by the standby generators would be required.

Building cooling would be accomplished using cooling towers with adiabatic cooling technology installed. The adiabatic cooling technology uses a radiator-style cooling system with wetted pre-cooling pads installed upstream of the cooling tube bundle. During lower ambient conditions, the tower operates without using water on the wetted pads. However, during higher ambient temperatures, the pre-cooling pads are wetted to reduce the incoming air temperature, resulting in greater heat rejection.

The expected total project water demand would be approximately 5.4 million gallons per year (equivalent to approximately 17 acre-feet/year (AFY)), excluding negligible landscaping and other maintenance uses.

### **Waste Management**

Construction/demolition-related wastes, similar to construction/demolition for comparable projects, would be generated, managed, and disposed of consistent with applicable law. No significant waste materials would be generated during operation of LDC.

### **Hazardous Materials Management**

Each standby generator would include a double-walled fuel tank to minimize the potential of an accidental fuel release. As diesel fuel is not highly volatile, vapor controls are not required. The space between the walls of the fuel tank would be monitored for the presence of liquids. This monitoring system would be monitored by the onsite operations staff who would receive automated alerts in the event of fuel leak or release. The diesel fuel and potentially battery electrolyte (sulfuric acid) represents the only hazardous materials that would be stored onsite in reportable quantities.

Fuel deliveries would occur as needed via a tanker truck. The tanker truck would park at the gated entrances to the backup generator yard for refueling. Fueling would occur within a spill catch basin located under each generator fill connection. The drain to the spill catch basin would be closed prior to the start of fueling. Spill control equipment would be stored within the backup generation yard to allow immediate responses in the event of an accident.

As a safety measure, to the extent feasible, fueling operations would be scheduled at times when storm events are improbable to avoid potential impacts to water resources.

The LDC would install warning signs at the fuel unloading areas to minimize the potential of refueling accidents occurring due to tanker trucks departing prior to disconnecting the transfer hose. Also, an emergency pump shut-off would be utilized if a pump hose breaks while fueling the tanks. Tanker truck loading and unloading procedures would be posted at the fuel unloading areas.

## **4.6 Existing Site Condition**

The LDC site is located at 2201 Laurelwood Road in Santa Clara, California (**Figure 4-2**). The approximately 12-acre site is bounded to the south by U.S. 101, to the west by a covered parking lot, to the east by Juliette Lane and commercial/industrial uses, and to the north by commercial/industrial uses. The site includes a 30-foot public easement along the southern edge of the parcel that also includes parking and landscaping. There are two existing access gates off Laurelwood Road.

The site is a single parcel previously used for electrical component manufacturing and office space with mature landscaping including trees and shrubs. Existing aboveground structures have been removed by the former owner as a condition of sale, pursuant to the demolition requirements of the City of Santa Clara. Existing perimeter trees and shrubs would be retained to the extent feasible.

The nearest airport, the Norman Y. Mineta San Jose International Airport, is located approximately 1.4 miles to the southeast.

## 4.7 Project Construction and Demolition

### Demolition

All aboveground existing buildings and structures have been removed by the previous owner. Foundations, asphalt, and underground utilities would be removed after receipt of the necessary approvals by the City of Santa Clara.

Demolition is expected to generate approximately 12,000 tons of concrete waste and 6,100 tons of asphalt waste. All of the concrete waste and approximately 4,900 tons of the asphalt waste would remain onsite for reuse. The balance of the asphalt waste (approximately 1,200 tons) consists of Petromat that would be hauled to the landfill for disposal. The offsite disposal of the asphalt generated during demolition is expected to require approximately 30 truck trips over the demolition period.

### Construction

The applicant would begin construction of the LDC after the existing foundations/asphalt and underground utilities have been removed from the project site. No offsite staging or laydown areas are proposed and all construction would occur within the project site boundaries or within the 75-foot distribution line construction corridor. Construction would require approximately 260 am peak hour round trips and 290 pm peak hour trips to the project site. These trips include workers, material, and equipment deliveries.

Building 1 would be a three-story, approximately 250,560-square-foot structure and would include a loading dock, parking lot/spaces (approximately 133 total parking spaces at full buildout), a 26-foot-wide perimeter road, bioswales, a backup generator yard, landscaping, and an approximately 31,150-square-foot substation with the distribution supply power line. The main entrance would be off Laurelwood Road, with a secondary entrance off Juliette Lane. All entrances would include security gates with controlled access. Building 2 would be a four-story, approximately 283,392-square-foot building and would include a loading dock, parking lot/spaces, the remainder of a 26-foot-wide perimeter road, bioswales, a backup generator yard, and landscaping. In addition, Class I bicycle lockers and Class II bicycle racks would be provided on site.

## 4.8 Demolition and Construction Schedule

Demolition and construction would take a total of 17 months. Demolition of the existing foundations, asphalt, and underground utilities is expected to take approximately 3 months. Construction of the LDC would follow and is expected to take approximately 14 months. Construction and demolition is expected to require a maximum of 129 workers (craft and supervisory) per month and an average of 60 workers per month.

## 4.9 Facility Operation

The standby generators would be run primarily for testing and maintenance purposes, and otherwise would not operate unless there is an interruption of the electrical supply. The California Air Resources

Board’s Airborne Toxic Control Measures (ATCM) limits each engine to no more than 50 hours of operation annually for reliability purposes (i.e., testing and maintenance). The monthly and quarterly tests would last approximately 25 minutes per standby generator, with up to five generators tested per day. The annual generation tests would be performed on up to four generators per day. The 3-Year Medium Voltage Breaker/Transformer Testing would be performed once every 3 years, with up to 2 generators tested per day. The contingency testing was included to provide standby generator operations to support unscheduled maintenance/testing requirements and would be performed using the monthly testing methodology.

## 4.10 Project Design Measures

The applicant proposes to implement project design measures (termed, Applicant Proposed Measures or APMs, in this analysis) as part of the project to avoid or reduce potential impacts from the project. **Table 4-1** presents the APMs that are incorporated into the project.

<b>TABLE 4-1 APPLICANT PROPOSED MEASURES (PROJECT DESIGN MEASURES)</b>	
<b>Project Description (Section 5.4, Biological Resources, Section 5.6, Cultural and Tribal Cultural Resources, and Section 5.7, Geology and Soils)</b>	
APM PD-1	Prior to the commencement of construction, the Applicant will secure the services of a qualified biologist, and archaeological, Native American, and paleontological specialists. These specialists will prepare a Worker Environmental Awareness Training program (program) to instruct construction workers of the obligation to protect and preserve valuable biological, archaeological, Native American, and paleontological resources for review by the City Director of Community Development. This program will be provided to all construction workers via a recorded presentation and will include a discussion of applicable laws and penalties under the laws; samples or visual aids of resources that could be encountered in the project vicinity; instructions regarding the need to halt work in the vicinity of any potential biological, archaeological, Native American, and paleontological resources encountered, and measures to notify their supervisor, the Applicant, and the specialists.
<b>Air and Soil (Section 5.3, Air Quality)</b>	
APM AQ-1	<p>Air and Soil:</p> <ul style="list-style-type: none"> <li>• Minimizing fugitive dust generation by watering exposed soils two times per day or as needed.</li> <li>• Covering truck loads when transporting soil, sand, or other loose materials to or from the site.</li> <li>• Performing street sweeping to remove all visible mud or dirt track-out onto adjacent public roads at least once per day. The use of dry power sweeping is prohibited.</li> <li>• Limiting onsite vehicle speeds on unpaved surfaces to 15 miles per hour (mph).</li> <li>• Paving onsite roads/driveways, and sidewalks as soon as possible in the construction schedule. Pouring foundations for building pads as soon as possible after grading.</li> <li>• Limiting construction equipment idling times to a maximum 5 minutes or shut equipment down when not in use.</li> <li>• Maintaining and tuning construction equipment in accordance with manufacturer’s specifications.</li> <li>• Employing a certified visible emission evaluator to verify construction equipment is functioning properly.</li> <li>• Posting a publicly visible sign with the telephone number and name of the person to contact regarding dust complaints and the Bay Area Air Quality Management District (BAAQMD) telephone number. The contact person will implement corrective measures, as needed, within 48 hours and the BAAQMD will be informed of any legitimate complaints received to ensure compliance with applicable regulations.</li> </ul>
<b>Biology (Section 5.4, Biological Resources)</b>	
APM BIO-1	Preconstruction surveys will be performed for biological resources by a qualified biologist. The surveys will identify any active nests that could be disturbed during construction. Surveys will be completed no

	more than 7 days prior to the initiation of ground disturbance. During this survey, the biologist shall inspect vegetation along the perimeter of the project site.
APM BIO-2	A no-work buffer will be established around any active nests with an appropriate buffer for the nesting species. The buffer widths will be developed by a qualified biologist, based on species' sensitive to disturbance, planned construction activities, and baseline level of human activity.
APM BIO-3	The biologist will draft a technical memorandum documenting the result of the survey and any designated buffer zones, which may be submitted to the Director of Community Development prior to the start of ground disturbance activities.
<b>Cultural (Section 5.6, Cultural and Tribal Cultural Resources)</b>	
APM CUL-1	The Applicant will secure the services of a Secretary of the Interior-qualified archaeologist and a Native American monitor to be on-call during construction, in the event a historic or prehistoric resource is encountered. If prehistoric and/or historic resources are encountered during construction, all activity within a 50-foot radius of the find will be stopped and the archaeologist/Native American monitor will examine the find and record the site, including field notes, measurements, and photography for a Department of Parks and Recreation 523 Primary Record form. The archaeologist will provide recommendations regarding eligibility for the California Register of Historical Resources, data recovery, curation, or other appropriate mitigation. Ground disturbance within the 50-foot radius can resume once these steps are taken and the City Director of Community Development has concurred with the recommendations.
APM CUL-2	If human remains are discovered during construction, a 50-foot radius exclusion zone will be established to protect the find and the Santa Clara County Coroner will be notified to make a determination as to whether the remains are of Native American origin or whether an investigation into the cause of death is required. If the remains are determined to be Native American, the Coroner will notify the Native American Heritage Commission. All actions taken under this mitigation measure will comply with Health and Human Safety Code Section 7050.5(b).
APM CUL-3	Within 30 days of the completion of construction or archaeological/Native American monitoring is terminated, the Applicant will have the archaeologist/Native American monitor prepare a report of findings. The report will document the archaeological/Native American resource finds, if any, recommendations, data recovery efforts, and other pertinent information gleaned during construction. The report may be submitted to the City of Santa Clara's Director of Community Development for review and approval. The Applicant will submit the final report to the Northwest Information Center at Sonoma State University.
<b>Paleontology (Section 5.7, Geology and Soils)</b>	
APM PALEO-1	The Applicant will secure the services of a qualified professional paleontologist, as defined by the Society of Vertebrate Paleontology, to be on-call prior to the commencement of construction. The paleontologist will be experienced in teaching non-specialists to recognize fossil materials and how to notify in the event of encountering a suspected fossil. If suspected fossils are encountered during construction, the construction workers will halt construction within 50 feet of any potential fossil find and notify the paleontologist, who will evaluate its significance.
APM PALEO-2	If a fossil is encountered and determined to be significant and avoidance is not feasible, the paleontologist will develop and implement an excavation and salvage plan in accordance with Society of Vertebrate Paleontology standards. Construction work in the immediate area will be halted or diverted to allow recovery of fossil remains in a timely manner. Fossil remains collected will be cleaned, repaired, sorted, and cataloged, along with copies of all pertinent field notes, photos, and maps.
APM PALEO-3	The paleontologist will prepare a paleontological resource monitoring report that outlines the results of the monitoring program and any encountered fossils. The report may be submitted to the Director of Community Development for review and approval. The report and any fossil remains collected will be submitted to a scientific institution with paleontological collections.

## 4.11 References

CEC 2019e – California Energy Commission (CEC). (TN 229381). Report of Conversation – Silicon Valley Power and Laurelwood Data Center, dated August 13, 2019. Available online at: <https://efiling.energy.ca.gov/Lists/DocketLog.aspx?docketnumber=19-SPPE-01>.



- CEC 2019f** – California Energy Commission (CEC). (TN 229557). Report of Conversation – Silicon Valley Power Responses to Questions from Staff, dated August 27 2019. Available online at: <https://efiling.energy.ca.gov/Lists/DocketLog.aspx?docketnumber=19-SPPE-01>.
- Jacobs 2019a** – Jacobs (Jacobs). (TN 227273-1). Application for Small Power Plant Exemption: Laurelwood Data Center, dated March 5, 2019. Available online at: <https://efiling.energy.ca.gov/Lists/DocketLog.aspx?docketnumber=19-SPPE-01>.
- Jacobs 2019c** – Jacobs (Jacobs). (TN 227626). LDC Responses to Formal and Informal Data Requests. Data Response Set 1A, dated April 11, 2019. Available online at: <https://efiling.energy.ca.gov/Lists/DocketLog.aspx?docketnumber=19-SPPE-01>.
- Jacobs 2019d** – Jacobs (Jacobs). (TN228748). LDC Updated SPPE Project Description, dated June 13, 2019. Available online at: <https://efiling.energy.ca.gov/Lists/DocketLog.aspx?docketnumber=19-SPPE-01>.
- Jacobs 2019e** – Jacobs (Jacobs). (TN 228822). LDC Response to Informal Data Requests. Data Response Set 3, dated June 21, 2019. Available online at: <https://efiling.energy.ca.gov/Lists/DocketLog.aspx?docketnumber=19-SPPE-01>.
- Jacobs 2019f** – Jacobs (Jacobs). (TN 228823). LDC Updated SPPE Project Description, dated June 21, 2019. Available online at: <https://efiling.energy.ca.gov/Lists/DocketLog.aspx?docketnumber=19-SPPE-01>.
- Jacobs 2019g** – Jacobs (Jacobs). (TN 228854). LDC Data Request Response Set 1B, dated June 27, 2019. Available online at: <https://efiling.energy.ca.gov/Lists/DocketLog.aspx?docketnumber=19-SPPE-01>.
- Jacobs 2019i** – Jacobs (Jacobs). (TN 229001). LDC Response to Data Request, Set 4, dated July 16, 2019. Available online at: <https://efiling.energy.ca.gov/Lists/DocketLog.aspx?docketnumber=19-SPPE-01>.
- Jacobs 2019k** – Jacobs (Jacobs). (TN 229160). LDC Response to Data Request, Set 5, dated July 31, 2019. Available online at: <https://efiling.energy.ca.gov/Lists/DocketLog.aspx?docketnumber=19-SPPE-01>.



## **Section 5**

---

### Environmental Analysis and Mitigation

## 5 Environmental Setting and Environmental Impacts

### 5.1 Aesthetics

This section describes the environmental and regulatory setting, and discusses impacts specific to aesthetics associated with the demolition/construction and operation of the Laurelwood Data Center (LDC or project) in the existing landscape.<sup>1</sup>

#### AESTHETICS

Except as provided in Public Resources Code Section 21099 <sup>2</sup> , would the project:	Potentially Significant Impact	Less Than Significant With Mitigation Incorporated	Less Than Significant Impact	No Impact
a. Have a substantial adverse effect on a scenic vista?	<input type="checkbox"/>	<input type="checkbox"/>	<input type="checkbox"/>	<input checked="" type="checkbox"/>
b. Substantially damage scenic resources, including, but not limited to, trees, rock outcroppings, and historic buildings within a State scenic highway?	<input type="checkbox"/>	<input type="checkbox"/>	<input type="checkbox"/>	<input checked="" type="checkbox"/>
c. In non-urbanized areas, substantially degrade the existing visual character or quality of public views of the site and its surroundings? (Public views are those that are experienced from publicly accessible vantage point). If the project is in an urbanized area, would the project conflict with applicable zoning and other regulations governing scenic quality?	<input type="checkbox"/>	<input type="checkbox"/>	<input checked="" type="checkbox"/>	<input type="checkbox"/>
d. Create a new source of substantial light or glare which would adversely affect day or nighttime views in the area?	<input type="checkbox"/>	<input type="checkbox"/>	<input checked="" type="checkbox"/>	<input type="checkbox"/>

Environmental checklist established by CEQA Guidelines, Appendix G.

#### 5.1.1 Setting

The proposed project is located on relatively flat land in a highly developed urban area within the City of Santa Clara, California. California's Great America and Levi's Stadium are approximately three-fourths of a mile and one mile to the north, respectively. San Tomas Aquino Creek and West Valley Mission College are 500 feet and one mile to the west, respectively. Agnews Historic Park and Oracle Santa Clara campus are one mile to the east and the Guadalupe River a half-mile further. U.S. Highway 101 is to the south and San Jose International Airport 1½ miles to the southeast. Light industrial, office, and research and development complexes and buildings complete the area.

The 11.7-acre project site currently includes an asphalt-paved area, and area where two buildings formerly used in the manufacturing of semiconductor products and passive components were removed. Mature trees and shrubs are along the perimeter.

<sup>1</sup> The author defines a landscape as "[t]he outdoor environment, natural or built, which can be directly perceived by a person visiting and using that environment. A scene is the subset of a landscape which is viewed from one location (vantage point) looking in one direction.... The term landscape clearly focuses upon the visual properties or characteristics of the environment, these include natural and man-made elements and physical and biological resources which could be identified visually; thus non-visual biological functions, cultural/historical values, wildlife and endangered species, wilderness value, opportunities for recreation activities and a large array of tastes, smells and feelings are not included." (Hull and Revell 1989)

<sup>2</sup> The proposed project is not an employment center project on an infill site within a transit priority area as defined in Public Resources Code, section 21099. "Aesthetic and parking impacts of a residential, mixed-use residential, or employment center project on an infill site within a transit priority area shall not be considered significant impacts on the environment" (Pub. Resources Code, §21099[d][1]).

Intel Corporation's Mission campus is along three sides of the project site. The approximate 50-acre campus houses several corporate organizations: engineering (design, research and development), software engineering, sales and marketing, legal, supply network, and human resources, and has more than 7,000 employees.

The LDC includes two buildings. Building 1 would be an approximate 250,560 square-foot three-story structure. Building 2 would be an approximate 283,392 square-foot four-story structure. Both buildings include loading docks, storm water bio-swales, paved surface parking, and landscaping. Standby diesel generators are to be located in equipment yards along the outside of each building. Each building having 28 standby generators. The project includes an onsite 31,150 square-foot substation with an electrical supply line that connects to a Silicon Valley Power distribution line 0.1-mile to the west. The electric supply line requires installation of three transmission line poles. Buildings 1 and 2 are to be constructed of steel structural components with metal-framed, and insulated exterior walls with stucco or metal panel façade containing accent fields and reveals. Entries would include curtain wall glazing and an aluminum canopy. (Jacobs 2019d) Refer to the **Section 4.1, Project Description** for further details regarding the project.

## **Regulatory Background**

### ***Federal***

No federal regulations related to aesthetics apply to the project.

### ***State***

**California Scenic Highway Program.** California's Scenic Highway Program is a provision of the Streets and Highways Code established by the Legislature in 1963 to preserve and enhance the natural beauty of California. The Scenic Highway Program includes highways that are eligible for designation as scenic highways or designated as such. The status of a state scenic highway changes from eligible to "officially designated" when the local jurisdiction adopts a scenic corridor protection program, applies to the California Department of Transportation (Caltrans) for scenic highway approval, and receives the designation from Caltrans. A city or county may propose to add routes with outstanding scenic elements to the list of eligible highways; however, state legislation is required for a highway to be officially designated. Review of the California Scenic Highway Mapping System shows no designated state scenic highway near the project.

### ***Local***

**City of Santa Clara.** The City of Santa Clara 2010–2035 General Plan (General Plan) adopted November 16, 2010 shows the project site designated Low Intensity Office/Research and Development. This land use designation "is intended for campus-like office development that includes office and R&D, as well as medical facilities and free-standing data centers..." (Santa Clara 2010).

The Santa Clara Zoning Map shows the project within the Planned Industrial (MP) zone district (Santa Clara 2019a, Chapter 18.46). "This district is intended to provide an environment exclusively for and conducive to the development and protection of modern large-scale administrative facilities, research institutions, and specialized manufacturing organizations, all of a non-nuisance type. Such permitted uses shall not cause objectionable noise, smoke, odor, dust, noxious gases, vibration, glare, heat, fire hazards, or other wastes emanating from the property. The district is to provide for an aesthetically attractive working environment with park-like grounds, attractive buildings, ample employee parking, and other amenities

appropriate to an employee-oriented activity where problems of product handling, storage, advertising, and distribution are not of significant concern.” (Santa Clara 2019a, §18.46.020)

The Santa Clara Zoning Code (Santa Clara 2019a) establishes zoning districts applied to individual properties consistent with the General Plan land use designations. For each of the zone districts, the Code identifies land uses that are permitted, conditionally permitted, and not permitted. It also establishes standards such as minimum lot size, maximum building height, and the minimum distance buildings are set back from the street. Provisions for parking, landscaping, lighting, and other rules that guide the development of projects are also included. Staff reviewed the following zone code requirements that have some relation to scenic quality:

- The MP zone district has a maximum building height of 70 feet (Santa Clara 2019a, §18.46.070).
- The MP zone district has a maximum building coverage of not more than 50 percent of the area of any lot (Santa Clara 2019a, §18.46.110).
- The MP zone district requires open landscaped area on a project site (Santa Clara 2019a, §18.46.120).
- The MP zone district requires new onsite lighting be reflected away from residential areas and public streets (Santa Clara 2019a, §18.46.140(c)).

The project’s buildings and site improvements would be subject to the City of Santa Clara’s architectural review (Santa Clara 2019a, Chapter 18.76). Architectural review is to “encourage the orderly and harmonious appearance of structures and property; maintain the public health, safety and welfare; maintain the property and improvement values, and to encourage the physical development of the City as intended by the general plan...” (Santa Clara 2019a, §18.76.010).

“The Architectural Review process is the responsibility of the Architectural Committee or Zoning Administrator, as designated.... The Committee reviews plans and drawings submitted for architectural review for design, aesthetic considerations, and consistency with zoning standards, generally prior to submittal for Building Permits. The Architectural Committee may require the applicant or owner of any such proposed development to modify buildings, parking areas, landscaping, signs, and other facilities and improvements as conditions of approval. No permit shall be issued, and no structure, building, or sign shall be constructed or used in any case until such plans and drawings have been approved by the Architectural Committee.” (Santa Clara 2019b)

## 5.1.2 Environmental Impacts and Mitigation Measures

### *a. Would the project have a substantial adverse effect on a scenic vista?*

#### **Demolition/Construction**

NO IMPACT. The removal of the onsite asphalt paved area and underground piping (demolition) and subsequent construction-related activity would not have a substantial adverse visual effect. The activities would not result in a permanent view alteration to the landscape provided the surface area(s) where the activity takes place is returned/restored to its pre-construction condition or an aesthetically better condition.

In addition, the demolition and construction–related activity would not have a substantial adverse effect on a scenic vista for the reasons explained below under operation and maintenance.

## Operation and Maintenance

NO IMPACT. Neither CEQA nor the CEQA Guidelines provide a clear-cut definition of what constitutes a scenic vista. Lead agencies may look to local planning documents for guidance when defining the visual impact standard for the purposes of CEQA.<sup>3</sup> “In general, in answering this question it is best to apply a broad approach to what constitutes a scenic vista. Not all of these relate to ocean views, mountains, hills, lakes, rivers, canyons, open spaces or other natural features. They can include an urban setting that is important on a communitywide basis and helps define the aesthetic character of a community.” (Street 2010) The Santa Clara General Plan does not identify a distinct scenic vista or a specific related policy.

In addition, staff used as the definition for a scenic vista “a distant view of high pictorial quality perceived through and along a corridor or opening.” The California Energy Commission in its Commission Decision (certification) for a number of thermal power plant projects used this definition.<sup>4</sup> Review of aerial and street imagery show the project site is not located within a scenic vista under any of these definitions. The project site is located on relatively flat land in a highly developed urban area within the city. In addition, aboveground buildings and structures, earthwork, trees, and vegetation that surround the project site restrict its public view. The project would not have a substantial adverse effect on a scenic vista.

**Proposed Mitigation Measures:** None.

**b. *Would the project substantially damage scenic resources, including, but not limited to, trees, rock outcroppings, and historic buildings within a state scenic highway?***

Neither CEQA nor the CEQA Guidelines provide a clear-cut definition of what constitutes a scenic resource. A scenic resource may be explained in general as a natural or man-made feature tangible in the landscape (e.g., a scenic resource designated in an adopted federal, state, or local government document, plan, or regulation, a landmark, or a cultural resource [historic values however differ from aesthetic or scenic values]). This analysis evaluated if the project would substantially damage—eliminate or obstruct—the public view<sup>5</sup> of a scenic resource, and if the project is situated so that it changes the visual aspect of the scenic resource by being different or in sharp contrast.

## Demolition/Construction

NO IMPACT. The demolition and construction-related activity would not have a substantial adverse visual effect. The activities would not result in a permanent view alteration to the landscape provided the surface area(s) where the activity takes place is returned/restored to its pre-construction condition or an aesthetically better condition.

In addition, the demolition and construction-related activity would not have a substantial adverse effect on a scenic resource for the reasons explained below under operation and maintenance.

---

<sup>3</sup> *Mira Mar Mobile Community v. City of Oceanside* (2004) 119 Cal. App. 4th 477.

<sup>4</sup> California Energy Commission Final Decision for GWF Tracy Combined Cycle Power Plant Project Docket Number 08-AFC-7, Visual Resources, p. 321; California Energy Commission Decision for Mariposa Energy Project Docket Number 09-AFC-3, Visual Resources, p. 5; California Energy Commission Decision for Blythe Solar Power Project Docket Number 09-AFC-6, Visual Resources, p. 514; California Energy Commission Decision for Genesis Solar Energy Project Docket Number 09-AFC-8, Visual Resources, p. 7-8; California Energy Commission Decision for Pio Pico Energy Center Docket Number 11-AFC-01, Visual Resources, p. 8.5-4.

<sup>5</sup> Public view is the visible area from a location where the public has a legal and physical right of access to real property (e.g., city sidewalk, public park, town square, state highway).

## Operation and Maintenance

NO IMPACT. Review of aerial and street view imagery and the city's General Plan found no scenic resource on the site or in the area. The project would not be situated such that it changes the visual aspect of a scenic resource by being different or in sharp contrast.

The Santa Clara General Plan Environmental Impact Report identified the Santa Cruz Mountains and the Diablo range of the Pacific Coast Ranges, San Tomas Aquino Creek, and the Guadalupe River as "dominant visual resources" (Santa Clara 2011). In a visual impact assessment, areas beyond the foreground-middleground zone from a viewpoint, but usually less than 15 miles away are in the background zone. Areas not seen as foreground-middleground or background are in the seldom-seen zone. The background and seldom-seen zones are viewed in less detail by the observer, and most impacts blend with the landscape because of distance. (BLM 1986) The Santa Cruz Mountains and Diablo range are in the seldom-seen zone from the project site. San Tomas Aquino Creek 500 feet to the west and the Guadalupe River 1½ miles to the east of the project site are not noticeable due to aboveground buildings and structures, earthwork, trees, and vegetation. The project would not substantially damage a scenic resource.

**Proposed Mitigation Measures:** None.

- c. ***Would the project, in non-urbanized areas, substantially degrade the existing visual character or quality of public views of the site and its surroundings? (Public views are those that are experienced from publicly accessible vantage point). If the project is in an urbanized area, would the project conflict with applicable zoning and other regulations governing scenic quality?***

The proposed project is within an urbanized area.<sup>6</sup> Based on information from the U.S. Census Bureau, the City of Santa Clara 2017-population was 127,134 (US Census 2017).

## Demolition/Construction

LESS THAN SIGNIFICANT IMPACT. The demolition and construction-related activity would not have a substantial adverse visual effect. The activities would not result in a permanent view alteration to the landscape provided the surface area(s) where the activity takes place is returned/restored to its pre-construction condition or an aesthetically better condition.

In addition, the demolition and construction-related activity would not have a substantial adverse effect in this urbanized area for the reasons explained below under operation and maintenance.

## Operation and Maintenance

LESS THAN SIGNIFICANT IMPACT. The MP zone district is to provide an environment exclusively for and conducive to the development and protection of modern large-scale administrative facilities, research institutions, and specialized manufacturing organizations, all of a non-nuisance type. Such permitted uses shall not cause objectionable noise, smoke, odor, dust, noxious gases, vibration, glare, heat, fire hazards, or other wastes emanating from the property (Santa Clara 2019a, Chapter 18.46).

The project would have 56 diesel generators to provide standby generation in case of an interruption in electrical supply. The cold start-up of the standby generators on a cool, humid day when the

<sup>6</sup> Under Public Resources Code section 21071 an urbanized area includes "(a) An incorporated city that meets either of the following criteria: (1) Has a population of a least 100,000 persons. (2) Has a population of less than 100,000 persons if the population of that city and not more than two contiguous incorporated cities combined equals at least 100,000 persons."



outdoor air is at or near saturation, may result in the formation of a publicly visible water vapor plume (visible plume) emitted to the atmosphere for a brief time until normal operating temperature is obtained. Although the plume could be large, and noticeable to the area, it would rarely occur. Because the plume would be a rare occurrence and of a relatively short duration it would not become a nuisance.

The MP zone district has a maximum building coverage of not more than 50 percent of the area of any lot (Santa Clara 2019a, §18.46.110). The project's building coverage would cover approximately 37 percent of the project site.

The MP zone district requires open landscaped area on a project site (Santa Clara 2019a, §18.46.120). Specifically, it requires that a lot have not less than 25 percent of the lot area developed into and permanently maintained as open landscaped area. The applicant has provided a site plan that shows the approximate 11.7-acre (509,652 square foot) project site would have open landscape area totaling 131,450 square feet: 25.8 percent of the lot (Jacobs 2019d, Figure 2-1R).

The MP zone district requires new onsite lighting be reflected away from residential areas and public streets (Santa Clara 2019a, §18.46.140 (c)). The project design includes directional and/or shielded light fixtures to keep lighting onsite and to minimize brightness and glare.

The MP zone district has a maximum building height of 70 feet (Santa Clara 2019a, §18.46.70). For zoning code conformance purposes, the applicant is currently working to obtain a minor modification from the city's Zoning Administrator to allow heights of 81 and 84 feet for Buildings 1 and 2, respectively. The height exceedance for the buildings being 11 and 14 feet. The applicant anticipates the granting of the minor modification during building permit review.

A few purposes of a height requirement are to preserve a scenic vista, protect the public view of a scenic resource (e.g., architectural structure, a landmark, natural feature), and to maintain the character of a site and surrounding area (e.g., residential or commercial area). As previously discussed, review of aerial and street imagery show the project site is not located within a scenic vista, and the project would not block the public view of a scenic resource. The project site is in a landscape that includes Intel Corporation's Mission campus. The 50-acre campus borders three sides of the project. It has 10-15 structures estimated by appearance to range in height between 40-110 feet.

The project as proposed would not significantly affect a scenic vista or scenic resources, and inclusive of the minor modification in allowable height would maintain the character of the site and surrounding area without resulting in a conflict with applicable zoning and other regulations governing scenic quality. The project would have a less than significant effect in this urbanized area.

**Proposed Mitigation Measures:** None.

**d. *Would the project create a new source of substantial light or glare which would adversely affect day or nighttime views in the area?***

A project may cause light trespass, sky glow, and glare affecting night and daytime views. Light trespass is "light falling where it is not wanted or needed" (e.g., spill light, obtrusive light) (IDA 2017). Sky glow is a result of light fixtures that emit a portion of their light directly upward into the sky where light scatters, creating an orange-yellow glow in the nighttime sky. Glare is "intense and blinding light that reduces visibility. A light within the field of vision that is brighter than the brightness to which the eyes are adapted" (IDA 2017).

## Demolition/Construction

LESS THAN SIGNIFICANT IMPACT. The demolition and construction-related activity would not create a new source of substantial light or glare adversely affecting day and nighttime views in the area.

Demolition would occur during daylight hours. Laydown and staging areas may have nighttime lighting for security purposes. Outdoor construction-related lighting would be directed away from offsite properties and the public right of way. Light fixtures are to be hooded/shielded.

## Operation and Maintenance

LESS THAN SIGNIFICANT IMPACT. The project includes outdoor lighting for driveways, entrances, walkways, parking areas, and security purposes. The MP zone district regulations section 18.46.140(c) states, "Lighting, if provided, shall reflect away from residential areas and public streets" (Santa Clara 2019a, §18.46.140 (c)). The project design includes directional and/or shielded light fixtures to keep lighting onsite and to minimize brightness and glare. Fully shielded light fixtures prevent light emission above the horizon into the sky, greatly reducing sky glow. Exterior surfaces of the buildings would have a low-glare finish to reduce reflectivity. The project would not have illuminated signage. The project would not create a new source of substantial light or glare that would adversely affect day or nighttime views in the area. The project would have a less than significant effect.

**Proposed Mitigation Measures:** None.

## 5.1.3 References

- BLM 1986** – Bureau of Land Management (BLM). U.S. Department of Interior Bureau of Land Management Manual Handbook H-8410-1 Visual Resources Inventory, January 17, 1986.
- Hull and Revell 1989** – Hull, R.B. and Revell, G.R.B. (1989). Issues in sampling landscapes for visual quality assessments. *Landscape and Urban Planning*, 17, 323-330. Available online at: <http://www.macaulay.ac.uk/ccw/task-two/evaluate.html>. Accessed on: May 8, 2017.
- IDA 2017** – International Dark-Sky Association (IDA). Available online at: <http://www.darksky.org/education/37-ida/education/98-glossary-of-basic-terms>. Accessed on: May 8, 2017.
- Jacobs 2019a** – Jacobs (Jacobs). (TN 227273-1). Application for Small Power Plant Exemption: Laurelwood Data Center dated February 28, 2019. Available online at: <https://efiling.energy.ca.gov/Lists/DocketLog.aspx?docketnumber=19-SPPE-01>
- Jacobs 2019b** – Jacobs (Jacobs). (TN 227273-2 through TN 227273-3). Laurelwood SPPE Application Appendices. Available online at: <https://efiling.energy.ca.gov/Lists/DocketLog.aspx?docketnumber=19-SPPE-01>.
- Jacobs 2019c** – Jacobs (Jacobs). (TN 227273-4). LDC Responses to Formal and Informal Data Requests - Data Response Set 1A. Available online at: <https://efiling.energy.ca.gov/Lists/DocketLog.aspx?docketnumber=19-SPPE-01>
- Jacobs 2019d** – Jacobs (Jacobs). (TN 228748). Updated SPE Project Description, dated June 13, 2019. Available online at: <https://efiling.energy.ca.gov/Lists/DocketLog.aspx?docketnumber=19-SPPE-01>.
- Kumares and Labi 2007** – Kumares C. Sinha, Samuel Labi, *Transportation Decision Making: Principles of Project Evaluation and Programming*, Wiley, Hoboken, New Jersey 2007.

**Santa Clara 2010** – City of Santa Clara (Santa Clara). 2010–2035 General Plan. Adopted November 16, 2010. Available online at: <http://santaclaraca.gov/government/departments/community-development/planning-division/general-plan>.

**Santa Clara 2011** – City of Santa Clara (Santa Clara). 2010-2035 General Plan Integrated Final Environmental Impact Report. January 2011. Available online at: <http://santaclaraca.gov/home/showdocument?id=12900>.

**Santa Clara 2019a** – City of Santa Clara (Santa Clara). City Code. February 2019. Available online at: <https://www.codepublishing.com/CA/SantaClara>. Accessed on: April 4, 2019.

**Santa Clara 2019b** – City of Santa Clara (Santa Clara). City Code. February 2019. Available online at: <https://www.codepublishing.com/CA/SantaClara>. Accessed on: April 4, 2019.

**Street 2010** – Street, Trevor. Guide to the CEQA Initial Study Checklist 2010. Ezine@rticles, May 28, 2010. Accessed on: May 8, 2017.

**US Census 2017** – United States Census Bureau (US Census). QuickFacts. Last updated: July 1, 2017. Available online at: <https://www.census.gov/quickfacts/>.

**USDOT FHA** – U.S. Department of Transportation Federal Highway Administration, “A Guide to Visual Quality in Noise Barrier Design,” Chapter 3. Visual Design Principles. n.d. Available online at: [https://www.fhwa.dot.gov/ENVIRONMENT/noise/noise\\_barriers/design\\_construction/visql/visql03.cfm](https://www.fhwa.dot.gov/ENVIRONMENT/noise/noise_barriers/design_construction/visql/visql03.cfm).

## 5.2 Agriculture and Forestry Resources

This section describes the environmental and regulatory setting and discusses impacts associated with the demolition/construction and operation of the Laurelwood Data Center (LDC or project) with respect to agriculture and forestry resources.

### AGRICULTURE AND FORESTRY RESOURCES

In determining whether impacts to agricultural resources are significant environmental effects, lead agencies may refer to the California Agricultural Land Evaluation and Site Assessment Model (1997) prepared by the California Department of Conservation as an optional model to use in assessing impacts on agriculture and farmland. In determining whether impacts to forest resources, including timberland, are significant environmental effects, lead agencies may refer to information compiled by the California Department of Forestry and Fire Protection regarding the state's inventory of forest land, including the Forest and Range Assessment Project and the Forest Legacy Assessment Project; and forest carbon measurement methodology provided in Forest Protocols adopted by the California Air Resources Board.

#### Would the project:

	Potentially Significant Impact	Less than Significant With Mitigation Incorporated	Less than Significant Impact	No Impact
a. Convert Prime Farmland, Unique Farmland, or Farmland of Statewide Importance (Farmland), as shown on the maps prepared pursuant to the Farmland Mapping and Monitoring Program of the California Resources Agency, to non-agricultural use?	<input type="checkbox"/>	<input type="checkbox"/>	<input type="checkbox"/>	<input checked="" type="checkbox"/>
b. Conflict with existing zoning for agricultural use, or a Williamson Act contract?	<input type="checkbox"/>	<input type="checkbox"/>	<input type="checkbox"/>	<input checked="" type="checkbox"/>
c. Conflict with existing zoning for, or cause rezoning of, forest land (as defined in Public Resources Code section 12220(g)), timberland (as defined by Public Resources Code section 4526), or timberland zoned Timberland Production (as defined by Government Code section 51104(g))?	<input type="checkbox"/>	<input type="checkbox"/>	<input type="checkbox"/>	<input checked="" type="checkbox"/>
d. Result in the loss of forest land or conversion of forest land to non-forest use?	<input type="checkbox"/>	<input type="checkbox"/>	<input type="checkbox"/>	<input checked="" type="checkbox"/>
e. Involve other changes in the existing environment which, due to their location or nature, could result in conversion of Farmland to non-agricultural use or conversion of forest land to non-forest use?	<input type="checkbox"/>	<input type="checkbox"/>	<input type="checkbox"/>	<input checked="" type="checkbox"/>

Environmental checklist established by CEQA Guidelines, Appendix G.

### 5.2.1 Setting

The project site is located in an existing industrial and office area in the City of Santa Clara. The project site is bounded by: Highway 101 to the south; Juliette Lane to the east; industrial, commercial, and office uses to the east and north; and a parking lot to the west.

### Regulatory Background

#### Federal

No federal regulations related to agriculture and forestry resources apply to the project.

### **State**

**Williamson Act.** The Williamson Act, or California Land Conservation Act (Gov. Code, § 51200 et seq.), is designed to preserve agricultural and open space land. It allows private landowners to enroll in contracts that voluntarily restrict land uses to agricultural and open space uses. In return, Williamson Act parcels receive a lower property tax rate consistent with agricultural and open space uses instead of with their market rate value. California Department of Conservation maps show that the project site is not subject to a Williamson Act contract (CDOC 2016a).

**Farmland Mapping and Monitoring Program.** The California Department of Conservation established the Farmland Mapping and Monitoring Program (FMMP) in 1982 to assess the location, quantity, and quality of agricultural lands and conversion of these lands to other uses. Every even-numbered year, FMMP publishes a Farmland Conversion Report. FMMP data are used in elements of some county and city general plans, in regional studies on agricultural land conversion, and in environmental documents as a way of assessing project-specific impacts on farmland. The FMMP identifies and maps agricultural lands as Prime Farmland, Farmland of Statewide Importance, Unique Farmland, Farmland of Local Importance, and Grazing Land.

The project site is within an extensive urban area designated as “Urban and Built-up Land” on the most recent (2016) Santa Clara County Important Farmland map. This designation applies to areas occupied by structures with a building density of at least one unit to 1.5 acres, or approximately six structures to a 10-acre parcel. Common land uses comprising the Urban and Built-up Land designation include residential, industrial, commercial, and institutional facilities. The region encompassing the project site is mostly “Urban and Built-up Land,” “Grazing Land,” and “Other Land,” and includes only minimal farmland (CDOC 2016b).

### **Local**

**City of Santa Clara General Plan/Zoning Ordinance.** The City of Santa Clara General Plan and Zoning Ordinance designate the project site for non-agricultural and non-forestland uses. The site’s General Plan designation is Low Intensity Office/Research and Development, which is “intended for campus-like office development that includes office and R&D, as well as medical facilities and free standing data centers” (Santa Clara 2010). The site’s zoning designation is Planned Industrial, which is “intended to provide an environment exclusively for and conducive to the development and protection of modern large-scale administrative facilities, research institutions, and specialized manufacturing institutions, all of a non-nuisance type” (Santa Clara 2019).

## **5.2.2 Environmental Impacts and Mitigation Measures**

- a. Would the project convert Prime Farmland, Unique Farmland, or Farmland of Statewide Importance (Farmland), as shown on the maps prepared pursuant to the Farmland Mapping and Monitoring Program of the California Resources Agency, to non-agricultural use?***

### **Demolition/Construction**

NO IMPACT. The project site is designated as “Urban and Built-up Land” on the Santa Clara County Important Farmland 2016 map, and there is no farmland near the project site. Demolition/construction activities would therefore not convert farmland to a non-agricultural use, and no impacts would occur.

### Operation and Maintenance

NO IMPACT. The project site is designated as “Urban and Built-up Land” on the Santa Clara County Important Farmland 2016 map, and there is no farmland near the project site. Operation and maintenance of the project would therefore not convert farmland to non-agricultural use, and no impacts would occur.

**Proposed Mitigation Measures:** None.

**b. *Would the project conflict with existing zoning for agricultural use, or a Williamson Act contract?***

### Demolition/Construction

NO IMPACT. The project site is zoned Planned Industrial, a non-agricultural zoning designation, and California Department of Conservation Maps show that the site is not subject to a Williamson Act contract. The project site is located in an urban area, and no farmland is located in the site vicinity. As a result, construction activities would not conflict with existing zoning for agricultural use or a Williamson Act contract.

### Operation and Maintenance

NO IMPACT. The project site is zoned Planned Industrial, a non-agricultural zoning designation, and California Department of Conservation Maps show that the site is not subject to a Williamson Act contract. The project site is located in an urban area, and no farmland is located in the site vicinity. As a result, operation and maintenance activities would not conflict with existing zoning for agricultural use or a Williamson Act contract.

**Proposed Mitigation Measures:** None.

**c. *Would the project conflict with existing zoning for, or cause rezoning of, forest land (as defined in Public Resources Code section 12220(g)), timberland (as defined by Public Resources Code section 4526), or timberland zoned Timberland Production (as defined by Government Code section 51104(g))?***

### Demolition/Construction

NO IMPACT. The project site is zoned Planned Industrial, which is “intended to provide an environment exclusively for and conducive to the development and protection of modern large-scale administrative facilities, research institutions, and specialized manufacturing institutions, all of a non-nuisance type” (Santa Clara 2019). The project site and vicinity are developed with various urban uses, and no nearby land is zoned for forest land, timberland, or timberland production. As a result, demolition/construction activities would cause no impacts.

### Operation and Maintenance

NO IMPACT. The project site is zoned Planned Industrial, which is “intended to provide an environment exclusively for and conducive to the development and protection of modern large-scale administrative facilities, research institutions, and specialized manufacturing institutions, all of a non-nuisance type” (Santa Clara 2019). The project site and vicinity are developed with various urban uses, and no nearby land is zoned for forest land, timberland, or timberland production. As a result, operation and maintenance of the project would cause no impacts.



**Proposed Mitigation Measures:** None.

**d. *Would the project result in the loss of forest land or conversion of forest land to non-forest use?***

**Demolition/Construction**

NO IMPACT. The project site does not contain forest land and is not in an area where forest land is present; therefore, demolition/construction would not result in the loss of forest land or conversion of forest land to non-forest use.

**Operation and Maintenance**

NO IMPACT. The project site does not contain forest land and is not in an area where forest land is present; therefore, operation and maintenance would not result in the loss of forest land or conversion of forest land to non-forest use.

**Proposed Mitigation Measures:** None.

**e. *Would the project involve other changes in the existing environment, which, due to their location or nature, could result in conversion of Farmland to non-agricultural use or conversion of forest land to non-forest use?***

**Demolition/Construction**

NO IMPACT. The site and surrounding region are developed with urban uses. Therefore, demolition/construction would not cause other changes to the environment that would result in conversion of farmland to non-agricultural use or conversion of forest land to non-forest use.

**Operation and Maintenance**

NO IMPACT. The site and surrounding region are developed with urban uses. Therefore, project operation and maintenance would not cause other changes to the environment that would result in conversion of farmland to non-agricultural use or conversion of forest land to non-forest use.

**Proposed Mitigation Measures:** None.

### 5.2.3 References

**CDOC 2016a** – California Department of Conservation (CDOC). 2016 Williamson Act Maps. Available online at: <ftp://ftp.consrv.ca.gov/pub/dlrp/wa/>. Accessed on: April 18, 2019.

**CDOC 2016b** – California Department of Conservation (CDOC). 2016 Farmland Mapping and Monitoring Program. County PDF Maps. Santa Clara County. Available online at: <ftp://ftp.consrv.ca.gov/pub/dlrp/FMMP/pdf/2016/scl16.pdf>. Accessed on: April 3, 2019.

**Jacobs 2019a** – Jacobs (Jacobs). (TN 227273-1). Application for Small Power Plant Exemption: Laurelwood Data Center, dated March 5, 2019. Available online at: <https://efiling.energy.ca.gov/Lists/DocketLog.aspx?docketnumber=19-SPPE-01>.

**Santa Clara 2019** – City of Santa Clara (Santa Clara). City Code, Chapter 18.46: Regulations for MP-Planned Industrial Zoning Districts. Available online at: <https://www.codepublishing.com/CA/SantaClara/#!/SantaClara18/SantaClara1846.html#18.46>. Accessed on: April 18, 2019.

**Santa Clara 2010** – City of Santa Clara (Santa Clara). 2010–2035 General Plan: Chapter 5 Goals and Policies, Land Use Diagrams Phases I, II, and III. Approved by City Council November 16, 2010. Available online at: <http://santaclaraca.gov/government/departments/community-development/planning-division/general-plan>. Accessed on: March 29, 2019.

## 5.3 Air Quality

This section describes the environmental and regulatory setting and discusses impacts associated with the demolition/construction and operation of the Laurelwood Data Center (LDC or project) with respect to air quality.

### AIR QUALITY

Where available, the significance criteria established by the applicable air quality management district or air pollution control district may be relied upon to make the following determinations.

#### Would the project:

	Potentially Significant Impact	Less than Significant With Mitigation Incorporated	Less than Significant Impact	No Impact
a. Conflict with or obstruct implementation of the applicable air quality plan?	<input type="checkbox"/>	<input type="checkbox"/>	<input checked="" type="checkbox"/>	<input type="checkbox"/>
b. Result in a cumulatively considerable net increase of any criteria pollutant for which the project region is non-attainment under an applicable federal or state ambient air quality standard?	<input type="checkbox"/>	<input type="checkbox"/>	<input checked="" type="checkbox"/>	<input type="checkbox"/>
c. Expose sensitive receptors to substantial pollutant concentrations?	<input type="checkbox"/>	<input type="checkbox"/>	<input checked="" type="checkbox"/>	<input type="checkbox"/>
d. Result in other emissions (such as those leading to odors) adversely affecting a substantial number of people?	<input type="checkbox"/>	<input type="checkbox"/>	<input checked="" type="checkbox"/>	<input type="checkbox"/>

Environmental checklist established CEQA Guidelines, Appendix G.

### 5.3.1 Setting

#### Criteria Pollutants

The United States Environmental Protection Agency (US EPA) and the California Air Resources Board (ARB) have established ambient air quality standards for several pollutants based on their adverse health effects. The US EPA has set National Ambient Air Quality Standards (NAAQS) for ozone (O<sub>3</sub>), carbon monoxide (CO), nitrogen dioxide (NO<sub>2</sub>), particulate matter less than 10 microns (PM<sub>10</sub>), fine particulate matter less than 2.5 microns (PM<sub>2.5</sub>), sulfur dioxide (SO<sub>2</sub>), and lead (Pb). These pollutants are commonly referred to as “criteria pollutants.” Primary standards were set to protect public health; secondary standards were set to protect public welfare against visibility impairment, damage to animals, crops, vegetation, and buildings. In addition, ARB has established California Ambient Air Quality Standards (CAAQS) for these pollutants, as well as for sulfate (SO<sub>4</sub>), visibility reducing particles, hydrogen sulfide (H<sub>2</sub>S), and vinyl chloride. California standards are generally stricter than national standards. The standards currently in effect in California and relevant to the project are shown in **Table 5.3-1**.

#### Attainment Status and Air Quality Plans

The US EPA, ARB, and the local air districts classify an area as attainment, unclassified, or nonattainment. The classification depends on whether the monitored ambient air quality data show compliance, insufficient data are available, or non-compliance with the ambient air quality standards, respectively. The proposed Laurelwood Data Center (LDC) would be located in Santa Clara County in the San Francisco Bay Area Air Basin (SFBAAB), under the jurisdiction of the Bay Area Air Quality Management District (BAAQMD). **Table 5.3-2** summarizes attainment status for the relevant criteria pollutants in the SFBAAB with both the federal and state standards.

**TABLE 5.3-1 NATIONAL AND CALIFORNIA AMBIENT AIR QUALITY STANDARDS**

Pollutant	Averaging Time	California Standards <sup>a</sup>	National Standards <sup>b</sup>	
			Primary	Secondary
O <sub>3</sub>	1-hour	0.09 ppm (180 µg/m <sup>3</sup> )	—	Same as Primary Standard
	8-hour	0.070 ppm (137 µg/m <sup>3</sup> )	0.070 ppm (137 µg/m <sup>3</sup> )	
PM <sub>10</sub>	24-hour	50 µg/m <sup>3</sup>	150 µg/m <sup>3</sup>	Same as Primary Standard
	Annual Mean	20 µg/m <sup>3</sup>	—	
PM <sub>2.5</sub>	24-hour	—	35 µg/m <sup>3</sup>	Same as Primary Standard
	Annual Mean	12 µg/m <sup>3</sup>	12 µg/m <sup>3</sup>	
CO	1-hour	20 ppm (23 mg/m <sup>3</sup> )	35 ppm (40 mg/m <sup>3</sup> )	—
	8-hour	9.0 ppm (10 mg/m <sup>3</sup> )	9 ppm (10 mg/m <sup>3</sup> )	—
NO <sub>2</sub>	1-hour	0.18 ppm (339 µg/m <sup>3</sup> )	100 ppb (188 µg/m <sup>3</sup> ) <sup>c</sup>	—
	Annual Mean	0.030 ppm (57 µg/m <sup>3</sup> )	0.053 ppm (100 µg/m <sup>3</sup> )	Same as Primary Standard
SO <sub>2</sub> <sup>d</sup>	1-hour	0.25 ppm (655 µg/m <sup>3</sup> )	75 ppb (196 µg/m <sup>3</sup> )	—
	3-hour	—	—	0.5 ppm (1,300 µg/m <sup>3</sup> )
	24-hour	0.04 ppm (105 µg/m <sup>3</sup> )	0.14 ppm (for certain areas) <sup>d</sup>	—
	Annual Mean	—	0.030 ppm (for certain areas) <sup>d</sup>	—

**Notes:** ppm=parts per million; ppb = parts per billion; µg/m<sup>3</sup> = micrograms per cubic meter; mg/m<sup>3</sup> = milligrams per cubic meter; "—" = no standard

<sup>a</sup> California standards for O<sub>3</sub>, CO (except 8-hour Lake Tahoe), SO<sub>2</sub> (1 and 24 hour), NO<sub>2</sub>, and particulate matter (PM<sub>10</sub>, PM<sub>2.5</sub>, and visibility reducing particles), are values that are not to be exceeded. All others are not to be equaled or exceeded.

<sup>b</sup> National standards (other than O<sub>3</sub>, PM, NO<sub>2</sub> [see note c below], and those based on annual arithmetic mean) are not to be exceeded more than once a year. The O<sub>3</sub> standard is attained when the fourth highest 8-hour concentration measured at each site in a year, averaged over three years, is equal to or less than the standard. For PM<sub>10</sub>, the 24 hour standard is attained when the expected number of days per calendar year with a 24-hour average concentration above 150 µg/m<sup>3</sup> is equal to or less than one. For PM<sub>2.5</sub>, the 24 hour standard is attained when 98 percent of the daily concentrations, averaged over three years, are equal to or less than the standard.

<sup>c</sup> To attain the 1-hour national standard, the 3-year average of the annual 98th percentile of the 1-hour daily maximum concentrations at each site must not exceed 100 ppb.

<sup>d</sup> On June 2, 2010, a new 1-hour SO<sub>2</sub> standard was established and the existing 24-hour and annual primary standards were revoked. To attain the 1-hour national standard, the 3-year average of the annual 99th percentile of the 1-hour daily maximum concentrations at each site must not exceed 75 ppb. The 1971 SO<sub>2</sub> national standards (24-hour and annual) remain in effect until one year after an area is designated for the 2010 standard, except that in areas designated nonattainment for the 1971 standards, the 1971 standards remain in effect until implementation plans to attain or maintain the 2010 standards are approved.

Source: ARB 2016

Overall air quality in the SFBAAB is better than most other developed areas in California, including the South Coast, San Joaquin Valley, and Sacramento regions. This is due to a more favorable climate, with cooler temperatures and regional air flow patterns that transports pollutants emitted in the air basin out of the air basin. Although air quality improvements have occurred, violations and exceedances of the state ozone and PM standards continue to persist in the SFBAAB, and still pose challenges to state and local air pollution control agencies (ARB 2013). The project area's proximity to both the Pacific Ocean and the San Francisco Bay has a moderating influence on the climate. This portion of the Santa Clara Valley is bounded by the San Francisco Bay to the north, the Santa Cruz Mountains to the southwest, and the Diablo Range to the east. The surrounding terrain greatly influences winds in the valley, resulting in a prevailing wind that flows along the valley's northwest-southeast axis.

Pollutants in the air can cause health problems, especially for children, the elderly, and people with heart or lung problems. Healthy adults may experience symptoms during periods of intense exercise. Pollutants can also cause damage to vegetation, animals, and property.

**TABLE 5.3-2 ATTAINMENT STATUS FOR SFBAAB**

Pollutant	Averaging Time	State Designation	Federal Designation
O <sub>3</sub>	1-hour	Nonattainment	—
	8-hour	Nonattainment	Nonattainment
PM <sub>10</sub>	24-hour	Nonattainment	Unclassified
	Annual	Nonattainment	—
PM <sub>2.5</sub>	24-hour	—	Nonattainment <sup>a</sup>
	Annual	Nonattainment	Unclassifiable/attainment <sup>b</sup>
CO	1-hour	Attainment	Attainment
	8-hour	Attainment	Attainment
NO <sub>2</sub>	1-hour	Attainment	Unclassifiable/Attainment
	Annual	Attainment	Attainment
SO <sub>2</sub>	1-hour	Attainment	Attainment/Unclassifiable <sup>c</sup>
	24-hour	Attainment	— <sup>d</sup>
	Annual	—	— <sup>d</sup>

**Notes:**

<sup>a</sup> On January 9, 2013, US EPA issued a final rule to determine that the Bay Area attains the 24-hour PM<sub>2.5</sub> national standard (US EPA 2013). This US EPA rule suspends key state implementation plan (SIP) requirements as long as monitoring data continues to show that the Bay Area attains the standard. Despite this US EPA action, the Bay Area will continue to be designated as “nonattainment” for the national 24-hour PM<sub>2.5</sub> standard until such time as the BAAQMD submits a “redesignation request” and a “maintenance plan” to US EPA, and US EPA approves the proposed redesignation.

<sup>b</sup> In December 2012, US EPA strengthened the annual PM 2.5 NAAQS from 15.0 to 12.0 µg/m<sup>3</sup>. In December 2014, US EPA issued final area designations for the 2012 primary annual PM 2.5 NAAQS (US EPA 2014). Areas designated “unclassifiable/attainment” must continue to take steps to prevent their air quality from deteriorating to unhealthy levels. The effective date of this standard is April 15, 2015.

<sup>c</sup> On January 9, 2018, US EPA issued a final rule to establish the initial air quality designations for certain areas in the US for the 2010 SO<sub>2</sub> primary NAAQS (US EPA 2018). This final rule designated the SFBAAB as attainment/unclassifiable for the 2010 SO<sub>2</sub> primary NAAQS.

<sup>d</sup> See note d under **Table 5.3-1**.

**Sources:** ARB 2019a, BAAQMD 2019a, US EPA 2011c, US EPA 2013, US EPA 2014, US EPA 2018

## Existing Ambient Air Quality

The nearest background ambient air quality monitoring station to the project is the San Jose – Jackson Street station, which is about 4.7 miles southeast of the project site. **Table 5.3-3** presents the air quality monitoring data San Jose – Jackson Street monitoring station from 2013 to 2018, the most recent years for which data are available. Data in **Table 5.3-3** that are marked in **bold** indicate that the most-stringent current standard was exceeded during that period.

**TABLE 5.3-3 AMBIENT AIR QUALITY MONITORING DATA**

Pollutant	Averaging Time	2013	2014	2015	2016	2017	2018
O <sub>3</sub> (ppm)	1-hour	<b>0.093</b>	0.089	<b>0.094</b>	0.087	<b>0.121</b>	0.078
	8-hour	<b>0.079</b>	0.066	<b>0.081</b>	0.066	<b>0.098</b>	0.061
PM10 (µg/m <sup>3</sup> )	24-hour	<b>58.1</b>	<b>54.7</b>	<b>58</b>	41	<b>69.8</b>	<b>155.8</b>
	Annual	<b>22.2</b>	20	<b>21.9</b>	18.3	<b>21.3</b>	<b>23.1</b>
PM2.5 (µg/m <sup>3</sup> )	24-hour (98th percentile)	35	28	32	20	<b>41</b>	<b>133.9</b>
	Annual	<b>12.4</b>	9.3	10.6	8.4	10.1	<b>12.9</b>
NO <sub>2</sub> (ppb)	1-hour (maximum)	59	58	49	51	68	86
	1-hour (98th percentile)	52	55	44	42	50	59
	Annual	15.18	13.07	12.81	11.26	12.24	12
CO (ppm)	1-hour	3	2.4	2.4	1.9	2.1	2.5
	8-hour	2.5	1.9	1.8	1.4	1.8	2.1
SO <sub>2</sub> (ppb)	1-hour (maximum)	2.5	3	3.1	1.8	3.6	6.9
	1-hour (99th percentile)	2	2	2	2	3	na
	24-hour	1.4	0.9	1.1	0.8	1.1	1.1

**Notes:**  
Concentrations in **bold** type are those that exceed the limiting ambient air quality standard.  
na – Not available.  
**Sources:** ARB 2019b, US EPA 2019, BAAQMD 2019c

The maximum concentration values listed below in **Table 5.3-3** have not been screened to remove values that are designated as extreme events. Extreme events, such as wildfires, are normally excluded from consideration as AAQS violations for their short-term or long-term ambient pollutant concentration contributions. Extreme events undoubtedly affected many of the maximum concentration values listed for 2018, most of which occurred in mid-November during a period of extensive wildfire activity. The types of major regional events that are normally excluded from AAQS violation as extreme events could also cause the project to operate the standby engine generators in emergency mode due these events causing regional or local electrical outages. However, electrical outages can also be caused locally by events that would not be considered extreme regional events, such as the circuits feeding the project being damaged by animals or metallic balloons.

### Toxic Air Contaminants

According to section 39655 of the California Health and Safety Code, a toxic air contaminant (TAC) is "an air pollutant which may cause or contribute to an increase in mortality or an increase in serious illness, or which may pose a present or potential hazard to human health." TACs, also referred to as hazardous air pollutants (HAPs) or air toxics, are different from criteria air pollutants such as ground-level ozone, particulate matter, carbon monoxide, nitrogen dioxide, sulfur dioxide and lead. Criteria air pollutants are regulated by national and state Ambient Air Quality Standards as noted above. However, there are no ambient standards for most TACs<sup>1</sup> so a site specific health risk assessment (HRA) is conducted to evaluate whether risks of exposure to TACs create an adverse impact. Specific TACs with known acute, chronic, and cancer health impacts have been identified by California Air Resources Board (ARB) in the California Code

<sup>1</sup> Ambient air quality standards for TACs exist for lead (federal and state standards), hydrogen sulfide (state standard), and vinyl chloride (state standard).



of Regulations, Title 17, section 90000. The nearly 200 regulated TACs include asbestos, organic and inorganic chemical compounds and compound categories, diesel exhaust, and certain metals. The requirements of the Air Toxic “Hot Spots” Information and Assessment Act apply to facilities that emit these listed TACs above regulated threshold quantities.

### ***Health Effects of TACs***

The health effects associated with TACs are quite diverse and generally are assessed locally, rather than regionally. TACs could cause long-term health effects such as cancer, birth defects, neurological damage, asthma, bronchitis or genetic damage; or short-term effects such as eye watering, respiratory irritation (a cough), running nose, throat pain, and headaches (BAAQMD 2017b, Section 5.1). Numerous other health effects also have been linked to exposure to TACs, including heart disease, Sudden Infant Death Syndrome, respiratory infections in children, lung cancer, and breast cancer (OEHHA 2015).

The primary on-site TAC emissions sources for the LDC are diesel engines, both during construction and operation. Diesel exhaust is a complex mixture of thousands of gases and fine particles and contains over 40 substances listed by the US EPA as hazardous air pollutants and by ARB as toxic air contaminants. The solid material in diesel exhaust is known as DPM (ARB 2019c). DPM is primarily composed of aggregates of spherical carbon particles coated with organic and inorganic substances. Diesel exhaust deserves particular attention mainly because of its ability to induce serious noncancerous effects and its status as a likely human carcinogen. Diesel exhaust is also characterized by ARB as “particulate matter from diesel-fueled engines.” The impacts from human exposure would include both short- and long-term health effects. Short-term effects can include increased coughing, labored breathing, chest tightness, wheezing, and eye and nasal irritation. Effects from long-term exposure can include increased coughing, chronic bronchitis, reductions in lung function, and inflammation of the lung. Epidemiological studies strongly suggest a causal relationship exists between occupational diesel exhaust exposure and lung cancer. Diesel exhaust is listed by the US EPA as “likely to be carcinogenic to humans” (US EPA 2003).

### **Sensitive Receptors**

Sensitive receptors are locations where sensitive individuals are likely to spend a significant amount of time. Sensitive individuals, such as infants, the aged, and people with specific illnesses or diseases, are the subpopulations which are more sensitive to the effects of toxic substance exposure. Examples of sensitive receptors include residences, schools and school yards, parks and playgrounds, daycare centers, nursing homes, and medical facilities. Residences could include houses, apartments, and senior living complexes. Medical facilities could include hospitals, convalescent homes, and health clinics. Playgrounds could be play areas associated with parks or community centers (BAAQMD 2017b). The potential sensitive receptor locations evaluated in the HRA for LDC include (BAAQMD 2012, Jacobs 2019a, Section 3.3.3.2.1):

- Residential dwellings
- Schools
- Daycare centers
- Hospitals
- Senior-care facilities

### ***Sensitive Receptors Near the Project***

BAAQMD recommends that any proposed project that includes the siting of a new TACs emissions source assess associated community risks and hazards impacts within 1,000 feet, take into account both individual and nearby cumulative sources (that is, proposed project plus existing and foreseeable future projects). Cumulative sources represent the combined total risk values of each individual source within the 1,000 foot evaluation zone (BAAQMD 2017b).

The approximately 12-acre site is bounded to the south by U.S. 101, to the west by a covered parking lot, to the east by Juliette Lane and commercial/industrial uses, and to the north by commercial/industrial uses (Jacobs 2019a, Section 2.3). A sensitive receptor search was conducted by the applicant within a 2-kilometer zone of influence, which is broader than the 1,000-foot (0.19 mile) distance recommended by BAAQMD. No schools, residences, parks, playgrounds, day care centers, nursing homes, or hospitals were found to be located within 1,000 feet of the LDC. Within the 2-kilometer zone of influence the nearest sensitive receptors include schools, elementary through college-level, and a hospital. The nearest residential neighborhoods are located approximately 0.4 miles north, 0.45 miles northeast, and 0.65 miles east of the project fence line. Additionally, there is a single small apartment complex approximately 0.5 miles east southeast of the project fence line. The area directly north and east of the LDC site consists of various business (commercial/industrial uses) (Jacobs 2019a, Section 3.3.3.2.1), which are not defined as sensitive receptors. Please see **Figure 5.3-1** for the map of sensitive receptors near the project.

## Regulatory Background

Federal, state, and regional agencies regulate air quality in the SFBAAB, within which the project site is located.

### *Federal*

**Clean Air Act.** The federal Clean Air Act (CAA) establishes the statutory framework for regulation of air quality in the United States. Under the CAA, the US EPA oversees implementation of federal programs for permitting new and modified stationary sources, controlling toxic air contaminants, and reducing emissions from motor vehicles and other mobile sources.

Title I (Air Pollution Prevention and Control) of the CAA requires establishment of NAAQS, air quality designations, and plan requirements for nonattainment areas. States are required to submit a state implementation plan (SIP) to the US EPA for areas in nonattainment with NAAQS. The SIP, which is reviewed and approved by the US EPA, must demonstrate how state and local regulatory agencies will institute rules, regulations, and/or other programs to achieve attainment with NAAQS.

CAA section 112 (Title 42, U.S. Code section 7412) addresses emissions of hazardous air pollutants (HAPs). This act requires new sources that emit more than ten tons per year (tpy) of any specified HAP or more than 25 tpy of any combination of HAPs to apply Maximum Achievable Control Technology (MACT).

**National Emission Standards for Hazardous Air Pollutants.** The CAA defines HAPs as a variety of substances that pose serious health risks. Direct exposure to HAPs has been shown to cause cancer, reproductive effects or birth defects, damage to brain and nervous system, and respiratory disorders. Categories of sources that cause HAP emissions are controlled through separate standards under CAA Section 112: National Emission Standards for Hazardous Air Pollutants (NESHAP). These standards are specifically designed to reduce the potency, persistence, or potential bioaccumulation of HAPs. New sources that emit more than ten tpy of any specified HAP or more than 25 tpy of any combination of HAPs are required to apply Maximum Achievable Control Technology (MACT).



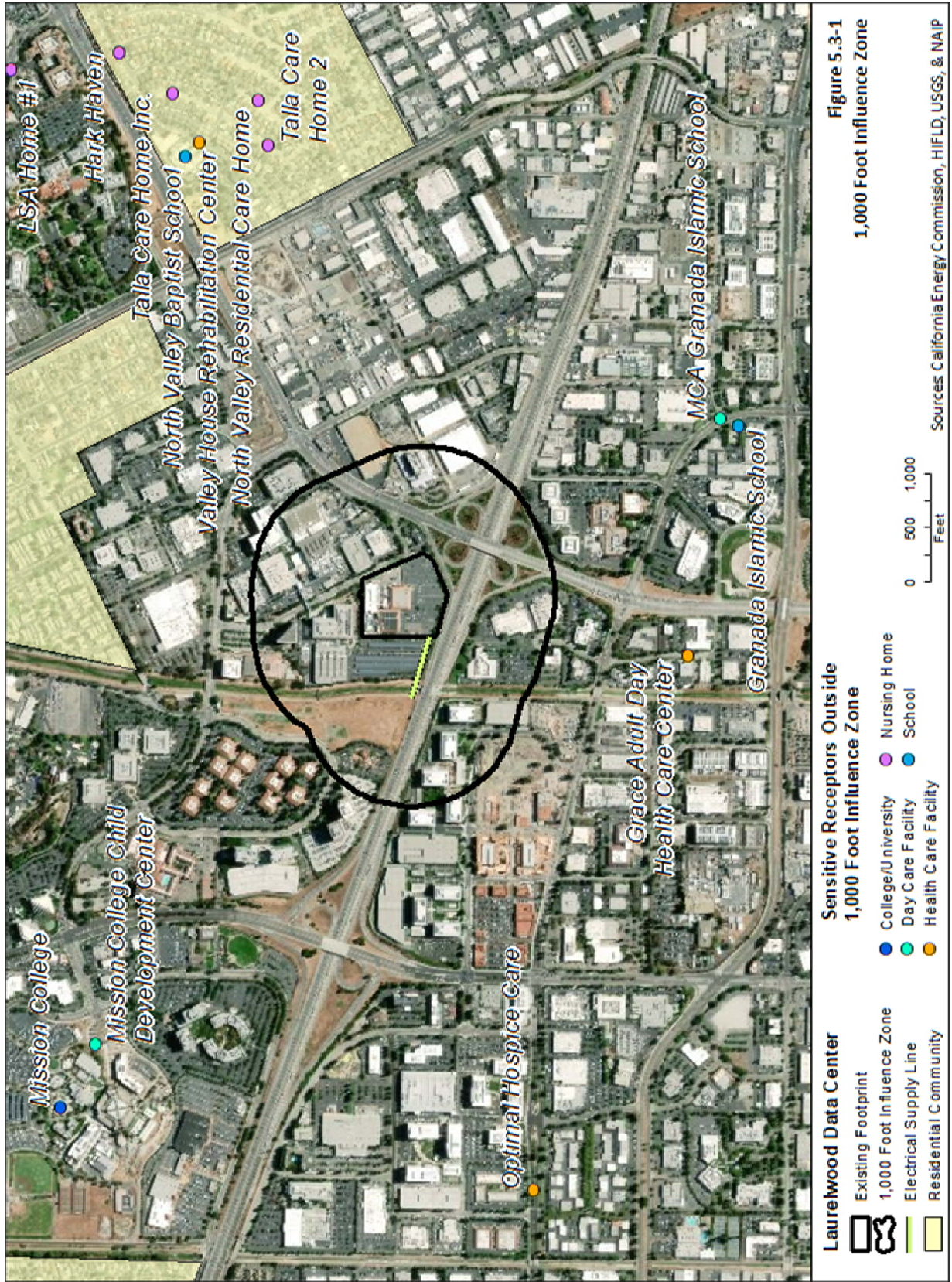

Asbestos is a HAP regulated under the US EPA NESHAP. The asbestos NESHAP is intended to provide protection from the release of asbestos fibers during activities involving the handling of asbestos. Air toxics regulations under the CAA specify work practices for asbestos to be followed during operations of demolitions and renovations. The regulations require a thorough inspection of the area where the demolition or renovation operations would occur and advance notification of the appropriate delegated entity. Work practice standards that control asbestos emissions must be implemented, such as removing, wetting, and sealing in leak-tight containers all asbestos-containing materials (ACM) and disposing of the waste as expediently as practicable.

### ***State***

ARB is the primary administrator of the California's federal CAA compliance efforts, while local air quality districts administer air rules and regulations at the local and regional levels. ARB is also responsible for California's state regulated air quality management, including establishment of CAAQS, mobile source/off-road equipment/portable equipment emission standards, portable equipment registration, greenhouse gas (GHG) regulations, as well as oversight of local or regional air quality districts and preparation of implementation plans, including regulations for stationary sources of air pollution.

**Air Toxic "Hot Spots" Information and Assessment Act.** The Air Toxic "Hot Spots" Information and Assessment Act, also known as Assembly Bill (AB) 2588, identifies toxic air contaminant hot spots where emissions from specific stationary sources may expose individuals to an elevated risk of adverse health effects, particularly cancer or reproductive harm. Many toxic air contaminants are also classified as HAPs. AB 2588 requires that a business or other establishment identified as a significant stationary source of toxic emissions provide the affected population with information about health risks posed by their emissions.

**Asbestos Airborne Toxic Control Measure for Construction, Grading, Quarrying, and Surface Mining Operations.** ARB has established the Asbestos ATCM for Construction, Grading, Quarrying, and Surface Mining Operations to minimize the generation of asbestos from earth disturbance or construction activities. The Asbestos ATCM applies to any project that would include sites to be disturbed in a geographic ultramafic rock unit area or an area where naturally occurring asbestos (NOA), serpentine, or ultramafic rocks are determined to be present. Based upon review of the US Geological Survey map detailing natural occurrence of asbestos in California, NOA is not expected to be present at the project site (CDOC 2011).

### ***Regional***

The BAAQMD is the regional agency charged with preparing, adopting, and implementing emission control measures and standards for stationary sources of air pollution pursuant to delegated state and federal authority, for all projects located within their jurisdiction. Under the California CAA, the BAAQMD is required to develop an air quality plan to achieve and/or maintain compliance with federal and state nonattainment criteria pollutants within the air district's boundary.

**Bay Area 2017 Clean Air Plan.** BAAQMD adopted the Bay Area 2017 Clean Air Plan (CAP) on April 19, 2017 (BAAQMD 2017a). The 2017 CAP provides a regional strategy to protect public health and protect the climate. The 2017 CAP updates the most recent Bay Area ozone plan, the 2010 Clean Air Plan, pursuant to air quality planning requirements defined in the California Health & Safety Code. The 2017 CAP defines an integrated, multi-pollutant control strategy to reduce emissions of particulate matter, TACs, ozone and key ozone precursors, and greenhouse gases.



**BAAQMD California Environmental Quality Act Guidelines.** BAAQMD publishes California Environmental Quality Act (CEQA) guidelines to assist lead agencies in evaluating a project's potential impacts on air quality. The BAAQMD published the most recent version of its CEQA Guidelines in May 2017 (BAAQMD 2017b).

**BAAQMD Regulation 2, Rule 2: New Source Review.** This rule applies to all new or modified sources requiring an Authority to Construct and/or Permit to Operate. It requires the applicant to use the Best Available Control Technology (BACT) to control emissions if the source will have the potential to emit a BAAQMD BACT pollutant in an amount of 10 or more pounds per day (lbs/day). Offsets are required at a 1:1 ratio if more than 10 tpy of nitrogen oxides (NO<sub>x</sub>) or Precursor Organic Compounds (POC), or more than 100 tpy of PM<sub>2.5</sub>, PM<sub>10</sub>, or SO<sub>2</sub>, are emitted. If the potential to emit for NO<sub>x</sub> or POC is 35 tons per year or more the offset ratio increases to 1.15:1 and offsets can no longer be obtained through the Small Facility Banking Account.

On June 3, 2019, the BAAQMD staff issued a new policy regarding the appropriate procedure for calculating a facility's potential to emit (PTE) to determine eligibility for emission reduction credits (ERCs) from the Small Facility Banking Account, for emergency backup power generators (BAAQMD 2019b, added to BAAQMD website on June 12, 2019). According to this policy, when determining the PTE for a facility with emergency backup power generators, the district shall include emissions resulting from emergency operation of 100 hours per year per engine, in addition to the permitted limit for reliability-related and testing operation (generally 50 hours/year or less per engine). However, the applicant would only be required to offset the emissions for the testing and reliability-related operation, not the emissions from emergency operation. Emissions offsets represent ongoing emission reductions that continue every year, year after year, in perpetuity. Offsets are used by BAAQMD to counterbalance regular and predictable emissions, not emissions that would only occur infrequently when emergency conditions arise. The BAAQMD will not allow an owner/operator to accept a permit condition to limit emergency operation to less than 100 hours per year to reduce the source's PTE. However, an owner/operator may reduce PTE for ERC mitigation purposes by accepting lower limits on testing and reliability-related operation or by installing an emissions control device (BAAQMD 2019b).

The LDC project as proposed by the applicant, due to the new BAAQMD policy on PTE calculations, would no longer qualify for offsets from the BAAQMD's Small Facility Banking Account. The applicant has confirmed that they now plan to purchase ERCs from the market to offset emissions from testing and reliability-related operation. The applicant's proposal seeks to limit the testing and reliability-related operation to 21 hours per year per engine<sup>2</sup>. Their NO<sub>x</sub> emissions calculations for that permit limit identify NO<sub>x</sub> emissions of 24.7 tons, which after applying a 1.15:1 offset ratio would require 28.4 tons of NO<sub>x</sub> ERCs from the District's emissions credit bank (Jacobs 2019j). Final details regarding the amount and the source of the NO<sub>x</sub> ERCs required for the project to comply with the offset requirements in BAAQMD's Regulation 2, Rule 2, under this new District policy, would be determined through the permitting process with the BAAQMD. Staff expects the NO<sub>x</sub> emissions of the emergency generators during normal testing would be fully offset through the permitting process with the BAAQMD.

**BAAQMD Regulation 2, Rule 5: New Source Review of Toxic Air Contaminants.** This rule provides for the review of new and modified sources of TAC emissions to evaluate potential public exposure and health

<sup>2</sup> The applicant's estimate of the expected testing and maintenance events for each engine, including generation tests (monthly, quarterly, and annual), 3-year medium voltage breaker/transformer testing, and contingency testing totals 12.3 hours of engine use per year per engine (Jacobs 2019d, Table 2-4). The monthly generation tests would require the engines to operate at 50 percent load. All other tests require 100 percent load.

risk. Under this rule, a project would be denied an Authority to Construct if it exceeds any of the specified risk limits, which are consistent with BAAQMD’s California Environmental Quality Act (CEQA) significance thresholds. Best Available Control Technology for Toxics (TBACT) would also be required for any new or modified source of TACs where the source has a cancer risk greater than 1.0 in 1 million or a chronic hazard index (HI) greater than 0.20. The specific toxicity values of each particular TAC, as identified by OEHHA, are listed in Table 2-5-1 of this rule for use in the HRA (BAAQMD 2017d).

### Significance Criteria

This analysis is based upon the methodologies and related thresholds in the most recent BAAQMD CEQA Guidelines (BAAQMD 2017b). These methodologies include qualitative determinations and determination of whether project construction and operation emissions would exceed numeric emissions and health risk thresholds.

BAAQMD project-level thresholds of significance for non-attainment and non-attainment precursor criteria pollutant emissions and TAC emissions health risks are shown in **Table 5.3-4**. If a project exceeds the identified significance thresholds, its emissions would be cumulatively considerable, resulting in significant adverse air quality impacts to the region’s existing air quality conditions.

For construction period fugitive dust emissions, BAAQMD CEQA Guidelines recommend following the current Best Management Practices (BMPs) approach, which has been a pragmatic and effective approach to the control of fugitive dust emissions.

**TABLE 5.3-4 BAAQMD THRESHOLDS OF SIGNIFICANCE**

Pollutant	Construction	Operation	
	Average Daily Emissions (lbs/day)	Average Daily Emissions (lbs/day)	Maximum Annual Emissions (tpy)
ROG	54	54	10
NOx	54	54	10
PM10	82 (exhaust)	82	15
PM2.5	54 (exhaust)	54	10
PM10/ PM2.5 (fugitive dust)	Best Management Practices	None	
Risk and Hazards for New Sources and Receptors (Individual Project)	Same as Operation Threshold	Compliance with Qualified Community Risk Reduction Plan OR Increased cancer risk of >10.0 in a million Increased non-cancer risk of > 1.0 Hazard Index (Chronic or Acute) Ambient PM2.5 increase: > 0.3 µg/m³ annual average Zone of Influence: 1,000-foot radius from property line of source or receptor	
Risk and Hazards for New Sources and Receptors (Cumulative Threshold)	Same as Operation Threshold	Compliance with Qualified Community Risk Reduction Plan OR Cancer: > 100 in a million (from all local sources) Non-cancer: > 10.0 Hazard Index (from all local sources) (Chronic) PM2.5: > 0.8 µg/m³ annual average (from all local sources) Zone of Influence: 1,000-foot radius from property line of source or receptor	

Source: BAAQMD 2017b



In addition to the BAAQMD thresholds provided above, staff considers a project's potential to expose sensitive receptors to substantive exposures to all criteria pollutants.<sup>3</sup> The BAAQMD emissions significance criteria, particularly in consideration that projects can use emissions reduction credits to reduce a project's emissions significance, do not always directly relate to the potential for substantial exposure impacts. The AAQS are health protective values, so staff uses these health based regulatory standards to help define what is considered a substantive exposure. Staff believes this criterion is an important aspect of the air quality analysis for LDC. Therefore, staff's analysis determines whether the project would exceed any air quality standard or contribute substantially to an existing or projected air quality violation, and if necessary propose mitigation to reduce or eliminate these pollutant exceedances or substantial contributions. To determine if the project could contribute to or create a substantial pollutant concentration for the nonattainment pollutant (PM<sub>10</sub>), the US EPA PM<sub>10</sub> Significant Impact Levels (SILs) for 24-hour impacts (5 µg/m<sup>3</sup>) and for annual impacts (1 µg/m<sup>3</sup>) have been used.<sup>4</sup> Additionally, as shown above in **Table 5.3-4**, the BAAQMD significance threshold for a project level annual ambient PM<sub>2.5</sub> increase (0.3 µg/m<sup>3</sup>), along with the potential to cause a new exceedance of an AAQS, is used to determine project significance for PM<sub>2.5</sub>.

For health risk evaluation purposes, TACs are separated into carcinogens and non-carcinogens based on the nature of the physiological effects associated with exposure to the pollutant. Therefore, there are two kinds of thresholds for TACs. Cancer risk is expressed as excess cancer cases per 1 million exposed individuals, typically over a lifetime of exposure. Acute and chronic exposure to non-carcinogens is expressed as a hazard index (HI), which is the ratio of expected exposure levels to acceptable reference exposure levels (REL) for each of the TACs with acute and chronic health effects (BAAQMD 2017b). The significance thresholds for TACs and PM<sub>2.5</sub> applied to the siting of a new source are listed in **Table 5.3-4** and summarized in the following text (BAAQMD 2017b).

The significance thresholds for a single source are as follows:

- An excess lifetime cancer risk level of more than 10 in 1 million
- A non-cancer chronic HI greater than 1.0
- A non-cancer acute HI greater than 1.0
- An incremental increase in the annual average PM<sub>2.5</sub> concentration of greater than 0.3 micrograms per cubic meter (µg/m<sup>3</sup>)

The significance thresholds for cumulative impacts are also summarized below. A project would have a cumulative considerable impact if the aggregate total of all past, present, and foreseeable future sources within a 1,000-foot distance from the fence line of a source plus the contribution from the project, exceeds the following:

- An excess lifetime cancer risk level of more than 100 in 1 million
- A non-cancer chronic HI greater than 10.0

<sup>3</sup> Staff believes that this approach provides a complete analysis that describes the foreseeable effects of the project in relation to all potential air quality related health impacts, including impacts of criteria pollutants to sensitive receptors; and therefore addresses the California Supreme Court December 2018 Sierra Club v. County of Fresno opinion (<https://www.courts.ca.gov/opinions/archive/S219783A.PDF>).

<sup>4</sup> BAAQMD does not have localized impact significance criteria for PM<sub>10</sub>, or 24-hour localized impact significance criteria for PM<sub>2.5</sub>. Comparable significance criteria, for an area with greater levels of particulate pollution, would be the SCAQMD project operation localized significant concentration threshold bases for PM<sub>10</sub> (24-hour = 2.5 µg/m<sup>3</sup>, and annual = 1.0 µg/m<sup>3</sup>) and PM<sub>2.5</sub> (24-hour = 2.5 µg/m<sup>3</sup>).

- An annual average PM<sub>2.5</sub> concentration of greater than 0.8 µg/m<sup>3</sup>

### 5.3.2 Environmental Impacts and Mitigation Measures

**Applicant Proposed Measures:** The applicant proposes to implement the following project design measures (termed Applicant Proposed Measures, or APMs, in this analysis) as part of the project to avoid or reduce potential impacts to air and water (Jacobs 2019a, Section 2.5.1, page 2-22).<sup>5</sup> The BAAQMD's CEQA Guidelines consider fugitive dust impacts to be less than significant through the application of BMPs. To assure fugitive dust impacts are less than significant, the applicant proposed to incorporate the BAAQMD's recommended "basic construction mitigation measures" (aka BMPs), that also include a couple of on-road vehicle/off-road equipment engine emissions reduction measures, as project design features.

#### **APM AQ-1: Air and Water Quality:**

- Minimizing fugitive dust generation by watering exposed soils two times per day or as needed.
- Covering truck loads when transporting soil, sand, or other loose materials to or from the site.
- Performing street sweeping to remove all visible mud or dirt track-out onto adjacent public roads at least once per day. The use of dry power sweeping is prohibited.
- Limiting onsite vehicle speeds on unpaved surfaces to 15 miles per hour (mph).
- Paving onsite roads/driveways, and sidewalks as soon as possible in the construction schedule. Pouring foundations for building pads as soon as possible after grading.
- Limiting construction equipment idling times to a maximum 5 minutes or shut equipment down when not in use.
- Maintaining and tuning construction equipment in accordance with manufacturer's specifications.
- Employing a certified visible emission evaluator to verify construction equipment is functioning properly.
- Posting a publicly visible sign with the telephone number and name of the person to contact regarding dust complaints and the Bay Area Air Quality Management District (BAAQMD) telephone number. The contact person will implement corrective measures, as needed, within 48 hours and the BAAQMD will be informed of any legitimate complaints received to ensure compliance with applicable regulations.

The construction emissions control measures as outlined in the BAAQMD-recommended BMPs have been determined by staff to be sufficient. Energy Commission staff would not be recommending any additional construction emissions controls as mitigation measures.

#### ***a. Would the project conflict with or obstruct implementation of the applicable air quality plan?***

##### **Demolition/Construction and Operation and Maintenance**

LESS THAN SIGNIFICANT IMPACT. The LDC project site is within the BAAQMD's jurisdiction, which is the agency primarily responsible for assuring that the federal and state ambient air quality standards are met and maintained in the SFBAAB. The BAAQMD has permit authority over stationary sources, acts as the primary reviewing agency for environmental documents, and develops regulations that must

---

<sup>5</sup> The BMPs listed in the SPPE Application Project Description do not exactly match those presented in the Air Quality Section of the SPPE Application. Additionally, neither version matches the BAAQMD BMPs verbatim, but generally include the actions listed in the BAAQMD BMPs.

be consistent with or more stringent than federal and state air quality laws and regulations. The applicable air quality plan (AQP) is the Bay Area 2017 CAP.

A project is considered to be consistent with the AQP if that project (BAAQMD 2017b, p. 9-2):

1. Supports the primary goals of the AQP.

The determination for this criterion, per BAAQMD, can be met through consistency with the District-approved CEQA thresholds of significance. As can be seen in the impact analysis discussions under checklist questions (b) and (c) below, the project would have less than significant impacts related to the District-approved CEQA thresholds. Therefore, the project would have a less than significant impact related to the primary goals of the AQP.

2. Includes applicable control measures from the AQP.

The project would include the implementation of applicable control measures from the AQP. These project level applicable control measures include Green Buildings (BL1), Urban Heat Island Mitigation (BL4), and Trip Reduction Programs (TR2) through Rule 14-1 compliance.

3. Does not disrupt or hinder implementation of any AQP control measures.

Examples of disrupting or hindering implementation of an AQP would be proposing excessive parking or precluding the extension of public transit or bike paths. The project design as proposed is not known to hinder the implementation of any AQP control measure.

Therefore, given that the project would not exceed CEQA thresholds of significance, see the discussions below under checklist questions (b) and (c), the project would be consistent with the AQP and would have less than significant impacts.

**Proposed Mitigation Measures:** None.

- b. Would the project result in a cumulatively considerable net increase of any criteria pollutant for which the project region is non-attainment under an applicable federal or state ambient air quality standard?***

This impact is evaluated on the basis of whether the project's criteria pollutant emissions exceed any of the BAAQMD construction or operation emissions significance thresholds.

### **Demolition/Construction**

LESS THAN SIGNIFICANT IMPACT. Demolition of the existing foundations, asphalt, and underground utilities is expected to take approximately 3 months. Construction of the LDC is expected to take approximately 14 months. Emissions would occur during the 17-month construction/demolition period as a result of construction/demolition equipment, material movement, paving activities, and on- and offsite vehicle trips, such as material haul trucks, worker commutes, and delivery vehicles.

The applicant estimated the emissions for the combined demolition and construction period using diesel-fueled equipment emission factors, horsepower, load factors, and paving emission factors from the California Emissions Estimator Model<sup>6</sup> (CalEEMod) User's Guide (CAPCOA 2017); and on- and

---

<sup>6</sup> CalEEMod was developed by the California Air Pollution Control Officers Association in collaboration with California Air Districts. This model is a construction and emissions estimating computer model that estimates direct criteria pollutant and direct and indirect greenhouse gas emissions for a variety of land use projects. The model calculates maximum daily and annual emissions. The model also identifies mitigation measures to reduce criteria pollutant and GHG emissions along with calculating the benefits achieved from measures.

offsite vehicle exhaust and idling emission factors from EMFAC2014 (the most recent US EPA approved version). The applicant derived the fugitive dust emission factors for truck dumping/loading, grading, demolition waste generation, and demolition waste loading activities using methodology from the CalEEMod User's Guide (CAPCOA 2017). The applicant derived the fugitive dust emission factors for vehicle travel on paved and unpaved roads using methodology from AP-42 (US EPA 2011a and US EPA 2006, respectively). **Table 5.3-5** shows the applicant estimated criteria pollutant emissions during the project's demolition and construction period.

**TABLE 5.3-5 CRITERIA POLLUTANT EMISSIONS FROM PROJECT DEMOLITION/CONSTRUCTION**

Pollutant	Average Daily Emissions (lbs/day) <sup>a</sup>	Maximum Project Emissions (tons)	BAAQMD Significance Thresholds for Construction-related Average Daily Emissions (lbs/day)	Threshold Exceeded?
ROG	3.6	0.7	54	No
CO	24.6	4.8	None	N/A
NOx	39.2	7.7	54	No
SOx	0.07	0.01	None	N/A
PM10 <sup>b</sup>	6.7	1.3	82	No
PM2.5 <sup>b</sup>	2.3	0.4	54	No

**Notes:**

<sup>a</sup> The BAAQMD's thresholds are average daily thresholds. Accordingly, the results reported are the total project emissions averaged over the entire demolition and construction duration.

<sup>b</sup> The PM emissions estimates conservatively include both exhaust and fugitive dust emissions, even though the BAAQMD's thresholds are specific to exhaust emissions only.

Source: Jacobs 2019h

The average daily demolition and construction emissions shown in **Table 5.3-5** are based on the total project emissions averaged over the entire demolition and construction duration. These average daily demolition and construction emissions are compared to the BAAQMD's significance thresholds for construction-related average daily emissions. The BAAQMD's significance thresholds for PM10 and PM2.5 emissions apply to exhaust emissions only. However, the applicant conservatively included both exhaust and fugitive dust emissions to compare with the BAAQMD's significance thresholds for PM10 and PM2.5 exhaust emissions.

**Table 5.3-5** shows that the average daily demolition and construction emissions would be lower than the thresholds of significance from the BAAQMD May 2017 CEQA Guidelines. There is no numerical threshold for fugitive dust generated during construction in BAAQMD. BAAQMD considers fugitive dust emissions to be significant without BMPs. Consequently, dust emissions generated by project construction activities would be potentially significant. The BAAQMD May 2017 CEQA Guidelines require control of fugitive dust through BMPs in order to conclude that impacts from fugitive dust emissions are less than significant. As mentioned under **Applicant Proposed Measures** in the beginning of **Section 5.3.2**, the applicant proposed to incorporate the BAAQMD's recommended construction BMPs as a project design feature. The project would not conflict with or obstruct implementation of the applicable air quality plan and impacts would be less than significant with the implementation of the **APM AQ-1** during demolition and construction.

### Operation and Maintenance

LESS THAN SIGNIFICANT IMPACT. Emissions would occur during project operation as a result of diesel fuel combustion from the standby diesel generators, offsite vehicle trips for worker commutes and

material deliveries, and facility upkeep, such as architectural coatings, consumer product use, landscaping, water use, waste generation, natural gas use for comfort heating, and electricity use. Each of these types of emission sources is described in more detail below.

**Stationary Sources.** The project would include 56 standby diesel fueled engine generators (standby generators or standby gensets) with an engine output of 4,423 horsepower at full load with a maximum generating capacity of 3.0 megawatts (MW) and a continuous generating capacity of 2.725 MW.<sup>7</sup> These generators would be made by Caterpillar, certified to comply with US EPA Tier 2 emission standards and equipped with a Miratech LTR<sup>®</sup> Diesel Particulate Filter (DPF) System, which would control particulate matter by at least 85 percent. All standby generators would be tested routinely to ensure they would function during an emergency. During routine readiness testing, criteria pollutants and TACs would be emitted directly from the generators. It is assumed, per the applicant proposed permit limit, that engine testing would occur 21 hours per year at full load for each of the 56 engines (Jacobs 2019j, Table 1). Emissions that could occur in the event of an outage that triggers emergency operations would not occur on a regular or predictable basis (BAAQMD 2019b) and are not included in the determination of whether the project would result in a cumulatively considerable net increase of non-attainment criteria air pollutants.

**Mobile Sources.** Approximately 54 employees, including 8 environmental personnel, 18 operations personnel, 3 mechanics, and 25 security or administrative personnel, would be employed at the project site on a daily basis. There would be an average of 74 total daily vehicle trips, including vendor and employee trips, which would result in mobile source criteria pollutant emissions. The applicant estimated these emissions using vehicle exhaust and idling emission factors from EMFAC2014.

**Area and Energy Sources.** The project would result in area and energy source criteria pollutant emissions associated with facility upkeep (that is, operation and maintenance). Area sources include landscaping activities, consumer product use, and periodic painting emissions. Energy sources include natural gas combustion for space heating, from sources assumed exempt from BAAQMD permitting.<sup>8</sup> The applicant estimated the facility upkeep emissions using the CalEEMod (version 2016.3.2), based on the square footage of the buildings to be constructed and paved areas. It should be noted that the applicant assumed the total area of the buildings to be 737,093 square feet for the original site plan, while the total area of the buildings would be reduced to 533,952 square feet for the revised site plan (Jacobs 2019d). Therefore, the applicant has overestimated the emissions for facility upkeep.

**ROG Emissions from Diesel Storage Tanks and Diesel Transfer.** In response to staff's data requests, the applicant estimated the ROG emissions to be  $8.4 \times 10^{-3}$  tpy from diesel storage tanks and diesel transfer (Jacobs 2019e).

**Table 5.3-6** provides the annual criteria pollutant emission estimates for project operation using the emissions source assumptions noted above. **Table 5.3-6** shows that with NO<sub>x</sub> emissions from the testing of the standby generators fully offset through the permitting process with the BAAQMD, the

<sup>7</sup> The applicant has made revisions to the project description, after the submittal of the SPPE application, including a reduction in the building footprint size (Jacobs 2019d) and a change in the building cooling technology (Jacobs 2019k); however, the applicant did not identify any change in the LDC electrical demand or the number of proposed standby generators. Therefore, this impact evaluation is based on the project including 56 standby generators as shown in the SPPE application.

<sup>8</sup> Note that CalEEMod does not calculate criteria pollutant emissions associated with electricity consumption, because that is considered an indirect source of emissions that occurs at an unknown location. Accordingly, the energy source criteria pollutant emissions only include emissions from the estimated amount of on-site natural gas combustion necessary for comfort heating (air and water). Similarly, criteria pollutant emissions associated with waste generation and water use would be tied to electricity consumption and are not included in this analysis.

project would not exceed any of the BAAQMD operation emissions significance thresholds. The BAAQMD significance thresholds for daily emissions are daily average values that multiply to equal the annual thresholds, so a separate comparison of the project’s average daily emissions versus the BAAQMD average daily significance thresholds is unnecessary.

**TABLE 5.3-6 ANNUAL CRITERIA POLLUTANT EMISSIONS FROM PROJECT OPERATION**

Source Type	Annual Emissions (tpy)					
	ROG	CO	NOx	SO <sub>2</sub>	PM10	PM2.5
Mobile Sources	0.02	0.5	0.4	0.003	0.04	0.02
Facility Upkeep (Area and Energy Sources)	4.1	0.8	1.0	0.01	0.07	0.07
Emissions from Diesel Storage Tanks and Diesel Transfer	8.4E-3	--	--	--	--	--
Standby Generators (Testing Only)	2.1	6.4	24.7	0.03	0.07	0.07
Proposed Offsets	--	--	(-28.4)	--	--	--
Total Mitigated Emissions	6.2	7.7	(-2.3)	0.04	0.18	0.16
BAAQMD Annual Significance Thresholds	10	--	10	--	15	10
Mitigated Emissions Exceed BAAQMD Threshold? (Y/N)	No	N/A	No	N/A	No	No

Sources: Jacobs 2019e, Jacobs 2019g, Jacobs 2019j

**Table 5.3-6** shows that the project would not be expected to result in a cumulatively considerable net increase of non-attainment criteria pollutants during the operational lifetime of the project, including routine testing and maintenance of the standby engine generators. Therefore, project operations would not result in a cumulatively considerable net increase of any criteria pollutant, and this impact would be less than significant.

**Proposed Mitigation Measures:** None.

**c. Would the project expose sensitive receptors to substantial pollutant concentrations?**

This impact analysis considers the potential for substantial pollutant concentrations for both criteria pollutants, which are analyzed in an Air Quality Impact Analysis (AQIA), and toxic air contaminants which are analyzed in a Health Risk Assessment (HRA).

**Criteria Pollutant Air Quality Impact Analysis**

Staff considers new AAQS exceedances and substantial contributions to any existing AAQS exceedance caused by project emissions to be substantial evidence of potentially significant impacts that would require the evaluation of potential mitigation measures.

**Demolition/Construction Air Quality Impact Assessment (AQIA)**

LESS THAN SIGNIFICANT IMPACT. As shown in **Table 5.3-5** under checklist question (b) above, the exhaust emissions during demolition and construction of the project would not exceed significance thresholds for construction activities established in the BAAQMD CEQA Guidelines. There is no numerical threshold for fugitive dust generated during construction in the BAAQMD Guidelines. Instead, the guidance calls for use of BMPs to reduce fugitive dust emissions to consider impacts from fugitive dust emissions less than significant. Without these BMPs, the impact from fugitive dust emissions would be considered significant. The applicant stated it would implement APMs consistent with the BAAQMD recommended BMPs to reduce fugitive dust emissions, and this would avoid the potential for generating substantial pollutant concentrations due to fugitive dust. In addition, the applicant provided the modeled annual PM impacts during the demolition and construction period (Jacobs 2019h, Appendix DR32-C Table 3). The maximum annual PM impacts during the demolition and



construction period was modeled to be approximately  $0.25 \mu\text{g}/\text{m}^3$ , which is less than the BAAQMD significance threshold for a project level annual ambient  $\text{PM}_{2.5}$  increase of  $0.3 \mu\text{g}/\text{m}^3$ . The  $\text{PM}_{2.5}$  impacts of the project during demolition and construction period would be less than significant.

### Operation and Maintenance AQIA

**LESS THAN SIGNIFICANT IMPACT.** The applicant provided an ambient air quality impact analysis to compare worst-case ground-level impacts resulting from the project's operation with established state and federal ambient air quality standards and applicable BAAQMD significance criteria. The applicant used the American Meteorological Society/Environmental Protection Agency Regulatory Model (AERMOD [Version 18081]) with regulatory default options, as recommended in US EPA's *Guideline on Air Quality Models* (US EPA 2017). The applicant's modeling analysis, described in more detail below, included the emergency engines emissions source, but did not include other on-site emissions sources, such as natural gas combustion emissions for space heating. Additionally, the applicant's modeling analysis only included engine testing and maintenance emissions; operation of the engines for emergency use was not included in the applicant's analysis. Staff subsequently completed an independent modeling analysis, which addressed certain issues with the applicant's modeling approach, as described in more detail below, and considered emergency operations.

**Meteorological Data.** The applicant used the 5-year (2013–2017) AERMOD-ready meteorological data provided by the BAAQMD (Jacobs 2019g). The meteorological data were collected at the San Jose International Airport surface station, which is located approximately 4.5 km (2.8 miles) southeast from the site and best represents the topography at the site. The concurrent daily upper air sounding data from the Oakland International Airport station were also included. The BAAQMD preprocessed the data with AERMET (Version 18081) for direct use in AERMOD.

**Refined Analysis for 1-Hour  $\text{NO}_2$  standards.** For comparison to the 1-hour  $\text{NO}_2$  NAAQS and CAAQS, the applicant's modeling followed a second-tier approach called Ambient Ratio Method 2 (ARM2), as described in US EPA's *Guideline on Air Quality Models* (US EPA 2017). For this modeling analysis, the applicant used the ARM2 option with an in-stack  $\text{NO}_2/\text{NO}_x$  ratio (ISR) of 0.1 and a maximum downwind ambient  $\text{NO}_2/\text{NO}_x$  ratio of 0.9. The  $\text{NO}_2$  ISR Database (US EPA 2016), developed using US EPA-verified testing, indicates that Caterpillar C175-16 engines typically have an ISR of 0.03. The applicant conservatively used 0.1 as an ISR for use in ARM2.

The model also included seasonal hour (SEASHR) background data for  $\text{NO}_2$  that provides a single background value for each hour of the day for each season. The applicant obtained the raw background data files from US EPA's Monitor Site ID 060850005 located at 158B Jackson Street in San Jose, California for years 2015, 2016, and 2017. For purposes of modeling for comparison to the CAAQS, the applicant conservatively assumed the high-first-high maximum hourly values from the three years of data apply to each hour of the day for each season of the modeling years (24 hourly background values for each season). For purposes of modeling for comparison to the NAAQS, the applicant used the high-second-high hourly values averaged across the three years of data to represent the 98th percentile background of each season, which are more conservative than the US EPA recommended third-highest values (US EPA 2011b).

For both 1-hour  $\text{NO}_2$  NAAQS and CAAQS analysis, the applicant assumed only one generator would operate at a time for testing and maintenance purposes.

### ***Applicant's Modeling Assumptions***

**Modeled Operating Scenarios.** In the Data Request Responses Set 1B (Jacobs 2019g), the applicant states that: 1) For 1-hour and 3-hour ambient air quality standards, applicant assumed a single generator could operate at 100 percent load for maintenance and testing purposes; 2) For 8-hour and 24-hour standards, the applicant assumed all generators could each operate at 100 percent load for a maximum of 4 hours per day for testing and maintenance purposes; and 3) For annual standards, the applicant assumed all generators could each operate at 100 percent load for a maximum of 50 hours per year. In response to staff's data requests, the applicant also modeled impacts for the 50 percent load and 75 percent load cases. The applicant's analysis showed that impacts for these intermediate loads would be lower than those for the 100 percent load case (Jacobs 2019g).

Staff reviewed the applicant's modeling files provided with the Data Request Responses Set 1B (Jacobs 2019g). Staff noticed that applicant's statement about 1-hour and 3-hour standards as shown in the above paragraph is inconsistent with how the modeling was actually conducted. For 1-hour CO, 1-hour SO<sub>2</sub>, and 3-hour SO<sub>2</sub> standards, the applicant also conservatively, and for modeling simplicity, assumed all generators could each operate at 100 percent load simultaneously, which is a scenario that would not occur during routine operation and maintenance, including readiness testing when only one single generator would operate at a time. The analysis for the 1-hour NO<sub>2</sub> state and federal standards assumes only one generator could operate at 100 percent load at a time for maintenance and testing purposes.

**Hour of Day Factor.** In the Data Request Responses Set 1B (Jacobs 2019g), the applicant states that an hour of day factor modeling refinement was used in AERMOD assuming each generator can operate a maximum of 4 hours per day only during the 8 am to 5 pm time frame. This assumes the generators would not operate for testing and maintenance purposes outside the 8 am to 5 pm time frame. In the Data Request Responses Set 1B (Jacobs 2019g), the applicant states that the hour of day factor was used for the 24-hour averaging period and was not included for the annual averaging period. In the applicant's modeling files provided with the Data Request Responses Set 1B (Jacobs 2019g), staff noticed that the applicant limited modeling during the 8 am to 5 pm time frame for not only the 24-hour averaging period, but also all the other short-term (i.e. 1-hour, 3-hour, and 8-hour) averaging periods. Staff believes the applicant's assumption that the generators would only operate during the 8 am to 5 pm time frame likely would not be enforced in a BAAQMD permit condition. Modeling with this time constraint limit could potentially underestimate the project impacts. Therefore, staff performed an independent modeling analysis, as described below, conservatively assuming that the generators could operate for testing and maintenance purposes during any hour of the year, not just between 8 am and 5 pm.

### ***Staff's Independent Analysis***

For 1-hour (except for the 1-hour NO<sub>2</sub> standards), 3-hour, 8-hour standards, and 24-hour SO<sub>2</sub> standard, for modeling simplicity and consistency with the applicant's approach, staff conservatively assumed all 56 generators could operate at 100 percent load simultaneously for testing and maintenance purposes. However, staff assumed testing and maintenance could occur during any hour of the year, instead of just between 8 am and 5 pm. Modeling was performed for every hour of the five modeling years to determine the worst-case impacts during potential worst-case meteorological conditions. This approach is overly conservative by assuming all generators would be tested at the same time during worst-case meteorological conditions. However, because the impacts from this overly conservative approach do not exceed corresponding standards, no refined modeling is needed.

For 1-hour NO<sub>2</sub> standards, consistent with the applicant’s approach, staff assumed only one generator could operate at 100 percent load at a time for testing and maintenance purposes. However, staff assumed testing and maintenance could occur during any hour of the year, instead of just between 8 am and 5 pm. For each generator, modeling was performed for every hour of the five modeling years assuming it could operate during potential worst-case meteorological conditions. AERMOD calculates total impacts on hourly basis by combining the project impacts with background NO<sub>2</sub>. For each generator, staff obtained the 5-year maximum 1-hour total impacts for 1-hour NO<sub>2</sub> CAAQS and the 5-year average of 98<sup>th</sup> percentile of maximum daily 1-hour total impacts for 1-hour NO<sub>2</sub> NAAQS (56 values for each standard). Staff then obtained the highest of the 56 values for the 5-year maximum 1-hour total impacts from each generator and compared it to the 1-hour NO<sub>2</sub> CAAQS. Staff also obtained the highest of the 56 values for the 5-year average of 98<sup>th</sup> percentile of maximum daily 1-hour total impacts from each generator and compared it to the 1-hour NO<sub>2</sub> NAAQS. **Table 5.3-7** shows the comparison of these worst-case NO<sub>2</sub> impacts with the 1-hour NO<sub>2</sub> CAAQS and NAAQS.

For 24-hour PM standards, consistent with the applicant’s approach, staff conservatively assumed all generators could operate at 100 percent load simultaneously for a maximum of 4 hours per day for testing and maintenance purposes. However, staff modeled every hour of the five modeling years assuming they could operate for testing and maintenance purposes during any hour of the year, instead of just between 8 am and 5 pm. Since each generator would only operate up to 4 hours per day but the impacts are analyzed for 24-hour averaging period, staff calculated the 24-hour averaged emission rate based on the maximum hourly emission rate multiplied by 4 and divided by 24. Modeling was done for every hour of the five modeling years assuming the generators would operate continuously with the 24-hour averaged emission rate. This approach is conservative by assuming all generators would be tested during the same day, which is not practical. In addition, modeling every hour of the five modeling years, instead of just between 8 am and 5 pm, accounts for the possibility that the generators could be tested under any meteorological conditions.

For annual standards, staff evaluated the impacts of the project with the applicant’s revised limit of 21 hours per year per generator (Jacobs 2019j). Modeling was completed for every hour of the five modeling years assuming an emission rate of 1 g/s for every engine. The annual modeling results for the project’s annual engine use were then determined by multiplying the modeled concentration by the annual average emissions rate assuming 21 hours of engine use, meaning that the annual average impacts are calculated as the average of the modeled hourly impacts. Annual impacts calculated this way account for the potential of the generators being operating during all meteorological conditions and the probability that the generators actually operate in a given hour.

It should be noted that proposed annual testing of 21 hours per year is an annual limit; it was only used for calculation of annual emissions and annual impacts. This annual limit does not apply to short-term (24-hour or shorter) ambient air quality standards. Description of how the short-term impacts were modeled is provided above.

**Table 5.3-7** summarizes the results of staff’s independent modeling analysis during operation of the project for testing and maintenance purposes. The project impact column shows the worst-case impacts of the project from modeling. The background column shows the highest (or 3-year averages for the 24-hour PM<sub>2.5</sub> and federal 1-hour SO<sub>2</sub> standards) of the background concentrations from the last three years (2015-2017) of available data collected at the San Jose – Jackson Street station. The background 24-hour and annual PM<sub>10</sub> concentrations are shown in bold because they already exceeded the corresponding CAAQS. Except for the 1-hour NO<sub>2</sub> total impacts, the total impact column

shows the sum of the existing background condition plus the maximum impact predicted by the modeling analysis for project operation. The 1-hour NO<sub>2</sub> total impacts shown in **Table 5.3-7** include project impact and a seasonal hour of day background. More detailed description regarding how the 1-hour NO<sub>2</sub> impacts are calculated is in the text above. The limiting standard column combines CAAQS and NAAQS, whichever is more stringent.

**Table 5.3-7** shows that the impacts from the standby generator engine testing during operation would not cause exceedances of the PM<sub>2.5</sub>, CO, NO<sub>2</sub>, or SO<sub>2</sub> standards. **Table 5.3-7** also shows that the existing 24-hour and annual PM<sub>10</sub> background concentrations are already above the CAAQS. The project would therefore contribute to existing exceedances of the 24-hour and annual PM<sub>10</sub> CAAQS. The modeled PM<sub>10</sub> and PM<sub>2.5</sub> concentrations from project engine testing are below the PM<sub>10</sub> SILs and the BAAQMD PM<sub>2.5</sub> annual concentration significance threshold. However, these modeling analysis results do not consider the impacts from emergency use of the engines.

**TABLE 5.3-7 LAURELWOOD MAXIMUM IMPACTS DURING OPERATION-TESTING ONLY (µg/m<sup>3</sup>)**

Pollutant	Averaging Time	Project Impact	Background	Total Impact	Limiting Standard	Percent of Standard
PM <sub>10</sub>	24-hour	2.2	<b>69.8</b>	<b>72.0</b>	<b>50</b>	<b>144</b>
	Annual	0.01	<b>21.9</b>	<b>21.9</b>	<b>20</b>	<b>110</b>
PM <sub>2.5</sub>	24-hour	2.2	31.0 <sup>a</sup>	33.2	35	95
	Annual	0.01	10.6	10.6	12	88
CO	1-hour	2,713.7	2,748.0	5,461.7	23,000	24
	8-hour	1,491.0	2,061.0	3,552.0	10,000	36
NO <sub>2</sub>	State 1-hour	-	-	192.0 <sup>b</sup>	339	57
	Federal 1-hour	-	-	127.8 <sup>b</sup>	188	68
	Annual	2.9	24.1	27.0	57	54
SO <sub>2</sub>	1-hour	11.3	9.4	20.7	655	3
	Federal 1-hour	11.3	6.1 <sup>a</sup>	17.4	196	9
	24-hour	1.3	2.9	4.2	105	4

**Notes:**

Concentrations in **bold** type are those that exceed the limiting ambient air quality standard.

<sup>a</sup> The federal 24-hour PM<sub>2.5</sub> and federal 1-hour SO<sub>2</sub> background data are based on 98<sup>th</sup>/99<sup>th</sup> percentiles averaged over last 3 years of available data (2015-2017).

<sup>b</sup> The total 1-hour NO<sub>2</sub> impacts include project impact and a seasonal hour of day background. This concentration is the worst-case impact due to a single generator operation because only a single generator would operate at a given time for testing and maintenance.

**Source:** Staff's independent analysis based on modeling files provided by the applicant with Data Request Response Set 1B (Jacobs 2019g)

The results provided in **Table 5.3-7** are the maximum impacts determined at any point at the project fence line or beyond. The maximum impacts for sensitive receptors will be lower than these maximum values.

In spite of the differences in applicant's modeling analysis and staff's independent analysis, the conclusions regarding the project impacts for standby diesel engine testing are the same. Staff's independent analysis assuming testing and maintenance could occur any hour of the year, rather than only during 8 am to 5 pm, would give more flexibility for the applicant to perform testing and maintenance of the engines.

**Localized CO Impacts**

Continuous engine exhaust may elevate localized CO concentrations, resulting in "hot spots". Receptors exposed to these CO hot spots may have a greater likelihood of developing adverse health

effects. CO hot spots are typically observed at heavily congested intersections where a substantial number of gasoline-powered vehicles idle for prolonged durations throughout the day. BAAQMD screening guidance indicates that a project would not exceed the CO significance threshold if a project's traffic projections indicate traffic levels would not increase at any affected intersection to more than 44,000 vehicles per hour or at any affected intersections to more than 24,000 vehicles per hour where vertical and/or horizontal mixing is substantially limited.

Construction and demolition would require a number of vehicle trips to the site. These trips include workers, material, and equipment deliveries. The applicant estimated that there would be a total of 240 and 260 trips during AM peak hour and PM peak hour respectively (Jacobs 2019f). During operation, there would be an average of 74 total daily vehicle trips, including vendor and employee trips. It is unlikely that the addition of vehicle trips from the project on any roadway in the vicinity of the project site would result in an exceedance of the BAAQMD screening threshold. As a result, the additional vehicle trips associated with the project would result in a negligible effect on CO concentrations in the vicinity of the project site.

**Table 5.3-7** shows that the CO impacts from the emergency engine generators, during testing operations, would be less than the BAAQMD significance thresholds of 20.0 ppm (23,000  $\mu\text{g}/\text{m}^3$ ) for 1-hour average concentrations and 9.0 ppm (10,000  $\mu\text{g}/\text{m}^3$ ) for 8-hour average concentrations.

**Proposed Mitigation Measures:** None.

### **Health Risk Assessment**

Staff is presenting a Health Risk Assessment (HRA) for normal standby generator testing and maintenance operation that separates the construction and operation long-term health impacts (cancer and chronic health risks). Staff is also presenting additional HRA results that include occasional standby generator emergency operations in the Emergency Operations Impact Analysis discussion below. The additional HRA result combines the construction and operation cancer risk to provide a project total maximum sensitive receptor cancer risk values.

### **Demolition/Construction HRA**

LESS THAN SIGNIFICANT IMPACT. The demolition and construction (aka construction) period for LDC would be 17 months (Jacobs 2019h). Construction emissions are a result of construction equipment, material movement, paving activities, and on- and offsite vehicle trips, such as material haul trucks, worker commutes, and delivery vehicles. The only TAC considered to result from construction activities was DPM, which was assumed equal to exhaust PM10 emissions from onsite construction and vehicles (Jacobs 2019a, Section 3.3.3.1).

### ***Applicant's Construction HRA***

A screening HRA was conducted to evaluate the potential health risks due to construction of the LDC. Diesel particulate matter (DPM) was the only TAC modeled; its emissions result from exhaust of onsite diesel-fueled construction equipment and vehicles. Since DPM was assumed to be best represented by PM10 emitted as a result of onsite fuel combustion, fugitive dust emissions were excluded as they are not expected to include DPM. Also, offsite contributions resulting from material haul truck trips, worker commute trips, and vendor delivery trips were excluded, as they are not expected to significantly contribute to localized impacts of DPM. The comparatively minor PM10 contributions

from gasoline-fueled light-duty trucks were conservatively included, although they would not emit DPM (Jacobs 2019a, Section 3.3.3.3.2).

The DPM emissions were averaged over the construction period (17 months) and spatially distributed within the construction area for modeling. The US EPA approved AERMOD air dispersion modeling program was used to derive the maximum annual ground-level concentrations. The modeled output (maximum ground-level concentrations), along with equations from the *Air Toxics Hot Spots Program Guidance Manual for Preparation of Health Risk Assessments* (OEHHA, 2015), were used to estimate the cancer and chronic (non-cancer) health risks for residential and worker exposure to DPM emissions (OEHHA 2015, OEHHA 2018, and Jacobs 2019a, Section 3.3.3.3.2).

The screening HRA estimated the 2-year rolling cancer risks during a 30-year exposure duration (starting with exposure during the third trimester of pregnancy) for residential exposure and a 25-year exposure duration (from age 16 to 40) for worker exposure, aligned with the expected construction duration, at the Maximally Exposed Individual Resident (MEIR), Maximally Exposed Individual Worker (MEIW), and Maximally Exposed Sensitive Receptor (MESR). Chronic risks were also estimated for the MEIR, MEIW, and MESR, based on the same emission rates and ground-level concentrations described above. To calculate chronic risk, the maximum annual ground-level concentration was divided by the DPM REL of  $5 \mu\text{g}/\text{m}^3$ . The ratio is characterized as a health index (HI) (OEHHA & CARB, 2018). Acute (non-cancer) health risks were not estimated because there is no acute inhalation REL for DPM, indicating that DPM is not known to result in acute health hazards (Jacobs 2019a, Section 3.3.3.3.2, and Jacobs 2019h).

The risk values at point of maximum impact (PMI) are also provided. The screening result of cancer risk at PMI is 74.766 in one million, much higher than the threshold of 10 in one million. However, the construction of the project would only take approximately 17 months to complete (Jacobs 2019h). The calculation of PMI excess cancer risk is based on very conservative assumptions (i.e. assuming a person stays at PMI for 30 years). To account for the significant difference in exposure time, staff conducted a refined analysis and assumed construction lasts for a period of 1.42 years. By using a scaling factor of  $1.42/30$  (i.e. 1.42 years of construction divided by 30 years of duration), the PMI excess cancer risk is reduced from 75.26 in one million to 3.56 in one million, lower than the significance threshold of 10 in one million.

The results of the HRA for construction activities are presented in **Table 5.3-8** and show that the excess cancer risks and chronic HIs at the MEIR, MEIW, and MESR are less than the BAAQMD's significance thresholds of 10 in 1 million and 1, respectively. The other risk values, for the specific receptor locations, are based on the conservative analysis approach without any additional refinement.



**TABLE 5.3-8 CONSTRUCTION -- MODELED RECEPTOR MAXIMUM HEALTH RISK**

Receptor Type	PMI <sup>1</sup>		MEIR <sup>2</sup>	MEIW <sup>3</sup>	MESR <sup>4</sup>	BAAQMD Threshold
	Screening	Refined				
Cancer Risk Impact (in one million)	75.26	3.56	4.01	1.21	1.15	10
Chronic Non-Cancer Hazard Index (HI)	0.052		0.002	0.0491	0.0008	1

**Notes:**

<sup>1</sup>Point of maximum impact (PMI)

<sup>2</sup>Maximally Exposed Individual Resident (MEIR). These values were revised from that provided by the applicant to account for a small apartment complex located 0.5 miles east southeast of the project fence line, which had higher long-term impacts than indicated by the applicant for the residential receptors included in their modeling analysis.

<sup>3</sup>Maximally Exposed Individual Worker (MEIW)

<sup>4</sup>Maximally Exposed Sensitive Receptor (MESR)

Source: Jacobs 2019h and Jacobs 2019l, Table 5 and Table DR-1-R1.

**Normal Operation and Maintenance HRA**

LESS THAN SIGNIFICANT IMPACT. Project operation would include TAC emissions from the standby engines, building heating (natural gas combustion), and vehicle traffic to the site. The only on-site emissions included in the applicant’s HRA are the TAC emissions from testing and maintenance of the emergency engines. Emissions resulting from emergency operations were not estimated and therefore are not included in the HRA completed by the applicant because, when permitting standby diesel generators, the BAAQMD typically limits HRAs to the emissions resulting from non-emergency use (Jacobs 2019a, Section 3.3.3.1).

The specific TACs evaluated in the project operation HRA were DPM, where it was assumed all PM10 is DPM, and the speciated air toxics from the total organic gases (TOG) in diesel exhaust. The TACs from speciated TOG include (Jacobs 2019a, Section 3.3.3.3.1):

- Acetaldehyde
- Acrolein
- Benzene
- Formaldehyde
- Naphthalene
- Propylene
- Toluene
- Total Polycyclic Aromatic Hydrocarbons (PAHs)
- Xylene

The Total PAHs include Benz(a)anthracene, Benzo(a)pyrene, Benzo(b)fluoranthene, Benzo(k)fluoranthene, Chrysene, Dibenz(a,h)anthracene, and Indeno(1,2,3-cd)pyrene. The TOG TACs emissions were determined using the speciated emission factors for large stationary diesel engines from AP-42 (US EPA 1996).

**Applicant’s Operation HRA**

The HRA included potential health impacts from TAC exposure on receptors through the inhalation, dermal absorption, soil ingestion, and mother’s milk pathways, as required by OEHHA Guidance. The inhalation cancer potency, oral slope factor values, and reference exposure levels (RELs) used to characterize health risks associated with the modeled impacts were obtained from the Consolidated Table of OEHHA/ARB Approved Risk Assessment Health Values (OEHHA 2018). The pathways for surface drinking water, still-water fishing, and subsistence farming are not applicable per regulatory guidance and thus were not included in the assessment. Residential exposure through the

consumption of homegrown produce, including pork, chicken, and eggs, were included. OEHHA default exposures were assumed for the mother's milk, homegrown produce, and soil exposure pathways (Jacobs 2019a, Section 3.3.3.3.1). Consistent with Appendix D of the *Air Toxics Hot Spots Program Guidance Manual for Preparation of Health Risk Assessments* (OEHHA 2015), cancer and non-cancer chronic risks were modeled based on annual DPM emissions, and non-cancer acute risks were modeled based on hourly emissions of Acetaldehyde, Acrolein, Benzene, DPM, Formaldehyde, Naphthalene, Propylene, Toluene, Total PAHs, and Xylenes (Jacobs 2019a, Section 3.3.3.3.3).

The HRA was conducted in accordance with the following guidance:

- Air Toxic Hot Spots Guidance Manual for Preparation of Health Risk Assessments (OEHHA 2015)
- BAAQMD Air Toxics NSR Program Health Risk Assessment (HRA) Guidelines (BAAQMD 2016)
- Guideline on Air Quality Models (EPA 2017)

AERMOD was used to predict ground level concentrations of TAC emissions associated with LDC engines testing and maintenance operation. A unit emission rate (1 g/s) was used to model each source, as outlined in the HARP2 air dispersion modeling risk tool (ADMRT) manual. The results of the AERMOD output plot files were imported into HARP2 to determine cancer, chronic, and acute health risks (Jacobs 2019a, Section 3.3.3.3.3). Staff relied on the revised modeling files to update the analysis (Jacobs 2019g and Jacobs 2019h).

These exposed populations include residential, worker, and sensitive receptors. Both long-term health impacts (cancer risk and chronic HI) and short-term health impacts (acute HI) were evaluated for all locations, as applicable. Offsite resident receptors were assumed to be present at one location for a 30-year period, beginning with exposure in the third trimester of pregnancy. Offsite worker receptors were assumed to be present at one location for a 25 year period, beginning with exposure at the age of 16, for 8 hours per day and 250 days per year (Jacobs 2019a, Section 3.3.4).

Hourly emissions from the standby diesel generators, used to determine acute impacts, were estimated differently by the applicant than the testing and maintenance operation cancer and chronic health impact analysis by conservatively assuming that all 56 generators could be operated concurrently, and the annual emissions were estimated assuming that all 56 generators would operate 50 hours per year. In practice, and likely as permitted, the engine testing and maintenance would be limited to testing to one generator per hour (Jacobs 2019a, Section 3.3.3.1, Table 3.3-5, Jacobs 2019b Appendix 3.3-B, Table 4). The applicant is now proposing to limit the engine testing and maintenance to 21 hours per year for each engine. Therefore, staff revised the applicant's modeled long-term health risks by 21/50 to account for the reduction in long-term engine testing TAC emissions.

The results of the applicant's HRA for facility wide LDC operation, as modified by staff, are presented in **Table 5.3-9** and show that the incremental cancer risk and chronic and acute HI at each of the PMI, MEIR, MEIW, and MESR locations would be less than the BAAQMD's significance thresholds of 10 in 1 million and 1, respectively.

**TABLE 5.3-9 NORMAL OPERATION – MODELED RECEPTOR MAXIMUM HEALTH RISK**

Receptor Type	PMI <sup>1</sup>	MEIR <sup>2</sup>	MEIW <sup>3</sup>	MESR <sup>4</sup>	BAAQMD Threshold
Cancer Risk Impact (in one million) <sup>5</sup>	6.15	1.27	0.52	0.45	10
Chronic Non-Cancer Hazard Index (HI) <sup>5</sup>	1.65E-03	3.37E-04	1.65E-03	1.21E-04	1
Acute Non-Cancer Hazard Index	0.319	0.323	0.319	0.043	1

**Notes:**

<sup>1</sup> Point of maximum impact (PMI)

<sup>2</sup> Maximally Exposed Individual Resident (MEIR). These values were revised from that provided by the applicant to account for a small apartment complex located 0.5 miles east southeast of the project fence line, which had higher long-term impacts than indicated by the applicant for the residential receptors included in their modeling analysis.

<sup>3</sup> Maximally Exposed Individual Worker (MEIW)

<sup>4</sup> Maximally Exposed Sensitive Receptor (MESR)

<sup>5</sup> Applicant long-term health impact results are corrected using a linear ratio of the newly proposed engine testing annual hours limit versus modeled engine testing hours limit (21/50).

Sources: Jacobs 2019g and Jacobs 2019l, Table 13 and Appendix DR 32-D, Table 2, Table DR-2-R1, and staff analysis.

### Emergency Operations Impact Analysis

The air quality impacts of emergency operations are typically not addressed in depth. Guidelines from US EPA and local air districts generally do not require air quality impact analysis of emissions that would be intermittent or triggered by an emergency, other than the emissions permitted for normal operations. In the case of the LDC, the permitted engine testing and maintenance operation is proposed to be limited to 21 hours per year at full load for each of the 56 engines (Jacobs 2019j), and the impact analysis for the proposed routine engine testing and maintenance has been provided above.

Energy Commission staff, when evaluating non-data center power plant siting cases, has limited the assessment of emergency operations to the routine testing and maintenance operation of standby generators and fire pumps. Assessing the impacts of emergency operations may require speculation, and such an analysis would not be required under CEQA (CEQA Guidelines § 15064(d)).

Staff believes that assessing the impacts of emergency operation of the standby generators could be speculative for the following reasons:

- Emergency operations only occur when the facility has a power outage. Power outages are very infrequent and irregular. Additionally, outages are unplanned and unpredictable, and during most years there would be no outages.
- Outage durations are variable. For example, some would be short enough to avoid triggering emergency operation of the standby generators.
- The number of gensets that would operate during a power outage and associated emissions would be variable, based on the actual power demand of the data center during the outage.
- The load levels that the gensets that would operate at during a power outage would be variable, based on the actual power demand during the outage.

However, occasional emergency operations are foreseeable, and the emissions that could occur during an emergency operation can be reasonably estimated. To disclose the potential air quality and

public health impacts during emergency operations, staff has completed the following three additional analyses:

- Historical SVP power outage frequency analysis,
- Standby generator emergency operation Air Quality Impact Analysis, and
- Standby generator emergency operation Health Risk Assessment.

### ***Historical SVP Power Outage Frequency***

#### **Discussion of Foreseeable Emergency Operations**

This section provides information on the likelihood of an interruption of the electrical supply that would trigger emergency operations of the standby engines. This portion of the analysis explores the potential frequency and duration of future electricity outages that might cause the diesel fueled standby gensets to operate as emergency backup generation for LDC. Based on historical outages of data centers in the SVP service territory, staff aims to establish the frequency and duration of reasonably foreseeable electrical outages that could trigger emergency operations.

By their very nature, emergency operations would be unplanned and infrequent. It is impossible to predict how frequently emergency operation of the backup standby generators could occur, and when emergency operation does occur to predict how long it will last. Although operation of the standby engines due to an electrical outage is reasonably foreseeable, such operation is unlikely to occur frequently or for any long duration, and it would be speculative to assign any level of certainty to any particular emergency use scenario.

**Emergency Operations.** The purpose of the standby gensets within the LDC Project Description is to provide LDC's customers with a high degree of electrical reliability, which requires installation of redundant systems (i.e., much more generating capability than necessary to operate the facility), that, in turn, must be available to operate if needed. The maintenance and readiness testing is required to prove the operability of the back-up emergency equipment. Emergency operation of the engines is, therefore, by definition not routine. However, power outages that might trigger emergency operations and standby generator engine emissions are possible and, therefore, foreseeable.

While emergency operations are foreseeable, several speculative factors would need to be known in order to define the scope of any particular emergency operation scenario, and the emissions profile that would result, making a definitive air quality impact analysis speculative. These other factors for the LDC include:

- Would major power outages that could cause substantial impacts from standby engine use occur at any meaningful frequency?
- How many of the proposed 56 diesel-fueled engines should be assumed to operate during any given emergency, at what load, and for what overall duration?
- What would the building loads be during an outage and how would they vary throughout an outage?
- How might ambient background air pollution levels change as behavior of other facilities or traffic systems respond during a major event that correlates with a widespread power outage (such as an earthquake, wildfires, etc.)?

Rather than address all of these factors that would need to be defined for a particular emergency use scenario, this discussion focuses on establishing the reasonable frequency and duration for power outages that could cause standby generator engine emergency operations.

**Data on Historical Outages.** Reliability statistics for all electric customers served by SVP appears within the 2018 Integrated Resource Plan (IRP), and to expand on this information, during the discovery process in this case, Energy Commission Staff explored specifically how data centers in SVP’s territory have been historically affected by outages.

According to the 2018 IRP, SVP’s electric system experiences approximately 0.5 to 1.5 hours of outage time per customer per year. This compares favorably with other utilities in California with reliability factors ranging from 1.0 to 2.5 hours outage per customer per year. The 2018 IRP for SVP reports the Average Service Availability Index (ASAI) – defined as the customer-minutes-available divided by the total customer-minutes, expressed as a percentage – and the ASAI has been 99.979% or higher in each recent year. On average, one or fewer outages have occurred for all customer types annually, in terms of interruptions per typical customer per year (SVP 2018a). This data for all customers is summarized in **Table 5.3-10**.

**TABLE 5.3-10 SVP RELIABILITY STATISTICS FOR ALL CUSTOMER TYPES**

Year	ASAI (%)	SAIDI (minutes)	SAIFI (interruptions per customer)	Total Outages (number)
2012	99.994	29.34	0.48	67
2013	99.991	47.33	0.49	69
2014	99.989	56.6	0.48	80
2015	99.986	73.96	0.59	123
2016	99.993	36.29	0.5	123
2017	99.979	109.08	1.03	195
2018	99.992	42.61	0.41	132

**Notes:**

ASAI (%): Average Service Availability Index - (customer minutes available / total customer minutes, as a %).

SAIDI (minutes): System Average Interruption Duration Index - (average minutes interrupted per customer for all customer).

SAIFI (number): System Average Interruption Frequency Index - (number of interruptions per customer for all customers)

Source: SVP 2018.

The proposed LDC would be a large customer that would receive better-than-average reliability by including a dedicated onsite substation that would be directly served by SVP’s 60 kV system. Staff reviewed the frequency and duration of known data center customers’ outages as provided by SVP (TN #229381, CEC 2019e) to discern how redundant features allow SVP’s system to provide greater reliability to data centers when compared with average customers.

The likelihood of an outage on SVP’s 60 kV system that forces emergency operation of a data center’s engines is “extremely rare” when the looped 60 kV service is provided to this type of data center customer (CEC 2019e). Project-specific design factors include: 100 percent redundant electrical supplies to the site with a 60 kV looped system, a limited number of commercial customers on the 60 kV looped system, redundant transformers to supply the 12 kV system at the LDC substation, and LDC’s proposed uninterruptible power supply (UPS) battery system that would allow this data center

to remain operable without triggering standby engine use during short-term electric service disruptions. The UPS system includes valve-regulated battery banks, with each bank capable of providing up to 10 minutes of backup at 100 percent load (Jacobs, 2019a).

In a series of email messages from SVP dated August 2 and August 8, 2019, staff obtained information allowing an approximation of the expected frequency of loss of power to a data center in the SVP service territory, rather than to the typical electric customer. The Record of Conversation (ROC) included a summary of the past 10 years of operating the SVP system. Between December 6, 2012 and August 2, 2019, there were a total of 31 outages to SVP’s 60 kV lines that provide electrical power to the 12 kV distribution system that feeds power to data centers and other customers. Of these 60 kV system outages, only two outages actually interrupted service to data centers due to the fact that these customers are served by a distribution system including “looped” lines that require two 60 kV failures to cause loss of data center power. One data center outage event occurred on May 28/29, 2016; the interruption lasted for 7 hours and 23 minutes and forced two data centers into emergency operations. The second data center outage event occurred on December 2, 2016 and lasted for 12 minutes, forcing four data centers into emergency operations. These noted historic service interruptions are summarized in **Table 5.3-11**.

**TABLE 5.3-11 OUTAGES KNOWN TO TRIGGER DATA CENTER EMERGENCY OPERATIONS**

Date of Outage	Number of Data Centers Experiencing Interruption	Duration of Each Data Center Outage (minutes)	Total Data Center-Minutes Interrupted (per event)	Data Center Minutes Interrupted per Interruption (minutes)
May 28/29, 2016	2	443	886	156
Dec 2, 2016	4	12	48	
<b>Total</b>	<b>6</b>	<b>---</b>	<b>934</b>	

**Notes:**

Data Center Minutes Interrupted per Interruption calculated by dividing total of data center-minutes interrupted by number of interruptions.

Sources: SVP 2018; CEC 2019e

Based on the terms of overall minutes of outages divided by minutes of total service provided, the discovery process for this proceeding, including conversations with SVP, confirmed that data centers may experience greater reliability than all customers overall (CEC 2019e). Over the seven years from 2012 forward, the existing data centers in SVP have had available electric service for greater than 99.999% of the total customer minutes, or an outage rate of less than 0.001% of customer minutes.

The following summarizes the prior information on historic outages causing emergency operations of standby generators.

**Frequency of Data Center Power Outages.** Information from SVP and in **Table 5.3-11** indicates that six data center customer interruptions occurred since 2009 (CEC 2019e), for an average of less than one data center outage per year (six interruptions over ten years). This implies a chance of 6-out-of-10 or 60%, that one data center somewhere across SVP’s entire territory could experience an outage in any given year. SVP indicates that there are 37 operating data centers in the service territory at the time of the Record of Conversation (CEC 2019e), and that they are interconnected to different loops within the territory, which minimizes the potential that more than one data center would experience simultaneous outages. The combined probability of any one given data center, like LDC, to experience



the outage would be the product of 60% (chance of outage for any data center within SVP) times the 1-out-of-37 (2.7%) chance of the LDC experiencing the outage. Therefore, out of the 37 or more data centers served by SVP, staff considers the probability of a given facility experiencing an outage in a given year to be about 1.6% (60% \* 2.7%).

**Duration of Data Center Power Outages.** The average duration of the six data center customer interruptions that have occurred in SVP territory as shown in in **Table 5.3-11** was about 156 minutes or 2.6 hours per outage.

#### Reasonably Foreseeable Future Outages

This discussion considers whether historical outages would be representative of future outages. Outages are always reviewed for root cause (CEC 2019e), and data center customers and SVP can be expected to implement preventative measures to ensure that reliability consistently improves over time.

However, the potential for future outages could also increase for reasons beyond the control of SVP or data center customers. For example, future outages may be caused by California's efforts to allow transmission systems improve public safety during wildfires. Specifically, in the future, the Public Safety Power Shutoff protocols being implemented by utilities may limit the availability of power delivered to SVP by PG&E. If PG&E curtails the supply of power to SVP through one of its six interconnection points, it may be able to reroute electricity to SVP via the other interconnection points. If SVP completely loses power from PG&E, SVP would be likely to provide about 200 MW of capacity from SVP's generation facilities that are located in Santa Clara (CEC 2019e, SVP 2018a). The peak demand of the SVP service territory exceeded 526 MW in 2018 (SVP 2019a), and growth in demand, including new data centers being added to SVP's system, would increase the need to rely on generation that is not local, which could increase the potential for future outages if transmission is shutoff forcing load to be dropped.

#### ***Standby Generator Emergency Operation Air Quality Impact Analysis (AQIA)***

In spite of the low emergency operation frequency expected for emergency operations, as explained in the analysis directly above, and the uncertainty in the modeling assumptions, staff performed an independent worst-case analysis of the project's potential air quality impacts during emergency operations, assuming historical data apply to future events.

Staff is applying the short-term (1-hour to 24-hour) AAQS thresholds to determine if the project's emergency operations could expose sensitive receptors to substantial pollutant concentrations. This assessment presents the maximum short-term impacts modeled at sensitive receptor locations that surround the project site. Regarding long-term (annual average) AAQS, the potential amount of emergency operation during any given year would be far too limited for the project's emergency operation to substantially effect annual AAQS. Annual-average impacts would be similar to the pollutant concentration results shown in **Table 5.3-7**.

The previous modeling results provided for CO and SO<sub>2</sub> conservatively assumed all engines would operate simultaneously at full load. The modeling results for the CO and SO<sub>2</sub> standards shown in **Table 5.3-7** apply to both testing/ maintenance and emergency operations, and show no exceedance of any AAQS, so no additional modeling is required for these two pollutants.

The following is staff's additional analysis regarding the 1-hour NO<sub>2</sub> standard, and the 24-hour particulate standards during emergency operations.

#### **Emergency Operation: 1-hour NO<sub>2</sub> Impacts**

The 1-hour NO<sub>2</sub> NAAQS is attained when the 3-year average of the 98<sup>th</sup> percentile (8<sup>th</sup> highest day) of the annual distribution of daily maximum 1-hour concentrations does not exceed 100 ppb (188 µg/m<sup>3</sup>). Because compliance with this NAAQS is determined based on the maximum 1-hour value on the 8<sup>th</sup> highest day of the year, it would take at least 8 days for the emergency operation of the facility to have an impact on the 1-hour NO<sub>2</sub> NAAQS. Based on the SVP outage history, an outage of this duration is not foreseeable, either in a single outage or even cumulatively over one year. Therefore, staff concludes that the incremental impact of the facility relative to the 1-hour NO<sub>2</sub> NAAQS is likely to be zero during emergency operations. This is consistent with US EPA's recommendation that "compliance demonstrations for the 1-hour NO<sub>2</sub> NAAQS address emission scenarios that can logically be assumed to be relatively continuous or which occur frequently enough to contribute significantly to the annual distribution of daily maximum 1-hour concentrations based on existing modeling guidelines, which provide sufficient discretion for reviewing authorities to not include intermittent emissions from emergency generators or startup/shutdown operations from compliance demonstrations for the 1-hour NO<sub>2</sub> standard under appropriate circumstances" (US EPA 2011b).

The 1-hour NO<sub>2</sub> CAAQS is set at 339 µg/m<sup>3</sup>, which is not to be exceeded. In order to compare the worst-case impacts with the 1-hour standard, staff modeled every hour of the five modeling years assuming emergency operation could occur during any hour of the year with potential worst-case meteorological conditions. It is assumed that the historical air quality and meteorological data are representative of future conditions during emergency operation.

Staff is presenting two modeled scenarios with simultaneous operation of multiple engines, one with 33 engines operating at full load and another with 41 engines operating at 75 percent load. Staff modeled 33 engines operating simultaneously at 100 percent load based on the physical limitation of electrical generation assuming a maximum 99-MW electrical demand by the facility (Jacobs 2019j). In addition, staff modeled 41 engines operating simultaneously at 75 percent load according to the applicant's response to data request #3 in LDC Responses to Formal and Informal Data Requests (Jacobs 2019c). However, it is unknown which engines would run during an actual emergency operation, and it would be impractical to model all the possible combinations of either 33 or 41 engines (or 4, 12, or other groupings of engines) operating simultaneously. Staff selected a few combinations of 33 and 41 engines to model the effects of the standby engines operating during an emergency. Other assumptions used in the 1-hour NO<sub>2</sub> modeling are the same as those used for the modeling of testing and maintenance.

**Table 5.3-12** shows the modeled 1-hour NO<sub>2</sub> impacts at the nearby apartment complex (0.5 mile east southeast of the project), at the nearest residential neighborhoods (approximately 0.4 miles north of the project), and at the sensitive receptors identified in the applicant's HRA analysis.

**TABLE 5.3-12 EMERGENCY OPERATION, NO<sub>2</sub> IMPACTS FOR SENSITIVE RECEPTORS**

Number of Engines Modeled	33	41
Engine Load	100 percent	75 percent
<b>Apartment Complex to the East Southeast</b>		
Peak Modeled 1-hour NO <sub>2</sub> Impact with Background <sup>1</sup> (µg/m <sup>3</sup> )	255.3 to 277.4	271.3 to 302.6
<b>Residential Neighborhoods to the North</b>		
Peak Modeled 1-hour NO <sub>2</sub> Impact with Background <sup>1</sup> (µg/m <sup>3</sup> )	245.5 to 292.0	262.8 to 308.7
<b>Sensitive Receptors</b>		
Peak Modeled 1-hour NO <sub>2</sub> Impact with Background <sup>1</sup> (µg/m <sup>3</sup> )	263.1 to 278.1	264.3 to 302.3

**Note:**

<sup>1</sup> The modeled 1-hour NO<sub>2</sub> impacts include project impact and a seasonal hour of day background.

**Source:** Staff analysis

**Table 5.3-12** shows that with the assumption of 33 engines operating at 100 percent load simultaneously or 41 engines operating at 75 percent load simultaneously, the 1-hour NO<sub>2</sub> standard would not be exceeded at the nearby apartment complex, or the nearest residential neighborhoods to the north, or the other sensitive receptors.

It should be noted that the 1-hour NO<sub>2</sub> modeling results shown above are based on the use of the ARM2 approach, which is a Tier 2 modeling approach, as described in US EPA’s *Guideline on Air Quality Models* (US EPA 2017), and this is consistent with the applicant’s modeling of 1-hour NO<sub>2</sub> impacts for testing and maintenance. It should also be noted that the 1-hour NO<sub>2</sub> modeling results shown above combined modeled project impacts with seasonal hour (SEASHR) background data for NO<sub>2</sub> that provides a single background value for each hour of a typical day in each season. Consistent with the applicant’s approach for the modeling of 1-hour NO<sub>2</sub> impacts for engine testing and maintenance, staff conservatively assumed that the high-first-high maximum hourly values from the three years of data apply to each hour of the day for each season of the five modeling years (24 hourly background values for each season). If more refined NO<sub>2</sub> background such as hourly NO<sub>2</sub> background data concurrent with the meteorological data were used, the modeled peak 1-hour NO<sub>2</sub> values would be lower than those presented above.

Additionally, ARM2 is more conservative than Tier 3 methods (Ozone Limiting Method [OLM] or the Plume Volume Molar Ratio Method [PVMRM]) that staff often use for other projects. The modeled 1-hour NO<sub>2</sub> impacts of the project would likely be lower using the more refined OLM or PVMRM method. However, staff did not have to use these more refined modeling approaches to demonstrate that the project’s modeled emergency operation would not cause AAQS exceedances at sensitive receptor locations.

**Emergency Operation: 24-hour PM10 and PM2.5 Impacts**

As shown in **Table 5.3-2**, BAAQMD is in nonattainment for the 24-hour PM10 CAAQS and the 24-hour PM2.5 NAAQS. **Table 5.3-7** shows that the existing 24-hour PM10 background concentrations are already above the CAAQS, but that the 24-hour PM2.5 background is below the NAAQS. To determine if the project could expose sensitive receptors to substantial PM10 pollutant concentration the US EPA PM10 SIL for 24-hour impacts (5 µg/m<sup>3</sup>) has been used. For PM2.5 the project would contribute to substantial sensitive receptor exposures if it were to create new PM2.5 exceedances.

In spite of the fact that the longest historical SVP outage over the last 6 years that affected data centers was 7 hours and 23 minutes, staff performed additional modeling analysis for the 24-hour

PM10 and PM2.5 impacts for the unlikely scenario that the engines could run continuously for 24-hours. Staff assumed that 33 engines at 100 percent load or 41 engines at 75 percent load could operate simultaneously and continuously for 24-hours. Modeling was completed assuming this simultaneous operation for every hour of the five modeling years and the 24-hour average impacts were calculated for each day at the residential and sensitive receptors assuming a 24-hour emergency could occur during any day with worst-case meteorological conditions. The worst-case modeled 24-hour PM10 and PM2.5 impacts are presented in **Table 5.3-13**.

<b>TABLE 5.3-13 EMERGENCY OPERATION, PM10/PM2.5 IMPACTS FOR SENSITIVE RECEPTORS</b>		
Number of Engines Modeled	33	41
Engine Load	100 percent	75 percent
<b>Apartment Complex to the East Southeast</b>		
Peak Modeled 24-hour PM10/PM2.5 Project only ( $\mu\text{g}/\text{m}^3$ )	1.7 to 2.0	1.8 to 2.1
Peak 24-hour PM2.5 Impact w/Background <sup>1</sup> ( $\mu\text{g}/\text{m}^3$ )	33.0	33.1
<b>Residential Neighborhoods to the North</b>		
Peak Modeled 24-hour PM10/PM2.5 Project only ( $\mu\text{g}/\text{m}^3$ )	1.2 to 1.4	1.3 to 1.5
Peak 24-hour PM2.5 Impact w/Background <sup>1</sup> ( $\mu\text{g}/\text{m}^3$ )	32.4	32.5
<b>Sensitive Receptors</b>		
Peak Modeled 24-hour PM10/PM2.5 Project only ( $\mu\text{g}/\text{m}^3$ )	1.0 to 1.1	1.0 to 1.1
Peak 24-hour PM2.5 Impact w/Background <sup>1</sup> ( $\mu\text{g}/\text{m}^3$ )	32.1	32.1

**Note:**

<sup>1</sup> The federal 24-hour PM2.5 background of 31.0  $\mu\text{g}/\text{m}^3$  is based on 98th percentile averaged over last 3 years of available data (2015-2017). The limiting standard is the PM2.5 24-hour NAAQS of 35  $\mu\text{g}/\text{m}^3$ .

**Source:** Staff analysis

**Table 5.3-13** shows that with the assumption of 33 engines operating at 100 percent load simultaneously or 41 engines operating at 75 percent load simultaneously, the 24-hour PM10 SIL and the 24-hour PM2.5 NAAQS would not be exceeded at the nearby apartment complex, or the nearest residential neighborhoods to the north, or the other sensitive receptors.

Staff's conservative 1-hour NO<sub>2</sub> and 24-hour PM10 and PM2.5 modeling results indicate that project's emergency operation would not expose sensitive receptors to substantive criteria pollutant concentrations.

**Standby Generator Emergency Operation Health Risk Assessment (HRA)**

This assessment addresses the health impacts of toxic air contaminants emitted as a result of emergency operations. The applicant's analysis of acute impacts, shown in **Table 5.3-9** includes all engines in operation for acute impacts determination related to the diesel engine TACs that have acute RELs; and that analysis showed the acute impacts to be below the significance threshold, so no additional impact analysis is required for acute risk. Therefore, including consideration of potential emergency operation, the project is determined to have less than significant acute health risks.

The chronic health risks determined for project construction and normal operation, shown in **Tables 5.3-8** and **5.3-9** are substantially below the significance threshold, and no reasonable emergency operation scenario would change that finding. Therefore, including consideration of potential emergency operations, the project would have less than significant chronic health risks.

To determine the project's potential maximum cancer risk to sensitive receptors, including potential emergency operation, the following conservative assumptions and methods have been used:

- Construction and operation cancer risks have been combined into the 30-year sensitive receptor cancer risk calculation. Construction emissions result in higher annual DPM concentrations, and risk is elevated in the first few years of life. Therefore, to be conservative construction is assumed to start in the third trimester of pregnancy for the maximally exposed individual residential and sensitive receptors.
- The ARB Risk Assessment Standalone Tool (RAST) has been used to calculate the cancer risk. Due to limitations in this program the construction emissions risk impacts are conservatively calculated for a 2 year exposure starting in the third trimester of pregnancy, rather than the proposed 17-month demolition/construction period, and the operation exposure occurs for 28 years of the ARB/OEHHA recommended 30-year exposure period.
- The maximum annual average emergency engine use is 33 engines operating at full load for 8 hours a year. This is a very conservative assumption and relates to the maximum single year SVP data center power outage that has occurred at any data center over the past six years.

**Table 5.3-14** provides the worst-case modeled project cancer risk values for sensitive receptors that was determined using the methods and assumptions provided above.

<b>TABLE 5.3-14 TOTAL CANCER HEALTH RISK WITH EMERGENCY OPERATION</b>			
<b>Receptor Type</b>	<b>MEIR<sup>1</sup></b>	<b>MESR<sup>2</sup></b>	<b>BAAQMD Threshold</b>
Construction Cancer Risk Impact (in one million)	4.92	1.42	10
Operation Cancer Risk Impact (in one million)	1.08	0.39	10
Total Cancer Risk	6.00	1.81	10

**Notes:**

<sup>1</sup>Maximally Exposed Individual Resident (MEIR).

<sup>2</sup>Maximally Exposed Sensitive Receptor (MESR)

**Source:** Staff analysis.

The maximum modeled cancer risk values presented above in **Table 5.3-14** are higher in comparison than the construction cancer risk values presented in **Table 5.3-8** due to the conservative start of exposure assumption used for the construction risk and the increase in the exposure period to two years, and are somewhat lower in comparison to the operation risk values presented in **Table 5.3-9** due to the reduction in the period of operation emissions exposure from 30 to 28 years.

The maximum modeled cancer risks, presented in **Table 5.3-14**, are substantially below the significance threshold. Therefore, including consideration of potential emergency operations the project is determined to have less than significant cancer health risks. Therefore, project emergency operation would not expose sensitive receptors to substantive TAC pollutant concentrations.

**Standby Generator Emergency Operations Impact Summary**

Staff has determined that standby generator emergency operation would result in less than significant air quality and public health impacts for the following reasons:

1. Staff believes that while occasional standby generator emergency operations are foreseeable, several speculative factors would need to be known in order to define the scope of any particular emergency operations, and the emissions profiles that would result, making a definitive air quality impact analysis speculative.

2. Staff's review of SVP outage frequencies, with consideration of the specific robust transmission connection to the LDC, has determined that the potential for outages would be infrequent, and outages are not expected to have long durations.
3. Staff's conservative modeling assessment of potential air quality impacts during emergency operations shows that the emergency operations would not expose sensitive receptors to substantial criteria pollutant or TAC concentrations.

**Proposed Mitigation Measures:** None.

**d. *Result in other emissions (such as those leading to odors) adversely affecting a substantial number of people?***

The BAAQMD states that, while offensive odors rarely cause direct health impacts or any physical harm, they still can be very unpleasant and lead to considerable distress among the public, often generating citizen complaints to local governments and the BAAQMD (BAAQMD 2017b). Any project with the potential to frequently expose members of the public to objectionable odors would be deemed to have a significant impact. Odor impacts on residential areas and other sensitive receptors warrant the closest scrutiny, but consideration should also be given to other land uses where people may congregate, such as recreational facilities, worksites, and commercial areas.

**Demolition/Construction**

LESS THAN SIGNIFICANT IMPACT. Potential odor sources during demolition and construction activities include diesel exhaust from heavy-duty equipment. Odors from demolition and construction activities near existing receptors would be temporary in nature and dissipate as a function of distance. Accordingly, construction/demolition of the project is not expected to result in odor impacts that would exceed BAAQMD's odor thresholds.

Fugitive dust emissions can also create a nuisance that can cause adverse effects. The project is proposing to comply with the BAAQMD construction fugitive dust control BMPs and so should not have substantial fugitive dust emissions during construction that could adversely affect a substantial number of people.

Therefore, during construction/demolition the project would not result in other emissions that could adversely affect a substantial number of people, and would have less than significant impacts.

**Operation and Maintenance**

LESS THAN SIGNIFICANT IMPACT. Potential odor sources from project operations would include diesel exhaust from standby generator testing, trash pick-up and other heavy-duty delivery vehicles, and the occasional use of architectural coatings during routine maintenance. When compared to existing odor sources near the project site, which include heavy and light industrial uses, odor impacts from project operations would be similar.

Under the BAAQMD CEQA guidelines determining the significance of potential odor impacts involves a two-step process. First, determine whether the project would result in an odor source and receptors being located within the distances indicated in **Table 5.3-15**. This table also lists types of facilities known to emit objectionable odors. Second, if the proposed project would result in an odor source and receptors being located closer than the screening level distances indicated in **Table 5.3-15**, a more



detailed analysis should be conducted, as described in the BAAQMD 2017 CEQA Guidelines (BAAQMD 2017b).

**TABLE 5.3-15 PROJECT SCREENING TRIGGER LEVELS FOR POTENTIAL ODOR SOURCES**

Land Use/Type of Operation	Project Screening Distance
Wastewater Treatment Plant	2 miles
Wastewater Pumping Facilities	1 mile
Sanitary Landfill	2 miles
Transfer Station	1 mile
Composting Facility	1 mile
Petroleum Refinery	2 miles
Asphalt Batch Plant	2 miles
Chemical Manufacturing	2 miles
Fiberglass Manufacturing	1 mile
Painting/Coating Operations	1 mile
Rendering Plant	2 miles
Coffee Roaster	1 mile
Food Processing Facility	1 mile
Confined Animal Facility/Feed Lot/Dairy	1 mile
Green Waste and Recycling Operations	1 mile
Metal Smelting Plants	2 miles

Source: BAAQMD 2017b

The project is not an odor source listed in **Table 5.3-15** and this project type is not known to cause any significant odor impacts. A further evaluation of this facility is not warranted by any local conditions or special circumstances. Therefore, staff finds that the project would not likely create objectionable odors affecting a substantial number of people.

The project would have no ongoing fugitive dust emissions sources once it is built and operating. Therefore, nuisance dust impacts would not occur during operation. During operation the project would not result in other emissions that could adversely affect a substantial number of people, and would have less than significant impacts.

**Proposed Mitigation Measures:** None.

### 5.3.3 References

- ARB 2013** – California Air Resources Board (ARB). The California Almanac of Emissions and Air Quality - 2013 Edition. Available online at: <https://www.arb.ca.gov/aqd/almanac/almanac13/almanac13.htm>. Accessed on: April 2019.
- ARB 2016** – California Air Resources Board (ARB). Ambient Air Quality Standards, dated 5/4/2016. Available online at: <http://www.arb.ca.gov/research/aaqs/aaqs2.pdf>.
- ARB 2019a** – California Air Resources Board (ARB). Area Designations Maps / State and National. Available online at: <https://www.arb.ca.gov/desig/adm/adm.htm>. Accessed on: April 2019.

- ARB 2019b** – California Air Resources Board (ARB). Air Quality Data Statistics Top 4 Summary. Available online at: <https://www.arb.ca.gov/adam/topfour/topfour1.php>. Accessed on: April 2019.
- ARB 2019c** – California Air Resources Board (ARB). 2019. Overview: Diesel Exhaust & Health. Available online at: <https://ww2.arb.ca.gov/resources/overview-diesel-exhaust-and-health>.
- BAAQMD 2012** – Bay Area Air Quality Management District (BAAQMD). 2012. Recommended Methods for Screening and Modeling Local Risks and Hazards. May. Available online at: <http://www.baaqmd.gov/~media/files/planning-and-research/ceqa/risk-modeling-approach-may-2012.pdf?la=en>.
- BAAQMD 2017a** – Bay Area Air Quality Management District (BAAQMD). Final 2017 Clean Air Plan, Adopted April 19, 2017. Available online at: [http://www.baaqmd.gov/~media/files/planning-and-research/plans/2017-clean-air-plan/attachment-a\\_-proposed-final-cap-vol-1-pdf.pdf](http://www.baaqmd.gov/~media/files/planning-and-research/plans/2017-clean-air-plan/attachment-a_-proposed-final-cap-vol-1-pdf.pdf). Accessed on: May 2019.
- BAAQMD 2017b** – Bay Area Air Quality Management District (BAAQMD). California Environmental Quality Act, Air Quality Guidelines. Updated May 2017. Available online at: [http://www.baaqmd.gov/~media/files/planning-and-research/ceqa/ceqa\\_guidelines\\_may2017-pdf.pdf?la=en](http://www.baaqmd.gov/~media/files/planning-and-research/ceqa/ceqa_guidelines_may2017-pdf.pdf?la=en). Accessed on: May 2019.
- BAAQMD 2019a** – Bay Area Air Quality Management District (BAAQMD). Air Quality Standards and Attainment Status. Available online at: <http://www.baaqmd.gov/about-air-quality/research-and-data/air-quality-standards-and-attainment-status>. Accessed on: April 2019.
- BAAQMD 2019b** – Bay Area Air Quality Management District (BAAQMD). Calculating Potential to Emit for Emergency Backup Power Generators. Dated June 3, 2019. Available online at: [http://www.baaqmd.gov/~media/files/engineering/policy\\_and\\_procedures/banking-and-offsets/calculating-pte-for-emergency-generators-06032019-pdf..](http://www.baaqmd.gov/~media/files/engineering/policy_and_procedures/banking-and-offsets/calculating-pte-for-emergency-generators-06032019-pdf..) Accessed on: July 8, 2019.
- BAAQMD 2019c** – Bay Area Air Quality Management District (BAAQMD). Annual Bay Area Air Quality Summaries. Available online at: <http://www.baaqmd.gov/about-air-quality/air-quality-summaries>. Accessed on: July 2019.
- BAAQMD 2019d** – Bay Area Air Quality Management District (BAAQMD). Rules and Regulations. Available online at: <http://www.baaqmd.gov/rules-and-compliance/current-rules>. Accessed on: July 2019.
- CAPCOA 2017** – California Air Pollution Control Officers Association (CAPCOA). California Emissions Estimator Model User’s Guide. Version 2016.3.2. November 2017. Available online at: <http://www.aqmd.gov/docs/default-source/caleemod/user-s-guide---october-2017.pdf?sfvrsn=6>.
- CDOC 2011** – California Department of Conservation (CDOC). Reported Historic Asbestos Mines, Historic Asbestos Prospects, and Other Natural Occurrences of Asbestos in California, 2011. Available online at: <https://www.conservation.ca.gov/cgs/Pages/HazardousMinerals/asbestos2.aspx>. Accessed on: July 2019.
- CEC 2019e** – California Energy Commission (CEC). (TN 229381). Report of Conversation – Silicon Valley Power and Laurelwood Data Center, dated August 13, 2019. Available online at: <https://efiling.energy.ca.gov/Lists/DocketLog.aspx?docketnumber=19-SPPE-01>.
- CNRA 2018** – California Natural Resources Agency (CNRA). 2018 Amendments and Additions to the State CEQA Guidelines. Available online at: <http://resources.ca.gov/ceqa/>. Accessed on: July 2019.

- Jacobs 2019a** – Jacobs (Jacobs). (TN 227273-1). Application for Small Power Plant Exemption: Laurelwood Data Center, dated February 28, 2019. Available online at: <https://efiling.energy.ca.gov/Lists/DocketLog.aspx?docketnumber=19-SPPE-01>.
- Jacobs 2019b** – Jacobs (Jacobs). (TN 227273-2 through TN 227273-3). Laurelwood SPPE Application Appendices. Available online at: <https://efiling.energy.ca.gov/Lists/DocketLog.aspx?docketnumber=19-SPPE-01>.
- Jacobs 2019c** – Jacobs (Jacobs). (TN 227626). LDC Responses to Formal and Informal Data Requests. Data Response Set 1A, dated April 11, 2019. Available online at: <https://efiling.energy.ca.gov/Lists/DocketLog.aspx?docketnumber=19-SPPE-01>.
- Jacobs 2019d** – Jacobs (Jacobs). (TN228748). LDC Updated SPPE Project Description, dated June 13, 2019. Available online at: <https://efiling.energy.ca.gov/Lists/DocketLog.aspx?docketnumber=19-SPPE-01>.
- Jacobs 2019e** – Jacobs (Jacobs). (TN 228822). LDC Response to Informal Data Requests. Data Response Set 3, dated June 21, 2019. Available online at: <https://efiling.energy.ca.gov/Lists/DocketLog.aspx?docketnumber=19-SPPE-01>.
- Jacobs 2019f** – Jacobs (Jacobs). (TN 228823). LDC Updated SPPE Project Description, dated June 21, 2019. Available online at: <https://efiling.energy.ca.gov/Lists/DocketLog.aspx?docketnumber=19-SPPE-01>.
- Jacobs 2019g** – Jacobs (Jacobs). (TN 228854). LDC Data Request Response Set 1B, dated June 27, 2019. Available online at: <https://efiling.energy.ca.gov/Lists/DocketLog.aspx?docketnumber=19-SPPE-01>.
- Jacobs 2019h** – Jacobs (Jacobs). (TN 228913). LDC Revised Construction Emission Estimates, dated July 8, 2019. Available online at: <https://efiling.energy.ca.gov/Lists/DocketLog.aspx?docketnumber=19-SPPE-01>.
- Jacobs 2019j** – Jacobs (Jacobs). (TN 229116). Laurelwood Data Center Bay Area AQMD Policy Compliance Letter, dated July 29, 2019. Available online at: <https://efiling.energy.ca.gov/Lists/DocketLog.aspx?docketnumber=19-SPPE-01>.
- Jacobs 2019k** – Jacobs (Jacobs). (TN 229160). LDC Response to Data Request, Set 5, dated July 31, 2019. Available online at: <https://efiling.energy.ca.gov/Lists/DocketLog.aspx?docketnumber=19-SPPE-01>.
- Jacobs 2019l** – Jacobs (Jacobs). (TN 229274). LDC Chiller GHG and HRA Data Responses, dated August 8, 2019. Available online at: <https://efiling.energy.ca.gov/Lists/DocketLog.aspx?docketnumber=19-SPPE-01>.
- OEHHA 2015** – Office of Environmental Health Hazard Assessment (OEHHA). Air Toxics Hot Spots Program Risk Assessment Guidelines. Guidance Manual for Preparation of Health Risk Assessments, March 6, 2015. Available online at: <https://oehha.ca.gov/media/downloads/crn/2015guidancemanual.pdf>.
- OEHHA 2018** – Office of Environmental Health Hazard Assessment and California Air Resources Board (OEHHA & ARB). 2018. Consolidated Table of OEHHA/ARB Approved Risk Assessment Health Values. May. Available online at: <https://ww3.arb.ca.gov/toxics/healthval/healthval.htm>.

- SVP 2018a** – Silicon Valley Power (SVP). Final 2018 Integrated Resource Plan for Silicon Valley Power. Adopted by the Santa Clara City Council, November 27, 2018. Available online at: <http://www.siliconvalleypower.com/svp-and-community/about-svp/integrated-resource-plan>.
- SVP 2019a** – Silicon Valley Power (SVP). Utility Fact Sheet. Available online at: <http://www.siliconvalleypower.com/svp-and-community/about-svp/utility-fact-sheet>. Accessed on: May 2019.
- US EPA 1996** – United States Environmental Protection Agency (US EPA). AP-42, Fifth Edition, Volume 1. Chapter 3: Stationary Internal Combustion Sources, Section 3.4: Large Stationary Diesel and All Stationary Dual-fuel Engines. October 1996. Available online at: <https://www3.epa.gov/ttn/chief/ap42/ch03/index.html>.
- US EPA 2003** – United States Environmental Protection Agency (US EPA). Diesel engine exhaust. Available online at: [http://cfpub.epa.gov/ncea/iris/index.cfm?fuseaction=iris.showQuickView&substance\\_nmbr=0642](http://cfpub.epa.gov/ncea/iris/index.cfm?fuseaction=iris.showQuickView&substance_nmbr=0642).
- US EPA 2006** – United States Environmental Protection Agency (US EPA). AP-42, Fifth Edition, Volume 1. Chapter 13: Miscellaneous Sources, Section 13.2.2: Unpaved Roads. November 2006. Available online at: <https://www3.epa.gov/ttn/chief/ap42/ch13/>.
- US EPA 2011a** – United States Environmental Protection Agency (US EPA). AP-42, Fifth Edition, Volume 1. Chapter 13: Miscellaneous Sources, Section 13.2.1: Paved Roads. January 2011. Available online at: <https://www3.epa.gov/ttn/chief/ap42/ch13/>.
- US EPA 2011b** – United States Environmental Protection Agency (US EPA). Additional Clarification Regarding Application of Appendix W Modeling Guidance for the 1-hour NO<sub>2</sub> National Ambient Air Quality Standard. March 2011. Available online at: [https://www3.epa.gov/ttn/scram/guidance/clarification/Additional\\_Clarifications\\_AppendixW\\_Hourly-NO2-NAAQS\\_FINAL\\_03-01-2011.pdf](https://www3.epa.gov/ttn/scram/guidance/clarification/Additional_Clarifications_AppendixW_Hourly-NO2-NAAQS_FINAL_03-01-2011.pdf).
- US EPA 2011c** – United States Environmental Protection Agency (US EPA). Air Quality Designations for the 2008 Lead (Pb) National Ambient Air Quality Standards. Available online at: <https://www.govinfo.gov/content/pkg/FR-2011-11-22/pdf/2011-29460.pdf>. Accessed on: April 2019.
- US EPA 2013** – United States Environmental Protection Agency (US EPA). Determination of Attainment for the San Francisco Bay Area Nonattainment Area for the 2006 Fine Particle Standard; California; Determination Regarding Applicability of Clean Air Act Requirements. Available online at: <https://www.federalregister.gov/documents/2013/01/09/2013-00170/determination-of-attainment-for-the-san-francisco-bay-area-nonattainment-area-for-the-2006-fine>. Accessed April 2019.
- US EPA 2014** – United States Environmental Protection Agency (US EPA). EPA Finalizes Initial Area Designations for the 2012 National Air Quality Standard for Fine Particles - Dec 2014. Available online at: <https://www.epa.gov/particle-pollution-designations/epa-finalizes-initial-area-designations-2012-national-air-quality>. Accessed on: April 2019.
- US EPA 2016** – United States Environmental Protection Agency (US EPA). NO<sub>2</sub>/NO<sub>x</sub> In-Stack Ratio (ISR) Database. Last updated on 9/27/2016. Available online at: [https://www3.epa.gov/scram001/no2\\_isr\\_database.htm](https://www3.epa.gov/scram001/no2_isr_database.htm). Accessed on: April 2019.

- US EPA 2017** – United States Environmental Protection Agency (US EPA). 2017. Guideline on Air Quality Models. 40 Code of Federal Regulations (CFR) Part 51, Appendix W. January. Available online at: [https://www3.epa.gov/ttn/scram/appendix\\_w-2016.htm](https://www3.epa.gov/ttn/scram/appendix_w-2016.htm). Accessed on: April 2019.
- US EPA 2018** – United States Environmental Protection Agency (US EPA). Air Quality Designations for the 2010 Sulfur Dioxide (SO<sub>2</sub>) Primary National Ambient Air Quality Standard—Round 3. Available online at: <https://www.govinfo.gov/content/pkg/FR-2018-01-09/pdf/2017-28423.pdf>. Accessed on: April 2019.
- US EPA 2019** – United States Environmental Protection Agency (US EPA). Outdoor Air Quality Data, Monitor Values Report. Available online at: <https://www.epa.gov/outdoor-air-quality-data/monitor-values-report>. Accessed on: April 2019.

## 5.4 Biological Resources

This section describes the environmental and regulatory setting and discusses impacts associated with the demolition/construction and operation of the Laurelwood Data Center (LDC or project) with respect to biological resources that occur in the project area.

BIOLOGICAL RESOURCES		Potentially Significant Impact	Less than Significant With Mitigation Incorporated	Less Than Significant Impact	No Impact
<b>Would the project:</b>					
a.	Have a substantial adverse effect, either directly or through habitat modifications, on any species identified as a candidate, sensitive, or special-status species in local or regional plans, policies, or regulations, or by the California Department of Fish and Wildlife or U.S. Fish and Wildlife Service?	<input type="checkbox"/>	<input checked="" type="checkbox"/>	<input type="checkbox"/>	<input type="checkbox"/>
b.	Have a substantial adverse effect on any riparian habitat or other sensitive natural community identified in local or regional plans, policies, regulations or by the California Department of Fish and Wildlife or U.S. Fish and Wildlife Service?	<input type="checkbox"/>	<input type="checkbox"/>	<input checked="" type="checkbox"/>	<input type="checkbox"/>
c.	Have a substantial adverse effect on state or federally protected wetlands (including, but not limited to, marsh, vernal pool, coastal, etc.) through direct removal, filling, hydrological interruption, or other means?	<input type="checkbox"/>	<input type="checkbox"/>	<input checked="" type="checkbox"/>	<input type="checkbox"/>
d.	Interfere substantially with the movement of any native resident or migratory fish or wildlife species or with established native resident or migratory wildlife corridors, or impede the use of native wildlife nursery sites?	<input type="checkbox"/>	<input checked="" type="checkbox"/>	<input type="checkbox"/>	<input type="checkbox"/>
e.	Conflict with any local policies or ordinances protecting biological resources, such as a tree preservation policy or ordinance?	<input type="checkbox"/>	<input type="checkbox"/>	<input checked="" type="checkbox"/>	<input type="checkbox"/>
f.	Conflict with the provisions of an adopted Habitat Conservation Plan, Natural Community Conservation Plan, or other approved local, regional, or State habitat conservation plan?	<input type="checkbox"/>	<input type="checkbox"/>	<input type="checkbox"/>	<input checked="" type="checkbox"/>

Environmental checklist established by CEQA Guidelines, Appendix G.

### 5.4.1 Setting

The 12-acre project site in the city of Santa Clara is within an established urbanized industrial zone, surrounded by commercial/industrial use buildings and bordered to the south by U.S. Highway 101. San Tomas Aquino Creek, with border trails defining the tops of bank, is located less than 500 feet west of the project site. The creek provides habitat for local wildlife and walking, running, and biking opportunities for local workers and residents. The Small Power Plant Exemption (SPPE) application states all land disturbance would avoid the San Tomas Aquino Creek and banks. Placement of the poles for the electric transmission line extension could occur within close proximity to the creek but would avoid the channel and banks.

The site was previously fully developed and the buildings located on the project property were used for electrical component manufacturing and office space. The former owner of the property obtained city permit(s) to demolish previously-existing site buildings and improvements. The majority of the vegetation on the property consists of non-native/non-native invasive trees and shrubs such as Eucalyptus (*Eucalyptus sp.*), Strawberry tree (*Arbutus x 'Marina'*), Green ash (*Fraxinus pennsylvanica*) and Trailing lantana (*Lantana montevidensis*) with the exception of native trees: one Toyon (*Heteromeles arbutifolia*),



two Western redbud (*Cercis occidentalis*), neighboring Coast redwoods (*Sequoia sempervirens*) and one neighboring Monterey pine (*Pinus radiata*). Twenty of the existing non-native/non-native invasive trees would be removed with development of the project.

## Regulatory Background

### *Federal*

**Endangered Species Act (16 U.S.C. § 1531 et seq. and 50 C.F.R. part 17.1 et seq.).** The Endangered Species Act (ESA) designates and provides for protection of threatened and endangered plant and animal species, and their critical habitat. “Take” of federally listed species as defined in the ESA is prohibited without incidental take authorization, which may be obtained through Section 7 consultation (between federal agencies) or a Section 10 Habitat Conservation Plan. The administering agencies are the United States Fish and Wildlife Service (USFWS), the National Oceanic Atmospheric Administration (NOAA), and National Marine Fisheries Service.

**Migratory Bird Treaty Act (16 U.S.C. §§ 703–711).** The Migratory Bird Treaty Act (MBTA) makes it unlawful to take or possess any migratory nongame bird (or any part of such migratory nongame bird including nests with viable eggs). The administering agency is the USFWS.

**Clean Water Act Sections 401 and 404.** The Clean Water Act (CWA) (33 U.S.C. §§ 1251–1376) requires the permitting and monitoring of all discharges to surface water bodies. Section 404 (33 U.S.C. § 1344) requires a permit from the United States Army Corps of Engineers (USACE) for a discharge from dredged or fill materials into a water of the United States, including wetlands. Section 401 (33 U.S.C. § 1341) requires a permit from the regional water quality control board for the discharge of pollutants.

**Rivers and Harbors Act Section 10.** Section 10 of the Rivers and Harbors Act of 1899 requires authorization from USACE for the construction of any structure in or over any navigable water of the United States. Structures or work outside the limits defined for navigable waters of the United States require a Section 10 permit if the structure or work affects the course, locations, or condition of the water body. This applies to any dredging or disposal of dredging materials, excavation, filling, rechannelization, or any other modification of a navigable water of the United States and applies to all structures.

### *State*

**California Endangered Species Act (Fish and G. Code, §§ 2050–2098).** The California Endangered Species Act of 1984 protects California’s rare, threatened, and endangered species. CESA allows California Department of Fish and Wildlife (CDFW) to issue an incidental take permit for a species listed as candidate, threatened, or endangered only if that take is incidental to otherwise lawful activities and specific criteria are met. These criteria are listed in Title 14, California Code of Regulations, section 783.4, subdivisions (a) and (b). For purposes of CESA, “take” means to hunt, pursue, catch, capture, or kill, or attempt to hunt, pursue, catch, capture, or kill (Fish and G. Code, § 86).

**California Fish and Game Code Section 3503.** This section makes it unlawful to take, possess, or needlessly destroy the nest or eggs of any bird, except as otherwise provided by this code or any regulation made pursuant thereto.

**California Fish and Game Code Section 3513.** This section protects California’s migratory birds by making it unlawful to take or possess any migratory nongame bird as designated in the MBTA or any part of such migratory nongame birds. The administering agency is CDFW.

**California Fish and Game Code Sections 3511, 4700, 5050, and 5515.** These sections designate certain species as fully protected and prohibit the take of such species or their habitat unless for scientific purposes (see also Cal. Code Regs., tit. 14, § 670.7). Incidental take of fully protected species may also be authorized in a Natural Community Conservation Plan (NCCP) (Fish and G. Code, § 2835).

**California Fish and Game Code Section 1602.** This section stipulates that an entity shall not substantially divert or obstruct the natural flow of, or substantially change or use any material from the bed, channel, or bank of, any river, stream, or lake, or deposit or dispose of debris, waste, or other material containing crumbled, flaked, or ground pavement where it may pass into any river, stream, or lake.

### **Local**

**City of Santa Clara 2010 – 2035 General Plan.** Goals and policies specific to the City of Santa Clara General Plan to protect and preserve the city’s natural habitat and wildlife are described in Chapter 5 Goals and Policies, Section 10 Environmental Quality. These goals and policies are important with respect to the proposed project:

- 5.3.1-P10 Provide opportunities for increased landscaping and trees in the community, including requirements for new development to provide street trees and a minimum 2:1 on- or off-site replacement for trees removed as part of the proposal to help increase the urban forest and minimize the heat island effect.
- 5.10.1-G1 The protection of fish, wildlife and their habitats, including rare and endangered species.
- 5.10.1-G2 Conservation and restoration of riparian vegetation and habitat.
- 5.10.1-P1 Require environmental review prior to approval of any development with the potential to degrade the habitat of any threatened or endangered species.
- 5.10.1-P2 Work with Santa Clara Valley Water District and require that new development follow the “Guidelines and Standards for Lands Near Streams” to protect streams and riparian habitats.
- 5.10.1-P3 Require preservation of all City-designated heritage trees listed in the Heritage Tree Appendix 8.10 of the General Plan.
- 5.10.1-P4 Protect all healthy cedars, redwoods, oaks, olives, bay laurel and pepper trees of any size, and all other trees over 36 inches in circumference measured from 48 inches above-grade on private and public property as well as in the public right-of-way.
- 5.10.1-P11 Require use of native plants and wildlife-compatible non-native plants, when feasible, for landscaping on City property.
- 5.10.1-P12 Encourage property owners and landscapers to use native plants and wildlife-compatible nonnative plants, when feasible.

**Santa Clara City Code.** Chapter 12.35: Trees and Shrubs, Sections .010, .020, .030, .040, .050. These sections of the Santa Clara City Code specify how to proceed with certain tree and shrub issues, such as

removal, alteration, misuse of trees and if trees become hazardous to public safety. Here is one section most applicable to proposed project:

- 12.35.020 Alteration or removal – Permit required. No tree, plant or shrub planted or growing in the streets or public places of the City shall be altered or removed without obtaining a written permit from the superintendent of streets. No person without such authorization shall trench around or alongside of any such tree, plant or shrub with the intent of cutting the roots thereof or otherwise damaging the same.

## 5.4.2 Environmental Impacts and Mitigation Measures

**Applicant Proposed Measures.** The applicant proposes to implement the following design measures (termed “Applicant Proposed Measures” or “APMs” in this analysis) as part of the project, that are intended to avoid and reduce potential impacts to biological resources. (Jacobs 2019a, Section 2.52, page 2-22 and 2-23). Also, **APM PD-1** includes the preparation of a Worker Environmental Awareness Training program (program) to instruct construction workers of the obligation to protect and preserve valuable resources, including biological resources. See **Section 4.0, Project Description, Table 4-5** for the full text of **APM PD-1**.

**APM BIO-1:** Preconstruction surveys will be performed for biological resources by a qualified biologist. The surveys will identify any active nests that could be disturbed during construction. Surveys will be completed no more than 7 days prior to the initiation of ground disturbance. During this survey, the biologist shall inspect vegetation along the perimeter of the project site.

**APM BIO-2:** A no-work buffer will be established around any active nests with an appropriate buffer for the nesting species. The buffer widths will be developed by a qualified biologist, based on species’ sensitivity to disturbance, planned construction activities, and baseline level of human activity.

**APM BIO-3:** The biologist will draft a technical memorandum documenting the result of the survey and any designated buffer zones, which may be submitted to the Director of Community Development prior to the start of ground disturbance activities.

**a. *Would the project have a substantial adverse effect, either directly or through habitat modifications, on any species identified as a candidate, sensitive, or special status species in local or regional plans, policies, or regulations, or by the California Department of Fish and Wildlife or U.S. Fish and Wildlife Service?***

Energy Commission staff conducted a California Natural Diversity Database (CNDDDB) search for special-status species with a nine quad search and considered this with the applicant’s search within a two-mile radius of the project site (CNDDDB 2019). A discussion of special-status species with recorded occurrences on the CNDDDB search is provided below.

Western burrowing owl (*Athene cunicularia*), a California species of special concern, are known to occur and breed within the two-mile radius of the proposed project site. Their presence has been consistent in the last decade and they have recently been spotted the last several years as recorded in the Santa Clara Valley Audubon Society (SCVAS) annual bird list count. The project site lacks the natural habitat, grasslands, and ruderal habitat with ground squirrel burrows that burrowing owls prefer, however they sometimes will burrow in man-made structures like pipe culverts. Although unlikely, since their presence is known in the area there is a potential for burrowing owl to occur on the site.

The yellow rail (*Coturnicops noveboracensis*), California black rail (*Laterallus jamaicensis coturniculus*) and tricolored blackbird (*Agelaius tricolor*) are listed birds that live within marshland, wet meadows, and the latter in wetland habitat. The yellow rail is a California species of special concern. Historical records indicate its presence in the City of Santa Clara and the SCVAS lists sighting them within the past several years. The California black rail, a state-listed threatened and fully protected species, was documented on CNDDDB as having occurred in the area as recently as 2016. As recently as March 2019, three California black rail were also sighted just outside the two-mile radius from the project site (SCVAS). The most recent record of tricolored blackbird, a state-listed threatened bird, in the CNDDDB in the project area was for 2015 and again the SCVAS has sighted this species in the last several years. However, none of these species are expected to occur on the project site due to its urbanized condition and lack of any surface water sources, so no impacts are anticipated.

Historically the Western pond turtle (*Emys marmorata*), a state species of special concern, has occurred within the two-mile radius of the project site but is presumed extant within this range in the City of Santa Clara as of 2017. Western pond turtles are found in aquatic habitats in and near ponds, creeks, and rivers. During the breeding season, March–June, turtles may travel over 1500 feet away from their aquatic habitat to lay eggs and sometimes even further than this when they are overwintering (CDFW 2014). The project site is within 500 feet of San Thomas Aquino Creek where there is potential for Western pond turtles to be found as they could travel anywhere along this corridor. However, the project site is separated from the creek by a neighboring developed parking lot and this makes it less likely that the turtles would travel to the project site. Thus, Western pond turtles are not expected to occur on the project site and no impacts are anticipated.

The Central California Coast Distinct Population Segment (DPS) Steelhead population (*Oncorhynchus mykiss irideus pop. 8*), which is a federally threatened species, also currently is known to occur within the two-mile radius within the Guadalupe River. Steelhead are born in freshwater migrating to the ocean and returning, possibly multiple times, to spawn in freshwater again. In California, spawning typically occurs between December to April (Calfish 2019). There is potential for steelhead to occur in San Thomas Aquino Creek. However, lack of aquatic habitat on the project site means there are no expected impacts to this species.

The other special-status species in the region, Alameda song sparrow (*Melospiza melodia pusillula*), California tiger salamander (*Ambystoma californiense*), Hoover's button-celery (*Eryngium aristulatum var. hooveri*), Congdon's tarplant (*Centromadia parryi ssp. congdonii*), and Contra Costa goldfields (*Lasthenia conjugens*) are not expected on the project site or immediate area due to the lack of suitable habitat and the developed condition of the project site.

## Demolition/Construction

LESS THAN SIGNIFICANT WITH MITIGATION INCORPORATED.

### *Special-Status Species- Nesting Birds*

If demolition/construction occurs during the nesting bird season from February to August, it is possible for construction activities to affect nesting and migratory birds that are attracted to the nearby San Tomas Aquino Creek and other, urban vegetated areas on and near the project site. Construction activity near nesting birds is disruptive and sometimes can cause nest abandonment.

The design measures **APM BIO-1**, **APM BIO-2**, and **APM BIO-3**, proposed by the applicant to avoid and reduce impacts to nesting birds, lack the specificity necessary to ensure project impacts would be reduced to less than significant levels. No concise protocol is proposed for preconstruction nest surveys, and proposed “no-work” buffers around active nests discovered prior to or during construction are not defined in accordance with established best practices to protect avian resources. Additionally, **APM BIO-3** does not ensure accountability because it stipulates a technical report of the bird surveys “may be submitted” to the city, rather than requiring it.

To ensure impacts to nesting birds are avoided and minimized to less than significant, staff is proposing **MM BIO-1**, which would replace nesting mitigation in **APM BIO-1**, provide details about buffers absent in **APM BIO-2**, and ensure the accountability in reporting that is absent in **APM BIO-3**. With adherence to **MM BIO-1** and **APM PD-1**, project impacts to nesting birds covered by the MBTA and other federal and state laws would be less than significant.

#### *Special Status Species- Western Burrowing Owl*

As noted previously, there is the potential for Western burrowing owl, a California species of special concern, to occur on the project site. The project area falls within high potential breeding habitat and is about 1.5 miles between two known Western burrowing owl breeding areas; thus, there is the possibility of burrowing owl presence on the project (SCVHA 201a). Should burrowing owl occupy the project site during construction, impacts to this special-status bird including take through disruption and destruction of active burrows would be considered significant unless mitigation is provided.

**APM BIO-1** and **APM BIO-2** do not address the potential presence of Western burrowing owl and related best practices for avoidance and impact minimization recommended by the CDFW (CDFW 2012). To ensure impacts to burrowing owls are avoided and minimized to less than significant levels, staff is proposing **MM BIO-2**, which would add specific measures for Western burrowing owl. **MM BIO-2** would require pre-construction surveys of suitable habitat areas (as determined by a qualified biologist) for Western burrowing owl before any ground disturbance activities regardless of the time of year, within 300 feet of proposed construction activities on the project site and the transmission line extension, or as directed by the City of Santa Clara. Where pre-construction surveys identify occupied burrows during the February 1 through August 31 breeding season, a no-disturbance buffer around the burrow would be required. Where pre-construction surveys identify occupied burrows outside the breeding season, the applicant may propose an eviction and exclusion plan for passive relocation of the birds, subject to preparation and approval of a Burrowing Owl Exclusion Plan (BOEP). **MM BIO-2** would also include accountability in reporting that is absent in **APM BIO-3**. With observance and implementation of the **MM BIO-2** and **APM PD-1**, construction impacts to Western burrowing owl that may occupy the project site would be avoided and minimized; reducing impacts to less than significant levels.

#### **MM BIO-1: Nesting bird avoidance and mitigation**

1. If work is scheduled during the nesting season (February 1 through August 31), pre-construction nest detection surveys will be conducted by a qualified biologist, with a bachelor’s degree or above in a biological science field and demonstrated field expertise in ornithology, in particular, nesting behavior. Surveys of suitable habitat areas as determined by a qualified biologist, will be conducted within 300 feet of the proposed project construction including staging, grading, site excavation and improvements, and the transmission line extension or as directed by the City of Santa Clara. Surveys will occur at least 14 days prior and again 24 hours prior to initial ground

disturbance activities, or as directed by the City of Santa Clara. Nest surveys will be accomplished by ground surveys and will support phased construction, with surveys scheduled to be repeated if construction lapses in a work area for 15 days between March and July. Any habitat areas adjacent to the project site but not publicly accessible will be surveyed with binoculars.

2. If active nests containing eggs or young are found on areas controlled by the project owner, the biologist will establish a species-appropriate nest buffer informed by the following **Table 5.4-1**, or as directed by the City of Santa Clara. Where warranted, the qualified biologist may increase or decrease the standard buffers based on an assessment of the individual circumstances of the nest. Nesting pair acclimation to disturbance in areas with regularly occurring human activities will be considered when establishing nest buffers. The established buffers will remain in effect until the young have fledged or the nest is no longer active as confirmed by the qualified biologist. Active nests will be periodically monitored until the qualified biologist has determined that the young have fledged or once construction ends. Hand removal of vegetation within nest buffers may be done at the discretion of the qualified biologist. Inactive nests may be removed upon a written determination by the qualified biologist that the nest and any eggs present are no longer viable. The qualified biologist will have authority to order the cessation of nearby project activities if nesting pairs exhibit signs of disturbance.

<b>Avian Group</b>	<b>Species Potentially Nesting in the Project Vicinity</b>	<b>Buffer for Construction Activities (feet)</b>
Bitterns and herons	Black-crowned night heron, great blue heron, great egret, green heron, snowy egret	250
Cormorants	Double-crested cormorant	100
Doves	Mourning dove	25
Geese and ducks	American widgeon, blue-winged teal, cinnamon teal, Canada goose, gadwall, mallard, northern pintail, ruddy duck	100
Grebes	Clark's grebe, eared grebe, horned grebe, pied-billed grebe, western grebe	100
Hummingbirds	Allen's hummingbird, Anna's hummingbird, black-chinned hummingbird	25
Plovers	Killdeer	50
Raptors (Category 1)	American kestrel, barn owl, red-tailed hawk	50
Raptors (Category 2)	Cooper's hawk, red-shouldered hawk, sharp-shinned hawk	150
Raptors (Category 3)	Northern harrier, white-tailed kite, burrowing owl	Special-status species; buffer determined in consultation with permitting agency, CDFW and as specified in <b>MM BIO-2</b> for burrowing owl.
Stilts and Avocets	American avocet, black-necked stilt	150
Terns	Elegant tern, Forster's tern, royal tern	100
Passerines (cavity and crevice nesters)	House wren, Say's phoebe, western bluebird	25



**TABLE 5.4-1 AVIAN NEST BUFFERS**

Avian Group	Species Potentially Nesting in the Project Vicinity	Buffer for Construction Activities (feet)
Passerines (bridge, culvert, and building nesters)	Black phoebe, cliff swallow, house finch, Say's phoebe	25
Passerines (ground nesters, open habitats)	Horned lark	100
Passerines (understory and thicket nesters)	American goldfinch, blue-gray gnatcatcher, bushtit, California towhee, common yellowthroat, red-winged blackbird, song sparrow, Swainson's thrush	25
Passerines (scrub and tree nesters)	American crow, American goldfinch, American robin, blue-gray gnatcatcher, Bullock's oriole, bushtit, Cassin's kingbird, common raven, hooded oriole, house finch, lesser goldfinch, northern mockingbird	25
Passerines (tower nesters)	Common raven, house finch	25
Passerines (marsh nesters)	Common yellowthroat, red-winged blackbird	25
Species not covered under MBTA	Domestic waterfowl, including domesticated mallards, feral (rock) pigeon, European starling, and house sparrow	N/A

3. The qualified biologist shall prepare a technical memorandum documenting the result of the survey and any designated buffer areas, to be submitted as directed by the City of Santa Clara prior to the start of ground disturbing activities.

**MM BIO-2: Burrowing owl avoidance and mitigation.** Surveys for burrowing owl shall be conducted by a qualified biologist, with a bachelor's degree or above in a biological science field and demonstrated field expertise in ornithology, and in particular, nesting behavior. Surveys of suitable habitat areas as determined by a qualified biologist, shall be conducted within 300 feet of the proposed project construction including staging, grading, site excavation and improvements, and the transmission line extension, or as directed by the City of Santa Clara. Surveys shall be conducted in accordance with the most recent California Department of Fish and Wildlife (CDFW) guidance (current guidance: CDFW 2012). Any habitat areas adjacent to the project site but not publicly accessible will be surveyed with binoculars. Surveys, avoidance and mitigation shall be conducted according to the parameters and limitations listed below, depending on the time of year:

- A. **Breeding Season (February 1 through August 31):** Pre-construction surveys for burrowing owls shall be performed at least 14 days prior and again 24 hours prior to initial ground disturbance activities, or as directed by the City of Santa Clara.
  1. Any occupied burrows shall not be disturbed and shall be provided with a 250-foot protective buffer on areas controlled by the Project Owner until and unless modified by the local permitting agency (City of Santa Clara) in consultation with CDFW, or unless a qualified biologist approved by the local permitting agency verifies through non-invasive means that either: (1) the birds have not begun egg laying, or (2) juveniles from the occupied burrows are foraging independently and are capable of independent survival.

- Once the fledglings in an active burrow are capable of independent survival, a Burrowing Owl Exclusion Plan (BOEP) is developed and approved by the local permitting agency, and habitat is mitigated in accordance with the California Department of Fish and Wildlife (CDFW) staff report guidance (CDFW 2012), then the burrow may be destroyed. Pre-construction surveys following destruction of burrows and prior to initial construction activities are required (24 hours prior) to ensure owls do not re-colonize the project.
2. If project activities are delayed or suspended for more than 15 days during the breeding season, surveys shall be repeated.
- B. Non-breeding Season (September 1 through January 31): Pre-construction surveys following the staff report on burrowing owls (CDFW 2012) shall be performed prior (at least 14 days prior and again 24 hours prior) to initial ground disturbance activities, or as directed by the City of Santa Clara. Burrowing owls may be evicted via passive exclusion after a BOEP is developed and approved by the local permitting agency, and habitat is mitigated in accordance with the CDFW staff report (CDFW 2012).

Pre-construction surveys following destruction of burrows are required 24 hours prior to initial construction activities to ensure owls do not re-colonize the project. If owls are found within 160 feet of the project, it is recommended that visual screens or other measures be implemented to limit disturbance of the owls without evicting them from the occupied burrows.

If no burrowing owls are detected, no further measures are required. If burrowing owls are detected, no construction activities will occur within 250 feet of occupied burrows during the breeding season or within 160 feet of occupied burrows during the non-breeding season. The size of any avoidance buffer may be increased or decreased as determined by the qualified biologist based on the planned construction activities and the sensitivity of the burrowing owls. Additionally, burrowing owls shall be monitored by a qualified biologist during construction to assess the sensitivity of the burrowing owls to the construction activities. During the non-breeding season passive relocation may be conducted in accord with an approved BOEP.

If a burrowing owl is observed at the project at any time during construction, then a buffer area shall be established in accord with the above seasonal criteria (consistent with CDFW 2012 guidance) until the animal can be passively relocated out of the construction area.

### **Operation and Maintenance**

NO IMPACT. Anticipated operation and maintenance activities associated with the project would not require ground disturbance on site or within the San Tomas Aquino creek corridor where the transmission line extension is proposed. Operation and maintenance activities are expected to be infrequent, benign and less disruptive compared to the current office and industrial activities in the surrounding business park and result in the same or lesser level of human presence and disturbance. Therefore, the project operation and maintenance activities would have no impact on special-status species.

### **Proposed Mitigation Measures: MM BIO-1 and MM BIO-2.**

**b. *Would the project have a substantial adverse effect on any riparian habitat or other sensitive natural community identified in local or regional plans, policies, and regulations or by the California Department of Fish and Wildlife or U.S. Fish and Wildlife Service?***

The project site and surrounding properties have been heavily developed and historically used for industrial electrical component manufacturing and offices. There are no sensitive habitats present on the project site or adjacent properties. However, San Tomas Aquino Creek, an open water riparian area, is located less than 500 feet west of the project site. As stipulated in the SPPE application and the applicant's response to staff's data requests, all of the project improvements and construction and staging activities would occur outside of the San Tomas Aquino creekbed and banks (Jacobs 2019a; Jacobs 2019c).

**Demolition/Construction**

LESS THAN SIGNIFICANT IMPACT. Demolition/construction activities would occur primarily on the project site, which has been previously developed and is surrounded by industrial and office park uses. As noted previously, construction of the transmission line extension over San Tomas Aquino Creek would avoid any surface disturbance of the creek corridor. Construction noise would be commensurate with existing ambient noise generated by surrounding sources including the adjacent U.S. Highway 101 and activities in the adjacent office and industrial buildings along Laurelwood Road and Juliette Drive. As such, project construction impacts to the riparian habitat associated with the creek would be less than significant.

**Operation and Maintenance**

LESS THAN SIGNIFICANT IMPACT. Operation of the 56 backup diesel generators would result in emissions of oxides of nitrogen. The accumulation of nitrogen in soils is known to adversely affect sensitive wetlands and other native habitats by facilitating growth of invasive non-native plants. Air Quality staff's modeling of potential nitrogen emissions from the generators concluded that under expected testing and maintenance conditions, and the predominant atmospheric conditions and wind direction in the area, nitrogen emissions at the nearest point of the at San Tomas Aquino Creek would be negligible, at approximately 0.00 to 2.76 kilograms/hectare/year. As such, impacts would be less than significant (CEC 2019d).

**Proposed Mitigation Measures:** None.

**c. *Would the project have a substantial adverse effect on state or federally protected wetlands (including, but not limited to, marsh, vernal pool, coastal, etc.) through direct removal, filling, hydrological interruption, or other means?***

There are no federally protected wetlands as defined by Section 404 of the Clean Water Act on the project site. San Tomas Aquino Creek is the nearest body of water under the jurisdiction of the U.S. Army Corps of Engineers and is the main component of a larger watershed that flows north to Guadalupe Slough eventually draining to South San Francisco Bay. The creek has slow flowing water year round and is contained within a excavated channel with a natural bottom cover consisting of sand, mud, and gravel. A little over 1.25 miles north from the portion of San Tomas Aquino Creek that is closest to the project, the creek gradually turns into estuarine waters becoming more influenced by tides and higher ocean salt water content. The nearest estuarine and marine wetlands cover 21.5

acres within Baylands Park just over 2.20 miles north of the project site. These wetlands are adjacent to the deepwater lake and wetlands of Don Edwards San Francisco Bay National Wildlife Refuge.

### **Demolition/Construction**

LESS THAN SIGNIFICANT IMPACT. As noted previously, construction of the project site improvements, buildings, and transmission line extension would avoid any surface disturbance at the nearest water feature to the project site – the San Tomas Aquino Creek. On-site adherence to discharge requirements for the control of solids and pollutants leaving the construction area, as required in the local National Pollution Discharge Elimination System (NPDES) authorization, would ensure that impacts to natural waterways are avoided.

### **Operation and Maintenance**

LESS THAN SIGNIFICANT IMPACT. Impacts from operation and maintenance of the project would be similar to those anticipated during construction. The project would drain to the existing City of Santa Clara storm drain system and to the permanent site improvements including retention swales to prevent overflow of floodwaters onto adjacent properties, ditches, or waterways.

**Proposed Mitigation Measures:** None.

- d. *Would the project interfere substantially with the movement of any native resident or migratory fish or wildlife species or with established native resident or migratory wildlife corridors, or impede the use of wildlife nursery sites?***

The project is located in an established urbanized area characterized by office and industrial uses. The site and adjacent properties do not support wildlife species or provide natural areas that could serve as corridors for the movement of wildlife. As noted previously, San Tomas Aquino Creek is located 500 feet to the west, and supports a variety of wildlife and potentially hosts Central California Coast Distinct Population Segment (DPS) of Steelhead.

### **Demolition/Construction**

LESS THAN SIGNIFICANT WITH MITIGATION INCORPORATED. As noted previously, the project would completely avoid any disturbance to San Tomas Aquino Creek and any steelhead that may use the creek for migration or spawning. **MM BIO-1** and **MM BIO-2** require the applicant to conduct pre-construction surveys of suitable habitat areas (as determined by a qualified biologist) for birds covered by the MBTA and the California Fish and Game Code and for Western burrowing owl on the site and vicinity before construction. If bird nests or owl burrows are discovered, appropriate non-disturbance buffers would be established and maintained during construction until such time as the burrow or nest is determined to not be active. With these measures and **APM PD-1** incorporated in the project, impacts to avian species covered by the MBTA and Fish and Game Code would be avoided or mitigated to less than significant.

### **Operation and Maintenance**

NO IMPACT. The operation and maintenance of the project would not interfere with the movement of any wildlife.

**Proposed Mitigation Measures:** **MM BIO-1** and **MM BIO-2**.

**e. Would the project conflict with any local policies or ordinances protecting biological resources, such as a tree preservation policy or ordinance?**

The proposal entails development of an industrial data center on a Planned Industrial (MP)- zoned property. There is no naturally-occurring vegetation existing on the project site as trees surrounding the site are part of the existing ornamental landscape, along with a strip of grassland and trees lining the southern boundary that borders U.S. Highway 101. There are no other resources on the site that would be subject to local ordinances protecting biological resources. Due to the lack of natural vegetation and habitats, the project would not conflict with any conservation land use goals or policies protecting natural habitats as mentioned in the City of Santa Clara General Plan. However, there are sections of the city's general plan that protect trees.

**Demolition/Construction**

LESS THAN SIGNIFICANT. A total of 98 trees are on the project site, three of which are native: one Toyon (*Heteromeles arbutifolia*) and two Western redbuds (*Cercis occidentalis*). Twenty of these trees are proposed for removal during construction including two olive trees (*Oliva europa* - Trees #1505 and #1506) according to the applicant's Tree Protection Report included in the SPPE application (Jacobs, 2019a). Although olive trees are non-native, the City of Santa Clara General Plan specifies (Policy 5.10.1-P4) that all olive trees must be protected whether on public or private land. Furthermore, new development should provide a minimum 2:1 tree replacement ratio on or off site for trees removed (Policy 5.3.1-P10) and private property owners should plant native or non-native wildlife friendly plants and trees (Policy 5.10.1-P12). The applicant's Tree Protection Report is consistent with city requirements, and would be a required element of the project as part of the city's Architectural Review process.

**Operation and Maintenance**

NO IMPACT. Once constructed, there is no indication that operation and maintenance of the project would require the removal of additional trees. However, if removal of trees becomes necessary in the future, the site owner would be required to comply with local policies and ordinances regarding the protection/replacement of trees. Operating the data center and maintaining the buildings, on-site ornamental landscaping, and maintenance of the transmission line would involve levels of intrusion and disturbance similar to or less than that at office and industrial uses in the vicinity. Thus, operation of the project would not conflict with local policies and ordinances protecting biological resources.

**Proposed Mitigation Measures:** None.

**f. Would the project conflict with the provisions of an adopted Habitat Conservation Plan, Natural Communities Conservation Plan, or other approved local, regional, or state habitat conservation plan?**

**Demolition/Construction and Operation and Maintenance**

The project and surrounding area is influenced by the Santa Clara Valley Habitat Plan (SCVHP). The SCVHP is a conservation plan adopted in 2012 for the protection and recovery of resources over a 519,000-acre study area encompassing the majority of land in Santa Clara County. However, the City of Santa Clara is not a plan participant or permittee to the SCVHP. The project site falls outside of the study area of the SCVHP, but the project site is within a 48,464-acre *extended study area* for Western burrowing owl conservation that includes the northern edge of the county in portions of the cities of

San José, Santa Clara, Mountain View, Milpitas, and Sunnyvale. The extended study area was created in recognition that in the 1990s nearly all of the burrowing owl population and breeding pairs in Santa Clara County<sup>1</sup> were concentrated on urban open spaces (airfields, parks and golf courses) and preserves at the southern side of San Francisco Bay in the Don Edwards National Wildlife Refuge and Bayland Park areas. Recovery of the species in Santa Clara Valley depends on concentrating conservation efforts near existing breeding burrowing owl colonies, along with the typical dispersal distances of burrowing owl. It was predicted that burrowing owls would move north of the main study area within 7.5 miles between natal, breeding, and overwintering sites. Thus near-term efforts to stabilize, protect, and better manage established and potential burrowing owl habitat in the Don Edwards and Baylands area was assigned elevated priority in the SCVHP.

Since the project area falls within high potential breeding habitat and is about 1.5 miles between two known and established breeding colonies, there is the possibility of burrowing owl presence on the project site (SCVHA 2012). Other than its inclusion in the extended study area for the protection and revival of the burrowing owl population, the project would not conflict with the underlying land use assumptions and inherent goals and conservation strategies incorporated in the habitat plan.

### Demolition/Construction

NO IMPACT. Although the project site is within the extended study area of the SCVHP for burrowing owl conservation, the land and surrounding properties have been fully urbanized, and do not support the open foraging or burrowing habitats that are listed as focus areas in the San Jose/ Baylands Region in the SCVHP's Burrowing Owl Conservation Strategy (SCVHA 2019, Appendix M, pp. 3-5).

### Operation and Maintenance

NO IMPACT. The site is fully urbanized and in the unlikely event that burrowing owls were to establish on the site during operation, these birds would be covered by the MBTA and Fish and Game Code along with the obligate responsibilities of the site owner under these laws.

**Proposed Mitigation Measures:** None.

## 5.4.3 References

- CalFish 2019** – CalFish - A California Cooperative Anadromous Fish and Habitat Data Program, *Steelhead (Oncorhynchus mykiss)*. Available online at: <https://www.calfish.org/FisheriesManagement/SpeciesPages/SteelheadTrout.aspx>. Accessed on: May 14, 2019.
- Calflora 2019** – Calflora. Search for Plants. Available online at: <https://www.calflora.org/>. Accessed on: April 4, 2019.
- CalHerps 2019** – California Herps. *Western Pond Turtle – Actinemys Marmorata*. Available online: <http://www.californiaherps.com/turtles/pages/a.marmorata.html>. Accessed on: May 14, 2019.
- Cal Fish & Game 2019** – California Fish and Game Code (Cal Fish & Game). Available online at: <http://leginfo.legislature.ca.gov/faces/codesTOCSelected.xhtml?tocCode=FGC&tocTitle=+Fish+and+Game+Code+-+FGC>. Accessed on: May 15, 2019.

---

<sup>1</sup> It was estimated that 75 percent of the San Francisco Bay area population of burrowing owl occurred in Santa Clara County (SCVHA 2012, Appendix M, page M-1).



- CDFW 2014** – California Department of Fish and Wildlife (CDFW). News, Michaels, Dana and Laura Patterson, “Recognizing California’s Heroes in a Half-Shell: Our Resident Turtles and Tortoises,” posted on May 23, 2014. Available online at: <https://cdfgnews.wordpress.com/tag/western-pond-turtle/>. Accessed on: May 14, 2019.
- CDFW 2012** – California Department of Fish and Wildlife (CDFW). Staff report on burrowing owl mitigation. State of California Natural Resources Agency. March 2012. Available online at: <https://nrm.dfg.ca.gov/FileHandlre.ashx?DocumentID=83843CDFG>.
- CEC 2019d** – California Energy Commission (CEC). Project communication and analysis – Nitrogen Deposition for Laurelwood Data Center, Energy Commission staff Jon Hilliard and Wenjun Qian, Ph.D, P.E.
- CLO 2019** – The Cornell Lab of Ornithology (CLO). All About Birds Search. Available online at: [https://www.allaboutbirds.org/?\\_\\_hstc=161696355.82e638173b73e9e2c33a86d99a3a6ce5.1558048498474.1558048498474.1558048498474.1&\\_\\_hssc=161696355.2.1558048498475&\\_\\_hsfp=1353874564#/\\_ga=2.251824393.1663171163.1558048476-2119268262.1558048475](https://www.allaboutbirds.org/?__hstc=161696355.82e638173b73e9e2c33a86d99a3a6ce5.1558048498474.1558048498474.1558048498474.1&__hssc=161696355.2.1558048498475&__hsfp=1353874564#/_ga=2.251824393.1663171163.1558048476-2119268262.1558048475). Accessed on: May 10, 2019.
- CNDDDB 2019** – California Natural Diversity Database (CNDDDB). 9Quad and 2mile Search. Available online: <https://www.wildlife.ca.gov/Data/CNDDDB/Maps-and-Data#43018408-cnddb-in-bios>. Accessed on: April – May, 2019.
- Gervais, J.A., D.K. Rosenberg, and L.A. Comrack 2008** – Burrowing Owl (*Athene cunicularia*). Pages 218-226 in W.D. Shuford and T. Gardali, editors. California Bird Species of Special Concern: a ranked assessment of species, subspecies, and distinct populations of birds of immediate conservation concern in California Studies of Western Birds. No. I. Western Field Ornithologists, Camarillo, California and California Department of Fish and Game, Sacramento, California.
- Horii 2019** – San Francisco Bay Area Parks, Recreation and Travel, Ron Horii, “San Tomas Aquino/Saratoga Creek Trail,” posted on August 2014. Available online at: <http://www.rhorii.com/STACT/SanTomasTrl.html>. Accessed on: April 4, 2019.
- Jacobs 2019a** – Jacobs (Jacobs). (TN 227273-1). Application for Small Power Plant Exemption: Laurelwood Data Center, dated March 5, 2019. Available online at: <https://efiling.energy.ca.gov/Lists/DocketLog.aspx?docketnumber=19-SPPE-01>.
- Jacobs 2019c** – Jacobs (Jacobs). (TN 227626). LDC Responses to Formal and Informal Data Requests. Data Response Set 1A, dated April 11, 2019. Available online at: [https://efiling.energy.ca.gov/Lists/DocketLog.aspx?docketnumber=19-SPPE-01\\_](https://efiling.energy.ca.gov/Lists/DocketLog.aspx?docketnumber=19-SPPE-01_)
- NOAAF 2019** – National Oceanic And Atmospheric Administration Fisheries - West Coast Region, *Central California Coast Steelhead*. Available online at: [https://www.westcoast.fisheries.noaa.gov/protected\\_species/salmon\\_steelhead/salmon\\_and\\_steelhead\\_listings/steelhead/central\\_california\\_coast/Central%20California%20Coast%20Steelhead.html](https://www.westcoast.fisheries.noaa.gov/protected_species/salmon_steelhead/salmon_and_steelhead_listings/steelhead/central_california_coast/Central%20California%20Coast%20Steelhead.html). Accessed on: May 10, 2019.
- Santa Clara 2019** – City of Santa Clara (Santa Clara). Santa Clara City Code 2019. Available online at: <https://www.codepublishing.com/CA/SantaClara/>. Accessed on: April 29, 2019.
- Santa Clara 2010** – City of Santa Clara (Santa Clara). 2010 – 2035 General Plan. Adopted November 16, 2010. Available online at: <http://santaclaraca.gov/government/departments/community-development/planning-division/general-plan>. Accessed on: April 29, 2019.

**SCVHA 2012** – Santa Clara Valley Habitat Agency (SCVHA). Final Santa Clara Valley Habitat Plan. August 2012. Available online at: <https://scv-habitatagency.org/178/Santa-Clara-Valley-Habitat-Plan>. Accessed on: March 13, 2019.

**SCVURPPP 2019** – Santa Clara Valley Urban Runoff Pollution Prevention Program (SCVURPPP). *San Tomas Aquino Creek Watershed*. Available online at: [http://www.scvurppp-w2k.com/ws\\_sta.shtml](http://www.scvurppp-w2k.com/ws_sta.shtml). Accessed on: April 4, 2019.

## 5.5 Cultural and Tribal Cultural Resources

This section describes the environmental and regulatory setting and discusses the impacts associated with the demolition/construction and operation of the proposed Laurelwood Data Center (LDC or project) with respect to cultural and tribal cultural resources.

CULTURAL RESOURCES				
Would the project:	Potentially Significant Impact	Less than Significant With Mitigation Incorporated	Less than Significant Impact	No Impact
a. Cause a substantial adverse change in the significance of a historical resource pursuant to §15064.5?	<input type="checkbox"/>	<input checked="" type="checkbox"/>	<input type="checkbox"/>	<input type="checkbox"/>
b. Cause a substantial adverse change in the significance of a unique archaeological resource pursuant to §15064.5?	<input type="checkbox"/>	<input checked="" type="checkbox"/>	<input type="checkbox"/>	<input type="checkbox"/>
c. Disturb any human remains, including those interred outside of dedicated cemeteries?	<input type="checkbox"/>	<input checked="" type="checkbox"/>	<input type="checkbox"/>	<input type="checkbox"/>

### TRIBAL CULTURAL RESOURCES

Would the project cause a substantial adverse change in the significance of a tribal cultural resource, defined in Public Resources Code section 21074 as either a site, feature, place, cultural landscape that is geographically defined in terms of the size and scope of the landscape, sacred place, or object with cultural value to a California Native American tribe, and that is:

	Potentially Significant Impact	Less Than Significant With Mitigation Incorporated	Less than Significant Impact	No Impact
a. Listed or eligible for listing in the California Register of Historical Resources, or in a local register of historical resources as defined in Public Resources Code section 5020.1(k), or	<input type="checkbox"/>	<input type="checkbox"/>	<input type="checkbox"/>	<input checked="" type="checkbox"/>
b. A resource determined by the lead agency, in its discretion and supported by substantial evidence, to be significant pursuant to criteria set forth in subdivision (c) of Public Resources Code Section 5024.1. In applying the criteria set forth in subdivision (c) of Public Resource Code Section 5024.1, the lead agency shall consider the significance of the resource to a California Native American tribe.	<input type="checkbox"/>	<input checked="" type="checkbox"/>	<input type="checkbox"/>	<input type="checkbox"/>

Environmental checklist established by CEQA Guidelines, Appendix G.

### 5.5.1 Setting

This section assesses the potential impacts of the proposed LDC (Jacobs 2019a, 2019c, 2019d) on cultural and tribal cultural resources. The section considers four broad classes of cultural resources: prehistoric, ethnographic, historic-period, and tribal cultural resources. The next four paragraphs briefly describe these classes of resources. Afterward, the Cultural and Tribal Cultural Resources section presents the environmental setting pertinent to these resources:

- *Prehistoric, ethnographic, and historic contexts*—generally describes who lived in the project vicinity, the timing of their occupation, and what uses they made of the area
- *Methods of analysis*—establishes what kinds of physical traces (cultural and tribal cultural resources) past peoples might have left in the project area, given the project vicinity’s prehistoric, ethnographic, and historic contexts

- *Results* ensuing from those methods—identifies the specific resources present or expectable in the project area
- *Regulatory setting*—presents the criteria for identifying *significant* cultural and tribal cultural resources under the California Environmental Quality Act (CEQA) and other applicable authorities, as well as criteria for identifying significant impacts on these resources
- *Impacts*—identifies any impacts on cultural and tribal cultural resources, along with the severity of any such impacts
- *Mitigation measures*—proposes measures to avoid, minimize, rectify, reduce or eliminate, or compensate for identified impacts

Prehistoric archaeological resources are those materials relating to Native American occupation and use of a particular environment. These resources may include sites and deposits, structures, artifacts, rock art, trails, and other traces of Native American activity. In California, the prehistoric period began more than 12,000 years ago and extended through the eighteenth century until A.D. 1769, when Europeans first settled in California.

Ethnographic resources are those materials important to the heritage of a particular ethnic or cultural group, such as Native Americans or African, European, or Asian immigrants. They may include traditional resource collecting areas, ceremonial sites, topographic features, value-imbued landscapes, cemeteries, shrines, or neighborhoods and structures. Ethnographic resources are variations of natural resources and standard cultural resource types. They are subsistence and ceremonial locales and sites, structures, objects, and rural and urban landscapes assigned cultural significance by traditional users. The decision to call resources “ethnographic” depends on whether associated peoples perceive them as traditionally meaningful to their identity as a group and the survival of their lifeways.

Historic-period resources are those materials, archaeological and architectural, usually but not necessarily associated with Euro-American exploration and settlement of an area and the beginning of a written historical record. They may include archaeological deposits, sites, structures, trail and road corridors, artifacts, or other evidence of historic human activity. Under federal and state requirements, historic period cultural resources must be 50 years or older to be considered of potential historic importance. A resource less than 50 years of age may be historically significant if the resource is of exceptional importance. The Office of Historic Preservation (OHP 1995, page 2) endorses recording and evaluating resources 45 years or older to accommodate a five-year lag in the planning process.

Tribal cultural resources are a category of historical resources recently introduced into CEQA by Assembly Bill 52 (Stats. 2014). Tribal cultural resources are resources that are any of the following: sites, features, places, cultural landscapes, sacred places, or objects that are included in or determined eligible to the California Register of Historical Resources (CRHR), or are included on a local register of historical resources as defined in Public Resources Code, section 5020.1(k). Tribal cultural resources can be prehistoric, ethnographic, or historic.

### **Prehistoric Context**

The archaeological record in the Santa Clara Valley began about 9,000 years before present (B.P.)<sup>3</sup> with the Metcalf Creek Aspect, the local expression of the Millingstone cultural pattern. Archaeological deposits dating to this time period contain milling slabs and handstones, and large wide-stemmed and

---

<sup>3</sup> The term “B.P.” (Before Present) is an international dating convention that refers to the year 1950 as the present.

leaf-shaped projectile points. Native people during this period were mobile foragers and burials were typically flexed and placed beneath millingstone cairns. (Milliken et al. 2007, page 114.)

This Early Holocene culture extended until the beginning of the Early Period (circa 5500 B.P.), which exhibits developments in groundstone technology (i.e., replacing millingstones with the mortar and pestle), less movement of entire communities, regional symbolic integration between cultural groups, and increased trade. Also referred to locally as the Sandhill Bluff Aspect, this cultural pattern lasted until circa 2500 B.P., when the Lower Middle Period began with a “major disruption in symbolic integration systems.” (Milliken et al. 2007, page 115.) Archaeological assemblages from the Lower Middle Period include more olive snail-shell saucer beads and circular abalone shell ornaments (and the disappearance of the rectangular shell beads), as well as bone tools and whistles.

The Upper Middle Period began ca. 1520 B.P. with a disruption of the olive snail-shell bead trade network, abandonment of some village sites, and changes in shell bead manufacture. Some South Bay burials from this period were extended inhumations rather than flexed burials, and grave goods were lacking. (Milliken et al. 2007, page 116.)

The Late Period began ca. 900 B.P., with groups increasing intensifying the creation of wealth objects, as seen in burials. Smaller projectile points for use in the bow and arrow emerged during this period and some of the mortuary evidence suggests the introduction of cremation, at least among the wealthiest of individuals. (Milliken et al. 2007, page 117.)

Archaeological research in the project vicinity reveals a rich and lengthy archaeological record. In particular, archaeologists have found numerous buried Native American sites throughout the lower Santa Clara Valley. Rapid development of the valley covered numerous archaeological sites in pavement or with structures (Busby et al. 1996a, pages 2–4; Hylkema 1994, page 252; Parsons and KEMCO 1983, pages 18 and 35). Below even the archaeological sites capped by the veneer of recent building, the Guadalupe River and smaller streams (Saratoga and San Tomas Aquino creeks) buried generations of Native American sites under layers of silt and clay. As a result, the surface archaeological record of Santa Clara Valley represents only the last 2,000 years of human occupation. The remaining 7,000 years of native history lay anywhere from near surface up to 30 feet below the modern ground surface. (Busby et al. 1996a, pages 2–4; Busby et al. 1996b, page 2; Jones et al. 2007, page 130; Parsons and KEMCO 1983, pages 16, 25–26, 33; Ruby et al. 1992:9, 12, 17–19.)

### **Ethnographic Context**

The Costanoans are the Native Americans who inhabited the Bay Area since time immemorial. The Costanoan designation refers to those who spoke one of eight separate but related languages (Shibley 1978:84, 89). The Costanoan languages are similar to Miwok, and are part of the Yok-Utian language family of the Penutian stock (Golla 2007, pages 75–76). Tamyen (Santa Clara Costanoan) was spoken around the southern end of San Francisco Bay and the lower Santa Clara Valley (and was spoken by Costanoans in the project vicinity). (Milliken et al. 2007, Figure 8.1; Shibley 1978, pages 84 and 89.)

Each village was a separate and politically autonomous tribelet, with about 200 people living within each. Tribelets were the basic unit of political organization, with chiefs, either women or men, descended from their patrilineal relative. In the late 1700s, there were two tribelets in close proximity to the proposed project site, San José Cupertino and Santa Clara; both are presumably Tamyen speakers. (Levy 1978, Figure 1.) Kroeber (1976, Figure 42) indicates that two settlements were located within a few miles of the project site on the Guadalupe River, Tamie-n near Santa Clara, and Ulis-tak farther north near the Bay.

Like most other Native Americans in California, acorns were the staple food of the Costanoan people in the Santa Clara region. Other nuts such as buckeye, California laurel, and hazelnuts were also eaten. The Costanoans set controlled fires to promote the growth of the nuts and seeds upon which they relied. The primary mammals taken by the Costanoan included the black-tailed deer, elk, antelope, grizzly bear, mountain lion, sea lion, and whale. Waterfowl, salmon, steelhead, and lampreys were also important components of the Costanoan diet. (Levy 1978, page 491.)

Thatched, domed houses were the most common type of structure for the Costanoans. Sweathouses along the banks of rivers were also constructed, in addition to dance enclosures and assembly houses. (Levy 1978, page 492.)

Bodies were either buried or cremated on the day of death. The community either buried the deceased's property with the body or destroyed their property. (Kroeber 1976, page 469; Levy 1978, page 490.)

Trade was important for the Costanoan groups, and their primary partners in trade were the Plains Miwok, Sierra Miwok, and Yokuts. The Costanoan provided coastal resources such as mussels, abalone shell, dried abalone, and salt to the Yokuts in exchange for piñon pine nuts. The Miwok obtained olive snail shells from the Costanoans. Warfare occurred between Costanoan tribelets as well as the Costanoans and the Esselen, Salinan, and Northern Valley Yokuts. (Davis 1961, page 19; Levy 1978, page 488.)

A common archaeological manifestation of a Costanoan village site is the shell mound deposits (Kroeber 1976, page 466). Mussels are the primary shells that constitute these mounds, in addition to other household wastes.

The Spanish established seven missions in Costanoan territory between 1770 and 1797. By 1810, the mission system subsumed the last Costanoan village. Missions in the Bay Area mixed together various language and cultural groups including the Esselen, Foothill Yokuts, Plains Miwok, Saclan Miwok, Lake Miwok, Coast Miwok, and Patwin. The mission closest to the proposed project area was Santa Clara de Asís, built in 1777. The mission is no longer extant but the area is still rich in archaeological manifestations from the mission period and before. (Levy 1978, page 486.)

## **Historic Context**

In order to inform understanding of the potential significance of built environment resources in the project vicinity, a review of the major historical timeline markers for the project area provides context. This subsection offers a brief look at those events and trends in the history of the Santa Clara Valley that provide that context, in particular for the project site:

- Spanish Mission Period
- Mexican Period
- American Period
  - Transportation and Railroads
  - Agriculture and Fruit Industry
  - Silicon Valley
  - Project Site History
  - San Tomas Aquino Creek



### ***Spanish/Mission Period (1769 to 1821)***

The Spanish Period was characterized by several developments: the establishment of Spanish Colonial military outposts (presidios), pueblos, and 21 missions throughout Alta California. Nearest to the location of the proposed project were the Santa Clara de Asís Mission (1777), El Pueblo de San José de Guadalupe (1777) and Mission (1797), and Santa Cruz Mission (1791). The Spanish government also awarded land grants to soldiers and others and thus began the tradition of large land grants used for agriculture and livestock. Little remains of the cultural landscape that existed during this time aside from some roads that follow early transportation routes (Santa Clara County 2012, pages 22–26).

### ***Mexican Period (1821 to 1848)***

Following Mexican independence from Spain in 1821, Mexican Governor Pío Pico granted lands to Mexican settlers, including the former lands of the missions, whose connection to the government was lost in the Decree of Secularization in 1834. Spanish and Mexican governors granted 43 ranchos in the Santa Clara Valley between 1802 and 1845. Local planning agencies lack detailed information on the location and integrity of these early California sites (Santa Clara County 2012 pages 30–32). The project site appears to be located within the boundaries of the Rancho Ulistác (USGS 1899). Governor Pío Pico granted the land in 1845 to two Santa Clara Mission Indians: Marcelo Pío and Cristóbal. After the Mexican-American War (1846–1848), Jacob D. Hoppe obtained title to the rancho. Following Hoppe’s death, his heirs divided and sold the land (Oosterhous et al. 2002 page 6). The County of Santa Clara’s historic context statement laments that most traces of original haciendas, adobes, and other rancho structures are not discernible in the landscape today and few records exist (Santa Clara County 2012, page 32).

### ***American Period (1848 to Present)***

California became the thirty-first state in the union in 1850. In 1851, Santa Clara College, now Santa Clara University, was founded on the site of the Santa Clara de Asís Mission. The incorporation of Santa Clara followed in 1852. In 1866, the city officially established a grid street system to accommodate anticipated growth. Today, this area is known as the Old Quad neighborhood. Early industries in the city included wheat production and flour milling, seed and fruit packing, and manufacturing. Leather tanning and wood products were two key industries of the city well into the twentieth century. Similarly, seed growing and fruit farming and packing (especially pears, cherries, apricots and prunes) were mainstays, contributing to the city’s exports (Santa Clara 2010, page 2).

**Transportation and Railroads.** In 1869, the Western Pacific Railroad completed a rail line from San Jose to Niles, California, effectively connecting San Jose with the Transcontinental Railroad. This opened new markets for the agricultural and manufactured products of the entire Santa Clara Valley. In 1982, Western Pacific merged with Union Pacific Railroad (Santa Clara County 2012, page 44).

Senator James Fair, a multi-millionaire, envisioned a route from the east side of San Francisco Bay, south to San Jose, then on to Los Gatos and through the mountains to Felton, ultimately connecting to Santa Cruz. Senator Fair incorporated the South Pacific Coast Railroad in 1876 and immediately began building the segment from Dumbarton in the East Bay to Los Gatos, by way of Santa Clara and San Jose. Following that segment, the rail line extended through the Santa Cruz Mountains to connect with the narrow gauge railroad at Felton. The Southern Pacific acquired these rail lines in 1887 and eventually converted the narrow gauge lines to standard gauge (Lehmann 2000, pages 31–33).

The Santa Cruz Division of the Southern Pacific Railroad passed adjacent to the eastern edge of the downtown grid of Santa Clara and east of the current project site (Santa Clara 2017a; USGS 1899). A 1915

USGS topographic map shows the route of the entire Santa Cruz division from San Jose through the Santa Cruz Mountains to Santa Cruz (USGS 1915). The Southern Pacific Railroad (Monterey Division) is also on the 1899 USGS topographic map, approximately 1 mile south of the project site. None of the railroads appear to have connected to the area encompassing the project site as it remained in agricultural production beyond the end of WWII and as recently as 1968 to 1979 (EDR 2017a).

The first San Jose Airport was completed in 1949 on the remaining undeveloped Stockton Ranch acreage. Attracted by the increasing job market, the population of the Santa Clara Valley experienced phenomenal growth after 1950 (Santa Clara County 2012, page 46). A modern airport terminal, known as Terminal C, opened in 1965. Designed by a local architect, Hollis Logue Jr., the San Jose Mercury News described it as a “palace of glass, concrete and steel” (Docomomo 2019). It was certainly a design of its time, with Google-inspired design elements at the cornice line, concrete columns, and glass walls. The San Jose Airport was demolished and replaced by the current Norman Y. Mineta San Jose International Airport in 2010, known as Terminal B.

**Santa Clara Valley Agriculture and Fruit Industry.** Fruit orchards and vegetable farms dominated the Santa Clara Valley from the 1890s to the 1940s. Wheat and flour milling were the first major agricultural activities. In support of the fruit and vegetable industry, canning operations flourished in the northeastern portion of the county. Fruit packing companies were common in Santa Clara Valley in the first third of the twentieth century. Nearly half of the world’s supply of fresh, dried, and canned fruit through the end of World War II (WWII) originated from the valley. The agricultural base economy and its support operations were gradually displaced by expanding suburban development, light industrial and high-tech research and development operations by the 1970s (Fike 2016, page 2).

The Santa Clara Valley’s current commercial and industrial operations are indicative of the shift that took place after WWII from agricultural-based businesses to light industrial and ultimately high-tech research and development facilities. Less than a mile southeast of the project site is the Owens-Corning Fiberglass Corporation plant. The Owens-Corning plant was one of the first new industrial businesses to settle in the Santa Clara Valley and represents the shift toward industrial business in the valley after WWII. A 1949 aerial photograph shows the brand new plant along Lafayette Street with agricultural uses surrounding it (Draper 1949). The plant remains in that location today. Throughout the valley, residential home developments slowly replaced the orchards and agricultural fields. Due to the increased pressure from housing, the city of Santa Clara grew from 6,500 residents in 1940 to 86,000 by 1970 (Fike 2016, page 2). The landscape was forever transformed.

**Silicon Valley.** Industrial growth expanded significantly from 1960 to 1980, much of the growth in the electronics research and manufacturing sectors. The City of Santa Clara is home to Intel, Applied Materials, Sun Microsystems, Nvidia, National Semiconductor and other high technology companies (Santa Clara 2010, pages 3-3–3-6).

**Project Site.** The land at 2201 Laurelwood Road was in agricultural production until 1968. The site was developed and two buildings were constructed in 1968 by Siliconix. Siliconix’s early products included analog switches and market analog multiplexers. Later products included transistors and circuits. Siliconix was acquired by Vishay in 2005 (Alonso and Castells 2019a, page 15). Dr. Felix Zandman established Vishay in 1962. Vishay manufactures and sells products for semiconductors and other passive electronic components (Vishay 2019). The two buildings which housed the Vishay facilities have been removed by the former owner as a condition of sale (Jacobs 2019d, page 21).

**San Tomas Aquino Creek.** San Tomas Aquino Creek’s origin is located in the foothills of the coast ranges. Through the early nineteenth century, with the exception of San Francisquito Creek, not a single creek originating in the foothills maintained a defined channel from the hills to the bay, including San Tomas Aquino Creek. The creek had a more sinuous watercourse compared to today’s channelized conveyance (SFEI 2010, pages 13–14). The creek appears to have been straightened and perhaps channelized by 1897. Originally appearing quite narrow and tree-lined in aerial imagery, the creek evolved after the construction of U.S. Highway 101 interchange at Montague Expressway (circa 1963) into a wider conveyance with distinct edges, likely consisting of raised sides or levees (EDR 2017a, 2017b). Today, a Class I bicycle trail traverses the west side of the channel on a levee and is accessed in the project vicinity from a commercial driveway and bridge approximately 900 feet to the north (Jacobs 2019a, page 3.17-5).

## Methods

### *Project Area of Analysis*

The project area of analysis (PAA) defines the geographic area in which the proposed project has the potential to affect cultural or tribal cultural resources. Effects may be immediate, further removed in time, or cumulative. They may be physical, visual, audible, or olfactory in character. The PAA may or may not be one uninterrupted expanse. It could include the site of the proposed project (project site), the routes of requisite transmission lines and water and natural gas pipelines, and other offsite ancillary facilities, in addition to one or several discontinuous areas where the project could arguably affect cultural or tribal cultural resources.

Staff defines the PAA as comprising (a) the proposed project site and all appurtenant, proposed improvements, including the transmission line interconnection to the Silicon Valley Power grid. This interconnection would cross over an adjacent parcel and San Tomas Aquino Creek. The PAA has archaeological, ethnographic, and historic built environment components, as described in the following paragraphs.

Staff defines the archaeological component of the PAA as all areas in which the applicant proposes ground disturbance to construct, operate, and decommission the proposed project. This includes the proposed building sites, below-grade demolition, areas slated for concrete and hardscape removal, areas to be graded, staging and laydown areas, subsurface drainage, and installation of transmission line poles. The applicant proposes demolition and excavation to variable depths. Excavation across much of the PAA would reach 2–6 feet below current grade (Jacobs 2019c, Figure SQ 10-1), whereas pipeline trenches, transmission line poles, and foundation piles would extend deeper into the underlying soil. The water supply pipeline would be buried in a trench 4 feet deep, 4 feet wide, and 80 feet long. The sanitary wastewater pipeline would be placed in a trench measuring 8 feet deep, 8 feet wide, and 60 feet long. (Alonso and Castells 2019b, Table 1-1.) Transmission line poles would be installed via truck-mounted auger to a depth of 20 feet. Foundation piles for generation yards, loading docks, and the substation would be vibrated into the ground to depths of approximately 25 feet. (Jacobs 2019c, page 32, Figure SQ 10-1.)

For ethnographic resources, the PAA takes into account sacred sites, tribal cultural resources, traditional cultural properties (places), and larger areas such as ethnographic landscapes that can be vast and encompassing, including view sheds that contribute to the historical significance of such resources. The Native American Heritage Commission (NAHC) assists project-specific cultural resources consultants and agency staff in identifying these resources, and consultation with Native Americans and other ethnic or community groups may contribute to defining the PAA. In the case of the proposed project, the immediate environs consist largely of office parks, industrial structures, a channelized creek, and a vacant lot. Staff

therefore treats the ethnographic component of the PAA as coterminous with the archaeological component.

The proposed project site consists primarily of pavement, hardscape, and modest landscape elements, much of which dates to the recent historic period. The historic built environment PAA for this project includes properties within a one-parcel boundary of the project site.

### ***Literature Review***

The literature review for this analysis consisted of a records search at the California Historical Resources Information System (CHRIS), review of the application for small power plant exemption, and examination of pertinent literature concerning cultural resources in the northern Santa Clara Valley.

The applicant conducted the records search on February 4, 2019, at the Northwest Information Center (NWIC) of the CHRIS. The NWIC is the State of California's official repository of all cultural resource records, previous cultural resources studies, and historical information concerning cultural resources for 16 counties, including Santa Clara County. The records search area included the PAA and a 1-mile buffer (Jacobs 2019a, page 3.5-5). In addition to the NWIC's maps of known cultural resources and previous cultural resources studies, the records search included perusal of the National Register of Historic Places (NRHP), OHP's Archaeological Determinations of Eligibility, and OHP's Directory of Properties in the Historic Property Data File (Alonso and Castells 2019a, page 16).

Staff also examined historic maps and aerial photographs of the PAA and vicinity to identify cultural resources (EDR 2017a<sup>4</sup>, 2017b<sup>5</sup>; Edward Denny & Co. 1913; GLO 1866; Oosterhous et al. 2002, page 6<sup>6</sup>; USGS 1897, 1899, 1961, 1980a, 1980b). These sources depict the historic appearance of the PAA each decade from 1857 through 1980 (excepting the 1880s, 1900s, and 1920s).

In addition, staff consulted:

- the City of Santa Clara's General Plan 2010–2035, including its Historic Preservation and Resource Inventory (Santa Clara 2010)
- County of Santa Clara Historic Context Statement (Santa Clara County 2012)
- County of Santa Clara Heritage Resource Inventory (Santa Clara County 2015)

Staff also consulted the NRHP, CRHR, Historic American Building Survey, Historic American Engineering Record, Historic American Landscape Survey, and other repositories of documentation of historical resources. Staff identified 15 listed historical resources within approximately 1 mile of the PAA. **Figure 5.5-1** depicts listed historical built environment resources located within approximately 1 mile of the PAA. Most of the listed historical resources mapped in **Figure 5.5-1** are located north and east of the PAA.

---

<sup>4</sup> This source contains historic topographic maps dated approximately 1895, 1953, 1961, 1968, 1973, 1980, and 2012.

<sup>5</sup> This source contains aerial photographs dated 1939, 1948, 1950, 1956, 1963, 1968, 1974, 1979, 1982, 1993, 1998, 2005–2006, 2009–2010, and 2012.

<sup>6</sup> This source contains a reproduction of a part of Thompson and West's 1876 map of Santa Clara County.



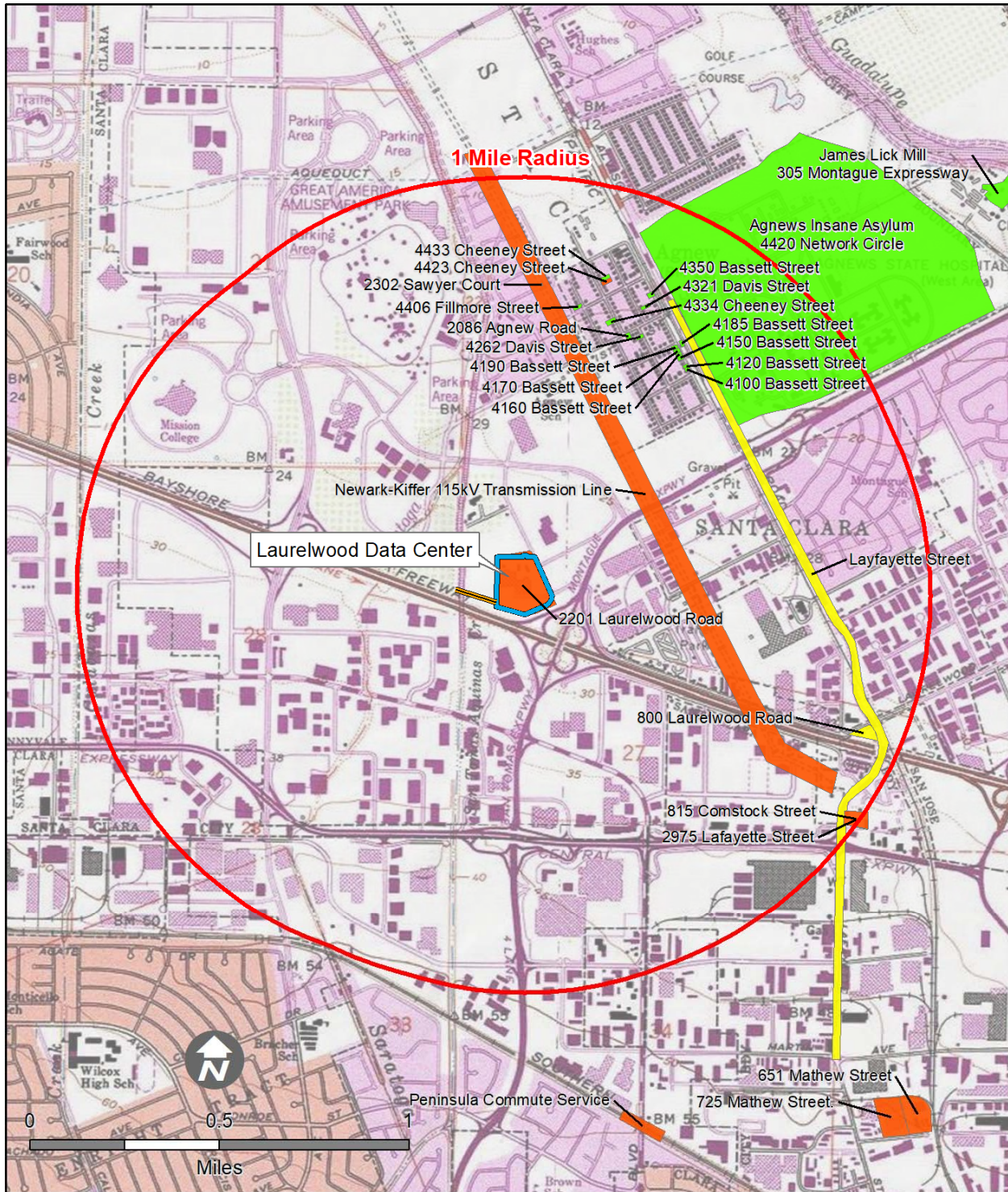

**Figure 5.5-1**  
**Built Environment Resources**  
**45 Years or Older Within One Mile**  
**of the Laurelwood Project Site**

Source: California Energy Commission

### ***Tribal Consultation***

PaleoWest Archaeology (PaleoWest), on behalf of the applicant, contacted the NAHC on February 1, 2019, to request a search of the Sacred Lands File and a list of tribes that might be interested in the proposed project. The NAHC responded on February 5, and provided a list of six California Native American tribes to contact:

1. Amah Mutsun Tribal Band
2. Amah Mutsun Tribal Band of Mission San Juan Bautista
3. Northern Valley Yokuts Tribe
4. Muwekma Ohlone Indian Tribe
5. The Ohlone Indian Tribe
6. Indian Canyon Mutsun Band of Costanoan

PaleoWest sent letters to these tribes on February 6, 2019, and placed follow-up phone calls on February 11, 2019. (Jacobs 2019a, page 3.18-4, Table 3.18-1.)

CEQA requires lead agencies to consult with all California Native American tribes that have traditional and cultural affiliation with the geographic area of a project, and that have previously requested consultation. To invoke an agency's requirement to consult under CEQA, a tribe must first send the lead agency a written request for formal notification of any projects within the geographic area with which they are traditionally and culturally affiliated. (Pub. Resources Code, § 21080.3.1(b).) The Energy Commission has not received any requests for formal notification from tribes that have traditional and cultural affiliation with the geographic area of the proposed project. Therefore, the Energy Commission has no obligations under CEQA's formal tribal notification or consultation requirements.

However, consistent with the Energy Commission's tribal consultation policy (CEC 2017), Energy Commission staff contacted the NAHC on March 6, 2019, to request a search of the Sacred Lands File and a list of California Native American tribes that might be interested in the proposed project (Bonitz 2019). The NAHC responded on March 7, 2019, and provided a list of six California Native American tribes to contact (Totton 2019); the listed tribes were the same six tribes listed above. Energy Commission staff mailed initial consultation letters to these six tribes on March 26, 2019 (CEC 2019a). See the following subsection, "Results," for tribal responses and lead agency follow-up.

### ***Archaeological Survey***

On February 11, 2019, an archaeologist surveyed unpaved ground surfaces in the archaeological PAA. The archaeological survey area included the project site and a 200-foot buffer surrounding the project site, as well as the proposed transmission line corridor and an area 50 feet to either side of the corridor. (Jacobs 2019c, page 22.) Less than 1 percent of the archaeological PAA consisted of unpaved ground surfaces. As such, the archaeologist had only relatively narrow, exposed strips of soil available for examination along the southern and western edges of the survey area. Much of the transmission line corridor contained unpaved ground surfaces. The archaeologist surveyed each of these areas by walking a single transect through them and making observations of the ground surface. (Alonso and Castells 2019b, pages 18–21, Figure 1-3.)



### Historic Architectural Survey

The architectural history survey was conducted inclusive of the project site and a one-parcel buffer from the proposed project boundaries and along the routes of all linear facilities. Structures and/or districts 45 years or older, or considered significant, were identified as part of this survey. Any building or structure constructed before 1974 or potentially eligible for the CRHR or local register was evaluated on Department of Parks and Recreation 523 series forms (Alonso and Castells 2019b, page 18). This included the former buildings on the project site, which are no longer extant.

## Results

### Literature Review

The NWIC records search indicates that 135 previous cultural resources studies occurred within 1 mile of the PAA (Jacobs 2019a, page 3.5-5, 2019c, page 21). Of these, 54 covered all or part of the PAA (Alonso and Castells 2019b, page 16, Table A-1; Jacobs 2019a, page 3.5-5). The NWIC has no records of previously recorded cultural resources in the PAA, but documents three previously recorded cultural resources within the 1-mile records search buffer (P-43-001475, P-43-002978 and P-43-003529). All three are built environment resources. Staff identified an additional 18 built environment resources 45 years or older within 1 mile of the PAA. Fifteen of these resources are listed on the City of Santa Clara’s Historic Preservation and Resource Inventory (Santa Clara 2010). These cultural resources are listed in **Table 5.5-1** and located on **Figure 5.5-1**.

**TABLE 5.5-1 BUILT ENVIRONMENT RESOURCES 45 YEARS OR OLDER WITHIN ONE MILE OF THE LAURELWOOD PROJECT SITE**

No.	Address	Resource Name/APN	Description, Year	Eligibility Status
1.	2086 Agnew Road	Agnew School/10412028	School, 1890	Listed
2.	4100 Bassett Street	10412196	Colonial Revival Cottage, 1906	Listed
3.	4120 Bassett Street	10412127	Colonial Revival Cottage, 1906	Listed
4.	4150 Bassett Street	10412125	ca. 1910	Listed
5.	4160 Bassett Street	10412124	ca. 1920	Listed
6.	4170 Bassett Street	10412123	Italianate Cottage	Listed
7.	4185 Bassett Street	Agnew Railroad Station, 10412162	Vernacular, 1896	Listed
8.	4190 Bassett Street	10412194	ca. 1900	Listed
9.	4350 Bassett Street	Floyd Jamison House, 10411004	Spanish Eclectic, 1918	Listed
10.	4334 Cheeney Street	10411041	Colonial Revival Cottage	Listed
11.	4433 Cheeney Street	10410025	Colonial Revival	Listed
12.	4262 Davis Street	10412019	Modified Greek Revival	Listed
13.	4321 Davis Street	10411084		Listed
14.	4406 Fillmore Street	J. M. Williamson House, 10410068	Colonial Revival Cottage, 1925	Listed
15.	4420 Network Circle	Agnews State Hospital/Insane Asylum, 09708058	Mediterranean Revival, 1911	Listed
16.	815 Comstock Street (P-43-003529)	Santa Clara Public Works Building Maintenance Facility, 22436014	Vernacular Industrial Buildings	Ineligible

17.	4423 Cheeney Street (P-43-001475)	10410024	Folk Victorian Cottage, ca. 1880	Ineligible
18.	2302 Sawyer Court (P-43-002978)	PG&E Transmission Tower, 10446038	Steel Lattice Transmission Tower, 1954	Ineligible
19.	2201 Laurelwood Road	Siliconix Industrial Facility, 10439023	Spanish Revival Industrial Buildings, 1968	Ineligible; no longer extant
20.	Newark Kifer 115kV Transmission Line	PG&E Newark to San Jose Transmission Line	Transmission Line and Structures, 1920s	Ineligible
21.	Lafayette Street	Lafayette Street	Four-lane road, 1850s to present	Not evaluated

Notes: APN = Assessor's Parcel Number; kV = kilovolt(s); PG&E = Pacific Gas and Electric Company

### **Tribal Consultation**

The NAHC's February 5 and March 7, 2019, searches of the Sacred Lands File did not identify Native American cultural resources in the search area (Jacobs 2019a, page 3.18-4; Totton 2019). Staff summarizes tribal responses to PaleoWest's letters and phone inquiries in **Table 5.5-2**. **Table 5.5-3** describes staff's consultation efforts.

**TABLE 5.5-2. SUMMARY OF TRIBES' RESPONSES TO APPLICANT**

Tribe	Cultural Affiliation	Response to Date
Amah Mutsun Tribal Band	Ohlone/Costanoan, Northern Valley Yokuts	The proposed project is outside of their traditional tribal territory; declined to comment.
Amah Mutsun Tribal Band of Mission San Juan Bautista	Ohlone/Costanoan	The tribe requested that construction crews receive cultural resources awareness training, and if anything is found to have an archaeological monitor and a Native American monitor.
Northern Valley Yokuts Tribe	Ohlone/Costanoan, Northern Valley Yokuts, Bay Miwok	No response.
Muwekma Ohlone Indian Tribe of the San Francisco Bay Area	Ohlone/Costanoan	No response.
The Ohlone Indian Tribe	Ohlone/Costanoan, Bay Miwok, Plains Miwok, Patwin	The tribe asked about the records search and pedestrian survey, and requested a copy of the Phase 1 report when completed. The applicant sent a copy of Alonso and Castells (2019b) on April 3, 2019.
Indian Canyon Mutsun Band of Costanoan	Ohlone/Costanoan	The tribe requested copies of the results of the records search and the pedestrian survey. They will respond if there are any concerns. The Indian Canyon Mutsun Band of Costanoan tribe was sent a copy of Alonso and Castells (2019a) with survey results and record search summary on February 26, 2019.

Sources: Alonso and Castells (2019a:17, Appendix B); Jacobs (2019a:Table 3.18-1, 2019c:25)

**TABLE 5.5-3 LAURELWOOD DATA CENTER TRIBAL CONTACT LOG**

Name/Affiliation Contact Information	Type of Contact	Date	Tribal Response/Staff Notes
Amah Mutsun Tribal Band	Letter	03/26/2019	Staff's letter provided a brief description of the proposed project, two figures showing its location, and invited consultation.
	Phone	05/17/2019	Staff reached the chairperson's voicemail and left a message with return number.
	Email	04/22/2019	Staff's email served as a second notice and invitation to consult. Staff attached the March 26 letter and figures to the email.
Amah Mutsun Tribal Band of Mission San Juan Bautista	Letter	03/26/2019	Staff's letter provided a brief description of the proposed project, two figures showing its location, and invited consultation.
	Phone		Staff reached the chairperson's voicemail and left a message with return number.
	Email	04/22/2019	Staff's email served as a second notice and invitation to consult. Staff attached the March 26 letter and figures to the email.
Indian Canyon Mutsun Band of Costanoan	Letter	03/26/2019	Staff's letter provided a brief description of the proposed project, two figures showing its location, and invited consultation.
	Phone		Staff reached the chairperson's voicemail and left a message with return number.
	Email	04/22/2019	Staff's email served as a second notice and invitation to consult. Staff attached the March 26 letter and figures to the email.
Muwekma Ohlone Tribe of the San Francisco Bay Area	Letter	03/26/2019	Staff's letter provided a brief description of the proposed project, two figures showing its location, and invited consultation.
	Phone		Staff reached the chairperson's voicemail and left a message with return number.
	Email	04/22/2019	Staff's email served as a second notice and invitation to consult. Staff attached the March 26 letter and figures to the email.
The Ohlone Indian Tribe	Letter	03/26/2019	Staff's letter provided a brief description of the proposed project, two figures showing its location, and invited consultation.
	Email	04/22/2019	Staff's email served as a second notice and invitation to consult. Staff attached the March 26 letter and figures to the email.
	Email	04/23/2019	Mr. Galvan expressed his desire to consult on the project. He suggested that consultation proceed by email.
	Email	04/24/2019	Staff accepted Mr. Galvan's consultation request and provided an overview of the project and SPPE process. Staff also asked whether Mr. Galvan knows of cultural or tribal cultural resources in the project area.
	Email	04/25/2019	Mr. Galvan thanked staff for the information, asked to be kept informed, and requested any

**TABLE 5.5-3 LAURELWOOD DATA CENTER TRIBAL CONTACT LOG**

Name/Affiliation Contact Information	Type of Contact	Date	Tribal Response/Staff Notes
			additional cultural resources reports as they are completed.
Northern Valley Yokuts Tribe	Letter	03/26/2019	Staff's letter provided a brief description of the proposed project, two figures showing its location, and invited consultation.
	Phone		Staff reached the chairperson's voicemail and left a message with return number.
	Email	04/22/2019	Staff's email served as a second notice and invitation to consult. Staff attached the March 26 letter and figures to the email.

Note: SPPE = small power plant exemption

### ***Archaeological Survey***

The archaeological survey did not identify archaeological or ethnographic resources in the PAA (Jacobs 2019a, page 3.5-5).

### ***Historic Architectural Survey***

The only buildings or structures found to be 45 years or older in the PAA were the two buildings formerly on the project site (2201 Laurelwood Road). PaleoWest evaluated the buildings for their potential as historical resources by applying the criteria for the CRHR and the local register. The buildings were recommended not eligible under criteria 1–4 of the CRHR and criteria 1–17 of the local register (Alonso and Castells 2019b, pages 21–24) and have been removed by the current owner as a condition of sale. (Jacobs 2019d, page 21).

San Tomas Aquino Creek is approximately 600 feet west of the project site and is a channelized water conveyance structure. San Tomas Aquino Creek does not follow its original watercourse and has been straightened and channelized since at least 1897 (EDR 2017a). While the water conveyance structure has not been formally surveyed or evaluated for this project, previous studies for the regional bicycle trail system, of which the creek is a segment, found no listed or eligible historical structures within the study area, including Reach 2 (the area closest to the project site). Southern Pacific Railroad structures were identified in Reach 1 and Reach 3; neither were recorded or evaluated for the study (Baker 1998, pages 6–9). Based on this previous study, San Tomas Aquino Creek is not considered a historical resource for the purposes of CEQA.

### ***Archaeological Sensitivity***

Staff's literature review indicates that the potential for buried archaeological resources to occur in the project vicinity mirrors the high frequency of buried archaeological deposits throughout the Santa Clara Valley (Byrd et al. 2017, page 4-2; Hylkema 1998, page 20). The NWIC records search documents 12 archaeological monitoring reports within 1 mile of the PAA. Of these, nine reports identified buried archaeological resources at depths ranging from 2.0 to 8.2 feet below ground surface. (**Table 5.5-4.**) Researchers have identified at least 16 buried prehistoric archaeological sites in the Santa Clara Valley (Rehor and Kubal 2014, page 4-1, Table 4-1).

**TABLE 5.5-4 RESULTS OF ARCHAEOLOGICAL MONITORING IN THE PROJECT VICINITY**

Author/Year	NWIC #	Surface Sensitivity <sup>1</sup>	Buried Sensitivity <sup>2</sup>	Discoveries
Hylkema 1998	S-020327	Moderate	High	Historic Chinatown refuse, sewer standpipe, road bed; discoveries at 2.0–8.2 ft bgs
Busby 1999a	S-023110	Moderate	Moderate	Undisclosed historic archaeological material
Busby 1999b	S-023362	Moderate	Moderate	Undisclosed historic archaeological material
Busby 1999c	S-019072b	Moderate and high	Moderate and high	FAR and baked clay; historic refuse, animal bones, structural material (roofing), and streetcar tracks
Busby 2000	S-024980	Moderate and high	Moderate and high	Historic roofing tiles and four common bricks
Busby 2002a	S-028015	Moderate	Moderate	Undisclosed historic archaeological material
Busby 2002b	S-028016	Moderate	Moderate	Undisclosed historic archaeological material, 2–3 ft bgs
Holson et al. 2002	S-025173	Moderate–highest	Low–highest	Native American habitation debris, artifacts and human remains; historic structural remnants, railroad remnants, and artifacts; finds made at up to 4 ft bgs
SWCA 2006	S-033061	Moderate–highest	Moderate–highest	None
Brady 2015	S-046801	Moderate	Moderate	None. Excavation went up to 5 ft bgs
Hammerle 2015	S-047529a	Highest and high	Highest and high	None. Excavation was 4–5 ft bgs (native soils found below 33 inches)
D'Oro 2017	S-049685	Moderate	Moderate	Milled redwood, whiteware ceramic sherd, shard of clear glass, metal, 12 roof tile fragments, two animal bone fragments. Surface to 5 ft bgs

Notes: bgs = below ground surface; ft = foot, feet; FAR = fire-affected rock; NWIC = Northwest Information Center

1. Surface sensitivity per Byrd et al. (2017:Figure 26) and Whitaker (2016:Figure 5)
2. Buried sensitivity per Byrd et al. (2017:Figure 27)

## Regulatory Background

### ***Federal***

No federal regulations related to cultural and tribal cultural resources apply to the project.

### ***State***

**California Environmental Quality Act.** Various laws apply to the evaluation and treatment of cultural resources. CEQA requires lead agencies to evaluate cultural resources by determining whether they meet several sets of specified criteria that make such resources eligible to the CRHR. Those cultural resources eligible to the CRHR are historical resources. The evaluation then influences the analysis of potential impacts to such historical resources and the mitigation that may be required to ameliorate any such impacts.

CEQA and the CEQA Guidelines define significant cultural resources under two regulatory definitions: historical resources and unique archaeological resources. A historical resource is defined as a “resource listed in, or determined to be eligible by the State Historical Resources Commission, for listing in the California Register of Historical Resources”, or “a resource included in a local register of historical resources, as defined in section 5020.1(k) of the Public Resources Code or identified as significant in an historical resource survey meeting the requirements of Section 5024.1(g) of the Public Resources Code,” or “any object, building, structure, site, area, place, record, or manuscript which a lead agency determines to be historically significant or significant in the architectural, engineering, scientific, economic, agricultural, educational, social, political, military, or cultural annals of California, provided the agency’s determination is supported by substantial evidence in light of the whole record.” (Cal. Code Regs., tit. 14, § 15064.5(a).) Historical resources that are automatically listed in the CRHR include California historical resources listed in or formally determined eligible for the NRHP and California Registered Historical Landmarks from No. 770 onward (Pub. Resources Code, § 5024.1(d)).

Under CEQA, a resource is generally considered historically significant if it meets the criteria for listing in the CRHR. In addition to being at least 50 years old, a resource must meet one or more of the following four criteria (Pub. Resources Code, § 5024.1):

- Criterion 1, is associated with events that have made a significant contribution to the broad patterns of California’s history and cultural heritage;
- Criterion 2, is associated with the lives of persons important in our past;
- Criterion 3, embodies the distinctive characteristics of a type, period, region, or method of construction, or represents the work of an important creative individual, or possesses high artistic values; or
- Criterion 4, has yielded, or may be likely to yield, information important in prehistory or history.

In addition, historical resources must also possess integrity of location, design, setting, materials, workmanship, feeling, and association (Cal. Code Regs., tit. 14, § 4852(c)).

Even if a resource is not listed or determined to be eligible for listing in the CRHR, CEQA requires the lead agency to make a determination as to whether the resource is a historical resource as defined in Public Resources Code, sections 5020.1(j) or 5024.1.

In addition to historical resources, archaeological artifacts, objects, or sites can meet CEQA’s definition of a unique archaeological resource, even if the resource does not qualify as a historical resource (Cal. Code Regs., tit. 14, § 15064.5(c)(3)). Archaeological artifacts, objects, or sites are considered unique archaeological resources if it can be clearly demonstrated that, without merely adding to the current body of knowledge, there is a high probability that the resource meets any of the following criteria:

1. Contains information needed to answer important scientific research questions and that there is a demonstrable public interest in that information.
2. Has a special and particular quality such as being the oldest of its type or the best available example of its type.
3. Is directly associated with a scientifically recognized important prehistoric or historic event or person. (Pub. Resources Code, § 21083.2(g).)

To determine whether a proposed project may have a significant effect on the environment, staff analyzes the project’s potential to cause a substantial adverse change in the significance of historical or unique archaeological resources. The magnitude of an impact depends on:



- the historical resource(s) affected;
- the specific historic significances of any potentially impacted historical resource(s);
- how the historical resource(s) significance is manifested physically and perceptually;
- appraisals of those aspects of any historical resource’s integrity that figure importantly in the manifestation of the resource’s historical significance; and
- how much the impact will change historical resource integrity appraisals.

Title 14, California Code of Regulations, section 15064.5(b) defines a “substantial adverse change” as the “physical demolition, destruction, relocation, or alteration of the resource or its immediate surroundings such that the significance of an historical resource would be materially impaired.”

**California Native American Tribes, Lead Agency Tribal Consultation Responsibilities, and Tribal Cultural Resources.** CEQA provides definitions for California Native American tribes, lead agency responsibilities to consult with California Native American tribes, and tribal cultural resources. A “California Native American tribe” is a “Native American tribe located in California that is on the contact list maintained by the Native American Heritage Commission (NAHC) for the purposes of Chapter 905 of the Statutes of 2004” (Pub. Resources Code, § 21073). Lead agencies implementing CEQA are responsible for consultation with California Native American tribes about tribal cultural resources within specific timeframes, observant of tribal confidentiality, and if tribal cultural resources could be impacted by a CEQA project, are to exhaust the consultation to points of agreement or termination.

Tribal cultural resources are either of the following:

1. Sites, features, places, cultural landscapes, sacred places, and objects with cultural value to a California Native American tribe that are either of the following:
  - a. Included or determined to be eligible for inclusion in the CRHR
  - b. Included in a local register of historical resources as defined in the Public Resources Code, section 5020.1(k).
2. A resource determined by the lead agency, in its discretion and supported by substantial evidence, to be significant pursuant to criteria set forth in the Public Resources Code, section 5024.1(c). In applying these criteria, the lead agency shall consider the significance of the resource to a California Native American tribe. (Pub. Resources Code, § 21074(a).)

A cultural landscape that meets the criteria of Public Resources Code, section 21074(a), is a tribal cultural resource to the extent that the landscape is geographically defined in terms of its size and scope (Pub. Resources Code, § 21074(b)). Historical resources, unique archaeological resources, and non-unique archaeological resources, as defined at Public Resources Code, sections 21084.1, 21083.2(g), and 21083.2(h), may also be tribal cultural resources if they conform to the criteria of Public Resources Code, section 21074(a).

CEQA also states that a project with an impact that may cause a substantial adverse change in the significance of a tribal cultural resource is a project that may have a significant effect on the environment (Pub. Resources Code, § 21084.2).

**City of Santa Clara General Plan.** Section 5.6.3 of the City of Santa Clara’s General Plan outlines the goals and policies related to archaeological and cultural resources. The applicable goals in this section of the General Plan encourage the protection and preservation of cultural resources, including archaeological

and paleontological sites, and encourage appropriate mitigation in the event of discovery during construction.

Relevant policies require protecting historic resources through avoidance or reduction of potential impacts, using the Secretary of the Interior's Standards for the Treatment of Historic Properties, and using the city's established historic preservation program for ensuring resource evaluation, protection, and integrity (Santa Clara 2010).

Appendix 8.9 of the General Plan, the Historic Preservation and Resource Inventory, established criteria for local significance and included a list of recorded historic properties (Santa Clara 2010). In addition, the city has embedded in its Municipal Code a section on Historic Preservation (Title 18 Zoning, Chapter 18.106, Historic Preservation). The purpose of Chapter 18.106 is "to promote the identification, protection, enhancement and perpetuation of buildings, structures and properties within the City that reflect special elements of the City's social, economical, historical, architectural, engineering, archaeological, cultural, natural, or aesthetic heritage" (Santa Clara 2018a). The chapter requires maintenance of a Historic Resource Inventory.

Appendix 8.9 of the General Plan also identifies significance criteria for local listings. The City of Santa Clara's City Council adopted the Criteria for Local Significance on April 20, 2004 and incorporated the criteria into the General Plan Appendix 8.9. Any building, site, or property in the city that is 50 years old or older and meets certain criteria of architectural, cultural, historical, geographical, or archaeological significance is potentially eligible. The Criteria for Local Significance established in General Plan Appendix 8.9 (Santa Clara 2010) are as follows:

Criteria for Historic Cultural Significance - To be historically or culturally significant, a property must meet at least one of the following criteria:

1. The site, building or property has character, interest, integrity and reflects the heritage and cultural development of the city, region, state, or nation.
2. The property is associated with a historical event.
3. The property is associated with an important individual or group who contributed in a significant way to the political, social and/or cultural life of the community.
4. The property is associated with a significant industrial, institutional, commercial, agricultural, or transportation activity.
5. A building's direct association with broad patterns of local area history, including development and settlement patterns, early or important transportation routes or social, political, or economic trends and activities. Included is the recognition of urban street pattern and infrastructure.
6. A notable historical relationship between a site, building, or property's site and its immediate environment, including original native trees, topographical features, outbuildings or agricultural setting.

Criteria for Architectural Significance - To be architecturally significant, a property must meet at least one of the following criteria:

1. The property characterizes an architectural style associated with a particular era and/or ethnic group.
2. The property is identified with a particular architect, master builder, or craftsman.
3. The property is architecturally unique or innovative.

4. The property has a strong or unique relationship to other areas potentially eligible for preservation because of architectural significance.
5. The property has a visual symbolic meaning or appeal for the community.
6. A building's unique or uncommon building materials or its historically early or innovative method of construction or assembly.
7. A building's notable or special attributes of an aesthetic or functional nature. These may include massing, proportion, materials, details, fenestration, ornamentation, artwork, or functional layout.

Criteria for Geographical Significance - To be geographically significant, a property must meet at least one of the following criteria:

1. A neighborhood, group, or unique area directly associated with broad patterns of local area history.
2. A building's continuity and compatibility with adjacent buildings and/or visual contribution to a group of similar buildings.
3. An intact, historical landscape or landscape features associated with an existing building.
4. A notable use of landscaping design in conjunction with an existing building.

Criteria for Archaeological Significance - For the purposes of CEQA, an "important archaeological resource" is one which:

1. Is associated with an event or person of
  - a. Recognized significance in California or American history, or
  - b. Recognized scientific importance in prehistory.
2. Can provide information, which is both of demonstrable public interest, and useful in addressing scientifically consequential and reasonable or archaeological research questions;
3. Has a special or particular quality such as oldest, best example, largest, or last surviving example of its kind;
4. Is at least 100 years old and possesses substantial stratigraphic integrity; or
5. Involves important research questions that historical research has shown can be answered only with archaeological methods.

## 5.5.2 Environmental Impacts and Mitigation Measures

**Applicant Proposed Measures:** The applicant proposes to implement the following project design measures (termed, Applicant Proposed Measures or APMs, in this analysis) as part of the project to avoid or reduce potential impacts to cultural resources (Jacobs 2019a, Section 2.5.3, page 2-23). Also, **APM PD-1** includes the preparation of a Worker Environmental Awareness Training program (program) to instruct construction workers of the obligation to protect and preserve valuable resources, including archaeological and Native American resources. See **Section 4.0, Project Description, Table 4-5** for the full text of **APM PD-1**.

**APM CUL-1:** The Applicant will secure the services of a Secretary of the Interior-qualified archaeologist and a Native American monitor to be on-call during construction in the event a historic or prehistoric resource is encountered. If prehistoric and/or historic resources are encountered during construction, all activity within a 50-foot radius of the find will be stopped and the archaeologist/Native American monitor

will examine the find and record the site, including field notes, measurements, and photography for a Department of Parks and Recreation 523 Primary Record form. The archaeologist will provide recommendations regarding eligibility for the California Register of Historical Resources, data recovery, curation, or other appropriate mitigation. Ground disturbance within the 50-foot radius can resume once these steps are taken and the City Director of Community Development has concurred with the recommendations.

**APM CUL-2:** If human remains are discovered during construction, a 50-foot radius exclusion zone will be established to protect the find and the Santa Clara County Coroner will be notified to make a determination as to whether the remains are of Native American origin or whether an investigation into the cause of death is required. If the remains are determined to be Native American, the Coroner will notify the Native American Heritage Commission. All actions taken under this mitigation measure will comply with Health and Human Safety Code Section 7050.5(b).

**APM CUL-3:** Within 30 days of the completion of construction or archaeological/Native American monitoring is terminated, the Applicant will have the archaeologist/Native American monitor prepare a report of findings. The report will document the archaeological/Native American resource finds, if any, recommendations, data recovery efforts, and other pertinent information gleaned during construction. The report may be submitted to the City of Santa Clara's Director of Community Development for review and approval. The Applicant will submit the final report to the Northwest Information Center at Sonoma State University.

### Cultural Resources CEQA Checklist Questions

- a. Would the project cause a substantial adverse change in the significance of a historical resource as defined in §15064.5?*

#### Demolition/Construction

LESS THAN SIGNIFICANT WITH MITIGATION INCORPORATED. No historic built environment resources meeting CEQA's criteria for historical resources are located in the PAA. No archaeological or ethnographic resources meeting CEQA's criteria for historical resources occupy the surface of the PAA. Previous studies and archaeological monitoring in the project vicinity, however, indicate that the PAA could harbor buried archaeological or ethnographic resources. The PAA is located between two waterways (San Tomas Aquino Creek and the Guadalupe River) on the former grounds of a historic farm (pear orchard). Previous studies have identified no fewer than 10 archaeological sites in the project vicinity and one ethnographic resource (Rancho Ulistac/site CA-SCL-000006) north of the PAA. Twelve archaeological monitoring studies occurred within 1 mile of the PAA and 75 percent of the studies identified historic and Native American archaeological sites from 2.0 to 8.2 feet below the modern ground surface (see **Table 5.5-4**). Archaeologists working independently of the present analysis have estimated the PAA's likelihood to contain buried archaeological resources as moderate to high (Byrd et al. 2017, Figures 26–27; Rehor and Kubal 2014, Figure 6-1; Whitaker 2016, Figure 5).

The ground disturbance required to build the proposed project would extend into native soils up to 25 feet below grade. A geotechnical study in the PAA found fill dirt from just below grade to 2.5 feet below grade in one out of eight borings (Cornerstone 2019, Appendix A). Therefore, the proposed project would involve excavation of native soils from about 2.5 to 25.0 feet below grade. Known

buried archaeological sites in Santa Clara Valley range in age from 295 to 5630 B.P.<sup>7</sup> and are located at depths of 1.0–10.5 feet below grade (Rehor and Kubal 2014, Table 4-1). If such resources were to be damaged during construction, it would be considered a significant impact, particularly since virtually all archaeological sites 5,000 years or older occur only in buried contexts. In addition, the City of Santa Clara frequently requires presence/absence excavations or archaeological monitoring of construction projects in the project vicinity (Santa Clara 2015, page 29, 2016a, pages 48–49, 2016b, page 48, 2016c, page 163, 2016d, page 36, 2017b, page 38, 2018b, pages 51–52). Therefore, staff recommends that one or more qualified archaeologists and Native Americans monitor construction-related excavation in the PAA (see Proposed Mitigation Measures below).

Staff evaluated **APM PD-1** and **APM CUL-1** through **APM CUL-3** in the context of the potential impacts and concludes that **APM CUL-1** and **APM CUL-3** are insufficient to reduce impacts to buried, as-yet-undiscovered historical resources to a less than significant level. **APM CUL-1** proposes that the applicant retain a qualified archaeologist and Native American monitor to respond to inadvertent cultural resource discoveries should any occur during construction. In short, **APM CUL-1** would place the responsibility of cultural resources management on construction workers instead of cultural resources professionals and Native Americans. Also, **APM CUL-1** does not include qualification standards for Native American monitors. Staff proposes modifications to **APM CUL-1** that would ensure the prompt identification and management of cultural and tribal cultural resource discoveries by requiring a professional archaeologist and qualified Native American monitor observe ground-disturbing activities associated with the proposed project. In addition, staff adds qualification criteria for Native American monitors. **MM CUL-1** would supersede **APM CUL-1**.

**APM CUL-3** does not ensure accountability because it stipulates that a technical report of the archaeological/Native American resource finds, recommendations, data recovery efforts, and other pertinent information “may be submitted” to the city, rather than requiring it. Staff proposes that submittal of the technical report to the city be compulsory. **MM CUL-3** would supersede **APM CUL-3**.

Staff concludes that implementation of **MM CUL-1** and **MM CUL-3** would reduce the impacts to buried historical resources to a less than significant level.

**MM CUL-1:** The applicant will secure the services of a Secretary of the Interior-qualified archaeologist and a Native American monitor, as directed by the City of Santa Clara, to observe grading of native soil once all pavement is removed from the project site. The applicant shall submit the name and qualifications of the selected archaeologist and Native American Monitor to the City of Santa Clara for approval. Preference in selecting Native American monitors shall be given to Native Americans with:

1. Traditional ties to the area being monitored.
2. Knowledge of local historic and prehistoric Native American village sites.
3. Knowledge and understanding of relevant regulations and laws with respect to the treatment of tribal cultural resources and the disposition of human remains.
4. Ability to cooperate with law enforcement officials and the Native American Heritage Commission to ensure the return of all associated grave goods taken from a Native American grave during excavation.

---

<sup>7</sup> The term “B.P.” (Before Present) is an international dating convention that refers to the year 1950 as the present.

5. Ability to travel to project sites within traditional tribal territory.
6. Knowledge and understanding of archaeological practices, including the phases of archaeological investigation.

After removal of pavement and prior to grading, the archaeologist shall conduct a pedestrian survey over the exposed soils to determine if any surface archaeological manifestations are present. The archaeologist will monitor full-time all grading and ground-disturbing activities in native soils associated with construction of the proposed project. If the archaeologist and/or Native American monitor believe that a reduction in monitoring activities is prudent, then a letter report detailing the rationale for making such a reduction and summarizing the monitoring results shall be provided to the Director of Community Development, Department of Parks and Recreation (DPR) 523 forms shall be submitted along with the report for any cultural resources encountered over 50 years old.

If prehistoric and/or historic resources are encountered during construction, all activity within a 50-foot radius of the find will be stopped and the archaeologist and/or Native American monitor will examine the find and record the site, including field notes, measurements, and photography for a DPR 523 Primary Record form. The archaeologist will provide recommendations regarding eligibility for the CRHR, data recovery, curation, or other appropriate mitigation. Ground disturbance within the 50-foot radius can resume once these steps are taken and the City of Santa Clara concurred with the recommendations.

**MM CUL-3:** Within 45 days of the completion of construction or archaeological/Native American monitoring is terminated, the Applicant will have the archaeologist/Native American monitor prepare a report of findings. The report will document the archaeological/Native American resource finds, if any, recommendations, data recovery efforts, and other pertinent information gleaned during construction. The report shall be submitted as directed by the City of Santa Clara. The Applicant will submit the final report to the NWIC at Sonoma State University.

### **Operation and Maintenance**

No IMPACT. Ground-disturbing activities are not part of the operational or maintenance profile of the proposed project. Impacts on historical resources are therefore not expectable during operation and maintenance.

**Proposed Mitigation Measures: MM CUL-1 and MM CUL-3.**

- b. Would the project cause a substantial adverse change in the significance of a unique archaeological resource pursuant to §15064.5?***

### **Demolition/Construction**

LESS THAN SIGNIFICANT WITH MITIGATION INCORPORATED. See the response to CEQA checklist question *a* above, which includes a discussion of historic, archaeological, and ethnographic resources. Implementation of **MM CUL-1** and **MM CUL-3** would reduce impacts on buried, unique archaeological resources to a less than significant level.



### Operation and Maintenance

NO IMPACT. Ground-disturbing activities are not part of the operational or maintenance profile of the proposed project. Impacts on unique archaeological resources are therefore not expectable during operation and maintenance.

**Proposed Mitigation Measures: MM CUL-1 and MM CUL-3.**

- c. *Would the project disturb any human remains, including those interred outside of formal cemeteries?*

### Demolition/Construction

LESS THAN SIGNIFICANT WITH MITIGATION INCORPORATED. See the response to CEQA checklist question a above, which includes a discussion of historic, archaeological, and ethnographic resources (all of which could include human remains). **MM CUL-1, APM CUL-2, and MM CUL-3** would reduce impacts on buried human remains to a less than significant level

### Operation and Maintenance

NO IMPACT. Ground-disturbing activities are not part of the operational or maintenance profile of the proposed project. Impacts on human remains are therefore not expectable during operation and maintenance.

**Proposed Mitigation Measures: MM CUL-1 and MM CUL-3.**

## Tribal Cultural Resources CEQA Checklist Questions

- a. *Would the project cause a substantial adverse change in the significance of a tribal cultural resource, defined in Public Resources Code section 21074 as either a site, feature, place, cultural landscape that is geographically defined in terms of the size and scope of the landscape, sacred place, or object with cultural value to a California Native American tribe, and that is listed or eligible for listing in the California Register of Historical Resources, or in a local register of historical resources as defined in Public Resources Code section 5020.1(k)?*

### Demolition/Construction

NO IMPACT. There will not be any impacts to tribal cultural resources listed or eligible for listing in the CRHR or other state registers, National Register of Historic Places (NRHP), or local register of historical resources.

### Operation and Maintenance

NO IMPACT. Ground-disturbing activities are not part of the operational or maintenance profile of the proposed project. Impacts on tribal cultural resources listed or eligible for listing in the CRHR or other state registers, NRHP, or local register of historical resources are therefore not expectable during operation and maintenance.

**Proposed Mitigation Measures: None.**

- b. *Would the project cause a substantial adverse change in the significance of a tribal cultural resource, defined in Public Resources Code section 21074 as either a site, feature, place, cultural*

*landscape that is geographically defined in terms of the size and scope of the landscape, sacred place, or object with cultural value to a California Native American tribe, and that is a resource determined by the lead agency, in its discretion and supported by substantial evidence, to be significant pursuant to criteria set forth in subdivision (c) of Public Resources Code Section 5024.1. In applying the criteria set forth in subdivision (c) of Public Resource Code Section 5024.1, the lead agency shall consider the significance of the resource to a California Native American tribe?*

### **Demolition/Construction**

LESS THAN SIGNIFICANT WITH MITIGATION INCORPORATED. Although there are no known tribal cultural resources on or directly adjacent to the proposed site, ground disturbance associated with the proposed project could result in the exposure and destruction of buried, as-yet unknown prehistoric archaeological resources that could qualify as tribal cultural resources. If these resources were to be exposed or destroyed, it would be a significant impact. Implementation of **MM CUL-1** and **MM CUL-3** would reduce impacts on buried, tribal cultural resources to a less than significant level.

### **Operation and Maintenance**

NO IMPACT. Ground-disturbing activities are not part of the operational or maintenance profile of the proposed project. Impacts on tribal cultural resources listed or eligible for listing in the CRHR or other state registers, NRHP, or local register of historical resources are therefore not expectable during operation and maintenance.

**Proposed Mitigation Measures: MM CUL-1 and MM CUL-3.**

## **5.5.3 References**

- Alonso and Castells 2019a** – Christina Alonso and Justin Castells. *Cultural Resource Investigation in Support of the 2201 Laurelwood Road Project, Santa Clara County, California*. February 13. Technical Report No. 19-37. PaleoWest Archaeology, Walnut Creek, CA. Prepared for Jacobs Engineering Group, Sacramento, CA. Appendix 3.5-A in *Small Power Plant Exemption Application for the Laurelwood Data Center Santa Clara, California*, by MECP1 Santa Clara 1, with Jacobs. February. Submitted to California Energy Commission, Sacramento. 19-SPPE-01.
- Alonso and Castells 2019b** – Christina Alonso and Justin Castells. *Cultural Resource Investigation in Support of the 2201 Laurelwood Road Project, Santa Clara County, California*. Revised. April 3. Technical Report No. 19-37. PaleoWest Archaeology, Walnut Creek, CA. Prepared for Jacobs Engineering Group, Sacramento, CA. Submitted to California Energy Commission, Sacramento. 19-SPPE-01.
- Baker 1998** – Susan Baker. *Archaeological Survey, San Tomas Aquino/Saratoga Creek Trail Project, Santa Clara County, California*. July. On file, Northwest Information Center, California Historical Resources Information System, Rohnert Park. Study S-022570.
- Bonitz 2019** – Jessica Bonitz. Request for SLF Search and Contact List. March 6. Tribal Program/Cultural Resources Unit, California Energy Commission, Sacramento. Submitted to Native American Heritage Commission, West Sacramento, CA.
- Brady 2015** – Ryan Brady. Letter Regarding Cultural Resources Monitoring at 3303 Scott Boulevard, Santa Clara, California. June 18. Albion Environmental, Santa Cruz, CA. Prepared for

Toeniskoetter Development, Santa Clara, CA. On file, Northwest Information Center, California Historical Resources Information System, Rohnert Park. Study S-046801.

**Busby 1999a** – Colin I. Busby. Letter Regarding Residential Facility at 1501 Agnew Road (Agnews West Campus), City of Santa Clara, Santa Clara County, California: Archaeological Monitoring Closure Report. October 22. Basin Research Associates, San Leandro, CA. Prepared for Mid-Peninsula Housing Coalition, Redwood City, CA. On file, Northwest Information Center, California Historical Resources Information System, Rohnert Park. Study S-023110.

**Busby 1999b** – Colin I. Busby. Letter Regarding Estancia Apartments Project on Hope Drive (Agnews West Campus), City of Santa Clara, Santa Clara County: Archaeological Monitoring Closure Report. November 21. Basin Research Associates, San Leandro, CA. Prepared for Hope Drive Associates, San Francisco. On file, Northwest Information Center, California Historical Resources Information System, Rohnert Park. Study S-023362.

**Busby 1999c** – Colin I. Busby. Letter Regarding South Bay Water Recycling Program - Cultural Resources Program, Subcontract No. 728106.3024: Monitoring Closure Report - Phase 1. May 7. Basin Research Associates, San Leandro, CA. Prepared for Parsons Engineering Science, Oakland, CA. On file, Northwest Information Center, California Historical Resources Information System, Rohnert Park. Study S-019072b.

**Busby 2000** – Colin I. Busby. Letter Regarding Sun Microsystems Santa Clara Campus Project, Agnews West Campus: Archaeological Monitoring Closure Report, Phase 1 (July 1998 to December 1999). November 22. Basin Research Associates, San Leandro, CA. Prepared for Jones Lang LaSalle, Santa Clara, CA. On file, Northwest Information Center, California Historical Resources Information System, Rohnert Park. Study S-024980.

**Busby 2002a** – Colin I. Busby. Letter Regarding Agnews [West] Family Housing, Rivermark Master Plan Parcel 22, Sobrato Family Living Center Phase 2, 1451-1491 Agnew Road, City of Santa Clara, Santa Clara County: Archaeological Monitoring Closure Report. October 30. Basin Research Associates, San Leandro, CA. Prepared for Housing Authority of the County of Santa Clara, San Jose, CA. On file, Northwest Information Center, California Historical Resources Information System, Rohnert Park. Study S-028015.

**Busby 2002b** – Colin I. Busby. Letter Regarding Agnews [West] Family Housing, Rivermark Master Plan Parcel 26, Currently Vacant Parcel, City of Santa Clara, Santa Clara County: Archaeological Monitoring Closure Report. October 30. Basin Research Associates, San Leandro, CA. Prepared for Housing Authority of the County of Santa Clara, San Jose, CA. On file, Northwest Information Center, California Historical Resources Information System, Rohnert Park. Study S-028016.

**Busby et al. 1996a** – Colin I. Busby, Donna M. Garaventa, Melody E. Tannam, and Stuart A. Guedon (Busby et al.). *Historic Properties Treatment Plan, South Bay Water Recycling Program*. Revised. July. Basin Research Associates, San Leandro, CA. Prepared for Parsons Engineering Science, Alameda, CA. On file, Northwest Information Center, California Historical Resources Information System, Rohnert Park. Study S-019072.

**Busby et al. 1996b** – Colin I. Busby, Donna M. Garaventa, Melody E. Tannam, and Stuart A. Guedon (Busby et al.). *Supplemental Report: Historic Properties Affected or Potentially Affected by the South Bay Water Recycling Program*. June. Prepared for Parsons Engineering Science, Alameda, CA. On file, Northwest Information Center, California Historical Resources Information System, Rohnert Park. Study S-019072a.

- Byrd et al. 2017** – Brian F. Byrd, Adrian R. Whitaker, Patricia J. Mikkelsen, and Jeffrey S. Rosenthal (Byrd et al.). *San Francisco Bay-Delta Regional Context and Research Design for Native American Archaeological Resources, Caltrans District 4*. June. Prepared for Office of Cultural Resources Studies, District 4, California Department of Transportation, Oakland. On file, Northwest Information Center, California Historical Resources Information System, Rohnert Park. Study S-049780.
- CEC 2017** – California Energy Commission (CEC). *Tribal Consultation Policy*. Revised. December 2017. Sacramento, CA. CEC-700-2017-002-D.
- CEC 2019a** – California Energy Commission (CEC). (TN 227446). Initial Tribal Consultation Letters, dated March 28, 2019. Available online at: <https://efiling.energy.ca.gov/Lists/DocketLog.aspx?docketnumber=19-SPPE-01>.
- Cornerstone 2019** – Cornerstone Earth Group (Cornerstone). *Geotechnical Investigation, 2201 Laurelwood Road, Santa Clara, California*. March 18. Sunnyvale, CA. Project No. 1075-1-2. Prepared for EdgeCore Internet Real Estate, Denver, CO.
- Davis 1961** – James T. Davis (Davis). *Trade Routes and Economic Exchange among the Indians of California*. Report No. 54. March 31. Berkeley: University of California Archaeological Survey.
- Docomomo 2019** – Docomomo NOCA. Available online at: <http://docomomo-noca.org/buildings/san-jose-airport/>. Accessed on: May 20, 2019.
- D’Oro 2017**– Stella D’Oro. Letter Regarding Archaeological Monitoring at the Mission Park MarketPlace Project, Santa Clara, California. December 8. Albion Environmental, Santa Cruz, CA. Submitted to Washington Holdings, TynanGroup, Tempe, AZ. On file, Northwest Information Center, California Historical Resources Information System, Rohnert Park. Study S-49685.
- Draper 1949** – W. Marvin Draper. Owens-Corning Fiberglas Plant, Santa Clara, CA, 1949. May 5. Aerial photograph. W. Marvin Draper Collection, Santa Clara City Library. Electronic document. Available online at: <https://oac.cdlib.org/ark:/13030/kt9s2024bv/?brand=oac4>. Accessed on: June 18, 2019.
- EDR 2017a** – Environmental Data Resources (EDR). EDR Historical Topo Map Report with QuadMatch™. May 17. Shelton, CT. Inquiry Number 4940607.4. Prepared for Vishay Siliconix, Santa Clara, CA. Appendix C to *Phase I Environmental Site Assessment, 2201 Laurelwood Road, Santa Clara, California*, by Cornerstone Earth Group. November 26, 2018. Project No. 1075-1-1. Prepared for MECP1 Santa Clara 1, LLC.
- EDR 2017b** – Environmental Data Resources (EDR). The EDR Aerial Photo Decade Package. May 18. Shelton, CT. Inquiry Number 4940607.12. Prepared for Vishay Siliconix, Santa Clara, CA. Appendix C to *Phase I Environmental Site Assessment, 2201 Laurelwood Road, Santa Clara, California*, by Cornerstone Earth Group. November 26, 2018. Project No. 1075-1-1. Prepared for MECP1 Santa Clara 1, LLC.
- Edward Denny & Co. 1913** – Edward Denny & Co. Map Publishers (Edward Denny & Co.). *Denny’s Pocket Map, Santa Clara County, California*.
- Fike 2016** – Aisha Fike. *651 Mathew Street*. California Department of Recreation Primary Record Form. October 25. ICF International. Prepared for the City of Santa Clara.
- GLO 1866** – General Land Office (GLO). Survey Plat of Township No. 6 South, Range No. 1 West, Mount Diablo Meridian. May 12. San Francisco, CA. Surveyed 1851, 1853, 1857–1862, 1865–1866.

- Golla 2007** – Victor Golla. Linguistic Prehistory. Chapter 6 in *California Prehistory: Colonization, Culture, and Complexity*, edited by Terry L. Jones and Kathryn A. Klar, pp. 71–82. Lanham, MD: Altamira.
- Hammerle 2015** – Esme Hammerle. Memorandum Regarding Archaeological Monitoring Summary Report for 31099142 Gas Main Bowers & Kifer, Santa Clara City and County. July 6. Garcia and Associates, Oakland, CA. Prepared for Pacific Gas and Electric Company, San Francisco. On file, Northwest Information Center, California Historical Resources Information System, Rohnert Park. Study S-047529a.
- Holson et al. 2002** – John Holson, Cordelia Sutch, and Stephanie Pau (Holson et al.). *Cultural Resources Report for San Jose Local Loops, Level 3 Fiber Optics Project in Santa Clara and Alameda Counties, California*. May. Pacific Legacy, Albany, CA. 647-20. Prepared for Fluor Global Services, Aliso Viejo, CA. On file, Northwest Information Center, California Historical Resources Information System, Rohnert Park. Study S-025173.
- Hylkema 1994** – Mark G. Hylkema. Tamien Station Archaeological Project. In *The Ohlone Past and Present: Native Americans of the San Francisco Bay Region*, compiled and edited by Lowell J. Bean, pp. 249–270. Anthropological Papers No. 42. Menlo Park, CA: Ballena.
- Hylkema 1998** – Mark G. Hylkema. *Extended Phase I Archaeological Survey Report: Subsurface Presence/Absence Testing at the Woolen Mills Chinatown Site (CA-SCL-807/H) and Three Storm Water Detention Basins, for the Route 87 Guadalupe Corridor Freeway Project, City of San Jose, Santa Clara County, California*. May 8. Office of Environmental Planning, South, District 4, California Department of Transportation, Oakland. 04-SCL-87 PM 6.3/9.4, 04-SCL-101 PM 40.2/41.2. On file, Northwest Information Center, California Historical Resources Information System, Rohnert Park. Study S-020327.
- Jacobs 2019a** – Jacobs (Jacobs). (TN 227273-1). Application for Small Power Plant Exemption: Laurelwood Data Center, dated March 5, 2019. Available online at: <https://efiling.energy.ca.gov/Lists/DocketLog.aspx?docketnumber=19-SPPE-01>.
- Jacobs 2019c** – Jacobs (Jacobs). (TN 227626). LDC Responses to Formal and Informal Data Requests. Data Response Set 1A, dated April 11, 2019. Available online at: <https://efiling.energy.ca.gov/Lists/DocketLog.aspx?docketnumber=19-SPPE-01>.
- Jacobs 2019d** – Jacobs (Jacobs). (TN228748). LDC Updated SPPE Project Description, dated June 13, 2019. Available online at: <https://efiling.energy.ca.gov/Lists/DocketLog.aspx?docketnumber=19-SPPE-01>.
- Jones et al. 2007** – Terry L. Jones, Nathan E. Stevens, Deborah A. Jones, Richard T. Fitzgerald, and Mark G. Hylkema (Jones et al.). The Central Coast: A Midlatitude Milieu. Chapter 9 in *California Prehistory: Colonization, Culture, and Complexity*, edited by Terry L. Jones and Kathryn A. Klar, pp. 125–146. Lanham, MD: Altamira.
- Kroeber 1976** – A. L. Kroeber. *Handbook of the Indians of California*. Reprinted. New York, NY: Dover Publications. Originally published in 1925, Bulletin No. 78, Bureau of American Ethnology, Smithsonian Institution, Washington, D.C.
- Lehmann 2000** – Susan Lehmann. Economic Development of the City of Santa Cruz, 1850-1950. From: *Fully Developed Context Statement for the City of Santa Cruz*. Prepared for City of Santa Cruz Planning and Development Department. Chapter 3, Context I: Economic Development of the City of Santa Cruz 1850-1950, pp. 25-27. Electronic document,

<https://history.santacruzpl.org/omeka/items/show/134510#?c=0&m=0&s=0&cv=0>. Accessed June 18, 2019.

- Levy 1978** – Richard Levy. Costanoan. In *California*, edited by Robert F. Heizer, pp. 485–495. Handbook of North American Indians, vol. 8, William C. Sturtevant, ed. Washington, D.C.: Smithsonian Institution.
- Milliken et al. 2007** – Randall Milliken, Richard T. Fitzgerald, Mark G. Hylkema, Randy Groza, Tom Origer, David G. Bieling, Alan Leventhal, Randy S. Wiberg, Andrew Gottsfield, Donna Gillette, Viviana Bellifemine, Eric Strother, Robert Cartier, and David A. Fredrickson (Miliken et al.). Punctuated Culture Change in the San Francisco Bay Area. Chapter 8 in *California Prehistory: Colonization, Culture, and Complexity*, edited by Terry L. Jones and Kathryn A. Klar, pp. 99–123. Lanham, MD: Altamira.
- OHP 1995** – Office of Historic Preservation (OHP). *Instructions for Recording Historical Resources*. March. Sacramento, CA: Office of Historic Preservation.
- Oosterhous et al. 2002** – Kara Oosterhous, Franklin Maggi, and Leslie A. G. Dill (Oosterhous et al.). *Historical and Architectural Evaluation: 4423 Cheeney Street, Santa Clara, County of Santa Clara, California*. September 17. Dill Design Group, Los Gatos, CA. Prepared for Lauson Fargher, Santa Clara, CA. On file, Northwest Information Center, California Historical Resources Information System, Rohnert Park. Study S-026095.
- Parsons and KEMCO 1983** – Parsons Brinckerhoff Quade & Douglas and Kobori Environmental Management Corp (Parsons and KEMCO). *Data Recovery Plan for the Guadalupe Corridor Transportation Project, Santa Clara County, California*. February. Prepared for Santa Clara County Transportation Agency. On file, Northwest Information Center, California Historical Resources Information System, Rohnert Park. Study S-006066.
- Rehor and Kubal 2014** – Jay Rehor and Kathleen Kubal. *Extended Phase I Study: US 101 Express Lands Project, Santa Clara County, California*. April. URS Corporation, Oakland, CA. Prepared for District 4, Department of Transportation, State of California, Oakland, and Santa Clara Valley Transportation Authority, San Jose, CA. US PM 16.0/52.55, SR 85 PM 23.0/R24.1. Project No. 0412000459. EA 2G7100. On file, Northwest Information Center, California Historical Resources Information System, Rohnert Park. Study S-045670c.
- Ruby et al. 1992** – Allika Ruby, Jason Bass, and Mike Kelley (Ruby et al.). *Evaluation of Archaeological Resources for the San Jose/Santa Clara Nonpotable Water Reclamation Project*. May 11. Archaeological Resource Management, San Jose, CA. Prepared for Engineering Science, Alameda, CA. Project #60800-92-62. On file, Northwest Information Center, California Historical Resources Information System, Rohnert Park. Study S-014230.
- Santa Clara 2010** – City of Santa Clara (Santa Clara). City of Santa Clara General Plan 2010-2035. Adopted on: November 16, 2010. Available online at: <http://santaclaraca.gov/government/departments/community-development/planning-division/general-plan>.
- Santa Clara 2015** – City of Santa Clara (Santa Clara). Initial Study: 3535 Garrett Drive Office Project. File Nos: PLN2015-11384/CEQ2015-01199.
- Santa Clara 2016a** – City of Santa Clara (Santa Clara). Initial Study: Building V5 Data Center Project. December. File Nos. PLN2016-12091/PLN2016-12097/CEQ2016-01018.



- Santa Clara 2016b** – City of Santa Clara (Santa Clara). Initial Study: 2895 Northwestern Parkway (Building V6) Data Center Project. August. File No. PLN2016-11966.
- Santa Clara 2016c** – City of Santa Clara (Santa Clara). Draft Environmental Impact Report: Great America Theme Park Master Plan. October. File Nos: PLN2014-10851/CEQ2016-01007. State Clearinghouse # 2016032036.
- Santa Clara 2016d** – City of Santa Clara (Santa Clara). Initial Study for the Mission Park MarketPlace Project. May. File Nos: PLN2016-11737/CEQ2016-01006.
- Santa Clara 2017a** – City of Santa Clara (Santa Clara). Initial Study: McLaren Data Center Project. February.
- Santa Clara 2017b** – City of Santa Clara (Santa Clara). Initial Study/Mitigated Negative Declaration: 3375 Scott Boulevard Office Project. March. File Nos: PLN2016-12232/CEQ2016-01021.
- Santa Clara 2018a** – City of Santa Clara (Santa Clara). City Code, Title 18 Zoning, Chapter 18.106 Historic Preservation. Available online at: <http://www.codepublishing.com/CA/SantaClara/#!/santaclara18/SantaClara18106.html#18.106.030>. Accessed on: January 10, 2018.
- Santa Clara 2018b** – City of Santa Clara (Santa Clara). *Initial Study for the 2305 Mission College Boulevard Data Center Project*. March. File No. PLN2017-12535.
- Santa Clara County 2012** – County of Santa Clara Department of Planning and Development, Planning Office (Santa Clara County). County of Santa Clara Historic Context Statement. December 2004, Revised February 2012.
- Santa Clara County 2015** – County of Santa Clara (Santa Clara County). County of Santa Clara Heritage Resource Inventory. Electronic document. Available online at: <https://www.sccgov.org/sites/dpd/Programs/HistoricPreservation/Pages/Inventory.aspx>. Accessed on: May 23, 2019.
- SFEI 2010** – San Francisco Estuary Institute (SFEI). Historical Vegetation and Drainage Patterns of Western Santa Clara Valley: A Technical Memorandum Describing Landscape Ecology in Lower Peninsula, West Valley, and Guadalupe Watershed Management Areas. Historical Ecology Program, Contribution No. 622.
- Shiple 1978** – William F. Shiple. Native Languages of California. In *California*, edited by Robert F. Heizer, pp. 80–90. Handbook of North American Indians, vol. 8, William C. Sturtevant, ed. Washington, D.C.: Smithsonian Institution.
- SWCA 2006** – SWCA Environmental Consultants (SWCA). *Cultural Resources Final Report of Monitoring and Findings for the Qwest Network Construction Project, State of California*. December. Sacramento, CA. SWCA Project No. 10715-180. SWCA Cultural Resources Report Database No. 06-507. Prepared for Qwest Communications, Denver, CO. On file, Northwest Information Center, California Historical Resources Information System, Rohnert Park. Study S-033061.
- Totton 2019** – Gayle Totton. Email Regarding Laurelwood Data Center Project, City of Santa Clara; Milpitas USGS Quadrangle, Santa Clara County, California. March 7. Cultural and Environmental Department, Native American Heritage Commission, West Sacramento, CA. Submitted to California Energy Commission, Sacramento.
- USGS 1897** – United States Geological Survey (USGS). San Jose, California, Sheet. 15-minute Topographic Series. September. Advanced proof. Surveyed 1895.

- USGS 1899** – United States Geological Survey (USGS). San Jose, California, Sheet. 15-minute Topographic Series. March. Surveyed 1895.
- USGS 1915** – United States Geological Survey (USGS). Geologic and Topographic Map of the Coast Route.
- USGS 1961** – United States Geological Survey (USGS). San Jose, California, Quadrangle. 15-minute Topographic Series. Denver, CO.
- USGS 1980a** – United States Geological Survey (USGS). Milpitas, California, Quadrangle. 7.5-minute Topographic Series. Photorevised version of 1961 edition. Aerial photographs taken 1948 and 1960. Denver, CO.
- USGS 1980b** – United States Geological Survey. San Jose West, California, Quadrangle. 7.5-minute Topographic Series. Photorevised version of 1961 edition. Aerial photographs taken 1948 and 1960. Denver, CO.
- Vishay 2019** – Vishay Corporate Website. Available online at: <https://www.vishay.com/>. Accessed on: April 8, 2019.
- Whitaker 2016** – Adrian R. Whitaker (Whitaker). *Cultural Resources Sensitivity Assessment for the 2016 Caltrain and Dumbarton Rail Fence Installation and Replacement Project*. August. Far Western Anthropological Research Group, Davis, CA. Prepared for Peninsula Corridor Joint Powers Board, San Carlos, CA. On file, Northwest Information Center, California Historical Resources Information System, Rohnert Park. Study S-048931.

## 5.6 Energy and Energy Resources

This section discusses impacts associated with the demolition/construction and operation of the Laurelwood Data Center (LDC or project) with respect to energy. Analysis of impacts applies to project components that would consume energy, or conflict with, or obstruct a state or local plan for renewable energy or energy efficiency. In addition, this section includes staff's analysis of the project's potential impact on Energy Resources, as required by Public Resources Code section 25541 when considering a Small Power Plant Exemption.

ENERGY	Potentially Significant Impact	Less than Significant With Mitigation Incorporated	Less than Significant Impact	No Impact
<b>Would the project:</b>				
a. Result in potentially significant environmental impact due to wasteful, inefficient, or unnecessary consumption of energy resources, during project construction or operation?	<input type="checkbox"/>	<input type="checkbox"/>	<input checked="" type="checkbox"/>	<input type="checkbox"/>
b. Conflict with or obstruct a state or local plan for renewable energy or energy efficiency?	<input type="checkbox"/>	<input type="checkbox"/>	<input type="checkbox"/>	<input checked="" type="checkbox"/>

Environmental checklist established by CEQA Guidelines, Appendix G

### 5.6.1 Setting

The Energy Commission makes findings as to whether energy use by the LDC would cause significant adverse impacts on the environment, as defined in the California Environmental Quality Act, Appendix F. If the Energy Commission finds that the LDC's consumption of energy would create a significant adverse impact, it must further determine if feasible mitigation measures would eliminate or minimize that impact.

The LDC would include 55 diesel-fired standby generators that would be used to provide backup power supply to support an uninterruptible power supply exclusively for the project plus one diesel-fired generator that would provide essential services (for fire suppression and other emergency operations) (Jacobs 2019a, page1-1 and 1-9). The backup generators would serve LDC only during times when electric service from Silicon Valley Power (SVP) is interrupted. The backup generators would be electrically isolated from the SVP electrical transmission grid with no means to deliver electricity offsite.

Staff has verified the output capacity of these generators from the product sheets (Caterpillar Model C175-16) (Jacobs 2019b, Appendix 3.3B). Each generator would have a nameplate output capacity of 3.0 MW and continuous steady-state output capacity of 2.725 MW. No more than 33 generators would operate at the same time, thus, the maximum total facility load requirement would not exceed 99 MW, which includes the electrical power load of the Information Technology (IT) servers, the cooling load of the IT buildings, and the facility's ancillary loads. See **Section 4.0, Project Description** for further information.

While no more than 33 backup generators would need to operate at or near their continuous output of 2.725 MW to reach the facility's maximum output requirement of 99 MW, the exact number of backup generators that would operate in an emergency, such as a power outage, depends on actual cooling and IT server loads, and the reliability and performance of the backup generators. In no case would the combined output of backup generators exceed the prescribed maximum load of 99 MW. Combined output would be limited by sizing the electricity handling equipment that would throttle transfer capacity to no more than 99 MW, which would prevent damage to IT servers and building equipment. Non-operating

backup generators would be reserved as redundant generators, ready to start if other generators fail. For the purposes of testing and maintenance, only one generator would operate at any given time.

## Regulatory Background

### *Federal*

No federal laws, regulations, or standards related to energy apply to the project.

### *State*

**California Energy Efficiency Standards for Residential and Nonresidential Buildings—California Green Building Code (2011), Title 24 Update (2014).** The California Green Building Code applies to newly constructed buildings and requires installation of energy-efficient indoor infrastructure.

**Senate Bill 100 (SB 100)—The 100 Percent Clean Energy Act of 2018.** SB 100 declares that the Public Utilities Commission, California Energy Commission, and California Air Resources Board should plan for 100 percent of total retail sales of electricity in California to come from eligible renewable energy resources and zero-carbon resources by December 31, 2045. This requirement applies to SVP, which would be the primary source of electricity supply for LDC.

### *Local*

**City of Santa Clara Climate Action Plan.** The Climate Action Plan (CAP) sets goals for the city to achieve its share of statewide emissions reductions for the 2020 timeframe established by the Global Warming Solution Act (Assembly Bill 32). The CAP was adopted on December 3, 2013 and it specifies the strategies and measures to be taken for a number of focus areas, one of which is energy efficiency. To achieve the goals set in the CAP, the city adopted some policies in its 2010-2035 General Plan as discussed below.

**City of Santa Clara General Plan Land Use Policies—Santa Clara’s 2010–2035 Master Plan.** This plan provides a comprehensive view of the city’s planned development to mid-century goals and policies which relate to energy and sustainability to guide land use development within the city. These goals and policies are promulgated by the Santa Clara General Plan 2010–2035 (Santa Clara 2010), addressing energy conservation, renewable power systems, and efficient use of fuel. Examples of policies are:

- **Energy Policy 5.10.3-P1** promotes the use of renewable energy resources, conservation and recycling programs;
- **Energy Policy 5.10.3-P3** requires maximization of the efficient use of energy throughout the community by achieving adopted electricity efficiency targets and promoting natural gas efficiency;
- **Water Policy 5.10.4-P6** requires maximizing use of recycled water for construction, maintenance, irrigation and other appropriate applications.

## 5.6.2 Environmental Impacts and Mitigation Measures

- a. *Would the project result in potentially significant environmental impact due to wasteful, inefficient, or unnecessary consumption of energy resources during project construction or operation?*

### Demolition/Construction

LESS THAN SIGNIFICANT IMPACT. Demolition/construction activities would consume nonrenewable energy resources, primarily fossil fuels (oil, gasoline, and diesel), for construction equipment and vehicles. It is anticipated that these nonrenewable energy resources would be used efficiently during construction activities and would not result in long-term significant depletion of these energy resources or permanently increase the project's reliance on them.

Implementation of the applicant-proposed design measures during demolition/construction, as described in **Section 5.3, Air Quality**, would ensure that fuel consumed during construction would not be wasted through unnecessary idling or through operation of poorly maintained equipment.

As described in **Sections 4.0, Project Description** and **5.14, Population and Housing**, the project would locate staging areas at or near the project site and would have access to a large local construction labor supply, thus minimizing transportation-related energy use inducement. LDC would use materials (wallboard partitions, ceiling tiles, floor surfaces) that include post-consumer waste (Jacobs 2019a, Table 3.6-1). These steps would further lessen the project's impact on energy resources.

Therefore, construction of the project would not have a significant adverse effect on local and regional energy supplies and would not result in a significant environmental impact due to wasteful, inefficient, or unnecessary consumption of energy resources.

### Operation and Maintenance

LESS THAN SIGNIFICANT IMPACT. The combined total number of hours of operation for reliability purposes (i.e.; readiness testing and maintenance) for all of the generators is limited to no more than 50 hours per generator annually (Jacobs 2019a, Table 2-4). At this rate, the total quantities of diesel fuel used for all the generators operating at full load would be approximately 14,280 barrels per year (bbl/yr)<sup>1</sup>. Compared to California's diesel fuel supply of approximately 341,036,000 bbl/yr<sup>2</sup>, this rate is insignificant (0.004 percent).

The standby generators would use nonrenewable resources (diesel and lubricating oils). However, the use of the standby generators would be limited to times when there is an interruption of SVP's electric service. According to the applicant, use of the standby generators is expected to be limited to approximately 21 hours per year per generator for testing and maintenance (Jacobs 2019j, Table 1). Under emergency conditions, defined as the loss of electrical power to the data center, the generators could operate and use nonrenewable resources during infrequent outages and for short durations, as necessary to maintain data center operations. The Caterpillar Model C175-16 selected for this project has an efficiency rating comparable to other popular diesel-fueled generators of similar generating capacity. Due to the intermittent nature of a data center's operation, the use of renewable generation sources (wind/hydroelectric/solar) on their own would not satisfy LDC's need for reliable standby generation. The space and resource requirements for 99 MWs of renewable power and their

<sup>1</sup> Calculated as: 214.2 gallons per hour x 50 hours per year x 56 generators = 599,760 gallons per year = 14,280 bbl/yr.

<sup>2</sup> The Energy Commission's Weekly Fuels Watch Report for 2018 (latest annual report available).

intermittent nature make such applications infeasible for this project and site. Renewable generation resources, such as solar or wind, coupled with a battery installation, would require significantly more space than would be occupied by the standby generators, and would not fit on the proposed project site. Current commercial fuel cells are generally limited to lower energy density gaseous fuels such as natural gas or hydrogen, with their inherent storage problems.

Therefore, the operational use of nonrenewable fuel for the generators would not be unnecessary, inefficient, or wasteful.

Power Usage Effectiveness (PUE) is a metric used to compare the efficiency of facilities that house computer servers. PUE is a common metric for determining how effectively a data center's infrastructure systems can deliver power to its computer systems. It is defined as the ratio of total facility energy use to IT server power draw ( $PUE = \text{total facility source energy} / \text{IT source energy}$ ). For example, a PUE of 2 means that the data center must draw two watts of electricity for each one watt of power consumed by the IT server equipment. The ideal PUE is 1, where all power drawn by the facility goes to the IT server equipment.

The PUE has been used as a guideline for measuring energy and power efficiencies associated with data centers since 2007 (ASHRAE 2013 and ASHRAE 2016). The PUE factor started at a base point of 2.0 and has since migrated down to 1.25 or lower, demonstrating a significant improvement over the years. LDC is expected to achieve a PUE of 1.25 or lower.

Measure 2.3 of the CAP calls for completion of a feasibility study of energy efficient practices for new data center projects with an average rack power rating<sup>3</sup> of 15 kilowatts or more to achieve a PUE of 1.2 or lower. The project would have an average rack power rating range of 8 to 10 kilowatts (Jacobs 2019a, §3.8.3). This would be below the criteria in Measure 2.3, such that a feasibility study of energy efficient practices is not required. The project would be consistent with the CAP.

According to the updated project description docketed on June 21, 2019 (TN 228823), instead of the evaporative wet cooling towers, the project would use adiabatic cooling using electric chillers with R-134a refrigerant and radiators, with wetted pads to augment heat rejection performance for a limited number of hours. Compared to the originally-proposed wet cooling towers, the refrigeration units consume more electricity to operate but can reject more heat on hot and humid days. The building footprint decreased from 737,093 square feet for the original site plan to 533,952 square feet according to the revised site plan (Jacobs 2019d), while the number of the engine generators proposed to be installed remains at 56 and the maximum total facility load requirements would remain at 99 MW.

Even with replacing the wet cooling with adiabatic cooling and reducing the size of the buildings, the building codes and energy policies described above ensure the project would achieve the projected PUE of 1.25. For example, the LDC buildings would have a "Cool Roof," using reflective surfaces to reduce heat gains (Jacobs 2019a, Table 3.8-5). Examples of other energy-efficient/energy-saving measures that may be incorporated in the project include the following:

---

<sup>3</sup> Average rack power rating is a measure of the power available for use on a rack used to store computer servers. The higher the value of kilowatts, the greater power density per rack and generally more energy use per square foot of building area in a data center.



- low-energy cooling systems such as high-efficiency air conditioners and air economizer integrated into the central air handling system;
- limiting mechanical refrigeration needs and lowering the required refrigerant volume;
- transferring waste heat from the servers to occupied areas of the building;
- energy-efficient lighting system to reduce lighting power density by incorporating occupancy sensors and aggressive daylighting; and
- building insulation.

The LDC's consumption of energy resources during operation would not be inefficient or wasteful. Project operation would not have a significant adverse effect on local or regional energy supplies and would not create a significant adverse impact on energy resources.

**Proposed Mitigation Measures:** None.

- b. *Would the project conflict with or obstruct a state or local plan for renewable energy or energy efficiency?***

#### **Demolition/Construction, Operation and Maintenance**

NO IMPACT. During operation, LDC would use both nonrenewable energy resources and renewable energy resources in SVP's portfolio of resources. As of December 31, 2017, the SVP power mix was composed of approximately 38 percent eligible renewable resources, 34 percent large hydroelectric, and 28 percent nonrenewable sources (SVP 2017). In addition, SVP's 2018 Integrated Resource Plan identified that it expects to exceed 50 percent eligible renewable resources in its portfolio by 2030 (SVP 2018). As SVP procures more renewable energy for its portfolio, less nonrenewable energy sources will be needed and less nonrenewable power would be provided to LDC.

LDC would receive electricity from SVP which is on track to meet the requirements of SB 100. SVP has committed to meeting California's Renewable Portfolio Standard through its 100-percent renewable energy program, the Santa Clara Green Power Program (Santa Clara 2018).

The project's use of diesel fuel is a significant departure from typical power generating facilities that use fossil fuels as their primary source of energy, as the LDC's gensets would operate only during emergencies when the primary source of energy to operate the project, electricity from SVP, is cut off. Thus, the project would not obstruct SVP's ability to meet the requirements of SB 100.

Through the city's design review process, LDC would be required to comply with the California Green Building Code and the city's General Plan Land Use Policies (related to energy)—Santa Clara's 2010–2035 Master Plan.

Through energy efficient design and increased renewable electricity use, the project would neither conflict with nor obstruct state or local plans for renewable energy or energy efficiency, and therefore would have no adverse impact on them.

**Proposed Mitigation Measures:** None.

### 5.6.3 References

- ASHRAE 2013** – American Society of Heating, Refrigerating, and Air-conditioning Engineers (ASHRAE). Journal. Article: Data Center Energy Metric, pp. 61-62, Published in January 2013.
- ASHRAE 2016** – American Society of Heating, Refrigerating, and Air-conditioning Engineers ASHRAE Journal. Article: Supercomputers, Super Efficiency, pp. 38-39, Published in January 2016.
- Jacobs 2019a** – Jacobs (Jacobs). (TN 227273-1). Application for Small Power Plant Exemption: Laurelwood Data Center, dated February 28, 2019. Available online at: <https://efiling.energy.ca.gov/Lists/DocketLog.aspx?docketnumber=19-SPPE-01>.
- Jacobs 2019b** – Jacobs (Jacobs). (TN 227273-2 through TN 227273-3). Laurelwood SPPE Application Appendices. Available online at: <https://efiling.energy.ca.gov/Lists/DocketLog.aspx?docketnumber=19-SPPE-01>.
- Jacobs 2019d** – Jacobs (Jacobs). (TN228823). LDC Updated SPPE Project Description, dated June 13, 2019. Available online at: <https://efiling.energy.ca.gov/Lists/DocketLog.aspx?docketnumber=19-SPPE-01>
- Jacobs 2019j** – Jacobs (Jacobs). (TN229116). Laurelwood Data Center Bay Area AQMD Policy Compliance Letter, dated July 29, 2019. Available online at: <https://efiling.energy.ca.gov/Lists/DocketLog.aspx?docketnumber=19-SPPE-01>
- Santa Clara 2018** – City of Santa Clara (Santa Clara). Green Power Program, 2018. Available online at: <http://www.siliconvalleypower.com/solar-and-green-power/santa-clara-green-power>.
- Santa Clara 2010** – City of Santa Clara (Santa Clara). 2010–2035 General Plan. Adopted November 2010. Available online at: <http://santaclaraca.gov/government/departments/community-development/planning-division/general-plan>.
- SVP 2018** – Silicon Valley Power (SVP). 2018 Integrated Resource Plan for Silicon Valley Power. November 12, 2018. Available online at: <http://www.siliconvalleypower.com/home/showdocument?id=62481>.
- SVP 2017** – Silicon Valley Power (SVP). 2017 Power Content Label. Available online at: <http://www.siliconvalleypower.com/svp-and-community/about-svp/power-content-label>.

## 5.7 Geology and Soils

This section describes the environmental and regulatory setting and discusses impacts associated with the demolition/construction and operation of the Laurelwood Data Center (LDC or project) with respect to geology and soils.

GEOLOGY AND SOILS				
Would the project:	Potentially Significant Impact	Less than Significant With Mitigation Incorporated	Less than Significant Impact	No Impact
a. Directly or indirectly cause potential substantial adverse effects, including the risk of loss, injury, or death involving:				
i. Rupture of a known earthquake fault, as delineated on the most recent Alquist-Priolo Earthquake Fault Zoning Map issued by the State Geologist for the area or based on other substantial evidence of a known fault? Refer to Division of Mines and Geology Special Publication 42.	<input type="checkbox"/>	<input type="checkbox"/>	<input type="checkbox"/>	<input checked="" type="checkbox"/>
ii. Strong seismic ground shaking?	<input type="checkbox"/>	<input type="checkbox"/>	<input checked="" type="checkbox"/>	<input type="checkbox"/>
iii. Seismic-related ground failure, including liquefaction?	<input type="checkbox"/>	<input type="checkbox"/>	<input checked="" type="checkbox"/>	<input type="checkbox"/>
iv. Landslides?	<input type="checkbox"/>	<input type="checkbox"/>	<input type="checkbox"/>	<input checked="" type="checkbox"/>
b. Result in substantial soil erosion or the loss of topsoil?	<input type="checkbox"/>	<input type="checkbox"/>	<input checked="" type="checkbox"/>	<input type="checkbox"/>
c. Be located on geologic units or soil that is unstable, or that would become unstable as a result of the project, and potentially result in on- or off-site landslide, lateral spreading, subsidence, liquefaction, or collapse?	<input type="checkbox"/>	<input type="checkbox"/>	<input checked="" type="checkbox"/>	<input type="checkbox"/>
d. Be located on expansive soil, as defined in Section 1803.5.3 of the California Building Code (2010), creating substantial direct or indirect risks to life or property?*	<input type="checkbox"/>	<input type="checkbox"/>	<input checked="" type="checkbox"/>	<input type="checkbox"/>
e. Have soils incapable of adequately supporting the use of septic tanks or alternative wastewater disposal systems where sewers are not available for the disposal of waste water?	<input type="checkbox"/>	<input type="checkbox"/>	<input type="checkbox"/>	<input checked="" type="checkbox"/>
f. Directly or indirectly destroy a unique paleontological resource or site or unique geologic feature?	<input type="checkbox"/>	<input type="checkbox"/>	<input checked="" type="checkbox"/>	<input type="checkbox"/>

\*Geology and Soils question (d) reflects the current 2013 California Building Code (CBC), effective January 1, 2014, which is based on the International Building Code (2009).

Environmental checklist established by CEQA Guidelines, Appendix G.

### 5.7.1 Setting

Analysis of existing data included reviews of publicly available literature, maps, air photos, and documents presented with the application. An online database search was performed to identify previously reported paleontological resources near the project site. The geologic map review of the project area included maps published by the U.S. Geological Survey (Helley and Wesling 1989; Wesling and Helley 1989, and Helley et al. 1994). The literature reviewed included published and unpublished scientific papers. A paleontological record search of the University of California Museum of Paleontology, Berkeley online paleontological database was conducted for the disturbed project areas, including a 10-mile buffer zone surrounding the proposed data center (UCMP 2019).

### Paleontological Sensitivity

The potential for paleontological resources to occur in the project area was evaluated using the federal Potential Fossil Yield Classification (PFYC) system developed by the Bureau of Land Management (BLM 2016). Because of its demonstrated usefulness as a resource management tool, the PFYC has been utilized

for many years for projects across the country, regardless of land ownership. It is a predictive resource management tool that classifies geologic units on their likelihood to contain paleontological resources on a scale of 1 (very low potential) to 5 (very high potential) or Unknown. This system is intended to aid in predicting, assessing, and mitigating impacts to, paleontological resources. The PFYC ranking system is summarized in **Table 5.7-1**.

<b>TABLE 5.7-1: POTENTIAL FOSSIL YIELD CLASSIFICATION</b>	
<b>BLM PFYC Designation</b>	<b>Assignment Criteria Guidelines and Management Summary</b>
1 Very Low Potential	Geologic units are not likely to contain recognizable paleontological resources.
	Units are igneous or metamorphic, excluding air-fall and reworked volcanic ash units.
	Units are Precambrian in age.
	Management concern is usually negligible, and impact mitigation is unnecessary except in rare or isolated circumstances.
2 Low	Geologic units are not likely to contain paleontological resources.
	Field surveys have verified that significant paleontological resources are not present or are very rare.
	Units are generally younger than 10,000 years before present.
	Recent aeolian deposits.
	Sediments exhibit significant physical and chemical changes (i.e., diagenetic alteration) that make fossil preservation unlikely
Management concern is generally low, and impact mitigation is usually unnecessary except in occasional or isolated circumstances.	
3 Moderate Potential	Sedimentary geologic units where fossil content varies in significance, abundance, and predictable occurrence.
	Marine in origin with sporadic known occurrences of paleontological resources.
	Paleontological resources may occur intermittently, but these occurrences are widely scattered.
	The potential for authorized land use to impact a significant paleontological resource is known to be low-to-moderate.
4 High Potential	Management concerns are moderate. Management options could include record searches, pre-disturbance surveys, monitoring, mitigation, or avoidance. Opportunities may exist for hobby collecting. Surface-disturbing activities may require sufficient assessment to determine whether significant paleontological resources occur in the area of a proposed action and whether the action could affect the paleontological resources.
	Geologic units that are known to contain a high occurrence of paleontological resources.
	Significant paleontological resources have been documented but may vary in occurrence and predictability.
	Surface-disturbing activities may adversely affect paleontological resources.
	Rare or uncommon fossils, including invertebrate (such as soft body preservation) or unusual plant fossils, may be present.
	Illegal collecting activities may impact some areas.
Management concern is moderate to high depending on the proposed action. A field survey by a qualified paleontologist is often needed to assess local conditions. On-site monitoring or spot-checking may be necessary during land disturbing activities. Avoidance of known paleontological resources may be necessary.	
5 Very High Potential	Highly fossiliferous geologic units that consistently and predictably produce significant paleontological resources.
	Significant paleontological resources have been documented and occur consistently.
	Paleontological resources are highly susceptible to adverse impacts from surface disturbing activities.
	Unit is frequently the focus of illegal collecting activities.
Management concern is high to very high. A field survey by a qualified paleontologist is almost always needed and on-site monitoring may be necessary during land use activities. Avoidance or	

**TABLE 5.7-1: POTENTIAL FOSSIL YIELD CLASSIFICATION**

BLM PFYC Designation	Assignment Criteria Guidelines and Management Summary
	resource preservation through controlled access, designation of areas of avoidance, or special management designations should be considered.
U Unknown	Geologic units that cannot receive an informed PFYC assignment.
	Geological units may exhibit features or preservation conditions that suggest significant paleontological resources could be present, but little information about the actual paleontological resources of the unit or area is known.
	Geologic units represented on a map are based on lithologic character or basis of origin, but have not been studied in detail.
	Scientific literature does not exist or does not reveal the nature of paleontological resources.
	Reports of paleontological resources are anecdotal or have not been verified.
	Area or geologic unit is poorly or under-studied.
	BLM staff has not yet been able to assess the nature of the geologic unit. Until a provisional assignment is made, geologic units with unknown potential have medium to high management concerns. Field surveys are normally necessary, especially prior to authorizing a ground-disturbing activity.

Source: Summarized and modified from BLM 2016

### Regional Geologic Setting

The proposed project is situated in the Southern Coastal Ranges geomorphic province (**Figure 5.7-1**). The division between the Northern and Southern Coastal Ranges is one of convenience. Both provinces contain many elongate ranges and narrow valleys that are approximately parallel to the coast, although the coast shows a somewhat more northern trend than do the ridges and valleys, except at San Francisco Bay where a pronounced gap separates the two provinces (Norris and Webb 1990). The differences between the two provinces occur because the northern Ranges lie east of the San Andreas, whereas the southern Ranges predominantly lie to the west (Norris and Webb 1990). The two Ranges have dissimilar basement rocks. The Northern Range and portions of the Southern Range east of the San Andreas are underlain by strongly deformed Franciscan subduction complex rocks, and the areas west of the San Andreas in both the Northern and Southern Range are underlain by a strongly deformed granitic-metamorphic complex known as the Salinian block. The basement rock beneath the project site, which lies east of the San Andreas Fault zone consists of Franciscan Complex rocks (Norris and Webb 1990).

### Local Geology

**Figure 5.7-2** depicts the surficial geology in the vicinity of the project. The project site is in the Santa Clara Valley, a relatively broad and level alluvial basin, bounded by the San Francisco Bay to the north, the Santa Cruz Mountains to the west and southwest, and the Diablo Mountain Range to the east and southeast. The Santa Clara Valley's basin contains alluvial deposits derived from the Diablo Range and the Santa Cruz Mountains. Alluvial deposits are interbedded with bay and lacustrine (lake) deposits in the north-central region. The valley sediments were deposited as a series of coalescing alluvial fans by streams that drain the adjacent mountains. These alluvial sediments make up the groundwater aquifers of the area. Soil types in the area include clay in the low-lying central areas, loam and gravelly loam in the upper portions of the valley, and eroded rocky clay loam in the foothills. The average grade of the valley floor ranges from nearly horizontal to about two percent, generally down to the northwest. Grades are steeper on the surrounding hillsides (Santa Clara 2011).





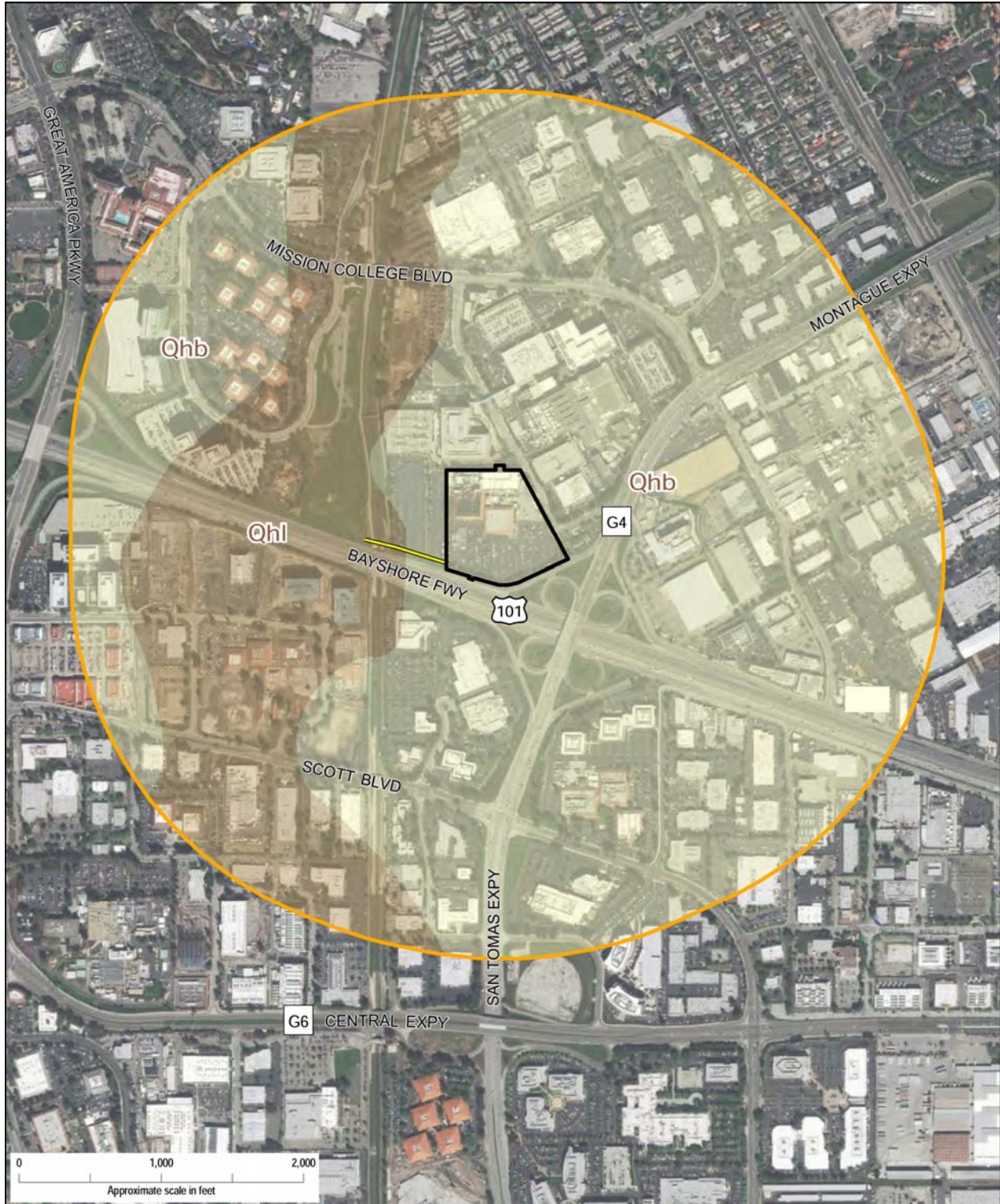

- Project Boundary
- Electrical Supply Line
- 1/2 Mile Radius
- Qhb: Floodbasin Deposits (Holocene)
- Qhl: Natural Levee Deposits (Holocene)

**Figure 5.7-2**  
**Geology Within Project Area**

Source: Jacobs 2019a

The majority of the project site is underlain by Holocene age (less than 11,000 years old) basin deposits (Qhb) (**Figure 5.7-2**). The basin deposits are generally described as dark-colored clay with very fine silty clay, rich in organic material, and deposited beyond the levees and flood plains. Based on borings conducted at the project site as part of geotechnical investigations in 2018 and 2019, the site is underlain predominately by alluvium interbedded with layers of medium stiff to hard clay, silty clay, clayey silt, sandy silt, and medium dense to very dense sand. The sand layers across the site appear to be discontinuous and variable in thickness ranging up to approximately 7.5 feet (Earthview Science 2018). There are no unique geologic features on or adjacent to the project site. The topography of the project site and the surrounding area is relatively flat (**Figure 5.7-2**).

### **Groundwater**

Based on the depth of historically high groundwater map prepared by the California Geological Survey for the Milpitas Quadrangle (CGS 2001), the depth of historically groundwater levels in the site vicinity is between the depths of 5 to 10 feet below the existing ground surface. Fluctuations in the level of the groundwater may occur due to variations in rainfall, underground drainage patterns, and other factors not evident at the time measurements were made. According to recent pore-pressure dissipation tests conducted at the project site, groundwater was encountered between depths of 5.5 to 9 feet below grade (Earthview Science 2018; Cornerstone 2019).

### **Seismicity and Seismic Hazards**

The significant earthquakes that occur in the Bay Area are generally associated with crustal movement along well-defined active fault zones of the San Andreas Fault system, which regionally trend in a northwesterly direction (**Figure 5.7-3**). Three of the major earthquake faults (the San Andreas Fault, the Hayward Fault, and the Calaveras Fault) that comprise the San Andreas Fault system extend through the Bay Area (CGS 2015). The Laurelwood Data Center site is not located within a currently designated Alquist-Priolo Earthquake Fault Zone (known formerly as a Special Studies Zone). No known surface expression of active faults is believed to cross the site (Earthview Science 2018; Cornerstone 2019). **Figure 5.7-3** identifies the regional earthquake faults in the project vicinity. The two faults closest to the site are the Silver Creek and San Jose Faults, which respectively are 2.7 and 1.9 miles distant. Both of these faults have not been active since early Quaternary time, more than 700,000 years ago. The closest historically active faults are the Hayward and San Andreas Faults, which are 6.2 and 10.5 miles, respectively, from the site. However, structural design of facilities in California are required to incorporate design features to ensure public safety if a seismic event generates sufficient ground motion to impact the structural integrity of the facility in accordance with California Building Code (CBC 2016). The geotechnical investigation utilized a design-level Peak Ground Acceleration (PGA) of 0.50g for analysis.

Loose unsaturated sandy soils can settle during strong seismic shaking. However, the soils encountered below the design groundwater level at the site are predominantly stiff to very stiff clays. Therefore the potential for significant differential seismic settlement affecting the proposed project is low (Cornerstone 2019).





## Soils

**Figure 5.7-4** depicts the surficial soil units at and near the project site. The soil at the site is classified as Urban Land by the U.S. Department of Agriculture (NRCS 2019). At the site this Urban Land is approximately 2.5 feet of undocumented fill consisting of hard fat clay with gravel (Jacobs 2019a). The near-surface material across the project site has been observed to be highly expansive (Earthview Science 2018; Cornerstone 2019). Expansive soil can undergo volume changes with changes in moisture content. Specifically, when wetted during the rainy season expansive soil tends to swell, and when dried during the summer months the material shrinks. However, expansive soil can be mitigated through removal or mixing with non-expansive soil.

Preliminary soil corrosion testing was performed on near-surface soil samples from the site. The soil was deemed to be severely corrosive for buried metallic structures, such as metal pipes. However, analytical results for corrosion potential for buried concrete does not suggest the need for using corrosion resistant concrete in building foundations or other buried concrete structures (Cornerstone 2019).

Demolition of the underground utilities would provide an opportunity to replace surface, and near-surface, soils with higher quality engineered fill as necessary.

## Liquefaction

During strong ground shaking, loose, saturated, cohesionless soils can experience a temporary loss of shear strength and act as a fluid. This phenomenon is known as liquefaction. Liquefaction depends on the depth to water, grain size distribution, relative soil density, degree of saturation, and intensity and duration of the earthquake (Youd et al. 2001). The potential hazard associated with liquefaction is seismically induced settlement.

The project site is within a State- and County-designated Liquefaction Hazard Zone (Cornerstone, 2019). To evaluate the potential impact from liquefaction, the geotechnical investigation determined that several layers could potentially experience liquefaction triggering settlements on the order of 1.33 inches. This was based on a design groundwater depth of 5 feet below grade (Cornerstone 2019). Observed groundwater depths at the site range from 6.5 to 13 feet below grade, and depth to groundwater inferred from CPT borings ranges from 5.7 to 8.8 feet below grade (Cornerstone 2019).

## Lateral Spreading

Lateral spreading typically occurs as a form of horizontal displacement of relatively flat-lying alluvial material toward an open or "free" face such as an open body of water, channel, or excavation. In soils, this movement is generally due to failure along a weak plane and may often be associated with liquefaction. As cracks develop within the weakened material, blocks of soil displace laterally towards the open face. Cracking and lateral movement may gradually propagate away from the face as blocks continue to break free. Generally, failure in this mode is analytically unpredictable because it is difficult to evaluate where the first tension crack will occur.

The San Tomas Aquino Creek is located approximately 400 to 450 feet west of the site. The preliminary geotechnical investigation determined that there is potential for lateral spreading to affect the proposed data building in the northern part of the site (Cornerstone 2019). Proposed structures would be designed and constructed to account for this in accordance with the California Building Code (CBC 2016).



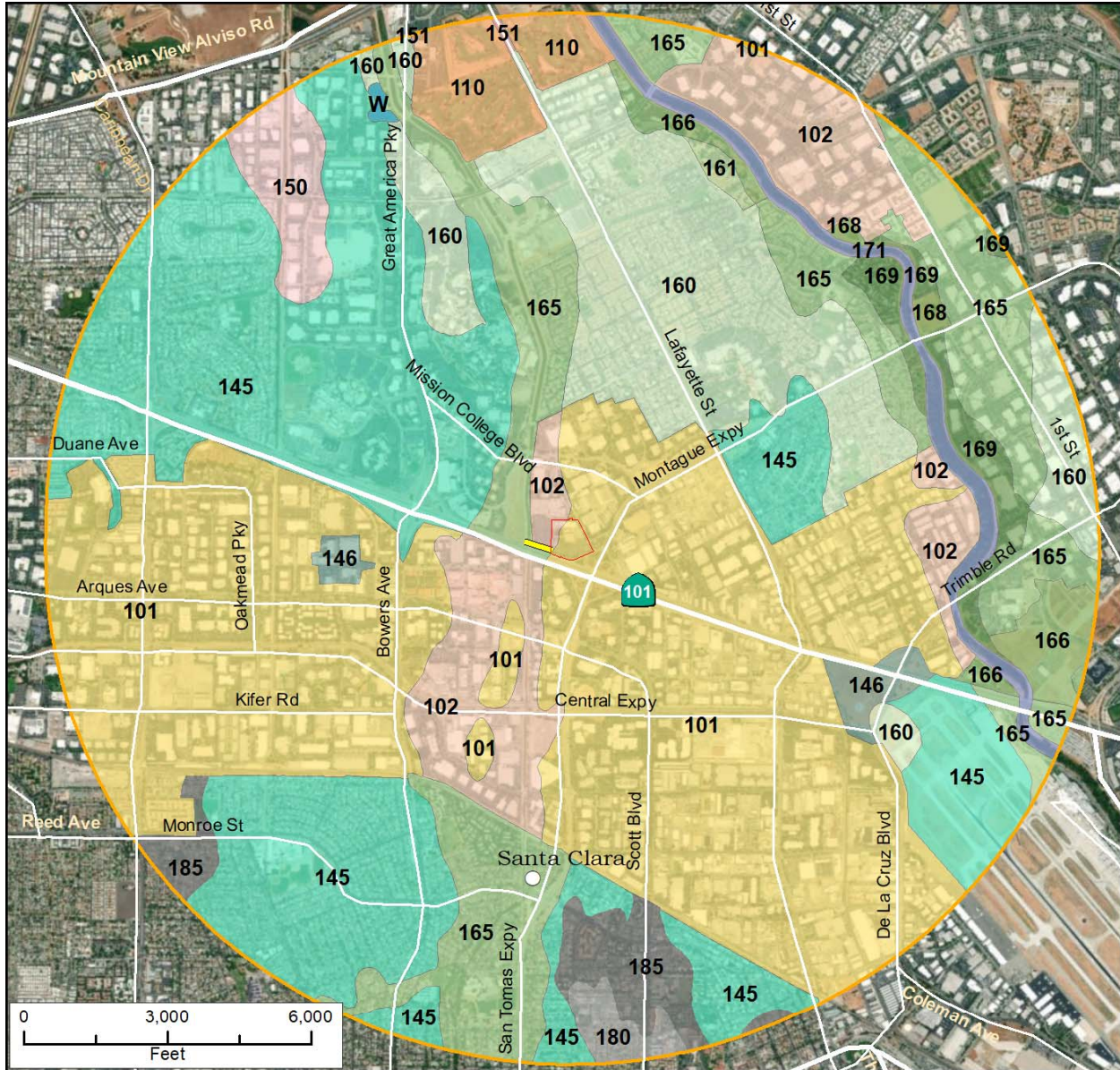

**Figure 5.7-4**

**Soil Types within Project Area**

- 101: Urban land, 0 to 2 percent slopes, basins
- 102: Urban land, 0 to 2 percent slopes, alluvial fans
- 110: Xerorthents, trash substratum, 0 to 2 percent slopes
- 145: Urbanland-Hangerone complex, 0 to 2 percent slopes, drained
- 146: Hangerone clay loam, drained, 0 to 2 percent slopes
- 150: Urbanland-Embarcadero complex, 0 to 2 percent slopes, drained
- 151: Embarcadero silty clay loam, drained, 0 to 2 percent slopes
- 160: Urbanland-Clear Lake complex, 0 to 2 percent slopes
- 161: Clear Lake silty clay, 0 to 2 percent slopes, drained
- 165: Urbanland-Campbell complex, 0 to 2 percent slopes, protected
- 166: Campbell silt loam, 0 to 2 percent slopes, protected
- 168: Elder fine sandy loam, protected, 0 to 2 percent slopes
- 169: Urbanland-Elder complex, 0 to 2 percent slopes, protected
- 171: Elder fine sandy loam, 0 to 2 percent slopes, rarely flooded
- 180: Urbanland-Newpark complex, 0 to 2 percent slopes
- 185: Urban Land - Bayshore complex, 0 to 2 percent slopes, drained
- W: Water
- Project Boundary
- Electrical Supply Line
- 2 Miles Radius

Sources: U.S.Department of Agricultural  
SSURGO, 2018 ESRI, Jacobs 2019a

## Regulatory Background

The project would be required to obtain building permits that would be issued by the City of Santa Clara. The issuance of the building permits and oversight provided by the City of Santa Clara would ensure that the project complies with the applicable building codes.

### *Federal*

There are no federal regulations related to geology and soils and paleontological resources that apply to this project.

### *State*

**State Paleontological Laws, Ordinances, Regulations, and Standards.** The California Environmental Quality Act (CEQA) encourages the protection of all aspects of the environment by requiring state and local agencies to prepare multidisciplinary analyses of the environmental impacts of a project and to make decisions based on the findings of those analyses. CEQA includes, in its definition of historical resources, any object or site that “has yielded, or may be likely to yield, information important in prehistory” (Cal. Code Regs., tit. 14, § 15064.5(a)(3)(D)), which is typically interpreted by professional scientists as including fossil materials and other paleontological resources. More specifically, destruction of a “unique paleontological resource or site or unique geologic feature” may be a significant impact under CEQA (CEQA Guidelines Appendix G.VII.(f)).

### *Local*

**Local Paleontological Regulations.** Staff reviewed the City of Santa Clara (Santa Clara 2010) for provisions relevant to paleontological resources. Section 5.6.3 of the general plan identifies protection of paleontological resources as a goal of the city and policies 5.6.3-P1 through P6 outline how the protection of paleontological resources would be achieved.

- 5.6.3-G1 Protection and preservation of cultural resources, as well as archaeological and paleontological sites.
- 5.6.3-G2 Appropriate mitigation in the event that human remains, archaeological resources or paleontological resources are discovered during construction activities.
- 5.6.3-P1 Require that new development avoid or reduce potential impacts to archaeological, paleontological and cultural resources.
- 5.6.3-P2 Encourage salvage and preservation of scientifically valuable paleontological or archaeological materials.
- 5.6.3-P3 Consult with California Native American tribes prior to considering amendments to the City’s General Plan.
- 5.6.3-P4 Require that a qualified paleontologist/archaeologist monitor all grading and/or excavation if there is a potential to affect archeological or paleontological resources, including sites within 500 feet of natural water courses and in the Old Quad neighborhood.
- 5.6.3-P5 In the event that archaeological/paleontological resources are discovered, require that work be suspended until the significance of the find and recommended actions are determined by a qualified archaeologist/paleontologist.



- 5.6.3-P6 In the event that human remains are discovered, work with the appropriate Native American representative and follow the procedures set forth in State law.

## 5.7.2 Environmental Impacts and Mitigation Measures

**Applicant Proposed Measures.** The applicant proposes to implement the following project design measures (termed, Applicant Proposed Measures or APMs, in this analysis) as part of the project to avoid or reduce potential impacts to paleontological resources (Jacobs 2019a, Section 2.5.4, page 2-23). Also, **APM PD-1** includes the preparation of a Worker Environmental Awareness Training program (program) to instruct construction workers of the obligation to protect and preserve valuable resources, including paleontological resources. See **Section 4.0, Project Description, Table 4-5** for the full text of **APM PD-1**.

**APM PALEO-1:** The Applicant will secure the services of a qualified professional paleontologist, as defined by the Society of Vertebrate Paleontology, to be on-call prior to the commencement of construction. The paleontologist will be experienced in teaching non-specialists to recognize fossil materials and who to notify in the event of encountering a suspected fossil. If suspected fossils are encountered during construction, the construction workers will halt construction within 50 feet of any potential fossil find and notify the paleontologist, who will evaluate its significance.

**APM PALEO-2:** If a fossil is encountered and determined to be significant and avoidance is not feasible, the paleontologist will develop and implement an excavation and salvage plan in accordance with Society of Vertebrate Paleontology standards. Construction work in the immediate area shall be halted or diverted to allow recovery of fossil remains in a timely manner. Fossil remains collected will be cleaned, repaired, sorted, and cataloged, along with copies of all pertinent field notes, photos, and maps.

**APM PALEO-3:** The paleontologist will prepare a paleontological resource monitoring report that outlines the results of the monitoring program and any encountered fossils. The report may be submitted to the Chief Building Official (CBO) for review and approval. The report and any fossil remains collected will be submitted to a scientific institution with paleontological collections.

- a. ***Would the project directly or indirectly cause potential substantial adverse effects, including the risk of loss, injury, or death involving:***
  - i. ***Rupture of a known earthquake fault, as delineated on the most recent Alquist-Priolo Earthquake Fault Zoning Map issued by the State Geologist for the area or based on other substantial evidence of a known fault? Refer to Division of Mines and Geology Special Publication 42.***

### Demolition/Construction

NO IMPACT. The probability that demolition followed by construction of the proposed project would have an impact on the risk of loss, injury, or death involving rupture of an earthquake fault during construction is remote. The project site is located within the seismically active San Francisco Bay region, and the nearest historically active fault, the Hayward Fault, is approximately 6.2 miles from the project site (**Figure 5.7-3**). The project site, however, is not within a state of California Earthquake Fault Zone or within the trace of any known active fault. Several potentially active faults have been mapped outside of the general project area, the closest being the San Jose fault, which is mapped approximately 1.9 miles southwest of the proposed project (**Figure 5.7-3**). The zone of damage is limited to a relatively narrow area along either side of the fault. Therefore, no impacts related to fault rupture would occur at the proposed project site.

## Operation and Maintenance

NO IMPACT. The probability that operation or maintenance of the proposed project would have an impact on the risk of loss, injury, or death involving rupture of an earthquake fault during construction is remote. There are no mapped Alquist-Priolo Special Studies Zones for active faults crossing the project site (**Figure 5.7-3**). Several potentially active faults have been mapped outside of the general project area, the closest being the San Jose and Silver Creek Faults, which are mapped approximately 1.9 and 1.4 miles from the proposed project, respectively (**Figure 5.7-3**). As described above, the zone of damage is limited to a relatively narrow area along either side of the fault. Therefore, no impacts related to fault rupture would occur.

**Proposed Mitigation Measures:** None.

### *ii. Strong seismic ground shaking?*

## Demolition/Construction

LESS THAN SIGNIFICANT IMPACT. The design of the project, including the building foundations, would assess potential impacts of strong seismic ground shaking. Seismic hazards would be minimized by conformance to the seismic design criteria of the 2016 California Building Code. Furthermore, a project-specific geotechnical engineering report would be provided to the City Building Official for review and approval prior to issuance of a building permit. With implementation of seismic design guidelines per the California Building Code (CBC 2016), as well as the anticipated project-specific recommendations in the final geotechnical engineering report, the project would not expose people or property, directly or indirectly, to significant impacts associated with geologic or seismic ground shaking.

## Operation and Maintenance

LESS THAN SIGNIFICANT IMPACT. During operation and maintenance of the proposed project, the project facility would be subject to strong seismic ground shaking. However, with implementation of seismic design guidelines per the California Building Code (CBC 2016), as well as the anticipated project-specific recommendations in the final geotechnical engineering report, the project would not expose people or property, directly or indirectly, to significant impacts associated with geologic or seismic ground shaking. Therefore, risks to people or structures from strong seismic ground-shaking would continue to be less than significant.

**Proposed Mitigation Measures:** None.

### *iii. Seismic-related ground failure, including liquefaction?*

## Construction

LESS THAN SIGNIFICANT IMPACT. The site is located within an earthquake-induced liquefaction hazard zone, and there is potential for soil layers at the site to liquefy during a seismic event. Analyses indicate that liquefaction-induced settlement at the project site could be about 1.33 inches between independent foundation elements (Cornerstone 2019). Therefore, the proposed structures would be designed and constructed to account for this in accordance with the California Building Code (CBC 2016).

In addition, as discussed under question (a)(i), a project-specific design would be included within a geotechnical engineering report and provided to the City building department for review and approval prior to the issuance of a building permit. Therefore, with implementation of the seismic design guidelines for ground failure, and the recommendations in the final geotechnical engineering report, the project would not expose people or property to any significant direct or indirect impacts associated with geologic or seismic conditions onsite.

### **Operation and Maintenance**

LESS THAN SIGNIFICANT IMPACT. During operation and maintenance of the proposed project the project facility would be subject to strong seismic ground shaking. However, with implementation of seismic design guidelines per the California Building Code (CBC 2016), as well as the anticipated project-specific recommendations in the final geotechnical engineering report, the project would not expose people or property, directly or indirectly, to significant impacts associated with geologic or seismic ground shaking, including ground failure, liquefaction, or seismically induced subsidence. Therefore, risks to people or structures from strong seismic ground-shaking would continue to be less than significant.

**Proposed Mitigation Measures:** None.

#### ***iv. Landslides?***

### **Demolition/Construction**

NO IMPACT. There would be no impact from landslides. The proposed project is located on very mildly sloping terrain and is not located in any of the areas subject to landslides as identified in the City of Santa Clara General Plan (2011). Grading of the substation expansion would not create steep slopes and construction of the proposed project would not cause a landslide.

### **Operation and Maintenance**

NO IMPACT. Operation and maintenance activities would not change materially from existing activities and would not include construction or grading of new slopes. For these reasons, and because the project components are not located in areas subject to landslides as identified in the City of Santa Clara General Plan 2010-2035 (Santa Clara 2011), no impact would occur.

**Proposed Mitigation Measures:** None.

#### ***b. Would the project result in substantial soil erosion or the loss of topsoil?***

### **Demolition/Construction**

LESS THAN SIGNIFICANT IMPACT. Demolition of asphalt/foundations and underground utilities would be necessary to make way for the project. Construction activities associated with the project including excavation, trenching, and grading may temporarily increase sedimentation and erosion by exposing soils to wind and runoff until construction is complete and new vegetation is established. As discussed in **Section 5.10, Hydrology and Water Quality**, the project is subject to construction-related storm water permit requirements. Prior to ground-disturbing construction activity, the project must comply with the Construction General Permit, which includes filing a Notice of Intent with the State Water Resources Control Board, coordinating with the City, and preparing and implementing a SWPPP. The SWPPP would include best management practices for storm water quality control, including soil

stabilization practices, sediment control practices, and wind erosion control practices. When construction is complete, the project would file a Notice of Termination with the San Francisco Bay RWQCB, documenting that all elements to the SWPPP have been implemented (Jacobs 2019a).

By complying with permits obtained for construction of this project, runoff from the project site would not violate the applicable waste discharge requirements or otherwise contribute to the degradation of storm water runoff quality. Therefore, impacts related to erosion and loss of topsoil would be less than significant and no mitigation is required.

### **Operation and Maintenance**

LESS THAN SIGNIFICANT IMPACT. Surface water runoff from the facility is not expected to impact soil erosion or cause the loss of topsoil during project operation. Occasional minor surface disturbance may continue to be required during maintenance activities but such disturbance would be temporary and small (Jacobs 2019a). Continuous operation and maintenance work would not result in increased erosion or topsoil loss and therefore, no significant impact associated with erosion or loss of topsoil would occur.

**Proposed Mitigation Measures:** None.

- c. *Would the project be located on geologic units or soil that is unstable, or that would become unstable as a result of the project, and potentially result in on- or off-site landslide, lateral spreading, subsidence, liquefaction, or collapse?*

### **Demolition/Construction**

LESS THAN SIGNIFICANT IMPACT. Lateral spreading appears possible for the proposed data center building (on the northern half of the site) (Jacobs 2019a). This potential impact would be reduced by the construction of a shear key of improved soil between the building and creek channel to the west, for instance. A project-specific geotechnical engineering investigation would be conducted prior to final design, which would incorporate project design features needed to address potential lateral spreading. Both the final geotechnical engineering report and final project design documents would be provided to the City's building official for review and approval prior to issuance of a building permit (Jacobs 2019a). With implementation of design guidelines per the California Building Code (CBC 2016) as well as the anticipated project-specific design recommendations in the final geotechnical engineering report, the project would not expose people or property, directly or indirectly, to unstable geologic or soil units.

### **Operation and Maintenance**

LESS THAN SIGNIFICANT IMPACT. Operation and maintenance activities would not change materially the surface runoff or geotechnical characteristics of the material beneath the project facilities. Thus, operation and maintenance activities would not introduce new soil stability hazards. Occasional minor surface disturbance may continue to be required during maintenance activities but such disturbance would be temporary and small. The project would not expose people or property, directly or indirectly, to unstable geologic or soil units.

**Proposed Mitigation Measures:** None.

- d. ***Would the project be located on expansive soil, as defined in Section 1803.5.3 of the California Building Code (2010), creating substantial direct or indirect risks to life or property?***

#### **Demolition/Construction**

LESS THAN SIGNIFICANT IMPACT. As discussed above in section 5.7.1 **Setting**, expansive soil behavior is a condition where clay soils react to changes in moisture content by expanding or contracting. Poorly-drained soils have greater shrink-swell potential. Highly to very highly expansive soils are present across the site (Jacobs 2019a). This condition can be eliminated by ensuring slabs-on-grade have sufficient reinforcement and be supported on a layer of non-expansive soil, along with limiting moisture changes in the near-surface soils, among other design criteria. The project specific final geotechnical engineering report along with the final project design would address, as needed, any potential issues arising from highly and very highly expansive soils. Both the geotechnical engineering report and final project design documents would be provided to the City's building official for review and approval prior to issuance of a building permit (Jacobs 2019a). With implementation of design guidelines per the California Building Code (CBC 2016) as well as the anticipated project-specific mitigation recommendations in the final geotechnical engineering report, the project would not create substantial direct or indirect risks to life or property.

#### **Operation and Maintenance**

NO IMPACT. Operation and maintenance activities would not change materially the surface runoff or geotechnical characteristics of the material beneath the project facilities. Thus, operation and maintenance activities would not introduce new soil stability hazards. Occasional minor surface disturbance may continue to be required during maintenance activities, but such disturbance would be temporary and small. The project would not expose people or property, directly or indirectly, to unstable geologic or soil units.

**Proposed Mitigation Measures:** None.

- e. ***Would the project have soils incapable of adequately supporting the use of septic tanks or alternative wastewater disposal systems where sewers are not available for the disposal of wastewater?***

#### **Demolition/Construction**

NO IMPACT. The project would connect to an existing city-provided sanitary sewer connection and would not require septic tanks or an alternative wastewater disposal system (Jacobs 2019a). Therefore, there would be no impact to soils as a result of sanitary waste disposal from the project during construction.

#### **Operation and Maintenance**

NO IMPACT. The project would connect to an existing City-provided sanitary sewer connection and would not require septic tanks or an alternative wastewater disposal system (Jacobs 2019a). Therefore, there would be no impact to soils as a result of sanitary waste disposal from the project during operation and maintenance.

**Proposed Mitigation Measures:** None.

**f. Would the project directly or indirectly destroy a unique paleontological resource or site or unique geologic feature?**

**Demolition/Construction**

LESS THAN SIGNIFICANT IMPACT. The level of paleontological sensitivity at the project site is considered to be moderate (Earthview Science 2019) (see Appendix 3.7-A). The project site is located in the Santa Clara Valley, an area known to have scientifically significant but widespread or intermittent fossil discoveries. Surficial sediment has been mapped as Holocene (11,700 years before present) and paleontological evidence indicates that Pleistocene (2.6 million to 11,700 years before present) sediment may also be present at or near the surface. Five fossil sites have been found at or near the ground surface within 1.5 miles of the project site, especially along stream beds. However, the general area has been extensively developed over the last 50 years as part of the technology research and development area known as Silicon Valley. The project site itself has been developed since the 1960s. The potential to disturb paleontological resources would occur during the demolition/construction activities requiring earth moving, such as grading, trenching for utilities, excavation for foundations, and installation of support structures where native soil would be disturbed.

Based on the ground disturbance necessary to complete the project components, there is a limited potential for adverse impacts to scientifically significant paleontological resources from moderate sensitivity (PFYC 3). The exact depth where native soil of moderate paleontological sensitivity would be encountered within the project area is uncertain. The first 2.5 feet below ground surface is considered to have no paleontological sensitivity because it consists of fill (Cornerstone 2019). However, pre-construction demolition of underground utilities would likely disturb this fill. Proposed grading plans suggest that as excavations may reach 8 feet below existing grade and below the building slab-on-grade foundations, ground improvement columns would be installed using vibratory techniques to depths reaching 25 feet below existing grade (Jacobs 2019c). While it is not possible to identify paleontological resources while installing ground improvement columns in this fashion, it is possible that paleontological resources could be identified in native soils, should they be exposed during grading of the site.

If a paleontological resource is uncovered during excavation of the site the design measures listed above (**APM PALEO-1, 2, and 3**) would ensure that the staff working at the site would contact the appropriate technical expert, who would then be able to determine the significance of the paleontological resource, and properly salvage that resource. Therefore, the project's impact would be less than significant.

**Operation and Maintenance**

NO IMPACT. There is no potential to disturb paleontological resources during operations because there would be no earth-moving activities required for operations. Occasional minor surface disturbance may continue to be required during maintenance activities, but such disturbance would be temporary, small and most likely limited to disturbance of fill. There would be no impact to paleontological resources.

**Proposed Mitigation Measures:** None.



### 5.7.3 References

- BLM 2016** – Bureau of Land Management (BLM). Potential Fossil Yield Classification System: BLM Instruction Memorandum No. 2016-124. July 8, 2016. Available online at: <https://edit.blm.gov/policy/im-2016-124>. Accessed on: 13 May 2019.
- CBC 2016** - California Building Code (CBC). California Building Standard Commission. Accessed February 4, 2019. Available online at: <http://www.bsc.ca.gov/Codes.aspx>.
- CGS 2001** – California Geological Survey (CGS), California Department of Conservation. Seismic Hazard Zone Report for the Milpitas 7.5-Minute Quadrangle, Alameda and Santa Clara Counties, California. Seismic Hazard Zones Report 051. California Geological Survey.
- CGS 2015** – California Geological Survey (CGS), California Department of Conservation. Fault Activity Map of California. Available online at: <http://maps.conservation.ca.gov/cgs/fam/>. Accessed on: February 4, 2019.
- CGS 2018** – California Geological Survey (CGS), California Department of Conservation. . Unified Hazard Tool. Interactive ground motion map showing peak ground accelerations – 2% probability of being exceeded in 50 years. Available online at: <https://earthquake.usgs.gov/hazards/interactive/>. Accessed on: January 23, 2018.
- Cornerstone 2019** – Cornerstone Earth Group, Draft Geotechnical Investigation, 2201 Laurelwood Road, Santa Clara, California. Project 1075-1-2. February 21.
- Earthview Science 2018**–Earthview Science. Laurelwood Data Center Small Power Plant Exemption Project – Paleontological Resources Assessment. TRC Companies, Inc. (TRC). 2018. Preliminary Geotechnical Investigation Santa Clara 2201 Laurelwood Road. Report No. 302733. Prepared for Edgecore. Santa Clara, California. June.
- Helley and Wealing 1989** – E.J. Helley and J.R. Wealing, 1989, Quaternary Geologic Map of the Milpitas Quadrangle, Alameda and Santa Clara Counties, California, U.S. Geological Survey Open-File Report 89-671, 1989. Available online at: <https://pubs.usgs.gov/of/1989/0671/report.pdf>. Accessed on: May 13, 2019.
- Helley et al. 1994** – E. J. Helley, R.W. Graymer, G.A. Phelps, P.K. Showalter, and C.M. Wentworth. Preliminary Quaternary geologic maps of Santa Clara Valley, Santa Clara, Alameda, and San Mateo Counties, California: A Digital Database, USGS Open-File Report 94.231, 1994. Available online at: <https://pubs.usgs.gov/of/1994/0231/report.pdf>. Accessed on: 13 May 2019.
- Jacobs 2019a** – Jacobs (Jacobs). (TN 227273-1). Application for Small Power Plant Exemption: Laurelwood Data Center, dated March 5, 2019. Available online at: <https://efiling.energy.ca.gov/Lists/DocketLog.aspx?docketnumber=19-SPPE-01>.
- Jacobs 2019c** – Jacobs (Jacobs). (TN 227626). LDC Responses to Formal and Informal Data Requests. Data Response Set 1A, dated April 11, 2019. Available online at: <https://efiling.energy.ca.gov/Lists/DocketLog.aspx?docketnumber=19-SPPE-01>.
- Norris and Webb 1990** – Robert M. Norris and Robert W. Webb, 1990, Geology of California, Second Edition, John Wiley and Sons.
- NRCS 2019** – Natural Resources Conservation Service (NRCS), U.S. Department of Agriculture, 2019, Interactive Soil Map. Available online at: <https://websoilsurvey.sc.egov.usda.gov/App/WebSoilSurvey.aspx>. Accessed on: June 10, 2019.

- Santa Clara 2010** – City of Santa Clara (Santa Clara). 2010-2035 General Plan. Approved November 16, 2010. Available online at: <http://santaclaraca.gov/government/departments/community-development/planning-division/general-plan>.
- Santa Clara 2011** – City of Santa Clara (Santa Clara). Integrated Final Environmental Impact Report, City of Santa Clara Draft 2010-2035 General Plan – Volume I EIR Text. January 2011. Available online at: <http://santaclaraca.gov/home/showdocument?id=12900>.
- Santa Clara County 2018** – Santa Clara County General Plan 1995-2010, Geologic Hazard Maps and Data, 27 February 2018. Available online at: <https://www.sccgov.org/sites/dpd/PlansOrdinances/GeoHazards/Pages/Geology.aspx>. Accessed on: May 13, 2019.
- UCMP 2019** – University of California Museum of Paleontology (UCMP) 2019. *UCMP database*. Available online at: <http://ucmpdb.berkeley.edu/>. Accessed on: May 13, 2019.
- Wesling and Helley 1989** – J.R. Wesling and E.J. Helley, Quaternary Geologic Map of the San Jose West Quadrangle, Santa Clara County, California, U.S. Geological Survey Open-File Report 89-672, 1989. Available online at: <https://pubs.usgs.gov/of/1989/0672/report.pdf>. Accessed on: May 13, 2019.
- Youd et al. 2001** – T. L. Youd, I. M. Idriss, Ronald D. Andrus, Ignacio Arango, Gonzalo Castro, John T. Christian, Richardo Dobry, W. D. Liam Finn, Leslie F. Harder, Mary Ellen Hynes, Kenji Ishihara, Joseph P. Koester, Sam S.C. Liao, William F. Marcuson, Geoffrey R. Martin, James K. Mitchell, Yoshiharu Moriwaki, Maurice S. Power, Peter K. Robertson, Raymond B. Seed, and Kenneth H Stokoe "Liquefaction Resistance of Soils: Summary Report from the 1996 NCEER and 1998 NCEER/NSF Workshops on Evaluation of Liquefaction Resistance of Soils." *ASCE Journal of Geotechnical and Geoenvironmental Engineering*, Vol 127, No. 10. October.

## 5.8 Greenhouse Gas Emissions

This section describes the environmental and regulatory setting and discusses impacts associated with the demolition/construction and operation of the Laurelwood Data Center (LDC or project) with respect to greenhouse gas (GHG) emissions.

GREENHOUSE GAS EMISSIONS				
Would the project:	Potentially Significant Impact	Less than Significant With Mitigation Incorporated	Less than Significant Impact	No Impact
a. Generate greenhouse gas emissions, either directly or indirectly, that may have a significant impact on the environment?	<input type="checkbox"/>	<input type="checkbox"/>	<input checked="" type="checkbox"/>	<input type="checkbox"/>
b. Conflict with an applicable plan, policy or regulation adopted for the purpose of reducing the emissions of greenhouse gases?	<input type="checkbox"/>	<input type="checkbox"/>	<input checked="" type="checkbox"/>	<input type="checkbox"/>

Environmental checklist established CEQA Guidelines, Appendix G.

### 5.8.1 Setting

Unlike emissions of criteria and toxic air pollutants, which have local or regional impacts, emissions of GHGs have a much broader, global impact. Global warming associated with the "greenhouse effect" is a process whereby GHGs accumulating in the atmosphere contribute to an increase in the temperature of the earth's atmosphere. The principal GHGs that contribute to global warming and climate change include carbon dioxide (CO<sub>2</sub>), methane (CH<sub>4</sub>), nitrous oxide (N<sub>2</sub>O), black carbon, and fluorinated gases (F-gases): hydrofluorocarbons (HFCs), perfluorocarbons (PFCs), and sulfur hexafluoride (SF<sub>6</sub>). Emissions of GHGs contributing to global climate change are attributable in large part to human activities associated with the transportation, industrial/manufacturing, utility, residential, commercial, and agricultural sectors.

Each GHG has its own potency and effect upon the earth's energy balance, expressed in terms of a global warming potential (GWP), with CO<sub>2</sub> being assigned a value of 1. Specifically, the GWP is a measure of how much energy the emissions of 1 ton of a gas will absorb over a given period of time, relative to the emissions of 1 ton of CO<sub>2</sub>. The larger the GWP, the more that a given gas warms the earth compared to CO<sub>2</sub> over that time period. The time period usually used for GWPs is 100 years.

For example, CH<sub>4</sub> has a GWP of 28 over 100 years from the Fifth Assessment Report (AR5) of the Intergovernmental Panel on Climate Change (IPCC 2013), which means that it has a global warming effect 28 times greater than CO<sub>2</sub> on an equal-mass basis. The F-gases are sometimes called high-GWP gases because, for a given amount of mass, they trap substantially more heat than CO<sub>2</sub>. The GWPs for these gases can be in the thousands or tens of thousands. The carbon dioxide equivalent (CO<sub>2</sub>e) for a source is obtained by multiplying each quantity of GHG by its GWP and then adding the results together to obtain a single, combined emission rate representing all GHGs in terms of CO<sub>2</sub>e.

### Regulatory Background

#### *Federal*

**Endangerment Finding and Cause or Contribute Finding.** In April 2007, the US Supreme Court held that GHG emissions are pollutants within the meaning of the Clean Air Act (CAA). In reaching its decision, the Court also acknowledged that climate change results, in part, from anthropogenic causes (*Massachusetts et al. v. Environmental Protection Agency*, 549 U.S. 497 [2007]). The Supreme Court's ruling paved the way for the regulation of GHG emissions by the US EPA under the CAA.

In response to this Supreme Court decision, on December 7, 2009, the US EPA Administrator signed two distinct findings regarding GHGs under the CAA, section 202(a):

- Endangerment Finding: That the current and projected concentrations of the GHGs in the atmosphere threaten the public health and welfare of current and future generations; and
- Cause or Contribute Finding: That the combined emissions of GHGs from new motor vehicles and new motor vehicle engines contribute to the GHG pollution, which threatens public health and welfare.

US EPA has also enacted regulations for GHG reporting, the phase-out and banning of high global warming potential chemicals, and stationary GHG emissions source permitting. However, the project, as it is currently proposed, would not be subject to any of these federal regulations.

### **State**

**Global Warming Solutions Act of 2006.** In 2006, the California State Legislature signed the Global Warming Solutions Act of 2006, or Assembly Bill (AB) 32, which provides the framework for regulating GHG emissions in California. This law requires the ARB to design and implement emission limits, regulations, and other measures such that statewide GHG emissions are reduced in a technologically feasible and cost-effective manner to 1990 levels by 2020. The statewide 2020 emissions limit is shown under **AB 32 Scoping Plan**.

**AB 32 Scoping Plan.** Part of ARB's direction under AB 32 was to develop a Scoping Plan that contains the main strategies California will use to reduce GHG emissions that cause climate change. ARB first approved the AB 32 Scoping Plan in 2008 and released its first update in 2014. The Scoping Plan includes a range of GHG reduction actions, which include direct regulations, alternative compliance mechanisms, monetary and non-monetary incentives, voluntary actions, market-based mechanisms such as a cap-and-trade system, and an AB 32 cost of implementation fee regulation to fund the program. In December 2007, ARB set the statewide 2020 emissions limit, defined as reducing emissions to 1990 levels, at 427 million metric tons of CO<sub>2</sub>e (MMTCO<sub>2</sub>e). The May 2014 First Update to the Climate Change Scoping Plan adjusted the 1990 emissions estimate and the statewide 2020 emissions limit goal to 431 MMTCO<sub>2</sub>e (ARB 2014).

**Regulation for the Mandatory Reporting of Greenhouse Gas Emissions.** One key regulation resulting from AB 32 was ARB's Regulation for the Mandatory Reporting of Greenhouse Gas Emissions, which came into effect in January 2009. It requires annual GHG emissions reporting from electric power entities, fuel suppliers, CO<sub>2</sub> suppliers, operators of petroleum and natural gas systems, and industrial facilities that emit 10,000 MTCO<sub>2</sub>e/yr from stationary combustion and/or process sources. The project would not be impacted by this regulation because its stationary combustion GHG emissions are expected to be below the reporting threshold of 10,000 MTCO<sub>2</sub>e/yr.

**Executive Order B-30-15.** On April 29, 2015, Governor Brown issued Executive Order B-30-15, directing state agencies to implement measures to reduce GHG emissions 40 percent below their 1990 levels by 2030 and to achieve the previously-stated goal of an 80 percent GHG reduction by 2050.

**Renewable Energy Programs.** In 2002, California initially established its Renewables Portfolio Standard, with the goal of increasing the percentage of renewable energy in the state's electricity mix to 20 percent by 2017. State energy agencies recommended accelerating that goal, and California Executive Order S-14-08 (November 2008) required California utilities to reach the 33 percent renewable electricity goal by 2020, consistent with the AB 32 Scoping Plan. In April 2011, Senate Bill 2 of the First Extraordinary Session (SB X1-2) was signed into law. SB X1-2 expressly applies the new 33 percent Renewables Portfolio

Standard by December 31, 2020, to all retail sellers of electricity and establishes renewable energy standards for interim years prior to 2020. On October 7, 2015, SB 350 was signed into law, establishing new clean energy, clean air and greenhouse gas reduction goals for 2030 and beyond. SB 350 increases California's renewable electricity procurement goal from 33 percent by 2020 to 50 percent by 2030. SB 100, signed into law on September 10, 2018, advances the RPS deadlines to 50 percent renewable resources by December 31, 2026, and 60 percent by December 31, 2030. In addition, SB 100 establishes policy that renewable energy resources and zero-carbon resources supply 100 percent of all retail sales of electricity by December 31, 2045.

**Mobile Source Strategy.** In May 2016, ARB prepared the Mobile Source Strategy, which addresses the current and proposed programs for reducing all mobile source emissions including GHG emissions. The Mobile Source Strategy identifies programs that the state and federal government have or will adopt, which further the goals of the Scoping Plan. Some programs provide incentives to facilitate increased purchase of new, lower emission light-, medium-, and heavy-duty vehicles to aid the state in achieving emission reduction goals. Other programs such as the On-Road, Low-NOx and Zero-Emission Technology Program require vehicle manufacturers to offer engines that reduce NOx emissions 90 percent from current levels. This will have a co-benefit for reducing GHG emissions depending on how this goal is met (ARB 2016). These programs calling for more stringent emissions limits are required by state and federal law and monitored by ARB or US EPA.

**Senate Bill 32 and Assembly Bill 197.** On September 8, 2016, SB 32, codified as Section 38566 of the Health and Safety Code, was enacted. It extends California's commitment to reduce GHG emissions by requiring the state to reduce statewide GHG emissions by 40 percent below 1990 levels by 2030. A companion bill, AB 197, assures that the state's implementation of its climate change policies is transparent and equitable, with the benefits reaching disadvantaged communities. In response, ARB updated the AB 32 Scoping Plan in November 2017 to establish a path that will get California to its 2030 target (ARB 2017a).

**Short-Lived Climate Pollutant Reduction Strategy.** In an effort to best support reduction of GHG emissions consistent with AB 32, ARB released the Short-Lived Climate Pollutant (SLCP) Reduction Strategy in March 2017. This plan, required by SB-605 (the Small Business Procurement and Contract Act), establishes targets for statewide reductions in SLCP emissions of 40 percent below 2013 levels by 2030 for methane and hydrofluorocarbons and 50 percent below 2013 levels by 2030 for anthropogenic black carbon (ARB 2017b). The SLCP Reduction Strategy was integrated into the 2017 update to ARB's Scoping Plan.

### **Regional**

**2017 Bay Area Clean Air Plan.** The BAAQMD adopted the 2017 Bay Area Clean Air Plan on April 19, 2017 (BAAQMD 2017a). It provides a regional strategy to protect public health and protect the climate. To protect public health, the plan describes how the BAAQMD will continue its progress toward attaining all state and federal ambient air quality standards and eliminating health risk disparities from exposure to air pollution among Bay Area communities. To protect the climate, the plan defines a vision for transitioning the region to a post-carbon economy needed to achieve ambitious GHGs reduction targets for 2030 and 2050, and provides a regional climate protection strategy that will put the Bay Area on a pathway to achieve those GHG reduction targets.

**BAAQMD CEQA guidelines.** BAAQMD publishes CEQA guidelines to assist lead agencies in evaluating a project's impacts on air quality (BAAQMD 2017b). This document describes the criteria that BAAQMD uses

when reviewing and commenting on the adequacy of environmental documents. It recommends thresholds for use in determining whether a project would have significant adverse environmental impacts, identifies methodologies for predicting project emissions and impacts, and identifies measures that can be used to avoid or reduce air quality impacts. The BAAQMD CEQA Guidelines also outline a methodology for estimating GHG emissions.

**Plan Bay Area 2040.** Under the requirements of SB 375, all metropolitan regions in California must complete a Sustainable Communities Strategy (SCS) as part of a Regional Transportation Plan. In the Bay Area, the Metropolitan Transportation Commission (MTC) and Association of Bay Area Governments (ABAG) are jointly responsible for developing and adopting an SCS that integrates transportation, land use, and housing to meet GHG reduction targets set by ARB. In July 2017, the MTC and ABAG approved Plan Bay Area 2040, which is a strategic update to the previous plan approved in July 2013. The Bay Area GHG reduction targets established by ARB in September 2010 include a seven percent reduction in GHG emissions per capita from passenger vehicles by 2020 compared to 2005 emissions. Similarly, Plan Bay Area 2040 includes a target to reduce GHG emissions per capita from passenger vehicles 15 percent by 2035 compared to 2005 emissions (MTC & ABAG 2017).

### ***Local***

**City of Santa Clara General Plan.** The City of Santa Clara (City) General Plan includes policies that address the reduction of GHG emissions during the planning horizon of the General Plan. Goals and policies that address sustainability (see Appendix 8.13: Sustainability Goals and Policies Matrix in the Santa Clara General Plan) are aimed at reducing the city's contribution to GHG emissions. As described below, the development of a comprehensive GHG emissions reduction strategy for the city is also included in the Santa Clara General Plan.

**City of Santa Clara Climate Action Plan.** The City has a comprehensive GHG emissions reduction strategy, referred to as the City's Climate Action Plan (CAP), to achieve its share of statewide emissions reductions for the 2020 timeframe established by AB 32. The City's CAP was adopted on December 3, 2013, and specifies the strategies and measures to be taken for a number of focus areas (for example, coal-free and large renewables, energy efficiency, water conservation, transportation and land use, waste reduction) city-wide to achieve the overall emission reduction target. The City's CAP also includes an adaptive management process that can incorporate new technology and respond when goals are not being met.

A key reduction measure that is being undertaken by the City under the CAP is in the Coal-Free and Large Renewables focus area. The City operates Silicon Valley Power (SVP), a publicly owned utility that provides electricity for the community of Santa Clara, including the project site. Since nearly half (48 percent) of Santa Clara's GHG emissions result from electricity use, removing GHG-intensive sources of electricity generation (such as coal) is a major focus area in the City's CAP for achieving the City's GHG reduction goals (City of Santa Clara 2013). This measure is being undertaken by SVP.

CEQA requires lead agencies to address the consistency of individual projects requiring discretionary approvals with reduction measures in the 2013 CAP and goals and policies in the Santa Clara General Plan designed to reduce GHG emissions. Compliance with appropriate measures in the City's CAP would ensure an individual project's consistency with an adopted GHG reduction plan.



## Existing Conditions

California is a substantial contributor to global GHG emissions. The total gross California GHG emissions in 2016 were 429.4 MMTCO<sub>2</sub>e (ARB 2018). The largest source of GHG emissions in California is transportation, followed by industrial activities and electricity generation in state and out of state (ARB 2018). In 2016, total gross US greenhouse gas emissions were 6,511.3 MMTCO<sub>2</sub>e (US EPA 2018).

The City prepares an annual report to assess progress towards meeting the GHG reduction targets established in the 2013 CAP and recommend next steps to help the City meet its targets. The City tracks changes in community-wide GHG emissions since 2008, which is the City’s jurisdictional baseline year for GHG emissions inventory. The CAP 2018 Annual Report provides the City’s GHG emissions inventory in 2016, which is the most recent GHG emissions inventory for the City. **Table 5.8-1** presents the City’s 2016 GHG emissions inventory (City of Santa Clara 2018). The Commercial and Industrial sector comprised 61 percent (1,080,261MTCO<sub>2</sub>e) of total emissions in Santa Clara. Transportation and Mobile Sources comprised 29 percent (505,989 MTCO<sub>2</sub>e) of total emissions in Santa Clara. Residential sources emitted 8 percent (132,912 MTCO<sub>2</sub>e), Solid Waste emitted 1 percent (25,724 MTCO<sub>2</sub>e) and Water & Wastewater emitted 1 percent (24,292 MTCO<sub>2</sub>e) of total emissions (City of Santa Clara 2018).

Sector	Carbon dioxide emissions (MTCO <sub>2</sub> e)
Commercial Energy	1,080,261
Residential Energy	132,912
Transportation & Mobile Sources	505,989
Solid Waste	25,724
Water & Wastewater	24,292
Total Emissions	1,769,178

Source: City of Santa Clara 2018

## 5.8.2 Environmental Impacts and Mitigation Measures

### Methodology

The applicant estimated GHG emissions for both construction/demolition and operation. Demolition and construction GHG emissions from the project are a result of demolition and construction equipment and on- and offsite vehicle trips, such as material haul trucks, worker commutes, and delivery vehicles. The applicant estimated the GHG emissions using construction/demolition equipment fuel consumption from the OFFROAD2017 Web Database<sup>1</sup>, vehicle fuel economy from the EMFAC2014 Web Database<sup>2</sup>, offsite vehicle idling emission factors from EMFAC2014, and emission factors by fuel type and/or vehicle category from The Climate Registry (TCR 2018).

Operation GHG emissions from the project are a result of diesel fuel combustion from operation of the standby diesel generators, offsite vehicle trips for worker commutes and material deliveries, and facility upkeep (such as architectural coatings, consumer product use, landscaping, water use, waste generation, natural gas use for comfort heating, and electricity use). The applicant estimated the diesel stationary combustion emissions using emission factors from US EPA’s Final Mandatory Reporting of Greenhouse

<sup>1</sup> The OFFROAD2017 Web Database is available online at: <https://www.arb.ca.gov/orion/>.

<sup>2</sup> The EMFAC2014 Web Database is available online at: <http://www.arb.ca.gov/emfac/2014/>.

Gases Rule, as presented in 40 CFR 98.33. The applicant estimated vehicle emissions using vehicle fuel economy from the EMFAC2014 Web Database, vehicle idling emission factors from EMFAC2014, and emission factors by fuel type and/or vehicle category from TCR. The applicant estimated facility upkeep emissions using the California Emissions Estimator Model (CalEEMod), based on the square footage of the buildings to be constructed, paved areas, and project-specific electricity use. It should be noted that in CalEEMod, the applicant assumed the total area of the buildings to be 737,093 square feet per the original site plan (Jacobs 2019a), while the total area of the buildings would be reduced to 533,952 square feet per the revised site plan (Jacobs 2019d). Therefore, the applicant has overestimated some of the GHG emissions, as estimated by CalEEMod, for operation. Staff did not revise the inputs and rerun CalEEMod in order to recalculate this reduced GHG emissions value, making this a conservative estimate of project GHG emissions with actual emissions likely to be lower.

### **Significance Criteria**

BAAQMD has published CEQA Guidelines that include recommended thresholds for use in determining whether projects would have significant adverse environmental impacts. For commercial/industrial land use development projects, BAAQMD has adopted a numeric threshold of 1,100 MTCO<sub>2</sub>e/yr and a qualitative threshold of complying with a qualified greenhouse gas reduction strategy; and for stationary-source projects, the numeric threshold is 10,000 MTCO<sub>2</sub>e/yr. Land use development projects include residential, commercial, industrial, and public land uses and facilities, whereas stationary-source projects include land uses that would accommodate processes and equipment that emit GHG emissions and require a local air district permit to operate (BAAQMD 2017b). Given that the project would include standby diesel generators requiring BAAQMD permits to operate, the significance threshold for stationary-source projects would be applicable to the project's stationary source emissions.

The BAAQMD threshold of 10,000 MTCO<sub>2</sub>e/yr is consistent with stationary source thresholds adopted by other air quality management districts throughout the state. According to BAAQMD CEQA guidelines (BAAQMD 2017b), the 10,000 MTCO<sub>2</sub>e/yr threshold will capture 95 percent of the stationary source sector GHG emissions in the Bay Area. The five percent of emissions that are from stationary source projects below the 10,000 MTCO<sub>2</sub>e/yr threshold account for a small portion of the Bay Area's total GHG emissions from stationary sources and these emissions come from very small projects. Such small stationary source projects would not significantly add to the global problem of climate change, and they would not hinder the Bay Area's ability to reach the AB 32 goal in any significant way, even when considered cumulatively (BAAQMD 2017b).

New permit applications to BAAQMD for stationary sources that comply with the quantitative threshold of 10,000 MTCO<sub>2</sub>e/yr would not be "cumulatively considerable" because they also would not hinder the state's ability to solve the cumulative greenhouse gas emissions problem pursuant to AB 32. The AB 32 Scoping Plan measures, including the cap-and-trade program, provide for necessary emissions reductions from the stationary source sector to achieve AB 32 2020 goals (BAAQMD 2017b).

GHG impacts from the project's standby diesel fueled engine generators (standby generators) would be considered to have a less-than-significant impact if emissions are below the BAAQMD's threshold of 10,000 MTCO<sub>2</sub>e/yr. Other project-related emissions from mobile sources, area sources, energy use and water use, would not be included for comparison to this threshold, based on guidance in the BAAQMD's CEQA Guidelines (BAAQMD 2017b). GHG impacts from all other project-related emission sources would be considered to have a less-than-significant impact if the project is consistent with the Santa Clara CAP and applicable regulatory programs and policies adopted by ARB or other California agencies.

- a. **Would the project generate greenhouse gas emissions, either directly or indirectly, that may have a significant impact on the environment?**

**Demolition/Construction**

LESS THAN SIGNIFICANT IMPACT. Construction of the project would result in GHG emissions generated by on- and offsite vehicle trips (material haul truck, worker commute, and delivery vehicle trips) and operation of construction equipment. The applicant estimated that these sources would generate approximately 1,043 MTCO<sub>2e</sub> during the 17-month demolition and construction period (Jacobs 2019h). The applicant’s estimates are based on GWPs of 25 and 298 for CH<sub>4</sub> and N<sub>2</sub>O respectively, which are from the IPCC Fourth Assessment Report (AR4 [IPCC 2007]), which for these type of emissions sources is marginally more conservative than using the more recent IPCC AR5 (IPCC 2013) recommended GWPs for CH<sub>4</sub> and N<sub>2</sub>O. Currently, most agencies in the United States, including US EPA, are still accepting and using the GWPs from AR4 as the basis for GHG carbon equivalent emission calculations.

Because construction emissions would cease once construction is complete, they are considered short-term. The BAAQMD CEQA guidelines do not identify a GHG emission threshold for construction-related emissions. Instead, BAAQMD recommends that GHG emissions from construction be quantified and disclosed. BAAQMD further recommends incorporation of Best Management Practices (BMPs) to reduce GHG emissions during construction, as feasible and applicable. BMPs may include use of alternative-fueled (for example, biodiesel or electric) construction vehicles and equipment for at least 15 percent of the fleet, use of at least 10 percent of local building materials, and recycling or reusing at least 50 percent of construction waste (BAAQMD 2017b).

**Operation and Maintenance**

LESS THAN SIGNIFICANT IMPACT. GHG emissions from project operation would consist of emissions from operation of the standby diesel generators (testing and maintenance operations and likely emergency operations), offsite vehicle trips for worker commutes and material deliveries, and facility upkeep, including architectural coatings, consumer product use, landscaping, water use, waste generation, natural gas use for comfort heating, and electricity use.

**Project Stationary Combustion Sources.** The 56 standby generators would be permitted to operate up to 21 hours per year per engine for testing and maintenance purposes<sup>3</sup>. **Table 5.8-2** shows the maximum potential annual GHG emission estimates for the standby generators testing and maintenance operation.

TABLE 5.8-2 GREENHOUSE GAS EMISSIONS FROM STATIONARY SOURCES DURING PROJECT OPERATION	
Source	Maximum Annual Emissions (MTCO <sub>2e</sub> /yr)
Standby Generators – Testing and Maintenance	2,583
BAAQMD Threshold	10,000
Exceeds Threshold?	No

Sources: BAAQMD 2017b, Jacobs 2019j, and staff calculations.

<sup>3</sup> The applicant’s estimate of the expected testing and maintenance events for each engine, including generation tests (monthly, quarterly, and annual), 3-year medium voltage breaker/transformer testing, and contingency testing totals 12.3 hours of engine use per year per engine (Jacobs 2019d, Table 2-4). The monthly generation tests would require the engines to operate at 50 percent load. All other tests require 100 percent load.

**Table 5.8-2** shows that the estimated average annual GHG emissions from the project’s stationary sources, the standby generators, for the permitted testing and maintenance operation are well below the BAAQMD GHG emissions significance threshold for stationary sources. The applicant’s expected 12.3 hours per engine of average annual testing (Jacobs 2019d), added to the expected annual average emergency operation hours is expected to be below the permitted 21 hours per engine per year that is evaluated above. Therefore, it can be concluded that annual average GHG emissions for the standby generators including emergency operation, would also be well below the BAAQMD GHG emissions significance threshold for stationary sources.

If all 56 standby generators were operated at full load for the full 21 hours per year for testing and maintenance, the generators would consume 5,355<sup>4</sup> barrels per year (bbl/year) of diesel fuel. The proposed consumption of diesel fuel by the generators for this level of operation would be approximately 0.0016<sup>5</sup> percent of the total California capacity without any emergency operations. This is an insignificant increase in statewide diesel fuel consumption. This conclusion includes the limited amount of expected annual average emergency operation.

**SVP Electricity Generation.** Electricity for the project would be provided by SVP. The City currently has ownership interest, or has purchase agreements, for about 1,268 megawatts (MW) of electricity (SVP 2019a). This capacity far exceeds the City’s current peak electricity demand of approximately 526 MW for 2018 (SVP 2019b). No new generation capacity is necessary to meet the capacity requirements of new construction or redeveloped facilities within the City to meet the near or projected future demand.

SVP follows the state’s preferred loading order in procuring new energy resources. First, the current load (customer) is encouraged to participate in energy efficiency programs to reduce their usage, thus freeing up existing resources (and any related emissions) for new load (electricity demand). In addition, the City, working together with SVP, encourages the use of renewable resources and clean distributed generation, and has seen a significant increase in its applications for large and small rooftop photovoltaics. Demand displaced by customer-based renewable projects is also available to meet new load requests.

SVP seeks to meet its RPS goal through the addition of new renewable resources. SVP has a lower GHG emission rate than the statewide California power mix because it uses a much higher portion of renewable sources. A comparison of SVP’s and the statewide power mix is shown in **Table 5.8-3**.

TABLE 5.8-3 COMPARISON OF SVP AND STATEWIDE POWER MIX		
Energy Resources	2017 SVP Power Mix	2017 California Power Mix
Renewable (Biomass, Geothermal, Eligible Hydroelectric, Solar, and Wind)	38%	29%
Coal	9%	4%
Large Hydroelectric	34%	15%
Natural Gas	16%	34%
Nuclear	0%	9%
Other	0%	< 1%

<sup>4</sup> Calculated as: 214.2 gallons per hour x 21 hours per year x 56 generators = 224,910 gallons per year / 42 gallons per bbl = 5,355 bbl/yr.  
<sup>5</sup> Calculated as follows, based on the California Energy Commission’s 2018 Weekly Fuels Watch Report: 5,355 bbl/yr / 341,036,000 bbl/yr = 0.0016 percent. Report is available at [https://www.energy.ca.gov/almanac/petroleum\\_data/fuels\\_watch/](https://www.energy.ca.gov/almanac/petroleum_data/fuels_watch/), accessed May 2019.

**TABLE 5.8-3 COMPARISON OF SVP AND STATEWIDE POWER MIX**

Energy Resources	2017 SVP Power Mix	2017 California Power Mix
Unspecified sources of power (not traceable to specific sources)	3%	9%
Total	100%	100%

Source: SVP 2019c

SVP’s carbon intensity factor for 2017 was determined to be 430 pounds (0.195 metric tons) of CO<sub>2</sub>e per MWh (City of Santa Clara 2018). SVP’s carbon intensity factor for electricity generation will continue to change as SVP’s power mix continues to reduce the percentage of electricity produced by coal-fired power plants and increase the use of renewable resources. As noted above, the City and SVP have committed to be coal-free and increased large renewables power generation as a part of the City’s CAP.

**Project Electricity Usage.** The primary function of the data center is to house computer servers, which require electricity and cooling 24 hours a day to operate. The projected maximum demand for the entire project is 99 MW. On an annual basis, the project would consume up to the maximum electrical usage of 867,240 MWh per year. SVP’s power mix, with its 2017 estimate of 430 pounds of CO<sub>2</sub>e per MWh, has a much lower average GHG emissions factor than the California statewide average emissions factor of 1,004 pounds of CO<sub>2</sub>e per MWh or the PG&E average emissions factor value of 644 pounds of CO<sub>2</sub>e per MWh that are provided in CalEEMod.

**Project Mobile Emission Sources.** There are an estimated 74 vehicle trips that occur daily, 50 employee trips and 20 material deliveries/vendor trips (Jacobs 2019c, Attachment DR-21 Table 6).

**Project Water Consumption and Waste Generation.** Water consumption results in indirect emissions from electricity usage for water conveyance and wastewater treatment. Recycled water would be utilized where feasible, based on availability from the City. Daily operations at the data center would generate waste, which results in fugitive GHG emissions during decomposition.

The project’s maximum annual water demand is currently estimated to be approximately 16 acre-feet per year, excluding negligible landscaping and other maintenance uses (Jacobs 2019f). The applicant originally proposed to use chillers for cooling in the SPPE application (Jacobs 2019a) with a total annual potable water demand of 1,032 acre-feet (350 million gallons), which was later updated to a maximum of 1,325 acre-feet (449 million gallons) per year. The applicant is now proposing to use an adiabatic condenser cooling system in place of the chillers which would substantially reduce water demand to the currently estimated 5.4 million gallons per year (Jacobs 2019f, Jacobs 2019k).

The water use input used in CalEEMod to determine the indirect GHG emission from water use is 502 acre-feet (170 million gallons) (Jacobs 2019g). Therefore, the CalEEMod indirect GHG emissions for water use are overestimated. Additionally, the historic property average (2004-2018) annual water demand is estimated to be 1,469 acre-feet (Jacobs 2019c, DR-61,62). Project GHG emissions are based on the project’s water consumption estimate, and no credit has been taken for the reduction in historic property water use.

**Summary of GHG Emissions.** GHG emissions from stationary combustion sources (standby diesel generator testing and maintenance) are presented in **Table 5.8-2** above. GHG emissions from energy

use, mobile and area sources, water use, and waste generation (i.e., project operation) are provided in **Table 5.8-4**.

As shown in **Table 5.8-4**, operation of the project is estimated to generate 171,770 MTCO<sub>2</sub>e/yr from maximum possible electricity use and other non-stationary sources. This emissions estimate does not include efficiency measures that would be pursued as part of the project, nor does it reflect implementation of state and local measures to reduce GHG emissions, for example, SB 350 and SB 100 that would continue the ongoing substantial reductions in GHG emissions from electricity generation.

**TABLE 5.8-4. GHG EMISSIONS FROM ENERGY USE, MOBILE SOURCES, AREA SOURCES, WATER USE, AND WASTE GENERATION DURING PROJECT OPERATION**

Source	Annual Emissions (MTCO <sub>2</sub> e/yr)
Energy Use <sup>a</sup>	170,170
Mobile Sources <sup>b</sup>	300
Area Sources <sup>c</sup>	0.01
Water Use <sup>d</sup>	16
Waste Generation	460
Cooling System R-134a Leakage <sup>e</sup>	824
<b>Total <sup>e</sup></b>	<b>171,770</b>

Sources: Jacobs 2019b, Jacobs 2019g, and Energy Commission staff analysis

<sup>a</sup> Energy use emissions include indirect emissions from electricity and direct emissions from natural gas use for comfort heating. The electricity based indirect emissions were corrected to use the SVP 2017 GHG emissions factor of 430 pounds of CO<sub>2</sub>e/MWh that reduced the applicant's CalEEMod estimated annual indirect emissions from 254,322 MTCO<sub>2</sub>e to the 170,170 MTCO<sub>2</sub>e value shown above.

<sup>b</sup> Mobile source emissions include emissions from worker commute and vendor trips.

<sup>c</sup> Area source emissions include emissions from architectural coatings, consumer products, and landscaping.

<sup>d</sup> Water use indirect GHG emissions were corrected to use the current 5.4 million gallon annual use estimate.

<sup>e</sup> Estimate based on an applicant estimate of approximately 63,550 pounds of R-134a in the cooling system and industry standard leak rate of two percent per year (Jacobs 2019f), and an AR4 GWP of 1,430 for R-134a (IPCC 2007). The regulatory leakage rate limit would be a leakage rate of 10 percent per year, which would increase the maximum allowable GHG annual emissions five-fold to 4,122 MTCO<sub>2</sub>e.

The project would comply with all applicable City and state green building measures, including Title 24, Part 6, California Energy Code baseline standard requirements for energy efficiency, based on the 2016 Energy Efficiency Standards requirements, Title 20 Appliance Efficiency Regulations, and the 2016 California Green Building Standards Code, commonly referred to as CALGreen (California Code of Regulations, Part 11). In addition, the project would include four electrical vehicle charging stations that would serve nine electrical vehicle parking spots (Jacobs 2019e). Water use reduction measures would also be incorporated in the building design, including the use of recycled water in the adiabatic condenser cooling system.

## Conclusion

For stationary-source projects, the threshold to determine the significance of an impact from GHG emissions is 10,000 MTCO<sub>2</sub>e/yr. Stationary-source projects include land uses that would accommodate processes and equipment that emit GHG emissions and would require a BAAQMD permit to operate. If annual emissions of operational-related GHGs exceed these levels, the project would result in a cumulatively considerable contribution of GHG emissions and a cumulatively significant impact to global climate change. For the LDC, the normal stationary source emissions are expected to be well less than this threshold and the maximum project emissions are expected to be just less than the 10,000 MTCO<sub>2</sub>e/yr threshold, and so the LDC would not be considered to be cumulatively significant. Furthermore, as discussed below, the project would conform with all applicable plans, policies, and regulations adopted for the purpose of GHG reductions; so, the



maximum operation non-stationary source GHG emissions (171,770 MTCO<sub>2</sub>e/yr ) are determined to have less than significant impacts..

**Proposed Mitigation Measures:** None.

- b. *Would the project conflict with an applicable plan, policy or regulation adopted for the purpose of reducing the emissions of greenhouse gases?***

### **Demolition/Construction**

LESS THAN SIGNIFICANT IMPACT. The project's minimal short-term demolition and construction GHG emissions would not interfere with the state's ability to achieve long-term GHG emissions reduction goals. The vehicles used during demolition and construction of the project are required to comply with the applicable GHG reduction programs for mobile sources. The project would conform to relevant programs and recommended actions detailed in the AB 32 Scoping Plan and Mobile Source Strategy. Similarly, the project components would not conflict with regulations adopted to achieve the goals of the Scoping Plan.

### **Operation and Maintenance**

LESS THAN SIGNIFICANT IMPACT. The CAP, which is part of the Santa Clara General Plan, identifies a series of GHG emissions reduction measures to be implemented by development projects that would allow the City to achieve its GHG reduction goals in 2020. The measures center around seven focus areas: coal-free and large renewables, energy efficiency, water conservation, waste reduction, off-road equipment, transportation and land use, and urban heat island effect. The CAP includes measures applicable to City government and existing and new development projects in the City. Discussion of the project's conformance with the applicable reduction measures for new development in the CAP are provided below.

**Energy Efficiency Measures.** Power Usage Effectiveness (PUE) is a metric used to compare the efficiency of facilities that house computer servers. PUE is defined as the ratio of total facility energy use to Information Technology (IT) (i.e., server) power draw (for example,  $PUE = \frac{\text{Total Facility Source Energy}}{\text{IT Source Energy}}$ ). For example, a PUE of two means that the data center or laboratory must draw two watts of electricity for each one watt of power consumed by the IT/server equipment. It is equal to the total energy consumption of a data center (for all fuels) divided by the energy consumption used for the IT equipment. The ideal PUE is one where all power drawn by the facility goes to the IT infrastructure. With implementation of the proposed mechanical and electrical design of the building and the anticipated data center occupancy, the PUE would be 1.25 or better at the LDC (Jacobs 2019a).

Measure 2.3 of the CAP calls for completion of a feasibility study of energy efficient practices for new data center projects with an average rack power rating<sup>6</sup> of 15 kilowatts or more to achieve a PUE of 1.2 or lower. The project would have an average rack power rating range of 8 to 10 kilowatts. This would be below the criteria in Measure 2.3, such that a formal feasibility study of energy efficient practices is not required.

---

<sup>6</sup> Average rack power rating is a measure of the power available for use on a rack used to store computer servers. The higher the value of kilowatts, the greater power density per rack and generally more energy use per square foot of building area in a data center.

**Water Conservation Measures.** Measure 3.1, Urban Water Management Plan targets, calls for a reduction in per capita water use to meet Urban Water Management Plan targets by 2020. Development standards for water conservation would be applied to increase efficiency in indoor and outdoor water use areas. Furthermore, the project would comply with all applicable City and state water conservation (indoor and outdoor) measures, including Title 24, Part 6, California Energy Code baseline standard requirements for energy efficiency, based on the 2016 Energy Efficiency Standards requirements, and CALGreen. For the project, these measures would include:

- Water efficient landscaping with low-usage plant material to minimize irrigation requirements
- Sourcing of site irrigation from 100 percent non-potable water, based on availability of recycled water
- Use of recycled water in an adiabatic condenser cooling system, based on availability of recycled water
- Use of ultra-low flow toilets and plumbing fixtures consistent with CALGreen mandatory measures for water reduction

In addition to the water conservation measures listed above the project has redesigned the project's cooling needs to be supplied by a technology (adiabatic condenser cooling system) that uses substantially less water than the technology originally proposed (chillers). The maximum annual water use estimate has been reduced from 1,325 acre-feet to approximately 17 acre-feet.

**Transportation and Land Use Measures.** Measure 6.1, Transportation Demand Management program, requires new development located in the city's transportation districts to implement a transportation demand management (TDM) program to reduce drive-alone trips. The applicant would develop a TDM program as required by the City of Santa Clara during design review process (Jacobs 2019e).

Measure 6.3, Electric Vehicle Parking, recommends the City of Santa Clara to revise parking standards for new multi-family residential and nonresidential development to allow that a minimum of one parking space, and a recommended level of 5 percent of all new parking spaces, be designated for electric vehicle charging. The project's current design includes four electrical vehicle charging stations that would serve nine electrical vehicle parking spots (Jacobs 2019a, p. 3.11-7). The project would have approximately 133 total parking spaces at full buildout (Jacobs 2019e, Figure 2-1R), the percentage of the electrical vehicle parking spots with the current design level of nine electrical vehicle parking spots would exceed 5 percent. However, the final number of electrical vehicle spaces that will be provided by the project will be determined in consultation with the City of Santa Clara (Jacobs 2019e, DR 84).

**Urban Heat Island Effect.** Measure 7.2, Urban Cooling, requires new parking lots to be surfaced with low-albedo materials to reduce heat gain, provided it is consistent with the Building Code. The LDC is being designed to achieve Leadership in Energy and Environmental Design (LEED) standards. The applicant would install all energy efficiency requirements, including the applicable parking lot surface, as specified by the City of Santa Clara during the design review process (Jacobs 2019e).

**Applicable General Plan Policies.** The City adopted the Santa Clara General Plan to accommodate planned housing and employment growth through 2035. As part of the City's General Plan Update in 2011, new policies were adopted that address the reduction of GHG emissions during the planning horizon of the Santa Clara General Plan. In addition to the reduction measures in the CAP, the

Santa Clara General Plan includes goals and policies to address sustainability aimed at reducing the City’s contribution to GHG emissions. For the project, implementation of policies that increase energy efficiency or reduce energy use would effectively reduce indirect GHG emissions associated with energy generation. The consistency of the project with the applicable land use, air quality, energy, and water policies in the Santa Clara General Plan is analyzed in **Table 5.8-5**. As shown, the project would be consistent with the applicable sustainability policies in the Santa Clara General Plan.

The project owner will apply for building permits from the City of Santa Clara. The project owner will incorporate measures specified by the City of Santa Clara during the design review process to ensure compliance with applicable laws, ordinances, regulations, and standards. Conformance with the applicable design codes and policies will be enforced by the City of Santa Clara (Jacobs 2019e).

**TABLE 5.8-5 PROJECT CONSISTENCY WITH SANTA CLARA GENERAL PLAN SUSTAINABILITY POLICIES**

Emission Reduction Policies	Project Consistency
<i>Land Use Policies</i>	
Encourage new developments proposed within a reasonable distance of an existing or proposed recycled water distribution system to utilize recycled water for landscape irrigation, industrial processes, cooling and other appropriate uses to reduce water use consistent with the CAP.	Consistent. The project would use recycled water for landscape irrigation and the adiabatic condenser cooling system, as available.
Encourage Transportation Demand Management strategies and the provision of bicycle and pedestrian amenities in all new development in order to decrease use of the single-occupant automobile and reduce vehicle miles traveled.	Consistent. The project would include bicycle and pedestrian amenities consistent with the City’s requirements.
<i>Air Quality Policies</i>	
Encourage implementation of technological advances that minimize public health hazards and reduce the generation of air pollutants.	Consistent. The project would include four electrical vehicle charging stations that would serve nine electrical vehicle parking spots (Jacobs 2019a, p. 3.11-7).
Encourage measures to reduce greenhouse gas emissions to reach 30 percent below 1990 levels by 2020.	Consistent. Water conservation and energy efficiency measures included in the project would reduce GHG emissions associated with the generation of electricity.
<i>Energy Policies</i>	
Promote the use of renewable energy resources, conservation, and recycling programs.	Consistent. The LDC is being designed to achieve LEED standards to reduce energy, water, air, and GHG impacts of the development. The project would use lighting control to reduce energy usage for new exterior lighting and air economization for building cooling. Water efficient landscaping and ultra-low flow plumbing fixtures in the proposed building would limit water consumption. In addition, the project would have a “Cool Roof,” using reflective surfaces to reduce heat gains. Waterside economizers would be used to cool data center loads.
Encourage new development to incorporate sustainable building design, site planning, and construction, including encouraging solar opportunities.	
Reduce energy consumption through sustainable construction practices, materials, and recycling.	
Promote sustainable buildings and land planning for all new development, including programs that reduce energy and water consumption in new development.	
<i>Water Use Policies</i>	
Maximize the use of recycled water for construction, maintenance, irrigation, and other appropriate applications.	Consistent. The project would use recycled water for landscape irrigation and the cooling technology needs, as available. The potential availability of recycled water is still being determined at the City of Santa Clara. Once the City has completed its review and assuming recycled water is determined to be “available” as defined

**TABLE 5.8-5 PROJECT CONSISTENCY WITH SANTA CLARA GENERAL PLAN SUSTAINABILITY POLICIES**

Emission Reduction Policies	Project Consistency
	by the California Water Code, it will be used by the project, consistent with applicable law (Jacobs 2019e).

**Bay Area 2017 Clean Air Plan.** The Bay Area 2017 Clean Air Plan (BAAQMD 2017a) includes performance objectives, consistent with the state’s climate protection goals under AB 32 and SB 375, designed to reduce emissions of GHG emissions to 1990 levels by 2030 and 80 percent below 1990 levels by 2050. The LDC is being designed to achieve LEED standards to reduce energy, water, air, and GHG impacts of the development. Due to the relatively high electrical demand of the LDC, energy efficiency measures are included in the design and operation of the onsite electrical and mechanical systems. The project owner would incorporate additional energy efficiency measures specified by the City of Santa Clara during the design review process to ensure compliance with applicable energy efficiency laws, ordinances, regulations, and standards (Jacobs 2019e). This would be consistent with the general purpose of Energy and Climate Measure (ECM)-1 – Energy Efficiency in the 2017 Bay Area Clean Air Plan.

**Plan Bay Area 2040/California SB 375.** Under the requirements of SB 375, the MTC and ABAG developed a SCS with the adopted Plan Bay Area 2040 to achieve the Bay Area’s regional GHG reduction target. Plan Bay Area 2040 sets a 15 percent GHG emissions reduction per capita target from passenger vehicles by 2035 when compared to the project 2005 emissions. However, these emission reduction targets are intended for land use and transportation strategies only. The project would generate an average of 74 total daily vehicle trips, including vendors and employee trips, which is expected to be similar to vehicle counts associated with the site’s existing land use. Due to the limited number of employees and visitors at the project site, particularly when compared to the site’s existing land use, the project would have less-than-significant traffic impacts during operation. Thus, the project would not contribute to a substantial increase in passenger vehicle travel within the region.

**California SB 100.** SB 100 advances the RPS renewable resources requirement to 50 percent by 2026 and 60 percent by 2030. It also requires renewable energy resources and zero-carbon resources to supply 100 percent of all retail sales of electricity by 2045. The project’s GHG emissions are predominantly from electricity usage. This project could significantly reduce GHG emissions by purchasing all of its electricity from Santa Clara Green Power, which is available through SVP. The project could further reduce its GHG impacts by installing solar panels over parking spaces and any roof area not being used for the adiabatic condenser cooling system or other equipment, consistent with a City of Santa Clara design review condition, should one be issued (Jacobs 2019e).

**AB 32 Scoping Plan.** The vast majority of the project’s GHG emissions would result from energy use. Multiple AB 32 Scoping Plan measures address GHG emissions from energy use. For example, the Cap-and-Trade Program, through the regulation of upstream electricity producers, will account for GHG emissions from the project and require emissions from covered sectors to be reduced by the amount needed to achieve AB 32’s 2030 goal.

## Conclusion

With implementation of the efficiency measures to be implemented with the project, in combination with the green power mix used by SVP, GHG emissions related to the project would not conflict with the Santa Clara CAP or other plans, policies, or regulations adopted for the purpose of reducing the emissions of GHGs. Furthermore, the project's stationary sources would not conflict with the Bay Area 2017 Clean Air Plan because their GHG emissions would be less than BAAQMD's threshold of 10,000 MTCO<sub>2</sub>e/yr, including both testing and maintenance and likely emergency operations.

**Proposed Mitigation Measures:** None.

### 5.3.3 References

- ARB 2014** – California Air Resources Board (ARB). First Update to the Climate Change Scoping Plan, dated May 2014. Available online at: <https://ww3.arb.ca.gov/cc/scopingplan/document/updatedscopingplan2013.htm>. Accessed on: April 2019.
- ARB 2016** – California Air Resources Board (ARB). Mobile Source Strategy. Available online at: <https://www.arb.ca.gov/planning/sip/2016sip/2016mobsrsrc.htm>. Accessed on: April 2019.
- ARB 2017a** – California Air Resources Board (ARB). California's 2017 Climate Change Scoping Plan, November 2017. Available online at: [https://www.arb.ca.gov/cc/scopingplan/scoping\\_plan\\_2017.pdf](https://www.arb.ca.gov/cc/scopingplan/scoping_plan_2017.pdf). Accessed on: April 2019.
- ARB 2017b** – California Air Resources Board (ARB). Short-Lived Climate Pollutant Reduction Strategy, March 2017. Available online at: [https://ww3.arb.ca.gov/cc/shortlived/meetings/03142017/final\\_slcp\\_report.pdf](https://ww3.arb.ca.gov/cc/shortlived/meetings/03142017/final_slcp_report.pdf). Accessed on: April 2019.
- ARB 2018** – California Air Resources Board (CARB). California Greenhouse Gas Emission Inventory – 2018 Edition, July 2018. Available online at: <https://www.arb.ca.gov/cc/inventory/data/data.htm>. Accessed on: May 2019.
- BAAQMD 2017a** – Bay Area Air Quality Management District (BAAQMD). Final 2017 Clean Air Plan, Adopted April 19, 2017. Available online at: [http://www.baaqmd.gov/~media/files/planning-and-research/plans/2017-clean-air-plan/attachment-a\\_-proposed-final-cap-vol-1-pdf.pdf](http://www.baaqmd.gov/~media/files/planning-and-research/plans/2017-clean-air-plan/attachment-a_-proposed-final-cap-vol-1-pdf.pdf). Accessed on: May 2019.
- BAAQMD 2017b** – Bay Area Air Quality Management District (BAAQMD). California Environmental Quality Act Air Quality Guidelines, Updated May 2017. Available online at: [http://www.baaqmd.gov/~media/files/planning-and-research/ceqa/ceqa\\_guidelines\\_may2017-pdf.pdf?la=en](http://www.baaqmd.gov/~media/files/planning-and-research/ceqa/ceqa_guidelines_may2017-pdf.pdf?la=en). Accessed on: May 2019.
- Santa Clara 2013** – City of Santa Clara (Santa Clara). Santa Clara Climate Action Plan. December 2013. Available online at: <http://santaclaraca.gov/Home/ShowDocument?id=10170>. Accessed on: May 2019.
- Santa Clara 2018** – City of Santa Clara (Santa Clara). City of Santa Clara Climate Action Plan Annual Report. July 2018. Available online at: <http://santaclaraca.gov/home/showdocument?id=62433>. Accessed on: May 2019.
- IPCC 2007** – Intergovernmental Panel on Climate Change (IPCC). Climate Change 2007: The Physical Science Basis. Contribution of Working Group I to the Fourth Assessment Report of the

Intergovernmental Panel on Climate Change [Solomon, S., D. Qin, M. Manning, Z. Chen, M. Marquis, K.B. Averyt, M. Tignor and H.L. Miller (eds.)]. Cambridge University Press, Cambridge, United Kingdom and New York, NY, USA, 996 pp. Available online at: <https://www.ipcc.ch/report/ar4/wg1/>. Accessed on: April 2019.

**IPCC 2013** – Intergovernmental Panel on Climate Change (IPCC). Climate Change 2013: The Physical Science Basis. Contribution of Working Group I to the Fifth Assessment Report of the Intergovernmental Panel on Climate Change [Stocker, T.F., D. Qin, G.-K. Plattner, M. Tignor, S.K. Allen, J. Boschung, A. Nauels, Y. Xia, V. Bex and P.M. Midgley (eds.)]. Cambridge University Press, Cambridge, United Kingdom and New York, NY, USA, 1535 pp, doi:10.1017/CBO9781107415324. Available online at: <https://www.ipcc.ch/report/ar5/wg1/>. Accessed April 2019.

**Jacobs 2019a** – Jacobs (Jacobs). (TN 227273-1). Application for Small Power Plant Exemption: Laurelwood Data Center, dated February 28, 2019. Available online at: <https://efiling.energy.ca.gov/Lists/DocketLog.aspx?docketnumber=19-SPPE-01>.

**Jacobs 2019b** – Jacobs (Jacobs). (TN 227273-2 through TN 227273-3). Laurelwood SPPE Application Appendices. Available online at: <https://efiling.energy.ca.gov/Lists/DocketLog.aspx?docketnumber=19-SPPE-01>.

**Jacobs 2019c** – Jacobs (Jacobs). (TN 227626). LDC Responses to Formal and Informal Data Requests. Data Response Set 1A, dated April 11, 2019. Available online at: <https://efiling.energy.ca.gov/Lists/DocketLog.aspx?docketnumber=19-SPPE-01>.

**Jacobs 2019d** – Jacobs (Jacobs). (TN228748). LDC Updated SPPE Project Description, dated June 13, 2019. Available online at: <https://efiling.energy.ca.gov/Lists/DocketLog.aspx?docketnumber=19-SPPE-01>.

**Jacobs 2019e** – Jacobs (Jacobs). (TN 228822). LDC Response to Informal Data Requests. Data Response Set 3, dated June 21, 2019. Available online at: <https://efiling.energy.ca.gov/Lists/DocketLog.aspx?docketnumber=19-SPPE-01>.

**Jacobs 2019f** – Jacobs (Jacobs). (TN 228823). LDC Updated SPPE Project Description, dated June 21, 2019. Available online at: <https://efiling.energy.ca.gov/Lists/DocketLog.aspx?docketnumber=19-SPPE-01>.

**Jacobs 2019g** – Jacobs (Jacobs). (TN 228854). LDC Data Request Response Set 1B, dated June 27, 2019. Available online at: <https://efiling.energy.ca.gov/Lists/DocketLog.aspx?docketnumber=19-SPPE-01>.

**Jacobs 2019h** – Jacobs (Jacobs). (TN 228913). LDC Revised Construction Emission Estimates, dated July 8, 2019. Available online at: <https://efiling.energy.ca.gov/Lists/DocketLog.aspx?docketnumber=19-SPPE-01>.

**Jacobs 2019j** – Jacobs (Jacobs). (TN 229116). Laurelwood Data Center Bay Area AQMD Policy Compliance Letter, dated July 29, 2019. Available online at: <https://efiling.energy.ca.gov/Lists/DocketLog.aspx?docketnumber=19-SPPE-01>.

**Jacobs 2019k** – Jacobs (Jacobs). (TN 229160). LDC Response to Data Request, Set 5, dated July 31, 2019. Available online at: <https://efiling.energy.ca.gov/Lists/DocketLog.aspx?docketnumber=19-SPPE-01>.



- Jacobs 2019I** – Jacobs (Jacobs). (TN 229274). LDC Chiller GHG and HRA Data Responses, dated August 8, 2019. Available online at: <https://efiling.energy.ca.gov/Lists/DocketLog.aspx?docketnumber=19-SPPE-01>.
- MTC & ABAG 2017** – Metropolitan Transportation Commission (MTC) and Association of Bay Area Governments (ABAG). 2017. Plan Bay Area 2040. July. Available online at: <https://mtc.ca.gov/our-work/plans-projects/plan-bay-area-2040>. Accessed on: May 2019.
- SVP 2019a** – Silicon Valley Power (SVP). Electric Resource Map. Available online at: <http://www.siliconvalleypower.com/home/showdocument?id=5763>. Accessed on: May 2019.
- SVP 2019b** – Silicon Valley Power (SVP). Utility Fact Sheet. Available online at: <http://www.siliconvalleypower.com/svp-and-community/about-svp/utility-fact-sheet>. Accessed on: May 2019.
- SVP 2019c** – Silicon Valley Power (SVP). Power Content Label. Available online at: <http://www.siliconvalleypower.com/svp-and-community/about-svp/power-content-label>. Accessed on: May 2019.
- TCR 2018** – The Climate Registry (TCR). 2018. 2018 Climate Registry Default Emission Factors. May. Available online at: <https://www.theclimateregistry.org/wp-content/uploads/2018/06/The-Climate-Registry-2018-Default-Emission-Factor-Document.pdf>. Accessed on: May 2019.
- US EPA 2018** – United States Environmental Protection Agency (US EPA). Inventory of U.S. Greenhouse Gas Emissions and Sinks: 1990-2016, EPA 430-R-18-003, April 2018. Available online at: [https://www.epa.gov/sites/production/files/2018-01/documents/2018\\_complete\\_report.pdf](https://www.epa.gov/sites/production/files/2018-01/documents/2018_complete_report.pdf). Accessed on: May 2019.

## 5.9 Hazards and Hazardous Materials

This section describes the environmental and regulatory setting and discusses impacts associated with the demolition/construction and operation of the Laurelwood Data Center (LDC or project) with respect to hazards and hazardous materials.

HAZARDS AND HAZARDOUS MATERIALS				
Would the project:	Potentially Significant Impact	Less than Significant With Mitigation Incorporated	Less than Significant Impact	No Impact
a. Create a significant hazard to the public or the environment through the routine transport, use, or disposal of hazardous materials?	<input type="checkbox"/>	<input type="checkbox"/>	<input checked="" type="checkbox"/>	<input type="checkbox"/>
b. Create a significant hazard to the public or the environment through reasonably foreseeable upset and accident conditions involving the release of hazardous materials into the environment?	<input type="checkbox"/>	<input type="checkbox"/>	<input checked="" type="checkbox"/>	<input type="checkbox"/>
c. Emit hazardous emissions or handle hazardous or acutely hazardous materials, substances, or waste within one-quarter mile of an existing or proposed school?	<input type="checkbox"/>	<input type="checkbox"/>	<input type="checkbox"/>	<input checked="" type="checkbox"/>
d. Be located on a site which is included on a list of hazardous materials sites compiled pursuant to Government Code Section 65962.5 and, as a result, would it create a significant hazard to the public or the environment?	<input type="checkbox"/>	<input type="checkbox"/>	<input checked="" type="checkbox"/>	<input type="checkbox"/>
e. For a project located within an airport land use plan or, where such a plan has not been adopted, within two miles of a public airport or public use airport, would the project result in a safety hazard or excessive noise for people residing or working in the project area?	<input type="checkbox"/>	<input type="checkbox"/>	<input type="checkbox"/>	<input checked="" type="checkbox"/>
f. Impair implementation of or physically interfere with an adopted emergency response plan or emergency evacuation plan?	<input type="checkbox"/>	<input type="checkbox"/>	<input type="checkbox"/>	<input checked="" type="checkbox"/>
g. Expose people or structures, either directly or indirectly, to a significant risk of loss, injury or death involving wildland fires?	<input type="checkbox"/>	<input type="checkbox"/>	<input type="checkbox"/>	<input checked="" type="checkbox"/>

Environmental checklist established by CEQA Guidelines, Appendix G.

### 5.9.1 Setting

#### Hazardous Waste and Substances Sites

The project owner hired Cornerstone Earth Group to conduct a Phase 1 Environmental Site Assessment and to determine the location of hazardous wastes and hazardous material release sites within 0.25 mile of the project. The analysis provided by Environmental Data Resources, Inc. (EDR) included within the Phase 1 Environmental Site Assessment a search through EDR's proprietary database related to generation, storage, handling, transportation, treatment of wastes, and the remediation of contaminated soil and groundwater sites. In addition, the EDR search included searches of 117 databases prepared by local, state, federal, and tribal agencies. The EDR search included searches of the State Water Resources Control Board's (SWRCB) GeoTracker database and the California Department of Toxic Substance Control's (DTSC) EnviroStor database. The EDR search revealed that the project is a Cortese Listed site and is under final cleanup order with the San Francisco Bay Regional Water Quality Control Board (RWQCB).

Siliconix owned and conducted operations on the site since its original development in 1969 until operations ceased in 2018. Effective December 20, 2018, Siliconix sold the site to MECP1 SANTA CLARA 1,

LLC, a Delaware limited liability corporation. Redevelopment plans include demolishing and removing or abandoning in place, existing site buildings, outbuildings, storage areas, and below ground utilities (to a depth of 8 feet below ground surface). Siliconix has engaged a contractor to complete the demolition project.

Soil and groundwater contamination was discovered at the site during the 1983 removal of three former underground storage tanks (USTs). A remedial investigation commenced in 1987 and additional potential source areas were identified beneath Building 3, where former waste neutralization sumps, waste solvent storage, and cleaning areas existed. Volatile organic compounds (VOCs) were detected in groundwater, and a plume of trichloroethylene (TCE) and associated degradation products cis-1,2-dichloroethylene (cis-1,2-DCE), trans-1,2-DCE (trans-1,2-DCE), and vinyl chloride is assumed to originate from the general vicinity of Building 3 and propagate to the north onto property owned by Intel. See **Figure 5.9-1** for location of Building 3.

Environmental investigation and remediation work at the site is being conducted under Order No. R2-2008-0058 (“2008 Order”) adopted by the San Francisco RWQCB, dated July 9, 2008. The 2008 order defines cleanup standards and requirements for investigation and remediation of impacted soil and groundwater at the project site. Under the 2008 order, a groundwater extraction and treatment system (“GWET System”) currently extracts and treats groundwater from three on-site groundwater extraction wells and one offsite groundwater extraction well. Treated groundwater is discharged to a storm drain under National Pollutant Discharge Elimination System (NPDES) General Permit No. CAG912002.

The site is also subject to the provisions of a Covenant and Environmental Restriction dated September 7, 2017, made by Siliconix for the benefit of the RWQCB and recorded on September 19, 2017 as document number 23755872 in the Official Records of Santa Clara County. The covenant and environmental restriction limits the amount of redevelopment uses for the site to industrial, commercial or office space. In addition, the property owner shall not drill, extract, or use the ground water on site without permission from the RWQCB due to the soil and groundwater contamination (Jacobs 2019a).

## **Airports**

The Norman Y. Mineta San Jose International Airport, a public airport, is located within 2 miles of the proposed project. The Santa Clara County Airport Land Use Commission (SCCALUC 2016) plan shows that the project does not fall within an airport safety zone and the height would not trigger the Federal Aviation Administration’s (FAA) review.

## **Schools**

There are no schools within 0.25 mile of the project site.

## **Emergency Evacuation Routes**

The Santa Clara Local Hazard Mitigation Plan (Santa Clara County 2017) identifies hazards and provides a risk assessment for the potential natural hazards that could impact the county. The plans do not identify any designated evacuation routes near the project site.

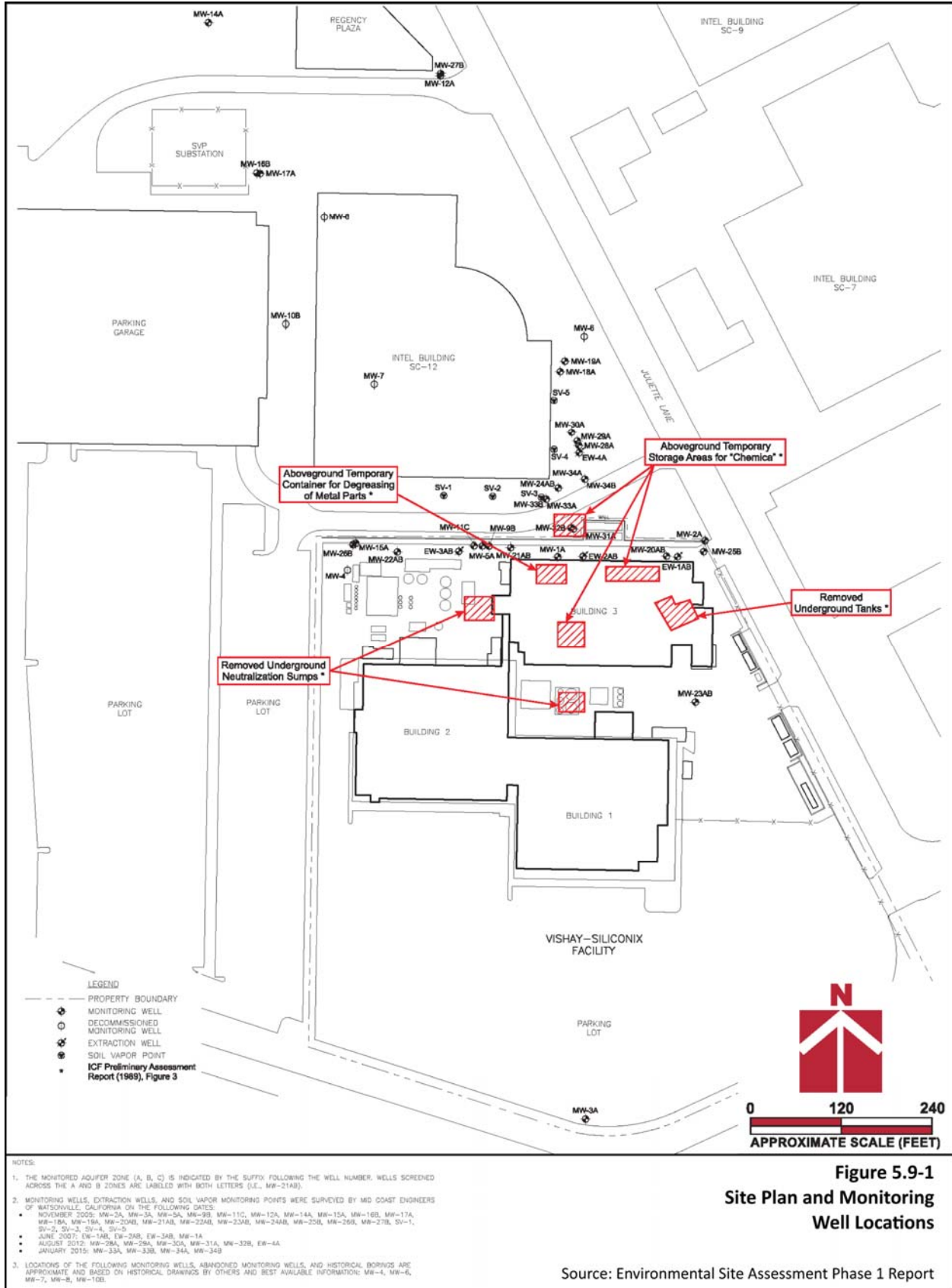

**Figure 5.9-1**  
**Site Plan and Monitoring Well Locations**

Source: Environmental Site Assessment Phase 1 Report

## Wildfire Hazards

The California Department of Forestry and Fire Protection (Cal Fire) identifies and maps areas of significant fire hazards based on fuels, terrain, and other relevant factors. The maps identify this information as a series of Fire Hazard Severity Zones, which are progressively ranked in severity as un-zoned, moderate, high, and very high. State responsibility areas (SRA) are locations where the State of California is responsible for wildland fire protection. Local responsibility areas (LRA) are locations where the responding agency is the local county or city. The new LDC would be located within Santa Clara County.

The Cal Fire maps for Santa Clara County (CalFire 2007) indicate that the project site is located in an LRA. Within the LRA, the project site falls within an un-zoned Fire Hazard Severity Zone that indicates that the project site has a less than moderate susceptibility to wildland fires. For more information on wildfire hazards, see **Section 5.19, Wildfire**.

## Regulatory Background

Hazardous substances are defined by federal and state regulations that aim to protect public health and the environment. Hazardous materials have certain chemical, physical, or infectious properties that cause them to be considered hazardous. Hazardous substances are defined in the federal Comprehensive Environmental Response, Compensation, and Liability Act (CERCLA) section 101(14), and also in Title 22, California Code of Regulations, section 66260.10 and California Health & Safety Code section 25501, which defines a “hazardous material” as:

a material listed in paragraph (2) that, because of its quantity, concentration, or physical or chemical characteristics, poses a significant present or potential hazard to human health and safety or to the environment if released into the workplace or the environment, or a material specified in an ordinance adopted pursuant to paragraph (3).

For this analysis, soil that is excavated from a site containing hazardous materials would be considered to be a hazardous waste if it exceeded specific Title 22, California Code of Regulations criteria, criteria defined in CERCLA, or other relevant federal regulations. (See Definition of Hazardous Waste, Cal. Code Regs., tit. 22, § 66261.3.) Remediation (cleanup and safe removal/disposal) of hazardous wastes found at a site is required if excavation of these materials occurs; remediation may also be required if certain other activities occur. Even if soils or groundwater at a contaminated site do not have the characteristics required to be defined as hazardous wastes, remediation of the site may be required by regulatory agencies with jurisdictional authority. Cleanup requirements are determined on a case-by-case basis by the agency taking lead jurisdiction.

### ***Federal***

**Resource Conservation and Recovery Act.** The federal Toxic Substances Control Act (1976) and the Resource Conservation and Recovery Act of 1976 (RCRA) established a program administered by the U.S. EPA for the regulation of the generation, transportation, treatment, storage, and disposal of hazardous waste. RCRA was amended in 1984 by the Hazardous and Solid Waste Act, which affirmed and extended the “cradle to grave” system of regulating hazardous wastes. The use of certain techniques for the disposal of some hazardous wastes was specifically prohibited by the Hazardous and Solid Waste Act.

**Comprehensive Environmental Response, Compensation, and Liability Act.** Congress enacted the federal CERCLA, including the Superfund program, on December 11, 1980. This law provided broad federal authority to respond directly to releases or threatened releases of hazardous substances that may

endanger public health or the environment. CERCLA established requirements concerning closed and abandoned hazardous waste sites; provided for liability of persons responsible for releases of hazardous waste at these sites; and established a trust fund to provide for cleanup when no responsible party could be identified. CERCLA also enabled the revision of the National Contingency Plan. The National Contingency Plan provided the guidelines and procedures needed to respond to releases and threatened releases of hazardous substances, pollutants, and/or contaminants. The National Contingency Plan also established the National Priorities List. CERCLA was amended by the Superfund Amendments and Reauthorization Act on October 17, 1986.

**Department of Transportation.** The United States Department of Transportation is the primary federal agency responsible for regulating the proper handling and storage of hazardous materials during transportation (49 C.F.R. §§ 171-177 and 350-399).

### ***State***

**California Environmental Protection Agency.** The California Environmental Protection Agency (CalEPA) was created in 1991. Its creation unified California's environmental authority in a single cabinet-level agency and brought the CARB, SWRCB, RWQCBs, Integrated Waste Management Board, DTSC, Office of Environmental Health Hazard Assessment, and Department of Pesticide Regulation under one agency. These agencies were placed within the CalEPA "umbrella" for the protection of human health and the environment and to ensure the coordinated deployment of state resources. Their mission is to restore, protect and enhance the environment, to ensure public health, environmental quality, and economic vitality.

**The California Hazardous Waste Control Law.** The California Hazardous Waste Control Law is administered by CalEPA to regulate hazardous wastes. The Hazardous Waste Control Law lists 791 chemicals and about 300 common materials that may be hazardous; establishes criteria for identifying, packaging and labeling hazardous wastes; prescribes management controls; establishes permit requirements for treatment, storage, disposal and transportation; and identifies some wastes that cannot be disposed of in landfills.

**Department of Toxic Substances Control.** DTSC is a department within CalEPA and is the primary agency in California that regulates hazardous waste, cleans-up existing contamination, and looks for ways to reduce the hazardous waste produced in California. DTSC regulates hazardous waste in California primarily under the authority of RCRA and the California Health and Safety Code. Other laws that affect hazardous waste are specific to handling, storage, transportation, disposal, treatment, reduction, cleanup, and emergency planning.

**California Occupational Safety and Health Administration.** California Occupational Safety and Health Administration (OSHA) is the primary agency responsible for worker safety related to the handling and use of chemicals in the workplace. California OSHA standards are generally more stringent than federal regulations. The employer is required to monitor worker exposure to listed hazardous substances and notify workers of exposure (Cal. Code Regs., tit. 8, §§ 337-340). The regulations specify requirements for employee training, availability of safety equipment, accident-prevention programs, and hazardous substance exposure warnings.

**Department of California Highway Patrol.** Department of California Highway Patrol is the primary agency responsible for enforcing the regulations related to the transport of hazardous materials on California roads and highway (Cal. Code Regs., tit. 13, §§ 1160-1167).



### **Local**

**Santa Clara County Operational Area Hazard Mitigation Plan.** The plan includes risk assessment that identifies the natural hazards and risks that can impact a community based on historical experience, estimate the potential frequency and magnitude of disasters, and assess potential losses to life and property. The plan also includes developed mitigation goals and objectives as part of a strategy for mitigating hazard-related losses.

## **5.9.2 Environmental Impacts and Mitigation Measures**

- a. *Would the project create a significant hazard to the public or the environment through the routine transport, use, or disposal of hazardous materials?***

### **Demolition/Construction**

LESS THAN SIGNIFICANT IMPACT. During the demolition and construction phases of the project, the only hazardous materials used would be paints, cleaners, solvents, gasoline, motor oil, welding gases, and lubricants. When not in use, any hazardous material would be stored in designated construction staging areas in compliance with local, state, and federal requirements. Any impacts resulting from spills or other accidental releases of these materials would be limited to the site due to the small quantities involved, their infrequent use and hence reduced chances of release. Temporary containment berms would also be used to help contain any spills during the construction of the project.

During construction, all 56 diesel generators would have to be filled. The transportation of the diesel fuel to the site would take several trucks. As diesel fuel has a long history of being routinely transported and used as a common motor fuel, it is appropriate to rely upon the extensive regulatory program that applies to the shipment of hazardous materials on California highways and roads to ensure safe handling in general transportation (see Federal Hazardous Materials Transportation Law 49 USC § 5101 et seq., DOT regulations 49 C.F.R. subpart H, §§ 172–700, and California Department of Motor Vehicles (DMV) regulations on hazardous cargo). Thus, the transportation of diesel fuel would pose a less than significant risk to the surrounding public.

Therefore, the routine transport, use or disposal of hazardous materials would have a less than significant impact to the public or environment.

### **Operation and Maintenance**

LESS THAN SIGNIFICANT IMPACT. During the operational phase of the project, diesel fuel would be stored on-site but the generators would only use diesel fuel during emergencies, testing, and maintenance. Since testing and maintenance is limited to no more than 50 hours of operation annually, routine deliveries of diesel fuel would be infrequent due to the limited amount of testing conducted for each generator and would comply with existing LORS covering transportation of diesel fuel.

**Proposed Mitigation Measures:** None.

- b. Would the project create a significant hazard to the public or the environment through reasonably foreseeable upset and accident conditions involving the release of hazardous materials into the environment?**

### **Demolition/Construction**

LESS THAN SIGNIFICANT IMPACT. As described under the discussion for impact *criterion a*, project demolition and construction would require the limited use of hazardous materials, such as fuels, lubricants, and solvents. The storage and use of hazardous materials during construction could result in the accidental release of small quantities of hazardous materials typically associated with minor spills or leaks. However, as discussed in impact *criterion a*, hazardous materials would be stored, handled, and used in accordance with applicable regulations. Personnel would be required to follow instructions on health and safety precautions and procedures to follow in the event of a release of hazardous materials. All equipment and materials storage would be routinely inspected for leaks. Records would be maintained for documenting compliance with the storage and handling of hazardous materials.

For the above reasons, the project impacts would be less than significant.

### **Operation and Maintenance**

LESS THAN SIGNIFICANT IMPACT. The project would not create a significant hazard to the public or environment due to an accidental release of a hazardous material. Although a substantial quantity of diesel fuel would be stored on-site, its storage would be split among many separate tanks, with a portion of it stored in the double-walled belly tank beneath each generator, effectively limiting a worst-case spill to the quantity held within one tank. Each belly tank is capable of holding 10,300 gallons of diesel fuel.

Each generator's integrated fuel tank would be of a double-walled high integrity design. The interstitial space between the inner and outer walls of each tank would be continuously monitored electronically for the presence of leaks through the inner wall. The monitoring system would be electronically linked to an alarm system in the security office that would alert personnel if a leak were detected in any of the tanks.

Deliveries of diesel fuel would be scheduled on an as-needed basis by tanker truck during the project's operation. Diesel delivery trucks would use wheel chocks to prevent the truck from moving before complete disconnection of the transfer lines. An emergency pump shut-off would be available in case a pump hose breaks during the fueling. In addition, a temporary spill catch basin would be located at the fill port of each belly tank during refilling. With the above listed safety features and precautions, the risk of an impact to the off-site public from a hazardous material release would be less than significant.

**Proposed Mitigation Measures:** None.

- c. *Would the project emit hazardous emissions or handle hazardous or acutely hazardous materials, substances, or waste within one-quarter mile of an existing or proposed school?***

#### **Demolition/Construction**

NO IMPACT. There are no schools located or proposed within 0.25 mile of the project site. In addition, there are no hazardous materials that would be emitted from the site at rates capable of creating offsite impacts. Therefore, there would be no impact.

#### **Operation and Maintenance**

NO IMPACT. There are no schools located or proposed within 0.25 mile of the project site. Therefore, no impact from the operation or maintenance of the project would occur.

**Proposed Mitigation Measures:** None.

- d. *Would the project be located on a site that is included on a list of hazardous materials sites compiled pursuant to Government Code Section 65962.5 and, as a result, would it create a significant hazard to the public or the environment?***

#### **Demolition/Construction**

LESS THAN SIGNIFICANT IMPACT. According to a review of the Envirostor and GeoTracker databases, the project site is listed on the hazardous materials sites compiled pursuant to Government Code section 65962.5. Volatile organic compounds (VOCs) were detected in groundwater, and a plume of trichloroethylene (TCE) and associated degradation products cis-1,2-dichloroethylene (cis-1,2-DCE), trans-1,2-DCE (trans-1,2-DCE), and vinyl chloride is assumed to originate from the general vicinity of Building 3 and migrate to the north onto property owned by Intel. The site is considered open by the San Francisco RWQCB and has a deed restriction and implementation of a soil management plan (SMP) for activities that include excavation of the subsurface soil. Groundwater and soil vapor monitoring currently are conducted at the site on a quarterly basis.

Ground disturbing activities associated with the demolition of existing buildings, the removal of underground utilities, and construction of the project would have the potential to encounter contaminated groundwater and soil. The SMP would require that any groundwater encountered during construction be retained in trailerized heavy-gauge steel “frac” tanks on-site, pending characterization. Following characterization, the groundwater could be treated using the existing treatment system and discharged to the storm drain system pursuant to the NPDES General permit, or transported offsite for permitted disposal. The Phase 1 Environmental Site Assessment found that the soil to a depth of 8 feet below ground surface (bgs) contained small amounts of contamination where the majority of subsurface excavation would occur. The soil management plan would require that the soil investigations be augmented during demolition and construction by real time visual and photoionization inspection of subsurface excavations. In addition, the San Francisco Bay RWQCB would review the groundwater and soil removal plans before the start of construction to ensure that worker safety, public health, and the environment are protected. Therefore, the construction of the project would create a less than significant impact to the public or the environment.

#### **Operation and Maintenance**

NO IMPACT. Operation and maintenance activities would not involve excavation activities and would therefore have no impact.

**Proposed Mitigation Measures:** None.

- e. *For a project located within an airport land use plan or, where such a plan has not been adopted, within two miles of a public airport or public use airport, would the project result in a safety hazard or excessive noise for people residing or working in the project area?*

### **Demolition/Construction**

NO IMPACT. The project site is located approximately 1.4 miles northwest of the Norman Y. Mineta San Jose International Airport. The project is located outside of any designated airport safety zones (SCCALUC 2016). The project would not exceed the FAA's height limitation and would not require FAA review. Therefore, the project would not result in a safety hazard and would have no impact. Project demolition and construction would not result in excessive noise impacts for people residing or working in the project area, as described in a more detailed analysis in **Section 5.13, Noise**.

### **Operation and Maintenance**

NO IMPACT. Operation and maintenance activities for the project site would be similar to those for a similarly sized industrial building and would not have an impact on people working or residing in the area. In addition, the thermal plume generated by the project would not pose a safety hazard to any aircraft near the Norman Y. Mineta San Jose International Airport. More detailed analysis of thermal plume impacts are addressed in **Section 5.17, Transportation**.

**Proposed Mitigation Measures:** None.

- f. *Would the project impair implementation of, or physically interfere with, an adopted emergency response plan or emergency evacuation plan?*

### **Demolition/Construction**

NO IMPACT. A review of the Santa Clara County Operational Area Hazard Mitigation Plan for the project revealed no specific mapping or delineation of emergency evacuation or access routes. The plans identified that the area police, fire department, and other emergency services would implement their emergency response or evacuation plans according to their communications protocols and hazard mitigation programs. The project site is not identified on any emergency evacuation or access routes. In addition, the construction would not require any road closures since the work would all be done onsite. During demolition and project construction, there would be no impact on an adopted response plan or emergency evacuation plan.

### **Operation and Maintenance**

NO IMPACT. After construction, no lane closures would be needed, and no impact on a response plan or emergency evacuation plan would occur.

**Proposed Mitigation Measures:** None.

**g. Would the project expose people or structures, either directly or indirectly, to a significant risk of loss, injury, or death involving wildland fires?**

**Demolition/Construction**

NO IMPACT. The project site is located in Santa Clara County. It is located within an un-zoned Fire Hazard Severity Zone, within an LRA, indicating that the project site has a less than moderate susceptibility to wildland fires. The project site is not adjacent to wildlands. Buildings bound the project to the north and east and US Route 101 is to the south. Although equipment and vehicles used during demolition and construction, as well as welding activities, have the potential to ignite dry vegetation, the project is located within an urban area surrounded by industrial and commercial zones that have very limited dry vegetation. In addition, the project is located within an un-zoned fire hazard area. Therefore, there would be no impact from wildland fires due to the demolition and construction activities related to the project.

**Operation and Maintenance**

NO IMPACT. The project site is located within an un-zoned Fire Hazard Severity Zone and therefore, there would be no impact from wildland fires.

**Proposed Mitigation Measures:** None.

**5.9.3 References**

**CalFire 2007** – California Department of Forestry and Fire Protection (CalFire). 2007 *Santa Clara County – Very High Fire Hazard Severity Zones in State Responsibility Area*. Department of Forestry and Fire Protection. Projection Albers, NAD 1927, Scale 1: 100,000 at 32" x 27".

**DTSC 2018** – Department of Toxic Substances Control (DTSC). Envirostor Database. Available online at: <http://www.envirostor.dtsc.ca.gov/public/>. Accessed on: April 19, 2019.

**Jacobs 2019a** – Jacobs (Jacobs). (TN 227273-1). Application for Small Power Plant Exemption: Laurelwood Data Center, dated February 28, 2019. Available online at: <https://efiling.energy.ca.gov/Lists/DocketLog.aspx?docketnumber=19-SPPE-01>.

**Jacobs 2019b** – Jacobs (Jacobs). (TN 227273-2 through TN 227273-3). Laurelwood SPPE Application Appendices. Available online at: <https://efiling.energy.ca.gov/Lists/DocketLog.aspx?docketnumber=19-SPPE-01>.

**Jacobs 2019f** – Jacobs (Jacobs). (TN 228823). LDC Updated SPPE Project Description, dated June 21, 2019. Available online at: <https://efiling.energy.ca.gov/Lists/DocketLog.aspx?docketnumber=19-SPPE-01>.

**Jacobs 2019i** – Jacobs (Jacobs). (TN 229001). LDC Response to Data Request, Set 4, dated July 16, 2019. Available online at: <https://efiling.energy.ca.gov/Lists/DocketLog.aspx?docketnumber=19-SPPE-01>.

**Santa Clara County 2017** – County of Santa Clara Emergency Management. October 15, 2017. *Santa Clara County Operational Area Hazard Mitigation Plan Volumes 1&2*.

**SCCALUC 2016** - Santa Clara County Airport Land Use Commission (SCCALUC). 2016. *Mineta San Jose International Airport Comprehensive Land Use Plan for Santa Clara County*. Available online at:

[https://www.sccgov.org/sites/dpd/DocsForms/Documents/ALUC\\_SJC\\_CLUP.pdf](https://www.sccgov.org/sites/dpd/DocsForms/Documents/ALUC_SJC_CLUP.pdf). Accessed on: April 18, 2019.

**SWRCB 2018** – State Water Resources Control Board (SWRCB). GeoTracker Database. Available online at: <http://geotracker.waterboards.ca.gov>. Accessed on: April 19, 2019.



## 5.10 Hydrology and Water Quality

This section describes the environmental and regulatory setting and discusses impacts associated with the demolition/construction and operation of the Laurelwood Data Center (LDC or project) with respect to hydrology and water quality.

HYDROLOGY AND WATER QUALITY		Potentially Significant Impact	Less than Significant With Mitigation Incorporated	Less than Significant Impact	No Impact
<b>Would the project:</b>					
a.	Violate water quality standards or waste discharge requirements or otherwise substantially degrade surface or ground water quality?	<input type="checkbox"/>	<input type="checkbox"/>	<input checked="" type="checkbox"/>	<input type="checkbox"/>
b.	Substantially decrease groundwater supplies or interfere substantially with groundwater recharge such that the project may impede sustainable groundwater management of the basin?	<input type="checkbox"/>	<input type="checkbox"/>	<input checked="" type="checkbox"/>	<input type="checkbox"/>
c.	Substantially alter the existing drainage pattern of the site or area, including through the alteration of the course of a stream or river, or through the addition of impervious surfaces in a manner which would:				
i.	result in substantial erosion or siltation, on- or offsite;	<input type="checkbox"/>	<input type="checkbox"/>	<input checked="" type="checkbox"/>	<input type="checkbox"/>
ii.	substantially increase the rate or amount of surface runoff in a manner which would result in flooding on- or offsite;	<input type="checkbox"/>	<input type="checkbox"/>	<input checked="" type="checkbox"/>	<input type="checkbox"/>
iii.	create or contribute runoff water which would exceed the capacity of existing or planned stormwater drainage systems or provide substantial additional sources of polluted runoff; or	<input type="checkbox"/>	<input type="checkbox"/>	<input checked="" type="checkbox"/>	<input type="checkbox"/>
iv.	impede or redirect flood flows?	<input type="checkbox"/>	<input type="checkbox"/>	<input checked="" type="checkbox"/>	<input type="checkbox"/>
d.	In flood hazard, tsunami, or seiche zones, risk release of pollutants due to project inundation?	<input type="checkbox"/>	<input type="checkbox"/>	<input checked="" type="checkbox"/>	<input type="checkbox"/>
e.	Conflict with or obstruct implementation of a water quality control plan or sustainable groundwater management plan?	<input type="checkbox"/>	<input type="checkbox"/>	<input checked="" type="checkbox"/>	<input type="checkbox"/>

Environmental checklist established by CEQA Guidelines, Appendix G

### 5.10.1 Setting

#### Storm Drainage and Water Quality

The project would be constructed in the City of Santa Clara, within the Guadalupe watershed. The Guadalupe watershed drains to the San Francisco Bay, located a few miles northwest of the proposed project site. The site is located west of the Guadalupe River and east of San Tomas Aquino Creek. Storm water from the project site drains into the City of Santa Clara's storm water drain system, which discharges to San Tomas Aquino Creek and ultimately the San Francisco Bay.

The water quality of San Tomas Aquino Creek and other creeks is influenced by pollutants contained in storm water runoff. Storm water runoff from urban area typically contains conventional pollutants such as sediment, metals, pesticides, herbicides, oil, grease, asbestos, lead, and animal wastes.

Since the site was occupied by another industrial manufacturing entity, it is developed and mostly impervious.

## Groundwater

The Santa Clara Valley groundwater basin is divided into four interconnected subbasins that border the southern San Francisco Bay. The proposed project would be located in the Santa Clara Subbasin, which extends across the Santa Clara Valley in the region south of San Francisco Bay.

Fluctuations in rainfall, changing drainage patterns, and other hydrologic factors can influence groundwater levels. Based on the Seismic Hazard Zone Report 051 prepared by the Department of Conservation for the Milpitas 7.5-Minute Quadrangle, the historic shallowest observed depth to groundwater in the general site area was about 5 feet below ground surface (bgs) (CGS 2001). According to a recent geotechnical investigation of the site, groundwater was encountered between 6 and 13 feet bgs. Additionally, according to the pore pressure dissipation tests conducted at the site, groundwater was encountered between depths of 5.5 and 9 feet bgs (Cornerstone 2019). As recommended by the geotechnical investigation, a reasonable design assumption should be that groundwater could be encountered at 5 feet below grade at the proposed project site.

The project site's historic industrial uses resulted in groundwater and soil contamination. The primary groundwater contaminants identified are trichloroethylene (TCE), dichloroethylene (DCE), vinyl chloride, gasoline, and breakdown products. Groundwater and soil vapor monitoring are currently conducted at the site on a quarterly basis in accordance with the San Francisco Bay Regional Water Quality Control Board (RWQCB) order (Jacobs 2019a).

## Flooding

The average elevation of the existing project site is approximately 20 feet above the 1988 North American Vertical Datum (NAVD88). Though the site is located near the Guadalupe River and San Tomas Aquino Creek, these waterways do not pose an obvious flooding risk. According to the Federal Emergency Management Agency's (FEMA) Flood Insurance Rate Map (FIRM) 06085C0064H, effective May 18, 2009, the project site is located within Zone X. Zone X is defined as areas of 0.2 percent annual chance of flood (or a 500-year flood), areas of one percent chance of annual flood with average depths of less than one foot, or with drainage areas less than one square mile, and areas protected by levees from one percent annual chance of flood.

The project site is also not within an area mapped as vulnerable to sea level rise in the National Oceanic and Atmospheric Administration's Digital Coast, Sea Level Rise Viewer (NOAA 2019).

## Regulatory Background

### *Federal*

**Clean Water Act and California's Porter-Cologne Water Quality Control Act.** The State Water Resources Control Board (SWRCB) and its nine RWQCBs are responsible for the regulation and enforcement of the water quality protection requirements of the federal Clean Water Act (CWA) and the state's Porter-Cologne Water Quality Control Act (Porter-Cologne). The National Pollutant Discharge Elimination System (NPDES) is the permitting program that allows point source dischargers to comply with the CWA and Porter-Cologne laws. This regulatory framework protects the beneficial uses of the state's surface and groundwater resources for public benefit and environmental protection. Protection of water quality could be achieved by ensuring the proposed project complies with applicable NPDES permits from the SWRCB or the San Francisco Bay RWQCB.

Under Section 303(d) of the CWA, states are required to identify impaired surface water bodies and develop total maximum daily loads (TMDLs) for contaminants of concern. The TMDL is the quantity of pollutant that can be safely assimilated by a water body without violating water quality standards. Listing of a water body as impaired does not necessarily suggest that the water body cannot support the beneficial uses; rather, the intent is to identify the water body as requiring future development of a TMDL to maintain water quality and reduce the potential for future water quality degradation. San Tomas Aquino Creek, west of the project site, is currently listed on the United States Environmental Protection Agency's Section 303(d) Listed Waters for California for trash.

The San Francisco Bay RWQCB issued a Municipal Regional Storm Water NPDES Permit (Permit Number CAS612008) that requires the City of Santa Clara to implement a storm water quality protection program. This regional permit applies to 77 Bay Area municipalities, including the City of Santa Clara. Under the provisions of the Municipal NPDES permit, redevelopment projects that disturb more than 10,000 square feet are required to design and construct storm water treatment controls to treat post-construction storm water runoff. The permit requires the post-construction runoff from qualifying projects to be treated by using Low Impact Development (LID) treatment controls, such as biotreatment facilities. The Santa Clara Valley Urban Runoff Pollution Prevention Program (SCVURPPP) assists co-permittees, such as the City of Santa Clara, in the implementation of the provisions of the Municipal NPDES permit. In addition to water quality controls, the Municipal NPDES permit requires all new and redevelopment projects that create or replace one acre or more of impervious surface to manage development-related increases in peak runoff flow, volume, and duration, where such hydromodification is likely to cause increased erosion, silt pollutant generation, or other impacts to beneficial uses of local rivers, streams, and creeks. Projects may be deemed exempt from the permit requirements if they do not meet the size threshold, drain into tidally influenced areas or directly into the Bay, drain into hardened channels, or are infill projects in subwatersheds or catchment areas that are at least 65 percent impervious (per the City of Santa Clara Hydromodification Management Applicability Map). The project site is located in a catchment area that drains to a "hardened channel and/or tidal area"; thus, the project site is not subject to the SCVURPPP hydromodification requirements.

**Federal Emergency Management Agency Flood Insurance Program.** The magnitude of flood used nationwide as the standard for floodplain management is a flood having a probability of occurrence of one percent in any given year. This flood is also known as the 100-year flood, or base flood. The Federal Insurance Rate Map (FIRM) is the official map created and distributed by Federal Emergency Management Agency (FEMA) for the National Flood Insurance Program that shows areas subject to inundation by the base flood for participating communities. FIRMs contain flood risk information based on historic, meteorologic, hydrologic, and hydraulic data, as well as open-space conditions, flood control works, and development.

As stated above, the proposed project site is located in Zone X and therefore protected from the one percent annual chance flood.

**State Sustainable Groundwater Management Act.** The 2014 Sustainable Groundwater Management Act (SGMA) requires local public agencies and Groundwater Sustainability Agencies (GSAs) in high- and medium-priority basins to develop and implement Groundwater Sustainability Plans (GSPs) or Alternatives to GSPs. GSPs are detailed road maps for how groundwater basins will reach long term sustainability.

The Santa Clara Valley Water District (SCVWD) is the exclusive GSA for the Santa Clara Valley groundwater Subbasin, which contains the proposed project. SCVWD developed a groundwater management plan for the Santa Clara and Llagas Subbasins that is intended to be functionally equivalent to a GSP.

### 5.10.2 Environmental Impacts and Mitigation Measures

- a. *Would the project violate water quality standards or waste discharge requirements or otherwise substantially degrade surface or ground water quality?*

#### **Demolition/Construction, Operation and Maintenance**

LESS THAN SIGNIFICANT IMPACT. The proposed project would disturb about 12 acres of land and is subject to construction-related storm water permit requirements of California's NPDES General Permit for Storm Water Discharges Associated with Construction and Land Disturbance Activities (Construction General Permit) administered by the SWRCB. Prior to any ground-disturbing construction activity, the applicant must comply with the Construction General Permit, which includes preparation of a Storm Water Pollution Prevention Plan (SWPPP). With implementation of the construction phase SWPPP, redevelopment of the site would not cause a substantial degradation in the quality, or an increase in the rate or volume, of storm water runoff from the site during construction. In addition, the Municipal NPDES permit (and the SCVURPPP) requires that redevelopment not result in a substantial net increase in storm water flow exiting the project site during operation. As a result, runoff from the project site would not be expected to exceed the capacity of the local drainage system or be expected to significantly contribute to the degradation of storm water runoff quality.

The project is expected to excavate soil at the existing site to a depth of about 8 feet below grade. It is therefore possible that groundwater would be encountered and that dewatering would be necessary. The previous site owner, Siliconix, is expected to maintain responsibility for the contamination of groundwater beneath the site. Siliconix is also expected to continue to operate a groundwater monitoring and treatment system onsite, in accordance with their Site Management Plan (SMP) approved by the San Francisco RWQCB on March 13, 2019 (Jacobs 2019i). Extracted groundwater resulting from dewatering activities required for the demolition or construction of the Laurelwood project would be treated and discharged under Siliconix's existing VOC and Fuel General Permit (San Francisco RWQCB *General Order No. R2-2017-0048 NPDES Permit No. CAG912002*), and in accordance with the SMP. Approval from the Regional Board would be required if significant modifications to Siliconix's existing SMP associated with this general permit are required, though this is not expected. The ongoing groundwater cleanup is expected to continue without influencing the project schedule (Jacobs 2019i).

Thus, the project's potential to violate water quality standards or waste discharge requirements during demolition/construction and operation would be less than significant.

**Proposed Mitigation Measures:** None.

- b. Would the project substantially decrease groundwater supplies or interfere substantially with groundwater recharge such that the project may impede sustainable groundwater management of the basin?***

### **Demolition/Construction, Operation and Maintenance**

LESS THAN SIGNIFICANT IMPACT. The water supply to the project is not expected to be from a groundwater source. The proposed project's demand of 17 acre-feet per year (AFY) of potable water constitutes a small percentage of the city's projected demand for 2020 and beyond. The city's UWMP for 2015 shows that the city has sufficient supply to meet the project's demand in normal and single dry year scenarios. However, the UWMP shows that the city would have a deficit in a multiple dry year scenario that assumes supply from SFPUC would be interrupted. Under this scenario, the city's supply from SFPUC might be interrupted if certain conditions specified in the interruptible contract between the city and SFPUC are met (UWMP 2016). If supply from SFPUC is interrupted, the city would have to replace the demand using groundwater or water supplied by SCVWD.

According to the UWMP the groundwater basin has been managed successfully to prevent overdraft conditions. In case of a water supply shortage, the city has adopted water conservation policies to reduce demand such that available supplies are sufficient to meet demand (UWMP 2016). As discussed in **Section 5.18, Utilities and Service Systems**, the project does not meet the definition of a "project" for the purposes of preparing a Water Supply Assessment (WSA) by the water supplier. The project's impact on groundwater supplies or recharge during demolition/construction and operation would therefore be less than significant.

**Proposed Mitigation Measures:** None.

- c. Would the project substantially alter the existing drainage pattern of the site or area, including through the alteration of the course of a stream or river, or through the addition of impervious surfaces in a manner which would:***

***i. Result in substantial erosion or siltation on- or off-site;***

### **Demolition/Construction, Operation and Maintenance**

LESS THAN SIGNIFICANT IMPACT. The existing site is nearly covered with impervious surfaces and includes storm water collection and disposal facilities throughout the parcel. The proposed project would result in a reduction in impervious areas and would also include a new storm water collection system that includes eleven bioswales to reduce the overall runoff into the city's collection system and to control runoff, erosion, and sedimentation impacts. This post-construction design is therefore not expected to result in increased runoff (rate or volume) from the site. The storm water design is expected to comply with the SCVURPPP as well. Therefore, the impacts would be less than significant.

**Proposed Mitigation Measures:** None.

***ii. Substantially increase the rate or amount of surface runoff in a manner which would result in flooding on- or offsite;***

**Demolition/Construction, Operation and Maintenance**

LESS THAN SIGNIFICANT IMPACT. Surface runoff would be controlled as described in section (c)(i) above. Therefore, the impacts would be less than significant.

**Proposed Mitigation Measures:** None.

***iii. Create or contribute runoff water which would exceed the capacity of existing or planned stormwater drainage systems or provide substantial additional sources of polluted runoff; or***

**Demolition/Construction, Operation and Maintenance**

LESS THAN SIGNIFICANT IMPACT. The proposed project would result in a reduction in impervious areas and would also include a new storm water collection system that includes eleven bioswales to reduce the overall runoff into the city's collection system. The discharge of polluted runoff would be expected to be similarly reduced. Therefore, the impacts would be less than significant.

**Proposed Mitigation Measures:** None.

***iv. Impede or redirect flood flows?***

**Demolition/Construction, Operation and Maintenance**

LESS THAN SIGNIFICANT IMPACT. Though the site is located near the Guadalupe River and San Tomas Aquino Creek, these waterways do not pose a likely flood risk. According to the FEMA FIRM 06085C0064H, effective May 18, 2009, the project site is located within Zone X. Zone X is defined as areas of 0.2 percent annual chance of flood, areas of one percent chance of annual flood with average depths of less than one foot, or with drainage areas less than one square mile, and areas protected by levees from one percent annual chance of flood. The project site is also not within an area mapped as vulnerable to sea level rise in the National Oceanic and Atmospheric Administration's Digital Coast, Sea Level Rise Viewer (NOAA 2019).

The proposed project is also not expected to add significantly to the existing potential of the site to impede flood flows. The proposed project would have significant structures, like the existing site did, that would similarly impede or redirect flood flows. Therefore, no net change in obstruction is expected from the proposed project and the impacts would be less than significant.

**Proposed Mitigation Measures:** None.

***d. Would the project, in flood hazard, tsunami, or seiche zones, risk release of pollutants due to project inundation?***

**Demolition/Construction, Operation and Maintenance**

LESS THAN SIGNIFICANT IMPACT. Though the site is located near the Guadalupe River and San Tomas Aquino Creek, these waterways do not pose a likely flood risk. The project site is located within Zone X. The project site is also not within an area mapped as vulnerable to sea level rise in the National Oceanic and Atmospheric Administration's Digital Coast, Sea Level Rise Viewer (NOAA 2019).



The project site is within the inundation zones of two upstream reservoirs. Lexington Reservoir and James J. Lenihan Dam are located on Los Gatos Creek approximately 15 miles upstream. The Lenihan Dam Flood Inundation Map shows that dam failure would result in flooding at the project site (Jacobs 2019a).

The project site is not located near a large body of water, the ocean, or steep slopes. Due to the location of the proposed project site, it would not be subject to inundation by seiche, tsunami, or mudflow.

In the unlikely event of a flood, release of on-site pollutants would be prevented by the SWPPP, Worker Environmental Training, a Spill Prevention, Control, and Countermeasure Plan, a Hazardous Materials Business Plan, and through an emergency spill response program. All of these measures would work together to help keep potential pollutants properly contained. Therefore, the impacts would be less than significant.

**Proposed Mitigation Measures:** None.

- e. Would the project conflict with or obstruct implementation of a water quality control plan or sustainable groundwater management plan?*

#### **Demolition/Construction, Operation and Maintenance**

LESS THAN SIGNIFICANT IMPACT. The Water Quality Control Plan for the San Francisco Bay Basin (Basin Plan) is the local water quality control plan. The project would comply with the Basin Plan by implementing the requirements of the Construction General Permit, as described in section (a) above, and through the preparation of a construction SWPPP. This impact would be less than significant.

SCVWD developed a groundwater management plan for the Santa Clara and Llagas subbasins that is intended to be functionally equivalent to a GSP. The information contained in the SCVWD groundwater management plan is used to inform the city of Santa Clara's UWMP about groundwater supplies. Therefore, the UWMP should be used to evaluate how a proposed project would impact the implementation of the sustainable groundwater management plan. The proposed project's demand of 17 AFY constitutes a small percentage of the city's projected demand for 2020 and beyond. The city's UWMP for 2015 shows that it has sufficient supply to meet the project's demand in normal and single dry year scenarios. However, the UWMP also shows that the city would have a deficit in a multiple dry year scenario that assumes that supply from SFPUC would be interrupted. Under this scenario, the city's supply from SFPUC might be interrupted if certain conditions specified in the interruptible contract between the city and SFPUC are met (UWMP 2016). If supply from SFPUC is interrupted the city would have to replace the demand using groundwater or supply water from SCVWD.

According to the UWMP, the groundwater basin has been managed successfully to prevent overdraft conditions. In case of a water supply shortage, the city has adopted water conservation policies to reduce demand such that available supplies are sufficient to meet demand (UWMP 2016). The proposed project would therefore not be expected to impede the implementation of the SCVWD's groundwater management plan. This impact would be less than significant.

**Proposed Mitigation Measures:** None.

### 5.10.3 References

- Cornerstone 2019** – Cornerstone Earth Group (Cornerstone). Geotechnical Investigation, 2201 Laurelwood Road, Santa Clara, California. Prepared by Cornerstone Earth Group, March, 2019.
- CEMA 2009** – California Emergency Management Agency (CEMA). Tsunami Inundation Map for Emergency Planning, Mountain View Quadrangle. Prepared by the California Emergency Management Agency. Published July 31, 2009.
- CGS 2001** – California Department of Conservation (CGS). Seismic Hazard Zone Report for the Milpitas 7.5-Minute Quadrangle, Santa Clara County, California. Seismic Hazard Zone Report 051. California Department of Conservation, 2001.
- Santa Clara 2014** – City of Santa Clara (Santa Clara). 2010-2035 General Plan. Approved December 9, 2014. Available online at: <http://santaclaraca.gov/government/departments/community-development/planning-division/general-plan>. Accessed on: May 9, 2019.
- DWR 2003** – Department of Water Resources (DWR). Guidebook for Implementation of Senate Bill 610 and Senate Bill 221 of 2001. California Department of Water Resources. October 8, 2003.
- Jacobs 2019a** – Jacobs (Jacobs). (TN 227273-1). Application for Small Power Plant Exemption: Laurelwood Data Center, dated February 28, 2019. Available online at: <https://efiling.energy.ca.gov/Lists/DocketLog.aspx?docketnumber=19-SPPE-01>.
- Jacobs 2019i** – Jacobs (Jacobs). (TN 229001). LDC Response to Data Request, Set 4, dated July 16, 2019. Available online at: <https://efiling.energy.ca.gov/Lists/DocketLog.aspx?docketnumber=19-SPPE-01>.
- NOAA 2019** – National Oceanic and Atmospheric Administration (NOAA). Digital Coast, Sea Level Rise Viewer. Accessed on May 9, 2019. Available online at: <https://coast.noaa.gov/slr/#/layer/slr/0/-11581024.663779823/5095888.569004184/4/satellite/none/0.8/2050/interHigh/midAccretion>.
- UWMP 2016** – City of Santa Clara 2015 Urban Water Management Plan (UWMP). Prepared by the City of Santa Clara Water and Sewer Utilities. Adopted November 22, 2016.

## 5.11 Land Use and Planning

This section describes the environmental and regulatory setting and discusses impacts associated with the demolition/construction and operation of the Laurelwood Data Center (LDC or project) with respect to land use and planning.

LAND USE PLANNING	Potentially Significant Impact	Less than Significant With Mitigation Incorporated	Less than Significant Impact	No Impact
<b>Would the project:</b>				
a. Physically divide an established community?	<input type="checkbox"/>	<input type="checkbox"/>	<input type="checkbox"/>	<input checked="" type="checkbox"/>
b. Cause a significant environmental impact due to a conflict with any land use plan, policy, or regulation adopted for the purpose of avoiding or mitigating an environmental effect?	<input type="checkbox"/>	<input type="checkbox"/>	<input checked="" type="checkbox"/>	<input type="checkbox"/>

Environmental checklist established by CEQA Guidelines, Appendix G.

### 5.11.1 Setting

The project site is located in an existing industrial and office area in the City of Santa Clara. The site was previously developed with industrial warehouse, manufacturing, and office facility uses and associated parking. The project site is bounded by: Highway 101 to the south; Juliette Lane to the east; industrial, commercial, and office uses to the east and north; and a parking lot to the west.

#### Regulatory Background:

##### *Federal*

No federal regulations related to land use and planning apply to the project.

##### *State*

No state regulations related to land use and planning apply to the project.

##### *Local*

**City of Santa Clara 2010-2035 General Plan.** The City of Santa Clara 2010–2035 General Plan (General Plan) was adopted on November 16, 2010. The project site is designated Low Intensity Office/Research and Development (R&D), as shown on the Land Use Diagrams for the General Plan’s three planning phases. The Low Intensity Office/R&D designation is “intended for campus-like office development that includes office and R&D, as well as medical facilities and free standing data centers....The maximum FAR (floor area ratio) is 1.00” (Santa Clara 2010).

**City of Santa Clara Zoning Ordinance.** Under the City of Santa Clara’s zoning ordinance, the project site is zoned Planned Industrial (MP). This zoning district is “intended to provide an environment exclusively for and conducive to the development and protection of modern large-scale administrative facilities, research institutions, and specialized manufacturing institutions, all of a non-nuisance type”. Permitted uses in the MP zoning district include light manufacturing and activity not dealing with large volumes of product handling, storage, and distribution and that, in the opinion of the Planning Commission, are similar in character and not more detrimental to the health, safety, and general welfare of the neighborhood than any other permitted uses. Other permitted uses include: science, engineering, research, and testing offices and laboratories; light manufacturing; and professional, financial, and administrative offices. Such permitted uses shall not cause objectionable noise, smoke, odor, dust, noxious gases, vibration, glare, heat, fire hazards, or other wastes emanating from the property (Santa Clara 2019a).

In the MP zoning district, buildings, including accessory buildings, shall not cover more than 50 percent of the area of any lot (Santa Clara 2019a). The maximum permitted building height in this zoning district is 70 feet. According to Section 18.90.020 of the City of Santa Clara Zoning Ordinance, the Zoning Administrator shall have the authority to permit minor modifications to height that do not exceed 25 percent of the zoning district's maximum height (Santa Clara 2019b).

### **5.11.2 Environmental Impacts and Mitigation Measures**

#### ***a. Would the project physically divide an established community?***

##### **Demolition/Construction**

NO IMPACT. Project demolition/construction activities would occur fully on site and would not physically divide an established community. Construction would occur on a parcel previously used for similar uses, and that never served as a link between communities. No impact would occur.

##### **Operation and Maintenance**

NO IMPACT. The project would replace existing industrial warehouse, manufacturing, and office facilities and their associated parking with: two data center buildings (one with a floor area of 250,560 square feet and one with a floor area of 283,392 square feet); 56 standby diesel generators; an approximately 31,150 square-foot substation; and associated parking. Operation and maintenance of the project would occur fully on site and would not physically divide an established community. The project would occupy a parcel previously used for similar uses, and that never served as a link between communities. No impact would occur.

**Proposed Mitigation Measures:** None.

#### ***b. Would the project cause a significant environmental impact due to a conflict with any land use plan, policy, or regulation adopted for the purpose of avoiding or mitigating an environmental effect?***

##### **Demolition/Construction**

NO IMPACT. Construction and demolition activities would occur fully within a parcel previously developed with similar uses. For these reasons, project construction would not conflict with any land use plan, policy, or regulation adopted for the purpose of avoiding or mitigating an environmental effect. No impact would occur.

##### **Operation and Maintenance**

LESS THAN SIGNIFICANT IMPACT.

##### ***General Plan***

The project is generally consistent with the City of Santa Clara's General Plan, and any minor inconsistencies would cause less than significant impacts. The project site's General Plan land use designation is Low Intensity Office/R&D, as shown on the Land Use Diagrams for the General Plan's three planning phases. The Low Intensity Office/R&D designation is "intended for campus-like office development that includes office and R&D, as well as medical facilities and free standing data centers" (Santa Clara 2010). The project's proposed data center use is consistent with the description of uses

allowed in the Low Intensity Office/R&D land use designation. However, the project has a FAR<sup>3</sup> of 1.02, which slightly exceeds the General Plan's maximum FAR of 1.00 for the Low Intensity Office/R&D land use designation (Santa Clara 2010).

FAR regulations are often used by local governments to predict and limit the intensity of land uses and their resulting environmental impacts. A project with a higher than allowed FAR could result in environmental impacts unanticipated by the General Plan, such as increased vehicle miles travelled, a potential transportation impact under the CEQA Guidelines. However, the project's FAR of 1.02 is very close to the maximum allowed FAR of 1.00, and data centers have low employment density despite their large size. For these reasons, the slightly increased project FAR would not increase the number of employees and vehicle miles travelled beyond that anticipated by the City's General Plan. Furthermore, the project applicant would obtain a "minor modification" from the City's Zoning Administrator to allow this minor deviation from FAR requirements. According to Section 18.90.020 of the City of Santa Clara's zoning ordinance, the Zoning Administrator may grant approval of minor modifications of height, area, and yard regulations, where the allowed regulations are not exceeded by more than 25 percent (Santa Clara 2019b). The applicant is currently working with the City's Zoning Administrator on this minor modification, and the applicant anticipates that the City will grant the minor modification during building permit review. With City Zoning Administrator approval of a slightly increased FAR, the project would be consistent with FAR policies. Therefore, the project's inconsistency with the General Plan's maximum FAR would cause less than significant impacts.

### ***Zoning Ordinance***

Although the City of Santa Clara's zoning ordinance does not specifically list data centers as a permitted use under the MP zoning designation, the project would be consistent with the listed permitted uses. The listed permitted uses include: science, engineering, research, and testing offices and laboratories; light manufacturing; and professional, financial, and administrative offices. The Zoning Ordinance states that other permitted uses are "[activities] not dealing with large volumes of product handling, storage, and distribution and that, in the opinion of the Planning Commission, are similar in character and not more detrimental to the health, safety, and general welfare of the neighborhood than any other permitted uses." The proposed data center would not deal with large volumes of product handling or distribution and would avoid creating nuisances in the MP zoning district, including objectionable noise, smoke, odor, dust, noxious gases, vibration, glare, heat, fire hazards, or other wastes emanating from the property. While the project does include storage of large amounts diesel fuel, storage would not cause any significant impacts, including the nuisances previously mentioned. (See **Section 5.9, Hazards and Hazardous Materials**, for more information.) Therefore, the proposed data center use is consistent with the uses allowed under the MP zoning designation.

The project applicant would obtain a "minor modification" from the City's Zoning Administrator to allow heights of 81 and 84 feet for the proposed data center buildings, which would exceed the MP zoning district's maximum building height of 70 feet. According to Section 18.90.020 of the City of Santa Clara's zoning ordinance, a height of 87.5 feet is the maximum that a minor modification would allow, as it represents a 25 percent increase from the permitted height of 70 feet (Santa Clara 2019b). The applicant is currently working with the City's Zoning Administrator on this minor modification,

---

<sup>3</sup> The FAR, or floor area ratio, of a development is the total square footage of each floor of the building/s on the lot divided by the square footage of the lot area. To obtain the FAR for this project, the proposed total floor area of 533,952 square feet is divided by the total lot area of 521,511 square feet. The result is a FAR of 1.02.

and the applicant anticipates that the City will grant the minor modification during building permit review. With City Zoning Administrator approval of a minor modification for increased building height, the project would be consistent with the MP zoning designation. Furthermore, height regulations are generally intended to reduce environmental impacts to the aesthetic quality of a site or area, and despite the project's height, aesthetic impacts from this project would be less than significant, given the lack of scenic resources in the area and the presence of nearby existing buildings exceeding the proposed project's height. See **Section 5.1, Aesthetics**, for more information. For these reasons, impacts from the project's increased height would be less than significant.

The project's building coverage, including the data centers and substation, would cover approximately 37 percent of the project site, which is below the maximum of 50 percent established by the MP zoning district.

**Proposed Mitigation Measures:** None.

### 5.11.3 References

- Jacobs 2019a** – Jacobs (Jacobs). (TN 227273-1). Application for Small Power Plant Exemption: Laurelwood Data Center, dated March 5, 2019. Available online at:  
<https://efiling.energy.ca.gov/Lists/DocketLog.aspx?docketnumber=19-SPPE-01>.
- Jacobs 2019f** – Jacobs (Jacobs). (TN 228823). LDC Updated SPPE Project Description, dated June 21, 2019. Available online at:  
<https://efiling.energy.ca.gov/Lists/DocketLog.aspx?docketnumber=19-SPPE-01>.
- Santa Clara 2010** – City of Santa Clara (Santa Clara). 2010–2035 General Plan: Chapter 5 Goals and Policies, Land Use Diagrams Phases I, II, and III. Adopted November 16, 2010. Available online at:  
<http://santaclaraca.gov/government/departments/community-development/planning-division/general-plan>. Accessed on: March 29, 2019.
- Santa Clara 2019a** – City of Santa Clara (Santa Clara). City Code, Chapter 18.46: Regulations for MP-Planned Industrial Zoning Districts. Available online at:  
<https://www.codepublishing.com/CA/SantaClara/#!/SantaClara18/SantaClara1846.html#18.46>. Accessed on: April 18, 2019.
- Santa Clara 2019b** – City of Santa Clara (Santa Clara). City Code, Chapter 18.90: Zoning Administrator. Available online at:  
<https://www.codepublishing.com/CA/SantaClara/#!/SantaClara18/SantaClara1890.html#18.90>. Accessed on: April 18, 2019.



## 5.12 Mineral Resources

This section describes the environmental and regulatory setting and discusses impacts associated with the demolition/construction and operation of the Laurelwood Data Center (LDC or project) with respect to mineral resources. Analysis of impacts is limited to project components where ground disturbance would occur, and operation of new facilities would limit access to mineral resources.

MINERAL RESOURCES	Potentially Significant Impact	Less than Significant With Mitigation Incorporated	Less than Significant Impact	No Impact
<b>Would the project:</b>				
a. Result in the loss of availability of a known mineral resource that would be of value to the region and the residents of the State?	<input type="checkbox"/>	<input type="checkbox"/>	<input type="checkbox"/>	<input checked="" type="checkbox"/>
b. Result in the loss of availability of a locally important mineral resource recovery site delineated on a local general plan, specific plan or other land use plan?	<input type="checkbox"/>	<input type="checkbox"/>	<input type="checkbox"/>	<input checked="" type="checkbox"/>

Environmental checklist established by CEQA Guidelines, Appendix G.

### 5.12.1 Setting

Information on mineral resources was compiled from published literature, maps, and review of aerial photographs. Impacts to mineral resources from project construction and operational activities were evaluated qualitatively based on the area occupied by the project, site conditions, expected construction practices, anticipated materials used, and the locations and duration of project construction and operational activities.

The project site, located within the City of Santa Clara, is in an area identified as Mineral Resource Zone 1 (MRZ-1) for aggregate materials by the State of California (DOC, 1996). MRZ-1 refers to an area where available geologic information indicates that little likelihood exists for the presence of significant mineral resources (Jensen and Silva 1988). The project site and surrounding area are not known to support significant mineral resources of any type. In addition, the Division of Mine Reclamation's list of mines, referred to as the AB 3098 List and regulated under the Surface Mining and Reclamation Act (SMARA), does not include any mines within the City of Santa Clara (DOC 2016)

### Regulatory Background

#### *Federal*

No federal regulations related to mineral resources apply to the project.

#### *State*

**Surface Mining and Reclamation Act.** The California Surface Mining and Reclamation Act of 1975 (SMARA) requires that the State Geologist classify land into MRZ or Scientific Zones according to the known or inferred mineral potential of the land (Pub. Resources Code, §§ 2710-2796).

MRZs are defined as the following (Jensen and Silva 1988):

- MRZ-1: Areas where adequate information indicates that no significant mineral deposits are present, or where it is judged that little likelihood exists for their presence.

- MRZ-2: Areas where adequate information indicates that significant deposits are present, or where it is judged that a high likelihood for their presence exists. The guidelines set forth two requirements to be used to determine if land should be classified MRZ-2:
  - The deposit must be composed of material that is suitable as a marketable commodity. The deposit must meet threshold value.
  - The projected value (gross selling price) of the deposit, based on the value of the first marketable product, must be at least \$5 million (1978 dollars).
- MRZ-3: Areas containing mineral deposits, but their significance cannot be evaluated from available data.
- MRZ-4: Areas where available information is inadequate for assignment to any other MRZ category.

Scientific Zones are defined as: Areas containing unique or rare occurrence of rocks, minerals, or fossils that are of outstanding scientific significance shall be classified in this zone.

### 5.12.2 Environmental Impacts and Mitigation Measures

- a. Would the project result in the loss of availability of a known mineral resource that would be of value to the region and the residents of the State?***

#### **Demolition/Construction**

NO IMPACT. The project site is in a developed urban area and does not contain any known or designated mineral resources. Therefore, the project would not result in the loss of availability of a known mineral resource.

#### **Operation and Maintenance**

NO IMPACT. The project site is in a developed urban area and does not contain any known or designated mineral resources. Therefore, the project would not result in the loss of availability of a locally important mineral resource recovery site.

**Proposed Mitigation Measures:** None.

- b. Would the project result in the loss of availability of a locally important mineral resource recovery site delineated on a local general plan, specific plan, or other land use plan?***

#### **Demolition/Construction**

NO IMPACT. The project site is in a developed urban area and does not contain any known or designated mineral resources. Therefore, the project would not result in the loss of availability of a locally important mineral resource recovery site.

#### **Operation and Maintenance**

NO IMPACT. The project site is in a developed urban area and does not contain any known or designated mineral resources. Therefore, the project would not result in the loss of availability of a locally important mineral resource recovery site.

**Proposed Mitigation Measures:** None.

### 5.12.3 References

- DOC 2016** – California Department of Conservation (DOC) - AB 3098 List. Available online at: <ftp://ftp.consrv.ca.gov/pub/omr/AB3098%20List/AB3098List.pdf>. Accessed on: May 6, 2019.
- DOC 1996** – California Department of Conservation (DOC) - Revised Mineral Land Classification Map. Aggregate Resources Only. South San Francisco Bay Production-Consumption Region. Mountain View Quadrangle. Open-File Report 96-03. Available online at: <https://maps.conservation.ca.gov/cgs/informationwarehouse/index.html?map=mlc>. Accessed on: May 6, 2019
- Jacobs 2019a** – Jacobs (Jacobs). (TN 227273-1). Application for Small Power Plant Exemption: Laurelwood Data Center, dated March 5, 2019. Available online at: <https://efiling.energy.ca.gov/Lists/DocketLog.aspx?docketnumber=19-SPPE-01>.
- Jensen, L.S. and Silva, M.A. 1988** – *Mineral Land Classification of Portland Cement Concrete Aggregate in the Stockton-Lodi Production-Consumption Region*. California Division of Mines and Geology, Special Report 160. Available online at: [https://water.ca.gov/LegacyFiles/floodmgmt/docs/misc\\_refs/Jensen\\_Silva\\_1988\\_minerallandclass.pdf](https://water.ca.gov/LegacyFiles/floodmgmt/docs/misc_refs/Jensen_Silva_1988_minerallandclass.pdf). Accessed on: November 7, 2018.

## 5.13 Noise

This section describes the environmental and regulatory setting and discusses impacts associated with the demolition/construction and operation of the Laurelwood Data Center (LDC or project) with respect to noise.

NOISE	Potentially Significant Impact	Less than Significant With Mitigation Incorporated	Less Than Significant Impact	No Impact
<b>Would the project result in:</b>				
a. Generation of a substantial temporary or permanent increase in ambient noise levels in the vicinity of the project in excess of standards established in the local general plan or noise ordinance, or applicable standards of other agencies?	<input type="checkbox"/>	<input type="checkbox"/>	<input checked="" type="checkbox"/>	<input type="checkbox"/>
b. Generation of excessive groundborne vibration or groundborne noise levels?	<input type="checkbox"/>	<input type="checkbox"/>	<input checked="" type="checkbox"/>	<input type="checkbox"/>
c. For a project located within the vicinity of a private airstrip or an airport land use plan or, where such a plan has not been adopted, within two miles of a public airport or public use airport, would the project expose people residing or working in the project area to excessive noise levels?	<input type="checkbox"/>	<input type="checkbox"/>	<input checked="" type="checkbox"/>	<input type="checkbox"/>

Environmental checklist established by CEQA Guidelines, Appendix G.

### 5.13.1 Setting

The project site is surrounded by industrial and commercial land uses. The project site is designated as Low Intensity Office/Research and Development under the City of Santa Clara 2010-2035 General Plan (Santa Clara 2014) and is zoned as MP (Planned Industrial). Surrounding zoning designations include PD - Planned Development, MP - Planned Industrial, and ML – Light Industrial. The nearest residential land use located approximately 0.5 mile north of the project site boundary. The nearest airport is the Norman Y. Mineta San Jose International Airport located approximately 1.4 miles to the southeast.

The project site is surrounded by industrial, commercial, and office/R&D. The closest residential area is located on Agnew Avenue. The predominant ambient noise sources are attributed to the automobile traffic on the adjacent US 101 Highway and Montague Expressway, as well as Mission College Boulevard located about 2,000 feet north of the project site. Another prominent noise source is aircraft traffic arriving to and departing from the Norman Y. Mineta San José International Airport. Additional ambient sounds in the area include construction activity occurring in the planned development area to the north of the project site. A noise survey that was conducted for the proposed development of another data center just about 2,000 feet north of the project site found that the ambient noise level at the residential area is fairly high. The day-night average noise level ( $L_{dn}$ ) at Agnew Road was 72 dBA in the area of this residential area, and 71 at Mission College Blvd. in the area of the nearby commercial buildings (Santa Clara 2018, Appendix G).

This noise analysis evaluates the LDC facility, including its backup generators (referred to as the project).

## Regulatory Background

### *Thresholds of Significance*

The CEQA Guidelines state that a project would normally be considered to have a significant impact if noise levels conflict with adopted environmental standards or plans, or if noise levels generated by the project would substantially increase existing noise levels at noise-sensitive receivers on a permanent or temporary basis. CEQA does not define what noise level increase would be substantial. The Santa Clara General Plan (City of Santa Clara 2014) defines an increase of 3 dBA as noticeable and 5 dBA as distinct. Typically, ambient noise level increases of more than 3 dBA due to a project are considered potentially significant where resulting exterior noise levels would exceed the normally acceptable noise level standard. Where noise level would remain at or below the normally acceptable noise level standard with the project, a noise level increase of 5 dBA or greater would be considered potentially significant.

**City of Santa Clara 2010-2035 General Plan.** The City of Santa Clara 2010-2035 General Plan describes the levels of exterior noise considered compatible for various land uses to guide land use planning decisions. The Santa Clara Municipal Code, discussed below, establishes more specific sound limits (Santa Clara 2019).

**City of Santa Clara Municipal Code.** Chapter 9.10 (noise ordinance) of the City of Santa Clara Municipal Code applies to the regulation of noise and vibration for this project. Section 9.10.040 specifies the exterior noise limits that apply to land use zones within the city. The city's exterior noise limit for light industrial (ML) and planned industrial (MP) land use zones is 70 dBA (anytime), the exterior noise limit for commercial land uses is 65 dBA (daytime), and the exterior noise limit for residential land uses is 55 dBA (daytime). The city's noise limits for stationary noise sources are not applicable to emergency work, including the operation of emergency generators during an emergency (Section 9.10.070); however, the intermittent testing of the emergency generators would be subject to the local noise regulations defined in the city's noise ordinance (Santa Clara 2019).

## 5.13.2 Environmental Impacts and Mitigation Measures

- a. Would the project result in generation of a substantial temporary or permanent increase in ambient noise levels in the vicinity of the project in excess of standards established in the local general plan or noise ordinance, or applicable standards of other agencies?*

### **Demolition/Construction**

LESS THAN SIGNIFICANT IMPACT. In addition to construction of the LDC, the project would require demolition of existing foundations and removal of underground utilities. Demolition activities would likely utilize equipment that could generate noise levels that exceed ambient noise such as bulldozers and jackhammers. Typical equipment used for construction and demolition of similar projects produce noise levels between 75 and 95 dBA at 50 feet.

Sound levels from stationary noise sources attenuate at a rate of 6 dBA for every doubling of distance. At the nearest commercial building, Intel Corp., the loudest project construction level of 95 dBA translates to an exterior level of 79 dBA. This is an increase of 8 dBA above the ambient level in this area (71 dBA) and is not considered significant because the use of the loudest equipment would not be frequent and would be for short durations (i.e., jackhammer to break up pavement and concrete). Also, if needed, quieter equipment is readily available. For example, jackhammers can be equipped with mufflers that reduce noise exposure.

Using the rate of 6 dBA for every doubling of distance, at the residences 0.5 mile away, the attenuation is about 34 dBA. Reducing the noise level of the loudest piece of equipment by 34 dBA, the exterior sound that would be detected at the closest residence would be 61 dBA. This is well below the existing ambient noise level at the residential area north of the project site. Moreover, the above calculation does not take into account the presence of several sound barriers such as perimeter walls, commercial buildings, and trees that separate the noise source from the receptor. These barriers would result in further reduction of the noise impact at the residential area.

The city exempts construction noise sources from its prescribed noise level limits as long as construction and demolition activities occur during the daytime hours of 7:00 am to 6:00 pm Monday through Friday and 9:00 am to 6:00 pm Saturday, but prohibits construction work on Sundays and holidays. Project construction activities would be limited to those prescribed by the city (Jacobs 2019a, page 3.13-7). Project construction activities would not be expected to result in a significant impact in terms of noise levels, especially in light of the fact that the project site is surrounded with mostly industrial and commercial areas and that the closest residence is about 0.5 mile away.

### **Operation and Maintenance**

LESS THAN SIGNIFICANT IMPACT. The proposed emergency generators, which would be enclosed in equipment yards along the outside of the two main buildings, would provide backup power to the data center buildings in the event that an equipment failure or other conditions result in an interruption of the electricity provided by Silicon Valley Power. As discussed above, the city's exterior noise limit for planned industrial land use zones is 70 dBA (anytime), the exterior noise limit for commercial land uses is 65 dBA (daytime), and the exterior noise limit for residential land uses is 55 dBA (daytime). As described in the city's Municipal Code (Section 9.10.070), the city's noise limits for stationary noise sources are not applicable to emergency work, including the operation of emergency generators during an emergency. However, emergency generator testing would occur intermittently and one at a time such that they would not generate significant noise in non-emergency situations. Furthermore, the tests are subject to the local noise regulations defined in the city's noise ordinance. The applicant would use generators with specifications that ensure sufficient exhaust silencing and other design measures, if required, such that the project meets the city noise requirements. The CAT C175-16 diesel generators that the project would use comes with exhaust muffler options that are capable of reducing noise levels by up to 34 dBA (CAT 2019).

During the LDC's normal operation, other noise sources would include HVAC units and cooling tower pumps and fans that would be on the LDC building rooftop. A worst-case scenario would occur if the generators would be tested in conjunction with the regularly operating equipment. However, since the frequency of testing the emergency generators is low, and emergency generators would be tested one at a time, the noise generated during the worst-case scenario would not be substantially higher than that during normal operation. Infrequent exceedance of the ambient noise levels is generally not considered a significant impact. In addition, since the surrounding areas are mostly industrial and commercial land uses with no residential receptors nearby, the acceptable noise level adjacent to the project site is quite high, or 65 dBA, according to city regulation. Furthermore, the project could implement a combination of commonly used measures to mitigate any potential increase in noise levels to below levels allowed by the local regulations.

The city's 65 dBA operational limit requirement at the adjacent commercial use (the Intel building) would be achieved through practical and available noise-reducing measures and devices, which are usually determined in the final design stage of a project. The following measures and devices are



typically implemented at data centers for the purpose of reducing noise levels to be compatible with regulations adopted by the local regulatory authorities:

- Acoustical wall: The project application states that acoustical walls would be installed around the generator yards in order to ensure that the noise level at the project boundary does not exceed city regulations.
- Enclosures, low speed fans, duct and transition silencers, and acoustic louvers: These are typically installed in facility yards to control noise levels at project perimeter.
- Acoustical building panels, tiles, and baffles: These are typically installed inside buildings to reduce internal noise levels.
- Sound dampening server cabinets: These are also to reduce noise levels inside buildings.

Since the closest residence is located 0.5 mile away, the 65 dBA level at the adjacent Intel building translates to approximately 49 dBA; much less than the existing ambient level at this location.

Therefore, the impact from project operation in terms of noise pollution would be less than significant.

Noise levels from project construction and operation would not conflict with adopted environmental standards or plans.

**Proposed Mitigation Measures:** None.

***b. Would the project result in generation of excessive groundborne vibration or groundborne noise levels?***

**Demolition/Construction**

LESS THAN SIGNIFICANT IMPACT. The only construction work likely to produce vibration that could be potentially significant when perceived off site would be pile driving, but pile driving would not occur for this project (Jacobs 2019a, section 3.13.5).

Activities associated with demolition of the subgrade infrastructure would likely include vibration generating equipment such as jackhammers and vibratory rollers. This analysis relies on the vibration thresholds identified by Caltrans to determine the significance of vibration impacts related to adverse human reaction. These thresholds are consistent with local regulations. The threshold of human response begins at 0.16 in/sec. Caltrans characterizes this as a “distinctly perceptible” event (Caltrans 2013). A level of 0.20 in/sec has been found to be annoying to people in buildings and can pose a risk of architectural damage to buildings.

Jackhammers can cause a ground-borne vibration rate of 0.035 in/sec at 25 feet (less than the threshold of human response) and vibratory rollers can cause a groundborne vibration of 0.21 in/sec at 25 feet (Caltrans 2013). At the adjacent Intel building, 0.21 in/sec translates to about 0.029 in/sec; less than the threshold of human response. Also, no residential land uses are in the proximity of the project site; the nearest residence is located roughly 0.5 mile away.

Construction and demolition equipment and activities would be similar to those used at similar projects and vibration impacts from project construction and demolition would be less than significant.

## Operation and Maintenance

LESS THAN SIGNIFICANT IMPACT. The project would be designed to use well balanced equipment to control vibration. The equipment that would be used in the project are well balanced and are designed to produce very low vibration levels throughout the life of the project. An imbalance could contribute to ground vibration levels only in the vicinity of the equipment and would be corrected. The applicant intends to consider the potential for low frequency noise in the design and specification of the project equipment and take necessary steps to prevent ground or airborne vibration impacts (Jacobs 2019a, section 3.13.5). In addition, the applicant is planning to use backup generators with specifications that ensure sufficient exhaust silencing to reduce vibration. Therefore, vibration impacts from project construction and demolition would be less than significant.

**Proposed Mitigation Measures:** None.

- c. *For a project located within the vicinity of a private airstrip or an airport land use plan or, where such a plan has not been adopted, within two miles of a public airport or public use airport, would the project expose people residing or working in the project area to excessive noise levels?*

## Demolition/Construction, Operation and Maintenance

LESS THAN SIGNIFICANT IMPACT. The project site is located within an airport land use plan as it is located approximately 1.4 miles northwest of the Norman Y. Mineta San Jose International Airport. However, the project is located outside the Airport Noise Zone (the 65 CNEL contour, as set forth by state law) as defined in the Comprehensive Land Use Plan for the airport. Also, the project would comply with the city's noise standards. Thus, the project would not combine with this or any other nearby public airport to expose people to excessive noise levels. Also, the project site is not in the vicinity of a private airstrip.

**Proposed Mitigation Measures:** None.

### 5.13.3 References

**Caltrans 2013** – California Department of Transportation (Caltrans). Technical Noise Supplement to the Caltrans Traffic Noise Analysis Protocol, A Guide for Measuring, Modeling, and Abating Highway Operation and Construction Noise Impacts, Division of Environmental Analysis, Environmental Engineering, September 2013. Report No. CT-HWANP-RT-13069.25.3. Available online at: [http://www.dot.ca.gov/hq/env/noise/pub/TCVGM\\_Sep13\\_FINAL.pdf](http://www.dot.ca.gov/hq/env/noise/pub/TCVGM_Sep13_FINAL.pdf).

**CAT 2019** – CAT C175-16 Diesel Generator Set specifications. Available online at: <https://s7d2.scene7.com/is/content/Caterpillar/CM20170823-21225-11085>. Accessed on: May 30, 2019.

**Jacobs 2019a** – Jacobs (Jacobs). (TN 227273-1). Application for Small Power Plant Exemption: Laurelwood Data Center, dated March 5, 2019. Available online at: <https://efiling.energy.ca.gov/Lists/DocketLog.aspx?docketnumber=19-SPPE-01>.

**Jacobs 2019f** – Jacobs (Jacobs). (TN 228823). LDC Updated SPPE Project Description, dated June 21, 2019. Available online at: <https://efiling.energy.ca.gov/Lists/DocketLog.aspx?docketnumber=19-SPPE-01>.

**Santa Clara 2019** – City of Santa Clara (Santa Clara). City of Santa Clara City Code, Chapter 9.0: Regulation of Noise and Vibration. Available online at:

<https://www.codepublishing.com/CA/SantaClara/html/SantaClara09/SantaClara0910.html>.

Accessed on: May 30, 2019.

**Santa Clara 2018** – City of Santa Clara (Santa Clara). Initial Study for the 2305 Mission College Boulevard Data Center Project. March 2018. Available online at:

<http://santaclaraca.gov/Home/Components/BusinessDirectory/BusinessDirectory/221/3649>.

Accessed on: June 21, 2019.

**Santa Clara 2014** – City of Santa Clara (Santa Clara). City of Santa Clara 2010-2035 General Plan.

Approved by City Council November 16, 2010 and updated December 9, 2014. Available online at: <http://santaclaraca.gov/government/departments/community-development/planning-division/general-plan>.

Accessed on: March 22, 2019.

## 5.14 Population and Housing

This section describes the environmental and regulatory setting and discusses the impacts associated with the demolition/construction and operation of the Laurelwood Data center (LDC or project) with respect to population and housing.

POPULATION AND HOUSING		Potentially Significant Impact	Less than Significant With Mitigation Incorporated	Less than Significant Impact	No Impact
<b>Would the project:</b>					
a.	Induce substantial unplanned population growth in an area, either directly (for example, by proposing new homes and businesses) or indirectly (for example, through extension of roads or other infrastructure)?	<input type="checkbox"/>	<input type="checkbox"/>	<input checked="" type="checkbox"/>	<input type="checkbox"/>
b.	Displace substantial numbers of existing people or housing, necessitating the construction of replacement housing elsewhere?	<input type="checkbox"/>	<input type="checkbox"/>	<input type="checkbox"/>	<input checked="" type="checkbox"/>

Environmental checklist established by CEQA Guidelines, Appendix G.

### 5.14.1 Setting

The following are the study areas for population and housing related project impacts:

- Population influx and housing supply
  - City of Santa Clara
- Local workforce – residing within a two-hour commute<sup>1</sup> for project construction and a one-hour commute for project operation.
  - San Jose-Sunnyvale-Santa Clara Metropolitan Statistical Area (MSA) (San Benito and Santa Clara counties)

The City of Santa Clara has an estimated land area of 18.4 square miles. The Housing Element of the Comprehensive General Plan for the City of Santa Clara (amended December 2014) forecasts population and housing estimates in three phases, reflecting the near (2010-2015), mid (2015-2023), and long term (2023-2035) horizons. By 2035, the general plan would allow for an additional 32,400 residents in 13,312 new housing units, and 25,040 new jobs in 24,253,600 square feet of new non-residential development. This development would occur in addition to “in progress” development taking place under the general plan, for a total population of 154,990 and a total employment base of 152,860 by 2035 (Santa Clara 2014). The estimated 2018 population for the city was 129,604 people (CA DOF 2019a). The Santa Clara County regional housing needs assessment allocation for the City of Santa Clara is 4,093 new housing units for a projected county total of 58,836 housing units by 2022 (ABAG 2013).

**Table 5.14-1** shows the historical and projected populations for the cities and communities within proximity of the project site, plus Santa Clara County. Population projections between 2018 and 2035 show a growth ranging from 8 to 24.8 percent or 0.5 to 1.5 percent per year in the cities within and around a 6-mile radius of the project site.

<sup>1</sup> Workers with a greater commute would be considered non-local and would tend to seek lodging closer to the project site (temporarily during construction or permanently during operations).

**TABLE 5.14-1 HISTORICAL AND PROJECTED POPULATIONS**

Area	2010 <sup>1</sup>	2018 <sup>2</sup>	2020 <sup>2</sup>	2035 <sup>2</sup>	Projected Population Change 2018-2035		
					Number	Percent (%)	Percent per Year (%)
Campbell	39,349	42,696	43,210	46,510	3,814	8.2	0.5
Cupertino	58,302	60,091	63,490	66,590	6,499	9.8	0.6
Milpitas	66,790	74,865	90,620	97,330	22,465	23.1	1.4
San Jose	945,942	1,051,316	1,028,450	1,283,845	232,529	18.1	1.1
Santa Clara	116,468	129,604	131,690	151,770	22,166	14.6	0.9
Sunnyvale	140,081	153,389	149,980	203,855	50,466	24.8	1.5
Santa Clara County	1,781,642	1,956,598	2,011,436	2,330,649	374,051	16.0	0.9

Sources: <sup>1</sup>US Census 2010; <sup>2</sup>CA DOF 2019a.

According to the California Employment Development Department 2014-2024 Occupational Employment Projections for the San Jose-Sunnyvale-Santa Clara MSA, the 2024 projected employment for the construction and extraction occupations is 49,540, which is a 1.9 percent annual average percent change from 2014 estimated employment levels (40,320) as shown in **Table 5.14-2** (CA EDD 2019). In addition, the projected employment for general and operations managers is 19,930, which is a 1.2 percent annual average percent change from 2014 estimated employment levels (17,730). The projected employment for security guards is 9,140, which is a 0.8 percent annual average percent change from 2014 estimated employment levels (8,430). The projected employment for janitors is 17,060, which is a 0.9 percent annual average percent change from 2014 estimated employment levels (15,630) (CA EDD 2019).

**TABLE 5.14-2 PROJECTED EMPLOYMENT GROWTH**

Area	Year 2014	Year 2024	Annual Average Percent Change
San Jose-Sunnyvale-Santa Clara MSA Construction and Extraction trades	40,320	49,540	1.9

Source: CA EDD 2019

**Table 5.14-3** presents housing supply data for the project area. Year 2018 housing estimates indicated 25,877 vacant housing units within Santa Clara County representing a vacancy rate of 3.9 percent (CA DOF 2019b).

**TABLE 5.14-3 HOUSING SUPPLY ESTIMATES IN THE PROJECT AREA**

Housing Supply		2018	
		Total	Vacant
Campbell	Number	17,868	896
	Percent	100	5.0
Cupertino	Number	21,031	907
	Percent	100	4.3
Milpitas	Number	21,643	709
	Percent	100	3.3
San Jose	Number	335,164	10,879
	Percent	100	3.2
Santa Clara	Number	48,144	1,699
	Percent	100	3.5
Sunnyvale	Number	59,242	2,664
	Percent	100	4.5
Santa Clara County	Number	667,970	25,877
	Percent	100	3.9

Source: CA DOF 2019b.

## Regulatory Background

No regulations related to population and housing apply to the project.

### 5.14.2 Environmental Impacts and Mitigation Measures

- a. Would the project induce substantial unplanned population growth in an area, either directly (for example, by proposing new homes and businesses) or indirectly (for example, through extension of roads or other infrastructure)?*

#### Demolition/Construction

LESS THAN SIGNIFICANT IMPACT. The project would not directly or indirectly induce substantial unplanned growth in the City of Santa Clara as the project does not propose new housing or land use changes nor does it facilitate growth by extending growth inducing infrastructure such as roads or water supply pipelines. While the project includes 56 backup generators, they would directly serve the project if power interruptions occurred and would not be an extension of infrastructure that would result in indirect population growth.

Demolition/construction of the project would employ an average of 60 workers per month and reach a peak workforce of 129 (Jacobs 2019f). Demolition is scheduled to commence in the first 3 months of the 4th quarter of 2019. Construction would follow over the next 14 months for an estimated project completion in the 2nd quarter of 2021. The total duration of project construction would be approximately 17 months (Jacobs 2019f).

The applicant anticipates all of the construction workforce for the project would come from the greater Bay Area. As shown in the Setting subsection of this analysis, there is a sufficient local construction workforce in the San Jose-Sunnyvale-Santa Clara MSA to accommodate the project; thus, the construction workforce would not likely seek temporary lodging closer to the project site.



Therefore, the project's demolition/construction workforce would not directly or indirectly induce substantial population growth in the project area. Impacts would be less than significant.

### **Operation and Maintenance**

LESS THAN SIGNIFICANT IMPACT. The project would employ a total of 54 operations workers including 2 facility managers, 2 account managers, 2 equipment managers, 2 environmental engineers, 18 facility operators, 3 mechanics, and 25 administration personnel (including security and onsite management) (Jacobs 2019a). The applicant anticipates all of the operations workforce would come from the greater Bay Area and would not likely relocate closer to the project site. As shown in the Setting subsection of this analysis, there is a sufficient local operations workforce in the San Jose-Sunnyvale-Santa Clara MSA. If some operations workers were to relocate, housing data shows a vacancy rate of 3.9 percent in Santa Clara County and 3.5 percent in the city of Santa Clara. A 5-percent vacancy is a largely industry-accepted minimum benchmark for a sufficient amount of housing available for occupancy (Virginia Tech 2006). While the vacancy rate in the city and county is slightly lower than the minimum benchmark, housing counts in the project area indicate a sufficient supply of available housing units for the possible few operations workers that could seek housing closer to the project. If the few new operation workers were to relocate closer to the project site, it would not result in unplanned population growth. Therefore, the project's operations workforce would not directly or indirectly induce a substantial population growth in the project area. Impacts would be less than significant.

**Proposed Mitigation Measures:** None.

- b. *Would the project displace substantial numbers of existing people or housing, necessitating the construction of replacement housing elsewhere?***

### **Demolition/Construction**

NO IMPACT. The project would be constructed on a planned industrial zoned parcel and would therefore not directly displace substantial numbers of people or housing. As the project's construction workers would come from the greater Bay Area, and few, if any, would seek temporary lodging closer to the project site, no people or housing would indirectly be displaced by new residents associated with the project in numbers that the construction of replacement housing elsewhere would be necessary. There would be no impacts.

### **Operation and Maintenance**

NO IMPACT. The San Jose-Sunnyvale-Santa Clara MSA includes a sufficient number of workers to support the project's operation workforce. If some operations workers were to move closer to the project and seek housing, there is a sufficient housing supply for these operations workers. Therefore, the project would not displace substantial numbers of people or housing, and no replacement housing would need to be constructed elsewhere. There would be no impacts.

**Proposed Mitigation Measures:** None.

## **5.14.3 References**

**ABAG 2013** – Association of Bay Area Governments (ABAG). Final Regional Housing Need Allocation 2015-2023, Adopted July 18, 2013. Available online at:

[https://abag.ca.gov/planning/housingneeds/pdfs/2015-2023\\_RHNA\\_Allocations.pdf](https://abag.ca.gov/planning/housingneeds/pdfs/2015-2023_RHNA_Allocations.pdf). Accessed on: March 2019.

**CA DOF 2019a** – California Department of Finance (CA DOF). Demographic Research Unit, P-1: State Population Projections (2010-2060): Total Estimated and Projected Population for California and Counties: July 1, 2010 to July 1, 2060 in 5-year Increments, 2016 baseline. Available online at: <http://www.dof.ca.gov/Forecasting/Demographics/Projections/>.

**CA DOF 2019b** – California Department of Finance (CA DOF). *E-5 Population and Housing Estimates for Cities, Counties and the State — January 1, 2011-2018, with 2010 Benchmark, May 1, 2018*. Available online at: <http://dof.ca.gov/Forecasting/Demographics/Estimates/E-5/>.

**CA EDD 2019** – Employment Development Department, State of California (CA EDD). Labor Market Information Division, 2014-2024 Occupational Employment Projections, San Jose-Sunnyvale-Santa Clara Metropolitan Statistical Area, (San Benito and Santa Clara Counties), published December 2016. Available online at: <https://www.labormarketinfo.edd.ca.gov/geography/msa/san-jose-sunnyvale-santa-clara.html>.

**Jacobs 2019a** – Jacobs (Jacobs). (TN 227273-1). Application for Small Power Plant Exemption: Laurelwood Data Center, dated February 28, 2019. Available online at: <https://efiling.energy.ca.gov/Lists/DocketLog.aspx?docketnumber=19-SPPE-01>.

**Jacobs 2019f** – Jacobs (Jacobs). (TN 228823). LDC Updated SPPE Project Description, dated June 21, 2019. Available online at: <https://efiling.energy.ca.gov/Lists/DocketLog.aspx?docketnumber=19-SPPE-01>.

**Santa Clara 2014** – City of Santa Clara (Santa Clara). General Plan Land Use Component and Housing Element Updates, EIR Addendum. Prepared by ESA, November 2014. March 2019. Available online at: <http://santaclaraca.gov/home/showdocument?id=46446>.

**US Census 2010** – United States Census Bureau (US Census). P1: TOTAL POPULATION - Universe: Total population, 2010 Census Summary File 1. Available online at: <http://factfinder2.census.gov/faces/nav/jsf/pages/index.xhtml>.

**Virginia Tech 2006** – Virginia Tech, *Virginia Tech Housing Needs and Market Analysis, Thomas Jefferson PDC*, Center for Housing Research Virginia Tech, October 2006. Available online at: <http://www.vchr.vt.edu/pdfreports/tjhousingreportfinalrev3.pdf>.

## 5.15 Public Services

This section describes the environmental and regulatory setting and discusses impacts associated with the demolition/construction and operation of the Laurelwood Data Center (LDC or project) with respect to Public Services.

### PUBLIC SERVICES

Would the project result in substantial adverse physical impacts associated with the provision of new or physically altered governmental facilities, need for new or physically altered governmental facilities, the construction of which could cause significant environmental impacts, in order to maintain acceptable service ratios, response times, or other performance objectives for any of the public services:

	Potentially Significant Impact	Less than Significant With Mitigation Incorporated	Less than Significant Impact	No Impact
a. Fire protection?	<input type="checkbox"/>	<input type="checkbox"/>	<input checked="" type="checkbox"/>	<input type="checkbox"/>
b. Police protection?	<input type="checkbox"/>	<input type="checkbox"/>	<input checked="" type="checkbox"/>	<input type="checkbox"/>
c. Schools?	<input type="checkbox"/>	<input type="checkbox"/>	<input checked="" type="checkbox"/>	<input type="checkbox"/>
d. Parks?	<input type="checkbox"/>	<input type="checkbox"/>	<input checked="" type="checkbox"/>	<input type="checkbox"/>
e. Other public facilities?	<input type="checkbox"/>	<input type="checkbox"/>	<input checked="" type="checkbox"/>	<input type="checkbox"/>

Environmental checklist established by CEQA Guidelines, Appendix G.

### 5.15.1 Setting

The project would include the construction of two, multi-story data center buildings (Building 1 and Building 2) (Jacobs 2019d). The following are the study areas for public services related project impacts:

- Fire protection, police protection, parks, and other public facilities (libraries).
  - City of Santa Clara
- Schools
  - Santa Clara Unified School District

The project would be served by the public service providers discussed below.

#### Fire Protection

The project would be located within the jurisdiction of the Santa Clara Fire Department (SCFD). The SCFD provides fire suppression, emergency medical, fire prevention, and hazardous materials services to the City of Santa Clara (Santa Clara 2019d). There are 10 fire station districts in the City of Santa Clara; the project site is located in District 8 at 2400 Agnew Road, approximately 0.5 mile northeast of the project site (Santa Clara 2019e).

SCFD has approximately 167 fire service personnel, which includes all fire prevention and administrative/clerical staff. Out of 167, 138 personnel are sworn emergency responders (CEC 2019b).

The department responds to over 9,000 calls for service annually. Approximately 70 percent of the calls are for emergency medical services, 20 percent are classified as “other” (fire alarm responses and service calls), 5 percent are for injuries (due to vehicle accidents), 2 percent for fires, 2 percent for hazardous materials, and less than 1 percent for rescue calls. (CEC 2019b). Based on the city’s 2018 estimated population and the department’s current fire personnel roster, the department’s staffing ratio is 1.07 fire personnel for every 1,000 residents (CEC 2019b).

## Police Protection

Police protection would be provided by the Santa Clara Police Department (SCPD). SCPD has two police stations. The Northside Police substation, located 1.25 miles northeast, is the closest station to the project site.

In 2018, there were 58,912 calls for service dispatched through the communications center. The department's average response time is approximately 4.26 minutes after dispatch for priority one (emergency) calls. Staff includes 159 sworn officers and 80 civilian professionals. There are 1.2 officers for every 1,000 residents. (Santa Clara 2019g)

## Schools

The project would be located within the Santa Clara Unified School District. The district covers 56 square miles and is located in the northwestern portion of Santa Clara County. This district serves the cities of Santa Clara, Sunnyvale, San Jose, and Cupertino. The Santa Clara Unified School District had an enrollment of 15,509 students in the 2017/2018 school year (CDE 2019). Santa Clara Unified School District facilities include: one adult school, five high schools, three middle schools, one K-8 school, one community school, and one preschool (SCUSD 2019). The nearest school, Don Callejon K-8 School, is 1.33-miles northeast of the project.

## Parks

The City of Santa Clara has total park acreage of 350 (made up of improved and unimproved acreage) (Santa Clara 2019c). Included in the park and recreation areas are community parks, mini/pocket parks, neighborhood parks, public open space, recreation facilities, recreational trails, and joint use facilities (Santa Clara 2014). The City of Santa Clara has a parkland dedication/in lieu standard based on the city's existing ratio of developed park acreage per 1,000 residents (Santa Clara 2014 and Santa Clara 2019c). The service population used to estimate existing service standard for parks in the current development impact fee update study (April 2019) is 126,408 residents (Santa Clara 2019c).<sup>1</sup> With a combined total of 328 acres (improved and unimproved parkland), Santa Clara has approximately 2.6 acres per 1,000 residents and meets its park standards (Santa Clara 2019c).

The Agnew Park is located 0.6 mile north of the project site. The two-acre park provides a neighborhood recreation building, a children's playground, restrooms, picnic facilities, and basketball courts. This park is maintained by the City of Santa Clara.

## Other Public Facilities

The Santa Clara City Library has three branches to serve the city of Santa Clara. The closest library to the project site is the Northside Branch Library, which is located approximately 1.25 miles to the northeast (Santa Clara 2019b).

## Regulatory Background

No regulations related to public services apply to the project.

---

<sup>1</sup> While the April 2019 City of Santa Clara Park and Recreation Facilities Development Impact Fee Update Study is an Administrative Draft, the methodology used to estimate park standard associated with mitigation fee is consistent with that used in the June 2014 Final Development Impact Fee Study.

## 5.15.2 Environmental Impacts and Mitigation Measures

*Would the project result in substantial adverse physical impacts associated with the provision of new or physically altered governmental facilities, need for new or physically altered governmental facilities, the construction of which could cause significant environmental impacts, in order to maintain acceptable service ratios, response times, or other performance objectives for any of the public services:*

**a. Fire protection?**

### **Demolition/Construction**

LESS THAN SIGNIFICANT IMPACT. The project site is clear of substantial vegetation and is surrounded by commercial and industrial land uses. In addition, the project would be located on a site already served by fire protection and emergency services.

Demolition and construction activities that could pose a risk for fire or the need for fire protection response due to heated exhaust or sparks, include the use of grinders, cranes, excavation equipment, vehicles, and bulldozers. Other demolition and construction activities with a potential fire risk due to heat sources or open flames could include the use of torches or welding.

Upon notification and dispatch, SCFD response time for all types of emergencies is within 6 minutes, 90 percent of the time (Santa Clara 2019f). As the project is located on a site already served, emergency response time to the project would be consistent with a 6-minute response.

While there may be a slight increased need for fire protection response during project demolition and construction, these effects would not be sufficient to induce the construction of new or physically altered governmental facilities that could result in significant environmental impacts; therefore, impacts would be less than significant.

### **Operation and Maintenance**

LESS THAN SIGNIFICANT IMPACT. The project would employ a total of 54 operations workers. The applicant estimates the workers would be hired from the greater Bay Area and are not likely to relocate to the City of Santa Clara but would instead commute from surrounding areas. The few operations employees that may move into the city and within the service area would have a negligible effect on the ability of the fire stations that serve the project site to meet their emergency service and response standards.

The diesel fuel tanks would be of a double-walled high integrity design with integral leak detection. The truck deliveries would be on an as needed basis due to the project's operation. There would be an emergency pump that shuts off the flow of fuel in case of a spill and a temporary spill catch basin near the fill port. Diesel fuel also has a low volatility. Also, to further reduce fire hazards, the project would include fire suppression systems consistent with local, state, and federal building standards and codes (Jacobs 2019a). With all of the above elements, the impacts to the fire protection service would be less than significant.

**Proposed Mitigation Measures:** None.

**b. Police Protection?**

**Demolition/Construction**

LESS THAN SIGNIFICANT IMPACT. The demolition/construction workforce is not expected to relocate closer to the project site and would not increase the demand for emergency response services, including police protection. Existing perimeter fencing would be retained to reduce potential criminal activity at the site, such as vandalism or theft. If an emergency occurred at the project site, the SCPD indicated their response time would be approximately 4.26 minutes, consistent with the department's average response time (CEC 2019b). The response goals for the police department would not be significantly affected by the project nor would the project induce construction of a new or physically altered governmental facilities, such as police stations that could result in significant environmental impacts; therefore, impacts would be less than significant.

**Operation and Maintenance**

LESS THAN SIGNIFICANT IMPACT. The 54 operations workers that would be employed by the project would have a negligible effect on the emergency response times of the stations that serve the project site and vicinity. This limited effect would be from the few workers who may choose to relocate closer to the project site. The project would be secured by existing fencing and include a sophisticated security system with full time video monitoring coverage as well as on-staff security personnel minimizing criminal activity during operations (Jacobs 2019a). Due to the perimeter fencing, security system, and onsite security personnel, criminal activity would be adequately deterred during operation. Therefore, the project would not result in substantial adverse physical environmental impacts associated with the provision of new or physically altered police service facilities in order to maintain acceptable service ratios, response times, or other performance objectives. Impacts would be less than significant.

**Proposed Mitigation Measures:** None.

**c. Schools?**

**Demolition/Construction, Operation and Maintenance**

LESS THAN SIGNIFICANT IMPACT. The project would be in the Santa Clara Unified School District. District Board Policy (BP 7211 Facilities: Developer Fees) allows the Board of Trustees to establish, levy, and collect developer fees on residential, commercial, and industrial construction within the district. Government Code section 65995 expressly provides that "[t]he payment or satisfaction of a fee, charge, or other requirement levied or imposed pursuant to Section 17620 of the Education Code in the amount specified in Section 65995... are hereby deemed to be full and complete mitigation of the impacts of any legislative or adjudicative act, or both, involving but not limited to, the planning, use, or development of real property, or any change in governmental organization... on the provision of adequate school facilities." The current school impact fee for the district is \$0.61 per square foot of covered, enclosed commercial/industrial space (SCUSD 2018). Based on the proposed size of the buildings (533,952 sq. ft. total) (Jacobs 2019d), an estimated \$325,710.72 fee would be assessed. These fees would be collected at the time the applicant applies for building permits from the City of Santa Clara; therefore, impacts would be less than significant.

**Proposed Mitigation Measures:** None.



**d. Parks?**

**Demolition/Construction**

NO IMPACT. As identified under “Setting,” the city is currently meeting its park standards with a ratio of 2.72 acres per 1,000 residents. Demolition/construction of the project would require an average of 60 workers and a peak of 129 (Jacobs 2019f). The demolition and construction needs of the project would not require an influx of new workers and would be met by the workforce from neighboring cities and counties within the greater Bay Area (see **Section 5.14, Population and Housing**). Also, construction workers who may temporarily relocate closer to the project do not typically visit area parks or park facilities as they are working while in the project area and tend to return to their primary residence for the weekends. Therefore, demolition and construction of the project would not affect park standards or increase the demand for park facilities. The project demolition and construction would have no impact on parks or park facilities.

**Operation and Maintenance**

LESS THAN SIGNIFICANT IMPACT. Approximately 54 operations workers are expected to be employed by the project. Like the demolition/construction workforce, operations employees would be drawn from the greater Bay Area and are not likely to relocate closer to the project. If some operations workers were to relocate, the few new residents would have a negligible increase on the usage of or demand for parks or other recreational facilities. Therefore, the project would not result in substantial adverse physical environmental impacts associated with the provision of new or physically altered park facilities in order to maintain acceptable service ratios or other performance objectives. Impacts would be less than significant.

**Proposed Mitigation Measures:** None.

**e. Other Public Facilities?**

**Demolition/Construction**

NO IMPACT. The demolition/construction workforce for the project would be drawn from the greater Bay Area and workers would not likely relocate closer to the project site. However, if some construction workers were to relocate, they are not likely to visit public facilities such as public libraries as they are working while in the project area and tend to return to their primary residence for the weekends. There would be no impacts to public facilities during demolition and construction.

**Operation and Maintenance**

LESS THAN SIGNIFICANT IMPACT. As discussed above, the project’s anticipated 54 operations employees are expected to be drawn from the greater Bay Area and are not expected to relocate closer to the project site. However, if some operations workers were to relocate, the few new residents would likely have a negligible increase in the usage of or demand for the surrounding libraries or public facilities; therefore, the project’s operations impacts would be less than significant.

**Proposed Mitigation Measures:** None.

### 5.15.3 References

- CA DOF 2019** – California Department of Finance (CA DOF). *E-5 Population and Housing Estimates for Cities, Counties and the State — January 1, 2011-2018*, with 2010 Census Benchmark, March 2019. Available online at: <http://www.dof.ca.gov/Forecasting/Demographics/Estimates/E-5/>.
- Cal Fire 2019** – Cal Fire. *Santa Clara County FHSZ Map in Local Responsibility Area*. Accessed on: April 30, 2019. Available online at: [http://frap.fire.ca.gov/webdata/maps/santa\\_clara/fhszs\\_map.43.pdf](http://frap.fire.ca.gov/webdata/maps/santa_clara/fhszs_map.43.pdf).
- CDE 2019** – California Department of Education (CDE). California Department of Education Educational Demographics Unit, Data Quest, Select District Level Data for the year 2017 - 2018, Santa Clara Unified Report (43-69674), March 2019. Available online at: <https://dq.cde.ca.gov/dataquest/dqcensus/EnrEthGrd.aspx?cds=4369674&aggllevel=District&year=2017-18&ro=y>.
- CEC 2019b** – California Energy Commission (CEC). (TN 228900). Report of Conversation – Communication with Employees of the City of Santa Clara Regarding Response Times and Staffing Levels, dated July 3, 2019. Available online at: <https://efiling.energy.ca.gov/Lists/DocketLog.aspx?docketnumber=19-SPPE-01>.
- DWK 2011** – Dannis Woliver Kelley (DWK). *Recent CEQA Decision Chawanakee Unified School District v. County of Madera*, The Point- Education Law Bulletin, Volume 2011, Client Bulletin No. 13 - July 11, 2011.
- Jacobs 2019f** – Jacobs (Jacobs). (TN 228823). LDC Updated SPPE Project Description, dated June 21, 2019. Available online at: <https://efiling.energy.ca.gov/Lists/DocketLog.aspx?docketnumber=19-SPPE-01>.
- Jacobs 2019d** – Jacobs (Jacobs). (TN228748). LDC Updated SPPE Project Description, dated June 13, 2019. Available online at: <https://efiling.energy.ca.gov/Lists/DocketLog.aspx?docketnumber=19-SPPE-01>.
- Jacobs 2019a** – Jacobs (Jacobs). (TN 227273-1). Application for Small Power Plant Exemption: Laurelwood Data Center, dated February 28, 2019. Available online at: <https://efiling.energy.ca.gov/Lists/DocketLog.aspx?docketnumber=19-SPPE-01>.
- KTMJ 2011** – Kronick Moskovitz Tiedmann & Girard (KTMJ). *Indirect Impacts On School Facilities Must be Considered and Mitigated Under CEQA*, Kronick Moskovitz Tiedmann & Girard Legal Alerts, Bulletin No. 975577.2, July 8, 2011. Available online at: <https://kmtg.com/news/legal-alerts/indirect-impacts-on-school-facilities-must-be-considered-and-mitigated-under-ceqa/>.
- RMM 2011** – Remy, Moose, Manley (RMM). *Fifth District Holds That, Unlike Impacts on School Facilities, a Development's Indirect Impacts on the Non-School Physical Environment Are Not Excused from Being Considered and Mitigated in an EIR*, June 28, 2011. Available online at: <http://www.rmmenvirolaw.com/2011/06/fifth-district-holds-that-unlike-impacts-on-school-facilities-a-developments-indirect-impacts-on-the-non-school-physical-environment-are-not-excused-from-being-considered-and-mitigated-in-a/>.
- Santa Clara 2014** – City of Santa Clara (Santa Clara). City of Santa Clara Park and Recreation Facilities Final Development Impact Fee Study, June 2014. Prepared by: Willdan Financial Services. Available online at: <http://santaclaraca.gov/Home/ShowDocument?id=18463>.

- Santa Clara 2019a** – City of Santa Clara (Santa Clara). Santa Clara Parks and Recreation Department Website. Available online at: <http://santaclaraca.gov/government/departments/parks-recreation>. Accessed on: February 2019.
- Santa Clara 2019b** – City of Santa Clara City (Santa Clara). Santa Clara City Library Website- About the Library. Available online at: <http://santaclaraca.gov/government/departments/library/about-the-library>. Accessed on: March, 2019.
- Santa Clara 2019c** – City of Santa Clara (Santa Clara). City of Santa Clara Park and Recreation Facilities Development Impact Fee Update Study. Administrative Draft. April 9, 2019. Prepared by: Willdan Financial Services. Available online at: <http://santaclaraca.gov/home/showdocument?id=63995>.
- Santa Clara 2019d** – City of Santa Clara (Santa Clara). Santa Clara Fire Department Website – About Us. Available online at: <http://santaclaraca.gov/government/departments/fire/about-us>. Accessed on: June 2019.
- Santa Clara 2019e** – City of Santa Clara (Santa Clara). Santa Clara Fire Department Website - City of Santa Clara: Public Safety. Available online at: <http://missioncity.maps.arcgis.com/apps/MapTour/index.html?appid=15779cefd9bc463d8bc6229b61d921d5>. Accessed on: June 2019.
- Santa Clara 2019f** – City of Santa Clara (Santa Clara). Santa Clara Fire Department Website - City of Santa Clara: Emergency Services. Available online at: <http://santaclaraca.gov/residents/emergency-services>. Accessed on: June 2019.
- Santa Clara 2019g** – City of Santa Clara (Santa Clara). Santa Clara Police Department Website – Fact Sheet. Available online at: <http://santaclaraca.gov/government/departments/police-department/about-us>. Accessed on: June 2019.
- SCUSD 2018**– Santa Clara Unified School District (SCUSD). Santa Clara Unified School District Developer Fee. Approved on March 22, 2018 and effective May 22, 2018. Available online at: <https://www.santaclarausd.org/Page/53>. Accessed on: May 2, 2019.

## 5.16 Recreation

This section describes the environmental and regulatory setting and discusses impacts associated with the demolition/construction and operation of the Laurelwood Data Center (LDC or project) with respect to recreation.

RECREATION	Potentially Significant Impact	Less than Significant With Mitigation Incorporated	Less than Significant Impact	No Impact
a. Would the project increase the use of existing neighborhood and regional parks or other recreational facilities such that substantial physical deterioration of the facility would occur or be accelerated?	<input type="checkbox"/>	<input type="checkbox"/>	<input checked="" type="checkbox"/>	<input type="checkbox"/>
b. Does the project include recreational facilities or require the construction or expansion of recreational facilities, which might have an adverse physical effect on the environment?	<input type="checkbox"/>	<input type="checkbox"/>	<input checked="" type="checkbox"/>	<input type="checkbox"/>

Environmental checklist established by CEQA Guidelines, Appendix G.

### 5.16.1 Setting

The project site is within the City of Santa Clara on property designated as planned industrial. The city has 1 community park, 5 mini parks, 26 neighborhood parks, 3 open space parks, 4 recreational facilities, 4 trail reaches, and 11 joint use facilities for a total of approximately 252 acres of developed parks, not including city golf courses. The city also has approximately 98 acres of undeveloped parks (SCPR 2019). The closest recreational resources are: Agnew Park located 0.6-mile northeast of the project site, Agnew Historic Park located 0.7-mile northeast of the project site, and Montague Park located 1.0 mile east of the project site (Jacobs 2019a).

### Regulatory Background

No regulations related to recreation apply to the project.

### 5.16.2 Environmental Impacts and Mitigation Measures

- a. Would the project increase the use of existing neighborhood and regional parks or other recreational facilities such that substantial physical deterioration of the facility would occur or be accelerated?***

#### Demolition/Construction

NO IMPACT. The project would require an average of 60 workers during demolition/construction and a maximum of 129 workers during the peak construction period. Demolition and construction is expected to last for approximately 17 months (Jacobs 2019e). The applicant estimates that all of the demolition/construction workforce would be recruited from the greater Bay Area and would likely be drawn from the San Jose-Sunnyvale-Santa Clara region.<sup>1</sup> Based on the proximity of the available workforce to the project, demolition/construction workers from neighboring cities and counties are not likely to temporarily relocate closer to the project site or visit the nearby parks. Thus, the project would not increase the use of or accelerate the physical deterioration of parks or other recreational

<sup>1</sup> Region in this instance is the Metropolitan Statistical Area. A Metropolitan Statistical Area is a geographical region with a relatively high population density at its core and close economic ties throughout the area.

facilities. Therefore, the project would have no impact on the surrounding parks and recreational facilities.

### **Operation and Maintenance**

LESS THAN SIGNIFICANT IMPACT. The project would employ 54 operations workers who would be drawn from the greater Bay Area (see **Section 5.14, Population and Housing**). Based on the proximity of the supply of operations workers, they are not likely to relocate closer to the project. Although, if some operations workers were to move closer to the project, they would not be in numbers where the use of existing parks or recreational facilities would be increased to the extent that substantial physical deterioration of the park or facility would result. Impacts to surrounding parks and recreational facilities would be less than significant.

**Proposed Mitigation Measures:** None.

- b. Does the project include recreational facilities or require the construction or expansion of recreational facilities, which might have an adverse physical effect on the environment?**

### **Demolition/Construction**

NO IMPACT. Recreational facilities are not included as part of the project nor would the project require the construction or expansion of recreational facilities. The demolition and construction needs of the project would not require an influx of new workers and would be supplied by the existing workforce from the surrounding greater Bay Area including nearby cities and counties. Demolition/construction workers would commute to the project site during the 17 months of construction and they are not likely to temporarily relocate closer to the project. Therefore, the project would have no impacts to recreational facilities.

### **Operation and Maintenance**

LESS THAN SIGNIFICANT IMPACT. Operation of the project would be conducted by 54 onsite employees (Jacobs 2019a). If some operations workers did move closer to the project, they would not be in numbers that would require the construction or expansion of recreational facilities. Therefore, the project would have less than significant impact on local recreation facilities and would not require the construction or expansion of recreational facilities to accommodate the project.

**Proposed Mitigation Measures:** None.

## **5.16.3 References**

- Jacobs 2019a** – Jacobs (Jacobs). (TN 227273-1). Application for Small Power Plant Exemption: Laurelwood Data Center, dated February 28, 2019. Available online at: <https://efiling.energy.ca.gov/Lists/DocketLog.aspx?docketnumber=19-SPPE-01>.
- Jacobs 2019e** – Jacobs (Jacobs). (TN 228822). LDC Response to Informal Data Requests. Data Response Set 3, dated June 21, 2019. Available online at: <https://efiling.energy.ca.gov/Lists/DocketLog.aspx?docketnumber=19-SPPE-01>.
- Santa Clara 2010** – City of Santa Clara (Santa Clara). 2010-2035 General Plan, Chapter 5, Goals and Policies. Available online at: <http://santaclaraca.gov/government/departments/community-development/planning-division/general-plan>.

**Santa Clara 2019** – City of Santa Clara (Santa Clara). City of Santa Clara Park and Recreation. Facilities Development Impact Fee Update Study – Administrative Draft, January 4, 2019, prepared by Willdan Financial Services. Available online at:  
<http://santaclaraca.gov/home/showdocument?id=62674>.



## 5.17 Transportation

This section describes the environmental and regulatory setting of the Laurelwood Data Center (LDC or project) with respect to transportation and discusses transportation impacts associated with demolition/construction and operation of the project.

TRANSPORTATION	Potentially Significant Impact	Less Than Significant With Mitigation Incorporated	Less than Significant Impact	No Impact
Would the project:				
a. Conflict with a program, plan, ordinance or policy addressing the circulation system, including transit, roadway, bicycle and pedestrian facilities?	<input type="checkbox"/>	<input type="checkbox"/>	<input type="checkbox"/>	<input checked="" type="checkbox"/>
b. Conflict or be inconsistent with CEQA Guidelines section 15064.3, subdivision (b)?	<input type="checkbox"/>	<input type="checkbox"/>	<input checked="" type="checkbox"/>	<input type="checkbox"/>
c. Substantially increase hazards due to a geometric design feature (e.g., sharp curves or dangerous intersections) or incompatible uses (e.g., farm equipment)?	<input type="checkbox"/>	<input type="checkbox"/>	<input checked="" type="checkbox"/>	<input type="checkbox"/>
d. Result in inadequate emergency access?	<input type="checkbox"/>	<input type="checkbox"/>	<input type="checkbox"/>	<input checked="" type="checkbox"/>

Environmental checklist established by CEQA Guidelines, Appendix G

### 5.17.1 Setting

The proposed project would be located in the City of Santa Clara on an approximately 12 acre site at 2201 Laurelwood Road. Direct access to the project site would be from an existing driveway on the corner of Juliette Lane and Laurelwood Road and from an existing driveway on Juliette Lane at the northwest corner of the site. Regional access would be provided by numerous urban roadways and freeways in the vicinity of the project, including U.S. Highway 101 (US-101) and Montague Expressway. Local roadways include Mission College Boulevard, Juliette Lane, and Laurelwood Road.

Other nearby transportation infrastructure includes bus transit and the Norman Y. Mineta San Jose International Airport. The closest bus stops to the site are located on each side of Mission College Boulevard, near the corner of Juliette Lane approximately 0.3 mile from the project site. The airport is located approximately 1.4 miles southeast of the site.

### Regulatory Background

The City of Santa Clara's level of service (LOS) standard, a measure of effectiveness for describing traffic flow and level of congestion on roadways, is LOS D or better for intersections during the AM and PM peak traffic periods. City intersections included as part of the Santa Clara County Congestion Management Plan (CMP) are expected to meet an LOS of "E" or better, unless they were already operating at LOS F as of 1991. In that case, LOS F is acceptable (VTA 2017).

The Santa Clara Valley Transportation Authority (VTA), which produces the CMP, requires a traffic impact analysis for a project that would generate 100 or more net new peak hour vehicle trips during the AM or PM peak period (VTA 2017).

Traffic generated by the project would not be expected to conflict with the LOS standards established by the City of Santa Clara and the VTA's CMP. Any discussion of LOS in this section is only for informational purposes, and not material to staff's CEQA analysis, as compliance with local LOS regulations is not

relevant to the project's potential transportation impacts under CEQA Guidelines section 15064.3 and Senate Bill 743 (Steinberg, 2013).

Demolition activities would take approximately three months and require a total of approximately 30 truck trips for the offsite disposal of asphalt waste. Project construction would take approximately 14 months and require up to 129 workers during peak construction. During construction there would be a maximum 290 daily round trips: 260 AM peak hour trips and 290 PM peak hour trips. Many of the construction worker trips would be expected to occur prior to the morning and evening peak hours, in accordance with typical construction schedules. Truck trips would occur throughout the day and would be scheduled for off-peak hours whenever possible.

Most segments of northbound US-101 are operating at LOS F during the morning peak hour and most segments of southbound US-101 are operating at LOS F during the afternoon peak hour. The project construction trips would result in a minimal increase (approximately 2%) to existing traffic volumes on US-101 during construction.

Project trips would result in negligible increases of traffic on US-101, Montague Expressway, and Mission College Boulevard. The number of construction trips would not cause conflicts with the City of Santa Clara and VTA's LOS standards because 1) truck trips would be distributed throughout the day and most would not occur during the peak commute hours, 2) most worker trips would occur prior to peak commute hours, and 3) construction trips would be temporary.

Project operations would average 100 daily trips (including workers and truck trips). The trips generated for project operations would include 40 AM peak hour trips and 40 PM peak hour trips. Based on the VTA Traffic Impact Study Guidelines, project operations generating fewer than 100 peak (AM or PM) hour trips would not require a traffic analysis.

### **5.17.2 Environmental Impacts and Mitigation Measures**

- a. Would the project conflict with a program, plan, ordinance or policy addressing the circulation system, including transit, roadway, bicycle and pedestrian facilities?*

#### **Demolition/Construction**

NO IMPACT. Project demolition/construction would not obstruct any transit, roadway, bicycle, or pedestrian facilities in the area. All construction activities would occur on site and outside the public right of way. Project demolition/construction would not block access to any roads and the project is not directly served by transit. Project construction would not conflict with any program, plan, ordinance, or policy addressing the circulation system, and would therefore have no impacts.

#### **Operation and Maintenance**

NO IMPACT. Project operations would require 54 onsite employees and generate approximately 100 daily trips. Operation of the project would be onsite and would not obstruct transit, bicycle, or pedestrian facilities. Additionally, the project would not interfere with any future pedestrian or bike plans for the area. Operation of the project would not conflict with any program plan, ordinance, or policy addressing the circulation system, and would therefore have no impacts.

**Proposed Mitigation Measures:** None.

**b. Would the project conflict or be inconsistent with CEQA Guidelines section 15064.3, subdivision (b)?**

**Demolition/Construction**

LESS THAN SIGNIFICANT IMPACT. CEQA Guidelines section 15064.3, subdivision (a), states that generally vehicle miles traveled (VMT) is the most appropriate measure of transportation impacts. VMT refers to the amount and distance of automobile travel attributable to a project. Increased VMT exceeding an applicable threshold could constitute a significant impact. If existing models or methods are not available to estimate the VMT for the particular project being considered, a lead agency may analyze the project's VMT qualitatively, evaluating factors such as the availability of transit or proximity to other destinations. For construction traffic, a qualitative analysis of VMT impacts (instead of a more detailed quantitative analysis) is often appropriate (CANRA 2018; see also CEQA Guidelines section 15064.3, subdivision (b)(3)).

The project would involve a temporary increase in vehicle trips resulting from workers commuting to the project site and trucks hauling equipment and materials to the project site. Demolition activities would require a total of approximately 30 truck trips over the approximately three month demolition period. Project construction would generate a maximum of 290 daily round trips (200 worker round trips and 90 delivery/truck haul round trips) during the approximately 14 month construction period. All workers would be from greater Bay Area and would not be traveling long distances.

The project would not conflict or be inconsistent with CEQA Guidelines section 15064.3, subdivision (b) because construction generated traffic would be temporary and all workers would commute from the greater Bay Area. Impacts to the road network would be less than significant.

**Operation and Maintenance**

LESS THAN SIGNIFICANT IMPACT. During operation, the project would employ approximately 54 people on a daily basis. The operation generated traffic would result in an average of 100 daily trips, including workers and truck trips. According to technical guidance by the Governor's Office of Planning and Research, absent substantial evidence indicating that a project would generate a potentially significant level of VMT or inconsistency with a Sustainable Communities Strategy or general plan, projects that generate fewer than 110 trips per day generally may be assumed to cause a less than significant transportation impact (OPR 2018). LDC operations would generate an average of 100 daily trips and thus, have a less than significant transportation impact. The project would not conflict with or be inconsistent with CEQA Guidelines section 15064.3, subdivision (b). VMT generated by the project operation would be less than significant.

**Proposed Mitigation Measures:** None.

**c. Would the project substantially increase hazards due to a geometric design feature (e.g., sharp curves or dangerous intersections) or incompatible uses (e.g., farm equipment)?**

**Demolition/Construction**

LESS THAN SIGNIFICANT IMPACT. Project demolition and construction would not alter any public roadways or intersection. All construction would occur within the project boundaries and would not result in any hazards to motorists, bicyclists, or pedestrians. Project construction would not increase hazards due to a geometric design feature or incompatible uses; therefore, impacts would be less than significant.

## Operation and Maintenance

LESS THAN SIGNIFICANT IMPACT. The project is located approximately 1.4 miles southeast of the Norman Y. Mineta San Jose International Airport. Tall structures can potentially pose a hazard to occupants of aircraft, depending on the heights of structures and their proximity to air traffic. The highest point of the proposed LDC, the top of the adiabatic condenser cooling system, is approximately 117.5 feet above ground level (AGL). The Federal Aviation Administration (FAA) establishes a maximum structure height of 212 feet above mean sea level (AMSL) at the project site (SCCALUC 2016). Even when accounting for the varying 20 to 23-foot elevation of the project site above mean sea level, the LDC, at 117.5 feet AGL, would not exceed the FAA's height limit of 212 AMSL. The project also does not meet the 200-foot threshold for FAA notification and review per Title 14, Part 77, Section 77.9 of the Code of Federal Regulations. The project is located outside all airport safety zones as depicted in the Norman Y. Mineta San Jose International Airport Comprehensive Land Use Plan for Santa Clara County (SCCALUC 2016).

The project's emergency standby generators would discharge thermal plumes, high-velocity columns of hot air, during operation. Thermal plume velocities would be greatest at the discharge points, with plume velocities decreasing with increasing altitude. Plume velocities would also be highest during certain weather conditions, such as cool temperatures and calm winds. High velocity thermal plumes have the potential to affect aviation safety, and the FAA Aeronautical Information Manual identifies thermal plumes as potential flight hazards (FAA 2017). Aircraft flying through thermal plumes may experience significant air disturbances, such as turbulence and vertical shear. The FAA manual advises that, when able, a pilot should fly upwind of smokestacks and cooling towers to avoid encountering thermal plumes.

Staff uses a peak vertical plume velocity of 10.6 meters per second (m/s) (5.3 m/s average plume velocity) as a screening threshold for potential impacts to aviation. Based on a literature search, this velocity generally defines the point at which aircraft begin to experience severe turbulence.

To determine whether LDC's thermal plume would exceed 10.6 m/s peak velocity at altitudes where aircraft would fly, Energy Commission staff performed a thermal plume analysis of the standby generators at LDC. Staff calculated plume average and peak vertical velocities for the LDC emergency generator stacks and the LCD server building cooling systems and determined the worst-case predicted plume velocities occurred at 30°F ambient temperature condition. Staff determined LDC's thermal plume velocity of 10.6 meters per second (m/s) (5.3 m/s average plume velocity) screening threshold from the standby generators would be expected to reach a maximum height around 103 feet AGL.

Staff also determined the height of LDC's thermal plume velocity of 10.6 meters per second (m/s) (5.3 m/s average plume velocity) screening threshold of the server buildings cooling system at LDC. On July 31, 2019, the applicant docketed data responses (Jacobs 2019k) to staff questions regarding thermal plumes, specifically for the cooling system of the server buildings. Staff determined LDC's thermal plume impacts from the LDC server building cooling system are consistent with the applicant's data responses at around 161 feet AGL assuming all 72 chiller plumes at each server building merged. Staff does not expect the thermal plumes from each of the two onsite buildings would overlap or merge.

The plumes with a velocity above the threshold velocities would be lower than the FAA Part 77 airspace surface at the project site, which starts at 212 feet AMSL. They would also be below 200 feet

AGL, the threshold for structure height that requires FAA notification. Although the FAA only regulates structures, not plumes, this indicates that aircraft are highly unlikely to be flying over the site at altitudes sufficiently low to encounter thermal plumes with the potential to cause severe turbulence. Additionally, Title 14, Section 91.119 of the Code of Federal Regulations states that unless necessary for takeoff or landing, the minimum safe altitudes for aircraft are 500 feet AGL for non-congested areas and 1,000 feet AGL for congested areas, such as the area around the project site. This regulation is another reason that aircraft in the area would not be expected to be flying at low altitudes over the project site.

The project would not be hazardous to air traffic because both the physical height of the project and the maximum height of the significant velocity thermal plume would be below the FAA's Part 77 airspace surface and maximum structure height of 212 feet AMSL, and below the 200-foot threshold that triggers FAA review. The project site is also located outside all airport safety zones.

The project would not increase any other hazards. Project operation would not increase hazards due to a geometric design feature or incompatible uses, therefore, impacts would be less than significant.

**Proposed Mitigation Measures:** None.

**d. *Would the project result in inadequate emergency access?***

**Demolition/Construction**

NO IMPACT. The project would not physically block any access roads or result in traffic congestion that could significantly compromise timely access to this facility or any other location during construction. Therefore, the impact would be less than significant.

**Operation and Maintenance**

NO IMPACT. The project would not physically block any access roads or result in traffic congestion that could significantly compromise timely access to this facility or any other location during operation. Therefore, the impact would be less than significant.

**Proposed Mitigation Measures:** None.

### 5.17.3 References

**CANRA 2018** – California Natural Resources Agency. CEQA: The California Environmental Quality Act, 2018 Amendments and Additions to the State CEQA Guidelines, Final Adopted Text. Available online at: [http://resources.ca.gov/ceqa/docs/2018\\_CEQA\\_FINAL\\_TEXT\\_122818.pdf](http://resources.ca.gov/ceqa/docs/2018_CEQA_FINAL_TEXT_122818.pdf). Accessed on: March 2019.

**FAA 2017** – Federal Aviation Administration, Aeronautical Information Manual, Chapter 7. Safety of Flight, Section 5: Potential Flight Hazards, Subsection 7-5-15: Avoid Flight in the Vicinity of Exhaust Plumes (Smoke Stacks and Cooling Towers), October 12, 2017. Available online at: [https://www.faa.gov/air\\_traffic/publications/atpubs/aim\\_html/index.html](https://www.faa.gov/air_traffic/publications/atpubs/aim_html/index.html). Accessed on: April 2019.

**Jacobs 2019c** – Jacobs (Jacobs). (TN 227626). LDC Responses to Formal and Informal Data Requests. Data Response Set 1A, dated April 11, 2019. Available online at: <https://efiling.energy.ca.gov/Lists/DocketLog.aspx?docketnumber=19-SPPE-01>.

- Jacobs 2019f** – Jacobs (Jacobs). (TN 228823). LDC Updated SPPE Project Description, dated June 21, 2019. Available online at:  
<https://efiling.energy.ca.gov/Lists/DocketLog.aspx?docketnumber=19-SPPE-01>.
- Jacobs 2019k** – Jacobs (Jacobs). (TN 229160). Laurelwood Data Center Data Response, Set 5, dated July 31, 2019. Available online at:  
<https://efiling.energy.ca.gov/Lists/DocketLog.aspx?docketnumber=19-SPPE-01>.
- OPR 2018** – Governor’s Office of Planning and Research, State of California (OPR). Technical Advisory on Evaluating Transportation Impacts in CEQA. December 2018. Available online at:  
[http://opr.ca.gov/docs/20190122-743\\_Technical\\_Advisory.pdf](http://opr.ca.gov/docs/20190122-743_Technical_Advisory.pdf). Accessed on: April 2019.
- Santa Clara 2010** – City of Santa Clara (Santa Clara). 2010-2035 General Plan. Adopted November 16, 2010. Available online at: <http://santaclaraca.gov/government/departments/community-development/planning-division/general-plan>. Accessed on: March 2019.
- SCCALUC 2016** – Santa Clara County Airport Land Use Commission. Norman Y. Mineta San Jose International Airport Comprehensive Land Use Plan for Santa Clara County. Available online at:  
[https://www.sccgov.org/sites/dpd/DocsForms/Documents/ALUC\\_SJC\\_CLUP.pdf](https://www.sccgov.org/sites/dpd/DocsForms/Documents/ALUC_SJC_CLUP.pdf). Accessed on: April 2019.
- VTA 2017** – Santa Clara Valley Transportation Authority (VTA). 2017 Congestion Management Program. Available online at: [http://vtaorgcontent.s3-us-west-1.amazonaws.com/Site\\_Content/2017\\_CMP\\_Document.pdf](http://vtaorgcontent.s3-us-west-1.amazonaws.com/Site_Content/2017_CMP_Document.pdf). Accessed on: March 2019.
- VTA 2019a** – Santa Clara Valley Transportation Authority (VTA). Bus and Rail Map. Available online at:  
<http://www.vta.org/getting-around/maps/bus-rail-map>. Accessed on: March 2019.
- VTA 2019b** – Santa Clara Valley Transportation Authority (VTA). Bikeways Map. Available online at:  
<http://www.vta.org/getting-around/maps/bikeways-map>. Accessed on: April 2019.



## 5.18 Utilities and Service Systems

This section describes the environmental and regulatory setting and discusses impacts associated with the demolition/construction and operation of the Laurelwood Data Center (LDC or project) with respect to utilities and service systems.

UTILITIES AND SERVICE SYSTEMS				
Would the project:	Potentially Significant Impact	Less than Significant With Mitigation Incorporated	Less than Significant Impact	No Impact
a. Require or result in the relocation or construction of new or expanded water, wastewater treatment or storm water drainage, electric power, natural gas, or telecommunications facilities, the construction or relocation of which could cause significant environmental effects?	<input type="checkbox"/>	<input type="checkbox"/>	<input checked="" type="checkbox"/>	<input type="checkbox"/>
b. Have sufficient water supplies available to serve the project and reasonably foreseeable future development during normal, dry and multiple dry years?	<input type="checkbox"/>	<input type="checkbox"/>	<input checked="" type="checkbox"/>	<input type="checkbox"/>
c. Result in a determination by the wastewater treatment provider which serves or may serve the project that it has adequate capacity to serve the project's projected demand in addition to the provider's existing commitments?	<input type="checkbox"/>	<input type="checkbox"/>	<input checked="" type="checkbox"/>	<input type="checkbox"/>
d. Generate solid waste in excess of State or local standards, or in excess of the capacity of local infrastructure, or otherwise impair the attainment of solid waste reduction goals?	<input type="checkbox"/>	<input type="checkbox"/>	<input checked="" type="checkbox"/>	<input type="checkbox"/>
e. Comply with federal, state, and local management and reduction statutes and regulations related to solid waste?	<input type="checkbox"/>	<input type="checkbox"/>	<input checked="" type="checkbox"/>	<input type="checkbox"/>

Environmental checklist established by CEQA Guidelines, Appendix G.

### 5.18.1 Setting

#### Potable Water Supply

The project would be supplied with potable water provided by the City of Santa Clara. The potable water system gets water from three sources: Santa Clara Valley Water District (SCVWD), the San Francisco Public Utilities Commission (SFPUC), and 26 groundwater wells operated by the City's Water and Sewer Utility. The project is located in the northern part of the city, which is served with water from SFPUC. In 2015, about one third of the city's potable water came from the imported treated water supplies (SCVWD and SFPUC) and groundwater made up approximately two thirds of the city's potable water supply. The water system in the city consists of more than 335 miles of distribution mains, the 26 groundwater wells, and seven storage tanks with a total capacity of approximately 28.8 million gallons. According to the city's 2015 Urban Water Management Plan (UWMP), which was approved and adopted by the Santa Clara City Council on November 22, 2016, the citywide demand for potable water in 2015 was 17,620 acre-feet (AF) (Santa Clara 2016).

#### Recycled Water Supply

Recycled water is supplied to the City of Santa Clara through the South Bay Water Recycling (SBWR) program. The SBWR obtains advanced tertiary treated water from the San Jose-Santa Clara Regional Wastewater Facility (RWF), formerly known as the San Jose/Santa Clara Water Pollution Control Plant. In 2015, the RWF treated 14,770 AF of wastewater, of which 3,529 AF was treated to Title 22 recycled water

standards for use by the City of Santa Clara, and the remaining 11,241 AF of treated wastewater was discharged to the San Francisco Bay (Santa Clara 2016). The recycled water purchased from the SBWR made up approximately 17 percent of the overall water use in the city. The City of Santa Clara uses recycled water for the non-potable needs of businesses, industries, parks, and schools located along pipeline routes. The state of California Water Code sections 13550 and 13551 include strong language prohibiting the use of potable water where recycled water can be used, such as cooling, if recycled water is available and economically feasible. The Santa Clara City Code also has similar requirements. A recycled water connection that can serve the proposed project is located about a quarter-mile away from the project site (Jacobs 2019a).

### **Wastewater Service**

The City of Santa Clara's Departments of Public Works and Water and Sewer Utilities are responsible for the wastewater collection system within the city. Wastewater is collected by sewer systems in Santa Clara and is conveyed by pipelines to the San Jose-Santa Clara RWF. The RWF is owned jointly by the cities of San Jose and Santa Clara and is operated by the City of San Jose's Department of Environmental Services. The RWF has a capacity to treat 167 million gallons per day (mgd) of wastewater and currently treats an average of 110 mgd, thus the RWF facility has 57 mgd, or 35 percent of available capacity. Approximately 13 percent of the RWF's effluent undergoes advanced tertiary treatment to meet Title 22 recycled water standards, after which it flows to SBWR's adjacent pump station to be distributed to several customers in the city. The remaining effluent flows into San Francisco Bay. The RWF's current Wastewater Discharge Requirements (WDRs) were issued by the San Francisco Regional Water Quality Control Board (RWQCB) in September of 2014.

### **Storm Sewer Service**

The City of Santa Clara owns and maintains the municipal storm drainage system in the vicinity of the project site. The project site drains by a combination of surface flow and underground pipes towards the city's storm water system located in Juliette Lane (LDC 2019), which discharges to San Tomas Aquino Creek and ultimately the San Francisco Bay (Santa Clara 2016).

### **Solid Waste**

Solid waste and recycling collection for businesses at commercial and institutional properties in the City of Santa Clara is provided by Mission Trail Waste Systems through a contract with the city. Newby Island Landfill, located in San Jose, provides disposal capacity to nearby cities, including San Jose, Milpitas, Santa Clara, Cupertino, Los Altos, and Los Altos Hills. According to the City's General Plan, the City of Santa Clara has an arrangement with the owners of the Newby Island Landfill, as well as other landfills located outside of the county, to provide disposal capacity for the city. The Newby Island Landfill is permitted to accept a maximum of 3,260 tons of solid waste per day and has an available disposal capacity of 21.2 million cubic yards (cy). The Santa Clara County Integrated Waste Management Plan estimates that there is adequate waste capacity through its planning horizon of 2024. According to the City of Santa Clara General Plan, the life of the Newby Island Landfill could be prolonged as a result of the increases in recycling and reduction in waste generation measures being implemented by the landfill. Also, the landfill has been evaluating an expansion plan. If the landfill cannot operate beyond 2024 for any reason, the City is planning to use property it owns outside its jurisdictional boundaries for waste disposal purposes (Santa Clara 2010). Solid waste and recycling collection for businesses at commercial and institutional properties in the City of Santa Clara is provided by Mission Trail Waste Systems through a contract with the City.

## Electric Power, Natural Gas, and Telecommunications

Electricity needed for project operation would be provided by SVP. Telecommunication services would be provided by one of several fiber optics providers in the project area, such as CenturyLink, Zayo, AT&T, and others. The applicant anticipates that telecommunication services would be provided to the facility via established rights of way, as is the industry's common practice. The project would not consume natural gas.

## Regulatory Background

### *Federal*

**Federal Clean Water Act.** The State Water Resources Control Board (SWRCB) and its nine RWQCBs are responsible for the regulation and enforcement of the water quality protection requirements of the federal Clean Water Act (CWA) and the state's Porter-Cologne Water Quality Control Act (Porter-Cologne). The National Pollutant Discharge Elimination System (NPDES) is the permitting program that allows point source dischargers to comply with the CWA and Porter-Cologne laws. This regulatory framework protects the beneficial uses of the state's surface and groundwater resources for public benefit and environmental protection. Protection of water quality could be achieved by the proposed project by complying with applicable NPDES permits from the SWRCB or the San Francisco Bay RWQCB. The RWF complies with the Clean Water Act through its current NPDES WDRs, which were issued by the San Francisco RWQCB September of 2014.

### *State*

**California Water Code, Sections 10910-10915.** California Water Code (Sections 10910-10915) requires water service providers to evaluate stresses to the water supply service system caused by proposed project developments. The code sections require public water systems to prepare water supply assessments (WSA) for certain defined development projects subject to the California Environmental Quality Act (CEQA).

According to Section 10912, if a "Project" meets any of the following criteria, then a detailed WSA would be required to be prepared by the water supplier:

- A proposed residential development of more than 500 dwelling units.
- A proposed shopping center or business establishment employing more than 1,000 persons or having more than 500,000 square feet of floor space.
- A proposed commercial office building employing more than 1,000 persons or having more than 250,000 square feet of floor space.
- A proposed hotel or motel, or both, having more than 500 rooms.
- A proposed industrial, manufacturing, or processing plant, or industrial park planned to house more than 1,000 persons, occupying more than 40 acres of land, or having more than 650,000 square feet of floor area.
- A mixed-use project that includes one or more of the projects specified in this subdivision.
- A project that would demand an amount of water equivalent to, or greater than, the amount of water required by a 500 dwelling unit project.

Further guidance for how to interpret these sections of the Water Code is provided in a California Department of Water Resources document titled “Guidebook for Implementation of Senate Bill 610 and Senate Bill 221 of 2001” (Guidebook) (DWR 2003). A helpful interpretive section on page 3 of the Guidebook explains how to interpret item (1) above. It states that one dwelling unit typically consumes 0.3 to 0.5 AF of water per year (DWR 2003). Therefore 500 dwelling units could be interpreted to mean 150 to 250 acre-feet per year (AFY) of potable water.

The Guidebook also provides guidance about how to interpret other items in the list, but the one central theme is that WSAs are necessary for projects that increase the demand on the local system substantially. The Guidebook also emphasizes that WSAs are necessary in areas with a poorly understood water supply, or in an area where the project would increase the demand substantially, or 10 percent (DWR 2003).

The project would be located in a very well-studied service area with many service connections. The total floor area is less than 650,000 sq. ft., which is the floor plan area criterion for an industrial facility for the purpose of a WSA to be required. Also, the project’s demand of 17 AFY is less than the amount needed for 500 dwelling units. Therefore, the project does not meet the criteria for a business operation to require a WSA to be prepared by the water supplier.

**California Energy Efficiency Standards for Residential and Nonresidential Buildings—Green Building Code (2011), Title 24 Update (2014).** The California Green Buildings Standards Code applies to planning, design, operation, construction, use, and occupancy of newly constructed buildings and requires installation of energy- and water-efficient indoor infrastructure. The related waste management plan is required to allow for diversion of 50 percent of the generated waste away from the landfill.

**Integrated Waste Management Act.** The Integrated Waste Management Act of 1989 requires cities and counties to reduce, by 50 percent, the amount of solid waste disposed of in landfills by the year 2000 and beyond. To comply with the Integrated Waste Management Act, counties adopt regulations and policies to fulfill the requirements of the Act.

### **Local**

**City of Santa Clara General Plan.** The Santa Clara General Plan includes numerous policies related to utilities and service systems. With respect to waste, General Plan Policy 5.10.1-P8 aims to increase reduction for solid waste tonnage to 80 percent by 2020, or as consistent with the Climate Action Plan, Plan 2014 (Santa Clara 2016).

**Santa Clara City Code.** According to Santa Clara City Code Section 8.25.285, applicants seeking building or demolition permits for projects greater than 5,000 square feet are required to recycle at least 50 percent of its discards (Santa Clara 2019).

## **5.18.2 Environmental Impacts and Mitigation Measures**

*a. Would the project require or result in the relocation or construction of new or expanded water, wastewater treatment or storm water drainage, electric power, natural gas, or telecommunications facilities, the construction or relocation of which could cause significant environmental effects?*

### **Demolition/Construction, Operation and Maintenance**

LESS THAN SIGNIFICANT IMPACT. The project’s wastewater flow during construction and operation would be treated by the RWF, which is monitored by the San Francisco Bay RWQCB to ensure compliance

with the facility's NPDES wastewater discharge permit. The RWF is permitted to treat the industrial and sanitary waste flows that would be generated by the project. Furthermore, as discussed below, the RWF has sufficient available capacity to accommodate the project's estimated wastewater flow. Therefore, the project would not cause the RWF to exceed its wastewater treatment requirements of the San Francisco Bay RWQCB for project construction and operation. The impact of the project on wastewater treatment capacity would be less than significant.

Electricity demand for construction and operation of the proposed project would be provided by the SVP. The SVP electrical resources available are reliable. SVP and its suppliers have sufficient energy to serve the expected future demand of the project. Project electricity demand during construction and operation would not be substantial and would not be expected to affect existing users. Construction and operation of the project would not require new or expanded electric power utilities. Therefore, potential impacts would be less than significant.

No natural gas would be used by the project during construction or operation. Therefore, there would be no impact from the project on natural gas supplies in the project area.

For telecommunication services, the applicant is in negotiation with several fiber optics providers in the project area, such as CenturyLink, Zayo, AT&T, and others, to provide those services to the project during construction and operation. Any of the providers mentioned has adequate available capacity to accommodate the project needs. The impact of the project on telecommunication services would be less than significant.

**Proposed Mitigation Measures:** None.

- b. Would the project have sufficient water supplies available to serve the project and reasonably foreseeable future development during normal, dry, and multiple dry years?***

#### **Demolition/Construction, Operation and Maintenance**

LESS THAN SIGNIFICANT IMPACT. The water system in the city is operated and maintained by the city's Water and Sewer Utility. This system is supplied with potable water from three sources: SCVWD, SFPUC, and 26 groundwater wells operated by the city's Water and Sewer Utility. The proposed project is located in an area served primarily with surface water from SFPUC. In 2015, about one third of the city's potable water came from the imported treated water supplies (SCVWD and SFPUC); the other two thirds came from groundwater. The water system in the city consists of more than 335 miles of distribution mains, the 26 groundwater wells discussed above, and seven storage tanks with approximately 28.8 million gallons of capacity. According to the 2015 UWMP, the citywide demand for potable water in 2015 was 17,620 acre-feet (Santa Clara 2016). The UWMP also concludes that the City is expected to meet projected future demands ranging from approximately 28,000 AFY in 2020 and gradually increasing to approximately 34,000 AFY in 2040.

No information was provided by the applicant about water use during construction. However, given the short duration of construction activities, the amount of water needed is expected to be small. The largest use of water during construction would be for dust suppression. Typically, dust suppression uses about 1,000 gallons per acre per day. Assuming that water would be applied to all 12 acres of the project site every day of the 14 months of construction (approximately 300 days assuming 22 work days in a month), that would add up to approximately 3.6 million gallons, or about 11 AF. This overly

conservative estimate is still less than the project demand for one year of operation. The impact of construction water demand would therefore be less than significant.

The proposed project's operation demand of 17 AFY constitutes a small fraction of the current demand in the city and a smaller fraction of the projected demand for 2020 through 2040. The city's UWMP for 2015 shows that the city has sufficient supply to meet the project's demand in normal and single dry year scenarios. However, the UWMP shows that the city could have a deficit in multiple dry year scenarios. This would be possible if supply from SFPUC is interrupted. Under a multi-year drought scenario, the city's supply from SFPUC might be interrupted if certain conditions specified in the interruptible contract between the city and SFPUC are met (City of Santa Clara 2016). However, if supply from SFPUC is interrupted for any reason, the city has conservation plans and other measures in place to manage supply to meet demand.

The proposed project would be constructed on a previously disturbed site that was occupied by an industrial manufacturing facility. Water used for the industrial activities was potable water supplied by the city. According to historic data provided by the applicant for the years from 2004 through 2017, which constitute the 14 years prior to complete cessation of industrial activities, the average water use at the site had been 1,574 AFY and the maximum use, which occurred in 2010, was 2,026 AFY (LDC 2019). Thus the proposed project's annual water use of 17 AFY would constitute a reduction of at least 1,557 AFY in potable water use and a net beneficial impact on local water supplies compared to the historic annual consumption at the site. In order to ensure that adequate water supplies would be available throughout the life of the project, the applicant requested a WSA from the city of Santa Clara, pursuant to Water Code sections 10910-10915. Based on the total square footage being less than 650,000 sq. ft, and the project demand being less than that of 500 dwelling units, the project does not meet the criteria for preparation of a WSA.

Additionally, the applicant has indicated that the project would use recycled water if it is available. Since the city has access to recycled water from the RWF and a recycled water line is within a quarter-mile of the LDC, the project could be served with recycled water for industrial uses at a future date. This would constitute an additional saving in potable water that can be available for other beneficial uses. Impacts to the local water supply for project construction and operation would therefore be less than significant.

**Proposed Mitigation Measures:** None.

- c. *Would the project result in a determination by the wastewater treatment provider which serves or may serve the project that it has adequate capacity to serve the project's projected demand in addition to the provider's existing commitments?***

### **Demolition/Construction, Operation and Maintenance**

LESS THAN SIGNIFICANT IMPACT. The RWF treats an average of 110 mgd of wastewater, which is 57 mgd less than its 167 mgd treatment capacity. The project would generate a maximum of 400,000 gallons per day, or 0.4 mgd, which is less than 1.0 percent of the available treatment capacity of the RWF. Implementation of the proposed project would not result in an increase in the RWF's need for wastewater treatment beyond its design capacity. Therefore, the RWF has the ability to treat wastewater generated by the project and the impact on wastewater treatment facilities would be less than significant.



The majority of the project site is currently covered with impervious surfaces. The project would reduce the amount of impervious areas at the site<sup>1</sup> which would result in more storm water infiltration and thus a reduction in storm water runoff. The proposed project would also include a storm water collection system that includes storm water bio-swales to reduce the overall runoff into the city's collection system and to control sedimentation impacts. In addition, the project would have to comply with the city's municipal storm water permit, which would further reduce the likelihood of the project causing an increase in storm water discharge from the site. The impact from the project on the storm water system capacity would be less than significant.

**Proposed Mitigation Measures:** None.

- d. *Would the project generate solid waste in excess of State or local standards, or in excess of the capacity of local infrastructure, or otherwise impair the attainment of solid waste reduction goals?***

#### **Demolition/Construction, Operation and Maintenance**

LESS THAN SIGNIFICANT IMPACT. Demolition and construction activities for the project would result in a temporary increase in solid wastes. Operations would result in long-term generation of a small amount of solid waste. The majority of the solid waste would be classified as nonhazardous, while a small fraction would be classified as hazardous. Hazardous waste would be handled by licensed services and disposed of at available facilities licensed to accept such waste. Nonhazardous solid waste would be disposed of at the Newby Island Landfill in San Jose. Operating the project would generate approximately 140 pounds (0.07 ton) of solid waste per day. This is a negligibly small increase of only 0.002 percent of the maximum daily amount of 3,260 tons per day of solid waste allowed at the Newby Island Landfill. Also, this amount is significantly smaller than what has been historically generated by the industrial facility that existed at the site. The Newby Island Landfill has a remaining capacity of 21.2 million cubic yards and would provide adequate disposal space for the solid waste associated with the project's construction, and for operations through 2024. According to the City of Santa Clara General Plan, the life of the Newby Island Landfill could be prolonged as a result of the increases in recycling and reduction in waste generation measures being implemented by the city. Also, the landfill has been evaluating an expansion plan. If the landfill cannot operate beyond 2024 for any reason, the city is planning to use property it owns outside its jurisdictional boundaries for waste disposal purposes (Santa Clara 2010). Therefore, the impact resulting from construction and operation of the proposed project on landfill capacity would be less than significant.

**Proposed Mitigation Measures:** None.

- e. *Would the project comply with federal, state, and local management and reduction statutes and regulations related to solid waste?***

#### **Demolition/Construction, Operation and Maintenance**

LESS THAN SIGNIFICANT IMPACT. The California Integrated Waste Management Act of 1989 (Assembly Bill 939) requires local jurisdictions in California to reduce, by 50 percent, the amount of solid waste disposed of in landfills by the year 2000 and beyond. During construction, the project would collect and haul construction debris off-site for recycling or disposal in local jurisdictions that comply with this state requirement and have programs in place to ensure that disposal of solid waste meets these requirements. The project would comply with these requirements pursuant to city requirements. The

---

<sup>1</sup> By removing some of the existing impervious land cover and replacing it with pervious areas such as planting areas and swales.

project would not result in an impact on solid waste collection and would comply with management and reduction regulations (Jacobs 2019a). Typically, data centers do not generate special or unique wastes that would make the project not comply with federal, state, and local statutes or solid waste management and reduction regulations. Management of hazardous waste and applicable federal regulations are discussed in **Section 5.9, Hazards and Hazardous Materials**.

During operation, the project would comply with federal, state, and local statutes and regulations related to solid waste. There would be no change in compliance with federal, state, or local statutes and regulations related to solid waste management and reduction. No impact would occur.

**Proposed Mitigation Measures:** None.

### 5.18.3 References

- Santa Clara 2010** – City of Santa Clara (Santa Clara). 2010-2035 General Plan. Approved November 16, 2010. Available online at: <http://santaclaraca.gov/government/departments/community-development/planning-division/general-plan>. Accessed on: March 22, 2019.
- Santa Clara 2016** – City of Santa Clara 2015 Urban Water Management Plan. Prepared by the City of Santa Clara Water and Sewer Utilities. Adopted November 22, 2016.
- Santa Clara 2019** – City of Santa Clara (Santa Clara). City Code, Chapter 8.25.285, Health and Safety, Accumulation, Transportation, and Disposal of Solid Waste, Construction and Demolition Debris Recycling. Available online at: <https://www.codepublishing.com/CA/SantaClara/#!/SantaClara18/SantaClara1846.html#18.46>.
- DWR 2003** – Department of Water Resources (DWR). Guidebook for Implementation of Senate Bill 610 and Senate Bill 221 of 2001. California Department of Water Resources. October 8, 2003.
- Jacobs 2019a** – Jacobs (Jacobs). (TN 227273-1). Application for Small Power Plant Exemption: Laurelwood Data Center, dated March 5, 2019. Available online at: <https://efiling.energy.ca.gov/Lists/DocketLog.aspx?docketnumber=19-SPPE-01>.
- Jacobs 2019c** – Jacobs (Jacobs). (TN 227626). LDC Responses to Formal and Informal Data Requests. Data Response Set 1A, dated April 11, 2019. Available online at: <https://efiling.energy.ca.gov/Lists/DocketLog.aspx?docketnumber=19-SPPE-01>.
- Jacobs 2019f** – Jacobs (Jacobs). (TN 228823). LDC Updated SPPE Project Description, dated June 21, 2019. Available online at: <https://efiling.energy.ca.gov/Lists/DocketLog.aspx?docketnumber=19-SPPE-01>.
- Jacobs 2019i** – Jacobs (Jacobs). (TN 229001). LDC Response to Data Request, Set 4, dated July 16, 2019. Available online at: <https://efiling.energy.ca.gov/Lists/DocketLog.aspx?docketnumber=19-SPPE-01>.

## 5.19 Wildfire

This section describes the environmental and regulatory setting and discusses impacts associated with the demolition/construction and operation of the Laurelwood Data Center (LDC or project) with respect to wildfires.

WILDFIRE	Potentially Significant Impact	Less than Significant With Mitigation Incorporated	Less than Significant Impact	No Impact
<b>If located in or near state responsibility areas or lands classified as very high fire hazard severity zones, would the project:</b>				
a. Substantially impair an adopted emergency response plan or emergency evacuation plan?	<input type="checkbox"/>	<input type="checkbox"/>	<input type="checkbox"/>	<input checked="" type="checkbox"/>
b. Due to slope, prevailing winds, and other factors, exacerbate wildfire risks, and thereby expose project occupants to, pollutant concentrations from a wildfire or the uncontrolled spread of a wildfire?	<input type="checkbox"/>	<input type="checkbox"/>	<input type="checkbox"/>	<input checked="" type="checkbox"/>
c. Require the installation or maintenance of associated infrastructure (such as roads, fuel breaks, emergency water sources, power lines or other utilities) that may exacerbate fire risk or that may result in temporary or ongoing impacts to the environment?	<input type="checkbox"/>	<input type="checkbox"/>	<input type="checkbox"/>	<input checked="" type="checkbox"/>
d. Expose people or structures to significant risks, including downslope or downstream flooding or landslides, as a result of runoff, post-fire slope instability, or drainage changes?	<input type="checkbox"/>	<input type="checkbox"/>	<input type="checkbox"/>	<input checked="" type="checkbox"/>

Environmental checklist established by CEQA Guidelines, Appendix G.

### 5.19.1 Setting

#### Wildfire Hazards

The Department of Forestry and Fire Protection (Cal Fire) identifies and maps areas of significant fire hazards based on fuels, terrain, and other relevant factors. These maps categorize this information by Fire Hazard Severity Zones (FHSZ), grouped into unzoned, moderate, high, and very high zones. State responsibility areas (SRA) are locations where the State of California is responsible for wildfire protection and Local Responsibility Areas are locations where the responding agency is the county or city.

The project would require an approximately 600-foot-long electrical supply line that would head west from the LDC to tie into Silicon Valley Power's (SVP) existing 60-kV distribution line located on the western side of the San Tomas Aquino Creek. The project would therefore be subject to regulations governing power line construction. The California Public Utilities Commission (CPUC) has promulgated updated regulations that enhance the fire safety of electric power lines and communication lines located in high fire threat areas. A new high fire-threat district map was created and adopted consisting of three-fire threat areas: Tier 1, Tier 2, and Tier 3. Tier 1 consists of High Hazard Zones (HHZ) on the United States Forest Service (USFS-CAL FIRE) joint map of Tree Mortality HHZ. This tier represents areas where tree mortality directly coincides with critical infrastructure such as communities, roads, and utility lines, and are a direct threat to public safety. Tier 2 consists of areas where there is an elevated risk (including likelihood and potential impacts on people and property) from wildfires associated with overhead utility power lines or overhead utility power-line facilities also supporting communication facilities. Tier 3 consists of areas where there is an extreme risk (including likelihood and potential impacts on people and property) from wildfires associated with overhead utility power lines or overhead utility power-line facilities also supporting communication facilities.

The project site and proposed power supply lines are surrounded by urban development in the City of Santa Clara, are not located in a state responsibility area, and are not located in lands classified as very high FHSZ. The City of Santa Clara is not within a state of California FHSZ (Cal Fire 2019) at the wildland and urban interface, and is not in the vicinity of wildlands.

## Regulatory Background

### *Federal*

No federal regulations related to wildfires apply to the project.

### *State*

**Fire Hazard Severity Zones (Pub. Resources Code, §§ 4201-4204).** The purpose is to provide for the classification of lands within SRA's in accordance with the severity of fire hazard present and identify measures to be taken to retard the rate of spreading and to reduce the potential intensity of uncontrolled fires that threaten to destroy resources, life, or property.

**Fire Hazard Severity (Cal. Code Regs., tit. 14, § 1280).** Fire Hazard Severity Zones designate the official maps that reflect the degree of severity of fire hazard that is expected to prevail in those zones.

**CPUC General Order 95: Rules for Overhead Electric Line Construction.** CPUC GO 95, Section 35, covers all aspects of design, construction, operation, and maintenance of overhead electrical lines and management of safety hazards. Its application would ensure adequate service and safety to persons engaged in the construction, maintenance, operation or use of overhead lines and to the public in general.

**CPUC General Order 166: Standards for Operation, Reliability, and Safety During Emergencies and Disasters.** CPUC GO 166 covers the standards which require all electric utilities to be prepared for emergencies and disasters in order to minimize damage and inconvenience to the public which may occur as a result of electric system failures, major outages or hazards posed by damage to electric distribution facilities.

**CPUC Final Decision D.17-12-024: Decision Adopting Regulations to Enhance Fire Safety in the High Fire –Threat District.** This decision adopts new regulations to enhance the fire safety of overhead electric power lines and communication lines located in high fire-threat areas.

### *Local*

**Santa Clara County Operational Area Hazard Mitigation Plan.** The plan includes risk assessment that identifies the natural hazards and risks that can impact a community based on historical experience, estimate the potential frequency and magnitude of disasters, and assess potential losses to life and property. The plan also includes developed mitigation goals and objectives as part of a strategy for mitigating hazard-related losses.

## 5.19.2 Environmental Impacts and Mitigation Measures

The project site is surrounded by urban development in the City of Santa Clara. The project is not located in or near a state responsibility area and is not located in lands classified as very high fire hazard severity zones. The City of Santa Clara is not identified to be within a State of California Fire Hazard Severity Zone (Cal Fire 2019) at the wildland and urban interface, and is not in the vicinity of wildlands.

**Applicant Proposed Mitigation Measures: None.**

- a. *If located in or near state responsibility areas or lands classified as very high fire hazard severity zones, would the project substantially impair an adopted emergency response plan or emergency evacuation plan?***

**Demolition/Construction**

NO IMPACT. The project is not located in or near a state responsibility area or lands classified as very high fire hazard severity, or a high fire threat zone identified by CPUC.

Furthermore, during project construction, traffic levels would experience a minimal increase that is not expected to degrade traffic performance significantly. Emergency response access during construction would not be significantly impeded. The project would not involve the development of structures that could potentially impair implementation of or physically interfere with an adopted emergency response plan or emergency evacuation plan. No streets would be closed, rerouted, or substantially altered during demolition and construction.

**Operation and Maintenance**

NO IMPACT. The project is not located in or near a state responsibility area or lands classified as very high fire hazard severity, or a high fire threat zone identified by CPUC.

Additionally, the project does not involve the addition of a large number of people to the local area who could increase emergency response demand during a potential evacuation. Thus, the project would not interfere with the coordination of the city's emergency operations plan at the emergency operations center or alternate emergency operations center, nor would the project interfere with any statewide emergency response, or evacuation routes or plans. Adequate emergency access to the project site and surrounding industrial area would be maintained.

**Proposed Mitigation Measures: None.**

- b. *If located in or near state responsibility areas or lands classified as very high fire hazard severity zones, would the project due to slope, prevailing winds, and other factors, exacerbate wildfire risks, and thereby expose project occupants to pollutant concentrations from a wildfire or the uncontrolled spread of a wildfire?***

**Demolition/Construction**

NO IMPACT. The project is not located in or near a state responsibility area or lands classified as very high fire hazard severity, or a high fire threat zone identified by CPUC.

Additionally, the topography of the project site is flat and the project area is highly developed with minimal open space areas, faces, or slopes. Therefore, demolition and construction would not exacerbate wildfire risk or expose occupants to pollutant concentrations from a wildfire.

**Operation and Maintenance**

NO IMPACT. The project is not located in or near a state responsibility area or lands classified as very high fire hazard severity, or a high fire threat zone identified by CPUC.

Additionally, the topography of the project site is flat and the project area is highly developed with minimal open space areas, faces, or slopes. Therefore, project operation would not exacerbate wildfire risk or expose occupants to pollutant concentrations from a wildfire.

**Proposed Mitigation Measures:** None.

- c. *If located in or near state responsibility areas or lands classified as very high fire hazard severity zones, would the project require the installation or maintenance of associated infrastructure (such as roads, fuel breaks, emergency water sources, power lines or other utilities) that may exacerbate fire risk or that may result in temporary or ongoing impacts to the environment?*

#### **Demolition/Construction**

NO IMPACT. The project is not located in or near a state responsibility area or lands classified as very high fire hazard severity, or a high fire threat zone identified by CPUC.

Furthermore, the project would require a single offsite feature: The installation of a 600-foot-long electrical distribution line to connect the proposed onsite substation to SVP's 60-kV distribution system. The distribution line would be located within a public utility corridor located on the southern part of the LDC site and the adjacent parcel, and would cross the San Tomas Aquino Creek Trail at sufficient height to allow passage of emergency vehicles. Therefore, the construction of the distribution line would not be expected to increase fire risk.

#### **Operation and Maintenance**

NO IMPACT. The project is not located in or near a state responsibility area or lands classified as very high fire hazard severity, or a high fire threat zone identified by CPUC.

Maintenance of the project site and associated facilities is not expected to increase fire risk.

**Proposed Mitigation Measures:** None.

- d. *If located in or near state responsibility areas or lands classified as very high fire hazard severity zones, would the project expose people or structures to significant risks, including downslope or downstream flooding or landslides, as a result of runoff, post-fire slope instability, or drainage changes?*

#### **Demolition/Construction**

NO IMPACT. The project is not located in or near a state responsibility area or lands classified as very high fire hazard severity, or a high fire threat zone identified by CPUC.

Moreover, the project is in a low flood potential area. Demolition/construction and operation of the project would not alter the course of a drainage (stream or river) and would not substantially alter local drainage patterns. Storm water discharge during construction would be managed according to the project's Storm Water Pollution Prevention Plan, and appropriately discharged to the City of Santa Clara's storm drain system. The project would therefore not be expected to contribute to a flooding hazard onsite or offsite.



As discussed in this section, the topography of the project site and surrounding area is relatively flat and highly developed. Therefore, the project would not be exposed to post-fire slope instability or drainage changes.

For further discussion of the potential flooding impacts that could result from the proposed project, please see the discussion in **Section 5.10, Hydrology and Water Quality**.

### **Operation and Maintenance**

NO IMPACT. The project is not located in or near a state responsibility area or lands classified as very high fire hazard severity, or a high fire threat zone identified by CPUC.

Moreover, the project is in a low flood potential area. Operation of the project would not alter the course of a drainage (stream or river) and would not substantially alter local drainage patterns. The proposed onsite storm drainage system would be designed to meet the city's storm water drainage standards and sized adequately to convey water away from the site and to the City of Santa Clara's storm drain system. The project would therefore not contribute to a flooding hazard onsite or offsite.

As discussed in this section, the topography of the project site and surrounding area is relatively flat and highly developed. Therefore, the project would not be exposed to post-fire slope instability or drainage changes.

**Proposed Mitigation Measures:** None.

### **5.19.3 References**

**CalFire 2019** – California Department of Forestry and Fire Protection (CalFire). *Santa Clara County FHSZ Map in Local Responsibility Area*. Available online at:

[https://frap.fire.ca.gov/media/6409/fhszl06\\_1\\_map43.pdf](https://frap.fire.ca.gov/media/6409/fhszl06_1_map43.pdf). Accessed on: April 30, 2019.

**Jacobs 2019a** – Jacobs (Jacobs). (TN 227273-1). Application for Small Power Plant Exemption: Laurelwood Data Center, dated March 5, 2019. Available online at:

<https://efiling.energy.ca.gov/Lists/DocketLog.aspx?docketnumber=19-SPPE-01>.

## Section 5.20 Mandatory Findings of Significance

MANDATORY FINDINGS OF SIGNIFICANCE				
	Potentially Significant Impact	Less than Significant With Mitigation Incorporated	Less than Significant Impact	No Impact
a. Does the project have the potential to substantially degrade the quality of the environment, substantially reduce the habitat of a fish or wildlife species, cause a fish or wildlife population to drop below self-sustaining levels, threaten to eliminate a plant or animal community, substantially reduce the number or restrict the range of a rare or endangered plant or animal or eliminate important examples of the major periods of California history or prehistory?	<input type="checkbox"/>	<input checked="" type="checkbox"/>	<input type="checkbox"/>	<input type="checkbox"/>
b. Does the project have impacts that are individually limited, but cumulatively considerable? ("Cumulatively considerable" means that the incremental effects of an individual project are significant when viewed in connection with the effects of past projects, the effects of other current projects, and the effects of probable future projects)?	<input type="checkbox"/>	<input checked="" type="checkbox"/>	<input type="checkbox"/>	<input type="checkbox"/>
c. Does the project have environmental effects which will cause substantial adverse effects on human beings, either directly or indirectly?	<input type="checkbox"/>	<input type="checkbox"/>	<input checked="" type="checkbox"/>	<input type="checkbox"/>

Environmental checklist established by CEQA Guidelines, Appendix G.

- a. Does the project have the potential to substantially degrade the quality of the environment; substantially reduce the habitat of a fish or wildlife species; cause a fish or wildlife population to drop below self-sustaining levels; threaten to eliminate a plant or animal community; substantially reduce the number or restrict the range of an endangered, rare or threatened species; or eliminate important examples of the major periods of California history or prehistory?**

LESS THAN SIGNIFICANT WITH MITIGATION INCORPORATED.

**Biological Resources.** With mitigation, the project would not substantially degrade the quality of the environment, reduce the existing habitat of any fish or wildlife species, cause any fish or wildlife population to drop below self-sustaining levels, threaten to eliminate any plant or animal community, or substantially reduce the number or restrict the range of an endangered, rare, or threatened species.

The project site and surrounding properties are highly developed with office and industrial buildings. The potential to degrade environmental quality is minimal, as the main project site and surrounding properties do not support natural vegetation or features that would entice wildlife foraging or occupancy. A review of the California Natural Diversity Database (CNDDDB) and the Santa Clara Valley Habitat Conservation Plan (SCVHCP) indicated that Western burrowing owl, a California species of special concern, could occur on the project site due to its location within 1.5 miles of known, active breeding colonies. Proposed mitigation measures to buffer and protect nesting birds and Western burrowing owl would ensure the project impacts on migratory or resident birds protected by the Migratory Bird Treaty Act and the Fish and Game Code would be less than significant.

Ground mounted poles to support the proposed electric power line extension would completely avoid the nearest wildlife habitat – an open creek and vegetated corridor. The project and surrounding area

is highly developed and the new buildings and power line would not fragment the natural landscape or interfere with the movement of fish or wildlife. **Section 5.4, Biological Resources** identifies the following mitigation measures:

- **MM BIO-1**, which requires pre construction bird nesting surveys and prescribes avoidance buffers for nests discovered on the site; and
- **MM BIO-2**, which outlines the parameters and requirements for Western burrowing owl avoidance and mitigation.

Implementation of these mitigation measures would ensure that the project would not substantially reduce species habitats, populations, and natural communities.

**Cultural and Tribal Cultural Resources.** Important examples of the major periods of California history or prehistory represented by historical, unique archaeological, or tribal cultural resources are not known to be present in the project area. Nevertheless, the extent of proposed ground disturbance has the potential to damage unknown, buried archaeological resources in the project area. As described in **Section 5.5, Cultural and Tribal Cultural Resources**, the majority of archaeological resources aged about 5,000 years or older are buried beneath the ground surface. If these resources were to be exposed or destroyed, it would be a significant impact. Implementation of mitigation measures **MM CUL-1** and **MM CUL-3** would reduce the impacts to buried cultural resources to a less-than-significant level. The proposed project therefore is unlikely to eliminate important examples of major periods of California history or prehistory.

- b. Does the project have impacts that are individually limited, but cumulatively considerable? (“Cumulatively considerable” means that the incremental effects of an individual project are significant when viewed in connection with the effects of past projects, the effects of other current projects, and the effects of probable future projects)?**

LESS THAN SIGNIFICANT WITH MITIGATION INCORPORATED. The analysis of cumulative impacts can employ one of two methods to establish the effects of other past, current, and probable future projects. A lead agency may select a list of projects, including those outside the control of the agency, or, alternatively, a summary of projections. These projections may be from an adopted general plan or related planning document, or from a prior environmental document that has been adopted or certified, and these documents may describe or evaluate the regional or area-wide conditions contributing to the cumulative impact.

This Initial Study evaluates cumulative impacts using the City of Santa Clara 2010-2035 General Plan Integrated Final Environmental Impact Report (General Plan EIR) since the project would be consistent with applicable land use plans and policies. The General Plan EIR evaluated future development, as identified in the current General Plan, and concluded that the city’s contribution to cumulative impacts would be less than significant or less than cumulatively considerable on Aesthetics, Air Quality, Biological Resources, Cultural Resources, Geology and Soils, Hazards and Hazardous Materials, Hydrology and Water Quality, Land Use, and Public Services. Given this, and given that the project, with mitigation, would have less than significant impacts on these resources, the project’s contribution to these impacts would not be singularly or cumulatively considerable.

Additional discussion regarding proposed mitigation measures for impacts to Biological Resources and Cultural and Tribal Cultural Resources continues below. Additional discussion for Air Quality is provided below for informational purposes.

**Air Quality.** The proposed project would be located in Santa Clara County in the San Francisco Bay Area Air Basin (SFBAAB), under the jurisdiction of the Bay Area Air Quality Management District (BAAQMD). The SFBAAB is designated as a nonattainment area for ozone and particulate matter less than 2.5 microns (PM<sub>2.5</sub>) under both California Ambient Air Quality Standards (CAAQS) and National Ambient Air Quality Standards (NAAQS). The SFBAAB is designated as nonattainment for particulate matter less than 10 microns (PM<sub>10</sub>) under CAAQS, but not NAAQS. SFBAAB's nonattainment status is attributed to the region's development history. Past, present and future development projects contribute to the region's adverse air quality impacts on a cumulative basis. In developing thresholds of significance for air pollutants, BAAQMD considered the emission levels for which a project's individual emissions would be cumulatively considerable. If a project exceeds the identified significance thresholds, its emissions would be cumulatively considerable, resulting in significant adverse air quality impacts to the region's existing air quality conditions. CEQA requires implementation of all feasible mitigation measures.

The demolition and construction emissions of the project would be lower than the thresholds of significance from the BAAQMD CEQA Air Quality Guidelines. There is no numerical threshold for fugitive dust generated during construction in BAAQMD. BAAQMD considers fugitive dust emissions to be potentially significant without incorporation of basic construction mitigation measures, also called best management practices (BMPs). The applicant proposed to incorporate the BAAQMD's recommended BMPs as a project design feature as applicant proposed measures. Therefore, the project's construction emissions would not be cumulatively considerable during demolition and construction.

During testing and maintenance operation, the oxides of nitrogen (NO<sub>x</sub>) emissions of the standby engine generators are estimated to exceed the BAAQMD significance threshold of 10 tons per year. All other pollutants would have estimated emission rates below BAAQMD significance thresholds. The NO<sub>x</sub> emissions from the standby engine generator testing and maintenance operation would be required to be fully offset at an offset ratio of 1.15 to 1 through the permitting process with the BAAQMD. Therefore, the project emissions during testing and maintenance operation would not be cumulatively considerable.

Staff completed a separate criteria pollutant air quality impact analysis that included analysis of potential standby engine generator testing at any hour of the year. Staff's analysis found that the concentrations from the non-concurrent, one at a time, testing of the standby engine generators did not cause exceedances of the ambient air quality standards. Therefore, the project's criteria air pollutant impacts from standby engine generator testing would be less than significant.

In spite of the low frequency expected for emergency operations and the uncertainty in the modeling assumptions, staff performed an independent worst-case analysis of the project's potential air quality impacts during emergency operations. Staff's conservative modeling results indicate that project's emergency operation would not expose sensitive receptors to substantial criteria pollutant concentrations.

Staff also reviewed the applicant's health risk assessment for demolition and construction and during operation due to standby engine generator testing, which found that the cancer and chronic long-term health risks would be below BAAQMD significance thresholds, and that when all standby engine generators are operating concurrently the acute health risks would be below BAAQMD significance thresholds. Staff also performed an independent analysis combining construction and operation

cancer risks into the 30-year cancer risk calculation for the sensitive receptors. Staff's independent analysis shows that, including consideration of potential emergency operations, the project would not expose sensitive receptors to substantial toxic air contaminant (TAC) concentrations.

Therefore, the project's air quality impacts would not be considered cumulatively significant.

**Biological Resources.** The General Plan EIR found less than significant biological resources impacts in the event of a full build-out scenario. The project site and surrounding properties are highly developed with office and industrial buildings. The potential to degrade environmental quality is minimal, as the main project site and surrounding properties do not support natural vegetation or features that would entice wildlife foraging or occupancy. However, ornamental landscaping and other features on and near the project site could provide nesting opportunities for birds protected under the Migratory Bird Treaty Act and Western burrowing owl. To ensure impact avoidance, **Section 5.4, Biological Resources** identifies the following mitigation measures: **MM BIO-1**, which requires pre-construction bird nesting surveys and prescribes avoidance buffers for nests discovered on the site, and **MM BIO-2**, which outlines the parameters and requirements for Western burrowing owl avoidance and mitigation. Biological resources impacts from the proposed project would be less than significant with mitigation measures in place and therefore would not be cumulatively considerable.

**Cultural and Tribal Cultural Resources.** The General Plan EIR does not specifically address impacts on tribal cultural resources. Historical resources and unique archaeological resources, as defined by CEQA, share several of the impact vulnerabilities that tribal cultural resources face, especially the effects of ground-disturbing activities. In addition, historical and unique archaeological resources can also qualify as tribal cultural resources. The suite of mitigation measures presented in the General Plan EIR would reduce the severity of some impacts on tribal cultural resources. No known tribal cultural resources have been found on or adjacent to the project, although ground disturbance associated with the proposed project could result in the exposure and destruction of buried, as-yet unknown prehistoric archaeological resources that could qualify as tribal cultural resources. Implementation of **MM CUL-1** and **MM CUL-3** would reduce impacts on buried, historical, unique archaeological and tribal cultural resources to a less than significant level. The project's impacts on cultural and tribal cultural resources therefore would not be cumulatively considerable.

The General Plan EIR identified the following significant environmental impacts:

- Climate Change – Contribution to GHG emission exceeding Santa Clara's emission reduction target for 2035;
- Noise – Increase in localized traffic noise level on roadway segments throughout Santa Clara;
- Population and Housing – Exacerbation of land use impacts arising from the jobs/housing imbalance;
- Traffic – Degradation of traffic operations on regional roadways and highways within Santa Clara of an unacceptable level of service; and
- Solid Waste – Contribution to solid waste generation beyond available capacity after 2024.

Although the project, in combination with future development in the City of Santa Clara, could conceivably have a significant cumulative impact to these environmental resources, the following discussion demonstrates how the project's contribution to these impacts would be less than cumulatively considerable.

### ***Climate Change Impacts***

**Greenhouse Gas Emissions.** The BAAQMD CEQA Air Quality Guidelines do not identify a greenhouse gas (GHG) emissions threshold for construction-related emissions. Instead, BAAQMD recommends that GHG emissions from construction be quantified and disclosed and the impacts be determined in relation to meeting Assembly Bill (AB) 32 GHG reduction goals. The BAAQMD further recommends incorporation of BMPs to reduce GHG emissions during construction, as feasible and applicable. The construction emissions would be in conformance with state and local GHG emissions reduction goals, so impacts would be less than significant.

For operation-related emissions, the BAAQMD CEQA Air Quality Guidelines states that for stationary-source projects, the threshold to determine the significance of an impact from GHG emissions is 10,000 metric tons per year of carbon dioxide equivalent (MTCO<sub>2</sub>e/yr). For commercial/industrial land use development projects, BAAQMD has adopted a numeric threshold of 1,100 MTCO<sub>2</sub>e/yr and a qualitative threshold of complying with a qualified greenhouse gas reduction strategy. The 10,000 MTCO<sub>2</sub>e/yr threshold would apply to the proposed LDC project, which includes stationary sources that are subject to BAAQMD permitting, and the project would not be subject to the 1,100 MTCO<sub>2</sub>e/yr threshold recommended for commercial/industrial land use developments. The standby generators would not be considered to have a cumulatively considerable contribution of GHG emissions if emissions are below the BAAQMD's threshold of 10,000 MTCO<sub>2</sub>e/yr. Other project-related emissions from mobile sources, area sources, energy use and water use, would not be included for comparison to this threshold, based on guidance in the BAAQMD's CEQA Guidelines (BAAQMD 2017b). GHG impacts from all other project-related emission sources would be considered to have a less-than-significant impact if the project is consistent with the City of Santa Clara Climate Action Plan and applicable regulatory programs and policies adopted by the Air Resources Board or other California agencies, which are considered a qualified greenhouse gas reduction strategy.

The GHG emissions of the stationary engines of the project are expected to be less than the 10,000 MTCO<sub>2</sub>e/yr threshold and would not be considered to be cumulatively significant. Additionally, the project would implement efficiency measures to meet California green building standards, and additional voluntary efficiency and use reduction measures, including measures necessary to meet the applicant proposed LEED green building certification. GHG emissions from energy use would be reduced by the green power mix used by Silicon Valley Power. As such, GHG emissions related to the project would not conflict with the City of Santa Clara Climate Action Plan or other plans, policies, or regulations adopted for the purpose of reducing the emissions of GHGs. Therefore, the project's GHG emissions would not be considered cumulatively significant.

### ***Noise Impacts***

The General Plan EIR anticipates significant noise impacts from the build-out of the General Plan. The significant noise impacts identified are attributed to noise associated with increased traffic. As discussed in **Section 5.16, Transportation**, traffic from the project would not have a significant impact on surrounding roadways and the transportation network. The project would contribute vehicle trips during the construction period as trucks deliver construction materials to the project site. These trips would be temporary in nature; therefore, they would not significantly add to regular traffic. The 54 operational employees would generate minimal daily trips and would not substantially increase the traffic in the project area. Any noise impacts associated with construction and operations traffic would be less than significant. The project's contribution to this cumulative impact would not be cumulatively considerable.



### ***Population and Housing Impacts***

The General Plan EIR identified significant impacts from the build-out of the General Plan land use designations. The General Plan EIR concluded that the proposed land uses would create a regional jobs/housing imbalance, as workers who are unable to live near their employment would commute long distances from outlying areas. As described in **Section 5.13, Population and Housing**, the project would not displace any people or housing, or necessitate construction of replacement housing elsewhere. Operation of the project is anticipated to require approximately 54 employees. The project's construction and operation workforce would not directly or indirectly induce a substantial population growth in the project area. Therefore, the project's contribution to this cumulative impact would not be cumulatively considerable.

### ***Traffic Impacts***

The General Plan EIR anticipates significant traffic impacts from the build-out of the General Plan. As discussed in **Section 5.16, Transportation**, traffic from the project would not have a significant impact on surrounding roadways and the transportation network. The project would contribute vehicle trips during the construction period as trucks deliver construction materials to the project site. These trips would be temporary in nature; therefore, they would not significantly add to regular traffic. The 54 operational employees would generate minimal daily trips and would not substantially increase the regular traffic in the project area. The project's contribution to this cumulative impact would not be cumulatively considerable.

### ***Solid Waste Impacts***

As stated in **Section 5.18, Utilities and Service Systems**, the City of Santa Clara has available landfill capacity at the Newby Island Landfill in the City of San Jose through 2024. The current landfill impacts are addressed within an ongoing Integrated Waste Management Plan of the City of Santa Clara to provide waste disposal services. The project would generate minimal operational waste as data centers typically require very little equipment turnover. Additionally, the project does not include a residential component and would not generate any increases in the supply and demand of utility services and infrastructure. Therefore, the project's contribution to this cumulative impact would not be cumulatively considerable.

**c. *Does the project have environmental effects which will cause substantial adverse effects on human beings, either directly or indirectly?***

LESS THAN SIGNIFICANT IMPACT. The proposed project would not cause substantial adverse effects on human beings either directly or indirectly. The proposed project would result in temporary impacts to human health during construction, including changes to air quality, exposure to geologic hazards, noise, and exposure to hazardous materials. As discussed in **Section 5.3, Air Quality**, with implementation of **APM AQ-1**, the project would result in a less than significant impact related to dust emissions during project construction. As discussed in **Section 5.7, Geology and Soils**, implementation of seismic design guidelines in the current California Building Code and project-specific recommendations in a final geotechnical engineering report would ensure the project would not expose people or property to significant impacts associated with geologic or seismic conditions onsite. The proposed project would result in temporary noise impacts to humans during construction. As discussed in **Section 5.13, Noise**, construction-related noise impacts would be less than significant. As discussed in **Section 5.9, Hazards and Hazardous Materials**, hazards impacts would be less than

significant. No additional impacts to human beings would occur during operation and maintenance activities.

## 5.20. References

**Santa Clara 2010** – City of Santa Clara (Santa Clara). City of Santa Clara 2010–2035 General Plan.

Adopted November 16, 2010. Available online at:

<http://santaclaraca.gov/government/departments/community-development/planning-division/general-plan>.

**Santa Clara 2011** – City of Santa Clara (Santa Clara). 2010–2035 General Plan Integrated Final Environmental Impact Report. January 2011. Available online at:

<http://santaclaraca.gov/home/showdocument?id=12900>.

## 5.21 Environmental Justice

### 5.21.1 Setting

The United States Environmental Protection Agency (U.S. EPA) defines environmental justice (EJ) as, “the fair treatment and meaningful involvement of all people regardless of race, color, national origin or income with respect to the development, implementation and enforcement of environmental laws, regulations and policies” (U.S. EPA 2015, page 4).

The Environmental Justice in the Energy Commission Siting Process subsection immediately below describes why EJ is part of the Energy Commission siting process, the methodology used to identify an EJ population, and the consideration of California Environmental Protection Agency’s (Cal/EPA) CalEnviroScreen data. Below that, the Environmental Justice Project Screening subsection presents the demographic data for those people living in a six-mile radius of the project site and a determination on presence or absence of an EJ population. When an EJ population is identified, staff in 12 technical areas<sup>1</sup> considers the project’s impacts on this population and whether any impacts would disproportionately affect the EJ population. Lastly, the Project Outreach subsection discusses the Energy Commission’s outreach program specifically as it relates to the proposed project.

### Environmental Justice in the Energy Commission Siting Process

Executive Order 12898, “Federal Actions to Address Environmental Justice in Minority Populations and Low-Income Populations,” focuses federal attention on the environment and human health conditions of minority communities and calls on federal agencies to achieve environmental justice as part of their mission. The order requires the U.S. EPA and all other federal agencies (as well as state agencies receiving federal funds) to develop strategies to address this issue. The agencies are required to identify and address any disproportionately high and adverse human health or environmental effects of their programs, policies, and activities on minority and/or low-income populations.

The California Natural Resources Agency recognizes that EJ communities are commonly identified as those where residents are predominantly minorities or live below the poverty level; where residents have been excluded from the environmental policy setting or decision-making process; where they are subject to a disproportionate impact from one or more environmental hazards; and where residents experience disparate implementation of environmental regulations, requirements, practices, and activities in their communities. Environmental justice efforts attempt to address the inequities of environmental protection in these communities.

An EJ analysis is composed of the following:

- Identification of areas potentially affected by various emissions or impacts from a proposed project;
- Providing notice in appropriate languages (when possible) of the proposed project and opportunities for participation in public workshops to EJ communities;
- A determination of whether there is a significant population of minority persons, or persons below the poverty level, living in an area potentially affected by the proposed project; and

---

<sup>1</sup> The 12 technical areas are Aesthetics, Air Quality, Hazards and Hazardous Materials, Hydrology and Water Quality, Land Use and Planning, Noise, Population and Housing, Public Services, Recreation, Transportation, Tribal Cultural Resources, and Utilities and Service Systems. Tribal Cultural Resources staff considers impacts to Native American populations.

- A determination of whether there may be a significant adverse impact on a population of minority persons or persons below the poverty level caused by the proposed project alone, or in combination with other existing and/or planned projects in the area.

California law defines EJ as “the fair treatment of people of all races, cultures and income with respect to the development, adoption, implementation, and enforcement of environmental laws, regulations, and policies” (Gov. Code, § 65040.12; Pub. Resources Code, §§ 71110-71118). All departments, boards, commissions, conservancies and special programs of the Resources Agency must consider EJ in their decision-making process if their actions have an impact on the environment, environmental laws, or policies. Such actions that require EJ consideration may include:

- adopting regulations;
- enforcing environmental laws or regulations;
- making discretionary decisions or taking actions that affect the environment;
- providing funding for activities affecting the environment; and
- interacting with the public on environmental issues

### **CalEnviroScreen - More Information About an EJ Population**

The California Communities Environmental Health Screening Tool (CalEnviroScreen) is a science-based mapping tool used by Cal/EPA to identify disadvantaged communities<sup>2</sup> pursuant to Senate Bill (SB) 535. As required by SB 535, disadvantaged communities are identified based on geographic, socioeconomic, public health and environmental hazard criteria. CalEnviroScreen identifies communities most burdened by pollution from multiple sources and most vulnerable to its effects, taking into account socioeconomic and health status of people living in those communities (Cal/EPA 2017, page 1).

CalEnviroScreen scores are calculated by multiplying the pollution burden and population characteristics categories together into a single unified score (Pollution Burden X Population Characteristics = CalEnviroScreen Score) (Cal/EPA 2017). Each group has a maximum score of 10, thus the maximum CalEnviroScreen score is 100. The CalEnviroScreen score derived for a given tract relative to other tracts in the state (Cal/EPA 2017, page 6). Values for the various components are shown as percentiles, which indicate the percent of all census tracts with a lower score. A higher percentile indicates a higher potential relative burden.

**Table 5.21-1** lists the indicators that go into the pollution burden score and the population characteristics score to form the unified CalEnviroScreen score. These indicators are used to measure factors that affect the potential for pollution impacts in communities.

---

<sup>2</sup> The California Environmental Protection Agency, for purposes of its Cap-and-Trade Program, has designated “disadvantaged communities” as census tracts having a CalEnviroScreen score at the top 25 percent (75<sup>th</sup> percentile) (Cal/EPA 2017).

**TABLE 5.21-1 COMPONENTS THAT FORM THE CALENVIROSCREEN 3.0 SCORE**

Pollution Burden	
<b>Exposure Indicators</b>	<b>Environmental Effects Indicators</b>
Ozone concentrations	Cleanup sites
Particulate Matter (PM) 2.5 concentrations	Groundwater threats
Diesel PM emissions	Hazardous waste
Drinking water contaminants	Impaired water bodies
Pesticide Use	Solid waste sites and facilities
Toxic releases from facilities	
Traffic density	
Population Characteristics	
<b>Sensitive Populations Indicators</b>	<b>Socioeconomic Factors Indicators</b>
Cardiovascular disease (emergency department visits for heart attacks)	Educational attainment
Low birth-weight infants	Linguistic isolation
Asthma emergency department visits	Poverty
	Rent-adjusted income
	Unemployment

Source: OEHHA 2018

Part of staff’s assessment of how, or if, the project would impact an EJ population includes a review of CalEnviroScreen data for the project area. There are four technical areas that could have project impacts that could combine with the indicators in CalEnviroScreen: Air Quality (Public Health), Hydrology and Water Quality, Hazards and Hazardous Materials, and Utilities and Service Systems.

The CalEnviroScreen indicators relevant to each of the four technical areas are:

**Air Quality:**

- Ozone concentrations
- Particulate Matter (PM) 2.5 concentrations
- Traffic density
- Diesel PM emissions
- Pesticide use
- Low birth-weight infants
- Toxic releases from facilities
- Cardiovascular disease
- Asthma
- Traffic density

**Hydrology and Water Quality:**

- Drinking water contaminants
- Groundwater threats
- Impaired water bodies

**Hazards and Hazardous Materials:**

- Cleanup sites

**Utilities and Service Systems**

- Cleanup sites
- Hazardous waste generators and facilities
- Solid waste sites and facilities

When staff members in these technical areas have identified a potential impact where an EJ population is present, they use CalEnviroScreen to better understand the characteristics of the areas where the impact would occur and ensure that disadvantaged communities in the vicinity of the proposed project have not been missed when screened by race/ethnicity and low income.

There are several limitations with CalEnviroScreen that are important to note (Cal/EPA 2017, pages iii, 1-3, 6, 12). Some limitations and items to note on CalEnviroScreen include the following:

- The core purpose of this tool is to characterize “impacts” of pollution in communities with respect to factors that are not routinely included in risk assessments, where “impacts,” for the purposes of this tool, refers broadly to stressors that can affect health and quality of life.
- The tool is a screening tool developed to conduct statewide evaluations of community-scale impacts.
- Many factors, or stressors, contribute to a community’s pollution burden and vulnerability.
- Integration of multiple stressors into a risk assessment is currently not feasible.
- The score provides a relative rather than absolute measure of pollution’s impacts and vulnerabilities in California communities.
- The score provides a broad picture of the burdens and vulnerabilities that communities confront from environmental pollutants.
- A percentile does not describe the magnitude of the difference between two tracts, rather it simply tells the percentage of tracts with lower values for that indicator.
- The score is for a given tract relative to other tracts in the state.

The tool did not/does not:

- substitute for a cumulative impact analysis under the California Environmental Quality Act (CEQA).
- restrict the authority of government agencies in permit and land use decisions.
- guide all public policy decisions.
- inform the implementation of many policies, programs and activities throughout the state.

### **Project Outreach**

As a part of the U.S. EPA’s definition of environmental justice, meaningful involvement is an important part of the siting process. Meaningful involvement occurs when:

- those whose environment and/or health would be potentially affected by the decision on the proposed activity have an appropriate opportunity to participate in the decision;
- the population’s contribution can influence the decision;
- the concerns of all participants involved are considered in the decision-making process; and,
- involvement of the population potentially affected by the decision on proposed

Energy Commission staff and the Public Adviser’s Office coordinated closely on public outreach early in the review process. A Notice of Receipt of the Laurelwood Data Center (LDC or project) Small Power Plant Exemption (SPPE) and Notice of Public Participation were filed to the docket and mailed to the project mail list on March 14, 2019 including environmental justice organizations and similar interest groups. Public notices for the project in both English and Chinese (Mandarin) were published in local newspapers on April 2, 2019 and April 5 and 6, 2019, respectively. In accordance with the Governor’s Executive Order B-10-11, the Energy Commission’s Tribal Consultation Policy, the Energy Commission’s Siting Regulations, and recent amendments to CEQA (i.e., AB 52), the Energy Commission Tribal Liaison contacted California Native American tribes, as defined in CEQA. This ongoing consultation effort includes contacting groups via hard-copy letters, emails, and follow-up phone calls, inviting them to comment on the proposed LDC



project and offering to hold face-to-face meetings regarding the project. Additional information regarding the specific groups contacted can be found in **Section 5.5, Cultural and Tribal Cultural Resources**.

Staff contacted local elected officials, Native American tribal groups.

Energy Commission regulations require staff to notice, at a minimum, property owners within 1,000 feet of a project and 500 feet of a linear facility (such as transmission lines, gas lines, and water lines). This was done for the project, and the property owners list has been augmented to include the surrounding political jurisdictions, school districts, state and federal agencies.

### Environmental Justice Project Screening

**Figure 5.21-1** shows 2010 census blocks in a six-mile radius of the project with a minority population greater than or equal to 50 percent (US Census 2010). The population in these census blocks represents an EJ population based on race and ethnicity as defined in the United States Environmental Protection Agency’s *Guidance on Considering Environmental Justice During the Development of Regulatory Actions* (U.S. EPA 2015).

Based on California Department of Education data in **Table 5.21-1** and presented in **Figure 5.21-2**, staff concludes that the percentage of those living in the school districts of East Side Union High, San Jose Unified, and Santa Clara Unified (in a six-mile radius of the project site) and enrolled in the free or reduced price meal program is larger than those in the reference geography, and thus are considered an EJ population based on a low income population as defined in *Guidance on Considering Environmental Justice During the Development of Regulatory Actions*.

**TABLE 5.21-2 LOW INCOME DATA WITHIN THE PROJECT AREA**

School Districts in a Six-Mile Radius of the Project Site	Enrollment Used for Meals	Free or Reduced Price Meals	
Campbell Union High	8,043	1,996	24.8%
<b>East Side Union High</b>	<b>27,263</b>	<b>14,560</b>	<b>53.4%</b>
Fremont Union High	11,140	1,688	15.2%
Milpitas Unified	10,318	3,452	33.5%
Mountain View – Los Altos Union High	4,304	848	19.7%
<b>San Jose Unified</b>	<b>31,713</b>	<b>14,479</b>	<b>45.7%</b>
<b>Santa Clara Unified</b>	<b>15,509</b>	<b>6,402</b>	<b>41.3%</b>
<b>Reference Geography</b>			
Santa Clara County	272,155	102,647	37.7%

Note: **Bold** indicates school districts considered having an EJ population based on low income. Source: CDE 2018.







## CalEnviroScreen- Disadvantaged Communities

CalEnviroScreen 3.0 was used to gather additional information about the population potentially impacted by the proposed project. The CalEnviroScreen indicators were used to measure factors that affect the potential<sup>3</sup> for pollution impacts in communities (OEHHA 2017). Staff used CalEnviroScreen 3.0 to identify disadvantaged communities<sup>4</sup> in the vicinity of the proposed project and better understand the characteristics of the areas where impacts would occur (see **Figure 5.21-1**, which includes CalEnviroScreen-defined disadvantaged communities by census tracts). **Table 5.21-3** presents the CalEnviroScreen data for the disadvantaged communities in the project area. Where percentiles for CalEnviroScreen indicators are 90 and above, the percentile is shown in bold. These relatively higher percentiles could be seen as drivers for the census tract’s identification as a disadvantaged community. None of the disadvantaged community census tracts around the project have an overall percentile (pollution burden percentile and population characteristics percentile combined) of 90 or above. As shown in **Table 5.21-4**, there are two census tracts where the combined pollution burden percentile is 90 or above and seven census tracts where individual indicators are in the 90 or above percentile.

**TABLE 5.21-3 CALENVIROSCREEN SCORES FOR DISADVANTAGED COMMUNITIES**

Census Tract No.	Total Population	CES 3.0 Percentile	Pollution Burden Percentile	Population Characteristics Percentile
06085504602	2,144	82.28	88.30	65.33
06085505202	5,867	76.89	88.04	57.65
06085504318	5,265	87.33	<b>94.51</b>	65.72
06085500100	6,339	88.86	<b>93.17</b>	70.94
06085501102	4,477	80.92	85.50	66.02
06085501401	3,295	79.98	81.88	68.08
06085503601	2,992	85.64	87.13	71.82

Note: Disadvantaged communities by census tract in the project’s 6-mile radius. Source: Cal/EPA 2018

**Table 5.21-4** presents the CalEnviroScreen 3.0 percentiles for the indicators that make up the pollution burden percentile in a six-mile radius of the project site. **Table 5.21-5** presents the CalEnviroScreen 3.0 percentiles for the indicators that make up the population characteristics in a six-mile radius of the project site.

<sup>3</sup> It is important to note that CalEnviroScreen is not an expression of health risk and does not provide quantitative information on increases of impacts for specific sites or project. CalEnviroScreen uses the criteria of “proximity” to a hazardous waste site, a leaking underground tank, contaminated soil, an emission stack (industry, power plant, etc.) to determine that a population is “impacted”. It does not address general principles of toxicology: dose/response and exposure pathways. For certain toxic chemicals to pose a risk to the public, offsite migration pathways must exist (through ingestion, inhalation, dermal contact, etc.) and contact to a certain amount – not just any amount – must exist.

<sup>4</sup> The California Environmental Protection Agency (Cal/EPA), for purposes of its Cap-and-Trade Program, has designated “disadvantaged communities” as census tracts having a CalEnviroScreen score at or above the 75th percentile (Cal/EPA 2017). As a comparative screening tool, it is not intended to be used as a health or ecological risk assessment for a specific area or site.

**TABLE 5.21-4 CALENVIROSCREEN INDICATOR PERCENTILES FOR POLLUTION BURDEN FOR DISADVANTAGED COMMUNITIES**

Census Tract No.	Percentiles												
	Pollution Burden	Ozone	PM2.5	Diesel PM	Drinking Water	Pesticides	Toxic Release	Traffic	Cleanup Sites	Groundwater Threats	Hazardous Waste	Impaired Water Bodies	Solid Waste
06085504602	88.30	16.94	42.86	25.50	30.45	38.47	35.40	88.24	<b>99.42</b>	<b>91.91</b>	88.36	<b>91.47</b>	<b>99.98</b>
06085505202	88.04	16.94	52.61	89.89	13.56	0.00	57.35	71.95	<b>99.84</b>	<b>98.30</b>	<b>99.11</b>	41.15	<b>95.02</b>
06085504318	<b>94.51</b>	16.94	52.61	<b>91.74</b>	56.64	0.00	53.89	88.43	<b>99.80</b>	<b>98.39</b>	<b>99.68</b>	29.25	<b>99.79</b>
06085500100	<b>93.17</b>	16.94	52.61	<b>91.75</b>	51.02	0.00	47.78	82.20	<b>98.74</b>	<b>96.94</b>	<b>97.41</b>	41.15	<b>97.24</b>
06085501102	85.50	16.94	52.61	88.77	51.02	0.00	43.68	64.46	89.13	89.79	88.42	29.25	<b>92.74</b>
06085501401	81.88	16.94	52.61	88.89	51.02	0.00	42.88	89.97	73.37	82.51	50.68	29.25	85.97
06085503601	87.13	16.94	52.61	87.94	51.02	0.00	43.71	82.75	83.95	84.79	89.92	29.25	<b>90.99</b>

**TABLE 5.21-5 CALENVIROSCREEN INDICATOR PERCENTILES FOR POPULATION CHARACTERISTICS FOR DISADVANTAGED COMMUNITIES**

Census Tract No.	Percentiles								
	Population Characteristics	Asthma	Low Birth Weight	Cardiovascular Disease	Education	Linguistic Isolation	Poverty	Unemployment	Housing Burden
06085504602	65.33	79.87	<b>99.82</b>	34.21	47.43	66.88	34.38	48.58	48.53
06085505202	57.65	34.95	79.87	51.84	65.90	76.00	54.83	6.94	69.61
06085504318	65.72	40.88	61.09	43.75	76.65	<b>95.35</b>	69.30	66.75	54.18
06085500100	70.94	70.94	49.03	65.33	71.65	69.02	59.97	59.88	68.95
06085501102	66.02	67.77	41.87	60.24	75.32	66.66	49.45	76.86	55.15
06085501401	68.08	52.79	67.72	38.00	87.90	<b>92.13</b>	68.81	33.82	73.80
06085503601	71.82	56.56	64.22	51.04	77.04	88.15	77.10	56.83	59.39



## 5.21.2 Environmental Impacts and Mitigation Measures

The following technical areas discuss impacts to EJ populations: Aesthetics, Air Quality, Hazards and Hazardous Materials, Hydrology and Water Quality, Land Use and Planning, Noise, Population and Housing, Public Services, Recreation, Transportation, Tribal Cultural Resources, Utilities and Service Systems, and Mandatory Findings of Significance. As there is no agriculture or forestry resources within a 6-mile radius of the project site, there would be no associated impacts to an EJ population in this technical area and it is therefore not discussed below.

Part of staff's assessment of how, or if, the project would impact an EJ population includes a review of CalEnviroScreen data for the project area. There are three technical areas that could have project impacts that could combine with the indicators in CalEnviroScreen: Air Quality, Hazards and Hazardous Materials, and Hydrology and Water Quality. When staff members in these technical areas have identified a potential impact where an EJ population is present, they use CalEnviroScreen to better understand the characteristics of the areas where the impact would occur and ensure that disadvantaged communities in the vicinity of the proposed project have not been missed when screened by race/ethnicity and low income.

### Aesthetics

LESS THAN SIGNIFICANT IMPACT. A disproportionate impact pertaining to Aesthetics to an EJ population may occur if a project is in proximity to an EJ population and the following:

- The project if in a non-urbanized area substantially degrades the existing visual character or quality of the public view of the site and its surroundings.
- The project if in an urbanized area conflicts with applicable zoning and other regulations governing scenic quality.
- The project creates a new source of substantial light and glare that would adversely affect day or nighttime views in the area.

The project is in an urban area. Aside from minor modifications that will be required from the City of Santa Clara for a height exceedance, the project would not conflict with the applicable city zoning and other regulations governing scenic quality. Staff using GIS data and viewing aerial and street view images concludes the closest EJ population would have no to low visibility of the project due to the existence of aboveground landscape elements (buildings, structures, earthworks, trees, etc.) obstructing or obscuring the public view of it. The project would not have a disproportionate effect to an EJ population and would have a less than significant effect.

### Air Quality

LESS THAN SIGNIFICANT IMPACT. Ambient air quality standards (AAQS) are established to protect the health of even the most sensitive individuals in our communities, which includes the EJ population, by defining the maximum amount of a pollutant that can be present in outdoor air without harm to the public's health. Both the California Air Resources Board and the U.S. EPA are authorized to set ambient air quality standards.

Staff examined individual contributions of indicators in CalEnviroScreen that are relevant to air quality (see **Table 5.21-1**). The indicator scores presented in **Tables 5.21-4** and **5.21-5** are similar among census tracts, as it relates to air quality for ozone and PM<sub>2.5</sub> impacts.



### ***Ozone Impacts***

Ozone is known to cause numerous health effects, which can potentially affect EJ communities as follows:

- lung irritation, inflammation and exacerbation of existing chronic conditions, even at low exposures (Alexis et al. 2010, Fann et al. 2012, Zanobetti and Schwartz 2011);
- increased risk of asthma among children under 2 years of age, young males, and African American children (Lin et al., 2008, Burnett et al., 2001); and,
- higher mortality, particularly in the elderly, women and African Americans (Medina- Ramon, 2008).

Even though ozone is not directly emitted from the emission sources such as at LDC, the precursor pollutants that create ozone such as nitrogen oxides (NOx) and volatile organic compounds (VOCs) are expected to be emitted. Before obtaining a permit to construct from the Bay Area Air Quality Management District (BAAQMD), the applicant will be required to purchase NOx emission reduction credits (ERCs) which would come from within the San Francisco Bay Area Air Basin. The applicant has stated they would purchase ERCs from the market to offset emissions from testing and reliability-related operation of the project (CEC 2019c). The BAAQMD would determine the quantity and location of ERCs during the permitting process. The NOx emissions of the emergency generators would be mitigated through the permitting process with the BAAQMD.

For CalEnviroScreen, the air monitoring data used in this indicator have been updated to reflect ozone measurements for the years 2011 to 2013. CalEnviroScreen 3.0 uses the average daily maximum ozone concentration. According to CalEnviroScreen data, ozone concentrations in each census tracts are ordered by ozone concentration values, and then are assigned a percentile based on the statewide distribution of values and are shown in **Table 5.21-4**. The percentile for all of the census tracts are the same at 16.9, meaning ozone levels in these census tracts are higher than just 16.9 percent of the census tracts in California, or 83 percent of all California census tracts have higher ozone levels than these near LDC.

### ***PM2.5 Impacts***

Particulate matter (PM) is a complex mixture of aerosolized solid and liquid particles including such substances as organic chemicals, dust, allergens and metals. These particles can come from many sources, including cars and trucks, industrial processes, wood burning, or other activities involving combustion. The composition of PM depends on the local and regional sources, time of year, location and weather.

PM2.5 refers to particles that have a diameter of 2.5 micrometers or less. PM2.5 is known to cause numerous health effects, which can potentially affect EJ communities. Particles in this size range can have adverse effects on the heart and lungs, including lung irritation, exacerbation of existing respiratory disease, and cardiovascular effects.

For CalEnviroScreen, the indicator PM2.5 is determined by the annual mean concentration of PM2.5 (average of quarterly means), averaged over three years (2011-2013). According to CalEnviroScreen data, PM2.5 concentrations in each census tracts are ordered by PM2.5 concentration values, and then are assigned a percentile based on the statewide distribution of values and are shown in **Table 5.21-4**. The percentiles are 52.6 for all census tracts except 6085504602, which was at the 42.8 percentile. This means these census tracts identified are higher than 52.6 and 42.8 percent, respectively of the census tracts in all of California. For this reason, the proposed project would not individually or cumulatively contribute to disproportionate PM2.5 air quality impacts to the EJ population.

### ***NO2 Impacts***

As stated in **Section 5.3, Air Quality**, staff did an additional assessment of other criteria pollutant impacts. Specifically, staff completed an independent modeling analysis for engine testing and maintenance emissions to determine NO<sub>2</sub> impacts, and considered emergency operations in that evaluation. Staff's conservative 1-hour NO<sub>2</sub> and 24-hour PM<sub>10</sub> and PM<sub>2.5</sub> modeling results indicate that project's emergency operation would not expose sensitive receptors or any EJ population to substantive criteria pollutant concentrations.

### **Environmental Justice Air Quality Conclusion**

LESS THAN SIGNIFICANT IMPACT. Staff does not expect adverse air quality impacts to members of the public, recreational users, or EJ population. Air quality impacts, specifically with regards to ozone and PM<sub>2.5</sub>, would not contribute to disproportionate impacts to the EJ population.

### ***Public Health and Toxic Air Contaminant Issues***

LESS THAN SIGNIFICANT IMPACT. Staff identified the potential public health impacts (i.e. cancer and non-cancer health effects) which could affect the EJ population represented in **Figure 5.21-1** and **5.21-2**. These potential public health risks were evaluated quantitatively based on the most sensitive population, which includes the EJ population, by conducting a health risk assessment. The results were presented by level of risks. The potential construction and operation risks are associated with exposure to diesel particulate matter, total organic gases in diesel exhaust, and evaporative and exhaust total organic gases from gasoline vehicles. The toxic air contaminants from total organic gases include 1,3-Butadiene, Acetaldehyde, Benzene, Ethylbenzene, Formaldehyde, n-Hexane, Methanol, Methyl Ethyl Ketone, Napthalene, Propylene, Styrene, Toluene, and Xylene. Staff concluded that construction and operation of the project would not cause significant adverse direct or indirect public health impacts from the project's toxic air emissions and that no additional mitigation is needed. Likewise, the project would not cause disproportionate public health impacts on sensitive populations, such as the EJ population represented in **Figure 5.21-1** and **5.21-2**.

The following section focuses on toxic air contaminant issues. This focus includes ozone and PM<sub>2.5</sub>, but also includes additional public health indicators. See **Tables 5.21-4** and **5.21-5**.

### ***Diesel PM***

This indicator represents how much diesel PM is emitted into the air within and near the census tract. The data are from 2012 California Air Resources Board's emission data from on-road vehicles (trucks and buses) and off-road sources (ships and trains, for example). Among these seven census tracts, two are higher than the 90th percentile. The highest percentile is 91.7 (in census tracts 6085500100 and 6085504318), meaning these two are higher than 91.7 percent of the census tracts in California. However, according to the results of the health risk assessment conducted for this project, impacts associated with diesel PM from the proposed project construction and operation activities (diesel-fueled equipment) would be less than significant and would not have a significant cumulative contribution to the diesel PM levels in the disadvantaged communities.

### ***Pesticide Use***

Specific pesticides included in the measurement of category were narrowed from the list of all registered pesticides in use in California to focus on a subset of 70 chemicals that are filtered for hazard and volatility for the years 2012-2014 collected by the California Department of Pesticide Regulation. Only pesticides

used on agricultural commodities are included in the indicator. Among these seven census tracts, none are higher than the 90th percentile; therefore, pesticide use is not a concern.

### ***Toxic Releases from Facilities***

This indicator represents modeled air concentrations of chemical releases from large facility emissions in and near the census tract. The U.S. EPA provides public information on the amount of chemicals released into the environment from many facilities. This indicator uses the modeled air concentration and toxicity of the chemical to determine the toxic release score. The data are from 2011-2013. Among these seven census tracts, none are higher than the 90th percentile; therefore, toxic releases from facilities are not a concern.

### ***Traffic Density***

This indicator represents the sum of traffic volumes adjusted by road segment length. It is calculated by dividing the traffic volumes by the total road length within 150 meters of the census tract boundary. It is not a measure of level of service on roadways. The data are from 2013. Among the seven census tracts of staff's focus, none are higher than the 90th percentile. The highest one is 89.9 (in census tract 6085501401), meaning it is higher than 89.9 percent of the census tracts in California. Traffic Density is related to the diesel PM emitted from vehicles. However, according to the results of the health risk assessment conducted for the project, impacts associated with diesel PM from the proposed project construction and operation activities (diesel-fueled equipment) would be less than significant and would not have a significant cumulative contribution to the diesel PM-related traffic density in the disadvantaged communities.

### ***Asthma ER Visits***

This indicator is a representation of an asthma rate. It measures the number of emergency room visits for asthma per 10,000 people over the years 2011 to 2013. The information was collected by the California Office of Statewide Health Planning and Development. Among these seven census tracts, none are higher than the 90th percentile; therefore, asthma is not a concern.

### ***Low Birth Weight Infants***

This indicator measures the percentage of babies born weighing less than 2500 grams (about 5.5 pounds) out of the total number of live births over the years 2006 to 2012. The information was collected by the California Department of Public Health. Among these seven census tracts, Census Tract 6085504602 has the highest potential relative burden. The low birth weight percentile for this census tract is 100, meaning the percent low birth weight is higher than all other census tracts in California. In this census tract the total population is of 2,144 people, with 10.38 percent of births were of low birth weight. Note that this tract has a relatively small population (94% of the California census tracts have a larger population than this tract) such that small changes in a particular metric like birth weight can skew the results compared to other tracts. Staff's health risk assessment was based on a highly conservative health-protective methodology that accounts for impacts on the most sensitive individuals in a given population. According to the results of the assessment, the risk of the nearest sensitive receptor (i.e. Maximally Exposed Sensitive Receptor) is below health-based thresholds. Therefore, the toxic emissions from the project would not cause significant health effects for the low birth weight infants in these disadvantaged communities or have a significant cumulative contribution to these disadvantaged communities.

### ***Cardiovascular Disease***

This indicator represents the rate of heart attacks. It measures the number of emergency department visits for acute myocardial infarction (or heart attack) per 10,000 people over the years 2011 to 2013. Among these seven census tracts, none are higher than the 90 percentile; therefore, cardiovascular disease is not a concern.

### **Environmental Justice Public Health Conclusion**

LESS THAN SIGNIFICANT IMPACT. Staff concludes that no one (including the public, off-site nonresidential workers, recreational users, and EJ populations) would experience any acute or chronic cancer or non-cancer effects of health significance during construction and operation of the proposed project. Further, construction and operation of the project would not cause significant adverse direct, indirect, or cumulative public health impacts from the project's toxic air emissions. As the public health impacts are calculated for sensitive populations, including the EJ population, and the project's toxic air emissions would not have a significant impact on the most sensitive population, the project's impact would not disproportionately affect the EJ population represented in **Figure 5.21-1** and **5.21-2**. Staff concludes that the project would not have a significant cumulative contribution to the indicators of ozone, PM2.5, diesel PM, pesticide use, toxic releases from facilities, traffic density, asthma ER visits, low birth weight infants, or cardiovascular disease in the disadvantaged community census tracts in the vicinity of the proposed project.

### **Cultural and Tribal Cultural Resources**

NO IMPACT. Staff considered environmental justice populations in its analysis of the project. Staff did not identify any Native American environmental justice populations that either reside within 6 miles of the project or that rely on any subsistence resources that could be impacted by the proposed project.

### **Hazards and Hazardous Materials**

LESS THAN SIGNIFICANT IMPACT. EJ populations may experience disproportionate hazards and hazardous materials impacts if the storage and use of hazardous materials within or near EJ communities occur to a greater extent than within the community at large. A disproportionate impact upon the EJ population resulting from the planned storage and use of hazardous materials on the site is extremely low. Diesel fuel to run the emergency generators is the hazardous material that the project site would have in greatest quantity. The total quantity would be divided up and stored in many separate double-walled containers (one for each generator) with proper spill controls. Therefore, the likelihood of a spill of sufficient quantity to impact the surrounding community and EJ population would be very unlikely, thus is considered less than significant.

### **Hydrology and Water Quality**

LESS THAN SIGNIFICANT IMPACT. A disproportionate hydrologic or water quality impact on an EJ population could occur if the project would contribute to impairment of drinking water, exacerbate groundwater contamination threats, or contribute pollutants to impaired water bodies.

Since the overall CalEnviroScreen score reflects the collective impacts of multiple pollutants and factors, staff examined the individual contributions to indicators as they relate to hydrology and water quality. The pollutants of concern in this analysis are those from construction and operational activities. The CalEnviroScreen scores for the disadvantaged community census tracts in a 6-mile radius of the project (see **Figure 5.21-1**) are presented in **Table 5.21-4** for each of the following environmental stressors that relate to hydrology and water quality: Drinking Water Contaminants, Groundwater Threat, and Impaired

Water Bodies. A disproportionate hydrology or water quality impact on an EJ population could occur if a project introduces an additional pollutant burden to a disadvantaged community.

CalEnviroScreen 3.0 assigns a score to each type of stressor. To assess the impact of a stressor on population within a census tract, the score is assigned a weighting factor that decreases with distance from the census tract. For stationary stressors related to hydrology or water quality, the weighting factor diminishes to zero for distances larger than 1,000 meters (0.6 mile). As **Figure 5.21-1** shows, all but one of the assessed census tracts are more than 1,000 meters away from the project. The only tract that is within 1,000 meters of the proposed project site is tract 6085505202. Therefore, this analysis focuses on that tract.

### ***Drinking Water Contaminants***

Low income and rural communities, particularly those served by small community water systems, can be disproportionately exposed to contaminants in their drinking water. CalEnviroScreen 3.0 aggregates drinking water quality data from the California Department of Public Health, the U.S. EPA, and the California State Water Resources Control Board (SWRCB). The score provided by the Drinking Water Contaminant metric calculation is intended to rank water supplies relative to their history or likelihood to provide water that exceeds drinking water standards.

Census tract 6085505202 has a percentile score of 14 for the Drinking Water Contaminants indicator (see **Table 5.21-4**). This indicates that drinking water contamination threats in this census tract are very low. This suggests that this community is not expected to have a high level of exposure to contaminants through drinking water.

The project would not be expected to contribute significantly to drinking water source degradation. The project would be required to comply with the Clean Water Act by controlling the discharge of pollutants during its construction and operation phases. The project would implement modern operational phase storm water and containment controls that would improve upon the site's potential to release contaminants to the environment. The project would therefore be expected to provide a long-term drinking water quality benefit relative to baseline conditions. The project's hydrology and water quality impacts would be reduced to less than significant for the census tract of concern and the general population.

### ***Groundwater Threats***

Common groundwater pollutants found at leaking underground storage tank and cleanup sites in California include gasoline and diesel fuels, chlorinated solvents and other volatile organic compounds (VOCs) such as benzene, toluene, and methyl tert-butyl ether (MTBE); heavy metals such as lead, chromium and arsenic; polycyclic aromatic hydrocarbons (PAHs); persistent organic pollutants like polychlorinated biphenyls (PCBs); dichloro-diphenyl-trichloroethane (DDT) and other insecticides; and perchlorate. CalEnviroScreen 3.0 aggregates data from the SWRCB's GeoTracker website about groundwater threats. The score provided by the Groundwater Threat metric calculation is intended to rank the relative risk of environmental contamination by groundwater contamination, within each census tract.

Census tract 6085505202 has a percentile score of 98 for the Groundwater Threat indicator (see **Table 5.21-4**). This indicates that groundwater contamination threats in this census tract are within the top 10 percent of tracts statewide. This indicates that this community is located alongside a high relative proportion of groundwater threats.

The project would not be expected to contribute significantly to groundwater degradation, relative to existing conditions. The project would be required to comply with the Clean Water Act by controlling the discharge of pollutants during its construction and operation phases. The project would implement modern operational phase storm water and containment controls that would improve upon the site's potential to release contaminants to groundwater. The project would therefore be expected to provide a long-term groundwater quality benefit relative to baseline conditions. The project's hydrology and water quality impacts would be reduced to less than significant for the census tract of concern and the general population.

### ***Impaired Water Bodies***

Rivers, lakes, estuaries and marine waters in California are important for many different uses. Water bodies used for recreation may also be important to the quality of life of nearby residents if subsistence fishing is critical to their livelihood. Water bodies also support abundant flora and fauna. Changes in aquatic environments can affect biological diversity and overall health of ecosystems. Aquatic species important to local economies may be impaired if the habitats where they seek food and reproduce are changed. Additionally, communities of color, low-income communities, and tribes generally depend on the fish, aquatic plants, and wildlife provided by nearby surface waters to a greater extent than the general population. CalEnviroScreen 3.0 aggregates data from the SWRCB's Final 2012 California Integrated Report (Clean Water Act Section 303(d) List / 305(b) Report). The score provided by the Impaired Water Bodies metric calculation is intended to rank the relative risk of impaired water bodies, within each census tract.

Census tract 6085505202 scored 41 percent in the Groundwater Threat category (see **Table 5.21-4**). This indicates that Impaired Water Bodies in this census tract are near the statewide average in terms of relative abundance. This indicates that these communities are not expected to contain a high abundance of impaired water bodies.

The project would not be expected to contribute significantly to the impairment of local or regional water bodies. The project would be required to comply with the Clean Water Act by controlling the discharge of pollutants during its construction and operation phases. The project would implement modern operational phase storm water and containment controls that would improve upon the site's potential to release contaminants to the environment. The project would therefore be expected to provide a long-term benefit to local and regional water bodies, relative to baseline conditions. The project's hydrology and water quality impacts would be reduced to less than significant for the census tract of concern and the general population.

### **Land Use and Planning**

LESS THAN SIGNIFICANT IMPACT. The project would not generate disproportionate land use impacts to the nearby EJ population. It would not physically divide an existing community, and minor inconsistencies with the general plan and zoning ordinance would result in less than significant environmental impacts. Furthermore, as discussed in **Section 5.1, Aesthetics**, the nearest EJ population would have no to low visibility of the project due to the existence of above-ground landscape elements (buildings, structures, earthwork, trees, etc.) obstructing or obscuring the public view of it. For this reason, the height of the project would not have a significant impact on any EJ population. The project would not result in disproportionate land use impacts to an EJ population, and therefore, land use impacts to the EJ population would be less than significant.



## Noise

LESS THAN SIGNIFICANT IMPACT. EJ populations may experience disproportionate noise impacts if the siting of unmitigated industrial facilities occurs within or near EJ communities to a greater extent than within the community at large. The project site is at least 0.5-mile from an area having an EJ population. Because the area surrounding the site is primarily industrial, warehouse, and commercial uses, and the nearest residences are at least 0.5-mile away from the project site, potential impacts would not be disproportionate.

Demolition and construction activities would increase existing noise levels at the adjacent commercial and industrial land uses, but they would be temporary and intermittent. In addition, demolition and construction would not occur on Sundays and holidays in compliance with the Santa Clara City Code, Section 9.10.230. Also, the loudest noise levels from construction and demolition activities are expected to be lower than the existing ambient noise levels at the closest residential area.

Therefore, potential noise effects related to demolition and construction would not result in a significant noise impact on the area's population, including the EJ population.

The noise from operating the facility would not exceed the city's noise limits at the surrounding land uses, including the residential uses. The operational noise levels would comply with the city's noise limits and would not elevate the existing ambient noise levels at the nearest residences. Thus, the impacts would be less than significant for all the area's population, including the EJ population.

## Population and Housing

LESS THAN SIGNIFICANT IMPACT. Because the study area used in this analysis for impacts related to population influx and housing supply includes Campbell, Cupertino, Milpitas, San Jose, Santa Clara, Sunnyvale, and Santa Clara County, staff considered the project's population and housing impacts on the EJ population living in these geographic areas.

The potential for population and housing impacts is predominantly driven by the temporary influx of non-local construction workers seeking lodging closer to a project site. For the project, the construction workers would be drawn from the greater Bay Area and thus would not likely seek temporary lodging closer to the project site. The operations workers are also anticipated to be drawn from the greater Bay Area and would not likely seek housing closer to the project site. If some operations workers were to relocate closer to the project site, there would be sufficient housing in the project area.

A population and housing impact could disproportionately affect an EJ population if the project were to displace minority or low income residents from where they live, causing them to find housing elsewhere. If this occurs, an EJ population may have a more difficult time finding replacement housing due to racial biases and possible financial constraints. As the project would not displace any residents or remove any housing, there would be no disproportionate impact to EJ populations from this project.

## Transportation

LESS THAN SIGNIFICANT IMPACT. Significant reductions in transportation options may significantly impact EJ populations. In particular, an impact to bus transit, pedestrian facilities, or bicycle facilities could cause disproportionate impacts to low-income communities, as low-income residents more often use these modes of transportation. However, all transportation impacts, including impacts to alternative

transportation, would be less than significant, and therefore would cause less than significant impacts to EJ populations. Likewise, transportation impacts would not be disproportionate.

### **Utilities and Service Systems**

LESS THAN SIGNIFICANT IMPACT. A disproportionate utilities and system services impact on an EJ population could occur if the project would contribute to or exacerbate the effects of cleanup sites, hazardous waste generators and facilities, and solid waste facilities.

Since the overall CalEnviroScreen score reflects the collective impacts of multiple pollutants and factors, staff examined the individual contributions to indicators as they relate to wastes addressed under utilities and system services. The wastes of concern in this analysis are those from construction and operational activities. The handling and disposal of each type of waste depends on the hazardous ranking of its constituent materials. Existing laws and regulations ensure the desired handling and disposal of waste materials without potential public or environmental health impacts. The CalEnviroScreen scores for the disadvantaged community census tracts in a 6-mile radius of the project (see **Figure 5.21-1**) for each of the following environmental stressors that relate to waste management: cleanup sites, hazardous waste generators and facilities, and solid waste facilities are presented in **Table 5.21-4**. The percentile for each disadvantaged census tract reflects its relative ranking among all of California's census tracts. A disproportionate waste management impact on an EJ population could occur if project wastes impacted the disadvantaged community.

CalEnviroScreen 3.0 assigns a score to each type of stressor. To assess the impact of a stressor on population within a census tract, the score is assigned a weighting factor that decreases with distance from the census tract. For stationery stressors, the weighting factor diminishes to zero for distances larger than 1,000 meters (0.6 mile). As **Figure 5.21-1** shows, all but one of the assessed census tracts are more than 1,000 meters away from the project. The only tract that is within 1,000 meters of the proposed project site is tract 6085505202. Therefore, this analysis focuses on that tract.

#### ***Cleanup Sites***

This indicator is calculated by considering the number of cleanup sites including Superfund sites on the National Priorities List, the weight of each site, and the distance to the census tract. Sites undergoing cleanup actions by governmental authorities, or by property owners, have suffered environmental degradation due to presence of hazardous substances. Of primary concern is the potential for people to come in contact with these substances.

The percentile score for the cleanup sites indicator for the only disadvantaged census tract within 1,000 meters of the project site (tract 6085505202) is 99.84 (see **Table 5.21-4**). The interpretation is that contamination threats due to the presence of cleanup sites in that census tract are among the highest of all tracts statewide. This is an indication that the communities within that tract are located alongside a high relative proportion of cleanup sites.

Past contamination at the project site would be remediated by the current owner and other responsible parties in accordance with regulatory requirements that would ensure there would be no impacts to on- or off-site receptors. In addition, the project owner would have to comply with appropriate laws and regulations that would require additional cleanup of contaminated soils and groundwater that might be encountered during construction and operation activities. Therefore, the project would not be expected

to contribute significantly to effects from cleanup sites for the relevant census tract and for the general population.

### ***Hazardous Waste Generators and Facilities***

This indicator is calculated by considering the number of permitted treatment, storage and disposal facilities or generators of hazardous waste, the weight of each generator or site, and the distance to the census tract. Most hazardous waste must be transported from hazardous waste generators to permitted recycling, treatment, storage, or disposal facilities by registered hazardous waste transporters. Most shipments must be accompanied by a hazardous waste manifest. There are widespread concerns for both human health and the environment from sites that serve for the processing and disposal of hazardous waste. Newer facilities are designed to prevent the contamination of air, water, and soil with hazardous material. However, even newer facilities may negatively affect perceptions of surrounding areas in ways that have economic, social, and health impacts.

The percentile score of the hazardous waste generators and facilities indicator for the only census tract within 1,000 meters of the project site is 99.11. The interpretation is that threats related to hazardous waste generation and facilities in this census tract is among the worst of all tracts statewide, meaning that the communities in that tract are located alongside sites with a high relative proportion of hazardous waste generators and facilities.

The project would not be expected to contribute significantly to hazardous waste generation or to the number or size of facilities handling hazardous waste processing. Further, the project would be required to comply with appropriate laws and regulations to control storage and disposal of hazardous waste during its construction and operation phases. The project would implement modern operational phase controls to prevent or reduce the generation of hazardous wastes and to dispose of them in a manner that would minimize impacts to the environment both during project construction and operation. The project's impacts related to hazardous waste generation and disposal would be reduced to less than significant for the relevant census tract and the general population.

### ***Solid Waste Facilities***

This indicator is calculated by considering the number of solid waste facilities including illegal sites, the weight of each, and the distance to a census tract. Newer solid waste landfills are designed to prevent the contamination of air, water, and soil with hazardous materials. However, older sites that are out of compliance with current standards or illegal solid waste sites may degrade environmental conditions in the surrounding area and pose a risk of exposure. Other types of facilities, such as composting, treatment, and recycling facilities may raise concerns about odors, vermin, and increased traffic.

The percentile score of the solid waste facilities indicator for the only assessed census tract within 1,000 meters is 95 (see **Table 5.21-4**). The interpretation is that the number and type of facilities within or nearby this census tract is in the upper 10 percent of the census tracts in California. This also indicates that environmental deterioration due to the presence of solid waste facilities in that census tract is within the top 10 percent of tracts statewide.

Solid waste generated during construction and operation of the project would be segregated, where practical, for recycling, and disposed where there is adequate capacity for disposal of nonhazardous waste. Also, the project would be required to develop and implement plans that would ensure proper disposal of nonhazardous waste at appropriately licensed facilities. The project owner would use solid wastes sites or facilities that are verified to be in compliance with current laws and regulations. In addition,

there would be no increase of solid waste generators and facilities in the area due to project construction or operation because there is adequate space for disposal of waste from the project. Therefore, there would be no impact due to solid waste facilities that would disproportionately impact an EJ community in the relevant census tract.

### Mandatory Findings of Significance

LESS THAN SIGNIFICANT IMPACT. Staff analysis concluded that cumulative project impacts would be mitigated to less than significant levels. Therefore, cumulative impacts would be less than significant for both the general population and the EJ population.

### List of Preparers and Contributors

The following are a list of preparers and contributors to the **Section 5.21, Environmental Justice**:

Lisa Worrall	General Environmental Justice information, CalEnviroScreen information, Environmental Justice screening, public outreach, CalEnviroScreen project screening, and Population and Housing impact analysis.
Mark Hamblin	Aesthetics impact analysis.
Hui-An (Ann) Chu, Wenjun Qian, Jacquelyn Leyva-Record, William Walters, Brewster Birdsall	Air Quality (public health) impact analysis.
Gabriel Roark	Cultural and Tribal Cultural Resources impact analysis
Brett Fooks	Hazards and Hazardous Materials impact analysis.
Abdel-Karim Abulaban and Mike Conway	Hydrology and Water Quality impact analysis.
Andrea Koch	Land Use and Planning impact analysis.
Scott Pollaske	Mandatory Findings of Significance impact analysis.
Abdel-Karim Abulaban	Noise and Utilities and Service Systems impact analysis.
Ellen LeFevre	Transportation impact analysis.

### 5.21.3 References

**Alexis NE et al. 2010** – Alexis NE, Lay JC, Hazucha M, Harris B, Hernandez ML, Bromberg PA, et al. Low-level ozone exposure induces airways inflammation and modifies cell surface phenotypes in healthy humans. *Inhal Toxicol* 22(7):593-600.

**Burnett RT et al. 2001** – Burnett RT, Smith-Doiron M, Stieb D, Raizenne ME, Brook JR, et al. Association between Ozone and Hospitalization for Acute Respiratory Diseases in Children Less than 2 Years of Age. *American Journal of Epidemiology* 153(5):444-452.

**Cal/EPA 2017** – California Environmental Protection Agency (Cal/EPA). *Designation of Disadvantaged Communities Pursuant to Senate Bill 535 (De Leon)*, April 2017. Available online at: <https://www.calepa.ca.gov/files/2017/04/SB-535-Designation-Final.pdf>.

**Cal/EPA 2018** – California Environmental Protection Agency (Cal/EPA). CalEnviroScreen 3.0 Microsoft Excel Spreadsheet data, last updated June 2018.

**CDE 2018** – California Department of Education (CDE). DataQuest, Free or Reduced Price Meals, District level data for the year 2017-2018. Available online at: <http://dq.cde.ca.gov/dataquest/>.

**Fann N et al. 2012** – Fann N, Lamson AD, Anenberg SC, Wesson K, Risley D, Hubbell BJ, Estimating the National Public Health Burden Associated with Exposure to Ambient PM2.5 and Ozone. Risk Analysis 32(1):81- 95.

**Lin S et al. 2008** – Lin S, Liu X, Le, LH, Hwang, S, Chronic Exposure to Ambient Ozone and Asthma Hospital Admissions among Children. Environ Health Perspect 116(12):1725-1730.

**Medina-Ramón M, Schwartz J 2008** – Who is more vulnerable to die from ozone air pollution? Epidemiology 19(5):672-9.

**OEHHA 2017** – California Environmental Protection Agency’s Office of Environmental Health Hazzard and Assessment (OEHHA). California Communities Environmental Health Screening Tool, Version. 3.0 (CalEnviroScreen 3.0), Guidance and Screening Tool, January 2017. Available online at: <http://oehha.ca.gov/calenviroscreen/report/calenviroscreen-30>.

**U.S. Census 2010** – United States Census Bureau (U.S. Census). QT-PL-Race, Hispanic or Latino, Age, and Housing Occupancy: 2010 – Census Redistricting Data (Public Law 94-171) Summary File, Tables P1, P2, P3, P4, H1. Available online at: <http://factfinder2.census.gov/faces/nav/jsf/pages/index.xhtml>.

**U.S. EPA 2015** – United States Environmental Protection Agency (U.S. EPA). Guidance on Considering Environmental Justice During the Development of Regulatory Actions, May 2015. Available online at: <https://www.epa.gov/environmentaljustice/guidance-considering-environmental-justice-during-development-action>.

**Zanobetti A, Schwartz J 2011** – Ozone and survival in four cohorts with potentially predisposing diseases. Am J Respir Crit Care Med 184(7):836-41.

## **Section 6**

---

Authors and Reviewers



# 6 Authors and Reviewers

## Lead Agency—California Energy Commission

### *Technical Staff /Section Authors*

Mark Hamblin (Aesthetics)

Andrea Koch (Agriculture/Forestry, Land Use)

Wenjun Qian, Jacque Leyva, Ann Chu, William Walters, Brian Birdsall (Air Quality, Greenhouse Gas)

Tia Taylor (Biology)

Gabriel Roark, Melissa Mourkas (Cultural and Tribal Cultural Resources)

Shahab Khoshmashrab (Energy/Energy Resources, Noise)

Ed Brady, Laiping Ng (Energy/Energy Resources)

Garry Maurath (Geology/Soils, Minerals)

Brett Fooks (Hazards/Hazardous Materials, Public Services)

Mike Conway (Hydrology/Water Resources, Wildfire)

Karim Abulaban (Noise, Utilities/Service Systems, Wildfire)

Ashley Gutierrez, Lisa Worrall (Population/Housing, Public Services, Recreation)

Ellen LeFevre (Transportation)

Scott Polaske (Mandatory Findings)

Lisa Worrall (Environmental Justice<sup>1</sup>)

### *Supervision and Management*

Gerry Bemis, Air Quality Unit Supervisor

Jon Hilliard, Biology Unit Supervisor

Tomas Gates, Cultural Unit Supervisor

Geoff Lesh, Engineering Unit Supervisor

Steve Kerr, CEQA Unit Supervisor

Mark Hesters, Transmission Unit Supervisor

Eric Knight, Environmental Office Manager

Matt Layton, Engineering Office Manager

Shawn Pittard, Deputy Director—Siting, Transmission and Environmental Protection

### *Project Management/Legal*

Lisa Worrall, CEQA Lead Project Manager

Nicolas Oliver, Staff Counsel

Kerry Willis, Assistant Chief Counsel

---

<sup>1</sup> With contribution from staff in the technical areas of Aesthetics, Air Quality, Hazards and Hazardous Materials, Hydrology and Water Quality, Land Use and Planning, Noise, Population and Housing, Public Services, Recreation, Transportation, Tribal Cultural Resources, and Utilities and Service Systems.

# **Appendix A**

---

## Project's Jurisdictional and Generating Capacity Determination

## Project's Jurisdictional and Generating Capacity Determination

The Laurelwood Data Center (LDC) would include 55 diesel-fired standby generators that would provide emergency backup power supply for the LDC project. The project would also include an additional 56<sup>th</sup> diesel-fired backup generator to provide essential services (for fire suppression and other emergency operations) (Jacobs 2019a, Section 1.2, page 1-2 and 1-9). The emergency backup generators (gensets) would serve LDC only during interruptions of electric service from Silicon Valley Power (SVP) or during an emergency. The gensets would be electrically isolated from the SVP electrical transmission grid with no means to deliver electricity offsite of LDC.

Each generator would have a nameplate output capacity of 3.0 megawatts (MW) and continuous steady-state output capacity of 2.725 MW. The maximum total LDC facility load requirements would not exceed 99 MW. This includes the critical Information Technology (IT) load of the servers and server bays, the cooling load of the IT servers and bays, and the facility's ancillary electrical and telecommunications equipment operating loads to support the data customers and campus.

The California Energy Commission is responsible for reviewing, and ultimately approving or denying, all applications for thermal electric power plants, 50 MW and greater, proposed for construction in California. (Pub. Resources Code, § 25500.) The Energy Commission has a regulatory process, referred to as the Small Power Plant Exemption (SPPE) process, which allows applicants with projects between 50 and 100 MW to obtain an exemption from the Energy Commission's jurisdiction and proceed with local approval rather than requiring an Energy Commission certificate. The Energy Commission can grant an exemption if it finds that the proposed project would not create a substantial adverse impact on the environment or energy resources. (See Pub. Resources Code, § 25541.)

In order to make a jurisdictional recommendation, staff must assess the generating capacity of the power plant site, answering the following questions:

*1. Is the backup generator facility a thermal power plant under the Energy Commission's definition?*

Yes. The Warren-Alquist Act defines a thermal power plant "as any stationary or floating electrical generating facility using any source of thermal energy, with a generating capacity of 50 megawatts or more, and any facilities appurtenant thereto." (Pub. Resources Code, § 25120.) The 56 gensets in the backup generator facility associated with LDC use diesel fossil-fueled engines to convert the thermal energy in the diesel fuel<sup>1</sup> into electricity from a rotating generator, thus—each genset is an electrical generating device that uses a source of thermal energy.

Title 20, California Code of Regulations, section 2003 specifies how the Energy Commission calculates "generating capacity" for jurisdictional determinations, including section 25120's 50 MW threshold for the definition of a thermal power plant. However, section 2003 only addresses steam and combustion turbines, not diesel-fueled gensets. Although section 2003 was last updated in 1993, at a time when California's thermal power plants of 50 MW and larger would almost exclusively use a combustion or steam turbine to drive a generator, this is simply not true anymore. Other types of thermal engines are now large enough, or are large enough when aggregated together, to result in thermal power plants of 50 MW or larger, while not using a combustion or steam turbine. The type of thermal fuel used or the

---

<sup>1</sup> Diesel fuel is composed of a mixture of hydrocarbons, containing chemical energy. When ignited, this chemical energy is converted to thermal energy.

type of thermal engine generating device (i.e., combustion, steam, reciprocating engine) can be mixed and matched to make a thermal power plant.

Since the generator is just the device that produces the electricity, the question of whether the power plant uses thermal energy or a thermal process applies to the engine and the fuel. The LDC backup gensets would use reciprocating engines operating in the thermodynamic Diesel Cycle. Gasoline engines in automobiles use reciprocating engines operating in the Otto Cycle, while all combustion turbines operate in the Brayton Cycle. Each of these thermodynamic cycles convert thermal energy that is embodied in the fossil fuel or fuel in an internal combustion process. There are other, less common, internal combustion thermodynamic cycles that could power a generator or cluster of generators that may also be considered a thermal power plant.

Steam turbines operate in the Rankine Cycle, which is an external heat input engine cycle. Other examples of external heat cycles include the Solar Sun Catchers proposed for the Imperial Valley Solar Project (08-AFC-05) and Calico Solar Energy Project (08-AFC-13), which would have used Stirling Cycle engines to drive generators. There are other external combustion thermodynamic cycles that could power a generator that could be considered a thermal power plant. Staff and the Energy Commission should evaluate each engine and its thermodynamic cycle on its components, inputs and outputs to reach a determination of whether the fuel, engine, and generator are a thermal power plant.

Engines are machines for converting thermal energy into mechanical energy or power to produce force and motion to drive the generator to produce electricity. They are electrical generating devices that use a source of thermal energy and meet the Energy Commission's thermal power plant definition under section 25120. A turbine is one of many types of engines that can spin a generator to make it generate electricity.

*2. Should the generating capacity of all of the engine generator sets on the power plant site, each with a generating capacity of less than 50 MW, be aggregated?*

Yes. The 56 gensets (55 backup units and one fire/life safety unit) in the proposed backup generation facility, and the associated LDC that they would support, would all be located on a common property under common ownership sharing common utilities. Most of the gensets would operate to provide backup electricity to LDC when its connection to the grid is lost; a few gensets would be installed for the purpose of redundancy, to operate to back up the grid back-up gensets. However, any genset can function either as a back up to the grid or a back up to the grid back up, so there is not a functional difference in the type of engine or generator between each genset. All of the backup gensets at the LDC would share a common trigger for operation during an emergency: the transfer switch isolating the LDC from the grid.

*3. Is there any uncertainty as to when the data center would be constructed and how much of the installed generation would be utilized?*

The plans for the construction of the proposed data center and the associated back-up generation facility with the gensets are certain. The LDC and 56 gensets would be installed in the initial construction of the project by the project owner. The genset type and installation date would not be left to the data customers. However, the exact timing of individual leases that fill server bay space is subject to the market decisions of disparate customers. Therefore, staff cannot estimate when the LDC critical IT and building HVAC loads would be 40 percent, 65 percent, or approach the maximum load limits of LDC.

Staff can only report that the worst-case load requirement, the LDC's worst-case day combined IT and building load<sup>2</sup>, is 99 MW. Additionally, the installed generation is not the same as the aggregated net or useful output capacity. The combined generating capacity of the installed operational gensets is autonomously determined by the electrical equipment in the LDC server bays and building equipment in use at the time of an emergency. The emergency operation of each set ("5 to make 4 server bay set") is fully automated. Once the LDC loses connection to the local grid, the transfer switch isolates the LDC from the local SVP grid and 4 of the 5 gensets in a server bay set initiate startup. As the gensets start, synchronize, and take up load associated with their server bays and building equipment, the uninterruptible power supply (UPS) system supplies up to 10 minutes<sup>3</sup> of power to smoothly transition the LDC customer's data servers from the grid to the emergency gensets (Jacobs 2019a, Section 2.2). If a genset or two fail to start or synchronize, the remaining genset initiates a startup and the other gensets in the server bay set ramp up to higher output levels. The genset output in the 5 to make 4 server bay set match (meet but cannot exceed) the LDC data customer's IT demand in their server bay and also the server bay heating, ventilation, air conditioning (HVAC) demand. The combined output of the server bay set is autonomously determined by the electrical equipment in the LDC server bays and building equipment.

Combined output would be limited by sizing the electricity handling equipment that would throttle transfer capacity to no more than 99 MW, which would prevent damage to IT servers and building equipment. Therefore, it would be physically impossible for the gensets to generate more electricity than what the data center would use, or more than 99 MW.

*4. Does the fact that some capacity will be operated only during grid outages preclude Energy Commission licensing jurisdiction?*

No. The jurisdictional determination does not depend on when the electricity is used, but instead, depends on what constitutes the definition of a thermal power plant under Pub. Resources Code, § 25120 and on a clear evaluation of the generation capacity. Section 25120 in its definition of a thermal power plant, considers "any" generating facility and "any" source of thermal energy, and contains no requirement regarding how frequently the generating facility be operated. Section 2003(a) defines the "generating capacity" of an electric generating facility as "the maximum gross rating of the plant's turbine [sic - engine] generator(s), in megawatts ("MW"), minus the minimum auxiliary load." A generator only generates electricity (i.e., spins) when connected to an engine and a turbine is just that - one of many types of engines that can spin a generator to make it generate electricity. Engines are machines for converting thermal energy (e.g., fossil fuel, heated steam, or captured solar energy) into mechanical energy or power to produce force and motion. Therefore, any jurisdictional recommendation would consider the thermal energy, thermodynamic cycle, and the resulting engine that converts that thermal energy to drive the generator to produce electricity, and is not dependent on the frequency or duration of the gensets' operation.

*5. Does the fact that the backup diesel capacity will not be capable of exporting power to the grid preclude Energy Commission licensing jurisdiction?*

No. Pub. Resources Code, § 25120, in its definition of a thermal power plant, considers "any" generating facility and "any" source of thermal energy, and contains no requirement that the generating facility be

---

<sup>2</sup> Based on the hottest, most humid day of the year and with all IT servers in use at their full usage rate

<sup>3</sup> The gensets are expected to be on and synchronized within a minute or so, but the UPS can supply up to 10 minutes of power to ensure a complete transition from the grid to the emergency gensets.

grid-connected. The jurisdictional determination does not depend on where the electricity is used, but on a clear evaluation of the generation capacity on a specific site that delivers a net electrical output.

Jurisdictional analyses are based on the net MWs of a facility's electricity generators that can be delivered for "use," not their gross or nameplate rating. Title 20, California Code of Regulations, section 2003 provides a framework to more accurately determine the generating capacity of a facility by providing certain definitions and conditions that apply to the determination. For example, section 2003 defines generating capacity as the net generating capacity; that is, the maximum gross rating of the facility minus the minimum auxiliary load. The section includes considerations of parasitic loads, definitions of generating capacity and maximum gross rating, and specifies average atmospheric conditions under which the generating capacity must be calculated. What type of prime mover, or source of electrical power (engine, turbine, etc.) that is selected for a project, or where the electricity is delivered to, do not render the regulations' methodology or framework inapplicable.

Any generating unit that is physically operable on a site is included in that site's generating capacity for jurisdictional determination. Large utility-scale units that are connected to water, fuel, and switchyard and the grid, can readily operate and feed the grid. The grid could absorb or use "added" generation by matching increasing demand, or other power plants connected to the grid would moderate their output to maintain grid voltage and frequency and to balance grid supply and demand. However, the LDC is an isolated grid, where excess generation from the facility cannot be moderated or balanced by curtailing generation elsewhere as there are no other facilities in the "LDC grid." The LDC load dictates the output of the aggregated backup gensets. If the safe capacity of the electrical equipment in LDC would be 99 MW, any generation above 99 MW would create "LDC grid" instability and LDC equipment damage, both of which are contrary to the intent of the LDC and backup generation facility.

### **Expanding On The Determination Of The Generating Capacity For The LDC**

As section 2003 highlights, an engine or turbine generator's performance can be affected by ambient conditions, so it is important to calculate and use the engine or turbine performance and generation output values that are actually produced by the generator at the location it is installed.

In traditional turbine-based power plants, parasitic loads (fans, pumps, and heaters) are external to the turbine; the generating capacity is the total net MWs at the switchyard bus, less parasitic loads. If the grid "demands" more, the power plant cannot deliver more electricity unless it burns fuel at a higher rate or reduces parasitic loads. Even then, equipment would have to have the physical capacity to burn more fuel and convert thermal energy into rotational energy, and then operate the generator at a higher output. The calculations assume normal conditions, where generation would be under average operating conditions, and assumes the onsite loads (often called parasitic loads) are also average (e.g., a filter backwash pumping load would not be included if that operation only occurs monthly or annually). Typically, at a traditional power plant, no redundant generating equipment is installed.<sup>4</sup> Generating capacity is determined based on the net capacity of all of the generators that are proposed to be installed because they are to be connected to the grid where there is almost no limitation on the amount of MWs the grid can "take" from the facility.

---

<sup>4</sup> At modern power plants, some equipment design includes 50 to 100 percent redundancy. The redundant equipment is generally limited to certain critical components like transformers, which are often custom items with long lead times for fabrication, or boiler water feed pumps, which are intended to protect the steam boiler components from damage from too much heat when circulating water flow is interrupted.



For reciprocating engines proposed at the LDC, parasitic loads are internal to the engine. Or, the self-contained diesel generators, the obvious parasitic loads (fans, pumps, and heaters) are internal to the self-contained genset. Moreover, since the genset parasitic loads are internal, and often mechanical, the genset electrical gross value has already netted out the generator's parasitic load and nearly reflects ideal engine performance and generator output. However, because the actual generator output of LDC would still be limited by actual building demand, contemplating whether to use the gross or net capacity is irrelevant to the determination of generating capacity for this project.

To determine the net generating capacity of a collection of backup gensets<sup>5</sup> for data centers, the approach is slightly different but consistent with that used on a traditional power plant. The differences are: 1) the end user is the building and data servers, not the grid, and 2) extra gensets or generating capacity are installed to provide electricity not only for building and data server loads, but to provide redundancy that achieves a statistical reliability that can be marketed to data customers.

Staff's approach is consistent with widely practiced standards. For example, ASHRAE's (American Society of Heating, Refrigerating and Air-Conditioning Engineers) Energy Standards for Data Centers do not use the nameplate or gross capacity, but the net generating capacity of data centers, or the IT load.<sup>6</sup> These ASHRAE standards are performance-based as opposed to prescriptive standards, advocating the position that determination of load requirements should be based on project-specific operational characteristics.

Staff's approach to calculating generating capacity has been devised based on the International Organization for Standardization (ISO), which sets standards for different industries including the energy industry. The ISO standards are widely accepted by, and used throughout, the energy industry. Consistent with staff's method, the ISO specifies that generating capacity should be the net capacity at average annual ambient conditions.<sup>7</sup>

In the case of LDC, the load served acts as a limit to the generation levels from the gensets in the backup generating facility. This factor is not present in a capacity generation determination for a typical power plant feeding to the grid because the grid does not act in the same way the "LDC grid" does. If the breakers between the LDC building and the gensets were to trip due to excess generation, the data center would be isolated from the backup generators, the servers and building cooling would be forced to shut down. This subverts the intention of using the backup generators to maintain reliable and high quality electricity. Excess electricity would damage components or at a minimum, isolate the load from the backup generators. If a building and cooling load were to increase (e.g., the day gets warmer), the genset(s) would open the engine fuel throttle to increase generation output and match demand but would still not exceed the combined 99 MW IT and building demand.

While no more than 37 backup generators would need to operate at or near their continuous output of 2.725 MW to reach the facility's maximum output requirement of 99 MW, the exact number of backup generators that could operate in an emergency depends on actual cooling and IT server loads, and the reliability and performance of the backup generators. In no case would the combined output of backup generators exceed the prescribed maximum load of 99 MW. As explained above, under Question #3, it would be physically impossible for the gensets to generate more electricity than the buildings require. Non-operating backup generators would be reserved as redundant generators, ready to start if other

---

<sup>5</sup> Backup generators, by definition, generally have the following characteristics: reliable starts, fast starting to full load, cheap to maintain as they sit idle most of the time, use cheap and stable fuel as the fuel sits unused most of the time, and use high-density fuels to limit storage volumes onsite so the project can operate if "islanded."

<sup>6</sup> American National Standards Institute (ANSI)/ASHRAE Standard 90.4-2016, [www.ashrae.org](http://www.ashrae.org).

<sup>7</sup> ISO 3046-1 Reciprocating Internal Combustion Engines – Performance, [www.iso.org/standards](http://www.iso.org/standards).

generators fail. For the purposes of testing and maintenance, only one generator would operate at any given time.

The maximum demand of 99 MW would be fixed by the specification and installation of electrical buses and panels, switchyard, and breakers that would have an upper electrical capacity limit. The cooling equipment's maximum demand would be fixed by the specification and installation of equipment that have an upper physical limit of cooling capacity, and would include some redundant cooling equipment. Redundant equipment could only be operated if a primary component fails, and could not be operated in addition to the primary components, which would damage the data center. The data center would be served from the grid or from the emergency gensets with electricity that matches and does not exceed demand for operations of the data server bays and buildings.

The heat rejected by the IT servers has to be removed from each server bay or else the server equipment and data would be damaged. Any attempt to add more servers to a bay would result in direct, immediate and dire consequences because the building and equipment would have been designed for an upper critical IT load. It is important to note that the maximum combined building load of 99 MW is based on 100 percent critical IT load with maximum cooling on the hottest day. In actuality, the critical IT load and related cooling load would typically be less than this worst-case scenario.

In recent years, the power and energy industries have leapfrogged in terms of software development and hardwired digital control to permanently limit generation capacity. The generation by the LDC backup generation facility would be regulated by each building and each bay in that building. Software would be used to operate the gensets in a manner that meets the bay and building demand. If the demand decreases (i.e., less mechanical load for cooling, etc.), the generator sets would automatically adjust the loading and corresponding electrical output. If a generator or the software were to malfunction and attempt to generate more electricity than the building demand, individual electrical generator controllers would shut down.

For the maximum generating capacity to increase, the project would have to be redesigned to physically fit more servers in a server bay or add more bays. The project owner would have to address the unplanned increase in electricity demand for normal operations, because the existing electrical equipment would not be sized for the higher electricity throughput. Additionally, the project owner would have to install additional cooling equipment units to address the increased heat rejected by the server bays and buildings, and install additional redundant cooling equipment, additional uninterruptable power supply battery units, and additional gensets to maintain the level of backup and reliability to match the new higher levels of load. This is an unlikely outcome because such changes are not trivial and would result in a cascade of design and physical changes to the facility. Consequently, this would likely obliterate the project owner's ability to meet its contractual obligations for electrical reliability and quality to their data customers. In addition, because the project changes would be considered permanent, the project owner must amend the design of the facility post-certification or exemption.

*6. How should the Energy Commission define its jurisdiction over the generating facilities to be located on the LDC site?*

As defined in Public Resources Code, section 25120, a thermal power plant is any electrical generating facility using any source of thermal energy, with a generating capacity of 50 megawatts or more. The Energy Commission should conclude that the LDC falls within this definition because its electrical generating devices, or gensets, would use thermal energy to produce electricity and that, its (total)

generating capacity would be greater than 50 MW, making it a jurisdictional thermal power plant facility. The Energy Commission should use the concepts in Title 20, California Code of Regulations, section 2003 to calculate a net deliverable or useable electricity capacity of more than 50 MW and less than 100 MW from the LDC backup generation facility, qualifying it for an Small Power Plant Exemption under the capacity criterion.

Following is a summary of the reasons as to why the LDC is a thermal power plant, why the generating capacity is no more than 99 MW, and why the project's generating capacity could qualify LDC for exemption as an SPPE, if it satisfied the other SPPE criteria.

1. The diesel-fueled reciprocating engine generators use a thermal energy source.
2. The gensets and the associated LDC that they would support would all be located on a common property under common ownership sharing common utilities.
3. The Energy Commission should aggregate the 55 gensets into one thermal power plant facility, and conclude that the generation capacity is greater than 50 MW, making the thermal power plant facility jurisdictional.
4. While LDC has an apparent installed generation capacity greater than 100 MW, the "extra" MW installed are redundant and not able to operate unless other generating units fail to operate, i.e., there are physical constraints that prevent them from operating. Generating capacity for traditional power plants is determined based on the net capacity of all of the generators that are proposed to be installed because they are to be connected to the grid where there is almost no limitation on the amount of MWs the grid can "take" from the traditional power plant facility.
5. The Energy Commission should use the principles in Title 20, California Code of Regulations, section 2003 to calculate a net deliverable or useable electricity capacity from the LDC backup generation facility. Jurisdictional analyses are based on the net MWs that can be delivered for "use," not the gross or nameplate rating. The maximum load being served is determinative and not the combined capacity of the installed generators. Here, the maximum facility-wide LDC load requirement would be 99 MW.
6. The backup generators would be exclusively connected to the LDC buildings and would not be capable of delivering electricity to any other user or to the electrical transmission grid. The proposed redundancies built into the design of the facility are to ensure performance reliability, not to generate and supply the LDC facility with more than 99 MW of electricity.
7. The restriction on the facility's load demand are hardwired through various control systems. It would be physically impossible for the gensets to generate more electricity than the buildings require. Excess electricity would damage components or at a minimum, isolate the LDC loads from the backup generators.
8. Because the LDC's generating capacity is above 50 MW, it falls under the Energy Commission's permitting jurisdiction, and because it does not exceed 100 MW, the Energy Commission can process the project application under its Small Power Plant Exemption process.
9. If post-certification or exemption, the generating capacity of the project is to be increased or the data center buildings are to be expanded, the project owner must amend the design of the facility, triggering review.

# **Appendix B**

---

## Silicon Valley Power System Details

## **Appendix B: Silicon Valley Power System Details**

Energy Commission staff provided a series of questions to Silicon Valley Power designed to understand when, why, and for how long backup generators would need to operate for any purpose other than readiness testing or maintenance at the proposed data centers in the Silicon Valley Power (SVP) service area. The questions were directed towards the Laurelwood Data Center (LDC or project) proceeding but descriptions of the overall SVP system as well as historical outage data would apply to any data centers connecting to the SVP 60 kilovolt (kV) system.

This Appendix includes the questions originally sent to SVP, the response SVP provided, and responses to staff's follow-up questions:

1. A direct written response to each of staff's questions and follow-up questions (including a table listing 10 years of faults on the SVP 60 kV system ),
2. A one-line diagram of the proposed substation for the LDC,
3. A schematic diagram of the SVP 230 kV, 115 kV and 60 kV transmission system,
4. A list of the customers connected to each of the five 60 kV loops in the SVP system, and
5. Silicon Valley Power System Map.

Outlined below is information related to MECP1's proposed substation located in the City of Santa Clara's Silicon Valley Power's service territory. The proposed substation will be located at 2201 Laurelwood Road under SVP's nomenclature, San Tomas Junction. This facility is designated as a Junction as the customer has elected to receive electric service from SVP at the 60,000V level.

1. Please provide for the 60 kV loop on the SVP system that will serve the MECP1 data center:
  - a. A physical description

San Tomas Junction is a three-50MVA (60kV:12.47kV) transformer bank substation on SVP's 60kV Northwest Loop. It is located between SVP's two 60kV Substations, Central (CEN) and Juliette (JUL). Each Transformer has a proposed rating of 30/40/50 MVA. The final buildout of San Tomas Junction will have a capability of 99 MVA, with 150 MVA of installed capacity which increases its reliability. The customer's Single Line Diagram (SLD) "LAUREL SITE SINGLE LINE DIAGRAM SIMPLIFIED" is attached.

- b. The interconnection points to SVP service

The Interconnection points to SVP will be the three high-side transformer gang switches. SVP's nomenclature will be drafted as GS36, GS26, and GS16.

- c. The breakers and isolation devices and use protocols

There are four 60kV Breakers at San Tomas Junction shown on customer SLD, CB1, CB2, CB3 and CB4 which will enable various isolation schemes to insure a transformer bank can be isolated while the other two transformers remain in service. The system is designed such that one of the transformers can be taken out of service for repairs or maintenance while the other two can fully support customer load.

- d. A list of other connected loads and type of industrial customers

See attached Excel Spreadsheet, Loop Customer and Loading Peak 8-1-19.xlsx

- e. A written description of the redundant features that allow the system to provide continuous service during maintenance and fault conditions

SVP's Northwest Loop is fed from Northern Receiving Station (NRS) and Scott Receiving Station (SRS). Both NRS and SRS are 115/60 kV receiving stations. NRS has five 115kV lines connected to the bulk electric system, two are connected to SRS, two are connected to PG&E's Newark Substation (NEW), and one is connected to PG&E's Nortech Substation (NOR). NRS also has one 230kV line connected to SVP's Switching Station (SSS) which is also connected to the greater bulk electric system (BES). SRS is connected to SVP's Duane Substation (DUA). The DUA Substation is connected to the City's 147 MW Donald Von Raesfeld Combined Cycle Power Plant. Both NRS and SRS have two 115/60kV transformers for redundancy and reliability. This arrangement allows for a high reliability electrical system.

The 60kV loop is designed to maintain power to all customers when any line on the loop is out of service due to either maintenance or an unplanned outage. Each Receiving



Station on the loop ends, NRS and SRS, is capable of delivering power to the entire loop. The full redundancy design of the system allows any line segment on the loop to be taken out of service for regular maintenance activities without causing a service interruption to any customers. Additionally, the protection systems on the loop are designed to detect fault conditions and isolate the fault to a single line segment. The isolation of the fault allows for continuous service for all customers during fault conditions.

As discussed above, San Tomas Junction will have three 30/40/50 MVA transformers. The maximum load being requested by the customer is 99 MVA. With 150MVA of transformers, one transformer can be removed from service for maintenance and the load can be provided by the remaining two transformers.

See attached SVP Network Diagram 082319 MEC1 San Tomas Junction (STJ).pdf.

2. Please provide a description of the SVP system in general and the other 60 kV loops that would serve data centers.
  - a. Could you provide a one-line diagram and a "\*.shp" file of the 60 kV and above lines serving the Silicon Valley Power System? Would you have any concerns with us using either of these in a public document?

Refer to SVP CA Energy Map 082319 MEC1 San Tomas Junction (STJ).pdf and SVP Network Diagram 082319 MEC1 San Tomas Junction (STJ).pdf.

- b. Are each of the 60 kV loops designed similarly or do some of them have features that make them more or less reliable than the others?

They are all designed similarly with the same redundancy/reliability philosophy.

3. Please describe any outages or service interruptions on the 60 kV systems that will serve the proposed data centers:
  - a. How many 60 kV double looped lines serve data centers in SVP, and how many data centers are on each?

The City currently has five 60kV Loops. They are as follows:

- East Loop
- Northeast Loop
- Northwest Loop
- Center Loop
- South Loop

Customer location per loop is provided in Question 1 d. above.

- b. What is the frequency of 60 kV double-looped lines having a "double outage" that would require use of backup generators?

Extremely Rare. There was only one outage between years 2009 current 2019 where SVP lost both 60kV feeds into a substation. The total duration of the outage was 7 hours and 23 min for the outage that occurred on May 28<sup>th</sup>, 2016 at 9:28 PM.

A balloon released by an individual made contact with the 60kV line between the Northwestern Substation (NWN) and the Zeno Substation (ZEN) at pole NWZ4. The balloon contact caused a pole fire and the bottom phase, bottom insulator and guy wire burned. The circuit breaker at ZEN substation tripped properly, isolating the fault from the ZEN substation and keeping the line from the ZEN substation to the Kiefer Receiving Station energized.

However, on the NWN Substation side, the circuit breaker failed to trip due to a faulty direct current (DC) voltage source which is required for the breaker tripping coil.

Once this breaker failed to open, due to the directional nature of the fault, the fault was picked up at the Scott Receiving Station (SRS) which caused the section of the loop from the ZEN to SRS to be without power. This included the NWN Substation and the Fairview (FVR) substation. Since this was an unusual event, SVP spent the required time determining the root cause and inspecting the system prior to re-energization.

c. How long were any outages and what were their causes?

60kV outage data since 2009 is in the below chart (10 years of data). The items highlighted in yellow indicate that there was some kind of fault associated with the outage. The items highlighted in blue is when we had customers out of power as a result. The non-highlighted items are where an outage was taken to correct an observed situation.

From 2009 through current 2019 there have been:

1. 15-60kV impacted outages due to faults.
2. 4- 60 kV impacted outages that caused customers to be out of power. Only the 12/2/16 outage and 5/28/16 involved data centers.
3. 31- 60kV total outages
4. The average 60kv outage lasts for 2.75 hours

Date	Line(s)	Cause	Duration	Customers out of power
3/30/19	URA-WAL	Bird @ UW43	1 Hour 46 Min	0
11/22/18	HOM-SER	Pole Fire HS9 (force out)	1 Hour 27 Min	0
7/5/18	SER-HOM	Force out to remove balloons	9 Min	0
5/5/18	SER-HOM	Force out to remove balloons	11 Min	0
9/1/17	AGN-NAJ	Force out to cut trees	1 hour 5 min	0
8/8/17	URA-ZEN	Force out to remove balloons	20 Min	0
5/25/17	SRS-FRV	Tripped during SCADA commissioning	1 Min	0
5/8/17	NWN-ZEN	Force out to remove bird	50 Min	0

4/29/17	SRS-HOM	Force out to remove balloons	2 hours 22 min	0
03/20/17	JUL-CEN	Third Party got into 60kV	9 hours 55 min	0
01/22/17	SER-BRO	Tree in wires	3 hours 31 min	0
01/22/17	NAJ-PLM	A phase contact guy wire when winds pick up	1 hour 47 min	0
01/19/17	KRS-PLM	Palm frond between phases	41 min	0
01/18/17	NAJ-PLM	A phase contact guy wire when winds pick up	1 Hour 44 min	0
12/02/16	RAY T1 & T2	Dropped both transformers during restoration switching due to relay not reset	12 minutes	257
09/06/16	SRS-CEN	Bird Contact	40 Min	0
06/30/16	WAL-FIB	Bird nest contact	12 hours and 4 min	0
5/28/16	SRS-FRV-NWN-ZEN	Balloons in line and breaker fail	7 hours 23 min	28
02/17/16	SRS-FRV	Palm tree with fire	7 hours	0
11/18/15	SER-BRO	Arcing wires forced	2 hours 59 min	0
11/16/15	SER-BRO	Rotten Pole- forced	22 hours 32 min	0
11/09/15	JUL CB32	Possible lightning	53 min	0
10/29/15	SER-BRO	Roller arcing-forced	3 hours 33 min	0
08/12/15	BRO-DCJ, BRO T1	Squirrel on CB100	3 hours 55 min	2155
06/24/15	CCA CB22	Bad JMUX card	3 hours 23 min	0
05/30/15	SER-BRO	No cause found	3 hours 12 min	0
03/31/15	BRO-DCJ 12KV BUS 1 & 2	Squirrel across 12kv bus tie	3 hours 26 min	2927
01/28/15	Mission CB12	Shorted control cable	6 hours 29 min	0
04/24/14	DCJ CB42	Tripped during relay work. BF wired as TT	1 Hour 30 Min	0
10/14/13	URA_WAL	Sheared Hydrant hit 60kV above	2 hours 26 min	0
12/06/12	Jul CB 32	Tripped due to cabinet vibration	2 min	0

- d. Have there been any changes to the SVP system that would prevent these types of outages from occurring in the future?

Every outage is analyzed for root cause. Most of the outages that occur on the 60kV system are outside SVP's control, e.g. Mylar balloon, squirrels or animals, car accidents, and similar events. If the outage is suspected to be caused by a failure of the intended protection scheme or equipment, then further analysis is performed and appropriate changes are implemented to minimize impact of future outages. After the outage in May,

2016, SVP performed additional circuit breaker testing and DC wire checks to maintain the reliability of its system.

- e. Given the large number of data centers with backup generators being developed in the SVP service area, would future outages likely affect more than one data center or are there elements of the SVP system design that might limit the impact of transmission outages?

Adding more data centers on the 60kV looped system would not make it more or less likely that an outage will occur. A “double outage,” which has occurred only once in the last ten years, has the potential to cause multiple data centers to go to back up generators depending on the locations of both line segments that are out of service.

- f. Are there data center customers served by SVP (ie, legacy data centers) that are not on the 60kV loops? How are they served and what are the expected service outage types and rates?

No, ALL data center customers are inherently part of our 60kV loop. The voltage level these data center customers are on our 12kV distribution system, which power is provided from our 60kV substations.

- 4. During the proceeding for the McClaren Backup Generating Facility, the project owner described a 5/29/2016 outage at their Vantage Santa Clara Campus. The project owner provided information that six backup generators operated during that outage; of those, two operated for 7 hours while four others operated approximately 19 hours.

- a. What was the reason for the outage?

Balloons made contact with the NWN-ZEN 60kV Line at Pole NWZ4. Original fault was A Phase and GRD due to contact with the Guy wire. NWN CB 32 failed to trip due to a bad DC power source to the breaker trip coil. FRV CB12 tripped as a result of NWN CB32 not tripping. FRV CB42 and SRS CB572 also tripped due to 3 phase differential fault that occurred which is believed to have been caused by the amount of time the A phase and ground fault lasted.

- b. How long did it last for the Vantage customer? For other customers on that loop?

The outage occurred on 5/28/2019 at 2128. On 5/29/19 @ 0429- Fairview was restored, @ 0434 NWN 60kV bus restored. The system outage was 7 hours and 23 minutes. We are not privileged to the information as to why the data center may have chosen to continue to operate on their back-up generators.

- c. Is the anything about the location or interconnection of the proposed data centers that protect against a similar outage?

No difference with this location.

5. Pacific Gas and Electric Company and other utilities have developed Public Safety Power Shutoff protocols that could disconnect electrical services during periods of concern in order to prevent their equipment from starting wildfires. These potential shutoffs could last hours or even days. How would these new protocols potentially affect SVP's service territory or access to bulk transmission assets?

The City of Santa Clara's SVP is not located in a California Public Utilities Commission/Cal Fire Tier 2 or Tier 3 high fire risk zone. Therefore, SVP does not have a Public Safety Power Shutoff as part of their Wildfire Mitigation Plan. However, we do receive power from PG&E through six interconnection points. Based on our discussion with PG&E, Santa Clara may be requested by PG&E or the California Independent System Operator (CAISO) to curtail load. This request may be because of the reduced capacity somewhere within the system which will require overall system load reduction. This experience may be similar to the energy crisis of the early 2000's when rolling black-outs were required to maintain electric grid reliability. SVP has the capability to provide 200 MW of generation in the City with its Donald Von Raesfeld Combined Cycle Power Plant (147 MW) and the Gianera Peaker Plant (49 MW) and Cogen Facility (6 MW), we may be requested to curtail load.

SVP is working with PG&E and the CAISO as to how this situation may occur.

Please note: These questions and responses are pertinent to the Silicon Valley Power system in general, and not specific to a particular transmission loop.

1. The Aug 2 response talks about the May 28/29, 2016 outage and the 28 customers that lost power. The table of outages in their response seems to list outages that affected 60kV customers, and these customers appear to be data centers customers and other, non-data center customers. Does SVP know how many of the 28 customers referred to on the May 28, 2016 entry were data centers?

Two Data Centers were affected.

2. The Aug 2 response talks about a Dec 2, 2016 outage and the 257 customers that lost power. The table of outages in their response seems to list outage that affected 60kV customers, and these customers appear to be data centers customers and other, non-data center customers. Does SVP know how many of the 257 referred to on the Dec 2, 2016 entry were data centers?

Four Data Centers were affected.

3. The Aug 2 response talks about a Dec 2, 2016 outage and the 257 customers that lost power. Can we get more information about this outage? Was it also an N-1-1 cascade like the series of faults that caused the May 28/29, 2016 outage? Why did we not hear about this outage earlier - was it different that the May 2016 outage (eg, internal faults versus an external fault like a balloon or squirrel)?

This outage was caused during maintenance work with the Relay Technician. During the testing, the relay was required to be reset prior to returning to service. Since the relay was not reset, when put back into service the device tripped. The Standard Operating Procedure was revised to include the step of resetting the relay prior to placing back into service. This was not a N-1-1 cascading type outage. The outage lasted 12 minutes.

4. The Aug 2 response has a table of 60kV outages. Just to confirm, only the Dec 2 and May 28, 2016 outages affected data centers. So, for example, none of the 2927 customers affected by Mar 31, 2015 outage were data centers - is that correct?

Correct, no data centers were effected during March 31, 2015 outage.

5. Also, it sounds like some data center customers are connected to 12kV feeds, but these feed are connected to the dual feed 60kV loops that are highly reliable. Is this correct, and how many customers might be on a 12kV line that comes off a 60kV loop? And how is reliability maintained on the 12kV line - looping, breakers and redundant equipment - like the 60kV loops?

Yes, this is correct. The electric services that supply power to our 12kV data center customers are from our general 60kV distribution substations, which is inherently connected to our 60kV looped system. The number of customers that are off a 12kV feeder (line) is limited to SVP's operational loading philosophy, which is 4.5MVA or 50% of the maximum 9MVA. Said in another way, we can have as few as one customer or as many as one-hundred on a feeder, as long as the entire load is less than 4.5MVA. To address reliability, by operating our 12kV feeders at half-loaded, SVP has operational flexibility to completely transfer loads to other 12kV feeders in the event of an outage. SVP may make an operational determination to limit a feeder to one data center customer, but at this time is not contractually obligated to provide as such.



6. The Aug 2 response has a 4.d. response regarding how the Vantage MECP1 data center responded to the the May 28/29, 2016 SVP outage that said "[t]he description of the Vantage event is reasonable, however cannot be directly applied to the Laurelwood Data Center. The Vantage event had a unique combination of contributing factors for which the resulting outcome cannot be reasonably assumed to be the expected outcome for line faults on the SVP 60kV network." Do you have more information on what were the "contributing factors", and why should we not assume that other data centers would have similar "expected outcomes"?

As discussed in the 8/2/19 document, had the DC voltage supply cable not had an issue, a similar event would have been contained. Our anticipation, an outage in the future the protection system would operate as expected.

7. Regarding the Aug 2 response to PG&E's PSPS plans, could SVP curtailments ever allow a data center to operate under emergency conditions?

To date this has not happened, the decision to operate during this situation would be by the data center. Our understanding is during emergency situation, individuals can operate their emergency generators.

8. Are SVP curtailments to PSPS conditions voluntary or emergency conditions? We understand that diesel emergency gensets cannot operate for economic reasons, only in response to an unplanned emergency or upset on their supply grid.

We will be instructed to reduce load to respond to emergency conditions somewhere within the CAISO controlled grid, we have to follow what the CAISO directs us to do. The CAISO instructions are not voluntary. We would request customers to reduce load to satisfy the emergency condition and if that is not sufficient we will begin shutdown of our customers to meet the emergency situation. We would be operating at the direction of the CAISO.

9. Are there any plans that part of the PSPS program might include payments to some loads to curtail or shed?

SVP does not have a plan to pay a data center to shed or curtail load.

10. Would the 6 interconnection points with the PG&E system allow SVP/PG&E to wheel bulk deliveries around potential shutdowns on the PG&E system? In other words, is the current understanding of the PSPS program that most shutdown will be in specific areas and not across the greater PG&E system, and that would allow PG&E to work around an area that would be fully shutdown?

The understanding is if the conditions are such where transmission has to be curtailed, the CAISO will require load reductions of the CAISO controlled grid, similar to the energy crisis from the early 2000's. SVP will request voluntary reductions to meet the CAISO demand or will make switching changes which to remove blocks of customers load. It will depend how much reductions the CAISO will be instructing us to reduce, voluntary load shedding and customer shutoff.



# SVP Transmission Overview

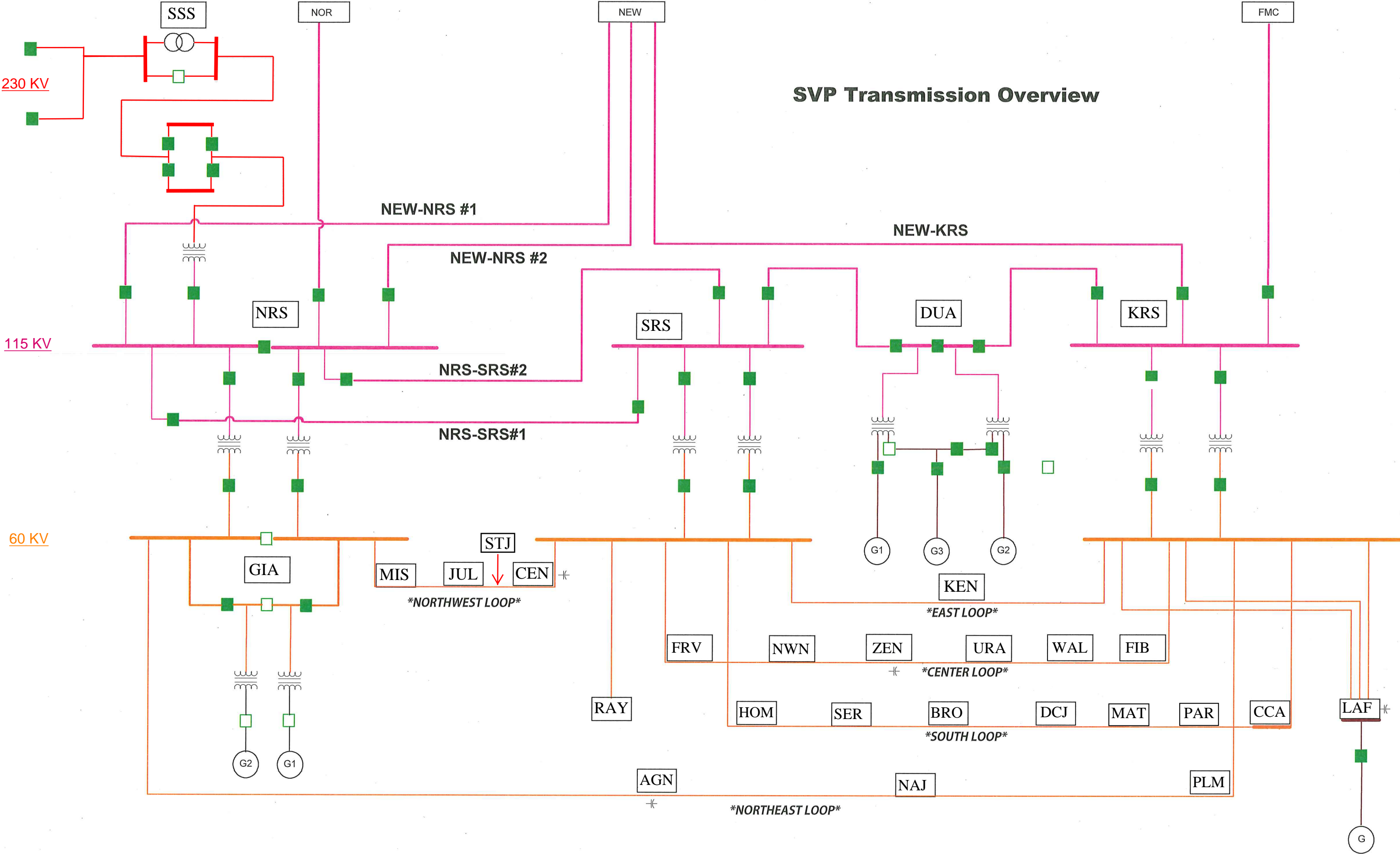

**SVP Loop Customers and Loading Peak - Substation:**

Substation	Loop	Customer/Industry	Substation	Loop	Customer/Industry
Fairview	Center	Mfg1	Central	Northwest	Medical2
Fairview	Center	Datacenter1	Central	Northwest	Real Estate2
Fairview	Center	Datacenter2	Central	Northwest	Real Estate3
Fairview	Center	Datacenter3	Central	Northwest	Real Estate4
Fairview	Center	Datacenter4	Central	Northwest	Datacenter24
FIB	Center	Mfg2	Central	Northwest	Datacenter25
Lafayette	Center	Mfg3	Central	Northwest	R&D2
Lafayette	Center	Datacenter5	Central	Northwest	Real Estate5
Lafayette	Center	Mfg4	Central	Northwest	Real Estate6
Lafayette	Center	Mfg5	Central	Northwest	Healthcare equipment
Lafayette	Center	Datacenter6	Central	Northwest	Education13
Lafayette	Center	Mfg6	Central	Northwest	Semiconductor/R&D
NWN	Center	Datacenter7	JUL	Northwest	Datacenter26
Uranium	Center	Datacenter8	Mission	Northwest	Property Management7
Uranium	Center	R&D1	Mission	Northwest	Computer hardware/software 2
Uranium	Center	Property Management1	Mission	Northwest	Real Estate7
Uranium	Center	Datacenter9	Mission	Northwest	Datacenter27
Uranium	Center	Datacenter10	Mission	Northwest	Software1
Uranium	Center	Datacenter11	Mission	Northwest	Computer hardware/software 3
Uranium	Center	Property Management2	Mission	Northwest	Cyber Security 2
Uranium	Center	Education1	Mission	Northwest	Conventions 2
Uranium	Center	Education2	Mission	Northwest	Hotel3
Uranium	Center	Education3	Mission	Northwest	Medical3
Uranium	Center	Education4	Mission	Northwest	Cyber Security 3
Uranium	Center	Semiconductor/ Telecommunications	Mission	Northwest	Education14
Uranium	Center	Gaming/AI/ Semiconductors1	Mission	Northwest	Datacenter28
Uranium	Center	R&D/Mfg	Mission	Northwest	R&D3
Uranium	Center	Mfg7	Mission	Northwest	Semiconductor6
Walsh	Center	Semiconductor1	Mission	Northwest	Storage1
Walsh	Center	Gaming/AI/ Semiconductors2	Mission	Northwest	Entertainment3
Walsh	Center	Mfg8	Mission	Northwest	Property Management8
Walsh	Center	Gaming/AI/ Semiconductors3	Mission	Northwest	Medical4
Walsh	Center	Datacenter12	Mission	Northwest	Telecommunications2
Walsh	Center	Education5	Mission	Northwest	NFL5
Walsh	Center	Government1	Raymond	Northwest	Datacenter29
Walsh	Center	Government2	Raymond	Northwest	Datacenter30
Walsh	Center	Semiconductor2	Raymond	Northwest	Datacenter31
Walsh	Center	Semiconductor/R&D/Mfg	Raymond	Northwest	Datacenter32
Walsh	Center	Mfg9	Raymond	Northwest	Telecommunications3
Walsh	Center	Telecommunications1	Raymond	Northwest	Datacenter33
Walsh	Center	Datacenter13	Raymond	Northwest	Gaming/AI/Semiconductors5
Walsh	Center	Education6	Raymond	Northwest	Datacenter34
Walsh	Center	Datacenter14	Brokaw	South	Government3
Zeno	Center	Education7	Brokaw	South	Education15
Zeno	Center	Education8	Brokaw	South	Education16
Zeno	Center	Semiconductor3	Brokaw	South	Education17

Substation	Loop	Customer/Industry	Substation	Loop	Customer/Industry
Zeno	Center	Datacenter15	Brokaw	South	Real Estate8
Zeno	Center	Bio Tech 1	Brokaw	South	Design1
Zeno	Center	Semiconductor/ Telecommunications	Brokaw	South	Security 2
Zeno	Center	Semiconductor/R&D/Mfg	Brokaw	South	Education18
Agnew	Northeast	Security1	Brokaw	South	Education19
Agnew	Northeast	Property Management3	CCA	South	Mfg12
Agnew	Northeast	Property Management4	DCJ	South	Datacenter35
Agnew	Northeast	Entertainment1	Homestead	South	Education20
Agnew	Northeast	NFL1	Homestead	South	Education21
Agnew	Northeast	Property Management5	Homestead	South	Education22
Agnew	Northeast	Entertainment2	Homestead	South	Education23
Agnew	Northeast	Hotel1	Homestead	South	Education24
Agnew	Northeast	Datacenter18	Homestead	South	Education25
Agnew	Northeast	Medical1	Homestead	South	Education26
Agnew	Northeast	Mfg10	Homestead	South	Healthcare1
Agnew	Northeast	Datacenter19	Homestead	South	Telecommunications4
Agnew	Northeast	Datacenter20	Homestead	South	Education27
Agnew	Northeast	Datacenter21	Homestead	South	Education28
Agnew	Northeast	Datacenter22	MAT	South	Datacenter36
Agnew	Northeast	Cyber Security 1	PRK	South	Datacenter37
Agnew	Northeast	Hotel2	Serra	South	Medical device
Agnew	Northeast	Property Management6	Serra	South	Education29
NAJ	Northeast	Mfg11	Serra	South	Education30
Palm	Northeast	Datacenter/software/ cloud computing	Serra	South	Healthcare2
Palm	Northeast	NFL2	Serra	South	Healthcare3
Palm	Northeast	NFL3	Serra	South	Healthcare4
Palm	Northeast	NFL4	Serra	South	Healthcare5
Palm	Northeast	Education9	Kenneth	East	Datacenter16
Palm	Northeast	Education10	Kenneth	East	Datacenter17
Palm	Northeast	Conventions 1	Kenneth	East	Gaming/AI/Semiconductors4
Palm	Northeast	Education11			
Palm	Northeast	Semiconductor4			
Palm	Northeast	Datacenter23			
Palm	Northeast	Education12			
Palm	Northeast	Real Estate1			
Palm	Northeast	Network hardware1			
Palm	Northeast	Semiconductor5			
Palm	Northeast	Computer hardware/software 1			

**SVP Loop Customers and Loading Peak - Loop:**

<b>Center 141MW</b>	<b>East Loop 15MW</b>	<b>Northeast Loop 28MW</b>	<b>Northwest Loop 112MW</b>	<b>South Loop 65MW</b>
Mfg1	Datacenter16	Security1	Medical2	Government3
Datacenter1	Datacenter17	Property Management3	Real Estate2	Education15
Datacenter2	Gaming/AI/Semiconductors4	Property Management4	Real Estate3	Education16
Datacenter3		Entertainment1	Real Estate4	Education17
Datacenter4		NFL1	Datacenter24	Real Estate8
Mfg2		Property Management5	Datacenter25	Design1
Mfg3		Entertainment2	R&D2	Security 2
Datacenter5		Hotel1	Real Estate5	Education18
Mfg4		Datacenter18	Real Estate6	Education19
Mfg5		Medical1	Healthcare equipment	Mfg12
Datacenter6		Mfg10	Education13	Datacenter35
Mfg6		Datacenter19	Semiconductor/R&D	Education20
Datacenter7		Datacenter20	Datacenter26	Education21
Datacenter8		Datacenter21	Property Management7	Education22
R&D1		Datacenter22	Computer hardware/software 2	Education23
Property Management1		Cyber Security 1	Real Estate7	Education24
Datacenter9		Hotel2	Datacenter27	Education25
Datacenter10		Property Management6	Software1	Education26
Datacenter11		Mfg11	Computer hardware/software 3	Healthcare1
Property Management2		Datacenter/software/cloud computing	Cyber Security 2	Telecommunications4
Education1		NFL2	Conventions 2	Education27
Education2		NFL3	Hotel3	Education28
Education3		NFL4	Medical3	Datacenter36
Education4		Education9	Cyber Security 3	Datacenter37
Semiconductor/Telecommunications		Education10	Education14	Medical device
Gaming/AI/Semiconductors1		Conventions 1	Datacenter28	Education29
R&D/Mfg		Education11	R&D3	Education30
Mfg7		Semiconductor4	Semiconductor6	Healthcare2
Semiconductor1		Datacenter23	Storage1	Healthcare3
Gaming/AI/Semiconductors2		Education12	Entertainment3	Healthcare4
Mfg8		Real Estate1	Property Management8	Healthcare5
Gaming/AI/Semiconductors3		Network hardware1	Medical4	
Datacenter12		Semiconductor5	Telecommunications2	
Education5		Computer hardware/software 1	NFL5	



Center 141MW	East Loop 15MW	Northeast Loop 28MW	Northwest Loop 112MW	South Loop 65MW
Government1			Datacenter29	
Government2			Datacenter30	
Semiconductor2			Datacenter31	
Semiconductor/R&D/Mfg			Datacenter32	
Mfg9			Telecommunications3	
Telecommunications1			Datacenter33	
Datacenter13			Gaming/AI/Semiconductors5	
Education6			Datacenter34	
Datacenter14				
Education7				
Education8				
Semiconductor3				
Datacenter15				
Bio Tech 1				
Semiconductor/Telecommunications				
Semiconductor/R&D/Mfg				



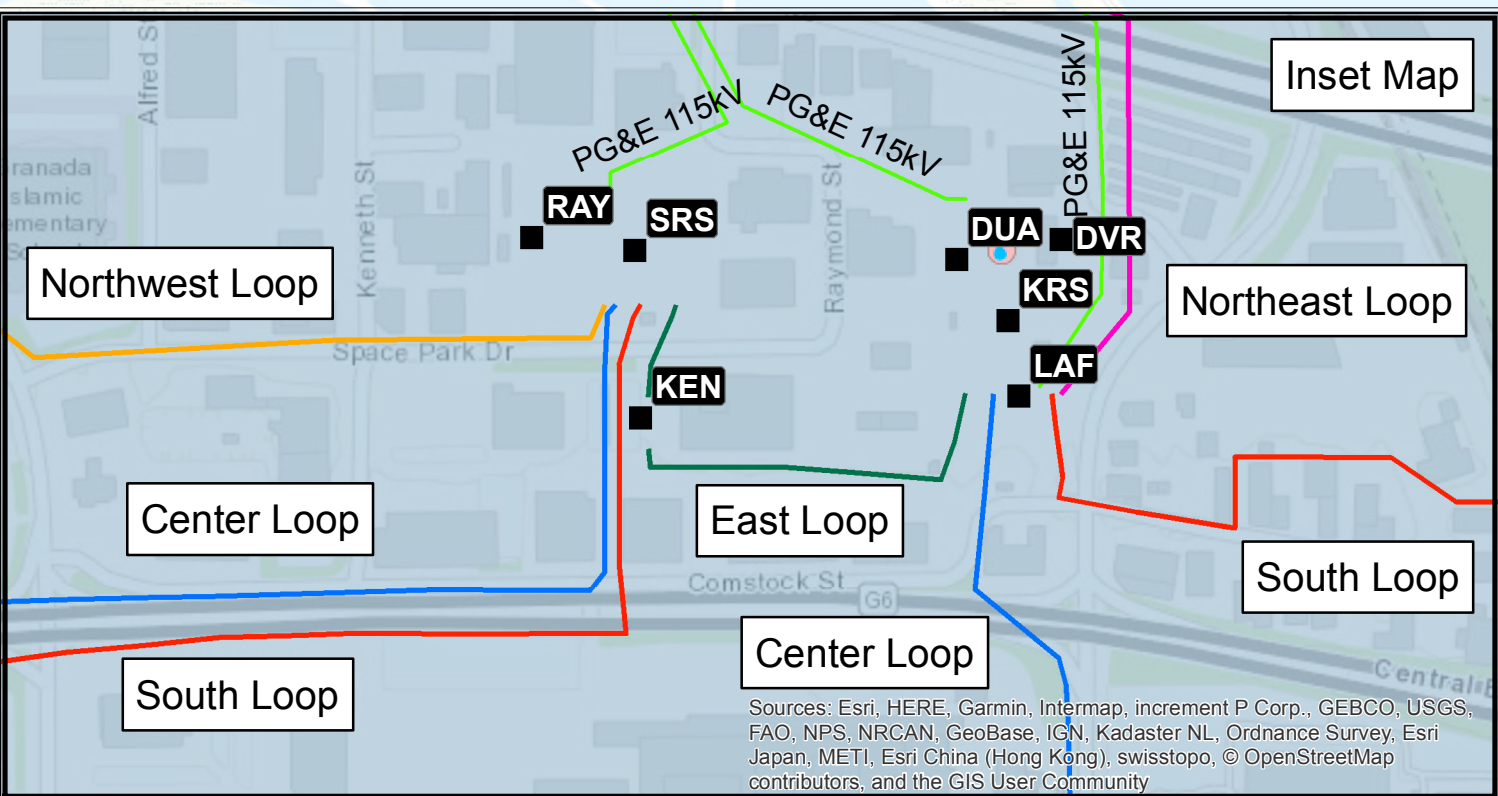
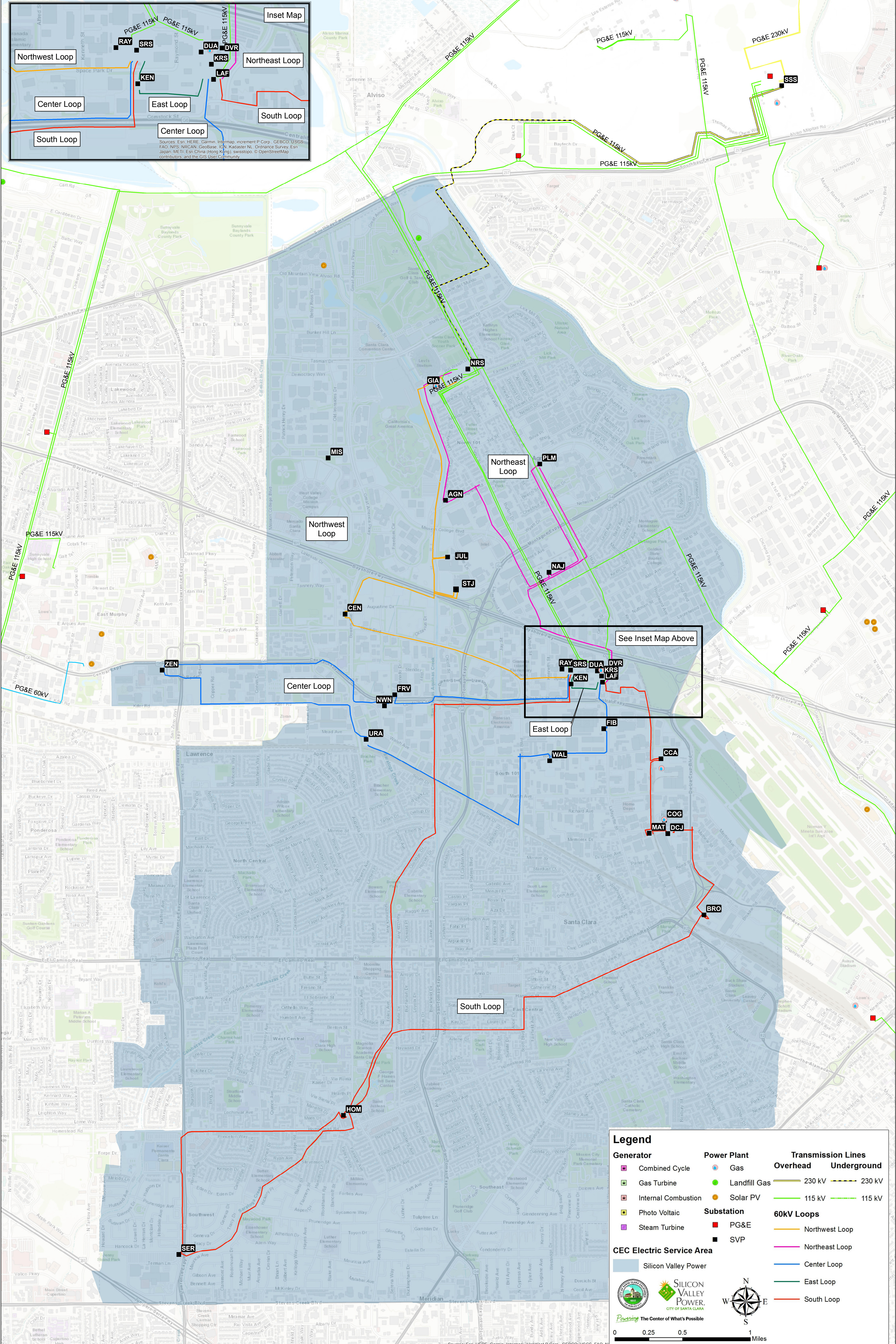

Sources: Esri, HERE, Garmin, Intermap, increment P Corp., GEBCO, USGS, FAO, NPS, NRCAN, Geobase, IGN, Kadaster NL, Ordnance Survey, Esri Japan, METI, Esri China (Hong Kong), swisstopo, OpenStreetMap contributors, and the GIS User Community

**Legend**

<b>Generator</b>	<b>Power Plant</b>	<b>Transmission Lines</b>
<ul style="list-style-type: none"> <li> Combined Cycle</li> <li> Gas Turbine</li> <li> Internal Combustion</li> <li> Photo Voltaic</li> <li> Steam Turbine</li> </ul>	<ul style="list-style-type: none"> <li> Gas</li> <li> Landfill Gas</li> <li> Solar PV</li> </ul>	<ul style="list-style-type: none"> <li><b>Overhead</b></li> <li> 230 kV</li> <li> 115 kV</li> <li><b>Underground</b></li> <li> 230 kV</li> <li> 115 kV</li> </ul>
<b>Substation</b> <ul style="list-style-type: none"> <li> PG&amp;E</li> <li> SVP</li> </ul>		<b>60kV Loops</b> <ul style="list-style-type: none"> <li> Northwest Loop</li> <li> Northeast Loop</li> <li> Center Loop</li> <li> East Loop</li> <li> South Loop</li> </ul>
<b>CEC Electric Service Area</b> <ul style="list-style-type: none"> <li> Silicon Valley Power</li> </ul>		

Sources: Esri, HERE, Garmin, Intermap, increment P Corp., GEBCO, USGS, FAO, NPS, NRCAN, Geobase, IGN, Kadaster NL, Ordnance Survey, Esri Japan, METI, Esri China (Hong Kong), swisstopo, OpenStreetMap contributors, and the GIS User Community