

BURBANK WATER AND POWER CAMPUS STORMWATER IMPROVEMENT PROJECT

Initial Study & Mitigated Negative Declaration



**WATER
AND
POWER**

**Lead Agency:
City of Burbank Department of
Water and Power**

**Revised MND Prepared By:
Sapphos Environmental, Inc.**

**November 2019 MND Prepared By:
Stevenson, Porto & Pierce, Inc.**

June 2022

Table of Contents

Project Information Summary.....	3
1. Project Title.....	3
2. Lead Agency Name and Address.....	3
3. Contact Person Name and Phone Number.....	3
4. Project Location.....	3
5. Project Sponsor's Name and Phone Number.....	3
6. General Plan Designation(s).....	3
7. Zoning.....	3
8. Description of Project.....	3
9. Surrounding Land Uses and Setting.....	4
10. Other Public Agencies Whose Approval is Required.....	4
11. Native American Tribe Notification (Public Resources Code section 21080.3.1).....	4
Environmental Factors Potentially Affected.....	6
Determination.....	6
Project Description.....	7
Project Location.....	7
Land Use and Zoning Designations.....	7
Background and Existing Conditions.....	7
Statement of Objectives and Project Goals.....	8
Project Elements.....	9
Project Construction.....	10
Required Approvals.....	12
Environmental Checklist.....	14
1. Aesthetics.....	14
2. Agricultural and Forest Resources.....	16
3. Air Quality.....	18
4. Biological Resources.....	21
5. Cultural Resources.....	25
6. Energy.....	29
7. Geology and Soils.....	31
8. Greenhouse Gas Emissions.....	35
9. Hazards and Hazardous Materials.....	37
10. Hydrology and Water Quality.....	39
11. Land Use and Land Use Planning.....	45
12. Mineral Resources.....	47
13. Noise.....	48
14. Population and Housing.....	50
15. Public Services.....	51
16. Recreation.....	53
17. Transportation and Traffic.....	54
18. Tribal Cultural Resources.....	57
19. Utilities and Service Systems.....	60
20. Wildfire.....	63

21. Mandatory Findings of Significance.....65
Summary of Mitigation Measures.....67

- Exhibit 1: Regional Vicinity
- Exhibit 2: Local Vicinity
- Exhibit 3: Site Context
- Exhibit 4: Site Plan Overview
- Exhibit 5: Proposed Onsite Improvements
- Exhibit 6: Proposed Offsite Improvements
- Exhibit 7: Offsite Improvements Work Area

- Attachment 1: Biological Reconnaissance Report
- Attachment 2: Greenhouse Gas Analysis
- Attachment 3: Acoustic Report

Project Information Summary

- 1. Project Title:** Burbank Water and Power Campus Storm Water Improvement Project
- 2. Lead Agency Name and Address:** City of Burbank
Burbank Water & Power
164 Magnolia Blvd. Burbank CA, 91502
- 3. Contact Person and Phone Number:** Claudia Reyes (818) 238-3510
Sean Kigerl (818) 238-3774
- 4. Project Location:** Burbank Water & Power Campus,
plus adjoining parcels
164 W. Magnolia Blvd.
Burbank
- 5. Project Sponsor's Name and Address:** Same as above
- 6. General Plan Designation(s):** Institutional
- 7. Zoning:** M-2, General Industrial
- 8. Description of Project:** (Describe the whole action involved, including but not limited to later phases of the Project, and any secondary, support, or off-site features necessary for its implementation. Attach additional sheets if necessary.)

The Project is located at the Burbank Water and Power Campus (BWP Campus) in the approximate central portion of the City of Burbank, at 164 West Magnolia Boulevard. The BWP Campus is approximately 22.5 acres in size, located on the south side of Magnolia Boulevard east of North Lake Street. The Burbank Western Channel (BWC), a tributary of the Los Angeles River, forms the eastern boundary of the Project site. In order to comply with Regional, State and Federal water quality standards, Burbank Water & Power is proposing to construct improvements to the storm water drainage system on the site, as well as the adjacent off-site storm water drainage system.

Currently, surface stormwater runoff discharges to the east of the Project site into the BWC, a tributary to the Los Angeles River. Existing off-site runoff originates upstream of the Project site from an adjacent area that includes a lumberyard and other miscellaneous industrial uses. The off-site runoff then comeslingles with the Project site runoff.

To improve the quality and quantity of the local storm drainage, the Burbank Water and Power proposes to construct drainage improvements that would allow storm water from adjacent properties to be intercepted and discharged into the BWC through a new outfall structure.

Once separated, on-site runoff would be largely retained on the BWP Campus and either infiltrated into the groundwater or used for cooling tower make-up (replenishment) water.

On-site runoff would be pretreated prior to infiltration to ensure compliance with all applicable water quality standards.

The Project would require approvals from the City of Burbank to authorize completion of Project engineering plans. Additional approvals may also be required from Regional Water Quality Control Board, Los Angeles County Flood Control District, California Department of Fish & Wildlife and the U.S. Army Corps of Engineers.

9. Surrounding Land Uses and Setting (Briefly describe the Project’s surroundings.).

The Project site currently zoned M-2, General Industrial. Properties located north and east of the site are zoned Burbank Center Commercial Manufacturing (BCCM). Properties to the south and west are zoned M-1, Limited Industrial Zone, M-2, and BCCM. Consistent with area zoning, all adjacent properties are developed for industrial uses, including but not limited to lumberyards, wood processing, storage, assembly and similar uses.

The Burbank General Plan Land Use Diagram designates the Project site as “Institutional.” Surrounding properties are designated as “North Victory Commercial/Industrial”, “Institutional”, and “Downtown Commercial”.

10. Other public agencies whose approval is required (e.g., permits, financing approval, or participation agreement.).

Actions and approvals that may be required from other agencies for the proposed Project include:

- City of Burbank-Excavation Permit, Building Permit & Encroachment Permit.
- U.S. Army Corps of Engineer-Clean Water Act Section 404 Permit
- State Water Resources Control Board (SWRCB) – National Pollutant Discharge Elimination System (NPDES) General Permit for Storm Water Discharges Associated with Construction and Land Disturbance Activities (Construction General Permit), Order No. 2012-0006-DWQ
- SWRCB – NPDES General Permit for Storm Water Discharges Associated with Industrial Activities (Industrial General Permit), Order No. 2014-0057-DWQ
- Los Angeles Regional Water Quality Control Board (LARWQCB) – Clean Water Act Section 401 Certification Permit
- California Department of Fish & Wildlife – Section 1602 Streambed Alteration Agreement
- Los Angeles Flood Control District – Flood Control Permit

11. Have California Native American tribes traditionally and culturally affiliated with the Project area requested consultation pursuant to Public Resources Code section 21080.3.1? If so, has consultation begun?

In response to the outreach undertaken by the City pursuant to Public Resources Code Section 21080.3.1 (Assembly Bill 52), the City received one (1) letter from the Fernandeno Tataviam Band of Mission Indians (FTBMI). Any Native American (Tribal) cultural resources found on the Project site as a result of construction will be protected by adherence to Mitigation Measures CUL-1, TRIBAL-1, and TRIBAL-2. On February 4, 2020, BWP staff met with Mr. Jairo Avila of the FTBMI to discuss how Native American resources could be protected during construction. BWP met, via teleconference, with FTBMI (Mr. Avila) again on March 15, 2022. On March 25, 2022, FTBMI

provided comments via email on the preliminary draft mitigation measures. FTBMI provided an additional email to BWP regarding the scope of the requested mitigation measures on June 13, 2022. Based on the consultation undertaken with FTBMI, Mitigation Measure CUL-1 contained in the 2019 Initial Study has been replaced by a revised version of CUL-1, TRIBAL-1, and TRIBAL-2. In addition, a second letter was received from the Gabrielino Band of Mission Indians – Kizh Nation, but that letter was received 13 months after the 30-day AB 52 consultation window closed and therefore was untimely.

Burbank Water and Power sent letters on November 16, 2021, to California Native American tribes that have requested to be notified of Projects within the City’s jurisdiction inviting them to participate in government-to-government consultation pursuant to Public Resources Code Section 21080.3.1 (Assembly Bill 52). The FBTMI responded on December 15, 2021, requesting additional information regarding the extent of proposed groundwork. Additional information was provided to FBTMI on January 21, 2022. No tribal consultation has been requested at this time.

Environmental Factors Potentially Affected

The environmental factors checked below would be potentially affected by this Project, involving at least one impact that is a "Potentially Significant Impact" as indicated by the checklist on the following pages.

- | | | |
|---|---|---|
| <input type="checkbox"/> Aesthetics | <input type="checkbox"/> Agriculture and Forestry Resources | <input type="checkbox"/> Air Quality |
| <input checked="" type="checkbox"/> Biological Resources | <input checked="" type="checkbox"/> Cultural Resources | <input type="checkbox"/> Energy |
| <input checked="" type="checkbox"/> Geology/Soils | <input type="checkbox"/> Greenhouse Gas Emissions | <input checked="" type="checkbox"/> Hazards & Hazardous Materials |
| <input type="checkbox"/> Hydrology/Water Quality | <input type="checkbox"/> Land Use/Planning | <input type="checkbox"/> Mineral Resources |
| <input type="checkbox"/> Noise | <input type="checkbox"/> Population/Housing | <input type="checkbox"/> Public Services |
| <input type="checkbox"/> Recreation | <input checked="" type="checkbox"/> Transportation/Traffic | <input checked="" type="checkbox"/> Tribal Cultural Resources |
| <input checked="" type="checkbox"/> Utilities/Service Systems | <input type="checkbox"/> Wildfire | <input type="checkbox"/> Mandatory Findings of Significance |

DETERMINATION: (To be completed by the Lead Agency)

On the basis of this initial study:

- I find that the proposed Project COULD NOT have a significant effect on the environment, and a NEGATIVE DECLARATION will be prepared.
- I find that although the proposed Project could have a significant effect on the environment, there will not be a significant effect in this case because revisions in the Project have been made by or agreed to by the Project proponent. A MITIGATED NEGATIVE DECLARATION will be prepared.
- I find that the proposed Project MAY have a significant effect on the environment, and an ENVIRONMENTAL IMPACT REPORT is required.
- I find that the proposed Project MAY have a "potentially significant impact" or "potentially significant unless mitigated" impact on the environment, but at least one effect 1) has been adequately analyzed in an earlier document pursuant to applicable legal standards, and 2) has been addressed by mitigation measures based on the earlier analysis as described on attached sheets. An ENVIRONMENTAL IMPACT REPORT (DR) is required, but it must analyze only the effects that remain to be addressed.
- I find that although the proposed Project could have a significant effect on the environment, because all potentially significant effects (a) have been analyzed adequately in an earlier EIR or NEGATIVE DECLARATION pursuant to applicable standards, and (b) have been avoided or mitigated pursuant to that earlier EIR. or NEGATIVE DECLARATION, including revisions or mitigation measures that are imposed upon the proposed Project, nothing further is required.



Signature

5/12/2022

Date

Federico Ramirez

Project Description

Project Location

The city encompasses a land area of approximately 17.1 square miles and is located in the central portion of Los Angeles County (**Exhibit 1, *Regional Vicinity***). The city is approximately 12 miles north of downtown Los Angeles, the northeastern edge of the city is bordered by the Verdugo Mountains, and the western edge of the city is located near the eastern part of the San Fernando Valley. The city is bisected by Interstate 5 (I-5) and is adjacent to the cities of Los Angeles and Glendale, 12 miles south and 4 miles east of the city, respectively. Regional access to the city is provided by I-5, State Route 134 (SR-134), and State Route 170 (SR-170).

The proposed Burbank Water and Power Campus Stormwater Improvement Project (proposed Project) is located at the Burbank Water & Power (BWP) campus at 164 West Magnolia Boulevard in the central portion of the City of Burbank (City) (**Exhibit 2, *Local Vicinity***).

Project activities would occur on and adjacent to the BWP Campus. The BWP Campus is approximately 22.5 acres in size. The BWP Campus is located on the south side of Magnolia Boulevard, and east of North Lake Street (**Exhibit 3, *Site Context***). The proposed Project extends from the stormwater improvements on the BWP Campus and connects to the Burbank Western Channel (BWC), which is a tributary of the Los Angeles River, via a stormwater drain.

Land Use and Zoning Designations

As described in the City General Plan and Zone Map, the Project site and surrounding area is planned and zoned for institutional/M-2 General Industrial uses (City of Burbank, 2013; City of Burbank, 2019). The Project site is located within the North Victory Commercial/Industrial area of the Burbank Center Plan specific plan area. The primary use of the Project site is the BWP Campus. The institutional land use designation provides for City facilities, public schools, flood control channels, railroad tracks, and other public and private institutions. The M-2 General Industrial zoning designation is intended for the development of manufacturing process as well as fabrication and assembly of goods and materials (City of Burbank, n.d.).

Background and Existing Conditions

The BWP Campus was constructed in 1913. The industrial portion of the BWP Campus includes two steam boilers, a simple cycle turbine and a combined cycle power plant. The combined cycle power plant (Magnolia Power Plant) is owned by the Southern California Public Power Authority (SCPPA), a joint powers authority.

The Participants in the Magnolia Power Plant include six local public agencies that operate power generation and distribution facilities in Southern California. Burbank is entitled to 31% of the total amount of energy produced by the Magnolia Power Plant and operates the plant. In addition to providing electricity to the residents and businesses of Burbank, BWP also provides water and broadband services.

The Project site comprises approximately 22.5 acres of land which is relatively flat. Burbank Water and Power provides electricity, water and broadband services to Burbank residents and businesses. The Project site is fully developed and consists of an on-site area and an off-site area.

On-Site Area

Under current conditions, a single 36-inch pipe drains the approximately 22-acre Project area and an additional 20.9 acres of industrial area of the BWP facilities before reaching the BWC (**Exhibit 4, Site Plan Overview**). In terms of storm water runoff and drainage, a 36-inch-diameter collector extends across the on-site BWP Campus with a series of drainage inlets. The collector then deposits water in the adjacent BWC, just east of the Project site.

Off-Site Area

The BWP Campus also receives storm water from an adjacent 22-acre industrial area north of the BWP Campus. This off-site area drains to an existing sump at the intersection of West Magnolia Boulevard and North Varney Street. The 36-inch line runs through the BWP Campus and co-mingles with storm water generated on site prior to discharge into the BWC.

Currently, BWP Campus storm water runoff discharges into the BWC. Existing runoff through the BWP Campus originates upstream from an adjacent area that includes a lumberyard and other miscellaneous industrial uses. The off-site runoff then comingles with the on-site BWP Campus runoff prior to discharge into the BWC.

Statement of Objectives and Project Goals

Goals

In order to comply with Regional, State, and Federal water quality standards, BWP is proposing to construct onsite storm water improvements, as well as improvements to the adjacent off-site storm water drainage system. As set forth by the CEQA Guidelines, the list of goals that the City seeks to achieve for the proposed Project is provided below.

1. Construct new storm water facilities to separate on-and off-site drainage.
2. Assist in recharging the regional aquifer.
3. Provide a source of make-up water for BWP Campus operations.
4. Achieve Regional, State, and Federal water quality standards for BWP Campus runoff.
5. Construct off-site storm water facilities to improve the quality of off-site storm water.

The purpose of this Project is to construct a new connection to the BWC to discharge storm water that is generated offsite of the BWP Campus. This would prevent comingling of offsite and onsite storm water. The new connection to the BWC would not bring stormwater to the channel; rather, it will move the existing discharge location and change the point at which it will make a connection to the channel. There will be no net increase in volume of water that is discharged into the channel. The existing discharge point will remain in place and be used as overflow in case the on-site discharge system has a greater than 85th percentile, 24-hour storm event.

Overall, storm water quality would be improved by the addition of the onsite pretreatment filter. The amount of storm water discharged to the BWC would be reduced, as the onsite storm water would be collected and used onsite as process cooling water.

Project Elements

The basis for the proposed Project is compliance with a mandated industrial stormwater quality regulation. The proposed design would improve drainage and separate local urban runoff from industrial runoff, facilitate collection and treatment of industrial runoff, reduce the total drainage area utilizing the storm drain by 50-percent, and improve local catch basin inlets to the maximum permissible capacities permitted to be discharged to the BWC. The connection to the BWC can be made without compromising the existing BWC; please see Attachment 3, *Structural Plans* and Attachment 4, *Structural Calculations*, that certify and detail the structural connection to the BWC.

The proposed Project would divert storm water that is generated offsite by constructing a new storm water pipeline, manholes, and connection to the BWC. Beginning at the boundary between the onsite and offsite systems, the connection to the BWP campus, which exists as a reinforced concrete box (RCB) in Magnolia Boulevard, would be blocked forcing offsite storm water to discharge through the new system. This would eliminate comingling and reduce the amount of storm water conveyed across the BWP campus.

On-Site Improvements

On-site improvements include two natural gas fired boilers, a simple cycle gas turbine, a combined cycle power plant, solar collectors, cooling towers, administrative offices, parking area and related ancillary equipment. Onsite drainage improvements would consist of diverting flow from an existing 36-inch diameter pipe into an on-site filter, then into an underground vault within the northeast portion of the BWP Campus. The proposed vault location is presently paved with an asphalt concrete (a/c) surface that would be removed and replaced after construction of the vault. The vault would be approximately 10-feet deep with a volume of 37,000 cubic feet. Following completion of the above improvements, drainage from the BWP Campus, up to the 85th percentile, 24-hour storm event, would flow through the filters and into the vault and not the existing BWC outfall. The storm water capture system would on average divert 8.2 million gallons per year of storm water from the BWC, assuming average rainfall of 16.3 inches per year. The treated storm water would either be used for cooling tower make-up water or infiltrated into the ground, or a combination of the two. The system would have the capacity to renew its capacity to accept a 24-hour, 85th percentile storm event within 24 hours of the discharge. The existing outfall would continue to be used to discharge flows above the 85th percentile, 24-hour storm event. Existing a/c material would be removed from the Project site and recycled. Please see **Exhibit 5, Proposed Onsite Improvements**, for more detail.

Off-Site Improvements

A second portion of the Project would include diverting storm water from adjacent properties to the north (approximately 22-acre area) before it runs on to the BWP Campus into a new 36-inch diameter storm drain that would be constructed within the right-of-way of North Varney Street and would terminate in a new drainage outfall into the BWC, approximately 950 feet north of the current outfall.

The total amount of the site that would be disturbed by the Project would be approximately 13,100 square feet (0.30 acre). Please see **Exhibit 6, Proposed Offsite Improvements**, and **Exhibit 7, Offsite Improvements Work Area**, for more details.

Exhibits 3 through 5 show preliminary drawings of the proposed on-site/off-site improvements.

Other Project features would include:

- Construction plans and specifications would include the following hours and days of construction to minimize noise off site:
Monday-Friday: 7:00 AM to 7:00 PM
Saturday: 8:00 AM to 5:00 PM
- No construction would be permitted by contractors or subcontractors after hours, on Sunday or on City Holidays, without prior written request and approval from the Community Development Department’s Building and Safety Division.
- Prior to commencement of construction, the Project contractor would prepare and implement a Construction & Demolition Diversion Plan to safely recycle and discard materials and construction debris.

At the conclusion of the Project, all Regional, State and Federal surface water quality standards would be met.

There are no anticipated changes in the existing Operations and Maintenance (O&M) activities of the Los Angeles County Flood Control District (LACFCD) for the BWC as result of the proposed Project. Overall storm water quality would be improved by the addition of the onsite pretreatment filter.

O&M of the new offsite storm water pipeline, manholes, and connection to the BWC is the responsibility of:

1. City of Burbank (City)
2. LACFCD

The City is responsible for maintenance and operation of the entire new storm system up to the LACFCD right-of-way, which is denoted by the last manhole upstream of the connection to the BWC, strategically located just outside the LACFCD right of way.

The LACFCD is responsible for maintenance and operation of the connection the BWC and the pipeline segment within its right of way, only.

Project Construction

The Project would be constructed within one phase beginning mid-2023 and is anticipated to be completed in 2024. All construction activities would occur during daytime hours, specifically from 7:00 a.m. to 7:00 p.m. Monday through Friday and from 8:00 a.m. through 5:00 p.m. on Saturdays.

Construction Scenario

This environmental analysis assumes the development of the proposed Project would require approximately 9 months to complete, from approximately June 2023 to November 2024. Connection to the BWC and all work within the BWC is expected to take approximately 2 weeks to complete. This work is planned to be completed during November of 2024. It is anticipated that no more than 25 employees would be needed to complete the proposed Project.

The construction schedule utilized in the analysis represents a “worst-case” analysis scenario should construction occur any time after the respective dates since emission factors for construction decrease as time passes and the analysis year increases due to emission regulations becoming more stringent.⁴ The duration of construction activity and associated equipment represents a reasonable approximation of the expected construction fleet as required per CEQA guidelines. Site-specific construction fleet may vary due to specific Project needs at the time of construction. The duration of construction activity is based on a 2022 opening year. The associated construction equipment was generally based on CalEEMod_2016.3.2 defaults. Please refer to specific detailed modeling inputs/outputs contained in Appendix 3.1 of this analysis.

A list of construction equipment types and quantities that would potentially be used in construction of the Burbank Water and Power Campus Stormwater Improvement Project is presented in Table 1. *Anticipated Construction Equipment.*

Table 1. Anticipated Construction Equipment

Activity	Type of Equipment/Vehicle	Approximate Quantities	Approximate Duration of On-Site Construction Activity (days)
Demolition	Concrete/Industrial Saws	1	10 days
	Rubber Tired Dozers	1	
	Tractors/Loaders/Backhoes	2	
Site Preparation	Graders	1	1 day
	Tractors/Loaders/Backhoes	1	
Graders	Concrete/Industrial Saws	1	2 days
	Rubber Tired Dozers	1	
	Tractors/Loaders/Backhoes	2	
Building Construction	Cranes	1	100 days
	Forklifts	2	
	Tractors/Loaders/Backhoes	2	
Paving	Cement and Mortar Mixers	4	5 days
	Pavers	1	
	Rollers	1	
	Tractors/Loaders/Backhoes	1	
Architectural Coating	Air Compressors	1	5 days

A Stormwater Pollution Prevention Plan (SWPPP) shall be prepared prior to the start of construction. The construction of the proposed Project shall be managed pursuant to the SWPPP throughout the duration of construction. The BMPs required in conjunction with the SWPPP would protect the BWC from erosion or siltation from construction of the proposed stormwater improvements.

Site preparation and construction of the proposed Project would be in accordance with all federal, state building codes, and applicable codes within the City Municipal Code. The Project site is accessible via the site of the BWP campus or via local streets at West Magnolia Boulevard or West Olive Avenue.

Required Approvals

Actions and approvals required from the City in association with the Project include:

- City of Burbank-Excavation Permit, Building Permit & Encroachment Permit
- U.S. Army Corps of Engineer-Clean Water Act Section 404 Permit
- State Water Resources Control Board (SWRCB) – National Pollutant Discharge Elimination System (NPDES) General Permit for Storm Water Discharges Associated with Construction and Land Disturbance Activities (Construction General Permit), Order No. 2012-0006-DWQ

- SWRCB – NPDES General Permit for Storm Water Discharges Associated with Industrial Activities (Industrial General Permit), Order No. 2014-0057-DWQ
- Los Angeles Regional Water Quality Control Board (LARWQCB) – Clean Water Act Section 401 Certification Permit
- California Department of Fish & Wildlife – Section 1602 Streambed Alteration Agreement
- Los Angeles Flood Control District – Flood Control Permit
- Any transportation of heavy construction equipment and/or materials which requires use of over-sized-transport vehicles on State highways would require a Caltrans transportation permit.

References

- City of Burbank. 2013. *Burbank2035* General Plan. Adopted February 19, 2013. Accessed September 27, 2021. Available at:
<https://www.burbankca.gov/documents/173607/0/The+Burbank2035+General+Plan.pdf/139656b0-80e9-3b11-dc6d-751642c85b38?version=1.2&t=1616616954424&imagePreview=1>
- . Effective 2019. *Zone Map*. Last Amended by Ordinance No. 3802. Available at:
https://www.burbankca.gov/documents/173607/0/20210101_Zoning_Map.pdf/c8bc55ed-98cf-505d-3892-7e1657bca8f1?t=1618866483006
- . N.d. *Burbank Municipal Code. Title 10 Zoning Regulations*. Accessed September 17, 2021. Available at:
<https://www.codepublishing.com/CA/Burbank/#!/Burbank10/Burbank100108.html#10-1-808>

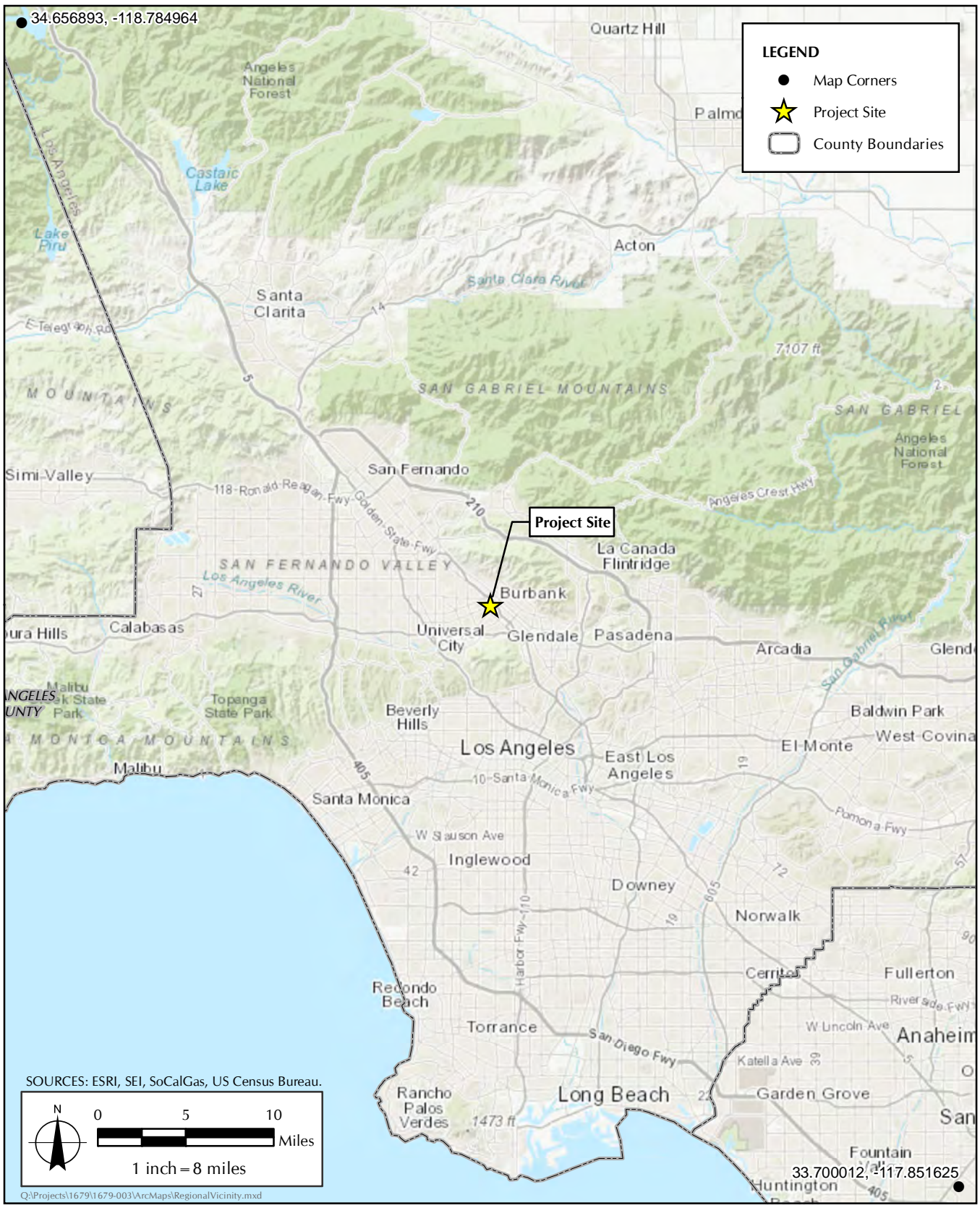

Date prepared: 9/27/2021
 Prepared by: Stefanie Paz
 Organization: Sapphos Environmental, Inc.

EXHIBIT 1
 Regional Vicinity

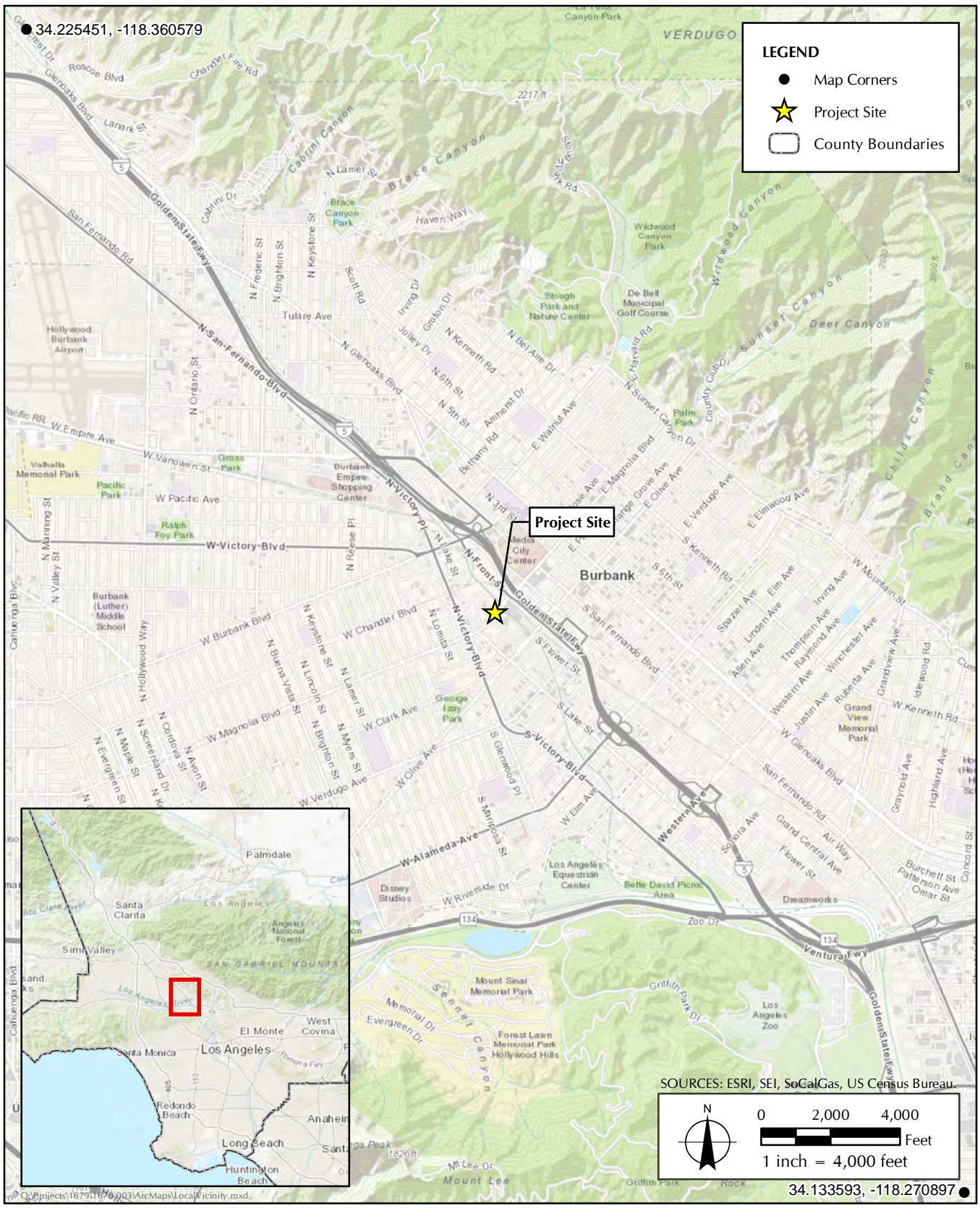









Date prepared: 9/27/2021
 Prepared by: Stefanie Paz
 Organization: Sapphos Environmental, Inc.

EXHIBIT 2
Local Vicinity



34.180497, -118.316377

LEGEND

 New 3-ft Diameter Pipe	 Proposed Work Area
 LA County Flood Control Right-of-Way	 Permanent Impact
 Storm Drain Inlet Protection	 Total Offsite Work Area
 Soil Stockpile Location	 Burbank Western Channel

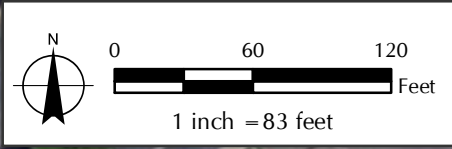

34.178571, -118.314453

Q:\Projects\1679\1679-003\ArcMaps\ProjectArea_20211113.mxd



Date prepared: 9/27/2021
 Prepared by: Stefanie Paz
 Organization: Sapphos Environmental, Inc.

EXHIBIT 7
 Offsite Improvements Work Area

Aesthetics

	Potentially Significant Impact	Less than Significant with Mitigation Incorporated	Less than Significant Impact	No Impact
I. AESTHETICS -- Would the project:				
a) Have a substantial adverse effect on a scenic vista?	<input type="checkbox"/>	<input type="checkbox"/>	<input type="checkbox"/>	<input checked="" type="checkbox"/>
b) Substantially damage scenic resources, including, but not limited to, trees, rock outcroppings, and historic buildings within a state scenic highway?	<input type="checkbox"/>	<input type="checkbox"/>	<input type="checkbox"/>	<input checked="" type="checkbox"/>
c) In non-urbanized areas, substantially degrade the existing visual character or quality of public views of the site and its surroundings? (Public views are those that are experienced from publicly accessible vantage point). If the project is in an urbanized area, would the project conflict with applicable zoning and other regulations governing scenic quality?	<input type="checkbox"/>	<input type="checkbox"/>	<input type="checkbox"/>	<input checked="" type="checkbox"/>
d) Create a new source of substantial light or glare which would adversely affect daytime or nighttime views in the area?	<input type="checkbox"/>	<input type="checkbox"/>	<input type="checkbox"/>	<input checked="" type="checkbox"/>

Discussion

- a) **No Impact.** A scenic vista generally provides focal views of objects, settings, or features of visual interest; or panoramic views of large geographic areas of scenic quality, primarily from a given vantage point. The *Burbank2035* General Plan (General Plan) Open Space and Conservation Element defines scenic vistas as viewpoints that provide expansive views of a highly valued landscape for the benefit of the general public. Scenic vistas within Burbank include views of the Verdugo Mountains to the northeast and views of the eastern Santa Monica Mountains to the south. Downslope views from hillside development in the Verdugo Mountains toward the City and the Santa Monica Mountains beyond are also considered a valued resource (City of Burbank 2013). According to the *Burbank2035* General Plan, the Project site is not located within an area identified as having a scenic vista (City of Burbank 2013). Additionally, the Project site is flat and has been developed with a major municipal power plant and other industrial land uses. The site is fenced and secured to prevent public access. Therefore, there would be no impact on scenic vistas.

- b) **No Impact.** There are no officially designated State scenic highways within proximity to the Project site. The nearest eligible State Scenic Highway is Interstate 210, located east/northeast of the Project site (Caltrans 2021). No rock outcroppings or historic buildings eligible for national or state designation are located on or near the Project site, since the area is used as a power generation facility and other industrial uses. Therefore, the Project would not substantially damage scenic resources within a State Scenic Highway and no impact would occur.

- c) **No Impact.** Implementation of the Project would involve construction of subsurface drainage facilities as well as an additional outfall to the BWC. In addition, the visual character of the Project site from public views would be similar to the existing condition based on the City's

General Plan, Complete Streets Plan, policies, and other guidelines for maintaining and preserving its small-town character that provides a sense of belonging to the community per its architecture, design, and density. Furthermore, the City's plans, policies and guidelines also protect the views and character of highly valued landscape for the benefit of the public (City of Burbank 2021). There would be no damage or impact to local or regional scenic resources.

- d) **No Impact.** The Project site is currently developed with a municipal power plant that has a large array of buildings and yard lighting for security and plant operations. Adjacent streets are equipped with streetlights. No additional light fixtures would be constructed as part of the Project. There would be no impacts related to this topic.

References

California Department of Transportation (Caltrans). 2021. California State Scenic Highways. Accessed September 28, 2021. Available at: <https://dot.ca.gov/programs/design/lap-landscape-architecture-and-community-livability/lap-liv-i-scenic-highways>

City of Burbank. 2013. *Burbank2035* General Plan. Adopted February 19, 2013. Accessed September 27, 2021. Available at: <https://www.burbankca.gov/documents/173607/0/The+Burbank2035+General+Plan.pdf/139656b0-80e9-3b11-dc6d-751642c85b38?version=1.2&t=1616616954424&imagePreview=1>

———. 2021. City of Burbank Municipal Code. August 10, 2021. Accessed September 28, 2021. Available at: <https://www.codepublishing.com/CA/Burbank/>

Agricultural and Forest Resources

	Potentially Significant Impact	Less than Significant with Mitigation Incorporated	Less than Significant Impact	No Impact
<p>II. Agricultural and Forest Resources -- In determining whether impacts to agricultural resources are significant environmental effects, lead agencies may refer to the California Agricultural Land Evaluation and Site Assessment Model (1997) prepared by the California Department of Conservation as an optional model to use in assessing impacts on agriculture and farmland. In determining whether impacts to forest resources, including timberland, are significant environmental effects, lead agencies may refer to information compiled by the California Department of Forestry and Fire Protection regarding the State's inventory of forest land, including the Forest and Range Assessment Project and the Forest Legacy Assessment Project; and forest carbon measurement methodology provided in Forest Protocols adopted by the California Air Resources Board.</p>				
<p>Would the project:</p>				
a) Convert Prime Farmland, Unique Farmland, or Farmland of Statewide Importance (Farmland), as shown on the maps prepared pursuant to the Farmland Mapping and Monitoring Program of the California Resources Agency, to non-agricultural use?	<input type="checkbox"/>	<input type="checkbox"/>	<input type="checkbox"/>	<input checked="" type="checkbox"/>
b) Conflict with existing zoning for agricultural use, or a Williamson Act contract?	<input type="checkbox"/>	<input type="checkbox"/>	<input type="checkbox"/>	<input checked="" type="checkbox"/>
c) Conflict with existing zoning for, or cause rezoning of, forest land (as defined in Public Resources Code section 12220(g)), timberland (as defined by Public Resources Code section 4526), or timberland zoned Timberland Production (as defined by Government Code section 51104(g))?	<input type="checkbox"/>	<input type="checkbox"/>	<input type="checkbox"/>	<input checked="" type="checkbox"/>
d) Result in the loss of forest land or conversion of forest land to non-forest use?	<input type="checkbox"/>	<input type="checkbox"/>	<input type="checkbox"/>	<input checked="" type="checkbox"/>
e) Involve other changes in the existing environment which, due to their location or nature, could result in conversion of Farmland, to non-agricultural use or conversion of forest land to non-forest use?	<input type="checkbox"/>	<input type="checkbox"/>	<input type="checkbox"/>	<input checked="" type="checkbox"/>

Discussion

a–e) **No Impact.** The city contains no designated Prime Farmland, Unique Farmland, or Farmland of Statewide Importance as shown on maps prepared pursuant the Farmland Mapping and Monitoring Program (California Department of Conservation, 2021). The Project site is fully developed with power generation facilities and related improvements. No crops or trees, other than ornamental landscape trees, are maintained on the site. No Williamson Act Land Conservation Agreements or Timberland Preserves are located on the site, and there is no zoning designation for agricultural use (Burbank, 2013, 2021). Therefore, approval and Implementation of the Project would have no impact on agriculture or forest resources.

References

California Department of Conservation. 2021. *Farmland Mapping & Monitoring Program: California Important Farmland Finder*. Available at: <https://maps.conservation.ca.gov/DLRP/CIFF/>

City of Burbank. 2013. *Burbank2035* General Plan. Adopted February 19, 2013. Accessed September 27, 2021. Available at: <https://www.burbankca.gov/documents/173607/0/The+Burbank2035+General+Plan.pdf/139656b0-80e9-3b11-dc6d-751642c85b38?version=1.2&t=1616616954424&imagePreview=1>

———. 2021. City of Burbank Zoning Code. August 10, 2021. Accessed September 28, 2021. Available at: <http://www.codepublishing.com/CA/Burbank/>

Air Quality

	Potentially Significant Impact	Less than Significant with Mitigation Incorporated	Less than Significant Impact	No Impact
III. AIR QUALITY -- Where available, the significance criteria established by the applicable air quality management or air pollution control district may be relied upon to make the following determinations. Would the project:				
a) Conflict with or obstruct implementation of the applicable air quality plan?	<input type="checkbox"/>	<input type="checkbox"/>	<input type="checkbox"/>	<input checked="" type="checkbox"/>
b) Result in a cumulatively considerable net increase of any criteria pollutant for which the project region is non-attainment under an applicable Federal or State ambient air quality standard?	<input type="checkbox"/>	<input type="checkbox"/>	<input type="checkbox"/>	<input checked="" type="checkbox"/>
c) Expose sensitive receptors to substantial pollutant concentrations?	<input type="checkbox"/>	<input type="checkbox"/>	<input type="checkbox"/>	<input checked="" type="checkbox"/>
d) Result in other emissions (such as those leading to odors) adversely affecting a substantial number of people?	<input type="checkbox"/>	<input type="checkbox"/>	<input type="checkbox"/>	<input checked="" type="checkbox"/>

Discussion

- a) **No Impact.** The Project site is located within the 6,600-square-mile South Coast Air Basin (Basin). The South Coast Air Quality Management District (SCAQMD), together with the Southern California Association of Governments (SCAG), is responsible for formulating and implementing air pollution control strategies throughout the Basin. The current Air Quality Management Plan (AQMP) was adopted March 3, 2017 and outlines the air pollution control measures needed to meet Federal particulate matter (PM_{2.5}) standards by 2015 and ozone (O₃) standards by 2024. The 2016 AQMP, adopted by SCAQMD is currently under State review and will contain measures to meet 24-hour PM_{2.5} standards by 2019, annual PM_{2.5} standards by 2025, and 1-hour ozone (O₃) standards by 2022.

The operation of the proposed Project would not add population or vehicle trips to the community that would be in conflict with population or trip assumptions used as the basis of the regional AQMP. There would be no impact with respect to this topic.

- b) **No Impact.** The operation of the proposed drainage Project would not result in any ongoing air quality impacts, since it would not involve vehicular trips or any industrial processes that would generate pollutants. Construction of the Project would involve removal of existing paved surfaces, trenching and grading for the addition of subsurface drains as well as for the construction of a new drainage outfall. The total amount of disturbance would be under approximately 20,000 square feet of surface area (both on the BWP site and adjacent roadway). Construction activities could release dust, particle matter and other pollutants into the atmosphere. The City of Burbank will add standard construction specifications and requirements for the Project contractor to implement the following Policies from the Air Quality and Climate Change Element of the *Burbank2035* General Plan.

- **Policy 1.6:** Require measures to control air pollutant emissions at construction sites and during soil disturbing dust generating activities (such as tilling, landscaping, etc.) for Projects requiring such activities.
- **Policy 1.7:** Require reduced idling, trip reduction and efficiency routing for City departments, where appropriate.

Such requirements could include, but not be limited to, a prohibition on truck idling for more than five minutes on the site, watering of disturbed (graded) area of the site every three hours, covering or enclosing stockpiles of debris, dirt or other dusty materials, suspending grading activities when wind speed exceeds 25 miles-per-hour (mph), limiting on-site speed for construction equipment at 15 mph and routing construction trips away from sensitive receptors.

The size of Project construction (approximately 20,000 square feet) would fall below screening criteria established by the SCAQMD. For construction projects below the sizes shown in the District CEQA Guidelines (Table 6.3) no impact would occur with respect to air quality. Table 6.3 of the District's CEQA Guidelines has determined that government office complexes of 559,000 square feet of floor area and demolition activities that would remove 23,214,000 cubic feet of building area would not result in a significant air quality impact. The proposed BWP project would fall substantially below the screening criteria established by the regional air quality district.

With adherence to *Burbank2035* General Plan policies as reflected in construction specifications, adherence to standard City construction reduction requirements and based on the regional air quality screening criteria the Project would not contribute cumulatively considerable pollutants. No impacts would result with respect to this topic.

- c) **No Impact.** The Project site is located in an industrial portion of Burbank with no schools, hospitals, parks, playgrounds, residences or other sensitive receptors located in the vicinity that could be impacted by emissions from Project construction. There would be no impact with respect to this topic.
- d) **No Impact.** Surrounding properties are developed with light industrial and commercial business establishments that do not have a large population base, based on a site investigation conducted on September 12, 2018.

References

- City of Burbank. 2013. *Burbank2035* General Plan. Adopted February 19, 2013. Accessed September 27, 2021. Available at: <https://www.burbankca.gov/documents/173607/0/The+Burbank2035+General+Plan.pdf/139656b0-80e9-3b11-dc6d-751642c85b38?version=1.2&t=1616616954424&imagePreview=1>
- South Coast Air Quality Management District. 2016. 2016 Air Quality Management Plan. Accessed September 28, 2021. Available at: <https://www.aqmd.gov/home/air-quality/clean-air-plans/air-quality-mgt-plan/final-2016-aqmp>

———. 1993. Air Quality Analysis Handbook. Accessed September 28, 2021. Available at: [http://www.aqmd.gov/home/rules-compliance/ceqa/air-quality-analysis-handbook/ceqa-air-quality-handbook-\(1993\)](http://www.aqmd.gov/home/rules-compliance/ceqa/air-quality-analysis-handbook/ceqa-air-quality-handbook-(1993))

Biological Resources

	Potentially Significant Impact	Less than Significant with Mitigation Incorporated	Less than Significant Impact	No Impact
IV. BIOLOGICAL RESOURCES -- Would the project:				
a) Have a substantial adverse effect, either directly or through habitat modifications, on any species identified as a candidate, sensitive, or special status species in local or regional plans, policies, or regulations, or by the California Department of Fish and Game or U.S. Fish and Wildlife Service?	<input type="checkbox"/>	<input checked="" type="checkbox"/>	<input type="checkbox"/>	<input type="checkbox"/>
b) Have a substantial adverse effect on any riparian habitat or other sensitive natural community identified in local or regional plans, policies, regulations or by the California Department of Fish and Game or U.S. Fish and Wildlife Service?	<input type="checkbox"/>	<input type="checkbox"/>	<input checked="" type="checkbox"/>	<input type="checkbox"/>
c) Have a substantial adverse effect on state or federally protected wetlands as defined by Section 404 of the Clean Water Act (including, but not limited to, marsh, vernal pool, coastal, etc.) through direct removal, filling, hydrological interruption, or other means?	<input type="checkbox"/>	<input type="checkbox"/>	<input checked="" type="checkbox"/>	<input type="checkbox"/>
d) Interfere substantially with the movement of any native resident or migratory fish or wildlife species or with established native resident or migratory wildlife corridors, or impede the use of native wildlife nursery sites?	<input type="checkbox"/>	<input type="checkbox"/>	<input type="checkbox"/>	<input checked="" type="checkbox"/>
e) Conflict with any local policies or ordinances protecting biological resources, such as a tree preservation policy or ordinance?	<input type="checkbox"/>	<input type="checkbox"/>	<input checked="" type="checkbox"/>	<input type="checkbox"/>
f) Conflict with the provisions of an adopted Habitat Conservation Plan, Natural Community Conservation Plan, or other approved local, regional, or state habitat conservation plan?	<input type="checkbox"/>	<input type="checkbox"/>	<input type="checkbox"/>	<input checked="" type="checkbox"/>

Discussion

The following section of the Initial Study is based on the following site-specific document: “Biological Resources Assessment: Stormwater Quality Improvements Project, City of Burbank, Los Angeles County, California” prepared by WRA Environmental Consultants, October 2018. This report is hereby incorporated into this Initial Study by reference and is attached to this document as Attachment 1.

- a) **Less than Significant with Mitigation.** The Project site is developed with the majority of the parcels consisting of paved parking lots with impervious surfaces, various buildings associated with the BWP Campus. No special-status plant or wildlife species were observed during the biological site assessment, and the Project site was determined to have little to no potential to host the special-status species identified in the literature and database searches.

However, the Project has the potential to impact special-status and non-special-status native nesting birds protected by California Fish and Game Code and guidelines for protection

provided by the Migratory Bird Treaty Act (MBTA). Project activities such as vegetation removal and ground disturbance associated with Project activities would have the potential to affect these species by causing direct mortality of eggs or young, or by causing auditory, vibratory, and/ or visual disturbance of a sufficient level to cause abandonment of an active nest. If Project activities occur during the bird nesting season, which generally extends from February 15 through August 31, nests of both special-status and non-special-status native birds could be impacted by construction and other ground disturbing activities. Impacts to nesting birds would be considered significant under CEQA. Implementation of Mitigation Measure BIO-1 will reduce this potential impact to less than significant.

Mitigation Measure BIO-1. No Project activities, including vegetation removal and grading shall be conducted during nesting bird season (February 15 to August 31) to the extent feasible. If such activities must be conducted during the nesting season, a pre-construction nesting-bird survey shall be performed by a qualified biologist no more than 14 days prior to vegetation removal or initial ground disturbance. The survey shall include the disturbance area and the surrounding 500 feet, to identify the location and status of any nests that could potentially be affected either directly or indirectly by Project activities. The nesting bird surveys shall be conducted during appropriate time of day and weather conditions and concentrate on potential roosting or perch sites.

If an active nest (containing eggs or chicks) of protected species is found within the survey area, it shall be designated as an ecologically sensitive area and protected (while occupied) during Project Activities. Established exclusion zones shall remain in place until all young in the nest have fledged or the nest otherwise becomes inactive (e.g., due to predation). Appropriate exclusion zone sizes shall be determined by a qualified biologist and vary dependent upon the species, nest location, existing visual buffers, noise levels, and other factors. An exclusion zone radius may be as small as 250 feet for common, disturbance-adapted species or as large as 500 feet or more for raptors. Exclusion zone size may be reduced from established levels if supported with nest monitoring findings by a qualified biologist indicating that work activities outside the reduced radius are not adversely affecting the nest and that a reduced exclusion zone would not adversely affect the subject nest.

These requirements shall be included in Project plans and construction specifications.

- b, c) Less than Significant Impact.** As discussed above, the Project site is located in an area that is entirely developed. The site survey performed by WRA biologists identified no riparian habitat, wetlands or designated sensitive natural communities exist on the Project site or in the surrounding area. No impacts would therefore result with approval and implementation of the proposed Project.

The Project's diversion of storm water flows would primarily occur during the winter rainy season and would correspond with high flows in the BWC. Accordingly, the Project's minor storm water diversion would have a less-than-significant impact on any riparian habitat or other sensitive natural communities, including wetlands.

Prior to disturbance of any jurisdictional waters, BWP would obtain all required resource agency permit approvals required for such disturbance (e.g., Section 404 Permit from the Corps, Section 401 Water Quality Certification from the RWQCB, Section 1602 Lake and

Streambed Alteration Agreement from the CDFW) and comply with all conditions of such approvals from the appropriate agency. BWP shall provide the County with documented evidence of such approvals and compliance with associated permit(s) conditions. The Project would be required to comply with all rules and regulations stipulated by the resource agencies during the construction of the Project to avoid any potential impacts to the BWC. Mitigation and avoidance measures, as defined in the Summary of Mitigation Measures, including active implementation of Best Management Practices (BMPs) to prevent erosion and the discharge of sediment, shall be used for the protection of water quality and habitat within the BWP and downstream resources. Compliance with Federal and State organizations with jurisdiction over the BWC will reduce the level of significance to less than significant under CEQA.

- d) **No Impact.** The Project site is currently paved and located within a developed portion of the city. The Project site is predominately covered with impervious surfaces and does not contain any quality biological habitat. Thus, the Project would not interfere with the movement of any native resident or migratory fish or wildlife species or established migratory wildlife corridor. No impacts would occur with respect to this topic.

The Project's diversion of storm water flows would primarily occur during the winter rainy season and would correspond with high flows in the BWC. Accordingly, the Project's minor storm water diversion would have no impact on the movement of any native resident or migratory fish or wildlife species or with established native resident or migratory wildlife corridors or impede the use of native wildlife nursery sites.

- e) **Less than Significant Impact.** Section 7-4-115 of the City of Burbank Municipal Code states that the no ground disturbing activities, including the excavation of any ditches, tunnels, trenches, or the installation of pavement, shall occur within ten feet from any public tree without prior notification to the City Community Development Director. Landscaped trees are present along the northwestern border of the Campus that would likely be removed during Project activities. The Project may remove five planted fan palm trees protected under the City of Burbank Trees and Vegetation ordinance. Impacts to protected trees would be considered significant under CEQA, however the Project has been designed to comply with ordinance. Replacement trees of equal size, of the same species would be placed in a location approved by the City of Burbank Park, Recreation and Community Services Director and the Community Development Director. Therefore, the Project's potential impacts to trees protected under the City of Burbank Vegetation and Trees Ordinance are considered less than significant without mitigation.
- f) **No Impact.** The City of Burbank does not have an adopted Habitat Conservation Plan (HCP) or Natural Community Conservation Plan (NCCP). There are no approved local, regional, or state habitat conservation plans. Therefore, the Project would have no impact to an adopted HCP, NCCP, or other approved local, regional, or state habitat conservation plan.

References

- City of Burbank. 2013. *Burbank2035* General Plan. Adopted February 19, 2013. Accessed September 27, 2021. Available at: <https://www.burbankca.gov/documents/173607/0/The+Burbank2035+General+Plan.pdf/139656b0-80e9-3b11-dc6d-751642c85b38?version=1.2&t=1616616954424&imagePreview=1>

———. 2021. City of Burbank Municipal Code. August 10, 2021. Accessed September 28, 2021.
Available at: <https://www.codepublishing.com/CA/Burbank/>

WRA Environmental Consultants. 2019. Biological Resources Assessment, Stormwater Quality
Improvements Project City of Burbank, Los Angeles County CA.

Cultural Resources

	Potentially Significant Impact	Less than Significant with Mitigation Incorporated	Less than Significant Impact	No Impact
V. CULTURAL RESOURCES -- Would the project:				
a) Cause a substantial adverse change in the significance of a historical resource as defined in Section 15064.5?	<input type="checkbox"/>	<input type="checkbox"/>	<input type="checkbox"/>	<input checked="" type="checkbox"/>
b) Cause a substantial adverse change in the significance of an archaeological resource pursuant to Section 15064.5?	<input type="checkbox"/>	<input checked="" type="checkbox"/>	<input type="checkbox"/>	<input type="checkbox"/>
c) Disturb any human remains, including those interred outside of formal cemeteries?	<input type="checkbox"/>	<input type="checkbox"/>	<input checked="" type="checkbox"/>	<input type="checkbox"/>

Discussion

a) **No Impact.** The Burbank Water and Power (BWP) Campus was fully developed and paved with power generating facilities, administrative offices, manufacturing uses and related facilities by 1952, based upon a review of historic aerial photographs. According to Los Angeles County Flood Control District records, the Burbank Western Channel (BWC) was constructed in 1957. Both resources are greater than 50 years of age and may be considered historical resources. However, the proposed Project is consistent with the original intended purpose and use of both the BWP campus and BWC. In addition, the proposed Project would not alter the seven qualities that convey the historical significance of the resource:

- **Location:** there is no change in the location of the BWP campus or BWC;
- **Setting:** the footprint of the Project is very small in relation to the overall setting of the BWP campus and BWC and does not substantially alter or compromise the setting;
- **Design:** the proposed Project does not alter any of the character-defining features of the BWP campus or BWC;
- **Materials:** the proposed Project consists largely of subterranean construction and does not add any visible materials that are inconsistent with the primary materials and would not cause a substantial adverse change in the significance of a historical resource as defined in Section 15064.5;
- **Workmanship:** the proposed Project elements do not change the workmanship that is characteristic of the BWP campus or BWC;
- **Feeling:** the setting of the BWP Campus and BWC are characteristic of mid-century infrastructure and would remain unchanged by the proposed Project; and
- **Association:** the proposed Project stormwater management improvements are consistent with the original flood control purpose of the BWP campus and BWC

Sapphos Environmental, Inc. conducted a site visit of the BWP Campus and BWC on February 10, 2022 and confirmed the proposed Project would not result in a significant impact on potential historical resources. Within a 0.25-mile radius of the Project site, fourteen (14) previous surveys were completed (Table 1. *Survey Reports*). Of seven (7) resources identified in the fourteen (14) previous surveys, two (2) are located within the Project site (Table 2. *Identified Resources*). Therefore, the proposed Project would have no impact on cultural

resources as a result of causing a substantial adverse change in the significance of a historical resource as defined in Section 15064.5.

Table 1. Survey Reports

Report No.	Year	Authors	Title	Affiliation
LA-01798	1989	Singer, Clay A. and John E. Atwood	Cultural Resources Survey and Impact Report for The Proposed Burbank Gateway Center	C.A. Singer and Associates, Inc
LA-02370	1991	Dillon, Brian D.	An Archeological and Historical Cultural Resources Study of the Burbank Water Reclamation Plant Expansion Project	
LA-02950	1992	Anonymous	Consolidated Report: Cultural Resource Study for the Proposed Pacific Pipeline Project	Peak and Associates, Inc.
LA-07189	2001	Morgan, Sally Salzman	Magnolia Power Project Cultural Resources (archeological resources)	URS Corporation
LA-07190	2002	Hahn, Douglas L.	Submittal of Revised Offsite Construction Laydown Area Magnolia Power Project	URS Corporation
LA-07191	2003	Unknown	Phase 1 Environmental Site Assessment Americold Facility 10 West Magnolia	URS Corporation
LA-08255	2006	Arrington, Cindy and Nancy Sikes	Cultural Resources Final Report of Monitoring and Findings for The Qwest Network Construction Project State of California	SWCA Environmental Consultants, Inc.
LA-09485	2008	Lasick, Sheri L.	Burbank Water Reclamation Plant Equalization Basin Project, Cultural Resources Report	Sylvir Consulting, Inc.
LA-10385	2009	Bonner Wayen H. and Kathleen Crawford	Direct APE Historic Architectural Assessment for T Mobile USA Candidate SV00120A	MBA
LA-10543	2003	Gust, Sherri	Archeological Initial Study Report and Mitigation Plan for The San Fernando Valley MRT Fiber Optic Line Project, Cities of Canoga Park, Burbank, and Los Angeles.	Cogstone Resource Management Inc.
LA-10642	2010	Tang "Bai" Tom	Preliminary Historical/Archeological Resources Study, Antelope Valley Line Positive Train Control PCT Project Southern California Regional Train Rail Authority	CRM Tech
LA-11772	2012	Meyer, Donna	Seismically Retrofit Storage Facility Building, 124 S Lake Street Burbank Ca	FEMA
LA-12122	2012	Bonner, Wayne, Williams, Sarah, and Crawford, Kathleen	Cultural Resources Records Search and Site Visit Results for T Mobile West	MBA
LA-12526	2013	Ehringer, Candace, Ramirez, Katherine, and Vader, Michael	Santa Clarita Valley Sanitation District Chloride TMDL Facilities Plan Project, Phase Cultural Resource Assessment	ESA

Table 2. Identified Resources

Primary Number	Description	Within Project Site	Within Search Radius
P-19-002530	Historic Site	x	x
P-19-003348	Historic Artifact Deposit	x	x
P-19-180751	U.S. Post Office		x
P-19-180773	U.S. Post Office		x
P-19-186688	Union Pacific Rail Road Wye and Rail Spurs		x
P-19-186689	Historic Site		x
P-19-188507	Commercial Building		x

- b) **Less than Significant with Mitigation.** While the Project site was fundamentally altered in the 1950s with respect to archaeological deposits through historic era development and previous ground-disturbing activities, construction of the Project could result in an unanticipated discovery of unknown archaeological resources as well as human remains. To ensure any such impacts to these resources are reduced to a less-than-significant level, the following measure shall be implemented by the Burbank Water & Power Department and Project contractor:

Mitigation Measure CUL-1. If an archaeological cultural resource is identified, work on the Project site shall cease immediately until a resource protection plan conforming to CEQA Guidelines Section 15064.5(e) is prepared by a qualified archaeologist and approved by the Community Development Director. Project work may be resumed in compliance with such plan. If human remains are encountered, the County Coroner shall be contacted immediately.

- c) **Less than Significant.** Based upon a review of historic topographic maps and aerial photographs there are no recorded formal cemeteries at the Project site. Similarly, there are no historic land uses typically associated with informal burials, such as hospitals or homestead sites, at the Project site that precede construction of the BWP Campus and the BWC. In addition, the depth of excavation required for the stormwater improvements that comprise the proposed Project would require a maximum depth of excavation of approximately 14 feet, which should be entirely within the area disturbed during the construction of the BWP campus and BWC; therefore, it not anticipated that human remains would be encountered. In the unanticipated event that human remains are encountered during construction, there shall be no further excavation or disturbance of the site or any nearby area reasonably suspected to overlie adjacent remains until the Los Angeles County Coroner determines, in accordance with Chapter 10 (commencing with Section 27460) of Part 3 of Division 2 of Title 3 of the Government Code , that the remains are not subject to the provisions of Section 27491 of the Government Code or any other related provisions of law concerning investigation of the circumstances, manner and cause of any death, and the recommendations concerning the treatment and disposition of the human remains have been made to the person responsible for the excavation, or to his or her authorized representative, in the manner provided in Section 5097.98 of the Public Resources Code. The coroner shall make his or her determination within two working days from the time the person responsible for the excavation, or his or her authorized representative, notifies the coroner of the discovery or recognition of the human remains. Therefore, in the unanticipated event of the discovery of human remains, conformance with the provisions of California Code, Health and Safety Code - HSC § 7050.5 and Chapter 10 (commencing with Section 27460) of Part 3 of Division 2 of Title 3 of the Government

Code shall ensure that such remain are properly repatriated or reinterred, and thus impact would be less than significant.

References

- City of Burbank. 2013. *Burbank2035* General Plan. Adopted February 19, 2013. Accessed September 27, 2021. Available at:
<https://www.burbankca.gov/documents/173607/0/The+Burbank2035+General+Plan.pdf/139656b0-80e9-3b11-dc6d-751642c85b38?version=1.2&t=1616616954424&imagePreview=1>
- Los Angeles County Flood Control District. Burbank Channel – Burbank Western System. Asset No. F02000118. Available at: <https://pw.lacounty.gov/fcd/StormDrain/index.cfm>
- NetroOnline. Historic Aerials. Accessed May 20, 2021. Available at:
<https://historicaerials.com/viewer>

Energy

	Potentially Significant Impact	Less than Significant with Mitigation Incorporated	Less than Significant Impact	No Impact
VI. ENERGY – Would the project:				
a) Result in potentially significant environmental impact due to wasteful, inefficient, or unnecessary consumption of energy resources, during project construction or operation?	<input type="checkbox"/>	<input type="checkbox"/>	<input checked="" type="checkbox"/>	<input type="checkbox"/>
b) Conflict with or obstruct a state or local plan for renewable energy or energy efficiency?	<input type="checkbox"/>	<input type="checkbox"/>	<input type="checkbox"/>	<input checked="" type="checkbox"/>

Discussion

- a) **Less than Significant Impact.** The City of Burbank General Plan Conservation Element includes goals and policies to conserve energy, use alternative energy resources, and promote sustainable energy practices that reduce pollution and fossil fuel consumption (City of Burbank, 2013). Construction of the proposed Project would require the temporary use of energy, including electricity and carbon-based fuels, for construction equipment. The temporary use electric power would be required for lighting, and electrically powered hand tools. The majority of energy that would be petroleum and diesel-fuels used for on-road vehicles and off-road construction equipment. Construction workers would travel to and from the Project site throughout the duration of construction. Heavy-duty construction equipment associated with construction activities, vendor trucks, and haul trucks would rely on diesel fuel. The amount of electricity used for construction would be temporary and minimal. Natural gas is not anticipated to be required for the construction of the proposed Project. There would also be vehicle miles traveled (VMT) associated with the transportation of construction materials and construction worker commutes which would also result in petroleum consumption. The use of construction equipment is necessary to complete the required stormwater management improvements; therefore, it does not constitute an inefficient or wasteful use of energy. Operation of the proposed Project would not result in any additional energy usage, and maintenance activities would not differ from existing conditions. Additionally, no habitable or other structures would be constructed as part of the proposed Project that would result in additional energy consumption. Therefore, impacts would be less than significant.
- b) **No Impact.** The proposed Project would not conflict with any adopted state or local plans related to use of renewable energy or energy efficiency, including the State Renewable Portfolio Standards (California Energy Commission, 2020); 2019 Building Energy Efficiency Standards for Residential and Nonresidential Buildings (California Energy Commission, 2019); Southern California Association of Governments (SCAG) Sustainable Communities Strategy (SCS) Goals and Policies for Energy Efficiency (Southern California Association of Governments, 2008); or the City of Burbank General Plan Conservation Element (City of Burbank, 2013). The proposed Project does not involve construction of habitable structures that would involve consumptive use of energy consumption during operation of the proposed Project. Similarly, the stormwater improvements would involve passive flows and not necessitate consumptive use of energy. The operation and maintenance of the facilities, involves operating and maintaining relocated stormwater conveyance facilities, and would not

increase per capita vehicle miles travelled. Therefore, there would be no conflict with or obstruction of a state or local plan for renewable energy or energy efficiency.

References

California Energy Commission. 2020. “Renewables Portfolio Standards.” Accessed September 28, 2021. Available at: <https://www.energy.ca.gov/programs-and-topics/programs/renewables-portfolio-standard>

———. 2019. 2019 Building Energy Efficiency Standards. Available at: <https://www.energy.ca.gov/programs-and-topics/programs/building-energy-efficiency-standards/2019-building-energy-efficiency>

City of Burbank. 2013. *Burbank2035* General Plan. Adopted February 19, 2013. Accessed September 27, 2021. Available at: <https://www.burbankca.gov/documents/173607/0/The+Burbank2035+General+Plan.pdf/139656b0-80e9-3b11-dc6d-751642c85b38?version=1.2&t=1616616954424&imagePreview=1>

Southern California Association of Governments. 2008. *Regional Comprehensive Plan*. Accessed September 28, 2021. Available at: <http://scag.ca.gov/NewsAndMedia/Pages/RegionalComprehensivePlan.aspx>

Geology and Soils

	Potentially Significant Impact	Less than Significant with Mitigation Incorporated	Less than Significant Impact	No Impact
VII. GEOLOGY AND SOILS -- Would the project:				
a) Directly or indirectly cause potential substantial adverse effects, including the risk of loss, injury, or death involving:				
i) Rupture of a known earthquake fault, as delineated on the most recent Alquist-Priolo Earthquake Fault Zoning Map issued by the State Geologist for the area or based on other substantial evidence of a known fault? Refer to Division of Mines and Geology Special Publication 42.	<input type="checkbox"/>	<input type="checkbox"/>	<input checked="" type="checkbox"/>	<input type="checkbox"/>
ii) Strong seismic ground shaking?	<input type="checkbox"/>	<input type="checkbox"/>	<input checked="" type="checkbox"/>	<input type="checkbox"/>
iii) Seismic-related ground failure, including liquefaction?	<input type="checkbox"/>	<input type="checkbox"/>	<input checked="" type="checkbox"/>	<input type="checkbox"/>
iv) Landslides?	<input type="checkbox"/>	<input type="checkbox"/>	<input type="checkbox"/>	<input checked="" type="checkbox"/>
b) Result in substantial soil erosion or the loss of topsoil?	<input type="checkbox"/>	<input type="checkbox"/>	<input checked="" type="checkbox"/>	<input type="checkbox"/>
c) Be located on a geologic unit or soil that is unstable, or that would become unstable as a result of the project, and potentially result in on- or off-site landslide, lateral spreading, subsidence, liquefaction, or collapse?	<input type="checkbox"/>	<input type="checkbox"/>	<input checked="" type="checkbox"/>	<input type="checkbox"/>
d) Be located on expansive soil, as defined in Table 18-1-B of the Uniform Building Code (1994), creating substantial risks to life or property?	<input type="checkbox"/>	<input type="checkbox"/>	<input checked="" type="checkbox"/>	<input type="checkbox"/>
e) Have soils incapable of adequately supporting the use of septic tanks or alternative waste water disposal systems where sewers are not available for the disposal of waste water?	<input type="checkbox"/>	<input type="checkbox"/>	<input type="checkbox"/>	<input checked="" type="checkbox"/>
f) Directly or indirectly destroy a unique paleontological resource or site or unique geologic feature?	<input type="checkbox"/>	<input checked="" type="checkbox"/>	<input type="checkbox"/>	<input type="checkbox"/>

Discussion

- a.i) Less than Significant Impact.** The Alquist-Priolo Earthquake Fault Zoning Act requires the State of California to map areas of high risk for surface fault rupture. This law prohibits locating structures designed for human occupancy on top of the surface traces of active faults, thereby reducing the loss of life and property from an earthquake. Southern California, including the Project site, is subject to the effects of seismic activity due to active faults that traverse the region. Act. According to the Safety Element of the General Plan, there are no Alquist-Priolo Earthquake Fault Zones designated within Burbank (City of Burbank, 2013). The closest Alquist-Priolo Earthquake Fault Zone to the Project site is the Sierra Madre Fault Zone, located to the northeast. Therefore, impacts related to ground rupture would be less-than-significant.

- a.ii) Less than Significant Impact.** Ground shaking is motion that occurs as a result of energy released during an earthquake and has the ability to damage or destroy important city infrastructure.

Although regional faults near Burbank would likely not cause a surface rupture in Burbank, a seismic event on any nearby faults, especially the Sierra Madre Fault, could cause ground shaking at the Project site and region that could cause damage in structures, especially older structures built to older standards (City of Burbank, 2013). However, the Project would be designed and constructed in conformance with all applicable design standards, including in accordance with the City's *Burbank2035* General Plan Safety Element, City Building Code, and the County's seismic safety standards and construction recommendations included Oakridge Geosciences soils report (2018). With conformance to current seismic design standards and recommendations contained in the Oakridge Report, the Project would be feasible from a geotechnical standpoint in regard to strong ground shaking. This impact would be less-than-significant.

- a.iii) Less than Significant Impact.** Liquefaction is a process by which sediments below the water table temporarily lose strength and behave as a viscous liquid rather than a solid. Liquefaction typically occurs in areas where the soils below the water table are composed of poorly consolidated, fine to medium-grained primarily sandy soil. The California Department of Conservation identifies the BWP campus as fully within a Liquefaction Zone (California Department Conservation, 2018), as much of the City of Burbank is located atop soils susceptible to liquefaction (City of Burbank, 2013). However, while the site is expected to experience ground-shaking and earthquake activity typical of the Southern California region, the Project soils report does not identify a significant hazard with respect to liquefaction (Oakridge Geosciences, 2018). The City's *Burbank2035* General Plan Safety Element states that, except in some areas along the Ventura Freeway (SR 134) in the southwestern portion of the city, most groundwater underlying Burbank is deeper than 100 feet below the ground surface. Thus, although the proposed Project site is located within a liquefaction zone, groundwater levels in Burbank can be expected to remain deeper than 50 feet, resulting in a low risk of liquefaction for most of the city (City of Burbank, 2013). Additionally, the proposed Project consists of stormwater drainage improvements to the existing BWP campus. The proposed project would not introduce new residents, businesses, or structures to the area, as it is already highly urbanized and currently used. Therefore, the proposed Project would not expose people or structures to greater effects of liquefaction than they are currently exposed to. Furthermore, the Project would be designed to be compliant with the most current safety standards to minimize effects from seismic activity, including liquefaction. This impact would be less-than-significant.

- a.iv) No Impact.** Landslide hazards are related to both slope and seismic activity. A landslide is the downhill movement of masses of earth material under the force of gravity. Factors contributing to landslide potential are steep slopes, unstable terrain, and proximity to earthquake faults. The Project site and surrounding area are developed and relatively flat, making the possibility for landslides very low. Additionally, the proposed Project site is not located in a zone mapped by the City's *Burbank2035* General Plan Safety Element as susceptible to earthquake-induced landslides (City of Burbank, 2013). Therefore, development of the Project would not result in significant impacts associated with the exposure of people or structures to potential substantial adverse effects involving landslides.

- b) **Less than Significant Impact.** Project construction would include grading and limited earthmoving activities at the site that could expose site soils to erosion from heavy winds, rainfall, or runoff. The proposed Project would be required to comply with the National Pollution Discharge Elimination System (NPDES) Construction General Permit, which would require the preparation and implementation of a Stormwater Pollution Prevention Plan (SWPPP) and associated Best Management Practices (BMPs) to minimize or eliminate sediment and soils discharged from the Project site. With adherence to these standards, no impact would result with respect to this topic.
- c) **Less than Significant Impact.** As stated above, the Project site is located within a developed area of the city and has a relatively flat topography. The proposed Project would be designed to be compliant with the City’s *Burbank2035* General Plan Safety Element and Building Code, the County’s seismic safety standards, and site-specific design recommendations included in the Project soils report (Oakridge Geosciences, 2018) to minimize the effects of seismic activity. The drainage improvements would be minimal additions to the existing BWP campus in highly urbanized area. These improvements would not result in greater instability than it is currently exposed to that may result in result in on- or off-site landslide, lateral spreading, subsidence, liquefaction, or collapse. Further, since the proposed drainage improvements would not be occupied by visitors or residents, no injury or loss of life would occur. This impact would therefore be less than significant.
- d) **Less than Significant Impact.** According to the Focused Geotechnical Investigation prepared for the Project, the soils underlain the Project site are considered to have very low potential for expansion (Oakridge Geosciences, 2018). Further, the Project would be designed in accordance with recommendations included in the geotechnical report (Oakridge Geosciences, 2018). This impact would be less than significant.
- e) **No Impact.** The Project would not generate any wastewater so it would require a connection to the City’s wastewater system or require use of a septic system. No impacts would result.
- f) **Less than Significant with Mitigation.** While the Project site is disturbed due to existing development and previous ground disturbing activities, construction of the Project could result in the inadvertent discovery of unknown paleontological or geological resources. To ensure any such impacts to these resources are reduced to a less-than-significant level, the following measure shall be implemented by the Burbank Water & Power Department and Project contractor:

Mitigation Measure GEO-1. If a paleontological resource is identified, work on the Project site shall cease immediately until a resource protection plan conforming to CEQA Guidelines Section 15064.5(e) is prepared by a qualified paleontologist and approved by the Community Development Director. Project work may be resumed in compliance with such plan.

References

California Department of Conservation and California Geological Survey. January 10, 2018. “DOC Maps: Geology Hazards – Seismic Hazard Zones; Liquefaction.” Accessed May 24, 2021.

City of Burbank. 2013. *Burbank2035* General Plan. Adopted February 19, 2013. Accessed September 27, 2021. Available at:
<https://www.burbankca.gov/documents/173607/0/The+Burbank2035+General+Plan.pdf/139656b0-80e9-3b11-dc6d-751642c85b38?version=1.2&t=1616616954424&imagePreview=1>

Oakridge Geosciences, Inc. 2016. Focused Geotechnical Report. Available at: Ecocampus NPDES Compliance Feasibility Study Project Burbank Water and Power.

Greenhouse Gas Emissions

	Potentially Significant Impact	Less than Significant with Mitigation Incorporated	Less than Significant Impact	No Impact
VIII. GREENHOUSE GAS EMISSIONS -- Would the project:				
a) Generate greenhouse gas emissions, either directly or indirectly, that may have a significant impact on the environment?	<input type="checkbox"/>	<input type="checkbox"/>	<input checked="" type="checkbox"/>	<input type="checkbox"/>
b) Conflict with an applicable plan, policy, or regulation adopted for the purpose of reducing the emissions of greenhouse gases?	<input type="checkbox"/>	<input type="checkbox"/>	<input checked="" type="checkbox"/>	<input type="checkbox"/>

Discussion

- a) **Less than Significant Impact.** Greenhouse gas (GHG) emissions from human activity are implicated in global climate change or global warming. The principal GHGs are carbon dioxide (CO₂), methane (CH₄), nitrogen oxides (NOX), ozone, water vapor, and fluorinated gases (hydrofluorocarbons, perfluorocarbons, and sulfur hexafluoride). No long-term operational greenhouse gas impacts are anticipated as a result of the Project since there would be no operational vehicle trips resulting from the Project improvements, since the Project is limited to drainage and water quality improvements. As such, there are also no operational (stationary-source) greenhouse gas sources anticipated as a result of the Project improvements since they would be constructed underground.

As shown on Table 3-3 of the Urban Crossroads GHG Report (see Attachment 2 of this Initial Study), the Project has the potential to generate a total of approximately 3.00 MTCO₂e per year from construction. As such, the Project would not exceed the South Coast Air Quality Management District's (SCAQMD) recommended numeric threshold of 3,000 MTCO₂e. Thus, the proposed Project would result in a less than significant impact with respect to GHG emissions.

- b) **Less than Significant Impact.** Greenhouse gas (GHG) emissions from human activity are implicated in global climate change or global warming. The principal GHGs are CO₂, CH₄, NOX, ozone, water vapor, and fluorinated gases (hydrofluorocarbons, perfluorocarbons, and sulfur hexafluoride).

The City's *Burbank2035* General Plan includes the following policy to deal with greenhouse gas emissions reduction:

- **Policy 3.4 (partial):** Reduce greenhouse gas emissions from new development by promoting water conservation and recycling.

On February 19, 2013, the City of Burbank adopted a Greenhouse Gas Reduction Plan as part of the *Burbank2035* General Plan. The Greenhouse Gas Reduction Plan (Plan) identifies a number of State actions adopted to reduce future emissions of greenhouse gasses, including but not limited to AB 32, AB 1493, SB 1078 and AB 1109.

The City's Greenhouse Gas Reduction Plan is a programmatic plan to respond to State mandates by identifying a number of specific steps to reduce future GHG emissions. The Plan anticipates a 6.7% reduction in the emission of GHGs by the City in the year 2020 over "business as usual" emissions and a 6.5 reduction of GHG emissions over "business as usual" in 2015.

The Plan identifies a number of actions to be taken by the City of Burbank to assist in GHG reduction. A number of these action identified in the Plan applicable to the Project include:

- Program E-1.6 BWP: Energy Conservation. The Department is anticipated to reduce GHGs through a series of conservation measures that would likely involve the Project.
- Program W-1.3: Stormwater Master Plan. The Project would be an element in reducing polluted runoff into the BWP
- Program SW-1.3: Lumber Diversion Ordinance: Lumber used for concrete forms and other uses would be recycled instead of diverted to the local landfill.

There would be no long-term operational emission of greenhouse gasses, since there would be no structures that would generate traffic or involve industrial processes that would generate GHGs. Short-term GHG emissions would be generated by Project construction but would be limited to a less-than-significant level by adherence to the City's Greenhouse Gas Reduction Plan and General Plan Policies 1.6 and 1.7.

The proposed Project would not include any elements that could conflict with the City's Greenhouse Reduction Plan, Regional, State or Federal plans or regulation involving greenhouse gasses.

References

- City of Burbank. 2013. *Burbank2035* General Plan. Adopted February 19, 2013. Accessed September 27, 2021. Available at:
<https://www.burbankca.gov/documents/173607/0/The+Burbank2035+General+Plan.pdf/139656b0-80e9-3b11-dc6d-751642c85b38?version=1.2&t=1616616954424&imagePreview=1>
- . 2013. Burbank Greenhouse Gas Reduction Plan. Adopted February 19, 2013. Accessed October 8, 2021. Available at:
https://www.burbankca.gov/documents/173607/240353/02192013_Burbank_Greenhouse_Gas_Reduction_Plan.pdf/39624e2e-ef46-b6a5-81fc-45b3f4c4c819?version=1.0&t=1616021724684&imagePreview=1

Hazards and Hazardous Materials

	Potentially Significant Impact	Less than Significant with Mitigation Incorporated	Less than Significant Impact	No Impact
IX. HAZARDS AND HAZARDOUS MATERIALS – Would the project:				
a) Create a significant hazard to the public or the environment through the routine transport, use, or disposal of hazardous materials?	<input type="checkbox"/>	<input type="checkbox"/>	<input type="checkbox"/>	<input checked="" type="checkbox"/>
b) Create a significant hazard to the public or the environment through reasonably foreseeable upset and accident conditions involving the release of hazardous materials into the environment?	<input type="checkbox"/>	<input checked="" type="checkbox"/>	<input type="checkbox"/>	<input type="checkbox"/>
c) Emit hazardous emissions or handle hazardous or acutely hazardous materials, substances, or waste within one-quarter mile of an existing or proposed school?	<input type="checkbox"/>	<input type="checkbox"/>	<input type="checkbox"/>	<input checked="" type="checkbox"/>
d) Be located on a site which is included on a list of hazardous materials sites compiled pursuant to Government Code Section 65962.5 and, as a result, would it create a significant hazard to the public or the environment?	<input type="checkbox"/>	<input checked="" type="checkbox"/>	<input type="checkbox"/>	<input type="checkbox"/>
e) For a project located within an airport land use plan or, where such a plan has not been adopted, within two miles of a public airport or public use airport, would the project result in a safety hazard for people residing or working in the Project area?	<input type="checkbox"/>	<input type="checkbox"/>	<input type="checkbox"/>	<input checked="" type="checkbox"/>
f) Impair implementation of or physically interfere with an adopted emergency response plan or emergency evacuation plan?	<input type="checkbox"/>	<input type="checkbox"/>	<input type="checkbox"/>	<input checked="" type="checkbox"/>
g) Expose people or structures to a significant risk of loss, injury, or death involving wildland fire?	<input type="checkbox"/>	<input type="checkbox"/>	<input type="checkbox"/>	<input checked="" type="checkbox"/>

Discussion

- a) **No Impact.** A hazardous material is defined as any material that, due to its quantity, concentration, or physical or chemical characteristics, poses a significant present or potential hazard to human health and safety or to the environment if released into the environment. Construction activities would require the use of certain hazardous materials such as fuels, oils, solvents, and adhesives. The proposed Project would involve a number of related drainage improvements at the City of Burbank’s BWP Campus to improve local surface water quality. There would be no transport, use, or disposal of hazardous materials during operation of the proposed Project. No impacts would result.
- b, d) **Less than Significant with Mitigation.** The Project site has been used as a power generating facility for a number of years. Properties to the north and west are used for industrial purposes. It is likely that current and historic uses of the area could have deposited hazardous and potentially hazardous materials into the local soil and/or groundwater. Such contamination could include but may not be limited to petroleum products, solvents, paints, and other chemical compounds. Construction of the proposed Project could release potentially hazardous

materials into the environment as a result of trenching, grading and related ground disturbing activities. The following measure shall be implemented prior to commencement of ground disturbing activities to ensure this impact would be less-than-significant:

Mitigation Measure HAZ-1. Prior to commencement of ground disturbing activities, a Phase I Environmental Site Assessment shall be completed by a qualified consulting firm as determined by BWP staff to determine possible presence of contaminated compounds or materials in the soil or groundwater near excavated or trenched areas. If such materials are identified, additional analysis, including soil testing, to determine the extent of any potential contamination. If needed, a remediation plan shall be prepared and implemented under the oversight of the Regional Water Quality Control Board. Grading and trenching operations may commence after clearances are granted by the appropriate regulatory agency.

- c) **No Impact.** There are no schools located within one-quarter mile of the Project site and the closest school is Disney Elementary School, located approximately one mile southwest of the Project site. Further, the surrounding area is designated as General Industrial uses on the Burbank2035 General Plan, which does not support school uses. Therefore, the Project would not emit hazardous emissions or handle hazardous or acutely hazardous materials, substances, or waste within one-quarter mile of an existing or proposed school. There would be no impact with respect to this topic.
- e) **No Impact.** Although the Project site is located southeast of Hollywood-Burbank Airport, no habitable structures would be built that would cause any impacts to safety or obstructions to aircraft operations. All Project facilities would be located underground. There would be no impact with respect to this topic.
- f) **No Impact.** Proposed drainage improvements to be constructed as part of the Project would not require access by emergency vehicles, since there would be no residents or visitors occupying Project improvements. Access to drainage facilities would be provided on the site of the BWP campus or via local streets. No impact would result with respect to this topic.
- g) **No Impact.** None of the proposed underground drainage or water quality improvements would be subject to wildland or urban fires, so that there would be no impact with respect to this topic.

References

City of Burbank. 2013. *Burbank2035* General Plan. Adopted February 19, 2013. Accessed September 27, 2021. Available at:
<https://www.burbankca.gov/documents/173607/0/The+Burbank2035+General+Plan.pdf/139656b0-80e9-3b11-dc6d-751642c85b38?version=1.2&t=1616616954424&imagePreview=1>

Hydrology and Water Quality

	Potentially Significant Impact	Less than Significant with Mitigation Incorporated	Less than Significant Impact	No Impact
X. HYDROLOGY AND WATER QUALITY --				
Would the project:				
a) Violate any water quality standards or waste discharge requirements or otherwise substantially degrade surface or groundwater quality?	<input type="checkbox"/>	<input type="checkbox"/>	<input type="checkbox"/>	<input checked="" type="checkbox"/>
b) Substantially decrease groundwater supplies or interfere substantially with groundwater recharge such that the project may impede sustainable groundwater management of the basin?	<input type="checkbox"/>	<input type="checkbox"/>	<input checked="" type="checkbox"/>	<input type="checkbox"/>
c) Substantially alter the existing drainage pattern of the site or area, including through the alteration of the course of a stream or river or through the addition of impervious surfaces, in a manner which would:				
i) result in substantial erosion or siltation on- or off-site;				
ii) substantially increase the rate or amount of surface runoff in a manner which would result in flooding on- or off-site;	<input type="checkbox"/>	<input type="checkbox"/>	<input checked="" type="checkbox"/>	<input type="checkbox"/>
iii) create or contribute runoff water which would exceed the capacity of existing or planned stormwater drainage systems or provide substantial additional sources of polluted runoff; or	<input type="checkbox"/>	<input type="checkbox"/>	<input checked="" type="checkbox"/>	<input type="checkbox"/>
iv) impede or redirect flows?	<input type="checkbox"/>	<input type="checkbox"/>	<input checked="" type="checkbox"/>	<input type="checkbox"/>
d) In flood hazard, tsunami, or seiche zones, risk release of pollutants due to project inundation?	<input type="checkbox"/>	<input type="checkbox"/>	<input type="checkbox"/>	<input checked="" type="checkbox"/>
e) Conflict with or obstruct implementation of a water quality control plan or sustainable groundwater management plan?	<input type="checkbox"/>	<input type="checkbox"/>	<input type="checkbox"/>	<input checked="" type="checkbox"/>

Discussion

- a) **No Impact.** This Project is located within an area that is in the jurisdiction of the Los Angeles Regional Water Quality Control Board (LARWQCB), for management of water quality pursuant to the Basin Plan for the Coastal Watersheds of Los Angeles and Ventura Counties (Los Angeles Basin Plan, 2014). Recent investigation of surface water quality by the firm of MNS Engineering indicated that stormwater running onto the BWP Campus exceeds the numeric action levels (NALs) for oil and grease, iron, zinc, and copper per the National Pollutant Discharge Elimination System (NPDES) Industrial General Permit (IGP) Order 2014-0057-DWQ (MNS, 2018). Concentrations of contaminants in stormwater discharged from the BWP Campus to the BWC exceeds the NALs for iron, zinc, and copper, as well as a one-time pH exceedance. For all sampling dates, the concentrations of zinc were higher in stormwater discharged from the BWP Campus to the BWC than stormwater running onto the campus from outside sources, indicating that the campus contributes to zinc concentrations. Data for other contaminants, including oil and grease, iron, copper,

cadmium, and lead, are inconclusive as to the source (MNS, 2018). The purpose of the Project is to improve localized drainage and water quality through installation of water quality filters and other devices prior to outfall into the BWC. In 2018, MNS Engineers and Burbank Water and Power (BWP) prepared the NPDES Compliance Stormwater Quality Improvement Options Feasibility Study. The BWP Campus currently experiences water quality issues and stormwater runoff issues such that they are not in compliance with existing water quality and waste discharge standards established by the IGP numeric limits (MNS, 2018). Current data shows that concentrations of contaminants in stormwater are in exceedance of the IGP numeric limits water quality standards; thus, the feasibility study analyzed options that would improve the water quality. The feasibility study analyzed 12 Project design alternatives that would improve the water quality and runoff of the proposed Project site. Based on this analysis, the feasibility study recommended combined storage and reuse with infiltration and off-site diversion for the 24-hour 85th percentile storm event. Similar to this recommendation, the proposed Project would include on-site drainage improvements that would divert and filter flows up to the 85th percentile, 24-hour storm event, and subsequently use or infiltrate the treated stormwater. The system would have the capacity to renew its capacity to accept a 24-hour 85th percentile storm event within 24 hours of the discharge, and the existing outfall would continue to be used to discharge flows above the 85th percentile, 24-hour storm event. Therefore, the alternative that was analyzed to be the best Project design that would result in improvements to water quality and stormwater runoff would be implemented under the proposed Project; thus, the proposed Project would improve water quality and stormwater runoff, consistent with the water quality goals and objectives articulated in the Basin Plan. One of the primary purposes of the Project is to meet current water quality requirements adopted by the LARWQCB by redirecting stormwater runoff and adding filtration systems to ensure that all applicable waste discharge requirements are met. Therefore, water quality would be improved after implementation of the Project and there would be no impact as a result of violation of any water quality standards or waste discharge requirements or any other degradation of surface or groundwater quality.

- b) **Less than Significant Impact.** As discussed in Section 1, *Project Description*, site preparation and grading would take approximately 3 working days (please see Table 1, *Anticipated Construction Equipment*). Dust control would be accomplished by using a water truck to spray down exposed areas. It is anticipated that a single 5,000-gallon water truck would be deployed each day. Given 3 working days with 5,000 gallons of water used each day, 15,000 total gallons of water would be required for Project construction. There are 10 licensed water haulers in Los Angeles County that would be able to provide this water (Los Angeles County Department of Public Health).

According to the City's *Urban Water Management Plan* (UWMP, 2021), the City of Burbank extracts its groundwater from the San Fernando Basin (SFB). The SFB underlies the city, including the Project site. One of the purposes of the Project is to redirect stormwater runoff from an existing outfall into the nearby BWC to an infiltration field on the BWP Campus. The proposed Project would implement storm water capture system that would divert an average of 8.2 million gallons per year of storm water from the BWC for filtration, assuming average rainfall of 16.3 inches per year. The treated storm water would either be used for cooling tower make-up water or infiltrated into the ground, or a combination of the two. Therefore, as captured stormwater is infiltrated, then the amount of local high-quality infiltration would be increased, and the proposed Project would not decrease groundwater supplies nor interfere with

sustainable groundwater management. Both the reuse and infiltration maintain or improve existing levels of regional groundwater recharge. As construction of the Project would not require use of groundwater, and the operation and maintenance of the Project would sustain or improve regional groundwater recharge, the Project would have no impact on hydrology or water quality resulting from substantially depleting or decreasing groundwater supplies or substantial interference with groundwater recharge such that the Project may impede sustainable groundwater management of the basin.

- c.i) Less than Significant Impact.** The Project site is located within an urban area of the city and is fully paved with asphalt. Existing storm drains are located within the roadways surrounding the Project site and on the BWP Campus of the power station. Construction of the proposed Project would include earthmoving activities, such as grading, excavation, and trenching. The proposed Project may produce sediment created by soil disturbance during or immediately after construction. Construction activities such as excavation, grading, and trenching would temporarily disturb the ground surface of the Project area and could result in erosion if not properly controlled and repaired. However, this would not result in substantial erosion or siltation on- or off-site, as these potential pollutants are regulated under the National Pollutant Discharge Elimination System (NPDES) General Permit. As stated in the Project Description, the required approvals for the proposed Project site include the NPDES Construction General Permit and Industrial General Permit, which require a Stormwater Pollution Prevention Plan (SWPPP) in order to obtain the permits (EPA, 2007). A SWPPP is a site-specific document that identifies the potential sources of pollution and plans the steps that will be taken to prevent pollution. The SWPPP will identify Best Management Practices (BMPs) that will prevent the proposed Project from erosion or siltation and protect water quality during construction. In addition to the SWPPP and BMPs, the geotechnical report prepared for the proposed Project states that projects such as these can become clogged with sediment or other debris over time; therefore, a maintenance program that addressed sediments would also be required for development and implementation as a part of the Project design. Therefore, the proposed Project would result in less than significant impacts on hydrology and water quality in relation to erosion and siltation.
- c.ii) Less than Significant Impact.** The Project site is located within an urban area of the city and is fully paved with asphalt. Existing storm drains are located within the roadways surrounding the Project site and on the BWP Campus of the power station. The proposed design will improve drainage and separate local urban runoff from industrial runoff, facilitate collection and treatment of industrial runoff, reduce the total drainage area utilizing the storm drain by 50-percent, and improve local catch basin inlets to the maximum permissible capacities permitted to be discharged to the BWC. The Project design also includes an underground vault with a volume of 37,000 cubic feet that would collect stormwater runoff up to the 24-hour 85-percentile storm event, which would prevent flooding in other areas on- or off-site rather than induce flooding. Thus, rather than increasing runoff, the proposed Project would make drainage improvements that would contain runoff volume and improve runoff quality. Rather than substantially increasing the rate or amount of surface runoff in a manner which would result in flooding on- or off-site, the drainage patterns in the Project area would be improved upon over their current conditions in that stormwater runoff would be reduced and infiltration increased. Therefore, the proposed Project would have a beneficial effect on drainage patterns in the city and

would result in less than significant impact on hydrology or water quality in relation to inducing on-site or off-site flooding.

- c.iii) Less than Significant Impact.** The Project site is located within an urban area of the city and is fully paved with asphalt. Existing storm drains are located within the roadways surrounding the Project site and on the BWP Campus. The proposed design will improve drainage and separate local urban runoff from industrial runoff, facilitate collection and treatment of industrial runoff, reduce the total drainage area utilizing the storm drain by 50 percent, and improve local catch basin inlets to the maximum permissible capacities permitted to be discharged to the BWC. The Project design also includes an underground vault with a volume of 37,000 cubic feet that would collect stormwater runoff up to the 24-hour 85-percentile storm event, which would prevent flooding in other areas on- or off-site. The Project would not result in the alteration of the Project site's existing topography or overall drainage pattern but would serve to reduce the quantity of stormwater leaving the Project site. The stormwater capture system would, on average, divert 8.2 million gallons per year of stormwater from the BWC, assuming average rainfall of 16.3 inches per year. The system would have the capacity to accept a 24-hour, 85th percentile storm event within 24 hours of the discharge, and the existing outfall would continue to be used to discharge flows above the 85th percentile, 24-hour storm event. There would be no potential to exceed the existing storm drain system since the drainage system would be engineered to accommodate the maximum flows from the Project site. Thus, rather than creating or contributing runoff which would exceed the capacity of the stormwater drainage systems, the proposed Project would improve the existing stormwater drainage systems to increase their capacity. Further, the proposed Project would not provide substantial sources of polluted runoff, as its purpose is to manage the existing runoff in order to filter stormwater and improve water quality. The drainage patterns in the Project area would be improved upon over their current conditions in that stormwater runoff would be reduced and infiltration increased. Therefore, the proposed Project would have a beneficial effect on drainage patterns in the city and would result in less than significant impacts in relation to runoff which would exceed the capacity of existing or planned stormwater drainage systems or provide substantial additional sources of polluted runoff.
- c.iv) Less than Significant Impact.** The proposed Project site is the BWP Campus which currently experiences water quality issues and stormwater runoff issues such that they are not in compliance with existing water quality and waste discharge standards established by the IGP numeric limits (MNS, 2018). Current data shows that concentrations of contaminants in stormwater are in exceedance of standards; thus, the 2018 feasibility study analyzed options that would improve the water quality. The 12 Project design alternatives that were analyzed to improve the water quality and runoff of the proposed Project site require the existing runoff flows to be impeded and/or redirected. However, while the proposed Project would alter the drainage on- and off-site such that flows would be impeded or redirected, the construction of these measures would be improvements in order to address the existing water quality and runoff concerns. As previously stated, the Project design was analyzed in the 2018 feasibility study as the best outcome and was determined to improve water quality and runoff. By combining multiple technologies such as diversion, filtration, infiltration, and reuse, the feasibility study states that the Project design would reduce the likelihood of runoff remaining in violation of water quality standards. Thus, while the proposed Project would impede and redirect flows, these improvements would have beneficial effect on drainage patterns in the city and would not result in a significant adverse

impact. Therefore, the proposed Project would result in less than significant impacts on hydrology and water quality, as a result of redirecting flows.

- d) **No Impact.** The Project site is located within an urban area of the city that is distanced from the ocean and other bodies of water. The proposed Project site is located outside of the area mapped as a tsunami hazard area by the California Department of Conservation and California Geological Survey. The nearest tsunami hazard area is approximately 15 miles south west (California Department of Conservation, 2019). Seismic activity may cause inundation by a seismically induced wave, called a seiche. As stated in the *Burbank2035* General Plan, there are three reservoirs upstream from the City of Burbank which impound water susceptible to seiche. However, these reservoirs are not large enough to result in considerable risk of inundation in Burbank that would result from failure of any of the facilities (City of Burbank, 2013). With regard to flood zones, as shown in the *Burbank2035* General Plan, the proposed Project site is not located within a FEMA 100-year or 500-year flood zone. Thus, the proposed Project site is not at risk of inundation due to flooding of the nearby Burbank Western Channel or Lockheed Channel. Thus, the proposed Project is not at risk of inundation due to tsunami, seiche, or flood that would release pollutants. Additionally, while the proposed Project includes improvements which would store water in an underground vault, this would prevent flooding in other areas on- or off-site rather than induce flooding. The system is designed to have the capacity to accept a 24-hour, 85th percentile storm event within 24 hours of the discharge, and should the storm event exceed this threshold, the existing outfall would continue to be used to discharge flows above the 85th percentile, 24-hour storm event. Rather than risk inundation and the release of pollutants, the proposed Project would filter runoff before being stored for the purposes of reducing runoff volume. and infiltration increased. Therefore, the proposed Project would result in less than significant impacts on hydrology and water quality, in relation to release of contaminants from inundation caused by tsunami, seiche, or flooding events.
- e) **No Impact.** The proposed Project is subject to the regulatory authority of the Los Angeles Regional Water Quality Control Board, which is administered pursuant to the Los Angeles Basin Plan (MNS Engineers, 2018). The goal of the Los Angeles Basin Plan is to develop water quality standards and objectives. The water quality objectives are intended (i) to protect the public health and welfare and (ii) to maintain or enhance water quality in relation to the designated existing and potential beneficial uses of the water (Los Angeles Basin Plan, 2014). Water quality objectives are achieved through Waste Discharge Requirements for concentrations of pollutants. As the proposed Project would capture, filter, and infiltrate stormwater in order to reduce contamination, the proposed Project would protect public health, enhance water quality, and reduce the concentration of pollutants. Therefore, the proposed Project achieves the objectives of the Los Angeles Basin Plan, rather than conflict with it.

References

- California Department of Conservation. 2019. "Los Angeles County Tsunami Hazard Area Maps." Accessed May 24, 2021. Available at:
<https://www.conservation.ca.gov/cgs/tsunami/maps/los-angeles>
- California Water Board. September 11, 2014. "Los Angeles Regional Water Quality Board Basin Plan for the Coastal Watersheds of Los Angeles and Ventura Counties." Available at:

https://www.waterboards.ca.gov/losangeles/water_issues/programs/basin_plan/basin_plan_documentation.html

City of Burbank. 2013. *Burbank2035* General Plan. Adopted February 19, 2013. Accessed September 27, 2021. Available at:
<https://www.burbankca.gov/documents/173607/0/The+Burbank2035+General+Plan.pdf/139656b0-80e9-3b11-dc6d-751642c85b38?version=1.2&t=1616616954424&imagePreview=1>

City of Burbank Department of Water and Power. Adopted June 2021. “2020 Urban Water Management Plan.” Accessed September 17, 2021. Available at:
https://www.burbankwaterandpower.com/images/administrative/downloads/BWP_2020UWMP_Final.pdf

Environmental Protection Agency. May 2007. “Developing Your Stormwater Pollution Prevent Plan: A Guide for Construction Sites.” Accessed May 24, 2021. Available at:
https://www3.epa.gov/npdes/pubs/sw_swppp_guide.pdf

Los Angeles County Department of Public Health. Licensed Water Haulers. Accessed June 2, 2021. Available at: http://publichealth.lacounty.gov/eh/docs/ep_dw_licensed_water_haulers.pdf

MNS Engineers for the City of Burbank Water and Power. June 1, 2018. Burbank Water and Power Campus and Magnolia Power Plant NPDES Compliance Stormwater Quality Improvements Options – Draft Feasibility Study.

Land Use and Planning

	Potentially Significant Impact	Less than Significant with Mitigation Incorporated	Less than Significant Impact	No Impact
XI. LAND USE AND PLANNING -- Would the project:				
a) Physically divide an established community?	<input type="checkbox"/>	<input type="checkbox"/>	<input type="checkbox"/>	<input checked="" type="checkbox"/>
b) Cause a significant environmental impact due to a conflict with any land use plan, policy, or regulation adopted for the purpose of avoiding or mitigating an environmental effect?	<input type="checkbox"/>	<input type="checkbox"/>	<input type="checkbox"/>	<input checked="" type="checkbox"/>

Discussion

- a) **No Impact.** As stated in the Project Description, the Project site is designated by the Land Use Element of the *Burbank2035* General Plan as Institutional with corresponding City zoning of M-2 General Industrial (City of Burbank, 2019). The BWP Campus is a part of the Burbank Center Plan specific plan area, the goal of which is to facilitate the revitalization of the Downtown Burbank, South San Fernando, and surrounding areas (City of Burbank, 2013). As the improvements would be limited to the BWP Campus property, the Project would not result in the physical division of the Burbank Center Plan specific plan area. Additionally, the nearest residential community is a low-density residential community to the west and southwest of the BWP Campus (City of Burbank, 2013). A commercial and industrial area lies between the residential community and the BWP campus. The BWP campus connects to the residential area by traveling less than 1,000 feet west or southwest along Magnolia Boulevard, Palm Avenue, or Orange Grove Avenue. However, the water quality improvements would involve no changes to these streets. As the improvements would be limited to the BWP Campus property, the Project would not result in the physical division of the residential community or result in changes to its connectivity with the rest of the City. Furthermore, the Project contains no improvements that would limit connectivity or facilitate blockages of roads or walking pathways on the BWP campus itself. The proposed improvements would occur on developed properties and would be limited to the existing BWP Campus so that no existing communities would be impacted or divided. No impacts would occur.
- b) **No Impact.** As stated in the Project Description, the Project site is designated by the Land Use Element of the *Burbank2035* General Plan as Institutional with corresponding City zoning of M-2 General Industrial (City of Burbank, 2019). The primary use of the Project site is the BWP Campus, and the land use would remain as such after the installation of the water quality enhancements. The Project would not include any amendments to the *Burbank2035* General Plan or the zoning code. The Project would not affect any existing City of Burbank General Plan goal or policy, zoning regulation, or other environmental protection or regulation. One of the principal goals of the Project is to provide enhanced water quality for the properties included in the Project area. As stated in the Open Space and Conservation Element of the *Burbank2035* General Plan, “The City will continue to require all new development and modifications to existing development to use Best Management Practices (BMPs) to reduce stormwater runoff and increase on-site retention. BMPs are effective methods of preventing and controlling the amount of pollutants entering the storm drain system, where pollutants

eventually enter the surface water system.” The proposed project would implement drainage improvements so that stormwater would flow through filters and not into the BWC, thereby reducing stormwater runoff and increasing on-site retention, consistent with the General Plan. Therefore, the Project is consistent with the applicable land use plan and does not result in conflict. No impacts would occur with respect to this topic.

References

- City of Burbank. 2013. *Burbank2035* General Plan. Adopted February 19, 2013. Accessed September 27, 2021. Available at:
<https://www.burbankca.gov/documents/173607/0/The+Burbank2035+General+Plan.pdf/139656b0-80e9-3b11-dc6d-751642c85b38?version=1.2&t=1616616954424&imagePreview=1>
- . 2019. *Zone Map*. Effective 2019. Accessed September 17, 2021. Available at:
https://www.burbankca.gov/documents/173607/0/20210101_Zoning_Map.pdf/c8bc55ed-98cf-505d-3892-7e1657bca8f1?t=1618866483006

Mineral Resources

	Potentially Significant Impact	Less than Significant with Mitigation Incorporated	Less than Significant Impact	No Impact
XII. MINERAL RESOURCES -- Would the project:				
a) Result in the loss of availability of a known mineral resource that would be of value to the region and the residents of the state?	<input type="checkbox"/>	<input type="checkbox"/>	<input type="checkbox"/>	<input checked="" type="checkbox"/>
b) Result in the loss of availability of a locally-important mineral resource recovery site delineated on a local general plan, specific plan or other land use plan?	<input type="checkbox"/>	<input type="checkbox"/>	<input type="checkbox"/>	<input checked="" type="checkbox"/>

Discussion

- a) **No Impact.** According to the Open Space and Conservation Element of the City of Burbank General Plan, the Project site is located atop an area classified by the State Mining and Geology Board as MRZ-2, which is a mineral classification that indicates that mineral resources may be present (City of Burbank, 2013). However, the Open Space and Conservation Element states that the city is an urbanized environment where existing land use designations preclude mineral extraction activities, as mining activities would destroy parts of the city (City of Burbank, 2013). While there is a possibility that significant mineral resources could be located in the MRZ-2 area, the Open Space and Conservation Element states that mining is not feasible, and Burbank is not considered to be a potential future source for mineral resources. Furthermore, the proposed Project site is planned and zoned for institutional/industrial uses and has been developed as the BWP Campus since 1913. Therefore, no impact would occur in relation to the loss of availability of a known mineral resource that would be of value to the region and the residents of the state.
- b) **No Impact.** As stated above, while the Project site is located within an MRZ-2 mineral classification area, the City of Burbank General Plan does not consider the city to be a potential source for mineral resources (City of Burbank, 2013). The City of Burbank General Plan does not delineate any locally important mineral resource recovery sites. Furthermore, the proposed Project site has been developed and used as the BWP Campus since 1913, and therefore, is not used as a mineral resource recovery site such as a mine. Thus, implementation of the proposed Project would not result in the loss of a locally important mineral resource recovery site and no impact would occur.

Reference

City of Burbank. 2013. *Burbank2035* General Plan. Adopted February 19, 2013. Accessed September 21, 2021. Available at: <https://www.burbankca.gov/documents/173607/0/The+Burbank2035+General+Plan.pdf/139656b0-80e9-3b11-dc6d-751642c85b38?version=1.2&t=1616616954424&imagePreview=1>

Noise

	Potentially Significant Impact	Less than Significant with Mitigation Incorporated	Less than Significant Impact	No Impact
XIII. NOISE -- Would the project result in:				
a) Generation of a substantial temporary or permanent increase in ambient noise levels in the vicinity of the project in excess of standards established in the local general plan or noise ordinance, or applicable standards of other agencies?	<input type="checkbox"/>	<input type="checkbox"/>	<input checked="" type="checkbox"/>	<input type="checkbox"/>
b) Generation of excessive groundborne vibration or groundborne noise levels?	<input type="checkbox"/>	<input type="checkbox"/>	<input checked="" type="checkbox"/>	<input type="checkbox"/>
c) For a project located within the vicinity of a private airstrip or an airport land use plan or, where such a plan has not been adopted, within two miles of a public airport or public use airport, would the project expose people residing or working in the project area to excessive noise levels?	<input type="checkbox"/>	<input type="checkbox"/>	<input type="checkbox"/>	<input checked="" type="checkbox"/>

Discussion

- a) **Less than Significant Impact.** Project construction is expected to create temporary elevated noise levels at receivers surrounding the Project site when certain activities occur at the closest point to the nearby receiver locations from primary Project construction activities. Construction trucks and related construction activities, including but not limited to grading, trenching and removal and replacement of paving material, could result in a potentially significant noise increase in close proximity to the Project site. This noise could affect employees on the BWP campus and nearby sites. As noted in the Project Description, construction plans and specifications would include the following limitations on hours of Project construction activities:

- Monday-Friday 7:00 AM to 7:00 PM
- Saturday 8:00 AM to 5:00 PM
- No construction is permitted by contractors or subcontractors after hours, on Sunday or on City Holidays. Without prior written request and approval from the Community Development Department.

Using sample reference noise levels to represent the planned construction activities on the site, the firm Urban Crossroads, Inc. estimated Project-related construction noise levels at nearby sensitive receiver locations (see the Urban Crossroads, Inc. report, Attachment 3 to this Initial Study). Properties located north and east of the Project site are developed for industrial uses, including but not limited to lumber yards, wood processing, storage, assembly, and similar uses. The closest noise-sensitive receiver locations to the Project site, consisting of residential homes to the west and south, are located over 1,000 feet away. The results of the construction noise analysis show that the unmitigated construction noise levels would approach 35.5 dBA L_{eq} at these noise-sensitive receiver locations and would result in a less-than-significant impact. This is documented in the Urban Crossroads noise analysis (Attachment 3).

No long-term operational noise would result from the proposed Project since there would be no new vehicles trips to or from the Project site or industrial operations, since proposed improvements would include drainage and water quality improvements. There would be no impact during operations with respect to this topic.

- b) **Less than Significant Impact.** Groundborne vibration and groundborne noise could occur during the construction phase of the Project as a result of grading, trenching and removal of existing paving. No residences, schools, hospitals or similar noise-sensitive land uses exist near the site that could be significantly impacted from these types of activities. The closest noise-sensitive receiver locations to the Project site are located over 1,000 feet away. Based on the reference vibration levels provided by the Federal Transit Administration, a large bulldozer represents the peak source of vibration with a reference velocity of 0.089 in/sec peak-particle-velocity (PPV) at 25 feet. At distances ranging from 1,210 to 1,918 feet from primary Project construction activities, construction vibration velocity levels are expected to range from 0.0001 to 0.0003 in/sec PPV, as shown on Table 7-10 in Attachment 3. Based on the Caltrans older residential building damage threshold of 0.3 in/sec PPV, the proposed Project construction activities would result in vibration levels which are anticipated to remain below the threshold for building damage, and therefore, represents a less than significant impact. A less than significant impact would result in terms of excessive ground vibration.
- c) **No Impact.** The Project site is located approximately one mile southeast of the Hollywood-Burbank Airport. Since the Project would include no above-ground structures and would not be occupied by residents, employees or visitors, there would be no impact with respect to this topic.

References

- City of Burbank. 2013. *Burbank2035 General Plan*. Adopted February 19, 2013. Accessed September 27, 2021. Available at: <https://www.burbankca.gov/documents/173607/0/The+Burbank2035+General+Plan.pdf/139656b0-80e9-3b11-dc6d-751642c85b38?version=1.2&t=1616616954424&imagePreview=1>
- . 2021. *City of Burbank Municipal Code*. August 10, 2021. Accessed September 28, 2021. Available at: <https://www.codepublishing.com/CA/Burbank/>
- Urban Crossroads, Inc. for City of Burbank Water and Power. April 30, 2019. *Burbank Water and Power Magnolia Campus, Noise Impact Analysis*.

Population and Housing

	Potentially Significant Impact	Less than Significant with Mitigation Incorporated	Less than Significant Impact	No Impact
XIV. POPULATION AND HOUSING -- Would the project:				
a) Induce substantial population growth in an area, either directly (for example, by proposing new homes and businesses) or indirectly (for example, through extension of roads or other infrastructure)?	<input type="checkbox"/>	<input type="checkbox"/>	<input type="checkbox"/>	<input checked="" type="checkbox"/>
b) Displace substantial numbers of existing people or housing, necessitating the construction of replacement housing elsewhere?	<input type="checkbox"/>	<input type="checkbox"/>	<input type="checkbox"/>	<input checked="" type="checkbox"/>

Discussion

- a) **No Impact.** The Project does not include a residential component and thus would not directly increase the City’s population. The Project would not extend roads or other infrastructure such that indirect population growth could occur. The Project would include drainage and water quality improvements to support the City of Burbank’s, Burbank Water and Power Department. There would be no impact with respect to this topic.
- b) **No Impact.** The Project site and surrounding area is developed with the BWP Campus and surrounding light industrial uses. The Project site does not contain existing housing units and is designated for institutional and industrial uses. Implementation of the Project would not result in the displacement of a substantial number of people and thus would not cause replacement housing to be built elsewhere within the city. No residences would be removed to accommodate Project improvements and no impact would result.

References

City of Burbank. 2013. *Burbank2035* General Plan. Adopted February 19, 2013. Accessed September 27, 2021. Available at: <https://www.burbankca.gov/documents/173607/0/The+Burbank2035+General+Plan.pdf/139656b0-80e9-3b11-dc6d-751642c85b38?version=1.2&t=1616616954424&imagePreview=1>

Public Services

	Potentially Significant Impact	Less than Significant with Mitigation Incorporated	Less than Significant Impact	No Impact
XV. PUBLIC SERVICES -- Would the project:				
a) Result in substantial adverse physical impacts associated with the provision of new or physically altered governmental facilities, need for new or physically altered government facilities, the construction of which could cause significant environmental impacts, in order to maintain acceptable service ratios, response times, or other performance objectives for any of the following public services:				
i) Fire Protection?	<input type="checkbox"/>	<input type="checkbox"/>	<input type="checkbox"/>	<input checked="" type="checkbox"/>
ii) Police Protection?	<input type="checkbox"/>	<input type="checkbox"/>	<input type="checkbox"/>	<input checked="" type="checkbox"/>
iii) Schools?	<input type="checkbox"/>	<input type="checkbox"/>	<input type="checkbox"/>	<input checked="" type="checkbox"/>
iv) Parks?	<input type="checkbox"/>	<input type="checkbox"/>	<input type="checkbox"/>	<input checked="" type="checkbox"/>
v) Other public facilities?	<input type="checkbox"/>	<input type="checkbox"/>	<input type="checkbox"/>	<input checked="" type="checkbox"/>

Discussion

- a.i) No Impact.** The Project would include the construction of storm drainage and water quality improvements on the existing developed BWP campus in an urbanized area of the City of Burbank. The Project would not involve construction or operation of any structures that could result in fire hazards or require paramedic service calls. Therefore, no impact would result with respect to this topic.
- a.ii) No Impact.** Similar to fire impacts, the Project would include construction of storm drainage and water quality improvements on the existing developed BWP campus in an urbanized area of the City of Burbank. No structures or other improvements would be built that would require police calls for services and no impacts would result with respect to this topic.
- a.iii) No Impact.** The Project does not include any components which would increase housing, increase businesses, or bring infrastructure into undeveloped areas, and would not otherwise directly or indirectly increase the City’s population. For this reason, the proposed Project would not generate new students and would not increase demand on local schools. No impact would occur.
- a.iv) No Impact.** As noted above, no impact would occur with respect to this Project since no habitable space would be created where new residents or visitors would use local parks, as there would be no increase in population.
- a.v) No Impact.** As noted above, no impact would occur with respect to this Project since no habitable space would be created where new residents or visitors would use City libraries, as there would be no increase in population.

Reference

City of Burbank. 2013. *Burbank2035* General Plan. Adopted February 19, 2013. Accessed September 27, 2021. Available at:
<https://www.burbankca.gov/documents/173607/0/The+Burbank2035+General+Plan.pdf/139656b0-80e9-3b11-dc6d-751642c85b38?version=1.2&t=1616616954424&imagePreview=1>

Recreation

	Potentially Significant Impact	Less than Significant with Mitigation Incorporated	Less than Significant Impact	No Impact
XVI. RECREATION				
a) Would the project increase the use of existing neighborhood and regional parks or other recreational facilities such that substantial physical deterioration of the facility would occur or be accelerated?	<input type="checkbox"/>	<input type="checkbox"/>	<input type="checkbox"/>	<input checked="" type="checkbox"/>
b) Does the project include recreational facilities or require the construction or expansion of recreational facilities which might have an adverse physical effect on the environment?	<input type="checkbox"/>	<input type="checkbox"/>	<input type="checkbox"/>	<input checked="" type="checkbox"/>

Discussion

- a) **No Impact.** The Project does not include a residential component and thus would not directly or indirectly increase the City’s population. There would be no increase in the use of local or regional parks as a result of Project construction. The City has recreation resources, including the nearest resource, Olive Recreation Center, which is located approximately 0.3 mile south of the Project site. As stated in the Construction Scenario, the work is expected to be completed in three (3) months, with no more than 25 employees on site at one time. There are sufficient labor resources in the greater Los Angeles Metropolitan area that the construction would be completed by existing available labor resources (City of Burbank, 2021; SCAG, 2019). Therefore, there would be no anticipated population growth that would impact the nearest park. No impact would occur with respect to this topic.
- b) **No Impact.** The Project does not include or require a recreation facility or expansion of existing recreational facilities. There is no residential component of the Project that would require the construction of recreational facilities to support planned population growth. Therefore, the Project would have no impact with respect to adverse effects physical effects on the environmental due to development of recreation facilities or expansion of existing recreational facilities.

References

- Karen Warner Associates, Inc. for City of Burbank Community Development Department, Planning Division. April 27, 2021. Draft Burbank Housing Element 2021-2029. Available at: <https://www.burbankhousingelement.com/wp-content/uploads/2021/05/Public-Review-Draft-2021-2029-Burbank-Housing-Element.pdf>
- Southern California Association of Governments (SCAG). May 2019. Local Profiles Report 2019: Profile of the City of Burbank. Available at: https://scag.ca.gov/sites/main/files/file-attachments/burbank_localprofile.pdf?1605663993

Transportation and Traffic

	Potentially Significant Impact	Less than Significant with Mitigation Incorporated	Less than Significant Impact	No Impact
XVII. TRANSPORTATION/TRAFFIC -- Would the project:				
a) Conflict with an applicable plan, ordinance or policy addressing the circulation system, including transit, roadway, bicycle, and pedestrian facilities?	<input type="checkbox"/>	<input checked="" type="checkbox"/>	<input type="checkbox"/>	<input type="checkbox"/>
b) Conflict with or be inconsistent with CEQA Guidelines Section 15064.3, subdivision (b)?	<input type="checkbox"/>	<input type="checkbox"/>	<input type="checkbox"/>	<input checked="" type="checkbox"/>
c) Substantially increase hazards due to a design feature (e.g., sharp curves or dangerous intersections) or incompatible uses (e.g., farm equipment)?	<input type="checkbox"/>	<input checked="" type="checkbox"/>	<input type="checkbox"/>	<input type="checkbox"/>
d) Result in inadequate emergency access?	<input type="checkbox"/>	<input checked="" type="checkbox"/>	<input type="checkbox"/>	<input type="checkbox"/>

Discussion

- a) **Less Than Significant with Mitigation.** The Project would result in temporary impacts during demolition and construction in relation to potential conflicts with an applicable plan, ordinance, or policy addressing the circulation system, including transit, roadway, bicycle, and pedestrian facilities. The Project site is located approximately 0.1 mile southwest of the Golden State Freeway (U.S. Interstate 5), with the off-site improvements proposed approximately 0.1 mile southwest of the freeway at N. Varney Street, and the on-site improvements located on the next block near W. Olive Avenue. The onsite improvements would occur where a single southwest bound lane connects the S. Flower Street and W. Olive Avenue intersection before the elevated Olive Avenue freeway overpass bridge drops to an at-grade level to the south of the Project site. The nearest transit stops to the project site are the Burbank – Downtown Metrolink Station, which faces S. Front Street to the northeast of the project site, and a bus line along Olive Avenue. Demolition and construction activities, which would require transport of construction equipment and materials to and from the Project site, has the potential for vehicles to temporarily affect circulation during the construction phase. Based on a discussion with the Transportation Division of the Burbank Community Development Department (Hannah Woo, Associate Transportation Planner, 11/29/18, reviewed by Vikki Davtian, Principal Traffic Engineer, 10/2021), the number of construction vehicles associated with the Project would result in a less than significant impact with the application of Mitigation Measure TRA-1 during Project demolition and construction:

Mitigation Measure TRA-1. Prior to commencement of construction of the Project (including demolition activities), the City of Burbank, Burbank Water and Power shall require the Project contractor to submit to the Burbank Public Works Department for approval, a Traffic Management Plan that includes, at minimum, the specified items:

- a) A haul route for demolition debris; and
- b) Provision to ensure that all adjacent public streets are accessible for emergency equipment and normal vehicle, bicycle and pedestrian traffic during Project demolition and construction.

Additionally, as stated in the Project Description, any transportation of heavy construction equipment and/or materials which requires use of over-sized-transport vehicles on State highways will require a Caltrans transportation permit. Large size truck trips should be limited to off-peak commute periods. The proposed Project would not result in a direct adverse impact to the existing State transportation facilities. The nearest state highway to the Project site is the Ventura Freeway (State Route 134), located approximately 1.5 miles south of the Project site.

The Project would not create any habitable space that would generate vehicular trips. There would therefore be no long-term impacts to local or regional roadways, public transit systems, and bicycle or pedestrian facilities.

The Project would not conflict with air traffic circulation. Although the Project site is located southeast of Hollywood-Burbank Airport, no habitable structures would be built that would cause any impacts to safety or obstructions to aircraft operations. All Project facilities would be located underground. In terms of potential blockage of emergency vehicle access, refer to Mitigation Measure TRA-1 “b,” that requires continued access around the Project area for emergency vehicles and all other forms of normal access.

There would be no impact with respect to conflicts to plans or policies dealing with public transit, bicycle or pedestrian facilities since the Project would be constructed underground and would not interfere with roads, bicycle routes or sidewalks.

Impacts would be less than significant with incorporation of Mitigation Measure TRA-1 because the Traffic Management Plan would reduce potential conflicts with an applicable plan, ordinance, or policy addressing the circulation system, including transit, roadway, bicycle, and pedestrian facilities. Therefore, impacts would be less than significant after incorporation of mitigation measure TRA-1.

- b) **No Impact.** Based on discussions with the Burbank Transportation Division, construction of the Project would not result in conflicts with any City congestion management plans or result in a significant amount of congestion at any nearby roadways or intersections (Hannah Woo, 11/29/18, reviewed by Vikki Davtian, Principal Traffic Engineer, 10/2021). Additionally, the Project would not create any habitable space that would generate vehicular trips. The Project would involve construction of drainage improvements that would allow stormwater from adjacent properties to be intercepted and discharged into the BWC through a new outfall structure. The Project does not involve any new residences, offices, or businesses that would generate per capita automobile vehicle miles traveled (VMT). There would be no impact with respect to this topic.
- c) **Less Than Significant with Mitigation.** No above-ground improvements would be constructed as part of the Project. The City’s construction contractor would be required to prepare and have the City’s Public Works Department to prepare a Traffic Management Plan (see Mitigation Measure TRA-1) to ensure vehicular and pedestrian safety. As shown in Exhibit 3, *Site Plan Overview*, and Exhibit 5, *Proposed Offsite Improvements*, the Project would involve installation of a new curb inlet, a new manhole, and a new 36-inch storm drain pipe, as well as replacement of an existing underground storm drain pipe and replacement of existing trees that interfere with construction. These Project features would occur off-site, above and below ground on N. Varney Street, and the adjacent right-of-way. With

implementation of Mitigation Measure TRA-1, vehicular and pedestrian safety impacts would be reduced to a less than significant level. With adherence to the approved Traffic Management Plan, there would be no impacts with respect to potential hazards due to construction and incompatible uses.

- d) **Less Than Significant with Mitigation.** Since all Project improvements would be located below grade, there would be no need for emergency access or blockage of emergency equipment during Project operation. During Project construction, adherence to Mitigation Measure TRA-1, above will ensure that emergency vehicle access would not be blocked on adjacent streets. Access to Project improvements for maintenance and repair would be provided by manhole access points as specified by City of Burbank Engineering standards. With adherence to the referenced mitigation measure, no significant impacts would be created.

References

- City of Burbank. 2013. *Burbank2035* General Plan. Adopted February 19, 2013. Accessed September 27, 2021. Available at:
<https://www.burbankca.gov/documents/173607/0/The+Burbank2035+General+Plan.pdf/139656b0-80e9-3b11-dc6d-751642c85b38?version=1.2&t=1616616954424&imagePreview=1>
- Discussion with Hannah Woo, Associate Transportation Planner, Burbank Traffic Division, November 29, 2018. Reviewed by Vikki Davtian, Principal Traffic Engineer, October 2021.

Tribal Cultural Resources

	Potentially Significant Impact	Less than Significant with Mitigation Incorporated	Less than Significant Impact	No Impact
XVIII. TRIBAL CULTURAL RESOURCES --				
Would the Project cause a substantial adverse change in the significance of a tribal cultural resource, defined in Public Resources Code section 21074 as either a site, feature, place, cultural landscape that is geographically defined in terms of the size and scope of the landscape, sacred place, or object with cultural value to a California Native American tribe, and that is:				
a) Listed or eligible for listing in the California Register of Historical Resources, or in a local register of historical resources as defined in Public Resources Code section 5020.1(k), or	<input type="checkbox"/>	<input checked="" type="checkbox"/>	<input type="checkbox"/>	<input type="checkbox"/>
b) A resource determined by the lead agency, in its discretion and supported by substantial evidence, to be significant pursuant to criteria set forth in subdivision (c) of Public Resources Code Section 5024.1. In applying the criteria set forth in subdivision (c) of Public Resources Code Section 5024.1, the lead agency shall consider the significance of the resource to a California Native American tribe.	<input type="checkbox"/>	<input checked="" type="checkbox"/>	<input type="checkbox"/>	<input type="checkbox"/>

Discussion

a, b) Less Than Significant With Mitigation. On February 4, 2020, BWP staff met with Mr. Jairo Avila of the Fernandeno Tataviam Band of Mission Indians (FTBMI) to discuss how Native American resources could be protected during construction. Burbank Water & Power met, via teleconference, with FTBMI (Mr. Avila) again on March 15, 2022. On March 25, 2022, FTBMI provided comments via email on the preliminary draft mitigation measures. FTBMI provided an additional email to Burbank Water & Power regarding the scope of the requested mitigation measures on June 13, 2022. Based on the consultation undertaken with FTBMI, Mitigation Measure CUL-1 contained in the 2019 Initial Study has been replaced by a revised version of CUL-1, TRIBAL-1, and TRIBAL-2. In addition, the Gabrielino Band of Mission Indians – Kizh Nation (Kizh Nation), provided a letter 13 months after the 30-day AB 52 consultation was conducted in 2020.

In preparing the updated Initial Study/MND for public review, Burbank Water & Power sent letters on November 16, 2021, to California Native American tribes that have requested to be notified of Projects within the City’s jurisdiction inviting them to participate in government-to-government consultation pursuant to Public Resources Code Section 21080.3.1 (Assembly Bill 52). The FTBMI responded on December 15, 2021, requesting additional information regarding the extent of proposed groundwork. Additional information was provided to FTBMI on January 21, 2022. No tribal consultation was requested during preparation of the updated Initial Study/MND. However, in addition to the February 4, 2020, meeting, via teleconference, between Burbank Water & Power and FTBMI (Mr. Avila), Burbank Water & Power met, again via teleconference, with FTBMI on March 15, 2022. On March 25, 2022, FTMI provided comments via email on the preliminary draft mitigation measures. On June 13, 2022, FTBMI provided an additional email to Burbank Water &

Power regarding the scope of the requested mitigation measures on June 13, 2022. Burbank Water & Power responded to FTBMI by phone and email and provided a copy of the three mitigation measures identified for the protection of Tribal cultural resources: Mitigation Measures CUL-1, TRIBAL-1, and TRIBAL-2. In response to the outreach undertaken by the City pursuant to AB 52, the City received one (1) letter from the FTBMI. Any Native American (Tribal) cultural resources found on the Project site as a result of construction would be protected by adherence to Mitigation Measure CUL-1, TRIBAL-1, and TRIBAL-2, found in the Cultural Resources section of this Initial Study. With adherence to the three specified mitigation measures, any impacts to Native American (Tribal) cultural resources would be less than significant. Sapphos Environmental, Inc. conducted a site visit of the BWP Campus and BWC on February 10, 2022, and confirmed the proposed Project would not result in a significant impact on potential historical resources.

Mitigation Measure TRIBAL-1: Tribal Resources – Avoidance and Monitoring. Prior to the initiation of ground-disturbing activities in native (*i.e.*, non-fill) soil, the City shall require monitoring of all ground-disturbing activities by a Qualified Archeologist. The Qualified Archeologist shall have a pre-construction meeting to explain the construction monitoring process and provide training. In addition, consultation and coordination shall be undertaken with the Native American local Tribal contacts designated by the Native American Heritage Commission (NAHC) and the Tribe(s) to determine if the city shall retain a Native American monitor to be present during all or a portion of the ground-disturbing activities within the Project area. In addition, representatives of tribes, with which the Most Likely Descendants, identified by the NAHC, or who have identified themselves directly to the City as having an interest in the BWP Campus Stormwater Improvement Project shall be invited to attend the pre-construction meeting to conduct Tribal cultural resource sensitivity training. Such sensitivity training may include a handout and focus on how to recognize Tribal cultural resources encountered during earthmoving activities.

In the event that previously unknown Tribal cultural resources are encountered during construction, the resources shall either be left *in situ* and avoided through redesign, or the resources shall be salvaged, recorded, and repositioned at a repository consistent with the provisions of a Phase III data recovery program and the provisions of the Resource Protection Plan, specified in CUL-1. The Resource Protection Plan shall include further consultation with the identified Tribal representatives. Data recovery is not required by law or regulation. It is, though, the most commonly agreed-upon measure to mitigate adverse effects to cultural resources eligible or listed under Section 106 Criterion D/CRHR Criterion 4, as it preserves important information that would otherwise be lost.

Mitigation Measure TRIBAL-2: Regulatory Requirements – Human Remains. In accordance with Section 7050.5 of the California Health and Safety Code, if human remains are encountered during excavation activities, the County Coroner shall be notified within 24 hours of the discovery. No further excavation or disturbance of the site or any nearby areas reasonably suspected to overlie adjacent remains within 100 feet shall occur until the County Coroner has determined the appropriate treatment and disposition of the human remains.

If the County Coroner determines that the remains are or are believed to be Native American, s/he shall notify the NAHC in Sacramento within 24 hours. In accordance with Section 5097.98 of the California Public Resources Code, the NAHC shall immediately notify the person(s) it believes to be the most likely descendant (MLD) of the deceased Native American. The descendants shall complete their inspection and make a recommendation within 48 hours of being granted access to the site. The designated Native American representative(s) would then determine, in consultation with the City, the disposition of the human remains. The MLD's recommendation shall be followed if feasible and may include scientific removal and non-destructive analysis of the human remains

and any items associated with Native American burials. If the City rejects the MLD's recommendations, the agency shall rebury the remains with appropriate dignity on the property within a time frame agreed upon between the City and the MLD's in a location that will not be subject to further subsurface disturbance (14 California Code of Regulations §15064.5(e)).

Utilities and Service Systems

	Potentially Significant Impact	Less than Significant with Mitigation Incorporated	Less than Significant Impact	No Impact
XIX. UTILITIES AND SERVICE SYSTEMS --				
Would the project:				
a) Require or result in the relocation or construction of new or expanded water, wastewater treatment or storm water drainage, electric power, natural gas, or telecommunications facilities, the construction or relocation of which could cause significant environmental effects?	<input type="checkbox"/>	<input type="checkbox"/>	<input type="checkbox"/>	<input checked="" type="checkbox"/>
b) Have sufficient water supplies available to serve the Project and reasonably foreseeable future development during normal, dry and multiple dry years?	<input type="checkbox"/>	<input type="checkbox"/>	<input type="checkbox"/>	<input checked="" type="checkbox"/>
c) Result in a determination by the wastewater treatment provider which serves or may serve the Project that it has adequate capacity to serve the Project's projected demand in addition to the provider's existing commitments?	<input type="checkbox"/>	<input type="checkbox"/>	<input type="checkbox"/>	<input checked="" type="checkbox"/>
d) Generate solid waste in excess of State or local standards, or in excess of the capacity of local infrastructure, or otherwise impair the attainment of solid waste reduction goals?	<input type="checkbox"/>	<input checked="" type="checkbox"/>	<input type="checkbox"/>	<input type="checkbox"/>
e) Comply with Federal, State, and local management and reduction statutes and regulations related to solid waste?	<input type="checkbox"/>	<input checked="" type="checkbox"/>	<input type="checkbox"/>	<input type="checkbox"/>

Discussion

- a) **No Impact.** The elements described as the onsite improvements in the Project Description are located on the developed BWP Campus, which is already served by water, wastewater, drainage, electric power, natural gas, and telecommunications infrastructure for daily operations. The offsite improvements in the Project Description are located within the right-of-way of North Varney Street and would terminate in a new drainage outfall into the BWC, approximately 950 feet north of the current outfall. As stated in the *Burbank2035* General Plan, water and power is provided to the City by BWP, wastewater is primarily treated at the Burbank Wastewater Reclamation Plant, and the City maintains a drainage system. The Project consists of stormwater infrastructure improvements to the BWP campus that would not involve any changes to water, wastewater, electric power, natural gas, or telecommunications infrastructure, and therefore would have no impact on these utilities. With regard to stormwater drainage infrastructure, the Project would implement improvements on the already-developed BWP campus that would increase on-site filtration and retention, increase infiltration into groundwater, and reduce runoff into the BWC. The Project would include the construction of drainage and water quality improvements, some of which would replace existing, older facilities. New drainage improvements would ensure that current regional surface water quality standards are met. Therefore, while the Project would involve the construction of new and expanded stormwater drainage facilities, these improvements would improve water quality and reduce stormwater runoff, thereby resulting in a net benefit. As discussed throughout the Initial Study, there would be no significant environmental effects as a result of the Project. Therefore,

there would be no impact with regard to the construction or relocation of utilities which could cause significant environmental effects.

- b) **No Impact.** As stated in the *Burbank2035* General Plan, the City's water is supplied by BWP, providing potable water, fire protection water, and recycled water. BWP receives most of its potable water from the Metropolitan Water District of Southern California and is supplemented by groundwater from the San Fernando Basin. As discussed in Section 1, *Project Description*, site preparation and grading would take approximately 3 working days (please see Table 1, *Anticipated Construction Equipment*). Dust control would be accomplished by using a water truck to spray down exposed areas. It is anticipated that a single 5,000-gallon water truck would be deployed each day. Given 3 working days with 5,000 gallons of water used each day, 15,000 total gallons of water would be required for Project construction. There are 10 licensed water haulers in Los Angeles County that would be able to provide this water (Los Angeles County Department of Public Health). According to the City's *Urban Water Management Plan* (UWMP, 2021), San Fernando Basin underlies the city, including the Project site. One of the purposes of the Project is to redirect stormwater runoff from an existing outfall into the nearby BWC to an infiltration field on the BWP Campus. The proposed Project would implement storm water capture system that would divert an average of 8.2 million gallons per year of storm water from the BWC for filtration, assuming average rainfall of 16.3 inches per year (MNS, 2018). The treated storm water would either be used for cooling tower make-up water or infiltrated into the ground, or a combination of the two. Therefore, as captured stormwater is infiltrated, then the amount of local high-quality infiltration would be increased, and the proposed Project would not decrease groundwater supplies nor interfere with sustainable groundwater management. Both the reuse and infiltration maintain or improve existing levels of regional groundwater recharge. Therefore, the 15,000 gallons of water used for project construction would be offset by the infiltration of water captured as a result of implementing the Project. Furthermore, after construction, the Project would require no additional water supplies for operation. Therefore, there would be no impacts with regard to sufficient water supplies available to serve the Project.
- c) **No Impact.** No habitable structures or other facilities would be constructed as part of the Project that would generate wastewater, and therefore the Project would not require new water or wastewater facilities. No changes to current City water or wastewater facilities would result from the Project. No impact would result with regard to wastewater capacity.
- d, e) **Less Than Significant with Mitigation.** Project improvements would not include generation of long-term solid waste, since no habitable space would be created that could generate waste material. In the short-term, construction activities could generate quantities of waste material, including but not limited to empty cartons, material wrappers, concrete and paving material. To ensure this impact is less than significant, the following mitigation measure shall be implemented.

Mitigation Measure Util-1. Prior to issuance of an Excavation Permit by the City of Burbank, the Project contractor shall prepare a Construction and Demolition Debris Plan. The Plan shall include methods for recycling construction debris and ultimate disposition of recycled material and shall and be approved by the Burbank Public Works Department prior to commencement of excavation activities. The Construction and Demolition Debris Plan shall specify how the contractor shall transport any waste generated by construction of the project to a landfill outside the City of Burbank. The project demolition contractor

shall determine the ultimate disposal site for asphalt, concrete, and other material. Any materials cleaned from the vault shall be treated as contaminated soil and transported out of the City for disposal.

As the project is relatively small, the quantity of debris generated from demolition would not be significantly large. Demolition material from industrial/commercial projects is not accepted at the City Landfill. The City of Burbank has adequate capacity to accommodate any solid waste not recycled per Mitigation Measure Util-1.

Waste generated from operations and maintenance is anticipated to be similar to the existing condition. Burbank Landfill No. 3, which accepts non-hazardous materials and does not typically accept construction materials, would continue to accept solid waste at the project site during operations and maintenance (Molinar, 10/09/21). Under no conditions does the Landfill accept any type of soil or any materials cleaned out of a vault because they are considered contaminated soils by the Regional Water Quality Control Board (RWQCB). As of November 2020, the total remaining capacity at the Burbank Landfill was 4,309,704 tons; at its current fill rate, Burbank Landfill No. 3 is projected to reach fill capacity in 129 years (Jordan, 10/08/21; Molinar, 10/09/21).

The Project contractor will adhere to all local, State and Federal requirements regulating solid waste handling and disposal. This impact would be less than significant.

References

- City of Burbank. 2013. *Burbank2035* General Plan. Adopted February 19, 2013. Accessed September 27, 2021. Available at: <https://www.burbankca.gov/documents/173607/0/The+Burbank2035+General+Plan.pdf/139656b0-80e9-3b11-dc6d-751642c85b38?version=1.2&t=1616616954424&imagePreview=1>
- City of Burbank Department of Water and Power. Adopted June 2021. “2020 Urban Water Management Plan.” Accessed September 17, 2021. Available at: https://www.burbankwaterandpower.com/images/administrative/downloads/BWP_2020UWMP_Final.pdf
- Jordan, Curtis, Burbank Public Works Department, Burbank, CA. October 8, 2021. Email to Laura Male, Sapphos Environmental, Inc., Pasadena, CA.
- MNS Engineers for City of Burbank Water and Power. June 1, 2018. Burbank Water and Power Campus and Magnolia Power Plant NPDES Compliance Stormwater Quality Improvements Options – Draft Feasibility Study.
- Molinar, John, Burbank Public Works Department, Burbank, CA. October 9, 2021. Email to Laura Male, Sapphos Environmental, Inc., Pasadena, CA.

Wildfire

	Potentially Significant Impact	Less than Significant with Mitigation Incorporated	Less than Significant Impact	No Impact
XX. WILDFIRE – If located in or near state responsibility areas or lands classified as very high fire hazard severity zones, would the project:				
a) Substantially impair an adopted emergency response plan or emergency evacuation plan?	<input type="checkbox"/>	<input type="checkbox"/>	<input type="checkbox"/>	<input checked="" type="checkbox"/>
b) Due to slope, prevailing winds, and other factors, exacerbate wildfire risks, and thereby expose project occupants to, pollutant concentrations from a wildfire or the uncontrolled spread of a wildfire?	<input type="checkbox"/>	<input type="checkbox"/>	<input type="checkbox"/>	<input checked="" type="checkbox"/>
c) Require the installation or maintenance of associated infrastructure (such as roads, fuel breaks, emergency water sources, power lines or other utilities) that may exacerbate fire risk or that may result in temporary or ongoing impacts to the environment?	<input type="checkbox"/>	<input type="checkbox"/>	<input type="checkbox"/>	<input checked="" type="checkbox"/>
d) Expose people or structures to significant risks, including downslope or downstream flooding or landslides, as a result of runoff, post-fire slope instability, or drainage changes?	<input type="checkbox"/>	<input type="checkbox"/>	<input type="checkbox"/>	<input checked="" type="checkbox"/>

Discussion

- a) **No Impact.** The proposed drainage improvements as part of the Project would not require access by emergency vehicles since there would be no residents or visitors occupying Project improvements. Access to drainage facilities would be provided on the site of the BWP campus or via local streets. Therefore, the proposed Project would result in no impacts to wildfire in relation to the substantial impairment of adopted emergency response and emergency evacuation plans in or near State Responsibility Area (SRA) or lands classified as very high fire hazard severity zones (VHFHSZ; California Department of Forestry and Fire Prevention [CAL FIRE], 2021).
- b) **No Impact.** The proposed Project improvements are within an urban setting on an existing facility and not located near an SRA or lands classified as VHFHSZ. The nearest VHFHSZ is within a Local Responsibility Area (LRA) located over 1.0-mile away from the proposed Project to the south (CAL FIRE, 2021). In addition, the proposed Project and surrounding area are located on a relatively flat terrain where drainage improvements will be constructed below ground connecting to the BWC and thereby reducing to a low possibility of exacerbated wildfire risk from natural factors such as slope and wind. Therefore, the proposed Project improvements would result in no impacts to wildfire in relation to exacerbated wildfire risk due to slope, prevailing winds, and other factors and thereby exposing Project occupants to pollutant concentrations from a wildfire or the uncontrolled spread of a wildfire.
- c) **No Impact.** The proposed Project improvements are within an urban setting on an existing facility that is served by current infrastructure and not located near an SRA or lands classified

as VHFHSZ. The nearest VHFHSZ is within an LRA located over 1.0-mile away from the proposed Project to the south and the area is relatively on flat terrain (CAL FIRE, 2021). In addition, the proposed drainage improvements will be constructed below ground and would not require access by emergency vehicles, since there would be no residents or visitors occupying the Project improvements. Access to the drainage facilities would be provided on the site of the BWP campus or via local streets. Therefore, the proposed Project improvements would not require the installation or maintenance of associated infrastructure (such as roads, fuel breaks, emergency water sources, power lines, or other utilities) that may exacerbate fire risk or that may result in the temporary or ongoing impacts to the environment in or near SRAs or lands classified as VHFHSZs as this Project site is already served by current infrastructure. Therefore, the proposed Project would not exacerbate fire risk.

- d) **No Impact.** The proposed Project improvements are within an urban setting on an existing facility where there would be no residents or visitors occupying the Project improvements. In addition, the proposed Project is not located near an SRA or lands classified as VHFHSZ. The nearest VHFHSZ is within an LRA located over 1.0 mile away from the proposed Project to the south (CAL FIRE, 2021). Furthermore, the proposed Project and surrounding area are located on a relatively flat terrain where drainage improvements will be constructed below ground connecting to the BWC and thereby reducing to a low possibility of exposure of people or structures to exacerbated wildfire risk. Therefore, the proposed Project would result in no impacts to wildfires related to exposure of people or structures to significant risks as a result of runoff, postfire slope instability, or drainage changes in or near SRAs or lands classified as VHFHSZs.

Reference

California Department of Forestry and Fire Prevention (CAL FIRE). 2021. *FHSZ Viewer*. Accessed September 28, 2021. Available at: <https://egis.fire.ca.gov/FHSZ/>

Mandatory Findings of Significance

	Potentially Significant Impact	Less than Significant with Mitigation Incorporated	Less than Significant Impact	No Impact
XXI. MANDATORY FINDINGS OF SIGNIFICANCE --				
a) Does the Project have the potential to degrade the quality of the environment, substantially reduce the habitat of a fish or wildlife species, cause a fish or wildlife population to drop below self-sustaining levels, threaten to eliminate a plant or animal community, reduce the number or restrict the range of a rare or endangered plant or animal or eliminate important examples of the major periods of California history or prehistory?	<input type="checkbox"/>	<input type="checkbox"/>	<input checked="" type="checkbox"/>	<input type="checkbox"/>
b) Does the Project have impacts that are individually limited but cumulatively considerable? ("Cumulatively considerable" means that the incremental effects of a Project are considerable when viewed in connection with the effects of past Projects, the effects of other current Projects, and the effects of probable future Projects)?	<input type="checkbox"/>	<input type="checkbox"/>	<input type="checkbox"/>	<input checked="" type="checkbox"/>
c) Does the Project have environmental effects which will cause substantial adverse effects on human beings, either directly or indirectly?	<input type="checkbox"/>	<input type="checkbox"/>	<input type="checkbox"/>	<input checked="" type="checkbox"/>

Discussion

- a) **Less than Significant Impact.** The Project site is located in a developed area of the City and is developed with buildings, power generation equipment, public rights-of-way and similar urban uses. Based on the Biological Resources Assessment performed on the site by WRA (attached to this Initial Study), there are limited biological resources that could be affected by construction of the Project. The one potentially significant impact would be impacts to nesting birds as a result of loss of five trees. This impact would be mitigated to a less-than-significant level as described in the Biological Resources section of this Initial Study. Therefore, the Project would not have the potential to degrade the quality of the environment, reduce a fish or wildlife species or eliminate any wildlife species. It would also not impact any rare, threatened species or eliminate any historic resources. As described in the Cultural Resources section of the Initial Study, the Project would result in no impact to historical resources and impacts to archaeological resources would be less than significant with incorporation of mitigation if there is unanticipated discovery of unknown archaeological resources as well as human remains. Although the BWP campus and BWC are both greater than 50 years of age and may be considered historical resources, the Project is consistent with the original intended purpose and use of both resources. The Project would not eliminate important examples of the major periods of California history or prehistory.
- b) **No Impact.** The proposed Project, in conjunction with other past, present, and reasonably foreseeable future related Projects, has no potential to result in significant cumulative impacts when the independent impacts of the proposed Project and the impacts of related Projects combine to create impacts greater than those of the proposed Project alone. Proposed drainage

and storm water quality improvements that would be constructed as part of the Project would be located in a limited area of the City of Burbank and would be completed in a single phase. No other changes to the environment are proposed on or adjacent to the site. No impact would result with respect to this topic.

- c) **No Impact.** The preceding Initial Study does not identify any effects that would result in substantial adverse impacts to human beings, either directly or indirectly. There would be no impact with respect to this topic.

Summary of Mitigation Measures

Biological Resources

Mitigation Measure BIO-1. No Project activities, including vegetation removal and grading shall be conducted during nesting bird season (February 15 to August 31) to the extent feasible. If such activities must be conducted during the nesting season, a pre-construction nesting-bird survey shall be performed by a qualified biologist no more than 14 days prior to vegetation removal or initial ground disturbance. The survey shall include the disturbance area and the surrounding 500 feet, to identify the location and status of any nests that could potentially be affected either directly or indirectly by Project activities. The nesting bird surveys shall be conducted during appropriate time of day and weather conditions and concentrate on potential roosting or perch sites.

If an active nest (containing eggs or chicks) of protected species is found within the survey area, it shall be designated as an ecologically sensitive area and protected (while occupied) during Project Activities. Established exclusion zones shall remain in place until all young in the nest have fledged or the nest otherwise becomes inactive (e.g., due to predation). Appropriate exclusion zone sizes shall be determined by a qualified biologist and vary dependent upon the species, nest location, existing visual buffers, noise levels, and other factors. An exclusion zone radius may be as small as 250 feet for common, disturbance-adapted species or as large as 500 feet or more for raptors. Exclusion zone size may be reduced from established levels if supported with nest monitoring findings by a qualified biologist indicating that work activities outside the reduced radius are not adversely affecting the nest and that a reduced exclusion zone would not adversely affect the subject nest.

These requirements shall be included in Project plans and construction specifications.

Cultural Resources

Mitigation Measure CUL-1. If an archaeological resource is identified, work on the Project site shall cease immediately until a resource protection plan conforming to CEQA Guidelines Section 15064.5(e) is prepared by a qualified archaeologist and approved by the Community Development Director. Project work may be resumed in compliance with such plan. If human remains are encountered, the County Coroner shall be contacted immediately.

Geology and Soils

Mitigation Measure GEO-1. If a paleontological resource is identified, work on the Project site shall cease immediately until a resource protection plan conforming to CEQA Guidelines Section 15064.5(e) is prepared by a qualified paleontologist and approved by the Community Development Director. Project work may be resumed in compliance with such plan.

Hazards and Hazardous Materials

Mitigation Measure HAZ-1. Prior to commencement of ground disturbing activities, a Phase I Environmental Site Assessment shall be completed by a qualified consulting firm as determined by BWP staff to determine possible presence of contaminated compounds or materials in the soil or groundwater near excavated or trenched areas. If such materials are identified, additional analysis, including soil testing, to determine the extent of any potential contamination. If needed, a remediation plan shall be prepared and implemented under the oversight of the Regional Water Quality Control Board. Grading and trenching operations may commence after clearances are granted by the appropriate regulatory agency.

Transportation/Traffic

Mitigation Measure TRA-1. Prior to commencement of construction of the Project (including demolition activities), the City of Burbank, Burbank Water and Power shall require the Project contractor to submit to the Burbank Public Works Department for approval, a Traffic Management Plan that includes, at minimum, the specified items:

- a) A haul route for demolition debris; and
- b) Provision to ensure that all adjacent public streets are accessible for emergency equipment and normal vehicle, bicycle and pedestrian traffic during Project demolition and construction.

Tribal Cultural Resources

Mitigation Measure TRIBAL-1: *Tribal Resources – Avoidance and Monitoring.* Prior to the initiation of ground-disturbing activities in native (*i.e.*, non-fill) soil, the City shall require monitoring of all ground-disturbing activities by a Qualified Archeologist. The Qualified Archeologist shall have a pre-construction meeting to explain the construction monitoring process and provide training. In addition, consultation and coordination shall be undertaken with the Native American local Tribal contacts designated by the Native American Heritage Commission (NAHC) and the Tribe(s) to determine if the city shall retain a Native American monitor to be present during all or a portion of the ground-disturbing activities within the Project area. In addition, representatives of tribes, with which the Most Likely Descendants, identified by the NAHC, or who have identified themselves directly to the City as having an interest in the BWP Campus Stormwater Improvement Project shall be invited to attend the pre-construction meeting to conduct Tribal cultural resource sensitivity training. Such sensitivity training may include a handout and focus on how to recognize Tribal cultural resources encountered during earthmoving activities.

In the event that previously unknown Tribal cultural resources are encountered during construction, the resources shall either be left *in situ* and avoided through redesign, or the resources shall be salvaged, recorded, and repositied at a repository consistent with the provisions of a Phase III data recovery program and the provisions of the Resource Protection Plan, specified in CUL-1. The Resource Protection Plan shall include further consultation with the identified Tribal representatives. Data recovery is not required by law or regulation. It is, though, the most commonly agreed-upon measure to mitigate adverse effects to cultural resources eligible or listed under Section 106 Criterion D/CRHR Criterion 4, as it preserves important information that would otherwise be lost.

Mitigation Measure TRIBAL-2: *Regulatory Requirements – Human Remains.* In accordance with Section 7050.5 of the California Health and Safety Code, if human remains are encountered during excavation activities, the County Coroner shall be notified within 24 hours of the discovery. No further excavation or disturbance of the site or any nearby areas reasonably suspected to overlie adjacent remains within 100 feet shall occur until the County Coroner has determined the appropriate treatment and disposition of the human remains.

If the County Coroner determines that the remains are or are believed to be Native American, s/he shall notify the NAHC in Sacramento within 24 hours. In accordance with Section 5097.98 of the California Public Resources Code, the NAHC shall immediately notify the person(s) it believes to be the most likely descendant (MLD) of the deceased Native American. The descendants shall complete their inspection and make a recommendation within 48 hours of being granted access to the site. The designated Native American representative(s) would then determine, in consultation with the City, the disposition of the human remains. The MLD's recommendation shall be followed if feasible and may include scientific removal and non-destructive analysis of the human remains and any items associated with Native American burials. If the City rejects the MLD's recommendations, the agency shall rebury the remains with appropriate dignity on the property within a time frame agreed upon between the City and the MLD's in a location that will not be subject to further subsurface disturbance (14 California Code of Regulations §15064.5(e)).

Utilities and Service Systems

Mitigation Measure Util-1. Prior to issuance of an Excavation Permit by the City of Burbank, the Project contractor shall prepare a Construction and Demolition Debris Plan. The Plan shall include methods for recycling construction debris and ultimate disposition of recycled material and shall be approved by the Burbank Public Works Department prior to commencement of excavation activities. The Construction and Demolition Debris Plan shall specify how the contractor shall transport any waste generated by construction of the project to a landfill outside the City of Burbank. The project demolition contractor shall determine the ultimate disposal site for asphalt, concrete, and other material. Any materials cleaned from the vault shall be treated as contaminated soil and transported out of the City for disposal.

Attachment 1

Biological Reconnaissance Report

Biological Resources Assessment

STORMWATER QUALITY IMPROVEMENTS PROJECT CITY OF BURBANK, LOS ANGELES COUNTY, CALIFORNIA

Prepared For:

Stevenson, Porto & Pierce
5519 Ayon Avenue
Irwindale, California 91706

Prepared By:

WRA, Inc.
2169-G East Francisco Boulevard
San Rafael, California 94901

Contact: Kari Dupler
dupler@wra-ca.com



Date:

October 2018

WRA Project Number:

28190



TABLE OF CONTENTS

1.0 INTRODUCTION.....	2
1.1 Project Description and Purpose	2
2.0 REGULATORY BACKGROUND	3
2.1 Sensitive Biological Communities	3
2.2 Special-Status Species and Critical Habitat	5
3.0 METHODS	6
3.1 Biological Communities	6
3.1.1 Non-Sensitive Biological Communities	6
3.1.2 Sensitive Biological Communities.....	7
3.2 Special-Status Species.....	8
3.2.1 Literature Review	8
3.2.2 Site Assessment	8
4.0 RESULTS	9
4.1 Biological Communities	10
4.1.1 Non-Sensitive Biological Communities	10
4.1.2 Sensitive Biological Communities.....	10
4.2 Special-Status Species.....	11
4.2.1 Plants.....	11
4.2.2 Wildlife	11
4.3 City of Burbank Trees and Vegetation Ordinance	11
5.0 POTENTIAL IMPACTS AND MITIGATION	11
5.1 Significance Threshold Criteria	12
5.2 Avoidance and Minimization Measures.....	13
5.3 Potential Impacts and Recommended Mitigation Measures.....	13
6.0 REFERENCES	16

LIST OF TABLES

Table 1. Description of CNPS Ranks and Threat Codes	6
Table 2. Summary of Non-Sensitive Biological Communities in the Project Site.....	10

LIST OF APPENDICES

- Appendix A – Figures
- Appendix B – List of Observed Plant and Wildlife Species
- Appendix C – Project Area and Site Photographs
- Appendix D – Potential for Special-Status Species to Occur in the Project Site

LIST OF ACRONYMS AND ABBREVIATIONS

BRA	Biological Resource Assessment
BWC	Burbank Western Channel
BWPC	Burbank Water and Power Campus
CAL-IPC	California Invasive Plant Council
CCR	California Code of Regulations
CEQA	California Environmental Quality Act
CDFW	California Department of Fish and Wildlife
CESA	California Endangered Species Act
CFGC	California Fish and Game Code
CFR	Code of Federal Regulations
CNDDB	California Natural Diversity Database
Corps	U.S. Army Corps of Engineers
CWA	Clean Water Act
EPA	Environmental Protection Agency
ESA	Endangered Species Act
HCP	Habitat Conservation Plan
MBTA	Migratory Bird Treaty Act
NAL	Numeric Action Level
NWI	National Wetland Inventory
RWQCB	Regional Water Quality Control Board
USFWS	United States Fish and Wildlife Service
USGS	United States Geologic Survey
WBWG	Western Bat Working Group
WRA	WRA, Inc.

1.0 INTRODUCTION

WRA, Inc. (WRA) prepared this biological resource assessment (BRA) report on behalf of the Burbank Water and Power Campus (BWPC) for the establishment of a new stormwater system (Project). The Project Site is located within downtown Burbank in Los Angeles, California (Assessor Parcel Numbers [APN] 2451-011-900, 2451-009-900, 2451-009-902, and 2451-009-901) (Appendix A, Figure 1). The approximately 24-acre Project Site is comprised of a series of buildings and associated parking lots utilized by the Burbank Water and Power Campus. Much of the proposed changes occur along the northwestern border and northeastern corner of the Project Site. This BRA report includes an evaluation of published background information relevant to the Project and findings from a site visit conducted throughout the Project Site on October 9, 2018.

The purpose of this BRA was to gather information necessary to complete a review of biological resources protected under the California Environmental Quality Act (CEQA) and to support the regulatory permit application process. This report describes the results of previous site visits that occurred in the Project Site and reviews relevant existing information in order to evaluate the Project Site for: (1) the potential to support special-status plant and wildlife species; (2) the potential presence of sensitive biological communities, such as wetlands or riparian habitats; and (3) the potential presence of other sensitive biological resources protected by local, state, and federal laws and regulations. This report also identifies potential impacts to biological resources that would result from the Project, discusses avoidance and minimization measures that would protect natural resources, and recommends mitigation measures for potentially significant impacts under CEQA.

This BRA is based on information available at the time of the study and on-site conditions observed during the October 9, 2018 survey performed in the Project Site. Habitat and species information associated with the Project Site are considered suitable for an evaluation of the Project's biological resources impacts under CEQA; however, additional protocol-level plant and wildlife surveys for certain species may be necessary to obtain permits or other regulatory approvals from state and federal regulatory agencies prior to Project implementation.

1.1 Project Description and Purpose

Currently, the 24-acre Project Site stormwater system collects run-off throughout the area and drains to a 36-inch storm drain collector, which discharges into the Burbank Western Channel (BWC), a tributary of the Los Angeles River. Run-off from an adjacent property also feeds into this same stormwater system and has resulted in discharges into the BWC containing elevated levels of zinc, copper and iron. Therefore, the Project seeks to divert the run-off from the adjacent property by plugging the pipes at the existing stormwater inlet that connect the BWPC to the adjacent property, as well as establishing 340 linear feet of new pipe and a new outflow into the BWC. Project activities associated with this diversion may result in the removal of five existing landscaped ornamental trees and underground work within the existing storm water system on Western Magnolia Blvd. Once the Project is completed, the adjacent property will no longer add to the levels of zinc, copper and iron within the stormwater discharge into the BWC that is currently resulting in exceeding of numeric action levels (NALs). Additionally, establishment of an on-site stormwater treatment system for the BWPC stormwater system that discharges into the BWC will result in the BWPC also complying with NALs of zinc, copper, and iron. This stormwater system will collect discharge as it currently does without receiving additional run-off from the adjacent property. Discharge for the entire BWPC will then be stored in an underground facility in the eastern corner, before being filtered through a pre-treatment

system equipped with valves and gates to let water infiltrate below as well as flow into the BWC. The Project would involve adding a new storage facility, pump and control housing, pretreatment system, and catch basin to the existing storm drain outfall that discharges into the BWC.

2.0 REGULATORY BACKGROUND

The following sections describe the regulatory context of the biological resources assessment, including applicable laws and regulations that were applied to the field investigations.

2.1 Sensitive Biological Communities

Sensitive biological communities include habitats that fulfill special functions or have special values, such as wetlands, streams, or riparian habitat. These habitats are protected under federal regulations, such as the CWA; state regulations, such as the Porter-Cologne Act, Section 1600-1616 of the California Fish and Game Code (CFGC), and CEQA; Habitat Conservation Plans (HCPs), or local ordinances or policies, such as city or county tree ordinances, and General Plan Elements.

Waters of the United States

The Corps regulates “Waters of the United States” under Section 404 of the CWA. Waters of the U.S. are defined in the Code of Federal Regulations (CFR) as waters susceptible to use in commerce, including interstate waters and wetlands, all other waters (intrastate waterbodies, including wetlands), and their tributaries (33 CFR 328.3). Potential wetland areas, according to the three criteria used to delineate wetlands as defined in the *Corps of Engineers Wetlands Delineation Manual* (Environmental Laboratory 1987), are identified by the presence of (1) hydrophytic vegetation, (2) hydric soils, and (3) wetland hydrology.

Areas that are inundated at a sufficient depth and for a sufficient duration to exclude growth of hydrophytic vegetation are subject to Section 404 jurisdiction as “other waters” and are often characterized by an ordinary high water mark (OHWM), and herein referred to as non-wetland waters. Non-wetland waters, for example, generally include lakes, rivers, and streams. The placement of fill material into Waters of the U.S. generally requires an individual or nationwide permit from the Corps under Section 404 of the CWA.

Waters of the State

The term “Waters of the State” is defined by the Porter-Cologne Act as “any surface water or groundwater, including saline waters, within the boundaries of the state.” The RWQCB protects all waters in its regulatory scope and has special responsibility for wetlands, riparian areas, and headwaters. These waterbodies have high resource value, are vulnerable to filling, and are not systematically protected by other programs. RWQCB jurisdiction includes wetlands and waters that may not be regulated by the Corps under Section 404.

Waters of the State are regulated by the RWQCB under the State Water Quality Certification Program which regulates discharges of fill and dredged material under Section 401 of the CWA and the Porter-Cologne Water Quality Control Act. Projects that require a Corps permit or fall under other federal jurisdiction and have the potential to impact Waters of the State are required

to comply with the terms of the Water Quality Certification determination. If a proposed project does not require a federal permit but does involve dredge or fill activities that may result in a discharge to Waters of the State, the RWQCB has the option to regulate the dredge and fill activities under its state authority in the form of Waste Discharge Requirements

Streams, Lakes, and Riparian Habitat

Streams and lakes, as habitat for fish and wildlife species, are subject to jurisdiction by CDFW under Sections 1600 et seq. of the California Fish and Game Code. Alterations to or work within or adjacent to streambeds or lakes generally require a Notification of Lake or Streambed Alteration. The term “stream”, which includes creeks and rivers, is defined in the California Code of Regulations (CCR) as “a body of water that flows at least periodically or intermittently through a bed or channel having banks and supports fish or other aquatic life [including] watercourses having a surface or subsurface flow that supports or has supported riparian vegetation” (14 CCR 1.72). In addition, the term “stream” can include ephemeral streams, dry washes, watercourses with subsurface flows, canals, aqueducts, irrigation ditches, and other means of water conveyance if they support aquatic life, riparian vegetation, or stream-dependent terrestrial wildlife (CDFG 1994). “Riparian” is defined as “on, or pertaining to, the banks of a stream.” Riparian vegetation is defined as “vegetation which occurs in and/or adjacent to a stream and is dependent on, and occurs because of, the stream itself” (CDFG 1994). Removal of riparian vegetation also requires a Notification of Lake or Streambed Alteration.

Other Sensitive Biological Communities

Other sensitive biological communities, not discussed above, include habitats that fulfill special functions or have special values. Natural communities considered sensitive are those identified by the California Department of Fish and Wildlife (CDFW) in local or regional plans, policies, or regulations. The CDFW ranks sensitive communities as “threatened” or “very threatened” and keeps records of their occurrences in its California Natural Diversity Database (CNDDDB; CDFW 2018a). Sensitive plant communities are also identified by the CDFW (2018b) and California Native Plant Society (CNPS; 2018a). Vegetation alliances are ranked 1 through 5 by CNDDDB based on NatureServe’s (2015) methodology, with those alliances ranked globally (G) or statewide (S) as 1 through 3 considered sensitive. Impacts to sensitive natural communities identified in local or regional plans, policies, or regulations or those identified by the CDFW or United States Fish and Wildlife Service (USFWS) must be considered and evaluated under CEQA (California Code of Regulations [CCR] Title 14, Div. 6, Chap. 3, Appendix G). Specific habitats may also be identified as sensitive in city or county general plans or ordinances.

City of Burbank Trees and Vegetation Ordinances

The City of Burbank has ordinances set for tree removal associated with construction. Both street trees and trees on private property shall be replaced if removed during construction. Street trees are defined as a tree within the width of public or right of way when any part is open for the use of the public, as a matter of right for purposes of vehicular and pedestrian traffic, including alleys. Tree replacement shall follow the below stipulations from the City of Burbank Municipal Code (Burbank 2018):

Street Trees: Any street tree requested by any person or property owner to be removed for the purpose of any type of construction shall be replaced with a tree of the nearest size available, of a species and in the location to be determined by the Director. The

person or property owner shall pay the total cost to the City of removal prior to any such action being undertaken. If such tree, or trees, are not replaced, the City shall be reimbursed the value of the tree as established in Section 7-4-105 of this article, in addition to the cost to the City of removal.

Private Trees: Any tree removed for the purpose of any type of construction shall be replaced with a tree of equal size, of the same species or an appropriate alternative, and in a location to be approved by the Park, Recreation and Community Services Director and the Community Development Director. Alternately, the City shall be reimbursed the value of the trees, pursuant to this section and Section 7-4-105 of this article; or, the project's landscaping shall be improved above what is required by subsection 10-1-1113E in the City of Burbank Municipal code, and in an amount equal to the value of the removed trees, or if the excess landscaping does not equal the value of the removed trees, then a fee for the shortfall shall be paid to the City; or, the tree(s) shall be moved elsewhere to the satisfaction of the Park, Recreation and Community Services Director; or a combination of moving or replacing the trees pursuant to Section 7-4-105 and this section shall be followed.

2.2 Special-Status Species and Critical Habitat

Special-Status Species

Special-status species include plants and wildlife species that have been formally listed, are proposed as endangered or threatened, or are candidates for such listing under the federal Endangered Species Act (ESA) or California Endangered Species Act (CESA). These acts afford protection to both listed species and species proposed for listing. In addition, CDFW Species of Special Concern, which are species that face extirpation in California if current population and habitat trends continue, and USFWS Birds of Conservation Concern are all considered special-status species. Although CDFW Species of Special Concern generally have no special legal status, they are given special consideration under CEQA. Bat species are also evaluated for conservation status by the Western Bat Working Group (WBWG), a non-governmental entity; bats named as a "High Priority" or "Medium Priority" species for conservation by the WBWG are typically considered special-status. In addition to regulations for special-status species, most birds in the United States, including non-special-status native species, are protected by the CFGC, i.e., sections 3503, 3503.5 and 3513. Under this law, destroying active bird nests, eggs, and/or young is illegal. The Migratory Bird Treaty Act of 1918 (MBTA) provides federal recommendations to protect birds, as well.

Plant species included within the CNPS Inventory of Rare and Endangered Plants (Inventory; CNPS 2018) with California Rare Plant Rank (Rank) of 1, 2, and 3 are also considered special-status plant species and must be considered under CEQA. Very few Rank 4 plant species meet the definitions of Section 1901 Chapter 10 of the Native Plant Protection Act or Sections 2062 and 2067 of the CFGC that outlines CESA. However, the CNPS and the CDFW strongly recommend that these species be fully considered during the preparation of environmental documentation related to CEQA. This may be particularly appropriate for the type locality of a Rank 4 plant species, for populations at the periphery of a species range, or in areas where the taxon is especially uncommon or has sustained heavy losses, or from populations exhibiting unusual morphology or occurring on unusual substrates. A description of the CNPS Ranks is provided below in Table 1.

Table 1. Description of CNPS Ranks and Threat Codes

California Rare Plant Ranks (formerly known as CNPS Lists)	
Rank 1A	Presumed extirpated in California and either rare or extinct elsewhere
Rank 1B	Rare, threatened, or endangered in California and elsewhere
Rank 2A	Presumed extirpated in California, but more common elsewhere
Rank 2B	Rare, threatened, or endangered in California, but more common elsewhere
Rank 3	Plants about which more information is needed - A review list
Rank 4	Plants of limited distribution - A watch list
Threat Ranks	
0.1	Seriously threatened in California
0.2	Moderately threatened in California
0.3	Not very threatened in California

3.0 METHODS

On October 9, 2018, the Project Site was traversed on foot to determine (1) plant communities present within the Project Site, (2) whether existing conditions potentially provide suitable habitat for any special-status plant or wildlife species, and (3) whether sensitive habitats are present. All plant and wildlife species encountered during the site visit were documented, and are listed in Appendix B. Plant nomenclature follows Baldwin et al. (2012) and subsequent revisions by the Jepson Flora Project (2018), except where noted. Because of recent changes in classification for many of the taxa treated by Baldwin et al. and the Jepson Flora Project, relevant synonyms are provided in brackets. For cases in which regulatory agencies, CNPS, or other entities base rarity on older taxonomic treatments, precedence was given to the treatment used by those entities.

3.1 Biological Communities

Biological communities present in the Project Site were classified based on existing plant community descriptions described in *A Manual of California Vegetation* (Sawyer et al. 2009) and *Preliminary Descriptions of the Terrestrial Natural Communities of California* (Holland 1986). However, in some cases it was necessary to identify variants of community types or communities that are not described in the literature. Biological communities were classified as sensitive or non-sensitive as defined by the CEQA and other applicable laws and regulations (see Section 2.2, above).

3.1.1 Non-Sensitive Biological Communities

Non-sensitive biological communities are those communities that are not afforded special protection under the CEQA or other state, federal, or local laws, regulations or ordinances. These communities may, however, provide suitable habitat for some special-status plant or wildlife species and are identified or described in Section 4.2.1, below.

3.1.2 Sensitive Biological Communities

Sensitive biological communities are defined as those communities that are given special protection under the CEQA or other applicable federal, state, or local laws, regulations or ordinances. Applicable laws and ordinances are discussed above in Section 2.0. Special methods used to identify sensitive biological communities are discussed below.

Wetlands and Non-Wetland Waters

The Project Site was surveyed to determine whether any wetlands or non-wetland waters potentially subject to jurisdiction by the Corps, RWQCB, or CDFW may be present. The preliminary assessment of wetlands was based primarily on the presence of wetland plant indicators, but may also include any observed indicators of wetland hydrology or wetland soils. Any potential wetland areas were identified as areas dominated by plant species with a wetland indicator status¹ of OBL, FACW, or FAC as given on the current National Wetlands Plant List (Lichvar 2013). Evidence of wetland hydrology may include direct evidence (i.e., primary indicators) such as visible inundation or saturation, algal mats, or oxidized root channels, or indirect evidence (i.e., secondary indicators) such as a water table within two feet of the soil surface during the dry season. Some indicators of wetland soils include dark colored soils, soils with a sulfidic odor, or soils that contain redoximorphic features, as defined by the Natural Resources Conservation Service (NRCS) publication *Field Indicators of Hydric Soils in the United States* (NRCS 2010). The preliminary assessment of non-wetland waters assessment was based primarily on the presence of unvegetated, ponded areas or flowing water, or evidence indicating their presence such as an OHWM or a defined drainage course.

The preliminary assessment conducted during the biological resources assessment does not constitute an official wetland delineation. Collection of additional data may be necessary to prepare a wetland delineation report suitable for submission to the Corps. However, no wetland or non-wetland waters were found on site during the assessment.

Other Sensitive Biological Communities

The Project Site was evaluated for the presence of other sensitive biological communities, including riparian areas, and sensitive plant communities recognized by the CDFW. Prior to the site visit, aerial photographs, local soil maps, and *A Manual of California Vegetation* (Sawyer et al. 2009) were reviewed to assess the potential for sensitive biological communities to occur in the Project Site. All vegetation alliances within the Project Site with a State Rank of 1 through 3 were considered sensitive biological communities and were mapped. Some communities in the Project Site may not be considered rare by the CDFW, but are afforded special protections when associated with wetland or riparian habitats. Sensitive biological communities observed in the Project Site are described in Section 4.1.2, below.

¹ OBL = Obligate, always found in wetlands (> 99% frequency of occurrence); FACW = Facultative Wetland, usually found in wetlands (67-99% frequency of occurrence); FAC = Facultative, equal occurrence in wetland or non-wetlands (34-66% frequency of occurrence).

3.2 Special-Status Species

3.2.1 Literature Review

The potential for special-status species to occur in the Project Site and immediately adjacent land was evaluated by first determining which special-status species have been documented previously in the Project Site and in the 5-mile vicinity of the Project Site through a literature and database search. Database searches for known occurrences of special-status species focused on the Burbank USGS 7.5-minute quadrangle (USGS 2015). The following sources were reviewed to determine which special-status plant and wildlife species have been documented to occur within and in the vicinity of the Project Site:

- California Natural Diversity Database (CDFW 2018)
- USFWS quadrangle species lists (USFWS 2018)
- CNPS Rare and Endangered Plant Inventory (CNPS 2018)
- CDFG publication *California's Wildlife, Volumes I-III* (Zeiner et al. 1990)
- CDFG publication *Amphibians and Reptile Species of Special Concern in California* (Jennings 1994)
- Western Bat Working Group, species accounts (WBWG 2018)
- California Bird Species of Special Concern (Shuford and Gardali 2008)
- *A Field Guide to Western Reptiles and Amphibians* (Stebbins 2003)

3.2.2 Site Assessment

An assessment of the potential for special-status plant and wildlife species to occur in the Project Site was conducted based on the literature review and types and condition of habitats observed in the Project Site. The potential for occurrence is a rating of general habitat suitability that considers several factors related to the ability of a site to support a particular species, including:

- Historic and existing species range and documented occurrences in the vicinity;
- Current understanding of the life history and habitat requirements of each species;
- Suitability of physical and biological conditions of the site to support sustainable populations including appropriate breeding, foraging, and dispersal habitat; and
- Existing and historic on-site and surrounding land uses that may affect habitat suitability.

Each special-status species identified in the literature search as occurring in the vicinity of the Project Site was assigned a potential for occurrence rating based on the following criteria:

- No Potential. Habitat on and adjacent to the site is clearly unsuitable for the species. For wildlife, this is based on a lack of one or more essential habitat elements (foraging, breeding, cover, substrate, elevation, hydrology, plant community, site history, or disturbance regime). Species surveys are not considered necessary.
- Unlikely. Few of the habitat components meeting the species requirements are present, and/or the majority of habitat on and adjacent to the site is unsuitable or of very poor quality. The species is not likely to be found on the site. Species surveys not considered necessary but may be performed to confirm species absence.

- Moderate Potential. Some of the habitat components meeting the species requirements are present, and/or only some of the habitat on or adjacent to the site is unsuitable. The species has a moderate probability of being found on the site. Species surveys may be necessary to avoid project impacts.
- High Potential. All of the habitat components meeting the species requirements are present and/or most of the habitat on or adjacent to the site is highly suitable. The species has a high probability of being found on the site. Species surveys may be necessary to avoid project impacts.

Statements of results and recommendation for further actions are provided for each species based on the potential for occurrence rating and available survey results if previous surveys have been conducted. Presence or absence results may utilize the following categories, if applicable:

- Presumed Absent. Species not observed during surveys or there is no potential for occurrence.
- Present. Species was observed on the site or has been documented recently as being on the site.

The site assessment is intended to identify the presence or absence of suitable habitat for each special-status species known to occur in the vicinity of the Project Site to determine its potential to occur in the Project Site. The site assessment does not constitute a protocol-level survey and is not intended to determine the actual presence or absence of a species; however, if a special-status species was observed during the site visit, its presence was recorded and it is discussed in Section 4, below. For some species, a site assessment visit at the level conducted for this report may not be sufficient to determine presence or absence of a species to the specifications of regulatory agencies. In these cases, a species may be assumed to be present or further protocol-level special-status species surveys may be necessary. Special-status species for which further protocol-level surveys may be necessary are described below in Section 5.0.

4.0 RESULTS

The following sections present the results of the biological resources assessment conducted within the Project Site. Plant and wildlife species observed in the Project Site during the site visit are listed in Appendix B. Representative photographs of the Project Site are provided in Appendix C.

The 24-acre Project Site consists of approximately 24 acres of landscaped/developed land. The Project Site is located in a developed area in downtown Burbank, and is located approximately half a mile southwest of Burbank City Hall. The Project Site is surrounded to the south, east, and west by government, residential and commercial development. The Project Site is dominated by developed surfaces and commercial buildings, but is bordered to the northeast by the BWC. Vegetation consists of landscaped trees which are planted in landscaped planters along the edges of buildings, parking areas, and streets. Elevations within the Project Site range from 553 to 570 feet above sea level.

The Project Site is highly developed with the majority of the parcels consisting of paved parking lots with impervious surfaces, various buildings associated the Burbank Water and Power Campus. No special-status plant or wildlife species were observed during the site assessment, and the site was determined to have little to no potential to host the special-status species identified in the literature and database searches.

4.1 Biological Communities

Descriptions for each biological community observed in the Project Site are contained in the following sections. Biological communities within the Project Site are shown on Figure 2 (Appendix A).

4.1.1 Non-Sensitive Biological Communities

Table 2 summarizes the area of each non-sensitive biological community within the Project Site. Non-sensitive biological communities in the Project Site include just developed/landscaped areas (24.0 acres).

Table 2. Summary of Non-Sensitive Biological Communities in the Project Site

Community Type	Area (acres)
Developed/Landscaped	24.0
Total	24.0

Developed/Landscaped

The Project Site (24 acres) is made up of developed and landscaped areas including parking lots and paved, impervious surfaces with numerous buildings associated with the Burbank Water and Power Campus. Ornamental trees and shrubs were observed within the Project Site including fan palms (*Washingtonia* sp.), holly oak (*Quercus ilex*), and birds of paradise (*Strelitzia reginae*).

4.1.2 Sensitive Biological Communities

Burbank Western Channel

The BWC is an intermittent stream that runs within a constructed concrete-lined trapezoidal channel, and is protected under the CWA and Porter Cologne Act. It runs outside of the Project Site on the northeastern boundary and currently receives stormwater discharge through an outfall that drains from the Project Site and adjacent property. This portion of the BWC does not sustain much vegetation and contains trash and other debris. The BWC is within the Los Angeles River watershed and is a tributary of the Los Angeles River. The Project will construct a new outfall into the BWC, potential impacts and mitigation are discussed below in section 5.0.

4.2 Special-Status Species

4.2.1 Plants

Appendix D summarizes the potential for occurrence determined for each special-status plant species documented from the vicinity of the Project Site. Based upon a review of the resources and databases given in Section 3.2.1, it was determined that 10 special-status plant species have been documented in the vicinity of the Project Site. Special-status plant species that have been documented within a five-mile radius of the Project Site are shown on Figure 3 (Appendix A). Given that the site is dominated by developed and landscaped areas with vegetated habitats consisting of planted non-native species, it was determined the Project Site does not contain suitable habitat for the any of the 10 special-status plant species documented from the vicinity. These species are generally associated with less disturbed habitats including forest, scrub, woodland, grassland, vernal pools, meadows and seeps, playas, alkaline or mesic marsh and swamps, or chaparral communities which are not present on the site. Additionally, the majority of the site is paved except for the landscaped trees which do not provide suitable habitat for any of the special status plant species documented within the Burbank USGS quadrangle.

4.2.2 Wildlife

Appendix D summarizes the potential for each of these species to occur in the Project Site. Based upon a review of the resources and databases given in Section 3.2.1, it was determined that 14 special-status wildlife species have been documented in the vicinity of the Project Site (Burbank USGS quadrangle) with nine of these species being documented within five miles of the Project Site (Appendix A, Figure 4). No special-status wildlife species were observed in the Project Site during the site assessment and none were determined to have a moderate or high potential to occur. These species are generally associated with grassland, sage scrub, chaparral, woodland, arid scrub, or riparian communities, which are not present on the site.

Bird species that are protected under the CFGC and the MBTA may use trees that are present within the Project Site to nest. Mitigation measures for these are included in Section 5.3.

4.3 City of Burbank Trees and Vegetation Ordinance

The Project Site contains several species of landscaped ornamental trees protected under the City of Burbank Trees and Vegetation Ordinance. Fan palms and holly oaks are present on the borders of the Project Site in rows along the sidewalk and street sides. These trees are protected and any removal or permanent impacts to them require compensatory mitigation discussed above in Section 2.1.

5.0 POTENTIAL IMPACTS AND MITIGATION

No sensitive biological community was identified within the Project Site, though the BWC is adjacent to the northeastern portion of the Project Site. No special-status plant or wildlife species were determined to have a moderate potential to occur within the Project Site. The following sections present a CEQA level discussion of potential impacts to these natural resources and subsequent mitigation to reduce the level of significance to acceptable levels.

5.1 Significance Threshold Criteria

Pursuant to Appendix G, Section IV of the State CEQA Guidelines, a project would have a significant impact on biological resources if it would:

- a) Have a substantial adverse effect, either directly or through habitat modifications, on any species identified as a candidate, sensitive, or special-status species in local or regional plans, policies, or regulations, or by the CDFW or USFWS;
- b) Have a substantial adverse effect on any riparian habitat or other sensitive natural community identified in local or regional plans, policies, regulations, or by the CDFW or USFWS;
- c) Have a substantial adverse effect on federally protected wetlands as defined by Section 404 of the CWA (including, but not limited to, marsh, vernal pool, coastal, etc.) through direct removal, filling, hydrological interruption, or other means;
- d) Interfere substantially with the movement of any native resident or migratory fish or wildlife species or with established native resident or migratory wildlife corridors, or impede the use of native wildlife nursery sites;
- e) Conflict with any local policies or ordinances protecting biological resources, such as a tree preservation policy or ordinance; and/or,
- f) Conflict with the provisions of an adopted HCP, Natural Community Conservation Plan, or other approved local, regional, or state habitat conservation plan.

This report uses these thresholds in the analysis of impacts and determination of the significance of those impacts. The assessment of impacts under CEQA is based on the change caused by the Project relative to the CEQA baseline, which in this case are the existing conditions at the site. In applying CEQA Appendix G, the terms “substantial” and “substantially” are used as the basis for significance determinations in many of the thresholds but are not defined qualitatively or quantitatively in CEQA or in technical literature. In some cases, the determination of a substantial adverse effect (*i.e.*, significant impact) may be relatively straightforward. For instance, “take” or other direct adverse impacts to special-status species listed under the CESA or ESA or their habitat without implementation of appropriate mitigation is considered a significant impact. In other cases, the determination of a substantial adverse effect (*i.e.*, significant impact) requires application of best professional judgment based on knowledge of site conditions as well as the ecology and physiology of biological resources present in a given area and the type of effect that would be caused by a project. Determinations of whether or not Project activities will result in a substantial adverse effect to biological resources are discussed in the following sections for sensitive biological communities, special-status plant species, and special-status wildlife species.

Regarding item c, above, there are no wetlands present within the Project Site, therefore the Project would not substantially impact wetlands.

Regarding item d, above, due the location of the Project in a developed urban environment there is limited capacity to provide habitat for wildlife species, therefore the Project would not substantially impact movement of wildlife or use of nursery sites.

Regarding item e, above, the Project may remove five trees protected under the City of Burbank Trees and Vegetation trees but the project design is such that it complies with local ordinances therefore the impacts will be less than significant.

Regarding item f, above, no Natural Community Conservation Plan, or other approved local, regional, or state habitat conservation plan are applicable within the Project Site.

5.2 Avoidance and Minimization Measures

Avoidance and minimization measures that would be implemented to minimize potential impacts to sensitive species and habitats are discussed below.

- Areas of disturbance will be limited to the construction area, including access routes and staging areas
- Utilize street sweeping and/or vacuuming to prevent sediments from entering storm drains

5.3 Potential Impacts and Recommended Mitigation Measures

Impact BIO-1: Project Activities Could Potentially Impact Protected Trees

Landscaped trees are present along the northwestern border of the Burbank Water and Power Campus that may be removed during project activities. The Project may remove five planted fan palm trees protected under the City of Burbank Trees and Vegetation ordinance. Impacts to protected trees would be considered significant under CEQA, however the project has been designed to comply with ordinance. Replacement trees of equal size, of the same species will be placed in a location approved by the City of Burbank Park, Recreation and Community Services Director and the Community Development Director. Therefore, the Project's potential impacts to trees protected under the City of Burbank Vegetation and Trees Ordinance are considered less than significant without mitigation due to the project design.

Level of Significance before Mitigation: Less than Significant without Mitigation

Impact BIO-2: Project Activities Could Potentially Impact the Burbank Western Channel

The Project includes installation of a reinforced concrete pipe outflow to divert discharge from the adjacent property into the BWC instead of the stormwater system of the BWPC (Appendix A, Figure 5). The BWC is within the jurisdiction of the Corps under Section 404 of the CWA and the RWQCB under Section 401 of the CWA and the Porter-Cologne Act, and CDFW under Section 1600 of the CDFG. Permits necessary for installation of the culvert may include a Section 404 Permit from the Corps, a Section 401 Water Quality Certification from the RWQCB, and a Section 1602 Lake and Streambed Alteration Agreement from the CDFW. BWPC will obtain all required resource agency permit approvals prior to beginning work within potentially jurisdictional waters, and will comply with any specific conditions of those approvals. Construction activities related to the installation of this new outflow could potentially impact the BWC and be considered significant under CEQA, however the implementation of Mitigation Measure BIO-2 will reduce this potential impact to less than significant.

Level of Significance before Mitigation: Potentially Significant without Mitigation

Mitigation Measure BIO-2: Obtain Regulatory Permits for Activities Adjacent to the Burbank Western Channel

Prior to disturbance of any jurisdictional waters, BWPC shall obtain all required resource agency permit approvals required for such disturbance (e.g., Section 404 Permit from the Corps, Section 401 Water Quality Certification from the RWQCB, Section 1602 Lake and Streambed Alteration Agreement from the CDFW) and shall comply with all conditions of such approvals. BWPC shall provide the County with documented evidence of such approvals and compliance with conditions. The Project will comply with all rules and regulations stipulated by the resource agencies during the construction of the Project to avoid any potential impacts to the BWC. Compliance with federal and state organizations with jurisdiction over the BWC will reduce the level of significance to less than significant under CEQA.

Level of Significance after Mitigation: Less than Significant

Impact BIO-3: Project Activities Could Potentially Impact Nesting Birds

The Project has the potential to impact special-status and non-special-status native nesting birds protected by California Fish and Game Code and guidelines for protection provided by the MBTA. Project activities such as vegetation removal and ground disturbance associated with Project activities would have the potential to affect these species by causing direct mortality of eggs or young, or by causing auditory, vibratory, and/ or visual disturbance of a sufficient level to cause abandonment of an active nest. If Project Activities occur during the bird nesting season, which generally extends from February 1 through August 31, nests of both special-status and non-special-status native birds could be impacted by construction and other ground disturbing activities. Impacts to nesting birds would be considered significant under CEQA. Implementation of Mitigation Measure BIO-3 will reduce this potential impact to less than significant.

Level of Significance before Mitigation: Potentially Significant

Mitigation Measure BIO-3: Nesting Bird Avoidance Measures

Project Activities such as vegetation removal and grading shall be conducted between September 1 and January 31 (outside of the February 1 to August 31 nesting season) to the extent feasible. If such activities must be conducted during the nesting season, a pre-construction nesting-bird survey shall be conducted by a qualified biologist no more than 14 days prior to vegetation removal or initial ground disturbance. The survey shall include the disturbance area and surrounding 250 feet to identify the location and status of any nests that could potentially be affected either directly or indirectly by Project activities.

If active nests of protected species are found within the survey area, a work exclusion zone shall be established around each nest by the qualified biologist. Established exclusion zones shall remain in place until all young in the nest have fledged or the nest otherwise becomes inactive (e.g., due to predation). Appropriate exclusion zone sizes shall be determined by a qualified biologist and vary dependent upon the species, nest location, existing visual buffers, noise levels, and other factors. An exclusion zone radius may be as small as 50 feet for common, disturbance-adapted species or as large as 250 feet or more for raptors. Exclusion

zone size may be reduced from established levels if supported with nest monitoring findings by a qualified biologist indicating that work activities outside the reduced radius are not adversely affecting the nest and that a reduced exclusion zone would not adversely affect the subject nest.

Level of Significance after Mitigation: Less than Significant

6.0 REFERENCES

- Baldwin, BG, DH Goldman, DJ Keil, R Patterson, TJ Rosatti, and DH Wilken (eds.). 2012. The Jepson Manual: Vascular Plants of California, second edition. University of California Press, Berkeley, CA.
- [CDFG] California Department of Fish and Game. 1994. A Field Guide to Lake and Streambed Alteration Agreements, Sections 1600-1607, California Fish and Game Code. Environmental Services Division, Sacramento, CA.
- [CDFW] California Department of Fish and Wildlife. 2018. California Natural Diversity Database. California Department of Fish and Wildlife. Biogeographic Data Branch, Vegetation Classification and Mapping Program, Sacramento, California. Available online at: <http://www.dfg.ca.gov/biogeodata/cnddb/mapsanddata.asp>; most recently accessed October 2018.
- [Burbank] City of Burbank Municipal Code. A Codification of the General Ordinances of the City of Burbank, California. 2018. <https://www.codepublishing.com/CA/Burbank/>; most recently accessed October 2018.
- [CNPS] California Native Plant Society (CNPS). 2018. Inventory of Rare and Endangered Plants of California. California Native Plant Society, Sacramento, California. Online at: <http://www.rareplants.cnps.org>; most recently accessed October 2018.
- Environmental Laboratory. 1987. Corps of Engineers Wetlands Delineation Manual. Department of the Army, Waterways Experiment Station, Vicksburg, Mississippi 39180-0631.
- Holland, RF. 1986. Preliminary Descriptions of the Terrestrial Natural Communities of California. Prepared for the California Department of Fish and Game, Sacramento, CA.
- Jennings, M. R. and M. P. Hayes. 1994. Amphibian and Reptile Species of Special Concern in California. Final report submitted to the California Department of Fish and Game, Inland Fisheries Division, Rancho Cordova, California. Contract No. 8023.
- Jepson Flora Project (eds.). 2018. Jepson eFlora. Online at: <http://ucjeps.berkeley.edu/IJM.html>; most recently accessed October 2018.
- Lichvar, RW. 2013. The National Wetland Plant List: 2013 wetland ratings. *Phytoneuron* 2013-49: 1-241.
- Natural Resources Conservation Service (NRCS). 2010. Field Indicators of Hydric Soils in the United States, version 7.0. In cooperation with the National Technical Committee for Hydric Soils, Fort Worth, TX.
- NatureServe. 2018. NatureServe Conservation Status. Available online at: <http://www.natureserve.org/explorer/ranking>.
- Sawyer, J, T Keeler-Wolf and J Evens. 2009. A Manual of California Vegetation. California Native Plant Society, Berkeley, CA.

- Shuford, W. D., and Gardali, T., editors. 2008. California Bird Species of Special Concern: A ranked assessment of species, subspecies, and distinct populations of birds of immediate conservation concern in California. Studies of Western Birds 1. Western Field Ornithologists, Camarillo, California, and California Department of Fish and Game, Sacramento.
- Stebbins, RC. 2003. A Field Guide to Western Reptiles and Amphibians, third edition. The Peterson Field Guide Series, Houghton Mifflin Company, NY.
- [USFWS] U.S. Fish and Wildlife Service. 2018b. IPaC - Information for Planning and Conservation Trust Resource Report. Sacramento Fish and Wildlife Office. Available online: <http://ecos.fws.gov/ipac/>; most recently accessed October 2018.
- [USGS] United States Geological Survey. 2015. Burbank 7.5-minute Quadrangle map
- [WBWG] Western Bat Working Group. 2018. Species accounts. Prepared by: Betsy C. Bolster. Available online at: <http://wbwg.org/western-bat-species/>; most recently accessed October 2018.
- Zeiner, DC, WF Laudenslayer, Jr., KE Mayer, and M White. 1990. California's Wildlife, Volume I-III: Amphibians and Reptiles, Birds, Mammals. California Statewide Wildlife Habitat Relationships System, California Department of Fish and Game, Sacramento, CA.

APPENDIX A
FIGURES

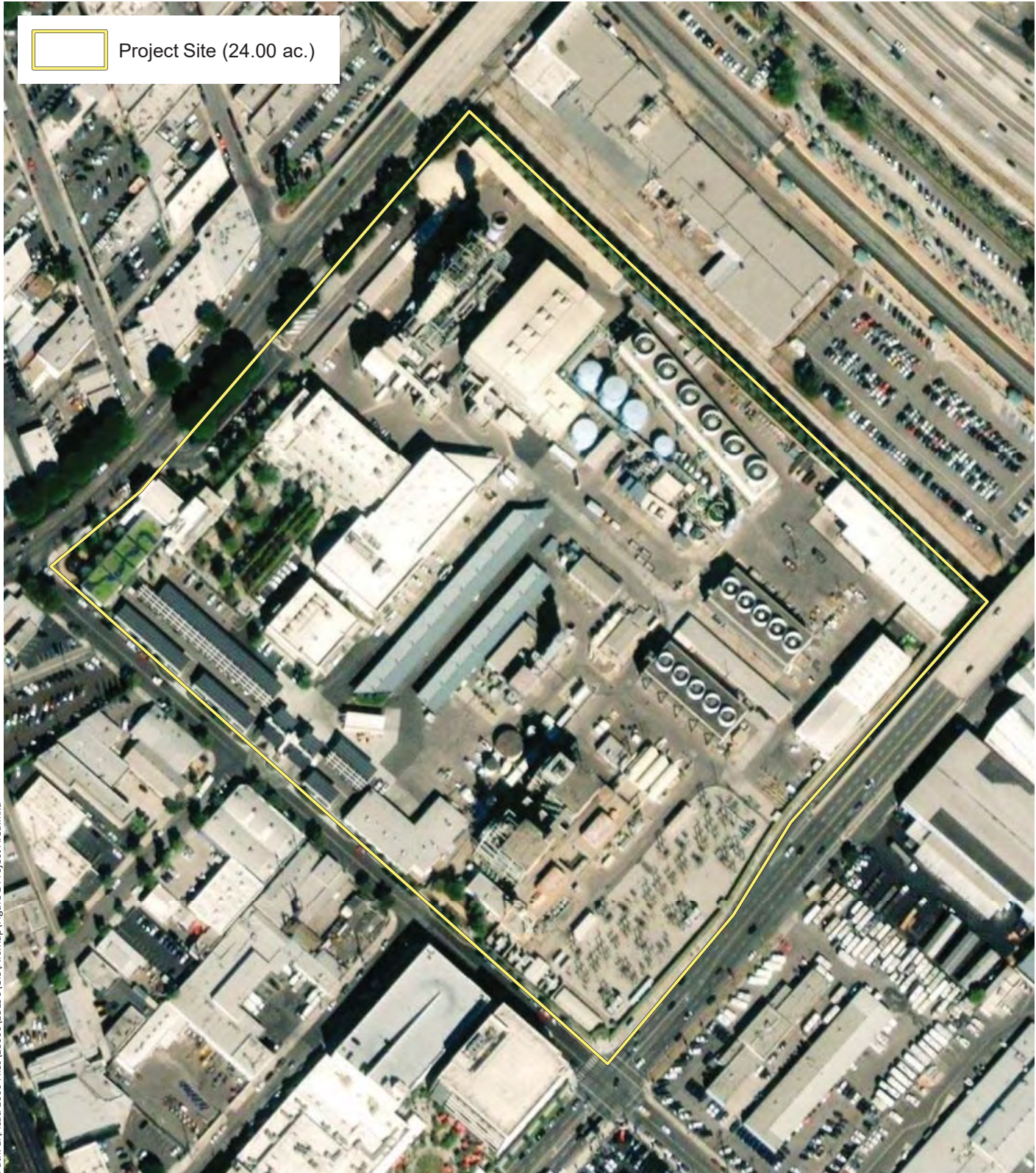

 Project Site (24.00 ac.)

Path: L:\Acad 2000 Files\28000\28190\GIS\ArcMap\Figure 1 Project Area.mxd

Sources: 2016 DigitalGlobe Aerial, WRA | Prepared By: pkobylarz, 10/19/2018

Figure 1. Project Area Map

City of Burbank W&P Improvement Project
Los Angeles County, California

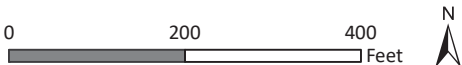
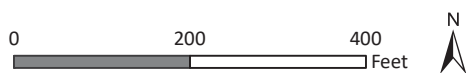
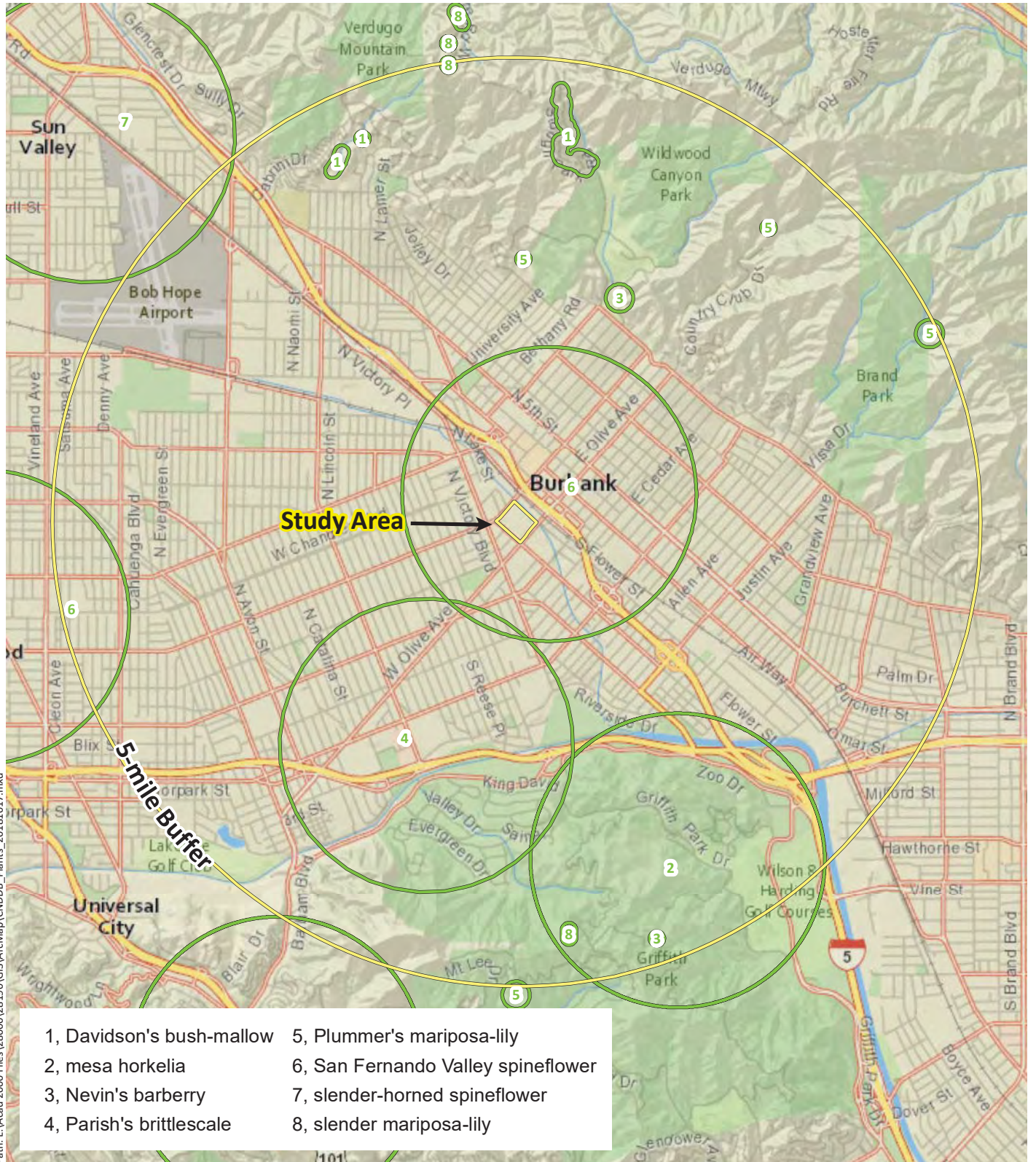



Figure 2. Biological Communities

City of Burbank W&P Improvement Project
 Los Angeles County, California





Sources: National Geographic, CNDDDB October 2018, WRA | Prepared By: pkobylarz, 10/17/2018

Figure 3. Special-Status Plant Species Documented within 5 miles of the Study Area

City of Burbank W&P Improvement Project
Los Angeles County, California

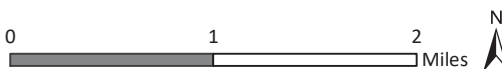

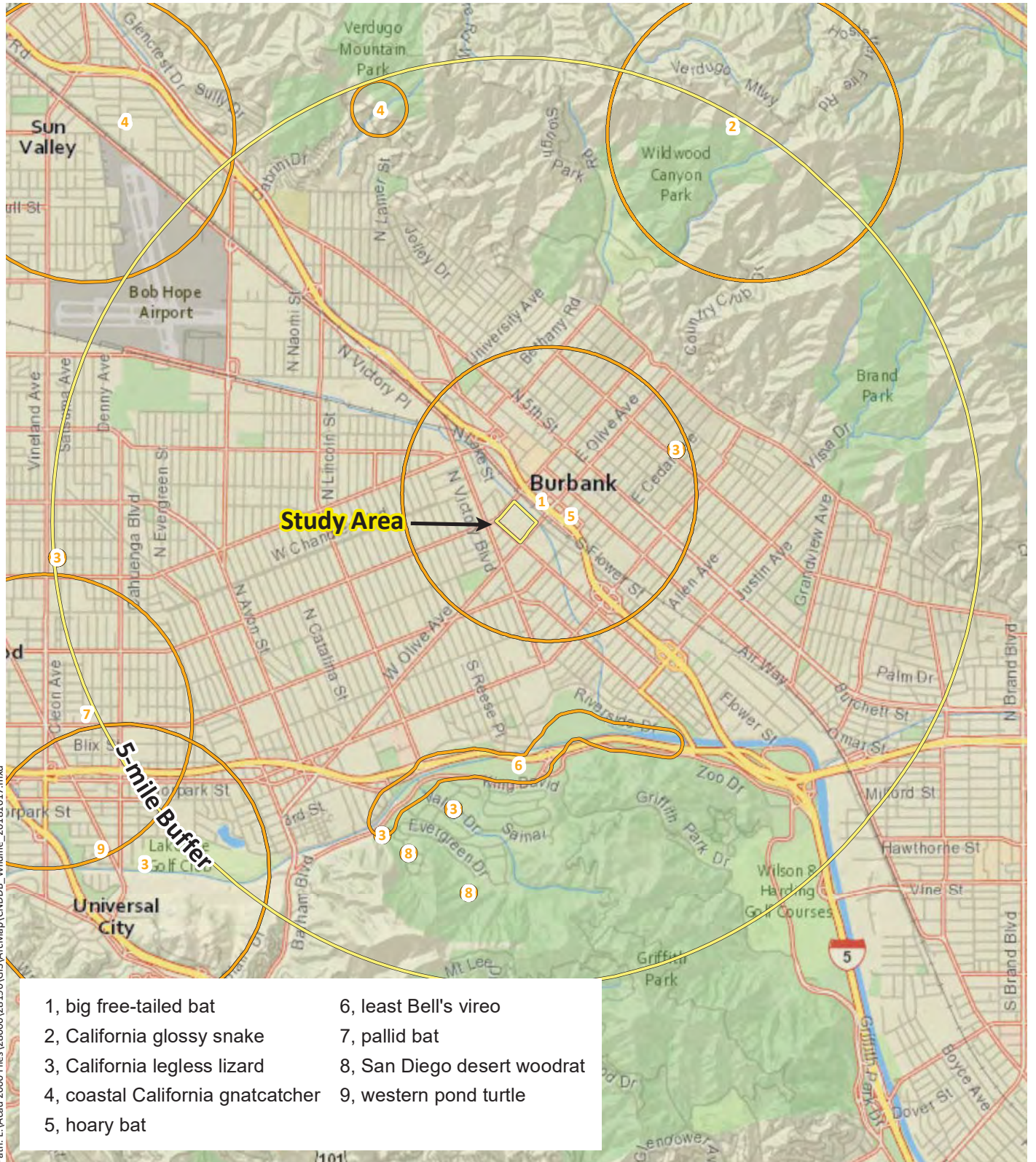

Sources: National Geographic, CNDDB October 2018, WRA | Prepared By: pkobylarz, 10/17/2018

Figure 4. Special-Status Wildlife Species Documented within 5 miles of the Study Area

City of Burbank W&P Improvement Project
Los Angeles County, California

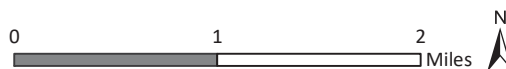

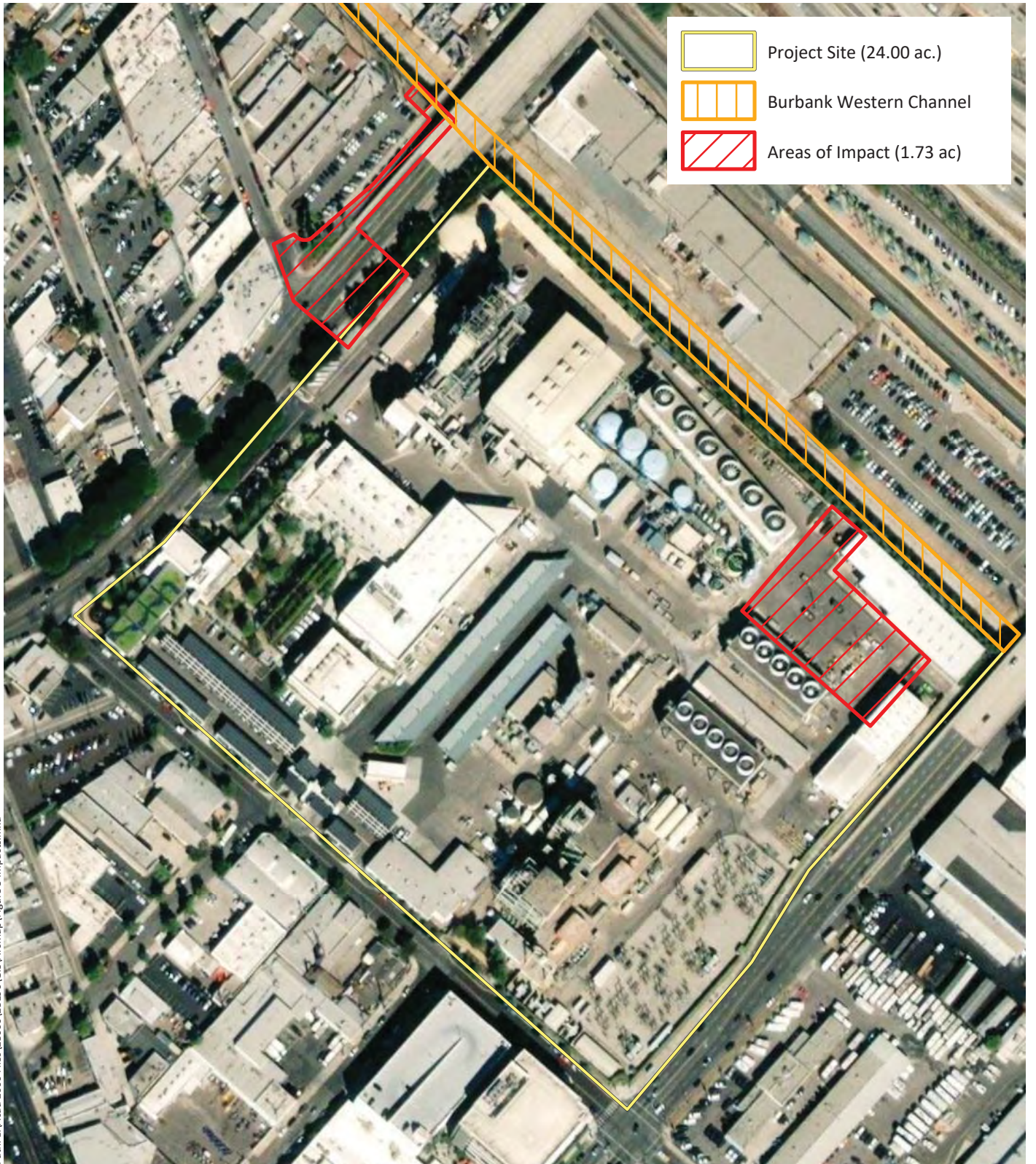

Path: L:\Acad 2000 Files\28000\28190\GIS\ArcMap\Figure 3 Impacts.mxd

Sources: 2016 DigitalGlobe Aerial, WRA | Prepared By: pkobylarz, 10/29/2018

Figure 5. Project Impacts

City of Burbank W&P Improvement Project
 Los Angeles County, California

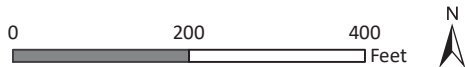

APPENDIX B

LIST OF OBSERVED PLANT AND WILDLIFE SPECIES

Appendix B. Observed Plant and Wildlife Species in the Project Site

Common Name	Scientific Name
Plants	
Holly oak	<i>Quercus ilex</i>
Birds of Paradise	<i>Strelitzia reginae</i>
Fan palms	<i>Washingtonia</i> sp.
Wildlife	
Common raven	<i>Corvus corax</i>
Western gull	<i>Larus occidentalis</i>
Northern mockingbird	<i>Mimus polyglottos</i>
Black phoebe	<i>Sayornis nigricans</i>

APPENDIX C
PROJECT AREA AND SITE PHOTOGRAPHS



Photograph 1: Representative photograph showing location of current stormwater system currently connecting adjacent property to Project Site



Photograph 2: Representative photograph showing the Burbank Western Channel



Photograph 3: Representative photograph show ornamental trees and vegetation



Photograph 4: Representative photograph showing developed area within the Project Site



Photograph 5: Representative photograph showing developed area within the Project Site



Photograph 6: Representative photograph showing developed area within the Project Site

APPENDIX D

POTENTIAL FOR SPECIAL-STATUS SPECIES
TO OCCUR IN THE PROJECT SITE

Appendix D. Potential for Special-Status Species to occur in the Project Site.

Name	Status*	Habitat	Potential to occur
Plants			
Parish's brittlescale <i>Atriplex parishii</i>	CNPS 1B.1	Annual herb typically occurring in vernal pools or on drying alkali flats with fine soils. 25-1900 m. Blooms Jun-Oct.	No potential. No vernal pools or alkali flat habitat in or adjacent to site.
Nevin's barberry <i>Berberis nevinii</i>	Federal Endangered State Endangered CNPS 1B.1	California endemic evergreen shrub occurring in foothill woodland, chaparral, and coastal sage scrub. 70-825m. Blooms Mar-Jun.	No potential. Associated habitat is not present in or adjacent to the site.
slender mariposa-lily <i>Calochortus clavatus</i> var. <i>gracilis</i>	CNPS 1B.2	California endemic perennial bulbiferous herb occurring in chaparral, coastal scrub, and grassland. 320-1000m. Blooms Mar-Jun.	No potential. Associated habitat is not present in or adjacent to the site.
Plummer's mariposa-lily <i>Calochortus plummerae</i>	CNPS 4.2	California endemic perennial bulbiferous herb occurring in chaparral, coastal scrub, grassland, cismontane woodland, and montane coniferous forest. 100-1700m. Blooms May-Jul.	No potential. Associated habitat is not present in or adjacent to the site.
San Fernando Valley spineflower <i>Chorizanthe parryi</i> var. <i>fernandina</i>	Federal Proposed Threatened State Endangered CNPS 1B.1	Annual herb presumed extinct but rediscovered in 1999. Occurs in sandy soils in coastal scrub and grasslands. 150-1220m. Blooms Apr-Jul.	No potential. Only two known populations exist: Laskey Mesa in Ventura Co. and Newhall Ranch in Los Angeles Co.
slender-horned spineflower <i>Dodecahema leptoceras</i>	Federal Endangered State Endangered CNPS 1B.1	California endemic annual herb occurring in alluvial fan habitat within chaparral and coastal sage scrub. 200-760m. Blooms Apr-Jun.	No potential. No alluvial fan habitat present within of adjacent to site.

Name	Status*	Habitat	Potential to occur
many-stemmed dudleya <i>Dudleya multicaulis</i>	CNPS 1B.2	California endemic perennial herb occurring in chaparral, coastal sage scrub, and valley grassland, often in clay soils. 15-790m. Blooms Apr-Jul.	No potential. Associated habitat is not present in or adjacent to the site.
mesa horkelia <i>Horkelia cuneata</i> var. <i>puberula</i>	CNPS 1B.1	California endemic perennial herb occurring in maritime chaparral, coastal scrub, and cismontane woodland in sandy or gravelly soil. 70-810m. Blooms Feb-Jul.	No potential. Associated habitat is not present in or adjacent to the site.
Davidson's bush-mallow <i>Malacothamnus davidsonii</i>	CNPS 1B.2	California endemic perennial shrub occurring in chaparral, coastal scrub, cismontane woodland, and riparian woodland. 185-1140m. Blooms Jun-Jan.	No potential. Associated habitat is not present in or adjacent to the site.
white rabbit-tobacco <i>Pseudognaphalium leucocephalum</i>	CNPS 2B.2	Perennial herb occurring in chaparral, coastal scrub, cismontane woodland, and riparian woodland in sandy or gravelly soils. 0-2100m Blooms Aug-Nov.	No potential. Associated habitat is not present in or adjacent to the site.
Plants			
burrowing owl <i>Athene cunicularia</i>	CDFW: Species of Special Concern USFWS: Birds of Conservation Concern	Occurs in open, dry grasslands and scrub habitats with low-growing vegetation, perches, and abundant mammal burrows. Preys upon insects and small vertebrates. Nests and roosts in old mammal burrows, most	No potential. Habitat on and adjacent to the site is unsuitable for the species. Burrows for nesting and roosting are not present.

Name	Status*	Habitat	Potential to occur
		commonly those of ground squirrels.	
coastal California gnatcatcher <i>Polioptila californica californica</i>	Federal Threatened CDFW: Species of Special Concern	Obligate, permanent resident of coastal sage scrub below 25 feet in southern California. Low, coastal sage scrub in arid washes, on mesas and slopes. Not all areas classified as coastal sage scrub are occupied.	No potential. Coastal sage scrub habitat is not present on or adjacent to the site.
least Bell's vireo <i>Vireo bellii pusillus</i>	Federal Endangered State Endangered	Dense brush, mesquite, willow-cottonwood forest, streamside thickets, and scrub oak, in arid regions, but often near water. Moist woodland, bottomlands, woodland edge, scattered cover, and hedgerows in cultivated areas. Summer resident of southern California in low riparian in vicinity of water or in dry river bottoms; below 2 feet. Nests placed along margins of bushes or on twigs projecting into pathways, usually willow, <i>Baccharis</i> , or mesquite.	No potential. Riparian habitat is not present on or adjacent to the site.
southwestern willow flycatcher <i>Empidonax traillii extimus</i>	Federal Endangered State Endangered	Summer breeder in the southwest needing dense riparian habitat for nesting. Nesting typically occurs in native willow and cottonwood stands, which the species also uses for perching and as foraging habitat for insects.	No potential. Necessary riparian habitat is not present on or adjacent to the site.

Name	Status*	Habitat	Potential to occur
American badger <i>Taxidea taxus</i>	CDFW: Species of Special Concern	Most abundant in drier open stages of most shrub, forest, and herbaceous habitats, with friable soils. Requires friable soils and open, uncultivated ground. Preys on burrowing rodents.	No potential. Habitat on and adjacent to the site is unsuitable for the species. Additionally, typical prey is not found on the site.
big free-tailed bat <i>Nyctinomops macrotis</i>	CDFW: Species of Special Concern Western Bat Working Group: Medium-High Priority	Occurs rarely in low-lying arid areas, including desert scrub, woodlands, and evergreen forests. Requires high cliffs or rocky outcrops for roosting sites.	Unlikely. Any occurrences on site are likely to be during foraging as there is no suitable roosting habitat on or adjacent to the site.
hoary bat <i>Lasiurus cinereus</i>	Western Bat Working Group: Medium-High Priority	Prefers open forested habitats or habitat mosaics, with access to trees for cover and open areas or habitat edges for feeding. Roosts in dense foliage of medium to large trees. Feeds primarily on moths.	Unlikely. Any occurrences on site are likely to be during foraging as there is no suitable roosting habitat on or adjacent to the site.
pallid bat <i>Antrozous pallidus</i>	CDFW: Species of Special Concern Western Bat Working Group: High Priority	Found in deserts, grasslands, shrublands, woodlands, and forests. Most common in open forages along river channels. Roost sites include crevices in rocky outcrops and cliffs, caves, mines, trees and various human structures, such as bridges, barns, and buildings (including occupied buildings). Very sensitive to disturbance of roosting sites.	Unlikely. Any occurrences on site are likely to be during foraging. No roosting habitat on-site due to the sensitivity of the species to disturbance.

Name	Status*	Habitat	Potential to occur
San Diego desert woodrat <i>Neotoma lepida intermedia</i>	CDFW: Species of Special Concern	Sagebrush scrub and chaparral in coastal southern California from San Diego County to San Luis Obispo County. Moderate to dense canopies preferred. Particularly abundant in rock outcrops and rocky cliffs and slopes.	No potential. Habitat on and adjacent to the site is unsuitable for the species.
southern grasshopper mouse <i>Onychomys torridus ramona</i>	CDFW: Species of Special Concern	Common in arid desert scrub, coastal scrub, mixed chaparral, and sagebrush habitat. Uncommon in valley foothill and montane riparian habitat. Feeds primarily on arthropods, specializing in scorpions and grasshoppers. Nests in burrows constructed in friable soils.	No potential. Habitat on and adjacent to the site is unsuitable for the species.
western mastiff bat <i>Eumops perotis californicus</i>	CDFW: Species of Special Concern Western Bat Working Group: High Priority	Found in a wide variety of open, arid, and semi-arid habitats. Distribution appears to be tied to large rock structures, which provide suitable roosting sites, including cliff crevices and cracks in boulders.	Unlikely. Any occurrences on site are likely to be during foraging as there is no suitable roosting habitat on or adjacent to the site.
western yellow bat <i>Lasiurus xanthinus</i>	CDFW: Species of Special Concern Western Bat Working Group: High Priority	Found in desert regions of the southwestern United States, where they occur with palms and other desert riparian habitats. They are known to from a number of palm oases, but are also believed to be expanding their range with the	Unlikely. Any occurrences on site are likely to be during foraging as there is no suitable roosting habitat on or adjacent to the site.

Name	Status*	Habitat	Potential to occur
southern California legless lizard <i>Anniella stebbinsi</i>	CDFW: Species of Special Concern	<p>increased usage of ornamental palms in landscaping.</p> <p>Occurs in moist, warm loose soil with plant cover, in sparsely vegetated areas of beach dunes, chaparral, pine-oak woodlands, desert scrub, sandy washes, alluvial fans, and stream terraces with sycamores, cottonwoods, or oaks. Leaf litter under trees and bushes in sunny areas and dunes stabilized with bush lupine and mock heather often indicate suitable habitat. Often can be found under surface objects such as rocks, boards, driftwood, and logs. Can also be found by gently raking leaf litter under bushes and trees. Sometimes found in suburban gardens in Southern California.</p>	<p>No potential. Any available habitat (moist soils with leaf litter) present on or adjacent to the site would be too heavily developed and fragmented to support a population of the species.</p>
southwestern pond turtle <i>Actinemys pallida</i> [= <i>Emys marmorata</i>]	CDFW: Species of Special Concern	<p>Found in a variety of wetland habitats with abundant vegetation, and either rocky or muddy bottoms. In streams, prefers pools to shallower areas. Logs, rocks, cattail mats, and exposed banks are required for basking. Omnivorous, feeding on aquatic plants, invertebrates,</p>	<p>No potential. No available aquatic habitat on or adjacent to site meeting the requirements for the species.</p>

Name	Status*	Habitat	Potential to occur
		and small aquatic vertebrates such as frogs and fish.	

*** Key to status codes:**

FE	Federal Endangered
FT	Federal Threatened
FC	Federal Candidate
BCC	USFWS Birds of Conservation Concern
SE	State Endangered
ST	State Threatened
SC	State Candidate
SSC	CDFW Species of Special Concern
CFP	CDFW Fully Protected Animal
WBWG	Western Bat Working Group High or Medium Priority Species
Rank 1A	CNPS Rank 1A: Plants presumed extinct in California
Rank 1B	CNPS Rank 1B: Plants rare, threatened or endangered in California and elsewhere
Rank 2A	CNPS Rank 2A: Plants presumed extirpated in California, but more common elsewhere
Rank 2B	CNPS Rank 2B: Plants rare, threatened, or endangered in California, but more common elsewhere

Potential to Occur:

No Potential. Habitat on and adjacent to the site is clearly unsuitable for the species requirements (cover, substrate, elevation, hydrology, plant community, site history, disturbance regime).

Unlikely. Few of the habitat components meeting the species requirements are present, and/or the majority of habitat on and adjacent to the site is unsuitable or of very poor quality. The species is not likely to be found on the site.

Moderate Potential. Some of the habitat components meeting the species requirements are present, and/or only some of the habitat on or adjacent to the site is unsuitable. The species has a moderate probability of being found on the site.

High Potential. All of the habitat components meeting the species requirements are present and/or most of the habitat on or adjacent to the site is highly suitable. The species has a high probability of being found on the site.

Attachment 2

Greenhouse Gas Analysis



**Burbank Water and Power
Magnolia Campus Drainage
Improvement
GREENHOUSE GAS ANALYSIS
CITY OF BURBANK**

PREPARED BY:

Haseeb Qureshi
hqureshi@urbanxroads.com
(949) 336-5987

Alyssa Tamase
atamase@urbanxroads.com
(949) 336-5988

APRIL 30, 2019

TABLE OF CONTENTS

TABLE OF CONTENTS	I
APPENDICES	II
LIST OF EXHIBITS	II
LIST OF TABLES	II
LIST OF ABBREVIATED TERMS	III
EXECUTIVE SUMMARY	1
ES.1 Regulatory Requirements	1
ES.2 City of Burbank Greenhouse Gas Reduction Plan.....	2
1 INTRODUCTION	4
1.1 Site Location.....	4
1.2 Project Description.....	4
2 CLIMATE CHANGE SETTING	4
2.1 Introduction to Global Climate Change	4
2.2 Global Climate Change Defined	4
2.3 Greenhouse Gases	5
2.4 Greenhouse Gas Emissions Inventories	8
2.5 Effects of Climate Change in California	9
2.6 Human Health Effects	11
2.7 Regulatory Setting.....	13
2.8 Discussion on Establishment of Significance Thresholds.....	35
3 PROJECT GREENHOUSE GAS IMPACT	37
3.1 Introduction	37
3.2 Standards of Significance	37
3.3 California Emissions Estimator Model™ Employed To Analyze GHG Emissions	37
3.4 Construction and Operational Life-Cycle Analysis Not Required.....	37
3.5 Construction Emissions	38
3.6 Operational Emissions	40
3.7 Emissions Summary	40
3.8 Greenhouse Gas Emissions Findings and Recommendations.....	40
4 REFERENCES	43
5 CERTIFICATION	47

APPENDICES

APPENDIX 3.1: CALEEMOD EMISSIONS MODEL OUTPUTS

LIST OF EXHIBITS

EXHIBIT 1-A: LOCATION MAP	1
EXHIBIT 1-A: SITE PLAN	2
EXHIBIT 2-A: SUMMARY OF PROJECTED GLOBAL WARMING IMPACT	12

LIST OF TABLES

TABLE ES-1: SUMMARY OF CEQA SIGNIFICANCE FINDINGS	1
TABLE ES-1: PROJECT CONSISTENCY WITH CITY OF BURBANK GGRP	2
TABLE 2-1: GLOBAL WARMING POTENTIAL AND ATMOSPHERIC LIFETIME OF SELECT GHGS	8
TABLE 2-2: TOP GHG PRODUCER COUNTRIES AND THE EUROPEAN UNION	9
TABLE 3-1: CONSTRUCTION DURATION	39
TABLE 3-2: CONSTRUCTION EQUIPMENT ASSUMPTIONS	39
TABLE 3-3: TOTAL PROJECT GREENHOUSE GAS EMISSIONS (ANNUAL)	40
TABLE 3-4: PROJECT CONSISTENCY WITH CITY OF BURBANK GGRP	41

LIST OF ABBREVIATED TERMS

(1)	Reference
AB	Assembly Bill
APA	Administrative Procedure Act
APS	Alternative Planning Organizations
AR5	IPCC's 5 th Assessment Report
ARB	California Air Resources Board
BAU	Business As Usual
C ₂ F ₆	Hexafluoroethane
C ₂ H ₆	Ethane
C ₂ H ₂ F ₄	Tetrafluoroethane
C ₂ H ₄ F ₂	Ethylidene Fluoride
CAA	Federal Clean Air Act
CalEEMod	California Emissions Estimator Model
CalEPA	California Environmental Protection Agency
CALGAPS	California LBNL GHG Analysis of Policies Spreadsheet
CALGreen	California Green Building Standards Code
CAPCOA	California Air Pollution Control Officers Association
CARB	California Air Resource Board
CAT	Climate Action Team
CBSC	California Building Standards Commission
CEC	California Energy Commission
CCR	California Code of Regulations
CEQA	California Environmental Quality Act
CF ₄	Tetrafluoromethane
CFC	Chlorofluorocarbons
CFR	Code of Federal Regulations
CH ₄	Methane
CHF ₃	Carbon Trifluoride
CO	Carbon Monoxide
CO ₂	Carbon Dioxide
CO ₂ e	Carbon Dioxide Equivalent
COP	Conference of the Parties
CPUC	California Public Utilities Commission
EPA	Environmental Protection Agency
EPS	Emission Performance Standard
FED	Functional Equivalent Document

GCC	Global Climate Change
GHGA	Greenhouse Gas Analysis
GWP	Global Warming Potential
GGRP	Greenhouse Gas Reduction Plan
H ₂ O	Water
HFC	Hydrofluorocarbons
HP	Horsepower
IPCC	Intergovernmental Panel on Climate Change
IS	Initial Study
ISO	Independent System Operator
LBL	Lawrence Berkeley National Laboratory
LCA	Life-Cycle Analysis
LCFS	Low Carbon Fuel Standard
LEV	Low-Emission Vehicle
MMR	Mandatory Reporting Rule
MMTCO ₂ e	Million Metric Ton of Carbon Dioxide Equivalent
MPG	Miles Per Gallon
MPOs	Metropolitan Planning Organizations
MTCO ₂ e	Metric Ton of Carbon Dioxide Equivalent
MY	Model Year
NHTSA	National Highway Traffic Safety Administration
N ₂ O	Nitrogen Dioxide/Nitrous Oxide
NCHRP	National Cooperative Highway Research Program
NDC	Nationally Determined Contributions
NF ₃	Nitrogen Trifluoride
NIOSH	National Institute for Occupational Safety and Health
NO _x	Oxides of Nitrogen
PFC	Perfluorocarbons
PM ₁₀	Particulate Matter 10 microns in diameter or less
PM _{2.5}	Particulate Matter 2.5 microns in diameter or less
PPM	Parts Per Million
PPT	Parts Per Trillion
Project	Burbank Water and Power Magnolia Campus Drainage Improvement
RPS	Renewable Portfolio Standard
RTP	Regional Transportation Plan
SAR	Second Assessment Report
SB	Senate Bill

SCAG	Southern California Association of Governments
SCAQMD	South Coast Air Quality Management District
SCS	Sustainable Communities Strategies
SF ₆	Sulfur Hexafluoride
SLPS	Short-Lived Climate Pollutant Strategy
SP	Service Population
TIA	Traffic Impact Analysis
UNFCCC	United Nations' Framework Convention on Climate Change
URBEMIS	Urban Emissions
UTR	Utility Tractors
VMT	Vehicle Miles Traveled
VOC	Volatile Organic Compounds
WRI	World Resources Institute
ZE/NZE	Zero and Near-Zero Emissions

This page intentionally left blank

EXECUTIVE SUMMARY

The results of this *Burbank Water and Power Magnolia Campus Drainage Improvement Greenhouse Gas Analysis* are summarized below based on the significance criteria in Section 3.7 of this report consistent with Appendix G of the California Environmental Quality Act (CEQA) Guidelines (1).

TABLE ES-1: SUMMARY OF CEQA SIGNIFICANCE FINDINGS

Analysis	Report Section	Significance Findings	
		Unmitigated	Mitigated
GHG Impact #1: The Project would not generate direct or indirect greenhouse gas emission that would result in a significant impact on the environment.	3.7	<i>Less Than Significant</i>	<i>n/a</i>
GHG Impact #2: The Project would not conflict with any applicable plan, policy or regulation of an agency adopted for the purpose of reducing the emissions of greenhouse gases.	3.7	<i>Less Than Significant</i>	<i>n/a</i>

ES.1 REGULATORY REQUIREMENTS

The Project would be required to comply with all mandates imposed by the State of California and the South Coast Air Quality Management District. Those that are applicable to the Project and that would assist in the reduction of greenhouse gas emissions are:

- Global Warming Solutions Act of 2006 (AB32) (2).
- Regional GHG Emissions Reduction Targets/Sustainable Communities Strategies (SB 375) (3).
- Pavley Fuel Efficiency Standards (AB1493). Establishes fuel efficiency ratings for new vehicles (4).
- Title 24 California Code of Regulations (California Building Code). Establishes energy efficiency requirements for new construction (5).
- Title 20 California Code of Regulations (Appliance Energy Efficiency Standards). Establishes energy efficiency requirements for appliances (6).
- Title 17 California Code of Regulations (Low Carbon Fuel Standard). Requires carbon content of fuel sold in California to be 10% less by 2020 (7).
- California Water Conservation in Landscaping Act of 2006 (AB1881). Requires local agencies to adopt the Department of Water Resources updated Water Efficient Landscape Ordinance or equivalent by January 1, 2010 to ensure efficient landscapes in new development and reduced water waste in existing landscapes (8).
- Statewide Retail Provider Emissions Performance Standards (SB 1368). Requires energy generators to achieve performance standards for GHG emissions (9).

- Renewable Portfolio Standards (SB 1078). Requires electric corporations to increase the amount of energy obtained from eligible renewable energy resources to 20 percent by 2010 and 33 percent by 2020 (10).
- Senate Bill 32 (SB 32). Requires the state to reduce statewide greenhouse gas emissions to 40% below 1990 levels by 2030, a reduction target that was first introduced in Executive Order B-30-15 (11).

Promulgated regulations that will affect the Project’s emissions are accounted for in the Project’s GHG calculations provided in this report. In particular, the Pavley Standards, Low Carbon Fuel Standards, and Renewable Portfolio Standards (RPS) will be in effect for the AB 32 target year of 2020, and therefore are accounted for in the Project’s emission calculations.

ES.2 CITY OF BURBANK GREENHOUSE GAS REDUCTION PLAN

Pursuant to the City of Burbank’s Greenhouse Gas Reduction Plan (GGRP). The Project shall ensure that the following measures are implemented:

TABLE ES-1: PROJECT CONSISTENCY WITH CITY OF BURBANK GGRP

GGRP Measure	Applicability to Proposed Project	Remarks
Measure E-1.6: BWP: Energy Conservation	Applicable	The Department is anticipated to reduce GHGs through a series of conservation measures that would likely involve the Project.
Measure W-1.3: Stormwater Master Plan	Applicable	The Project would be an element in reducing polluted runoff into the BWP.
Measure SW-1.3: Lumber Diversion Ordinance	Applicable	Lumber used for concrete forms and other uses would be recycled instead of diverted to the local landfill.

This page intentionally left blank

1 INTRODUCTION

This report presents the results of the greenhouse gas analysis (GHGA) prepared by Urban Crossroads, Inc., for the *Burbank Water and Power Magnolia Campus Drainage Improvement* (referred to as “Project”). The purpose of this GHGA is to evaluate Project-related construction emissions and determine the level of greenhouse gas (GHG) impacts as a result of constructing and operating the proposed Project.

1.1 SITE LOCATION

The proposed Burbank Water and Power Magnolia Campus Drainage Improvement Project is located at 164 West Magnolia Boulevard within the BWP Campus, in the City of Burbank, as shown on Exhibit 1-A. Properties located north and east of the Project site are developed for industrial uses, including but not limited to lumber yards, wood processing, storage, assembly and similar uses. Existing sensitive land uses in the Project study area include residential homes to the west, west of Victory Boulevard, and south, south of Lake Street.

1.2 PROJECT DESCRIPTION

The Project proposes to construct drainage improvements that would allow storm water from adjacent properties to be intercepted and discharged into the BWC through a new outfall structure, as shown on Exhibit 1-B.

No long-term operational greenhouse gas impacts are anticipated as a result of the proposed Project since there would be no operational vehicle trips resulting from the proposed Project improvements, since the Project is limited to drainage and water quality improvements. As such, there are also no operational (stationary-source) greenhouse gas sources anticipated as a result of the Project improvements since they would be constructed underground.

EXHIBIT 1-A: LOCATION MAP



EXHIBIT 1-A: SITE PLAN

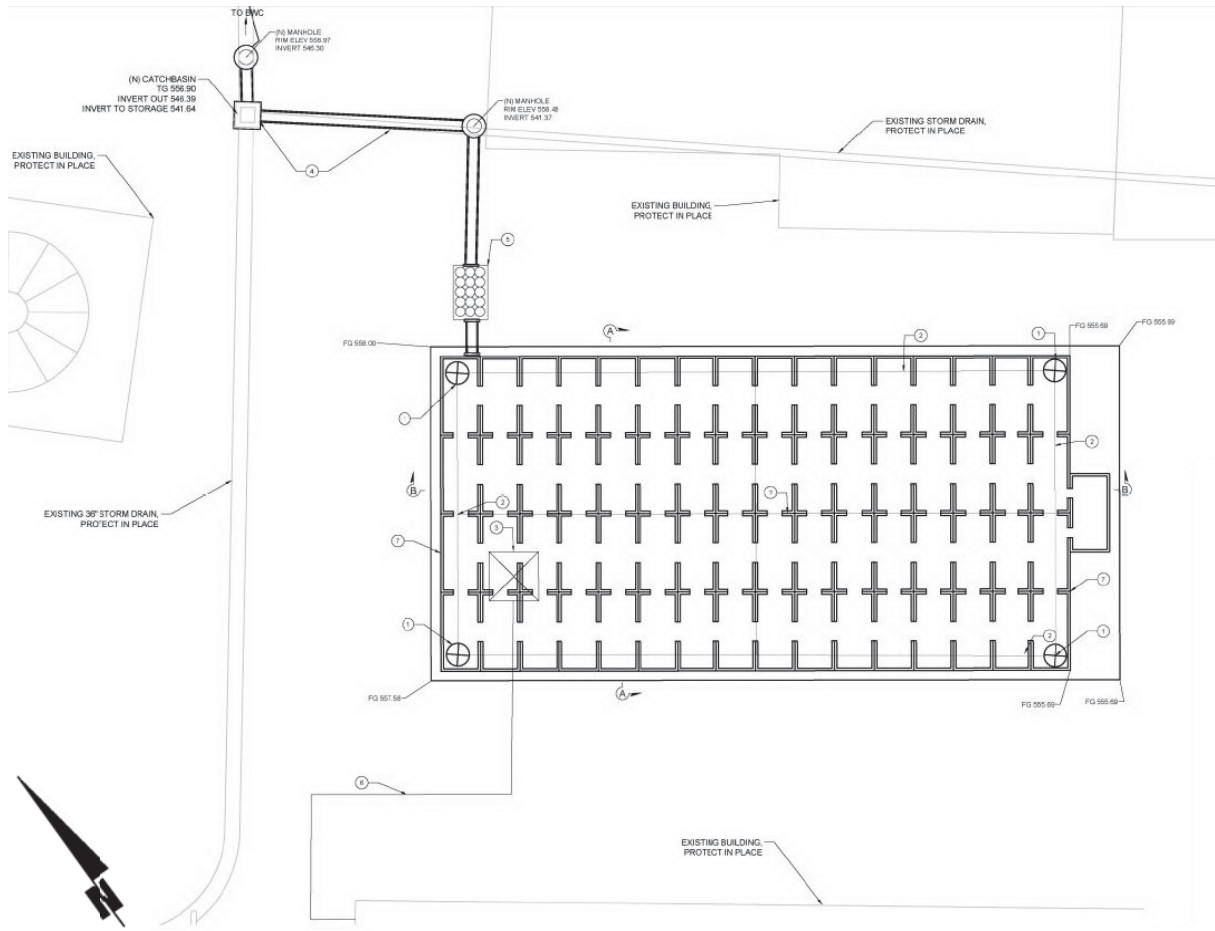

This page intentionally left blank

2 CLIMATE CHANGE SETTING

2.1 INTRODUCTION TO GLOBAL CLIMATE CHANGE

Global Climate Change (GCC) is defined as the change in average meteorological conditions on the earth with respect to temperature, precipitation, and storms. GCC is currently one of the most controversial environmental issues in the United States, and much debate exists within the scientific community about whether or not GCC is occurring naturally or as a result of human activity. Some data suggests that GCC has occurred in the past over the course of thousands or millions of years. These historical changes to the earth's climate have occurred naturally without human influence, as in the case of an ice age. However, many scientists believe that the climate shift taking place since the industrial revolution (1900) is occurring at a quicker rate and magnitude than in the past. Scientific evidence suggests that GCC is the result of increased concentrations of greenhouse gases in the earth's atmosphere, including carbon dioxide, methane, nitrous oxide, and fluorinated gases. Many scientists believe that this increased rate of climate change is the result of greenhouse gases resulting from human activity and industrialization over the past 200 years.

An individual project like the proposed Project evaluated in this GHGA cannot generate enough greenhouse gas emissions to affect a discernible change in global climate. However, the proposed Project may participate in the potential for GCC by its incremental contribution of greenhouse gases combined with the cumulative increase of all other sources of greenhouse gases, which when taken together constitute potential influences on GCC. Because these changes may have serious environmental consequences, Section 3.0 will evaluate the potential for the proposed Project to have a significant effect upon the environment as a result of its potential contribution to the greenhouse effect.

2.2 GLOBAL CLIMATE CHANGE DEFINED

GCC refers to the change in average meteorological conditions on the earth with respect to temperature, wind patterns, precipitation and storms. Global temperatures are regulated by naturally occurring atmospheric gases such as water vapor, CO₂ (carbon dioxide), N₂O (nitrous oxide), CH₄ (methane), hydrofluorocarbons, perfluorocarbons and sulfur hexafluoride. These particular gases are important due to their residence time (duration they stay) in the atmosphere, which ranges from 10 years to more than 100 years. These gases allow solar radiation into the earth's atmosphere, but prevent radioactive heat from escaping, thus warming the earth's atmosphere. GCC can occur naturally as it has in the past with the previous ice ages.

Gases that trap heat in the atmosphere are often referred to as greenhouse gases. Greenhouse gases are released into the atmosphere by both natural and anthropogenic (human) activity. Without the natural greenhouse gas effect, the earth's average temperature would be approximately 61° Fahrenheit (F) cooler than it is currently. The cumulative accumulation of these gases in the earth's atmosphere is considered to be the cause for the observed increase in the earth's temperature.

2.3 GREENHOUSE GASES

For the purposes of this analysis, emissions of CO₂, CH₄, and NO₂ were evaluated (see Table 3-1 later in this report) because these gasses are the primary contributors to GCC from development projects. Although there are other substances such as fluorinated gases that also contribute to GCC, these fluorinated gases were not evaluated as their sources are not well-defined and do not contain accepted emissions factors or methodology to accurately calculate these gases.

Water Vapor: Water vapor (H₂O) is the most abundant, important, and variable greenhouse gas in the atmosphere. Water vapor is not considered a pollutant; in the atmosphere it maintains a climate necessary for life. Changes in its concentration are primarily considered to be a result of climate feedbacks related to the warming of the atmosphere rather than a direct result of industrialization. A climate feedback is an indirect, or secondary, change, either positive or negative, that occurs within the climate system in response to a forcing mechanism. The feedback loop in which water is involved is critically important to projecting future climate change.

As the temperature of the atmosphere rises, more water is evaporated from ground storage (rivers, oceans, reservoirs, soil). Because the air is warmer, the relative humidity can be higher (in essence, the air is able to ‘hold’ more water when it is warmer), leading to more water vapor in the atmosphere. As a GHG, the higher concentration of water vapor is then able to absorb more thermal indirect energy radiated from the Earth, thus further warming the atmosphere. The warmer atmosphere can then hold more water vapor and so on and so on. This is referred to as a “positive feedback loop.” The extent to which this positive feedback loop will continue is unknown as there are also dynamics that hold the positive feedback loop in check. As an example, when water vapor increases in the atmosphere, more of it will eventually condense into clouds, which are more able to reflect incoming solar radiation (thus allowing less energy to reach the earth’s surface and heat it up) (12).

There are no human health effects from water vapor itself; however, when some pollutants come in contact with water vapor, they can dissolve, and the water vapor can then act as a pollutant-carrying agent. The main source of water vapor is evaporation from the oceans (approximately 85 percent). Other sources include evaporation from other water bodies, sublimation (change from solid to gas) from sea ice and snow, and transpiration from plant leaves.

Carbon Dioxide: Carbon dioxide (CO₂) is an odorless and colorless GHG. Outdoor levels of carbon dioxide are not high enough to result in negative health effects. Carbon dioxide is emitted from natural and manmade sources. Natural sources include: the decomposition of dead organic matter; respiration of bacteria, plants, animals and fungus; evaporation from oceans; and volcanic outgassing. Anthropogenic sources include: the burning of coal, oil, natural gas, and wood. Carbon dioxide is naturally removed from the air by photosynthesis, dissolution into ocean water, transfer to soils and ice caps, and chemical weathering of carbonate rocks (13).

Since the industrial revolution began in the mid-1700s, the sort of human activity that increases GHG emissions has increased dramatically in scale and distribution. Data from the past 50 years suggests a corollary increase in levels and concentrations. As an example, prior to the industrial revolution, CO₂ concentrations were fairly stable at 280 parts per million (ppm). Today, they are around 370 ppm, an increase of more than 30 percent. Left unchecked, the concentration of carbon dioxide in the atmosphere is projected to increase to a minimum of 540 ppm by 2100 as a direct result of anthropogenic sources (14).

Methane: Methane (CH₄) is an extremely effective absorber of radiation, although its atmospheric concentration is less than carbon dioxide and its lifetime in the atmosphere is brief (10-12 years), compared to other GHGs. Exposure to high levels of methane can cause asphyxiation, loss of consciousness, headache and dizziness, nausea and vomiting, weakness, loss of coordination, and an increased breathing rate

Methane has both natural and anthropogenic sources. It is released as part of the biological processes in low oxygen environments, such as in swamplands or in rice production (at the roots of the plants). Over the last 50 years, human activities such as growing rice, raising cattle, using natural gas, and mining coal have added to the atmospheric concentration of methane. Other anthropogenic sources include fossil-fuel combustion and biomass burning (15).

Nitrous Oxide: Nitrous oxide (N₂O), also known as laughing gas, is a colorless greenhouse gas. Nitrous oxide can cause dizziness, euphoria, and sometimes slight hallucinations. In small doses, it is considered harmless. However, in some cases, heavy and extended use can cause Olney's Lesions (brain damage) (16).

Concentrations of nitrous oxide also began to rise at the beginning of the industrial revolution. In 1998, the global concentration was 314 parts per billion (ppb). Nitrous oxide is produced by microbial processes in soil and water, including those reactions which occur in fertilizer containing nitrogen. In addition to agricultural sources, some industrial processes (fossil fuel-fired power plants, nylon production, nitric acid production, and vehicle emissions) also contribute to its atmospheric load. It is used as an aerosol spray propellant, i.e., in whipped cream bottles. It is also used in potato chip bags to keep chips fresh. It is used in rocket engines and in race cars. Nitrous oxide can be transported into the stratosphere, be deposited on the earth's surface, and be converted to other compounds by chemical reaction (16).

Chlorofluorocarbons: Chlorofluorocarbons (CFCs) are gases formed synthetically by replacing all hydrogen atoms in methane or ethane (C₂H₆) with chlorine and/or fluorine atoms. CFCs are nontoxic, nonflammable, insoluble and chemically unreactive in the troposphere (the level of air at the earth's surface). CFCs are no longer being used; therefore, it is not likely that health effects would be experienced. Nonetheless, in confined indoor locations, working with CFC-113 or other CFCs is thought to result in death by cardiac arrhythmia (heart frequency too high or too low) or asphyxiation.

CFCs have no natural source but were first synthesized in 1928. They were used for refrigerants, aerosol propellants and cleaning solvents. Due to the discovery that they are able to destroy stratospheric ozone, a global effort to halt their production was undertaken and was

extremely successful, so much so that levels of the major CFCs are now remaining steady or declining. However, their long atmospheric lifetimes mean that some of the CFCs will remain in the atmosphere for over 100 years (17).

Hydrofluorocarbons: Hydrofluorocarbons (HFCs) are synthetic, man-made chemicals that are used as a substitute for CFCs. Out of all the greenhouse gases, they are one of three groups with the highest global warming potential. The HFCs with the largest measured atmospheric abundances are (in order), HFC-23 (CHF_3), HFC-134a (CH_2FCF), and HFC-152a (CH_3CF_2). Prior to 1990, the only significant emissions were of HFC-23. HFC-134a emissions are increasing due to its use as a refrigerant. No health effects are known to result from exposure to HFCs, which are manmade for applications such as automobile air conditioners and refrigerants.

Perfluorocarbons: Perfluorocarbons (PFCs) have stable molecular structures and do not break down through chemical processes in the lower atmosphere. High-energy ultraviolet rays, which occur about 60 kilometers above earth's surface, are able to destroy the compounds. Because of this, PFCs have very long lifetimes, between 10,000 and 50,000 years. Two common PFCs are tetrafluoromethane (CF_4) and hexafluoroethane (C_2F_6). The U.S. EPA estimates that concentrations of CF_4 in the atmosphere are over 70 ppt.

No health effects are known to result from exposure to PFCs. The two main sources of PFCs are primary aluminum production and semiconductor manufacture.

Sulfur Hexafluoride: Sulfur hexafluoride (SF_6) is an inorganic, odorless, colorless, nontoxic, nonflammable gas. It also has the highest global warming potential (GWP) of any gas evaluated (23,900) (18). The U.S. EPA indicates that concentrations in the 1990s were about 4 ppt. In high concentrations in confined areas, the gas presents the hazard of suffocation because it displaces the oxygen needed for breathing.

Sulfur hexafluoride is used for insulation in electric power transmission and distribution equipment, in the magnesium industry, in semiconductor manufacturing, and as a tracer gas for leak detection.

Nitrogen Trifluoride: Nitrogen trifluoride (NF_3) is a colorless gas with a distinctly moldy odor. NF_3 is used in industrial processes and is produced in the manufacture of semiconductors and LCD (Liquid Crystal Display) panels, and types of solar panels and chemical lasers. The World Resources Institute (WRI) indicates that NF_3 has a 100-year GWP of 17,200 (19).

Long-term or repeated exposure may affect the liver and kidneys and may cause fluorosis (20).

Carbon Dioxide Equivalent: Carbon dioxide equivalent (CO_2e) is a term used for describing the difference greenhouse gases in a common unit. CO_2e signifies the amount of CO_2 which would have the equivalent global warming potential.

Greenhouse gases have varying GWP values. GWP of a greenhouse gas indicates the amount of warming a gas causes over a given period of time and represents the potential of a gas to trap heat in the atmosphere. Carbon dioxide is utilized as the reference gas for GWP, and thus has a GWP of 1.

The atmospheric lifetime and GWP of selected greenhouse gases are summarized at Table 2-1. As shown in the table below, GWP for the Second Assessment Report (SAR), the Intergovernmental Panel on Climate Change (IPCC)’s scientific and socio-economic assessment on climate change, range from 1 for carbon dioxide to 23,900 for sulfur hexafluoride and GWP for the IPCC’s 5th Assessment Report (AR5) range from 1 for CO₂ to 23,500 for SF₆ (21).

TABLE 2-1: GLOBAL WARMING POTENTIAL AND ATMOSPHERIC LIFETIME OF SELECT GHGS

Gas	Atmospheric Lifetime (years)	Global Warming Potential (100-year time horizon)	
		Second Assessment	5 th Assessment Report
CO ₂	See*	1	1
CH ₄	12 .4	21	28
N ₂ O	121	310	265
HFC-23	222	11,700	12,400
HFC-134a	13.4	1,300	1,300
HFC-152a	1.5	140	138
SF ₆	3,200	23,900	23,500

*As per Appendix 8.A. of IPCC’s 5th Assessment Report (AR5), no single lifetime can be given.
 Source: Table 2.14 of the IPCC Fourth Assessment Report, 2007

2.4 GREENHOUSE GAS EMISSIONS INVENTORIES

Global

Worldwide anthropogenic (human) GHG emissions are tracked by the Intergovernmental Panel on Climate Change for industrialized nations (referred to as Annex I) and developing nations (referred to as Non-Annex I). Human GHG emissions data for Annex I nations are available through 2016. For the Year 2016, the sum of these emissions totaled approximately 28,747,554 Gg CO₂e¹ (22) (23). The GHG emissions in more recent years may differ from the inventories presented in Table 2-2; however, the data is representative of currently available inventory data.

United States

As noted in Table 2-2, the United States, as a single country, was the number two producer of GHG emissions in 2016. The primary greenhouse gas emitted by human activities in the United States was CO₂, representing approximately 81.6 percent of total greenhouse gas emissions in the US. Carbon dioxide from fossil fuel combustion, the largest source of US greenhouse gas emissions, accounted for approximately 93.5 percent of the CO₂ emissions (24).

1 The global emissions are the sum of Annex I and non-Annex I countries, without counting Land-Use, Land-Use Change and Forestry (LULUCF). For countries without 2016 data, the UNFCCC data for the most recent year were used. United Nations Framework Convention on Climate Change, “Annex I Parties – GHG total without LULUCF,” The most recent GHG emissions for China were taken in 2012, while the most recent GHG emissions for India were taken in 2010.

TABLE 2-2: TOP GHG PRODUCER COUNTRIES AND THE EUROPEAN UNION ²

Emitting Countries	GHG Emissions (Gg CO₂e)
China	11,895,765
United States	6,511,302
European Union (28-member countries)	4,291,252
India	2,643,817
Russian Federation	2,100,850
Japan	1,304,568
Total	28,747,554

State of California

California has significantly slowed the rate of growth of greenhouse gas emissions due to the implementation of energy efficiency programs as well as adoption of strict emission controls but is still a substantial contributor to the U.S. emissions inventory total (25). CARB compiles GHG inventories for the State of California. Based upon the 2018 GHG inventory data (i.e., the latest year for which data are available) for the 2000-2016 greenhouse gas emissions inventory, California emitted 429.4 MMTCO₂e including emissions resulting from imported electrical power in 2015 (26).

2.5 EFFECTS OF CLIMATE CHANGE IN CALIFORNIA

Public Health

Higher temperatures may increase the frequency, duration, and intensity of conditions conducive to air pollution formation. For example, days with weather conducive to ozone formation could increase from 25 to 35 percent under the lower warming range to 75 to 85 percent under the medium warming range. In addition, if global background ozone levels increase as predicted in some scenarios, it may become impossible to meet local air quality standards. Air quality could be further compromised by increases in wildfires, which emit fine particulate matter that can travel long distances, depending on wind conditions. The Climate Scenarios report indicates that large wildfires could become up to 55 percent more frequent if GHG emissions are not significantly reduced.

In addition, under the higher warming range scenario, there could be up to 100 more days per year with temperatures above 90°F in Los Angeles and 95°F in Sacramento by 2100. This is a large increase over historical patterns and approximately twice the increase projected if temperatures remain within or below the lower warming range. Rising temperatures could increase the risk of death from dehydration, heat stroke/exhaustion, heart attack, stroke, and respiratory distress caused by extreme heat.

Water Resources

² Used <http://unfccc.int> data for Annex I countries. Consulted the CAIT Climate Data Explorer in <http://www.wri.org> site to reference Non-Annex I countries such as China and India.

A vast network of man-made reservoirs and aqueducts captures and transports water throughout the state from northern California rivers and the Colorado River. The current distribution system relies on Sierra Nevada snowpack to supply water during the dry spring and summer months. Rising temperatures, potentially compounded by decreases in precipitation, could severely reduce spring snowpack, increasing the risk of summer water shortages.

If temperatures continue to increase, more precipitation could fall as rain instead of snow, and the snow that does fall could melt earlier, reducing the Sierra Nevada spring snowpack by as much as 70 to 90 percent. Under the lower warming range scenario, snowpack losses could be only half as large as those possible if temperatures were to rise to the higher warming range. How much snowpack could be lost depends in part on future precipitation patterns, the projections for which remain uncertain. However, even under the wetter climate projections, the loss of snowpack could pose challenges to water managers and hamper hydropower generation. It could also adversely affect winter tourism. Under the lower warming range, the ski season at lower elevations could be reduced by as much as a month. If temperatures reach the higher warming range and precipitation declines, there might be many years with insufficient snow for skiing and snowboarding.

The State's water supplies are also at risk from rising sea levels. An influx of saltwater could degrade California's estuaries, wetlands, and groundwater aquifers. Saltwater intrusion caused by rising sea levels is a major threat to the quality and reliability of water within the southern edge of the Sacramento/San Joaquin River Delta – a major fresh water supply.

Agriculture

Increased temperatures could cause widespread changes to the agriculture industry reducing the quantity and quality of agricultural products statewide. First, California farmers could possibly lose as much as 25 percent of the water supply needed. Although higher CO₂ levels can stimulate plant production and increase plant water-use efficiency, California's farmers could face greater water demand for crops and a less reliable water supply as temperatures rise. Crop growth and development could change, as could the intensity and frequency of pest and disease outbreaks. Rising temperatures could aggravate O₃ pollution, which makes plants more susceptible to disease and pests and interferes with plant growth.

Plant growth tends to be slow at low temperatures, increasing with rising temperatures up to a threshold. However, faster growth can result in less-than-optimal development for many crops, so rising temperatures could worsen the quantity and quality of yield for a number of California's agricultural products. Products likely to be most affected include wine grapes, fruits and nuts.

In addition, continued global climate change could shift the ranges of existing invasive plants and weeds and alter competition patterns with native plants. Range expansion could occur in many species while range contractions may be less likely in rapidly evolving species with significant populations already established. Should range contractions occur, new or different weed species could fill the emerging gaps. Continued global climate change could alter the

abundance and types of many pests, lengthen pests' breeding season, and increase pathogen growth rates.

Forests and Landscapes

Global climate change has the potential to intensify the current threat to forests and landscapes by increasing the risk of wildfire and altering the distribution and character of natural vegetation. If temperatures rise into the medium warming range, the risk of large wildfires in California could increase by as much as 55 percent, which is almost twice the increase expected if temperatures stay in the lower warming range. However, since wildfire risk is determined by a combination of factors, including precipitation, winds, temperature, and landscape and vegetation conditions, future risks will not be uniform throughout the state. In contrast, wildfires in northern California could increase by up to 90 percent due to decreased precipitation.

Moreover, continued global climate change has the potential to alter natural ecosystems and biological diversity within the state. For example, alpine and subalpine ecosystems could decline by as much as 60 to 80 percent by the end of the century as a result of increasing temperatures. The productivity of the state's forests has the potential to decrease as a result of global climate change.

Rising Sea Levels

Rising sea levels, more intense coastal storms, and warmer water temperatures could increasingly threaten the state's coastal regions. Under the higher warming range scenario, sea level is anticipated to rise 22 to 35 inches by 2100. Elevations of this magnitude would inundate low-lying coastal areas with salt water, accelerate coastal erosion, threaten vital levees and inland water systems, and disrupt wetlands and natural habitats. Under the lower warming range scenario, sea level could rise 12-14 inches.

2.6 HUMAN HEALTH EFFECTS

The potential health effects related directly to the emissions of carbon dioxide, methane, and nitrous oxide as they relate to development projects such as the proposed Project are still being debated in the scientific community. Their cumulative effects to global climate change have the potential to cause adverse effects to human health. Increases in Earth's ambient temperatures would result in more intense heat waves, causing more heat-related deaths. Scientists also purport that higher ambient temperatures would increase disease survival rates and result in more widespread disease. Climate change will likely cause shifts in weather patterns, potentially resulting in devastating droughts and food shortages in some areas (27). Exhibit 2-A presents the potential impacts of global warming (28).

EXHIBIT 2-A: SUMMARY OF PROJECTED GLOBAL WARMING IMPACT

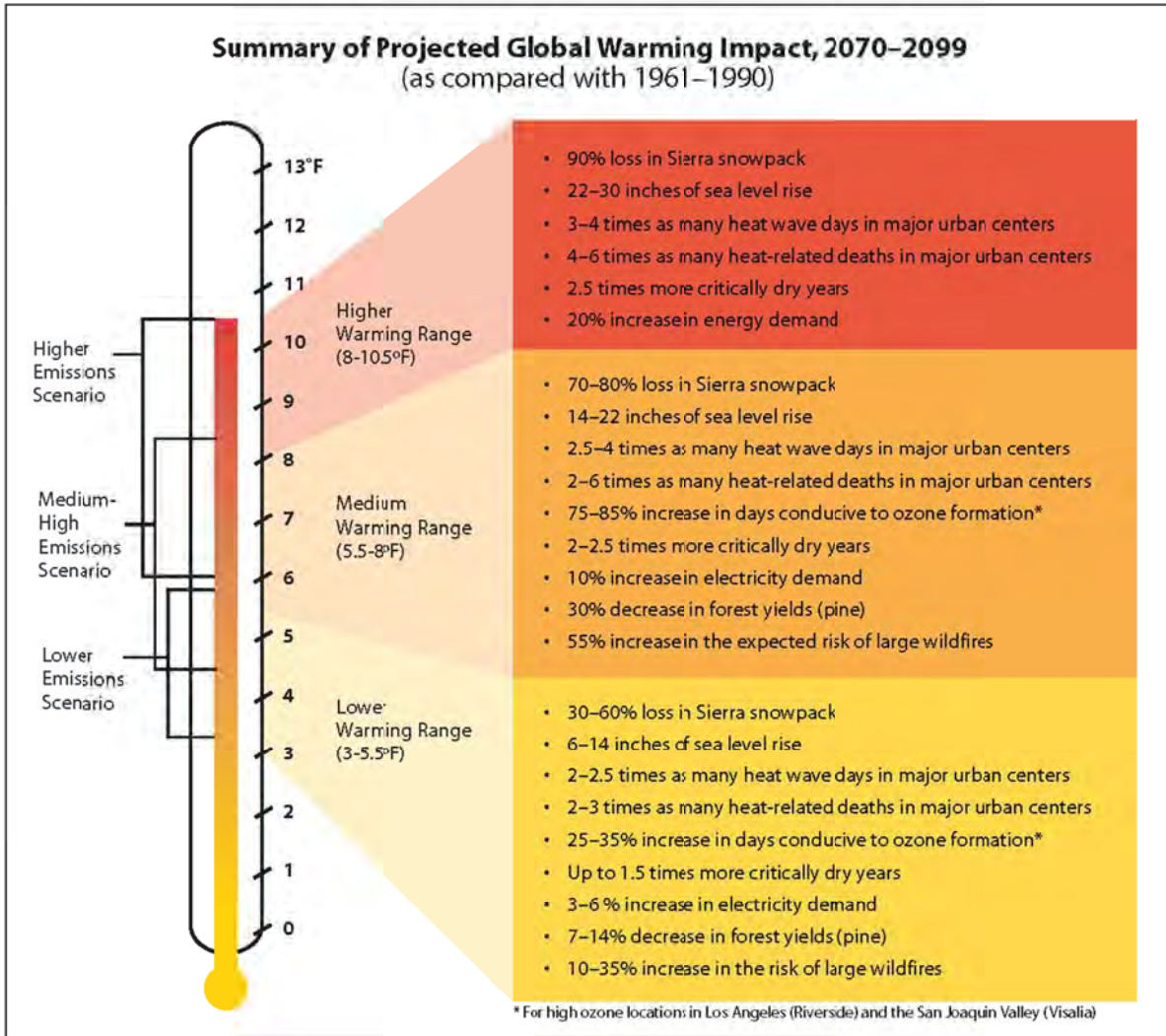

Source: Barbara H. Allen-Diaz. "Climate change affects us all." *University of California, Agriculture and Natural Resources*, 2009.

Specific health effects associated with directly emitted GHG emissions are as follows:

Water Vapor: There are no known direct health effects related to water vapor at this time. It should be noted however that when some pollutants react with water vapor, the reaction forms a transport mechanism for some of these pollutants to enter the human body through water vapor.

Carbon Dioxide: According to the National Institute for Occupational Safety and Health (NIOSH) high concentrations of carbon dioxide can result in health effects such as: headaches, dizziness, restlessness, difficulty breathing, sweating, increased heart rate, increased cardiac output, increased blood pressure, coma, asphyxia, and/or convulsions. It should be noted that current concentrations of carbon dioxide in the earth's atmosphere are estimated to be approximately 370 parts per million (ppm), the actual reference exposure level (level at which adverse health effects typically occur) is at exposure levels of 5,000 ppm averaged over 10 hours in a 40-hour

workweek and short-term reference exposure levels of 30,000 ppm averaged over a 15 minute period (29).

Methane: Methane is extremely reactive with oxidizers, halogens, and other halogen-containing compounds. Methane is also an asphyxiant and may displace oxygen in an enclosed space.

Nitrous Oxide: Nitrous Oxide is often referred to as laughing gas; it is a colorless greenhouse gas. The health effects associated with exposure to elevated concentrations of nitrous oxide include dizziness, euphoria, slight hallucinations, and in extreme cases of elevated concentrations nitrous oxide can also cause brain damage (30).

Fluorinated Gases: High concentrations of fluorinated gases can also result in adverse health effects such as asphyxiation, dizziness, headache, cardiovascular disease, cardiac disorders, and in extreme cases, increased mortality.

Aerosols: The health effects of aerosols are similar to that of other fine particulate matter. Thus, aerosols can cause elevated respiratory and cardiovascular diseases as well as increased mortality (31).

2.7 REGULATORY SETTING

INTERNATIONAL

Climate change is a global issue involving GHG emissions from all around the world; therefore, countries such as the ones discussed below have made an effort to reduce GHGs.

Intergovernmental Panel on Climate Change. In 1988, the United Nations and the World Meteorological Organization established the Intergovernmental Panel on Climate Change to assess the scientific, technical and socioeconomic information relevant to understanding the scientific basis of risk of human-induced climate change, its potential impacts, and options for adaptation and mitigation.

United Nations Framework Convention on Climate Change (Convention). On March 21, 1994, the U.S. joined a number of countries around the world in signing the Convention. Under the Convention, governments gather and share information on GHG emissions, national policies, and best practices; launch national strategies for addressing GHG emissions and adapting to expected impacts, including the provision of financial and technological support to developing countries; and cooperate in preparing for adaptation to the impacts of climate change.

International Climate Change Treaties. The Kyoto Protocol is an international agreement linked to the Convention. The major feature of the Kyoto Protocol is that it sets binding targets for 37 industrialized countries and the European community for reducing GHG emissions at an average of five percent against 1990 levels over the five-year period 2008–2012. The Convention (as discussed above) encouraged industrialized countries to stabilize emissions; however, the Protocol commits them to do so. Developed countries have contributed more emissions over the last 150 years; therefore, the Protocol places a heavier burden on developed nations under the principle of “common but differentiated responsibilities.”

In 2001, President George W. Bush indicated that he would not submit the treaty to the U.S. Senate for ratification, which effectively ended American involvement in the Kyoto Protocol. In December 2009, international leaders met in Copenhagen to address the future of international climate change commitments post-Kyoto. No binding agreement was reached in Copenhagen; however, the Committee identified the long-term goal of limiting the maximum global average temperature increase to no more than 2°C above pre-industrial levels, subject to a review in 2015. The UN Climate Change Committee held additional meetings in Durban, South Africa in November 2011; Doha, Qatar in November 2012; and Warsaw, Poland in November 2013. The meetings are gradually gaining consensus among participants on individual climate change issues.

On September 23, 2014 more than 100 Heads of State and Government and leaders from the private sector and civil society met at the Climate Summit in New York hosted by the United Nations. At the Summit, heads of government, business and civil society announced actions in areas that would have the greatest impact on reducing emissions, including climate finance, energy, transport, industry, agriculture, cities, forests, and building resilience.

Parties to the U.N. Framework Convention on Climate Change (UNFCCC) reached a landmark agreement on December 12, 2015 in Paris, charting a fundamentally new course in the two-decade-old global climate effort. Culminating a four-year negotiating round, the new treaty ends the strict differentiation between developed and developing countries that characterized earlier efforts, replacing it with a common framework that commits all countries to put forward their best efforts and to strengthen them in the years ahead. This includes, for the first time, requirements that all parties report regularly on their emissions and implementation efforts and undergo international review.

The agreement and a companion decision by parties were the key outcomes of the conference, known as the 21st session of the UNFCCC Conference of the Parties (COP) 21. Together, the Paris Agreement and the accompanying COP decision:

- Reaffirm the goal of limiting global temperature increase well below 2 degrees Celsius, while urging efforts to limit the increase to 1.5 degrees;
- Establish binding commitments by all parties to make “nationally determined contributions” (NDCs), and to pursue domestic measures aimed at achieving them;
- Commit all countries to report regularly on their emissions and “progress made in implementing and achieving” their NDCs, and to undergo international review;
- Commit all countries to submit new NDCs every five years, with the clear expectation that they will “represent a progression” beyond previous ones;
- Reaffirm the binding obligations of developed countries under the UNFCCC to support the efforts of developing countries, while for the first time encouraging voluntary contributions by developing countries too;
- Extend the current goal of mobilizing \$100 billion a year in support by 2020 through 2025, with a new, higher goal to be set for the period after 2025;
- Extend a mechanism to address “loss and damage” resulting from climate change, which explicitly will not “involve or provide a basis for any liability or compensation;”

- Require parties engaging in international emissions trading to avoid “double counting;” and
- Call for a new mechanism, similar to the Clean Development Mechanism under the Kyoto Protocol, enabling emission reductions in one country to be counted toward another country’s NDC (C2ES 2015a) (32).

On June 2, 2017 President Donald Trump announced his intention to withdraw from the Paris Agreement. It should be noted that under the terms of the agreement, the United States cannot formally announce its resignation until November 4, 2019. Subsequently, withdrawal would be effective one year after notification in 2020.

NATIONAL

Prior to the last decade, there have been no concrete federal regulations of GHGs or major planning for climate change adaptation. The following are actions regarding the federal government, GHGs, and fuel efficiency.

GHG Endangerment. In *Massachusetts v. Environmental Protection Agency* 549 U.S. 497 (2007), decided on April 2, 2007, the Supreme Court found that four GHGs, including carbon dioxide, are air pollutants subject to regulation under Section 202(a)(1) of the Clean Air Act. The Court held that the EPA Administrator must determine whether emissions of GHGs from new motor vehicles cause or contribute to air pollution, which may reasonably be anticipated to endanger public health or welfare, or whether the science is too uncertain to make a reasoned decision. On December 7, 2009, the EPA Administrator signed two distinct findings regarding GHGs under section 202(a) of the Clean Air Act:

- **Endangerment Finding:** The Administrator finds that the current and projected concentrations of the six key well-mixed GHGs—carbon dioxide, methane, nitrous oxide, hydrofluorocarbons, perfluorocarbons, and sulfur hexafluoride—in the atmosphere threaten the public health and welfare of current and future generations.
- **Cause or Contribute Finding:** The Administrator finds that the combined emissions of these well-mixed GHGs from new motor vehicles and new motor vehicle engines contribute to the GHG pollution, which threatens public health and welfare.

These findings do not impose requirements on industry or other entities. However, this was a prerequisite for implementing GHG emissions standards for vehicles, as discussed in the section “Clean Vehicles” below. After a lengthy legal challenge, the U.S. Supreme Court declined to review an Appeals Court ruling that upheld the EPA Administrator’s findings (33).

Clean Vehicles. Congress first passed the Corporate Average Fuel Economy law in 1975 to increase the fuel economy of cars and light duty trucks. The law has become more stringent over time. On May 19, 2009, President Obama put in motion a new national policy to increase fuel economy for all new cars and trucks sold in the U.S. On April 1, 2010, the EPA and the Department of Transportation’s National Highway Safety Administration announced a joint final rule establishing a national program that would reduce GHG emissions and improve fuel economy for new cars and trucks sold in the U.S.

The first phase of the national program applies to passenger cars, light-duty trucks, and medium-duty passenger vehicles, covering model years 2012 through 2016. They require these vehicles to meet an estimated combined average emissions level of 250 grams of carbon dioxide per mile, equivalent to 35.5 miles per gallon if the automobile industry were to meet this carbon dioxide level solely through fuel economy improvements. Together, these standards would cut carbon dioxide emissions by an estimated 960 million metric tons and 1.8 billion barrels of oil over the lifetime of the vehicles sold under the program (model years 2012–2016). The EPA and the National Highway Safety Administration issued final rules on a second-phase joint rulemaking establishing national standards for light-duty vehicles for model years 2017 through 2025 in August 2012 (EPA 2012c). The new standards for model years 2017 through 2025 apply to passenger cars, light-duty trucks, and medium duty passenger vehicles. The final standards are projected to result in an average industry fleetwide level of 163 grams/mile of carbon dioxide (CO₂) in model year 2025, which is equivalent to 54.5 miles per gallon (mpg) if achieved exclusively through fuel economy improvements.

The EPA and the U.S. Department of Transportation issued final rules for the first national standards to reduce GHG emissions and improve fuel efficiency of heavy-duty trucks and buses on September 15, 2011, effective November 14, 2011. For combination tractors, the agencies are proposing engine and vehicle standards that begin in the 2014 model year and achieve up to a 20 percent reduction in carbon dioxide emissions and fuel consumption by the 2018 model year. For heavy-duty pickup trucks and vans, the agencies are proposing separate gasoline and diesel truck standards, which phase in starting in the 2014 model year and achieve up to a 10-percent reduction for gasoline vehicles and a 15 percent reduction for diesel vehicles by the 2018 model year (12 and 17 percent respectively if accounting for air conditioning leakage). Lastly, for vocational vehicles, the engine and vehicle standards would achieve up to a 10 percent reduction in fuel consumption and carbon dioxide emissions from the 2014 to 2018 model years.

On April 2, 2018, the USEPA signed the Mid-term Evaluation Final Determination, which finds that the model year 2022-2025 greenhouse gas standards are not appropriate and should be revised (34). This Final Determination serves to initiate a notice to further consider appropriate standards for model year 2022-2025 light-duty vehicles. On August 24, 2018, the USEPA and NHTSA published a proposal to freeze the model year 2020 standards through model year 2026 and to revoke California's waiver under the Clean Air Act to establish more stringent standards (35).

Mandatory Reporting of GHGs. The Consolidated Appropriations Act of 2008, passed in December 2007, requires the establishment of mandatory GHG reporting requirements. On September 22, 2009, the EPA issued the Final Mandatory Reporting of GHGs Rule, which became effective January 1, 2010. The rule requires reporting of GHG emissions from large sources and suppliers in the U.S., and is intended to collect accurate and timely emissions data to inform future policy decisions. Under the rule, suppliers of fossil fuels or industrial GHGs, manufacturers of vehicles and engines, and facilities that emit 25,000 metric tons or more per year of GHG emissions are required to submit annual reports to the EPA.

New Source Review. The EPA issued a final rule on May 13, 2010, that establishes thresholds for GHGs that define when permits under the New Source Review Prevention of Significant Deterioration and Title V Operating Permit programs are required for new and existing industrial facilities. This final rule “tailors” the requirements of these Clean Air Act permitting programs to limit which facilities will be required to obtain Prevention of Significant Deterioration and Title V permits. In the preamble to the revisions to the Federal Code of Regulations, the EPA states:

This rulemaking is necessary because without it the Prevention of Significant Deterioration and Title V requirements would apply, as of January 2, 2011, at the 100 or 250 tons per year levels provided under the Clean Air Act, greatly increasing the number of required permits, imposing undue costs on small sources, overwhelming the resources of permitting authorities, and severely impairing the functioning of the programs. EPA is relieving these resource burdens by phasing in the applicability of these programs to GHG sources, starting with the largest GHG emitters. This rule establishes two initial steps of the phase-in. The rule also commits the agency to take certain actions on future steps addressing smaller sources, but excludes certain smaller sources from Prevention of Significant Deterioration and Title V permitting for GHG emissions until at least April 30, 2016.

The EPA estimates that facilities responsible for nearly 70 percent of the national GHG emissions from stationary sources will be subject to permitting requirements under this rule. This includes the nation’s largest GHG emitters—power plants, refineries, and cement production facilities.

Standards of Performance for GHG Emissions for New Stationary Sources: Electric Utility Generating Units. As required by a settlement agreement, the EPA proposed new performance standards for emissions of carbon dioxide for new, affected, fossil fuel-fired electric utility generating units on March 27, 2012. New sources greater than 25 megawatts would be required to meet an output based standard of 1,000 pounds of carbon dioxide per megawatt-hour, based on the performance of widely used natural gas combined cycle technology. It should be noted that on February 9, 2016 the U.S. Supreme Court issued a stay of this regulation pending litigation. Additionally, the current EPA Administrator has also signed a measure to repeal the Clean Power Plan, including the CO2 standards.

Cap and Trade. Cap and trade refers to a policy tool where emissions are limited to a certain amount and can be traded, or provides flexibility on how the emitter can comply. Successful examples in the U.S. include the Acid Rain Program and the NO_x Budget Trading Program and Clean Air Interstate Rule in the northeast. There is no federal GHG cap and trade program currently; however, some states have joined to create initiatives to provide a mechanism for cap and trade.

The Regional GHG Initiative is an effort to reduce GHGs among the states of Connecticut, Delaware, Maine, Maryland, Massachusetts, New Hampshire, New York, Rhode Island, and Vermont. Each state caps carbon dioxide emissions from power plants, auctions carbon dioxide emission allowances, and invests the proceeds in strategic energy programs that further reduce

emissions, save consumers money, create jobs, and build a clean energy economy. The Initiative began in 2008.

The Western Climate Initiative partner jurisdictions have developed a comprehensive initiative to reduce regional GHG emissions to 15 percent below 2005 levels by 2020. The partners were originally California, British Columbia, Manitoba, Ontario, and Quebec. However, Manitoba and Ontario are not currently participating. California linked with Quebec's cap and trade system January 1, 2014, and joint offset auctions took place in 2015 (C2ES 2015).

SmartWay Program. The SmartWay Program is a public-private initiative between the EPA, large and small trucking companies, rail carriers, logistics companies, commercial manufacturers, retailers, and other federal and state agencies. Its purpose is to improve fuel efficiency and the environmental performance (reduction of both GHG emissions and air pollution) of the goods movement supply chains. SmartWay is comprised of four components (EPA 2014):

1. SmartWay Transport Partnership: A partnership in which freight carriers and shippers commit to benchmark operations, track fuel consumption, and improve performance annually.
2. SmartWay Technology Program: A testing, verification, and designation program to help freight companies identify equipment, technologies, and strategies that save fuel and lower emissions.
3. SmartWay Vehicles: A program that ranks light-duty cars and small trucks and identifies superior environmental performers with the SmartWay logo.
4. SmartWay International Interests: Guidance and resources for countries seeking to develop freight sustainability programs modeled after SmartWay.

SmartWay effectively refers to requirements geared towards reducing fuel consumption. Most large trucking fleets driving newer vehicles are compliant with SmartWay design requirements. Moreover, over time, all heavy-duty trucks will have to comply with the ARB GHG Regulation that is designed with the SmartWay Program in mind, to reduce GHG emissions by making them more fuel-efficient. For instance, in 2015, 53 foot or longer dry vans or refrigerated trailers equipped with a combination of SmartWay-verified low-rolling resistance tires and SmartWay-verified aerodynamic devices would obtain a total of 10 percent or more fuel savings over traditional trailers.

Through the SmartWay Technology Program, the EPA has evaluated the fuel saving benefits of various devices through grants, cooperative agreements, emissions and fuel economy testing, demonstration projects and technical literature review. As a result, the EPA has determined the following types of technologies provide fuel saving and/or emission reducing benefits when used properly in their designed applications, and has verified certain products:

- Idle reduction technologies – less idling of the engine when it is not needed would reduce fuel consumption.
- Aerodynamic technologies minimize drag and improve airflow over the entire tractor-trailer vehicle. Aerodynamic technologies include gap fairings that reduce turbulence between the tractor and trailer, side skirts that minimize wind under the trailer, and rear fairings that reduce turbulence and pressure drop at the rear of the trailer.

- Low rolling resistance tires can roll longer without slowing down, thereby reducing the amount of fuel used. Rolling resistance (or rolling friction or rolling drag) is the force resisting the motion when a tire rolls on a surface. The wheel will eventually slow down because of this resistance.
- Retrofit technologies include things such as diesel particulate filters, emissions upgrades (to a higher tier), etc., which would reduce emissions.
- Federal excise tax exemptions.

CALIFORNIA

Legislative Actions to Reduce GHGs

The State of California legislature has enacted a series of bills that constitute the most aggressive program to reduce GHGs of any state in the nation. Some legislation such as the landmark Assembly Bill (AB 32) California Global Warming Solutions Act of 2006 was specifically enacted to address GHG emissions. Other legislation such as Title 24 and Title 20 energy standards were originally adopted for other purposes such as energy and water conservation, but also provide GHG reductions. This section describes the major provisions of the legislation.

AB 32. The California State Legislature enacted AB 32, which requires that GHGs emitted in California be reduced to 1990 levels by the year 2020. “GHGs” as defined under AB 32 include carbon dioxide, methane, N₂O, hydrofluorocarbons, perfluorocarbons, and sulfur hexafluoride. Since AB 32 was enacted, a seventh chemical, nitrogen trifluoride, has also been added to the list of GHGs. The California Air Resources Board (ARB) is the state agency charged with monitoring and regulating sources of GHGs. AB 32 states the following:

Global warming poses a serious threat to the economic well-being, public health, natural resources, and the environment of California. The potential adverse impacts of global warming include the exacerbation of air quality problems, a reduction in the quality and supply of water to the state from the Sierra snowpack, a rise in sea levels resulting in the displacement of thousands of coastal businesses and residences, damage to marine ecosystems and the natural environment, and an increase in the incidences of infectious diseases, asthma, and other human health-related problems.

ARB approved the 1990 GHG emissions level of 427 MMTCO₂e on December 6, 2007 (ARB 2007). Therefore, emissions generated in California in 2020 are required to be equal to or less than 427 MMTCO₂e. Emissions in 2020 in a “business as usual” (BAU) scenario were estimated to be 596 MMTCO₂e, which do not account for reductions from AB 32 regulations (ARB 2008). At that level, a 28.4 percent reduction was required to achieve the 427 million MTCO₂e 1990 inventory. In October 2010, ARB prepared an updated 2020 forecast to account for the recession and slower forecasted growth. The forecasted inventory without the benefits of adopted regulation is now estimated at 545 million MTCO₂e. Therefore, under the updated forecast, a 21.7 percent reduction from BAU is required to achieve 1990 levels (ARB 2010).

Progress in Achieving AB 32 Targets and Remaining Reductions Required

The State has made steady progress in implementing AB 32 and achieving targets included in Executive Order S-3-05. The progress is shown in updated emission inventories prepared by ARB for 2000 through 2012 (ARB 2014a). The State has achieved the Executive Order S-3-05 target for 2010 of reducing GHG emissions to 2000 levels. As shown below, the 2010 emission inventory achieved this target.

- 1990: 427 million MTCO₂e (AB 32 2020 target)
- 2000: 463 million MTCO₂e (an average 8 percent reduction needed to achieve 1990 base)
- 2010: 450 million MTCO₂e (an average 5 percent reduction needed to achieve 1990 base)

ARB has also made substantial progress in achieving its goal of achieving 1990 emissions levels by 2020. As described earlier in this section, ARB revised the 2020 BAU inventory forecast to account for new lower growth projections, which resulted in a new lower reduction from BAU to achieve the 1990 base. The previous reduction from 2020 BAU needed to achieve 1990 levels was 28.4 percent and the latest reduction from 2020 BAU is 21.7 percent.

- 2020: 545 million MTCO₂e BAU (an average 21.7 percent reduction from BAU needed to achieve 1990 base)

ARB Scoping Plan. ARB's Climate Change Scoping Plan (Scoping Plan) contains measures designed to reduce the State's emissions to 1990 levels by the year 2020 to comply with AB 32 (ARB 2008). The Scoping Plan identifies recommended measures for multiple GHG emission sectors and the associated emission reductions needed to achieve the year 2020 emissions target—each sector has a different emission reduction target. Most of the measures target the transportation and electricity sectors. As stated in the Scoping Plan, the key elements of the strategy for achieving the 2020 GHG target include:

- Expanding and strengthening existing energy efficiency programs as well as building and appliance standards;
- Achieving a statewide renewables energy mix of 33 percent;
- Developing a California cap-and-trade program that links with other Western Climate Initiative partner programs to create a regional market system;
- Establishing targets for transportation-related GHG emissions for regions throughout California and pursuing policies and incentives to achieve those targets;
- Adopting and implementing measures pursuant to existing State laws and policies, including California's clean car standards, goods movement measures, and the Low Carbon Fuel Standard; and
- Creating targeted fees, including a public goods charge on water use, fees on high global warming potential gases, and a fee to fund the administrative costs of the State's long-term commitment to AB 32 implementation.

The ARB approved the First Update to the Scoping Plan (Update) on May 22, 2014. The Update identifies the next steps for California's climate change strategy. The Update shows how California continues on its path to meet the near-term 2020 GHG limit, but also sets a path toward long-term, deep GHG emission reductions. The report establishes a broad framework for continued emission reductions beyond 2020, on the path to 80 percent below 1990 levels

by 2050. The Update identifies progress made to meet the near-term objectives of AB 32 and defines California’s climate change priorities and activities for the next several years. The Update does not set new targets for the State but describes a path that would achieve the long term 2050 goal of Executive Order S-05-03 for emissions to decline to 80 percent below 1990 levels by 2050 (ARB 2014).

Forecasting the amount of emissions that would occur in 2020 if no actions are taken was necessary to assess the amount of reductions California must achieve to return to the 1990 emissions level by 2020 as required by AB 32. The no-action scenario is known as “business-as-usual” or BAU. The ARB originally defined the BAU scenario as emissions in the absence of any GHG emission reduction measures discussed in the Scoping Plan.

As part of CEQA compliance for the Scoping Plan, ARB prepared a Supplemental Functional Equivalent Document (FED) in 2011. The FED included an updated 2020 BAU emissions inventory projection based on current economic forecasts (i.e., as influenced by the economic downturn) and emission reduction measures already in place, replacing its prior 2020 BAU emissions inventory. ARB staff derived the updated emissions estimates by projecting emissions growth, by sector, from the state’s average emissions from 2006–2008. The new BAU estimate includes emission reductions for the million-solar-roofs program, the AB 1493 (Pavley I) motor vehicle GHG emission standards, and the Low Carbon Fuels Standard. In addition, ARB factored into the 2020 BAU inventory emissions reductions associated with 33 percent RPS for electricity generation. The updated BAU estimate of 507 MMTCO₂e by 2020 requires a reduction of 80 MMTCO₂e, or a 16 percent reduction below the estimated BAU levels to return to 1990 levels (i.e., 427 MMTCO₂e) by 2020.

In order to provide a BAU reduction that is consistent with the original definition in the Scoping Plan and with threshold definitions used in thresholds adopted by lead agencies for CEQA purposes and many climate action plans, the updated inventory without regulations was also included in the Supplemental FED. The ARB 2020 BAU projection for GHG emissions in California was originally estimated to be 596 MMTCO₂e. The updated ARB 2020 BAU projection in the Supplemental FED is 545 MMTCO₂e. Considering the updated BAU estimate of 545 MMTCO₂e by 2020, ARB estimates a 21.7 percent reduction below the estimated statewide BAU levels is necessary to return to 1990 emission levels (i.e., 427 MMTCO₂e) by 2020, instead of the approximate 28.4 percent BAU reduction previously reported under the original Climate Change Scoping Plan (2008).

2017 Climate Change Scoping Plan Update

In November 2017, ARB released the final 2017 Scoping Plan Update, which identifies the State’s post-2020 reduction strategy. The 2017 Scoping Plan Update reflects the 2030 target of a 40 percent reduction below 1990 levels, set by Executive Order B-30-15 and codified by Senate Bill 32 (SB 32). Key programs that the proposed Second Update builds upon include the Cap-and-Trade Regulation, the Low Carbon Fuel Standard, and much cleaner cars, trucks and freight movement, utilizing cleaner, renewable energy, and strategies to reduce methane emissions from agricultural and other wastes.

The 2017 Scoping Plan establishes a new emissions limit of 260 MMTCO₂e for the year 2030, which corresponds to a 40 percent decrease in 1990 levels by 2030.

California's climate strategy will require contributions from all sectors of the economy, including the land base, and will include enhanced focus on zero- and near-zero-emission (ZE/NZE) vehicle technologies; continued investment in renewables, including solar roofs, wind, and other distributed generation; greater use of low carbon fuels; integrated land conservation and development strategies; coordinated efforts to reduce emissions of short-lived climate pollutants (methane, black carbon, and fluorinated gases); and an increased focus on integrated land use planning to support livable, transit-connected communities and conservation of agricultural and other lands. Requirements for direct GHG reductions at refineries will further support air quality co-benefits in neighborhoods, including in disadvantaged communities historically located adjacent to these large stationary sources, as well as efforts with California's local air pollution control and air quality management districts (air districts) to tighten emission limits on a broad spectrum of industrial sources. Major elements of the 2017 Scoping Plan framework include:

- Implementing and/or increasing the standards of the Mobile Source Strategy, which include increasing ZEV buses and trucks.
- Low Carbon Fuel Standard (LCFS), with an increased stringency (18 percent by 2030).
- Implementing SB 350, which expands the Renewables Portfolio Standard (RPS) to 50 percent RPS and doubles energy efficiency savings by 2030.
- California Sustainable Freight Action Plan, which improves freight system efficiency, utilizes near-zero emissions technology, and deployment of ZEV trucks.
- Implementing the proposed Short-Lived Climate Pollutant Strategy (SLPS), which focuses on reducing methane and hydrofluorocarbon emissions by 40 percent and anthropogenic black carbon emissions by 50 percent by year 2030.
- Continued implementation of SB 375.
- Post-2020 Cap-and-Trade Program that includes declining caps.
- 20 percent reduction in GHG emissions from refineries by 2030.
- Development of a Natural and Working Lands Action Plan to secure California's land base as a net carbon sink.

Note, however, that the 2017 Scoping Plan acknowledges that:

[a]chieving net zero increases in GHG emissions, resulting in no contribution to GHG impacts, may not be feasible or appropriate for every project, however, and the inability of a project to mitigate its GHG emissions to net zero does not imply the project results in a substantial contribution to the cumulatively significant environmental impact of climate change under CEQA.

In addition to the statewide strategies listed above, the 2017 Scoping Plan also identifies local governments as essential partners in achieving the State's long-term GHG reduction goals and identifies local actions to reduce GHG emissions. As part of the recommended actions, CARB recommends that local governments achieve a community-wide goal to achieve emissions of no

more than 6 MTCO₂e or less per capita by 2030 and 2 MTCO₂e or less per capita by 2050. For CEQA projects, CARB states that lead agencies may develop evidenced-based bright-line numeric thresholds—consistent with the Scoping Plan and the State’s long-term GHG goals—and projects with emissions over that amount may be required to incorporate on-site design features and mitigation measures that avoid or minimize project emissions to the degree feasible; or, a performance-based metric using a climate action plan or other plan to reduce GHG emissions is appropriate.

According to research conducted by the Lawrence Berkeley National Laboratory and supported by ARB, California, under its existing and proposed GHG reduction policies, is on track to meet the 2020 reduction targets under AB 32 and could achieve the 2030 goals under SB 32. The research utilized a new, validated model known as the California LBNL GHG Analysis of Policies Spreadsheet (CALGAPS), which simulates GHG and criteria pollutant emissions in California from 2010 to 2050 in accordance to existing and future GHG-reducing policies. The CALGAPS model showed that GHG emissions through 2020 could range from 317 to 415 MTCO₂e per year, “indicating that existing state policies will likely allow California to meet its target [of 2020 levels under AB 32].” CALGAPS also showed that by 2030, emissions could range from 211 to 428 MTCO₂e per year, indicating that “even if all modeled policies are not implemented, reductions could be sufficient to reduce emissions 40 percent below the 1990 level [of SB 32].” CALGAPS analyzed emissions through 2050 even though it did not generally account for policies that might be put in place after 2030. Although the research indicated that the emissions would not meet the State’s 80 percent reduction goal by 2050, various combinations of policies could allow California’s cumulative emissions to remain very low through 2050 (36) (37).

Senate Bill 32. On September 8, 2016, Governor Jerry Brown signed the Senate Bill (SB) 32 and its companion bill, Assembly Bill (AB) 197. SB 32 requires the state to reduce statewide GHG emissions to 40 percent below 1990 levels by 2030, a reduction target that was first introduced in Executive Order B-30-15. The new legislation builds upon the AB 32 goal of 1990 levels by 2020 and provides an intermediate goal to achieving S-3-05, which sets a statewide GHG reduction target of 80 percent below 1990 levels by 2050. AB 197 creates a legislative committee to oversee regulators to ensure that ARB not only responds to the Governor, but also the Legislature (11).

Cap and Trade Program. The Scoping Plan identifies a Cap-and-Trade Program as one of the key strategies for California to reduce GHG emissions. According to ARB, a cap-and-trade program will help put California on the path to meet its goal of reducing GHG emissions to 1990 levels by the year 2020 and ultimately achieving an 80 percent reduction from 1990 levels by 2050. Under cap-and-trade, an overall limit on GHG emissions from capped sectors is established, and facilities subject to the cap will be able to trade permits to emit GHGs within the overall limit.

ARB adopted a California Cap-and-Trade Program pursuant to its authority under AB 32. See Title 17 of the California Code of Regulations (CCR) §§ 95800 to 96023). The Cap-and-Trade Program is designed to reduce GHG emissions from major sources (deemed “covered entities”) by setting a firm cap on statewide GHG emissions and employing market mechanisms to achieve AB 32’s emission-reduction mandate of returning to 1990 levels of emissions by 2020. The statewide cap for GHG emissions from the capped sectors (e.g., electricity generation,

petroleum refining, and cement production) commenced in 2013 and will decline over time, achieving GHG emission reductions throughout the program's duration.

Covered entities that emit more than 25,000 MTCO₂e per year must comply with the Cap-and-Trade Program. Triggering of the 25,000 MTCO₂e per year “inclusion threshold” is measured against a subset of emissions reported and verified under the California Regulation for the Mandatory Reporting of GHG Emissions (Mandatory Reporting Rule or “MRR”).

Under the Cap-and-Trade Program, ARB issues allowances equal to the total amount of allowable emissions over a given compliance period and distributes these to regulated entities. Covered entities are allocated free allowances in whole or part (if eligible), and may buy allowances at auction, purchase allowances from others, or purchase offset credits. Each covered entity with a compliance obligation is required to surrender “compliance instruments” (30) for each MTCO₂e of GHG they emit. There also are requirements to surrender compliance instruments covering 30 percent of the prior year’s compliance obligation by November of each year. For example, in November 2014, a covered entity was required to submit compliance instruments to cover 30 percent of its 2013 GHG emissions.

The Cap-and-Trade Program provides a firm cap, ensuring that the 2020 statewide emission limit will not be exceeded. An inherent feature of the Cap-and-Trade program is that it does not guarantee GHG emissions reductions in any discrete location or by any particular source. Rather, GHG emissions reductions are only guaranteed on an accumulative basis. As summarized by ARB in the First Update:

The Cap-and-Trade Regulation gives companies the flexibility to trade allowances with others or take steps to cost-effectively reduce emissions at their own facilities. Companies that emit more have to turn in more allowances or other compliance instruments. Companies that can cut their GHG emissions have to turn in fewer allowances. But as the cap declines, aggregate emissions must be reduced. In other words, a covered entity theoretically could increase its GHG emissions every year and still comply with the Cap-and-Trade Program if there is a reduction in GHG emissions from other covered entities. Such a focus on aggregate GHG emissions is considered appropriate because climate change is a global phenomenon, and the effects of GHG emissions are considered cumulative (ARB 2014).

The Cap-and-Trade Program works with other direct regulatory measures and provides an economic incentive to reduce emissions. If California’s direct regulatory measures reduce GHG emissions more than expected, then the Cap-and-Trade Program will be responsible for relatively fewer emissions reductions. If California’s direct regulatory measures reduce GHG emissions less than expected, then the Cap-and-Trade Program will be responsible for relatively more emissions reductions. Thus, the Cap-and-Trade Program assures that California will meet its 2020 GHG emissions reduction mandate:

The Cap-and-Trade Program establishes an overall limit on GHG emissions from most of the California economy—the “capped sectors.” Within the capped

sectors, some of the reductions are being accomplished through direct regulations, such as improved building and appliance efficiency standards, the [Low Carbon Fuel Standard] LCFS, and the 33 percent [Renewables Portfolio Standard] RPS. Whatever additional reductions are needed to bring emissions within the cap is accomplished through price incentives posed by emissions allowance prices. Together, direct regulation and price incentives assure that emissions are brought down cost-effectively to the level of the overall cap. The Cap-and-Trade Regulation provides assurance that California's 2020 limit will be met because the regulation sets a firm limit on 85 percent of California's GHG emissions. In sum, the Cap-and-Trade Program will achieve aggregate, rather than site specific or project-level, GHG emissions reductions. Also, due to the regulatory architecture adopted by ARB in AB 32, the reductions attributed to the Cap-and-Trade Program can change over time depending on the State's emissions forecasts and the effectiveness of direct regulatory measures (ARB 2014).

As of January 1, 2015, the Cap-and-Trade Program covered approximately 85 percent of California's GHG emissions. The Cap-and-Trade Program covers the GHG emissions associated with electricity consumed in California, whether generated in-state or imported. Accordingly, GHG emissions associated with CEQA projects' electricity usage are covered by the Cap-and-Trade Program.

The Cap-and-Trade Program also covers fuel suppliers (natural gas and propane fuel providers and transportation fuel providers) to address emissions from such fuels and from combustion of other fossil fuels not directly covered at large sources in the Program's first compliance period. While the Cap-and-Trade Program technically covered fuel suppliers as early as 2012, they did not have a compliance obligation (i.e., they were not fully regulated) until 2015. The Cap-and-Trade Program covers the GHG emissions associated with the combustion of transportation fuels in California, whether refined in-state or imported. The point of regulation for transportation fuels is when they are "supplied" (i.e., delivered into commerce). Accordingly, as with stationary source GHG emissions and GHG emissions attributable to electricity use, virtually all, if not all, of GHG emissions from CEQA projects associated with vehicle-miles traveled (VMT) are covered by the Cap-and-Trade Program (ARB 2015) (38).

In addition, the Scoping Plan differentiates between "capped" and "uncapped" strategies. "Capped" strategies are subject to the proposed cap-and-trade program. The Scoping Plan states that the inclusion of these emissions within the Program will help ensure that the year 2020 emission targets are met despite some degree of uncertainty in the emission reduction estimates for any individual measure. Implementation of the capped strategies is calculated to achieve a sufficient amount of reductions by 2020 to achieve the emission target contained in AB 32. "Uncapped" strategies that will not be subject to the cap-and-trade emissions caps and

requirements are provided as a margin of safety by accounting for additional GHG emission reductions.³

SB 375 - the Sustainable Communities and Climate Protection Act of 2008. Passing the Senate on August 30, 2008, Senate Bill (SB) 375 was signed by the Governor on September 30, 2008. According to SB 375, the transportation sector is the largest contributor of GHG emissions, which emits over 40 percent of the total GHG emissions in California. SB 375 states, “Without improved land use and transportation policy, California will not be able to achieve the goals of AB 32.” SB 375 does the following: it (1) requires metropolitan planning organizations to include sustainable community strategies in their regional transportation plans for reducing GHG emissions, (2) aligns planning for transportation and housing, and (3) creates specified incentives for the implementation of the strategies.

Concerning CEQA, SB 375, as codified in Public Resources Code Section 21159.28, states that CEQA findings for certain projects are not required to reference, describe, or discuss (1) growth inducing impacts, or (2) any project-specific or cumulative impacts from cars and light-duty truck trips generated by the project on global warming or the regional transportation network, if the project:

1. Is in an area with an approved sustainable communities strategy or an alternative planning strategy that the ARB accepts as achieving the GHG emission reduction targets.
2. Is consistent with that strategy (in designation, density, building intensity, and applicable policies).
3. Incorporates the mitigation measures required by an applicable prior environmental document.

AB 1493 Pavley Regulations and Fuel Efficiency Standards. California AB 1493, enacted on July 22, 2002, required ARB to develop and adopt regulations that reduce GHGs emitted by passenger vehicles and light duty trucks. Implementation of the regulation was delayed by lawsuits filed by automakers and by the EPA’s denial of an implementation waiver. The EPA subsequently granted the requested waiver in 2009, which was upheld by the U.S. District Court for the District of Columbia in 2011.

The standards phase in during the 2009 through 2016 model years. When fully phased in, the near-term (2009–2012) standards will result in about a 22 percent reduction compared with the 2002 fleet, and the mid-term (2013–2016) standards will result in about a 30 percent reduction. Several technologies stand out as providing significant reductions in emissions at favorable costs. These include discrete variable valve lift or camless valve actuation to optimize valve operation rather than relying on fixed valve timing and lift as has historically been done; turbocharging to boost power and allow for engine downsizing; improved multi-speed transmissions; and improved air conditioning systems that operate optimally, leak less, and/or use an alternative refrigerant.

³ On March 17, 2011, the San Francisco Superior Court issued a final decision in *Association of Irrigated Residents v. California Air Resources Board* (Case No. CPF-09-509562). While the Court upheld the validity of the ARB Scoping Plan for the implementation of AB 32, the Court enjoined ARB from further rulemaking under AB 32 until ARB amends its CEQA environmental review of the Scoping Plan to address the flaws identified by the Court. On May 23, 2011, ARB filed an appeal. On June 24, 2011, the Court of Appeal granted ARB’s petition staying the trial court’s order pending consideration of the appeal. In the interest of informed decision-making, on June 13, 2011, ARB released the expanded alternatives analysis in a draft Supplement to the AB 32 Scoping Plan Functional Equivalent Document. The ARB Board approved the Scoping Plan and the CEQA document on August 24, 2011.

The second phase of the implementation for the Pavley bill was incorporated into Amendments to the Low-Emission Vehicle Program referred to as LEV III or the Advanced Clean Cars program. The Advanced Clean Car program combines the control of smog-causing pollutants and GHG emissions into a single coordinated package of requirements for model years 2017 through 2025. The regulation will reduce GHGs from new cars by 34 percent from 2016 levels by 2025. The new rules will clean up gasoline and diesel-powered cars, and deliver increasing numbers of zero-emission technologies, such as full battery electric cars, newly emerging plug-in hybrid electric vehicles and hydrogen fuel cell cars. The package will also ensure adequate fueling infrastructure is available for the increasing numbers of hydrogen fuel cell vehicles planned for deployment in California.

SB 350— Clean Energy and Pollution Reduction Act of 2015. In October 2015, the legislature approved, and the Governor signed SB 350, which reaffirms California’s commitment to reducing its GHG emissions and addressing climate change. Key provisions include an increase in the renewables portfolio standard (RPS), higher energy efficiency requirements for buildings, initial strategies towards a regional electricity grid, and improved infrastructure for electric vehicle charging stations. Provisions for a 50 percent reduction in the use of petroleum statewide were removed from the Bill because of opposition and concern that it would prevent the Bill’s passage. Specifically, SB 350 requires the following to reduce statewide GHG emissions:

- Increase the amount of electricity procured from renewable energy sources from 33 percent to 50 percent by 2030, with interim targets of 40 percent by 2024, and 25 percent by 2027.
- Double the energy efficiency in existing buildings by 2030. This target will be achieved through the California Public Utility Commission (CPUC), the California Energy Commission (CEC), and local publicly-owned utilities.
- Reorganize the Independent System Operator (ISO) to develop more regional electrify transmission markets and to improve accessibility in these markets, which will facilitate the growth of renewable energy markets in the western United States (California Leginfo 2015).

EXECUTIVE ORDERS RELATED TO GHG EMISSIONS

California’s Executive Branch has taken several actions to reduce GHGs through the use of Executive Orders. Although not regulatory, they set the tone for the state and guide the actions of state agencies.

Executive Order B-55-18 and SB 100. Executive Order B-55-18 and SB 100. SB 100 and Executive Order B-55-18 were signed by Governor Brown on September 10, 2018. Under the existing RPS, 25 percent of retail sales are required to be from renewable sources by December 31, 2016, 33 percent by December 31, 2020, 40 percent by December 31, 2024, 45 percent by December 31, 2027, and 50 percent by December 31, 2030. SB 100 raises California’s RPS requirement to 50 percent renewable resources target by December 31, 2026, and to achieve a 60 percent target by December 31, 2030. SB 100 also requires that retail sellers and local publicly owned electric utilities procure a minimum quantity of electricity products from eligible renewable energy resources so that the total kilowatt hours of those products sold to their retail end-use customers achieve 44 percent of retail sales by December 31, 2024, 52 percent

by December 31, 2027, and 60 percent by December 31, 2030. In addition to targets under AB 32 and SB32, Executive Order B-55-18 establishes a carbon neutrality goal for the state of California by 2045; and sets a goal to maintain net negative emissions thereafter. The Executive Order directs the California Natural Resources Agency, CalEPA, the Department of Food and Agriculture, and CARB to include sequestration targets in the Natural and Working Lands Climate Change Implementation Plan consistent with the carbon neutrality goal.

Executive Order S-3-05. Former California Governor Arnold Schwarzenegger announced on June 1, 2005, through Executive Order S-3-05, the following reduction targets for GHG emissions:

- By 2010, reduce GHG emissions to 2000 levels.
- By 2020, reduce GHG emissions to 1990 levels.
- By 2050, reduce GHG emissions to 80 percent below 1990 levels.

The 2050 reduction goal represents what some scientists believe is necessary to reach levels that will stabilize the climate. The 2020 goal was established to be a mid-term target. Because this is an executive order, the goals are not legally enforceable for local governments or the private sector.

Executive Order S-01-07 – Low Carbon Fuel Standard. The Governor signed Executive Order S-01-07 on January 18, 2007. The order mandates that a statewide goal shall be established to reduce the carbon intensity of California’s transportation fuels by at least 10 percent by 2020. In particular, the Executive Order established a Low Carbon Fuel Standard and directed the Secretary for Environmental Protection to coordinate the actions of the California Energy Commission, the ARB, the University of California, and other agencies to develop and propose protocols for measuring the “life-cycle carbon intensity” of transportation fuels. This analysis supporting development of the protocols was included in the State Implementation Plan for alternative fuels (State Alternative Fuels Plan adopted by California Energy Commission on December 24, 2007) and was submitted to ARB for consideration as an “early action” item under AB 32. The ARB adopted the Low Carbon Fuel Standard on April 23, 2009.

The Low Carbon Fuel Standard was challenged in the U.S. District Court in Fresno in 2011. The court’s ruling issued on December 29, 2011, included a preliminary injunction against ARB’s implementation of the rule. The Ninth Circuit Court of Appeals stayed the injunction on April 23, 2012, pending final ruling on appeal, allowing ARB to continue to implement and enforce the regulation. The Ninth Circuit Court’s decision, filed September 18, 2013, vacated the preliminary injunction. In essence, the court held that Low Carbon Fuel Standards adopted by ARB were not in conflict with federal law. On August 8, 2013, the Fifth District Court of Appeal (California) ruled ARB failed to comply with CEQA and the Administrative Procedure Act (APA) when adopting regulations for Low Carbon Fuel Standards. In a partially published opinion, the Court of Appeal reversed the trial court’s judgment and directed issuance of a writ of mandate setting aside Resolution 09-31 and two executive orders of ARB approving Low Carbon Fuel Standards (LCFS) regulations promulgated to reduce GHG emissions. However, the court tailored its remedy to protect the public interest by allowing the LCFS regulations to remain operative while ARB complies with the procedural requirements it failed to satisfy.

To address the Court ruling, ARB was required to bring a new LCFS regulation to the Board for consideration in February 2015. The proposed LCFS regulation was required to contain revisions to the 2010 LCFS as well as new provisions designed to foster investments in the production of the low-carbon intensity (low-CI) fuels, offer additional flexibility to regulated parties, update critical technical information, simplify and streamline program operations, and enhance enforcement. On November 16, 2015 the Office of Administrative Law (OAL) approved the Final Rulemaking Package. The new LCFS regulation became effective on January 1, 2016.

Executive Order S-13-08. Executive Order S-13-08 states that “climate change in California during the next century is expected to shift precipitation patterns, accelerate sea level rise and increase temperatures, thereby posing a serious threat to California’s economy, to the health and welfare of its population and to its natural resources.” Pursuant to the requirements in the Order, the 2009 California Climate Adaptation Strategy (California Natural Resources Agency 2009) was adopted, which is the “. . . first statewide, multi-sector, region-specific, and information-based climate change adaptation strategy in the United States.” Objectives include analyzing risks of climate change in California, identifying and exploring strategies to adapt to climate change, and specifying a direction for future research.

Executive Order B-30-15. On April 29, 2015, Governor Edmund G. Brown Jr. issued an executive order to establish a California GHG reduction target of 40 percent below 1990 levels by 2030. The Governor’s executive order aligns California’s GHG reduction targets with those of leading international governments ahead of the United Nations Climate Change Conference in Paris late 2015. The Order sets a new interim statewide GHG emission reduction target to reduce GHG emissions to 40 percent below 1990 levels by 2030 in order to ensure California meets its target of reducing GHG emissions to 80 percent below 1990 levels by 2050 and directs ARB to update the Climate Change Scoping Plan to express the 2030 target in terms of million metric tons of CO₂ equivalent (MMCO₂e). The Order also requires the state’s climate adaptation plan to be updated every three years, and for the State to continue its climate change research program, among other provisions. As with Executive Order S-3-05, this Order is not legally enforceable for local governments and the private sector. Legislation that would update AB 32 to make post 2020 targets and requirements a mandate is in process in the State Legislature.

CALIFORNIA REGULATIONS AND BUILDING CODES

California has a long history of adopting regulations to improve energy efficiency in new and remodeled buildings. These regulations have kept California’s energy consumption relatively flat even with rapid population growth.

Title 20 Appliance Efficiency Standards. California Code of Regulations, Title 20: Division 2, Chapter 4, Article 4, Sections 1601-1608: Appliance Efficiency Regulations regulates the sale of appliances in California. The Appliance Efficiency Regulations include standards for both federally regulated appliances and non-federally regulated appliances. 23 categories of appliances are included in the scope of these regulations. The standards within these regulations apply to appliances that are sold or offered for sale in California, except those sold

wholesale in California for final retail sale outside the state and those designed and sold exclusively for use in recreational vehicles or other mobile equipment (CEC 2012).

Title 24 Energy Efficiency Standards and California Green Building Standards. California Code of Regulations Title 24 Part 6: California’s Energy Efficiency Standards for Residential and Nonresidential Buildings, was first adopted in 1978 in response to a legislative mandate to reduce California’s energy consumption. The standards are updated periodically to allow consideration and possible incorporation of new energy efficient technologies and methods. Energy efficient buildings require less electricity; therefore, increased energy efficiency reduces fossil fuel consumption and decreases GHG emissions. The 2019 version of Title 24 was adopted by the California Energy Commission (CEC) and will become effective on January 1, 2020 and is therefore applicable to the Project.

The CEC indicates that the 2019 Title 24 standards may require solar photovoltaic systems for new homes, establish requirements for newly constructed healthcare facilities, encourage demand responsive technologies for residential buildings, update indoor and outdoor lighting for nonresidential buildings. The CEC anticipates that single-family homes built with the 2019 standards will use approximately 7 percent less energy compared to the residential homes built under the 2016 standards. Additionally, after implementation of solar photovoltaic systems, homes built under the 2019 standards will about 53 percent less energy than homes built under the 2016 standards. Nonresidential buildings will use approximately 30 percent less energy due to lighting upgrades (39).

California Code of Regulations, Title 24, Part 11: California Green Building Standards Code (CALGreen) is a comprehensive and uniform regulatory code for all residential, commercial, and school buildings that went in effect on January 1, 2011, and is administered by the California Building Standards Commission. CALGreen is updated on a regular basis, with the most recent approved update consisting of the 2016 California Green Building Code Standards that became effective January 1, 2017. It should be noted that the CALGreen standards are currently in the process of being updated, but final rulemaking activity has not occurred, therefore at this time the 2016 CalGreen standards are the currently adopted standards in effect. Local jurisdictions are permitted to adopt more stringent requirements, as state law provides methods for local enhancements. CALGreen recognizes that many jurisdictions have developed existing construction and demolition ordinances and defers to them as the ruling guidance provided, they establish a minimum 65 percent diversion requirement. The code also provides exemptions for areas not served by construction and demolition recycling infrastructure. The State Building Code provides the minimum standard that buildings must meet in order to be certified for occupancy, which is generally enforced by the local building official. CALGreen requires:

- Short-term bicycle parking. If a commercial project is anticipated to generate visitor traffic, provide permanently anchored bicycle racks within 200 feet of the visitors’ entrance, readily visible to passers-by, for 5 percent of visitor motorized vehicle parking capacity, with a minimum of one two-bike capacity rack (5.106.4.1.1).

- Long-term bicycle parking. For new buildings with 10 or more tenant-occupants, provide secure bicycle parking for 5 percent of tenant-occupied motorized vehicle parking capacity, with a minimum of one space (5.106.4.1.2).
- Designated parking. Provide designated parking in commercial projects for any combination of low-emitting, fuel-efficient and carpool/van pool vehicles as shown in Table 5.106.5.2 (5.106.5.2).
- Recycling by Occupants. Provide readily accessible areas that serve the entire building and are identified for the depositing, storage and collection of nonhazardous materials for recycling (5.410.1).
- Construction waste. A minimum 65 percent diversion of construction and demolition waste from landfills, increasing voluntarily to 80 percent for new homes and commercial projects (5.408.1, A5.408.3.1 [nonresidential], A5.408.3.1 [residential]). All (100 percent) of trees, stumps, rocks and associated vegetation and soils resulting from land clearing shall be reused or recycled (5.408.3).
- Wastewater reduction. Each building shall reduce the generation of wastewater by one of the following methods:
 - The installation of water-conserving fixtures (5.303.3) or
 - Using nonpotable water systems (5.303.4).
- Water use savings. 20 percent mandatory reduction of indoor water use with voluntary goal standards for 30, 35 and 40 percent reductions (5.303.2, A5303.2.3 [nonresidential]).
- Water meters. Separate water meters for buildings in excess of 50,000 sf or buildings projected to consume more than 1,000 gallons per day (5.303.1).
- Irrigation efficiency. Moisture-sensing irrigation systems for larger landscaped areas (5.304.3).
- Materials pollution control. Low-pollutant emitting interior finish materials such as paints, carpet, vinyl flooring, and particleboard (5.404).
- Building commissioning. Mandatory inspections of energy systems (i.e., heat furnace, air conditioner, mechanical equipment) for nonresidential buildings over 10,000 sf to ensure that all are working at their maximum capacity according to their design efficiencies (5.410.2).

Model Water Efficient Landscape Ordinance. The Model Water Efficient Landscape Ordinance (Ordinance) was required by AB 1881, the Water Conservation Act. The bill required local agencies to adopt a local landscape ordinance at least as effective in conserving water as the Model Ordinance by January 1, 2010. Reductions in water use of 20 percent consistent with (SBX-7-7) 2020 mandate are expected upon compliance with the ordinance. Governor Brown’s Drought Executive Order of April 1, 2015 (EO B-29-15) directed Department of Water Resources (DWR) to update the Ordinance through expedited regulation. The California Water Commission approved the revised Ordinance on July 15, 2015 effective December 15, 2015. New development projects that include landscape areas of 500 sf or more are subject to the Ordinance. The update requires:

- More efficient irrigation systems;
- Incentives for graywater usage;
- Improvements in on-site stormwater capture;
- Limiting the portion of landscapes that can be planted with high water use plants; and

- Reporting requirements for local agencies.

ARB Refrigerant Management Program. ARB adopted a regulation in 2009 to reduce refrigerant GHG emissions from stationary sources through refrigerant leak detection and monitoring, leak repair, system retirement and retrofitting, reporting and recordkeeping, and proper refrigerant cylinder use, sale, and disposal. The regulation is set forth in sections 95380 to 95398 of Title 17, California Code of Regulations. The rules implementing the regulation establish a limit on statewide GHG emissions from stationary facilities with refrigeration systems with more than 50 pounds of a high GWP refrigerant. The refrigerant management program is designed to (1) reduce emissions of high-GWP GHG refrigerants from leaky stationary, non-residential refrigeration equipment; (2) reduce emissions from the installation and servicing of refrigeration and air-conditioning appliances using high-GWP refrigerants; and (3) verify GHG emission reductions.

Tractor-Trailer GHG Regulation. The tractors and trailers subject to this regulation must either use EPA SmartWay certified tractors and trailers or retrofit their existing fleet with SmartWay verified technologies. The regulation applies primarily to owners of 53-foot or longer box-type trailers, including both dry-van and refrigerated-van trailers, and owners of the heavy-duty tractors that pull them on California highways. These owners are responsible for replacing or retrofitting their affected vehicles with compliant aerodynamic technologies and low rolling resistance tires. Sleeper cab tractors model year 2011 and later must be SmartWay certified. All other tractors must use SmartWay verified low rolling resistance tires. There are also requirements for trailers to have low rolling resistance tires and aerodynamic devices.

Phase 1 and 2 Heavy-Duty Vehicle GHG Standards. ARB has adopted a new regulation for greenhouse gas (GHG) emissions from heavy-duty trucks and engines sold in California. It establishes GHG emission limits on truck and engine manufacturers and harmonizes with the U.S. EPA rule for new trucks and engines nationally. Existing heavy-duty vehicle regulations in California include engine criteria emission standards, tractor-trailer GHG requirements to implement SmartWay strategies (i.e., the Heavy-Duty Tractor-Trailer Greenhouse Gas Regulation), and in-use fleet retrofit requirements such as the Truck and Bus Regulation. In September 2011, the U.S. EPA adopted their new rule for heavy-duty trucks and engines. The U.S. EPA rule has compliance requirements for new compression and spark ignition engines, as well as trucks from Class 2b through Class 8. Compliance requirements begin with model year (MY) 2014 with stringency levels increasing through MY 2018. The rule organizes truck compliance into three groupings, which include a) heavy-duty pickups and vans; b) vocational vehicles; and c) combination tractors. The U.S. EPA rule does not regulate trailers.

ARB staff has worked jointly with the U.S. Environmental Protection Agency (U.S. EPA) and the National Highway Traffic Safety Administration (NHTSA) on the next phase of federal greenhouse gas (GHG) emission standards for medium- and heavy-duty vehicles, called federal Phase 2. The federal Phase 2 standards were built on the improvements in engine and vehicle efficiency required by the Phase 1 emission standards and represent a significant opportunity to achieve further GHG reductions for 2018 and later model year heavy-duty vehicles, including trailers. But as discussed above, the USEPA and NHTSA have proposed to roll back GHG and fuel

economy standards for cars and light-duty trucks, which suggests a similar rollback of Phase 2 standards for medium and heavy-duty vehicles may be pursued.

SB 97 and the CEQA Guidelines Update. Passed in August 2007, SB 97 added Section 21083.05 to the Public Resources Code. The code states “(a) On or before July 1, 2009, the Office of Planning and Research shall prepare, develop, and transmit to the Resources Agency guidelines for the mitigation of GHG emissions or the effects of GHG emissions as required by this division, including, but not limited to, effects associated with transportation or energy consumption. (b) On or before January 1, 2010, the Resources Agency shall certify and adopt guidelines prepared and developed by the Office of Planning and Research pursuant to subdivision (a).” Section 21097 was also added to the Public Resources Code. It provided CEQA protection until January 1, 2010 for transportation projects funded by the Highway Safety, Traffic Reduction, Air Quality, and Port Security Bond Act of 2006 or projects funded by the Disaster Preparedness and Flood Prevention Bond Act of 2006, in stating that the failure to analyze adequately the effects of GHGs would not violate CEQA.

On December 28, 2018, the Natural Resources Agency announced the Office of Administrative law approved the amendments to the CEQA guidelines for implementing the California Environmental Quality Act. The CEQA Amendments provide guidance to public agencies regarding the analysis and mitigation of the effects of GHG emissions in CEQA documents. The CEQA Amendments fit within the existing CEQA framework by amending existing CEQA Guidelines to reference climate change.

Section 1506.4 was amended to state that in determining the significance of a project’s greenhouse gas emissions, the lead agency should focus its analysis on the reasonably foreseeable incremental contribution of the project’s emissions to the effects of climate change. A project’s incremental contribution may be cumulatively considerable even if it appears relatively small compared to statewide, national or global emissions. The agency’s analysis should consider a timeframe that is appropriate for the project. The agency’s analysis also must reasonably reflect evolving scientific knowledge and state regulatory schemes. Additionally, a lead agency may use a model or methodology to estimate greenhouse gas emissions resulting from a project. The lead agency has discretion to select the model or methodology it considers most appropriate to enable decision makers to intelligently take into account the project’s incremental contribution to climate change. The lead agency must support its selection of a model or methodology with substantial evidence. The lead agency should explain the limitations of the particular model or methodology selected for use (1).

REGIONAL

The project is within the South Coast Air Basin (SCAB), which is under the jurisdiction of the SCAQMD.

South Coast Air Quality Management District

SCAQMD is the agency responsible for air quality planning and regulation in the SCAB. The SCAQMD addresses the impacts to climate change of projects subject to SCAQMD permit as a lead agency if they are the only agency having discretionary approval for the project and acts as

a responsible agency when a land use agency must also approve discretionary permits for the project. The SCAQMD acts as an expert commenting agency for impacts to air quality. This expertise carries over to GHG emissions, so the agency helps local land use agencies through the development of models and emission thresholds that can be used to address GHG emissions.

In 2008, SCAQMD formed a Working Group to identify GHG emissions thresholds for land use projects that could be used by local lead agencies in the SCAB. The Working Group developed several different options that are contained in the SCAQMD Draft Guidance Document – Interim CEQA GHG Significance Threshold, that could be applied by lead agencies. The working group has not provided additional guidance since release of the interim guidance in 2008. The SCAQMD Board has not approved the thresholds; however, the Guidance Document provides substantial evidence supporting the approaches to significance of GHG emissions that can be considered by the lead agency in adopting its own threshold. The current interim thresholds consist of the following tiered approach:

- Tier 1 consists of evaluating whether or not the project qualifies for any applicable exemption under CEQA.
- Tier 2 consists of determining whether the project is consistent with a GHG reduction plan. If a project is consistent with a qualifying local GHG reduction plan, it does not have significant GHG emissions.
- Tier 3 consists of screening values, which the lead agency can choose, but must be consistent with all projects within its jurisdiction. A project's construction emissions are averaged over 30 years and are added to the project's operational emissions. If a project's emissions are below one of the following screening thresholds, then the project is less than significant:
 - Residential and Commercial land use: 3,000 MTCO₂e per year
 - Industrial land use: 10,000 MTCO₂e per year
 - Based on land use type: residential: 3,500 MTCO₂e per year; commercial: 1,400 MTCO₂e per year; or mixed use: 3,000 MTCO₂e per year
- Tier 4 has the following options:
 - Option 1: Reduce BAU emissions by a certain percentage; this percentage is currently undefined.
 - Option 2: Early implementation of applicable AB 32 Scoping Plan measures
 - Option 3, 2020 target for service populations (SP), which includes residents and employees: 4.8 MTCO₂e/SP/year for projects and 6.6 MTCO₂e/SP/year for plans;
 - Option 3, 2035 target: 3.0 MTCO₂e/SP/year for projects and 4.1 MTCO₂e/SP/year for plans
- Tier 5 involves mitigation offsets to achieve target significance threshold.

The SCAQMD's interim thresholds used the Executive Order S-3-05-year 2050 goal as the basis for the Tier 3 screening level. Achieving the Executive Order's objective would contribute to worldwide efforts to cap carbon dioxide concentrations at 450 ppm, thus stabilizing global climate.

SCAQMD only has authority over GHG emissions from development projects that include air quality permits. At this time, it is unknown if the project would include stationary sources of emissions subject to SCAQMD permits. Notwithstanding, if the Project requires a stationary permit, it would be subject to the applicable SCAQMD regulations.

SCAQMD Regulation XXVII, adopted in 2009 includes the following rules:

- Rule 2700 defines terms and post global warming potentials.
- Rule 2701, SoCal Climate Solutions Exchange, establishes a voluntary program to encourage, quantify, and certify voluntary, high quality certified GHG emission reductions in the SCAQMD.
- Rule 2702, GHG Reduction Program created a program to produce GHG emission reductions within the SCAQMD. The SCAQMD will fund projects through contracts in response to requests for proposals or purchase reductions from other parties.

CITY OF BURBANK GGRP

On February 19, 2013, the City of Burbank adopted the GGRP as part of the Burbank 2035 General Plan. The GGRP identifies a number of State actions adopted to reduce future emissions of greenhouse gasses, including but not limited to AB 32, AB 1493, SB 1078 and AB 1109 (40).

2.8 DISCUSSION ON ESTABLISHMENT OF SIGNIFICANCE THRESHOLDS

The City of Burbank has not adopted a numeric threshold of significance for determining impacts with respect to GHG emissions. Within this GHGA, a screening threshold of 3,000 MTCO₂e per year is employed to determine if additional analysis is required. This approach is a widely accepted small project screening threshold used by numerous lead agencies within SCAB and is based on the SCAQMD staff's proposed GHG screening threshold for stationary source emissions for non-industrial projects, as described in the SCAQMD's Interim CEQA GHG Significance Threshold for Stationary Sources, Rules and Plans ("SCAQMD Interim GHG Threshold"). The SCAQMD Interim GHG Threshold identifies a screening threshold to determine whether additional analysis is required.

This page intentionally left blank

3 PROJECT GREENHOUSE GAS IMPACT

3.1 INTRODUCTION

The Project has been evaluated to determine if it will result in a significant greenhouse gas impact. The significance of these potential impacts is described in the following section.

3.2 STANDARDS OF SIGNIFICANCE

The criteria used to determine the significance of potential Project-related greenhouse gas impacts are taken from the Initial Study Checklist in Appendix G of the State CEQA Guidelines (14 California Code of Regulations §§15000, et seq.). Based on these thresholds, a project would result in a significant impact related to greenhouse gas if it would (1):

- Generate greenhouse gas emissions, either directly or indirectly, that may have a significant impact on the environment?
- Conflict with an applicable plan, policy or regulation adopted for the purpose of reducing the emissions of greenhouse gases?

3.3 CALIFORNIA EMISSIONS ESTIMATOR MODEL™ EMPLOYED TO ANALYZE GHG EMISSIONS

On October 17, 2017, the SCAQMD, in conjunction with the California Air Pollution Control Officers Association (CAPCOA) and other California air districts, released the latest version of the California Emissions Estimator Model™ (CalEEMod™) v2016.3.2. The purpose of this model is to calculate construction-source and operational-source criteria pollutant (VOCs, NO_x, SO_x, CO, PM₁₀, and PM_{2.5}) and greenhouse gas emissions from direct and indirect sources; and quantify applicable air quality and GHG reductions achieved from mitigation measures (41). CalEEMod utilizes widely accepted models for emissions estimates combined with default data that can be used if site-specific information is not available. It should be noted that a majority of the default data associated with locations and land use is based on surveys of existing land uses. Caution should be taken if the project deviates significantly from the types and features included in the survey that forms the evidence supporting the default data (42). The latest version of CalEEMod™ has been used for this Project to determine greenhouse gas emissions. Output from the model runs for construction activity are provided in Appendix 3.1.

3.4 CONSTRUCTION AND OPERATIONAL LIFE-CYCLE ANALYSIS NOT REQUIRED

A full life-cycle analysis (LCA) for construction and operational activity is not included in this analysis due to the lack of consensus guidance on LCA methodology at this time (43). Life-cycle analysis (i.e., assessing economy-wide GHG emissions from the processes in manufacturing and transporting all raw materials used in the project development, infrastructure and on-going operations) depends on emission factors or econometric factors that are not well established for all processes. At this time, an LCA would be extremely speculative and thus has not been prepared.

Additionally, the SCAQMD recommends analyzing direct and indirect project GHG emissions generated within California and not life-cycle emissions because the life-cycle effects from a project could occur outside of California, might not be very well understood or documented, and would be challenging to mitigate (44). Additionally, the science to calculate life cycle emissions is not yet established or well defined; therefore, SCAQMD has not recommended, and is not requiring, life-cycle emissions analysis.

3.5 CONSTRUCTION EMISSIONS

Construction activities associated with the Project will result in emissions of VOCs, NO_x, SO_x, CO, PM₁₀, and PM_{2.5}. Construction related emissions are expected from the following construction activities:

- Demolition
- Site Preparation
- Grading
- Building Construction
- Paving
- Architectural Coating

Construction is expected to commence in mid-2020 and will last through beginning of 2021. Construction duration by phase is shown on Table 3-1. The construction schedule utilized in the analysis represents a “worst-case” analysis scenario should construction occur any time after the respective dates since emission factors for construction decrease as time passes and the analysis year increases due to emission regulations becoming more stringent.⁴ The duration of construction activity and associated equipment represents a reasonable approximation of the expected construction fleet as required per CEQA guidelines. Site specific construction fleet may vary due to specific project needs at the time of construction. The duration of construction activity was based on a 2021 opening year. The associated construction equipment was generally based on CalEEMod 2016.3.2 defaults. Please refer to specific detailed modeling inputs/outputs contained in Appendix 3.1 of this analysis. A detailed summary of construction equipment assumptions by phase is provided at Table 3-2.

As per information provided in the Initial Study (IS), the proposed vault location is presently paved with an asphalt/concrete (a/c) surface that would be removed and replaced after the construction of the vault. As a conservative measure, it is assumed that the total Project area of 12,195.69 sf would be demolished which would result in 561 tons of debris (45).

Construction activities associated with the proposed Project will result in emissions of CO₂ and CH₄ from construction activities. For construction phase Project emissions, GHGs are quantified and amortized over the life of the Project. To amortize the emissions over the life of the

⁴ As shown in the California Emissions Estimator Model (CalEEMod) User’s Guide Version 2016.3.2, Section 4.3 “OFFROAD Equipment” as the analysis year increases, emission factors for the same equipment pieces decrease due to the natural turnover of older equipment being replaced by newer less polluting equipment and new regulatory requirements.

Project, the SCAQMD recommends calculating the total greenhouse gas emissions for the construction activities, dividing it by a 30-year project life then adding that number to the annual operational phase GHG emissions (46). For purposes of analysis, since no long-term operational greenhouse gas impacts are anticipated, this GHGA analyzes construction emissions were amortized over a 30-year period.

TABLE 3-1: CONSTRUCTION DURATION

Phase Name	Start Date	End Date	Days
Demolition	07/20/2020	07/31/2020	10
Site Preparation	08/01/2020	08/03/2020	1
Grading	08/04/2020	08/05/2020	2
Building Construction	08/06/2020	12/23/2020	100
Paving	12/24/2020	12/30/2020	5
Architectural Coating	12/31/2020	01/06/2021	5

TABLE 3-2: CONSTRUCTION EQUIPMENT ASSUMPTIONS

Activity	Equipment	Amount	Hours Per Day
Demolition	Concrete/Industrial Saws	1	8
	Rubber Tired Dozers	1	8
	Tractors/Loaders/Backhoes	2	8
Site Preparation	Graders	1	8
	Tractors/Loaders/Backhoes	1	8
Graders	Concrete/Industrial Saws	1	8
	Rubber Tired Dozers	1	8
	Tractors/Loaders/Backhoes	2	8
Building Construction	Cranes	1	8
	Forklifts	2	8
	Tractors/Loaders/Backhoes	2	8
Paving	Cement and Mortar Mixers	4	8
	Pavers	1	8
	Rollers	1	8
	Tractors/Loaders/Backhoes	1	8
Architectural Coating	Air Compressors	1	8

3.6 OPERATIONAL EMISSIONS

No long-term operational greenhouse gas impacts are anticipated as a result of the proposed Project since there would be no operational vehicle trips resulting from the proposed Project improvements, since the Project is limited to drainage and water quality improvements. As such, there are also no operational (stationary-source) greenhouse gas sources anticipated as a result of the Project improvements since they would be constructed underground.

3.7 EMISSIONS SUMMARY

As shown on Table 3-3, the Project has the potential to generate a total of approximately 3.00 MTCO₂e per year from construction. As such, the Project would not exceed the SCAQMD’s recommended numeric threshold of 3,000 MTCO₂e if it were applied. Thus, the proposed Project would result in a less than significant impact with respect to GHG emissions.

TABLE 3-3: TOTAL PROJECT GREENHOUSE GAS EMISSIONS (ANNUAL)

Emission Source	Emissions (metric tons per year)			
	CO ₂	CH ₄	N ₂ O	Total CO ₂ E
Annual construction-related emissions amortized over 30 years	2.98	--	--	3.00
Total CO₂E (All Sources)	3.00			
SCAQMD Threshold	3,000			
Threshold Exceeded?	NO			

3.8 GREENHOUSE GAS EMISSIONS FINDINGS AND RECOMMENDATIONS

GHG Impact #1: The Project would generate direct or indirect greenhouse gas emission that would result in a significant impact on the environment

The City of Burbank has not adopted a numeric threshold of significance for determining impacts with respect to GHG emissions. Within this GHGA, a screening threshold of 3,000 MTCO₂e per year is employed to determine if additional analysis is required. This approach is a widely accepted small project screening threshold used by numerous lead agencies within the SCAB and is based on the SCAQMD staff’s proposed GHG screening threshold for stationary source emissions for non-industrial projects, as described in the SCAQMD’s Interim CEQA GHG Significance Threshold for Stationary Sources, Rules and Plans (“SCAQMD Interim GHG Threshold”). The SCAQMD Interim GHG Threshold identifies a screening threshold to determine whether additional analysis is required.

The Project will result in approximately 3.00 MTCO₂e per year from construction activity. As such, the Project would not exceed the SCAQMD’s recommended numeric threshold of 3,000 MTCO₂e if it were applied. Thus, project-related emissions would not have a significant direct or indirect impact on GHG and climate change and no mitigation or further analysis is required.

GHG Impact #2: The Project would not conflict with any applicable plan, policy or regulation of an agency adopted for the purpose of reducing the emissions of greenhouse gases.

Consistency with City of Burbank’s GGRP

On February 19, 2013, the City of Burbank adopted a Greenhouse Gas Reduction Plan (GGRP) as part of the Burbank 2035 General Plan. The GGRP identifies a number of State actions adopted to reduce future emissions of greenhouse gasses, including but not limited to AB 32, AB 1493, SB 1078 and AB 1109 (40).

The GGRP identifies a number of actions to be taken by the City to assist in GHG reduction. A number of these action identified in the GGRP applicable to the plan are listed in Table 3-4.

TABLE 3-4: PROJECT CONSISTENCY WITH CITY OF BURBANK GGRP

GGRP Measure	Applicability to Proposed Project	Remarks
Measure E-1.6: BWP: Energy Conservation	Applicable	The Department is anticipated to reduce GHGs through a series of conservation measures that would likely involve the Project.
Measure W-1.3: Stormwater Master Plan	Applicable	The Project would be an element in reducing polluted runoff into the BWP.
Measure SW-1.3: Lumber Diversion Ordinance	Applicable	Lumber used for concrete forms and other uses would be recycled instead of diverted to the local landfill.

This page intentionally left blank

4 REFERENCES

1. **Association of Environmental Professionals.** *2018 CEQA California Environmental Quality Act.* 2018.
2. **Air Resources Board.** Assembly Bill 32: Global Warming Solutions Act. [Online] 2006.
<http://www.arb.ca.gov/cc/ab32/ab32.htm>.
3. —. Sustainable Communities. [Online] 2008. <http://www.arb.ca.gov/cc/sb375/sb375.htm>.
4. —. Clean Car Standards - Pavley, Assembly Bill 1493. [Online] September 24, 2009.
<http://www.arb.ca.gov/cc/ccms/ccms.htm>.
5. **Building Standards Commission.** California Building Standards Code (Title 24, California Code of Regulations). [Online] <http://www.bsc.ca.gov/codes.aspx>.
6. **California Energy Commission.** California Code of Regulations, TITLE 20, Division 2. [Online] September 3, 2013. <http://www.energy.ca.gov/reports/title20/index.html>.
7. **Air Resources Board.** Title 17 - California Code of Regulation. [Online] 2010.
<http://www.arb.ca.gov/regs/regs-17.htm>.
8. **Department of Water Resources.** Updated Model Water Efficient Landscape Ordinance AB 1881. [Online] 2006.
http://www.water.ca.gov/wateruseefficiency/landscapeordinance/updatedOrd_history.cfm.
9. **California Energy Commission.** SB 1368 Emission Performance Standards. [Online] September 29, 2006. http://www.energy.ca.gov/emission_standards/.
10. —. Renewables Portfolio Standard (RPS). [Online] 2002. <http://www.energy.ca.gov/portfolio/>.
11. **California Legislative Information.** Senate Bill No. 32. [Online] September 8, 2016.
https://leginfo.legislature.ca.gov/faces/billNavClient.xhtml?bill_id=201520160SB32.
12. **National Oceanic and Atmospheric Administration.** Greenhouse Gases - Water Vapor. *NOAA National Centers For Environmental Information.* [Online] <https://www.ncdc.noaa.gov/monitoring-references/faq/greenhouse-gases.php?section=watervapor>.
13. *The Carbon Cycle and Climate Change.* **Bennington, Bret J.** 1, s.l. : Brooks/Cole. ISBN 1 3: 978-0-495-73855-8.
14. *Climate Change 2007: The Physical Science Basis. Contribution of Working Group I to the Fourth Assessment Report.* **International Panel on Climate Change.** 4, 2007.
15. **National Oceanic and Atmospheric Administration.** Greenhouse Gases - Methane. *NOAA National Centers for Environmental Information.* [Online] <https://www.ncdc.noaa.gov/monitoring-references/faq/greenhouse-gases.php?section=methane>.
16. **The National Institute for Occupational Safety and Health.** Workplace Safety and Health Topics - Nitrous Oxide. *Centers for Disease Control and Prevention.* [Online] <https://www.cdc.gov/niosh/topics/nitrousoxide/default.html>.
17. **National Oceanic and Atmospheric Administration.** Greenhouse Gases - Chlorofluorocarbons. *NOAA National Centers For Environmental Information.* [Online] <https://www.ncdc.noaa.gov/monitoring-references/faq/greenhouse-gases.php?section=chlorofluorocarbons>.
18. **United States Environmental Protection Agency.** Regulation for Reducing Sulfur Hexafluoride Emissions from Gas Insulated Switchgear. *Environmental Protection Agency.* [Online] May 7, 2014.
<https://www.epa.gov/sites/production/files/2016-02/documents/mehl-arb-presentation-2014-wkshp.pdf>.

19. **World Resources Institute.** Nitrogen Trifluoride Now Required in GHG Protocol Greenhouse Gas Emissions Inventory. [Online] May 22, 2013. <https://www.wri.org/blog/2013/05/nitrogen-trifluoride-now-required-ghg-protocol-greenhouse-gas-emissions-inventories>.
20. **National Center for Biotechnology Information.** Nitrogen Trifluoride. *PubChem Compound Database*. [Online] <https://pubchem.ncbi.nlm.nih.gov/compound/24553> .
21. **Intergovernmental Panel on Climate Change.** Climate Change 2013 The Physical Science Basis - Working Group I Contribution to the Fifth Assessment Report of the Intergovernmental Panel on Climate Change. *AR5 Climate Change 2013: The Physical Science Basis*. [Online] September 2013. https://www.ipcc.ch/site/assets/uploads/2018/02/WG1AR5_all_final.pdf.
22. **United Nations.** GHG Profiles - Annex I. [Online] http://di.unfccc.int/ghg_profile_annex1.
23. —. GHG Profiles - Non-Annex I. [Online] http://di.unfccc.int/ghg_profile_non_annex1.
24. **Environmental Protection Agency.** Inventory of U.S. Greenhouse Gas Emissions and Sinks 1990-2016. [Online] 2018. https://www.epa.gov/sites/production/files/2018-01/documents/2018_complete_report.pdf.
25. **World Resources Institute.** Climate Analysis Indicator Tool (CAIT). [Online] <http://cait.wri.org>.
26. **Air Resources Board.** California Greenhouse Gas Emission Inventory 2000-2016 Edition. [Online] June 17, 2016. <http://www.arb.ca.gov/cc/inventory/data/data.htm>.
27. **American Lung Association.** Climate Change. [Online] <http://www.lung.org/our-initiatives/healthy-air/outdoor/climate-change/>.
28. **Barbara H. Allen-Diaz.** Climate change affects us all. *University of California Agriculture and Natural Resources*. [Online] April 1, 2009. <http://calag.ucanr.edu/Archive/?article=ca.v063n02p51>.
29. **The National Institute for Occupational Safety and Health.** Carbon Dioxide. *Centers for Disease Control and Prevention*. [Online] <https://www.cdc.gov/niosh/npg/npgd0103.html>.
30. **United States Department of Labor.** Nitrous Oxide in Workplace Atmospheres (Passive Monitor). *Occupational Health and Safety Administration*. [Online] 1994. <https://www.osha.gov/dts/sltc/methods/inorganic/id166/id166.html>.
31. **Hardin, Mary and Kahn, Ralph.** Aerosols & Climate Change. *Earth Observatory*. [Online] <http://earthobservatory.nasa.gov/Features/Aerosols/>.
32. **Center for Climate and Energy Solutions (C2ES).** Outcomes of the U.N. Climate Change Conference. *Center for Climate and Energy Solutions (C2ES)*. [Online] 2015. <http://www.c2es.org/international/negotiations/cop21-paris/summary>.
33. **Agency, United States Environmental Protection.** Endangerment and Cause or Contribute Findings for Greenhouse Gases under the Section 202(a) of the Clean Air Act. *United States Environmental Protection Agency*. [Online] <https://www.epa.gov/ghgemissions/endangerment-and-cause-or-contribute-findings-greenhouse-gases-under-section-202a-clean>.
34. **Federal Register.** Mid-Term Evaluation of Greenhouse Gas Emissions Standards for Model Year 2022-2025 Light-Duty Vehicles. [Online] April 13, 2018. <https://www.federalregister.gov/documents/2018/04/13/2018-07364/mid-term-evaluation-of-greenhouse-gas-emissions-standards-for-model-year-2022-2025-light-duty>.
35. **Environmental Protection Agency.** The Safer Affordable Fuel-Efficient Vehicles Rule for Model Years 2021-2026 Passenger Cars and Light Trucks. [Online] August 24, 2018. <https://www.regulations.gov/document?D=EPA-HQ-OAR-2018-0283-0756>.

36. **Lawrence Berkeley National Laboratory.** California's Policies Can Significantly Cut Greenhouse Gas Emissions through 2030. *Lawrence Berkeley National Laboratory*. [Online] January 22, 2015. <http://newscenter.lbl.gov/2015/01/22/californias-policies-can-significantly-cut-greenhouse-gas-emissions-2030/>.
37. **Ernest Orlando Lawrence Berkeley National Laboratory.** Modeling California policy impacts on greenhouse gas emissions. [Online] 2015. <https://eaei.lbl.gov/sites/all/files/lbnl-7008e.pdf>.
38. **California Air Resources Board (ARB).** Cap and Trade Overview. *California Air Resources Board*. [Online] [Cited: May 10, 2016.] http://www.arb.ca.gov/cc/capandtrade/guidance/cap_trade_overview.pdf.
39. **The California Energy Commission.** 2019 Building Energy Efficiency Standards . *California Energy Commission*. [Online] 2018. https://www.energy.ca.gov/title24/2019standards/documents/2018_Title_24_2019_Building_Standards_FAQ.pdf.
40. **City of Burbank.** *City of Burbank Greenhouse Gas Reduction Plan*. 2013.
41. **California Air Pollution Control Officers Association (CAPCOA).** California Emissions Estimator Model (CalEEMod). [Online] September 2016. www.caleemod.com.
42. **California Air Pollution Control Officers Association.** Appendix A Calculation Details for CalEEMod. [Online] 2017. <http://www.caleemod.com/>.
43. **California Natural Resources Agency.** Final Statement of Reasons for Regulatory Action, Amendments to the State CEQA Guidelines Addressing Analysis and Mitigation of Greenhouse Gas Emissions Pursuant to SB97. [Online] December 2009.
44. *Minutes for the GHG CEQA Significance.* **South Coast Air Quality Management District.** 2008.
45. **City of Burbank.** *Burbank Water and Power Campus Stormwater Improvement Project Initial Study*. 2019.
46. **South Coast Air Quality Management District.** *Greenhouse Gas CEQA Significance Threshold Stakeholder Working Group #13*. [Powerpoint] Diamond Bar : s.n., 2009.

This page intentionally left blank

5 CERTIFICATION

The contents of this greenhouse gas study report represent an accurate depiction of the greenhouse gas impacts associated with the proposed Burbank Water and Power Magnolia Campus Drainage Improvement. The information contained in this greenhouse gas report is based on the best available data at the time of preparation. If you have any questions, please contact me directly at (949) 336-5987.

Haseeb Qureshi
Senior Associate
URBAN CROSSROADS, INC.
260 E. Baker St., Suite 200
Costa Mesa, CA 92626
(949) 336-5987
hqureshi@urbanxroads.com

EDUCATION

Master of Science in Environmental Studies
California State University, Fullerton • May, 2010

Bachelor of Arts in Environmental Analysis and Design
University of California, Irvine • June, 2006

PROFESSIONAL AFFILIATIONS

AEP – Association of Environmental Planners
AWMA – Air and Waste Management Association
ASTM – American Society for Testing and Materials

PROFESSIONAL CERTIFICATIONS

Planned Communities and Urban Infill – Urban Land Institute • June, 2011
Indoor Air Quality and Industrial Hygiene – EMSL Analytical • April, 2008
Principles of Ambient Air Monitoring – California Air Resources Board • August, 2007
AB2588 Regulatory Standards – Trinity Consultants • November, 2006
Air Dispersion Modeling – Lakes Environmental • June, 2006

This page intentionally left blank

APPENDIX 3.1:

CALEEMOD EMISSIONS MODEL OUTPUTS

Burbank Water & Power Magnolia Campus (Construction) - Los Angeles-South Coast County, Annual

Burbank Water & Power Magnolia Campus (Construction)
Los Angeles-South Coast County, Annual

1.0 Project Characteristics

1.1 Land Usage

Land Uses	Size	Metric	Lot Acreage	Floor Surface Area	Population
User Defined Industrial	12.20	User Defined Unit	0.00	0.00	0

1.2 Other Project Characteristics

Urbanization	Urban	Wind Speed (m/s)	2.2	Precipitation Freq (Days)	33
Climate Zone	12			Operational Year	2021
Utility Company	Burbank Water & Power				
CO2 Intensity (lb/MW hr)	1096.12	CH4 Intensity (lb/MW hr)	0.029	N2O Intensity (lb/MW hr)	0.006

1.3 User Entered Comments & Non-Default Data

Burbank Water & Power Magnolia Campus (Construction) - Los Angeles-South Coast County, Annual

Project Characteristics -

Land Use - Total Project Area is 12,195.69 Square Feet/0.28 acres.

Construction Phase - Consistent with the Initial Study, the Project's Operational Year is anticipated to be early 2021.

Off-road Equipment - Hours are based on an 8-hour workday.

Off-road Equipment - Hours are based on an 8-hour workday.

Off-road Equipment - Hours are based on an 8-hour workday.

Off-road Equipment - Hours are based on an 8-hour workday.

Off-road Equipment - Hours are based on an 8-hour workday.

Off-road Equipment -

Demolition -

Architectural Coating - Rule 1113

Construction Off-road Equipment Mitigation -

Grading - For purposes of analysis, total acres graded per day is based on the equipment specific grading rates (CalEEMod Appendix A) and the equipment list.

Table Name	Column Name	Default Value	New Value
tblArchitecturalCoating	ConstArea_Nonresidential_Exterior	0.00	6,098.00
tblArchitecturalCoating	ConstArea_Nonresidential_Interior	0.00	18,294.00
tblArchitecturalCoating	EF_Nonresidential_Exterior	100.00	50.00
tblArchitecturalCoating	EF_Nonresidential_Interior	100.00	50.00
tblArchitecturalCoating	EF_Parking	100.00	50.00
tblAreaCoating	Area_Nonresidential_Exterior	0	6098
tblAreaCoating	Area_Nonresidential_Interior	0	18294
tblConstructionPhase	NumDays	0.00	10.00
tblConstructionPhase	NumDays	0.00	1.00
tblConstructionPhase	NumDays	0.00	2.00
tblConstructionPhase	NumDays	0.00	100.00
tblConstructionPhase	NumDays	0.00	5.00

Burbank Water & Power Magnolia Campus (Construction) - Los Angeles-South Coast County, Annual

tblConstructionPhase	NumDays	0.00	5.00
tblGrading	AcresOfGrading	0.00	1.00
tblOffRoadEquipment	UsageHours	1.00	8.00
tblOffRoadEquipment	UsageHours	6.00	8.00
tblOffRoadEquipment	UsageHours	1.00	8.00
tblOffRoadEquipment	UsageHours	6.00	8.00
tblOffRoadEquipment	UsageHours	4.00	8.00
tblOffRoadEquipment	UsageHours	6.00	8.00
tblOffRoadEquipment	UsageHours	6.00	8.00
tblOffRoadEquipment	UsageHours	7.00	8.00
tblOffRoadEquipment	UsageHours	7.00	8.00
tblOffRoadEquipment	UsageHours	7.00	8.00
tblOffRoadEquipment	UsageHours	6.00	8.00
tblTripsAndVMT	VendorTripNumber	0.00	2.00
tblTripsAndVMT	WorkerTripNumber	0.00	5.00
tblTripsAndVMT	WorkerTripNumber	0.00	1.00

2.0 Emissions Summary

Burbank Water & Power Magnolia Campus (Construction) - Los Angeles-South Coast County, Annual

Quarter	Start Date	End Date	Maximum Unmitigated ROG + NOX (tons/quarter)	Maximum Mitigated ROG + NOX (tons/quarter)
1	7-20-2020	10-19-2020	0.4857	0.4857
2	10-20-2020	1-19-2021	0.3742	0.3742
		Highest	0.4857	0.4857

2.2 Overall Operational

Unmitigated Operational

	ROG	NOx	CO	SO2	Fugitive PM10	Exhaust PM10	PM10 Total	Fugitive PM2.5	Exhaust PM2.5	PM2.5 Total	Bio- CO2	NBio- CO2	Total CO2	CH4	N2O	CO2e
Category	tons/yr										MT/yr					
Area	5.6700e-003	0.0000	1.6000e-004	0.0000		0.0000	0.0000		0.0000	0.0000	0.0000	3.0000e-004	3.0000e-004	0.0000	0.0000	3.2000e-004
Energy	0.0000	0.0000	0.0000	0.0000		0.0000	0.0000		0.0000	0.0000	0.0000	0.0000	0.0000	0.0000	0.0000	0.0000
Mobile	0.0000	0.0000	0.0000	0.0000	0.0000	0.0000	0.0000	0.0000	0.0000	0.0000	0.0000	0.0000	0.0000	0.0000	0.0000	0.0000
Waste						0.0000	0.0000		0.0000	0.0000	0.0000	0.0000	0.0000	0.0000	0.0000	0.0000
Water						0.0000	0.0000		0.0000	0.0000	0.0000	0.0000	0.0000	0.0000	0.0000	0.0000
Total	5.6700e-003	0.0000	1.6000e-004	0.0000	0.0000	0.0000	0.0000	0.0000	0.0000	0.0000	0.0000	3.0000e-004	3.0000e-004	0.0000	0.0000	3.2000e-004

Burbank Water & Power Magnolia Campus (Construction) - Los Angeles-South Coast County, Annual

2.2 Overall Operational

Mitigated Operational

	ROG	NOx	CO	SO2	Fugitive PM10	Exhaust PM10	PM10 Total	Fugitive PM2.5	Exhaust PM2.5	PM2.5 Total	Bio- CO2	NBio- CO2	Total CO2	CH4	N2O	CO2e
Category	tons/yr										MT/yr					
Area	5.6700e-003	0.0000	1.6000e-004	0.0000		0.0000	0.0000		0.0000	0.0000	0.0000	3.0000e-004	3.0000e-004	0.0000	0.0000	3.2000e-004
Energy	0.0000	0.0000	0.0000	0.0000		0.0000	0.0000		0.0000	0.0000	0.0000	0.0000	0.0000	0.0000	0.0000	0.0000
Mobile	0.0000	0.0000	0.0000	0.0000	0.0000	0.0000	0.0000	0.0000	0.0000	0.0000	0.0000	0.0000	0.0000	0.0000	0.0000	0.0000
Waste						0.0000	0.0000		0.0000	0.0000	0.0000	0.0000	0.0000	0.0000	0.0000	0.0000
Water						0.0000	0.0000		0.0000	0.0000	0.0000	0.0000	0.0000	0.0000	0.0000	0.0000
Total	5.6700e-003	0.0000	1.6000e-004	0.0000	0.0000	0.0000	0.0000	0.0000	0.0000	0.0000	0.0000	3.0000e-004	3.0000e-004	0.0000	0.0000	3.2000e-004

	ROG	NOx	CO	SO2	Fugitive PM10	Exhaust PM10	PM10 Total	Fugitive PM2.5	Exhaust PM2.5	PM2.5 Total	Bio- CO2	NBio- CO2	Total CO2	CH4	N2O	CO2e
Percent Reduction	0.00	0.00	0.00	0.00	0.00	0.00	0.00	0.00	0.00	0.00	0.00	0.00	0.00	0.00	0.00	0.00

3.0 Construction Detail

Construction Phase

Burbank Water & Power Magnolia Campus (Construction) - Los Angeles-South Coast County, Annual

Phase Number	Phase Name	Phase Type	Start Date	End Date	Num Days Week	Num Days	Phase Description
1	Demolition	Demolition	7/20/2020	7/31/2020	5	10	
2	Site Preparation	Site Preparation	8/1/2020	8/3/2020	5	1	
3	Grading	Grading	8/4/2020	8/5/2020	5	2	
4	Building Construction	Building Construction	8/6/2020	12/23/2020	5	100	
5	Paving	Paving	12/24/2020	12/30/2020	5	5	
6	Architectural Coating	Architectural Coating	12/31/2020	1/6/2021	5	5	

Acres of Grading (Site Preparation Phase): 0.5

Acres of Grading (Grading Phase): 1

Acres of Paving: 0

Residential Indoor: 0; Residential Outdoor: 0; Non-Residential Indoor: 18,294; Non-Residential Outdoor: 6,098; Striped Parking Area: 0 (Architectural Coating – sqft)

OffRoad Equipment

Burbank Water & Power Magnolia Campus (Construction) - Los Angeles-South Coast County, Annual

Phase Name	Offroad Equipment Type	Amount	Usage Hours	Horse Power	Load Factor
Demolition	Concrete/Industrial Saws	1	8.00	81	0.73
Demolition	Rubber Tired Dozers	1	8.00	247	0.40
Demolition	Tractors/Loaders/Backhoes	2	8.00	97	0.37
Site Preparation	Graders	1	8.00	187	0.41
Site Preparation	Tractors/Loaders/Backhoes	1	8.00	97	0.37
Grading	Concrete/Industrial Saws	1	8.00	81	0.73
Grading	Rubber Tired Dozers	1	8.00	247	0.40
Grading	Tractors/Loaders/Backhoes	2	8.00	97	0.37
Building Construction	Cranes	1	8.00	231	0.29
Building Construction	Forklifts	2	8.00	89	0.20
Building Construction	Tractors/Loaders/Backhoes	2	8.00	97	0.37
Paving	Cement and Mortar Mixers	4	8.00	9	0.56
Paving	Pavers	1	8.00	130	0.42
Paving	Rollers	1	8.00	80	0.38
Paving	Tractors/Loaders/Backhoes	1	8.00	97	0.37
Architectural Coating	Air Compressors	1	8.00	78	0.48

Trips and VMT

Phase Name	Offroad Equipment Count	Worker Trip Number	Vendor Trip Number	Hauling Trip Number	Worker Trip Length	Vendor Trip Length	Hauling Trip Length	Worker Vehicle Class	Vendor Vehicle Class	Hauling Vehicle Class
Demolition	4	10.00	0.00	55.00	14.70	6.90	20.00	LD_Mix	HDT_Mix	HHDT
Site Preparation	2	5.00	0.00	0.00	14.70	6.90	20.00	LD_Mix	HDT_Mix	HHDT
Grading	4	10.00	0.00	0.00	14.70	6.90	20.00	LD_Mix	HDT_Mix	HHDT
Building Construction	5	5.00	2.00	0.00	14.70	6.90	20.00	LD_Mix	HDT_Mix	HHDT
Paving	7	18.00	0.00	0.00	14.70	6.90	20.00	LD_Mix	HDT_Mix	HHDT
Architectural Coating	1	1.00	0.00	0.00	14.70	6.90	20.00	LD_Mix	HDT_Mix	HHDT

Burbank Water & Power Magnolia Campus (Construction) - Los Angeles-South Coast County, Annual

3.1 Mitigation Measures Construction

Water Exposed Area

3.2 Demolition - 2020

Unmitigated Construction On-Site

	ROG	NOx	CO	SO2	Fugitive PM10	Exhaust PM10	PM10 Total	Fugitive PM2.5	Exhaust PM2.5	PM2.5 Total	Bio- CO2	NBio- CO2	Total CO2	CH4	N2O	CO2e
Category	tons/yr										MT/yr					
Fugitive Dust					6.0000e-003	0.0000	6.0000e-003	9.1000e-004	0.0000	9.1000e-004	0.0000	0.0000	0.0000	0.0000	0.0000	0.0000
Off-Road	9.5800e-003	0.0942	0.0619	1.0000e-004		5.1000e-003	5.1000e-003		4.7700e-003	4.7700e-003	0.0000	9.1696	9.1696	2.2700e-003	0.0000	9.2262
Total	9.5800e-003	0.0942	0.0619	1.0000e-004	6.0000e-003	5.1000e-003	0.0111	9.1000e-004	4.7700e-003	5.6800e-003	0.0000	9.1696	9.1696	2.2700e-003	0.0000	9.2262

Burbank Water & Power Magnolia Campus (Construction) - Los Angeles-South Coast County, Annual

3.2 Demolition - 2020

Unmitigated Construction Off-Site

	ROG	NOx	CO	SO2	Fugitive PM10	Exhaust PM10	PM10 Total	Fugitive PM2.5	Exhaust PM2.5	PM2.5 Total	Bio- CO2	NBio- CO2	Total CO2	CH4	N2O	CO2e
Category	tons/yr										MT/yr					
Hauling	2.4000e-004	8.1700e-003	1.8000e-003	2.0000e-005	4.7000e-004	3.0000e-005	5.0000e-004	1.3000e-004	2.0000e-005	1.5000e-004	0.0000	2.1197	2.1197	1.5000e-004	0.0000	2.1233
Vendor	0.0000	0.0000	0.0000	0.0000	0.0000	0.0000	0.0000	0.0000	0.0000	0.0000	0.0000	0.0000	0.0000	0.0000	0.0000	0.0000
Worker	2.3000e-004	1.9000e-004	2.0600e-003	1.0000e-005	5.5000e-004	0.0000	5.5000e-004	1.5000e-004	0.0000	1.5000e-004	0.0000	0.5107	0.5107	2.0000e-005	0.0000	0.5111
Total	4.7000e-004	8.3600e-003	3.8600e-003	3.0000e-005	1.0200e-003	3.0000e-005	1.0500e-003	2.8000e-004	2.0000e-005	3.0000e-004	0.0000	2.6303	2.6303	1.7000e-004	0.0000	2.6344

Mitigated Construction On-Site

	ROG	NOx	CO	SO2	Fugitive PM10	Exhaust PM10	PM10 Total	Fugitive PM2.5	Exhaust PM2.5	PM2.5 Total	Bio- CO2	NBio- CO2	Total CO2	CH4	N2O	CO2e
Category	tons/yr										MT/yr					
Fugitive Dust					2.3400e-003	0.0000	2.3400e-003	3.5000e-004	0.0000	3.5000e-004	0.0000	0.0000	0.0000	0.0000	0.0000	0.0000
Off-Road	9.5800e-003	0.0942	0.0619	1.0000e-004		5.1000e-003	5.1000e-003		4.7700e-003	4.7700e-003	0.0000	9.1696	9.1696	2.2700e-003	0.0000	9.2262
Total	9.5800e-003	0.0942	0.0619	1.0000e-004	2.3400e-003	5.1000e-003	7.4400e-003	3.5000e-004	4.7700e-003	5.1200e-003	0.0000	9.1696	9.1696	2.2700e-003	0.0000	9.2262

Burbank Water & Power Magnolia Campus (Construction) - Los Angeles-South Coast County, Annual

3.2 Demolition - 2020

Mitigated Construction Off-Site

	ROG	NOx	CO	SO2	Fugitive PM10	Exhaust PM10	PM10 Total	Fugitive PM2.5	Exhaust PM2.5	PM2.5 Total	Bio- CO2	NBio- CO2	Total CO2	CH4	N2O	CO2e
Category	tons/yr										MT/yr					
Hauling	2.4000e-004	8.1700e-003	1.8000e-003	2.0000e-005	4.7000e-004	3.0000e-005	5.0000e-004	1.3000e-004	2.0000e-005	1.5000e-004	0.0000	2.1197	2.1197	1.5000e-004	0.0000	2.1233
Vendor	0.0000	0.0000	0.0000	0.0000	0.0000	0.0000	0.0000	0.0000	0.0000	0.0000	0.0000	0.0000	0.0000	0.0000	0.0000	0.0000
Worker	2.3000e-004	1.9000e-004	2.0600e-003	1.0000e-005	5.5000e-004	0.0000	5.5000e-004	1.5000e-004	0.0000	1.5000e-004	0.0000	0.5107	0.5107	2.0000e-005	0.0000	0.5111
Total	4.7000e-004	8.3600e-003	3.8600e-003	3.0000e-005	1.0200e-003	3.0000e-005	1.0500e-003	2.8000e-004	2.0000e-005	3.0000e-004	0.0000	2.6303	2.6303	1.7000e-004	0.0000	2.6344

3.3 Site Preparation - 2020

Unmitigated Construction On-Site

	ROG	NOx	CO	SO2	Fugitive PM10	Exhaust PM10	PM10 Total	Fugitive PM2.5	Exhaust PM2.5	PM2.5 Total	Bio- CO2	NBio- CO2	Total CO2	CH4	N2O	CO2e
Category	tons/yr										MT/yr					
Fugitive Dust					2.7000e-004	0.0000	2.7000e-004	3.0000e-005	0.0000	3.0000e-005	0.0000	0.0000	0.0000	0.0000	0.0000	0.0000
Off-Road	3.4000e-004	4.2200e-003	2.0500e-003	0.0000		1.7000e-004	1.7000e-004		1.5000e-004	1.5000e-004	0.0000	0.4280	0.4280	1.4000e-004	0.0000	0.4314
Total	3.4000e-004	4.2200e-003	2.0500e-003	0.0000	2.7000e-004	1.7000e-004	4.4000e-004	3.0000e-005	1.5000e-004	1.8000e-004	0.0000	0.4280	0.4280	1.4000e-004	0.0000	0.4314

Burbank Water & Power Magnolia Campus (Construction) - Los Angeles-South Coast County, Annual

3.3 Site Preparation - 2020

Unmitigated Construction Off-Site

	ROG	NOx	CO	SO2	Fugitive PM10	Exhaust PM10	PM10 Total	Fugitive PM2.5	Exhaust PM2.5	PM2.5 Total	Bio- CO2	NBio- CO2	Total CO2	CH4	N2O	CO2e
Category	tons/yr										MT/yr					
Hauling	0.0000	0.0000	0.0000	0.0000	0.0000	0.0000	0.0000	0.0000	0.0000	0.0000	0.0000	0.0000	0.0000	0.0000	0.0000	0.0000
Vendor	0.0000	0.0000	0.0000	0.0000	0.0000	0.0000	0.0000	0.0000	0.0000	0.0000	0.0000	0.0000	0.0000	0.0000	0.0000	0.0000
Worker	1.0000e-005	1.0000e-005	1.0000e-004	0.0000	3.0000e-005	0.0000	3.0000e-005	1.0000e-005	0.0000	1.0000e-005	0.0000	0.0255	0.0255	0.0000	0.0000	0.0256
Total	1.0000e-005	1.0000e-005	1.0000e-004	0.0000	3.0000e-005	0.0000	3.0000e-005	1.0000e-005	0.0000	1.0000e-005	0.0000	0.0255	0.0255	0.0000	0.0000	0.0256

Mitigated Construction On-Site

	ROG	NOx	CO	SO2	Fugitive PM10	Exhaust PM10	PM10 Total	Fugitive PM2.5	Exhaust PM2.5	PM2.5 Total	Bio- CO2	NBio- CO2	Total CO2	CH4	N2O	CO2e
Category	tons/yr										MT/yr					
Fugitive Dust					1.0000e-004	0.0000	1.0000e-004	1.0000e-005	0.0000	1.0000e-005	0.0000	0.0000	0.0000	0.0000	0.0000	0.0000
Off-Road	3.4000e-004	4.2200e-003	2.0500e-003	0.0000		1.7000e-004	1.7000e-004		1.5000e-004	1.5000e-004	0.0000	0.4280	0.4280	1.4000e-004	0.0000	0.4314
Total	3.4000e-004	4.2200e-003	2.0500e-003	0.0000	1.0000e-004	1.7000e-004	2.7000e-004	1.0000e-005	1.5000e-004	1.6000e-004	0.0000	0.4280	0.4280	1.4000e-004	0.0000	0.4314

Burbank Water & Power Magnolia Campus (Construction) - Los Angeles-South Coast County, Annual

3.3 Site Preparation - 2020

Mitigated Construction Off-Site

	ROG	NOx	CO	SO2	Fugitive PM10	Exhaust PM10	PM10 Total	Fugitive PM2.5	Exhaust PM2.5	PM2.5 Total	Bio- CO2	NBio- CO2	Total CO2	CH4	N2O	CO2e
Category	tons/yr										MT/yr					
Hauling	0.0000	0.0000	0.0000	0.0000	0.0000	0.0000	0.0000	0.0000	0.0000	0.0000	0.0000	0.0000	0.0000	0.0000	0.0000	0.0000
Vendor	0.0000	0.0000	0.0000	0.0000	0.0000	0.0000	0.0000	0.0000	0.0000	0.0000	0.0000	0.0000	0.0000	0.0000	0.0000	0.0000
Worker	1.0000e-005	1.0000e-005	1.0000e-004	0.0000	3.0000e-005	0.0000	3.0000e-005	1.0000e-005	0.0000	1.0000e-005	0.0000	0.0255	0.0255	0.0000	0.0000	0.0256
Total	1.0000e-005	1.0000e-005	1.0000e-004	0.0000	3.0000e-005	0.0000	3.0000e-005	1.0000e-005	0.0000	1.0000e-005	0.0000	0.0255	0.0255	0.0000	0.0000	0.0256

3.4 Grading - 2020

Unmitigated Construction On-Site

	ROG	NOx	CO	SO2	Fugitive PM10	Exhaust PM10	PM10 Total	Fugitive PM2.5	Exhaust PM2.5	PM2.5 Total	Bio- CO2	NBio- CO2	Total CO2	CH4	N2O	CO2e
Category	tons/yr										MT/yr					
Fugitive Dust					6.5500e-003	0.0000	6.5500e-003	3.3700e-003	0.0000	3.3700e-003	0.0000	0.0000	0.0000	0.0000	0.0000	0.0000
Off-Road	1.9200e-003	0.0188	0.0124	2.0000e-005		1.0200e-003	1.0200e-003		9.5000e-004	9.5000e-004	0.0000	1.8339	1.8339	4.5000e-004	0.0000	1.8453
Total	1.9200e-003	0.0188	0.0124	2.0000e-005	6.5500e-003	1.0200e-003	7.5700e-003	3.3700e-003	9.5000e-004	4.3200e-003	0.0000	1.8339	1.8339	4.5000e-004	0.0000	1.8453

Burbank Water & Power Magnolia Campus (Construction) - Los Angeles-South Coast County, Annual

3.4 Grading - 2020

Unmitigated Construction Off-Site

	ROG	NOx	CO	SO2	Fugitive PM10	Exhaust PM10	PM10 Total	Fugitive PM2.5	Exhaust PM2.5	PM2.5 Total	Bio- CO2	NBio- CO2	Total CO2	CH4	N2O	CO2e
Category	tons/yr										MT/yr					
Hauling	0.0000	0.0000	0.0000	0.0000	0.0000	0.0000	0.0000	0.0000	0.0000	0.0000	0.0000	0.0000	0.0000	0.0000	0.0000	0.0000
Vendor	0.0000	0.0000	0.0000	0.0000	0.0000	0.0000	0.0000	0.0000	0.0000	0.0000	0.0000	0.0000	0.0000	0.0000	0.0000	0.0000
Worker	5.0000e-005	4.0000e-005	4.1000e-004	0.0000	1.1000e-004	0.0000	1.1000e-004	3.0000e-005	0.0000	3.0000e-005	0.0000	0.1021	0.1021	0.0000	0.0000	0.1022
Total	5.0000e-005	4.0000e-005	4.1000e-004	0.0000	1.1000e-004	0.0000	1.1000e-004	3.0000e-005	0.0000	3.0000e-005	0.0000	0.1021	0.1021	0.0000	0.0000	0.1022

Mitigated Construction On-Site

	ROG	NOx	CO	SO2	Fugitive PM10	Exhaust PM10	PM10 Total	Fugitive PM2.5	Exhaust PM2.5	PM2.5 Total	Bio- CO2	NBio- CO2	Total CO2	CH4	N2O	CO2e
Category	tons/yr										MT/yr					
Fugitive Dust					2.5600e-003	0.0000	2.5600e-003	1.3100e-003	0.0000	1.3100e-003	0.0000	0.0000	0.0000	0.0000	0.0000	0.0000
Off-Road	1.9200e-003	0.0188	0.0124	2.0000e-005		1.0200e-003	1.0200e-003		9.5000e-004	9.5000e-004	0.0000	1.8339	1.8339	4.5000e-004	0.0000	1.8452
Total	1.9200e-003	0.0188	0.0124	2.0000e-005	2.5600e-003	1.0200e-003	3.5800e-003	1.3100e-003	9.5000e-004	2.2600e-003	0.0000	1.8339	1.8339	4.5000e-004	0.0000	1.8452

Burbank Water & Power Magnolia Campus (Construction) - Los Angeles-South Coast County, Annual

3.4 Grading - 2020

Mitigated Construction Off-Site

	ROG	NOx	CO	SO2	Fugitive PM10	Exhaust PM10	PM10 Total	Fugitive PM2.5	Exhaust PM2.5	PM2.5 Total	Bio- CO2	NBio- CO2	Total CO2	CH4	N2O	CO2e
Category	tons/yr										MT/yr					
Hauling	0.0000	0.0000	0.0000	0.0000	0.0000	0.0000	0.0000	0.0000	0.0000	0.0000	0.0000	0.0000	0.0000	0.0000	0.0000	0.0000
Vendor	0.0000	0.0000	0.0000	0.0000	0.0000	0.0000	0.0000	0.0000	0.0000	0.0000	0.0000	0.0000	0.0000	0.0000	0.0000	0.0000
Worker	5.0000e-005	4.0000e-005	4.1000e-004	0.0000	1.1000e-004	0.0000	1.1000e-004	3.0000e-005	0.0000	3.0000e-005	0.0000	0.1021	0.1021	0.0000	0.0000	0.1022
Total	5.0000e-005	4.0000e-005	4.1000e-004	0.0000	1.1000e-004	0.0000	1.1000e-004	3.0000e-005	0.0000	3.0000e-005	0.0000	0.1021	0.1021	0.0000	0.0000	0.1022

3.5 Building Construction - 2020

Unmitigated Construction On-Site

	ROG	NOx	CO	SO2	Fugitive PM10	Exhaust PM10	PM10 Total	Fugitive PM2.5	Exhaust PM2.5	PM2.5 Total	Bio- CO2	NBio- CO2	Total CO2	CH4	N2O	CO2e
Category	tons/yr										MT/yr					
Off-Road	0.0580	0.6098	0.4518	7.5000e-004		0.0341	0.0341		0.0314	0.0314	0.0000	66.0607	66.0607	0.0214	0.0000	66.5948
Total	0.0580	0.6098	0.4518	7.5000e-004		0.0341	0.0341		0.0314	0.0314	0.0000	66.0607	66.0607	0.0214	0.0000	66.5948

Burbank Water & Power Magnolia Campus (Construction) - Los Angeles-South Coast County, Annual

3.5 Building Construction - 2020

Unmitigated Construction Off-Site

	ROG	NOx	CO	SO2	Fugitive PM10	Exhaust PM10	PM10 Total	Fugitive PM2.5	Exhaust PM2.5	PM2.5 Total	Bio- CO2	NBio- CO2	Total CO2	CH4	N2O	CO2e
Category	tons/yr										MT/yr					
Hauling	0.0000	0.0000	0.0000	0.0000	0.0000	0.0000	0.0000	0.0000	0.0000	0.0000	0.0000	0.0000	0.0000	0.0000	0.0000	0.0000
Vendor	3.6000e-004	0.0108	2.9300e-003	3.0000e-005	6.3000e-004	5.0000e-005	6.8000e-004	1.8000e-004	5.0000e-005	2.3000e-004	0.0000	2.4843	2.4843	1.6000e-004	0.0000	2.4882
Worker	1.1500e-003	9.3000e-004	0.0103	3.0000e-005	2.7400e-003	2.0000e-005	2.7600e-003	7.3000e-004	2.0000e-005	7.5000e-004	0.0000	2.5534	2.5534	8.0000e-005	0.0000	2.5554
Total	1.5100e-003	0.0118	0.0132	6.0000e-005	3.3700e-003	7.0000e-005	3.4400e-003	9.1000e-004	7.0000e-005	9.8000e-004	0.0000	5.0376	5.0376	2.4000e-004	0.0000	5.0436

Mitigated Construction On-Site

	ROG	NOx	CO	SO2	Fugitive PM10	Exhaust PM10	PM10 Total	Fugitive PM2.5	Exhaust PM2.5	PM2.5 Total	Bio- CO2	NBio- CO2	Total CO2	CH4	N2O	CO2e
Category	tons/yr										MT/yr					
Off-Road	0.0580	0.6098	0.4518	7.5000e-004		0.0341	0.0341		0.0314	0.0314	0.0000	66.0606	66.0606	0.0214	0.0000	66.5947
Total	0.0580	0.6098	0.4518	7.5000e-004		0.0341	0.0341		0.0314	0.0314	0.0000	66.0606	66.0606	0.0214	0.0000	66.5947

Burbank Water & Power Magnolia Campus (Construction) - Los Angeles-South Coast County, Annual

3.5 Building Construction - 2020

Mitigated Construction Off-Site

	ROG	NOx	CO	SO2	Fugitive PM10	Exhaust PM10	PM10 Total	Fugitive PM2.5	Exhaust PM2.5	PM2.5 Total	Bio- CO2	NBio- CO2	Total CO2	CH4	N2O	CO2e
Category	tons/yr										MT/yr					
Hauling	0.0000	0.0000	0.0000	0.0000	0.0000	0.0000	0.0000	0.0000	0.0000	0.0000	0.0000	0.0000	0.0000	0.0000	0.0000	0.0000
Vendor	3.6000e-004	0.0108	2.9300e-003	3.0000e-005	6.3000e-004	5.0000e-005	6.8000e-004	1.8000e-004	5.0000e-005	2.3000e-004	0.0000	2.4843	2.4843	1.6000e-004	0.0000	2.4882
Worker	1.1500e-003	9.3000e-004	0.0103	3.0000e-005	2.7400e-003	2.0000e-005	2.7600e-003	7.3000e-004	2.0000e-005	7.5000e-004	0.0000	2.5534	2.5534	8.0000e-005	0.0000	2.5554
Total	1.5100e-003	0.0118	0.0132	6.0000e-005	3.3700e-003	7.0000e-005	3.4400e-003	9.1000e-004	7.0000e-005	9.8000e-004	0.0000	5.0376	5.0376	2.4000e-004	0.0000	5.0436

3.6 Paving - 2020

Unmitigated Construction On-Site

	ROG	NOx	CO	SO2	Fugitive PM10	Exhaust PM10	PM10 Total	Fugitive PM2.5	Exhaust PM2.5	PM2.5 Total	Bio- CO2	NBio- CO2	Total CO2	CH4	N2O	CO2e
Category	tons/yr										MT/yr					
Off-Road	2.2900e-003	0.0212	0.0208	3.0000e-005		1.1500e-003	1.1500e-003		1.0700e-003	1.0700e-003	0.0000	2.7492	2.7492	7.9000e-004	0.0000	2.7689
Paving	0.0000					0.0000	0.0000		0.0000	0.0000	0.0000	0.0000	0.0000	0.0000	0.0000	0.0000
Total	2.2900e-003	0.0212	0.0208	3.0000e-005		1.1500e-003	1.1500e-003		1.0700e-003	1.0700e-003	0.0000	2.7492	2.7492	7.9000e-004	0.0000	2.7689

Burbank Water & Power Magnolia Campus (Construction) - Los Angeles-South Coast County, Annual

3.6 Paving - 2020

Unmitigated Construction Off-Site

	ROG	NOx	CO	SO2	Fugitive PM10	Exhaust PM10	PM10 Total	Fugitive PM2.5	Exhaust PM2.5	PM2.5 Total	Bio- CO2	NBio- CO2	Total CO2	CH4	N2O	CO2e
Category	tons/yr										MT/yr					
Hauling	0.0000	0.0000	0.0000	0.0000	0.0000	0.0000	0.0000	0.0000	0.0000	0.0000	0.0000	0.0000	0.0000	0.0000	0.0000	0.0000
Vendor	0.0000	0.0000	0.0000	0.0000	0.0000	0.0000	0.0000	0.0000	0.0000	0.0000	0.0000	0.0000	0.0000	0.0000	0.0000	0.0000
Worker	2.1000e-004	1.7000e-004	1.8500e-003	1.0000e-005	4.9000e-004	0.0000	5.0000e-004	1.3000e-004	0.0000	1.3000e-004	0.0000	0.4596	0.4596	1.0000e-005	0.0000	0.4600
Total	2.1000e-004	1.7000e-004	1.8500e-003	1.0000e-005	4.9000e-004	0.0000	5.0000e-004	1.3000e-004	0.0000	1.3000e-004	0.0000	0.4596	0.4596	1.0000e-005	0.0000	0.4600

Mitigated Construction On-Site

	ROG	NOx	CO	SO2	Fugitive PM10	Exhaust PM10	PM10 Total	Fugitive PM2.5	Exhaust PM2.5	PM2.5 Total	Bio- CO2	NBio- CO2	Total CO2	CH4	N2O	CO2e
Category	tons/yr										MT/yr					
Off-Road	2.2900e-003	0.0212	0.0208	3.0000e-005		1.1500e-003	1.1500e-003		1.0700e-003	1.0700e-003	0.0000	2.7492	2.7492	7.9000e-004	0.0000	2.7689
Paving	0.0000					0.0000	0.0000		0.0000	0.0000	0.0000	0.0000	0.0000	0.0000	0.0000	0.0000
Total	2.2900e-003	0.0212	0.0208	3.0000e-005		1.1500e-003	1.1500e-003		1.0700e-003	1.0700e-003	0.0000	2.7492	2.7492	7.9000e-004	0.0000	2.7689

Burbank Water & Power Magnolia Campus (Construction) - Los Angeles-South Coast County, Annual

3.6 Paving - 2020

Mitigated Construction Off-Site

	ROG	NOx	CO	SO2	Fugitive PM10	Exhaust PM10	PM10 Total	Fugitive PM2.5	Exhaust PM2.5	PM2.5 Total	Bio- CO2	NBio- CO2	Total CO2	CH4	N2O	CO2e
Category	tons/yr										MT/yr					
Hauling	0.0000	0.0000	0.0000	0.0000	0.0000	0.0000	0.0000	0.0000	0.0000	0.0000	0.0000	0.0000	0.0000	0.0000	0.0000	0.0000
Vendor	0.0000	0.0000	0.0000	0.0000	0.0000	0.0000	0.0000	0.0000	0.0000	0.0000	0.0000	0.0000	0.0000	0.0000	0.0000	0.0000
Worker	2.1000e-004	1.7000e-004	1.8500e-003	1.0000e-005	4.9000e-004	0.0000	5.0000e-004	1.3000e-004	0.0000	1.3000e-004	0.0000	0.4596	0.4596	1.0000e-005	0.0000	0.4600
Total	2.1000e-004	1.7000e-004	1.8500e-003	1.0000e-005	4.9000e-004	0.0000	5.0000e-004	1.3000e-004	0.0000	1.3000e-004	0.0000	0.4596	0.4596	1.0000e-005	0.0000	0.4600

3.7 Architectural Coating - 2020

Unmitigated Construction On-Site

	ROG	NOx	CO	SO2	Fugitive PM10	Exhaust PM10	PM10 Total	Fugitive PM2.5	Exhaust PM2.5	PM2.5 Total	Bio- CO2	NBio- CO2	Total CO2	CH4	N2O	CO2e
Category	tons/yr										MT/yr					
Archit. Coating	5.6500e-003					0.0000	0.0000		0.0000	0.0000	0.0000	0.0000	0.0000	0.0000	0.0000	0.0000
Off-Road	1.6000e-004	1.1200e-003	1.2200e-003	0.0000		7.0000e-005	7.0000e-005		7.0000e-005	7.0000e-005	0.0000	0.1702	0.1702	1.0000e-005	0.0000	0.1706
Total	5.8100e-003	1.1200e-003	1.2200e-003	0.0000		7.0000e-005	7.0000e-005		7.0000e-005	7.0000e-005	0.0000	0.1702	0.1702	1.0000e-005	0.0000	0.1706

Burbank Water & Power Magnolia Campus (Construction) - Los Angeles-South Coast County, Annual

3.7 Architectural Coating - 2020

Unmitigated Construction Off-Site

	ROG	NOx	CO	SO2	Fugitive PM10	Exhaust PM10	PM10 Total	Fugitive PM2.5	Exhaust PM2.5	PM2.5 Total	Bio- CO2	NBio- CO2	Total CO2	CH4	N2O	CO2e
Category	tons/yr										MT/yr					
Hauling	0.0000	0.0000	0.0000	0.0000	0.0000	0.0000	0.0000	0.0000	0.0000	0.0000	0.0000	0.0000	0.0000	0.0000	0.0000	0.0000
Vendor	0.0000	0.0000	0.0000	0.0000	0.0000	0.0000	0.0000	0.0000	0.0000	0.0000	0.0000	0.0000	0.0000	0.0000	0.0000	0.0000
Worker	0.0000	0.0000	2.0000e-005	0.0000	1.0000e-005	0.0000	1.0000e-005	0.0000	0.0000	0.0000	0.0000	5.1100e-003	5.1100e-003	0.0000	0.0000	5.1100e-003
Total	0.0000	0.0000	2.0000e-005	0.0000	1.0000e-005	0.0000	1.0000e-005	0.0000	0.0000	0.0000	0.0000	5.1100e-003	5.1100e-003	0.0000	0.0000	5.1100e-003

Mitigated Construction On-Site

	ROG	NOx	CO	SO2	Fugitive PM10	Exhaust PM10	PM10 Total	Fugitive PM2.5	Exhaust PM2.5	PM2.5 Total	Bio- CO2	NBio- CO2	Total CO2	CH4	N2O	CO2e
Category	tons/yr										MT/yr					
Archit. Coating	5.6500e-003					0.0000	0.0000		0.0000	0.0000	0.0000	0.0000	0.0000	0.0000	0.0000	0.0000
Off-Road	1.6000e-004	1.1200e-003	1.2200e-003	0.0000		7.0000e-005	7.0000e-005		7.0000e-005	7.0000e-005	0.0000	0.1702	0.1702	1.0000e-005	0.0000	0.1706
Total	5.8100e-003	1.1200e-003	1.2200e-003	0.0000		7.0000e-005	7.0000e-005		7.0000e-005	7.0000e-005	0.0000	0.1702	0.1702	1.0000e-005	0.0000	0.1706

Burbank Water & Power Magnolia Campus (Construction) - Los Angeles-South Coast County, Annual

3.7 Architectural Coating - 2020

Mitigated Construction Off-Site

	ROG	NOx	CO	SO2	Fugitive PM10	Exhaust PM10	PM10 Total	Fugitive PM2.5	Exhaust PM2.5	PM2.5 Total	Bio- CO2	NBio- CO2	Total CO2	CH4	N2O	CO2e
Category	tons/yr										MT/yr					
Hauling	0.0000	0.0000	0.0000	0.0000	0.0000	0.0000	0.0000	0.0000	0.0000	0.0000	0.0000	0.0000	0.0000	0.0000	0.0000	0.0000
Vendor	0.0000	0.0000	0.0000	0.0000	0.0000	0.0000	0.0000	0.0000	0.0000	0.0000	0.0000	0.0000	0.0000	0.0000	0.0000	0.0000
Worker	0.0000	0.0000	2.0000e-005	0.0000	1.0000e-005	0.0000	1.0000e-005	0.0000	0.0000	0.0000	0.0000	5.1100e-003	5.1100e-003	0.0000	0.0000	5.1100e-003
Total	0.0000	0.0000	2.0000e-005	0.0000	1.0000e-005	0.0000	1.0000e-005	0.0000	0.0000	0.0000	0.0000	5.1100e-003	5.1100e-003	0.0000	0.0000	5.1100e-003

3.7 Architectural Coating - 2021

Unmitigated Construction On-Site

	ROG	NOx	CO	SO2	Fugitive PM10	Exhaust PM10	PM10 Total	Fugitive PM2.5	Exhaust PM2.5	PM2.5 Total	Bio- CO2	NBio- CO2	Total CO2	CH4	N2O	CO2e
Category	tons/yr										MT/yr					
Archit. Coating	0.0226					0.0000	0.0000		0.0000	0.0000	0.0000	0.0000	0.0000	0.0000	0.0000	0.0000
Off-Road	5.8000e-004	4.0700e-003	4.8500e-003	1.0000e-005		2.5000e-004	2.5000e-004		2.5000e-004	2.5000e-004	0.0000	0.6809	0.6809	5.0000e-005	0.0000	0.6820
Total	0.0232	4.0700e-003	4.8500e-003	1.0000e-005		2.5000e-004	2.5000e-004		2.5000e-004	2.5000e-004	0.0000	0.6809	0.6809	5.0000e-005	0.0000	0.6820

Burbank Water & Power Magnolia Campus (Construction) - Los Angeles-South Coast County, Annual

3.7 Architectural Coating - 2021

Unmitigated Construction Off-Site

	ROG	NOx	CO	SO2	Fugitive PM10	Exhaust PM10	PM10 Total	Fugitive PM2.5	Exhaust PM2.5	PM2.5 Total	Bio- CO2	NBio- CO2	Total CO2	CH4	N2O	CO2e
Category	tons/yr										MT/yr					
Hauling	0.0000	0.0000	0.0000	0.0000	0.0000	0.0000	0.0000	0.0000	0.0000	0.0000	0.0000	0.0000	0.0000	0.0000	0.0000	0.0000
Vendor	0.0000	0.0000	0.0000	0.0000	0.0000	0.0000	0.0000	0.0000	0.0000	0.0000	0.0000	0.0000	0.0000	0.0000	0.0000	0.0000
Worker	1.0000e-005	1.0000e-005	8.0000e-005	0.0000	2.0000e-005	0.0000	2.0000e-005	1.0000e-005	0.0000	1.0000e-005	0.0000	0.0198	0.0198	0.0000	0.0000	0.0198
Total	1.0000e-005	1.0000e-005	8.0000e-005	0.0000	2.0000e-005	0.0000	2.0000e-005	1.0000e-005	0.0000	1.0000e-005	0.0000	0.0198	0.0198	0.0000	0.0000	0.0198

Mitigated Construction On-Site

	ROG	NOx	CO	SO2	Fugitive PM10	Exhaust PM10	PM10 Total	Fugitive PM2.5	Exhaust PM2.5	PM2.5 Total	Bio- CO2	NBio- CO2	Total CO2	CH4	N2O	CO2e
Category	tons/yr										MT/yr					
Archit. Coating	0.0226					0.0000	0.0000		0.0000	0.0000	0.0000	0.0000	0.0000	0.0000	0.0000	0.0000
Off-Road	5.8000e-004	4.0700e-003	4.8500e-003	1.0000e-005		2.5000e-004	2.5000e-004		2.5000e-004	2.5000e-004	0.0000	0.6809	0.6809	5.0000e-005	0.0000	0.6820
Total	0.0232	4.0700e-003	4.8500e-003	1.0000e-005		2.5000e-004	2.5000e-004		2.5000e-004	2.5000e-004	0.0000	0.6809	0.6809	5.0000e-005	0.0000	0.6820

Burbank Water & Power Magnolia Campus (Construction) - Los Angeles-South Coast County, Annual

3.7 Architectural Coating - 2021

Mitigated Construction Off-Site

	ROG	NOx	CO	SO2	Fugitive PM10	Exhaust PM10	PM10 Total	Fugitive PM2.5	Exhaust PM2.5	PM2.5 Total	Bio- CO2	NBio- CO2	Total CO2	CH4	N2O	CO2e
Category	tons/yr										MT/yr					
Hauling	0.0000	0.0000	0.0000	0.0000	0.0000	0.0000	0.0000	0.0000	0.0000	0.0000	0.0000	0.0000	0.0000	0.0000	0.0000	0.0000
Vendor	0.0000	0.0000	0.0000	0.0000	0.0000	0.0000	0.0000	0.0000	0.0000	0.0000	0.0000	0.0000	0.0000	0.0000	0.0000	0.0000
Worker	1.0000e-005	1.0000e-005	8.0000e-005	0.0000	2.0000e-005	0.0000	2.0000e-005	1.0000e-005	0.0000	1.0000e-005	0.0000	0.0198	0.0198	0.0000	0.0000	0.0198
Total	1.0000e-005	1.0000e-005	8.0000e-005	0.0000	2.0000e-005	0.0000	2.0000e-005	1.0000e-005	0.0000	1.0000e-005	0.0000	0.0198	0.0198	0.0000	0.0000	0.0198

4.0 Operational Detail - Mobile

4.1 Mitigation Measures Mobile

Burbank Water & Power Magnolia Campus (Construction) - Los Angeles-South Coast County, Annual

	ROG	NOx	CO	SO2	Fugitive PM10	Exhaust PM10	PM10 Total	Fugitive PM2.5	Exhaust PM2.5	PM2.5 Total	Bio- CO2	NBio- CO2	Total CO2	CH4	N2O	CO2e
Category	tons/yr										MT/yr					
Mitigated	0.0000	0.0000	0.0000	0.0000	0.0000	0.0000	0.0000	0.0000	0.0000	0.0000	0.0000	0.0000	0.0000	0.0000	0.0000	0.0000
Unmitigated	0.0000	0.0000	0.0000	0.0000	0.0000	0.0000	0.0000	0.0000	0.0000	0.0000	0.0000	0.0000	0.0000	0.0000	0.0000	0.0000

4.2 Trip Summary Information

Land Use	Average Daily Trip Rate			Unmitigated	Mitigated
	Weekday	Saturday	Sunday	Annual VMT	Annual VMT
User Defined Industrial	0.00	0.00	0.00		
Total	0.00	0.00	0.00		

4.3 Trip Type Information

Land Use	Miles			Trip %			Trip Purpose %		
	H-W or C-W	H-S or C-C	H-O or C-NW	H-W or C-W	H-S or C-C	H-O or C-NW	Primary	Diverted	Pass-by
User Defined Industrial	16.60	8.40	6.90	0.00	0.00	0.00	0	0	0

4.4 Fleet Mix

Land Use	LDA	LDT1	LDT2	MDV	LHD1	LHD2	MHD	HHD	OBUS	UBUS	MCY	SBUS	MH
User Defined Industrial	0.547192	0.045177	0.202743	0.121510	0.016147	0.006143	0.019743	0.029945	0.002479	0.002270	0.005078	0.000682	0.000891

5.0 Energy Detail

Historical Energy Use: N

Burbank Water & Power Magnolia Campus (Construction) - Los Angeles-South Coast County, Annual

5.2 Energy by Land Use - Natural Gas

Mitigated

	Natural Gas Use	ROG	NOx	CO	SO2	Fugitive PM10	Exhaust PM10	PM10 Total	Fugitive PM2.5	Exhaust PM2.5	PM2.5 Total	Bio- CO2	NBio- CO2	Total CO2	CH4	N2O	CO2e
Land Use	kBTU/yr	tons/yr										MT/yr					
User Defined Industrial	0	0.0000	0.0000	0.0000	0.0000		0.0000	0.0000		0.0000	0.0000	0.0000	0.0000	0.0000	0.0000	0.0000	0.0000
Total		0.0000	0.0000	0.0000	0.0000		0.0000	0.0000		0.0000	0.0000	0.0000	0.0000	0.0000	0.0000	0.0000	0.0000

5.3 Energy by Land Use - Electricity

Unmitigated

	Electricity Use	Total CO2	CH4	N2O	CO2e
Land Use	kWh/yr	MT/yr			
User Defined Industrial	0	0.0000	0.0000	0.0000	0.0000
Total		0.0000	0.0000	0.0000	0.0000

Burbank Water & Power Magnolia Campus (Construction) - Los Angeles-South Coast County, Annual

5.3 Energy by Land Use - Electricity

Mitigated

	Electricity Use	Total CO2	CH4	N2O	CO2e
Land Use	kWh/yr	MT/yr			
User Defined Industrial	0	0.0000	0.0000	0.0000	0.0000
Total		0.0000	0.0000	0.0000	0.0000

6.0 Area Detail

6.1 Mitigation Measures Area

	ROG	NOx	CO	SO2	Fugitive PM10	Exhaust PM10	PM10 Total	Fugitive PM2.5	Exhaust PM2.5	PM2.5 Total	Bio- CO2	NBio- CO2	Total CO2	CH4	N2O	CO2e
Category	tons/yr										MT/yr					
Mitigated	5.6700e-003	0.0000	1.6000e-004	0.0000		0.0000	0.0000		0.0000	0.0000	0.0000	3.0000e-004	3.0000e-004	0.0000	0.0000	3.2000e-004
Unmitigated	5.6700e-003	0.0000	1.6000e-004	0.0000		0.0000	0.0000		0.0000	0.0000	0.0000	3.0000e-004	3.0000e-004	0.0000	0.0000	3.2000e-004

Burbank Water & Power Magnolia Campus (Construction) - Los Angeles-South Coast County, Annual

6.2 Area by SubCategory

Unmitigated

	ROG	NOx	CO	SO2	Fugitive PM10	Exhaust PM10	PM10 Total	Fugitive PM2.5	Exhaust PM2.5	PM2.5 Total	Bio- CO2	NBio- CO2	Total CO2	CH4	N2O	CO2e
SubCategory	tons/yr										MT/yr					
Architectural Coating	5.6500e-003					0.0000	0.0000		0.0000	0.0000	0.0000	0.0000	0.0000	0.0000	0.0000	0.0000
Consumer Products	0.0000					0.0000	0.0000		0.0000	0.0000	0.0000	0.0000	0.0000	0.0000	0.0000	0.0000
Landscaping	1.0000e-005	0.0000	1.6000e-004	0.0000		0.0000	0.0000		0.0000	0.0000	0.0000	3.0000e-004	3.0000e-004	0.0000	0.0000	3.2000e-004
Total	5.6600e-003	0.0000	1.6000e-004	0.0000		0.0000	0.0000		0.0000	0.0000	0.0000	3.0000e-004	3.0000e-004	0.0000	0.0000	3.2000e-004

Mitigated

	ROG	NOx	CO	SO2	Fugitive PM10	Exhaust PM10	PM10 Total	Fugitive PM2.5	Exhaust PM2.5	PM2.5 Total	Bio- CO2	NBio- CO2	Total CO2	CH4	N2O	CO2e
SubCategory	tons/yr										MT/yr					
Architectural Coating	5.6500e-003					0.0000	0.0000		0.0000	0.0000	0.0000	0.0000	0.0000	0.0000	0.0000	0.0000
Consumer Products	0.0000					0.0000	0.0000		0.0000	0.0000	0.0000	0.0000	0.0000	0.0000	0.0000	0.0000
Landscaping	1.0000e-005	0.0000	1.6000e-004	0.0000		0.0000	0.0000		0.0000	0.0000	0.0000	3.0000e-004	3.0000e-004	0.0000	0.0000	3.2000e-004
Total	5.6600e-003	0.0000	1.6000e-004	0.0000		0.0000	0.0000		0.0000	0.0000	0.0000	3.0000e-004	3.0000e-004	0.0000	0.0000	3.2000e-004

7.0 Water Detail

Burbank Water & Power Magnolia Campus (Construction) - Los Angeles-South Coast County, Annual

7.1 Mitigation Measures Water

	Total CO2	CH4	N2O	CO2e
Category	MT/yr			
Mitigated	0.0000	0.0000	0.0000	0.0000
Unmitigated	0.0000	0.0000	0.0000	0.0000

7.2 Water by Land Use

Unmitigated

	Indoor/Outdoor Use	Total CO2	CH4	N2O	CO2e
Land Use	Mgal	MT/yr			
User Defined Industrial	0 / 0	0.0000	0.0000	0.0000	0.0000
Total		0.0000	0.0000	0.0000	0.0000

Burbank Water & Power Magnolia Campus (Construction) - Los Angeles-South Coast County, Annual

7.2 Water by Land Use

Mitigated

	Indoor/Outdoor Use	Total CO2	CH4	N2O	CO2e
Land Use	Mgal	MT/yr			
User Defined Industrial	0 / 0	0.0000	0.0000	0.0000	0.0000
Total		0.0000	0.0000	0.0000	0.0000

8.0 Waste Detail

8.1 Mitigation Measures Waste

Category/Year

	Total CO2	CH4	N2O	CO2e
	MT/yr			
Mitigated	0.0000	0.0000	0.0000	0.0000
Unmitigated	0.0000	0.0000	0.0000	0.0000

Burbank Water & Power Magnolia Campus (Construction) - Los Angeles-South Coast County, Annual

8.2 Waste by Land Use

Unmitigated

	Waste Disposed	Total CO2	CH4	N2O	CO2e
Land Use	tons	MT/yr			
User Defined Industrial	0	0.0000	0.0000	0.0000	0.0000
Total		0.0000	0.0000	0.0000	0.0000

Mitigated

	Waste Disposed	Total CO2	CH4	N2O	CO2e
Land Use	tons	MT/yr			
User Defined Industrial	0	0.0000	0.0000	0.0000	0.0000
Total		0.0000	0.0000	0.0000	0.0000

9.0 Operational Offroad

Equipment Type	Number	Hours/Day	Days/Year	Horse Power	Load Factor	Fuel Type
----------------	--------	-----------	-----------	-------------	-------------	-----------

Burbank Water & Power Magnolia Campus (Construction) - Los Angeles-South Coast County, Annual

10.0 Stationary Equipment

Fire Pumps and Emergency Generators

Equipment Type	Number	Hours/Day	Hours/Year	Horse Power	Load Factor	Fuel Type
----------------	--------	-----------	------------	-------------	-------------	-----------

Boilers

Equipment Type	Number	Heat Input/Day	Heat Input/Year	Boiler Rating	Fuel Type
----------------	--------	----------------	-----------------	---------------	-----------

User Defined Equipment

Equipment Type	Number
----------------	--------

11.0 Vegetation

Attachment 3

Acoustic Report



**Burbank Water and Power
Magnolia Campus Drainage
Improvement
NOISE IMPACT ANALYSIS
CITY OF BURBANK**

PREPARED BY:

Bill Lawson, PE, INCE
blawson@urbanxroads.com
(949) 336-5979

Alex Wolfe, INCE
awolfe@urbanxroads.com
(949) 336-5977

APRIL 30, 2019

TABLE OF CONTENTS

TABLE OF CONTENTS	III
APPENDICES	IV
LIST OF EXHIBITS	IV
LIST OF TABLES	IV
LIST OF ABBREVIATED TERMS	V
EXECUTIVE SUMMARY	1
Construction Noise Analysis	1
Construction Vibration Analysis	2
1 INTRODUCTION	3
1.1 Site Location.....	3
1.2 Project Description.....	3
2 FUNDAMENTALS	7
2.1 Range of Noise	7
2.2 Noise Descriptors	8
2.3 Sound Propagation.....	8
2.4 Noise Control	9
2.5 Noise Barrier Attenuation	10
2.6 Land Use Compatibility With Noise	10
2.7 Community Response to Noise	10
2.8 Exposure to High Noise Levels	11
2.9 Vibration	11
3 REGULATORY SETTING	15
3.1 State of California Noise Requirements	15
3.2 State of California Building Code	15
3.3 City of Burbank General Plan Noise Element.....	16
3.4 Construction Vibration Standards.....	16
4 SIGNIFICANCE CRITERIA	17
4.1 CEQA Guidelines Not Further Analyzed	17
4.2 Significance Criteria.....	17
5 EXISTING NOISE LEVEL MEASUREMENTS	19
5.1 Measurement Procedure and Criteria	19
5.2 Noise Measurement Locations	19
5.3 Noise Measurement Results	20
6 RECEIVER LOCATIONS	23
7 CONSTRUCTION IMPACTS	25
7.1 Construction Noise Levels.....	25
7.2 Construction Reference Noise Levels	25
7.3 Construction Noise Analysis.....	26
7.4 Construction Noise Levels of Significance.....	31
7.5 Construction Vibration Assessment.....	32
7.6 Construction Vibration Impacts	32

8 REFERENCES..... 35
9 CERTIFICATION..... 37

APPENDICES

- APPENDIX 3.1: CITY OF BURBANK MUNICIPAL CODE
- APPENDIX 5.1: STUDY AREA PHOTOS
- APPENDIX 5.2: NOISE LEVEL MEASUREMENT WORKSHEETS

LIST OF EXHIBITS

EXHIBIT 1-A: LOCATION MAP 4
EXHIBIT 1-B: SITE PLAN..... 5
EXHIBIT 2-A: TYPICAL NOISE LEVELS 7
EXHIBIT 2-B: NOISE LEVEL INCREASE PERCEPTION 11
EXHIBIT 2-C: TYPICAL LEVELS OF GROUND-BORNE VIBRATION 13
EXHIBIT 5-A: NOISE MEASUREMENT LOCATIONS..... 22
EXHIBIT 6-A: RECEIVER LOCATIONS 24
EXHIBIT 7-A: CONSTRUCTION NOISE SOURCE AND RECEIVER LOCATIONS..... 30

LIST OF TABLES

TABLE 4-1: SIGNIFICANCE CRITERIA SUMMARY 18
TABLE 5-1: 24-HOUR AMBIENT NOISE LEVEL MEASUREMENTS 21
TABLE 7-1: CONSTRUCTION REFERENCE NOISE LEVELS 26
TABLE 7-2: DEMOLITION EQUIPMENT NOISE LEVELS 27
TABLE 7-3: SITE PREPARATION EQUIPMENT NOISE LEVELS 27
TABLE 7-4: GRADING EQUIPMENT NOISE LEVELS..... 28
TABLE 7-5: BUILDING CONSTRUCTION EQUIPMENT NOISE LEVELS..... 28
TABLE 7-6: PAVING EQUIPMENT NOISE LEVELS 29
TABLE 7-7: ARCHITECTURAL COATING EQUIPMENT NOISE LEVELS..... 29
TABLE 7-8: UNMITIGATED CONSTRUCTION EQUIPMENT NOISE LEVEL SUMMARY (DBA L_{EQ}) 31
TABLE 7-9: VIBRATION SOURCE LEVELS FOR CONSTRUCTION EQUIPMENT 32
TABLE 7-10: CONSTRUCTION EQUIPMENT VIBRATION LEVELS 34

LIST OF ABBREVIATED TERMS

(1)	Reference
ANSI	American National Standards Institute
BWC	Burbank Western Channel
BWP	Burbank Water and Power
CEQA	California Environmental Quality Act
CNEL	Community Noise Equivalent Level
dBA	A-weighted decibels
EPA	Environmental Protection Agency
FHWA	Federal Highway Administration
FTA	Federal Transit Administration
INCE	Institute of Noise Control Engineering
L_{eq}	Equivalent continuous (average) sound level
L_{max}	Maximum level measured over the time interval
L_{min}	Minimum level measured over the time interval
NIOSH	National Institute for Occupational Safety and Health
OSHA	Occupational Safety and Health Administration
PPV	Peak Particle Velocity
Project	Burbank Water and Power Magnolia Campus Drainage Improvement
RMS	Root-mean-square
VdB	Vibration Decibels

This page intentionally left blank

EXECUTIVE SUMMARY

Urban Crossroads, Inc. has prepared this noise study to determine the potential noise and vibration impacts related to the construction of the proposed Burbank Water and Power Magnolia Campus Drainage Improvement (“Project”). The Project site is located at 164 West Magnolia Boulevard within the Burbank Water and Power Campus (BWP Campus), in the City of Burbank. The Project proposes to construct drainage improvements that would allow storm water from adjacent properties to be intercepted and discharged into the Burbank Western Channel (BWC) through a new outfall structure. This study has been prepared consistent with applicable City of Burbank noise standards and significance criteria, and guidance provided in Appendix G of the California Environmental Quality Act (CEQA). (1)

CONSTRUCTION NOISE ANALYSIS

Project construction is expected to create temporary noise levels at receivers surrounding the Project site when certain activities occur at the closest point to the nearby receiver locations from primary Project construction activities. Using sample reference noise levels to represent the planned construction activities of Burbank Water and Power Magnolia Campus Drainage Improvement site, this analysis estimates the Project-related construction noise levels at nearby sensitive receiver locations. The closest noise-sensitive receiver locations to the Project site are located over 1,000 feet away. The results of the construction noise analysis show that the unmitigated construction noise levels will approach 35.5 dBA L_{eq} at these noise-sensitive receiver locations.

Per the City of Burbank General Plan Noise Element, *construction noise that occurs between the hours of 7 a.m. and 7 p.m. Monday through Friday and 8 a.m. to 5 p.m. on Saturday is exempt from applicable noise standards. With this regulatory exemption, the City acknowledges that construction noise is an acceptable public nuisance when conducted during the least noise-sensitive hours of the day. The City also acknowledges that construction noise could cause a substantial temporary increase in the ambient noise environment at nearby noise-sensitive receptors if construction occurs during the more noise-sensitive hours (i.e., evening, nighttime, early morning), or if construction equipment is not properly equipped with noise control devices.*

In addition to the exemption for construction noise, the Project construction noise levels of up to 35.5 dBA L_{eq} are shown to remain below the Noise Element Table N-4 stationary-source noise level limits for noise-sensitive land uses of 55 dBA L_{eq} during the daytime hours. Moreover, ambient noise levels in the Project study area were measured during the daytime hours when construction would normally take place and ranged from 54.0 to 71.4 dBA L_{eq} . Since Project construction noise levels are shown to approach up to 35.5 dBA L_{eq} , they would not be high enough to increase overall ambient conditions by *barely perceptible* levels. In order for the Project construction noise levels to increase ambient noise level conditions by 3 dBA L_{eq} , or a *barely perceptible* increase, the noise source (i.e., construction noise) would need to be equal to that of the ambient.

As such, since Project construction noise levels are considered exempt from the Municipal Code standards, are shown to remain below applicable Noise Element standards for stationary noise sources despite the exemption, and would not generate *barely perceptible* temporary noise level increases, the unmitigated Project construction noise level impacts are considered *less than significant*.

CONSTRUCTION VIBRATION ANALYSIS

Based on the reference vibration levels provided by the Federal Transit Administration, a large bulldozer represents the peak source of vibration with a reference velocity of 0.089 in/sec peak-particle-velocity (PPV) at 25 feet. At distances of over 1,000 feet from primary Project construction activities, construction vibration velocity levels are expected to approach 0.0003 in/sec PPV. Based on the Caltrans building damage threshold of 0.3 in/sec PPV for older residential structures, the proposed Project construction activities would result in vibration levels which would remain below the threshold for building damage at sensitive receiver locations, and therefore, represents a *less than significant* impact.

1 INTRODUCTION

This noise analysis has been completed to determine the noise impacts associated with the development of the proposed Burbank Water and Power Magnolia Campus Drainage Improvement (“Project”). This noise study describes the proposed Project, provides information regarding noise fundamentals, outlines the local regulatory setting, provides the study methods and procedures for construction noise and vibration analysis, and evaluates the potential Project-related construction noise and vibration levels.

1.1 SITE LOCATION

The proposed Burbank Water and Power Magnolia Campus Drainage Improvement Project is located at 164 West Magnolia Boulevard within the BWP Campus, in the City of Burbank, as shown on Exhibit 1-A. Properties located north and east of the Project site are developed for industrial uses, including but not limited to lumber yards, wood processing, storage, assembly and similar uses. Existing noise-sensitive land uses in the Project study area include residential homes to the west, west of Victory Boulevard, and south, south of Lake Street.

1.2 PROJECT DESCRIPTION

The Project proposes to construct drainage improvements that would allow storm water from adjacent properties to be intercepted and discharged into the BWC through a new outfall structure, as shown on Exhibit 1-B.

No long-term operational noise levels are anticipated as a result of the proposed Project since there would be no operational vehicle trips resulting from the proposed Project improvements, since the Project is limited to drainage and water quality improvements. As such, there are also no operational (stationary-source) noise sources anticipated as a result of the Project improvements since they would be constructed underground.

EXHIBIT 1-A: LOCATION MAP



EXHIBIT 1-B: SITE PLAN

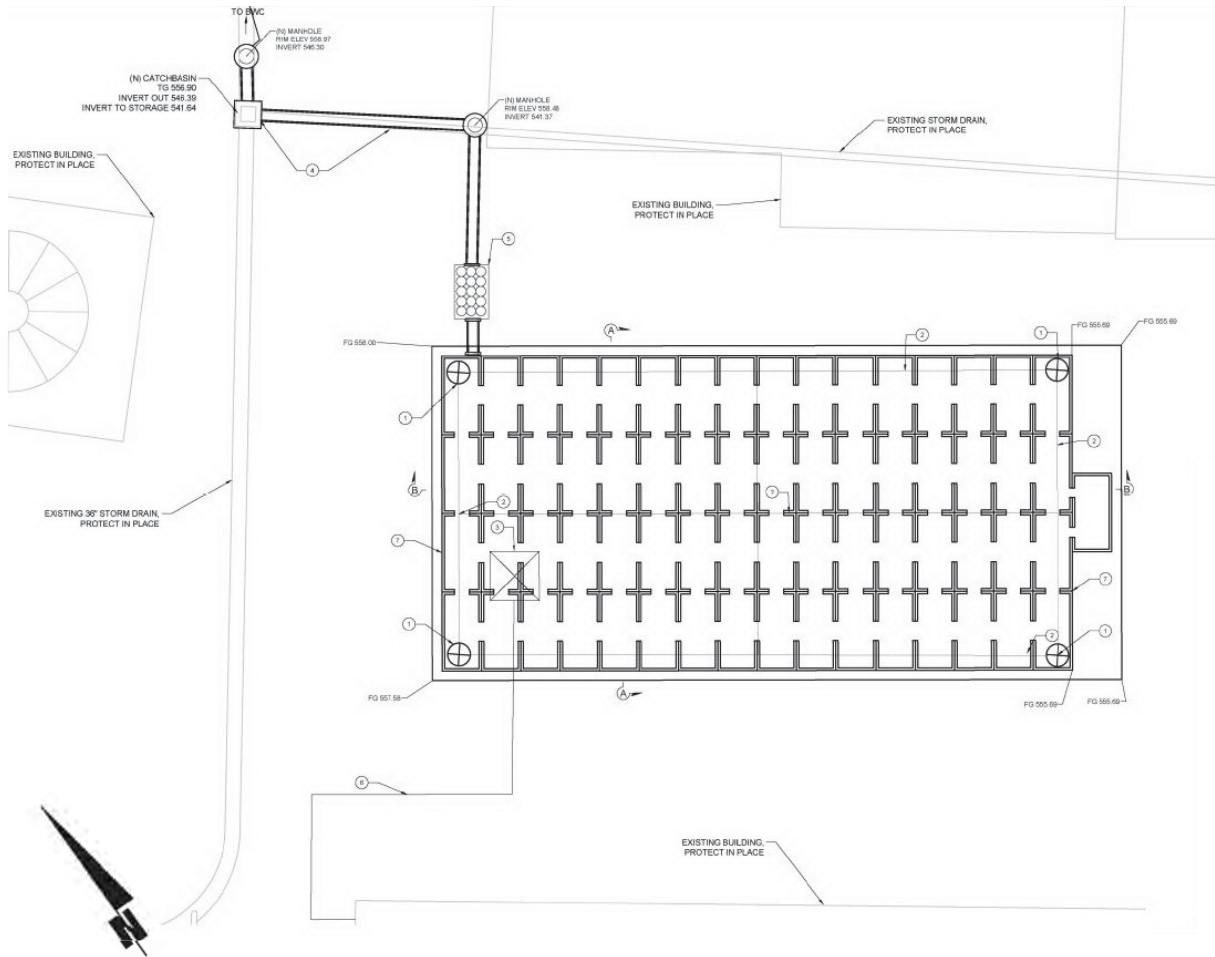

This page intentionally left blank

2 FUNDAMENTALS

Noise has been simply defined as "unwanted sound." Sound becomes unwanted when it interferes with normal activities, when it causes actual physical harm or when it has adverse effects on health. Noise is measured on a logarithmic scale of sound pressure level known as a decibel (dB). A-weighted decibels (dBA) approximate the subjective response of the human ear to broad frequency noise source by discriminating against very low and very high frequencies of the audible spectrum. They are adjusted to reflect only those frequencies which are audible to the human ear. Exhibit 2-A presents a summary of the typical noise levels and their subjective loudness and effects that are described in more detail below.

EXHIBIT 2-A: TYPICAL NOISE LEVELS

COMMON OUTDOOR ACTIVITIES	COMMON INDOOR ACTIVITIES	A - WEIGHTED SOUND LEVEL dBA	SUBJECTIVE LOUDNESS	EFFECTS OF NOISE
THRESHOLD OF PAIN		140	INTOLERABLE OR DEAFENING	HEARING LOSS
NEAR JET ENGINE		130		
		120		
JET FLY-OVER AT 300m (1000 ft)	ROCK BAND	110	VERY NOISY	SPEECH INTERFERENCE
LOUD AUTO HORN		100		
GAS LAWN MOWER AT 1m (3 ft)		90	LOUD	SPEECH INTERFERENCE
DIESEL TRUCK AT 15m (50 ft), at 80 km/hr (50 mph)	FOOD BLENDER AT 1m (3 ft)	80		
NOISY URBAN AREA, DAYTIME	VACUUM CLEANER AT 3m (10 ft)	70		
HEAVY TRAFFIC AT 90m (300 ft)	NORMAL SPEECH AT 1m (3 ft)	60	MODERATE	SLEEP DISTURBANCE
QUIET URBAN DAYTIME	LARGE BUSINESS OFFICE	50		
QUIET URBAN NIGHTTIME	THEATER, LARGE CONFERENCE ROOM (BACKGROUND)	40	FAINT	NO EFFECT
QUIET SUBURBAN NIGHTTIME	LIBRARY	30		
QUIET RURAL NIGHTTIME	BEDROOM AT NIGHT, CONCERT HALL (BACKGROUND)	20		
	BROADCAST/RECORDING STUDIO	10	VERY FAINT	NO EFFECT
LOWEST THRESHOLD OF HUMAN HEARING	LOWEST THRESHOLD OF HUMAN HEARING	0		

Source: Environmental Protection Agency Office of Noise Abatement and Control, Information on Levels of Environmental Noise Requisite to Protect Public Health and Welfare with an Adequate Margin of Safety (EPA/ONAC 550/9-74-004) March 1974.

2.1 RANGE OF NOISE

Since the range of intensities that the human ear can detect is so large, the scale frequently used to measure intensity is a scale based on multiples of 10, the logarithmic scale. The scale for measuring intensity is the decibel scale. Each interval of 10 decibels indicates a sound energy ten times greater than before, which is perceived by the human ear as being roughly twice as loud. (2) The most common sounds vary between 40 dBA (very quiet) to 100 dBA (very loud). Normal conversation at three feet is roughly at 60 dBA, while loud jet engine noises equate to 110 dBA

at approximately 100 feet, which can cause serious discomfort. (3) Another important aspect of noise is the duration of the sound and the way it is described and distributed in time.

2.2 NOISE DESCRIPTORS

Environmental noise descriptors are generally based on averages, rather than instantaneous, noise levels. The most commonly used figure is the equivalent level (L_{eq}). Equivalent sound levels are not measured directly but are calculated from sound pressure levels typically measured in A-weighted decibels (dBA). The equivalent sound level (L_{eq}) represents a steady state sound level containing the same total energy as a time varying signal over a given sample period and is commonly used to describe the “average” noise levels within the environment.

Peak hour or average noise levels, while useful, do not completely describe a given noise environment. Noise levels lower than peak hour may be disturbing if they occur during times when quiet is most desirable, namely evening and nighttime (sleeping) hours. To account for this, the Day-Night Average Noise Level (LDN) and the Community Noise Equivalent Level (CNEL), representing a composite 24-hour noise level is utilized. The LDN and CNEL are weighted averages of the intensity of a sound, with corrections for time of day, and averaged over 24 hours. The LDN time of day corrections include the addition of 10 decibels to dBA L_{eq} sound levels at night between 10:00 p.m. and 7:00 a.m. The CNEL time of day corrections require the addition of 5 decibels to dBA L_{eq} sound levels in the evening from 7:00 p.m. to 10:00 p.m., in addition to the corrections for the LDN. These additions are made to account for the noise sensitive time periods during the evening and night hours when sound appears louder. LDN and CNEL do not represent the actual sound level heard at any time, but rather represent the total sound exposure. The City of Burbank relies on the 24-hour LDN level to assess land use compatibility with transportation related noise sources, however, this analysis uses the CNEL noise level to apply the more conservative evening hour corrections to the 24-hour noise levels.

2.3 SOUND PROPAGATION

When sound propagates over a distance, it changes in level and frequency content. The way noise reduces with distance depends on the following factors.

2.3.1 GEOMETRIC SPREADING

Sound from a localized source (i.e., a stationary point source) propagates uniformly outward in a spherical pattern. The sound level attenuates (or decreases) at a rate of 6 dB for each doubling of distance from a point source. Highways consist of several localized noise sources on a defined path and hence can be treated as a line source, which approximates the effect of several point sources. Noise from a line source propagates outward in a cylindrical pattern, often referred to as cylindrical spreading. Sound levels attenuate at a rate of 3 dB for each doubling of distance from a line source.

2.3.2 GROUND ABSORPTION

The propagation path of noise from a highway to a receiver is usually very close to the ground. Noise attenuation from ground absorption and reflective wave canceling adds to the attenuation associated with geometric spreading. Traditionally, the excess attenuation has also been expressed in terms of attenuation per doubling of distance. This approximation is usually sufficiently accurate for distances of less than 200 ft. For acoustically hard sites (i.e., sites with a reflective surface between the source and the receiver, such as a parking lot or body of water), no excess ground attenuation is assumed. For acoustically absorptive or soft sites (i.e., those sites with an absorptive ground surface between the source and the receiver such as soft dirt, grass, or scattered bushes and trees), an excess ground attenuation value of 1.5 dB per doubling of distance is normally assumed. When added to the cylindrical spreading, the excess ground attenuation results in an overall drop-off rate of 4.5 dB per doubling of distance from a line source.

2.3.3 ATMOSPHERIC EFFECTS

Receivers located downwind from a source can be exposed to increased noise levels relative to calm conditions, whereas locations upwind can have lowered noise levels. Sound levels can be increased at large distances (e.g., more than 500 feet) due to atmospheric temperature inversion (i.e., increasing temperature with elevation). Other factors such as air temperature, humidity, and turbulence can also have significant effects.

2.3.4 SHIELDING

A large object or barrier in the path between a noise source and a receiver can substantially attenuate noise levels at the receiver. The amount of attenuation provided by shielding depends on the size of the object and the frequency content of the noise source. Shielding by trees and other such vegetation typically only has an “out of sight, out of mind” effect. That is, the perception of noise impact tends to decrease when vegetation blocks the line-of-sight to nearby resident. However, for vegetation to provide a substantial, or even noticeable, noise reduction, the vegetation area must be at least 15 feet in height, 100 feet wide and dense enough to completely obstruct the line-of sight between the source and the receiver. This size of vegetation may provide up to 5 dBA of noise reduction. The FHWA does not consider the planting of vegetation to be a noise abatement measure.

2.4 NOISE CONTROL

Noise control is the process of obtaining an acceptable noise environment for an observation point or receiver by controlling the noise source, transmission path, receiver, or all three. This concept is known as the source-path-receiver concept. In general, noise control measures can be applied to these three elements.

2.5 NOISE BARRIER ATTENUATION

Effective noise barriers can reduce noise levels by 10 to 15 dBA, cutting the loudness of traffic noise in half. A noise barrier is most effective when placed close to the noise source or receiver. Noise barriers, however, do have limitations. For a noise barrier to work, it must be high enough and long enough to block the path of the noise source. (4)

2.6 LAND USE COMPATIBILITY WITH NOISE

Some land uses are more tolerant of noise than others. For example, schools, hospitals, churches and residences are more sensitive to noise intrusion than are commercial or industrial developments and related activities. As ambient noise levels affect the perceived amenity or livability of a development, so too can the mismanagement of noise impacts impair the economic health and growth potential of a community by reducing the area's desirability as a place to live, shop and work. For this reason, land use compatibility with the noise environment is an important consideration in the planning and design process. The FHWA encourages State and Local government to regulate land development in such a way that noise-sensitive land uses are either prohibited from being located adjacent to a highway, or that the developments are planned, designed, and constructed in such a way that noise impacts are minimized. (5)

2.7 COMMUNITY RESPONSE TO NOISE

Community responses to noise may range from registering a complaint by telephone or letter, to initiating court action, depending upon everyone's susceptibility to noise and personal attitudes about noise. Several factors are related to the level of community annoyance including:

- Fear associated with noise producing activities;
- Socio-economic status and educational level;
- Perception that those affected are being unfairly treated;
- Attitudes regarding the usefulness of the noise-producing activity;
- Belief that the noise source can be controlled.

Approximately ten percent of the population has a very low tolerance for noise and will object to any noise not of their making. Consequently, even in the quietest environment, some complaints will occur. Another twenty-five percent of the population will not complain even in very severe noise environments. Thus, a variety of reactions can be expected from people exposed to any given noise environment. (6) Surveys have shown that about ten percent of the people exposed to traffic noise of 60 dBA will report being highly annoyed with the noise, and each increase of one dBA is associated with approximately two percent more people being highly annoyed. When traffic noise exceeds 60 dBA or aircraft noise exceeds 55 dBA, people may begin to complain. (6)

Despite this variability in behavior on an individual level, the population can be expected to exhibit the following responses to changes in noise levels as shown on Exhibit 2-B. An increase or decrease of 1 dBA cannot be perceived except in carefully controlled laboratory experiments, a change of 3 dBA are considered *barely perceptible*, and changes of 5 dBA are considered *readily perceptible*. (4)

EXHIBIT 2-B: NOISE LEVEL INCREASE PERCEPTION

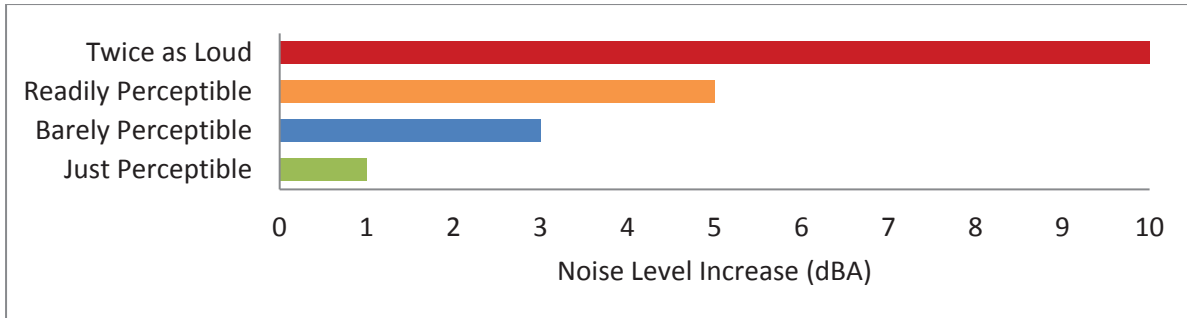

2.8 EXPOSURE TO HIGH NOISE LEVELS

The Occupational Safety and Health Administration (OSHA) sets legal limits on noise exposure in the workplace. The permissible exposure limit (PEL) for a worker over an eight-hour day is 90 dBA. The OSHA standard uses a 5 dBA exchange rate. This means that when the noise level is increased by 5 dBA, the amount of time a person can be exposed to a certain noise level to receive the same dose is cut in half. The National Institute for Occupational Safety and Health (NIOSH) has recommended that all worker exposures to noise should be controlled below a level equivalent to 85 dBA for eight hours to minimize occupational noise induced hearing loss. NIOSH also recommends a 3 dBA exchange rate so that every increase by 3 dBA doubles the amount of the noise and halves the recommended amount of exposure time. (7)

OSHA has implemented requirements to protect all workers in general industry (e.g. the manufacturing and the service sectors) for employers to implement a Hearing Conservation Program where workers are exposed to a time weighted average noise level of 85 dBA or higher over an eight-hour work shift. Hearing Conservation Programs require employers to measure noise levels, provide free annual hearing exams and free hearing protection, provide training, and conduct evaluations of the adequacy of the hearing protectors in use unless changes to tools, equipment and schedules are made so that they are less noisy and worker exposure to noise is less than the 85 dBA. This noise study does not evaluate the noise exposure of workers within a project or construction site based on CEQA requirements, and instead, evaluates Project-related operational and construction noise levels at the nearby sensitive receiver locations in the Project study area. Further, periodic exposure to high noise levels in short duration, such as Project construction, is typically considered an annoyance and not impactful to human health. It would take several years of exposure to high noise levels to result in hearing impairment. (8)

2.9 VIBRATION

Per the Federal Transit Administration (FTA) *Transit Noise Impact and Vibration Assessment* (9), vibration is the periodic oscillation of a medium or object. The rumbling sound caused by the vibration of room surfaces is called structure-borne noise. Sources of ground-borne vibrations include natural phenomena (e.g., earthquakes, volcanic eruptions, sea waves, landslides) or human-made causes (e.g., explosions, machinery, traffic, trains, construction equipment). Vibration sources may be continuous, such as factory machinery, or transient, such as explosions.

As is the case with airborne sound, ground-borne vibrations may be described by amplitude and frequency.

There are several different methods that are used to quantify vibration. The peak particle velocity (PPV) is defined as the maximum instantaneous peak of the vibration signal. The PPV is most frequently used to describe vibration impacts to buildings, but is not always suitable for evaluating human response (annoyance) because it takes some time for the human body to respond to vibration signals. Instead, the human body responds to average vibration amplitude often described as the root mean square (RMS). The RMS amplitude is defined as the average of the squared amplitude of the signal, and is most frequently used to describe the effect of vibration on the human body. Decibel notation (VdB) is commonly used to measure RMS. Decibel notation (VdB) serves to reduce the range of numbers used to describe human response to vibration. Typically, ground-borne vibration generated by man-made activities attenuates rapidly with distance from the source of the vibration. Sensitive receivers for vibration include structures (especially older masonry structures), people (especially residents, the elderly, and sick), and vibration-sensitive equipment.

The background vibration-velocity level in residential areas is generally 50 VdB. Ground-borne vibration is normally perceptible to humans at approximately 65 VdB. For most people, a vibration-velocity level of 75 VdB is the approximate dividing line between barely perceptible and distinctly perceptible levels. Typical outdoor sources of perceptible ground-borne vibration are construction equipment, steel-wheeled trains, and traffic on rough roads. If a roadway is smooth, the ground-borne vibration is rarely perceptible. The range of interest is from approximately 50 VdB, which is the typical background vibration-velocity level, to 100 VdB, which is the general threshold where minor damage can occur in fragile buildings. Exhibit 2-C illustrates common vibration sources and the human and structural response to ground-borne vibration.

EXHIBIT 2-C: TYPICAL LEVELS OF GROUND-BORNE VIBRATION

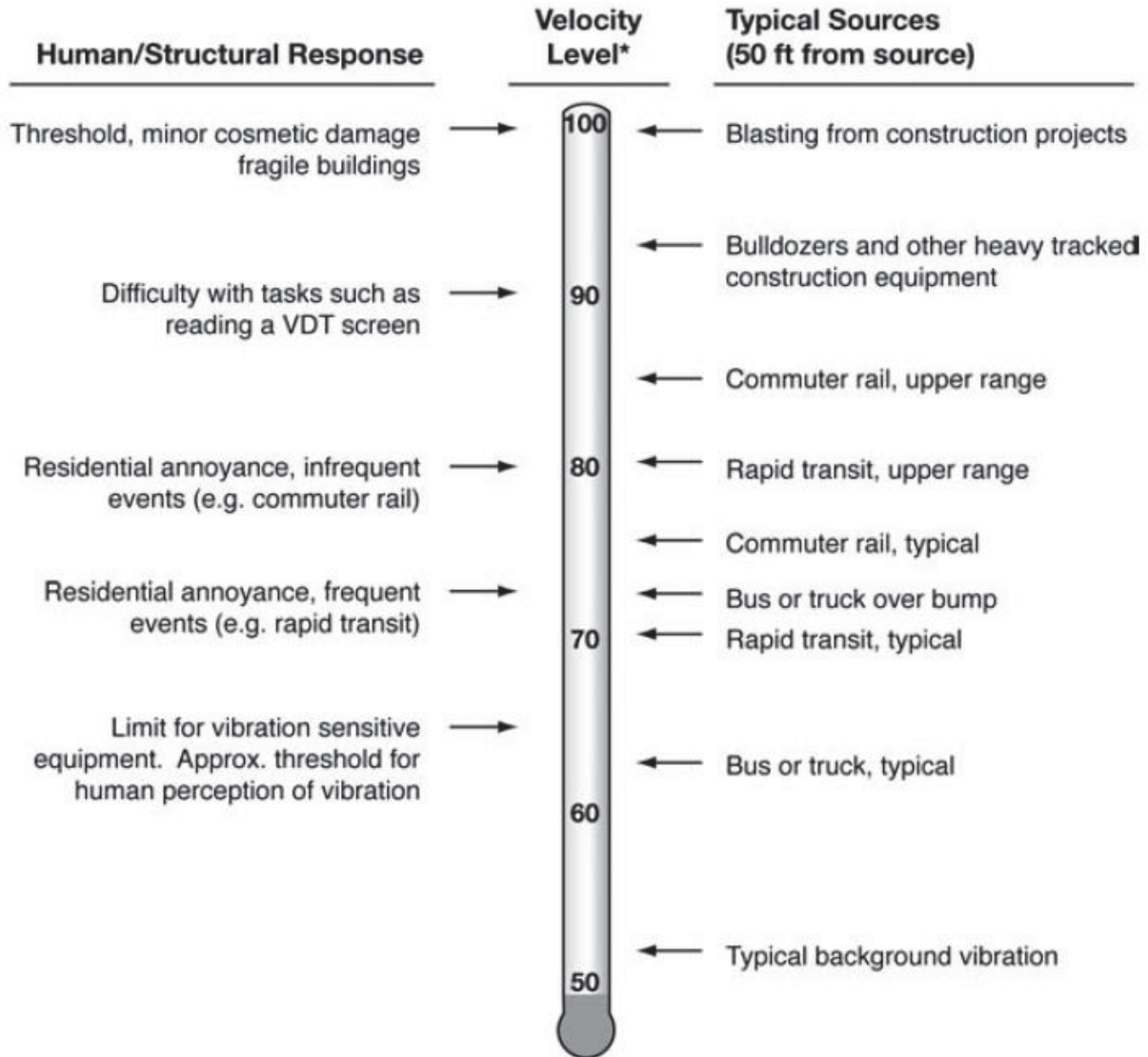

* RMS Vibration Velocity Level in VdB relative to 10⁻⁶ inches/second

Source: Federal Transit Administration (FTA) Transit Noise Impact and Vibration Assessment.

This page intentionally left blank

3 REGULATORY SETTING

To limit population exposure to physically and/or psychologically damaging as well as intrusive noise levels, the federal government, the State of California, various county governments, and most municipalities in the state have established standards and ordinances to control noise. In most areas, automobile and truck traffic is the major source of environmental noise. Traffic activity generally produces an average sound level that remains constant with time. Air and rail traffic, and commercial and industrial activities are also major sources of noise in some areas. Federal, state, and local agencies regulate different aspects of environmental noise. Federal and state agencies generally set noise standards for mobile sources such as aircraft and motor vehicles, while regulation of stationary sources is left to local agencies.

3.1 STATE OF CALIFORNIA NOISE REQUIREMENTS

The State of California regulates freeway noise, sets standards for sound transmission, provides occupational noise control criteria, identifies noise standards and provides guidance for local land use compatibility. State law requires that each county and city adopt a General Plan that includes a Noise Element which is to be prepared per guidelines adopted by the Governor's Office of Planning and Research. (10) The purpose of the Noise Element is to *limit the exposure of the community to excessive noise levels*. In addition, the California Environmental Quality Act (CEQA) requires that all known environmental effects of a project be analyzed, including the potential environmental noise impacts.

3.2 STATE OF CALIFORNIA BUILDING CODE

The State of California's noise insulation standards are codified in the California Code of Regulations, Title 24, Building Standards Administrative Code, Part 2, and the California Building Code. These noise standards are applied to new construction in California for controlling interior noise levels resulting from exterior noise sources. The regulations specify that acoustical studies must be prepared when noise-sensitive structures, such as residential buildings, schools, or hospitals, are developed near major transportation noise sources, and where such noise sources create an exterior noise level of 60 dBA CNEL or higher. Acoustical studies that accompany building plans for noise-sensitive land uses must demonstrate that the structure has been designed to limit interior noise in habitable rooms to acceptable noise levels. For new residential buildings, schools, and hospitals, the acceptable interior noise limit for new construction is 45 dBA CNEL.

3.3 CITY OF BURBANK GENERAL PLAN NOISE ELEMENT

The City of Burbank has adopted a Noise Element of the General Plan *to safeguard the community from excessive noise as the ambient noise level in the community rises.* (11) For this analysis, City's construction-related noise standards are used to evaluate potential impact related to the Project.

CITY OF BURBANK CONSTRUCTION NOISE STANDARDS

The City of Burbank General Plan Noise Element indicates:

...construction noise that occurs between the hours of 7 a.m. and 7 p.m. Monday through Friday and 8 a.m. to 5 p.m. on Saturday is exempt from applicable noise standards. With this regulatory exemption, the City acknowledges that construction noise is an acceptable public nuisance when conducted during the least noise-sensitive hours of the day. The City also acknowledges that construction noise could cause a substantial temporary increase in the ambient noise environment at nearby noise-sensitive receptors if construction occurs during the more noise-sensitive hours (i.e., evening, nighttime, early morning), or if construction equipment is not properly equipped with noise control devices.

Although exempt, this noise study compares Project construction noise levels with the Noise Element Table N-4 stationary-source noise level limits for noise-sensitive land uses of 55 dBA L_{eq} for the daytime hours when construction activities would occur.

3.4 CONSTRUCTION VIBRATION STANDARDS

The City of Burbank General Plan and Municipal Code do not identify specific vibration level standards. Therefore, applicable vibration standards identified by the California Department of Transportation ("Caltrans") *Transportation and Construction Vibration Guidance Manual* are used in this noise study. (2) The Caltrans vibration manual establishes thresholds for determining potential vibration impacts resulting in building damage. For older residential structures, Caltrans identifies a building damage threshold of 0.3 in/sec PPV which is used in this analysis to evaluate potential Project-related construction vibration impacts at the closest sensitive receiver locations.

4 SIGNIFICANCE CRITERIA

The following significance criteria are based on currently adopted guidance provided by Appendix G of the California Environmental Quality Act (CEQA) Guidelines. (1) For the purposes of this report, impacts would be potentially significant if the Project results in or causes:

- A. Generation of a substantial temporary or permanent increase in ambient noise levels in the vicinity of the project in excess of standards established in the local general plan or noise ordinance, or applicable standards of other agencies?
- B. Generation of excessive ground-borne vibration or ground-borne noise levels?
- C. For a project located within the vicinity of a private airstrip or an airport land use plan or, where such a plan has not been adopted, within two miles of a public airport or public use airport, would the project expose people residing or working in the project area to excessive noise levels?

While the City of Burbank General Plan Guidelines provide direction on noise compatibility and establish noise standards by land use type that are sufficient to assess the significance of noise impacts, they do not define the levels at which increases are considered substantial for use under Guideline A. CEQA Appendix G Guideline C applies to nearby public and private airports, if any, and the Project's land use compatibility.

4.1 CEQA GUIDELINES NOT FURTHER ANALYZED

No long-term operational noise levels are anticipated as a result of the proposed Project since there would be no operational vehicle trips resulting from the proposed Project improvements, since the Project is limited to drainage and water quality improvements. As such, there are also no operational (stationary-source) noise sources anticipated as a result of the Project improvements since they would be constructed underground, and no further analysis is provided for these noise sources under Guideline A.

The Project site is located greater than two miles southeast of Burbank Airport and is not located within the vicinity of a private airstrip. As such, the Project site would not be exposed to excessive noise levels from airport operations, and therefore, impacts are considered *less than significant*, and no further noise analysis is conducted in relation to Guideline C.

4.2 SIGNIFICANCE CRITERIA

Noise impacts shall be considered significant if any of the following occur as a direct result of the proposed development. Table 4-1 shows the significance criteria summary matrix.

CONSTRUCTION NOISE

- If Project construction activities occur outside of the hours of 7:00 a.m. and 7:00 p.m. Monday through Friday and 8:00 a.m. to 5:00 p.m. on Saturday. Construction noise is considered exempt from applicable noise standards if it occurs within the specific hours. While not required, this noise study identifies the City of Burbank General Plan Noise Element, Table N-4 stationary noise level limits for noise-sensitive receiver locations for comparison purposes.

CONSTRUCTION VIBRATION

- If short-term Project generated construction vibration levels exceed Caltrans building damage vibration standard of 0.3 in/sec PPV at sensitive receiver locations (Caltrans Transportation and Construction Vibration Guidance Manual, Table 19).

TABLE 4-1: SIGNIFICANCE CRITERIA SUMMARY

Analysis	Land Use	Condition(s)	Significance Criteria
Construction Noise & Vibration	Noise-Sensitive	Exempt; However, Exterior Noise Level Standards Considered: ¹	55 dBA L _{eq} (Daytime)
		Vibration Level Threshold ²	0.3 in/sec PPV

¹ In the City of Burbank Municipal Code, construction noise that occurs between the hours of 7:00 a.m. and 7:00 p.m. Monday through Friday and 8:00 a.m. to 5:00 p.m. on Saturday is exempt from applicable noise standards. City of Burbank General Plan Noise Element, Table N-4 stationary noise level limits are provided for noise-sensitive receiver locations for comparison purposes.

² Source: Caltrans, Transportation & Construction Vibration Guidance Manual, September 2013. "Daytime" = 7:00 a.m. to 10:00 p.m.

5 EXISTING NOISE LEVEL MEASUREMENTS

To assess the existing noise level environment, five 24-hour noise level measurements were taken at sensitive receiver locations in the Project study area. The receiver locations were selected to describe and document the existing noise environment within the Project study area. Exhibit 5-A provides the boundaries of the Project study area and the noise level measurement locations. To fully describe the existing noise conditions, noise level measurements were collected by Urban Crossroads, Inc. on Tuesday, April 9th, 2019. Appendix 5.1 provides a series of study area photos.

5.1 MEASUREMENT PROCEDURE AND CRITERIA

To describe the existing noise environment, the hourly noise levels were measured during typical weekday conditions over a 24-hour period. By collecting individual hourly noise level measurements, it is possible to describe the daytime and nighttime hourly noise levels and calculate the 24-hour CNEL. The long-term noise readings were recorded using Piccolo Type 2 integrating sound level meter and dataloggers. The Piccolo sound level meters were calibrated using a Larson-Davis calibrator, Model CAL 150. All noise meters were programmed in "slow" mode to record noise levels in "A" weighted form. The sound level meters and microphones were equipped with a windscreen during all measurements. All noise level measurement equipment satisfies the American National Standards Institute (ANSI) standard specifications for sound level meters ANSI S1.4-2014/IEC 61672-1:2013. (12)

5.2 NOISE MEASUREMENT LOCATIONS

The long-term noise level measurements were positioned as close to the nearest sensitive receiver locations as possible to assess the existing ambient hourly noise levels surrounding the Project site. Both Caltrans and the FTA recognize that it is not reasonable to collect noise level measurements that can fully represent any part of a private yard, patio, deck or balcony normally used for human activity when estimating impacts for new development projects. This is demonstrated in the Caltrans general site location guidelines which indicate that, *sites must be free of noise contamination by sources other than sources of interest. Avoid sites located near sources such as barking dogs, lawnmowers, pool pumps, and air conditioners unless it is the express intent of the analyst to measure these sources.* (2) Further, FTA guidance states, *that it is not necessary nor recommended that existing noise exposure be determined by measuring at every noise-sensitive location in the project area. Rather, the recommended approach is to characterize the noise environment for clusters of sites based on measurements or estimates at representative locations in the community.* (9)

Based on recommendations of Caltrans and the FTA, it is not necessary to collect measurements at each individual building or residence, because each receiver measurement represents a group of buildings that share acoustical equivalence. (9) In other words, the area represented by the receiver shares similar shielding, terrain, and geometric relationship to the reference noise source. Receivers represent a location of noise sensitive areas and are used to estimate the future noise level impacts. Collecting reference ambient noise level measurements at the nearby

sensitive receiver locations allows for a comparison of the before and after Project noise levels and is necessary to assess potential noise impacts due to the Project's contribution to the ambient noise levels.

5.3 NOISE MEASUREMENT RESULTS

The noise measurements presented below focus on the average or equivalent sound levels (L_{eq}). The equivalent sound level (L_{eq}) represents a steady state sound level containing the same total energy as a time varying signal over a given sample period. Table 5-1 identifies the hourly daytime (7:00 a.m. to 10:00 p.m.) and nighttime (10:00 p.m. to 7:00 a.m.) noise levels at each noise level measurement location. Appendix 5.2 provides a summary of the existing hourly ambient noise levels described below:

- Location L1 represents the noise levels on North First Street, northeast of the Project site, east of the I-5 Highway, adjacent to an existing commercial area. The energy (logarithmic) average daytime noise level was calculated at 68.5 dBA L_{eq} with an average nighttime noise level of 63.5 dBA L_{eq} .
- Location L2 represents the noise levels on West Olive Avenue, southeast of the Project site, adjacent to an existing general industrial area. The energy (logarithmic) average daytime noise level was calculated at 71.4 dBA L_{eq} with an average nighttime noise level of 65.4 dBA L_{eq} .
- Location L3 represents the noise levels on Victory Boulevard, south of the Project site, adjacent to an existing general commercial area. The energy (logarithmic) average daytime noise level was calculated at 70.6 dBA L_{eq} with an average nighttime noise level of 64.9 dBA L_{eq} .
- Location L4 represents the noise levels on Palm Avenue, southwest of the Project site, adjacent to an existing residential area. The energy (logarithmic) average daytime noise level was calculated at 54.0 dBA L_{eq} with an average nighttime noise level of 51.7 dBA L_{eq} .
- Location L5 represents the noise levels on Victory Boulevard, west of the Project site, adjacent to an existing commercial area. The energy (logarithmic) average daytime noise level was calculated at 68.5 dBA L_{eq} with an average nighttime noise level of 63.9 dBA L_{eq} .

Table 5-1 provides the (energy average) noise levels used to describe the daytime and nighttime ambient conditions. These daytime and nighttime energy average noise levels represent the average of all hourly noise levels observed during these time periods expressed as a single number. Appendix 5.2 provides summary worksheets of the noise levels for each hour as well as the minimum, maximum, L_1 , L_2 , L_5 , L_8 , L_{25} , L_{50} , L_{90} , L_{95} , and L_{99} percentile noise levels observed during the daytime and nighttime periods.

The background ambient noise levels in the Project study area are dominated by the transportation-related noise associated with the arterial roadway network and Union Pacific Railroad lines, in addition to existing industrial noise sources. This includes auto and heavy truck activity near the noise level measurement locations. The 24-hour existing noise level measurements shown on Table 5-1 present the worst-case existing unmitigated ambient noise conditions.

TABLE 5-1: 24-HOUR AMBIENT NOISE LEVEL MEASUREMENTS

Location ¹	Description	Energy Average Noise Level (dBA L _{eq}) ²	
		Daytime	Nighttime
L1	Located on North First Street, northeast of the Project site, east of the I-5 Highway, adjacent to an existing commercial area.	68.5	63.5
L2	Located on West Olive Avenue, southeast of the Project site, adjacent to an existing general industrial area.	71.4	65.4
L3	Located on Victory Boulevard, south of the Project site, adjacent to an existing general commercial area.	70.6	64.9
L4	Located on Palm Avenue, southwest of the Project site, adjacent to an existing residential area.	54.0	51.7
L5	Located on Victory Boulevard, west of the Project site, adjacent to an existing commercial area.	68.5	63.9

¹ See Exhibit 5-A for the noise level measurement locations.

² The long-term 24-hour measurement printouts are included in Appendix 5.2.
 "Daytime" = 7:00 a.m. to 10:00 p.m.; "Nighttime" = 10:00 p.m. to 7:00 a.m.

EXHIBIT 5-A: NOISE MEASUREMENT LOCATIONS

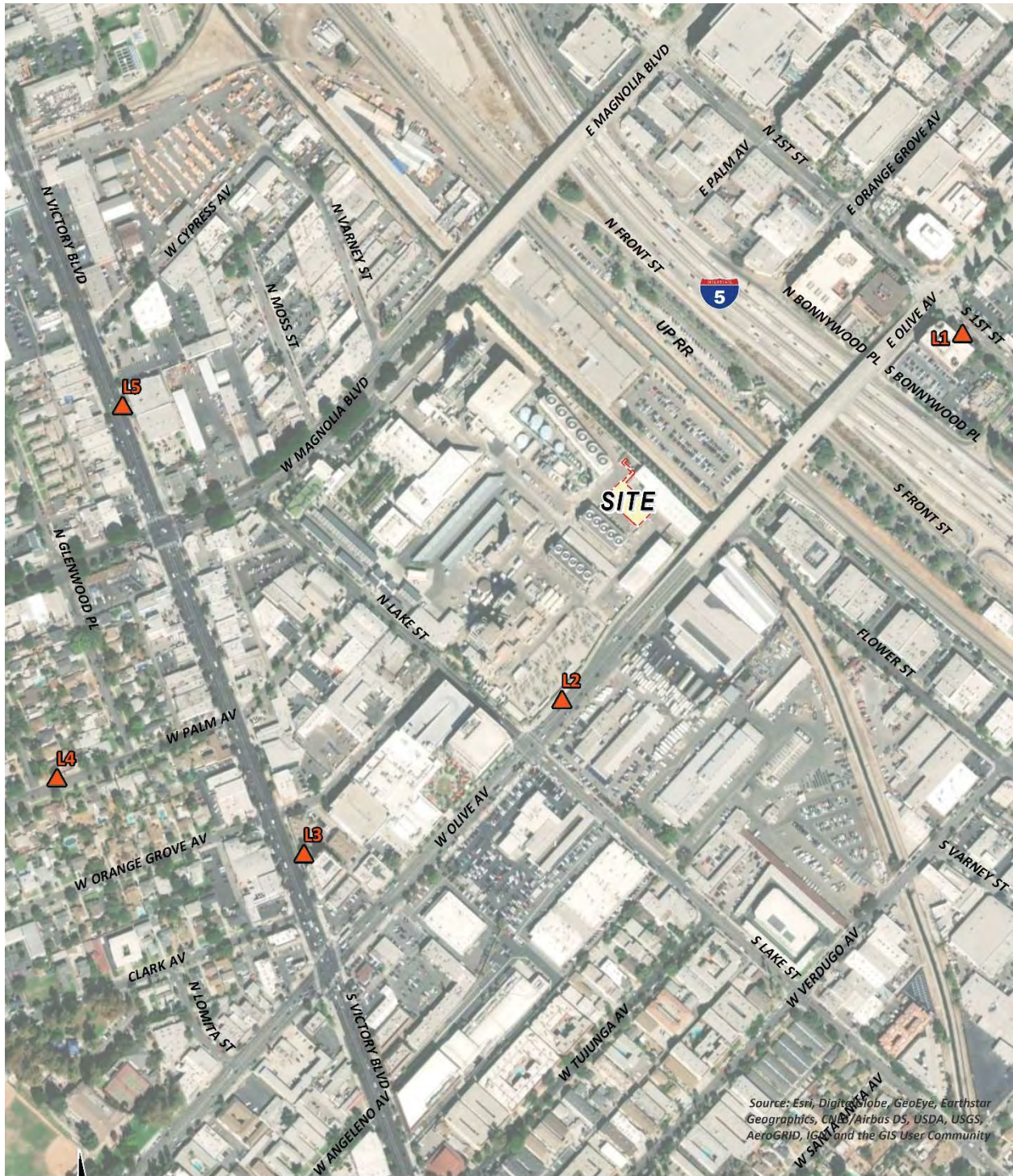

Source: Esri, DigitalGlobe, GeoEye, Earthstar Geographics, CNR/Airbus DS, USDA, USGS, AeroGRID, IGN, and the GIS User Community

LEGEND:

▲ Noise Measurement Locations

6 RECEIVER LOCATIONS

To assess the potential for short-term construction impacts, the following receiver locations as shown on Exhibit 6-A were identified as representative locations for analysis. The City of Burbank General Plan Noise Element defines noise-sensitive uses as: *residences, hospitals, schools, and nursing homes*. (11) Land uses that are considered relatively insensitive to noise include business, commercial, and professional developments. Land uses that are typically not affected by noise include: industrial, manufacturing, utilities, agriculture, natural open space, undeveloped land, parking lots, warehousing, liquid and solid waste facilities, salvage yards, and transit terminals.

Other sensitive land uses in the Project study area that are located at greater distances than those identified in this noise study will experience lower noise levels than those presented in this report due to the additional attenuation from distance and the shielding of intervening structures.

- R1: Located approximately 1,608 feet west of the Project site, R1 represents existing residential homes east of Glenwood Place.
- R2: Location R2 represents the existing residential homes located approximately 1,506 feet west of the Project site on Victory Boulevard.
- R3: Location R3 represents the existing residential homes located roughly 1,918 feet from the Project site boundary on the north side of Clark Avenue.
- R4: Location R4 represents the existing residential homes located roughly 1,210 feet south of the Project site boundary on the south side of Lake Street.

EXHIBIT 6-A: RECEIVER LOCATIONS

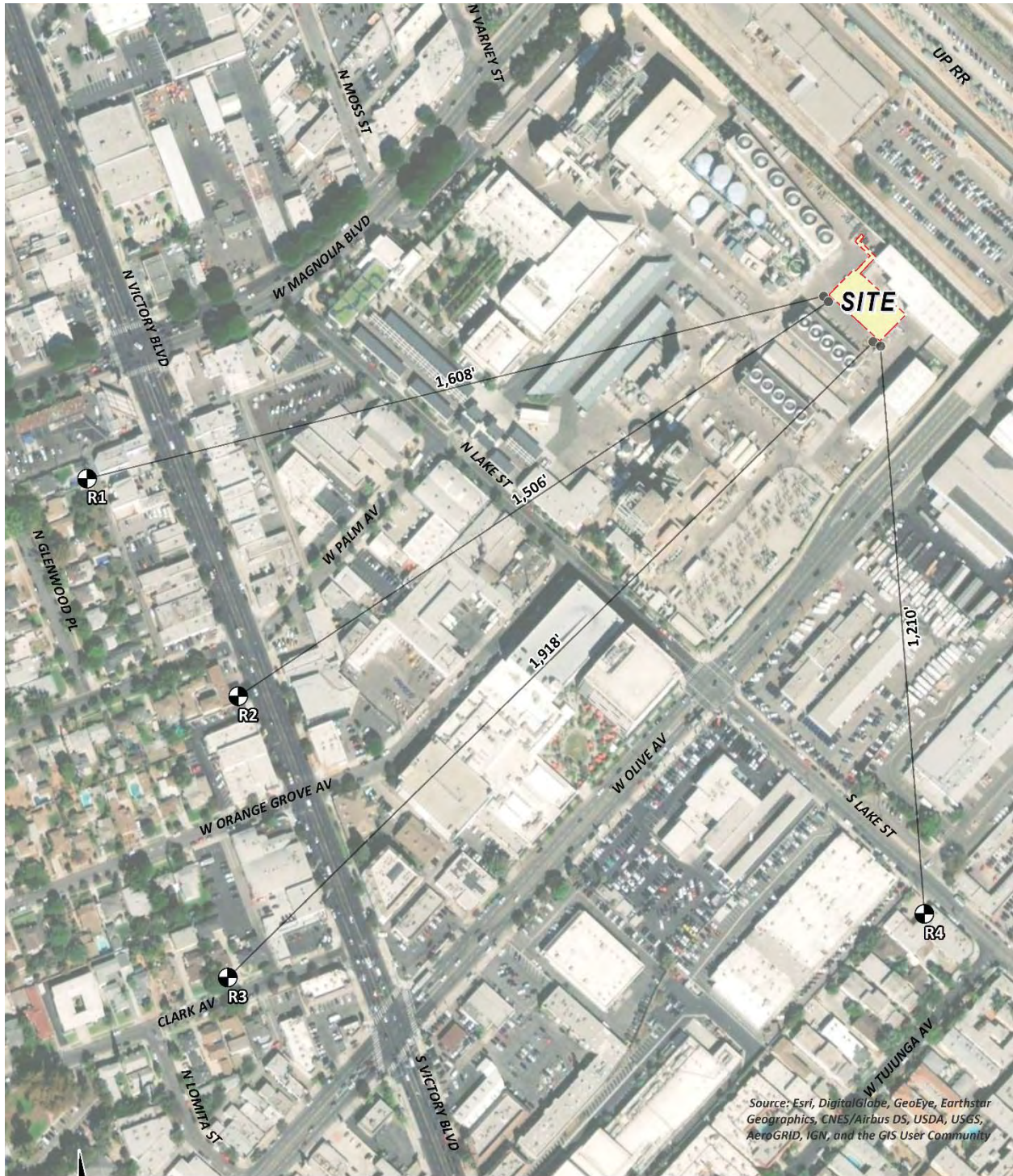

Source: Esri, DigitalGlobe, GeoEye, Earthstar Geographics, CNES/Airbus DS, USDA, USGS, AeroGRID, IGN, and the GIS User Community

LEGEND:

- ⊕ Receiver Locations
- Distance from receiver to Project site boundary (in feet)

7 CONSTRUCTION IMPACTS

This section analyzes potential impacts resulting from the short-term construction activities associated with the development of the Project. Exhibit 7-A shows the construction activity boundaries in relation to the nearby sensitive receiver locations.

7.1 CONSTRUCTION NOISE LEVELS

Noise generated by the Project construction equipment will include a combination of trucks, power tools, concrete mixers and portable generators that when combined can reach high levels. The number and mix of construction equipment is expected to occur in the following stages:

- Demolition
- Site Preparation
- Grading
- Building Construction
- Paving
- Architectural Coating

This construction noise analysis was prepared using reference noise level measurements taken by Urban Crossroads, Inc. to describe the typical construction activity noise levels for each stage of Project construction. The construction reference noise level measurements represent a list of typical construction activity noise levels. Noise levels generated by heavy construction equipment can range from approximately 62 dBA to more than 80 dBA when measured at 50 feet. However, these noise levels diminish with distance from the construction site at a rate of 6 dBA per doubling of distance. For example, a noise level of 80 dBA measured at 50 feet from the noise source to the receiver would be reduced to 74 dBA at 100 feet from the source to the receiver, and would be further reduced to 68 dBA at 200 feet from the source to the receiver. The construction stages used in this analysis are consistent with the data used to support the construction emissions in *Burbank Water and Power Magnolia Campus Drainage Improvement Focused Greenhouse Gas Assessment* prepared by Urban Crossroads Inc. (13)

7.2 CONSTRUCTION REFERENCE NOISE LEVELS

To describe the Project construction noise levels, measurements were collected for similar activities at several construction sites. Table 7-1 provides a summary of the reference construction noise level measurements. Since the reference noise levels were collected at varying distances, all construction noise level measurements presented on Table 7-1 have been adjusted to describe a common reference distance of 50 feet.

TABLE 7-1: CONSTRUCTION REFERENCE NOISE LEVELS

ID	Noise Source	Duration (h:mm:ss)	Reference Distance From Source (Feet)	Reference Noise Levels @ Reference Distance (dBA L _{eq})	Reference Noise Levels @ 50 Feet (dBA L _{eq}) ⁶
1	Truck Pass-Bys & Dozer Activity ¹	0:01:15	30'	63.6	59.2
2	Dozer Activity ¹	0:01:00	30'	68.6	64.2
3	Construction Vehicle Maintenance Activities ²	0:01:00	30'	71.9	67.5
4	Foundation Trenching ²	0:01:01	30'	72.6	68.2
6	Framing ³	0:02:00	30'	66.7	62.3
7	Concrete Paver Activities ⁴	0:01:00	30'	70.0	65.6
8	Concrete Mixer Pour & Paving Activities ⁴	0:01:00	30'	70.3	65.9
9	Forklift, Jackhammer, & Metal Truck Bed Loading ⁵	0:02:06	50'	67.9	67.9

¹ As measured by Urban Crossroads, Inc. on 10/14/15 at a business park construction site located at the northwest corner of Barranca Parkway and Alton Parkway in the City of Irvine.

² As measured by Urban Crossroads, Inc. on 10/20/15 at a construction site located in Rancho Mission Viejo.

³ As measured by Urban Crossroads, Inc. on 10/20/15 at a residential construction site located in Rancho Mission Viejo.

⁴ Reference noise level measurements were collected from a nighttime concrete pour at an industrial construction site, located at 27334 San Bernardino Avenue in the City of Redlands, between 1:00 a.m. to 2:00 a.m. on 7/1/15.

⁵ As measured by Urban Crossroads, Inc. on 9/9/16 during the demolition of an existing paved parking lot at 41 Corporate Park in Irvine.

⁶ Reference noise levels are calculated at 50 feet using a drop off rate of 6 dBA per doubling of distance (point source).

7.3 CONSTRUCTION NOISE ANALYSIS

Tables 7-2 to 7-7 show the Project construction stages and the reference construction noise levels used for each stage. Table 7-8 provides a summary of the noise levels from each stage of construction at each of the sensitive receiver locations in the City of Burbank. Based on the reference construction noise levels, the Project-related construction noise levels when the highest reference noise level is operating at a single point nearest the sensitive receiver location will range from 25.6 to 35.5 dBA L_{eq} at the sensitive receiver locations in the City of Burbank. Exhibit 7-A shows the construction activity noise source location and the distance to each nearby sensitive receiver location.

TABLE 7-2: DEMOLITION EQUIPMENT NOISE LEVELS

Reference Construction Activity ¹	Reference Noise Level @ 50 Feet (dBA L _{eq})
Truck Pass-Bys & Dozer Activity	59.2
Dozer Activity	64.2
Forklift, Jackhammer, & Metal Truck Bed Activities	67.9
Highest Reference Noise Level at 50 Feet (dBA L _{eq}):	67.9

Receiver Location	Distance to Construction Activity (Feet) ²	Distance Attenuation (dBA L _{eq}) ³	Estimated Noise Barrier Attenuation (dBA L _{eq}) ⁴	Construction Noise Level (dBA L _{eq})
R1	1,608'	-30.1	-5.0	32.8
R2	1,506'	-29.6	-5.0	33.3
R3	1,918'	-31.7	-5.0	31.2
R4	1,210'	-27.7	-5.0	35.2

¹ Reference construction noise level measurements taken by Urban Crossroads, Inc.

² Distance from the nearest point of construction activity to the nearest receiver.

³ Point (stationary) source drop off rate of 6.0 dBA per doubling of distance.

⁴ Estimated barrier attenuation from existing barriers/buildings in the Project study area.

TABLE 7-3: SITE PREPARATION EQUIPMENT NOISE LEVELS

Reference Construction Activity ¹	Reference Noise Level @ 50 Feet (dBA L _{eq})
Truck Pass-Bys & Dozer Activity	59.2
Dozer Activity	64.2
Highest Reference Noise Level at 50 Feet (dBA L _{eq}):	64.2

Receiver Location	Distance to Construction Activity (Feet) ²	Distance Attenuation (dBA L _{eq}) ³	Estimated Noise Barrier Attenuation (dBA L _{eq}) ⁴	Construction Noise Level (dBA L _{eq})
R1	1,608'	-30.1	-5.0	29.0
R2	1,506'	-29.6	-5.0	29.6
R3	1,918'	-31.7	-5.0	27.5
R4	1,210'	-27.7	-5.0	31.5

¹ Reference construction noise level measurements taken by Urban Crossroads, Inc.

² Distance from the nearest point of construction activity to the nearest receiver.

³ Point (stationary) source drop off rate of 6.0 dBA per doubling of distance.

⁴ Estimated barrier attenuation from existing barriers/buildings in the Project study area.

TABLE 7-4: GRADING EQUIPMENT NOISE LEVELS

Reference Construction Activity ¹	Reference Noise Level @ 50 Feet (dBA L _{eq})
Truck Pass-Bys & Dozer Activity	59.2
Dozer Activity	64.2
Highest Reference Noise Level at 50 Feet (dBA L _{eq}):	64.2

Receiver Location	Distance to Construction Activity (Feet) ²	Distance Attenuation (dBA L _{eq}) ³	Estimated Noise Barrier Attenuation (dBA L _{eq}) ⁴	Construction Noise Level (dBA L _{eq})
R1	1,608'	-30.1	-5.0	29.0
R2	1,506'	-29.6	-5.0	29.6
R3	1,918'	-31.7	-5.0	27.5
R4	1,210'	-27.7	-5.0	31.5

¹ Reference construction noise level measurements taken by Urban Crossroads, Inc.

² Distance from the nearest point of construction activity to the nearest receiver.

³ Point (stationary) source drop off rate of 6.0 dBA per doubling of distance.

⁴ Estimated barrier attenuation from existing barriers/buildings in the Project study area.

TABLE 7-5: BUILDING CONSTRUCTION EQUIPMENT NOISE LEVELS

Reference Construction Activity ¹	Reference Noise Level @ 50 Feet (dBA L _{eq})
Construction Vehicle Maintenance Activities	67.5
Foundation Trenching	68.2
Framing	62.3
Highest Reference Noise Level at 50 Feet (dBA L _{eq}):	68.2

Receiver Location	Distance to Construction Activity (Feet) ²	Distance Attenuation (dBA L _{eq}) ³	Estimated Noise Barrier Attenuation (dBA L _{eq}) ⁴	Construction Noise Level (dBA L _{eq})
R1	1,608'	-30.1	-5.0	33.0
R2	1,506'	-29.6	-5.0	33.6
R3	1,918'	-31.7	-5.0	31.5
R4	1,210'	-27.7	-5.0	35.5

¹ Reference construction noise level measurements taken by Urban Crossroads, Inc.

² Distance from the nearest point of construction activity to the nearest receiver.

³ Point (stationary) source drop off rate of 6.0 dBA per doubling of distance.

⁴ Estimated barrier attenuation from existing barriers/buildings in the Project study area.

TABLE 7-6: PAVING EQUIPMENT NOISE LEVELS

Reference Construction Activity ¹	Reference Noise Level @ 50 Feet (dBA L _{eq})
Concrete Paver Activities	65.6
Concrete Mixer Pour & Paving Activities	65.9
Highest Reference Noise Level at 50 Feet (dBA L _{eq}):	65.9

Receiver Location	Distance to Construction Activity (Feet) ²	Distance Attenuation (dBA L _{eq}) ³	Estimated Noise Barrier Attenuation (dBA L _{eq}) ⁴	Construction Noise Level (dBA L _{eq})
R1	1,608'	-30.1	-5.0	30.7
R2	1,506'	-29.6	-5.0	31.3
R3	1,918'	-31.7	-5.0	29.2
R4	1,210'	-27.7	-5.0	33.2

¹ Reference construction noise level measurements taken by Urban Crossroads, Inc.

² Distance from the nearest point of construction activity to the nearest receiver.

³ Point (stationary) source drop off rate of 6.0 dBA per doubling of distance.

⁴ Estimated barrier attenuation from existing barriers/buildings in the Project study area.

TABLE 7-7: ARCHITECTURAL COATING EQUIPMENT NOISE LEVELS

Reference Construction Activity ¹	Reference Noise Level @ 50 Feet (dBA L _{eq})
Framing	62.3
Highest Reference Noise Level at 50 Feet (dBA L _{eq}):	62.3

Receiver Location	Distance to Construction Activity (Feet) ²	Distance Attenuation (dBA L _{eq}) ³	Estimated Noise Barrier Attenuation (dBA L _{eq}) ⁴	Construction Noise Level (dBA L _{eq})
R1	1,608'	-30.1	-5.0	27.1
R2	1,506'	-29.6	-5.0	27.7
R3	1,918'	-31.7	-5.0	25.6
R4	1,210'	-27.7	-5.0	29.6

¹ Reference construction noise level measurements taken by Urban Crossroads, Inc.

² Distance from the nearest point of construction activity to the nearest receiver.

³ Point (stationary) source drop off rate of 6.0 dBA per doubling of distance.

⁴ Estimated barrier attenuation from existing barriers/buildings in the Project study area.

EXHIBIT 7-A: CONSTRUCTION NOISE SOURCE AND RECEIVER LOCATIONS

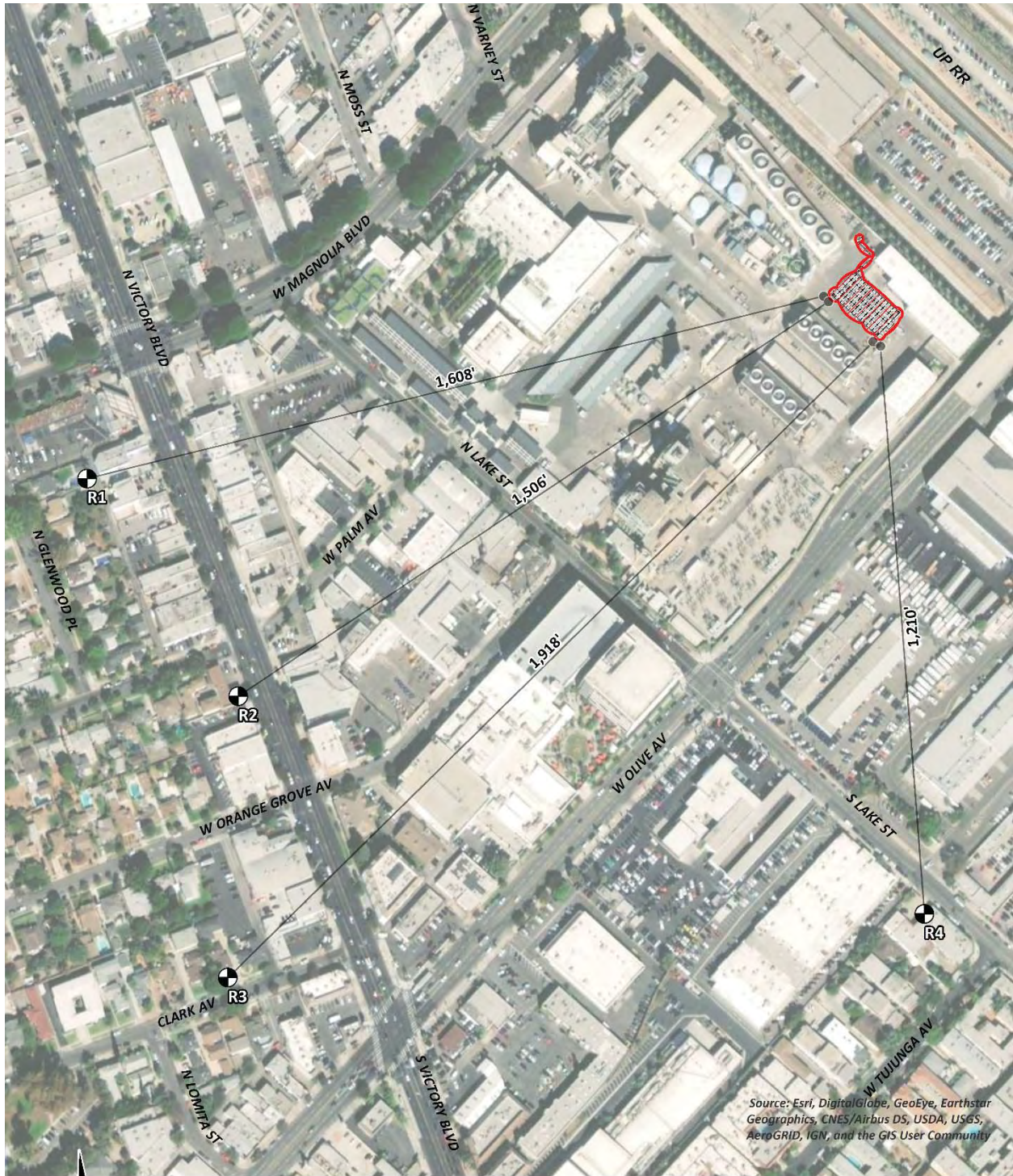

LEGEND:

- ⊕ Receiver Locations
- ▨ Construction Activity
- Distance from receiver to construction activity (in feet)

7.4 CONSTRUCTION NOISE LEVELS OF SIGNIFICANCE

The construction noise analysis shows that the highest construction noise levels will occur when construction activities take place at the edge of the Project site boundaries. As shown on Table 7-8, the unmitigated construction noise levels are expected to range from 25.6 to 35.5 dBA L_{eq} at the sensitive receiver locations in the City of Burbank.

TABLE 7-8: UNMITIGATED CONSTRUCTION EQUIPMENT NOISE LEVEL SUMMARY (DBA L_{EQ})

Receiver Location ¹	Construction Phase Hourly Noise Level (dBA Leq)						Highest Noise Levels ²
	Demolition	Site Preparation	Grading	Building Construction	Paving	Architectural Coating	
R1	32.8	29.0	29.0	33.0	30.7	27.1	33.0
R2	33.3	29.6	29.6	33.6	31.3	27.7	33.6
R3	31.2	27.5	27.5	31.5	29.2	25.6	31.5
R4	35.2	31.5	31.5	35.5	33.2	29.6	35.5

¹ Noise receiver locations are shown on Exhibit 7-A.

² Estimated construction noise levels based on the highest reference noise level of each stage.

The results of the construction noise analysis show that the unmitigated construction noise levels will approach 35.5 dBA L_{eq} at these noise-sensitive receiver locations. Per the City of Burbank General Plan Noise Element, *construction noise that occurs between the hours of 7 a.m. and 7 p.m. Monday through Friday and 8 a.m. to 5 p.m. on Saturday is exempt from applicable noise standards. With this regulatory exemption, the City acknowledges that construction noise is an acceptable public nuisance when conducted during the least noise-sensitive hours of the day. The City also acknowledges that construction noise could cause a substantial temporary increase in the ambient noise environment at nearby noise-sensitive receptors if construction occurs during the more noise-sensitive hours (i.e., evening, nighttime, early morning), or if construction equipment is not properly equipped with noise control devices.*

In addition to the exemption for construction noise, the Project construction noise levels of up to 35.5 dBA L_{eq} are shown to remain below the Noise Element Table N-4 stationary-source noise level limits for noise-sensitive land uses of 55 dBA L_{eq} during the daytime hours. Moreover, ambient noise levels in the Project study area were measured during the daytime hours when construction would normally take place and ranged from 54.0 to 71.4 dBA L_{eq} . Since Project construction noise levels are shown to approach up to 35.5 dBA L_{eq} , they would not be high enough to increase overall ambient conditions by *barely perceptible* levels. In order for the Project construction noise levels to increase ambient noise level conditions by 3 dBA L_{eq} , or a *barely perceptible* increase, the noise source (i.e., construction noise) would need to be equal to that of the ambient.

7.5 CONSTRUCTION VIBRATION ASSESSMENT

This analysis focuses on the potential ground-borne vibration associated with vehicular traffic and construction activities. Ground-borne vibration levels from automobile traffic are generally overshadowed by vibration generated by heavy trucks that roll over the same uneven roadway surfaces. However, due to the rapid drop-off rate of ground-borne vibration and the short duration of the associated events, vehicular traffic-induced ground-borne vibration is rarely perceptible beyond the roadway right-of-way, and rarely results in vibration levels that cause damage to buildings in the vicinity.

However, while vehicular traffic is rarely perceptible, construction has the potential to result in varying degrees of temporary ground vibration, depending on the specific construction activities and equipment used. Ground vibration levels associated with various types of construction equipment are summarized on Table 7-9. Based on the representative vibration levels presented for various construction equipment types, it is possible to estimate potential vibration impacts with the following vibration assessment methods defined by the FTA. To describe potential vibration impacts the FTA provides the following equation: $PPV_{\text{equip}} = PPV_{\text{ref}} \times (25/D)^{1.5}$

TABLE 7-9: VIBRATION SOURCE LEVELS FOR CONSTRUCTION EQUIPMENT

Equipment	PPV (in/sec) at 25 feet
Small bulldozer	0.003
Jackhammer	0.035
Loaded Trucks	0.076
Large bulldozer	0.089

Source: Federal Transit Administration, Transit Noise and Vibration Impact Assessment, September 2018.

7.6 CONSTRUCTION VIBRATION IMPACTS

Construction activity can result in varying degrees of ground vibration, depending on the equipment and methods used, distance to the affected structures and soil type. The proposed Project’s construction activities most likely to cause vibration impacts are:

- Heavy Construction Equipment: Although all heavy mobile construction equipment has the potential of causing at least some perceptible vibration while operating close to buildings, the vibration is usually short-term and is not of sufficient magnitude to cause building damage.
- Trucks: Trucks hauling building materials to construction sites can be sources of vibration intrusion if the haul routes pass through residential neighborhoods on streets with bumps or potholes. Repairing the bumps and potholes generally eliminates the problem.

Ground-borne vibration levels resulting from construction activities occurring within the Project site were estimated by data published by the Federal Transit Administration. Construction activities that would have the potential to generate low levels of ground-borne vibration within the Project site include grading. Using the vibration source level of construction equipment

provided on Table 7-9 and the construction vibration assessment methodology published by the FTA, it is possible to estimate the Project vibration impacts. Table 7-10 presents the expected Project related vibration levels at each of the sensitive receiver locations.

Based on the reference vibration levels provided by the Federal Transit Administration, a large bulldozer represents the peak source of vibration with a reference velocity of 0.089 in/sec peak-particle-velocity (PPV) at 25 feet. At distances ranging from 1,210 to 1,918 feet from primary Project construction activities, construction vibration velocity levels are expected to range from 0.0001 to 0.0003 in/sec PPV, as shown on Table 7-10. Based on the Caltrans older residential building damage threshold of 0.3 in/sec PPV, the proposed Project construction activities would result in vibration levels which are anticipated to remain below the threshold for building damage, and therefore, represents a *less than significant* impact.

TABLE 7-10: CONSTRUCTION EQUIPMENT VIBRATION LEVELS

Receiver ¹	Distance to Const. Activity (Feet)	Reference Vibration Levels @ 25' & Resulting Vibration at Receiver Locations (in/sec) ²					Threshold Exceeded? ³
		Small Bulldozer (0.003 in/sec)	Jack-Hammer (0.035)	Loaded Trucks (0.076)	Large Bulldozer (0.089)	Peak Vibration Levels	
R1	1,608'	0.0000	0.0001	0.0001	0.0002	0.0002	No
R2	1,506'	0.0000	0.0001	0.0002	0.0002	0.0002	No
R3	1,918'	0.0000	0.0001	0.0001	0.0001	0.0001	No
R4	1,210'	0.0000	0.0001	0.0002	0.0003	0.0003	No

¹ Receiver locations are shown on Exhibit 7-A.

² Based on the FTA's Vibration Source Levels of Construction Equipment previously shown on Table 7-9 at a reference distance of 25 feet. Calculated using the following equation per FTA guidance: $PPV_{equip} = PPV_{ref} \times (25/D)^{1.5}$

Where "PPV_{equip}" = the vibration level at the receiver; "PPV_{ref}" = the reference vibration level at 25 feet; and "D" = the distance to each receiver location.

³ Does the peak vibration exceed the maximum acceptable vibration threshold?

8 REFERENCES

1. **State of California.** *California Environmental Quality Act, Appendix G.* 2018.
2. **California Department of Transportation Environmental Program.** *Technical Noise Supplement - A Technical Supplement to the Traffic Noise Analysis Protocol.* Sacramento, CA : s.n., September 2013.
3. **Environmental Protection Agency Office of Noise Abatement and Control.** *Information on Levels of Environmental Noise Requisite to Protect Public Health and Welfare with an Adequate Margin of Safety.* March 1974. EPA/ONAC 550/9/74-004.
4. **U.S. Department of Transportation, Federal Highway Administration, Office of Environment and Planning, Noise and Air Quality Branch.** *Highway Traffic Noise Analysis and Abatement Policy and Guidance.* June, 1995.
5. **U.S. Department of Transportation, Federal Highway Administration.** *Highway Traffic Noise in the United States, Problem and Response.* April 2000. p. 3.
6. **U.S. Environmental Protection Agency Office of Noise Abatement and Control.** *Noise Effects Handbook-A Desk Reference to Health and Welfare Effects of Noise.* October 1979 (revised July 1981). EPA 550/9/82/106.
7. **Occupational Safety and Health Administration.** *Standard 29 CFR, Part 1910.*
8. **Center for Disease Control and Prevention.** About Hearing Loss. [Online] [Cited: 04 15, 2016.] <http://www.cdc.gov/healthyschools/noise/signs.htm>.
9. **U.S. Department of Transportation, Federal Transit Administration.** *Transit Noise and Vibration Impact Assessment.* May 2006. FTA-VA-90-1003-06.
10. **Office of Planning and Research.** *State of California General Plan Guidelines.* 2018.
11. **City of Burbank.** *General Plan.* February 2013.
12. **American National Standards Institute (ANSI).** *Specification for Sound Level Meters ANSI S1.4-2014/IEC 61672-1:2013.*
13. **Urban Crossroads, Inc.** *Burbank Water and Power Magnolia Campus Drainage Improvement Focused Greenhouse Gas Assessment.* April 2019.

This page intentionally left blank

9 CERTIFICATION

The contents of this noise study report represent an accurate depiction of the noise environment and impacts associated with the proposed Burbank Water and Power Magnolia Campus Drainage Improvement Project. The information contained in this noise study report is based on the best available data at the time of preparation. If you have any questions, please contact me directly at (949) 336-5979.

Bill Lawson, P.E., INCE
Principal
URBAN CROSSROADS, INC.
260 E. Baker Street, Suite 200
Costa Mesa, CA 92626
(949) 336-5979
blawson@urbanxroads.com



EDUCATION

Master of Science in Civil and Environmental Engineering
California Polytechnic State University, San Luis Obispo • December, 1993

Bachelor of Science in City and Regional Planning
California Polytechnic State University, San Luis Obispo • June, 1992

PROFESSIONAL REGISTRATIONS

PE – Registered Professional Traffic Engineer – TR 2537 • January, 2009
AICP – American Institute of Certified Planners – 013011 • June, 1997–January 1, 2012
PTP – Professional Transportation Planner • May, 2007 – May, 2013
INCE – Institute of Noise Control Engineering • March, 2004

PROFESSIONAL AFFILIATIONS

ASA – Acoustical Society of America
ITE – Institute of Transportation Engineers

PROFESSIONAL CERTIFICATIONS

Certified Acoustical Consultant – County of Orange • February, 2011
FHWA-NHI-142051 Highway Traffic Noise Certificate of Training • February, 2013

This page intentionally left blank

APPENDIX 3.1:

CITY OF BURBANK MUNICIPAL CODE

This page intentionally left blank

CHAPTER 3 ENVIRONMENTAL PROTECTION

SECTION:

Article 1. Environmental Quality

- 9-3-101: Environmental Quality; Purpose
- 9-3-102: Definitions
- 9-3-103: State CEQA Guidelines Adopted
- 9-3-104: Departmental Responsibility
- 9-3-105: Director's Responsibility
- 9-3-106: Completion Deadlines
- 9-3-107: Public Notice of Environmental Decision
- 9-3-108: Appeal of Environmental Decision
- 9-3-109: Conflict Determinations
- 9-3-110: through 9-3-117: Reserved
- 9-3-118: Adoption of Los Angeles County Hazardous Waste Management Plan

Article 2. Noise Control

Division 1. General Provisions

- 9-3-201: Declaration of Policy
- 9-3-202: Definitions
- 9-3-203: Decibel Measurement Criteria
- 9-3-204: Emergency Work; Exemption
- 9-3-205: Injunction; Additional Remedy
- 9-3-206: City Attorney Authorized to Take Legal Proceedings

Division 2. Special Noise Sources

- 9-3-207: Animals and Fowl
- 9-3-208: Machinery, Equipment, Fans and Air Conditioning
- 9-3-209: Deleted
- 9-3-210: Vehicle Repairs in Residential Areas
- 9-3-211: Vehicle Operation on Private Property, Etc.
- 9-3-212: Sound Suppression on Gasoline and Gas Engines
- 9-3-213: Radios, Television Sets and Similar Devices
- 9-3-213.5: Radios, Television Sets and Similar Devices in and Adjacent to Park Facilities
- 9-3-214: Restrictions on Leaf Blower Operation

Division 3. Sound Trucks

- 9-3-215: Purpose of Regulation
- 9-3-216: Sound Trucks Must be Registered
- 9-3-217: Disapproval of Registration
- 9-3-218: Amending Registration
- 9-3-219: Copy of Registration to Chief of Police
- 9-3-220: Certified Copy of Registration Must be Carried in Sound Truck
- 9-3-221: Regulations for Use of Sound Trucks

Division 4. Miscellaneous

- 9-3-222: Octave Band Sound Frequency Level Limits
- 9-3-223: Noise Sources Not Specifically Covered
- 9-3-224: Schools, Hospitals and Churches

Article 3. Removal of Graffiti or Other Inscribed Material

- 9-3-301: Purpose
- 9-3-302: Removal of Graffiti or Other Inscribed Material

Article 4. Standard Urban Storm Water and Urban Runoff Management Programs

- 9-3-401: Purpose
- 9-3-402: Applicability
- 9-3-403: General Construction Permit
- 9-3-404: Construction Priority Projects
- 9-3-405: Other Construction Projects
- 9-3-406: Exempt Projects
- 9-3-407: Best Management Practices (BMPs)
- 9-3-408: Permit Issuance
- 9-3-409: Retention of Documents
- 9-3-410: Inspections
- 9-3-411: Enforcement
- 9-3-412: Fees
- 9-3-413: Adoption of the "Standard Urban Storm Water Mitigation Plan for Los Angeles County and Cities in Los Angeles" Issued by the Regional Water Quality Control Board, Los Angeles Region on March 8, 2000
- 9-3-414: Storm Water Pollution Control Measures for Development Planning

Article 5. Model Water Efficient Landscaping Ordinance

- 9-3-500: Adoption of the Water Conservation in Landscaping Act (Assembly Bill 1881) "Model Water Efficient Landscaping Ordinance"

ARTICLE 1. ENVIRONMENTAL QUALITY

9-3-201: DECLARATION OF POLICY:

It is the policy of the City to prohibit unnecessary, excessive and annoying sounds which at certain levels and frequencies are detrimental to the health and welfare of the City's inhabitants and in the public interest must be systematically proscribed. [Formerly Numbered Section 21-20; renumbered by Ord. No. 3058, eff. 2/21/87; 2383, 2338, 2336.]

9-3-202: DEFINITIONS:

Unless the context otherwise clearly indicates, the words and phrases used in this article are defined as follows:

AMBIENT NOISE: The all encompassing noise associated with a given environment, usually being a composite of sounds with many sources near and far, but excluding the noise source being measured.

A-WEIGHTED LEVEL OR "A": Used in conjunction with dB is the total sound level of all noise as measured with a sound level meter using the A-weighting network as defined in American National Standards Specification for sound level meters S1.4-1971. The unit is the dBA.

BAND PRESSURE LEVEL: "Band pressure level" of a sound for a specified frequency band is the sound pressure level for the sound contained within the restricted band.

CYCLE: The complete sequence of values of a periodic quantity which occurs during a period.

DAYTIME: The hours from seven o'clock (7:00) A.M. to ten o'clock (10:00) P.M.

DECIBEL OR dB: A unit of level which denotes the ratio between two (2) quantities which are proportional to power; the number of decibels corresponding to the ratio of two (2) amounts of power is ten (10) times the logarithm to the base ten (10) of this ratio.

FREQUENCY: "Frequency" of a function periodic in time is the reciprocal of the primitive period. The unit is hertz and shall be specified.

HERTZ OR Hz: Cycles per second.

MICROBAR: A unit of pressure commonly used in acoustics and is equal to one dyne per square centimeter.

MOTOR VEHICLE: Includes, but shall not be limited to, minibikes and go-carts.

NIGHTTIME: The hours from ten o'clock (10:00) P.M. until seven o'clock (7:00) A.M. of the following day.

NOISE: Includes all sound.

PERIOD: "Period" of a periodic quantity is the smallest increment of time for which the function repeats itself.

PERIODIC QUANTITY: Oscillating quantity, the values of which recur for equal increments of time.

SOUND AMPLIFYING EQUIPMENT: Any machine or device for the amplification of the human voice, music, or any other sound, but shall not include standard automobile radios when used and heard only by the occupants of the vehicle in which the automobile radio is installed, and as used in this chapter shall not include warning devices on authorized emergency vehicles or horns or other warning devices on any vehicle used only for traffic safety purposes.

SOUND ANALYZER: A device for measuring the band pressure level or pressure spectrum level of a sound as a function of frequency.

SOUND LEVEL METER: An instrument including a microphone, an amplifier, an output meter, and frequency weighting networks for the measurement of noise and sound levels in a specified manner.

SOUND PRESSURE LEVEL: "Sound pressure level" of a sound, in decibels, is twenty (20) times the logarithm to the base ten (10) of the ratio of the pressure of the sound to the reference pressure, which for the purposes of this chapter shall be 0.0002 microbars.

SOUND TRUCK: Any vehicle regardless of motive power, whether in motion or stationary, having mounted thereon, or attached thereto, any sound amplifying equipment.

SPECTRUM: "Spectrum" of a function of time is a description of its resolution into components, each of a different frequency or frequency band. [Formerly Numbered Section 21-21; Renumbered by Ord. No. 3058, eff. 2/21/87; 2383.]

9-3-203: DECIBEL MEASUREMENT CRITERIA:

A. Any decibel measurement made pursuant to the provisions of this article shall be based on a reference sound pressure of 0.0002 microbars as measured in any octave band with center frequency, in hertz, as follows: 31.5, 63, 125, 250, 500, 1,000, 2,000, 4,000 and 8,000 or as measured with a sound level meter using the A-weighting, and using the slow meter response.

B. Unless otherwise provided, measurements shall be taken with the microphone located at any point on the property line of the noise source, but no closer than five feet (5') from any wall or vertical obstruction and not less than five feet (5') above ground level whenever possible. In no case shall such measurements be taken at less than three feet (3'). When measurements are taken at less than five feet (5'), the distance shall be recorded and appropriate corrections to the reading may be applied.

C. A minimum of three (3) readings shall be taken at two (2) minute intervals. The sound level shall be the average of these readings.

D. Sound pressure levels shall be measured with a sound level meter and an octave band analyzer that conform to specifications published by the American National Standards Institute. (American Standard Sound Level Meters for Measurement of Noise and Other Sounds, S1.4-1971 American National Standards Institute, New York, New York, and American Standard Specification for octave, half octave and third octave band filter set for the analysis of noise and other sounds, S1.11-1966, American National Standards Institute, New York, New York, shall be used.) [Formerly Numbered Section 21-22; Renumbered by Ord. No. 3058, eff. 2/21/87; 2383.]

9-3-204: EMERGENCY WORK; EXEMPTION:

This article shall not apply to emergency work necessary to restore property to a safe condition following a public calamity, or work required to protect persons or property from an imminent exposure to danger, or work by a private or public utility when restoring utility service. [Formerly Numbered Section 21-23; Renumbered by Ord. No. 3058, eff. 2/21/87; 2383.]

9-3-205: INJUNCTION; ADDITIONAL REMEDY:

The operation or maintenance of any device, instrument, vehicle or machinery in violation of any provision of this article, which causes discomfort or annoyance to reasonable persons of normal sensitiveness or which endangers the comfort, repose, health or peace of residents in the area shall be deemed, and is declared to be, a public nuisance and may be subject to summary abatement by a restraining order or injunction issued by a court of competent jurisdiction. This is not intended to preclude resort to any other legal remedy. [Formerly Numbered Section 21-24; Renumbered by Ord. No. 3058, eff. 2/21/87; 2383.]

9-3-206: CITY ATTORNEY AUTHORIZED TO TAKE LEGAL PROCEEDINGS:

The City Attorney, upon request of the Building Director, is authorized to institute necessary legal proceedings to enforce the provisions of this article. [Formerly Numbered Section 21-25; Renumbered by Ord. No. 3058, eff. 2/21/87; 2383.]

DIVISION 2. SPECIAL NOISE SOURCES

9-3-207: ANIMALS AND FOWL:

A. No person shall keep or maintain upon any premises owned, occupied or controlled by him any animal or fowl which, by any sound, cry or behavior, shall cause discomfort or annoyance to a reasonable person of normal sensitiveness in any residential area.

B. A violation of this section shall constitute an infraction. [Formerly Numbered Section 21-30; Renumbered by Ord. No. 3058, eff. 2/21/87; 2749, 2383.]

9-3-208: MACHINERY, EQUIPMENT, FANS AND AIR CONDITIONING:

A. Decibel Limit: No person shall operate any machinery, equipment, pump, fan, air conditioning apparatus, or similar mechanical device in such a manner as to cause the ambient noise level to be exceeded by more than five (5) decibels. In the case of leaf blowers, as defined by Section 9-3-214 of this article, the ambient noise level may not be exceeded by more than twenty (20) decibels.

B. Ambient Noise Base Level: For the purposes of this section only, all ambient noise measurements shall commence at the following ambient noise base levels in the zones and during the times shown:

Base Levels	Time	Zone
45 dBA	Nighttime	Residential
55 dBA	Daytime	Residential
65 dBA	Anytime	Commercial
70 dBA	Anytime	All other zones

Accordingly, and by way of illustration, the ambient noise level in commercial zones shall be deemed to be sixty five (65) dBA notwithstanding a lower reading; provided, however, that when the ambient noise base level for the property on which the machinery, equipment, pump, fan, air conditioning apparatus or similar mechanical device is located is higher than the ambient noise base level for adjacent property, the ambient noise base level for the adjacent property shall apply. Properties separated by a street shall be deemed to be adjacent to one another.

C. Exception For Home Air Conditioners: Air conditioning appliances and equipment installed on or before June 1, 1972, in residences in residential zones may be operated until January 1, 1974, between the hours of eight o'clock (8:00) A.M. and ten o'clock (10:00) P.M. without complying with the decibel limits prescribed in this section. [Formerly Numbered Section 21-31; Renumbered by Ord. No. 3058, eff. 2/21/87; 3122, 2383, 2361.]

9-3-209: CONSTRUCTION IN RESIDENTIAL AREAS; EXCEPTION:

[Deleted by Ord. No. 3797, eff. 12/3/10; Formerly Numbered Section 21-32; Renumbered by Ord. No. 3058, eff. 2/21/87; Amended by Ord. 3588, eff. 11/3/01; 2383.]

9-3-210: VEHICLE REPAIRS IN RESIDENTIAL AREAS:

It is unlawful for any person in a residential zone of the City, or within a radius of five hundred feet (500') from any residential zone, to repair, rebuild or test any motor vehicle during the nighttime in such manner that a reasonable person of normal sensitiveness residing in the zone is caused discomfort or annoyance. [Formerly Numbered Section 21-33; Renumbered by Ord. No. 3058, eff. 2/21/87; 2383.]

9-3-211: VEHICLE OPERATION ON PRIVATE PROPERTY, ETC.:

No person shall operate any motor driven vehicle within the City in such manner that a reasonable person of normal sensitiveness residing in the area where the vehicle is being operated is caused discomfort or annoyance. This section shall apply only if the operation of the vehicle is not regulated by State law. [Formerly Numbered Section 21-34; Renumbered by Ord. No. 3058, eff. 2/21/87; 2383.]

9-3-212: SOUND SUPPRESSION ON GASOLINE AND GAS ENGINES:

No person having charge or control of any engine in which gas, gasoline, distillate or other similar substance is used as a motive power, shall run or operate such engine without having the exhaust pipe thereof connected with an underground air chamber or having attached to such exhaust pipe a muffler or other device so constructed as to deaden the sound of the exhaust of

such engine and effectually prevent such exhaust from making any loud noise or disturbing the peace and quiet of persons in its vicinity. This section shall apply to the engine of a motor vehicle only if its exhaust equipment is not regulated by State law. [Formerly Numbered Section 21-35; Renumbered by Ord. No. 3058, eff. 2/21/87; 2383.]

9-3-213: RADIOS, TELEVISION SETS AND SIMILAR DEVICES:

A. Disturbing Residents: No person shall use or operate any radio receiving set, musical instrument, phonograph, television set or other machine or device for the producing or reproducing of sound in such manner as to disturb the peace, quiet, and comfort of neighboring residents or any reasonable person of normal sensitiveness residing in the area.

B. Prima Facie Violation: Any noise causing the ambient noise level to be exceeded by more than five (5) decibels shall be deemed to be prima facie evidence of a violation of this section. Noise measurements shall be taken within any adjoining apartment if the radio receiving set, musical instrument, phonograph, television set or other machine or device is in an apartment house, condominium or other multiple dwelling. [Formerly Numbered Section 21-36; Renumbered by Ord. No. 3058, eff. 2/21/87; 2383.]

9-3-213.5: RADIOS, TELEVISION SETS AND SIMILAR DEVICES IN AND ADJACENT TO PARK FACILITIES:

A. Disturbing Residents: No person in a park (including public parking lots) or on a right of way adjacent to a park shall use or operate any radio receiving set, musical instrument, phonograph, television set or other machine or device for the producing or reproducing of sound or other sound amplification systems in such manner as to disturb the peace, quiet, and comfort of neighboring residents or any reasonable person of normal sensitiveness residing in the area.

B. Prima Facie Violation: Any person who operates or permits the operation of an outdoor sound amplification device which can be heard seventy five feet (75') or more away: 1) from the closest boundary of the park, when the source of the noise is within the boundaries of a park; or 2) from the actual source of the noise, when the source is of noise is located in the right of way adjacent to a park; shall be deemed to be prima facie evidence of a violation of this section.

C. Exceptions: This prohibition shall not apply to a park permit or other City approval that expressly authorizes the use of outdoor sound amplification devices. [Added by Ord. No. 3642, eff. 7/24/04.]

9-3-214: RESTRICTIONS ON LEAF BLOWER OPERATION:

A. Definitions:

LEAF BLOWER: Any machine however powered used to blow leaves, dirt and other debris off sidewalks, driveways, lawns and other surfaces.

PARCEL: An area of real property with a separate and distinct number or other designation shown on a plat recorded in the office of the County Recorder. Contiguous parcels owned by the same individual or entity shall be considered one parcel for the purposes of this section.

B. Time Restrictions: No person shall operate a leaf blower within a residential zone or within two hundred feet (200') of a residential zone between the hours of six o'clock (6:00) P.M. to eight o'clock (8:00) A.M.

C. Duration of Use: No person shall operate any leaf blower within a residential zone or within two hundred feet (200') of a residential zone for more than fifteen (15) minutes per hour on parcels less than one-half (1/2) acre and no more than thirty (30) minutes per hour on parcels greater than one-half (1/2) acre.

D. Number of Leaf Blowers: No person shall operate more than one leaf blower per parcel within any residential zone or within two hundred feet (200') of a residential zone.

E. Debris Restriction: No person shall operate any leaf blower within the City in such a way as to blow leaves, dirt, and other debris on to adjoining properties and public rights of way and to allow the material to remain there for more than fifteen (15) minutes. [Added by Ord. No. 3122; Formerly Numbered Section 21-37; Renumbered by Ord. No. 3058, eff. 2/21/87; 2383.]

DIVISION 3. SOUND TRUCKS

9-3-215: PURPOSE OF REGULATION:

The Council recognizes that the use of sound amplifying equipment when operated for free speech purposes is protected by the constitutional rights of freedom of speech and assembly, but nevertheless feels obligated to reasonably regulate the use of such equipment in order to protect the correlative constitutional rights of those who wish privacy and freedom from the nuisance of loud and unnecessary noise. [Formerly Numbered Section 21-40; Renumbered by Ord. No. 3058, eff. 2/21/87; 2383.]

9-3-216: SOUND TRUCKS MUST BE REGISTERED:

No person shall use a sound truck on the street with its sound amplifying equipment in operation without having first filed a registration statement with the Community Development Department in writing. This registration shall be filed in triplicate and shall state the following:

- A. Name and home address of the registrant;
- B. Address and place of business of registrant;
- C. License number and motor number of the sound truck to be used by registrant;
- D. Name, address and telephone number of person who owns the sound truck;
- E. Name, address and telephone number of person having direct charge of the sound truck;
- F. Names and addresses of all persons who will use or operate the sound truck;
- G. The purpose for which the sound truck will be used;
- H. A general statement as to the section or sections of the City in which the sound truck will be used;
- I. The proposed hours of operation of the sound truck;
- J. The number of days of proposed operation of the sound truck;
- K. A general description of the sound truck amplifying equipment which is to be used;
- L. The maximum sound producing power of the sound amplifying equipment, expressed in decibels at a reference distance of thirty feet (30'); and
- M. Whether the sound amplifying equipment will be used for commercial or noncommercial purposes. [Formerly Numbered Section 21-41; Renumbered by Ord. No. 3058, eff. 2/21/87; Amended by Ord. No. 3828, eff. 8/24/12; 2383, 2338, 2336, 2194.]

9-3-217: DISAPPROVAL OF REGISTRATION:

The Community Development Department shall accept such registration unless the Community Development Director finds that the regulations for the use of sound trucks set forth in Section

9-3-221 of this article would be violated in whole or part. If the registration is disapproved, the reasons for disapproval shall be endorsed on the statement and it shall be returned to the applicant forthwith. [Formerly Numbered Section 21-42; Renumbered by Ord. No. 3058, eff. 2/21/87; Amended by Ord. No. 3828, eff. 8/24/12; 2383.]

9-3-218: AMENDING REGISTRATION:

All persons using sound trucks shall amend any registration statement filed pursuant to this article within forty eight (48) hours after any change in the information therein furnished. [Formerly Numbered Section 21-44; Renumbered by Ord. No. 3058, eff. 2/21/87; 2383, 2338, 2336.]

9-3-219: COPY OF REGISTRATION TO CHIEF OF POLICE:

The Community Development Department shall furnish the Chief of Police with a copy of such registration statement and all amendments thereto. [Formerly Numbered Section 21-45; Renumbered by Ord. No. 3058, eff. 2/21/87; Amended by Ord. No. 3828, eff. 8/24/12; 2383, 2338, 2336, 2194.]

9-3-220: CERTIFIED COPY OF REGISTRATION MUST BE CARRIED IN SOUND TRUCK:

The Community Development Department shall return to each registrant hereunder one copy of said registration statement duly certified as a correct copy of said registration. Said certified copy of the registration shall be in the possession of any person operating the sound truck at all times while the sound truck's sound amplifying equipment is in operation, and said copy shall be promptly displayed and shown to any police officer or Community Development Director of the City upon request. [Formerly Numbered Section 21-46; Renumbered by Ord. No. 3058, eff. 2/21/87; Amended by Ord. No. 3828, eff. 8/24/12; 2383, 2338, 2336, 2194.]

9-3-221: REGULATIONS FOR USE OF SOUND TRUCKS:

All persons using sound trucks with sound amplifying equipment in operation shall be subject to the following regulations:

- A. The only sound permitted is music or human speech or both;
- B. The human speech and music amplified shall not be obscene, profane, lewd, indecent, vulgar, or slanderous, nor shall such music or speech induce, request, or incite any persons to injure or damage persons or property, or to do any illegal act;
- C. Sound shall not be issued within three hundred feet (300') of any hospital, church, courthouse, or school;
- D. No sound emanating from sound amplifying equipment shall exceed fifteen (15) dBA above the ambient noise level as measured at the property line of the affected property;
- E. Sound amplifying equipment shall not be operated between the hours of nine o'clock (9:00) P.M. and nine o'clock (9:00) A.M. of the following day during weekdays and at no time on Sundays;
- F. No sound truck with its amplifying equipment in operation shall be operated when:
 - 1. The conditions of motor vehicle movement are such that in the opinion of the Chief of Police use of the equipment would constitute a detriment to traffic safety; or
 - 2. The conditions of pedestrian movement are such that use of the equipment would constitute a detriment to traffic safety; and

G. The volume of sound shall be so controlled that it will not be unreasonably loud, raucous, jarring, disturbing or a nuisance to reasonable persons of normal sensitiveness within the area of audibility. [Formerly Numbered Section 21-47; Renumbered by Ord. No. 3058, eff. 2/21/87; 2383, 2338, 2336.]

DIVISION 4. MISCELLANEOUS

9-3-222: OCTAVE BAND SOUND FREQUENCY LEVEL LIMITS:

A. For those marginal cases where an objectionable noise is clearly audible, but where the measured A-weighted noise level is not violated, sound measurements shall be taken utilizing an octave band sound analyzer and compared to the table on the next page:

Allowable A-Weighted Sound Levels

- 40
- 45
- 50
- 55
- 60
- 65
- 70
- 75

Octave Band Frequency Sound Level Limits (In Decibels) For Each Frequency (In Hz)

31.5	63	125	250	500	1000	2000	4000	8000
61	54	47	42	37	34	31	28	25
64	58	51	46	42	39	36	33	30
57	61	55	51	47	44	41	38	35
70	65	60	55	52	49	46	43	40
73	68	64	60	56	54	51	48	45
76	72	68	64	61	59	56	53	50
79	76	72	69	66	64	61	58	55
82	79	76	73	71	69	66	63	60

Where the A-weighted sound level is between any of the figures shown, octave band frequency sound level limits for such A-weighted sound level shall be determined by proportionally adjusting the figures shown to the nearest whole figure.

B. Any measured sound pressure level in any octave band exceeding the noise limits prescribed above, as adjusted using the following table, is prohibited:

Condition	Adjustment To Be Added To Values Given (Decibels)
Steady audible tone such as hum, whine, or screech	Minus 5
Continuous impulsive noise such as hammering or riveting	Minus 5
Noise occurring more than 5 but less than 15 minutes per hour	Plus 5
Noise occurring more than 1 but less than 5 minutes per hour	Plus 10

Condition	Adjustment To Be Added To Values Given (Decibels)
Noise occurring less than 1 minute per hour	Plus 20

[Formerly Numbered Section 21-50; Renumbered by Ord. No. 3058, eff. 2/21/87; 2383.]

9-3-223: NOISE SOURCES NOT SPECIFICALLY COVERED:

Notwithstanding any other provision of this article and in addition thereto, it shall be unlawful for any person to wilfully make or continue any loud, unnecessary or unusual noise which disturbs the peace or quiet of any neighborhood or which causes discomfort or annoyance to any reasonable person of normal sensitiveness residing in the area. The standards which shall be considered in determining whether a violation of this section exists shall include, but not be limited to, the following:

- A. The sound pressure level of the noise;
- B. The octave band sound pressure level of the noise;
- C. Whether the nature of the noise is usual or unusual;
- D. Whether the origin of the noise is natural or unnatural;
- E. The sound pressure level and octave band sound pressure level of the background noise, if any;
- F. The proximity of the noise to residential sleeping facilities;
- G. The nature and zoning of the area within which the noise emanates;
- H. The density of the inhabitation of the area within which the noise emanates;
- I. The time of the day or night when the noise occurs;
- J. The duration of the noise;
- K. Whether the noise is recurrent, intermittent or constant; and
- L. Whether the noise is produced by a commercial or noncommercial activity. [Formerly Numbered Section 21-51; Renumbered by Ord. No. 3058, eff. 2/21/87; 2383.]

9-3-224: SCHOOLS, HOSPITALS AND CHURCHES:

It shall be unlawful for any person to create any noise on any street, sidewalk or public place adjacent to any hospital or to any school, institution of learning or church while the same is in use, which noise unreasonably interferes with the workings of such institution or which disturbs or unduly annoys patients in the hospital, provided conspicuous signs are displayed in such streets, sidewalk or public place indicating the presence of a school, church or hospital. [Formerly Numbered Section 21-52; Renumbered by Ord. No. 3058, eff. 2/21/87; 2383.]

ARTICLE 3. REMOVAL OF GRAFFITI OR OTHER INSCRIBED MATERIAL

APPENDIX 5.1:
STUDY AREA PHOTOS

This page intentionally left blank

JN:12343 Study Area Photos



L1 Northeast
34, 10' 45.750000", 118, 18' 35.140000"



L1 Northwest
34, 10' 45.800000", 118, 18' 35.140000"



L1 Southeast
34, 10' 45.790000", 118, 18' 35.170000"



L1 Southwest
34, 10' 45.850000", 118, 18' 35.170000"



L2 Northeast
34, 10' 33.690000", 118, 18' 50.600000"



L2 Northwest
34, 10' 33.680000", 118, 18' 50.580000"

JN:12343 Study Area Photos



L2 Southeast
34, 10' 33.660000", 118, 18' 50.630000"



L2 Southwest
34, 10' 33.580000", 118, 18' 50.600000"



L3 Northeast
34, 10' 28.390000", 118, 19' 0.520000"



L3 Northwest
34, 10' 28.390000", 118, 19' 0.600000"



L3 Southeast
34, 10' 28.430000", 118, 19' 0.490000"



L3 Southwest
34, 10' 28.460000", 118, 19' 0.710000"

JN:12343 Study Area Photos



L4 Northeast
34, 10' 30.750000", 118, 19' 10.300000"



L4 Northwest
34, 10' 30.710000", 118, 19' 10.380000"



L4 Southeast
34, 10' 30.740000", 118, 19' 10.270000"



L4 Southwest
34, 10' 30.710000", 118, 19' 10.350000"



L5 Northeast
34, 10' 42.880000", 118, 19' 8.100000"



L5 Northwest
34, 10' 43.000000", 118, 19' 7.960000"

JN:12343 Study Area Photos



L5 Southeast
34, 10' 42.890000", 118, 19' 8.070000"



L5 Southwest
34, 10' 42.950000", 118, 19' 8.020000"

APPENDIX 5.2:
NOISE LEVEL MEASUREMENT WORKSHEETS

This page intentionally left blank

24-Hour Noise Level Measurement Summary

Date: Tuesday, April 09, 2019
 Project: Burbank Water & Power Campus

Location: L1 - Located on North First Street, northeast of the Project site, east of the I-5 Highway, adjacent to an existing commercial area.

Meter: Piccolo I

JN: 12343

Analyst: R. Saber

Hourly L_{eq} dBA Readings (unadjusted)

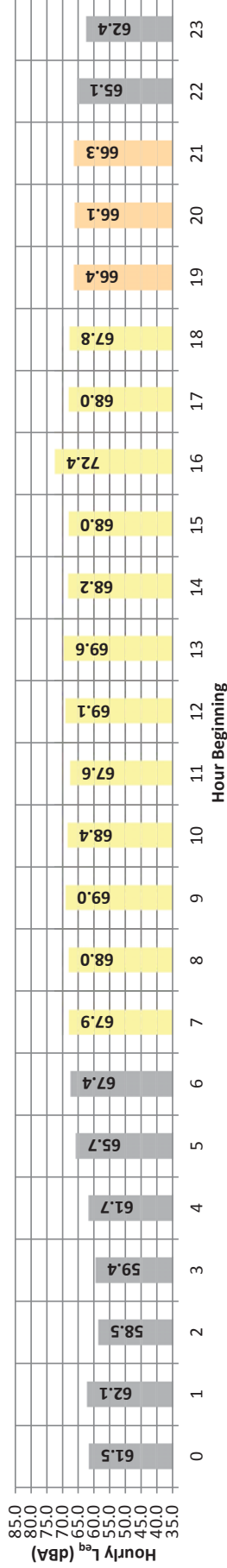

Timeframe	Hour	L_{eq}	L_{max}	L_{min}	Hour Beginning								$L_{99\%}$	L_{eq}	Adj.	Adj. L_{eq}
					L1%	L2%	L5%	L8%	L25%	L50%	L90%	L95%				
Night	0	61.5	81.4	52.2	70.0	68.0	65.0	64.0	60.0	58.0	55.0	54.0	61.5	10.0	71.5	
	1	62.1	87.1	51.0	70.0	67.0	64.0	62.0	58.0	57.0	54.0	52.0	62.1	10.0	72.1	
	2	58.5	82.1	48.9	66.0	64.0	62.0	60.0	57.0	60.0	55.0	51.0	58.5	10.0	68.5	
	3	59.4	76.9	48.4	69.0	67.0	63.0	61.0	58.0	57.0	54.0	50.0	59.4	10.0	69.4	
	4	61.7	78.8	54.8	69.0	67.0	65.0	64.0	61.0	60.0	57.0	56.0	61.7	10.0	71.7	
	5	65.7	79.1	58.8	74.0	73.0	70.0	68.0	65.0	60.0	60.0	60.0	59.0	65.7	10.0	75.7
Day	6	67.4	84.1	59.8	76.0	75.0	71.0	70.0	67.0	64.0	61.0	60.0	67.4	10.0	77.4	
	7	67.9	83.3	58.2	76.0	75.0	72.0	71.0	67.0	65.0	62.0	60.0	67.9	0.0	67.9	
	8	68.0	88.0	57.8	76.0	75.0	72.0	70.0	67.0	65.0	62.0	59.0	68.0	0.0	68.0	
	9	69.0	89.3	59.0	79.0	77.0	73.0	71.0	67.0	65.0	62.0	60.0	69.0	0.0	69.0	
	10	68.4	89.8	59.7	77.0	75.0	72.0	70.0	67.0	65.0	62.0	60.0	68.4	0.0	68.4	
	11	67.6	88.1	59.4	75.0	74.0	71.0	70.0	67.0	65.0	62.0	60.0	67.6	0.0	67.6	
	12	69.1	90.6	60.2	77.0	75.0	72.0	71.0	68.0	66.0	63.0	61.0	69.1	0.0	69.1	
	13	69.6	93.6	39.1	77.0	76.0	74.0	73.0	70.0	64.0	41.0	40.0	40.0	69.6	0.0	69.6
	14	68.2	87.2	59.7	76.0	75.0	72.0	70.0	67.0	65.0	62.0	61.0	68.2	0.0	68.2	
	15	68.0	86.4	59.0	76.0	74.0	71.0	70.0	68.0	66.0	62.0	60.0	68.0	0.0	68.0	
	16	72.4	100.6	59.3	80.0	77.0	73.0	71.0	68.0	65.0	62.0	60.0	72.4	0.0	72.4	
	17	68.0	89.0	58.4	76.0	74.0	72.0	71.0	67.0	65.0	61.0	59.0	68.0	0.0	68.0	
	18	67.8	89.9	57.3	76.0	74.0	71.0	70.0	67.0	65.0	62.0	59.0	67.8	0.0	67.8	
	19	66.4	80.5	58.7	73.0	72.0	70.0	69.0	66.0	64.0	61.0	59.0	66.4	5.0	71.4	
	20	66.1	82.8	57.9	73.0	71.0	70.0	69.0	66.0	64.0	60.0	59.0	66.1	5.0	71.1	
	21	66.3	90.0	56.9	74.0	72.0	70.0	69.0	65.0	63.0	60.0	58.0	66.3	5.0	71.3	
	22	65.1	84.9	54.4	74.0	72.0	69.0	68.0	64.0	62.0	59.0	57.0	65.1	10.0	75.1	
	23	62.4	78.3	54.3	71.0	69.0	67.0	65.0	62.0	60.0	57.0	55.0	62.4	10.0	72.4	
Timeframe	Hour	L_{eq}	L_{max}	L_{min}	L1%	L2%	L5%	L8%	L25%	L50%	L90%	L95%	$L_{99\%}$	L_{eq} (dBA)		
	Day	67.6	83.3	39.1	75.0	74.0	71.0	70.0	67.0	64.0	41.0	40.0	40.0	24-Hour	Daytime	Nighttime
	Energy Average	68.9	Average:	60.2	76.8	75.1	72.1	70.7	67.5	65.1	60.3	59.6	58.3	67.2	68.5	63.5
	Evening	66.1	80.5	56.9	73.0	71.0	70.0	69.0	65.0	63.0	60.0	59.0	58.0	24-Hour CNEL (dBA)	71.5	
Night	Energy Average	66.4	90.0	58.7	74.0	72.0	70.0	69.0	66.0	64.0	61.0	59.0	58.0			
	Energy Average	66.3	Average:	48.4	73.3	71.7	70.0	69.0	65.7	63.7	60.3	60.0	58.7			
Night	Min	58.5	76.9	48.4	66.0	64.0	62.0	60.0	57.0	55.0	53.0	50.0	50.0			
	Max	67.4	87.1	59.8	76.0	75.0	71.0	70.0	67.0	64.0	61.0	60.0	60.0			
Energy Average	63.5	Average:	59.8	71.0	69.1	66.2	64.7	61.3	59.6	56.8	54.9	54.9				



24-Hour Noise Level Measurement Summary

Date: Tuesday, April 09, 2019
 Project: Burbank Water & Power Campus

Location: L2 - Located on West Olive Avenue, southeast of the Project site, adjacent to an existing general industrial area.

Meter: Piccolo I

JN: 12343

Analyst: R. Saber

Hourly L_{eq} dBA Readings (unadjusted)

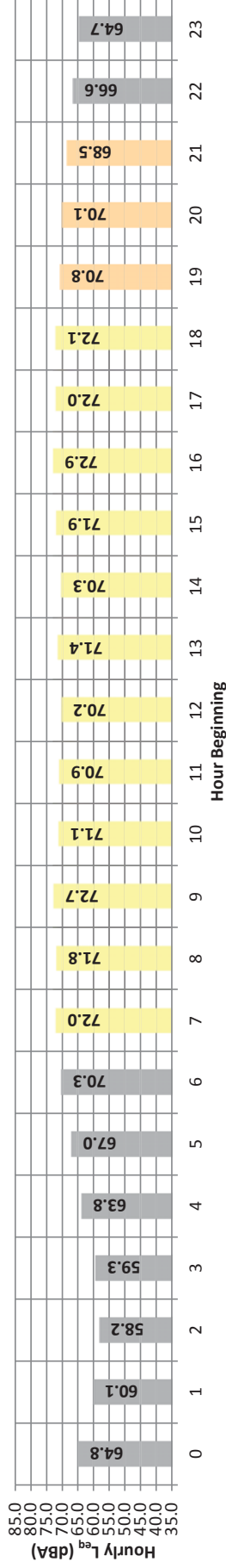

Timeframe	Hour	L _{eq}	L _{max}	L _{min}	Hour Beginning										L _{99%}	L _{eq}	Adj.	Adj. L _{eq}
					L1%	L2%	L5%	L8%	L25%	L50%	L90%	L95%						
Night	0	64.8	87.1	51.7	75.0	72.0	69.0	67.0	61.0	57.0	54.0	53.0	52.0	64.8	10.0	74.8		
	1	60.1	83.2	48.8	71.0	69.0	65.0	63.0	55.0	53.0	50.0	49.0	49.0	60.1	10.0	70.1		
	2	58.2	77.0	49.0	70.0	68.0	64.0	61.0	55.0	53.0	50.0	50.0	49.0	58.2	10.0	68.2		
	3	59.3	79.4	47.1	70.0	68.0	64.0	61.1	56.0	54.0	51.0	50.0	48.0	59.3	10.0	69.3		
	4	63.8	82.1	54.3	73.0	72.0	69.0	67.0	62.0	60.0	57.0	56.0	55.0	63.8	10.0	73.8		
	5	67.0	81.8	54.2	76.0	75.0	73.0	71.0	67.0	62.0	57.0	56.0	54.0	67.0	10.0	77.0		
Day	6	70.3	85.6	51.9	78.0	77.0	76.0	75.0	71.0	69.0	58.0	56.0	53.0	70.3	10.0	80.3		
	7	72.0	89.6	54.5	79.0	78.0	77.0	76.0	73.0	69.0	61.0	59.0	57.0	72.0	0.0	72.0		
	8	71.8	87.2	55.3	78.0	77.0	76.0	75.0	73.0	69.0	61.0	59.0	57.0	71.8	0.0	71.8		
	9	72.7	96.8	55.9	80.0	78.0	76.0	75.0	72.0	69.0	61.0	60.0	57.0	72.7	0.0	72.7		
	10	71.1	89.6	57.8	78.0	77.0	76.0	75.0	72.0	68.0	61.0	60.0	59.0	71.1	0.0	71.1		
	11	70.9	86.2	52.5	78.0	77.0	75.0	75.0	72.0	67.0	60.0	58.0	55.0	70.9	0.0	70.9		
	12	70.2	81.9	51.4	76.0	76.0	75.0	74.0	71.0	68.0	60.0	58.0	54.0	70.2	0.0	70.2		
	13	71.4	93.7	39.7	82.0	78.0	75.0	74.0	71.0	65.0	41.0	41.0	40.0	71.4	0.0	71.4		
	14	70.3	84.7	51.7	77.0	76.0	75.0	74.0	71.0	68.0	60.0	58.0	55.0	70.3	0.0	70.3		
	15	71.9	94.3	53.3	80.0	77.0	75.0	75.0	73.0	69.0	61.0	60.0	57.0	71.9	0.0	71.9		
	16	72.9	98.1	55.8	80.0	78.0	76.0	76.0	73.0	70.0	62.0	60.0	58.0	72.9	0.0	72.9		
	17	72.0	88.2	53.1	78.0	77.0	76.0	75.0	73.0	70.0	63.0	61.0	58.0	72.0	0.0	72.0		
18	72.1	94.2	52.7	78.0	77.0	76.0	75.0	73.0	70.0	61.0	59.0	56.0	72.1	0.0	72.1			
Evening	19	70.8	88.4	56.1	78.0	77.0	75.0	74.0	71.0	68.0	60.0	59.0	57.0	70.8	5.0	75.8		
	20	70.1	87.9	55.1	77.0	76.0	75.0	74.0	71.0	67.0	59.0	58.0	57.0	70.1	5.0	75.1		
	21	68.5	86.1	53.5	76.0	75.0	74.0	73.0	69.0	64.0	57.0	56.0	54.0	68.5	5.0	73.5		
Night	22	66.6	86.6	53.5	75.0	73.0	72.0	71.0	67.0	62.0	56.0	55.0	54.0	66.6	10.0	76.6		
	23	64.7	85.0	53.1	73.0	72.0	70.0	69.0	64.0	59.0	56.0	55.0	55.0	64.7	10.0	74.7		
	24-Hour	L _{eq} (dBA)											L _{99%}	L _{eq} (dBA)	Daytime	Nighttime		
Day	Min	70.2	81.9	39.7	76.0	76.0	75.0	74.0	71.0	65.0	41.0	41.0	40.0	70.0	70.0	71.4	65.4	
	Max	72.9	98.1	57.8	82.0	78.0	77.0	76.0	73.0	70.0	63.0	61.0	59.0	73.5	70.0	71.4	65.4	
Energy Average		Average:			78.7	77.2	75.7	74.8	72.2	68.5	59.3	57.8	55.3	70.0	71.4	65.4		
Evening	Min	68.5	86.1	53.5	76.0	75.0	74.0	73.0	69.0	64.0	57.0	56.0	54.0	70.0	71.4	65.4		
	Max	70.8	88.4	56.1	78.0	77.0	75.0	74.0	71.0	68.0	60.0	59.0	57.0	73.5	71.4	65.4		
Energy Average		Average:			77.0	76.0	74.7	73.7	70.3	66.3	58.7	57.7	56.0	70.0	71.4	65.4		
Night	Min	58.2	77.0	47.1	70.0	68.0	64.0	61.0	55.0	53.0	50.0	49.0	48.0	70.0	71.4	65.4		
	Max	70.3	87.1	54.3	78.0	77.0	76.0	75.0	71.0	67.0	58.0	56.0	55.0	70.0	71.4	65.4		
Energy Average		Average:			73.4	71.8	69.1	67.2	62.0	58.6	54.3	53.3	52.1	70.0	71.4	65.4		
24-Hour CNEL (dBA)																		
73.8																		



24-Hour Noise Level Measurement Summary

Date: Tuesday, April 09, 2019
 Project: Burbank Water & Power Campus

Location: L3 - Located on Victory Boulevard, south of the Project site,
 adjacent to an existing general commercial area.

Meter: Piccolo I

JN: 12343
 Analyst: R. Saber

Hourly L_{eq} dBA Readings (unadjusted)

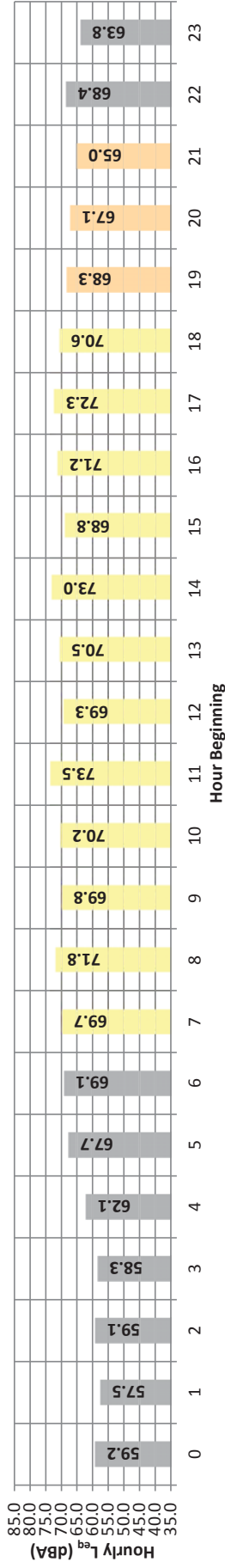

Timeframe	Hour	L_{eq}	L_{max}	L_{min}	Hour Beginning										Adj. L_{eq}		
					L1%	L2%	L5%	L8%	L25%	L50%	L90%	L95%	L99%	L_{eq}		Adj.	
Night	0	59.2	80.3	50.2	69.0	66.0	64.0	63.0	57.0	53.0	52.0	51.0	51.0	50.0	59.2	10.0	69.2
	1	57.5	74.9	50.1	67.0	66.0	63.0	61.0	55.0	53.0	51.0	51.0	51.0	51.0	57.5	10.0	67.5
	2	59.1	84.2	50.3	69.0	66.0	62.0	60.0	54.0	55.0	51.0	52.0	51.0	50.0	59.1	10.0	69.1
	3	58.3	76.8	51.2	69.0	66.0	63.0	61.0	55.0	54.0	52.0	52.0	52.0	51.0	58.3	10.0	68.3
	4	62.1	85.2	53.6	71.0	69.0	66.0	65.0	60.0	57.0	55.0	54.0	54.0	54.0	62.1	10.0	72.1
	5	67.7	89.3	55.7	79.0	75.0	71.0	69.0	65.0	64.0	58.0	57.0	56.0	56.0	56.0	67.7	10.0
Day	6	69.1	94.0	55.0	78.0	77.0	73.0	72.0	67.0	65.0	64.0	64.0	64.0	64.0	69.1	10.0	79.1
	7	69.7	94.2	56.6	78.0	76.0	73.0	72.0	68.0	65.0	60.0	59.0	60.0	57.0	69.7	0.0	69.7
	8	71.8	95.5	57.5	82.0	78.0	75.0	73.0	69.0	66.0	61.0	60.0	60.0	58.0	71.8	0.0	71.8
	9	69.8	87.9	55.2	79.0	77.0	74.0	72.0	69.0	66.0	61.0	60.0	60.0	57.0	69.8	0.0	69.8
	10	70.2	95.5	55.2	79.0	76.0	73.0	71.0	68.0	65.0	60.0	59.0	59.0	57.0	70.2	0.0	70.2
	11	73.5	90.0	55.9	84.0	83.0	80.0	77.0	71.0	68.0	60.0	61.0	60.0	58.0	73.5	0.0	73.5
	12	69.3	88.0	53.9	79.0	76.0	73.0	71.0	68.0	66.0	60.0	60.0	60.0	57.0	69.3	0.0	69.3
	13	70.5	96.4	56.9	78.0	75.0	72.0	71.0	68.0	66.0	60.0	61.0	60.0	58.0	70.5	0.0	70.5
	14	73.0	99.0	53.7	87.0	80.0	74.0	72.0	69.0	65.0	59.0	59.0	58.0	56.0	73.0	0.0	73.0
	15	68.8	87.8	55.0	77.0	75.0	72.0	71.0	69.0	66.0	60.0	59.0	58.0	56.0	68.8	0.0	68.8
	16	71.2	94.0	55.3	82.0	77.0	73.0	72.0	68.0	66.0	60.0	60.0	59.0	57.0	71.2	0.0	71.2
	17	72.3	101.3	55.2	81.0	77.0	74.0	72.0	69.0	67.0	60.0	61.0	60.0	57.0	72.3	0.0	72.3
18	70.6	94.5	55.2	80.0	77.0	74.0	72.0	69.0	66.0	60.0	59.0	59.0	57.0	70.6	0.0	70.6	
Evening	19	68.3	93.8	55.1	75.0	73.0	71.0	70.0	67.0	64.0	59.0	58.0	58.0	56.0	68.3	5.0	73.3
	20	67.1	85.8	54.6	77.0	74.0	71.0	69.0	66.0	63.0	58.0	57.0	56.0	56.0	67.1	5.0	72.1
Night	21	65.0	90.7	53.8	72.0	70.0	68.0	67.0	64.0	61.0	57.0	56.0	54.0	65.0	5.0	70.0	
	22	68.4	96.1	52.4	77.0	74.0	70.0	68.0	64.0	60.0	54.0	54.0	53.0	68.4	10.0	78.4	
Night	23	63.8	93.5	51.1	70.0	68.0	66.0	64.0	60.0	56.0	52.0	52.0	51.0	63.8	10.0	73.8	
	24-Hour	69.2	70.6	64.9	72.1	70.0	68.0	64.8	59.7	56.7	53.6	53.1	52.4	69.2	70.6	64.9	
Day	Energy Average	71.1	Average:	57.5	80.5	77.3	73.9	72.2	68.8	65.9	60.3	59.3	57.1	71.1	71.1	71.1	
	Min	65.0	53.8	53.8	72.0	70.0	68.0	67.0	64.0	61.0	57.0	56.0	54.0	65.0	65.0		
Evening	Max	68.3	93.8	55.1	77.0	74.0	71.0	70.0	67.0	64.0	59.0	58.0	56.0	68.3	68.3		
	Energy Average	67.0	Average:	50.1	74.7	72.3	70.0	68.7	65.7	62.7	58.0	57.0	55.3	67.0	67.0		
Night	Min	57.5	74.9	50.1	67.0	66.0	62.0	60.0	54.0	51.0	51.0	51.0	50.0	57.5	57.5		
	Max	69.1	96.1	55.7	79.0	77.0	73.0	72.0	67.0	64.0	58.0	57.0	56.0	69.1	69.1		
Night	Energy Average	64.9	Average:	55.7	72.1	69.8	66.4	64.8	59.7	56.7	53.6	53.1	52.4	64.9	64.9		
	24-Hour CNEL (dBA)	73.0															



24-Hour Noise Level Measurement Summary

Date: Tuesday, April 09, 2019
 Project: Burbank Water & Power Campus

Location: L4 - Located on Palm Avenue, southwest of the Project site,
 adjacent to an existing residential area.

Meter: Piccolo I

JN: 12343
 Analyst: R. Saber

Hourly L_{eq} dBA Readings (unadjusted)

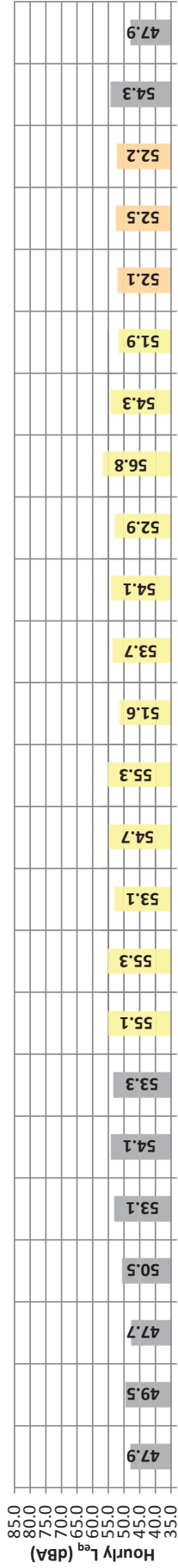

Timeframe	Hour	L_{eq}	L_{max}	L_{min}	Hour Beginning										Adj. L_{eq}	
					L1%	L2%	L5%	L8%	L25%	L50%	L90%	L95%	L99%			
Night	0	47.9	62.5	44.2	52.0	51.0	49.0	49.0	48.0	47.0	45.0	45.0	44.0	44.0	47.9	
	1	49.5	65.3	44.3	56.0	55.0	51.0	51.0	49.0	48.0	46.0	46.0	45.0	45.0	49.5	
	2	47.7	55.2	42.8	51.0	51.0	49.0	49.0	48.0	47.0	45.0	45.0	44.0	44.0	47.7	
	3	50.5	69.1	45.9	53.0	52.0	51.0	51.0	50.0	49.0	48.0	48.0	47.0	47.0	50.5	
	4	53.1	61.3	48.0	56.0	55.0	54.0	54.0	53.0	53.0	50.0	50.0	49.0	49.0	53.1	
	5	54.1	66.5	49.5	61.0	60.0	60.0	57.0	57.0	52.0	52.0	50.0	50.0	50.0	54.1	
Day	6	53.3	69.7	46.8	61.0	60.0	60.0	57.0	53.0	51.0	48.0	48.0	47.0	47.0	53.3	
	7	55.1	79.7	44.9	65.0	62.0	58.0	56.0	52.0	50.0	47.0	46.0	45.0	45.0	55.1	
	8	55.3	77.8	42.7	65.0	63.0	61.0	59.0	53.0	49.0	45.0	44.0	43.0	43.0	55.3	
	9	53.1	72.7	42.3	63.0	61.0	58.0	56.0	51.0	48.0	44.0	44.0	43.0	43.0	53.1	
	10	54.7	74.4	45.3	66.0	64.0	60.0	58.0	51.0	49.0	47.0	46.0	45.0	45.0	54.7	
	11	55.3	79.9	44.1	65.0	62.0	58.0	56.0	51.0	49.0	46.0	46.0	45.0	45.0	55.3	
	12	51.6	68.5	42.2	62.0	60.0	56.0	55.0	50.0	47.0	44.0	44.0	43.0	43.0	51.6	
	13	53.7	67.7	43.7	63.0	62.0	59.0	58.0	53.0	50.0	46.0	46.0	45.0	44.0	53.7	
	14	54.1	73.2	43.5	63.0	62.0	59.0	57.0	53.0	50.0	46.0	46.0	44.0	44.0	54.1	
	15	52.9	68.5	41.2	63.0	62.0	59.0	57.0	51.0	48.0	44.0	44.0	42.0	42.0	52.9	
	16	56.8	75.3	45.9	66.0	64.0	60.0	60.0	55.0	52.0	48.0	48.0	47.0	47.0	56.8	
	17	54.3	73.9	43.1	64.0	63.0	60.0	58.0	52.0	48.0	44.0	44.0	44.0	44.0	54.3	
18	51.9	73.9	43.6	62.0	60.0	56.0	54.0	49.0	47.0	45.0	45.0	44.0	44.0	51.9		
Evening	19	52.1	68.4	47.0	61.0	59.0	56.0	55.0	51.0	50.0	48.0	48.0	47.0	47.0	52.1	
	20	52.5	65.0	46.1	60.0	58.0	55.0	54.0	52.0	51.0	49.0	49.0	48.0	48.0	52.5	
	21	52.2	73.1	46.7	59.0	56.0	54.0	53.0	51.0	50.0	49.0	48.0	48.0	52.2		
Night	22	54.3	73.7	46.1	66.0	63.0	57.0	55.0	51.0	50.0	49.0	48.0	47.0	47.0	54.3	
	23	47.9	60.2	44.3	53.0	51.0	50.0	49.0	48.0	47.0	45.0	45.0	44.0	44.0	47.9	
Timeframe	Hour	L_{eq}	L_{max}	L_{min}	L1%	L2%	L5%	L8%	L25%	L50%	L90%	L95%	L99%	L_{eq} (dBA)		
	Day	Min	67.7	41.2	62.0	60.0	60.0	56.0	49.0	47.0	44.0	43.0	42.0	42.0	24-Hour	Nighttime
Evening	Energy Average	54.3	79.9	45.9	63.9	62.1	58.8	57.0	51.8	48.9	45.6	44.9	44.1	53.2	Daytime	Nighttime
	Min	52.1	65.0	46.1	59.0	56.0	54.0	53.0	51.0	50.0	48.0	48.0	47.0	53.2	54.0	51.7
Night	Max	52.5	73.1	47.0	61.0	59.0	56.0	55.0	52.0	51.0	49.0	49.0	48.0	53.2	54.0	51.7
	Energy Average	52.3	Average:	Average:	60.0	57.7	55.0	54.0	51.3	50.3	48.7	48.3	47.3	47.3	24-Hour CNEL (dBA)	
Night	Min	47.7	55.2	42.8	51.0	51.0	49.0	49.0	48.0	47.0	45.0	44.0	44.0	58.8		
	Max	54.3	73.7	49.5	66.0	63.0	58.0	57.0	53.0	53.0	50.0	50.0	50.0	58.8		
Energy Average	51.7	Average:	Average:	56.6	55.3	53.3	52.3	50.3	49.3	47.3	47.0	46.3	46.3			



24-Hour Noise Level Measurement Summary

Date: Tuesday, April 09, 2019
 Project: Burbank Water & Power Campus

Location: L5 - Located on Victory Boulevard, west of the Project site,
 adjacent to an existing commercial area.

Meter: Piccolo I

JN: 12343
 Analyst: R. Saber

Hourly L_{eq} dBA Readings (unadjusted)

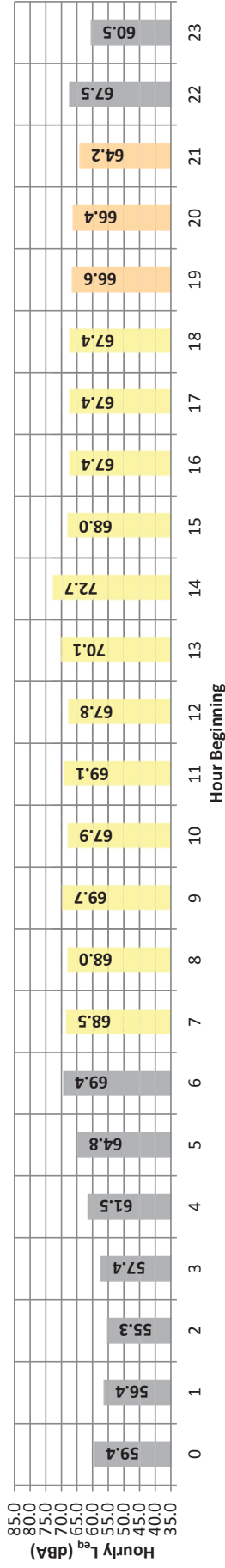

Timeframe	Hour	L _{eq}	L _{max}	L _{min}	Hour Beginning								L _{99%}	L _{eq}	Adj.	Adj. L _{eq}
					L1%	L2%	L5%	L8%	L25%	L50%	L90%	L95%				
Night	0	59.4	81.6	45.9	69.0	67.0	64.0	62.0	55.0	50.0	48.0	47.0	46.0	59.4	10.0	69.4
	1	56.4	74.2	45.2	67.0	66.0	64.0	60.0	60.0	50.0	47.0	47.0	46.0	56.4	10.0	66.4
	2	55.3	76.3	45.2	67.0	64.0	61.0	58.0	50.0	50.0	46.0	46.0	45.0	55.3	10.0	65.3
	3	57.4	78.6	45.8	69.0	66.0	63.0	61.0	54.0	51.0	47.0	47.0	46.0	57.4	10.0	67.4
	4	61.5	84.4	48.9	71.0	69.0	66.0	65.0	59.0	55.0	51.0	50.0	50.0	61.5	10.0	71.5
	5	64.8	83.9	51.2	74.0	72.0	69.0	68.0	64.0	60.0	54.0	53.0	52.0	64.8	10.0	74.8
Day	6	69.4	91.7	54.1	79.0	76.0	73.0	71.0	67.0	64.0	58.0	56.0	55.0	69.4	10.0	79.4
	7	68.5	90.5	55.0	76.0	74.0	72.0	71.0	68.0	66.0	60.0	59.0	57.0	68.5	0.0	68.5
	8	68.0	86.9	54.8	76.0	74.0	72.0	71.0	68.0	65.0	59.0	58.0	56.0	68.0	0.0	68.0
	9	69.7	93.3	55.0	79.0	76.0	73.0	71.0	69.0	66.0	60.0	59.0	57.0	69.7	0.0	69.7
	10	67.9	89.1	53.1	77.0	75.0	72.0	70.0	67.0	65.0	59.0	58.0	56.0	67.9	0.0	67.9
	11	69.1	91.9	54.8	78.0	74.0	72.0	71.0	68.0	66.0	61.0	59.0	56.0	69.1	0.0	69.1
	12	67.8	84.9	54.1	76.0	75.0	72.0	70.0	67.0	65.0	60.0	59.0	57.0	67.8	0.0	67.8
	13	70.1	95.3	54.5	78.0	76.0	72.0	70.0	67.0	65.0	59.0	58.0	56.0	70.1	0.0	70.1
	14	72.7	91.0	51.8	85.0	83.0	78.0	76.0	69.0	66.0	59.0	56.0	54.0	72.7	0.0	72.7
	15	68.0	89.9	51.8	77.0	74.0	71.0	70.0	67.0	65.0	59.0	57.0	54.0	68.0	0.0	68.0
	16	67.4	89.9	52.5	74.0	73.0	71.0	70.0	67.0	65.0	59.0	57.0	55.0	67.4	0.0	67.4
	17	67.4	83.2	52.3	75.0	73.0	71.0	70.0	68.0	65.0	58.0	57.0	55.0	67.4	0.0	67.4
18	67.4	85.7	52.2	76.0	74.0	71.0	70.0	67.0	65.0	59.0	57.0	55.0	67.4	0.0	67.4	
Evening	19	66.6	84.6	52.4	73.0	72.0	70.0	70.0	67.0	65.0	59.0	58.0	55.0	66.6	5.0	71.6
	20	66.4	86.7	51.5	75.0	73.0	70.0	69.0	66.0	63.0	57.0	55.0	53.0	66.4	5.0	71.4
Night	21	64.2	77.7	49.5	71.0	70.0	69.0	65.0	65.0	61.0	55.0	53.0	51.0	64.2	5.0	69.2
	22	67.5	94.8	49.9	72.0	70.0	68.0	67.0	63.0	59.0	52.0	51.0	50.0	67.5	10.0	77.5
24-Hour	23	60.5	77.4	48.3	70.0	69.0	66.0	65.0	60.0	55.0	50.0	49.0	49.0	60.5	10.0	70.5
	Average	69.0	Average:	55.0	77.3	75.1	72.3	70.8	67.7	65.3	59.3	57.8	55.7	67.3	68.5	63.9
Day	Min	67.4	83.2	51.8	74.0	73.0	71.0	70.0	67.0	64.0	58.0	56.0	54.0	67.3	68.5	63.9
	Max	72.7	95.3	55.0	85.0	83.0	78.0	76.0	69.0	66.0	61.0	59.0	57.0	72.7	71.6	70.5
Evening	Min	64.2	77.7	49.5	71.0	70.0	69.0	68.0	65.0	61.0	55.0	53.0	51.0	64.2	5.0	69.2
	Max	66.6	86.7	52.4	75.0	73.0	70.0	70.0	67.0	65.0	59.0	58.0	55.0	66.6	5.0	71.4
Night	Min	55.3	74.2	45.2	67.0	64.0	61.0	58.0	50.0	48.0	46.0	46.0	45.0	55.3	10.0	65.3
	Max	69.4	94.8	54.1	79.0	76.0	73.0	71.0	67.0	64.0	58.0	56.0	55.0	69.4	10.0	79.4
Energy Average		63.9	Average:	48.8	70.9	68.8	65.8	64.1	58.3	54.7	50.3	49.6	48.8	63.9	68.5	63.9
24-Hour CNEL (dBA)														71.7		



This page intentionally left blank

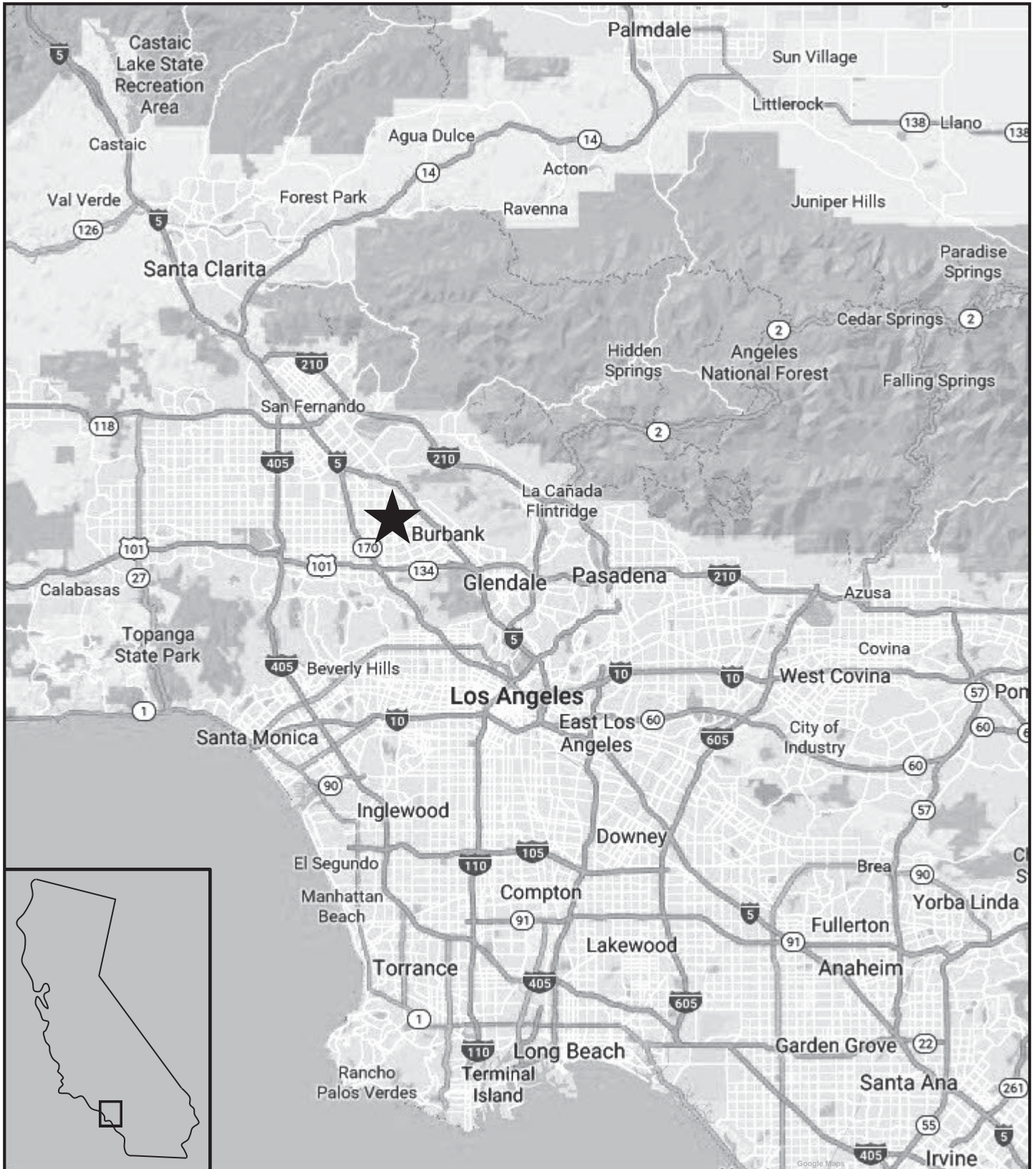

CITY OF BURBANK
 INITIAL STUDY / BURBANK WATER AND POWER CAMPUS PROJECT

Exhibit 1
REGIONAL LOCATION

N

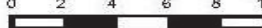
0 2 4 6 8 10 miles



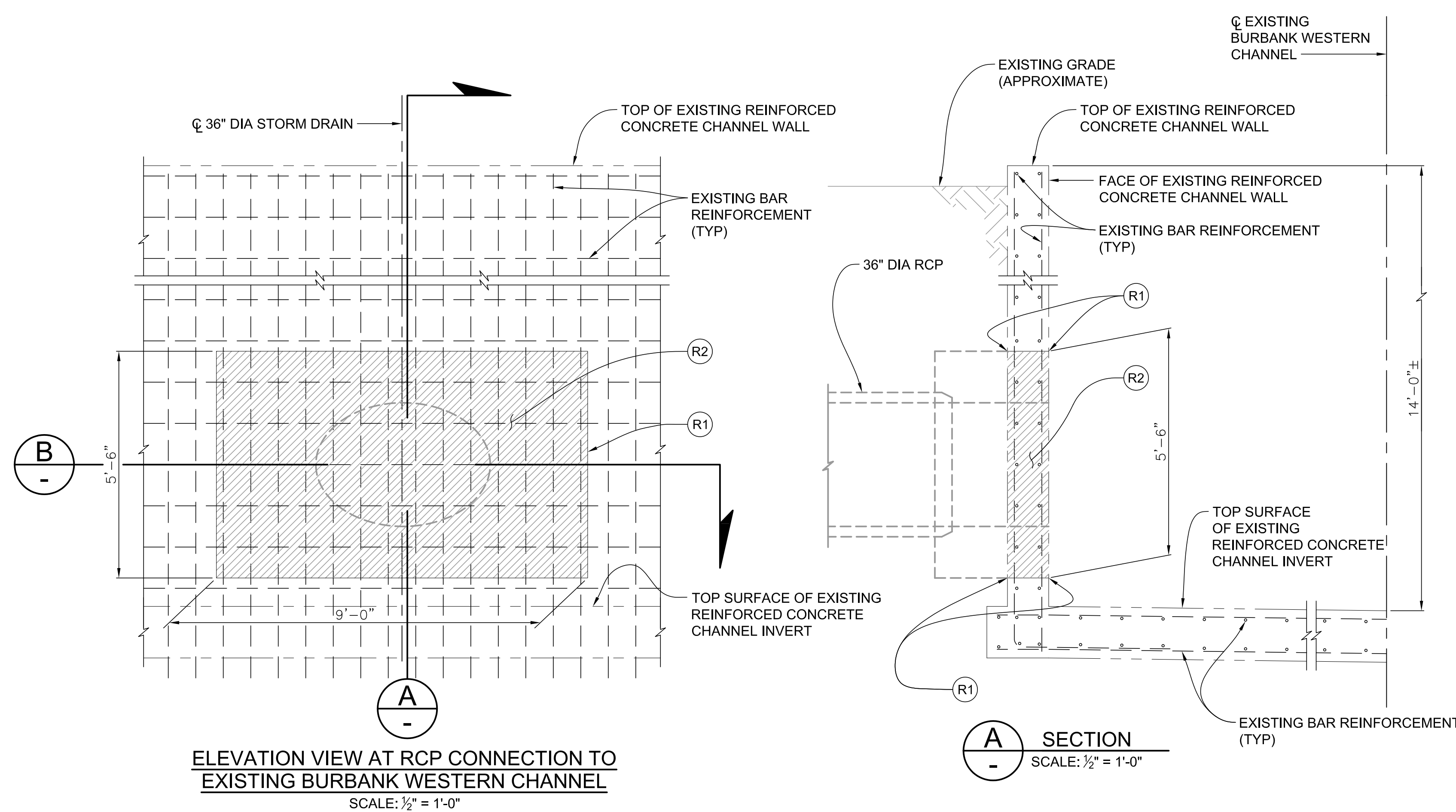

ELEVATION VIEW AT RCP CONNECTION TO EXISTING BURBANK WESTERN CHANNEL
SCALE: 1/2" = 1'-0"

SECTION A
SCALE: 1/2" = 1'-0"

**COUNTY OF LOS ANGELES
CONCRETE REMOVAL NOTES:**

1. A SAWCUT SHALL BE MADE 1 1/2" DEEP AT THE REMOVAL LIMITS. CARE SHALL BE EXERCISED IN SAWING AT THE REMOVAL LIMITS SO AS NOT TO CUT THE REINFORCING STEEL IN THE REMAINING STRUCTURE. THE EXISTING REINFORCING STEEL SHALL BE RETAINED AND EXTENDED INTO THE NEW CONSTRUCTION AS INDICATED IN THE DETAILS SHOWN IN THESE PLANS.
2. USING HANDHELD EQUIPMENT, THE CONCRETE SHALL BE CAREFULLY REMOVED FOR THE FULL DEPTH OF THE WALL.
3. EXISTING REINFORCEMENT SHALL BE CUT SUCH THAT THE EMBEDMENT INTO THE NEW CONSTRUCTION IS MAXIMIZED AND PROVIDES A 6" LONG 90° OR 135° HOOK AT THE BAR END (AS SHOWN).
4. THE REMAINING CONCRETE MAY BE REMOVED BY ANY SUITABLE METHOD UPON APPROVAL OF THE ENGINEER, WHO SHALL BE THE SOLE JUDGE OF THE SUITABILITY OF ANY CONCRETE REMOVAL EQUIPMENT. EXPLOSIVES, WRECKING BALL, OR OTHER SIMILAR DEVICES, WHICH ARE LIKELY TO DAMAGE THE CONCRETE TO BE LEFT IN PLACE, SHALL NOT BE USED.

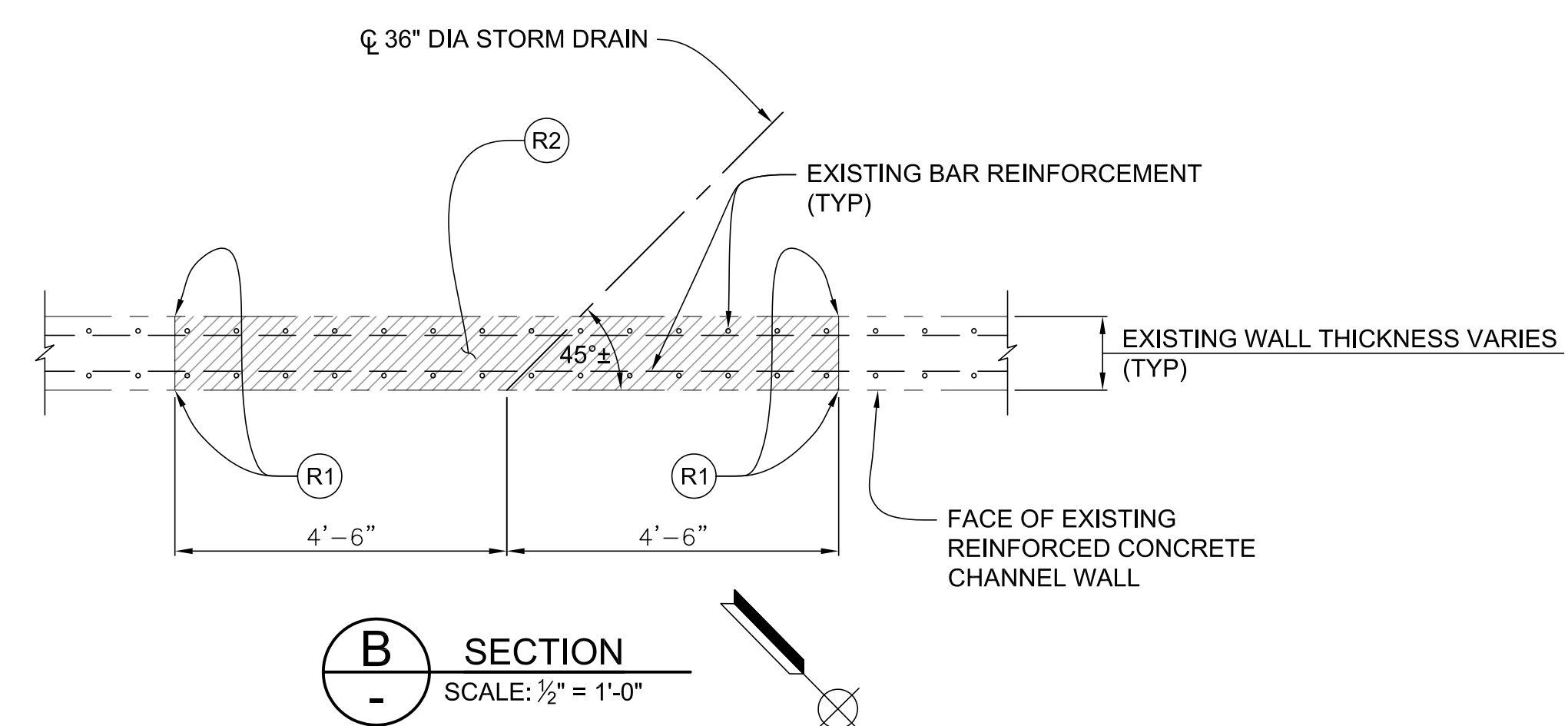

SECTION B
SCALE: 1/2" = 1'-0"

REMOVAL LEGEND:

- (R1) SAWCUT 1 1/2" DEEP ALL-AROUND PERIMETER OF PORTION OF EXISTING CHANNEL WALL TO BE REMOVED
- (R2) REMOVE PORTION OF EXISTING REINFORCED CONCRETE CHANNEL WALL AND PROTECT EXISTING BAR REINFORCEMENT IN PLACE

NOTES:

1. FOR CONSTRUCTION NOTES AND DETAILS, SEE "OFFSITE STRUCTURAL DETAILS 2" SHEET.
2. CONNECT 36 INCH RCP STORM DRAIN TO BURBANK WESTERN CHANNEL AT APPROXIMATE STATION 13+50 PER DRAWING C-02.

LEGEND:

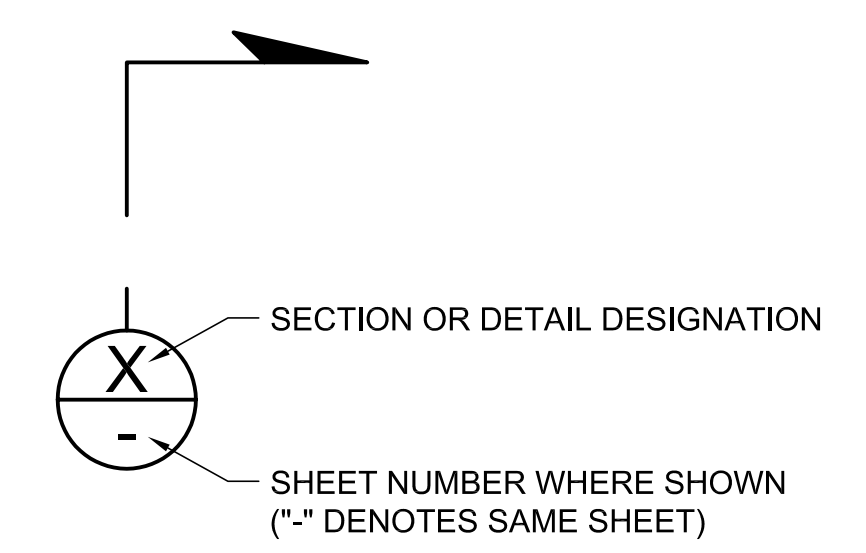

THE CONTRACTOR MUST VERIFY ALL CONTROLLING FIELD DIMENSIONS BEFORE ORDERING OR FABRICATING ANY MATERIAL.



**CHANNEL CONNECTION
REMOVAL DETAILS**

** 100% DRAFT - NOT FOR CONSTRUCTION **



DESIGNED: GLR DATE: MARCH 2021 DRAWN: GLR DATE: MARCH 2021 CHECKED: TNH DATE: _____ REVIEWED: NEP DATE: _____		FIELD BOOK: _____ PAGE NO.: N/A RECOMMENDED: _____ CITY ENGINEER: _____ DATE: _____ APPROVED: _____ PUBLIC WORKS DIRECTOR: _____ DATE: _____	CITY OF BURBANK PUBLIC WORKS DEPARTMENT	OFFSITE STRUCTURAL DETAILS 1 STORM WATER QUALITY IMPROVEMENT PROJECT	S-01 PLAN NO. ST-5124	SHEET 16 OF 23
REVISION	DESCRIPTION	APP	DATE			

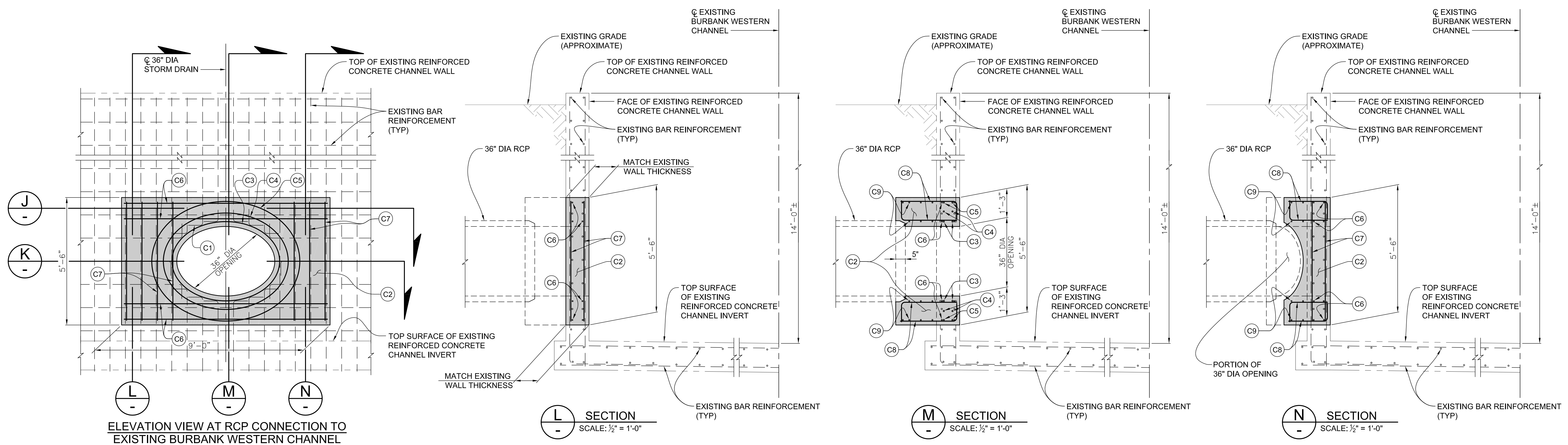

ELEVATION VIEW AT RCP CONNECTION TO EXISTING BURBANK WESTERN CHANNEL
SCALE: 1/2" = 1'-0"

L SECTION
SCALE: 1/2" = 1'-0"

M SECTION
SCALE: 1/2" = 1'-0"

N SECTION
SCALE: 1/2" = 1'-0"

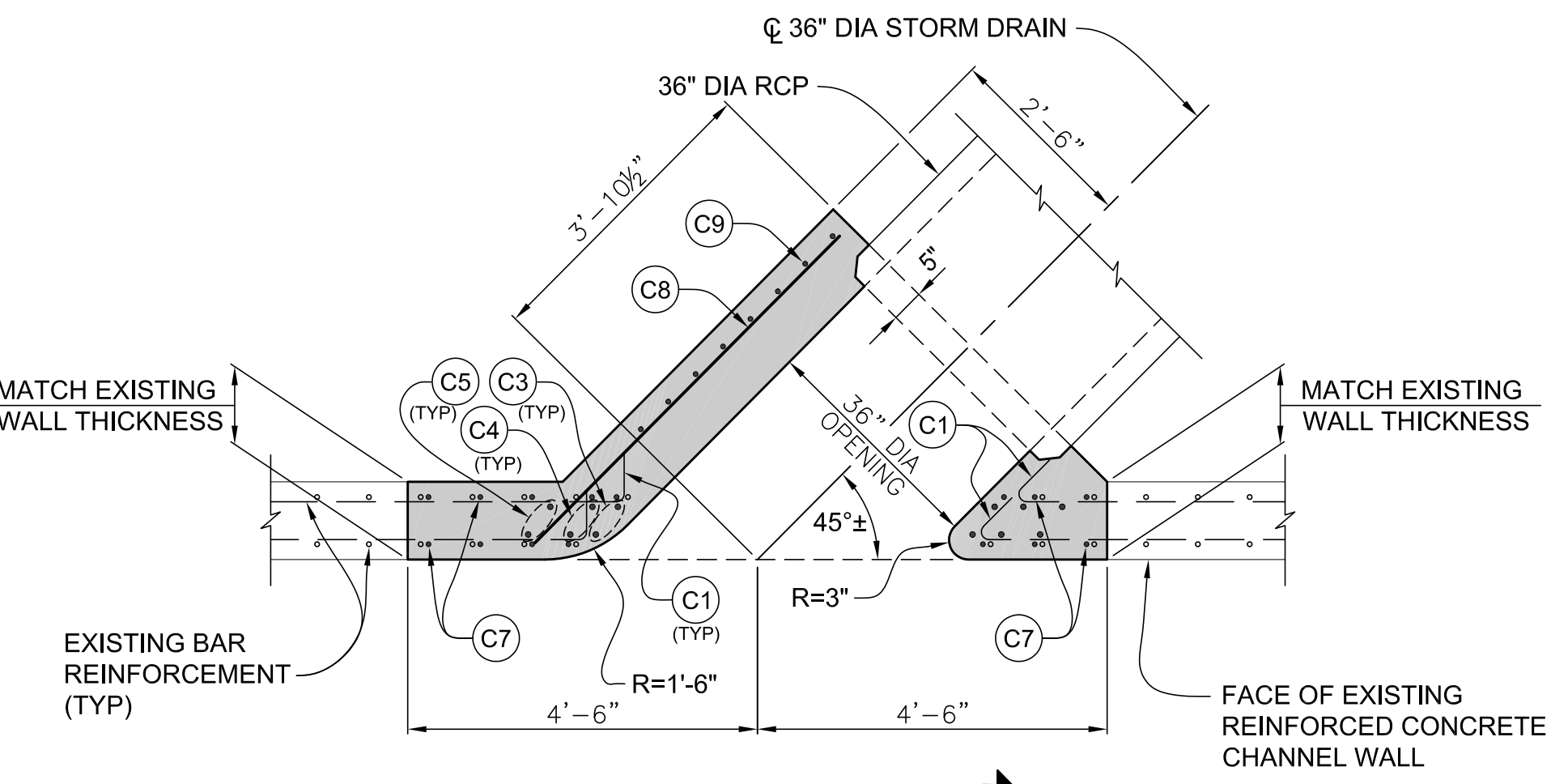

J SECTION
SCALE: 1/2" = 1'-0"

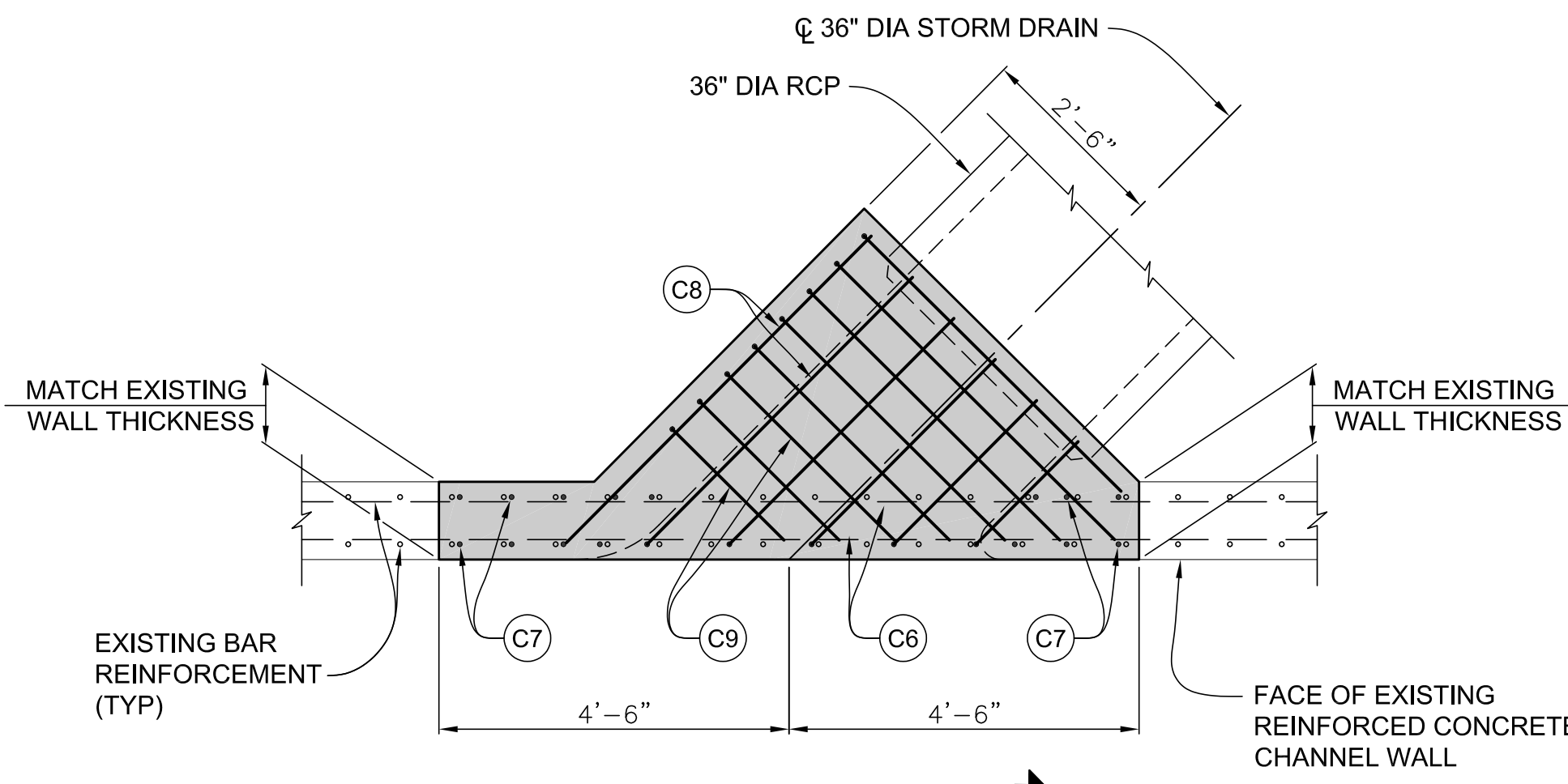

K SECTION
SCALE: 1/2" = 1'-0"

CONSTRUCTION LEGEND:

- (C1) CUT ONLY THE EXISTING BAR REINFORCEMENT WHOSE CLEARANCE TO THE INSIDE SURFACE OF THE 36" DIA FORMED OPENING IS LESS THAN 3". CUT BARS SUCH THAT THE EMBEDMENT INTO THE CONCRETE COLLAR IS MAXIMIZED AND PROVIDES A 6" LONG 90° OR 135° HOOK AT THE BAR END (AS SHOWN).
- (C2) REINFORCED CONCRETE COLLAR
- (C3) 2-#7 ELLIPTICAL HOOPS (3'-6" INSIDE HEIGHT x 5'-0" INSIDE WIDTH)
- (C4) 2-#7 ELLIPTICAL HOOPS (4'-3" INSIDE HEIGHT x 5'-9" INSIDE WIDTH)
- (C5) 2-#7 ELLIPTICAL HOOPS (5'-0" INSIDE HEIGHT x 6'-6" INSIDE WIDTH)
- (C6) 8-#6 HORIZ WITHIN WALL (4 BARS ABOVE 36" DIA OPENING AND 4 BARS BELOW 36" DIA OPENING) (L = 8"=8")
- (C7) #6 VERT @ 8" EACH FACE WITHIN WALL EACH SIDE OF 36" DIA OPENING (L = 5'-2")
- (C8) #5 @ 9" MAX
- (C9) #5 @ 6" MAX

GENERAL NOTES:

- CONSTRUCTION:**
CONSTRUCTION SHALL BE IN ACCORDANCE WITH THE 2018 EDITION OF THE STANDARD SPECIFICATIONS FOR PUBLIC WORKS CONSTRUCTION AND THE PROJECT SPECIAL PROVISIONS.
- REINFORCED CONCRETE:**
- ALL CONCRETE SHALL OBTAIN A MINIMUM COMPRESSIVE STRENGTH OF 5,000 PSI AT 28 DAYS AND A MAXIMUM WATER/CEMENT RATIO OF 0.40.
 - CONCRETE MIX DESIGN SHALL CONFORM TO THE REQUIREMENTS FOR "SEVERE EXPOSURE" PER SECTION 201-1.1.3 OF THE STANDARD SPECIFICATIONS FOR PUBLIC WORKS CONSTRUCTION.
 - ASTM C-150 TYPE II (MODIFIED) OR TYPE V CEMENT SHALL BE USED FOR ALL CONCRETE.
 - CONCRETE AGGREGATE SHALL CONFORM TO ASTM C-33 FOR NORMAL WEIGHT CONCRETE.
 - CONCRETE CONSTRUCTION SHALL BE IN ACCORDANCE WITH ACI CODE 318 AND ACI DETAILING MANUAL 315.
 - ALL REINFORCING BARS SHALL BE DEFORMED BARS OF NEW BILLET STEEL ASTM SPECIFICATION A615 GRADE 60.
 - DIMENSIONS LOCATING REINFORCING BARS ARE CLEAR AND DENOTE CONCRETE COVER TO MAIN STEEL.
 - UNLESS DETAILED OTHERWISE, REINFORCING BARS SHALL HAVE 3" OF CONCRETE COVER TO ADJACENT CONCRETE SURFACE.
 - UNLESS DETAILED OTHERWISE, ALL HOOKS AND BENDS SHALL CONFORM TO THE BUILDING CODE REQUIREMENTS FOR STRUCTURAL CONCRETE (ACI 318).
 - ANY LAP SPLICES IN REINFORCING STEEL SHALL BE LAPPED A MINIMUM OF 45 BAR DIAMETERS.
 - HOOPS SHALL BE MADE CONTINUOUS WITH FULL-PENETRATION BUTT WELDS.

NOTES:

- FOR REMOVAL NOTES AND DETAILS, SEE "OFFSITE STRUCTURAL DETAILS 1" SHEET.
- CONNECT 36 INCH RCP STORM DRAIN TO BURBANK WESTERN CHANNEL AT APPROXIMATE STATION 13+50 PER DRAWING C-02.

LEGEND:

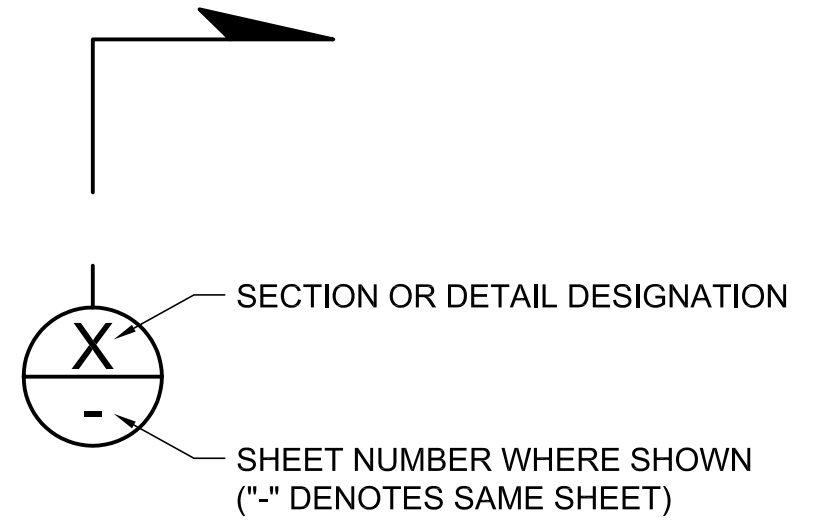

THE CONTRACTOR MUST VERIFY ALL CONTROLLING FIELD DIMENSIONS BEFORE ORDERING OR FABRICATING ANY MATERIAL.



CHANNEL CONNECTION CONSTRUCTION DETAILS

** 100% DRAFT - NOT FOR CONSTRUCTION **



REVISION DESCRIPTION APP DATE		FIELD BOOK PAGE NO. N/A DESIGNED GLR DATE MARCH 2021 DRAWN GLR DATE MARCH 2021 CHECKED TNH DATE REVIEWED NEP DATE	RECOMMENDED: CITY ENGINEER DATE APPROVED: PUBLIC WORKS DIRECTOR DATE	CITY OF BURBANK PUBLIC WORKS DEPARTMENT	OFFSITE STRUCTURAL DETAILS 2 STORM WATER QUALITY IMPROVEMENT PROJECT	S-02 PLAN NO. ST-5124	SHEET 17 OF 23
--	--	---	---	---	---	--------------------------	-------------------

Structural Design Calculations
for
Reinforced Concrete Collar
connection to the
Existing Western Burbank Channel Wall

City of Burbank, CA

Prepared for:

MNS Engineers, Inc.
201 N. Calle Cesar Chavez, Suite 300
Santa Barbara, CA 93103

Prepared by:

Gregory L. Rende, P.E.
R.C.E. No. 54529

March 31, 2021



RENDE CONSULTING GROUP

22431 ANTONIO PARKWAY • SUITE B160-470 • RANCHO SANTA MARGARITA • CA • 92688
• 949-713-6780 •

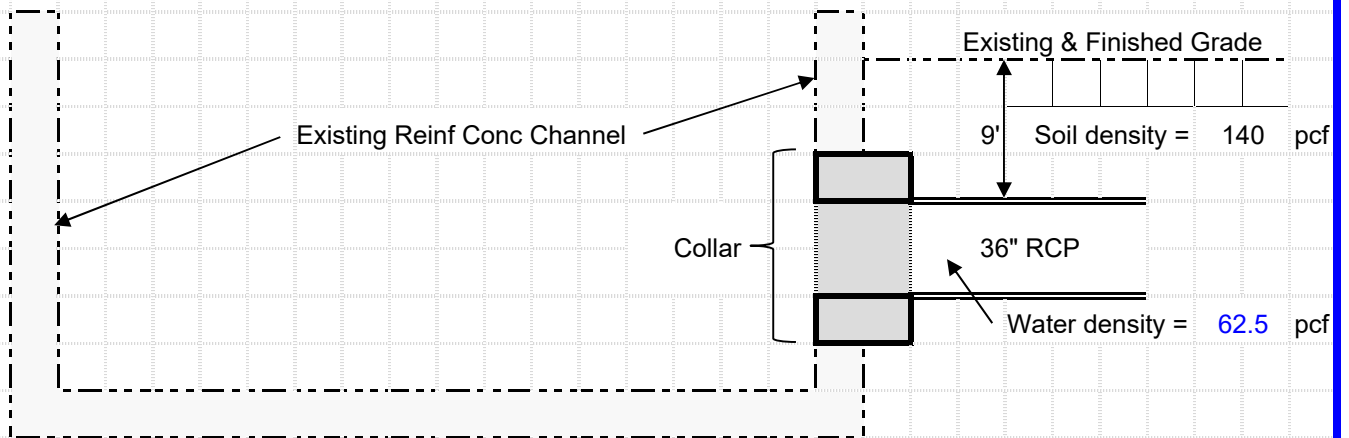

A. Design Criteria

1 / Code References

- a- EM 1110-2-2014
- b- EM 1110-2-2100
- c- EM 1110-2-2007
- d- EM 1110-2-2502
- e- EM 1110-2-2902
- f- Concrete Pipe Design Manual, American Concrete Pipe Association
- g- Design Data, Highway Live Load on Concrete Pipe, American Concrete Pipe Association

2 / Loading

For 18 inch RCP (D-Load 1900) located at 9ft from the finished grade

Pipe Inside Diameter	$D_i = 3.00$ ft	
Pipe Outside Diameter	$D = 3.67$ ft	
Pipe Length	$L = 4.00$ ft	
Soil Height Above Pipe	$h = 9.00$ ft	
Soil Density	$g = 140$ pcf	
Pipe Self Weight	$w_p = 526$ lb/ft	
Soil Weight Above Pipe	$w_s = 4624$ lb/ft	
Water Weight Inside Pipe	$w_w = 442$ lb/ft	
Load Factor	$LF = 2.2$	(3-2, EM-1100-2-2014)
Load Combination: $U = LF*(w_p + w_s + w_w)$	$U = 12303$ lb/ft	

B. Shear and Moment

Moment at Collar:	$M_u = U*0.5*L^2$	$M_u = 98.4$ k-ft
Shear at Collar:	$V_u = U*L$	$V_u = 49.2$ kips

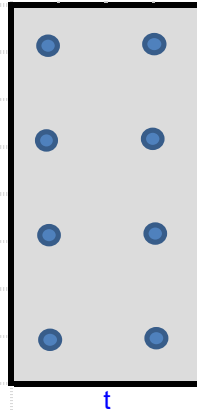
C. Analysis of Collar Connection**Reinforced Concrete:**

$$\begin{aligned}\beta_1 &= 0.85 \\ f'_c &= 4 \text{ ksi} \\ f_y &= 60 \text{ ksi} \\ E_s &= 29000 \text{ ksi} \\ t &= 30 \text{ in} \\ b &= 66 \text{ in} \\ A_s &= 1.24 \text{ in}^2\end{aligned}$$

a. Steel Ratio (3.5, EM-1100-2-2014)

$$\rho_{act} = \frac{A_s}{(b)(d)} = \frac{1.24}{(66.00)(30.00)} =$$

$$\rho_{act} = 0.00063$$

$$\rho_{bal} = \frac{0.85\beta_1 f'_c}{f_y} \times \frac{87}{87 + f_y} =$$

$$\rho_{bal} = 0.02851$$

$$\rho_{act} / \rho_{bal} = 0.00063 / 0.02851 = \rho_{act} / \rho_{bal} = 0.0219689 < 0.25 - \text{OK} - \text{Detailed Analysis NOT Required}$$

=> The detailed analyses of the serviceability limit states ARE NOT required.

b. Compute the Flexural Capacity

Rebar Cover (to center of rebar), c:

$$c = 3.50 \text{ in}$$

Effective Depth, $d = t - c$

$$d = 26.50 \text{ in}$$

Strength Reduction Factor, ϕ :

$$\phi = 0.85$$

Depth of Compression Block, $a = A_s * f_y / (0.85 * f'_c * b)$

$$a = 0.3316 \text{ in}$$

Flexural Capacity, $\phi M_n = \phi A_s f_y (d - a/2)$

$$\phi M_n = 1665.4 \text{ k-ft} > 98.4 \text{ k-ft} \quad \text{OK}$$

c. Check ShearStrength Reduction Factor, ϕ :

$$\phi = 0.85$$

Shear Capacity, $\phi V_c = \phi 2(f'_c)^{1/2}(b)(d)$

$$\phi V_c = 188.0 \text{ kips} > 49.2 \text{ kips} \quad \text{OK}$$

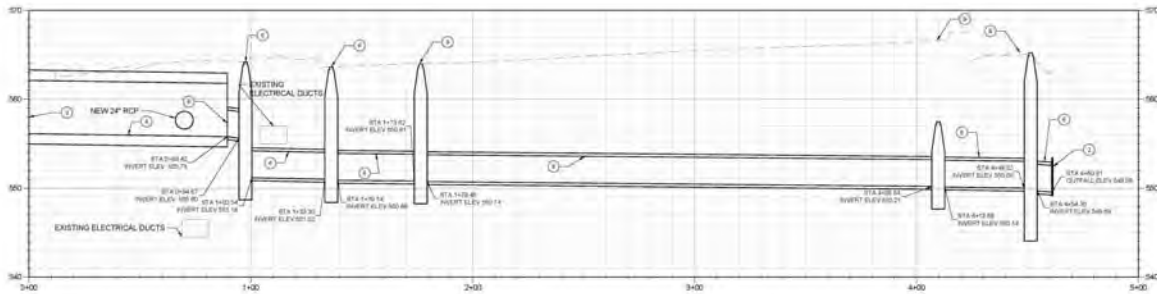

CONSTRUCTION NOTES

- 1. INSTALL NEW 8" 75' CURB INLET, PER DETAIL 1, SHEET C-01.
- 2. DRILL THROUGH CHANNEL WALL AND INSTALL OUTLET FOR 36-INCH PIPE PER DETAIL 4, SHEET C-05.
- 3. SEAL EXISTING PIPE PER SPECIFICATIONS.
- 4. RECONFIGURE FOR WITH SLURRY, PER DETAIL 3, SHEET C-05.
- 5. REPLACE (E) 18" RCP WITH (N) 24-INCH STORM DRAIN PIPE.
- 6. INSTALL NEW MANHOLE, CONNECT RGS AND NEW 36-INCH STORM DRAIN PIPE PER DETAIL 2, SHEET C-05.
- 7. REMOVE AND REPLACE EXISTING TREES INTERFERING WITH CONSTRUCTION.
- 8. INSTALL NEW 36-INCH STORM DRAIN PIPE, TRENCH PER DETAIL 6, SHEET C-02.
- 9. INSTALL 48" MANHOLE PER DETAIL 5, SHEET C-05.

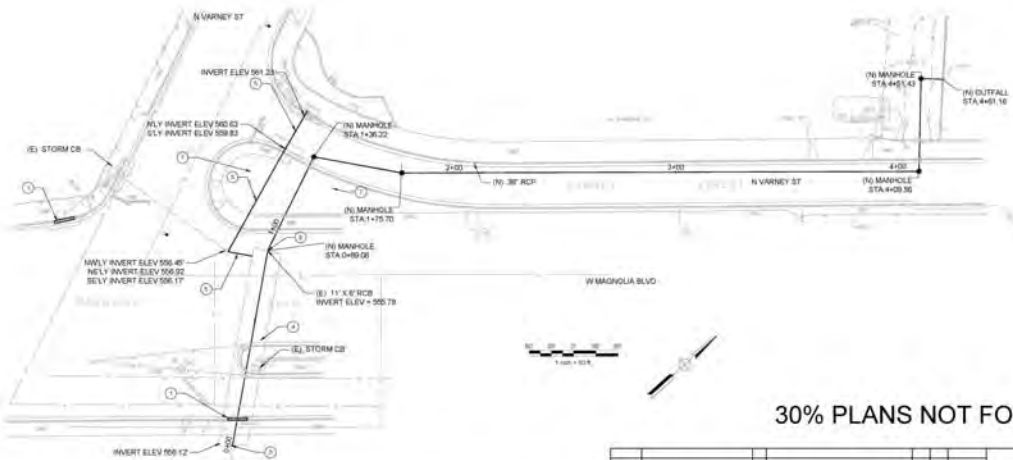

30% PLANS NOT FOR CONSTRUCTION



MNS
ENGINEERS, INC.
4392 E. Thousand Oaks Blvd.
Suite 171
Houston, Texas, TX 77061
Phone: 281-684-8342
www.mnsengineers.com

NO.	DATE	DESCRIPTION

CITY OF BURBANK
Water and Power
1916

OFFSITE IMPROVEMENTS
ECCOCAMPUS NPDES COMPLIANCE STORMWATER QUALITY IMPROVEMENT PROJECT

DATE: 3/24/2023
DRAWN BY: [Name]
CHECKED BY: [Name]
SCALE: 3" = 8'

WATER DIVISION
C-02

CITY OF BURBANK
INITIAL STUDY / BURBANK WATER AND POWER CAMPUS PROJECT

Exhibit 5
PROPOSED OFFSITE IMPROVEMENTS