

APPENDIX C

**San Francisco Public Works' Standard Construction Measures for
Public Works Projects and Draft Construction Contract Procedures**



Edwin M. Lee
Mayor

Mohammed Nuru
Director

San Francisco Public Works
1 Dr. Carlton B. Goodlett Pl.
Room 348
San Francisco, CA 94102
tel 415-554-6920

sfpublicworks.org
facebook.com/sfpublicworks
twitter.com/sfpublicworks
twitter.com/mrcleansf

June 26, 2017

TO: Public Works Staff
FROM: Mohammed Nuru, Director 
SUBJECT: Standard Construction Measures for Public Works Projects

With the issuance of these Standard Construction Measures (“Measures”), I direct Public Works staff to incorporate these Measures into Public Works projects. The purpose of these measures is for Public Works to adopt environmentally responsible practices to apply to Public Works projects.

In addition to complying with applicable local, State, and federal laws and regulations, these Measures are to be followed as a standard practice in the execution of every Public Works project. While some of the Measures may not apply to a project, it is important to address each of the Measures either by implementing the Measure as described, or by documenting in a note to file why it is not applicable to the particular project. Some of the Measures are very broad and will be tailored to suit each project site and surrounding circumstances, which may involve undertaking further investigation and developing a more detailed work plan to address the resource or impact addressed by a specific measure.

For projects that undergo full CEQA review (Mitigated Negative Declarations or Environmental Impact Reports), are assigned environmental commitments as part of the NEPA process, and/or receive resource agency permits (e.g., US Army Corps of Engineers, California Department of Fish and Wildlife, etc.), these Measures may be superseded and/or amplified with more detailed, project-specific mitigation measures or conditions stipulated in the project CEQA document and/or permits.

The responsibility for implementation of the Standard Construction Measures rests with each Public Works Project Manager. If you have any questions please contact Boris Deunert, Manager, Regulatory Affairs Section, at 415-558-4011.

Please begin implementing these Measures immediately. Thank you for your cooperation.

Public Works Standard Construction Measures

1. SEISMIC AND GEOTECHNICAL STUDIES: The project manager shall ensure that projects that may potentially be affected by existing soil, slope and/or geologic conditions at the project site will be screened for liquefaction, subsidence, landslide, fault displacement, and other geological hazards at the project site, and will be engineered and designed as necessary to minimize risks to safety and reliability due to such hazards. As necessary, geotechnical investigations will be performed.
2. AIR QUALITY: All projects will comply with the Construction Dust Control Ordinance (see Attachment A). Major construction projects that are estimated to require 20 or more days of cumulative days of work within the Air Pollutant Exposure Zone must comply with the additional clean construction requirements of the Clean Construction Ordinance (see Attachment B).
3. WATER QUALITY: All projects will implement erosion and sedimentation controls to be tailored to the project site, such as fiber rolls and/or gravel bags around stormdrain inlets, installation of silt fences, and other such measures sufficient to prevent discharges of sediment and other pollutants to storm drains and all surface waterways, such as San Francisco Bay, the Pacific Ocean, water supply reservoirs, wetlands, swales, and streams. As required based on project location and size, a Stormwater Control Plan (in most areas of San Francisco) or a Stormwater Pollution Prevention Plan (SWPPP) (in certain areas of San Francisco) will be prepared. If uncontaminated groundwater is encountered during excavation activities, it will be discharged in compliance with applicable water quality standards and discharge permit requirements. Groundwater contamination is addressed in item 6 below.
4. TRAFFIC: All projects will implement traffic control measures sufficient to maintain traffic and pedestrian circulation on streets affected by construction of the project. The measures will also, at a minimum, be consistent with the requirements of San Francisco Municipal Transportation Agency (SFMTA)'s Blue Book. Traffic control measures may include, but not be limited to, flaggers and/or construction warning signage of work ahead; scheduling truck trips during non-peak hours to the extent feasible; maintaining access to driveways, private roads, and off-street commercial loading facilities by using steel trench plates or other such method; and coordination with local emergency responders to maintain emergency access. Any temporary rerouting of transit vehicles or relocation of transit facilities would be coordinated with SFMTA Muni Operations.
5. NOISE: All projects will comply with local noise ordinances regulating construction noise. Public Works shall undertake measures to minimize noise disruption to nearby neighbors and sensitive receptors during construction. These efforts could include using best

available noise control technologies on equipment (i.e., mufflers, ducts, and acoustically attenuating shields), locating stationary noise sources (i.e., pumps and generators) away from sensitive receptors, erecting temporary noise barriers, and other such measures.

During nighttime construction activities, the following shall apply: impact tools and vibratory pile drivers shall have intake exhaust mufflers and/or acoustically attenuating shields or shrouds recommended by the manufacturers and approved by the Director of Public Works; the construction contractor shall avoid using water blasters; and the use of vehicles that are legally required to be equipped with backing warning alarms will be reduced to the extent feasible; and administrative controls as defined in the California Code of Regulations, Title 8 Sec. 1592 will be used for worker protection for backing movements by other vehicles. Hours of vibration-intensive activities, such as vibratory pile driving, shall be restricted to between 7:00 a.m. and 8:00 p.m.

6. HAZARDOUS MATERIALS: Projects that involve excavation of 50 cubic yards of soil in the Maher Z will comply with the Maher Ordinance (see Attachment C). Projects on sites that are not currently located in the Maher Zone but have the potential to contain hazardous materials in soil and/or groundwater will be referred to the Department of Public Health as newly identified Maher sites.

7. BIOLOGICAL RESOURCES: Public Works will comply with all local, State, and federal requirements for surveys, analysis, and protection of biological resources (e.g., Migratory Bird Treaty Act, Federal and State Endangered Species Acts, etc.). All project sites and the immediately surrounding area will be screened to determine whether biological resources may be affected by construction. If biological resources are present, a qualified biologist will carry out a survey of the project site to note the presence of general biological resources and to identify whether habitat for special-status species and/or migratory birds is present. If necessary, measures will be implemented to protect biological resources, such as installing wildlife exclusion fencing, establishing work buffer zones, installing bird deterrents, monitoring by a qualified biologist and other such measures. If tree removal is required, Public Works will comply with any applicable tree protection ordinance.

8. VISUAL AND AESTHETIC CONSIDERATIONS, PROJECT SITE: All project sites will be maintained in a clean and orderly state. Construction staging areas will be sited away from public view, and on currently paved or previously disturbed areas, where possible. Nighttime lighting will be directed away from residential areas and have shields to prevent light spillover effects. Upon project completion, project sites on City-owned lands will be returned to their general pre-project condition, including re-grading of the site and re-vegetation or re-paving of disturbed areas to the extent this is consistent with Public Works Bureau of Urban Forestry policy and San Francisco Code. Project sites on non-City land will be restored to their general

pre-project condition so that the owner may return them to their prior use, unless otherwise arranged with the property owner.

9. CULTURAL RESOURCES: All projects that will alter a building or structure, produce vibrations, or include soil disturbance¹ will be screened to assess whether cultural resources are or may be present and could be affected, as detailed below.

Archeological Resources. No archeological review is required for a project that will not entail soil disturbance. Projects involving soil disturbance will initially be screened by Public Works Regulatory Affairs staff to identify whether there is demonstrable evidence of prior soil disturbance at the project site to the maximum vertical and horizontal extent of the current project's planned disturbance. Public Works will complete the Public Works Preliminary Archeological Checklist (PAC), Part I only (see Attachment D). For projects where prior complete soil disturbance has occurred throughout areas of planned work, Public Works will provide evidence of the previous disturbance in the environmental application to be reviewed by EP Archeological staff.

- 1) For projects that are on previously undisturbed sites or where the depth/extent of prior soil disturbance cannot be documented, or where the planned project-related soil disturbance will extend beyond the depth/extent of prior soil disturbance, additional screening will be carried out as detailed below and shown on the flow chart titled "Public Works Standard Construction Measure #9 Archeological Assessment Process" (see Attachment E). The EP Archeologist will complete the Preliminary Archeological Checklist, Part II (PAC) for the project, which will include recommendations for one of three Standard Archeological Measures (I - Discovery, II – Monitoring, or III – Testing/Data Recovery) to be implemented by Public Works to protect and/or treat significant archeological resources identified as being present within the site and potentially affected by the project (see Attachments F, G, and H). Additional research and documentation, such as an Archeological Research Design and Treatment Plan (ARDTP), Archeological Sensitivity Study (ASA), or an archeological field survey, may also be requested by the EP Archeologist. These documents should be completed by a qualified consultant from the EP Archeological Resources Consultant Pool and should be scoped, reviewed, and approved by the EP Archeologist.
- 2) Public Works shall implement the PAC recommendations prior to and/or during project construction consistent with Standard Archeological Measures I, II, and III, and shall consult with the EP Archeologist in selecting a qualified archeological consultant from

¹ Soil is defined as native earthen deposits or introduced earthen fill. Soil does not include materials that were previously introduced as part of the roadway pavement section including asphalt concrete wearing surface, roadway base, and subbase.

the EP Archeological Resources Consultant Pool, as needed, to implement these measures.

- 3) Soil-disturbing activities in archeologically sensitive areas, as identified through the above screening, will not begin until required preconstruction archeological measures of the PAC (e.g., preparation of an Archeological Monitoring Plan, Archeological Treatment Plan, and/or an Archeological Research Design and Data Recovery Plan) have been implemented.

Public Works, the EP Archeologist and the ERO will revisit the PAC process outlined above one year after these measures are finalized.

Historic (Built Environment) Resources. Public Works will consult with CCSF Planning Department Preservation staff to determine if projects that would modify an existing building, structure, or landscape feature require preservation review and if a Historic Resource Evaluation (HRE) will be required. The HRE will be prepared by a qualified architectural historian and will be scoped with CCSF Planning Department Preservation staff. Where the potential for the project to have adverse effects on an historical resource is identified by CCSF Planning Department Preservation staff, the CCSF Planning Department Preservation Planner will consult with Public Works to determine if the project can be conducted as planned or if the project design can be revised to avoid the significant impact. If these options are not feasible, the project will need to undergo further environmental review with the CCSF Planning Department and mitigation may be required. If so, the project would not qualify for a Categorical Exemption from CEQA review.

Within historic districts established by ordinance, and/or mapped by the San Francisco Planning Department as eligible for or on the California Register of Historic Resources and/or the National Register of Historic Places, all distinctive sidewalk elements such as brick surfacing, brick gutters, granite curbs, cobblestones and non-standard sidewalk scoring, and streetscape elements that may include, but are not limited to, streetlights, sidewalk lights, sidewalk elevators and chutes, benches, and utility plates, that appear to be 45 years or older will be treated as potentially character-defining features of their respective historic districts. For those locations, historic materials will be protected in place (preferred method), salvaged and re-installed, or replaced in-kind to match the existing color, texture, material, and character of the existing condition.

Where construction will take place in proximity to a building or structure identified as a significant historical resource but would not otherwise directly affect it, Public Works will implement protective measures, such as but not limited to, the erection of temporary construction barriers to ensure that inadvertent impacts to such buildings or structures are avoided. These measures shall require the development of a Construction Best Practices for

Historical Resources Plan and a plan outlining the Construction Monitoring for Historical Resources Program to be reviewed and approved by CCSF Planning Department Preservation staff.

If a project includes or is directly adjacent to historic buildings or structures susceptible to vibration (such as but not limited to unreinforced masonry, earthen construction, lathe and plaster, or fragile architectural ornamentation) as determined in consultation with CCSF Planning Department Preservation staff, Public Works will determine if vibrations associated with proposed construction activities has the potential to cause damage to such buildings or structures. Generally, vibration below 0.12 inches per second peak particle velocity does not have the potential to damage sensitive buildings or structures. A vibration study may be necessary to determine if such vibration levels will occur. If Public Works determines in consultation with CCSF Planning Department Preservation staff that vibration damage may occur, Public Works will engage a qualified historic architect or historic preservation professional to document and photograph the pre-construction condition of the building and prepare a plan for monitoring the building during construction. The monitoring plan will be submitted to and approved by CCSF Planning Department Preservation Planner prior to the beginning of construction and will be implemented during construction. The monitoring plan will identify how often monitoring will occur, who will undertake the monitoring, reporting requirements on vibration levels, reporting requirements on damage to adjacent historical resources during construction, reporting procedures to follow if such damage occurs, and the scope of the preconstruction survey and post-construction conditions assessment.

If any damage to a historic building or structure occurs, Public Works will modify activities to minimize further vibration. If any damage occurs, the building will be repaired following the Secretary of the Interior's Standards for the Treatment of Historic Properties under the guidance of a qualified historic architect or historic preservation professional in consultation with CCSF Department Preservation Planner.

cc: Lisa Gibson, Environmental Review Officer, San Francisco Planning Department

ATTACHMENTS

- A. Construction Dust Measures
- B. Clean Construction Measures
- C. Maher Compliance
- D. Public Works Preliminary Archeological Checklist (PAC)

- E. Flow Chart: Public Works Standard Construction Measure #9 Archeological Assessment Process
- F. Public Works Archeological Measure I (Archeological Discovery)
- G. Public Works Archeological Measure II (Archeological Monitoring)
- H. Public Works Archeological Measure III (Archeological Testing/Data Recovery)

Attachment A: Public Works Dust-Control Measures

For the purposes of this document, “sensitive receptor” means residence, school, childcare center, hospital or other health-care facility or group living quarters, and “visible dust” means dust comprising visible emissions as defined in Bay Area Air Quality Management Board Regulation 6 – Particulate Matter.

For all projects, Public Works will institute through its construction specifications the following dust-control measures to achieve a goal of no visible dust emissions:

- Clean up spillage on City streets, whether directly or indirectly caused by construction operations.
- Remove demolition debris from the Site no later than the end of each workday. Any hazardous materials and/or suspected hazardous materials stored on site shall be stored in accordance with all applicable Cal EPA regulations, including being stored in proper containers and being protected from exposure from the elements. Any such materials shall be removed from the site as soon as possible for disposal/recycling in accordance with all applicable statutes and regulations.
- Keep the Site and adjacent areas clean and perform wet sweeping at the end of each shift.
- Perform continuous water spraying during dust generating activities. Mist or spraying shall be conducted in such a way as to prevent puddling or generation of runoff. Mist any immediate area of demolition with a water spray to prevent airborne dust particles.
- Wet all exposed soil surfaces at least three times daily during dry weather or more frequently if dust is blowing or if required by the City. Any serpentine residuals on the street shall be wet swept immediately.
- Use dust enclosures, curtains, and dust collectors as necessary to control dust.
- Load haul trucks, hauling debris, soils, sand or other such materials so that the material does not extend above the walls or back of the truck bed. Wet before covering and tightly cover the surface of each load before the haul truck leaves the loading area.
- Limit vehicle speed limit on unpaved roads to 15 miles per hour (mph).
- Cover any inactive (no disturbance for more than seven days) stockpiles greater than ten cubic yards or 500 square feet of excavated materials, backfill material, import material, gravel, sand, road base, and soil with a 10 mil (0.01 inch) polyethylene plastic or equivalent tarp and brace it down or use other equivalent soil stabilization techniques.
- Reclaimed water will be used for all dust-control operations to the extent feasible (without resorting to extraordinary means and measures) and allowed by law.

If the project grades or excavates more than one half acre surface area at any given time, and the project is within 1,000 feet of a sensitive receptor as defined above, Public Works or its contractor shall prepare a Site-Specific Dust Control Plan for the review and approval of the Department of Public Health. The site-specific dust control plan shall contain mapping identifying locations of sensitive receptors and contain additional site-specific dust monitoring and control measures that will apply to the project. These site-specific measures may include the following or equivalent measures, which accomplish the goal of minimizing visible dust:

- Wetting down areas around soil improvement operations, visibly dry disturbed soil surface areas, and visibly dry disturbed unpaved driveways at least three times per shift per day.
- Analysis of the wind direction.
- Placement of upwind and downwind particulate dust monitors.
- Recordkeeping for particulate monitoring results.
- Hiring of an independent third party to conduct inspections for visible dust and keeping records of those inspections.
- Requirements for when dust generating operations have to be shut down due to dust crossing the property boundary or if dust is contained within the property boundary but not controlled after a specified number of minutes.
- Establishing a hotline for surrounding community members to call and report visible dust problems so that Public Works or its contractor can promptly fix those problems; posting signs around the site with the hotline number and making sure that the number is given to adjacent residents, schools and businesses.
- Limiting the area subject to excavation, grading, and other demolition or construction activities at any one time.
- Minimizing the amount of excavated material or waste materials stored at the site.
- Installing dust curtains, plastic tarps or windbreaks, or planting tree windbreaks on the property line on windward and down windward sides of construction areas, as necessary.
- Paving, applying water three times daily, or applying non-toxic soil stabilizers on all unpaved access roads, parking areas and staging areas at the construction site. Reclaimed water must be used if required by Article 21, Section 1100 et seq. of the San Francisco Public Works Code, Article 22. If not required, reclaimed water should be used whenever possible.
- Establishing speed limits so that vehicles entering or exiting construction areas shall travel at a speed that minimizes dust emissions. This speed shall be no more than 15 mph.
- Installing wheel washers to clean all trucks and equipment leaving the construction site. If wheel washers cannot be installed, tires or tracks and spoil trucks shall be brushed off before they re-enter City streets to minimize deposition of dust-causing materials.
- Terminating excavation, grading, and other construction activities when winds speeds exceed 25 mph.
- Hydroseeding inactive construction areas, including previously graded areas inactive for at least 10 calendar days, or applying non-toxic soil stabilizers.
- Sweeping of surrounding streets during demolition, excavation and construction at least once per day to reduce particulate emissions.

SECTION 01 35 48

**ADDITIONAL CLEAN CONSTRUCTION REQUIREMENTS ON MAJOR
CONSTRUCTION PROJECTS**

PART 1 – GENERAL

1.01 SUMMARY

- A. This Section 01 35 48 incorporates additional requirements of the San Francisco Clean Construction Ordinance (“Ordinance”) for projects that meet the requirements of Environment Code Section 2504(a), which are located in the Air Pollutant Exposure Zone and which are within 1,000 feet of a Sensitive Use, as set forth in Chapter 25 of the Environment Code and Section 6.25 of the Administrative Code.
- B. For projects that meet Environment Code Section 2504(b), which are located outside the Air Pollutant Exposure Zone, or which are in the Air Pollutant Exposure Zone but are not within 1,000 feet of a Sensitive Use, refer to Section 00 73 73, Article "CLEAN CONSTRUCTION REQUIREMENTS ON MAJOR CONSTRUCTION PROJECTS."
- C. The Department of the Environment is responsible for administering the Ordinance. For more information about the Ordinance and its implementation, please visit the Department of Public Health website at:
<https://www.sfdph.org/dph/EH/Air/CleanConstruction.asp> and
https://www.sfdph.org/dph/files/EHSdocs/AirQuality/San_Francisco_Clean_Construction_Ordinance_2015.pdf.

1.02 DEFINITIONS

- A. "Air Pollutant Exposure Zone" means a zone having a substantially greater than average concentration of air pollutants as defined in Health Code Section 3804.
- B. "Alternative Fuels" means any transportation fuel that is less polluting than gasoline or petroleum diesel fuel, as determined by the California Air Resource Board and that is shown to have lower lifecycle carbon emissions than gasoline or petroleum diesel. Alternative Fuels may include, but are not limited to: natural gas; propane; biofuels from low carbon, sustainable and preferably local sources; hydrogen produced from low carbon and/or renewable sources; and electricity.
- C. "Alternative Sources of Power" means utility-based electric power or other power sources other than diesel engines.
- D. "ARB" means the California Air Resources Board.

- E. "Clean Construction" means the performance of all work required to be performed under a Public Works contract meeting the requirements in Sections 2504, 2505 and 2506 of the Environment Code, as applicable.
- F. "Construction" means building, demolition, excavation, grading or foundation work, whether or not the work requires a City permit.
- G. "Construction Activities" means the performance of all work involved in or required for Construction, except for the issuance or obtaining of a site permit for a project.
- H. "Construction Phase" means a particular construction activity over a certain period of time. Construction phases may include, but are not limited to, demolition, site preparation, grading, building construction, architectural coatings, and paving. Multiple Construction Phases of a single project may take place at the same time.
- I. "Equipment" means off-road and on-road equipment.
- J. "Equipment Type" means a category of off-road equipment. Types of off-road equipment include bore/drill rigs, cranes, crawler tractors, excavators, graders, off-highway tractors, off-highway trucks, other construction equipment, pavers, paving equipment, rollers, rough terrain forklifts, rubber-tired dozers, rubber-tired loaders, scrapers, skid steer loaders, surfacing equipment, tractors/loaders/backhoes, and trenchers.
- K. "Major Construction Project" means a public work to be performed within the geographic limits of the City that uses off-road equipment and that is estimated to require 20 or more cumulative days of work, including non-consecutive days, to complete.
- L. "Most Effective Verified Diesel Emission Control Strategy" means a device, system or strategy that is verified, pursuant to Division 3, Chapter 14, of Title 13 of the California Code of Regulations, to achieve the highest level of pollution control from an off-road vehicle.
- M. "Off-Road Engine" means a non-road engine as defined in Title 40 of the Code of Federal Regulations, Section 89.2.
- N. "Off-Road Equipment" means equipment with an off-road engine having greater than 25 horsepower and operating for more than 20 total hours over the entire duration of Construction Activities.
- O. "On-Road Equipment" means a heavy-duty vehicle as defined in Title 40 of the Code of Federal Regulations, Section 86.1803-01.
- P. "Portable Diesel Engine" means a diesel engine that is portable as defined in 71 California Code of Regulations, Section 93116.2(bb).

- Q. "Sensitive Use" means a category of building use identified as a "Sensitive Use" in Health Code Section 3804.
- R. "Tier 2 Off-Road Emission Standards" means the Tier 2 new engine emission standards in Title 13, California Code of Regulations, Section 2423(b)(1)(A) and/or Title 40, Code of Federal Regulations, Part 89.112(a).
- S. "VDECS" means a verified diesel emission control strategy, designed primarily for the reduction of diesel particulate matter emissions, which has been verified by ARB pursuant to "Verification Procedures, Warranty and In-Use Strategies to Control Emissions from Diesel Engines," Title 13, California Code of Regulations, Sections 2700-2710. VDECS can be verified to achieve Level 1 diesel particulate matter reductions (at least 25 percent), Level 2 diesel particulate matter reductions (at least 50 percent), or Level 3 diesel particulate matter reductions (at least 85 percent).

1.03 SUBMITTALS

- A. Construction Emissions Minimization Plan:
 - 1. Contractor shall submit its initial Construction Emissions Minimization Plan no less than 28 days prior to mobilization. (See Subsection 1.04B.)
 - 2. Contractor shall submit an updated Construction Emissions Plan on a quarterly basis in compliance with Subsection 1.04B.5.a, and submit each quarterly report within seven business days of the end of each quarter.
 - 3. Contractor shall submit a final Construction Emissions Minimization Plan report summarizing construction activities within two weeks of achieving Substantial Completion in compliance with Subsection 1.04B.5.b.
- B. Clean Construction Emissions Plan Certification Statement: Contractor shall submit this statement with its Construction Emissions Minimization Plan. (See Subsection 1.04B.3.)
- C. Waiver Request: Contractor shall submit a waiver request to the Department Head no less than two weeks prior to the planned use of a specific piece of off-road equipment. (See Subsection 1.05A.)

1.04 REQUIREMENTS FOR MAJOR CONSTRUCTION PROJECTS WITHIN THE AIR POLLUTANT EXPOSURE ZONE

- A. For all Major Construction Projects that meet the requirements of Environment Code Section 2504(a) and which are located in the Air Pollutant Exposure Zone and within 1,000 feet of a Sensitive Use, the following requirements apply:
 - 1. All off-road equipment shall have engines that (a) meet or exceed either United States Environmental Protection Agency or ARB Tier 2 off-road

emission standards, and (b) have been retrofitted with an ARB Level 3 VDECS. Equipment with engines meeting Tier 4 Interim or Tier 4 Final off- road emission standards automatically meet this requirement. See Section 1.05A regarding the procedure for requesting a waiver to this requirement.

2. Where access to alternative sources of power is available, use of portable diesel engines to perform work on the project shall be prohibited. See Section 1.05B regarding the waiver procedure for this requirement.
 3. Diesel engines, whether for off-road or on-road equipment, shall not be left idling for more than two minutes at any location, except as allowed for in applicable state regulations regarding idling for off-road and on-road equipment (e.g., traffic conditions, safe operating conditions). The Contractor shall post legible and visible signs, in English, Spanish, and Chinese, in designated queuing areas and at the construction site to remind operators of the idling limit. Refer to the following link for the Clean Construction Sign Template:
<https://www.sfdph.org/dph/EH/Air/CleanConstruction.asp>.
 4. The Contractor shall instruct construction workers and equipment operators on the maintenance and tuning of construction equipment, and require that such workers and operators properly maintain and tune equipment in accordance with manufacturer specifications.
- B. Construction Emissions Minimization Plan: All Major Construction Projects that meet the requirements of Environment Code Section 2504(a), which are located in the Air Pollutant Exposure Zone and are within 1,000 feet of a Sensitive Use, also must comply with the following requirements:
1. Before starting on-site Construction Activities, the Contractor shall submit a Construction Emissions Minimization Plan ("Emissions Plan") to the City Representative for review and approval. The Emissions Plan shall state, in reasonable detail, how the Contractor will meet the requirements of Section 2505 of the Environment Code.
 2. The Emissions Plan shall include estimates of the construction timeline by phase, with a description of each piece of off-road equipment required for each Construction Phase.
 - a. The description may include, but is not limited to: equipment type, equipment manufacturer, equipment identification number, engine model year, engine certification (Tier rating), horsepower, engine serial number, and expected fuel usage and hours of operation.
 - b. For the VDECS installed, the description may include, but is not limited to: technology type, serial number, make, model,

- manufacturer, ARB verification number level, and installation date and hour meter reading on installation date.
- c. For off-road equipment using alternative fuels, the description shall also specify the type of alternative fuel.
 - d. Contractor may use the Clean Construction Equipment Inventory Template to satisfy the Emissions Plan requirements. Refer to the following link for that template:
<https://www.sfdph.org/dph/EH/Air/CleanConstruction.asp>.
3. The Contractor agrees to comply fully with the Emissions Plan and acknowledges that a significant violation of the Emissions Plan shall constitute a material breach of the Agreement. Contractor must submit a signed Clean Construction Emissions Plan Certification Statement to the City Representative. Refer to the following link for the Emissions Plan Certification Statement Template:
<https://www.sfdph.org/dph/EH/Air/CleanConstruction.asp>.
4. After City review and approval, the Contractor shall make the Emissions Plan available to the public for review onsite during working hours.
- a. The Contractor shall post at the construction site a legible and visible sign summarizing the Emissions Plan. Refer to the following link for the Clean Construction Sign Template:
<https://www.sfdph.org/dph/EH/Air/CleanConstruction.asp>.
 - b. The sign shall also state that the public may ask to inspect the Emissions Plan for the project at any time during working hours, and shall explain how to request to inspect the Emissions Plan.
 - c. The Contractor shall post at least one copy of the sign in a visible location on each side of the construction site facing a public right-of-way.
5. Reporting:
- a. After Construction Activities begin, the Contractor shall update the Emissions Plan on a quarterly basis documenting changes from the original plan and demonstrating compliance with the Emissions Plan. The report shall be submitted to the City Representative quarterly and a copy shall also be maintained at the construction site.
 - b. Prior to receiving a Notice of Final Completion, or within six months of completion of Construction Activities if a final certificate of acceptance is not required, the Contractor shall submit to the City Representative a final report summarizing Construction Activities, including the start and end dates and duration of each Construction Phase, and the specific information required in the Emissions Plan.

1.05 WAIVERS

A. Waivers Under Subsection 1.04A.

1. The Contractor may request to waive the equipment requirements of Paragraph 1.04A.1 if: (a) a particular piece of off-road equipment with an ARB Level 3 VDECS is technically not feasible; (b) the equipment would not produce desired emissions reduction due to expected operating modes; (c) installation of the equipment would create a safety hazard or impaired visibility for the operator; or, (d) there is a compelling emergency need to use off-road equipment that is not retrofitted with an ARB Level 3 VDECS.
2. Contractor shall submit a waiver request to the Department Head, or designee, no less than two weeks prior to the planned use of a specific piece of off-road equipment.
3. If the Department Head, or designee, grants the waiver specified in Section 1.05A.1, the Contractor must use the next cleanest piece of off-road equipment, according to Table 1, below.

<i>Table 1</i> Off-Road Equipment Compliance Step Down Schedule*		
Compliance Alternative	Engine Emission Standard	Emissions Control
1	Tier 2	ARB Level 2 VDECS
2	Tier 2	ARB Level 1 VDECS
3	Tier 2	Alternative Fuel**
* If the City determines that the equipment requirements cannot be met, the Contractor must meet Compliance Alternative 1. If the City determines that the Contractor cannot supply off-road equipment meeting Compliance Alternative 1, then the Contractor must meet Compliance Alternative 2. If the City determines that the Contractor cannot supply off-road equipment meeting Compliance Alternative 2, then the Contractor must meet Compliance Alternative 3.		
** Alternative fuels are not a VDECS		

B. Waivers Under Subsection 1.04A.2.

1. The Department Head, or designee, may waive the alternative source of power requirement set forth in Subsection 1.04A.2 if an alternative source of power is limited or infeasible at the project site. If the City grants the waiver, the Contractor must submit documentation that the equipment used for onsite power generation meets the requirements of Subsection 1.04A.1, above.

- C. All Other Waivers: The Department Head or designee also may waive the requirements of the Ordinance on the grounds set forth in Section 2507 of the Environment Code.
- D. For any waiver granted in this Subsection 1.05, the City Representative will within two business days prepare a written notice of the waiver and a written memorandum explaining the basis for the waiver and the steps that will be taken to safeguard public and City employee health during the noncomplying work. The memorandum will also state the steps that the City and the Contractor will take to minimize the use of noncomplying equipment or engines during the noncomplying work.

1.06 NONCOMPLIANCE AND PENALTIES

- A. Liquidated Damages: By entering into the Agreement, Contractor and City agree that if Contractor uses off-road equipment and/or off-road engines in violation of the Clean Construction requirements set forth in Administrative Code Section 6.25 and Chapter 25 of the Environment Code, the City will suffer actual damages that will be impractical or extremely difficult to determine. Accordingly, Contractor and the City agree that Contractor shall pay the City the amount of \$100 per day per each piece of off-road equipment and each off-road engine used to complete Work on the Project in violation of the Ordinance. Such amount shall not be considered a penalty, but rather agreed monetary damages sustained by City because of Contractor's failure to comply with the Clean Construction requirements.
- B. False Representations: False representations by the Contractor, in connection with the bidding, execution or performance of any City contract, regarding the nature or character of the off-road equipment and/or off-road engines to be utilized, on the contract, or to the City about the nature or character of the off-road equipment and/or off-road engines actually used may subject the Contractor to the consequences of noncompliance specified in Section 2510 of the Environment Code, including but not limited to the penalties prescribed therein. The assessment of penalties for noncompliance shall not preclude the City from exercising any other rights or remedies to which it is entitled.

END OF SECTION

Maher Ordinance Screening Request

For a project to which you have been assigned as a Public Works project manager, complete the top of this form and submit to SAR, with plan showing the limits of excavation and of known Maher locations in the work area.

Project Name: _____ JO# _____ Date submitted: _____

Submitted by: _____ Date requested by (minimum of 20 working days): _____

Describe the general project scope, and give details of ground-disturbing activities:

Describe the project location(s). For work in parcels, provide street addresses. For work in the public right-of-way, provide street addresses for the beginning and ends of each street segment in which work will be done:

Estimated volume of excavated native material or earthen fill that the project will generate: yd³ Does the project require a building or grading permit from DBI? Yes No

FOR SITE ASSESSMENT & REMEDIATION USE

SA&R: Complete this section, initial, and forward to Project Manager and Regulatory Affairs Manager:

Date returned to PM: _____ Initial: _____ Date forwarded to RA: _____ Initial: _____

- Project does not meet excavation-volume threshold and/or intersect with a known Maher site. Maher does not apply.
- Project does not require a building or grading permit from the Department of Building Inspection. This includes all projects for the repair and replacement ("R&R") of existing structures in the public right-of-way for end-of-life replacement and/or to address structural inadequacies found during regular inspection. Per Health Code §22A.3 and Building Code §106A.2.4, the Maher Ordinance does not apply.
- Project does not require a building or grading permit and Maher does not apply, but the project will require construction specifications for protection for workers and the public, and for hazardous-materials handling and disposal to meet state and federal regulatory requirements. Please budget an estimated \$_____ for specification development.
- Project requires a building permit and/or grading permit and will bring to the surface 50 or more cubic yards of native material or earthen fill. A Maher application is required. Please budget an initial \$_____ in SFPH fees. We anticipate that the following will also be required:
 - Site history (Phase I ESA).
 - Phase II / Phase II workplan.
 - With site mitigation plan.
 - With site mitigation report/ Environmental inspection.

Recommended by: _____

Signature

Print Name

Date

To complete this form, you will need the following information:

You will need to know that approximate total amount of excavated earth and earthen fill your project will bring to the surface, both permanent excavation and excavation that later will be backfilled. The key to whether or not activities add to your Maher total is whether or not the material brought up is earth or earthen fill -- roadway base, for example, does not count -- and whether or not it is brought to the surface -- pile driving does not count, but the spoils of holes drilled for piles will.

The easiest way to arrive at an approximate total is to classify excavations by type. For example, your project may have 12 pole footings, and two linear trenches. Each footing requires excavation of an area approximately 5' x 5' to a depth of 5'. There are 12 of these, so $5' \times 5' \times 5' \times 12 = 1,500$ ft³. For the trenches, one is 10' deep, 5' wide, and 40' long, and the other is 8' deep, 5' wide, and 20' long. This would be $(10' \times 5' \times 40') + (8' \times 5' \times 20') = 2,800$ ft³. Together, the total excavation for Maher is about 150 yd³, which would go over the 50 yd³ limit that triggers Maher screening.

You'll need to provide a brief description of your project. Provide a general scope of your project (whether it is a streetscape project, a building-rehabilitation project, etc.) and provide details on the construction activities that will disturb the soil. For example, discuss the pole footings and the excavation that will accompany their construction. Provide identifiable project location(s). If your project is on a parcel, give the project address. If the project is in the public right-of-way, give, at a minimum, the street addresses at the beginning and end of each street segment. If the project is on a large public parcel (such as a park/open space), give enough information so that the location can clearly be identified.

You will need to provide mapping of your excavations with the Maher mapping overlain in order to facilitate SAR's presentation of your project information to San Francisco Public Health (SFPH), who oversee Maher compliance. Present the layers of your plans that contain the bulk of your excavation activities, and overlay the Maher Map. Maher mapping in GIS and DWG form can be found on the Public Works GIS server at \\dpwhyd1\boe5m\sfgGeology\MaherSitesAndBlocks. (You may have \\dpwhyd1\boe5m mapped as the K: drive.)

Email this mapping along with the filled-out (top section only) digital version of the PDF form to the Site Assessment and Remediation (SAR) section. SAR will respond (after a minimum of 20 working days) with an assessment of whether or not your project requires further action, and what this action will be.

SAR: Stanley DeSouza <stanley.desouza@sfdpw.org>

Regulatory Affairs: Boris Deunert <boris.deunert@sfdpw.org>



SAN FRANCISCO PLANNING DEPARTMENT

San Francisco Public Works Preliminary Archeological Checklist (PAC)

1650 Mission St.
Suite 400
San Francisco,
CA 94103-2479

Reception:
415.558.6378

Fax:
415.558.6409

Planning
Information:
415.558.6377

PART I - PROJECT INFORMATION:

Date: _____ Public Works RA Staff: _____

Project name: _____ Case No: _____

Application type: EE CatEx

Project address: _____

APN/Cross streets: _____

EP Planner: _____ EP Archeologist: _____

Consultant Archeologist name/firm (if applicable): _____

1. **PROJECT DESCRIPTION:** (include description of construction methods, all potentially ground-disturbing activities including parking, staging, equipment and spoils storage, temporary and permanent work areas, utility lines)

2. POTENTIAL GROUND DISTURBANCE

Yes	No	Project Component
<input type="checkbox"/>	<input type="checkbox"/>	Excavation (basement, elevator, utilities, seismic retrofit, remediation, underground vaults, septic tank system, culverts, etc.)

Maximum depth: _____

2. POTENTIAL GROUND DISTURBANCE (cont.)

- Pipeline replacement or installation (specify cut and cover, directional drilling, pipe bursting, etc):
- Tunnels, transport storage boxes
- Bore pits, test pits
- Shallow Building Foundation (Mat, Spread Footings, etc.)
Depth:
- Piles, piers, micropiles, pilings, piling replacement
- Grading, scraping
- Demolition
- Construction staging, spoils on unpaved area, fill
- Road construction
- Geotechnical trenching (dimensions)_____
- New rip rap
- Wharf or seawall modification
- Other (specify):

Anticipated maximum extent of project ground disturbance:

Vertical_____Horizontal_____

APE Map Attached Y N

3. PREVIOUS SOILS DISTURBANCE AT PROJECT SITE:

Has the project site been previously disturbed by any of the following?

- | Yes | No | Component of disturbance |
|--------------------------|--------------------------|---|
| <input type="checkbox"/> | <input type="checkbox"/> | Existing Basement Depth:_____ Area:_____ |
| <input type="checkbox"/> | <input type="checkbox"/> | Existing Foundation (footings, perimeter, piles, micropiles, etc.) Depth: |
| <input type="checkbox"/> | <input type="checkbox"/> | Site remediation/UST installation or removal, other excavation. Depth: |
| <input type="checkbox"/> | <input type="checkbox"/> | Site Grading |
| <input type="checkbox"/> | <input type="checkbox"/> | Demolition |
| <input type="checkbox"/> | <input type="checkbox"/> | Dredging |
| <input type="checkbox"/> | <input type="checkbox"/> | Piling installation (width and depth of trench):_____ |
| <input type="checkbox"/> | <input type="checkbox"/> | Riprap |
| <input type="checkbox"/> | <input type="checkbox"/> | Seawall construction |
| <input type="checkbox"/> | <input type="checkbox"/> | Other (specify): |

4. Has the entire project area previously been disturbed to the maximum depth and extent of proposed project disturbance? Y N

(Attach documentary evidence such as plans and profiles of prior trenching, utility street occupancy, historic photos, specifications from prior projects, etc.)

List attachments provided:_____

Complete prior disturbance adequately documented. No further archeological assessment is required. EP Archeologist Concur:_____

Prior ground disturbance is unknown or cannot be adequately documented; Part II Required.

PART II - ARCHEOLOGICAL DATA ASSESSMENT

1. ARCHIVAL AND DATA REVIEW

Dates of review: _____

Resources reviewed:

- Maher zone maps. Dates/ origin/ depth of fill if known _____
- Geotechnical data for project site and vicinity. Report _____
- EP Archeological GIS maps (all layers or specify applicable layers) _____

-
- Sanborn Insurance maps (1887-93, 1899-1900)
 - U.S. Coast Survey maps (1853, 1857, 1869)
 - Information Center archeological records search (attach request and response)
 - NAHC Sacred Lands File
 - Native American/ Ethnic group consultation
 - Other: _____
 - Historical Maps or other information provided by Public Works

2. ARCHEOLOGICAL FIELD INVENTORY

- Not warranted; no exposed ground surface in project area
- Results negative
- Results positive
- Survey results inconclusive

Archeologist/ Firm _____ Date of Survey _____

Attach Archeological Survey Report/Memo; may combine with results of archival review.

3. SUMMARY OF RESULTS OF PROJECT ASSESSMENT

Site History/Formation:

Recorded/documented archeological sites/ investigations on/in the vicinity of the project site:

4. CONCLUSIONS AND RECOMMENDATIONS

a) **NO EFFECTS TO ARCHEOLOGICAL RESOURCES EXPECTED:**

- Project effects limited to previously-disturbed soils
- Project effects limited to culturally sterile soils
- Based on assessment above, no potentially CEQA-significant archeological resources are expected within project area affected soils.

b) **AVOIDANCE AND TREATMENT MEASURES NECESSARY TO AVOID AN ADVERSE EFFECT TO SIGNIFICANT ARCHEOLOGICAL RESOURCES:**

- Discovery: potential to adversely affect archeological resources; may be avoided by implementation of **Public Works Standard Archeological Measure I** (Discovery during Construction), with implementation of Standard Archeological Measures II (Monitoring) and/or III (Testing/ Data Recovery) in the event of a discovery during construction.
- Monitoring: some potential for the project to adversely affect archeological resources; may be avoided by implementation of **Public Works Standard Archeological Measure II** (Archeological Monitoring) during construction.
- Testing/Data Recovery: potential of the project to adversely affect archeological resources; may be avoided by implementation of **Public Works Standard Archeological Measure III** (Archeological Testing/Data Recovery)
Implementation Require:
 prior to or during construction.
- CEQA evaluation of the project requires preparation and implementation of an archeological research design and treatment plan (ARDTP) by a qualified archeological consultant. See attached scope of work for the ARDTP

Attachment E:

Public Works Standard Construction Measure #9 Archeological Assessment Process

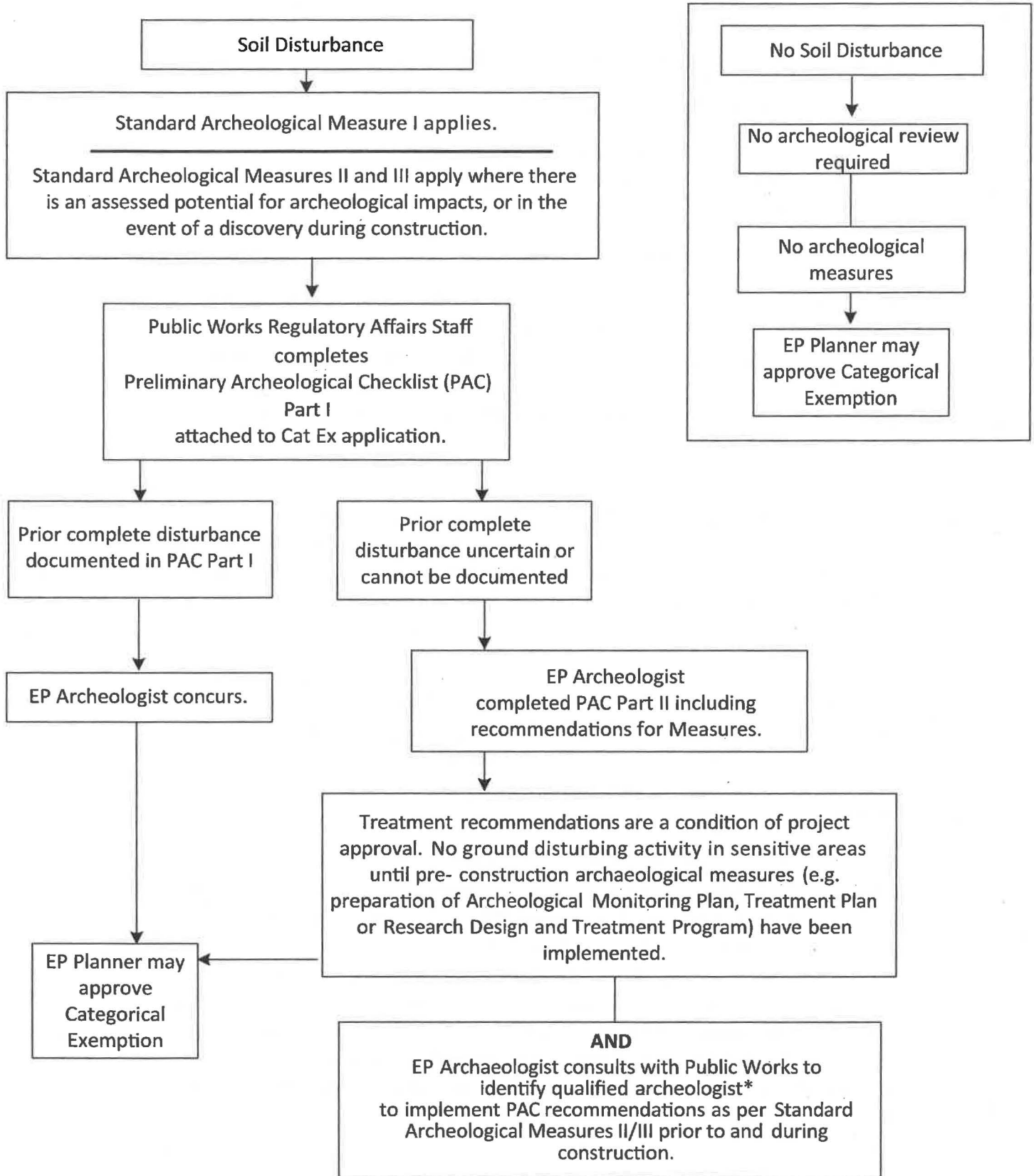

* Archeologist or archeological consultant who meets the Secretary of the Interior's Professional Qualifications Standards (36 CFR 61) as defined in Standard Archeological Measure I.

Attachment F: Public Works Archeological Measure I (Archeological Discovery)

The following requirements are applicable to:

- All projects that will include soil disturbance,
- Any discovery of a potential historical resource or of human remains, with or without an archeological monitor present.

Prior to ground disturbing activities:

A. Alert Sheet. Public Works shall, prior to any soils disturbing activities, distribute the Planning Department archeological resource "ALERT" sheet to each project contractor or vendor involved in project-related soils disturbing activities; ensure that each contractor circulates it to all field personnel; and provide the Environmental Review Officer (ERO) with a signed affidavit from each contractor confirming distribution to all field personnel.

Upon making a discovery:

B. Work Suspension. Should a potential archeological resource be encountered during project soils disturbing activity, with or without an archeological monitor present, the project Head Foreman shall immediately suspend soils-disturbing activities within 50 feet (15 meters) of the discovery in order to protect the find from further disturbance, and notify the Public Works Project Manager (PM) and/or environmental planning staff, who shall immediately notify the ERO for further consultation.

C. Qualified Archeologist. All archeological work conducted under this measure shall be performed by an archeologist who meets the Secretary of the Interior's Professional Qualifications Standards (36-CFR 61); consultants will be selected in consultation with the ERO and meeting the criteria or specialization required for the resource type as identified by the ERO in a manner consistent with Public Works's on-call contracting requirements.

D. Assessment and Additional Measures. If the ERO determines that the discovery is a potential archeological/historical resource, the archeologist, in consultation with the ERO, shall document the find, evaluate based on available information whether it qualifies as a significant historical resource under the CEQA criteria, and provide recommendations for additional treatment as warranted. The ERO will consult with Public Works and the qualified archeologist on these recommendations and may require implementation of additional measures as set forth below in Archeological Measures II and III, such as preparation and implementation of an Archeological Monitoring Plan, an Archeological Testing Plan, and/or an Archeological Data Recovery Plan, and including associated research designs, descendant group consultation, other reporting, curation, and public interpretation of results.

E. Report Reviews. All plans and reports prepared by an archeological consultant, as specified herein, shall be submitted first and directly to the ERO for review and comment with a copy to the Public Works and shall be considered draft reports subject to revision until final approval by the ERO.

F. Draft and Final Archeological Resources Reports. For projects in which a significant archeological resource is encountered and treated during project implementation (see Archeological Measures II and III), the archeological consultant shall submit a draft Final Archeological Resources Report (FARR) to the ERO that evaluates the historical significance of any discovered archeological resource and describes the archeological and historical research methods employed in the archeological testing/monitoring/data recovery program(s) undertaken, research questions addressed, and research results. Information that may put at risk any archeological resource shall be provided in a separate, removable insert within the draft final report.

Once approved by the ERO, copies of the FARR shall be distributed as follows: two copies to the applicable California Historic Information System Information Center (CHRIS), one copy to each descendant group involved in the project, and documentation to the San Francisco Planning Department of transmittal of the above copies. In addition, the Planning Department shall be provided one bound, one unbound and one unlocked, searchable PDF copy on CD of the FARR, which shall include copies of any formal site recordation forms (CA DPR 523 series) and/or National Register of Historic Places/California Register of Historical Resources nominations.

G. Other Reports. In instances of high public interest or interpretive value, the ERO may require different or additional final report content, format, and distribution than that presented above.

H. Human Remains, Associated or Unassociated Funerary Objects. Public Works shall ensure that human remains and associated or unassociated funerary objects discovered during any soils disturbing activity are treated in compliance with applicable State and federal laws. In the event of the discovery of potential human remains, the construction contractor shall ensure that construction activity within 50 feet of the find is halted and the Public Works PM, ERO, and the County Coroner are notified immediately. If the Coroner determines that the remains are of Native American origin, he/she will notify the California State Native American Heritage Commission. Subsequent consultation on and treatment of the remains shall be conducted consistent with Public Resources Code Section 5097.98 and CEQA Guidelines Section 15064.5(d), in consultation with the ERO.

I. Consultation with Descendant Communities. Consistent with AB 52 requirements, if requested, Public Works shall provide opportunities for Native American descendant groups to provide input during project planning for projects that may affect potential Tribal Cultural Resources. In addition, on discovery during construction of an archeological site associated with descendant Native Americans, the Overseas Chinese, or other descendant group, an appropriate representative of the descendant group shall be contacted by Public Works at the direction of the ERO. Public Works will offer this representative the opportunity to monitor archeological field investigations of the site and to consult with the ERO regarding the appropriate treatment and, if applicable, interpretation of the site and the recovered materials.

J. Construction Delays. Archeological monitoring and/or data recovery programs required by this measure may suspend construction of the project for up to a maximum of four weeks. At the direction of the ERO, the suspension of construction can be extended beyond four weeks only if this is the only feasible means to reduce potential effects on a significant archeological find to a less-than-significant level.

Attachment G. Public Works Archeological Measure II (Archeological Monitoring)

A. Archeological Monitoring Plan (AMP). Where an archeological field investigation to identify expected buried or submerged resources cannot reasonably be carried out during project planning/ environmental review (for example, where definitive determination would require extensive street opening prior to construction), prior to any project-related soils-disturbing activities the qualified archeologist identified under Archeological Measure I.C. shall consult with Public Works and the ERO to develop an Archeological Monitoring Plan (AMP). The AMP which will be implemented in conjunction with soil-disturbing activities during construction. Preparation and implementation of an AMP also may be required based on the results of pre-construction archeological testing or upon a discovery during construction.

The AMP shall include the following elements, at minimum:

- Historical context and research design for assessment of resource types likely to be encountered;
- Project activities to be archeologically monitored and intensity of monitoring of each type and location of project construction activity; and
- Procedures for the documentation, significance and integrity assessment, treatment, interpretation and reporting of the types of resources likely to be encountered.

B. Reporting. Whether or not significant archeological resources are encountered, the archeological consultant shall submit a written report of the findings of the monitoring program to the ERO at the end of construction (See Archeological Measure I.E [Report Reviews] and I.F. [Draft and Final Archeological Research Report]).

C. Monitoring Authorities

- The archeological monitor will have the authority to halt construction activity at the location of a suspected resource for inspection, documentation, and assessment of the need for further measures as set forth in Archeological Measure III.
- The Archeological Monitor shall record and be authorized to collect soil samples and artifactual/ecofactual material as warranted for analysis.
- The Archeological Monitor(s) shall be present on the project site according to a schedule identified in the AMP, subject to modification upon ERO concurrence, based on findings.

D. Testing/Data Recovery. In the event of a discovery during construction, if the ERO and archeological consultant determine that the discovery is a significant resource (that is, a

resource that meets the eligibility criteria of the California Register of Historic Resources or qualifies as a unique archeological resource) that will be adversely affected (that is, where the project would result in loss of data potential) or that additional investigation is required to make this determination, all applicable elements of Archeological Measure III (Archeological Testing/Data Recovery) also shall be implemented.

Attachment H. Public Works Archeological Measure III (Testing / Data Recovery)

The following provisions apply prior to or during construction when a significant archeological resource (as defined in Measure II.D) or an archeological resource of undetermined significance is expected to be present in the work area and the ERO, in consultation with the qualified archeologist, determines that an archeological field investigation is needed to determine: a) the presence of an archeological resource, b) whether it retains depositional integrity, and c) whether it qualifies as a legally significant resource under CEQA criteria. All archeological work under this Measure will be carried out by a qualified archeologist as identified in Archeological Measure I.C. Per Archeological Measure I.J, implementation of this measure shall not exceed four weeks except at the direction of the ERO and only if this is the only feasible means to reduce potential effects on a significant archeological find to a less-than-significant level.

A. Archeological Testing Program. If an archeological investigation is required in order to verify resource location and/ or assess the significance of the resource, the archeological consultant shall consult with the ERO to prepare and implement an Archeological Testing Plan (ATP) that identifies:

- Key research questions and associated data needs,
- Testing/ sampling methods, and
- Testing locations.

Results of testing shall be presented to ERO in a written report following Measure I.E. If, based on the archeological testing program, the archeological consultant finds and the ERO concurs that significant archeological resources may be present, Measures III.B and/or III.C below will be implemented.

B. Treatment. If the project could adversely affect a significant (CRHR-eligible) archeological resource, preservation in place is the preferred manner of mitigating impacts, as detailed in CEQA Guidelines 15126.6(b) (3)(a) and (b).

If preservation in place is determined to be infeasible, the Public Works at its discretion shall either:

- Re-design the proposed project so as to reduce the adverse effect to a less-than-significant level through preservation in place or other feasible measures; and/or
- For a resource important for its association with an important event or person, or which is of demonstrable public interest for both its scientific and historical values (e.g., a submerged ship), and where feasible, preserve the resource in

place with appropriate documentation; or, if not feasible to preserve in place, systematically document and/or recover for interpretive use, at the discretion of the ERO, and/or;

- For an archeological resource significant primarily for its data potential, design and implement an archeological data recovery program, as detailed under Measure III.D, below.

C. Archeological Data Recovery Plan (ADRP). For resources for which the elected treatment is archeological data recovery, the archeological consultant, in consultation with the ERO, shall prepare and implement an ADRP. It will identify how the significant information the archeological resource is expected to contain will be recovered and preserved. Data recovery results will be reported in the FARR, as detailed in Measure I.F. The ADRP shall include the following elements:

- Historic context and research design
- Field methods and procedures, including sampling strategy
- Archeological monitoring recommendations for ongoing construction
- Cataloguing and laboratory analysis
- Discard, deaccession, and curation policy
- Interpretive program
- Security measures

VIBRATION CONTROL PROCEDURES FOR INCLUSION IN CONSTRUCTION CONTRACTS

SECTION 01 35 51
VIBRATION CONTROL PROCEDURES

PART 1 - GENERAL

1.1 SUMMARY

- A. This Section includes minimum provisions for compliance with City, state, and federal laws and regulations for vibration control, and notes to which Standard Construction Measure (SCM) the section refers.
 - 1. Vibration Control (SCM-5).

- B. Related Sections:
 - 1. Section 00 41 00 Bid Form
 - 2. Section 01 35 49 Minimum Environmental Procedures
 - 3. Section 01 31 19 Project Meetings

1.2 REFERENCES

- A. Refer to the following references:
 - 1. Andrews, Jim, et al. Transportation and Construction Vibration Guidance Manual. California Department of Transportation Report No. CT-HWANP-RT-13-069.25.3, September 2013.

1.3 DEFINITIONS

- A. For the purposes of this Section, the following definitions apply:
 - 1. Historic buildings or historic structures: Buildings or structures labeled as historic structures on project plans.

1.4 SUBMITTALS

- A. Contractor shall submit the following prior to the start of construction and prior to performing any vibration monitoring:
 - 1. A record of laboratory calibration shall be provided for all vibration-monitoring instruments to be used on site. Certification shall be provided to indicate that the instruments are calibrated and maintained in accordance with the equipment manufacturer's calibration requirements and that calibrations are traceable to the U. S. National Institute of Standards and Technology (NIST). The record shall certify that all seismographs shall have been calibrated by the manufacturer or certified calibration laboratory within one year of their use on site.
 - 2. Manufacturer's product data for all vibration-monitoring instruments to be used on site describing all specified vibration-monitoring instruments, together with product data and instruction manuals.
 - 3. Documentation and photography of the properties that are the subject of the Vibration Monitoring Plan, as specified below in 3.4.G.

4. A written Vibration Monitoring Plan detailing the procedures for vibration monitoring. Such plan shall include:
 - (a) The name of the Firm providing the vibration monitoring services.
 - (b) Description of the instrumentation and equipment to be used.
 - (c) Measurement locations and methods for mounting the vibration sensors.
 - (d) Procedures for data collection and analysis.
 - (e) A limiting value as applied in 3.4, below.
 - (f) Means and methods of providing warning when a limiting value is reached.
 - (g) Generalized plans of action to be implemented in the event the limiting values is reached. The generalized plans of action shall be positive measures by the Contractor to control vibrations (e.g. using alternative construction methods).
 - (h) Procedures for post-construction assessment of any damage due to vibration during construction to historic buildings or structures susceptible to vibration in or adjacent to the project, and reporting requirements and procedures if such damage occurs.
 5. Within 10 working days after the completion of the background vibration monitoring as described in 3.4.G, Contractor shall submit a hard copy report documenting the results of background vibration monitoring at each monitoring location.
- B. Qualification Data: For firms and persons specified in subsection 1.5 "Quality Assurance" of this Section to demonstrate their capabilities and experience.

1.5 QUALITY ASSURANCE

- A. Qualifications
1. Qualified Vibration Instrumentation Engineer: a registered Professional Engineer in the State of California, who has a minimum of a Bachelor of Science degree in civil engineering, and who has at least 4 years of experience in the installation and use of vibration-monitoring instrumentation and in interpreting instrumentation data.
- B. Regulatory Requirements
1. All work shall comply with the following:
 - (a) San Francisco Police Code, Article 29, Ordinance #274-72 ("Noise Ordinance")
 - (b) San Francisco Public Works Code, Article 2.4 ("Excavation in the Public Right-of-Way")
 - (c) San Francisco Public Works Code Ordinance #175-91, Sections 1100-1107
- C. The City will inspect and monitor Contractor's adherence to the requirements specified herein and will report on Contractor's compliance.
1. Said inspection, monitoring, and reporting activities may include, but are not limited to, qualitative, quantitative and photographic observations and data collection on the impacts of vibration.
 2. Contractor shall cooperate with such inspection and monitoring activities, provide access to the Work site to establish and secure monitoring stations, and make its facilities and records available to the City for performing such monitoring.

3. The City will issue a Non-Compliance Notice to Contractor for any detected non-compliance with the provisions herein or of any environmentally objectionable acts and the corrective action to be taken.

1.6 SEQUENCING

- A. Contractor shall submit a Vibration Control Plan to the City for review and approval at least 30 days prior to commencing construction.
- B. Contractor shall notify the City Representative at least 24 hours prior to starting a new construction task potentially capable of exceeding the project's vibration Threshold Value.

1.8 DAMAGES FOR FAILURE TO MEET ENVIRONMENTAL REQUIREMENTS

- A. The Contractor shall be liable for all fines, penalties, liquidated damages and costs arising from any failure to implement mitigation measures to control vibration impacts that are subject to Federal, State, and local regulatory fines.

PART 2 - PRODUCTS

2.1 MATERIALS

- A. Materials necessary for compliance with the Vibration Monitoring Program:
 1. The seismograph(s) used as part of the program shall have the following minimum features:
 - (a) Seismic range: 0.01 to 4 inches per second with an accuracy of +5 percent of the measured peak particle velocity or better at frequencies between 10 Hertz and 100 Hertz, and with a resolution of 0.01 inches per second or less.
 - (b) Frequency response (+3 dB points): 2 to 200 Hertz.
 - (c) Three channels for simultaneous time-domain monitoring of vibration velocities in digital format on three perpendicular axes.
 - (d) Two power sources: internal rechargeable battery and charger and 115 volts AC. Battery must be capable of supplying power to monitor vibrations continuously for up to 24 hours.
 - (e) Capable of internal, dynamic calibration.
 - (f) Direct writing to printer and capability to transfer data from memory to a secure digital memory card and/or USB mass storage device. Instruments must be capable of producing strip chart recordings of readings on site within one hour of obtaining the readings. Provide computer software to perform analysis and produce reports of continuous monitoring.
 - (g) Continuous monitoring mode must be capable of recording single-component peak particle velocities, and frequency of peaks with an interval of one minute or less.

PART 3 - EXECUTION

3.1 VIBRATION CONTROL

- A. This subsection applies when trees, rock outcroppings, historic buildings, historic structures, or other resources or landscape features are shown on the project plans and are labeled as requiring a vibration-monitoring program.
- B. Where the project includes or is directly adjacent to a resource susceptible to vibration, as shown on project plans, the Contractor shall institute a vibration-monitoring program to protect such properties from excess vibration during demolition and construction activities associated with the project.
- C. The Contractor shall submit a Vibration Control Plan to the City for review and approval, to be fully implemented upon approval.
 1. For purposes of this subsection, "limiting value" shall be:
 - (a) For Vibration Control Plans for historic buildings or historic structures, 0.12 inches per second peak particle velocity (in/sec PPV) for sustained vibration (e.g. impact pile drivers, vibratory equipment) in any direction, unless a greater value is approved in writing by the City Representative.
 - (b) For Vibration Control Plans for all other resources, 0.2 inches per second peak particle velocity (in/sec PPV) for sustained vibration (e.g. impact pile drivers, vibratory equipment) in any direction, unless a greater value is approved in writing by the City Representative.
 2. The Contractor's vibration-monitoring personnel shall include a Qualified Vibration Instrumentation Engineer approved by the City's Representative. The Qualified Vibration Instrumentation Engineer shall:
 - (a) Be on site and supervise the initial installation of each vibration-monitoring instrument.
 - (b) Supervise interpretations of vibration-monitoring data.
 3. Contractor shall collect seismograph data prior to any vibration-producing demolition or construction activities to document background vibrations at each monitoring location. The background monitoring shall be performed for a minimum of two non-consecutive workdays, spanning the hours during which demolition and construction activities will take place. Monitoring shall consist of a continuous recording of the maximum single-component peak particle velocities for one-minute intervals, which shall be printed on a strip chart.
 4. Contractor shall have seismographs in place and functioning at least 24 hours prior to any such activity within 200 feet of the monitoring locations. No significant vibration-producing activity shall occur within this zone unless the monitoring equipment is functioning properly, as determined by the City Representative.
 5. Contractor shall monitor vibration during demolition and other significant vibration-producing construction activities as determined by the City Representative. This monitoring shall consist of a continuous recording of the maximum single-component peak particle velocities for one-minute intervals, which shall be printed on a strip chart. During the monitoring, Contractor shall document all events that are responsible for the measured vibration levels, and submit the documentation to the City Representative with the data.
 6. All vibration monitoring data shall be recorded contemporaneously and plotted continuously on a graph by the data acquisition equipment. Each graph shall show time-domain wave traces (particle velocity versus time) for each transducer with the same vertical and horizontal axes scale
 7. The Contractor shall interpret the data collected, including making correlations between seismograph data and specific construction activities. The data shall be

evaluated to determine whether the measured vibrations can be reasonably attributed to construction activities

8. The equipment shall be set up in a manner such that an immediate warning is given when the peak particle velocity in any direction exceeds the Threshold Value in the previously submitted Vibration Monitoring Plan. The warning emitted by the vibration-monitoring equipment shall be instantaneously transmitted to the responsible person designated by Contractor by means of warning lights, audible sounds or electronic transmission.
9. If a Limiting Value is reached, the Contractor shall:
 - (a) Immediately notify the City Representative and suspend activities in the affected area, with the exception of those actions necessary to avoid exceeding the Limiting Value.
 - (b) Meet with the City Representative to discuss the need for response action(s).
 - (c) If directed by the City Representative during the above meeting that a response action is needed, submit within 24 hours a detailed specific plan of action based as appropriate on the generalized plan of action submitted previously as part of the vibration-monitoring plan.
 - (d) If directed by the City Representative, implement response action(s) within 24 hours of submitting a detailed specific plan of action, so that the Limiting Value is not exceeded.
10. Where the subject of the Vibration Monitoring Plan is a historic building or structure, Contractor shall engage a Qualified Historic Architect or Historic Preservation Professional to document and photograph the properties that are the subject of the Vibration Monitoring Plan to ensure structural damage does not result from construction activities that could cause ground vibration.
 - (a) The post-construction survey and monitoring results will be evaluated to determine whether the new structural and/or architectural damage was caused by vibration due to Contractor's performance of this Work.
 - (b) If, following completion of construction, changes in the architectural or structural conditions the properties that are the subject of the Vibration Monitoring Plan have occurred, Contractor shall restore the buildings to pre-construction conditions, and to the satisfaction of the City Representative.

END OF SECTION

**DRAFT WATER AND AWSS PROTECTION
PROCEDURES FOR INCLUSION IN CONSTRUCTION
CONTRACTS**

SECTION 01 41 28**PROTECTION OF EXISTING WATER AND AWSS FACILITIES****PART 1 GENERAL****1.01 DESCRIPTION**

- A. Design and install temporary supports to work around the San Francisco Public Utilities Commission's (SFPUC) Potable Water (PW), Recycled Water (RW), and Auxiliary Water Supply System (AWSS) facilities to protect and provide uninterrupted service to these facilities. Contractor will be held responsible for any damage related to or caused by failure to exercise due care. Repair of existing utilities and improvements damaged during construction shall be at the Contractor's expense.
- B. The Contractor shall furnish, install and remove upon completion of the work, Settlement Reference Points (SRP) and Settlement Monitoring Points (SMP) for the San Francisco Public Utilities Commission's (SFPUC) Auxiliary Water Supply System (AWSS) piping as shown on drawings and conduct the survey of SRPs and SMPs as specified hereinafter.
- C. The Contractor shall perform all required work as stated in this specification section and as shown on the Drawing(s) and furnish all materials, other than those specified to be furnished by the City, which are necessary or required to complete the work.

1.02 RELATED SECTIONS

Not Used

1.03 RECORD DRAWINGS AND STANDARDS

Records of the existing PW, RW, and AWSS facilities and Standard requirements are available for examination by bidders/awarded Contractor at the SFPUC's City Distribution Division (CDD), Engineering Section, 1990 Newcomb Ave, San Francisco, CA 94124. Telephone number 415-550-4994.

Contractors are warned that changes which do not appear in the records for existing CDD facilities may have been made. The City makes no representation as to the completeness or accuracy of said records and assumes no responsibility thereto.

1.04 DEFINITIONS

- A. Maximum Allowable Settlement: Level at which no further movement will be acceptable and if reached requires work to be halted until submittal and acceptance of a written plan detailing corrective actions and restorative measures.
- B. Response Values: Predetermined values within the instrument range indicating different levels of response as specified herein.
- C. Settlement Monitoring Point: A system of points along the alignment of the AWSS for monitoring vertical deformation (settlement or heave) at or near the ground surface using optical survey techniques.
- E. Settlement Reference Point: A stable, fixed control point established at a surface structure above ground that is referenced during settlement monitoring point measurements to permit calculation of vertical movements.

1.05 REFERENCES

- A. AWSS Standard Plans

<u>Drawing No.</u>	<u>Title</u>
HPL-5993 Ch. 3	AWSS Standard Details AWSS Settlement Point; 07/09/84
HPL-5993.1 Ch. 1	AWSS Settlement Point for Double Spigot; 05/16/83

- B. AWSS Settlement Monitoring Drawings in the Contract showing approximate locations of settlement monitoring and reference points.
- C. State of California Labor Code, Section 6705 and 6707.
- D. State of California Construction Safety Orders, Article 6 - Excavation.

1.06 SUBMITTALS

Submit the following to City Representative for review:

- A. Work plan, support details, and calculations.
 - 1. Work Plan for working around existing PW, RW, and AWSS facilities. The plan shall show the locations of proposed facilities, existing utilities and pipelines, proposed pipe supports for SFPUC CDD facilities, pipe storage, spoil bank, excavation and pipe laying equipment, shoring system, and a description of how the work will proceed around the

existing SFPUC CDD facilities. Provide drawings that include dimensions to allow determining the distances of objects relative to the SFPUC CDD facilities. Sizes of existing and proposed facilities, width and depth of proposed trench, and any other pertinent information must be shown in the drawings. For proposed structural facilities, such as retaining walls, potentially impacting CDD facilities, submit elevation and or section views showing horizontal and vertical locations of CDD facilities relative to the proposed structure.

2. Where supports are required, submit support details and calculations, signed and stamped by a California licensed Civil or Structural Engineer, for structural support for the protection of all exposed and/or undermined sections of SFPUC CDD pipe or facilities. At the discretion of SFPUC CDD Engineering, revised support details and calculations may be required to be submitted if conditions vary significantly following excavation.
 3. Submit minimum (7) days before planned excavation.
- B. Control Density Fill (CDF) mix design where CDF is required per this Specification. Submit certified laboratory test results within the past 1-year that the mix proportions and materials comply with these Specifications.
- C. Survey of Settlement Reference and Monitoring Points data: The Contractor shall submit elevations of all SMPs and SRPs (to be provided in "feet") by a State of California licensed Land Surveyor in addition to deflection calculations for each pipe joint.

Data and calculations shall be submitted once prior to the start of construction, once a week during construction, once at the end of construction and final survey is completed, and when threshold values are exceeded as specified below. Pipe deflection angles and elevation readings calculated from SMPs and SRPs are to be tabulated in chronological order with all previous results for review and approval within 24 hours of the survey being performed.

PART 2 PRODUCTS

2.01 CONTROLLED DENSITY FILL

- A. Materials shall conform to the following:
1. Cement: ASTM C150, Type II or V.
 2. Aggregate: ASTM C33. Aggregate shall consist of fine aggregate with a maximum size of 1/4", free of clay, organics, and other deleterious

materials. Less than 10 percent by weight shall pass the No. 200 sieve, and material passing the No. 40 sieve shall be nonplastic as determined in accordance with ASTM D4318.

3. Water: Potable.
 4. Pozzolans: ASTM C618, Class C fly ash. Class F fly ash and slag is not permitted.
 5. Air entraining: ASTM C260. Air content shall not exceed 25 percent.
 6. Admixtures: Shall not contain chloride ions and shall not cause delayed strength gain.
- B. Mixes:
1. Performance requirement: proportioned to be free-flowing, self-consolidating, hand tool excavatable, low-shrink slurry.
 2. Mix design requirement: The Contractor and its supplier shall determine the materials and proportions used to meet the requirements of the Specifications.
 3. Strength: Unconfined compressive strength at 28 days shall be between 50 to 125 psi tested per ASTM D 4832.
 4. Flowability: 6 to 9 inches when tested per ASTM C-143 or ASTM D 6103.
 5. Cementitious Material: Portland Cement. Where pozzolans are used, pozzolans shall be limited to maximum 60% of the weight of cement.

2.02 AWSS SETTLEMENT REFERENCE AND MONITORING POINTS

A. AWSS Settlement Reference and Monitoring Well Covers

6-inch valve cover, H-20 load rated, cover similar to the San Francisco Water Department's 6-inch gate valve cover.

B. Required survey monitoring of AWSS facilities outside of trenches and/or excavations:

1. Refer to the AWSS Settlement Monitoring Drawing(s) for the minimum number of SMPs to be installed as part of the contract work; and

2. For trench/excavation crossing AWSS, the SMPs shall be located starting on the closest pipe bell near the edge of the trench and/or excavation and installed outward away from the trench and/or excavation; and
 3. Rod, guide pipe, and monitoring well shall be per Drawings “HPL-5993” and/or “HPL-5993.1”, which are attached to this specification section and shall be at the approximate locations as shown on the AWSS work contract drawing(s), which are included in the contract documents. The exact SRP and SMP locations shall be determined in the field and approved by the SFPUC CDD Representative.
- C. Required monitoring of AWSS facilities inside of trenches and/or excavations:
1. Exposed AWSS pipe joints in trenches and/or excavations shall be identified as a SMP regardless of whether the joint is called out on the AWSS Settlement Monitoring Drawing(s) to be surveyed and monitored. Price for additional survey locations when required by the specifications and/or by the SFPUC CDD Representative shall be based on the Contractor’s total bid price for SMPs divided by the quantity of SMPs as shown on the AWSS work drawing(s) to be installed, surveyed and removed. Field verification of the exact location shall be required and approved by SFPUC CDD Engineering.
 2. Additional SMPs within trenches and/or excavations may be necessary on either or both sides of the AWSS joint to distinguish the difference between vertical displacement and joint deflection.
- D. Placement of SRP(s) for survey monitoring of SMPs:
1. A settlement reference point shall be designated by a marking on a hydrant or other stable, permanent fixture located within the public right-of-way. The same location shall be surveyed for reference over the course of the project. Refer to the AWSS Settlement Monitoring Drawing(s) for the minimum number of SRP(s) to be installed as part of the survey monitoring work.

PART 3 EXECUTION

3.01 SUPPORT OF EXISTING PW, RW, AND AWSS FACILITIES

- A. Inspection, Review and Approval of Methods

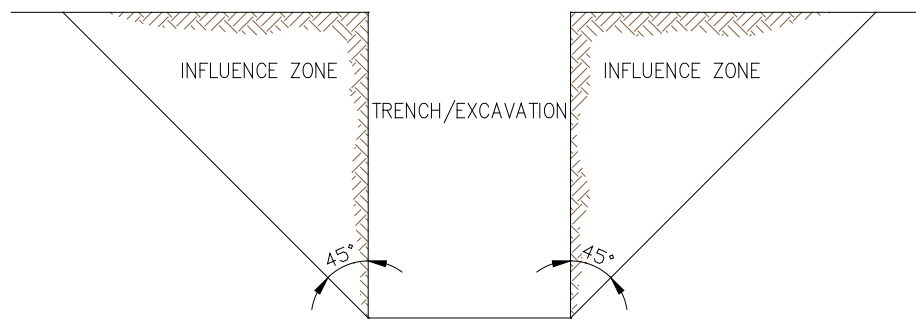

1. If existing SFPUC CDD facility, not shown on the drawing or is shown on the drawing outside of the influence zone, is found to be within the influence zone of the proposed trench/excavation as shown in the figure above, the Contractor is required to contact CDD Engineering and request an inspection to review and approve the field methods being used and/or proposed for the protection of CDD facility. CDD Engineering reserves the right to require the Contractor to implement protection methods, such as placement of steel plates over AWSS or water facilities, additional shoring and pipe supports, use of hand-digging, change shoring system around impacted CDD facilities, or other protective methods, as appropriate for full protection of the CDD facilities.
2. If two or more consecutive SFPUC CDD lead filled, cast-iron pipe joints are located within the trench/excavation, CDD requires replacement of the existing pipe with new ductile iron pipe with elastomeric EPDM joint gaskets within the influence zone prior to excavating below the pipe.
3. Existing valves exposed in trench/excavation:
 - a. If existing valve with lead filled joints will be exposed within the trench/excavation, CDD requires replacement of the existing valve and cast-iron pipe with new ductile iron pipe with elastomeric EPDM joint gaskets within the influence zone prior to excavating below the pipe as shown in the drawings.
 - b. If existing valve with restrained elastomeric gasketed joints connecting to ductile-iron pipe will be exposed within trench/excavation, pipe support requirement shall be the same as that for ductile-iron pipe as specified in the following requirement. If valve is not restrained, restraints shall be added by CDD prior to excavating below the valve.
4. Pipe supports are required where CDD pipe is exposed more than:
 - a. 6 ft. for cast-iron pipe with no exposed joint.

- b. 3.5 ft. for cast-iron pipe with exposed joint.
 - c. 10 ft. for ductile-iron pipe with no exposed joint.
 - d. 6 ft. for ductile iron pipe with exposed joint(s).
5. Sheet pile driving adjacent to existing CDD pipe shall maintain a minimum clear spacing between back of sheet pile and edge of pipe of:
 - a. 1.5 ft. for ductile iron pipes.
 - b. 4 ft. for cast-iron pipes. If within 4 ft., settlement monitoring is required for both LPW and AWSS lines. Settlement monitoring of LPW lines shall be the same as for AWSS lines unless approved otherwise by CDD Engineering.
 6. Main disconnection/reconnection, and valve replacement work for PW and RW shall be performed by SFPUC CDD. Excavation, backfilling, pipe laying, paving, traffic control, permitting, and any other support work necessary for the PW and RW replacement work shall be the Contractor's responsibility. All AWSS replacement work shall be performed by Contractor or subcontractor qualified by CDD to perform AWSS main installation. All replacement valves and piping for CDD replacement is supplied by CDD.
 7. Provide details and calculations for structural support for the protection of exposed and/or undermined sections of SFPUC CDD facilities. Details and calculations shall be signed and stamped by a California licensed Civil or Structural Engineer. Structural supports shall be designed to protect (1) AWSS pipes constructed with Class H cast iron lead jointed pipe operating at 350 psi static pressure, (2) AWSS pipes constructed with Class 56 ductile iron pipe, (3) PW pipes constructed with Class B cast iron lead jointed pipe operating at 150 psi static pressure, and (4) PW or RW pipes constructed with Class 53 ductile iron pipe operating at 150 psi static pressure. Maximum deflection in pipe support members shall not exceed $L/500$, where L is the unsupported length of the member.

B. Restoration of Facilities

If project work exposes CDD facilities, the Contractor is required to

1. backfill and compact in compliance with San Francisco Department of Public Works (SFDPW) Street Excavation Code or as required by SFPUC CDD; and

2. perform soil compaction testing for backfill material placed within three (3) feet, horizontally or vertically, from the outside edge of a water facility, with all test results furnished to CDD Engineering.

For excavations that expose more than four (4) feet of CDD facilities or pipe joint (4-inch and smaller pipes are excluded), backfill is required to be constructed with control density fill (CDF) material. CDF material shall be free of organic materials and other deleterious substances. The CDF material shall have produced 28 days unconfined compressive strength from 50 pounds per square inch (psi) to a maximum of 100 psi and shall contain aggregate no larger than 3/8" top size with the 3/8" aggregate comprise less than 30% of the total aggregate content.

CDF material shall begin at one (1) foot above the top of any utility crossing under a CDD facility and continue up to the bottom of the CDD facility. CDF material shall not extend beyond the spring-line of any CDD facility. Width of CDF backfill shall be OD of CDD pipe + 1ft on each side.

3.02 INSTALLATION OF AWSS SETTLEMENT REFERENCE AND MONITORING POINTS AND SUPPORT OF PIPE

A. Installation

The SRPs and SMPs shall be installed prior to the start of construction work requiring excavation around AWSS pipe.

For SRPs at fire hydrants, the contractor shall select the top center of fire hydrant. The contractor must ensure that the exact same point is used to establish survey control prior to monitoring of SMPs and additional SRPs.

For installation of SMPs outside of trench/excavations, the Contractor shall expose the bell of the pipe so that the position of the guide pipe on the bell can be visually verified before backfilling. The installation method used shall not cause the guide pipe to move from its intended position.

For installation of SMPs inside of trench/excavations, the Contractor shall verify the leveling rod is positioned on top of the pipe by verifying the pipe crown with a level vial and marking the exact location on the pipe to ensure consistent monitoring of the same point.

The correct positioning of each SRP and SMP on the top of the pipe bell shall be verified and approved by a CDD Representative by visual inspection. To request an inspection by a CDD Representative, please contact CDD Engineering a minimum of five (5) business days in advance to schedule the inspection.

It is the responsibility of the Contractor to maintain all SRP and SMP installations in working order at all times.

The Contractor shall contact CDD Engineering to perform a “drop test” before installation of SMPs or SRPs to determine the ability of the pipe to maintain pressure. The CDD Representative will isolate the AWSS line during the installation of SMPs and SRPs and reactivate the line after the construction of the SMPs and SRPs is completed by the Contractor. To request a drop test by a CDD Representative, please contact CDD Engineering a minimum of five (5) business days in advance to schedule the test.

B. Removal

The SMPs and SRPs shall be removed by the Contractor, including pipe guides, monitoring well frames and covers and the roadway restored to its original condition(s).

C. Survey of Settlement Reference and Monitoring Points

1. The Contractor shall obtain elevations of all SMPs and SRPs, by a State of California licensed Land Surveyor.
2. Initial Survey: Record the elevations within an accuracy of 0.005 feet (1/16-inch) for each settlement monitoring point on all surveys. After completion of each instrument installation, take 3 sets of verification data readings for each instrument to demonstrate the adequacy of the installation, to demonstrate the proper operation and precision of the instrument, and to establish an initial value. Differential Leveling and Total station accuracy shall comply with the accuracy standard specified in Caltrans Second Order Differential Leveling Specifications and Second Order (Vertical) TSSS Survey Specifications respectively. If differential leveling survey method is used, a collimation (Two-Peg) test shall be performed to ensure accuracy within 0.003 feet prior to each survey run. Submit the initial readings to the City Representative.
3. Monitoring Schedule: Take readings of all SMPs and SRPs prior to the start of construction, once after the construction work is completed, and a final time a week after all construction work is completed. Intermediate monitoring frequency during construction shall as a minimum comply with the following:

Monitoring Frequency During Sheet Pile Driving	Monitoring Frequency During Excavation or Backfill	Monitoring Frequency in or Around Open Trench	Monitoring Frequency Away from Open Trench
Daily ¹	Daily ²	3 Days ³	Once ⁴

Notes:

- ¹ For SMP's within 25 ft. of pile driving, monitor daily if pile installation using vibratory hammer and every four hours if pile installation using impact hammer.
 - ² Daily for SMPs within 25 ft. of a trench section being actively excavated or backfilled.
 - ³ Once every three days for SMPs within 25 ft. of an open trench after excavation is completed and utilities are being installed.
 - ⁴ Once after trench within 25 ft of SMP is completely backfilled unless directed otherwise by the City Representative.
4. Elevation readings from SMPs and SRPs are to be tabulated in chronological order with all previous results and sent to CDD Engineering for review and approval within 24 hours of the survey being performed. Measurements shall be provided in "feet". Provide a plot of measured values versus time, including a time history of construction activity likely to influence such readings.

D. Response Values and Required Actions

1. The Maximum Allowable Settlement shall not result in any joint deflecting more than 1/4 degrees, where the deflection angle is calculated using this equation:

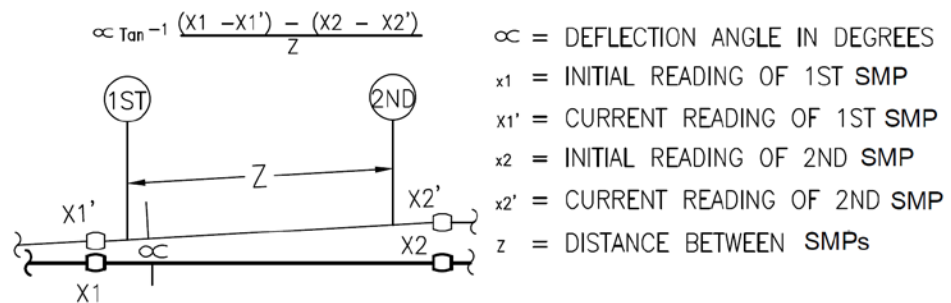

2. The response values are measured as a percentage of the Maximum Allowable Settlement. The Contractor shall abide by the following Response Values.

Threshold Value	Contractor Response Value	Shutdown Value
50%	80%	100%

3. When a given response value is reached, the Contractor shall provide written notice within the specified time and respond in accordance with the following:
- a. **Threshold Value:** The Contractor shall provide written notice within 24 hours of occurrence and meet with the City Representative within 24 hours of providing notice to discuss his means and method to determine what changes, if any, shall be made to better control ground movement. Instrument readings shall be required on a daily basis, unless instructed otherwise, until five consecutive working days of readings do not worsen the settlement by more than 5% of the Maximum Allowable.
 - b. **Contractor Response Value:** The Contractor shall provide written notice and meet with the City Representative within 24 hours to discuss his means and method to determine what changes shall be made to better control ground movement. The Contractor shall actively control ground movement in accordance with the approved plan to prevent reaching the Shutdown Value:
 - c. **Shutdown Value:** Contractor shall stop all work immediately and provide written notice within one hour upon occurrence. The Contractor shall meet with the City Representative to develop a plan of action before the work can be resumed. A drop-test will be performed by CDD prior to continuation of work.

E. Arrangement with Utility Companies

The Contractor shall make all necessary arrangements with the public service utility companies and obtain all necessary permits for any work or alteration of facilities as may be required due to the above described work.

E. Street and Sidewalk Restoration

Sidewalk and pavement restoration shall include the replacement of traffic lane(s) and crosswalk stripes, parking stall markings, and curb painting that might be obliterated during the installation/removal of the SRPs and SMPs construction.

F. Expose, Test, Realign, and Repair of AWSS Facilities

1. Requirement of Repair Work

Should readings from any two sets of surveys indicate a change in deflection at or exceeding the Shut Down Value, the Contractor shall stop all construction work in the vicinity of the AWSS facilities until the AWSS facilities have been inspected, repaired, if necessary, and the CDD Representative authorizes the Contractor to resume construction work.

If the CDD Representative determines that repairs are required, the Contractor will be responsible for preparing and restoring the site(s) for repairing the damaged joint(s). Repair of damaged joint(s) shall be done by CDD at Contractor's expense.

Site preparation and restoration will include

- a. Contractor shall submit for review and approval by CDD Engineering, structural plans and details for the support and protection of AWSS facilities in the vicinity during repair of the damaged joint;
- b. Contractor shall support and protect AWSS facilities per approved submittal(s);
- c. Contractor shall excavate a trench as required by CDD Engineering to expose the damaged AWSS pipe joint for repair purposes;
- d. Upon direction and approval from a CDD Representative, Contractor shall remove support and protection devices, and restore facilities as described in this Section; and
- e. CDD Representative shall inspect and approve all site preparation and restoration for AWSS joint repair work.

2. Contractor Responsible for all Costs

Exposure and restoration, testing, realignment, replacement, and repair of existing AWSS facilities as described in this Section including furnishing of materials, labor, equipment including pump and tools necessary, or required, to do such work shall be at the expense of the Contractor.

The Contractor shall be responsible for all CDD labor and material costs associated with repairing the damaged AWSS facilities.

3. Testing

The Contractor is hereby notified that change in deflection of an AWSS pipe joint will require all the joints between two adjacent SRPs (on each side of the surveyed joint) to be exposed and realigned to the original alignment. The realignment of the pipe shall require CDD to isolate the pipe by closing gate valve(s), testing the aligned pipe at a pressure of 350 psi (or other pressure designed by the CDD Engineer), repair any joints showing leakage or lead extrusions, and reactivating the pipe.

A CDD Representative will witness all pressure tests when performed by the Contractor where alignment of the pipe is not required. The Contractor shall inform CDD Engineering a minimum of five (5) business days before all tests.

NOTES:

1. THE CONTRACTOR SHALL REPORT THE LENGTH OF THE ROD TO THE NEAREST HUNDREDTH OF A FOOT TO THE CITY.
2. PLYWOOD SHALL BE PRESS FIT TO THE 7/8"Ø STEEL ROD AND SHALL FLOAT IN THE GUIDE PIPE.
3. MONITORING HOLE COVER AND FRAME ASSEMBLIES SHALL BE RATED FOR H-20 LOADING.
4. CONTRACTOR SHALL RESTORE ROADWAY TO (E) CONDITIONS UPON COMPLETION OF SURVEY WORK.

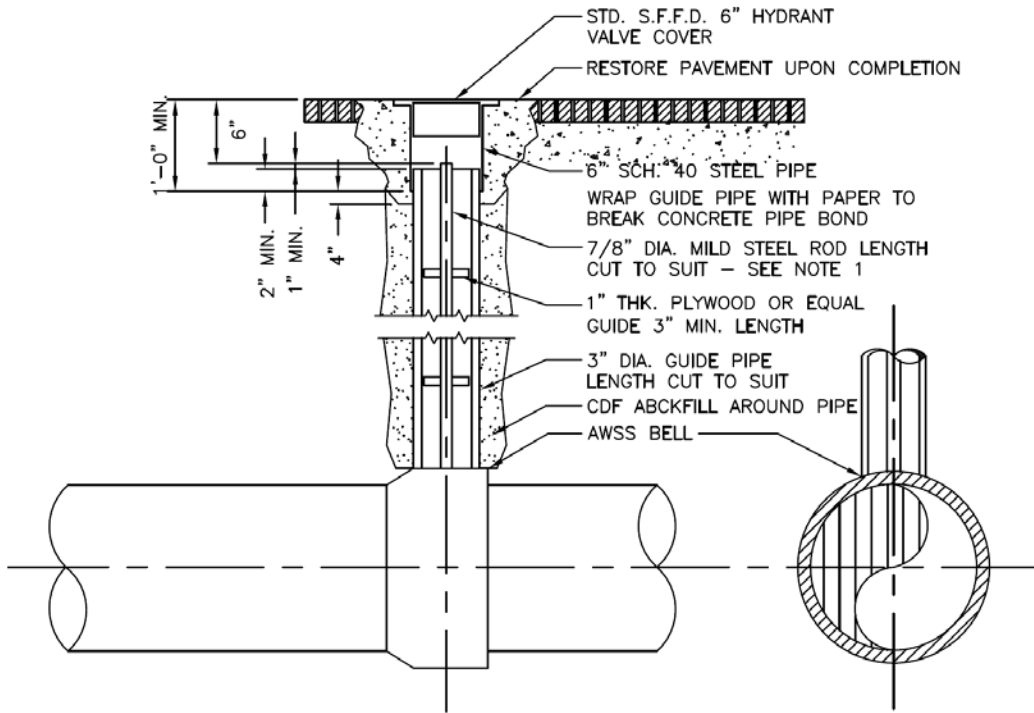

**CITY AND COUNTY OF SAN FRANCISCO
PUBLIC UTILITIES COMMISSION
SAN FRANCISCO WATER DEPARTMENT**

AUXILIARY WATER SUPPLY SYSTEM - STANDARD DETAILS

AWSS SETTLEMENT MONITORING POINT FOR BELL AND SPIGOT PIPE

	BY: DOUG LEE	DR: GLORIA CHU	DRAWING NO.
APPROVED: SAM YOUNG	CH: THANH NGUYEN	SCALE: NONE	HPL-5993
CDD MANAGER: KATIE MILLER	DATE: 01/2015	VERSION:	

NOTES:

1. THE CONTRACTOR SHALL REPORT THE LENGTH OF THE ROD TO THE NEAREST HUNDREDTH OF A FOOT TO THE CITY.
2. PLYWOOD SHALL BE A PRESS FIT TO THE 7/8"Ø STEEL ROD AND SHALL FLOAT IN THE GUIDE PIPE.
3. MONITORING HOLE COVER AND FRAME ASSEMBLIES SHALL BE RATED FOR H-20 LOADING.
4. CONTRACTOR SHALL RESTORE ROADWAY TO (E) CONDITIONS UPON COMPLETION OF SURVEY WORK.

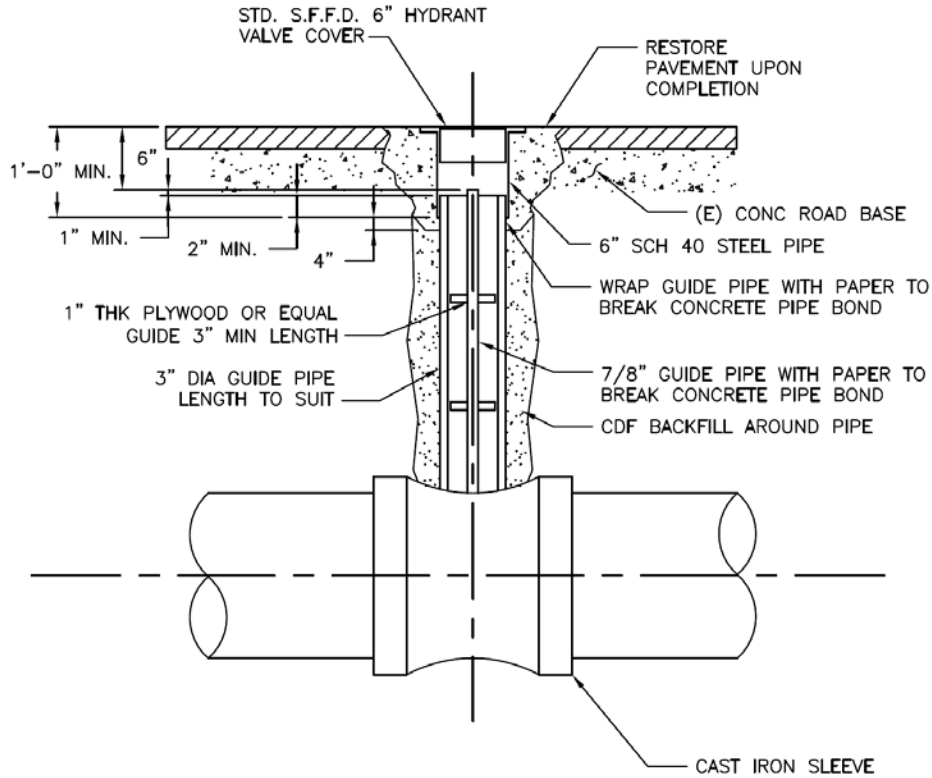

**CITY AND COUNTY OF SAN FRANCISCO
PUBLIC UTILITIES COMMISSION
SAN FRANCISCO WATER DEPARTMENT**

AUXILIARY WATER SUPPLY SYSTEM -- STANDARD DETAILS

AWSS SETTLEMENT MONITORING POINT FOR DOUBLE SPIGOT PIPE

	BY: DOUG LEE	DR: GLORIA CHU	DRAWING NO. HPL-5993.1
APPROVED: SAM YOUNG	CH: THANH NGUYEN	SCALE: NONE	
CDD MANAGER KATIE MILLER	DATE: 01/2015		

END OF SECTION