

Low Impact Development (LID) Plan

**Tract Map No. 82836
Rorimer Street Condominiums
Unincorporated Territory of Los Angeles County, California**

Prepared for:

The Olson Company
3010 Old Ranch Parkway, Suite 100
Seal Beach, CA 90740
Contact: Steve Armanino
(562) 596-4770

Property:

18616 Rorimer Street
La Puente, CA 91744

Prepared by:



6 Orchard, Suite 200
Lake Forest, CALIFORNIA 92630
T. 949.916.3800
Contact: Ryan Bittner, P.E.
David Terry, Project Manager

Prepared: August 15, 2019
1st Revision: November 2019
2nd Revision: March 2020
3rd Revision: May 2020

Table of Contents

<u>SECTION</u>	<u>PAGE</u>
<u>SECTION 100</u>	
COVER	I
TABLE OF CONTENTS	I
LIST OF APPENDICES	II
OWNER/DEVELOPER'S CERTIFICATION STANDARD URBAN STORMWATER MITIGATION PLAN ..	III
<u>SECTION 200</u>	1
A.Contact Information/List of Responsible Parties	1
<u>SECTION 300</u>	2
A.References	2
<u>SECTION 400 – BODY OF SUSMP</u>	3
A.Objectives	3
B.Project Background and Description	3
C.Vicinity Map	3
D.Site Drainage Condition.....	4
E.LID Project Types, Characteristics, & Activities.....	4
F.Pollutant Source Identification and BMP Selection	5
G.Source Control BMPs	5
H.Structural BMPs.....	12
I.BMP Maintenance, Inspection, and Repair.....	14
J.Inspection, Maintenance, and Responsibility for BMPs	14
K.Operation/Maintenance Funding after Project Completion	17

List of Figures

- Figure -1:
Project Vicinity Map
- Figure -2:
Project Location Map
- Figure -3:
Project BMPs Exhibit
- Figure -4:
Impaired Waters
- List of Appendices
- Appendix A:
Volume and Flow Rate Calculations and Hydrologic Report
- Appendix B:
Site BMPs
- Appendix C:
'Wetland Mod' Biofiltration Treatment System, Catch Basin Insert Filter, Sump Pump, and Detention System Specifications/Details
- Appendix D:
"NO DUMPING – DRAINS TO OCEAN" Stencil Examples
- Appendix E:
Catch Basin Cleaning
- Appendix F:
General Education Materials
- Appendix G:
BMP Maintenance, Inspection, and Repair Log and Checklist

**Owner/Developer's Certification
Low Impact Development Plan
for
Tract Map No. 82836
La Puente Condominiums
18616 Rorimer Street**

This Low Impact Development Plan (LID) for the LA Puente Condominiums development has been prepared for The Olson Company by C&V Consulting, Inc. It is intended to comply with the requirements of the County of Los Angeles, requiring the preparation of a project specific LID Plan.

I certify under penalty of law that this document and all attachments were prepared under my jurisdiction or supervision in accordance with a system designed to assure that qualified personnel properly gather and evaluate the information submitted. Based on my inquiry of the person or persons who manage the system or those persons directly responsible for the gathered the information, to the best of my knowledge and belief, the information submitted is true, accurate, and complete. I am aware that there are significant penalties for submitting false information, including the possibility of fine and imprisonment for knowing violations.”

The undersigned, while it owns the subject property, is responsible for the implementation of the provisions of this plan and will ensure that this plan is amended as appropriate to reflect up-to-date conditions on the site consistent with the current Los Angeles County Storm-water Quality Management Plan (SQMP), and the intent of the storm-water and urban runoff NPDES Permit and Waste Discharge Requirements for the County of Los Angeles, Los Angeles County Flood Control District and the incorporated Cities of Los Angeles County under the jurisdiction of the Los Angeles Regional Water Quality Control Board. A copy of this LID Plan will be maintained at the project site/office.

This LID Plan will be reviewed with the facility operator, facility supervisors, employees, tenants, maintenance and service contractors, or any other party having responsibility for implementing portions of this LID Plan. At least one copy of the approved and certified copy of this LID Plan shall be available on the subject property in perpetuity. Once the undersigned transfers its interest in the property, its successors-in-interest shall bear the aforementioned responsibility to implement and amend the LID Plan.

	The Olson Company
Owner/Developer's Signature	Company
Thomas Moore, Vice President, 3010 Old Ranch Parkway, Suite 100, Seal Beach, California	
Owner/Developer's Name and Title	Company Address
(562) 596-4770	
Telephone Number	Date

Section 200

A. Contact Information/List of Responsible Parties

The property contact information is:

**Mr. Thomas Moore
Tel: (562) 596-4770
The Olson Company
3010 Old Ranch Parkway, Suite 100
Seal Beach, California 90740**

The Property Owner initially will maintain and then the Homeowner's Association shall have primary responsibility and significant authority for the implementation, maintenance, and inspection of the property BMPs along with the Homeowner's Association as it takes over the management responsibilities. Duties will include, but are not limited to:

- To comply with the Los Angeles County requirements and the requirements of the Los Angeles County MS4 Permit.
- Implementing all elements of the LID Plan, including but not limited to:
 - Maintaining BMPs
 - Inspection
 - Providing education to Condominium Owner's
- Pre-storm inspections;
- Storm event inspections;
- Post-storm inspections;
- Routine inspections as described in the LID Plan;
- Ensuring elimination of all unauthorized discharges;
- The Homeowner's Association shall be the responsible authority to mobilize crews in order to make immediate repairs to the site BMPs;
- Coordinate all of the necessary corrections/repairs are made immediately, and that the project complies with the LID Plan at all times;

Section 300

A. References

The following documents are made a part of this LID Plan by reference:

- Vesting Tentative Tract Map and Exhibit A for Tract No. 82836, 6 sheets, prepared by C&V Consulting, Inc., 6 Orchard, Suite 200, Lake Forest, California 92630;
- MS4 Permit, California Regional Water Quality Control Board, Los Angeles Region, Order No. R4-2012-0175, National Pollutant Discharge Elimination System (NPDES) Permit No. CAS 004001, Waste Discharge Requirements for Municipal Separate Storm Sewer System (MS4) Discharges within Coastal Watershed of Los Angeles County, except those discharges originating from the City of Long Beach MS4, November 8, 2012.
- State Water Resources Control Board (SWRCB) National Pollutant Discharge
- California Stormwater BMP Handbook – Construction, January 2003;
- California Stormwater BMP Handbook – New Development and Redevelopment, January 2003.

Section 400 – Body of LID Plan

A. Objectives

This Low Impact Development Plan (LID) has four main objectives:

- 1) Identify all pollutant sources, including sources of sediment that may affect the quality of storm water discharges associated with daily use / activity (storm water discharges) from the property site.
- 2) Identify non-storm water discharges.
- 3) Identify, construct, implement and maintain Best Management Practices (BMPs) to reduce or eliminate pollutants in storm water discharges and authorized non-storm water discharges from the property site.
- 4) Develop a maintenance schedule for BMPs designed to reduce or eliminate pollutants.

B. Project Background and Description

The project is a land development which proposes to create a residential community from an existing Church Site and parking lot. This project proposes 56 residential condominium units within 10 buildings. The site will be accessible via one proposed driveway entrance along Rorimer Street, and units along the southern property line will be accessible via Pacato Road. At grade parking is provided along private drive aisles. Total project net area is approximately 1.94 acres. There is no pool and/or spa proposed for this project.

The existing use was used as Church site and was mostly paved with concrete pavement, asphalt pavement and existing structures with concrete foundations which cover 89% of the site. The existing site is 89% impervious and 11% pervious.

The proposed use of residential development will comprise of approximately 78% impervious cover and 22% pervious cover.

The proposed project increased perviousness by 11%. In addition, the project will discharge to an engineered storm drain system and/or street section to storm drain. Therefore hydromodification improvements are not necessary.

The Olson Company and subsequent Homeowner's Association will be responsible for the maintenance of the project.

C. Vicinity Map

The subject project is located in the South San Jose Hills portion of Unincorporated Territory of Los Angeles County in the LA Puente area characterized by commercial and residential uses. Surrounding the project site is La Seda Road to the west, Pacato Road to the south and a Mobile Home Park, single family homes to the east, and Rorimer Street and single family homes to the north. Please refer to Figures 1 & 2 for Vicinity and Location maps.

D. Site Drainage Conditions

Under the existing condition, site runoff generally sheet flows from north to south towards Pacado Road. Flows continue west along Pacado Road in a concrete v-ditch on the south side of the road adjacent to an existing masonry wall. The v-ditch outlets to La Seda Road through a parkway drain and then continues south in La Seda Road. Within La Seda Road, stormwater is captured by an existing public storm drain system which flows south in La Seda Road and ultimately outlets to San Jose Creek. San Jose Creek drains through the San Gabriel River which ultimately discharges to the Pacific Ocean. San Gabriel River Reach 3 is listed as a 303(d) water body for Indicator Bacteria, San Gabriel River Reach 2 is listed as a 303(d) water body for Lead, Cyanide, and Water Temperature, San Gabriel River Reach 1 is listed as a 303(d) water body for pH and Water Temperature, and the San Gabriel River Estuary is listed a 303(d) water body for Copper, Nickel, Dioxin, Indicator Bacteria, and Dissolved Oxygen.

The proposed site will utilize a proposed WetlandMod biofiltration unit with upstream detention to temporarily store and biotreat 1.5x the treatment volume for the 85th percentile storm event prior to discharging to Pacato Road. Surface runoff will be collected by several grate inlets within the proposed onsite drive aisles and by a series of area drains within landscaped areas and conveyed to the proposed detention system. Runoff tributary to area drains is pretreated through landscaping, and all grate inlets within the street will be equipped with Oldcastle FloGard catch basin insert filters for pretreatment of street runoff. The proposed detention system has been sized for 1.5x the treatment volume and will drain to a diversion structure which diverts low flows to the proposed WetlandMod. Treated stormwater is then pumped to an outlet grate near the southern property line. During larger storm events and when the detention system is at capacity, an overflow pipe within the proposed diversion structure will allow high flows to bypass the WetlandMod and flow directly to a separate overflow grate. Both the pump discharge grate and high flows overflow grate will be open-bottom to allow nuisance water to percolate and prevent vector control issues. Refer to separate Hydrology Study prepared by C&V Consulting, Inc. within Appendix A.

The project site is currently subject to offsite run-on from a portion of the easterly adjacent property. In the proposed condition, a proposed concrete swale will capture and convey offsite run-on towards Pacato Road. Offsite run-on will not be treated nor will it comingle with site runoff.

Hydromodification: The project is exempt from hydromodification analysis and control criteria all downstream receiving waters are engineered channels.

E. LID Project Types, Characteristics, & Activities

This proposed development of 56 residential condominiums and is subject to the Los Angeles County Department of Public Works (LACDPW) requirement for the LID Plan under the “Redevelopment” category. According to the LACDPW, “redevelopment” means land-disturbing activity that result in the creation, addition, or replacement of 5,000 square-feet or more of impervious surface area on an already developed site. Redevelopment includes, but not limited to: the expansion of a building footprint; addition or replacement of a structure; replacement of impervious surface area that is

not part of a routine maintenance activity; and land disturbing activities related to structural impervious surfaces. It does not include the routine maintenance to maintain original line and grade, hydraulic capacity, or original purpose of facility, nor does it include emergency construction activities required to immediately protect public health and safety. Where redevelopment results in an increase of less than fifty percent of the impervious surfaces of a previously existing development, and the existing development was not subject to the LID Plan, the Design Standards apply only to the addition, and not to the entire development.

Per the Los Angeles Department of Public Works (LACDPW), Low Impact Development Standards Manual, dated February 2014, the proposed project is classified as a "Designated Project." A "Designated Project" is defined by the LACDPW as follows:

"Redevelopment projects, which are developments that result in creation or addition or replacement of either: (1) 5,000 square feet or more of impervious surface on a site that was previously developed as described in the above bullets; or (2) 10,000 square feet or more of impervious surface area on a site that was previous developed as a single family home."

F. Pollutant Source Identification and BMP Selection

The following is a list of materials to be used in the daily post-construction activities at the project site, which will potentially contribute to pollutants to storm water runoff. Control Practices for each activity are identified below:

- Vehicle fluids, including oil, grease, petroleum, and coolants from personal vehicles
- Landscaping materials and wastes (topsoil, plant materials, herbicides, fertilizers, mulch, pesticides)
- General trash debris and litter
- Pet waste (bacteria/ fecal coliform)

The Best Management Practices (BMPs) that have been selected for implementation on this project are detailed in the following sections.

G. Source Control BMPs

Project proponents shall implement Site Design concepts that achieve each of the following:

- Minimize Urban Runoff
- Minimize Impervious Footprint
- Conserve Natural Areas
- Minimize Directly Connected Impervious Areas (DCIAs)

The following tables identify the source control and treatment BMPs and how each implemented to achieve each Site Design concept.

**Low Impact Development Plan
Vesting Tentative Tract Map No. 82836
Unincorporated Territory of Los Angeles County, California**

Table-1: Site Design BMPs

BMP	TECHNIQUE	INCLUDED?		BRIEF DESCRIPTION OF METHOD
		YES	NO	
	Minimize Impervious Area/Maximize Permeability (C-Factor Reduction)	X		We have incorporated landscape areas wherever possible within the project. See Appendix "B" for details.
	Minimize Directly Connected Impervious Areas (DCIAs) (C-Factor Reduction)	X		We minimize DCIAs by limiting sidewalks and patios to the minimum necessary for proper use. Stepping stones are used in areas with minimal foot traffic.
	Create Reduced or "Zero Discharge" Areas (Runoff Volume Reduction)	X		The project drains toward the center of the site where a landscape and pedestrian pathway traverse the site east to west.

**Low Impact Development Plan
Vesting Tentative Tract Map No. 82836
Unincorporated Territory of Los Angeles County, California**

Table-2: Treatment Control BMPs

BMP	NAME	INCLUDED?		IF NOT APPLICABLE, STATE BRIEF REASON
		YES	NO	
TC-10	Infiltration Trench		X	Space not available for BMP & Geotechnical Engineer determined infiltration not feasible.
TC-11	Infiltration Basin		X	Space not available for BMP due to close spacing of buildings & Geotechnical Engineer determined infiltration not feasible.
TC-12	Retention/Irrigation (Rainwater Harvest)		X	Harvest and reuse measures are considered as infeasible for this type of development due to the nature of providing cisterns and pumps throughout the site as being cost prohibitive and only being effective during the rainy season doubled with the dry nature of Southern California climate. Additionally, with site landscaping at approximately only 22% of the project site, the demand for grey water from harvest and reuse measures is relatively low making this type of control measure ineffective. This is not a practical solution for this multi-tenant high density project.
TC-20	Wet Detention Basin		X	This is not a wetland area/ development.
TC-21	Constructed Wetland		X	This is not a wetland area/ development.
TC-22	Dry Detention Basin (Extended Detention Basin)		X	Space not available for BMP.
TC-31	Vegetated (Grass) Strips		X	Space not available for BMP.
TC-30	Vegetated (Grass) Swales		X	Space not available for BMP.
TC-32	Bioretention		X	Retention/infiltration is considered infeasible for this development as determined by the Geotechnical Engineer.
MP-40	Media Filter	X		Catch basin insert filters will be installed in grate inlets in drive aisles for pretreatment of street runoff.
BIO-1	Biofiltration	X		A proposed WetlandMod Biofiltration unit will provide treatment of 1.5 x the SWQDV.

BIO-1 – Biofiltration ('WetlandMod' Biofiltration Treatment System)

The unique treatment capabilities of the 'WetlandMod' System - 'Bioclean' System) incorporates capture, screening, hydrodynamic separation, advanced media filtration, biofiltration, and high flow bypass pipe outside vault to allow larger storm flows around the treatment structure.

The 'BioClean' System removes a range of pollutants associated with urban run-off. Suspended Solids, Heavy metals, Pathogens, Phosphorus, oil and grease pollutants are removed from storm water runoff at a high level of efficiency. The public Agency has found that this system is an acceptable solution to biological treatment of first flush storm water during the project Entitlement Phase of the project when infiltration is not an option for a site due to Geotechnical issues with underlying soils. The 'Bioclean' System treats runoff by first intercepting flow through a pre-treatment chamber and pipe inlet from the area drain storm drains and storage pipe where it's screened through a filter where trash, litter, gross solids and sediment are captured. The second stage of treatment provides treatment through biofiltration media. The perimeter filter utilizing bio-media provides physical treatment by physically and chemically capturing fine total suspended solids, metals, nutrients, and bacteria. The final stage of treatment provides treatment in the wetland chamber through sub-surface flow by biological remediation through a combination of physical, chemical, and biological processes. High flows have an internal bypass when flows exceed flow rates greater than the systems treatment capacity, where they drain directly into the discharge chamber.

The 'Bioclean' System is a flow-based BMP for this project and is designed based on the Manufacturer's design calculations for the device at the Treatment Design Flow Rate provided in Appendix 'A'. Since the site is not providing infiltration the design flow rate is 1.5 times the LID volume. Storage chambers are provided upstream of the biofiltration system to ensure this volume is captured and fed to the biofiltration system. See Appendix 'A' for volume calculations.

MP-40 – Media Filter (Oldcastle FloGard Catch Basin Insert Filter)

Oldcastle FloGard catch basin insert filters are certified by the Water Board as full trash capture systems. The filters are designed to remove suspended solids, trash, and hydrocarbons from stormwater which are primary pollutants of drive aisles and parking areas. These filters will be installed in all grate inlets with the proposed onsite drive aisles. The filters will minimize the susceptibility of storm drain clogging and provide pretreatment of the treatment volume prior to the primary treatment device.

**Low Impact Development Plan
Vesting Tentative Tract Map No. 82836
Unincorporated Territory of Los Angeles County, California**

Table-4: Source Control BMPs

BMP	BMP DESCRIPTION	INCLUDED?		IF NOT APPLICABLE, STATE BRIEF REASON
		YES	NO	
	Non-Structural Source Control BMPs:			
	Education for Owners, Leasors, Operators, Occupants, or Employees	X		
	Activity Restrictions (CC&Rs)	X		
S-8	Efficient Irrigation System and Landscape Maintenance	X		
S-3	Common Area Litter Control	X		
SE-7	Street Sweeping Private Streets and Parking Lots	X		
	Drainage Facility Inspection and Maintenance	X		
	Structural Source Control BMPs:			
S-1	MS4 Stenciling and Signage	X		
S-8	Landscape and Irrigation System Design	X		
SD-10	Protect Slopes and Channels		X	Not Applicable
S-9	Building Materials Selection	X		
	Proper Site Design:			
SD-30	Fueling Areas		X	Not Applicable
SD-31	Maintenance Bays and Loading Docks		X	Not Applicable
S-3	Trash Storage Areas	X		
SD-33	Vehicle and Equipment Wash Areas		X	Car Wash Areas are not permitted within the proposed development – Not Applicable.
SD-34	Outdoor Material Storage		X	Not Applicable
SD-35	Outdoor Material Storage Areas		X	Not Applicable
SD-36	Outdoor Work Areas or Processing Areas		X	Not Applicable
	Provide Wash Water Controls for Food Preparation Areas		X	Not Applicable

Non-Structural Measures

Non-structural BMPs are generally managerial, educational, inspection and/ or maintenance oriented. These items consist of educating employees and occupants, developing and implementing The Olson Company guidelines, implementing BMPs and enforcing Code requirements. Non-structural BMPs used for this project are summarized below:

Education for Employees and Occupants

Practical informational materials will be provided to homeowners, business owner's by The Olson Company and its employees on general good housekeeping practices that contribute to protection of storm water quality. Among other things, these materials will describe the use of chemicals (including household type) that should be limited to the property, with no discharge of specified wastes via hosing or other direct discharge to gutters, catch basins and storm drains.

Initially The Olson Company will provide these materials. Thereafter, such materials will be available through The Olson Company education program.

This program must be maintained, enforced, and updated periodically by The Olson Company. Educational materials including, but not limited to, the materials included in the Appendix E of this plan will be made available to the employees and contractors of The Olson Company.

Activity Restrictions

Activities on this site will be limited to activities related to residential living or the limited commercial retail business limited to lots 2 and 3. The project's Conditions, Covenants, and Restrictions (CC&Rs) will outline the activities that are restricted on the property. Such activities related to the LID Plan include car washing, car maintenance and disposal of used motor fluids, pet waste cleanup, and trash container areas.

Common Area Landscape Management

Management programs will be designed and established by The Olson Company and subsequently the Homeowner's Association, which will maintain the common areas within the project site. These programs will include how to mitigate the potential dangers of fertilizer and pesticide usage (refer to the Maintenance and Frequency Table).

Ongoing maintenance will be consistent with the State of California Model Water-Efficient Landscape Ordinance.

Fertilizer and pesticide usage shall be consistent with County Management Guidelines for use of Fertilizers and Pesticides.

BMP Maintenance

The Olson Company will be responsible for implementing each of the BMPs detailed in this plan. The Olson Company and the subsequent Homeowner's Association will also be responsible for cleaning and maintaining the BMPs on a regular basis. Maintenance operations should be logged in Appendix G.

Title 22 CCR Compliance

The Olson Company will comply with this Regulation.

Uniform Fire Code Implementation

The Olson Company will comply with this Code.

Common Area Litter Control

The Olson Company will be required to implement trash management and litter control procedures in the common areas aimed at reducing pollution of drainage water. The Olson Company may also contract with their landscape maintenance firm to provide this service during regularly scheduled maintenance, which should consist of litter patrol, emptying of trash receptacles in common areas, and noting trash disposal violations and reporting the violations to The Olson Company for remediation.

Employee Training

A training program will be established as it would apply to future employees, contractors, and homeowners of The Olson Company to inform and train in maintenance activities regarding the impact of dumping oil, paints, solvents, or other potentially harmful chemicals into storm drains; the proper use of fertilizers and pesticides in landscaping maintenance practices; and the impacts of littering and improper water disposal.

The Olson Company (or a hired firm) will conduct the training program which will include targeted training sessions with specific construction disciplines (landscaping, concrete finishers, painters, etc.). See Appendix E for examples of educational materials that will be provided to the Employees.

The project's CC&Rs will include provisions for future employee training programs conducted on a yearly based prior to the rainy season.

Catch Basin Inspection

The Olson Company will maintain the drainage systems, including catch basins until ownership is transferred to the Homeowner's Association. The Homeowner's Association is required to have catch basins inspected and, if necessary, cleaned prior to the storm season, no later than October 15th each year prior to the "first flush" storm. These duties may be contracted out to the landscape maintenance firm hired by the Homeowner's Association. Please see Appendix E for maintenance program. Maintenance operations should be logged in Appendix G.

Street Sweeping Private Streets and Parking Lots

The Olson Company and the subsequent Homeowner's Association shall have all streets and parking lots swept on a weekly basis. This procedure will be intensified around October 15th of each year prior to the "first flush" storm.

H. Structural BMPs

Structural BMPs shall be installed by The Olson Company, the developer, as part of the development of the project, for instance; slope planting and irrigation systems shall be designed by licensed landscape architects and installed by qualified contractors to specifications and standards of the County of Los Angeles. The structural BMPs used for this project are summarized below:

With this project we anticipate minimal sediment runoff during the initial occupancy of the project, on-site trash, and the potential of on-site automobile oil. To mitigate these pollutants we propose the structural best management practices listed:

Biofiltration

Much of the site will be driveways and buildings and will be swept to remove litter. Storm runoff in the street and parking areas will flow to the catch basins, storm runoff in the landscape areas will flow to area drain inlets thru grass swales or planter areas wherever possible. All site drainage will run through the 'Bioclean' System biofiltration treatment vaults prior to discharge to the public right-of-way.

Efficient Irrigation

As part of the design of all common area landscape irrigation shall employ water conservation principals, including, but not limited to, such provisions as water sensors, programmable irrigation times (for short cycles), etc. will be used. Such common areas will be maintained by The Olson Company and the subsequent Homeowner's Association.

Runoff-Minimizing Landscape Design

As part of the design of all common area landscape areas, similar planting material with similar water requirements will be used in order to reduce excess irrigation runoff and promote surface filtration. Such common areas will be maintained by The Olson Company and the subsequent Homeowner's Association.

Community Car Wash Racks

No community car wash rack or area will be provided, therefore, washing of vehicles by residents on the property will not be allow per the CC&R agreement.

Wash Water Controls for Food Preparation Areas

A sign will be posted indicating that discharge of wash water to the municipal storm drain system is prohibited. All wash water should be disposed of to the sanitary sewer system. Restrictions will be enforced per the CC&R agreement.

Trash Container (Dumpster) Areas

Trash enclosure is provided at one location for the Commercial Retail portion of the project only and will be maintained regularly by Commercial Tenants.

Self Contained Washing

Self-contained washing of vehicles by residents or owners on the property will not be allowed per the CC&R agreement.

Outdoor Material Storage Areas

Outdoor material storage areas refer to storage areas or storage facilities solely for the storage of materials. Improper storage of materials outdoors may provide an opportunity for toxic compounds, oil and grease, heavy metals, nutrients, suspended solids, and other pollutants to enter the storm water conveyance system. Outdoor Storage by residents or owners on the property will not be allowed per the CC&R agreement.

Catch Basin Stenciling

Phrase "No Dumping – Drains to Ocean" or equally effective phrase to be stenciled on catch basins to alert the public to the destination of pollutants discharged into storm water. This stenciling will be inspected and re-stenciled on a periodic basis by The Olson Company. Please see Figure five (5) for maintenance frequency.

Inlet trash Racks

The 'Bioclean' System treatment system acts as a collector for trash. The units are designed to capture trash and hold it until the next maintenance event. Also, the development will be swept regularly to minimize the amount of trash and debris on-site. Please see the maintenance frequency schedule provided herein.

Water Quality Inlets

This BMP is provided with a pretreatment chamber as part of the 'Bioclean' System treatment system for trash and debris removal, plus removal of petroleum hydrocarbons (grease and oil) and other such pollutants before it enters the public street and storm drain system and thereby reduce the chemical pollutants which enter the storm drain system. Please see the maintenance frequency schedule provided herein.

Building Materials Selection

Materials for the roofs and exterior of all proposed buildings will be selected such that potential for metal pollutants are minimized and minimal maintenance/painting is required. Materials preferred include cement-fiber, vinyl, coated metal, recycled rubber and plastic.

I. BMP Maintenance, Inspection, and Repair

Inspections will be conducted as follows or as recommended by the manufacturer of proprietary systems:

- Annually prior to the start of the rainy season
- Every (1) month during rainy season
- At any other time(s) or intervals of time specified in the contract documents

An inspection form shall be completed at least once per year prior to the start of the rainy season. This inspection checklist (see Appendix G) shall be included in this report and kept onsite at all times. The checklist should be filled out completely and clearly indicate any BMPs that are in need of repair or maintenance. These repairs and/or maintenance procedures shall be carried out at the soonest possible time.

A legible log shall be kept on site to record the inspection of the stormwater pollution abatement control measures. The record must contain the following information: (i) type of maintenance activities or source-control practices; (ii) date the activities are completed; and (iii) the name of the operator performing the activities. During transfer of ownership/operation of the facility, the current owner must notify the new owner/operator of the BMPs and the associated maintenance activities that also transfer to the new owner/operator of the property. See Appendix G.

J. Inspection, Maintenance, and Responsibility for BMPs

The following tables show the lists of the post-construction BMPs (routine non-structural and structural), the required ongoing maintenance, the inspection and maintenance frequency, the inspection criteria, and the entity or party responsible for implementation, maintenance, and/or inspection.

**Low Impact Development Plan
Vesting Tentative Tract Map No. 82836
Unincorporated Territory of Los Angeles County, California**

Table-5: Non-Structural BMP Maintenance Responsibility/Frequency Matrix

BMP	RESPONSIBILITY	FREQUENCY
Homeowner/ Business owner Education, Activity Restrictions	The Olson Company will provide educational materials. Those materials and responsibilities must be passed onto subsequent property owners.	Continuous. CC&R's to be provided to homeowners/ business owners at the time they purchase the property and updates provided by The Olson Company as they occur.
Common Area Landscape Management	The Olson Company through its landscape maintenance contractor	Monthly during regular maintenance and use with management guidelines for use of fertilizers and pesticides.
Parking Areas and Drives Management	The Olson Company through its landscape maintenance contractor	The Parking Areas and Drives are to be swept on a routine scheduled basis to facilitate the pickup of trash and debris (plant or otherwise) and to remove excessive oil, grease and build-up. During sweeping, debris is to be removed from the parking areas and drives and then scrubbed and rinsed. This sweeping schedule will be at a minimum occurrence of once a month and as necessary to rid / reduce active pollutants from the pavement areas. This maintenance requirement will be listed in the CC&R's of this project. These CC&R's will be recorded to the property at the County Recorder's Office and be included on the final Title report of these properties.
Litter Control by Sweeping	The Olson Company through its landscape maintenance contractor.	Daily inspection of trash receptacles to ensure that lids are closed and pick up any excess trash on the ground, noting trash disposal violations to the The Olson Company for remediation.
Employee Training	The Olson Company will train the landscape contractors after construction. Business owners will be required by the CC&Rs to train staff.	Monthly for maintenance personnel and employees to include the educational materials contained in the approved LID Plan.

**Low Impact Development Plan
Vesting Tentative Tract Map No. 82836
Unincorporated Territory of Los Angeles County, California**

Table-6: Structural BMP Maintenance Responsibility/Frequency Matrix

BMP	RESPONSIBILITY	FREQUENCY
'Wetland Mod Systems - Linear' Bio-Treatment System	Modular Wetlands for 1 year after activation/ The Olson Company or contract maintenance after that	'Modular Wetland Systems - Linear' maintenance will conform to manufacturer's specifications. Recommended at least once per year or as needed. Please see Appendix "C".
Oldcastle FloGard Catch Basin Insert Filter	The Olson Company providing maintenance	Inspections and servicing per manufacturer's specifications should occur prior to and following the rainy season and no less than 3 times per year. Inspect for defects and replace as necessary. See Appendix "C" for manufacturer's specifications.
Common Area Efficient Irrigation	The Olson through its landscape contractors after construction	Once a week, in conjunction with maintenance activities. Verify that runoff minimizing landscape design continues to function by checking that water sensors are functioning properly, that irrigation heads are adjusted properly to eliminate overspray to hardscape areas, and to verify that irrigation timing and cycle lengths are adjusted in accordance with water demands, given time of year, weather and day or night time temperatures.
Common Area Runoff Efficient Landscape Design	The Olson Company through its landscaping contractors	Once a week in conjunction with maintenance activities and prior to finalizing any replanting schemes. Verify that plants continue to be grouped according to similar water requirements in order to reduce excess irrigation runoff.
Common Area Catch Basin Inspection & Cleaning	The Olson Company through its landscape maintenance contractor for common areas and storm drain facilities	Inspect basins once a month or as needed. Clean debris and silt in bottom of catch basins as needed. Intensified on or about October 1 of each year, prior to "first flush" storm. See Appendix "E"
Catch Basin Stenciling	The Olson Company providing maintenance	A warning stencil will be painted on top and in view with the words: "No-Dumping – Drains to Ocean" At all catch basin, drain inlets draining to the street or storm drain system. See Appendix "D" (example). Once every 6 months or as needed, inspect for re-stenciling needs. Re-stencil as needed immediately.

K. Operation/Maintenance Funding after Project Completion

The post-construction BMPs as described above will be funded and maintained by:

**Mr. Thomas Moore
Tel: (562) 596-4770
The Olson Company
3010 Old Ranch Parkway, Suite 100
Seal Beach, CA 90740**

- Maintenance and requirements of the maintenance for the properties will be listed in the Covenants, Conditions and Restrictions (CC&R's) of this project and will be the responsibility of the property owner at all times. These CC&R's will be recorded to the property at the County Recorder's Office and be included on the Title report of these properties.

**Low Impact Development Plan
Vesting Tentative Tract Map No. 82836
Unincorporated Territory of Los Angeles County, California**

Figure -1:

Project Vicinity Map

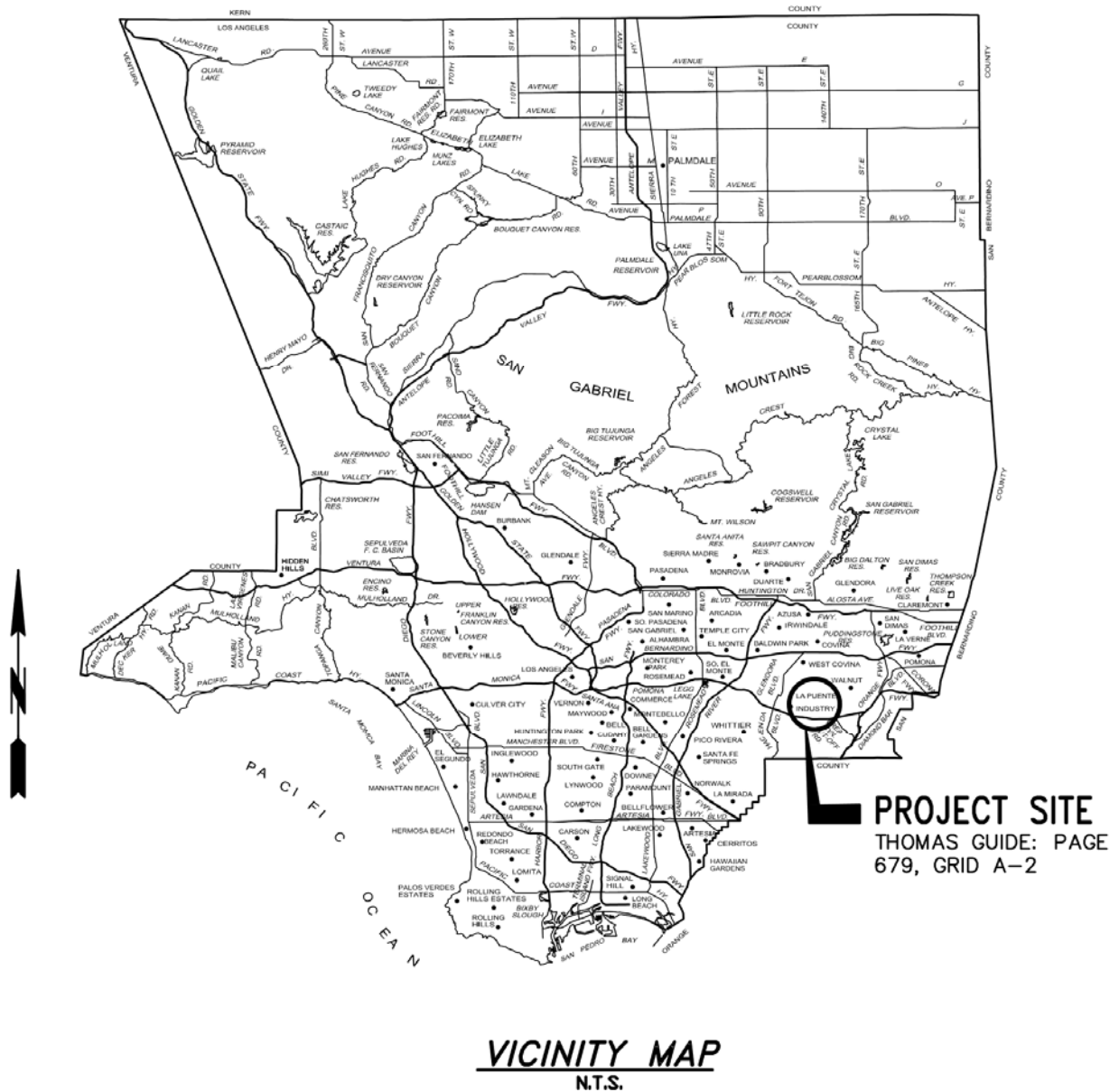

Figure -2:

Project Location Map

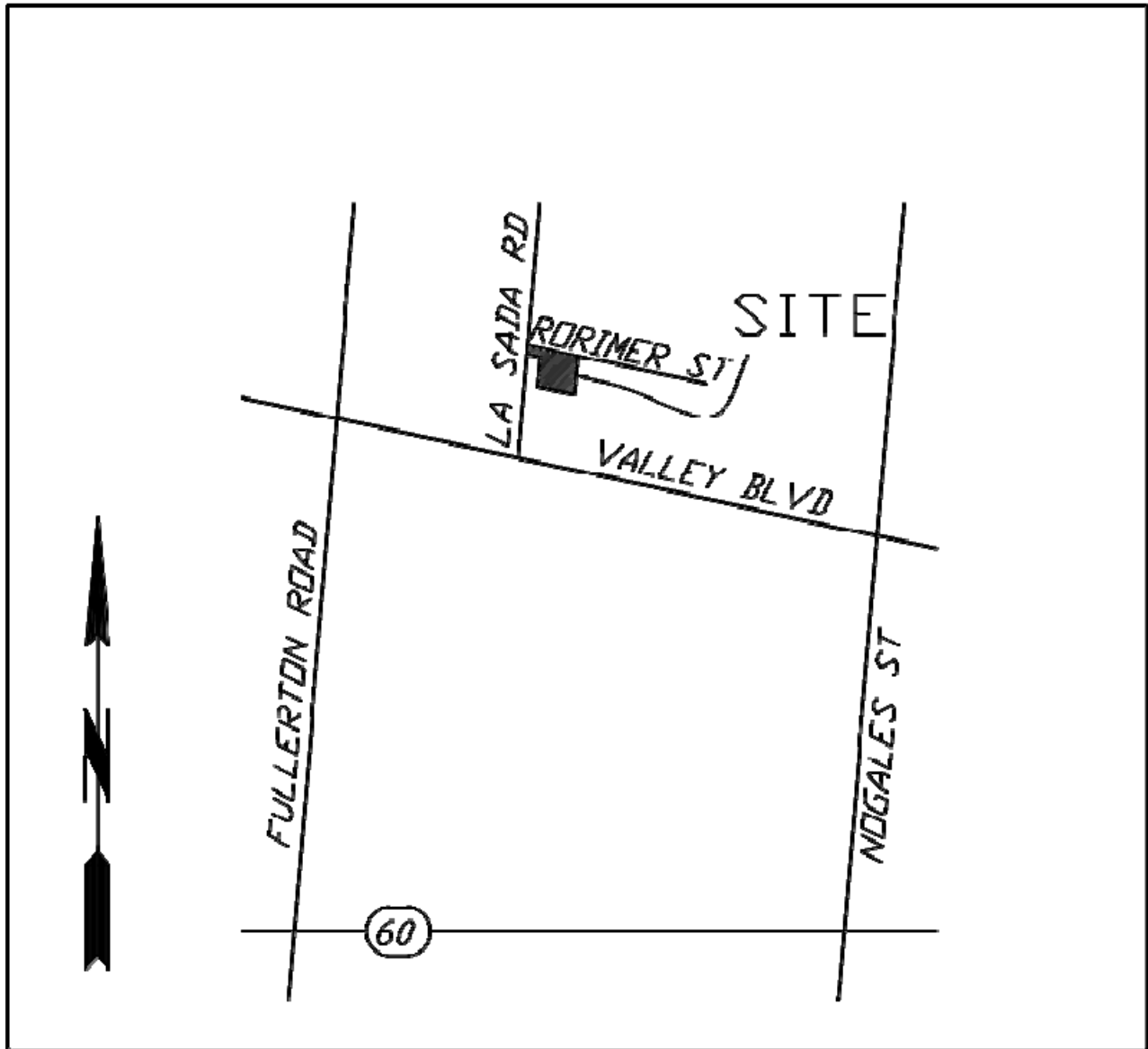

Figure -3:

Project BMPs Exhibit

MAJOR LAND DIVISION VESTING TENTATIVE TRACT NO. 82836

"FOR CONDOMINIUM PURPOSES"

IN UNINCORPORATED TERRITORY OF THE COUNTY OF LOS ANGELES, STATE OF CALIFORNIA

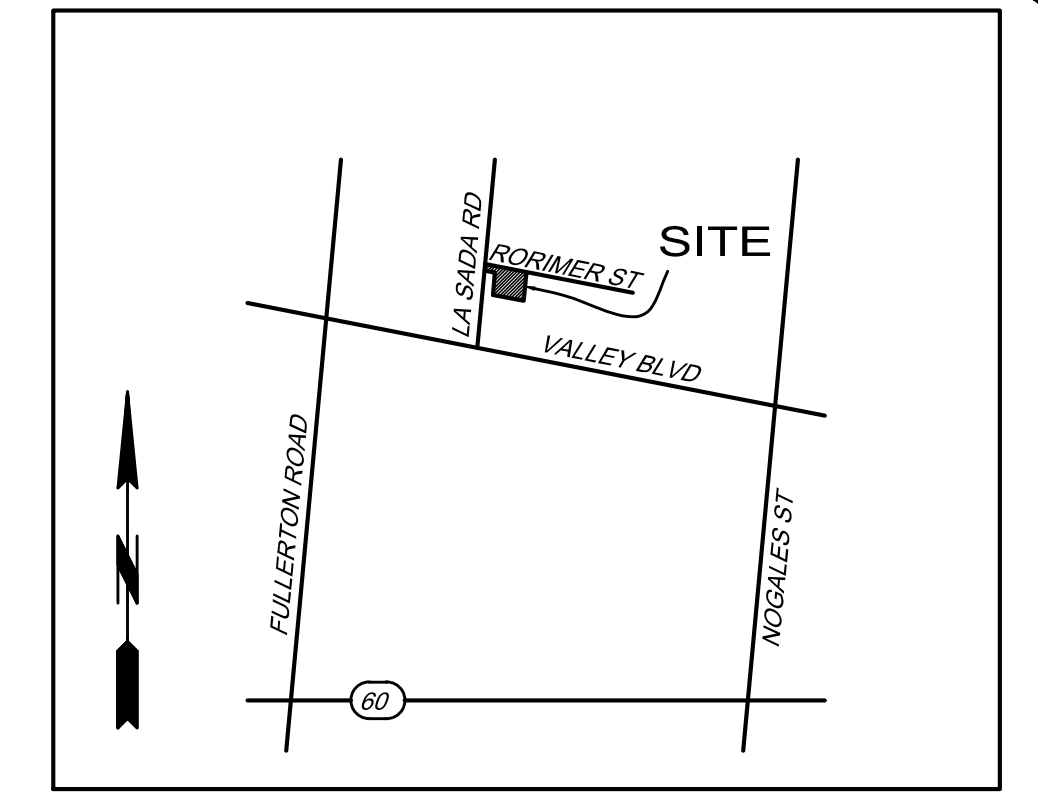

LOCATION MAP
N.T.S.

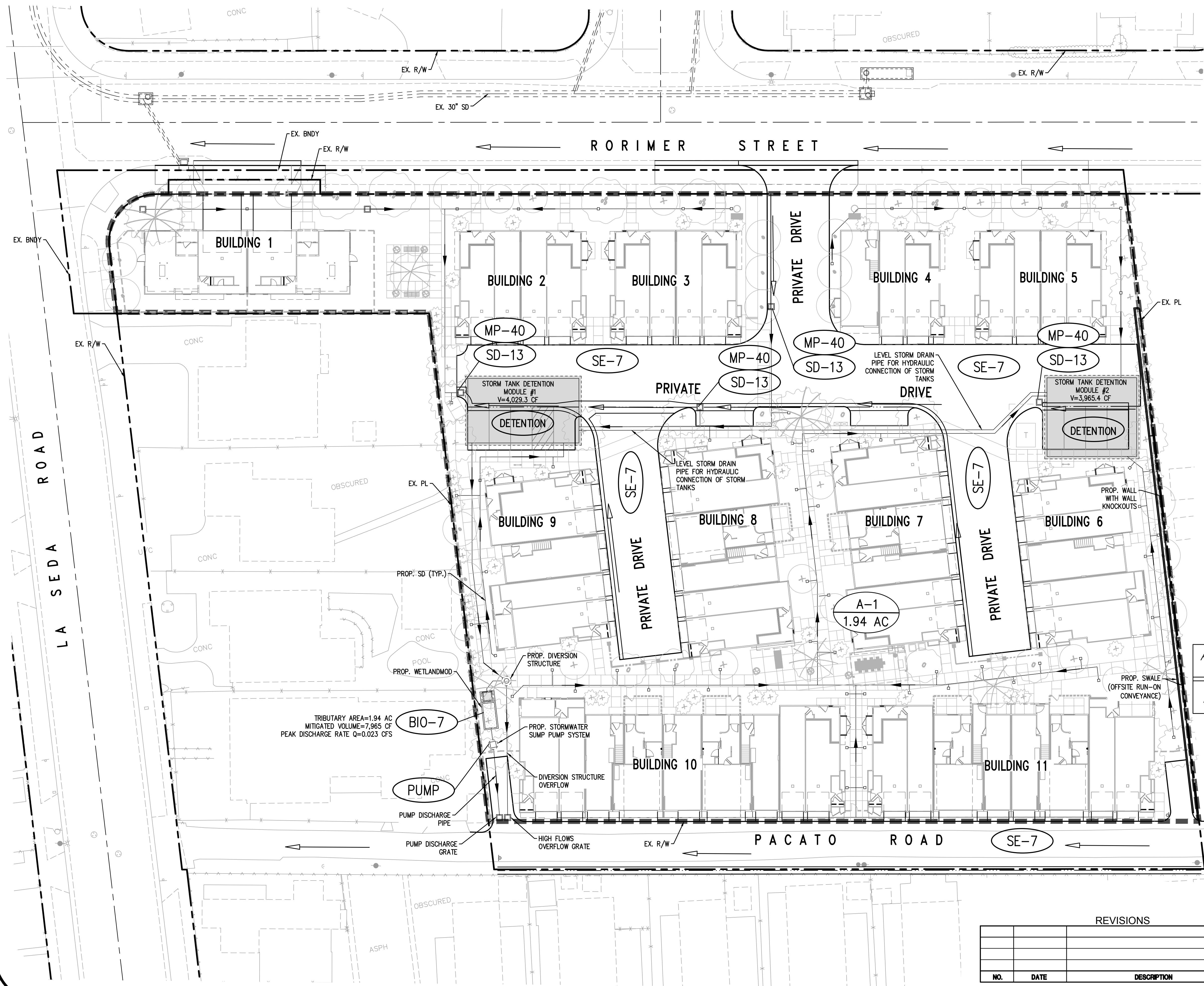

LEGEND:

A-1 TREATMENT AREA NO.
1.12 AC. AREA (AC.)

----- AREA BOUNDARY

BEST MANAGEMENT PRACTICE NOTES:

- SE-7** — STREET SWEEPING AND VACUUMING AREA
- SD-13** — CATCH BASIN STENCILING "NO DUMPING - DRAINS TO RIVER"
- BIO-7** — MODULAR WETLANDS SYSTEMS BIOFILTRATION SYSTEM
- MP-40** — MEDIA FILTER - OLDCASTLE FLOGARD CATCH BASIN INSERT FILTER

SITE INFORMATION

1. SITE AREA: TOTAL NET AREA: 84,570 SQ.FT. (1.94 AC.)
2. ZONING: R-3 (LIMITED MULTI-FAMILY RESIDENCE)
3. PROPOSED USE: MULTI-FAMILY CONDOMINIUMS
4. TOTAL UNITS: 56 RESIDENTIAL

NOTES:

1. STRUCTURAL BMPs MUST BE ACCESSIBLE TO CITY PERSONAL DURING REGULAR BUSINESS HOURS FOR INSPECTION.
2. DOWNSPOUTS MUST HAVE SPLASH BLOCKS OR EQUIVALENT IF NOT HARD PIPED TO DRAINAGE SYSTEM.
3. ALL PROPOSED ONSITE DRAINAGE FACILITIES WILL BE PRIVATELY MAINTAINED BY THE PROPERTY OWNER AND/OR APPOINTED HOMEOWNER'S ASSOCIATION.

SUMMARY TABLE:

AREA NO.	AREA	LID FLOW	LID VOLUME	LID VOLUME (X1.5)	CHAMBER COORDINATES
A-1	1.94 AC	0.45 cfs	5,310 CF	7,965 CF	N 34.006419 E -117.897586

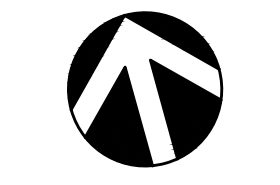

SCALE: 1" = 20'
0 10 20 40



LID PLAN EXHIBIT MAP
ESTU2019000464
MAJOR LAND DIVISION
VESTING TENTATIVE
TRACT NO. 82836

IN UNINCORPORATED TERRITORY OF LOS ANGELES COUNTY
COUNTY OF LOS ANGELES, CALIFORNIA

DATE: 03/03/2020
SHEET 1 OF 1 SHEETS

REVISIONS

NO.	DATE	DESCRIPTION	BY

DATE: 03/03/2020 09:59 AM DRAWN: J. BITTNER CHECKED: J. BITTNER PLOT: 03/03/2020

Figure -4:
Impaired Waters

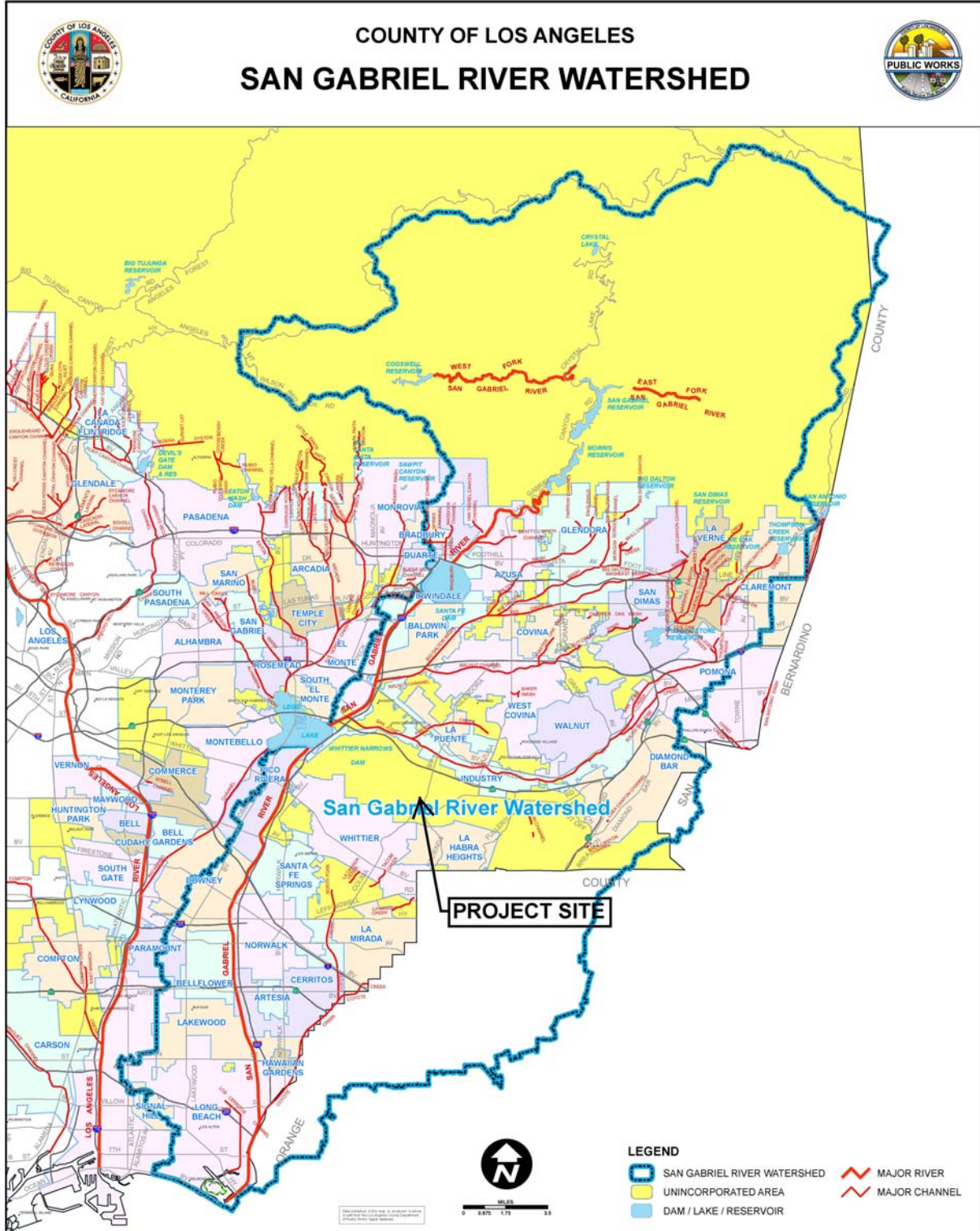

Appendix A:

Volume and Flow Rate Calculations and Hydrologic Report

Peak Flow Hydrologic Analysis

File location: P:/O/OLSO-105/Admin/Reports/Hydrology/Appendix C - Water Quality/20200508_0.75 INCH.pdf
Version: HydroCalc 1.0.3

Input Parameters

Project Name	OLSO-105
Subarea ID	A-1
Area (ac)	1.94
Flow Path Length (ft)	331.0
Flow Path Slope (vft/hft)	0.007
0.75-inch Rainfall Depth (in)	0.75
Percent Impervious	0.78
Soil Type	3
Design Storm Frequency	0.75 inch storm
Fire Factor	0
LID	True

Output Results

Modeled (0.75 inch storm) Rainfall Depth (in)	0.75
Peak Intensity (in/hr)	0.2026
Undeveloped Runoff Coefficient (Cu)	0.1
Developed Runoff Coefficient (Cd)	0.724
Time of Concentration (min)	27.0
Clear Peak Flow Rate (cfs)	0.2845
Burned Peak Flow Rate (cfs)	0.2845
24-Hr Clear Runoff Volume (ac-ft)	0.0871
24-Hr Clear Runoff Volume (cu-ft)	3792.3472

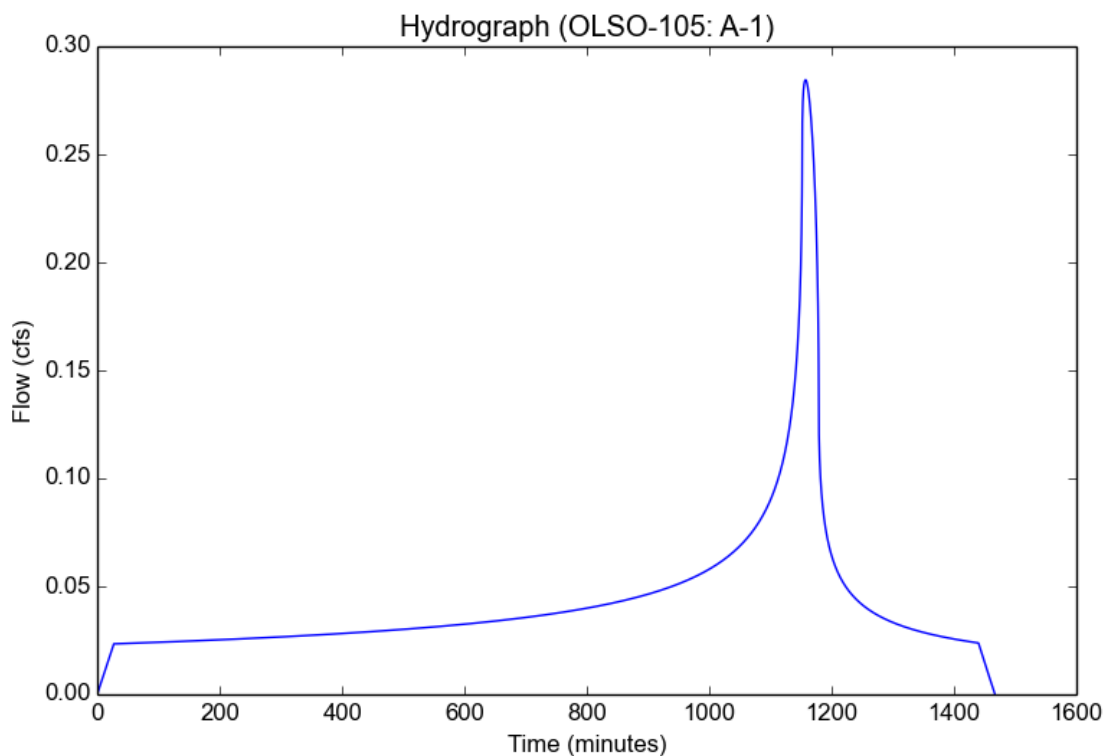

Peak Flow Hydrologic Analysis

File location: P:/O/OLSO-105/Admin/Reports/Hydrology/Appendix C - Water Quality/20200508_85TH PERCENTILE.pdf
Version: HydroCalc 1.0.3

Input Parameters

Project Name	OLSO-105
Subarea ID	A-1
Area (ac)	1.94
Flow Path Length (ft)	331.0
Flow Path Slope (vft/hft)	0.007
85th Percentile Rainfall Depth (in)	1.05
Percent Impervious	0.78
Soil Type	3
Design Storm Frequency	85th percentile storm
Fire Factor	0
LID	True

Output Results

Modeled (85th percentile storm) Rainfall Depth (in)	1.05
Peak Intensity (in/hr)	0.3191
Undeveloped Runoff Coefficient (Cu)	0.1
Developed Runoff Coefficient (Cd)	0.724
Time of Concentration (min)	21.0
Clear Peak Flow Rate (cfs)	0.4482
Burned Peak Flow Rate (cfs)	0.4482
24-Hr Clear Runoff Volume (ac-ft)	0.1219
24-Hr Clear Runoff Volume (cu-ft)	5309.2665

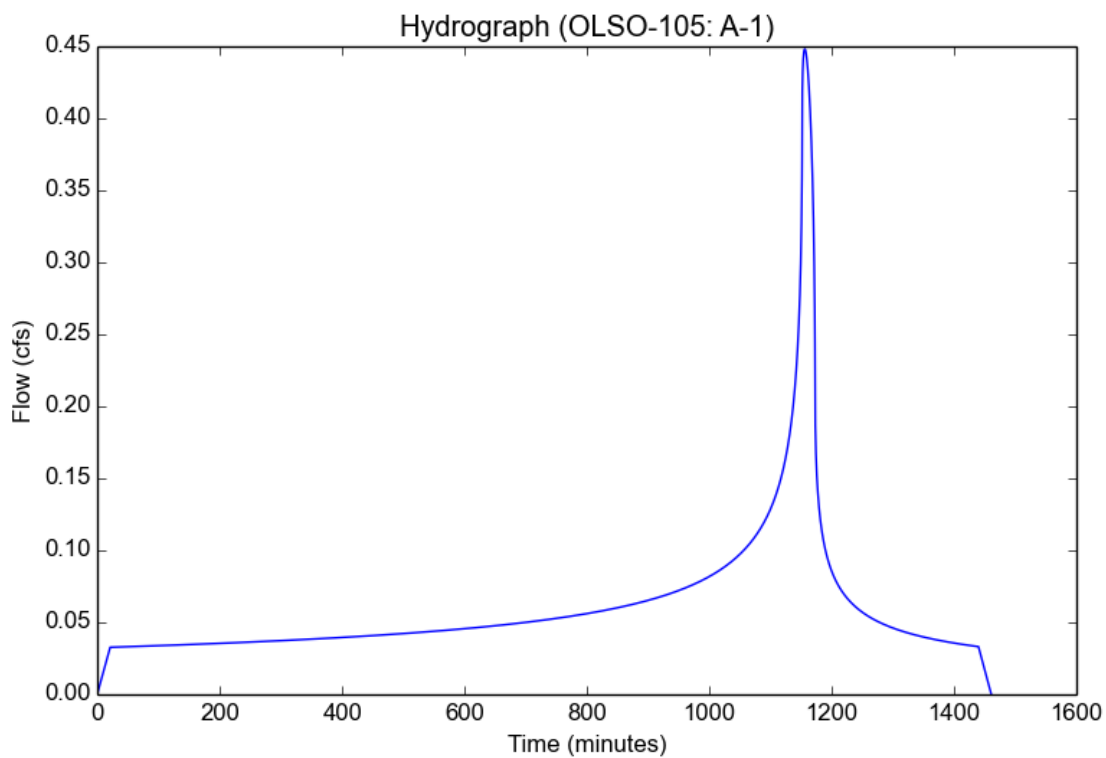

Appendix B:

Site BMPs

BIO-1: Biofiltration



Definition

A biofiltration area is a vegetated shallow depression that is designed to receive and treat stormwater runoff from downspouts, piped inlets, or sheet flow from adjoining paved areas. A shallow ponding zone is provided above the vegetated surface for temporary storage of stormwater runoff. During storm events, stormwater runoff accumulates in the ponding zone and gradually infiltrates the surface and filters through the biofiltration soil media before being collected by an underdrain system.

Stormwater runoff treatment occurs through a variety of natural mechanisms as stormwater runoff filters through the vegetation root zone. In biofiltration areas, microbes and organic material in the biofiltration soil media help promote the adsorption of pollutants (e.g., dissolved metals and petroleum hydrocarbons) into the soil matrix. Plants utilize soil moisture and promote the drying of the soil through transpiration. Biofiltration areas are typically planted with native, drought-tolerant plant species that do not require fertilization and can withstand wet soils for at least 96 hours.

A schematic of a typical biofiltration area is presented in Figure E-7.

LID Ordinance Requirements

Biofiltration can be used as an alternative compliance measure.

Pollutant of Concern	Treated by Biofiltration?
Suspended solids	No
Total phosphorus	No
Total nitrogen	Yes
Total Kjeldahl nitrogen	Yes
Cadmium, total	No
Chromium, total	Yes
Copper, total	No
Lead, total	Yes
Zinc, total	No

Source: Treatment Best Management Practices Performance, Los Angeles Regional Water Quality Control Board, December 9, 2013.

Advantages

- Has a low cost for installation
- Enhances site aesthetics
- Requires little maintenance

Disadvantages

- May require individual owner/tenants to perform maintenance

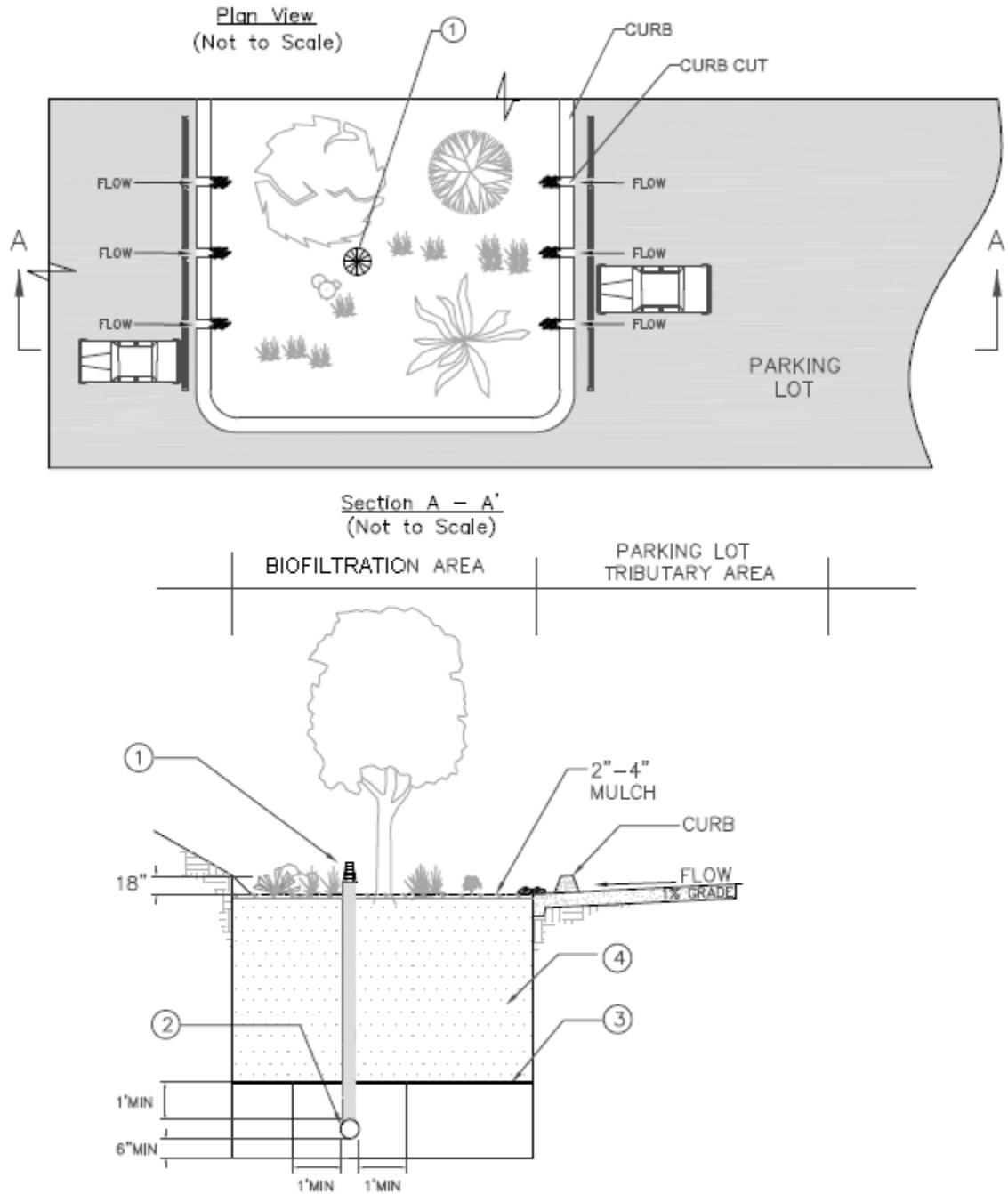

Figure E-7. Biofiltration Area Schematic

General Constraints and Implementation Considerations

- Biofiltration areas can be applied in various settings including, but not limited to:
 - Individual lots for rooftop, driveway, and other on-site impervious surface
 - Shared facilities located in common areas for individual lots
 - Areas within loop roads or cul-de-sacs
 - Landscaped parking lot islands
 - Within right-of-ways along roads
 - Common landscaped areas in apartment complexes or other multi-family housing designs
 - Parks and along open space perimeter
- If tire curbs are provided and parking stalls are shortened, cars are allowed to overhang the biofiltration area.
- Biofiltration areas must be located sufficiently far from structure foundations to avoid damage to structures (as determined by a certified structural or geotechnical engineer).
- Any parking areas bordering the biofiltration area must be monolithically poured concrete or deepened curb concrete to provide structural stability to the adjacent parking section.
- Geomembrane liners must be used in areas subject to spills or pollutant hot spots.
- During construction activities should avoid compaction of native soils below planting media layer or gravel zone.
- Stormwater runoff must be diverted around the biofiltration area during the period of vegetation establishment. If diversion is not feasible, the graded and seeded areas must be protected with suitable sediment controls (i.e., silt fences). All damaged areas should be repaired, seeded, or re-planted immediately.
- The general landscape irrigation system should incorporate the biofiltration area, as applicable.

Design Specifications

The following sections describe the design specifications for biofiltration areas.

Geotechnical

Due to the potential to contaminate groundwater, cause slope instability, impact surrounding structures, and potential for insufficient infiltration capacity, an extensive geotechnical site investigation must be conducted during the site planning process to verify site suitability for biofiltration. All geotechnical investigations must be performed according to the most recent GMED Policy GS 200.1. Soil infiltration rates and the

groundwater table depth must be evaluated to ensure that conditions are satisfactory for proper operation of a biofiltration area. The project applicant must demonstrate through infiltration testing, soil logs, and the written opinion of a licensed civil engineer that sufficiently permeable soils exist on-site to allow the construction of a properly functioning biofiltration system.

Biofiltration areas are appropriate for soils with a minimum corrected in-situ infiltration rate of 0.3 in/hr. The geotechnical report must determine if the proposed project site is suitable for a biofiltration area and must recommend a design infiltration rate (see “Design Infiltration Rate” under the “Sizing” section). The geotechnical investigation should be such that a good understanding is gained as to how the stormwater runoff will move through the soil (horizontally or vertically) and if there are any geological conditions that could inhibit the movement of water.

Pretreatment

Pretreatment refers to design features that provide settling of large particles before stormwater runoff enters a stormwater quality control measure in order to reduce the long-term maintenance burden. Pretreatment should be provided to reduce the sediment load entering a biofiltration area in order to maintain the infiltration rate of the biofiltration area. To ensure that biofiltration areas are effective, the project applicant must incorporate pretreatment devices that provide sediment removal (e.g., vegetated swales, vegetated filter strips, sedimentation manholes, and proprietary devices). The use of at least two pretreatment devices is highly recommended for biofiltration areas.

Geometry

- Biofiltration areas must be sized to capture and treat 1.5 times the SWQDv that is not reliably retained on the project site with an 18-inch maximum ponding depth.
- The planting soil depth must be a minimum of two feet, although three feet is preferred. The planting soil depth should provide a beneficial root zone for the chosen vegetation and adequate water storage for the stormwater runoff. A deeper planting soil depth will also provide a smaller surface area footprint.
- A gravel storage layer below the biofiltration area soil media is required to provide adequate temporary storage to retain 1.5 times the SWQDv that is not reliably retained on the project site and to promote infiltration.

Sizing

Biofiltration areas are sized using a simple sizing method where 1.5 times the SWQDv that is not reliably retained on the project site must be completely filtered within 96 hours. If the incoming stormwater runoff flow rate is lower than the long term filtration rate, above ground storage does not need to be provided. If the incoming stormwater runoff flow rate is higher than the long term filtration rate, above ground storage shall be provided (see steps below).

Step 1: Calculate the design volume

Biofiltration areas should be sized to capture and treat 1.5 times the portion of the SWQDv (see Section 6 for SWQDv calculation procedures) that is not reliability retained on the project site, as calculated by the equation below:

$$V_B = 1.5 \times (SWQDv - V_R)$$

Where:

V_B = Biofiltration volume [ft³];
 $SWQDv$ = Stormwater quality design volume [ft³]; and
 V_R = Volume of stormwater runoff reliably retained on-site [ft³].

Step 2: Calculate the design infiltration rate

Determine the corrected in-situ infiltration rate (f_{design}) of the native soil using the procedures described in the most recent GMED Policy GS 200.1.

Step 3: Calculate the surface area

Select a surface ponding depth (d) that satisfies the geometric criteria and meets the site constraints. Selecting a deeper ponding depth (up to 1.5 ft) generally yields a smaller footprint, however, it will require greater consideration for public safety, energy dissipation, and plant selection.

Calculate the time for the selected ponding depth to filter through the planting media using the following equation:

$$d = t_p \times \frac{f_{\text{design}}}{12}$$

Where:

d = Ponding depth (max 1.5 ft) [ft];
 t_p = Required detention time for surface ponding (max 96 hr) [hr]; and
 f_{design} = Design infiltration rate [in/hr].

If t_p exceeds 96 hours, reduce surface ponding depth (d). In nearly all cases, t_p should not approach 96 hours unless f_{design} is low.

Calculate the required infiltrating surface (filter bottom area) using the following equation:

$$A = \frac{V_B}{d}$$

Where:

A = Bottom surface area of biofiltration area [ft²];
V_B = Biofiltration design volume [ft³]; and
d = Ponding depth (max 1.5 ft) [ft].

Flow Entrance and Energy Dissipation

Maintain a minimum slope of 1 percent for pervious surfaces and 0.5 percent for impervious surfaces to the biofiltration area inlet. The following types of flow entrance can be used for biofiltration cells:

- Level spreaders (i.e., slotted curbs) can be used to facilitate sheet flow.
- Dispersed, low velocity flow across a landscape area. Dispersed flow may not be possible given space limitations or if the biofiltration area is controlling roadway or parking lot flows where curbs are mandatory.
- Dispersed flow across pavement or gravel and past wheel stops for parking areas.
- Flow spreading trench around perimeter of biofiltration area. May be filled with pea gravel or vegetated with 3:1 side slopes similar to a swale. A vertical-walled open trench may also be used at the discretion of LACDPW.
- Curb cuts for roadside or parking lot areas, if approved by LACDPW: curb cuts should include rock or other erosion controls in the channel entrance to dissipate energy. Flow entrance should drop two to three inches from curb line and provide an area for settling and periodic removal of sediment and coarse material before flow dissipates to the remainder of the biofiltration area.
- Piped entrances, such as roof downspouts, should include rock, splash blocks, or other erosion controls at the entrance to dissipate energy and disperse flows.
- Woody plants (trees, shrubs, etc.) can restrict or concentrate flows and can be damaged by erosion around the root ball and must not be placed directly in the entrance flow path.

Drainage

Biofiltration areas must be designed to drain below the planting soil in less than 96 hours. Soils must be allowed to dry out periodically in order to restore hydraulic capacity to receive stormwater runoff from subsequent storm events, maintain infiltration rates, maintain adequate soil oxygen levels for healthy soil biota and vegetation, and provide proper soil conditions for biodegradation and retention of pollutants.

Underdrain

Biofiltration areas require an underdrain to collect and discharge stormwater runoff that has been filtered through the soil media, but not infiltrated, to another stormwater quality control measure, storm drain system, or receiving water. The underdrain must have a mainline diameter of eight inches using slotted PVC SDR 26 or PVC C9000. Slotted PVC allows for pressure water cleaning and root cutting, if necessary. The slotted pipe

should have two to four rows of slots cut perpendicular to the axis of the pipe or at right angles to the pitch of corrugations. Slots should be 0.04 to 0.1 inches wide with a length of 1 to 1.25 inches. Slots should be longitudinally-spaced such that the pipe has a minimum of one square inch opening per lineal foot and should face down.

The underdrain should be placed in a gravel envelope (Class 2 Permeable Material per Caltrans Spec. 68-1.025) that measures three feet wide and six inches deep. The underdrain is elevated from the bottom of the biofiltration area by six inches within the gravel envelope to create a fluctuating anaerobic/aerobic zone below the underdrain to facilitate denitrification within the anaerobic/anoxic zone and reduce nutrient concentrations. The top and sides of the underdrain pipe should be covered with gravel to a minimum depth of 12 inches. The underdrain and gravel envelope should be covered with a geomembrane liner to prevent clogging. The following aggregate should be used for the gravel envelope:

Particle Size (ASTM D422)	% Passing by Weight
¾ inch	100%
¼ inch	30-60%
#8	20-50%
#50	3-12%
#200	0-1%

Underdrains should be sloped at a minimum of 0.5 percent and must drain freely to an approved discharge point.

Rigid non-perforated observation pipes with a diameter equal to the underdrain diameter should be connected to the underdrain to provide a clean-out port as well as an observation well to monitor drainage rates. The wells/clean-outs should be connected to the perforated underdrain with the appropriate manufactured connections. The wells/clean-outs should extend six inches above the top elevation of the biofiltration area mulch, and should be capped with a lockable screw cap. The ends of underdrain pipes not terminating in an observation well/clean-out should also be capped.

Hydraulic Restriction Layer

Lateral infiltration pathways may need to be restricted due to the close proximity of roads, foundations, or other infrastructure. A geomembrane liner, or other equivalent waterproofing, may be placed along the vertical walls to reduce lateral flows. This geomembrane liner must have a minimum thickness of 30 mils and meet the requirements of Table E-12. Generally, waterproof barriers should not be placed on the bottom of the biofiltration unit, as this would prevent incidental infiltration which is important to meeting the required pollutant load reduction.

Table E-12. Geomembrane Liner Specifications for Biofiltration Areas

Parameter	Test Method	Specifications
Material		Nonwoven geomembrane liner
Unit weight		8 oz/yd ³ (minimum)
Filtration rate		0.08 in/sec (minimum)
Puncture strength	ASTM D-751 (Modified)	125 lbs (minimum)
Mullen burst strength	ASTM D-751	400 lb/in ² (minimum)
Tensile strength	AST D-1682	300 lbs (minimum)
Equiv. opening size	US Standard Sieve	No. 80 (minimum)

Planting/Storage Media

- The planting media placed in the biofiltration area should achieve a long-term, in-place infiltration rate of at least 5 in/hr. Higher infiltration rates of up to 12 in/hr are permissible. The biofiltration soil media must retain sufficient moisture to support vigorous plant growth.
- The planting media mix must consist of 60 to 80 percent sand and 20 to 40 percent compost.
- Sand should be free of wood, waste, coatings such as clay, stone dust, carbonate, or any other deleterious material. All aggregate passing the No. 200 sieve size should be non-plastic. Sand for biofiltration should be analyzed by an accredited laboratory using #200, #100, #40, #30, #16, #8, #4, and 3/8 sieves (ASTM D422 or as approved by the local permitting authority) and meet the following gradations (Note: all sand complying with ASTM C33 for fine aggregate comply with the gradation requirements listed below):

Particle Size (ASTM D422)	% Passing by Weight
3/8 inch	100%
#4	90-100%
#8	70-100%
#16	40-95%
#30	15-70%
#40	5-55%
#110	0-15%
#200	0-5%

Note: The gradation of the sand component of the biofiltration soil media is believed to be a major factor in the infiltration rate of the media mix. If the desired hydraulic conductivity of the biofiltration soil media cannot be achieved within the specified proportions of sand and compost (#2), then it may be necessary to utilize sand at the coarser end of the range specified minimum percent passing.

- Compost should be a well-decomposed, stable, weed-free organic matter source derived from waste materials including yard debris, wood wastes, or other organic material not including manure or biosolids meeting standards developed by the USCC. The product shall be certified through the USCC STA Program (a compost testing and information disclosure program). Compost quality shall be verified via a laboratory analysis to be:
 - Feedstock materials must be specified and include one or more of the following: landscape/yard trimmings, grass clippings, food scraps, and agricultural crop residues.
 - pH between 6.5 and 8.0 (may vary with plant palette)
 - Organic Matter: 35 to 75 percent dry weight basis
 - Carbon and Nitrogen Ratio: 15:1 < C:N < 25:1
 - Maturity/Stability: Compost must have a dark brown color and a soil-like odor. Compost exhibiting a sour or putrid smell, containing recognizable grass or leaves, or is hot (120°F) upon delivery or rewetting is not acceptable.
 - Toxicity: any one of the following measures is sufficient to indicate non-toxicity:
 - $\text{NH}_4:\text{NH}_3 < 3$
 - Ammonium < 500 ppm, dry weight basis
 - Seed germination > 80 percent of control
 - Plant trials > 80 percent of control
 - Solvita® > 5 index value
 - Nutrient content:
 - Total Nitrogen content ≥ 0.9 percent preferred
 - Total Boron should be < 80 ppm; soluble boron < 2.5 ppm
 - Salinity: < 6.0 mmhos/cm
 - Compost for biofiltration area should be analyzed by an accredited laboratory using #200, ¼-inch, ½-inch, and 1-inch sieves (ASTM D422) and meet the gradation requirements in the table below:

Particle Size (ASTM D422)	% Passing by Weight
1 inch	99-100
½ inch	90-100
¼ inch	40-90
#200	2-10

Tests should be sufficiently recent to represent the actual material that is anticipated to be delivered to the site. If processes or sources used by the supplier have changed significantly since the most recent testing, new tests should be requested.

The gradation of compost used in biofiltration soil media is believed to play an important role in the saturated infiltration rate of the media. To achieve a higher saturated infiltration rate, it may be necessary to utilize compost at the coarser end of the range (minimum percent passing). The percent passing the #200 sieve (fines) is believed to be the most important factor in hydraulic conductivity.

In addition, coarser compost mix provides more heterogeneity of the biofiltration soil media, which is believed to be advantageous for more rapid development of soil structure needed to support healthy biological processes. This may be an advantage for plant establishment with lower nutrient and water input.

- Biofiltration soil media not meeting the above criteria should be evaluated on a case-by-case basis. Alternative biofiltration soil media must meet the following specifications:

“Soils for biofiltration facilities must be sufficiently permeable to infiltrate stormwater runoff at a minimum of rate of 5 in/hr during the life of the facility, and provide sufficient retention of moisture and nutrients to support healthy vegetation.” The following steps shall be followed by LACDPW to verify that alternative biofiltration soil media mixes meet the specification:

- Submittals – The applicant must submit to LACDPW for approval:
 - A sample of mixed biofiltration soil media.
 - Certification from the soil supplier or an accredited laboratory that the biofiltration soil media meets the requirements of this specification.
 - Certification from an accredited geotechnical testing laboratory that the biofiltration soil media has an infiltration rate between 5 and 12 in/hr.
 - Organic content test results of the biofiltration soil media. Organic content test shall be performed in accordance with the Testing Methods for the Examination of Compost and Composting (TMECC) 05.07A, “Loss-On-Ignition Organic Matter Method”.
 - Organic grain size analysis results of mixed biofiltration soil media performed in accordance with ASTM D422, Standard Test Method for Particle Size Analysis of Soils.
 - A description of the equipment and methods used to mix the sand and compost to produce the biofiltration soil media.
- The name of the testing laboratory(ies) and the following information:

- Contact person(s)
- Address(es)
- Phone contact(s)
- E-mail address(es)
- Qualifications of laboratory(ies) and personnel including date of current certification by STA, ASTM, or approved equal.
- Biofiltration soils shall be analyzed by an accredited laboratory using #200 and ½-inch sieves (ASTM D422 or as approved by LACDPW), and meet the gradation described in the table below:

Particle Size (ASTM D422)	% Passing by Weight
½ inch	97-100
#200	2-5

- Biofiltration soil media shall be analyzed by an accredited geotechnical laboratory for the following tests:
 - Moisture – density relationships (compaction tests) must be conducted on biofiltration soil media. Biofiltration soil media for the permeability test shall be compacted to 85 to 90 percent of the maximum dry density (ASTM D1557).
 - Constant head permeability testing in accordance with ASTM D2434 shall be conducted on a minimum of two samples with a 6-inch mold and vacuum saturation.
- Mulch is recommended for the purpose of retaining moisture, preventing erosion, and minimizing weed growth. Projects subject to the California Model Water Efficiency Landscaping Ordinance (or comparable local ordinance) will be required to provide at least 2 inches of mulch. Aged mulch, also called compost mulch, reduces the ability of weeds to establish, keeps soil moist, and replenishes soil nutrients. Biofiltration areas must be covered with two to four inches (average three inches) of mulch at the start and an annual placement (preferably in June after weeding) of one to two inches of mulch beneath plants.
- The planting media design height must be marked appropriately, such as a collar on the overflow device or with a stake inserted two feet into the planting media and notched, to show biofiltration surface level and ponding level.

Vegetation

Prior to installation, a licensed landscape architect must certify that all plants, unless otherwise specifically permitted, conform to the standards of the current edition of American Standard for Nursery Stock as approved by the American Standards Institute, Inc. All plant grades shall be those established in the current edition of American Standards for Nursery Stock.

- Shade trees must have a single main trunk. Trunks must be free of branches below the following heights:

CALIPER (in)	Height (ft)
1½-2½	5
3	6

- Plants must be tolerant of summer drought, ponding fluctuations, and saturated soil conditions for 96 hours.
- It is recommended that a minimum of three types of tree, shrubs, and/or herbaceous groundcover species be incorporated to protect against facility failure due to disease and insect infestations of a single species.
- Native plant species and/or hardy cultivars that are not invasive and do not require chemical inputs must be used to the maximum extent practicable.

The biofiltration area should be vegetated to resemble a terrestrial forest community ecosystem, which is dominated by understory trees, a shrub layer, and herbaceous ground cover. Select vegetation that:

- Is suited to well-drained soil;
- Will be dense and strong enough to stay upright, even in flowing water;
- Has minimum need for fertilizers;
- Is not prone to pests and is consistent with Integrated Pest Management practices; and
- Is consistent with local water conservation ordinance requirements.

Irrigation System

Provide an irrigation system to maintain viability of vegetation, if applicable. The irrigation system must be designed to local code or ordinance specifications.

Restricted Construction Materials

The use of pressure-treated wood or galvanized metal at or around a biofiltration area is prohibited.

Overflow Device

An overflow device is required at the 18-inch ponding depth. The following, or equivalent, should be provided:

- A vertical PVC pipe (SDR 26) to act as an overflow riser.
- The overflow riser(s) should be eight inches or greater in diameter, so it can be cleaned without damage to the pipe.

- The inlet to the riser should be at the ponding depth (18 inches for fenced biofiltration areas and 6 inches for areas that are not fenced), and be capped with a spider cap to exclude floating mulch and debris. Spider caps should be screwed in or glued (e.g., not removable). The overflow device should convey stormwater runoff in excess of 1.5 times the SWQDv that is not reliably retained on the project site to an approved discharge location (another stormwater quality control measure, storm drain system, or receiving water).

Maintenance Requirements

Maintenance and regular inspections are important for proper function of biofiltration areas. Biofiltration areas require annual plant, soil, and mulch layer maintenance to ensure optimal infiltration, storage, and pollutant removal capabilities. In general, biofiltration maintenance requirements are typical landscape care procedures and include:

- Irrigate plants as needed during prolonged dry periods. In general, plants should be selected to be drought-tolerant and not require irrigation after establishment (two to three years).
- Inspect flow entrances, ponding area, and surface overflow areas periodically, and replace soil, plant material, and/or mulch layer in areas if erosion has occurred. Properly-designed facilities with appropriate flow velocities should not cause erosion except potentially during in extreme events. If erosion occurs, the flow velocities and gradients within the biofiltration area and flow dissipation and erosion protection strategies in the pretreatment area and flow entrance should be reassessed. If sediment is deposited in the biofiltration area, identify the source of the sediment within the tributary area, stabilize the source, and remove excess surface deposits.
- Prune and remove dead plant material as needed. Replace all dead plants, and if specific plants have a high mortality rate, assess the cause and, if necessary, replace with more appropriate species.
- Remove weeds as needed until plants are established. Weed removal should become less frequent if the appropriate plant species are used and planting density is attained.
- Select the proper soil mix and plants for optimal fertility, plant establishment, and growth to preclude the use of nutrient and pesticide supplements. By design, biofiltration facilities are located in areas where phosphorous and nitrogen levels are often elevated such that these should not be limiting nutrients. Addition of nutrients and pesticides may contribute pollutant loads to receiving waters.
- In areas where heavy metals deposition is likely (i.e., tributary areas to industrial, vehicle dealerships/repair, parking lots, roads), replace mulch annually. In areas where metals deposition is less likely (i.e., residential lots), replace or add mulch as needed to maintain a two to three inch depth at least once every two years.

- Analyze soil for fertility and pollutant levels if necessary. Biofiltration soil media are designed to maintain long-term fertility and pollutant processing capability.
- Eliminate standing water to prevent vector breeding.
- Inspect overflow devices for obstructions or debris, which should be removed immediately. Repair or replace damaged pipes upon discovery.
- Inspect, and clean if necessary, the underdrain.

A summary of potential problems that need to be addressed by maintenance activities is presented in Table E-13.

The County requires execution of a maintenance agreement to be recorded by the property owner for the on-going maintenance of any privately-maintained stormwater quality control measures. The property owner is responsible for compliance with the maintenance agreement. A sample maintenance agreement is presented in Appendix H.

Table E-13. Biofiltration Troubleshooting Summary

Problem	Conditions When Maintenance Is Needed	Maintenance Required
Vegetation	Overgrown vegetation	Mow and prune vegetation as appropriate.
	Presence of invasive, poisonous, nuisance, or noxious vegetation or weeds	Remove this vegetation and plant native species as needed.
Trash and Debris	Trash, plant litter, and dead leaves present	Remove and properly dispose of trash and debris.
Irrigation (if applicable)	Not functioning correctly	Check irrigation system for clogs or broken lines and repair as needed.
Inlet/Overflow	Inlet/overflow areas clogged with sediment and/or debris	Remove material.
	Overflow pipe blocked or broken	Repair as needed.
Erosion/Sediment Accumulation	Splash pads or spreader incorrectly placed Presence of erosion or sediment accumulation	Check inlet structure to ensure proper function. Repair, or replace if necessary, the inlet device. Repair eroded areas with gravel as needed. Re-grade the biofiltration area as needed.
Contaminants and Pollution	Any evidence of oil, gasoline, contaminants, or other pollutants	Remove any evidence of visual contamination from floatables such as oil and grease.
Standing water	Standing water observed more than 96 hours after storm event	Inspect, and clean as needed, the underdrain to ensure proper function. Clear clogs as needed. Remove and replace planter media (sand, gravel, topsoil, mulch) and vegetation.

Description

Stormwater media filters are usually two-chambered including a pretreatment settling basin and a filter bed filled with sand or other absorptive filtering media. As stormwater flows into the first chamber, large particles settle out, and then finer particles and other pollutants are removed as stormwater flows through the filtering media in the second chamber.

There are currently three manufacturers of stormwater filter systems. Two are similar in that they use cartridges of a standard size. The cartridges are placed in vaults; the number of cartridges a function of the design flow rate. The water flows laterally (horizontally) into the cartridge to a centerwell, then downward to an underdrain system. The third product is a flatbed filter, similar in appearance to sand filters.

California Experience

There are currently about 75 facilities in California that use manufactured filters.

Advantages

- Requires a smaller area than standard flatbed sand filters, wet ponds, and constructed wetlands.
- There is no standing water in the units between storms, minimizing but does not entirely eliminate the opportunity for mosquito breeding.
- Media capable of removing dissolved pollutants can be selected.
- One system utilizes media in layers, allowing for selective removal of pollutants.
- The modular concept allows the design engineer to more closely match the size of the facility to the design storm.

Limitations

- As some of the manufactured filter systems function at higher flow rates and/or have larger media than found in flatbed filters, the former may not provide the same level of performance as standard sand filters. However, the level of treatment may still be satisfactory.
- As with all filtration systems, use in catchments that have significant areas of non-stabilized soils can lead to premature clogging.

Design Considerations

- Design Storm
- Media Type
- Maintenance Requirement

Targeted Constituents

- ✓ Sediment
- ✓ Nutrients
- ✓ Trash
- ✓ Metals
- ✓ Bacteria
- ✓ Oil and Grease
- ✓ Organics

Removal Effectiveness

See New Development and Redevelopment Handbook-Section 5.



Design and Sizing Guidelines

There are currently three manufacturers of stormwater filter systems.

Filter System A: This system is similar in appearance to a slow-rate sand filter. However, the media is cellulose material treated to enhance its ability to remove hydrocarbons and other organic compounds. The media depth is 12 inches (30 cm). It operates at a very high rate, 20 gpm/ft² at peak flows. Normal operating rates are much lower assuming that the stormwater covers the entire bed at flows less than the peak rate. The system uses vortex separation for pretreatment. As the media is intended to remove sediments (with attached pollutants) and organic compounds, it would not be expected to remove dissolved pollutants such as nutrients and metals unless they are complexed with the organic compounds that are removed.

Filter System B: It uses a simple vertical filter consisting of 3 inch diameter, 30 inch high slotted plastic pipe wrapped with fabric. The standard fabric has nominal openings of 10 microns. The stormwater flows into the vertical filter pipes and out through an underdrain system. Several units are placed vertically at 1 foot intervals to give the desired capacity. Pretreatment is typically a dry extended detention basin, with a detention time of about 30 hours. Stormwater is retained in the basin by a bladder that is automatically inflated when rainfall begins. This action starts a timer which opens the bladder 30 hours later. The filter bay has an emptying time of 12 to 24 hours, or about 1 to 2 gpm/ft² of filter area. This provides a total elapsed time of 42 to 54 hours. Given that the media is fabric, the system does not remove dissolved pollutants. It does remove pollutants attached to the sediment that is removed.

Filter System C: The system use vertical cartridges in which stormwater enters radially to a center well within the filter unit, flowing downward to an underdrain system. Flow is controlled by a passive float valve system, which prevents water from passing through the cartridge until the water level in the vault rises to the top of the cartridge. Full use of the entire filter surface area and the volume of the cartridge is assured by a passive siphon mechanism as the water surface recedes below the top of the cartridge. A balance between hydrostatic forces assures a more or less equal flow potential across the vertical face of the filter surface. Hence, the filter surface receives suspended solids evenly. Absent the float valve and siphon systems, the amount of water treated over time per unit area in a vertical filter is not constant, decreasing with the filter height; furthermore, a filter would clog unevenly. Restriction of the flow using orifices ensures consistent hydraulic conductivity of the cartridge as a whole by allowing the orifice, rather than the media, whose hydraulic conductivity decreases over time, to control flow.

The manufacturer offers several media used singly or in combination (dual- or multi-media). Total media thickness is about 7 inches. Some media, such as fabric and perlite, remove only suspended solids (with attached pollutants). Media that also remove dissolved include compost, zeolite, and iron-infused polymer. Pretreatment occurs in an upstream unit and/or the vault within which the cartridges are located.

Water quality volume or flow rate (depending on the particular product) is determined by local governments or sized so that 85% of the annual runoff volume is treated.

Construction/Inspection Considerations

- Inspect one or more times as necessary during the first wet season of operation to be certain that it is draining properly.

Performance

The mechanisms of pollutant removal are essentially the same as with public domain filters (TC-40) if of a similar design. Whether removal of dissolved pollutants occurs depends on the media. Perlite and fabric do not remove dissolved pollutants, whereas for examples, zeolites, compost, activated carbon, and peat have this capability.

As most manufactured filter systems function at higher flow rates and have larger media than found in flatbed filters, they may not provide the same level of performance as standard sand filters. However, the level of treatment may still be satisfactory.

Siting Criteria

There are no unique siting criteria.

Additional Design Guidelines

Follow guidelines provided by the manufacturer.

Maintenance

- Maintenance activities and frequencies are specific to each product. Annual maintenance is typical.
- Manufactured filters, like standard filters (TC-40), require more frequent maintenance than most standard treatment systems like wet ponds and constructed wetlands, typically annually for most sites.
- Pretreatment systems that may precede the filter unit should be maintained at a frequency specified for the particular process.

Cost

Manufacturers provide costs for the units including delivery. Installation costs are generally on the order of 50 to 100 % of the manufacturer's costs.

Cost Considerations

- Filters are generally more expensive to maintain than swales, ponds, and basins.
- The modularity of the manufactured systems allows the design engineer to closely match the capacity of the facility to the design storm, more so than with most other manufactured products.

References and Sources of Additional Information

Minton, G.R., 2002, Stormwater Treatment: Biological, Chemical, and Engineering Principles, RPA Press, 416 pages.

S-1: Storm Drain Message and Signage

Purpose

Waste material dumped into storm drain inlets can adversely impact surface and ground waters. In fact, any material discharged into the storm drain system has the potential to significantly impact downstream receiving waters. Storm drain messages have become a popular method of alerting and reminding the public about the effects of and the prohibitions against waste disposal into the storm drain system. The signs are typically stenciled or affixed near the storm drain inlet or catch basin. The message simply informs the public that dumping of wastes into storm drain inlets is prohibited and/or that the drain ultimately discharges into receiving waters.

General Guidance

- The signs must be placed so they are easily visible to the public.
- Be aware that signs placed on sidewalk will be worn by foot traffic.

Design Specifications

- Signs with language and/or graphical icons that prohibit illegal dumping, must be posted at designated public access points along channels and streams within the project area. Consult with Los Angeles County Department of Public Works (LACDPW) staff to determine specific signage requirements for channels and streams.
- Storm drain message markers, placards, concrete stamps, or stenciled language/icons (e.g., “No Dumping – Drains to the Ocean”) are required at all storm drain inlets and catch basins within the project area to discourage illegal or inadvertent dumping. Signs should be placed in clear sight facing anyone approaching the storm drain inlet or catch basin from either side (see Figure D-1 and Figure D-2). LACDPW staff should be contacted to determine specific requirements for types of signs and methods of application. A stencil can be purchased for a nominal fee from LACDPW Building and Safety Office by calling (626) 458-3171. All storm drain inlet and catch basin locations must be identified on the project site map.

Maintenance Requirements

Legibility and visibility of markers and signs should be maintained (e.g., signs should be repainted or replaced as necessary). If required by LACDPW, the owner/operator or homeowner’s association shall enter into a maintenance agreement with the agency or record a deed restriction upon the property title to maintain the legibility of placards and signs.

S-1: Storm Drain Message and Signage

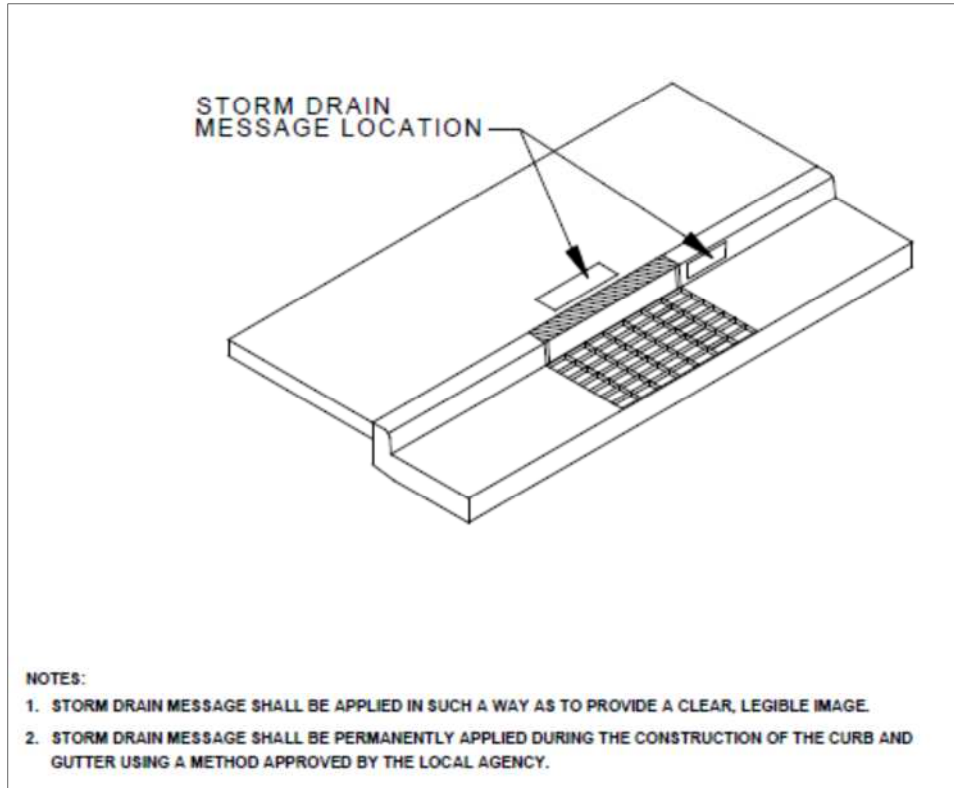

Figure D-1. Storm Drain Message Location – Curb Type Inlet

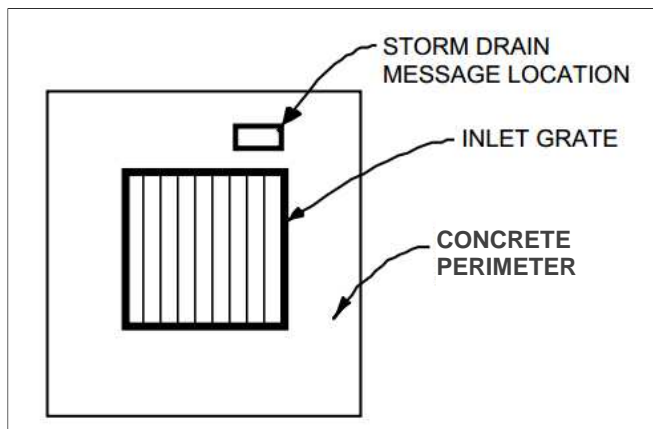

Figure D-2. Storm Drain Message Location – Catch Basin/Area Type Inlet

S-3: Outdoor Trash Storage and Waste Handling Area

Purpose

Stormwater runoff from areas where trash is stored or handled can be polluted. Loose trash and debris can be easily transported by water or wind into nearby storm drain inlets, channels, and/or receiving waters. Waste handling operations (i.e., dumpsters, litter control, waste piles) may be sources of stormwater pollution.

Design Specifications

Wastes from commercial and industrial sites are typically hauled away for disposal by either public or commercial carriers that may have design or access requirements for waste storage areas. Design specifications for waste handling areas are regulated by local building and fire codes and by current County ordinances and zoning requirements. The design specifications, listed below in Table D-3, are recommendations and are not intended to conflict with requirements established by the waste hauler. The design specifications are intended to enhance local codes and ordinances while addressing stormwater runoff concerns. The waste hauler should be contacted prior to the design of trash storage and collection areas to determine established and accepted guidelines for designing trash collection areas. All hazardous waste must be handled in accordance with the legal requirements established in Title 22 of the California Code of Regulations. Conflicts or issues should be discussed with LACDPW staff.

Table D-3. Design Specifications for Outdoor Trash Storage and Waste Handling Area

Design Feature	Design Specifications
Surfacing	<ul style="list-style-type: none"> • Construct/pave outdoor trash storage and waste handling area with Portland cement concrete or an equivalent impervious surface.
Screens/Covers	<ul style="list-style-type: none"> • Install a screen or wall around trash storage area to prevent off-site transport of loose trash. • Use lined bins or dumpsters to reduce leaking of liquid wastes. • Use waterproof lids on bins/dumpsters or provide a roof to cover storage area enclosure (LACDPW discretion) to prevent precipitation from entering containers.
Grading/Drainage	<ul style="list-style-type: none"> • Berm and/or grade waste handling area to prevent stormwater run-on. • Locate waste handling area at least 35 feet from storm drains. • Divert drainage from adjoining roofs and pavement away from adjacent trash storage areas.
Signs	<ul style="list-style-type: none"> • Post signs on all dumpsters and/or inside enclosures prohibiting disposal of liquids and hazardous materials in accordance with any waste disposal ordinance.

S-3: Outdoor Trash Storage and Waste Handling Area

Accumulated Water

Stormwater runoff, non-stormwater runoff, and spills will accumulate in containment areas and sumps with impervious surfaces. Contaminated accumulated water must be disposed of in accordance with applicable laws and regulations, and cannot be discharged directly to the storm drain or sanitary sewer system without appropriate permitting. Contact LACDPW (1-888-CLEAN-LA) for information regarding discharge of contaminated accumulated water.

Maintenance Requirements

The integrity of structural elements that are subject to damage (e.g., screens, covers, signs) must be maintained by the owner/operator as required by local codes and ordinances. Outdoor trash storage and waste handling areas must be checked periodically to ensure containment of accumulated water and prevention of stormwater run-on. Maintenance agreements between LACDPW and the owner/operator may be required. Failure to properly maintain building and property may subject the property owner to citation.

S-8: Landscape Irrigation Practices

Purpose

Irrigation runoff provides a pathway for pollutants (i.e., nutrients, bacteria, organics, sediment) to enter the storm drain system. By effectively irrigating, less runoff is produced resulting in less potential for pollutants to enter the storm drain system.

General Guidance

- Do not allow irrigation runoff from the landscaped area to drain directly to storm drain system.
- Minimize use of fertilizer, pesticides, and herbicides on landscaped areas.
- Plan sites with sufficient landscaped area and dispersal capacity (e.g., ability to receive irrigation water without generating runoff).
- Consult a landscape professional regarding appropriate plants, fertilizer, mulching applications, and irrigation requirements (if any) to ensure healthy vegetation growth.

Design Specifications

- Choose plants that minimize the need for fertilizer and pesticides.
- Group plants with similar water requirements and water accordingly.
- Use mulch to minimize evaporation and erosion.
- Include a vegetative boundary around project site to act as a filter.
- Design the irrigation system to only water areas that need it.
- Install an approved subsurface drip, pop-up, or other irrigation system.¹ The irrigation system should employ effective energy dissipation and uniform flow spreading methods to prevent erosion and facilitate efficient dispersion.
- Install rain sensors to shut off the irrigation system during and after storm events.
- Include pressure sensors to shut off flow-through system in case of sudden pressure drop. A sudden pressure drop may indicate a broken irrigation head or water line.
- If the hydraulic conductivity in the soil is not sufficient for the necessary water application rate, implement soil amendments to avoid potential geotechnical hazards (i.e., liquefaction, landslide, collapsible soils, and expansive soils).

¹ If alternative distribution systems (e.g., spray irrigation) are approved, the County will establish guidelines to implement these new systems.

S-8: Landscape Irrigation Practices

- For sites located on or within 50 feet of a steep slope (15% or greater), do not irrigate landscape within three days of a storm event to avoid potential geotechnical instability.²
- Implement Integrated Pest Management practices.

For additional guidelines and requirements, refer to the Los Angeles County Department of Health Services.

Maintenance Requirements

Maintain irrigation areas to remove trash and debris and loose vegetation. Rehabilitate areas of bare soil. If a rain or pressure sensor is installed, it should be checked periodically to ensure proper function. Inspect and maintain irrigation equipment and components to ensure proper functionality. Clean equipment as necessary to prevent algae growth and vector breeding. Maintenance agreements between LACDPW and the owner/operator may be required. Failure to properly maintain building and property may subject the property owner to citation.

² As determined by the City of Los Angeles, Building and Safety Division

S-9: Building Materials Selection

Purpose

Building materials can potentially contribute pollutants of concern to stormwater runoff through leaching. For example, metal buildings, roofing, and fencing materials may be significant sources of metals in stormwater runoff, especially due to acidic precipitation. The use of alternative building materials can reduce pollutant sources in stormwater runoff by eliminating compounds that can leach into stormwater runoff. Alternative building materials may also reduce the need to perform maintenance activities (i.e., painting) that involve pollutants of concern, and may reduce the volume of stormwater runoff. Alternative materials are available to replace lumber and paving.

Design Specifications

Lumber

Decks and other house components constructed using pressure-treated wood that is typically treated using arsenate, copper, and chromium compounds are hazardous to the environment. Pressure-treated wood may be replaced with cement-fiber or vinyl.

Roofs, Fencing, and Metals

Minimizing the use of copper and galvanized (zinc-coated) metals on buildings and fencing can reduce leaching of these pollutants into stormwater runoff. The following building materials are conventionally made of galvanized metals:

- Metal roofs;
- Chain-link fencing and siding; and
- Metal downspouts, vents, flashing, and trim on roofs.

Architectural use of copper for roofs and gutters should be avoided. As an alternative to copper and galvanized materials, coated metal products are available for both roofing and gutter application. Vinyl-coated fencing is an alternative to traditional galvanized chain-link fences. These products eliminate contact of bare metal with precipitation or stormwater runoff, and reduce the potential for stormwater runoff contamination. Roofing materials are also made of recycled rubber and plastic.

Green roofs may be an option. Green roofs use vegetation such as grasses and other plants as an exterior surface. The plants reduce the velocity of stormwater runoff and absorb water to reduce the volume of stormwater runoff. One potential problem with using green roofs in the Los Angeles County area is the long, hot and dry summers, which may kill the plants if they are not watered. See the Green Roof Fact Sheet (RET-7) in Appendix E.

Pesticides

The use of pesticides around foundations can be reduced through the use of alternative barriers. Sand barriers can be applied around foundations to deter termites, as they cannot tunnel through sand. Metal shields also block termites from tunneling. Additionally, diatomaceous earth can be used to repel or kill a wide variety of other pests.

Maintenance Requirements

The integrity of structural elements that are subject to damage (e.g., signs) must be maintained by the owner/operator as required by local codes and ordinances. Maintenance agreements between LACDPW and the owner/operator may be required. Failure to properly maintain building and property may subject the property owner to citation.



Description and Purpose

Street sweeping and vacuuming includes use of self-propelled and walk-behind equipment to remove sediment from streets and roadways, and to clean paved surfaces in preparation for final paving. Sweeping and vacuuming prevents sediment from the project site from entering storm drains or receiving waters.

Suitable Applications

Sweeping and vacuuming are suitable anywhere sediment is tracked from the project site onto public or private paved streets and roads, typically at points of egress. Sweeping and vacuuming are also applicable during preparation of paved surfaces for final paving.

Limitations

Sweeping and vacuuming may not be effective when sediment is wet or when tracked soil is caked (caked soil may need to be scraped loose).

Implementation

- Controlling the number of points where vehicles can leave the site will allow sweeping and vacuuming efforts to be focused, and perhaps save money.
- Inspect potential sediment tracking locations daily.
- Visible sediment tracking should be swept or vacuumed on a daily basis.

Objectives

EC	Erosion Control	
SE	Sediment Control	<input checked="" type="checkbox"/>
TR	Tracking Control	<input checked="" type="checkbox"/>
WE	Wind Erosion Control	
NS	Non-Stormwater Management Control	
WM	Waste Management and Materials Pollution Control	

Legend:

- Primary Objective
- Secondary Objective

Targeted Constituents

Sediment	<input checked="" type="checkbox"/>
Nutrients	
Trash	<input checked="" type="checkbox"/>
Metals	
Bacteria	
Oil and Grease	<input checked="" type="checkbox"/>
Organics	

Potential Alternatives

None



SE-7 Street Sweeping and Vacuuming

- Do not use kick brooms or sweeper attachments. These tend to spread the dirt rather than remove it.
- If not mixed with debris or trash, consider incorporating the removed sediment back into the project

Costs

Rental rates for self-propelled sweepers vary depending on hopper size and duration of rental. Expect rental rates from \$58/hour (3 yd³ hopper) to \$88/hour (9 yd³ hopper), plus operator costs. Hourly production rates vary with the amount of area to be swept and amount of sediment. Match the hopper size to the area and expect sediment load to minimize time spent dumping.

Inspection and Maintenance

- Inspect BMPs prior to forecast rain, daily during extended rain events, after rain events, weekly during the rainy season, and at two-week intervals during the non-rainy season.
- When actively in use, points of ingress and egress must be inspected daily.
- When tracked or spilled sediment is observed outside the construction limits, it must be removed at least daily. More frequent removal, even continuous removal, may be required in some jurisdictions.
- Be careful not to sweep up any unknown substance or any object that may be potentially hazardous.
- Adjust brooms frequently; maximize efficiency of sweeping operations.
- After sweeping is finished, properly dispose of sweeper wastes at an approved dumpsite.

References

Stormwater Quality Handbooks - Construction Site Best Management Practices (BMPs) Manual, State of California Department of Transportation (Caltrans), November 2000.

Labor Surcharge and Equipment Rental Rates, State of California Department of Transportation (Caltrans), April 1, 2002 – March 31, 2003.

Appendix C:

**'Wetland Mod' Biofiltration Treatment System, Catch Basin Insert
Filter, Sump Pump, and Detention System Specifications/Details**

WetlandMOD - 24" Media Thickness, Volume Based

Project ID:	10641
Project Name:	Tract 82836
City, State, ZIP:	La Puente, CA
Date:	

Blue = User Input
Gray = Formula
Green = Proceed
Red = Redo

Actual unit length 1' shorter

WetlandMOD Size	WM-6-18-V
------------------------	------------------

LA County 24"; Bay Area 18"
 Provided by EOR/ DMA area(s)
 Drain Down Time in hours
 LA 5-10in/hr; Bay Area 5-12in/hr
 Add Row(s) to change footprint

User Input Data	
Media Thickness (in)	24
Treatment Volume (CF)	7965
Drain Down Time (hrs)	96
Infiltration Rate (in/hr)	10
Number of Row(s)	1
RIM/FG elevation	5.00
WM IE Out	0.00
Unit Depth (ft)	5.00
Bypass elevation	4.00
Operating head (ft)	4.00

Max depth = 5', height increments = 6"

RIM/FG to Outlet pipe
 Elevation flows will bypass WM
 Hydraulically connected to detention

treatment volume x 448.8 =
 in/hr / 100 =
 treatment flow / loading rate =

Treatment Data	
Treatment Flow (gpm)	10.34
Media Loading Rate (gpm/sf)	0.10
Required Media Area (sf)	103.43

Providing 3" Mulch on top
 Reduced by 4" from FS
 Length of cage in each row

Cage, HGL Height	
Cage Height (ft)	4.75
HGL Height (ft)	4.00
Cage Length/ Row (ft)	13.0

Set to equal cell D20 or D22

Based on Gravel Layer surface area
 Unit discharge rate
 Orifice Diameter in inches

Final Checks	
Provided Media Surface Area (sf)	104.00
Discharge Rate (cfs)	0.023
Orifice Diameter per Row (in)	0.66

Provided >= Required surface area, unit dimensions in good standing.

Length of Media row + Baffle wall
 Pre-treatment + Filtration chm.
 Total width of unit

Unit Dimensions	
Length Media Row(s) (ft)	14.0
Length of Unit (ft)	18.0
Width of Unit (ft)	6.000

Media, Gravel Volume	
WM Media Volume (cy)	9.15
Gravel Layer Volume (cy)	1.91

<p>Feel free to fax or email proposed sizing calculations to BioClean, for assistance with sizing, compliance, and design. Phone: 760.433.7640 Fax: 760.433.3176 Email: Info@modularwetlands.com</p>	 A Forterra Company
--	---

SITE SPECIFIC DATA			
PROJECT ID	10641		
PROJECT NAME	TRACT 82836		
PROJECT LOCATION	LA PUENTE, CA		
STRUCTURE ID			
TREATMENT REQUIRED			
VOLUME BASED (CF)	FLOW BASED (CFS)		
7965	N/A		
TREATMENT HGL AVAILABLE (FT)	N/K		
PEAK BYPASS REQUIRED (CFS) - IF APPLICABLE	OFFLINE		
PIPE DATA	I.E.	MATERIAL	DIAMETER
INLET PIPE 1	N/K	N/K	N/K
INLET PIPE 2	N/A	N/A	N/A
OUTLET PIPE	N/K	PVC-SDR35	6"
	PRETREATMENT	BIOFILTRATION	N/A
RIM ELEVATION	N/K	N/K	N/A
SURFACE LOAD	PEDESTRIAN	OPEN PLANTER	N/A
FRAME & COVER	36" X 36"	N/A	N/A
LA COUNTY MEDIA MIX VOLUME (CY)	9.15		
GRAVEL LAYER WITHIN MEDIA CHAMBER (CY)	1.91		
ORIFICE DIAMETER (IN)	ø0.66"		
NOTES: PRELIMINARY, NOT FOR CONSTRUCTION. UPSTREAM BYPASS PIPE TO BE SET EQUAL TO OR HIGHER THAN HGL IN DETENTION SYSTEM, ELEVATION TBD. UNIT SIZED ASSUMING 4' OF TREATMENT HGL.			

INSTALLATION NOTES

- CONTRACTOR TO PROVIDE ALL LABOR, EQUIPMENT, MATERIALS AND INCIDENTALS REQUIRED TO OFFLOAD AND INSTALL THE SYSTEM AND APPURTENANCES IN ACCORDANCE WITH THIS DRAWING AND THE MANUFACTURER'S SPECIFICATIONS, UNLESS OTHERWISE STATED IN MANUFACTURER'S CONTRACT.
- UNIT MUST BE INSTALLED ON LEVEL BASE. MANUFACTURER RECOMMENDS A MINIMUM 6" LEVEL ROCK BASE UNLESS SPECIFIED BY THE PROJECT ENGINEER. CONTRACTOR IS RESPONSIBLE FOR VERIFYING PROJECT ENGINEER'S RECOMMENDED BASE SPECIFICATIONS.
- ALL PIPES MUST BE FLUSH WITH INSIDE SURFACE OF CONCRETE. (PIPES CANNOT INTRUDE BEYOND FLUSH). INVERT OF OUTFLOW PIPE MUST BE FLUSH WITH DISCHARGE CHAMBER FLOOR. ALL GAPS AROUND PIPES SHALL BE SEALED WATER TIGHT WITH A NON-SHRINK GROUT PER MANUFACTURER'S STANDARD CONNECTION DETAIL AND SHALL MEET OR EXCEED REGIONAL PIPE CONNECTION STANDARDS.
- CONTRACTOR TO SUPPLY AND INSTALL ALL EXTERNAL CONNECTING PIPES.
- CONTRACTOR RESPONSIBLE FOR INSTALLATION OF ALL RISERS, MANHOLES, AND HATCHES. CONTRACTOR TO GROUT ALL MANHOLES AND HATCHES TO MATCH FINISHED SURFACE UNLESS SPECIFIED OTHERWISE.
- DRIP OR SPRAY IRRIGATION REQUIRED ON ALL UNITS WITH VEGETATION.

GENERAL NOTES

- MANUFACTURER TO PROVIDE ALL MATERIALS UNLESS OTHERWISE NOTED.
- ALL DIMENSIONS, ELEVATIONS, SPECIFICATIONS AND CAPACITIES ARE SUBJECT TO CHANGE. FOR PROJECT SPECIFIC DRAWINGS DETAILING EXACT DIMENSIONS, WEIGHTS AND ACCESSORIES PLEASE CONTACT MANUFACTURER.

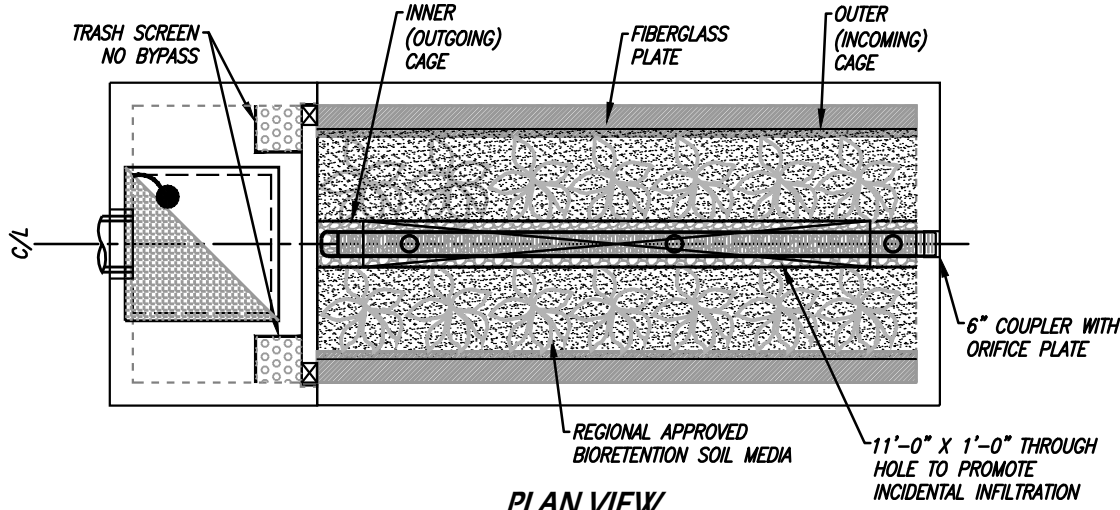

PLAN VIEW

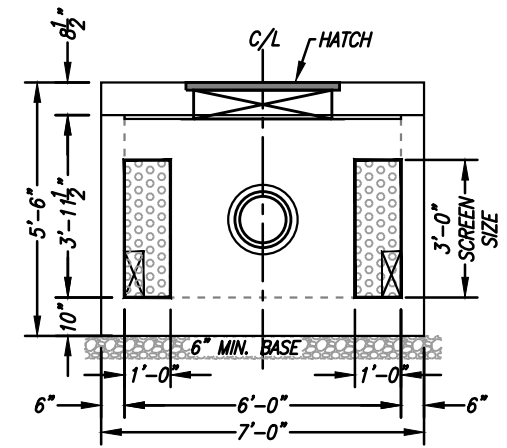

INLET VIEW

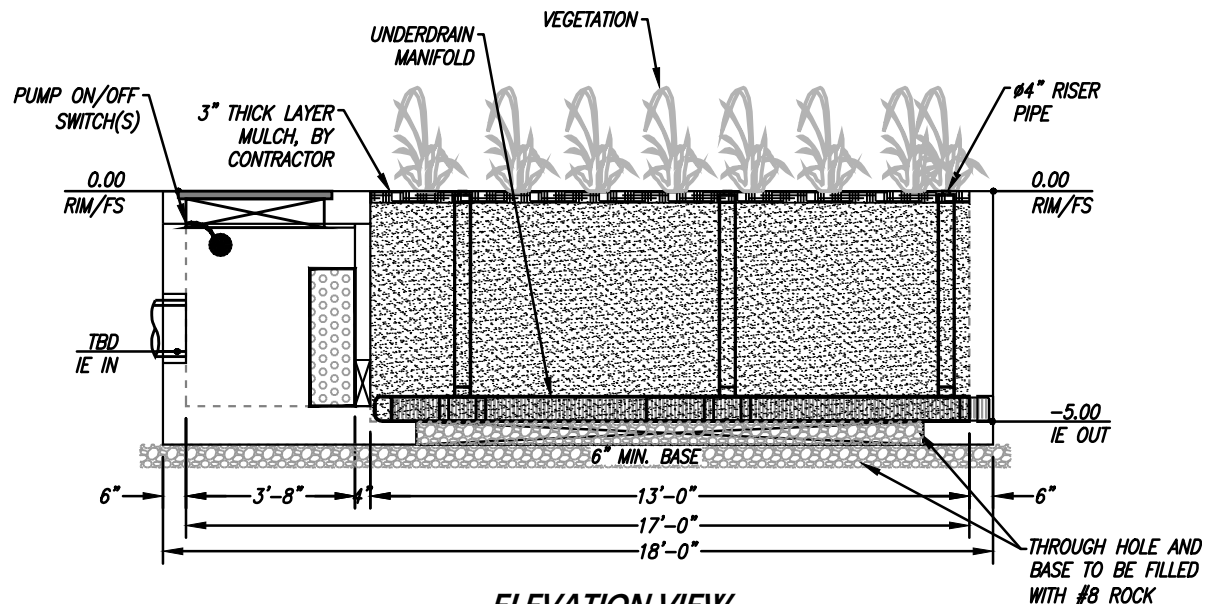

ELEVATION VIEW

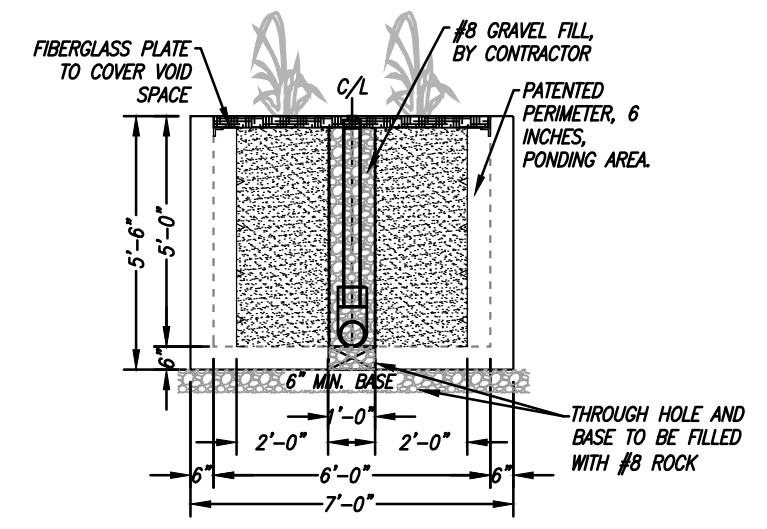

OUTLET VIEW

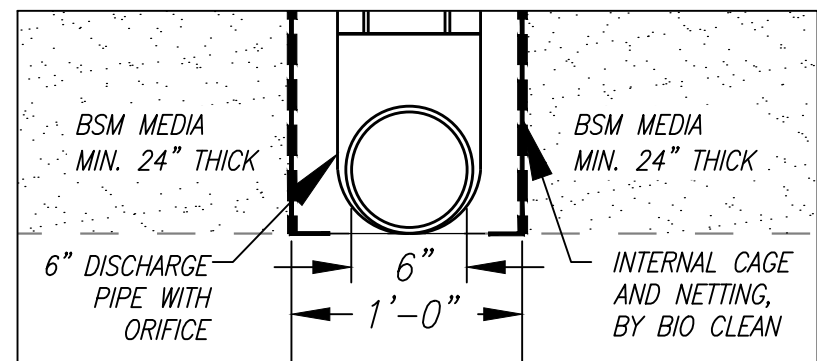

INTERNAL CAGE DETAILS

TREATMENT SURFACE AREA SIZING		
	INCOMING SURFACE AREA	OUTGOING SURFACE AREA
SURFACE AREA	2(13' x 4') = 104.00 SF	2(13' x 4') = 104.00 SF

REQUIRED HORIZ. MEDIA THICKNESS (INCHES)	24
TREATMENT VOLUME (CF)	7965
TARGETED DRAINDOWN DURATION (HR)	96
WETLAND MEDIA INFILTRATION RATE (IN/HR)	10
WETLAND MEDIA LOADING RATE (GPM/SF)	OR 0.10
DISCHARGE RATE (CFS)	0.023
REQUIRED TOTAL MEDIA SURFACE AREA (SF)	103.43
PROVIDED TOTAL MEDIA SURFACE AREA (SF)	104.00
NUMBER OF ROW(S)	1

THE PRODUCT DESCRIBED MAY BE PROTECTED BY ONE OR MORE OF THE FOLLOWING US PATENTS: 7,425,262; 7,470,362; 7,674,378; 8,303,816; RELATED FOREIGN PATENTS OR OTHER PATENTS PENDING

PROPRIETARY AND CONFIDENTIAL:
THE INFORMATION CONTAINED IN THIS DRAWING IS THE SOLE PROPERTY OF MODULAR WETLANDS SYSTEMS. ANY REPRODUCTION IN PART OR AS A WHOLE WITHOUT THE WRITTEN PERMISSION OF MODULAR WETLANDS SYSTEMS IS PROHIBITED.



WetlandMOD-6-17-V
STORMWATER BIOFILTRATION SYSTEM
STANDARD DETAIL

5/8/2005MTH

SPECIFIER CHART

MODEL	INLET ID	GRATE OD	COMMENTS
FF-12D	12" X 12"	15" X 15"	GRATED INLET
FF-16D	16" X 16"	18" X 18"	GRATED INLET
FF-18D	18" X 18"	20" X 20"	GRATED INLET
FF-1836SD	18" X 36"	18" X 40"	GRATED INLET
FF-1836DGO	18" X 36"	18" X 40"	COMBINATION INLET
FF-24D	24" X 24"	26" X 26"	GRATED INLET
FF-2436SD	24" X 36"	24" X 40"	GRATED INLET
FF-24DGO	24" X 24"	18" X 26"	COMBINATION INLET
FF-2436DGO	24" X 36"	24" X 40"	COMBINATION INLET
FF-36D (2 PIECE)	36" X 36"	36" X 40"	GRATED INLET
FF-3648D (2 PIECE)	36" X 48"	40" X 48"	GRATED INLET

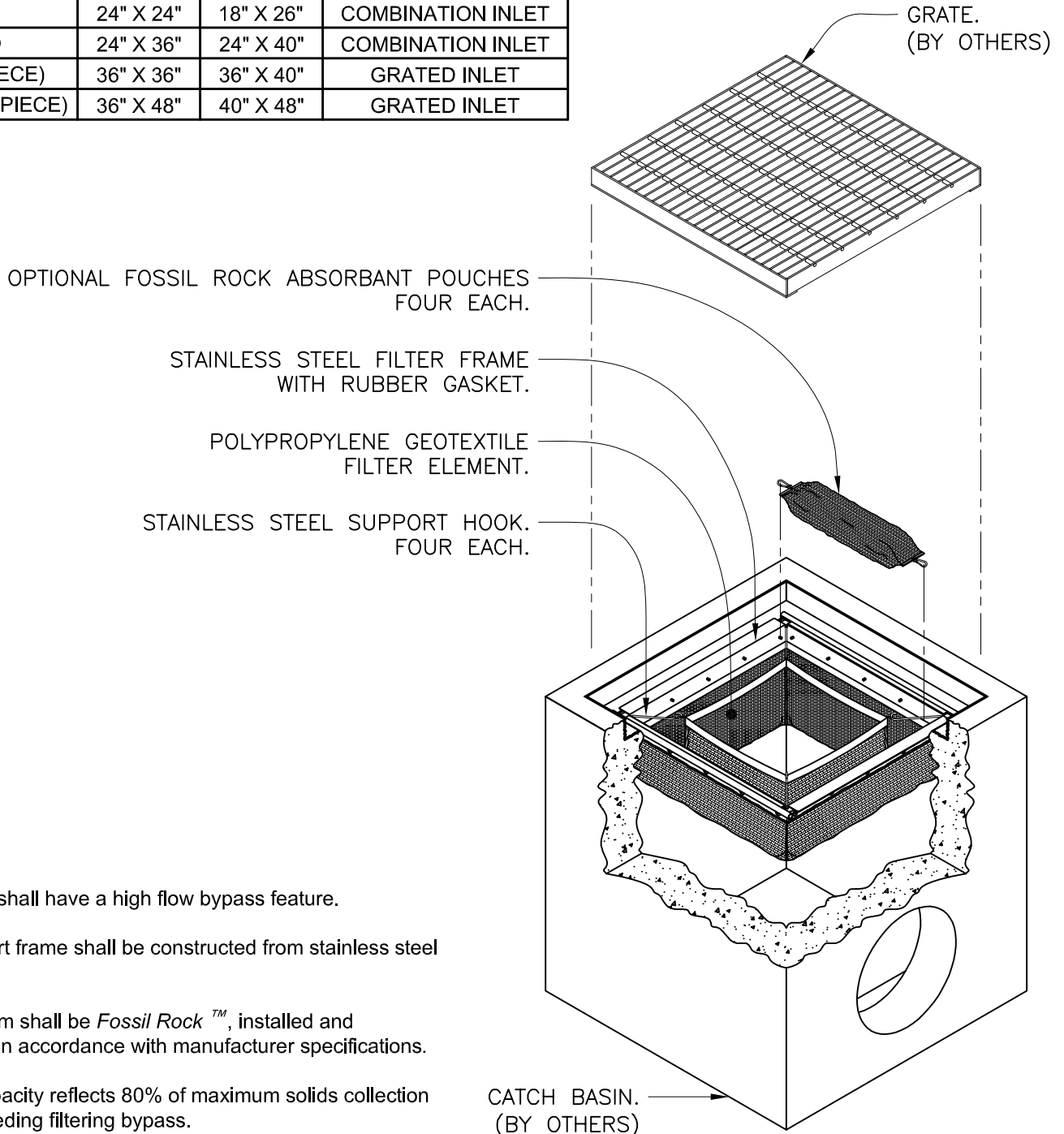

NOTES:

1. Filter insert shall have a high flow bypass feature.
2. Filter support frame shall be constructed from stainless steel Type 304.
3. Filter medium shall be *Fossil Rock™*, installed and maintained in accordance with manufacturer specifications.
4. Storage capacity reflects 80% of maximum solids collection prior to impeding filtering bypass.



FloGard®
Catch Basin Insert Filter
Grated Inlet Style



Oldcastle®
 Stormwater Solutions

7921 Southpark Plaza, Suite 200 | Littleton, CO | 80120 | Ph: 800.579.8819 | oldcastlestormwater.com
 THIS DOCUMENT IS THE PROPERTY OF OLDCASTLE PRECAST, INC. IT IS SUBMITTED FOR REFERENCE PURPOSES ONLY AND SHALL NOT BE USED IN ANY WAY INJURIOUS TO THE INTERESTS OF SAID COMPANY. COPYRIGHT © 2016 OLDCASTLE PRECAST, INC. ALL RIGHTS RESERVED.

DRAWING NO. FG-0001	REV E	ECO ECO-0142	DATE JPR 7/13/16	DATE JPR 12/18/06	SHEET 1 OF 2
------------------------	----------	-----------------	---------------------	----------------------	--------------



FLOGARD +PLUS®

Technical Note

Independent field tests conducted in Hawaii and New Zealand on FloGard +PLUS® Catch Basin Insert Filters to determine removal efficiency of Total Suspended Solids (TSS). Results were extrapolated to a typical street deposited sediment particle size. Removal efficiencies were plotted and reflect effective TSS removal over a typical range of operating flow rates. Results are shown below as a function of unit internal surface area.

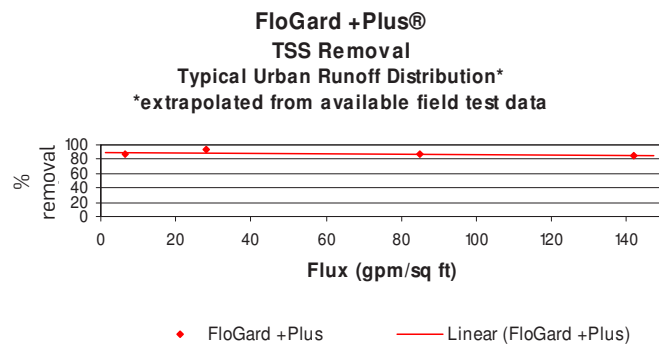

Street Deposited Sediment Typical Particle Size Distribution from urban runoff TSS survey data

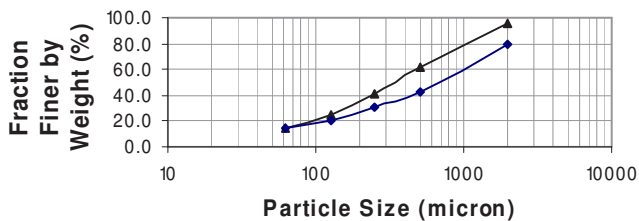

—▲ Woodward-Clyde (1997) —◆ Honolulu Street Sediment (2004)

Units are sized to fit most common styles of drainage inlet grate frames or inlet widths. Rated filtered flow capacities for each model typically exceed the required "first flush" treatment flow rate, and account for reduction in capacity as the unit accumulates suspended pollutants. Rated bypass capacity for each model also typically exceeds the inlet capacity of the catch basin.

FloGard +PLUS® Catch Basin Insert Filter is an efficient inlet prefilter designed to remove suspended sediment and floatable trash and hydrocarbons from stormwater runoff in new or retrofit applications. It is ideally suited for removal of primary pollutants from paved surfaces in commercial and residential areas, or may form part of a treatment train. The device features a unique dual-bypass design, durable components, flexible installation options and easy maintenance access.

FloGard +PLUS® Test Results Summary

Testing Agency	%TSS Removal	% Oil & Grease Removal
UCLA	80*	70-80
U of Auckland Tonkin & Taylor LTD (City of Auckland)	95** 78-86***	
U of Hawaii (City of Honolulu)	80***	

*Sand larger than ~ 575 µm

**Sand distribution ~ 100-1000 µm

***Local street sweep material (distribution consistent with NURP)

See product specifications for standard model details.



FLOGARD+PLUS® CATCH BASIN INSERT FILTER

Inspection and Maintenance Guide



A division of
Oldcastle Precast

SCOPE:

Federal, State and Local Clean Water Act regulations and those of insurance carriers require that stormwater filtration systems be maintained and serviced on a recurring basis. The intent of the regulations is to ensure that the systems, on a continuing basis, efficiently remove pollutants from stormwater runoff thereby preventing pollution of the nation's water resources. These specifications apply to the FloGard+Plus® Catch Basin Insert Filter.

RECOMMENDED FREQUENCY OF SERVICE:

Drainage Protection Systems (DPS) recommends that installed FloGard+Plus Catch Basin Insert Filters be serviced on a recurring basis. Ultimately, the frequency depends on the amount of runoff, pollutant loading and interference from debris (leaves, vegetation, cans, paper, etc.); however, it is recommended that each installation be serviced a minimum of three times per year, with a change of filter medium once per year. DPS technicians are available to do an onsite evaluation, upon request.

RECOMMENDED TIMING OF SERVICE:

DPS guidelines for the timing of service are as follows:

1. For areas with a definite rainy season: Prior to, during and following the rainy season.
2. For areas subject to year-round rainfall: On a recurring basis (at least three times per year).
3. For areas with winter snow and summer rain: Prior to and just after the snow season and during the summer rain season.
4. For installed devices not subject to the elements (washracks, parking garages, etc.): On a recurring basis (no less than three times per year).

SERVICE PROCEDURES:

1. The catch basin grate shall be removed and set to one side. The catch basin shall be visually inspected for defects and possible illegal dumping. If illegal dumping has occurred, the proper authorities and property owner representative shall be notified as soon as practicable.
2. Using an industrial vacuum, the collected materials shall be removed from the liner. (Note: DPS uses a truck-mounted vacuum for servicing FloGard+Plus catch basin inserts.)
3. When all of the collected materials have been removed, the filter medium pouches shall be removed by unsnapping the tether from the D-ring and set to one side. The filter liner, gaskets, stainless steel frame and mounting brackets, etc., shall be inspected for continued serviceability. Minor damage or defects found shall be corrected on-the-spot and a notation made on the Maintenance Record. More extensive deficiencies that affect the efficiency of the filter (torn liner, etc.), if approved by the customer representative, will be corrected and an invoice submitted to the representative along with the Maintenance Record.
4. The filter medium pouches shall be inspected for defects and continued serviceability and replaced as necessary and the pouch tethers re-attached to the liner's D-ring. See below.
5. The grate shall be replaced.

REPLACEMENT AND DISPOSAL OF EXPOSED FILTER MEDIUM AND COLLECTED DEBRIS

The frequency of filter medium exchange will be in accordance with the existing DPS-Customer Maintenance Contract. DPS recommends that the medium be changed at least once per year. During the appropriate service, or if so determined by the service technician during a non-scheduled service, the filter medium will be replaced with new material. Once the exposed pouches and debris have been removed, DPS has possession and must dispose of it in accordance with local, state and federal agency requirements.

DPS also has the capability of servicing all manner of storm drain filters, catch basin inserts and catch basins without inserts, underground oil/water separators, stormwater interceptors and other such devices. All DPS personnel are highly qualified technicians and are confined space trained and certified. Call us at (888) 950-8826 for further information and assistance.

PACKAGED PUMP LIFT STATION
18616 RORIMER ST. LA PUENTE, CA - STROM PUMP

Lift Station model #PSI-C&V012220 as manufactured by Pacific Southwest Industries (national phone # 800-358-9095)

The pre-packaged Lift Station, in its entirety, is to be non-corrosive and shall incorporate a quick removal system manufactured by the pump manufacturer. The pump(s) shall be guided to the discharge base elbow by stainless steel guide rails. The rails shall extend from the discharge base elbow to the upper guide bracket mounted on fiberglass channel just below the basin cover. Stainless steel lifting chain or cable shall be supplied and properly installed to remove the pump from the wet well. The internal discharge piping shall be completely pre-plumbed in PVC pipe and extend 12" beyond the wet well side wall for contractor connection to the force main piping. The pump(s) discharge pipe shall have a check and ball valve installed on each discharge line. The Lift Station shall include three liquid level controls on a removable float tree and a control panel suitable for surface mounting. The pump(s), quick removal system and the level sensors shall be housed in a fiberglass wet well (basin) and shall be of sufficient length to maintain the rim of the wet well at grade.

PUMP(S):

Furnish and install Tsurumi, VANC'S Model 50PU2.15S submersible pump(s). Each unit shall be capable of delivering 21 GPM at 14.58 FT TDH. The pump(s) shall be designed to pump waste water, sewage or effluent containing 1.5 inch (38mm) diameter solids without damage during operation. The pump(s) shall be designed so that the shaft power required (BHP) / (kW) shall not exceed the motor rated output throughout the entire operating range of the pump performance curve. A two year warranty "out of the box" shall be standard.

MATERIALS OF CONSTRUCTION:

Construction of major parts of the pumping unit(s) including pump casing, impeller, motor head cover and intermediate brackets shall be manufactured from recyclable, application appropriate resins. The need for a protective coating shall not be required. All exposed fasteners shall be stainless steel and shall have stainless mating anchors integrally cast into the mating part. All units shall be furnished with a NPT discharge companion flange. Impellers shall be of the multi-vane, semi-vortex, solids handling design and shall be slip fit to the shaft. The motor shaft shall be machined to provide a positive drive of the impeller. The pump casing shall incorporate an air relief valve.

MECHANICAL SEAL:

All units shall be furnished with a dual inside mechanical shaft seal located completely out of the pumpage, running in a separate oil filled chamber. Units shall be fitted with a device that shall provide positive lubrication of top mechanical seal, (down to one third of the standard oil level). The device shall not consume any additional electrical power. Units shall have silicone carbide mechanical seal faces. Mechanical seal hardware shall be stainless steel.

MOTOR:

The pump motor(s) shall be 1/5 HP, .15 KW, 120 V, 60 Hz, 1 Phase and shall be NEMA MG-1, Design Type B equivalent. Motor(s) shall be rated at 3.1 full load amps. Motor(s) shall have a 1.15 service factor and shall be rated for 6 starts per hour. Motor(s) shall be air filled, copper wound, class E insulated with built-in thermal protection. Motor shaft shall be 403 stainless steel and shall be supported by two permanently lubricated, high temperature ball bearings, with a B-10 life rating at best efficiency point of 60,000 hours. The bearings shall be single row, double shielded, C3, deep groove type ball bearings. Bearing seats shall be rolled carbon steel or aluminum die casting. Motor housing shall be 304 stainless steel. Motors shall be suitable variable speed applications, utilizing a properly sized variable frequency drive. (Only for 3 phase.)

POWER CABLE AND CABLE ENTRANCE:

The pump power cable shall be suitable for submersible pump applications. The cable entrance shall incorporate built in strain relief, a one piece, three way mechanical compression seal with a fatigue reducing cable boot. The cable entrance assembly shall contain an anti-wicking block to eliminate water incursion into the motor due to Capillary wicking should the power cable be accidentally damaged.

QUICK REMOVAL SYSTEM:

The pumping unit(s) shall be equipped with quick removal system (QRS). The construction shall be such that the pump(s) will automatically connect to the discharge piping when lowered into place on the discharge connector. There shall be no need for personnel to enter the wet well to accomplish installation or removal of the pump(s). The pumping unit(s) shall be fitted with stainless steel lifting chain(s) of sufficient length and strength to permit the raising and lowering of the unit(s). The chain(s) shall be fastened at the top of the structure near the access opening. All parts of the QRS system including base elbow, sliding guide bracket, and guide support shall be manufactured from recyclable, application appropriate resins. The need for a protective coating shall not be required.

A sliding guide bracket shall be an integral part of the pumping unit and the pump casing shall have a machined connection with a bracket to connect with the discharge connection.

Sealing of the pumping unit to the discharge connection shall be accomplished by a single linear downward motion of the pump with the entire weight of the pumping unit guided by a pawl, thereby wedging the pumping unit tightly against the discharge connector. No portion of the pump shall bear directly on the floor of the sump nor shall a rotary motion of the pump be required for sealing. All fasteners coming into contact with the pumpage shall be stainless steel.

Two corrosion resistant guide pipes shall be furnished and installed for each pump to permit raising and lowering of the pump. Guide pipes shall be 3/4 inch (20 mm) in diameter and shall be of adequate length to extend from the lower guide holder to the upper guide bar bracket(s) mounted on the access frame.

CONTROL PANEL:

The control panel shall have a NEMA 4X semi dead front enclosure suitable for wall mounting. The outer face of the door shall have only the following: 1 high water alarm light with silence switch, 1 buzzer. The inner workings of the control panel shall have no less than motor circuit protectors (overloads) that shall be adjustable, motor contactor, HOA selector switches, circuit breakers, Smart relay with exercise timers, elapsed timer meters, and float indicators, numbered terminal switch, and shall be listed by U.L. 508.

FIBERGLASS WET WELL:

The fiberglass wet well shall have a minimum inside diameter of 30 inches and shall be of sufficient length to maintain the rim at grade and shall be 156 inches in length. The fiberglass wet well shall be manufactured using a process that insures that the bottom of the basin will be fabricated at the same time as the sidewalls, eliminating the possibility of any joints or seams in the wet well in the area of greatest stress concentration. The tank will be fitted with 3 re-inforcement ribs to strength the tank. The laminate shall have a barcol hardness of at least 90% of the resin manufactures minimum specified hardness for cured resin on both the interior and exterior surfaces. The minimum wall thickness of the wet well shall not be less than 3/16". 2" x 4" lumber shall be encapsulated in the bottom of the wet well to allow the mounting of the polypropylene bottom and the quick removal system. The wet well shall be provided with "uniseal" fittings that can be installed in the field to insure proper elevation of the inlet, vent, and electrical on the side of the wet well.

STEEL H20 SUITABLE FRAME AND COVER:

The cover of the wet well shall be no less than 1/2" thick and shall be suitable for H-20 traffic loads. The cover shall be solid with no penetrations through the top and shall be secured to the rim of the wet well with steel hardware. The cover is to be suspended in a Class A bed of concrete a minimum of 6" thick and to extended a minimum of 18" past the frame. The covers will be supplied with enamel primer paint.

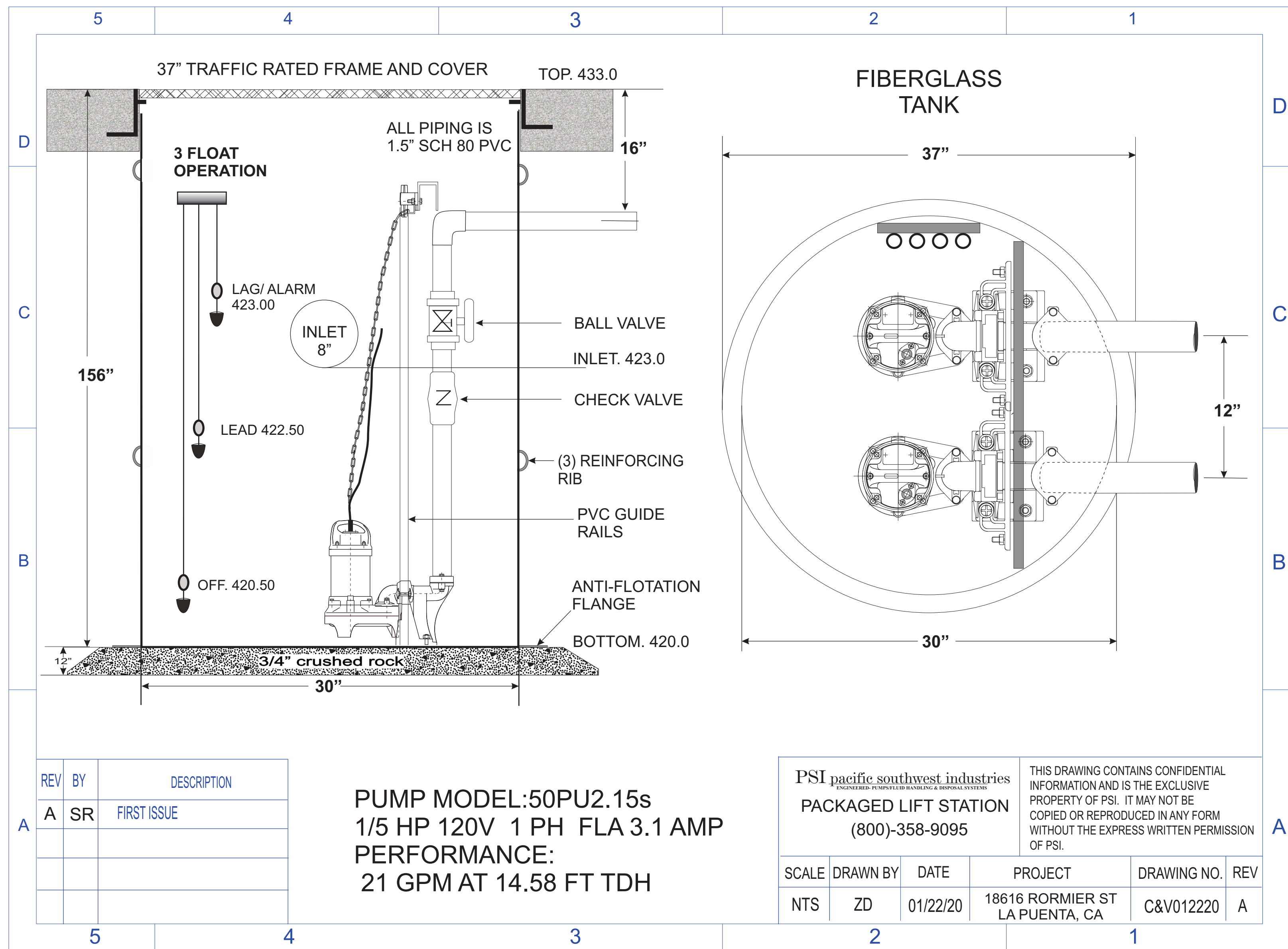
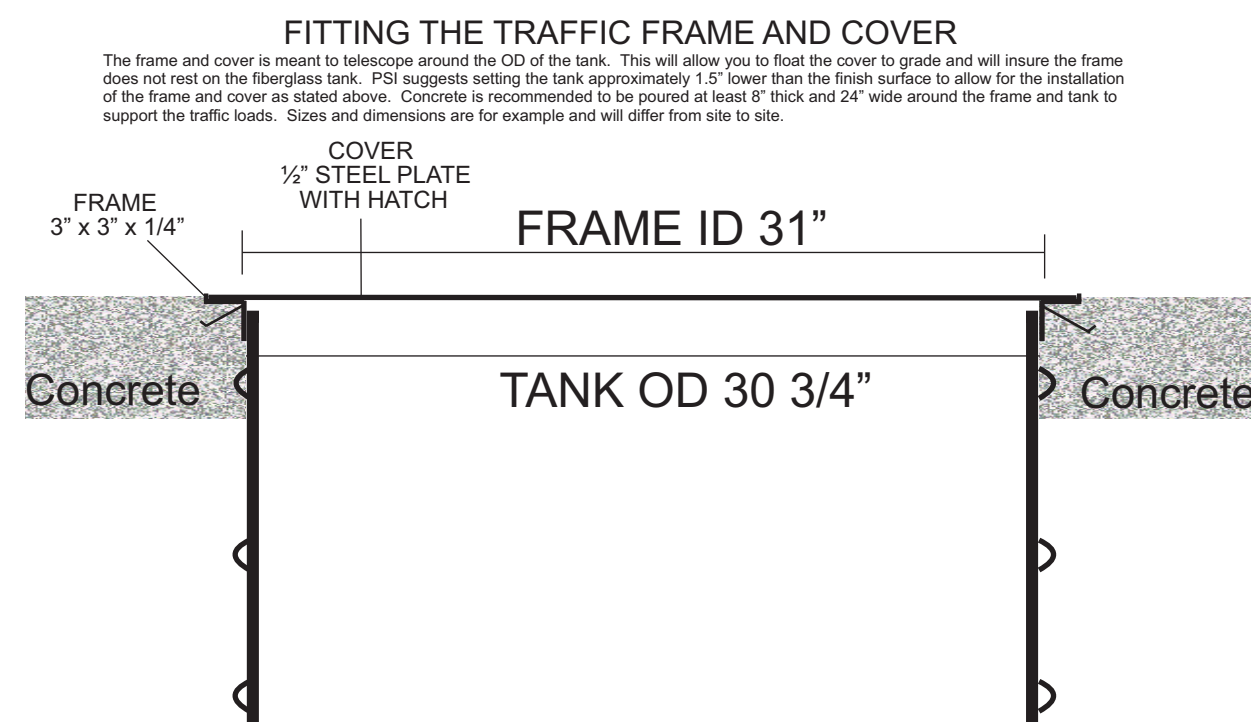

REV	BY	DESCRIPTION
A	SR	FIRST ISSUE

PUMP MODEL: 50PU2.15s
1/5 HP 120V 1 PH FLA 3.1 AMP
PERFORMANCE:
21 GPM AT 14.58 FT TDH

PSI <i>pacific southwest industries</i> ENGINEERED - PUMPS/FLUID HANDLING & DISPOSAL SYSTEMS 30520 COPLASA ST., LAKE ELSINORE, CA 92530 PH: 800-358-9095		THIS DRAWING CONTAINS CONFIDENTIAL INFORMATION AND IS THE EXCLUSIVE PROPERTY OF PSI. IT MAY NOT BE COPIED OR REPRODUCED IN ANY FORM WITHOUT THE EXPRESS WRITTEN PERMISSION OF PSI.	
SCALE	DRAWN BY	DATE	PROJECT
NTS	ZD	01/22/20	18616 RORIMER ST LA PUENTA, CA
DRAWING NO.	REV		
C&V012220	A		

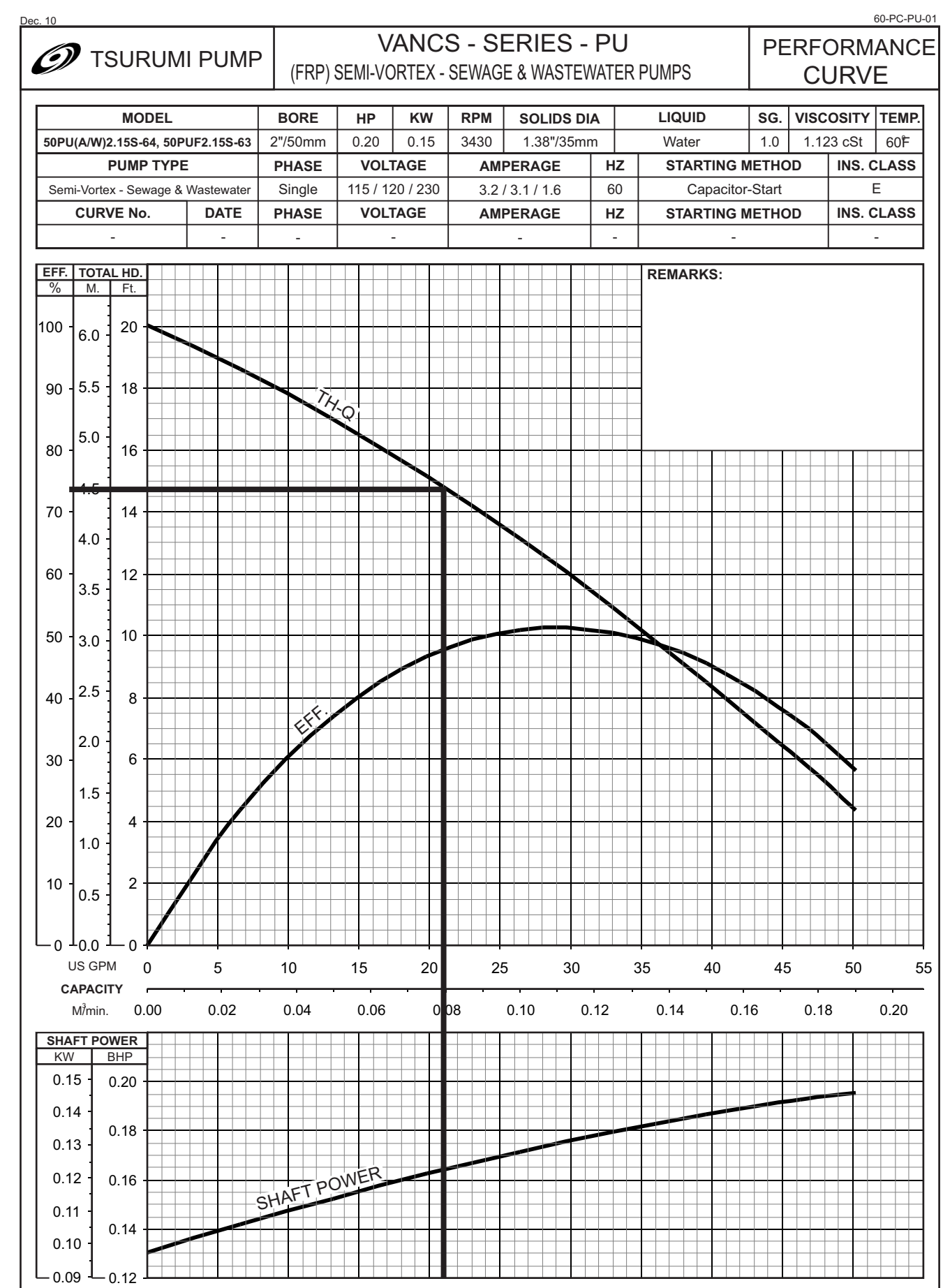

LIFT STATION PROFILE & CALCULATIONS

EQUIVALENT PIPE RUN CALCULATION

1.5" SCH 80 PVC PIPE	20.0 FT
1.5" PVC SCH 80 90 ELBOW (1) X 4.3 FT	4.3 FT
1.5" PVC SCH 80 45 BEND (0) X 2 FT	0.0 FT
1.5" GATE VALVE (1) X .95 FT	.95 FT
1.5" CHECK VALVE (1) X 11 FT	11.0 FT
TOTAL EQUIVALENT LENGTH	36.25 FT
FRICTION LOSS PER 100 FT 2" PVC @ 21 GPM	4.36 FT PER 100 FT
FRICTION LOSS 1.5"	36.25/100 X 4.36 FT = 1.58 FT
FRICTION LOSS	1.58 FT
STATIC HEAD	13.00 FT
TOTAL DEVELOPED HEAD	14.58 FT
PERFORMANCE 21 GPM @ 14.58 FT TDH THRU 2" PVC LINE	

STORM WATER PUMP SYSTEM

PSI *pacific southwest industries*
ENGINEERED - PUMPS/FLUID HANDLING & DISPOSAL SYSTEMS
30520 COPLASA ST., LAKE ELSINORE, CA 92530 PH: 800-358-9095

Description	
Date	
No.	
LIFT STATION DETAILS 18616 RORIMER ST. LA PUENTA, CA	Scale: NTS Sheet No. 1 OF 1
Date: 01/22/20	Drawn by: ZD
Checked by: OR	

LSD-1

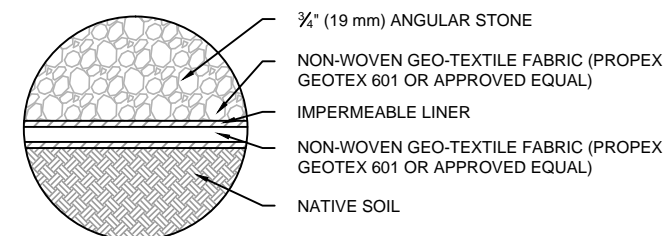
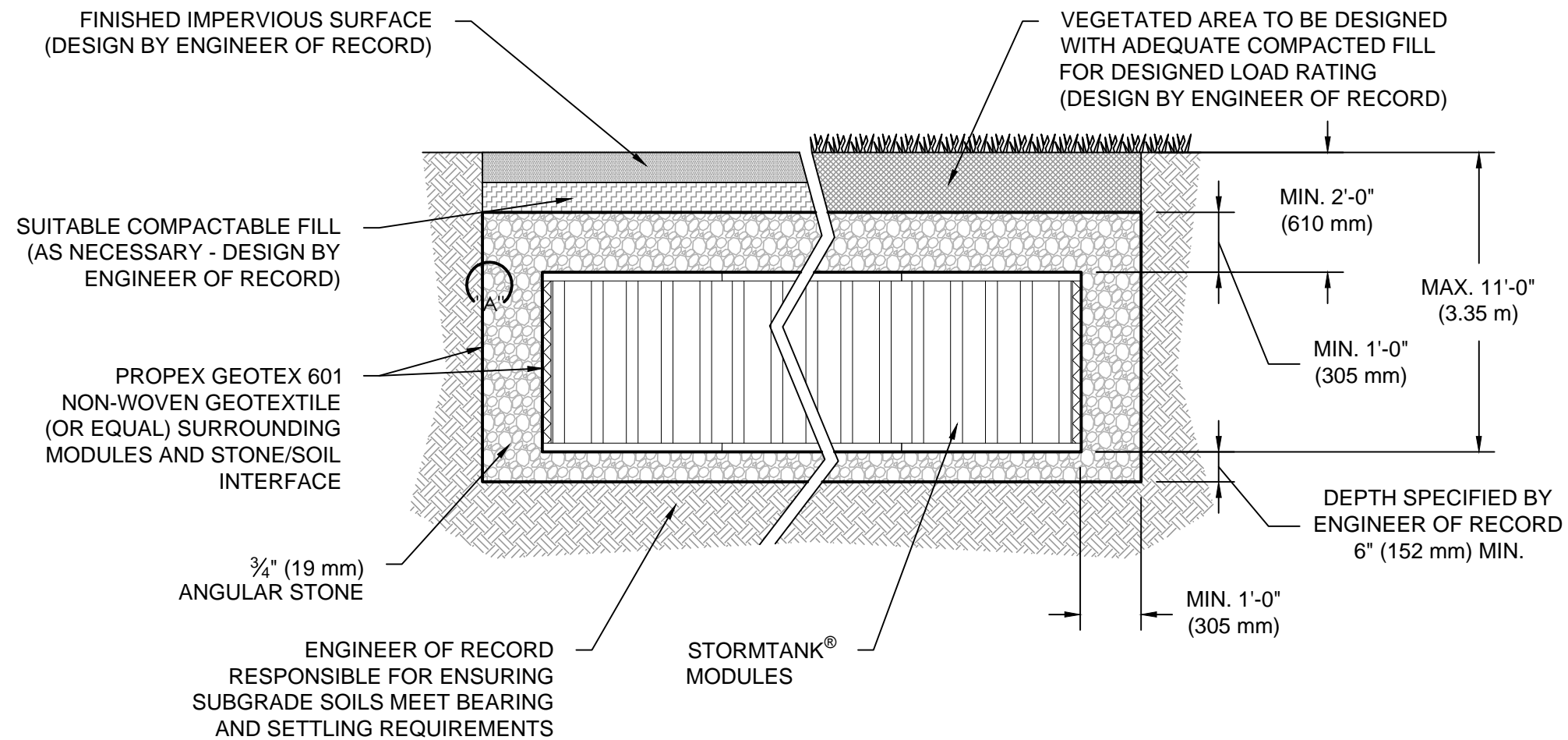

DETAIL "A"

NOTES:

- a. REFERENCE CURRENT INSTALLATION INSTRUCTIONS FOR PROPER INSTALLATION PRACTICES.
- b. IMPERMEABLE LINER IS REQUIRED TO BE INSTALLED AROUND BOTTOM AND SIDES OF EXCAVATION ONLY

REV.	DATE	RECORD OF CHANGES	BY	APPRV.
D	11/10/14	GEOTEXTILE PRODUCT SPECIFIED	CGB	
C	9/9/13	NOTE REVISION, FORMATTING UPDATE & DWG. NO. UPDATE	JKB	JKB
B	7/6/12	FORMATTING & DWG. NO. UPDATE	JKB	FK
A	1/10/12	INITIAL RELEASE	BLL	FK

This is the property of Brentwood Industries, Inc. It may not be reproduced or used for any purpose other than those expressly authorized by Brentwood Industries. It shall be returned immediately upon request of Brentwood Industries.



610 Morgantown Road
Reading, PA 19611 U.S.A.
Phone: (610) 374-5109
Fax: (610) 376-6022
www.brentwoodindustries.com

Project Name
**TYPICAL SINGLE STK. DETENTION
BASIN CROSS-SECTION DETAIL**

Title
**STORMTANK®
MODULE**

Drawn By B.LINE	Date 1/10/12
Drawing No. STM-001-01	Sheet 1 of 1
	Scale NTS

STORMTANK[®] Module Volume Calculator

Inputs	Project Name:	La Puente - Module #1		Dimensions	Module		
	Engineer:	BB	Date:		5/7/2020	Footprint:	1255.5 sf
	Units:	US				Perimeter:	147 ft
	Liner:	Yes	Location:		Excavation	Excavation	
	Stacking:	Single	Height:		30	Footprint:	1406.5 sf
	Stone Storage:	All	Porosity:		40%	Perimeter:	155 ft
						Stone	
						Leveling Bed:	0.5 ft
				Top Backfill:	1 ft		
				Compacted Fill:	1 ft		

Results

Capacity:

Stone Storage Volume:	994.90	cf
Module Storage Volume:	3,034.40	cf
Total Storage Volume:	4,029.30	cf

Storage Capacity Ratio

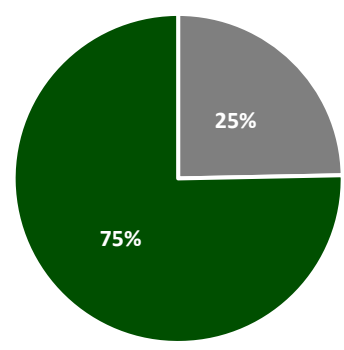

Quantities:

Required Excavation:	260.46	cy
Required Stone:	92.12	cy

Estimated Geotextile:		
Surrounding Module:	355.37	sy
Surrounding Excavation:	847.65	sy
Estimated Liner:	3,814.44	sf

(Estimations include 10% for scrap and overlap)

■ Stone Storage Volume: ■ Module Storage Volume:

Basin Detail

Component Quantities:

	Bottom Layer	Top Layer	Total
Height	30.0	N/A	30.0
# of Modules	279	N/A	279
# of Platens	558	N/A	558
# of Side Panels	98	N/A	98
# of Columns	2,232	N/A	2,232
# of Stacking Pins	0	N/A	0

Cross-Section:

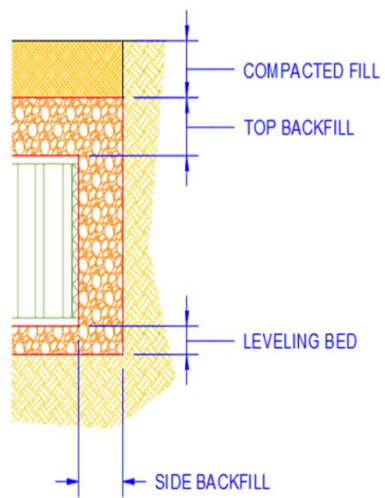

STORMTANK[®] Module Volume Calculator

Inputs	Project Name:	La Puente - Module #2		Dimensions	Module		
	Engineer:	BB	Date:		5/7/2020	Footprint:	1237.5 sf
	Units:	US				Perimeter:	141 ft
	Liner:	Yes	Location:		Excavation	Excavation	
	Stacking:	Single	Height:		30	Footprint:	1382.5 sf
	Stone Storage:	All	Porosity:		40%	Perimeter:	149 ft
						Stone	
						Leveling Bed:	0.5 ft
				Top Backfill:	1 ft		
				Compacted Fill:	1 ft		

Results

Capacity:

Stone Storage Volume:	974.50	cf
Module Storage Volume:	2,990.90	cf
Total Storage Volume:	3,965.40	cf

Quantities:

Required Excavation:	256.02	cy
Required Stone:	90.23	cy
Estimated Geotextile:		
Surrounding Module:	349.07	sy
Surrounding Excavation:	829.88	sy
Estimated Liner:	3,734.44	sf

(Estimations include 10% for scrap and overlap)

Storage Capacity Ratio

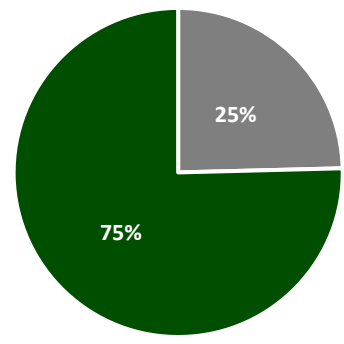

■ Stone Storage Volume: ■ Module Storage Volume:

Basin Detail

Component Quantities:

	Bottom Layer	Top Layer	Total
Height	30.0	N/A	30.0
# of Modules	275	N/A	275
# of Platens	550	N/A	550
# of Side Panels	94	N/A	94
# of Columns	2,200	N/A	2,200
# of Stacking Pins	0	N/A	0

Cross-Section:

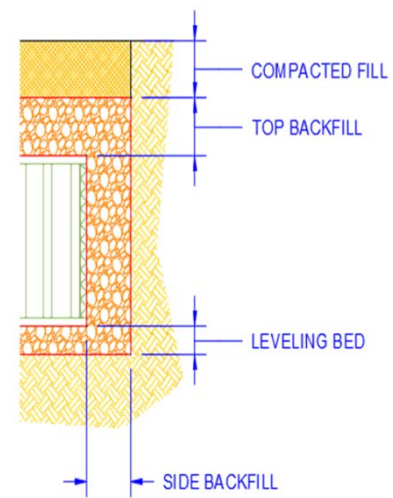

Appendix D:

“NO DUMPING – DRAINS TO OCEAN” Stencil Examples

Appendix B:
“NO DUMPING – DRAINS TO OCEAN” Stencil Example



Sample Stencil 1



Sample Stencil 2

Appendix E:

Catch Basin Cleaning



Storm Water O&M Fact Sheet Catch Basin Cleaning

DESCRIPTION

Catch basins are chambers or sumps, usually built at the curb line, which allow surface water runoff to enter the storm water conveyance system. Many catch basins have a low area below the invert of the outlet pipe intended to retain coarse sediment. By trapping sediment, the catch basin prevents solids from clogging the storm sewer and being washed into receiving waters. Catch basins must be cleaned periodically to maintain their ability to trap sediment, and consequently their ability to prevent flooding. The removal of sediment, decaying debris, and highly polluted water from catch basins has aesthetic and water quality benefits, including reducing foul odors, reducing suspended solids, and reducing the load of oxygen-demanding substances that reach receiving waters.

APPLICABILITY

Catch basin cleaning should be performed at any facility that has an on-site storm sewer system that includes catch basins and manholes.

Although catch basin cleaning is easily implemented, it is often overlooked in an overall storm water management plan. In addition, many of the catch basin cleaning programs that have been implemented focus only on removal of debris from grate openings; full implementation of the catch basin cleaning BMP should also include removal of debris from the catch basin itself.

ADVANTAGES AND DISADVANTAGES

Catch basin cleaning is an efficient and cost-effective method for preventing the transport of

sediment and pollutants to receiving water bodies. This improves both the aesthetics and the quality of the receiving water body.

Limitations associated with cleaning catch basins include:

- Catch basin debris usually contains appreciable amounts of water and offensive organic material which must be properly disposed.
- Catch basins may be difficult to clean in areas with poor accessibility and in areas with traffic congestion and parking problems.
- Cleaning is difficult during the winter when snow and ice are present.

Sediment and debris removed from catch basins can potentially be classified as hazardous waste. As a result, the materials must be disposed in a proper manner to avoid negative environmental impacts.

PERFORMANCE

Based on current data, it is not possible to quantify the water quality benefits to receiving waters resulting from catch basin cleaning. The rate at which catch basins fill with debris, as well as the total amount of material which can be removed by different frequencies of cleaning, are highly variable and cannot be readily predicted. Past studies have estimated that typical catch basins retain up to 57 percent of coarse solids and 17 percent of equivalent biological oxygen demand (BOD).

In addition, data collected as part of a Nationwide Urban Runoff Program (NURP) project in Castro Valley Creek, California, indicated that catch basins, cleaned on an average of once every year and a half, contained approximately 60 pounds of material each at the time of the cleaning.

OPERATION AND MAINTENANCE

Catch basins should be inspected at least annually to determine if they need to be cleaned. Typically, a catch basin should be cleaned if the depth of deposits is greater than or equal to one-third the depth from the basin to the invert of the lowest pipe or opening into or out of the basin. If a catch basin significantly exceeds the one-third depth standard during the annual inspection, then it should be cleaned more frequently. If woody debris or trash accumulates in a catch basin, then it should be cleaned on at least a weekly basis.

Catch basins can be cleaned either manually or by specially designed equipment. This equipment may include bucket loaders and vacuum pumps. Material removed from catch basins is usually disposed in conventional landfills. Before any materials can be disposed, it is necessary to perform a detailed chemical analysis to determine if the materials meet the EPA criteria for hazardous waste. This will help determine how the materials should be stored, treated, and disposed.

COSTS

Catch basin cleaning costs will vary depending upon the method used, the required cleaning frequency, the amount of debris removed, and debris disposal costs.

Cleaning costs for catch basins were estimated in three NURP program studies (Midwest Research Institute, 1982). These estimates are summarized in Table 1.

In communities equipped with vacuum street sweepers, a cleaning cost of \$8 per basin cleaned is recommended for budgetary purposes (Southeastern Wisconsin Regional Planning Commission, 1991.) Cleaning catch basins manually costs

TABLE 1 CLEANING COST PER CATCH BASIN

Location	Method	Cost
Castro Valley, CA	Vacuum attached to street sweeper	\$7.70
Salt Lake County, UT	Vacuum attached to street sweeper	\$10.30
Winston-Salem, NC	Vacuum attached to street sweeper	\$6.30

Source: MRI, 1982.

approximately twice as much as cleaning the basins with a vacuum attached to a sweeper. Therefore, a cost estimate of \$16 per catch basin cleaned may be used for manual cleaning. It should be noted that costs vary depending on local market conditions.

REFERENCES

1. Midwest Research Institute, 1982. *Collection of Economic Data from Nationwide Urban Runoff Program Projects-Final Report*. Report to U.S. Environmental Protection Agency.
2. Minnesota Pollution Control Agency, 1989. *Protecting Water Quality in Urban Areas*.
3. Southeastern Wisconsin Regional Planning Commission, 1991. *Cost of Urban Nonpoint Source Water Pollution Control Measures*, Technical Report No. 31.
4. U.S. EPA, 1983. *Final Report of the Nationwide Urban Runoff Program*. EPA 841/583109.
5. U.S. EPA, 1977. *Catch Basin Technology Overview and Assessment*. EPA-600/2-77-051.
6. Washington State Department of Ecology, 1992. *Storm Water Management Manual for Puget Sound*.

ADDITIONAL INFORMATION

Alameda County, California
Jim Scanlin
Alameda Countywide Clean Water Program
951 Turner Court, Room 300
Hayward, CA 94545

King County, Washington
Dave Hancock
Department of Natural Resources, Water and Land
Resources Division, Drainage Services Section
700 5th Avenue, Suite 2200
Seattle, WA 98104

Salt Lake County, Utah
Terry Way
Salt Lake County Engineering Division
2001 South State Street, Suite N3300
Salt Lake City, UT 84190

Southeastern Wisconsin Regional Planning
Commission
Bob Biebel
916 N. East Avenue, P.O. Box 1607
Waukesha, WI 53187

City of Winston Salem, North Carolina
Terry Cornett
Department of Public Works, Streets Division
P.O. Box 2511
Winston Salem, NC 27106

The mention of trade names or commercial products does not constitute endorsement or recommendation for the use by the U.S. Environmental Protection Agency.

For more information contact:

Municipal Technology Branch
U.S. EPA
Mail Code 4204
401 M St., S.W.
Washington, D.C., 20460

OWM
MTB

Excellence in compliance through optimal technical solutions
MUNICIPAL TECHNOLOGY BRANCH



Appendix F:

General Education Materials

How can you help in your community?

Como puedes ayudar en tu comunidad?

Home & Garden

Casa y Jardines

- Properly use and store all hazardous household products, including cleaners, solvents and paints.
Use y almacene de manera adecuada productos domésticos peligrosos, incluyendo limpiadores, solventes, y pinturas.
- Be an environmentally aware consumer. Buy non-toxic products for use in your home and garden whenever possible.
Sea un consumidor consciente del medio ambiente. Compre productos que no sean tóxicos para su casa o jardín.
- Use pesticides, herbicides and fertilizers carefully and sparingly.
Use pesticidas, herbicidas y fertilizantes cuidadosamente y a la medida justa.
- Conserve water and reduce the amount of runoff by not over watering your lawn and garden.
Conserve el agua y reduzca la cantidad de derrame no sobre-regando el jardín.
- Use a broom rather than a hose to clean up garden clippings, dirt and litter from sidewalks, patios and driveways.
Use una escoba en vez de la manguera al limpiar tierra y basura de las aceras, patios y caminos de entrada.
- Compost yard trimmings and leaves. Do not sweep them into the streets or catch basins.
Convierta ramas y hojas en abono. No las barría a la calle o drenajes.
- Divert rain spouts and other sources of runoff onto grass or vegetation.
Desvíe los caños y otros recursos de derrame hacia el césped o la vegetación.
- Dispose of pet waste in trash cans. Leaving it on the lawn sends harmful bacteria into the storm drains whenever you water or when it rains.
Desheche el excremento de los animales en botes de basura. Si se dejan en el césped, estos crean bacterias dañinas que van hacia los drenajes cuando se riega o cuando llueve.
- Donate unwanted paint, fertilizer, etc. to friends or community organizations.
Regale pintura, fertilizante, etc. a sus amistades u organizaciones comunitarias.

Automotive

Automóviles

- When changing car fluids, use a drip pan to collect any spills. If a spill occurs, soak it up using an absorbent material such as kitty litter or sawdust and dispose of it properly.
Cuando cambie lubricantes, use un envase debajo del goteo para contener cualquier derrame. Si un derrame ocurre, limpie usando cualquier material absorbente, como aserrín o "kitty litter", luego desheche de manera apropiada.
- Wash your car with biodegradable soap using as little water as possible. Shut off the hose while washing your car and then rinse.
Lave su vehículo con jabón biodegradable usando la menor cantidad de agua posible. Cierre la llave del agua mientras lo lave y luego enjuégalo.
- Keep a trash bag in the car and use it! Do not throw anything out the window.
¿Mantenga una bolsa de basura dentro del carro y usela! No arroje nada por la ventana.
- Keep up car maintenance to reduce leakage of oil, anti-freeze and other fluids.
De un buen mantenimiento a su carro para reducir derrames de aceite, anticongelante u otros lubricantes.
- Buy batteries, anti-freeze and motor oil from stores that will recycle used products, or
Compre baterías, anticongelantes y aceites para motores en tiendas que reciclen los productos que ha usado.
- Take these items to a local Household Hazardous Waste roundup.
Lleve estos productos a su centro de colección local de desechos domésticos peligrosos.

SPILL RESPONSE AGENCIES AGENCIAS PARA EL CONTROL DE DERRAMES

City of Los Angeles

Stormwater Program Hotline
(800) 974-9794

Los Angeles County

(888) CLEAN-LA / 253-2652

RECYCLING & HAZARDOUS WASTE DISPOSAL RECICLAJE Y DESECHO DE DESPERDICIOS PELIGROSOS

City of Los Angeles

Small Business Hazardous Waste Hotline
(800) 98-TOXIC / 988-6942

City of L.A. Recycling

(800) 773-CITY

Los Angeles County

Department of Public Works
(888) CLEAN-LA / 253-2652

TO REPORT ILLEGAL DUMPING PARA REPORTAR ARROJOS ILEGALES

City of Los Angeles

Stormwater Program Hotline
(800) 974-9794

Los Angeles County

Department of Public Works
Illegal Dumping Hotline
(888) CLEAN-LA / 253-2652

TO REPORT CLOGGED CATCH BASINS PARA REPORTAR DRENAJES TAPADOS

City of Los Angeles

Stormwater Program Hotline
(800) 974-9794

Los Angeles County

Department of Public Works
(888) CLEAN-LA / 253-2652



Illustration: Greg Deery, © Greg Deery

City of Los Angeles, Department of Public Works, Stormwater Program, 1201 S. Figueroa Street, Los Angeles, CA 90015. For more information, visit www.LAstormwater.org.

THE OCEAN BEGINS

El Oceano Empieza



IN YOUR NEIGHBORHOOD

En Su Vecindad



How So?

Water running off your yard, sidewalk or street flows down gutters to curbside openings called **catch basins**.

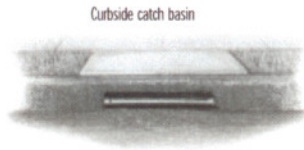

Curbside catch basin

Anything carried by this runoff — pesticides, pet waste, oil and anti freeze from leaky cars and trucks, foam containers and plastic bags — ends up trashing the beaches, polluting the ocean, and harming wildlife... and humans. This contaminated flow is the reason some of our most scenic beaches are closed to the public after a heavy rainstorm.

Just one quart of used motor oil dumped into a catch basin can pollute 250,000 gallons of ocean water!

Unlike the wastewater from inside homes and businesses that flows to sewers and treatment plants, outside runoff water flows to the ocean untreated. That's because the storm drain system was designed to prevent flooding during heavy rains by quickly diverting billions of gallons of rainwater to the ocean.

The open portions of this system are called flood control channels.

Even during the driest day in Southern California, we produce tens of millions of gallons of runoff, the result of activities such as car washing, lawn watering and yard cleanup.

For our own protection, and for a cleaner ocean, we need to keep trash off the streets, out of catch basins, and runoff water free from pollutants.

Underground storm drain tunnel



Flood control channel

Beach outfall

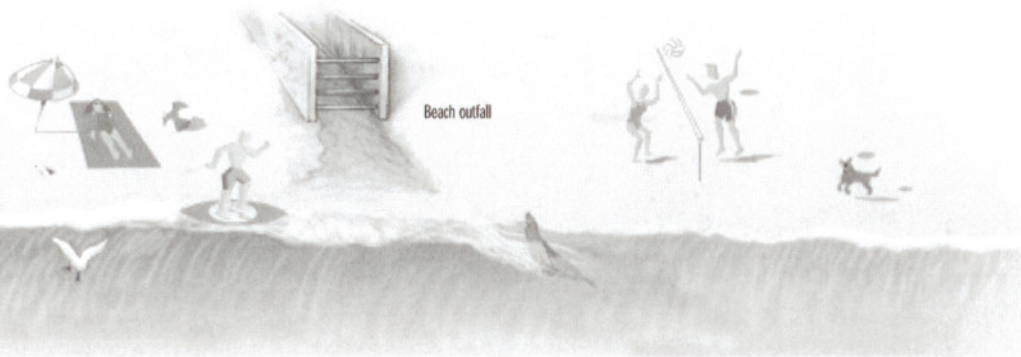

¿Cómo Puede Ser?

El agua que se desborda en jardines, aceras y calles se vierte a las cunetas, las cuales la transportan hacia las aperturas en las calzadas llamadas alcantarillas.

De allí, es vaciada al sistema del alcantarillado pluvial, el cual es una gran red de tuberías y canales que eventualmente terminan en el océano.

Cualquier cosa acarreada por este flujo, como por ejemplo pesticidas, excremento de animales, aceite o anticongelante derramados de carros y envases plásticos terminan ensuciando las playas, contaminando el océano, dañando a la fauna y al mismo tiempo a los humanos. Este flujo contaminado es la razón del cierre al público de algunas de nuestras playas más hermosas luego de una tormenta severa.

¡Basta un cuarto de galón de aceite de automóvil arrojado dentro del drenaje para contaminar 250,000 galones de agua marina!

A diferencia de las aguas que fluyen de las casas y negocios por medio del sistema de desagüe hacia las plantas de tratamiento, el agua que fluye por las calles va al océano sin ser tratada. El sistema de drenaje de lluvias es diseñado para prevenir inundaciones durante tormentas severas. Este sistema recoge rápidamente billones de galones de agua de las calles llevándolos directamente al océano.

Aún durante el día más seco en el sur de California se producen decenas de millones de galones de agua que fluyen por las calles como resultado de actividades tales como el lavado de carros, o riego y limpieza de jardines y patios.

Por nuestra propia protección debemos impedir que la basura llegue a nuestras calles y colectores de lluvia, así como asegurar que el agua que fluye hacia las calles, este libre de contaminantes.

BIO-DEGRADATION TIMELINE

Depending upon their composition, products take different lengths of time to break down (bio-degrade) in the environment. Here are average times for these products.

Según la composición de los productos, estos varían en la cantidad de tiempo para descomponerse en el medio ambiente. Los siguientes son los periodos promedio para esos productos:



- Every year, over 40 tons of trash washes up on our beaches.
- Approximately 80% of that trash could have been recycled.
- An average of 870,000 cigarette butts are tossed into the streets every month. These eventually wash into the storm drain system and onto the beaches and ocean. Fish and birds swallow cigarette butts often mistaking them for food, and die.
- The County of Los Angeles spends an average of \$1.3 million cleaning the beaches after rainstorms every year.





Construction Site Activities

Common sources of pollutants from construction sites include: sediments from soil erosion; construction materials and waste (e.g. paint, solvents, concrete, drywall); overspray from water tenders for dust control; and hosing down of spilled oil, fuel, and other fluids from construction vehicles and heavy equipment.

Signs of Illicit Discharge

During your routine activities, look for the following indications of ongoing or intermittent illicit discharges:

- Staining, discoloration or structural damage on city street or gutter
- Unusual vegetative growth
- Unpleasant or chemical odors emanating from catch basins
- Temporary or suspicious looking hoses, PVC pipes or connections discharging directly into a catch basin

Photos (top to bottom): 1) Illicit discharge from washing down cement truck chute. 2) Erosion and runoff from a construction site. 3) Inadequate containment at a construction site resulting in runoff into the street. 4) Unusual vegetative growth indicates a constant discharge. 5) Restaurant worker dumping floor wash water from bucket into the gutter.

This guide is intended as a supplement to the Stormwater Program video **Make the Call**.

As a City employee, it is your responsibility to report any illicit discharges, connections or activity you may encounter in your duties.

For more information on how you can prevent stormwater pollution, visit us at:

www.lacity.org/san/swmld

Or call the
Stormwater Hotline
 (800) 974-9794



FOR A COMPLETE GUIDE, VISIT
www.lacity.org/san/swmld
 OR CALL (800) 974-9794
 (800) 974-9794

Revised 1/2008, Green Team

Make the Call



**Recognizing and Reporting
 Illicit Discharges and Connections**



A Publication of the
 City of Los Angeles Stormwater Program

The City of Los Angeles' Stormwater and Urban Runoff Pollution Control Ordinance Section 64.70 of the L.A.M.C. prohibits the entry of illicit discharges into the municipal storm drain system.

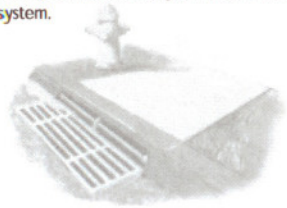

The City's storm drain system consists of over 45,000 catch basins that feed into a 1,500 mile network of underground pipes and tunnels. This system, which was designed to quickly route rainwater off city streets, does not treat or filter runoff before it is discharged into the Santa Monica and San Pedro Bays. The Bureau of Sanitation maintains this system by cleaning catch basins at least once a year.

Illicit discharges into this system pose a serious health threat to swimmers and marine life, as well as have a negative economic impact on tourism and on the overall quality of life. Such discharges are in violation of the City's Stormwater and Urban Runoff Pollution Control Ordinance.

By identifying sources of illicit discharges, potentially harmful stormwater runoff can be eliminated. If you observe any illicit discharge or connection during the course of your daily activities, contact the Stormwater Hotline at (800) 974-9794.

Illicit Discharges

Any discharge that is not exempted, conditionally exempted or authorized by the California Regional Water Quality Control Board through a National Pollutant Discharge Elimination System (NPDES) permit is considered illicit.

The following is a list of exempt and conditionally exempt discharges:

- Flows from riparian habitats or wetlands
- Diverted stream flows
- Flows from natural springs
- Rising ground waters
- Uncontaminated ground-water infiltration
- Runoff from emergency fire fighting activities
- Runoff from lawn and landscape irrigation
- Water line flushing
- Discharge from potable water sources
- Runoff from foundation or footing drains
- Air conditioning condensate
- Irrigation water
- Water from crawl space pumps
- Dechlorinated swimming pool discharges
- Discharges from individual residential car washing
- Discharges from non-profit car washing, and
- Runoff from street and sidewalk washing

Illicit Connections

Illicit discharges may be carried by a make-shift pipe, hose or man-made conveyance that is connected to the storm drain system. Such connections are also considered illicit.



Abandoned Waste

Waste products in barrels, containers or buckets, are often found abandoned on city streets, sidewalks or alleys. These can be a potential source of illicit discharge as they can rupture or break upon exposure to the environment, or if accidentally or intentionally hit by ongoing pedestrian or vehicular traffic. Abandoned waste can also be a significant health hazard for residents and passersby's who come in contact with the waste.

The most commonly abandoned wastes are motor oil, human feces, paint, solvents, or pesticides.

Accidental or Unintentional Spills

Illicit discharges may arise from incidents such as traffic accidents or spills from the receiving or shipping of goods in an industrial facility.

Illicit discharges may also be a result of torrential rain causing sewage system overflow to spill into the streets.

Deliberate Discharges

A deliberate discharge can be runoff generated from fluid leaks coming from an automotive repair shop, or the washing down of paved or concrete surfaces at a restaurant or other commercial facility.

Photos (top to bottom) 1) Oil drums abandoned in alleys are frequent targets of "barrel-hipping." 2) Gasoline spill from tanker truck accident discharges into the storm drain system. 3) Toxic chemicals and leaking fluids from an auto body repair shop. 4) Containers of paint waste and solvents abandoned in alley. 5) Worker hosing down blood and waste from poultry plant. 6) Food suppliers generate illicit discharges by hosing waste and debris off of equipment and into storm drains.

HELP THE
**GREASE
AVENGER**

YECH!! WHAT A MESS!

**KEEP FATS, OIL AND
GREASE OUT OF SEWERS!**

USE BASKETS OR STRAINERS
IN SINKS TO CATCH FOOD
SCRAPS AND OTHER SOLIDS...
DON'T POUR FATS, OIL AND
GREASE DOWN SINKS, FLOOR
DRAINS OR TOILETS!

GARBAGE DISPOSALS USE
LARGE AMOUNTS OF WATER
AND ELECTRICITY...REDUCE
OR ELIMINATE USAGE TO
LOWER YOUR UTILITY BILLS!

SCRAPE GREASE AND FOOD
SCRAPS FROM PLATES &
PANS...AND RECYCLE OR
PLACE THEM IN THE TRASH!

FOR RESTAURANT OWNERS...
KEEP GREASE
INTERCEPTORS AND TRAPS
IN PROPER WORKING
CONDITION BY MAINTAINING
AND CLEANING THEM ON A
REGULAR BASIS

Illustration & Design by Oscar Amaro



Produced by THE CITY OF LOS ANGELES • DEPARTMENT OF PUBLIC WORKS • BUREAU OF SANITATION
www.lacity.org/san



Appendix G:

BMP Maintenance, Inspection, and Repair Log and Checklist

MAINTENANCE, INSPECTION, AND REPAIR LOG

Site: 18616 Rorimer Street,
La Puente _____

Page: 1 of 3

SE-7 – Street Sweeping & Vacuuming No. Onsite: ____ No. Inspected: ____ No. Requiring Action: ____ ____ No evidence of sediment or trash accumulation ____ Contractor scheduled for regular visits (more frequent during rainy season) ____ Signs posted indicating sweeping schedule Corrective Action Required:
Scheduled Completion Date:

TC-32 – WetlandMod Unit No. Onsite: ____ No. Inspected: ____ No. Requiring Action: ____ ____ Device is clean and free of all debris ____ Much is replaced with new mulch ____ Vegetation is healthy and in good condition ____ No structural damage to module Corrective Action Required:
Scheduled Completion Date:

MAINTENANCE, INSPECTION, AND REPAIR LOG

Site: 18616 Rorimer Street,
La Puente _____

Page: 2 of 3

<p>SD-12 – Efficient Irrigation</p> <p>No. Onsite: ____ No. Inspected: ____ No. Requiring Action: ____</p> <p>____ Timing of irrigation is proper for efficient irrigation</p> <p>____ Sprinkler heads are oriented properly to avoid overspray on pavement</p> <p>____ Proper amount of water is dispersed for the type of landscaping</p> <p>____ Drip line irrigation systems are still functioning properly</p> <p>____ Valves and switches are working properly</p> <p>Corrective Action Required:</p>
Scheduled Completion Date:

<p>SD-13 – Storm Drain Signage</p> <p>No. Onsite: ____ No. Inspected: ____ No. Requiring Action: ____</p> <p>____ Signs are in good condition and have not faded or broken</p> <p>Corrective Action Required:</p>
Scheduled Completion Date:

MAINTENANCE, INSPECTION, AND REPAIR LOG

Site: 18616 Rorimer Street,
La Puente _____

Page: 3 of 3

SD-10 – Landscape Planning No. Onsite: ____ No. Inspected: ____ No. Requiring Action: ____ ____ Vegetated slopes show no signs of erosion ____ Planted areas allow water to enter, but not to leave the area ____ Adequate mulch or gravel is present in the landscape areas Corrective Action Required: Scheduled Completion Date:

SC-44 – Drainage System Maintenance (Catch Basins) No. Onsite: ____ No. Inspected: ____ No. Requiring Action: ____ ____ Remove any trash building. ____ No evidence of standing water. ____ Repair any structural damage. ____ No evidence of sediment or silt buildup Corrective Action Required: Scheduled Completion Date: