

APPENDIX I3A: PRELIMINARY WQMP SITE 3

This page intentionally left blank.

Preliminary Water Quality Management Plan

For:

Bloomington Business Park SP Site 3

APN # 0256-101-02, -03, -10, -11, -12, -14, -15, -34, -35, -36, -45, -48, -49, -57, -58, -60

Prepared for:

Howard Industrial Partners

1944 North Tustin Street, Suite 122

Orange, CA 92865

(714) 769-9155

Prepared by:

FMCivil Engineers, Inc

29995 Technology Drive, Suite 306

Murrieta, CA 92563

(951) 973-0201

1st Submittal Date: March 26, 2021

Approval Date: _____

Project Owner’s Certification

This Water Quality Management Plan (WQMP) has been prepared for **Howard Industrial Partners** by **FM Civil Engineers, Inc.** The WQMP is intended to comply with the requirements of the County of San Bernardino and the NPDES Areawide Stormwater Program requiring the preparation of a WQMP. The undersigned, while it owns the subject property, is responsible for the implementation of the provisions of this plan and will ensure that this plan is amended as appropriate to reflect up-to-date conditions on the site consistent with San Bernardino County’s Municipal Storm Water Management Program and the intent of the NPDES Permit for San Bernardino County and the incorporated cities of San Bernardino County within the Santa Ana Region. Once the undersigned transfers its interest in the property, its successors in interest and the city/county shall be notified of the transfer. The new owner will be informed of its responsibility under this WQMP. A copy of the approved WQMP shall be available on the subject site in perpetuity.

“I certify under a penalty of law that the provisions (implementation, operation, maintenance, and funding) of the WQMP have been accepted and that the plan will be transferred to future successors.”

Project Data			
Permit/Application Number(s):	TBD	Grading Permit Number(s):	TBD
Tract/Parcel Map Number(s):	TPM No. 20340	Building Permit Number(s):	TBD
CUP, SUP, and/or APN (Specify Lot Numbers if Portions of Tract):			APN # 0256-101-02, -03, -10, -11, -12, -14, -15, -34, -35, -36, -45, -48, -49, -57, -58, -60
Owner’s Signature			
Owner Name: Tim Howard			
Title	Member		
Company	Howard Industrial Partners		
Address	1944 North Tustin Street, Suite 122		
Email	thoward@hipre.net		
Telephone #	(714) 769-9155		
Signature		Date	

Preparer's Certification

Project Data			
Permit/Application Number(s):	TBD	Grading Permit Number(s):	TBD
Tract/Parcel Map Number(s):	TPM No. 20340	Building Permit Number(s):	TBD
CUP, SUP, and/or APN (Specify Lot Numbers if Portions of Tract):			APN # 0256-101-02, -03, -10, -11, -12, -14, -15, -34, -35, -36, -45, -48, -49, -57, -58, -60

“The selection, sizing and design of stormwater treatment and other stormwater quality and quantity control measures in this plan were prepared under my oversight and meet the requirements of Regional Water Quality Control Board Order No. R8-2010-0036.”

Engineer: Francisco Martinez		PE Stamp Below 
Title	Principal	
Company	FMCivil Engineers, Inc	
Address	29995 Technology Drive, Suite 306 Murrieta, CA 92563	
Email	francisco.martinez@fmcivil.com	
Telephone #	(951) 973-0201	
Signature		
Date		

Table of Contents

Section 1	Discretionary Permits	1-1
Section 2	Project Description	2-1
	2.1 Project Information	2-1
	2.2 Property Ownership / Management	2-2
	2.3 Potential Stormwater Pollutants	2-3
	2.4 Water Quality Credits	2-4
Section 3	Site and Watershed Description	3-1
Section 4	Best Management Practices	4-1
	4.1 Source Control BMP	4-1
	4.1.1 Pollution Prevention	4-1
	4.1.2 Preventative LID Site Design Practices	4-6
	4.2 Project Performance Criteria	4-7
	4.3 Project Conformance Analysis	4-12
	4.3.1 Site Design Hydrologic Source Control BMP	4-14
	4.3.2 Infiltration BMP	4-16
	4.3.3 Harvest and Use BMP	4-18
	4.3.4 Biotreatment BMP	4-19
	4.3.5 Conformance Summary	4-23
	4.3.6 Hydromodification Control BMP	4-24
	4.4 Alternative Compliance Plan (if applicable)	4-25
Section 5	Inspection & Maintenance Responsibility Post Construction BMPs	5-1
Section 6	6.1. Site Plan and Drainage Plan	6-1
	6.2 Electronic Data Submittal	6-1
	6.3 Post Construction	6-1
	6.4 Other Supporting Documentation	6-1
	6.4.1 – BMP Design Details	6-3
	6.4.2 – Conceptual Grading Plans	6-4
	6.4.3 – DCV and Factor of Safety Calculations	6-5
	6.4.4 – Infiltration Testing and USDA Soil Report	6-6
	6.4.5 – NOAA Precipitation Estimates	6-7
	6.4.6 – BMP Educational Materials/Fact Sheets	6-8

Forms

Form 1-1	Project Information	1-1
Form 2.1-1	Description of Proposed Project	2-1
Form 2.2-1	Property Ownership/Management	2-2
Form 2.3-1	Pollutants of Concern	2-3
Form 2.4-1	Water Quality Credits	2-4
Form 3-1	Site Location and Hydrologic Features	3-1
Form 3-2	Hydrologic Characteristics	3-2
Form 3-3	Watershed Description	3-3
Form 4.1-1	Non-Structural Source Control BMP	4-2
Form 4.1-2	Structural Source Control BMP	4-4

Form 4.1-3 Site Design Practices Checklist	4-6
Form 4.2-1 LID BMP Performance Criteria for Design Capture Volume	4-7
Form 4.2-2 Summary of HCOC Assessment	4-8
Form 4.2-3 HCOC Assessment for Runoff Volume	4-9
Form 4.2-4 HCOC Assessment for Time of Concentration.....	4-10
Form 4.2-5 HCOC Assessment for Peak Runoff.....	4-11
Form 4.3-1 Infiltration BMP Feasibility	4-13
Form 4.3-2 Site Design Hydrologic Source Control BMP	4-14
Form 4.3-3 Infiltration LID BMP	4-17
Form 4.3-4 Harvest and Use BMP	4-18
Form 4.3-5 Selection and Evaluation of Biotreatment BMP.....	4-19
Form 4.3-6 Volume Based Biotreatment – Bioretention and Planter Boxes w/Underdrains	4-20
Form 4.3-7 Volume Based Biotreatment- Constructed Wetlands and Extended Detention	4-21
Form 4.3-8 Flow Based Biotreatment	4-22
Form 4.3-9 Conformance Summary and Alternative Compliance Volume Estimate	4-23
Form 4.3-10 Hydromodification Control BMP.....	4-24
Form 5-1 BMP Inspection and Maintenance.....	5-1

Section 1 Discretionary Permit(s)

Form 1-1 Project Information					
Project Name		Bloomington Business Park SP Site 3			
Project Owner Contact Name:		Tim Howard			
Mailing Address:	1944 North Tustin Street, Suite 122 Orange, CA 92865	E-mail Address:	thoward@hipre.net	Telephone:	(714) 769-9155
Permit/Application Number(s):	TBD	Tract/Parcel Map Number(s):	TPM No. 20340		
Additional Information/ Comments:					
Description of Project:	<p>The project site is a proposed industrial building that will be used as a warehouse distribution facility or other similar use. The project site consists of one large building, landscaped area, subsurface basins, storm drain infrastructure, and parking area. The project site will retain flows up to the DCV in a 2-year, 1-hour storm event and will discharge flows in excess of a 100-year, 24-hour event into a proposed storm drain that will run south along Locust Avenue, which will itself discharge into a basin immediately north of 11th Street.</p>				
Provide summary of Conceptual WQMP conditions (if previously submitted and approved). Attach complete copy.					

Section 2 Project Description

2.1 Project Information

This section of the WQMP should provide the information listed below. The information provided for Conceptual/ Preliminary WQMP should give sufficient detail to identify the major proposed site design and LID BMPs and other anticipated water quality features that impact site planning. Final Project WQMP must specifically identify all BMP incorporated into the final site design and provide other detailed information as described herein.

The purpose of this information is to help determine the applicable development category, pollutants of concern, watershed description, and long term maintenance responsibilities for the project, and any applicable water quality credits. This information will be used in conjunction with the information in Section 3, Site Description, to establish the performance criteria and to select the LID BMP or other BMP for the project or other alternative programs that the project will participate in, which are described in Section 4.

Form 2.1-1 Description of Proposed Project					
1 Development Category (Select all that apply):					
<input type="checkbox"/> Significant re-development involving the addition or replacement of 5,000 ft ² or more of impervious surface on an already developed site	<input checked="" type="checkbox"/> New development involving the creation of 10,000 ft ² or more of impervious surface collectively over entire site	<input type="checkbox"/> Automotive repair shops with standard industrial classification (SIC) codes 5013, 5014, 5541, 7532- 7534, 7536-7539	<input type="checkbox"/> Restaurants (with SIC code 5812) where the land area of development is 5,000 ft ² or more		
<input type="checkbox"/> Hillside developments of 5,000 ft ² or more which are located on areas with known erosive soil conditions or where the natural slope is 25 percent or more	<input type="checkbox"/> Developments of 2,500 ft ² of impervious surface or more adjacent to (within 200 ft) or discharging directly into environmentally sensitive areas or waterbodies listed on the CWA Section 303(d) list of impaired waters.	<input checked="" type="checkbox"/> Parking lots of 5,000 ft ² or more exposed to storm water	<input type="checkbox"/> Retail gasoline outlets that are either 5,000 ft ² or more, or have a projected average daily traffic of 100 or more vehicles per day		
<input type="checkbox"/> Non-Priority / Non-Category Project <i>May require source control LID BMPs and other LIP requirements. Please consult with local jurisdiction on specific requirements.</i>					
2 Project Area (ft ²):	1,328,168	3 Number of Dwelling Units:	N/A	4 SIC Code:	4225 – General Warehousing and Storage
5 Is Project going to be phased? Yes <input checked="" type="checkbox"/> No <input type="checkbox"/> <i>If yes, ensure that the WQMP evaluates each phase as a distinct DA, requiring LID BMPs to address runoff at time of completion.</i>					
6 Does Project include roads? Yes <input checked="" type="checkbox"/> No <input type="checkbox"/> <i>If yes, ensure that applicable requirements for transportation projects are addressed (see Appendix A of TGD for WQMP)</i>					

2.2 Property Ownership/Management

Describe the ownership/management of all portions of the project and site. State whether any infrastructure will transfer to public agencies (City, County, Caltrans, etc.) after project completion. State if a homeowners or property owners association will be formed and be responsible for the long-term maintenance of project stormwater facilities. Describe any lot-level stormwater features that will be the responsibility of individual property owners.

Form 2.2-1 Property Ownership/Management

Describe property ownership/management responsible for long-term maintenance of WQMP stormwater facilities:

Maintenance of the WQMP facilities will be the sole responsibility of the property owner. The owner may choose to contract out the maintenance of the storm water facilities to a contractor with the proper equipment (i.e. Vac Truck) or other maintenance mechanism per manufacturer recommendation.

-Tim Howard

-Partner

-Howard Industrial Partners

-1944 North Tustin Street, Suite 122

-Orange, CA 92865

-thoward@hipre.net

The maintenance of the proposed development is the responsibility of the owner until the property is sold to a new owner and then they assume responsibility of the BMP maintenance and management. There is no homeowner's or property owner's association set up for this proposed development. All of the BMP's are the responsibility of the owner to maintain. BMPs include, but are not limited to, BMP maintenance; e.g. inspection, storm drain stenciling, efficient irrigation and landscape maintenance, BMP maintenance of sub-surface infiltration system, trenches, basins, mechanical separators and pervious pavement.

No infrastructure will be transferred to a public agency after project completion.

2.3 Potential Stormwater Pollutants

Determine and describe expected stormwater pollutants of concern based on land uses and site activities (refer to Table 3-3 in the TGD for WQMP).

Form 2.3-1 Pollutants of Concern			
Pollutant	Please check: E=Expected, N=Not Expected		Additional Information and Comments
Pathogens (Bacterial / Virus)	E <input checked="" type="checkbox"/>	N <input type="checkbox"/>	Wild Birds/Animal Waste/Garbage
Nutrients - Phosphorous	E <input checked="" type="checkbox"/>	N <input type="checkbox"/>	Fertilizer/Food Waste/Garbage
Nutrients - Nitrogen	E <input checked="" type="checkbox"/>	N <input type="checkbox"/>	Fertilizer/Food Waste/Garbage
Noxious Aquatic Plants	E <input type="checkbox"/>	N <input checked="" type="checkbox"/>	N/A
Sediment	E <input checked="" type="checkbox"/>	N <input type="checkbox"/>	Driveways/Sidewalks
Metals	E <input checked="" type="checkbox"/>	N <input type="checkbox"/>	Cars/Trucks
Oil and Grease	E <input checked="" type="checkbox"/>	N <input type="checkbox"/>	Cars/Trucks
Trash/Debris	E <input checked="" type="checkbox"/>	N <input type="checkbox"/>	Parking Lot/Poorly managed trash containers
Pesticides / Herbicides	E <input checked="" type="checkbox"/>	N <input type="checkbox"/>	Landscape Use
Organic Compounds	E <input checked="" type="checkbox"/>	N <input type="checkbox"/>	Landscape Use
Other: Oxygen Demanding Compounds	E <input checked="" type="checkbox"/>	N <input type="checkbox"/>	Cars/Trucks
Other: Petroleum Hydrocarbons	E <input checked="" type="checkbox"/>	N <input type="checkbox"/>	Cars/Trucks
Other: Solvents	E <input checked="" type="checkbox"/>	N <input type="checkbox"/>	Cars/Trucks
Other:	E <input type="checkbox"/>	N <input type="checkbox"/>	
Other:	E <input type="checkbox"/>	N <input type="checkbox"/>	

2.4 Water Quality Credits

A water quality credit program is applicable for certain types of development projects if it is not feasible to meet the requirements for on-site LID. Proponents for eligible projects, as described below, can apply for water quality credits that would reduce project obligations for selecting and sizing other treatment BMP or participating in other alternative compliance programs. Refer to Section 6.2 in the TGD for WQMP to determine if water quality credits are applicable for the project.

Form 2.4-1 Water Quality Credits			
1 Project Types that Qualify for Water Quality Credits: <i>Select all that apply</i>			
<input type="checkbox"/> Redevelopment projects that reduce the overall impervious footprint of the project site. [Credit = % impervious reduced]	Higher density development projects <input type="checkbox"/> Vertical density [20%] <input type="checkbox"/> 7 units/ acre [5%]	<input type="checkbox"/> Mixed use development, (combination of residential, commercial, industrial, office, institutional, or other land uses which incorporate design principles that demonstrate environmental benefits not realized through single use projects) [20%]	<input type="checkbox"/> Brownfield redevelopment (redevelop real property complicated by presence or potential of hazardous contaminants) [25%]
<input type="checkbox"/> Redevelopment projects in established historic district, historic preservation area, or similar significant core city center areas [10%]	<input type="checkbox"/> Transit-oriented developments (mixed use residential or commercial area designed to maximize access to public transportation) [20%]	<input type="checkbox"/> In-fill projects (conversion of empty lots & other underused spaces < 5 acres, substantially surrounded by urban land uses, into more beneficially used spaces, such as residential or commercial areas) [10%]	<input type="checkbox"/> Live-Work developments (variety of developments designed to support residential and vocational needs) [20%]
2 Total Credit % N/A			
Description of Water Quality Credit Eligibility (if applicable)	This project is not eligible for any Water Quality Credits.		

Section 3 Site and Watershed Description

Describe the project site conditions that will facilitate the selection of BMP through an analysis of the physical conditions and limitations of the site and its receiving waters. Identify distinct drainage areas (DA) that collect flow from a portion of the site and describe how runoff from each DA (and sub-watershed DMAs) is conveyed to the site outlet(s). Refer to Section 3.2 in the TGD for WQMP. The form below is provided as an example. Then complete Forms 3.2 and 3.3 for each DA on the project site. ***If the project has more than one drainage area for stormwater management, then complete additional versions of these forms for each DA / outlet.***

Form 3-1 Site Location and Hydrologic Features			
Site coordinates <i>take GPS measurement at approximate center of site</i>	Latitude 34°03'11.38"N	Longitude 117°27'41.97"W	Thomas Bros Map page 645
<p>¹ San Bernardino County climatic region: <input checked="" type="checkbox"/> Valley <input type="checkbox"/> Mountain</p>			
<p>² Does the site have more than one drainage area (DA): Yes <input checked="" type="checkbox"/> No <input type="checkbox"/> <i>If no, proceed to Form 3-2. If yes, then use this form to show a conceptual schematic describing DMAs and hydrologic feature connecting DMAs to the site outlet(s). An example is provided below that can be modified for proposed project or a drawing clearly showing DMA and flow routing may be attached</i></p>			
<pre> graph TD DA1[DA1] --> Chamber1[Chamber 1] DA2[DA2] --> Chamber2[Chamber 2] DA3[DA3] --> Chamber2 </pre>			
Conveyance	Briefly describe on-site drainage features to convey runoff that is not retained within a DMA		
DA1 to Chamber 1	Onsite flows will be conveyed to an underground infiltration system via underground storm drain.		
DA2 to Chamber 2	Onsite flows will be conveyed to an underground infiltration system via underground storm drain.		
DA3 to Chamber 2	Onsite flows from a future phase will be conveyed via underground storm drain and connect to the underground infiltration system serving DA2.		
All other DAs	DAs not described above are predominantly landscaped and self-treating, and flows will be directed toward the street.		

Form 3-2 Existing Hydrologic Characteristics for Drainage Area 1

For Drainage Area 1's sub-watershed DMA, provide the following characteristics	DMA A	DMA B	DMA C	DMA D
1 DMA drainage area (ft ²)	659,807			
2 Existing site impervious area (ft ²)	25,000			
3 Antecedent moisture condition <i>For desert areas, use</i> http://www.sbcounty.gov/dpw/floodcontrol/pdf/20100412_map.pdf	II			
4 Hydrologic soil group <i>Refer to Watershed Mapping Tool –</i> http://permitrack.sbcounty.gov/wap/	A			
5 Longest flowpath length (ft)	1,558			
6 Longest flowpath slope (ft/ft)	0.010			
7 Current land cover type(s) <i>Select from Fig C-3 of Hydrology Manual</i>	Commercial Landscaping			
8 Pre-developed pervious area condition: <i>Based on the extent of wet season vegetated cover good >75%; Fair 50-75%; Poor <50% Attach photos of site to support rating</i>	Poor			

Form 3-2 Existing Hydrologic Characteristics for Drainage Area 2

For Drainage Area 1's sub-watershed DMA, provide the following characteristics	DMA A	DMA B	DMA C	DMA D
1 DMA drainage area (ft ²)	623,538			
2 Existing site impervious area (ft ²)	33,200			
3 Antecedent moisture condition <i>For desert areas, use http://www.sbcounty.gov/dpw/floodcontrol/pdf/20100412_map.pdf</i>	II			
4 Hydrologic soil group <i>Refer to Watershed Mapping Tool – http://permitrack.sbcounty.gov/wap/</i>	A			
5 Longest flowpath length (ft)	2,348			
6 Longest flowpath slope (ft/ft)	0.008			
7 Current land cover type(s) <i>Select from Fig C-3 of Hydrology Manual</i>	Commercial Landscaping			
8 Pre-developed pervious area condition: <i>Based on the extent of wet season vegetated cover good >75%; Fair 50-75%; Poor <50% Attach photos of site to support rating</i>	Poor			

Form 3-2 Existing Hydrologic Characteristics for Drainage Area 3

For Drainage Area 1's sub-watershed DMA, provide the following characteristics	DMA A	DMA B	DMA C	DMA D
1 DMA drainage area (ft ²)	101,574			
2 Existing site impervious area (ft ²)	8,300			
3 Antecedent moisture condition <i>For desert areas, use http://www.sbcounty.gov/dpw/floodcontrol/pdf/20100412_map.pdf</i>	II			
4 Hydrologic soil group <i>Refer to Watershed Mapping Tool – http://permitrack.sbcounty.gov/wap/</i>	A			
5 Longest flowpath length (ft)	634			
6 Longest flowpath slope (ft/ft)	0.006			
7 Current land cover type(s) <i>Select from Fig C-3 of Hydrology Manual</i>	Commercial Landscaping			
8 Pre-developed pervious area condition: <i>Based on the extent of wet season vegetated cover good >75%; Fair 50-75%; Poor <50% Attach photos of site to support rating</i>	Poor			

Form 3-3 Watershed Description for Drainage Area	
Receiving waters <i>Refer to Watershed Mapping Tool - http://permitrack.sbcounty.gov/wap/ See "Drainage Facilities" link at this website</i>	Santa Ana River, Reach 4 Santa Ana River, Reach 3 Santa Ana River, Reach 2 Santa Ana River, Reach 1
Applicable TMDLs <i>Refer to Local Implementation Plan</i>	Pathogens
303(d) listed impairments <i>Refer to Local Implementation Plan and Watershed Mapping Tool - http://permitrack.sbcounty.gov/wap/ and State Water Resources Control Board website - http://www.waterboards.ca.gov/santaana/water_issues/programs/tmdl/index.shtml</i>	Pathogens, Copper, Lead
Environmentally Sensitive Areas (ESA) <i>Refer to Watershed Mapping Tool - http://permitrack.sbcounty.gov/wap/</i>	Delhi Sands
Unlined Downstream Water Bodies <i>Refer to Watershed Mapping Tool - http://permitrack.sbcounty.gov/wap/</i>	Santa Ana River
Hydrologic Conditions of Concern	<input type="checkbox"/> Yes Complete Hydrologic Conditions of Concern (HCOC) Assessment. Include Forms 4.2-2 through Form 4.2-5 and Hydromodification BMP Form 4.3-10 in submittal <input checked="" type="checkbox"/> No
Watershed-based BMP included in a RWQCB approved WAP	<input type="checkbox"/> Yes Attach verification of regional BMP evaluation criteria in WAP <ul style="list-style-type: none"> • More Effective than On-site LID • Remaining Capacity for Project DCV • Upstream of any Water of the US • Operational at Project Completion • Long-Term Maintenance Plan <input checked="" type="checkbox"/> No

Section 4 Best Management Practices (BMP)

4.1 Source Control BMP

4.1.1 Pollution Prevention

Non-structural and structural source control BMP are required to be incorporated into all new development and significant redevelopment projects. Form 4.1-1 and 4.1-2 are used to describe specific source control BMPs used in the WQMP or to explain why a certain BMP is not applicable. Table 7-3 of the TGD for WQMP provides a list of applicable source control BMP for projects with specific types of potential pollutant sources or activities. The source control BMP in this table must be implemented for projects with these specific types of potential pollutant sources or activities.

The preparers of this WQMP have reviewed the source control BMP requirements for new development and significant redevelopment projects. The preparers have also reviewed the specific BMP required for project as specified in Forms 4.1-1 and 4.1-2. All applicable non-structural and structural source control BMP shall be implemented in the project.

Form 4.1-1 Non-Structural Source Control BMPs				
Identifier	Name	Check One		Describe BMP Implementation OR, if not applicable, state reason
		Included	Not Applicable	
N1	Education of Property Owners, Tenants and Occupants on Stormwater BMPs	<input checked="" type="checkbox"/>	<input type="checkbox"/>	The owner shall familiarize himself with the contents of the WQMP and County Ordinances and brochures and furnish copies of the County BMP factsheets to all future tenants through lease agreements.
N2	Activity Restrictions	<input checked="" type="checkbox"/>	<input type="checkbox"/>	Activity restrictions will be enforced, including requiring dumpster lids to be closed at all times; and prohibit blowing, sweeping, or hosing of debris into streets, storm drain inlets, or infiltration basin.
N3	Landscape Management BMPs	<input checked="" type="checkbox"/>	<input type="checkbox"/>	The landscapes areas within the project site are to be tended to and maintained by outside contractor.
N4	BMP Maintenance	<input checked="" type="checkbox"/>	<input type="checkbox"/>	BMP maintenance will be provided by the property owner and will take place at a minimum of twice a year and after any major rainfall event.
N5	Title 22 CCR Compliance (How development will comply)	<input checked="" type="checkbox"/>	<input type="checkbox"/>	The owner/tenant will file appropriate hazardous material disclosures, if any storage is conducted, and must comply with all the Title 22 CCR, Chapter 29 regulations.
N6	Local Water Quality Ordinances	<input checked="" type="checkbox"/>	<input type="checkbox"/>	The owner shall ensure that all business activities at the site comply with the County of San Bernardino's Stormwater Ordinance through the implementation of BMP's.
N7	Spill Contingency Plan	<input checked="" type="checkbox"/>	<input type="checkbox"/>	Hazardous material storage, if any, will require a business/emergency response plan as required by the San Bernardino County Fire Hazmat.
N8	Underground Storage Tank Compliance	<input type="checkbox"/>	<input checked="" type="checkbox"/>	The project site does not incorporate underground storage tanks.
N9	Hazardous Materials Disclosure Compliance	<input checked="" type="checkbox"/>	<input type="checkbox"/>	Compliance through the environmental site assessments to be performed as part of this project.

Form 4.1-1 Non-Structural Source Control BMPs				
Identifier	Name	Check One		Describe BMP Implementation OR, if not applicable, state reason
		Included	Not Applicable	
N10	Uniform Fire Code Implementation	<input checked="" type="checkbox"/>	<input type="checkbox"/>	All fire code requirements shall be implemented at this site.
N11	Litter/Debris Control Program	<input checked="" type="checkbox"/>	<input type="checkbox"/>	The project will implement the maintenance and removal of litter from common areas by private contractor.
N12	Employee Training	<input checked="" type="checkbox"/>	<input type="checkbox"/>	Training will be required within 6 months of hire dates for new employees, and then annually thereafter. Training will cover the impact of dumping oil, paint, solvents, or other potentially harmful chemical into the storm drain system; the use of fertilizers and pesticides in landscaping maintenance practices; and the impacts of litter and improper waste disposal.
N13	Housekeeping of Loading Docks	<input checked="" type="checkbox"/>	<input type="checkbox"/>	General good housekeeping procedures will include maintenance of loading docks such as inspection/monitoring, cleaning, lubricating, adjusting, and documenting.
N14	Catch Basin Inspection Program	<input checked="" type="checkbox"/>	<input type="checkbox"/>	The project site will incorporate a catch basin inspection program which will inspect the catch basins on a bi-annual or as needed basis for trash, debris, and other factors that could impact the functionality of the catch basins.
N15	Vacuum Sweeping of Private Streets and Parking Lots	<input checked="" type="checkbox"/>	<input type="checkbox"/>	Parking lots shall be swept weekly and will be done by a landscape contractor or other contractor provided by the owner.
N16	Other Non-structural Measures for Public Agency Projects	<input type="checkbox"/>	<input checked="" type="checkbox"/>	This is not a Public Agency Project.
N17	Comply with all other applicable NPDES permits	<input checked="" type="checkbox"/>	<input type="checkbox"/>	The developer of this site shall comply with the state's General Construction Stormwater Permit by filing an NOI, SWPPP, and obtain a WDID# prior to the start of grading/construction. All future occupants requiring coverage under the NPDES General Industrial Activities Permit shall comply with the

Form 4.1-2 Structural Source Control BMPs

Identifier	Name	Check One		Describe BMP Implementation OR, If not applicable, state reason
		Included	Not Applicable	
S1	Provide storm drain system stencilling and signage (CASQA New Development BMP Handbook SD-13)	<input checked="" type="checkbox"/>	<input type="checkbox"/>	This project will incorporate stenciling and signage at storm drain inlets with prohibitive language to discourage the illegal dumping of improper and hazardous materials.
S2	Design and construct outdoor material storage areas to reduce pollution introduction (CASQA New Development BMP Handbook SD-34)	<input type="checkbox"/>	<input checked="" type="checkbox"/>	There will be no outside storage as this project site will not produce pollutants which will require specialized handling or storage.
S3	Design and construct trash and waste storage areas to reduce pollution introduction (CASQA New Development BMP Handbook SD-32)	<input checked="" type="checkbox"/>	<input type="checkbox"/>	All dumpsters shall have working lids which shall be kept closed at all times. Trash enclosures shall comply with CASQA SD-32 and have doors.
S4	Use efficient irrigation systems & landscape design, water conservation, smart controllers, and source control (Statewide Model Landscape Ordinance; CASQA New Development BMP Handbook SD-12)	<input checked="" type="checkbox"/>	<input type="checkbox"/>	Landscape irrigation systems will be designed efficiently to reduce excessive runoff, through drought tolerant landscaping and/or drip system irrigation.
S5	Finish grade of landscaped areas at a minimum of 1-2 inches below top of curb, sidewalk, or pavement	<input checked="" type="checkbox"/>	<input type="checkbox"/>	Landscaping to comply with depressed area requirements.
S6	Protect slopes and channels and provide energy dissipation (CASQA New Development BMP Handbook SD-10)	<input checked="" type="checkbox"/>	<input type="checkbox"/>	Sloped areas vary from 2:1 to 5:1 with most slopes occurring within the infiltration basin. The slopes will be protected to prevent erosion.
S7	Covered dock areas (CASQA New Development BMP Handbook SD-31)	<input checked="" type="checkbox"/>	<input type="checkbox"/>	Project will incorporate covered dock areas that comply with CASQA SD-31
S8	Covered maintenance bays with spill containment plans (CASQA New Development BMP Handbook SD-31)	<input checked="" type="checkbox"/>	<input type="checkbox"/>	Project site will incorporate covered maintenance bays with spill containment plans. See BMP Fact sheets included.
S9	Vehicle wash areas with spill containment plans (CASQA New Development BMP Handbook SD-33)	<input type="checkbox"/>	<input checked="" type="checkbox"/>	This project will not incorporate vehicle wash areas.
S10	Covered outdoor processing areas (CASQA New Development BMP Handbook SD-36)	<input type="checkbox"/>	<input checked="" type="checkbox"/>	This project will not incorporate outdoor processing areas.

Form 4.1-2 Structural Source Control BMPs

Identifier	Name	Check One		Describe BMP Implementation OR, If not applicable, state reason
		Included	Not Applicable	
S11	Equipment wash areas with spill containment plans (CASQA New Development BMP Handbook SD-33)	<input type="checkbox"/>	<input checked="" type="checkbox"/>	This project will not incorporate equipment wash areas.
S12	Fueling areas (CASQA New Development BMP Handbook SD-30)	<input type="checkbox"/>	<input checked="" type="checkbox"/>	This project will not incorporate fueling areas.
S13	Hillside landscaping (CASQA New Development BMP Handbook SD-10)	<input type="checkbox"/>	<input checked="" type="checkbox"/>	This project will not incorporate hillside landscaping.
S14	Wash water control for food preparation areas	<input type="checkbox"/>	<input checked="" type="checkbox"/>	This project will not incorporate food preparation areas.
S15	Community car wash racks (CASQA New Development BMP Handbook SD-33)	<input type="checkbox"/>	<input checked="" type="checkbox"/>	This project will not incorporate community car wash racks.

4.1.2 Preventative LID Site Design Practices

Site design practices associated with new LID requirements in the MS4 Permit should be considered in the earliest phases of a project. Preventative site design practices can result in smaller DCV for LID BMP and hydromodification control BMP by reducing runoff generation. Describe site design and drainage plan including:

- A narrative of site design practices utilized or rationale for not using practices
- A narrative of how site plan incorporates preventive site design practices
- Include an attached Site Plan layout which shows how preventative site design practices are included in WQMP

Refer to Section 5.2 of the TGD for WQMP for more details.

Form 4.1-3 Preventative LID Site Design Practices Checklist
<p>Site Design Practices <i>If yes, explain how preventative site design practice is addressed in project site plan. If no, other LID BMPs must be selected to meet targets</i></p>
<p>Minimize impervious areas: Yes <input checked="" type="checkbox"/> No <input type="checkbox"/> Explanation: The project site will minimize the impervious areas by incorporating landscaping in all feasible areas to the maximum extent practicable.</p>
<p>Maximize natural infiltration capacity: Yes <input checked="" type="checkbox"/> No <input type="checkbox"/> Explanation: The project site will utilize subsurface infiltration basins to maximize natural infiltration capacity.</p>
<p>Preserve existing drainage patterns and time of concentration: Yes <input checked="" type="checkbox"/> No <input type="checkbox"/> Explanation: Existing drainage patterns will be preserved as flows currently drain to a basin north of 11th Street and will continue to drain there post-development. Time of concentration changes will be mitigated through the use of the infiltration BMPs.</p>
<p>Disconnect impervious areas: Yes <input checked="" type="checkbox"/> No <input type="checkbox"/> Explanation: Flows from impervious areas up to the DCV will be diverted to the infiltration BMPs</p>
<p>Protect existing vegetation and sensitive areas: Yes <input type="checkbox"/> No <input checked="" type="checkbox"/> Explanation: Entire site will be graded, and existing vegetation will not be preserved.</p>
<p>Re-vegetate disturbed areas: Yes <input checked="" type="checkbox"/> No <input type="checkbox"/> Explanation: Disturbed areas will be re-vegetated in all feasible areas.</p>
<p>Minimize unnecessary compaction in stormwater retention/infiltration basin/trench areas: Yes <input checked="" type="checkbox"/> No <input type="checkbox"/> Explanation: The project will minimize unnecessary compaction in the infiltration BMP areas.</p>
<p>Utilize vegetated drainage swales in place of underground piping or imperviously lined swales: Yes <input type="checkbox"/> No <input checked="" type="checkbox"/> Explanation: Surface drainage paths will be trafficked areas not suitable for vegetation. Vegetated swales will be present, but they will discharge to impervious surfaces and flow to the proposed BMPs via underground storm drain.</p>
<p>Stake off areas that will be used for landscaping to minimize compaction during construction : Yes <input checked="" type="checkbox"/> No <input type="checkbox"/> Explanation: The project will stake off areas that will be used for landscaping to minimize compaction during construction.</p>

4.2 Project Performance Criteria

The purpose of this section of the Project WQMP is to establish targets for post-development hydrology based on performance criteria specified in the MS4 Permit. These targets include runoff volume for water quality control (referred to as LID design capture volume), and runoff volume, time of concentration, and peak runoff for protection of any downstream waterbody segments with a HCOC. ***If the project has more than one outlet for stormwater runoff, then complete additional versions of these forms for each DA / outlet.***

Methods applied in the following forms include:

- For LID BMP Design Capture Volume (DCV), the San Bernardino County Stormwater Program requires use of the P₆ method (MS4 Permit Section XI.D.6a.ii) – Form 4.2-1
- For HCOC pre- and post-development hydrologic calculation, the San Bernardino County Stormwater Program requires the use of the Rational Method (San Bernardino County Hydrology Manual Section D). Forms 4.2-2 through Form 4.2-5 calculate hydrologic variables including runoff volume, time of concentration, and peak runoff from the project site pre- and post-development using the Hydrology Manual Rational Method approach. For projects greater than 640 acres (1.0 mi²), the Rational Method and these forms should not be used. For such projects, the Unit Hydrograph Method (San Bernardino County Hydrology Manual Section E) shall be applied for hydrologic calculations for HCOC performance criteria.

Refer to Section 4 in the TGD for WQMP for detailed guidance and instructions.

Form 4.2-1 LID BMP Performance Criteria for Design Capture Volume (DA 1)		
1 Project area DA 1 (ft ²): 659,807	2 Imperviousness after applying preventative site design practices (Imp%): 90.4	3 Runoff Coefficient (Rc): 0.7363 $R_c = 0.858(Imp\%)^{0.3} - 0.78(Imp\%)^{0.2} + 0.774(Imp\%) + 0.04$
4 Determine 1-hour rainfall depth for a 2-year return period P _{2yr-1hr} (in): 0.521 http://hdsc.nws.noaa.gov/hdsc/pfds/so/sca_pfds.html		
5 Compute P ₆ , Mean 6-hr Precipitation (inches): 0.7714 <i>P₆ = Item 4 * C₁, where C₁ is a function of site climatic region specified in Form 3-1 Item 1 (Valley = 1.4807; Mountain = 1.909; Desert = 1.2371)</i>		
6 Drawdown Rate <i>Use 48 hours as the default condition. Selection and use of the 24 hour drawdown time condition is subject to approval by the local jurisdiction. The necessary BMP footprint is a function of drawdown time. While shorter drawdown times reduce the performance criteria for LID BMP design capture volume, the depth of water that can be stored is also reduced.</i>		24-hrs <input type="checkbox"/> 48-hrs <input checked="" type="checkbox"/>
7 Compute design capture volume, DCV (ft ³): 61,308 $DCV = 1/12 * [Item 1 * Item 3 * Item 5 * C_2]$, where C ₂ is a function of drawdown rate (24-hr = 1.582; 48-hr = 1.963) <i>Compute separate DCV for each outlet from the project site per schematic drawn in Form 3-1 Item 2</i>		

Form 4.2-1 LID BMP Performance Criteria for Design Capture Volume (DA 2)		
1 Project area DA 1 (ft ²): 623,538	2 Imperviousness after applying preventative site design practices (Imp%): 87.2	3 Runoff Coefficient (Rc): 0.6911 $R_c = 0.858(\text{Imp}\%)^{0.3} - 0.78(\text{Imp}\%)^{0.2} + 0.774(\text{Imp}\%) + 0.04$
4 Determine 1-hour rainfall depth for a 2-year return period $P_{2\text{yr-1hr}}$ (in): 0.521 http://hdsc.nws.noaa.gov/hdsc/pfds/so/sca_pfds.html		
5 Compute P_6 , Mean 6-hr Precipitation (inches): 0.7714 $P_6 = \text{Item 4} * C_1$, where C_1 is a function of site climatic region specified in Form 3-1 Item 1 (Valley = 1.4807; Mountain = 1.909; Desert = 1.2371)		
6 Drawdown Rate Use 48 hours as the default condition. Selection and use of the 24 hour drawdown time condition is subject to approval by the local jurisdiction. The necessary BMP footprint is a function of drawdown time. While shorter drawdown times reduce the performance criteria for LID BMP design capture volume, the depth of water that can be stored is also reduced.		24-hrs <input type="checkbox"/> 48-hrs <input checked="" type="checkbox"/>
7 Compute design capture volume, DCV (ft ³): 54,382 $DCV = 1/12 * [\text{Item 1} * \text{Item 3} * \text{Item 5} * C_2]$, where C_2 is a function of drawdown rate (24-hr = 1.582; 48-hr = 1.963) Compute separate DCV for each outlet from the project site per schematic drawn in Form 3-1 Item 2		

Form 4.2-1 LID BMP Performance Criteria for Design Capture Volume (DA 3)		
1 Project area DA 1 (ft ²): 101,574	2 Imperviousness after applying preventative site design practices (Imp%): 100.0	3 Runoff Coefficient (Rc): 0.8920 $R_c = 0.858(Imp\%)^3 - 0.78(Imp\%)^2 + 0.774(Imp\%) + 0.04$
4 Determine 1-hour rainfall depth for a 2-year return period $P_{2yr-1hr}$ (in): 0.521 http://hdsc.nws.noaa.gov/hdsc/pfds/sa/sca_pfds.html		
5 Compute P_6 , Mean 6-hr Precipitation (inches): 0.7714 <i>$P_6 = \text{Item 4} * C_1$, where C_1 is a function of site climatic region specified in Form 3-1 Item 1 (Valley = 1.4807; Mountain = 1.909; Desert = 1.2371)</i>		
6 Drawdown Rate <i>Use 48 hours as the default condition. Selection and use of the 24 hour drawdown time condition is subject to approval by the local jurisdiction. The necessary BMP footprint is a function of drawdown time. While shorter drawdown times reduce the performance criteria for LID BMP design capture volume, the depth of water that can be stored is also reduced.</i>		24-hrs <input type="checkbox"/> 48-hrs <input checked="" type="checkbox"/>
7 Compute design capture volume, DCV (ft ³): 11,434 <i>$DCV = 1/12 * [\text{Item 1} * \text{Item 3} * \text{Item 5} * C_2]$, where C_2 is a function of drawdown rate (24-hr = 1.582; 48-hr = 1.963)</i> <i>Compute separate DCV for each outlet from the project site per schematic drawn in Form 3-1 Item 2</i>		

N/A – Project site is HCOC exempt.

Form 4.2-2 Summary of HCOC Assessment (DA 1)

Does project have the potential to cause or contribute to an HCOC in a downstream channel: Yes No

Go to: <http://permittrack.sbcounty.gov/wap/>

If “Yes”, then complete HCOC assessment of site hydrology for 2yr storm event using Forms 4.2-3 through 4.2-5 and insert results below
(Forms 4.2-3 through 4.2-5 may be replaced by computer software analysis based on the San Bernardino County Hydrology Manual)

If “No,” then proceed to Section 4.3 Project Conformance Analysis

Condition	Runoff Volume (ft ³)	Time of Concentration (min)	Peak Runoff (cfs)
Pre-developed	1 <i>Form 4.2-3 Item 12</i>	2 <i>Form 4.2-4 Item 13</i>	3 <i>Form 4.2-5 Item 10</i>
Post-developed	4 <i>Form 4.2-3 Item 13</i>	5 <i>Form 4.2-4 Item 14</i>	6 <i>Form 4.2-5 Item 14</i>
Difference	7 <i>Item 4 – Item 1</i>	8 <i>Item 2 – Item 5</i>	9 <i>Item 6 – Item 3</i>
Difference (as % of pre-developed)	10 % <i>Item 7 / Item 1</i>	11 % <i>Item 8 / Item 2</i>	12 % <i>Item 9 / Item 3</i>

N/A – Project site is HCOC exempt.

Form 4.2-3 HCOC Assessment for Runoff Volume (DA 1)								
Weighted Curve Number Determination for: Pre-developed DA	DMA A	DMA B	DMA C	DMA D	DMA E	DMA F	DMA G	DMA H
1a Land Cover type								
2a Hydrologic Soil Group (HSG)								
3a DMA Area, ft ² sum of areas of DMA should equal area of DA								
4a Curve Number (CN) use Items 1 and 2 to select the appropriate CN from Appendix C-2 of the TGD for WQMP								
Weighted Curve Number Determination for: Post-developed DA	DMA A	DMA B	DMA C	DMA D	DMA E	DMA F	DMA G	DMA H
1b Land Cover type								
2b Hydrologic Soil Group (HSG)								
3b DMA Area, ft ² sum of areas of DMA should equal area of DA								
4b Curve Number (CN) use Items 5 and 6 to select the appropriate CN from Appendix C-2 of the TGD for WQMP								
5 Pre-Developed area-weighted CN:	7 Pre-developed soil storage capacity, S (in): $S = (1000 / \text{Item 5}) - 10$				9 Initial abstraction, I _a (in): $I_a = 0.2 * \text{Item 7}$			
6 Post-Developed area-weighted CN:	8 Post-developed soil storage capacity, S (in): $S = (1000 / \text{Item 6}) - 10$				10 Initial abstraction, I _a (in): $I_a = 0.2 * \text{Item 8}$			
11 Precipitation for 2 yr, 24 hr storm (in): Go to: http://hdsc.nws.noaa.gov/hdsc/pfds/sa/sca_pfds.html								
12 Pre-developed Volume (ft ³): $V_{pre} = (1 / 12) * (\text{Item sum of Item 3}) * [(\text{Item 11} - \text{Item 9})^2 / ((\text{Item 11} - \text{Item 9} + \text{Item 7}))]$								
13 Post-developed Volume (ft ³): $V_{pre} = (1 / 12) * (\text{Item sum of Item 3}) * [(\text{Item 11} - \text{Item 10})^2 / ((\text{Item 11} - \text{Item 10} + \text{Item 8}))]$								
14 Volume Reduction needed to meet HCOC Requirement, (ft ³): $V_{HCOC} = (\text{Item 13} * 0.95) - \text{Item 12}$								

N/A – Project site is HCOC exempt.

Form 4.2-4 HCOC Assessment for Time of Concentration (DA 1)								
Compute time of concentration for pre and post developed conditions for each DA (For projects using the Hydrology Manual complete the form below)								
Variables	Pre-developed DA1 <i>Use additional forms if there are more than 4 DMA</i>				Post-developed DA1 <i>Use additional forms if there are more than 4 DMA</i>			
	DMA A	DMA B	DMA C	DMA D	DMA A	DMA B	DMA C	DMA D
1 Length of flowpath (ft) <i>Use Form 3-2 Item 5 for pre-developed condition</i>								
2 Change in elevation (ft)								
3 Slope (ft/ft), $S_o = \text{Item 2} / \text{Item 1}$								
4 Land cover								
5 Initial DMA Time of Concentration (min) <i>Appendix C-1 of the TGD for WQMP</i>								
6 Length of conveyance from DMA outlet to project site outlet (ft) <i>May be zero if DMA outlet is at project site outlet</i>								
7 Cross-sectional area of channel (ft ²)								
8 Wetted perimeter of channel (ft)								
9 Manning’s roughness of channel (n)								
10 Channel flow velocity (ft/sec) $V_{fps} = (1.49 / \text{Item 9}) * (\text{Item 7}/\text{Item 8})^{0.67} * (\text{Item 3})^{0.5}$								
11 Travel time to outlet (min) $T_t = \text{Item 6} / (\text{Item 10} * 60)$								
12 Total time of concentration (min) $T_c = \text{Item 5} + \text{Item 11}$								
13 Pre-developed time of concentration (min):	<i>Minimum of Item 12 pre-developed DMA</i>							
14 Post-developed time of concentration (min):	<i>Minimum of Item 12 post-developed DMA</i>							
15 Additional time of concentration needed to meet HCOC requirement (min):	$T_{C-HCOC} = (\text{Item 13} * 0.95) - \text{Item 14}$							

N/A – Project site is HCOC exempt.

Form 4.2-5 HCOC Assessment for Peak Runoff (DA 1)

Compute peak runoff for pre- and post-developed conditions						
Variables	Pre-developed DA to Project Outlet (Use additional forms if more than 3 DMA)			Post-developed DA to Project Outlet (Use additional forms if more than 3 DMA)		
	DMA A	DMA B	DMA C	DMA A	DMA B	DMA C
1 Rainfall Intensity for storm duration equal to time of concentration $I_{peak} = 10^{(LOG Form 4.2-1 Item 4 - 0.6 LOG Form 4.2-4 Item 5 / 60)}$						
2 Drainage Area of each DMA (Acres) For DMA with outlet at project site outlet, include upstream DMA (Using example schematic in Form 3-1, DMA A will include drainage from DMA C)						
3 Ratio of pervious area to total area For DMA with outlet at project site outlet, include upstream DMA (Using example schematic in Form 3-1, DMA A will include drainage from DMA C)						
4 Pervious area infiltration rate (in/hr) Use pervious area CN and antecedent moisture condition with Appendix C-3 of the TGD for WQMP						
5 Maximum loss rate (in/hr) $F_m = Item 3 * Item 4$ Use area-weighted F_m from DMA with outlet at project site outlet, include upstream DMA (Using example schematic in Form 3-1, DMA A will include drainage from DMA C)						
6 Peak Flow from DMA (cfs) $Q_p = Item 2 * 0.9 * (Item 1 - Item 5)$						
7 Time of concentration adjustment factor for other DMA to site discharge point Form 4.2-4 Item 12 DMA / Other DMA upstream of site discharge point (If ratio is greater than 1.0, then use maximum value of 1.0)	DMA A	n/a		n/a		
	DMA B		n/a		n/a	
	DMA C			n/a		n/a
8 Pre-developed Q_p at T_c for DMA A: $Q_p = Item 6_{DMAA} + [Item 6_{DMAB} * (Item 1_{DMAA} - Item 5_{DMAB}) / (Item 1_{DMAB} - Item 5_{DMAB}) * Item 7_{DMAA/2}] + [Item 6_{DMAC} * (Item 1_{DMAA} - Item 5_{DMAC}) / (Item 1_{DMAC} - Item 5_{DMAC}) * Item 7_{DMAA/3}]$	9 Pre-developed Q_p at T_c for DMA B: $Q_p = Item 6_{DMAB} + [Item 6_{DMAA} * (Item 1_{DMAB} - Item 5_{DMAA}) / (Item 1_{DMAA} - Item 5_{DMAA}) * Item 7_{DMAB/1}] + [Item 6_{DMAC} * (Item 1_{DMAB} - Item 5_{DMAC}) / (Item 1_{DMAC} - Item 5_{DMAC}) * Item 7_{DMAB/3}]$		10 Pre-developed Q_p at T_c for DMA C: $Q_p = Item 6_{DMAC} + [Item 6_{DMAA} * (Item 1_{DMAC} - Item 5_{DMAA}) / (Item 1_{DMAA} - Item 5_{DMAA}) * Item 7_{DMAC/1}] + [Item 6_{DMAB} * (Item 1_{DMAC} - Item 5_{DMAB}) / (Item 1_{DMAB} - Item 5_{DMAB}) * Item 7_{DMAC/2}]$			
10 Peak runoff from pre-developed condition confluence analysis (cfs): <i>Maximum of Item 8, 9, and 10 (including additional forms as needed)</i>						
11 Post-developed Q_p at T_c for DMA A: Same as Item 8 for post-developed values	12 Post-developed Q_p at T_c for DMA B: Same as Item 9 for post-developed values		13 Post-developed Q_p at T_c for DMA C: Same as Item 10 for post-developed values			
14 Peak runoff from post-developed condition confluence analysis (cfs): <i>Maximum of Item 11, 12, and 13 (including additional forms as needed)</i>						
15 Peak runoff reduction needed to meet HCOC Requirement (cfs): $Q_{p-HCOC} = (Item 14 * 0.95) - Item 10$						

4.3 Project Conformance Analysis

Complete the following forms for each project site DA to document that the proposed LID BMPs conform to the project DCV developed to meet performance criteria specified in the MS₄ Permit (WQMP Template Section 4.2). For the LID DCV, the forms are ordered according to hierarchy of BMP selection as required by the MS₄ Permit (see Section 5.3.1 in the TGD for WQMP). The forms compute the following for on-site LID BMP:

- Site Design and Hydrologic Source Controls (Form 4.3-2)
- Retention and Infiltration (Form 4.3-3)
- Harvested and Use (Form 4.3-4) or
- Biotreatment (Form 4.3-5).

At the end of each form, additional fields facilitate the determination of the extent of mitigation provided by the specific BMP category, allowing for use of the next category of BMP in the hierarchy, if necessary.

The first step in the analysis, using Section 5.3.2.1 of the TGD for WQMP, is to complete Forms 4.3-1 and 4.3-3) to determine if retention and infiltration BMPs are infeasible for the project. For each feasibility criterion in Form 4.3-1, if the answer is “Yes,” provide all study findings that includes relevant calculations, maps, data sources, etc. used to make the determination of infeasibility.

Next, complete Forms 4.3-2 and 4.3-4 to determine the feasibility of applicable HSC and harvest and use BMPs, and, if their implementation is feasible, the extent of mitigation of the DCV.

If no site constraints exist that would limit the type of BMP to be implemented in a DA, evaluate the use of combinations of LID BMPs, including all applicable HSC BMPs to maximize on-site retention of the DCV. If no combination of BMP can mitigate the entire DCV, implement the single BMP type, or combination of BMP types, that maximizes on-site retention of the DCV within the minimum effective area.

If the combination of LID HSC, retention and infiltration, and harvest and use BMPs are unable to mitigate the entire DCV, then biotreatment BMPs may be implemented by the project proponent. If biotreatment BMPs are used, then they must be sized to provide sufficient capacity for effective treatment of the remainder of the volume-based performance criteria that cannot be achieved with LID BMPs (TGD for WQMP Section 5.4.4.2). **Under no circumstances shall any portion of the DCV be released from the site without effective mitigation and/or treatment.**

Form 4.3-1 Infiltration BMP Feasibility (DA 1)	
Feasibility Criterion – Complete evaluation for each DA on the Project Site	
<p>¹ Would infiltration BMP pose significant risk for groundwater related concerns? <i>Refer to Section 5.3.2.1 of the TGD for WQMP</i></p>	Yes <input type="checkbox"/> No <input checked="" type="checkbox"/>
If Yes, Provide basis: (attach)	
<p>² Would installation of infiltration BMP significantly increase the risk of geotechnical hazards? (Yes, if the answer to any of the following questions is yes, as established by a geotechnical expert):</p> <ul style="list-style-type: none"> • The location is less than 50 feet away from slopes steeper than 15 percent • The location is less than eight feet from building foundations or an alternative setback. • A study certified by a geotechnical professional or an available watershed study determines that stormwater infiltration would result in significantly increased risks of geotechnical hazards. 	Yes <input type="checkbox"/> No <input checked="" type="checkbox"/>
If Yes, Provide basis: (attach)	
<p>³ Would infiltration of runoff on a Project site violate downstream water rights?</p>	Yes <input type="checkbox"/> No <input checked="" type="checkbox"/>
If Yes, Provide basis: (attach)	
<p>⁴ Is proposed infiltration facility located on hydrologic soil group (HSG) D soils or does the site geotechnical investigation indicate presence of soil characteristics, which support categorization as D soils?</p>	Yes <input type="checkbox"/> No <input checked="" type="checkbox"/>
If Yes, Provide basis: (attach)	
<p>⁵ Is the design infiltration rate, after accounting for safety factor of 2.0, below proposed facility less than 0.3 in/hr (accounting for soil amendments)?</p>	Yes <input type="checkbox"/> No <input checked="" type="checkbox"/>
If Yes, Provide basis: (attach)	
<p>⁶ Would on-site infiltration or reduction of runoff over pre-developed conditions be partially or fully inconsistent with watershed management strategies as defined in the WAP, or impair beneficial uses? <i>See Section 3.5 of the TGD for WQMP and WAP</i></p>	Yes <input type="checkbox"/> No <input checked="" type="checkbox"/>
If Yes, Provide basis: (attach)	
<p>⁷ Any answer from Item 1 through Item 3 is “Yes”: <i>If yes, infiltration of any volume is not feasible onsite. Proceed to Form 4.3-4, Harvest and Use BMP. If no, then proceed to Item 8 below.</i></p>	Yes <input type="checkbox"/> No <input checked="" type="checkbox"/>
<p>⁸ Any answer from Item 4 through Item 6 is “Yes”: <i>If yes, infiltration is permissible but is not required to be considered. Proceed to Form 4.3-2, Hydrologic Source Control BMP. If no, then proceed to Item 9, below.</i></p>	Yes <input type="checkbox"/> No <input checked="" type="checkbox"/>
<p>⁹ All answers to Item 1 through Item 6 are “No”: <i>Infiltration of the full DCV is potentially feasible, LID infiltration BMP must be designed to infiltrate the full DCV to the MEP. Proceed to Form 4.3-2, Hydrologic Source Control BMP.</i></p>	

Form 4.3-1 Infiltration BMP Feasibility (DA 2 & DA 3)

Feasibility Criterion – Complete evaluation for each DA on the Project Site

¹ Would infiltration BMP pose significant risk for groundwater related concerns? Yes No
Refer to Section 5.3.2.1 of the TGD for WQMP

If Yes, Provide basis: (attach)

² Would installation of infiltration BMP significantly increase the risk of geotechnical hazards? Yes No
 (Yes, if the answer to any of the following questions is yes, as established by a geotechnical expert):

- The location is less than 50 feet away from slopes steeper than 15 percent
- The location is less than eight feet from building foundations or an alternative setback.
- A study certified by a geotechnical professional or an available watershed study determines that stormwater infiltration would result in significantly increased risks of geotechnical hazards.

If Yes, Provide basis: (attach)

³ Would infiltration of runoff on a Project site violate downstream water rights? Yes No

If Yes, Provide basis: (attach)

⁴ Is proposed infiltration facility located on hydrologic soil group (HSG) D soils or does the site geotechnical investigation indicate presence of soil characteristics, which support categorization as D soils? Yes No

If Yes, Provide basis: (attach)

⁵ Is the design infiltration rate, after accounting for safety factor of 2.0, below proposed facility less than 0.3 in/hr (accounting for soil amendments)? Yes No

If Yes, Provide basis: (attach)

⁶ Would on-site infiltration or reduction of runoff over pre-developed conditions be partially or fully inconsistent with watershed management strategies as defined in the WAP, or impair beneficial uses? Yes No
See Section 3.5 of the TGD for WQMP and WAP

If Yes, Provide basis: (attach)

⁷ Any answer from Item 1 through Item 3 is “Yes”: Yes No
If yes, infiltration of any volume is not feasible onsite. Proceed to Form 4.3-4, Harvest and Use BMP. If no, then proceed to Item 8 below.

⁸ Any answer from Item 4 through Item 6 is “Yes”: Yes No
If yes, infiltration is permissible but is not required to be considered. Proceed to Form 4.3-2, Hydrologic Source Control BMP. If no, then proceed to Item 9, below.

⁹ All answers to Item 1 through Item 6 are “No”:
Infiltration of the full DCV is potentially feasible, LID infiltration BMP must be designed to infiltrate the full DCV to the MEP. Proceed to Form 4.3-2, Hydrologic Source Control BMP.

4.3.1 Site Design Hydrologic Source Control BMP

Section XI.E. of the Permit emphasizes the use of LID preventative measures; and the use of LID HSC BMPs reduces the portion of the DCV that must be addressed in downstream BMPs. Therefore, all applicable HSC shall be provided except where they are mutually exclusive with each other, or with other BMPs. Mutual exclusivity may result from overlapping BMP footprints such that either would be potentially feasible by itself, but both could not be implemented. Please note that while there are no numeric standards regarding the use of HSC, if a project cannot feasibly meet BMP sizing requirements or cannot fully address HCOCs, feasibility of all applicable HSC must be part of demonstrating that the BMP system has been designed to retain the maximum feasible portion of the DCV. Complete Form 4.3-2 to identify and calculate estimated retention volume from implementing site design HSC BMP. Refer to Section 5.4.1 in the TGD for more detailed guidance.

Form 4.3-2 Site Design Hydrologic Source Control BMPs (DA 1)			
1 Implementation of Impervious Area Dispersion BMP (i.e. routing runoff from impervious to pervious areas), excluding impervious areas planned for routing to on-lot infiltration BMP: Yes <input type="checkbox"/> No <input type="checkbox"/> <i>If yes, complete Items 2-5; If no, proceed to Item 6</i>	DA DMA BMP Type	DA DMA BMP Type	DA DMA BMP Type <i>(Use additional forms for more BMPs)</i>
2 Total impervious area draining to pervious area (ft ²)			
3 Ratio of pervious area receiving runoff to impervious area			
4 Retention volume achieved from impervious area dispersion (ft ³) $V = \text{Item 2} * \text{Item 3} * (0.5/12)$, assuming retention of 0.5 inches of runoff			
5 Sum of retention volume achieved from impervious area dispersion (ft ³):		$V_{\text{retention}} = \text{Sum of Item 4 for all BMPs}$	
6 Implementation of Localized On-lot Infiltration BMPs (e.g. on-lot rain gardens): Yes <input type="checkbox"/> No <input type="checkbox"/> <i>If yes, complete Items 7-13 for aggregate of all on-lot infiltration BMP in each DA; if no, proceed to Item 14</i>	DA DMA BMP Type	DA DMA BMP Type	DA DMA BMP Type <i>(Use additional forms for more BMPs)</i>
7 Ponding surface area (ft ²)			
8 Ponding depth (ft)			
9 Surface area of amended soil/gravel (ft ²)			
10 Average depth of amended soil/gravel (ft)			
11 Average porosity of amended soil/gravel			
12 Retention volume achieved from on-lot infiltration (ft ³) $V_{\text{retention}} = (\text{Item 7} * \text{Item 8}) + (\text{Item 9} * \text{Item 10} * \text{Item 11})$			
13 Runoff volume retention from on-lot infiltration (ft ³):		$V_{\text{retention}} = \text{Sum of Item 12 for all BMPs}$	

Form 4.3-2 cont. Site Design Hydrologic Source Control BMPs (DA 1)

14 Implementation of evapotranspiration BMP (green, brown, or blue roofs): Yes <input type="checkbox"/> No <input type="checkbox"/> <i>If yes, complete Items 15-20. If no, proceed to Item 21</i>	DA DMA BMP Type	DA DMA BMP Type	DA DMA BMP Type <i>(Use additional forms for more BMPs)</i>
15 Rooftop area planned for ET BMP (ft ²)			
16 Average wet season ET demand (in/day) <i>Use local values, typical ~ 0.1</i>			
17 Daily ET demand (ft ³ /day) <i>Item 15 * (Item 16 / 12)</i>			
18 Drawdown time (hrs) <i>Copy Item 6 in Form 4.2-1</i>			
19 Retention Volume (ft ³) <i>V_{retention} = Item 17 * (Item 18 / 24)</i>			
20 Runoff volume retention from evapotranspiration BMPs (ft ³): <i>V_{retention} = Sum of Item 19 for all BMPs</i>			
21 Implementation of Street Trees: Yes <input type="checkbox"/> No <input type="checkbox"/> <i>If yes, complete Items 22-25. If no, proceed to Item 26</i>	DA DMA BMP Type	DA DMA BMP Type	DA DMA BMP Type <i>(Use additional forms for more BMPs)</i>
22 Number of Street Trees			
23 Average canopy cover over impervious area (ft ²)			
24 Runoff volume retention from street trees (ft ³) <i>V_{retention} = Item 22 * Item 23 * (0.05/12) assume runoff retention of 0.05 inches</i>			
25 Runoff volume retention from street tree BMPs (ft ³): <i>V_{retention} = Sum of Item 24 for all BMPs</i>			
26 Implementation of residential rain barrel/cisterns: Yes <input type="checkbox"/> No <input type="checkbox"/> <i>If yes, complete Items 27-29; If no, proceed to Item 30</i>	DA DMA BMP Type	DA DMA BMP Type	DA DMA BMP Type <i>(Use additional forms for more BMPs)</i>
27 Number of rain barrels/cisterns			
28 Runoff volume retention from rain barrels/cisterns (ft ³) <i>V_{retention} = Item 27 * 3</i>			
29 Runoff volume retention from residential rain barrels/Cisterns (ft ³): <i>V_{retention} = Sum of Item 28 for all BMPs</i>			
30 Total Retention Volume from Site Design Hydrologic Source Control BMPs: <i>Sum of Items 5, 13, 20, 25 and 29</i>			

4.3.2 Infiltration BMPs

Use Form 4.3-3 to compute on-site retention of runoff from proposed retention and infiltration BMPs. Volume retention estimates are sensitive to the percolation rate used, which determines the amount of runoff that can be infiltrated within the specified drawdown time. The infiltration safety factor reduces field measured percolation to account for potential inaccuracy associated with field measurements, declining BMP performance over time, and compaction during construction. Appendix D of the TGD for WQMP provides guidance on estimating an appropriate safety factor to use in Form 4.3-3.

If site constraints limit the use of BMPs to a single type and implementation of retention and infiltration BMPs mitigate no more than 40% of the DCV, then they are considered infeasible and the Project Proponent may evaluate the effectiveness of BMPs lower in the LID hierarchy of use (Section 5.5.1 of the TGD for WQMP)

If implementation of infiltrations BMPs is feasible as determined using Form 4.3-1, then LID infiltration BMPs shall be implemented to the MEP (section 4.1 of the TGD for WQMP).

Form 4.3-3 Infiltration LID BMP - including underground BMPs (DA 1)

1 Remaining LID DCV not met by site design HSC BMP (ft³): 61,308 $V_{unmet} = \text{Form 4.2-1 Item 7} - \text{Form 4.3-2 Item 30}$

BMP Type <i>Use columns to the right to compute runoff volume retention from proposed infiltration BMP (select BMP from Table 5-4 in TGD for WQMP) - Use additional forms for more BMPs</i>	DA 1 DMA A BMP Type: Infiltration	DA DMA BMP Type	DA DMA BMP Type <i>(Use additional forms for more BMPs)</i>
2 Infiltration rate of underlying soils (in/hr) <i>See Section 5.4.2 and Appendix D of the TGD for WQMP for minimum requirements for assessment methods</i>	11.4		
3 Infiltration safety factor <i>See TGD Section 5.4.2 and Appendix D</i>	3		
4 Design percolation rate (in/hr) $P_{design} = \text{Item 2} / \text{Item 3}$	3.80		
5 Pondered water drawdown time (hr) <i>Copy Item 6 in Form 4.2-1</i>	48		
6 Maximum ponding depth (ft) <i>BMP specific, see Table 5-4 of the TGD for WQMP for BMP design details</i>	4.5		
7 Ponding Depth (ft) $d_{BMP} = \text{Minimum of } (1/12 * \text{Item 4} * \text{Item 5}) \text{ or Item 6}$	4.5		
8 Infiltrating surface area, SA_{BMP} (ft ²) <i>the lesser of the area needed for infiltration of full DCV or minimum space requirements from Table 5.7 of the TGD for WQMP</i>	38,397		
9 Amended soil depth, d_{media} (ft) <i>Only included in certain BMP types, see Table 5-4 in the TGD for WQMP for reference to BMP design details</i>	-		
10 Amended soil porosity	-		
11 Gravel depth, d_{media} (ft) <i>Only included in certain BMP types, see Table 5-4 of the TGD for WQMP for BMP design details</i>	-		
12 Gravel porosity	-		
13 Duration of storm as basin is filling (hrs) <i>Typical ~ 3hrs</i>	3		
14 Above Ground Retention Volume (ft ³) $V_{retention} = \text{Item 8} * [\text{Item 7} + (\text{Item 9} * \text{Item 10}) + (\text{Item 11} * \text{Item 12}) + (\text{Item 13} * (\text{Item 4} / 12))]$	N/A		
15 Underground Retention Volume (ft ³) <i>Volume determined using manufacturer's specifications and calculations</i>	206,243		

16 Total Retention Volume from LID Infiltration BMPs: 206,243 *(Sum of Items 14 and 15 for all infiltration BMP included in plan)*

17 Fraction of DCV achieved with infiltration BMP: 336.4% $\text{Retention\%} = \text{Item 16} / \text{Form 4.2-1 Item 7}$

18 Is full LID DCV retained onsite with combination of hydrologic source control and LID retention/infiltration BMPs? Yes No
If yes, demonstrate conformance using Form 4.3-10; If no, then reduce Item 3, Factor of Safety to 2.0 and increase Item 8, Infiltrating Surface Area, such that the portion of the site area used for retention and infiltration BMPs equals or exceeds the minimum effective area thresholds (Table 5-7 of the TGD for WQMP) for the applicable category of development and repeat all above calculations.

Form 4.3-3 Infiltration LID BMP - including underground BMPs (DA 2&3)

1 Remaining LID DCV not met by site design HSC BMP (ft³): 54,382 (DA 2), 11,434 (DA 3) $V_{unmet} = \text{Form 4.2-1 Item 7} - \text{Form 4.3-2 Item 30}$

BMP Type <i>Use columns to the right to compute runoff volume retention from proposed infiltration BMP (select BMP from Table 5-4 in TGD for WQMP) - Use additional forms for more BMPs</i>	DA 2 DMA A BMP Type: Infiltration	DA 3 DMA A BMP Type Infiltration	DA DMA BMP Type <i>(Use additional forms for more BMPs)</i>
2 Infiltration rate of underlying soils (in/hr) <i>See Section 5.4.2 and Appendix D of the TGD for WQMP for minimum requirements for assessment methods</i>	20.0	20.0	
3 Infiltration safety factor <i>See TGD Section 5.4.2 and Appendix D</i>	3	3	
4 Design percolation rate (in/hr) $P_{design} = \text{Item 2} / \text{Item 3}$	6.67	6.67	
5 Ponded water drawdown time (hr) <i>Copy Item 6 in Form 4.2-1</i>	48	48	
6 Maximum ponding depth (ft) <i>BMP specific, see Table 5-4 of the TGD for WQMP for BMP design details</i>	4.5	4.5	
7 Ponding Depth (ft) $d_{BMP} = \text{Minimum of } (1/12 * \text{Item 4} * \text{Item 5}) \text{ or Item 6}$	4.5	4.5	
8 Infiltrating surface area, SA_{BMP} (ft ²) <i>the lesser of the area needed for infiltration of full DCV or minimum space requirements from Table 5.7 of the TGD for WQMP</i>	41,069	41,069	
9 Amended soil depth, d_{media} (ft) <i>Only included in certain BMP types, see Table 5-4 in the TGD for WQMP for reference to BMP design details</i>	-	-	
10 Amended soil porosity	-	-	
11 Gravel depth, d_{media} (ft) <i>Only included in certain BMP types, see Table 5-4 of the TGD for WQMP for BMP design details</i>	-	-	
12 Gravel porosity	-	-	
13 Duration of storm as basin is filling (hrs) <i>Typical ~ 3hrs</i>	3	3	
14 Above Ground Retention Volume (ft ³) $V_{retention} = \text{Item 8} * [\text{Item 7} + (\text{Item 9} * \text{Item 10}) + (\text{Item 11} * \text{Item 12}) + (\text{Item 13} * (\text{Item 4} / 12))]$	N/A	N/A	
15 Underground Retention Volume (ft ³) <i>Volume determined using manufacturer's specifications and calculations</i>	178,030		
16 Total Retention Volume from LID Infiltration BMPs: 178,030 <i>(Sum of Items 14 and 15 for all infiltration BMP included in plan)</i>			
17 Fraction of DCV achieved with infiltration BMP: 270.5% $\text{Retention\%} = \text{Item 16} / \text{Form 4.2-1 Item 7}$			
18 Is full LID DCV retained onsite with combination of hydrologic source control and LID retention/infiltration BMPs? Yes <input checked="" type="checkbox"/> No <input type="checkbox"/> <i>If yes, demonstrate conformance using Form 4.3-10; If no, then reduce Item 3, Factor of Safety to 2.0 and increase Item 8, Infiltrating Surface Area, such that the portion of the site area used for retention and infiltration BMPs equals or exceeds the minimum effective area thresholds (Table 5-7 of the TGD for WQMP) for the applicable category of development and repeat all above calculations.</i>			

4.3.3 Harvest and Use BMP

Harvest and use BMP may be considered if the full LID DCV cannot be met by maximizing infiltration BMPs. Use Form 4.3-4 to compute on-site retention of runoff from proposed harvest and use BMPs.

Volume retention estimates for harvest and use BMPs are sensitive to the on-site demand for captured stormwater. Since irrigation water demand is low in the wet season, when most rainfall events occur in San Bernardino County, the volume of water that can be used within a specified drawdown period is relatively low. The bottom portion of Form 4.3-4 facilitates the necessary computations to show infeasibility if a minimum incremental benefit of 40 percent of the LID DCV would not be achievable with MEP implementation of on-site harvest and use of stormwater (Section 5.5.4 of the TGD for WQMP).

Form 4.3-4 Harvest and Use BMPs (DA 1)			
1 Remaining LID DCV not met by site design HSC or infiltration BMP (ft ³): <i>V_{unmet} = Form 4.2-1 Item 7 - Form 4.3-2 Item 30 - Form 4.3-3 Item 16</i>			
BMP Type(s) <i>Compute runoff volume retention from proposed harvest and use BMP (Select BMPs from Table 5-4 of the TGD for WQMP) - Use additional forms for more BMPs</i>	DA BMP Type	DMA BMP Type	DA DMA BMP Type <i>(Use additional forms for more BMPs)</i>
2 Describe cistern or runoff detention facility			
3 Storage volume for proposed detention type (ft ³) <i>Volume of cistern</i>			
4 Landscaped area planned for use of harvested stormwater (ft ²)			
5 Average wet season daily irrigation demand (in/day) <i>Use local values, typical ~ 0.1 in/day</i>			
6 Daily water demand (ft ³ /day) <i>Item 4 * (Item 5 / 12)</i>			
7 Drawdown time (hrs) <i>Copy Item 6 from Form 4.2-1</i>			
8 Retention Volume (ft ³) <i>V_{retention} = Minimum of (Item 3) or (Item 6 * (Item 7 / 24))</i>			
9 Total Retention Volume (ft ³) from Harvest and Use BMP <i>Sum of Item 8 for all harvest and use BMP included in plan</i>			
10 Is the full DCV retained with a combination of LID HSC, retention and infiltration, and harvest & use BMPs? Yes <input type="checkbox"/> No <input type="checkbox"/> <i>If yes, demonstrate conformance using Form 4.3-10. If no, then re-evaluate combinations of all LID BMP and optimize their implementation such that the maximum portion of the DCV is retained on-site (using a single BMP type or combination of BMP types). If the full DCV cannot be mitigated after this optimization process, proceed to Section 4.3.4.</i>			

4.3.4 Biotreatment BMP

Biotreatment BMPs may be considered if the full LID DCV cannot be met by maximizing retention and infiltration, and harvest and use BMPs. A key consideration when using biotreatment BMP is the effectiveness of the proposed BMP in addressing the pollutants of concern for the project (see Table 5-5 of the TGD for WQMP).

Use Form 4.3-5 to summarize the potential for volume based and/or flow based biotreatment options to biotreat the remaining unmet LID DCV w. Biotreatment computations are included as follows:

- Use Form 4.3-6 to compute biotreatment in small volume based biotreatment BMP (e.g. bioretention w/underdrains);
- Use Form 4.3-7 to compute biotreatment in large volume based biotreatment BMP (e.g. constructed wetlands);
- Use Form 4.3-8 to compute sizing criteria for flow-based biotreatment BMP (e.g. bioswales)

Form 4.3-5 Selection and Evaluation of Biotreatment BMP (DA 1)		
<p>1 Remaining LID DCV not met by site design HSC, infiltration, or harvest and use BMP for potential biotreatment (ft³): <i>Form 4.2-1 Item 7 - Form 4.3-2 Item 30 – Form 4.3-3 Item 16- Form 4.3-4 Item 9</i></p>	<p>List pollutants of concern <i>Copy from Form 2.3-1.</i></p>	
<p>2 Biotreatment BMP Selected <i>(Select biotreatment BMP(s) necessary to ensure all pollutants of concern are addressed through Unit Operations and Processes, described in Table 5-5 of the TGD for WQMP)</i></p>	<p style="text-align: center;">Volume-based biotreatment <i>Use Forms 4.3-6 and 4.3-7 to compute treated volume</i></p> <p><input type="checkbox"/> Bioretention with underdrain <input type="checkbox"/> Planter box with underdrain <input type="checkbox"/> Constructed wetlands <input type="checkbox"/> Wet extended detention <input type="checkbox"/> Dry extended detention</p>	<p style="text-align: center;">Flow-based biotreatment <i>Use Form 4.3-8 to compute treated volume</i></p> <p><input type="checkbox"/> Vegetated swale <input type="checkbox"/> Vegetated filter strip <input type="checkbox"/> Proprietary biotreatment</p>
<p>3 Volume biotreated in volume based biotreatment BMP (ft³): <i>Form 4.3-6 Item 15 + Form 4.3-7 Item 13</i></p>	<p>4 Compute remaining LID DCV with implementation of volume based biotreatment BMP (ft³): <i>Item 1 – Item 3</i></p>	<p>5 Remaining fraction of LID DCV for sizing flow based biotreatment BMP: % <i>Item 4 / Item 1</i></p>
<p>6 Flow-based biotreatment BMP capacity provided (cfs): <i>Use Figure 5-2 of the TGD for WQMP to determine flow capacity required to provide biotreatment of remaining percentage of unmet LID DCV (Item 5), for the project's precipitation zone (Form 3-1 Item 1)</i></p>		
<p>7 Metrics for MEP determination:</p> <ul style="list-style-type: none"> • Provided a WQMP with the portion of site area used for suite of LID BMP equal to minimum thresholds in Table 5-7 of the TGD for WQMP for the proposed category of development: <input type="checkbox"/> <i>If maximized on-site retention BMPs is feasible for partial capture, then LID BMP implementation must be optimized to retain and infiltrate the maximum portion of the DCV possible within the prescribed minimum effective area. The remaining portion of the DCV shall then be mitigated using biotreatment BMP.</i> 		

Form 4.3-6 Volume Based Biotreatment (DA 1) – Bioretention and Planter Boxes with Underdrains

Biotreatment BMP Type <i>(Bioretention w/underdrain, planter box w/underdrain, other comparable BMP)</i>	DA BMP Type	DMA BMP Type	DA BMP Type	DMA BMP Type <i>(Use additional forms for more BMPs)</i>
1 Pollutants addressed with BMP <i>List all pollutant of concern that will be effectively reduced through specific Unit Operations and Processes described in Table 5-5 of the TGD for WQMP</i>				
2 Amended soil infiltration rate <i>Typical ~ 5.0</i>				
3 Amended soil infiltration safety factor <i>Typical ~ 2.0</i>				
4 Amended soil design percolation rate (in/hr) $P_{design} = \text{Item 2} / \text{Item 3}$				
5 Pondered water drawdown time (hr) <i>Copy Item 6 from Form 4.2-1</i>				
6 Maximum ponding depth (ft) <i>see Table 5-6 of the TGD for WQMP for reference to BMP design details</i>				
7 Ponding Depth (ft) $d_{BMP} = \text{Minimum of } (1/12 * \text{Item 4} * \text{Item 5}) \text{ or Item 6}$				
8 Amended soil surface area (ft ²)				
9 Amended soil depth (ft) <i>see Table 5-6 of the TGD for WQMP for reference to BMP design details</i>				
10 Amended soil porosity, <i>n</i>				
11 Gravel depth (ft) <i>see Table 5-6 of the TGD for WQMP for reference to BMP design details</i>				
12 Gravel porosity, <i>n</i>				
13 Duration of storm as basin is filling (hrs) <i>Typical ~ 3hrs</i>				
14 Biotreated Volume (ft ³) $V_{biotreated} = \text{Item 8} * [(\text{Item 7}/2) + (\text{Item 9} * \text{Item 10}) + (\text{Item 11} * \text{Item 12}) + (\text{Item 13} * (\text{Item 4} / 12))]$				
15 Total biotreated volume from bioretention and/or planter box with underdrains BMP: <i>Sum of Item 14 for all volume-based BMPs included in this form</i>				

Form 4.3-7 Volume Based Biotreatment (DA 1) – Constructed Wetlands and Extended Detention

Biotreatment BMP Type <i>Constructed wetlands, extended wet detention, extended dry detention, or other comparable proprietary BMP. If BMP includes multiple modules (e.g. forebay and main basin), provide separate estimates for storage and pollutants treated in each module.</i>	DA DMA BMP Type		DA DMA BMP Type <i>(Use additional forms for more BMPs)</i>	
	Forebay	Basin	Forebay	Basin
1 Pollutants addressed with BMP forebay and basin <i>List all pollutant of concern that will be effectively reduced through specific Unit Operations and Processes described in Table 5-5 of the TGD for WQMP</i>				
2 Bottom width (ft)				
3 Bottom length (ft)				
4 Bottom area (ft ²) <i>A_{bottom} = Item 2 * Item 3</i>				
5 Side slope (ft/ft)				
6 Depth of storage (ft)				
7 Water surface area (ft ²) <i>A_{surface} = (Item 2 + (2 * Item 5 * Item 6)) * (Item 3 + (2 * Item 5 * Item 6))</i>				
8 Storage volume (ft ³) <i>For BMP with a forebay, ensure fraction of total storage is within ranges specified in BMP specific fact sheets, see Table 5-6 of the TGD for WQMP for reference to BMP design details</i> <i>V = Item 6 / 3 * [Item 4 + Item 7 + (Item 4 * Item 7)^{0.5}]</i>				
9 Drawdown Time (hrs) <i>Copy Item 6 from Form 2.1</i>				
10 Outflow rate (cfs) <i>Q_{BMP} = (Item 8_{forebay} + Item 8_{basin}) / (Item 9 * 3600)</i>				
11 Duration of design storm event (hrs)				
12 Biotreated Volume (ft ³) <i>V_{biotreated} = (Item 8_{forebay} + Item 8_{basin}) + (Item 10 * Item 11 * 3600)</i>				
13 Total biotreated volume from constructed wetlands, extended dry detention, or extended wet detention : <i>(Sum of Item 12 for all BMP included in plan)</i>				

Form 4.3-8 Flow Based Biotreatment (DA 1)			
Biotreatment BMP Type <i>Vegetated swale, vegetated filter strip, or other comparable proprietary BMP</i>	DA DMA BMP Type	DA DMA BMP Type	DA DMA BMP Type <i>(Use additional forms for more BMPs)</i>
1 Pollutants addressed with BMP <i>List all pollutant of concern that will be effectively reduced through specific Unit Operations and Processes described in TGD Table 5-5</i>			
2 Flow depth for water quality treatment (ft) <i>BMP specific, see Table 5-6 of the TGD for WQMP for reference to BMP design details</i>			
3 Bed slope (ft/ft) <i>BMP specific, see Table 5-6 of the TGD for WQMP for reference to BMP design details</i>			
4 Manning's roughness coefficient			
5 Bottom width (ft) $b_w = (\text{Form 4.3-5 Item 6} * \text{Item 4}) / (1.49 * \text{Item 2}^{1.67} * \text{Item 3}^{0.5})$			
6 Side Slope (ft/ft) <i>BMP specific, see Table 5-6 of the TGD for WQMP for reference to BMP design details</i>			
7 Cross sectional area (ft ²) $A = (\text{Item 5} * \text{Item 2}) + (\text{Item 6} * \text{Item 2}^2)$			
8 Water quality flow velocity (ft/sec) $V = \text{Form 4.3-5 Item 6} / \text{Item 7}$			
9 Hydraulic residence time (min) <i>Pollutant specific, see Table 5-6 of the TGD for WQMP for reference to BMP design details</i>			
10 Length of flow based BMP (ft) $L = \text{Item 8} * \text{Item 9} * 60$			
11 Water surface area at water quality flow depth (ft ²) $SA_{top} = (\text{Item 5} + (2 * \text{Item 2} * \text{Item 6})) * \text{Item 10}$			

4.3.5 Conformance Summary

Complete Form 4.3-9 to demonstrate how on-site LID DCV is met with proposed site design hydrologic source control, infiltration, harvest and use, and/or biotreatment BMP. The bottom line of the form is used to describe the basis for infeasibility determination for on-site LID BMP to achieve full LID DCV, and provides methods for computing remaining volume to be addressed in an alternative compliance plan. If the project has more than one outlet, then complete additional versions of this form for each outlet.

Form 4.3-9 Conformance Summary and Alternative Compliance Volume Estimate (DA 1)	
1	Total LID DCV for the Project DA-1 (ft ³): 61,308 <i>Copy Item 7 in Form 4.2-1</i>
2	On-site retention with site design hydrologic source control LID BMP (ft ³):N/A <i>Copy Item 30 in Form 4.3-2</i>
3	On-site retention with LID infiltration BMP (ft ³): 206,243 <i>Copy Item 16 in Form 4.3-3</i>
4	On-site retention with LID harvest and use BMP (ft ³): N/A <i>Copy Item 9 in Form 4.3-4</i>
5	On-site biotreatment with volume based biotreatment BMP (ft ³): N/A <i>Copy Item 3 in Form 4.3-5</i>
6	Flow capacity provided by flow based biotreatment BMP (cfs): N/A <i>Copy Item 6 in Form 4.3-5</i>
7	<p>LID BMP performance criteria are achieved if answer to any of the following is "Yes":</p> <ul style="list-style-type: none"> • Full retention of LID DCV with site design HSC, infiltration, or harvest and use BMP: Yes <input checked="" type="checkbox"/> No <input type="checkbox"/> <i>If yes, sum of Items 2, 3, and 4 is greater than Item 1</i> • Combination of on-site retention BMPs for a portion of the LID DCV and volume-based biotreatment BMP that address all pollutants of concern for the remaining LID DCV: Yes <input type="checkbox"/> No <input checked="" type="checkbox"/> <i>If yes, a) sum of Items 2, 3, 4, and 5 is greater than Item 1, and Items 2, 3 and 4 are maximized; or b) Item 6 is greater than Form 4.3--5 Item 6 and Items 2, 3 and 4 are maximized</i> ▪ On-site retention and infiltration is determined to be infeasible and biotreatment BMP provide biotreatment for all pollutants of concern for full LID DCV: Yes <input type="checkbox"/> No <input checked="" type="checkbox"/> <i>If yes, Form 4.3-1 Items 7 and 8 were both checked yes</i>
8	<p>If the LID DCV is not achieved by any of these means, then the project may be allowed to develop an alternative compliance plan. Check box that describes the scenario which caused the need for alternative compliance:</p> <ul style="list-style-type: none"> • Combination of HSC, retention and infiltration, harvest and use, and biotreatment BMPs provide less than full LID DCV capture: <input type="checkbox"/> <i>Checked yes for Form 4.3-5 Item 7, Item 6 is zero, and sum of Items 2, 3, 4, and 5 is less than Item 1. If so, apply water quality credits and calculate volume for alternative compliance, $V_{alt} = (Item\ 1 - Item\ 2 - Item\ 3 - Item\ 4 - Item\ 5) * (100 - Form\ 2.4-1\ Item\ 2)\%$</i> • An approved Watershed Action Plan (WAP) demonstrates that water quality and hydrologic impacts of urbanization are more effective when managed in at an off-site facility: <input type="checkbox"/> <i>Attach appropriate WAP section, including technical documentation, showing effectiveness comparisons for the project site and regional watershed</i>

Form 4.3-9 Conformance Summary and Alternative Compliance Volume Estimate (DA 2 & DA 3)

1 Total LID DCV for the Project DA-2&3 (ft³): 65,816 *Copy Item 7 in Form 4.2-1*

2 On-site retention with site design hydrologic source control LID BMP (ft³):N/A *Copy Item 30 in Form 4.3-2*

3 On-site retention with LID infiltration BMP (ft³): 178,030 *Copy Item 16 in Form 4.3-3*

4 On-site retention with LID harvest and use BMP (ft³): N/A *Copy Item 9 in Form 4.3-4*

5 On-site biotreatment with volume based biotreatment BMP (ft³): N/A *Copy Item 3 in Form 4.3-5*

6 Flow capacity provided by flow based biotreatment BMP (cfs): N/A *Copy Item 6 in Form 4.3-5*

7 LID BMP performance criteria are achieved if answer to any of the following is "Yes":

- Full retention of LID DCV with site design HSC, infiltration, or harvest and use BMP: Yes No
If yes, sum of Items 2, 3, and 4 is greater than Item 1
- Combination of on-site retention BMPs for a portion of the LID DCV and volume-based biotreatment BMP that address all pollutants of concern for the remaining LID DCV: Yes No
If yes, a) sum of Items 2, 3, 4, and 5 is greater than Item 1, and Items 2, 3 and 4 are maximized; or b) Item 6 is greater than Form 4.3-5 Item 6 and Items 2, 3 and 4 are maximized
- On-site retention and infiltration is determined to be infeasible and biotreatment BMP provide biotreatment for all pollutants of concern for full LID DCV: Yes No
If yes, Form 4.3-1 Items 7 and 8 were both checked yes

8 If the LID DCV is not achieved by any of these means, then the project may be allowed to develop an alternative compliance plan. Check box that describes the scenario which caused the need for alternative compliance:

- Combination of HSC, retention and infiltration, harvest and use, and biotreatment BMPs provide less than full LID DCV capture:
*Checked yes for Form 4.3-5 Item 7, Item 6 is zero, and sum of Items 2, 3, 4, and 5 is less than Item 1. If so, apply water quality credits and calculate volume for alternative compliance, $V_{alt} = (Item\ 1 - Item\ 2 - Item\ 3 - Item\ 4 - Item\ 5) * (100 - Form\ 2.4-1\ Item\ 2)\%$*
- An approved Watershed Action Plan (WAP) demonstrates that water quality and hydrologic impacts of urbanization are more effective when managed in at an off-site facility:
Attach appropriate WAP section, including technical documentation, showing effectiveness comparisons for the project site and regional watershed

4.3.6 Hydromodification Control BMP

Use Form 4.3-10 to compute the remaining runoff volume retention, after LID BMP are implemented, needed to address HCOC, and the increase in time of concentration and decrease in peak runoff necessary to meet targets for protection of waterbodies with a potential HCOC. Describe hydromodification control BMP that address HCOC, which may include off-site BMP and/or in-stream controls. Section 5.6 of the TGD for WQMP provides additional details on selection and evaluation of hydromodification control BMP.

N/A – Project will not require HCOC BMPs

Form 4.3-10 Hydromodification Control BMPs (DA 1)	
<p>1 Volume reduction needed for HCOC performance criteria (ft³): <i>(Form 4.2-2 Item 4 * 0.95) – Form 4.2-2 Item 1</i></p>	<p>2 On-site retention with site design hydrologic source control, infiltration, and harvest and use LID BMP (ft³): <i>Sum of Form 4.3-9 Items 2, 3, and 4 Evaluate option to increase implementation of on-site retention in Forms 4.3-2, 4.3-3, and 4.3-4 in excess of LID DCV toward achieving HCOC volume reduction</i></p>
<p>3 Remaining volume for HCOC volume capture (ft³): <i>Item 1 – Item 2</i></p>	<p>4 Volume capture provided by incorporating additional on-site or off-site retention BMPs (ft³): <i>Existing downstream BMP may be used to demonstrate additional volume capture (if so, attach to this WQMP a hydrologic analysis showing how the additional volume would be retained during a 2-yr storm event for the regional watershed)</i></p>
<p>5 If Item 4 is less than Item 3, incorporate in-stream controls on downstream waterbody segment to prevent impacts due to hydromodification <input type="checkbox"/> <i>Attach in-stream control BMP selection and evaluation to this WQMP</i></p>	
<p>6 Is Form 4.2-2 Item 11 less than or equal to 5%: Yes <input type="checkbox"/> No <input type="checkbox"/> <i>If yes, HCOC performance criteria is achieved. If no, select one or more mitigation options below:</i></p> <ul style="list-style-type: none"> • Demonstrate increase in time of concentration achieved by proposed LID site design, LID BMP, and additional on-site or off-site retention BMP <input type="checkbox"/> <i>BMP upstream of a waterbody segment with a potential HCOC may be used to demonstrate increased time of concentration through hydrograph attenuation (if so, show that the hydraulic residence time provided in BMP for a 2-year storm event is equal or greater than the addition time of concentration requirement in Form 4.2-4 Item 15)</i> • Increase time of concentration by preserving pre-developed flow path and/or increase travel time by reducing slope and increasing cross-sectional area and roughness for proposed on-site conveyance facilities <input type="checkbox"/> • Incorporate appropriate in-stream controls for downstream waterbody segment to prevent impacts due to hydromodification, in a plan approved and signed by a licensed engineer in the State of California <input type="checkbox"/> 	
<p>7 Form 4.2-2 Item 12 less than or equal to 5%: Yes <input type="checkbox"/> No <input type="checkbox"/> <i>If yes, HCOC performance criteria is achieved. If no, select one or more mitigation options below:</i></p> <ul style="list-style-type: none"> • Demonstrate reduction in peak runoff achieved by proposed LID site design, LID BMPs, and additional on-site or off-site retention BMPs <input type="checkbox"/> <i>BMPs upstream of a waterbody segment with a potential HCOC may be used to demonstrate additional peak runoff reduction through hydrograph attenuation (if so, attach to this WQMP, a hydrograph analysis showing how the peak runoff would be reduced during a 2-yr storm event)</i> • Incorporate appropriate in-stream controls for downstream waterbody segment to prevent impacts due to hydromodification, in a plan approved and signed by a licensed engineer in the State of California <input type="checkbox"/> 	

4.4 Alternative Compliance Plan (if applicable)

Describe an alternative compliance plan (if applicable) for projects not fully able to infiltrate, harvest and use, or biotreat the DCV via on-site LID practices. A project proponent must develop an alternative compliance plan to address the remainder of the LID DCV. Depending on project type some projects may qualify for water quality credits that can be applied to reduce the DCV that must be treated prior to development of an alternative compliance plan (see Form 2.4-1, Water Quality Credits). Form 4.3-9 Item 8 includes instructions on how to apply water quality credits when computing the DCV that must be met through alternative compliance. Alternative compliance plans may include one or more of the following elements:

- On-site structural treatment control BMP - All treatment control BMP should be located as close to possible to the pollutant sources and should not be located within receiving waters;
- Off-site structural treatment control BMP - Pollutant removal should occur prior to discharge of runoff to receiving waters;
- Urban runoff fund or In-lieu program, if available

Depending upon the proposed alternative compliance plan, approval by the executive officer may or may not be required (see Section 6 of the TGD for WQMP).

Section 5 Inspection and Maintenance Responsibility for Post Construction BMP

Form 5-1 BMP Inspection and Maintenance (use additional forms as necessary)			
BMP	Reponsible Party(s)	Inspection/ Maintenance Activities Required	Minimum Frequency of Activities
Above Ground and Subsurface Infiltration Basins	Property Owner	Check for ponding water longer than 72 hours, inspect outlet structure and fix if necessary, mow/maintain vegetation, remove litter and debris, stabilize eroded banks if necessary, remove sediment volume when volume has been reduced by 10%.	Bi-annually or after storm event
Trash Receptacles	Property Owner	Receptacle lids to remain closed. Add stencil "No Dumping Hazardous Materials" or similar on receptacles.	As Needed
Private Parking Lot Sweeping	Property Owner	Sweeping of parking lots.	Biweekly
Catch Basins	Property Owner	Inspect catch basins, remove trash and debris.	Bi-annually or after storm event
Catch Basin Stenciling	Property Owner	Check that signage is visible. Remove and replace stenciling if illegible or broken. Remove graffiti.	Minimum of twice annually, or as needed
Loading Docks	Property Owner/ POA	Sweep and clear debris from dock areas to remove potential stormwater contaminants.	Monthly
Landscape Maintenance	Property Owner/ POA	Maintain landscape area vegetation, slope protection and 1" - 2" depressed grades, adjacent to hardscape and prevent discharges of landscape maintenance waste into storm drains	Weekly
N1 Education for Property Owners, Tenants, and Occupants	Property Owner/ POA	The current property owner/POA shall be familiar with the contents of the WQMP and the County & City Ordinance and brochures and furnish copies of city and County BMP factsheets to all future property owners.	Education reference material to be onsite at all times
N2 Activity Restrictions	Property Owner/ POA	Property owners and their tenants or occupants shall not be allowed to discharge chemicals, chemical residues, wastewater or other prohibited discharges listed in the City stormwater Ordinance, to the outside, paved areas of the site; or store chemicals or other pollutant sources in a non-spill contained or covered facilities as stipulated in the CC&Rs	As needed

N3 Landscape Management	Property Owner/ POA	The POA and their landscape maintenance contractor shall inspect the irrigation system plant health and erosion problems after each landscape procedure and shall report all repairs and problems to the POA. All routine landscaping maintenance.	Weekly
N4 BMP Maintenance	Property Owner/ POA	The POA shall inspect for standing water in the water retention/infiltration basins, 48 hours after storm events. BMP maintenance shall be performed per the schedule in Form 5-1, as needed to restore free drainage.	After storm events
N10 Uniform Fire Code Implementation	Property Owner/ POA	The current owners or the future POA shall require all fire code requirements to be implemented at this project site.	On-going
N11 Litter Control	Property Owner/ POA	The property owners, POA and their contractor shall pick up litter and sweep and clean the existing trash enclosure weekly. The trash enclosure is designed to divert all flows around the dumpsters and shall be roofed. The HOA shall contract with a refuse company to have the dumpsters emptied on a weekly basis, at a minimum.	Quickly
N14 Catch Basin Inspection	Property Owner/ POA	The on-site catch basins shall be inspected monthly during the rainy season (October-May) and before and after each storm to ensure proper operation. The HOA shall contract with a qualified landscape contractor to inspect and clean out accumulation of trash, litter and sediment and check for evidence of illegal dumping of waste materials into on-site drains.	Monthly from October to May, Before and After Storm Events
N15 Vacuum Sweeping of Private Streets and Parking Lots	Property Owner/ POA	The paved areas and common open areas of the project site shall be swept and cleaned weekly by the POA's contractor.	Biweekly
S3 Design and Construct Outdoor Material Storage Areas to Reduce Pollution Introduction	Property Owner/ POA	Stormwater flows are diverted away from the trash enclosure. All dumpsters shall have working lids which shall be kept closed at all times. Trash enclosure shall comply with CASQA SD-32 and shall have doors and a solid roof.	As needed
S4 Use Efficient Irrigation Systems & Landscape Design, Water Conservation, Smart Controllers, and Source Control	Property Owner/ POA	The irrigation system will include devices to prevent low head drainage, overspray and run off using pressure regulating devices, check valves, rain shutoff valves, flow sensors, pressure drop sensors, proper spacing, low precipitation emission devices and ET or weather-based controllers. Landscape and irrigation shall be consistent with the State Model Water Efficient Landscape Ordinance and the City of Ontario landscape Development Standards. Plants installed will be arranged according to similar hydrozones and meet the required water budget for the site. Shade trees shall be used to intercept rainwater and reduce heat gain on paving.	Inspect weekly
S5 Finish Grade of Landscaped Areas	Property Owner/ POA	All landscaped areas shall comply with depressed grading requirements by finish grading to a minimum of 1" below pavement grades or top-of-curb.	Inspect weekly

Section 6 WQMP Attachments

6.1 Site Plan and Drainage Plan

Include a site plan and drainage plan sheet set containing the following minimum information:

- Project location
- Site boundary
- Land uses and land covers, as applicable
- Suitability/feasibility constraints
- Structural Source Control BMP locations
- Site Design Hydrologic Source Control BMP locations
- LID BMP details
- Drainage delineations and flow information
- Drainage connections

6.2 Electronic Data Submittal

An electronic submittal of the Report and PDF Exhibits can be found on the included CD in the binder sleeve.

6.3 Post Construction

O&M Plans and Maintenance Agreements for BMPs can be found in the binder sleeve.

6.4 Other Supporting Documentation

- 6.4.1 - BMP Design Details
- 6.4.2 - Conceptual Grading Plans
- 6.4.3 - DCV and Factor of Safety Calculations
- 6.4.4 - USDA Soil Report
- 6.4.5 - NOAA Precipitation Estimates
- 6.4.6 - BMP Educational Materials/Fact Sheets

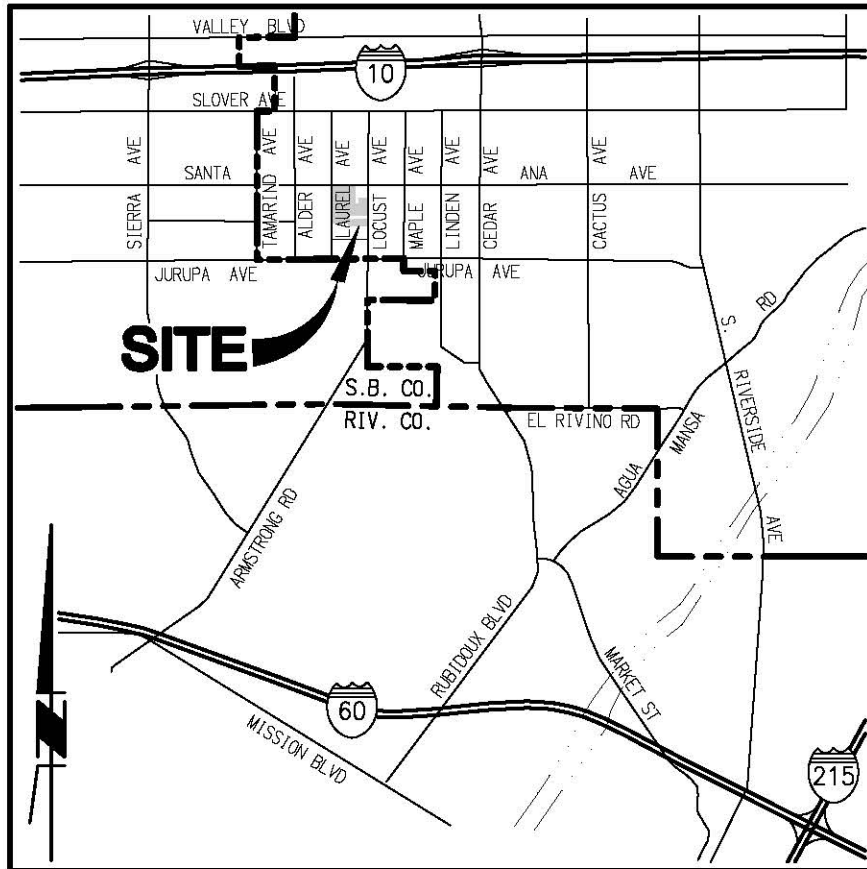

VICINITY MAP

T01S, R05W, SEC. 28
NOT TO SCALE

FMCIVIL
ENGINEERS INC.

29995 TECHNOLOGY DRIVE, SUITE
306 | MURRIETA | CA 92563
951.973.0201 - FMCIVIL.COM

BLOOMINGTON BUSINESS PARK SP8

**FIGURE 1
VICINITY MAP**

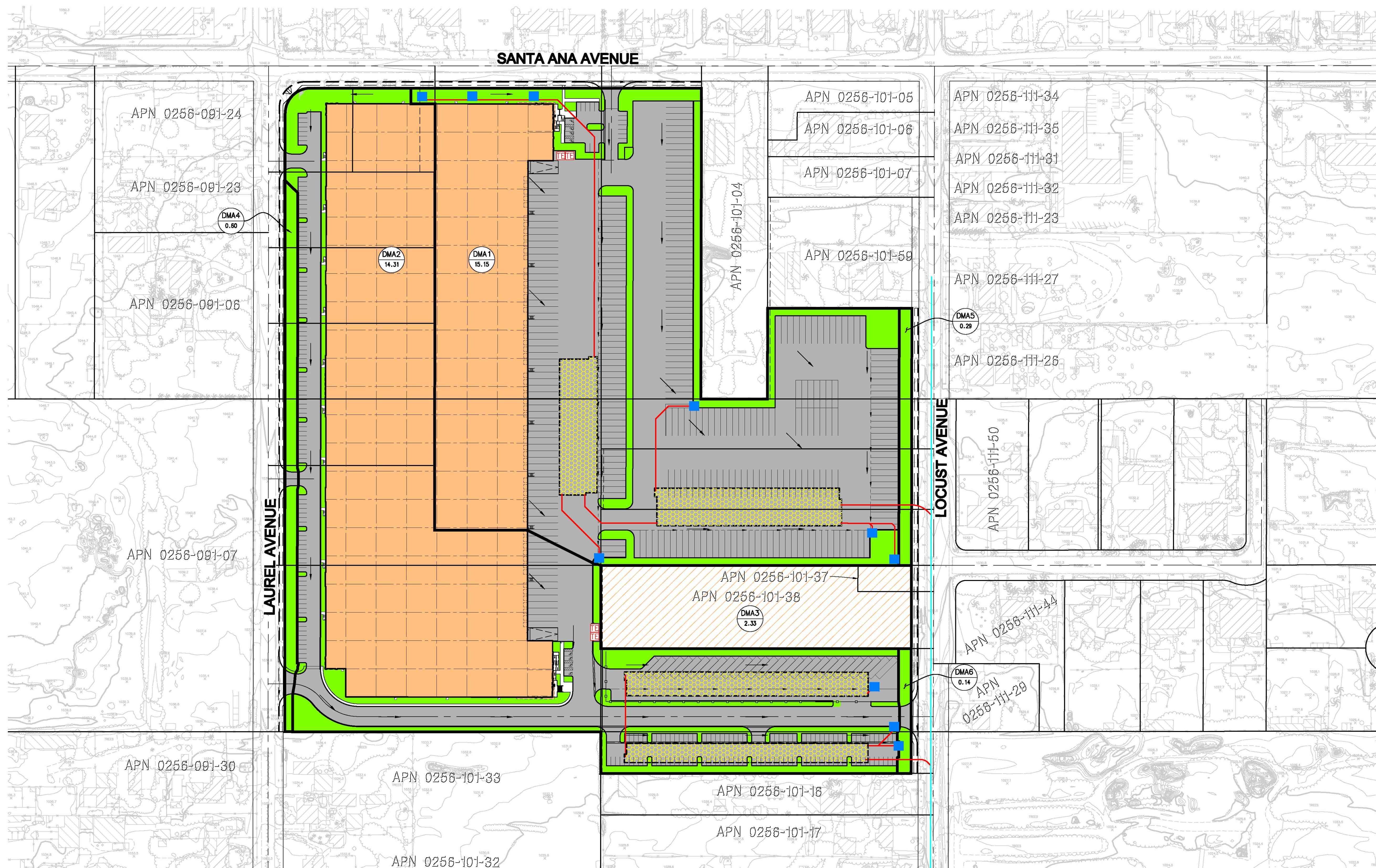

LEGEND

- DMA1 DA AREA NUMBER
- 3.38 AREA IN ACRES
- LANDSCAPE AREA
- PERVIOUS SLOPED AREA
- PROPOSED CONCRETE DRIVE AISLE & PARKING AREAS
- PROPOSED ROOFTOP
- FUTURE IMPERVIOUS AREA
- PROPOSED HARDSCAPE AREA
- UNDERGROUND INFILTRATION (SEE PLANS ATTACHED IN SECTION 6.4.1)
- DRAIN INLET STENCIL
- DMA BOUNDARY
- PROPOSED STORM DRAIN
- FUTURE STORM DRAIN (BY OTHERS)
- EXIST. PROPERTY LINE
- DIRECTION OF FLOW
- TE TRASH ENCLOSURE

DMA	TOTAL	PERVIOUS	IMPERVIOUS	% PERVIOUS	% IMPERVIOUS	C _{imp}	P _a	DCV	DRAWDOWN	STORAGE VOLUME PROVIDED
DA 1	659,807 SF	63,262 SF	596,545 SF	9.6%	90.4%	0.7363	0.7714	61,308 CF	48 HR	206,243 CF
DA 2	623,538 SF	79,638 SF	543,900 SF	12.8%	87.2%	0.6911	0.7714	54,382 CF	48 HR	178,030 CF (SHARED WITH DA 3)
DA 3	101,574 SF	0 SF	101,574 SF	0.0%	100.0%	0.8920	0.7714	11,434 CF	48 HR	178,030 CF (SHARED WITH DA 2)
DA 4	25,904 SF	24,312 SF	1,592 SF	93.9%	6.1%	---	---	---	---	---
DA 5	12,745 SF	12,745 SF	0 SF	100.0%	0.0%	---	---	---	---	---
DA 6	6,202 SF	5,156 SF	1,046 SF	83.2%	16.8%	---	---	---	---	---

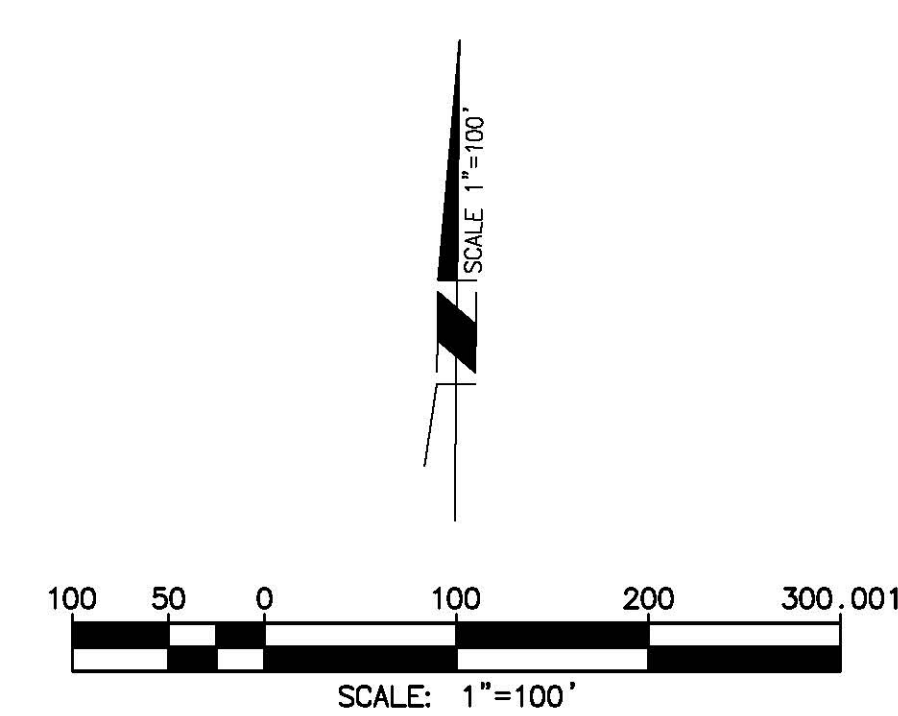

SECTION 6.4.1
BMP DESIGN DETAILS

PROJECT INFORMATION	
ENGINEERED PRODUCT MANAGER	
ADS SALES REP	
PROJECT NO.	



ADVANCED DRAINAGE SYSTEMS, INC.



DA 1 EAST, BLOOMINGTON SITE 3 SCHEME 1

BLOOMINGTON, CA

MC-4500 STORMTECH CHAMBER SPECIFICATIONS

- CHAMBERS SHALL BE STORMTECH MC-4500.
- CHAMBERS SHALL BE ARCH-SHAPED AND SHALL BE MANUFACTURED FROM VIRGIN, IMPACT-MODIFIED POLYPROPYLENE COPOLYMERS.
- CHAMBERS SHALL MEET THE REQUIREMENTS OF ASTM F2418-16a, "STANDARD SPECIFICATION FOR POLYPROPYLENE (PP) CORRUGATED WALL STORMWATER COLLECTION CHAMBERS" CHAMBER CLASSIFICATION 60x101.
- CHAMBER ROWS SHALL PROVIDE CONTINUOUS, UNOBSTRUCTED INTERNAL SPACE WITH NO INTERNAL SUPPORTS THAT WOULD IMPEDE FLOW OR LIMIT ACCESS FOR INSPECTION.
- THE STRUCTURAL DESIGN OF THE CHAMBERS, THE STRUCTURAL BACKFILL, AND THE INSTALLATION REQUIREMENTS SHALL ENSURE THAT THE LOAD FACTORS SPECIFIED IN THE AASHTO LRFD BRIDGE DESIGN SPECIFICATIONS, SECTION 12.12, ARE MET FOR: 1) LONG-DURATION DEAD LOADS AND 2) SHORT-DURATION LIVE LOADS, BASED ON THE AASHTO DESIGN TRUCK WITH CONSIDERATION FOR IMPACT AND MULTIPLE VEHICLE PRESENCES.
- CHAMBERS SHALL BE DESIGNED, TESTED AND ALLOWABLE LOAD CONFIGURATIONS DETERMINED IN ACCORDANCE WITH ASTM F2787, "STANDARD PRACTICE FOR STRUCTURAL DESIGN OF THERMOPLASTIC CORRUGATED WALL STORMWATER COLLECTION CHAMBERS". LOAD CONFIGURATIONS SHALL INCLUDE: 1) INSTANTANEOUS (<1 MIN) AASHTO DESIGN TRUCK LIVE LOAD ON MINIMUM COVER 2) MAXIMUM PERMANENT (75-YR) COVER LOAD AND 3) ALLOWABLE COVER WITH PARKED (1-WEEK) AASHTO DESIGN TRUCK.
- REQUIREMENTS FOR HANDLING AND INSTALLATION:
 - TO MAINTAIN THE WIDTH OF CHAMBERS DURING SHIPPING AND HANDLING, CHAMBERS SHALL HAVE INTEGRAL, INTERLOCKING STACKING LUGS.
 - TO ENSURE A SECURE JOINT DURING INSTALLATION AND BACKFILL, THE HEIGHT OF THE CHAMBER JOINT SHALL NOT BE LESS THAN 3".
 - TO ENSURE THE INTEGRITY OF THE ARCH SHAPE DURING INSTALLATION, a) THE ARCH STIFFNESS CONSTANT AS DEFINED IN SECTION 6.2.8 OF ASTM F2418 SHALL BE GREATER THAN OR EQUAL TO 500 LBS/IN/IN. AND b) TO RESIST CHAMBER DEFORMATION DURING INSTALLATION AT ELEVATED TEMPERATURES (ABOVE 73° F / 23° C), CHAMBERS SHALL BE PRODUCED FROM REFLECTIVE GOLD OR YELLOW COLORS.
- ONLY CHAMBERS THAT ARE APPROVED BY THE SITE DESIGN ENGINEER WILL BE ALLOWED. UPON REQUEST BY THE SITE DESIGN ENGINEER OR OWNER, THE CHAMBER MANUFACTURER SHALL SUBMIT A STRUCTURAL EVALUATION FOR APPROVAL BEFORE DELIVERING CHAMBERS TO THE PROJECT SITE AS FOLLOWS:
 - THE STRUCTURAL EVALUATION SHALL BE SEALED BY A REGISTERED PROFESSIONAL ENGINEER.
 - THE STRUCTURAL EVALUATION SHALL DEMONSTRATE THAT THE SAFETY FACTORS ARE GREATER THAN OR EQUAL TO 1.95 FOR DEAD LOAD AND 1.75 FOR LIVE LOAD, THE MINIMUM REQUIRED BY ASTM F2787 AND BY SECTIONS 3 AND 12.12 OF THE AASHTO LRFD BRIDGE DESIGN SPECIFICATIONS FOR THERMOPLASTIC PIPE.
 - THE TEST DERIVED CREEP MODULUS AS SPECIFIED IN ASTM F2418 SHALL BE USED FOR PERMANENT DEAD LOAD DESIGN EXCEPT THAT IT SHALL BE THE 75-YEAR MODULUS USED FOR DESIGN.
- CHAMBERS AND END CAPS SHALL BE PRODUCED AT AN ISO 9001 CERTIFIED MANUFACTURING FACILITY.

IMPORTANT - NOTES FOR THE BIDDING AND INSTALLATION OF MC-4500 CHAMBER SYSTEM

- STORMTECH MC-4500 CHAMBERS SHALL NOT BE INSTALLED UNTIL THE MANUFACTURER'S REPRESENTATIVE HAS COMPLETED A PRE-CONSTRUCTION MEETING WITH THE INSTALLERS.
- STORMTECH MC-4500 CHAMBERS SHALL BE INSTALLED IN ACCORDANCE WITH THE "STORMTECH MC-3500/MC-4500 CONSTRUCTION GUIDE".
- CHAMBERS ARE NOT TO BE BACKFILLED WITH A DOZER OR EXCAVATOR SITUATED OVER THE CHAMBERS. STORMTECH RECOMMENDS 3 BACKFILL METHODS:
 - STONESHOOTER LOCATED OFF THE CHAMBER BED.
 - BACKFILL AS ROWS ARE BUILT USING AN EXCAVATOR ON THE FOUNDATION STONE OR SUBGRADE.
 - BACKFILL FROM OUTSIDE THE EXCAVATION USING A LONG BOOM HOE OR EXCAVATOR.
- THE FOUNDATION STONE SHALL BE LEVELED AND COMPACTED PRIOR TO PLACING CHAMBERS.
- JOINTS BETWEEN CHAMBERS SHALL BE PROPERLY SEATED PRIOR TO PLACING STONE.
- MAINTAIN MINIMUM 9" (230 mm) SPACING BETWEEN THE CHAMBER ROWS.
- INLET AND OUTLET MANIFOLDS MUST BE INSERTED A MINIMUM OF 12" (300 mm) INTO CHAMBER END CAPS.
- EMBEDMENT STONE SURROUNDING CHAMBERS MUST BE A CLEAN, CRUSHED, ANGULAR STONE MEETING THE AASHTO M43 DESIGNATION OF #3 OR #4.
- STONE SHALL BE BROUGHT UP EVENLY AROUND CHAMBERS SO AS NOT TO DISTORT THE CHAMBER SHAPE. STONE DEPTHS SHOULD NEVER DIFFER BY MORE THAN 12" (300 mm) BETWEEN ADJACENT CHAMBER ROWS.
- STONE MUST BE PLACED ON THE TOP CENTER OF THE CHAMBER TO ANCHOR THE CHAMBERS IN PLACE AND PRESERVE ROW SPACING.
- THE CONTRACTOR MUST REPORT ANY DISCREPANCIES WITH CHAMBER FOUNDATION MATERIAL BEARING CAPACITIES TO THE SITE DESIGN ENGINEER.
- ADS RECOMMENDS THE USE OF "FLEXSTORM CATCH IT" INSERTS DURING CONSTRUCTION FOR ALL INLETS TO PROTECT THE SUBSURFACE STORMWATER MANAGEMENT SYSTEM FROM CONSTRUCTION SITE RUNOFF.

NOTES FOR CONSTRUCTION EQUIPMENT

- STORMTECH MC-4500 CHAMBERS SHALL BE INSTALLED IN ACCORDANCE WITH THE "STORMTECH MC-3500/MC-4500 CONSTRUCTION GUIDE".
- THE USE OF EQUIPMENT OVER MC-4500 CHAMBERS IS LIMITED:
 - NO EQUIPMENT IS ALLOWED ON BARE CHAMBERS.
 - NO RUBBER Tired LOADER, DUMP TRUCK, OR EXCAVATORS ARE ALLOWED UNTIL PROPER FILL DEPTHS ARE REACHED IN ACCORDANCE WITH THE "STORMTECH MC-3500/MC-4500 CONSTRUCTION GUIDE".
 - WEIGHT LIMITS FOR CONSTRUCTION EQUIPMENT CAN BE FOUND IN THE "STORMTECH MC-3500/MC-4500 CONSTRUCTION GUIDE".
- FULL 36" (900 mm) OF STABILIZED COVER MATERIALS OVER THE CHAMBERS IS REQUIRED FOR DUMP TRUCK TRAVEL OR DUMPING.

USE OF A DOZER TO PUSH EMBEDMENT STONE BETWEEN THE ROWS OF CHAMBERS MAY CAUSE DAMAGE TO CHAMBERS AND IS NOT AN ACCEPTABLE BACKFILL METHOD. ANY CHAMBERS DAMAGED BY USING THE "DUMP AND PUSH" METHOD ARE NOT COVERED UNDER THE STORMTECH STANDARD WARRANTY.

CONTACT STORMTECH AT 1-888-892-2694 WITH ANY QUESTIONS ON INSTALLATION REQUIREMENTS OR WEIGHT LIMITS FOR CONSTRUCTION EQUIPMENT.

PROPOSED LAYOUT		CONCEPTUAL ELEVATIONS		*INVERT ABOVE BASE OF CHAMBER				
				PART TYPE	ITEM ON LAYOUT	DESCRIPTION	INVERT*	MAX FLOW
704	STORMTECH MC-4500 CHAMBERS	MAXIMUM ALLOWABLE GRADE (TOP OF PAVEMENT/UNPAVED):	12.75					
16	STORMTECH MC-4500 END CAPS	MINIMUM ALLOWABLE GRADE (UNPAVED WITH TRAFFIC):	8.25					
12	STONE ABOVE (in)	MINIMUM ALLOWABLE GRADE (UNPAVED NO TRAFFIC):	7.75	PREFABRICATED END CAP	A	24" BOTTOM PARTIAL CUT END CAP, PART#: MC4500IEPP24B / TYP OF ALL 24" BOTTOM CONNECTIONS AND ISOLATOR PLUS ROWS	2.26"	
9	STONE BELOW (in)	MINIMUM ALLOWABLE GRADE (TOP OF RIGID CONCRETE PAVEMENT):	7.75	FLAMP	B	INSTALL FLAMP ON 24" ACCESS PIPE / PART#: MC450024RAMP		
40	STONE VOID	MINIMUM ALLOWABLE GRADE (BASE OF FLEXIBLE PAVEMENT):	7.75	MANIFOLD	C	24" x 24" BOTTOM MANIFOLD, ADS N-12	2.26"	
118974	INSTALLED SYSTEM VOLUME (CF) (PERIMETER STONE INCLUDED) (COVER STONE INCLUDED) (BASE STONE INCLUDED)	TOP OF STONE:	6.75	MANIFOLD	D	24" x 24" BOTTOM MANIFOLD, ADS N-12	2.26"	
		TOP OF MC-4500 CHAMBER:	5.75	CONCRETE STRUCTURE	E	OCS (DESIGN BY ENGINEER / PROVIDED BY OTHERS)		14.0 CFS OUT
		24" x 24" BOTTOM MANIFOLD INVERT:	0.94	CONCRETE STRUCTURE	F	(DESIGN BY ENGINEER / PROVIDED BY OTHERS)		41.5 CFS IN
		24" x 24" BOTTOM MANIFOLD INVERT:	0.94	W/WEIR				
27262	SYSTEM AREA (SF)	24" ISOLATOR ROW PLUS INVERT:	0.94	UNDERDRAIN	G	6" ADS N-12 DUAL WALL PERFORATED HDPE UNDERDRAIN		
890.3	SYSTEM PERIMETER (ft)	24" BOTTOM CONNECTION INVERT:	0.94					
		BOTTOM OF MC-4500 CHAMBER:	0.75					
		UNDERDRAIN INVERT:	0.00					
		BOTTOM OF STONE:	0.00					

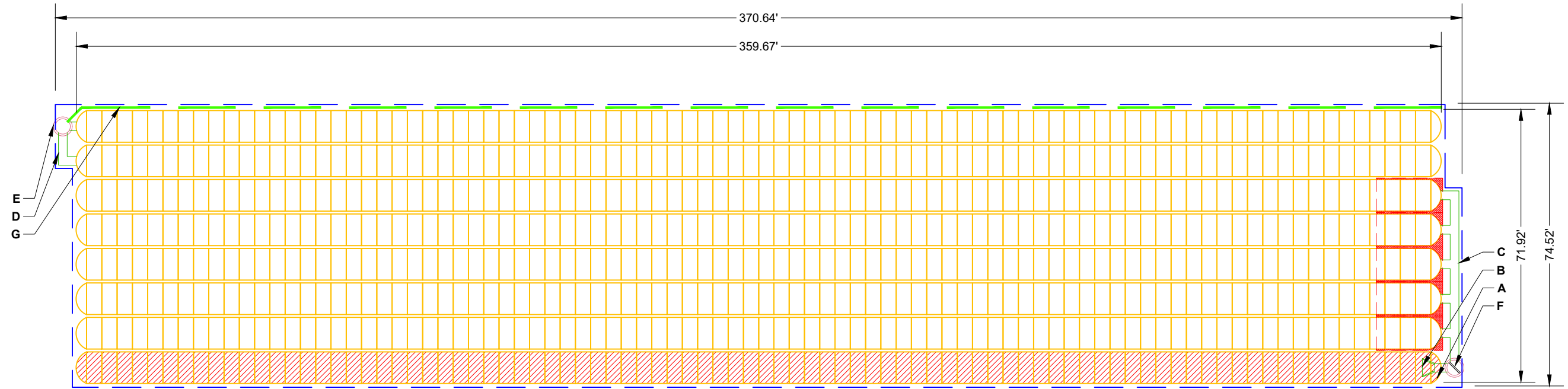

- ISOLATOR ROW PLUS (SEE DETAIL)
- PLACE MINIMUM 17.50' OF ADSPLUS175 WOVEN GEOTEXTILE OVER BEDDING STONE AND UNDERNEATH CHAMBER FEET FOR SCOUR PROTECTION AT ALL CHAMBER INLET ROWS
- BED LIMITS

NOTES

- MANIFOLD SIZE TO BE DETERMINED BY SITE DESIGN ENGINEER. SEE TECH NOTE #6.32 FOR MANIFOLD SIZING GUIDANCE.
- DUE TO THE ADAPTATION OF THIS CHAMBER SYSTEM TO SPECIFIC SITE AND DESIGN CONSTRAINTS, IT MAY BE NECESSARY TO CUT AND COUPLE ADDITIONAL PIPE TO STANDARD MANIFOLD COMPONENTS IN THE FIELD.
- THE SITE DESIGN ENGINEER MUST REVIEW ELEVATIONS AND IF NECESSARY ADJUST GRADING TO ENSURE THE CHAMBER COVER REQUIREMENTS ARE MET.
- THIS CHAMBER SYSTEM WAS DESIGNED WITHOUT SITE-SPECIFIC INFORMATION ON SOIL CONDITIONS OR BEARING CAPACITY. THE SITE DESIGN ENGINEER IS RESPONSIBLE FOR DETERMINING THE SUITABILITY OF THE SOIL AND PROVIDING THE BEARING CAPACITY OF THE INSITU SOILS. THE BASE STONE DEPTH MAY BE INCREASED OR DECREASED ONCE THIS INFORMATION IS PROVIDED.
- **NOT FOR CONSTRUCTION:** THIS LAYOUT IS FOR DIMENSIONAL PURPOSES ONLY TO PROVE CONCEPT & THE REQUIRED STORAGE VOLUME CAN BE ACHIEVED ON SITE.

DA 1 EAST, BLOOMINGTON SITE 3
 SCHEME 1
 BLOOMINGTON, CA
 DATE: 12/7/2020
 PROJECT #:

REV	DRW	CHK	DESCRIPTION

DRAWN: HP
 CHECKED: N/A

520 CROMWELL AVENUE | ROCKY HILL | CT | 06067
 860-528-8188 | 888-892-2894 | WWW.STORMTECH.COM

4840 TRUEMAN BLVD
 HILLIARD, OH 43026
 1-800-733-7473
 ADVANCED DRAINAGE SYSTEMS, INC.

THIS DRAWING HAS BEEN PREPARED BASED ON INFORMATION PROVIDED TO ADS UNDER THE DIRECTION OF THE SITE DESIGN ENGINEER OR OTHER PROJECT REPRESENTATIVE. THE SITE DESIGN ENGINEER SHALL REVIEW THIS DRAWING PRIOR TO CONSTRUCTION. IT IS THE ULTIMATE RESPONSIBILITY OF THE SITE DESIGN ENGINEER TO ENSURE THAT THE PRODUCT(S) DEPICTED AND ALL ASSOCIATED DETAILS MEET ALL APPLICABLE LAWS, REGULATIONS, AND PROJECT REQUIREMENTS.

SHEET
2 OF 5

ACCEPTABLE FILL MATERIALS: STORMTECH MC-4500 CHAMBER SYSTEMS

MATERIAL LOCATION		DESCRIPTION	AASHTO MATERIAL CLASSIFICATIONS	COMPACTION / DENSITY REQUIREMENT
D	FINAL FILL: FILL MATERIAL FOR LAYER 'D' STARTS FROM THE TOP OF THE 'C' LAYER TO THE BOTTOM OF FLEXIBLE PAVEMENT OR UNPAVED FINISHED GRADE ABOVE. NOTE THAT PAVEMENT SUBBASE MAY BE PART OF THE 'D' LAYER	ANY SOIL/ROCK MATERIALS, NATIVE SOILS, OR PER ENGINEER'S PLANS. CHECK PLANS FOR PAVEMENT SUBGRADE REQUIREMENTS.	N/A	PREPARE PER SITE DESIGN ENGINEER'S PLANS. PAVED INSTALLATIONS MAY HAVE STRINGENT MATERIAL AND PREPARATION REQUIREMENTS.
C	INITIAL FILL: FILL MATERIAL FOR LAYER 'C' STARTS FROM THE TOP OF THE EMBEDMENT STONE ('B' LAYER) TO 24" (600 mm) ABOVE THE TOP OF THE CHAMBER. NOTE THAT PAVEMENT SUBBASE MAY BE A PART OF THE 'C' LAYER.	GRANULAR WELL-GRADED SOIL/AGGREGATE MIXTURES, <35% FINES OR PROCESSED AGGREGATE. MOST PAVEMENT SUBBASE MATERIALS CAN BE USED IN LIEU OF THIS LAYER.	AASHTO M145 ¹ A-1, A-2-4, A-3 OR AASHTO M43 ¹ 3, 357, 4, 467, 5, 56, 57, 6, 67, 68, 7, 78, 8, 89, 9, 10	BEGIN COMPACTIONS AFTER 24" (600 mm) OF MATERIAL OVER THE CHAMBERS IS REACHED. COMPACT ADDITIONAL LAYERS IN 12" (300 mm) MAX LIFTS TO A MIN. 95% PROCTOR DENSITY FOR WELL GRADED MATERIAL AND 95% RELATIVE DENSITY FOR PROCESSED AGGREGATE MATERIALS.
B	EMBEDMENT STONE: FILL SURROUNDING THE CHAMBERS FROM THE FOUNDATION STONE ('A' LAYER) TO THE 'C' LAYER ABOVE.	CLEAN, CRUSHED, ANGULAR STONE	AASHTO M43 ¹ 3, 4	NO COMPACTION REQUIRED.
A	FOUNDATION STONE: FILL BELOW CHAMBERS FROM THE SUBGRADE UP TO THE FOOT (BOTTOM) OF THE CHAMBER.	CLEAN, CRUSHED, ANGULAR STONE	AASHTO M43 ¹ 3, 4	PLATE COMPACT OR ROLL TO ACHIEVE A FLAT SURFACE. ^{2,3}

PLEASE NOTE:

- THE LISTED AASHTO DESIGNATIONS ARE FOR GRADATIONS ONLY. THE STONE MUST ALSO BE CLEAN, CRUSHED, ANGULAR. FOR EXAMPLE, A SPECIFICATION FOR #4 STONE WOULD STATE: "CLEAN, CRUSHED, ANGULAR NO. 4 (AASHTO M43) STONE".
- STORMTECH COMPACTION REQUIREMENTS ARE MET FOR 'A' LOCATION MATERIALS WHEN PLACED AND COMPACTED IN 9" (230 mm) (MAX) LIFTS USING TWO FULL COVERAGES WITH A VIBRATORY COMPACTOR.
- WHERE INFILTRATION SURFACES MAY BE COMPROMISED BY COMPACTION, FOR STANDARD DESIGN LOAD CONDITIONS, A FLAT SURFACE MAY BE ACHIEVED BY RAKING OR DRAGGING WITHOUT COMPACTION EQUIPMENT. FOR SPECIAL LOAD DESIGNS, CONTACT STORMTECH FOR COMPACTION REQUIREMENTS.
- ONCE LAYER 'C' IS PLACED, ANY SOIL/MATERIAL CAN BE PLACED IN LAYER 'D' UP TO THE FINISHED GRADE. MOST PAVEMENT SUBBASE SOILS CAN BE USED TO REPLACE THE MATERIAL REQUIREMENTS OF LAYER 'C' OR 'D' AT THE SITE DESIGN ENGINEER'S DISCRETION.

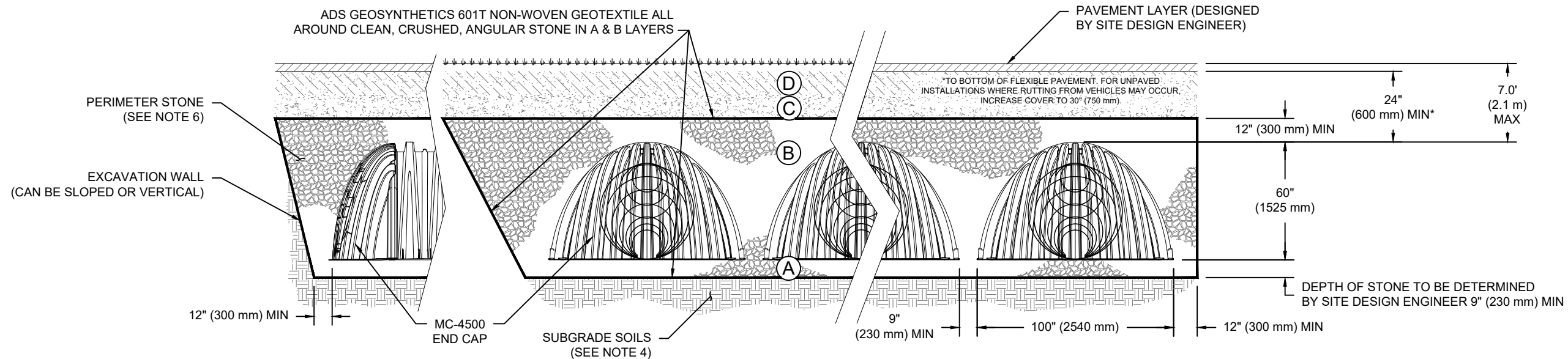

NOTES:

- CHAMBERS SHALL MEET THE REQUIREMENTS OF ASTM F2418-16a, "STANDARD SPECIFICATION FOR POLYPROPYLENE (PP) CORRUGATED WALL STORMWATER COLLECTION CHAMBERS" CHAMBER CLASSIFICATION 60x101
- MC-4500 CHAMBERS SHALL BE DESIGNED IN ACCORDANCE WITH ASTM F2787 "STANDARD PRACTICE FOR STRUCTURAL DESIGN OF THERMOPLASTIC CORRUGATED WALL STORMWATER COLLECTION CHAMBERS".
- THE SITE DESIGN ENGINEER IS RESPONSIBLE FOR ASSESSING THE BEARING RESISTANCE (ALLOWABLE BEARING CAPACITY) OF THE SUBGRADE SOILS AND THE DEPTH OF FOUNDATION STONE WITH CONSIDERATION FOR THE RANGE OF EXPECTED SOIL MOISTURE CONDITIONS.
- PERIMETER STONE MUST BE EXTENDED HORIZONTALLY TO THE EXCAVATION WALL FOR BOTH VERTICAL AND SLOPED EXCAVATION WALLS.
- REQUIREMENTS FOR HANDLING AND INSTALLATION:
 - TO MAINTAIN THE WIDTH OF CHAMBERS DURING SHIPPING AND HANDLING, CHAMBERS SHALL HAVE INTEGRAL, INTERLOCKING STACKING LUGS.
 - TO ENSURE A SECURE JOINT DURING INSTALLATION AND BACKFILL, THE HEIGHT OF THE CHAMBER JOINT SHALL NOT BE LESS THAN 3".
 - TO ENSURE THE INTEGRITY OF THE ARCH SHAPE DURING INSTALLATION, a) THE ARCH STIFFNESS CONSTANT AS DEFINED IN SECTION 6.2.8 OF ASTM F2418 SHALL BE GREATER THAN OR EQUAL TO 500 LBS/IN/IN. AND b) TO RESIST CHAMBER DEFORMATION DURING INSTALLATION AT ELEVATED TEMPERATURES (ABOVE 73° F / 23° C), CHAMBERS SHALL BE PRODUCED FROM REFLECTIVE GOLD OR YELLOW COLORS.

DA 1 EAST, BLOOMINGTON SITE 3
 SCHEME 1
 BLOOMINGTON, CA
 DATE: 12/7/2020
 DRAWN: HP
 PROJECT #:
 CHECKED: N/A

DESCRIPTION
 REV
 DRW
 CHK

StormTech
 Determination • Retention • Water Quality
 520 CROMWELL AVENUE | ROCKY HILL | CT | 06067
 860-529-8188 | 888-892-2894 | WWW.STORMTECH.COM

4840 TRUEMAN BLVD
 HILLIARD, OH 43026
 1-800-733-7473
ADS
 ADVANCED DRAINAGE SYSTEMS, INC.

THIS DRAWING HAS BEEN PREPARED BASED ON INFORMATION PROVIDED TO ADS UNDER THE DIRECTION OF THE SITE DESIGN ENGINEER OR OTHER PROJECT REPRESENTATIVE. THE SITE DESIGN ENGINEER SHALL REVIEW THIS DRAWING PRIOR TO CONSTRUCTION. IT IS THE ULTIMATE RESPONSIBILITY OF THE SITE DESIGN ENGINEER TO ENSURE THAT THE PRODUCT(S) DEPICTED AND ALL ASSOCIATED DETAILS MEET ALL APPLICABLE LAWS, REGULATIONS, AND PROJECT REQUIREMENTS.

SHEET
3 OF 5

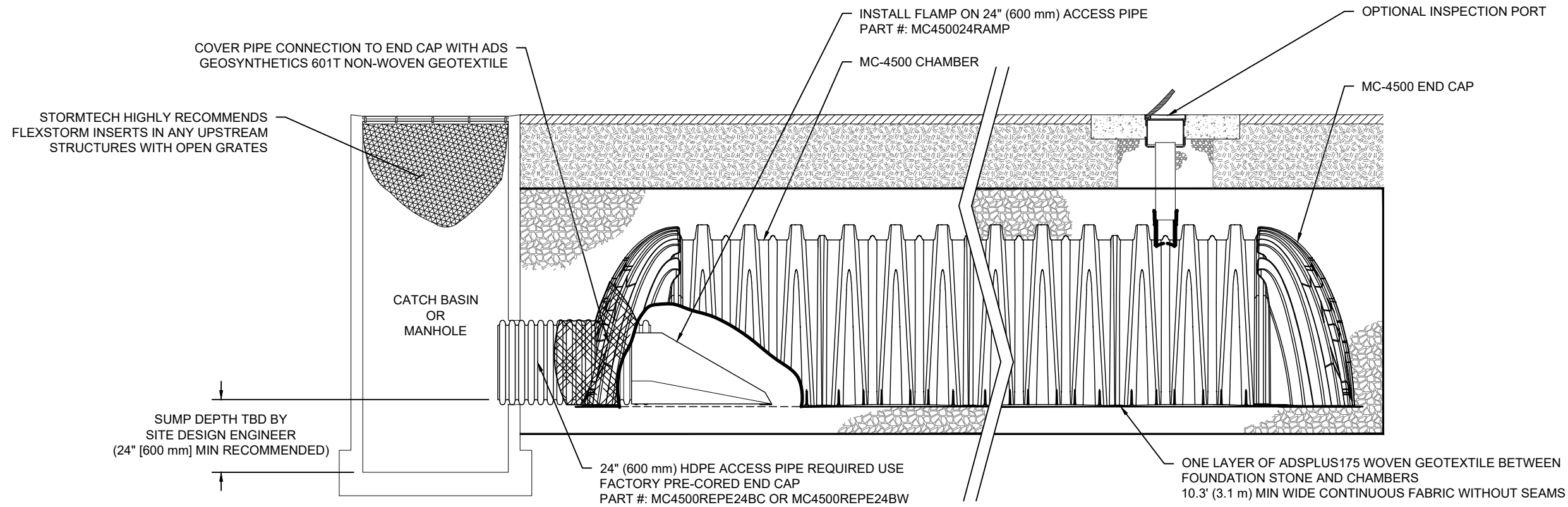

MC-4500 ISOLATOR ROW PLUS DETAIL
NTS

INSPECTION & MAINTENANCE

- STEP 1) INSPECT ISOLATOR ROW PLUS FOR SEDIMENT
- A. INSPECTION PORTS (IF PRESENT)
 - A.1. REMOVE/OPEN LID ON NYLOPLAST INLINE DRAIN
 - A.2. REMOVE AND CLEAN FLEXSTORM FILTER IF INSTALLED
 - A.3. USING A FLASHLIGHT AND STADIA ROD, MEASURE DEPTH OF SEDIMENT AND RECORD ON MAINTENANCE LOG
 - A.4. LOWER A CAMERA INTO ISOLATOR ROW PLUS FOR VISUAL INSPECTION OF SEDIMENT LEVELS (OPTIONAL)
 - A.5. IF SEDIMENT IS AT, OR ABOVE, 3" (80 mm) PROCEED TO STEP 2. IF NOT, PROCEED TO STEP 3.
 - B. ALL ISOLATOR PLUS ROWS
 - B.1. REMOVE COVER FROM STRUCTURE AT UPSTREAM END OF ISOLATOR ROW PLUS
 - B.2. USING A FLASHLIGHT, INSPECT DOWN THE ISOLATOR ROW PLUS THROUGH OUTLET PIPE
 - i) MIRRORS ON POLES OR CAMERAS MAY BE USED TO AVOID A CONFINED SPACE ENTRY
 - ii) FOLLOW OSHA REGULATIONS FOR CONFINED SPACE ENTRY IF ENTERING MANHOLE
 - B.3. IF SEDIMENT IS AT, OR ABOVE, 3" (80 mm) PROCEED TO STEP 2. IF NOT, PROCEED TO STEP 3.
- STEP 2) CLEAN OUT ISOLATOR ROW PLUS USING THE JETVAC PROCESS
- A. A FIXED CULVERT CLEANING NOZZLE WITH REAR FACING SPREAD OF 45" (1.1 m) OR MORE IS PREFERRED
 - B. APPLY MULTIPLE PASSES OF JETVAC UNTIL BACKFLUSH WATER IS CLEAN
 - C. VACUUM STRUCTURE SUMP AS REQUIRED
- STEP 3) REPLACE ALL COVERS, GRATES, FILTERS, AND LIDS; RECORD OBSERVATIONS AND ACTIONS.
- STEP 4) INSPECT AND CLEAN BASINS AND MANHOLES UPSTREAM OF THE STORMTECH SYSTEM.

NOTES

1. INSPECT EVERY 6 MONTHS DURING THE FIRST YEAR OF OPERATION. ADJUST THE INSPECTION INTERVAL BASED ON PREVIOUS OBSERVATIONS OF SEDIMENT ACCUMULATION AND HIGH WATER ELEVATIONS.
2. CONDUCT JETTING AND VACTORING ANNUALLY OR WHEN INSPECTION SHOWS THAT MAINTENANCE IS NECESSARY.

<p>DA 1 EAST, BLOOMINGTON SITE 3 SCHEME 1 BLOOMINGTON, CA</p>	<p>DATE: 12/7/2020 DRAWN: HP PROJECT #:</p>	<p>DESCRIPTION</p>	<p>CHK</p>	<p>REV</p>	<p>DRW</p>
<p>520 CROMWELL AVENUE ROCKY HILL CT 06067 860-525-8188 888-892-2894 WWW.STORMTECH.COM</p>					
<p>4840 TRUEMAN BLVD HILLIARD, OH 43026 1-800-733-7473</p>					
<p>ADS ADVANCED DRAINAGE SYSTEMS, INC.</p>					
<p>THIS DRAWING HAS BEEN PREPARED BASED ON INFORMATION PROVIDED TO ADS UNDER THE DIRECTION OF THE SITE DESIGN ENGINEER OR OTHER PROJECT REPRESENTATIVE. THE SITE DESIGN ENGINEER SHALL REVIEW THIS DRAWING PRIOR TO CONSTRUCTION. IT IS THE ULTIMATE RESPONSIBILITY OF THE SITE DESIGN ENGINEER TO ENSURE THAT THE PRODUCT(S) DEPICTED AND ALL ASSOCIATED DETAILS MEET ALL APPLICABLE LAWS, REGULATIONS, AND PROJECT REQUIREMENTS.</p>					
<p>SHEET 4 OF 5</p>					

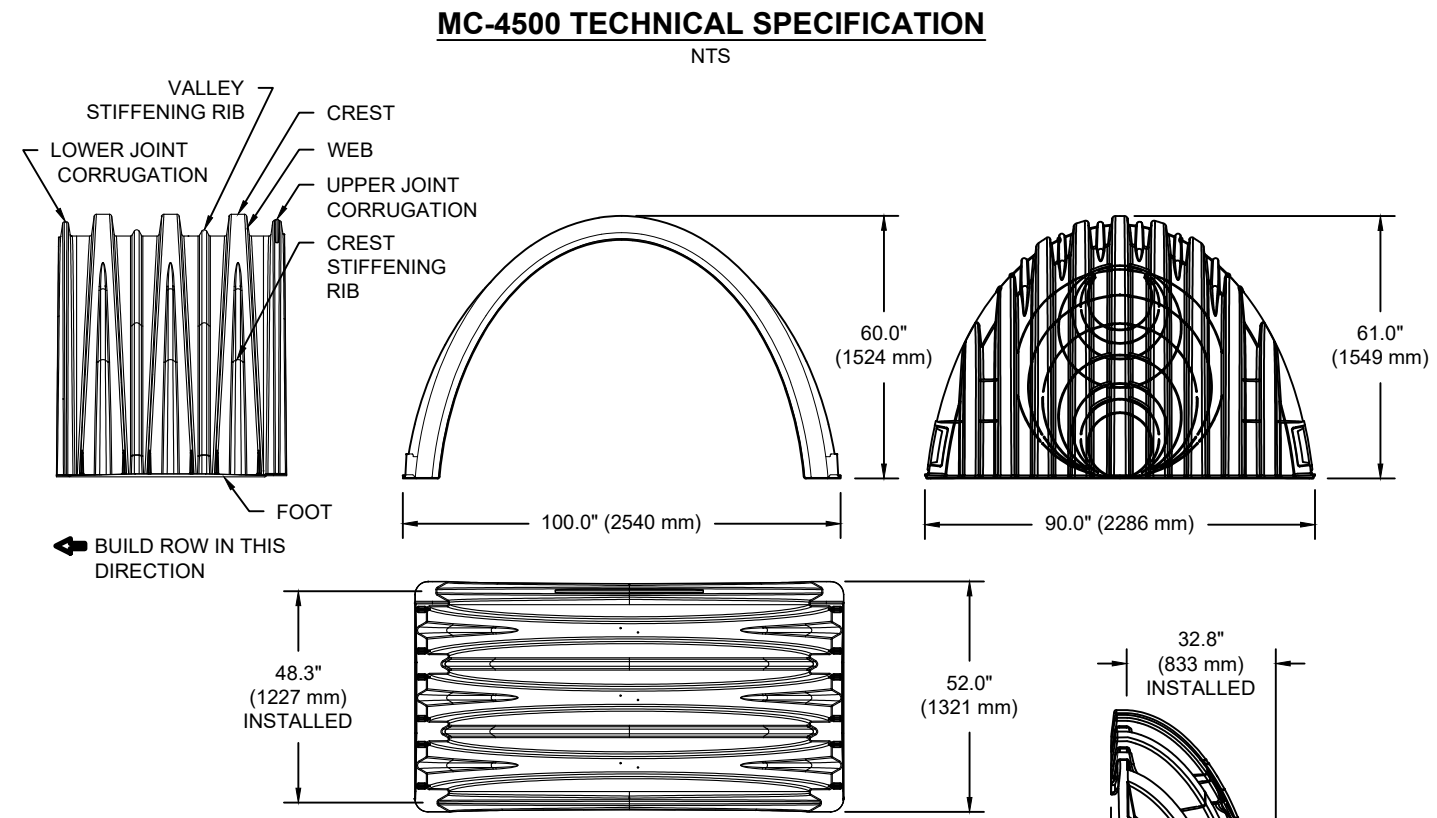
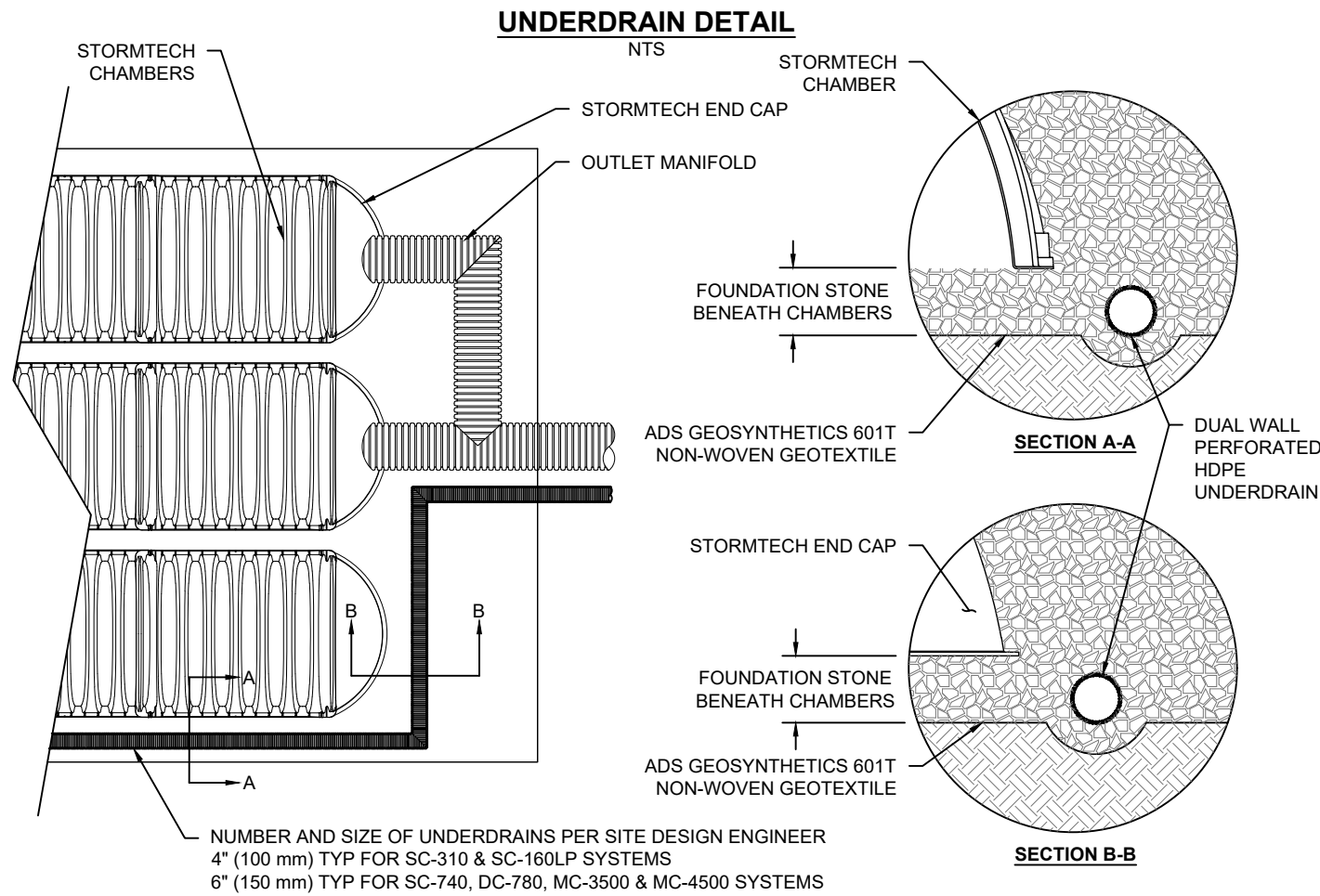

NOMINAL CHAMBER SPECIFICATIONS

SIZE (W X H X INSTALLED LENGTH)	100.0" X 60.0" X 48.3"	(2540 mm X 1524 mm X 1227 mm)
CHAMBER STORAGE	106.5 CUBIC FEET	(3.01 m ³)
MINIMUM INSTALLED STORAGE*	162.6 CUBIC FEET	(4.60 m ³)
WEIGHT (NOMINAL)	125.0 lbs.	(56.7 kg)

NOMINAL END CAP SPECIFICATIONS

SIZE (W X H X INSTALLED LENGTH)	90.0" X 61.0" X 32.8"	(2286 mm X 1549 mm X 833 mm)
END CAP STORAGE	39.5 CUBIC FEET	(1.12 m ³)
MINIMUM INSTALLED STORAGE*	115.3 CUBIC FEET	(3.26 m ³)
WEIGHT (NOMINAL)	90 lbs.	(40.8 kg)

*ASSUMES 12" (305 mm) STONE ABOVE, 9" (229 mm) STONE FOUNDATION AND BETWEEN CHAMBERS, 12" (305 mm) STONE PERIMETER IN FRONT OF END CAPS AND 40% STONE POROSITY.

PARTIAL CUT HOLES AT BOTTOM OF END CAP FOR PART NUMBERS ENDING WITH "B"
PARTIAL CUT HOLES AT TOP OF END CAP FOR PART NUMBERS ENDING WITH "T"
END CAPS WITH A PREFABRICATED WELDED STUB END WITH "W"

PART #	STUB	B	C
MC4500IEPP06T		42.54" (1081 mm)	---
MC4500IEPP06B	6" (150 mm)	---	0.86" (22 mm)
MC4500IEPP08T		40.50" (1029 mm)	---
MC4500IEPP08B	8" (200 mm)	---	1.01" (26 mm)
MC4500IEPP10T		38.37" (975 mm)	---
MC4500IEPP10B	10" (250 mm)	---	1.33" (34 mm)
MC4500IEPP12T		35.69" (907 mm)	---
MC4500IEPP12B	12" (300 mm)	---	1.55" (39 mm)
MC4500IEPP15T		32.72" (831 mm)	---
MC4500IEPP15B	15" (375 mm)	---	1.70" (43 mm)
MC4500IEPP18T		29.36" (746 mm)	---
MC4500IEPP18TW	18" (450 mm)	---	---
MC4500IEPP18B		---	1.97" (50 mm)
MC4500IEPP18BW		---	---
MC4500IEPP24T		23.05" (585 mm)	---
MC4500IEPP24TW	24" (600 mm)	---	---
MC4500IEPP24B		---	2.26" (57 mm)
MC4500IEPP24BW		---	---
MC4500IEPP30BW	30" (750 mm)	---	2.95" (75 mm)
MC4500IEPP36BW	36" (900 mm)	---	3.25" (83 mm)
MC4500IEPP42BW	42" (1050 mm)	---	3.55" (90 mm)

NOTE: ALL DIMENSIONS ARE NOMINAL

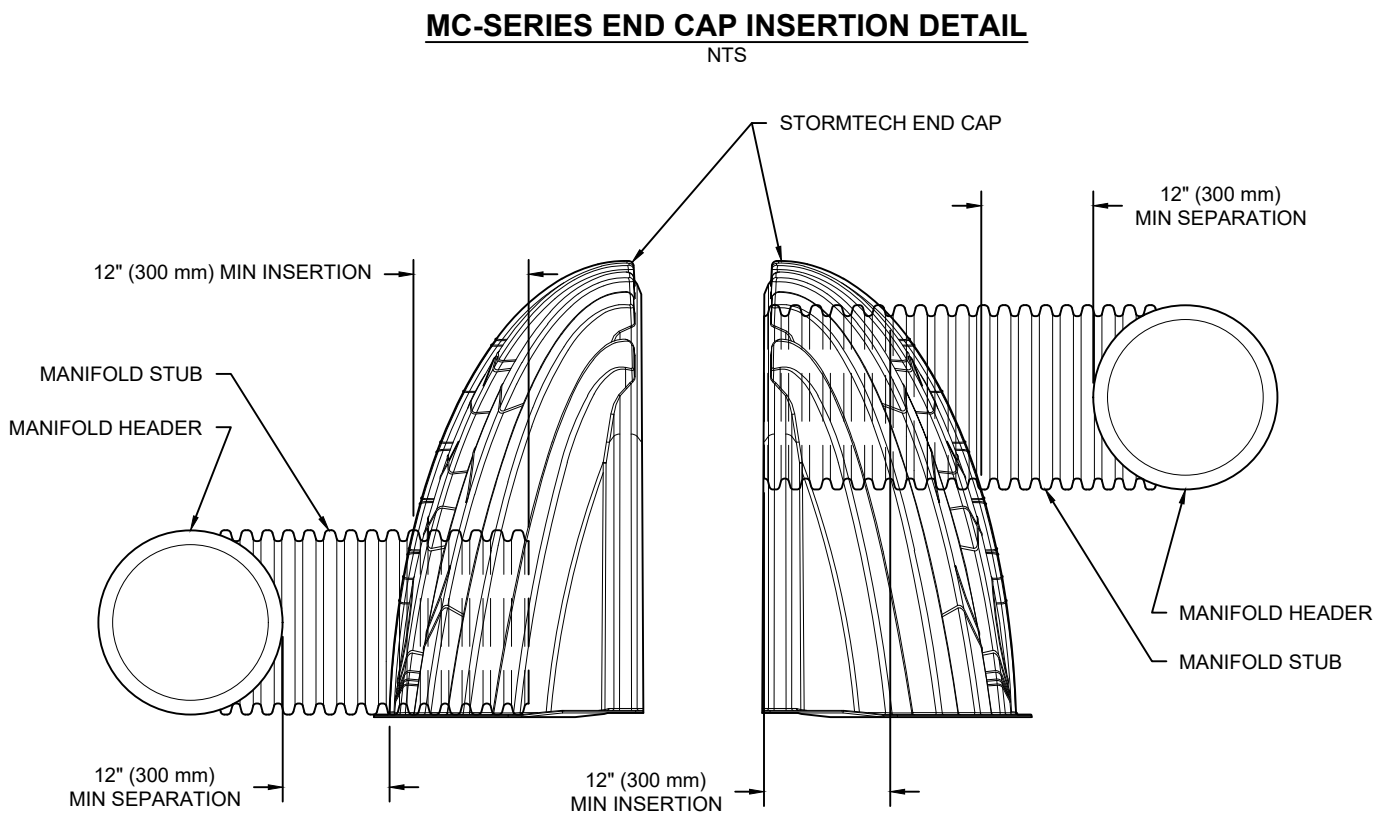

NOTE: MANIFOLD STUB MUST BE LAID HORIZONTAL FOR A PROPER FIT IN END CAP OPENING.

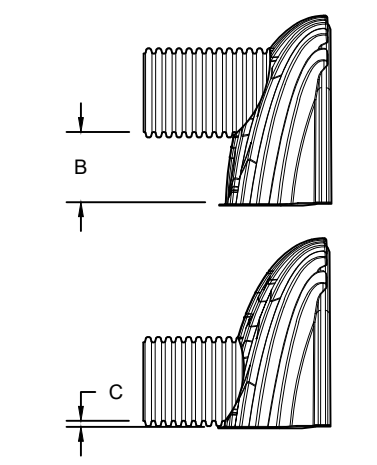

CUSTOM PARTIAL CUT INVERTS ARE AVAILABLE UPON REQUEST. INVENTORIED MANIFOLDS INCLUDE 12-24" (300-600 mm) SIZE ON SIZE AND 15-48" (375-1200 mm) ECCENTRIC MANIFOLDS. CUSTOM INVERT LOCATIONS ON THE MC-4500 END CAP CUT IN THE FIELD ARE NOT RECOMMENDED FOR PIPE SIZES GREATER THAN 10" (250 mm). THE INVERT LOCATION IN COLUMN 'B' ARE THE HIGHEST POSSIBLE FOR THE PIPE SIZE.

DA 1 EAST, BLOOMINGTON SITE 3
SCHEME 1
BLOOMINGTON, CA

DATE: 12/7/2020
DRAWN: HP
PROJECT #:
CHECKED: N/A

REV	DRW	CHK	DESCRIPTION

520 CROMWELL AVENUE | ROCKY HILL | CT | 06067
860-525-8188 | 888-892-2894 | WWW.STORMTECH.COM

4840 TRUEMAN BLVD
HILLIARD, OH 43026
1-800-733-7473

ADVANCED DRAINAGE SYSTEMS, INC.

THIS DRAWING HAS BEEN PREPARED BASED ON INFORMATION PROVIDED TO ADS UNDER THE DIRECTION OF THE SITE DESIGN ENGINEER OR OTHER PROJECT REPRESENTATIVE. THE SITE DESIGN ENGINEER SHALL REVIEW THIS DRAWING PRIOR TO CONSTRUCTION. IT IS THE ULTIMATE RESPONSIBILITY OF THE SITE DESIGN ENGINEER TO ENSURE THAT THE PRODUCT(S) DEPICTED AND ALL ASSOCIATED DETAILS MEET ALL APPLICABLE LAWS, REGULATIONS, AND PROJECT REQUIREMENTS.

SHEET
5 OF 5

APN 0256-101-11



APN

APN 0256-111-38

APN 0256

PROJECT INFORMATION	
ENGINEERED PRODUCT MANAGER	
ADS SALES REP	
PROJECT NO.	



ADVANCED DRAINAGE SYSTEMS, INC.



DA 1 WEST, BLOOMINGTON SITE 3 SCHEME 1

BLOOMINGTON, CA

MC-4500 STORMTECH CHAMBER SPECIFICATIONS

1. CHAMBERS SHALL BE STORMTECH MC-4500.
2. CHAMBERS SHALL BE ARCH-SHAPED AND SHALL BE MANUFACTURED FROM VIRGIN, IMPACT-MODIFIED POLYPROPYLENE COPOLYMERS.
3. CHAMBERS SHALL MEET THE REQUIREMENTS OF ASTM F2418-16a, "STANDARD SPECIFICATION FOR POLYPROPYLENE (PP) CORRUGATED WALL STORMWATER COLLECTION CHAMBERS" CHAMBER CLASSIFICATION 60x101.
4. CHAMBER ROWS SHALL PROVIDE CONTINUOUS, UNOBSTRUCTED INTERNAL SPACE WITH NO INTERNAL SUPPORTS THAT WOULD IMPEDE FLOW OR LIMIT ACCESS FOR INSPECTION.
5. THE STRUCTURAL DESIGN OF THE CHAMBERS, THE STRUCTURAL BACKFILL, AND THE INSTALLATION REQUIREMENTS SHALL ENSURE THAT THE LOAD FACTORS SPECIFIED IN THE AASHTO LRFD BRIDGE DESIGN SPECIFICATIONS, SECTION 12.12, ARE MET FOR: 1) LONG-DURATION DEAD LOADS AND 2) SHORT-DURATION LIVE LOADS, BASED ON THE AASHTO DESIGN TRUCK WITH CONSIDERATION FOR IMPACT AND MULTIPLE VEHICLE PRESENCES.
6. CHAMBERS SHALL BE DESIGNED, TESTED AND ALLOWABLE LOAD CONFIGURATIONS DETERMINED IN ACCORDANCE WITH ASTM F2787, "STANDARD PRACTICE FOR STRUCTURAL DESIGN OF THERMOPLASTIC CORRUGATED WALL STORMWATER COLLECTION CHAMBERS". LOAD CONFIGURATIONS SHALL INCLUDE: 1) INSTANTANEOUS (<1 MIN) AASHTO DESIGN TRUCK LIVE LOAD ON MINIMUM COVER 2) MAXIMUM PERMANENT (75-YR) COVER LOAD AND 3) ALLOWABLE COVER WITH PARKED (1-WEEK) AASHTO DESIGN TRUCK.
7. REQUIREMENTS FOR HANDLING AND INSTALLATION:
 - TO MAINTAIN THE WIDTH OF CHAMBERS DURING SHIPPING AND HANDLING, CHAMBERS SHALL HAVE INTEGRAL, INTERLOCKING STACKING LUGS.
 - TO ENSURE A SECURE JOINT DURING INSTALLATION AND BACKFILL, THE HEIGHT OF THE CHAMBER JOINT SHALL NOT BE LESS THAN 3".
 - TO ENSURE THE INTEGRITY OF THE ARCH SHAPE DURING INSTALLATION, a) THE ARCH STIFFNESS CONSTANT AS DEFINED IN SECTION 6.2.8 OF ASTM F2418 SHALL BE GREATER THAN OR EQUAL TO 500 LBS/IN/IN. AND b) TO RESIST CHAMBER DEFORMATION DURING INSTALLATION AT ELEVATED TEMPERATURES (ABOVE 73° F / 23° C), CHAMBERS SHALL BE PRODUCED FROM REFLECTIVE GOLD OR YELLOW COLORS.
8. ONLY CHAMBERS THAT ARE APPROVED BY THE SITE DESIGN ENGINEER WILL BE ALLOWED. UPON REQUEST BY THE SITE DESIGN ENGINEER OR OWNER, THE CHAMBER MANUFACTURER SHALL SUBMIT A STRUCTURAL EVALUATION FOR APPROVAL BEFORE DELIVERING CHAMBERS TO THE PROJECT SITE AS FOLLOWS:
 - THE STRUCTURAL EVALUATION SHALL BE SEALED BY A REGISTERED PROFESSIONAL ENGINEER.
 - THE STRUCTURAL EVALUATION SHALL DEMONSTRATE THAT THE SAFETY FACTORS ARE GREATER THAN OR EQUAL TO 1.95 FOR DEAD LOAD AND 1.75 FOR LIVE LOAD, THE MINIMUM REQUIRED BY ASTM F2787 AND BY SECTIONS 3 AND 12.12 OF THE AASHTO LRFD BRIDGE DESIGN SPECIFICATIONS FOR THERMOPLASTIC PIPE.
 - THE TEST DERIVED CREEP MODULUS AS SPECIFIED IN ASTM F2418 SHALL BE USED FOR PERMANENT DEAD LOAD DESIGN EXCEPT THAT IT SHALL BE THE 75-YEAR MODULUS USED FOR DESIGN.
9. CHAMBERS AND END CAPS SHALL BE PRODUCED AT AN ISO 9001 CERTIFIED MANUFACTURING FACILITY.

IMPORTANT - NOTES FOR THE BIDDING AND INSTALLATION OF MC-4500 CHAMBER SYSTEM

1. STORMTECH MC-4500 CHAMBERS SHALL NOT BE INSTALLED UNTIL THE MANUFACTURER'S REPRESENTATIVE HAS COMPLETED A PRE-CONSTRUCTION MEETING WITH THE INSTALLERS.
2. STORMTECH MC-4500 CHAMBERS SHALL BE INSTALLED IN ACCORDANCE WITH THE "STORMTECH MC-3500/MC-4500 CONSTRUCTION GUIDE".
3. CHAMBERS ARE NOT TO BE BACKFILLED WITH A DOZER OR EXCAVATOR SITUATED OVER THE CHAMBERS. STORMTECH RECOMMENDS 3 BACKFILL METHODS:
 - STONESHOOTER LOCATED OFF THE CHAMBER BED.
 - BACKFILL AS ROWS ARE BUILT USING AN EXCAVATOR ON THE FOUNDATION STONE OR SUBGRADE.
 - BACKFILL FROM OUTSIDE THE EXCAVATION USING A LONG BOOM HOE OR EXCAVATOR.
4. THE FOUNDATION STONE SHALL BE LEVELED AND COMPACTED PRIOR TO PLACING CHAMBERS.
5. JOINTS BETWEEN CHAMBERS SHALL BE PROPERLY SEATED PRIOR TO PLACING STONE.
6. MAINTAIN MINIMUM 9" (230 mm) SPACING BETWEEN THE CHAMBER ROWS.
7. INLET AND OUTLET MANIFOLDS MUST BE INSERTED A MINIMUM OF 12" (300 mm) INTO CHAMBER END CAPS.
8. EMBEDMENT STONE SURROUNDING CHAMBERS MUST BE A CLEAN, CRUSHED, ANGULAR STONE MEETING THE AASHTO M43 DESIGNATION OF #3 OR #4.
9. STONE SHALL BE BROUGHT UP EVENLY AROUND CHAMBERS SO AS NOT TO DISTORT THE CHAMBER SHAPE. STONE DEPTHS SHOULD NEVER DIFFER BY MORE THAN 12" (300 mm) BETWEEN ADJACENT CHAMBER ROWS.
10. STONE MUST BE PLACED ON THE TOP CENTER OF THE CHAMBER TO ANCHOR THE CHAMBERS IN PLACE AND PRESERVE ROW SPACING.
11. THE CONTRACTOR MUST REPORT ANY DISCREPANCIES WITH CHAMBER FOUNDATION MATERIAL BEARING CAPACITIES TO THE SITE DESIGN ENGINEER.
12. ADS RECOMMENDS THE USE OF "FLEXSTORM CATCH IT" INSERTS DURING CONSTRUCTION FOR ALL INLETS TO PROTECT THE SUBSURFACE STORMWATER MANAGEMENT SYSTEM FROM CONSTRUCTION SITE RUNOFF.

NOTES FOR CONSTRUCTION EQUIPMENT

1. STORMTECH MC-4500 CHAMBERS SHALL BE INSTALLED IN ACCORDANCE WITH THE "STORMTECH MC-3500/MC-4500 CONSTRUCTION GUIDE".
2. THE USE OF EQUIPMENT OVER MC-4500 CHAMBERS IS LIMITED:
 - NO EQUIPMENT IS ALLOWED ON BARE CHAMBERS.
 - NO RUBBER Tired LOADER, DUMP TRUCK, OR EXCAVATORS ARE ALLOWED UNTIL PROPER FILL DEPTHS ARE REACHED IN ACCORDANCE WITH THE "STORMTECH MC-3500/MC-4500 CONSTRUCTION GUIDE".
 - WEIGHT LIMITS FOR CONSTRUCTION EQUIPMENT CAN BE FOUND IN THE "STORMTECH MC-3500/MC-4500 CONSTRUCTION GUIDE".
3. FULL 36" (900 mm) OF STABILIZED COVER MATERIALS OVER THE CHAMBERS IS REQUIRED FOR DUMP TRUCK TRAVEL OR DUMPING.

USE OF A DOZER TO PUSH EMBEDMENT STONE BETWEEN THE ROWS OF CHAMBERS MAY CAUSE DAMAGE TO CHAMBERS AND IS NOT AN ACCEPTABLE BACKFILL METHOD. ANY CHAMBERS DAMAGED BY USING THE "DUMP AND PUSH" METHOD ARE NOT COVERED UNDER THE STORMTECH STANDARD WARRANTY.

CONTACT STORMTECH AT 1-888-892-2694 WITH ANY QUESTIONS ON INSTALLATION REQUIREMENTS OR WEIGHT LIMITS FOR CONSTRUCTION EQUIPMENT.

PROPOSED LAYOUT		CONCEPTUAL ELEVATIONS		*INVERT ABOVE BASE OF CHAMBER				
				PART TYPE	ITEM ON LAYOUT	DESCRIPTION	INVERT*	MAX FLOW
512	STORMTECH MC-4500 CHAMBERS	MAXIMUM ALLOWABLE GRADE (TOP OF PAVEMENT/UNPAVED):	12.75					
16	STORMTECH MC-4500 END CAPS	MINIMUM ALLOWABLE GRADE (UNPAVED WITH TRAFFIC):	8.25					
12	STONE ABOVE (in)	MINIMUM ALLOWABLE GRADE (UNPAVED NO TRAFFIC):	7.75	PREFABRICATED END CAP	A	24" BOTTOM PARTIAL CUT END CAP, PART#: MC4500IEPP24B / TYP OF ALL 24" BOTTOM CONNECTIONS AND ISOLATOR PLUS ROWS	2.26"	
9	STONE BELOW (in)	MINIMUM ALLOWABLE GRADE (TOP OF RIGID CONCRETE PAVEMENT):	7.75	FLAMP	B	INSTALL FLAMP ON 24" ACCESS PIPE / PART#: MC450024RAMP		
40	STONE VOID	MINIMUM ALLOWABLE GRADE (BASE OF FLEXIBLE PAVEMENT):	7.75	MANIFOLD	C	24" x 24" BOTTOM MANIFOLD, ADS N-12	2.26"	
87269	INSTALLED SYSTEM VOLUME (CF) (PERIMETER STONE INCLUDED) (COVER STONE INCLUDED) (BASE STONE INCLUDED)	TOP OF STONE:	6.75	MANIFOLD	D	24" x 24" BOTTOM MANIFOLD, ADS N-12	2.26"	
		TOP OF MC-4500 CHAMBER:	5.75	MANIFOLD	E	24" x 24" BOTTOM MANIFOLD, ADS N-12	2.26"	
		24" x 24" BOTTOM MANIFOLD INVERT:	0.94	CONCRETE STRUCTURE	F	OCS (DESIGN BY ENGINEER / PROVIDED BY OTHERS)		14.0 CFS OUT
		24" x 24" BOTTOM MANIFOLD INVERT:	0.94	CONCRETE STRUCTURE	F	(DESIGN BY ENGINEER / PROVIDED BY OTHERS)		41.5 CFS IN
20063	SYSTEM AREA (SF)	24" ISOLATOR ROW PLUS INVERT:	0.94	W/WEIR				
697.1	SYSTEM PERIMETER (ft)	24" BOTTOM CONNECTION INVERT:	0.94	UNDERDRAIN	G	6" ADS N-12 DUAL WALL PERFORATED HDPE UNDERDRAIN		
		BOTTOM OF MC-4500 CHAMBER:	0.75					
		UNDERDRAIN INVERT:	0.00					
		BOTTOM OF STONE:	0.00					

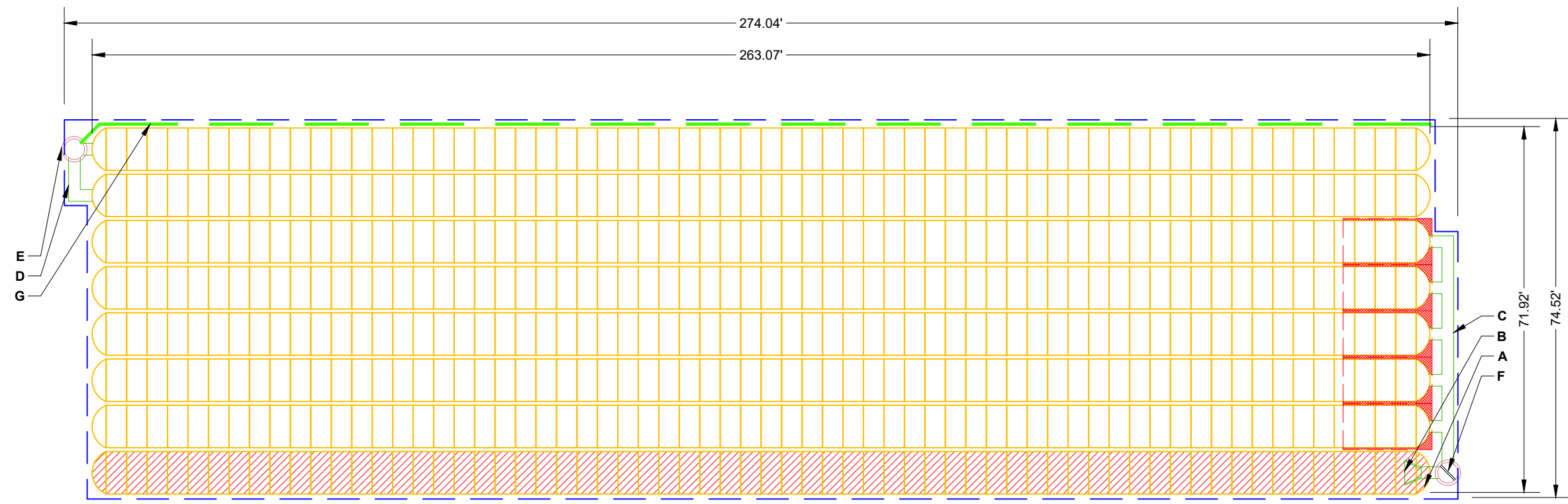

- ISOLATOR ROW PLUS (SEE DETAIL)
- PLACE MINIMUM 17.50' OF ADSPLUS175 WOVEN GEOTEXTILE OVER BEDDING STONE AND UNDERNEATH CHAMBER FEET FOR SCOUR PROTECTION AT ALL CHAMBER INLET ROWS
- BED LIMITS

NOTES

- MANIFOLD SIZE TO BE DETERMINED BY SITE DESIGN ENGINEER. SEE TECH NOTE #6.32 FOR MANIFOLD SIZING GUIDANCE.
- DUE TO THE ADAPTATION OF THIS CHAMBER SYSTEM TO SPECIFIC SITE AND DESIGN CONSTRAINTS, IT MAY BE NECESSARY TO CUT AND COUPLE ADDITIONAL PIPE TO STANDARD MANIFOLD COMPONENTS IN THE FIELD.
- THE SITE DESIGN ENGINEER MUST REVIEW ELEVATIONS AND IF NECESSARY ADJUST GRADING TO ENSURE THE CHAMBER COVER REQUIREMENTS ARE MET.
- THIS CHAMBER SYSTEM WAS DESIGNED WITHOUT SITE-SPECIFIC INFORMATION ON SOIL CONDITIONS OR BEARING CAPACITY. THE SITE DESIGN ENGINEER IS RESPONSIBLE FOR DETERMINING THE SUITABILITY OF THE SOIL AND PROVIDING THE BEARING CAPACITY OF THE INSITU SOILS. THE BASE STONE DEPTH MAY BE INCREASED OR DECREASED ONCE THIS INFORMATION IS PROVIDED.
- **NOT FOR CONSTRUCTION:** THIS LAYOUT IS FOR DIMENSIONAL PURPOSES ONLY TO PROVE CONCEPT & THE REQUIRED STORAGE VOLUME CAN BE ACHIEVED ON SITE.

DA 1 WEST, BLOOMINGTON SITE 3
 SCHEME 1
 BLOOMINGTON, CA
 DATE: 12/7/2020
 PROJECT #:

REV	DRW	CHK	DESCRIPTION

StormTech
Determination • Retention • Water Quality

520 CROMWELL AVENUE | ROCKY HILL | CT | 06067
 860-529-8188 | 888-892-2894 | WWW.STORMTECH.COM

4840 TRUEMAN BLVD
 HILLIARD, OH 43026
 1-800-733-7473

ADS
ADVANCED DRAINAGE SYSTEMS, INC.

50'

25'

0'

THIS DRAWING HAS BEEN PREPARED BASED ON INFORMATION PROVIDED TO ADS UNDER THE DIRECTION OF THE SITE DESIGN ENGINEER OR OTHER PROJECT REPRESENTATIVE. THE SITE DESIGN ENGINEER SHALL REVIEW THIS DRAWING PRIOR TO CONSTRUCTION. IT IS THE ULTIMATE RESPONSIBILITY OF THE SITE DESIGN ENGINEER TO ENSURE THAT THE PRODUCT(S) DEPICTED AND ALL ASSOCIATED DETAILS MEET ALL APPLICABLE LAWS, REGULATIONS, AND PROJECT REQUIREMENTS.

DRAWN: HP

CHECKED: N/A

SHEET

2 OF 5

ACCEPTABLE FILL MATERIALS: STORMTECH MC-4500 CHAMBER SYSTEMS

MATERIAL LOCATION		DESCRIPTION	AASHTO MATERIAL CLASSIFICATIONS	COMPACTION / DENSITY REQUIREMENT
D	FINAL FILL: FILL MATERIAL FOR LAYER 'D' STARTS FROM THE TOP OF THE 'C' LAYER TO THE BOTTOM OF FLEXIBLE PAVEMENT OR UNPAVED FINISHED GRADE ABOVE. NOTE THAT PAVEMENT SUBBASE MAY BE PART OF THE 'D' LAYER	ANY SOIL/ROCK MATERIALS, NATIVE SOILS, OR PER ENGINEER'S PLANS. CHECK PLANS FOR PAVEMENT SUBGRADE REQUIREMENTS.	N/A	PREPARE PER SITE DESIGN ENGINEER'S PLANS. PAVED INSTALLATIONS MAY HAVE STRINGENT MATERIAL AND PREPARATION REQUIREMENTS.
C	INITIAL FILL: FILL MATERIAL FOR LAYER 'C' STARTS FROM THE TOP OF THE EMBEDMENT STONE ('B' LAYER) TO 24" (600 mm) ABOVE THE TOP OF THE CHAMBER. NOTE THAT PAVEMENT SUBBASE MAY BE A PART OF THE 'C' LAYER.	GRANULAR WELL-GRADED SOIL/AGGREGATE MIXTURES, <35% FINES OR PROCESSED AGGREGATE. MOST PAVEMENT SUBBASE MATERIALS CAN BE USED IN LIEU OF THIS LAYER.	AASHTO M145 ¹ A-1, A-2-4, A-3 OR AASHTO M43 ¹ 3, 357, 4, 467, 5, 56, 57, 6, 67, 68, 7, 78, 8, 89, 9, 10	BEGIN COMPACTIONS AFTER 24" (600 mm) OF MATERIAL OVER THE CHAMBERS IS REACHED. COMPACT ADDITIONAL LAYERS IN 12" (300 mm) MAX LIFTS TO A MIN. 95% PROCTOR DENSITY FOR WELL GRADED MATERIAL AND 95% RELATIVE DENSITY FOR PROCESSED AGGREGATE MATERIALS.
B	EMBEDMENT STONE: FILL SURROUNDING THE CHAMBERS FROM THE FOUNDATION STONE ('A' LAYER) TO THE 'C' LAYER ABOVE.	CLEAN, CRUSHED, ANGULAR STONE	AASHTO M43 ¹ 3, 4	NO COMPACTION REQUIRED.
A	FOUNDATION STONE: FILL BELOW CHAMBERS FROM THE SUBGRADE UP TO THE FOOT (BOTTOM) OF THE CHAMBER.	CLEAN, CRUSHED, ANGULAR STONE	AASHTO M43 ¹ 3, 4	PLATE COMPACT OR ROLL TO ACHIEVE A FLAT SURFACE. ^{2,3}

PLEASE NOTE:

- THE LISTED AASHTO DESIGNATIONS ARE FOR GRADATIONS ONLY. THE STONE MUST ALSO BE CLEAN, CRUSHED, ANGULAR. FOR EXAMPLE, A SPECIFICATION FOR #4 STONE WOULD STATE: "CLEAN, CRUSHED, ANGULAR NO. 4 (AASHTO M43) STONE".
- STORMTECH COMPACTION REQUIREMENTS ARE MET FOR 'A' LOCATION MATERIALS WHEN PLACED AND COMPACTED IN 9" (230 mm) (MAX) LIFTS USING TWO FULL COVERAGES WITH A VIBRATORY COMPACTOR.
- WHERE INFILTRATION SURFACES MAY BE COMPROMISED BY COMPACTION, FOR STANDARD DESIGN LOAD CONDITIONS, A FLAT SURFACE MAY BE ACHIEVED BY RAKING OR DRAGGING WITHOUT COMPACTION EQUIPMENT. FOR SPECIAL LOAD DESIGNS, CONTACT STORMTECH FOR COMPACTION REQUIREMENTS.
- ONCE LAYER 'C' IS PLACED, ANY SOIL/MATERIAL CAN BE PLACED IN LAYER 'D' UP TO THE FINISHED GRADE. MOST PAVEMENT SUBBASE SOILS CAN BE USED TO REPLACE THE MATERIAL REQUIREMENTS OF LAYER 'C' OR 'D' AT THE SITE DESIGN ENGINEER'S DISCRETION.

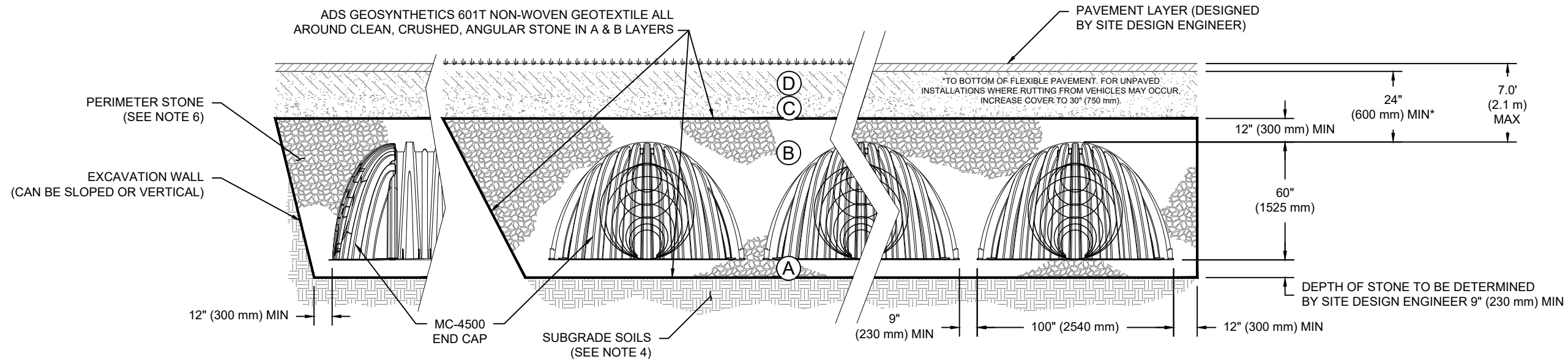

NOTES:

- CHAMBERS SHALL MEET THE REQUIREMENTS OF ASTM F2418-16a, "STANDARD SPECIFICATION FOR POLYPROPYLENE (PP) CORRUGATED WALL STORMWATER COLLECTION CHAMBERS" CHAMBER CLASSIFICATION 60x101
- MC-4500 CHAMBERS SHALL BE DESIGNED IN ACCORDANCE WITH ASTM F2787 "STANDARD PRACTICE FOR STRUCTURAL DESIGN OF THERMOPLASTIC CORRUGATED WALL STORMWATER COLLECTION CHAMBERS".
- THE SITE DESIGN ENGINEER IS RESPONSIBLE FOR ASSESSING THE BEARING RESISTANCE (ALLOWABLE BEARING CAPACITY) OF THE SUBGRADE SOILS AND THE DEPTH OF FOUNDATION STONE WITH CONSIDERATION FOR THE RANGE OF EXPECTED SOIL MOISTURE CONDITIONS.
- PERIMETER STONE MUST BE EXTENDED HORIZONTALLY TO THE EXCAVATION WALL FOR BOTH VERTICAL AND SLOPED EXCAVATION WALLS.
- REQUIREMENTS FOR HANDLING AND INSTALLATION:
 - TO MAINTAIN THE WIDTH OF CHAMBERS DURING SHIPPING AND HANDLING, CHAMBERS SHALL HAVE INTEGRAL, INTERLOCKING STACKING LUGS.
 - TO ENSURE A SECURE JOINT DURING INSTALLATION AND BACKFILL, THE HEIGHT OF THE CHAMBER JOINT SHALL NOT BE LESS THAN 3".
 - TO ENSURE THE INTEGRITY OF THE ARCH SHAPE DURING INSTALLATION, a) THE ARCH STIFFNESS CONSTANT AS DEFINED IN SECTION 6.2.8 OF ASTM F2418 SHALL BE GREATER THAN OR EQUAL TO 500 LBS/IN/IN. AND b) TO RESIST CHAMBER DEFORMATION DURING INSTALLATION AT ELEVATED TEMPERATURES (ABOVE 73° F / 23° C), CHAMBERS SHALL BE PRODUCED FROM REFLECTIVE GOLD OR YELLOW COLORS.

DA 1 WEST, BLOOMINGTON SITE 3
 SCHEME 1
 BLOOMINGTON, CA

DESCRIPTION

DATE: 12/7/2020

DRAWN: HP

PROJECT #:

REV | DRW | CHK

CHECKED: N/A

4840 TRUEMAN BLVD
 HILLIARD, OH 43026
 1-800-733-7473

StormTech
 Determination • Retention • Water Quality
 520 CROMWELL AVENUE | ROCKY HILL | CT | 06067
 860-529-8188 | 888-892-2894 | WWW.STORMTECH.COM

THIS DRAWING HAS BEEN PREPARED BASED ON INFORMATION PROVIDED TO ADS UNDER THE DIRECTION OF THE SITE DESIGN ENGINEER OR OTHER PROJECT REPRESENTATIVE. THE SITE DESIGN ENGINEER SHALL REVIEW THIS DRAWING PRIOR TO CONSTRUCTION. IT IS THE ULTIMATE RESPONSIBILITY OF THE SITE DESIGN ENGINEER TO ENSURE THAT THE PRODUCT(S) DEPICTED AND ALL ASSOCIATED DETAILS MEET ALL APPLICABLE LAWS, REGULATIONS, AND PROJECT REQUIREMENTS.

SHEET
3 OF 5

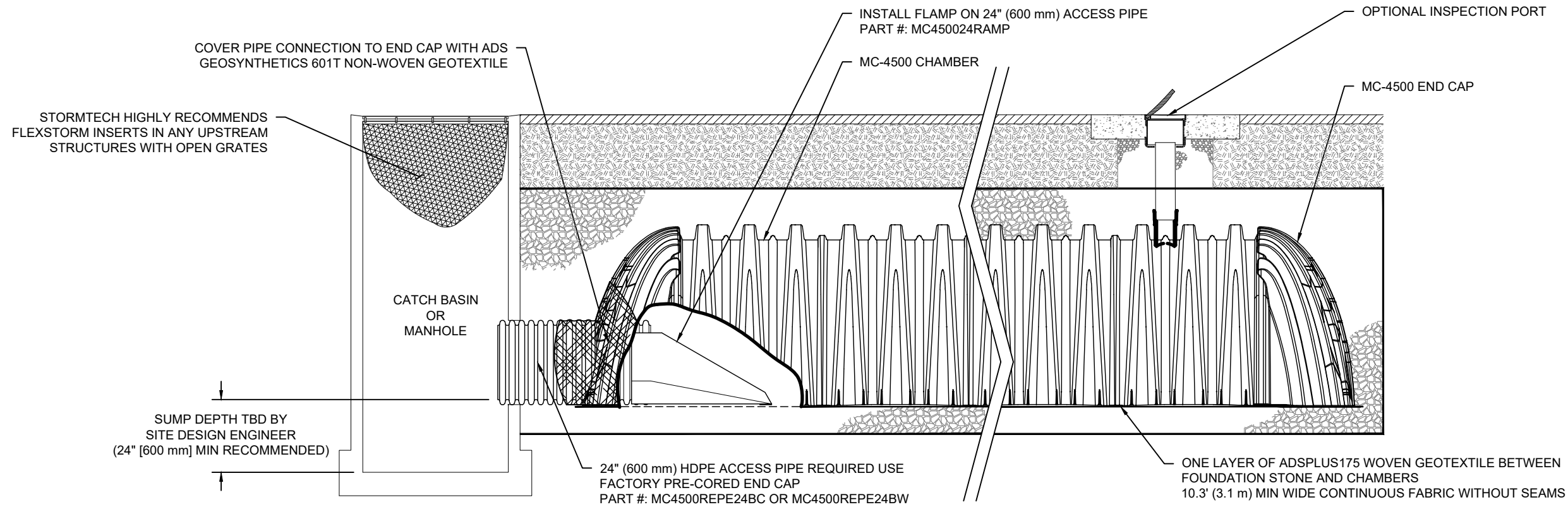

MC-4500 ISOLATOR ROW PLUS DETAIL
NTS

INSPECTION & MAINTENANCE

- STEP 1) INSPECT ISOLATOR ROW PLUS FOR SEDIMENT
- A. INSPECTION PORTS (IF PRESENT)
 - A.1. REMOVE/OPEN LID ON NYLOPLAST INLINE DRAIN
 - A.2. REMOVE AND CLEAN FLEXSTORM FILTER IF INSTALLED
 - A.3. USING A FLASHLIGHT AND STADIA ROD, MEASURE DEPTH OF SEDIMENT AND RECORD ON MAINTENANCE LOG
 - A.4. LOWER A CAMERA INTO ISOLATOR ROW PLUS FOR VISUAL INSPECTION OF SEDIMENT LEVELS (OPTIONAL)
 - A.5. IF SEDIMENT IS AT, OR ABOVE, 3" (80 mm) PROCEED TO STEP 2. IF NOT, PROCEED TO STEP 3.
 - B. ALL ISOLATOR PLUS ROWS
 - B.1. REMOVE COVER FROM STRUCTURE AT UPSTREAM END OF ISOLATOR ROW PLUS
 - B.2. USING A FLASHLIGHT, INSPECT DOWN THE ISOLATOR ROW PLUS THROUGH OUTLET PIPE
 - i) MIRRORS ON POLES OR CAMERAS MAY BE USED TO AVOID A CONFINED SPACE ENTRY
 - ii) FOLLOW OSHA REGULATIONS FOR CONFINED SPACE ENTRY IF ENTERING MANHOLE
 - B.3. IF SEDIMENT IS AT, OR ABOVE, 3" (80 mm) PROCEED TO STEP 2. IF NOT, PROCEED TO STEP 3.
- STEP 2) CLEAN OUT ISOLATOR ROW PLUS USING THE JETVAC PROCESS
- A. A FIXED CULVERT CLEANING NOZZLE WITH REAR FACING SPREAD OF 45" (1.1 m) OR MORE IS PREFERRED
 - B. APPLY MULTIPLE PASSES OF JETVAC UNTIL BACKFLUSH WATER IS CLEAN
 - C. VACUUM STRUCTURE SUMP AS REQUIRED
- STEP 3) REPLACE ALL COVERS, GRATES, FILTERS, AND LIDS; RECORD OBSERVATIONS AND ACTIONS.
- STEP 4) INSPECT AND CLEAN BASINS AND MANHOLES UPSTREAM OF THE STORMTECH SYSTEM.

NOTES

1. INSPECT EVERY 6 MONTHS DURING THE FIRST YEAR OF OPERATION. ADJUST THE INSPECTION INTERVAL BASED ON PREVIOUS OBSERVATIONS OF SEDIMENT ACCUMULATION AND HIGH WATER ELEVATIONS.
2. CONDUCT JETTING AND VACTORING ANNUALLY OR WHEN INSPECTION SHOWS THAT MAINTENANCE IS NECESSARY.

<p>DA 1 WEST, BLOOMINGTON SITE 3 SCHEME 1 BLOOMINGTON, CA</p>	<p>DATE: 12/7/2020 DRAWN: HP PROJECT #:</p>	<p>DATE: 12/7/2020 DRAWN: HP CHECKED: N/A</p>	
DESCRIPTION	CHK	REV	DRW

520 CROMWELL AVENUE | ROCKY HILL | CT | 06067
860-525-8188 | 888-892-2894 | WWW.STORMTECH.COM

4840 TRUEMAN BLVD
HILLIARD, OH 43026
1-800-733-7473

THIS DRAWING HAS BEEN PREPARED BASED ON INFORMATION PROVIDED TO ADS UNDER THE DIRECTION OF THE SITE DESIGN ENGINEER OR OTHER PROJECT REPRESENTATIVE. THE SITE DESIGN ENGINEER SHALL REVIEW THIS DRAWING PRIOR TO CONSTRUCTION. IT IS THE ULTIMATE RESPONSIBILITY OF THE SITE DESIGN ENGINEER TO ENSURE THAT THE PRODUCT(S) DEPICTED AND ALL ASSOCIATED DETAILS MEET ALL APPLICABLE LAWS, REGULATIONS, AND PROJECT REQUIREMENTS.

SHEET
4 OF 5

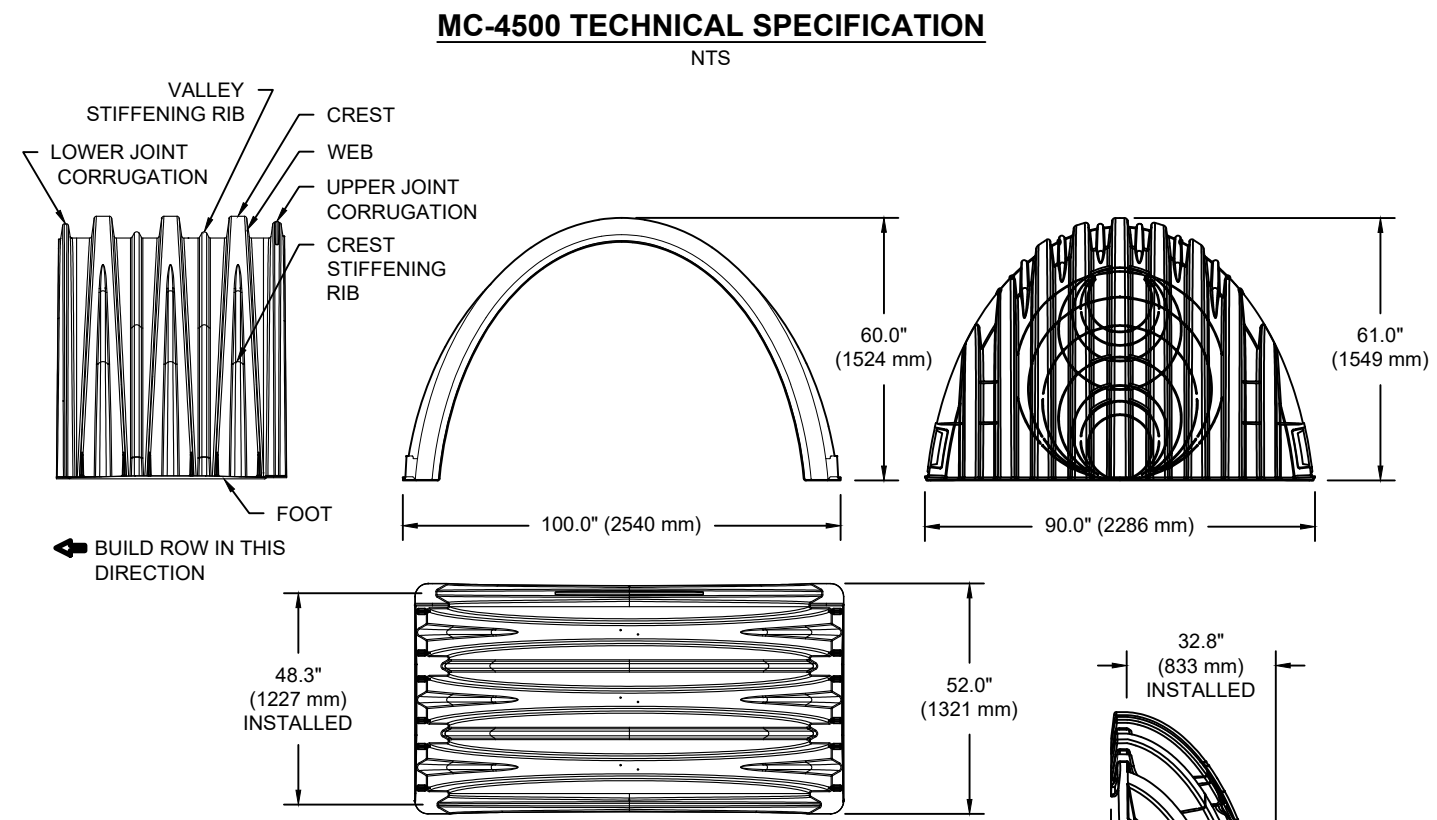
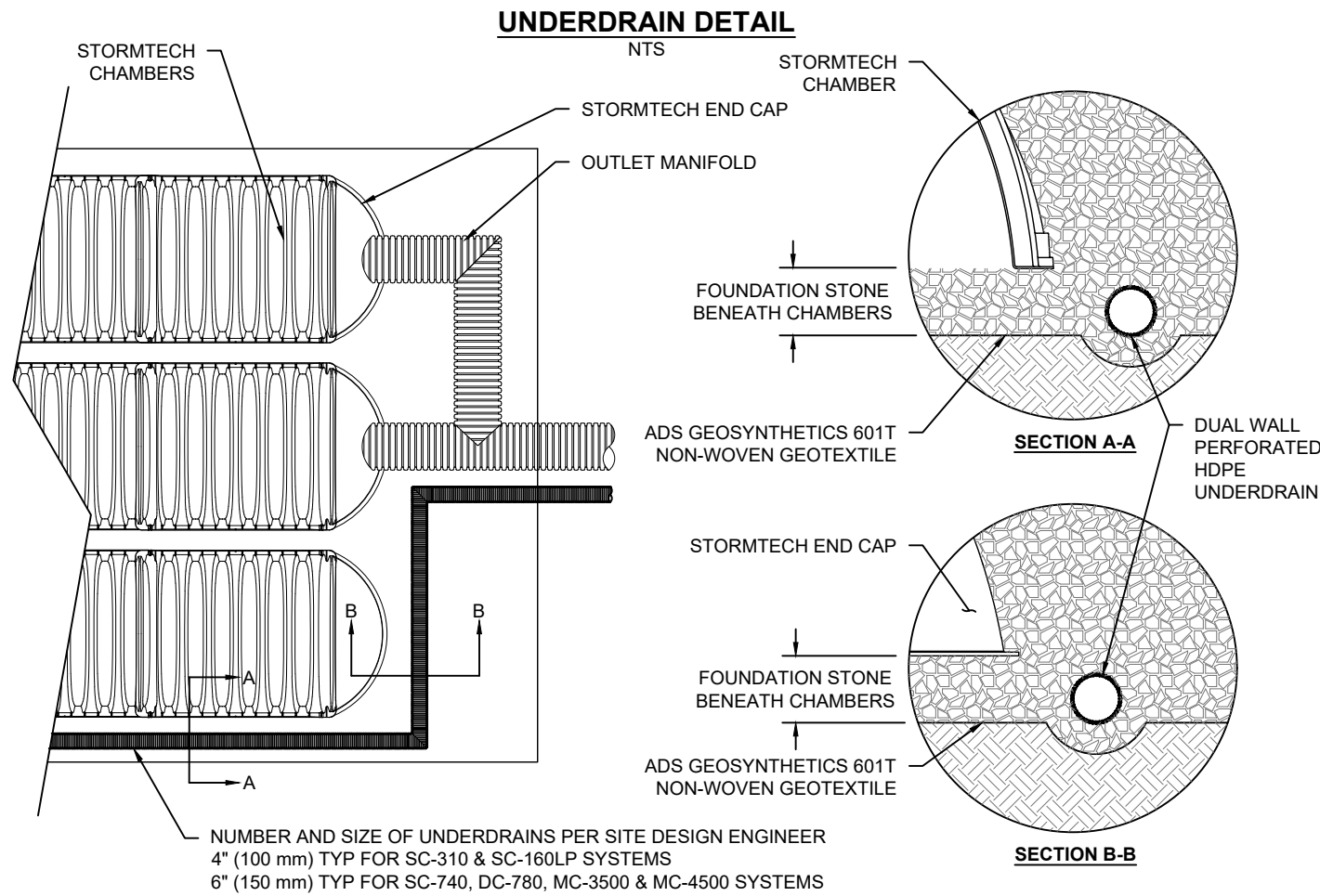

NOMINAL CHAMBER SPECIFICATIONS

SIZE (W X H X INSTALLED LENGTH)	100.0" X 60.0" X 48.3"	(2540 mm X 1524 mm X 1227 mm)
CHAMBER STORAGE	106.5 CUBIC FEET	(3.01 m ³)
MINIMUM INSTALLED STORAGE*	162.6 CUBIC FEET	(4.60 m ³)
WEIGHT (NOMINAL)	125.0 lbs.	(56.7 kg)

NOMINAL END CAP SPECIFICATIONS

SIZE (W X H X INSTALLED LENGTH)	90.0" X 61.0" X 32.8"	(2286 mm X 1549 mm X 833 mm)
END CAP STORAGE	39.5 CUBIC FEET	(1.12 m ³)
MINIMUM INSTALLED STORAGE*	115.3 CUBIC FEET	(3.26 m ³)
WEIGHT (NOMINAL)	90 lbs.	(40.8 kg)

*ASSUMES 12" (305 mm) STONE ABOVE, 9" (229 mm) STONE FOUNDATION AND BETWEEN CHAMBERS, 12" (305 mm) STONE PERIMETER IN FRONT OF END CAPS AND 40% STONE POROSITY.

PARTIAL CUT HOLES AT BOTTOM OF END CAP FOR PART NUMBERS ENDING WITH "B"
PARTIAL CUT HOLES AT TOP OF END CAP FOR PART NUMBERS ENDING WITH "T"
END CAPS WITH A PREFABRICATED WELDED STUB END WITH "W"

PART #	STUB	B	C
MC4500IEPP06T		42.54" (1081 mm)	---
MC4500IEPP06B	6" (150 mm)	---	0.86" (22 mm)
MC4500IEPP08T		40.50" (1029 mm)	---
MC4500IEPP08B	8" (200 mm)	---	1.01" (26 mm)
MC4500IEPP10T		38.37" (975 mm)	---
MC4500IEPP10B	10" (250 mm)	---	1.33" (34 mm)
MC4500IEPP12T		35.69" (907 mm)	---
MC4500IEPP12B	12" (300 mm)	---	1.55" (39 mm)
MC4500IEPP15T		32.72" (831 mm)	---
MC4500IEPP15B	15" (375 mm)	---	1.70" (43 mm)
MC4500IEPP18T		29.36" (746 mm)	---
MC4500IEPP18TW	18" (450 mm)	---	1.97" (50 mm)
MC4500IEPP18B			
MC4500IEPP18BW			
MC4500IEPP24T	24" (600 mm)	23.05" (585 mm)	---
MC4500IEPP24TW			
MC4500IEPP24B			
MC4500IEPP24BW		---	2.26" (57 mm)
MC4500IEPP30BW	30" (750 mm)	---	2.95" (75 mm)
MC4500IEPP36BW	36" (900 mm)	---	3.25" (83 mm)
MC4500IEPP42BW	42" (1050 mm)	---	3.55" (90 mm)

NOTE: ALL DIMENSIONS ARE NOMINAL

MC-SERIES END CAP INSERTION DETAIL

NTS

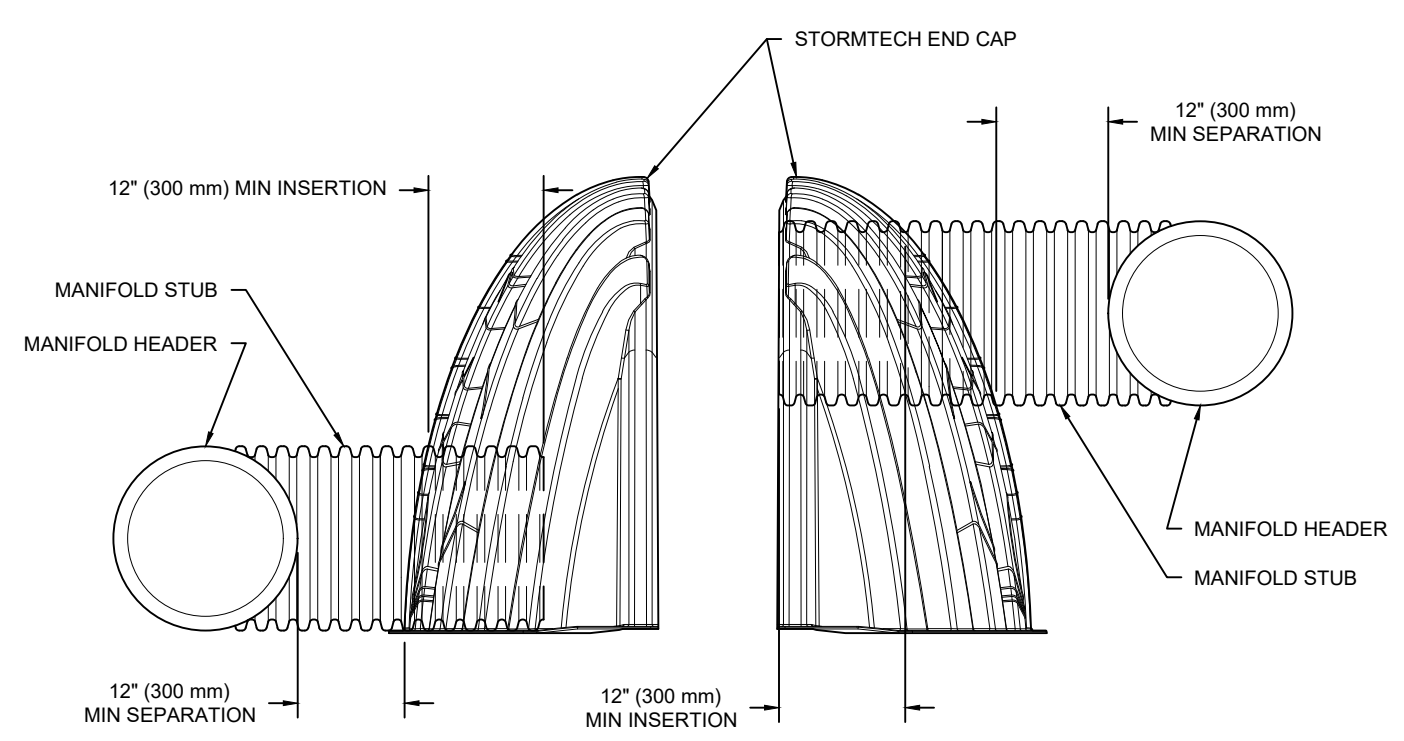

NOTE: MANIFOLD STUB MUST BE LAID HORIZONTAL FOR A PROPER FIT IN END CAP OPENING.

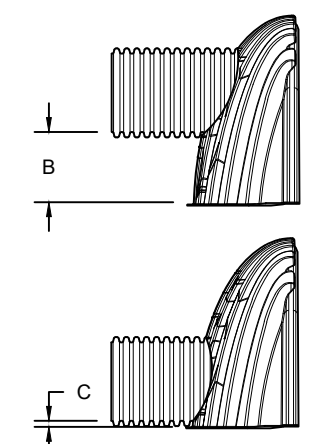

CUSTOM PARTIAL CUT INVERTS ARE AVAILABLE UPON REQUEST. INVENTORIED MANIFOLDS INCLUDE 12-24" (300-600 mm) SIZE ON SIZE AND 15-48" (375-1200 mm) ECCENTRIC MANIFOLDS. CUSTOM INVERT LOCATIONS ON THE MC-4500 END CAP CUT IN THE FIELD ARE NOT RECOMMENDED FOR PIPE SIZES GREATER THAN 10" (250 mm). THE INVERT LOCATION IN COLUMN 'B' ARE THE HIGHEST POSSIBLE FOR THE PIPE SIZE.

DA 1 WEST, BLOOMINGTON SITE 3
SCHEME 1
BLOOMINGTON, CA

DATE: 12/7/2020
DRAWN: HP
PROJECT #:
CHECKED: N/A

REV	DRW	CHK

DESCRIPTION

520 CROMWELL AVENUE | ROCKY HILL | CT | 06067
860-525-8188 | 888-892-2894 | WWW.STORMTECH.COM

4840 TRUEMAN BLVD
HILLIARD, OH 43026
1-800-733-7473

ADVANCED DRAINAGE SYSTEMS, INC.

SHEET
5 OF 5

THIS DRAWING HAS BEEN PREPARED BASED ON INFORMATION PROVIDED TO ADS UNDER THE DIRECTION OF THE SITE DESIGN ENGINEER OR OTHER PROJECT REPRESENTATIVE. THE SITE DESIGN ENGINEER SHALL REVIEW THIS DRAWING PRIOR TO CONSTRUCTION. IT IS THE ULTIMATE RESPONSIBILITY OF THE SITE DESIGN ENGINEER TO ENSURE THAT THE PRODUCT(S) DEPICTED AND ALL ASSOCIATED DETAILS MEET ALL APPLICABLE LAWS, REGULATIONS, AND PROJECT REQUIREMENTS.

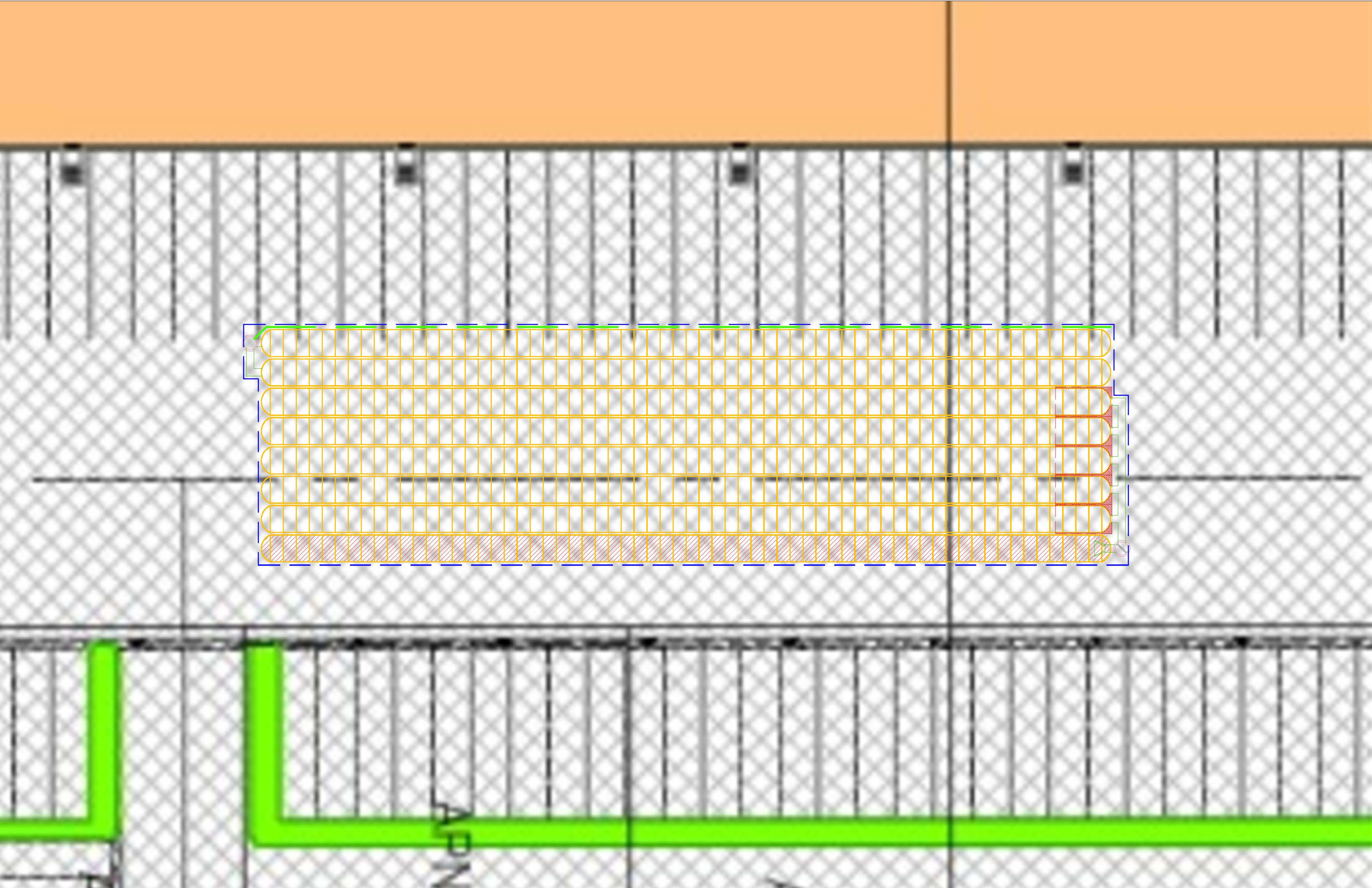

PROJECT INFORMATION	
ENGINEERED PRODUCT MANAGER	
ADS SALES REP	
PROJECT NO.	



ADVANCED DRAINAGE SYSTEMS, INC.



DA 2 NORTH, BLOOMINGTON SITE 3 SCHEME 1

BLOOMINGTON, CA

MC-4500 STORMTECH CHAMBER SPECIFICATIONS

- CHAMBERS SHALL BE STORMTECH MC-4500.
- CHAMBERS SHALL BE ARCH-SHAPED AND SHALL BE MANUFACTURED FROM VIRGIN, IMPACT-MODIFIED POLYPROPYLENE COPOLYMERS.
- CHAMBERS SHALL MEET THE REQUIREMENTS OF ASTM F2418-16a, "STANDARD SPECIFICATION FOR POLYPROPYLENE (PP) CORRUGATED WALL STORMWATER COLLECTION CHAMBERS" CHAMBER CLASSIFICATION 60x101.
- CHAMBER ROWS SHALL PROVIDE CONTINUOUS, UNOBSTRUCTED INTERNAL SPACE WITH NO INTERNAL SUPPORTS THAT WOULD IMPEDE FLOW OR LIMIT ACCESS FOR INSPECTION.
- THE STRUCTURAL DESIGN OF THE CHAMBERS, THE STRUCTURAL BACKFILL, AND THE INSTALLATION REQUIREMENTS SHALL ENSURE THAT THE LOAD FACTORS SPECIFIED IN THE AASHTO LRFD BRIDGE DESIGN SPECIFICATIONS, SECTION 12.12, ARE MET FOR: 1) LONG-DURATION DEAD LOADS AND 2) SHORT-DURATION LIVE LOADS, BASED ON THE AASHTO DESIGN TRUCK WITH CONSIDERATION FOR IMPACT AND MULTIPLE VEHICLE PRESENCES.
- CHAMBERS SHALL BE DESIGNED, TESTED AND ALLOWABLE LOAD CONFIGURATIONS DETERMINED IN ACCORDANCE WITH ASTM F2787, "STANDARD PRACTICE FOR STRUCTURAL DESIGN OF THERMOPLASTIC CORRUGATED WALL STORMWATER COLLECTION CHAMBERS". LOAD CONFIGURATIONS SHALL INCLUDE: 1) INSTANTANEOUS (<1 MIN) AASHTO DESIGN TRUCK LIVE LOAD ON MINIMUM COVER 2) MAXIMUM PERMANENT (75-YR) COVER LOAD AND 3) ALLOWABLE COVER WITH PARKED (1-WEEK) AASHTO DESIGN TRUCK.
- REQUIREMENTS FOR HANDLING AND INSTALLATION:
 - TO MAINTAIN THE WIDTH OF CHAMBERS DURING SHIPPING AND HANDLING, CHAMBERS SHALL HAVE INTEGRAL, INTERLOCKING STACKING LUGS.
 - TO ENSURE A SECURE JOINT DURING INSTALLATION AND BACKFILL, THE HEIGHT OF THE CHAMBER JOINT SHALL NOT BE LESS THAN 3".
 - TO ENSURE THE INTEGRITY OF THE ARCH SHAPE DURING INSTALLATION, a) THE ARCH STIFFNESS CONSTANT AS DEFINED IN SECTION 6.2.8 OF ASTM F2418 SHALL BE GREATER THAN OR EQUAL TO 500 LBS/IN/IN. AND b) TO RESIST CHAMBER DEFORMATION DURING INSTALLATION AT ELEVATED TEMPERATURES (ABOVE 73° F / 23° C), CHAMBERS SHALL BE PRODUCED FROM REFLECTIVE GOLD OR YELLOW COLORS.
- ONLY CHAMBERS THAT ARE APPROVED BY THE SITE DESIGN ENGINEER WILL BE ALLOWED. UPON REQUEST BY THE SITE DESIGN ENGINEER OR OWNER, THE CHAMBER MANUFACTURER SHALL SUBMIT A STRUCTURAL EVALUATION FOR APPROVAL BEFORE DELIVERING CHAMBERS TO THE PROJECT SITE AS FOLLOWS:
 - THE STRUCTURAL EVALUATION SHALL BE SEALED BY A REGISTERED PROFESSIONAL ENGINEER.
 - THE STRUCTURAL EVALUATION SHALL DEMONSTRATE THAT THE SAFETY FACTORS ARE GREATER THAN OR EQUAL TO 1.95 FOR DEAD LOAD AND 1.75 FOR LIVE LOAD, THE MINIMUM REQUIRED BY ASTM F2787 AND BY SECTIONS 3 AND 12.12 OF THE AASHTO LRFD BRIDGE DESIGN SPECIFICATIONS FOR THERMOPLASTIC PIPE.
 - THE TEST DERIVED CREEP MODULUS AS SPECIFIED IN ASTM F2418 SHALL BE USED FOR PERMANENT DEAD LOAD DESIGN EXCEPT THAT IT SHALL BE THE 75-YEAR MODULUS USED FOR DESIGN.
- CHAMBERS AND END CAPS SHALL BE PRODUCED AT AN ISO 9001 CERTIFIED MANUFACTURING FACILITY.

IMPORTANT - NOTES FOR THE BIDDING AND INSTALLATION OF MC-4500 CHAMBER SYSTEM

- STORMTECH MC-4500 CHAMBERS SHALL NOT BE INSTALLED UNTIL THE MANUFACTURER'S REPRESENTATIVE HAS COMPLETED A PRE-CONSTRUCTION MEETING WITH THE INSTALLERS.
- STORMTECH MC-4500 CHAMBERS SHALL BE INSTALLED IN ACCORDANCE WITH THE "STORMTECH MC-3500/MC-4500 CONSTRUCTION GUIDE".
- CHAMBERS ARE NOT TO BE BACKFILLED WITH A DOZER OR EXCAVATOR SITUATED OVER THE CHAMBERS. STORMTECH RECOMMENDS 3 BACKFILL METHODS:
 - STONESHOOTER LOCATED OFF THE CHAMBER BED.
 - BACKFILL AS ROWS ARE BUILT USING AN EXCAVATOR ON THE FOUNDATION STONE OR SUBGRADE.
 - BACKFILL FROM OUTSIDE THE EXCAVATION USING A LONG BOOM HOE OR EXCAVATOR.
- THE FOUNDATION STONE SHALL BE LEVELED AND COMPACTED PRIOR TO PLACING CHAMBERS.
- JOINTS BETWEEN CHAMBERS SHALL BE PROPERLY SEATED PRIOR TO PLACING STONE.
- MAINTAIN MINIMUM 9" (230 mm) SPACING BETWEEN THE CHAMBER ROWS.
- INLET AND OUTLET MANIFOLDS MUST BE INSERTED A MINIMUM OF 12" (300 mm) INTO CHAMBER END CAPS.
- EMBEDMENT STONE SURROUNDING CHAMBERS MUST BE A CLEAN, CRUSHED, ANGULAR STONE MEETING THE AASHTO M43 DESIGNATION OF #3 OR #4.
- STONE SHALL BE BROUGHT UP EVENLY AROUND CHAMBERS SO AS NOT TO DISTORT THE CHAMBER SHAPE. STONE DEPTHS SHOULD NEVER DIFFER BY MORE THAN 12" (300 mm) BETWEEN ADJACENT CHAMBER ROWS.
- STONE MUST BE PLACED ON THE TOP CENTER OF THE CHAMBER TO ANCHOR THE CHAMBERS IN PLACE AND PRESERVE ROW SPACING.
- THE CONTRACTOR MUST REPORT ANY DISCREPANCIES WITH CHAMBER FOUNDATION MATERIAL BEARING CAPACITIES TO THE SITE DESIGN ENGINEER.
- ADS RECOMMENDS THE USE OF "FLEXSTORM CATCH IT" INSERTS DURING CONSTRUCTION FOR ALL INLETS TO PROTECT THE SUBSURFACE STORMWATER MANAGEMENT SYSTEM FROM CONSTRUCTION SITE RUNOFF.

NOTES FOR CONSTRUCTION EQUIPMENT

- STORMTECH MC-4500 CHAMBERS SHALL BE INSTALLED IN ACCORDANCE WITH THE "STORMTECH MC-3500/MC-4500 CONSTRUCTION GUIDE".
- THE USE OF EQUIPMENT OVER MC-4500 CHAMBERS IS LIMITED:
 - NO EQUIPMENT IS ALLOWED ON BARE CHAMBERS.
 - NO RUBBER Tired LOADER, DUMP TRUCK, OR EXCAVATORS ARE ALLOWED UNTIL PROPER FILL DEPTHS ARE REACHED IN ACCORDANCE WITH THE "STORMTECH MC-3500/MC-4500 CONSTRUCTION GUIDE".
 - WEIGHT LIMITS FOR CONSTRUCTION EQUIPMENT CAN BE FOUND IN THE "STORMTECH MC-3500/MC-4500 CONSTRUCTION GUIDE".
- FULL 36" (900 mm) OF STABILIZED COVER MATERIALS OVER THE CHAMBERS IS REQUIRED FOR DUMP TRUCK TRAVEL OR DUMPING.

USE OF A DOZER TO PUSH EMBEDMENT STONE BETWEEN THE ROWS OF CHAMBERS MAY CAUSE DAMAGE TO CHAMBERS AND IS NOT AN ACCEPTABLE BACKFILL METHOD. ANY CHAMBERS DAMAGED BY USING THE "DUMP AND PUSH" METHOD ARE NOT COVERED UNDER THE STORMTECH STANDARD WARRANTY.



CONTACT STORMTECH AT 1-888-892-2694 WITH ANY QUESTIONS ON INSTALLATION REQUIREMENTS OR WEIGHT LIMITS FOR CONSTRUCTION EQUIPMENT.

PROPOSED LAYOUT		CONCEPTUAL ELEVATIONS	
580	STORMTECH MC-4500 CHAMBERS	MAXIMUM ALLOWABLE GRADE (TOP OF PAVEMENT/UNPAVED):	12.75
10	STORMTECH MC-4500 END CAPS	MINIMUM ALLOWABLE GRADE (UNPAVED WITH TRAFFIC):	8.25
12	STONE ABOVE (in)	MINIMUM ALLOWABLE GRADE (UNPAVED NO TRAFFIC):	7.75
9	STONE BELOW (in)	MINIMUM ALLOWABLE GRADE (TOP OF RIGID CONCRETE PAVEMENT):	7.75
40	STONE VOID	MINIMUM ALLOWABLE GRADE (BASE OF FLEXIBLE PAVEMENT):	7.75
98617	INSTALLED SYSTEM VOLUME (CF) (PERIMETER STONE INCLUDED) (COVER STONE INCLUDED) (BASE STONE INCLUDED)	TOP OF STONE:	6.75
		TOP OF MC-4500 CHAMBER:	5.75
		24" x 24" BOTTOM MANIFOLD INVERT:	0.94
		24" x 24" BOTTOM MANIFOLD INVERT:	0.94
		24" ISOLATOR ROW PLUS INVERT:	0.94
22709	SYSTEM AREA (SF)	24" BOTTOM CONNECTION INVERT:	0.94
1061.2	SYSTEM PERIMETER (ft)	24" BOTTOM CONNECTION INVERT:	0.94
		BOTTOM OF MC-4500 CHAMBER:	0.75
		UNDERDRAIN INVERT:	0.00
		BOTTOM OF STONE:	0.00

PART TYPE	ITEM ON LAYOUT	DESCRIPTION	INVERT*	MAX FLOW
PREFABRICATED END CAP	A	24" BOTTOM PARTIAL CUT END CAP, PART#: MC4500IEPP24B / TYP OF ALL 24" BOTTOM CONNECTIONS AND ISOLATOR PLUS ROWS	2.26"	
FLAMP	B	INSTALL FLAMP ON 24" ACCESS PIPE / PART#: MC450024RAMP		
MANIFOLD	C	24" x 24" BOTTOM MANIFOLD, ADS N-12	2.26"	
MANIFOLD	D	24" x 24" BOTTOM MANIFOLD, ADS N-12	2.26"	
CONCRETE STRUCTURE	E	OCS (DESIGN BY ENGINEER / PROVIDED BY OTHERS)		14.0 CFS OUT
CONCRETE STRUCTURE	F	(DESIGN BY ENGINEER / PROVIDED BY OTHERS)		38.0 CFS IN
W/WEIR				
UNDERDRAIN	G	6" ADS N-12 DUAL WALL PERFORATED HDPE UNDERDRAIN		

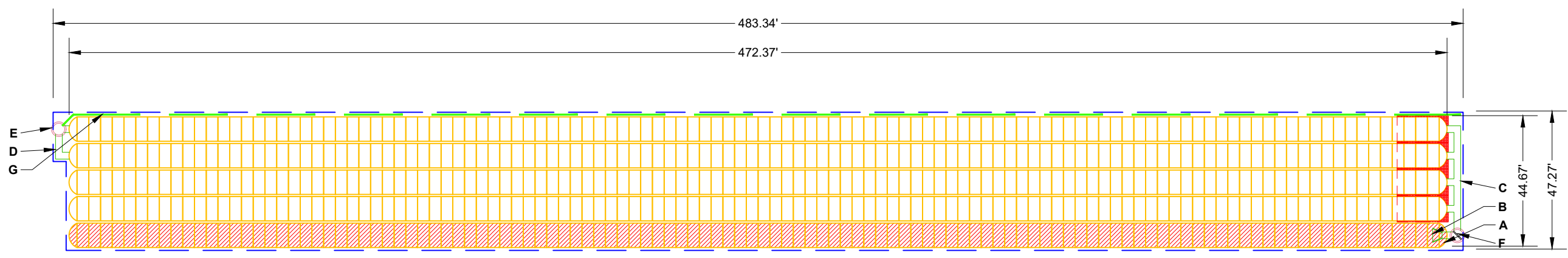
*INVERT ABOVE BASE OF CHAMBER 3



-  ISOLATOR ROW PLUS (SEE DETAIL)
-  PLACE MINIMUM 17.50' OF ADSPLUS175 WOVEN GEOTEXTILE OVER BEDDING STONE AND UNDERNEATH CHAMBER FEET FOR SCOUR PROTECTION AT ALL CHAMBER INLET ROWS
-  BED LIMITS

NOTES

- MANIFOLD SIZE TO BE DETERMINED BY SITE DESIGN ENGINEER. SEE TECH NOTE #6.32 FOR MANIFOLD SIZING GUIDANCE.
- DUE TO THE ADAPTATION OF THIS CHAMBER SYSTEM TO SPECIFIC SITE AND DESIGN CONSTRAINTS, IT MAY BE NECESSARY TO CUT AND COUPLE ADDITIONAL PIPE TO STANDARD MANIFOLD COMPONENTS IN THE FIELD.
- THE SITE DESIGN ENGINEER MUST REVIEW ELEVATIONS AND IF NECESSARY ADJUST GRADING TO ENSURE THE CHAMBER COVER REQUIREMENTS ARE MET.
- THIS CHAMBER SYSTEM WAS DESIGNED WITHOUT SITE-SPECIFIC INFORMATION ON SOIL CONDITIONS OR BEARING CAPACITY. THE SITE DESIGN ENGINEER IS RESPONSIBLE FOR DETERMINING THE SUITABILITY OF THE SOIL AND PROVIDING THE BEARING CAPACITY OF THE INSITU SOILS. THE BASE STONE DEPTH MAY BE INCREASED OR DECREASED ONCE THIS INFORMATION IS PROVIDED.
- **NOT FOR CONSTRUCTION:** THIS LAYOUT IS FOR DIMENSIONAL PURPOSES ONLY TO PROVE CONCEPT & THE REQUIRED STORAGE VOLUME CAN BE ACHIEVED ON SITE.

DA 2 NORTH, BLOOMINGTON SITE 3

SCHEME 1

BLOOMINGTON, CA

DATE: 12/7/2020

PROJECT #:

DESCRIPTION

REV

DRW

CHK

DRAWN: HP

CHECKED: N/A



520 CROMWELL AVENUE | ROCKY HILL | CT | 06067
860-529-8188 | 888-892-2894 | WWW.STORMTECH.COM



4840 TRUEMAN BLVD
HILLIARD, OH 43026
1-800-733-7473

ADVANCED DRAINAGE SYSTEMS, INC.

80'

40'

0'

THIS DRAWING HAS BEEN PREPARED BASED ON INFORMATION PROVIDED TO ADS UNDER THE DIRECTION OF THE SITE DESIGN ENGINEER OR OTHER PROJECT REPRESENTATIVE. THE SITE DESIGN ENGINEER SHALL REVIEW THIS DRAWING PRIOR TO CONSTRUCTION. IT IS THE ULTIMATE RESPONSIBILITY OF THE SITE DESIGN ENGINEER TO ENSURE THAT THE PRODUCT(S) DEPICTED AND ALL ASSOCIATED DETAILS MEET ALL APPLICABLE LAWS, REGULATIONS, AND PROJECT REQUIREMENTS.

SHEET

2 OF 5

ACCEPTABLE FILL MATERIALS: STORMTECH MC-4500 CHAMBER SYSTEMS

MATERIAL LOCATION		DESCRIPTION	AASHTO MATERIAL CLASSIFICATIONS	COMPACTION / DENSITY REQUIREMENT
D	FINAL FILL: FILL MATERIAL FOR LAYER 'D' STARTS FROM THE TOP OF THE 'C' LAYER TO THE BOTTOM OF FLEXIBLE PAVEMENT OR UNPAVED FINISHED GRADE ABOVE. NOTE THAT PAVEMENT SUBBASE MAY BE PART OF THE 'D' LAYER	ANY SOIL/ROCK MATERIALS, NATIVE SOILS, OR PER ENGINEER'S PLANS. CHECK PLANS FOR PAVEMENT SUBGRADE REQUIREMENTS.	N/A	PREPARE PER SITE DESIGN ENGINEER'S PLANS. PAVED INSTALLATIONS MAY HAVE STRINGENT MATERIAL AND PREPARATION REQUIREMENTS.
C	INITIAL FILL: FILL MATERIAL FOR LAYER 'C' STARTS FROM THE TOP OF THE EMBEDMENT STONE ('B' LAYER) TO 24" (600 mm) ABOVE THE TOP OF THE CHAMBER. NOTE THAT PAVEMENT SUBBASE MAY BE A PART OF THE 'C' LAYER.	GRANULAR WELL-GRADED SOIL/AGGREGATE MIXTURES, <35% FINES OR PROCESSED AGGREGATE. MOST PAVEMENT SUBBASE MATERIALS CAN BE USED IN LIEU OF THIS LAYER.	AASHTO M145 ¹ A-1, A-2-4, A-3 OR AASHTO M43 ¹ 3, 357, 4, 467, 5, 56, 57, 6, 67, 68, 7, 78, 8, 89, 9, 10	BEGIN COMPACTIONS AFTER 24" (600 mm) OF MATERIAL OVER THE CHAMBERS IS REACHED. COMPACT ADDITIONAL LAYERS IN 12" (300 mm) MAX LIFTS TO A MIN. 95% PROCTOR DENSITY FOR WELL GRADED MATERIAL AND 95% RELATIVE DENSITY FOR PROCESSED AGGREGATE MATERIALS.
B	EMBEDMENT STONE: FILL SURROUNDING THE CHAMBERS FROM THE FOUNDATION STONE ('A' LAYER) TO THE 'C' LAYER ABOVE.	CLEAN, CRUSHED, ANGULAR STONE	AASHTO M43 ¹ 3, 4	NO COMPACTION REQUIRED.
A	FOUNDATION STONE: FILL BELOW CHAMBERS FROM THE SUBGRADE UP TO THE FOOT (BOTTOM) OF THE CHAMBER.	CLEAN, CRUSHED, ANGULAR STONE	AASHTO M43 ¹ 3, 4	PLATE COMPACT OR ROLL TO ACHIEVE A FLAT SURFACE. ^{2,3}

PLEASE NOTE:

- THE LISTED AASHTO DESIGNATIONS ARE FOR GRADATIONS ONLY. THE STONE MUST ALSO BE CLEAN, CRUSHED, ANGULAR. FOR EXAMPLE, A SPECIFICATION FOR #4 STONE WOULD STATE: "CLEAN, CRUSHED, ANGULAR NO. 4 (AASHTO M43) STONE".
- STORMTECH COMPACTION REQUIREMENTS ARE MET FOR 'A' LOCATION MATERIALS WHEN PLACED AND COMPACTED IN 9" (230 mm) (MAX) LIFTS USING TWO FULL COVERAGES WITH A VIBRATORY COMPACTOR.
- WHERE INFILTRATION SURFACES MAY BE COMPROMISED BY COMPACTION, FOR STANDARD DESIGN LOAD CONDITIONS, A FLAT SURFACE MAY BE ACHIEVED BY RAKING OR DRAGGING WITHOUT COMPACTION EQUIPMENT. FOR SPECIAL LOAD DESIGNS, CONTACT STORMTECH FOR COMPACTION REQUIREMENTS.
- ONCE LAYER 'C' IS PLACED, ANY SOIL/MATERIAL CAN BE PLACED IN LAYER 'D' UP TO THE FINISHED GRADE. MOST PAVEMENT SUBBASE SOILS CAN BE USED TO REPLACE THE MATERIAL REQUIREMENTS OF LAYER 'C' OR 'D' AT THE SITE DESIGN ENGINEER'S DISCRETION.

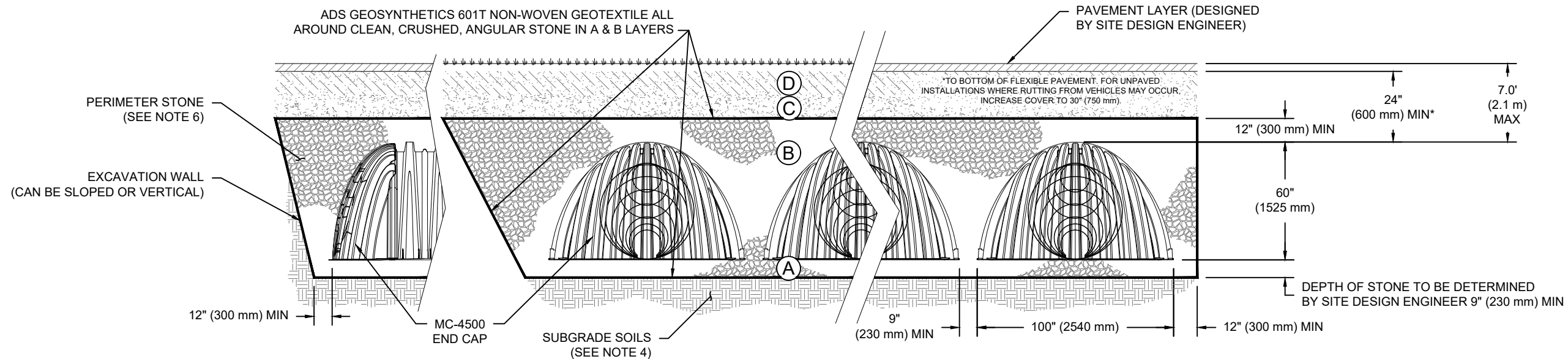

NOTES:

- CHAMBERS SHALL MEET THE REQUIREMENTS OF ASTM F2418-16a, "STANDARD SPECIFICATION FOR POLYPROPYLENE (PP) CORRUGATED WALL STORMWATER COLLECTION CHAMBERS" CHAMBER CLASSIFICATION 60x101
- MC-4500 CHAMBERS SHALL BE DESIGNED IN ACCORDANCE WITH ASTM F2787 "STANDARD PRACTICE FOR STRUCTURAL DESIGN OF THERMOPLASTIC CORRUGATED WALL STORMWATER COLLECTION CHAMBERS".
- THE SITE DESIGN ENGINEER IS RESPONSIBLE FOR ASSESSING THE BEARING RESISTANCE (ALLOWABLE BEARING CAPACITY) OF THE SUBGRADE SOILS AND THE DEPTH OF FOUNDATION STONE WITH CONSIDERATION FOR THE RANGE OF EXPECTED SOIL MOISTURE CONDITIONS.
- PERIMETER STONE MUST BE EXTENDED HORIZONTALLY TO THE EXCAVATION WALL FOR BOTH VERTICAL AND SLOPED EXCAVATION WALLS.
- REQUIREMENTS FOR HANDLING AND INSTALLATION:
 - TO MAINTAIN THE WIDTH OF CHAMBERS DURING SHIPPING AND HANDLING, CHAMBERS SHALL HAVE INTEGRAL, INTERLOCKING STACKING LUGS.
 - TO ENSURE A SECURE JOINT DURING INSTALLATION AND BACKFILL, THE HEIGHT OF THE CHAMBER JOINT SHALL NOT BE LESS THAN 3".
 - TO ENSURE THE INTEGRITY OF THE ARCH SHAPE DURING INSTALLATION, a) THE ARCH STIFFNESS CONSTANT AS DEFINED IN SECTION 6.2.8 OF ASTM F2418 SHALL BE GREATER THAN OR EQUAL TO 500 LBS/IN/IN. AND b) TO RESIST CHAMBER DEFORMATION DURING INSTALLATION AT ELEVATED TEMPERATURES (ABOVE 73° F / 23° C), CHAMBERS SHALL BE PRODUCED FROM REFLECTIVE GOLD OR YELLOW COLORS.

DA 2 NORTH, BLOOMINGTON SITE 3
 SCHEME 1
 BLOOMINGTON, CA
 DATE: 12/7/2020
 DRAWN: HP
 PROJECT #:
 CHECKED: N/A

DESCRIPTION
 REV
 DRW
 CHK

StormTech
 Determination • Retention • Water Quality
 520 CROMWELL AVENUE | ROCKY HILL | CT | 06067
 860-529-8188 | 888-892-2894 | WWW.STORMTECH.COM

4840 TRUEMAN BLVD
 HILLIARD, OH 43026
 1-800-733-7473
ADS
 ADVANCED DRAINAGE SYSTEMS, INC.

THIS DRAWING HAS BEEN PREPARED BASED ON INFORMATION PROVIDED TO ADS UNDER THE DIRECTION OF THE SITE DESIGN ENGINEER OR OTHER PROJECT REPRESENTATIVE. THE SITE DESIGN ENGINEER SHALL REVIEW THIS DRAWING PRIOR TO CONSTRUCTION. IT IS THE ULTIMATE RESPONSIBILITY OF THE SITE DESIGN ENGINEER TO ENSURE THAT THE PRODUCT(S) DEPICTED AND ALL ASSOCIATED DETAILS MEET ALL APPLICABLE LAWS, REGULATIONS, AND PROJECT REQUIREMENTS.

SHEET
3 OF 5

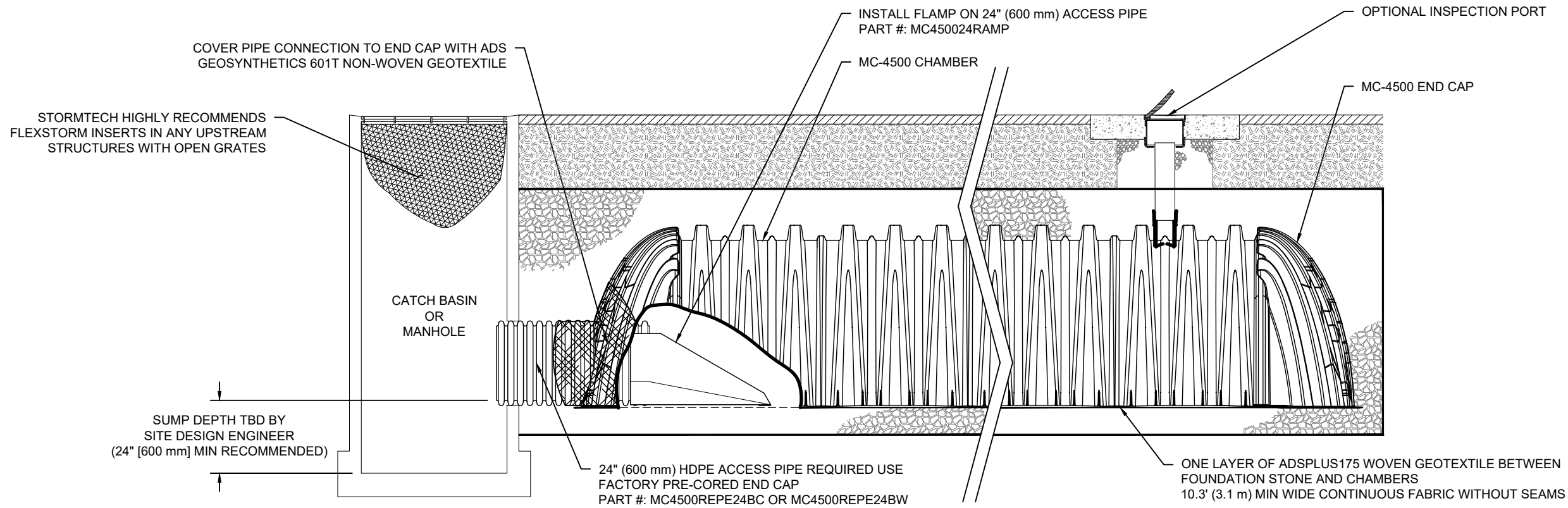

MC-4500 ISOLATOR ROW PLUS DETAIL
NTS

INSPECTION & MAINTENANCE

- STEP 1) INSPECT ISOLATOR ROW PLUS FOR SEDIMENT
- A. INSPECTION PORTS (IF PRESENT)
 - A.1. REMOVE/OPEN LID ON NYLOPLAST INLINE DRAIN
 - A.2. REMOVE AND CLEAN FLEXSTORM FILTER IF INSTALLED
 - A.3. USING A FLASHLIGHT AND STADIA ROD, MEASURE DEPTH OF SEDIMENT AND RECORD ON MAINTENANCE LOG
 - A.4. LOWER A CAMERA INTO ISOLATOR ROW PLUS FOR VISUAL INSPECTION OF SEDIMENT LEVELS (OPTIONAL)
 - A.5. IF SEDIMENT IS AT, OR ABOVE, 3" (80 mm) PROCEED TO STEP 2. IF NOT, PROCEED TO STEP 3.
 - B. ALL ISOLATOR PLUS ROWS
 - B.1. REMOVE COVER FROM STRUCTURE AT UPSTREAM END OF ISOLATOR ROW PLUS
 - B.2. USING A FLASHLIGHT, INSPECT DOWN THE ISOLATOR ROW PLUS THROUGH OUTLET PIPE
 - i) MIRRORS ON POLES OR CAMERAS MAY BE USED TO AVOID A CONFINED SPACE ENTRY
 - ii) FOLLOW OSHA REGULATIONS FOR CONFINED SPACE ENTRY IF ENTERING MANHOLE
 - B.3. IF SEDIMENT IS AT, OR ABOVE, 3" (80 mm) PROCEED TO STEP 2. IF NOT, PROCEED TO STEP 3.
- STEP 2) CLEAN OUT ISOLATOR ROW PLUS USING THE JETVAC PROCESS
- A. A FIXED CULVERT CLEANING NOZZLE WITH REAR FACING SPREAD OF 45" (1.1 m) OR MORE IS PREFERRED
 - B. APPLY MULTIPLE PASSES OF JETVAC UNTIL BACKFLUSH WATER IS CLEAN
 - C. VACUUM STRUCTURE SUMP AS REQUIRED
- STEP 3) REPLACE ALL COVERS, GRATES, FILTERS, AND LIDS; RECORD OBSERVATIONS AND ACTIONS.
- STEP 4) INSPECT AND CLEAN BASINS AND MANHOLES UPSTREAM OF THE STORMTECH SYSTEM.

NOTES

1. INSPECT EVERY 6 MONTHS DURING THE FIRST YEAR OF OPERATION. ADJUST THE INSPECTION INTERVAL BASED ON PREVIOUS OBSERVATIONS OF SEDIMENT ACCUMULATION AND HIGH WATER ELEVATIONS.
2. CONDUCT JETTING AND VACTORING ANNUALLY OR WHEN INSPECTION SHOWS THAT MAINTENANCE IS NECESSARY.

	DESCRIPTION	CHK	REV	DRW	PROJECT #:	DATE: 12/7/2020	DRAWN: HP
<p>DA 2 NORTH, BLOOMINGTON SITE 3 SCHEME 1 BLOOMINGTON, CA</p>							
<p>StormTech Determination • Retention • Water Quality</p> <p>520 CROMWELL AVENUE ROCKY HILL CT 06067 860-525-8188 888-892-2894 WWW.STORMTECH.COM</p>							
<p>4840 TRUEMAN BLVD HILLIARD, OH 43026 1-800-733-7473</p>							
<p>ADS ADVANCED DRAINAGE SYSTEMS, INC.</p>							
<p>THIS DRAWING HAS BEEN PREPARED BASED ON INFORMATION PROVIDED TO ADS UNDER THE DIRECTION OF THE SITE DESIGN ENGINEER OR OTHER PROJECT REPRESENTATIVE. THE SITE DESIGN ENGINEER SHALL REVIEW THIS DRAWING PRIOR TO CONSTRUCTION. IT IS THE ULTIMATE RESPONSIBILITY OF THE SITE DESIGN ENGINEER TO ENSURE THAT THE PRODUCT(S) DEPICTED AND ALL ASSOCIATED DETAILS MEET ALL APPLICABLE LAWS, REGULATIONS, AND PROJECT REQUIREMENTS.</p>							
<p>SHEET 4 OF 5</p>							

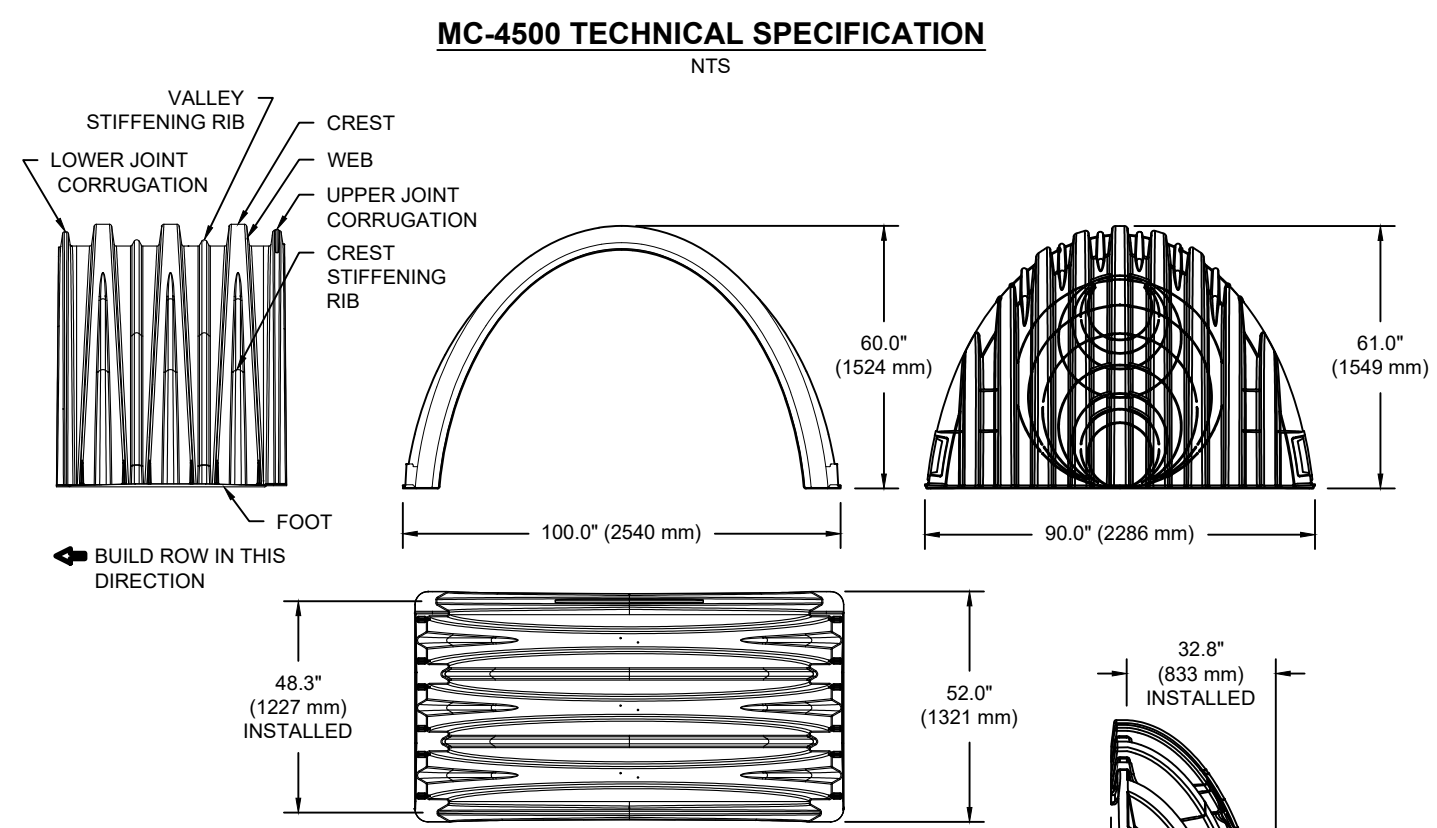
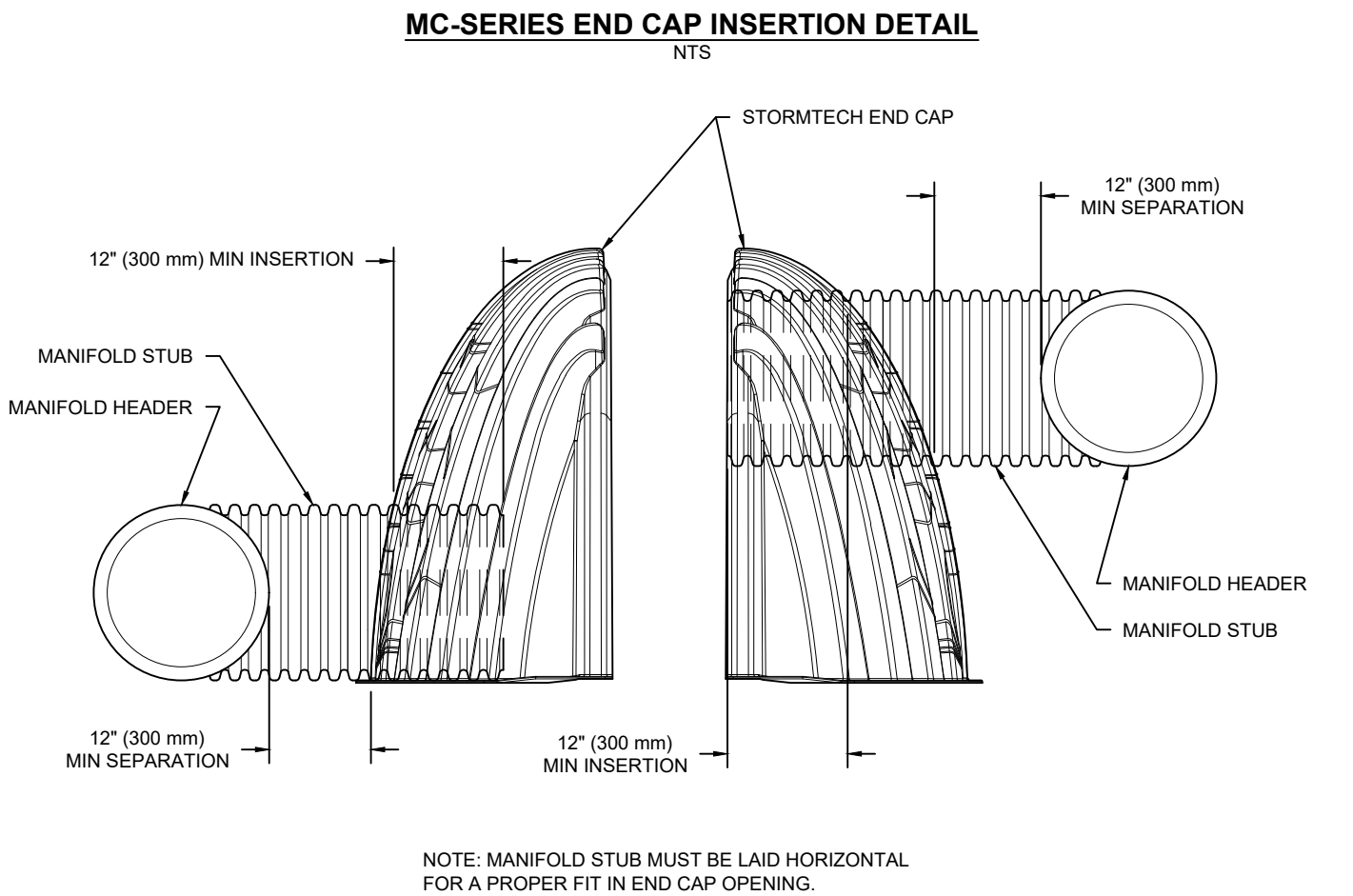
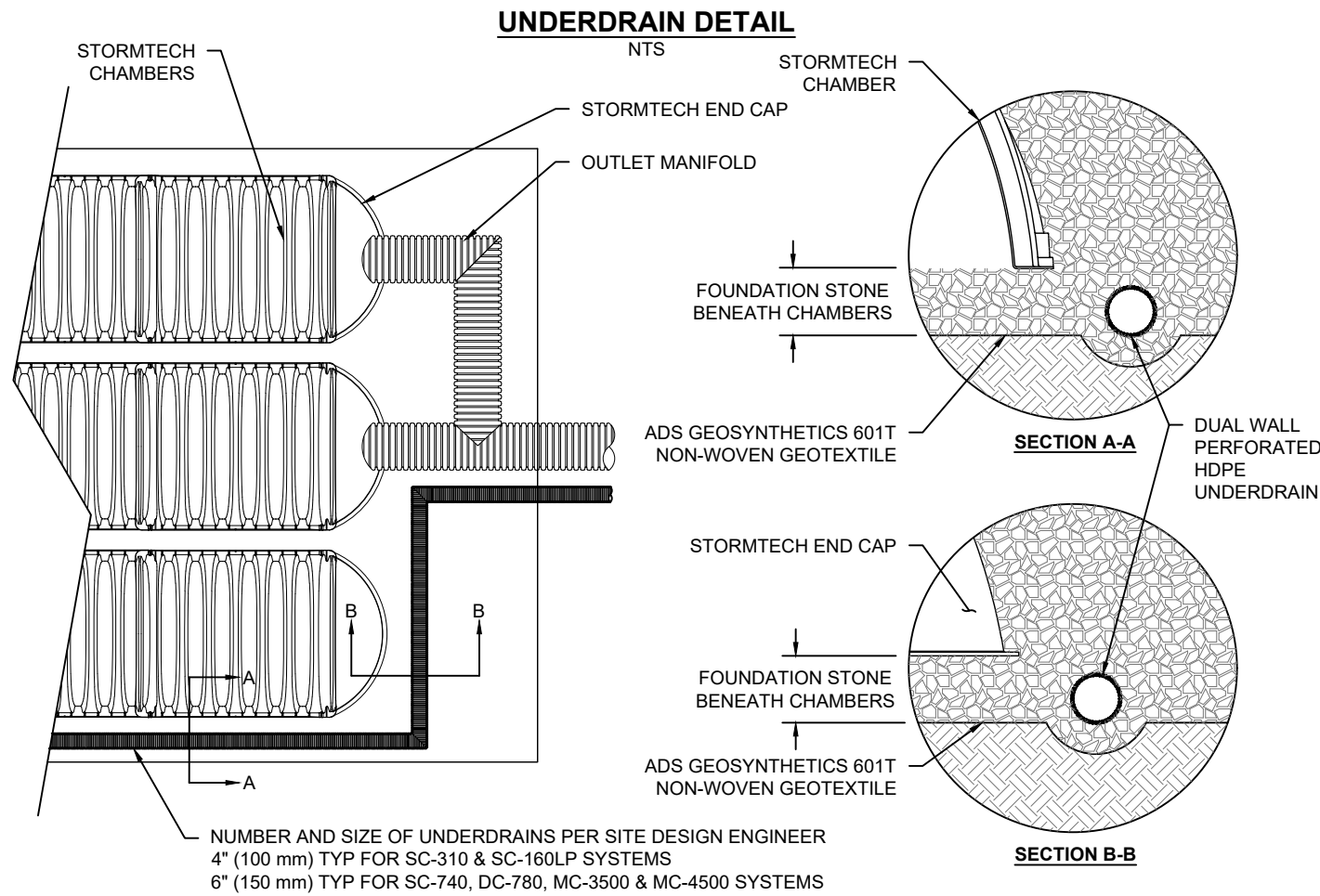

NOMINAL CHAMBER SPECIFICATIONS

SIZE (W X H X INSTALLED LENGTH)	100.0" X 60.0" X 48.3"	(2540 mm X 1524 mm X 1227 mm)
CHAMBER STORAGE	106.5 CUBIC FEET	(3.01 m ³)
MINIMUM INSTALLED STORAGE*	162.6 CUBIC FEET	(4.60 m ³)
WEIGHT (NOMINAL)	125.0 lbs.	(56.7 kg)

NOMINAL END CAP SPECIFICATIONS

SIZE (W X H X INSTALLED LENGTH)	90.0" X 61.0" X 32.8"	(2286 mm X 1549 mm X 833 mm)
END CAP STORAGE	39.5 CUBIC FEET	(1.12 m ³)
MINIMUM INSTALLED STORAGE*	115.3 CUBIC FEET	(3.26 m ³)
WEIGHT (NOMINAL)	90 lbs.	(40.8 kg)

*ASSUMES 12" (305 mm) STONE ABOVE, 9" (229 mm) STONE FOUNDATION AND BETWEEN CHAMBERS, 12" (305 mm) STONE PERIMETER IN FRONT OF END CAPS AND 40% STONE POROSITY.

PARTIAL CUT HOLES AT BOTTOM OF END CAP FOR PART NUMBERS ENDING WITH "B"
 PARTIAL CUT HOLES AT TOP OF END CAP FOR PART NUMBERS ENDING WITH "T"
 END CAPS WITH A PREFABRICATED WELDED STUB END WITH "W"

PART #	STUB	B	C
MC4500IEPP06T	6" (150 mm)	42.54" (1081 mm)	---
MC4500IEPP06B		---	0.86" (22 mm)
MC4500IEPP08T	8" (200 mm)	40.50" (1029 mm)	---
MC4500IEPP08B		---	1.01" (26 mm)
MC4500IEPP10T	10" (250 mm)	38.37" (975 mm)	---
MC4500IEPP10B		---	1.33" (34 mm)
MC4500IEPP12T	12" (300 mm)	35.69" (907 mm)	---
MC4500IEPP12B		---	1.55" (39 mm)
MC4500IEPP15T	15" (375 mm)	32.72" (831 mm)	---
MC4500IEPP15B		---	1.70" (43 mm)
MC4500IEPP18T	18" (450 mm)	29.36" (746 mm)	---
MC4500IEPP18TW		---	1.97" (50 mm)
MC4500IEPP18B		---	---
MC4500IEPP18BW		---	---
MC4500IEPP24T	24" (600 mm)	23.05" (585 mm)	---
MC4500IEPP24TW		---	2.26" (57 mm)
MC4500IEPP24B	30" (750 mm)	---	2.95" (75 mm)
MC4500IEPP24BW		---	3.25" (83 mm)
MC4500IEPP30BW	36" (900 mm)	---	3.55" (90 mm)
MC4500IEPP36BW	42" (1050 mm)	---	---
MC4500IEPP42BW	---	---	---

NOTE: ALL DIMENSIONS ARE NOMINAL

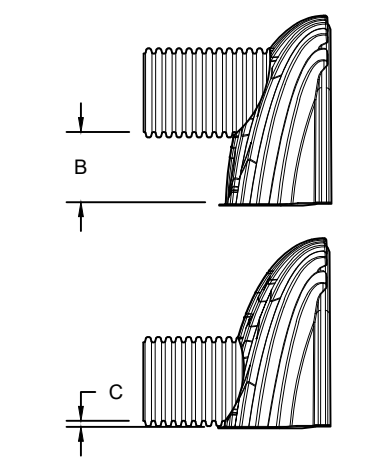

CUSTOM PARTIAL CUT INVERTS ARE AVAILABLE UPON REQUEST. INVENTORIED MANIFOLDS INCLUDE 12-24" (300-600 mm) SIZE ON SIZE AND 15-48" (375-1200 mm) ECCENTRIC MANIFOLDS. CUSTOM INVERT LOCATIONS ON THE MC-4500 END CAP CUT IN THE FIELD ARE NOT RECOMMENDED FOR PIPE SIZES GREATER THAN 10" (250 mm). THE INVERT LOCATION IN COLUMN 'B' ARE THE HIGHEST POSSIBLE FOR THE PIPE SIZE.

DA 2 NORTH, BLOOMINGTON SITE 3
 SCHEME 1
 BLOOMINGTON, CA

DATE: 12/7/2020
 DRAWN: HP
 PROJECT #:
 CHECKED: N/A

REV	DRW	CHK	DESCRIPTION

StormTech
 Precision Retention Water Quality
 520 CROMWELL AVENUE | ROCKY HILL | CT | 06067
 860-525-8188 | 888-892-2894 | WWW.STORMTECH.COM

4840 TRUEMAN BLVD
 HILLIARD, OH 43026
 1-800-733-7473
 ADS
 ADVANCED DRAINAGE SYSTEMS, INC.

THIS DRAWING HAS BEEN PREPARED BASED ON INFORMATION PROVIDED TO ADS UNDER THE DIRECTION OF THE SITE DESIGN ENGINEER OR OTHER PROJECT REPRESENTATIVE. THE SITE DESIGN ENGINEER SHALL REVIEW THIS DRAWING PRIOR TO CONSTRUCTION. IT IS THE ULTIMATE RESPONSIBILITY OF THE SITE DESIGN ENGINEER TO ENSURE THAT THE PRODUCT(S) DEPICTED AND ALL ASSOCIATED DETAILS MEET ALL APPLICABLE LAWS, REGULATIONS, AND PROJECT REQUIREMENTS.

SHEET
 5 OF 5

ICT

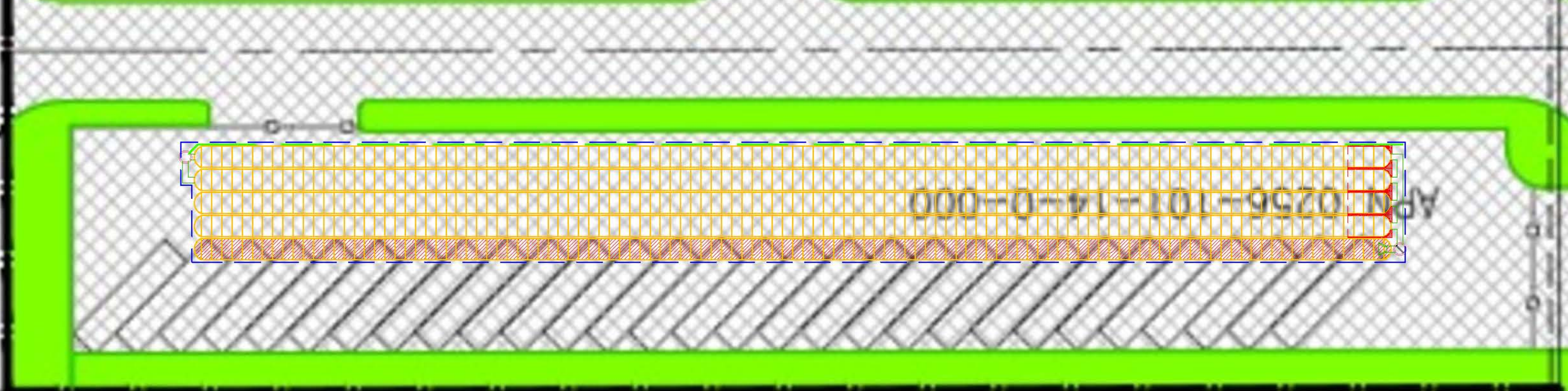
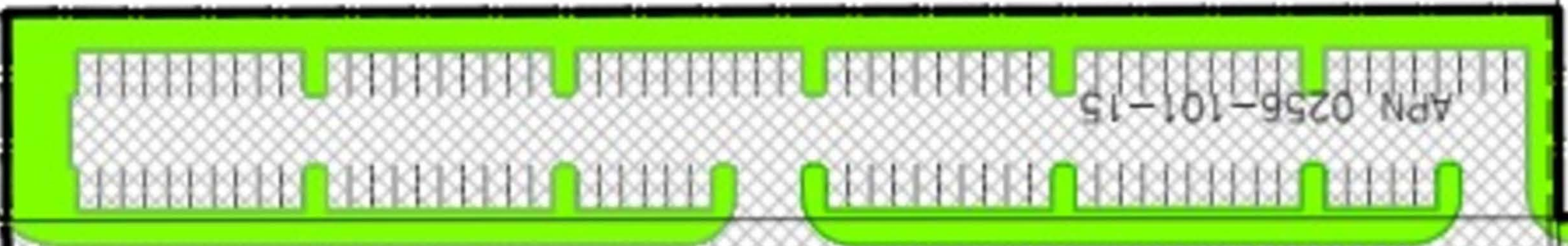

APN 0256-101-3

41

PROJECT INFORMATION	
ENGINEERED PRODUCT MANAGER	
ADS SALES REP	
PROJECT NO.	



ADVANCED DRAINAGE SYSTEMS, INC.



DA 2 SOUTH, BLOOMINGTON SITE 3 SCHEME 1

BLOOMINGTON, CA

MC-4500 STORMTECH CHAMBER SPECIFICATIONS

1. CHAMBERS SHALL BE STORMTECH MC-4500.
2. CHAMBERS SHALL BE ARCH-SHAPED AND SHALL BE MANUFACTURED FROM VIRGIN, IMPACT-MODIFIED POLYPROPYLENE COPOLYMERS.
3. CHAMBERS SHALL MEET THE REQUIREMENTS OF ASTM F2418-16a, "STANDARD SPECIFICATION FOR POLYPROPYLENE (PP) CORRUGATED WALL STORMWATER COLLECTION CHAMBERS" CHAMBER CLASSIFICATION 60x101.
4. CHAMBER ROWS SHALL PROVIDE CONTINUOUS, UNOBSTRUCTED INTERNAL SPACE WITH NO INTERNAL SUPPORTS THAT WOULD IMPEDE FLOW OR LIMIT ACCESS FOR INSPECTION.
5. THE STRUCTURAL DESIGN OF THE CHAMBERS, THE STRUCTURAL BACKFILL, AND THE INSTALLATION REQUIREMENTS SHALL ENSURE THAT THE LOAD FACTORS SPECIFIED IN THE AASHTO LRFD BRIDGE DESIGN SPECIFICATIONS, SECTION 12.12, ARE MET FOR: 1) LONG-DURATION DEAD LOADS AND 2) SHORT-DURATION LIVE LOADS, BASED ON THE AASHTO DESIGN TRUCK WITH CONSIDERATION FOR IMPACT AND MULTIPLE VEHICLE PRESENCES.
6. CHAMBERS SHALL BE DESIGNED, TESTED AND ALLOWABLE LOAD CONFIGURATIONS DETERMINED IN ACCORDANCE WITH ASTM F2787, "STANDARD PRACTICE FOR STRUCTURAL DESIGN OF THERMOPLASTIC CORRUGATED WALL STORMWATER COLLECTION CHAMBERS". LOAD CONFIGURATIONS SHALL INCLUDE: 1) INSTANTANEOUS (<1 MIN) AASHTO DESIGN TRUCK LIVE LOAD ON MINIMUM COVER 2) MAXIMUM PERMANENT (75-YR) COVER LOAD AND 3) ALLOWABLE COVER WITH PARKED (1-WEEK) AASHTO DESIGN TRUCK.
7. REQUIREMENTS FOR HANDLING AND INSTALLATION:
 - TO MAINTAIN THE WIDTH OF CHAMBERS DURING SHIPPING AND HANDLING, CHAMBERS SHALL HAVE INTEGRAL, INTERLOCKING STACKING LUGS.
 - TO ENSURE A SECURE JOINT DURING INSTALLATION AND BACKFILL, THE HEIGHT OF THE CHAMBER JOINT SHALL NOT BE LESS THAN 3".
 - TO ENSURE THE INTEGRITY OF THE ARCH SHAPE DURING INSTALLATION, a) THE ARCH STIFFNESS CONSTANT AS DEFINED IN SECTION 6.2.8 OF ASTM F2418 SHALL BE GREATER THAN OR EQUAL TO 500 LBS/IN/IN. AND b) TO RESIST CHAMBER DEFORMATION DURING INSTALLATION AT ELEVATED TEMPERATURES (ABOVE 73° F / 23° C), CHAMBERS SHALL BE PRODUCED FROM REFLECTIVE GOLD OR YELLOW COLORS.
8. ONLY CHAMBERS THAT ARE APPROVED BY THE SITE DESIGN ENGINEER WILL BE ALLOWED. UPON REQUEST BY THE SITE DESIGN ENGINEER OR OWNER, THE CHAMBER MANUFACTURER SHALL SUBMIT A STRUCTURAL EVALUATION FOR APPROVAL BEFORE DELIVERING CHAMBERS TO THE PROJECT SITE AS FOLLOWS:
 - THE STRUCTURAL EVALUATION SHALL BE SEALED BY A REGISTERED PROFESSIONAL ENGINEER.
 - THE STRUCTURAL EVALUATION SHALL DEMONSTRATE THAT THE SAFETY FACTORS ARE GREATER THAN OR EQUAL TO 1.95 FOR DEAD LOAD AND 1.75 FOR LIVE LOAD, THE MINIMUM REQUIRED BY ASTM F2787 AND BY SECTIONS 3 AND 12.12 OF THE AASHTO LRFD BRIDGE DESIGN SPECIFICATIONS FOR THERMOPLASTIC PIPE.
 - THE TEST DERIVED CREEP MODULUS AS SPECIFIED IN ASTM F2418 SHALL BE USED FOR PERMANENT DEAD LOAD DESIGN EXCEPT THAT IT SHALL BE THE 75-YEAR MODULUS USED FOR DESIGN.
9. CHAMBERS AND END CAPS SHALL BE PRODUCED AT AN ISO 9001 CERTIFIED MANUFACTURING FACILITY.

IMPORTANT - NOTES FOR THE BIDDING AND INSTALLATION OF MC-4500 CHAMBER SYSTEM

1. STORMTECH MC-4500 CHAMBERS SHALL NOT BE INSTALLED UNTIL THE MANUFACTURER'S REPRESENTATIVE HAS COMPLETED A PRE-CONSTRUCTION MEETING WITH THE INSTALLERS.
2. STORMTECH MC-4500 CHAMBERS SHALL BE INSTALLED IN ACCORDANCE WITH THE "STORMTECH MC-3500/MC-4500 CONSTRUCTION GUIDE".
3. CHAMBERS ARE NOT TO BE BACKFILLED WITH A DOZER OR EXCAVATOR SITUATED OVER THE CHAMBERS. STORMTECH RECOMMENDS 3 BACKFILL METHODS:
 - STONESHOOTER LOCATED OFF THE CHAMBER BED.
 - BACKFILL AS ROWS ARE BUILT USING AN EXCAVATOR ON THE FOUNDATION STONE OR SUBGRADE.
 - BACKFILL FROM OUTSIDE THE EXCAVATION USING A LONG BOOM HOE OR EXCAVATOR.
4. THE FOUNDATION STONE SHALL BE LEVELED AND COMPACTED PRIOR TO PLACING CHAMBERS.
5. JOINTS BETWEEN CHAMBERS SHALL BE PROPERLY SEATED PRIOR TO PLACING STONE.
6. MAINTAIN MINIMUM 9" (230 mm) SPACING BETWEEN THE CHAMBER ROWS.
7. INLET AND OUTLET MANIFOLDS MUST BE INSERTED A MINIMUM OF 12" (300 mm) INTO CHAMBER END CAPS.
8. EMBEDMENT STONE SURROUNDING CHAMBERS MUST BE A CLEAN, CRUSHED, ANGULAR STONE MEETING THE AASHTO M43 DESIGNATION OF #3 OR #4.
9. STONE SHALL BE BROUGHT UP EVENLY AROUND CHAMBERS SO AS NOT TO DISTORT THE CHAMBER SHAPE. STONE DEPTHS SHOULD NEVER DIFFER BY MORE THAN 12" (300 mm) BETWEEN ADJACENT CHAMBER ROWS.
10. STONE MUST BE PLACED ON THE TOP CENTER OF THE CHAMBER TO ANCHOR THE CHAMBERS IN PLACE AND PRESERVE ROW SPACING.
11. THE CONTRACTOR MUST REPORT ANY DISCREPANCIES WITH CHAMBER FOUNDATION MATERIAL BEARING CAPACITIES TO THE SITE DESIGN ENGINEER.
12. ADS RECOMMENDS THE USE OF "FLEXSTORM CATCH IT" INSERTS DURING CONSTRUCTION FOR ALL INLETS TO PROTECT THE SUBSURFACE STORMWATER MANAGEMENT SYSTEM FROM CONSTRUCTION SITE RUNOFF.

NOTES FOR CONSTRUCTION EQUIPMENT

1. STORMTECH MC-4500 CHAMBERS SHALL BE INSTALLED IN ACCORDANCE WITH THE "STORMTECH MC-3500/MC-4500 CONSTRUCTION GUIDE".
2. THE USE OF EQUIPMENT OVER MC-4500 CHAMBERS IS LIMITED:
 - NO EQUIPMENT IS ALLOWED ON BARE CHAMBERS.
 - NO RUBBER Tired LOADER, DUMP TRUCK, OR EXCAVATORS ARE ALLOWED UNTIL PROPER FILL DEPTHS ARE REACHED IN ACCORDANCE WITH THE "STORMTECH MC-3500/MC-4500 CONSTRUCTION GUIDE".
 - WEIGHT LIMITS FOR CONSTRUCTION EQUIPMENT CAN BE FOUND IN THE "STORMTECH MC-3500/MC-4500 CONSTRUCTION GUIDE".
3. FULL 36" (900 mm) OF STABILIZED COVER MATERIALS OVER THE CHAMBERS IS REQUIRED FOR DUMP TRUCK TRAVEL OR DUMPING.

USE OF A DOZER TO PUSH EMBEDMENT STONE BETWEEN THE ROWS OF CHAMBERS MAY CAUSE DAMAGE TO CHAMBERS AND IS NOT AN ACCEPTABLE BACKFILL METHOD. ANY CHAMBERS DAMAGED BY USING THE "DUMP AND PUSH" METHOD ARE NOT COVERED UNDER THE STORMTECH STANDARD WARRANTY.

CONTACT STORMTECH AT 1-888-892-2694 WITH ANY QUESTIONS ON INSTALLATION REQUIREMENTS OR WEIGHT LIMITS FOR CONSTRUCTION EQUIPMENT.

PROPOSED LAYOUT		CONCEPTUAL ELEVATIONS	
464	STORMTECH MC-4500 CHAMBERS	MAXIMUM ALLOWABLE GRADE (TOP OF PAVEMENT/UNPAVED):	12.75
8	STORMTECH MC-4500 END CAPS	MINIMUM ALLOWABLE GRADE (UNPAVED WITH TRAFFIC):	8.25
12	STONE ABOVE (in)	MINIMUM ALLOWABLE GRADE (UNPAVED NO TRAFFIC):	7.75
9	STONE BELOW (in)	MINIMUM ALLOWABLE GRADE (TOP OF RIGID CONCRETE PAVEMENT):	7.75
40	STONE VOID	MINIMUM ALLOWABLE GRADE (BASE OF FLEXIBLE PAVEMENT):	7.75
79413	INSTALLED SYSTEM VOLUME (CF) (PERIMETER STONE INCLUDED) (COVER STONE INCLUDED) (BASE STONE INCLUDED)	TOP OF STONE:	6.75
		TOP OF MC-4500 CHAMBER:	5.75
		24" x 24" BOTTOM MANIFOLD INVERT:	0.94
		24" x 24" BOTTOM MANIFOLD INVERT:	0.94
		24" ISOLATOR ROW PLUS INVERT:	0.94
18360	SYSTEM AREA (SF)	24" BOTTOM CONNECTION INVERT:	0.94
1043.1	SYSTEM PERIMETER (ft)	24" BOTTOM CONNECTION INVERT:	0.94
		BOTTOM OF MC-4500 CHAMBER:	0.75
		UNDERDRAIN INVERT:	0.00
		BOTTOM OF STONE:	0.00

PART TYPE	ITEM ON LAYOUT	DESCRIPTION	INVERT*	MAX FLOW
PREFABRICATED END CAP	A	24" BOTTOM PARTIAL CUT END CAP, PART#: MC4500IEPP24B / TYP OF ALL 24" BOTTOM CONNECTIONS AND ISOLATOR PLUS ROWS	2.26"	
FLAMP	B	INSTALL FLAMP ON 24" ACCESS PIPE / PART#: MC450024RAMP		
MANIFOLD	C	24" x 24" BOTTOM MANIFOLD, ADS N-12	2.26"	
MANIFOLD	D	24" x 24" BOTTOM MANIFOLD, ADS N-12	2.26"	
CONCRETE STRUCTURE	E	OCS (DESIGN BY ENGINEER / PROVIDED BY OTHERS)		14.0 CFS OUT
CONCRETE STRUCTURE	F	(DESIGN BY ENGINEER / PROVIDED BY OTHERS)		28.5 CFS IN
W/WEIR				
UNDERDRAIN	G	6" ADS N-12 DUAL WALL PERFORATED HDPE UNDERDRAIN		

*INVERT ABOVE BASE OF CHAMBER 3

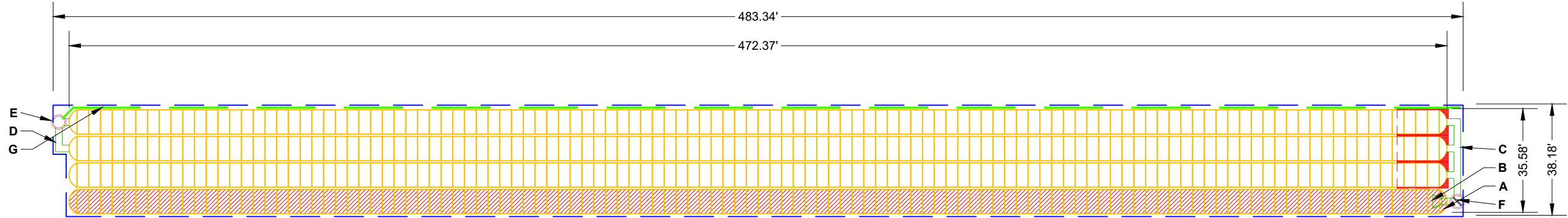

- ISOLATOR ROW PLUS (SEE DETAIL)
- PLACE MINIMUM 17.50' OF ADSPLUS175 WOVEN GEOTEXTILE OVER BEDDING STONE AND UNDERNEATH CHAMBER FEET FOR SCOUR PROTECTION AT ALL CHAMBER INLET ROWS
- BED LIMITS

NOTES

- MANIFOLD SIZE TO BE DETERMINED BY SITE DESIGN ENGINEER. SEE TECH NOTE #6.32 FOR MANIFOLD SIZING GUIDANCE.
- DUE TO THE ADAPTATION OF THIS CHAMBER SYSTEM TO SPECIFIC SITE AND DESIGN CONSTRAINTS, IT MAY BE NECESSARY TO CUT AND COUPLE ADDITIONAL PIPE TO STANDARD MANIFOLD COMPONENTS IN THE FIELD.
- THE SITE DESIGN ENGINEER MUST REVIEW ELEVATIONS AND IF NECESSARY ADJUST GRADING TO ENSURE THE CHAMBER COVER REQUIREMENTS ARE MET.
- THIS CHAMBER SYSTEM WAS DESIGNED WITHOUT SITE-SPECIFIC INFORMATION ON SOIL CONDITIONS OR BEARING CAPACITY. THE SITE DESIGN ENGINEER IS RESPONSIBLE FOR DETERMINING THE SUITABILITY OF THE SOIL AND PROVIDING THE BEARING CAPACITY OF THE INSITU SOILS. THE BASE STONE DEPTH MAY BE INCREASED OR DECREASED ONCE THIS INFORMATION IS PROVIDED.
- **NOT FOR CONSTRUCTION:** THIS LAYOUT IS FOR DIMENSIONAL PURPOSES ONLY TO PROVE CONCEPT & THE REQUIRED STORAGE VOLUME CAN BE ACHIEVED ON SITE.

DA 2 SOUTH, BLOOMINGTON SITE 3
 SCHEME 1
 BLOOMINGTON, CA
 DATE: 12/7/2020
 PROJECT #:

REV	DRW	CHK	DESCRIPTION

DRAWN: HP	CHECKED: N/A
-----------	--------------

520 CROMWELL AVENUE | ROCKY HILL | CT | 06067
 860-529-8188 | 888-892-2894 | WWW.STORMTECH.COM

4840 TRUEMAN BLVD
 HILLIARD, OH 43026
 1-800-733-7473

ADVANCED DRAINAGE SYSTEMS, INC.

THIS DRAWING HAS BEEN PREPARED BASED ON INFORMATION PROVIDED TO ADS UNDER THE DIRECTION OF THE SITE DESIGN ENGINEER OR OTHER PROJECT REPRESENTATIVE. THE SITE DESIGN ENGINEER SHALL REVIEW THIS DRAWING PRIOR TO CONSTRUCTION. IT IS THE ULTIMATE RESPONSIBILITY OF THE SITE DESIGN ENGINEER TO ENSURE THAT THE PRODUCT(S) DEPICTED AND ALL ASSOCIATED DETAILS MEET ALL APPLICABLE LAWS, REGULATIONS, AND PROJECT REQUIREMENTS.

SHEET
2 OF 5

ACCEPTABLE FILL MATERIALS: STORMTECH MC-4500 CHAMBER SYSTEMS

MATERIAL LOCATION	DESCRIPTION	AASHTO MATERIAL CLASSIFICATIONS	COMPACTION / DENSITY REQUIREMENT
D	FINAL FILL: FILL MATERIAL FOR LAYER 'D' STARTS FROM THE TOP OF THE 'C' LAYER TO THE BOTTOM OF FLEXIBLE PAVEMENT OR UNPAVED FINISHED GRADE ABOVE. NOTE THAT PAVEMENT SUBBASE MAY BE PART OF THE 'D' LAYER	N/A	PREPARE PER SITE DESIGN ENGINEER'S PLANS. PAVED INSTALLATIONS MAY HAVE STRINGENT MATERIAL AND PREPARATION REQUIREMENTS.
C	INITIAL FILL: FILL MATERIAL FOR LAYER 'C' STARTS FROM THE TOP OF THE EMBEDMENT STONE ('B' LAYER) TO 24" (600 mm) ABOVE THE TOP OF THE CHAMBER. NOTE THAT PAVEMENT SUBBASE MAY BE A PART OF THE 'C' LAYER.	AASHTO M145 ¹ A-1, A-2-4, A-3 OR AASHTO M43 ¹ 3, 357, 4, 467, 5, 56, 57, 6, 67, 68, 7, 78, 8, 89, 9, 10	BEGIN COMPACTIONS AFTER 24" (600 mm) OF MATERIAL OVER THE CHAMBERS IS REACHED. COMPACT ADDITIONAL LAYERS IN 12" (300 mm) MAX LIFTS TO A MIN. 95% PROCTOR DENSITY FOR WELL GRADED MATERIAL AND 95% RELATIVE DENSITY FOR PROCESSED AGGREGATE MATERIALS.
B	EMBEDMENT STONE: FILL SURROUNDING THE CHAMBERS FROM THE FOUNDATION STONE ('A' LAYER) TO THE 'C' LAYER ABOVE.	AASHTO M43 ¹ 3, 4	NO COMPACTION REQUIRED.
A	FOUNDATION STONE: FILL BELOW CHAMBERS FROM THE SUBGRADE UP TO THE FOOT (BOTTOM) OF THE CHAMBER.	AASHTO M43 ¹ 3, 4	PLATE COMPACT OR ROLL TO ACHIEVE A FLAT SURFACE. ^{2,3}

PLEASE NOTE:

1. THE LISTED AASHTO DESIGNATIONS ARE FOR GRADATIONS ONLY. THE STONE MUST ALSO BE CLEAN, CRUSHED, ANGULAR. FOR EXAMPLE, A SPECIFICATION FOR #4 STONE WOULD STATE: "CLEAN, CRUSHED, ANGULAR NO. 4 (AASHTO M43) STONE".
2. STORMTECH COMPACTION REQUIREMENTS ARE MET FOR 'A' LOCATION MATERIALS WHEN PLACED AND COMPACTED IN 9" (230 mm) (MAX) LIFTS USING TWO FULL COVERAGES WITH A VIBRATORY COMPACTOR.
3. WHERE INFILTRATION SURFACES MAY BE COMPROMISED BY COMPACTION, FOR STANDARD DESIGN LOAD CONDITIONS, A FLAT SURFACE MAY BE ACHIEVED BY RAKING OR DRAGGING WITHOUT COMPACTION EQUIPMENT. FOR SPECIAL LOAD DESIGNS, CONTACT STORMTECH FOR COMPACTION REQUIREMENTS.
4. ONCE LAYER 'C' IS PLACED, ANY SOIL/MATERIAL CAN BE PLACED IN LAYER 'D' UP TO THE FINISHED GRADE. MOST PAVEMENT SUBBASE SOILS CAN BE USED TO REPLACE THE MATERIAL REQUIREMENTS OF LAYER 'C' OR 'D' AT THE SITE DESIGN ENGINEER'S DISCRETION.

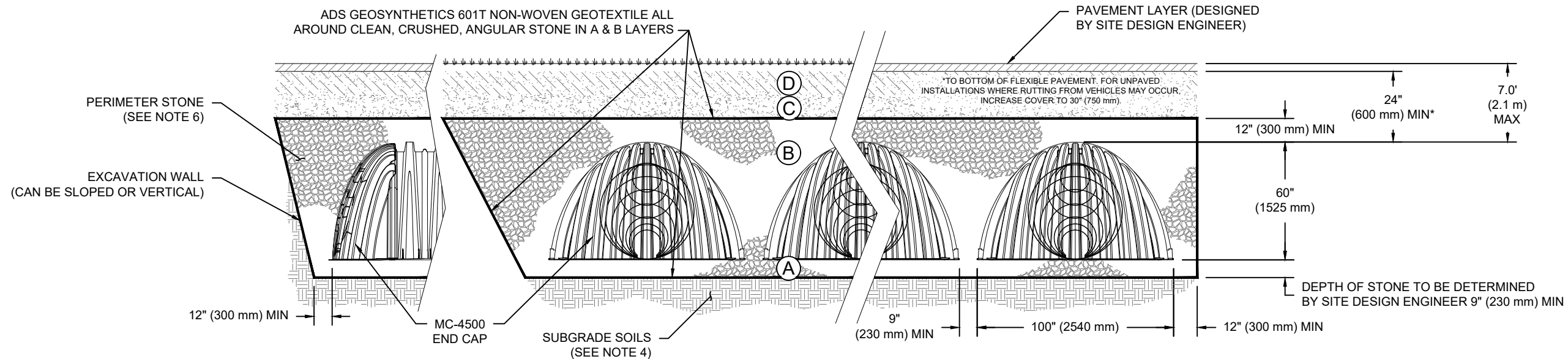

NOTES:

1. CHAMBERS SHALL MEET THE REQUIREMENTS OF ASTM F2418-16a, "STANDARD SPECIFICATION FOR POLYPROPYLENE (PP) CORRUGATED WALL STORMWATER COLLECTION CHAMBERS" CHAMBER CLASSIFICATION 60x101
2. MC-4500 CHAMBERS SHALL BE DESIGNED IN ACCORDANCE WITH ASTM F2787 "STANDARD PRACTICE FOR STRUCTURAL DESIGN OF THERMOPLASTIC CORRUGATED WALL STORMWATER COLLECTION CHAMBERS".
3. THE SITE DESIGN ENGINEER IS RESPONSIBLE FOR ASSESSING THE BEARING RESISTANCE (ALLOWABLE BEARING CAPACITY) OF THE SUBGRADE SOILS AND THE DEPTH OF FOUNDATION STONE WITH CONSIDERATION FOR THE RANGE OF EXPECTED SOIL MOISTURE CONDITIONS.
4. PERIMETER STONE MUST BE EXTENDED HORIZONTALLY TO THE EXCAVATION WALL FOR BOTH VERTICAL AND SLOPED EXCAVATION WALLS.
5. REQUIREMENTS FOR HANDLING AND INSTALLATION:
 - TO MAINTAIN THE WIDTH OF CHAMBERS DURING SHIPPING AND HANDLING, CHAMBERS SHALL HAVE INTEGRAL, INTERLOCKING STACKING LUGS.
 - TO ENSURE A SECURE JOINT DURING INSTALLATION AND BACKFILL, THE HEIGHT OF THE CHAMBER JOINT SHALL NOT BE LESS THAN 3".
 - TO ENSURE THE INTEGRITY OF THE ARCH SHAPE DURING INSTALLATION, a) THE ARCH STIFFNESS CONSTANT AS DEFINED IN SECTION 6.2.8 OF ASTM F2418 SHALL BE GREATER THAN OR EQUAL TO 500 LBS/IN/IN. AND b) TO RESIST CHAMBER DEFORMATION DURING INSTALLATION AT ELEVATED TEMPERATURES (ABOVE 73° F / 23° C), CHAMBERS SHALL BE PRODUCED FROM REFLECTIVE GOLD OR YELLOW COLORS.

DA 2 SOUTH, BLOOMINGTON SITE 3
 SCHEME 1
 BLOOMINGTON, CA
 DATE: 12/7/2020
 DRAWN: HP
 PROJECT #:
 CHECKED: N/A

REV | DRW | CHK | DESCRIPTION

520 CROMWELL AVENUE | ROCKY HILL | CT | 06067
 860-529-8188 | 888-892-2894 | WWW.STORMTECH.COM

4840 TRUEMAN BLVD
 HILLIARD, OH 43026
 1-800-733-7473

StormTech
 Determination • Retention • Water Quality

THIS DRAWING HAS BEEN PREPARED BASED ON INFORMATION PROVIDED TO ADS UNDER THE DIRECTION OF THE SITE DESIGN ENGINEER OR OTHER PROJECT REPRESENTATIVE. THE SITE DESIGN ENGINEER SHALL REVIEW THIS DRAWING PRIOR TO CONSTRUCTION. IT IS THE ULTIMATE RESPONSIBILITY OF THE SITE DESIGN ENGINEER TO ENSURE THAT THE PRODUCT(S) DEPICTED AND ALL ASSOCIATED DETAILS MEET ALL APPLICABLE LAWS, REGULATIONS, AND PROJECT REQUIREMENTS.

SHEET
 3 OF 5

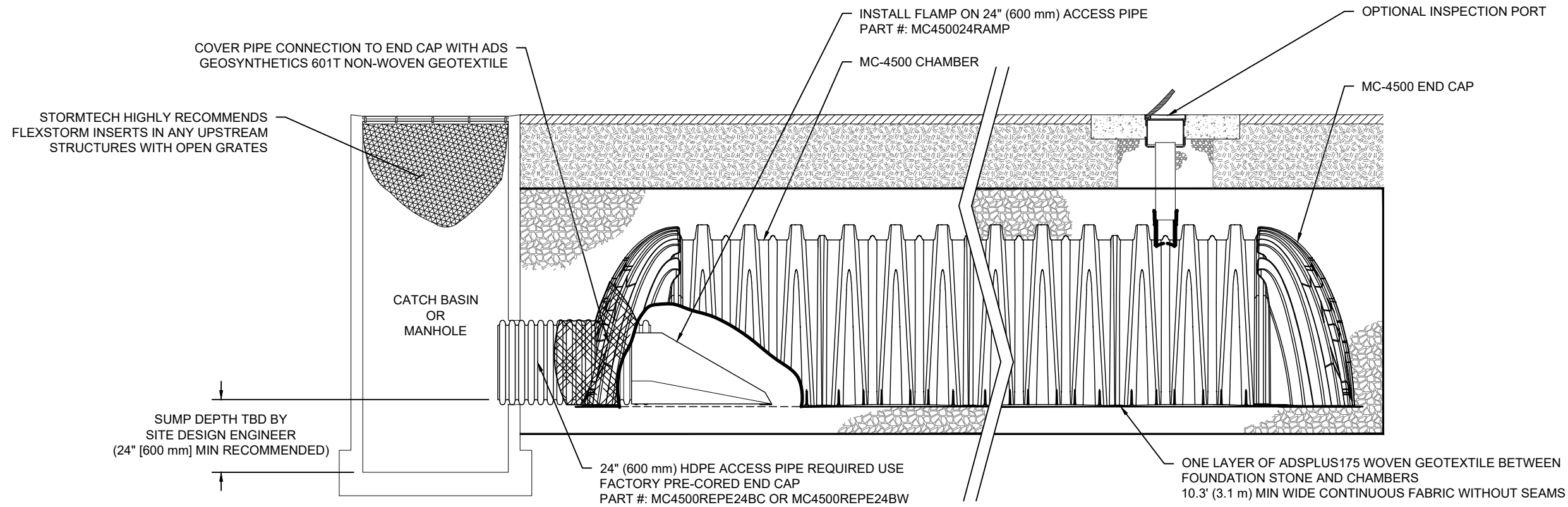

MC-4500 ISOLATOR ROW PLUS DETAIL
NTS

INSPECTION & MAINTENANCE

- STEP 1) INSPECT ISOLATOR ROW PLUS FOR SEDIMENT
- A. INSPECTION PORTS (IF PRESENT)
 - A.1. REMOVE/OPEN LID ON NYLOPLAST INLINE DRAIN
 - A.2. REMOVE AND CLEAN FLEXSTORM FILTER IF INSTALLED
 - A.3. USING A FLASHLIGHT AND STADIA ROD, MEASURE DEPTH OF SEDIMENT AND RECORD ON MAINTENANCE LOG
 - A.4. LOWER A CAMERA INTO ISOLATOR ROW PLUS FOR VISUAL INSPECTION OF SEDIMENT LEVELS (OPTIONAL)
 - A.5. IF SEDIMENT IS AT, OR ABOVE, 3" (80 mm) PROCEED TO STEP 2. IF NOT, PROCEED TO STEP 3.
 - B. ALL ISOLATOR PLUS ROWS
 - B.1. REMOVE COVER FROM STRUCTURE AT UPSTREAM END OF ISOLATOR ROW PLUS
 - B.2. USING A FLASHLIGHT, INSPECT DOWN THE ISOLATOR ROW PLUS THROUGH OUTLET PIPE
 - i) MIRRORS ON POLES OR CAMERAS MAY BE USED TO AVOID A CONFINED SPACE ENTRY
 - ii) FOLLOW OSHA REGULATIONS FOR CONFINED SPACE ENTRY IF ENTERING MANHOLE
 - B.3. IF SEDIMENT IS AT, OR ABOVE, 3" (80 mm) PROCEED TO STEP 2. IF NOT, PROCEED TO STEP 3.
- STEP 2) CLEAN OUT ISOLATOR ROW PLUS USING THE JETVAC PROCESS
- A. A FIXED CULVERT CLEANING NOZZLE WITH REAR FACING SPREAD OF 45" (1.1 m) OR MORE IS PREFERRED
 - B. APPLY MULTIPLE PASSES OF JETVAC UNTIL BACKFLUSH WATER IS CLEAN
 - C. VACUUM STRUCTURE SUMP AS REQUIRED
- STEP 3) REPLACE ALL COVERS, GRATES, FILTERS, AND LIDS; RECORD OBSERVATIONS AND ACTIONS.
- STEP 4) INSPECT AND CLEAN BASINS AND MANHOLES UPSTREAM OF THE STORMTECH SYSTEM.

NOTES

1. INSPECT EVERY 6 MONTHS DURING THE FIRST YEAR OF OPERATION. ADJUST THE INSPECTION INTERVAL BASED ON PREVIOUS OBSERVATIONS OF SEDIMENT ACCUMULATION AND HIGH WATER ELEVATIONS.
2. CONDUCT JETTING AND VACTORING ANNUALLY OR WHEN INSPECTION SHOWS THAT MAINTENANCE IS NECESSARY.

<p>DA 2 SOUTH, BLOOMINGTON SITE 3 SCHEME 1 BLOOMINGTON, CA</p>	<p>DATE: 12/7/2020 DRAWN: HP PROJECT #: CHECKED: N/A</p>	
		<p>DESCRIPTION</p>
		<p>CHK</p>
		<p>REV</p>
		<p>DRW</p>
		<p>NO. 1</p>
		<p>NO. 2</p>
		<p>NO. 3</p>
		<p>NO. 4</p>
		<p>NO. 5</p>
		<p>NO. 6</p>
		<p>NO. 7</p>
		<p>NO. 8</p>
		<p>NO. 9</p>
		<p>NO. 10</p>
		<p>NO. 11</p>
		<p>NO. 12</p>
		<p>NO. 13</p>
		<p>NO. 14</p>
		<p>NO. 15</p>
		<p>NO. 16</p>
		<p>NO. 17</p>
		<p>NO. 18</p>
		<p>NO. 19</p>
		<p>NO. 20</p>
		<p>NO. 21</p>
		<p>NO. 22</p>
		<p>NO. 23</p>
		<p>NO. 24</p>
		<p>NO. 25</p>
		<p>NO. 26</p>
		<p>NO. 27</p>
		<p>NO. 28</p>
		<p>NO. 29</p>
		<p>NO. 30</p>
		<p>NO. 31</p>
		<p>NO. 32</p>
		<p>NO. 33</p>
		<p>NO. 34</p>
		<p>NO. 35</p>
		<p>NO. 36</p>
		<p>NO. 37</p>
		<p>NO. 38</p>
		<p>NO. 39</p>
		<p>NO. 40</p>
		<p>NO. 41</p>
		<p>NO. 42</p>
		<p>NO. 43</p>
		<p>NO. 44</p>
		<p>NO. 45</p>
		<p>NO. 46</p>
		<p>NO. 47</p>
		<p>NO. 48</p>
		<p>NO. 49</p>
		<p>NO. 50</p>
		<p>NO. 51</p>
		<p>NO. 52</p>
		<p>NO. 53</p>
		<p>NO. 54</p>
		<p>NO. 55</p>
		<p>NO. 56</p>
		<p>NO. 57</p>
		<p>NO. 58</p>
		<p>NO. 59</p>
		<p>NO. 60</p>
		<p>NO. 61</p>
		<p>NO. 62</p>
		<p>NO. 63</p>
		<p>NO. 64</p>
		<p>NO. 65</p>
		<p>NO. 66</p>
		<p>NO. 67</p>
		<p>NO. 68</p>
		<p>NO. 69</p>
		<p>NO. 70</p>
		<p>NO. 71</p>
		<p>NO. 72</p>
		<p>NO. 73</p>
		<p>NO. 74</p>
		<p>NO. 75</p>
		<p>NO. 76</p>
		<p>NO. 77</p>
		<p>NO. 78</p>
		<p>NO. 79</p>
		<p>NO. 80</p>
		<p>NO. 81</p>
		<p>NO. 82</p>
		<p>NO. 83</p>
		<p>NO. 84</p>
		<p>NO. 85</p>
		<p>NO. 86</p>
		<p>NO. 87</p>
		<p>NO. 88</p>
		<p>NO. 89</p>
		<p>NO. 90</p>
		<p>NO. 91</p>
		<p>NO. 92</p>
		<p>NO. 93</p>
		<p>NO. 94</p>
		<p>NO. 95</p>
		<p>NO. 96</p>
		<p>NO. 97</p>
		<p>NO. 98</p>
		<p>NO. 99</p>
		<p>NO. 100</p>

4840 TRUEMAN BLVD
HILLIARD, OH 43026
1-800-733-7473

520 CROMWELL AVENUE | ROCKY HILL | CT | 06067
860-525-8188 | 888-892-2894 | WWW.STORMTECH.COM

THIS DRAWING HAS BEEN PREPARED BASED ON INFORMATION PROVIDED TO ADS UNDER THE DIRECTION OF THE SITE DESIGN ENGINEER OR OTHER PROJECT REPRESENTATIVE. THE SITE DESIGN ENGINEER SHALL REVIEW THIS DRAWING PRIOR TO CONSTRUCTION. IT IS THE ULTIMATE RESPONSIBILITY OF THE SITE DESIGN ENGINEER TO ENSURE THAT THE PRODUCT(S) DEPICTED AND ALL ASSOCIATED DETAILS MEET ALL APPLICABLE LAWS, REGULATIONS, AND PROJECT REQUIREMENTS.

SHEET
4 OF 5

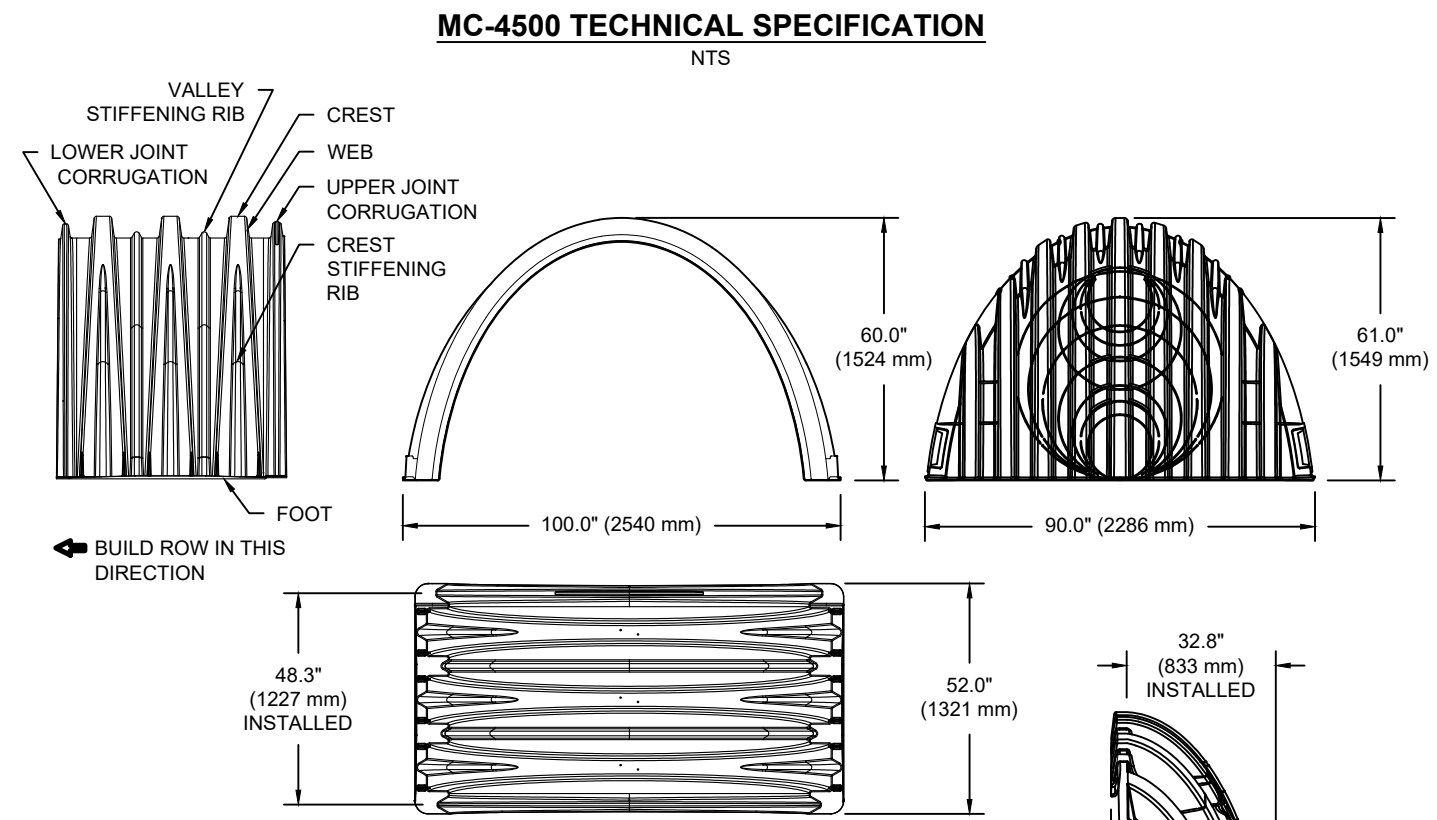
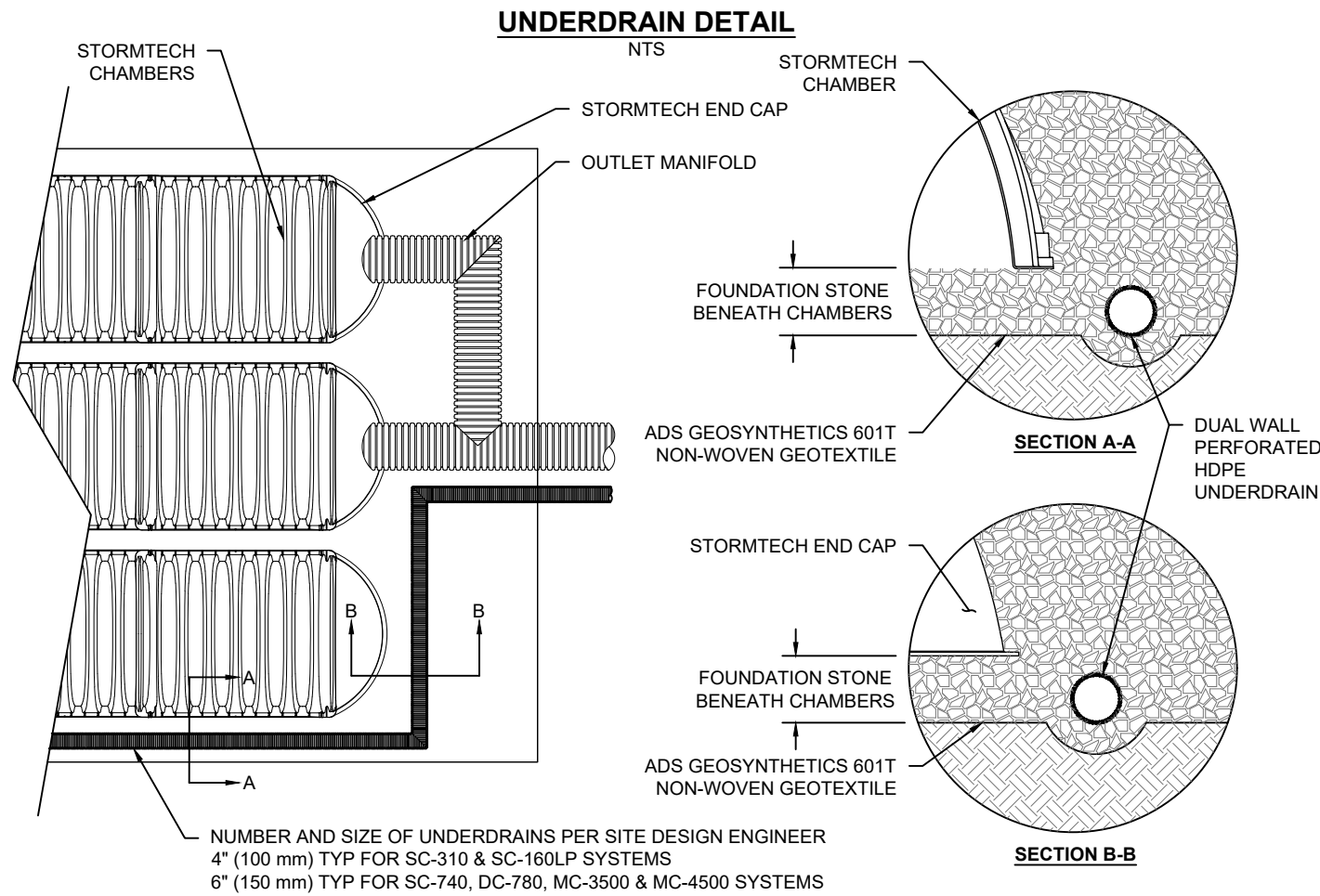

NOMINAL CHAMBER SPECIFICATIONS

SIZE (W X H X INSTALLED LENGTH)	100.0" X 60.0" X 48.3"	(2540 mm X 1524 mm X 1227 mm)
CHAMBER STORAGE	106.5 CUBIC FEET	(3.01 m ³)
MINIMUM INSTALLED STORAGE*	162.6 CUBIC FEET	(4.60 m ³)
WEIGHT (NOMINAL)	125.0 lbs.	(56.7 kg)

NOMINAL END CAP SPECIFICATIONS

SIZE (W X H X INSTALLED LENGTH)	90.0" X 61.0" X 32.8"	(2286 mm X 1549 mm X 833 mm)
END CAP STORAGE	39.5 CUBIC FEET	(1.12 m ³)
MINIMUM INSTALLED STORAGE*	115.3 CUBIC FEET	(3.26 m ³)
WEIGHT (NOMINAL)	90 lbs.	(40.8 kg)

*ASSUMES 12" (305 mm) STONE ABOVE, 9" (229 mm) STONE FOUNDATION AND BETWEEN CHAMBERS, 12" (305 mm) STONE PERIMETER IN FRONT OF END CAPS AND 40% STONE POROSITY.

PARTIAL CUT HOLES AT BOTTOM OF END CAP FOR PART NUMBERS ENDING WITH "B"
PARTIAL CUT HOLES AT TOP OF END CAP FOR PART NUMBERS ENDING WITH "T"
END CAPS WITH A PREFABRICATED WELDED STUB END WITH "W"

PART #	STUB	B	C
MC4500IEPP06T		42.54" (1081 mm)	---
MC4500IEPP06B	6" (150 mm)	---	0.86" (22 mm)
MC4500IEPP08T		40.50" (1029 mm)	---
MC4500IEPP08B	8" (200 mm)	---	1.01" (26 mm)
MC4500IEPP10T		38.37" (975 mm)	---
MC4500IEPP10B	10" (250 mm)	---	1.33" (34 mm)
MC4500IEPP12T		35.69" (907 mm)	---
MC4500IEPP12B	12" (300 mm)	---	1.55" (39 mm)
MC4500IEPP15T		32.72" (831 mm)	---
MC4500IEPP15B	15" (375 mm)	---	1.70" (43 mm)
MC4500IEPP18T		29.36" (746 mm)	---
MC4500IEPP18TW	18" (450 mm)	---	1.97" (50 mm)
MC4500IEPP18B			
MC4500IEPP18BW			
MC4500IEPP24T		23.05" (585 mm)	---
MC4500IEPP24TW	24" (600 mm)	---	2.26" (57 mm)
MC4500IEPP24B			
MC4500IEPP24BW			
MC4500IEPP30BW	30" (750 mm)	---	2.95" (75 mm)
MC4500IEPP36BW	36" (900 mm)	---	3.25" (83 mm)
MC4500IEPP42BW	42" (1050 mm)	---	3.55" (90 mm)

NOTE: ALL DIMENSIONS ARE NOMINAL

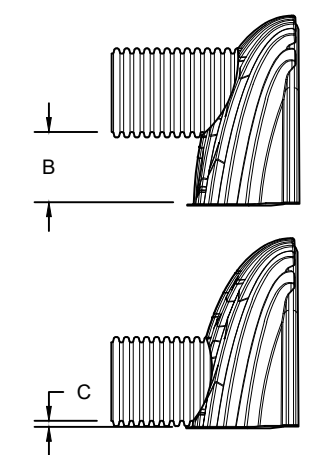
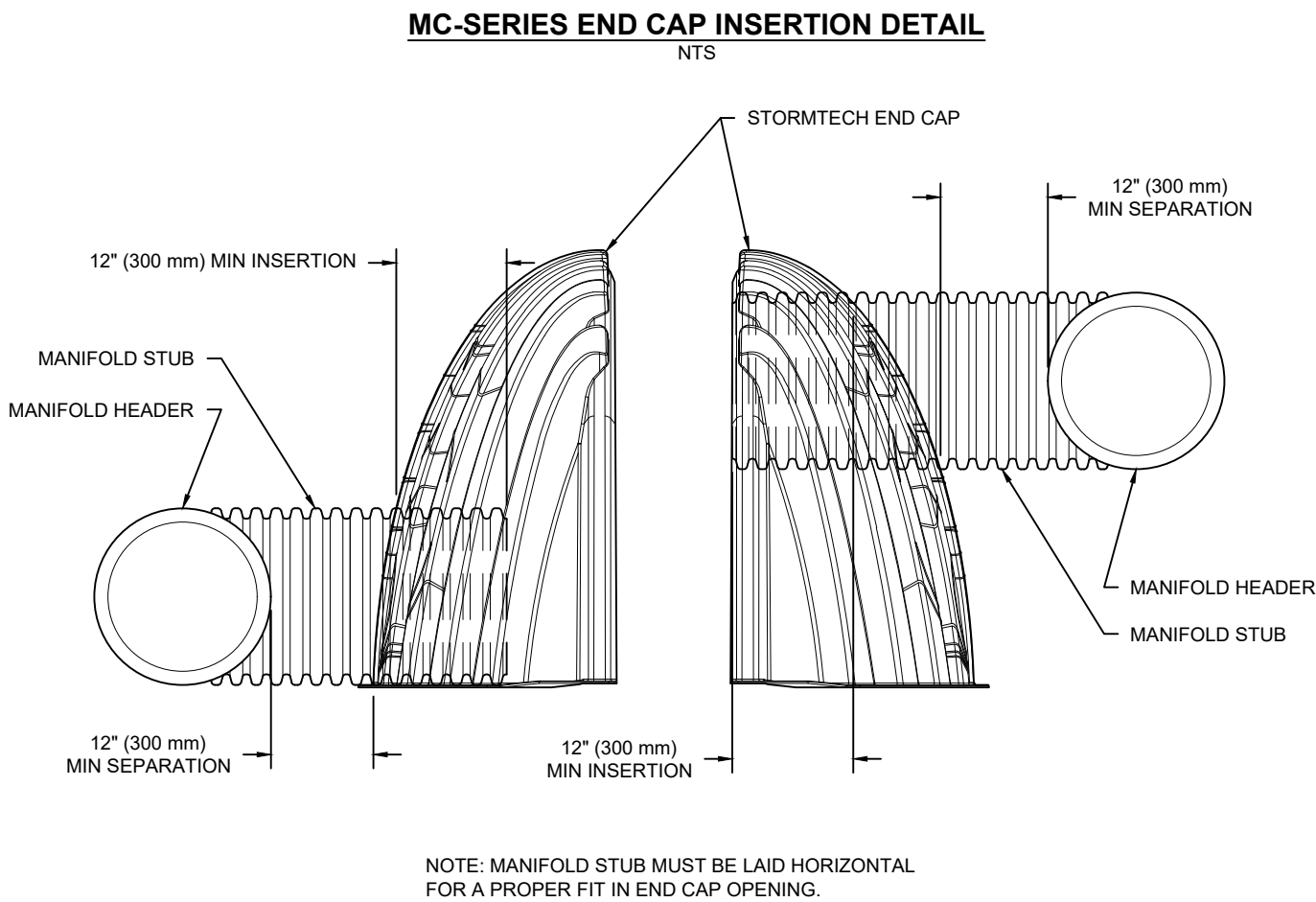

CUSTOM PARTIAL CUT INVERTS ARE AVAILABLE UPON REQUEST. INVENTORIED MANIFOLDS INCLUDE 12-24" (300-600 mm) SIZE ON SIZE AND 15-48" (375-1200 mm) ECCENTRIC MANIFOLDS. CUSTOM INVERT LOCATIONS ON THE MC-4500 END CAP CUT IN THE FIELD ARE NOT RECOMMENDED FOR PIPE SIZES GREATER THAN 10" (250 mm). THE INVERT LOCATION IN COLUMN 'B' ARE THE HIGHEST POSSIBLE FOR THE PIPE SIZE.

DA 2 SOUTH, BLOOMINGTON SITE 3
SCHEME 1
BLOOMINGTON, CA

DATE: 12/7/2020
DRAWN: HP
PROJECT #:
CHECKED: N/A

DESCRIPTION

CHK

REV

4840 TRUEMAN BLVD
HILLIARD, OH 43026
1-800-733-7473

StormTech
Dedication • Retention • Water Quality

520 CROMWELL AVENUE | ROCKY HILL | CT | 06067
860-525-8188 | 888-892-2894 | WWW.STORMTECH.COM

ADVANCED DRAINAGE SYSTEMS, INC.

THIS DRAWING HAS BEEN PREPARED BASED ON INFORMATION PROVIDED TO ADS UNDER THE DIRECTION OF THE SITE DESIGN ENGINEER OR OTHER PROJECT REPRESENTATIVE. THE SITE DESIGN ENGINEER SHALL REVIEW THIS DRAWING PRIOR TO CONSTRUCTION. IT IS THE ULTIMATE RESPONSIBILITY OF THE SITE DESIGN ENGINEER TO ENSURE THAT THE PRODUCT(S) DEPICTED AND ALL ASSOCIATED DETAILS MEET ALL APPLICABLE LAWS, REGULATIONS, AND PROJECT REQUIREMENTS.

SHEET

5 OF 5

LOCUST

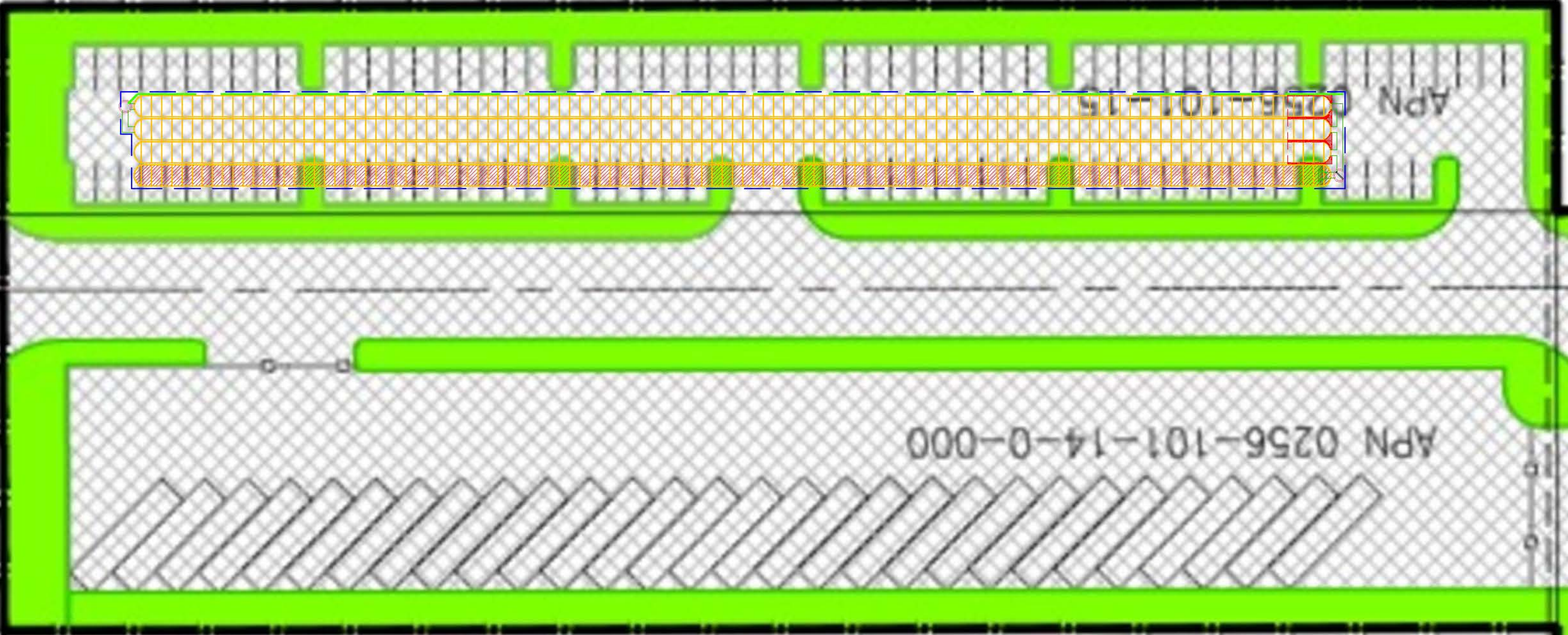

APN 0256-101-15

APN 0256-101-14-0-000

100
0

Bloomington Business Park SP3 DA1

Chamber Model -
 Units -
 Number of Chambers -
 Number of End Caps -
 Voids in the stone (porosity) -
 Base of Stone Elevation -
 Amount of Stone Above Chambers -
 Amount of Stone Below Chambers -

MC-4500
Imperial
1216
32
40
-0.75
12
9

[Click Here for Metric](#)



Include Perimeter Stone in Calculations

StormTech MC-4500 Cumulative Storage Volumes

Height of System (inches)	Incremental Single Chamber (cubic feet)	Incremental Single End Cap (cubic feet)	Incremental Chambers (cubic feet)	Incremental End Cap (cubic feet)	Incremental Stone (cubic feet)	Incremental Ch, EC and Stone (cubic feet)	Cumulative System (cubic feet)	Elevation (feet)
81	0.00	0.00	0.00	0.00	1516.33	1516.33	201215.66	6.00
80	0.00	0.00	0.00	0.00	1516.33	1516.33	199699.32	5.92
79	0.00	0.00	0.00	0.00	1516.33	1516.33	198182.99	5.83
78	0.00	0.00	0.00	0.00	1516.33	1516.33	196666.66	5.75
77	0.00	0.00	0.00	0.00	1516.33	1516.33	195150.33	5.67
76	0.00	0.00	0.00	0.00	1516.33	1516.33	193634.00	5.58
75	0.00	0.00	0.00	0.00	1516.33	1516.33	192117.67	5.50
74	0.00	0.00	0.00	0.00	1516.33	1516.33	190601.34	5.42
73	0.00	0.00	0.00	0.00	1516.33	1516.33	189085.01	5.33
72	0.00	0.00	0.00	0.00	1516.33	1516.33	187568.67	5.25
71	0.00	0.00	0.00	0.00	1516.33	1516.33	186052.34	5.17
70	0.00	0.00	0.00	0.00	1516.33	1516.33	184536.01	5.08
69	0.04	0.00	49.81	0.00	1496.41	1546.22	183019.68	5.00
68	0.12	0.01	141.17	0.32	1459.73	1601.23	181473.46	4.92
67	0.16	0.03	200.32	0.84	1435.87	1637.03	179872.23	4.83
66	0.21	0.05	253.81	1.52	1414.20	1669.53	178235.21	4.75
65	0.27	0.07	326.31	2.16	1384.94	1713.41	176565.68	4.67
64	0.45	0.09	550.59	2.81	1294.97	1848.37	174852.26	4.58
63	0.67	0.11	808.96	3.61	1191.30	2003.87	173003.89	4.50
62	0.80	0.14	971.60	4.53	1125.88	2102.01	171000.02	4.42
61	0.91	0.17	1104.28	5.36	1072.47	2182.12	168898.01	4.33
60	1.00	0.19	1219.53	6.13	1026.07	2251.73	166715.89	4.25
59	1.09	0.22	1322.20	6.89	984.70	2313.78	164464.16	4.17
58	1.16	0.24	1414.79	7.72	947.32	2369.84	162150.38	4.08
57	1.23	0.27	1500.56	8.65	912.65	2421.85	159780.54	4.00
56	1.30	0.30	1580.41	9.52	880.36	2470.29	157358.69	3.92
55	1.36	0.32	1655.01	10.35	850.19	2515.55	154888.39	3.83
54	1.42	0.35	1725.16	11.13	821.82	2558.10	152372.85	3.75
53	1.47	0.37	1791.57	11.88	794.95	2598.40	149814.74	3.67
52	1.53	0.39	1854.58	12.61	769.45	2636.65	147216.35	3.58
51	1.57	0.42	1914.58	13.35	745.16	2673.09	144579.70	3.50
50	1.62	0.44	1971.61	14.09	722.05	2707.75	141906.61	3.42
49	1.67	0.46	2026.13	14.80	699.96	2740.89	139198.86	3.33
48	1.71	0.48	2078.28	15.49	678.82	2772.59	136457.97	3.25
47	1.75	0.50	2128.11	16.16	658.63	2802.89	133685.37	3.17
46	1.79	0.53	2175.78	16.81	639.29	2831.89	130882.48	3.08
45	1.83	0.55	2221.87	17.44	620.61	2859.92	128050.60	3.00
44	1.86	0.56	2265.94	18.06	602.73	2886.73	125190.68	2.92
43	1.90	0.58	2308.36	18.66	585.52	2912.55	122303.95	2.83
42	1.93	0.60	2349.11	19.26	568.98	2937.35	119391.40	2.75
41	1.96	0.62	2388.32	19.84	553.07	2961.23	116454.05	2.67
40	2.00	0.64	2426.06	20.42	537.74	2984.22	113492.82	2.58
39	2.03	0.66	2462.41	20.98	522.97	3006.37	110508.60	2.50
38	2.05	0.67	2497.40	21.54	508.75	3027.70	107502.23	2.42
37	2.08	0.69	2531.10	22.09	495.05	3048.25	104474.53	2.33
36	2.11	0.71	2563.42	22.63	481.91	3067.96	101426.29	2.25
35	2.13	0.72	2594.76	23.16	469.16	3087.08	98358.32	2.17
34	2.16	0.74	2624.95	23.68	456.88	3105.51	95271.24	2.08
33	2.18	0.76	2653.97	24.19	445.07	3123.23	92165.73	2.00
32	2.21	0.77	2681.92	24.69	433.69	3140.30	89042.50	1.92
31	2.23	0.79	2708.82	25.18	422.73	3156.73	85902.20	1.83
30	2.25	0.80	2734.62	25.66	412.22	3172.50	82745.47	1.75
29	2.27	0.82	2759.53	26.26	402.01	3187.81	79572.97	1.67
28	2.29	0.84	2783.41	26.90	392.21	3202.52	76385.16	1.58
27	2.31	0.85	2806.35	27.07	382.96	3216.38	73182.64	1.50
26	2.33	0.86	2828.35	27.48	374.00	3229.83	69966.26	1.42
25	2.34	0.87	2849.45	27.91	365.39	3242.74	66736.43	1.33
24	2.36	0.89	2869.65	28.32	357.14	3255.11	63493.69	1.25
23	2.38	0.90	2888.97	28.73	349.25	3266.95	60238.57	1.17
22	2.39	0.91	2907.43	29.13	341.71	3278.27	56971.62	1.08
21	2.41	0.92	2925.04	29.52	334.51	3289.07	53693.36	1.00
20	2.42	0.93	2941.82	29.90	327.65	3299.36	50404.29	0.92
19	2.43	0.95	2957.78	30.26	321.12	3309.15	47104.93	0.83
18	2.44	0.96	2972.92	30.62	314.92	3318.45	43795.77	0.75
17	2.46	0.97	2987.27	30.96	309.04	3327.27	40477.32	0.67
16	2.47	0.98	3000.82	31.29	303.49	3335.60	37150.05	0.58
15	2.48	0.99	3013.59	31.61	298.25	3343.45	33814.45	0.50
14	2.49	1.00	3025.72	31.92	293.28	3350.91	30471.00	0.42
13	2.50	1.01	3037.19	32.22	288.57	3357.98	27120.09	0.33
12	2.51	1.02	3047.91	32.51	284.16	3364.58	23762.11	0.25
11	2.51	1.02	3057.90	32.78	280.06	3370.74	20397.52	0.17
10	2.53	1.03	3072.75	33.04	274.02	3379.80	17026.79	0.08
9	0.00	0.00	0.00	0.00	1516.33	1516.33	13646.98	0.00
8	0.00	0.00	0.00	0.00	1516.33	1516.33	12130.65	-0.08
7	0.00	0.00	0.00	0.00	1516.33	1516.33	10614.32	-0.17
6	0.00	0.00	0.00	0.00	1516.33	1516.33	9097.99	-0.25
5	0.00	0.00	0.00	0.00	1516.33	1516.33	7581.66	-0.33
4	0.00	0.00	0.00	0.00	1516.33	1516.33	6065.32	-0.42
3	0.00	0.00	0.00	0.00	1516.33	1516.33	4548.99	-0.50
2	0.00	0.00	0.00	0.00	1516.33	1516.33	3032.66	-0.58
1	0.00	0.00	0.00	0.00	1516.33	1516.33	1516.33	-0.67

Bloomington Business Park SP3 DA2

Chamber Model -
 Units -
 Number of Chambers -
 Number of End Caps -
 Voids in the stone (porosity) -
 Base of Stone Elevation -
 Amount of Stone Above Chambers -
 Amount of Stone Below Chambers -

MC-4500
Imperial
1044
18
40
-0.75
12
9

[Click Here for Metric](#)



Include Perimeter Stone in Calculations

StormTech MC-4500 Cumulative Storage Volumes								
Height of System (inches)	Incremental Single Chamber (cubic feet)	Incremental Single End Cap (cubic feet)	Incremental Chambers (cubic feet)	Incremental End Cap (cubic feet)	Incremental Stone (cubic feet)	Incremental Ch. EC and Stone (cubic feet)	Cumulative System (cubic feet)	Elevation (feet)
81	0.00	0.00	0.00	0.00	1291.64	1291.64	171724.54	6.00
80	0.00	0.00	0.00	0.00	1291.64	1291.64	170432.90	5.92
79	0.00	0.00	0.00	0.00	1291.64	1291.64	169141.25	5.83
78	0.00	0.00	0.00	0.00	1291.64	1291.64	167849.61	5.75
77	0.00	0.00	0.00	0.00	1291.64	1291.64	166557.96	5.67
76	0.00	0.00	0.00	0.00	1291.64	1291.64	165266.32	5.58
75	0.00	0.00	0.00	0.00	1291.64	1291.64	163974.68	5.50
74	0.00	0.00	0.00	0.00	1291.64	1291.64	162683.03	5.42
73	0.00	0.00	0.00	0.00	1291.64	1291.64	161391.39	5.33
72	0.00	0.00	0.00	0.00	1291.64	1291.64	160099.75	5.25
71	0.00	0.00	0.00	0.00	1291.64	1291.64	158808.10	5.17
70	0.00	0.00	0.00	0.00	1291.64	1291.64	157516.46	5.08
69	0.04	0.00	42.76	0.00	1274.54	1317.30	156224.81	5.00
68	0.12	0.01	121.21	0.18	1243.09	1364.47	154907.51	4.92
67	0.16	0.03	171.98	0.47	1222.66	1395.12	153543.04	4.83
66	0.21	0.05	217.91	0.86	1204.14	1422.90	152147.92	4.75
65	0.27	0.07	280.15	1.22	1179.10	1460.46	150725.01	4.67
64	0.45	0.09	472.71	1.58	1101.93	1576.22	149264.55	4.58
63	0.67	0.11	694.53	2.03	1013.02	1709.58	147688.33	4.50
62	0.80	0.14	834.17	2.55	956.96	1793.68	145978.75	4.42
61	0.91	0.17	948.08	3.02	911.20	1862.30	144185.07	4.33
60	1.00	0.19	1047.03	3.45	871.45	1921.93	142322.77	4.25
59	1.09	0.22	1135.18	3.87	836.02	1975.07	140400.84	4.17
58	1.16	0.24	1214.68	4.35	804.04	2023.06	138425.76	4.08
57	1.23	0.27	1288.31	4.86	774.38	2067.55	136402.71	4.00
56	1.30	0.30	1356.87	5.36	746.75	2108.98	134335.16	3.92
55	1.36	0.32	1420.91	5.82	720.95	2147.69	132226.18	3.83
54	1.42	0.35	1481.14	6.26	696.68	2184.08	130078.50	3.75
53	1.47	0.37	1538.15	6.68	673.71	2218.54	127894.42	3.67
52	1.53	0.39	1592.26	7.09	651.90	2251.26	125675.87	3.58
51	1.57	0.42	1643.77	7.51	631.13	2282.41	123424.62	3.50
50	1.62	0.44	1692.73	7.92	611.38	2312.04	121142.21	3.42
49	1.67	0.46	1739.54	8.33	592.50	2340.36	118830.17	3.33
48	1.71	0.48	1784.31	8.71	574.43	2367.46	116489.81	3.25
47	1.75	0.50	1827.09	9.09	557.17	2393.35	114122.35	3.17
46	1.79	0.53	1868.03	9.45	540.65	2418.13	111729.00	3.08
45	1.83	0.55	1907.59	9.81	524.68	2442.08	109310.86	3.00
44	1.86	0.56	1945.43	10.16	509.41	2465.00	106868.78	2.92
43	1.90	0.58	1981.85	10.50	494.70	2487.05	104403.78	2.83
42	1.93	0.60	2016.84	10.83	480.58	2508.25	101916.73	2.75
41	1.96	0.62	2050.50	11.16	466.98	2528.64	99408.48	2.67
40	2.00	0.64	2082.90	11.48	453.89	2548.28	96879.84	2.58
39	2.03	0.66	2114.11	11.80	441.28	2567.19	94331.57	2.50
38	2.05	0.67	2144.15	12.12	429.14	2585.41	91764.38	2.42
37	2.08	0.69	2173.08	12.43	417.44	2602.95	89178.97	2.33
36	2.11	0.71	2200.83	12.73	406.22	2619.78	86576.02	2.25
35	2.13	0.72	2227.74	13.03	395.34	2636.10	83956.24	2.17
34	2.16	0.74	2253.66	13.32	384.85	2651.83	81320.13	2.08
33	2.18	0.76	2278.57	13.61	374.77	2666.95	78668.30	2.00
32	2.21	0.77	2302.57	13.89	365.06	2681.52	76001.35	1.92
31	2.23	0.79	2325.67	14.16	355.71	2695.54	73319.83	1.83
30	2.25	0.80	2347.82	14.43	346.74	2709.00	70624.29	1.75
29	2.27	0.82	2369.20	14.77	338.05	2722.03	67915.29	1.67
28	2.29	0.84	2389.70	15.13	329.71	2734.55	65193.27	1.58
27	2.31	0.85	2409.40	15.23	321.79	2746.42	62458.72	1.50
26	2.33	0.86	2428.29	15.46	314.15	2757.89	59712.30	1.42
25	2.34	0.87	2446.40	15.70	306.80	2768.90	56954.41	1.33
24	2.36	0.89	2463.74	15.93	299.77	2779.45	54185.51	1.25
23	2.38	0.90	2480.33	16.16	293.05	2789.54	51406.06	1.17
22	2.39	0.91	2496.18	16.39	286.62	2799.18	48616.52	1.08
21	2.41	0.92	2511.30	16.60	280.48	2808.39	45817.34	1.00
20	2.42	0.93	2525.71	16.82	274.63	2817.16	43008.95	0.92
19	2.43	0.95	2539.41	17.02	269.07	2825.50	40191.79	0.83
18	2.44	0.96	2552.41	17.22	263.79	2833.42	37366.29	0.75
17	2.46	0.97	2564.73	17.41	258.79	2840.93	34532.87	0.67
16	2.47	0.98	2576.36	17.60	254.06	2848.02	31691.94	0.58
15	2.48	0.99	2587.33	17.78	249.60	2854.71	28843.92	0.50
14	2.49	1.00	2597.74	17.96	245.37	2861.06	25989.21	0.42
13	2.50	1.01	2607.59	18.12	241.36	2867.07	23128.15	0.33
12	2.51	1.02	2616.79	18.29	237.61	2872.69	20261.08	0.25
11	2.51	1.02	2625.37	18.44	234.12	2877.93	17388.39	0.17
10	2.53	1.03	2638.11	18.59	228.96	2885.66	14510.46	0.08
9	0.00	0.00	0.00	0.00	1291.64	1291.64	11624.79	0.00
8	0.00	0.00	0.00	0.00	1291.64	1291.64	10333.15	-0.08
7	0.00	0.00	0.00	0.00	1291.64	1291.64	9041.51	-0.17
6	0.00	0.00	0.00	0.00	1291.64	1291.64	7749.86	-0.25
5	0.00	0.00	0.00	0.00	1291.64	1291.64	6458.22	-0.33
4	0.00	0.00	0.00	0.00	1291.64	1291.64	5166.57	-0.42
3	0.00	0.00	0.00	0.00	1291.64	1291.64	3874.93	-0.50
2	0.00	0.00	0.00	0.00	1291.64	1291.64	2583.29	-0.58
1	0.00	0.00	0.00	0.00	1291.64	1291.64	1291.64	-0.67

SECTION 6.4.2
CONCEPTUAL GRADING PLANS

IN THE UNINCORPORATED AREA OF THE
COUNTY OF SAN BERNARDINO, CALIFORNIA
VESTING TENTATIVE PARCEL MAP NO. 20340
CONCEPTUAL GRADING

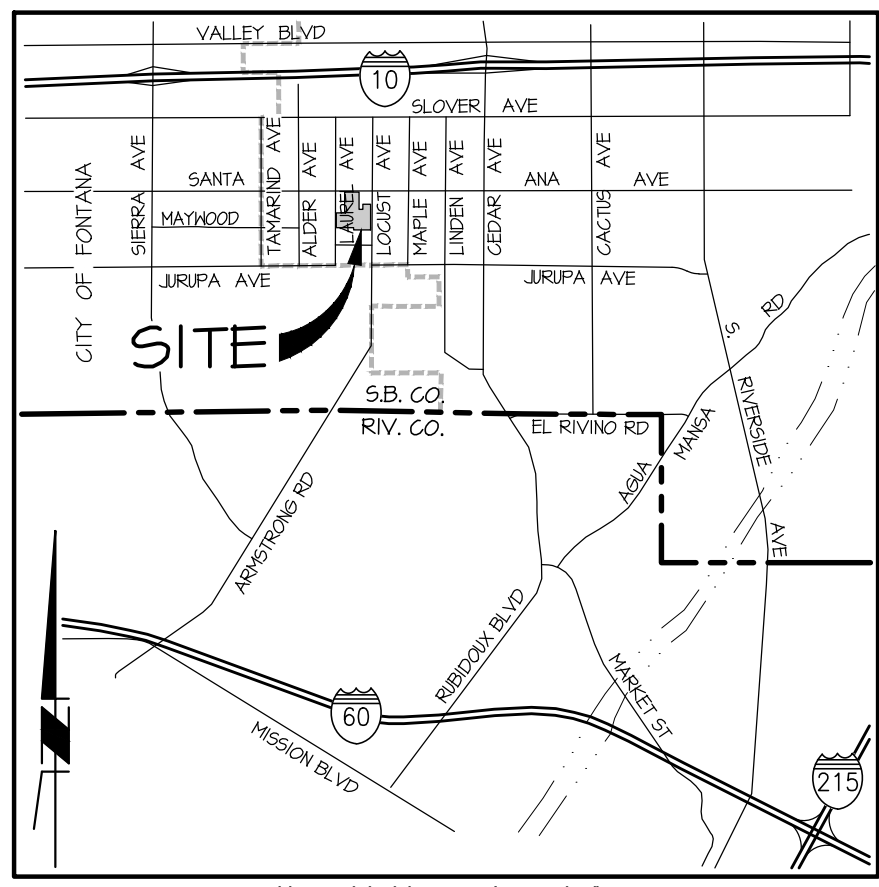

VICINITY MAP
TO IS, ROSH, SEC. 20
NOT TO SCALE

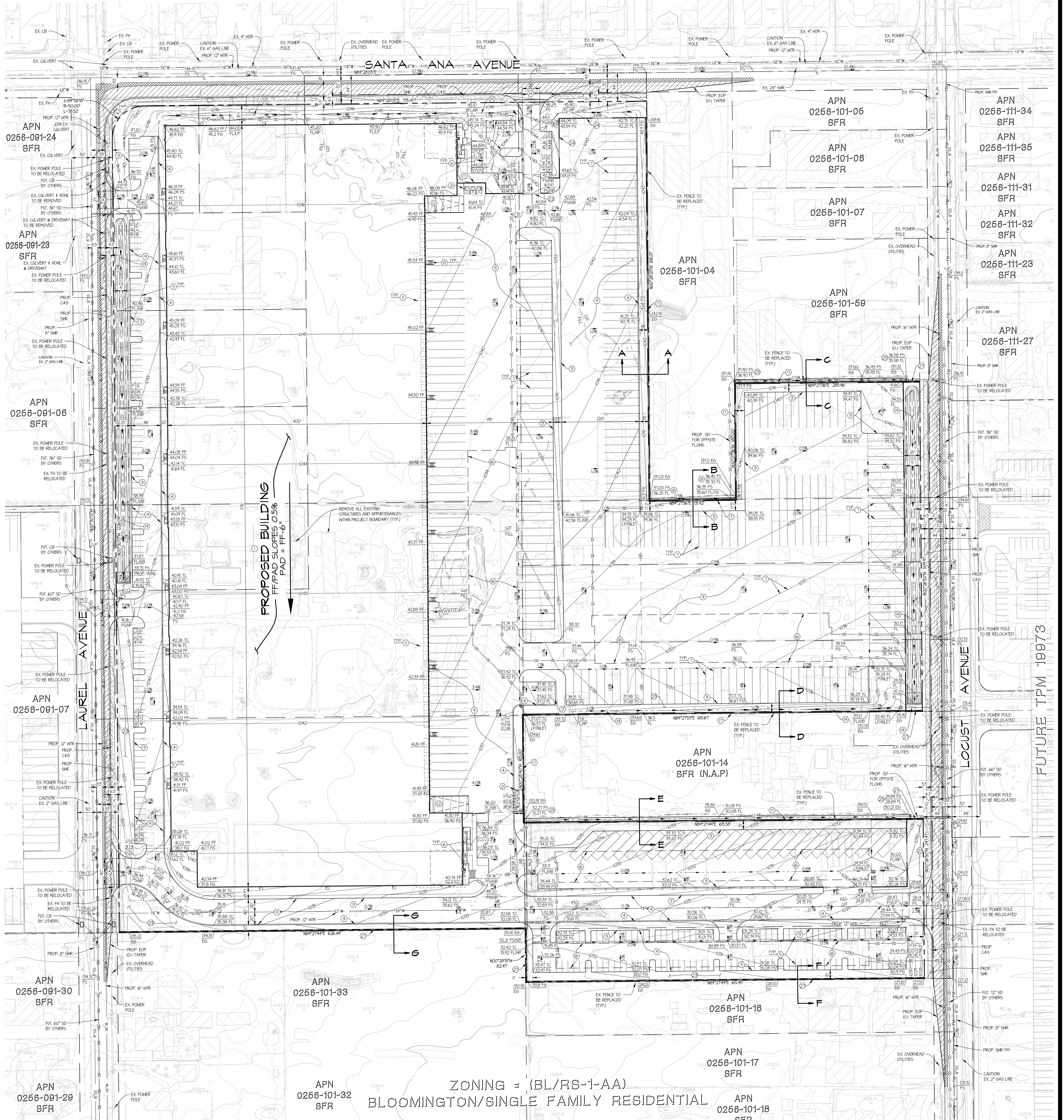

SITE PLAN KEYNOTES

- 1 PAINTED CONCRETE TILT-UP WAREHOUSE / OFFICE / MANUFACTURING FACILITY. BUILDING TO BE DESIGNED PER ARCHITECT'S PLANS
- 2 ON SITE ACCESSIBLE SIDEWALK AND CURB RAMPS.
- 3 CONCRETE CURB
- 4 CONCRETE CURB & GUTTER
- 5 STANDARD PARKING STALL MIN. 4' X 10' - STRIPE PER STANDARDS SHOWN ON ARCHITECT'S PLANS
- 6 HANDICAP PARKING STALL MIN. 4' X 10' - STRIPE PER STANDARDS SHOWN ON ARCHITECT'S PLANS
- 7 TRAILER PARKING STALL MIN. 12' X 55' - STRIPE PER STANDARDS SHOWN ON ARCHITECT'S PLANS
- 8 ACCESSIBLE BUILDING ENTRY WITH ADJACENT BICYCLE RACKS PER ARCHITECT'S PLANS
- 9 PORTLAND CONC. GEMENT (PCG) PAVED TRUCK YARD ARCHITECT'S PLANS
- 10 ASPHALT CONCRETE (AC) PAVED PARKING PER ARCHITECT'S PLANS
- 11 DOCK HIGH TRUCK DOOR PER ARCHITECT'S PLANS
- 12 GRADE LEVEL RAMP DOOR PER ARCHITECT'S PLANS
- 13 EXTERIOR MAN DOOR AND STAIRS IN GUARD POST PER ARCHITECT'S PLANS
- 14 COMMERCIAL DRIVEWAY APPROACH PER SAN BERNARDINO COUNTY STD. (2015) LOCATED PER STD. (30) WITH DECORATIVE CONCRETE PAVING PER ARCHITECT'S PLANS
- 15 UNDERGROUND STORM WATER CHAMBER SYSTEM
- 16 PROPOSED COMBINATION SCREEN- CONCRETE RETAINING WALL PER ARCHITECT'S PLANS
- 17 CONCRETE DRAINAGE SHALE
- 18 VEGETATED SHALE
- 19 SEWER LIFT STATION
- 20 APPROXIMATE LOCATION OF TRASH ENCLOSURE PER ARCHITECT'S PLANS
- 21 METAL, MANUAL OPERATED SECURITY GATE WITH KNOX-PAD LOCK FOR FIRE DEPARTMENT ACCESS PER ARCHITECT'S PLANS
- 22 LANDSCAPE AREA PER LANDSCAPE ARCHITECT'S PLANS
- 23 CONCRETE SCREEN WALL PER ARCHITECT'S PLANS
- 24 CONCRETE DRAINAGE CHANNEL
- 25 RETAINING WALL

LEGEND

- INDEX CONTOUR
- RETAINING WALL
- FENCE
- EDGE OF PAVEMENT
- MANHOLE
- RIGHT OF WAY
- EASEMENT
- PARCEL MAP BOUNDARY
- STREET CENTER LINE
- SCREEN WALL
- COMBINATION SCREEN/RETAINING WALL
- EXISTING LOT LINE
- RIDGE LINE
- REBORN GUTTER
- FLOW ARROW
- PROPOSED EDGE OF PAVEMENT
- EXISTING WATER LINE
- EXISTING SHR LINE
- EXISTING STORM DRAIN PIPE
- PROPOSED STORM DRAIN PIPE
- CUT/FILL LINE
- SLOPE SYMBOL
- PROPOSED STREET AC PAVEMENT
- GRIND AND OVERLAY

EARTHWORK ESTIMATE:

RAIN CUT: 16,155 CY
RAIN FILL: 109,375 CY
NET: 94,220 CY (IMPORT)

HALL TRIPS:
ASSUMED (15 CY PER TRIP) = 6,263

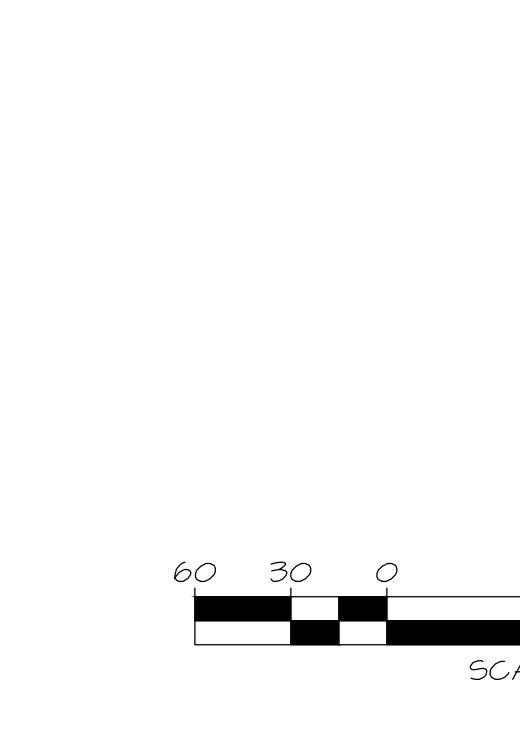

ZONING = (BL/RS-1-AA)
BLOOMINGTON/SINGLE FAMILY RESIDENTIAL

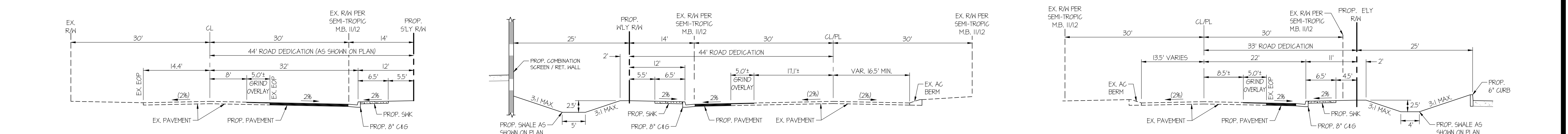

*TYPICAL SECONDARY HIGHWAY PER SAN BERNARDINO COUNTY STD. NO. 102
TYPICAL SECTION SANTA ANA AVENUE
*SECONDARY HIGHWAY
HOR. SCALE: 1"=10'

*TYPICAL SECONDARY HIGHWAY PER SAN BERNARDINO COUNTY STD. NO. 102
TYPICAL SECTION LOUST AVENUE
*SECONDARY HIGHWAY
HOR. SCALE: 1"=10'

*TYPICAL COLLECTOR STREET PER SAN BERNARDINO COUNTY STD. NO. 103
TYPICAL SECTION LAUREL AVENUE
*COLLECTOR STREET
HOR. SCALE: 1"=10'

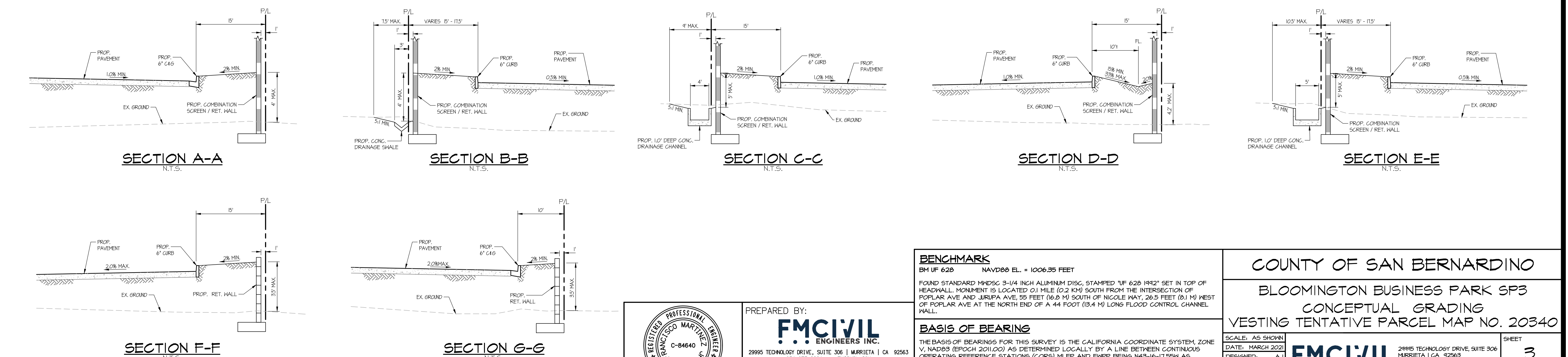

SECTION A-A N.T.S.
SECTION B-B N.T.S.
SECTION C-C N.T.S.
SECTION D-D N.T.S.
SECTION E-E N.T.S.
SECTION F-F N.T.S.
SECTION G-G N.T.S.



PREPARED BY:
FM CIVIL
ENGINEERS INC.
2995 TENDON DRIVE, SUITE 301, MARIETTA, CA 92663
925.923.0201 - FM CIVIL.COM
FRANCISCO MARTINEZ, JR. 3/31/2024
R.C.E. / C.P. / C.E.

BENCHMARK
BM UP 620 NAVD83 EL. = 1006.35 FEET
FOUND STANDARD 1/4" DISC 3/4" INCH ALUMINUM DISC, STAMPED "UP 620 1942" SET IN TOP OF HEADWALL. MONUMENT IS LOCATED 0.1 MILE (0.2 KM) SOUTH FROM THE INTERSECTION OF POPLAR AVE AND JIRAPA AVE 50 FEET (15.2 M) SOUTH OF NICKLE WAY, 26.5 FEET (8.1 M) WEST OF POPLAR AVE AT THE NORTH END OF A 44 FOOT (13.4 M) LONG FLOOD CONTROL CHANNEL WALL.

BASIS OF BEARING
THE BASIS OF BEARINGS FOR THIS SURVEY IS THE CALIFORNIA COORDINATE SYSTEM, ZONE V, NAD83 (EPSCA 201102) AS DETERMINED LOCALLY BY A LINE BETWEEN CONTIGUOUS OPERATING REFERENCE STATIONS GORS M11P AND ENPP BEING 145-16-1150M AS DERIVED FROM GEODETIC VALUES PUBLISHED BY THE CALIFORNIA SPATIAL REFERENCE CENTER (CSRC) AND/OR NATIONAL GEODETIC SURVEY (NGS), RESPECTIVELY.

COUNTY OF SAN BERNARDINO
BLOOMINGTON BUSINESS PARK SP3
CONCEPTUAL GRADING
VESTING TENTATIVE PARCEL MAP NO. 20340

SCALE: AS SHOWN
DATE: MARCH 2024
DESIGNED: AJ
CHECKED: FM
PLN CK REF.

2995 TENDON DRIVE, SUITE 301
MARIETTA, CA 92663
925.923.0201 - FM CIVIL.COM

FM CIVIL
ENGINEERS INC.

SHEET
3
OF 3 SHEETS

P:\PROJECTS\2024\BLOOMINGTON BUSINESS PARK SP3\202403\202403-03-01-001-DWG-ALPHA-3/26/2024 4:03 PM

SECTION 6.4.3
DCV AND FACTOR OF SAFETY CALCULATIONS

Santa Ana Watershed

BMP Design Volume, V_{BMP}

Company Name	FM CIVIL Engineers Inc.
Designed by	Francisco Martinez, PE
Project	Bloomington Commerce Center SP3, Drainage Area 1
Date	3/19/2021

Surface Type	Area (SF)
Roof	161,925.03
Concrete or Asphalt	434,619.85
Future Impervious Area	-
Restore to Natural	-
Ornamental Landscaping	63,262.37
Total Area (SF)	659,807.25
Total Area (Acres)	15.1

Impervious Ratio =	(i)	90.4%
C_{BMP} = Runoff Coefficient	$0.858i^3 - 0.78i^2 + 0.774i + 0.04$	0.7363
$P_{2yr,1hr}$	NOAA - 2-yr 1-hr rainfall depth	0.521
a_1 = San Bernardino Climate Region	Valley = 1.4807 Mountain = 1.909 Desert = 1.2371	1.4807
P_6 - Mean Storm Rainfall Depth	$P_6 = a_1 * P_{2yr,1hr}$	0.7714
a_2 = Drawdown rate of Basin	1.582 for 24-hr 1.963 for 48-hr	1.9630
Project Area (SF)	(DA)	659,807.25
Design Capture Volume (cu.ft.)	$DCV = DA * C_{BMP} * a_2 * P_6 / 12$	61,308.00
Volume Provided, cu. Ft.	Chamber Capacity	206,243.00

Santa Ana Watershed

BMP Design Volume, V_{BMP}

Company Name	FMCIVIL Engineers Inc.
Designed by	Francisco Martinez, PE
Project	Bloomington Commerce Center SP3, Drainage Area 2
Date	3/11/2021

Surface Type	Area (SF)
Roof	318,805.56
Concrete or Asphalt	225,094.01
Future Impervious Area	-
Restore to Natural	-
Ornamental Landscaping	79,638.18
Total Area (SF)	623,537.75
Total Area (Acres)	14.3

Impervious Ratio =	(i)	87.2%
C_{BMP} = Runoff Coefficient	$0.858i^3 - 0.78i^2 + 0.774i + 0.04$	0.6911
$P_{2yr,1hr}$	NOAA - 2-yr 1-hr rainfall depth	0.521
a_1 = San Bernardino Climate Region	Valley = 1.4807 Mountain = 1.909 Desert = 1.2371	1.4807
P_6 - Mean Storm Rainfall Depth	$P_6 = a_1 * P_{2yr,1hr}$	0.7714
a_2 = Drawdown rate of Basin	1.582 for 24-hr 1.963 for 48-hr	1.9630
Project Area (SF)	(DA)	623,537.75
Design Capture Volume (cu.ft.)	$DCV = DA * C_{BMP} * a_2 * P_6 / 12$	54,382.11
Volume Provided, cu. Ft.	Chamber Capacity	178,030.00
DA2 will share Chamber Capacity with DA3 when future phase is built		

Santa Ana Watershed

BMP Design Volume, V_{BMP}

Company Name	FM CIVIL Engineers Inc.
Designed by	Francisco Martinez, PE
Project	Bloomington Commerce Center SP3, Drainage Area 3 (Future Phase)
Date	3/11/2021

Surface Type	Area (SF)
Roof	-
Concrete or Asphalt	-
Future Impervious Area	101,573.65
Restore to Natural	-
Ornamental Landscaping	-
Total Area (SF)	101,573.65
Total Area (Acres)	2.3

Impervious Ratio =	(i)	100.0%
C_{BMP} = Runoff Coefficient	$0.858i^3 - 0.78i^2 + 0.774i + 0.04$	0.8920
$P_{2yr,1hr}$	NOAA - 2-yr 1-hr rainfall depth	0.521
a_1 = San Bernardino Climate Region	Valley = 1.4807 Mountain = 1.909 Desert = 1.2371	1.4807
P_6 - Mean Storm Rainfall Depth	$P_6 = a_1 * P_{2yr,1hr}$	0.7714
a_2 = Drawdown rate of Basin	1.582 for 24-hr 1.963 for 48-hr	1.9630
Project Area (SF)	(DA)	101,573.65
Design Capture Volume (cu.ft.)	$DCV = DA * C_{BMP} * a_2 * P_6 / 12$	11,433.78
Volume Provided, cu. Ft.	Chamber Capacity	178,030.00
DA3 will share Chamber Capacity with DA2 when future phase is built		

Santa Ana Watershed

BMP Design Volume, V_{BMP}

Company Name	FM CIVIL Engineers Inc.
Designed by	Francisco Martinez, PE
Project	Bloomington Commerce Center SP3, Drainage Area 4 (Flowing Offsite)
Date	3/11/2021

Surface Type	Area (SF)
Roof	-
Concrete or Asphalt	1,591.87
Future Impervious Area	-
Restore to Natural	-
Ornamental Landscaping	24,312.25
Total Area (SF)	25,904.11
Total Area (Acres)	0.6

Impervious Ratio =	(i)	6.1%
C_{BMP} = Runoff Coefficient	$0.858i^3 - 0.78i^2 + 0.774i + 0.04$	0.0848
$P_{2yr,1hr}$	NOAA - 2-yr 1-hr rainfall depth	0.521
a_1 = San Bernardino Climate Region	Valley = 1.4807 Mountain = 1.909 Desert = 1.2371	1.4807
P_6 - Mean Storm Rainfall Depth	$P_6 = a_1 * P_{2yr,1hr}$	0.7714
a_2 = Drawdown rate of Basin	1.582 for 24-hr 1.963 for 48-hr	1.9630
Project Area (SF)	(DA)	25,904.11
Design Capture Volume (cu.ft.)	$DCV = DA * C_{BMP} * a_2 * P_6 / 12$	277.27
Volume Provided, cu. Ft.	Chamber Capacity	--

Santa Ana Watershed

BMP Design Volume, V_{BMP}

Company Name	FM CIVIL Engineers Inc.
Designed by	Francisco Martinez, PE
Project	Bloomington Commerce Center SP3, Drainage Area 5 (Flowing Offsite)
Date	3/11/2021

Surface Type	Area (SF)
Roof	-
Concrete or Asphalt	-
Future Impervious Area	-
Restore to Natural	-
Ornamental Landscaping	12,745.07
Total Area (SF)	12,745.07
Total Area (Acres)	0.3

Impervious Ratio =	(i)	0.0%
C_{BMP} = Runoff Coefficient	$0.858i^3 - 0.78i^2 + 0.774i + 0.04$	0.0400
$P_{2yr,1hr}$	NOAA - 2-yr 1-hr rainfall depth	0.521
a_1 = San Bernardino Climate Region	Valley = 1.4807 Mountain = 1.909 Desert = 1.2371	1.4807
P_6 - Mean Storm Rainfall Depth	$P_6 = a_1 * P_{2yr,1hr}$	0.7714
a_2 = Drawdown rate of Basin	1.582 for 24-hr 1.963 for 48-hr	1.9630
Project Area (SF)	(DA)	12,745.07
Design Capture Volume (cu.ft.)	$DCV = DA * C_{BMP} * a_2 * P_6 / 12$	64.33
Volume Provided, cu. Ft.	Chamber Capacity	--

Santa Ana Watershed

BMP Design Volume, V_{BMP}

Company Name	FM CIVIL Engineers Inc.
Designed by	Francisco Martinez, PE
Project	Bloomington Commerce Center SP3, Drainage Area 6 (Flowing Offsite)
Date	3/11/2021

Surface Type	Area (SF)
Roof	-
Concrete or Asphalt	1,044.62
Future Impervious Area	-
Restore to Natural	-
Ornamental Landscaping	5,157.82
Total Area (SF)	6,202.44
Total Area (Acres)	0.1

Impervious Ratio =	(i)	16.8%
C_{BMP} = Runoff Coefficient	$0.858i^3 - 0.78i^2 + 0.774i + 0.04$	0.1523
$P_{2yr,1hr}$	NOAA - 2-yr 1-hr rainfall depth	0.521
a_1 = San Bernardino Climate Region	Valley = 1.4807 Mountain = 1.909 Desert = 1.2371	1.4807
P_6 - Mean Storm Rainfall Depth	$P_6 = a_1 * P_{2yr,1hr}$	0.7714
a_2 = Drawdown rate of Basin	1.582 for 24-hr 1.963 for 48-hr	1.9630
Project Area (SF)	(DA)	6,202.44
Design Capture Volume (cu.ft.)	$DCV = DA * C_{BMP} * a_2 * P_6 / 12$	119.23
Volume Provided, cu. Ft.	Chamber Capacity	--

Infiltration Test No.	Infiltration Rate (in/hr)
I-12	20.4
I-11	11.4
Infiltration Rate (lowest) =	11.4 Used
Geotechnical Report recommendation =	11.40

Worksheet H: Factor of Safety and Design Infiltration Rate and Worksheet

Factor Category		Factor Description	Assigned Weight (w)	Factor Value (v)	Product (p) p = w x v
A	Suitability Assessment	Soil assessment methods	0.25	3	0.75
		Predominant soil texture	0.25	1	0.25
		Site soil variability	0.25	1	0.25
		Depth to groundwater / impervious layer	0.25	1	0.25
		Suitability Assessment Safety Factor, $S_A = \sum p$			
B	Design	Tributary area size	0.25	2	0.5
		Level of pretreatment/ expected sediment loads	0.25	2	0.5
		Redundancy	0.25	2	0.5
		Compaction during construction	0.25	2	0.5
		Design Safety Factor, $S_B = \sum p$			
Combined Safety Factor, $S_{total} = S_A \times S_B$				3.00	
Observed Infiltration Rate, inch/hr, $K_{observed}$ (corrected for test-specific bias)				11.40	
Design Infiltration Rate, in/hr, $K_{design} = K_{observed} / S_{total}$				3.80	

Infiltration rates from Preliminary Southern California Geotechnical Report 20G172-6 dated February 15, 2021.

Note: The minimum combined adjustment factor shall not be less than 2.0 and the maximum combined adjustment factor shall not exceed 9.0.

Infiltration Test No.	Infiltration Rate (in/hr)
I-10 (20G172-6)	20
I-1 (20G172-2)	20.4
Infiltration Rate (lowest) =	20 Used
Geotechnical Report recommendation =	20.0

Worksheet H: Factor of Safety and Design Infiltration Rate and Worksheet





Factor Category		Factor Description	Assigned Weight (w)	Factor Value (v)	Product (p) p = w x v
A	Suitability Assessment	Soil assessment methods	0.25	3	0.75
		Predominant soil texture	0.25	1	0.25
		Site soil variability	0.25	1	0.25
		Depth to groundwater / impervious layer	0.25	1	0.25
		Suitability Assessment Safety Factor, $S_A = \sum p$			
B	Design	Tributary area size	0.25	2	0.5
		Level of pretreatment/ expected sediment loads	0.25	2	0.5
		Redundancy	0.25	2	0.5
		Compaction during construction	0.25	2	0.5
		Design Safety Factor, $S_B = \sum p$			
Combined Safety Factor, $S_{total} = S_A \times S_B$				3.00	
Observed Infiltration Rate, inch/hr, $K_{observed}$ (corrected for test-specific bias)				20.00	
Design Infiltration Rate, in/hr, $K_{design} = K_{observed} / S_{total}$				6.67	

Infiltration rates from Preliminary Southern California Geotechnical Report 20G172-6 dated February 15, 2021, and Report 20G172-2 dated October 20, 2020.

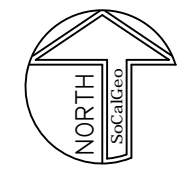
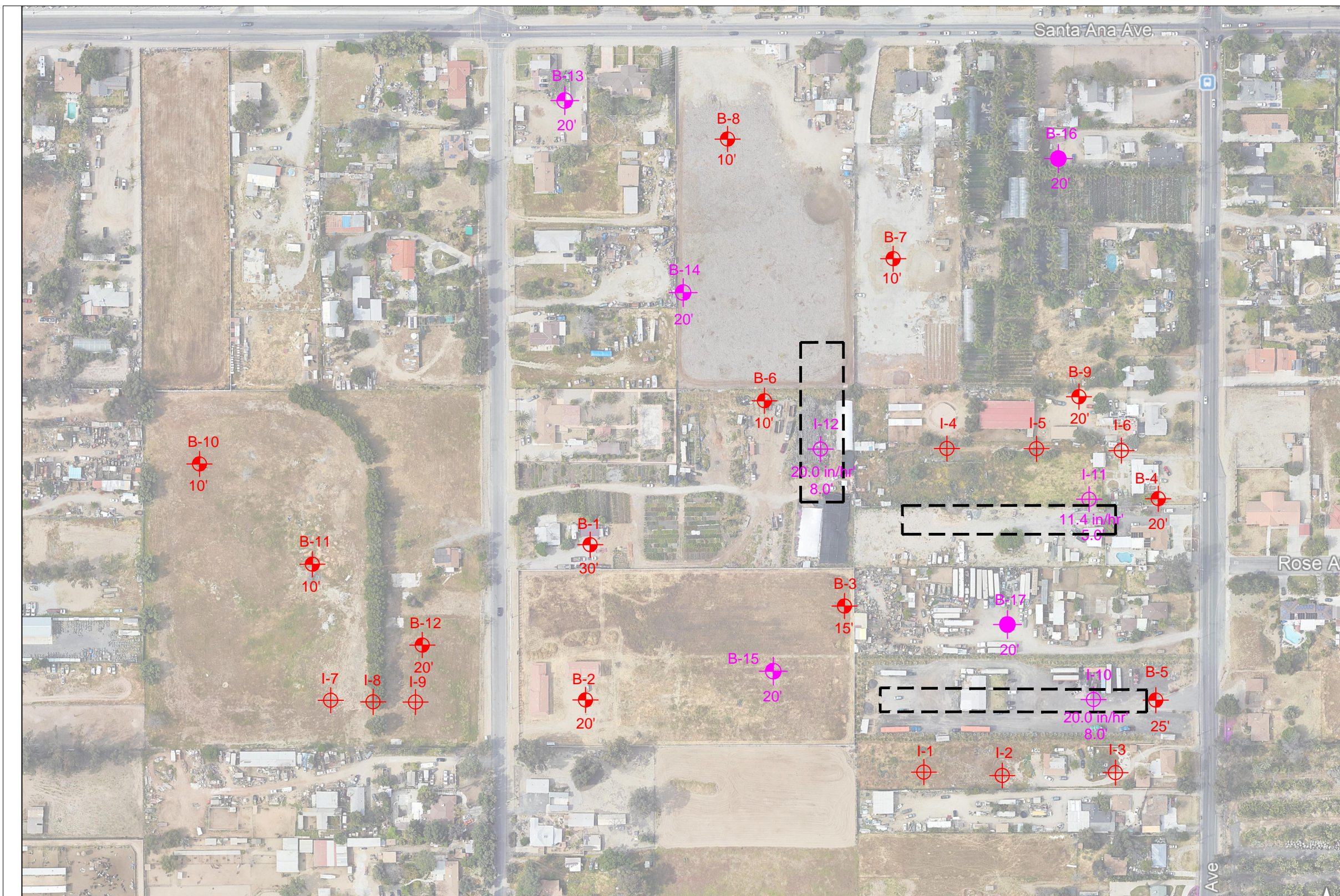
Note: The minimum combined adjustment factor shall not be less than 2.0 and the maximum combined adjustment factor shall not exceed 9.0.

SECTION 6.4.4
INFILTRATION &
USDA SOIL REPORT



- GEOTECHNICAL LEGEND**
-  PROPOSED INFILTRATION TEST LOCATION
 -  PROPOSED BORING LOCATION
 -  PROPOSED BORING LOCATION (SCHEME 2 ONLY)
 -  PREVIOUS INFILTRATION TEST (SCG REPORT NO. 20G172-2)
 -  PREVIOUS BORING LOCATION (SCG REPORT NO. 20G172-1)



EXPLORATION LOCATION PLAN	
PROPOSED COMMERCIAL/INDUSTRIAL DEVELOPMENT BLOOMINGTON, CALIFORNIA	
SCALE: 1" = 200'	 SOUTHERN CALIFORNIA GEOTECHNICAL
DRAWN: XXX	
CHKD: XXX	
SCG PROJECT 20G172-5	
PLATE 2	

October 20, 2020

Howard Industrial Partners
1944 North Tustin Street, Suite 122
Orange, California 92865



**SOUTHERN
CALIFORNIA
GEOTECHNICAL**
A California Corporation

Attention: Mr. Mike Tunney
Vice President

Project No.: **20G172-2**

Subject: **Results of Infiltration Testing**
Proposed Commercial/Industrial Development
Laurel Avenue, South of Santa Ana Avenue
Bloomington (Unincorporated San Bernardino County), California

Reference: Geotechnical Investigation, Proposed Commercial/Industrial Development, Bloomington, California, prepared by Southern California Geotechnical, Inc. (SCG), prepared for Howard Industrial Partners, SCG project No. 20G172-4.

Mr. Tunney:

In accordance with your request, we have conducted infiltration testing at the subject site. We are pleased to present this report summarizing the results of the infiltration testing and our design recommendations.

Scope of Services

The scope of services performed for this project was in general accordance with our Proposal No. 19P389R4, dated August 20, 2020. The scope of services included site reconnaissance, subsurface exploration, field testing, and engineering analysis to determine the infiltration rates of the on-site soils. The infiltration testing was performed in general accordance with the Technical Guidance Document for Water Quality Management Plans prepared for the County of San Bernardino Areawide Stormwater Program dated June 7, 2013. The San Bernardino County standards defer to guidelines published by Riverside County Department of Environmental Health (RCDEH).

Site and Project Description

The overall subject site consists of four (4) contiguous areas (identified as Site 1 through Site 4), approximately 213 acres in size, in an unincorporated portion of San Bernardino County, California. This investigation only includes Site 3 and Site 4. The general location of the site is illustrated on the Site Location Map, enclosed as Plate 1 of this report.

Site 3

Site 3 is located on the west side of Locust Avenue, south of Santa Ana Avenue in Bloomington area of unincorporated San Bernardino County, California. The site is bounded to the north by

Santa Ana Avenue and single-family residences, to the west by Laurel Avenue, to the south by single-family residences, and to the east by Locust Avenue.

The site consists of multiple contiguous rectangular-shaped parcels which total 28.09± acres in size. The site is developed with several single-family residences, commercial/industrial buildings, and trailer storage yards.

Detailed topographic information was not available at the time of this report. Based on visual observations made at the time of the subsurface investigation and from elevations obtained from Google Earth, the overall site topography of Site 3 appears to slope gently to the southwest with an estimated gradient of 1.5± percent. The topographic low point of Site 3 is 1,027± feet mean sea level (msl) in the central-southern region of the site. The topographic high point of Site 3 appears to be 1,047± feet msl, located in the northeastern region of the site.

Site 4

Site 4 is located on the west side of Laurel Avenue, south of Santa Ana Avenue in Bloomington area of unincorporated San Bernardino County, California. The site is bounded to the north, west, and south by single-family residences, and to the east by Laurel Avenue.

The site consists of multiple contiguous rectangular-shaped parcels which total 9.55± acres in size. The site is developed with a single-family residence.

Detailed topographic information was not available at the time of this report. Based on visual observations made at the time of the subsurface investigation and from elevations obtained from Google Earth, the overall site topography of Site 4 appears to slope gently to the southeast with an estimated gradient of 0.7± percent. The topographic high point of Site 4 is 1,049 feet msl, located in the northwestern corner of the site. The topographic low point of Site 4 is 1,038 feet msl, located in the central-east portion of the site. A north-south trending 5 to 7± foot berm exists within Site 4, located 200± feet west of Laurel Avenue and contains a concentration of trees.

Proposed Development

A conceptual master plan identified as the Bloomington Industrial Master Plan, prepared by AO, has been provided to our office by the client. As previously stated, this investigation only includes Site 3 and Site 4 of the overall development.

Site 3

Site 3 will be developed with a commercial/industrial building, 440,000± ft² in size. The building will be constructed with dock-high doors located along the north side of the building. It is also assumed that the building will be a tilt-up concrete structure, supported on conventional shallow foundations with a concrete slab-on-grade floor. The building will be surrounded by asphaltic concrete pavements in the parking and drive lanes, Portland cement concrete in the loading dock areas, and landscape planters throughout.

Site 4

Site 4 will be developed as an asphaltic concrete parking lot. The parking lot will consist of 310 trailer parking stalls with associated drive lanes.

Based on conversations with representatives of the project civil engineer, Site 3 and Site 4 will include on-site storm water infiltration. A below-grade chamber system will be constructed in the east-central area of Site 3 and a detention basin will be constructed in the southeastern area of Site 3. A below-grade chamber system will be constructed in the southeastern area of Site 4. The bottom of the infiltration systems will extend to depths up to 10 feet below the existing site grades.

Concurrent Study

Southern California Geotechnical, Inc. (SCG) concurrently conducted a geotechnical investigation at the subject site, referenced above. As a part of this study, twelve (12) borings were advanced to depths of 10 to 30± feet below existing site grades.

Artificial fill soils and possible fill soils were encountered at the ground surface of all twelve (12) boring locations, extending to depths of 1½ to 5½± feet below the existing site grades. The artificial fill soils consist of very loose to medium dense silty fine sands and medium dense fine sandy silts. Trace to little quantities of medium to coarse sand were encountered within the artificial fill soils and occasional trace quantities of fine to coarse gravel were present in the strata. Possible fill soils were also encountered at the ground surface of B-10 and beneath the artificial fill soils at B-6. The possible fill soils are comprised of loose silty fine sands with the same characteristics as the fill soils, except lacking indications of being disturbed. Native alluvium was encountered beneath the fill soils at all twelve (12) boring locations, extending to the maximum explored depth of 30± feet below existing site grades. The shallow native alluvial soils at depths less than 10± feet consist of loose to very dense fine to coarse sands, medium dense to very dense silty fine sands, loose to very dense fine to medium sands, dense silty fine to coarse sands, dense to very dense fine sands, and dense to very dense fine sandy silts. Variable constituent quantities of fine to coarse sand, silt, fine to coarse gravel, and occasional cobbles were encountered throughout these strata. At depths greater than 10± feet, the alluvium consists of medium dense to very dense fine to coarse sands, medium dense to very dense silty fine to coarse sands, medium dense to very dense fine to medium sands, dense fine sands, medium dense to very dense silty fine sands, and medium dense to very dense fine sandy silts. Trace to some quantity of silts, fine to coarse sands, fine to coarse gravels, and occasional cobbles were also encountered within the deeper alluvial strata. At Boring No. B-5, trace quantities of clays were encountered at depths of 22 to 27± feet below existing site grades.

Groundwater

Groundwater was not encountered at any of the borings. Based on the lack of any water within the borings, and the moisture contents of the recovered soil samples, the static groundwater table is considered to have existed at a depth in excess of 30± feet below existing site grades, at the time of the subsurface investigation.

As part of our research, we reviewed available groundwater data in order to determine the historic and more recent high groundwater levels for the site. The primary reference used to determine the groundwater depths in this area is the California Department of Water Resources website, <http://www.water.ca.gov/waterdatalibrary/>. The nearest monitoring well is located approximately 2,600 feet southeast from the site. Water level readings within this monitoring well indicate a historic high groundwater levels of 176± feet in October 2011, and more recent groundwater levels of 187± feet below the ground surface in October 2019.

Subsurface Exploration

Scope of Exploration

The subsurface exploration conducted for the infiltration testing consisted of nine (9) infiltration test borings, advanced to depths of 10± feet below the existing site grades. The infiltration borings were advanced using a truck-mounted drilling rig, equipped with 8-inch-diameter hollow-stem augers and were logged during drilling by a member of our staff. The approximate locations of the infiltration test borings (identified as Infiltration Test Nos. I-1 through I-9) are indicated on the Infiltration Test Location Plan, enclosed as Plate 2 of this report.

Upon the completion of the infiltration borings, the bottom of each test boring was covered with 2± inches of clean ¾-inch gravel. A sufficient length of 3-inch-diameter perforated PVC casing was then placed into each test hole so that the PVC casing extended from the bottom of the test hole to the ground surface. Clean ¾-inch gravel was then installed in the annulus surrounding the PVC casing.

Geotechnical Conditions

Artificial Fill

Artificial fill and possible fill soils were encountered at the ground surface of all nine (9) infiltration test locations, extending to depths of 5½ to 7± feet below existing site grades. The artificial fill soils consist of loose to medium dense fine sandy silts and loose to medium dense silty fine sands. Variable quantities of medium to coarse sand and trace quantities of fine to coarse gravel were encountered within the artificial fill soils. Occasional Cobbles were encountered at Infiltration Test No. I-7.

Alluvium

Native alluvium was encountered beneath the artificial fill soils at all nine (9) infiltration test locations, extending to the maximum explored depth of 10± feet below existing site grades. The native alluvial soils generally consist of medium dense silty fine sands and fine to coarse sands, dense fine to coarse sands and silty fine to coarse sands, and very dense fine to coarse sands. Trace to little medium to coarse sand, fine to coarse gravel, and variable silt content was encountered within the alluvial strata. The Boring Logs, which illustrate the conditions encountered at each boring location is included within this report.

Infiltration Testing

As previously mentioned, the infiltration testing was performed in general accordance with Technical Guidance Document for Water Quality Management Plans, prepared for the County of San Bernardino Areawide Stormwater Program.

Pre-soaking

In accordance with the county infiltration standards for sandy soils, all infiltration test borings were pre-soaked 2 hours prior to the infiltration testing or until all of the water had percolated through the test holes. The pre-soaking process consisted of filling test borings by inverting a full 5-gallon bottle of clear water supported over each hole so that the water flow into the hole holds constant at a level at least 5 times the hole's radius above the gravel at the bottom of each hole. Pre-soaking was completed after all of the water had percolated through the test holes.

Infiltration Testing

Following the pre-soaking process of the infiltration test borings, SCG performed the infiltration testing. Each test hole was filled with water to a depth of at least 5 times the hole's radius above the gravel at the bottom of the test hole. In accordance with the San Bernardino County guidelines, since "sandy soils" were encountered at the bottom of all of the infiltration test borings (where 6 inches of water infiltrated into the surrounding soils for two consecutive 25-minute readings), readings were taken at 10-minute intervals for a total of 1 hour at all three (3) test locations. After each reading, water was added to the borings so that the depth of the water was at least 5 times the radius of the hole. The water level readings are presented on the spreadsheets enclosed with this report. The infiltration rates for each of the timed intervals are also tabulated on the spreadsheets.

The infiltration rates from the test are tabulated in inches per hour. In accordance with the typically accepted practice, it is recommended that the most conservative reading from the latter part of the infiltration tests be used as the design infiltration rate. The rates are summarized below:

<u>Infiltration Test No.</u>	<u>Depth (feet)</u>	<u>Soil Description</u>	<u>Infiltration Rate (inches/hour)</u>
I-1	10	Brown Gray fine to coarse Sand, some fine to coarse Gravel, trace Silt	21.4
I-2	10	Light Gray Brown fine to coarse Sand, some fine to coarse Gravel, little Silt	20.4
I-3	10	Light Gray Brown fine to coarse Sand, some fine to coarse Gravel, trace Silt	22.9
I-4	10	Light Brown Gray fine to coarse Sand, some fine to coarse Gravel	20.4
I-5	10	Gray fine to coarse Sand, some fine to coarse Gravel, trace Silt	14.2
I-6	10	Light Gray Brown fine to coarse Sand, little fine to coarse Gravel, trace Silt	19.5

I-7	10	Light Brown Gray fine to coarse Sand, little to some Silt, trace fine Gravel	12.1
I-8	10	Light Brown Gray fine to coarse Sand, little Silt, little fine Gravel	13.1
I-9	10	Brown Silty fine to coarse Sand, trace fine Gravel	2.6

Laboratory Testing

Moisture Content

The moisture contents for the recovered soil samples within the borings were determined in accordance with ASTM D-2216 and are expressed as a percentage of the dry weight. These test results are presented on the Boring Logs.

Grain Size Analysis

The grain size distribution of selected soils collected from the base of each infiltration test boring have been determined using a range of wire mesh screens. These tests were performed in general accordance with ASTM D-422 and/or ASTM D-1140. The weight of the portion of the sample retained on each screen is recorded and the percentage finer or coarser of the total weight is calculated. The results of these tests are presented on Plates C-1 through C-9 of this report.

Design Recommendations

Nine (9) infiltration tests were performed at the subject site. As noted above, the infiltration rates at these locations vary from 2.6 to 22.9 inches per hour. The primary factor affecting the infiltration rates is the varying silt content in the soil. **Based on the infiltration test results from Infiltration Test Nos. I-1 through I-9, the following design infiltration rates are recommended:**

Infiltration Test Nos.	Infiltration System	Design Infiltration Rate (inches per hour)
I-1, I-2, I-3	A	20.4
I-4, I-5, I-6	B	14.2
I-7, I-8, I-9	C	2.6

We recommend that a representative from the geotechnical engineer be on-site during the construction of the proposed infiltration system to identify the soil classification at the base of the system. It should be confirmed that the soils at the base of the proposed infiltration system correspond with those presented in this report to ensure that the performance of the system will be consistent with the rates reported herein.

The design of the storm water infiltration system should be performed by the project civil engineer, in accordance with the City of Bloomington and/or County of San Bernardino guidelines. It is recommended that the system be constructed so as to facilitate removal of silt and clay, or other deleterious materials from any water that may enter the system. The presence of such

materials would decrease the effective infiltration rates. **It is recommended that the project civil engineer apply an appropriate factor of safety. The infiltration rate recommended above is based on the assumption that only clean water will be introduced to the subsurface profile. Any fines, debris, or organic materials could significantly impact the infiltration rate.** It should be noted that the recommended infiltration rates are based on infiltration testing at nine (9) discrete locations and that the overall infiltration rates of the proposed infiltration system could vary considerably.

Construction Considerations

The infiltration rates presented in this report are specific to the tested locations and tested depths. Infiltration rates can be significantly reduced if the soils are exposed to excessive disturbance or compaction during construction. Therefore, the subgrade soils within proposed infiltration system areas should not be over-excavated, undercut or compacted in any significant manner. **It is recommended that a note to this effect be added to the project plans and/or specifications.**

Infiltration versus Permeability

Infiltration rates are based on unsaturated flow. As water is introduced into soils by infiltration, the soils become saturated and the wetting front advances from the unsaturated zone to the saturated zone. Once the soils become saturated, infiltration rates become zero, and water can only move through soils by hydraulic conductivity at a rate determined by pressure head and soil permeability. The infiltration rate presented herein was determined in accordance with the San Bernardino County guidelines and is considered valid for the time and place of the actual test. Changes in soil moisture content will affect the infiltration rate. Infiltration rates should be expected to decrease until the soils become saturated. Soil permeability values will then govern groundwater movement. Permeability values may be on the order of 10 to 20 times less than infiltration rates. The system designer should incorporate adequate factors of safety and allow for overflow design into appropriate traditional storm drain systems, which would transport storm water off-site.

Location of Infiltration System

The use of on-site storm water infiltration system carries a risk of creating adverse geotechnical conditions. Increasing the moisture content of the soil can cause the soil to lose internal shear strength and increase its compressibility, resulting in a change in the designed engineering properties. Overlying structures and pavements in the infiltration area could potentially be damaged due to saturation of subgrade soils. **The proposed infiltration system for this site should be located at least 25 feet away from any structures, including retaining walls.** Even with this provision of locating the infiltration system at least 25 feet from the building, it is possible that infiltrating water into the subsurface soils could have an adverse effect on the proposed or existing structures. It should also be noted that utility trenches which happen to collect storm water can also serve as conduits to transmit storm water toward the structure, depending on the slope of the utility trench. Therefore, consideration should also be given to the proposed locations of underground utilities which may pass near the proposed infiltration system.

General Comments

This report has been prepared as an instrument of service for use by the client in order to aid in the evaluation of this property and to assist the architects and engineers in the design and preparation of the project plans and specifications. This report may be provided to the contractor(s) and other design consultants to disclose information relative to the project. However, this report is not intended to be utilized as a specification in and of itself, without appropriate interpretation by the project architect, structural engineer, and/or civil engineer. The design of the proposed storm water infiltration system is the responsibility of the civil engineer. The role of the geotechnical engineer is limited to determination of infiltration rate only. By using the design infiltration rate contained herein, the civil engineer agrees to indemnify, defend, and hold harmless the geotechnical engineer for all aspects of the design and performance of the proposed storm water infiltration system. The reproduction and distribution of this report must be authorized by the client and Southern California Geotechnical, Inc. Furthermore, any reliance on this report by an unauthorized third party is at such party's sole risk, and we accept no responsibility for damage or loss which may occur.

The analysis of this site was based on a subsurface profile interpolated from limited discrete soil samples. While the materials encountered in the project area are considered to be representative of the total area, some variations should be expected between boring locations and testing depths. If the conditions encountered during construction vary significantly from those detailed herein, we should be contacted immediately to determine if the conditions alter the recommendations contained herein.

This report has been based on assumed or provided characteristics of the proposed development. It is recommended that the owner, client, architect, structural engineer, and civil engineer carefully review these assumptions to ensure that they are consistent with the characteristics of the proposed development. If discrepancies exist, they should be brought to our attention to verify that they do not affect the conclusions and recommendations contained herein. We also recommend that the project plans and specifications be submitted to our office for review to verify that our recommendations have been correctly interpreted. The analysis, conclusions, and recommendations contained within this report have been promulgated in accordance with generally accepted professional geotechnical engineering practice. No other warranty is implied or expressed.

Closure

We sincerely appreciate the opportunity to be of service on this project. We look forward to providing additional consulting services during the course of the project. If we may be of further assistance in any manner, please contact our office.

Respectfully Submitted,

SOUTHERN CALIFORNIA GEOTECHNICAL, INC.



Ryan Bremer
Staff Geologist



Robert G. Trazo, GE 2655
Principal Engineer

Distribution: (1) Addressee

- Enclosures:
- Plate 1 - Site Location Map
 - Plate 2 - Infiltration Test Location Plan
 - Boring Log Legend and Logs
 - Infiltration Test Results Spreadsheets (22 pages)
 - Grain Size Distribution Graphs (9 pages)

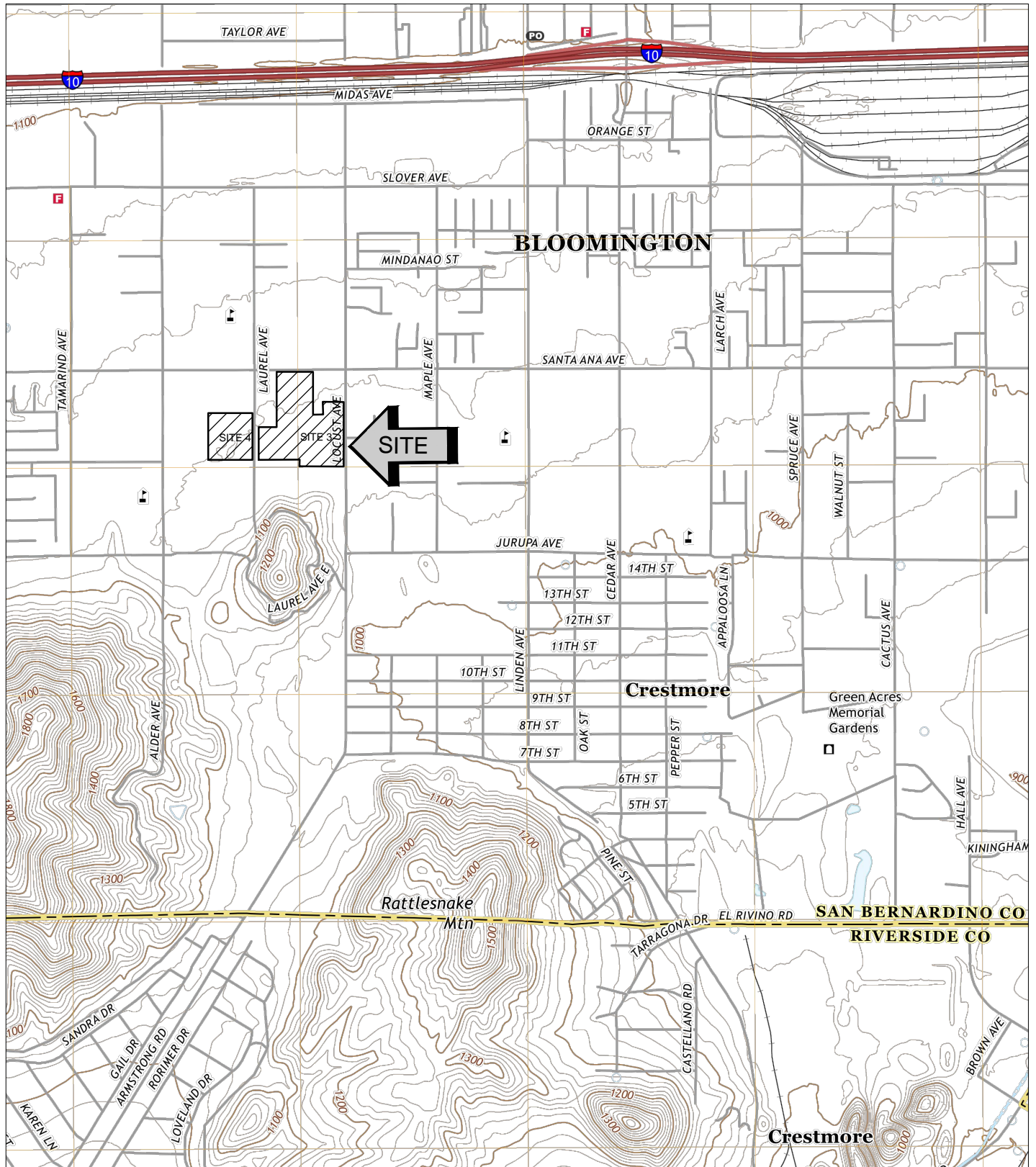

LEGEND

 PROJECT SITES 3 AND 4



SOURCE: USGS TOPOGRAPHIC MAP OF THE FONTANA QUADRANGLE, SAN BERNARDINO COUNTY, CALIFORNIA, 2018.

SITE LOCATION MAP

PROPOSED COMMERCIAL/INDUSTRIAL DEVELOPMENT
UNINCORPORATED SAN BERNARDINO COUNTY, CALIFORNIA

SCALE: 1" = 2000'

DRAWN: OS

CHKD: RGT

SCG PROJECT

20G172-2

PLATE 1



SOUTHERN CALIFORNIA GEOTECHNICAL

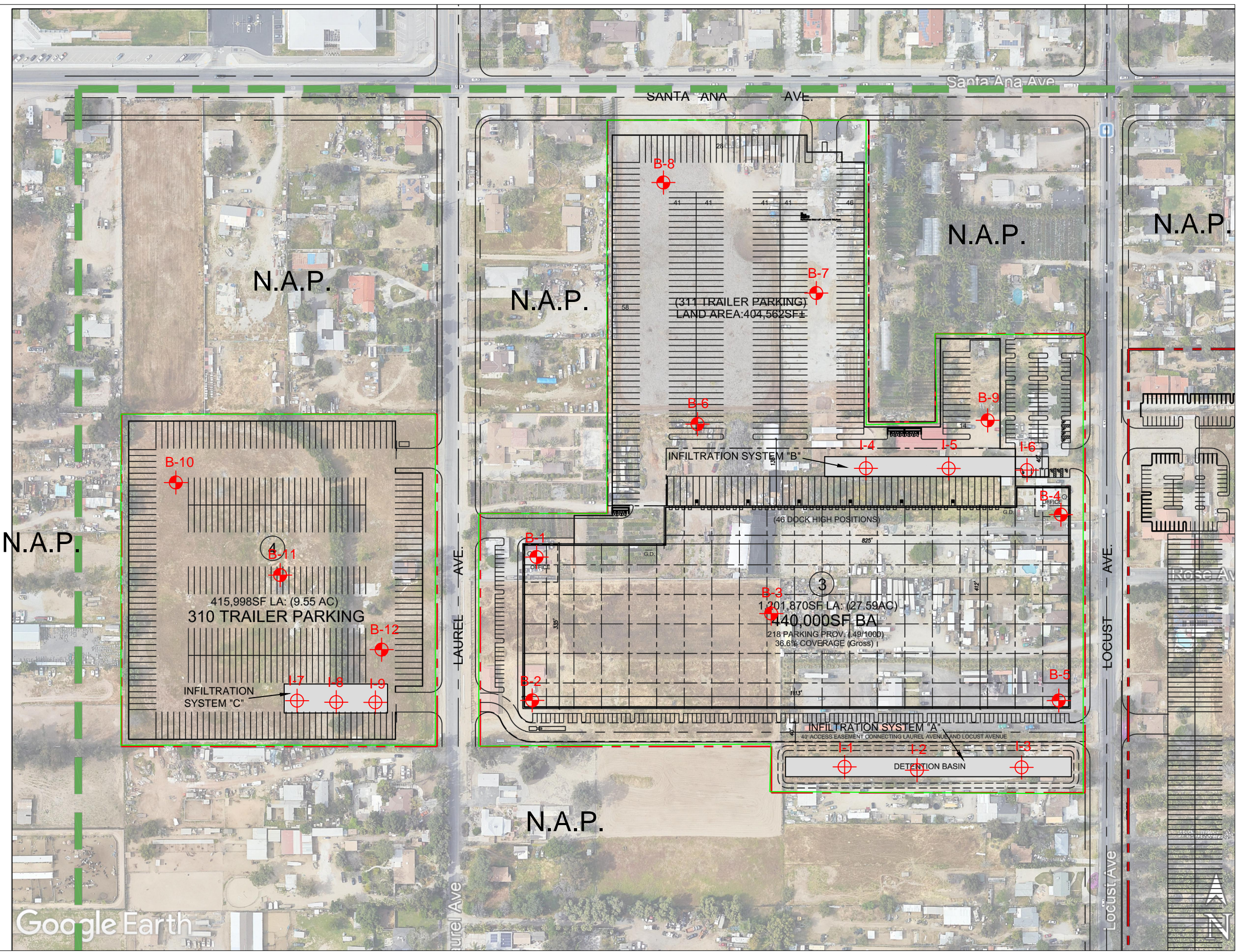

- GEOTECHNICAL LEGEND**
- APPROXIMATE INFILTRATION TEST LOCATION
 - APPROXIMATE BORING LOCATION (SCG PROJECT NO. 20G172-4)
 - APPROXIMATE INFILTRATION SYSTEM LOCATION







INFILTRATION TEST LOCATION PLAN
 PROPOSED COMMERCIAL/INDUSTRIAL DEVELOPMENT
 BLOOMINGTON, CALIFORNIA

SCALE: 1" = 200'
 DRAWN: RB
 CHKD: RGT
 SCG PROJECT
 20G172-2
PLATE 2

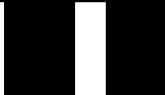

Google Earth

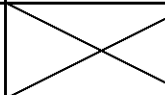
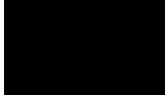
BORING LOG LEGEND

SAMPLE TYPE	GRAPHICAL SYMBOL	SAMPLE DESCRIPTION
AUGER		SAMPLE COLLECTED FROM AUGER CUTTINGS, NO FIELD MEASUREMENT OF SOIL STRENGTH. (DISTURBED)
CORE		ROCK CORE SAMPLE: TYPICALLY TAKEN WITH A DIAMOND-TIPPED CORE BARREL. TYPICALLY USED ONLY IN HIGHLY CONSOLIDATED BEDROCK.
GRAB		SOIL SAMPLE TAKEN WITH NO SPECIALIZED EQUIPMENT, SUCH AS FROM A STOCKPILE OR THE GROUND SURFACE. (DISTURBED)
CS		CALIFORNIA SAMPLER: 2-1/2 INCH I.D. SPLIT BARREL SAMPLER, LINED WITH 1-INCH HIGH BRASS RINGS. DRIVEN WITH SPT HAMMER. (RELATIVELY UNDISTURBED)
NSR		NO RECOVERY: THE SAMPLING ATTEMPT DID NOT RESULT IN RECOVERY OF ANY SIGNIFICANT SOIL OR ROCK MATERIAL.
SPT		STANDARD PENETRATION TEST: SAMPLER IS A 1.4 INCH INSIDE DIAMETER SPLIT BARREL, DRIVEN 18 INCHES WITH THE SPT HAMMER. (DISTURBED)
SH		SHELBY TUBE: TAKEN WITH A THIN WALL SAMPLE TUBE, PUSHED INTO THE SOIL AND THEN EXTRACTED. (UNDISTURBED)
VANE		VANE SHEAR TEST: SOIL STRENGTH OBTAINED USING A 4 BLADED SHEAR DEVICE. TYPICALLY USED IN SOFT CLAYS-NO SAMPLE RECOVERED.

COLUMN DESCRIPTIONS

DEPTH:

Distance in feet below the ground surface.

SAMPLE:

Sample Type as depicted above.

BLOW COUNT:

Number of blows required to advance the sampler 12 inches using a 140 lb hammer with a 30-inch drop. 50/3" indicates penetration refusal (>50 blows) at 3 inches. WH indicates that the weight of the hammer was sufficient to push the sampler 6 inches or more.

POCKET PEN.:

Approximate shear strength of a cohesive soil sample as measured by pocket penetrometer.

GRAPHIC LOG:

Graphic Soil Symbol as depicted on the following page.

DRY DENSITY:

Dry density of an undisturbed or relatively undisturbed sample in lbs/ft³.

MOISTURE CONTENT:

Moisture content of a soil sample, expressed as a percentage of the dry weight.

LIQUID LIMIT:

The moisture content above which a soil behaves as a liquid.

PLASTIC LIMIT:

The moisture content above which a soil behaves as a plastic.

PASSING #200 SIEVE:

The percentage of the sample finer than the #200 standard sieve.

UNCONFINED SHEAR:

The shear strength of a cohesive soil sample, as measured in the unconfined state.

SOIL CLASSIFICATION CHART

MAJOR DIVISIONS			SYMBOLS		TYPICAL DESCRIPTIONS
			GRAPH	LETTER	
<p>COARSE GRAINED SOILS</p> <p>MORE THAN 50% OF MATERIAL IS LARGER THAN NO. 200 SIEVE SIZE</p>	<p>GRAVEL AND GRAVELLY SOILS</p> <p>MORE THAN 50% OF COARSE FRACTION RETAINED ON NO. 4 SIEVE</p>	<p>CLEAN GRAVELS</p> <p>(LITTLE OR NO FINES)</p>		GW	WELL-GRADED GRAVELS, GRAVEL - SAND MIXTURES, LITTLE OR NO FINES
		<p>GRAVELS WITH FINES</p> <p>(APPRECIABLE AMOUNT OF FINES)</p>		GP	POORLY-GRADED GRAVELS, GRAVEL - SAND MIXTURES, LITTLE OR NO FINES
		<p>GRAVELS WITH FINES</p> <p>(APPRECIABLE AMOUNT OF FINES)</p>		GM	SILTY GRAVELS, GRAVEL - SAND - SILT MIXTURES
		<p>GRAVELS WITH FINES</p> <p>(APPRECIABLE AMOUNT OF FINES)</p>		GC	CLAYEY GRAVELS, GRAVEL - SAND - CLAY MIXTURES
	<p>SAND AND SANDY SOILS</p> <p>MORE THAN 50% OF COARSE FRACTION PASSING ON NO. 4 SIEVE</p>	<p>CLEAN SANDS</p> <p>(LITTLE OR NO FINES)</p>		SW	WELL-GRADED SANDS, GRAVELLY SANDS, LITTLE OR NO FINES
		<p>CLEAN SANDS</p> <p>(LITTLE OR NO FINES)</p>		SP	POORLY-GRADED SANDS, GRAVELLY SAND, LITTLE OR NO FINES
		<p>SANDS WITH FINES</p> <p>(APPRECIABLE AMOUNT OF FINES)</p>		SM	SILTY SANDS, SAND - SILT MIXTURES
		<p>SANDS WITH FINES</p> <p>(APPRECIABLE AMOUNT OF FINES)</p>		SC	CLAYEY SANDS, SAND - CLAY MIXTURES
<p>FINE GRAINED SOILS</p> <p>MORE THAN 50% OF MATERIAL IS SMALLER THAN NO. 200 SIEVE SIZE</p>	<p>SILTS AND CLAYS</p> <p>LIQUID LIMIT LESS THAN 50</p>		ML	INORGANIC SILTS AND VERY FINE SANDS, ROCK FLOUR, SILTY OR CLAYEY FINE SANDS OR CLAYEY SILTS WITH SLIGHT PLASTICITY	
			CL	INORGANIC CLAYS OF LOW TO MEDIUM PLASTICITY, GRAVELLY CLAYS, SANDY CLAYS, SILTY CLAYS, LEAN CLAYS	
			OL	ORGANIC SILTS AND ORGANIC SILTY CLAYS OF LOW PLASTICITY	
	<p>SILTS AND CLAYS</p> <p>LIQUID LIMIT GREATER THAN 50</p>		MH	INORGANIC SILTS, MICACEOUS OR DIATOMACEOUS FINE SAND OR SILTY SOILS	
			CH	INORGANIC CLAYS OF HIGH PLASTICITY	
			OH	ORGANIC CLAYS OF MEDIUM TO HIGH PLASTICITY, ORGANIC SILTS	
<p>HIGHLY ORGANIC SOILS</p>				PT	PEAT, HUMUS, SWAMP SOILS WITH HIGH ORGANIC CONTENTS

NOTE: DUAL SYMBOLS ARE USED TO INDICATE BORDERLINE SOIL CLASSIFICATIONS



JOB NO.: 20G172-2	DRILLING DATE: 9/15/20	WATER DEPTH: ---
PROJECT: Proposed C/I Development	DRILLING METHOD: Hollow Stem Auger	CAVE DEPTH: ---
LOCATION: Bloomington, California	LOGGED BY: Ryan Bremer	READING TAKEN: At Completion

FIELD RESULTS				DESCRIPTION	LABORATORY RESULTS						COMMENTS
DEPTH (FEET)	SAMPLE	BLOW COUNT	POCKET PEN. (TSF)		GRAPHIC LOG	DRY DENSITY (PCF)	MOISTURE CONTENT (%)	LIQUID LIMIT	PLASTIC LIMIT	PASSING #200 SIEVE (%)	
SURFACE ELEVATION: --- MSL											
5	X	9		[Symbol]	<u>FILL</u> : Light Brown fine Sandy Silt, trace medium to coarse Sand, trace fine to coarse Gravel, trace fine root fibers, occasional Cobbles, loose-dry		1				
8	X	8		[Symbol]			2				
19	X	19		[Symbol]	<u>ALLUVIUM</u> : Light Brown Silty fine Sand, little medium to coarse Sand, trace fine to coarse Gravel, medium dense-dry		1				
36	X	36		[Symbol]	Brown Gray fine to coarse Sand, some fine to coarse Gravel, trace Silt, dense-dry		1				
10					Boring Terminated at 10'						

TBL_20G172-2.GPJ_SOCALGEO.GDT 10/20/20



JOB NO.: 20G172-2	DRILLING DATE: 9/15/20	WATER DEPTH: ---
PROJECT: Proposed C/I Development	DRILLING METHOD: Hollow Stem Auger	CAVE DEPTH: ---
LOCATION: Bloomington, California	LOGGED BY: Ryan Bremer	READING TAKEN: At Completion

FIELD RESULTS				DESCRIPTION	LABORATORY RESULTS						COMMENTS
DEPTH (FEET)	SAMPLE	BLOW COUNT	POCKET PEN. (TSF)		GRAPHIC LOG	DRY DENSITY (PCF)	MOISTURE CONTENT (%)	LIQUID LIMIT	PLASTIC LIMIT	PASSING #200 SIEVE (%)	
SURFACE ELEVATION: --- MSL											
5	X	5		[Symbol]	<u>FILL</u> : Light Brown fine Sandy Silt, trace medium to coarse Sand, trace fine root fibers, trace fine to coarse Gravel, loose to medium dense-dry		1				
12	X	12		[Symbol]			1				
25	X	25		[Symbol]	<u>ALLUVIUM</u> : Light Brown fine to coarse Sand, little Silt, trace fine to coarse Gravel, occasional Cobbles, medium dense-dry		1				
51	X	51		[Symbol]	Light Gray Brown fine to coarse Sand, some fine to coarse Gravel, little Silt, very dense-dry		1				
10					Boring Terminated at 10'						

TBL_20G172-2.GPJ_SOCALGEO.GDT 10/20/20



JOB NO.: 20G172-2	DRILLING DATE: 9/15/20	WATER DEPTH: ---
PROJECT: Proposed C/I Development	DRILLING METHOD: Hollow Stem Auger	CAVE DEPTH: ---
LOCATION: Bloomington, California	LOGGED BY: Ryan Bremer	READING TAKEN: At Completion

FIELD RESULTS				DESCRIPTION	LABORATORY RESULTS						COMMENTS
DEPTH (FEET)	SAMPLE	BLOW COUNT	POCKET PEN. (TSF)		GRAPHIC LOG	DRY DENSITY (PCF)	MOISTURE CONTENT (%)	LIQUID LIMIT	PLASTIC LIMIT	PASSING #200 SIEVE (%)	
SURFACE ELEVATION: --- MSL											
5	X	14		[Symbol]	<u>FILL</u> : Light Brown fine Sandy Silt, trace medium to coarse Sand, trace fine Gravel, medium dense-dry		1				
10	X	32		[Symbol]	<u>ALLUVIUM</u> : Light Gray Brown fine to coarse Sand, some fine to coarse Gravel, trace Silt, dense-dry		2				
					Boring Terminated at 10'						

TBL_20G172-2.GPJ_SOCALGEO.GDT 10/20/20



JOB NO.: 20G172-2	DRILLING DATE: 9/15/20	WATER DEPTH: ---
PROJECT: Proposed C/I Development	DRILLING METHOD: Hollow Stem Auger	CAVE DEPTH: ---
LOCATION: Bloomington, California	LOGGED BY: Ryan Bremer	READING TAKEN: At Completion

FIELD RESULTS				DESCRIPTION	LABORATORY RESULTS						COMMENTS
DEPTH (FEET)	SAMPLE	BLOW COUNT	POCKET PEN. (TSF)		GRAPHIC LOG	DRY DENSITY (PCF)	MOISTURE CONTENT (%)	LIQUID LIMIT	PLASTIC LIMIT	PASSING #200 SIEVE (%)	
SURFACE ELEVATION: --- MSL											
5		22			<u>FILL:</u> Light Brown fine Sandy Silt, little to some medium to coarse Sand, trace fine to coarse Gravel, medium dense-dry		1				
10		30			<u>ALLUVIUM:</u> Light Brown Gray fine to coarse Sand, some fine to coarse Gravel, dense-dry		1				
					Boring Terminated at 10'						

TBL_20G172-2.GPJ_SOCALGEO.GDT 10/20/20



JOB NO.: 20G172-2	DRILLING DATE: 9/15/20	WATER DEPTH: ---
PROJECT: Proposed C/I Development	DRILLING METHOD: Hollow Stem Auger	CAVE DEPTH: ---
LOCATION: Bloomington, California	LOGGED BY: Ryan Bremer	READING TAKEN: At Completion

FIELD RESULTS				DESCRIPTION	LABORATORY RESULTS						COMMENTS
DEPTH (FEET)	SAMPLE	BLOW COUNT	POCKET PEN. (TSF)		GRAPHIC LOG	DRY DENSITY (PCF)	MOISTURE CONTENT (%)	LIQUID LIMIT	PLASTIC LIMIT	PASSING #200 SIEVE (%)	
SURFACE ELEVATION: --- MSL											
5		18			FILL: Light Gray Brown fine Sandy Silt, trace medium to coarse Sand, trace fine Gravel, medium dense-dry		1				
10		29			ALLUVIUM: Gray fine to coarse Sand, some fine to coarse Gravel, trace Silt, medium dense-dry		1				
					Boring Terminated at 10'						

TBL_20G172-2.GPJ_SOCALGEO.GDT 10/20/20



JOB NO.: 20G172-2	DRILLING DATE: 9/15/20	WATER DEPTH: ---
PROJECT: Proposed C/I Development	DRILLING METHOD: Hollow Stem Auger	CAVE DEPTH: ---
LOCATION: Bloomington, California	LOGGED BY: Ryan Bremer	READING TAKEN: At Completion

FIELD RESULTS				GRAPHIC LOG	DESCRIPTION	LABORATORY RESULTS						COMMENTS
DEPTH (FEET)	SAMPLE	BLOW COUNT	POCKET PEN. (TSF)			DRY DENSITY (PCF)	MOISTURE CONTENT (%)	LIQUID LIMIT	PLASTIC LIMIT	PASSING #200 SIEVE (%)	ORGANIC CONTENT (%)	
SURFACE ELEVATION: --- MSL												
5	X	12		[Symbol]	FILL: Light Gray Brown fine Sandy Silt, little medium to coarse Sand, trace fine Gravel, medium dense-dry		1					
10	X	31		[Symbol]	ALLUVIUM Light Gray Brown fine to coarse Sand, little fine to coarse Gravel, little Silt, dense-dry		1					
Boring Terminated at 10'												

TBL_20G172-2.GPJ_SOCALGEO.GDT 10/20/20



JOB NO.: 20G172-2	DRILLING DATE: 9/15/20	WATER DEPTH: ---
PROJECT: Proposed C/I Development	DRILLING METHOD: Hollow Stem Auger	CAVE DEPTH: ---
LOCATION: Bloomington, California	LOGGED BY: Ryan Bremer	READING TAKEN: At Completion

FIELD RESULTS				DESCRIPTION	LABORATORY RESULTS						COMMENTS
DEPTH (FEET)	SAMPLE	BLOW COUNT	POCKET PEN. (TSF)		GRAPHIC LOG	DRY DENSITY (PCF)	MOISTURE CONTENT (%)	LIQUID LIMIT	PLASTIC LIMIT	PASSING #200 SIEVE (%)	
SURFACE ELEVATION: --- MSL											
5	X	28		[Symbol]	POSSIBLE FILL: Light Gray Brown Silty fine Sand, little to some medium to coarse Sand, trace fine to coarse Gravel, occasional Cobbles, medium dense-dry		2				
10	X	20		[Symbol]	ALLUVIUM: Light Brown Gray fine to coarse Sand, trace fine Gravel, little to some Silt, medium dense-dry		1				
					Boring Terminated at 10'						

TBL_20G172-2.GPJ_SOCALGEO.GDT 10/20/20





JOB NO.: 20G172-2	DRILLING DATE: 9/15/20	WATER DEPTH: ---
PROJECT: Proposed C/I Development	DRILLING METHOD: Hollow Stem Auger	CAVE DEPTH: ---
LOCATION: Bloomington, California	LOGGED BY: Ryan Bremer	READING TAKEN: At Completion

FIELD RESULTS				DESCRIPTION	LABORATORY RESULTS						COMMENTS	
DEPTH (FEET)	SAMPLE	BLOW COUNT	POCKET PEN. (TSF)		GRAPHIC LOG	DRY DENSITY (PCF)	MOISTURE CONTENT (%)	LIQUID LIMIT	PLASTIC LIMIT	PASSING #200 SIEVE (%)		ORGANIC CONTENT (%)
SURFACE ELEVATION: --- MSL												
5	X	8		[Symbol]	<u>POSSIBLE FILL</u> : Brown fine Sandy Silt, trace medium Sand, trace fine root fibers, loose-damp		3					
10	X	45		[Symbol]	<u>ALLUVIUM</u> : Light Brown Gray fine to coarse Sand, little Silt, little fine Gravel, dense-damp		1					
					Boring Terminated at 10'							

TBL_20G172-2.GPJ_SOCALGEO.GDT 10/20/20



JOB NO.: 20G172-2	DRILLING DATE: 9/15/20	WATER DEPTH: ---
PROJECT: Proposed C/I Development	DRILLING METHOD: Hollow Stem Auger	CAVE DEPTH: ---
LOCATION: Bloomington, California	LOGGED BY: Ryan Bremer	READING TAKEN: At Completion

FIELD RESULTS				DESCRIPTION	LABORATORY RESULTS						COMMENTS
DEPTH (FEET)	SAMPLE	BLOW COUNT	POCKET PEN. (TSF)		GRAPHIC LOG	DRY DENSITY (PCF)	MOISTURE CONTENT (%)	LIQUID LIMIT	PLASTIC LIMIT	PASSING #200 SIEVE (%)	
SURFACE ELEVATION: --- MSL											
5		9			<u>FILL:</u> Brown Silty fine Sand, trace medium to coarse Sand, trace fine Gravel, loose-damp		3				
10		36			<u>ALLUVIUM:</u> Brown Silty fine to coarse Sand, trace fine Gravel, dense-damp		2				
					Boring Terminated at 10'						

TBL_20G172-2.GPJ_SOCALGEO.GDT 10/20/20

INFILTRATION CALCULATIONS

Project Name	Proposed Commercial/Industrial Development
Project Location	Bloomington, California
Project Number	20G172-2
Engineer	Ryan Bremer

Test Hole Radius	4 (in)
Test Depth	9.7 (ft)

Infiltration Test Hole I-1

Interval Number		Time	Time Interval (min)	Water Depth (ft)	Change in Water Level (ft)	Average Head Height (ft)	Infiltration Rate Q (in/hr)	
1	Initial	7:15 AM	0.5	7.00	0.50	2.45	47.44	PRE-SOAK
	Final	7:15 AM		7.50				
2	Initial	7:18 AM	0.5	7.00	0.50	2.45	44.38	
	Final	7:18 AM		7.50				
3	Initial	7:21 AM	1.0	7.00	0.88	2.26	43.52	INFILTRATION TESTING
	Final	7:22 AM		7.88				
4	Initial	7:24 AM	1.0	7.00	0.88	2.26	43.52	
	Final	7:25 AM		7.88				
5	Initial	7:26 AM	1.0	7.00	0.88	2.26	43.52	
	Final	7:27 AM		7.88				
6	Initial	7:28 AM	1.0	7.00	0.82	2.29	40.05	
	Final	7:29 AM		7.82				
7	Initial	7:31 AM	1.0	7.00	0.81	2.30	39.49	
	Final	7:32 AM		7.81				
8	Initial	7:33 AM	1.0	7.00	0.81	2.30	39.49	
	Final	7:34 AM		7.81				
9	Initial	7:35 AM	1.0	7.00	0.80	2.30	38.92	
	Final	7:36 AM		7.80				
10	Initial	7:38 AM	1.0	7.00	0.78	2.31	37.79	
	Final	7:39 AM		7.78				

Per County Standards, Infiltration Rate calculated as follows:

$$Q = \frac{\Delta H(60r)}{\Delta t(r + 2H_{avg})}$$

- Where:
- Q = Infiltration Rate (in inches per hour)
 - ΔH = Change in Height (Water Level) over the time interval
 - r = Test Hole (Borehole) Radius
 - Δt = Time Interval
 - H_{avg} = Average Head Height over the time interval

INFILTRATION CALCULATIONS

Project Name	Proposed Commercial/Industrial Development
Project Location	Bloomington, California
Project Number	20G172-2
Engineer	Ryan Bremer

Test Hole Radius	4 (in)
Test Depth	9.7 (ft)

Infiltration Test Hole I-1 (Continued)

Interval Number		Time	Time Interval (min)	Water Depth (ft)	Change in Water Level (ft)	Average Head Height (ft)	Infiltration Rate Q (in/hr)	INFILTRATION TESTING
11	Initial	7:40 AM	1.0	7.00	0.74	2.33	35.57	
	Final	7:41 AM		7.74				
12	Initial	7:43 AM	1.0	7.00	0.74	2.33	35.57	
	Final	7:44 AM		7.74				
13	Initial	7:45 AM	1.0	7.00	0.72	2.34	34.47	
	Final	7:46 AM		7.72				
14	Initial	7:48 AM	1.0	7.00	0.70	2.35	33.38	
	Final	7:49 AM		7.70				
15	Initial	7:50 AM	1.0	7.00	0.68	2.36	32.30	
	Final	7:51 AM		7.68				
16	Initial	7:52 AM	1.0	7.00	0.68	2.36	32.30	
	Final	7:53 AM		7.68				
17	Initial	7:55 AM	1.0	7.00	0.64	2.38	30.16	
	Final	7:56 AM		7.64				
18	Initial	7:57 AM	1.0	7.00	0.62	2.39	29.10	
	Final	7:58 AM		7.62				
19	Initial	7:59 AM	1.0	7.00	0.60	2.40	28.05	
	Final	8:00 AM		7.60				
20	Initial	8:01 AM	1.0	7.00	0.56	2.42	25.98	
	Final	8:02 AM		7.56				

Per County Standards, Infiltration Rate calculated as follows:

$$Q = \frac{\Delta H(60r)}{\Delta t(r + 2H_{avg})}$$

- Where:
- Q = Infiltration Rate (in inches per hour)
 - ΔH = Change in Height (Water Level) over the time interval
 - r = Test Hole (Borehole) Radius
 - Δt = Time Interval
 - H_{avg} = Average Head Height over the time interval

INFILTRATION CALCULATIONS

Project Name	Proposed Commercial/Industrial Development
Project Location	Bloomington, California
Project Number	20G172-2
Engineer	Ryan Bremer

Test Hole Radius	4 (in)
Test Depth	9.7 (ft)

Infiltration Test Hole I-1 (Continued)

Interval Number		Time	Time Interval (min)	Water Depth (ft)	Change in Water Level (ft)	Average Head Height (ft)	Infiltration Rate Q (in/hr)	INFILTRATION TESTING
21	Initial	8:03 AM	1.0	7.00	0.55	2.43	25.47	
	Final	8:04 AM		7.55				
22	Initial	8:05 AM	1.0	7.00	0.52	2.44	23.94	
	Final	8:06 AM		7.52				
23	Initial	8:07 AM	1.0	7.00	0.49	2.46	22.43	
	Final	8:08 AM		7.49				
24	Initial	8:09 AM	1.0	7.00	0.47	2.47	21.43	
	Final	8:10 AM		7.47				
25	Initial	8:11 AM	1.0	7.00	0.47	2.47	21.43	
	Final	8:12 AM		7.47				

Per County Standards, Infiltration Rate calculated as follows:

$$Q = \frac{\Delta H(60r)}{\Delta t(r + 2H_{avg})}$$

- Where:
- Q = Infiltration Rate (in inches per hour)
 - ΔH = Change in Height (Water Level) over the time interval
 - r = Test Hole (Borehole) Radius
 - Δt = Time Interval
 - H_{avg} = Average Head Height over the time interval

INFILTRATION CALCULATIONS

Project Name	Proposed Commercial/Industrial Development
Project Location	Bloomington, California
Project Number	20G172-2
Engineer	Ryan Bremer

Test Hole Radius	4 (in)
Test Depth	9.7 (ft)

Infiltration Test Hole I-2

Interval Number		Time	Time Interval (min)	Water Depth (ft)	Change in Water Level (ft)	Average Head Height (ft)	Infiltration Rate Q (in/hr)	
1	Initial	8:40 AM	0.6	7.00	0.50	2.45	40.46	PRE-SOAK INFILTRATION TESTING
	Final	8:40 AM		7.50				
2	Initial	8:42 AM	0.6	7.00	0.50	2.45	38.22	
	Final	8:42 AM		7.50				
3	Initial	8:44 AM	1.0	7.00	0.81	2.30	39.49	
	Final	8:45 AM		7.81				
4	Initial	8:46 AM	1.0	7.00	0.78	2.31	37.79	
	Final	8:47 AM		7.78				
5	Initial	8:48 AM	1.0	7.00	0.77	2.32	37.23	
	Final	8:49 AM		7.77				
6	Initial	8:50 AM	1.0	7.00	0.74	2.33	35.57	
	Final	8:51 AM		7.74				
7	Initial	8:52 AM	1.0	7.00	0.74	2.33	35.57	
	Final	8:53 AM		7.74				
8	Initial	8:54 AM	1.0	7.00	0.72	2.34	34.47	
	Final	8:55 AM		7.72				
9	Initial	8:57 AM	1.0	7.00	0.72	2.34	34.47	
	Final	8:58 AM		7.72				
10	Initial	8:59 AM	1.0	7.00	0.68	2.36	32.30	
	Final	9:00 AM		7.68				

Per County Standards, Infiltration Rate calculated as follows:

$$Q = \frac{\Delta H(60r)}{\Delta t(r + 2H_{avg})}$$

- Where:
- Q = Infiltration Rate (in inches per hour)
 - ΔH = Change in Height (Water Level) over the time interval
 - r = Test Hole (Borehole) Radius
 - Δt = Time Interval
 - H_{avg} = Average Head Height over the time interval

INFILTRATION CALCULATIONS

Project Name	Proposed Commercial/Industrial Development
Project Location	Bloomington, California
Project Number	20G172-2
Engineer	Ryan Bremer

Test Hole Radius	4 (in)
Test Depth	9.7 (ft)

Infiltration Test Hole I-2 (Continued)

Interval Number		Time	Time Interval (min)	Water Depth (ft)	Change in Water Level (ft)	Average Head Height (ft)	Infiltration Rate Q (in/hr)	INFILTRATION TESTING
11	Initial	9:01 AM	1.0	7.00	0.67	2.37	31.76	
	Final	9:02 AM		7.67				
12	Initial	9:03 AM	1.0	7.00	0.65	2.38	30.69	
	Final	9:04 AM		7.65				
13	Initial	9:06 AM	1.0	7.00	0.62	2.39	29.10	
	Final	9:07 AM		7.62				
14	Initial	9:08 AM	1.0	7.00	0.60	2.40	28.05	
	Final	9:09 AM		7.60				
15	Initial	9:10 AM	1.0	7.00	0.58	2.41	27.01	
	Final	9:11 AM		7.58				
16	Initial	9:13 AM	1.0	7.00	0.58	2.41	27.01	
	Final	9:14 AM		7.58				
17	Initial	9:15 AM	1.0	7.00	0.54	2.43	24.96	
	Final	9:16 AM		7.54				
18	Initial	9:18 AM	1.0	7.00	0.54	2.43	24.96	
	Final	9:19 AM		7.54				
19	Initial	9:21 AM	1.0	7.00	0.53	2.44	24.45	
	Final	9:22 AM		7.53				
20	Initial	9:23 AM	1.0	7.00	0.53	2.44	24.45	
	Final	9:24 AM		7.53				

Per County Standards, Infiltration Rate calculated as follows:

$$Q = \frac{\Delta H(60r)}{\Delta t(r + 2H_{avg})}$$

- Where:
- Q = Infiltration Rate (in inches per hour)
 - ΔH = Change in Height (Water Level) over the time interval
 - r = Test Hole (Borehole) Radius
 - Δt = Time Interval
 - H_{avg} = Average Head Height over the time interval

INFILTRATION CALCULATIONS

Project Name	Proposed Commercial/Industrial Development
Project Location	Bloomington, California
Project Number	20G172-2
Engineer	Ryan Bremer

Test Hole Radius	4 (in)
Test Depth	9.7 (ft)

Infiltration Test Hole I-2 (Continued)

Interval Number		Time	Time Interval (min)	Water Depth (ft)	Change in Water Level (ft)	Average Head Height (ft)	Infiltration Rate Q (in/hr)	INFILTRATION TESTING
21	Initial	9:25 AM	1.0	7.00	0.51	2.45	23.43	
	Final	9:26 AM		7.51				
22	Initial	9:27 AM	1.0	7.00	0.51	2.45	23.43	
	Final	9:28 AM		7.51				
23	Initial	9:30 AM	1.0	7.00	0.50	2.45	22.93	
	Final	9:31 AM		7.50				
24	Initial	9:32 AM	1.0	7.00	0.49	2.46	22.43	
	Final	9:33 AM		7.49				
25	Initial	9:35 AM	1.0	7.00	0.47	2.47	21.43	
	Final	9:36 AM		7.47				
26	Initial	9:37 AM	1.0	7.00	0.45	2.48	20.44	
	Final	9:38 AM		7.45				
27	Initial	9:39 AM	1.0	7.00	0.45	2.48	20.44	
	Final	9:40 AM		7.45				
28	Initial	9:42 AM	1.0	7.00	0.45	2.48	20.44	
	Final	9:43 AM		7.45				
29	Initial	9:44 AM	1.0	7.00	0.45	2.48	20.44	
	Final	9:45 AM		7.45				
30	Initial	9:46 AM	1.0	7.00	0.45	2.48	20.44	
	Final	9:47 AM		7.45				

Per County Standards, Infiltration Rate calculated as follows:

$$Q = \frac{\Delta H(60r)}{\Delta t(r + 2H_{avg})}$$

- Where:
- Q = Infiltration Rate (in inches per hour)
 - ΔH = Change in Height (Water Level) over the time interval
 - r = Test Hole (Borehole) Radius
 - Δt = Time Interval
 - H_{avg} = Average Head Height over the time interval

INFILTRATION CALCULATIONS

Project Name	Proposed Commercial/Industrial Development
Project Location	Bloomington, California
Project Number	20G172-2
Engineer	Ryan Bremer

Test Hole Radius	4 (in)
Test Depth	9.7 (ft)

Infiltration Test Hole I-3

Interval Number		Time	Time Interval (min)	Water Depth (ft)	Change in Water Level (ft)	Average Head Height (ft)	Infiltration Rate Q (in/hr)	
1	Initial	9:55 AM	0.6	7.00	0.50	2.45	40.46	PRE-SOAK
	Final	9:55 AM		7.50				
2	Initial	9:57 AM	0.6	7.00	0.50	2.45	39.31	
	Final	9:57 AM		7.50				
3	Initial	9:59 AM	1.0	7.00	0.77	2.32	37.23	INFILTRATION TESTING
	Final	10:00 AM		7.77				
4	Initial	10:01 AM	1.0	7.00	0.77	2.32	37.23	
	Final	10:02 AM		7.77				
5	Initial	10:04 AM	1.0	7.00	0.74	2.33	35.57	
	Final	10:05 AM		7.74				
6	Initial	10:06 AM	1.0	7.00	0.74	2.33	35.57	
	Final	10:07 AM		7.74				
7	Initial	10:09 AM	1.0	7.00	0.73	2.34	35.02	
	Final	10:10 AM		7.73				
8	Initial	10:11 AM	1.0	7.00	0.71	2.35	33.92	
	Final	10:12 AM		7.71				

Per County Standards, Infiltration Rate calculated as follows:

$$Q = \frac{\Delta H(60r)}{\Delta t(r + 2H_{avg})}$$

- Where:
- Q = Infiltration Rate (in inches per hour)
 - ΔH = Change in Height (Water Level) over the time interval
 - r = Test Hole (Borehole) Radius
 - Δt = Time Interval
 - H_{avg} = Average Head Height over the time interval

INFILTRATION CALCULATIONS

Project Name	Proposed Commercial/Industrial Development
Project Location	Bloomington, California
Project Number	20G172-2
Engineer	Ryan Bremer

Test Hole Radius	4 (in)
Test Depth	9.7 (ft)

Infiltration Test Hole I-3 (Continued)

Interval Number		Time	Time Interval (min)	Water Depth (ft)	Change in Water Level (ft)	Average Head Height (ft)	Infiltration Rate Q (in/hr)	INFILTRATION TESTING
9	Initial	10:13 AM	1.0	7.00	0.70	2.35	33.38	
	Final	10:14 AM		7.70				
10	Initial	10:16 AM	1.0	7.00	0.70	2.35	33.38	
	Final	10:17 AM		7.70				
11	Initial	10:19 AM	1.0	7.00	0.67	2.37	31.76	
	Final	10:20 AM		7.67				
12	Initial	10:21 AM	1.0	7.00	0.64	2.38	30.16	
	Final	10:22 AM		7.64				
13	Initial	10:24 AM	1.0	7.00	0.62	2.39	29.10	
	Final	10:25 AM		7.62				
14	Initial	10:26 AM	1.0	7.00	0.60	2.40	28.05	
	Final	10:27 AM		7.60				
15	Initial	10:29 AM	1.0	7.00	0.58	2.41	27.01	
	Final	10:30 AM		7.58				
16	Initial	10:32 AM	1.0	7.00	0.54	2.43	24.96	
	Final	10:33 AM		7.54				
17	Initial	10:35 AM	1.0	7.00	0.54	2.43	24.96	
	Final	10:36 AM		7.54				
18	Initial	10:38 AM	1.0	7.00	0.54	2.43	24.96	
	Final	10:39 AM		7.54				

Per County Standards, Infiltration Rate calculated as follows:

$$Q = \frac{\Delta H(60r)}{\Delta t(r + 2H_{avg})}$$

- Where:
- Q = Infiltration Rate (in inches per hour)
 - ΔH = Change in Height (Water Level) over the time interval
 - r = Test Hole (Borehole) Radius
 - Δt = Time Interval
 - H_{avg} = Average Head Height over the time interval

INFILTRATION CALCULATIONS

Project Name	Proposed Commercial/Industrial Development
Project Location	Bloomington, California
Project Number	20G172-2
Engineer	Ryan Bremer

Test Hole Radius	4 (in)
Test Depth	9.7 (ft)

Infiltration Test Hole I-3 (Continued)

Interval Number		Time	Time Interval (min)	Water Depth (ft)	Change in Water Level (ft)	Average Head Height (ft)	Infiltration Rate Q (in/hr)	INFILTRATION TESTING
19	Initial	10:40 AM	1.0	7.00	0.70	2.35	33.38	
	Final	10:41 AM		7.70				
20	Initial	10:43 AM	1.0	7.00	0.70	2.35	33.38	
	Final	10:44 AM		7.70				
21	Initial	10:45 AM	1.0	7.00	0.67	2.37	31.76	
	Final	10:46 AM		7.67				
22	Initial	10:47 AM	1.0	7.00	0.64	2.38	30.16	
	Final	10:48 AM		7.64				
23	Initial	10:50 AM	1.0	7.00	0.62	2.39	29.10	
	Final	10:51 AM		7.62				
24	Initial	10:52 AM	1.0	7.00	0.60	2.40	28.05	
	Final	10:53 AM		7.60				
25	Initial	10:55 AM	1.0	7.00	0.56	2.42	25.98	
	Final	10:56 AM		7.56				
26	Initial	10:57 AM	1.0	7.00	0.51	2.45	23.43	
	Final	10:58 AM		7.51				
27	Initial	10:59 AM	1.0	7.00	0.50	2.45	22.93	
	Final	11:00 AM		7.50				
28	Initial	11:02 AM	1.0	7.00	0.50	2.45	22.93	
	Final	11:03 AM		7.50				

Per County Standards, Infiltration Rate calculated as follows:

$$Q = \frac{\Delta H(60r)}{\Delta t(r + 2H_{avg})}$$

- Where:
- Q = Infiltration Rate (in inches per hour)
 - ΔH = Change in Height (Water Level) over the time interval
 - r = Test Hole (Borehole) Radius
 - Δt = Time Interval
 - H_{avg} = Average Head Height over the time interval

INFILTRATION CALCULATIONS

Project Name	Proposed Commercial/Industrial Development
Project Location	Bloomington, California
Project Number	20G172-2
Engineer	Ryan Bremer

Test Hole Radius	4 (in)
Test Depth	9.7 (ft)

Infiltration Test Hole I-4

Interval Number		Time	Time Interval (min)	Water Depth (ft)	Change in Water Level (ft)	Average Head Height (ft)	Infiltration Rate Q (in/hr)	
1	Initial	11:25 AM	0.7	7.00	0.50	2.45	35.28	PRE-SOAK INFILTRATION TESTING
	Final	11:25 AM		7.50				
2	Initial	11:27 AM	0.7	7.00	0.50	2.45	33.56	
	Final	11:27 AM		7.50				
3	Initial	11:29 AM	1.0	7.00	0.70	2.35	33.38	
	Final	11:30 AM		7.70				
4	Initial	11:31 AM	1.0	7.00	0.68	2.36	32.30	
	Final	11:32 AM		7.68				
5	Initial	11:34 AM	1.0	7.00	0.68	2.36	32.30	
	Final	11:35 AM		7.68				
6	Initial	11:37 AM	1.0	7.00	0.65	2.38	30.69	
	Final	11:38 AM		7.65				
7	Initial	11:39 AM	1.0	7.00	0.64	2.38	30.16	
	Final	11:40 AM		7.64				
8	Initial	11:42 AM	1.0	7.00	0.63	2.39	29.63	
	Final	11:43 AM		7.63				
9	Initial	11:45 AM	1.0	7.00	0.63	2.39	29.63	
	Final	11:46 AM		7.63				
10	Initial	11:48 AM	1.0	7.00	0.60	2.40	28.05	
	Final	11:49 AM		7.60				

Per County Standards, Infiltration Rate calculated as follows:

$$Q = \frac{\Delta H(60r)}{\Delta t(r + 2H_{avg})}$$

- Where:
- Q = Infiltration Rate (in inches per hour)
 - ΔH = Change in Height (Water Level) over the time interval
 - r = Test Hole (Borehole) Radius
 - Δt = Time Interval
 - H_{avg} = Average Head Height over the time interval

INFILTRATION CALCULATIONS

Project Name	Proposed Commercial/Industrial Development
Project Location	Bloomington, California
Project Number	20G172-2
Engineer	Ryan Bremer

Test Hole Radius	4 (in)
Test Depth	9.7 (ft)

Infiltration Test Hole I-4 (Continued)

Interval Number		Time	Time Interval (min)	Water Depth (ft)	Change in Water Level (ft)	Average Head Height (ft)	Infiltration Rate Q (in/hr)	INFILTRATION TESTING
11	Initial	11:50 AM	1.0	7.00	0.60	2.40	28.05	
	Final	11:51 AM		7.60				
12	Initial	11:53 AM	1.0	7.00	0.58	2.41	27.01	
	Final	11:54 AM		7.58				
13	Initial	11:56 AM	1.0	7.00	0.57	2.42	26.49	
	Final	11:57 AM		7.57				
14	Initial	11:58 AM	1.0	7.00	0.54	2.43	24.96	
	Final	11:59 AM		7.54				
15	Initial	12:00 PM	1.0	7.00	0.52	2.44	23.94	
	Final	12:01 PM		7.52				
16	Initial	12:03 PM	1.0	7.00	0.51	2.45	23.43	
	Final	12:04 PM		7.51				
17	Initial	12:05 PM	1.0	7.00	0.51	2.45	23.43	
	Final	12:06 PM		7.51				
18	Initial	12:08 PM	1.0	7.00	0.50	2.45	22.93	
	Final	12:09 PM		7.50				
19	Initial	12:10 PM	1.0	7.00	0.49	2.46	22.43	
	Final	12:11 PM		7.49				
20	Initial	12:12 PM	1.0	7.00	0.48	2.46	21.93	
	Final	12:13 PM		7.48				

Per County Standards, Infiltration Rate calculated as follows:

$$Q = \frac{\Delta H(60r)}{\Delta t(r + 2H_{avg})}$$

- Where:
- Q = Infiltration Rate (in inches per hour)
 - ΔH = Change in Height (Water Level) over the time interval
 - r = Test Hole (Borehole) Radius
 - Δt = Time Interval
 - H_{avg} = Average Head Height over the time interval

INFILTRATION CALCULATIONS

Project Name	Proposed Commercial/Industrial Development
Project Location	Bloomington, California
Project Number	20G172-2
Engineer	Ryan Bremer

Test Hole Radius	4 (in)
Test Depth	9.7 (ft)

Infiltration Test Hole I-4 (Continued)

Interval Number		Time	Time Interval (min)	Water Depth (ft)	Change in Water Level (ft)	Average Head Height (ft)	Infiltration Rate Q (in/hr)	INFILTRATION TESTING
21	Initial	12:14 PM	1.0	7.00	0.48	2.46	21.93	
	Final	12:15 PM		7.48				
22	Initial	12:17 PM	1.0	7.00	0.47	2.47	21.43	
	Final	12:18 PM		7.47				
23	Initial	12:20 PM	1.0	7.00	0.45	2.48	20.44	
	Final	12:21 PM		7.45				
24	Initial	12:22 PM	1.0	7.00	0.45	2.48	20.44	
	Final	12:23 PM		7.45				
25	Initial	12:25 PM	1.0	7.00	0.45	2.48	20.44	
	Final	12:26 PM		7.45				
26	Initial	12:28 PM	1.0	7.00	0.45	2.48	20.44	
	Final	12:29 PM		7.45				
27	Initial	12:30 PM	1.0	7.00	0.45	2.48	20.44	
	Final	12:31 PM		7.45				
28	Initial	12:34 PM	1.0	7.00	0.45	2.48	20.44	
	Final	12:35 PM		7.45				
29	Initial	12:37 PM	1.0	7.00	0.45	2.48	20.44	
	Final	12:38 PM		7.45				
30	Initial	12:39 PM	1.0	7.00	0.45	2.48	20.44	
	Final	12:40 PM		7.45				

Per County Standards, Infiltration Rate calculated as follows:

$$Q = \frac{\Delta H(60r)}{\Delta t(r + 2H_{avg})}$$

- Where:
- Q = Infiltration Rate (in inches per hour)
 - ΔH = Change in Height (Water Level) over the time interval
 - r = Test Hole (Borehole) Radius
 - Δt = Time Interval
 - H_{avg} = Average Head Height over the time interval

INFILTRATION CALCULATIONS

Project Name	Proposed Commercial/Industrial Development
Project Location	Bloomington, California
Project Number	20G172-2
Engineer	Ryan Bremer

Test Hole Radius	4 (in)
Test Depth	10 (ft)

Infiltration Test Hole I-5

Interval Number		Time	Time Interval (min)	Water Depth (ft)	Change in Water Level (ft)	Average Head Height (ft)	Infiltration Rate Q (in/hr)	
1	Initial	12:42 PM	0.8	6.50	0.50	3.25	22.42	PRE-SOAK INFILTRATION TESTING
	Final	12:42 PM		7.00				
2	Initial	12:44 PM	0.8	6.50	0.50	3.25	21.50	
	Final	12:44 PM		7.00				
3	Initial	12:45 PM	1.0	6.50	0.58	3.21	20.61	
	Final	12:46 PM		7.08				
4	Initial	12:48 PM	1.0	6.50	0.58	3.21	20.61	
	Final	12:49 PM		7.08				
5	Initial	12:50 PM	1.0	6.50	0.57	3.22	20.23	
	Final	12:51 PM		7.07				
6	Initial	12:53 PM	1.0	6.50	0.56	3.22	19.84	
	Final	12:54 PM		7.06				
7	Initial	12:55 PM	1.0	6.50	0.56	3.22	19.84	
	Final	12:56 PM		7.06				
8	Initial	12:59 PM	1.0	6.50	0.55	3.23	19.46	
	Final	1:00 PM		7.05				
9	Initial	1:01 PM	1.0	6.50	0.52	3.24	18.32	
	Final	1:02 PM		7.02				
10	Initial	1:04 PM	1.0	6.50	0.52	3.24	18.32	
	Final	1:05 PM		7.02				

Per County Standards, Infiltration Rate calculated as follows:

$$Q = \frac{\Delta H(60r)}{\Delta t(r + 2H_{avg})}$$

- Where:
- Q = Infiltration Rate (in inches per hour)
 - ΔH = Change in Height (Water Level) over the time interval
 - r = Test Hole (Borehole) Radius
 - Δt = Time Interval
 - H_{avg} = Average Head Height over the time interval

INFILTRATION CALCULATIONS

Project Name	Proposed Commercial/Industrial Development
Project Location	Bloomington, California
Project Number	20G172-2
Engineer	Ryan Bremer

Test Hole Radius	4 (in)
Test Depth	10 (ft)

Infiltration Test Hole I-5 (Continued)

Interval Number		Time	Time Interval (min)	Water Depth (ft)	Change in Water Level (ft)	Average Head Height (ft)	Infiltration Rate Q (in/hr)	INFILTRATION TESTING
11	Initial	1:07 PM	1.0	6.50	0.51	3.25	17.94	
	Final	1:08 PM		7.01				
12	Initial	1:09 PM	1.0	6.50	0.51	3.25	17.94	
	Final	1:10 PM		7.01				
13	Initial	1:12 PM	1.0	6.50	0.50	3.25	17.56	
	Final	1:13 PM		7.00				
14	Initial	1:15 PM	1.0	6.50	0.48	3.26	16.81	
	Final	1:16 PM		6.98				
15	Initial	1:18 PM	1.0	6.50	0.47	3.27	16.44	
	Final	1:19 PM		6.97				
16	Initial	1:20 PM	1.0	6.50	0.47	3.27	16.44	
	Final	1:21 PM		6.97				
17	Initial	1:23 PM	1.0	6.50	0.45	3.28	15.69	
	Final	1:24 PM		6.95				
18	Initial	1:26 PM	1.0	6.50	0.44	3.28	15.32	
	Final	1:27 PM		6.94				
19	Initial	1:28 PM	1.0	6.50	0.44	3.28	15.32	
	Final	1:29 PM		6.94				
20	Initial	1:30 PM	1.0	6.50	0.43	3.29	14.95	
	Final	1:31 PM		6.93				

Per County Standards, Infiltration Rate calculated as follows:

$$Q = \frac{\Delta H(60r)}{\Delta t(r + 2H_{avg})}$$

- Where:
- Q = Infiltration Rate (in inches per hour)
 - ΔH = Change in Height (Water Level) over the time interval
 - r = Test Hole (Borehole) Radius
 - Δt = Time Interval
 - H_{avg} = Average Head Height over the time interval

INFILTRATION CALCULATIONS

Project Name	Proposed Commercial/Industrial Development
Project Location	Bloomington, California
Project Number	20G172-2
Engineer	Ryan Bremer

Test Hole Radius	4 (in)
Test Depth	10 (ft)

Infiltration Test Hole I-5 (Continued)

Interval Number		Time	Time Interval (min)	Water Depth (ft)	Change in Water Level (ft)	Average Head Height (ft)	Infiltration Rate Q (in/hr)	INFILTRATION TESTING
21	Initial	1:32 PM	1.0	6.50	0.42	3.29	14.58	
	Final	1:33 PM		6.92				
22	Initial	1:34 PM	1.0	6.50	0.41	3.30	14.21	
	Final	1:35 PM		6.91				
23	Initial	1:38 PM	1.0	6.50	0.41	3.30	14.21	
	Final	1:39 PM		6.91				
24	Initial	1:40 PM	1.0	6.50	0.41	3.30	14.21	
	Final	1:41 PM		6.91				
25	Initial	1:43 PM	1.0	6.50	0.41	3.30	14.21	
	Final	1:44 PM		6.91				
26	Initial	1:46 PM	1.0	6.50	0.40	3.30	13.85	
	Final	1:47 PM		6.90				
27	Initial	1:49 PM	1.0	6.50	0.40	3.30	13.85	
	Final	1:50 PM		6.90				
28	Initial	1:51 PM	1.0	6.50	0.41	3.30	14.21	
	Final	1:52 PM		6.91				
29	Initial	1:53 PM	1.0	6.50	0.41	3.30	14.21	
	Final	1:54 PM		6.91				
30	Initial	1:55 PM	1.0	6.50	0.41	3.30	14.21	
	Final	1:56 PM		6.91				

Per County Standards, Infiltration Rate calculated as follows:

$$Q = \frac{\Delta H(60r)}{\Delta t(r + 2H_{avg})}$$

- Where:
- Q = Infiltration Rate (in inches per hour)
 - ΔH = Change in Height (Water Level) over the time interval
 - r = Test Hole (Borehole) Radius
 - Δt = Time Interval
 - H_{avg} = Average Head Height over the time interval

INFILTRATION CALCULATIONS

Project Name	Proposed Commercial/Industrial Development
Project Location	Bloomington, California
Project Number	20G172-2
Engineer	Ryan Bremer

Test Hole Radius	4 (in)
Test Depth	9.7 (ft)

Infiltration Test Hole I-6

Interval Number		Time	Time Interval (min)	Water Depth (ft)	Change in Water Level (ft)	Average Head Height (ft)	Infiltration Rate Q (in/hr)	
1	Initial	7:09 AM	0.7	7.00	0.50	2.45	34.39	PRE-SOAK INFILTRATION TESTING
	Final	7:09 AM		7.50				
2	Initial	7:11 AM	0.8	7.00	0.50	2.45	28.66	
	Final	7:11 AM		7.50				
3	Initial	7:12 AM	1.0	7.00	0.58	2.41	27.01	
	Final	7:13 AM		7.58				
4	Initial	7:15 AM	1.0	7.00	0.58	2.41	27.01	
	Final	7:16 AM		7.58				
5	Initial	7:17 AM	1.0	7.00	0.57	2.42	26.49	
	Final	7:18 AM		7.57				
6	Initial	7:20 AM	1.0	7.00	0.56	2.42	25.98	
	Final	7:21 AM		7.56				
7	Initial	7:22 AM	1.0	7.00	0.55	2.43	25.47	
	Final	7:23 AM		7.55				
8	Initial	7:25 AM	1.0	7.00	0.55	2.43	25.47	
	Final	7:26 AM		7.55				
9	Initial	7:27 AM	1.0	7.00	0.53	2.44	24.45	
	Final	7:28 AM		7.53				
10	Initial	7:29 AM	1.0	7.00	0.53	2.44	24.45	
	Final	7:30 AM		7.53				

Per County Standards, Infiltration Rate calculated as follows:

$$Q = \frac{\Delta H(60r)}{\Delta t(r + 2H_{avg})}$$

- Where:
- Q = Infiltration Rate (in inches per hour)
 - ΔH = Change in Height (Water Level) over the time interval
 - r = Test Hole (Borehole) Radius
 - Δt = Time Interval
 - H_{avg} = Average Head Height over the time interval

INFILTRATION CALCULATIONS

Project Name	Proposed Commercial/Industrial Development
Project Location	Bloomington, California
Project Number	20G172-2
Engineer	Ryan Bremer

Test Hole Radius	4 (in)
Test Depth	9.7 (ft)

Infiltration Test Hole I-6 (Continued)

Interval Number		Time	Time Interval (min)	Water Depth (ft)	Change in Water Level (ft)	Average Head Height (ft)	Infiltration Rate Q (in/hr)	INFILTRATION TESTING
11	Initial	7:31 AM	1.0	7.00	0.53	2.44	24.45	
	Final	7:32 AM		7.53				
12	Initial	7:34 AM	1.0	7.00	0.52	2.44	23.94	
	Final	7:35 AM		7.52				
13	Initial	7:36 AM	1.0	7.00	0.52	2.44	23.94	
	Final	7:37 AM		7.52				
14	Initial	7:39 AM	1.0	7.00	0.51	2.45	23.43	
	Final	7:40 AM		7.51				
15	Initial	7:42 AM	1.0	7.00	0.50	2.45	22.93	
	Final	7:43 AM		7.50				
16	Initial	7:44 AM	1.0	7.00	0.49	2.46	22.43	
	Final	7:45 AM		7.49				
17	Initial	7:47 AM	1.0	7.00	0.47	2.47	21.43	
	Final	7:48 AM		7.47				
18	Initial	7:49 AM	1.0	7.00	0.46	2.47	20.94	
	Final	7:50 AM		7.46				
19	Initial	7:52 AM	1.0	7.00	0.45	2.48	20.44	
	Final	7:53 AM		7.45				
20	Initial	7:54 AM	1.0	7.00	0.45	2.48	20.44	
	Final	7:55 AM		7.45				

Per County Standards, Infiltration Rate calculated as follows:

$$Q = \frac{\Delta H(60r)}{\Delta t(r + 2H_{avg})}$$

- Where:
- Q = Infiltration Rate (in inches per hour)
 - ΔH = Change in Height (Water Level) over the time interval
 - r = Test Hole (Borehole) Radius
 - Δt = Time Interval
 - H_{avg} = Average Head Height over the time interval

INFILTRATION CALCULATIONS

Project Name	Proposed Commercial/Industrial Development
Project Location	Bloomington, California
Project Number	20G172-2
Engineer	Ryan Bremer

Test Hole Radius	4 (in)
Test Depth	9.7 (ft)

Infiltration Test Hole I-6 (Continued)

Interval Number		Time	Time Interval (min)	Water Depth (ft)	Change in Water Level (ft)	Average Head Height (ft)	Infiltration Rate Q (in/hr)	INFILTRATION TESTING
21	Initial	7:56 AM	1.0	7.00	0.45	2.48	20.44	
	Final	7:57 AM		7.45				
22	Initial	7:59 AM	1.0	7.00	0.44	2.48	19.95	
	Final	8:00 AM		7.44				
23	Initial	8:01 AM	1.0	7.00	0.44	2.48	19.95	
	Final	8:02 AM		7.44				
24	Initial	8:03 AM	1.0	7.00	0.43	2.49	19.46	
	Final	8:04 AM		7.43				
25	Initial	8:06 AM	1.0	7.00	0.43	2.49	19.46	
	Final	8:07 AM		7.43				
26	Initial	8:08 AM	1.0	7.00	0.43	2.49	19.46	
	Final	8:09 AM		7.43				
27	Initial	8:11 AM	1.0	7.00	0.43	2.49	19.46	
	Final	8:12 AM		7.43				
28	Initial	8:14 AM	1.0	7.00	0.43	2.49	19.46	
	Final	8:15 AM		7.43				
29	Initial	8:16 AM	1.0	7.00	0.43	2.49	19.46	
	Final	8:17 AM		7.43				
30	Initial	8:19 AM	1.0	7.00	0.43	2.49	19.46	
	Final	8:20 AM		7.43				

Per County Standards, Infiltration Rate calculated as follows:

$$Q = \frac{\Delta H(60r)}{\Delta t(r + 2H_{avg})}$$

- Where:
- Q = Infiltration Rate (in inches per hour)
 - ΔH = Change in Height (Water Level) over the time interval
 - r = Test Hole (Borehole) Radius
 - Δt = Time Interval
 - H_{avg} = Average Head Height over the time interval

INFILTRATION CALCULATIONS

Project Name	Proposed Commercial/Industrial Development
Project Location	Bloomington, California
Project Number	20G172-2
Engineer	LA

Test Hole Radius	4 (in)
Test Depth	9.9 (ft)

Infiltration Test Hole I-7

Interval Number		Time	Time Interval (min)	Water Depth (ft)	Change in Water Level (ft)	Average Head Height (ft)	Infiltration Rate Q (in/hr)	
1	Initial	9:55 AM	1.1	7.20	0.50	2.45	21.17	PRE-SOAK
	Final	9:56 AM		7.70				
2	Initial	9:57 AM	1.7	7.20	0.50	2.45	13.90	
	Final	9:58 AM		7.70				
3	Initial	9:59 AM	10.0	7.50	1.88	1.46	13.87	INFILTRATION TESTING
	Final	10:09 AM		9.38				
4	Initial	10:10 AM	10.0	7.50	1.80	1.50	12.96	
	Final	10:20 AM		9.30				
5	Initial	10:21 AM	10.0	7.50	1.78	1.51	12.74	
	Final	10:31 AM		9.28				
6	Initial	10:33 AM	10.0	7.50	1.76	1.52	12.52	
	Final	10:43 AM		9.26				
7	Initial	10:44 AM	10.0	7.50	1.76	1.52	12.52	
	Final	10:54 AM		9.26				
8	Initial	10:55 AM	10.0	7.50	1.72	1.54	12.09	
	Final	11:05 AM		9.22				

Per County Standards, Infiltration Rate calculated as follows:

$$Q = \frac{\Delta H(60r)}{\Delta t(r + 2H_{avg})}$$

- Where:
- Q = Infiltration Rate (in inches per hour)
 - ΔH = Change in Height (Water Level) over the time interval
 - r = Test Hole (Borehole) Radius
 - Δt = Time Interval
 - H_{avg} = Average Head Height over the time interval

INFILTRATION CALCULATIONS

Project Name	Proposed Commercial/Industrial Development
Project Location	Bloomington, California
Project Number	20G172-2
Engineer	LA

Test Hole Radius	4 (in)
Test Depth	10 (ft)

Infiltration Test Hole I-8

Interval Number		Time	Time Interval (min)	Water Depth (ft)	Change in Water Level (ft)	Average Head Height (ft)	Infiltration Rate Q (in/hr)					
1	Initial	11:09 AM	0.7	6.17	0.50	3.58	22.88	PRE-SOAK				
	Final	11:09 AM		6.67								
2	Initial	11:11 AM	0.8	6.17	0.50	3.58	19.61		INFILTRATION TESTING			
	Final	11:11 AM		6.67								
3	Initial	11:13 AM	5.0	6.47	1.73	2.67	14.66	INFILTRATION TESTING				
	Final	11:18 AM		8.20								
4	Initial	11:19 AM	5.0	6.47	1.70	2.68	14.33		INFILTRATION TESTING			
	Final	11:24 AM		8.17								
5	Initial	11:25 AM	5.0	6.47	1.70	2.68	14.33			INFILTRATION TESTING		
	Final	11:30 AM		8.17								
6	Initial	11:32 AM	5.0	6.47	1.70	2.68	14.33				INFILTRATION TESTING	
	Final	11:37 AM		8.17								
7	Initial	11:39 AM	5.0	6.47	1.69	2.69	14.22					INFILTRATION TESTING
	Final	11:44 AM		8.16								
8	Initial	11:45 AM	5.0	6.47	1.63	2.72	13.58	INFILTRATION TESTING				
	Final	11:50 AM		8.10								
9	Initial	11:52 AM	5.0	6.47	1.62	2.72	13.47		INFILTRATION TESTING			
	Final	11:57 AM		8.09								
10	Initial	11:59 AM	5.0	6.47	1.61	2.73	13.36			INFILTRATION TESTING		
	Final	12:04 PM		8.08								

Per County Standards, Infiltration Rate calculated as follows:

$$Q = \frac{\Delta H(60r)}{\Delta t(r + 2H_{avg})}$$

- Where:
- Q = Infiltration Rate (in inches per hour)
 - ΔH = Change in Height (Water Level) over the time interval
 - r = Test Hole (Borehole) Radius
 - Δt = Time Interval
 - H_{avg} = Average Head Height over the time interval

INFILTRATION CALCULATIONS

Project Name	Proposed Commercial/Industrial Development
Project Location	Bloomington, California
Project Number	20G172-2
Engineer	LA

Test Hole Radius	4 (in)
Test Depth	10 (ft)

Infiltration Test Hole I-8 (Continued)

Interval Number		Time	Time Interval (min)	Water Depth (ft)	Change in Water Level (ft)	Average Head Height (ft)	Infiltration Rate Q (in/hr)	INFILTRATION TESTING
11	Initial	12:05 PM	5.0	6.47	1.60	2.73	13.26	
	Final	12:10 PM		8.07				
12	Initial	12:12 PM	5.0	6.47	1.60	2.73	13.26	
	Final	12:17 PM		8.07				
13	Initial	12:19 PM	5.0	6.47	1.59	2.74	13.15	
	Final	12:24 PM		8.06				
14	Initial	12:25 PM	5.0	6.47	1.58	2.74	13.05	
	Final	12:30 PM		8.05				
15	Initial	12:31 PM	5.0	6.47	1.58	2.74	13.05	
	Final	12:36 PM		8.05				

Per County Standards, Infiltration Rate calculated as follows:

$$Q = \frac{\Delta H(60r)}{\Delta t(r + 2H_{avg})}$$

- Where:
- Q = Infiltration Rate (in inches per hour)
 - ΔH = Change in Height (Water Level) over the time interval
 - r = Test Hole (Borehole) Radius
 - Δt = Time Interval
 - H_{avg} = Average Head Height over the time interval

INFILTRATION CALCULATIONS

Project Name	Proposed Commercial/Industrial Development
Project Location	Bloomington, California
Project Number	20G172-2
Engineer	LA

Test Hole Radius	4 (in)
Test Depth	9.54 (ft)

Infiltration Test Hole I-9

Interval Number		Time	Time Interval (min)	Water Depth (ft)	Change in Water Level (ft)	Average Head Height (ft)	Infiltration Rate Q (in/hr)		
1	Initial	12:40 PM	3.4	6.84	0.50	2.45	6.74	PRE-SOAK	
	Final	12:43 PM		7.34					
2	Initial	12:45 PM	5.5	6.84	0.50	2.45	4.21		INFILTRATION TESTING
	Final	12:50 PM		7.34					
3	Initial	12:51 PM	10.0	7.00	0.58	2.25	2.88		
	Final	1:01 PM		7.58					
4	Initial	1:03 PM	10.0	7.00	0.58	2.25	2.88		
	Final	1:13 PM		7.58					
5	Initial	1:14 PM	10.0	7.00	0.57	2.26	2.82		
	Final	1:24 PM		7.57					
6	Initial	1:25 PM	10.0	7.00	0.56	2.26	2.77		
	Final	1:35 PM		7.56					
7	Initial	1:38 PM	10.0	7.00	0.55	2.27	2.71		
	Final	1:48 PM		7.55					
8	Initial	1:50 PM	10.0	7.00	0.55	2.27	2.71		
	Final	2:00 PM		7.55					
9	Initial	2:05 PM	10.0	7.00	0.53	2.28	2.60		
	Final	2:15 PM		7.53					
10	Initial	2:16 PM	10.0	7.00	0.53	2.28	2.60		
	Final	2:26 PM		7.53					

Per County Standards, Infiltration Rate calculated as follows:

$$Q = \frac{\Delta H(60r)}{\Delta t(r + 2H_{avg})}$$

- Where:
- Q = Infiltration Rate (in inches per hour)
 - ΔH = Change in Height (Water Level) over the time interval
 - r = Test Hole (Borehole) Radius
 - Δt = Time Interval
 - H_{avg} = Average Head Height over the time interval

Grain Size Distribution

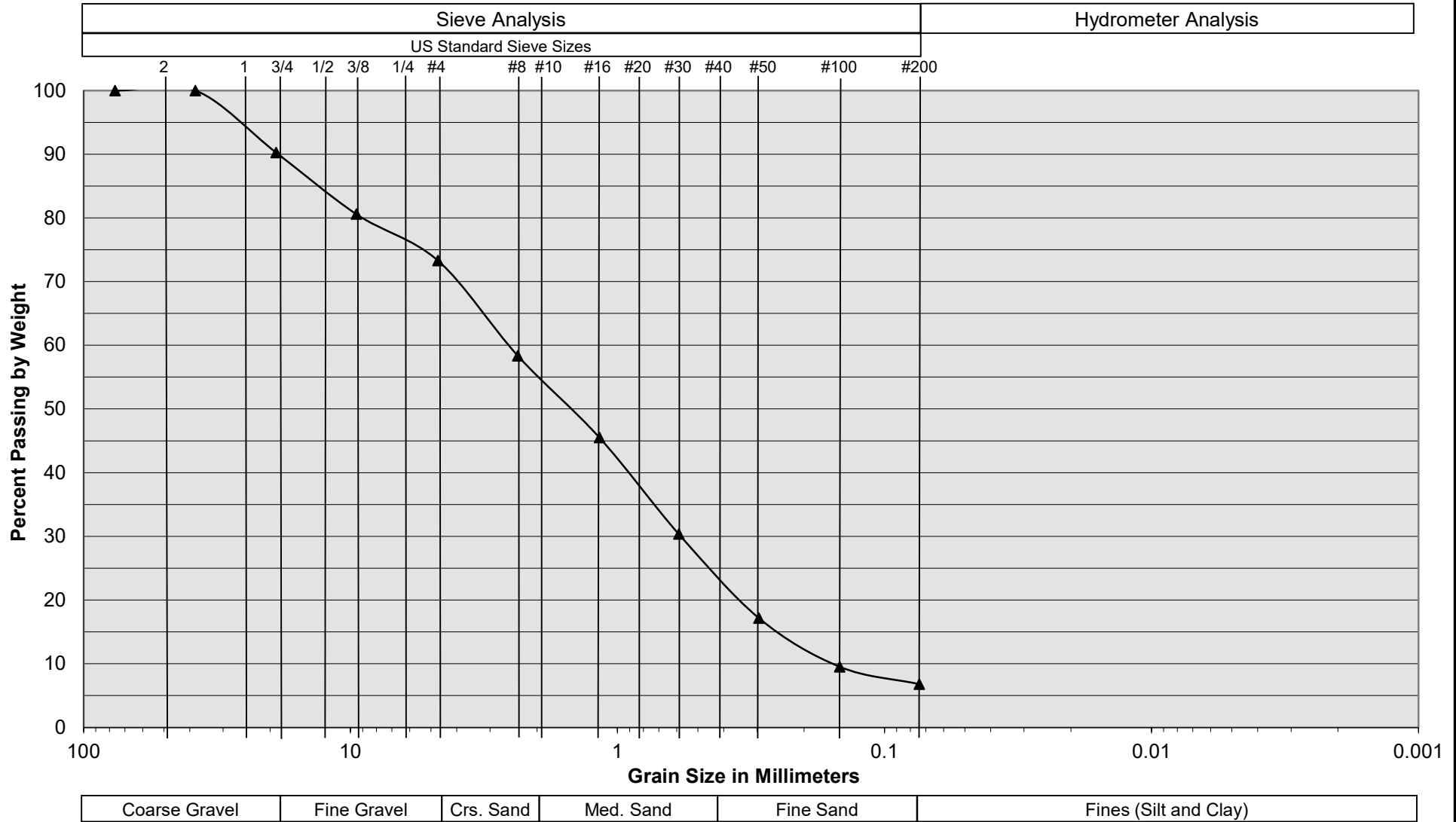

Sample Description	I-1 @ 8.5'
Soil Classification	Brown Gray fine to coarse Sand, some fine to coarse Gravel, trace Silt

Proposed Commercial/Industrial Development
 Bloomington, California
 Project No. 20G172-2
PLATE C-1



Grain Size Distribution

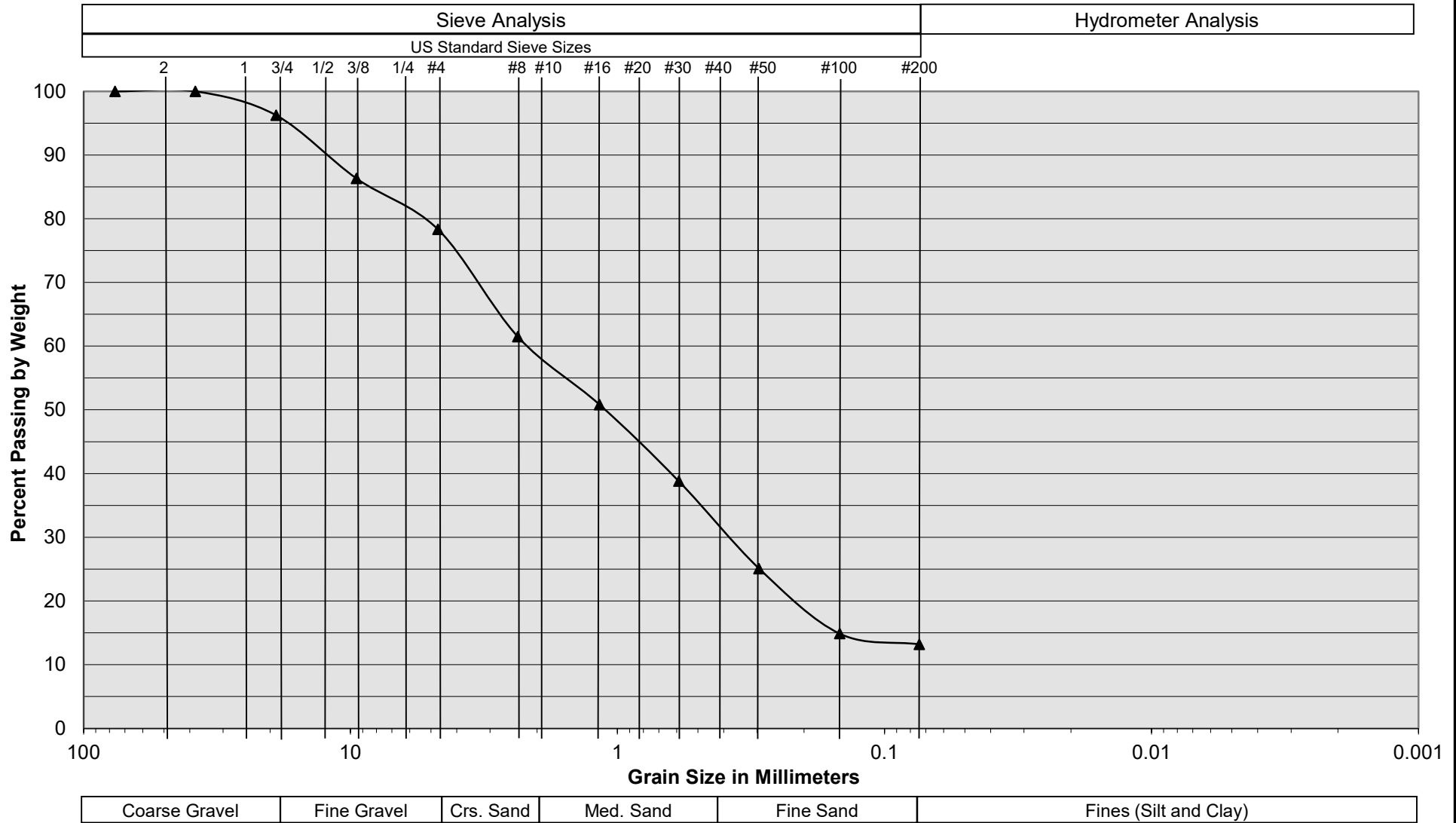

Sample Description	I-2 @ 8.5'
Soil Classification	Light Gray Brown fine to coarse Sand, some fine to coarse Gravel, little Silt

Proposed Commercial/Industrial Development
 Bloomington, California
 Project No. 20G172-2
PLATE C-2



Grain Size Distribution

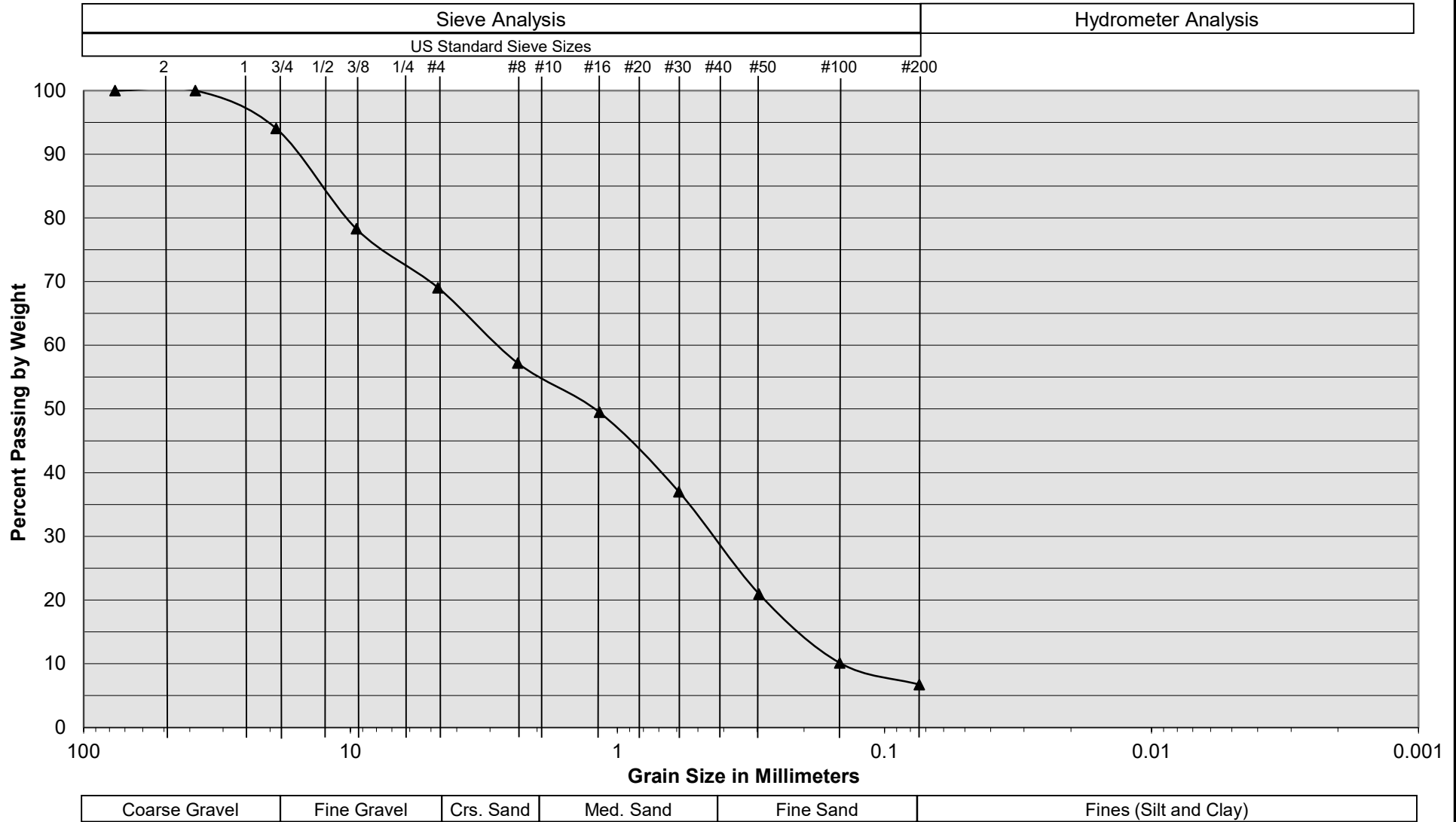

Sample Description	I-3 @ 8.5'
Soil Classification	Light Gray Brown fine to coarse Sand, some fine to coarse Gravel, trace Silt

Proposed Commercial/Industrial Development
 Bloomington, California
 Project No. 20G172-2
PLATE C-3



SOUTHERN CALIFORNIA GEOTECHNICAL
A California Corporation

Grain Size Distribution

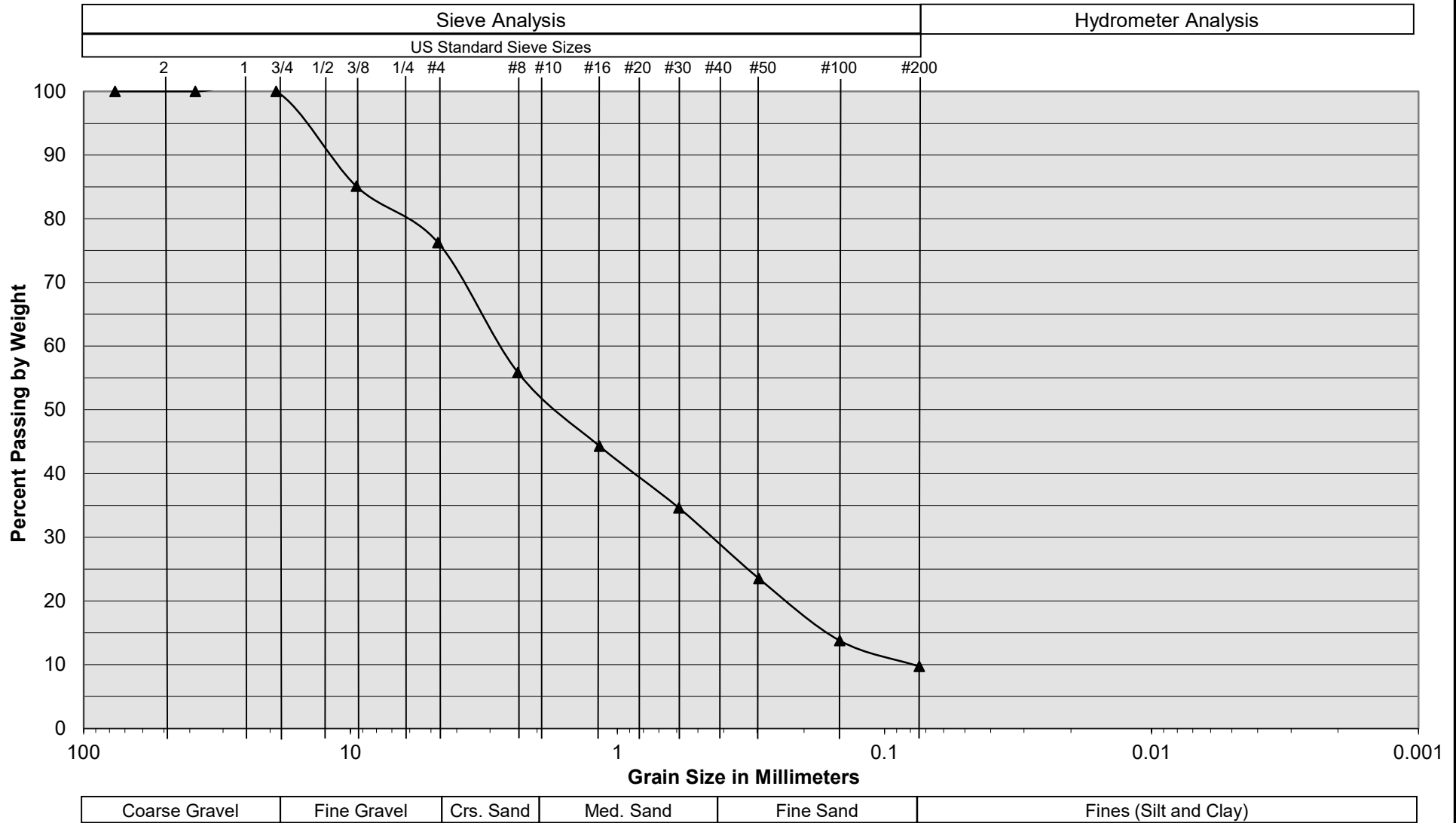

Sample Description	I-4 @ 8.5'
Soil Classification	Light Brown Gray fine to coarse Sand, some fine to coarse Gravel

Proposed Commercial/Industrial Development
 Bloomington, California
 Project No. 20G172-2
PLATE C-4



SOUTHERN CALIFORNIA GEOTECHNICAL
A California Corporation

Grain Size Distribution

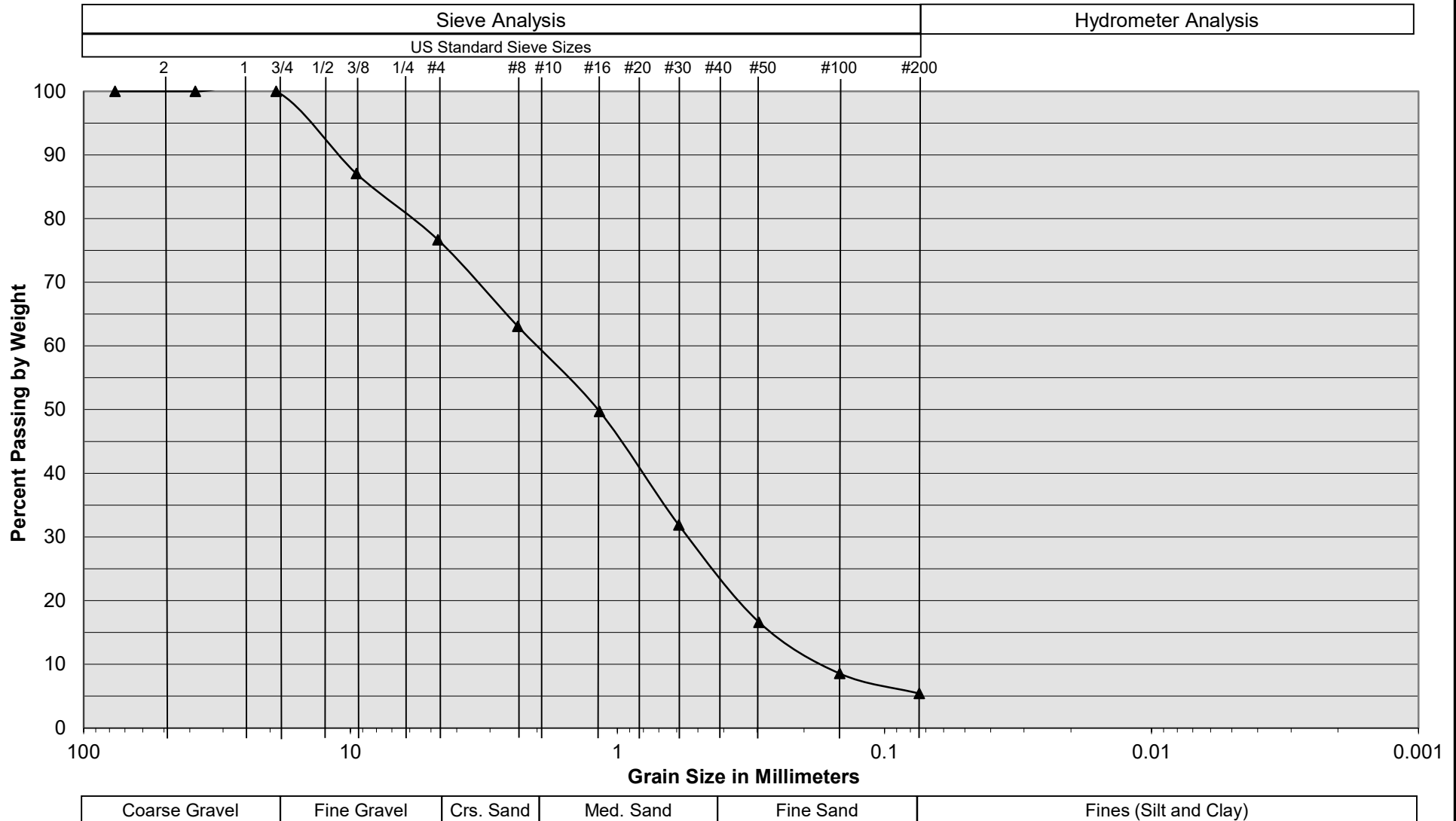

Sample Description	I-5 @ 8.5'
Soil Classification	Gray fine to coarse Sand, some fine to coarse Gravel, trace Silt

Proposed Commercial/Industrial Development Bloomington, California Project No. 20G172-2 PLATE C-5		 SOUTHERN CALIFORNIA GEOTECHNICAL <i>A California Corporation</i>
---	--	--

Grain Size Distribution

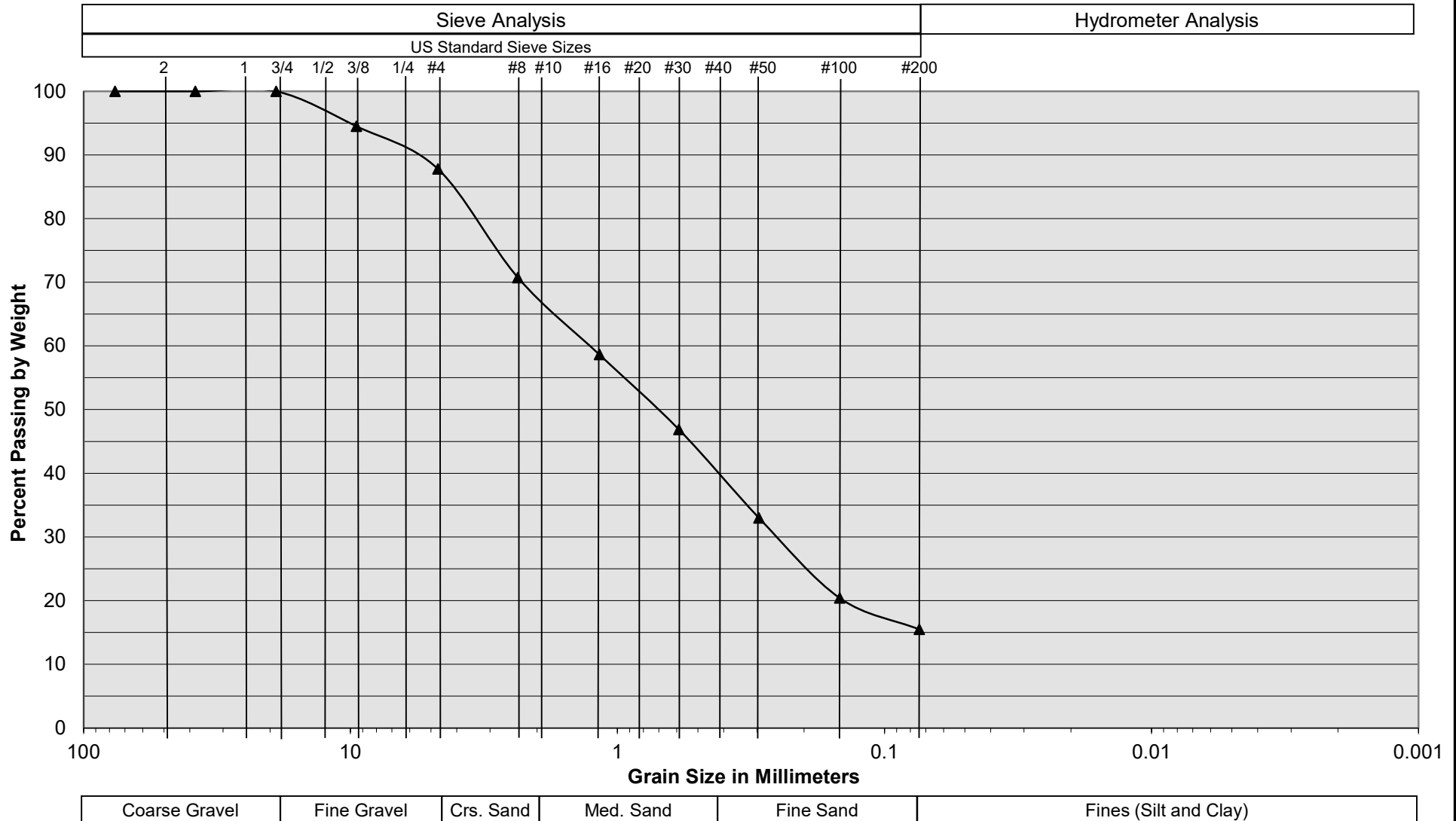

Sample Description	I-6 @ 8.5'
Soil Classification	Light Gray Brown fine to coarse Sand, little fine to coarse Gravel, little Silt

Proposed Commercial/Industrial Development
 Bloomington, California
 Project No. 20G172-2
PLATE C-6



SOUTHERN CALIFORNIA GEOTECHNICAL
A California Corporation

Grain Size Distribution

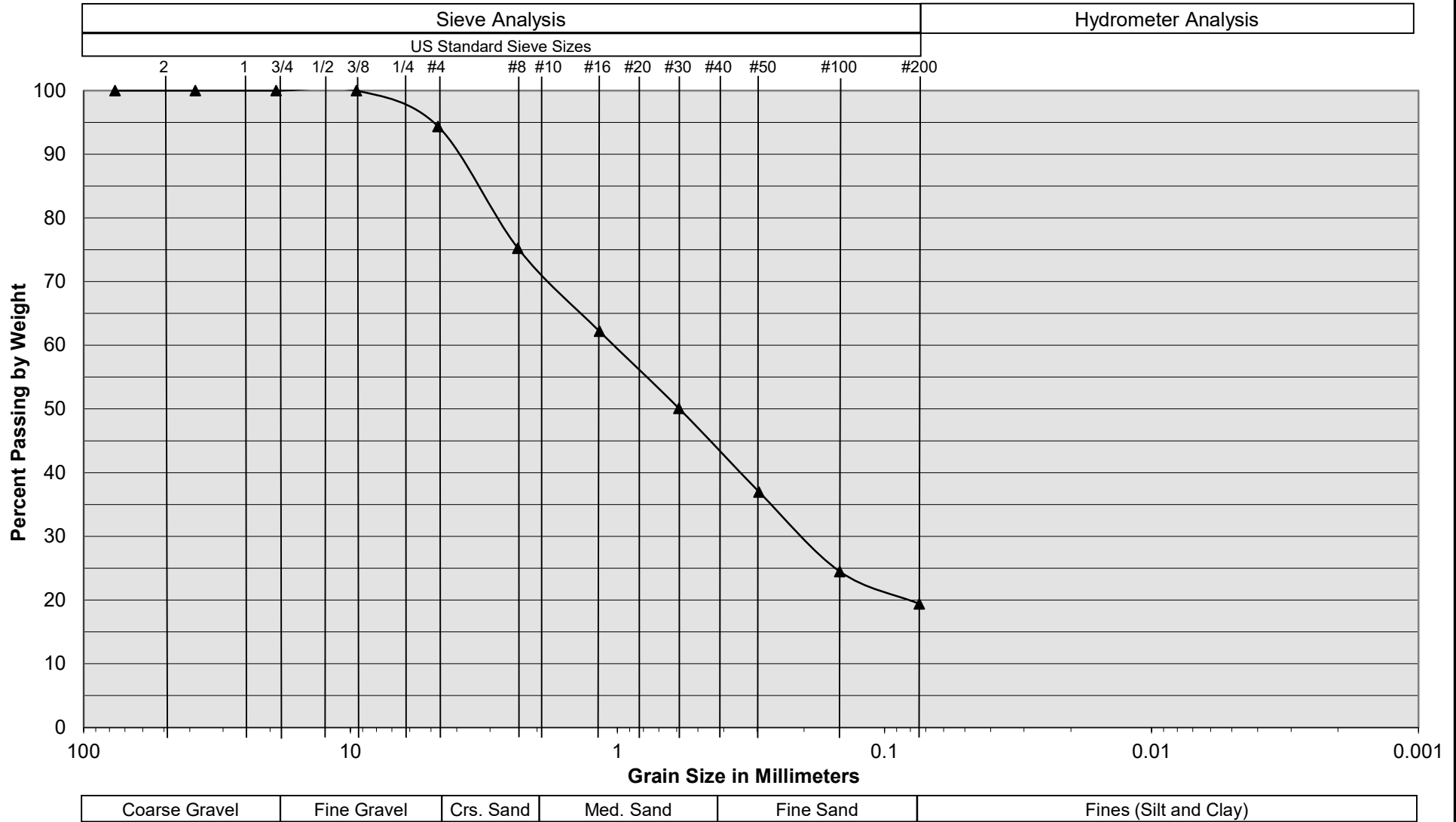

Sample Description	I-7 @ 8.5'
Soil Classification	Light Brown Gray fine to coarse Sand, little to some Silt, trace fine Gravel

Proposed Commercial/Industrial Development
 Bloomington, California
 Project No. 20G172-2
PLATE C-7



SOUTHERN CALIFORNIA GEOTECHNICAL
A California Corporation

Grain Size Distribution

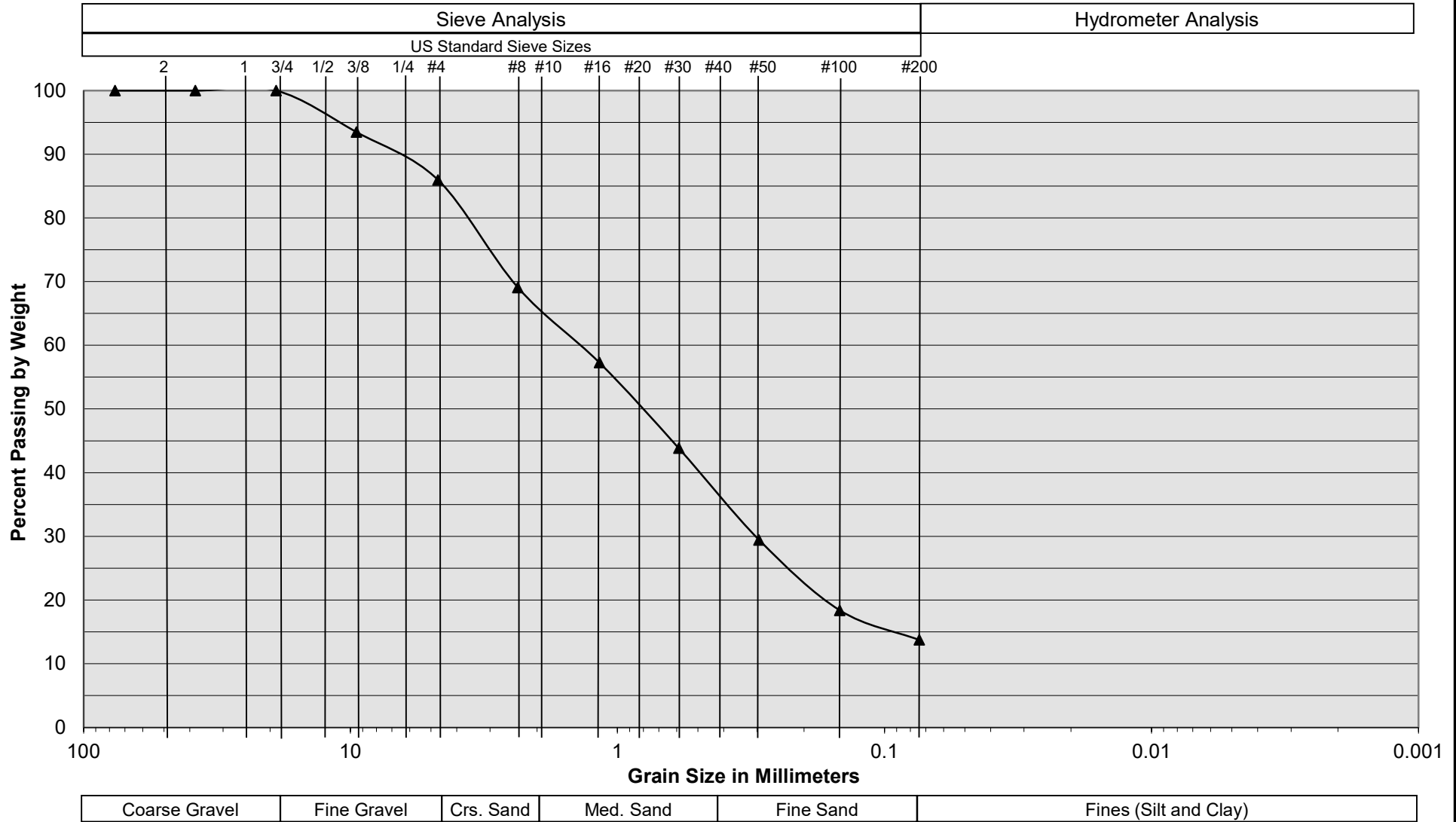

Sample Description	I-8 @ 8.5'
Soil Classification	Light Brown Gray fine to coarse Sand, little Silt, little fine Gravel

Proposed Commercial/Industrial Development
 Bloomington, California
 Project No. 20G172-2
PLATE C-8



SOUTHERN CALIFORNIA GEOTECHNICAL
A California Corporation

Grain Size Distribution

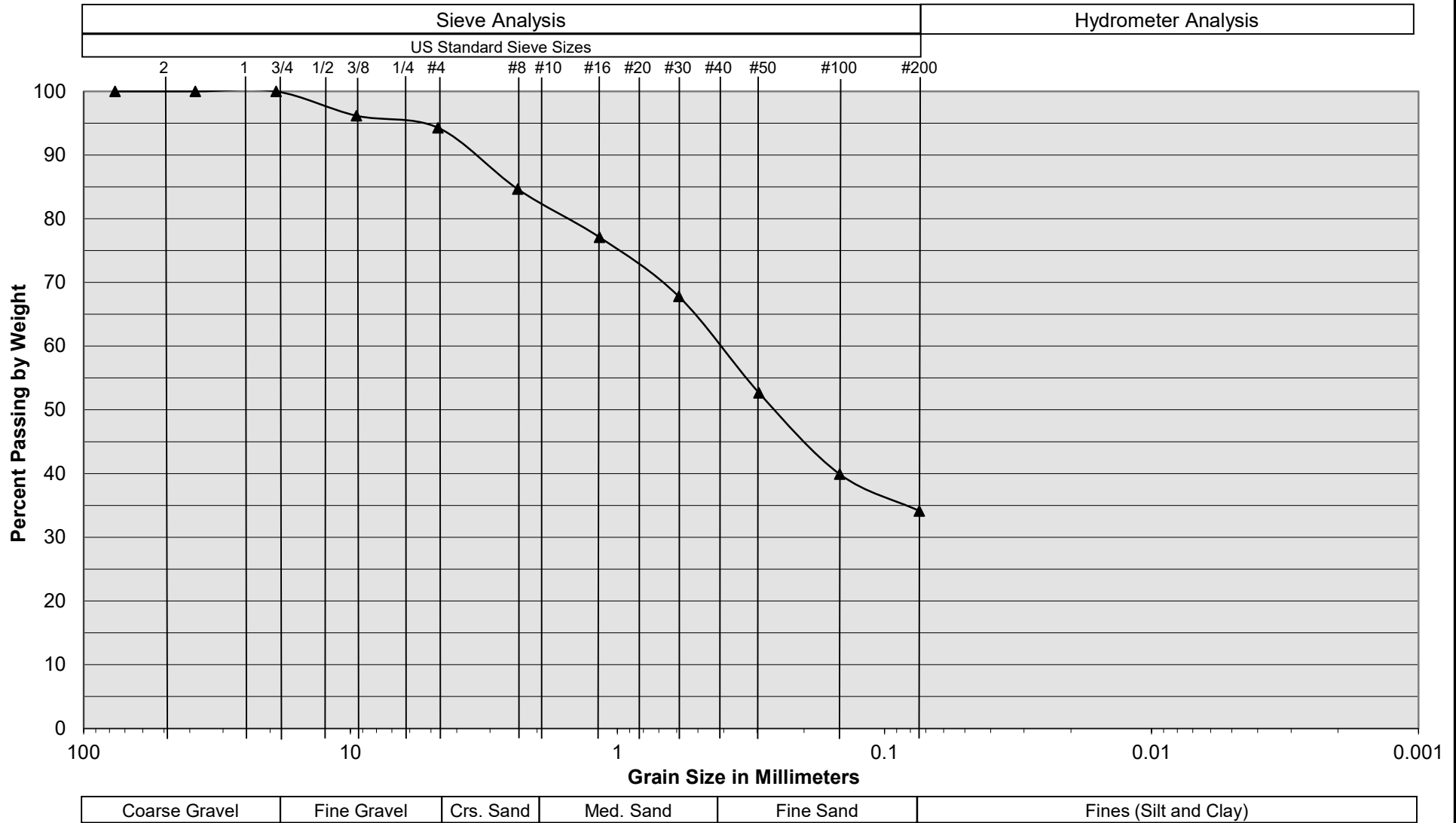

Sample Description	I-9 @ 8.5'
Soil Classification	Brown Silty fine to coarse Sand, trace fine Gravel

Proposed Commercial/Industrial Development
 Bloomington, California
 Project No. 20G172-2
PLATE C-9





SOUTHERN CALIFORNIA GEOTECHNICAL
A California Corporation



United States
Department of
Agriculture

NRCS

Natural
Resources
Conservation
Service

A product of the National
Cooperative Soil Survey,
a joint effort of the United
States Department of
Agriculture and other
Federal agencies, State
agencies including the
Agricultural Experiment
Stations, and local
participants

Custom Soil Resource Report for San Bernardino County Southwestern Part, California

Bloomington Commerce Center SP3 Scheme 1



Preface

Soil surveys contain information that affects land use planning in survey areas. They highlight soil limitations that affect various land uses and provide information about the properties of the soils in the survey areas. Soil surveys are designed for many different users, including farmers, ranchers, foresters, agronomists, urban planners, community officials, engineers, developers, builders, and home buyers. Also, conservationists, teachers, students, and specialists in recreation, waste disposal, and pollution control can use the surveys to help them understand, protect, or enhance the environment.

Various land use regulations of Federal, State, and local governments may impose special restrictions on land use or land treatment. Soil surveys identify soil properties that are used in making various land use or land treatment decisions. The information is intended to help the land users identify and reduce the effects of soil limitations on various land uses. The landowner or user is responsible for identifying and complying with existing laws and regulations.

Although soil survey information can be used for general farm, local, and wider area planning, onsite investigation is needed to supplement this information in some cases. Examples include soil quality assessments (<http://www.nrcs.usda.gov/wps/portal/nrcs/main/soils/health/>) and certain conservation and engineering applications. For more detailed information, contact your local USDA Service Center (<https://offices.sc.egov.usda.gov/locator/app?agency=nrcs>) or your NRCS State Soil Scientist (http://www.nrcs.usda.gov/wps/portal/nrcs/detail/soils/contactus/?cid=nrcs142p2_053951).

Great differences in soil properties can occur within short distances. Some soils are seasonally wet or subject to flooding. Some are too unstable to be used as a foundation for buildings or roads. Clayey or wet soils are poorly suited to use as septic tank absorption fields. A high water table makes a soil poorly suited to basements or underground installations.

The National Cooperative Soil Survey is a joint effort of the United States Department of Agriculture and other Federal agencies, State agencies including the Agricultural Experiment Stations, and local agencies. The Natural Resources Conservation Service (NRCS) has leadership for the Federal part of the National Cooperative Soil Survey.

Information about soils is updated periodically. Updated information is available through the NRCS Web Soil Survey, the site for official soil survey information.

The U.S. Department of Agriculture (USDA) prohibits discrimination in all its programs and activities on the basis of race, color, national origin, age, disability, and where applicable, sex, marital status, familial status, parental status, religion, sexual orientation, genetic information, political beliefs, reprisal, or because all or a part of an individual's income is derived from any public assistance program. (Not all prohibited bases apply to all programs.) Persons with disabilities who require

alternative means for communication of program information (Braille, large print, audiotape, etc.) should contact USDA's TARGET Center at (202) 720-2600 (voice and TDD). To file a complaint of discrimination, write to USDA, Director, Office of Civil Rights, 1400 Independence Avenue, S.W., Washington, D.C. 20250-9410 or call (800) 795-3272 (voice) or (202) 720-6382 (TDD). USDA is an equal opportunity provider and employer.

Contents

Preface	2
How Soil Surveys Are Made	5
Soil Map	8
Soil Map.....	9
Legend.....	10
Map Unit Legend.....	12
Map Unit Descriptions.....	12
San Bernardino County Southwestern Part, California.....	14
Db—Delhi fine sand.....	14
TuB—Tujunga loamy sand, 0 to 5 percent slopes.....	15
Soil Information for All Uses	17
Soil Properties and Qualities.....	17
Soil Qualities and Features.....	17
Hydrologic Soil Group.....	17
References	23

How Soil Surveys Are Made

Soil surveys are made to provide information about the soils and miscellaneous areas in a specific area. They include a description of the soils and miscellaneous areas and their location on the landscape and tables that show soil properties and limitations affecting various uses. Soil scientists observed the steepness, length, and shape of the slopes; the general pattern of drainage; the kinds of crops and native plants; and the kinds of bedrock. They observed and described many soil profiles. A soil profile is the sequence of natural layers, or horizons, in a soil. The profile extends from the surface down into the unconsolidated material in which the soil formed or from the surface down to bedrock. The unconsolidated material is devoid of roots and other living organisms and has not been changed by other biological activity.

Currently, soils are mapped according to the boundaries of major land resource areas (MLRAs). MLRAs are geographically associated land resource units that share common characteristics related to physiography, geology, climate, water resources, soils, biological resources, and land uses (USDA, 2006). Soil survey areas typically consist of parts of one or more MLRA.

The soils and miscellaneous areas in a survey area occur in an orderly pattern that is related to the geology, landforms, relief, climate, and natural vegetation of the area. Each kind of soil and miscellaneous area is associated with a particular kind of landform or with a segment of the landform. By observing the soils and miscellaneous areas in the survey area and relating their position to specific segments of the landform, a soil scientist develops a concept, or model, of how they were formed. Thus, during mapping, this model enables the soil scientist to predict with a considerable degree of accuracy the kind of soil or miscellaneous area at a specific location on the landscape.

Commonly, individual soils on the landscape merge into one another as their characteristics gradually change. To construct an accurate soil map, however, soil scientists must determine the boundaries between the soils. They can observe only a limited number of soil profiles. Nevertheless, these observations, supplemented by an understanding of the soil-vegetation-landscape relationship, are sufficient to verify predictions of the kinds of soil in an area and to determine the boundaries.

Soil scientists recorded the characteristics of the soil profiles that they studied. They noted soil color, texture, size and shape of soil aggregates, kind and amount of rock fragments, distribution of plant roots, reaction, and other features that enable them to identify soils. After describing the soils in the survey area and determining their properties, the soil scientists assigned the soils to taxonomic classes (units). Taxonomic classes are concepts. Each taxonomic class has a set of soil characteristics with precisely defined limits. The classes are used as a basis for comparison to classify soils systematically. Soil taxonomy, the system of taxonomic classification used in the United States, is based mainly on the kind and character of soil properties and the arrangement of horizons within the profile. After the soil

Custom Soil Resource Report

scientists classified and named the soils in the survey area, they compared the individual soils with similar soils in the same taxonomic class in other areas so that they could confirm data and assemble additional data based on experience and research.

The objective of soil mapping is not to delineate pure map unit components; the objective is to separate the landscape into landforms or landform segments that have similar use and management requirements. Each map unit is defined by a unique combination of soil components and/or miscellaneous areas in predictable proportions. Some components may be highly contrasting to the other components of the map unit. The presence of minor components in a map unit in no way diminishes the usefulness or accuracy of the data. The delineation of such landforms and landform segments on the map provides sufficient information for the development of resource plans. If intensive use of small areas is planned, onsite investigation is needed to define and locate the soils and miscellaneous areas.

Soil scientists make many field observations in the process of producing a soil map. The frequency of observation is dependent upon several factors, including scale of mapping, intensity of mapping, design of map units, complexity of the landscape, and experience of the soil scientist. Observations are made to test and refine the soil-landscape model and predictions and to verify the classification of the soils at specific locations. Once the soil-landscape model is refined, a significantly smaller number of measurements of individual soil properties are made and recorded. These measurements may include field measurements, such as those for color, depth to bedrock, and texture, and laboratory measurements, such as those for content of sand, silt, clay, salt, and other components. Properties of each soil typically vary from one point to another across the landscape.

Observations for map unit components are aggregated to develop ranges of characteristics for the components. The aggregated values are presented. Direct measurements do not exist for every property presented for every map unit component. Values for some properties are estimated from combinations of other properties.

While a soil survey is in progress, samples of some of the soils in the area generally are collected for laboratory analyses and for engineering tests. Soil scientists interpret the data from these analyses and tests as well as the field-observed characteristics and the soil properties to determine the expected behavior of the soils under different uses. Interpretations for all of the soils are field tested through observation of the soils in different uses and under different levels of management. Some interpretations are modified to fit local conditions, and some new interpretations are developed to meet local needs. Data are assembled from other sources, such as research information, production records, and field experience of specialists. For example, data on crop yields under defined levels of management are assembled from farm records and from field or plot experiments on the same kinds of soil.

Predictions about soil behavior are based not only on soil properties but also on such variables as climate and biological activity. Soil conditions are predictable over long periods of time, but they are not predictable from year to year. For example, soil scientists can predict with a fairly high degree of accuracy that a given soil will have a high water table within certain depths in most years, but they cannot predict that a high water table will always be at a specific level in the soil on a specific date.

After soil scientists located and identified the significant natural bodies of soil in the survey area, they drew the boundaries of these bodies on aerial photographs and

Custom Soil Resource Report

identified each as a specific map unit. Aerial photographs show trees, buildings, fields, roads, and rivers, all of which help in locating boundaries accurately.

Soil Map

The soil map section includes the soil map for the defined area of interest, a list of soil map units on the map and extent of each map unit, and cartographic symbols displayed on the map. Also presented are various metadata about data used to produce the map, and a description of each soil map unit.

Custom Soil Resource Report Soil Map

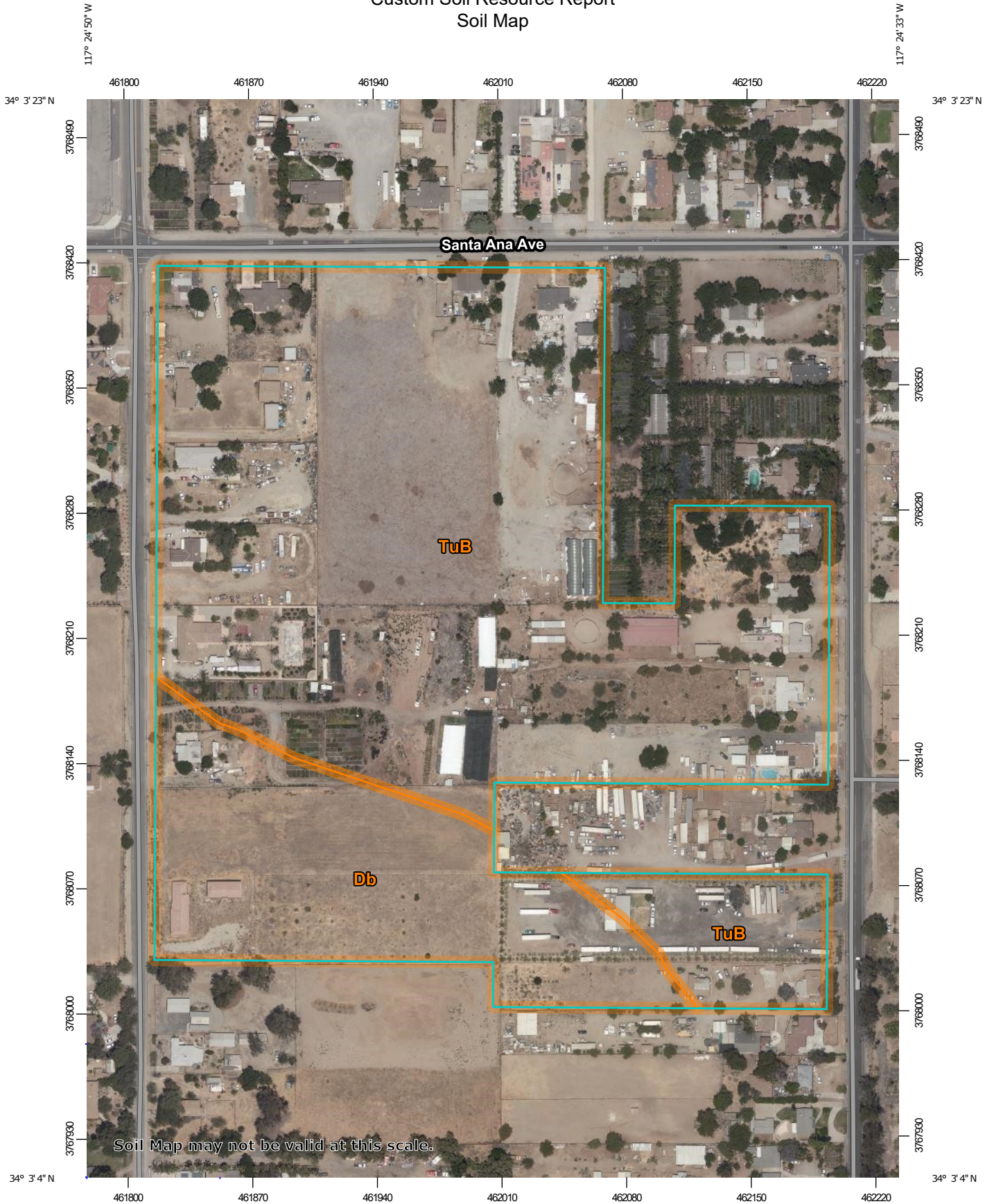

Map Scale: 1:2,940 if printed on A portrait (8.5" x 11") sheet.

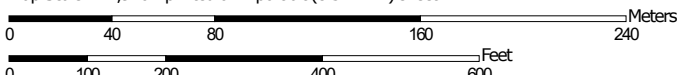

Map projection: Web Mercator Corner coordinates: WGS84 Edge tics: UTM Zone 11N WGS84

MAP LEGEND

Area of Interest (AOI)

 Area of Interest (AOI)

Soils







 Soil Map Unit Polygons

 Soil Map Unit Lines

 Soil Map Unit Points

Special Point Features





-  Blowout
-  Borrow Pit
-  Clay Spot
-  Closed Depression
-  Gravel Pit
-  Gravelly Spot
-  Landfill
-  Lava Flow
-  Marsh or swamp
-  Mine or Quarry
-  Miscellaneous Water
-  Perennial Water
-  Rock Outcrop
-  Saline Spot
-  Sandy Spot
-  Severely Eroded Spot
-  Sinkhole
-  Slide or Slip
-  Sodic Spot

-  Spoil Area
-  Stony Spot
-  Very Stony Spot
-  Wet Spot
-  Other
-  Special Line Features

Water Features

 Streams and Canals

Transportation

-  Rails
-  Interstate Highways
-  US Routes
-  Major Roads
-  Local Roads

Background

 Aerial Photography

MAP INFORMATION

The soil surveys that comprise your AOI were mapped at 1:24,000.

Warning: Soil Map may not be valid at this scale.

Enlargement of maps beyond the scale of mapping can cause misunderstanding of the detail of mapping and accuracy of soil line placement. The maps do not show the small areas of contrasting soils that could have been shown at a more detailed scale.

Please rely on the bar scale on each map sheet for map measurements.

Source of Map: Natural Resources Conservation Service
 Web Soil Survey URL:
 Coordinate System: Web Mercator (EPSG:3857)

Maps from the Web Soil Survey are based on the Web Mercator projection, which preserves direction and shape but distorts distance and area. A projection that preserves area, such as the Albers equal-area conic projection, should be used if more accurate calculations of distance or area are required.

This product is generated from the USDA-NRCS certified data as of the version date(s) listed below.

Soil Survey Area: San Bernardino County Southwestern Part, California
 Survey Area Data: Version 12, May 27, 2020

Soil map units are labeled (as space allows) for map scales 1:50,000 or larger.

Date(s) aerial images were photographed: Apr 1, 2018—Jun 30, 2018

The orthophoto or other base map on which the soil lines were compiled and digitized probably differs from the background

MAP LEGEND

MAP INFORMATION

imagery displayed on these maps. As a result, some minor shifting of map unit boundaries may be evident.

Map Unit Legend

Map Unit Symbol	Map Unit Name	Acres in AOI	Percent of AOI
Db	Delhi fine sand	6.8	22.1%
TuB	Tujungang loamy sand, 0 to 5 percent slopes	23.8	77.9%
Totals for Area of Interest		30.5	100.0%

Map Unit Descriptions

The map units delineated on the detailed soil maps in a soil survey represent the soils or miscellaneous areas in the survey area. The map unit descriptions, along with the maps, can be used to determine the composition and properties of a unit.

A map unit delineation on a soil map represents an area dominated by one or more major kinds of soil or miscellaneous areas. A map unit is identified and named according to the taxonomic classification of the dominant soils. Within a taxonomic class there are precisely defined limits for the properties of the soils. On the landscape, however, the soils are natural phenomena, and they have the characteristic variability of all natural phenomena. Thus, the range of some observed properties may extend beyond the limits defined for a taxonomic class. Areas of soils of a single taxonomic class rarely, if ever, can be mapped without including areas of other taxonomic classes. Consequently, every map unit is made up of the soils or miscellaneous areas for which it is named and some minor components that belong to taxonomic classes other than those of the major soils.

Most minor soils have properties similar to those of the dominant soil or soils in the map unit, and thus they do not affect use and management. These are called noncontrasting, or similar, components. They may or may not be mentioned in a particular map unit description. Other minor components, however, have properties and behavioral characteristics divergent enough to affect use or to require different management. These are called contrasting, or dissimilar, components. They generally are in small areas and could not be mapped separately because of the scale used. Some small areas of strongly contrasting soils or miscellaneous areas are identified by a special symbol on the maps. If included in the database for a given area, the contrasting minor components are identified in the map unit descriptions along with some characteristics of each. A few areas of minor components may not have been observed, and consequently they are not mentioned in the descriptions, especially where the pattern was so complex that it was impractical to make enough observations to identify all the soils and miscellaneous areas on the landscape.

The presence of minor components in a map unit in no way diminishes the usefulness or accuracy of the data. The objective of mapping is not to delineate pure taxonomic classes but rather to separate the landscape into landforms or landform segments that have similar use and management requirements. The delineation of such segments on the map provides sufficient information for the development of resource plans. If intensive use of small areas is planned, however,

Custom Soil Resource Report

onsite investigation is needed to define and locate the soils and miscellaneous areas.

An identifying symbol precedes the map unit name in the map unit descriptions. Each description includes general facts about the unit and gives important soil properties and qualities.

Soils that have profiles that are almost alike make up a *soil series*. Except for differences in texture of the surface layer, all the soils of a series have major horizons that are similar in composition, thickness, and arrangement.

Soils of one series can differ in texture of the surface layer, slope, stoniness, salinity, degree of erosion, and other characteristics that affect their use. On the basis of such differences, a soil series is divided into *soil phases*. Most of the areas shown on the detailed soil maps are phases of soil series. The name of a soil phase commonly indicates a feature that affects use or management. For example, Alpha silt loam, 0 to 2 percent slopes, is a phase of the Alpha series.

Some map units are made up of two or more major soils or miscellaneous areas. These map units are complexes, associations, or undifferentiated groups.

A *complex* consists of two or more soils or miscellaneous areas in such an intricate pattern or in such small areas that they cannot be shown separately on the maps. The pattern and proportion of the soils or miscellaneous areas are somewhat similar in all areas. Alpha-Beta complex, 0 to 6 percent slopes, is an example.

An *association* is made up of two or more geographically associated soils or miscellaneous areas that are shown as one unit on the maps. Because of present or anticipated uses of the map units in the survey area, it was not considered practical or necessary to map the soils or miscellaneous areas separately. The pattern and relative proportion of the soils or miscellaneous areas are somewhat similar. Alpha-Beta association, 0 to 2 percent slopes, is an example.

An *undifferentiated group* is made up of two or more soils or miscellaneous areas that could be mapped individually but are mapped as one unit because similar interpretations can be made for use and management. The pattern and proportion of the soils or miscellaneous areas in a mapped area are not uniform. An area can be made up of only one of the major soils or miscellaneous areas, or it can be made up of all of them. Alpha and Beta soils, 0 to 2 percent slopes, is an example.

Some surveys include *miscellaneous areas*. Such areas have little or no soil material and support little or no vegetation. Rock outcrop is an example.

San Bernardino County Southwestern Part, California

Db—Delhi fine sand

Map Unit Setting

National map unit symbol: hcjq
Elevation: 30 to 1,400 feet
Mean annual precipitation: 10 to 16 inches
Mean annual air temperature: 59 to 64 degrees F
Frost-free period: 225 to 310 days
Farmland classification: Prime farmland if irrigated

Map Unit Composition

Delhi and similar soils: 85 percent
Minor components: 15 percent
Estimates are based on observations, descriptions, and transects of the mapunit.

Description of Delhi

Setting

Landform: Alluvial fans
Landform position (two-dimensional): Backslope
Landform position (three-dimensional): Tread
Down-slope shape: Linear
Across-slope shape: Linear
Parent material: Sandy alluvium derived from granite

Typical profile

H1 - 0 to 18 inches: fine sand
H2 - 18 to 60 inches: sand

Properties and qualities

Slope: 0 to 2 percent
Depth to restrictive feature: More than 80 inches
Drainage class: Somewhat excessively drained
Runoff class: Negligible
Capacity of the most limiting layer to transmit water (Ksat): High to very high (5.95 to 19.98 in/hr)
Depth to water table: More than 80 inches
Frequency of flooding: None
Frequency of ponding: None
Available water capacity: Low (about 4.4 inches)

Interpretive groups

Land capability classification (irrigated): 3e
Land capability classification (nonirrigated): 4e
Hydrologic Soil Group: A
Hydric soil rating: No

Minor Components

Unnamed

Percent of map unit: 5 percent
Landform: Depressions
Hydric soil rating: Yes

Unnamed

Percent of map unit: 5 percent
Hydric soil rating: No

Tujungang, loamy sand

Percent of map unit: 5 percent
Hydric soil rating: No

TuB—Tujungang loamy sand, 0 to 5 percent slopes

Map Unit Setting

National map unit symbol: 2sx6y
Elevation: 650 to 3,110 feet
Mean annual precipitation: 10 to 25 inches
Mean annual air temperature: 62 to 65 degrees F
Frost-free period: 325 to 365 days
Farmland classification: Farmland of statewide importance

Map Unit Composition

Tujungang, loamy sand, and similar soils: 85 percent
Minor components: 15 percent
Estimates are based on observations, descriptions, and transects of the mapunit.

Description of Tujungang, Loamy Sand

Setting

Landform: Alluvial fans
Landform position (three-dimensional): Tread
Down-slope shape: Linear
Across-slope shape: Linear
Parent material: Alluvium derived from granite

Typical profile

A - 0 to 6 inches: loamy sand
C1 - 6 to 18 inches: loamy sand
C2 - 18 to 60 inches: loamy sand

Properties and qualities

Slope: 0 to 5 percent
Depth to restrictive feature: More than 80 inches
Drainage class: Somewhat excessively drained
Runoff class: Very low
Capacity of the most limiting layer to transmit water (Ksat): High to very high (5.95 to 19.98 in/hr)
Depth to water table: More than 80 inches
Frequency of flooding: Rare
Frequency of ponding: None
Available water capacity: Low (about 4.2 inches)

Interpretive groups

Land capability classification (irrigated): None specified

Custom Soil Resource Report

Land capability classification (nonirrigated): 4e
Hydrologic Soil Group: A
Hydric soil rating: No

Minor Components

Tujunga, gravelly loamy sand

Percent of map unit: 10 percent
Landform: Alluvial fans
Landform position (three-dimensional): Tread
Down-slope shape: Linear
Across-slope shape: Linear
Hydric soil rating: No

Hanford, sandy loam

Percent of map unit: 5 percent
Landform: Alluvial fans
Landform position (three-dimensional): Tread
Down-slope shape: Linear
Across-slope shape: Linear
Hydric soil rating: No

Soil Information for All Uses

Soil Properties and Qualities

The Soil Properties and Qualities section includes various soil properties and qualities displayed as thematic maps with a summary table for the soil map units in the selected area of interest. A single value or rating for each map unit is generated by aggregating the interpretive ratings of individual map unit components. This aggregation process is defined for each property or quality.

Soil Qualities and Features

Soil qualities are behavior and performance attributes that are not directly measured, but are inferred from observations of dynamic conditions and from soil properties. Example soil qualities include natural drainage, and frost action. Soil features are attributes that are not directly part of the soil. Example soil features include slope and depth to restrictive layer. These features can greatly impact the use and management of the soil.

Hydrologic Soil Group

Hydrologic soil groups are based on estimates of runoff potential. Soils are assigned to one of four groups according to the rate of water infiltration when the soils are not protected by vegetation, are thoroughly wet, and receive precipitation from long-duration storms.

The soils in the United States are assigned to four groups (A, B, C, and D) and three dual classes (A/D, B/D, and C/D). The groups are defined as follows:

Group A. Soils having a high infiltration rate (low runoff potential) when thoroughly wet. These consist mainly of deep, well drained to excessively drained sands or gravelly sands. These soils have a high rate of water transmission.

Group B. Soils having a moderate infiltration rate when thoroughly wet. These consist chiefly of moderately deep or deep, moderately well drained or well drained soils that have moderately fine texture to moderately coarse texture. These soils have a moderate rate of water transmission.

Custom Soil Resource Report

Group C. Soils having a slow infiltration rate when thoroughly wet. These consist chiefly of soils having a layer that impedes the downward movement of water or soils of moderately fine texture or fine texture. These soils have a slow rate of water transmission.

Group D. Soils having a very slow infiltration rate (high runoff potential) when thoroughly wet. These consist chiefly of clays that have a high shrink-swell potential, soils that have a high water table, soils that have a claypan or clay layer at or near the surface, and soils that are shallow over nearly impervious material. These soils have a very slow rate of water transmission.

If a soil is assigned to a dual hydrologic group (A/D, B/D, or C/D), the first letter is for drained areas and the second is for undrained areas. Only the soils that in their natural condition are in group D are assigned to dual classes.

Custom Soil Resource Report
Map—Hydrologic Soil Group

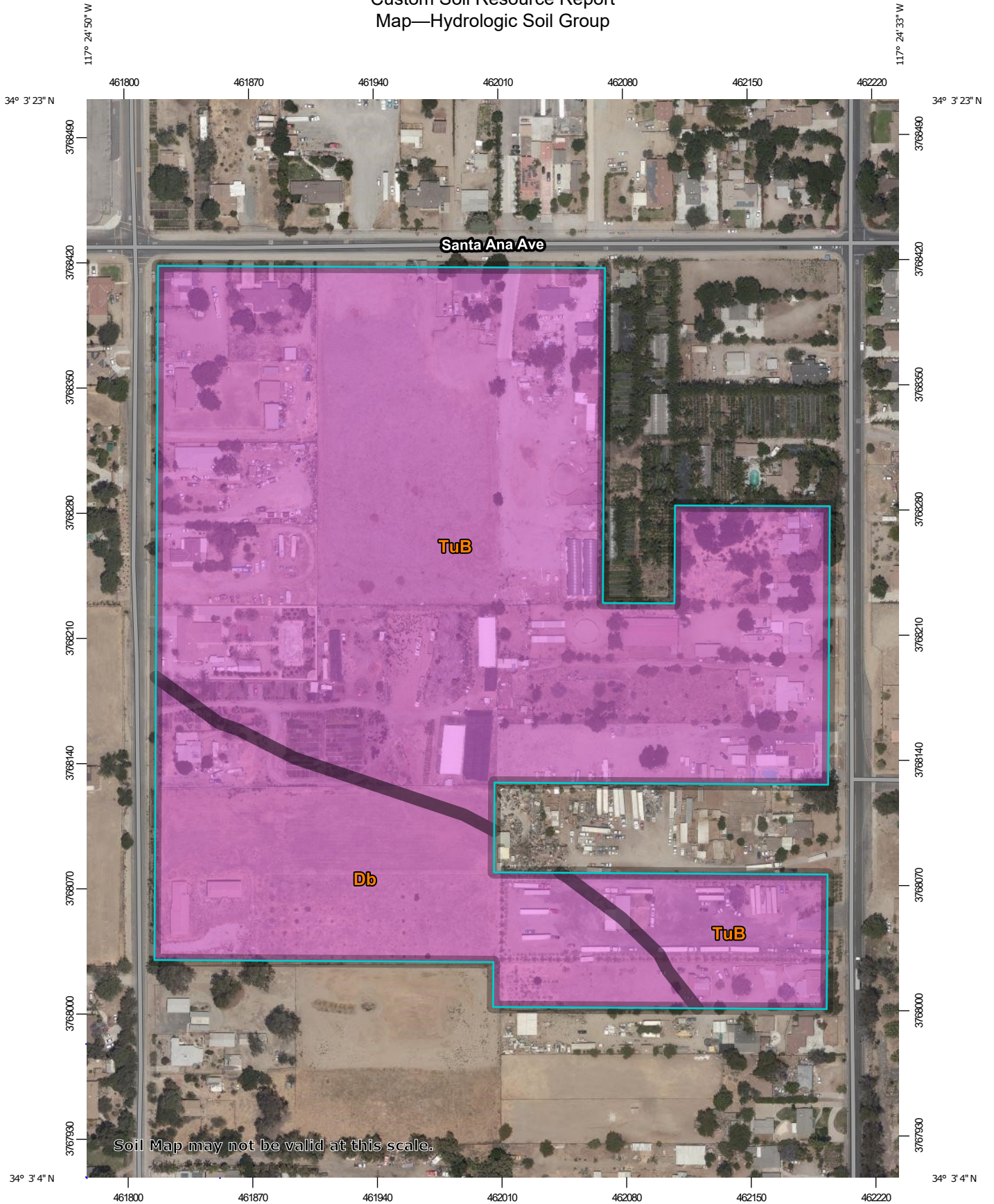

Map Scale: 1:2,940 if printed on A portrait (8.5" x 11") sheet.

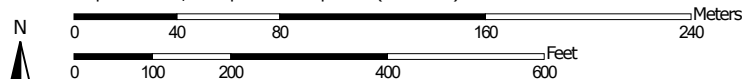

Map projection: Web Mercator Corner coordinates: WGS84 Edge tics: UTM Zone 11N WGS84

MAP LEGEND

Area of Interest (AOI)









 Area of Interest (AOI)

Soils

Soil Rating Polygons





-  A
-  A/D
-  B
-  B/D
-  C
-  C/D
-  D
-  Not rated or not available

Soil Rating Lines

-  A
-  A/D
-  B
-  B/D
-  C
-  C/D
-  D
-  Not rated or not available

Soil Rating Points





-  A
-  A/D
-  B
-  B/D

-  C
-  C/D
-  D
-  Not rated or not available

Water Features

 Streams and Canals

Transportation

-  Rails
-  Interstate Highways
-  US Routes
-  Major Roads
-  Local Roads

Background

 Aerial Photography

MAP INFORMATION

The soil surveys that comprise your AOI were mapped at 1:24,000.

Warning: Soil Map may not be valid at this scale.

Enlargement of maps beyond the scale of mapping can cause misunderstanding of the detail of mapping and accuracy of soil line placement. The maps do not show the small areas of contrasting soils that could have been shown at a more detailed scale.

Please rely on the bar scale on each map sheet for map measurements.

Source of Map: Natural Resources Conservation Service
 Web Soil Survey URL:
 Coordinate System: Web Mercator (EPSG:3857)

Maps from the Web Soil Survey are based on the Web Mercator projection, which preserves direction and shape but distorts distance and area. A projection that preserves area, such as the Albers equal-area conic projection, should be used if more accurate calculations of distance or area are required.

This product is generated from the USDA-NRCS certified data as of the version date(s) listed below.

Soil Survey Area: San Bernardino County Southwestern Part, California
 Survey Area Data: Version 12, May 27, 2020

Soil map units are labeled (as space allows) for map scales 1:50,000 or larger.

Date(s) aerial images were photographed: Apr 1, 2018—Jun 30, 2018

The orthophoto or other base map on which the soil lines were compiled and digitized probably differs from the background

MAP LEGEND

MAP INFORMATION

imagery displayed on these maps. As a result, some minor shifting of map unit boundaries may be evident.

Table—Hydrologic Soil Group

Map unit symbol	Map unit name	Rating	Acres in AOI	Percent of AOI
Db	Delhi fine sand	A	6.8	22.1%
TuB	Tujunga loamy sand, 0 to 5 percent slopes	A	23.8	77.9%
Totals for Area of Interest			30.5	100.0%

Rating Options—Hydrologic Soil Group

Aggregation Method: Dominant Condition

Component Percent Cutoff: None Specified

Tie-break Rule: Higher

References

- American Association of State Highway and Transportation Officials (AASHTO). 2004. Standard specifications for transportation materials and methods of sampling and testing. 24th edition.
- American Society for Testing and Materials (ASTM). 2005. Standard classification of soils for engineering purposes. ASTM Standard D2487-00.
- Cowardin, L.M., V. Carter, F.C. Golet, and E.T. LaRoe. 1979. Classification of wetlands and deep-water habitats of the United States. U.S. Fish and Wildlife Service FWS/OBS-79/31.
- Federal Register. July 13, 1994. Changes in hydric soils of the United States.
- Federal Register. September 18, 2002. Hydric soils of the United States.
- Hurt, G.W., and L.M. Vasilas, editors. Version 6.0, 2006. Field indicators of hydric soils in the United States.
- National Research Council. 1995. Wetlands: Characteristics and boundaries.
- Soil Survey Division Staff. 1993. Soil survey manual. Soil Conservation Service. U.S. Department of Agriculture Handbook 18. http://www.nrcs.usda.gov/wps/portal/nrcs/detail/national/soils/?cid=nrcs142p2_054262
- Soil Survey Staff. 1999. Soil taxonomy: A basic system of soil classification for making and interpreting soil surveys. 2nd edition. Natural Resources Conservation Service, U.S. Department of Agriculture Handbook 436. http://www.nrcs.usda.gov/wps/portal/nrcs/detail/national/soils/?cid=nrcs142p2_053577
- Soil Survey Staff. 2010. Keys to soil taxonomy. 11th edition. U.S. Department of Agriculture, Natural Resources Conservation Service. http://www.nrcs.usda.gov/wps/portal/nrcs/detail/national/soils/?cid=nrcs142p2_053580
- Tiner, R.W., Jr. 1985. Wetlands of Delaware. U.S. Fish and Wildlife Service and Delaware Department of Natural Resources and Environmental Control, Wetlands Section.
- United States Army Corps of Engineers, Environmental Laboratory. 1987. Corps of Engineers wetlands delineation manual. Waterways Experiment Station Technical Report Y-87-1.
- United States Department of Agriculture, Natural Resources Conservation Service. National forestry manual. http://www.nrcs.usda.gov/wps/portal/nrcs/detail/soils/home/?cid=nrcs142p2_053374
- United States Department of Agriculture, Natural Resources Conservation Service. National range and pasture handbook. <http://www.nrcs.usda.gov/wps/portal/nrcs/detail/national/landuse/rangepasture/?cid=stelprdb1043084>

Custom Soil Resource Report

United States Department of Agriculture, Natural Resources Conservation Service. National soil survey handbook, title 430-VI. http://www.nrcs.usda.gov/wps/portal/nrcs/detail/soils/scientists/?cid=nrcs142p2_054242

United States Department of Agriculture, Natural Resources Conservation Service. 2006. Land resource regions and major land resource areas of the United States, the Caribbean, and the Pacific Basin. U.S. Department of Agriculture Handbook 296. http://www.nrcs.usda.gov/wps/portal/nrcs/detail/national/soils/?cid=nrcs142p2_053624

United States Department of Agriculture, Soil Conservation Service. 1961. Land capability classification. U.S. Department of Agriculture Handbook 210. http://www.nrcs.usda.gov/Internet/FSE_DOCUMENTS/nrcs142p2_052290.pdf

SECTION 6.4.5
NOAA PRECIPITATION ESTIMATES AND STORMWATER REPORT



NOAA Atlas 14, Volume 6, Version 2
 Location name: **Bloomington, California, USA***
 Latitude: **34.0535°**, Longitude: **-117.4117°**
 Elevation: **1036.19 ft****
 * source: ESRI Maps
 ** source: USGS



POINT PRECIPITATION FREQUENCY ESTIMATES

Sanja Perica, Sarah Dietz, Sarah Heim, Lillian Hiner, Kazungu Maitaria, Deborah Martin, Sandra Pavlovic, Ishani Roy, Carl Trypaluk, Dale Unruh, Fenglin Yan, Michael Yekta, Tan Zhao, Geoffrey Bonnin, Daniel Brewer, Li-Chuan Chen, Tye Parzybok, John Yarchoan

NOAA, National Weather Service, Silver Spring, Maryland

[PF_tabular](#) | [PF_graphical](#) | [Maps_&_aerials](#)

PF tabular

PDS-based point precipitation frequency estimates with 90% confidence intervals (in inches)¹										
Duration	Average recurrence interval (years)									
	1	2	5	10	25	50	100	200	500	1000
5-min	0.107 (0.089-0.129)	0.138 (0.115-0.167)	0.180 (0.149-0.219)	0.215 (0.177-0.264)	0.264 (0.210-0.336)	0.303 (0.236-0.393)	0.343 (0.260-0.457)	0.386 (0.285-0.529)	0.447 (0.315-0.639)	0.496 (0.338-0.735)
10-min	0.153 (0.127-0.185)	0.198 (0.165-0.240)	0.258 (0.214-0.314)	0.308 (0.254-0.378)	0.379 (0.301-0.481)	0.434 (0.338-0.564)	0.492 (0.373-0.655)	0.554 (0.408-0.759)	0.640 (0.452-0.916)	0.711 (0.484-1.05)
15-min	0.185 (0.154-0.224)	0.239 (0.199-0.290)	0.312 (0.259-0.380)	0.373 (0.307-0.458)	0.458 (0.364-0.582)	0.525 (0.408-0.682)	0.595 (0.451-0.792)	0.670 (0.493-0.918)	0.774 (0.547-1.11)	0.859 (0.585-1.27)
30-min	0.275 (0.230-0.334)	0.357 (0.297-0.433)	0.465 (0.386-0.566)	0.556 (0.458-0.683)	0.683 (0.543-0.867)	0.783 (0.609-1.02)	0.888 (0.673-1.18)	0.999 (0.736-1.37)	1.16 (0.815-1.65)	1.28 (0.873-1.90)
60-min	0.403 (0.336-0.488)	0.521 (0.434-0.633)	0.680 (0.565-0.828)	0.813 (0.669-0.998)	0.998 (0.793-1.27)	1.15 (0.890-1.49)	1.30 (0.984-1.73)	1.46 (1.08-2.00)	1.69 (1.19-2.42)	1.87 (1.28-2.78)
2-hr	0.591 (0.492-0.716)	0.758 (0.631-0.920)	0.980 (0.813-1.19)	1.16 (0.956-1.43)	1.41 (1.12-1.79)	1.61 (1.25-2.08)	1.81 (1.37-2.40)	2.01 (1.48-2.76)	2.30 (1.63-3.30)	2.53 (1.73-3.76)
3-hr	0.737 (0.614-0.893)	0.944 (0.786-1.15)	1.22 (1.01-1.48)	1.44 (1.18-1.76)	1.74 (1.38-2.21)	1.97 (1.53-2.56)	2.21 (1.68-2.94)	2.46 (1.81-3.37)	2.80 (1.97-4.00)	3.07 (2.09-4.54)
6-hr	1.04 (0.866-1.26)	1.33 (1.11-1.62)	1.71 (1.42-2.08)	2.02 (1.66-2.48)	2.43 (1.94-3.09)	2.75 (2.14-3.57)	3.07 (2.33-4.09)	3.40 (2.51-4.66)	3.85 (2.72-5.50)	4.20 (2.86-6.22)
12-hr	1.38 (1.15-1.67)	1.78 (1.48-2.16)	2.30 (1.91-2.79)	2.71 (2.23-3.33)	3.26 (2.59-4.14)	3.68 (2.86-4.78)	4.10 (3.11-5.46)	4.53 (3.34-6.20)	5.10 (3.60-7.30)	5.55 (3.78-8.22)
24-hr	1.84 (1.63-2.13)	2.41 (2.13-2.78)	3.13 (2.76-3.62)	3.71 (3.24-4.32)	4.48 (3.79-5.40)	5.06 (4.20-6.22)	5.64 (4.57-7.10)	6.23 (4.91-8.07)	7.02 (5.31-9.47)	7.63 (5.58-10.6)
2-day	2.24 (1.98-2.58)	2.98 (2.63-3.44)	3.93 (3.47-4.55)	4.70 (4.11-5.49)	5.74 (4.86-6.92)	6.53 (5.42-8.03)	7.33 (5.94-9.23)	8.14 (6.42-10.5)	9.24 (7.00-12.5)	10.1 (7.39-14.1)
3-day	2.40 (2.13-2.77)	3.25 (2.87-3.75)	4.34 (3.83-5.03)	5.24 (4.59-6.11)	6.46 (5.47-7.79)	7.40 (6.14-9.10)	8.35 (6.77-10.5)	9.34 (7.36-12.1)	10.7 (8.08-14.4)	11.7 (8.58-16.4)
4-day	2.58 (2.29-2.98)	3.53 (3.12-4.07)	4.76 (4.20-5.51)	5.77 (5.05-6.73)	7.15 (6.06-8.62)	8.23 (6.83-10.1)	9.32 (7.55-11.7)	10.5 (8.24-13.5)	12.0 (9.09-16.2)	13.2 (9.68-18.5)
7-day	2.96 (2.62-3.41)	4.08 (3.61-4.71)	5.56 (4.91-6.44)	6.78 (5.93-7.91)	8.46 (7.16-10.2)	9.77 (8.10-12.0)	11.1 (9.00-14.0)	12.5 (9.86-16.2)	14.4 (10.9-19.5)	16.0 (11.7-22.3)
10-day	3.21 (2.84-3.70)	4.46 (3.94-5.15)	6.11 (5.39-7.07)	7.48 (6.54-8.72)	9.36 (7.93-11.3)	10.8 (8.99-13.3)	12.4 (10.0-15.6)	14.0 (11.0-18.1)	16.2 (12.2-21.8)	17.9 (13.1-25.0)
20-day	3.88 (3.43-4.47)	5.43 (4.80-6.27)	7.51 (6.62-8.69)	9.25 (8.09-10.8)	11.7 (9.88-14.1)	13.6 (11.3-16.7)	15.6 (12.6-19.6)	17.7 (13.9-22.9)	20.6 (15.6-27.8)	23.0 (16.8-32.1)
30-day	4.59 (4.06-5.29)	6.43 (5.69-7.42)	8.91 (7.86-10.3)	11.0 (9.62-12.8)	13.9 (11.8-16.8)	16.3 (13.5-20.0)	18.7 (15.2-23.6)	21.3 (16.8-27.6)	25.0 (18.9-33.7)	28.0 (20.5-39.1)
45-day	5.48 (4.85-6.32)	7.62 (6.73-8.79)	10.5 (9.28-12.2)	13.0 (11.4-15.1)	16.4 (13.9-19.8)	19.2 (16.0-23.7)	22.2 (18.0-28.0)	25.4 (20.0-32.9)	30.0 (22.7-40.4)	33.7 (24.6-47.0)
60-day	6.41 (5.67-7.39)	8.81 (7.79-10.2)	12.1 (10.7-14.0)	14.9 (13.0-17.4)	18.9 (16.0-22.7)	22.1 (18.3-27.2)	25.5 (20.7-32.1)	29.2 (23.0-37.8)	34.6 (26.2-46.6)	39.0 (28.5-54.4)

¹ Precipitation frequency (PF) estimates in this table are based on frequency analysis of partial duration series (PDS). Numbers in parenthesis are PF estimates at lower and upper bounds of the 90% confidence interval. The probability that precipitation frequency estimates (for a given duration and average recurrence interval) will be greater than the upper bound (or less than the lower bound) is 5%. Estimates at upper bounds are not checked against probable maximum precipitation (PMP) estimates and may be higher than currently valid PMP values. Please refer to NOAA Atlas 14 document for more information.

[Back to Top](#)

PF graphical

PDS-based depth-duration-frequency (DDF) curves
 Latitude: 34.0535°, Longitude: -117.4117°

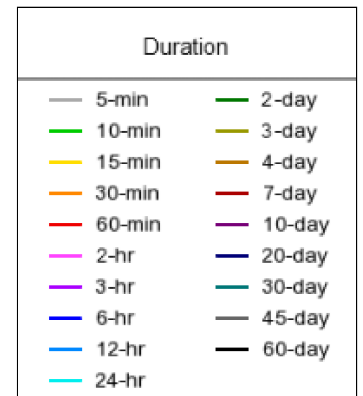
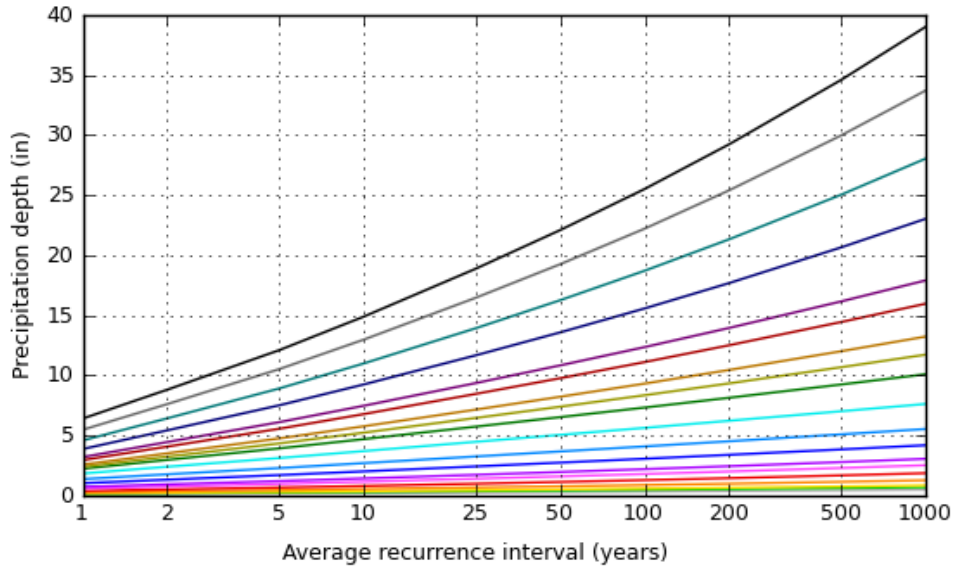
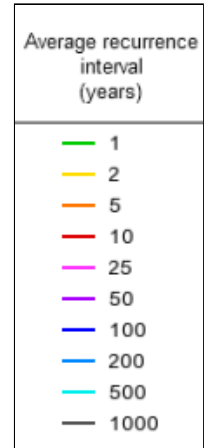
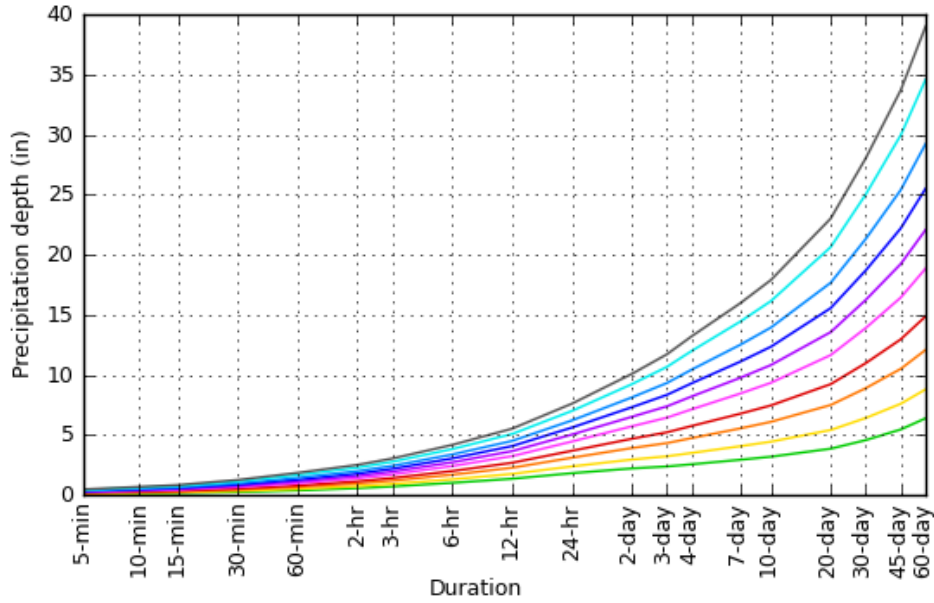

[Back to Top](#)

Maps & aerials

Small scale terrain

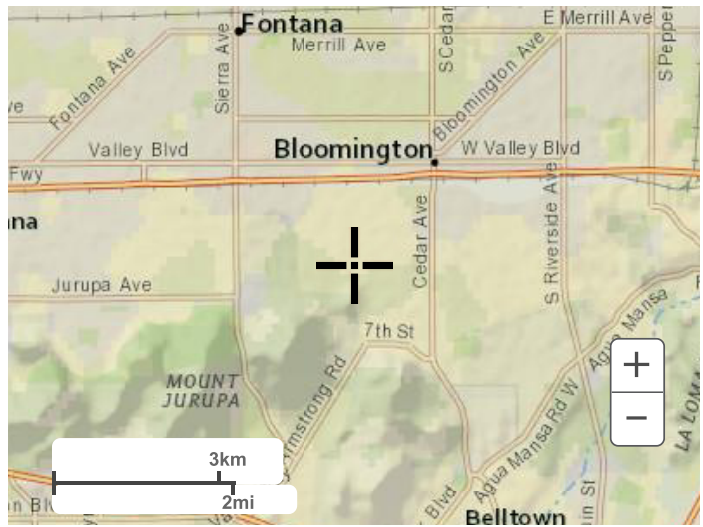

Large scale terrain



Large scale map



Large scale aerial



[Back to Top](#)

[US Department of Commerce](#)
[National Oceanic and Atmospheric Administration](#)
[National Weather Service](#)
[National Water Center](#)
1325 East West Highway
Silver Spring, MD 20910
Questions?: HDSC.Questions@noaa.gov

[Disclaimer](#)

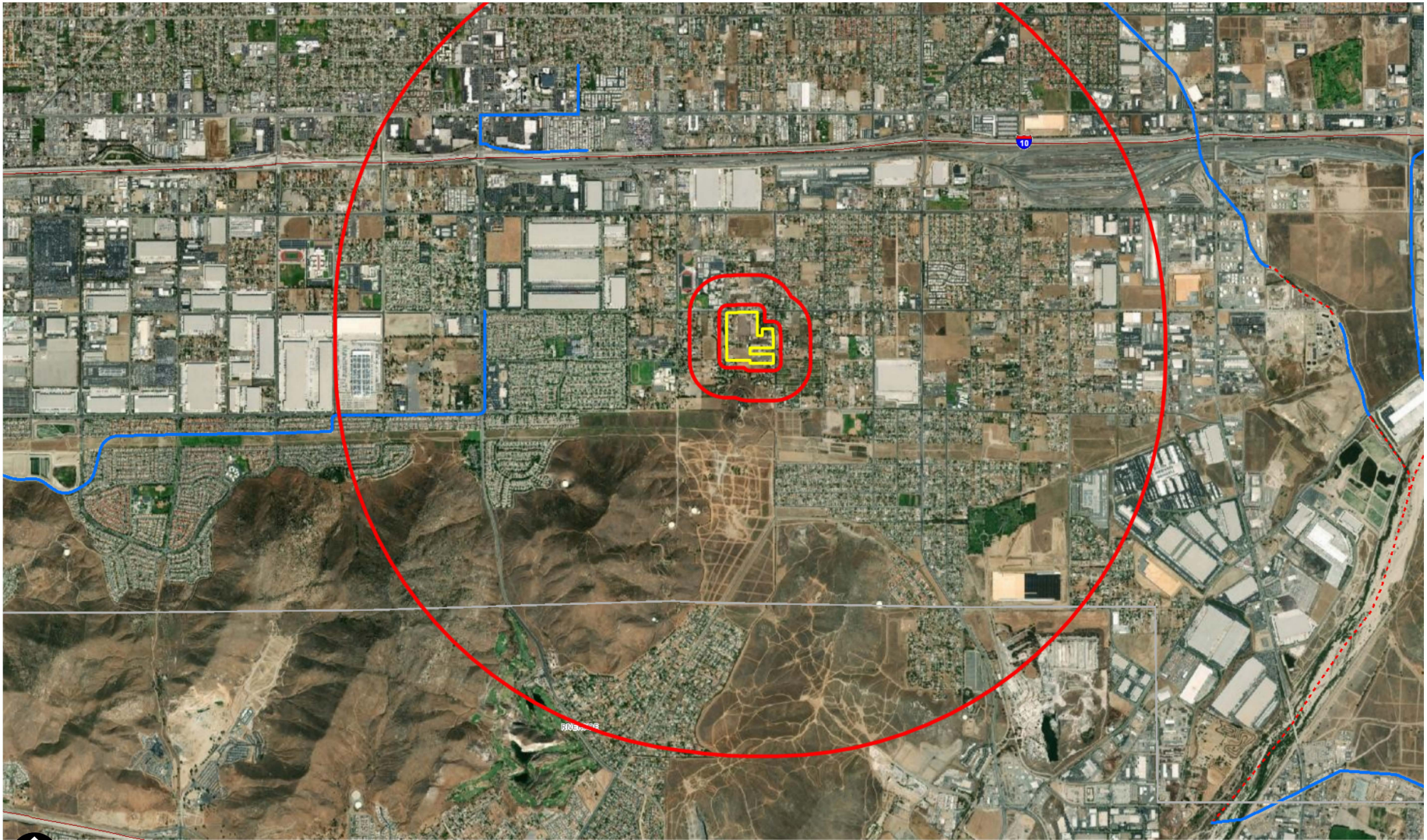

1 Miles



Site Address: permittrack.sbcounty.gov/wap

County of San Bernardino
Stormwater Facility Mapping
Stormwater Map



WQMP Project Report

County of San Bernardino Stormwater Program

Santa Ana River Watershed Geodatabase

Thursday, March 11, 2021

Note: The information provided in this report and on the Stormwater Geodatabase for the County of San Bernardino Stormwater Program is intended to provide basic guidance in the preparation of the applicant's Water Quality Management Plan (WQMP) and should not be relied upon without independent verification.

Project Site Parcel Number(s):	025610102, 025610157, 025610149, 025610134, 025610160, 025610145, 025610135, 025610103, 025610148, 025610158, 025610111, 025610112, 025610110, 025610136, 025610114, 025610115
Project Site Acreage:	30.882
HCOC Exempt Area:	Yes. Verify that the project is completely with the HCOC exemption area.
Closest Receiving Waters: <small>(Applicant to verify based on local drainage facilities and topography.)</small>	System Number - Facility Name - Mulberry Channel Owner - SBCFCD
Closest channel segment's susceptibility to Hydromodification:	EHM
Highest downstream hydromodification susceptibility:	EHM
Is this drainage segment subject to TMDLs?	No
Are there downstream drainage segments subject to TMDLs?	No
Is this drainage segment a 303d listed stream?	No
Are there 303d listed streams downstream?	No
Are there unlined downstream waterbodies?	No
Project Site Onsite Soil Group(s):	A
Environmentally Sensitive Areas within 200':	DELHI SANDS
Groundwater Depth (FT):	-230
Parcels with potential septic tanks within 1000':	No
Known Groundwater Contamination Plumes within 1000':	No
Studies and Reports Related to Project Site:	Chino Basin Recharge Master Plan Chino Basin Water Master 32nd Annual Report Cactus Basin CSDP 3-3 Rialto Channel Drainage Area Volume I CSDP 3-3 Rialto Channel Drainage Area Volume II CSDP 3-3 Rialto Channel Drainage Area Volume III CSDP 3-3 Rialto Channel Drainage Area Volume I CSDP 3-3 Rialto Channel Drainage Area Volume IV CSDP 3-3 Rialto Channel Drainage Area Volume V CSDP 3-4 100yr Hydrology Update CSDP 3-4 Engineers Report Volume 1 CSDP 3-4 Hydrology Study West Portion Only CSDP 3-4 Hydrology Study East Portion CSDP 3 CALC SHEET FOR HYDRO CSDP 3-3 Rialto Channel Drain Area Draft Hydrology Study Project 3-4 East Portion Hydrology Study Project 3-4 West portion Only Project #3-4 100yr Hydrology Update Sept1997 San Sevaine - Boyle Map 0001 San Sevaine - Boyle Map 0002 San Sevaine - Boyle Map 0003 SBCounty CSDP Project No.2 Volume 1 SBCounty CSDP Project No.2 Volume 2 Volume 2 Map SBCounty CSDP Project No.3 Volume I SBCounty CSDP Project No.3 Volume II SBVMWD High Groundwater / Pressure Zone Area

SECTION 6.4.6
BMP EDUCATIONAL MATERIALS/FACT SHEETS

Spill Prevention, Control & Cleanup SC-11



Objectives

- Cover
- Contain
- Educate
- Reduce/Minimize
- Product Substitution

Description

Spills and leaks, if not properly controlled, can adversely impact the storm drain system and receiving waters. Due to the type of work or the materials involved, many activities that occur either at a municipal facility or as a part of municipal field programs have the potential for accidental spills and leaks. Proper spill response planning and preparation can enable municipal employees to effectively respond to problems when they occur and minimize the discharge of pollutants to the environment.

Approach

- An effective spill response and control plan should include:
 - Spill/leak prevention measures;
 - Spill response procedures;
 - Spill cleanup procedures;
 - Reporting; and
 - Training
- A well thought out and implemented plan can prevent pollutants from entering the storm drainage system and can be used as a tool for training personnel to prevent and control future spills as well.

Pollution Prevention

- Develop and implement a Spill Prevention Control and Response Plan. The plan should include:

Targeted Constituents

Sediment	
Nutrients	☑
Trash	
Metals	☑
Bacteria	
Oil and Grease	☑
Organics	☑
Oxygen Demanding	☑



SC-11 Spill Prevention, Control & Cleanup

- A description of the facility, the address, activities and materials involved
- Identification of key spill response personnel
- Identification of the potential spill areas or operations prone to spills/leaks
- Identification of which areas should be or are bermed to contain spills/leaks
- Facility map identifying the key locations of areas, activities, materials, structural BMPs, etc.
- Material handling procedures
- Spill response procedures including:
 - Assessment of the site and potential impacts
 - Containment of the material
 - Notification of the proper personnel and evacuation procedures
 - Clean up of the site
 - Disposal of the waste material and
 - Proper record keeping
- Product substitution – use less toxic materials (i.e. use water based paints instead of oil based paints)
- Recycle, reclaim, or reuse materials whenever possible. This will reduce the amount of materials that are brought into the facility or into the field.

Suggested Protocols

Spill/Leak Prevention Measures

- If possible, move material handling indoors, under cover, or away from storm drains or sensitive water bodies.
- Properly label all containers so that the contents are easily identifiable.
- Berm storage areas so that if a spill or leak occurs, the material is contained.
- Cover outside storage areas either with a permanent structure or with a seasonal one such as a tarp so that rain can not come into contact with the materials.
- Check containers (and any containment sumps) often for leaks and spills. Replace containers that are leaking, corroded, or otherwise deteriorating with containers in good condition. Collect all spilled liquids and properly dispose of them.

Spill Prevention, Control & Cleanup SC-11

- Store, contain and transfer liquid materials in such a manner that if the container is ruptured or the contents spilled, they will not discharge, flow or be washed into the storm drainage system, surface waters, or groundwater.
- Place drip pans or absorbent materials beneath all mounted taps and at all potential drip and spill locations during the filling and unloading of containers. Any collected liquids or soiled absorbent materials should be reused/recycled or properly disposed of.
- For field programs, only transport the minimum amount of material needed for the daily activities and transfer materials between containers at a municipal yard where leaks and spill are easier to control.
- If paved, sweep and clean storage areas monthly, do not use water to hose down the area unless all of the water will be collected and disposed of properly.
- Install a spill control device (such as a tee section) in any catch basins that collect runoff from any storage areas if the materials stored are oil, gas, or other materials that separate from and float on water. This will allow for easier cleanup if a spill occurs.
- If necessary, protect catch basins while conducting field activities so that if a spill occurs, the material will be contained.

Training

- Educate employees about spill prevention, spill response and cleanup on a routine basis.
- Well-trained employees can reduce human errors that lead to accidental releases or spills:
 - The employees should have the tools and knowledge to immediately begin cleaning up a spill if one should occur.
 - Employees should be familiar with the Spill Prevention Control and Countermeasure Plan if one is available.
- Training of staff from all municipal departments should focus on recognizing and reporting potential or current spills/leaks and who they should contact.
- Employees responsible for aboveground storage tanks and liquid transfers for large bulk containers should be thoroughly familiar with the Spill Prevention Control and Countermeasure Plan and the plan should be readily available.

Spill Response and Prevention

- Identify key spill response personnel and train employees on who they are.
- Store and maintain appropriate spill cleanup materials in a clearly marked location near storage areas; and train employees to ensure familiarity with the site's spill control plan and/or proper spill cleanup procedures.
- Locate spill cleanup materials, such as absorbents, where they will be readily accessible (e.g. near storage and maintenance areas, on field trucks).

SC-11 Spill Prevention, Control & Cleanup

- Follow the Spill Prevention Control and Countermeasure Plan if one is available.
- If a spill occurs, notify the key spill response personnel immediately. If the material is unknown or hazardous, the local fire department may also need to be contacted.
- If safe to do so, attempt to contain the material and block the nearby storm drains so that the area impacted is minimized. If the material is unknown or hazardous wait for properly trained personnel to contain the materials.
- Perform an assessment of the area where the spill occurred and the downstream area that it could impact. Relay this information to the key spill response and clean up personnel.

Spill Cleanup Procedures

- Small non-hazardous spills
 - Use a rag, damp cloth or absorbent materials for general clean up of liquids
 - Use brooms or shovels for the general clean up of dry materials
 - If water is used, it must be collected and properly disposed of. The wash water can not be allowed to enter the storm drain.
 - Dispose of any waste materials properly
 - Clean or dispose of any equipment used to clean up the spill properly
- Large non-hazardous spills
 - Use absorbent materials for general clean up of liquids
 - Use brooms, shovels or street sweepers for the general clean up of dry materials
 - If water is used, it must be collected and properly disposed of. The wash water can not be allowed to enter the storm drain.
 - Dispose of any waste materials properly
 - Clean or dispose of any equipment used to clean up the spill properly
- For hazardous or very large spills, a private cleanup company or Hazmat team may need to be contacted to assess the situation and conduct the cleanup and disposal of the materials.
- Chemical cleanups of material can be achieved with the use of absorbents, gels, and foams. Remove the adsorbent materials promptly and dispose of according to regulations.
- If the spilled material is hazardous, then the used cleanup materials are also hazardous and must be sent to a certified laundry (rags) or disposed of as hazardous waste.

Reporting

- Report any spills immediately to the identified key municipal spill response personnel.

Spill Prevention, Control & Cleanup SC-11

- Report spills in accordance with applicable reporting laws. Spills that pose an immediate threat to human health or the environment must be reported immediately to the Office of Emergency Service (OES)
- Spills that pose an immediate threat to human health or the environment may also need to be reported within 24 hours to the Regional Water Quality Control Board.
- Federal regulations require that any oil spill into a water body or onto an adjoining shoreline be reported to the National Response Center (NRC) at 800-424-8802 (24 hour)
- After the spill has been contained and cleaned up, a detailed report about the incident should be generated and kept on file (see the section on Reporting below). The incident may also be used in briefing staff about proper procedures

Other Considerations

- State regulations exist for facilities with a storage capacity of 10,000 gallons or more of petroleum to prepare a Spill Prevention Control and Countermeasure Plan (SPCC) Plan (Health & Safety Code Chapter 6.67).
- State regulations also exist for storage of hazardous materials (Health & Safety Code Chapter 6.95), including the preparation of area and business plans for emergency response to the releases or threatened releases.
- Consider requiring smaller secondary containment areas (less than 200 sq. ft.) to be connected to the sanitary sewer, if permitted to do so, prohibiting any hard connections to the storm drain.

Requirements

Costs

- Will vary depending on the size of the facility and the necessary controls.
- Prevention of leaks and spills is inexpensive. Treatment and/or disposal of wastes, contaminated soil and water is very expensive

Maintenance

- This BMP has no major administrative or staffing requirements. However, extra time is needed to properly handle and dispose of spills, which results in increased labor costs

Supplemental Information

Further Detail of the BMP

Reporting

Record keeping and internal reporting represent good operating practices because they can increase the efficiency of the response and containment of a spill. A good record keeping system helps the municipality minimize incident recurrence, correctly respond with appropriate containment and cleanup activities, and comply with legal requirements.

A record keeping and reporting system should be set up for documenting spills, leaks, and other discharges, including discharges of hazardous substances in reportable quantities. Incident records describe the quality and quantity of non-stormwater discharges to the storm drain.

SC-11 Spill Prevention, Control & Cleanup

These records should contain the following information:

- Date and time of the incident
- Weather conditions
- Duration of the spill/leak/discharge
- Cause of the spill/leak/discharge
- Response procedures implemented
- Persons notified
- Environmental problems associated with the spill/leak/discharge

Separate record keeping systems should be established to document housekeeping and preventive maintenance inspections, and training activities. All housekeeping and preventive maintenance inspections should be documented. Inspection documentation should contain the following information:

- The date and time the inspection was performed
- Name of the inspector
- Items inspected
- Problems noted
- Corrective action required
- Date corrective action was taken

Other means to document and record inspection results are field notes, timed and dated photographs, videotapes, and drawings and maps.

Examples

The City of Palo Alto includes spill prevention and control as a major element of its highly effective program for municipal vehicle maintenance shops.

References and Resources

King County Stormwater Pollution Control Manual - <http://dnr.metrokc.gov/wlr/dss/spcm.htm>

Orange County Stormwater Program

http://www.ocwatersheds.com/stormwater/swp_introduction.asp

San Diego Stormwater Co-permittees Jurisdictional Urban Runoff Management Program (URMP)

<http://www.projectcleanwater.org/pdf/Model%20Program%20Municipal%20Facilities.pdf>

Parking/Storage Area Maintenance SC-43



Description

Parking lots and storage areas can contribute a number of substances, such as trash, suspended solids, hydrocarbons, oil and grease, and heavy metals that can enter receiving waters through stormwater runoff or non-stormwater discharges. The following protocols are intended to prevent or reduce the discharge of pollutants from parking/storage areas and include using good housekeeping practices, following appropriate cleaning BMPs, and training employees.

Approach

Pollution Prevention

- Encourage alternative designs and maintenance strategies for impervious parking lots. (See New Development and Redevelopment BMP Handbook).
- Keep accurate maintenance logs to evaluate BMP implementation.

Suggested Protocols

General

- Keep the parking and storage areas clean and orderly. Remove debris in a timely fashion.
- Allow sheet runoff to flow into biofilters (vegetated strip and swale) and/or infiltration devices.
- Utilize sand filters or oleophilic collectors for oily waste in low concentrations.

Objectives

- Cover
- Contain
- Educate
- Reduce/Minimize
- Product Substitution

Targeted Constituents

Sediment	<input checked="" type="checkbox"/>
Nutrients	<input checked="" type="checkbox"/>
Trash	<input checked="" type="checkbox"/>
Metals	<input checked="" type="checkbox"/>
Bacteria	<input checked="" type="checkbox"/>
Oil and Grease	<input checked="" type="checkbox"/>
Organics	<input checked="" type="checkbox"/>
Oxygen Demanding	<input checked="" type="checkbox"/>



SC-43 Parking/Storage Area Maintenance

- Arrange rooftop drains to prevent drainage directly onto paved surfaces.
- Design lot to include semi-permeable hardscape.

Controlling Litter

- Post “No Littering” signs and enforce anti-litter laws.
- Provide an adequate number of litter receptacles.
- Clean out and cover litter receptacles frequently to prevent spillage.
- Provide trash receptacles in parking lots to discourage litter.
- Routinely sweep, shovel and dispose of litter in the trash.

Surface cleaning

- Use dry cleaning methods (e.g. sweeping or vacuuming) to prevent the discharge of pollutants into the stormwater conveyance system.
- Establish frequency of public parking lot sweeping based on usage and field observations of waste accumulation.
- Sweep all parking lots at least once before the onset of the wet season.
- If water is used follow the procedures below:
 - Block the storm drain or contain runoff.
 - Wash water should be collected and pumped to the sanitary sewer or discharged to a pervious surface, do not allow wash water to enter storm drains.
 - Dispose of parking lot sweeping debris and dirt at a landfill.
- When cleaning heavy oily deposits:
 - Use absorbent materials on oily spots prior to sweeping or washing.
 - Dispose of used absorbents appropriately.

Surface Repair

- Pre-heat, transfer or load hot bituminous material away from storm drain inlets.
- Apply concrete, asphalt, and seal coat during dry weather to prevent contamination from contacting stormwater runoff.
- Cover and seal nearby storm drain inlets (with waterproof material or mesh) and manholes before applying seal coat, slurry seal, etc., where applicable. Leave covers in place until job is complete and until all water from emulsified oil sealants has drained or evaporated. Clean any debris from these covered manholes and drains for proper disposal.

Parking/Storage Area Maintenance SC-43

- Use only as much water as necessary for dust control, to avoid runoff.
- Catch drips from paving equipment that is not in use with pans or absorbent material placed under the machines. Dispose of collected material and absorbents properly.

Inspection

- Have designated personnel conduct inspections of the parking facilities and stormwater conveyance systems associated with them on a regular basis.
- Inspect cleaning equipment/sweepers for leaks on a regular basis.

Training

- Provide regular training to field employees and/or contractors regarding cleaning of paved areas and proper operation of equipment.
- Train employees and contractors in proper techniques for spill containment and cleanup.

Spill Response and Prevention

- Refer to SC-11, Spill Prevention, Control & Cleanup.
- Keep your Spill Prevention Control and countermeasure (SPCC) plan up-to-date, and implement accordingly.
- Have spill cleanup materials readily available and in a known location.
- Cleanup spills immediately and use dry methods if possible.
- Properly dispose of spill cleanup material.

Other Considerations

- Limitations related to sweeping activities at large parking facilities may include high equipment costs, the need for sweeper operator training, and the inability of current sweeper technology to remove oil and grease.

Requirements

Costs

Cleaning/sweeping costs can be quite large, construction and maintenance of stormwater structural controls can be quite expensive as well.

Maintenance

- Sweep parking lot to minimize cleaning with water.
- Clean out oil/water/sand separators regularly, especially after heavy storms.
- Clean parking facilities on a regular basis to prevent accumulated wastes and pollutants from being discharged into conveyance systems during rainy conditions.

SC-43 Parking/Storage Area Maintenance

Supplemental Information

Further Detail of the BMP

Surface Repair

Apply concrete, asphalt, and seal coat during dry weather to prevent contamination from contacting stormwater runoff. Where applicable, cover and seal nearby storm drain inlets (with waterproof material or mesh) and manholes before applying seal coat, slurry seal, etc. Leave covers in place until job is complete and until all water from emulsified oil sealants has drained or evaporated. Clean any debris from these covered manholes and drains for proper disposal. Use only as much water as necessary for dust control, to avoid runoff.

References and Resources

<http://www.stormwatercenter.net/>

California's Nonpoint Source Program Plan <http://www.swrcb.ca.gov/nps/index.html>

Model Urban Runoff Program: A How-To Guide for Developing Urban Runoff Programs for Small Municipalities. Prepared by City of Monterey, City of Santa Cruz, California Coastal Commission, Monterey Bay National Marine Sanctuary, Association of Monterey Bay Area Governments, Woodward-Clyde, Central Coast Regional Water Quality Control Board. July 1998 (Revised February 2002 by the California Coastal Commission).

Orange County Stormwater Program

http://www.ocwatersheds.com/StormWater/swp_introduction.asp

Oregon Association of Clean Water Agencies. Oregon Municipal Stormwater Toolbox for Maintenance Practices. June 1998.

Pollution from Surface Cleaning Folder. 1996. Bay Area Stormwater Management Agencies Association (BASMAA) <http://www.basma.org>

San Diego Stormwater Co-permittees Jurisdictional Urban Runoff Management Program (URMP)

<http://www.projectcleanwater.org/pdf/Model%20Program%20Municipal%20Facilities.pdf>

Description

Promote efficient and safe housekeeping practices (storage, use, and cleanup) when handling potentially harmful materials such as fertilizers, pesticides, cleaning solutions, paint products, automotive products, and swimming pool chemicals. Related information is provided in BMP fact sheets SC-11 Spill Prevention, Control & Cleanup and SC-34 Waste Handling & Disposal.

Approach

Pollution Prevention

- Purchase only the amount of material that will be needed for foreseeable use. In most cases this will result in cost savings in both purchasing and disposal. See SC-61 Safer Alternative Products for additional information.
- Be aware of new products that may do the same job with less environmental risk and for less or the equivalent cost. Total cost must be used here; this includes purchase price, transportation costs, storage costs, use related costs, clean up costs and disposal costs.

Suggested Protocols

General

- Keep work sites clean and orderly. Remove debris in a timely fashion. Sweep the area.
- Dispose of wash water, sweepings, and sediments, properly.
- Recycle or dispose of fluids properly.
- Establish a daily checklist of office, yard and plant areas to confirm cleanliness and adherence to proper storage and security. Specific employees should be assigned specific inspection responsibilities and given the authority to remedy any problems found.
- Post waste disposal charts in appropriate locations detailing for each waste its hazardous nature (poison, corrosive, flammable), prohibitions on its disposal (dumpster, drain, sewer) and the recommended disposal method (recycle, sewer, burn, storage, landfill).
- Summarize the chosen BMPs applicable to your operation and post them in appropriate conspicuous places.

Objectives

- Cover
- Contain
- Educate
- Reduce/Minimize
- Product Substitution

Targeted Constituents

Sediment	<input checked="" type="checkbox"/>
Nutrients	<input checked="" type="checkbox"/>
Trash	<input checked="" type="checkbox"/>
Metals	<input checked="" type="checkbox"/>
Bacteria	<input checked="" type="checkbox"/>
Oil and Grease	<input checked="" type="checkbox"/>
Organics	<input checked="" type="checkbox"/>
Oxygen Demanding	<input checked="" type="checkbox"/>



- Require a signed checklist from every user of any hazardous material detailing amount taken, amount used, amount returned and disposal of spent material.
- Do a before audit of your site to establish baseline conditions and regular subsequent audits to note any changes and whether conditions are improving or deteriorating.
- Keep records of water, air and solid waste quantities and quality tests and their disposition.
- Maintain a mass balance of incoming, outgoing and on hand materials so you know when there are unknown losses that need to be tracked down and accounted for.
- Use and reward employee suggestions related to BMPs, hazards, pollution reduction, work place safety, cost reduction, alternative materials and procedures, recycling and disposal.
- Have, and review regularly, a contingency plan for spills, leaks, weather extremes etc. Make sure all employees know about it and what their role is so that it comes into force automatically.

Training

- Train all employees, management, office, yard, manufacturing, field and clerical in BMPs and pollution prevention and make them accountable.
- Train municipal employees who handle potentially harmful materials in good housekeeping practices.
- Train personnel who use pesticides in the proper use of the pesticides. The California Department of Pesticide Regulation license pesticide dealers, certify pesticide applicators and conduct onsite inspections.
- Train employees and contractors in proper techniques for spill containment and cleanup. The employee should have the tools and knowledge to immediately begin cleaning up a spill if one should occur.

Spill Response and Prevention

- Refer to SC-11, Spill Prevention, Control & Cleanup.
- Keep your Spill Prevention Control and Countermeasure (SPCC) plan up-to-date, and implement accordingly.
- Have spill cleanup materials readily available and in a known location.
- Cleanup spills immediately and use dry methods if possible.
- Properly dispose of spill cleanup material.

Other Considerations

- There are no major limitations to this best management practice.
- There are no regulatory requirements to this BMP. Existing regulations already require municipalities to properly store, use, and dispose of hazardous materials

Requirements

Costs

- Minimal cost associated with this BMP. Implementation of good housekeeping practices may result in cost savings as these procedures may reduce the need for more costly BMPs.

Maintenance

- Ongoing maintenance required to keep a clean site. Level of effort is a function of site size and type of activities.

Supplemental Information

Further Detail of the BMP

- The California Integrated Waste Management Board's Recycling Hotline, 1-800-553-2962, provides information on household hazardous waste collection programs and facilities.

Examples

There are a number of communities with effective programs. The most pro-active include Santa Clara County and the City of Palo Alto, the City and County of San Francisco, and the Municipality of Metropolitan Seattle (Metro).

References and Resources

British Columbia Lake Stewardship Society. Best Management Practices to Protect Water Quality from Non-Point Source Pollution. March 2000.

<http://www.nalms.org/bclss/bmphome.html#bmp>

King County Stormwater Pollution Control Manual - <http://dnr.metrokc.gov/wlr/dss/spcm.htm>

Model Urban Runoff Program: A How-To Guide for Developing Urban Runoff Programs for Small Municipalities, Prepared by City of Monterey, City of Santa Cruz, California Coastal Commission, Monterey Bay National Marine Sanctuary, Association of Monterey Bay Area Governments, Woodward-Clyde, Central Coast Regional Water Quality Control Board. July, 1998, Revised by California Coastal Commission, February 2002.

Orange County Stormwater Program

http://www.ocwatersheds.com/stormwater/swp_introduction.asp

San Mateo STOPPP - (<http://stoppp.tripod.com/bmp.html>)



Description

Landscape maintenance activities include vegetation removal; herbicide and insecticide application; fertilizer application; watering; and other gardening and lawn care practices. Vegetation control typically involves a combination of chemical (herbicide) application and mechanical methods. All of these maintenance practices have the potential to contribute pollutants to the storm drain system. The major objectives of this BMP are to minimize the discharge of pesticides, herbicides and fertilizers to the storm drain system and receiving waters; prevent the disposal of landscape waste into the storm drain system by collecting and properly disposing of clippings and cuttings, and educating employees and the public.

Approach

Pollution Prevention

- Implement an integrated pest management (IPM) program. IPM is a sustainable approach to managing pests by combining biological, cultural, physical, and chemical tools.
- Choose low water using flowers, trees, shrubs, and groundcover.
- Consider alternative landscaping techniques such as naturescaping and xeriscaping.
- Conduct appropriate maintenance (i.e. properly timed fertilizing, weeding, pest control, and pruning) to help preserve the landscapes water efficiency.

Objectives

- Contain
- Educate
- Reduce/Minimize
- Product Substitution

Targeted Constituents

Sediment	<input checked="" type="checkbox"/>
Nutrients	<input checked="" type="checkbox"/>
Trash	<input checked="" type="checkbox"/>
Metals	
Bacteria	
Oil and Grease	
Organics	
Oxygen Demanding	<input checked="" type="checkbox"/>



- Consider grass cycling (grass cycling is the natural recycling of grass by leaving the clippings on the lawn when mowing. Grass clippings decompose quickly and release valuable nutrients back into the lawn).

Suggested Protocols

Mowing, Trimming, and Weeding

- Whenever possible use mechanical methods of vegetation removal (e.g. mowing with tractor-type or push mowers, hand cutting with gas or electric powered weed trimmers) rather than applying herbicides. Use hand weeding where practical.
- Avoid loosening the soil when conducting mechanical or manual weed control, this could lead to erosion. Use mulch or other erosion control measures when soils are exposed.
- Performing mowing at optimal times. Mowing should not be performed if significant rain events are predicted.
- Mulching mowers may be recommended for certain flat areas. Other techniques may be employed to minimize mowing such as selective vegetative planting using low maintenance grasses and shrubs.
- Collect lawn and garden clippings, pruning waste, tree trimmings, and weeds. Chip if necessary, and compost or dispose of at a landfill (see waste management section of this fact sheet).
- Place temporarily stockpiled material away from watercourses, and berm or cover stockpiles to prevent material releases to storm drains.

Planting

- Determine existing native vegetation features (location, species, size, function, importance) and consider the feasibility of protecting them. Consider elements such as their effect on drainage and erosion, hardiness, maintenance requirements, and possible conflicts between preserving vegetation and the resulting maintenance needs.
- Retain and/or plant selected native vegetation whose features are determined to be beneficial, where feasible. Native vegetation usually requires less maintenance (e.g., irrigation, fertilizer) than planting new vegetation.
- Consider using low water use groundcovers when planting or replanting.

Waste Management

- Compost leaves, sticks, or other collected vegetation or dispose of at a permitted landfill. Do not dispose of collected vegetation into waterways or storm drainage systems.
- Place temporarily stockpiled material away from watercourses and storm drain inlets, and berm or cover stockpiles to prevent material releases to the storm drain system.
- Reduce the use of high nitrogen fertilizers that produce excess growth requiring more frequent mowing or trimming.

- Avoid landscape wastes in and around storm drain inlets by either using bagging equipment or by manually picking up the material.

Irrigation

- Where practical, use automatic timers to minimize runoff.
- Use popup sprinkler heads in areas with a lot of activity or where there is a chance the pipes may be broken. Consider the use of mechanisms that reduce water flow to sprinkler heads if broken.
- Ensure that there is no runoff from the landscaped area(s) if re-claimed water is used for irrigation.
- If bailing of muddy water is required (e.g. when repairing a water line leak), do not put it in the storm drain; pour over landscaped areas.
- Irrigate slowly or pulse irrigate to prevent runoff and then only irrigate as much as is needed.
- Apply water at rates that do not exceed the infiltration rate of the soil.

Fertilizer and Pesticide Management

- Utilize a comprehensive management system that incorporates integrated pest management (IPM) techniques. There are many methods and types of IPM, including the following:
 - Mulching can be used to prevent weeds where turf is absent, fencing installed to keep rodents out, and netting used to keep birds and insects away from leaves and fruit.
 - Visible insects can be removed by hand (with gloves or tweezers) and placed in soapy water or vegetable oil. Alternatively, insects can be sprayed off the plant with water or in some cases vacuumed off of larger plants.
 - Store-bought traps, such as species-specific, pheromone-based traps or colored sticky cards, can be used.
 - Slugs can be trapped in small cups filled with beer that are set in the ground so the slugs can get in easily.
 - In cases where microscopic parasites, such as bacteria and fungi, are causing damage to plants, the affected plant material can be removed and disposed of (pruning equipment should be disinfected with bleach to prevent spreading the disease organism).
 - Small mammals and birds can be excluded using fences, netting, tree trunk guards.
 - Beneficial organisms, such as bats, birds, green lacewings, ladybugs, praying mantis, ground beetles, parasitic nematodes, trichogramma wasps, seed head weevils, and spiders that prey on detrimental pest species can be promoted.
- Follow all federal, state, and local laws and regulations governing the use, storage, and disposal of fertilizers and pesticides and training of applicators and pest control advisors.

- Use pesticides only if there is an actual pest problem (not on a regular preventative schedule).
- Do not use pesticides if rain is expected. Apply pesticides only when wind speeds are low (less than 5 mph).
- Do not mix or prepare pesticides for application near storm drains.
- Prepare the minimum amount of pesticide needed for the job and use the lowest rate that will effectively control the pest.
- Employ techniques to minimize off-target application (e.g. spray drift) of pesticides, including consideration of alternative application techniques.
- Fertilizers should be worked into the soil rather than dumped or broadcast onto the surface.
- Calibrate fertilizer and pesticide application equipment to avoid excessive application.
- Periodically test soils for determining proper fertilizer use.
- Sweep pavement and sidewalk if fertilizer is spilled on these surfaces before applying irrigation water.
- Purchase only the amount of pesticide that you can reasonably use in a given time period (month or year depending on the product).
- Triple rinse containers, and use rinse water as product. Dispose of unused pesticide as hazardous waste.
- Dispose of empty pesticide containers according to the instructions on the container label.

Inspection

- Inspect irrigation system periodically to ensure that the right amount of water is being applied and that excessive runoff is not occurring. Minimize excess watering, and repair leaks in the irrigation system as soon as they are observed.
- Inspect pesticide/fertilizer equipment and transportation vehicles daily.

Training

- Educate and train employees on use of pesticides and in pesticide application techniques to prevent pollution. Pesticide application must be under the supervision of a California qualified pesticide applicator.
- Train/encourage municipal maintenance crews to use IPM techniques for managing public green areas.
- Annually train employees within departments responsible for pesticide application on the appropriate portions of the agency's IPM Policy, SOPs, and BMPs, and the latest IPM techniques.

- Employees who are not authorized and trained to apply pesticides should be periodically (at least annually) informed that they cannot use over-the-counter pesticides in or around the workplace.
- Use a training log or similar method to document training.

Spill Response and Prevention

- Refer to SC-11, Spill Prevention, Control & Cleanup
- Have spill cleanup materials readily available and in a known location
- Cleanup spills immediately and use dry methods if possible.
- Properly dispose of spill cleanup material.

Other Considerations

- The Federal Pesticide, Fungicide, and Rodenticide Act and California Title 3, Division 6, Pesticides and Pest Control Operations place strict controls over pesticide application and handling and specify training, annual refresher, and testing requirements. The regulations generally cover: a list of approved pesticides and selected uses, updated regularly; general application information; equipment use and maintenance procedures; and record keeping. The California Department of Pesticide Regulations and the County Agricultural Commission coordinate and maintain the licensing and certification programs. All public agency employees who apply pesticides and herbicides in “agricultural use” areas such as parks, golf courses, rights-of-way and recreation areas should be properly certified in accordance with state regulations. Contracts for landscape maintenance should include similar requirements.
- All employees who handle pesticides should be familiar with the most recent material safety data sheet (MSDS) files.
- Municipalities do not have the authority to regulate the use of pesticides by school districts, however the California Healthy Schools Act of 2000 (AB 2260) has imposed requirements on California school districts regarding pesticide use in schools. Posting of notification prior to the application of pesticides is now required, and IPM is stated as the preferred approach to pest management in schools.

Requirements

Costs

Additional training of municipal employees will be required to address IPM techniques and BMPs. IPM methods will likely increase labor cost for pest control which may be offset by lower chemical costs.

Maintenance

Not applicable

Supplemental Information***Further Detail of the BMP******Waste Management***

Composting is one of the better disposal alternatives if locally available. Most municipalities either have or are planning yard waste composting facilities as a means of reducing the amount of waste going to the landfill. Lawn clippings from municipal maintenance programs as well as private sources would probably be compatible with most composting facilities

Contractors and Other Pesticide Users

Municipal agencies should develop and implement a process to ensure that any contractor employed to conduct pest control and pesticide application on municipal property engages in pest control methods consistent with the IPM Policy adopted by the agency. Specifically, municipalities should require contractors to follow the agency's IPM policy, SOPs, and BMPs; provide evidence to the agency of having received training on current IPM techniques when feasible; provide documentation of pesticide use on agency property to the agency in a timely manner.

References and Resources

King County Stormwater Pollution Control Manual. Best Management Practices for Businesses. 1995. King County Surface Water Management. July. On-line: <http://dnr.metrokc.gov/wlr/dss/spcm.htm>

Los Angeles County Stormwater Quality Model Programs. Public Agency Activities http://ladpw.org/wmd/npdes/model_links.cfm

Model Urban Runoff Program: A How-To Guide for Developing Urban Runoff Programs for Small Municipalities. Prepared by City of Monterey, City of Santa Cruz, California Coastal Commission, Monterey Bay National Marine Sanctuary, Association of Monterey Bay Area Governments, Woodward-Clyde, Central Coast Regional Water Quality Control Board. July. 1998.

Orange County Stormwater Program

http://www.ocwatersheds.com/StormWater/swp_introduction.asp

Santa Clara Valley Urban Runoff Pollution Prevention Program. 1997 Urban Runoff Management Plan. September 1997, updated October 2000.

United States Environmental Protection Agency (USEPA). 2002. Pollution Prevention/Good Housekeeping for Municipal Operations Landscaping and Lawn Care. Office of Water. Office of Wastewater Management. On-line: http://www.epa.gov/npdes/menuofbmps/poll_8.htm



Photo Credit: Geoff Brosseau

Objectives

- Contain
- Educate
- Reduce/Minimize

Description

As a consequence of its function, the stormwater conveyance system collects and transports urban runoff that may contain certain pollutants. Maintaining catch basins, stormwater inlets, and other stormwater conveyance structures on a regular basis will remove pollutants, prevent clogging of the downstream conveyance system, restore catch basins' sediment trapping capacity, and ensure the system functions properly hydraulically to avoid flooding.

Approach

Suggested Protocols

Catch Basins/Inlet Structures

- Municipal staff should regularly inspect facilities to ensure the following:
 - Immediate repair of any deterioration threatening structural integrity.
 - Cleaning before the sump is 40% full. Catch basins should be cleaned as frequently as needed to meet this standard.
 - Stenciling of catch basins and inlets (see SC-75 Waste Handling and Disposal).
- Clean catch basins, storm drain inlets, and other conveyance structures in high pollutant load areas just before the wet season to remove sediments and debris accumulated during the summer.

Targeted Constituents

Sediment	<input checked="" type="checkbox"/>
Nutrients	<input checked="" type="checkbox"/>
Trash	<input checked="" type="checkbox"/>
Metals	<input checked="" type="checkbox"/>
Bacteria	<input checked="" type="checkbox"/>
Oil and Grease	<input checked="" type="checkbox"/>
Organics	<input checked="" type="checkbox"/>
Oxygen Demanding	<input checked="" type="checkbox"/>



SC-74 Drainage System Maintenance

- Conduct inspections more frequently during the wet season for problem areas where sediment or trash accumulates more often. Clean and repair as needed.
- Keep accurate logs of the number of catch basins cleaned.
- Record the amount of waste collected.
- Store wastes collected from cleaning activities of the drainage system in appropriate containers or temporary storage sites in a manner that prevents discharge to the storm drain.
- Dewater the wastes with outflow into the sanitary sewer if permitted. Water should be treated with an appropriate filtering device prior to discharge to the sanitary sewer. If discharge to the sanitary sewer is not allowed, water should be pumped or vacuumed to a tank and properly disposed of. Do not dewater near a storm drain or stream.
- Except for small communities with relatively few catch basins that may be cleaned manually, most municipalities will require mechanical cleaners such as eductors, vacuums, or bucket loaders.

Storm Drain Conveyance System

- Locate reaches of storm drain with deposit problems and develop a flushing schedule that keeps the pipe clear of excessive buildup.
- Collect flushed effluent and pump to the sanitary sewer for treatment.

Pump Stations

- Clean all storm drain pump stations prior to the wet season to remove silt and trash.
- Do not allow discharge from cleaning a storm drain pump station or other facility to reach the storm drain system.
- Conduct quarterly routine maintenance at each pump station.
- Inspect, clean, and repair as necessary all outlet structures prior to the wet season.
- Sample collected sediments to determine if landfill disposal is possible, or illegal discharges in the watershed are occurring.

Open Channel

- Consider modification of storm channel characteristics to improve channel hydraulics, to increase pollutant removals, and to enhance channel/creek aesthetic and habitat value.
- Conduct channel modification/improvement in accordance with existing laws. Any person, government agency, or public utility proposing an activity that will change the natural (emphasis added) state of any river, stream, or lake in California, must enter into a stream or Lake Alteration Agreement with the Department of Fish and Game. The developer-applicant should also contact local governments (city, county, special districts), other state agencies

(SWRCB, RWQCB, Department of Forestry, Department of Water Resources), and Federal Corps of Engineers and USFWS

Illicit Connections and Discharges

- During routine maintenance of conveyance system and drainage structures field staff should look for evidence of illegal discharges or illicit connections:
 - Is there evidence of spills such as paints, discoloring, etc.
 - Are there any odors associated with the drainage system
 - Record locations of apparent illegal discharges/illicit connections
 - Track flows back to potential dischargers and conduct aboveground inspections. This can be done through visual inspection of up gradient manholes or alternate techniques including zinc chloride smoke testing, fluorometric dye testing, physical inspection testing, or television camera inspection.
 - Once the origin of flow is established, require illicit discharger to eliminate the discharge.
- Stencil storm drains, where applicable, to prevent illegal disposal of pollutants. Storm drain inlets should have messages such as “Dump No Waste Drains to Stream” stenciled next to them to warn against ignorant or intentional dumping of pollutants into the storm drainage system.
- Refer to fact sheet SC-10 Non-Stormwater Discharges.

Illegal Dumping

- Regularly inspect and clean up hot spots and other storm drainage areas where illegal dumping and disposal occurs.
- Establish a system for tracking incidents. The system should be designed to identify the following:
 - Illegal dumping hot spots
 - Types and quantities (in some cases) of wastes
 - Patterns in time of occurrence (time of day/night, month, or year)
 - Mode of dumping (abandoned containers, “midnight dumping” from moving vehicles, direct dumping of materials, accidents/spills)
 - Responsible parties
- Post “No Dumping” signs in problem areas with a phone number for reporting dumping and disposal. Signs should also indicate fines and penalties for illegal dumping.
- Refer to fact sheet SC-10 Non-Stormwater Discharges.

- The State Department of Fish and Game has a hotline for reporting violations called Cal TIP (1-800-952-5400). The phone number may be used to report any violation of a Fish and Game code (illegal dumping, poaching, etc.).
- The California Department of Toxic Substances Control's Waste Alert Hotline, 1-800-69TOXIC, can be used to report hazardous waste violations.

Training

- Train crews in proper maintenance activities, including record keeping and disposal.
- Only properly trained individuals are allowed to handle hazardous materials/wastes.
- Train municipal employees from all departments (public works, utilities, street cleaning, parks and recreation, industrial waste inspection, hazardous waste inspection, sewer maintenance) to recognize and report illegal dumping.
- Train municipal employees and educate businesses, contractors, and the general public in proper and consistent methods for disposal.
- Train municipal staff regarding non-stormwater discharges (See SC-10 Non-Stormwater Discharges).

Spill Response and Prevention

- Refer to SC-11, Prevention, Control & Cleanup
- Have spill cleanup materials readily available and in a known location.
- Cleanup spills immediately and use dry methods if possible.
- Properly dispose of spill cleanup material.

Other Considerations

- Cleanup activities may create a slight disturbance for local aquatic species. Access to items and material on private property may be limited. Trade-offs may exist between channel hydraulics and water quality/riparian habitat. If storm channels or basins are recognized as wetlands, many activities, including maintenance, may be subject to regulation and permitting.
- Storm drain flushing is most effective in small diameter pipes (36-inch diameter pipe or less, depending on water supply and sediment collection capacity). Other considerations associated with storm drain flushing may include the availability of a water source, finding a downstream area to collect sediments, liquid/sediment disposal, and disposal of flushed effluent to sanitary sewer may be prohibited in some areas.
- Regulations may include adoption of substantial penalties for illegal dumping and disposal.
- Municipal codes should include sections prohibiting the discharge of soil, debris, refuse, hazardous wastes, and other pollutants into the storm drain system.
- Private property access rights may be needed to track illegal discharges up gradient.

- Requirements of municipal ordinance authority for suspected source verification testing for illicit connections necessary for guaranteed rights of entry.

Requirements

Costs

- An aggressive catch basin cleaning program could require a significant capital and O&M budget. A careful study of cleaning effectiveness should be undertaken before increased cleaning is implemented. Catch basin cleaning costs are less expensive if vacuum street sweepers are available; cleaning catch basins manually can cost approximately twice as much as cleaning the basins with a vacuum attached to a sweeper.
- Methods used for illicit connection detection (smoke testing, dye testing, visual inspection, and flow monitoring) can be costly and time-consuming. Site-specific factors, such as the level of impervious area, the density and ages of buildings, and type of land use will determine the level of investigation necessary. Encouraging reporting of illicit discharges by employees can offset costs by saving expense on inspectors and directing resources more efficiently. Some programs have used funds available from “environmental fees” or special assessment districts to fund their illicit connection elimination programs.

Maintenance

- Two-person teams may be required to clean catch basins with vector trucks.
- Identifying illicit discharges requires teams of at least two people (volunteers can be used), plus administrative personnel, depending on the complexity of the storm sewer system.
- Arrangements must be made for proper disposal of collected wastes.
- Requires technical staff to detect and investigate illegal dumping violations, and to coordinate public education.

Supplemental Information

Further Detail of the BMP

Storm Drain flushing

Sanitary sewer flushing is a common maintenance activity used to improve pipe hydraulics and to remove pollutants in sanitary sewer systems. The same principles that make sanitary sewer flushing effective can be used to flush storm drains. Flushing may be designed to hydraulically convey accumulated material to strategic locations, such as to an open channel, to another point where flushing will be initiated, or over to the sanitary sewer and on to the treatment facilities, thus preventing re-suspension and overflow of a portion of the solids during storm events. Flushing prevents “plug flow” discharges of concentrated pollutant loadings and sediments. The deposits can hinder the designed conveyance capacity of the storm drain system and potentially cause backwater conditions in severe cases of clogging.

Storm drain flushing usually takes place along segments of pipe with grades that are too flat to maintain adequate velocity to keep particles in suspension. An upstream manhole is selected to place an inflatable device that temporarily plugs the pipe. Further upstream, water is pumped into the line to create a flushing wave. When the upstream reach of pipe is sufficiently full to

SC-74 Drainage System Maintenance

cause a flushing wave, the inflated device is rapidly deflated with the assistance of a vacuum pump, releasing the backed up water and resulting in the cleaning of the storm drain segment.

To further reduce the impacts of stormwater pollution, a second inflatable device, placed well downstream, may be used to re-collect the water after the force of the flushing wave has dissipated. A pump may then be used to transfer the water and accumulated material to the sanitary sewer for treatment. In some cases, an interceptor structure may be more practical or required to re-collect the flushed waters.

It has been found that cleansing efficiency of periodic flush waves is dependent upon flush volume, flush discharge rate, sewer slope, sewer length, sewer flow rate, sewer diameter, and population density. As a rule of thumb, the length of line to be flushed should not exceed 700 feet. At this maximum recommended length, the percent removal efficiency ranges between 65-75 percent for organics and 55-65 percent for dry weather grit/inorganic material. The percent removal efficiency drops rapidly beyond that. Water is commonly supplied by a water truck, but fire hydrants can also supply water. To make the best use of water, it is recommended that reclaimed water be used or that fire hydrant line flushing coincide with storm drain flushing.

Flow Management

Flow management has been one of the principal motivations for designing urban stream corridors in the past. Such needs may or may not be compatible with the stormwater quality goals in the stream corridor.

Downstream flood peaks can be suppressed by reducing through flow velocity. This can be accomplished by reducing gradient with grade control structures or increasing roughness with boulders, dense vegetation, or complex banks forms. Reducing velocity correspondingly increases flood height, so all such measures have a natural association with floodplain open space. Flood elevations laterally adjacent to the stream can be lowered by increasing through flow velocity.

However, increasing velocity increases flooding downstream and inherently conflicts with channel stability and human safety. Where topography permits, another way to lower flood elevation is to lower the level of the floodway with drop structures into a large but subtly excavated bowl where flood flows we allowed to spread out.

Stream Corridor Planning

Urban streams receive and convey stormwater flows from developed or developing watersheds. Planning of stream corridors thus interacts with urban stormwater management programs. If local programs are intended to control or protect downstream environments by managing flows delivered to the channels, then it is logical that such programs should be supplemented by management of the materials, forms, and uses of the downstream riparian corridor. Any proposal for steam alteration or management should be investigated for its potential flow and stability effects on upstream, downstream, and laterally adjacent areas. The timing and rate of flow from various tributaries can combine in complex ways to alter flood hazards. Each section of channel is unique, influenced by its own distribution of roughness elements, management activities, and stream responses.

Flexibility to adapt to stream features and behaviors as they evolve must be included in stream reclamation planning. The amenity and ecology of streams may be enhanced through the landscape design options of 1) corridor reservation, 2) bank treatment, 3) geomorphic restoration, and 4) grade control.

Corridor reservation - Reserving stream corridors and valleys to accommodate natural stream meandering, aggradation, degradation, and over bank flows allows streams to find their own form and generate less ongoing erosion. In California, open stream corridors in recent urban developments have produced recreational open space, irrigation of streamside plantings, and the aesthetic amenity of flowing water.

Bank treatment - The use of armoring, vegetative cover, and flow deflection may be used to influence a channel's form, stability, and biotic habitat. To prevent bank erosion, armoring can be done with rigid construction materials, such as concrete, masonry, wood planks and logs, riprap, and gabions. Concrete linings have been criticized because of their lack of provision of biotic habitat. In contrast, riprap and gabions make relatively porous and flexible linings. Boulders, placed in the bed reduce velocity and erosive power.

Riparian vegetation can stabilize the banks of streams that are at or near a condition of equilibrium. Binding networks of roots increase bank shear strength. During flood flows, resilient vegetation is forced into erosion-inhibiting mats. The roughness of vegetation leads to lower velocity, further reducing erosive effects. Structural flow deflection can protect banks from erosion or alter fish habitat. By concentrating flow, a deflector causes a pool to be scoured in the bed.

Geomorphic restoration – Restoration refers to alteration of disturbed streams so their form and behavior emulate those of undisturbed streams. Natural meanders are retained, with grading to gentle slopes on the inside of curves to allow point bars and riffle-pool sequences to develop. Trees are retained to provide scenic quality, biotic productivity, and roots for bank stabilization, supplemented by plantings where necessary.

A restorative approach can be successful where the stream is already approaching equilibrium. However, if upstream urbanization continues new flow regimes will be generated that could disrupt the equilibrium of the treated system.

Grade Control - A grade control structure is a level shelf of a permanent material, such as stone, masonry, or concrete, over which stream water flows. A grade control structure is called a sill, weir, or drop structure, depending on the relation of its invert elevation to upstream and downstream channels.

A sill is installed at the preexisting channel bed elevation to prevent upstream migration of nick points. It establishes a firm base level below which the upstream channel can not erode.

A weir or check dam is installed with invert above the preexisting bed elevation. A weir raises the local base level of the stream and causes aggradation upstream. The gradient, velocity, and erosive potential of the stream channel are reduced. A drop structure lowers the downstream invert below its preexisting elevation, reducing downstream gradient and velocity. Weirs and drop structure control erosion by dissipating energy and reducing slope velocity.

When carefully applied, grade control structures can be highly versatile in establishing human and environmental benefits in stabilized channels. To be successful, application of grade control structures should be guided by analysis of the stream system both upstream and downstream from the area to be reclaimed.

Examples

The California Department of Water Resources began the Urban Stream Restoration Program in 1985. The program provides grant funds to municipalities and community groups to implement stream restoration projects. The projects reduce damages from streambank and watershed instability and floods while restoring streams' aesthetic, recreational, and fish and wildlife values.

In Buena Vista Park, upper floodway slopes are gentle and grassed to achieve continuity of usable park land across the channel of small boulders at the base of the slopes.

The San Diego River is a large, vegetative lined channel, which was planted in a variety of species to support riparian wildlife while stabilizing the steep banks of the floodway.

References and Resources

Ferguson, B.K. 1991. Urban Stream Reclamation, p. 324-322, Journal of Soil and Water Conservation.

Los Angeles County Stormwater Quality. Public Agency Activities Model Program. On-line: http://ladpw.org/wmd/npdes/public_TC.cfm

Model Urban Runoff Program: A How-To Guide for Developing Urban Runoff Programs for Small Municipalities. Prepared by City of Monterey, City of Santa Cruz, California Coastal Commission, Monterey Bay National Marine Sanctuary, Association of Monterey Bay Area Governments, Woodward-Clyde, Central Coast Regional Water Quality Control Board. July, 1998.

Orange County Stormwater Program

http://www.ocwatersheds.com/StormWater/swp_introduction.asp

Santa Clara Valley Urban Runoff Pollution Prevention Program. 1997 Urban Runoff Management Plan. September 1997, updated October 2000.

San Diego Stormwater Co-permittees Jurisdictional Urban Runoff Management Program (URMP) Municipal Activities Model Program Guidance. 2001. Project Clean Water. November.

United States Environmental Protection Agency (USEPA). 1999. Stormwater Management Fact Sheet Non-stormwater Discharges to Storm Sewers. EPA 832-F-99-022. Office of Water, Washington, D.C. September.

United States Environmental Protection Agency (USEPA). 1999. Stormwater O&M Fact Sheet Catch Basin Cleaning. EPA 832-F-99-011. Office of Water, Washington, D.C. September.

United States Environmental Protection Agency (USEPA). 2002. Pollution Prevention/Good Housekeeping for Municipal Operations Illegal Dumping Control. On line:
http://www.epa.gov/npdes/menuofbmps/poll_7.htm

United States Environmental Protection Agency (USEPA). 2002. Pollution Prevention/Good Housekeeping for Municipal Operations Storm Drain System Cleaning. On line:
http://www.epa.gov/npdes/menuofbmps/poll_16.htm

Site Design & Landscape Planning SD-10



Design Objectives

- Maximize Infiltration
 - Provide Retention
 - Slow Runoff
 - Minimize Impervious Land Coverage
 - Prohibit Dumping of Improper Materials
 - Contain Pollutants
 - Collect and Convey
-

Description

Each project site possesses unique topographic, hydrologic, and vegetative features, some of which are more suitable for development than others. Integrating and incorporating appropriate landscape planning methodologies into the project design is the most effective action that can be done to minimize surface and groundwater contamination from stormwater.

Approach

Landscape planning should couple consideration of land suitability for urban uses with consideration of community goals and projected growth. Project plan designs should conserve natural areas to the extent possible, maximize natural water storage and infiltration opportunities, and protect slopes and channels.

Suitable Applications

Appropriate applications include residential, commercial and industrial areas planned for development or redevelopment.

Design Considerations

Design requirements for site design and landscapes planning should conform to applicable standards and specifications of agencies with jurisdiction and be consistent with applicable General Plan and Local Area Plan policies.



SD-10 Site Design & Landscape Planning

Designing New Installations

Begin the development of a plan for the landscape unit with attention to the following general principles:

- Formulate the plan on the basis of clearly articulated community goals. Carefully identify conflicts and choices between retaining and protecting desired resources and community growth.
- Map and assess land suitability for urban uses. Include the following landscape features in the assessment: wooded land, open unwooded land, steep slopes, erosion-prone soils, foundation suitability, soil suitability for waste disposal, aquifers, aquifer recharge areas, wetlands, floodplains, surface waters, agricultural lands, and various categories of urban land use. When appropriate, the assessment can highlight outstanding local or regional resources that the community determines should be protected (e.g., a scenic area, recreational area, threatened species habitat, farmland, fish run). Mapping and assessment should recognize not only these resources but also additional areas needed for their sustenance.

Project plan designs should conserve natural areas to the extent possible, maximize natural water storage and infiltration opportunities, and protect slopes and channels.

Conserve Natural Areas during Landscape Planning

If applicable, the following items are required and must be implemented in the site layout during the subdivision design and approval process, consistent with applicable General Plan and Local Area Plan policies:

- Cluster development on least-sensitive portions of a site while leaving the remaining land in a natural undisturbed condition.
- Limit clearing and grading of native vegetation at a site to the minimum amount needed to build lots, allow access, and provide fire protection.
- Maximize trees and other vegetation at each site by planting additional vegetation, clustering tree areas, and promoting the use of native and/or drought tolerant plants.
- Promote natural vegetation by using parking lot islands and other landscaped areas.
- Preserve riparian areas and wetlands.

Maximize Natural Water Storage and Infiltration Opportunities Within the Landscape Unit

- Promote the conservation of forest cover. Building on land that is already deforested affects basin hydrology to a lesser extent than converting forested land. Loss of forest cover reduces interception storage, detention in the organic forest floor layer, and water losses by evapotranspiration, resulting in large peak runoff increases and either their negative effects or the expense of countering them with structural solutions.
- Maintain natural storage reservoirs and drainage corridors, including depressions, areas of permeable soils, swales, and intermittent streams. Develop and implement policies and

Site Design & Landscape Planning SD-10

regulations to discourage the clearing, filling, and channelization of these features. Utilize them in drainage networks in preference to pipes, culverts, and engineered ditches.

- Evaluating infiltration opportunities by referring to the stormwater management manual for the jurisdiction and pay particular attention to the selection criteria for avoiding groundwater contamination, poor soils, and hydrogeological conditions that cause these facilities to fail. If necessary, locate developments with large amounts of impervious surfaces or a potential to produce relatively contaminated runoff away from groundwater recharge areas.

Protection of Slopes and Channels during Landscape Design

- Convey runoff safely from the tops of slopes.
- Avoid disturbing steep or unstable slopes.
- Avoid disturbing natural channels.
- Stabilize disturbed slopes as quickly as possible.
- Vegetate slopes with native or drought tolerant vegetation.
- Control and treat flows in landscaping and/or other controls prior to reaching existing natural drainage systems.
- Stabilize temporary and permanent channel crossings as quickly as possible, and ensure that increases in run-off velocity and frequency caused by the project do not erode the channel.
- Install energy dissipaters, such as riprap, at the outlets of new storm drains, culverts, conduits, or channels that enter unlined channels in accordance with applicable specifications to minimize erosion. Energy dissipaters shall be installed in such a way as to minimize impacts to receiving waters.
- Line on-site conveyance channels where appropriate, to reduce erosion caused by increased flow velocity due to increases in tributary impervious area. The first choice for linings should be grass or some other vegetative surface, since these materials not only reduce runoff velocities, but also provide water quality benefits from filtration and infiltration. If velocities in the channel are high enough to erode grass or other vegetative linings, riprap, concrete, soil cement, or geo-grid stabilization are other alternatives.
- Consider other design principles that are comparable and equally effective.

Redeveloping Existing Installations

Various jurisdictional stormwater management and mitigation plans (SUSMP, WQMP, etc.) define “redevelopment” in terms of amounts of additional impervious area, increases in gross floor area and/or exterior construction, and land disturbing activities with structural or impervious surfaces. The definition of “redevelopment” must be consulted to determine whether or not the requirements for new development apply to areas intended for redevelopment. If the definition applies, the steps outlined under “designing new installations” above should be followed.

SD-10 Site Design & Landscape Planning

Redevelopment may present significant opportunity to add features which had not previously been implemented. Examples include incorporation of depressions, areas of permeable soils, and swales in newly redeveloped areas. While some site constraints may exist due to the status of already existing infrastructure, opportunities should not be missed to maximize infiltration, slow runoff, reduce impervious areas, disconnect directly connected impervious areas.

Other Resources

A Manual for the Standard Urban Stormwater Mitigation Plan (SUSMP), Los Angeles County Department of Public Works, May 2002.

Stormwater Management Manual for Western Washington, Washington State Department of Ecology, August 2001.

Model Standard Urban Storm Water Mitigation Plan (SUSMP) for San Diego County, Port of San Diego, and Cities in San Diego County, February 14, 2002.

Model Water Quality Management Plan (WQMP) for County of Orange, Orange County Flood Control District, and the Incorporated Cities of Orange County, Draft February 2003.

Ventura Countywide Technical Guidance Manual for Stormwater Quality Control Measures, July 2002.



Design Objectives

- Maximize Infiltration
- Provide Retention
- Slow Runoff
- Minimize Impervious Land Coverage
- Prohibit Dumping of Improper Materials
- Contain Pollutants
- Collect and Convey

Description

Irrigation water provided to landscaped areas may result in excess irrigation water being conveyed into stormwater drainage systems.

Approach

Project plan designs for development and redevelopment should include application methods of irrigation water that minimize runoff of excess irrigation water into the stormwater conveyance system.

Suitable Applications

Appropriate applications include residential, commercial and industrial areas planned for development or redevelopment. (Detached residential single-family homes are typically excluded from this requirement.)

Design Considerations

Designing New Installations

The following methods to reduce excessive irrigation runoff should be considered, and incorporated and implemented where determined applicable and feasible by the Permittee:

- Employ rain-triggered shutoff devices to prevent irrigation after precipitation.
- Design irrigation systems to each landscape area's specific water requirements.
- Include design featuring flow reducers or shutoff valves triggered by a pressure drop to control water loss in the event of broken sprinkler heads or lines.
- Implement landscape plans consistent with County or City water conservation resolutions, which may include provision of water sensors, programmable irrigation times (for short cycles), etc.



- Design timing and application methods of irrigation water to minimize the runoff of excess irrigation water into the storm water drainage system.
- Group plants with similar water requirements in order to reduce excess irrigation runoff and promote surface filtration. Choose plants with low irrigation requirements (for example, native or drought tolerant species). Consider design features such as:
 - Using mulches (such as wood chips or bar) in planter areas without ground cover to minimize sediment in runoff
 - Installing appropriate plant materials for the location, in accordance with amount of sunlight and climate, and use native plant materials where possible and/or as recommended by the landscape architect
 - Leaving a vegetative barrier along the property boundary and interior watercourses, to act as a pollutant filter, where appropriate and feasible
 - Choosing plants that minimize or eliminate the use of fertilizer or pesticides to sustain growth
- Employ other comparable, equally effective methods to reduce irrigation water runoff.

Redeveloping Existing Installations

Various jurisdictional stormwater management and mitigation plans (SUSMP, WQMP, etc.) define “redevelopment” in terms of amounts of additional impervious area, increases in gross floor area and/or exterior construction, and land disturbing activities with structural or impervious surfaces. The definition of “redevelopment” must be consulted to determine whether or not the requirements for new development apply to areas intended for redevelopment. If the definition applies, the steps outlined under “designing new installations” above should be followed.

Other Resources

A Manual for the Standard Urban Stormwater Mitigation Plan (SUSMP), Los Angeles County Department of Public Works, May 2002.

Model Standard Urban Storm Water Mitigation Plan (SUSMP) for San Diego County, Port of San Diego, and Cities in San Diego County, February 14, 2002.

Model Water Quality Management Plan (WQMP) for County of Orange, Orange County Flood Control District, and the Incorporated Cities of Orange County, Draft February 2003.

Ventura Countywide Technical Guidance Manual for Stormwater Quality Control Measures, July 2002.



Design Objectives

- Maximize Infiltration
- Provide Retention
- Slow Runoff
- Minimize Impervious Land Coverage
- Prohibit Dumping of Improper Materials
- Contain Pollutants
- Collect and Convey

Description

Waste materials dumped into storm drain inlets can have severe impacts on receiving and ground waters. Posting notices regarding discharge prohibitions at storm drain inlets can prevent waste dumping. Storm drain signs and stencils are highly visible source controls that are typically placed directly adjacent to storm drain inlets.

Approach

The stencil or affixed sign contains a brief statement that prohibits dumping of improper materials into the urban runoff conveyance system. Storm drain messages have become a popular method of alerting the public about the effects of and the prohibitions against waste disposal.

Suitable Applications

Stencils and signs alert the public to the destination of pollutants discharged to the storm drain. Signs are appropriate in residential, commercial, and industrial areas, as well as any other area where contributions or dumping to storm drains is likely.

Design Considerations

Storm drain message markers or placards are recommended at all storm drain inlets within the boundary of a development project. The marker should be placed in clear sight facing toward anyone approaching the inlet from either side. All storm drain inlet locations should be identified on the development site map.

Designing New Installations

The following methods should be considered for inclusion in the project design and show on project plans:

- Provide stenciling or labeling of all storm drain inlets and catch basins, constructed or modified, within the project area with prohibitive language. Examples include “NO DUMPING



– DRAINS TO OCEAN” and/or other graphical icons to discourage illegal dumping.

- Post signs with prohibitive language and/or graphical icons, which prohibit illegal dumping at public access points along channels and creeks within the project area.

Note - Some local agencies have approved specific signage and/or storm drain message placards for use. Consult local agency stormwater staff to determine specific requirements for placard types and methods of application.

Redeveloping Existing Installations

Various jurisdictional stormwater management and mitigation plans (SUSMP, WQMP, etc.) define “redevelopment” in terms of amounts of additional impervious area, increases in gross floor area and/or exterior construction, and land disturbing activities with structural or impervious surfaces. If the project meets the definition of “redevelopment”, then the requirements stated under “designing new installations” above should be included in all project design plans.

Additional Information

Maintenance Considerations

- Legibility of markers and signs should be maintained. If required by the agency with jurisdiction over the project, the owner/operator or homeowner’s association should enter into a maintenance agreement with the agency or record a deed restriction upon the property title to maintain the legibility of placards or signs.

Placement

- Signage on top of curbs tends to weather and fade.
- Signage on face of curbs tends to be worn by contact with vehicle tires and sweeper brooms.

Supplemental Information

Examples

- Most MS4 programs have storm drain signage programs. Some MS4 programs will provide stencils, or arrange for volunteers to stencil storm drains as part of their outreach program.

Other Resources

A Manual for the Standard Urban Stormwater Mitigation Plan (SUSMP), Los Angeles County Department of Public Works, May 2002.

Model Standard Urban Storm Water Mitigation Plan (SUSMP) for San Diego County, Port of San Diego, and Cities in San Diego County, February 14, 2002.

Model Water Quality Management Plan (WQMP) for County of Orange, Orange County Flood Control District, and the Incorporated Cities of Orange County, Draft February 2003.

Ventura Countywide Technical Guidance Manual for Stormwater Quality Control Measures, July 2002.



Design Objectives

- Maximize Infiltration
- Provide Retention
- Slow Runoff
- Minimize Impervious Land Coverage
- Prohibit Dumping of Improper Materials
- Contain Pollutants
- Collect and Convey

Description

Several measures can be taken to prevent operations at maintenance bays and loading docks from contributing a variety of toxic compounds, oil and grease, heavy metals, nutrients, suspended solids, and other pollutants to the stormwater conveyance system.

Approach

In designs for maintenance bays and loading docks, containment is encouraged. Preventative measures include overflow containment structures and dead-end sumps. However, in the case of loading docks from grocery stores and warehouse/distribution centers, engineered infiltration systems may be considered.

Suitable Applications

Appropriate applications include commercial and industrial areas planned for development or redevelopment.

Design Considerations

Design requirements for vehicle maintenance and repair are governed by Building and Fire Codes, and by current local agency ordinances, and zoning requirements. The design criteria described in this fact sheet are meant to enhance and be consistent with these code requirements.

Designing New Installations

Designs of maintenance bays should consider the following:

- Repair/maintenance bays and vehicle parts with fluids should be indoors; or designed to preclude urban run-on and runoff.
- Repair/maintenance floor areas should be paved with Portland cement concrete (or equivalent smooth impervious surface).



- Repair/maintenance bays should be designed to capture all wash water leaks and spills. Provide impermeable berms, drop inlets, trench catch basins, or overflow containment structures around repair bays to prevent spilled materials and wash-down waters from entering the storm drain system. Connect drains to a sump for collection and disposal. Direct connection of the repair/maintenance bays to the storm drain system is prohibited. If required by local jurisdiction, obtain an Industrial Waste Discharge Permit.
- Other features may be comparable and equally effective.

The following designs of loading/unloading dock areas should be considered:

- Loading dock areas should be covered, or drainage should be designed to preclude urban run-on and runoff.
- Direct connections into storm drains from depressed loading docks (truck wells) are prohibited.
- Below-grade loading docks from grocery stores and warehouse/distribution centers of fresh food items should drain through water quality inlets, or to an engineered infiltration system, or an equally effective alternative. Pre-treatment may also be required.
- Other features may be comparable and equally effective.

Redeveloping Existing Installations

Various jurisdictional stormwater management and mitigation plans (SUSMP, WQMP, etc.) define “redevelopment” in terms of amounts of additional impervious area, increases in gross floor area and/or exterior construction, and land disturbing activities with structural or impervious surfaces. The definition of “redevelopment” must be consulted to determine whether or not the requirements for new development apply to areas intended for redevelopment. If the definition applies, the steps outlined under “designing new installations” above should be followed.

Additional Information

Stormwater and non-stormwater will accumulate in containment areas and sumps with impervious surfaces. Contaminated accumulated water must be disposed of in accordance with applicable laws and cannot be discharged directly to the storm drain or sanitary sewer system without the appropriate permit.

Other Resources

A Manual for the Standard Urban Stormwater Mitigation Plan (SUSMP), Los Angeles County Department of Public Works, May 2002.

Model Standard Urban Storm Water Mitigation Plan (SUSMP) for San Diego County, Port of San Diego, and Cities in San Diego County, February 14, 2002.

Model Water Quality Management Plan (WQMP) for County of Orange, Orange County Flood Control District, and the Incorporated Cities of Orange County, Draft February 2003.

Ventura Countywide Technical Guidance Manual for Stormwater Quality Control Measures, July 2002.

Description

Trash storage areas are areas where a trash receptacle (s) are located for use as a repository for solid wastes. Stormwater runoff from areas where trash is stored or disposed of can be polluted. In addition, loose trash and debris can be easily transported by water or wind into nearby storm drain inlets, channels, and/or creeks. Waste handling operations that may be sources of stormwater pollution include dumpsters, litter control, and waste piles.

Approach

This fact sheet contains details on the specific measures required to prevent or reduce pollutants in stormwater runoff associated with trash storage and handling. Preventative measures including enclosures, containment structures, and impervious pavements to mitigate spills, should be used to reduce the likelihood of contamination.

Suitable Applications

Appropriate applications include residential, commercial and industrial areas planned for development or redevelopment. (Detached residential single-family homes are typically excluded from this requirement.)

Design Considerations

Design requirements for waste handling areas are governed by Building and Fire Codes, and by current local agency ordinances and zoning requirements. The design criteria described in this fact sheet are meant to enhance and be consistent with these code and ordinance requirements. Hazardous waste should be handled in accordance with legal requirements established in Title 22, California Code of Regulation.

Wastes from commercial and industrial sites are typically hauled by either public or commercial carriers that may have design or access requirements for waste storage areas. The design criteria in this fact sheet are recommendations and are not intended to be in conflict with requirements established by the waste hauler. The waste hauler should be contacted prior to the design of your site trash collection areas. Conflicts or issues should be discussed with the local agency.

Designing New Installations

Trash storage areas should be designed to consider the following structural or treatment control BMPs:

- Design trash container areas so that drainage from adjoining roofs and pavement is diverted around the area(s) to avoid run-on. This might include berming or grading the waste handling area to prevent run-on of stormwater.
- Make sure trash container areas are screened or walled to prevent off-site transport of trash.

Design Objectives

- Maximize Infiltration
- Provide Retention
- Slow Runoff
- Minimize Impervious Land Coverage
- Prohibit Dumping of Improper Materials
- Contain Pollutants
- Collect and Convey



- Use lined bins or dumpsters to reduce leaking of liquid waste.
- Provide roofs, awnings, or attached lids on all trash containers to minimize direct precipitation and prevent rainfall from entering containers.
- Pave trash storage areas with an impervious surface to mitigate spills.
- Do not locate storm drains in immediate vicinity of the trash storage area.
- Post signs on all dumpsters informing users that hazardous materials are not to be disposed of therein.

Redeveloping Existing Installations

Various jurisdictional stormwater management and mitigation plans (SUSMP, WQMP, etc.) define “redevelopment” in terms of amounts of additional impervious area, increases in gross floor area and/or exterior construction, and land disturbing activities with structural or impervious surfaces. The definition of “redevelopment” must be consulted to determine whether or not the requirements for new development apply to areas intended for redevelopment. If the definition applies, the steps outlined under “designing new installations” above should be followed.

Additional Information

Maintenance Considerations

The integrity of structural elements that are subject to damage (i.e., screens, covers, and signs) must be maintained by the owner/operator. Maintenance agreements between the local agency and the owner/operator may be required. Some agencies will require maintenance deed restrictions to be recorded of the property title. If required by the local agency, maintenance agreements or deed restrictions must be executed by the owner/operator before improvement plans are approved.

Other Resources

A Manual for the Standard Urban Stormwater Mitigation Plan (SUSMP), Los Angeles County Department of Public Works, May 2002.

Model Standard Urban Storm Water Mitigation Plan (SUSMP) for San Diego County, Port of San Diego, and Cities in San Diego County, February 14, 2002.

Model Water Quality Management Plan (WQMP) for County of Orange, Orange County Flood Control District, and the Incorporated Cities of Orange County, Draft February 2003.

Ventura Countywide Technical Guidance Manual for Stormwater Quality Control Measures, July 2002.



Design Considerations

- Soil for Infiltration
- Slope
- Aesthetics

Description

An infiltration basin is a shallow impoundment that is designed to infiltrate stormwater. Infiltration basins use the natural filtering ability of the soil to remove pollutants in stormwater runoff. Infiltration facilities store runoff until it gradually exfiltrates through the soil and eventually into the water table. This practice has high pollutant removal efficiency and can also help recharge groundwater, thus helping to maintain low flows in stream systems. Infiltration basins can be challenging to apply on many sites, however, because of soils requirements. In addition, some studies have shown relatively high failure rates compared with other management practices.

California Experience

Infiltration basins have a long history of use in California, especially in the Central Valley. Basins located in Fresno were among those initially evaluated in the National Urban Runoff Program and were found to be effective at reducing the volume of runoff, while posing little long-term threat to groundwater quality (EPA, 1983; Schroeder, 1995). Proper siting of these devices is crucial as underscored by the experience of Caltrans in siting two basins in Southern California. The basin with marginal separation from groundwater and soil permeability failed immediately and could never be rehabilitated.

Advantages

- Provides 100% reduction in the load discharged to surface waters.
- The principal benefit of infiltration basins is the approximation of pre-development hydrology during which a

Targeted Constituents

- | | | |
|-------------------------------------|----------------|---|
| <input checked="" type="checkbox"/> | Sediment | ■ |
| <input checked="" type="checkbox"/> | Nutrients | ■ |
| <input checked="" type="checkbox"/> | Trash | ■ |
| <input checked="" type="checkbox"/> | Metals | ■ |
| <input checked="" type="checkbox"/> | Bacteria | ■ |
| <input checked="" type="checkbox"/> | Oil and Grease | ■ |
| <input checked="" type="checkbox"/> | Organics | ■ |

Legend (Removal Effectiveness)

- Low ■ High
▲ Medium



significant portion of the average annual rainfall runoff is infiltrated and evaporated rather than flushed directly to creeks.

- If the water quality volume is adequately sized, infiltration basins can be useful for providing control of channel forming (erosion) and high frequency (generally less than the 2-year) flood events.

Limitations

- May not be appropriate for industrial sites or locations where spills may occur.
- Infiltration basins require a minimum soil infiltration rate of 0.5 inches/hour, not appropriate at sites with Hydrologic Soil Types C and D.
- If infiltration rates exceed 2.4 inches/hour, then the runoff should be fully treated prior to infiltration to protect groundwater quality.
- Not suitable on fill sites or steep slopes.
- Risk of groundwater contamination in very coarse soils.
- Upstream drainage area must be completely stabilized before construction.
- Difficult to restore functioning of infiltration basins once clogged.

Design and Sizing Guidelines

- Water quality volume determined by local requirements or sized so that 85% of the annual runoff volume is captured.
- Basin sized so that the entire water quality volume is infiltrated within 48 hours.
- Vegetation establishment on the basin floor may help reduce the clogging rate.

Construction/Inspection Considerations

- Before construction begins, stabilize the entire area draining to the facility. If impossible, place a diversion berm around the perimeter of the infiltration site to prevent sediment entrance during construction or remove the top 2 inches of soil after the site is stabilized. Stabilize the entire contributing drainage area, including the side slopes, before allowing any runoff to enter once construction is complete.
- Place excavated material such that it can not be washed back into the basin if a storm occurs during construction of the facility.
- Build the basin without driving heavy equipment over the infiltration surface. Any equipment driven on the surface should have extra-wide ("low pressure") tires. Prior to any construction, rope off the infiltration area to stop entrance by unwanted equipment.
- After final grading, till the infiltration surface deeply.
- Use appropriate erosion control seed mix for the specific project and location.

Performance

As water migrates through porous soil and rock, pollutant attenuation mechanisms include precipitation, sorption, physical filtration, and bacterial degradation. If functioning properly, this approach is presumed to have high removal efficiencies for particulate pollutants and moderate removal of soluble pollutants. Actual pollutant removal in the subsurface would be expected to vary depending upon site-specific soil types. This technology eliminates discharge to surface waters except for the very largest storms; consequently, complete removal of all stormwater constituents can be assumed.

There remain some concerns about the potential for groundwater contamination despite the findings of the NURP and Nightingale (1975; 1987a,b,c; 1989). For instance, a report by Pitt et al. (1994) highlighted the potential for groundwater contamination from intentional and unintentional stormwater infiltration. That report recommends that infiltration facilities not be sited in areas where high concentrations are present or where there is a potential for spills of toxic material. Conversely, Schroeder (1995) reported that there was no evidence of groundwater impacts from an infiltration basin serving a large industrial catchment in Fresno, CA.

Siting Criteria

The key element in siting infiltration basins is identifying sites with appropriate soil and hydrogeologic properties, which is critical for long term performance. In one study conducted in Prince George's County, Maryland (Galli, 1992), all of the infiltration basins investigated clogged within 2 years. It is believed that these failures were for the most part due to allowing infiltration at sites with rates of less than 0.5 in/hr, basing siting on soil type rather than field infiltration tests, and poor construction practices that resulted in soil compaction of the basin invert.

A study of 23 infiltration basins in the Pacific Northwest showed better long-term performance in an area with highly permeable soils (Hilding, 1996). In this study, few of the infiltration basins had failed after 10 years. Consequently, the following guidelines for identifying appropriate soil and subsurface conditions should be rigorously adhered to.

- Determine soil type (consider RCS soil type 'A, B or C' only) from mapping and consult USDA soil survey tables to review other parameters such as the amount of silt and clay, presence of a restrictive layer or seasonal high water table, and estimated permeability. The soil should not have more than 30% clay or more than 40% of clay and silt combined. Eliminate sites that are clearly unsuitable for infiltration.
- Groundwater separation should be at least 3 m from the basin invert to the measured ground water elevation. There is concern at the state and regional levels of the impact on groundwater quality from infiltrated runoff, especially when the separation between groundwater and the surface is small.
- Location away from buildings, slopes and highway pavement (greater than 6 m) and wells and bridge structures (greater than 30 m). Sites constructed of fill, having a base flow or with a slope greater than 15% should not be considered.
- Ensure that adequate head is available to operate flow splitter structures (to allow the basin to be offline) without ponding in the splitter structure or creating backwater upstream of the splitter.

- Base flow should not be present in the tributary watershed.

Secondary Screening Based on Site Geotechnical Investigation

- At least three in-hole conductivity tests shall be performed using USBR 7300-89 or Bouwer-Rice procedures (the latter if groundwater is encountered within the boring), two tests at different locations within the proposed basin and the third down gradient by no more than approximately 10 m. The tests shall measure permeability in the side slopes and the bed within a depth of 3 m of the invert.
- The minimum acceptable hydraulic conductivity as measured in any of the three required test holes is 13 mm/hr. If any test hole shows less than the minimum value, the site should be disqualified from further consideration.
- Exclude from consideration sites constructed in fill or partially in fill unless no silts or clays are present in the soil boring. Fill tends to be compacted, with clays in a dispersed rather than flocculated state, greatly reducing permeability.
- The geotechnical investigation should be such that a good understanding is gained as to how the stormwater runoff will move in the soil (horizontally or vertically) and if there are any geological conditions that could inhibit the movement of water.

Additional Design Guidelines

- (1) Basin Sizing - The required water quality volume is determined by local regulations or sufficient to capture 85% of the annual runoff.
- (2) Provide pretreatment if sediment loading is a maintenance concern for the basin.
- (3) Include energy dissipation in the inlet design for the basins. Avoid designs that include a permanent pool to reduce opportunity for standing water and associated vector problems.
- (4) Basin invert area should be determined by the equation:

$$A = \frac{WQV}{kt}$$

where A = Basin invert area (m²)

WQV = water quality volume (m³)

k = 0.5 times the lowest field-measured hydraulic conductivity (m/hr)

t = drawdown time (48 hr)

- (5) The use of vertical piping, either for distribution or infiltration enhancement shall not be allowed to avoid device classification as a Class V injection well per 40 CFR146.5(e)(4).

Maintenance

Regular maintenance is critical to the successful operation of infiltration basins. Recommended operation and maintenance guidelines include:

- Inspections and maintenance to ensure that water infiltrates into the subsurface completely (recommended infiltration rate of 72 hours or less) and that vegetation is carefully managed to prevent creating mosquito and other vector habitats.
- Observe drain time for the design storm after completion or modification of the facility to confirm that the desired drain time has been obtained.
- Schedule semiannual inspections for beginning and end of the wet season to identify potential problems such as erosion of the basin side slopes and invert, standing water, trash and debris, and sediment accumulation.
- Remove accumulated trash and debris in the basin at the start and end of the wet season.
- Inspect for standing water at the end of the wet season.
- Trim vegetation at the beginning and end of the wet season to prevent establishment of woody vegetation and for aesthetic and vector reasons.
- Remove accumulated sediment and regrade when the accumulated sediment volume exceeds 10% of the basin.
- If erosion is occurring within the basin, revegetate immediately and stabilize with an erosion control mulch or mat until vegetation cover is established.
- To avoid reversing soil development, scarification or other disturbance should only be performed when there are actual signs of clogging, rather than on a routine basis. Always remove deposited sediments before scarification, and use a hand-guided rotary tiller, if possible, or a disc harrow pulled by a very light tractor.

Cost

Infiltration basins are relatively cost-effective practices because little infrastructure is needed when constructing them. One study estimated the total construction cost at about \$2 per ft (adjusted for inflation) of storage for a 0.25-acre basin (SWRPC, 1991). As with other BMPs, these published cost estimates may deviate greatly from what might be incurred at a specific site. For instance, Caltrans spent about \$18/ft³ for the two infiltration basins constructed in southern California, each of which had a water quality volume of about 0.34 ac.-ft. Much of the higher cost can be attributed to changes in the storm drain system necessary to route the runoff to the basin locations.

Infiltration basins typically consume about 2 to 3% of the site draining to them, which is relatively small. Additional space may be required for buffer, landscaping, access road, and fencing. Maintenance costs are estimated at 5 to 10% of construction costs.

One cost concern associated with infiltration practices is the maintenance burden and longevity. If improperly maintained, infiltration basins have a high failure rate. Thus, it may be necessary to replace the basin with a different technology after a relatively short period of time.

References and Sources of Additional Information

- Caltrans, 2002, BMP Retrofit Pilot Program Proposed Final Report, Rpt. CTSW-RT-01-050, California Dept. of Transportation, Sacramento, CA.
- Galli, J. 1992. *Analysis of Urban BMP Performance and Longevity in Prince George's County, Maryland*. Metropolitan Washington Council of Governments, Washington, DC.
- Hilding, K. 1996. Longevity of infiltration basins assessed in Puget Sound. *Watershed Protection Techniques* 1(3):124-125.
- Maryland Department of the Environment (MDE). 2000. *Maryland Stormwater Design Manual*. <http://www.mde.state.md.us/environment/wma/stormwatermanual>. Accessed May 22, 2002.
- Metzger, M. E., D. F. Messer, C. L. Beitia, C. M. Myers, and V. L. Kramer. 2002. The Dark Side Of Stormwater Runoff Management: Disease Vectors Associated With Structural BMPs. *Stormwater* 3(2): 24-39.
- Nightingale, H.I., 1975, "Lead, Zinc, and Copper in Soils of Urban Storm-Runoff Retention Basins," *American Water Works Assoc. Journal*. Vol. 67, p. 443-446.
- Nightingale, H.I., 1987a, "Water Quality beneath Urban Runoff Water Management Basins," *Water Resources Bulletin*, Vol. 23, p. 197-205.
- Nightingale, H.I., 1987b, "Accumulation of As, Ni, Cu, and Pb in Retention and Recharge Basin Soils from Urban Runoff," *Water Resources Bulletin*, Vol. 23, p. 663-672.
- Nightingale, H.I., 1987c, "Organic Pollutants in Soils of Retention/Recharge Basins Receiving Urban Runoff Water," *Soil Science* Vol. 148, pp. 39-45.
- Nightingale, H.I., Harrison, D., and Salo, J.E., 1985, "An Evaluation Technique for Groundwater Quality Beneath Urban Runoff Retention and Percolation Basins," *Ground Water Monitoring Review*, Vol. 5, No. 1, pp. 43-50.
- Oberts, G. 1994. Performance of Stormwater Ponds and Wetlands in Winter. *Watershed Protection Techniques* 1(2): 64-68.
- Pitt, R., et al. 1994, *Potential Groundwater Contamination from Intentional and Nonintentional Stormwater Infiltration*, EPA/600/R-94/051, Risk Reduction Engineering Laboratory, U.S. EPA, Cincinnati, OH.
- Schueler, T. 1987. *Controlling Urban Runoff: A Practical Manual for Planning and Designing Urban BMPs*. Metropolitan Washington Council of Governments, Washington, DC.
- Schroeder, R.A., 1995, *Potential For Chemical Transport Beneath a Storm-Runoff Recharge (Retention) Basin for an Industrial Catchment in Fresno, CA*, USGS Water-Resource Investigations Report 93-4140.

Southeastern Wisconsin Regional Planning Commission (SWRPC). 1991. *Costs of Urban Nonpoint Source Water Pollution Control Measures*. Southeastern Wisconsin Regional Planning Commission, Waukesha, WI.

U.S. EPA, 1983, *Results of the Nationwide Urban Runoff Program: Volume 1 – Final Report*, WH-554, Water Planning Division, Washington, DC.

Watershed Management Institute (WMI). 1997. *Operation, Maintenance, and Management of Stormwater Management Systems*. Prepared for U.S. Environmental Protection Agency Office of Water, Washington, DC.

Information Resources

Center for Watershed Protection (CWP). 1997. *Stormwater BMP Design Supplement for Cold Climates*. Prepared for U.S. Environmental Protection Agency Office of Wetlands, Oceans and Watersheds. Washington, DC.

Ferguson, B.K., 1994. *Stormwater Infiltration*. CRC Press, Ann Arbor, MI.

USEPA. 1993. *Guidance to Specify Management Measures for Sources of Nonpoint Pollution in Coastal Waters*. EPA-840-B-92-002. U.S. Environmental Protection Agency, Office of Water, Washington, DC.

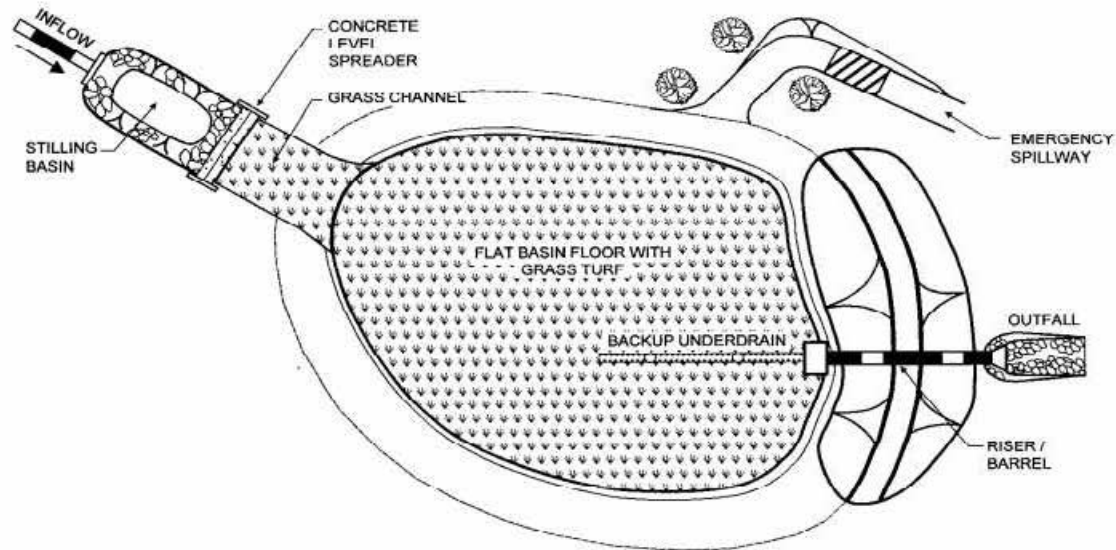

PLAN VIEW

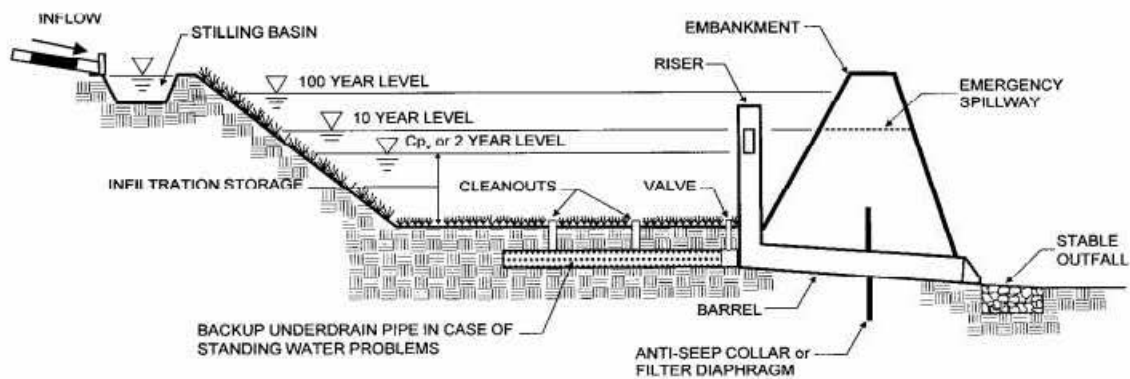

PROFILE

Description

Drain inserts are manufactured filters or fabric placed in a drop inlet to remove sediment and debris. There are a multitude of inserts of various shapes and configurations, typically falling into one of three different groups: socks, boxes, and trays. The sock consists of a fabric, usually constructed of polypropylene. The fabric may be attached to a frame or the grate of the inlet holds the sock. Socks are meant for vertical (drop) inlets. Boxes are constructed of plastic or wire mesh. Typically a polypropylene “bag” is placed in the wire mesh box. The bag takes the form of the box. Most box products are one box; that is, the setting area and filtration through media occur in the same box. Some products consist of one or more trays or mesh grates. The trays may hold different types of media. Filtration media vary by manufacturer. Types include polypropylene, porous polymer, treated cellulose, and activated carbon.

California Experience

The number of installations is unknown but likely exceeds a thousand. Some users have reported that these systems require considerable maintenance to prevent plugging and bypass.

Advantages

- Does not require additional space as inserts as the drain inlets are already a component of the standard drainage systems.
- Easy access for inspection and maintenance.
- As there is no standing water, there is little concern for mosquito breeding.
- A relatively inexpensive retrofit option.

Limitations

Performance is likely significantly less than treatment systems that are located at the end of the drainage system such as ponds and vaults. Usually not suitable for large areas or areas with trash or leaves than can plug the insert.

Design and Sizing Guidelines

Refer to manufacturer’s guidelines. Drain inserts come in many configurations but can be placed into three general groups: socks, boxes, and trays. The sock consists of a fabric, usually constructed of polypropylene. The fabric may be attached to a frame or the grate of the inlet holds the sock. Socks are meant for vertical (drop) inlets. Boxes are constructed of plastic or wire mesh. Typically a polypropylene “bag” is placed in the wire mesh box. The bag takes the form of the box. Most box products are

Design Considerations

- Use with other BMPs
- Fit and Seal Capacity within Inlet

Targeted Constituents

- Sediment
- Nutrients
- Trash
- Metals
- Bacteria
- Oil and Grease
- Organics

Removal Effectiveness

See New Development and Redevelopment Handbook-Section 5.



one box; that is, the setting area and filtration through media occurs in the same box. One manufacturer has a double-box. Stormwater enters the first box where setting occurs. The stormwater flows into the second box where the filter media is located. Some products consist of one or more trays or mesh grates. The trays can hold different types of media. Filtration media vary with the manufacturer: types include polypropylene, porous polymer, treated cellulose, and activated carbon.

Construction/Inspection Considerations

Be certain that installation is done in a manner that makes certain that the stormwater enters the unit and does not leak around the perimeter. Leakage between the frame of the insert and the frame of the drain inlet can easily occur with vertical (drop) inlets.

Performance

Few products have performance data collected under field conditions.

Siting Criteria

It is recommended that inserts be used only for retrofit situations or as pretreatment where other treatment BMPs presented in this section area used.

Additional Design Guidelines

Follow guidelines provided by individual manufacturers.

Maintenance

Likely require frequent maintenance, on the order of several times per year.

Cost

- The initial cost of individual inserts ranges from less than \$100 to about \$2,000. The cost of using multiple units in curb inlet drains varies with the size of the inlet.
- The low cost of inserts may tend to favor the use of these systems over other, more effective treatment BMPs. However, the low cost of each unit may be offset by the number of units that are required, more frequent maintenance, and the shorter structural life (and therefore replacement).

References and Sources of Additional Information

Hrachovec, R., and G. Minton, 2001, Field testing of a sock-type catch basin insert, Planet CPR, Seattle, Washington

Interagency Catch Basin Insert Committee, Evaluation of Commercially-Available Catch Basin Inserts for the Treatment of Stormwater Runoff from Developed Sites, 1995

Larry Walker Associates, June 1998, NDMP Inlet/In-Line Control Measure Study Report

Manufacturers literature

Santa Monica (City), Santa Monica Bay Municipal Stormwater/Urban Runoff Project - Evaluation of Potential Catch basin Retrofits, Woodward Clyde, September 24, 1998

Woodward Clyde, June 11, 1996, Parking Lot Monitoring Report, Santa Clara Valley Nonpoint Source Pollution Control Program.

Round Curb Inlet Filter (R-GISB)

PROVEN STORMWATER TREATMENT TECHNOLOGY



A Forterra Company

Overview

The Bio Clean Round Curb Inlet Filter (R-GISB) is a favorite amongst cities and municipalities nationwide. Many agencies have chosen this system as their standard due to its quick cleaning time and large storage capacity.

Its patented 'Shelf System' allows cleaning to be done in less than 15 minutes, and its larger storage capacity of 3.85 cubic feet allows for maximized cleaning intervals and minimized attention required by maintenance crews.

The modularized design of the 'Shelf System' for curb inlets makes it adaptable to any size or type catch basin.

Its multi-stage filtration screens allow this device to meet "full trash capture" requirements by removing 100% of trash & debris 5 mm and greater. Made of marine grade fiberglass and high grade stainless steel these filters come in standard and custom designs.

This filtration system addresses a wide array of pollutants including trash and debris, sediments, TSS, nutrients, metals, and hydrocarbons.

Includes the Patented 'Shelf System'
Higher Storage Capacity & 15 Minute Service Time



Advantages

- 8 Year Warranty
- Works in Any Size Catch Basin
- No Nets or Geofabrics
- 15+ Year User Life
- Meets **LEED** Requirements
- Patented Shelf System
- Fiberglass Construction

Performance

- 74%-86% Removal of TSS
- 54% Removal of Oils & Grease
- 57%-71% Removal of Phosphorus
- 56%-60% Removal of Nitrogen

Specifications

Model #	Treatment Flow (CFS)	Bypass Flow (CFS)
BC-RGISB-22-24	2.4	Unlimited

Operation

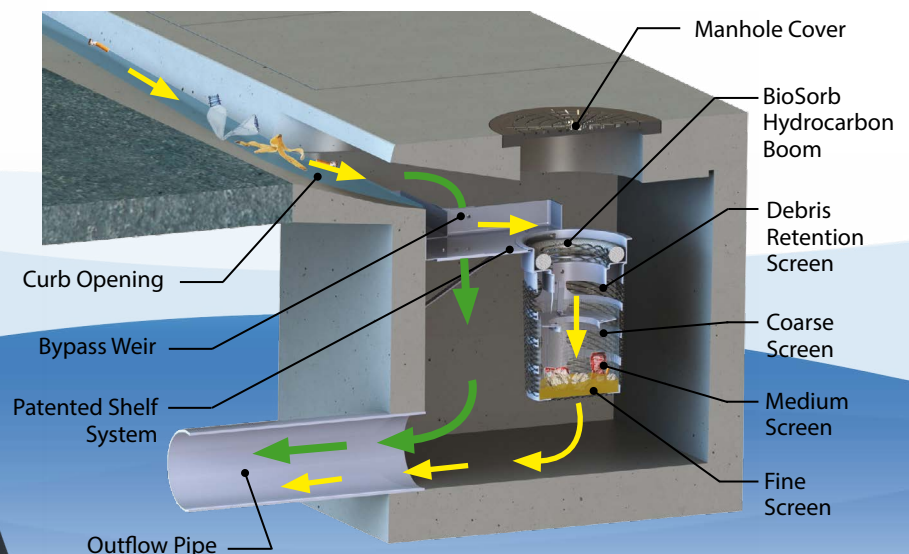
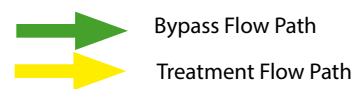

Round Curb Inlet Filter (R-GISB)

PROVEN STORMWATER TREATMENT TECHNOLOGY

Media Filter

The Bio Clean Round Curb Inlet Media Filter (RGISB-MF) is an advanced level filtration device designed with a multi-layered media filter for increased removal efficiencies.

Performance

- 85% Removal of Fine TSS
- 69% Removal of Dissolved Phosphorus
- 95% Removal of Copper
- 87% Removal of Lead
- 95% Removal of Zinc
- 90% to 95% Removal of Oils & Grease
- 68% Removal of Fecal Coliform (bacteria)

Specifications

Model #	Media Treatment Flow (CFS)	Screen Treatment Flow (CFS)	Bypass Flow (CFS)
BC-RGISB-MF-22-24	0.12	2	Unlimited

Higher Flow Rate Models Available

Operation

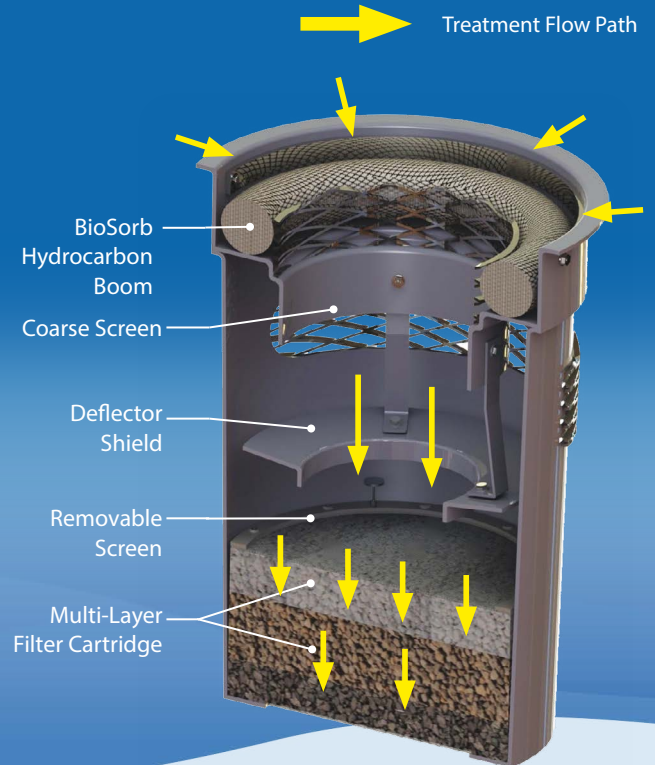

Installation & Maintenance



Vac Truck Hose

Cleaned Without Catch Basin Entry



Cleaned Easily With Vac Truck



15 Minute Service Time



Application

- Parking Lots
- Roadways



Easily Removed without Entry into Basin



Always Positioned Under Manhole Opening

Approvals



City and County of Honolulu



County of San Diego



County of Orange



Meets Full Capture Requirements

Bio Clean

A Forterra Company

398 Via El Centro
Oceanside, CA 92058
p 760.433.7640 f 760.433.3176
www.BioCleanEnvironmental.com