

Appendix A

Notice of Preparation and Comment Letters



City of Pismo Beach
Community Development Department
760 Mattie Road
Pismo Beach, California 93449
T: (805) 773-4657

www.pismo beach.org

Notice of Preparation

TO: Responsible Agencies & Interested Parties

SUBJECT: NOTICE OF PREPARATION OF A DRAFT ENVIRONMENTAL IMPACT REPORT

NOTICE IS HEREBY GIVEN that the City of Pismo Beach will be the Lead Agency and will prepare an Environmental Impact Report (EIR) for the project identified below. We need to know your views as to the scope and content of the environmental information that is germane to your agency's statutory responsibilities in connection with the proposed project. The City is issuing this Notice of Preparation to notify public agencies and the public to request input regarding the scope and content of the Draft EIR for this project.

The public review and comment period for this Notice of Preparation begins Friday, January 15, 2021 and ends Monday, February 15, 2021 at 5:00 p.m. A detailed project description with a project location map is available online at <http://www.pismo beach.org/905/DOCUMENTS>. No Initial Study is attached because the lead agency has already determined that an EIR is clearly required for the project and is therefore not required to prepare an Initial Study per CEQA Guidelines Section 15063(a).

Written comments may be submitted to City of Pismo Beach, Attn: Jeff Winklepleck, 760 Mattie Road, Pismo Beach, California 93449. In addition, because the project is of regional and areawide significance, a scoping meeting will be held by the City of Pismo Beach on Thursday, January 28, 2021 at 5:30 p.m. via video conference. This videoconference will be held in accordance with the provisions of Executive Order N-29-20, which authorizes local legislative bodies to hold public meetings via teleconferencing and to make public meetings accessible telephonically or otherwise electronically to all members of the public seeking to observe and to address the local legislative body during the period in which state or local public health officials have imposed or recommended social distancing measures. Executive Order N-29-20 (extended by Executive Order N-80-20) also waives all requirements in the Brown Act requiring the physical presence of personnel of the legislative body or of the public as a condition of participation in or quorum for a public meeting during the period in which state or local public health officials have imposed or recommended social distancing measures. To access the video conference, visit <https://dudek.zoom.us/j/96637299844?pwd=bVQyR0g5bWduRHIHOWdyRGVEbENFQT09> or use the call-in number 669-900-6833 and enter the meeting ID 966-3729-9844# on Thursday, January 28, 2021 at 5:30 p.m.

Project Title: Pismo Beach General Plan/Local Coastal Plan (GP/LCP) Update

State Clearinghouse #: *Pending*

Project Location:

The project focuses on the land area of the City of Pismo Beach, which is located on the Central Coast of California, midway between San Francisco and Los Angeles. Pismo Beach lies within the San Luis Bay Planning Area of the San Luis Obispo County General Plan. Pismo Beach has a total area of 13.5 square miles, the majority of which is located in the Coastal Zone. 9.9 square miles of the City is water and the remaining 3.6 square miles is land area. Pismo Beach is one of seven incorporated cities within San Luis Obispo County. Pismo Beach is bordered by the beach and ocean on the southwest and hills to the northeast. The Cities of Grover Beach and Arroyo Grande are south and east of Pismo Beach and the unincorporated community of Avila Beach is just north of Pismo Beach.

Project Sponsor: City of Pismo Beach, Planning Division
760 Mattie Road, Pismo Beach, CA 93449

Brief Project Description:

The project is an update to the City of Pismo Beach GP/LCP, which includes updates to the Land Use, Safety, Conservation and Open Space, Noise, Facilities, and Parks, Recreation, and Access Elements of the City's GP/LCP. The GP/LCP Update does not include updates to the Circulation, Design, Growth Management, Housing Elements. The GP/LCP Update is an update of the City's 1992 GP/LCP and presents the community's vision for Pismo Beach through the GP/LCP horizon (year 2040). The GP/LCP Update was developed through an extensive public outreach and involvement process, including careful analysis by advisory committees, City staff, elected officials, and the community. Each element of the plan addresses different aspects of the community and identifies measurable actions to guide residents, decision-makers, businesses, and City staff toward achieving the community vision. Goals established in the GP/LCP Update are intended to maintain the City's small beach town character, manage growth effectively, provide a safe community, and enhance the City's tourist-based economy. The GP/LCP Update establishes overarching City policies and priorities that describe how the community intends to use and manage its physical, social, and economic resources. The GP/LCP Land Use Element guides the future development of Pismo Beach by establishing the allowable distribution, location, and extent of development across the city for residential, commercial, open space, public and semi-public facilities, and other uses. The LCP consists of two parts as required by the Coastal Act: a Land Use Plan, which was last updated in 1993, and the Implementation Plan, which was last updated in 1983, with several amendments to both documents occurring since. The Implementation Plan provides the zoning regulations that implement the LUP goals, policies and actions and serves as the City's Coastal Zoning Ordinance. Potential environmental effects include, but are not necessarily limited to, impacts related to air quality, biological resources, cultural and tribal cultural resources, energy, greenhouse gas emissions, hazards and hazardous materials, hydrology/water quality, land use, noise, and transportation.

Consulting firm retained to prepare draft EIR:

Firm Name: Rincon Consultants, Inc.
Address: 1530 Monterey Street, Suite D, San Luis Obispo, California 93401
Contact: Christopher Bersbach, Senior Environmental Planner

Date: January 15, 2021

Signature:



Jeff Winklepleck

Title: Senior Management Analyst, City of Pismo Beach
Phone: (805) 773-4658



Air Pollution Control District
San Luis Obispo County

Via Email

February 11, 2021

Jeff Winklepleck
City of Pismo Beach
Community Development Department
760 Mattie Road
Pismo Beach, California 93449

SUBJECT: Notice of Preparation (NOP) of a Draft Environmental Impact Report (DEIR)
for the Pismo Beach General Plan/Local Coastal Plan (GP/LCP) update

To Jeff Winklepleck:

Thank you for including the San Luis Obispo County Air Pollution Control District (APCD) in the environmental review process. We have completed our review of the Pismo Beach GP/LCP update NOP/DEIR referral.

The City of Pismo Beach GP/LCP will include updates to the Land Use, Safety, Conservation and Open Space, Noise, Facilities, and Parks, Recreation, and Access Elements of the City's GP/LCP. The GP/LCP Update does not include updates to the Circulation, Design, Growth Management, Housing Elements. The GP/LCP Update is an update of the City's 1992 GP/LCP and presents the community's vision for Pismo Beach through the GP/LCP horizon (year 2040). Each element of the updated plan will address different aspects of the community and identifies measurable actions to guide residents, decision-makers, businesses, and City staff toward achieving the community vision. Goals established in the GP/LCP Update are intended to maintain the City's small beach town character, manage growth effectively, provide a safe community, and enhance the City's tourist-based economy. The GP/LCP Update establishes overarching City policies and priorities that describe how the community intends to use and manage its physical, social, and economic resources. The GP/LCP Land Use Element guides the future development of Pismo Beach by establishing the allowable distribution, location, and extent of development across the city for residential, commercial, open space, public and semi-public facilities, and other uses.

The following APCD comments are pertinent to this plan update.

The DEIR should include a description of existing air quality and emissions in the impact area, including the attainment status of the APCD relative to State and Federal air quality standards and any existing regulatory restrictions to development.

The most appropriate standard for assessing the significance of potential air quality impacts for General Plan and Local Coastal Plan update EIRs is the preparation of a

consistency analysis. This analysis should evaluate the proposed update against the land use and transportation goals, policies, and population projections contained in the [APCD Clean Air Plan](#), the San Luis Obispo Council of Government's [Regional Transportation Plan](#), and local Climate Action Plans. The rationale for requiring the preparation of a consistency analysis is to ensure that the attainment projections developed by the APCD and state requirements are met and maintained. Failure to comply with these plans could result in long term air quality impacts.

The APCD's [CEQA Air Quality Handbook](#) and recently refreshed [Land Use & CEQA webpage](#) provides guidance for preparing the consistency analysis. In addition, the APCD also recently issued [CEQA greenhouse gas guidance](#) which, although has a project level focus, also cites legal cases, some of which may have general plan relevance. Another reference that should be insightful to updating several GP/LUC elements in ways that minimize air quality impacts is APCD's July 6, 2020 comments for the San Luis Obispo Countywide Regional Housing Compact (attached).

The DEIR should include a range of alternatives that could effectively minimize air quality impacts. A consistency analysis should be performed for each of the proposed alternatives identified, as described above. A qualitative analysis of the air quality impacts should be generated for each of the proposed alternatives. Examples include but are not limited to:

- Flexible zoning to promote mixed use and design standards that protect mixed use.
- Increase the amount of neighborhood scale mixed use.
- Additional density beyond proposed zoning allowances.
- Design standards that require narrow streets and minimum front setbacks on structures.

Limiting the size of each arterial through the development. This reduces the need for noise barriers such as cinder block walls along roadways, decreases roadway widths, and slows the speed of traffic, creating an atmosphere that encourages active transportation.

Finally, development adjacent to high-volume roadways and railroads where mobile sources produce diesel particulate matter can present health risks to sensitive receptors. Diesel particulate matter has been classified by the California Air Resource Board's (CARB) as a toxic air contaminant and a carcinogen. Because of this, the APCD does not support sensitive receptor development near Highway 101 and railroads. Non-sensitive uses and developments such as commercial, parking lots and offices in which occupants are exposed to the health risk for a shorter duration—are better suited to be nearest to Highway 101 and railroads. Health risk decreases with decreased rate of exposure to the toxic source.

Should development occur near Highway 101 and railroads, the APCD recommends the following:

- Orient the sensitive receptor as far back as possible from the toxic source, which will directly reduce cancer risk;
- Incorporate strategies stated in Table 1 from the California Air Resource Board's technical advisory document [Strategies to Reduce Air Pollution Exposure Near High-Volume Roadways](#);
- Note: Implementing strategies such as air filtration systems, sound walls, and vegetation barriers have not been proven to be as effective as moving a sensitive receptor farther from the toxic source; and
- Disclose potential health risks to future sensitive receptors for informational purposes.

APCD Comments for the Pismo Beach GP/LCP update
February 11, 2021
Page 3 of 3

Further, residential units sited near pollution sources are generally lower in market value, indicating it is possible residential homes would become affordable to lower-income populations. Low-income community members often face existing health disparities, so siting housing near air pollution sources which has a possibility to become affordable may need further consideration ([See Page 57 of the CARB's 2017 Scoping Plan update](#)).

Thank you for the opportunity to comment on this plan update. The APCD looks forward to reviewing the Draft EIR for the GP/LUC update when it is complete and please contact me at 805-781-5912 if there are APCD questions during the DEIR development.

Sincerely,

 for

GARY ARCEMONT
Air Quality Specialist

GJA/lmg

Cc: Christopher Bersbach, Agent

COPY
Attachment



Air Pollution Control District
San Luis Obispo County

Via Email

July 6, 2020

Carolyn K. Berg
San Luis Obispo County
1055 Monterey Street
San Luis Obispo, CA 93408
cberg@co.slo.ca.us

SUBJECT: APCD Comments Regarding the San Luis Obispo Countywide Regional Housing Compact

Dear Ms. Berg:

The San Luis Obispo County Air Pollution Control District (APCD) reviewed the Draft San Luis Obispo Countywide Regional Housing Compact (Regional Compact). The APCD would like to commend the County of San Luis Obispo for leading the region to a unified vision for this compact. The Regional Compact develops an initial list of regional policies for jurisdictions to consider in their efforts to achieve their Regional Housing Needs Allocation requirements and support this effort. The APCD supports the stated regional goals in the Regional Compact to guide collaborative resolution of underlying housing and infrastructure needs.

The APCD specifically supports *Goal 3: Create Balanced Communities*, *Goal 4: Value Agriculture & Natural Resources* and *Goal 5: Support Equitable Opportunities*. These goals not only support the regional housing and infrastructure vision; but can also improve the region's air quality. Balancing jobs/housing can reduce emissions and vehicle miles traveled (VMT) by minimizing the number of trips and commute distances. Preserving agriculture and natural resources avoids the loss of sequestration potential; a long-term path for reducing greenhouse gases (GHGs) in the natural environment. It also avoids air quality impacts when agricultural land outside of Urban Reserve Lines (URLs) are converted to more intense land uses.

Goal 3 and 4 can also ensure the development of walkable and bikeable communities within the URLs. When people can walk and cycle to nearby workplaces, traffic is reduced, and physical activity is promoted which can help to create healthier communities. The APCD supports these goals, as they are consistent with the SLO APCD's Clean Air Plan and SLOCOG's Regional Transportation Plan and Sustainable Communities Strategy. Additionally, Goal 5 supports the development of housing within our jurisdictions that is available to people at all income levels. By improving housing affordability within the URLs

there is an opportunity to improve jobs/housing balance which reduces VMT and related air pollution.

The housing elements currently available for review show updates with the Regional Compact goals and policies in mind. The table below displays some examples:

<p>City of Atascadero's proposed Program 1.C Mixed-Use Development</p>	<p>Continue to allow mixed residential and commercial development and promote second- and third-story residential development in the Downtown zoning districts. To increase project certainty and streamline development, the City will consider identifying appropriate, mid-block locations, outside of the downtown, for future mixed-use/residential development (in commercial zoning districts) while considering appropriate jobs/housing balance and fiscal impacts. Considering market conditions and development costs, the City will provide, when possible, developer incentives such as expedited permit processing and flexible development standards for units that are affordable to lower-income households.</p>
<p>City of San Luis Obispo's proposed Program (5.6) Housing Variety</p>	<p>This program proposes that the City evaluate ways in which to increase the number of housing units available to the missing middle by specifically exploring ways to promote housing types such as duplexes, triplexes, quadplexes, cottages, etc.</p>
<p>San Luis Obispo County's proposed Program B: AB 686 Affirmatively Further Fair Housing</p>	<p>Take actions and/or update the Fair Housing Plan to affirmatively further fair housing and ensure compliance with AB 686 to ensure that meaningful actions will be taken to combat discrimination, overcome patterns of segregation, and foster inclusive communities free from barriers that restrict access to opportunity based on protected characteristics.</p>
<p>City of Morro Bay's Program H-1.4</p>	<p>In order to create a vibrant, pedestrian- and bicycle-friendly small urban atmosphere in the downtown area and ensure optimal access to services and public transportation, the City will encourage the development of new high-density housing in and adjacent to the downtown commercial district. To facilitate this goal, the City will inventory vacant and underutilized lots in and adjacent to the downtown business district, identify sites or areas where re-zoning to high-density residential or mixed-use categories might be desirable and modify the City's zoning map as appropriate.</p>

The APCD would like to commend the many goals, policies and programs in the Regional Compact and housing elements that minimize air quality impacts from development. However, the siting of housing units should be done in accordance with the California Air Resource Board's technical advisory document [Strategies to Reduce Air Pollution Exposure Near High-Volume Roadways](#) to reduce diesel particulate matter impacts. Diesel particulate matter has been classified by the state as a toxic air contaminant and a carcinogen. Locating housing near some sections of rail lines may

also pose toxic risk impacts due to locomotive traffic or idling. Finally, siting lower-income housing near diesel impact sources may need further consideration because these community members often face existing health disparities ([See Page 57 of the CARB's 2017 Scoping Plan update](#)).

Local governments should also consider localized air pollution resulting from the concentration of various stationary sources, such as freight-handling facilities, manufacturing facilities or other industrial air pollution sources. When siting new housing near potential sources of pollution, layout and design considerations to reduce exposure to sensitive land uses should be incorporated. For example, policies can identify minimum setbacks and orientation strategies to be sited as far as possible from the toxic source to avoid health risks. Further, ensuring housing is located near or developed with transit services and active transportation infrastructure, offers the opportunity to minimize trip and commute distances and provide alternative transportation options to employment, schools, and services which can help reduce emissions and improve our region's air quality.

The APCD hopes the other proposed housing elements will also pursue goals and policies from the Regional Compact. Again, thank you for the opportunity to comment on this proposal. If you have any questions or comments, feel free to contact me at (805) 781-5912.

Sincerely,



JACKIE MANSOOR
Air Quality Specialist

JNM/jjh

cc: Rachel Cohen, City of San Luis Obispo
John Holder, City of Atascadero
Janet Reese, City of Grover Beach
Corey Hanh, County of San Luis Obispo
Darcy Delgado, City of Paso Robles
Andrew Perez, City of Arroyo Grande
Matt Downing, City of Pismo Beach
Nancy Hubbard, City of Morro Bay

DEPARTMENT OF TRANSPORTATION

CALTRANS DISTRICT 5
50 HIGUERA STREET
SAN LUIS OBISPO, CA 93401-5415
PHONE (805) 549-3101
FAX (805) 549-3329
TTY 711
www.dot.ca.gov/dist05/



Making Conservation
a California Way of Life.

February 16, 2021

SLO Various
SCH# 2021010158

Jeff Winklepleck,
Senior Management Analyst
City of Pismo Beach
760 Mattie Road
Pismo Beach, CA 93449

COMMENTS FOR THE NOTICE OF PREPARATION (NOP) FOR THE PISMO BEACH
GENERAL PLAN & LOCAL COASTAL PLAN UPDATE

Dear Mr. Winklepleck:

The California Department of Transportation (Caltrans) appreciates the opportunity to review the NOP for the Pismo Beach General Plan & Local Coastal Plan Update. Caltrans offers the following comments in response to the NOP:

1. Caltrans supports local development that is consistent with State planning priorities intended to promote equity, strengthen the economy, protect the environment, and promote public health and safety. We accomplish this by working with local jurisdictions to achieve a shared vision of how the transportation system should and can accommodate interregional and local travel and development. Projects that support smart growth principles which include improvements to pedestrian, bicycle, and transit infrastructure (or other key Transportation Demand Strategies) are supported by Caltrans and are consistent with our mission, vision, and goals.
2. As a result of Senate Bill (SB) 743, effective July 2020 Caltrans replaced vehicle level of service (LOS) with vehicle miles traveled (VMT) as the primary metric for identifying transportation impacts from local development. The focus now will be on how projects are expected to influence the overall amount of automobile use instead of traffic congestion as a significant

impact. For more information, please visit: http://opr.ca.gov/docs/20190122-743_Technical_Advisory.pdf.

3. Employing VMT as the metric of transportation impact Statewide will help to promote Green House Gas (GHG) emission reductions consistent with SB 375 and can be achieved through influencing on-the-ground development. Implementation of this change will rely, in part, on local land use decisions to reduce GHG emissions associated with the transportation sector, both at the project level, and in long-term plans (including general plans, climate action plans, specific plans, and transportation plans) and supporting Sustainable Community Strategies (SCS) developed under SB 375.
4. Caltrans encourages a Transportation Demand Strategies (TDM) plan that increases the efficiency of the transportation system by providing options for users other than driving alone, or by shifting travel away from peak periods to help lower VMT. Examples include: locating higher density projects near transit; incorporating Complete Streets; mix use development, and traffic calming measures to enhance walkability.
5. Climate change's impact on the State Highway System (SHS) and local roadways should be addressed given the forecasted regional increase in wildfires, precipitation, and sea level rise. The SHS is the backbone of most county-level evacuation plans and often provides the only high-capacity evacuation routes from rural communities. Further, the SHS serves as the main access routes for emergency responders, and may serve as a physical line of defense such as a firebreak or an embankment against floodwaters, etc.

Caltrans requests to be included in any future public noticing regarding this project to allow us to prepare for and participate in the public process.

We look forward to continued coordination with the City on this effort. If you have any questions, or need further clarification on items discussed above, please contact me at (805) 835-6432 or Jenna.Schudson@dot.ca.gov.

Sincerely,

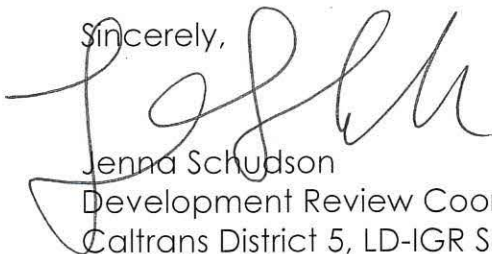

Jenna Schudson
Development Review Coordinator
Caltrans District 5, LD-IGR South Branch

Appendix B

Buildout Methodology

Pismo General Plan/Local Coastal Plan: Methodology for Determining Projected Development at Full Build Out

Used to create the LU-4 Table in the Land Use Element

1. Urban Footprint Base Canvas Assumptions

Urban Footprint's Base Canvas constitutes a baseline assessment of existing land use, demographic characteristics, and other conditions in the City, providing the context for scenario planning and the foundation for analysis of alternative scenarios. The default source for parcel information in Urban Footprint is CoreLogic, which is a leading provider of real estate data in the United States.

2. Determination of Land Uses for Inclusion

This buildout compares existing on-the-ground Base Canvas development to the buildout potential of four General Plan land use categories in the City where change is anticipated, including Commercial, Central Commercial, High Density Residential, Mixed Use, and Public/Semi-Public land uses. Only vacant and underutilized parcels within these designations were selected for potential growth.

3. Creation of Future Assumptions

When generating assumptions for the four land uses, Dudek first looked at the stated requirements or maximums for residential dwelling units per acre (du/ac), floor area ratio (FAR), height, and parking where possible. For each land use, employment and density limits were determined by matching them closely to the average employment and du/ac of current developed parcels within each land use category. An example formula to calculate commercial employment density can be seen below.

$$\begin{aligned} & \textit{Current Commercial Employment Density} \\ & = \left(\frac{\textit{Total Commercial Zoned Jobs} - \textit{Underutilized Commercial Zoned Jobs}}{\textit{Total Commercial Zoned Acres} - \textit{Underutilized Commercial Zoned Acres}} \right) \end{aligned}$$

Future assumptions for each land use were built in Urban Footprint using combinations of building components which created numbers closest to the determined employment and residential densities, and that worked to be within FAR, height, and parking requirements. Previous limitations within Urban Footprint required us to match Pismo's land use designations to prescribed building typologies in Urban Footprint, and adjusting them to match as closely as possible with Pismo's land use requirements and growth expectations.

Current standards per the Land Use Element Update and Future Assumptions used in the build out model can be seen for each of the included land uses below.

Current Land Use Density/Intensity Standards

Land Use Designations	FAR or Density	Height**	Implementing Zone(s)	Total Acreage
	<i>Coastal Zone/Non-Coastal Zone</i>	<i>Coastal Zone</i>		
Low-Density Residential	1 to 8 units per ac.	25 feet	R-1, R-R	76.5
Medium-Density Residential	9 to 15 units per ac.	25 - 35 feet	R-2, R-R	247.5
High-Density Residential	16 to 30 units per ac.	25 feet	R-3, R-R	22.2
Very High-Density Residential Overlay	20 to 50 units per ac.	35 – 45 feet***	R-3	1.1
Mobile Home Park	Maximum 8 units to the acre		M-H	58.5
Commercial	Maximum FAR of 2.0	25 - 42 feet	R-4, R-R, C-R, C-1, C-2, C-M	32.5
Resort Commercial	Maximum FAR of 1.25	35 feet	RR, R-4, and CR	73.9
Central Commercial	Maximum FAR of 1.25	35 feet	R-4, R-R, MU	66.4
Mixed-Use	Residential 1.25 maximum Commercial uses: 2.0 maximum	Determined by overlay zone	C-1, C-2, MU	57.2
Industrial	Maximum FAR of 0.5	25 feet	C-M	30.2
Public/Semi Public	Maximum FAR of 2.0	25 feet	G	468.38
Open Space	N/A	15 feet*	OS-1, OS-R	32.21

* Consistency with the View Consideration Overlay Zone must be determined for applicable properties

** Coastal height limits are provided to ensure that the scenic and visual qualities of coastal areas are considered and protected consistent with Coastal Act Section 30251.

*** Buildings may be up to forty-five (45) feet in height where the Planning Commission finds that significant public views to and along the coast and other scenic areas are protected.

Central Commercial Assumptions

Building Type Name <input type="text" value="Central Commercial Pismo (new)"/>	CCP
Land Use Category <input type="text" value="Commercial centers"/>	
Description <input type="text"/>	

Building Type Summary	
Floor area ratio - FAR	0.58
Residential density (net)	0 du/ac
Population density (net)	0 pop/ac
Employment density (net)	28.49 emp/ac

The Central Commercial land use had a maximum FAR of 1.25, and a maximum height of 35 feet. In looking at the currently built out Central Commercial sites, an FAR of 0.58 was determined to be more in line with what Pismo is likely to see built out, with an employment density of 28.49 employees per acre.

Commercial Assumptions

Building Type Name <input type="text" value="Commercial Pismo (new)"/>	CPN
Land Use Category <input type="text" value="Commercial centers"/>	
Description <input type="text"/>	

Building Type Summary	
Floor area ratio - FAR	0.31
Residential density (net)	0 du/ac
Population density (net)	0 pop/ac
Employment density (net)	15.8 emp/ac

The Commercial land use had a maximum FAR of 2.0, with maximum heights between 25 and 42. Due to the parking required and often offered at commercial sites and in looking at previously built out Commercial sites, an FAR of 0.31 was determined to be more in line with what Pismo is likely to see built out, with an employment density of 15.8 employees per acre.

High-Density Residential Assumptions

Building Type Name <input type="text" value="High-Density Residential"/>	HR
Land Use Category <input type="text" value="Multifamily"/>	
Description <input type="text" value="16-30 units per acre"/>	

Building Type Summary	
Floor area ratio - FAR	0.93
Residential density (net)	25.6 du/ac
Population density (net)	45.71 pop/ac
Employment density (net)	0 emp/ac

The High-Density Residential land use had an allowable range of 16-30 du/ac and a maximum height of 25 feet. Within the model, 25.6 du/ac were allotted for this land use.

Mixed-Use Assumptions

Building Type Name <input type="text" value="Low-rise Mixed Use Pismo (new)"/>	LMU
Land Use Category <input type="text" value="Mixed use commercial"/>	
Description <input type="text" value="16-30 units per acre"/>	

Building Type Summary	
Floor area ratio - FAR	3.66
Residential density (net)	88.67 du/ac
Population density (net)	150.03 pop/ac
Employment density (net)	33.39 emp/ac

The Mixed-Use land use had a maximum FAR of 1.25 for residential and 2.0 for commercial. Height maximums varied based on the overlay zoning. The model's FAR for mixed use is shown to be 3.66, far higher than what is allowed by these regulations. Heights were pre-set within the model and its

components, so to balance this in the model and create a zoning which is within the FAR requirements, vacant space was added to this mixed use zone. This is the equivalent of reducing the building height, and in turn the FAR, because by removing buildable space building volume is reduced to meet standards.

Medium-Density Residential Assumptions

Building Type Name MR

Medium-Density Residential

Land Use Category
Single-family detached

Description
9-15 units per acre

Building Type Summary

Floor area ratio - FAR	0.71
Residential density (net)	15.92 du/ac
Population density (net)	32.93 pop/ac
Employment density (net)	0 emp/ac

The Medium-Density Residential land use had an allowed range of 9-15 dwelling units per acre, and a maximum height of 25-35 feet. The closest building type in the model to these requirements slightly overshoots these requirements, coming in at 15.92 dwelling units per acre and leading to 32.93 people per acre. Sites that this assumption applied to were only those that are currently vacant (32 sites), as those were decided to be the only parcels in this land use designation that would experience growth. The slightly increased density is offset by the reduced density in the High-Density Residential designation.

Public/Semi-Public Assumptions

Component Name Density

Urban Public Library (Main Branch, Oakland CA) Medium

Land Use Category
Civic facilities

Address
Oakland, CA

Component Summary

Floor area ratio - FAR	0.53
Residential density (net)	0 du/ac
Population density (net)	0 pop/ac
Employment density (net)	68.7 emp/ac

The Public/Semi-Public land use has a maximum FAR or 2.0, and a maximum height of 25 feet. The closest building type in the model to these requirements is a modified public library, coming in at a 0.53 FAR and 68.7 employees per acre. Only one site was identified for build out.

4. Application of Future Assumptions

Future assumptions were applied to all underutilized and vacant parcels. For the Medium-Density Residential land use, as described above, only vacant parcels had future assumptions applied to them. The result of this was a “built out” Pismo Beach. Numbers generated and recorded include increases in population, DU, jobs, and non-residential square footage from 2020 to 2040. These increases can be seen on the table below.

Land Use	Number of Vacant or Underutilized Parcels	Potential Increase in Population	Potential Increase in Dwelling Units	Potential Increase in Jobs
Commercial	42	N/A	N/A	242
Central Commercial	26	N/A	N/A	33

Land Use	Number of Vacant or Underutilized Parcels	Potential Increase in Population	Potential Increase in Dwelling Units	Potential Increase in Jobs
High Density Residential	139	289	162	-12
Mixed Use	48	1,221	722	272
Medium Density Residential	32	471	228	0
Public/Semi-Public	1	-2	-1	10
Total	288	1,979	1,111	545

5. Comparison to SLOCOG Predictions

To compare to SLOCOG employment and dwelling unit predictions, growth per year ratios were utilized. SLOCOG’s predictions are from 2015 to 2030, or a 15 year range. Dudek’s predictions are from 2020 to 2040, a 20 year range. Build outs and assumptions were altered to create predictions closer to SLOCOG’s predicted growth, while staying within the land use requirements.

The discrepancies between growth predictions can be seen on the table below.

Growth Comparisons		
	Increase in DU	Increase in Jobs
Dudek Growth Per Year	55.5	25.8
SLOCOG Growth Per Year	47.7	27.4

Dudek’s current methodology assumes a 100% build out for the identified underutilized and vacant parcels.

Appendix C

Conservation and Open Space Fact Sheet

Conservation and Open Space

The Conservation and Open Space Element of the General Plan guides the conservation of resources important to the environment and sustained economic prosperity of Pismo Beach. How the City of Pismo Beach (City) manages its natural resources directly relates to its citizens' overall quality of life. The Conservation and Open Space Element will address the development, utilization, preservation and management of natural resources, including coastal resources, groundwater recharge areas, environmentally sensitive habitat areas, wetlands, areas with major mineral deposits, scenic resources, and historical and archaeological sites. It will also address the quality of the air and water as essential resources for the health and sustainability of the environment and those residing and visiting Pismo Beach.

Conservation Areas

The following section describes important conservation areas in Pismo Beach. Each area is related to the ocean, Pismo's foothills, or riparian corridors. These areas vary in plant and animal communities, location, ownership, and use. **Figure CO-1, Conservation Areas**, displays the location of each conservation area and Table CO-1 outlines the vegetation and wildlife for each conservation area.

Ocean

The Pacific Ocean is the most significant natural resource for Pismo Beach. It is also the most vulnerable and complex of natural resources due to the varied and intense uses to which it is subjected. The city's shoreline can be divided into four areas: the Northern Rocky Beaches, Southern Beach Community, Intertidal Zone, and Subtidal Zone.

Northern Rocky Beaches

North of Pismo State Beach is an area defined by rocky beaches and points, and sea cliffs. This area includes the Dinosaur Caves, Shell Beach, and Sunset Palisades locations. Many birds nest, feed, roost, and float in these areas, such as Black Oystercatcher, Brandt's Cormorant, Brown Pelican, Double-crested Cormorant, Pelagic Cormorant, Peregrine Falcon, Pigeon Guillemot and Western Gull. Shell Beach includes cliffs and a small sand and cobble beach. Seal haul-outs (i.e., seals that temporarily leave the water) may also occur for California Sea Lions and Harbor Seals. Marine life is abundant within the reefs and rocky area abutting the beach, and is covered in the intertidal and subtidal sections, below. North of Shell Beach are the South Palisades and Sunset Palisades areas, which continue the line of cliffs, rocky points, and reefs, with occasional sandy pocket beaches dotting the coastline.

Figure CO-1: Conservation Areas



Source: City of Pismo Beach 2014.

**Table CO-1
Pismo Beach Wildlife Habitats**

Conservation Area	Vegetation/Plant Communities	Wildlife
Northern Rocky Beach Areas	Black-flowered Figwort	Black Oystercatcher, Brandt's Cormorant, Brown Pelican, California Sea Lion, Double-crested Cormorant, Harbor Seal, Pelagic Cormorant, Peregrine Falcon, Pigeon Guillemot, Western Gull
Southern Beach Community	Coastal Dune Scrub, Primary Dunes, Beach Spectaclepod (ST), Blochman's Leafy Daisy, Surf Thistle (ST)	Ground Squirrel, mice, gophers, foxes, weasels, turkey vultures, owls, hawks, falcons, Sandy Beach Tiger Beetle, Western Gull, Western Snowy Plover (T)
Intertidal Zone	Reef	Black Abalone (E), Pismo Clam
Subtidal Zone	Kelp Forest, Reef	Blue Whale (E), Dali Porpoise, East Pacific Green Turtle (T), Fin Whale (E), Gray Whale, Guadalupe Fur Seal (E), Humpback Whale (E), Leatherback Sea Turtle (E), North Pacific Loggerhead Sea Turtle (E), North Pacific Pilot Whale, North Pacific Right Whale (E), Olive Ridley Sea Turtle (T), Pacific White Sided Dolphin, Sea Otter (E), Sei Whale (E), Southern Resident Killer Whale (E), and Sperm Whale (E)
Freeway Foothills	Black-flowered Figwort, Coastal Scrub, Grassland, Maritime Chaparral, Oak Woodlands, Sycamore and Willow Riparian Corridors	Ground squirrels, mice, gophers, foxes, weasels, opossum, deer, mountain lions, meadowlarks, finches, sparrows, turkey vultures, owls, hawks, falcons, South-Central California Coast Steelhead (T), California red-legged frog (E), Western Pond Turtle
Price Canyon	Sycamores, oaks, willows, nettles, poison hemlock, Mesa Horkelia	Ground squirrels, mice, gophers, foxes, weasels, opossum, deer, mountain lions, meadowlarks, finches, sparrows, turkey vultures, owls, hawks, falcons, South-Central California Coast Steelhead (T), California red-legged frog (E), Western Pond Turtle
Oak Park Heights	Black-flowered Figwort, Pockets of Grassland, Maritime Chaparral, Oak Woodland, Riparian Corridors	Ground squirrels, mice, gophers, foxes, weasels, opossum, deer, mountain lions, meadowlarks, finches, sparrows, turkey vultures, owls, hawks, falcons
Pismo Marsh	Alkali Heath Marsh, Arroyo Willow Thickets, Black-flowered Figwort, California Bulrush Marsh, Coast Live Oak Woodland, Creeping Rye Grass Turfs, Freshwater Marsh, Marsh Sandwort (E), Purple Needlegrass Grassland, Sedge Series	Allen's Hummingbird, Bewick's Wren, California Least Tern (E), Caspian Least Tern, Caspian Tern, Common Yellowthroat, Double-crested Cormorant, Nuttall's Woodpecker, Oak Titmouse, Wrentit, Western Pond Turtle
Pismo Creek	Riparian Corridors	Rainbow trout, speckled dace, prickly sculpin, threespined stickleback, brown bullhead, tidewater goby (E), starry flounder, jacksnelt, white surfperch, waterfowl, Green Sturgeon (T), South-Central California Coast Steelhead (T)
Monarch Butterfly Grove	Eucalyptus grove	Monarch butterflies

Sources: City of Pismo Beach 2014; Coastal San Luis Resource Conservation District 2010; LCSLO 2019; USFWS 2019.

Note: ST = State Threatened, T = Federally Threatened, E = Federally Endangered.

Southern Beach Community

The beach from the southern city limits to approximately three miles north is predominantly an area called Pismo State Beach which is under the ownership of the State of California, controlled by the state Department of Parks and Recreation and managed by Pismo Beach. This location is a wide, sandy beach which provides the opportunity for both passive and active recreational and educational activities.

At the southern end of the city are sand dunes that are considered part of the coastal strand community, which is composed mainly of beach and primary dunes, with some coastal dune scrub habitat mixed in. Since the plant life must adapt to constantly shifting sand conditions created by the winds, plants that are low growing and often succulent are typical of the plant community.

Northern Rocky Beaches

See Intertidal and Subtidal Zones.

Intertidal Zone

The intertidal zone is a unique area between the high tide and low tide lines. This stretch of shoreline spends multiple times each day covered and uncovered by water. Its form varies and can include hard, fine sand or a rocky tide-pool substrate. Within the boundaries of Pismo State Beach, the State Lands Commission has jurisdiction over all matters concerning the area's wildlife populations and owns the intertidal zone.

Populations of the Pismo clam live in the intertidal zone and a variety of bird species also feed in the intertidal zone. The federally endangered black abalone also has a chance of living in rocky intertidal reefs off of Pismo Beach. Recreational activities include bird watching, tide-pooling, walking, and jogging. At high tides, this zone is also popular for surf fishing. In the past this area was used intensively by clammers until the clams disappeared from the area; however, management of the area by the California State Department of Parks has allowed for clams to repopulate to a degree. Despite this, there is only a limited possibility that the clam beds will ever reach the population size they once had.

Subtidal Zone

The subtidal zone is an area between the mean-lower low tide line and the point where the ocean reaches a depth of 100 feet. Subtidal land is under the jurisdiction of the State Lands Commission. Along Pismo State Beach, this area is generally a sand or mud bottom and is relatively level. In the northern half of the city, the subtidal zone is rocky near the shore.

Portions of Pismo Beach's subtidal zone are home to kelp beds which are a supremely important habitat. The federally endangered black abalone can be found in rocky reefs in the subtidal zone. The threatened sea turtles found at times in the subtidal zone are East Pacific Green Turtles and Olive Ridley Sea Turtles. The Leatherback Sea Turtle and North Pacific Loggerhead Sea Turtle are found in the area and are endangered. The subtidal zone also includes the following endangered mammals: Blue Whale, Fin Whale, Guadalupe Fur Seal, Humpback Whale, Southern Resident Killer Whale, North Pacific Right Whale, Sea Otter, Sei Whale, and Sperm Whale (NOAA 2012). Other marine mammals found in this area are the Dali Porpoise, Gray Whale, North Pacific Pilot Whale and Pacific White Sided Dolphin.

Uses for this area currently include recreation in the form of fishing, boating, swimming, kayaking, and paddle boarding. As of right now there is no offshore drilling, which would require not only federal and state permits, but also county voter approval for onshore facilities supporting offshore drilling. This is due to Measure A, a measure adopted by San Luis Obispo County in 1986 (County of San Luis Obispo 1992).

Foothills

Foothills are a major aspect of the visual character and biological functions of Pismo Beach. They act as a backdrop for the city and a complement to the Pacific Ocean. Three major coastal foothill areas exist in Pismo Beach including the freeway foothills, Price Canyon, and the Pismo Heights area. Much of these areas include heavily grazed, open grassland, pockets of oak woodland, riparian corridors, and chaparral vegetation. Portions of steep topography in these foothills have constrained growth and shaped the soil, hazards, and species present in the area.

Freeway Foothills

Freeway foothills about Highway 101 to the north, and are the predominant land form in northwestern Pismo Beach. The hills consist of grassland with pockets of oak woodlands and coastal scrub. Barrancas, or finger canyons, line the hills and add texture and valuable habitat to the area. This land is primarily privately owned.

Within the stretch of freeway foothills is Pismo Preserve. Pismo Preserve is 900 acres of open space located on the eastern portion of the Freeway Foothills. It's owned and managed by the Land Conservancy of San Luis Obispo County. The preserve includes multiple plant communities, including grassland, coastal scrub, maritime chaparral, oak woodlands, and sycamore and willow riparian corridors. As of September 2019, construction of a parking lot off of Mattie Road began to allow access to the preserve. Scenic views, hiking, mountain biking, and horseback riding along several miles of dirt roads and trails are anticipated. The preserve contains oak woodlands and coastal ridgelines that provide ecological value (LCSLO 2019).

These foothills offer habitat to federally threatened South-Central California Coast Steelhead, federally endangered California red-legged frog, and other species of concern such as the southwestern pond turtle.

Price Canyon

Price Canyon surrounds and drains into the northeastern portion of Pismo Creek. It is similar to the Pismo Preserve, and contains pockets of oak woodlands and sycamores, as well as willows and cottonwood and other riparian tree species among the surrounding grazing land. Much of this land is not directly within city limits, but its conservation is integral to the quality of Pismo Creek.

Oak Park Heights

The Oak Park area is located in the Southeastern portion of Pismo Beach. This area has been built out mainly for residential development, however it still includes pockets of grassland, native chaparral, oak woodlands, and riparian corridors. Some of this area drains into Pismo Marsh, giving it extra ecological importance. This area is different than the others listed here due to its developed nature. Because only pockets or corridors of biodiversity are left, it's more important to conserve them and keep connectivity between Pismo Marsh and other areas possible.

Riparian

Riparian habitat is the environment associated with lands adjacent to freshwater sources. These areas fulfill an important role in Central California, performing a variety of biological and recreational functions. Habitat can vary but is generally characterized by plant and animal communities requiring more moisture than that which is available from precipitation. Pismo Beach has three such areas of importance including the Pismo Marsh, Pismo Creek, and Pismo Beach Monarch Butterfly Grove. Each supports a different variety of species and are unique features in Pismo Beach.

Pismo Marsh

Pismo Marsh, also known as Pismo Lake Ecological Preserve, is located in the southeastern portion of the city. It is primarily a freshwater marsh, though an area of salt marsh vegetation also exists in the southwest portion of the preserve.

Pismo Creek originally fed this marsh, however Meadow Creek is now the sole freshwater water source for Pismo Marsh. The marsh is 54 acres and is under the ownership and management of the California Department of Fish and Wildlife.

The California Department of Fish and Game has estimated that as many as 59 species of birds, 24 species of mammals and four species of reptiles and amphibians may be found in the relatively undisturbed lake habitats. Therefore, it plays an important role as habitat for a wide variety of wildlife. It also provides a vital link in the Pacific Flyway used by numerous species of migratory birds. Some of the sensitive plants and plant communities found here as of 2010 include Alkali Heath Marsh, Arroyo Willow Thickets, Black-flowered Figwort, California Bulrush Marsh, Coast Live Oak Woodland, Creeping Rye Grass Turfs, Freshwater Marsh, Purple Needlegrass Grassland and Sedge Series. Allen's Hummingbird, Bewick's Wren, California Least Tern, Caspian Least Tern, Caspian Tern, Common Yellowthroat, Double-crested Cormorant, Nuttall's Woodpecker, Oak Titmouse, and Wrenit are all sensitive birds which have been found here. Western pond turtles were the only sensitive reptile or amphibian found in the marsh (Coastal San Luis Resource Conservation District 2010).

The preserve's management does not allow interpretive, educational or passive recreational access to the marsh at this time.

Pismo Creek

The previously mentioned Price Canyon foothills feed Pismo Creek, a 5.5 mile stream originating in the San Luis Valley. This creek flows westward, forming a major inland entrance to Pismo Beach. Pismo Creek is an intermittent creek, meaning the creek bed is generally dry in the summer and fall, but seasonally flows with up to 5 feet of freshwater. At low tide, a sand bar prevents the creek from draining into the ocean and creates a small, intermittent lagoon at the mouth of the creek. Pismo Creek offers habitat for various fish including the federally endangered tidewater goby and threatened South-Central California Coast Steelhead and Green Sturgeon (USFWS 2019).

Monarch Butterfly Grove

The Monarch Butterfly Grove at Meadow Creek is located in the southeastern portion of the city. The habitat consists of eucalyptus trees, which are used by over 10,000 monarchs annually as a resting point. This area is a sanctuary for butterflies in the winter, which is the most sensitive part of the monarch's life cycle. Land uses for this area include educational, scientific, and recreational use.

Open Space

Open space is a special purpose zoning district intended to protect areas with significant natural resources, environmentally sensitive habitats, and/or scenic views. These areas include: hillsides, waterways, coastal and hillside view corridors, public beaches, and parks. Land use on open space is meant to be less intense, and often includes recreation and limited residential uses. Additionally, open space lands are not intended to be intensively developed with buildings or other structures, however there are some permits which can be obtained for these structures. **Figure CO-2** displays all open space designated land uses, as well as an overlay showing the aforementioned conservation areas. It should be noted that not all open space areas are conservation areas, as some are used for recreation, education, public assembly, or more.

Figure CO-2: Pismo Beach Open Space



Sources: City of Pismo Beach 2014; Coastal San Luis Resource Conservation District 2010; LCSLO 2019; USFWS 2019.

Other Natural Resources

The following outlines other important natural resources that are important to conserve and which are currently protected from development.

Geology and Minerals

The City has no active mineral operations within their jurisdiction, nor does it have any land classified as a grade II machine-readable zone (MRZ-2) for containing concrete-grade aggregate within their jurisdiction.

No oil fields lie within the city, nor are there any active offshore drilling operations.

Soils

Class I soil is considered to have slight limitations for agricultural use, while Class II soil has moderate limitations for agricultural uses which could include a reduction of plant choices or a need for moderate conservation practices.

Approximately 18 acres of prime, class I soil exists within the city, however this area is currently used for recreation as it covers Pismo Beach Golf Course and North Beach Campground (County of San Luis Obispo n.d.). Approximately 33 acres of class II soil is contained within the city, which is used primarily for residential or commercial purposes. All soils below class II have severe limitations for agricultural uses and will not be discussed (USDA n.d.).

Cultural / Tribal Resources

The coast of Pismo Beach is home to archaeological sites that are a result of thousands of years of settlement and are a fragile resource of the city. These sites are declared culturally and historically important and should be conserved. The Chumash are a Native American people who originally inhabited areas of Southern California including the land where Pismo Beach currently exists. Archaeological evidence suggests the Chumash people lived in this area and near the Santa Barbara channel for thousands of years. Chumash tribal sites and related archaeological sites are designated as natural and historical resources and have psychological function associated with the core of Pismo Beach's identity and existence, and many are preserved as open space.

The Coastal Act was updated in 2004 to require intergovernmental consultation with Native American tribes. The new provisions require cities and counties to contact, and consult with, California Native American tribes prior to amending or adopting a general plan or specific plan, or designating land as open space.

Environmental Quality

The following section describes the quality of air and water in Pismo Beach, which are essential natural resources for sustaining the health and quality of life for residents and visitors. Environmental quality is regulated by various state and federal agencies and must meet certain standards to comply with the law. Light pollution is also addressed, as preserving dark sky at night is important for sustaining the life and health of wildlife.

Air Quality

The clean air and pleasant climate of Pismo Beach are an important asset of the city that attracts residents and visitors alike. Rising population and increased tourism have caused some degradation of the air quality of the region, most notably through the increase in the number of vehicles in the city, subsequent increase in vehicle miles traveled (VMT) in recent years, and particulate matter emissions from the Oceano Dunes to the south due to high winds blowing sand and dust into the air.

National Ambient Air Quality Standards (NAAQS) and California Ambient Air Quality Standards (CAAQS) are clean air standards established to protect the public from high levels of air pollutants. The San Luis Obispo County Air Pollution Control District (APCD) is a regional agency that works to preserve air quality through implementing regulations and programs to assist the county in reaching attainment for those NAAQS and CAAQS. San Luis Obispo County suffers from high levels of particulate matter (PM₁₀) several times a year and has received the nonattainment designation for current ozone standards. Table CO-2 details the County's NAAQS and CAAQS attainment status based on pollutants defined by the California Air Resources Board. If pollutants are in nonattainment, implementation plans are put in place to outline actionable steps for the county to work towards attainment. The general plan should be consistent with these implementation plans.

**Table CO-2
San Luis Obispo County Air Quality Attainm**

Pollutant	Federal Designation	California Designation
Ozone (O ₃)	Non-Attainment Eastern SLO County - Attainment Western SLO County	Non-Attainment
Respirable Particulate Matter (PM ₁₀)	Unclassified / Attainment	Non-Attainment
Fine Particulate Matter (PM _{2.5})	Unclassified / Attainment	Attainment
Carbon Monoxide (CO)	Unclassified	Attainment
Nitrogen Dioxide (NO ₂)	Unclassified	Attainment
Sulfur Dioxide (SO ₂)	Unclassified	Attainment
Lead	No Attainment Information	Attainment
Visibility Reducing Particles	No Federal Standards	Attainment
Sulfates	No Federal Standards	Attainment
Hydrogen Sulfide	No Federal Standards	Attainment
Vinyl Chloride	No Federal Standards	No Attainment Information

Source: APCD 2019.

Note: Attainment = meets the standards; Attainment (Maintenance) = achieve the standards after a nonattainment designation; Nonattainment = does not meet the standards; Unclassified or Unclassifiable = insufficient data to classify; Unclassifiable/Attainment = meets the standard or is expected to be meet the standard despite a lack of monitoring data.

Water Quality and Supply

The Pacific Ocean is among the city's most significant natural resources and is valued for its aesthetic beauty and provision of open space. It is protected against development that would significantly alter its quality as a natural resource, and the

quality of the surrounding landscape and natural features. Pismo Marsh and Meadow Creek are among Pismo Beach’s most significant inland freshwater resources, and as such have been protected by the City against significant alteration.

The primary threat to the city’s water quality is intrusion of seawater into groundwater aquifers, which has been mitigated by maintaining a net outflow of groundwater into the ocean and reducing groundwater pumping to maintain levels above mean sea level. The City has met all federal and state standards for drinking water in 2018 and abides by their own certified Local Coastal Program (LCP) that aids in maintaining high standards for resource protection of water and coastal assets. The County of San Luis Obispo routinely monitors the water supply for chlorite and chlorate presence, both by-products of the water treatment process. The City maintains best practices by alternating disinfectants used in water treatment and monitoring chemical levels that can potentially degrade the quality of water or pose a risk to residents.

Nonpoint Source Pollution

Nonpoint source (NPS) pollution is the most significant cause of water pollution in the nation in both coastal and inland regions. NPS pollution is pollution from many sources, diffused over space and time. Common occurrences of NPS are excessive use of fertilizer; pesticide runoff from upstream agricultural areas; and oil, grease, and other toxic chemicals running off from energy generation sites or industrial production zones. This type of water pollution likely affects Pismo Beach through runoff from agricultural installations and through excess soil and dust entering water from grading and construction.

The City complies with the U.S. Environmental Protection Agency and State Water Resources Board approved Total Maximum Daily Load (TMDL) to monitor and maintain water quality for use and particulate material. The TMDL identifies maximum levels of given pollutants that are acceptable per volume in a water body, designates responsible parties for managing and controlling pollutant levels, establishes quantitative measurements of water quality, and sets forth implementation to achieve acceptable levels of pollutant loading. Table CO-3 identifies the potential pollutant sources for each land use.

**Table CO-3
Nonpoint Pollution Sources**

Land Use	Possible Nonpoint Pollutant Sources
Residential / Planned Residential	Driveway and sidewalk cleaning Vehicle and equipment maintenance/washing Landscape maintenance and washing Swimming pool and spa discharges Illicit connections Sump dewatering Painting
Commercial / Resort Commercial	Building maintenance (power washing) Dumping and spills Outdoor fluid storage Parking lot maintenance (power washing) Wash down of greasy equipment and grease traps Illicit connections Sump dewatering

**Table CO-3 Cont.
Nonpoint Pollution Sources**

Land Use	Possible Nonpoint Pollutant Sources
Industrial	Building maintenance (power washing) Dumping and spills Equipment washing Illicit connections Sump dewatering Outdoor fluid storage
Public/semi-public	Building maintenance (power washing) Dumping and spills Landscaping and grounds care (irrigation) Outdoor fluid storage Parking lot maintenance (power washing) Road maintenance Spill prevention and response Vehicle fueling, maintenance, repair, and washing Illicit connections
Mobile Home Parks	Vehicle accidents Mobile car wash and auto detailers, painters, power washers, pet washers, and food vendors New developments and redevelopment Homeless encampments Operations and maintenance

Point Source Pollution

Point source pollution is any singular, identifiable source that discharges pollutants. In Pismo Beach, sewage systems present the most significant production of point source pollution.

Light Pollution

The presence of bright lights at night has been proven to disrupt the normal foraging and breeding behaviors of seabirds. These birds can also experience "light entrapment", a state where they continually circle around light sources and become confused or disoriented, and as a result are "trapped" near the light source until the next dawn.

Plankton and fish are also adversely affected by bright artificial light sources, as they tend to be attracted to water that is typically better lit by artificial lighting. This behavior has been observed by predators, who recognize and use the artificial light to aid in hunting.

The main sources of light pollution in Pismo Beach are streetlights and exterior lighting for the downtown area, as well as lighting bordering scenic Highway 101.

Correlation with Coastal Act

The Pismo General Plan and Local Coastal Plan (GP/LCP) are a joint-document which means that they must correlate with the Coastal Act. The following section includes topics or aspects of topics which are unique to the Coastal Act, such as Environmentally Sensitive Habitat Areas (ESHA), wetlands, marine resources, and water quality.

Environmentally Sensitive Habitat Areas

ESHA is defined in the Coastal Act as “any area in which plant or animal life or their habitats are either rare or especially valuable because of their special nature or role in an ecosystem and which could be easily disturbed or degraded by human activities and developments” (Section 30107.5). ESHA designations are often based on the presence of rare, sensitive, or especially valuable species or habitats. In making ESHA determinations, the California Coastal Commission asks if either of the following conditions are met:

- 1) There are rare species of habitat in the subject area; or
- 2) There are especially valuable species or habitat in the area, which is determined based on:
 - a) whether any species or habitat that is present has a special nature, or
 - b) whether any species or habitat that is present has a special role in the ecosystem.

When the California Coastal Commission (CCC) finds that either of these two conditions is met, it assesses whether the habitat or species is easily disturbed or degraded by human activity and development. If they are, the CCC determines that area to be ESHA. To identify sensitive species and habitats, the following resources should be considered:

- the list of rare, threatened or endangered species prepared under the California or Federal Endangered Species Act
- the list of “fully protected species” or “species of special concern” by the California Department of Fish and Wildlife (CDFW)
- the list of “1b” species prepared by the California Native Plant Society
- the CDFW List of California Terrestrial Natural Communities Recognized by the California Natural Diversity Database

Generally, Environmentally Sensitive Habitat Areas (ESHA) include many types of woodlands, riparian areas, coastal plains and prairies. Pismo Beach’s ESHA includes Pismo State Beach, Pismo Marsh, Price Canyon, Pismo Creek, Pismo Preserve, Meadow Creek, the Oceano Dunes, and the Monarch Butterfly Grove. Habitat which supports endangered species in the area would likely qualify as ESHA. An important component of the combined GP/LCP will be to have ESHA areas delineated and mapped and policies in place to ensure their future protection pursuant to Coastal Act requirements. The Coastal Act restricts development within ESHA to only resource-dependent uses, and requires that ESHA be protected against significant disruption of habitat values (Section 30240). The Coastal Act also requires areas adjacent to ESHA to be sited and designed to prevent degradation of ESHA and to be compatible with the continuance of those habitat areas. This is typically established through ESHA buffers, among other policies.

Wetlands

Wetland is defined in the Coastal Act as “lands within the coastal zone which may be covered periodically or permanently with shallow water and include saltwater marshes, freshwater marshes, open or closed brackish water marshes, swamps, mudflats, and fens”(Section 30121). California Public Resources Code defines wetlands as “land where the water table is at,

near, or above the land surface long enough to promote the formation of hydric soils or to support the growth of hydrophytes, and shall also include those types of wetlands where vegetation is lacking and soil is poorly developed or absent as a result of frequent and drastic fluctuations of surface water levels, wave action, water flow, turbidity or high concentrations of salts or other substances in the substrate”(CCCR Section 13577[b]). Based on these definitions, wetlands under the Coastal Act may only display one of the wetland parameters typically used to define wetland areas, unlike the U.S. Army Corps of Engineers, which uses a three parameter definition under its federal authorities. In addition, the Coastal Act definition of wetland does not distinguish between wetlands according to their quality; poorly functioning, or degraded wetlands are afforded the same protection under the Coastal Act.

Wetlands within Pismo Beach include Pismo Marsh and Pismo Creek.

Marine and Coastal Resources

In addition to being Pismo Beach’s most significant conservation area, the ocean is Pismo Beach’s largest and most valuable marine and coastal resource. It provides ecological, recreational, economic, and aesthetic value, among others. The community's lineal physical form and related circulation patterns reflect the residents' strong desire to be as close as possible to the water. Historically, the community's economic basis was the ocean, and today Pismo Beach still heavily depends on the ocean for tourism. It is protected from development and must remain a natural and recreation asset for the city. The kelp beds and any other coastal habitats are also important marine resources that preserve biodiversity and the overall health of the coastal region. Coastal access points and surf breaks make the beach more accessible and attractive as a scenic and recreational resource of the city, and as such are also important coastal resources.

Other marine and coastal resources, some of which are described above, include:

- The municipal pier
- Beachfront facilities and amenities (parks, trails, open spaces, restrooms, sports facilities, community centers, parking lots)
- Groundwater resources
- Environmentally sensitive habitat areas and wetlands
- Scenic and visual resources, including scenic viewpoints and rock outcroppings
- Beach wrack, or washed up mounds of seaweed and organic material, which provides nutrients and ecosystem stability. Grooming of beaches for aesthetic purposes, including removal of beach wrack, can degrade the shore habitat and negatively affect coastal birds that nest in or near the coastal zone.

Water Quality

The Coastal Act requires the protection and enhancement of marine and coastal water resources, including water quality. Protection of coastal water resources requires not only minimizing pollutants in runoff, but also minimizing alterations in a site’s natural hydrologic balance, including the runoff flow regime. The City’s LCP is a key mechanism for achieving a high standard for coastal water resource protection and provides an important planning and regulatory framework for enhancing coastal NPS pollution control and minimizing changes in watershed hydrology.

Climate Change

It’s important to note that Pismo Beach’s natural resources may be impacted by climate change. In addition to changes in temperature and rainfall, increases in sea level is anticipated to alter the physical characteristics of wildlife habitat and plant/vegetation communities—inundating beaches, converting dry beach to intertidal or subtidal areas, and relocating the intertidal areas of wetlands to a more inland or upland location. The species that depend on these habitat areas may either be lost or relocate with the habitat. Other potential climate change concerns with regards to sensitive coastal

habitats include: 1) increased erosion of habitats due to sea level rise, 2) loss of wetland habitat due to sea level rise, 3) increased competition from non-native species as native species become more vulnerable, 4) increased fires and 5) loss and fragmentation of migration corridors. Each of these concerns will be important policy considerations for the GP/LCP.

Citations

- APCD (San Luis Obispo County Air Pollution Control District). 2019. "San Luis Obispo County Attainment Status." Accessed August 2019. <https://storage.googleapis.com/slocleanair-org/images/cms/upload/files/AttainmentStatus29January2019.pdf>
- City of Pismo Beach. 2014. City of Pismo Beach General Plan. Accessed August 2019. <https://www.pismobeach.org/109/General-Plan>
- Coastal San Luis Resource Conservation District. 2010. "Pismo Lake Natural Resources Inventory." Pismo Lake Natural Resources Inventory. California Department of Parks and Recreation, December 2010. http://www.coastalrcd.org/images/cms/files/NRI_Pismo_Lake_Final_1-21-110.pdf.
- County of San Luis Obispo. n.d. "Planning & Building." Natural Resource Maps. Accessed September 4, 2019. <https://www.slocounty.ca.gov/Departments/Planning-Building/Forms-Documents/Maps/Natural-Resource-Maps.aspx>.
- County of San Luis Obispo. 1992. Offshore Energy Element §. <https://www.slocounty.ca.gov/getattachment/d5774a1e-06c0-418f-b589-224ccd1857fb/Offshore-Energy-Element.aspx>.
- LCSLO (The Land Conservancy of San Luis Obispo County). 2019. "Pismo Preserve." May 2019. <https://lcslo.org/project/pismopreserve/>.
- NOAA (National Oceanic and Atmospheric Administration Fisheries West Coast Region). 2012. "California Species List Tools." NOAA Fisheries West Coast Region, October 22, 2012. https://www.westcoast.fisheries.noaa.gov/maps_data/california_species_list_tools.html.
- USDA (United States Department of Agriculture). n.d. Land Capability Classification, Land Capability Classification §. Accessed September 4, 2019. http://www.ncrcd.org/files/4414/0968/3285/NRCS_Land_Capability_Classes.pdf.
- USFWS (United States Fish & Wildlife Service). 2019. "Critical Habitat for Threatened and Endangered Species (USFWS)." September 3, 2019. <https://fws.maps.arcgis.com/home/webmap/viewer.html?webmap=9d8de5e265ad4fe09893cf75b8dbfb77>.

Appendix D

Land Use Fact Sheet

Land Use

The Land Use Element will guide the future development of Pismo Beach by establishing the allowable distribution, location, and extent of development across the city for residential, commercial, open space, public and semi-public facilities, and other uses. In addition to policies that apply to the entire city, the Land Use Element also contains specific goals and policies for individual neighborhood planning areas. The Land Use Element gives an overall framework for addressing community values and expectations into specific strategies for managing growth and enhancing quality of life. The Land Use Element will address topics unique to Pismo Beach such as coastal resources, planned residential developments, overnight accommodations, and cultural sites, and will align well with other general plan elements.

Planning Context

Pismo Beach is a small, central coast city and one of seven incorporated cities within San Luis Obispo County (County). The county is frequently divided into four general sub-regions: North Coast, Northeast County, South County, and Central San Luis Obispo. South County includes the incorporated cities of Pismo Beach, Grover City, and Arroyo Grande and the unincorporated communities of Avila Beach, Oceano, and Nipomo. Pismo Beach lies within the San Luis Bay Planning Area of the San Luis Obispo County General Plan, and has a total area of 13.5 square miles. Pismo Beach is bordered by the beach and ocean on the southwest and hills to the northeast. The cities of Grove Beach and Arroyo Grande are south and east of Pismo Beach and the unincorporated community of Avila Beach is just north of Pismo Beach.

The city's geologic setting contains coastal bluffs, coves, rolling hills, sand dunes, beaches, Pismo Creek, and Pismo Marsh. Pismo Beach has a general gradient that slopes south and west towards the Pacific Ocean and Pismo Creek. These unique geologic and coastal features host a variety of plant and wildlife species. The scenic Highway 101 runs through the city, with the majority of land uses southwest of Highway 101. Northeast of Highway 101 is generally residential uses and open space. This portion of the city abuts the Pismo Preserve to the north and east. The Pismo Preserve, managed by the Land Conservancy of San Luis Obispo County is within the County's jurisdiction and contains trails that offer panoramic views of the Pacific Ocean, Pismo Beach, and incorporated coastal communities. Southwest of Highway 101 provides a diverse mix of land uses that complement and utilize the city's coastal resources. As shown in the photos below, Pismo Beach offers a place where residents of all demographics can enjoy the city's visual, cultural, recreational, and natural resources.

Planning Areas

The City of Pismo Beach (City) is organized into neighborhood planning areas, each with its own name and unique characteristics. All of these planning areas are largely built-out, with only small (<1 acre) parcels remaining for new development. Therefore, demolition, reuse, and repurposing of existing buildings is more common than new construction on vacant land. The first General Plan in 1992 contained 18 planning areas and the City has since been working on consolidating these into 10 planning areas described briefly below. Figure LU-1 presents a map of these neighborhood planning areas and the current approximate development within each planning area is provided in Table LU-1.

Sunset Palisades/ Ontario Ridge/ South Palisades

This planning areas combines three planned residential uses and open space. The northern portion, identified as Ontario Ridge, includes relatively large single-family residential lots along Bluff Drive. South of the Ontario Ridge neighborhood is Sunset Palisades, which is also comprised of low-density single family residential and open space. South Palisades, south of Sunset Palisades is comprised of low-density single family residential and open space/recreational uses west of Shell Beach Road.

North Spyglass/ Spyglass

This planning area is comprised of resort commercial uses. North Spyglass, located north of Spyglass Drive, consists of three large parcels with three hotel/motels. South of Spyglass Drive is the Spyglass community, which is characterized by low- and high-density residential and commercial uses, with open space at the southwestern-most tip.

St. Andrews/ Spindrift

St. Andrews Tract is comprised of predominantly low-density residential, with open space along the northern border and high-density residential and the Pismo Beach Fire Department Station 63 on the northern end of Coburn Lane. South of the St. Andrews Tract area is Spindrift, a planned residential community consisting of multifamily housing uses in the larger southern parcel and single-family residential and open space/recreational uses to the north, west, and east.

Terrace Avenue/ Shell Beach/ Dinosaur Caves

The Terrace Avenue area is home to Shell Beach Elementary School and a mix of low, medium, and high-density residential uses. South of the Terrace Avenue area is Shell Beach, which is predominantly low-density residential, with high-density residential bordering the eastern side of the low-density residential, and commercial uses bordering the west side of Shell Beach Road. Just south of Cliff Avenue is Dinosaur Caves Park which offers walking trails, a playground, and ocean views on an 11-acre park. The Dinosaur Caves planning area extends south covering a resort commercial parcel, currently the Inn at the Cove.

Motel District

South of the Dinosaur Caves planning area is the Motel District, which is comprised of resort commercial uses with some medium residential uses along Franklin Drive, Wilmar Avenue, and Harbor View Avenue.

Commercial Core

This planning area has a variety of land uses, including resort commercial, commercial, public/semi-public, open space, and low-density residential uses. This planning area acts as Pismo Beach's downtown that provides uses like shops, restaurants, cafes, art studios, and the Pismo Beach Pier. The Pismo Beach Pier offers stunning ocean and sunset views, as well as a space for fishing and walking. The Commercial Core creates a public space for residents and visitors to eat, shop, and recreate in a small beach-town environment.

Pismo Creek/ Pismo Marsh

The Pismo Creek planning area is separated from the Commercial Core planning area by Pismo Creek. This planning area is comprised of mobile home park, commercial, open space, and industrial uses. Along Pismo Creek, this planning area is currently used as commercial recreational areas in the form of recreational vehicle (RV) parks and mobile homes. The relatively large parcel in the center of the Pismo Creek planning area is a mobile home park. The Pismo Marsh planning area is comprised of open space in the form of Pismo Marsh, open space, and walking trails, as well as mobile home park, campground, industrial, commercial, and resort commercial uses. The commercial area is the home of the Pismo Beach Premium Outlets which provides a range of retail for residents and visitors. The industrial uses in these planning areas are non-polluting uses such as a trailer storage.

Oak Park Heights

The Oak Park Heights planning area contains low- and medium-density residential with open space areas surrounding the residential. Additionally, there are commercial areas at the southern boundary of Pismo Beach and along Highway 101. The commercial uses along the southern city boundary are strip malls, and the commercial uses along Highway 101 are office parks and hotels.

Pismo Heights

The Pismo Heights planning area is comprised of low-density residential with some medium-density residential in the southern portion and high density residential along Highway 101. Open space is located east of the low-density residential and public/semi-public uses are located in the southeastern portion of the Pismo Heights area. The public/semi-public uses currently include Judkins Middle School, the Pismo Beach Police Department, and churches.

Freeway Foothills

The Freeway Foothills planning area is located east of Highway 101, and consists of low- and medium-density planned residential neighborhoods. The Freeway Foothills are considered an asset to the City and provide scenic panoramic views along Highway 101.

Figure LU-1 Planning Area Boundaries



Source: City of Pismo Beach 2019.

**Table LU-1
Existing Development by Neighborhood Planning Area (2019)**

Planning Area	Residential (units)			Visitor Serving (rooms)	Retail, Service, Office (1,000 square feet)			Open Space (acres)
	Single Family	Mobile Home	Multi-Family	Resort Commercial	Commercial	Industrial	Public/Semi Public	Open Space
Sunset Palisades/ The Bluffs/ South Palisades	478	0	0	0	253.5	0.0	0.8	97.0
North Spyglass/ Spyglass	108	0	71	298	500.9	0.0	1.1	7.3
St. Andrews/ Spindrift	228	0	25	0	51.0	0.0	8.8	9.1
Shell Beach/ Dinosaur Caves	910	0	44	24	321.5	0.0	9.7	13.6
Motel	79	0	0	572	2028.6	0.0	0.0	25.2
Downtown Core	512	0	279	596	1,672.7	0.0	16.4	150.1
Pismo Creek/ Pismo Marsh	417	515	141	370	2,491.2	142.9	21.7	211.9
Oak Park Heights	1,189	0	0	120	1,968.9	1,172.6	207.8	113.4
Pismo Heights	656	0	46	0	0.0	0.0	49.2	3.4
Freeway Foothills/ Mattie Road	404	0	0	0	306.6	0.0	5.6	177.9
Total:	4,981	515	418	1,980	9,594.9	1,315.5	321.1	808.9

Source: City of Pismo Beach 2019; San Luis Obispo County Assessor's Office 2019.

General Plan Land Uses

The City's General Plan land uses are shown in Figure LU-2. The existing General Plan designates 10 land uses in the city: commercial, industrial, public/semi-public, open space, mobile home park, low-density residential, medium-density residential, high-density residential, resort commercial, and planned residential. As shown in Figure LU-2, low-density residential covers the majority of land area in the city, the commercial and resort commercial uses are more concentrated towards downtown Pismo Beach, and open space is generally located around the residential uses and along the city limits. Table LU-2 lists total acreage for each land use, including the percentage of total land area per land use designation.

Table LU-2
Land Use Designations and Acreage

Land Uses Designation	Acreage	Percentage of Total Land Area
Commercial	126.38	7.1%
Resort Commercial	73.94	4.2%
Industrial	30.2	1.7%
Public/Semi-Public	99.8	5.6%
Open Space	736.41	41.3%
Mobile Home Park	58.51	3.3%
Single-Family Residential	566.12	31.8%
Multi-Family Residential	22.21	1.3%
Vacant/Other	68.19	3.8%
Total	1,781.76	100%

Figure LU-2 General Plan Land Use Map

General Plan Map

LEGEND

— Pismo Beach City Limits

PARCELS

- Commercial (C)
- Industrial (I)
- Public/Semi Public (P)
- Open Space (OS)
- Mobile Home Park (MHP)
- Low-Density Residential (RSL)
- Medium-Density Residential (RSM)
- High-Density Residential (RSH)
- Resort Commercial (RR)
- Planned Residential (PR)
- No value

2,000 FT.

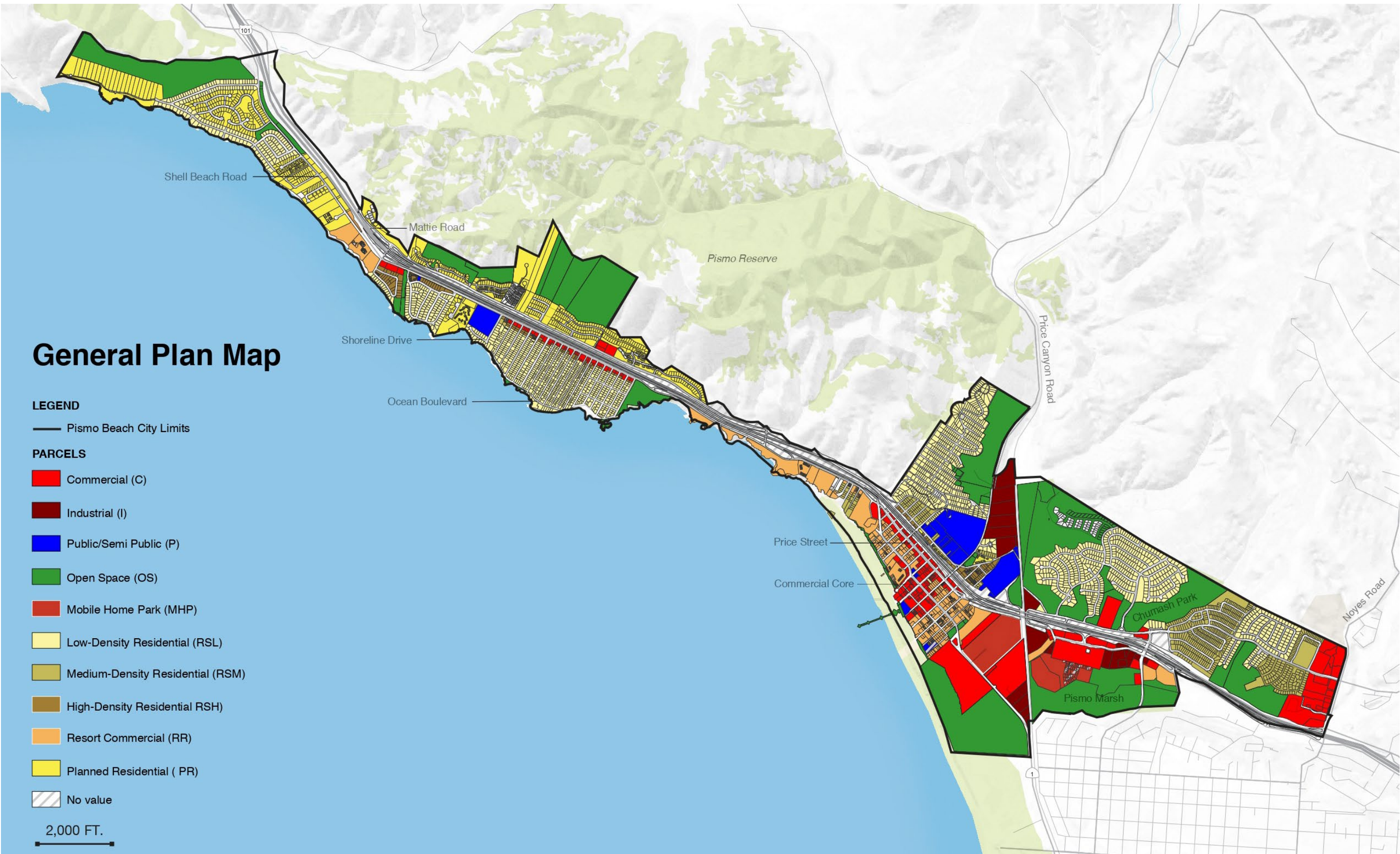

Demographics

Pismo Beach had an estimated population of 8,213 as of July 2018, and is comprised of approximately 90% White, 8% Hispanic or Latino, and 2% Asian (U.S. Census Bureau 2010). Pismo Beach has a relatively low persons per household of 1.97, compared to 2.96 for California and 2.51 for the County. The low person per household means more people are living alone in Pismo Beach. The median age is 54, meaning a high proportion of the population is over 50, and nearly a third of the population (29%) is over 65, compared to 20% for both the state and the County. Conversely, Pismo Beach’s population under 18 years old is approximately 11%, compared to 23% for the state and 18% for the County (U.S. Census Bureau 2018). Figure LU-3 illustrates the age and gender breakdown of Pismo Beach at the time of the 2010 Census. The relatively heightened number of single-person households and people over 65 helps guide the City’s land use decisions.

The median household income in Pismo Beach is \$77,316, with 8.4% of the population in poverty (i.e., family income is less than the federal poverty threshold). Pismo Beach has a highly educated population, with approximately 96% of the Pismo Beach population graduated from high school, compared to 83% for the state and 91% for the County; and 45% of the population graduated with a bachelor’s degree or higher, compared to 33% for the state and 34% for the County.

Figure LU-3 City of Pismo Beach Population (2017)

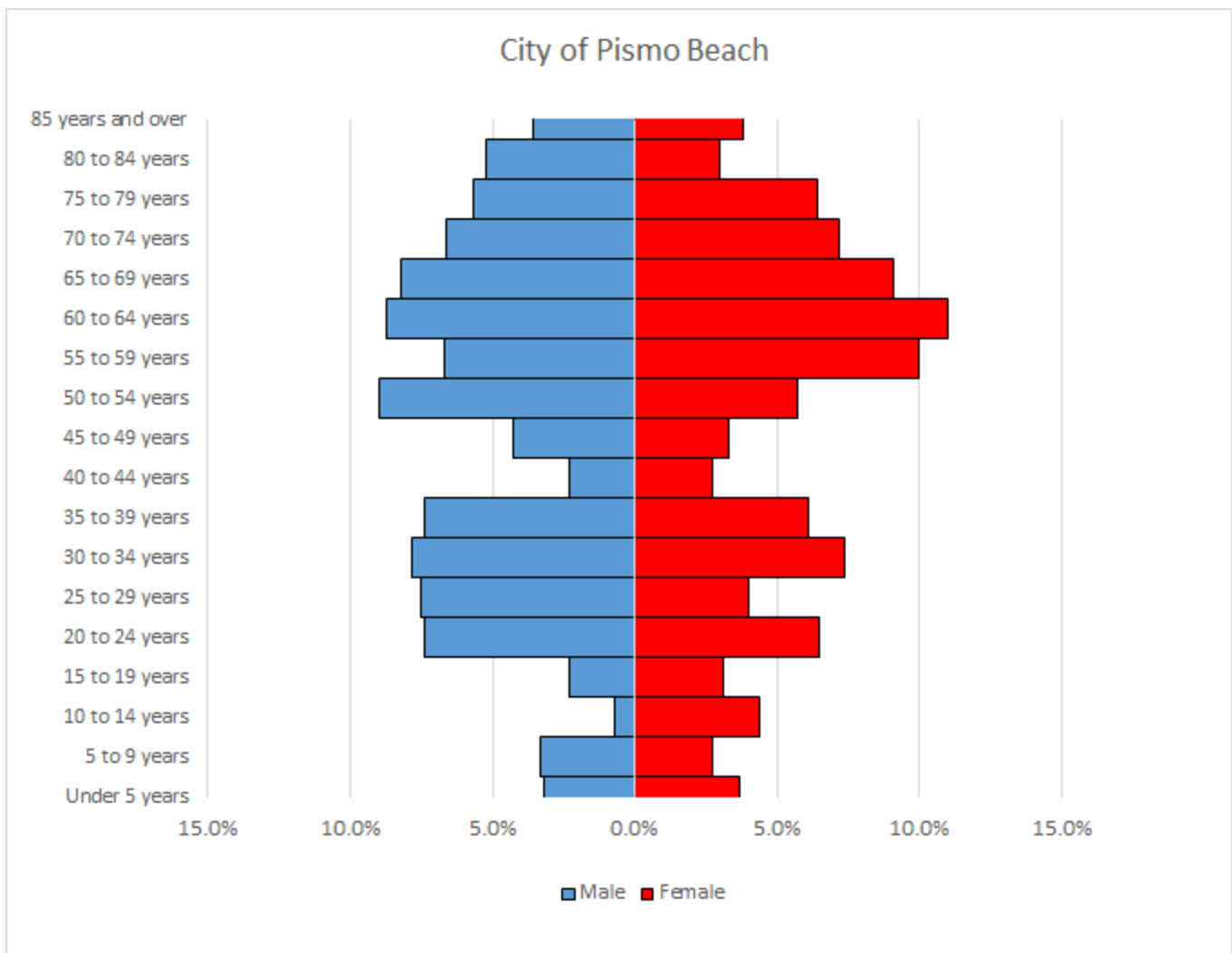

Source: U.S. Census Bureau 2017.

Growth Management

Growth is limited in Pismo Beach due to both physical and economic factors. Pismo Beach is bordered by the Pacific Ocean to the southwest, the unincorporated town of Avila Beach to the northwest, the City of Grover Beach to the southeast, and the unincorporated open space to the northeast of the city. These factors lead to little area for future annexation outward. Pismo Beach's SOI is a defined area that identifies the probable future physical boundary and service area of the city.¹ The SOI is strategically established to encourage orderly growth and development which are essential to the social, fiscal, and economic well-being of the City. The Pismo Beach SOI includes everything within the city limits in addition to two large areas to the northeast of the city boundary. As shown in Figure LU-4, Sphere of Influence, the SOI includes a large portion of land southeast of Price Canyon Road and a portion of land northwest of North Old Park Boulevard/Old Oak Park Road. These additional areas included in the SOI are predominantly open space with a couple water storage facilities and a few scattered single-family residences. The SOI creates a geographic boundary to which the city will not extend past, thus limiting the outward growth of the city.

With a large portion of the population over or nearing retirement age, the workforce in Pismo Beach is relatively low, limiting the demand for outward growth. Additionally, Pismo Beach's tourism industry, which is a large contributor to the economy, is oriented towards the coast, which keeps the commercial uses west of Highway 101 stable. However, there are still ways in which Pismo Beach can continue to expand, grow, and flourish. Upward growth, by means of higher-density uses, is a tool in which the city can strategically grow. For example, placing high-density residential and office uses in areas that are in proximity to transit provide an increase in housing and job opportunities without an extreme increase in vehicle trips. In addition, increasing housing density helps meet the City's Housing Element goals, the Regional Housing Needs Allocation (RHNA) goals, and state housing goals, as well as coastal access, circulation, and conservation goals.

Infrastructure

Infrastructure capacity, such as water and sewer, can be a limit to growth as well. Water is currently obtained from the State Water Project, Lopez Reservoir, and groundwater suppliers, and recycled water from the Pismo Beach Wastewater Treatment Plant. The City's 2015 Urban Water Management Plan shows the City has a future available water supply of 4,253 acre feet a year (AFY) and their water demand in 2035 is 2,213 AFY. Drought is likely to decrease the water supply in dry years, however, a goal of the 2015 Urban Water Management Plan Contingency Plan is to reduce water use by 10%-15% (City of Pismo Beach 2015). Sewage treatment is performed at the Pismo Beach Wastewater Treatment Plant, which was upgraded and expanded in 2006 to accommodate a build-out population of 9,414 people (City of Pismo Beach 2019a). The Cold Canyon Landfill (CCL) facility is the nearest site for solid waste disposal with an average daily capacity of 1,200 tons. CCL is expected to reach capacity in 2027 and accepts an average of 180,000 tons of waste per year. CCL is actively pursuing expansion plans to increase the site to 209 acres according to the Draft Environmental Impact Report (EIR) for the expansion project. The CCL Expansion Draft EIR indicates that with the expansion of CCL the site would potentially accommodate regional waste disposal needs until the year 2040.

¹ A SOI is generally considered a 20-year, long-range planning tool. The San Luis Obispo Local Agency Formation Commission (LAFCO) currently has released a Public Review Draft Sphere of Influence Update Municipal Service Review for the City of Pismo Beach on June 20, 2019.

Figure LU-4 Sphere of Influence

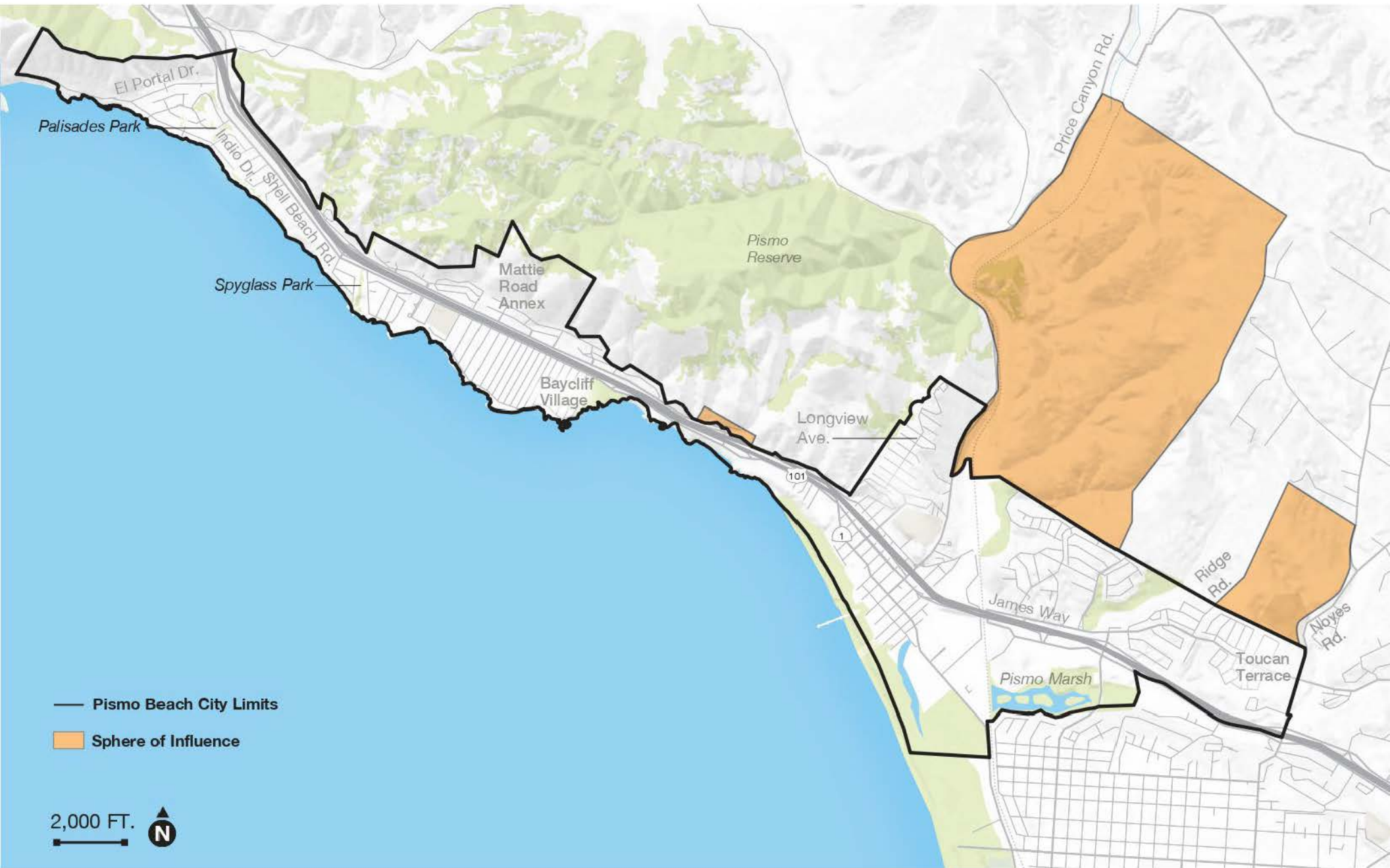

Source: San Luis Obispo Local Agency Formation Commission 2019

Public Services and Facilities

Pismo Beach relies on city-managed services and facilities to provide and support its residents' education, health and safety. The City's Public Facilities and Services Element correlates facility and service needs with projected population and visitor growth and the annexation of areas in the sphere of influence. In addition, the City's Parks, Recreation and Access Element establish goals to provide a wide range of recreational opportunities for all ages. The Shell Beach Library, Pismo Beach City Hall, Pismo Beach Parks and Recreation Department, Pismo Beach Fire Department (Pbfd), and Pismo Beach Police Department (Pbpd) are some of the public buildings and services within city limits. Figure LU-5, Public Services and Facilities, displays the locations of public buildings and services throughout the city.

Fire Protection

The Pbfd and the San Luis Obispo County Fire Department/California Department of Forestry and Fire Protection (CAL FIRE) Pbpd Station 63 are responsible for providing fire prevention and protection services in Pismo Beach. Station 63 serves north Pismo Beach through cooperative fire protection between CAL FIRE and the City. The Pbfd is located at 760 Mattie Road and, in a cooperative fire protection agreement with CAL FIRE, employs full-time staff including a Battalion Chief, three fire captains, three fire apparatus engineers, and an administrative assistant.

Police Services

The Pbpd provides public safety services for Pismo Beach, with its service area bordered by the Cities of Arroyo Grande and Grover Beach to the south and the community of Avila Beach to the north. The Pbpd is located at 1000 Bello Street in Pismo Beach and consists of 34 full-time employees, 23 of which are sworn police personnel (Pbpd 2018).

Schools

Public schools and educational facilities are mandated by the State Department of Education and administered by the San Luis Obispo County Board of Education and the San Luis Obispo County Office of Education. Two unified school districts provide service to the residents of Pismo Beach. The San Luis Coastal Unified School District provides service to northern Pismo Beach, while the Lucia Mar Unified School District provides services to southern Pismo Beach.

As previously noted under Demographics, Pismo Beach highly values their education, with relatively high percentages of high school and college graduates. Education facilities within the city limits of Pismo Beach include Happy Time Co-Op Preschool, Judkins Middle School, New Life Pre-School, and Shell Beach Elementary School. Figure LU-5 depicts the locations of these facilities. To be classified as a Critically Overcrowded School, a school must have a pupil density greater than 115 pupils per acre for grades kindergarten to six and 90 pupils per acre for grades seven to twelve. None of the schools listed on the state's Critically Overcrowded School list are located within Pismo Beach city limits.

Libraries

The City of Pismo Beach does not provide library services to city residents. This service is provided by the San Luis Obispo City-County Library system, which presently maintains a small neighborhood library in the Shell Beach area. More extensive services are provided Pismo Beach residents at the South County Regional Library, located in Arroyo Grande, approximately 5 miles from Pismo Beach.

Parks

Pismo Beach has 13 City parks, beach volleyball courts, and a 5.5-acre sports complex. The California Department of Parks and Recreation manages the recreational facilities within Pismo State Beach. The Price Historical Park is the only National Historic Landmark in Pismo Beach. The City also owns the Chapman Estate in the community of Shell Beach. As a result of the City taking ownership of the property in 2013, the City adopted the Chapman Estate Strategic Plan to guide the maintenance and programming of the Chapman Estate, which may include pursuing historical designation.

Solid and Liquid Disposal Facilities

The southeastern portion of Pismo Beach contains the Pismo Beach Wastewater Treatment Plant. This is a plant which treats wastewater to potable levels and injects the resulting water into the groundwater. Disposal of landfill waste, compost, and recycling is done outside of city limits. Landfill waste is disposed of at the Cold Canyon Landfill, north of Pismo Beach.

Figure LU-5 Public Services and Facilities



Relationship to the Local Coastal Program

The City of Pismo Beach General Plan and Local Coastal Plan is a combined document that meets both the state General Plan requirements and state Coastal Act requirements. The City's current LCP includes both a Land Use Plan, which was last updated in 1993, and the Implementation Plan (Coastal Zoning Ordinance), which was last updated in 1983, with several amendments to both documents occurring since. The Land Use Plan is integrated into applicable elements of the General Plan and must meet all of the requirements of the California Coastal Act (Coastal Act) as determined by the California Coastal Commission (CCC). The Coastal Act guides the development and protection of coastal resources in the City's Coastal Zone and prioritizes public access as well as coastal-dependent commercial, agricultural, and industrial uses. The Coastal Act also includes protection for open space along the coast and preservation of marine and upland habitats and sensitive coastal biodiversity. These sections of the Coastal Act related to habitat and open space land uses, as well as cultural resources, are described in the Conservation and Open Space Background Report.

Public Access and Recreation Facilities

The arrangement of land uses plays a role in the placement of public access and recreation facilities. For example, a beach access point would be underutilized in an industrial area but highly-utilized in a residential neighborhood or downtown area. Pismo Beach provides a variety of recreational facilities in the coastal zone, such as parks, beaches, and the City pier. There are 22 beach access points in the City of Pismo Beach, the highest concentration of which are in the downtown area. The City owns four parking lots within walking distance to the coast, two of which are directly adjacent to the beach. Additionally, there are 10 City-owned parks and one California state campground with direct access to the beach (Moffat and Nichol 2019). Each of these facilities are further described in the Parks, Recreation, and Access Element.

Overnight Accommodations

Pismo Beach has a range of overnight accommodations including hotels, motels, state campground and privately-owned RV sites, and short-term vacation rentals. These uses are important for sustaining the tourist industry of Pismo Beach while also supporting visitor access to coastal resources. Overnight accommodations are either allowable uses or conditional uses in the resort commercial, commercial, and industrial land use designations. An inventory of these uses as of 2019 is presented in Table LU-3. In addition, the locations of these accommodations is depicted in Figure LU-6, Overnight Accommodations.

Table LU-3
Overnight Accommodations¹

Accommodation	Number of Units	Price Range (per night) ²
Campground and RV parks)	515	\$35-55
Hotel and motel	1,980	\$66 – 391
Short-term vacation rentals	Approx. 340 ³	\$65 – 1,114

¹ Source: City of Pismo Beach 2019b

² The prices shown for campground and RV parks and hotel and motel categories reflect the least expensive options available for that date, as some hotels and motels surveyed have multiple price levels.

³ A search of STR websites with no dates of stay entered produced 334 available STRs.

Energy and Industrial Development

Energy and industrial development uses are allowable in the industrial land use designation. There are currently no industrial land use designations west of Highway 101, as industrial uses are discouraged on highly valuable waterfront property. Private electrical and natural gas utility companies provide service to customers in Central and Southern California, including the City of Pismo Beach. The City of Pismo Beach Draft Climate Action Plan (CAP) included an inventory of community-wide

greenhouse gas (GHG) emissions. According to the CAP, commercial/industrial energy use contribute 17% of Pismo Beach GHG emissions. Industrial uses within Pismo Beach are all considered light industrial uses, such as utility facilities, RV storage, big box retail, and gas stations. The majority of industrial uses are located in a central sliver of the city limits, east of Highway 101, east of Price Canyon Road, and west of the railroad track. These industrial uses include the Pismo Beach Wastewater Treatment Plant (PBWTR) and a Pacific Gas and Electric (PG&E) facility. The PG&E facility is not within the coastal zone, however the PBWTR is within the coastal zone. Development standards will be applied to any existing or future coastal dependent energy or industrial facilities, such as offshore wind turbines, fishing, and shipping facilities.

Agriculture

Pismo Beach does not contain any lands classified as important farmland (CDOC 2019). There are no commercial-scale agriculture uses in the city; however, Pismo Beach is surrounded by agricultural uses including grape, broccoli, and strawberry production (City of Pismo Beach 2014).

Figure LU-6 Overnight Accommodations (placeholder)

Relationship to the Housing Element

The Housing Element of the Pismo Beach General Plan is currently under development. The housing element outlines how the City will accommodate Pismo Beach’s regional housing needs assessment (RHNA) as determined by the California Department of Housing (HCD) and Community Development and the San Luis Obispo Council of Governments (SLOCOG). Table LU-4 outlines the number of housing elements Pismo Beach and the County must accommodate in each of the income brackets determined by HCD.

**Table LU-4
Total Required Housing Accommodations by Income Bracket**

Jurisdiction	Income Category	Percent	Housing Unit Need
San Luis Obispo County	Very-Low	24.6%	2,660
	Low	15.5%	1,675
	Moderate	18%	1,940
	Above-Moderate	41.9%	4,535
	Total	100%	10,810
Pismo Beach	Very-Low	24.6%	113
	Low	15.5%	71
	Moderate	18.0%	82
	Above Moderate	41.9%	193
	Total	100%	459

Source: City of Pismo Beach 2019c.

Notes: Very low income: 30% to 50% of Area Median Income (AMI); Lower income: 50% to 80% of AMI, the term may also be used to mean 0% to 80% of AMI; Moderate income: 80% to 120% of AMI.

Relationship to the Circulation Element

Considering transportation planning is required for updating the Land Use Element according to Government Code §65302(b). The Pismo Beach Circulation Element² was updated in 2018 and includes goals and policies which reference land use or should be considered moving forward with the Land Use Element. The following goals guide the Circulation Element:

1. Provide a circulation system that supports safe and efficient travel for all modes of transportation.
2. Plan and provide pedestrian and bicycle facilities to encourage and meet the walking and bicycling needs of the city.
3. Promote the use of public transit and seasonal shuttle services.
4. Provide connectivity and guidance for safe rail and truck movement of people and goods.

The Land Use Section should further these goals through land use decisions and policies.

The 2018 Circulation Element also contains more specific guiding policies (GPs) that relate to land use. It addresses coordination of activities with various agencies in GPs 1.7, 1.10, and 3.2. GP 1.11 cites land use as an action recommended to reduce vehicle miles traveled. GP 2.5 specifies that land use policies be implemented to enable shopping, recreating, commuting, and personal business activities without driving. GP's 1.16, 1.17, and 2.12 address consideration for the land use context when providing complete streets, neighborhood streets, and bikeways, respectively. When referencing new development, GP 3.15 promotes transit-oriented developments, GP 3.16 supports SB 375³ and GP 4.6 continues industrial expansion in the southeastern industrial area of Pismo Beach.

² The updated Circulation Element was approved by the CCC in 2018 with suggested modifications related to the extension of Mattie Road, which were later accepted by the City.

³ SB 375 builds on the existing framework of regional planning to tie together the regional allocation of housing needs and regional transportation planning in an effort to reduce GHG emissions from motor vehicle trips. SB 375 directs the Air Resources Board to set regional targets for the reduction of greenhouse gas emissions. Aligning these regional plans is intended to help California achieve GHG reduction goals for cars and light trucks under AB 32, the state's landmark climate change legislation.

Citations

- California Department of Conservation (CDOC). 2019. *California Important Farmland Finder*. Accessed August 2019. <https://maps.conservation.ca.gov/DLRP/CIFF/>
- City of Pismo Beach. 2014. *City of Pismo Beach General Plan and Local Coastal Program*. Adopted November 1992, Amended April 2014. Accessed February 2019. <http://pismo beach.org/DocumentCenter/View/247>.
- City of Pismo Beach. 2015. *Final 2015 Urban Water Management Plan for the City of Pismo Beach*. Water Systems Consulting. Accessed August 2019. <http://www.pismo beach.org/DocumentCenter/View/3785/Urban-Water-Mgmt-Plan---2015?bidId=>.
- City of Pismo Beach. 2019a. *Draft Lower-Cost Visitor-Serving Accommodations Technical Memorandum*. July 26, 2019.
- City of Pismo Beach. 2019b. *Initial Study of Environmental Impact for Pismo Beach General Plan Housing Element Update*. Accessed August 2019. https://www.pismo beach.org/DocumentCenter/View/53463/Pismo-Draft-Housing-Element-Update_IS-MND--71219-Public-Draft.
- City of Pismo Beach. 2019c. *City of Pismo Beach 2014-2019 Housing Element*. March 2019.
- Moffat and Nichol. 2019. *Draft Existing Conditions Report for City of Pismo Beach General Plan/Local Coastal Program Update*. August 2019.
- PBPD (Pismo Beach Police Department). 2018. *2018 Police Annual Report*. Accessed August 2019. <http://www.pismo beach.org/DocumentCenter/View/53653/Annual-Report-2018>
- San Luis Obispo LAFCO. 2019. *City of Pismo Beach Public Review Draft Sphere Of Influence Update Municipal Service Review*. June 2019.
- U.S. Census Bureau. 2010. "DP-1. Profile of General Population and Housing Characteristics: 2010; 2010 Demographic Profile Data." American Fact Finder.
- U.S. Census Bureau. 2017. "Community Facts. ACS Demographics and Housing Estimates." Accessed August 2019. <https://factfinder.census.gov/faces/tableservices/jsf/pages/productview.xhtml?src=CF>.
- U.S. Census Bureau. 2018. "Quick Facts Pismo Beach City, California." Accessed August 2019. <https://www.census.gov/quickfacts/fact/table/pismo beach city califonia/PST045218>.

Appendix E

Noise Element Technical Background Report

CITY OF PISMO BEACH

GENERAL PLAN NOISE ELEMENT UPDATE 2020

TECHNICAL BACKGROUND REPORT

1 Acoustics Principles

1.1 Sound and Environmental Noise

Acoustics is the science of sound. Sound can be described as the energy of a vibrating object transmitted by pressure waves through a medium (e.g., air) to human (or animal) ear. If the pressure variations occur frequently enough (at least 20 times per second), they can be heard and are called sound. The number of pressure variations per second is called the frequency of sound and is expressed as cycles per second, or hertz (Hz). As an example of this phenomenon, a person speaking creates energy through vibration of the vocal chords, pressure waves caused from this vibration are carried through the air to a nearby listener's ear, where they are detected as the sound of a human voice.

The speed of sound in air is approximately 770 miles per hour, or 1,130 feet/second. Knowing the speed and frequency of a sound, one may calculate its wavelength, the physical distance in air from one compression of the atmosphere to the next. An understanding of wavelength is useful in evaluating the effectiveness of physical sound control devices such as mufflers or barriers, which depend upon either absorbing or blocking sound waves to reduce sound levels.

Noise is defined as loud, unexpected, or annoying sound. The fundamental acoustics model consists of a noise source, receptor, and the propagation path between the two. The loudness of the noise source, obstructions, or atmospheric factors affecting the propagation path, determine the perceived sound level and noise characteristics at the receptor. Acoustics deal primarily with the propagation and control of sound. A typical noise environment consists of ambient noise that is the sum of many distant and indistinguishable noise sources. Superimposed on this ambient noise is the sound from individual local sources. These sources can vary from an occasional aircraft or train passing by to continuous noise from traffic on a major highway. Perceptions of sound and noise are highly subjective from person to person.

Measuring sound directly in terms of pressure would require a large range of numbers. To avoid this, the decibel (dB) scale was devised. The dB scale uses the hearing threshold of 20 micropascals (μPa) as a point of reference, defined as 0 dB. Other sound pressures are then compared to this reference pressure, and the logarithm is taken to keep the numbers in a practical range. The dB scale allows a million-fold increase in pressure to be expressed as 120 dB; another useful aspect of the decibel scale is that changes in levels (dB) are uniform throughout the scale, which corresponds closely to human perception of relative loudness.

1.2 Noise Descriptors

The dB scale alone does not adequately characterize how humans perceive noise. The dominant frequencies of a sound have a substantial effect on the human response to that sound. Several rating scales have been developed to analyze the adverse effect of community noise on people. Because environmental noise fluctuates over time, these scales consider that the effect of noise on people is largely dependent on the total acoustical energy content of the noise, as well as the time of day when the noise occurs. The equivalent noise level (L_{eq}) is the average noise level averaged over the measurement period, while the day-night noise level (L_{dn}) and Community Equivalent Noise Level (CNEL) are measures of energy average during a 24-hour period, with dB weighted sound levels from 7:00 PM to 7:00 AM. Most commonly, environmental sounds are described in terms of L_{eq} that has the same acoustical energy as the summation of all the time-varying events.

1.3 Metrics Used in Noise Assessment

A-Weighted Decibel Scale

The A weighted decibel (dBA) sound level scale gives greater weight to the frequencies of sound to which the human ear is most sensitive. Because sound levels can vary markedly over a short period of time, a method for describing either the average character of the sound or the statistical behavior of the variations must be used. Most commonly, environmental sounds are described in terms of an average level that has the same acoustical energy as the summation of all the time-varying events.

The scientific instrument used to measure noise is the sound level meter. Sound level meters can accurately measure environmental noise levels to within about plus or minus 1 dBA. Various computer models are used to predict environmental noise levels from sources, such as roadways and airports. The accuracy of the predicted models depends on the distance between the receptor and the noise source.

The perceived loudness of sounds is dependent on many factors, including sound pressure level and frequency content. However, within the usual range of environmental noise levels, perception of loudness is relatively predictable and can be approximated by dBA values. There is a strong correlation between dBA and the way the human ear perceives sound. For this reason, the dBA has become the standard tool of environmental noise assessment. All noise levels reported in this document are in terms of dBA, but are expressed as dB, unless otherwise noted.

Addition of Decibels

The dB scale is logarithmic, not linear, and therefore sound levels cannot be added or subtracted through ordinary arithmetic. Two sound levels 10 dB apart differ in acoustic energy by a factor of 10. When the standard logarithmic dB is A-weighted, an increase of 10 dBA is generally perceived as a doubling in loudness. For example, a 70-dBA sound is half as loud as an 80-dBA sound and twice as loud as a 60-dBA sound (Caltrans 2013). When two identical sources are each producing sound of the same loudness, the resulting sound level at a given distance would be 3 dBA higher than one source under the same conditions. Under the dB scale, three sources of equal loudness together would produce an increase of approximately 5 dBA. (Caltrans 2013)

Sound Propagation and Attenuation

Sound spreads (propagates uniformly outward in a spherical pattern, and the sound level decreases (attenuates) at a rate of approximately 6 dB for each doubling of distance from a stationary or point source. Sound from a line source, such as a highway, propagates outward in a cylindrical pattern. Sound levels attenuate at a rate of approximately 3 dB for each doubling of distance from a line source, such as a roadway, depending on ground surface characteristics (Caltrans 2013). No excess attenuation is assumed for hard surfaces like a parking lot or a body of water. Soft surfaces, such as soft dirt or grass, can absorb sound, so an excess ground-attenuation value of 1.5 dB per doubling of distance is normally assumed. Thus, soft-site attenuation from a point source is at a rate of 7.5 dB for each doubling of distance, while soft-site attenuation from a line source is 4.5 dB per each doubling of distance (Caltrans 2013).

Noise levels may also be reduced by intervening structures; generally, a single row of buildings between the receptor and the noise source reduces the noise level by about 5 dBA, while a solid wall or berm reduces noise levels by 5 to 10 dBA (Cowan 1994). The way older homes in California were constructed generally provides a

reduction of exterior-to-interior noise levels of about 20 to 25 dBA with closed windows. The exterior-to-interior reduction of newer residential units is generally 30 dBA or more (HUD 2009).

1.4 Human Response to Noise

The human response to environmental noise is subjective and varies considerably from individual to individual. Noise in the community has often been cited as a health problem, not in terms of actual physiological damage, such as hearing impairment, but in terms of inhibiting general well-being and contributing to undue stress and annoyance. The health effects of noise in the community arise from interference with human activities, including sleep, speech, recreation, and tasks that demand concentration or coordination. When community noise interferes with human activities or contributes to stress, public annoyance with the noise source increases, and the acceptability of the environment for people decreases. This decrease in acceptability and the threat to public well-being is the basis for land use planning policies directed towards the prevention of exposure to excessive community noise levels. Hearing loss can occur at the highest noise intensity levels.

Noise environments and consequences of human activities are usually well represented by median noise levels during the day or night or over a 24-hour period. Environmental noise levels are generally considered low when the CNEL is below 60 dBA, moderate in the 60 to 70 dBA range, and high above 70 dBA. Examples of low daytime levels are isolated, natural settings with noise levels as low as 20 dBA and quiet, suburban, residential streets with noise levels around 40 dBA (Cowan 1994). Interior noise levels above 45 dBA at night can disrupt sleep. Examples of moderate-level noise environments are urban residential or semi-commercial areas (typically 55 to 60 dBA) and commercial locations (typically 60 dBA). People may consider louder environments adverse, but most will accept the higher levels associated with noisier urban residential or residential-commercial areas (60 to 75 dBA) or dense urban or industrial areas (65 to 80 dBA). Regarding increases in dBA, the following relationships should be noted (Caltrans 2013).

- Except in carefully controlled laboratory experiments, a 1-dBA change cannot be perceived by humans.
- Outside of the laboratory, a 3-dBA change is considered a just-perceivable difference.
- A minimum 5-dBA change is required before any noticeable change in community response would be expected. A 5-dBA increase is typically considered substantial.
- A 10-dBA change is subjectively heard as an approximate doubling in loudness and would almost certainly cause an adverse change in community response.

Health Effects of Noise on People

Hearing Loss. While physical damage to the ear from an intense noise impulse is rare, a degradation of auditory acuity can occur even within a community noise environment. Hearing loss occurs mainly due to chronic exposure to excessive noise but may be due to a single event such as an explosion. Natural hearing loss associated with aging may also be accelerated from chronic exposure to loud noise. The Occupational Safety and Health Administration has a noise exposure standard that is set at the noise threshold where hearing loss may occur from long-term exposures. The maximum allowable level is 90 dBA averaged over 8 hours. If the noise is above 90 dBA, the allowable exposure time is correspondingly shorter.

Annoyance. Attitude surveys are used for measuring the annoyance felt in a community for noises intruding into homes or affecting outdoor activity areas. In these surveys, it was determined that causes for annoyance include interference with speech, radio and television, house vibrations, and interference with sleep and rest. The L_{dn} as a measure of noise has been found to provide a valid correlation of noise level and the percentage of people annoyed. People have been asked to judge the annoyance caused by aircraft noise and ground transportation noise. There continues to be disagreement about the relative annoyance of these different sources. A noise level of about 55 dBA L_{dn} is the threshold at which a substantial percentage of people begin to report annoyance (FICON 1992).

2 Community Noise Survey

2.1 Description of Major Noise Sources in the Community

2.1.1 Transportation Noise Sources

Aviation

The nearest public airports to the study area are the San Luis Obispo County Regional Airport located approximately 5 miles due northwest, and the Oceano County Airport located approximately 2 miles to the south. According to the Airport Land Use Plan (ALUP 2005) the mapped 60 dB noise contour for the San Luis Obispo County Regional Airport extends no further than 1,000 feet from the runways in the direction of Pismo Beach; this 60 dB contour is therefore located more than 4.5 miles from Pismo Beach. According to the ALUP for Ocean County Airport (ALUP 2007), the 65 dB noise contour for Oceano Airport extends no closer to Pismo Beach than approximately Farroll Road in Grover Beach (approximately one mile south of the Pismo Beach City limits). High-altitude overflights for aircraft using the San Luis Obispo County Airport occur over the study area, but do not contribute to the ambient noise environment within the study area. Consequently the Pismo Beach noise environment is not affected by aircraft operations associated with airport facilities in the region.

Roadways

Highways are a major noise source in many jurisdictions, and they are the primary means of circulation throughout Pismo Beach. Pismo Beach is primarily subject to noise impacts from US Highway 101 and State Route 1. US Highway 101 roughly bisects Pismo Beach in the southern and central portions of the City, and is aligned along the east side of urban development in the northern portion of the City. The relatively central alignment of US Highway 101 means that traffic noise from this facility affects much of the area within the City. State Route 1 is a separate two-lane at grade highway only within the southern section of the City, joining with US Highway 101 in the vicinity of Pismo Preserve. State Route 1 generally bisects the western urban areas of the City between US Highway 101 and the beach. With more limited traffic and only two travel lanes, noise from Route 1 is not as extensive as that from US Highway 101. One short-term noise measurement and manual traffic counts were conducted for each of these highways to characterize existing noise levels.

Major arterial roadways in Pismo Beach also contribute traffic noise to the ambient noise environment. While traffic speeds are lower on these facilities than on highways, setback distances from travel lanes to adjacent uses tend to be less, and therefore noise from arterial roadways can result in unacceptably high noise levels at adjacent noise-sensitive land uses. Dudek completed a short-term noise measurement and manual traffic counts

for Ocean Boulevard, North 4th Street, Mattie Road, North Oak Boulevard, Price Canyon Road, and Shell Beach Road, to characterize existing traffic noise levels along these roadways.

Railroads

The Union Pacific Railroad (UPRR) owns rail lines that traverse Pismo Beach, carrying UPRR freight trains and Amtrak passenger trains. The UPRR line extends from the Bello Street industrial area at the City's northern boundary, due south to the vicinity of Pismo State Beach before continuing on to Grover Beach.

Although train noise is intermittent, it is a significant source of noise due to its magnitude and associated vibration effects. Train noise is comprised of the sounds of the locomotive engine, wheel-on-rail noise, and train whistles near at-grade roadway crossings. For train horns to be an effective warning device for motorists, they must provide a sound level capable of initiating a response from the driver as the train approaches the crossing. Dudek completed a 24-hour continuous sound level measurement adjacent to the UPRR alignment in order to characterize community noise levels associated with train operations.

2.1.2 Industrial - Commercial Noise Sources

Industrial Sources

Noise from industrial businesses and large stationary sources varies but can result in substantially elevated noise levels and impacts on adjacent noise-sensitive land uses. Industrial operations often involve the use of mechanical equipment, generators, and vehicles that contribute to noise levels at industrial sites, particularly if operations occur outdoors. Pismo Beach has one area designated for industrial uses; the area is situated east of Price Canyon Road, generally north of Bello Street, and along the west side of the UPRR alignment (described above). Currently this area serves as storage and staging for Pacific Gas and Electric. Dudek conducted a 24-hour measurement near the closest residences west of this industrial area to characterize community noise levels from industrial operations.

Commercial Sources

Most of the commercial businesses in Pismo Beach are aligned along Price Street, Shell Beach Road, 5 Cities Drive, and Hinds Avenue/Price Canyon Road. The Pismo Beach Premium Outlets represents the largest commercial use, by size and in relation to traffic generation. As a major commercial land use and stationary noise source, Dudek completed a 24-hour measurement near the closest residences south of Pismo Beach Premium Outlets area to characterize community noise levels from major commercial retail operations.

2.2 Existing Noise Levels

2.2.1 Sound Level Measurement Program

Existing noise conditions present in the City of Pismo Beach were inventoried by Dudek in October 2019. Two types of sound-level measurements were taken: short-term (varying from 5 to 30 minutes) measurements were performed along highways and major local roadways to characterize noise levels associated with transportation facilities and for calibration of the transportation noise model; and, 24-hour measurements were performed

adjacent to the railroad, in the vicinity of the Price Canyon Road industrial area, and adjacent to the Pismo Beach Premium outlets. Noise measurement location points are illustrated in Exhibit 1 (at the back of this report).

Sound-level measurements were performed using two different integrating sound-level meters: A Rion Model NL-32 (American National Standards Institute [ANSI] Type I), and three SoftdB Piccolo II Model (ANSI Type II). ANSI Type I and Type II sound-level meters both have sufficient accuracy to be used for environmental noise evaluation. The sound-level meters were calibrated before and after each series of measurements using a Rion Model NC-74 calibrator.

SHORT-TERM MEASUREMENTS

Roadway Sound Level Measurements

Since roadway traffic is often a primary contributor to the noise environment in any community, short-term noise measurements were conducted adjacent to selected existing roadways within Pismo Beach. These measurements are useful in characterizing ambient noise levels along roadways, as well as providing sound data and manual traffic counts used to calibrate the transportation noise model. A total of 10 short-term noise measurements were conducted. The results of short-term roadway traffic noise measurements are presented in Table 1. Field data for each short-term sound level measurement are provided in Attachment 1 (Short-term Noise Measurements Field Data Sheets), including measured sound levels, manual traffic count results, distance from the roadway edge to the measurement point, vehicle speed on the roadway, and measurement point identification.

Table 1
Roadway Noise Level Measurements (Existing) (dBA)

ST #	Date Measured	Measurement Time Period	Leq	Lmax	Lmin	Roadway
1	10/22/19	11:35 - 11:50	55	62	50	Seacliff Drive (between Paddock & Baker)
2		12:30 - 12:45	54	61	49	Ocean Blvd. (between Palisade & Seaview)
3		14:05 - 14:20	43	46	41	Dugan Road. (between Christine & Elaine)
4		9:40 - 9:45	72	76	69	US Highway 101 (at southbound 5 Cities Drive ramps)
5		13:00 - 13:10	69	83	51	State Route 1 (between Park & Addie)
6		10:10 - 10:20	73	82	49	North 4 th Street (south of 5 Cities Drive)
7		10:50 - 11:20	66	80	62	Mattie Road (between Foothill and Bayfront)
8		13:50 - 14:00	67	79	45	North Oak Park Blvd. (south of Dell Ct.)
9		13:20 - 13:30	71	86	48	Price Canyon Road. (south of Meadowlark)
10		12:00 - 12:15	66	83	55	Shell Beach Road. (south of Ebb Tide Lane)

Traffic noise measurements (short-term) were collected using the Rion NL-32 ANSI Type I Meter. The meter was placed on a tri-pod at approximately five feet above the ground, in accordance with the ANSI standard for environmental noise measurements. The sound level meter was oriented toward the adjacent street, and a windscreen was employed. The distance from the edge of the pavement to the sound level meter was noted in the field data sheet for each measurement location. The number of cars, medium trucks, and heavy trucks

passing the measurement point during the measurement period were tallied, along with identification of the posted speed limit for the roadway. The duration was noted for each measurement, and sound levels including L_{eq} , L_{max} , L_{min} , and other percentile statistics were recorded on the data sheet for each measurement location (Refer to Attachment 1). The measurement identifications (ST#) in Table 1 correspond to locations illustrated in Exhibit 1 for these short-term measurements.

As presented in Table 1, recorded traffic noise levels range from a high of 73 dBA L_{eq} to a low of 43 dBA L_{eq} . The highest traffic noise levels are associated with US Highway 101, North 4th Street, and Price Canyon Road, with each of these roadways carrying a large number of vehicles at higher speeds. Dugan Road (LT3) had the lowest recorded noise level, and there were also no vehicles that passed the measurement point during the measurement. There were also no vehicles that passed the measurement point on Seacliff Drive (LT1) during the measurement, but background surf noise was dominant at this measurement point along the sea cliff, resulting in a moderate recorded noise level of 55 dBA L_{eq} .

LONG-TERM MEASUREMENTS

Dudek completed a total of three long-term (24-hour) measurements to characterize environmental noise associated with industrial, commercial, and railroad operations. Long term measurement locations (LT#) are indicated on Exhibit 1 (at the end of this report). Measurements were conducted using three SoftdB Piccolo II Model (ANSI Type II) sound level meters. The measurements were unattended, but locked cases were employed to prevent tampering of the meters. The Piccolo meters were calibrated before and after the 24-hour measurements to verify accuracy.

The Piccolo meters were configured to record data each hour (using a one-hour averaging period) across the entire 24-hour measurement. Sound level metrics including L_{eq} , L_{max} , L_{min} , and other percentile statistics were recorded for each hourly period. Data logs for each long term measurement location are included in Attachment 3. Based on the recorded hourly averages at each long-term measurement location, the CNEL was calculated at these monitoring locations; a CNEL worksheet for each location is also provided in Attachment 3.

Table 2 summarizes the minimum (L_{min}) and maximum (L_{max}) sound levels recorded for each monitor location during the 24-hour measurement, as well as the calculated 24-hour weighted average noise level (CNEL). The sound monitor location description and source being measured are also provided in Table 2 for each monitor location. More detail about each monitoring location is provided below Table 2.

**Table 2
Ambient Sound Level Measurements (dBA)**

Site	Location	Noise Sources	Dates	CNEL	L_{max}	L_{min}
LT1	Closest residences west of Price Canyon Industrial Area	Price Canyon Industrial Area	10/22/19 – 10/23/19	56	82.5	37.1
LT2	Adjacent to UPRR alignment, vicinity of Park View Avenue	UPRR train operations	10/22/19 – 10/23/19	66	94.9	43
LT3	Near closest residences, southwest corner of Pismo Premium Outlets	Pismo Premium Outlets	10/22/19 – 10/23/19	64	92.7	43.1

Industrial Noise Sources (LT1)

The only area designated for industrial uses within Pismo Beach is located along the west side of the UPRR alignment, north of Bello Street, and east of Price Canyon Road. To characterize industrial noise levels, a 24-hour measurement was conducted along Dell Court, between two widely-spaced residences closest to the western boundary of the industrial area (LT1 on Exhibit 1). The measurement location is approximately 300 feet from the western boundary of the industrial area. A 56 dBA CNEL at this location was determined from hourly average noise levels. Using this CNEL value and separation distance from the industrial area, the distance to the 70, 65 and 60 CNEL contours was calculated. This calculation was based upon outdoor attenuation rates of 6 dBA per doubling of distance for a point source. This calculation ignores topography, the presence of structures or walls, and the presence of vegetation, and is therefore very conservative (i.e., the presence of topography between the industrial uses and receivers would partially or fully block the propagation of sound, reducing the distance from the industrial noise source to the calculated noise contour boundary). The distance to the 70, 65, and 60 dBA CNEL contour associated with the industrial area operations is reported in Table C (Attachment 2).

Railroad Noise Sources (LT2)

To characterize community noise levels from rail (train) operations, a 24-hour measurement was conducted along the UPRR tracks, in the vicinity of Park View Avenue (LT2 on Exhibit 1). The measurement location is approximately 40 feet from the center of the tracks. A 66 dBA CNEL at this location was determined from hourly average noise levels. Using this CNEL value and separation distance from the industrial area, the distance to the 70, 65 and 60 CNEL contours was calculated. This calculation was based upon outdoor attenuation rates of 3 dBA per doubling of distance for a line source. This calculation is a conservative worst-case distance, ignoring topography, the presence of structures or walls, and the presence of vegetation. The distance to the 70, 65, and 60 dBA CNEL contour associated with UPRR operations is reported in Table C (Attachment 2).

Commercial Noise Sources (LT3)

The Pismo Beach Premium Outlets represents the largest commercial use, by size and in relation to traffic generation. To characterize noise levels associated with major commercial operations, a 24-hour measurement was conducted at the southwest corner of the Pismo Premium Outlets, near the closest adjacent residences (LT3 on Exhibit 1). The measurement location is approximately 55 feet from the southern boundary of the Pismo Premium Outlets site. A 64 dBA CNEL at this location was determined from hourly average noise levels. Using this CNEL value and separation distance from the commercial retail operations, the distance to the 70, 65 and 60 CNEL contours was calculated. This calculation was based upon outdoor attenuation rates of 6 dBA per doubling of distance for a point source. This calculation is a conservative worst-case distance, ignoring topography, the presence of structures or walls, and the presence of vegetation. The distance to the 70, 65, and 60 dBA CNEL contour associated with UPRR operations is reported in Table C (Attachment 2).

2.2.2 Traffic Noise Modeling (Existing Conditions)

The traffic noise levels presented in Table 1 are the average noise level (L_{eq}) over the period of the measurement. In order to determine the CNEL associated with current traffic volumes, traffic modeling is performed. The existing CNEL was calculated for each of the roadways represented by the short-term measurement locations, except for ST1 and ST3. The roadway segments adjacent to ST1 and ST3 had no traffic occurring during the measurement, and no published traffic data exists for these roads (Seacliff Drive and Dugan Road). As such, ST1 and ST3 are representative of ambient noise levels in residential areas removed from major transportation noise

sources. Adjacent to the ocean, residences can expect a background level of approximately 55 dBA L_{eq} .hourly; in areas removed from both the ocean and US Highway 101, residential neighborhood noise levels are as low as 43 dBA L_{eq} .hourly.

Traffic counts, vehicle speeds, roadway configuration, and noise levels recorded during the short-term measurement at ST2 and at ST4 through ST10 were used to set up and calibrate the TNM 2.5 Traffic Noise Model (FHWA 2004) in order to model existing traffic noise (CNEL) along the roadway segments adjacent to these measurement points. In accordance with FHWA guidelines for TNM 2.5, the counted vehicles at each measurement point were normalized to a one-hour volume (for example if the measurement period was for thirty minutes, the counted number of vehicles was doubled to account for vehicles passing the measurement point during a 60-minute period). The normalized traffic volume, vehicle composition ratios, vehicle speeds, and lane configurations recorded during the noise measurement at each location were used to calibrate the model and verify the input used in the noise model. The modeled L_{eq} for short-term measurement locations are within one dB of the measured noise levels. This result generally confirms the assumptions used in the noise model.

The calibrated noise model was then run using “existing” average daily trip (ADT) for each of the selected highway and roadway segments. The existing scenario input ADT data for the model runs is presented in Attachment 2 (Table A - Traffic Count Data and Future Traffic Volume Forecast Summary), including the identification of sources for the “existing” scenario ADT data. The calculated existing CNEL for each selected highway and roadway segment is also presented in Attachment 2 (Table B - Traffic Noise Levels and Noise Contour Boundary Distances). The TNM 2.5 model runs used a uniform distance of 50 feet from the centerline of US Highway 101, and 25 feet from the center-line of all other roadways. The CNEL values at this uniform distance are reported in Table B.

The modeled CNEL at a given distance of 50 feet (US Highway 101) or 25 feet (all other roadways) from the roadway was then used to calculate the distance from the roadway center-line to the boundary of the 70, 65, and 60 dBA CNEL contours. This calculation was based upon outdoor attenuation rates of 3 dBA per doubling of distance for a line source. This calculation ignores topography, the presence of structures or walls, and the presence of vegetation, and is therefore very conservative (i.e., the presence of buildings along a roadway would partially or fully block the propagation of sound, reducing the distance from the roadway to the calculated noise contour boundary). The distance to the 70, 65, and 60 dBA CNEL contour is also reported in Table B.

2.3 Predicted Future Noise Levels

Roadway transportation represents the most important and pervasive noise source for a compact community such as Pismo Beach. Therefore, the prediction of future community noise levels in Pismo Beach rests heavily on modeling of traffic noise associated with ADT forecasts pertaining to major local roadways and highways. For freeways and highways, Dudek used the Citywide Transportation Model and Circulation Study, Final Report (Pismo Beach 2016) ADT to the year 2035 for each of the selected highway segments. In order to extend the forecast to Year 2040, Dudek applied the annual growth rate indicated in the 2019 Regional Transportation Plan (SLOCOG 2019). The RTP identifies an annual growth rate of 0.053%, which Dudek applied to the 2035 ADT values in the Circulation Study, to increment the predicted ADT values to the Year 2040. For local street segment volumes, Dudek used 2040 forecasted peak intersection volume data for local streets in the Pismo Beach Circulation Element Update, Final Report (GHD September 2021)

The calibrated noise model was then run using the calculated Year 2040 ADT data (described above) for each of the selected highway and roadway segments. The Year 2040 scenario input ADT data for the model runs is presented in Attachment 2 (Table A - Traffic Count Data and Future Traffic Volume Forecast Summary). Notes in the table identify the sources for the forecasted ADT data in the table. The calculated Year 2040 CNEL for each selected highway and roadway segment is also presented in Attachment 2 (Table B - Traffic Noise Levels and Noise Contour Boundary Distances). The TNM 2.5 model runs used a uniform distance of 50 feet from the centerline of US Highway 101, and 25 feet from the center-line of all other roadways. The modeled Year 2040 CNEL values at this uniform distance are reported in Table B.

The modeled Year 2040 CNEL at a given distance of 50 feet (US Highway 101) or 25 feet (all other roadways) from the roadway was then used to calculate the distance from the roadway center-line to the boundary of the 70, 65, and 60 dBA CNEL contours. This calculation was based upon outdoor attenuation rates of 3 dBA per doubling of distance for a line source. This calculation is a conservative worst-case distance, ignoring topography, the presence of structures or walls, and the presence of vegetation. The distance to the 70, 65, and 60 dBA CNEL contour is also reported in Table B.

3 References Cited

Airport Land Use Commission of San Luis Obispo County. 2005. *Airport Land Use Plan for the San Luis Obispo County Regional Airport, May 18, 2005.*

Airport Land Use Commission of San Luis Obispo County. 2007. *Airport Land Use Plan for the Oceano County Airport, May 16, 2007.*

California Department of Transportation (Caltrans), 1987, *California Vehicle Noise Emission Levels, (FHWA/CA/TL-87/03).*

California Department of Transportation. 2011. *Traffic Noise Analysis Protocol.*

California Department of Transportation. 2013. *Technical Noise Supplement to the Traffic Noise Analysis Protocol.*

City of Pismo Beach. 2016 . *City of Pismo Beach Citywide Transportation Model and Circulation Study, Final Report, August 23, 2016.*

City of Pismo Beach. 2018. *Pismo Beach General Plan Circulation Element Update Initial Study/Mitigated Negative Declaration (IS/MND).* March 2018

Cowan, James P. 1994. *Handbook of Environmental Acoustics*

Federal Highway Administration (FHWA), 2004, *Traffic Noise Model Version 2.5 (TNM 2.5)*

Federal Interagency Committee on Noise (FICON), *Federal Agency Review of Selected Airport Noise Analysis Issues*, August 1992

GHD Inc. 2021. *Pismo Beach Circulation Element Final Report.* September 2021

HUD, *Noise Guidebook*, 2009. Available at: <https://www.hudexchange.info/resource/313/hud-noise-guidebook/>

San Luis Obispo Council of Governments (SLOCOG). 2019. *Regional Transportation Plan*



Pismo Beach City Limit
Noise Measurement Location
▣ LT - Long Term Measurement
▣ ST - Short Term Measurement

SOURCE: NAIP 2016; San Luis Obispo County 2019



INTENTIONALLY LEFT BLANK

ATTACHMENT 1

FIELD DATA SHEETS - SHORT TERM MEASUREMENTS

FIELD NOISE MEASUREMENT DATA

PROJECT <u>PISMO BEACH NEU</u>	PROJECT # <u>11924</u>
SITE ID <u>ST-1 MEMORY PARK</u>	OBSERVER(S) <u>JVL</u>
SITE ADDRESS _____	
START DATE <u>10/22</u>	END DATE <u>10/22</u>
START TIME <u>11:35</u>	END TIME <u>11:50</u>

METEOROLOGICAL CONDITIONS

TEMP 72 F HUMIDITY 38 % R.H. WIND CALM LIGHT MODERATE
 WINDSPD 0 MPH DIR. N NE S SE S SW W NW VARIABLE STEADY GUSTY
 SKY SUNNY CLEAR OVRCAST PRTLY CLDY FOG RAIN

ACOUSTIC MEASUREMENTS

MEAS. INSTRUMENT RION NL-32 TYPE 1 2 SERIAL # 01030561
 CALIBRATOR RION NC-74 SERIAL # 34678576
 CALIBRATION CHECK PRE-MEASUREMENT 94 dBA SPL POST-MEASUREMENT 94 dBA SPL WINDSCRN X

SETTINGS A-WTD SLOW FAST FRONTAL RANDOM ANSI OTHER: _____

REC. #	BEGIN	END	Leq	Lmax	Lmin	L90	L50	L10	OTHER (SPECIFY METRIC)
<u>1</u>	<u>11:35</u>	<u>11:50</u>	<u>55.2</u>	<u>61.6</u>	<u>50.1</u>	<u>52.3</u>	<u>54.3</u>	<u>57.4</u>	

COMMENTS
MEMORY PARK - ADJACENT TO CLIFF STREET
TYPICAL DOWNTIME FOR RESIDENTIAL NEIGHBORHOOD

SOURCE INFO AND TRAFFIC COUNTS

PRIMARY NOISE SOURCE _____ TRAFFIC AIRCRAFT RAIL INDUSTRIAL OTHER: BACKGROUND
 ROADWAY TYPE: _____ DIST. TO RDWY C/L OR EOP: _____

TRAFFIC COUNT DURATION:	MIN		SPEED		IF COUNTING BOTH DIRECTIONS AS ONE, CHECK HERE	MIN		SPEED	
	NB/EB	SB/WB	NB/EB	SB/WB		NB/EB	SB/WB	NB/EB	SB/WB
COUNT 1 (OR RDWY 1)									
DIRECTION									
AUTOS									
MED TRKS									
HVY TRKS									
BUSES									
MOTRCLS									
COUNT 2 (OR RDWY 2)									
DIRECTION									
AUTOS									
MED TRKS									
HVY TRKS									
BUSES									
MOTRCLS									

SPEEDS ESTIMATED BY: RADAR / DRIVING THE PACE
 POSTED SPEED LIMIT SIGNS SAY: _____

OTHER NOISE SOURCES (BACKGROUND): DIST. AIRCRAFT RUSTLING LEAVES DIST. BARKING DOGS BIRDS DIST. INDUSTRIAL
 DIST. KIDS PLAYING DIST. CONVRSTNS / YELLING DIST. TRAFFIC (LIST RDWYS BELOW) DISTD GARDENERS/LANDSCAPING NOISE
 OTHER: OCEAN SURF

DESCRIPTION / SKETCH

TERRAIN HARD SOFT MIXED FLAT OTHER: _____
 PHOTOS #8 #9
 OTHER COMMENTS / SKETCH _____

FIELD NOISE MEASUREMENT DATA

PROJECT <u>PISMO BEACH NEU</u>	PROJECT # <u>11924</u>
SITE ID <u>ST-2</u>	OBSERVER(S) <u>JVL</u>
SITE ADDRESS <u>OCEAN BLVD.</u>	
START DATE <u>10/22</u>	END DATE <u>10/22</u>
START TIME <u>12:30</u>	END TIME <u>12:45</u>

METEOROLOGICAL CONDITIONS

TEMP 74 F HUMIDITY 35 % R.H. WIND CALM LIGHT MODERATE
 WINDSPD 2 MPH DIR. N NE S SE S SW W NW VARIABLE STEADY GUSTY
 SKY SUNNY CLEAR OVRCAST PRTLY CLDY FOG RAIN

ACOUSTIC MEASUREMENTS

MEAS. INSTRUMENT RION NL-32 TYPE 1 SERIAL # 01030561
 CALIBRATOR RION NC-74 SERIAL # 34670576
 CALIBRATION CHECK PRE-MEASUREMENT 94 dBA SPL POST-MEASUREMENT 94 dBA SPL WINDSCRN

SETTINGS A-WTD SLOW FAST FRONTAL RANDOM ANSI OTHER: _____

REC. #	BEGIN	END	Leq	Lmax	Lmin	L90	L50	L10	OTHER (SPECIFY METRIC)
<u>1</u>	<u>12:30</u>	<u>12:45</u>	<u>58.6</u>	<u>60.9</u>	<u>49.3</u>	<u>51.3</u>	<u>52.6</u>	<u>55.6</u>	

COMMENTS BACKGROUND FOR RESIDENTIAL NEIGHBORHOOD AT BEACH. LITTLE TRAFFIC ON OCEAN BLVD DURING MEASURE.

SOURCE INFO AND TRAFFIC COUNTS

PRIMARY NOISE SOURCE _____ TRAFFIC AIRCRAFT RAIL INDUSTRIAL OTHER: SURF BREAK / SEA WAVES
 ROADWAY TYPE: COLLECTOR DIST. TO RDWY C/L OR EOP: 10'

TRAFFIC COUNT DURATION: _____		MIN		SPEED <u>25</u>		MIN		SPEED		
COUNT 1 (OR RDWY 1)	DIRECTION	NB/EB	SB/WB	NB/EB	SB/WB	COUNT 2 (OR RDWY 2)	NB/EB	SB/WB	NB/EB	SB/WB
	AUTOS	<u>5</u>								
MED TRKS	<u>0</u>									
HVY TRKS	<u>0</u>									
BUSES	<u>0</u>									
MOTRCLS	<u>0</u>									

IF COUNTING BOTH DIRECTIONS AS ONE, CHECK HERE _____

SPEEDS ESTIMATED BY: RADAR / DRIVING THE PACE
 POSTED SPEED LIMIT SIGNS SAY: 25

OTHER NOISE SOURCES (BACKGROUND): DIST. AIRCRAFT RUSTLING LEAVES DIST. BARKING DOGS BIRDS DIST. INDUSTRIAL
 DIST. KIDS PLAYING DIST. CONVRSTNS / YELLING DIST. TRAFFIC (LIST RDWYS BELOW) DISTD GARDENERS/LANDSCAPING NOISE
 OTHER: OCEAN SURF

DESCRIPTION / SKETCH

TERRAIN HARD SOFT MIXED FLAT OTHER: _____
 PHOTOS #13 & #11
 OTHER COMMENTS / SKETCH _____

FIELD NOISE MEASUREMENT DATA

PROJECT Pismo Beach NEU PROJECT # 11924
 SITE ID ST-3
 SITE ADDRESS DUGAN RD @ FLAME WAY OBSERVER(S) TVL
 START DATE 10/22/19 END DATE 10/22/19
 START TIME 2:05 END TIME 2:25

METEOROLOGICAL CONDITIONS
 TEMP 74 F HUMIDITY 32 % R.H. WIND CALM LIGHT MODERATE
 WINDSPD 3 MPH DIR. N NE S SE S SW W NW VARIABLE STEADY GUSTY
 SKY SUNNY CLEAR OVRCAST PRTLY CLDY FOG RAIN

ACOUSTIC MEASUREMENTS
 MEAS. INSTRUMENT RION NL-32 TYPE 1 2 SERIAL # 01030561
 CALIBRATOR Rion NC-74 SERIAL # 34678576
 CALIBRATION CHECK PRE-MEASUREMENT 94.0 dBA SPL POST-MEASUREMENT 94.0 dBA SPL WINDSCRN x

SETTINGS A-WTD SLOW FAST FRONTAL RANDOM ANSI OTHER: _____

REC. #	BEGIN	END	Leq	Lmax	Lmin	L90	L50	L10	OTHER (SPECIFY METRIC)
<u>1</u>	<u>2:05</u>	<u>2:20</u>	<u>42.7</u>	<u>45.9</u>	<u>41.1</u>	<u>41.7</u>	<u>42.3</u>	<u>44.1</u>	

COMMENTS _____

SOURCE INFO AND TRAFFIC COUNTS

PRIMARY NOISE SOURCE ROADWAY TYPE: _____ TRAFFIC AIRCRAFT RAIL INDUSTRIAL OTHER: BACKGROUND
 DIST. TO RDWY C/L OR EOP 0'

TRAFFIC COUNT DURATION:	MIN	SPEED		IF COUNTING BOTH DIRECTIONS AS ONE, CHECK HERE	MIN	SPEED		
		NB/EB	SB/WB			NB/EB	SB/WB	
COUNT 1 (OR RDWY 1)								
DIRECTION	NB/EB	SB/WB	NB/EB	SB/WB	NB/EB	SB/WB	NB/EB	SB/WB
AUTOS								
MED TRKS								
HVY TRKS								
BUSES								
MOTRCLS								
COUNT 2 (OR RDWY 2)								

SPEEDS ESTIMATED BY: RADAR / DRIVING THE PACE
 POSTED SPEED LIMIT SIGNS SAY: _____

OTHER NOISE SOURCES (BACKGROUND): DIST. AIRCRAFT RUSTLING LEAVES DIST. BARKING DOGS BIRDS DIST. INDUSTRIAL
 DIST. KIDS PLAYING DIST. CONVRTNS / YELLING DIST. TRAFFIC (LIST RDWYS BELOW) DISTD GARDENERS/LANDSCAPING NOISE
 OTHER: DISTANT US101, TRAW HORN

DESCRIPTION / SKETCH
 TERRAIN HARD SOFT MIXED FLAT OTHER: _____
 PHOTOS #19, #20
 OTHER COMMENTS / SKETCH

FIELD NOISE MEASUREMENT DATA

PROJECT <u>PISMO BEACH NEU</u>	PROJECT # <u>11924</u>
SITE ID <u>ST-4</u>	
SITE ADDRESS <u>FIVE CITIES DRIVE McDONALDS</u>	OBSERVER(S) <u>JVL</u>
START DATE <u>10/22</u> END DATE <u>10/22</u>	
START TIME _____ END TIME _____	

METEOROLOGICAL CONDITIONS

TEMP 72 F HUMIDITY 36 % R.H. WIND CALM LIGHT MODERATE
WINDSPD 0 MPH DIR. N NE S SE S SW W NW VARIABLE STEADY GUSTY
SKY SUNNY CLEAR OVRCAST PRTLY CLDY FOG RAIN

ACOUSTIC MEASUREMENTS

MEAS. INSTRUMENT RION NL-32 TYPE 1 2 SERIAL # 01030561
CALIBRATOR RION NL-74 SERIAL # 34678576
CALIBRATION CHECK PRE-MEASUREMENT 94 dBA SPL POST-MEASUREMENT 94 dBA SPL WINDSCRN X

SETTINGS A-WTD SLOW FAST FRONTAL RANDOM ANSI OTHER: _____

REC. #	BEGIN	END	Leq	Lmax	Lmin	L90	L50	L10	OTHER (SPECIFY METRIC)
<u>1</u>	<u>9:40</u>	<u>9:45</u>	<u>72.4</u>	<u>75.8</u>	<u>63.7</u>	<u>69.3</u>	<u>72.1</u>	<u>74.4</u>	

COMMENTS 10-15' ABOVE ELEVATION OF U.S. 101

SOURCE INFO AND TRAFFIC COUNTS

PRIMARY NOISE SOURCE TRAFFIC AIRCRAFT RAIL INDUSTRIAL OTHER: _____
ROADWAY TYPE: US 101 DIST. TO RDWY C/L OR EOP: 125'

	TRAFFIC COUNT DURATION: _____				IF COUNTING BOTH DIRECTIONS AS ONE, CHECK HERE	SPEEDS ESTIMATED BY: _____			
	MIN	SPEED		MIN		SPEED			
	NB/EB	SB/WB	NB/EB	SB/WB		NB/EB	SB/WB	NB/EB	SB/WB
COUNT 1 (OR RDWY 1)					X				
DIRECTION	NB/EB	SB/WB	NB/EB	SB/WB					
AUTOS	<u>316</u>								
MED TRKS	<u>4</u>								
HVY TRKS	<u>14</u>								
BUSES	<u>1</u>								
MOTRCLS	<u>2</u>								

POSTED SPEED LIMIT SIGNS SAY: 65

OTHER NOISE SOURCES (BACKGROUND): DIST. AIRCRAFT RUSTLING LEAVES DIST. BARKING DOGS BIRDS DIST. INDUSTRIAL
DIST. KIDS PLAYING DIST. CONVRSTNS / YELLING DIST. TRAFFIC (LIST RDWYS BELOW) DISTD GARDENERS/LANDSCAPING NOISE
OTHER: _____

DESCRIPTION / SKETCH

TERRAIN HARD SOFT MIXED FLAT OTHER: _____
PHOTOS #1 & #2

OTHER COMMENTS / SKETCH

FIELD NOISE MEASUREMENT DATA

PROJECT Memo Beach NEU PROJECT # 11924
 SITE ID ST-5
 SITE ADDRESS US 1 OBSERVER(S) JVL
 START DATE 10/22 END DATE 10/22
 START TIME 1:00 END TIME _____

METEOROLOGICAL CONDITIONS
 TEMP 74 F HUMIDITY 32 % R.H. WIND CALM LIGHT MODERATE
 WINDSPD 3 MPH DIR. N NE S SE S SW W NW VARIABLE STEADY GUSTY
 SKY SUNNY CLEAR OVRCAST PRTLY CLDY FOG RAIN

ACOUSTIC MEASUREMENTS
 MEAS. INSTRUMENT Rion NL-32 TYPE 1 2 SERIAL # 01030561
 CALIBRATOR Rion NC-74 SERIAL # 34678576
 CALIBRATION CHECK PRE-MEASUREMENT 94.0 dBA SPL POST-MEASUREMENT 94.0 dBA SPL WINDSCRN X

SETTINGS A-WTD SLOW FAST FRONTAL RANDOM ANSI OTHER: _____

REC. #	BEGIN	END	Leq	Lmax	Lmin	L90	L50	L10	OTHER (SPECIFY METRIC)
<u>1</u>	<u>1:00</u>	<u>1:10</u>	<u>69.3</u>	<u>83.0</u>	<u>51.3</u>	<u>58.7</u>	<u>67.2</u>	<u>72.2</u>	

COMMENTS

SOURCE INFO AND TRAFFIC COUNTS

PRIMARY NOISE SOURCE _____ TRAFFIC AIRCRAFT RAIL INDUSTRIAL OTHER: _____
 ROADWAY TYPE: _____ DIST. TO RDWY C/L OR EOP: _____

TRAFFIC COUNT DURATION:	MIN		SPEED		IF COUNTING BOTH DIRECTIONS AS ONE, CHECK HERE	MIN		SPEED		
	NB/EB	SB/WB	NB/EB	SB/WB		NB/EB	SB/WB	NB/EB	SB/WB	
COUNT 1 (OR RDWY 1)					X					
DIRECTION	NB/EB	SB/WB	NB/EB	SB/WB		COUNT 2 (OR RDWY 2)				
AUTOS	<u>129</u>									
MED TRKS	<u>3</u>									
HVY TRKS	<u>3</u>									
BUSES	<u>0</u>									
MOTRCLS	<u>2</u>									

SPEEDS ESTIMATED BY: RADAR / DRIVING THE PACE
 POSTED SPEED LIMIT SIGNS SAY: 45

OTHER NOISE SOURCES (BACKGROUND): DIST. AIRCRAFT RUSTLING LEAVES DIST. BARKING DOGS BIRDS DIST. INDUSTRIAL
 DIST. KIDS PLAYING DIST. CONVRSTNS / YELLING DIST. TRAFFIC (LIST RDWYS BELOW) DISTD GARDENERS/LANDSCAPING NOISE
 OTHER: _____

DESCRIPTION / SKETCH
 TERRAIN HARD SOFT MIXED FLAT OTHER: _____
 PHOTOS # 15 # 16
 OTHER COMMENTS / SKETCH

FIELD NOISE MEASUREMENT DATA

PROJECT PISMO BEACH NEU PROJECT # 11924
 SITE ID ST-6
 SITE ADDRESS 4TH STREET OBSERVER(S) JVL
 START DATE 10/22 END DATE 10/22
 START TIME _____ END TIME _____

METEOROLOGICAL CONDITIONS

TEMP 72 F HUMIDITY 36 % R.H. WIND CALM LIGHT MODERATE
 WINDSPD 0 MPH DIR. N NE S SE S SW W NW VARIABLE STEADY GUSTY
 SKY SUNNY CLEAR OVRCAST PRTLY CLDY FOG RAIN

ACOUSTIC MEASUREMENTS

MEAS. INSTRUMENT RION NL-32 TYPE 1 2 SERIAL # 01030561
 CALIBRATOR RION NC-14 SERIAL # 34678576
 CALIBRATION CHECK PRE-MEASUREMENT 94 dBA SPL POST-MEASUREMENT 94 dBA SPL WINDSCRN X

SETTINGS

A-WTD SLOW FAST FRONTAL RANDOM ANSI OTHER: _____

REC. #	BEGIN	END	Leq	Lmax	Lmin	L90	L50	L10	OTHER (SPECIFY METRIC)
	<u>10:10</u>	<u>10:20</u>	<u>72.8</u>	<u>81.5</u>	<u>49.5</u>	<u>59.9</u>	<u>70.2</u>	<u>76.7</u>	

COMMENTS

SOURCE INFO AND TRAFFIC COUNTS

PRIMARY NOISE SOURCE TRAFFIC AIRCRAFT RAIL INDUSTRIAL OTHER: _____
 ROADWAY TYPE: ARTERIAL DIST. TO RDWY C/L OR EOP: 10' EDGE OF LANE
 TRAFFIC COUNT DURATION: _____ MIN SPEED _____ MIN SPEED _____

COUNT 1 (OR RDWY 1)	DIRECTION	NB/EB		SB/WB		IF COUNTING BOTH DIRECTIONS AS ONE, CHECK HERE	COUNT 2 (OR RDWY 2)	NB/EB		SB/WB	
		NB/EB	SB/WB	NB/EB	SB/WB			NB/EB	SB/WB		
	AUTOS	<u>128</u>									
	MED TRKS	<u>1</u>									
	HVY TRKS	<u>3</u>									
	BUSES	<u>1</u>				<u>X</u>					
	MOTRCLS	<u>0</u>									

SPEEDS ESTIMATED BY: RADAR / DRIVING THE PACE

POSTED SPEED LIMIT SIGNS SAY: 45

OTHER NOISE SOURCES (BACKGROUND): DIST. AIRCRAFT RUSTLING LEAVES DIST. BARKING DOGS BIRDS DIST. INDUSTRIAL
 DIST. KIDS PLAYING DIST. CONVRSTNS / YELLING DIST. TRAFFIC (LIST RDWYS BELOW) DISTD GARDENERS/LANDSCAPING NOISE
 OTHER: _____

DESCRIPTION / SKETCH

TERRAIN HARD SOFT MIXED FLAT OTHER: _____
 PHOTOS #3 & #4
 OTHER COMMENTS / SKETCH _____

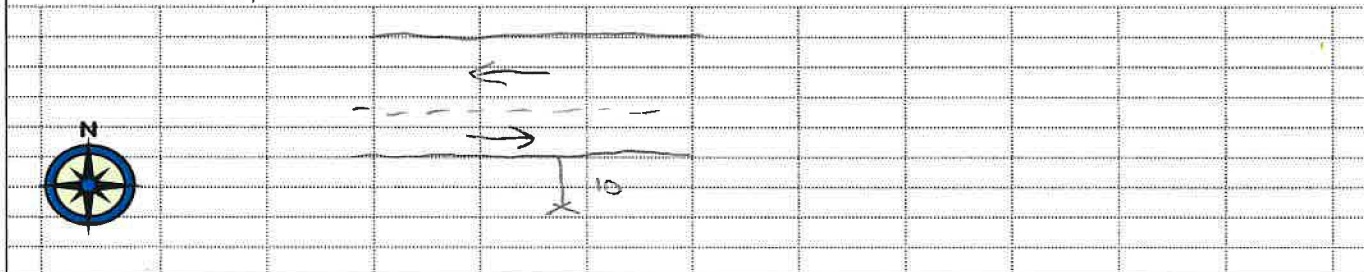

FIELD NOISE MEASUREMENT DATA

PROJECT <u>PISMO BEACH NEU</u>	PROJECT # <u>11924</u>
SITE ID <u>ST-7</u>	
SITE ADDRESS <u>MATTIE ROAD</u>	OBSERVER(S) <u>JVL</u>
START DATE <u>10/22</u>	END DATE <u>10/22</u>
START TIME <u>10:50</u>	END TIME <u>11:20</u>

METEOROLOGICAL CONDITIONS

TEMP 72 F HUMIDITY 36 %R.H. WIND CALM LIGHT MODERATE
 WINDSPD 3 MPH DIR. N NE S SE S SW W NW VARIABLE STEADY GUSTY
 SKY SUNNY CLEAR OVRCAST PRTLY CLDY FOG RAIN

ACOUSTIC MEASUREMENTS

MEAS. INSTRUMENT RION NL-32 TYPE 1 2 SERIAL # 01030561
 CALIBRATOR RION NC-74 SERIAL # 34678576
 CALIBRATION CHECK PRE-MEASUREMENT 94 dBA SPL POST-MEASUREMENT 94 dBA SPL WINDSCRN X

SETTINGS A-WTD SLOW FAST FRONTAL RANDOM ANSI OTHER: _____

REC. #	BEGIN	END	Leq	Lmax	Lmin	L90	L50	L10	OTHER (SPECIFY METRIC)
	<u>10:50</u>	<u>11:20</u>	<u>65.7</u>	<u>79.8</u>	<u>51.1</u>	<u>62.0</u>	<u>64.5</u>	<u>67.3</u>	

COMMENTS _____

SOURCE INFO AND TRAFFIC COUNTS

PRIMARY NOISE SOURCE TRAFFIC AIRCRAFT RAIL INDUSTRIAL OTHER: _____
 ROADWAY TYPE: _____ DIST. TO RDWY C/L OR EOP: 9'

TRAFFIC COUNT DURATION: _____		MIN		SPEED		MIN		SPEED	
		NB/EB	SB/WB	NB/EB	SB/WB	NB/EB	SB/WB	NB/EB	SB/WB
COUNT 1 (OR RDWY 1)	DIRECTION								
	AUTOS	<u>38</u>							
	MED TRKS	<u>0</u>							
	HVY TRKS	<u>0</u>							
	BUSES	<u>0</u>							
MOTRCLS	<u>1</u>								

IF COUNTING BOTH DIRECTIONS AS ONE, CHECK HERE X

SPEEDS ESTIMATED BY: RADAR / DRIVING THE PACE
 POSTED SPEED LIMIT SIGNS SAY: 35

OTHER NOISE SOURCES (BACKGROUND): DIST. AIRCRAFT RUSTLING LEAVES DIST. BARKING DOGS BIRDS DIST. INDUSTRIAL
 DIST. KIDS PLAYING DIST. CONVRSTNS / YELLING DIST. TRAFFIC (LIST RDWYS BELOW) DISTD GARDENERS/LANDSCAPING NOISE
 OTHER: US 101 BACKGROUND

DESCRIPTION / SKETCH

TERRAIN HARD SOFT MIXED FLAT OTHER: _____
 PHOTOS #5 & #6 & #7
 OTHER COMMENTS / SKETCH

FIELD NOISE MEASUREMENT DATA

PROJECT <u>PISMO BEACH NEU</u>	PROJECT # <u>11924</u>
SITE ID <u>ST-8</u>	
SITE ADDRESS <u>N. OAK PARK BLVD</u>	OBSERVER(S) <u>JVL</u>
START DATE <u>10/22/19</u> END DATE <u>10/22/19</u>	
START TIME <u>11:50</u> END TIME _____	

METEOROLOGICAL CONDITIONS

TEMP _____ F HUMIDITY _____ % R.H. WIND CALM LIGHT MODERATE
 WINDSPD _____ MPH DIR. N NE S SE S SW W NW VARIABLE STEADY GUSTY
 SKY SUNNY CLEAR OVRCAST PRTLY CLDY FOG RAIN

ACOUSTIC MEASUREMENTS

MEAS. INSTRUMENT RION NL-32 TYPE ① 2 SERIAL # 01030561
 CALIBRATOR RION NC-74 SERIAL # 34678576
 CALIBRATION CHECK PRE-MEASUREMENT 94.0 dBA SPL POST-MEASUREMENT 94.0 dBA SPL WINDSCRN X

SETTINGS A-WTD SLOW FAST FRONTAL RANDOM ANSI OTHER: _____

REC. #	BEGIN	END	Leq	Lmax	Lmin	L90	L50	L10	OTHER (SPECIFY METRIC)
_____	<u>1:50</u>	<u>2:00</u>	<u>67.3</u>	<u>79.1</u>	<u>45.1</u>	<u>49.6</u>	<u>63.3</u>	<u>71.3</u>	_____
_____	_____	_____	_____	_____	_____	_____	_____	_____	_____
_____	_____	_____	_____	_____	_____	_____	_____	_____	_____
_____	_____	_____	_____	_____	_____	_____	_____	_____	_____

COMMENTS _____

SOURCE INFO AND TRAFFIC COUNTS

PRIMARY NOISE SOURCE ROADWAY TYPE: _____ TRAFFIC AIRCRAFT RAIL INDUSTRIAL OTHER: _____
 DIST. TO RDWY C/L OR EOP: 10'

TRAFFIC COUNT DURATION:	MIN		SPEED		IF COUNTING BOTH DIRECTIONS AS ONE, CHECK HERE	MIN		SPEED	
	NB/EB	SB/WB	NB/EB	SB/WB		NB/EB	SB/WB	NB/EB	SB/WB
COUNT 1 (OR RDWY 1)				<u>40</u>					
DIRECTION	NB/EB	SB/WB	NB/EB	SB/WB		NB/EB	SB/WB	NB/EB	SB/WB
AUTOS	<u>82</u>	_____	_____	_____		_____	_____	_____	_____
MED TRKS	<u>3</u>	_____	_____	_____		_____	_____	_____	_____
HVY TRKS	<u>0</u>	_____	_____	_____		_____	_____	_____	_____
BUSES	<u>1</u>	_____	_____	_____		_____	_____	_____	_____
MOTRCLS	<u>0</u>	_____	_____	_____		_____	_____	_____	_____

SPEEDS ESTIMATED BY: RADAR / DRIVING THE PACE
 POSTED SPEED LIMIT SIGNS SAY: 40

OTHER NOISE SOURCES (BACKGROUND): DIST. AIRCRAFT RUSTLING LEAVES DIST. BARKING DOGS BIRDS DIST. INDUSTRIAL
 DIST. KIDS PLAYING DIST. CONVRSTNS / YELLING DIST. TRAFFIC (LIST RDWYS BELOW) DISTD GARDENERS/LANDSCAPING NOISE
 OTHER: _____

DESCRIPTION / SKETCH

TERRAIN HARD SOFT MIXED FLAT OTHER: _____
 PHOTOS #17 #18
 OTHER COMMENTS / SKETCH CITRUS SCHOOL

FIELD NOISE MEASUREMENT DATA

PROJECT <u>PISMO BEACH NEU</u>	PROJECT # <u>119124</u>
SITE ID <u>ST-9</u>	OBSERVER(S) <u>JVL</u>
SITE ADDRESS <u>TRICE CANYON ROAD @ DELL CT</u>	
START DATE <u>10/22/19</u>	END DATE <u>10/22/19</u>
START TIME <u>1:20</u>	END TIME <u>1:30</u>

METEOROLOGICAL CONDITIONS

TEMP 74 F HUMIDITY 34 % R.H. WIND CALM LIGHT MODERATE
 WINDSPD 0 MPH DIR. N NE S SE S SW W NW VARIABLE STEADY GUSTY
 SKY SUNNY CLEAR OVRCAST PRTLY CLDY FOG RAIN

ACOUSTIC MEASUREMENTS

MEAS. INSTRUMENT RION NL-32 TYPE 1 2 SERIAL # 01030561
 CALIBRATOR RION NC-74 SERIAL # 34678576
 CALIBRATION CHECK PRE-MEASUREMENT 94 dBA SPL POST-MEASUREMENT 94 dBA SPL WINDSCRN X

SETTINGS A-WTD SLOW FAST FRONTAL RANDOM ANSI OTHER: _____

REC. #	BEGIN	END	Leq	Lmax	Lmin	L90	L50	L10	OTHER (SPECIFY METRIC)
<u>1</u>	<u>1:20</u>	<u>1:30</u>	<u>71.0</u>	<u>86.5</u>	<u>48.3</u>	<u>53.5</u>	<u>64.9</u>	<u>74.2</u>	

COMMENTS _____

SOURCE INFO AND TRAFFIC COUNTS

PRIMARY NOISE SOURCE TRAFFIC AIRCRAFT RAIL INDUSTRIAL OTHER: _____
 ROADWAY TYPE: DIST. TO RDWY C/L OR EOP: 12 ft.

TRAFFIC COUNT DURATION: _____		MIN		SPEED <u>45</u>		MIN		SPEED			
COUNT 1 (OR RDWY 1)	DIRECTION	NB/EB	SB/WB	NB/EB	SB/WB	COUNT 2 (OR RDWY 2)	NB/EB	SB/WB	NB/EB	SB/WB	
	AUTOS	<u>81</u>									
	MED TRKS	<u>4</u>									
	HVY TRKS	<u>7</u>									
	BUSES	<u>0</u>									
MOTRCLS	<u>0</u>										

IF COUNTING BOTH DIRECTIONS AS ONE, CHECK HERE _____

SPEEDS ESTIMATED BY: RADAR / DRIVING THE PACE
 POSTED SPEED LIMIT SIGNS SAY: 45

OTHER NOISE SOURCES (BACKGROUND): DIST. AIRCRAFT RUSTLING LEAVES DIST. BARKING DOGS BIRDS DIST. INDUSTRIAL
 DIST. KIDS PLAYING DIST. CONVRSTNS / YELLING DIST. TRAFFIC (LIST RDWYS BELOW) DISTD GARDENERS/LANDSCAPING NOISE
 OTHER: BACKGROUND LEAF BLOWER

DESCRIPTION / SKETCH

TERRAIN HARD SOFT MIXED FLAT OTHER: _____
 PHOTOS #15, #16
 OTHER COMMENTS / SKETCH

FIELD NOISE MEASUREMENT DATA

PROJECT <u>PISMO BEACH NEW</u>	PROJECT # <u>11924</u>
SITE ID <u>ST-10</u>	OBSERVER(S) _____
SITE ADDRESS <u>SHELL BEACH ROAD</u>	
START DATE <u>10/22</u> END DATE <u>10/22</u>	
START TIME <u>NOON</u> END TIME <u>12:15</u>	

METEOROLOGICAL CONDITIONS

TEMP 76 F HUMIDITY 34 % R.H. WIND CALM (LIGHT) MODERATE
 WINDSPD 3 MPH DIR. N (NE) S SE S SW W NW VARIABLE STEADY GUSTY
 SKY (SUNNY) (CLEAR) OVRCAST PRTLY CLDY FOG RAIN

ACOUSTIC MEASUREMENTS

MEAS. INSTRUMENT RION NL-32 TYPE (1) 2 SERIAL # 0030561
 CALIBRATOR RION NL-74 SERIAL # 346705760
 CALIBRATION CHECK PRE-MEASUREMENT 94 dBA SPL POST-MEASUREMENT 94 dBA SPL WINDSCRN X

SETTINGS A-WTD SLOW FAST FRONTAL RANDOM ANSI OTHER: _____

REC. #	BEGIN	END	Leq	Lmax	Lmin	L90	L50	L10	OTHER (SPECIFY METRIC)
	<u>12:00</u>	<u>12:15</u>	<u>66.1</u>	<u>83.3</u>	<u>54.9</u>	<u>58.7</u>	<u>62.1</u>	<u>69.3</u>	

COMMENTS BACKGROUND US101 NOISE MICROPHONE ORIENTED TOWARD SHELL BEACH ROAD, AWAY FROM US101.

SOURCE INFO AND TRAFFIC COUNTS

PRIMARY NOISE SOURCE (TRAFFIC) AIRCRAFT RAIL INDUSTRIAL OTHER: US 101 BACKGROUND
 ROADWAY TYPE: ARTERIAL DIST. TO RDWY C/L OR EOP: 7 FT.

TRAFFIC COUNT DURATION:	MIN				SPEED			
	NB/EB		SB/WB		NB/EB		SB/WB	
COUNT 1 (OR RDWY 1)	AUTOS		<u>71</u>		IF COUNTING BOTH DIRECTIONS AS ONE, CHECK HERE		COUNT 2 (OR RDWY 2)	
	MED TRKS		<u>2</u>					
	HVY TRKS		<u>1</u>					
	BUSES		<u>0</u>					
	MOTRCLS		<u>0</u>					

SPEEDS ESTIMATED BY: RADAR / DRIVING THE PACE
 POSTED SPEED LIMIT SIGNS SAY: 35

OTHER NOISE SOURCES (BACKGROUND): DIST. AIRCRAFT RUSTLING LEAVES DIST. BARKING DOGS BIRDS DIST. INDUSTRIAL
 DIST. KIDS PLAYING DIST. CONVRSTNS / YELLING DIST. TRAFFIC (LIST RDWYS BELOW) DISTD GARDENERS/LANDSCAPING NOISE
 OTHER: _____

DESCRIPTION / SKETCH

TERRAIN (HARD) SOFT MIXED FLAT OTHER: _____
 PHOTOS #12 & 11 E 12
 OTHER COMMENTS / SKETCH _____

ATTACHMENT 2

TRAFFIC NOISE MODELING DATA AND RESULTS

TABLE A - Traffic Count Data and Future Traffic Volume Forecast Summary

Site	Road	Minutes	Autos	MT/Bus	HT	Total A+MT+HT	% Auto	% MT	% HT	Hourly Trips	Speed (mph)	EOP Distance	# of Lanes	L _{eq}	Existing ADT City Streets ³	Existing ADT Highway ⁵	2040 ADT Highway ⁵	2040 ADT City Streets ⁶
ST-1	Seacliff Drive ¹	15	0	0	0	0	N/A	N/A	N/A	0	25	8	2	55.2	-	-	-	-
ST-2	Ocean Boulevard	15	5	0	0	5	100%	0%	0%	20	25	10	2	53.6	200 ⁴	-	-	221 ⁷
ST-3	Dugan Road (at Elawe Way) ¹	15	0	0	0	0	N/A	N/A	N/A	0	25	8	2	42.7	-	-	-	-
ST-4	US Highway 101 (adjacent to 5 Cities Drive)	5	318	5	14	337	94%	1%	4%	4044	65	125	4	72.4	-	69600	77652	-
ST-5	US 1	10	131	3	3	137	96%	2%	2%	822	45	14	2	69.3	-	7900	8814	-
ST-6	4th Street	10	128	2	3	133	96%	2%	2%	798	45	10	2	72.8	15480	-	-	18150
ST-7	Mattie Road	30	39	0	0	39	100%	0%	0%	78	35	9	2	65.7	1210	-	-	1300
ST-8	N. Oak Park Boulevard	10	82	4	0	86	95%	5%	0%	516	40	10	2	67.3	16090 ⁵	-	-	19283 ⁵
ST-9	Price Canyon Road (at Dell Court)	10	81	4	7	92	88%	4%	8%	552	45	12	2	71	11210	-	-	14100
ST-10	Shell Beach Road	15	71	2	1	74	96%	3%	1%	296	35	7	2	66.1	1970	-	-	2800
2018 Circulation Element Update IS/MND Data	US 101: Price St (North) to Mattie Road	-	-	-	-	-	-	-	-	-	65	50	4	-	-	64670	72152	-
	US 101: North of Avila Beach Drive ²	-	-	-	-	-	-	-	-	-	65	50	4	-	-	62020	69195	-
	US 101: South of Oak Park Blvd. ²	-	-	-	-	-	-	-	-	-	65	50	4	-	-	62230	69429	-
	US 101: Price St (South) to Price St (North)	-	-	-	-	-	-	-	-	-	65	50	4	-	-	62840	70110	-
	US 101: Mattie Road to Spyglass Drive	-	-	-	-	-	-	-	-	-	65	50	4	-	-	63550	70902	-
	US 101: Spyglass Drive to Avila Beach Drive	-	-	-	-	-	-	-	-	-	65	50	4	-	-	64860	72364	-
	US 101: Oak Park Blvd to Fourth St	-	-	-	-	-	-	-	-	-	65	50	4	-	-	71070	79292	-
	US 101: Fourth St to Price St	-	-	-	-	-	-	-	-	-	65	50	4	-	-	78600	87693	-

Table Notes:

- 1 Measurement collected to characterize residential neighborhood sound levels distant from major traffic sources, no traffic occurred on adjacent street during measurement.
- 2 This segment of US 101 is adjacent to, but outside, Pismo Beach City limits.
- 3 Existing Local Street Roadway Volume calculated from peak intersection volumes, Pismo Beach Circulation Element Update, September 2021.
- 4 ADT for local roadway not included in 2021 study; based upon manual traffic count during short-term sound measurement.
- 5 ADT for US 101 segments, US 1 segment, Oak Park Blvd from 2018 Pismo Beach General Plan Circulation Element Update IS/MND.
- 6 Year 2040 ADT calculated from peak intersection volumes, Pismo Beach Circulation Element Update, September 2021.
- 7 Year 2040 volume based upon 2019 manual traffic count, with 2019 RTP annual growth rates (0.5%) applied to predict increase from 2019 to 2040.

October 2021

TABLE A - Traffic Count Data and Future Traffic Volume Forecast Summary

TABLE B - TRAFFIC NOISE LEVELS AND NOISE CONTOUR BOUNDARY DISTANCES



Project Number: 11924
Project Name: Pismo Beach NEU

October 2021

Noise Model Assumptions and Background Data

Model Description: FHWA Highway Noise Prediction Model (FHWA-RD-77-108) with California Vehicle Noise (CALVENO) Emission Levels.
 Traffic Data Source: 2018 Circulation Element Update MND, San Luis Obispo County RTP 2019, 2021 Circulation Element Update
 Community Noise Descriptor: CNEL

CNEL Contour Notes:

" - " contour is located within the roadway right-of-way
 Distance is from the centerline of the roadway segment to the receptor location.

24 Hour Traffic Distribution Assumptions	Day			Evening			Night			Lanes	Median Width	ADT Volume	Design Speed (mph)	Vehicle Mix			Distance from Centerline of Roadway to Contour		
	77.70%	12.70%	9.60%	87.43%	5.05%	7.52%	89.10%	2.64%	8.06%					50 Feet	60 Feet	70 Feet	50 Feet	60 Feet	70 Feet
Total ADT Volumes	77.70%	12.70%	9.60%	87.43%	5.05%	7.52%	89.10%	2.64%	8.06%	4	25	64,670	65	5%	6%	6%	177	561	1774
Medium Trucks										4	25	72,152	65	5%	6%	6%	199	629	1991
Heavy Trucks																			
Analysis Condition																			
Highway Segment																			
US Highway 101																			
Price Street to Mattie Road, Existing										4	25	64,670	65	5%	6%	6%	177	561	1774
Price Street to Mattie Road, 2040										4	25	72,152	65	5%	6%	6%	199	629	1991
US Highway 101																			
North of Avila Beach Drive, Existing										4	25	62,020	65	5%	6%	6%	182	574	1815
North of Avila Beach Drive, 2040										4	25	69,195	65	5%	6%	6%	204	644	2037
US Highway 101																			
South of Oak Park Blvd, Existing										4	25	62,230	65	5%	6%	6%	182	574	1815
South of Oak Park Blvd, 2040										4	25	69,429	65	5%	6%	6%	204	644	2037
US Highway 101																			
Price Street (south) to Price Street (north), Existing										4	25	62,840	65	5%	6%	6%	182	574	1815
Price Street (south) to Price Street (north), 2040										4	25	70,110	65	5%	6%	6%	204	644	2037
US Highway 101																			
Mattie Road to Spyglass Drive, Existing										4	25	63,550	65	5%	6%	6%	186	587	1858
Mattie Road to Spyglass Drive, 2040										4	25	70,902	65	5%	6%	6%	208	659	2084
US Highway 101																			
Spyglass Drive to Avila Beach Drive, Existing										4	25	64,860	65	5%	6%	6%	190	601	1901
Spyglass Drive to Avila Beach Drive, 2040										4	25	72,364	65	5%	6%	6%	213	674	2133
US Highway 101																			
Oak Park Blvd. to Fourth Street, Existing										4	25	71,070	65	5%	6%	6%	229	723	2285
Oak Park Blvd. to Fourth Street, 2040										4	25	79,292	65	5%	6%	6%	256	811	2564
US Highway 101																			
Fourth Street to Price Street, Existing										4	25	78,600	65	5%	6%	6%	251	792	2506
Fourth Street to Price Street, 2040										4	25	87,693	65	5%	6%	6%	281	889	2812

Analysis Condition Roadway Segment	Lanes	Median Width	ADT Volume	Design Speed (mph)	Vehicle Mix			Distance from Centerline of Roadway to Contour		
					Medium Trucks	Heavy Trucks	CNEL at 25 Feet	70 CNEL	65 CNEL	60 CNEL
Ocean Boulevard										
Between Palisade Ave and Seaview Ave, Existing	2	0	200	25	1%	1%	48.1	-	-	-
Between Palisade Ave and Seaview Ave, 2040	2	0	221	25	1%	1%	48.5	-	-	-
North 4th Street										
South of 5 Cities Drive, Existing	2	0	15,480	45	2%	2%	72.4	43	137	434
South of 5 Cities Drive, 2040	2	0	18,150	45	2%	2%	73.1	51	161	510
Mattie Road										
Between Foothill Road and Baycliff Drive, Existing	2	0	1,210	35	1%	1%	59.0	-	-	-
Between Foothill Road and Baycliff Drive, 2040	2	0	1,300	35	1%	1%	59.4	-	-	-
North Oak Park Blvd.										
South of Meadowlark Drive, Existing	2	0	16,090	40	2%	1%	71.5	35	112	353
South of Meadowlark Drive, 2040	2	0	19,283	40	2%	1%	72.3	42	134	425
Price Canyon Road										
South of Dell Court, Existing	2	0	11,210	45	2%	4%	71.0	31	100	315
South of Dell Court, 2040	2	0	14,100	45	2%	4%	72.0	40	125	396
Shell Beach Road										
Between Solano Road and Ebb Tide Lane, Existing	2	0	1,970	35	3%	1%	61.2	-	-	-
Between Solano Road and Ebb Tide Lane, 2040	2	0	2,800	35	3%	1%	62.7	-	-	-
Cabrillo Highway (US-1)										
Between Addie Street and Park Avenue, Existing	2	0	7,900	45	2%	2%	69.5	25	70	223
Between Addie Street and Park Avenue, 2040	2	0	8,814	45	2%	2%	70.0	25	79	250

TABLE C: NON-TRAFFIC NOISE LEVELS AND NOISE CONTOUR BOUNDARY DISTANCES

Project Number: 11924
Project Name: Noise Element Update



Noise Source	CNEL (dBA)	Distance from Noise Source	Distance to Contour Boundary (feet)		
			70 CNEL	65 CNEL	60 CNEL
UPRR Rail Line (Distance reference is center of tracks)	66.3	40	17	54	171
Industrial Area (Distance Reference is from boundary of Industrial Area)	56.1	300	61	108	191
Retail Center (Distance Reference is from boundary of Retail Center)	63.7	55	27	47	84

ATTACHMENT 3

LONG-TERM MEASUREMENTS AND CALCULATIONS

Number	Start Date	Start Time	End Time	SPL Time		Weight	Freq	LAeq	LAmx	LAmin	LApeak	L1%	L5%	L10%	L50%	L90%
				Weight	Time											
1	10/22/2019	9:00:00 AM	10:00:00 AM	Slow	AM	dBA	49.7	72.5	42.3	86.8	55.5	53.2	52	48.2	45	
2	10/22/2019	10:00:00 AM	11:00:00 AM	Slow	AM	dBA	46.3	57.9	38.7	74.7	53.4	50.4	49.1	44.8	41.9	
3	10/22/2019	11:00:00 AM	12:00:00 PM	Slow	PM	dBA	49.3	66.2	38.1	87.4	61	56.4	48.9	43.6	41.3	
4	10/22/2019	12:00:00 PM	1:00:00 PM	Slow	PM	dBA	50	67.2	43	86.6	61.4	53.2	49.5	47.1	45.7	
5	10/22/2019	1:00:00 PM	2:00:00 PM	Slow	PM	dBA	57.1	80.8	44.3	100.4	68.4	61.9	58.7	51.7	46.4	
6	10/22/2019	2:00:00 PM	3:00:00 PM	Slow	PM	dBA	49.5	75.5	44.6	86.6	54.5	50.4	49.5	47.9	46.2	
7	10/22/2019	3:00:00 PM	4:00:00 PM	Slow	PM	dBA	51.3	78.1	44.5	93.4	57.3	53	51.7	49.4	46.8	
8	10/22/2019	4:00:00 PM	5:00:00 PM	Slow	PM	dBA	50.9	63.9	44.9	89.9	58.3	53.3	52.1	50.2	48	
9	10/22/2019	5:00:00 PM	6:00:00 PM	Slow	PM	dBA	50.4	63.4	41.6	84.5	58	55.6	53.3	48.9	45	
10	10/22/2019	6:00:00 PM	7:00:00 PM	Slow	PM	dBA	54.2	65.4	48.8	84	58.2	56.9	56.1	53.7	51.2	
11	10/22/2019	7:00:00 PM	8:00:00 PM	Slow	PM	dBA	52.5	59.5	47.4	75	57.2	56.1	55.2	51.2	49.3	
12	10/22/2019	8:00:00 PM	9:00:00 PM	Slow	PM	dBA	49.7	56.9	45.9	76	53.6	52	51.3	49.4	47.7	
13	10/22/2019	9:00:00 PM	10:00:00 PM	Slow	PM	dBA	55.2	82.5	45.7	96.1	57.3	53.6	52.5	49.8	48.3	
14	10/22/2019	10:00:00 PM	11:00:00 PM	Slow	PM	dBA	49	61.5	43.1	80.9	54.6	52.1	51.1	48.2	46.1	
15	10/22/2019	11:00:00 PM	12:00:00 AM	Slow	AM	dBA	47.8	58.3	42.2	74	53.5	51.3	50.2	46.8	44.4	
16	10/23/2019	12:00:00 AM	1:00:00 AM	Slow	AM	dBA	44.7	53.6	40	70.3	49.3	47	46.3	44.3	42.2	
17	10/23/2019	1:00:00 AM	2:00:00 AM	Slow	AM	dBA	44.2	53.3	37.9	66.9	49.4	47.6	46.5	43.3	41.2	
18	10/23/2019	2:00:00 AM	3:00:00 AM	Slow	AM	dBA	46.1	60.6	39.1	75.3	52.5	49.8	48.3	45	42.2	
19	10/23/2019	3:00:00 AM	4:00:00 AM	Slow	AM	dBA	47.6	60.2	37.2	74.5	55.1	52.4	50.8	45.8	41.7	
20	10/23/2019	4:00:00 AM	5:00:00 AM	Slow	AM	dBA	48.1	71.8	37.1	86.8	54.5	51.6	50.3	45.7	42	
21	10/23/2019	5:00:00 AM	6:00:00 AM	Slow	AM	dBA	50.5	61.3	41.2	73.8	57.3	55.3	53.9	48.7	45.2	
22	10/23/2019	6:00:00 AM	7:00:00 AM	Slow	AM	dBA	51.4	72.3	42.6	96.1	57.6	55.2	53.9	50	47	
23	10/23/2019	7:00:00 AM	8:00:00 AM	Slow	AM	dBA	51	66.8	43	82.7	60.7	53.7	52.6	49.3	46.4	
24	10/23/2019	8:00:00 AM	9:00:00 AM	Slow	AM	dBA	49	60.5	42.4	83.3	54.6	51.9	51	48.2	46.2	
25	10/23/2019	9:00:00 AM	9:04:13 AM	Slow	AM	dBA	64.4	79.5	44.8	110.6	76.6	71.4	67.5	51.7	46.4	

Number	Start Date	Start Time	End Time	SPL Time		Weight	Freq	LAeq	LAmx	L Amin	LApeak	L1%	L5%	L10%	L50%	L90%
				Weight	Time											
1	10/22/2019	9:00:00 AM	10:00:00 AM	Slow	dB	62.5	90.1	44.7	118.1	71.2	64.6	63	58	49.2		
2	10/22/2019	10:00:00 AM	11:00:00 AM	Slow	dB	58.7	72.3	43.9	85.8	65.9	63.2	61.9	57.2	49.4		
3	10/22/2019	11:00:00 AM	12:00:00 PM	Slow	dB	60.7	73.4	54.1	91.8	67.6	63.9	62.8	59.8	56.7		
4	10/22/2019	12:00:00 PM	1:00:00 PM	Slow	dB	60.9	71.5	52	88.3	67.8	64.4	63.1	60	56.5		
5	10/22/2019	1:00:00 PM	2:00:00 PM	Slow	dB	60.3	74.8	51.9	87.8	67.2	64.2	62.9	59.1	54.7		
6	10/22/2019	2:00:00 PM	3:00:00 PM	Slow	dB	64.8	88.7	51.3	107.3	69.2	65.3	64.2	60.7	55.7		
7	10/22/2019	3:00:00 PM	4:00:00 PM	Slow	dB	72.3	94.9	51.1	114.1	79.2	68.3	66.5	61.6	56.1		
8	10/22/2019	4:00:00 PM	5:00:00 PM	Slow	dB	67.2	93.3	50.4	112.8	68.4	64.2	63.1	59.5	54.7		
9	10/22/2019	5:00:00 PM	6:00:00 PM	Slow	dB	61.6	79.8	50.2	99.9	68.8	64.9	63.9	60.4	55.9		
10	10/22/2019	6:00:00 PM	7:00:00 PM	Slow	dB	62.4	80.1	54.6	105.7	68.4	65.4	64.6	61.3	57.6		
11	10/22/2019	7:00:00 PM	8:00:00 PM	Slow	dB	60.5	69.1	53.7	82.4	65.7	64	63.3	59.7	56.2		
12	10/22/2019	8:00:00 PM	9:00:00 PM	Slow	dB	60.8	82.3	51.6	99.9	67.7	63.6	62.8	58.8	54.6		
13	10/22/2019	9:00:00 PM	10:00:00 PM	Slow	dB	63.2	84.6	51.9	101.3	74.1	64.6	63.1	58	54.4		
14	10/22/2019	10:00:00 PM	11:00:00 PM	Slow	dB	59	71.3	50.7	87.3	65.8	63.6	62.2	57.3	53.8		
15	10/22/2019	11:00:00 PM	12:00:00 AM	Slow	dB	55.9	67.1	43.8	82.1	64.2	61.5	59.8	52.9	46.7		
16	10/23/2019	12:00:00 AM	1:00:00 AM	Slow	dB	54.1	69.2	44.9	81.5	63.8	60.3	57.8	50.2	47.3		
17	10/23/2019	1:00:00 AM	2:00:00 AM	Slow	dB	52.4	65.9	43	79.2	62.1	56.6	54.3	50.6	46.8		
18	10/23/2019	2:00:00 AM	3:00:00 AM	Slow	dB	51.8	66.7	43	89.3	61.5	57.8	53.6	48.9	45		
19	10/23/2019	3:00:00 AM	4:00:00 AM	Slow	dB	56.2	66.2	49.5	79.9	63.3	60	58.8	54.9	52.1		
20	10/23/2019	4:00:00 AM	5:00:00 AM	Slow	dB	55.8	67.1	47.7	80.3	64.3	60.5	58.6	54	51.2		
21	10/23/2019	5:00:00 AM	6:00:00 AM	Slow	dB	58.1	71.4	46.8	88.8	65.6	63.1	61.9	55.3	50.6		
22	10/23/2019	6:00:00 AM	7:00:00 AM	Slow	dB	61.7	75.1	49.2	90.5	68.9	66.4	65.3	60	52.7		
23	10/23/2019	7:00:00 AM	8:00:00 AM	Slow	dB	67.9	93.1	50.2	110.1	69.8	67.8	67.1	63.3	56.2		
24	10/23/2019	8:00:00 AM	9:00:00 AM	Slow	dB	61.9	70.9	47.6	92	67.1	65.7	64.9	61.2	53.7		
25	10/23/2019	9:00:00 AM	9:12:30 AM	Slow	dB	61.5	74.6	47.6	104.9	69	66	64.7	59.8	52.3		

Number	Start Date	Start Time	End Time	SPL Time		Weight	Freq	LAeq	LAmax	LAmin	LApeak	L1%	L5%	L10%	L50%	L90%
				Weight	Time											
1	10/22/2019	9:00:00 AM	10:00:00 AM	Slow	Slow	dBA	62.2	92.7	50.7	125.8	70.1	61.5	59	56.4	53.3	
2	10/22/2019	10:00:00 AM	11:00:00 AM	Slow	Slow	dBA	53.1	64.4	49.4	82.8	57.4	55.6	54.7	52.6	51.2	
3	10/22/2019	11:00:00 AM	12:00:00 PM	Slow	Slow	dBA	58.4	67.3	49.4	80.7	63.6	62.3	61.4	57.7	52.5	
4	10/22/2019	12:00:00 PM	1:00:00 PM	Slow	Slow	dBA	55.6	72.9	49.2	93	63.5	60.6	58.4	53	51.1	
5	10/22/2019	1:00:00 PM	2:00:00 PM	Slow	Slow	dBA	62.6	89.7	50.9	107.8	72.8	62.9	59.1	54.6	52.7	
6	10/22/2019	2:00:00 PM	3:00:00 PM	Slow	Slow	dBA	57.3	70.3	52.7	85.9	62	59.2	58.5	56.8	55.1	
7	10/22/2019	3:00:00 PM	4:00:00 PM	Slow	Slow	dBA	56	75.1	50.6	88.2	61.7	58.2	57.1	55.1	53.5	
8	10/22/2019	4:00:00 PM	5:00:00 PM	Slow	Slow	dBA	54.6	67.9	50	84.1	59.4	57	56.3	54.1	51.8	
9	10/22/2019	5:00:00 PM	6:00:00 PM	Slow	Slow	dBA	55.6	71.2	49.6	91.6	60.1	57.7	56.9	55.1	53.2	
10	10/22/2019	6:00:00 PM	7:00:00 PM	Slow	Slow	dBA	56	63.7	51	79.7	60.2	59	58.1	55.4	53.1	
11	10/22/2019	7:00:00 PM	8:00:00 PM	Slow	Slow	dBA	57.3	64.7	52.1	81.1	61.4	59.8	59	56.8	55	
12	10/22/2019	8:00:00 PM	9:00:00 PM	Slow	Slow	dBA	55	61.4	51.3	75.2	58.5	57.5	56.8	54.5	52.8	
13	10/22/2019	9:00:00 PM	10:00:00 PM	Slow	Slow	dBA	56.6	79.7	50.2	90.9	61.9	59.4	58.1	55.3	53.4	
14	10/22/2019	10:00:00 PM	11:00:00 PM	Slow	Slow	dBA	56.1	63.4	49.6	79.7	61	59.1	58.2	55.5	53.1	
15	10/22/2019	11:00:00 PM	12:00:00 AM	Slow	Slow	dBA	53.9	62.9	45.8	76.8	58.9	57.1	56.4	53.1	49.9	
16	10/23/2019	12:00:00 AM	1:00:00 AM	Slow	Slow	dBA	55.3	69.2	43.6	82.2	63.1	59.5	58	53.6	48.6	
17	10/23/2019	1:00:00 AM	2:00:00 AM	Slow	Slow	dBA	54.6	65.9	43.1	80	61.8	59.5	58.1	52.8	47.8	
18	10/23/2019	2:00:00 AM	3:00:00 AM	Slow	Slow	dBA	54.1	63.7	43.1	82.5	61.4	59	57.5	52.3	47.1	
19	10/23/2019	3:00:00 AM	4:00:00 AM	Slow	Slow	dBA	55.8	69	43	80.1	63.9	61	59.2	53.5	47.2	
20	10/23/2019	4:00:00 AM	5:00:00 AM	Slow	Slow	dBA	56.8	71.2	45.8	88	62.3	60.7	59.6	55.8	52	
21	10/23/2019	5:00:00 AM	6:00:00 AM	Slow	Slow	dBA	60	79.1	51.1	99.1	65.7	63.5	62.1	59.1	56.3	
22	10/23/2019	6:00:00 AM	7:00:00 AM	Slow	Slow	dBA	59.5	72.3	53.6	91.5	64.1	62.1	61.4	58.9	56.1	
23	10/23/2019	7:00:00 AM	8:00:00 AM	Slow	Slow	dBA	61.3	68.6	53.8	87.1	66	64.9	64.2	60.4	56.6	
24	10/23/2019	8:00:00 AM	9:00:00 AM	Slow	Slow	dBA	58.6	79.9	50.2	102	67.3	61	59.9	56.8	54	
25	10/23/2019	9:00:00 AM	9:21:03 AM	Slow	Slow	dBA	59.6	79.2	52.1	103.7	70.7	61.8	59.6	56.5	54.4	

Industrial CNEL

Leq	Time	Adjustment					
44.7	Midnight	10	54.7	54.7			
44.2	1	10	54.2	54.2			
46.1	2	10	56.1	56.1			
47.6	3	10	57.6	57.6			
48.1	4	10	58.1	58.1			
50.5	5	10	60.5	60.5			
51.4	6	10	61.4	61.4			
51	7am		51	51			
49	8		49	49			
49.7	9		49.7	49.7			
46.3	10		46.3	46.3			
49.3	11		49.3	49.3			
50	noon		50	50			
57.1	1		57.1	57.1			
49.5	2		49.5	49.5			
51.3	3		51.3	51.3			
50.9	4		50.9	50.9			
50.4	5		50.4	50.4			
54.2	6		54.2	54.2			
52.5	7	5	57.5	52.5			
49.7	8	5	54.7	49.7			
55.2	9	5	60.2	55.2			
49	10	10	59	59			
47.8	11	10	57.8	57.8			
			56.1	55.5			
			CNEL	LDN			

Train CNEL

Leq	Time	Adjustment					
54.1	Midnight	10	64.1	64.1			
52.4	1	10	62.4	62.4			
51.8	2	10	61.8	61.8			
56.2	3	10	66.2	66.2			
55.8	4	10	65.8	65.8			
58.1	5	10	68.1	68.1			
61.7	6	10	71.7	71.7			
67.9	7am		67.9	67.9			
61.9	8		61.9	61.9			
62.5	9		62.5	62.5			
58.7	10		58.7	58.7			
60.7	11		60.7	60.7			
60.9	noon		60.9	60.9			
60.3	1		60.3	60.3			
64.8	2		64.8	64.8			
72.3	3		72.3	72.3			
67.2	4		67.2	67.2			
61.6	5		61.6	61.6			
62.4	6		62.4	62.4			
60.5	7	5	65.5	60.5			
60.8	8	5	65.8	60.8			
63.2	9	5	68.2	63.2			
59	10	10	69	69			
55.9	11	10	65.9	65.9			
			66.3	65.9			
			CNEL	LDN			

Retail Center CNEL

Leq	Time	Adjustment					
55.3	Midnight	10	65.3	65.3			
54.6	1	10	64.6	64.6			
54.1	2	10	64.1	64.1			
55.8	3	10	65.8	65.8			
56.8	4	10	66.8	66.8			
60	5	10	70	70			
59.5	6	10	69.5	69.5			
61.3	7am		61.3	61.3			
58.6	8		58.6	58.6			
62.2	9		62.2	62.2			
53.1	10		53.1	53.1			
58.4	11		58.4	58.4			
55.6	noon		55.6	55.6			
62.6	1		62.6	62.6			
57.3	2		57.3	57.3			
56	3		56	56			
54.6	4		54.6	54.6			
55.6	5		55.6	55.6			
56	6		56	56			
57.3	7	5	62.3	57.3			
55	8	5	60	55			
56.6	9	5	61.6	56.6			
56.1	10	10	66.1	66.1			
53.9	11	10	63.9	63.9			
			63.7	63.4			
			CNEL	LDN			

Appendix F

Safety Fact Sheet

Safety

The Safety Element includes goals, policies, and actions to guide development towards locations and patterns that reduce risk and increase resilience to hazard events. Like many California coastal communities, Pismo Beach is most susceptible to hazards involving earthquakes, flooding, landslides, and wildfires. As a result of climate change and sea level rise, Pismo Beach is forecasted to experience more severe fire and flooding and worsening air pollution, coastal erosion, and extreme heat. Pismo Beach is also susceptible to, but unlikely to experience, radiation and tsunami hazards. Each of these hazards are explored in more detail below, as are the community's strengths and challenges in responding to hazards, including emergency response facilities and vulnerable populations.

Climate Related Hazards

The intensity of climate change is, in part, determined by current carbon dioxide emission levels and the global community's ability to reduce emissions in the future. A range of forecasts were used to determine potential impacts in Pismo Beach, and are generally categorized as a low emissions scenario where emissions begin to drop in 2040, and a high emissions scenario where emissions continue to rise until 2100.

Air Pollution

Air pollution will increase as a result of climate change with added ozone production, increased wildfire frequency and intensity, and higher allergens.

Ozone

Ground level ozone is an air pollutant and is involved in the creation of smog. Ozone is created through a photochemical reaction involving sunlight and other pollutants. The most pertinent contributor to ozone in Pismo Beach is car and truck exhaust. Increased extreme heat events are projected to increase ground-level ozone (CDC 2018).

Allergens

With warmer seasonal air temperatures due to climate change, flowering time can lengthen and result in more pollen released into the air. This has the potential to increase allergic reactions and asthma attacks (CDC 2014). As these events occur more frequently, people are likely to miss school and work more often, and visit the hospital in extreme cases.

Smoke

Due to increased frequency of drought and overall temperatures, the frequency and intensity of wildfires are expected to increase in the region (NOAA 2018). Smoke from wildfires contains various pollutants and when wildfires burn, these pollutants can cause short- and long-term heart and lung diseases (EPA 2017).

Coastal Erosion

Slope and bluff erosion and instability has historically been a common hazard in Pismo Beach, and is expected to increase as a result of sea level rise. Approximately five miles of the northwestern coastline of the City consists of cliffs and bluffs, which range from 10 to 100 feet tall. There is a high risk for erosion across nearly all of Pismo Beach's coastline (Herberger 2009). Erosion has claimed public and private investments in the past and continues to threaten these abutting properties today. In 1991, the City completed a bluff erosion study for public oceanfront property; however, information pertaining to privately owned coastline is not available except on a site-to-site basis.

Extreme Heat

Extreme heat days in Pismo Beach are considered days which reach or exceed 87.9°F. Pismo Beach is projected to experience five extreme heat days per year under both the low emission and high emission scenarios. This is one more day per year than historical averages for the area from 1961-1990. Figure S-1 displays the projected average number of extreme heat days over time.

Figure S-1 Historic and Projected Extreme Heat Days in Pismo Beach

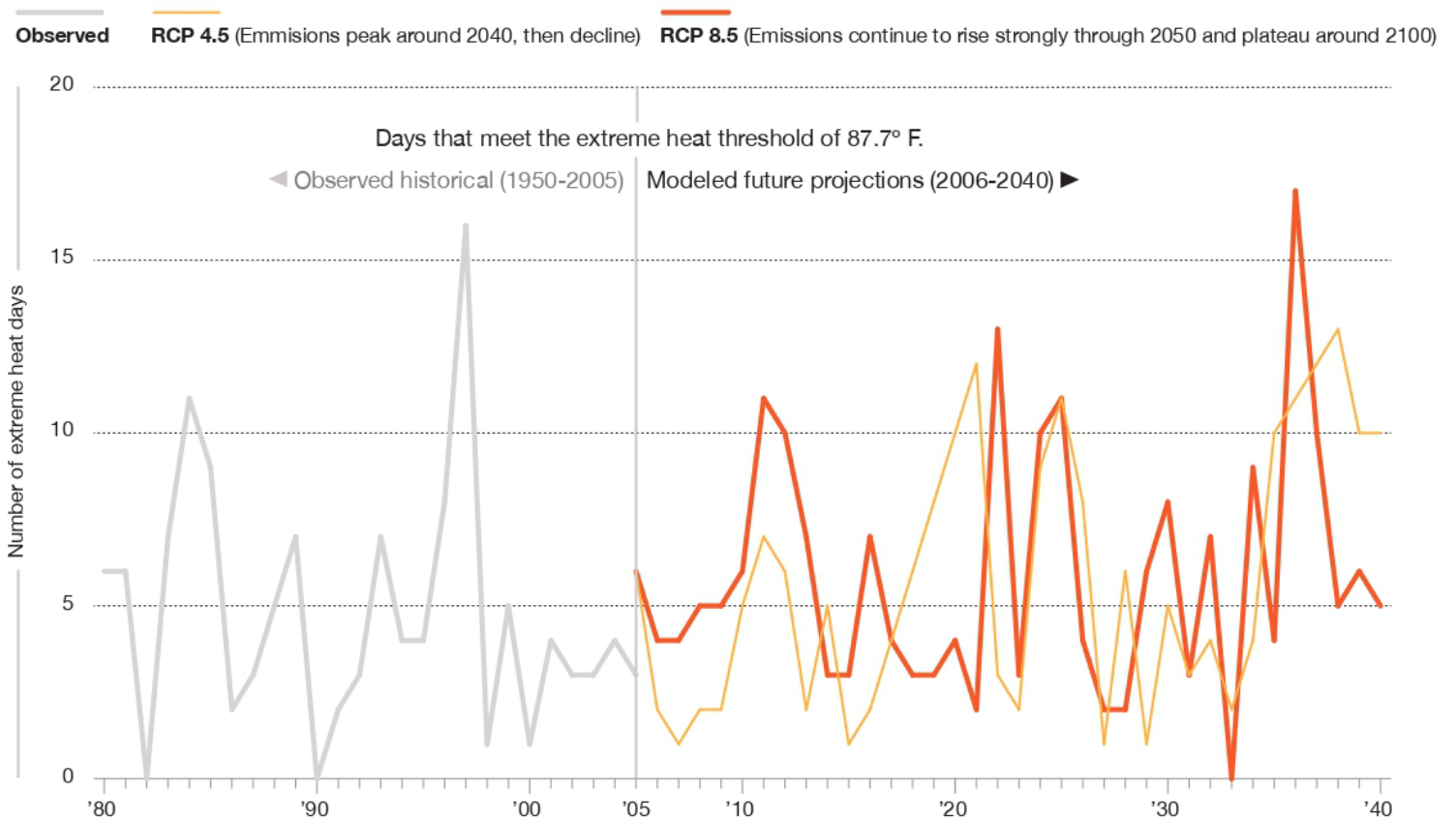

Source: CEC 2019

Fire

Pismo Beach is bordered to the north and west with open space. These open spaces are more at risk of burning, and much of the native vegetation present has evolved to rely on fire to reproduce. CALFire Fire Hazard Severity Zone Maps are presented in Figure S-2, and illustrate that there are significant fire hazards surrounding Pismo and along the northern and western portions of the city. Generally, the risk of fire increases in the late summer and early autumn during dry periods, especially after wet winters allowing fuel to grow. In the low emissions scenario for emissions, on average 51.7 hectares of land in Pismo Beach will burn annually. This is 11 more hectares burned annually than the annual mean from 1961-1990. In the high emissions scenario, 24.1 more hectares of land in Pismo Beach will burn annually than the average from 1961-1990. Approximately 24% of the City is located in a Very High Fire Hazard Severity Zone. The San Luis Obispo County Fire Department is responsible for fire protection in Pismo Beach. There are two fire stations in Pismo Beach which are located at 760 Mattie Road and 2555 Shell Beach Road.

Figure S-2 Fire Hazard Severity Zones

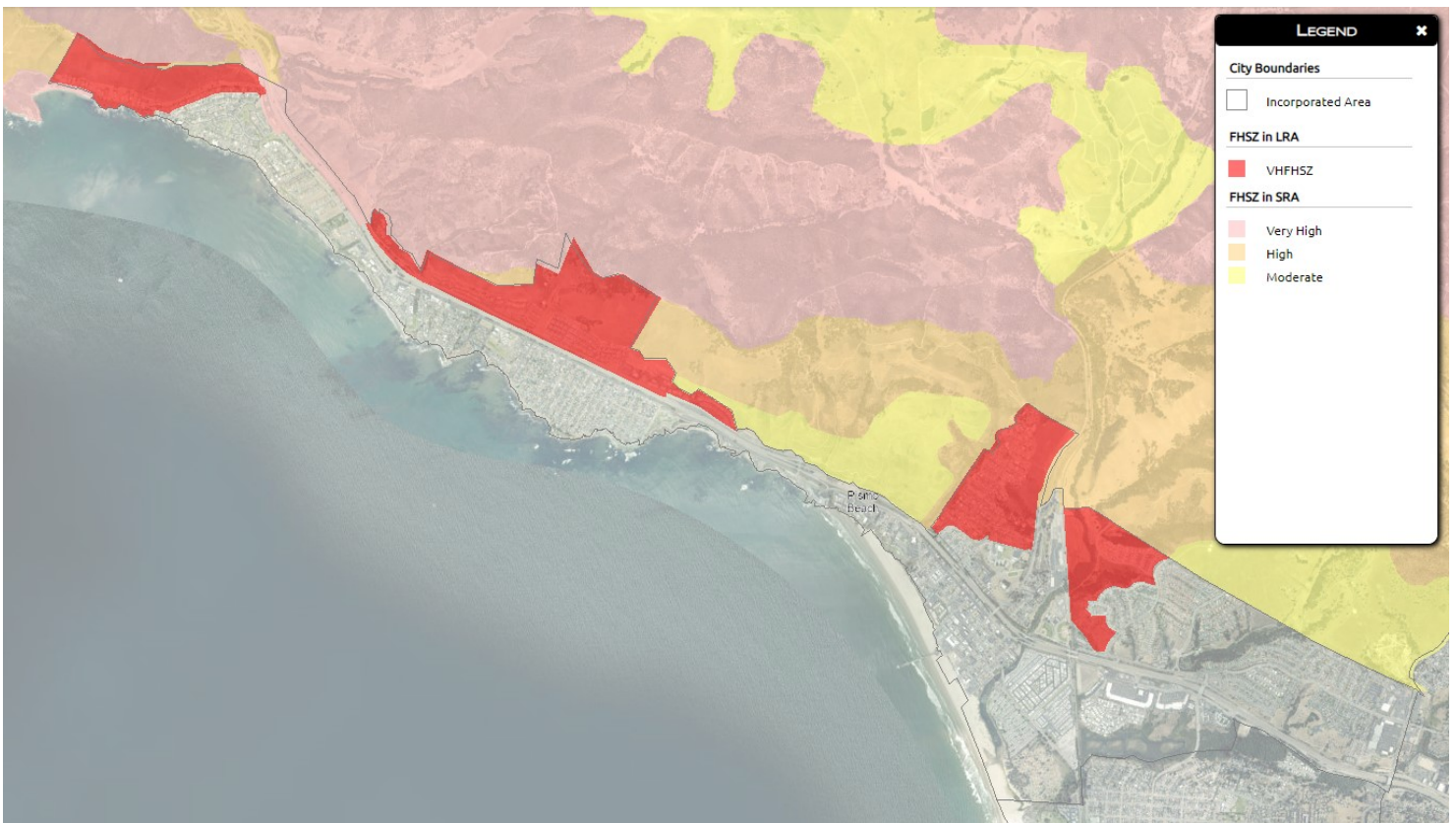

Source: CAL FIRE 2021

Flooding

Pismo Beach runs along a portion of the Central California coastline. The northwestern portion of Pismo Beach coastline consists of steep bluffs, while the southern shoreline is characterized by wide, sandy beaches. The small Meadow Creek and larger Pismo Creek meet to form a lagoon behind the beach in the southern portion of Pismo Beach. The northern, bluff portion of the City is referred to as the Bluffs and the southern area abutting Meadow Creek and Pismo Creek is referred to as the low-lying area. Downtown Pismo Beach is located between the Bluffs and the low-lying areas. The downtown area is currently exposed to coastal erosion, wave runup, and flooding during extreme events, although a sea wall offers some protection. The low-lying area is most prone to coastal and riverine flooding. Flood potential could increase significantly in this area due to sea level rise, if left unmitigated. A more detailed Sea Level Rise Vulnerability Assessment for the City of Pismo Beach was completed by Moffatt & Nichol in 2019.

Non-Climate Related Hazards

Pismo Beach also experiences non-climate related hazards. Similar to climate-related hazards, some small hazards occur regularly, while others are not likely to occur between 2020 and 2040 if at all.

Seismic Hazards

Pismo Beach is susceptible to seismic hazards due to multiple potentially capable faults (San Luis Obispo County Planning and Building Department 2016). Seismic hazards, including active and potentially active faults, are viewable on Figure S-3.

Liquefaction can occur due to earthquakes, and makes a normally stiff and solid soil act like a liquid. There is only one area of high liquefaction risk, on the beach west of North Beach Campground and at the mouth of Pismo Creek. Areas of moderate liquefaction risk can be found in the southernmost coastal area of Pismo Beach as well as along Pismo Creek (San Luis Obispo County Planning and Building Department 2016).

It's important to identify peakload water supply when discussing seismic risks because large seismic events have the potential to destroy or incapacitate normal water supply. The existing water supply comes from multiple sources, including Lopez Reservoir, the State Water Project, and groundwater wells. If a local earthquake occurs, local water piping would be at risk, and water from Lopez Lake, the groundwater wells, and recycled water could become temporarily out of service. Earthquakes farther away could impact the State Water Project. In the event of a loss of water sources, the City has an emergency connection with the City of Arroyo Grande and has the opportunity to purchase water allocations from the District or SWP subcontractors (Water Systems Consulting Inc. 2016).

Landslides

Landsliding was observed in 1998 along the sea bluffs as a result of sea wave erosion, surface water erosion, and urban irrigation. More recently, landslides were observed in the Pismo Beach foothills after the 2003 San Simeon earthquake. Much of the Pismo Foothills abutting the city to the north and east are considered a high landslide risk (SLO County Planning and Building Department 2016). While much of this does not include developed portions of Pismo Beach, these areas are uphill from developed areas and could impact them in the event of a landslide due to high precipitation or earthquake.

Soils have the ability to damage houses by being especially expansive or corrosive. There are three soil types present within Pismo Beach city limits. The primary soil type are mollisols, with entisols and alfisols covering a smaller portion of land in eastern Pismo Beach (NRCS 1994). None of these soils are considered expansive. Additionally, their acidity is low and they have a lower corrosive tendency.

Figure S-3 Faults Near Pismo Beach

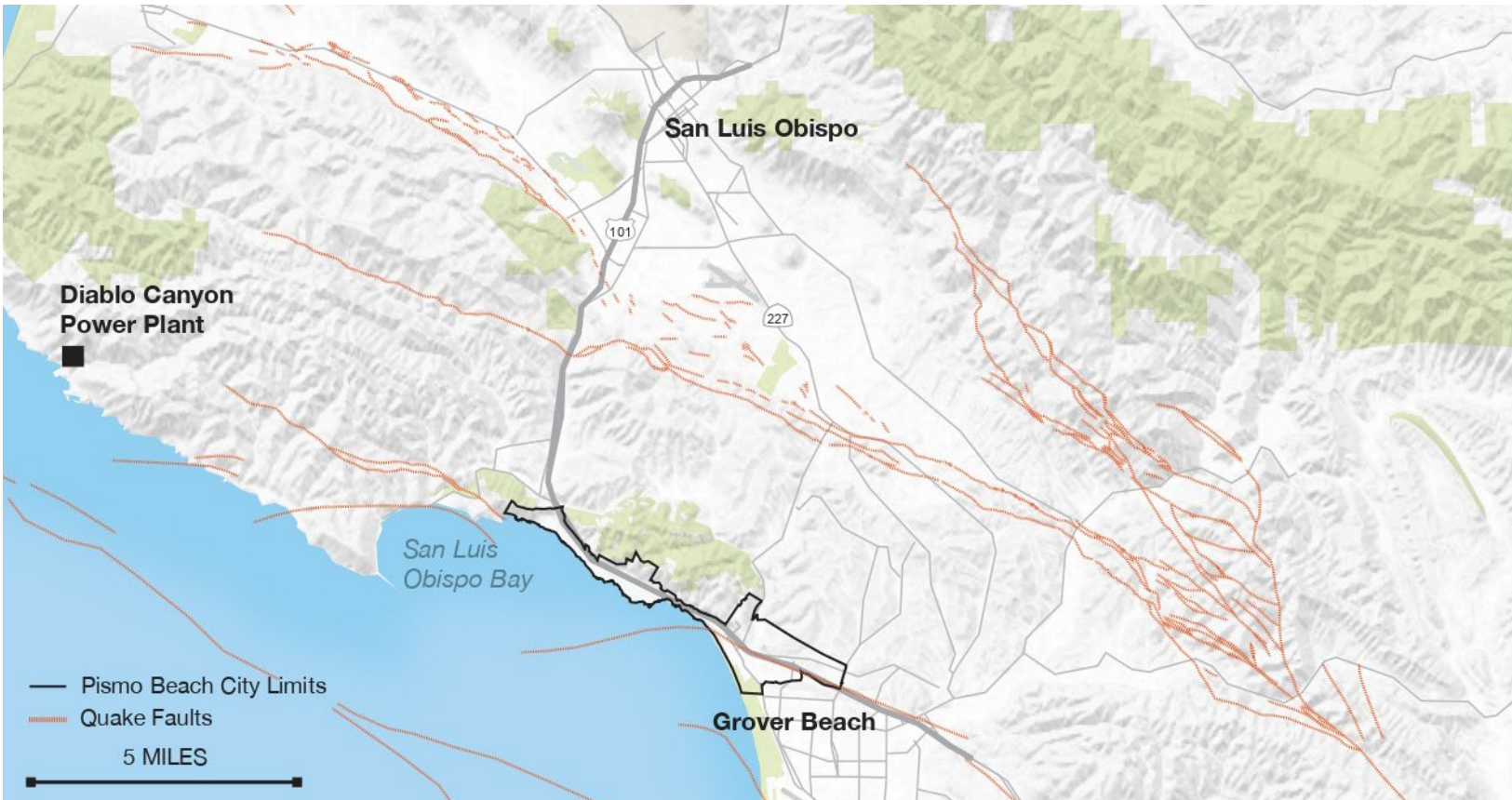

Source: CDC 2019

Radiation

Pismo Beach is located approximately 8 miles southwest from the Pacific Gas and Electric's Diablo Canyon Nuclear Power Plant. Radioactive waste from the plant is stored on site and the plant is permitted to run until 2025, when the plant's permits will expire and not be renewed (PG&E 2019). Energy production operations then will be shut down indefinitely, with storage continuing on site until further notice (City of Pismo Beach 2007). An earthquake or tsunami could potentially release the nuclear waste stored on site and expose Pismo Beach to radiation.

Tsunamis

A tsunami is a large wave generally caused by an earthquake which can cause substantial damage to coastal communities such as Pismo Beach. Previous studies within San Luis Obispo County have determined a 100-year tsunami to be 9.5 feet above sea level; however, this could increase if the tsunami occurred during a storm event. Land in Pismo Beach below elevations for 100- and 500- year tsunami events (24 and 39 feet respectively) are most at risk. In general, developments within Pismo Beach are protected from tsunami hazards by high bluffs, dune systems, and wide beaches. The portion of Shell Beach and southern Pismo Beach that are within the Tsunami Inundation Area is presented on Figure S-4.

Figure S-4 Tsunami Inundation



Source: CEMA 2009

Community Vulnerabilities

Pismo Beach is considered a relatively healthy and affluent community compared to California as a whole. CalEnviroScreen, a mapping tool provided by the Office of Environmental Health Hazard Assessment, is a common tool used to measure the cumulative impact of social vulnerabilities (such as poverty or English language proficiency) and pollution burden (such as air quality and proximity to hazardous waste sites). Pismo Beach scores between 5%–10% on CalEnviroScreen, far below the 75% threshold to consider a community disadvantaged (OEHHA 2018). Additionally, both City census tracts are in the top 25% for living conditions according to the Healthy Places Index (CDPH 2018). Despite these rankings specific people and populations in Pismo Beach may be vulnerable to specific hazards. Children, pregnant women, older adults, and those with certain preexisting conditions are considered a “sensitive population” due to their physiological susceptibility. Additionally, people with fewer economic resources, limited mobility, lack of access to transportation, lower English language proficiency and education, and uncertain citizenship can be considered vulnerable because they have fewer resources to adapt, evacuate, or access information. In Pismo Beach the most notable vulnerable population is older adults. As of 2017, 33.3% of Pismo Beach’s population was over the age of 65 (U.S. Census Bureau 2019). Older adults experience more extreme health events per year, as they experience heat stroke and other heat related illnesses at lower temperatures than the general population. Additionally, older adults may be less mobile, or less able to evacuate, in the case of a fire or tsunami evacuation notice.

Facilities and Assets

Certain assets in a community are more important or necessary while hazards are impacting a community as they are important in responding and recovering in a disaster. The San Luis Obispo County Emergency Organization oversees response to emergencies. They coordinate evacuations, evacuation routes, and emergency facilities. Facilities which can be activated in case of an emergency include eight schools and three district buildings, two police stations, and two fire stations. These facilities are presented on Figure S-5. The City also has planned evacuation routes, which are fluid in nature and are based on the specific hazard type and location; however, they generally include major roads and highways. In Pismo Beach this would include, most notably, Highway 101, Oak Park Boulevard, and Price Canyon Road. Pismo Beach has 14.2 miles of state and federal highways, as well as 18 bridges.

Other essential assets in Pismo Beach include:

- Public Facilities
 - one wastewater treatment facility
 - 14 lift stations
 - one water treatment plant
 - two wells
 - ten reservoirs
 - five water-pressure booster stations (Water Systems Consulting Inc. 2016)
- Residential Zones
 - 791 acres of residentially zoned land

Figure S-5 Emergency Facility Locations



Source: City of Pismo Beach

Correlation with Coastal Act

In addition to General Plan requirements, the Safety Element will implement provisions of the Coastal Act regarding minimizing hazard potential in the Coastal Zone. The Coastal Act requires new development to reduce risks to life and property and avoid substantial changes to natural landforms. The Coastal Act also requires that safety and stability be assured for the life of a development. The response to coastal hazards in the Safety Element will provide for solutions that have the least impact on coastal resources, as required by the Coastal Act. Development of the Safety Element is in accordance with the CCC's 2017 LCP Update Guide, the adopted 2018 Sea Level Rise Policy Guidance Document, and the draft 2018 Coastal Adaptation Planning Document: Residential Development. The information and guidance in the Safety Element is also incorporated into the City's Local Hazard Mitigation Plan, which outlines the City's mitigation planning measures to reduce vulnerability to natural and human-caused hazards.

Citations

- CAL FIRE (California Department of Forestry and Fire Protection). "Fire Hazard Severity by Community." Data Basin. 2006. Accessed August 22, 2019. <https://databasin.org/datasets/91fded1492a94468acf22388563ecf09>.
- CCC (California Coastal Commission). LCP Update Guide Section 8. Coastal Hazards. By California Coastal Commission. February 14, 2017. Accessed August 23, 2019. https://documents.coastal.ca.gov/assets/lcp/LUPUpdate/REVISED_DRAFT_LUP_Guide_Update_8_Hazards_Feb_14_2016.pdf.
- CCC (California Coastal Commission). Sea Level Rise Policy Guidance. By California Coastal Commission. November 7, 2018. Accessed August 23, 2019. https://documents.coastal.ca.gov/assets/slr/guidance/2018/0_Full_2018AdoptedSLRGuidanceUpdate.pdf.
- CDC (California Department of Conservation). "CGS Regulatory Maps." ArcGIS. August 12, 2019. Accessed August 22, 2019. <http://www.arcgis.com/home/item.html?id=ce450e2f3d314d03bc250cb3f783457f>.
- CEC (California Energy Commission). "Exploring California's Climate Change Research." Cal-Adapt. 2019. Accessed August 14, 2019. <https://cal-adapt.org/>.
- CEMA (California Emergency Management Agency). Tsunami Inundation Map for Emergency Planning - Pismo Beach Quadrangle. By California Emergency Management Agency, California Geologic Survey, and University of Southern California. July 1, 2009. Accessed August 22, 2019. https://www.conservation.ca.gov/cgs/Documents/Tsunami/Maps/Tsunami_Inundation_PismoBeach_Quad_SLO.pdf
- City of Pismo Beach. City of Pismo Beach Local Hazard Mitigation Plan. By URS. January 2007. Accessed August 22, 2019. <http://www.pismo-beach.org/DocumentCenter/View/285/R-2007-004?bidId=>.
- Herberger, Matthew, Heather Cooley, Peter Gleick, and Pablo Herrera. "The Impacts of Sea-Level Rise on the California Coast ." Data Basin. Pacific Institute, 2009. <https://databasin.org/datasets/ef30cb0220ce41228528ad231c0b1279>.
- NRCS (Natural Resources Conservation Service). "State Soil Geographic (STATSGO2) Data Base for California." State Soil Geographic Database for California. Data Basin, 1994. <https://databasin.org/datasets/1ff4328039f948529c33e7e71bb9b5fc>.
- OEHHA (Office of Environmental Health Hazard Assessment). "CalEnviroScreen 3.0." Oehha.ca.gov. June 2018. Accessed August 22, 2019. <https://oehha.ca.gov/calenviroscreen/report/calenviroscreen-30>.
- PG&E. "Diablo Canyon Power Plant." PG&E, 2019. https://www.pge.com/en_US/safety/how-the-system-works/diablo-canyon-power-plant/diablo-canyon-power-plant.page.
- SLO County Planning and Building Department (San Luis Obispo County Planning and Building Department). "San Luis Obispo County Planning MapServer," 2016. http://gis.slocounty.ca.gov/arcgis/rest/services/Planning/PLN_WEB_SERVICES/MapServer.
- US Census Bureau. "American Community Survey (ACS)." Census.gov. May 14, 2019. Accessed August 22, 2019. <https://www.census.gov/programs-surveys/acs/>.

USGS (United States Geographic Survey). "Areas of Land Subsidence in California." USGS, n.d. https://ca.water.usgs.gov/land_subsidence/california-subsidence-areas.html.

Water Systems Consulting, Inc. Pismo Beach, Pismo Beach § (2016). <http://www.pismoeach.org/DocumentCenter/View/3785/Urban-Water-Mgmt-Plan---2015?bidId=>.

Appendix G

Special Status Species Tables

Table G-1 Special Status Plant Species Documented in or with the Potential to Occur in Pismo Beach

Scientific Name	Common Name	FESA/CESA Status	CRPR
<i>Agrostis hooveri</i>	Hoover's bent grass	-/-	1B.2
<i>Arctostaphylos cruzensis</i>	Arroyo de la Cruz manzanita	-/-	1B.2
<i>Arctostaphylos luciana</i>	Santa Lucia manzanita	-/-	1B.2
<i>Arctostaphylos morroensis</i>	Morro manzanita	FT/-	1B.1
<i>Arctostaphylos osoensis</i>	Oso manzanita	-/-	1B.2
<i>Arctostaphylos pechoensis</i>	Pecho manzanita	-/-	1B.2
<i>Arctostaphylos pilosula</i>	Santa Margarita manzanita	-/-	1B.2
<i>Arctostaphylos rudis</i>	sand mesa manzanita	-/-	1B.2
<i>Arctostaphylos tomentosa</i> ssp. <i>daciticola</i>	dacite manzanita	-/-	1B.1
<i>Arenaria paludicola</i>	marsh sandwort	FE/SE	1B.1
<i>Astragalus didymocarpus</i> var. <i>milesianus</i>	Miles' milk-vetch	-/-	1B.2
<i>Atriplex coulteri</i>	Coulter's saltbush	-/-	1B.2
<i>Bryoria spiralifera</i>	twisted horsehair lichen	-/-	1B.1
<i>Calochortus obispoensis</i>	San Luis mariposa lily	-/-	1B.2
<i>Calochortus simulans</i>	La Panza mariposa lily	-/-	1B.3
<i>Calycadenia villosa</i>	dwarf calycadenia	-/-	1B.1
<i>Camissoniopsis hardhamiae</i>	Hardham's evening-primrose	-/-	1B.2
<i>Carex obispoensis</i>	San Luis Obispo sedge	-/-	1B.2
<i>Castilleja densiflora</i> var. <i>obispoensis</i>	San Luis Obispo owl's-clover	-/-	1B.2
<i>Ceanothus impressus</i> var. <i>nipomensis</i>	Nimpomo Mesa ceanothus	-/-	1B.1
<i>Ceanothus thyrsiflorus</i> var. <i>obispoensis</i>	San Luis Obispo ceanothus	-/-	1B.1
<i>Centromadia parryi</i> ssp. <i>congdonii</i>	Congdon's tarplant	-/-	1B.1
<i>Chenopodium littoreum</i>	coastal goosefoot	-/-	1B.2
<i>Chlorogalum pomeridianum</i> var. <i>minus</i>	dwarf soaproot	-/-	1B.2
<i>Chloropyron maritimum</i> ssp. <i>maritimum</i>	salt marsh bird's-beak	FE/SE	1B.2
<i>Chorizanthe aphanantha</i>	Irish Hills spineflower	-/-	1B.1
<i>Chorizanthe breweri</i>	Brewer's spineflower	-/-	1B.3
<i>Chorizanthe rectispina</i>	straight-awned spineflower	-/-	1B.3
<i>Cirsium fontinale</i> var. <i>obispoense</i>	San Luis Obispo fountain thistle	FE/SE	1B.2
<i>Cirsium occidentale</i> var. <i>lucianum</i>	Cuesta Ridge thistle	-/-	1B.2
<i>Cirsium rhotophilum</i>	Surf thistle	-/ST	1B.2
<i>Cirsium scariosum</i> var. <i>loncholepis</i>	La Graciosa thistle	FE/ST	1B.1
<i>Cladium californicum</i>	California sawgrass	-/-	2B.2
<i>Cladonia firma</i>	popcorn lichen	-/-	2B.1
<i>Clarkia speciosa</i> ssp. <i>immaculata</i>	Pismo clarkia	FE/SR	1B.1
<i>Delphinium parryi</i> ssp. <i>blochmaniae</i>	dune larkspur	-/-	1B.2
<i>Delphinium parryi</i> ssp. <i>eastwoodiae</i>	Eastwood's larkspur	-/-	1B.2
<i>Delphinium umbraculorum</i>	umbrella larkspur	-/-	1B.3

Pismo Beach General Plan/Local Coastal Plan Update

Scientific Name	Common Name	FESA/CESA Status	CRPR
<i>Dithyrea maritima</i>	beach spectaclepod	-/ST	1B.1
<i>Dudleya abramsii</i> ssp. <i>bettinae</i>	Betty's dudleya	-/-	1B.2
<i>Dudleya abramsii</i> ssp. <i>murina</i>	mouse-gray dudleya	-/-	1B.3
<i>Dudleya blochmaniae</i> ssp. <i>blochmaniae</i>	Blochman's dudleya	-/-	1B.1
<i>Erigeron blochmaniae</i>	Blochman's leafy daisy	-/-	1B.2
<i>Eriodictyon altissimum</i>	Indian Knob mountainbalm	FE/SE	1B.1
<i>Eryngium aristulatum</i> var. <i>hooveri</i>	Hoover's button-celery	-/-	1B.1
<i>Extriplex joaquinana</i>	San Joaquin spearscale	-/-	1B.2
<i>Fritillaria ojaiensis</i>	Ojai fritillary	-/-	1B.2
<i>Fritillaria viridea</i>	San Benito fritillary	-/-	1B.2
<i>Horkelia cuneata</i> var. <i>puberula</i>	mesa horkelia	-/-	1B.1
<i>Horkelia cuneata</i> var. <i>sericea</i>	Kellogg's horkelia	-/-	1B.1
<i>Lasthenia californica</i> ssp. <i>macrantha</i>	perennial goldfields	-/-	1B.2
<i>Lasthenia glabrata</i> ssp. <i>coulteri</i>	Coulter's goldfields	-/-	1B.1
<i>Layia jonesii</i>	Jones' layia	-/-	1B.2
<i>Lupinus ludovicianus</i>	San Luis Obispo County lupine	-/-	1B.2
<i>Lupinus nipomensis</i>	Nipomo Mesa lupine	FE/SE	1B.1
<i>Malacothamnus gracilis</i>	slender bush-mallow	-/-	1B.1
<i>Monardella palmeri</i>	Palmer's monardella	-/-	1B.2
<i>Monardella sinuata</i> ssp. <i>sinuata</i>	southern curly-leaved monardella	-/-	1B.2
<i>Monardella undulata</i> ssp. <i>undulata</i>	San Luis Obispo monardella	-/-	1B.2
<i>Monolopia gracilens</i>	woodland woollythreads	-/-	1B.2
<i>Muhlenbergia utilis</i>	aparejo grass	-/-	2B.2
<i>Nasturtium gambelii</i>	Gambel's water cress	FE/ST	1B.1
<i>Nemacaulis denudata</i> var. <i>denudata</i>	coast woolly-heads	-/-	1B.2
<i>Plagiobothrys uncinatus</i>	hooked popcornflower	-/-	1B.2
<i>Poa diaboli</i>	Diablo Canyon blue grass	-/-	1B.2
<i>Sanicula maritima</i>	adobe sanicle	-/SR	1B.1
<i>Scrophularia atrata</i>	black-flowered figwort	-/-	1B.2
<i>Senecio aphanactis</i>	chaparral ragwort	-/-	2B.2
<i>Sidalcea hickmanii</i> ssp. <i>anomala</i>	Cuesta Pass checkerbloom	-/SR	1B.2
<i>Streptanthus albidus</i> ssp. <i>peramoenus</i>	most beautiful jewelflower	-/-	1B.2
<i>Suaeda californica</i>	California seablite	FE/-	1B.1
<i>Sulcaria isidiifera</i>	splitting yarn lichen	-/-	1B.1
<i>Symphotrichum defoliatum</i>	San Bernardino aster	-/-	1B.2
<i>Trifolium hydrophilum</i>	saline clover	-/-	1B.2
<i>Tropidocarpum capparideum</i>	caper-fruited tropidocarpum	-/-	1B.2

FT: Federally threatened FE: Federally endangered SE: State endangered ST: State threatened SR: State rare
CRPR: California Rare Plant Rank

Table G-2 Special Status Wildlife Species Documented in or with the Potential to Occur in Pismo Beach

Scientific Name	Common Name	FESA/CESA Status	Other CDFW & Local Status
Invertebrates			
<i>Bombus crotchii</i>	Crotch bumble bee	-/SCE	-
<i>Bombus occidentalis</i>	western bumble bee	-/SCE	-
<i>Branchinecta lynchi</i>	Vernal pool fairy shrimp	FT/-	-
<i>Danaus plexippus</i>	monarch butterfly	-/-	Locally Important
<i>Helminthoglypta walkeriana</i>	Morro shoulderband (=banded dune) snail	FE/-	-
Fish			
<i>Eucyclogobius newberryi</i>	tidewater goby	FE/-	SSC
<i>Oncorhynchus mykiss irideus pop. 9</i>	steelhead - south-central California coast DPS	FT/-	-
Amphibians			
<i>Batrachoseps minor</i>	lesser slender salamander	-/-	SSC
<i>Rana boylei</i>	foothill yellow-legged frog	-/SE	SSC
<i>Rana draytonii</i>	California red-legged frog	FT/-	SSC
<i>Taricha torosa</i>	Coast Range newt	-/-	SSC
Reptiles			
<i>Anniella pulchra</i>	silvery legless lizard	-/-	SSC
<i>Emys marmorata [Actinemys pallida]</i>	western pond turtle	-/-	SSC
<i>Thamnophis hammondi</i>	two-striped garter snake	-/-	SSC
Birds			
<i>Accipiter cooperii</i>	Cooper's hawk	-/-	WL
<i>Accipiter striatus</i>	sharp-shinned hawk	-/-	WL
<i>Agelaius tricolor</i>	tricolored blackbird	-/ST	SSC
<i>Athene cunicularia</i>	burrowing owl	-/-	SSC
<i>Buteo regalis</i>	ferruginous hawk	-/-	WL
<i>Coccyzus americanus occidentalis</i>	western yellow-billed cuckoo	FT/SE	-
<i>Elanus leucurus</i>	white-tailed kite	-/-	FP
<i>Eremophila alpestris actia</i>	California horned lark	-/-	WL
<i>Falco columbarius</i>	merlin	-/-	WL
<i>Falco mexicanus</i>	prairie falcon	-/-	WL
<i>Lanius ludovicianus</i>	Loggerhead shrike	-/-	SSC
<i>Laterallus jamaicensis coturniculus</i>	California black rail	-/ST	FP
<i>Progne subis</i>	purple martin	-/-	SSC
<i>Rallus obsoletus obsoletus</i>	California Ridgway's rail	FE/SE	FP
<i>Sterna antillarum browni</i>	California least tern	FE/-	FP

City of Pismo Beach
Pismo Beach General Plan/Local Coastal Plan Update

Scientific Name	Common Name	FESA/CESA Status	Other CDFW & Local Status
Mammals			
<i>Antrozous pallidus</i>	pallid bat	-/-	SSC
<i>Corynorhinus townsendii</i>	Townsend's big-eared bat	-/-	SSC
<i>Dipodomys heermanni morroensis</i>	Morro Bay kangaroo rat	FE/SE	FP
<i>Eumetopias jubatus</i>	Steller sea-lion	DL/-	-
<i>Eumops perotis californicus</i>	western mastiff bat	-/-	SSC
<i>Neotoma lepida intermedia</i>	San Diego desert woodrat	-/-	SSC
<i>Nyctinomops macrotis</i>	big free-tailed bat	-/-	SSC
<i>Taxidea taxus</i>	American badger	-/-	SSC
FT: Federally threatened	FE: Federally endangered	SE: State endangered	
ST: State threatened	SR: State rare	SCE: State candidate endangered	
FP: Fully Protected	SSC: Species of Special Concern		
DL: Delisted	WL: Watch List		

Appendix H

Energy Calculations

City of Pismo Beach General Plan/LCP Update

Last Updated: 12/3/21

Populate one of the following tables (Leave the other blank):

Annual VMT	OR	Daily Vehicle Trips
Annual VMT: 13,422,120		Daily Vehicle Trips: Average Trip Distance:

Fleet Class	Fleet Mix	Fuel Economy (MPG) [1]	
Light Duty Auto (LDA)	0.537981	Passenger Vehicles	24.1
Light Duty Truck 1 (LDT1)	0.060917	Light-Med Duty Trucks	17.6
Light Duty Truck 2 (LDT2)	0.197944	Heavy Trucks/Other	7.5
Medium Duty Vehicle (MDV)	0.129503	Motorcycles	44
Light Heavy Duty 1 (LHD1)	0.022130		
Light Heavy Duty 2 (LHD2)	0.006150		
Medium Heavy Duty (MHD)	0.007595		
Heavy Heavy Duty (HHD)	0.005434		
Other Bus (OBUS)	0.000841		
Urban Bus (UBUS)	0.000325		
Motorcycle (MCY)	0.027432		
School Bus (SBUS)	0.000740		
Motorhome (MH)	0.003008		

Fleet Mix

Vehicle Type	Percent	Fuel Type	Annual VMT:		Fuel Consumption
			VMT	Vehicle Trips: VMT	(Gallons)
Passenger Vehicles	53.80%	Gasoline	7,220,846	0.00	299,620
Light-Medium Duty Trucks	38.84%	Gasoline	5,212,668	0.00	296,174
Heavy Trucks/Other	4.62%	Diesel	620,411	0.00	82,721
Motorcycle	2.74%	Gasoline	368,196	0.00	8,368

Total Gasoline Consumption (gallons)	604,163
Total Diesel Consumption (gallons)	82,721

Sources:

[1] United States Department of Transportation, Bureau of Transportation Statistics. 2021. National Transportation Statistics. Available at: <https://www.bts.gov/topics/national-transportation-statistics>.

	Natural Gas			Electricity		
	kBTU/year	Therms/year	Per SP	kWh/year	2019 Title 24 % (efficiency)	2019 Title 24 % (PV)
Total new energy consumption	1.80E+07	1.94E+05		80.2	1.61E+07	
Apartments Low Rise	2.25E+06	2.42E+04			7%	53%
Apartments Mid Rise	1.36E+00	1.46E-02			7%	53%
Apartments Mid Rise	6.05E+06	6.51E+04			7%	53%
Government (Civic Center)	1.03E+05	1.10E+03			30%	0%
Office Park	8.80E+06	9.47E+04			30%	0%
Strip Mall	2.53E+05	2.72E+03			30%	0%
Strip Mall	5.80E+05	6.24E+03			30%	0%
					https://www.energy.ca.gov/sites/default/files/2019-07/07_2019_title_24_efficiency_requirements.pdf	
2019 Pismo Beach Population	8,237	Population			"Single-family homes built with the 2019 standards"	
Pismo Beach New Population	1,875	Population			"Homes built under the 2019 standards"	
2040 Pismo Beach Population	10,112	Population			"Nonresidential buildings will use about 10% of the energy used by residential buildings"	
2019 SLO County Population	277,259	Population				
				kWh/year	Per SP	
2019 Employment	4,919	employees		1.37E+08	56,514.4	
New non-residential development (sq ft)	783,268	square feet		1.36E+06		
Median sf/employee for Other Retail	585	sf/employee		1.54E+06		
New employees	545	employees		-4.71E+04		
2040 Pismo Beach Employment	5,464	employees		5.22E+06		
2019 SLO County Employment	118,150	employees		4.43E+06		
				2.60E+06		
Existing Service Pop	13,156	service population		-2.82E+04		
New Service Pop	2,420	service population		1.16E+08		
2040 Buildout Service Pop	15,576	service population		8.27E+05		
2019 SLO County Service Pop	395,409	service population		4.47E+06		
2040 Annual VMT from CalEEMod	13,467,463					
2040 Daily VMT	36,897					
VMT Per Capita	19.6784847					
VMT Per SP	3.64884878					

rev kWh/year	Per SP
1.01E+07	4,172.6
4.05E+05	
1.22E+06	
2.74E+05	
7.62E+04	
5.53E+06	
7.85E+05	
1.80E+06	

[ult/files/2020-03/Title 24 2019 Building Standards FAQ_ada.pdf](#)

.9 standards will use about 7 percent less energy due to energy efficiency measures versus those built under the 2016 standards."

; will use about 53 percent less energy than those under the 2016 standards."

t 30 percent less energy due mainly to lighting upgrades."

Table 4.5-1 2019 Annual Gasoline and Diesel Consumption

San Luis Obispo County	
(gallons)	
Gasoline	138,000,000
Diesel	22,000,000
Total	160,000,000

Table 4.5-2 2019 Electricity Consumption

San Luis Obispo County (MWh)	
Electricity	1,715,000

Table 4.5-3 2019 Natural Gas Consumption

San Luis Obispo County	
(US therms)	
Natural Gas	90,000,000

Table 4.5-4 Projected 2040 Annual Natural Gas and Electricity Consumption in Pismo Beach

Per Service Population Consumption	
Natural Gas	U.S. Therms
2019 (SLO County Existing)	227.6
2040 (Pismo Beach New Development)	80.2
Electricity	kWh
2019 (SLO County Existing)	4,337.3
2040 (Pismo Beach New Development)	4,172.6

Based on VMT developed in CalEEMod

Table 4.5-5 Direct Transportation Energy Use in Pismo Beach

Service Population

Existing	13,156
2040 (New Development)	2,420

County Per Service Population Consumption (gallons)	County Per Service Population Consumption (MMBtu)	2040 Pismo fuel consumption (gallons)	2040 Per SP Consumption (gallons)	2040 Per SP Consumption (MMBtu)
349.0	38.3	604,163	249.7	27.4
55.6	7.1	82,721	34.2	3.8
404.6	45.4	686,884	283.8	31.2

County Per Service Population Consumption (kWh)	County Per Service Population Consumption (MMBtu)
4337.3	14.8

County Per Service Population Consumption (U.S. Therms)	County Per Capita Consumption (MMBtu)
227.6	21.2

Direct Energy Consumption (Daily Per Service Population MMBtu)
21.2
7.5
14.8
14.2

Based on VMT analysis in 2021Traffic Study

Table 4.5-5

Daily VMT	Per Service Population Btu/ VMT Factor	Direct Energy Consumption (Daily Per Service Population MMBtu)
20,757	2,187.6	45.4
36,897	844.5	31.2



(Existing)

2040 (New Development Only)

2040 (Buildout + New Development)

2.25%

2016	45.4
2017	44.4
2018	43.4
2019	42.4
2020	41.5
2021	40.5
2022	39.6
2023	38.7
2024	37.8
2025	37.0
2026	36.2
2027	35.4
2028	34.6
2029	33.8
2030	33.0
2031	32.3
2032	31.5
2033	30.8
2034	30.1
2035	29.5
2036	28.8
2037	28.2
2038	27.5
2039	26.9
2040	26.3



Direct Transportation Energy Use in Pismo Beach

Service Population	Daily VMT	Per Service Population Btu/	Direct Energy Consumption
		VMT Factor	(Daily Per Service Population MMBtu)
13,156	30,757	1,476.3	45.4
2,420	6,015	5,180.6	31.2
15,576	36,897	844.5	31.2

2.25%

2016	45.4
2017	44.4
2018	43.4
2019	42.4
2020	41.5
2021	40.5
2022	39.6
2023	38.7
2024	37.8
2025	37.0
2026	36.2
2027	35.4
2028	34.6
2029	33.8
2030	33.0
2031	32.3
2032	31.5
2033	30.8
2034	30.1
2035	29.5
2036	28.8
2037	28.2
2038	27.5
2039	26.9
2040	26.3

Local Area Unemployment Statistics Original Data Value

Series Id: LAUMT064202000000005

Not Seasonally Adjusted

Area: San Luis Obispo-Paso Robles-Arroyo Grande, CA

Area Type: Metropolitan areas

State/Region/Division: California

Years: 2018 to 2018

Year	Jan	Feb	Mar	Apr	May	Jun	Jul	Aug	Sep	Oct	Nov
2018	134146	136866	136480	136874	137858	136921	135458	132641	135376	137487	137399

Bureau of Labor Statistics, 2020, accessed April 28, 2020

Dec

134736

Average

136020

Appendix I

Greenhouse Gas Modeling Greenhouse Gas Modeling

Pismo Beach GP/LCP PEIR - GHG - San Luis Obispo County APCD Air District, Annual

EMFAC Off-Model Adjustment Factors for Gasoline Light Duty Vehicle to Account for the SAFE Vehicle Rule Applied

Pismo Beach GP/LCP PEIR - GHG
San Luis Obispo County APCD Air District, Annual

1.0 Project Characteristics

1.1 Land Usage

Land Uses	Size	Metric	Lot Acreage	Floor Surface Area	Population
Government (Civic Center)	6.34	1000sqft	0.15	6,340.00	-2
Office Park	420.93	1000sqft	9.66	420,930.00	0
Apartments Low Rise	228.00	Dwelling Unit	14.25	228,000.00	471
Apartments Mid Rise	162.00	Dwelling Unit	4.26	162,000.00	185
Apartments Mid Rise	722.00	Dwelling Unit	19.00	722,000.00	1221
Strip Mall	248.00	1000sqft	5.69	248,000.00	0
Strip Mall	108.00	1000sqft	2.48	108,000.00	0

1.2 Other Project Characteristics

Urbanization	Urban	Wind Speed (m/s)	3.2	Precipitation Freq (Days)	44
Climate Zone	4			Operational Year	2040
Utility Company	Pacific Gas and Electric Company				
CO2 Intensity (lb/MW hr)	203.98	CH4 Intensity (lb/MW hr)	0.033	N2O Intensity (lb/MW hr)	0.004

1.3 User Entered Comments & Non-Default Data

Project Characteristics -

Land Use - Data given by applicant

Construction Phase - Similar Buildout schedule as other City General Plan Update for 2040.

Grading -

Architectural Coating - SLOAPCD Rule 433

Vehicle Trips - Adjusted trip length and trip generation rates

Pismo Beach GP/LCP PEIR - GHG - San Luis Obispo County APCD Air District, Annual

EMFAC Off-Model Adjustment Factors for Gasoline Light Duty Vehicle to Account for the SAFE Vehicle Rule Applied

Area Coating - SLOAPCD Rule 433

Mobile Land Use Mitigation -

Water Mitigation -

Table Name	Column Name	Default Value	New Value
tblArchitecturalCoating	EF_Nonresidential_Exterior	250.00	150.00
tblArchitecturalCoating	EF_Nonresidential_Interior	250.00	150.00
tblArchitecturalCoating	EF_Residential_Exterior	250.00	100.00
tblArchitecturalCoating	EF_Residential_Interior	250.00	100.00
tblAreaCoating	Area_EF_Nonresidential_Exterior	250	150
tblAreaCoating	Area_EF_Nonresidential_Interior	250	150
tblAreaCoating	Area_EF_Residential_Exterior	250	100
tblAreaCoating	Area_EF_Residential_Interior	250	100
tblConstructionPhase	NumDays	75.00	330.00
tblConstructionPhase	NumDays	1,110.00	4,650.00
tblConstructionPhase	NumDays	70.00	300.00
tblConstructionPhase	NumDays	110.00	465.00
tblConstructionPhase	NumDays	75.00	330.00
tblConstructionPhase	NumDays	40.00	180.00
tblLandUse	Population	0.00	-2.00
tblLandUse	Population	652.00	471.00
tblLandUse	Population	463.00	185.00
tblLandUse	Population	2,065.00	1,221.00
tblVehicleTrips	CC_TL	5.00	10.73
tblVehicleTrips	CC_TL	5.00	9.60
tblVehicleTrips	CC_TL	5.00	18.00
tblVehicleTrips	CNW_TL	5.00	12.48
tblVehicleTrips	CNW_TL	5.00	6.60
tblVehicleTrips	CNW_TL	5.00	18.00

Pismo Beach GP/LCP PEIR - GHG - San Luis Obispo County APCD Air District, Annual

EMFAC Off-Model Adjustment Factors for Gasoline Light Duty Vehicle to Account for the SAFE Vehicle Rule Applied

tblVehicleTrips	CW_TL	13.00	12.87
tblVehicleTrips	CW_TL	13.00	24.95
tblVehicleTrips	CW_TL	13.00	46.79
tblVehicleTrips	HO_TL	5.00	9.01
tblVehicleTrips	HO_TL	5.00	9.01
tblVehicleTrips	HS_TL	5.00	9.01
tblVehicleTrips	HS_TL	5.00	9.01
tblVehicleTrips	HW_TL	13.00	23.42
tblVehicleTrips	HW_TL	13.00	23.42
tblVehicleTrips	ST_TR	8.14	0.98
tblVehicleTrips	ST_TR	4.91	0.59
tblVehicleTrips	ST_TR	1.64	0.20
tblVehicleTrips	ST_TR	42.04	5.07
tblVehicleTrips	SU_TR	6.28	0.76
tblVehicleTrips	SU_TR	4.09	0.49
tblVehicleTrips	SU_TR	0.76	0.09
tblVehicleTrips	SU_TR	20.43	2.46
tblVehicleTrips	WD_TR	7.32	0.88
tblVehicleTrips	WD_TR	5.44	0.70
tblVehicleTrips	WD_TR	33.98	4.10
tblVehicleTrips	WD_TR	11.07	1.33
tblVehicleTrips	WD_TR	44.32	5.40

2.0 Emissions Summary

2.1 Overall Construction

Unmitigated Construction

Pismo Beach GP/LCP PEIR - GHG - San Luis Obispo County APCD Air District, Annual

EMFAC Off-Model Adjustment Factors for Gasoline Light Duty Vehicle to Account for the SAFE Vehicle Rule Applied

	ROG	NOx	CO	SO2	Fugitive PM10	Exhaust PM10	PM10 Total	Fugitive PM2.5	Exhaust PM2.5	PM2.5 Total	Bio- CO2	NBio- CO2	Total CO2	CH4	N2O	CO2e
Year	tons/yr										MT/yr					
2021	0.0531	0.5195	0.3635	6.6000e-004	2.3800e-003	0.0256	0.0280	6.3000e-004	0.0238	0.0244	0.0000	58.0478	58.0478	0.0159	6.0000e-005	58.4624
2022	1.1886	11.0056	9.0932	0.0202	3.5221	0.4923	4.0145	1.4158	0.4553	1.8711	0.0000	1,796.7255	1,796.7255	0.4162	0.0299	1,816.0366
2023	1.1258	8.0825	9.9399	0.0277	3.0095	0.2938	3.3032	0.9087	0.2725	1.1812	0.0000	2,527.3558	2,527.3558	0.3434	0.0976	2,565.0297
2024	0.6786	3.7142	6.2428	0.0197	2.2807	0.1087	2.3894	0.5116	0.1019	0.6136	0.0000	1,830.4869	1,830.4869	0.1276	0.0947	1,861.8951
2025	0.6030	3.1611	5.6774	0.0185	1.4670	0.0820	1.5490	0.3933	0.0771	0.4704	0.0000	1,731.3751	1,731.3751	0.1052	0.0913	1,761.2131
2026	0.5825	3.1094	5.4903	0.0181	1.4670	0.0815	1.5485	0.3933	0.0767	0.4700	0.0000	1,701.2542	1,701.2542	0.1034	0.0886	1,730.2371
2027	0.5633	3.0629	5.3292	0.0177	1.4670	0.0810	1.5481	0.3933	0.0762	0.4695	0.0000	1,672.0371	1,672.0371	0.1018	0.0860	1,700.2149
2028	0.5425	3.0116	5.1743	0.0173	1.4614	0.0802	1.5417	0.3918	0.0755	0.4672	0.0000	1,638.8703	1,638.8703	0.1000	0.0834	1,666.2184
2029	0.5263	2.9854	5.0754	0.0170	1.4671	0.0800	1.5471	0.3933	0.0753	0.4686	0.0000	1,619.8691	1,619.8691	0.0992	0.0815	1,646.6435
2030	0.5012	2.3630	4.9845	0.0173	1.4671	0.0301	1.4972	0.3933	0.0295	0.4228	0.0000	1,637.7256	1,637.7256	0.0408	0.0796	1,662.4759
2031	0.4836	2.3359	4.8960	0.0170	1.4671	0.0297	1.4968	0.3933	0.0291	0.4224	0.0000	1,617.3690	1,617.3690	0.0398	0.0780	1,641.5949
2032	0.4689	2.3214	4.8380	0.0168	1.4727	0.0295	1.5022	0.3948	0.0289	0.4237	0.0000	1,605.3215	1,605.3215	0.0391	0.0768	1,629.1814
2033	0.4513	2.2844	4.7368	0.0165	1.4615	0.0289	1.4904	0.3918	0.0284	0.4202	0.0000	1,576.9521	1,576.9521	0.0381	0.0750	1,600.2400
2034	0.4390	2.2677	4.6808	0.0163	1.4615	0.0286	1.4901	0.3918	0.0281	0.4199	0.0000	1,562.4857	1,562.4857	0.0374	0.0739	1,585.4314
2035	0.4173	2.1605	4.6448	0.0162	1.4671	0.0209	1.4881	0.3933	0.0204	0.4137	0.0000	1,555.7172	1,555.7172	0.0360	0.0732	1,578.4285
2036	0.4189	2.1687	4.6626	0.0162	1.4727	0.0210	1.4938	0.3948	0.0205	0.4153	0.0000	1,561.6778	1,561.6778	0.0362	0.0735	1,584.4761
2037	0.4173	2.1605	4.6448	0.0162	1.4671	0.0209	1.4881	0.3933	0.0204	0.4137	0.0000	1,555.7172	1,555.7172	0.0360	0.0732	1,578.4285
2038	0.4173	2.1605	4.6448	0.0162	1.4671	0.0209	1.4881	0.3933	0.0204	0.4137	0.0000	1,555.7172	1,555.7172	0.0360	0.0732	1,578.4285
2039	0.4157	2.1522	4.6270	0.0161	1.4615	0.0209	1.4824	0.3918	0.0204	0.4122	0.0000	1,549.7566	1,549.7566	0.0359	0.0729	1,572.3809

Pismo Beach GP/LCP PEIR - GHG - San Luis Obispo County APCD Air District, Annual

EMFAC Off-Model Adjustment Factors for Gasoline Light Duty Vehicle to Account for the SAFE Vehicle Rule Applied

	ROG	NOx	CO	SO2	Fugitive PM10	Exhaust PM10	PM10 Total	Fugitive PM2.5	Exhaust PM2.5	PM2.5 Total	Bio- CO2	NBio- CO2	Total CO2	CH4	N2O	CO2e
Year	tons/yr										MT/yr					
2040	2.1535	1.3633	3.5119	0.0106	0.8574	0.0170	0.8743	0.2297	0.0167	0.2464	0.0000	1,007.1490	1,007.1490	0.0239	0.0386	1,019.2487
2041	0.1613	0.5044	2.3189	5.0100e-003	0.2791	0.0138	0.2929	0.0742	0.0138	0.0879	0.0000	457.4352	457.4352	0.0116	3.5000e-003	458.7693
2042	3.8200e-003	8.5400e-003	0.0457	1.4000e-004	0.0192	1.1000e-004	0.0193	5.1000e-003	1.0000e-004	5.2100e-003	0.0000	14.1162	14.1162	2.2000e-004	2.4000e-004	14.1934
Maximum	2.1535	11.0056	9.9399	0.0277	3.5221	0.4923	4.0145	1.4158	0.4553	1.8711	0.0000	2,527.3558	2,527.3558	0.4162	0.0976	2,565.0297

2.1 Overall Construction

Mitigated Construction

	ROG	NOx	CO	SO2	Fugitive PM10	Exhaust PM10	PM10 Total	Fugitive PM2.5	Exhaust PM2.5	PM2.5 Total	Bio- CO2	NBio- CO2	Total CO2	CH4	N2O	CO2e
Year	tons/yr										MT/yr					
2021	0.0531	0.5195	0.3635	6.6000e-004	2.3800e-003	0.0256	0.0280	6.3000e-004	0.0238	0.0244	0.0000	58.0477	58.0477	0.0159	6.0000e-005	58.4624
2022	1.1886	11.0056	9.0932	0.0202	3.5221	0.4923	4.0145	1.4158	0.4553	1.8711	0.0000	1,796.7239	1,796.7239	0.4162	0.0299	1,816.0350
2023	1.1258	8.0825	9.9399	0.0277	3.0095	0.2938	3.3032	0.9087	0.2725	1.1812	0.0000	2,527.3546	2,527.3546	0.3434	0.0976	2,565.0285
2024	0.6786	3.7142	6.2428	0.0197	2.2807	0.1087	2.3894	0.5116	0.1019	0.6136	0.0000	1,830.4865	1,830.4865	0.1276	0.0947	1,861.8946
2025	0.6029	3.1611	5.6774	0.0185	1.4670	0.0820	1.5490	0.3933	0.0771	0.4704	0.0000	1,731.3747	1,731.3747	0.1052	0.0913	1,761.2127
2026	0.5825	3.1094	5.4903	0.0181	1.4670	0.0815	1.5485	0.3933	0.0767	0.4700	0.0000	1,701.2538	1,701.2538	0.1034	0.0886	1,730.2367
2027	0.5633	3.0629	5.3292	0.0177	1.4670	0.0810	1.5481	0.3933	0.0762	0.4695	0.0000	1,672.0367	1,672.0367	0.1018	0.0860	1,700.2146
2028	0.5425	3.0116	5.1743	0.0173	1.4614	0.0802	1.5417	0.3918	0.0755	0.4672	0.0000	1,638.8700	1,638.8700	0.1000	0.0834	1,666.2180

Pismo Beach GP/LCP PEIR - GHG - San Luis Obispo County APCD Air District, Annual

EMFAC Off-Model Adjustment Factors for Gasoline Light Duty Vehicle to Account for the SAFE Vehicle Rule Applied

Quarter	Start Date	End Date	Maximum Unmitigated ROG + NOX (tons/quarter)	Maximum Mitigated ROG + NOX (tons/quarter)
1	11-17-2021	2-16-2022	1.0355	1.0355
2	2-17-2022	5-16-2022	2.3928	2.3928
3	5-17-2022	8-16-2022	3.5283	3.5283
4	8-17-2022	11-16-2022	4.0777	4.0777
5	11-17-2022	2-16-2023	3.0019	3.0019
6	2-17-2023	5-16-2023	2.2276	2.2276
7	5-17-2023	8-16-2023	2.2871	2.2871
8	8-17-2023	11-16-2023	2.3035	2.3035
9	11-17-2023	2-16-2024	2.0358	2.0358
10	2-17-2024	5-16-2024	0.9784	0.9784
11	5-17-2024	8-16-2024	0.9853	0.9853
12	8-17-2024	11-16-2024	1.0008	1.0008
13	11-17-2024	2-16-2025	0.9870	0.9870
14	2-17-2025	5-16-2025	0.9138	0.9138
15	5-17-2025	8-16-2025	0.9306	0.9306
16	8-17-2025	11-16-2025	0.9454	0.9454
17	11-17-2025	2-16-2026	0.9502	0.9502
18	2-17-2026	5-16-2026	0.8965	0.8965
19	5-17-2026	8-16-2026	0.9132	0.9132
20	8-17-2026	11-16-2026	0.9275	0.9275
21	11-17-2026	2-16-2027	0.9325	0.9325
22	2-17-2027	5-16-2027	0.8807	0.8807
23	5-17-2027	8-16-2027	0.8974	0.8974
24	8-17-2027	11-16-2027	0.9111	0.9111
25	11-17-2027	2-16-2028	0.9166	0.9166
26	2-17-2028	5-16-2028	0.8765	0.8765
27	5-17-2028	8-16-2028	0.8833	0.8833
28	8-17-2028	11-16-2028	0.8965	0.8965

Pismo Beach GP/LCP PEIR - GHG - San Luis Obispo County APCD Air District, Annual

EMFAC Off-Model Adjustment Factors for Gasoline Light Duty Vehicle to Account for the SAFE Vehicle Rule Applied

29	11-17-2028	2-16-2029	0.9019	0.9019
30	2-17-2029	5-16-2029	0.8531	0.8531
31	5-17-2029	8-16-2029	0.8697	0.8697
32	8-17-2029	11-16-2029	0.8825	0.8825
33	11-17-2029	2-16-2030	0.8113	0.8113
34	2-17-2030	5-16-2030	0.6954	0.6954
35	5-17-2030	8-16-2030	0.7071	0.7071
36	8-17-2030	11-16-2030	0.7195	0.7195
37	11-17-2030	2-16-2031	0.7255	0.7255
38	2-17-2031	5-16-2031	0.6846	0.6846
39	5-17-2031	8-16-2031	0.6963	0.6963
40	8-17-2031	11-16-2031	0.7083	0.7083
41	11-17-2031	2-16-2032	0.7145	0.7145
42	2-17-2032	5-16-2032	0.6826	0.6826
43	5-17-2032	8-16-2032	0.6866	0.6866
44	8-17-2032	11-16-2032	0.6982	0.6982
45	11-17-2032	2-16-2033	0.7050	0.7050
46	2-17-2033	5-16-2033	0.6667	0.6667
47	5-17-2033	8-16-2033	0.6785	0.6785
48	8-17-2033	11-16-2033	0.6898	0.6898
49	11-17-2033	2-16-2034	0.6968	0.6968
50	2-17-2034	5-16-2034	0.6596	0.6596
51	5-17-2034	8-16-2034	0.6713	0.6713
52	8-17-2034	11-16-2034	0.6825	0.6825
53	11-17-2034	2-16-2035	0.6751	0.6751
54	2-17-2035	5-16-2035	0.6257	0.6257
55	5-17-2035	8-16-2035	0.6364	0.6364
56	8-17-2035	11-16-2035	0.6474	0.6474
57	11-17-2035	2-16-2036	0.6578	0.6578

Pismo Beach GP/LCP PEIR - GHG - San Luis Obispo County APCD Air District, Annual

EMFAC Off-Model Adjustment Factors for Gasoline Light Duty Vehicle to Account for the SAFE Vehicle Rule Applied

58	2-17-2036	5-16-2036	0.6328	0.6328
59	5-17-2036	8-16-2036	0.6364	0.6364
60	8-17-2036	11-16-2036	0.6474	0.6474
61	11-17-2036	2-16-2037	0.6578	0.6578
62	2-17-2037	5-16-2037	0.6257	0.6257
63	5-17-2037	8-16-2037	0.6364	0.6364
64	8-17-2037	11-16-2037	0.6474	0.6474
65	11-17-2037	2-16-2038	0.6578	0.6578
66	2-17-2038	5-16-2038	0.6257	0.6257
67	5-17-2038	8-16-2038	0.6364	0.6364
68	8-17-2038	11-16-2038	0.6474	0.6474
69	11-17-2038	2-16-2039	0.6578	0.6578
70	2-17-2039	5-16-2039	0.6257	0.6257
71	5-17-2039	8-16-2039	0.6364	0.6364
72	8-17-2039	11-16-2039	0.6474	0.6474
73	11-17-2039	2-16-2040	0.6391	0.6391
74	2-17-2040	5-16-2040	0.5978	0.5978
75	5-17-2040	8-16-2040	0.4556	0.4556
76	8-17-2040	11-16-2040	0.8376	0.8376
77	11-17-2040	2-16-2041	1.4067	1.4067
78	2-17-2041	5-16-2041	0.1910	0.1910
79	5-17-2041	8-16-2041	0.1964	0.1964
80	8-17-2041	11-16-2041	0.1555	0.1555
81	11-17-2041	2-16-2042	0.0344	0.0344
		Highest	4.0777	4.0777

Pismo Beach GP/LCP PEIR - GHG - San Luis Obispo County APCD Air District, Annual

EMFAC Off-Model Adjustment Factors for Gasoline Light Duty Vehicle to Account for the SAFE Vehicle Rule Applied

2.2 Overall Operational

Unmitigated Operational

	ROG	NOx	CO	SO2	Fugitive PM10	Exhaust PM10	PM10 Total	Fugitive PM2.5	Exhaust PM2.5	PM2.5 Total	Bio- CO2	NBio- CO2	Total CO2	CH4	N2O	CO2e
Category	tons/yr										MT/yr					
Area	9.0943	0.1741	15.0840	8.0000e-004		0.0840	0.0840		0.0840	0.0840	0.0000	24.7522	24.7522	0.0236	0.0000	25.3423
Energy	0.1046	0.9224	0.5904	5.7000e-003		0.0723	0.0723		0.0723	0.0723	0.0000	2,520.6964	2,520.6964	0.2602	0.0481	2,541.5375
Mobile	1.3370	1.5521	14.8323	0.0339	5.0175	0.0178	5.0352	1.3382	0.0166	1.3548	0.0000	3,423.2443	3,423.2443	0.1625	0.1342	3,467.2826
Waste						0.0000	0.0000		0.0000	0.0000	266.5109	0.0000	266.5109	15.7503	0.0000	660.2695
Water						0.0000	0.0000		0.0000	0.0000	55.4858	122.6841	178.1699	5.7188	0.1370	361.9562
Total	10.5359	2.6486	30.5066	0.0404	5.0175	0.1740	5.1915	1.3382	0.1729	1.5110	321.9967	6,091.3770	6,413.3737	21.9154	0.3192	7,056.3880

Pismo Beach GP/LCP PEIR - GHG - San Luis Obispo County APCD Air District, Annual

EMFAC Off-Model Adjustment Factors for Gasoline Light Duty Vehicle to Account for the SAFE Vehicle Rule Applied

2.2 Overall Operational

Mitigated Operational

	ROG	NOx	CO	SO2	Fugitive PM10	Exhaust PM10	PM10 Total	Fugitive PM2.5	Exhaust PM2.5	PM2.5 Total	Bio- CO2	NBio- CO2	Total CO2	CH4	N2O	CO2e
Category	tons/yr										MT/yr					
Area	9.0943	0.1741	15.0840	8.0000e-004		0.0840	0.0840		0.0840	0.0840	0.0000	24.7522	24.7522	0.0236	0.0000	25.3423
Energy	0.1046	0.9224	0.5904	5.7000e-003		0.0723	0.0723		0.0723	0.0723	0.0000	2,520.6964	2,520.6964	0.2602	0.0481	2,541.5375
Mobile	1.3370	1.5521	14.8323	0.0339	5.0175	0.0178	5.0352	1.3382	0.0166	1.3548	0.0000	3,423.2443	3,423.2443	0.1625	0.1342	3,467.2826
Waste						0.0000	0.0000		0.0000	0.0000	266.5109	0.0000	266.5109	15.7503	0.0000	660.2695
Water						0.0000	0.0000		0.0000	0.0000	44.3887	105.1721	149.5607	4.5762	0.1097	296.6592
Total	10.5359	2.6486	30.5066	0.0404	5.0175	0.1740	5.1915	1.3382	0.1729	1.5110	310.8995	6,073.8649	6,384.7645	20.7727	0.2920	6,991.0911

	ROG	NOx	CO	SO2	Fugitive PM10	Exhaust PM10	PM10 Total	Fugitive PM2.5	Exhaust PM2.5	PM2.5 Total	Bio- CO2	NBio- CO2	Total CO2	CH4	N2O	CO2e
Percent Reduction	0.00	0.00	0.00	0.00	0.00	0.00	0.00	0.00	0.00	0.00	3.45	0.29	0.45	5.21	8.54	0.93

3.0 Construction Detail

Construction Phase

Phase Number	Phase Name	Phase Type	Start Date	End Date	Num Days Week	Num Days	Phase Description
1	Demolition	Demolition	11/17/2021	1/10/2023	5	300	
2	Site Preparation	Site Preparation	2/23/2022	11/1/2022	5	180	
3	Grading	Grading	4/20/2022	1/30/2024	5	465	

Pismo Beach GP/LCP PEIR - GHG - San Luis Obispo County APCD Air District, Annual

EMFAC Off-Model Adjustment Factors for Gasoline Light Duty Vehicle to Account for the SAFE Vehicle Rule Applied

4	Building Construction	Building Construction	9/21/2022	7/17/2040	5	4650
5	Paving	Paving	7/18/2040	10/22/2041	5	330
6	Architectural Coating	Architectural Coating	10/23/2040	1/27/2042	5	330

Acres of Grading (Site Preparation Phase): 270

Acres of Grading (Grading Phase): 1395

Acres of Paving: 0

Residential Indoor: 2,251,800; Residential Outdoor: 750,600; Non-Residential Indoor: 1,174,905; Non-Residential Outdoor: 391,635; Striped Parking Area: 0 (Architectural Coating – sqft)

OffRoad Equipment

Phase Name	Offroad Equipment Type	Amount	Usage Hours	Horse Power	Load Factor
Demolition	Concrete/Industrial Saws	1	8.00	81	0.73
Demolition	Excavators	3	8.00	158	0.38
Demolition	Rubber Tired Dozers	2	8.00	247	0.40
Site Preparation	Rubber Tired Dozers	3	8.00	247	0.40
Site Preparation	Tractors/Loaders/Backhoes	4	8.00	97	0.37
Grading	Excavators	2	8.00	158	0.38
Grading	Graders	1	8.00	187	0.41
Grading	Rubber Tired Dozers	1	8.00	247	0.40
Grading	Scrapers	2	8.00	367	0.48
Grading	Tractors/Loaders/Backhoes	2	8.00	97	0.37
Building Construction	Cranes	1	7.00	231	0.29
Building Construction	Forklifts	3	8.00	89	0.20
Building Construction	Generator Sets	1	8.00	84	0.74
Building Construction	Tractors/Loaders/Backhoes	3	7.00	97	0.37
Building Construction	Welders	1	8.00	46	0.45
Paving	Pavers	2	8.00	130	0.42
Paving	Paving Equipment	2	8.00	132	0.36

Pismo Beach GP/LCP PEIR - GHG - San Luis Obispo County APCD Air District, Annual

EMFAC Off-Model Adjustment Factors for Gasoline Light Duty Vehicle to Account for the SAFE Vehicle Rule Applied

Paving	Rollers	2	8.00	80	0.38
Architectural Coating	Air Compressors	1	6.00	78	0.48

Trips and VMT

Phase Name	Offroad Equipment Count	Worker Trip Number	Vendor Trip Number	Hauling Trip Number	Worker Trip Length	Vendor Trip Length	Hauling Trip Length	Worker Vehicle Class	Vendor Vehicle Class	Hauling Vehicle Class
Demolition	6	15.00	0.00	0.00	13.00	5.00	20.00	LD_Mix	HDT_Mix	HHDT
Site Preparation	7	18.00	0.00	0.00	13.00	5.00	20.00	LD_Mix	HDT_Mix	HHDT
Grading	8	20.00	0.00	0.00	13.00	5.00	20.00	LD_Mix	HDT_Mix	HHDT
Building Construction	9	1,051.00	247.00	0.00	13.00	5.00	20.00	LD_Mix	HDT_Mix	HHDT
Paving	6	15.00	0.00	0.00	13.00	5.00	20.00	LD_Mix	HDT_Mix	HHDT
Architectural Coating	1	210.00	0.00	0.00	13.00	5.00	20.00	LD_Mix	HDT_Mix	HHDT

3.1 Mitigation Measures Construction

3.2 Demolition - 2021

Unmitigated Construction On-Site

	ROG	NOx	CO	SO2	Fugitive PM10	Exhaust PM10	PM10 Total	Fugitive PM2.5	Exhaust PM2.5	PM2.5 Total	Bio- CO2	NBio- CO2	Total CO2	CH4	N2O	CO2e
Category	tons/yr										MT/yr					
Off-Road	0.0522	0.5188	0.3558	6.4000e-004		0.0256	0.0256		0.0238	0.0238	0.0000	56.1013	56.1013	0.0158	0.0000	56.4961
Total	0.0522	0.5188	0.3558	6.4000e-004		0.0256	0.0256		0.0238	0.0238	0.0000	56.1013	56.1013	0.0158	0.0000	56.4961

Pismo Beach GP/LCP PEIR - GHG - San Luis Obispo County APCD Air District, Annual

EMFAC Off-Model Adjustment Factors for Gasoline Light Duty Vehicle to Account for the SAFE Vehicle Rule Applied

3.2 Demolition - 2021

Unmitigated Construction Off-Site

	ROG	NOx	CO	SO2	Fugitive PM10	Exhaust PM10	PM10 Total	Fugitive PM2.5	Exhaust PM2.5	PM2.5 Total	Bio- CO2	NBio- CO2	Total CO2	CH4	N2O	CO2e
Category	tons/yr										MT/yr					
Hauling	0.0000	0.0000	0.0000	0.0000	0.0000	0.0000	0.0000	0.0000	0.0000	0.0000	0.0000	0.0000	0.0000	0.0000	0.0000	0.0000
Vendor	0.0000	0.0000	0.0000	0.0000	0.0000	0.0000	0.0000	0.0000	0.0000	0.0000	0.0000	0.0000	0.0000	0.0000	0.0000	0.0000
Worker	9.0000e-004	7.4000e-004	7.7100e-003	2.0000e-005	2.3800e-003	1.0000e-005	2.4000e-003	6.3000e-004	1.0000e-005	6.5000e-004	0.0000	1.9465	1.9465	6.0000e-005	6.0000e-005	1.9664
Total	9.0000e-004	7.4000e-004	7.7100e-003	2.0000e-005	2.3800e-003	1.0000e-005	2.4000e-003	6.3000e-004	1.0000e-005	6.5000e-004	0.0000	1.9465	1.9465	6.0000e-005	6.0000e-005	1.9664

Mitigated Construction On-Site

	ROG	NOx	CO	SO2	Fugitive PM10	Exhaust PM10	PM10 Total	Fugitive PM2.5	Exhaust PM2.5	PM2.5 Total	Bio- CO2	NBio- CO2	Total CO2	CH4	N2O	CO2e
Category	tons/yr										MT/yr					
Off-Road	0.0522	0.5188	0.3558	6.4000e-004		0.0256	0.0256		0.0238	0.0238	0.0000	56.1012	56.1012	0.0158	0.0000	56.4960
Total	0.0522	0.5188	0.3558	6.4000e-004		0.0256	0.0256		0.0238	0.0238	0.0000	56.1012	56.1012	0.0158	0.0000	56.4960

Pismo Beach GP/LCP PEIR - GHG - San Luis Obispo County APCD Air District, Annual

EMFAC Off-Model Adjustment Factors for Gasoline Light Duty Vehicle to Account for the SAFE Vehicle Rule Applied

3.2 Demolition - 2021

Mitigated Construction Off-Site

	ROG	NOx	CO	SO2	Fugitive PM10	Exhaust PM10	PM10 Total	Fugitive PM2.5	Exhaust PM2.5	PM2.5 Total	Bio- CO2	NBio- CO2	Total CO2	CH4	N2O	CO2e
Category	tons/yr										MT/yr					
Hauling	0.0000	0.0000	0.0000	0.0000	0.0000	0.0000	0.0000	0.0000	0.0000	0.0000	0.0000	0.0000	0.0000	0.0000	0.0000	0.0000
Vendor	0.0000	0.0000	0.0000	0.0000	0.0000	0.0000	0.0000	0.0000	0.0000	0.0000	0.0000	0.0000	0.0000	0.0000	0.0000	0.0000
Worker	9.0000e-004	7.4000e-004	7.7100e-003	2.0000e-005	2.3800e-003	1.0000e-005	2.4000e-003	6.3000e-004	1.0000e-005	6.5000e-004	0.0000	1.9465	1.9465	6.0000e-005	6.0000e-005	1.9664
Total	9.0000e-004	7.4000e-004	7.7100e-003	2.0000e-005	2.3800e-003	1.0000e-005	2.4000e-003	6.3000e-004	1.0000e-005	6.5000e-004	0.0000	1.9465	1.9465	6.0000e-005	6.0000e-005	1.9664

3.2 Demolition - 2022

Unmitigated Construction On-Site

	ROG	NOx	CO	SO2	Fugitive PM10	Exhaust PM10	PM10 Total	Fugitive PM2.5	Exhaust PM2.5	PM2.5 Total	Bio- CO2	NBio- CO2	Total CO2	CH4	N2O	CO2e
Category	tons/yr										MT/yr					
Off-Road	0.3431	3.3435	2.6772	5.0500e-003		0.1615	0.1615		0.1502	0.1502	0.0000	441.8730	441.8730	0.1241	0.0000	444.9759
Total	0.3431	3.3435	2.6772	5.0500e-003		0.1615	0.1615		0.1502	0.1502	0.0000	441.8730	441.8730	0.1241	0.0000	444.9759

Pismo Beach GP/LCP PEIR - GHG - San Luis Obispo County APCD Air District, Annual

EMFAC Off-Model Adjustment Factors for Gasoline Light Duty Vehicle to Account for the SAFE Vehicle Rule Applied

3.2 Demolition - 2022

Unmitigated Construction Off-Site

	ROG	NOx	CO	SO2	Fugitive PM10	Exhaust PM10	PM10 Total	Fugitive PM2.5	Exhaust PM2.5	PM2.5 Total	Bio- CO2	NBio- CO2	Total CO2	CH4	N2O	CO2e
Category	tons/yr										MT/yr					
Hauling	0.0000	0.0000	0.0000	0.0000	0.0000	0.0000	0.0000	0.0000	0.0000	0.0000	0.0000	0.0000	0.0000	0.0000	0.0000	0.0000
Vendor	0.0000	0.0000	0.0000	0.0000	0.0000	0.0000	0.0000	0.0000	0.0000	0.0000	0.0000	0.0000	0.0000	0.0000	0.0000	0.0000
Worker	6.6300e-003	5.1100e-003	0.0559	1.6000e-004	0.0188	1.0000e-004	0.0189	4.9900e-003	9.0000e-005	5.0800e-003	0.0000	14.9526	14.9526	4.4000e-004	4.5000e-004	15.0970
Total	6.6300e-003	5.1100e-003	0.0559	1.6000e-004	0.0188	1.0000e-004	0.0189	4.9900e-003	9.0000e-005	5.0800e-003	0.0000	14.9526	14.9526	4.4000e-004	4.5000e-004	15.0970

Mitigated Construction On-Site

	ROG	NOx	CO	SO2	Fugitive PM10	Exhaust PM10	PM10 Total	Fugitive PM2.5	Exhaust PM2.5	PM2.5 Total	Bio- CO2	NBio- CO2	Total CO2	CH4	N2O	CO2e
Category	tons/yr										MT/yr					
Off-Road	0.3431	3.3435	2.6772	5.0500e-003		0.1615	0.1615		0.1502	0.1502	0.0000	441.8724	441.8724	0.1241	0.0000	444.9754
Total	0.3431	3.3435	2.6772	5.0500e-003		0.1615	0.1615		0.1502	0.1502	0.0000	441.8724	441.8724	0.1241	0.0000	444.9754

Pismo Beach GP/LCP PEIR - GHG - San Luis Obispo County APCD Air District, Annual

EMFAC Off-Model Adjustment Factors for Gasoline Light Duty Vehicle to Account for the SAFE Vehicle Rule Applied

3.2 Demolition - 2022

Mitigated Construction Off-Site

	ROG	NOx	CO	SO2	Fugitive PM10	Exhaust PM10	PM10 Total	Fugitive PM2.5	Exhaust PM2.5	PM2.5 Total	Bio- CO2	NBio- CO2	Total CO2	CH4	N2O	CO2e
Category	tons/yr										MT/yr					
Hauling	0.0000	0.0000	0.0000	0.0000	0.0000	0.0000	0.0000	0.0000	0.0000	0.0000	0.0000	0.0000	0.0000	0.0000	0.0000	0.0000
Vendor	0.0000	0.0000	0.0000	0.0000	0.0000	0.0000	0.0000	0.0000	0.0000	0.0000	0.0000	0.0000	0.0000	0.0000	0.0000	0.0000
Worker	6.6300e-003	5.1100e-003	0.0559	1.6000e-004	0.0188	1.0000e-004	0.0189	4.9900e-003	9.0000e-005	5.0800e-003	0.0000	14.9526	14.9526	4.4000e-004	4.5000e-004	15.0970
Total	6.6300e-003	5.1100e-003	0.0559	1.6000e-004	0.0188	1.0000e-004	0.0189	4.9900e-003	9.0000e-005	5.0800e-003	0.0000	14.9526	14.9526	4.4000e-004	4.5000e-004	15.0970

3.2 Demolition - 2023

Unmitigated Construction On-Site

	ROG	NOx	CO	SO2	Fugitive PM10	Exhaust PM10	PM10 Total	Fugitive PM2.5	Exhaust PM2.5	PM2.5 Total	Bio- CO2	NBio- CO2	Total CO2	CH4	N2O	CO2e
Category	tons/yr										MT/yr					
Off-Road	7.9400e-003	0.0752	0.0688	1.4000e-004		3.4900e-003	3.4900e-003		3.2500e-003	3.2500e-003	0.0000	11.8972	11.8972	3.3300e-003	0.0000	11.9805
Total	7.9400e-003	0.0752	0.0688	1.4000e-004		3.4900e-003	3.4900e-003		3.2500e-003	3.2500e-003	0.0000	11.8972	11.8972	3.3300e-003	0.0000	11.9805

Pismo Beach GP/LCP PEIR - GHG - San Luis Obispo County APCD Air District, Annual

EMFAC Off-Model Adjustment Factors for Gasoline Light Duty Vehicle to Account for the SAFE Vehicle Rule Applied

3.2 Demolition - 2023

Unmitigated Construction Off-Site

	ROG	NOx	CO	SO2	Fugitive PM10	Exhaust PM10	PM10 Total	Fugitive PM2.5	Exhaust PM2.5	PM2.5 Total	Bio- CO2	NBio- CO2	Total CO2	CH4	N2O	CO2e
Category	tons/yr										MT/yr					
Hauling	0.0000	0.0000	0.0000	0.0000	0.0000	0.0000	0.0000	0.0000	0.0000	0.0000	0.0000	0.0000	0.0000	0.0000	0.0000	0.0000
Vendor	0.0000	0.0000	0.0000	0.0000	0.0000	0.0000	0.0000	0.0000	0.0000	0.0000	0.0000	0.0000	0.0000	0.0000	0.0000	0.0000
Worker	1.7000e-004	1.2000e-004	1.3900e-003	0.0000	5.1000e-004	0.0000	5.1000e-004	1.3000e-004	0.0000	1.4000e-004	0.0000	0.3927	0.3927	1.0000e-005	1.0000e-005	0.3963
Total	1.7000e-004	1.2000e-004	1.3900e-003	0.0000	5.1000e-004	0.0000	5.1000e-004	1.3000e-004	0.0000	1.4000e-004	0.0000	0.3927	0.3927	1.0000e-005	1.0000e-005	0.3963

Mitigated Construction On-Site

	ROG	NOx	CO	SO2	Fugitive PM10	Exhaust PM10	PM10 Total	Fugitive PM2.5	Exhaust PM2.5	PM2.5 Total	Bio- CO2	NBio- CO2	Total CO2	CH4	N2O	CO2e
Category	tons/yr										MT/yr					
Off-Road	7.9400e-003	0.0752	0.0688	1.4000e-004		3.4900e-003	3.4900e-003		3.2500e-003	3.2500e-003	0.0000	11.8972	11.8972	3.3300e-003	0.0000	11.9805
Total	7.9400e-003	0.0752	0.0688	1.4000e-004		3.4900e-003	3.4900e-003		3.2500e-003	3.2500e-003	0.0000	11.8972	11.8972	3.3300e-003	0.0000	11.9805

Pismo Beach GP/LCP PEIR - GHG - San Luis Obispo County APCD Air District, Annual

EMFAC Off-Model Adjustment Factors for Gasoline Light Duty Vehicle to Account for the SAFE Vehicle Rule Applied

3.2 Demolition - 2023

Mitigated Construction Off-Site

	ROG	NOx	CO	SO2	Fugitive PM10	Exhaust PM10	PM10 Total	Fugitive PM2.5	Exhaust PM2.5	PM2.5 Total	Bio- CO2	NBio- CO2	Total CO2	CH4	N2O	CO2e
Category	tons/yr										MT/yr					
Hauling	0.0000	0.0000	0.0000	0.0000	0.0000	0.0000	0.0000	0.0000	0.0000	0.0000	0.0000	0.0000	0.0000	0.0000	0.0000	0.0000
Vendor	0.0000	0.0000	0.0000	0.0000	0.0000	0.0000	0.0000	0.0000	0.0000	0.0000	0.0000	0.0000	0.0000	0.0000	0.0000	0.0000
Worker	1.7000e-004	1.2000e-004	1.3900e-003	0.0000	5.1000e-004	0.0000	5.1000e-004	1.3000e-004	0.0000	1.4000e-004	0.0000	0.3927	0.3927	1.0000e-005	1.0000e-005	0.3963
Total	1.7000e-004	1.2000e-004	1.3900e-003	0.0000	5.1000e-004	0.0000	5.1000e-004	1.3000e-004	0.0000	1.4000e-004	0.0000	0.3927	0.3927	1.0000e-005	1.0000e-005	0.3963

3.3 Site Preparation - 2022

Unmitigated Construction On-Site

	ROG	NOx	CO	SO2	Fugitive PM10	Exhaust PM10	PM10 Total	Fugitive PM2.5	Exhaust PM2.5	PM2.5 Total	Bio- CO2	NBio- CO2	Total CO2	CH4	N2O	CO2e
Category	tons/yr										MT/yr					
Fugitive Dust					1.7691	0.0000	1.7691	0.9092	0.0000	0.9092	0.0000	0.0000	0.0000	0.0000	0.0000	0.0000
Off-Road	0.2853	2.9775	1.7728	3.4200e-003		0.1451	0.1451		0.1335	0.1335	0.0000	300.9545	300.9545	0.0973	0.0000	303.3879
Total	0.2853	2.9775	1.7728	3.4200e-003	1.7691	0.1451	1.9143	0.9092	0.1335	1.0427	0.0000	300.9545	300.9545	0.0973	0.0000	303.3879

Pismo Beach GP/LCP PEIR - GHG - San Luis Obispo County APCD Air District, Annual

EMFAC Off-Model Adjustment Factors for Gasoline Light Duty Vehicle to Account for the SAFE Vehicle Rule Applied

3.3 Site Preparation - 2022

Unmitigated Construction Off-Site

	ROG	NOx	CO	SO2	Fugitive PM10	Exhaust PM10	PM10 Total	Fugitive PM2.5	Exhaust PM2.5	PM2.5 Total	Bio- CO2	NBio- CO2	Total CO2	CH4	N2O	CO2e
Category	tons/yr										MT/yr					
Hauling	0.0000	0.0000	0.0000	0.0000	0.0000	0.0000	0.0000	0.0000	0.0000	0.0000	0.0000	0.0000	0.0000	0.0000	0.0000	0.0000
Vendor	0.0000	0.0000	0.0000	0.0000	0.0000	0.0000	0.0000	0.0000	0.0000	0.0000	0.0000	0.0000	0.0000	0.0000	0.0000	0.0000
Worker	5.5100e-003	4.2500e-003	0.0464	1.3000e-004	0.0156	8.0000e-005	0.0157	4.1400e-003	7.0000e-005	4.2200e-003	0.0000	12.4222	12.4222	3.7000e-004	3.7000e-004	12.5421
Total	5.5100e-003	4.2500e-003	0.0464	1.3000e-004	0.0156	8.0000e-005	0.0157	4.1400e-003	7.0000e-005	4.2200e-003	0.0000	12.4222	12.4222	3.7000e-004	3.7000e-004	12.5421

Mitigated Construction On-Site

	ROG	NOx	CO	SO2	Fugitive PM10	Exhaust PM10	PM10 Total	Fugitive PM2.5	Exhaust PM2.5	PM2.5 Total	Bio- CO2	NBio- CO2	Total CO2	CH4	N2O	CO2e
Category	tons/yr										MT/yr					
Fugitive Dust					1.7691	0.0000	1.7691	0.9092	0.0000	0.9092	0.0000	0.0000	0.0000	0.0000	0.0000	0.0000
Off-Road	0.2853	2.9775	1.7728	3.4200e-003		0.1451	0.1451		0.1335	0.1335	0.0000	300.9542	300.9542	0.0973	0.0000	303.3875
Total	0.2853	2.9775	1.7728	3.4200e-003	1.7691	0.1451	1.9143	0.9092	0.1335	1.0427	0.0000	300.9542	300.9542	0.0973	0.0000	303.3875

Pismo Beach GP/LCP PEIR - GHG - San Luis Obispo County APCD Air District, Annual

EMFAC Off-Model Adjustment Factors for Gasoline Light Duty Vehicle to Account for the SAFE Vehicle Rule Applied

3.3 Site Preparation - 2022

Mitigated Construction Off-Site

	ROG	NOx	CO	SO2	Fugitive PM10	Exhaust PM10	PM10 Total	Fugitive PM2.5	Exhaust PM2.5	PM2.5 Total	Bio- CO2	NBio- CO2	Total CO2	CH4	N2O	CO2e
Category	tons/yr										MT/yr					
Hauling	0.0000	0.0000	0.0000	0.0000	0.0000	0.0000	0.0000	0.0000	0.0000	0.0000	0.0000	0.0000	0.0000	0.0000	0.0000	0.0000
Vendor	0.0000	0.0000	0.0000	0.0000	0.0000	0.0000	0.0000	0.0000	0.0000	0.0000	0.0000	0.0000	0.0000	0.0000	0.0000	0.0000
Worker	5.5100e-003	4.2500e-003	0.0464	1.3000e-004	0.0156	8.0000e-005	0.0157	4.1400e-003	7.0000e-005	4.2200e-003	0.0000	12.4222	12.4222	3.7000e-004	3.7000e-004	12.5421
Total	5.5100e-003	4.2500e-003	0.0464	1.3000e-004	0.0156	8.0000e-005	0.0157	4.1400e-003	7.0000e-005	4.2200e-003	0.0000	12.4222	12.4222	3.7000e-004	3.7000e-004	12.5421

3.4 Grading - 2022

Unmitigated Construction On-Site

	ROG	NOx	CO	SO2	Fugitive PM10	Exhaust PM10	PM10 Total	Fugitive PM2.5	Exhaust PM2.5	PM2.5 Total	Bio- CO2	NBio- CO2	Total CO2	CH4	N2O	CO2e
Category	tons/yr										MT/yr					
Fugitive Dust					1.2907	0.0000	1.2907	0.3828	0.0000	0.3828	0.0000	0.0000	0.0000	0.0000	0.0000	0.0000
Off-Road	0.3317	3.5542	2.6573	5.6800e-003		0.1496	0.1496		0.1376	0.1376	0.0000	498.9916	498.9916	0.1614	0.0000	503.0262
Total	0.3317	3.5542	2.6573	5.6800e-003	1.2907	0.1496	1.4403	0.3828	0.1376	0.5204	0.0000	498.9916	498.9916	0.1614	0.0000	503.0262

Pismo Beach GP/LCP PEIR - GHG - San Luis Obispo County APCD Air District, Annual

EMFAC Off-Model Adjustment Factors for Gasoline Light Duty Vehicle to Account for the SAFE Vehicle Rule Applied

3.4 Grading - 2022

Unmitigated Construction Off-Site

	ROG	NOx	CO	SO2	Fugitive PM10	Exhaust PM10	PM10 Total	Fugitive PM2.5	Exhaust PM2.5	PM2.5 Total	Bio- CO2	NBio- CO2	Total CO2	CH4	N2O	CO2e
Category	tons/yr										MT/yr					
Hauling	0.0000	0.0000	0.0000	0.0000	0.0000	0.0000	0.0000	0.0000	0.0000	0.0000	0.0000	0.0000	0.0000	0.0000	0.0000	0.0000
Vendor	0.0000	0.0000	0.0000	0.0000	0.0000	0.0000	0.0000	0.0000	0.0000	0.0000	0.0000	0.0000	0.0000	0.0000	0.0000	0.0000
Worker	6.2200e-003	4.8000e-003	0.0525	1.5000e-004	0.0176	9.0000e-005	0.0177	4.6800e-003	8.0000e-005	4.7700e-003	0.0000	14.0324	14.0324	4.2000e-004	4.2000e-004	14.1680
Total	6.2200e-003	4.8000e-003	0.0525	1.5000e-004	0.0176	9.0000e-005	0.0177	4.6800e-003	8.0000e-005	4.7700e-003	0.0000	14.0324	14.0324	4.2000e-004	4.2000e-004	14.1680

Mitigated Construction On-Site

	ROG	NOx	CO	SO2	Fugitive PM10	Exhaust PM10	PM10 Total	Fugitive PM2.5	Exhaust PM2.5	PM2.5 Total	Bio- CO2	NBio- CO2	Total CO2	CH4	N2O	CO2e
Category	tons/yr										MT/yr					
Fugitive Dust					1.2907	0.0000	1.2907	0.3828	0.0000	0.3828	0.0000	0.0000	0.0000	0.0000	0.0000	0.0000
Off-Road	0.3317	3.5542	2.6573	5.6800e-003		0.1496	0.1496		0.1376	0.1376	0.0000	498.9910	498.9910	0.1614	0.0000	503.0256
Total	0.3317	3.5542	2.6573	5.6800e-003	1.2907	0.1496	1.4403	0.3828	0.1376	0.5204	0.0000	498.9910	498.9910	0.1614	0.0000	503.0256

Pismo Beach GP/LCP PEIR - GHG - San Luis Obispo County APCD Air District, Annual

EMFAC Off-Model Adjustment Factors for Gasoline Light Duty Vehicle to Account for the SAFE Vehicle Rule Applied

3.4 Grading - 2022

Mitigated Construction Off-Site

	ROG	NOx	CO	SO2	Fugitive PM10	Exhaust PM10	PM10 Total	Fugitive PM2.5	Exhaust PM2.5	PM2.5 Total	Bio- CO2	NBio- CO2	Total CO2	CH4	N2O	CO2e
Category	tons/yr										MT/yr					
Hauling	0.0000	0.0000	0.0000	0.0000	0.0000	0.0000	0.0000	0.0000	0.0000	0.0000	0.0000	0.0000	0.0000	0.0000	0.0000	0.0000
Vendor	0.0000	0.0000	0.0000	0.0000	0.0000	0.0000	0.0000	0.0000	0.0000	0.0000	0.0000	0.0000	0.0000	0.0000	0.0000	0.0000
Worker	6.2200e-003	4.8000e-003	0.0525	1.5000e-004	0.0176	9.0000e-005	0.0177	4.6800e-003	8.0000e-005	4.7700e-003	0.0000	14.0324	14.0324	4.2000e-004	4.2000e-004	14.1680
Total	6.2200e-003	4.8000e-003	0.0525	1.5000e-004	0.0176	9.0000e-005	0.0177	4.6800e-003	8.0000e-005	4.7700e-003	0.0000	14.0324	14.0324	4.2000e-004	4.2000e-004	14.1680

3.4 Grading - 2023

Unmitigated Construction On-Site

	ROG	NOx	CO	SO2	Fugitive PM10	Exhaust PM10	PM10 Total	Fugitive PM2.5	Exhaust PM2.5	PM2.5 Total	Bio- CO2	NBio- CO2	Total CO2	CH4	N2O	CO2e
Category	tons/yr										MT/yr					
Fugitive Dust					1.5226	0.0000	1.5226	0.5102	0.0000	0.5102	0.0000	0.0000	0.0000	0.0000	0.0000	0.0000
Off-Road	0.4318	4.4870	3.6467	8.0700e-003		0.1852	0.1852		0.1704	0.1704	0.0000	708.9577	708.9577	0.2293	0.0000	714.6900
Total	0.4318	4.4870	3.6467	8.0700e-003	1.5226	0.1852	1.7078	0.5102	0.1704	0.6806	0.0000	708.9577	708.9577	0.2293	0.0000	714.6900

Pismo Beach GP/LCP PEIR - GHG - San Luis Obispo County APCD Air District, Annual

EMFAC Off-Model Adjustment Factors for Gasoline Light Duty Vehicle to Account for the SAFE Vehicle Rule Applied

3.4 Grading - 2023

Unmitigated Construction Off-Site

	ROG	NOx	CO	SO2	Fugitive PM10	Exhaust PM10	PM10 Total	Fugitive PM2.5	Exhaust PM2.5	PM2.5 Total	Bio- CO2	NBio- CO2	Total CO2	CH4	N2O	CO2e
Category	tons/yr										MT/yr					
Hauling	0.0000	0.0000	0.0000	0.0000	0.0000	0.0000	0.0000	0.0000	0.0000	0.0000	0.0000	0.0000	0.0000	0.0000	0.0000	0.0000
Vendor	0.0000	0.0000	0.0000	0.0000	0.0000	0.0000	0.0000	0.0000	0.0000	0.0000	0.0000	0.0000	0.0000	0.0000	0.0000	0.0000
Worker	8.2900e-003	6.0300e-003	0.0688	2.1000e-004	0.0250	1.2000e-004	0.0252	6.6500e-003	1.1000e-004	6.7700e-003	0.0000	19.4491	19.4491	5.4000e-004	5.5000e-004	19.6269
Total	8.2900e-003	6.0300e-003	0.0688	2.1000e-004	0.0250	1.2000e-004	0.0252	6.6500e-003	1.1000e-004	6.7700e-003	0.0000	19.4491	19.4491	5.4000e-004	5.5000e-004	19.6269

Mitigated Construction On-Site

	ROG	NOx	CO	SO2	Fugitive PM10	Exhaust PM10	PM10 Total	Fugitive PM2.5	Exhaust PM2.5	PM2.5 Total	Bio- CO2	NBio- CO2	Total CO2	CH4	N2O	CO2e
Category	tons/yr										MT/yr					
Fugitive Dust					1.5226	0.0000	1.5226	0.5102	0.0000	0.5102	0.0000	0.0000	0.0000	0.0000	0.0000	0.0000
Off-Road	0.4318	4.4870	3.6467	8.0700e-003		0.1852	0.1852		0.1704	0.1704	0.0000	708.9569	708.9569	0.2293	0.0000	714.6891
Total	0.4318	4.4870	3.6467	8.0700e-003	1.5226	0.1852	1.7078	0.5102	0.1704	0.6806	0.0000	708.9569	708.9569	0.2293	0.0000	714.6891

Pismo Beach GP/LCP PEIR - GHG - San Luis Obispo County APCD Air District, Annual

EMFAC Off-Model Adjustment Factors for Gasoline Light Duty Vehicle to Account for the SAFE Vehicle Rule Applied

3.4 Grading - 2023

Mitigated Construction Off-Site

	ROG	NOx	CO	SO2	Fugitive PM10	Exhaust PM10	PM10 Total	Fugitive PM2.5	Exhaust PM2.5	PM2.5 Total	Bio- CO2	NBio- CO2	Total CO2	CH4	N2O	CO2e
Category	tons/yr										MT/yr					
Hauling	0.0000	0.0000	0.0000	0.0000	0.0000	0.0000	0.0000	0.0000	0.0000	0.0000	0.0000	0.0000	0.0000	0.0000	0.0000	0.0000
Vendor	0.0000	0.0000	0.0000	0.0000	0.0000	0.0000	0.0000	0.0000	0.0000	0.0000	0.0000	0.0000	0.0000	0.0000	0.0000	0.0000
Worker	8.2900e-003	6.0300e-003	0.0688	2.1000e-004	0.0250	1.2000e-004	0.0252	6.6500e-003	1.1000e-004	6.7700e-003	0.0000	19.4491	19.4491	5.4000e-004	5.5000e-004	19.6269
Total	8.2900e-003	6.0300e-003	0.0688	2.1000e-004	0.0250	1.2000e-004	0.0252	6.6500e-003	1.1000e-004	6.7700e-003	0.0000	19.4491	19.4491	5.4000e-004	5.5000e-004	19.6269

3.4 Grading - 2024

Unmitigated Construction On-Site

	ROG	NOx	CO	SO2	Fugitive PM10	Exhaust PM10	PM10 Total	Fugitive PM2.5	Exhaust PM2.5	PM2.5 Total	Bio- CO2	NBio- CO2	Total CO2	CH4	N2O	CO2e
Category	tons/yr										MT/yr					
Fugitive Dust					0.8059	0.0000	0.8059	0.1163	0.0000	0.1163	0.0000	0.0000	0.0000	0.0000	0.0000	0.0000
Off-Road	0.0354	0.3562	0.3050	6.8000e-004		0.0147	0.0147		0.0135	0.0135	0.0000	59.9715	59.9715	0.0194	0.0000	60.4564
Total	0.0354	0.3562	0.3050	6.8000e-004	0.8059	0.0147	0.8206	0.1163	0.0135	0.1298	0.0000	59.9715	59.9715	0.0194	0.0000	60.4564

Pismo Beach GP/LCP PEIR - GHG - San Luis Obispo County APCD Air District, Annual

EMFAC Off-Model Adjustment Factors for Gasoline Light Duty Vehicle to Account for the SAFE Vehicle Rule Applied

3.4 Grading - 2024

Unmitigated Construction Off-Site

	ROG	NOx	CO	SO2	Fugitive PM10	Exhaust PM10	PM10 Total	Fugitive PM2.5	Exhaust PM2.5	PM2.5 Total	Bio- CO2	NBio- CO2	Total CO2	CH4	N2O	CO2e
Category	tons/yr										MT/yr					
Hauling	0.0000	0.0000	0.0000	0.0000	0.0000	0.0000	0.0000	0.0000	0.0000	0.0000	0.0000	0.0000	0.0000	0.0000	0.0000	0.0000
Vendor	0.0000	0.0000	0.0000	0.0000	0.0000	0.0000	0.0000	0.0000	0.0000	0.0000	0.0000	0.0000	0.0000	0.0000	0.0000	0.0000
Worker	6.6000e-004	4.6000e-004	5.4200e-003	2.0000e-005	2.1200e-003	1.0000e-005	2.1300e-003	5.6000e-004	1.0000e-005	5.7000e-004	0.0000	1.6068	1.6068	4.0000e-005	4.0000e-005	1.6207
Total	6.6000e-004	4.6000e-004	5.4200e-003	2.0000e-005	2.1200e-003	1.0000e-005	2.1300e-003	5.6000e-004	1.0000e-005	5.7000e-004	0.0000	1.6068	1.6068	4.0000e-005	4.0000e-005	1.6207

Mitigated Construction On-Site

	ROG	NOx	CO	SO2	Fugitive PM10	Exhaust PM10	PM10 Total	Fugitive PM2.5	Exhaust PM2.5	PM2.5 Total	Bio- CO2	NBio- CO2	Total CO2	CH4	N2O	CO2e
Category	tons/yr										MT/yr					
Fugitive Dust					0.8059	0.0000	0.8059	0.1163	0.0000	0.1163	0.0000	0.0000	0.0000	0.0000	0.0000	0.0000
Off-Road	0.0354	0.3562	0.3050	6.8000e-004		0.0147	0.0147		0.0135	0.0135	0.0000	59.9714	59.9714	0.0194	0.0000	60.4563
Total	0.0354	0.3562	0.3050	6.8000e-004	0.8059	0.0147	0.8206	0.1163	0.0135	0.1298	0.0000	59.9714	59.9714	0.0194	0.0000	60.4563

Pismo Beach GP/LCP PEIR - GHG - San Luis Obispo County APCD Air District, Annual

EMFAC Off-Model Adjustment Factors for Gasoline Light Duty Vehicle to Account for the SAFE Vehicle Rule Applied

3.4 Grading - 2024

Mitigated Construction Off-Site

	ROG	NOx	CO	SO2	Fugitive PM10	Exhaust PM10	PM10 Total	Fugitive PM2.5	Exhaust PM2.5	PM2.5 Total	Bio- CO2	NBio- CO2	Total CO2	CH4	N2O	CO2e
Category	tons/yr										MT/yr					
Hauling	0.0000	0.0000	0.0000	0.0000	0.0000	0.0000	0.0000	0.0000	0.0000	0.0000	0.0000	0.0000	0.0000	0.0000	0.0000	0.0000
Vendor	0.0000	0.0000	0.0000	0.0000	0.0000	0.0000	0.0000	0.0000	0.0000	0.0000	0.0000	0.0000	0.0000	0.0000	0.0000	0.0000
Worker	6.6000e-004	4.6000e-004	5.4200e-003	2.0000e-005	2.1200e-003	1.0000e-005	2.1300e-003	5.6000e-004	1.0000e-005	5.7000e-004	0.0000	1.6068	1.6068	4.0000e-005	4.0000e-005	1.6207
Total	6.6000e-004	4.6000e-004	5.4200e-003	2.0000e-005	2.1200e-003	1.0000e-005	2.1300e-003	5.6000e-004	1.0000e-005	5.7000e-004	0.0000	1.6068	1.6068	4.0000e-005	4.0000e-005	1.6207

3.5 Building Construction - 2022

Unmitigated Construction On-Site

	ROG	NOx	CO	SO2	Fugitive PM10	Exhaust PM10	PM10 Total	Fugitive PM2.5	Exhaust PM2.5	PM2.5 Total	Bio- CO2	NBio- CO2	Total CO2	CH4	N2O	CO2e
Category	tons/yr										MT/yr					
Off-Road	0.0623	0.5700	0.5973	9.8000e-004		0.0295	0.0295		0.0278	0.0278	0.0000	84.5797	84.5797	0.0203	0.0000	85.0863
Total	0.0623	0.5700	0.5973	9.8000e-004		0.0295	0.0295		0.0278	0.0278	0.0000	84.5797	84.5797	0.0203	0.0000	85.0863

Pismo Beach GP/LCP PEIR - GHG - San Luis Obispo County APCD Air District, Annual

EMFAC Off-Model Adjustment Factors for Gasoline Light Duty Vehicle to Account for the SAFE Vehicle Rule Applied

3.5 Building Construction - 2022

Unmitigated Construction Off-Site

	ROG	NOx	CO	SO2	Fugitive PM10	Exhaust PM10	PM10 Total	Fugitive PM2.5	Exhaust PM2.5	PM2.5 Total	Bio- CO2	NBio- CO2	Total CO2	CH4	N2O	CO2e
Category	tons/yr										MT/yr					
Hauling	0.0000	0.0000	0.0000	0.0000	0.0000	0.0000	0.0000	0.0000	0.0000	0.0000	0.0000	0.0000	0.0000	0.0000	0.0000	0.0000
Vendor	0.0174	0.4457	0.1343	1.3900e-003	0.0410	4.3300e-003	0.0453	0.0118	4.1400e-003	0.0160	0.0000	134.7639	134.7639	3.1200e-003	0.0199	140.7567
Worker	0.1304	0.1006	1.0995	3.1900e-003	0.3693	1.9200e-003	0.3712	0.0982	1.7700e-003	0.0999	0.0000	294.1557	294.1557	8.7500e-003	8.8000e-003	296.9966
Total	0.1479	0.5463	1.2338	4.5800e-003	0.4103	6.2500e-003	0.4165	0.1100	5.9100e-003	0.1159	0.0000	428.9196	428.9196	0.0119	0.0287	437.7533

Mitigated Construction On-Site

	ROG	NOx	CO	SO2	Fugitive PM10	Exhaust PM10	PM10 Total	Fugitive PM2.5	Exhaust PM2.5	PM2.5 Total	Bio- CO2	NBio- CO2	Total CO2	CH4	N2O	CO2e
Category	tons/yr										MT/yr					
Off-Road	0.0623	0.5700	0.5973	9.8000e-004		0.0295	0.0295		0.0278	0.0278	0.0000	84.5796	84.5796	0.0203	0.0000	85.0862
Total	0.0623	0.5700	0.5973	9.8000e-004		0.0295	0.0295		0.0278	0.0278	0.0000	84.5796	84.5796	0.0203	0.0000	85.0862

Pismo Beach GP/LCP PEIR - GHG - San Luis Obispo County APCD Air District, Annual

EMFAC Off-Model Adjustment Factors for Gasoline Light Duty Vehicle to Account for the SAFE Vehicle Rule Applied

3.5 Building Construction - 2022

Mitigated Construction Off-Site

	ROG	NOx	CO	SO2	Fugitive PM10	Exhaust PM10	PM10 Total	Fugitive PM2.5	Exhaust PM2.5	PM2.5 Total	Bio- CO2	NBio- CO2	Total CO2	CH4	N2O	CO2e
Category	tons/yr										MT/yr					
Hauling	0.0000	0.0000	0.0000	0.0000	0.0000	0.0000	0.0000	0.0000	0.0000	0.0000	0.0000	0.0000	0.0000	0.0000	0.0000	0.0000
Vendor	0.0174	0.4457	0.1343	1.3900e-003	0.0410	4.3300e-003	0.0453	0.0118	4.1400e-003	0.0160	0.0000	134.7639	134.7639	3.1200e-003	0.0199	140.7567
Worker	0.1304	0.1006	1.0995	3.1900e-003	0.3693	1.9200e-003	0.3712	0.0982	1.7700e-003	0.0999	0.0000	294.1557	294.1557	8.7500e-003	8.8000e-003	296.9966
Total	0.1479	0.5463	1.2338	4.5800e-003	0.4103	6.2500e-003	0.4165	0.1100	5.9100e-003	0.1159	0.0000	428.9196	428.9196	0.0119	0.0287	437.7533

3.5 Building Construction - 2023

Unmitigated Construction On-Site

	ROG	NOx	CO	SO2	Fugitive PM10	Exhaust PM10	PM10 Total	Fugitive PM2.5	Exhaust PM2.5	PM2.5 Total	Bio- CO2	NBio- CO2	Total CO2	CH4	N2O	CO2e
Category	tons/yr										MT/yr					
Off-Road	0.2045	1.8700	2.1117	3.5000e-003		0.0910	0.0910		0.0856	0.0856	0.0000	301.3462	301.3462	0.0717	0.0000	303.1383
Total	0.2045	1.8700	2.1117	3.5000e-003		0.0910	0.0910		0.0856	0.0856	0.0000	301.3462	301.3462	0.0717	0.0000	303.1383

Pismo Beach GP/LCP PEIR - GHG - San Luis Obispo County APCD Air District, Annual

EMFAC Off-Model Adjustment Factors for Gasoline Light Duty Vehicle to Account for the SAFE Vehicle Rule Applied

3.5 Building Construction - 2023

Unmitigated Construction Off-Site

	ROG	NOx	CO	SO2	Fugitive PM10	Exhaust PM10	PM10 Total	Fugitive PM2.5	Exhaust PM2.5	PM2.5 Total	Bio- CO2	NBio- CO2	Total CO2	CH4	N2O	CO2e
Category	tons/yr										MT/yr					
Hauling	0.0000	0.0000	0.0000	0.0000	0.0000	0.0000	0.0000	0.0000	0.0000	0.0000	0.0000	0.0000	0.0000	0.0000	0.0000	0.0000
Vendor	0.0376	1.3269	0.4257	4.7700e-003	0.1460	7.5200e-003	0.1535	0.0422	7.2000e-003	0.0494	0.0000	463.2648	463.2648	0.0103	0.0681	483.8052
Worker	0.4355	0.3171	3.6169	0.0110	1.3154	6.4800e-003	1.3218	0.3496	5.9700e-003	0.3555	0.0000	1,022.0481	1,022.0481	0.0282	0.0290	1,031.3924
Total	0.4732	1.6441	4.0426	0.0158	1.4614	0.0140	1.4754	0.3918	0.0132	0.4049	0.0000	1,485.3130	1,485.3130	0.0385	0.0971	1,515.1977

Mitigated Construction On-Site

	ROG	NOx	CO	SO2	Fugitive PM10	Exhaust PM10	PM10 Total	Fugitive PM2.5	Exhaust PM2.5	PM2.5 Total	Bio- CO2	NBio- CO2	Total CO2	CH4	N2O	CO2e
Category	tons/yr										MT/yr					
Off-Road	0.2045	1.8700	2.1117	3.5000e-003		0.0910	0.0910		0.0856	0.0856	0.0000	301.3458	301.3458	0.0717	0.0000	303.1380
Total	0.2045	1.8700	2.1117	3.5000e-003		0.0910	0.0910		0.0856	0.0856	0.0000	301.3458	301.3458	0.0717	0.0000	303.1380

Pismo Beach GP/LCP PEIR - GHG - San Luis Obispo County APCD Air District, Annual

EMFAC Off-Model Adjustment Factors for Gasoline Light Duty Vehicle to Account for the SAFE Vehicle Rule Applied

3.5 Building Construction - 2023

Mitigated Construction Off-Site

	ROG	NOx	CO	SO2	Fugitive PM10	Exhaust PM10	PM10 Total	Fugitive PM2.5	Exhaust PM2.5	PM2.5 Total	Bio- CO2	NBio- CO2	Total CO2	CH4	N2O	CO2e
Category	tons/yr										MT/yr					
Hauling	0.0000	0.0000	0.0000	0.0000	0.0000	0.0000	0.0000	0.0000	0.0000	0.0000	0.0000	0.0000	0.0000	0.0000	0.0000	0.0000
Vendor	0.0376	1.3269	0.4257	4.7700e-003	0.1460	7.5200e-003	0.1535	0.0422	7.2000e-003	0.0494	0.0000	463.2648	463.2648	0.0103	0.0681	483.8052
Worker	0.4355	0.3171	3.6169	0.0110	1.3154	6.4800e-003	1.3218	0.3496	5.9700e-003	0.3555	0.0000	1,022.0481	1,022.0481	0.0282	0.0290	1,031.3924
Total	0.4732	1.6441	4.0426	0.0158	1.4614	0.0140	1.4754	0.3918	0.0132	0.4049	0.0000	1,485.3130	1,485.3130	0.0385	0.0971	1,515.1977

3.5 Building Construction - 2024

Unmitigated Construction On-Site

	ROG	NOx	CO	SO2	Fugitive PM10	Exhaust PM10	PM10 Total	Fugitive PM2.5	Exhaust PM2.5	PM2.5 Total	Bio- CO2	NBio- CO2	Total CO2	CH4	N2O	CO2e
Category	tons/yr										MT/yr					
Off-Road	0.1928	1.7611	2.1179	3.5300e-003		0.0803	0.0803		0.0756	0.0756	0.0000	303.7223	303.7223	0.0718	0.0000	305.5179
Total	0.1928	1.7611	2.1179	3.5300e-003		0.0803	0.0803		0.0756	0.0756	0.0000	303.7223	303.7223	0.0718	0.0000	305.5179

Pismo Beach GP/LCP PEIR - GHG - San Luis Obispo County APCD Air District, Annual

EMFAC Off-Model Adjustment Factors for Gasoline Light Duty Vehicle to Account for the SAFE Vehicle Rule Applied

3.5 Building Construction - 2024

Unmitigated Construction Off-Site

	ROG	NOx	CO	SO2	Fugitive PM10	Exhaust PM10	PM10 Total	Fugitive PM2.5	Exhaust PM2.5	PM2.5 Total	Bio- CO2	NBio- CO2	Total CO2	CH4	N2O	CO2e
Category	tons/yr										MT/yr					
Hauling	0.0000	0.0000	0.0000	0.0000	0.0000	0.0000	0.0000	0.0000	0.0000	0.0000	0.0000	0.0000	0.0000	0.0000	0.0000	0.0000
Vendor	0.0366	1.3117	0.4208	4.7200e-003	0.1471	7.4500e-003	0.1546	0.0425	7.1300e-003	0.0497	0.0000	459.6446	459.6446	0.0105	0.0675	480.0212
Worker	0.4132	0.2848	3.3938	0.0107	1.3255	6.2000e-003	1.3317	0.3523	5.7200e-003	0.3580	0.0000	1,005.5418	1,005.5418	0.0259	0.0272	1,014.2789
Total	0.4498	1.5965	3.8145	0.0155	1.4726	0.0137	1.4863	0.3948	0.0129	0.4076	0.0000	1,465.1864	1,465.1864	0.0363	0.0947	1,494.3001

Mitigated Construction On-Site

	ROG	NOx	CO	SO2	Fugitive PM10	Exhaust PM10	PM10 Total	Fugitive PM2.5	Exhaust PM2.5	PM2.5 Total	Bio- CO2	NBio- CO2	Total CO2	CH4	N2O	CO2e
Category	tons/yr										MT/yr					
Off-Road	0.1928	1.7611	2.1179	3.5300e-003		0.0803	0.0803		0.0756	0.0756	0.0000	303.7220	303.7220	0.0718	0.0000	305.5175
Total	0.1928	1.7611	2.1179	3.5300e-003		0.0803	0.0803		0.0756	0.0756	0.0000	303.7220	303.7220	0.0718	0.0000	305.5175

Pismo Beach GP/LCP PEIR - GHG - San Luis Obispo County APCD Air District, Annual

EMFAC Off-Model Adjustment Factors for Gasoline Light Duty Vehicle to Account for the SAFE Vehicle Rule Applied

3.5 Building Construction - 2024

Mitigated Construction Off-Site

	ROG	NOx	CO	SO2	Fugitive PM10	Exhaust PM10	PM10 Total	Fugitive PM2.5	Exhaust PM2.5	PM2.5 Total	Bio- CO2	NBio- CO2	Total CO2	CH4	N2O	CO2e
Category	tons/yr										MT/yr					
Hauling	0.0000	0.0000	0.0000	0.0000	0.0000	0.0000	0.0000	0.0000	0.0000	0.0000	0.0000	0.0000	0.0000	0.0000	0.0000	0.0000
Vendor	0.0366	1.3117	0.4208	4.7200e-003	0.1471	7.4500e-003	0.1546	0.0425	7.1300e-003	0.0497	0.0000	459.6446	459.6446	0.0105	0.0675	480.0212
Worker	0.4132	0.2848	3.3938	0.0107	1.3255	6.2000e-003	1.3317	0.3523	5.7200e-003	0.3580	0.0000	1,005.5418	1,005.5418	0.0259	0.0272	1,014.2789
Total	0.4498	1.5965	3.8145	0.0155	1.4726	0.0137	1.4863	0.3948	0.0129	0.4076	0.0000	1,465.1864	1,465.1864	0.0363	0.0947	1,494.3001

3.5 Building Construction - 2025

Unmitigated Construction On-Site

	ROG	NOx	CO	SO2	Fugitive PM10	Exhaust PM10	PM10 Total	Fugitive PM2.5	Exhaust PM2.5	PM2.5 Total	Bio- CO2	NBio- CO2	Total CO2	CH4	N2O	CO2e
Category	tons/yr										MT/yr					
Off-Road	0.1785	1.6273	2.0991	3.5200e-003		0.0689	0.0689		0.0648	0.0648	0.0000	302.6549	302.6549	0.0711	0.0000	304.4335
Total	0.1785	1.6273	2.0991	3.5200e-003		0.0689	0.0689		0.0648	0.0648	0.0000	302.6549	302.6549	0.0711	0.0000	304.4335

Pismo Beach GP/LCP PEIR - GHG - San Luis Obispo County APCD Air District, Annual

EMFAC Off-Model Adjustment Factors for Gasoline Light Duty Vehicle to Account for the SAFE Vehicle Rule Applied

3.5 Building Construction - 2025

Unmitigated Construction Off-Site

	ROG	NOx	CO	SO2	Fugitive PM10	Exhaust PM10	PM10 Total	Fugitive PM2.5	Exhaust PM2.5	PM2.5 Total	Bio- CO2	NBio- CO2	Total CO2	CH4	N2O	CO2e
Category	tons/yr										MT/yr					
Hauling	0.0000	0.0000	0.0000	0.0000	0.0000	0.0000	0.0000	0.0000	0.0000	0.0000	0.0000	0.0000	0.0000	0.0000	0.0000	0.0000
Vendor	0.0353	1.2790	0.4128	4.6200e-003	0.1466	7.2500e-003	0.1538	0.0424	6.9300e-003	0.0493	0.0000	449.9612	449.9612	0.0106	0.0660	469.9017
Worker	0.3892	0.2548	3.1656	0.0104	1.3204	5.9000e-003	1.3263	0.3509	5.4400e-003	0.3563	0.0000	978.7590	978.7590	0.0235	0.0253	986.8778
Total	0.4245	1.5338	3.5784	0.0150	1.4670	0.0132	1.4802	0.3933	0.0124	0.4056	0.0000	1,428.7202	1,428.7202	0.0341	0.0913	1,456.7796

Mitigated Construction On-Site

	ROG	NOx	CO	SO2	Fugitive PM10	Exhaust PM10	PM10 Total	Fugitive PM2.5	Exhaust PM2.5	PM2.5 Total	Bio- CO2	NBio- CO2	Total CO2	CH4	N2O	CO2e
Category	tons/yr										MT/yr					
Off-Road	0.1784	1.6273	2.0991	3.5200e-003		0.0689	0.0689		0.0648	0.0648	0.0000	302.6545	302.6545	0.0711	0.0000	304.4331
Total	0.1784	1.6273	2.0991	3.5200e-003		0.0689	0.0689		0.0648	0.0648	0.0000	302.6545	302.6545	0.0711	0.0000	304.4331

Pismo Beach GP/LCP PEIR - GHG - San Luis Obispo County APCD Air District, Annual

EMFAC Off-Model Adjustment Factors for Gasoline Light Duty Vehicle to Account for the SAFE Vehicle Rule Applied

3.5 Building Construction - 2025

Mitigated Construction Off-Site

	ROG	NOx	CO	SO2	Fugitive PM10	Exhaust PM10	PM10 Total	Fugitive PM2.5	Exhaust PM2.5	PM2.5 Total	Bio- CO2	NBio- CO2	Total CO2	CH4	N2O	CO2e
Category	tons/yr										MT/yr					
Hauling	0.0000	0.0000	0.0000	0.0000	0.0000	0.0000	0.0000	0.0000	0.0000	0.0000	0.0000	0.0000	0.0000	0.0000	0.0000	0.0000
Vendor	0.0353	1.2790	0.4128	4.6200e-003	0.1466	7.2500e-003	0.1538	0.0424	6.9300e-003	0.0493	0.0000	449.9612	449.9612	0.0106	0.0660	469.9017
Worker	0.3892	0.2548	3.1656	0.0104	1.3204	5.9000e-003	1.3263	0.3509	5.4400e-003	0.3563	0.0000	978.7590	978.7590	0.0235	0.0253	986.8778
Total	0.4245	1.5338	3.5784	0.0150	1.4670	0.0132	1.4802	0.3933	0.0124	0.4056	0.0000	1,428.7202	1,428.7202	0.0341	0.0913	1,456.7796

3.5 Building Construction - 2026

Unmitigated Construction On-Site

	ROG	NOx	CO	SO2	Fugitive PM10	Exhaust PM10	PM10 Total	Fugitive PM2.5	Exhaust PM2.5	PM2.5 Total	Bio- CO2	NBio- CO2	Total CO2	CH4	N2O	CO2e
Category	tons/yr										MT/yr					
Off-Road	0.1785	1.6273	2.0991	3.5200e-003		0.0689	0.0689		0.0648	0.0648	0.0000	302.6549	302.6549	0.0711	0.0000	304.4335
Total	0.1785	1.6273	2.0991	3.5200e-003		0.0689	0.0689		0.0648	0.0648	0.0000	302.6549	302.6549	0.0711	0.0000	304.4335

Pismo Beach GP/LCP PEIR - GHG - San Luis Obispo County APCD Air District, Annual

EMFAC Off-Model Adjustment Factors for Gasoline Light Duty Vehicle to Account for the SAFE Vehicle Rule Applied

3.5 Building Construction - 2026

Unmitigated Construction Off-Site

	ROG	NOx	CO	SO2	Fugitive PM10	Exhaust PM10	PM10 Total	Fugitive PM2.5	Exhaust PM2.5	PM2.5 Total	Bio- CO2	NBio- CO2	Total CO2	CH4	N2O	CO2e
Category	tons/yr										MT/yr					
Hauling	0.0000	0.0000	0.0000	0.0000	0.0000	0.0000	0.0000	0.0000	0.0000	0.0000	0.0000	0.0000	0.0000	0.0000	0.0000	0.0000
Vendor	0.0342	1.2513	0.4079	4.5300e-003	0.1466	7.0600e-003	0.1537	0.0424	6.7500e-003	0.0491	0.0000	441.8965	441.8965	0.0108	0.0648	461.4732
Worker	0.3698	0.2309	2.9833	0.0100	1.3204	5.6200e-003	1.3260	0.3509	5.1800e-003	0.3561	0.0000	956.7028	956.7028	0.0215	0.0238	964.3303
Total	0.4040	1.4822	3.3912	0.0146	1.4670	0.0127	1.4797	0.3933	0.0119	0.4052	0.0000	1,398.5993	1,398.5993	0.0322	0.0886	1,425.8036

Mitigated Construction On-Site

	ROG	NOx	CO	SO2	Fugitive PM10	Exhaust PM10	PM10 Total	Fugitive PM2.5	Exhaust PM2.5	PM2.5 Total	Bio- CO2	NBio- CO2	Total CO2	CH4	N2O	CO2e
Category	tons/yr										MT/yr					
Off-Road	0.1784	1.6273	2.0991	3.5200e-003		0.0689	0.0689		0.0648	0.0648	0.0000	302.6545	302.6545	0.0711	0.0000	304.4331
Total	0.1784	1.6273	2.0991	3.5200e-003		0.0689	0.0689		0.0648	0.0648	0.0000	302.6545	302.6545	0.0711	0.0000	304.4331

Pismo Beach GP/LCP PEIR - GHG - San Luis Obispo County APCD Air District, Annual

EMFAC Off-Model Adjustment Factors for Gasoline Light Duty Vehicle to Account for the SAFE Vehicle Rule Applied

3.5 Building Construction - 2026

Mitigated Construction Off-Site

	ROG	NOx	CO	SO2	Fugitive PM10	Exhaust PM10	PM10 Total	Fugitive PM2.5	Exhaust PM2.5	PM2.5 Total	Bio- CO2	NBio- CO2	Total CO2	CH4	N2O	CO2e
Category	tons/yr										MT/yr					
Hauling	0.0000	0.0000	0.0000	0.0000	0.0000	0.0000	0.0000	0.0000	0.0000	0.0000	0.0000	0.0000	0.0000	0.0000	0.0000	0.0000
Vendor	0.0342	1.2513	0.4079	4.5300e-003	0.1466	7.0600e-003	0.1537	0.0424	6.7500e-003	0.0491	0.0000	441.8965	441.8965	0.0108	0.0648	461.4732
Worker	0.3698	0.2309	2.9833	0.0100	1.3204	5.6200e-003	1.3260	0.3509	5.1800e-003	0.3561	0.0000	956.7028	956.7028	0.0215	0.0238	964.3303
Total	0.4040	1.4822	3.3912	0.0146	1.4670	0.0127	1.4797	0.3933	0.0119	0.4052	0.0000	1,398.5993	1,398.5993	0.0322	0.0886	1,425.8036

3.5 Building Construction - 2027

Unmitigated Construction On-Site

	ROG	NOx	CO	SO2	Fugitive PM10	Exhaust PM10	PM10 Total	Fugitive PM2.5	Exhaust PM2.5	PM2.5 Total	Bio- CO2	NBio- CO2	Total CO2	CH4	N2O	CO2e
Category	tons/yr										MT/yr					
Off-Road	0.1785	1.6273	2.0991	3.5200e-003		0.0689	0.0689		0.0648	0.0648	0.0000	302.6549	302.6549	0.0711	0.0000	304.4335
Total	0.1785	1.6273	2.0991	3.5200e-003		0.0689	0.0689		0.0648	0.0648	0.0000	302.6549	302.6549	0.0711	0.0000	304.4335

Pismo Beach GP/LCP PEIR - GHG - San Luis Obispo County APCD Air District, Annual

EMFAC Off-Model Adjustment Factors for Gasoline Light Duty Vehicle to Account for the SAFE Vehicle Rule Applied

3.5 Building Construction - 2027

Unmitigated Construction Off-Site

	ROG	NOx	CO	SO2	Fugitive PM10	Exhaust PM10	PM10 Total	Fugitive PM2.5	Exhaust PM2.5	PM2.5 Total	Bio- CO2	NBio- CO2	Total CO2	CH4	N2O	CO2e
Category	tons/yr										MT/yr					
Hauling	0.0000	0.0000	0.0000	0.0000	0.0000	0.0000	0.0000	0.0000	0.0000	0.0000	0.0000	0.0000	0.0000	0.0000	0.0000	0.0000
Vendor	0.0333	1.2251	0.4040	4.4400e-003	0.1466	6.8700e-003	0.1535	0.0424	6.5700e-003	0.0490	0.0000	433.1952	433.1952	0.0109	0.0635	452.3850
Worker	0.3515	0.2106	2.8262	9.7500e-003	1.3204	5.3000e-003	1.3257	0.3509	4.8800e-003	0.3558	0.0000	936.1870	936.1870	0.0197	0.0225	943.3964
Total	0.3848	1.4357	3.2302	0.0142	1.4670	0.0122	1.4792	0.3933	0.0115	0.4047	0.0000	1,369.3822	1,369.3822	0.0306	0.0860	1,395.7814

Mitigated Construction On-Site

	ROG	NOx	CO	SO2	Fugitive PM10	Exhaust PM10	PM10 Total	Fugitive PM2.5	Exhaust PM2.5	PM2.5 Total	Bio- CO2	NBio- CO2	Total CO2	CH4	N2O	CO2e
Category	tons/yr										MT/yr					
Off-Road	0.1784	1.6273	2.0991	3.5200e-003		0.0689	0.0689		0.0648	0.0648	0.0000	302.6545	302.6545	0.0711	0.0000	304.4331
Total	0.1784	1.6273	2.0991	3.5200e-003		0.0689	0.0689		0.0648	0.0648	0.0000	302.6545	302.6545	0.0711	0.0000	304.4331

Pismo Beach GP/LCP PEIR - GHG - San Luis Obispo County APCD Air District, Annual

EMFAC Off-Model Adjustment Factors for Gasoline Light Duty Vehicle to Account for the SAFE Vehicle Rule Applied

3.5 Building Construction - 2027

Mitigated Construction Off-Site

	ROG	NOx	CO	SO2	Fugitive PM10	Exhaust PM10	PM10 Total	Fugitive PM2.5	Exhaust PM2.5	PM2.5 Total	Bio- CO2	NBio- CO2	Total CO2	CH4	N2O	CO2e
Category	tons/yr										MT/yr					
Hauling	0.0000	0.0000	0.0000	0.0000	0.0000	0.0000	0.0000	0.0000	0.0000	0.0000	0.0000	0.0000	0.0000	0.0000	0.0000	0.0000
Vendor	0.0333	1.2251	0.4040	4.4400e-003	0.1466	6.8700e-003	0.1535	0.0424	6.5700e-003	0.0490	0.0000	433.1952	433.1952	0.0109	0.0635	452.3850
Worker	0.3515	0.2106	2.8262	9.7500e-003	1.3204	5.3000e-003	1.3257	0.3509	4.8800e-003	0.3558	0.0000	936.1870	936.1870	0.0197	0.0225	943.3964
Total	0.3848	1.4357	3.2302	0.0142	1.4670	0.0122	1.4792	0.3933	0.0115	0.4047	0.0000	1,369.3822	1,369.3822	0.0306	0.0860	1,395.7814

3.5 Building Construction - 2028

Unmitigated Construction On-Site

	ROG	NOx	CO	SO2	Fugitive PM10	Exhaust PM10	PM10 Total	Fugitive PM2.5	Exhaust PM2.5	PM2.5 Total	Bio- CO2	NBio- CO2	Total CO2	CH4	N2O	CO2e
Category	tons/yr										MT/yr					
Off-Road	0.1778	1.6211	2.0910	3.5000e-003		0.0686	0.0686		0.0645	0.0645	0.0000	301.4953	301.4953	0.0709	0.0000	303.2671
Total	0.1778	1.6211	2.0910	3.5000e-003		0.0686	0.0686		0.0645	0.0645	0.0000	301.4953	301.4953	0.0709	0.0000	303.2671

Pismo Beach GP/LCP PEIR - GHG - San Luis Obispo County APCD Air District, Annual

EMFAC Off-Model Adjustment Factors for Gasoline Light Duty Vehicle to Account for the SAFE Vehicle Rule Applied

3.5 Building Construction - 2028

Unmitigated Construction Off-Site

	ROG	NOx	CO	SO2	Fugitive PM10	Exhaust PM10	PM10 Total	Fugitive PM2.5	Exhaust PM2.5	PM2.5 Total	Bio- CO2	NBio- CO2	Total CO2	CH4	N2O	CO2e
Category	tons/yr										MT/yr					
Hauling	0.0000	0.0000	0.0000	0.0000	0.0000	0.0000	0.0000	0.0000	0.0000	0.0000	0.0000	0.0000	0.0000	0.0000	0.0000	0.0000
Vendor	0.0323	1.1978	0.3996	4.3400e-003	0.1461	6.6800e-003	0.1528	0.0422	6.3900e-003	0.0486	0.0000	423.2607	423.2607	0.0110	0.0620	442.0082
Worker	0.3324	0.1928	2.6837	9.4500e-003	1.3154	4.9500e-003	1.3203	0.3496	4.5600e-003	0.3541	0.0000	914.1144	914.1144	0.0181	0.0214	920.9431
Total	0.3647	1.3906	3.0833	0.0138	1.4614	0.0116	1.4731	0.3918	0.0110	0.4027	0.0000	1,337.375 1	1,337.375 1	0.0292	0.0834	1,362.951 3

Mitigated Construction On-Site

	ROG	NOx	CO	SO2	Fugitive PM10	Exhaust PM10	PM10 Total	Fugitive PM2.5	Exhaust PM2.5	PM2.5 Total	Bio- CO2	NBio- CO2	Total CO2	CH4	N2O	CO2e
Category	tons/yr										MT/yr					
Off-Road	0.1778	1.6211	2.0910	3.5000e-003		0.0686	0.0686		0.0645	0.0645	0.0000	301.4949	301.4949	0.0709	0.0000	303.2667
Total	0.1778	1.6211	2.0910	3.5000e-003		0.0686	0.0686		0.0645	0.0645	0.0000	301.4949	301.4949	0.0709	0.0000	303.2667

Pismo Beach GP/LCP PEIR - GHG - San Luis Obispo County APCD Air District, Annual

EMFAC Off-Model Adjustment Factors for Gasoline Light Duty Vehicle to Account for the SAFE Vehicle Rule Applied

3.5 Building Construction - 2028

Mitigated Construction Off-Site

	ROG	NOx	CO	SO2	Fugitive PM10	Exhaust PM10	PM10 Total	Fugitive PM2.5	Exhaust PM2.5	PM2.5 Total	Bio- CO2	NBio- CO2	Total CO2	CH4	N2O	CO2e
Category	tons/yr										MT/yr					
Hauling	0.0000	0.0000	0.0000	0.0000	0.0000	0.0000	0.0000	0.0000	0.0000	0.0000	0.0000	0.0000	0.0000	0.0000	0.0000	0.0000
Vendor	0.0323	1.1978	0.3996	4.3400e-003	0.1461	6.6800e-003	0.1528	0.0422	6.3900e-003	0.0486	0.0000	423.2607	423.2607	0.0110	0.0620	442.0082
Worker	0.3324	0.1928	2.6837	9.4500e-003	1.3154	4.9500e-003	1.3203	0.3496	4.5600e-003	0.3541	0.0000	914.1144	914.1144	0.0181	0.0214	920.9431
Total	0.3647	1.3906	3.0833	0.0138	1.4614	0.0116	1.4731	0.3918	0.0110	0.4027	0.0000	1,337.375 1	1,337.375 1	0.0292	0.0834	1,362.951 3

3.5 Building Construction - 2029

Unmitigated Construction On-Site

	ROG	NOx	CO	SO2	Fugitive PM10	Exhaust PM10	PM10 Total	Fugitive PM2.5	Exhaust PM2.5	PM2.5 Total	Bio- CO2	NBio- CO2	Total CO2	CH4	N2O	CO2e
Category	tons/yr										MT/yr					
Off-Road	0.1785	1.6273	2.0991	3.5200e-003		0.0689	0.0689		0.0648	0.0648	0.0000	302.6549	302.6549	0.0711	0.0000	304.4335
Total	0.1785	1.6273	2.0991	3.5200e-003		0.0689	0.0689		0.0648	0.0648	0.0000	302.6549	302.6549	0.0711	0.0000	304.4335

Pismo Beach GP/LCP PEIR - GHG - San Luis Obispo County APCD Air District, Annual

EMFAC Off-Model Adjustment Factors for Gasoline Light Duty Vehicle to Account for the SAFE Vehicle Rule Applied

3.5 Building Construction - 2029

Unmitigated Construction Off-Site

	ROG	NOx	CO	SO2	Fugitive PM10	Exhaust PM10	PM10 Total	Fugitive PM2.5	Exhaust PM2.5	PM2.5 Total	Bio- CO2	NBio- CO2	Total CO2	CH4	N2O	CO2e
Category	tons/yr										MT/yr					
Hauling	0.0000	0.0000	0.0000	0.0000	0.0000	0.0000	0.0000	0.0000	0.0000	0.0000	0.0000	0.0000	0.0000	0.0000	0.0000	0.0000
Vendor	0.0317	1.1792	0.3984	4.2600e-003	0.1467	6.5300e-003	0.1532	0.0424	6.2500e-003	0.0486	0.0000	416.4572	416.4572	0.0112	0.0610	434.9014
Worker	0.3162	0.1789	2.5779	9.2500e-003	1.3204	4.6600e-003	1.3251	0.3509	4.2900e-003	0.3552	0.0000	900.7571	900.7571	0.0169	0.0206	907.3086
Total	0.3479	1.3581	2.9763	0.0135	1.4671	0.0112	1.4783	0.3933	0.0105	0.4038	0.0000	1,317.2143	1,317.2143	0.0281	0.0815	1,342.2100

Mitigated Construction On-Site

	ROG	NOx	CO	SO2	Fugitive PM10	Exhaust PM10	PM10 Total	Fugitive PM2.5	Exhaust PM2.5	PM2.5 Total	Bio- CO2	NBio- CO2	Total CO2	CH4	N2O	CO2e
Category	tons/yr										MT/yr					
Off-Road	0.1784	1.6273	2.0991	3.5200e-003		0.0689	0.0689		0.0648	0.0648	0.0000	302.6545	302.6545	0.0711	0.0000	304.4331
Total	0.1784	1.6273	2.0991	3.5200e-003		0.0689	0.0689		0.0648	0.0648	0.0000	302.6545	302.6545	0.0711	0.0000	304.4331

Pismo Beach GP/LCP PEIR - GHG - San Luis Obispo County APCD Air District, Annual

EMFAC Off-Model Adjustment Factors for Gasoline Light Duty Vehicle to Account for the SAFE Vehicle Rule Applied

3.5 Building Construction - 2029

Mitigated Construction Off-Site

	ROG	NOx	CO	SO2	Fugitive PM10	Exhaust PM10	PM10 Total	Fugitive PM2.5	Exhaust PM2.5	PM2.5 Total	Bio- CO2	NBio- CO2	Total CO2	CH4	N2O	CO2e
Category	tons/yr										MT/yr					
Hauling	0.0000	0.0000	0.0000	0.0000	0.0000	0.0000	0.0000	0.0000	0.0000	0.0000	0.0000	0.0000	0.0000	0.0000	0.0000	0.0000
Vendor	0.0317	1.1792	0.3984	4.2600e-003	0.1467	6.5300e-003	0.1532	0.0424	6.2500e-003	0.0486	0.0000	416.4572	416.4572	0.0112	0.0610	434.9014
Worker	0.3162	0.1789	2.5779	9.2500e-003	1.3204	4.6600e-003	1.3251	0.3509	4.2900e-003	0.3552	0.0000	900.7571	900.7571	0.0169	0.0206	907.3086
Total	0.3479	1.3581	2.9763	0.0135	1.4671	0.0112	1.4783	0.3933	0.0105	0.4038	0.0000	1,317.2143	1,317.2143	0.0281	0.0815	1,342.2100

3.5 Building Construction - 2030

Unmitigated Construction On-Site

	ROG	NOx	CO	SO2	Fugitive PM10	Exhaust PM10	PM10 Total	Fugitive PM2.5	Exhaust PM2.5	PM2.5 Total	Bio- CO2	NBio- CO2	Total CO2	CH4	N2O	CO2e
Category	tons/yr										MT/yr					
Off-Road	0.1708	1.0355	2.1085	4.0400e-003		0.0193	0.0193		0.0193	0.0193	0.0000	343.0336	343.0336	0.0138	0.0000	343.3777
Total	0.1708	1.0355	2.1085	4.0400e-003		0.0193	0.0193		0.0193	0.0193	0.0000	343.0336	343.0336	0.0138	0.0000	343.3777

Pismo Beach GP/LCP PEIR - GHG - San Luis Obispo County APCD Air District, Annual

EMFAC Off-Model Adjustment Factors for Gasoline Light Duty Vehicle to Account for the SAFE Vehicle Rule Applied

3.5 Building Construction - 2030

Unmitigated Construction Off-Site

	ROG	NOx	CO	SO2	Fugitive PM10	Exhaust PM10	PM10 Total	Fugitive PM2.5	Exhaust PM2.5	PM2.5 Total	Bio- CO2	NBio- CO2	Total CO2	CH4	N2O	CO2e
Category	tons/yr										MT/yr					
Hauling	0.0000	0.0000	0.0000	0.0000	0.0000	0.0000	0.0000	0.0000	0.0000	0.0000	0.0000	0.0000	0.0000	0.0000	0.0000	0.0000
Vendor	0.0310	1.1611	0.3969	4.1900e-003	0.1467	6.3900e-003	0.1531	0.0424	6.1200e-003	0.0485	0.0000	408.9874	408.9874	0.0114	0.0598	427.1019
Worker	0.2994	0.1664	2.4791	9.0300e-003	1.3204	4.3700e-003	1.3248	0.3509	4.0200e-003	0.3549	0.0000	885.7047	885.7047	0.0156	0.0198	891.9963
Total	0.3304	1.3275	2.8760	0.0132	1.4671	0.0108	1.4778	0.3933	0.0101	0.4034	0.0000	1,294.6920	1,294.6920	0.0270	0.0796	1,319.0982

Mitigated Construction On-Site

	ROG	NOx	CO	SO2	Fugitive PM10	Exhaust PM10	PM10 Total	Fugitive PM2.5	Exhaust PM2.5	PM2.5 Total	Bio- CO2	NBio- CO2	Total CO2	CH4	N2O	CO2e
Category	tons/yr										MT/yr					
Off-Road	0.1708	1.0355	2.1085	4.0400e-003		0.0193	0.0193		0.0193	0.0193	0.0000	343.0332	343.0332	0.0138	0.0000	343.3773
Total	0.1708	1.0355	2.1085	4.0400e-003		0.0193	0.0193		0.0193	0.0193	0.0000	343.0332	343.0332	0.0138	0.0000	343.3773

Pismo Beach GP/LCP PEIR - GHG - San Luis Obispo County APCD Air District, Annual

EMFAC Off-Model Adjustment Factors for Gasoline Light Duty Vehicle to Account for the SAFE Vehicle Rule Applied

3.5 Building Construction - 2030

Mitigated Construction Off-Site

	ROG	NOx	CO	SO2	Fugitive PM10	Exhaust PM10	PM10 Total	Fugitive PM2.5	Exhaust PM2.5	PM2.5 Total	Bio- CO2	NBio- CO2	Total CO2	CH4	N2O	CO2e
Category	tons/yr										MT/yr					
Hauling	0.0000	0.0000	0.0000	0.0000	0.0000	0.0000	0.0000	0.0000	0.0000	0.0000	0.0000	0.0000	0.0000	0.0000	0.0000	0.0000
Vendor	0.0310	1.1611	0.3969	4.1900e-003	0.1467	6.3900e-003	0.1531	0.0424	6.1200e-003	0.0485	0.0000	408.9874	408.9874	0.0114	0.0598	427.1019
Worker	0.2994	0.1664	2.4791	9.0300e-003	1.3204	4.3700e-003	1.3248	0.3509	4.0200e-003	0.3549	0.0000	885.7047	885.7047	0.0156	0.0198	891.9963
Total	0.3304	1.3275	2.8760	0.0132	1.4671	0.0108	1.4778	0.3933	0.0101	0.4034	0.0000	1,294.6920	1,294.6920	0.0270	0.0796	1,319.0982

3.5 Building Construction - 2031

Unmitigated Construction On-Site

	ROG	NOx	CO	SO2	Fugitive PM10	Exhaust PM10	PM10 Total	Fugitive PM2.5	Exhaust PM2.5	PM2.5 Total	Bio- CO2	NBio- CO2	Total CO2	CH4	N2O	CO2e
Category	tons/yr										MT/yr					
Off-Road	0.1708	1.0355	2.1085	4.0400e-003		0.0193	0.0193		0.0193	0.0193	0.0000	343.0336	343.0336	0.0138	0.0000	343.3777
Total	0.1708	1.0355	2.1085	4.0400e-003		0.0193	0.0193		0.0193	0.0193	0.0000	343.0336	343.0336	0.0138	0.0000	343.3777

Pismo Beach GP/LCP PEIR - GHG - San Luis Obispo County APCD Air District, Annual

EMFAC Off-Model Adjustment Factors for Gasoline Light Duty Vehicle to Account for the SAFE Vehicle Rule Applied

3.5 Building Construction - 2031

Unmitigated Construction Off-Site

	ROG	NOx	CO	SO2	Fugitive PM10	Exhaust PM10	PM10 Total	Fugitive PM2.5	Exhaust PM2.5	PM2.5 Total	Bio- CO2	NBio- CO2	Total CO2	CH4	N2O	CO2e
Category	tons/yr										MT/yr					
Hauling	0.0000	0.0000	0.0000	0.0000	0.0000	0.0000	0.0000	0.0000	0.0000	0.0000	0.0000	0.0000	0.0000	0.0000	0.0000	0.0000
Vendor	0.0305	1.1451	0.3965	4.1100e-003	0.1467	6.2700e-003	0.1529	0.0424	6.0000e-003	0.0484	0.0000	402.1808	402.1808	0.0115	0.0588	419.9965
Worker	0.2823	0.1553	2.3911	8.8400e-003	1.3204	4.1000e-003	1.3245	0.3509	3.7700e-003	0.3547	0.0000	872.1546	872.1546	0.0146	0.0191	878.2207
Total	0.3128	1.3004	2.7875	0.0130	1.4671	0.0104	1.4775	0.3933	9.7700e-003	0.4031	0.0000	1,274.3354	1,274.3354	0.0261	0.0780	1,298.2172

Mitigated Construction On-Site

	ROG	NOx	CO	SO2	Fugitive PM10	Exhaust PM10	PM10 Total	Fugitive PM2.5	Exhaust PM2.5	PM2.5 Total	Bio- CO2	NBio- CO2	Total CO2	CH4	N2O	CO2e
Category	tons/yr										MT/yr					
Off-Road	0.1708	1.0355	2.1085	4.0400e-003		0.0193	0.0193		0.0193	0.0193	0.0000	343.0332	343.0332	0.0138	0.0000	343.3773
Total	0.1708	1.0355	2.1085	4.0400e-003		0.0193	0.0193		0.0193	0.0193	0.0000	343.0332	343.0332	0.0138	0.0000	343.3773

Pismo Beach GP/LCP PEIR - GHG - San Luis Obispo County APCD Air District, Annual

EMFAC Off-Model Adjustment Factors for Gasoline Light Duty Vehicle to Account for the SAFE Vehicle Rule Applied

3.5 Building Construction - 2031

Mitigated Construction Off-Site

	ROG	NOx	CO	SO2	Fugitive PM10	Exhaust PM10	PM10 Total	Fugitive PM2.5	Exhaust PM2.5	PM2.5 Total	Bio- CO2	NBio- CO2	Total CO2	CH4	N2O	CO2e
Category	tons/yr										MT/yr					
Hauling	0.0000	0.0000	0.0000	0.0000	0.0000	0.0000	0.0000	0.0000	0.0000	0.0000	0.0000	0.0000	0.0000	0.0000	0.0000	0.0000
Vendor	0.0305	1.1451	0.3965	4.1100e-003	0.1467	6.2700e-003	0.1529	0.0424	6.0000e-003	0.0484	0.0000	402.1808	402.1808	0.0115	0.0588	419.9965
Worker	0.2823	0.1553	2.3911	8.8400e-003	1.3204	4.1000e-003	1.3245	0.3509	3.7700e-003	0.3547	0.0000	872.1546	872.1546	0.0146	0.0191	878.2207
Total	0.3128	1.3004	2.7875	0.0130	1.4671	0.0104	1.4775	0.3933	9.7700e-003	0.4031	0.0000	1,274.3354	1,274.3354	0.0261	0.0780	1,298.2172

3.5 Building Construction - 2032

Unmitigated Construction On-Site

	ROG	NOx	CO	SO2	Fugitive PM10	Exhaust PM10	PM10 Total	Fugitive PM2.5	Exhaust PM2.5	PM2.5 Total	Bio- CO2	NBio- CO2	Total CO2	CH4	N2O	CO2e
Category	tons/yr										MT/yr					
Off-Road	0.1715	1.0394	2.1166	4.0600e-003		0.0194	0.0194		0.0194	0.0194	0.0000	344.3479	344.3479	0.0138	0.0000	344.6933
Total	0.1715	1.0394	2.1166	4.0600e-003		0.0194	0.0194		0.0194	0.0194	0.0000	344.3479	344.3479	0.0138	0.0000	344.6933

Pismo Beach GP/LCP PEIR - GHG - San Luis Obispo County APCD Air District, Annual

EMFAC Off-Model Adjustment Factors for Gasoline Light Duty Vehicle to Account for the SAFE Vehicle Rule Applied

3.5 Building Construction - 2032

Unmitigated Construction Off-Site

	ROG	NOx	CO	SO2	Fugitive PM10	Exhaust PM10	PM10 Total	Fugitive PM2.5	Exhaust PM2.5	PM2.5 Total	Bio- CO2	NBio- CO2	Total CO2	CH4	N2O	CO2e
Category	tons/yr										MT/yr					
Hauling	0.0000	0.0000	0.0000	0.0000	0.0000	0.0000	0.0000	0.0000	0.0000	0.0000	0.0000	0.0000	0.0000	0.0000	0.0000	0.0000
Vendor	0.0301	1.1355	0.3984	4.0600e-003	0.1472	6.1900e-003	0.1534	0.0426	5.9200e-003	0.0485	0.0000	397.5717	397.5717	0.0117	0.0581	415.1886
Worker	0.2673	0.1465	2.3230	8.7000e-003	1.3255	3.8600e-003	1.3293	0.3523	3.5500e-003	0.3558	0.0000	863.4018	863.4018	0.0136	0.0187	869.2995
Total	0.2974	1.2820	2.7215	0.0128	1.4727	0.0101	1.4828	0.3948	9.4700e-003	0.4043	0.0000	1,260.9735	1,260.9735	0.0253	0.0768	1,284.4881

Mitigated Construction On-Site

	ROG	NOx	CO	SO2	Fugitive PM10	Exhaust PM10	PM10 Total	Fugitive PM2.5	Exhaust PM2.5	PM2.5 Total	Bio- CO2	NBio- CO2	Total CO2	CH4	N2O	CO2e
Category	tons/yr										MT/yr					
Off-Road	0.1715	1.0394	2.1166	4.0600e-003		0.0194	0.0194		0.0194	0.0194	0.0000	344.3475	344.3475	0.0138	0.0000	344.6929
Total	0.1715	1.0394	2.1166	4.0600e-003		0.0194	0.0194		0.0194	0.0194	0.0000	344.3475	344.3475	0.0138	0.0000	344.6929

Pismo Beach GP/LCP PEIR - GHG - San Luis Obispo County APCD Air District, Annual

EMFAC Off-Model Adjustment Factors for Gasoline Light Duty Vehicle to Account for the SAFE Vehicle Rule Applied

3.5 Building Construction - 2032

Mitigated Construction Off-Site

	ROG	NOx	CO	SO2	Fugitive PM10	Exhaust PM10	PM10 Total	Fugitive PM2.5	Exhaust PM2.5	PM2.5 Total	Bio- CO2	NBio- CO2	Total CO2	CH4	N2O	CO2e
Category	tons/yr										MT/yr					
Hauling	0.0000	0.0000	0.0000	0.0000	0.0000	0.0000	0.0000	0.0000	0.0000	0.0000	0.0000	0.0000	0.0000	0.0000	0.0000	0.0000
Vendor	0.0301	1.1355	0.3984	4.0600e-003	0.1472	6.1900e-003	0.1534	0.0426	5.9200e-003	0.0485	0.0000	397.5717	397.5717	0.0117	0.0581	415.1886
Worker	0.2673	0.1465	2.3230	8.7000e-003	1.3255	3.8600e-003	1.3293	0.3523	3.5500e-003	0.3558	0.0000	863.4018	863.4018	0.0136	0.0187	869.2995
Total	0.2974	1.2820	2.7215	0.0128	1.4727	0.0101	1.4828	0.3948	9.4700e-003	0.4043	0.0000	1,260.9735	1,260.9735	0.0253	0.0768	1,284.4881

3.5 Building Construction - 2033

Unmitigated Construction On-Site

	ROG	NOx	CO	SO2	Fugitive PM10	Exhaust PM10	PM10 Total	Fugitive PM2.5	Exhaust PM2.5	PM2.5 Total	Bio- CO2	NBio- CO2	Total CO2	CH4	N2O	CO2e
Category	tons/yr										MT/yr					
Off-Road	0.1702	1.0315	2.1004	4.0200e-003		0.0193	0.0193		0.0193	0.0193	0.0000	341.7193	341.7193	0.0137	0.0000	342.0621
Total	0.1702	1.0315	2.1004	4.0200e-003		0.0193	0.0193		0.0193	0.0193	0.0000	341.7193	341.7193	0.0137	0.0000	342.0621

Pismo Beach GP/LCP PEIR - GHG - San Luis Obispo County APCD Air District, Annual

EMFAC Off-Model Adjustment Factors for Gasoline Light Duty Vehicle to Account for the SAFE Vehicle Rule Applied

3.5 Building Construction - 2033

Unmitigated Construction Off-Site

	ROG	NOx	CO	SO2	Fugitive PM10	Exhaust PM10	PM10 Total	Fugitive PM2.5	Exhaust PM2.5	PM2.5 Total	Bio- CO2	NBio- CO2	Total CO2	CH4	N2O	CO2e
Category	tons/yr										MT/yr					
Hauling	0.0000	0.0000	0.0000	0.0000	0.0000	0.0000	0.0000	0.0000	0.0000	0.0000	0.0000	0.0000	0.0000	0.0000	0.0000	0.0000
Vendor	0.0296	1.1150	0.3964	3.9800e-003	0.1461	6.0600e-003	0.1522	0.0422	5.7900e-003	0.0480	0.0000	389.0707	389.0707	0.0117	0.0569	406.3191
Worker	0.2516	0.1379	2.2401	8.4800e-003	1.3154	3.6100e-003	1.3190	0.3496	3.3200e-003	0.3529	0.0000	846.1621	846.1621	0.0127	0.0181	851.8589
Total	0.2811	1.2529	2.6364	0.0125	1.4615	9.6700e-003	1.4711	0.3918	9.1100e-003	0.4009	0.0000	1,235.2328	1,235.2328	0.0244	0.0750	1,258.1780

Mitigated Construction On-Site

	ROG	NOx	CO	SO2	Fugitive PM10	Exhaust PM10	PM10 Total	Fugitive PM2.5	Exhaust PM2.5	PM2.5 Total	Bio- CO2	NBio- CO2	Total CO2	CH4	N2O	CO2e
Category	tons/yr										MT/yr					
Off-Road	0.1702	1.0315	2.1004	4.0200e-003		0.0193	0.0193		0.0193	0.0193	0.0000	341.7189	341.7189	0.0137	0.0000	342.0617
Total	0.1702	1.0315	2.1004	4.0200e-003		0.0193	0.0193		0.0193	0.0193	0.0000	341.7189	341.7189	0.0137	0.0000	342.0617

Pismo Beach GP/LCP PEIR - GHG - San Luis Obispo County APCD Air District, Annual

EMFAC Off-Model Adjustment Factors for Gasoline Light Duty Vehicle to Account for the SAFE Vehicle Rule Applied

3.5 Building Construction - 2033

Mitigated Construction Off-Site

	ROG	NOx	CO	SO2	Fugitive PM10	Exhaust PM10	PM10 Total	Fugitive PM2.5	Exhaust PM2.5	PM2.5 Total	Bio- CO2	NBio- CO2	Total CO2	CH4	N2O	CO2e
Category	tons/yr										MT/yr					
Hauling	0.0000	0.0000	0.0000	0.0000	0.0000	0.0000	0.0000	0.0000	0.0000	0.0000	0.0000	0.0000	0.0000	0.0000	0.0000	0.0000
Vendor	0.0296	1.1150	0.3964	3.9800e-003	0.1461	6.0600e-003	0.1522	0.0422	5.7900e-003	0.0480	0.0000	389.0707	389.0707	0.0117	0.0569	406.3191
Worker	0.2516	0.1379	2.2401	8.4800e-003	1.3154	3.6100e-003	1.3190	0.3496	3.3200e-003	0.3529	0.0000	846.1621	846.1621	0.0127	0.0181	851.8589
Total	0.2811	1.2529	2.6364	0.0125	1.4615	9.6700e-003	1.4711	0.3918	9.1100e-003	0.4009	0.0000	1,235.2328	1,235.2328	0.0244	0.0750	1,258.1780

3.5 Building Construction - 2034

Unmitigated Construction On-Site

	ROG	NOx	CO	SO2	Fugitive PM10	Exhaust PM10	PM10 Total	Fugitive PM2.5	Exhaust PM2.5	PM2.5 Total	Bio- CO2	NBio- CO2	Total CO2	CH4	N2O	CO2e
Category	tons/yr										MT/yr					
Off-Road	0.1702	1.0315	2.1004	4.0200e-003		0.0193	0.0193		0.0193	0.0193	0.0000	341.7193	341.7193	0.0137	0.0000	342.0621
Total	0.1702	1.0315	2.1004	4.0200e-003		0.0193	0.0193		0.0193	0.0193	0.0000	341.7193	341.7193	0.0137	0.0000	342.0621

Pismo Beach GP/LCP PEIR - GHG - San Luis Obispo County APCD Air District, Annual

EMFAC Off-Model Adjustment Factors for Gasoline Light Duty Vehicle to Account for the SAFE Vehicle Rule Applied

3.5 Building Construction - 2034

Unmitigated Construction Off-Site

	ROG	NOx	CO	SO2	Fugitive PM10	Exhaust PM10	PM10 Total	Fugitive PM2.5	Exhaust PM2.5	PM2.5 Total	Bio- CO2	NBio- CO2	Total CO2	CH4	N2O	CO2e
Category	tons/yr										MT/yr					
Hauling	0.0000	0.0000	0.0000	0.0000	0.0000	0.0000	0.0000	0.0000	0.0000	0.0000	0.0000	0.0000	0.0000	0.0000	0.0000	0.0000
Vendor	0.0293	1.1044	0.3976	3.9200e-003	0.1461	5.9700e-003	0.1521	0.0422	5.7100e-003	0.0480	0.0000	384.0597	384.0597	0.0118	0.0562	401.0944
Worker	0.2395	0.1318	2.1827	8.3400e-003	1.3154	3.4000e-003	1.3188	0.3496	3.1300e-003	0.3527	0.0000	836.7068	836.7068	0.0119	0.0177	842.2750
Total	0.2688	1.2362	2.5804	0.0123	1.4615	9.3700e-003	1.4709	0.3918	8.8400e-003	0.4007	0.0000	1,220.7664	1,220.7664	0.0237	0.0739	1,243.3694

Mitigated Construction On-Site

	ROG	NOx	CO	SO2	Fugitive PM10	Exhaust PM10	PM10 Total	Fugitive PM2.5	Exhaust PM2.5	PM2.5 Total	Bio- CO2	NBio- CO2	Total CO2	CH4	N2O	CO2e
Category	tons/yr										MT/yr					
Off-Road	0.1702	1.0315	2.1004	4.0200e-003		0.0193	0.0193		0.0193	0.0193	0.0000	341.7189	341.7189	0.0137	0.0000	342.0617
Total	0.1702	1.0315	2.1004	4.0200e-003		0.0193	0.0193		0.0193	0.0193	0.0000	341.7189	341.7189	0.0137	0.0000	342.0617

Pismo Beach GP/LCP PEIR - GHG - San Luis Obispo County APCD Air District, Annual

EMFAC Off-Model Adjustment Factors for Gasoline Light Duty Vehicle to Account for the SAFE Vehicle Rule Applied

3.5 Building Construction - 2034

Mitigated Construction Off-Site

	ROG	NOx	CO	SO2	Fugitive PM10	Exhaust PM10	PM10 Total	Fugitive PM2.5	Exhaust PM2.5	PM2.5 Total	Bio- CO2	NBio- CO2	Total CO2	CH4	N2O	CO2e
Category	tons/yr										MT/yr					
Hauling	0.0000	0.0000	0.0000	0.0000	0.0000	0.0000	0.0000	0.0000	0.0000	0.0000	0.0000	0.0000	0.0000	0.0000	0.0000	0.0000
Vendor	0.0293	1.1044	0.3976	3.9200e-003	0.1461	5.9700e-003	0.1521	0.0422	5.7100e-003	0.0480	0.0000	384.0597	384.0597	0.0118	0.0562	401.0944
Worker	0.2395	0.1318	2.1827	8.3400e-003	1.3154	3.4000e-003	1.3188	0.3496	3.1300e-003	0.3527	0.0000	836.7068	836.7068	0.0119	0.0177	842.2750
Total	0.2688	1.2362	2.5804	0.0123	1.4615	9.3700e-003	1.4709	0.3918	8.8400e-003	0.4007	0.0000	1,220.7664	1,220.7664	0.0237	0.0739	1,243.3694

3.5 Building Construction - 2035

Unmitigated Construction On-Site

	ROG	NOx	CO	SO2	Fugitive PM10	Exhaust PM10	PM10 Total	Fugitive PM2.5	Exhaust PM2.5	PM2.5 Total	Bio- CO2	NBio- CO2	Total CO2	CH4	N2O	CO2e
Category	tons/yr										MT/yr					
Off-Road	0.1588	0.9346	2.1034	4.0400e-003		0.0118	0.0118		0.0118	0.0118	0.0000	343.0336	343.0336	0.0128	0.0000	343.3530
Total	0.1588	0.9346	2.1034	4.0400e-003		0.0118	0.0118		0.0118	0.0118	0.0000	343.0336	343.0336	0.0128	0.0000	343.3530

Pismo Beach GP/LCP PEIR - GHG - San Luis Obispo County APCD Air District, Annual

EMFAC Off-Model Adjustment Factors for Gasoline Light Duty Vehicle to Account for the SAFE Vehicle Rule Applied

3.5 Building Construction - 2035

Unmitigated Construction Off-Site

	ROG	NOx	CO	SO2	Fugitive PM10	Exhaust PM10	PM10 Total	Fugitive PM2.5	Exhaust PM2.5	PM2.5 Total	Bio- CO2	NBio- CO2	Total CO2	CH4	N2O	CO2e
Category	tons/yr										MT/yr					
Hauling	0.0000	0.0000	0.0000	0.0000	0.0000	0.0000	0.0000	0.0000	0.0000	0.0000	0.0000	0.0000	0.0000	0.0000	0.0000	0.0000
Vendor	0.0291	1.0985	0.4003	3.8900e-003	0.1467	5.9200e-003	0.1526	0.0424	5.6600e-003	0.0481	0.0000	381.0270	381.0270	0.0119	0.0557	397.9358
Worker	0.2294	0.1274	2.1411	8.2500e-003	1.3204	3.2200e-003	1.3236	0.3509	2.9600e-003	0.3539	0.0000	831.6566	831.6566	0.0113	0.0175	837.1397
Total	0.2585	1.2259	2.5414	0.0121	1.4671	9.1400e-003	1.4763	0.3933	8.6200e-003	0.4019	0.0000	1,212.6835	1,212.6835	0.0232	0.0732	1,235.0755

Mitigated Construction On-Site

	ROG	NOx	CO	SO2	Fugitive PM10	Exhaust PM10	PM10 Total	Fugitive PM2.5	Exhaust PM2.5	PM2.5 Total	Bio- CO2	NBio- CO2	Total CO2	CH4	N2O	CO2e
Category	tons/yr										MT/yr					
Off-Road	0.1588	0.9346	2.1034	4.0400e-003		0.0118	0.0118		0.0118	0.0118	0.0000	343.0332	343.0332	0.0128	0.0000	343.3526
Total	0.1588	0.9346	2.1034	4.0400e-003		0.0118	0.0118		0.0118	0.0118	0.0000	343.0332	343.0332	0.0128	0.0000	343.3526

Pismo Beach GP/LCP PEIR - GHG - San Luis Obispo County APCD Air District, Annual

EMFAC Off-Model Adjustment Factors for Gasoline Light Duty Vehicle to Account for the SAFE Vehicle Rule Applied

3.5 Building Construction - 2035

Mitigated Construction Off-Site

	ROG	NOx	CO	SO2	Fugitive PM10	Exhaust PM10	PM10 Total	Fugitive PM2.5	Exhaust PM2.5	PM2.5 Total	Bio- CO2	NBio- CO2	Total CO2	CH4	N2O	CO2e
Category	tons/yr										MT/yr					
Hauling	0.0000	0.0000	0.0000	0.0000	0.0000	0.0000	0.0000	0.0000	0.0000	0.0000	0.0000	0.0000	0.0000	0.0000	0.0000	0.0000
Vendor	0.0291	1.0985	0.4003	3.8900e-003	0.1467	5.9200e-003	0.1526	0.0424	5.6600e-003	0.0481	0.0000	381.0270	381.0270	0.0119	0.0557	397.9358
Worker	0.2294	0.1274	2.1411	8.2500e-003	1.3204	3.2200e-003	1.3236	0.3509	2.9600e-003	0.3539	0.0000	831.6566	831.6566	0.0113	0.0175	837.1397
Total	0.2585	1.2259	2.5414	0.0121	1.4671	9.1400e-003	1.4763	0.3933	8.6200e-003	0.4019	0.0000	1,212.6835	1,212.6835	0.0232	0.0732	1,235.0755

3.5 Building Construction - 2036

Unmitigated Construction On-Site

	ROG	NOx	CO	SO2	Fugitive PM10	Exhaust PM10	PM10 Total	Fugitive PM2.5	Exhaust PM2.5	PM2.5 Total	Bio- CO2	NBio- CO2	Total CO2	CH4	N2O	CO2e
Category	tons/yr										MT/yr					
Off-Road	0.1594	0.9381	2.1114	4.0600e-003		0.0118	0.0118		0.0118	0.0118	0.0000	344.3479	344.3479	0.0128	0.0000	344.6686
Total	0.1594	0.9381	2.1114	4.0600e-003		0.0118	0.0118		0.0118	0.0118	0.0000	344.3479	344.3479	0.0128	0.0000	344.6686

Pismo Beach GP/LCP PEIR - GHG - San Luis Obispo County APCD Air District, Annual

EMFAC Off-Model Adjustment Factors for Gasoline Light Duty Vehicle to Account for the SAFE Vehicle Rule Applied

3.5 Building Construction - 2036

Unmitigated Construction Off-Site

	ROG	NOx	CO	SO2	Fugitive PM10	Exhaust PM10	PM10 Total	Fugitive PM2.5	Exhaust PM2.5	PM2.5 Total	Bio- CO2	NBio- CO2	Total CO2	CH4	N2O	CO2e
Category	tons/yr										MT/yr					
Hauling	0.0000	0.0000	0.0000	0.0000	0.0000	0.0000	0.0000	0.0000	0.0000	0.0000	0.0000	0.0000	0.0000	0.0000	0.0000	0.0000
Vendor	0.0292	1.1028	0.4019	3.9000e-003	0.1473	5.9400e-003	0.1532	0.0426	5.6800e-003	0.0483	0.0000	382.4869	382.4869	0.0120	0.0560	399.4604
Worker	0.2303	0.1279	2.1493	8.2800e-003	1.3255	3.2300e-003	1.3287	0.3523	2.9800e-003	0.3552	0.0000	834.8430	834.8430	0.0114	0.0175	840.3471
Total	0.2595	1.2306	2.5512	0.0122	1.4727	9.1700e-003	1.4819	0.3948	8.6600e-003	0.4035	0.0000	1,217.3298	1,217.3298	0.0233	0.0735	1,239.8076

Mitigated Construction On-Site

	ROG	NOx	CO	SO2	Fugitive PM10	Exhaust PM10	PM10 Total	Fugitive PM2.5	Exhaust PM2.5	PM2.5 Total	Bio- CO2	NBio- CO2	Total CO2	CH4	N2O	CO2e
Category	tons/yr										MT/yr					
Off-Road	0.1594	0.9381	2.1114	4.0600e-003		0.0118	0.0118		0.0118	0.0118	0.0000	344.3475	344.3475	0.0128	0.0000	344.6682
Total	0.1594	0.9381	2.1114	4.0600e-003		0.0118	0.0118		0.0118	0.0118	0.0000	344.3475	344.3475	0.0128	0.0000	344.6682

Pismo Beach GP/LCP PEIR - GHG - San Luis Obispo County APCD Air District, Annual

EMFAC Off-Model Adjustment Factors for Gasoline Light Duty Vehicle to Account for the SAFE Vehicle Rule Applied

3.5 Building Construction - 2036

Mitigated Construction Off-Site

	ROG	NOx	CO	SO2	Fugitive PM10	Exhaust PM10	PM10 Total	Fugitive PM2.5	Exhaust PM2.5	PM2.5 Total	Bio- CO2	NBio- CO2	Total CO2	CH4	N2O	CO2e
Category	tons/yr										MT/yr					
Hauling	0.0000	0.0000	0.0000	0.0000	0.0000	0.0000	0.0000	0.0000	0.0000	0.0000	0.0000	0.0000	0.0000	0.0000	0.0000	0.0000
Vendor	0.0292	1.1028	0.4019	3.9000e-003	0.1473	5.9400e-003	0.1532	0.0426	5.6800e-003	0.0483	0.0000	382.4869	382.4869	0.0120	0.0560	399.4604
Worker	0.2303	0.1279	2.1493	8.2800e-003	1.3255	3.2300e-003	1.3287	0.3523	2.9800e-003	0.3552	0.0000	834.8430	834.8430	0.0114	0.0175	840.3471
Total	0.2595	1.2306	2.5512	0.0122	1.4727	9.1700e-003	1.4819	0.3948	8.6600e-003	0.4035	0.0000	1,217.3298	1,217.3298	0.0233	0.0735	1,239.8076

3.5 Building Construction - 2037

Unmitigated Construction On-Site

	ROG	NOx	CO	SO2	Fugitive PM10	Exhaust PM10	PM10 Total	Fugitive PM2.5	Exhaust PM2.5	PM2.5 Total	Bio- CO2	NBio- CO2	Total CO2	CH4	N2O	CO2e
Category	tons/yr										MT/yr					
Off-Road	0.1588	0.9346	2.1034	4.0400e-003		0.0118	0.0118		0.0118	0.0118	0.0000	343.0336	343.0336	0.0128	0.0000	343.3530
Total	0.1588	0.9346	2.1034	4.0400e-003		0.0118	0.0118		0.0118	0.0118	0.0000	343.0336	343.0336	0.0128	0.0000	343.3530

Pismo Beach GP/LCP PEIR - GHG - San Luis Obispo County APCD Air District, Annual

EMFAC Off-Model Adjustment Factors for Gasoline Light Duty Vehicle to Account for the SAFE Vehicle Rule Applied

3.5 Building Construction - 2037

Unmitigated Construction Off-Site

	ROG	NOx	CO	SO2	Fugitive PM10	Exhaust PM10	PM10 Total	Fugitive PM2.5	Exhaust PM2.5	PM2.5 Total	Bio- CO2	NBio- CO2	Total CO2	CH4	N2O	CO2e
Category	tons/yr										MT/yr					
Hauling	0.0000	0.0000	0.0000	0.0000	0.0000	0.0000	0.0000	0.0000	0.0000	0.0000	0.0000	0.0000	0.0000	0.0000	0.0000	0.0000
Vendor	0.0291	1.0985	0.4003	3.8900e-003	0.1467	5.9200e-003	0.1526	0.0424	5.6600e-003	0.0481	0.0000	381.0270	381.0270	0.0119	0.0557	397.9358
Worker	0.2294	0.1274	2.1411	8.2500e-003	1.3204	3.2200e-003	1.3236	0.3509	2.9600e-003	0.3539	0.0000	831.6566	831.6566	0.0113	0.0175	837.1397
Total	0.2585	1.2259	2.5414	0.0121	1.4671	9.1400e-003	1.4763	0.3933	8.6200e-003	0.4019	0.0000	1,212.6835	1,212.6835	0.0232	0.0732	1,235.0755

Mitigated Construction On-Site

	ROG	NOx	CO	SO2	Fugitive PM10	Exhaust PM10	PM10 Total	Fugitive PM2.5	Exhaust PM2.5	PM2.5 Total	Bio- CO2	NBio- CO2	Total CO2	CH4	N2O	CO2e
Category	tons/yr										MT/yr					
Off-Road	0.1588	0.9346	2.1034	4.0400e-003		0.0118	0.0118		0.0118	0.0118	0.0000	343.0332	343.0332	0.0128	0.0000	343.3526
Total	0.1588	0.9346	2.1034	4.0400e-003		0.0118	0.0118		0.0118	0.0118	0.0000	343.0332	343.0332	0.0128	0.0000	343.3526

Pismo Beach GP/LCP PEIR - GHG - San Luis Obispo County APCD Air District, Annual

EMFAC Off-Model Adjustment Factors for Gasoline Light Duty Vehicle to Account for the SAFE Vehicle Rule Applied

3.5 Building Construction - 2037

Mitigated Construction Off-Site

	ROG	NOx	CO	SO2	Fugitive PM10	Exhaust PM10	PM10 Total	Fugitive PM2.5	Exhaust PM2.5	PM2.5 Total	Bio- CO2	NBio- CO2	Total CO2	CH4	N2O	CO2e
Category	tons/yr										MT/yr					
Hauling	0.0000	0.0000	0.0000	0.0000	0.0000	0.0000	0.0000	0.0000	0.0000	0.0000	0.0000	0.0000	0.0000	0.0000	0.0000	0.0000
Vendor	0.0291	1.0985	0.4003	3.8900e-003	0.1467	5.9200e-003	0.1526	0.0424	5.6600e-003	0.0481	0.0000	381.0270	381.0270	0.0119	0.0557	397.9358
Worker	0.2294	0.1274	2.1411	8.2500e-003	1.3204	3.2200e-003	1.3236	0.3509	2.9600e-003	0.3539	0.0000	831.6566	831.6566	0.0113	0.0175	837.1397
Total	0.2585	1.2259	2.5414	0.0121	1.4671	9.1400e-003	1.4763	0.3933	8.6200e-003	0.4019	0.0000	1,212.6835	1,212.6835	0.0232	0.0732	1,235.0755

3.5 Building Construction - 2038

Unmitigated Construction On-Site

	ROG	NOx	CO	SO2	Fugitive PM10	Exhaust PM10	PM10 Total	Fugitive PM2.5	Exhaust PM2.5	PM2.5 Total	Bio- CO2	NBio- CO2	Total CO2	CH4	N2O	CO2e
Category	tons/yr										MT/yr					
Off-Road	0.1588	0.9346	2.1034	4.0400e-003		0.0118	0.0118		0.0118	0.0118	0.0000	343.0336	343.0336	0.0128	0.0000	343.3530
Total	0.1588	0.9346	2.1034	4.0400e-003		0.0118	0.0118		0.0118	0.0118	0.0000	343.0336	343.0336	0.0128	0.0000	343.3530

Pismo Beach GP/LCP PEIR - GHG - San Luis Obispo County APCD Air District, Annual

EMFAC Off-Model Adjustment Factors for Gasoline Light Duty Vehicle to Account for the SAFE Vehicle Rule Applied

3.5 Building Construction - 2038

Unmitigated Construction Off-Site

	ROG	NOx	CO	SO2	Fugitive PM10	Exhaust PM10	PM10 Total	Fugitive PM2.5	Exhaust PM2.5	PM2.5 Total	Bio- CO2	NBio- CO2	Total CO2	CH4	N2O	CO2e
Category	tons/yr										MT/yr					
Hauling	0.0000	0.0000	0.0000	0.0000	0.0000	0.0000	0.0000	0.0000	0.0000	0.0000	0.0000	0.0000	0.0000	0.0000	0.0000	0.0000
Vendor	0.0291	1.0985	0.4003	3.8900e-003	0.1467	5.9200e-003	0.1526	0.0424	5.6600e-003	0.0481	0.0000	381.0270	381.0270	0.0119	0.0557	397.9358
Worker	0.2294	0.1274	2.1411	8.2500e-003	1.3204	3.2200e-003	1.3236	0.3509	2.9600e-003	0.3539	0.0000	831.6566	831.6566	0.0113	0.0175	837.1397
Total	0.2585	1.2259	2.5414	0.0121	1.4671	9.1400e-003	1.4763	0.3933	8.6200e-003	0.4019	0.0000	1,212.6835	1,212.6835	0.0232	0.0732	1,235.0755

Mitigated Construction On-Site

	ROG	NOx	CO	SO2	Fugitive PM10	Exhaust PM10	PM10 Total	Fugitive PM2.5	Exhaust PM2.5	PM2.5 Total	Bio- CO2	NBio- CO2	Total CO2	CH4	N2O	CO2e
Category	tons/yr										MT/yr					
Off-Road	0.1588	0.9346	2.1034	4.0400e-003		0.0118	0.0118		0.0118	0.0118	0.0000	343.0332	343.0332	0.0128	0.0000	343.3526
Total	0.1588	0.9346	2.1034	4.0400e-003		0.0118	0.0118		0.0118	0.0118	0.0000	343.0332	343.0332	0.0128	0.0000	343.3526

Pismo Beach GP/LCP PEIR - GHG - San Luis Obispo County APCD Air District, Annual

EMFAC Off-Model Adjustment Factors for Gasoline Light Duty Vehicle to Account for the SAFE Vehicle Rule Applied

3.5 Building Construction - 2038

Mitigated Construction Off-Site

	ROG	NOx	CO	SO2	Fugitive PM10	Exhaust PM10	PM10 Total	Fugitive PM2.5	Exhaust PM2.5	PM2.5 Total	Bio- CO2	NBio- CO2	Total CO2	CH4	N2O	CO2e
Category	tons/yr										MT/yr					
Hauling	0.0000	0.0000	0.0000	0.0000	0.0000	0.0000	0.0000	0.0000	0.0000	0.0000	0.0000	0.0000	0.0000	0.0000	0.0000	0.0000
Vendor	0.0291	1.0985	0.4003	3.8900e-003	0.1467	5.9200e-003	0.1526	0.0424	5.6600e-003	0.0481	0.0000	381.0270	381.0270	0.0119	0.0557	397.9358
Worker	0.2294	0.1274	2.1411	8.2500e-003	1.3204	3.2200e-003	1.3236	0.3509	2.9600e-003	0.3539	0.0000	831.6566	831.6566	0.0113	0.0175	837.1397
Total	0.2585	1.2259	2.5414	0.0121	1.4671	9.1400e-003	1.4763	0.3933	8.6200e-003	0.4019	0.0000	1,212.6835	1,212.6835	0.0232	0.0732	1,235.0755

3.5 Building Construction - 2039

Unmitigated Construction On-Site

	ROG	NOx	CO	SO2	Fugitive PM10	Exhaust PM10	PM10 Total	Fugitive PM2.5	Exhaust PM2.5	PM2.5 Total	Bio- CO2	NBio- CO2	Total CO2	CH4	N2O	CO2e
Category	tons/yr										MT/yr					
Off-Road	0.1582	0.9310	2.0953	4.0200e-003		0.0118	0.0118		0.0118	0.0118	0.0000	341.7193	341.7193	0.0127	0.0000	342.0375
Total	0.1582	0.9310	2.0953	4.0200e-003		0.0118	0.0118		0.0118	0.0118	0.0000	341.7193	341.7193	0.0127	0.0000	342.0375

Pismo Beach GP/LCP PEIR - GHG - San Luis Obispo County APCD Air District, Annual

EMFAC Off-Model Adjustment Factors for Gasoline Light Duty Vehicle to Account for the SAFE Vehicle Rule Applied

3.5 Building Construction - 2039

Unmitigated Construction Off-Site

	ROG	NOx	CO	SO2	Fugitive PM10	Exhaust PM10	PM10 Total	Fugitive PM2.5	Exhaust PM2.5	PM2.5 Total	Bio- CO2	NBio- CO2	Total CO2	CH4	N2O	CO2e
Category	tons/yr										MT/yr					
Hauling	0.0000	0.0000	0.0000	0.0000	0.0000	0.0000	0.0000	0.0000	0.0000	0.0000	0.0000	0.0000	0.0000	0.0000	0.0000	0.0000
Vendor	0.0290	1.0943	0.3988	3.8800e-003	0.1461	5.8900e-003	0.1520	0.0423	5.6400e-003	0.0479	0.0000	379.5671	379.5671	0.0119	0.0555	396.4111
Worker	0.2285	0.1269	2.1329	8.2200e-003	1.3154	3.2100e-003	1.3186	0.3496	2.9500e-003	0.3525	0.0000	828.4701	828.4701	0.0113	0.0174	833.9323
Total	0.2575	1.2212	2.5317	0.0121	1.4615	9.1000e-003	1.4706	0.3918	8.5900e-003	0.4004	0.0000	1,208.0373	1,208.0373	0.0232	0.0729	1,230.3434

Mitigated Construction On-Site

	ROG	NOx	CO	SO2	Fugitive PM10	Exhaust PM10	PM10 Total	Fugitive PM2.5	Exhaust PM2.5	PM2.5 Total	Bio- CO2	NBio- CO2	Total CO2	CH4	N2O	CO2e
Category	tons/yr										MT/yr					
Off-Road	0.1582	0.9310	2.0953	4.0200e-003		0.0118	0.0118		0.0118	0.0118	0.0000	341.7189	341.7189	0.0127	0.0000	342.0371
Total	0.1582	0.9310	2.0953	4.0200e-003		0.0118	0.0118		0.0118	0.0118	0.0000	341.7189	341.7189	0.0127	0.0000	342.0371

Pismo Beach GP/LCP PEIR - GHG - San Luis Obispo County APCD Air District, Annual

EMFAC Off-Model Adjustment Factors for Gasoline Light Duty Vehicle to Account for the SAFE Vehicle Rule Applied

3.5 Building Construction - 2039

Mitigated Construction Off-Site

	ROG	NOx	CO	SO2	Fugitive PM10	Exhaust PM10	PM10 Total	Fugitive PM2.5	Exhaust PM2.5	PM2.5 Total	Bio- CO2	NBio- CO2	Total CO2	CH4	N2O	CO2e
Category	tons/yr										MT/yr					
Hauling	0.0000	0.0000	0.0000	0.0000	0.0000	0.0000	0.0000	0.0000	0.0000	0.0000	0.0000	0.0000	0.0000	0.0000	0.0000	0.0000
Vendor	0.0290	1.0943	0.3988	3.8800e-003	0.1461	5.8900e-003	0.1520	0.0423	5.6400e-003	0.0479	0.0000	379.5671	379.5671	0.0119	0.0555	396.4111
Worker	0.2285	0.1269	2.1329	8.2200e-003	1.3154	3.2100e-003	1.3186	0.3496	2.9500e-003	0.3525	0.0000	828.4701	828.4701	0.0113	0.0174	833.9323
Total	0.2575	1.2212	2.5317	0.0121	1.4615	9.1000e-003	1.4706	0.3918	8.5900e-003	0.4004	0.0000	1,208.0373	1,208.0373	0.0232	0.0729	1,230.3434

3.5 Building Construction - 2040

Unmitigated Construction On-Site

	ROG	NOx	CO	SO2	Fugitive PM10	Exhaust PM10	PM10 Total	Fugitive PM2.5	Exhaust PM2.5	PM2.5 Total	Bio- CO2	NBio- CO2	Total CO2	CH4	N2O	CO2e
Category	tons/yr										MT/yr					
Off-Road	0.0850	0.4892	1.1444	2.2000e-003		5.2300e-003	5.2300e-003		5.2300e-003	5.2300e-003	0.0000	186.6314	186.6314	6.7100e-003	0.0000	186.7990
Total	0.0850	0.4892	1.1444	2.2000e-003		5.2300e-003	5.2300e-003		5.2300e-003	5.2300e-003	0.0000	186.6314	186.6314	6.7100e-003	0.0000	186.7990

Pismo Beach GP/LCP PEIR - GHG - San Luis Obispo County APCD Air District, Annual

EMFAC Off-Model Adjustment Factors for Gasoline Light Duty Vehicle to Account for the SAFE Vehicle Rule Applied

3.5 Building Construction - 2040

Unmitigated Construction Off-Site

	ROG	NOx	CO	SO2	Fugitive PM10	Exhaust PM10	PM10 Total	Fugitive PM2.5	Exhaust PM2.5	PM2.5 Total	Bio- CO2	NBio- CO2	Total CO2	CH4	N2O	CO2e
Category	tons/yr										MT/yr					
Hauling	0.0000	0.0000	0.0000	0.0000	0.0000	0.0000	0.0000	0.0000	0.0000	0.0000	0.0000	0.0000	0.0000	0.0000	0.0000	0.0000
Vendor	0.0156	0.5721	0.2219	2.0100e-003	0.0798	3.1100e-003	0.0829	0.0231	2.9700e-003	0.0261	0.0000	197.4724	197.4724	6.8300e-003	0.0288	206.2378
Worker	0.1021	0.0612	1.0715	4.2700e-003	0.7184	1.3800e-003	0.7198	0.1909	1.2700e-003	0.1922	0.0000	437.2753	437.2753	4.8700e-003	9.0200e-003	440.0845
Total	0.1177	0.6333	1.2933	6.2800e-003	0.7982	4.4900e-003	0.8027	0.2140	4.2400e-003	0.2182	0.0000	634.7477	634.7477	0.0117	0.0379	646.3223

Mitigated Construction On-Site

	ROG	NOx	CO	SO2	Fugitive PM10	Exhaust PM10	PM10 Total	Fugitive PM2.5	Exhaust PM2.5	PM2.5 Total	Bio- CO2	NBio- CO2	Total CO2	CH4	N2O	CO2e
Category	tons/yr										MT/yr					
Off-Road	0.0850	0.4892	1.1444	2.2000e-003		5.2300e-003	5.2300e-003		5.2300e-003	5.2300e-003	0.0000	186.6311	186.6311	6.7100e-003	0.0000	186.7988
Total	0.0850	0.4892	1.1444	2.2000e-003		5.2300e-003	5.2300e-003		5.2300e-003	5.2300e-003	0.0000	186.6311	186.6311	6.7100e-003	0.0000	186.7988

Pismo Beach GP/LCP PEIR - GHG - San Luis Obispo County APCD Air District, Annual

EMFAC Off-Model Adjustment Factors for Gasoline Light Duty Vehicle to Account for the SAFE Vehicle Rule Applied

3.5 Building Construction - 2040

Mitigated Construction Off-Site

	ROG	NOx	CO	SO2	Fugitive PM10	Exhaust PM10	PM10 Total	Fugitive PM2.5	Exhaust PM2.5	PM2.5 Total	Bio- CO2	NBio- CO2	Total CO2	CH4	N2O	CO2e
Category	tons/yr										MT/yr					
Hauling	0.0000	0.0000	0.0000	0.0000	0.0000	0.0000	0.0000	0.0000	0.0000	0.0000	0.0000	0.0000	0.0000	0.0000	0.0000	0.0000
Vendor	0.0156	0.5721	0.2219	2.0100e-003	0.0798	3.1100e-003	0.0829	0.0231	2.9700e-003	0.0261	0.0000	197.4724	197.4724	6.8300e-003	0.0288	206.2378
Worker	0.1021	0.0612	1.0715	4.2700e-003	0.7184	1.3800e-003	0.7198	0.1909	1.2700e-003	0.1922	0.0000	437.2753	437.2753	4.8700e-003	9.0200e-003	440.0845
Total	0.1177	0.6333	1.2933	6.2800e-003	0.7982	4.4900e-003	0.8027	0.2140	4.2400e-003	0.2182	0.0000	634.7477	634.7477	0.0117	0.0379	646.3223

3.6 Paving - 2040

Unmitigated Construction On-Site

	ROG	NOx	CO	SO2	Fugitive PM10	Exhaust PM10	PM10 Total	Fugitive PM2.5	Exhaust PM2.5	PM2.5 Total	Bio- CO2	NBio- CO2	Total CO2	CH4	N2O	CO2e
Category	tons/yr										MT/yr					
Off-Road	0.0602	0.2176	0.9412	1.6700e-003		6.9300e-003	6.9300e-003		6.9300e-003	6.9300e-003	0.0000	143.3921	143.3921	4.8200e-003	0.0000	143.5126
Paving	0.0000					0.0000	0.0000		0.0000	0.0000	0.0000	0.0000	0.0000	0.0000	0.0000	0.0000
Total	0.0602	0.2176	0.9412	1.6700e-003		6.9300e-003	6.9300e-003		6.9300e-003	6.9300e-003	0.0000	143.3921	143.3921	4.8200e-003	0.0000	143.5126

Pismo Beach GP/LCP PEIR - GHG - San Luis Obispo County APCD Air District, Annual

EMFAC Off-Model Adjustment Factors for Gasoline Light Duty Vehicle to Account for the SAFE Vehicle Rule Applied

3.6 Paving - 2040

Unmitigated Construction Off-Site

	ROG	NOx	CO	SO2	Fugitive PM10	Exhaust PM10	PM10 Total	Fugitive PM2.5	Exhaust PM2.5	PM2.5 Total	Bio- CO2	NBio- CO2	Total CO2	CH4	N2O	CO2e
Category	tons/yr										MT/yr					
Hauling	0.0000	0.0000	0.0000	0.0000	0.0000	0.0000	0.0000	0.0000	0.0000	0.0000	0.0000	0.0000	0.0000	0.0000	0.0000	0.0000
Vendor	0.0000	0.0000	0.0000	0.0000	0.0000	0.0000	0.0000	0.0000	0.0000	0.0000	0.0000	0.0000	0.0000	0.0000	0.0000	0.0000
Worker	1.2200e-003	7.3000e-004	0.0128	5.0000e-005	8.5900e-003	2.0000e-005	8.6100e-003	2.2800e-003	2.0000e-005	2.3000e-003	0.0000	5.2300	5.2300	6.0000e-005	1.1000e-004	5.2636
Total	1.2200e-003	7.3000e-004	0.0128	5.0000e-005	8.5900e-003	2.0000e-005	8.6100e-003	2.2800e-003	2.0000e-005	2.3000e-003	0.0000	5.2300	5.2300	6.0000e-005	1.1000e-004	5.2636

Mitigated Construction On-Site

	ROG	NOx	CO	SO2	Fugitive PM10	Exhaust PM10	PM10 Total	Fugitive PM2.5	Exhaust PM2.5	PM2.5 Total	Bio- CO2	NBio- CO2	Total CO2	CH4	N2O	CO2e
Category	tons/yr										MT/yr					
Off-Road	0.0602	0.2176	0.9412	1.6700e-003		6.9300e-003	6.9300e-003		6.9300e-003	6.9300e-003	0.0000	143.3919	143.3919	4.8200e-003	0.0000	143.5124
Paving	0.0000					0.0000	0.0000		0.0000	0.0000	0.0000	0.0000	0.0000	0.0000	0.0000	0.0000
Total	0.0602	0.2176	0.9412	1.6700e-003		6.9300e-003	6.9300e-003		6.9300e-003	6.9300e-003	0.0000	143.3919	143.3919	4.8200e-003	0.0000	143.5124

Pismo Beach GP/LCP PEIR - GHG - San Luis Obispo County APCD Air District, Annual

EMFAC Off-Model Adjustment Factors for Gasoline Light Duty Vehicle to Account for the SAFE Vehicle Rule Applied

3.6 Paving - 2040

Mitigated Construction Off-Site

	ROG	NOx	CO	SO2	Fugitive PM10	Exhaust PM10	PM10 Total	Fugitive PM2.5	Exhaust PM2.5	PM2.5 Total	Bio- CO2	NBio- CO2	Total CO2	CH4	N2O	CO2e
Category	tons/yr										MT/yr					
Hauling	0.0000	0.0000	0.0000	0.0000	0.0000	0.0000	0.0000	0.0000	0.0000	0.0000	0.0000	0.0000	0.0000	0.0000	0.0000	0.0000
Vendor	0.0000	0.0000	0.0000	0.0000	0.0000	0.0000	0.0000	0.0000	0.0000	0.0000	0.0000	0.0000	0.0000	0.0000	0.0000	0.0000
Worker	1.2200e-003	7.3000e-004	0.0128	5.0000e-005	8.5900e-003	2.0000e-005	8.6100e-003	2.2800e-003	2.0000e-005	2.3000e-003	0.0000	5.2300	5.2300	6.0000e-005	1.1000e-004	5.2636
Total	1.2200e-003	7.3000e-004	0.0128	5.0000e-005	8.5900e-003	2.0000e-005	8.6100e-003	2.2800e-003	2.0000e-005	2.3000e-003	0.0000	5.2300	5.2300	6.0000e-005	1.1000e-004	5.2636

3.6 Paving - 2041

Unmitigated Construction On-Site

	ROG	NOx	CO	SO2	Fugitive PM10	Exhaust PM10	PM10 Total	Fugitive PM2.5	Exhaust PM2.5	PM2.5 Total	Bio- CO2	NBio- CO2	Total CO2	CH4	N2O	CO2e
Category	tons/yr										MT/yr					
Off-Road	0.1067	0.3858	1.6688	2.9600e-003		0.0123	0.0123		0.0123	0.0123	0.0000	254.2499	254.2499	8.5500e-003	0.0000	254.4635
Paving	0.0000					0.0000	0.0000		0.0000	0.0000	0.0000	0.0000	0.0000	0.0000	0.0000	0.0000
Total	0.1067	0.3858	1.6688	2.9600e-003		0.0123	0.0123		0.0123	0.0123	0.0000	254.2499	254.2499	8.5500e-003	0.0000	254.4635

Pismo Beach GP/LCP PEIR - GHG - San Luis Obispo County APCD Air District, Annual

EMFAC Off-Model Adjustment Factors for Gasoline Light Duty Vehicle to Account for the SAFE Vehicle Rule Applied

3.6 Paving - 2041

Unmitigated Construction Off-Site

	ROG	NOx	CO	SO2	Fugitive PM10	Exhaust PM10	PM10 Total	Fugitive PM2.5	Exhaust PM2.5	PM2.5 Total	Bio- CO2	NBio- CO2	Total CO2	CH4	N2O	CO2e
Category	tons/yr										MT/yr					
Hauling	0.0000	0.0000	0.0000	0.0000	0.0000	0.0000	0.0000	0.0000	0.0000	0.0000	0.0000	0.0000	0.0000	0.0000	0.0000	0.0000
Vendor	0.0000	0.0000	0.0000	0.0000	0.0000	0.0000	0.0000	0.0000	0.0000	0.0000	0.0000	0.0000	0.0000	0.0000	0.0000	0.0000
Worker	2.1700e-003	1.3000e-003	0.0227	9.0000e-005	0.0152	3.0000e-005	0.0153	4.0500e-003	3.0000e-005	4.0800e-003	0.0000	9.2734	9.2734	1.0000e-004	1.9000e-004	9.3330
Total	2.1700e-003	1.3000e-003	0.0227	9.0000e-005	0.0152	3.0000e-005	0.0153	4.0500e-003	3.0000e-005	4.0800e-003	0.0000	9.2734	9.2734	1.0000e-004	1.9000e-004	9.3330

Mitigated Construction On-Site

	ROG	NOx	CO	SO2	Fugitive PM10	Exhaust PM10	PM10 Total	Fugitive PM2.5	Exhaust PM2.5	PM2.5 Total	Bio- CO2	NBio- CO2	Total CO2	CH4	N2O	CO2e
Category	tons/yr										MT/yr					
Off-Road	0.1067	0.3858	1.6688	2.9600e-003		0.0123	0.0123		0.0123	0.0123	0.0000	254.2496	254.2496	8.5500e-003	0.0000	254.4632
Paving	0.0000					0.0000	0.0000		0.0000	0.0000	0.0000	0.0000	0.0000	0.0000	0.0000	0.0000
Total	0.1067	0.3858	1.6688	2.9600e-003		0.0123	0.0123		0.0123	0.0123	0.0000	254.2496	254.2496	8.5500e-003	0.0000	254.4632

Pismo Beach GP/LCP PEIR - GHG - San Luis Obispo County APCD Air District, Annual

EMFAC Off-Model Adjustment Factors for Gasoline Light Duty Vehicle to Account for the SAFE Vehicle Rule Applied

3.6 Paving - 2041

Mitigated Construction Off-Site

	ROG	NOx	CO	SO2	Fugitive PM10	Exhaust PM10	PM10 Total	Fugitive PM2.5	Exhaust PM2.5	PM2.5 Total	Bio- CO2	NBio- CO2	Total CO2	CH4	N2O	CO2e
Category	tons/yr										MT/yr					
Hauling	0.0000	0.0000	0.0000	0.0000	0.0000	0.0000	0.0000	0.0000	0.0000	0.0000	0.0000	0.0000	0.0000	0.0000	0.0000	0.0000
Vendor	0.0000	0.0000	0.0000	0.0000	0.0000	0.0000	0.0000	0.0000	0.0000	0.0000	0.0000	0.0000	0.0000	0.0000	0.0000	0.0000
Worker	2.1700e-003	1.3000e-003	0.0227	9.0000e-005	0.0152	3.0000e-005	0.0153	4.0500e-003	3.0000e-005	4.0800e-003	0.0000	9.2734	9.2734	1.0000e-004	1.9000e-004	9.3330
Total	2.1700e-003	1.3000e-003	0.0227	9.0000e-005	0.0152	3.0000e-005	0.0153	4.0500e-003	3.0000e-005	4.0800e-003	0.0000	9.2734	9.2734	1.0000e-004	1.9000e-004	9.3330

3.7 Architectural Coating - 2040

Unmitigated Construction On-Site

	ROG	NOx	CO	SO2	Fugitive PM10	Exhaust PM10	PM10 Total	Fugitive PM2.5	Exhaust PM2.5	PM2.5 Total	Bio- CO2	NBio- CO2	Total CO2	CH4	N2O	CO2e
Category	tons/yr										MT/yr					
Archit. Coating	1.8794					0.0000	0.0000		0.0000	0.0000	0.0000	0.0000	0.0000	0.0000	0.0000	0.0000
Off-Road	2.8700e-003	0.0182	0.0448	7.0000e-005		1.9000e-004	1.9000e-004		1.9000e-004	1.9000e-004	0.0000	6.3831	6.3831	2.2000e-004	0.0000	6.3888
Total	1.8822	0.0182	0.0448	7.0000e-005		1.9000e-004	1.9000e-004		1.9000e-004	1.9000e-004	0.0000	6.3831	6.3831	2.2000e-004	0.0000	6.3888

Pismo Beach GP/LCP PEIR - GHG - San Luis Obispo County APCD Air District, Annual

EMFAC Off-Model Adjustment Factors for Gasoline Light Duty Vehicle to Account for the SAFE Vehicle Rule Applied

3.7 Architectural Coating - 2040

Unmitigated Construction Off-Site

	ROG	NOx	CO	SO2	Fugitive PM10	Exhaust PM10	PM10 Total	Fugitive PM2.5	Exhaust PM2.5	PM2.5 Total	Bio- CO2	NBio- CO2	Total CO2	CH4	N2O	CO2e
Category	tons/yr										MT/yr					
Hauling	0.0000	0.0000	0.0000	0.0000	0.0000	0.0000	0.0000	0.0000	0.0000	0.0000	0.0000	0.0000	0.0000	0.0000	0.0000	0.0000
Vendor	0.0000	0.0000	0.0000	0.0000	0.0000	0.0000	0.0000	0.0000	0.0000	0.0000	0.0000	0.0000	0.0000	0.0000	0.0000	0.0000
Worker	7.1800e-003	4.3000e-003	0.0754	3.0000e-004	0.0505	1.0000e-004	0.0506	0.0134	9.0000e-005	0.0135	0.0000	30.7647	30.7647	3.4000e-004	6.3000e-004	30.9624
Total	7.1800e-003	4.3000e-003	0.0754	3.0000e-004	0.0505	1.0000e-004	0.0506	0.0134	9.0000e-005	0.0135	0.0000	30.7647	30.7647	3.4000e-004	6.3000e-004	30.9624

Mitigated Construction On-Site

	ROG	NOx	CO	SO2	Fugitive PM10	Exhaust PM10	PM10 Total	Fugitive PM2.5	Exhaust PM2.5	PM2.5 Total	Bio- CO2	NBio- CO2	Total CO2	CH4	N2O	CO2e
Category	tons/yr										MT/yr					
Archit. Coating	1.8794					0.0000	0.0000		0.0000	0.0000	0.0000	0.0000	0.0000	0.0000	0.0000	0.0000
Off-Road	2.8700e-003	0.0182	0.0448	7.0000e-005		1.9000e-004	1.9000e-004		1.9000e-004	1.9000e-004	0.0000	6.3831	6.3831	2.2000e-004	0.0000	6.3887
Total	1.8822	0.0182	0.0448	7.0000e-005		1.9000e-004	1.9000e-004		1.9000e-004	1.9000e-004	0.0000	6.3831	6.3831	2.2000e-004	0.0000	6.3887

Pismo Beach GP/LCP PEIR - GHG - San Luis Obispo County APCD Air District, Annual

EMFAC Off-Model Adjustment Factors for Gasoline Light Duty Vehicle to Account for the SAFE Vehicle Rule Applied

3.7 Architectural Coating - 2040

Mitigated Construction Off-Site

	ROG	NOx	CO	SO2	Fugitive PM10	Exhaust PM10	PM10 Total	Fugitive PM2.5	Exhaust PM2.5	PM2.5 Total	Bio- CO2	NBio- CO2	Total CO2	CH4	N2O	CO2e
Category	tons/yr										MT/yr					
Hauling	0.0000	0.0000	0.0000	0.0000	0.0000	0.0000	0.0000	0.0000	0.0000	0.0000	0.0000	0.0000	0.0000	0.0000	0.0000	0.0000
Vendor	0.0000	0.0000	0.0000	0.0000	0.0000	0.0000	0.0000	0.0000	0.0000	0.0000	0.0000	0.0000	0.0000	0.0000	0.0000	0.0000
Worker	7.1800e-003	4.3000e-003	0.0754	3.0000e-004	0.0505	1.0000e-004	0.0506	0.0134	9.0000e-005	0.0135	0.0000	30.7647	30.7647	3.4000e-004	6.3000e-004	30.9624
Total	7.1800e-003	4.3000e-003	0.0754	3.0000e-004	0.0505	1.0000e-004	0.0506	0.0134	9.0000e-005	0.0135	0.0000	30.7647	30.7647	3.4000e-004	6.3000e-004	30.9624

3.7 Architectural Coating - 2041

Unmitigated Construction On-Site

	ROG	NOx	CO	SO2	Fugitive PM10	Exhaust PM10	PM10 Total	Fugitive PM2.5	Exhaust PM2.5	PM2.5 Total	Bio- CO2	NBio- CO2	Total CO2	CH4	N2O	CO2e
Category	tons/yr										MT/yr					
Off-Road	0.0150	0.0949	0.2339	3.9000e-004		9.7000e-004	9.7000e-004		9.7000e-004	9.7000e-004	0.0000	33.3200	33.3200	1.1700e-003	0.0000	33.3493
Total	0.0150	0.0949	0.2339	3.9000e-004		9.7000e-004	9.7000e-004		9.7000e-004	9.7000e-004	0.0000	33.3200	33.3200	1.1700e-003	0.0000	33.3493

Pismo Beach GP/LCP PEIR - GHG - San Luis Obispo County APCD Air District, Annual

EMFAC Off-Model Adjustment Factors for Gasoline Light Duty Vehicle to Account for the SAFE Vehicle Rule Applied

3.7 Architectural Coating - 2041

Unmitigated Construction Off-Site

	ROG	NOx	CO	SO2	Fugitive PM10	Exhaust PM10	PM10 Total	Fugitive PM2.5	Exhaust PM2.5	PM2.5 Total	Bio- CO2	NBio- CO2	Total CO2	CH4	N2O	CO2e
Category	tons/yr										MT/yr					
Hauling	0.0000	0.0000	0.0000	0.0000	0.0000	0.0000	0.0000	0.0000	0.0000	0.0000	0.0000	0.0000	0.0000	0.0000	0.0000	0.0000
Vendor	0.0000	0.0000	0.0000	0.0000	0.0000	0.0000	0.0000	0.0000	0.0000	0.0000	0.0000	0.0000	0.0000	0.0000	0.0000	0.0000
Worker	0.0375	0.0225	0.3935	1.5700e-003	0.2638	5.1000e-004	0.2643	0.0701	4.7000e-004	0.0706	0.0000	160.5919	160.5919	1.7900e-003	3.3100e-003	161.6236
Total	0.0375	0.0225	0.3935	1.5700e-003	0.2638	5.1000e-004	0.2643	0.0701	4.7000e-004	0.0706	0.0000	160.5919	160.5919	1.7900e-003	3.3100e-003	161.6236

Mitigated Construction On-Site

	ROG	NOx	CO	SO2	Fugitive PM10	Exhaust PM10	PM10 Total	Fugitive PM2.5	Exhaust PM2.5	PM2.5 Total	Bio- CO2	NBio- CO2	Total CO2	CH4	N2O	CO2e
Category	tons/yr										MT/yr					
Off-Road	0.0150	0.0949	0.2339	3.9000e-004		9.7000e-004	9.7000e-004		9.7000e-004	9.7000e-004	0.0000	33.3199	33.3199	1.1700e-003	0.0000	33.3492
Total	0.0150	0.0949	0.2339	3.9000e-004		9.7000e-004	9.7000e-004		9.7000e-004	9.7000e-004	0.0000	33.3199	33.3199	1.1700e-003	0.0000	33.3492

Pismo Beach GP/LCP PEIR - GHG - San Luis Obispo County APCD Air District, Annual

EMFAC Off-Model Adjustment Factors for Gasoline Light Duty Vehicle to Account for the SAFE Vehicle Rule Applied

3.7 Architectural Coating - 2041

Mitigated Construction Off-Site

	ROG	NOx	CO	SO2	Fugitive PM10	Exhaust PM10	PM10 Total	Fugitive PM2.5	Exhaust PM2.5	PM2.5 Total	Bio- CO2	NBio- CO2	Total CO2	CH4	N2O	CO2e
Category	tons/yr										MT/yr					
Hauling	0.0000	0.0000	0.0000	0.0000	0.0000	0.0000	0.0000	0.0000	0.0000	0.0000	0.0000	0.0000	0.0000	0.0000	0.0000	0.0000
Vendor	0.0000	0.0000	0.0000	0.0000	0.0000	0.0000	0.0000	0.0000	0.0000	0.0000	0.0000	0.0000	0.0000	0.0000	0.0000	0.0000
Worker	0.0375	0.0225	0.3935	1.5700e-003	0.2638	5.1000e-004	0.2643	0.0701	4.7000e-004	0.0706	0.0000	160.5919	160.5919	1.7900e-003	3.3100e-003	161.6236
Total	0.0375	0.0225	0.3935	1.5700e-003	0.2638	5.1000e-004	0.2643	0.0701	4.7000e-004	0.0706	0.0000	160.5919	160.5919	1.7900e-003	3.3100e-003	161.6236

3.7 Architectural Coating - 2042

Unmitigated Construction On-Site

	ROG	NOx	CO	SO2	Fugitive PM10	Exhaust PM10	PM10 Total	Fugitive PM2.5	Exhaust PM2.5	PM2.5 Total	Bio- CO2	NBio- CO2	Total CO2	CH4	N2O	CO2e
Category	tons/yr										MT/yr					
Off-Road	1.0900e-003	6.9100e-003	0.0170	3.0000e-005		7.0000e-005	7.0000e-005		7.0000e-005	7.0000e-005	0.0000	2.4256	2.4256	9.0000e-005	0.0000	2.4277
Total	1.0900e-003	6.9100e-003	0.0170	3.0000e-005		7.0000e-005	7.0000e-005		7.0000e-005	7.0000e-005	0.0000	2.4256	2.4256	9.0000e-005	0.0000	2.4277

Pismo Beach GP/LCP PEIR - GHG - San Luis Obispo County APCD Air District, Annual

EMFAC Off-Model Adjustment Factors for Gasoline Light Duty Vehicle to Account for the SAFE Vehicle Rule Applied

3.7 Architectural Coating - 2042

Unmitigated Construction Off-Site

	ROG	NOx	CO	SO2	Fugitive PM10	Exhaust PM10	PM10 Total	Fugitive PM2.5	Exhaust PM2.5	PM2.5 Total	Bio- CO2	NBio- CO2	Total CO2	CH4	N2O	CO2e
Category	tons/yr										MT/yr					
Hauling	0.0000	0.0000	0.0000	0.0000	0.0000	0.0000	0.0000	0.0000	0.0000	0.0000	0.0000	0.0000	0.0000	0.0000	0.0000	0.0000
Vendor	0.0000	0.0000	0.0000	0.0000	0.0000	0.0000	0.0000	0.0000	0.0000	0.0000	0.0000	0.0000	0.0000	0.0000	0.0000	0.0000
Worker	2.7300e-003	1.6400e-003	0.0287	1.1000e-004	0.0192	4.0000e-005	0.0192	5.1000e-003	3.0000e-005	5.1400e-003	0.0000	11.6906	11.6906	1.3000e-004	2.4000e-004	11.7657
Total	2.7300e-003	1.6400e-003	0.0287	1.1000e-004	0.0192	4.0000e-005	0.0192	5.1000e-003	3.0000e-005	5.1400e-003	0.0000	11.6906	11.6906	1.3000e-004	2.4000e-004	11.7657

Mitigated Construction On-Site

	ROG	NOx	CO	SO2	Fugitive PM10	Exhaust PM10	PM10 Total	Fugitive PM2.5	Exhaust PM2.5	PM2.5 Total	Bio- CO2	NBio- CO2	Total CO2	CH4	N2O	CO2e
Category	tons/yr										MT/yr					
Off-Road	1.0900e-003	6.9100e-003	0.0170	3.0000e-005		7.0000e-005	7.0000e-005		7.0000e-005	7.0000e-005	0.0000	2.4256	2.4256	9.0000e-005	0.0000	2.4277
Total	1.0900e-003	6.9100e-003	0.0170	3.0000e-005		7.0000e-005	7.0000e-005		7.0000e-005	7.0000e-005	0.0000	2.4256	2.4256	9.0000e-005	0.0000	2.4277

Pismo Beach GP/LCP PEIR - GHG - San Luis Obispo County APCD Air District, Annual

EMFAC Off-Model Adjustment Factors for Gasoline Light Duty Vehicle to Account for the SAFE Vehicle Rule Applied

3.7 Architectural Coating - 2042

Mitigated Construction Off-Site

	ROG	NOx	CO	SO2	Fugitive PM10	Exhaust PM10	PM10 Total	Fugitive PM2.5	Exhaust PM2.5	PM2.5 Total	Bio- CO2	NBio- CO2	Total CO2	CH4	N2O	CO2e
Category	tons/yr										MT/yr					
Hauling	0.0000	0.0000	0.0000	0.0000	0.0000	0.0000	0.0000	0.0000	0.0000	0.0000	0.0000	0.0000	0.0000	0.0000	0.0000	0.0000
Vendor	0.0000	0.0000	0.0000	0.0000	0.0000	0.0000	0.0000	0.0000	0.0000	0.0000	0.0000	0.0000	0.0000	0.0000	0.0000	0.0000
Worker	2.7300e-003	1.6400e-003	0.0287	1.1000e-004	0.0192	4.0000e-005	0.0192	5.1000e-003	3.0000e-005	5.1400e-003	0.0000	11.6906	11.6906	1.3000e-004	2.4000e-004	11.7657
Total	2.7300e-003	1.6400e-003	0.0287	1.1000e-004	0.0192	4.0000e-005	0.0192	5.1000e-003	3.0000e-005	5.1400e-003	0.0000	11.6906	11.6906	1.3000e-004	2.4000e-004	11.7657

4.0 Operational Detail - Mobile

4.1 Mitigation Measures Mobile

Pismo Beach GP/LCP PEIR - GHG - San Luis Obispo County APCD Air District, Annual

EMFAC Off-Model Adjustment Factors for Gasoline Light Duty Vehicle to Account for the SAFE Vehicle Rule Applied

	ROG	NOx	CO	SO2	Fugitive PM10	Exhaust PM10	PM10 Total	Fugitive PM2.5	Exhaust PM2.5	PM2.5 Total	Bio- CO2	NBio- CO2	Total CO2	CH4	N2O	CO2e
Category	tons/yr										MT/yr					
Mitigated	1.3370	1.5521	14.8323	0.0339	5.0175	0.0178	5.0352	1.3382	0.0166	1.3548	0.0000	3,423,244 3	3,423,244 3	0.1625	0.1342	3,467,282 6
Unmitigated	1.3370	1.5521	14.8323	0.0339	5.0175	0.0178	5.0352	1.3382	0.0166	1.3548	0.0000	3,423,244 3	3,423,244 3	0.1625	0.1342	3,467,282 6

4.2 Trip Summary Information

Land Use	Average Daily Trip Rate			Unmitigated	Mitigated
	Weekday	Saturday	Sunday	Annual VMT	Annual VMT
Apartments Low Rise	200.64	223.44	173.28	915,611	915,611
Apartments Mid Rise	113.40	95.58	79.38	485,275	485,275
Apartments Mid Rise	505.40	425.98	353.78	2,162,770	2,162,770
Government (Civic Center)	25.99	0.00	0.00	49,223	49,223
Office Park	559.84	84.19	37.88	1,836,518	1,836,518
Strip Mall	1,339.20	1,257.36	610.08	5,585,619	5,585,619
Strip Mall	583.20	547.56	265.68	2,432,447	2,432,447
Total	3,327.67	2,634.11	1,520.08	13,467,463	13,467,463

4.3 Trip Type Information

Land Use	Miles			Trip %			Trip Purpose %		
	H-W or C-W	H-S or C-C	H-O or C-NW	H-W or C-W	H-S or C-C	H-O or C-NW	Primary	Diverted	Pass-by
Apartments Low Rise	23.42	9.01	9.01	35.80	21.00	43.20	86	11	3
Apartments Mid Rise	23.42	9.01	9.01	35.80	21.00	43.20	86	11	3
Apartments Mid Rise	23.42	9.01	9.01	35.80	21.00	43.20	86	11	3
Government (Civic Center)	12.87	10.73	12.48	75.00	20.00	5.00	50	34	16
Office Park	24.95	9.60	6.60	33.00	48.00	19.00	82	15	3

Pismo Beach GP/LCP PEIR - GHG - San Luis Obispo County APCD Air District, Annual

EMFAC Off-Model Adjustment Factors for Gasoline Light Duty Vehicle to Account for the SAFE Vehicle Rule Applied

Land Use	Miles			Trip %			Trip Purpose %		
	H-W or C-W	H-S or C-C	H-O or C-NW	H-W or C-W	H-S or C-C	H-O or C-NW	Primary	Diverted	Pass-by
Strip Mall	46.79	18.00	18.00	16.60	64.40	19.00	45	40	15
Strip Mall	46.79	18.00	18.00	16.60	64.40	19.00	45	40	15

4.4 Fleet Mix

Land Use	LDA	LDT1	LDT2	MDV	LHD1	LHD2	MHD	HHD	OBUS	UBUS	MCY	SBUS	MH
Apartments Low Rise	0.537981	0.060917	0.197944	0.129503	0.022130	0.006150	0.007595	0.005434	0.000841	0.000325	0.027432	0.000740	0.003008
Apartments Mid Rise	0.537981	0.060917	0.197944	0.129503	0.022130	0.006150	0.007595	0.005434	0.000841	0.000325	0.027432	0.000740	0.003008
Government (Civic Center)	0.537981	0.060917	0.197944	0.129503	0.022130	0.006150	0.007595	0.005434	0.000841	0.000325	0.027432	0.000740	0.003008
Office Park	0.537981	0.060917	0.197944	0.129503	0.022130	0.006150	0.007595	0.005434	0.000841	0.000325	0.027432	0.000740	0.003008
Strip Mall	0.537981	0.060917	0.197944	0.129503	0.022130	0.006150	0.007595	0.005434	0.000841	0.000325	0.027432	0.000740	0.003008

5.0 Energy Detail

Historical Energy Use: N

5.1 Mitigation Measures Energy

Pismo Beach GP/LCP PEIR - GHG - San Luis Obispo County APCD Air District, Annual

EMFAC Off-Model Adjustment Factors for Gasoline Light Duty Vehicle to Account for the SAFE Vehicle Rule Applied

	ROG	NOx	CO	SO2	Fugitive PM10	Exhaust PM10	PM10 Total	Fugitive PM2.5	Exhaust PM2.5	PM2.5 Total	Bio- CO2	NBio- CO2	Total CO2	CH4	N2O	CO2e
Category	tons/yr										MT/yr					
Electricity Mitigated						0.0000	0.0000		0.0000	0.0000	0.0000	1,485.6170	1,485.6170	0.2403	0.0291	1,500.3071
Electricity Unmitigated						0.0000	0.0000		0.0000	0.0000	0.0000	1,485.6170	1,485.6170	0.2403	0.0291	1,500.3071
Natural Gas Mitigated	0.1046	0.9224	0.5904	5.7000e-003		0.0723	0.0723		0.0723	0.0723	0.0000	1,035.0794	1,035.0794	0.0198	0.0190	1,041.2304
Natural Gas Unmitigated	0.1046	0.9224	0.5904	5.7000e-003		0.0723	0.0723		0.0723	0.0723	0.0000	1,035.0794	1,035.0794	0.0198	0.0190	1,041.2304

Pismo Beach GP/LCP PEIR - GHG - San Luis Obispo County APCD Air District, Annual

EMFAC Off-Model Adjustment Factors for Gasoline Light Duty Vehicle to Account for the SAFE Vehicle Rule Applied

5.2 Energy by Land Use - NaturalGas

Unmitigated

	NaturalGas Use	ROG	NOx	CO	SO2	Fugitive PM10	Exhaust PM10	PM10 Total	Fugitive PM2.5	Exhaust PM2.5	PM2.5 Total	Bio- CO2	NBio- CO2	Total CO2	CH4	N2O	CO2e
Land Use	kBTU/yr	tons/yr										MT/yr					
Apartments Low Rise	2.24986e+006	0.0121	0.1037	0.0441	6.6000e-004		8.3800e-003	8.3800e-003		8.3800e-003	8.3800e-003	0.0000	120.0609	120.0609	2.3000e-003	2.2000e-003	120.7744
Apartments Mid Rise	1.35783e+006	7.3200e-003	0.0626	0.0266	4.0000e-004		5.0600e-003	5.0600e-003		5.0600e-003	5.0600e-003	0.0000	72.4591	72.4591	1.3900e-003	1.3300e-003	72.8897
Apartments Mid Rise	6.05157e+006	0.0326	0.2789	0.1187	1.7800e-003		0.0226	0.0226		0.0226	0.0226	0.0000	322.9350	322.9350	6.1900e-003	5.9200e-003	324.8540
Government (Civic Center)	102708	5.5000e-004	5.0300e-003	4.2300e-003	3.0000e-005		3.8000e-004	3.8000e-004		3.8000e-004	3.8000e-004	0.0000	5.4809	5.4809	1.1000e-004	1.0000e-004	5.5135
Office Park	8.80165e+006	0.0475	0.4315	0.3624	2.5900e-003		0.0328	0.0328		0.0328	0.0328	0.0000	469.6894	469.6894	9.0000e-003	8.6100e-003	472.4805
Strip Mall	252720	1.3600e-003	0.0124	0.0104	7.0000e-005		9.4000e-004	9.4000e-004		9.4000e-004	9.4000e-004	0.0000	13.4861	13.4861	2.6000e-004	2.5000e-004	13.5662
Strip Mall	580320	3.1300e-003	0.0285	0.0239	1.7000e-004		2.1600e-003	2.1600e-003		2.1600e-003	2.1600e-003	0.0000	30.9681	30.9681	5.9000e-004	5.7000e-004	31.1521
Total		0.1046	0.9224	0.5904	5.7000e-003		0.0723	0.0723		0.0723	0.0723	0.0000	1,035.0794	1,035.0794	0.0198	0.0190	1,041.2304

Pismo Beach GP/LCP PEIR - GHG - San Luis Obispo County APCD Air District, Annual

EMFAC Off-Model Adjustment Factors for Gasoline Light Duty Vehicle to Account for the SAFE Vehicle Rule Applied

5.2 Energy by Land Use - NaturalGas

Mitigated

	NaturalGas Use	ROG	NOx	CO	SO2	Fugitive PM10	Exhaust PM10	PM10 Total	Fugitive PM2.5	Exhaust PM2.5	PM2.5 Total	Bio- CO2	NBio- CO2	Total CO2	CH4	N2O	CO2e
Land Use	kBTU/yr	tons/yr										MT/yr					
Apartments Low Rise	2.24986e+006	0.0121	0.1037	0.0441	6.6000e-004		8.3800e-003	8.3800e-003		8.3800e-003	8.3800e-003	0.0000	120.0609	120.0609	2.3000e-003	2.2000e-003	120.7744
Apartments Mid Rise	1.35783e+006	7.3200e-003	0.0626	0.0266	4.0000e-004		5.0600e-003	5.0600e-003		5.0600e-003	5.0600e-003	0.0000	72.4591	72.4591	1.3900e-003	1.3300e-003	72.8897
Apartments Mid Rise	6.05157e+006	0.0326	0.2789	0.1187	1.7800e-003		0.0226	0.0226		0.0226	0.0226	0.0000	322.9350	322.9350	6.1900e-003	5.9200e-003	324.8540
Government (Civic Center)	102708	5.5000e-004	5.0300e-003	4.2300e-003	3.0000e-005		3.8000e-004	3.8000e-004		3.8000e-004	3.8000e-004	0.0000	5.4809	5.4809	1.1000e-004	1.0000e-004	5.5135
Office Park	8.80165e+006	0.0475	0.4315	0.3624	2.5900e-003		0.0328	0.0328		0.0328	0.0328	0.0000	469.6894	469.6894	9.0000e-003	8.6100e-003	472.4805
Strip Mall	252720	1.3600e-003	0.0124	0.0104	7.0000e-005		9.4000e-004	9.4000e-004		9.4000e-004	9.4000e-004	0.0000	13.4861	13.4861	2.6000e-004	2.5000e-004	13.5662
Strip Mall	580320	3.1300e-003	0.0285	0.0239	1.7000e-004		2.1600e-003	2.1600e-003		2.1600e-003	2.1600e-003	0.0000	30.9681	30.9681	5.9000e-004	5.7000e-004	31.1521
Total		0.1046	0.9224	0.5904	5.7000e-003		0.0723	0.0723		0.0723	0.0723	0.0000	1,035.0794	1,035.0794	0.0198	0.0190	1,041.2304

Pismo Beach GP/LCP PEIR - GHG - San Luis Obispo County APCD Air District, Annual

EMFAC Off-Model Adjustment Factors for Gasoline Light Duty Vehicle to Account for the SAFE Vehicle Rule Applied

5.3 Energy by Land Use - Electricity

Unmitigated

Land Use	Electricity Use kWh/yr	Total CO2 MT/yr	CH4 MT/yr	N2O MT/yr	CO2e MT/yr
Apartments Low Rise	925910	85.6687	0.0139	1.6800e-003	86.5158
Apartments Mid Rise	2.79156e+006	258.2859	0.0418	5.0600e-003	260.8399
Apartments Mid Rise	626362	57.9533	9.3800e-003	1.1400e-003	58.5264
Government (Civic Center)	108858	10.0719	1.6300e-003	2.0000e-004	10.1715
Office Park	7.90507e+006	731.4065	0.1183	0.0143	738.6388
Strip Mall	1.12212e+006	103.8228	0.0168	2.0400e-003	104.8494
Strip Mall	2.57672e+006	238.4079	0.0386	4.6800e-003	240.7653
Total		1,485.6170	0.2404	0.0291	1,500.3071

Pismo Beach GP/LCP PEIR - GHG - San Luis Obispo County APCD Air District, Annual

EMFAC Off-Model Adjustment Factors for Gasoline Light Duty Vehicle to Account for the SAFE Vehicle Rule Applied

5.3 Energy by Land Use - Electricity

Mitigated

Land Use	Electricity Use kWh/yr	Total CO2 MT/yr	CH4 MT/yr	N2O MT/yr	CO2e MT/yr
Apartments Low Rise	925910	85.6687	0.0139	1.6800e-003	86.5158
Apartments Mid Rise	2.79156e+006	258.2859	0.0418	5.0600e-003	260.8399
Apartments Mid Rise	626362	57.9533	9.3800e-003	1.1400e-003	58.5264
Government (Civic Center)	108858	10.0719	1.6300e-003	2.0000e-004	10.1715
Office Park	7.90507e+006	731.4065	0.1183	0.0143	738.6388
Strip Mall	1.12212e+006	103.8228	0.0168	2.0400e-003	104.8494
Strip Mall	2.57672e+006	238.4079	0.0386	4.6800e-003	240.7653
Total		1,485.6170	0.2404	0.0291	1,500.3071

6.0 Area Detail

6.1 Mitigation Measures Area

Pismo Beach GP/LCP PEIR - GHG - San Luis Obispo County APCD Air District, Annual

EMFAC Off-Model Adjustment Factors for Gasoline Light Duty Vehicle to Account for the SAFE Vehicle Rule Applied

	ROG	NOx	CO	SO2	Fugitive PM10	Exhaust PM10	PM10 Total	Fugitive PM2.5	Exhaust PM2.5	PM2.5 Total	Bio- CO2	NBio- CO2	Total CO2	CH4	N2O	CO2e
Category	tons/yr										MT/yr					
Mitigated	9.0943	0.1741	15.0840	8.0000e-004		0.0840	0.0840		0.0840	0.0840	0.0000	24.7522	24.7522	0.0236	0.0000	25.3423
Unmitigated	9.0943	0.1741	15.0840	8.0000e-004		0.0840	0.0840		0.0840	0.0840	0.0000	24.7522	24.7522	0.0236	0.0000	25.3423

6.2 Area by SubCategory

Unmitigated

	ROG	NOx	CO	SO2	Fugitive PM10	Exhaust PM10	PM10 Total	Fugitive PM2.5	Exhaust PM2.5	PM2.5 Total	Bio- CO2	NBio- CO2	Total CO2	CH4	N2O	CO2e
SubCategory	tons/yr										MT/yr					
Architectural Coating	1.2404					0.0000	0.0000		0.0000	0.0000	0.0000	0.0000	0.0000	0.0000	0.0000	0.0000
Consumer Products	7.4020					0.0000	0.0000		0.0000	0.0000	0.0000	0.0000	0.0000	0.0000	0.0000	0.0000
Hearth	0.0000	0.0000	0.0000	0.0000		0.0000	0.0000		0.0000	0.0000	0.0000	0.0000	0.0000	0.0000	0.0000	0.0000
Landscaping	0.4520	0.1741	15.0840	8.0000e-004		0.0840	0.0840		0.0840	0.0840	0.0000	24.7522	24.7522	0.0236	0.0000	25.3423
Total	9.0943	0.1741	15.0840	8.0000e-004		0.0840	0.0840		0.0840	0.0840	0.0000	24.7522	24.7522	0.0236	0.0000	25.3423

Pismo Beach GP/LCP PEIR - GHG - San Luis Obispo County APCD Air District, Annual

EMFAC Off-Model Adjustment Factors for Gasoline Light Duty Vehicle to Account for the SAFE Vehicle Rule Applied

6.2 Area by SubCategory

Mitigated

	ROG	NOx	CO	SO2	Fugitive PM10	Exhaust PM10	PM10 Total	Fugitive PM2.5	Exhaust PM2.5	PM2.5 Total	Bio- CO2	NBio- CO2	Total CO2	CH4	N2O	CO2e
SubCategory	tons/yr										MT/yr					
Architectural Coating	1.2404					0.0000	0.0000		0.0000	0.0000	0.0000	0.0000	0.0000	0.0000	0.0000	0.0000
Consumer Products	7.4020					0.0000	0.0000		0.0000	0.0000	0.0000	0.0000	0.0000	0.0000	0.0000	0.0000
Hearth	0.0000	0.0000	0.0000	0.0000		0.0000	0.0000		0.0000	0.0000	0.0000	0.0000	0.0000	0.0000	0.0000	0.0000
Landscaping	0.4520	0.1741	15.0840	8.0000e-004		0.0840	0.0840		0.0840	0.0840	0.0000	24.7522	24.7522	0.0236	0.0000	25.3423
Total	9.0943	0.1741	15.0840	8.0000e-004		0.0840	0.0840		0.0840	0.0840	0.0000	24.7522	24.7522	0.0236	0.0000	25.3423

7.0 Water Detail

7.1 Mitigation Measures Water

- Apply Water Conservation Strategy
- Use Water Efficient Irrigation System

Pismo Beach GP/LCP PEIR - GHG - San Luis Obispo County APCD Air District, Annual

EMFAC Off-Model Adjustment Factors for Gasoline Light Duty Vehicle to Account for the SAFE Vehicle Rule Applied

	Total CO2	CH4	N2O	CO2e
Category	MT/yr			
Mitigated	149.5607	4.5762	0.1097	296.6592
Unmitigated	178.1699	5.7188	0.1370	361.9562

7.2 Water by Land Use

Unmitigated

	Indoor/Outdoor Use	Total CO2	CH4	N2O	CO2e
Land Use	Mgal	MT/yr			
Apartments Low Rise	14.8551 / 9.36518	15.1828	0.4858	0.0116	30.7937
Apartments Mid Rise	57.5962 / 36.3106	58.8665	1.8833	0.0451	119.3929
Government (Civic Center)	1.2595 / 0.771953	1.2801	0.0412	9.9000e-004	2.6036
Office Park	74.8135 / 45.8534	76.0388	2.4463	0.0586	154.6543
Strip Mall	26.3698 / 16.1621	26.8017	0.8622	0.0207	54.5117
Total		178.1699	5.7188	0.1370	361.9562

Pismo Beach GP/LCP PEIR - GHG - San Luis Obispo County APCD Air District, Annual

EMFAC Off-Model Adjustment Factors for Gasoline Light Duty Vehicle to Account for the SAFE Vehicle Rule Applied

7.2 Water by Land Use

Mitigated

	Indoor/Outdoor Use	Total CO2	CH4	N2O	CO2e
Land Use	Mgal	MT/yr			
Apartments Low Rise	11.8841 / 9.36518	12.7528	0.3887	9.3200e-003	25.2475
Apartments Mid Rise	46.0769 / 36.3106	49.4449	1.5071	0.0361	97.8893
Government (Civic Center)	1.0076 / 0.771953	1.0741	0.0330	7.9000e-004	2.1334
Office Park	59.8508 / 45.8534	63.8008	1.9575	0.0469	126.7226
Strip Mall	21.0959 / 16.1621	22.4881	0.6900	0.0165	44.6664
Total		149.5607	4.5762	0.1097	296.6592

8.0 Waste Detail

8.1 Mitigation Measures Waste

Pismo Beach GP/LCP PEIR - GHG - San Luis Obispo County APCD Air District, Annual

EMFAC Off-Model Adjustment Factors for Gasoline Light Duty Vehicle to Account for the SAFE Vehicle Rule Applied

Category/Year

	Total CO2	CH4	N2O	CO2e
	MT/yr			
Mitigated	266.5109	15.7503	0.0000	660.2695
Unmitigated	266.5109	15.7503	0.0000	660.2695

8.2 Waste by Land Use

Unmitigated

	Waste Disposed	Total CO2	CH4	N2O	CO2e
Land Use	tons	MT/yr			
Apartments Low Rise	104.88	21.2897	1.2582	0.0000	52.7443
Apartments Mid Rise	406.64	82.5443	4.8782	0.0000	204.4999
Government (Civic Center)	36.14	7.3361	0.4336	0.0000	18.1749
Office Park	391.46	79.4628	4.6961	0.0000	196.8658
Strip Mall	373.8	75.8780	4.4843	0.0000	187.9846
Total		266.5109	15.7503	0.0000	660.2695

Pismo Beach GP/LCP PEIR - GHG - San Luis Obispo County APCD Air District, Annual

EMFAC Off-Model Adjustment Factors for Gasoline Light Duty Vehicle to Account for the SAFE Vehicle Rule Applied

8.2 Waste by Land Use

Mitigated

	Waste Disposed	Total CO2	CH4	N2O	CO2e
Land Use	tons	MT/yr			
Apartments Low Rise	104.88	21.2897	1.2582	0.0000	52.7443
Apartments Mid Rise	406.64	82.5443	4.8782	0.0000	204.4999
Government (Civic Center)	36.14	7.3361	0.4336	0.0000	18.1749
Office Park	391.46	79.4628	4.6961	0.0000	196.8658
Strip Mall	373.8	75.8780	4.4843	0.0000	187.9846
Total		266.5109	15.7503	0.0000	660.2695

9.0 Operational Offroad

Equipment Type	Number	Hours/Day	Days/Year	Horse Power	Load Factor	Fuel Type
----------------	--------	-----------	-----------	-------------	-------------	-----------

10.0 Stationary Equipment

Fire Pumps and Emergency Generators

Equipment Type	Number	Hours/Day	Hours/Year	Horse Power	Load Factor	Fuel Type
----------------	--------	-----------	------------	-------------	-------------	-----------

Boilers

Equipment Type	Number	Heat Input/Day	Heat Input/Year	Boiler Rating	Fuel Type
----------------	--------	----------------	-----------------	---------------	-----------

Pismo Beach GP/LCP PEIR - GHG - San Luis Obispo County APCD Air District, Annual

EMFAC Off-Model Adjustment Factors for Gasoline Light Duty Vehicle to Account for the SAFE Vehicle Rule Applied

User Defined Equipment

Equipment Type	Number
----------------	--------

11.0 Vegetation

Pismo Beach GP/LCP PEIR - GHG - San Luis Obispo County APCD Air District, Summer

EMFAC Off-Model Adjustment Factors for Gasoline Light Duty Vehicle to Account for the SAFE Vehicle Rule Applied

Pismo Beach GP/LCP PEIR - GHG
San Luis Obispo County APCD Air District, Summer

1.0 Project Characteristics

1.1 Land Usage

Land Uses	Size	Metric	Lot Acreage	Floor Surface Area	Population
Government (Civic Center)	6.34	1000sqft	0.15	6,340.00	-2
Office Park	420.93	1000sqft	9.66	420,930.00	0
Apartments Low Rise	228.00	Dwelling Unit	14.25	228,000.00	471
Apartments Mid Rise	162.00	Dwelling Unit	4.26	162,000.00	185
Apartments Mid Rise	722.00	Dwelling Unit	19.00	722,000.00	1221
Strip Mall	248.00	1000sqft	5.69	248,000.00	0
Strip Mall	108.00	1000sqft	2.48	108,000.00	0

1.2 Other Project Characteristics

Urbanization	Urban	Wind Speed (m/s)	3.2	Precipitation Freq (Days)	44
Climate Zone	4			Operational Year	2040
Utility Company	Pacific Gas and Electric Company				
CO2 Intensity (lb/MW hr)	203.98	CH4 Intensity (lb/MW hr)	0.033	N2O Intensity (lb/MW hr)	0.004

1.3 User Entered Comments & Non-Default Data

Project Characteristics -

Land Use - Data given by applicant

Construction Phase - Similar Buildout schedule as other City General Plan Update for 2040.

Grading -

Architectural Coating - SLOAPCD Rule 433

Vehicle Trips - Adjusted trip length and trip generation rates

Pismo Beach GP/LCP PEIR - GHG - San Luis Obispo County APCD Air District, Summer

EMFAC Off-Model Adjustment Factors for Gasoline Light Duty Vehicle to Account for the SAFE Vehicle Rule Applied

Area Coating - SLOAPCD Rule 433

Mobile Land Use Mitigation -

Water Mitigation -

Table Name	Column Name	Default Value	New Value
tblArchitecturalCoating	EF_Nonresidential_Exterior	250.00	150.00
tblArchitecturalCoating	EF_Nonresidential_Interior	250.00	150.00
tblArchitecturalCoating	EF_Residential_Exterior	250.00	100.00
tblArchitecturalCoating	EF_Residential_Interior	250.00	100.00
tblAreaCoating	Area_EF_Nonresidential_Exterior	250	150
tblAreaCoating	Area_EF_Nonresidential_Interior	250	150
tblAreaCoating	Area_EF_Residential_Exterior	250	100
tblAreaCoating	Area_EF_Residential_Interior	250	100
tblConstructionPhase	NumDays	75.00	330.00
tblConstructionPhase	NumDays	1,110.00	4,650.00
tblConstructionPhase	NumDays	70.00	300.00
tblConstructionPhase	NumDays	110.00	465.00
tblConstructionPhase	NumDays	75.00	330.00
tblConstructionPhase	NumDays	40.00	180.00
tblLandUse	Population	0.00	-2.00
tblLandUse	Population	652.00	471.00
tblLandUse	Population	463.00	185.00
tblLandUse	Population	2,065.00	1,221.00
tblVehicleTrips	CC_TL	5.00	10.73
tblVehicleTrips	CC_TL	5.00	9.60
tblVehicleTrips	CC_TL	5.00	18.00
tblVehicleTrips	CNW_TL	5.00	12.48
tblVehicleTrips	CNW_TL	5.00	6.60
tblVehicleTrips	CNW_TL	5.00	18.00

Pismo Beach GP/LCP PEIR - GHG - San Luis Obispo County APCD Air District, Summer

EMFAC Off-Model Adjustment Factors for Gasoline Light Duty Vehicle to Account for the SAFE Vehicle Rule Applied

tblVehicleTrips	CW_TL	13.00	12.87
tblVehicleTrips	CW_TL	13.00	24.95
tblVehicleTrips	CW_TL	13.00	46.79
tblVehicleTrips	HO_TL	5.00	9.01
tblVehicleTrips	HO_TL	5.00	9.01
tblVehicleTrips	HS_TL	5.00	9.01
tblVehicleTrips	HS_TL	5.00	9.01
tblVehicleTrips	HW_TL	13.00	23.42
tblVehicleTrips	HW_TL	13.00	23.42
tblVehicleTrips	ST_TR	8.14	0.98
tblVehicleTrips	ST_TR	4.91	0.59
tblVehicleTrips	ST_TR	1.64	0.20
tblVehicleTrips	ST_TR	42.04	5.07
tblVehicleTrips	SU_TR	6.28	0.76
tblVehicleTrips	SU_TR	4.09	0.49
tblVehicleTrips	SU_TR	0.76	0.09
tblVehicleTrips	SU_TR	20.43	2.46
tblVehicleTrips	WD_TR	7.32	0.88
tblVehicleTrips	WD_TR	5.44	0.70
tblVehicleTrips	WD_TR	33.98	4.10
tblVehicleTrips	WD_TR	11.07	1.33
tblVehicleTrips	WD_TR	44.32	5.40

2.0 Emissions Summary

2.1 Overall Construction (Maximum Daily Emission)

Unmitigated Construction

Pismo Beach GP/LCP PEIR - GHG - San Luis Obispo County APCD Air District, Summer

EMFAC Off-Model Adjustment Factors for Gasoline Light Duty Vehicle to Account for the SAFE Vehicle Rule Applied

	ROG	NOx	CO	SO2	Fugitive PM10	Exhaust PM10	PM10 Total	Fugitive PM2.5	Exhaust PM2.5	PM2.5 Total	Bio- CO2	NBio- CO2	Total CO2	CH4	N2O	CO2e
Year	lb/day										lb/day					
2021	3.2192	31.4808	22.0481	0.0402	0.1483	1.5521	1.7004	0.0393	1.4418	1.4812	0.0000	3,882.7242	3,882.7242	1.0589	3.8400e-003	3,910.3396
2022	15.3450	127.7166	121.9441	0.2989	40.9224	5.4727	46.3951	16.9814	5.0682	22.0496	0.0000	29,738.5790	29,738.5790	5.1598	0.8592	30,123.6076
2023	10.8880	82.5518	96.7599	0.2552	21.0876	3.2309	24.3185	6.8318	2.9996	9.8314	0.0000	25,518.6719	25,518.6719	3.9244	0.8132	25,859.1266
2024	8.1550	57.5246	74.1911	0.2117	20.9394	2.0537	22.9931	6.7926	1.9042	8.6968	0.0000	21,364.4043	21,364.4043	2.8471	0.7844	21,669.3313
2025	4.5922	23.7307	44.1049	0.1446	11.5382	0.6282	12.1665	3.0864	0.5910	3.6774	0.0000	14,920.0264	14,920.0264	0.8788	0.7562	15,167.3335
2026	4.4340	23.3598	42.6116	0.1414	11.5384	0.6246	12.1629	3.0865	0.5875	3.6740	0.0000	14,658.3055	14,658.3055	0.8639	0.7341	14,898.6675
2027	4.2867	23.0248	41.3300	0.1384	11.5385	0.6207	12.1592	3.0865	0.5839	3.6704	0.0000	14,404.8920	14,404.8920	0.8510	0.7132	14,638.6888
2028	4.1434	22.7386	40.2559	0.1356	11.5386	0.6170	12.1555	3.0865	0.5804	3.6669	0.0000	14,172.1058	14,172.1058	0.8401	0.6942	14,399.9810
2029	4.0037	22.4648	39.3145	0.1330	11.5387	0.6133	12.1519	3.0866	0.5769	3.6635	0.0000	13,953.1316	13,953.1316	0.8306	0.6763	14,175.4434
2030	3.8121	17.7093	38.5906	0.1347	11.5388	0.2305	11.7693	3.0866	0.2257	3.3123	0.0000	14,099.3853	14,099.3853	0.3373	0.6608	14,304.7452
2031	3.6775	17.5136	37.8900	0.1326	11.5388	0.2275	11.7664	3.0866	0.2230	3.3096	0.0000	13,923.3835	13,923.3835	0.3296	0.6470	14,124.4403
2032	3.5515	17.3445	37.2848	0.1307	11.5389	0.2248	11.7637	3.0867	0.2204	3.3071	0.0000	13,766.3089	13,766.3089	0.3228	0.6350	13,963.6126
2033	3.4444	17.2046	36.7752	0.1291	11.5390	0.2224	11.7614	3.0867	0.2182	3.3048	0.0000	13,626.5334	13,626.5334	0.3168	0.6247	13,820.6175
2034	3.3496	17.0824	36.3308	0.1276	11.5390	0.2202	11.7592	3.0867	0.2161	3.3028	0.0000	13,501.1000	13,501.1000	0.3118	0.6156	13,692.3532
2035	3.1705	16.1997	35.9066	0.1263	11.5391	0.1604	11.6995	3.0867	0.1564	3.2432	0.0000	13,390.7625	13,390.7625	0.2988	0.6078	13,579.3485
2036	3.1705	16.1997	35.9066	0.1263	11.5391	0.1604	11.6995	3.0867	0.1564	3.2432	0.0000	13,390.7625	13,390.7625	0.2988	0.6078	13,579.3485
2037	3.1705	16.1997	35.9066	0.1263	11.5391	0.1604	11.6995	3.0867	0.1564	3.2432	0.0000	13,390.7625	13,390.7625	0.2988	0.6078	13,579.3485
2038	3.1705	16.1997	35.9066	0.1263	11.5391	0.1604	11.6995	3.0867	0.1564	3.2432	0.0000	13,390.7625	13,390.7625	0.2988	0.6078	13,579.3485
2039	3.1705	16.1997	35.9066	0.1263	11.5391	0.1604	11.6995	3.0867	0.1564	3.2432	0.0000	13,390.7625	13,390.7625	0.2988	0.6078	13,579.3485

Pismo Beach GP/LCP PEIR - GHG - San Luis Obispo County APCD Air District, Summer

EMFAC Off-Model Adjustment Factors for Gasoline Light Duty Vehicle to Account for the SAFE Vehicle Rule Applied

	ROG	NOx	CO	SO2	Fugitive PM10	Exhaust PM10	PM10 Total	Fugitive PM2.5	Exhaust PM2.5	PM2.5 Total	Bio- CO2	NBio- CO2	Total CO2	CH4	N2O	CO2e
Year	lb/day										lb/day					
2040	76.6009	15.4735	34.6162	0.1216	11.5393	0.1369	11.6762	3.0868	0.1334	3.2202	0.0000	12,994.0878	12,994.0878	0.2816	0.5778	13,173.3103
2041	1.4267	4.5502	20.9138	0.0444	2.2244	0.1280	2.3524	0.5900	0.1277	0.7177	0.0000	4,443.8098	4,443.8098	0.1144	0.0280	4,455.0120
2042	0.3954	0.8825	4.8758	0.0154	2.0761	0.0113	2.0874	0.5506	0.0110	0.5616	0.0000	1,686.9033	1,686.9033	0.0241	0.0261	1,695.2920
Maximum	76.6009	127.7166	121.9441	0.2989	40.9224	5.4727	46.3951	16.9814	5.0682	22.0496	0.0000	29,738.5790	29,738.5790	5.1598	0.8592	30,123.6076

2.1 Overall Construction (Maximum Daily Emission)

Mitigated Construction

	ROG	NOx	CO	SO2	Fugitive PM10	Exhaust PM10	PM10 Total	Fugitive PM2.5	Exhaust PM2.5	PM2.5 Total	Bio- CO2	NBio- CO2	Total CO2	CH4	N2O	CO2e
Year	lb/day										lb/day					
2021	3.2192	31.4808	22.0481	0.0402	0.1483	1.5521	1.7004	0.0393	1.4418	1.4812	0.0000	3,882.7242	3,882.7242	1.0589	3.8400e-003	3,910.3396
2022	15.3450	127.7166	121.9441	0.2989	40.9224	5.4727	46.3951	16.9814	5.0682	22.0496	0.0000	29,738.5790	29,738.5790	5.1598	0.8592	30,123.6076
2023	10.8880	82.5518	96.7599	0.2552	21.0876	3.2309	24.3185	6.8318	2.9996	9.8314	0.0000	25,518.6719	25,518.6719	3.9244	0.8132	25,859.1266
2024	8.1550	57.5246	74.1911	0.2117	20.9394	2.0537	22.9931	6.7926	1.9042	8.6968	0.0000	21,364.4043	21,364.4043	2.8471	0.7844	21,669.3313
2025	4.5922	23.7307	44.1049	0.1446	11.5382	0.6282	12.1665	3.0864	0.5910	3.6774	0.0000	14,920.0264	14,920.0264	0.8788	0.7562	15,167.3335
2026	4.4340	23.3598	42.6116	0.1414	11.5384	0.6246	12.1629	3.0865	0.5875	3.6740	0.0000	14,658.3055	14,658.3055	0.8639	0.7341	14,898.6675
2027	4.2867	23.0248	41.3300	0.1384	11.5385	0.6207	12.1592	3.0865	0.5839	3.6704	0.0000	14,404.8920	14,404.8920	0.8510	0.7132	14,638.6888
2028	4.1434	22.7386	40.2559	0.1356	11.5386	0.6170	12.1555	3.0865	0.5804	3.6669	0.0000	14,172.1058	14,172.1058	0.8401	0.6942	14,399.9810

Pismo Beach GP/LCP PEIR - GHG - San Luis Obispo County APCD Air District, Summer

EMFAC Off-Model Adjustment Factors for Gasoline Light Duty Vehicle to Account for the SAFE Vehicle Rule Applied

Pismo Beach GP/LCP PEIR - GHG - San Luis Obispo County APCD Air District, Summer

EMFAC Off-Model Adjustment Factors for Gasoline Light Duty Vehicle to Account for the SAFE Vehicle Rule Applied

2.2 Overall Operational

Unmitigated Operational

	ROG	NOx	CO	SO2	Fugitive PM10	Exhaust PM10	PM10 Total	Fugitive PM2.5	Exhaust PM2.5	PM2.5 Total	Bio- CO2	NBio- CO2	Total CO2	CH4	N2O	CO2e
Category	lb/day										lb/day					
Area	50.0945	1.0550	91.4179	4.8500e-003		0.5090	0.5090		0.5090	0.5090	0.0000	165.3616	165.3616	0.1577	0.0000	169.3035
Energy	0.5731	5.0543	3.2348	0.0313		0.3960	0.3960		0.3960	0.3960		6,251.9438	6,251.9438	0.1198	0.1146	6,289.0959
Mobile	8.5040	8.9562	90.1899	0.2162	31.8757	0.1100	31.9857	8.4836	0.1031	8.5866		24,048.4979	24,048.4979	1.0724	0.8777	24,336.8545
Total	59.1715	15.0655	184.8425	0.2523	31.8757	1.0150	32.8907	8.4836	1.0081	9.4916	0.0000	30,465.8032	30,465.8032	1.3499	0.9923	30,795.2539

Mitigated Operational

	ROG	NOx	CO	SO2	Fugitive PM10	Exhaust PM10	PM10 Total	Fugitive PM2.5	Exhaust PM2.5	PM2.5 Total	Bio- CO2	NBio- CO2	Total CO2	CH4	N2O	CO2e
Category	lb/day										lb/day					
Area	50.0945	1.0550	91.4179	4.8500e-003		0.5090	0.5090		0.5090	0.5090	0.0000	165.3616	165.3616	0.1577	0.0000	169.3035
Energy	0.5731	5.0543	3.2348	0.0313		0.3960	0.3960		0.3960	0.3960		6,251.9438	6,251.9438	0.1198	0.1146	6,289.0959
Mobile	8.5040	8.9562	90.1899	0.2162	31.8757	0.1100	31.9857	8.4836	0.1031	8.5866		24,048.4979	24,048.4979	1.0724	0.8777	24,336.8545
Total	59.1715	15.0655	184.8425	0.2523	31.8757	1.0150	32.8907	8.4836	1.0081	9.4916	0.0000	30,465.8032	30,465.8032	1.3499	0.9923	30,795.2539

Pismo Beach GP/LCP PEIR - GHG - San Luis Obispo County APCD Air District, Summer

EMFAC Off-Model Adjustment Factors for Gasoline Light Duty Vehicle to Account for the SAFE Vehicle Rule Applied

	ROG	NOx	CO	SO2	Fugitive PM10	Exhaust PM10	PM10 Total	Fugitive PM2.5	Exhaust PM2.5	PM2.5 Total	Bio- CO2	NBio-CO2	Total CO2	CH4	N2O	CO2e
Percent Reduction	0.00	0.00	0.00	0.00	0.00	0.00	0.00	0.00	0.00	0.00	0.00	0.00	0.00	0.00	0.00	0.00

3.0 Construction Detail

Construction Phase

Phase Number	Phase Name	Phase Type	Start Date	End Date	Num Days Week	Num Days	Phase Description
1	Demolition	Demolition	11/17/2021	1/10/2023	5	300	
2	Site Preparation	Site Preparation	2/23/2022	11/1/2022	5	180	
3	Grading	Grading	4/20/2022	1/30/2024	5	465	
4	Building Construction	Building Construction	9/21/2022	7/17/2040	5	4650	
5	Paving	Paving	7/18/2040	10/22/2041	5	330	
6	Architectural Coating	Architectural Coating	10/23/2040	1/27/2042	5	330	

Acres of Grading (Site Preparation Phase): 270

Acres of Grading (Grading Phase): 1395

Acres of Paving: 0

Residential Indoor: 2,251,800; Residential Outdoor: 750,600; Non-Residential Indoor: 1,174,905; Non-Residential Outdoor: 391,635; Striped Parking Area: 0 (Architectural Coating – sqft)

OffRoad Equipment

Phase Name	Offroad Equipment Type	Amount	Usage Hours	Horse Power	Load Factor
Demolition	Concrete/Industrial Saws	1	8.00	81	0.73
Demolition	Excavators	3	8.00	158	0.38
Demolition	Rubber Tired Dozers	2	8.00	247	0.40
Site Preparation	Rubber Tired Dozers	3	8.00	247	0.40
Site Preparation	Tractors/Loaders/Backhoes	4	8.00	97	0.37

Pismo Beach GP/LCP PEIR - GHG - San Luis Obispo County APCD Air District, Summer

EMFAC Off-Model Adjustment Factors for Gasoline Light Duty Vehicle to Account for the SAFE Vehicle Rule Applied

Grading	Excavators	2	8.00	158	0.38
Grading	Graders	1	8.00	187	0.41
Grading	Rubber Tired Dozers	1	8.00	247	0.40
Grading	Scrapers	2	8.00	367	0.48
Grading	Tractors/Loaders/Backhoes	2	8.00	97	0.37
Building Construction	Cranes	1	7.00	231	0.29
Building Construction	Forklifts	3	8.00	89	0.20
Building Construction	Generator Sets	1	8.00	84	0.74
Building Construction	Tractors/Loaders/Backhoes	3	7.00	97	0.37
Building Construction	Welders	1	8.00	46	0.45
Paving	Pavers	2	8.00	130	0.42
Paving	Paving Equipment	2	8.00	132	0.36
Paving	Rollers	2	8.00	80	0.38
Architectural Coating	Air Compressors	1	6.00	78	0.48

Trips and VMT

Phase Name	Offroad Equipment Count	Worker Trip Number	Vendor Trip Number	Hauling Trip Number	Worker Trip Length	Vendor Trip Length	Hauling Trip Length	Worker Vehicle Class	Vendor Vehicle Class	Hauling Vehicle Class
Demolition	6	15.00	0.00	0.00	13.00	5.00	20.00	LD_Mix	HDT_Mix	HHDT
Site Preparation	7	18.00	0.00	0.00	13.00	5.00	20.00	LD_Mix	HDT_Mix	HHDT
Grading	8	20.00	0.00	0.00	13.00	5.00	20.00	LD_Mix	HDT_Mix	HHDT
Building Construction	9	1,051.00	247.00	0.00	13.00	5.00	20.00	LD_Mix	HDT_Mix	HHDT
Paving	6	15.00	0.00	0.00	13.00	5.00	20.00	LD_Mix	HDT_Mix	HHDT
Architectural Coating	1	210.00	0.00	0.00	13.00	5.00	20.00	LD_Mix	HDT_Mix	HHDT

3.1 Mitigation Measures Construction

Pismo Beach GP/LCP PEIR - GHG - San Luis Obispo County APCD Air District, Summer

EMFAC Off-Model Adjustment Factors for Gasoline Light Duty Vehicle to Account for the SAFE Vehicle Rule Applied

3.2 Demolition - 2021

Unmitigated Construction On-Site

	ROG	NOx	CO	SO2	Fugitive PM10	Exhaust PM10	PM10 Total	Fugitive PM2.5	Exhaust PM2.5	PM2.5 Total	Bio- CO2	NBio- CO2	Total CO2	CH4	N2O	CO2e
Category	lb/day										lb/day					
Off-Road	3.1651	31.4407	21.5650	0.0388		1.5513	1.5513		1.4411	1.4411		3,747.9449	3,747.9449	1.0549		3,774.3174
Total	3.1651	31.4407	21.5650	0.0388		1.5513	1.5513		1.4411	1.4411		3,747.9449	3,747.9449	1.0549		3,774.3174

Unmitigated Construction Off-Site

	ROG	NOx	CO	SO2	Fugitive PM10	Exhaust PM10	PM10 Total	Fugitive PM2.5	Exhaust PM2.5	PM2.5 Total	Bio- CO2	NBio- CO2	Total CO2	CH4	N2O	CO2e
Category	lb/day										lb/day					
Hauling	0.0000	0.0000	0.0000	0.0000	0.0000	0.0000	0.0000	0.0000	0.0000	0.0000		0.0000	0.0000	0.0000	0.0000	0.0000
Vendor	0.0000	0.0000	0.0000	0.0000	0.0000	0.0000	0.0000	0.0000	0.0000	0.0000		0.0000	0.0000	0.0000	0.0000	0.0000
Worker	0.0541	0.0401	0.4831	1.3300e-003	0.1483	7.9000e-004	0.1491	0.0393	7.3000e-004	0.0401		134.7792	134.7792	3.9800e-003	3.8400e-003	136.0222
Total	0.0541	0.0401	0.4831	1.3300e-003	0.1483	7.9000e-004	0.1491	0.0393	7.3000e-004	0.0401		134.7792	134.7792	3.9800e-003	3.8400e-003	136.0222

Pismo Beach GP/LCP PEIR - GHG - San Luis Obispo County APCD Air District, Summer

EMFAC Off-Model Adjustment Factors for Gasoline Light Duty Vehicle to Account for the SAFE Vehicle Rule Applied

3.2 Demolition - 2021

Mitigated Construction On-Site

	ROG	NOx	CO	SO2	Fugitive PM10	Exhaust PM10	PM10 Total	Fugitive PM2.5	Exhaust PM2.5	PM2.5 Total	Bio- CO2	NBio- CO2	Total CO2	CH4	N2O	CO2e
Category	lb/day										lb/day					
Off-Road	3.1651	31.4407	21.5650	0.0388		1.5513	1.5513		1.4411	1.4411	0.0000	3,747.9449	3,747.9449	1.0549		3,774.3174
Total	3.1651	31.4407	21.5650	0.0388		1.5513	1.5513		1.4411	1.4411	0.0000	3,747.9449	3,747.9449	1.0549		3,774.3174

Mitigated Construction Off-Site

	ROG	NOx	CO	SO2	Fugitive PM10	Exhaust PM10	PM10 Total	Fugitive PM2.5	Exhaust PM2.5	PM2.5 Total	Bio- CO2	NBio- CO2	Total CO2	CH4	N2O	CO2e
Category	lb/day										lb/day					
Hauling	0.0000	0.0000	0.0000	0.0000	0.0000	0.0000	0.0000	0.0000	0.0000	0.0000		0.0000	0.0000	0.0000	0.0000	0.0000
Vendor	0.0000	0.0000	0.0000	0.0000	0.0000	0.0000	0.0000	0.0000	0.0000	0.0000		0.0000	0.0000	0.0000	0.0000	0.0000
Worker	0.0541	0.0401	0.4831	1.3300e-003	0.1483	7.9000e-004	0.1491	0.0393	7.3000e-004	0.0401		134.7792	134.7792	3.9800e-003	3.8400e-003	136.0222
Total	0.0541	0.0401	0.4831	1.3300e-003	0.1483	7.9000e-004	0.1491	0.0393	7.3000e-004	0.0401		134.7792	134.7792	3.9800e-003	3.8400e-003	136.0222

Pismo Beach GP/LCP PEIR - GHG - San Luis Obispo County APCD Air District, Summer

EMFAC Off-Model Adjustment Factors for Gasoline Light Duty Vehicle to Account for the SAFE Vehicle Rule Applied

3.2 Demolition - 2022

Unmitigated Construction On-Site

	ROG	NOx	CO	SO2	Fugitive PM10	Exhaust PM10	PM10 Total	Fugitive PM2.5	Exhaust PM2.5	PM2.5 Total	Bio- CO2	NBio- CO2	Total CO2	CH4	N2O	CO2e
Category	lb/day										lb/day					
Off-Road	2.6392	25.7194	20.5941	0.0388		1.2427	1.2427		1.1553	1.1553		3,746.7812	3,746.7812	1.0524		3,773.0920
Total	2.6392	25.7194	20.5941	0.0388		1.2427	1.2427		1.1553	1.1553		3,746.7812	3,746.7812	1.0524		3,773.0920

Unmitigated Construction Off-Site

	ROG	NOx	CO	SO2	Fugitive PM10	Exhaust PM10	PM10 Total	Fugitive PM2.5	Exhaust PM2.5	PM2.5 Total	Bio- CO2	NBio- CO2	Total CO2	CH4	N2O	CO2e
Category	lb/day										lb/day					
Hauling	0.0000	0.0000	0.0000	0.0000	0.0000	0.0000	0.0000	0.0000	0.0000	0.0000		0.0000	0.0000	0.0000	0.0000	0.0000
Vendor	0.0000	0.0000	0.0000	0.0000	0.0000	0.0000	0.0000	0.0000	0.0000	0.0000		0.0000	0.0000	0.0000	0.0000	0.0000
Worker	0.0506	0.0354	0.4435	1.2900e-003	0.1483	7.5000e-004	0.1490	0.0393	6.9000e-004	0.0400		131.3977	131.3977	3.5900e-003	3.5400e-003	132.5417
Total	0.0506	0.0354	0.4435	1.2900e-003	0.1483	7.5000e-004	0.1490	0.0393	6.9000e-004	0.0400		131.3977	131.3977	3.5900e-003	3.5400e-003	132.5417

Pismo Beach GP/LCP PEIR - GHG - San Luis Obispo County APCD Air District, Summer

EMFAC Off-Model Adjustment Factors for Gasoline Light Duty Vehicle to Account for the SAFE Vehicle Rule Applied

3.2 Demolition - 2022

Mitigated Construction On-Site

	ROG	NOx	CO	SO2	Fugitive PM10	Exhaust PM10	PM10 Total	Fugitive PM2.5	Exhaust PM2.5	PM2.5 Total	Bio- CO2	NBio- CO2	Total CO2	CH4	N2O	CO2e
Category	lb/day										lb/day					
Off-Road	2.6392	25.7194	20.5941	0.0388		1.2427	1.2427		1.1553	1.1553	0.0000	3,746.781 2	3,746.781 2	1.0524		3,773.092 0
Total	2.6392	25.7194	20.5941	0.0388		1.2427	1.2427		1.1553	1.1553	0.0000	3,746.781 2	3,746.781 2	1.0524		3,773.092 0

Mitigated Construction Off-Site

	ROG	NOx	CO	SO2	Fugitive PM10	Exhaust PM10	PM10 Total	Fugitive PM2.5	Exhaust PM2.5	PM2.5 Total	Bio- CO2	NBio- CO2	Total CO2	CH4	N2O	CO2e
Category	lb/day										lb/day					
Hauling	0.0000	0.0000	0.0000	0.0000	0.0000	0.0000	0.0000	0.0000	0.0000	0.0000		0.0000	0.0000	0.0000	0.0000	0.0000
Vendor	0.0000	0.0000	0.0000	0.0000	0.0000	0.0000	0.0000	0.0000	0.0000	0.0000		0.0000	0.0000	0.0000	0.0000	0.0000
Worker	0.0506	0.0354	0.4435	1.2900e-003	0.1483	7.5000e-004	0.1490	0.0393	6.9000e-004	0.0400		131.3977	131.3977	3.5900e-003	3.5400e-003	132.5417
Total	0.0506	0.0354	0.4435	1.2900e-003	0.1483	7.5000e-004	0.1490	0.0393	6.9000e-004	0.0400		131.3977	131.3977	3.5900e-003	3.5400e-003	132.5417

Pismo Beach GP/LCP PEIR - GHG - San Luis Obispo County APCD Air District, Summer

EMFAC Off-Model Adjustment Factors for Gasoline Light Duty Vehicle to Account for the SAFE Vehicle Rule Applied

3.2 Demolition - 2023

Unmitigated Construction On-Site

	ROG	NOx	CO	SO2	Fugitive PM10	Exhaust PM10	PM10 Total	Fugitive PM2.5	Exhaust PM2.5	PM2.5 Total	Bio- CO2	NBio- CO2	Total CO2	CH4	N2O	CO2e
Category	lb/day										lb/day					
Off-Road	2.2691	21.4844	19.6434	0.0388		0.9975	0.9975		0.9280	0.9280		3,746.9840	3,746.9840	1.0494		3,773.2183
Total	2.2691	21.4844	19.6434	0.0388		0.9975	0.9975		0.9280	0.9280		3,746.9840	3,746.9840	1.0494		3,773.2183

Unmitigated Construction Off-Site

	ROG	NOx	CO	SO2	Fugitive PM10	Exhaust PM10	PM10 Total	Fugitive PM2.5	Exhaust PM2.5	PM2.5 Total	Bio- CO2	NBio- CO2	Total CO2	CH4	N2O	CO2e
Category	lb/day										lb/day					
Hauling	0.0000	0.0000	0.0000	0.0000	0.0000	0.0000	0.0000	0.0000	0.0000	0.0000		0.0000	0.0000	0.0000	0.0000	0.0000
Vendor	0.0000	0.0000	0.0000	0.0000	0.0000	0.0000	0.0000	0.0000	0.0000	0.0000		0.0000	0.0000	0.0000	0.0000	0.0000
Worker	0.0474	0.0314	0.4090	1.2500e-003	0.1483	7.1000e-004	0.1490	0.0393	6.6000e-004	0.0400		128.1704	128.1704	3.2500e-003	3.2700e-003	129.2270
Total	0.0474	0.0314	0.4090	1.2500e-003	0.1483	7.1000e-004	0.1490	0.0393	6.6000e-004	0.0400		128.1704	128.1704	3.2500e-003	3.2700e-003	129.2270

Pismo Beach GP/LCP PEIR - GHG - San Luis Obispo County APCD Air District, Summer

EMFAC Off-Model Adjustment Factors for Gasoline Light Duty Vehicle to Account for the SAFE Vehicle Rule Applied

3.2 Demolition - 2023

Mitigated Construction On-Site

	ROG	NOx	CO	SO2	Fugitive PM10	Exhaust PM10	PM10 Total	Fugitive PM2.5	Exhaust PM2.5	PM2.5 Total	Bio- CO2	NBio- CO2	Total CO2	CH4	N2O	CO2e
Category	lb/day										lb/day					
Off-Road	2.2691	21.4844	19.6434	0.0388		0.9975	0.9975		0.9280	0.9280	0.0000	3,746.9840	3,746.9840	1.0494		3,773.2183
Total	2.2691	21.4844	19.6434	0.0388		0.9975	0.9975		0.9280	0.9280	0.0000	3,746.9840	3,746.9840	1.0494		3,773.2183

Mitigated Construction Off-Site

	ROG	NOx	CO	SO2	Fugitive PM10	Exhaust PM10	PM10 Total	Fugitive PM2.5	Exhaust PM2.5	PM2.5 Total	Bio- CO2	NBio- CO2	Total CO2	CH4	N2O	CO2e
Category	lb/day										lb/day					
Hauling	0.0000	0.0000	0.0000	0.0000	0.0000	0.0000	0.0000	0.0000	0.0000	0.0000		0.0000	0.0000	0.0000	0.0000	0.0000
Vendor	0.0000	0.0000	0.0000	0.0000	0.0000	0.0000	0.0000	0.0000	0.0000	0.0000		0.0000	0.0000	0.0000	0.0000	0.0000
Worker	0.0474	0.0314	0.4090	1.2500e-003	0.1483	7.1000e-004	0.1490	0.0393	6.6000e-004	0.0400		128.1704	128.1704	3.2500e-003	3.2700e-003	129.2270
Total	0.0474	0.0314	0.4090	1.2500e-003	0.1483	7.1000e-004	0.1490	0.0393	6.6000e-004	0.0400		128.1704	128.1704	3.2500e-003	3.2700e-003	129.2270

Pismo Beach GP/LCP PEIR - GHG - San Luis Obispo County APCD Air District, Summer

EMFAC Off-Model Adjustment Factors for Gasoline Light Duty Vehicle to Account for the SAFE Vehicle Rule Applied

3.3 Site Preparation - 2022

Unmitigated Construction On-Site

	ROG	NOx	CO	SO2	Fugitive PM10	Exhaust PM10	PM10 Total	Fugitive PM2.5	Exhaust PM2.5	PM2.5 Total	Bio- CO2	NBio- CO2	Total CO2	CH4	N2O	CO2e
Category	lb/day										lb/day					
Fugitive Dust					19.6570	0.0000	19.6570	10.1025	0.0000	10.1025			0.0000			0.0000
Off-Road	3.1701	33.0835	19.6978	0.0380		1.6126	1.6126		1.4836	1.4836		3,686.0619	3,686.0619	1.1922		3,715.8655
Total	3.1701	33.0835	19.6978	0.0380	19.6570	1.6126	21.2696	10.1025	1.4836	11.5860		3,686.0619	3,686.0619	1.1922		3,715.8655

Unmitigated Construction Off-Site

	ROG	NOx	CO	SO2	Fugitive PM10	Exhaust PM10	PM10 Total	Fugitive PM2.5	Exhaust PM2.5	PM2.5 Total	Bio- CO2	NBio- CO2	Total CO2	CH4	N2O	CO2e
Category	lb/day										lb/day					
Hauling	0.0000	0.0000	0.0000	0.0000	0.0000	0.0000	0.0000	0.0000	0.0000	0.0000		0.0000	0.0000	0.0000	0.0000	0.0000
Vendor	0.0000	0.0000	0.0000	0.0000	0.0000	0.0000	0.0000	0.0000	0.0000	0.0000		0.0000	0.0000	0.0000	0.0000	0.0000
Worker	0.0607	0.0425	0.5322	1.5500e-003	0.1780	9.0000e-004	0.1789	0.0472	8.3000e-004	0.0480		157.6773	157.6773	4.3100e-003	4.2400e-003	159.0500
Total	0.0607	0.0425	0.5322	1.5500e-003	0.1780	9.0000e-004	0.1789	0.0472	8.3000e-004	0.0480		157.6773	157.6773	4.3100e-003	4.2400e-003	159.0500

Pismo Beach GP/LCP PEIR - GHG - San Luis Obispo County APCD Air District, Summer

EMFAC Off-Model Adjustment Factors for Gasoline Light Duty Vehicle to Account for the SAFE Vehicle Rule Applied

3.3 Site Preparation - 2022

Mitigated Construction On-Site

	ROG	NOx	CO	SO2	Fugitive PM10	Exhaust PM10	PM10 Total	Fugitive PM2.5	Exhaust PM2.5	PM2.5 Total	Bio- CO2	NBio- CO2	Total CO2	CH4	N2O	CO2e
Category	lb/day										lb/day					
Fugitive Dust					19.6570	0.0000	19.6570	10.1025	0.0000	10.1025			0.0000			0.0000
Off-Road	3.1701	33.0835	19.6978	0.0380		1.6126	1.6126		1.4836	1.4836	0.0000	3,686.0619	3,686.0619	1.1922		3,715.8655
Total	3.1701	33.0835	19.6978	0.0380	19.6570	1.6126	21.2696	10.1025	1.4836	11.5860	0.0000	3,686.0619	3,686.0619	1.1922		3,715.8655

Mitigated Construction Off-Site

	ROG	NOx	CO	SO2	Fugitive PM10	Exhaust PM10	PM10 Total	Fugitive PM2.5	Exhaust PM2.5	PM2.5 Total	Bio- CO2	NBio- CO2	Total CO2	CH4	N2O	CO2e
Category	lb/day										lb/day					
Hauling	0.0000	0.0000	0.0000	0.0000	0.0000	0.0000	0.0000	0.0000	0.0000	0.0000		0.0000	0.0000	0.0000	0.0000	0.0000
Vendor	0.0000	0.0000	0.0000	0.0000	0.0000	0.0000	0.0000	0.0000	0.0000	0.0000		0.0000	0.0000	0.0000	0.0000	0.0000
Worker	0.0607	0.0425	0.5322	1.5500e-003	0.1780	9.0000e-004	0.1789	0.0472	8.3000e-004	0.0480		157.6773	157.6773	4.3100e-003	4.2400e-003	159.0500
Total	0.0607	0.0425	0.5322	1.5500e-003	0.1780	9.0000e-004	0.1789	0.0472	8.3000e-004	0.0480		157.6773	157.6773	4.3100e-003	4.2400e-003	159.0500

Pismo Beach GP/LCP PEIR - GHG - San Luis Obispo County APCD Air District, Summer

EMFAC Off-Model Adjustment Factors for Gasoline Light Duty Vehicle to Account for the SAFE Vehicle Rule Applied

3.4 Grading - 2022

Unmitigated Construction On-Site

	ROG	NOx	CO	SO2	Fugitive PM10	Exhaust PM10	PM10 Total	Fugitive PM2.5	Exhaust PM2.5	PM2.5 Total	Bio- CO2	NBio- CO2	Total CO2	CH4	N2O	CO2e
Category	lb/day										lb/day					
Fugitive Dust					9.2036	0.0000	9.2036	3.6538	0.0000	3.6538			0.0000			0.0000
Off-Road	3.6248	38.8435	29.0415	0.0621		1.6349	1.6349		1.5041	1.5041		6,011.4105	6,011.4105	1.9442		6,060.0158
Total	3.6248	38.8435	29.0415	0.0621	9.2036	1.6349	10.8385	3.6538	1.5041	5.1579		6,011.4105	6,011.4105	1.9442		6,060.0158

Unmitigated Construction Off-Site

	ROG	NOx	CO	SO2	Fugitive PM10	Exhaust PM10	PM10 Total	Fugitive PM2.5	Exhaust PM2.5	PM2.5 Total	Bio- CO2	NBio- CO2	Total CO2	CH4	N2O	CO2e
Category	lb/day										lb/day					
Hauling	0.0000	0.0000	0.0000	0.0000	0.0000	0.0000	0.0000	0.0000	0.0000	0.0000		0.0000	0.0000	0.0000	0.0000	0.0000
Vendor	0.0000	0.0000	0.0000	0.0000	0.0000	0.0000	0.0000	0.0000	0.0000	0.0000		0.0000	0.0000	0.0000	0.0000	0.0000
Worker	0.0675	0.0472	0.5913	1.7200e-003	0.1977	1.0000e-003	0.1987	0.0524	9.2000e-004	0.0534		175.1970	175.1970	4.7900e-003	4.7200e-003	176.7223
Total	0.0675	0.0472	0.5913	1.7200e-003	0.1977	1.0000e-003	0.1987	0.0524	9.2000e-004	0.0534		175.1970	175.1970	4.7900e-003	4.7200e-003	176.7223

Pismo Beach GP/LCP PEIR - GHG - San Luis Obispo County APCD Air District, Summer

EMFAC Off-Model Adjustment Factors for Gasoline Light Duty Vehicle to Account for the SAFE Vehicle Rule Applied

3.4 Grading - 2022

Mitigated Construction On-Site

	ROG	NOx	CO	SO2	Fugitive PM10	Exhaust PM10	PM10 Total	Fugitive PM2.5	Exhaust PM2.5	PM2.5 Total	Bio- CO2	NBio- CO2	Total CO2	CH4	N2O	CO2e
Category	lb/day										lb/day					
Fugitive Dust					9.2036	0.0000	9.2036	3.6538	0.0000	3.6538			0.0000			0.0000
Off-Road	3.6248	38.8435	29.0415	0.0621		1.6349	1.6349		1.5041	1.5041	0.0000	6,011.4105	6,011.4105	1.9442		6,060.0158
Total	3.6248	38.8435	29.0415	0.0621	9.2036	1.6349	10.8385	3.6538	1.5041	5.1579	0.0000	6,011.4105	6,011.4105	1.9442		6,060.0158

Mitigated Construction Off-Site

	ROG	NOx	CO	SO2	Fugitive PM10	Exhaust PM10	PM10 Total	Fugitive PM2.5	Exhaust PM2.5	PM2.5 Total	Bio- CO2	NBio- CO2	Total CO2	CH4	N2O	CO2e
Category	lb/day										lb/day					
Hauling	0.0000	0.0000	0.0000	0.0000	0.0000	0.0000	0.0000	0.0000	0.0000	0.0000		0.0000	0.0000	0.0000	0.0000	0.0000
Vendor	0.0000	0.0000	0.0000	0.0000	0.0000	0.0000	0.0000	0.0000	0.0000	0.0000		0.0000	0.0000	0.0000	0.0000	0.0000
Worker	0.0675	0.0472	0.5913	1.7200e-003	0.1977	1.0000e-003	0.1987	0.0524	9.2000e-004	0.0534		175.1970	175.1970	4.7900e-003	4.7200e-003	176.7223
Total	0.0675	0.0472	0.5913	1.7200e-003	0.1977	1.0000e-003	0.1987	0.0524	9.2000e-004	0.0534		175.1970	175.1970	4.7900e-003	4.7200e-003	176.7223

Pismo Beach GP/LCP PEIR - GHG - San Luis Obispo County APCD Air District, Summer

EMFAC Off-Model Adjustment Factors for Gasoline Light Duty Vehicle to Account for the SAFE Vehicle Rule Applied

3.4 Grading - 2023

Unmitigated Construction On-Site

	ROG	NOx	CO	SO2	Fugitive PM10	Exhaust PM10	PM10 Total	Fugitive PM2.5	Exhaust PM2.5	PM2.5 Total	Bio- CO2	NBio- CO2	Total CO2	CH4	N2O	CO2e
Category	lb/day										lb/day					
Fugitive Dust					9.2036	0.0000	9.2036	3.6538	0.0000	3.6538			0.0000			0.0000
Off-Road	3.3217	34.5156	28.0512	0.0621		1.4245	1.4245		1.3105	1.3105		6,011.4777	6,011.4777	1.9442		6,060.0836
Total	3.3217	34.5156	28.0512	0.0621	9.2036	1.4245	10.6281	3.6538	1.3105	4.9643		6,011.4777	6,011.4777	1.9442		6,060.0836

Unmitigated Construction Off-Site

	ROG	NOx	CO	SO2	Fugitive PM10	Exhaust PM10	PM10 Total	Fugitive PM2.5	Exhaust PM2.5	PM2.5 Total	Bio- CO2	NBio- CO2	Total CO2	CH4	N2O	CO2e
Category	lb/day										lb/day					
Hauling	0.0000	0.0000	0.0000	0.0000	0.0000	0.0000	0.0000	0.0000	0.0000	0.0000		0.0000	0.0000	0.0000	0.0000	0.0000
Vendor	0.0000	0.0000	0.0000	0.0000	0.0000	0.0000	0.0000	0.0000	0.0000	0.0000		0.0000	0.0000	0.0000	0.0000	0.0000
Worker	0.0632	0.0418	0.5453	1.6700e-003	0.1977	9.5000e-004	0.1987	0.0524	8.7000e-004	0.0533		170.8939	170.8939	4.3300e-003	4.3600e-003	172.3027
Total	0.0632	0.0418	0.5453	1.6700e-003	0.1977	9.5000e-004	0.1987	0.0524	8.7000e-004	0.0533		170.8939	170.8939	4.3300e-003	4.3600e-003	172.3027

Pismo Beach GP/LCP PEIR - GHG - San Luis Obispo County APCD Air District, Summer

EMFAC Off-Model Adjustment Factors for Gasoline Light Duty Vehicle to Account for the SAFE Vehicle Rule Applied

3.4 Grading - 2023

Mitigated Construction On-Site

	ROG	NOx	CO	SO2	Fugitive PM10	Exhaust PM10	PM10 Total	Fugitive PM2.5	Exhaust PM2.5	PM2.5 Total	Bio- CO2	NBio- CO2	Total CO2	CH4	N2O	CO2e
Category	lb/day										lb/day					
Fugitive Dust					9.2036	0.0000	9.2036	3.6538	0.0000	3.6538			0.0000			0.0000
Off-Road	3.3217	34.5156	28.0512	0.0621		1.4245	1.4245		1.3105	1.3105	0.0000	6,011.4777	6,011.4777	1.9442		6,060.0836
Total	3.3217	34.5156	28.0512	0.0621	9.2036	1.4245	10.6281	3.6538	1.3105	4.9643	0.0000	6,011.4777	6,011.4777	1.9442		6,060.0836

Mitigated Construction Off-Site

	ROG	NOx	CO	SO2	Fugitive PM10	Exhaust PM10	PM10 Total	Fugitive PM2.5	Exhaust PM2.5	PM2.5 Total	Bio- CO2	NBio- CO2	Total CO2	CH4	N2O	CO2e
Category	lb/day										lb/day					
Hauling	0.0000	0.0000	0.0000	0.0000	0.0000	0.0000	0.0000	0.0000	0.0000	0.0000		0.0000	0.0000	0.0000	0.0000	0.0000
Vendor	0.0000	0.0000	0.0000	0.0000	0.0000	0.0000	0.0000	0.0000	0.0000	0.0000		0.0000	0.0000	0.0000	0.0000	0.0000
Worker	0.0632	0.0418	0.5453	1.6700e-003	0.1977	9.5000e-004	0.1987	0.0524	8.7000e-004	0.0533		170.8939	170.8939	4.3300e-003	4.3600e-003	172.3027
Total	0.0632	0.0418	0.5453	1.6700e-003	0.1977	9.5000e-004	0.1987	0.0524	8.7000e-004	0.0533		170.8939	170.8939	4.3300e-003	4.3600e-003	172.3027

Pismo Beach GP/LCP PEIR - GHG - San Luis Obispo County APCD Air District, Summer

EMFAC Off-Model Adjustment Factors for Gasoline Light Duty Vehicle to Account for the SAFE Vehicle Rule Applied

3.4 Grading - 2024

Unmitigated Construction On-Site

	ROG	NOx	CO	SO2	Fugitive PM10	Exhaust PM10	PM10 Total	Fugitive PM2.5	Exhaust PM2.5	PM2.5 Total	Bio- CO2	NBio- CO2	Total CO2	CH4	N2O	CO2e
Category	lb/day										lb/day					
Fugitive Dust					9.2036	0.0000	9.2036	3.6538	0.0000	3.6538			0.0000			0.0000
Off-Road	3.2181	32.3770	27.7228	0.0621		1.3354	1.3354		1.2286	1.2286		6,009.7487	6,009.7487	1.9437		6,058.3405
Total	3.2181	32.3770	27.7228	0.0621	9.2036	1.3354	10.5390	3.6538	1.2286	4.8823		6,009.7487	6,009.7487	1.9437		6,058.3405

Unmitigated Construction Off-Site

	ROG	NOx	CO	SO2	Fugitive PM10	Exhaust PM10	PM10 Total	Fugitive PM2.5	Exhaust PM2.5	PM2.5 Total	Bio- CO2	NBio- CO2	Total CO2	CH4	N2O	CO2e
Category	lb/day										lb/day					
Hauling	0.0000	0.0000	0.0000	0.0000	0.0000	0.0000	0.0000	0.0000	0.0000	0.0000		0.0000	0.0000	0.0000	0.0000	0.0000
Vendor	0.0000	0.0000	0.0000	0.0000	0.0000	0.0000	0.0000	0.0000	0.0000	0.0000		0.0000	0.0000	0.0000	0.0000	0.0000
Worker	0.0594	0.0373	0.5071	1.6200e-003	0.1977	9.0000e-004	0.1986	0.0524	8.3000e-004	0.0533		166.8356	166.8356	3.9300e-003	4.0600e-003	168.1428
Total	0.0594	0.0373	0.5071	1.6200e-003	0.1977	9.0000e-004	0.1986	0.0524	8.3000e-004	0.0533		166.8356	166.8356	3.9300e-003	4.0600e-003	168.1428

Pismo Beach GP/LCP PEIR - GHG - San Luis Obispo County APCD Air District, Summer

EMFAC Off-Model Adjustment Factors for Gasoline Light Duty Vehicle to Account for the SAFE Vehicle Rule Applied

3.4 Grading - 2024

Mitigated Construction On-Site

	ROG	NOx	CO	SO2	Fugitive PM10	Exhaust PM10	PM10 Total	Fugitive PM2.5	Exhaust PM2.5	PM2.5 Total	Bio- CO2	NBio- CO2	Total CO2	CH4	N2O	CO2e
Category	lb/day										lb/day					
Fugitive Dust					9.2036	0.0000	9.2036	3.6538	0.0000	3.6538			0.0000			0.0000
Off-Road	3.2181	32.3770	27.7228	0.0621		1.3354	1.3354		1.2286	1.2286	0.0000	6,009.7487	6,009.7487	1.9437		6,058.3405
Total	3.2181	32.3770	27.7228	0.0621	9.2036	1.3354	10.5390	3.6538	1.2286	4.8823	0.0000	6,009.7487	6,009.7487	1.9437		6,058.3405

Mitigated Construction Off-Site

	ROG	NOx	CO	SO2	Fugitive PM10	Exhaust PM10	PM10 Total	Fugitive PM2.5	Exhaust PM2.5	PM2.5 Total	Bio- CO2	NBio- CO2	Total CO2	CH4	N2O	CO2e
Category	lb/day										lb/day					
Hauling	0.0000	0.0000	0.0000	0.0000	0.0000	0.0000	0.0000	0.0000	0.0000	0.0000		0.0000	0.0000	0.0000	0.0000	0.0000
Vendor	0.0000	0.0000	0.0000	0.0000	0.0000	0.0000	0.0000	0.0000	0.0000	0.0000		0.0000	0.0000	0.0000	0.0000	0.0000
Worker	0.0594	0.0373	0.5071	1.6200e-003	0.1977	9.0000e-004	0.1986	0.0524	8.3000e-004	0.0533		166.8356	166.8356	3.9300e-003	4.0600e-003	168.1428
Total	0.0594	0.0373	0.5071	1.6200e-003	0.1977	9.0000e-004	0.1986	0.0524	8.3000e-004	0.0533		166.8356	166.8356	3.9300e-003	4.0600e-003	168.1428

Pismo Beach GP/LCP PEIR - GHG - San Luis Obispo County APCD Air District, Summer

EMFAC Off-Model Adjustment Factors for Gasoline Light Duty Vehicle to Account for the SAFE Vehicle Rule Applied

3.5 Building Construction - 2022

Unmitigated Construction On-Site

	ROG	NOx	CO	SO2	Fugitive PM10	Exhaust PM10	PM10 Total	Fugitive PM2.5	Exhaust PM2.5	PM2.5 Total	Bio- CO2	NBio- CO2	Total CO2	CH4	N2O	CO2e
Category	lb/day										lb/day					
Off-Road	1.7062	15.6156	16.3634	0.0269		0.8090	0.8090		0.7612	0.7612		2,554.3336	2,554.3336	0.6120		2,569.6322
Total	1.7062	15.6156	16.3634	0.0269		0.8090	0.8090		0.7612	0.7612		2,554.3336	2,554.3336	0.6120		2,569.6322

Unmitigated Construction Off-Site

	ROG	NOx	CO	SO2	Fugitive PM10	Exhaust PM10	PM10 Total	Fugitive PM2.5	Exhaust PM2.5	PM2.5 Total	Bio- CO2	NBio- CO2	Total CO2	CH4	N2O	CO2e
Category	lb/day										lb/day					
Hauling	0.0000	0.0000	0.0000	0.0000	0.0000	0.0000	0.0000	0.0000	0.0000	0.0000		0.0000	0.0000	0.0000	0.0000	0.0000
Vendor	0.4798	11.8485	3.6080	0.0380	1.1475	0.1184	1.2658	0.3305	0.1132	0.4438		4,069.1201	4,069.1201	0.0945	0.5988	4,249.9340
Worker	3.5460	2.4809	31.0724	0.0905	10.3903	0.0526	10.4429	2.7557	0.0485	2.8042		9,206.5998	9,206.5998	0.2519	0.2478	9,286.7541
Total	4.0259	14.3295	34.6804	0.1285	11.5378	0.1709	11.7087	3.0863	0.1617	3.2479		13,275.7199	13,275.7199	0.3464	0.8467	13,536.6881

Pismo Beach GP/LCP PEIR - GHG - San Luis Obispo County APCD Air District, Summer

EMFAC Off-Model Adjustment Factors for Gasoline Light Duty Vehicle to Account for the SAFE Vehicle Rule Applied

3.5 Building Construction - 2022

Mitigated Construction On-Site

	ROG	NOx	CO	SO2	Fugitive PM10	Exhaust PM10	PM10 Total	Fugitive PM2.5	Exhaust PM2.5	PM2.5 Total	Bio- CO2	NBio- CO2	Total CO2	CH4	N2O	CO2e
Category	lb/day										lb/day					
Off-Road	1.7062	15.6156	16.3634	0.0269		0.8090	0.8090		0.7612	0.7612	0.0000	2,554.3336	2,554.3336	0.6120		2,569.6322
Total	1.7062	15.6156	16.3634	0.0269		0.8090	0.8090		0.7612	0.7612	0.0000	2,554.3336	2,554.3336	0.6120		2,569.6322

Mitigated Construction Off-Site

	ROG	NOx	CO	SO2	Fugitive PM10	Exhaust PM10	PM10 Total	Fugitive PM2.5	Exhaust PM2.5	PM2.5 Total	Bio- CO2	NBio- CO2	Total CO2	CH4	N2O	CO2e
Category	lb/day										lb/day					
Hauling	0.0000	0.0000	0.0000	0.0000	0.0000	0.0000	0.0000	0.0000	0.0000	0.0000		0.0000	0.0000	0.0000	0.0000	0.0000
Vendor	0.4798	11.8485	3.6080	0.0380	1.1475	0.1184	1.2658	0.3305	0.1132	0.4438		4,069.1201	4,069.1201	0.0945	0.5988	4,249.9340
Worker	3.5460	2.4809	31.0724	0.0905	10.3903	0.0526	10.4429	2.7557	0.0485	2.8042		9,206.5998	9,206.5998	0.2519	0.2478	9,286.7541
Total	4.0259	14.3295	34.6804	0.1285	11.5378	0.1709	11.7087	3.0863	0.1617	3.2479		13,275.7199	13,275.7199	0.3464	0.8467	13,536.6881

Pismo Beach GP/LCP PEIR - GHG - San Luis Obispo County APCD Air District, Summer

EMFAC Off-Model Adjustment Factors for Gasoline Light Duty Vehicle to Account for the SAFE Vehicle Rule Applied

3.5 Building Construction - 2023

Unmitigated Construction On-Site

	ROG	NOx	CO	SO2	Fugitive PM10	Exhaust PM10	PM10 Total	Fugitive PM2.5	Exhaust PM2.5	PM2.5 Total	Bio- CO2	NBio- CO2	Total CO2	CH4	N2O	CO2e
Category	lb/day										lb/day					
Off-Road	1.5728	14.3849	16.2440	0.0269		0.6997	0.6997		0.6584	0.6584		2,555.2099	2,555.2099	0.6079		2,570.4061
Total	1.5728	14.3849	16.2440	0.0269		0.6997	0.6997		0.6584	0.6584		2,555.2099	2,555.2099	0.6079		2,570.4061

Unmitigated Construction Off-Site

	ROG	NOx	CO	SO2	Fugitive PM10	Exhaust PM10	PM10 Total	Fugitive PM2.5	Exhaust PM2.5	PM2.5 Total	Bio- CO2	NBio- CO2	Total CO2	CH4	N2O	CO2e
Category	lb/day										lb/day					
Hauling	0.0000	0.0000	0.0000	0.0000	0.0000	0.0000	0.0000	0.0000	0.0000	0.0000		0.0000	0.0000	0.0000	0.0000	0.0000
Vendor	0.2933	9.8965	3.2111	0.0366	1.1476	0.0577	1.2054	0.3306	0.0552	0.3858		3,925.4610	3,925.4610	0.0876	0.5763	4,099.3846
Worker	3.3205	2.1972	28.6560	0.0877	10.3903	0.0498	10.4401	2.7557	0.0459	2.8016		8,980.4749	8,980.4749	0.2278	0.2293	9,054.5045
Total	3.6138	12.0937	31.8671	0.1244	11.5380	0.1075	11.6455	3.0863	0.1011	3.1874		12,905.9359	12,905.9359	0.3154	0.8056	13,153.8890

Pismo Beach GP/LCP PEIR - GHG - San Luis Obispo County APCD Air District, Summer

EMFAC Off-Model Adjustment Factors for Gasoline Light Duty Vehicle to Account for the SAFE Vehicle Rule Applied

3.5 Building Construction - 2023

Mitigated Construction On-Site

	ROG	NOx	CO	SO2	Fugitive PM10	Exhaust PM10	PM10 Total	Fugitive PM2.5	Exhaust PM2.5	PM2.5 Total	Bio- CO2	NBio- CO2	Total CO2	CH4	N2O	CO2e
Category	lb/day										lb/day					
Off-Road	1.5728	14.3849	16.2440	0.0269		0.6997	0.6997		0.6584	0.6584	0.0000	2,555.2099	2,555.2099	0.6079		2,570.4061
Total	1.5728	14.3849	16.2440	0.0269		0.6997	0.6997		0.6584	0.6584	0.0000	2,555.2099	2,555.2099	0.6079		2,570.4061

Mitigated Construction Off-Site

	ROG	NOx	CO	SO2	Fugitive PM10	Exhaust PM10	PM10 Total	Fugitive PM2.5	Exhaust PM2.5	PM2.5 Total	Bio- CO2	NBio- CO2	Total CO2	CH4	N2O	CO2e
Category	lb/day										lb/day					
Hauling	0.0000	0.0000	0.0000	0.0000	0.0000	0.0000	0.0000	0.0000	0.0000	0.0000		0.0000	0.0000	0.0000	0.0000	0.0000
Vendor	0.2933	9.8965	3.2111	0.0366	1.1476	0.0577	1.2054	0.3306	0.0552	0.3858		3,925.4610	3,925.4610	0.0876	0.5763	4,099.3846
Worker	3.3205	2.1972	28.6560	0.0877	10.3903	0.0498	10.4401	2.7557	0.0459	2.8016		8,980.4749	8,980.4749	0.2278	0.2293	9,054.5045
Total	3.6138	12.0937	31.8671	0.1244	11.5380	0.1075	11.6455	3.0863	0.1011	3.1874		12,905.9359	12,905.9359	0.3154	0.8056	13,153.8890

Pismo Beach GP/LCP PEIR - GHG - San Luis Obispo County APCD Air District, Summer

EMFAC Off-Model Adjustment Factors for Gasoline Light Duty Vehicle to Account for the SAFE Vehicle Rule Applied

3.5 Building Construction - 2024

Unmitigated Construction On-Site

	ROG	NOx	CO	SO2	Fugitive PM10	Exhaust PM10	PM10 Total	Fugitive PM2.5	Exhaust PM2.5	PM2.5 Total	Bio- CO2	NBio- CO2	Total CO2	CH4	N2O	CO2e
Category	lb/day										lb/day					
Off-Road	1.4716	13.4438	16.1668	0.0270		0.6133	0.6133		0.5769	0.5769		2,555.6989	2,555.6989	0.6044		2,570.8077
Total	1.4716	13.4438	16.1668	0.0270		0.6133	0.6133		0.5769	0.5769		2,555.6989	2,555.6989	0.6044		2,570.8077

Unmitigated Construction Off-Site

	ROG	NOx	CO	SO2	Fugitive PM10	Exhaust PM10	PM10 Total	Fugitive PM2.5	Exhaust PM2.5	PM2.5 Total	Bio- CO2	NBio- CO2	Total CO2	CH4	N2O	CO2e
Category	lb/day										lb/day					
Hauling	0.0000	0.0000	0.0000	0.0000	0.0000	0.0000	0.0000	0.0000	0.0000	0.0000		0.0000	0.0000	0.0000	0.0000	0.0000
Vendor	0.2834	9.7082	3.1492	0.0360	1.1478	0.0567	1.2045	0.3306	0.0543	0.3849		3,864.9119	3,864.9119	0.0885	0.5672	4,036.1357
Worker	3.1225	1.9583	26.6453	0.0850	10.3903	0.0474	10.4377	2.7557	0.0436	2.7994		8,767.2092	8,767.2092	0.2066	0.2132	8,835.9046
Total	3.4059	11.6666	29.7945	0.1210	11.5381	0.1041	11.6422	3.0864	0.0979	3.1843		12,632.1212	12,632.1212	0.2952	0.7803	12,872.0403

Pismo Beach GP/LCP PEIR - GHG - San Luis Obispo County APCD Air District, Summer

EMFAC Off-Model Adjustment Factors for Gasoline Light Duty Vehicle to Account for the SAFE Vehicle Rule Applied

3.5 Building Construction - 2024

Mitigated Construction On-Site

	ROG	NOx	CO	SO2	Fugitive PM10	Exhaust PM10	PM10 Total	Fugitive PM2.5	Exhaust PM2.5	PM2.5 Total	Bio- CO2	NBio- CO2	Total CO2	CH4	N2O	CO2e
Category	lb/day										lb/day					
Off-Road	1.4716	13.4438	16.1668	0.0270		0.6133	0.6133		0.5769	0.5769	0.0000	2,555.6989	2,555.6989	0.6044		2,570.8077
Total	1.4716	13.4438	16.1668	0.0270		0.6133	0.6133		0.5769	0.5769	0.0000	2,555.6989	2,555.6989	0.6044		2,570.8077

Mitigated Construction Off-Site

	ROG	NOx	CO	SO2	Fugitive PM10	Exhaust PM10	PM10 Total	Fugitive PM2.5	Exhaust PM2.5	PM2.5 Total	Bio- CO2	NBio- CO2	Total CO2	CH4	N2O	CO2e
Category	lb/day										lb/day					
Hauling	0.0000	0.0000	0.0000	0.0000	0.0000	0.0000	0.0000	0.0000	0.0000	0.0000		0.0000	0.0000	0.0000	0.0000	0.0000
Vendor	0.2834	9.7082	3.1492	0.0360	1.1478	0.0567	1.2045	0.3306	0.0543	0.3849		3,864.9119	3,864.9119	0.0885	0.5672	4,036.1357
Worker	3.1225	1.9583	26.6453	0.0850	10.3903	0.0474	10.4377	2.7557	0.0436	2.7994		8,767.2092	8,767.2092	0.2066	0.2132	8,835.9046
Total	3.4059	11.6666	29.7945	0.1210	11.5381	0.1041	11.6422	3.0864	0.0979	3.1843		12,632.1212	12,632.1212	0.2952	0.7803	12,872.0403

Pismo Beach GP/LCP PEIR - GHG - San Luis Obispo County APCD Air District, Summer

EMFAC Off-Model Adjustment Factors for Gasoline Light Duty Vehicle to Account for the SAFE Vehicle Rule Applied

3.5 Building Construction - 2025

Unmitigated Construction On-Site

	ROG	NOx	CO	SO2	Fugitive PM10	Exhaust PM10	PM10 Total	Fugitive PM2.5	Exhaust PM2.5	PM2.5 Total	Bio- CO2	NBio- CO2	Total CO2	CH4	N2O	CO2e
Category	lb/day										lb/day					
Off-Road	1.3674	12.4697	16.0847	0.0270		0.5276	0.5276		0.4963	0.4963		2,556.474 4	2,556.474 4	0.6010		2,571.498 1
Total	1.3674	12.4697	16.0847	0.0270		0.5276	0.5276		0.4963	0.4963		2,556.474 4	2,556.474 4	0.6010		2,571.498 1

Unmitigated Construction Off-Site

	ROG	NOx	CO	SO2	Fugitive PM10	Exhaust PM10	PM10 Total	Fugitive PM2.5	Exhaust PM2.5	PM2.5 Total	Bio- CO2	NBio- CO2	Total CO2	CH4	N2O	CO2e
Category	lb/day										lb/day					
Hauling	0.0000	0.0000	0.0000	0.0000	0.0000	0.0000	0.0000	0.0000	0.0000	0.0000		0.0000	0.0000	0.0000	0.0000	0.0000
Vendor	0.2746	9.5018	3.1010	0.0354	1.1479	0.0554	1.2033	0.3307	0.0530	0.3837		3,797.857 4	3,797.857 4	0.0899	0.5569	3,966.060 1
Worker	2.9502	1.7593	24.9192	0.0822	10.3903	0.0452	10.4356	2.7557	0.0417	2.7974		8,565.694 7	8,565.694 7	0.1879	0.1993	8,629.775 4
Total	3.2248	11.2611	28.0202	0.1176	11.5382	0.1007	11.6389	3.0864	0.0947	3.1811		12,363.55 21	12,363.55 21	0.2778	0.7562	12,595.83 55

Pismo Beach GP/LCP PEIR - GHG - San Luis Obispo County APCD Air District, Summer

EMFAC Off-Model Adjustment Factors for Gasoline Light Duty Vehicle to Account for the SAFE Vehicle Rule Applied

3.5 Building Construction - 2025

Mitigated Construction On-Site

	ROG	NOx	CO	SO2	Fugitive PM10	Exhaust PM10	PM10 Total	Fugitive PM2.5	Exhaust PM2.5	PM2.5 Total	Bio- CO2	NBio- CO2	Total CO2	CH4	N2O	CO2e
Category	lb/day										lb/day					
Off-Road	1.3674	12.4697	16.0847	0.0270		0.5276	0.5276		0.4963	0.4963	0.0000	2,556.474 4	2,556.474 4	0.6010		2,571.498 1
Total	1.3674	12.4697	16.0847	0.0270		0.5276	0.5276		0.4963	0.4963	0.0000	2,556.474 4	2,556.474 4	0.6010		2,571.498 1

Mitigated Construction Off-Site

	ROG	NOx	CO	SO2	Fugitive PM10	Exhaust PM10	PM10 Total	Fugitive PM2.5	Exhaust PM2.5	PM2.5 Total	Bio- CO2	NBio- CO2	Total CO2	CH4	N2O	CO2e
Category	lb/day										lb/day					
Hauling	0.0000	0.0000	0.0000	0.0000	0.0000	0.0000	0.0000	0.0000	0.0000	0.0000		0.0000	0.0000	0.0000	0.0000	0.0000
Vendor	0.2746	9.5018	3.1010	0.0354	1.1479	0.0554	1.2033	0.3307	0.0530	0.3837		3,797.857 4	3,797.857 4	0.0899	0.5569	3,966.060 1
Worker	2.9502	1.7593	24.9192	0.0822	10.3903	0.0452	10.4356	2.7557	0.0417	2.7974		8,565.694 7	8,565.694 7	0.1879	0.1993	8,629.775 4
Total	3.2248	11.2611	28.0202	0.1176	11.5382	0.1007	11.6389	3.0864	0.0947	3.1811		12,363.55 21	12,363.55 21	0.2778	0.7562	12,595.83 55

Pismo Beach GP/LCP PEIR - GHG - San Luis Obispo County APCD Air District, Summer

EMFAC Off-Model Adjustment Factors for Gasoline Light Duty Vehicle to Account for the SAFE Vehicle Rule Applied

3.5 Building Construction - 2026

Unmitigated Construction On-Site

	ROG	NOx	CO	SO2	Fugitive PM10	Exhaust PM10	PM10 Total	Fugitive PM2.5	Exhaust PM2.5	PM2.5 Total	Bio- CO2	NBio- CO2	Total CO2	CH4	N2O	CO2e
Category	lb/day										lb/day					
Off-Road	1.3674	12.4697	16.0847	0.0270		0.5276	0.5276		0.4963	0.4963		2,556.474 4	2,556.474 4	0.6010		2,571.498 1
Total	1.3674	12.4697	16.0847	0.0270		0.5276	0.5276		0.4963	0.4963		2,556.474 4	2,556.474 4	0.6010		2,571.498 1

Unmitigated Construction Off-Site

	ROG	NOx	CO	SO2	Fugitive PM10	Exhaust PM10	PM10 Total	Fugitive PM2.5	Exhaust PM2.5	PM2.5 Total	Bio- CO2	NBio- CO2	Total CO2	CH4	N2O	CO2e
Category	lb/day										lb/day					
Hauling	0.0000	0.0000	0.0000	0.0000	0.0000	0.0000	0.0000	0.0000	0.0000	0.0000		0.0000	0.0000	0.0000	0.0000	0.0000
Vendor	0.2666	9.2956	3.0646	0.0347	1.1480	0.0540	1.2020	0.3307	0.0516	0.3823		3,729.673 5	3,729.673 5	0.0912	0.5465	3,894.808 4
Worker	2.8000	1.5945	23.4624	0.0797	10.3903	0.0431	10.4334	2.7557	0.0397	2.7954		8,372.157 6	8,372.157 6	0.1717	0.1876	8,432.361 1
Total	3.0666	10.8901	26.5270	0.1144	11.5384	0.0970	11.6354	3.0865	0.0913	3.1777		12,101.83 12	12,101.83 12	0.2630	0.7341	12,327.16 94

Pismo Beach GP/LCP PEIR - GHG - San Luis Obispo County APCD Air District, Summer

EMFAC Off-Model Adjustment Factors for Gasoline Light Duty Vehicle to Account for the SAFE Vehicle Rule Applied

3.5 Building Construction - 2026

Mitigated Construction On-Site

	ROG	NOx	CO	SO2	Fugitive PM10	Exhaust PM10	PM10 Total	Fugitive PM2.5	Exhaust PM2.5	PM2.5 Total	Bio- CO2	NBio- CO2	Total CO2	CH4	N2O	CO2e
Category	lb/day										lb/day					
Off-Road	1.3674	12.4697	16.0847	0.0270		0.5276	0.5276		0.4963	0.4963	0.0000	2,556.474 4	2,556.474 4	0.6010		2,571.498 1
Total	1.3674	12.4697	16.0847	0.0270		0.5276	0.5276		0.4963	0.4963	0.0000	2,556.474 4	2,556.474 4	0.6010		2,571.498 1

Mitigated Construction Off-Site

	ROG	NOx	CO	SO2	Fugitive PM10	Exhaust PM10	PM10 Total	Fugitive PM2.5	Exhaust PM2.5	PM2.5 Total	Bio- CO2	NBio- CO2	Total CO2	CH4	N2O	CO2e
Category	lb/day										lb/day					
Hauling	0.0000	0.0000	0.0000	0.0000	0.0000	0.0000	0.0000	0.0000	0.0000	0.0000		0.0000	0.0000	0.0000	0.0000	0.0000
Vendor	0.2666	9.2956	3.0646	0.0347	1.1480	0.0540	1.2020	0.3307	0.0516	0.3823		3,729.673 5	3,729.673 5	0.0912	0.5465	3,894.808 4
Worker	2.8000	1.5945	23.4624	0.0797	10.3903	0.0431	10.4334	2.7557	0.0397	2.7954		8,372.157 6	8,372.157 6	0.1717	0.1876	8,432.361 1
Total	3.0666	10.8901	26.5270	0.1144	11.5384	0.0970	11.6354	3.0865	0.0913	3.1777		12,101.83 12	12,101.83 12	0.2630	0.7341	12,327.16 94

Pismo Beach GP/LCP PEIR - GHG - San Luis Obispo County APCD Air District, Summer

EMFAC Off-Model Adjustment Factors for Gasoline Light Duty Vehicle to Account for the SAFE Vehicle Rule Applied

3.5 Building Construction - 2027

Unmitigated Construction On-Site

	ROG	NOx	CO	SO2	Fugitive PM10	Exhaust PM10	PM10 Total	Fugitive PM2.5	Exhaust PM2.5	PM2.5 Total	Bio- CO2	NBio- CO2	Total CO2	CH4	N2O	CO2e
Category	lb/day										lb/day					
Off-Road	1.3674	12.4697	16.0847	0.0270		0.5276	0.5276		0.4963	0.4963		2,556.474 4	2,556.474 4	0.6010		2,571.498 1
Total	1.3674	12.4697	16.0847	0.0270		0.5276	0.5276		0.4963	0.4963		2,556.474 4	2,556.474 4	0.6010		2,571.498 1

Unmitigated Construction Off-Site

	ROG	NOx	CO	SO2	Fugitive PM10	Exhaust PM10	PM10 Total	Fugitive PM2.5	Exhaust PM2.5	PM2.5 Total	Bio- CO2	NBio- CO2	Total CO2	CH4	N2O	CO2e
Category	lb/day										lb/day					
Hauling	0.0000	0.0000	0.0000	0.0000	0.0000	0.0000	0.0000	0.0000	0.0000	0.0000		0.0000	0.0000	0.0000	0.0000	0.0000
Vendor	0.2596	9.1007	3.0352	0.0340	1.1481	0.0526	1.2007	0.3308	0.0503	0.3810		3,656.126 3	3,656.126 3	0.0924	0.5354	3,817.996 9
Worker	2.6596	1.4545	22.2101	0.0774	10.3903	0.0406	10.4309	2.7557	0.0374	2.7931		8,192.291 4	8,192.291 4	0.1576	0.1777	8,249.193 9
Total	2.9193	10.5552	25.2453	0.1114	11.5385	0.0932	11.6316	3.0865	0.0877	3.1742		11,848.41 77	11,848.41 77	0.2500	0.7132	12,067.19 07

Pismo Beach GP/LCP PEIR - GHG - San Luis Obispo County APCD Air District, Summer

EMFAC Off-Model Adjustment Factors for Gasoline Light Duty Vehicle to Account for the SAFE Vehicle Rule Applied

3.5 Building Construction - 2027

Mitigated Construction On-Site

	ROG	NOx	CO	SO2	Fugitive PM10	Exhaust PM10	PM10 Total	Fugitive PM2.5	Exhaust PM2.5	PM2.5 Total	Bio- CO2	NBio- CO2	Total CO2	CH4	N2O	CO2e
Category	lb/day										lb/day					
Off-Road	1.3674	12.4697	16.0847	0.0270		0.5276	0.5276		0.4963	0.4963	0.0000	2,556.474 4	2,556.474 4	0.6010		2,571.498 1
Total	1.3674	12.4697	16.0847	0.0270		0.5276	0.5276		0.4963	0.4963	0.0000	2,556.474 4	2,556.474 4	0.6010		2,571.498 1

Mitigated Construction Off-Site

	ROG	NOx	CO	SO2	Fugitive PM10	Exhaust PM10	PM10 Total	Fugitive PM2.5	Exhaust PM2.5	PM2.5 Total	Bio- CO2	NBio- CO2	Total CO2	CH4	N2O	CO2e
Category	lb/day										lb/day					
Hauling	0.0000	0.0000	0.0000	0.0000	0.0000	0.0000	0.0000	0.0000	0.0000	0.0000		0.0000	0.0000	0.0000	0.0000	0.0000
Vendor	0.2596	9.1007	3.0352	0.0340	1.1481	0.0526	1.2007	0.3308	0.0503	0.3810		3,656.126 3	3,656.126 3	0.0924	0.5354	3,817.996 9
Worker	2.6596	1.4545	22.2101	0.0774	10.3903	0.0406	10.4309	2.7557	0.0374	2.7931		8,192.291 4	8,192.291 4	0.1576	0.1777	8,249.193 9
Total	2.9193	10.5552	25.2453	0.1114	11.5385	0.0932	11.6316	3.0865	0.0877	3.1742		11,848.41 77	11,848.41 77	0.2500	0.7132	12,067.19 07

Pismo Beach GP/LCP PEIR - GHG - San Luis Obispo County APCD Air District, Summer

EMFAC Off-Model Adjustment Factors for Gasoline Light Duty Vehicle to Account for the SAFE Vehicle Rule Applied

3.5 Building Construction - 2028

Unmitigated Construction On-Site

	ROG	NOx	CO	SO2	Fugitive PM10	Exhaust PM10	PM10 Total	Fugitive PM2.5	Exhaust PM2.5	PM2.5 Total	Bio- CO2	NBio- CO2	Total CO2	CH4	N2O	CO2e
Category	lb/day										lb/day					
Off-Road	1.3674	12.4697	16.0847	0.0270		0.5276	0.5276		0.4963	0.4963		2,556.474 4	2,556.474 4	0.6010		2,571.498 1
Total	1.3674	12.4697	16.0847	0.0270		0.5276	0.5276		0.4963	0.4963		2,556.474 4	2,556.474 4	0.6010		2,571.498 1

Unmitigated Construction Off-Site

	ROG	NOx	CO	SO2	Fugitive PM10	Exhaust PM10	PM10 Total	Fugitive PM2.5	Exhaust PM2.5	PM2.5 Total	Bio- CO2	NBio- CO2	Total CO2	CH4	N2O	CO2e
Category	lb/day										lb/day					
Hauling	0.0000	0.0000	0.0000	0.0000	0.0000	0.0000	0.0000	0.0000	0.0000	0.0000		0.0000	0.0000	0.0000	0.0000	0.0000
Vendor	0.2533	8.9323	3.0135	0.0333	1.1483	0.0513	1.1995	0.3308	0.0491	0.3799		3,585.927 8	3,585.927 8	0.0938	0.5248	3,744.674 9
Worker	2.5227	1.3367	21.1578	0.0753	10.3903	0.0381	10.4284	2.7557	0.0351	2.7908		8,029.703 7	8,029.703 7	0.1453	0.1694	8,083.808 0
Total	2.7760	10.2689	24.1712	0.1086	11.5386	0.0894	11.6280	3.0865	0.0842	3.1707		11,615.63 15	11,615.63 15	0.2392	0.6942	11,828.48 29

Pismo Beach GP/LCP PEIR - GHG - San Luis Obispo County APCD Air District, Summer

EMFAC Off-Model Adjustment Factors for Gasoline Light Duty Vehicle to Account for the SAFE Vehicle Rule Applied

3.5 Building Construction - 2028

Mitigated Construction On-Site

	ROG	NOx	CO	SO2	Fugitive PM10	Exhaust PM10	PM10 Total	Fugitive PM2.5	Exhaust PM2.5	PM2.5 Total	Bio- CO2	NBio- CO2	Total CO2	CH4	N2O	CO2e
Category	lb/day										lb/day					
Off-Road	1.3674	12.4697	16.0847	0.0270		0.5276	0.5276		0.4963	0.4963	0.0000	2,556.474 4	2,556.474 4	0.6010		2,571.498 1
Total	1.3674	12.4697	16.0847	0.0270		0.5276	0.5276		0.4963	0.4963	0.0000	2,556.474 4	2,556.474 4	0.6010		2,571.498 1

Mitigated Construction Off-Site

	ROG	NOx	CO	SO2	Fugitive PM10	Exhaust PM10	PM10 Total	Fugitive PM2.5	Exhaust PM2.5	PM2.5 Total	Bio- CO2	NBio- CO2	Total CO2	CH4	N2O	CO2e
Category	lb/day										lb/day					
Hauling	0.0000	0.0000	0.0000	0.0000	0.0000	0.0000	0.0000	0.0000	0.0000	0.0000		0.0000	0.0000	0.0000	0.0000	0.0000
Vendor	0.2533	8.9323	3.0135	0.0333	1.1483	0.0513	1.1995	0.3308	0.0491	0.3799		3,585.927 8	3,585.927 8	0.0938	0.5248	3,744.674 9
Worker	2.5227	1.3367	21.1578	0.0753	10.3903	0.0381	10.4284	2.7557	0.0351	2.7908		8,029.703 7	8,029.703 7	0.1453	0.1694	8,083.808 0
Total	2.7760	10.2689	24.1712	0.1086	11.5386	0.0894	11.6280	3.0865	0.0842	3.1707		11,615.63 15	11,615.63 15	0.2392	0.6942	11,828.48 29

Pismo Beach GP/LCP PEIR - GHG - San Luis Obispo County APCD Air District, Summer

EMFAC Off-Model Adjustment Factors for Gasoline Light Duty Vehicle to Account for the SAFE Vehicle Rule Applied

3.5 Building Construction - 2029

Unmitigated Construction On-Site

	ROG	NOx	CO	SO2	Fugitive PM10	Exhaust PM10	PM10 Total	Fugitive PM2.5	Exhaust PM2.5	PM2.5 Total	Bio- CO2	NBio- CO2	Total CO2	CH4	N2O	CO2e
Category	lb/day										lb/day					
Off-Road	1.3674	12.4697	16.0847	0.0270		0.5276	0.5276		0.4963	0.4963		2,556.474 4	2,556.474 4	0.6010		2,571.498 1
Total	1.3674	12.4697	16.0847	0.0270		0.5276	0.5276		0.4963	0.4963		2,556.474 4	2,556.474 4	0.6010		2,571.498 1

Unmitigated Construction Off-Site

	ROG	NOx	CO	SO2	Fugitive PM10	Exhaust PM10	PM10 Total	Fugitive PM2.5	Exhaust PM2.5	PM2.5 Total	Bio- CO2	NBio- CO2	Total CO2	CH4	N2O	CO2e
Category	lb/day										lb/day					
Hauling	0.0000	0.0000	0.0000	0.0000	0.0000	0.0000	0.0000	0.0000	0.0000	0.0000		0.0000	0.0000	0.0000	0.0000	0.0000
Vendor	0.2472	8.7591	2.9936	0.0327	1.1484	0.0500	1.1983	0.3309	0.0478	0.3786		3,514.681 5	3,514.681 5	0.0952	0.5141	3,670.260 9
Worker	2.3891	1.2361	20.2362	0.0734	10.3903	0.0357	10.4261	2.7557	0.0329	2.7886		7,881.975 7	7,881.975 7	0.1344	0.1622	7,933.684 4
Total	2.6363	9.9951	23.2299	0.1060	11.5387	0.0857	11.6244	3.0866	0.0807	3.1673		11,396.65 72	11,396.65 72	0.2296	0.6763	11,603.94 53

Pismo Beach GP/LCP PEIR - GHG - San Luis Obispo County APCD Air District, Summer

EMFAC Off-Model Adjustment Factors for Gasoline Light Duty Vehicle to Account for the SAFE Vehicle Rule Applied

3.5 Building Construction - 2029

Mitigated Construction On-Site

	ROG	NOx	CO	SO2	Fugitive PM10	Exhaust PM10	PM10 Total	Fugitive PM2.5	Exhaust PM2.5	PM2.5 Total	Bio- CO2	NBio- CO2	Total CO2	CH4	N2O	CO2e
Category	lb/day										lb/day					
Off-Road	1.3674	12.4697	16.0847	0.0270		0.5276	0.5276		0.4963	0.4963	0.0000	2,556.474 4	2,556.474 4	0.6010		2,571.498 1
Total	1.3674	12.4697	16.0847	0.0270		0.5276	0.5276		0.4963	0.4963	0.0000	2,556.474 4	2,556.474 4	0.6010		2,571.498 1

Mitigated Construction Off-Site

	ROG	NOx	CO	SO2	Fugitive PM10	Exhaust PM10	PM10 Total	Fugitive PM2.5	Exhaust PM2.5	PM2.5 Total	Bio- CO2	NBio- CO2	Total CO2	CH4	N2O	CO2e
Category	lb/day										lb/day					
Hauling	0.0000	0.0000	0.0000	0.0000	0.0000	0.0000	0.0000	0.0000	0.0000	0.0000		0.0000	0.0000	0.0000	0.0000	0.0000
Vendor	0.2472	8.7591	2.9936	0.0327	1.1484	0.0500	1.1983	0.3309	0.0478	0.3786		3,514.681 5	3,514.681 5	0.0952	0.5141	3,670.260 9
Worker	2.3891	1.2361	20.2362	0.0734	10.3903	0.0357	10.4261	2.7557	0.0329	2.7886		7,881.975 7	7,881.975 7	0.1344	0.1622	7,933.684 4
Total	2.6363	9.9951	23.2299	0.1060	11.5387	0.0857	11.6244	3.0866	0.0807	3.1673		11,396.65 72	11,396.65 72	0.2296	0.6763	11,603.94 53

Pismo Beach GP/LCP PEIR - GHG - San Luis Obispo County APCD Air District, Summer

EMFAC Off-Model Adjustment Factors for Gasoline Light Duty Vehicle to Account for the SAFE Vehicle Rule Applied

3.5 Building Construction - 2030

Unmitigated Construction On-Site

	ROG	NOx	CO	SO2	Fugitive PM10	Exhaust PM10	PM10 Total	Fugitive PM2.5	Exhaust PM2.5	PM2.5 Total	Bio- CO2	NBio- CO2	Total CO2	CH4	N2O	CO2e
Category	lb/day										lb/day					
Off-Road	1.3091	7.9346	16.1570	0.0310		0.1481	0.1481		0.1481	0.1481		2,897.5468	2,897.5468	0.1162		2,900.4529
Total	1.3091	7.9346	16.1570	0.0310		0.1481	0.1481		0.1481	0.1481		2,897.5468	2,897.5468	0.1162		2,900.4529

Unmitigated Construction Off-Site

	ROG	NOx	CO	SO2	Fugitive PM10	Exhaust PM10	PM10 Total	Fugitive PM2.5	Exhaust PM2.5	PM2.5 Total	Bio- CO2	NBio- CO2	Total CO2	CH4	N2O	CO2e
Category	lb/day										lb/day					
Hauling	0.0000	0.0000	0.0000	0.0000	0.0000	0.0000	0.0000	0.0000	0.0000	0.0000		0.0000	0.0000	0.0000	0.0000	0.0000
Vendor	0.2424	8.6249	2.9824	0.0320	1.1484	0.0489	1.1973	0.3309	0.0468	0.3777		3,451.5684	3,451.5684	0.0963	0.5047	3,604.3653
Worker	2.2606	1.1498	19.4512	0.0717	10.3903	0.0335	10.4238	2.7557	0.0308	2.7865		7,750.2702	7,750.2702	0.1247	0.1562	7,799.9270
Total	2.5029	9.7746	22.4336	0.1037	11.5388	0.0824	11.6211	3.0866	0.0776	3.1642		11,201.8386	11,201.8386	0.2210	0.6608	11,404.2923

Pismo Beach GP/LCP PEIR - GHG - San Luis Obispo County APCD Air District, Summer

EMFAC Off-Model Adjustment Factors for Gasoline Light Duty Vehicle to Account for the SAFE Vehicle Rule Applied

3.5 Building Construction - 2030

Mitigated Construction On-Site

	ROG	NOx	CO	SO2	Fugitive PM10	Exhaust PM10	PM10 Total	Fugitive PM2.5	Exhaust PM2.5	PM2.5 Total	Bio- CO2	NBio- CO2	Total CO2	CH4	N2O	CO2e
Category	lb/day										lb/day					
Off-Road	1.3091	7.9346	16.1570	0.0310		0.1481	0.1481		0.1481	0.1481	0.0000	2,897.5468	2,897.5468	0.1162		2,900.4529
Total	1.3091	7.9346	16.1570	0.0310		0.1481	0.1481		0.1481	0.1481	0.0000	2,897.5468	2,897.5468	0.1162		2,900.4529

Mitigated Construction Off-Site

	ROG	NOx	CO	SO2	Fugitive PM10	Exhaust PM10	PM10 Total	Fugitive PM2.5	Exhaust PM2.5	PM2.5 Total	Bio- CO2	NBio- CO2	Total CO2	CH4	N2O	CO2e
Category	lb/day										lb/day					
Hauling	0.0000	0.0000	0.0000	0.0000	0.0000	0.0000	0.0000	0.0000	0.0000	0.0000		0.0000	0.0000	0.0000	0.0000	0.0000
Vendor	0.2424	8.6249	2.9824	0.0320	1.1484	0.0489	1.1973	0.3309	0.0468	0.3777		3,451.5684	3,451.5684	0.0963	0.5047	3,604.3653
Worker	2.2606	1.1498	19.4512	0.0717	10.3903	0.0335	10.4238	2.7557	0.0308	2.7865		7,750.2702	7,750.2702	0.1247	0.1562	7,799.9270
Total	2.5029	9.7746	22.4336	0.1037	11.5388	0.0824	11.6211	3.0866	0.0776	3.1642		11,201.8386	11,201.8386	0.2210	0.6608	11,404.2923

Pismo Beach GP/LCP PEIR - GHG - San Luis Obispo County APCD Air District, Summer

EMFAC Off-Model Adjustment Factors for Gasoline Light Duty Vehicle to Account for the SAFE Vehicle Rule Applied

3.5 Building Construction - 2031

Unmitigated Construction On-Site

	ROG	NOx	CO	SO2	Fugitive PM10	Exhaust PM10	PM10 Total	Fugitive PM2.5	Exhaust PM2.5	PM2.5 Total	Bio- CO2	NBio- CO2	Total CO2	CH4	N2O	CO2e
Category	lb/day										lb/day					
Off-Road	1.3091	7.9346	16.1570	0.0310		0.1481	0.1481		0.1481	0.1481		2,897.5468	2,897.5468	0.1162		2,900.4529
Total	1.3091	7.9346	16.1570	0.0310		0.1481	0.1481		0.1481	0.1481		2,897.5468	2,897.5468	0.1162		2,900.4529

Unmitigated Construction Off-Site

	ROG	NOx	CO	SO2	Fugitive PM10	Exhaust PM10	PM10 Total	Fugitive PM2.5	Exhaust PM2.5	PM2.5 Total	Bio- CO2	NBio- CO2	Total CO2	CH4	N2O	CO2e
Category	lb/day										lb/day					
Hauling	0.0000	0.0000	0.0000	0.0000	0.0000	0.0000	0.0000	0.0000	0.0000	0.0000		0.0000	0.0000	0.0000	0.0000	0.0000
Vendor	0.2384	8.5053	2.9796	0.0315	1.1485	0.0480	1.1965	0.3309	0.0459	0.3768		3,394.0537	3,394.0537	0.0975	0.4961	3,544.3274
Worker	2.1300	1.0737	18.7534	0.0701	10.3903	0.0314	10.4217	2.7557	0.0289	2.7846		7,631.7831	7,631.7831	0.1159	0.1509	7,679.6601
Total	2.3684	9.5790	21.7330	0.1016	11.5388	0.0794	11.6182	3.0866	0.0748	3.1614		11,025.8367	11,025.8367	0.2134	0.6470	11,223.9875

Pismo Beach GP/LCP PEIR - GHG - San Luis Obispo County APCD Air District, Summer

EMFAC Off-Model Adjustment Factors for Gasoline Light Duty Vehicle to Account for the SAFE Vehicle Rule Applied

3.5 Building Construction - 2031

Mitigated Construction On-Site

	ROG	NOx	CO	SO2	Fugitive PM10	Exhaust PM10	PM10 Total	Fugitive PM2.5	Exhaust PM2.5	PM2.5 Total	Bio- CO2	NBio- CO2	Total CO2	CH4	N2O	CO2e
Category	lb/day										lb/day					
Off-Road	1.3091	7.9346	16.1570	0.0310		0.1481	0.1481		0.1481	0.1481	0.0000	2,897.5468	2,897.5468	0.1162		2,900.4529
Total	1.3091	7.9346	16.1570	0.0310		0.1481	0.1481		0.1481	0.1481	0.0000	2,897.5468	2,897.5468	0.1162		2,900.4529

Mitigated Construction Off-Site

	ROG	NOx	CO	SO2	Fugitive PM10	Exhaust PM10	PM10 Total	Fugitive PM2.5	Exhaust PM2.5	PM2.5 Total	Bio- CO2	NBio- CO2	Total CO2	CH4	N2O	CO2e
Category	lb/day										lb/day					
Hauling	0.0000	0.0000	0.0000	0.0000	0.0000	0.0000	0.0000	0.0000	0.0000	0.0000		0.0000	0.0000	0.0000	0.0000	0.0000
Vendor	0.2384	8.5053	2.9796	0.0315	1.1485	0.0480	1.1965	0.3309	0.0459	0.3768		3,394.0537	3,394.0537	0.0975	0.4961	3,544.3274
Worker	2.1300	1.0737	18.7534	0.0701	10.3903	0.0314	10.4217	2.7557	0.0289	2.7846		7,631.7831	7,631.7831	0.1159	0.1509	7,679.6601
Total	2.3684	9.5790	21.7330	0.1016	11.5388	0.0794	11.6182	3.0866	0.0748	3.1614		11,025.8367	11,025.8367	0.2134	0.6470	11,223.9875

Pismo Beach GP/LCP PEIR - GHG - San Luis Obispo County APCD Air District, Summer

EMFAC Off-Model Adjustment Factors for Gasoline Light Duty Vehicle to Account for the SAFE Vehicle Rule Applied

3.5 Building Construction - 2032

Unmitigated Construction On-Site

	ROG	NOx	CO	SO2	Fugitive PM10	Exhaust PM10	PM10 Total	Fugitive PM2.5	Exhaust PM2.5	PM2.5 Total	Bio- CO2	NBio- CO2	Total CO2	CH4	N2O	CO2e
Category	lb/day										lb/day					
Off-Road	1.3091	7.9346	16.1570	0.0310		0.1481	0.1481		0.1481	0.1481		2,897.5468	2,897.5468	0.1162		2,900.4529
Total	1.3091	7.9346	16.1570	0.0310		0.1481	0.1481		0.1481	0.1481		2,897.5468	2,897.5468	0.1162		2,900.4529

Unmitigated Construction Off-Site

	ROG	NOx	CO	SO2	Fugitive PM10	Exhaust PM10	PM10 Total	Fugitive PM2.5	Exhaust PM2.5	PM2.5 Total	Bio- CO2	NBio- CO2	Total CO2	CH4	N2O	CO2e
Category	lb/day										lb/day					
Hauling	0.0000	0.0000	0.0000	0.0000	0.0000	0.0000	0.0000	0.0000	0.0000	0.0000		0.0000	0.0000	0.0000	0.0000	0.0000
Vendor	0.2351	8.4009	2.9829	0.0310	1.1486	0.0472	1.1958	0.3309	0.0451	0.3761		3,342.2800	3,342.2800	0.0985	0.4885	3,490.3078
Worker	2.0073	1.0089	18.1449	0.0688	10.3903	0.0295	10.4198	2.7557	0.0271	2.7829		7,526.4821	7,526.4821	0.1081	0.1465	7,572.8519
Total	2.2424	9.4099	21.1278	0.0998	11.5389	0.0767	11.6156	3.0867	0.0723	3.1589		10,868.7621	10,868.7621	0.2065	0.6350	11,063.1598

Pismo Beach GP/LCP PEIR - GHG - San Luis Obispo County APCD Air District, Summer

EMFAC Off-Model Adjustment Factors for Gasoline Light Duty Vehicle to Account for the SAFE Vehicle Rule Applied

3.5 Building Construction - 2032

Mitigated Construction On-Site

	ROG	NOx	CO	SO2	Fugitive PM10	Exhaust PM10	PM10 Total	Fugitive PM2.5	Exhaust PM2.5	PM2.5 Total	Bio- CO2	NBio- CO2	Total CO2	CH4	N2O	CO2e
Category	lb/day										lb/day					
Off-Road	1.3091	7.9346	16.1570	0.0310		0.1481	0.1481		0.1481	0.1481	0.0000	2,897.5468	2,897.5468	0.1162		2,900.4529
Total	1.3091	7.9346	16.1570	0.0310		0.1481	0.1481		0.1481	0.1481	0.0000	2,897.5468	2,897.5468	0.1162		2,900.4529

Mitigated Construction Off-Site

	ROG	NOx	CO	SO2	Fugitive PM10	Exhaust PM10	PM10 Total	Fugitive PM2.5	Exhaust PM2.5	PM2.5 Total	Bio- CO2	NBio- CO2	Total CO2	CH4	N2O	CO2e
Category	lb/day										lb/day					
Hauling	0.0000	0.0000	0.0000	0.0000	0.0000	0.0000	0.0000	0.0000	0.0000	0.0000		0.0000	0.0000	0.0000	0.0000	0.0000
Vendor	0.2351	8.4009	2.9829	0.0310	1.1486	0.0472	1.1958	0.3309	0.0451	0.3761		3,342.2800	3,342.2800	0.0985	0.4885	3,490.3078
Worker	2.0073	1.0089	18.1449	0.0688	10.3903	0.0295	10.4198	2.7557	0.0271	2.7829		7,526.4821	7,526.4821	0.1081	0.1465	7,572.8519
Total	2.2424	9.4099	21.1278	0.0998	11.5389	0.0767	11.6156	3.0867	0.0723	3.1589		10,868.7621	10,868.7621	0.2065	0.6350	11,063.1598

Pismo Beach GP/LCP PEIR - GHG - San Luis Obispo County APCD Air District, Summer

EMFAC Off-Model Adjustment Factors for Gasoline Light Duty Vehicle to Account for the SAFE Vehicle Rule Applied

3.5 Building Construction - 2033

Unmitigated Construction On-Site

	ROG	NOx	CO	SO2	Fugitive PM10	Exhaust PM10	PM10 Total	Fugitive PM2.5	Exhaust PM2.5	PM2.5 Total	Bio- CO2	NBio- CO2	Total CO2	CH4	N2O	CO2e
Category	lb/day										lb/day					
Off-Road	1.3091	7.9346	16.1570	0.0310		0.1481	0.1481		0.1481	0.1481		2,897.5468	2,897.5468	0.1162		2,900.4529
Total	1.3091	7.9346	16.1570	0.0310		0.1481	0.1481		0.1481	0.1481		2,897.5468	2,897.5468	0.1162		2,900.4529

Unmitigated Construction Off-Site

	ROG	NOx	CO	SO2	Fugitive PM10	Exhaust PM10	PM10 Total	Fugitive PM2.5	Exhaust PM2.5	PM2.5 Total	Bio- CO2	NBio- CO2	Total CO2	CH4	N2O	CO2e
Category	lb/day										lb/day					
Hauling	0.0000	0.0000	0.0000	0.0000	0.0000	0.0000	0.0000	0.0000	0.0000	0.0000		0.0000	0.0000	0.0000	0.0000	0.0000
Vendor	0.2327	8.3128	2.9907	0.0306	1.1487	0.0465	1.1952	0.3310	0.0445	0.3754		3,295.9103	3,295.9103	0.0993	0.4818	3,441.9540
Worker	1.9025	0.9571	17.6276	0.0675	10.3903	0.0278	10.4181	2.7557	0.0255	2.7813		7,433.0764	7,433.0764	0.1013	0.1430	7,478.2106
Total	2.1352	9.2700	20.6182	0.0981	11.5390	0.0743	11.6132	3.0867	0.0700	3.1567		10,728.9867	10,728.9867	0.2006	0.6247	10,920.1646

Pismo Beach GP/LCP PEIR - GHG - San Luis Obispo County APCD Air District, Summer

EMFAC Off-Model Adjustment Factors for Gasoline Light Duty Vehicle to Account for the SAFE Vehicle Rule Applied

3.5 Building Construction - 2033

Mitigated Construction On-Site

	ROG	NOx	CO	SO2	Fugitive PM10	Exhaust PM10	PM10 Total	Fugitive PM2.5	Exhaust PM2.5	PM2.5 Total	Bio- CO2	NBio- CO2	Total CO2	CH4	N2O	CO2e
Category	lb/day										lb/day					
Off-Road	1.3091	7.9346	16.1570	0.0310		0.1481	0.1481		0.1481	0.1481	0.0000	2,897.5468	2,897.5468	0.1162		2,900.4529
Total	1.3091	7.9346	16.1570	0.0310		0.1481	0.1481		0.1481	0.1481	0.0000	2,897.5468	2,897.5468	0.1162		2,900.4529

Mitigated Construction Off-Site

	ROG	NOx	CO	SO2	Fugitive PM10	Exhaust PM10	PM10 Total	Fugitive PM2.5	Exhaust PM2.5	PM2.5 Total	Bio- CO2	NBio- CO2	Total CO2	CH4	N2O	CO2e
Category	lb/day										lb/day					
Hauling	0.0000	0.0000	0.0000	0.0000	0.0000	0.0000	0.0000	0.0000	0.0000	0.0000		0.0000	0.0000	0.0000	0.0000	0.0000
Vendor	0.2327	8.3128	2.9907	0.0306	1.1487	0.0465	1.1952	0.3310	0.0445	0.3754		3,295.9103	3,295.9103	0.0993	0.4818	3,441.9540
Worker	1.9025	0.9571	17.6276	0.0675	10.3903	0.0278	10.4181	2.7557	0.0255	2.7813		7,433.0764	7,433.0764	0.1013	0.1430	7,478.2106
Total	2.1352	9.2700	20.6182	0.0981	11.5390	0.0743	11.6132	3.0867	0.0700	3.1567		10,728.9867	10,728.9867	0.2006	0.6247	10,920.1646

Pismo Beach GP/LCP PEIR - GHG - San Luis Obispo County APCD Air District, Summer

EMFAC Off-Model Adjustment Factors for Gasoline Light Duty Vehicle to Account for the SAFE Vehicle Rule Applied

3.5 Building Construction - 2034

Unmitigated Construction On-Site

	ROG	NOx	CO	SO2	Fugitive PM10	Exhaust PM10	PM10 Total	Fugitive PM2.5	Exhaust PM2.5	PM2.5 Total	Bio- CO2	NBio- CO2	Total CO2	CH4	N2O	CO2e
Category	lb/day										lb/day					
Off-Road	1.3091	7.9346	16.1570	0.0310		0.1481	0.1481		0.1481	0.1481		2,897.5468	2,897.5468	0.1162		2,900.4529
Total	1.3091	7.9346	16.1570	0.0310		0.1481	0.1481		0.1481	0.1481		2,897.5468	2,897.5468	0.1162		2,900.4529

Unmitigated Construction Off-Site

	ROG	NOx	CO	SO2	Fugitive PM10	Exhaust PM10	PM10 Total	Fugitive PM2.5	Exhaust PM2.5	PM2.5 Total	Bio- CO2	NBio- CO2	Total CO2	CH4	N2O	CO2e
Category	lb/day										lb/day					
Hauling	0.0000	0.0000	0.0000	0.0000	0.0000	0.0000	0.0000	0.0000	0.0000	0.0000		0.0000	0.0000	0.0000	0.0000	0.0000
Vendor	0.2307	8.2327	3.0002	0.0301	1.1487	0.0459	1.1946	0.3310	0.0439	0.3749		3,253.3979	3,253.3979	0.1003	0.4756	3,397.6301
Worker	1.8097	0.9150	17.1737	0.0665	10.3903	0.0262	10.4165	2.7557	0.0241	2.7798		7,350.1554	7,350.1554	0.0952	0.1401	7,394.2703
Total	2.0404	9.1477	20.1739	0.0966	11.5390	0.0720	11.6111	3.0867	0.0680	3.1547		10,603.5533	10,603.5533	0.1955	0.6156	10,791.9004

Pismo Beach GP/LCP PEIR - GHG - San Luis Obispo County APCD Air District, Summer

EMFAC Off-Model Adjustment Factors for Gasoline Light Duty Vehicle to Account for the SAFE Vehicle Rule Applied

3.5 Building Construction - 2034

Mitigated Construction On-Site

	ROG	NOx	CO	SO2	Fugitive PM10	Exhaust PM10	PM10 Total	Fugitive PM2.5	Exhaust PM2.5	PM2.5 Total	Bio- CO2	NBio- CO2	Total CO2	CH4	N2O	CO2e
Category	lb/day										lb/day					
Off-Road	1.3091	7.9346	16.1570	0.0310		0.1481	0.1481		0.1481	0.1481	0.0000	2,897.5468	2,897.5468	0.1162		2,900.4529
Total	1.3091	7.9346	16.1570	0.0310		0.1481	0.1481		0.1481	0.1481	0.0000	2,897.5468	2,897.5468	0.1162		2,900.4529

Mitigated Construction Off-Site

	ROG	NOx	CO	SO2	Fugitive PM10	Exhaust PM10	PM10 Total	Fugitive PM2.5	Exhaust PM2.5	PM2.5 Total	Bio- CO2	NBio- CO2	Total CO2	CH4	N2O	CO2e
Category	lb/day										lb/day					
Hauling	0.0000	0.0000	0.0000	0.0000	0.0000	0.0000	0.0000	0.0000	0.0000	0.0000		0.0000	0.0000	0.0000	0.0000	0.0000
Vendor	0.2307	8.2327	3.0002	0.0301	1.1487	0.0459	1.1946	0.3310	0.0439	0.3749		3,253.3979	3,253.3979	0.1003	0.4756	3,397.6301
Worker	1.8097	0.9150	17.1737	0.0665	10.3903	0.0262	10.4165	2.7557	0.0241	2.7798		7,350.1554	7,350.1554	0.0952	0.1401	7,394.2703
Total	2.0404	9.1477	20.1739	0.0966	11.5390	0.0720	11.6111	3.0867	0.0680	3.1547		10,603.5533	10,603.5533	0.1955	0.6156	10,791.9004

Pismo Beach GP/LCP PEIR - GHG - San Luis Obispo County APCD Air District, Summer

EMFAC Off-Model Adjustment Factors for Gasoline Light Duty Vehicle to Account for the SAFE Vehicle Rule Applied

3.5 Building Construction - 2035

Unmitigated Construction On-Site

	ROG	NOx	CO	SO2	Fugitive PM10	Exhaust PM10	PM10 Total	Fugitive PM2.5	Exhaust PM2.5	PM2.5 Total	Bio- CO2	NBio- CO2	Total CO2	CH4	N2O	CO2e
Category	lb/day										lb/day					
Off-Road	1.2168	7.1613	16.1178	0.0310		0.0904	0.0904		0.0904	0.0904		2,897.5468	2,897.5468	0.1079		2,900.2448
Total	1.2168	7.1613	16.1178	0.0310		0.0904	0.0904		0.0904	0.0904		2,897.5468	2,897.5468	0.1079		2,900.2448

Unmitigated Construction Off-Site

	ROG	NOx	CO	SO2	Fugitive PM10	Exhaust PM10	PM10 Total	Fugitive PM2.5	Exhaust PM2.5	PM2.5 Total	Bio- CO2	NBio- CO2	Total CO2	CH4	N2O	CO2e
Category	lb/day										lb/day					
Hauling	0.0000	0.0000	0.0000	0.0000	0.0000	0.0000	0.0000	0.0000	0.0000	0.0000		0.0000	0.0000	0.0000	0.0000	0.0000
Vendor	0.2287	8.1575	3.0091	0.0298	1.1488	0.0453	1.1940	0.3310	0.0433	0.3743		3,215.2843	3,215.2843	0.1011	0.4701	3,357.8997
Worker	1.7249	0.8809	16.7797	0.0655	10.3903	0.0247	10.4150	2.7557	0.0227	2.7784		7,277.9314	7,277.9314	0.0898	0.1377	7,321.2040
Total	1.9536	9.0383	19.7888	0.0953	11.5391	0.0700	11.6091	3.0867	0.0660	3.1527		10,493.2157	10,493.2157	0.1909	0.6078	10,679.1038

Pismo Beach GP/LCP PEIR - GHG - San Luis Obispo County APCD Air District, Summer

EMFAC Off-Model Adjustment Factors for Gasoline Light Duty Vehicle to Account for the SAFE Vehicle Rule Applied

3.5 Building Construction - 2035

Mitigated Construction On-Site

	ROG	NOx	CO	SO2	Fugitive PM10	Exhaust PM10	PM10 Total	Fugitive PM2.5	Exhaust PM2.5	PM2.5 Total	Bio- CO2	NBio- CO2	Total CO2	CH4	N2O	CO2e
Category	lb/day										lb/day					
Off-Road	1.2168	7.1613	16.1178	0.0310		0.0904	0.0904		0.0904	0.0904	0.0000	2,897.5468	2,897.5468	0.1079		2,900.2448
Total	1.2168	7.1613	16.1178	0.0310		0.0904	0.0904		0.0904	0.0904	0.0000	2,897.5468	2,897.5468	0.1079		2,900.2448

Mitigated Construction Off-Site

	ROG	NOx	CO	SO2	Fugitive PM10	Exhaust PM10	PM10 Total	Fugitive PM2.5	Exhaust PM2.5	PM2.5 Total	Bio- CO2	NBio- CO2	Total CO2	CH4	N2O	CO2e
Category	lb/day										lb/day					
Hauling	0.0000	0.0000	0.0000	0.0000	0.0000	0.0000	0.0000	0.0000	0.0000	0.0000		0.0000	0.0000	0.0000	0.0000	0.0000
Vendor	0.2287	8.1575	3.0091	0.0298	1.1488	0.0453	1.1940	0.3310	0.0433	0.3743		3,215.2843	3,215.2843	0.1011	0.4701	3,357.8997
Worker	1.7249	0.8809	16.7797	0.0655	10.3903	0.0247	10.4150	2.7557	0.0227	2.7784		7,277.9314	7,277.9314	0.0898	0.1377	7,321.2040
Total	1.9536	9.0383	19.7888	0.0953	11.5391	0.0700	11.6091	3.0867	0.0660	3.1527		10,493.2157	10,493.2157	0.1909	0.6078	10,679.1038

Pismo Beach GP/LCP PEIR - GHG - San Luis Obispo County APCD Air District, Summer

EMFAC Off-Model Adjustment Factors for Gasoline Light Duty Vehicle to Account for the SAFE Vehicle Rule Applied

3.5 Building Construction - 2036

Unmitigated Construction On-Site

	ROG	NOx	CO	SO2	Fugitive PM10	Exhaust PM10	PM10 Total	Fugitive PM2.5	Exhaust PM2.5	PM2.5 Total	Bio- CO2	NBio- CO2	Total CO2	CH4	N2O	CO2e
Category	lb/day										lb/day					
Off-Road	1.2168	7.1613	16.1178	0.0310		0.0904	0.0904		0.0904	0.0904		2,897.5468	2,897.5468	0.1079		2,900.2448
Total	1.2168	7.1613	16.1178	0.0310		0.0904	0.0904		0.0904	0.0904		2,897.5468	2,897.5468	0.1079		2,900.2448

Unmitigated Construction Off-Site

	ROG	NOx	CO	SO2	Fugitive PM10	Exhaust PM10	PM10 Total	Fugitive PM2.5	Exhaust PM2.5	PM2.5 Total	Bio- CO2	NBio- CO2	Total CO2	CH4	N2O	CO2e
Category	lb/day										lb/day					
Hauling	0.0000	0.0000	0.0000	0.0000	0.0000	0.0000	0.0000	0.0000	0.0000	0.0000		0.0000	0.0000	0.0000	0.0000	0.0000
Vendor	0.2287	8.1575	3.0091	0.0298	1.1488	0.0453	1.1940	0.3310	0.0433	0.3743		3,215.2843	3,215.2843	0.1011	0.4701	3,357.8997
Worker	1.7249	0.8809	16.7797	0.0655	10.3903	0.0247	10.4150	2.7557	0.0227	2.7784		7,277.9314	7,277.9314	0.0898	0.1377	7,321.2040
Total	1.9536	9.0383	19.7888	0.0953	11.5391	0.0700	11.6091	3.0867	0.0660	3.1527		10,493.2157	10,493.2157	0.1909	0.6078	10,679.1038

Pismo Beach GP/LCP PEIR - GHG - San Luis Obispo County APCD Air District, Summer

EMFAC Off-Model Adjustment Factors for Gasoline Light Duty Vehicle to Account for the SAFE Vehicle Rule Applied

3.5 Building Construction - 2036

Mitigated Construction On-Site

	ROG	NOx	CO	SO2	Fugitive PM10	Exhaust PM10	PM10 Total	Fugitive PM2.5	Exhaust PM2.5	PM2.5 Total	Bio- CO2	NBio- CO2	Total CO2	CH4	N2O	CO2e
Category	lb/day										lb/day					
Off-Road	1.2168	7.1613	16.1178	0.0310		0.0904	0.0904		0.0904	0.0904	0.0000	2,897.5468	2,897.5468	0.1079		2,900.2448
Total	1.2168	7.1613	16.1178	0.0310		0.0904	0.0904		0.0904	0.0904	0.0000	2,897.5468	2,897.5468	0.1079		2,900.2448

Mitigated Construction Off-Site

	ROG	NOx	CO	SO2	Fugitive PM10	Exhaust PM10	PM10 Total	Fugitive PM2.5	Exhaust PM2.5	PM2.5 Total	Bio- CO2	NBio- CO2	Total CO2	CH4	N2O	CO2e
Category	lb/day										lb/day					
Hauling	0.0000	0.0000	0.0000	0.0000	0.0000	0.0000	0.0000	0.0000	0.0000	0.0000		0.0000	0.0000	0.0000	0.0000	0.0000
Vendor	0.2287	8.1575	3.0091	0.0298	1.1488	0.0453	1.1940	0.3310	0.0433	0.3743		3,215.2843	3,215.2843	0.1011	0.4701	3,357.8997
Worker	1.7249	0.8809	16.7797	0.0655	10.3903	0.0247	10.4150	2.7557	0.0227	2.7784		7,277.9314	7,277.9314	0.0898	0.1377	7,321.2040
Total	1.9536	9.0383	19.7888	0.0953	11.5391	0.0700	11.6091	3.0867	0.0660	3.1527		10,493.2157	10,493.2157	0.1909	0.6078	10,679.1038

Pismo Beach GP/LCP PEIR - GHG - San Luis Obispo County APCD Air District, Summer

EMFAC Off-Model Adjustment Factors for Gasoline Light Duty Vehicle to Account for the SAFE Vehicle Rule Applied

3.5 Building Construction - 2037

Unmitigated Construction On-Site

	ROG	NOx	CO	SO2	Fugitive PM10	Exhaust PM10	PM10 Total	Fugitive PM2.5	Exhaust PM2.5	PM2.5 Total	Bio- CO2	NBio- CO2	Total CO2	CH4	N2O	CO2e
Category	lb/day										lb/day					
Off-Road	1.2168	7.1613	16.1178	0.0310		0.0904	0.0904		0.0904	0.0904		2,897.5468	2,897.5468	0.1079		2,900.2448
Total	1.2168	7.1613	16.1178	0.0310		0.0904	0.0904		0.0904	0.0904		2,897.5468	2,897.5468	0.1079		2,900.2448

Unmitigated Construction Off-Site

	ROG	NOx	CO	SO2	Fugitive PM10	Exhaust PM10	PM10 Total	Fugitive PM2.5	Exhaust PM2.5	PM2.5 Total	Bio- CO2	NBio- CO2	Total CO2	CH4	N2O	CO2e
Category	lb/day										lb/day					
Hauling	0.0000	0.0000	0.0000	0.0000	0.0000	0.0000	0.0000	0.0000	0.0000	0.0000		0.0000	0.0000	0.0000	0.0000	0.0000
Vendor	0.2287	8.1575	3.0091	0.0298	1.1488	0.0453	1.1940	0.3310	0.0433	0.3743		3,215.2843	3,215.2843	0.1011	0.4701	3,357.8997
Worker	1.7249	0.8809	16.7797	0.0655	10.3903	0.0247	10.4150	2.7557	0.0227	2.7784		7,277.9314	7,277.9314	0.0898	0.1377	7,321.2040
Total	1.9536	9.0383	19.7888	0.0953	11.5391	0.0700	11.6091	3.0867	0.0660	3.1527		10,493.2157	10,493.2157	0.1909	0.6078	10,679.1038

Pismo Beach GP/LCP PEIR - GHG - San Luis Obispo County APCD Air District, Summer

EMFAC Off-Model Adjustment Factors for Gasoline Light Duty Vehicle to Account for the SAFE Vehicle Rule Applied

3.5 Building Construction - 2037

Mitigated Construction On-Site

	ROG	NOx	CO	SO2	Fugitive PM10	Exhaust PM10	PM10 Total	Fugitive PM2.5	Exhaust PM2.5	PM2.5 Total	Bio- CO2	NBio- CO2	Total CO2	CH4	N2O	CO2e
Category	lb/day										lb/day					
Off-Road	1.2168	7.1613	16.1178	0.0310		0.0904	0.0904		0.0904	0.0904	0.0000	2,897.5468	2,897.5468	0.1079		2,900.2448
Total	1.2168	7.1613	16.1178	0.0310		0.0904	0.0904		0.0904	0.0904	0.0000	2,897.5468	2,897.5468	0.1079		2,900.2448

Mitigated Construction Off-Site

	ROG	NOx	CO	SO2	Fugitive PM10	Exhaust PM10	PM10 Total	Fugitive PM2.5	Exhaust PM2.5	PM2.5 Total	Bio- CO2	NBio- CO2	Total CO2	CH4	N2O	CO2e
Category	lb/day										lb/day					
Hauling	0.0000	0.0000	0.0000	0.0000	0.0000	0.0000	0.0000	0.0000	0.0000	0.0000		0.0000	0.0000	0.0000	0.0000	0.0000
Vendor	0.2287	8.1575	3.0091	0.0298	1.1488	0.0453	1.1940	0.3310	0.0433	0.3743		3,215.2843	3,215.2843	0.1011	0.4701	3,357.8997
Worker	1.7249	0.8809	16.7797	0.0655	10.3903	0.0247	10.4150	2.7557	0.0227	2.7784		7,277.9314	7,277.9314	0.0898	0.1377	7,321.2040
Total	1.9536	9.0383	19.7888	0.0953	11.5391	0.0700	11.6091	3.0867	0.0660	3.1527		10,493.2157	10,493.2157	0.1909	0.6078	10,679.1038

Pismo Beach GP/LCP PEIR - GHG - San Luis Obispo County APCD Air District, Summer

EMFAC Off-Model Adjustment Factors for Gasoline Light Duty Vehicle to Account for the SAFE Vehicle Rule Applied

3.5 Building Construction - 2038

Unmitigated Construction On-Site

	ROG	NOx	CO	SO2	Fugitive PM10	Exhaust PM10	PM10 Total	Fugitive PM2.5	Exhaust PM2.5	PM2.5 Total	Bio- CO2	NBio- CO2	Total CO2	CH4	N2O	CO2e
Category	lb/day										lb/day					
Off-Road	1.2168	7.1613	16.1178	0.0310		0.0904	0.0904		0.0904	0.0904		2,897.5468	2,897.5468	0.1079		2,900.2448
Total	1.2168	7.1613	16.1178	0.0310		0.0904	0.0904		0.0904	0.0904		2,897.5468	2,897.5468	0.1079		2,900.2448

Unmitigated Construction Off-Site

	ROG	NOx	CO	SO2	Fugitive PM10	Exhaust PM10	PM10 Total	Fugitive PM2.5	Exhaust PM2.5	PM2.5 Total	Bio- CO2	NBio- CO2	Total CO2	CH4	N2O	CO2e
Category	lb/day										lb/day					
Hauling	0.0000	0.0000	0.0000	0.0000	0.0000	0.0000	0.0000	0.0000	0.0000	0.0000		0.0000	0.0000	0.0000	0.0000	0.0000
Vendor	0.2287	8.1575	3.0091	0.0298	1.1488	0.0453	1.1940	0.3310	0.0433	0.3743		3,215.2843	3,215.2843	0.1011	0.4701	3,357.8997
Worker	1.7249	0.8809	16.7797	0.0655	10.3903	0.0247	10.4150	2.7557	0.0227	2.7784		7,277.9314	7,277.9314	0.0898	0.1377	7,321.2040
Total	1.9536	9.0383	19.7888	0.0953	11.5391	0.0700	11.6091	3.0867	0.0660	3.1527		10,493.2157	10,493.2157	0.1909	0.6078	10,679.1038

Pismo Beach GP/LCP PEIR - GHG - San Luis Obispo County APCD Air District, Summer

EMFAC Off-Model Adjustment Factors for Gasoline Light Duty Vehicle to Account for the SAFE Vehicle Rule Applied

3.5 Building Construction - 2038

Mitigated Construction On-Site

	ROG	NOx	CO	SO2	Fugitive PM10	Exhaust PM10	PM10 Total	Fugitive PM2.5	Exhaust PM2.5	PM2.5 Total	Bio- CO2	NBio- CO2	Total CO2	CH4	N2O	CO2e
Category	lb/day										lb/day					
Off-Road	1.2168	7.1613	16.1178	0.0310		0.0904	0.0904		0.0904	0.0904	0.0000	2,897.5468	2,897.5468	0.1079		2,900.2448
Total	1.2168	7.1613	16.1178	0.0310		0.0904	0.0904		0.0904	0.0904	0.0000	2,897.5468	2,897.5468	0.1079		2,900.2448

Mitigated Construction Off-Site

	ROG	NOx	CO	SO2	Fugitive PM10	Exhaust PM10	PM10 Total	Fugitive PM2.5	Exhaust PM2.5	PM2.5 Total	Bio- CO2	NBio- CO2	Total CO2	CH4	N2O	CO2e
Category	lb/day										lb/day					
Hauling	0.0000	0.0000	0.0000	0.0000	0.0000	0.0000	0.0000	0.0000	0.0000	0.0000		0.0000	0.0000	0.0000	0.0000	0.0000
Vendor	0.2287	8.1575	3.0091	0.0298	1.1488	0.0453	1.1940	0.3310	0.0433	0.3743		3,215.2843	3,215.2843	0.1011	0.4701	3,357.8997
Worker	1.7249	0.8809	16.7797	0.0655	10.3903	0.0247	10.4150	2.7557	0.0227	2.7784		7,277.9314	7,277.9314	0.0898	0.1377	7,321.2040
Total	1.9536	9.0383	19.7888	0.0953	11.5391	0.0700	11.6091	3.0867	0.0660	3.1527		10,493.2157	10,493.2157	0.1909	0.6078	10,679.1038

Pismo Beach GP/LCP PEIR - GHG - San Luis Obispo County APCD Air District, Summer

EMFAC Off-Model Adjustment Factors for Gasoline Light Duty Vehicle to Account for the SAFE Vehicle Rule Applied

3.5 Building Construction - 2039

Unmitigated Construction On-Site

	ROG	NOx	CO	SO2	Fugitive PM10	Exhaust PM10	PM10 Total	Fugitive PM2.5	Exhaust PM2.5	PM2.5 Total	Bio- CO2	NBio- CO2	Total CO2	CH4	N2O	CO2e
Category	lb/day										lb/day					
Off-Road	1.2168	7.1613	16.1178	0.0310		0.0904	0.0904		0.0904	0.0904		2,897.5468	2,897.5468	0.1079		2,900.2448
Total	1.2168	7.1613	16.1178	0.0310		0.0904	0.0904		0.0904	0.0904		2,897.5468	2,897.5468	0.1079		2,900.2448

Unmitigated Construction Off-Site

	ROG	NOx	CO	SO2	Fugitive PM10	Exhaust PM10	PM10 Total	Fugitive PM2.5	Exhaust PM2.5	PM2.5 Total	Bio- CO2	NBio- CO2	Total CO2	CH4	N2O	CO2e
Category	lb/day										lb/day					
Hauling	0.0000	0.0000	0.0000	0.0000	0.0000	0.0000	0.0000	0.0000	0.0000	0.0000		0.0000	0.0000	0.0000	0.0000	0.0000
Vendor	0.2287	8.1575	3.0091	0.0298	1.1488	0.0453	1.1940	0.3310	0.0433	0.3743		3,215.2843	3,215.2843	0.1011	0.4701	3,357.8997
Worker	1.7249	0.8809	16.7797	0.0655	10.3903	0.0247	10.4150	2.7557	0.0227	2.7784		7,277.9314	7,277.9314	0.0898	0.1377	7,321.2040
Total	1.9536	9.0383	19.7888	0.0953	11.5391	0.0700	11.6091	3.0867	0.0660	3.1527		10,493.2157	10,493.2157	0.1909	0.6078	10,679.1038

Pismo Beach GP/LCP PEIR - GHG - San Luis Obispo County APCD Air District, Summer

EMFAC Off-Model Adjustment Factors for Gasoline Light Duty Vehicle to Account for the SAFE Vehicle Rule Applied

3.5 Building Construction - 2039

Mitigated Construction On-Site

	ROG	NOx	CO	SO2	Fugitive PM10	Exhaust PM10	PM10 Total	Fugitive PM2.5	Exhaust PM2.5	PM2.5 Total	Bio- CO2	NBio- CO2	Total CO2	CH4	N2O	CO2e
Category	lb/day										lb/day					
Off-Road	1.2168	7.1613	16.1178	0.0310		0.0904	0.0904		0.0904	0.0904	0.0000	2,897.5468	2,897.5468	0.1079		2,900.2448
Total	1.2168	7.1613	16.1178	0.0310		0.0904	0.0904		0.0904	0.0904	0.0000	2,897.5468	2,897.5468	0.1079		2,900.2448

Mitigated Construction Off-Site

	ROG	NOx	CO	SO2	Fugitive PM10	Exhaust PM10	PM10 Total	Fugitive PM2.5	Exhaust PM2.5	PM2.5 Total	Bio- CO2	NBio- CO2	Total CO2	CH4	N2O	CO2e
Category	lb/day										lb/day					
Hauling	0.0000	0.0000	0.0000	0.0000	0.0000	0.0000	0.0000	0.0000	0.0000	0.0000		0.0000	0.0000	0.0000	0.0000	0.0000
Vendor	0.2287	8.1575	3.0091	0.0298	1.1488	0.0453	1.1940	0.3310	0.0433	0.3743		3,215.2843	3,215.2843	0.1011	0.4701	3,357.8997
Worker	1.7249	0.8809	16.7797	0.0655	10.3903	0.0247	10.4150	2.7557	0.0227	2.7784		7,277.9314	7,277.9314	0.0898	0.1377	7,321.2040
Total	1.9536	9.0383	19.7888	0.0953	11.5391	0.0700	11.6091	3.0867	0.0660	3.1527		10,493.2157	10,493.2157	0.1909	0.6078	10,679.1038

Pismo Beach GP/LCP PEIR - GHG - San Luis Obispo County APCD Air District, Summer

EMFAC Off-Model Adjustment Factors for Gasoline Light Duty Vehicle to Account for the SAFE Vehicle Rule Applied

3.5 Building Construction - 2040

Unmitigated Construction On-Site

	ROG	NOx	CO	SO2	Fugitive PM10	Exhaust PM10	PM10 Total	Fugitive PM2.5	Exhaust PM2.5	PM2.5 Total	Bio- CO2	NBio- CO2	Total CO2	CH4	N2O	CO2e
Category	lb/day										lb/day					
Off-Road	1.1970	6.8903	16.1185	0.0310		0.0737	0.0737		0.0737	0.0737		2,897.547 1	2,897.547 1	0.1041		2,900.150 3
Total	1.1970	6.8903	16.1185	0.0310		0.0737	0.0737		0.0737	0.0737		2,897.547 1	2,897.547 1	0.1041		2,900.150 3

Unmitigated Construction Off-Site

	ROG	NOx	CO	SO2	Fugitive PM10	Exhaust PM10	PM10 Total	Fugitive PM2.5	Exhaust PM2.5	PM2.5 Total	Bio- CO2	NBio- CO2	Total CO2	CH4	N2O	CO2e
Category	lb/day										lb/day					
Hauling	0.0000	0.0000	0.0000	0.0000	0.0000	0.0000	0.0000	0.0000	0.0000	0.0000		0.0000	0.0000	0.0000	0.0000	0.0000
Vendor	0.2255	7.8052	3.0654	0.0283	1.1490	0.0437	1.1926	0.3311	0.0418	0.3728		3,062.571 7	3,062.571 7	0.1064	0.4470	3,198.447 0
Worker	1.4039	0.7780	15.4324	0.0624	10.3903	0.0195	10.4098	2.7557	0.0179	2.7737		7,033.969 0	7,033.969 0	0.0710	0.1308	7,074.713 0
Total	1.6295	8.5832	18.4978	0.0907	11.5393	0.0632	11.6025	3.0868	0.0597	3.1465		10,096.54 07	10,096.54 07	0.1775	0.5778	10,273.16 00

Pismo Beach GP/LCP PEIR - GHG - San Luis Obispo County APCD Air District, Summer

EMFAC Off-Model Adjustment Factors for Gasoline Light Duty Vehicle to Account for the SAFE Vehicle Rule Applied

3.5 Building Construction - 2040

Mitigated Construction On-Site

	ROG	NOx	CO	SO2	Fugitive PM10	Exhaust PM10	PM10 Total	Fugitive PM2.5	Exhaust PM2.5	PM2.5 Total	Bio- CO2	NBio- CO2	Total CO2	CH4	N2O	CO2e
Category	lb/day										lb/day					
Off-Road	1.1970	6.8903	16.1185	0.0310		0.0737	0.0737		0.0737	0.0737	0.0000	2,897.547 1	2,897.547 1	0.1041		2,900.150 3
Total	1.1970	6.8903	16.1185	0.0310		0.0737	0.0737		0.0737	0.0737	0.0000	2,897.547 1	2,897.547 1	0.1041		2,900.150 3

Mitigated Construction Off-Site

	ROG	NOx	CO	SO2	Fugitive PM10	Exhaust PM10	PM10 Total	Fugitive PM2.5	Exhaust PM2.5	PM2.5 Total	Bio- CO2	NBio- CO2	Total CO2	CH4	N2O	CO2e
Category	lb/day										lb/day					
Hauling	0.0000	0.0000	0.0000	0.0000	0.0000	0.0000	0.0000	0.0000	0.0000	0.0000		0.0000	0.0000	0.0000	0.0000	0.0000
Vendor	0.2255	7.8052	3.0654	0.0283	1.1490	0.0437	1.1926	0.3311	0.0418	0.3728		3,062.571 7	3,062.571 7	0.1064	0.4470	3,198.447 0
Worker	1.4039	0.7780	15.4324	0.0624	10.3903	0.0195	10.4098	2.7557	0.0179	2.7737		7,033.969 0	7,033.969 0	0.0710	0.1308	7,074.713 0
Total	1.6295	8.5832	18.4978	0.0907	11.5393	0.0632	11.6025	3.0868	0.0597	3.1465		10,096.54 07	10,096.54 07	0.1775	0.5778	10,273.16 00

Pismo Beach GP/LCP PEIR - GHG - San Luis Obispo County APCD Air District, Summer

EMFAC Off-Model Adjustment Factors for Gasoline Light Duty Vehicle to Account for the SAFE Vehicle Rule Applied

3.6 Paving - 2040

Unmitigated Construction On-Site

	ROG	NOx	CO	SO2	Fugitive PM10	Exhaust PM10	PM10 Total	Fugitive PM2.5	Exhaust PM2.5	PM2.5 Total	Bio- CO2	NBio- CO2	Total CO2	CH4	N2O	CO2e
Category	lb/day										lb/day					
Off-Road	1.0112	3.6566	15.8177	0.0281		0.1164	0.1164		0.1164	0.1164		2,656.5168	2,656.5168	0.0893		2,658.7489
Paving	0.0000					0.0000	0.0000		0.0000	0.0000			0.0000			0.0000
Total	1.0112	3.6566	15.8177	0.0281		0.1164	0.1164		0.1164	0.1164		2,656.5168	2,656.5168	0.0893		2,658.7489

Unmitigated Construction Off-Site

	ROG	NOx	CO	SO2	Fugitive PM10	Exhaust PM10	PM10 Total	Fugitive PM2.5	Exhaust PM2.5	PM2.5 Total	Bio- CO2	NBio- CO2	Total CO2	CH4	N2O	CO2e
Category	lb/day										lb/day					
Hauling	0.0000	0.0000	0.0000	0.0000	0.0000	0.0000	0.0000	0.0000	0.0000	0.0000		0.0000	0.0000	0.0000	0.0000	0.0000
Vendor	0.0000	0.0000	0.0000	0.0000	0.0000	0.0000	0.0000	0.0000	0.0000	0.0000		0.0000	0.0000	0.0000	0.0000	0.0000
Worker	0.0200	0.0111	0.2203	8.9000e-004	0.1483	2.8000e-004	0.1486	0.0393	2.6000e-004	0.0396		100.3897	100.3897	1.0100e-003	1.8700e-003	100.9712
Total	0.0200	0.0111	0.2203	8.9000e-004	0.1483	2.8000e-004	0.1486	0.0393	2.6000e-004	0.0396		100.3897	100.3897	1.0100e-003	1.8700e-003	100.9712

Pismo Beach GP/LCP PEIR - GHG - San Luis Obispo County APCD Air District, Summer

EMFAC Off-Model Adjustment Factors for Gasoline Light Duty Vehicle to Account for the SAFE Vehicle Rule Applied

3.6 Paving - 2040

Mitigated Construction On-Site

	ROG	NOx	CO	SO2	Fugitive PM10	Exhaust PM10	PM10 Total	Fugitive PM2.5	Exhaust PM2.5	PM2.5 Total	Bio- CO2	NBio- CO2	Total CO2	CH4	N2O	CO2e
Category	lb/day										lb/day					
Off-Road	1.0112	3.6566	15.8177	0.0281		0.1164	0.1164		0.1164	0.1164	0.0000	2,656.5168	2,656.5168	0.0893		2,658.7489
Paving	0.0000					0.0000	0.0000		0.0000	0.0000			0.0000			0.0000
Total	1.0112	3.6566	15.8177	0.0281		0.1164	0.1164		0.1164	0.1164	0.0000	2,656.5168	2,656.5168	0.0893		2,658.7489

Mitigated Construction Off-Site

	ROG	NOx	CO	SO2	Fugitive PM10	Exhaust PM10	PM10 Total	Fugitive PM2.5	Exhaust PM2.5	PM2.5 Total	Bio- CO2	NBio- CO2	Total CO2	CH4	N2O	CO2e
Category	lb/day										lb/day					
Hauling	0.0000	0.0000	0.0000	0.0000	0.0000	0.0000	0.0000	0.0000	0.0000	0.0000		0.0000	0.0000	0.0000	0.0000	0.0000
Vendor	0.0000	0.0000	0.0000	0.0000	0.0000	0.0000	0.0000	0.0000	0.0000	0.0000		0.0000	0.0000	0.0000	0.0000	0.0000
Worker	0.0200	0.0111	0.2203	8.9000e-004	0.1483	2.8000e-004	0.1486	0.0393	2.6000e-004	0.0396		100.3897	100.3897	1.0100e-003	1.8700e-003	100.9712
Total	0.0200	0.0111	0.2203	8.9000e-004	0.1483	2.8000e-004	0.1486	0.0393	2.6000e-004	0.0396		100.3897	100.3897	1.0100e-003	1.8700e-003	100.9712

Pismo Beach GP/LCP PEIR - GHG - San Luis Obispo County APCD Air District, Summer

EMFAC Off-Model Adjustment Factors for Gasoline Light Duty Vehicle to Account for the SAFE Vehicle Rule Applied

3.6 Paving - 2041

Unmitigated Construction On-Site

	ROG	NOx	CO	SO2	Fugitive PM10	Exhaust PM10	PM10 Total	Fugitive PM2.5	Exhaust PM2.5	PM2.5 Total	Bio- CO2	NBio- CO2	Total CO2	CH4	N2O	CO2e
Category	lb/day										lb/day					
Off-Road	1.0112	3.6566	15.8177	0.0281		0.1164	0.1164		0.1164	0.1164		2,656.5168	2,656.5168	0.0893		2,658.7489
Paving	0.0000					0.0000	0.0000		0.0000	0.0000			0.0000			0.0000
Total	1.0112	3.6566	15.8177	0.0281		0.1164	0.1164		0.1164	0.1164		2,656.5168	2,656.5168	0.0893		2,658.7489

Unmitigated Construction Off-Site

	ROG	NOx	CO	SO2	Fugitive PM10	Exhaust PM10	PM10 Total	Fugitive PM2.5	Exhaust PM2.5	PM2.5 Total	Bio- CO2	NBio- CO2	Total CO2	CH4	N2O	CO2e
Category	lb/day										lb/day					
Hauling	0.0000	0.0000	0.0000	0.0000	0.0000	0.0000	0.0000	0.0000	0.0000	0.0000		0.0000	0.0000	0.0000	0.0000	0.0000
Vendor	0.0000	0.0000	0.0000	0.0000	0.0000	0.0000	0.0000	0.0000	0.0000	0.0000		0.0000	0.0000	0.0000	0.0000	0.0000
Worker	0.0200	0.0111	0.2203	8.9000e-004	0.1483	2.8000e-004	0.1486	0.0393	2.6000e-004	0.0396		100.3897	100.3897	1.0100e-003	1.8700e-003	100.9712
Total	0.0200	0.0111	0.2203	8.9000e-004	0.1483	2.8000e-004	0.1486	0.0393	2.6000e-004	0.0396		100.3897	100.3897	1.0100e-003	1.8700e-003	100.9712

Pismo Beach GP/LCP PEIR - GHG - San Luis Obispo County APCD Air District, Summer

EMFAC Off-Model Adjustment Factors for Gasoline Light Duty Vehicle to Account for the SAFE Vehicle Rule Applied

3.6 Paving - 2041

Mitigated Construction On-Site

	ROG	NOx	CO	SO2	Fugitive PM10	Exhaust PM10	PM10 Total	Fugitive PM2.5	Exhaust PM2.5	PM2.5 Total	Bio- CO2	NBio- CO2	Total CO2	CH4	N2O	CO2e
Category	lb/day										lb/day					
Off-Road	1.0112	3.6566	15.8177	0.0281		0.1164	0.1164		0.1164	0.1164	0.0000	2,656.5168	2,656.5168	0.0893		2,658.7489
Paving	0.0000					0.0000	0.0000		0.0000	0.0000			0.0000			0.0000
Total	1.0112	3.6566	15.8177	0.0281		0.1164	0.1164		0.1164	0.1164	0.0000	2,656.5168	2,656.5168	0.0893		2,658.7489

Mitigated Construction Off-Site

	ROG	NOx	CO	SO2	Fugitive PM10	Exhaust PM10	PM10 Total	Fugitive PM2.5	Exhaust PM2.5	PM2.5 Total	Bio- CO2	NBio- CO2	Total CO2	CH4	N2O	CO2e
Category	lb/day										lb/day					
Hauling	0.0000	0.0000	0.0000	0.0000	0.0000	0.0000	0.0000	0.0000	0.0000	0.0000		0.0000	0.0000	0.0000	0.0000	0.0000
Vendor	0.0000	0.0000	0.0000	0.0000	0.0000	0.0000	0.0000	0.0000	0.0000	0.0000		0.0000	0.0000	0.0000	0.0000	0.0000
Worker	0.0200	0.0111	0.2203	8.9000e-004	0.1483	2.8000e-004	0.1486	0.0393	2.6000e-004	0.0396		100.3897	100.3897	1.0100e-003	1.8700e-003	100.9712
Total	0.0200	0.0111	0.2203	8.9000e-004	0.1483	2.8000e-004	0.1486	0.0393	2.6000e-004	0.0396		100.3897	100.3897	1.0100e-003	1.8700e-003	100.9712

Pismo Beach GP/LCP PEIR - GHG - San Luis Obispo County APCD Air District, Summer

EMFAC Off-Model Adjustment Factors for Gasoline Light Duty Vehicle to Account for the SAFE Vehicle Rule Applied

3.7 Architectural Coating - 2040

Unmitigated Construction On-Site

	ROG	NOx	CO	SO2	Fugitive PM10	Exhaust PM10	PM10 Total	Fugitive PM2.5	Exhaust PM2.5	PM2.5 Total	Bio- CO2	NBio- CO2	Total CO2	CH4	N2O	CO2e
Category	lb/day										lb/day					
Archit. Coating	75.1742					0.0000	0.0000		0.0000	0.0000			0.0000			0.0000
Off-Road	0.1149	0.7270	1.7923	2.9700e-003		7.4300e-003	7.4300e-003		7.4300e-003	7.4300e-003		281.4481	281.4481	9.9000e-003		281.6957
Total	75.2891	0.7270	1.7923	2.9700e-003		7.4300e-003	7.4300e-003		7.4300e-003	7.4300e-003		281.4481	281.4481	9.9000e-003		281.6957

Unmitigated Construction Off-Site

	ROG	NOx	CO	SO2	Fugitive PM10	Exhaust PM10	PM10 Total	Fugitive PM2.5	Exhaust PM2.5	PM2.5 Total	Bio- CO2	NBio- CO2	Total CO2	CH4	N2O	CO2e
Category	lb/day										lb/day					
Hauling	0.0000	0.0000	0.0000	0.0000	0.0000	0.0000	0.0000	0.0000	0.0000	0.0000		0.0000	0.0000	0.0000	0.0000	0.0000
Vendor	0.0000	0.0000	0.0000	0.0000	0.0000	0.0000	0.0000	0.0000	0.0000	0.0000		0.0000	0.0000	0.0000	0.0000	0.0000
Worker	0.2805	0.1555	3.0835	0.0125	2.0761	3.8900e-003	2.0800	0.5506	3.5800e-003	0.5542		1,405.4553	1,405.4553	0.0142	0.0261	1,413.5963
Total	0.2805	0.1555	3.0835	0.0125	2.0761	3.8900e-003	2.0800	0.5506	3.5800e-003	0.5542		1,405.4553	1,405.4553	0.0142	0.0261	1,413.5963

Pismo Beach GP/LCP PEIR - GHG - San Luis Obispo County APCD Air District, Summer

EMFAC Off-Model Adjustment Factors for Gasoline Light Duty Vehicle to Account for the SAFE Vehicle Rule Applied

3.7 Architectural Coating - 2040

Mitigated Construction On-Site

	ROG	NOx	CO	SO2	Fugitive PM10	Exhaust PM10	PM10 Total	Fugitive PM2.5	Exhaust PM2.5	PM2.5 Total	Bio- CO2	NBio- CO2	Total CO2	CH4	N2O	CO2e
Category	lb/day										lb/day					
Archit. Coating	75.1742					0.0000	0.0000		0.0000	0.0000			0.0000			0.0000
Off-Road	0.1149	0.7270	1.7923	2.9700e-003		7.4300e-003	7.4300e-003		7.4300e-003	7.4300e-003	0.0000	281.4481	281.4481	9.9000e-003		281.6957
Total	75.2891	0.7270	1.7923	2.9700e-003		7.4300e-003	7.4300e-003		7.4300e-003	7.4300e-003	0.0000	281.4481	281.4481	9.9000e-003		281.6957

Mitigated Construction Off-Site

	ROG	NOx	CO	SO2	Fugitive PM10	Exhaust PM10	PM10 Total	Fugitive PM2.5	Exhaust PM2.5	PM2.5 Total	Bio- CO2	NBio- CO2	Total CO2	CH4	N2O	CO2e
Category	lb/day										lb/day					
Hauling	0.0000	0.0000	0.0000	0.0000	0.0000	0.0000	0.0000	0.0000	0.0000	0.0000		0.0000	0.0000	0.0000	0.0000	0.0000
Vendor	0.0000	0.0000	0.0000	0.0000	0.0000	0.0000	0.0000	0.0000	0.0000	0.0000		0.0000	0.0000	0.0000	0.0000	0.0000
Worker	0.2805	0.1555	3.0835	0.0125	2.0761	3.8900e-003	2.0800	0.5506	3.5800e-003	0.5542		1,405.4553	1,405.4553	0.0142	0.0261	1,413.5963
Total	0.2805	0.1555	3.0835	0.0125	2.0761	3.8900e-003	2.0800	0.5506	3.5800e-003	0.5542		1,405.4553	1,405.4553	0.0142	0.0261	1,413.5963

Pismo Beach GP/LCP PEIR - GHG - San Luis Obispo County APCD Air District, Summer

EMFAC Off-Model Adjustment Factors for Gasoline Light Duty Vehicle to Account for the SAFE Vehicle Rule Applied

3.7 Architectural Coating - 2041

Unmitigated Construction On-Site

	ROG	NOx	CO	SO2	Fugitive PM10	Exhaust PM10	PM10 Total	Fugitive PM2.5	Exhaust PM2.5	PM2.5 Total	Bio- CO2	NBio- CO2	Total CO2	CH4	N2O	CO2e
Category	lb/day										lb/day					
Off-Road	0.1149	0.7270	1.7923	2.9700e-003		7.4300e-003	7.4300e-003		7.4300e-003	7.4300e-003		281.4481	281.4481	9.9000e-003		281.6957
Total	0.1149	0.7270	1.7923	2.9700e-003		7.4300e-003	7.4300e-003		7.4300e-003	7.4300e-003		281.4481	281.4481	9.9000e-003		281.6957

Unmitigated Construction Off-Site

	ROG	NOx	CO	SO2	Fugitive PM10	Exhaust PM10	PM10 Total	Fugitive PM2.5	Exhaust PM2.5	PM2.5 Total	Bio- CO2	NBio- CO2	Total CO2	CH4	N2O	CO2e
Category	lb/day										lb/day					
Hauling	0.0000	0.0000	0.0000	0.0000	0.0000	0.0000	0.0000	0.0000	0.0000	0.0000		0.0000	0.0000	0.0000	0.0000	0.0000
Vendor	0.0000	0.0000	0.0000	0.0000	0.0000	0.0000	0.0000	0.0000	0.0000	0.0000		0.0000	0.0000	0.0000	0.0000	0.0000
Worker	0.2805	0.1555	3.0835	0.0125	2.0761	3.8900e-003	2.0800	0.5506	3.5800e-003	0.5542		1,405.4553	1,405.4553	0.0142	0.0261	1,413.5963
Total	0.2805	0.1555	3.0835	0.0125	2.0761	3.8900e-003	2.0800	0.5506	3.5800e-003	0.5542		1,405.4553	1,405.4553	0.0142	0.0261	1,413.5963

Pismo Beach GP/LCP PEIR - GHG - San Luis Obispo County APCD Air District, Summer

EMFAC Off-Model Adjustment Factors for Gasoline Light Duty Vehicle to Account for the SAFE Vehicle Rule Applied

3.7 Architectural Coating - 2041

Mitigated Construction On-Site

	ROG	NOx	CO	SO2	Fugitive PM10	Exhaust PM10	PM10 Total	Fugitive PM2.5	Exhaust PM2.5	PM2.5 Total	Bio- CO2	NBio- CO2	Total CO2	CH4	N2O	CO2e
Category	lb/day										lb/day					
Off-Road	0.1149	0.7270	1.7923	2.9700e-003		7.4300e-003	7.4300e-003		7.4300e-003	7.4300e-003	0.0000	281.4481	281.4481	9.9000e-003		281.6957
Total	0.1149	0.7270	1.7923	2.9700e-003		7.4300e-003	7.4300e-003		7.4300e-003	7.4300e-003	0.0000	281.4481	281.4481	9.9000e-003		281.6957

Mitigated Construction Off-Site

	ROG	NOx	CO	SO2	Fugitive PM10	Exhaust PM10	PM10 Total	Fugitive PM2.5	Exhaust PM2.5	PM2.5 Total	Bio- CO2	NBio- CO2	Total CO2	CH4	N2O	CO2e
Category	lb/day										lb/day					
Hauling	0.0000	0.0000	0.0000	0.0000	0.0000	0.0000	0.0000	0.0000	0.0000	0.0000		0.0000	0.0000	0.0000	0.0000	0.0000
Vendor	0.0000	0.0000	0.0000	0.0000	0.0000	0.0000	0.0000	0.0000	0.0000	0.0000		0.0000	0.0000	0.0000	0.0000	0.0000
Worker	0.2805	0.1555	3.0835	0.0125	2.0761	3.8900e-003	2.0800	0.5506	3.5800e-003	0.5542		1,405.4553	1,405.4553	0.0142	0.0261	1,413.5963
Total	0.2805	0.1555	3.0835	0.0125	2.0761	3.8900e-003	2.0800	0.5506	3.5800e-003	0.5542		1,405.4553	1,405.4553	0.0142	0.0261	1,413.5963

Pismo Beach GP/LCP PEIR - GHG - San Luis Obispo County APCD Air District, Summer

EMFAC Off-Model Adjustment Factors for Gasoline Light Duty Vehicle to Account for the SAFE Vehicle Rule Applied

3.7 Architectural Coating - 2042

Unmitigated Construction On-Site

	ROG	NOx	CO	SO2	Fugitive PM10	Exhaust PM10	PM10 Total	Fugitive PM2.5	Exhaust PM2.5	PM2.5 Total	Bio- CO2	NBio- CO2	Total CO2	CH4	N2O	CO2e
Category	lb/day										lb/day					
Off-Road	0.1149	0.7270	1.7923	2.9700e-003		7.4300e-003	7.4300e-003		7.4300e-003	7.4300e-003		281.4481	281.4481	9.9000e-003		281.6957
Total	0.1149	0.7270	1.7923	2.9700e-003		7.4300e-003	7.4300e-003		7.4300e-003	7.4300e-003		281.4481	281.4481	9.9000e-003		281.6957

Unmitigated Construction Off-Site

	ROG	NOx	CO	SO2	Fugitive PM10	Exhaust PM10	PM10 Total	Fugitive PM2.5	Exhaust PM2.5	PM2.5 Total	Bio- CO2	NBio- CO2	Total CO2	CH4	N2O	CO2e
Category	lb/day										lb/day					
Hauling	0.0000	0.0000	0.0000	0.0000	0.0000	0.0000	0.0000	0.0000	0.0000	0.0000		0.0000	0.0000	0.0000	0.0000	0.0000
Vendor	0.0000	0.0000	0.0000	0.0000	0.0000	0.0000	0.0000	0.0000	0.0000	0.0000		0.0000	0.0000	0.0000	0.0000	0.0000
Worker	0.2805	0.1555	3.0835	0.0125	2.0761	3.8900e-003	2.0800	0.5506	3.5800e-003	0.5542		1,405.4553	1,405.4553	0.0142	0.0261	1,413.5963
Total	0.2805	0.1555	3.0835	0.0125	2.0761	3.8900e-003	2.0800	0.5506	3.5800e-003	0.5542		1,405.4553	1,405.4553	0.0142	0.0261	1,413.5963

Pismo Beach GP/LCP PEIR - GHG - San Luis Obispo County APCD Air District, Summer

EMFAC Off-Model Adjustment Factors for Gasoline Light Duty Vehicle to Account for the SAFE Vehicle Rule Applied

3.7 Architectural Coating - 2042

Mitigated Construction On-Site

	ROG	NOx	CO	SO2	Fugitive PM10	Exhaust PM10	PM10 Total	Fugitive PM2.5	Exhaust PM2.5	PM2.5 Total	Bio- CO2	NBio- CO2	Total CO2	CH4	N2O	CO2e
Category	lb/day										lb/day					
Off-Road	0.1149	0.7270	1.7923	2.9700e-003		7.4300e-003	7.4300e-003		7.4300e-003	7.4300e-003	0.0000	281.4481	281.4481	9.9000e-003		281.6957
Total	0.1149	0.7270	1.7923	2.9700e-003		7.4300e-003	7.4300e-003		7.4300e-003	7.4300e-003	0.0000	281.4481	281.4481	9.9000e-003		281.6957

Mitigated Construction Off-Site

	ROG	NOx	CO	SO2	Fugitive PM10	Exhaust PM10	PM10 Total	Fugitive PM2.5	Exhaust PM2.5	PM2.5 Total	Bio- CO2	NBio- CO2	Total CO2	CH4	N2O	CO2e
Category	lb/day										lb/day					
Hauling	0.0000	0.0000	0.0000	0.0000	0.0000	0.0000	0.0000	0.0000	0.0000	0.0000		0.0000	0.0000	0.0000	0.0000	0.0000
Vendor	0.0000	0.0000	0.0000	0.0000	0.0000	0.0000	0.0000	0.0000	0.0000	0.0000		0.0000	0.0000	0.0000	0.0000	0.0000
Worker	0.2805	0.1555	3.0835	0.0125	2.0761	3.8900e-003	2.0800	0.5506	3.5800e-003	0.5542		1,405.4553	1,405.4553	0.0142	0.0261	1,413.5963
Total	0.2805	0.1555	3.0835	0.0125	2.0761	3.8900e-003	2.0800	0.5506	3.5800e-003	0.5542		1,405.4553	1,405.4553	0.0142	0.0261	1,413.5963

4.0 Operational Detail - Mobile

Pismo Beach GP/LCP PEIR - GHG - San Luis Obispo County APCD Air District, Summer

EMFAC Off-Model Adjustment Factors for Gasoline Light Duty Vehicle to Account for the SAFE Vehicle Rule Applied

4.1 Mitigation Measures Mobile

	ROG	NOx	CO	SO2	Fugitive PM10	Exhaust PM10	PM10 Total	Fugitive PM2.5	Exhaust PM2.5	PM2.5 Total	Bio- CO2	NBio- CO2	Total CO2	CH4	N2O	CO2e
Category	lb/day										lb/day					
Mitigated	8.5040	8.9562	90.1899	0.2162	31.8757	0.1100	31.9857	8.4836	0.1031	8.5866		24,048.4979	24,048.4979	1.0724	0.8777	24,336.8545
Unmitigated	8.5040	8.9562	90.1899	0.2162	31.8757	0.1100	31.9857	8.4836	0.1031	8.5866		24,048.4979	24,048.4979	1.0724	0.8777	24,336.8545

4.2 Trip Summary Information

Land Use	Average Daily Trip Rate			Unmitigated	Mitigated
	Weekday	Saturday	Sunday	Annual VMT	Annual VMT
Apartments Low Rise	200.64	223.44	173.28	915,611	915,611
Apartments Mid Rise	113.40	95.58	79.38	485,275	485,275
Apartments Mid Rise	505.40	425.98	353.78	2,162,770	2,162,770
Government (Civic Center)	25.99	0.00	0.00	49,223	49,223
Office Park	559.84	84.19	37.88	1,836,518	1,836,518
Strip Mall	1,339.20	1,257.36	610.08	5,585,619	5,585,619
Strip Mall	583.20	547.56	265.68	2,432,447	2,432,447
Total	3,327.67	2,634.11	1,520.08	13,467,463	13,467,463

4.3 Trip Type Information

Land Use	Miles			Trip %			Trip Purpose %		
	H-W or C-W	H-S or C-C	H-O or C-NW	H-W or C-W	H-S or C-C	H-O or C-NW	Primary	Diverted	Pass-by
Apartments Low Rise	23.42	9.01	9.01	35.80	21.00	43.20	86	11	3
Apartments Mid Rise	23.42	9.01	9.01	35.80	21.00	43.20	86	11	3

Pismo Beach GP/LCP PEIR - GHG - San Luis Obispo County APCD Air District, Summer

EMFAC Off-Model Adjustment Factors for Gasoline Light Duty Vehicle to Account for the SAFE Vehicle Rule Applied

Land Use	Miles			Trip %			Trip Purpose %		
	H-W or C-W	H-S or C-C	H-O or C-NW	H-W or C-W	H-S or C-C	H-O or C-NW	Primary	Diverted	Pass-by
Apartments Mid Rise	23.42	9.01	9.01	35.80	21.00	43.20	86	11	3
Government (Civic Center)	12.87	10.73	12.48	75.00	20.00	5.00	50	34	16
Office Park	24.95	9.60	6.60	33.00	48.00	19.00	82	15	3
Strip Mall	46.79	18.00	18.00	16.60	64.40	19.00	45	40	15
Strip Mall	46.79	18.00	18.00	16.60	64.40	19.00	45	40	15

4.4 Fleet Mix

Land Use	LDA	LDT1	LDT2	MDV	LHD1	LHD2	MHD	HHD	OBUS	UBUS	MCY	SBUS	MH
Apartments Low Rise	0.537981	0.060917	0.197944	0.129503	0.022130	0.006150	0.007595	0.005434	0.000841	0.000325	0.027432	0.000740	0.003008
Apartments Mid Rise	0.537981	0.060917	0.197944	0.129503	0.022130	0.006150	0.007595	0.005434	0.000841	0.000325	0.027432	0.000740	0.003008
Government (Civic Center)	0.537981	0.060917	0.197944	0.129503	0.022130	0.006150	0.007595	0.005434	0.000841	0.000325	0.027432	0.000740	0.003008
Office Park	0.537981	0.060917	0.197944	0.129503	0.022130	0.006150	0.007595	0.005434	0.000841	0.000325	0.027432	0.000740	0.003008
Strip Mall	0.537981	0.060917	0.197944	0.129503	0.022130	0.006150	0.007595	0.005434	0.000841	0.000325	0.027432	0.000740	0.003008

5.0 Energy Detail

Historical Energy Use: N

5.1 Mitigation Measures Energy

Pismo Beach GP/LCP PEIR - GHG - San Luis Obispo County APCD Air District, Summer

EMFAC Off-Model Adjustment Factors for Gasoline Light Duty Vehicle to Account for the SAFE Vehicle Rule Applied

	ROG	NOx	CO	SO2	Fugitive PM10	Exhaust PM10	PM10 Total	Fugitive PM2.5	Exhaust PM2.5	PM2.5 Total	Bio- CO2	NBio- CO2	Total CO2	CH4	N2O	CO2e
Category	lb/day										lb/day					
NaturalGas Mitigated	0.5731	5.0543	3.2348	0.0313		0.3960	0.3960		0.3960	0.3960		6,251.9438	6,251.9438	0.1198	0.1146	6,289.0959
NaturalGas Unmitigated	0.5731	5.0543	3.2348	0.0313		0.3960	0.3960		0.3960	0.3960		6,251.9438	6,251.9438	0.1198	0.1146	6,289.0959

Pismo Beach GP/LCP PEIR - GHG - San Luis Obispo County APCD Air District, Summer

EMFAC Off-Model Adjustment Factors for Gasoline Light Duty Vehicle to Account for the SAFE Vehicle Rule Applied

5.2 Energy by Land Use - NaturalGas

Unmitigated

	NaturalGas Use	ROG	NOx	CO	SO2	Fugitive PM10	Exhaust PM10	PM10 Total	Fugitive PM2.5	Exhaust PM2.5	PM2.5 Total	Bio- CO2	NBio- CO2	Total CO2	CH4	N2O	CO2e
Land Use	kBTU/yr	lb/day										lb/day					
Apartments Low Rise	6163.99	0.0665	0.5681	0.2417	3.6300e-003		0.0459	0.0459		0.0459	0.0459		725.1752	725.1752	0.0139	0.0133	729.4846
Apartments Mid Rise	16579.7	0.1788	1.5279	0.6502	9.7500e-003		0.1235	0.1235		0.1235	0.1235		1,950.5473	1,950.5473	0.0374	0.0358	1,962.1384
Apartments Mid Rise	3720.09	0.0401	0.3428	0.1459	2.1900e-003		0.0277	0.0277		0.0277	0.0277		437.6574	437.6574	8.3900e-003	8.0200e-003	440.2582
Government (Civic Center)	281.392	3.0300e-003	0.0276	0.0232	1.7000e-004		2.1000e-003	2.1000e-003		2.1000e-003	2.1000e-003		33.1049	33.1049	6.3000e-004	6.1000e-004	33.3016
Office Park	24114.1	0.2601	2.3641	1.9859	0.0142		0.1797	0.1797		0.1797	0.1797		2,836.9529	2,836.9529	0.0544	0.0520	2,853.8115
Strip Mall	1589.92	0.0172	0.1559	0.1309	9.4000e-004		0.0119	0.0119		0.0119	0.0119		187.0492	187.0492	3.5900e-003	3.4300e-003	188.1607
Strip Mall	692.384	7.4700e-003	0.0679	0.0570	4.1000e-004		5.1600e-003	5.1600e-003		5.1600e-003	5.1600e-003		81.4569	81.4569	1.5600e-003	1.4900e-003	81.9410
Total		0.5731	5.0543	3.2348	0.0313		0.3960	0.3960		0.3960	0.3960		6,251.9438	6,251.9438	0.1198	0.1146	6,289.0959

Pismo Beach GP/LCP PEIR - GHG - San Luis Obispo County APCD Air District, Summer

EMFAC Off-Model Adjustment Factors for Gasoline Light Duty Vehicle to Account for the SAFE Vehicle Rule Applied

5.2 Energy by Land Use - NaturalGas

Mitigated

	NaturalGas Use	ROG	NOx	CO	SO2	Fugitive PM10	Exhaust PM10	PM10 Total	Fugitive PM2.5	Exhaust PM2.5	PM2.5 Total	Bio- CO2	NBio- CO2	Total CO2	CH4	N2O	CO2e
Land Use	kBTU/yr	lb/day										lb/day					
Apartments Low Rise	6.16399	0.0665	0.5681	0.2417	3.6300e-003		0.0459	0.0459		0.0459	0.0459		725.1752	725.1752	0.0139	0.0133	729.4846
Apartments Mid Rise	16.5797	0.1788	1.5279	0.6502	9.7500e-003		0.1235	0.1235		0.1235	0.1235		1,950.5473	1,950.5473	0.0374	0.0358	1,962.1384
Apartments Mid Rise	3.72009	0.0401	0.3428	0.1459	2.1900e-003		0.0277	0.0277		0.0277	0.0277		437.6574	437.6574	8.3900e-003	8.0200e-003	440.2582
Government (Civic Center)	0.281392	3.0300e-003	0.0276	0.0232	1.7000e-004		2.1000e-003	2.1000e-003		2.1000e-003	2.1000e-003		33.1049	33.1049	6.3000e-004	6.1000e-004	33.3016
Office Park	24.1141	0.2601	2.3641	1.9859	0.0142		0.1797	0.1797		0.1797	0.1797		2,836.9529	2,836.9529	0.0544	0.0520	2,853.8115
Strip Mall	0.692384	7.4700e-003	0.0679	0.0570	4.1000e-004		5.1600e-003	5.1600e-003		5.1600e-003	5.1600e-003		81.4569	81.4569	1.5600e-003	1.4900e-003	81.9410
Strip Mall	1.58992	0.0172	0.1559	0.1309	9.4000e-004		0.0119	0.0119		0.0119	0.0119		187.0492	187.0492	3.5900e-003	3.4300e-003	188.1607
Total		0.5731	5.0543	3.2348	0.0313		0.3960	0.3960		0.3960	0.3960		6,251.9438	6,251.9438	0.1198	0.1146	6,289.0959

6.0 Area Detail

6.1 Mitigation Measures Area

Pismo Beach GP/LCP PEIR - GHG - San Luis Obispo County APCD Air District, Summer

EMFAC Off-Model Adjustment Factors for Gasoline Light Duty Vehicle to Account for the SAFE Vehicle Rule Applied

	ROG	NOx	CO	SO2	Fugitive PM10	Exhaust PM10	PM10 Total	Fugitive PM2.5	Exhaust PM2.5	PM2.5 Total	Bio- CO2	NBio- CO2	Total CO2	CH4	N2O	CO2e
Category	lb/day										lb/day					
Mitigated	50.0945	1.0550	91.4179	4.8500e-003		0.5090	0.5090		0.5090	0.5090	0.0000	165.3616	165.3616	0.1577	0.0000	169.3035
Unmitigated	50.0945	1.0550	91.4179	4.8500e-003		0.5090	0.5090		0.5090	0.5090	0.0000	165.3616	165.3616	0.1577	0.0000	169.3035

6.2 Area by SubCategory

Unmitigated

	ROG	NOx	CO	SO2	Fugitive PM10	Exhaust PM10	PM10 Total	Fugitive PM2.5	Exhaust PM2.5	PM2.5 Total	Bio- CO2	NBio- CO2	Total CO2	CH4	N2O	CO2e
SubCategory	lb/day										lb/day					
Architectural Coating	6.7966					0.0000	0.0000		0.0000	0.0000			0.0000			0.0000
Consumer Products	40.5588					0.0000	0.0000		0.0000	0.0000			0.0000			0.0000
Hearth	0.0000	0.0000	0.0000	0.0000		0.0000	0.0000		0.0000	0.0000	0.0000	0.0000	0.0000	0.0000	0.0000	0.0000
Landscaping	2.7391	1.0550	91.4179	4.8500e-003		0.5090	0.5090		0.5090	0.5090		165.3616	165.3616	0.1577		169.3035
Total	50.0945	1.0550	91.4179	4.8500e-003		0.5090	0.5090		0.5090	0.5090	0.0000	165.3616	165.3616	0.1577	0.0000	169.3035

Pismo Beach GP/LCP PEIR - GHG - San Luis Obispo County APCD Air District, Summer

EMFAC Off-Model Adjustment Factors for Gasoline Light Duty Vehicle to Account for the SAFE Vehicle Rule Applied

6.2 Area by SubCategory

Mitigated

	ROG	NOx	CO	SO2	Fugitive PM10	Exhaust PM10	PM10 Total	Fugitive PM2.5	Exhaust PM2.5	PM2.5 Total	Bio- CO2	NBio- CO2	Total CO2	CH4	N2O	CO2e
SubCategory	lb/day										lb/day					
Architectural Coating	6.7966					0.0000	0.0000		0.0000	0.0000			0.0000			0.0000
Consumer Products	40.5588					0.0000	0.0000		0.0000	0.0000			0.0000			0.0000
Hearth	0.0000	0.0000	0.0000	0.0000		0.0000	0.0000		0.0000	0.0000	0.0000	0.0000	0.0000	0.0000	0.0000	0.0000
Landscaping	2.7391	1.0550	91.4179	4.8500e-003		0.5090	0.5090		0.5090	0.5090		165.3616	165.3616	0.1577		169.3035
Total	50.0945	1.0550	91.4179	4.8500e-003		0.5090	0.5090		0.5090	0.5090	0.0000	165.3616	165.3616	0.1577	0.0000	169.3035

7.0 Water Detail

7.1 Mitigation Measures Water

- Apply Water Conservation Strategy
- Use Water Efficient Irrigation System

Pismo Beach GP/LCP PEIR - GHG - San Luis Obispo County APCD Air District, Summer

EMFAC Off-Model Adjustment Factors for Gasoline Light Duty Vehicle to Account for the SAFE Vehicle Rule Applied

8.0 Waste Detail

8.1 Mitigation Measures Waste

9.0 Operational Offroad

Equipment Type	Number	Hours/Day	Days/Year	Horse Power	Load Factor	Fuel Type
----------------	--------	-----------	-----------	-------------	-------------	-----------

10.0 Stationary Equipment

Fire Pumps and Emergency Generators

Equipment Type	Number	Hours/Day	Hours/Year	Horse Power	Load Factor	Fuel Type
----------------	--------	-----------	------------	-------------	-------------	-----------

Boilers

Equipment Type	Number	Heat Input/Day	Heat Input/Year	Boiler Rating	Fuel Type
----------------	--------	----------------	-----------------	---------------	-----------

User Defined Equipment

Equipment Type	Number
----------------	--------

11.0 Vegetation

Pismo Beach GP/LCP PEIR - GHG - San Luis Obispo County APCD Air District, Winter

EMFAC Off-Model Adjustment Factors for Gasoline Light Duty Vehicle to Account for the SAFE Vehicle Rule Applied

Pismo Beach GP/LCP PEIR - GHG
San Luis Obispo County APCD Air District, Winter

1.0 Project Characteristics

1.1 Land Usage

Land Uses	Size	Metric	Lot Acreage	Floor Surface Area	Population
Government (Civic Center)	6.34	1000sqft	0.15	6,340.00	-2
Office Park	420.93	1000sqft	9.66	420,930.00	0
Apartments Low Rise	228.00	Dwelling Unit	14.25	228,000.00	471
Apartments Mid Rise	162.00	Dwelling Unit	4.26	162,000.00	185
Apartments Mid Rise	722.00	Dwelling Unit	19.00	722,000.00	1221
Strip Mall	248.00	1000sqft	5.69	248,000.00	0
Strip Mall	108.00	1000sqft	2.48	108,000.00	0

1.2 Other Project Characteristics

Urbanization	Urban	Wind Speed (m/s)	3.2	Precipitation Freq (Days)	44
Climate Zone	4			Operational Year	2040
Utility Company	Pacific Gas and Electric Company				
CO2 Intensity (lb/MW hr)	203.98	CH4 Intensity (lb/MW hr)	0.033	N2O Intensity (lb/MW hr)	0.004

1.3 User Entered Comments & Non-Default Data

Project Characteristics -

Land Use - Data given by applicant

Construction Phase - Similar Buildout schedule as other City General Plan Update for 2040.

Grading -

Architectural Coating - SLOAPCD Rule 433

Vehicle Trips - Adjusted trip length and trip generation rates

Pismo Beach GP/LCP PEIR - GHG - San Luis Obispo County APCD Air District, Winter

EMFAC Off-Model Adjustment Factors for Gasoline Light Duty Vehicle to Account for the SAFE Vehicle Rule Applied

Area Coating - SLOAPCD Rule 433

Mobile Land Use Mitigation -

Water Mitigation -

Table Name	Column Name	Default Value	New Value
tblArchitecturalCoating	EF_Nonresidential_Exterior	250.00	150.00
tblArchitecturalCoating	EF_Nonresidential_Interior	250.00	150.00
tblArchitecturalCoating	EF_Residential_Exterior	250.00	100.00
tblArchitecturalCoating	EF_Residential_Interior	250.00	100.00
tblAreaCoating	Area_EF_Nonresidential_Exterior	250	150
tblAreaCoating	Area_EF_Nonresidential_Interior	250	150
tblAreaCoating	Area_EF_Residential_Exterior	250	100
tblAreaCoating	Area_EF_Residential_Interior	250	100
tblConstructionPhase	NumDays	75.00	330.00
tblConstructionPhase	NumDays	1,110.00	4,650.00
tblConstructionPhase	NumDays	70.00	300.00
tblConstructionPhase	NumDays	110.00	465.00
tblConstructionPhase	NumDays	75.00	330.00
tblConstructionPhase	NumDays	40.00	180.00
tblLandUse	Population	0.00	-2.00
tblLandUse	Population	652.00	471.00
tblLandUse	Population	463.00	185.00
tblLandUse	Population	2,065.00	1,221.00
tblVehicleTrips	CC_TL	5.00	10.73
tblVehicleTrips	CC_TL	5.00	9.60
tblVehicleTrips	CC_TL	5.00	18.00
tblVehicleTrips	CNW_TL	5.00	12.48
tblVehicleTrips	CNW_TL	5.00	6.60
tblVehicleTrips	CNW_TL	5.00	18.00

Pismo Beach GP/LCP PEIR - GHG - San Luis Obispo County APCD Air District, Winter

EMFAC Off-Model Adjustment Factors for Gasoline Light Duty Vehicle to Account for the SAFE Vehicle Rule Applied

tblVehicleTrips	CW_TL	13.00	12.87
tblVehicleTrips	CW_TL	13.00	24.95
tblVehicleTrips	CW_TL	13.00	46.79
tblVehicleTrips	HO_TL	5.00	9.01
tblVehicleTrips	HO_TL	5.00	9.01
tblVehicleTrips	HS_TL	5.00	9.01
tblVehicleTrips	HS_TL	5.00	9.01
tblVehicleTrips	HW_TL	13.00	23.42
tblVehicleTrips	HW_TL	13.00	23.42
tblVehicleTrips	ST_TR	8.14	0.98
tblVehicleTrips	ST_TR	4.91	0.59
tblVehicleTrips	ST_TR	1.64	0.20
tblVehicleTrips	ST_TR	42.04	5.07
tblVehicleTrips	SU_TR	6.28	0.76
tblVehicleTrips	SU_TR	4.09	0.49
tblVehicleTrips	SU_TR	0.76	0.09
tblVehicleTrips	SU_TR	20.43	2.46
tblVehicleTrips	WD_TR	7.32	0.88
tblVehicleTrips	WD_TR	5.44	0.70
tblVehicleTrips	WD_TR	33.98	4.10
tblVehicleTrips	WD_TR	11.07	1.33
tblVehicleTrips	WD_TR	44.32	5.40

2.0 Emissions Summary

2.1 Overall Construction (Maximum Daily Emission)

Unmitigated Construction

Pismo Beach GP/LCP PEIR - GHG - San Luis Obispo County APCD Air District, Winter

EMFAC Off-Model Adjustment Factors for Gasoline Light Duty Vehicle to Account for the SAFE Vehicle Rule Applied

	ROG	NOx	CO	SO2	Fugitive PM10	Exhaust PM10	PM10 Total	Fugitive PM2.5	Exhaust PM2.5	PM2.5 Total	Bio- CO2	NBio- CO2	Total CO2	CH4	N2O	CO2e
Year	lb/day										lb/day					
2021	3.2245	31.4862	22.0345	0.0401	0.1483	1.5521	1.7004	0.0393	1.4418	1.4812	0.0000	3,877.0463	3,877.0463	1.0592	4.1800e-003	3,904.7702
2022	15.7163	128.4125	121.2459	0.2950	40.9224	5.4732	46.3956	16.9814	5.0687	22.0501	0.0000	29,334.3221	29,334.3221	5.1794	0.8830	29,726.9458
2023	11.2382	83.1899	96.1804	0.2514	21.0876	3.2313	24.3189	6.8318	2.9999	9.8318	0.0000	25,136.4728	25,136.4728	3.9423	0.8356	25,484.0504
2024	8.4894	58.1236	73.7217	0.2081	20.9394	2.0540	22.9934	6.7926	1.9045	8.6971	0.0000	20,997.8226	20,997.8226	2.8635	0.8050	21,309.3066
2025	4.9100	24.2955	43.7243	0.1412	11.5382	0.6285	12.1668	3.0864	0.5912	3.6777	0.0000	14,569.8177	14,569.8177	0.8937	0.7752	14,823.1664
2026	4.7439	23.8997	42.2898	0.1381	11.5384	0.6249	12.1632	3.0865	0.5878	3.6743	0.0000	14,316.8951	14,316.8951	0.8778	0.7521	14,562.9614
2027	4.5877	23.5436	41.0538	0.1352	11.5385	0.6210	12.1595	3.0865	0.5842	3.6707	0.0000	14,071.4585	14,071.4585	0.8639	0.7303	14,310.6731
2028	4.4337	23.2395	40.0171	0.1325	11.5386	0.6172	12.1558	3.0865	0.5806	3.6672	0.0000	13,845.7402	13,845.7402	0.8522	0.7106	14,078.7894
2029	4.2829	22.9499	39.1042	0.1300	11.5387	0.6135	12.1522	3.0866	0.5772	3.6637	0.0000	13,633.0541	13,633.0541	0.8419	0.6921	13,860.3306
2030	4.0800	18.1812	38.4056	0.1318	11.5388	0.2307	11.7695	3.0866	0.2259	3.3125	0.0000	13,784.8023	13,784.8023	0.3478	0.6760	13,994.9469
2031	3.9330	17.9742	37.7259	0.1297	11.5388	0.2277	11.7666	3.0866	0.2231	3.3098	0.0000	13,613.6729	13,613.6729	0.3395	0.6617	13,819.3582
2032	3.7948	17.7959	37.1379	0.1279	11.5389	0.2250	11.7639	3.0867	0.2206	3.3073	0.0000	13,460.8781	13,460.8781	0.3320	0.6493	13,662.6790
2033	3.6774	17.6488	36.6416	0.1263	11.5390	0.2226	11.7616	3.0867	0.2183	3.3050	0.0000	13,324.8719	13,324.8719	0.3256	0.6387	13,523.3458
2034	3.5738	17.5210	36.2081	0.1249	11.5390	0.2204	11.7594	3.0867	0.2163	3.3030	0.0000	13,202.7749	13,202.7749	0.3200	0.6294	13,398.3303
2035	3.3867	16.6338	35.7924	0.1236	11.5391	0.1606	11.6997	3.0867	0.1566	3.2433	0.0000	13,095.3338	13,095.3338	0.3066	0.6213	13,288.1499
2036	3.3867	16.6338	35.7924	0.1236	11.5391	0.1606	11.6997	3.0867	0.1566	3.2433	0.0000	13,095.3338	13,095.3338	0.3066	0.6213	13,288.1499
2037	3.3867	16.6338	35.7924	0.1236	11.5391	0.1606	11.6997	3.0867	0.1566	3.2433	0.0000	13,095.3338	13,095.3338	0.3066	0.6213	13,288.1499
2038	3.3867	16.6338	35.7924	0.1236	11.5391	0.1606	11.6997	3.0867	0.1566	3.2433	0.0000	13,095.3338	13,095.3338	0.3066	0.6213	13,288.1499
2039	3.3867	16.6338	35.7924	0.1236	11.5391	0.1606	11.6997	3.0867	0.1566	3.2433	0.0000	13,095.3338	13,095.3338	0.3066	0.6213	13,288.1499

Pismo Beach GP/LCP PEIR - GHG - San Luis Obispo County APCD Air District, Winter

EMFAC Off-Model Adjustment Factors for Gasoline Light Duty Vehicle to Account for the SAFE Vehicle Rule Applied

	ROG	NOx	CO	SO2	Fugitive PM10	Exhaust PM10	PM10 Total	Fugitive PM2.5	Exhaust PM2.5	PM2.5 Total	Bio- CO2	NBio- CO2	Total CO2	CH4	N2O	CO2e
Year	lb/day										lb/day					
2040	76.6437	15.8948	34.5254	0.1191	11.5393	0.1371	11.6764	3.0868	0.1336	3.2204	0.0000	12,708.4908	12,708.4908	0.2877	0.5908	12,891.7328
2041	1.4695	4.5728	20.8693	0.0438	2.2244	0.1280	2.3524	0.5900	0.1277	0.7177	0.0000	4,380.9842	4,380.9842	0.1159	0.0304	4,392.9538
2042	0.4354	0.9036	4.8343	0.0149	2.0761	0.0113	2.0874	0.5506	0.0110	0.5616	0.0000	1,628.2662	1,628.2662	0.0255	0.0284	1,637.3709
Maximum	76.6437	128.4125	121.2459	0.2950	40.9224	5.4732	46.3956	16.9814	5.0687	22.0501	0.0000	29,334.3221	29,334.3221	5.1794	0.8830	29,726.9458

2.1 Overall Construction (Maximum Daily Emission)

Mitigated Construction

	ROG	NOx	CO	SO2	Fugitive PM10	Exhaust PM10	PM10 Total	Fugitive PM2.5	Exhaust PM2.5	PM2.5 Total	Bio- CO2	NBio- CO2	Total CO2	CH4	N2O	CO2e
Year	lb/day										lb/day					
2021	3.2245	31.4862	22.0345	0.0401	0.1483	1.5521	1.7004	0.0393	1.4418	1.4812	0.0000	3,877.0463	3,877.0463	1.0592	4.1800e-003	3,904.7702
2022	15.7163	128.4125	121.2459	0.2950	40.9224	5.4732	46.3956	16.9814	5.0687	22.0501	0.0000	29,334.3221	29,334.3221	5.1794	0.8830	29,726.9458
2023	11.2382	83.1899	96.1804	0.2514	21.0876	3.2313	24.3189	6.8318	2.9999	9.8318	0.0000	25,136.4727	25,136.4727	3.9423	0.8356	25,484.0504
2024	8.4894	58.1236	73.7217	0.2081	20.9394	2.0540	22.9934	6.7926	1.9045	8.6971	0.0000	20,997.8226	20,997.8226	2.8635	0.8050	21,309.3066
2025	4.9100	24.2955	43.7243	0.1412	11.5382	0.6285	12.1668	3.0864	0.5912	3.6777	0.0000	14,569.8177	14,569.8177	0.8937	0.7752	14,823.1664
2026	4.7439	23.8997	42.2898	0.1381	11.5384	0.6249	12.1632	3.0865	0.5878	3.6743	0.0000	14,316.8951	14,316.8951	0.8778	0.7521	14,562.9614
2027	4.5877	23.5436	41.0538	0.1352	11.5385	0.6210	12.1595	3.0865	0.5842	3.6707	0.0000	14,071.4585	14,071.4585	0.8639	0.7303	14,310.6731
2028	4.4337	23.2395	40.0171	0.1325	11.5386	0.6172	12.1558	3.0865	0.5806	3.6672	0.0000	13,845.7402	13,845.7402	0.8522	0.7106	14,078.7894

Pismo Beach GP/LCP PEIR - GHG - San Luis Obispo County APCD Air District, Winter

EMFAC Off-Model Adjustment Factors for Gasoline Light Duty Vehicle to Account for the SAFE Vehicle Rule Applied

Pismo Beach GP/LCP PEIR - GHG - San Luis Obispo County APCD Air District, Winter

EMFAC Off-Model Adjustment Factors for Gasoline Light Duty Vehicle to Account for the SAFE Vehicle Rule Applied

2.2 Overall Operational

Unmitigated Operational

	ROG	NOx	CO	SO2	Fugitive PM10	Exhaust PM10	PM10 Total	Fugitive PM2.5	Exhaust PM2.5	PM2.5 Total	Bio- CO2	NBio- CO2	Total CO2	CH4	N2O	CO2e
Category	lb/day										lb/day					
Area	50.0945	1.0550	91.4179	4.8500e-003		0.5090	0.5090		0.5090	0.5090	0.0000	165.3616	165.3616	0.1577	0.0000	169.3035
Energy	0.5731	5.0543	3.2348	0.0313		0.3960	0.3960		0.3960	0.3960		6,251.9438	6,251.9438	0.1198	0.1146	6,289.0959
Mobile	8.3769	9.6920	94.1100	0.2091	31.8757	0.1101	31.9857	8.4836	0.1031	8.5867		23,247.0508	23,247.0508	1.1306	0.9238	23,550.5942
Total	59.0445	15.8012	188.7626	0.2452	31.8757	1.0151	32.8907	8.4836	1.0081	9.4917	0.0000	29,664.3561	29,664.3561	1.4081	1.0384	30,008.9936

Mitigated Operational

	ROG	NOx	CO	SO2	Fugitive PM10	Exhaust PM10	PM10 Total	Fugitive PM2.5	Exhaust PM2.5	PM2.5 Total	Bio- CO2	NBio- CO2	Total CO2	CH4	N2O	CO2e
Category	lb/day										lb/day					
Area	50.0945	1.0550	91.4179	4.8500e-003		0.5090	0.5090		0.5090	0.5090	0.0000	165.3616	165.3616	0.1577	0.0000	169.3035
Energy	0.5731	5.0543	3.2348	0.0313		0.3960	0.3960		0.3960	0.3960		6,251.9438	6,251.9438	0.1198	0.1146	6,289.0959
Mobile	8.3769	9.6920	94.1100	0.2091	31.8757	0.1101	31.9857	8.4836	0.1031	8.5867		23,247.0508	23,247.0508	1.1306	0.9238	23,550.5942
Total	59.0445	15.8012	188.7626	0.2452	31.8757	1.0151	32.8907	8.4836	1.0081	9.4917	0.0000	29,664.3561	29,664.3561	1.4081	1.0384	30,008.9936

Pismo Beach GP/LCP PEIR - GHG - San Luis Obispo County APCD Air District, Winter

EMFAC Off-Model Adjustment Factors for Gasoline Light Duty Vehicle to Account for the SAFE Vehicle Rule Applied

	ROG	NOx	CO	SO2	Fugitive PM10	Exhaust PM10	PM10 Total	Fugitive PM2.5	Exhaust PM2.5	PM2.5 Total	Bio- CO2	NBio-CO2	Total CO2	CH4	N2O	CO2e
Percent Reduction	0.00	0.00	0.00	0.00	0.00	0.00	0.00	0.00	0.00	0.00	0.00	0.00	0.00	0.00	0.00	0.00

3.0 Construction Detail

Construction Phase

Phase Number	Phase Name	Phase Type	Start Date	End Date	Num Days Week	Num Days	Phase Description
1	Demolition	Demolition	11/17/2021	1/10/2023	5	300	
2	Site Preparation	Site Preparation	2/23/2022	11/1/2022	5	180	
3	Grading	Grading	4/20/2022	1/30/2024	5	465	
4	Building Construction	Building Construction	9/21/2022	7/17/2040	5	4650	
5	Paving	Paving	7/18/2040	10/22/2041	5	330	
6	Architectural Coating	Architectural Coating	10/23/2040	1/27/2042	5	330	

Acres of Grading (Site Preparation Phase): 270

Acres of Grading (Grading Phase): 1395

Acres of Paving: 0

Residential Indoor: 2,251,800; Residential Outdoor: 750,600; Non-Residential Indoor: 1,174,905; Non-Residential Outdoor: 391,635; Striped Parking Area: 0 (Architectural Coating – sqft)

OffRoad Equipment

Phase Name	Offroad Equipment Type	Amount	Usage Hours	Horse Power	Load Factor
Demolition	Concrete/Industrial Saws	1	8.00	81	0.73
Demolition	Excavators	3	8.00	158	0.38
Demolition	Rubber Tired Dozers	2	8.00	247	0.40
Site Preparation	Rubber Tired Dozers	3	8.00	247	0.40
Site Preparation	Tractors/Loaders/Backhoes	4	8.00	97	0.37

Pismo Beach GP/LCP PEIR - GHG - San Luis Obispo County APCD Air District, Winter

EMFAC Off-Model Adjustment Factors for Gasoline Light Duty Vehicle to Account for the SAFE Vehicle Rule Applied

Grading	Excavators	2	8.00	158	0.38
Grading	Graders	1	8.00	187	0.41
Grading	Rubber Tired Dozers	1	8.00	247	0.40
Grading	Scrapers	2	8.00	367	0.48
Grading	Tractors/Loaders/Backhoes	2	8.00	97	0.37
Building Construction	Cranes	1	7.00	231	0.29
Building Construction	Forklifts	3	8.00	89	0.20
Building Construction	Generator Sets	1	8.00	84	0.74
Building Construction	Tractors/Loaders/Backhoes	3	7.00	97	0.37
Building Construction	Welders	1	8.00	46	0.45
Paving	Pavers	2	8.00	130	0.42
Paving	Paving Equipment	2	8.00	132	0.36
Paving	Rollers	2	8.00	80	0.38
Architectural Coating	Air Compressors	1	6.00	78	0.48

Trips and VMT

Phase Name	Offroad Equipment Count	Worker Trip Number	Vendor Trip Number	Hauling Trip Number	Worker Trip Length	Vendor Trip Length	Hauling Trip Length	Worker Vehicle Class	Vendor Vehicle Class	Hauling Vehicle Class
Demolition	6	15.00	0.00	0.00	13.00	5.00	20.00	LD_Mix	HDT_Mix	HHDT
Site Preparation	7	18.00	0.00	0.00	13.00	5.00	20.00	LD_Mix	HDT_Mix	HHDT
Grading	8	20.00	0.00	0.00	13.00	5.00	20.00	LD_Mix	HDT_Mix	HHDT
Building Construction	9	1,051.00	247.00	0.00	13.00	5.00	20.00	LD_Mix	HDT_Mix	HHDT
Paving	6	15.00	0.00	0.00	13.00	5.00	20.00	LD_Mix	HDT_Mix	HHDT
Architectural Coating	1	210.00	0.00	0.00	13.00	5.00	20.00	LD_Mix	HDT_Mix	HHDT

3.1 Mitigation Measures Construction

Pismo Beach GP/LCP PEIR - GHG - San Luis Obispo County APCD Air District, Winter

EMFAC Off-Model Adjustment Factors for Gasoline Light Duty Vehicle to Account for the SAFE Vehicle Rule Applied

3.2 Demolition - 2021

Unmitigated Construction On-Site

	ROG	NOx	CO	SO2	Fugitive PM10	Exhaust PM10	PM10 Total	Fugitive PM2.5	Exhaust PM2.5	PM2.5 Total	Bio- CO2	NBio- CO2	Total CO2	CH4	N2O	CO2e
Category	lb/day										lb/day					
Off-Road	3.1651	31.4407	21.5650	0.0388		1.5513	1.5513		1.4411	1.4411		3,747.9449	3,747.9449	1.0549		3,774.3174
Total	3.1651	31.4407	21.5650	0.0388		1.5513	1.5513		1.4411	1.4411		3,747.9449	3,747.9449	1.0549		3,774.3174

Unmitigated Construction Off-Site

	ROG	NOx	CO	SO2	Fugitive PM10	Exhaust PM10	PM10 Total	Fugitive PM2.5	Exhaust PM2.5	PM2.5 Total	Bio- CO2	NBio- CO2	Total CO2	CH4	N2O	CO2e
Category	lb/day										lb/day					
Hauling	0.0000	0.0000	0.0000	0.0000	0.0000	0.0000	0.0000	0.0000	0.0000	0.0000		0.0000	0.0000	0.0000	0.0000	0.0000
Vendor	0.0000	0.0000	0.0000	0.0000	0.0000	0.0000	0.0000	0.0000	0.0000	0.0000		0.0000	0.0000	0.0000	0.0000	0.0000
Worker	0.0594	0.0455	0.4695	1.2700e-003	0.1483	7.9000e-004	0.1491	0.0393	7.3000e-004	0.0401		129.1014	129.1014	4.2700e-003	4.1800e-003	130.4528
Total	0.0594	0.0455	0.4695	1.2700e-003	0.1483	7.9000e-004	0.1491	0.0393	7.3000e-004	0.0401		129.1014	129.1014	4.2700e-003	4.1800e-003	130.4528

Pismo Beach GP/LCP PEIR - GHG - San Luis Obispo County APCD Air District, Winter

EMFAC Off-Model Adjustment Factors for Gasoline Light Duty Vehicle to Account for the SAFE Vehicle Rule Applied

3.2 Demolition - 2021

Mitigated Construction On-Site

	ROG	NOx	CO	SO2	Fugitive PM10	Exhaust PM10	PM10 Total	Fugitive PM2.5	Exhaust PM2.5	PM2.5 Total	Bio- CO2	NBio- CO2	Total CO2	CH4	N2O	CO2e
Category	lb/day										lb/day					
Off-Road	3.1651	31.4407	21.5650	0.0388		1.5513	1.5513		1.4411	1.4411	0.0000	3,747.9449	3,747.9449	1.0549		3,774.3174
Total	3.1651	31.4407	21.5650	0.0388		1.5513	1.5513		1.4411	1.4411	0.0000	3,747.9449	3,747.9449	1.0549		3,774.3174

Mitigated Construction Off-Site

	ROG	NOx	CO	SO2	Fugitive PM10	Exhaust PM10	PM10 Total	Fugitive PM2.5	Exhaust PM2.5	PM2.5 Total	Bio- CO2	NBio- CO2	Total CO2	CH4	N2O	CO2e
Category	lb/day										lb/day					
Hauling	0.0000	0.0000	0.0000	0.0000	0.0000	0.0000	0.0000	0.0000	0.0000	0.0000		0.0000	0.0000	0.0000	0.0000	0.0000
Vendor	0.0000	0.0000	0.0000	0.0000	0.0000	0.0000	0.0000	0.0000	0.0000	0.0000		0.0000	0.0000	0.0000	0.0000	0.0000
Worker	0.0594	0.0455	0.4695	1.2700e-003	0.1483	7.9000e-004	0.1491	0.0393	7.3000e-004	0.0401		129.1014	129.1014	4.2700e-003	4.1800e-003	130.4528
Total	0.0594	0.0455	0.4695	1.2700e-003	0.1483	7.9000e-004	0.1491	0.0393	7.3000e-004	0.0401		129.1014	129.1014	4.2700e-003	4.1800e-003	130.4528

Pismo Beach GP/LCP PEIR - GHG - San Luis Obispo County APCD Air District, Winter

EMFAC Off-Model Adjustment Factors for Gasoline Light Duty Vehicle to Account for the SAFE Vehicle Rule Applied

3.2 Demolition - 2022

Unmitigated Construction On-Site

	ROG	NOx	CO	SO2	Fugitive PM10	Exhaust PM10	PM10 Total	Fugitive PM2.5	Exhaust PM2.5	PM2.5 Total	Bio- CO2	NBio- CO2	Total CO2	CH4	N2O	CO2e
Category	lb/day										lb/day					
Off-Road	2.6392	25.7194	20.5941	0.0388		1.2427	1.2427		1.1553	1.1553		3,746.7812	3,746.7812	1.0524		3,773.0920
Total	2.6392	25.7194	20.5941	0.0388		1.2427	1.2427		1.1553	1.1553		3,746.7812	3,746.7812	1.0524		3,773.0920

Unmitigated Construction Off-Site

	ROG	NOx	CO	SO2	Fugitive PM10	Exhaust PM10	PM10 Total	Fugitive PM2.5	Exhaust PM2.5	PM2.5 Total	Bio- CO2	NBio- CO2	Total CO2	CH4	N2O	CO2e
Category	lb/day										lb/day					
Hauling	0.0000	0.0000	0.0000	0.0000	0.0000	0.0000	0.0000	0.0000	0.0000	0.0000		0.0000	0.0000	0.0000	0.0000	0.0000
Vendor	0.0000	0.0000	0.0000	0.0000	0.0000	0.0000	0.0000	0.0000	0.0000	0.0000		0.0000	0.0000	0.0000	0.0000	0.0000
Worker	0.0557	0.0402	0.4320	1.2400e-003	0.1483	7.5000e-004	0.1490	0.0393	6.9000e-004	0.0400		125.8786	125.8786	3.8700e-003	3.8500e-003	127.1225
Total	0.0557	0.0402	0.4320	1.2400e-003	0.1483	7.5000e-004	0.1490	0.0393	6.9000e-004	0.0400		125.8786	125.8786	3.8700e-003	3.8500e-003	127.1225

Pismo Beach GP/LCP PEIR - GHG - San Luis Obispo County APCD Air District, Winter

EMFAC Off-Model Adjustment Factors for Gasoline Light Duty Vehicle to Account for the SAFE Vehicle Rule Applied

3.2 Demolition - 2022

Mitigated Construction On-Site

	ROG	NOx	CO	SO2	Fugitive PM10	Exhaust PM10	PM10 Total	Fugitive PM2.5	Exhaust PM2.5	PM2.5 Total	Bio- CO2	NBio- CO2	Total CO2	CH4	N2O	CO2e
Category	lb/day										lb/day					
Off-Road	2.6392	25.7194	20.5941	0.0388		1.2427	1.2427		1.1553	1.1553	0.0000	3,746.7812	3,746.7812	1.0524		3,773.0920
Total	2.6392	25.7194	20.5941	0.0388		1.2427	1.2427		1.1553	1.1553	0.0000	3,746.7812	3,746.7812	1.0524		3,773.0920

Mitigated Construction Off-Site

	ROG	NOx	CO	SO2	Fugitive PM10	Exhaust PM10	PM10 Total	Fugitive PM2.5	Exhaust PM2.5	PM2.5 Total	Bio- CO2	NBio- CO2	Total CO2	CH4	N2O	CO2e
Category	lb/day										lb/day					
Hauling	0.0000	0.0000	0.0000	0.0000	0.0000	0.0000	0.0000	0.0000	0.0000	0.0000		0.0000	0.0000	0.0000	0.0000	0.0000
Vendor	0.0000	0.0000	0.0000	0.0000	0.0000	0.0000	0.0000	0.0000	0.0000	0.0000		0.0000	0.0000	0.0000	0.0000	0.0000
Worker	0.0557	0.0402	0.4320	1.2400e-003	0.1483	7.5000e-004	0.1490	0.0393	6.9000e-004	0.0400		125.8786	125.8786	3.8700e-003	3.8500e-003	127.1225
Total	0.0557	0.0402	0.4320	1.2400e-003	0.1483	7.5000e-004	0.1490	0.0393	6.9000e-004	0.0400		125.8786	125.8786	3.8700e-003	3.8500e-003	127.1225

Pismo Beach GP/LCP PEIR - GHG - San Luis Obispo County APCD Air District, Winter

EMFAC Off-Model Adjustment Factors for Gasoline Light Duty Vehicle to Account for the SAFE Vehicle Rule Applied

3.2 Demolition - 2023

Unmitigated Construction On-Site

	ROG	NOx	CO	SO2	Fugitive PM10	Exhaust PM10	PM10 Total	Fugitive PM2.5	Exhaust PM2.5	PM2.5 Total	Bio- CO2	NBio- CO2	Total CO2	CH4	N2O	CO2e
Category	lb/day										lb/day					
Off-Road	2.2691	21.4844	19.6434	0.0388		0.9975	0.9975		0.9280	0.9280		3,746.9840	3,746.9840	1.0494		3,773.2183
Total	2.2691	21.4844	19.6434	0.0388		0.9975	0.9975		0.9280	0.9280		3,746.9840	3,746.9840	1.0494		3,773.2183

Unmitigated Construction Off-Site

	ROG	NOx	CO	SO2	Fugitive PM10	Exhaust PM10	PM10 Total	Fugitive PM2.5	Exhaust PM2.5	PM2.5 Total	Bio- CO2	NBio- CO2	Total CO2	CH4	N2O	CO2e
Category	lb/day										lb/day					
Hauling	0.0000	0.0000	0.0000	0.0000	0.0000	0.0000	0.0000	0.0000	0.0000	0.0000		0.0000	0.0000	0.0000	0.0000	0.0000
Vendor	0.0000	0.0000	0.0000	0.0000	0.0000	0.0000	0.0000	0.0000	0.0000	0.0000		0.0000	0.0000	0.0000	0.0000	0.0000
Worker	0.0523	0.0356	0.3993	1.2000e-003	0.1483	7.1000e-004	0.1490	0.0393	6.6000e-004	0.0400		122.8016	122.8016	3.5100e-003	3.5600e-003	123.9505
Total	0.0523	0.0356	0.3993	1.2000e-003	0.1483	7.1000e-004	0.1490	0.0393	6.6000e-004	0.0400		122.8016	122.8016	3.5100e-003	3.5600e-003	123.9505

Pismo Beach GP/LCP PEIR - GHG - San Luis Obispo County APCD Air District, Winter

EMFAC Off-Model Adjustment Factors for Gasoline Light Duty Vehicle to Account for the SAFE Vehicle Rule Applied

3.2 Demolition - 2023

Mitigated Construction On-Site

	ROG	NOx	CO	SO2	Fugitive PM10	Exhaust PM10	PM10 Total	Fugitive PM2.5	Exhaust PM2.5	PM2.5 Total	Bio- CO2	NBio- CO2	Total CO2	CH4	N2O	CO2e
Category	lb/day										lb/day					
Off-Road	2.2691	21.4844	19.6434	0.0388		0.9975	0.9975		0.9280	0.9280	0.0000	3,746.9840	3,746.9840	1.0494		3,773.2183
Total	2.2691	21.4844	19.6434	0.0388		0.9975	0.9975		0.9280	0.9280	0.0000	3,746.9840	3,746.9840	1.0494		3,773.2183

Mitigated Construction Off-Site

	ROG	NOx	CO	SO2	Fugitive PM10	Exhaust PM10	PM10 Total	Fugitive PM2.5	Exhaust PM2.5	PM2.5 Total	Bio- CO2	NBio- CO2	Total CO2	CH4	N2O	CO2e
Category	lb/day										lb/day					
Hauling	0.0000	0.0000	0.0000	0.0000	0.0000	0.0000	0.0000	0.0000	0.0000	0.0000		0.0000	0.0000	0.0000	0.0000	0.0000
Vendor	0.0000	0.0000	0.0000	0.0000	0.0000	0.0000	0.0000	0.0000	0.0000	0.0000		0.0000	0.0000	0.0000	0.0000	0.0000
Worker	0.0523	0.0356	0.3993	1.2000e-003	0.1483	7.1000e-004	0.1490	0.0393	6.6000e-004	0.0400		122.8016	122.8016	3.5100e-003	3.5600e-003	123.9505
Total	0.0523	0.0356	0.3993	1.2000e-003	0.1483	7.1000e-004	0.1490	0.0393	6.6000e-004	0.0400		122.8016	122.8016	3.5100e-003	3.5600e-003	123.9505

Pismo Beach GP/LCP PEIR - GHG - San Luis Obispo County APCD Air District, Winter

EMFAC Off-Model Adjustment Factors for Gasoline Light Duty Vehicle to Account for the SAFE Vehicle Rule Applied

3.3 Site Preparation - 2022

Unmitigated Construction On-Site

	ROG	NOx	CO	SO2	Fugitive PM10	Exhaust PM10	PM10 Total	Fugitive PM2.5	Exhaust PM2.5	PM2.5 Total	Bio- CO2	NBio- CO2	Total CO2	CH4	N2O	CO2e
Category	lb/day										lb/day					
Fugitive Dust					19.6570	0.0000	19.6570	10.1025	0.0000	10.1025			0.0000			0.0000
Off-Road	3.1701	33.0835	19.6978	0.0380		1.6126	1.6126		1.4836	1.4836		3,686.0619	3,686.0619	1.1922		3,715.8655
Total	3.1701	33.0835	19.6978	0.0380	19.6570	1.6126	21.2696	10.1025	1.4836	11.5860		3,686.0619	3,686.0619	1.1922		3,715.8655

Unmitigated Construction Off-Site

	ROG	NOx	CO	SO2	Fugitive PM10	Exhaust PM10	PM10 Total	Fugitive PM2.5	Exhaust PM2.5	PM2.5 Total	Bio- CO2	NBio- CO2	Total CO2	CH4	N2O	CO2e
Category	lb/day										lb/day					
Hauling	0.0000	0.0000	0.0000	0.0000	0.0000	0.0000	0.0000	0.0000	0.0000	0.0000		0.0000	0.0000	0.0000	0.0000	0.0000
Vendor	0.0000	0.0000	0.0000	0.0000	0.0000	0.0000	0.0000	0.0000	0.0000	0.0000		0.0000	0.0000	0.0000	0.0000	0.0000
Worker	0.0668	0.0482	0.5184	1.4800e-003	0.1780	9.0000e-004	0.1789	0.0472	8.3000e-004	0.0480		151.0544	151.0544	4.6400e-003	4.6200e-003	152.5470
Total	0.0668	0.0482	0.5184	1.4800e-003	0.1780	9.0000e-004	0.1789	0.0472	8.3000e-004	0.0480		151.0544	151.0544	4.6400e-003	4.6200e-003	152.5470

Pismo Beach GP/LCP PEIR - GHG - San Luis Obispo County APCD Air District, Winter

EMFAC Off-Model Adjustment Factors for Gasoline Light Duty Vehicle to Account for the SAFE Vehicle Rule Applied

3.3 Site Preparation - 2022

Mitigated Construction On-Site

	ROG	NOx	CO	SO2	Fugitive PM10	Exhaust PM10	PM10 Total	Fugitive PM2.5	Exhaust PM2.5	PM2.5 Total	Bio- CO2	NBio- CO2	Total CO2	CH4	N2O	CO2e
Category	lb/day										lb/day					
Fugitive Dust					19.6570	0.0000	19.6570	10.1025	0.0000	10.1025			0.0000			0.0000
Off-Road	3.1701	33.0835	19.6978	0.0380		1.6126	1.6126		1.4836	1.4836	0.0000	3,686.0619	3,686.0619	1.1922		3,715.8655
Total	3.1701	33.0835	19.6978	0.0380	19.6570	1.6126	21.2696	10.1025	1.4836	11.5860	0.0000	3,686.0619	3,686.0619	1.1922		3,715.8655

Mitigated Construction Off-Site

	ROG	NOx	CO	SO2	Fugitive PM10	Exhaust PM10	PM10 Total	Fugitive PM2.5	Exhaust PM2.5	PM2.5 Total	Bio- CO2	NBio- CO2	Total CO2	CH4	N2O	CO2e
Category	lb/day										lb/day					
Hauling	0.0000	0.0000	0.0000	0.0000	0.0000	0.0000	0.0000	0.0000	0.0000	0.0000		0.0000	0.0000	0.0000	0.0000	0.0000
Vendor	0.0000	0.0000	0.0000	0.0000	0.0000	0.0000	0.0000	0.0000	0.0000	0.0000		0.0000	0.0000	0.0000	0.0000	0.0000
Worker	0.0668	0.0482	0.5184	1.4800e-003	0.1780	9.0000e-004	0.1789	0.0472	8.3000e-004	0.0480		151.0544	151.0544	4.6400e-003	4.6200e-003	152.5470
Total	0.0668	0.0482	0.5184	1.4800e-003	0.1780	9.0000e-004	0.1789	0.0472	8.3000e-004	0.0480		151.0544	151.0544	4.6400e-003	4.6200e-003	152.5470

Pismo Beach GP/LCP PEIR - GHG - San Luis Obispo County APCD Air District, Winter

EMFAC Off-Model Adjustment Factors for Gasoline Light Duty Vehicle to Account for the SAFE Vehicle Rule Applied

3.4 Grading - 2022

Unmitigated Construction On-Site

	ROG	NOx	CO	SO2	Fugitive PM10	Exhaust PM10	PM10 Total	Fugitive PM2.5	Exhaust PM2.5	PM2.5 Total	Bio- CO2	NBio- CO2	Total CO2	CH4	N2O	CO2e
Category	lb/day										lb/day					
Fugitive Dust					9.2036	0.0000	9.2036	3.6538	0.0000	3.6538			0.0000			0.0000
Off-Road	3.6248	38.8435	29.0415	0.0621		1.6349	1.6349		1.5041	1.5041		6,011.4105	6,011.4105	1.9442		6,060.0158
Total	3.6248	38.8435	29.0415	0.0621	9.2036	1.6349	10.8385	3.6538	1.5041	5.1579		6,011.4105	6,011.4105	1.9442		6,060.0158

Unmitigated Construction Off-Site

	ROG	NOx	CO	SO2	Fugitive PM10	Exhaust PM10	PM10 Total	Fugitive PM2.5	Exhaust PM2.5	PM2.5 Total	Bio- CO2	NBio- CO2	Total CO2	CH4	N2O	CO2e
Category	lb/day										lb/day					
Hauling	0.0000	0.0000	0.0000	0.0000	0.0000	0.0000	0.0000	0.0000	0.0000	0.0000		0.0000	0.0000	0.0000	0.0000	0.0000
Vendor	0.0000	0.0000	0.0000	0.0000	0.0000	0.0000	0.0000	0.0000	0.0000	0.0000		0.0000	0.0000	0.0000	0.0000	0.0000
Worker	0.0743	0.0536	0.5760	1.6500e-003	0.1977	1.0000e-003	0.1987	0.0524	9.2000e-004	0.0534		167.8382	167.8382	5.1600e-003	5.1300e-003	169.4967
Total	0.0743	0.0536	0.5760	1.6500e-003	0.1977	1.0000e-003	0.1987	0.0524	9.2000e-004	0.0534		167.8382	167.8382	5.1600e-003	5.1300e-003	169.4967

Pismo Beach GP/LCP PEIR - GHG - San Luis Obispo County APCD Air District, Winter

EMFAC Off-Model Adjustment Factors for Gasoline Light Duty Vehicle to Account for the SAFE Vehicle Rule Applied

3.4 Grading - 2022

Mitigated Construction On-Site

	ROG	NOx	CO	SO2	Fugitive PM10	Exhaust PM10	PM10 Total	Fugitive PM2.5	Exhaust PM2.5	PM2.5 Total	Bio- CO2	NBio- CO2	Total CO2	CH4	N2O	CO2e
Category	lb/day										lb/day					
Fugitive Dust					9.2036	0.0000	9.2036	3.6538	0.0000	3.6538			0.0000			0.0000
Off-Road	3.6248	38.8435	29.0415	0.0621		1.6349	1.6349		1.5041	1.5041	0.0000	6,011.4105	6,011.4105	1.9442		6,060.0158
Total	3.6248	38.8435	29.0415	0.0621	9.2036	1.6349	10.8385	3.6538	1.5041	5.1579	0.0000	6,011.4105	6,011.4105	1.9442		6,060.0158

Mitigated Construction Off-Site

	ROG	NOx	CO	SO2	Fugitive PM10	Exhaust PM10	PM10 Total	Fugitive PM2.5	Exhaust PM2.5	PM2.5 Total	Bio- CO2	NBio- CO2	Total CO2	CH4	N2O	CO2e
Category	lb/day										lb/day					
Hauling	0.0000	0.0000	0.0000	0.0000	0.0000	0.0000	0.0000	0.0000	0.0000	0.0000		0.0000	0.0000	0.0000	0.0000	0.0000
Vendor	0.0000	0.0000	0.0000	0.0000	0.0000	0.0000	0.0000	0.0000	0.0000	0.0000		0.0000	0.0000	0.0000	0.0000	0.0000
Worker	0.0743	0.0536	0.5760	1.6500e-003	0.1977	1.0000e-003	0.1987	0.0524	9.2000e-004	0.0534		167.8382	167.8382	5.1600e-003	5.1300e-003	169.4967
Total	0.0743	0.0536	0.5760	1.6500e-003	0.1977	1.0000e-003	0.1987	0.0524	9.2000e-004	0.0534		167.8382	167.8382	5.1600e-003	5.1300e-003	169.4967

Pismo Beach GP/LCP PEIR - GHG - San Luis Obispo County APCD Air District, Winter

EMFAC Off-Model Adjustment Factors for Gasoline Light Duty Vehicle to Account for the SAFE Vehicle Rule Applied

3.4 Grading - 2023

Unmitigated Construction On-Site

	ROG	NOx	CO	SO2	Fugitive PM10	Exhaust PM10	PM10 Total	Fugitive PM2.5	Exhaust PM2.5	PM2.5 Total	Bio- CO2	NBio- CO2	Total CO2	CH4	N2O	CO2e
Category	lb/day										lb/day					
Fugitive Dust					9.2036	0.0000	9.2036	3.6538	0.0000	3.6538			0.0000			0.0000
Off-Road	3.3217	34.5156	28.0512	0.0621		1.4245	1.4245		1.3105	1.3105		6,011.4777	6,011.4777	1.9442		6,060.0836
Total	3.3217	34.5156	28.0512	0.0621	9.2036	1.4245	10.6281	3.6538	1.3105	4.9643		6,011.4777	6,011.4777	1.9442		6,060.0836

Unmitigated Construction Off-Site

	ROG	NOx	CO	SO2	Fugitive PM10	Exhaust PM10	PM10 Total	Fugitive PM2.5	Exhaust PM2.5	PM2.5 Total	Bio- CO2	NBio- CO2	Total CO2	CH4	N2O	CO2e
Category	lb/day										lb/day					
Hauling	0.0000	0.0000	0.0000	0.0000	0.0000	0.0000	0.0000	0.0000	0.0000	0.0000		0.0000	0.0000	0.0000	0.0000	0.0000
Vendor	0.0000	0.0000	0.0000	0.0000	0.0000	0.0000	0.0000	0.0000	0.0000	0.0000		0.0000	0.0000	0.0000	0.0000	0.0000
Worker	0.0698	0.0475	0.5323	1.6000e-003	0.1977	9.5000e-004	0.1987	0.0524	8.7000e-004	0.0533		163.7354	163.7354	4.6800e-003	4.7500e-003	165.2673
Total	0.0698	0.0475	0.5323	1.6000e-003	0.1977	9.5000e-004	0.1987	0.0524	8.7000e-004	0.0533		163.7354	163.7354	4.6800e-003	4.7500e-003	165.2673

Pismo Beach GP/LCP PEIR - GHG - San Luis Obispo County APCD Air District, Winter

EMFAC Off-Model Adjustment Factors for Gasoline Light Duty Vehicle to Account for the SAFE Vehicle Rule Applied

3.4 Grading - 2023

Mitigated Construction On-Site

	ROG	NOx	CO	SO2	Fugitive PM10	Exhaust PM10	PM10 Total	Fugitive PM2.5	Exhaust PM2.5	PM2.5 Total	Bio- CO2	NBio- CO2	Total CO2	CH4	N2O	CO2e
Category	lb/day										lb/day					
Fugitive Dust					9.2036	0.0000	9.2036	3.6538	0.0000	3.6538			0.0000			0.0000
Off-Road	3.3217	34.5156	28.0512	0.0621		1.4245	1.4245		1.3105	1.3105	0.0000	6,011.4777	6,011.4777	1.9442		6,060.0836
Total	3.3217	34.5156	28.0512	0.0621	9.2036	1.4245	10.6281	3.6538	1.3105	4.9643	0.0000	6,011.4777	6,011.4777	1.9442		6,060.0836

Mitigated Construction Off-Site

	ROG	NOx	CO	SO2	Fugitive PM10	Exhaust PM10	PM10 Total	Fugitive PM2.5	Exhaust PM2.5	PM2.5 Total	Bio- CO2	NBio- CO2	Total CO2	CH4	N2O	CO2e
Category	lb/day										lb/day					
Hauling	0.0000	0.0000	0.0000	0.0000	0.0000	0.0000	0.0000	0.0000	0.0000	0.0000		0.0000	0.0000	0.0000	0.0000	0.0000
Vendor	0.0000	0.0000	0.0000	0.0000	0.0000	0.0000	0.0000	0.0000	0.0000	0.0000		0.0000	0.0000	0.0000	0.0000	0.0000
Worker	0.0698	0.0475	0.5323	1.6000e-003	0.1977	9.5000e-004	0.1987	0.0524	8.7000e-004	0.0533		163.7354	163.7354	4.6800e-003	4.7500e-003	165.2673
Total	0.0698	0.0475	0.5323	1.6000e-003	0.1977	9.5000e-004	0.1987	0.0524	8.7000e-004	0.0533		163.7354	163.7354	4.6800e-003	4.7500e-003	165.2673

Pismo Beach GP/LCP PEIR - GHG - San Luis Obispo County APCD Air District, Winter

EMFAC Off-Model Adjustment Factors for Gasoline Light Duty Vehicle to Account for the SAFE Vehicle Rule Applied

3.4 Grading - 2024

Unmitigated Construction On-Site

	ROG	NOx	CO	SO2	Fugitive PM10	Exhaust PM10	PM10 Total	Fugitive PM2.5	Exhaust PM2.5	PM2.5 Total	Bio- CO2	NBio- CO2	Total CO2	CH4	N2O	CO2e
Category	lb/day										lb/day					
Fugitive Dust					9.2036	0.0000	9.2036	3.6538	0.0000	3.6538			0.0000			0.0000
Off-Road	3.2181	32.3770	27.7228	0.0621		1.3354	1.3354		1.2286	1.2286		6,009.7487	6,009.7487	1.9437		6,058.3405
Total	3.2181	32.3770	27.7228	0.0621	9.2036	1.3354	10.5390	3.6538	1.2286	4.8823		6,009.7487	6,009.7487	1.9437		6,058.3405

Unmitigated Construction Off-Site

	ROG	NOx	CO	SO2	Fugitive PM10	Exhaust PM10	PM10 Total	Fugitive PM2.5	Exhaust PM2.5	PM2.5 Total	Bio- CO2	NBio- CO2	Total CO2	CH4	N2O	CO2e
Category	lb/day										lb/day					
Hauling	0.0000	0.0000	0.0000	0.0000	0.0000	0.0000	0.0000	0.0000	0.0000	0.0000		0.0000	0.0000	0.0000	0.0000	0.0000
Vendor	0.0000	0.0000	0.0000	0.0000	0.0000	0.0000	0.0000	0.0000	0.0000	0.0000		0.0000	0.0000	0.0000	0.0000	0.0000
Worker	0.0658	0.0423	0.4960	1.5500e-003	0.1977	9.0000e-004	0.1986	0.0524	8.3000e-004	0.0533		159.8641	159.8641	4.2500e-003	4.4100e-003	161.2856
Total	0.0658	0.0423	0.4960	1.5500e-003	0.1977	9.0000e-004	0.1986	0.0524	8.3000e-004	0.0533		159.8641	159.8641	4.2500e-003	4.4100e-003	161.2856

Pismo Beach GP/LCP PEIR - GHG - San Luis Obispo County APCD Air District, Winter

EMFAC Off-Model Adjustment Factors for Gasoline Light Duty Vehicle to Account for the SAFE Vehicle Rule Applied

3.4 Grading - 2024

Mitigated Construction On-Site

	ROG	NOx	CO	SO2	Fugitive PM10	Exhaust PM10	PM10 Total	Fugitive PM2.5	Exhaust PM2.5	PM2.5 Total	Bio- CO2	NBio- CO2	Total CO2	CH4	N2O	CO2e
Category	lb/day										lb/day					
Fugitive Dust					9.2036	0.0000	9.2036	3.6538	0.0000	3.6538			0.0000			0.0000
Off-Road	3.2181	32.3770	27.7228	0.0621		1.3354	1.3354		1.2286	1.2286	0.0000	6,009.7487	6,009.7487	1.9437		6,058.3405
Total	3.2181	32.3770	27.7228	0.0621	9.2036	1.3354	10.5390	3.6538	1.2286	4.8823	0.0000	6,009.7487	6,009.7487	1.9437		6,058.3405

Mitigated Construction Off-Site

	ROG	NOx	CO	SO2	Fugitive PM10	Exhaust PM10	PM10 Total	Fugitive PM2.5	Exhaust PM2.5	PM2.5 Total	Bio- CO2	NBio- CO2	Total CO2	CH4	N2O	CO2e
Category	lb/day										lb/day					
Hauling	0.0000	0.0000	0.0000	0.0000	0.0000	0.0000	0.0000	0.0000	0.0000	0.0000		0.0000	0.0000	0.0000	0.0000	0.0000
Vendor	0.0000	0.0000	0.0000	0.0000	0.0000	0.0000	0.0000	0.0000	0.0000	0.0000		0.0000	0.0000	0.0000	0.0000	0.0000
Worker	0.0658	0.0423	0.4960	1.5500e-003	0.1977	9.0000e-004	0.1986	0.0524	8.3000e-004	0.0533		159.8641	159.8641	4.2500e-003	4.4100e-003	161.2856
Total	0.0658	0.0423	0.4960	1.5500e-003	0.1977	9.0000e-004	0.1986	0.0524	8.3000e-004	0.0533		159.8641	159.8641	4.2500e-003	4.4100e-003	161.2856

Pismo Beach GP/LCP PEIR - GHG - San Luis Obispo County APCD Air District, Winter

EMFAC Off-Model Adjustment Factors for Gasoline Light Duty Vehicle to Account for the SAFE Vehicle Rule Applied

3.5 Building Construction - 2022

Unmitigated Construction On-Site

	ROG	NOx	CO	SO2	Fugitive PM10	Exhaust PM10	PM10 Total	Fugitive PM2.5	Exhaust PM2.5	PM2.5 Total	Bio- CO2	NBio- CO2	Total CO2	CH4	N2O	CO2e
Category	lb/day										lb/day					
Off-Road	1.7062	15.6156	16.3634	0.0269		0.8090	0.8090		0.7612	0.7612		2,554.3336	2,554.3336	0.6120		2,569.6322
Total	1.7062	15.6156	16.3634	0.0269		0.8090	0.8090		0.7612	0.7612		2,554.3336	2,554.3336	0.6120		2,569.6322

Unmitigated Construction Off-Site

	ROG	NOx	CO	SO2	Fugitive PM10	Exhaust PM10	PM10 Total	Fugitive PM2.5	Exhaust PM2.5	PM2.5 Total	Bio- CO2	NBio- CO2	Total CO2	CH4	N2O	CO2e
Category	lb/day										lb/day					
Hauling	0.0000	0.0000	0.0000	0.0000	0.0000	0.0000	0.0000	0.0000	0.0000	0.0000		0.0000	0.0000	0.0000	0.0000	0.0000
Vendor	0.4764	12.1918	3.7525	0.0380	1.1475	0.1189	1.2664	0.3305	0.1137	0.4442		4,071.0674	4,071.0674	0.0940	0.5997	4,252.1219
Worker	3.9027	2.8166	30.2702	0.0867	10.3903	0.0526	10.4429	2.7557	0.0485	2.8042		8,819.8964	8,819.8964	0.2710	0.2697	8,907.0519
Total	4.3791	15.0084	34.0227	0.1247	11.5378	0.1714	11.7093	3.0863	0.1622	3.2484		12,890.9638	12,890.9638	0.3650	0.8694	13,159.1739

Pismo Beach GP/LCP PEIR - GHG - San Luis Obispo County APCD Air District, Winter

EMFAC Off-Model Adjustment Factors for Gasoline Light Duty Vehicle to Account for the SAFE Vehicle Rule Applied

3.5 Building Construction - 2022

Mitigated Construction On-Site

	ROG	NOx	CO	SO2	Fugitive PM10	Exhaust PM10	PM10 Total	Fugitive PM2.5	Exhaust PM2.5	PM2.5 Total	Bio- CO2	NBio- CO2	Total CO2	CH4	N2O	CO2e
Category	lb/day										lb/day					
Off-Road	1.7062	15.6156	16.3634	0.0269		0.8090	0.8090		0.7612	0.7612	0.0000	2,554.3336	2,554.3336	0.6120		2,569.6322
Total	1.7062	15.6156	16.3634	0.0269		0.8090	0.8090		0.7612	0.7612	0.0000	2,554.3336	2,554.3336	0.6120		2,569.6322

Mitigated Construction Off-Site

	ROG	NOx	CO	SO2	Fugitive PM10	Exhaust PM10	PM10 Total	Fugitive PM2.5	Exhaust PM2.5	PM2.5 Total	Bio- CO2	NBio- CO2	Total CO2	CH4	N2O	CO2e
Category	lb/day										lb/day					
Hauling	0.0000	0.0000	0.0000	0.0000	0.0000	0.0000	0.0000	0.0000	0.0000	0.0000		0.0000	0.0000	0.0000	0.0000	0.0000
Vendor	0.4764	12.1918	3.7525	0.0380	1.1475	0.1189	1.2664	0.3305	0.1137	0.4442		4,071.0674	4,071.0674	0.0940	0.5997	4,252.1219
Worker	3.9027	2.8166	30.2702	0.0867	10.3903	0.0526	10.4429	2.7557	0.0485	2.8042		8,819.8964	8,819.8964	0.2710	0.2697	8,907.0519
Total	4.3791	15.0084	34.0227	0.1247	11.5378	0.1714	11.7093	3.0863	0.1622	3.2484		12,890.9638	12,890.9638	0.3650	0.8694	13,159.1739

Pismo Beach GP/LCP PEIR - GHG - San Luis Obispo County APCD Air District, Winter

EMFAC Off-Model Adjustment Factors for Gasoline Light Duty Vehicle to Account for the SAFE Vehicle Rule Applied

3.5 Building Construction - 2023

Unmitigated Construction On-Site

	ROG	NOx	CO	SO2	Fugitive PM10	Exhaust PM10	PM10 Total	Fugitive PM2.5	Exhaust PM2.5	PM2.5 Total	Bio- CO2	NBio- CO2	Total CO2	CH4	N2O	CO2e
Category	lb/day										lb/day					
Off-Road	1.5728	14.3849	16.2440	0.0269		0.6997	0.6997		0.6584	0.6584		2,555.2099	2,555.2099	0.6079		2,570.4061
Total	1.5728	14.3849	16.2440	0.0269		0.6997	0.6997		0.6584	0.6584		2,555.2099	2,555.2099	0.6079		2,570.4061

Unmitigated Construction Off-Site

	ROG	NOx	CO	SO2	Fugitive PM10	Exhaust PM10	PM10 Total	Fugitive PM2.5	Exhaust PM2.5	PM2.5 Total	Bio- CO2	NBio- CO2	Total CO2	CH4	N2O	CO2e
Category	lb/day										lb/day					
Hauling	0.0000	0.0000	0.0000	0.0000	0.0000	0.0000	0.0000	0.0000	0.0000	0.0000		0.0000	0.0000	0.0000	0.0000	0.0000
Vendor	0.2868	10.2274	3.3360	0.0367	1.1476	0.0581	1.2057	0.3306	0.0555	0.3861		3,931.9686	3,931.9686	0.0870	0.5778	4,106.3292
Worker	3.6657	2.4945	27.9743	0.0841	10.3903	0.0498	10.4401	2.7557	0.0459	2.8016		8,604.2955	8,604.2955	0.2457	0.2495	8,684.7956
Total	3.9525	12.7219	31.3103	0.1208	11.5380	0.1079	11.6458	3.0863	0.1015	3.1878		12,536.2641	12,536.2641	0.3326	0.8273	12,791.1248

Pismo Beach GP/LCP PEIR - GHG - San Luis Obispo County APCD Air District, Winter

EMFAC Off-Model Adjustment Factors for Gasoline Light Duty Vehicle to Account for the SAFE Vehicle Rule Applied

3.5 Building Construction - 2023

Mitigated Construction On-Site

	ROG	NOx	CO	SO2	Fugitive PM10	Exhaust PM10	PM10 Total	Fugitive PM2.5	Exhaust PM2.5	PM2.5 Total	Bio- CO2	NBio- CO2	Total CO2	CH4	N2O	CO2e
Category	lb/day										lb/day					
Off-Road	1.5728	14.3849	16.2440	0.0269		0.6997	0.6997		0.6584	0.6584	0.0000	2,555.2099	2,555.2099	0.6079		2,570.4061
Total	1.5728	14.3849	16.2440	0.0269		0.6997	0.6997		0.6584	0.6584	0.0000	2,555.2099	2,555.2099	0.6079		2,570.4061

Mitigated Construction Off-Site

	ROG	NOx	CO	SO2	Fugitive PM10	Exhaust PM10	PM10 Total	Fugitive PM2.5	Exhaust PM2.5	PM2.5 Total	Bio- CO2	NBio- CO2	Total CO2	CH4	N2O	CO2e
Category	lb/day										lb/day					
Hauling	0.0000	0.0000	0.0000	0.0000	0.0000	0.0000	0.0000	0.0000	0.0000	0.0000		0.0000	0.0000	0.0000	0.0000	0.0000
Vendor	0.2868	10.2274	3.3360	0.0367	1.1476	0.0581	1.2057	0.3306	0.0555	0.3861		3,931.9686	3,931.9686	0.0870	0.5778	4,106.3292
Worker	3.6657	2.4945	27.9743	0.0841	10.3903	0.0498	10.4401	2.7557	0.0459	2.8016		8,604.2955	8,604.2955	0.2457	0.2495	8,684.7956
Total	3.9525	12.7219	31.3103	0.1208	11.5380	0.1079	11.6458	3.0863	0.1015	3.1878		12,536.2641	12,536.2641	0.3326	0.8273	12,791.1248

Pismo Beach GP/LCP PEIR - GHG - San Luis Obispo County APCD Air District, Winter

EMFAC Off-Model Adjustment Factors for Gasoline Light Duty Vehicle to Account for the SAFE Vehicle Rule Applied

3.5 Building Construction - 2024

Unmitigated Construction On-Site

	ROG	NOx	CO	SO2	Fugitive PM10	Exhaust PM10	PM10 Total	Fugitive PM2.5	Exhaust PM2.5	PM2.5 Total	Bio- CO2	NBio- CO2	Total CO2	CH4	N2O	CO2e
Category	lb/day										lb/day					
Off-Road	1.4716	13.4438	16.1668	0.0270		0.6133	0.6133		0.5769	0.5769		2,555.6989	2,555.6989	0.6044		2,570.8077
Total	1.4716	13.4438	16.1668	0.0270		0.6133	0.6133		0.5769	0.5769		2,555.6989	2,555.6989	0.6044		2,570.8077

Unmitigated Construction Off-Site

	ROG	NOx	CO	SO2	Fugitive PM10	Exhaust PM10	PM10 Total	Fugitive PM2.5	Exhaust PM2.5	PM2.5 Total	Bio- CO2	NBio- CO2	Total CO2	CH4	N2O	CO2e
Category	lb/day										lb/day					
Hauling	0.0000	0.0000	0.0000	0.0000	0.0000	0.0000	0.0000	0.0000	0.0000	0.0000		0.0000	0.0000	0.0000	0.0000	0.0000
Vendor	0.2762	10.0371	3.2727	0.0361	1.1478	0.0571	1.2049	0.3306	0.0546	0.3852		3,871.6542	3,871.6542	0.0879	0.5687	4,043.3122
Worker	3.4577	2.2235	26.0634	0.0814	10.3903	0.0474	10.4377	2.7557	0.0436	2.7994		8,400.8568	8,400.8568	0.2233	0.2320	8,475.5606
Total	3.7339	12.2605	29.3361	0.1175	11.5381	0.1044	11.6425	3.0864	0.0982	3.1846		12,272.5110	12,272.5110	0.3112	0.8006	12,518.8728

Pismo Beach GP/LCP PEIR - GHG - San Luis Obispo County APCD Air District, Winter

EMFAC Off-Model Adjustment Factors for Gasoline Light Duty Vehicle to Account for the SAFE Vehicle Rule Applied

3.5 Building Construction - 2024

Mitigated Construction On-Site

	ROG	NOx	CO	SO2	Fugitive PM10	Exhaust PM10	PM10 Total	Fugitive PM2.5	Exhaust PM2.5	PM2.5 Total	Bio- CO2	NBio- CO2	Total CO2	CH4	N2O	CO2e
Category	lb/day										lb/day					
Off-Road	1.4716	13.4438	16.1668	0.0270		0.6133	0.6133		0.5769	0.5769	0.0000	2,555.6989	2,555.6989	0.6044		2,570.8077
Total	1.4716	13.4438	16.1668	0.0270		0.6133	0.6133		0.5769	0.5769	0.0000	2,555.6989	2,555.6989	0.6044		2,570.8077

Mitigated Construction Off-Site

	ROG	NOx	CO	SO2	Fugitive PM10	Exhaust PM10	PM10 Total	Fugitive PM2.5	Exhaust PM2.5	PM2.5 Total	Bio- CO2	NBio- CO2	Total CO2	CH4	N2O	CO2e
Category	lb/day										lb/day					
Hauling	0.0000	0.0000	0.0000	0.0000	0.0000	0.0000	0.0000	0.0000	0.0000	0.0000		0.0000	0.0000	0.0000	0.0000	0.0000
Vendor	0.2762	10.0371	3.2727	0.0361	1.1478	0.0571	1.2049	0.3306	0.0546	0.3852		3,871.6542	3,871.6542	0.0879	0.5687	4,043.3122
Worker	3.4577	2.2235	26.0634	0.0814	10.3903	0.0474	10.4377	2.7557	0.0436	2.7994		8,400.8568	8,400.8568	0.2233	0.2320	8,475.5606
Total	3.7339	12.2605	29.3361	0.1175	11.5381	0.1044	11.6425	3.0864	0.0982	3.1846		12,272.5110	12,272.5110	0.3112	0.8006	12,518.8728

Pismo Beach GP/LCP PEIR - GHG - San Luis Obispo County APCD Air District, Winter

EMFAC Off-Model Adjustment Factors for Gasoline Light Duty Vehicle to Account for the SAFE Vehicle Rule Applied

3.5 Building Construction - 2025

Unmitigated Construction On-Site

	ROG	NOx	CO	SO2	Fugitive PM10	Exhaust PM10	PM10 Total	Fugitive PM2.5	Exhaust PM2.5	PM2.5 Total	Bio- CO2	NBio- CO2	Total CO2	CH4	N2O	CO2e
Category	lb/day										lb/day					
Off-Road	1.3674	12.4697	16.0847	0.0270		0.5276	0.5276		0.4963	0.4963		2,556.474 4	2,556.474 4	0.6010		2,571.498 1
Total	1.3674	12.4697	16.0847	0.0270		0.5276	0.5276		0.4963	0.4963		2,556.474 4	2,556.474 4	0.6010		2,571.498 1

Unmitigated Construction Off-Site

	ROG	NOx	CO	SO2	Fugitive PM10	Exhaust PM10	PM10 Total	Fugitive PM2.5	Exhaust PM2.5	PM2.5 Total	Bio- CO2	NBio- CO2	Total CO2	CH4	N2O	CO2e
Category	lb/day										lb/day					
Hauling	0.0000	0.0000	0.0000	0.0000	0.0000	0.0000	0.0000	0.0000	0.0000	0.0000		0.0000	0.0000	0.0000	0.0000	0.0000
Vendor	0.2668	9.8281	3.2231	0.0355	1.1479	0.0557	1.2036	0.3307	0.0533	0.3840		3,804.786 8	3,804.786 8	0.0893	0.5584	3,973.421 8
Worker	3.2758	1.9977	24.4165	0.0788	10.3903	0.0452	10.4356	2.7557	0.0417	2.7974		8,208.556 5	8,208.556 5	0.2035	0.2168	8,278.246 6
Total	3.5426	11.8258	27.6397	0.1142	11.5382	0.1010	11.6392	3.0864	0.0950	3.1814		12,013.34 33	12,013.34 33	0.2928	0.7752	12,251.66 84

Pismo Beach GP/LCP PEIR - GHG - San Luis Obispo County APCD Air District, Winter

EMFAC Off-Model Adjustment Factors for Gasoline Light Duty Vehicle to Account for the SAFE Vehicle Rule Applied

3.5 Building Construction - 2025

Mitigated Construction On-Site

	ROG	NOx	CO	SO2	Fugitive PM10	Exhaust PM10	PM10 Total	Fugitive PM2.5	Exhaust PM2.5	PM2.5 Total	Bio- CO2	NBio- CO2	Total CO2	CH4	N2O	CO2e
Category	lb/day										lb/day					
Off-Road	1.3674	12.4697	16.0847	0.0270		0.5276	0.5276		0.4963	0.4963	0.0000	2,556.474 4	2,556.474 4	0.6010		2,571.498 1
Total	1.3674	12.4697	16.0847	0.0270		0.5276	0.5276		0.4963	0.4963	0.0000	2,556.474 4	2,556.474 4	0.6010		2,571.498 1

Mitigated Construction Off-Site

	ROG	NOx	CO	SO2	Fugitive PM10	Exhaust PM10	PM10 Total	Fugitive PM2.5	Exhaust PM2.5	PM2.5 Total	Bio- CO2	NBio- CO2	Total CO2	CH4	N2O	CO2e
Category	lb/day										lb/day					
Hauling	0.0000	0.0000	0.0000	0.0000	0.0000	0.0000	0.0000	0.0000	0.0000	0.0000		0.0000	0.0000	0.0000	0.0000	0.0000
Vendor	0.2668	9.8281	3.2231	0.0355	1.1479	0.0557	1.2036	0.3307	0.0533	0.3840		3,804.786 8	3,804.786 8	0.0893	0.5584	3,973.421 8
Worker	3.2758	1.9977	24.4165	0.0788	10.3903	0.0452	10.4356	2.7557	0.0417	2.7974		8,208.556 5	8,208.556 5	0.2035	0.2168	8,278.246 6
Total	3.5426	11.8258	27.6397	0.1142	11.5382	0.1010	11.6392	3.0864	0.0950	3.1814		12,013.34 33	12,013.34 33	0.2928	0.7752	12,251.66 84

Pismo Beach GP/LCP PEIR - GHG - San Luis Obispo County APCD Air District, Winter

EMFAC Off-Model Adjustment Factors for Gasoline Light Duty Vehicle to Account for the SAFE Vehicle Rule Applied

3.5 Building Construction - 2026

Unmitigated Construction On-Site

	ROG	NOx	CO	SO2	Fugitive PM10	Exhaust PM10	PM10 Total	Fugitive PM2.5	Exhaust PM2.5	PM2.5 Total	Bio- CO2	NBio- CO2	Total CO2	CH4	N2O	CO2e
Category	lb/day										lb/day					
Off-Road	1.3674	12.4697	16.0847	0.0270		0.5276	0.5276		0.4963	0.4963		2,556.474 4	2,556.474 4	0.6010		2,571.498 1
Total	1.3674	12.4697	16.0847	0.0270		0.5276	0.5276		0.4963	0.4963		2,556.474 4	2,556.474 4	0.6010		2,571.498 1

Unmitigated Construction Off-Site

	ROG	NOx	CO	SO2	Fugitive PM10	Exhaust PM10	PM10 Total	Fugitive PM2.5	Exhaust PM2.5	PM2.5 Total	Bio- CO2	NBio- CO2	Total CO2	CH4	N2O	CO2e
Category	lb/day										lb/day					
Hauling	0.0000	0.0000	0.0000	0.0000	0.0000	0.0000	0.0000	0.0000	0.0000	0.0000		0.0000	0.0000	0.0000	0.0000	0.0000
Vendor	0.2582	9.6193	3.1852	0.0348	1.1480	0.0542	1.2023	0.3307	0.0519	0.3826		3,736.750 4	3,736.750 4	0.0906	0.5480	3,902.315 7
Worker	3.1182	1.8107	23.0199	0.0764	10.3903	0.0431	10.4334	2.7557	0.0397	2.7954		8,023.670 4	8,023.670 4	0.1863	0.2041	8,089.147 6
Total	3.3765	11.4300	26.2051	0.1112	11.5384	0.0973	11.6357	3.0865	0.0916	3.1780		11,760.42 08	11,760.42 08	0.2769	0.7521	11,991.46 34

Pismo Beach GP/LCP PEIR - GHG - San Luis Obispo County APCD Air District, Winter

EMFAC Off-Model Adjustment Factors for Gasoline Light Duty Vehicle to Account for the SAFE Vehicle Rule Applied

3.5 Building Construction - 2026

Mitigated Construction On-Site

	ROG	NOx	CO	SO2	Fugitive PM10	Exhaust PM10	PM10 Total	Fugitive PM2.5	Exhaust PM2.5	PM2.5 Total	Bio- CO2	NBio- CO2	Total CO2	CH4	N2O	CO2e
Category	lb/day										lb/day					
Off-Road	1.3674	12.4697	16.0847	0.0270		0.5276	0.5276		0.4963	0.4963	0.0000	2,556.474 4	2,556.474 4	0.6010		2,571.498 1
Total	1.3674	12.4697	16.0847	0.0270		0.5276	0.5276		0.4963	0.4963	0.0000	2,556.474 4	2,556.474 4	0.6010		2,571.498 1

Mitigated Construction Off-Site

	ROG	NOx	CO	SO2	Fugitive PM10	Exhaust PM10	PM10 Total	Fugitive PM2.5	Exhaust PM2.5	PM2.5 Total	Bio- CO2	NBio- CO2	Total CO2	CH4	N2O	CO2e
Category	lb/day										lb/day					
Hauling	0.0000	0.0000	0.0000	0.0000	0.0000	0.0000	0.0000	0.0000	0.0000	0.0000		0.0000	0.0000	0.0000	0.0000	0.0000
Vendor	0.2582	9.6193	3.1852	0.0348	1.1480	0.0542	1.2023	0.3307	0.0519	0.3826		3,736.750 4	3,736.750 4	0.0906	0.5480	3,902.315 7
Worker	3.1182	1.8107	23.0199	0.0764	10.3903	0.0431	10.4334	2.7557	0.0397	2.7954		8,023.670 4	8,023.670 4	0.1863	0.2041	8,089.147 6
Total	3.3765	11.4300	26.2051	0.1112	11.5384	0.0973	11.6357	3.0865	0.0916	3.1780		11,760.42 08	11,760.42 08	0.2769	0.7521	11,991.46 34

Pismo Beach GP/LCP PEIR - GHG - San Luis Obispo County APCD Air District, Winter

EMFAC Off-Model Adjustment Factors for Gasoline Light Duty Vehicle to Account for the SAFE Vehicle Rule Applied

3.5 Building Construction - 2027

Unmitigated Construction On-Site

	ROG	NOx	CO	SO2	Fugitive PM10	Exhaust PM10	PM10 Total	Fugitive PM2.5	Exhaust PM2.5	PM2.5 Total	Bio- CO2	NBio- CO2	Total CO2	CH4	N2O	CO2e
Category	lb/day										lb/day					
Off-Road	1.3674	12.4697	16.0847	0.0270		0.5276	0.5276		0.4963	0.4963		2,556.474 4	2,556.474 4	0.6010		2,571.498 1
Total	1.3674	12.4697	16.0847	0.0270		0.5276	0.5276		0.4963	0.4963		2,556.474 4	2,556.474 4	0.6010		2,571.498 1

Unmitigated Construction Off-Site

	ROG	NOx	CO	SO2	Fugitive PM10	Exhaust PM10	PM10 Total	Fugitive PM2.5	Exhaust PM2.5	PM2.5 Total	Bio- CO2	NBio- CO2	Total CO2	CH4	N2O	CO2e
Category	lb/day										lb/day					
Hauling	0.0000	0.0000	0.0000	0.0000	0.0000	0.0000	0.0000	0.0000	0.0000	0.0000		0.0000	0.0000	0.0000	0.0000	0.0000
Vendor	0.2507	9.4219	3.1545	0.0341	1.1481	0.0528	1.2010	0.3308	0.0505	0.3813		3,663.317 5	3,663.317 5	0.0917	0.5369	3,825.616 7
Worker	2.9696	1.6520	21.8146	0.0742	10.3903	0.0406	10.4309	2.7557	0.0374	2.7931		7,851.666 6	7,851.666 6	0.1712	0.1933	7,913.558 3
Total	3.2203	11.0739	24.9691	0.1083	11.5385	0.0934	11.6319	3.0865	0.0879	3.1744		11,514.98 41	11,514.98 41	0.2630	0.7303	11,739.17 50

Pismo Beach GP/LCP PEIR - GHG - San Luis Obispo County APCD Air District, Winter

EMFAC Off-Model Adjustment Factors for Gasoline Light Duty Vehicle to Account for the SAFE Vehicle Rule Applied

3.5 Building Construction - 2027

Mitigated Construction On-Site

	ROG	NOx	CO	SO2	Fugitive PM10	Exhaust PM10	PM10 Total	Fugitive PM2.5	Exhaust PM2.5	PM2.5 Total	Bio- CO2	NBio- CO2	Total CO2	CH4	N2O	CO2e
Category	lb/day										lb/day					
Off-Road	1.3674	12.4697	16.0847	0.0270		0.5276	0.5276		0.4963	0.4963	0.0000	2,556.474 4	2,556.474 4	0.6010		2,571.498 1
Total	1.3674	12.4697	16.0847	0.0270		0.5276	0.5276		0.4963	0.4963	0.0000	2,556.474 4	2,556.474 4	0.6010		2,571.498 1

Mitigated Construction Off-Site

	ROG	NOx	CO	SO2	Fugitive PM10	Exhaust PM10	PM10 Total	Fugitive PM2.5	Exhaust PM2.5	PM2.5 Total	Bio- CO2	NBio- CO2	Total CO2	CH4	N2O	CO2e
Category	lb/day										lb/day					
Hauling	0.0000	0.0000	0.0000	0.0000	0.0000	0.0000	0.0000	0.0000	0.0000	0.0000		0.0000	0.0000	0.0000	0.0000	0.0000
Vendor	0.2507	9.4219	3.1545	0.0341	1.1481	0.0528	1.2010	0.3308	0.0505	0.3813		3,663.317 5	3,663.317 5	0.0917	0.5369	3,825.616 7
Worker	2.9696	1.6520	21.8146	0.0742	10.3903	0.0406	10.4309	2.7557	0.0374	2.7931		7,851.666 6	7,851.666 6	0.1712	0.1933	7,913.558 3
Total	3.2203	11.0739	24.9691	0.1083	11.5385	0.0934	11.6319	3.0865	0.0879	3.1744		11,514.98 41	11,514.98 41	0.2630	0.7303	11,739.17 50

Pismo Beach GP/LCP PEIR - GHG - San Luis Obispo County APCD Air District, Winter

EMFAC Off-Model Adjustment Factors for Gasoline Light Duty Vehicle to Account for the SAFE Vehicle Rule Applied

3.5 Building Construction - 2028

Unmitigated Construction On-Site

	ROG	NOx	CO	SO2	Fugitive PM10	Exhaust PM10	PM10 Total	Fugitive PM2.5	Exhaust PM2.5	PM2.5 Total	Bio- CO2	NBio- CO2	Total CO2	CH4	N2O	CO2e
Category	lb/day										lb/day					
Off-Road	1.3674	12.4697	16.0847	0.0270		0.5276	0.5276		0.4963	0.4963		2,556.474 4	2,556.474 4	0.6010		2,571.498 1
Total	1.3674	12.4697	16.0847	0.0270		0.5276	0.5276		0.4963	0.4963		2,556.474 4	2,556.474 4	0.6010		2,571.498 1

Unmitigated Construction Off-Site

	ROG	NOx	CO	SO2	Fugitive PM10	Exhaust PM10	PM10 Total	Fugitive PM2.5	Exhaust PM2.5	PM2.5 Total	Bio- CO2	NBio- CO2	Total CO2	CH4	N2O	CO2e
Category	lb/day										lb/day					
Hauling	0.0000	0.0000	0.0000	0.0000	0.0000	0.0000	0.0000	0.0000	0.0000	0.0000		0.0000	0.0000	0.0000	0.0000	0.0000
Vendor	0.2439	9.2515	3.1316	0.0334	1.1483	0.0515	1.1998	0.3308	0.0493	0.3801		3,593.199 2	3,593.199 2	0.0931	0.5263	3,752.372 9
Worker	2.8224	1.5183	20.8009	0.0722	10.3903	0.0381	10.4284	2.7557	0.0351	2.7908		7,696.066 7	7,696.066 7	0.1581	0.1842	7,754.918 5
Total	3.0663	10.7698	23.9325	0.1056	11.5386	0.0896	11.6282	3.0865	0.0844	3.1709		11,289.26 59	11,289.26 59	0.2513	0.7106	11,507.29 14

Pismo Beach GP/LCP PEIR - GHG - San Luis Obispo County APCD Air District, Winter

EMFAC Off-Model Adjustment Factors for Gasoline Light Duty Vehicle to Account for the SAFE Vehicle Rule Applied

3.5 Building Construction - 2028

Mitigated Construction On-Site

	ROG	NOx	CO	SO2	Fugitive PM10	Exhaust PM10	PM10 Total	Fugitive PM2.5	Exhaust PM2.5	PM2.5 Total	Bio- CO2	NBio- CO2	Total CO2	CH4	N2O	CO2e
Category	lb/day										lb/day					
Off-Road	1.3674	12.4697	16.0847	0.0270		0.5276	0.5276		0.4963	0.4963	0.0000	2,556.474 4	2,556.474 4	0.6010		2,571.498 1
Total	1.3674	12.4697	16.0847	0.0270		0.5276	0.5276		0.4963	0.4963	0.0000	2,556.474 4	2,556.474 4	0.6010		2,571.498 1

Mitigated Construction Off-Site

	ROG	NOx	CO	SO2	Fugitive PM10	Exhaust PM10	PM10 Total	Fugitive PM2.5	Exhaust PM2.5	PM2.5 Total	Bio- CO2	NBio- CO2	Total CO2	CH4	N2O	CO2e
Category	lb/day										lb/day					
Hauling	0.0000	0.0000	0.0000	0.0000	0.0000	0.0000	0.0000	0.0000	0.0000	0.0000		0.0000	0.0000	0.0000	0.0000	0.0000
Vendor	0.2439	9.2515	3.1316	0.0334	1.1483	0.0515	1.1998	0.3308	0.0493	0.3801		3,593.199 2	3,593.199 2	0.0931	0.5263	3,752.372 9
Worker	2.8224	1.5183	20.8009	0.0722	10.3903	0.0381	10.4284	2.7557	0.0351	2.7908		7,696.066 7	7,696.066 7	0.1581	0.1842	7,754.918 5
Total	3.0663	10.7698	23.9325	0.1056	11.5386	0.0896	11.6282	3.0865	0.0844	3.1709		11,289.26 59	11,289.26 59	0.2513	0.7106	11,507.29 14

Pismo Beach GP/LCP PEIR - GHG - San Luis Obispo County APCD Air District, Winter

EMFAC Off-Model Adjustment Factors for Gasoline Light Duty Vehicle to Account for the SAFE Vehicle Rule Applied

3.5 Building Construction - 2029

Unmitigated Construction On-Site

	ROG	NOx	CO	SO2	Fugitive PM10	Exhaust PM10	PM10 Total	Fugitive PM2.5	Exhaust PM2.5	PM2.5 Total	Bio- CO2	NBio- CO2	Total CO2	CH4	N2O	CO2e
Category	lb/day										lb/day					
Off-Road	1.3674	12.4697	16.0847	0.0270		0.5276	0.5276		0.4963	0.4963		2,556.474 4	2,556.474 4	0.6010		2,571.498 1
Total	1.3674	12.4697	16.0847	0.0270		0.5276	0.5276		0.4963	0.4963		2,556.474 4	2,556.474 4	0.6010		2,571.498 1

Unmitigated Construction Off-Site

	ROG	NOx	CO	SO2	Fugitive PM10	Exhaust PM10	PM10 Total	Fugitive PM2.5	Exhaust PM2.5	PM2.5 Total	Bio- CO2	NBio- CO2	Total CO2	CH4	N2O	CO2e
Category	lb/day										lb/day					
Hauling	0.0000	0.0000	0.0000	0.0000	0.0000	0.0000	0.0000	0.0000	0.0000	0.0000		0.0000	0.0000	0.0000	0.0000	0.0000
Vendor	0.2373	9.0761	3.1106	0.0327	1.1484	0.0502	1.1985	0.3309	0.0480	0.3789		3,522.016 5	3,522.016 5	0.0945	0.5156	3,678.020 9
Worker	2.6782	1.4041	19.9090	0.0703	10.3903	0.0357	10.4261	2.7557	0.0329	2.7886		7,554.563 2	7,554.563 2	0.1464	0.1765	7,610.811 6
Total	2.9155	10.4802	23.0196	0.1031	11.5387	0.0859	11.6246	3.0866	0.0809	3.1675		11,076.57 97	11,076.57 97	0.2409	0.6921	11,288.83 25

Pismo Beach GP/LCP PEIR - GHG - San Luis Obispo County APCD Air District, Winter

EMFAC Off-Model Adjustment Factors for Gasoline Light Duty Vehicle to Account for the SAFE Vehicle Rule Applied

3.5 Building Construction - 2029

Mitigated Construction On-Site

	ROG	NOx	CO	SO2	Fugitive PM10	Exhaust PM10	PM10 Total	Fugitive PM2.5	Exhaust PM2.5	PM2.5 Total	Bio- CO2	NBio- CO2	Total CO2	CH4	N2O	CO2e
Category	lb/day										lb/day					
Off-Road	1.3674	12.4697	16.0847	0.0270		0.5276	0.5276		0.4963	0.4963	0.0000	2,556.474 4	2,556.474 4	0.6010		2,571.498 1
Total	1.3674	12.4697	16.0847	0.0270		0.5276	0.5276		0.4963	0.4963	0.0000	2,556.474 4	2,556.474 4	0.6010		2,571.498 1

Mitigated Construction Off-Site

	ROG	NOx	CO	SO2	Fugitive PM10	Exhaust PM10	PM10 Total	Fugitive PM2.5	Exhaust PM2.5	PM2.5 Total	Bio- CO2	NBio- CO2	Total CO2	CH4	N2O	CO2e
Category	lb/day										lb/day					
Hauling	0.0000	0.0000	0.0000	0.0000	0.0000	0.0000	0.0000	0.0000	0.0000	0.0000		0.0000	0.0000	0.0000	0.0000	0.0000
Vendor	0.2373	9.0761	3.1106	0.0327	1.1484	0.0502	1.1985	0.3309	0.0480	0.3789		3,522.016 5	3,522.016 5	0.0945	0.5156	3,678.020 9
Worker	2.6782	1.4041	19.9090	0.0703	10.3903	0.0357	10.4261	2.7557	0.0329	2.7886		7,554.563 2	7,554.563 2	0.1464	0.1765	7,610.811 6
Total	2.9155	10.4802	23.0196	0.1031	11.5387	0.0859	11.6246	3.0866	0.0809	3.1675		11,076.57 97	11,076.57 97	0.2409	0.6921	11,288.83 25

Pismo Beach GP/LCP PEIR - GHG - San Luis Obispo County APCD Air District, Winter

EMFAC Off-Model Adjustment Factors for Gasoline Light Duty Vehicle to Account for the SAFE Vehicle Rule Applied

3.5 Building Construction - 2030

Unmitigated Construction On-Site

	ROG	NOx	CO	SO2	Fugitive PM10	Exhaust PM10	PM10 Total	Fugitive PM2.5	Exhaust PM2.5	PM2.5 Total	Bio- CO2	NBio- CO2	Total CO2	CH4	N2O	CO2e
Category	lb/day										lb/day					
Off-Road	1.3091	7.9346	16.1570	0.0310		0.1481	0.1481		0.1481	0.1481		2,897.5468	2,897.5468	0.1162		2,900.4529
Total	1.3091	7.9346	16.1570	0.0310		0.1481	0.1481		0.1481	0.1481		2,897.5468	2,897.5468	0.1162		2,900.4529

Unmitigated Construction Off-Site

	ROG	NOx	CO	SO2	Fugitive PM10	Exhaust PM10	PM10 Total	Fugitive PM2.5	Exhaust PM2.5	PM2.5 Total	Bio- CO2	NBio- CO2	Total CO2	CH4	N2O	CO2e
Category	lb/day										lb/day					
Hauling	0.0000	0.0000	0.0000	0.0000	0.0000	0.0000	0.0000	0.0000	0.0000	0.0000		0.0000	0.0000	0.0000	0.0000	0.0000
Vendor	0.2320	8.9404	3.0985	0.0321	1.1484	0.0491	1.1976	0.3309	0.0470	0.3779		3,458.9429	3,458.9429	0.0956	0.5061	3,612.1630
Worker	2.5389	1.3061	19.1501	0.0687	10.3903	0.0335	10.4238	2.7557	0.0308	2.7865		7,428.3127	7,428.3127	0.1360	0.1699	7,482.3310
Total	2.7709	10.2466	22.2486	0.1008	11.5388	0.0826	11.6214	3.0866	0.0778	3.1644		10,887.2556	10,887.2556	0.2316	0.6760	11,094.4940

Pismo Beach GP/LCP PEIR - GHG - San Luis Obispo County APCD Air District, Winter

EMFAC Off-Model Adjustment Factors for Gasoline Light Duty Vehicle to Account for the SAFE Vehicle Rule Applied

3.5 Building Construction - 2030

Mitigated Construction On-Site

	ROG	NOx	CO	SO2	Fugitive PM10	Exhaust PM10	PM10 Total	Fugitive PM2.5	Exhaust PM2.5	PM2.5 Total	Bio- CO2	NBio- CO2	Total CO2	CH4	N2O	CO2e
Category	lb/day										lb/day					
Off-Road	1.3091	7.9346	16.1570	0.0310		0.1481	0.1481		0.1481	0.1481	0.0000	2,897.5468	2,897.5468	0.1162		2,900.4529
Total	1.3091	7.9346	16.1570	0.0310		0.1481	0.1481		0.1481	0.1481	0.0000	2,897.5468	2,897.5468	0.1162		2,900.4529

Mitigated Construction Off-Site

	ROG	NOx	CO	SO2	Fugitive PM10	Exhaust PM10	PM10 Total	Fugitive PM2.5	Exhaust PM2.5	PM2.5 Total	Bio- CO2	NBio- CO2	Total CO2	CH4	N2O	CO2e
Category	lb/day										lb/day					
Hauling	0.0000	0.0000	0.0000	0.0000	0.0000	0.0000	0.0000	0.0000	0.0000	0.0000		0.0000	0.0000	0.0000	0.0000	0.0000
Vendor	0.2320	8.9404	3.0985	0.0321	1.1484	0.0491	1.1976	0.3309	0.0470	0.3779		3,458.9429	3,458.9429	0.0956	0.5061	3,612.1630
Worker	2.5389	1.3061	19.1501	0.0687	10.3903	0.0335	10.4238	2.7557	0.0308	2.7865		7,428.3127	7,428.3127	0.1360	0.1699	7,482.3310
Total	2.7709	10.2466	22.2486	0.1008	11.5388	0.0826	11.6214	3.0866	0.0778	3.1644		10,887.2556	10,887.2556	0.2316	0.6760	11,094.4940

Pismo Beach GP/LCP PEIR - GHG - San Luis Obispo County APCD Air District, Winter

EMFAC Off-Model Adjustment Factors for Gasoline Light Duty Vehicle to Account for the SAFE Vehicle Rule Applied

3.5 Building Construction - 2031

Unmitigated Construction On-Site

	ROG	NOx	CO	SO2	Fugitive PM10	Exhaust PM10	PM10 Total	Fugitive PM2.5	Exhaust PM2.5	PM2.5 Total	Bio- CO2	NBio- CO2	Total CO2	CH4	N2O	CO2e
Category	lb/day										lb/day					
Off-Road	1.3091	7.9346	16.1570	0.0310		0.1481	0.1481		0.1481	0.1481		2,897.5468	2,897.5468	0.1162		2,900.4529
Total	1.3091	7.9346	16.1570	0.0310		0.1481	0.1481		0.1481	0.1481		2,897.5468	2,897.5468	0.1162		2,900.4529

Unmitigated Construction Off-Site

	ROG	NOx	CO	SO2	Fugitive PM10	Exhaust PM10	PM10 Total	Fugitive PM2.5	Exhaust PM2.5	PM2.5 Total	Bio- CO2	NBio- CO2	Total CO2	CH4	N2O	CO2e
Category	lb/day										lb/day					
Hauling	0.0000	0.0000	0.0000	0.0000	0.0000	0.0000	0.0000	0.0000	0.0000	0.0000		0.0000	0.0000	0.0000	0.0000	0.0000
Vendor	0.2276	8.8199	3.0951	0.0316	1.1485	0.0482	1.1967	0.3309	0.0461	0.3770		3,401.4777	3,401.4777	0.0967	0.4976	3,552.1741
Worker	2.3963	1.2196	18.4738	0.0672	10.3903	0.0314	10.4217	2.7557	0.0289	2.7846		7,314.6484	7,314.6484	0.1266	0.1642	7,366.7312
Total	2.6239	10.0396	21.5689	0.0988	11.5388	0.0796	11.6184	3.0866	0.0750	3.1616		10,716.1261	10,716.1261	0.2233	0.6617	10,918.9053

Pismo Beach GP/LCP PEIR - GHG - San Luis Obispo County APCD Air District, Winter

EMFAC Off-Model Adjustment Factors for Gasoline Light Duty Vehicle to Account for the SAFE Vehicle Rule Applied

3.5 Building Construction - 2031

Mitigated Construction On-Site

	ROG	NOx	CO	SO2	Fugitive PM10	Exhaust PM10	PM10 Total	Fugitive PM2.5	Exhaust PM2.5	PM2.5 Total	Bio- CO2	NBio- CO2	Total CO2	CH4	N2O	CO2e
Category	lb/day										lb/day					
Off-Road	1.3091	7.9346	16.1570	0.0310		0.1481	0.1481		0.1481	0.1481	0.0000	2,897.5468	2,897.5468	0.1162		2,900.4529
Total	1.3091	7.9346	16.1570	0.0310		0.1481	0.1481		0.1481	0.1481	0.0000	2,897.5468	2,897.5468	0.1162		2,900.4529

Mitigated Construction Off-Site

	ROG	NOx	CO	SO2	Fugitive PM10	Exhaust PM10	PM10 Total	Fugitive PM2.5	Exhaust PM2.5	PM2.5 Total	Bio- CO2	NBio- CO2	Total CO2	CH4	N2O	CO2e
Category	lb/day										lb/day					
Hauling	0.0000	0.0000	0.0000	0.0000	0.0000	0.0000	0.0000	0.0000	0.0000	0.0000		0.0000	0.0000	0.0000	0.0000	0.0000
Vendor	0.2276	8.8199	3.0951	0.0316	1.1485	0.0482	1.1967	0.3309	0.0461	0.3770		3,401.4777	3,401.4777	0.0967	0.4976	3,552.1741
Worker	2.3963	1.2196	18.4738	0.0672	10.3903	0.0314	10.4217	2.7557	0.0289	2.7846		7,314.6484	7,314.6484	0.1266	0.1642	7,366.7312
Total	2.6239	10.0396	21.5689	0.0988	11.5388	0.0796	11.6184	3.0866	0.0750	3.1616		10,716.1261	10,716.1261	0.2233	0.6617	10,918.9053

Pismo Beach GP/LCP PEIR - GHG - San Luis Obispo County APCD Air District, Winter

EMFAC Off-Model Adjustment Factors for Gasoline Light Duty Vehicle to Account for the SAFE Vehicle Rule Applied

3.5 Building Construction - 2032

Unmitigated Construction On-Site

	ROG	NOx	CO	SO2	Fugitive PM10	Exhaust PM10	PM10 Total	Fugitive PM2.5	Exhaust PM2.5	PM2.5 Total	Bio- CO2	NBio- CO2	Total CO2	CH4	N2O	CO2e
Category	lb/day										lb/day					
Off-Road	1.3091	7.9346	16.1570	0.0310		0.1481	0.1481		0.1481	0.1481		2,897.5468	2,897.5468	0.1162		2,900.4529
Total	1.3091	7.9346	16.1570	0.0310		0.1481	0.1481		0.1481	0.1481		2,897.5468	2,897.5468	0.1162		2,900.4529

Unmitigated Construction Off-Site

	ROG	NOx	CO	SO2	Fugitive PM10	Exhaust PM10	PM10 Total	Fugitive PM2.5	Exhaust PM2.5	PM2.5 Total	Bio- CO2	NBio- CO2	Total CO2	CH4	N2O	CO2e
Category	lb/day										lb/day					
Hauling	0.0000	0.0000	0.0000	0.0000	0.0000	0.0000	0.0000	0.0000	0.0000	0.0000		0.0000	0.0000	0.0000	0.0000	0.0000
Vendor	0.2239	8.7152	3.0982	0.0311	1.1486	0.0474	1.1960	0.3309	0.0453	0.3763		3,349.7593	3,349.7593	0.0977	0.4900	3,498.2103
Worker	2.2617	1.1461	17.8827	0.0659	10.3903	0.0295	10.4198	2.7557	0.0271	2.7829		7,213.5721	7,213.5721	0.1181	0.1594	7,264.0159
Total	2.4857	9.8612	20.9809	0.0970	11.5389	0.0769	11.6158	3.0867	0.0725	3.1591		10,563.3314	10,563.3314	0.2158	0.6493	10,762.2261

Pismo Beach GP/LCP PEIR - GHG - San Luis Obispo County APCD Air District, Winter

EMFAC Off-Model Adjustment Factors for Gasoline Light Duty Vehicle to Account for the SAFE Vehicle Rule Applied

3.5 Building Construction - 2032

Mitigated Construction On-Site

	ROG	NOx	CO	SO2	Fugitive PM10	Exhaust PM10	PM10 Total	Fugitive PM2.5	Exhaust PM2.5	PM2.5 Total	Bio- CO2	NBio- CO2	Total CO2	CH4	N2O	CO2e
Category	lb/day										lb/day					
Off-Road	1.3091	7.9346	16.1570	0.0310		0.1481	0.1481		0.1481	0.1481	0.0000	2,897.5468	2,897.5468	0.1162		2,900.4529
Total	1.3091	7.9346	16.1570	0.0310		0.1481	0.1481		0.1481	0.1481	0.0000	2,897.5468	2,897.5468	0.1162		2,900.4529

Mitigated Construction Off-Site

	ROG	NOx	CO	SO2	Fugitive PM10	Exhaust PM10	PM10 Total	Fugitive PM2.5	Exhaust PM2.5	PM2.5 Total	Bio- CO2	NBio- CO2	Total CO2	CH4	N2O	CO2e
Category	lb/day										lb/day					
Hauling	0.0000	0.0000	0.0000	0.0000	0.0000	0.0000	0.0000	0.0000	0.0000	0.0000		0.0000	0.0000	0.0000	0.0000	0.0000
Vendor	0.2239	8.7152	3.0982	0.0311	1.1486	0.0474	1.1960	0.3309	0.0453	0.3763		3,349.7593	3,349.7593	0.0977	0.4900	3,498.2103
Worker	2.2617	1.1461	17.8827	0.0659	10.3903	0.0295	10.4198	2.7557	0.0271	2.7829		7,213.5721	7,213.5721	0.1181	0.1594	7,264.0159
Total	2.4857	9.8612	20.9809	0.0970	11.5389	0.0769	11.6158	3.0867	0.0725	3.1591		10,563.3314	10,563.3314	0.2158	0.6493	10,762.2261

Pismo Beach GP/LCP PEIR - GHG - San Luis Obispo County APCD Air District, Winter

EMFAC Off-Model Adjustment Factors for Gasoline Light Duty Vehicle to Account for the SAFE Vehicle Rule Applied

3.5 Building Construction - 2033

Unmitigated Construction On-Site

	ROG	NOx	CO	SO2	Fugitive PM10	Exhaust PM10	PM10 Total	Fugitive PM2.5	Exhaust PM2.5	PM2.5 Total	Bio- CO2	NBio- CO2	Total CO2	CH4	N2O	CO2e
Category	lb/day										lb/day					
Off-Road	1.3091	7.9346	16.1570	0.0310		0.1481	0.1481		0.1481	0.1481		2,897.5468	2,897.5468	0.1162		2,900.4529
Total	1.3091	7.9346	16.1570	0.0310		0.1481	0.1481		0.1481	0.1481		2,897.5468	2,897.5468	0.1162		2,900.4529

Unmitigated Construction Off-Site

	ROG	NOx	CO	SO2	Fugitive PM10	Exhaust PM10	PM10 Total	Fugitive PM2.5	Exhaust PM2.5	PM2.5 Total	Bio- CO2	NBio- CO2	Total CO2	CH4	N2O	CO2e
Category	lb/day										lb/day					
Hauling	0.0000	0.0000	0.0000	0.0000	0.0000	0.0000	0.0000	0.0000	0.0000	0.0000		0.0000	0.0000	0.0000	0.0000	0.0000
Vendor	0.2211	8.6270	3.1059	0.0306	1.1487	0.0467	1.1954	0.3310	0.0447	0.3756		3,303.4386	3,303.4386	0.0986	0.4832	3,449.9061
Worker	2.1472	1.0872	17.3787	0.0647	10.3903	0.0278	10.4181	2.7557	0.0255	2.7813		7,123.8865	7,123.8865	0.1108	0.1555	7,172.9868
Total	2.3683	9.7142	20.4846	0.0954	11.5390	0.0745	11.6134	3.0867	0.0702	3.1569		10,427.3251	10,427.3251	0.2093	0.6387	10,622.8929

Pismo Beach GP/LCP PEIR - GHG - San Luis Obispo County APCD Air District, Winter

EMFAC Off-Model Adjustment Factors for Gasoline Light Duty Vehicle to Account for the SAFE Vehicle Rule Applied

3.5 Building Construction - 2033

Mitigated Construction On-Site

	ROG	NOx	CO	SO2	Fugitive PM10	Exhaust PM10	PM10 Total	Fugitive PM2.5	Exhaust PM2.5	PM2.5 Total	Bio- CO2	NBio- CO2	Total CO2	CH4	N2O	CO2e
Category	lb/day										lb/day					
Off-Road	1.3091	7.9346	16.1570	0.0310		0.1481	0.1481		0.1481	0.1481	0.0000	2,897.5468	2,897.5468	0.1162		2,900.4529
Total	1.3091	7.9346	16.1570	0.0310		0.1481	0.1481		0.1481	0.1481	0.0000	2,897.5468	2,897.5468	0.1162		2,900.4529

Mitigated Construction Off-Site

	ROG	NOx	CO	SO2	Fugitive PM10	Exhaust PM10	PM10 Total	Fugitive PM2.5	Exhaust PM2.5	PM2.5 Total	Bio- CO2	NBio- CO2	Total CO2	CH4	N2O	CO2e
Category	lb/day										lb/day					
Hauling	0.0000	0.0000	0.0000	0.0000	0.0000	0.0000	0.0000	0.0000	0.0000	0.0000		0.0000	0.0000	0.0000	0.0000	0.0000
Vendor	0.2211	8.6270	3.1059	0.0306	1.1487	0.0467	1.1954	0.3310	0.0447	0.3756		3,303.4386	3,303.4386	0.0986	0.4832	3,449.9061
Worker	2.1472	1.0872	17.3787	0.0647	10.3903	0.0278	10.4181	2.7557	0.0255	2.7813		7,123.8865	7,123.8865	0.1108	0.1555	7,172.9868
Total	2.3683	9.7142	20.4846	0.0954	11.5390	0.0745	11.6134	3.0867	0.0702	3.1569		10,427.3251	10,427.3251	0.2093	0.6387	10,622.8929

Pismo Beach GP/LCP PEIR - GHG - San Luis Obispo County APCD Air District, Winter

EMFAC Off-Model Adjustment Factors for Gasoline Light Duty Vehicle to Account for the SAFE Vehicle Rule Applied

3.5 Building Construction - 2034

Unmitigated Construction On-Site

	ROG	NOx	CO	SO2	Fugitive PM10	Exhaust PM10	PM10 Total	Fugitive PM2.5	Exhaust PM2.5	PM2.5 Total	Bio- CO2	NBio- CO2	Total CO2	CH4	N2O	CO2e
Category	lb/day										lb/day					
Off-Road	1.3091	7.9346	16.1570	0.0310		0.1481	0.1481		0.1481	0.1481		2,897.5468	2,897.5468	0.1162		2,900.4529
Total	1.3091	7.9346	16.1570	0.0310		0.1481	0.1481		0.1481	0.1481		2,897.5468	2,897.5468	0.1162		2,900.4529

Unmitigated Construction Off-Site

	ROG	NOx	CO	SO2	Fugitive PM10	Exhaust PM10	PM10 Total	Fugitive PM2.5	Exhaust PM2.5	PM2.5 Total	Bio- CO2	NBio- CO2	Total CO2	CH4	N2O	CO2e
Category	lb/day										lb/day					
Hauling	0.0000	0.0000	0.0000	0.0000	0.0000	0.0000	0.0000	0.0000	0.0000	0.0000		0.0000	0.0000	0.0000	0.0000	0.0000
Vendor	0.2187	8.5470	3.1156	0.0302	1.1487	0.0461	1.1948	0.3310	0.0441	0.3750		3,260.9784	3,260.9784	0.0995	0.4771	3,405.6354
Worker	2.0460	1.0394	16.9356	0.0637	10.3903	0.0262	10.4165	2.7557	0.0241	2.7798		7,044.2497	7,044.2497	0.1042	0.1523	7,092.2421
Total	2.2647	9.5864	20.0512	0.0939	11.5390	0.0722	11.6113	3.0867	0.0681	3.1548		10,305.2281	10,305.2281	0.2038	0.6294	10,497.8774

Pismo Beach GP/LCP PEIR - GHG - San Luis Obispo County APCD Air District, Winter

EMFAC Off-Model Adjustment Factors for Gasoline Light Duty Vehicle to Account for the SAFE Vehicle Rule Applied

3.5 Building Construction - 2034

Mitigated Construction On-Site

	ROG	NOx	CO	SO2	Fugitive PM10	Exhaust PM10	PM10 Total	Fugitive PM2.5	Exhaust PM2.5	PM2.5 Total	Bio- CO2	NBio- CO2	Total CO2	CH4	N2O	CO2e
Category	lb/day										lb/day					
Off-Road	1.3091	7.9346	16.1570	0.0310		0.1481	0.1481		0.1481	0.1481	0.0000	2,897.5468	2,897.5468	0.1162		2,900.4529
Total	1.3091	7.9346	16.1570	0.0310		0.1481	0.1481		0.1481	0.1481	0.0000	2,897.5468	2,897.5468	0.1162		2,900.4529

Mitigated Construction Off-Site

	ROG	NOx	CO	SO2	Fugitive PM10	Exhaust PM10	PM10 Total	Fugitive PM2.5	Exhaust PM2.5	PM2.5 Total	Bio- CO2	NBio- CO2	Total CO2	CH4	N2O	CO2e
Category	lb/day										lb/day					
Hauling	0.0000	0.0000	0.0000	0.0000	0.0000	0.0000	0.0000	0.0000	0.0000	0.0000		0.0000	0.0000	0.0000	0.0000	0.0000
Vendor	0.2187	8.5470	3.1156	0.0302	1.1487	0.0461	1.1948	0.3310	0.0441	0.3750		3,260.9784	3,260.9784	0.0995	0.4771	3,405.6354
Worker	2.0460	1.0394	16.9356	0.0637	10.3903	0.0262	10.4165	2.7557	0.0241	2.7798		7,044.2497	7,044.2497	0.1042	0.1523	7,092.2421
Total	2.2647	9.5864	20.0512	0.0939	11.5390	0.0722	11.6113	3.0867	0.0681	3.1548		10,305.2281	10,305.2281	0.2038	0.6294	10,497.8774

Pismo Beach GP/LCP PEIR - GHG - San Luis Obispo County APCD Air District, Winter

EMFAC Off-Model Adjustment Factors for Gasoline Light Duty Vehicle to Account for the SAFE Vehicle Rule Applied

3.5 Building Construction - 2035

Unmitigated Construction On-Site

	ROG	NOx	CO	SO2	Fugitive PM10	Exhaust PM10	PM10 Total	Fugitive PM2.5	Exhaust PM2.5	PM2.5 Total	Bio- CO2	NBio- CO2	Total CO2	CH4	N2O	CO2e
Category	lb/day										lb/day					
Off-Road	1.2168	7.1613	16.1178	0.0310		0.0904	0.0904		0.0904	0.0904		2,897.5468	2,897.5468	0.1079		2,900.2448
Total	1.2168	7.1613	16.1178	0.0310		0.0904	0.0904		0.0904	0.0904		2,897.5468	2,897.5468	0.1079		2,900.2448

Unmitigated Construction Off-Site

	ROG	NOx	CO	SO2	Fugitive PM10	Exhaust PM10	PM10 Total	Fugitive PM2.5	Exhaust PM2.5	PM2.5 Total	Bio- CO2	NBio- CO2	Total CO2	CH4	N2O	CO2e
Category	lb/day										lb/day					
Hauling	0.0000	0.0000	0.0000	0.0000	0.0000	0.0000	0.0000	0.0000	0.0000	0.0000		0.0000	0.0000	0.0000	0.0000	0.0000
Vendor	0.2164	8.4719	3.1246	0.0299	1.1488	0.0454	1.1942	0.3310	0.0435	0.3745		3,222.9117	3,222.9117	0.1003	0.4716	3,365.9529
Worker	1.9535	1.0006	16.5501	0.0628	10.3903	0.0247	10.4150	2.7557	0.0227	2.7784		6,974.8753	6,974.8753	0.0984	0.1497	7,021.9523
Total	2.1699	9.4725	19.6747	0.0926	11.5391	0.0701	11.6092	3.0867	0.0662	3.1529		10,197.7870	10,197.7870	0.1987	0.6213	10,387.9052

Pismo Beach GP/LCP PEIR - GHG - San Luis Obispo County APCD Air District, Winter

EMFAC Off-Model Adjustment Factors for Gasoline Light Duty Vehicle to Account for the SAFE Vehicle Rule Applied

3.5 Building Construction - 2035

Mitigated Construction On-Site

	ROG	NOx	CO	SO2	Fugitive PM10	Exhaust PM10	PM10 Total	Fugitive PM2.5	Exhaust PM2.5	PM2.5 Total	Bio- CO2	NBio- CO2	Total CO2	CH4	N2O	CO2e
Category	lb/day										lb/day					
Off-Road	1.2168	7.1613	16.1178	0.0310		0.0904	0.0904		0.0904	0.0904	0.0000	2,897.5468	2,897.5468	0.1079		2,900.2448
Total	1.2168	7.1613	16.1178	0.0310		0.0904	0.0904		0.0904	0.0904	0.0000	2,897.5468	2,897.5468	0.1079		2,900.2448

Mitigated Construction Off-Site

	ROG	NOx	CO	SO2	Fugitive PM10	Exhaust PM10	PM10 Total	Fugitive PM2.5	Exhaust PM2.5	PM2.5 Total	Bio- CO2	NBio- CO2	Total CO2	CH4	N2O	CO2e
Category	lb/day										lb/day					
Hauling	0.0000	0.0000	0.0000	0.0000	0.0000	0.0000	0.0000	0.0000	0.0000	0.0000		0.0000	0.0000	0.0000	0.0000	0.0000
Vendor	0.2164	8.4719	3.1246	0.0299	1.1488	0.0454	1.1942	0.3310	0.0435	0.3745		3,222.9117	3,222.9117	0.1003	0.4716	3,365.9529
Worker	1.9535	1.0006	16.5501	0.0628	10.3903	0.0247	10.4150	2.7557	0.0227	2.7784		6,974.8753	6,974.8753	0.0984	0.1497	7,021.9523
Total	2.1699	9.4725	19.6747	0.0926	11.5391	0.0701	11.6092	3.0867	0.0662	3.1529		10,197.7870	10,197.7870	0.1987	0.6213	10,387.9052

Pismo Beach GP/LCP PEIR - GHG - San Luis Obispo County APCD Air District, Winter

EMFAC Off-Model Adjustment Factors for Gasoline Light Duty Vehicle to Account for the SAFE Vehicle Rule Applied

3.5 Building Construction - 2036

Unmitigated Construction On-Site

	ROG	NOx	CO	SO2	Fugitive PM10	Exhaust PM10	PM10 Total	Fugitive PM2.5	Exhaust PM2.5	PM2.5 Total	Bio- CO2	NBio- CO2	Total CO2	CH4	N2O	CO2e
Category	lb/day										lb/day					
Off-Road	1.2168	7.1613	16.1178	0.0310		0.0904	0.0904		0.0904	0.0904		2,897.5468	2,897.5468	0.1079		2,900.2448
Total	1.2168	7.1613	16.1178	0.0310		0.0904	0.0904		0.0904	0.0904		2,897.5468	2,897.5468	0.1079		2,900.2448

Unmitigated Construction Off-Site

	ROG	NOx	CO	SO2	Fugitive PM10	Exhaust PM10	PM10 Total	Fugitive PM2.5	Exhaust PM2.5	PM2.5 Total	Bio- CO2	NBio- CO2	Total CO2	CH4	N2O	CO2e
Category	lb/day										lb/day					
Hauling	0.0000	0.0000	0.0000	0.0000	0.0000	0.0000	0.0000	0.0000	0.0000	0.0000		0.0000	0.0000	0.0000	0.0000	0.0000
Vendor	0.2164	8.4719	3.1246	0.0299	1.1488	0.0454	1.1942	0.3310	0.0435	0.3745		3,222.9117	3,222.9117	0.1003	0.4716	3,365.9529
Worker	1.9535	1.0006	16.5501	0.0628	10.3903	0.0247	10.4150	2.7557	0.0227	2.7784		6,974.8753	6,974.8753	0.0984	0.1497	7,021.9523
Total	2.1699	9.4725	19.6747	0.0926	11.5391	0.0701	11.6092	3.0867	0.0662	3.1529		10,197.7870	10,197.7870	0.1987	0.6213	10,387.9052

Pismo Beach GP/LCP PEIR - GHG - San Luis Obispo County APCD Air District, Winter

EMFAC Off-Model Adjustment Factors for Gasoline Light Duty Vehicle to Account for the SAFE Vehicle Rule Applied

3.5 Building Construction - 2036

Mitigated Construction On-Site

	ROG	NOx	CO	SO2	Fugitive PM10	Exhaust PM10	PM10 Total	Fugitive PM2.5	Exhaust PM2.5	PM2.5 Total	Bio- CO2	NBio- CO2	Total CO2	CH4	N2O	CO2e
Category	lb/day										lb/day					
Off-Road	1.2168	7.1613	16.1178	0.0310		0.0904	0.0904		0.0904	0.0904	0.0000	2,897.5468	2,897.5468	0.1079		2,900.2448
Total	1.2168	7.1613	16.1178	0.0310		0.0904	0.0904		0.0904	0.0904	0.0000	2,897.5468	2,897.5468	0.1079		2,900.2448

Mitigated Construction Off-Site

	ROG	NOx	CO	SO2	Fugitive PM10	Exhaust PM10	PM10 Total	Fugitive PM2.5	Exhaust PM2.5	PM2.5 Total	Bio- CO2	NBio- CO2	Total CO2	CH4	N2O	CO2e
Category	lb/day										lb/day					
Hauling	0.0000	0.0000	0.0000	0.0000	0.0000	0.0000	0.0000	0.0000	0.0000	0.0000		0.0000	0.0000	0.0000	0.0000	0.0000
Vendor	0.2164	8.4719	3.1246	0.0299	1.1488	0.0454	1.1942	0.3310	0.0435	0.3745		3,222.9117	3,222.9117	0.1003	0.4716	3,365.9529
Worker	1.9535	1.0006	16.5501	0.0628	10.3903	0.0247	10.4150	2.7557	0.0227	2.7784		6,974.8753	6,974.8753	0.0984	0.1497	7,021.9523
Total	2.1699	9.4725	19.6747	0.0926	11.5391	0.0701	11.6092	3.0867	0.0662	3.1529		10,197.7870	10,197.7870	0.1987	0.6213	10,387.9052

Pismo Beach GP/LCP PEIR - GHG - San Luis Obispo County APCD Air District, Winter

EMFAC Off-Model Adjustment Factors for Gasoline Light Duty Vehicle to Account for the SAFE Vehicle Rule Applied

3.5 Building Construction - 2037

Unmitigated Construction On-Site

	ROG	NOx	CO	SO2	Fugitive PM10	Exhaust PM10	PM10 Total	Fugitive PM2.5	Exhaust PM2.5	PM2.5 Total	Bio- CO2	NBio- CO2	Total CO2	CH4	N2O	CO2e
Category	lb/day										lb/day					
Off-Road	1.2168	7.1613	16.1178	0.0310		0.0904	0.0904		0.0904	0.0904		2,897.5468	2,897.5468	0.1079		2,900.2448
Total	1.2168	7.1613	16.1178	0.0310		0.0904	0.0904		0.0904	0.0904		2,897.5468	2,897.5468	0.1079		2,900.2448

Unmitigated Construction Off-Site

	ROG	NOx	CO	SO2	Fugitive PM10	Exhaust PM10	PM10 Total	Fugitive PM2.5	Exhaust PM2.5	PM2.5 Total	Bio- CO2	NBio- CO2	Total CO2	CH4	N2O	CO2e
Category	lb/day										lb/day					
Hauling	0.0000	0.0000	0.0000	0.0000	0.0000	0.0000	0.0000	0.0000	0.0000	0.0000		0.0000	0.0000	0.0000	0.0000	0.0000
Vendor	0.2164	8.4719	3.1246	0.0299	1.1488	0.0454	1.1942	0.3310	0.0435	0.3745		3,222.9117	3,222.9117	0.1003	0.4716	3,365.9529
Worker	1.9535	1.0006	16.5501	0.0628	10.3903	0.0247	10.4150	2.7557	0.0227	2.7784		6,974.8753	6,974.8753	0.0984	0.1497	7,021.9523
Total	2.1699	9.4725	19.6747	0.0926	11.5391	0.0701	11.6092	3.0867	0.0662	3.1529		10,197.7870	10,197.7870	0.1987	0.6213	10,387.9052

Pismo Beach GP/LCP PEIR - GHG - San Luis Obispo County APCD Air District, Winter

EMFAC Off-Model Adjustment Factors for Gasoline Light Duty Vehicle to Account for the SAFE Vehicle Rule Applied

3.5 Building Construction - 2037

Mitigated Construction On-Site

	ROG	NOx	CO	SO2	Fugitive PM10	Exhaust PM10	PM10 Total	Fugitive PM2.5	Exhaust PM2.5	PM2.5 Total	Bio- CO2	NBio- CO2	Total CO2	CH4	N2O	CO2e
Category	lb/day										lb/day					
Off-Road	1.2168	7.1613	16.1178	0.0310		0.0904	0.0904		0.0904	0.0904	0.0000	2,897.5468	2,897.5468	0.1079		2,900.2448
Total	1.2168	7.1613	16.1178	0.0310		0.0904	0.0904		0.0904	0.0904	0.0000	2,897.5468	2,897.5468	0.1079		2,900.2448

Mitigated Construction Off-Site

	ROG	NOx	CO	SO2	Fugitive PM10	Exhaust PM10	PM10 Total	Fugitive PM2.5	Exhaust PM2.5	PM2.5 Total	Bio- CO2	NBio- CO2	Total CO2	CH4	N2O	CO2e
Category	lb/day										lb/day					
Hauling	0.0000	0.0000	0.0000	0.0000	0.0000	0.0000	0.0000	0.0000	0.0000	0.0000		0.0000	0.0000	0.0000	0.0000	0.0000
Vendor	0.2164	8.4719	3.1246	0.0299	1.1488	0.0454	1.1942	0.3310	0.0435	0.3745		3,222.9117	3,222.9117	0.1003	0.4716	3,365.9529
Worker	1.9535	1.0006	16.5501	0.0628	10.3903	0.0247	10.4150	2.7557	0.0227	2.7784		6,974.8753	6,974.8753	0.0984	0.1497	7,021.9523
Total	2.1699	9.4725	19.6747	0.0926	11.5391	0.0701	11.6092	3.0867	0.0662	3.1529		10,197.7870	10,197.7870	0.1987	0.6213	10,387.9052

Pismo Beach GP/LCP PEIR - GHG - San Luis Obispo County APCD Air District, Winter

EMFAC Off-Model Adjustment Factors for Gasoline Light Duty Vehicle to Account for the SAFE Vehicle Rule Applied

3.5 Building Construction - 2038

Unmitigated Construction On-Site

	ROG	NOx	CO	SO2	Fugitive PM10	Exhaust PM10	PM10 Total	Fugitive PM2.5	Exhaust PM2.5	PM2.5 Total	Bio- CO2	NBio- CO2	Total CO2	CH4	N2O	CO2e
Category	lb/day										lb/day					
Off-Road	1.2168	7.1613	16.1178	0.0310		0.0904	0.0904		0.0904	0.0904		2,897.5468	2,897.5468	0.1079		2,900.2448
Total	1.2168	7.1613	16.1178	0.0310		0.0904	0.0904		0.0904	0.0904		2,897.5468	2,897.5468	0.1079		2,900.2448

Unmitigated Construction Off-Site

	ROG	NOx	CO	SO2	Fugitive PM10	Exhaust PM10	PM10 Total	Fugitive PM2.5	Exhaust PM2.5	PM2.5 Total	Bio- CO2	NBio- CO2	Total CO2	CH4	N2O	CO2e
Category	lb/day										lb/day					
Hauling	0.0000	0.0000	0.0000	0.0000	0.0000	0.0000	0.0000	0.0000	0.0000	0.0000		0.0000	0.0000	0.0000	0.0000	0.0000
Vendor	0.2164	8.4719	3.1246	0.0299	1.1488	0.0454	1.1942	0.3310	0.0435	0.3745		3,222.9117	3,222.9117	0.1003	0.4716	3,365.9529
Worker	1.9535	1.0006	16.5501	0.0628	10.3903	0.0247	10.4150	2.7557	0.0227	2.7784		6,974.8753	6,974.8753	0.0984	0.1497	7,021.9523
Total	2.1699	9.4725	19.6747	0.0926	11.5391	0.0701	11.6092	3.0867	0.0662	3.1529		10,197.7870	10,197.7870	0.1987	0.6213	10,387.9052

Pismo Beach GP/LCP PEIR - GHG - San Luis Obispo County APCD Air District, Winter

EMFAC Off-Model Adjustment Factors for Gasoline Light Duty Vehicle to Account for the SAFE Vehicle Rule Applied

3.5 Building Construction - 2038

Mitigated Construction On-Site

	ROG	NOx	CO	SO2	Fugitive PM10	Exhaust PM10	PM10 Total	Fugitive PM2.5	Exhaust PM2.5	PM2.5 Total	Bio- CO2	NBio- CO2	Total CO2	CH4	N2O	CO2e
Category	lb/day										lb/day					
Off-Road	1.2168	7.1613	16.1178	0.0310		0.0904	0.0904		0.0904	0.0904	0.0000	2,897.5468	2,897.5468	0.1079		2,900.2448
Total	1.2168	7.1613	16.1178	0.0310		0.0904	0.0904		0.0904	0.0904	0.0000	2,897.5468	2,897.5468	0.1079		2,900.2448

Mitigated Construction Off-Site

	ROG	NOx	CO	SO2	Fugitive PM10	Exhaust PM10	PM10 Total	Fugitive PM2.5	Exhaust PM2.5	PM2.5 Total	Bio- CO2	NBio- CO2	Total CO2	CH4	N2O	CO2e
Category	lb/day										lb/day					
Hauling	0.0000	0.0000	0.0000	0.0000	0.0000	0.0000	0.0000	0.0000	0.0000	0.0000		0.0000	0.0000	0.0000	0.0000	0.0000
Vendor	0.2164	8.4719	3.1246	0.0299	1.1488	0.0454	1.1942	0.3310	0.0435	0.3745		3,222.9117	3,222.9117	0.1003	0.4716	3,365.9529
Worker	1.9535	1.0006	16.5501	0.0628	10.3903	0.0247	10.4150	2.7557	0.0227	2.7784		6,974.8753	6,974.8753	0.0984	0.1497	7,021.9523
Total	2.1699	9.4725	19.6747	0.0926	11.5391	0.0701	11.6092	3.0867	0.0662	3.1529		10,197.7870	10,197.7870	0.1987	0.6213	10,387.9052

Pismo Beach GP/LCP PEIR - GHG - San Luis Obispo County APCD Air District, Winter

EMFAC Off-Model Adjustment Factors for Gasoline Light Duty Vehicle to Account for the SAFE Vehicle Rule Applied

3.5 Building Construction - 2039

Unmitigated Construction On-Site

	ROG	NOx	CO	SO2	Fugitive PM10	Exhaust PM10	PM10 Total	Fugitive PM2.5	Exhaust PM2.5	PM2.5 Total	Bio- CO2	NBio- CO2	Total CO2	CH4	N2O	CO2e
Category	lb/day										lb/day					
Off-Road	1.2168	7.1613	16.1178	0.0310		0.0904	0.0904		0.0904	0.0904		2,897.5468	2,897.5468	0.1079		2,900.2448
Total	1.2168	7.1613	16.1178	0.0310		0.0904	0.0904		0.0904	0.0904		2,897.5468	2,897.5468	0.1079		2,900.2448

Unmitigated Construction Off-Site

	ROG	NOx	CO	SO2	Fugitive PM10	Exhaust PM10	PM10 Total	Fugitive PM2.5	Exhaust PM2.5	PM2.5 Total	Bio- CO2	NBio- CO2	Total CO2	CH4	N2O	CO2e
Category	lb/day										lb/day					
Hauling	0.0000	0.0000	0.0000	0.0000	0.0000	0.0000	0.0000	0.0000	0.0000	0.0000		0.0000	0.0000	0.0000	0.0000	0.0000
Vendor	0.2164	8.4719	3.1246	0.0299	1.1488	0.0454	1.1942	0.3310	0.0435	0.3745		3,222.9117	3,222.9117	0.1003	0.4716	3,365.9529
Worker	1.9535	1.0006	16.5501	0.0628	10.3903	0.0247	10.4150	2.7557	0.0227	2.7784		6,974.8753	6,974.8753	0.0984	0.1497	7,021.9523
Total	2.1699	9.4725	19.6747	0.0926	11.5391	0.0701	11.6092	3.0867	0.0662	3.1529		10,197.7870	10,197.7870	0.1987	0.6213	10,387.9052

Pismo Beach GP/LCP PEIR - GHG - San Luis Obispo County APCD Air District, Winter

EMFAC Off-Model Adjustment Factors for Gasoline Light Duty Vehicle to Account for the SAFE Vehicle Rule Applied

3.5 Building Construction - 2039

Mitigated Construction On-Site

	ROG	NOx	CO	SO2	Fugitive PM10	Exhaust PM10	PM10 Total	Fugitive PM2.5	Exhaust PM2.5	PM2.5 Total	Bio- CO2	NBio- CO2	Total CO2	CH4	N2O	CO2e
Category	lb/day										lb/day					
Off-Road	1.2168	7.1613	16.1178	0.0310		0.0904	0.0904		0.0904	0.0904	0.0000	2,897.5468	2,897.5468	0.1079		2,900.2448
Total	1.2168	7.1613	16.1178	0.0310		0.0904	0.0904		0.0904	0.0904	0.0000	2,897.5468	2,897.5468	0.1079		2,900.2448

Mitigated Construction Off-Site

	ROG	NOx	CO	SO2	Fugitive PM10	Exhaust PM10	PM10 Total	Fugitive PM2.5	Exhaust PM2.5	PM2.5 Total	Bio- CO2	NBio- CO2	Total CO2	CH4	N2O	CO2e
Category	lb/day										lb/day					
Hauling	0.0000	0.0000	0.0000	0.0000	0.0000	0.0000	0.0000	0.0000	0.0000	0.0000		0.0000	0.0000	0.0000	0.0000	0.0000
Vendor	0.2164	8.4719	3.1246	0.0299	1.1488	0.0454	1.1942	0.3310	0.0435	0.3745		3,222.9117	3,222.9117	0.1003	0.4716	3,365.9529
Worker	1.9535	1.0006	16.5501	0.0628	10.3903	0.0247	10.4150	2.7557	0.0227	2.7784		6,974.8753	6,974.8753	0.0984	0.1497	7,021.9523
Total	2.1699	9.4725	19.6747	0.0926	11.5391	0.0701	11.6092	3.0867	0.0662	3.1529		10,197.7870	10,197.7870	0.1987	0.6213	10,387.9052

Pismo Beach GP/LCP PEIR - GHG - San Luis Obispo County APCD Air District, Winter

EMFAC Off-Model Adjustment Factors for Gasoline Light Duty Vehicle to Account for the SAFE Vehicle Rule Applied

3.5 Building Construction - 2040

Unmitigated Construction On-Site

	ROG	NOx	CO	SO2	Fugitive PM10	Exhaust PM10	PM10 Total	Fugitive PM2.5	Exhaust PM2.5	PM2.5 Total	Bio- CO2	NBio- CO2	Total CO2	CH4	N2O	CO2e
Category	lb/day										lb/day					
Off-Road	1.1970	6.8903	16.1185	0.0310		0.0737	0.0737		0.0737	0.0737		2,897.547 1	2,897.547 1	0.1041		2,900.150 3
Total	1.1970	6.8903	16.1185	0.0310		0.0737	0.0737		0.0737	0.0737		2,897.547 1	2,897.547 1	0.1041		2,900.150 3

Unmitigated Construction Off-Site

	ROG	NOx	CO	SO2	Fugitive PM10	Exhaust PM10	PM10 Total	Fugitive PM2.5	Exhaust PM2.5	PM2.5 Total	Bio- CO2	NBio- CO2	Total CO2	CH4	N2O	CO2e
Category	lb/day										lb/day					
Hauling	0.0000	0.0000	0.0000	0.0000	0.0000	0.0000	0.0000	0.0000	0.0000	0.0000		0.0000	0.0000	0.0000	0.0000	0.0000
Vendor	0.2119	8.1206	3.1824	0.0284	1.1490	0.0439	1.1928	0.3311	0.0419	0.3730		3,070.439 8	3,070.439 8	0.1056	0.4486	3,206.750 5
Worker	1.6039	0.8839	15.2245	0.0598	10.3903	0.0195	10.4098	2.7557	0.0179	2.7737		6,740.503 9	6,740.503 9	0.0780	0.1422	6,784.831 9
Total	1.8158	9.0045	18.4069	0.0881	11.5393	0.0633	11.6026	3.0868	0.0599	3.1467		9,810.943 7	9,810.943 7	0.1836	0.5908	9,991.582 4

Pismo Beach GP/LCP PEIR - GHG - San Luis Obispo County APCD Air District, Winter

EMFAC Off-Model Adjustment Factors for Gasoline Light Duty Vehicle to Account for the SAFE Vehicle Rule Applied

3.5 Building Construction - 2040

Mitigated Construction On-Site

	ROG	NOx	CO	SO2	Fugitive PM10	Exhaust PM10	PM10 Total	Fugitive PM2.5	Exhaust PM2.5	PM2.5 Total	Bio- CO2	NBio- CO2	Total CO2	CH4	N2O	CO2e
Category	lb/day										lb/day					
Off-Road	1.1970	6.8903	16.1185	0.0310		0.0737	0.0737		0.0737	0.0737	0.0000	2,897.547 1	2,897.547 1	0.1041		2,900.150 3
Total	1.1970	6.8903	16.1185	0.0310		0.0737	0.0737		0.0737	0.0737	0.0000	2,897.547 1	2,897.547 1	0.1041		2,900.150 3

Mitigated Construction Off-Site

	ROG	NOx	CO	SO2	Fugitive PM10	Exhaust PM10	PM10 Total	Fugitive PM2.5	Exhaust PM2.5	PM2.5 Total	Bio- CO2	NBio- CO2	Total CO2	CH4	N2O	CO2e
Category	lb/day										lb/day					
Hauling	0.0000	0.0000	0.0000	0.0000	0.0000	0.0000	0.0000	0.0000	0.0000	0.0000		0.0000	0.0000	0.0000	0.0000	0.0000
Vendor	0.2119	8.1206	3.1824	0.0284	1.1490	0.0439	1.1928	0.3311	0.0419	0.3730		3,070.439 8	3,070.439 8	0.1056	0.4486	3,206.750 5
Worker	1.6039	0.8839	15.2245	0.0598	10.3903	0.0195	10.4098	2.7557	0.0179	2.7737		6,740.503 9	6,740.503 9	0.0780	0.1422	6,784.831 9
Total	1.8158	9.0045	18.4069	0.0881	11.5393	0.0633	11.6026	3.0868	0.0599	3.1467		9,810.943 7	9,810.943 7	0.1836	0.5908	9,991.582 4

Pismo Beach GP/LCP PEIR - GHG - San Luis Obispo County APCD Air District, Winter

EMFAC Off-Model Adjustment Factors for Gasoline Light Duty Vehicle to Account for the SAFE Vehicle Rule Applied

3.6 Paving - 2040

Unmitigated Construction On-Site

	ROG	NOx	CO	SO2	Fugitive PM10	Exhaust PM10	PM10 Total	Fugitive PM2.5	Exhaust PM2.5	PM2.5 Total	Bio- CO2	NBio- CO2	Total CO2	CH4	N2O	CO2e
Category	lb/day										lb/day					
Off-Road	1.0112	3.6566	15.8177	0.0281		0.1164	0.1164		0.1164	0.1164		2,656.5168	2,656.5168	0.0893		2,658.7489
Paving	0.0000					0.0000	0.0000		0.0000	0.0000			0.0000			0.0000
Total	1.0112	3.6566	15.8177	0.0281		0.1164	0.1164		0.1164	0.1164		2,656.5168	2,656.5168	0.0893		2,658.7489

Unmitigated Construction Off-Site

	ROG	NOx	CO	SO2	Fugitive PM10	Exhaust PM10	PM10 Total	Fugitive PM2.5	Exhaust PM2.5	PM2.5 Total	Bio- CO2	NBio- CO2	Total CO2	CH4	N2O	CO2e
Category	lb/day										lb/day					
Hauling	0.0000	0.0000	0.0000	0.0000	0.0000	0.0000	0.0000	0.0000	0.0000	0.0000		0.0000	0.0000	0.0000	0.0000	0.0000
Vendor	0.0000	0.0000	0.0000	0.0000	0.0000	0.0000	0.0000	0.0000	0.0000	0.0000		0.0000	0.0000	0.0000	0.0000	0.0000
Worker	0.0229	0.0126	0.2173	8.5000e-004	0.1483	2.8000e-004	0.1486	0.0393	2.6000e-004	0.0396		96.2013	96.2013	1.1100e-003	2.0300e-003	96.8340
Total	0.0229	0.0126	0.2173	8.5000e-004	0.1483	2.8000e-004	0.1486	0.0393	2.6000e-004	0.0396		96.2013	96.2013	1.1100e-003	2.0300e-003	96.8340

Pismo Beach GP/LCP PEIR - GHG - San Luis Obispo County APCD Air District, Winter

EMFAC Off-Model Adjustment Factors for Gasoline Light Duty Vehicle to Account for the SAFE Vehicle Rule Applied

3.6 Paving - 2040

Mitigated Construction On-Site

	ROG	NOx	CO	SO2	Fugitive PM10	Exhaust PM10	PM10 Total	Fugitive PM2.5	Exhaust PM2.5	PM2.5 Total	Bio- CO2	NBio- CO2	Total CO2	CH4	N2O	CO2e
Category	lb/day										lb/day					
Off-Road	1.0112	3.6566	15.8177	0.0281		0.1164	0.1164		0.1164	0.1164	0.0000	2,656.5168	2,656.5168	0.0893		2,658.7489
Paving	0.0000					0.0000	0.0000		0.0000	0.0000			0.0000			0.0000
Total	1.0112	3.6566	15.8177	0.0281		0.1164	0.1164		0.1164	0.1164	0.0000	2,656.5168	2,656.5168	0.0893		2,658.7489

Mitigated Construction Off-Site

	ROG	NOx	CO	SO2	Fugitive PM10	Exhaust PM10	PM10 Total	Fugitive PM2.5	Exhaust PM2.5	PM2.5 Total	Bio- CO2	NBio- CO2	Total CO2	CH4	N2O	CO2e
Category	lb/day										lb/day					
Hauling	0.0000	0.0000	0.0000	0.0000	0.0000	0.0000	0.0000	0.0000	0.0000	0.0000		0.0000	0.0000	0.0000	0.0000	0.0000
Vendor	0.0000	0.0000	0.0000	0.0000	0.0000	0.0000	0.0000	0.0000	0.0000	0.0000		0.0000	0.0000	0.0000	0.0000	0.0000
Worker	0.0229	0.0126	0.2173	8.5000e-004	0.1483	2.8000e-004	0.1486	0.0393	2.6000e-004	0.0396		96.2013	96.2013	1.1100e-003	2.0300e-003	96.8340
Total	0.0229	0.0126	0.2173	8.5000e-004	0.1483	2.8000e-004	0.1486	0.0393	2.6000e-004	0.0396		96.2013	96.2013	1.1100e-003	2.0300e-003	96.8340

Pismo Beach GP/LCP PEIR - GHG - San Luis Obispo County APCD Air District, Winter

EMFAC Off-Model Adjustment Factors for Gasoline Light Duty Vehicle to Account for the SAFE Vehicle Rule Applied

3.6 Paving - 2041

Unmitigated Construction On-Site

	ROG	NOx	CO	SO2	Fugitive PM10	Exhaust PM10	PM10 Total	Fugitive PM2.5	Exhaust PM2.5	PM2.5 Total	Bio- CO2	NBio- CO2	Total CO2	CH4	N2O	CO2e
Category	lb/day										lb/day					
Off-Road	1.0112	3.6566	15.8177	0.0281		0.1164	0.1164		0.1164	0.1164		2,656.5168	2,656.5168	0.0893		2,658.7489
Paving	0.0000					0.0000	0.0000		0.0000	0.0000			0.0000			0.0000
Total	1.0112	3.6566	15.8177	0.0281		0.1164	0.1164		0.1164	0.1164		2,656.5168	2,656.5168	0.0893		2,658.7489

Unmitigated Construction Off-Site

	ROG	NOx	CO	SO2	Fugitive PM10	Exhaust PM10	PM10 Total	Fugitive PM2.5	Exhaust PM2.5	PM2.5 Total	Bio- CO2	NBio- CO2	Total CO2	CH4	N2O	CO2e
Category	lb/day										lb/day					
Hauling	0.0000	0.0000	0.0000	0.0000	0.0000	0.0000	0.0000	0.0000	0.0000	0.0000		0.0000	0.0000	0.0000	0.0000	0.0000
Vendor	0.0000	0.0000	0.0000	0.0000	0.0000	0.0000	0.0000	0.0000	0.0000	0.0000		0.0000	0.0000	0.0000	0.0000	0.0000
Worker	0.0229	0.0126	0.2173	8.5000e-004	0.1483	2.8000e-004	0.1486	0.0393	2.6000e-004	0.0396		96.2013	96.2013	1.1100e-003	2.0300e-003	96.8340
Total	0.0229	0.0126	0.2173	8.5000e-004	0.1483	2.8000e-004	0.1486	0.0393	2.6000e-004	0.0396		96.2013	96.2013	1.1100e-003	2.0300e-003	96.8340

Pismo Beach GP/LCP PEIR - GHG - San Luis Obispo County APCD Air District, Winter

EMFAC Off-Model Adjustment Factors for Gasoline Light Duty Vehicle to Account for the SAFE Vehicle Rule Applied

3.6 Paving - 2041

Mitigated Construction On-Site

	ROG	NOx	CO	SO2	Fugitive PM10	Exhaust PM10	PM10 Total	Fugitive PM2.5	Exhaust PM2.5	PM2.5 Total	Bio- CO2	NBio- CO2	Total CO2	CH4	N2O	CO2e
Category	lb/day										lb/day					
Off-Road	1.0112	3.6566	15.8177	0.0281		0.1164	0.1164		0.1164	0.1164	0.0000	2,656.5168	2,656.5168	0.0893		2,658.7489
Paving	0.0000					0.0000	0.0000		0.0000	0.0000			0.0000			0.0000
Total	1.0112	3.6566	15.8177	0.0281		0.1164	0.1164		0.1164	0.1164	0.0000	2,656.5168	2,656.5168	0.0893		2,658.7489

Mitigated Construction Off-Site

	ROG	NOx	CO	SO2	Fugitive PM10	Exhaust PM10	PM10 Total	Fugitive PM2.5	Exhaust PM2.5	PM2.5 Total	Bio- CO2	NBio- CO2	Total CO2	CH4	N2O	CO2e
Category	lb/day										lb/day					
Hauling	0.0000	0.0000	0.0000	0.0000	0.0000	0.0000	0.0000	0.0000	0.0000	0.0000		0.0000	0.0000	0.0000	0.0000	0.0000
Vendor	0.0000	0.0000	0.0000	0.0000	0.0000	0.0000	0.0000	0.0000	0.0000	0.0000		0.0000	0.0000	0.0000	0.0000	0.0000
Worker	0.0229	0.0126	0.2173	8.5000e-004	0.1483	2.8000e-004	0.1486	0.0393	2.6000e-004	0.0396		96.2013	96.2013	1.1100e-003	2.0300e-003	96.8340
Total	0.0229	0.0126	0.2173	8.5000e-004	0.1483	2.8000e-004	0.1486	0.0393	2.6000e-004	0.0396		96.2013	96.2013	1.1100e-003	2.0300e-003	96.8340

Pismo Beach GP/LCP PEIR - GHG - San Luis Obispo County APCD Air District, Winter

EMFAC Off-Model Adjustment Factors for Gasoline Light Duty Vehicle to Account for the SAFE Vehicle Rule Applied

3.7 Architectural Coating - 2040

Unmitigated Construction On-Site

	ROG	NOx	CO	SO2	Fugitive PM10	Exhaust PM10	PM10 Total	Fugitive PM2.5	Exhaust PM2.5	PM2.5 Total	Bio- CO2	NBio- CO2	Total CO2	CH4	N2O	CO2e
Category	lb/day										lb/day					
Archit. Coating	75.1742					0.0000	0.0000		0.0000	0.0000			0.0000			0.0000
Off-Road	0.1149	0.7270	1.7923	2.9700e-003		7.4300e-003	7.4300e-003		7.4300e-003	7.4300e-003		281.4481	281.4481	9.9000e-003		281.6957
Total	75.2891	0.7270	1.7923	2.9700e-003		7.4300e-003	7.4300e-003		7.4300e-003	7.4300e-003		281.4481	281.4481	9.9000e-003		281.6957

Unmitigated Construction Off-Site

	ROG	NOx	CO	SO2	Fugitive PM10	Exhaust PM10	PM10 Total	Fugitive PM2.5	Exhaust PM2.5	PM2.5 Total	Bio- CO2	NBio- CO2	Total CO2	CH4	N2O	CO2e
Category	lb/day										lb/day					
Hauling	0.0000	0.0000	0.0000	0.0000	0.0000	0.0000	0.0000	0.0000	0.0000	0.0000		0.0000	0.0000	0.0000	0.0000	0.0000
Vendor	0.0000	0.0000	0.0000	0.0000	0.0000	0.0000	0.0000	0.0000	0.0000	0.0000		0.0000	0.0000	0.0000	0.0000	0.0000
Worker	0.3205	0.1766	3.0420	0.0119	2.0761	3.8900e-003	2.0800	0.5506	3.5800e-003	0.5542		1,346.8181	1,346.8181	0.0156	0.0284	1,355.6753
Total	0.3205	0.1766	3.0420	0.0119	2.0761	3.8900e-003	2.0800	0.5506	3.5800e-003	0.5542		1,346.8181	1,346.8181	0.0156	0.0284	1,355.6753

Pismo Beach GP/LCP PEIR - GHG - San Luis Obispo County APCD Air District, Winter

EMFAC Off-Model Adjustment Factors for Gasoline Light Duty Vehicle to Account for the SAFE Vehicle Rule Applied

3.7 Architectural Coating - 2040

Mitigated Construction On-Site

	ROG	NOx	CO	SO2	Fugitive PM10	Exhaust PM10	PM10 Total	Fugitive PM2.5	Exhaust PM2.5	PM2.5 Total	Bio- CO2	NBio- CO2	Total CO2	CH4	N2O	CO2e
Category	lb/day										lb/day					
Archit. Coating	75.1742					0.0000	0.0000		0.0000	0.0000			0.0000			0.0000
Off-Road	0.1149	0.7270	1.7923	2.9700e-003		7.4300e-003	7.4300e-003		7.4300e-003	7.4300e-003	0.0000	281.4481	281.4481	9.9000e-003		281.6957
Total	75.2891	0.7270	1.7923	2.9700e-003		7.4300e-003	7.4300e-003		7.4300e-003	7.4300e-003	0.0000	281.4481	281.4481	9.9000e-003		281.6957

Mitigated Construction Off-Site

	ROG	NOx	CO	SO2	Fugitive PM10	Exhaust PM10	PM10 Total	Fugitive PM2.5	Exhaust PM2.5	PM2.5 Total	Bio- CO2	NBio- CO2	Total CO2	CH4	N2O	CO2e
Category	lb/day										lb/day					
Hauling	0.0000	0.0000	0.0000	0.0000	0.0000	0.0000	0.0000	0.0000	0.0000	0.0000		0.0000	0.0000	0.0000	0.0000	0.0000
Vendor	0.0000	0.0000	0.0000	0.0000	0.0000	0.0000	0.0000	0.0000	0.0000	0.0000		0.0000	0.0000	0.0000	0.0000	0.0000
Worker	0.3205	0.1766	3.0420	0.0119	2.0761	3.8900e-003	2.0800	0.5506	3.5800e-003	0.5542		1,346.8181	1,346.8181	0.0156	0.0284	1,355.6753
Total	0.3205	0.1766	3.0420	0.0119	2.0761	3.8900e-003	2.0800	0.5506	3.5800e-003	0.5542		1,346.8181	1,346.8181	0.0156	0.0284	1,355.6753

Pismo Beach GP/LCP PEIR - GHG - San Luis Obispo County APCD Air District, Winter

EMFAC Off-Model Adjustment Factors for Gasoline Light Duty Vehicle to Account for the SAFE Vehicle Rule Applied

3.7 Architectural Coating - 2041

Unmitigated Construction On-Site

	ROG	NOx	CO	SO2	Fugitive PM10	Exhaust PM10	PM10 Total	Fugitive PM2.5	Exhaust PM2.5	PM2.5 Total	Bio- CO2	NBio- CO2	Total CO2	CH4	N2O	CO2e
Category	lb/day										lb/day					
Off-Road	0.1149	0.7270	1.7923	2.9700e-003		7.4300e-003	7.4300e-003		7.4300e-003	7.4300e-003		281.4481	281.4481	9.9000e-003		281.6957
Total	0.1149	0.7270	1.7923	2.9700e-003		7.4300e-003	7.4300e-003		7.4300e-003	7.4300e-003		281.4481	281.4481	9.9000e-003		281.6957

Unmitigated Construction Off-Site

	ROG	NOx	CO	SO2	Fugitive PM10	Exhaust PM10	PM10 Total	Fugitive PM2.5	Exhaust PM2.5	PM2.5 Total	Bio- CO2	NBio- CO2	Total CO2	CH4	N2O	CO2e
Category	lb/day										lb/day					
Hauling	0.0000	0.0000	0.0000	0.0000	0.0000	0.0000	0.0000	0.0000	0.0000	0.0000		0.0000	0.0000	0.0000	0.0000	0.0000
Vendor	0.0000	0.0000	0.0000	0.0000	0.0000	0.0000	0.0000	0.0000	0.0000	0.0000		0.0000	0.0000	0.0000	0.0000	0.0000
Worker	0.3205	0.1766	3.0420	0.0119	2.0761	3.8900e-003	2.0800	0.5506	3.5800e-003	0.5542		1,346.8181	1,346.8181	0.0156	0.0284	1,355.6753
Total	0.3205	0.1766	3.0420	0.0119	2.0761	3.8900e-003	2.0800	0.5506	3.5800e-003	0.5542		1,346.8181	1,346.8181	0.0156	0.0284	1,355.6753

Pismo Beach GP/LCP PEIR - GHG - San Luis Obispo County APCD Air District, Winter

EMFAC Off-Model Adjustment Factors for Gasoline Light Duty Vehicle to Account for the SAFE Vehicle Rule Applied

3.7 Architectural Coating - 2041

Mitigated Construction On-Site

	ROG	NOx	CO	SO2	Fugitive PM10	Exhaust PM10	PM10 Total	Fugitive PM2.5	Exhaust PM2.5	PM2.5 Total	Bio- CO2	NBio- CO2	Total CO2	CH4	N2O	CO2e
Category	lb/day										lb/day					
Off-Road	0.1149	0.7270	1.7923	2.9700e-003		7.4300e-003	7.4300e-003		7.4300e-003	7.4300e-003	0.0000	281.4481	281.4481	9.9000e-003		281.6957
Total	0.1149	0.7270	1.7923	2.9700e-003		7.4300e-003	7.4300e-003		7.4300e-003	7.4300e-003	0.0000	281.4481	281.4481	9.9000e-003		281.6957

Mitigated Construction Off-Site

	ROG	NOx	CO	SO2	Fugitive PM10	Exhaust PM10	PM10 Total	Fugitive PM2.5	Exhaust PM2.5	PM2.5 Total	Bio- CO2	NBio- CO2	Total CO2	CH4	N2O	CO2e
Category	lb/day										lb/day					
Hauling	0.0000	0.0000	0.0000	0.0000	0.0000	0.0000	0.0000	0.0000	0.0000	0.0000		0.0000	0.0000	0.0000	0.0000	0.0000
Vendor	0.0000	0.0000	0.0000	0.0000	0.0000	0.0000	0.0000	0.0000	0.0000	0.0000		0.0000	0.0000	0.0000	0.0000	0.0000
Worker	0.3205	0.1766	3.0420	0.0119	2.0761	3.8900e-003	2.0800	0.5506	3.5800e-003	0.5542		1,346.8181	1,346.8181	0.0156	0.0284	1,355.6753
Total	0.3205	0.1766	3.0420	0.0119	2.0761	3.8900e-003	2.0800	0.5506	3.5800e-003	0.5542		1,346.8181	1,346.8181	0.0156	0.0284	1,355.6753

Pismo Beach GP/LCP PEIR - GHG - San Luis Obispo County APCD Air District, Winter

EMFAC Off-Model Adjustment Factors for Gasoline Light Duty Vehicle to Account for the SAFE Vehicle Rule Applied

3.7 Architectural Coating - 2042

Unmitigated Construction On-Site

	ROG	NOx	CO	SO2	Fugitive PM10	Exhaust PM10	PM10 Total	Fugitive PM2.5	Exhaust PM2.5	PM2.5 Total	Bio- CO2	NBio- CO2	Total CO2	CH4	N2O	CO2e
Category	lb/day										lb/day					
Off-Road	0.1149	0.7270	1.7923	2.9700e-003		7.4300e-003	7.4300e-003		7.4300e-003	7.4300e-003		281.4481	281.4481	9.9000e-003		281.6957
Total	0.1149	0.7270	1.7923	2.9700e-003		7.4300e-003	7.4300e-003		7.4300e-003	7.4300e-003		281.4481	281.4481	9.9000e-003		281.6957

Unmitigated Construction Off-Site

	ROG	NOx	CO	SO2	Fugitive PM10	Exhaust PM10	PM10 Total	Fugitive PM2.5	Exhaust PM2.5	PM2.5 Total	Bio- CO2	NBio- CO2	Total CO2	CH4	N2O	CO2e
Category	lb/day										lb/day					
Hauling	0.0000	0.0000	0.0000	0.0000	0.0000	0.0000	0.0000	0.0000	0.0000	0.0000		0.0000	0.0000	0.0000	0.0000	0.0000
Vendor	0.0000	0.0000	0.0000	0.0000	0.0000	0.0000	0.0000	0.0000	0.0000	0.0000		0.0000	0.0000	0.0000	0.0000	0.0000
Worker	0.3205	0.1766	3.0420	0.0119	2.0761	3.8900e-003	2.0800	0.5506	3.5800e-003	0.5542		1,346.8181	1,346.8181	0.0156	0.0284	1,355.6753
Total	0.3205	0.1766	3.0420	0.0119	2.0761	3.8900e-003	2.0800	0.5506	3.5800e-003	0.5542		1,346.8181	1,346.8181	0.0156	0.0284	1,355.6753

Pismo Beach GP/LCP PEIR - GHG - San Luis Obispo County APCD Air District, Winter

EMFAC Off-Model Adjustment Factors for Gasoline Light Duty Vehicle to Account for the SAFE Vehicle Rule Applied

3.7 Architectural Coating - 2042

Mitigated Construction On-Site

	ROG	NOx	CO	SO2	Fugitive PM10	Exhaust PM10	PM10 Total	Fugitive PM2.5	Exhaust PM2.5	PM2.5 Total	Bio- CO2	NBio- CO2	Total CO2	CH4	N2O	CO2e
Category	lb/day										lb/day					
Off-Road	0.1149	0.7270	1.7923	2.9700e-003		7.4300e-003	7.4300e-003		7.4300e-003	7.4300e-003	0.0000	281.4481	281.4481	9.9000e-003		281.6957
Total	0.1149	0.7270	1.7923	2.9700e-003		7.4300e-003	7.4300e-003		7.4300e-003	7.4300e-003	0.0000	281.4481	281.4481	9.9000e-003		281.6957

Mitigated Construction Off-Site

	ROG	NOx	CO	SO2	Fugitive PM10	Exhaust PM10	PM10 Total	Fugitive PM2.5	Exhaust PM2.5	PM2.5 Total	Bio- CO2	NBio- CO2	Total CO2	CH4	N2O	CO2e
Category	lb/day										lb/day					
Hauling	0.0000	0.0000	0.0000	0.0000	0.0000	0.0000	0.0000	0.0000	0.0000	0.0000		0.0000	0.0000	0.0000	0.0000	0.0000
Vendor	0.0000	0.0000	0.0000	0.0000	0.0000	0.0000	0.0000	0.0000	0.0000	0.0000		0.0000	0.0000	0.0000	0.0000	0.0000
Worker	0.3205	0.1766	3.0420	0.0119	2.0761	3.8900e-003	2.0800	0.5506	3.5800e-003	0.5542		1,346.8181	1,346.8181	0.0156	0.0284	1,355.6753
Total	0.3205	0.1766	3.0420	0.0119	2.0761	3.8900e-003	2.0800	0.5506	3.5800e-003	0.5542		1,346.8181	1,346.8181	0.0156	0.0284	1,355.6753

4.0 Operational Detail - Mobile

Pismo Beach GP/LCP PEIR - GHG - San Luis Obispo County APCD Air District, Winter

EMFAC Off-Model Adjustment Factors for Gasoline Light Duty Vehicle to Account for the SAFE Vehicle Rule Applied

4.1 Mitigation Measures Mobile

	ROG	NOx	CO	SO2	Fugitive PM10	Exhaust PM10	PM10 Total	Fugitive PM2.5	Exhaust PM2.5	PM2.5 Total	Bio- CO2	NBio- CO2	Total CO2	CH4	N2O	CO2e
Category	lb/day										lb/day					
Mitigated	8.3769	9.6920	94.1100	0.2091	31.8757	0.1101	31.9857	8.4836	0.1031	8.5867		23,247.0508	23,247.0508	1.1306	0.9238	23,550.5942
Unmitigated	8.3769	9.6920	94.1100	0.2091	31.8757	0.1101	31.9857	8.4836	0.1031	8.5867		23,247.0508	23,247.0508	1.1306	0.9238	23,550.5942

4.2 Trip Summary Information

Land Use	Average Daily Trip Rate			Unmitigated	Mitigated
	Weekday	Saturday	Sunday	Annual VMT	Annual VMT
Apartments Low Rise	200.64	223.44	173.28	915,611	915,611
Apartments Mid Rise	113.40	95.58	79.38	485,275	485,275
Apartments Mid Rise	505.40	425.98	353.78	2,162,770	2,162,770
Government (Civic Center)	25.99	0.00	0.00	49,223	49,223
Office Park	559.84	84.19	37.88	1,836,518	1,836,518
Strip Mall	1,339.20	1,257.36	610.08	5,585,619	5,585,619
Strip Mall	583.20	547.56	265.68	2,432,447	2,432,447
Total	3,327.67	2,634.11	1,520.08	13,467,463	13,467,463

4.3 Trip Type Information

Land Use	Miles			Trip %			Trip Purpose %		
	H-W or C-W	H-S or C-C	H-O or C-NW	H-W or C-W	H-S or C-C	H-O or C-NW	Primary	Diverted	Pass-by
Apartments Low Rise	23.42	9.01	9.01	35.80	21.00	43.20	86	11	3
Apartments Mid Rise	23.42	9.01	9.01	35.80	21.00	43.20	86	11	3

Pismo Beach GP/LCP PEIR - GHG - San Luis Obispo County APCD Air District, Winter

EMFAC Off-Model Adjustment Factors for Gasoline Light Duty Vehicle to Account for the SAFE Vehicle Rule Applied

Land Use	Miles			Trip %			Trip Purpose %		
	H-W or C-W	H-S or C-C	H-O or C-NW	H-W or C-W	H-S or C-C	H-O or C-NW	Primary	Diverted	Pass-by
Apartments Mid Rise	23.42	9.01	9.01	35.80	21.00	43.20	86	11	3
Government (Civic Center)	12.87	10.73	12.48	75.00	20.00	5.00	50	34	16
Office Park	24.95	9.60	6.60	33.00	48.00	19.00	82	15	3
Strip Mall	46.79	18.00	18.00	16.60	64.40	19.00	45	40	15
Strip Mall	46.79	18.00	18.00	16.60	64.40	19.00	45	40	15

4.4 Fleet Mix

Land Use	LDA	LDT1	LDT2	MDV	LHD1	LHD2	MHD	HHD	OBUS	UBUS	MCY	SBUS	MH
Apartments Low Rise	0.537981	0.060917	0.197944	0.129503	0.022130	0.006150	0.007595	0.005434	0.000841	0.000325	0.027432	0.000740	0.003008
Apartments Mid Rise	0.537981	0.060917	0.197944	0.129503	0.022130	0.006150	0.007595	0.005434	0.000841	0.000325	0.027432	0.000740	0.003008
Government (Civic Center)	0.537981	0.060917	0.197944	0.129503	0.022130	0.006150	0.007595	0.005434	0.000841	0.000325	0.027432	0.000740	0.003008
Office Park	0.537981	0.060917	0.197944	0.129503	0.022130	0.006150	0.007595	0.005434	0.000841	0.000325	0.027432	0.000740	0.003008
Strip Mall	0.537981	0.060917	0.197944	0.129503	0.022130	0.006150	0.007595	0.005434	0.000841	0.000325	0.027432	0.000740	0.003008

5.0 Energy Detail

Historical Energy Use: N

5.1 Mitigation Measures Energy

Pismo Beach GP/LCP PEIR - GHG - San Luis Obispo County APCD Air District, Winter

EMFAC Off-Model Adjustment Factors for Gasoline Light Duty Vehicle to Account for the SAFE Vehicle Rule Applied

	ROG	NOx	CO	SO2	Fugitive PM10	Exhaust PM10	PM10 Total	Fugitive PM2.5	Exhaust PM2.5	PM2.5 Total	Bio- CO2	NBio- CO2	Total CO2	CH4	N2O	CO2e
Category	lb/day										lb/day					
Natural Gas Mitigated	0.5731	5.0543	3.2348	0.0313		0.3960	0.3960		0.3960	0.3960		6,251.9438	6,251.9438	0.1198	0.1146	6,289.0959
Natural Gas Unmitigated	0.5731	5.0543	3.2348	0.0313		0.3960	0.3960		0.3960	0.3960		6,251.9438	6,251.9438	0.1198	0.1146	6,289.0959

Pismo Beach GP/LCP PEIR - GHG - San Luis Obispo County APCD Air District, Winter

EMFAC Off-Model Adjustment Factors for Gasoline Light Duty Vehicle to Account for the SAFE Vehicle Rule Applied

5.2 Energy by Land Use - NaturalGas

Unmitigated

	NaturalGas Use	ROG	NOx	CO	SO2	Fugitive PM10	Exhaust PM10	PM10 Total	Fugitive PM2.5	Exhaust PM2.5	PM2.5 Total	Bio- CO2	NBio- CO2	Total CO2	CH4	N2O	CO2e
Land Use	kBTU/yr	lb/day										lb/day					
Apartments Low Rise	6163.99	0.0665	0.5681	0.2417	3.6300e-003		0.0459	0.0459		0.0459	0.0459		725.1752	725.1752	0.0139	0.0133	729.4846
Apartments Mid Rise	16579.7	0.1788	1.5279	0.6502	9.7500e-003		0.1235	0.1235		0.1235	0.1235		1,950.5473	1,950.5473	0.0374	0.0358	1,962.1384
Apartments Mid Rise	3720.09	0.0401	0.3428	0.1459	2.1900e-003		0.0277	0.0277		0.0277	0.0277		437.6574	437.6574	8.3900e-003	8.0200e-003	440.2582
Government (Civic Center)	281.392	3.0300e-003	0.0276	0.0232	1.7000e-004		2.1000e-003	2.1000e-003		2.1000e-003	2.1000e-003		33.1049	33.1049	6.3000e-004	6.1000e-004	33.3016
Office Park	24114.1	0.2601	2.3641	1.9859	0.0142		0.1797	0.1797		0.1797	0.1797		2,836.9529	2,836.9529	0.0544	0.0520	2,853.8115
Strip Mall	1589.92	0.0172	0.1559	0.1309	9.4000e-004		0.0119	0.0119		0.0119	0.0119		187.0492	187.0492	3.5900e-003	3.4300e-003	188.1607
Strip Mall	692.384	7.4700e-003	0.0679	0.0570	4.1000e-004		5.1600e-003	5.1600e-003		5.1600e-003	5.1600e-003		81.4569	81.4569	1.5600e-003	1.4900e-003	81.9410
Total		0.5731	5.0543	3.2348	0.0313		0.3960	0.3960		0.3960	0.3960		6,251.9438	6,251.9438	0.1198	0.1146	6,289.0959

Pismo Beach GP/LCP PEIR - GHG - San Luis Obispo County APCD Air District, Winter

EMFAC Off-Model Adjustment Factors for Gasoline Light Duty Vehicle to Account for the SAFE Vehicle Rule Applied

5.2 Energy by Land Use - NaturalGas

Mitigated

	NaturalGas Use	ROG	NOx	CO	SO2	Fugitive PM10	Exhaust PM10	PM10 Total	Fugitive PM2.5	Exhaust PM2.5	PM2.5 Total	Bio- CO2	NBio- CO2	Total CO2	CH4	N2O	CO2e
Land Use	kBTU/yr	lb/day										lb/day					
Apartments Low Rise	6.16399	0.0665	0.5681	0.2417	3.6300e-003		0.0459	0.0459		0.0459	0.0459		725.1752	725.1752	0.0139	0.0133	729.4846
Apartments Mid Rise	16.5797	0.1788	1.5279	0.6502	9.7500e-003		0.1235	0.1235		0.1235	0.1235		1,950.5473	1,950.5473	0.0374	0.0358	1,962.1384
Apartments Mid Rise	3.72009	0.0401	0.3428	0.1459	2.1900e-003		0.0277	0.0277		0.0277	0.0277		437.6574	437.6574	8.3900e-003	8.0200e-003	440.2582
Government (Civic Center)	0.281392	3.0300e-003	0.0276	0.0232	1.7000e-004		2.1000e-003	2.1000e-003		2.1000e-003	2.1000e-003		33.1049	33.1049	6.3000e-004	6.1000e-004	33.3016
Office Park	24.1141	0.2601	2.3641	1.9859	0.0142		0.1797	0.1797		0.1797	0.1797		2,836.9529	2,836.9529	0.0544	0.0520	2,853.8115
Strip Mall	0.692384	7.4700e-003	0.0679	0.0570	4.1000e-004		5.1600e-003	5.1600e-003		5.1600e-003	5.1600e-003		81.4569	81.4569	1.5600e-003	1.4900e-003	81.9410
Strip Mall	1.58992	0.0172	0.1559	0.1309	9.4000e-004		0.0119	0.0119		0.0119	0.0119		187.0492	187.0492	3.5900e-003	3.4300e-003	188.1607
Total		0.5731	5.0543	3.2348	0.0313		0.3960	0.3960		0.3960	0.3960		6,251.9438	6,251.9438	0.1198	0.1146	6,289.0959

6.0 Area Detail

6.1 Mitigation Measures Area

Pismo Beach GP/LCP PEIR - GHG - San Luis Obispo County APCD Air District, Winter

EMFAC Off-Model Adjustment Factors for Gasoline Light Duty Vehicle to Account for the SAFE Vehicle Rule Applied

	ROG	NOx	CO	SO2	Fugitive PM10	Exhaust PM10	PM10 Total	Fugitive PM2.5	Exhaust PM2.5	PM2.5 Total	Bio- CO2	NBio- CO2	Total CO2	CH4	N2O	CO2e
Category	lb/day										lb/day					
Mitigated	50.0945	1.0550	91.4179	4.8500e-003		0.5090	0.5090		0.5090	0.5090	0.0000	165.3616	165.3616	0.1577	0.0000	169.3035
Unmitigated	50.0945	1.0550	91.4179	4.8500e-003		0.5090	0.5090		0.5090	0.5090	0.0000	165.3616	165.3616	0.1577	0.0000	169.3035

6.2 Area by SubCategory

Unmitigated

	ROG	NOx	CO	SO2	Fugitive PM10	Exhaust PM10	PM10 Total	Fugitive PM2.5	Exhaust PM2.5	PM2.5 Total	Bio- CO2	NBio- CO2	Total CO2	CH4	N2O	CO2e
SubCategory	lb/day										lb/day					
Architectural Coating	6.7966					0.0000	0.0000		0.0000	0.0000			0.0000			0.0000
Consumer Products	40.5588					0.0000	0.0000		0.0000	0.0000			0.0000			0.0000
Hearth	0.0000	0.0000	0.0000	0.0000		0.0000	0.0000		0.0000	0.0000	0.0000	0.0000	0.0000	0.0000	0.0000	0.0000
Landscaping	2.7391	1.0550	91.4179	4.8500e-003		0.5090	0.5090		0.5090	0.5090		165.3616	165.3616	0.1577		169.3035
Total	50.0945	1.0550	91.4179	4.8500e-003		0.5090	0.5090		0.5090	0.5090	0.0000	165.3616	165.3616	0.1577	0.0000	169.3035

Pismo Beach GP/LCP PEIR - GHG - San Luis Obispo County APCD Air District, Winter

EMFAC Off-Model Adjustment Factors for Gasoline Light Duty Vehicle to Account for the SAFE Vehicle Rule Applied

6.2 Area by SubCategory

Mitigated

	ROG	NOx	CO	SO2	Fugitive PM10	Exhaust PM10	PM10 Total	Fugitive PM2.5	Exhaust PM2.5	PM2.5 Total	Bio- CO2	NBio- CO2	Total CO2	CH4	N2O	CO2e
SubCategory	lb/day										lb/day					
Architectural Coating	6.7966					0.0000	0.0000		0.0000	0.0000			0.0000			0.0000
Consumer Products	40.5588					0.0000	0.0000		0.0000	0.0000			0.0000			0.0000
Hearth	0.0000	0.0000	0.0000	0.0000		0.0000	0.0000		0.0000	0.0000	0.0000	0.0000	0.0000	0.0000	0.0000	0.0000
Landscaping	2.7391	1.0550	91.4179	4.8500e-003		0.5090	0.5090		0.5090	0.5090		165.3616	165.3616	0.1577		169.3035
Total	50.0945	1.0550	91.4179	4.8500e-003		0.5090	0.5090		0.5090	0.5090	0.0000	165.3616	165.3616	0.1577	0.0000	169.3035

7.0 Water Detail

7.1 Mitigation Measures Water

- Apply Water Conservation Strategy
- Use Water Efficient Irrigation System

Pismo Beach GP/LCP PEIR - GHG - San Luis Obispo County APCD Air District, Winter

EMFAC Off-Model Adjustment Factors for Gasoline Light Duty Vehicle to Account for the SAFE Vehicle Rule Applied

8.0 Waste Detail

8.1 Mitigation Measures Waste

9.0 Operational Offroad

Equipment Type	Number	Hours/Day	Days/Year	Horse Power	Load Factor	Fuel Type
----------------	--------	-----------	-----------	-------------	-------------	-----------

10.0 Stationary Equipment

Fire Pumps and Emergency Generators

Equipment Type	Number	Hours/Day	Hours/Year	Horse Power	Load Factor	Fuel Type
----------------	--------	-----------	------------	-------------	-------------	-----------

Boilers

Equipment Type	Number	Heat Input/Day	Heat Input/Year	Boiler Rating	Fuel Type
----------------	--------	----------------	-----------------	---------------	-----------

User Defined Equipment

Equipment Type	Number
----------------	--------

11.0 Vegetation

Appendix J

Vehicle Miles Traveled (VMT) Memorandum



Memorandum

December 13, 2021

To: Chris Bersbach, Rincon Project: Pismo Beach GPU

From: Jake Hudson, GHD Ref/Job No.: 11225678
Kenneth Isenhower
Rosanna Southern

CC: File No.: 11225678MEM001.DOCX

Subject: Draft: Pismo Land Use Element Update: Transportation Impact Analysis

1. Introduction

Rincon has retained GHD to assess CEQA Impacts under Senate Bill 743 for the proposed Land Use Element update of the City of Pismo Beach's General Plan. This analysis included assessing the update's consistency with Circulation Element Plan & Policy, Vehicle Miles of Travel, Transportation Safety, Emergency Access, & Induced Travel.

Dudek has prepared the proposed land use assumptions based on the methodology provided in attachment A. These assumptions were developed using a combination of parcel information provided by CoreLogic, an inventory of vacant or underutilized parcels, and potential growth & redevelopment growth based dwelling units per acre and floor to area ratios.

The current land use element was adopted in 2008 and was the basis for the subsequent Circulation element adopted in 2018. The 2008 land use element provided for the growth of 476 residential units and growth of 690 jobs. The proposed land use element update increases that growth to 1,111 residential units and 545 jobs.

2. Significance Thresholds

Based on Appendix G of the CEQA guidelines, impacts are considered significant if implementation of the Land Use Element satisfies any of the following criteria:

- A. Conflict with a program, plan, ordinance or policy addressing the circulation system, including transit, roadway, bicycle, and pedestrian facilities (with the exception of automobile delay & level of service);
- B. Conflict or be inconsistent with CEQA Guidelines Section 15064.3, subdivision (b), Criteria for Analyzing Transportation Impacts;



- C. Substantially increase hazards due to a design feature (eg. Sharp curves or dangerous intersection) or incompatible uses (e.g. farm equipment); and/or
- D. Result in inadequate emergency access.

The City has not yet adopted local Vehicle Miles of Travel Thresholds and associated impact/mitigation policies; therefore, impact criteria is based on California Office of Planning & Research Guidance.

3. Threshold A: Would the Land Use Element Conflict with a Transportation program, plan, ordinance, or policy?

The City's current circulation element was adopted in June of 2018 based on the current Land Use element, adopted in 2008. The city is concurrently preparing a focused update of its Circulation Element, consistent the underlying growth assumptions of the proposed Land Use element. The City also adopted its Bicycle and Pedestrian Master Plan in June of 2010. The primary plan affected by the proposed Land Use Element is the City's Circulation Element.

3.1 Circulation Element Sections 1 & 3

Circulation Element Section 1 summarizes Citywide traffic operations analysis under buildout conditions and provides justification/support for proposed Multimodal Circulation Plan Improvements throughout section 3. As part of the concurrent focused Circulation Element update, planned improvements have been reassessed under the proposed land use assumptions. This was conducted to identify inconsistencies with the Circulation Element and ensure that the City's transportation network can accommodate the increased traffic generation.

3.2 Circulation Element Section 4

Senate Bill 743 replaced level of service as the primary CEQA metric with Vehicle Miles of Travel. However, SB 743 allows local agencies to retain automobile level of service as a local policy threshold outside of CEQA.

Increasing traffic generation is projected to result in deficiencies associated with the City's local level of service thresholds, however new transportation improvements are proposed within the City's Circulation Element to offset those deficiencies. Also, under Senate Bill 743 Automobile Delay and Level of Service are no longer considered impact metrics for determining environmental impacts.

The proposed Land Use Element is consistent with the City's Bicycle & Pedestrian Master Plan. The City is also concurrently preparing a focused update of its Circulation Element, consistent the underlying growth assumptions of the proposed Land Use Element. Therefore, if adopted concurrently, consistency impacts associated with transportation program, plan, ordinance, or policy are less than significant.



4. Threshold B: Vehicle Miles of Travel

Under SB 743, automobile delay, traditionally measured as level of service (LOS), is no longer considered the metric for environmental transportation impacts under the California Environmental Quality Act (CEQA), but rather VMT. VMT measures the number and length of vehicle trips made daily. VMT is a valuable indicator of overall land use and transportation efficiency. The most efficient system minimizes VMT by encouraging shorter vehicle trip lengths, more walking, and biking, or increased carpooling and transit.

4.1 VMT Methodology

The VMT estimates with and without the proposed Land Use Element have been evaluated utilizing the Pismo Beach Travel Demand Model (Pismo Model, 2015). The proposed Element’s planning Horizon is 2040, whereas the City’s travel demand model’s planning horizon is 2035. Although these planning horizons have different theoretical years, they both represent buildout conditions. The Pismo Model was built upon the 2014 San Luis Obispo Council of Governments (SLOCOG) Regional Travel Demand Model, with refinements to the traffic analysis zone structure, roadway network, and land uses. To account for non-boundary-based trip lengths, the model's distance associated with the external gateway cordons was adjusted to reflect distances beyond the model boundaries. The average trip length added to these gateway cordons were determined in the EIR for the Cal Poly San Luis Obispo 2035 Master Plan, Appendix G (2019). The added lengths and gateway cordons are shown in Table 3.1.

Table 3.1 External Gateway Link Distance Added

Location	External Node	Link ID	Distance Added (miles)
Hwy 1 N	1	28442	75
US 101 N (A)	2	28443	40
US 101 N (B)	3	28455	40
Hwy 41 N	4	28445	75
Hwy 46 E	5	28447	50
Hwy 58 E	6	28449	50
Hwy 166 E	7	28451	60
Hwy 33 S	8	28450	60
US 101 S (A)	9	28452	2
US 101 S (B)	9	28453	2
Hwy 1 S	10	28454	10

Notes:

1. Distance added to external Node and corresponding link ID to capture VMT outside of the SLOCOG County boundary.

For the VMT analysis with the proposed Plan, a model scenario was created that modified the Pismo Model forecast land use data to include the proposed General Plan buildout development. The VMT analysis consists of both (1) evaluating net change in total VMT and (2) the change in VMT efficiency metrics for the region. The net change in total VMT Countywide has been evaluated for the proposed Land Use Element against the baseline or “Existing” conditions and the “current General Plan” forecast scenario.

A trip-based VMT assessment was conducted for the model area (County) to estimate the total VMT for each scenario. The trip-based methodology is quantified by the length of the vehicle trips that start or end within the region and does not include VMT associated with vehicles that pass through the region. Project impacts on transportation are determined based on an increase in total VMT with the proposed plan. This methodology is consistent with the Office of Planning and Research’s Technical Advisory on Evaluating



Transportation Impacts in CEQA (OPR Technical Advisory, December 2018) and CEQA Guidelines. The list below describes the scenarios analyzed.

- “2010 Base Year” scenario represents existing land uses and existing transportation network
- “2035 Current GP” scenario represents the current General Plan Buildout
- “2035 Proposed GPU” scenario represents the proposed General Plan Buildout (Update)

Regional VMT efficiency metrics have also been analyzed as part of this analysis. The change in Residential VMT per capita and Work VMT per employee have been calculated countywide utilizing the Pismo Model, as previously described. For Residential VMT, all home-based automobile trips were selected for evaluation. For Work VMT, all home-based-work automobile trips were selected for evaluation. The population and employment metrics utilized to calculate residential VMT per capita and work VMT per employee were based on the model’s inputs for each scenario.

4.2 VMT Analysis Results

Table 3.2 presents the summary of the net change in total VMT results.

Table 3.2 Total VMT Results Summary

Model Scenario	Net VMT
2010 Base Year	11,226,484
Buildout Current GPU	13,311,157
Buildout Proposed GPU	13,476,666
Difference from 2035	+ 165,510
Difference from 2010	+ 2,250,182

The VMT results show a net increase in VMT and therefore the proposed land use plan would create a significant and unavoidable impact on transportation.

Table 3.3 presents the Residential VMT per capita results comparing the proposed Plan against the 2010 base year and current General Plan forecast. Table 3.4 present the Work VMT per employee results comparing the proposed Plan against the 2010 base year and current General Plan forecast.

Table 3.3 Residential VMT Results Summary

Pismo Model Scenario	Residential VMT	Residential Trips	Population	Residential VMT per Capita	Average Trip Distance
2010	7,420,936	717,564	255,085	29.09	10.34
2035	8,684,684	861,337	282,559	30.74	10.08
2035 GPU	8,694,346	860,802	283,671	30.65	10.10
Difference from 2035	9,662	(535)	1,112	-0.28%	0.17%
Difference from 2010	1,273,410	143,237	28,586	5.35%	-2.34%



Table 3.4 Work VMT Results Summary

Pismo Model Scenario	Work VMT	Work Trips	Employment	Work VMT per Employee	Average Trip Distance
2010	2,046,641	177,372	92,732	22.07	11.54
2035	2,260,727	197,741	113,867	19.85	11.43
2035 GPU	2,293,885	199,498	112,982	20.30	11.50
Difference from 2035	33,158	1,757	(885)	2.26%	0.57%
Difference from 2010	247,244	22,126	20,250	-8.01%	-0.35%

As shown in Table 3.3, the regional Residential VMT per capita is estimated to decrease by 0.28% with the proposed land uses. As shown in Table 3.4, the regional Work (commute) VMT per employee is estimated to increase by 2.26% with the proposed land uses. Although there are more residents and jobs within Pismo Beach, the model estimates a resulting higher VMT for the work trip purpose.

4.3 Thresholds C & D Induced Travel

The proposed Land Use Element Update proposes no changes to transportation facilities and therefore can be assumed to have a less than significant travel-inducing effect.

The proposed Land Use element is forecasted to increase Net VMT, Residential VMT per Capita, & Work VMT per Employee. These increases exceed thresholds established by the State Office of Planning & Research Guidance as well as the Caltrans Transportation Impact Study Guide. Therefore, this increase is considered a significant an unavoidable transportation impact.

5. Transportation Safety & Emergency Access

In 2020 the City of Pismo prepared a Citywide Systemic Traffic Safety Analysis & Local Roadway Safety Plan. This analysis & plan found that the number of annual traffic collisions remained relatively static from 2014 to 2018. The highest collision concentrations were within the Downtown core, and the primary contributing factor was visibility for vehicles turning from side streets and two-way stop-controlled intersections.

Planned land use growth is expected to occur primarily on vacant or underutilized sites, mainly located in the Downtown core and the U.S. 101 corridor in Shell Beach. Although this coincides with the City's highest collision concentrations, the primary factors associated with those concentrations are roadway geometrics, not incompatible land use patterns. Although more growth is planned as part of the proposed update, overall land use designations are essentially unchanged and have proven not to be incompatible uses in the context of vehicle types.

The proposed Land Use element does not change to the City's roadway network and therefore would not increase hazards due to geometric design features or affect overall Emergency Access. Therefore, the impacts to Transportation Safety & Emergency Access are considered less than significant.



ATTACHMENT A

DUDEK LAND USE PROJECTION METHODOLOGY AND ASSUMPTIONS

Pismo General Plan/Local Coastal Plan: Methodology for Determining Projected Development at Full Build Out

Used to create the LU-4 Table in the Land Use Element

1. Urban Footprint Base Canvas Assumptions

Urban Footprint's Base Canvas constitutes a baseline assessment of existing land use, demographic characteristics, and other conditions in the City, providing the context for scenario planning and the foundation for analysis of alternative scenarios. The default source for parcel information in Urban Footprint is CoreLogic, which is a leading provider of real estate data in the United States.

2. Determination of Land Uses for Inclusion

This buildout compares existing on-the-ground Base Canvas development to the buildout potential of four General Plan land use categories in the City where change is anticipated, including Commercial, Central Commercial, High Density Residential, Mixed Use, and Public/Semi-Public land uses. Only vacant and underutilized parcels within these designations were selected for potential growth.

3. Creation of Future Assumptions

When generating assumptions for the four land uses, Dudek first looked at the stated requirements or maximums for residential dwelling units per acre (du/ac), floor area ratio (FAR), height, and parking where possible. For each land use, employment and density limits were determined by matching them closely to the average employment and du/ac of current developed parcels within each land use category. An example formula to calculate commercial employment density can be seen below.

$$\begin{aligned} & \textit{Current Commercial Employment Density} \\ & = \left(\frac{\textit{Total Commercial Zoned Jobs} - \textit{Underutilized Commercial Zoned Jobs}}{\textit{Total Commercial Zoned Acres} - \textit{Underutilized Commercial Zoned Acres}} \right) \end{aligned}$$

Future assumptions for each land use were built in Urban Footprint using combinations of building components which created numbers closest to the determined employment and residential densities, and that worked to be within FAR, height, and parking requirements. Previous limitations within Urban Footprint required us to match Pismo's land use designations to prescribed building typologies in Urban Footprint, and adjusting them to match as closely as possible with Pismo's land use requirements and growth expectations.

Current standards per the Land Use Element Update and Future Assumptions used in the build out model can be seen for each of the included land uses below.

Current Land Use Density/Intensity Standards

Land Use Designations	FAR or Density	Height**	Implementing Zone(s)	Total Acreage
	<i>Coastal Zone/Non-Coastal Zone</i>	<i>Coastal Zone</i>		
Low-Density Residential	1 to 8 units per ac.	25 feet	R-1, R-R	76.5
Medium-Density Residential	9 to 15 units per ac.	25 - 35 feet	R-2, R-R	247.5
High-Density Residential	16 to 30 units per ac.	25 feet	R-3, R-R	22.2
Very High-Density Residential Overlay	20 to 50 units per ac.	35 – 45 feet***	R-3	1.1
Mobile Home Park	Maximum 8 units to the acre		M-H	58.5
Commercial	Maximum FAR of 2.0	25 - 42 feet	R-4, R-R, C-R, C-1, C-2, C-M	32.5
Resort Commercial	Maximum FAR of 1.25	35 feet	RR, R-4, and CR	73.9
Central Commercial	Maximum FAR of 1.25	35 feet	R-4, R-R, MU	66.4
Mixed-Use	Residential 1.25 maximum Commercial uses: 2.0 maximum	Determined by overlay zone	C-1, C-2, MU	57.2
Industrial	Maximum FAR of 0.5	25 feet	C-M	30.2
Public/Semi Public	Maximum FAR of 2.0	25 feet	G	468.38
Open Space	N/A	15 feet*	OS-1, OS-R	32.21

* Consistency with the View Consideration Overlay Zone must be determined for applicable properties

** Coastal height limits are provided to ensure that the scenic and visual qualities of coastal areas are considered and protected consistent with Coastal Act Section 30251.

*** Buildings may be up to forty-five (45) feet in height where the Planning Commission finds that significant public views to and along the coast and other scenic areas are protected.

Central Commercial Assumptions

Building Type Name <input type="text" value="Central Commercial Pismo (new)"/>	CCP
Land Use Category <input type="text" value="Commercial centers"/>	
Description <input type="text"/>	

Building Type Summary	
Floor area ratio - FAR	0.58
Residential density (net)	0 du/ac
Population density (net)	0 pop/ac
Employment density (net)	28.49 emp/ac

The Central Commercial land use had a maximum FAR of 1.25, and a maximum height of 35 feet. In looking at the currently built out Central Commercial sites, an FAR of 0.58 was determined to be more in line with what Pismo is likely to see built out, with an employment density of 28.49 employees per acre.

Commercial Assumptions

Building Type Name <input type="text" value="Commercial Pismo (new)"/>	CPN
Land Use Category <input type="text" value="Commercial centers"/>	
Description <input type="text"/>	

Building Type Summary	
Floor area ratio - FAR	0.31
Residential density (net)	0 du/ac
Population density (net)	0 pop/ac
Employment density (net)	15.8 emp/ac

The Commercial land use had a maximum FAR of 2.0, with maximum heights between 25 and 42. Due to the parking required and often offered at commercial sites and in looking at previously built out Commercial sites, an FAR of 0.31 was determined to be more in line with what Pismo is likely to see built out, with an employment density of 15.8 employees per acre.

High-Density Residential Assumptions

Building Type Name <input type="text" value="High-Density Residential"/>	HR
Land Use Category <input type="text" value="Multifamily"/>	
Description <input type="text" value="16-30 units per acre"/>	

Building Type Summary	
Floor area ratio - FAR	0.93
Residential density (net)	25.6 du/ac
Population density (net)	45.71 pop/ac
Employment density (net)	0 emp/ac

The High-Density Residential land use had an allowable range of 16-30 du/ac and a maximum height of 25 feet. Within the model, 25.6 du/ac were allotted for this land use.

Mixed-Use Assumptions

Building Type Name <input type="text" value="Low-rise Mixed Use Pismo (new)"/>	LMU
Land Use Category <input type="text" value="Mixed use commercial"/>	
Description <input type="text" value="16-30 units per acre"/>	

Building Type Summary	
Floor area ratio - FAR	3.66
Residential density (net)	88.67 du/ac
Population density (net)	150.03 pop/ac
Employment density (net)	33.39 emp/ac

The Mixed-Use land use had a maximum FAR of 1.25 for residential and 2.0 for commercial. Height maximums varied based on the overlay zoning. The model's FAR for mixed use is shown to be 3.66, far higher than what is allowed by these regulations. Heights were pre-set within the model and its

components, so to balance this in the model and create a zoning which is within the FAR requirements, vacant space was added to this mixed use zone. This is the equivalent of reducing the building height, and in turn the FAR, because by removing buildable space building volume is reduced to meet standards.

Medium-Density Residential Assumptions

Building Type Name MR

Medium-Density Residential

Land Use Category
Single-family detached

Description
9-15 units per acre

Building Type Summary

Floor area ratio - FAR	0.71
Residential density (net)	15.92 du/ac
Population density (net)	32.93 pop/ac
Employment density (net)	0 emp/ac

The Medium-Density Residential land use had an allowed range of 9-15 dwelling units per acre, and a maximum height of 25-35 feet. The closest building type in the model to these requirements slightly overshoots these requirements, coming in at 15.92 dwelling units per acre and leading to 32.93 people per acre. Sites that this assumption applied to were only those that are currently vacant (32 sites), as those were decided to be the only parcels in this land use designation that would experience growth. The slightly increased density is offset by the reduced density in the High-Density Residential designation.

Public/Semi-Public Assumptions

Component Name Density
Medium

Urban Public Library (Main Branch, Oakland CA)

Land Use Category
Civic facilities

Address
Oakland, CA

Component Summary

Floor area ratio - FAR	0.53
Residential density (net)	0 du/ac
Population density (net)	0 pop/ac
Employment density (net)	68.7 emp/ac

The Public/Semi-Public land use has a maximum FAR or 2.0, and a maximum height of 25 feet. The closest building type in the model to these requirements is a modified public library, coming in at a 0.53 FAR and 68.7 employees per acre. Only one site was identified for build out.

4. Application of Future Assumptions

Future assumptions were applied to all underutilized and vacant parcels. For the Medium-Density Residential land use, as described above, only vacant parcels had future assumptions applied to them. The result of this was a “built out” Pismo Beach. Numbers generated and recorded include increases in population, DU, jobs, and non-residential square footage from 2020 to 2040. These increases can be seen on the table below.

Land Use	Number of Vacant or Underutilized Parcels	Potential Increase in Population	Potential Increase in Dwelling Units	Potential Increase in Jobs
Commercial	42	N/A	N/A	242
Central Commercial	26	N/A	N/A	33

Land Use	Number of Vacant or Underutilized Parcels	Potential Increase in Population	Potential Increase in Dwelling Units	Potential Increase in Jobs
High Density Residential	139	289	162	-12
Mixed Use	48	1,221	722	272
Medium Density Residential	32	471	228	0
Public/Semi-Public	1	-2	-1	10
Total	288	1,979	1,111	545

5. Comparison to SLOCOG Predictions

To compare to SLOCOG employment and dwelling unit predictions, growth per year ratios were utilized. SLOCOG’s predictions are from 2015 to 2030, or a 15 year range. Dudek’s predictions are from 2020 to 2040, a 20 year range. Build outs and assumptions were altered to create predictions closer to SLOCOG’s predicted growth, while staying within the land use requirements.

The discrepancies between growth predictions can be seen on the table below.

Growth Comparisons		
	Increase in DU	Increase in Jobs
Dudek Growth Per Year	55.5	25.8
SLOCOG Growth Per Year	47.7	27.4

Dudek’s current methodology assumes a 100% build out for the identified underutilized and vacant parcels.

Appendix K

Citywide Transportation Model and Circulation Study



City of Pismo Beach Citywide Transportation Model and Circulation Study

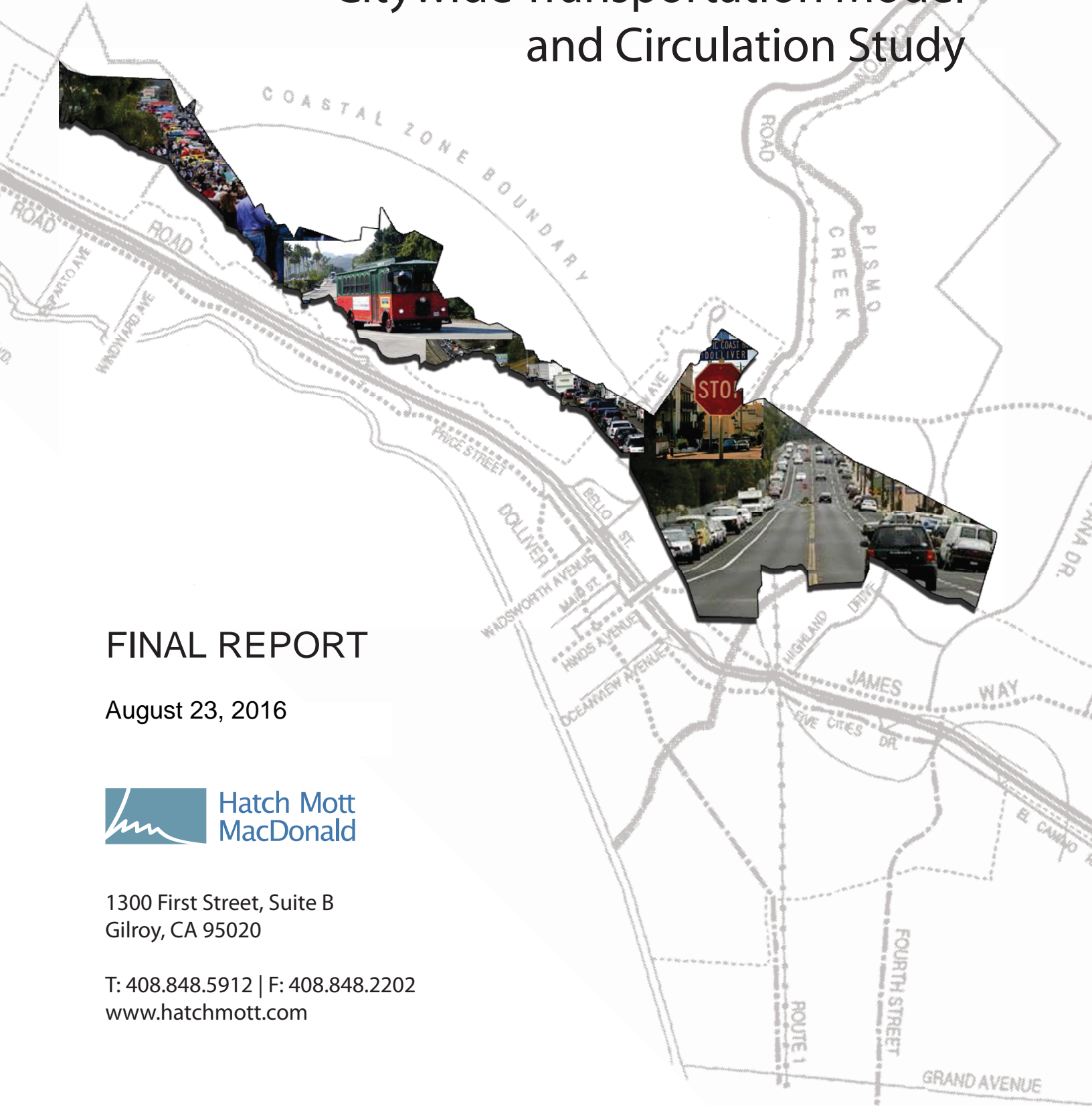

FINAL REPORT

August 23, 2016



1300 First Street, Suite B
Gilroy, CA 95020

T: 408.848.5912 | F: 408.848.2202
www.hatchmott.com

Table of Contents

- 1. Introduction1**
 - A. Background 1
 - B. Specific Transportation Issues Facing Pismo Beach..... 6
- 2. Existing Conditions7**
 - A. Roadway Network..... 7
 - B. Pedestrian and Bicycle Circulation..... 7
 - C. Pedestrian Facilities 9
 - D. Bicycle Facilities 13
 - E. Support Facilities..... 17
 - F. Trip Generators and Attractors..... 18
 - G. Existing Pedestrian and Bicycle Activity..... 18
 - H. Transit 25
 - I. Parking 27
 - J. Traffic Operations and Recommendations – Existing Conditions..... 31
 - K. Community Participation 53
- 3. General Plan Buildout Conditions57**
 - A. Weekday PM – Volume Derivation..... 57
 - B. Summer Sunday and Memorial Day Sunday – Volume Derivation 63
 - C. Traffic Operations and Recommendations - General Plan Buildout..... 64
 - D. Improvements Recommended in Previous Studies..... 75
 - E. Network Alternatives 79
 - F. Regional Highway Improvements 113
- 4. Recommendations..... 115**
 - A. Pedestrian and Bicycle 115
 - B. Transit 122
 - C. Rail..... 122
 - D. Parking 122
 - E. Traffic Operations 123
 - F. Transportation Demand Management 124
- 5. Public Comments on Recommendations..... 129**
- 6. References 130**
- 7. Report Preparation..... 132**

List of Exhibits

1. Regional Setting of Greater Pismo Beach Area..... 2

2. Historical Growth on Dolliver Street (SR 1) at Pismo Creek 4

3. Historical Growth on Dolliver Street (SR 1) at US 101 4

4. Historical Growth on US 101 at Pismo Creek..... 5

5. Historical Growth on US 101 North of Price Street 5

6. Existing Pedestrian Facilities in Pismo Beach..... 11

7. Existing Bicycle Facilities in Pismo Beach..... 15

8. Pedestrian Volumes – Existing Weekday PM Peak Hour 19

9. Pedestrian Volumes – Existing Summer Sunday Midday Peak Hour 20

10. Pedestrian Volumes – Existing Memorial Day Sunday Midday Peak Hour..... 21

11. Bicycle Volumes – Existing Weekday PM Peak Hour 22

12. Bicycle Volumes – Existing Summer Sunday Midday Peak Hour 23

13. Bicycle Volumes – Existing Memorial Day Sunday Midday Peak Hour 24

14. Existing Transit Routes in Pismo Beach 26

15. Downtown Pismo Beach Parking Space Inventory 28

16A. Location of Current Public Parking Facilities within Downtown Pismo Beach 29

16B. Location of Time-Limit On-Street Parking Areas in Downtown Pismo Beach 29

17A. Greater Pismo Beach Study Area (North) 35

17B. Greater Pismo Beach Study Area (South)..... 36

18A. Existing Weekday PM Peak Hour Volumes..... 37

18B. Existing Weekday PM Peak Hour Volumes (Continued)..... 38

18C. Existing Weekday PM Peak Hour Volumes (Continued)..... 39

18D. Existing Weekday PM Peak Hour Volumes (Continued)..... 40=

19. Existing Summer Sunday Midday Peak Hour Volumes 41

20. Existing Memorial Day Sunday Midday Peak Hour Volumes..... 42

21. Intersection Levels of Service – Existing Conditions 43-47

22A. Intersection Operations – Existing Weekday PM Peak Hour..... 49

22B. Intersection Operations – Existing Weekday PM Peak Hour (Continued)..... 50

23. Intersection Operations – Existing Summer Sunday Midday Peak Hour 51

24. Intersection Operations – Existing Memorial Day Sunday Midday Peak Hour..... 52

25. Public Comments from September 2014 Workshop 54

26. Street Network Issues Discussed at September 2014 Workshop..... 55

List of Exhibits (Continued)

27. Suggested Future Parking Areas Discussed at September 2014 Workshop 56

28. Other Issues Discussed at September 2014 Workshop 56

29A. Segment Volumes in Greater Pismo Beach Area – Roadways..... 59-60

29B. Segment Volumes in Greater Pismo Beach Area – Freeways..... 61

29C. Segment Volumes in Greater Pismo Beach Area – Ramps 62

30. Intersection Levels of Service – General Plan Buildout (Year 2035)..... 66-70

31A. Intersection Operations – General Plan Buildout Weekday PM Peak Hour 71

31B. Intersection Operations – General Plan Buildout PM Peak Hour (Continued)..... 72

32. Intersection Operations – General Plan Buildout Summer Sunday Midday Peak Hour 73

33. Intersection Operations – General Plan Buildout Memorial Day Sunday Midday Peak Hour 74

34. Dolliver St. (SR 1) / Price St. Roundabout 77

35. Dolliver St. (SR 1) / Price St. Roundabout with Future US 101 SB Onramp 78

36. Price Street / James Way Extension Alternatives 81

37. Projected Traffic Diversions with Price Street Extension (Year 2035) 82

38. Intersection LOS – GPBO Weekday PM Peak Hour – With Price Street Extension..... 83

39. Five Cities Drive / US 101 SB Ramps – Outlets Main Entrance
Improvements with Price Street Extension..... 85

40. Projected Traffic Diversions with James Way Extension (Year 2035)..... 86

41. Frady Lane Improvements 89

42. Projected Traffic Diversions with Frady Lane
Realignment and Mattie Road Extension (Year 2035) 90

43A. Mattie Road Extension Conceptual Plan / Profile..... 93

43B. Mattie Road Extension Conceptual Cross Sections – STA 5+00 to STA 20+00 94

43C. Mattie Road Extension Conceptual Cross Sections – STA 25+00 to STA 40+00 95

44. Mattie Road Area Intersection Levels of Service – General Plan Buildout
Weekday PM Peak Hour – With Mattie Road Extension 97

45A. Stimson Ave. / Ocean View Ave. One Way Couplet
With Two Eastbound Price St. Through Lanes 99

45B... Stimson Ave. / Ocean View Ave. One Way Couplet
With Two-Way Cycle Track..... 100

List of Exhibits (Continued)

46. Recommended Pier Area Improvements..... 103

47. Example of a Pedestrian Scramble 105

48. Left Turn Pocket Alternatives on Dolliver St. (SR1)..... 107

49. Example of Bike Boulevard Pavement Striping..... 109

50. Regional Improvement Concept List in Five Cities Area 114

51. Summary of Recommendations.....116-117

52. Transportation Demand Management Options124

53A. Price St. from San Luis Ave. to Pomeroy Ave. -
Possible Double Loaded Median Back-In Angled Parking..... 125

53B. Pomeroy Ave. from Cypress St. to Price St. – Possible Back-In Angled Parking 126

53C. Hinds Ave. from Cypress St. to Price St. – Possible Back-In Angled Parking..... 127

List of Appendices

A. Intersection Traffic Counts

B. Level of Service Calculations – Existing Conditions

C. Summary of Stakeholder Interviews

D. Summary of Public Workshops
D1. September 2014
D2. January 2015

E. Citywide Model Volume Plots
E1. Existing (Year 2014)
E2. General Plan Buildout (Year 2035) with Existing Street Network
E3. Model Documentation

F. Net Change in Land Use – 2014 vs. 2035

G. General Plan Buildout Volume Adjustment Factors – 2014 vs. 2035

H. Future Sunday Land Use – 2014 vs. 2035

I. Future Statewide Growth Projections

J. Level of Service Calculations – General Plan Buildout (Year 2035) Conditions

K. Year 2035 Network Alternative Model Volume Plots

L. Two-Way Bicycle Lanes – Best Practices

M. Pismo Creek Recreational Path – Proposed Alignment

N. Transportation Demand Management Report

1. Introduction

Pismo Beach is a coastal city in southern San Luis Obispo County, within the “Five Cities” region south of the City of San Luis Obispo. Its population has remained at about 8,000 people since the 1980’s. This is due to the limited expansion that is possible given its geographic location between the Pacific Ocean and the steep coastal mountains. Also during this time, the city has realized an increase in vacation home ownership and a reduction in resident occupied homes. Pismo Creek flows through Price Canyon, which forms a natural barrier between the downtown and the southern part of the city. A rail line – owned by Union Pacific Railroad – also follows Price Canyon and serves as an additional barrier. US 101 provides the only roadway connection across these barriers, although other routes exist outside of Pismo Beach (such as State Route 1 and West Grand Avenue, to the south). **Exhibit 1 (Page 2)** depicts the location of Pismo Beach in the southern portion of San Luis Obispo County.

The city experiences an inundation of traffic during the summer months, especially in its downtown, as well as on weekends, special events and holidays. This is due to the attractive unique small businesses and a classic California coastal city culture, as well as its beachfront and pier, located adjacent to its downtown. Pismo State Beach, in Grover Beach, is the only beach in California that allows vehicles to drive on its sand dunes, attracting thousands of visitors each year.

Special events occur frequently in Downtown Pismo Beach throughout the year, including the annual downtown Jazz Festival, The Classic at Pismo Beach Car Show in June, Fourth of July celebrations, and the Clam Festival in October, which attract tens of thousands of visitors per event from across the country. In May 2014 and 2015, the Amgen Tour of California bicycle race started or ended in Downtown Pismo Beach, attracting thousands of visitors and temporarily closing some of the city street network.

A. Background

Pismo Beach is facing a number of major policy and program decisions that will guide the quality of life, economic vitality, and overall future character of the community, with its transportation system being one key factor. It has updated elements of its General Plan and an update to the Circulation Element is anticipated. The General Plan was last updated in 1992. Much has changed since 1992, including major retail and hotel development along Five Cities Drive, residential and retail development on James Way and residential development along Mattie Road. In addition to land use changes within Pismo Beach, substantial development has occurred throughout the Five Cities Area as well as southern San Luis Obispo and northern Santa Barbara Counties.

Other important changes have taken place in our society’s overall approach to providing transportation services for our communities. There is now more emphasis on providing a safer, healthier, friendlier environment for pedestrians and bicyclists. Transit is being enhanced to provide an alternative to automobiles. The interrelationship between land use and transportation in terms of energy consumption and environmental impacts is now officially recognized at the State level, most notably with the passage of Senate Bill 375. In response, the San Luis Obispo Council of Governments (SLOCOG) recently adopted a Sustainable Communities Strategy (SCS) as a part of the Regional Transportation Plan. This further encourages the development of transportation modes other than single occupant vehicles as well as compatible land use patterns.

Exhibit 1 – Regional Setting of Greater Pismo Beach Area

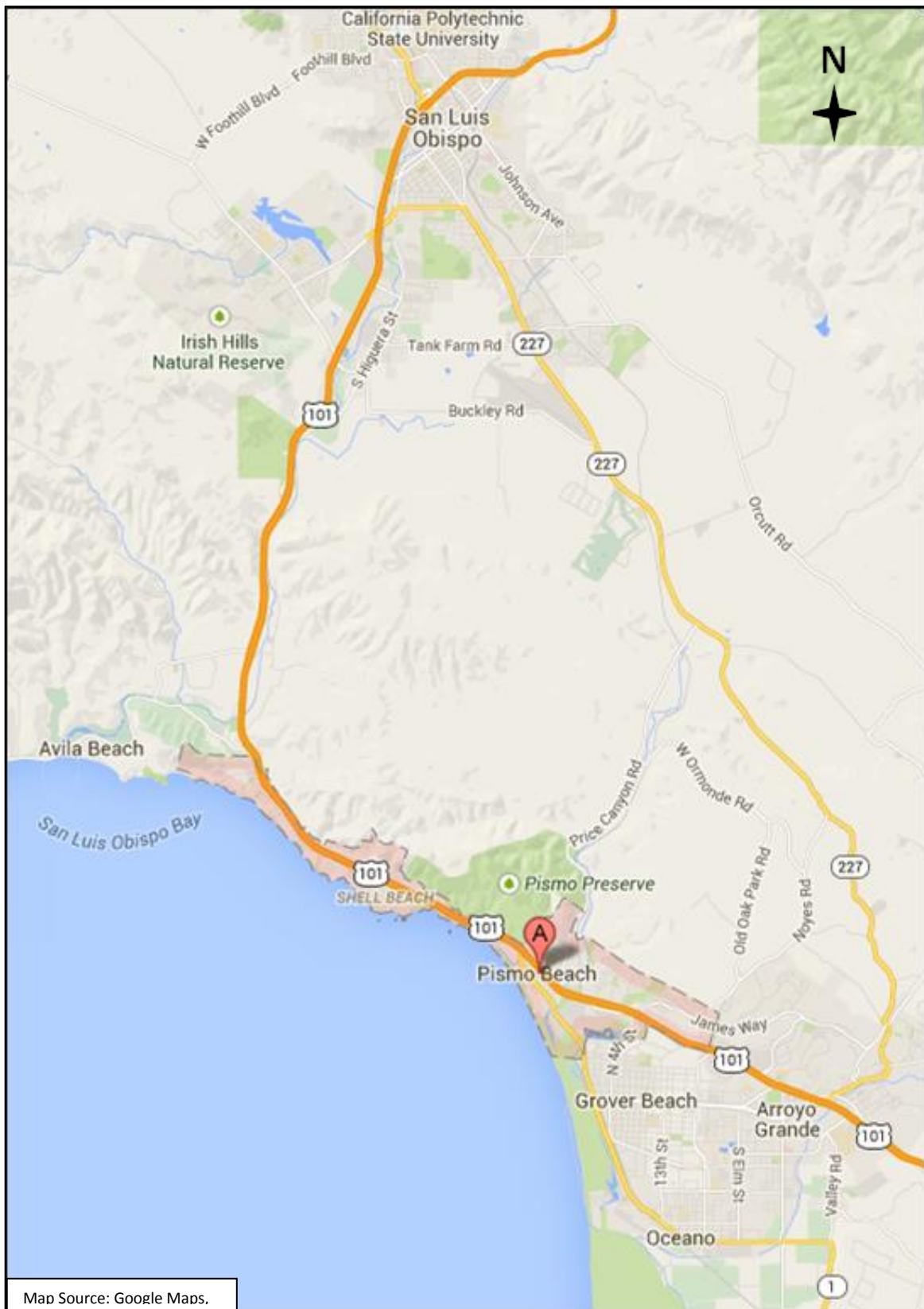

Despite these changes, the population of Pismo Beach itself has remained relatively constant over the past several decades. The 2000 United States Census reported a population of approximately 8,600 people, while the 2010 United States Census reported a population of about 7,700 people. Much of the traffic growth on regional routes through Pismo Beach has been due to through traffic, not only from other Five Cities communities like Grover Beach, Oceano and Arroyo Grande, but also regional travel between Santa Barbara and San Luis Obispo Counties and statewide travel between Northern and Southern California. US 101 is the only alternate route to Interstate 5 and Highway 99 for traffic between northern and southern California. This is illustrated by **Exhibits 2 through 5 (Pages 4-5)**, which depict the traffic growth on Dolliver Street (State Route 1, or SR 1) and US 101 between 1980 and 2013, according to Caltrans counts. While traffic has been relatively stable on Dolliver Street (SR 1) over the past 20-plus years, growth on US 101 has been substantial. Traffic volumes on US 101 in the Pismo Beach area are noticeably higher than normal when incidents occur on Interstate 5 such as major accidents or road closures from construction or weather (San Joaquin Valley fog or snow on the Grapevine).

SLOCOG has a regional transportation model that forecasts traffic growth in all of San Luis Obispo County. SLOCOG also recently completed the U.S. 101 Corridor Mobility Study, which evaluates the need for U.S. 101 corridor improvements in San Luis Obispo County, including in Pismo Beach. The City has determined that specific circulation issues and alternatives should be evaluated, building on the SLOCOG model and the U.S. 101 Corridor Mobility Study. Therefore, the City has commissioned the preparation of this Citywide Multimodal Transportation Model, which encompasses the City's current City limits and its Sphere of Influence (SOI). It also includes a Citywide Circulation Study that incorporates community input through a public outreach program and exploration of complete streets transportation improvements to meet the needs of the community.

The City has been actively and continuously engaging the community in recent years to address multimodal transportation issues. Public comment, concerns and recommendations have been well documented and helped guide the preparation of the Shell Beach Road Streetscape Plan (Phase I) and *Pismo Beach Complete Street Plan*, the *Bicycle and Pedestrian Master Plan*, and most recently the *Pismo Beach Downtown Strategic Plan*. This Citywide Multimodal Transportation Model and Circulation Study incorporates these local plans, programs, and projects, as well as regional transportation policies to address circulation and mobility in Pismo Beach. The Plan focuses on automobile, transit, bicycle, and pedestrian mobility in an effort to reduce congestion, vehicle miles traveled and associated emissions, meet diverse socioeconomic and mobility needs, and to advance public health, quality-of-life, and economic prosperity.

Exhibit 2 – Historical Growth on Dolliver Street (SR 1) at Pismo Creek

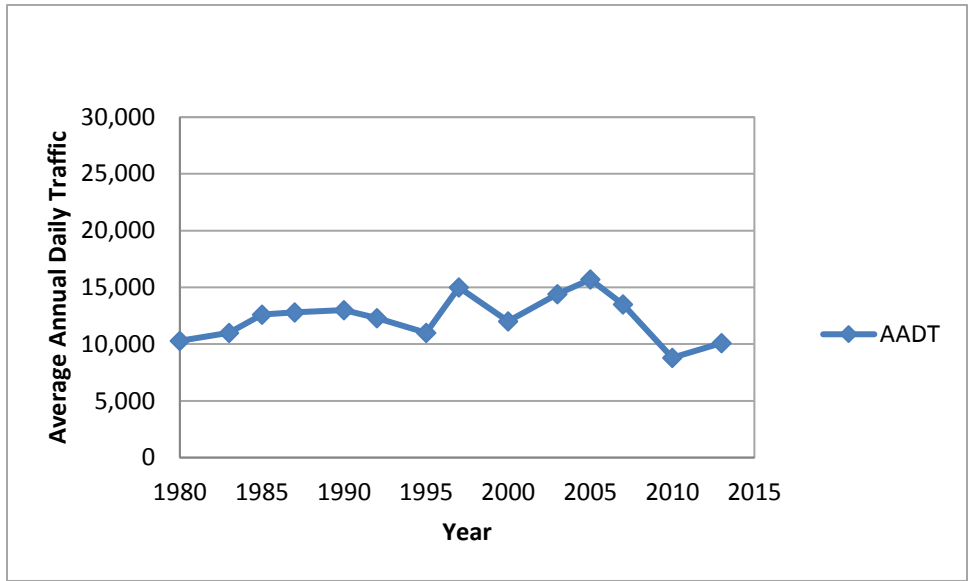

Exhibit 3 – Historical Growth on Dolliver Street (SR 1) at US 101

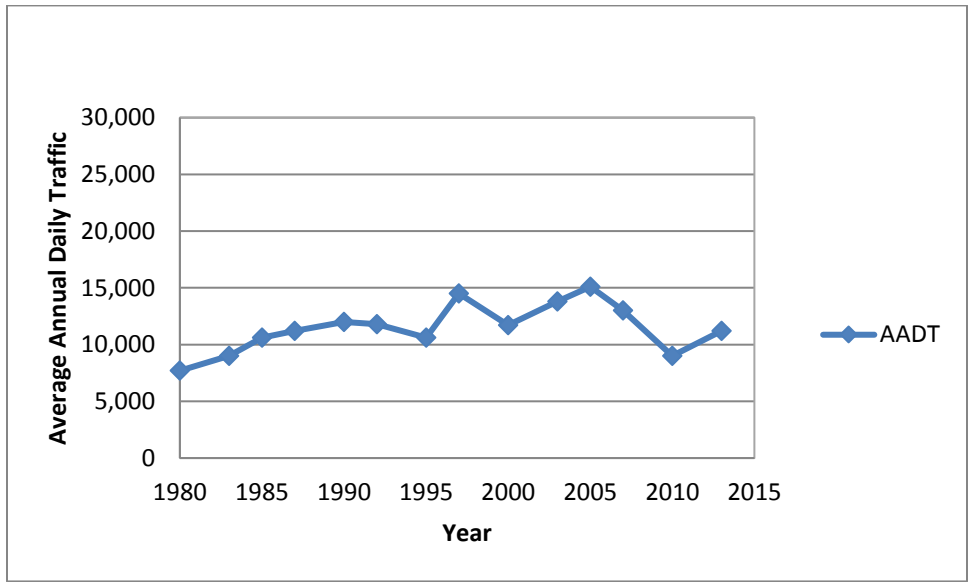

Exhibit 4 – Historical Growth on US 101 at Pismo Creek

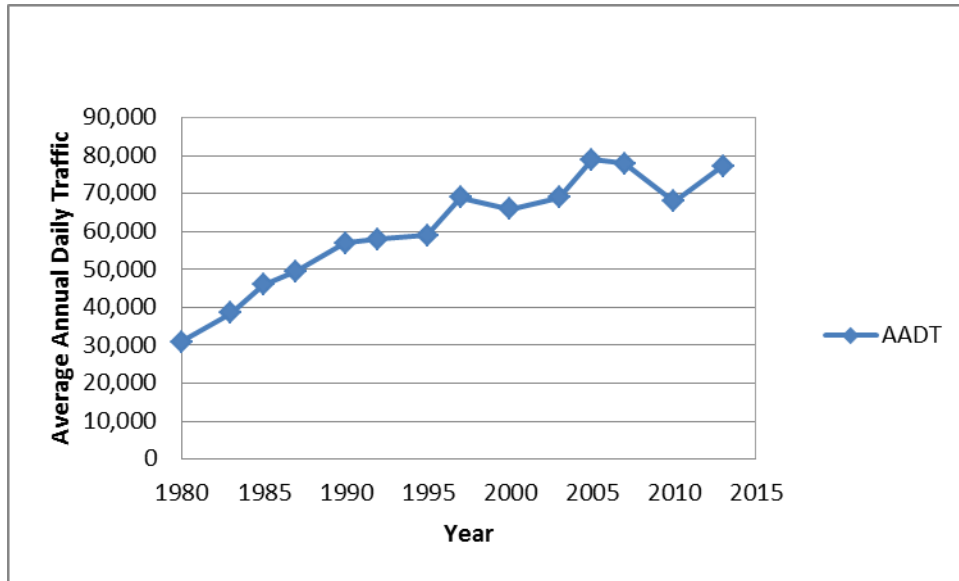
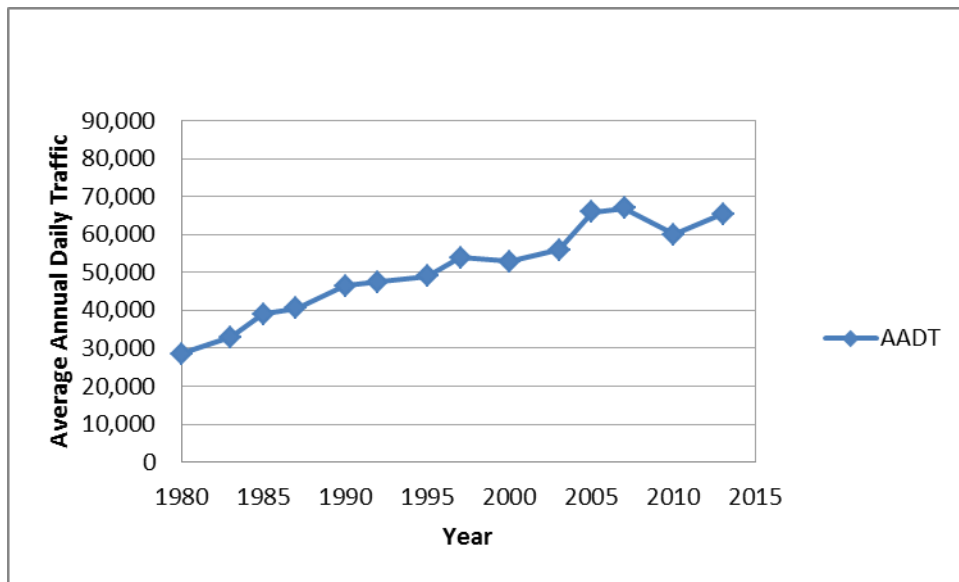

Exhibit 5 – Historical Growth on US 101 North of Price Street



Data Source (Exhibits 2 through 5): Caltrans traffic counts, 1980 through 2013.

B. Specific Transportation Issues Facing Pismo Beach

The City of Pismo Beach has a range of specific transportation goals that are addressed in this study. Several of them are listed below.

- **Identify major transportation improvement projects.** The 1992 General Plan identified a number of major street improvements that will be needed as the City approaches the buildout of the land uses anticipated at the time of that update. These include widening US 101 and Price Canyon Road, US 101 frontage roads to connect the downtown area with Five Cities Drive and/or James Way, various interchange improvements and other street extensions. A variety of studies have been prepared over the years to identify improvements along US 101. These are referred to throughout this document with regard to their relation with current and future travel demand.
- **Provide a safe, efficient system for pedestrians and bicyclists.** Pismo Beach has also been on the leading edge of multi-modal transportation planning, evidenced by the recently adopted *Pismo Beach Complete Street Plan*, March 2014, the *Bicycle and Pedestrian Master Plan*, June 15, 2010 and the *City of Pismo Beach Bikeshare Feasibility Study*, August 25, 2014 (<http://pismobikeshare.com>). Summaries are provided of these studies in Section 2.B - Existing Conditions – Pedestrian and Bicycle Circulation (page 8).
- **Promote transit usage by providing better connectivity with existing and proposed transit facilities as well as transit oriented development.** The *South County Transit Plan*, *San Luis Obispo County Highway 101 Bus Rapid Transit Applications Study*, June 2013, and *SLOCOG 2013 Park & Ride Lot Study*, August 2013 are referenced herein.
- **Analyze traffic impacts of land use alternatives.** The November 2014 election included the *City of Pismo Beach Planning Area R Development Standards General Plan Amendment - Measure H*, which was approved by Pismo Beach voters in November 2014. Measure H amended the General Plan to limit development on 1,100 acres in Price Canyon area if annexed into the City. The initiative designates the land with "watershed and resource management" zoning, a new category that will be in effect for at least the next 30 years. Land with this zoning restricts parcels to a minimum of 40 acres in size, which yields a maximum of two residential units for this development area. The measure precludes development projects such as the Spanish Springs project, which was proposed to consist of hundreds of homes, a hotel, conference center and a nine-hole golf course. With the reduction in development potential in and near Price Canyon, future development in Pismo Beach will be comprised primarily of infill and redevelopment projects within the existing city limits.
- **Develop strategies and improvements to enhance access to the Downtown and Pier area.** Several substantial development projects are in various stages of implementation in the downtown and pier area. One of the challenges will be to reduce the congestion that already occurs in the peak season while providing more convenient access and parking. The *Pismo Beach Downtown Strategic Plan* provided a valuable start on this effort.

2. Existing Conditions

A. Roadway Network

As indicated on **Exhibit 1 (Page 2)**, Pismo Beach is located in the southern coastal area of San Luis Obispo County. It is a part of the “Five Cities” region, comprised of Pismo Beach, Arroyo Grande, Grover Beach, Shell Beach and Oceano. It is located approximately 10 miles south of the City of San Luis Obispo.

US 101 is the backbone for travel to and from the Five Cities region. It also serves as an important route for regional and state-wide travel. It is a four-lane freeway through most of Pismo Beach, with auxiliary (weaving lanes) and truck climbing lanes in specific locations. Interchanges along US 101 in Pismo Beach include Spyglass Drive, Mattie Road (northbound on ramp and off ramp only), Price Street north of downtown (southbound off ramp only), State Route (SR) 1 (southbound off ramp only), Wadsworth Avenue (northbound off ramp only), Hinds Avenue – Price Canyon Road (southbound off ramp only), Price Street south of downtown (northbound off ramp and southbound on ramp only), Five Cities Drive (southbound off ramp and on ramp only), Fourth Street and Oak Park Boulevard. Other routes that provide access into and out of the region include SR 1, Price Canyon Road, Noyes Road, and State Route 227.

Within Pismo Beach, there are many arterial and collector roadways that provide local and regional circulation routes. These include Price Street, Shell Beach Road, Mattie Road, Dolliver Street (SR 1), Wadsworth Avenue, Pomeroy Avenue, Hinds Avenue, Fourth Street, James Way, Five Cities Drive and Oak Park Boulevard.

The directional designation of the majority of streets in this study is based upon their orientation, i.e., “north-south” streets are roadways that generally travel in a general north-south alignment. However, exceptions include many streets in downtown, where Price, Dolliver (SR 1), and Cypress Streets are designated north-south streets and their cross streets (e.g. Pomeroy Avenue, Hinds Avenue) are designated as east-west streets.

B. Pedestrian and Bicycle Circulation

The climate and topography of Pismo Beach provide an attractive environment for bicycling, walking, and recreational trail use within the City. The primarily level terrain in the downtown area, extending along the Pacific Ocean, combined with its abundant sunshine, low levels of precipitation, and increasingly dense land use pattern, help make bicycling and walking viable transportation and recreational options year-round. The City has made bicycle and pedestrian mobility a priority with adoption of the following plans related to multimodal circulation access and enhancement:

Pismo Beach General Plan and Local Coastal Plan (Adopted 1992/Updated 2014)

The currently adopted *City of Pismo Beach General Plan/Local Coastal Program* (City of Pismo Beach, 1992) was originally developed in 1992 and certified in 1993 by the California Coastal Commission. It was most recently updated in April, 2014; however, no changes were made to the Circulation Element at that time. The *General Plan* guides growth, development, and infrastructure in Pismo Beach and contains elements that address: land use, housing, growth management, transportation and circulation, conservation, design, public facilities and services, parks and recreation, noise and safety. The *City’s Bicycle and Pedestrian Master Plan* is intended to serve as the bicycle, pedestrian, and trails component of the *General Plan*.

Pismo Beach Bicycle and Pedestrian Master Plan (2010)

According to the California Streets and Highways Code, Sections 891.2 and 891.4, local agencies must complete a Bicycle Transportation Plan to qualify for Bicycle Transportation Account (BTA) grant funds issued by the California Department of Transportation Division of Local Assistance. Conforming plans must contain required Bicycle Transportation Plan elements and be no more than five years old. The City of Pismo Beach developed the Bicycle and Pedestrian Master Plan in 2010 and updated it in 2015. This plan establishes goals, policies, implementation actions, and priorities for the development of bicycling and walking facilities in Pismo Beach, as envisioned by the General Plan. Key elements of the plan include maps of existing and proposed bicycle facilities and their proximity to major activity centers. The implementation plan identifies project priorities, locations, improvement descriptions, facility types, and cost estimates. The plan will guide development of the proposed improvements. Recommendations from this Plan are summarized in Section 4.A – Recommendations - Pedestrian and Bicycle.

Pismo Beach Complete Street Plan (2013)

The “Complete Street” Plan provides design concepts, goals and a framework for enhancing Pismo Beach’s street network. The plan area extends approximately five miles through the City from its northern boundary to the City of Grover Beach, and includes Shell Beach Road, Price Street and Dolliver Street (Pacific Coast Highway). The plan directs improvements along this major north-south corridor with the goal of increasing the frequency of bicycle and pedestrian use by enhancing the corridor’s safety, comfort, connectivity and attractiveness.

Pismo Beach Downtown Strategic Plan (2014)

The City of Pismo Beach prepared the Downtown Strategic Plan as a visioning and guidance tool, developed to help shape future development in the City’s downtown. It incorporates adopted transportation infrastructure and mobility strategies from the General Plan, Bicycle and Pedestrian Master Plan, and the Complete Street Plan. The Downtown Strategic Plan includes suggestions ideas such as a roundabout at the Price Street/Dolliver Street intersection and new bike facilities on Dolliver Street. It also builds on the Complete Street Plan by providing additional pedestrian, bicycle, transit, vehicular, and parking opportunities.

City of Pismo Beach Bikeshare Feasibility Study (2014)

The Downtown Strategic Plan noted that a bicycle sharing program – where the public can freely use a city-provided bicycle – may be worth pursuing within the downtown area. A feasibility study was subsequently prepared that determined that a bicycle sharing program is feasible, and identified locations in the downtown area that the shared bicycles can be stored. The website <http://pismobikeshare.com> was also created to educate citizens and tourists about the concept of bike sharing. The City anticipates that a bike sharing program may be operational by 2019.

US 101 Corridor Mobility Master Plan (2014)

The San Luis Obispo Council of Governments (SLOCOG) sponsored the preparation of the US 101 Mobility Master Plan in partnership with the City of Pismo Beach and other municipalities and agencies in San Luis Obispo County. The purpose was to develop a unified transportation and mobility vision for the US 101 corridor throughout the entire County. The plan contains data and transportation improvement recommendations along US 101 through the City of Pismo Beach; including evaluating opportunities to enhance bicycle and pedestrian connectivity and safety, alleviate traffic in Pismo Beach and improve transit and roadway connectivity. Recommendations from this study that are related to Pismo Beach are included in Section 3.F – Regional Highway Improvements.

Statewide Initiatives and Legislation

Bicycle and pedestrian planning in the City must strive to be consistent with statewide programs governing the implementation of bicycle and pedestrian transportation facilities. These include:

- Assembly Bill 32 (2006) and Senate Bill 375 (2008)
Senate Bill 375 (SB 375) (Steinberg, 2008) is the implementation legislation for *Assembly Bill 32 (AB 32) (Nunez and Pavley, 2006)*. AB 32 requires the reduction of greenhouse gases (GHG) by 28 percent by the year 2020 and by 50 percent by the year 2050. Reducing automobile trips is one method of reducing GHG emissions. This may be achieved by promoting modes other than the automobile, such as walking, bicycling, or riding transit. Land use strategies that create less auto-dependent development is also encouraged.
- Assembly Bill 1358 (2007)
Assembly Bill 1358 (Leno and Levine, 2007) is the Complete Streets Act. It calls for the inclusion of all modes of transportation (pedestrian, bicycles, transit, and automobile) into the design of roadways.
- Assembly Bill 1581 (2012)
Assembly Bill 1581 (Wieckowski and Wolk, 2012) requires that new actuated traffic signals or modified existing traffic signals include technology that is able to detect bicycles and motorcycles. It also calls for the timing of actuated traffic signals to account for bicycles.
- Caltrans Deputy Directive 64 (Revision 1) DD-64-R1 (2008)
Deputy Directive 64-R1 (DD-64-R1) (Caltrans, 2008) was issued to ensure that travelers of all ages and modes may move “safely and efficiently along and across a network of ‘complete streets’.” The directive establishes responsibilities for Caltrans staff to safely accommodate bicyclists, pedestrians, and transit users.

C. Pedestrian Facilities

Walkability is an important component of every city. Common pedestrian facilities include sidewalks, marked crosswalks, and curb ramps. There are several different types of crosswalk enhancements that aim to improve safety for pedestrians. **Exhibit 6 (Page 11)** provides the locations of pedestrian facilities within the Pismo Beach Area.

SIDEWALKS AND CURB RAMPS

Sidewalks typically are at least 4 feet of width in most non-commercial areas throughout the City. Sidewalks are typically 9 to 10 feet wide in the downtown and 6 feet wide in newer subdivisions. Streets in Downtown Pismo Beach generally have sidewalks on both sides of the street, with the exception of parts of Park Avenue (east of Dolliver Street), Addie Street (west of Dolliver Street), and Cypress Street (north of Main Street).

There are numerous streets within the City of Pismo Beach where sidewalks are not provided or are intermittently available. These occur primarily in Shell Beach, Pismo Heights, along portions of Mattie Road and within private mobile home parks, parks and gated communities.

Curb ramps provide wheelchair and stroller access to sidewalks at corners of intersections. Truncated domes alert visually impaired pedestrians as they approach a street crossing. New standards for the construction of ADA compliant curb ramps have prompted recent renovation of several street corners by the City.

This page was intentionally left blank
(For Duplex Printing)

Exhibit 6 – Existing Pedestrian Facilities in Pismo Beach

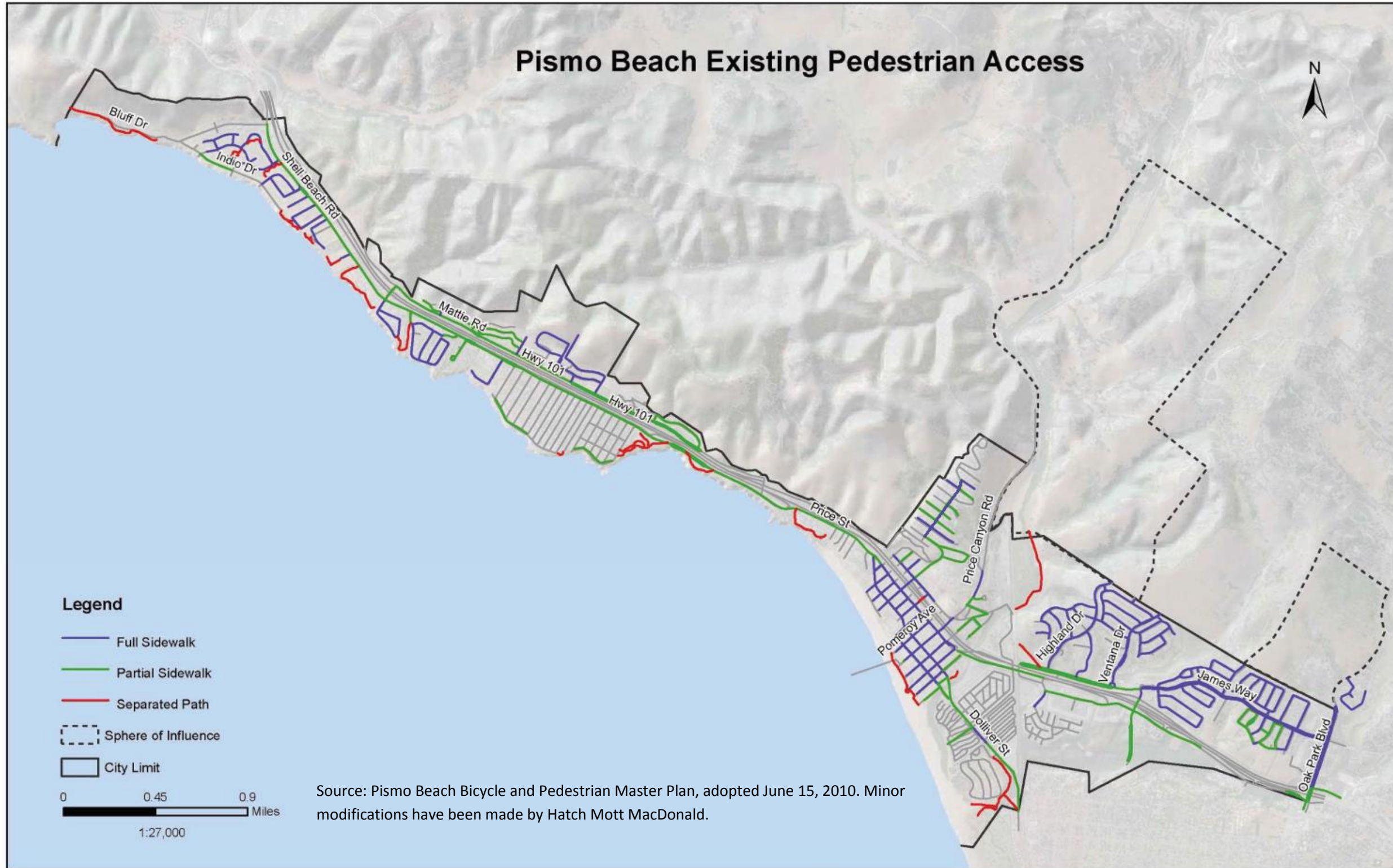

This page was intentionally left blank
(For Duplex Printing)

CROSSWALKS

Crosswalks are defined as either “that portion of a roadway included within the prolongation or connection of the boundary lines of sidewalks at intersections” or “any portion of a roadway distinctly indicated for pedestrian crossing by lines or other markings” (California Vehicle Code (CVC) Section 275). Therefore, legal unmarked crossings are those at intersections defined by the prolongation of sidewalk areas.

Marked crosswalks feature striping and other enhancements to delineate a street crossing for pedestrians. There are two types of crosswalks: controlled and uncontrolled. At uncontrolled crosswalks, drivers are legally required to yield to pedestrians, but do not have to stop when a pedestrian is not present. Controlled crosswalks are located at intersections with stop signs or traffic signals.

D. Bicycle Facilities

EXISTING BIKEWAYS AND TRAILS

Bicycle facilities can be classified into two types: 1) Bikeways or facilities provided for bicycle travel; and 2) Support facilities for use by bicyclists while travelling or once they have reached their destination. Both types of facilities are described below. The locations of bikeways in Pismo Beach are indicated on **Exhibit 7 (Page 15)**.

BIKEWAYS

The *Guide for the Development of Bicycle Facilities* (American Association of State Highway and Transportation Officials [AASHTO], 2011) and Chapter 1000 of the *Highway Design Manual* (Caltrans, 2015) identify four primary types of bikeways: Class I Bike Paths, Class II Bike Lanes, Class III Bike Routes, and Class IV Bikeways.

- ***Bike Path or Shared Use Path (Class I Bikeway)***
Off-street bike paths are facilities for use exclusively by bicycles, pedestrians, equestrians, and other non-motorized users, with minimal cross-flow by motor vehicles. They are almost always located in an exclusive right-of-way.
- ***Bike Lane (Class II Bikeway)***
Bike lanes are areas within paved streets that are identified with striping, stencils, and signs for preferential (semi-exclusive) bicycle use.
- ***Bike Route or Shared Roadways (Class III Bikeway)***
Shared roadways are on-street routes intended to provide continuity to the bikeway system. Bike routes are designated by signs or pavement marking and are shared by motorists. Many bike routes provide shoulders that can be used by bicyclists or pedestrians.
- ***Cycle Tracks or Separated Bikeway (Class IV Bikeway)***
Cycle tracks or separated bikeways, also referred to as “Class IV bikeways,” promote active transportation. They provide a separate travel way that is designated exclusively for bicycle travel adjacent to a roadway and are protected from vehicular traffic. Types of separation include, but are not limited to, grade separation, flexible posts, inflexible physical barriers, or on-street parking.
- ***Innovative Bikeways (Including Bicycle Boulevards)***
The *NACTO Urban Bikeway Design Guide* (National Association of City Transportation Officials [NACTO], 2014) includes design guidance for a standardized set of treatments for bicycling streets in the United States. Several of these treatments can be implemented using guidance in the *California Manual on Uniform Traffic Control Devices* (CAMUTCD) (Caltrans, 2014). The *NACTO Urban Bikeway Design Guide* also includes design guidance for a variety of bike lanes, cycle tracks, signal enhancements, intersection enhancements, signing and marking enhancements, and bicycle boulevards.

This page was intentionally left blank
(For Duplex Printing)

Exhibit 7 – Existing Bikeways in Pismo Beach



This page was intentionally left blank
(For Duplex Printing)

Roadways with bicycle lanes (Class II) in Pismo Beach include Dolliver Street (SR 1/Pacific Coast Highway) through the downtown, Mattie Street and James Way. Bicycle path (Class I) examples include the bike path over Pismo Creek, adjacent to and immediately south of US 101 that connects Price Street and Five Cities Drive as well as along a portion of Mattie Road.

E. Support Facilities

Support facilities include pedestrian and bicycle bridges and overpasses, short and long-term bicycle parking and gear storage, showers and changing stations, and other amenities not exclusive to, but supportive of walking and bicycling (including wayfinding signage, benches, water fountains and restrooms). The primary examples in Pismo Beach include:

- A pedestrian pathway underneath US 101 at Pismo Avenue, connecting the downtown and Bello Street neighborhood. This is currently the only exclusively non-motorized connection across the US 101 freeway in Pismo Beach.
- A pedestrian bridge exists across Pismo Creek along Dolliver Street, which connects the downtown area to Pismo State Beach and the mobile home parks south of downtown.
- The Cypress Street bridge over Pismo Creek accommodates vehicle and bicycle travel with a separated pedestrian walkway.
- Pedestrian access along Price Street and Shell Beach Road, connecting Downtown Pismo Beach to the Shell Beach neighborhood, is maintained through a network of sidewalks and pedestrian pathways.
- A promenade, or boardwalk, currently extends along the beachfront from Main Street south to Addie Street. The *Pismo Beach Downtown Strategic Plan* proposes to extend this promenade to the north, in order to provide a convenient facility to walk between the downtown and the neighborhoods and hotels north of the downtown.
- There are multiple companies in Pismo Beach and the surrounding area that offer pedicab rides, rent bicycles (capacity for one and two people) and surreys (capacity for two to four people) to members of the public.
- The City of Pismo Beach has prepared a feasibility study to consider initiating a bicycle sharing program. The program would provide bicycles for rent at key locations around the City.

REGIONAL CONNECTIONS

There is currently no continuous dedicated bicycle or pedestrian facility between San Luis Obispo and the Five Cities region. The Bob Jones Trail currently is a discontinuous multi-use paved pathway along San Luis Obispo Creek in the city of San Luis Obispo and the unincorporated community of Avila Beach. In San Luis Obispo, the trail connects Prado Road near Higuera Street with Los Osos Valley Road at US 101. In Avila Beach, the trail starts at a trailhead and parking lot along Ontario Road north of Avila Beach Drive and extends westward to the intersection of San Juan Street and Avila Beach Road. A connection of these two distinct trails is currently being studied.

Within the Five Cities region, the City of Grover Beach published a trail feasibility study in 2010 – *Beach Cities Multi-Purpose Trail* — to create a new multi-use trail between the unincorporated community of Oceano and eastern Pismo Beach via Pismo State Beach, downtown Pismo Beach, and the Pismo Lakes Ecological Reserve (in

southeastern Pismo Beach). This route would be usable by both pedestrians and bicyclists. It is currently not funded and is in need of garnering support throughout the Five Cities Area.

F. Trip Generators and Attractors

Pismo Beach includes a diversity of land uses that range from high density and pedestrian-focused retail commercial in the downtown area, commercial development along Five Cities Drive and Oak Park Boulevard, medium and low density residential throughout the foothill and ocean side communities, and recreation land uses to the south.

Destination areas include multiple City parks, Shell Beach neighborhood commercial and beach access areas, downtown shopping, the beach, and three large shopping areas on the southeast side of the City. The Shell Beach area and downtown are prime bicycling and walking areas given the limited parking during busy periods. Shopping centers located along Five Cities Drive and Oak Park Boulevard in the southeasterly portion of the City have large parking lots, by providing improved bicycling facilities (such as bike racks and bike lockers), they could encourage customers and shopping center employees to travel there by bicycle.

G. Existing Pedestrian and Bicycle Activity

Exhibits 8 through 10 (Pages 19-21) depict the existing pedestrian volumes in Downtown Pismo Beach during the Weekday PM, Summer Sunday Midday, and Memorial Day Sunday Midday (i.e., the Sunday before Memorial Day) peak hours. The corresponding tabular traffic count worksheets are included in **Appendix A**. The most recent counts indicate that pedestrian activity in the downtown is greatest during the Summer Sunday and Memorial Day Sunday peak hours, with hundreds of pedestrians per hour travelling along and across Dolliver Street (State Route 1 – SR 1) and Pomeroy Avenue to and from the beach, pier, and various small businesses. These large concentrations of pedestrians are a main contributor to the circulation challenges in the downtown.

Pedestrian volumes are relatively low outside of the downtown. Pedestrians do not contribute to any vehicle congestion issues in other portions of the city and are generally accommodated by existing sidewalks. The exceptions are locations where sidewalks are not provided. These have been identified in the previously cited Pismo Beach Bicycle and Pedestrian Master Plan.

Exhibits 11 through 13 (Pages 22-24) depict the existing bicycle volumes in Downtown Pismo Beach under Weekday PM, Sunday Summer Midday, and Memorial Day Sunday Midday peak hour conditions. Traffic count worksheets for these volumes are tabulated in **Appendix A**. Bicycle volumes are relatively low in the downtown. The largest volume was about 20-30 bicycles an hour in each direction on Dolliver Street (SR 1) during the Memorial Day Sunday peak hour.

Bicycle use outside of Downtown Pismo Beach is negligible and does not contribute to vehicle congestion.

Exhibit 8 – Pedestrian Volumes - Existing Weekday PM Peak Hour

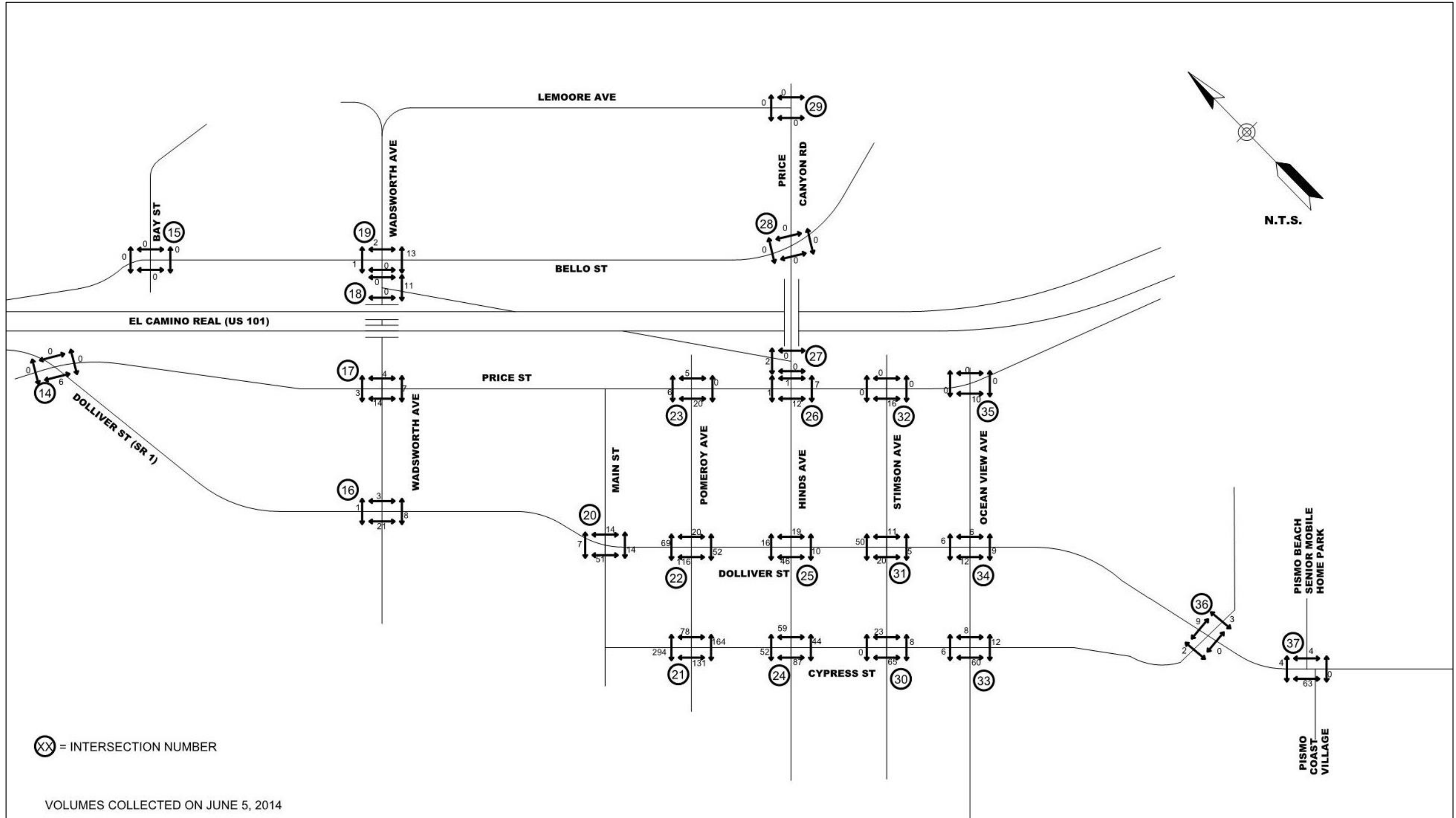

VOLUMES COLLECTED ON JUNE 5, 2014

Exhibit 9 – Pedestrian Volumes - Existing Summer Sunday Midday Peak Hour

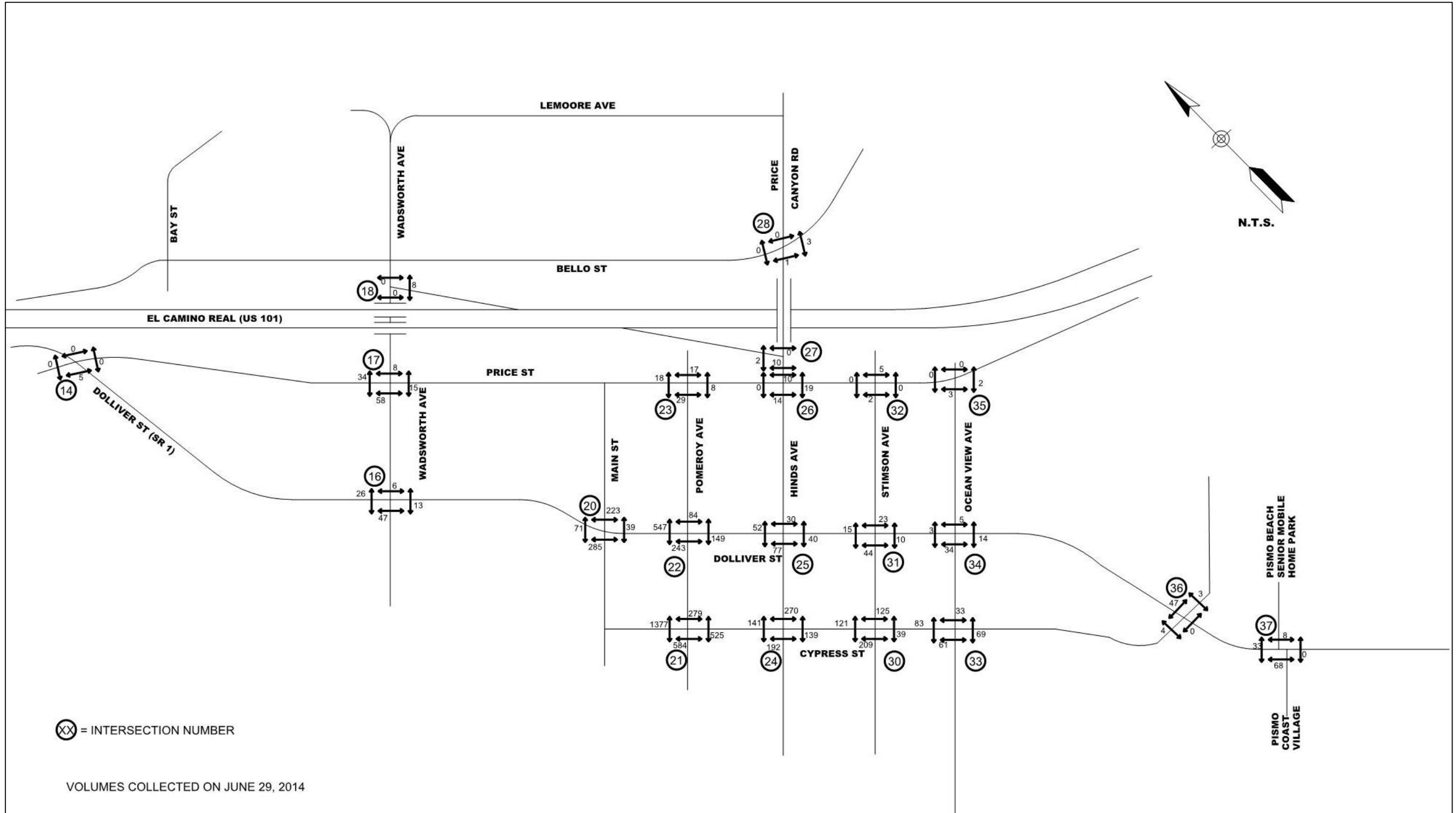

VOLUMES COLLECTED ON JUNE 29, 2014

Exhibit 10 – Pedestrian Volumes - Existing Memorial Day Sunday Midday Peak Hour

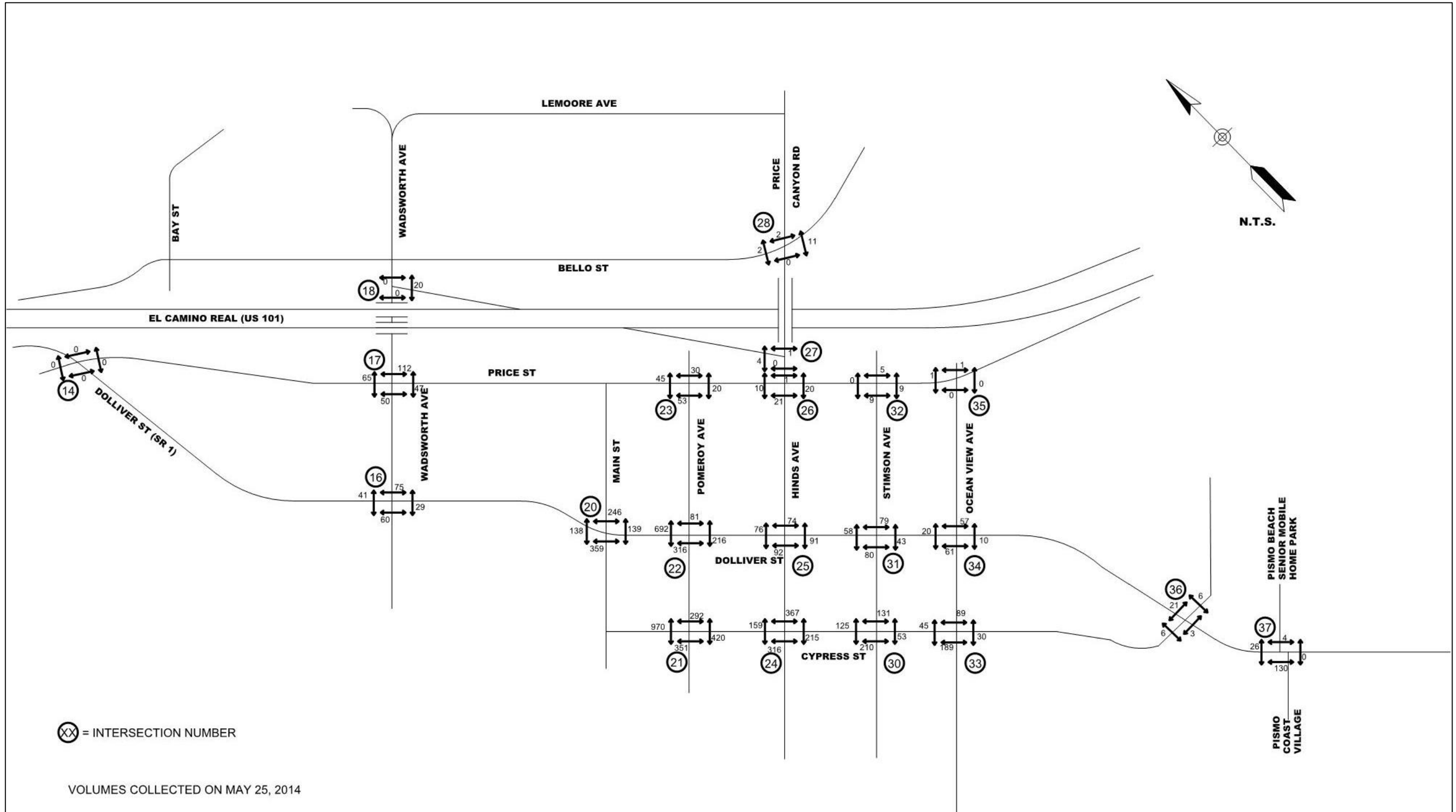

Exhibit 11 – Bicycle Volumes - Existing Weekday PM Peak Hour

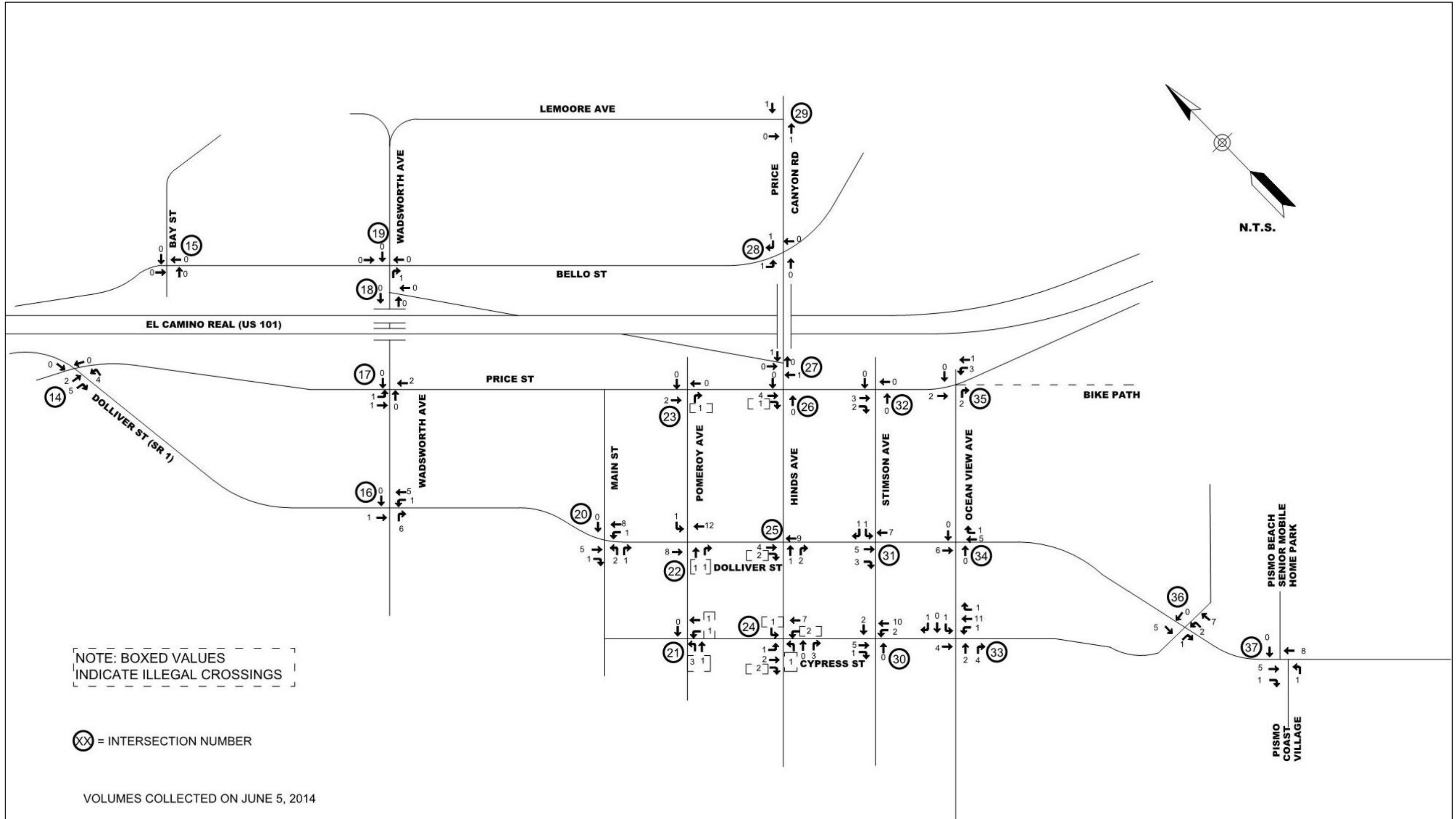

Exhibit 12 – Bicycle Volumes - Existing Summer Sunday Midday Peak Hour

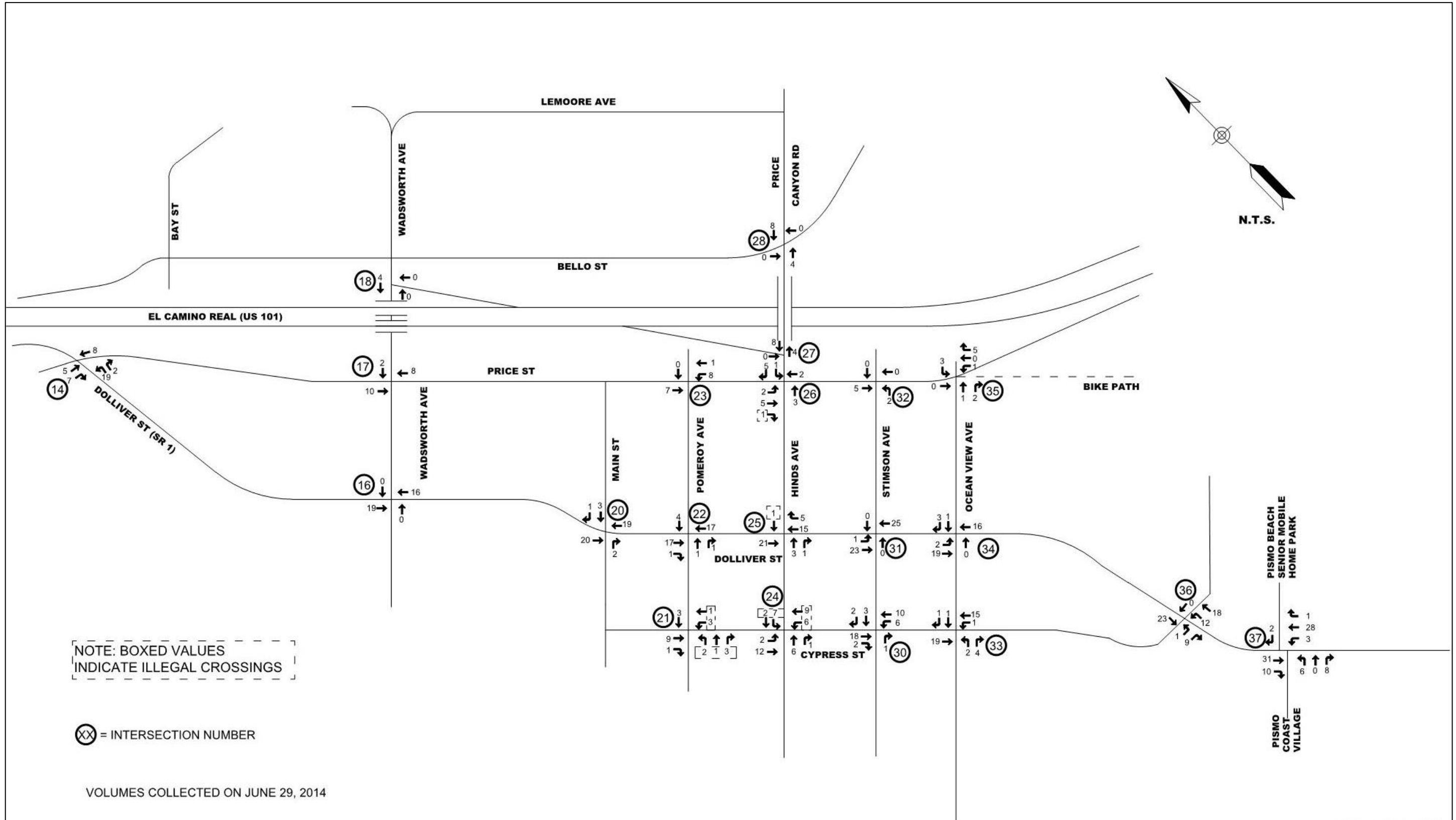
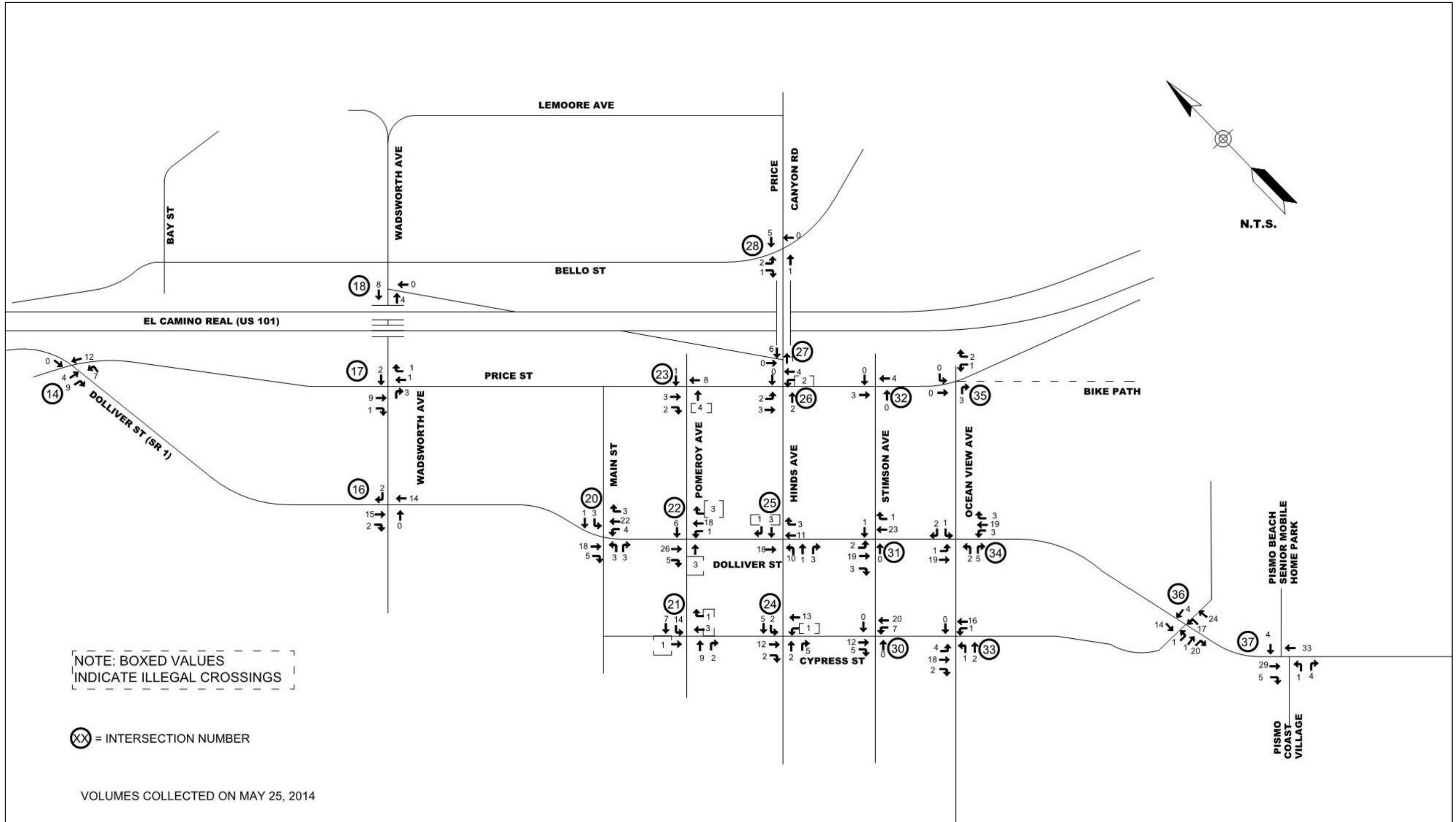

Exhibit 13 – Bicycle Volumes - Existing Memorial Day Sunday Midday Peak Hour



H. Transit

EXISTING TRANSIT SERVICE

The San Luis Obispo Regional Transit Authority (RTA) operates four transit routes through Pismo Beach. **Exhibit 14 (Page 26)** depicts the transit routes in the Pismo Beach Area.

Route 10 is a regional route between San Luis Obispo and Santa Maria, operating hourly on weekdays between roughly 5:45 AM and 8:30 PM in the northbound direction and 6:30 AM and 9:45 PM in the southbound direction. Route 10 also operates every three hours on Saturdays (roughly 7:15 AM – 7:30 PM northbound and 8:30 AM – 8:45 PM southbound) and three trips in each direction on Sundays (between roughly 8:15 AM and 6:45 PM). The only stop along this route in Pismo Beach is at the Pismo Beach Premium Outlets. Approximately 35 passengers were observed exiting from the southbound Route 10 bus on Thursday, March 6, 2014 at 6:00 PM, which represented the evening peak commute period. Route 10 has approximately 1,100 passengers per weekday and approximately 300 passengers per weekend day according to RTA.

The remaining routes are contracted through and branded as “South County Transit,” and provide local service within Pismo Beach and to the surrounding communities. **Routes 21 and 24** are interlocking routes that travel in opposing directions on overlapping portions of their routes, with Route 21 traveling clockwise and Route 24 traveling counterclockwise. Route 21 serves the communities of Shell Beach, downtown Pismo Beach, the Pismo Beach Premium Outlets, downtown Grover Beach, and eastern Arroyo Grande. Route 24 follows a similar route, except that it also serves downtown Arroyo Grande and does not serve Shell Beach. Both routes operate hourly between approximately 6:30 AM and 6:30 PM. Three or fewer passengers boarded or disembarked the Route 21 and Route 24 buses at 6pm, which is the evening peak commute period. Route 21 has approximately 240 passengers per day and Route 24 has approximately 200 passengers per day according to RTA.

Finally, RTA also operates the **Avila to Pismo Trolley**, a local bus built to look like a trolley car. The trolley only operates between late March and mid-October, with extended service between June and September. During normal operations, the trolley operates hourly between 10:00 AM and 4:00 PM on Saturdays and Sundays. During the summer months, the trolley operates from 10:00 AM to 6:00 PM on Thursdays through Sundays. It travels between Avila Beach and Pismo Beach, stopping at the Pismo Beach Premium Outlets and many local stops within greater Avila Beach, Shell Beach, and downtown Pismo Beach. The route forms a loop between Avila Beach and Pismo Beach. All of the local bus stops in Shell Beach are bypassed on the way from Pismo Beach Premium Outlets to the outskirts of Avila Beach. The trolley carries approximately 160 passengers per day according to RTA.

FUTURE TRANSIT SERVICE

SLOCOG has been studying potential upgrades to transit service in the South County for the past few years. In 2011, SLOCOG commissioned the *South County Transit Plan*, which evaluated current transit service and identified opportunities to expand service and increase revenues. In 2013, SLOCOG studied the establishment of bus rapid transit along the US 101 corridor (*San Luis Obispo County Highway 101 Bus Rapid Transit Application Study*), including service to the park and ride lot and bus stops at the Pismo Beach Premium Outlets. As a corollary to the bus rapid transit study, SLOCOG also released its *2013 Park & Ride Lot Study* in August 2013, which suggested adding a new park and ride facility on Mattie Road near Spyglass Drive and adjacent to US 101. SLOCOG and the City are now evaluating the implementation of this facility.

Exhibit 14 – Existing Transit Routes Within Pismo Beach



Source: San Luis Obispo Regional Transit Authority, 2015

EXISTING TRAIN SERVICE

A railroad track owned by Union Pacific Railroad extends through Pismo Beach by way of Price Canyon between the greater San Luis Obispo area and Grover Beach. The only roadway crossing of the railroad within Pismo Beach is a grade-separated crossing at US 101. The nearest crossing of the railroad in the vicinity of Pismo Beach is to the south at Grand Avenue in the City of Grover Beach. This is an at-grade crossing near State Route 1.

The nearest rail station is adjacent to the Grand Avenue crossing in Grover Beach and is commonly referred to as “The Train Station”. It is serviced four times each day (two northbound and two southbound trains) by the Pacific Surfliner service operated by Amtrak on its route between San Luis Obispo and San Diego. The station also is served three times per day by buses connecting to other train stations along the Pacific Surfliner route and by twice daily, round-trip bus service to the Central Valley and Southern California.

I. Parking

Pismo Beach, due to its beach front location, is typical of numerous coastal communities in California. It is inundated with guests and visitors that not only increase traffic during the summer months, but also significantly increase parking demand. This, in turn, increases traffic volumes and congestion as drivers circulate the downtown area in search of parking. Improving parking operations will assist the City in improving the experience of visitors to the downtown area.

This seasonal swell of traffic and parkers results in high parking occupancies during the seasonal peak periods and very low parking demands during the off-season. The exception is the pier parking lot, which is heavily used throughout the year. These swings in overall downtown parking demand present challenges for how much parking to provide, how to manage the parking and how it is maintained and supported financially.

This parking assessment is designed to provide a high level overview of the parking challenges, and recommendations to adjust parking to enhance the traffic, circulation and public parking operations. This parking study is not intended to serve as a detailed, microscopic level parking strategic plan or parking management plan.

EXISTING PARKING SUPPLY WITHIN DOWNTOWN PISMO BEACH

Exhibit 15 (Page 28) tabulates a parking space inventory of Downtown Pismo Beach. Most parking in Downtown Pismo Beach is on-street parking – virtually all streets in the downtown allow on-street parking. Approximately 873 parking spaces are on-street parking spaces with seasonal enforcement of time limits. The exceptions are Pomeroy and Hinds Avenues from Dolliver Street [SR 1] to the pier area and Cypress Street from Pomeroy to Hinds Avenues, which all have pay parking year round. A total of 588 spaces are provided in parking lots in the downtown. A small number of parking spaces are located in lots with time limited parking only (e.g. Addie Street at Mary Harrington Park of Dolliver Street (SR 1) and a small lot behind the Pismo Beach Chamber of Commerce building at the corner of Dolliver Street (SR 1) and Hinds Avenue). The total number of public parking spaces in downtown, including the Addie Street lot and the Price Street lot is approximately 1,461 spaces. The downtown hotel parking lots provide 816 spaces and the private parking lots include approximately 495 spaces. Thus, a total 2,772 parking spaces are provided.

There are multiple parking lots in the downtown, some of which are heavily utilized. **Exhibit 16A (Page 29)** depicts their locations within the downtown. Except as noted above, on-street parking spaces operate as free parking with no charge for parking but are managed with time-limited parking during the timed parking season. Their locations are illustrated on **Exhibit 16B (Page 29)**. A small number of on-street pay parking spaces are provided on Cypress Street, Hinds Avenue and Pomeroy Avenue near the pier.

Exhibit 15 – Downtown Pismo Beach Parking Space Inventory

Parking Type	Number of Spaces
Public Parking	
<i>Pay Parking – Downtown (lots)</i>	<i>380</i>
Time-Limit Parking	
Downtown (street)	114
Price Street (street)	94
<i>Year-Round Free Spaces (street)</i>	<i>873</i>
Downtown Hotel Spaces	816
Downtown Commercial Spaces	495
Total Spaces	2,772

Source: City of Pismo Beach, 2014.

Two of the largest lots are located near the pier. The largest public lot (210 spaces) is accessible off of Pomeroy (inbound only) and Hinds Avenue (outbound only) and is located at the foot of the pier. This parking lot is the parking location most desired by patrons who want to go to the beach, pier and associated commercial area. As it is located the closest to the beach and pier, many patrons unsuccessfully attempt to park at this location first, and then circulate throughout the downtown looking for other places to park. This causes vehicles to recirculate on downtown streets, which compounds traffic congestion.

Until recently, the second largest parking lot in the downtown was a private dirt parking lot on Cypress Street between Pomeroy and Hinds Avenues, directly adjacent to the pier area. There was no charge for parking in this private lot. This property is being developed as a hotel; thus, this parking lot is no longer available.

The public parking lot at the beach end of Addie Street and Park Avenue is free to the public with no time limits. It serves beach activity at the south end of downtown. This lot, which also has approximately 100 spaces, is not utilized as much as the pier parking lot during most of the year, but during peak seasons it is heavily used. Lifeguard towers are also stored here during the off-season.

The parking lots on Main Street (bordered by Main Street, Dolliver Street (SR 1) and Pismo Avenue) are pay to park lots. Ownership is split between the City of Pismo Beach and a private owner. These lots have approximately 130 spaces.

The public lot on Pomeroy Avenue between Price and Dolliver (SR 1) Streets has approximately 40 spaces and is the public parking lot with the lowest utilization. While it is located less than three blocks from the beach and pier, it is routinely bypassed by patrons hoping to get a parking space closer to those attractions. This could be due to the lot being accessed by Pomeroy, with one-way traffic in the opposite direction of traffic that would attempt to enter it from Dolliver.

A few smaller private lots are available for public use scattered throughout the downtown area, each having between 20 and 40 spaces.

Private lots are not managed or patrolled by the City’s Parking Division.

Exhibit 16A – Location of Public Parking Facilities in Downtown Pismo Beach



Source: Pismo Beach Downtown Strategic Plan, 2014. Minor modifications by Hatch Mott MacDonald.

Exhibit 16B – Location of Time-Limit On-Street Parking Areas in Downtown Pismo Beach

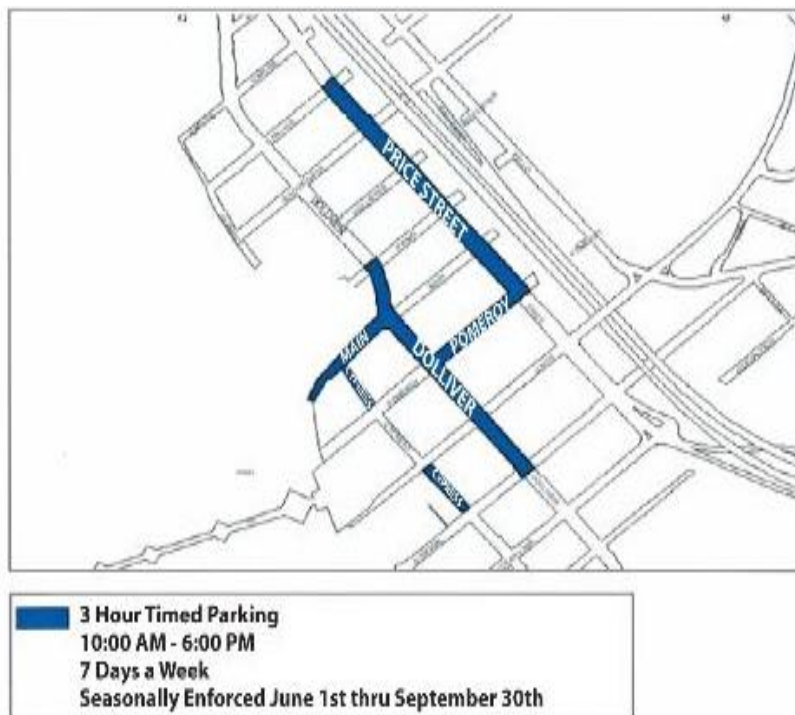

Source: City of Pismo Beach web site (<http://www.pismo-beach.org>). Accessed December 14, 2015.

PARKING DATA COLLECTION AND ANALYSIS -- DOWNTOWN PISMO BEACH

Information about the City's parking program was collected from a variety of sources including the following:

- Interviews with City staff, downtown stakeholders, and members of the Parking Advisory Committee.
- Collection of data and parking policy and management information from City Staff.
- Review of historical data collected during the last decade including previous parking studies, and other studies with parking information.
- Discussion with the Parking Advisory Committee during a regularly scheduled meeting.
- Weekday and Weekend day and evening parking counts of public parking areas in downtown during the peak seasonal time period in late July, 2014.

This data collection and review provided a good understanding of how parking is utilized and managed. During the summer weekday and weekend counts, parking lots for the most part fill to capacity and remain fully occupied as do on-street spaces. As soon as one vehicle leaves a space, another vehicle is waiting to take its place. All downtown lots and pay parking spaces exceed 85% capacity from approximately 10:00 AM through 4:00 PM for both weekday and weekend count periods. The lot located on Pomeroy Avenue, between Dolliver (SR 1) and Price Streets, is the last to become fully occupied. This is believed to be caused by the lack of parking wayfinding signs and the one-way flow to access that parking lot at the time of the observations in July, 2014.

Parking utilization in Downtown Pismo Beach is similar to that in other coastal communities, in that:

1. There is a seasonal use of parking spaces, i.e., high parking occupancy occurs during the late spring, summer, and early fall. Demand is lower during the other times of year. Parking occupancies were noted to exceed the 85% level for on-street spaces, the pier lot and parking lots located off of Main Street from 11:00 AM until 4:00 PM during the weekday and 10:00 AM through 4:00 PM count during the weekend.
2. There is an adequate supply of parking during the off-season and "shoulder" seasons (i.e., the very start and very end of the peak season). This was based on a review of the data provided by City staff and the Parking Committee for parking occupancy counts during shoulder and off-season time.
3. There is a shortage of parking spaces within select areas of the downtown. The prime downtown destination for visitors during the peak periods is the pier and surrounding core area. This results in parking demand exceeding supply in this area. Consequently, traffic congestion is intensified as vehicles circulate around the downtown area in search of available parking.
4. In several locations, the on-street parallel parking further adds to traffic congestion due to vehicle maneuvers to enter and leave the parking spaces impeding traffic flows. This is especially true for on-street spaces along Pomeroy and Hinds Avenues (from Price Street to the pier parking lot) and along Price Street (both the curb spaces and the center aisle spaces).
5. The parking lot on Pomeroy Avenue, between Price Street and Dolliver Street (SR 1), rarely reaches 100% occupancy, even though it is within a short walking distance from the pier area. This is primarily due to the one-way access of Pomeroy to the lot. Users of this lot have to be traveling from Price Street to Dolliver Street (SR 1) to access the lot and current wayfinding signage does not indicate how to access this lot from Dolliver Street. Wayfinding signs were recently added by the City that substantially improve the ability of visitors to navigate to parking facilities throughout the downtown area. This will result in better utilization of the current parking supply, but overall demand will continue to exceed the supply during peak times.
6. The City of Pismo Beach recently completed the "Downtown Parking Enhancements and Opportunities Study," Walker Parking Consultants, April 14, 2016, which can be found at

(<http://www.pismo-beach.org/DocumentCenter/View/47660>). It made similar observations to those described above. The study also made an additional observation that enhanced parking management (primarily parking fees that vary according to demand) would largely increase efficiency and reduce the parking supply deficiency during peak seasons.

J. Traffic Operations and Recommendations – Existing Conditions

Exhibit 17 (Pages 35 and 36) shows the study area, which encompasses all of Pismo Beach plus areas in surrounding communities that provide immediate access to Pismo Beach, such as portions of Arroyo Grande, Grover Beach, and unincorporated Avila Beach.

Areas outside of the downtown region experience relatively little variation during the year, traffic volumes within the downtown area substantially increase during the peak season (i.e., roughly June through September). Therefore, in addition to the standard Weekday PM peak hour for the peak season, the downtown area was also analyzed for Summer Sunday and Memorial Day Sunday peak hours in order to obtain data to evaluate peak traffic conditions.

Exhibits 18A-D, 19, and 20 (Pages 37-42) depict the existing traffic volumes in the city. These volumes were collected in May and June, 2014. The three collection periods include Weekday PM Peak Hour, Summer Sunday Midday Peak Hour, and Memorial Day Sunday Midday Peak Hour (i.e., the Sunday before Memorial Day). In total, there are 50 study intersections included in the Weekday PM peak hour and 23 study intersections counted during the Summer Sunday Midday and Memorial Day Sunday Midday peak hours. Raw traffic count data is tabulated in **Appendix A**.

Intersection operations were characterized using the concept of Level of Service (LOS). Average control delays experienced at an intersection correspond to a letter-grade scale of “A” through “F”, with LOS A representing little to no delay and LOS F representing very long delay. For signalized and all-way stop intersections, a single level of service grade – representing overall intersection conditions – is presented. For one-way and two-way stop-controlled intersections, both overall and worst side street approach levels of service are presented.

INTERSECTIONS WITH ACCEPTABLE OPERATIONS

Exhibit 21 (Pages 43-47) summarizes the existing levels of service at the study intersections. **Exhibits 22A-B, 23, and 24 (Pages 49-52)** graphically depict the levels of service at those same intersections. The level of service calculations are included in **Appendix B**. The study intersections were evaluated based on the City standard of LOS C (1992 City of Pismo Beach General Plan Circulation Element Principle P-1.c), the San Luis Obispo County standard of LOS C (2009 San Luis Bay Coastal Area Plan) and the Caltrans standard of the transition between LOS C and LOS D (*Guide for the Preparation of Traffic Impact Studies*, December 2002; henceforth referred to as LOS C/D). A total of 47 of 50 intersections studied during the Weekday PM peak hour, 13 of the 21 intersections during the Summer Sunday Midday peak hour, and 12 of the 21 intersections studied under the Memorial Day Sunday Midday peak hour operate acceptably and require no operational improvements based on congestion.

INTERSECTIONS WITH DEFICIENT OPERATIONS

Exhibit 21 (Pages 43-47) also indicates the study intersections that currently operate deficiently, as well as the recommended improvements to correct each deficiency and the resulting operations with implementation of the identified improvements. The deficient intersections, their current operations and their respective improvements are also described below, listed by intersection number. More information about the recommended

improvements and why they are recommended is provided in **Section 3.D – Improvements Recommended in Previous Studies (Page 75)** and **Section 3.E - Network Alternatives (Page 79)**.

The following four (4) intersections operate deficiently under the Weekday PM peak hour:

- 26. Price Street/Hinds Avenue (Overall LOS B, but long queues on Southbound Hinds) – Review signal timing and consider widening the Hinds bridge over US 101. Vertical clearance about US 101 may be an issue.
- 34. Dolliver Street (SR 1) / Ocean View Avenue (Side Street LOS F - Implement Ocean View – Stimson Couplet)
- 42. Fourth Street / Five Cities Drive (Signal LOS D - Add Right Turn Overlap Phase on Eastbound Five Cities Drive)
- 48. US 101 Southbound Ramps / El Camino Real (All-Way Stop LOS D - Install Signal)

The following eight (8) intersections operate deficiently under the Summer Sunday Midday peak hour:

- 14. US 101 Southbound Off-ramp - Dolliver Street (SR 1) / Price Street (All-way stop LOS E - Install Roundabout)
- 20. Dolliver Street (SR 1) / Main Street (Side Street LOS F - Eliminate One On-Street Parking Space to Accommodate a Right Turn Lane on Westbound Main. Consider left turn pockets as an alternative.)
- 21. Cypress Street / Pomeroy Avenue (Side Street LOS F - Install Signal with Pedestrian Scramble – described in Section 3.5.a – General Plan Buildout Conditions - Network Alternatives – Pier Area Improvements – Cypress Street/Pomeroy, see discussion below)
- 22. Dolliver Street (SR 1) / Pomeroy Avenue (Signal LOS E - Eliminate Three On-Street Parking Spaces to Accommodate a Right Turn Lane on Southbound Dolliver. Consider northbound left turn pocket as an alternative. Also consider Modifying Signal to include Pedestrian Scramble – described in Section 3.5.b – General Plan Buildout Conditions - Network Alternatives – Pier Area Improvements – Dolliver Street (State Route 1)/Pomeroy, see discussion below)
- 25. Dolliver Street (SR 1) / Hinds Avenue (Signal LOS D - Eliminate Two On-Street Parking Spaces to Accommodate a Right Turn Lane on Northbound Dolliver Consider left turn pockets as an alternative..)
- 32. Price Street / Stimson Avenue (Side Street LOS F - Implement Ocean View - Stimson Couplet)
- 34. Dolliver Street (SR 1) / Ocean View Avenue (Side Street LOS F - Implement Ocean View - Stimson Couplet)
- 35. US 101 Ramps - Price Street / Ocean View Avenue (Side Street LOS F - Implement Ocean View - Stimson Couplet)

The following nine (9) intersections operate deficiently under the Memorial Day Sunday Midday peak hour:

- 14. US 101 Southbound Off-ramp - Dolliver Street (SR 1) / Price Street (All-way stop LOS E - Install Roundabout)
- 20. Dolliver Street (SR 1) / Main Street (Side Street LOS F - Eliminate One On-Street Parking Space to Accommodate a Right Turn Lane on Westbound Main. Consider left turn pockets as an alternative.)
- 21. Cypress Street / Pomeroy Avenue (Side Street LOS F - Install Signal with Pedestrian Scramble – described in Section 3.5.a – General Plan Buildout Conditions - Network Alternatives – Pier Area Improvements – Cypress Street/Pomeroy, see discussion below)
- 22. Dolliver Street (SR 1) / Pomeroy Avenue (Signal LOS F - Eliminate Three On-Street Parking Spaces to Accommodate a Right Turn Lane on Southbound Dolliver. Consider northbound left turn pocket as an alternative. Also consider Modifying Signal to include Pedestrian Scramble – described in Section 3.5.b – General Plan Buildout Conditions - Network Alternatives – Pier Area Improvements – Dolliver Street (State Route 1)/Pomeroy, see discussion below)

- 25. Dolliver Street (SR 1) / Hinds Avenue (Signal LOS F - Eliminate Two On-Street Parking Spaces to Accommodate a Right Turn Lane on Northbound Dolliver. Consider left turn pockets as an alternative.)
- 31. Dolliver Street (SR 1) / Stimson Avenue (Side Street LOS F - Implement Ocean View - Stimson Couplet)
- 32. Price Street / Stimson Avenue (Side Street LOS F - Implement Ocean View - Stimson Couplet)
- 34. Dolliver Street (SR 1) / Ocean View Avenue (Side Street LOS F - Implement Ocean View - Stimson Couplet)
- 35. US 101 Northbound Ramps - Price Street / Ocean View Avenue (Side Street LOS F - Implement Ocean View - Stimson Couplet)

Intersection 22, Dolliver Street (SR 1) / Pomeroy Avenue - Left turns from northbound Dolliver (SR 1) onto Pomeroy (i.e., towards the pier area) are prohibited during peak tourist periods. This prohibition is indicated by the activation of a NO LEFT TURN (R3-2) “activated blankout” (i.e., back lit) electronic sign posted on a signal mast arm at the intersection.

Intersections 16, 20, 22, 25, 31 and 34 - Dolliver Street (SR 1) Between Wadsworth Avenue and Ocean View Avenue - The addition of short exclusive left turn pockets on Dolliver Street (SR 1) at key intersections in Downtown Pismo Beach, such as at Pomeroy Avenue and Hinds Avenue, should be considered. These are discussed in more detail in **Section 3.E.5) c – General Plan Buildout – Network Alternatives – Pier Area Improvements – Dolliver Street Left Turn Pockets.**

Intersections 21 and 22, Cypress Street / Pomeroy Avenue and Dolliver Street (SR 1) / Pomeroy Avenue - Within Downtown Pismo Beach, some of the traffic congestion on Sundays during the peak season is created by the very large volumes of pedestrian crossings. This is especially true near the pier area, which is one of the primary destinations of many visitors to the area. At the Cypress / Pomeroy intersection, these crossings – both mid-block and at intersections – combine with the congestion caused by the parking maneuvers to create vehicle queues that can extend back to the Dolliver (SR 1) / Pomeroy intersection one block away. This congestion can then radiate out to affect operations at other intersections in the downtown area.

Pedestrian activity is still relatively high on Sundays during the peak season at the Dolliver (SR 1) / Pomeroy intersection, although it is not as high as at the Cypress / Pomeroy intersection one block to the south. Here, the large number of right turning vehicles from southbound Dolliver Street (SR 1) onto westbound Pomeroy (i.e., bound for the pier area) can limit the number of pedestrians that can cross Pomeroy Avenue. This is especially true when congestion at the Cypress / Pomeroy intersection affects upstream operations at Dolliver (SR 1) / Pomeroy, just one block away. A detailed discussion of the causes of this congestion and the recommended remedial measures is included in **Section 3.E.5.a and b - General Plan Buildout Conditions – Network Alternatives - Pier Area Improvements (Page 79).**

This page was intentionally left blank
(For Duplex Printing)

Exhibit 17A – Greater Pismo Beach Study Area

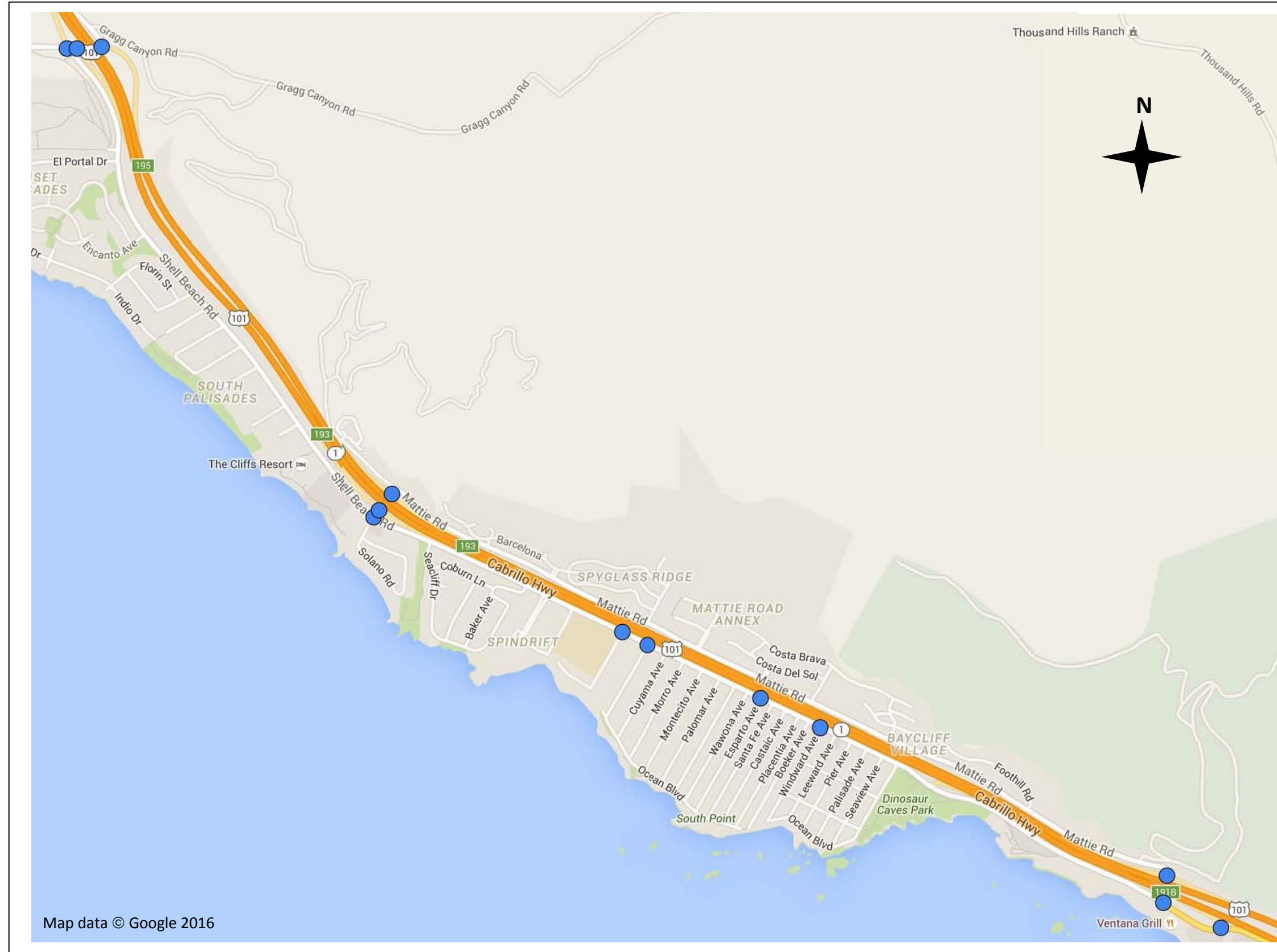

Exhibit 17B– Greater Pismo Beach Study Area

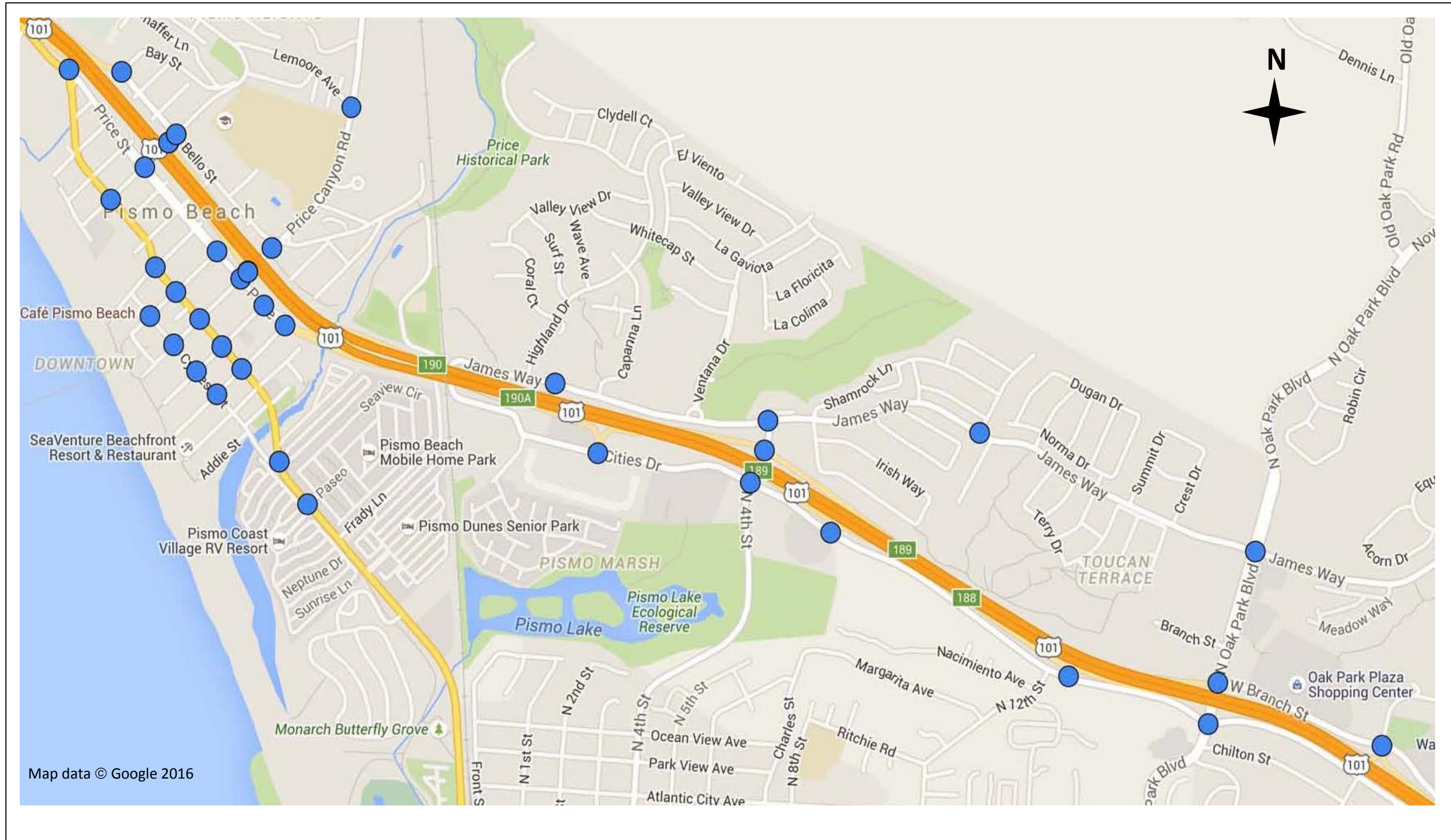

Exhibit 18A – Existing Weekday PM Peak Hour Volumes

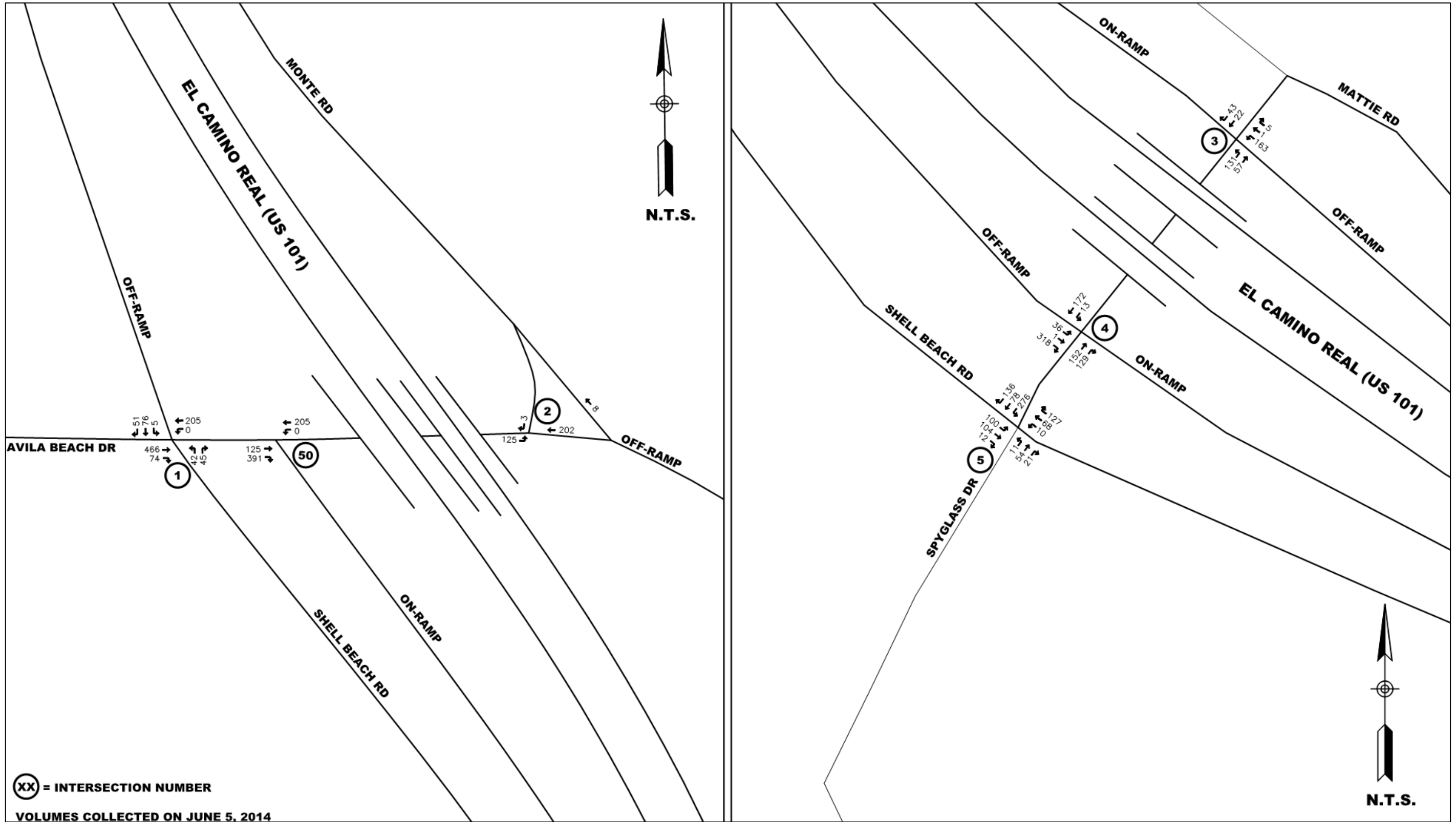

Exhibit 18B – Existing Weekday PM Peak Hour Volumes (continued)

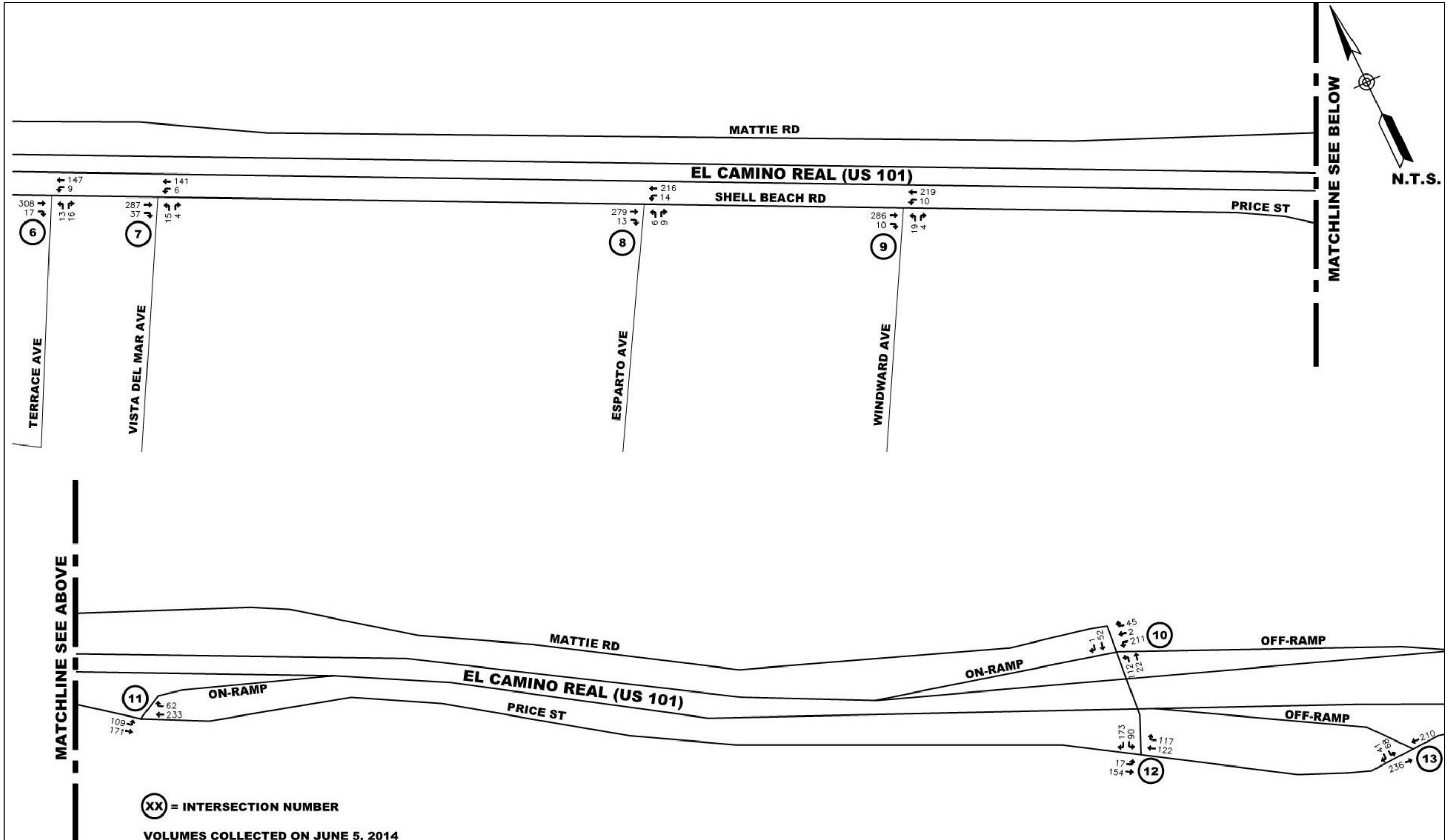

Exhibit 18C – Existing Weekday PM Peak Hour Volumes (continued)

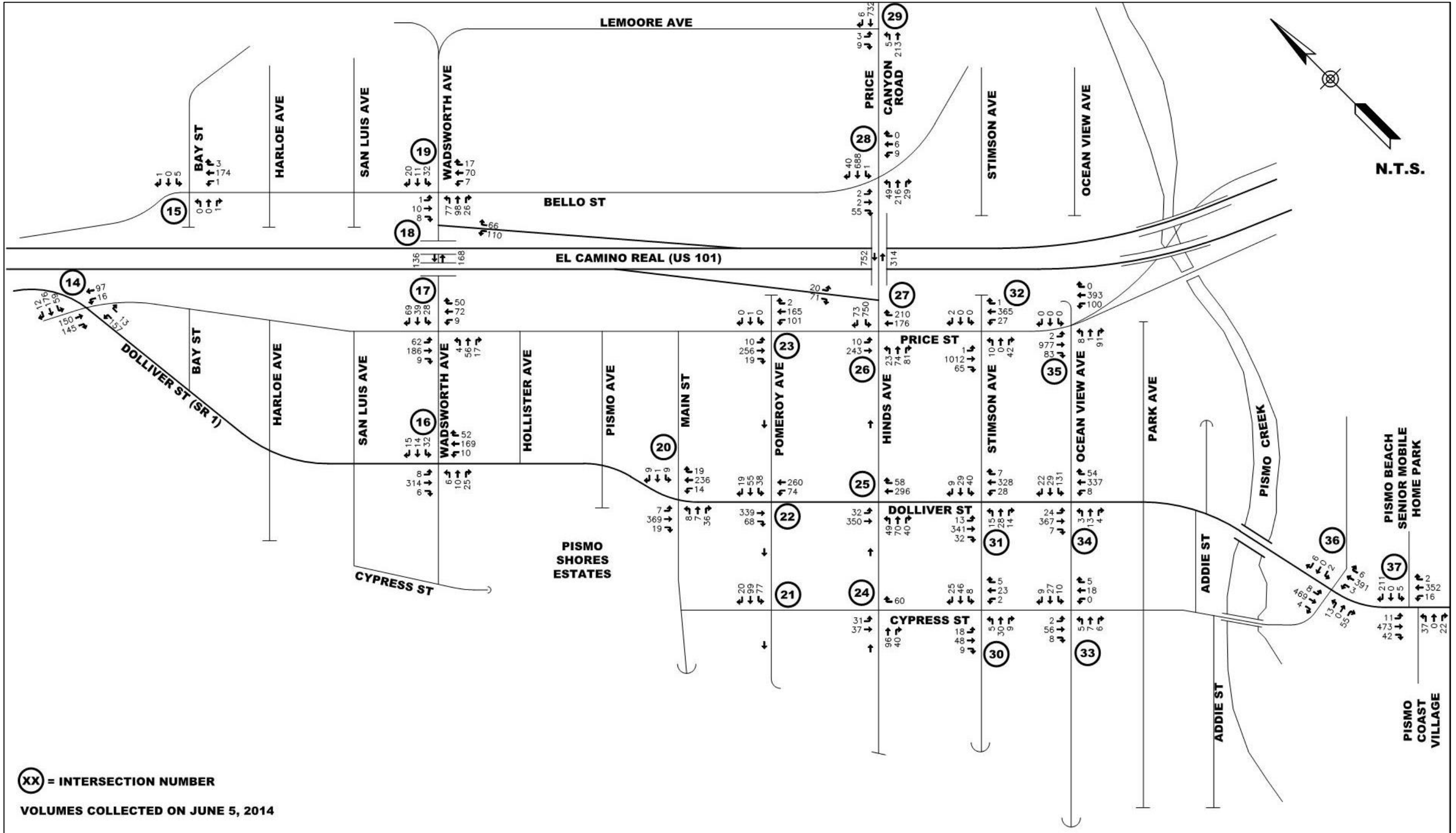

Exhibit 18D – Existing Weekday PM Peak Hour Volumes (continued)

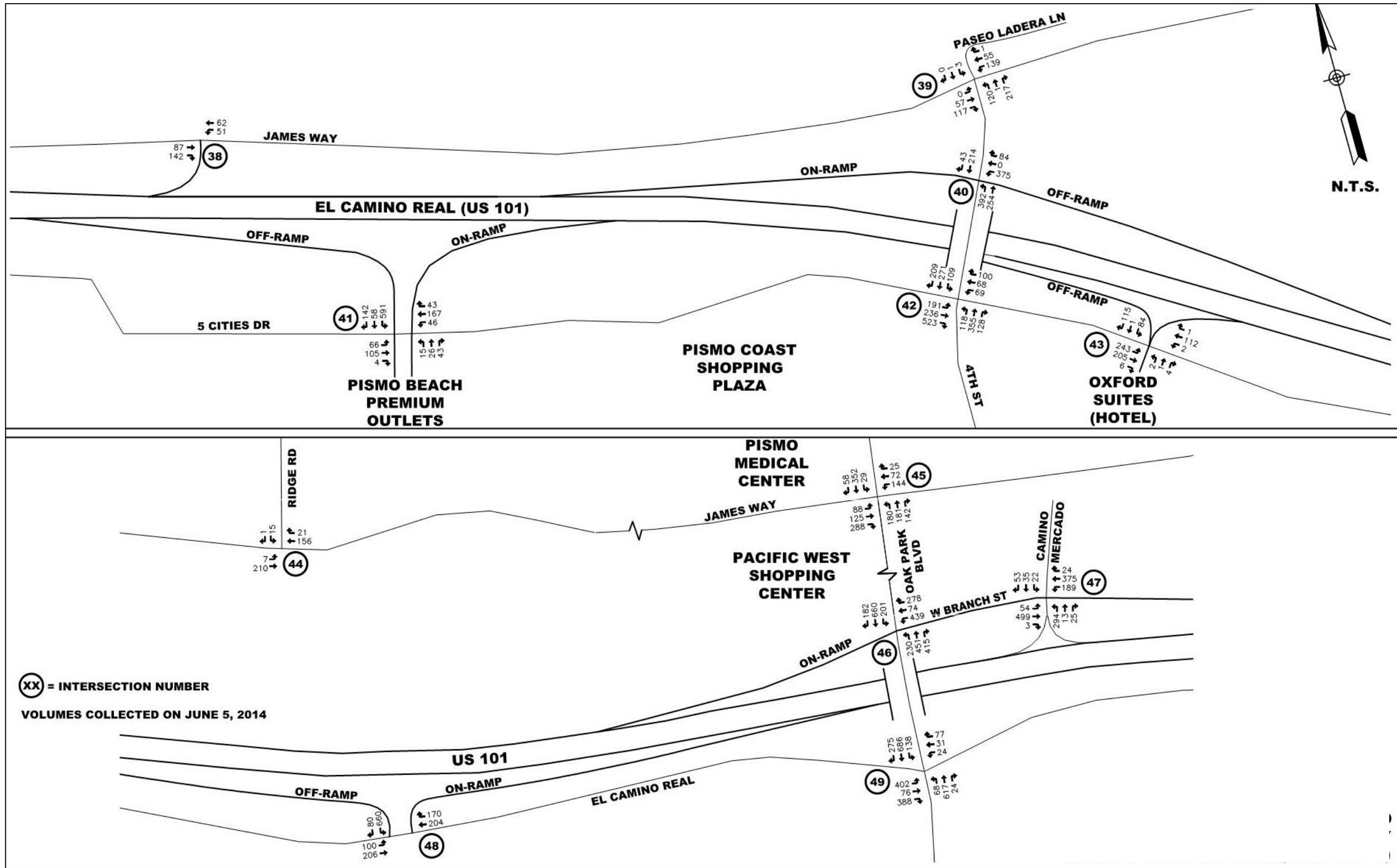

Exhibit 19 – Existing Summer Sunday Midday Peak Hour Volumes

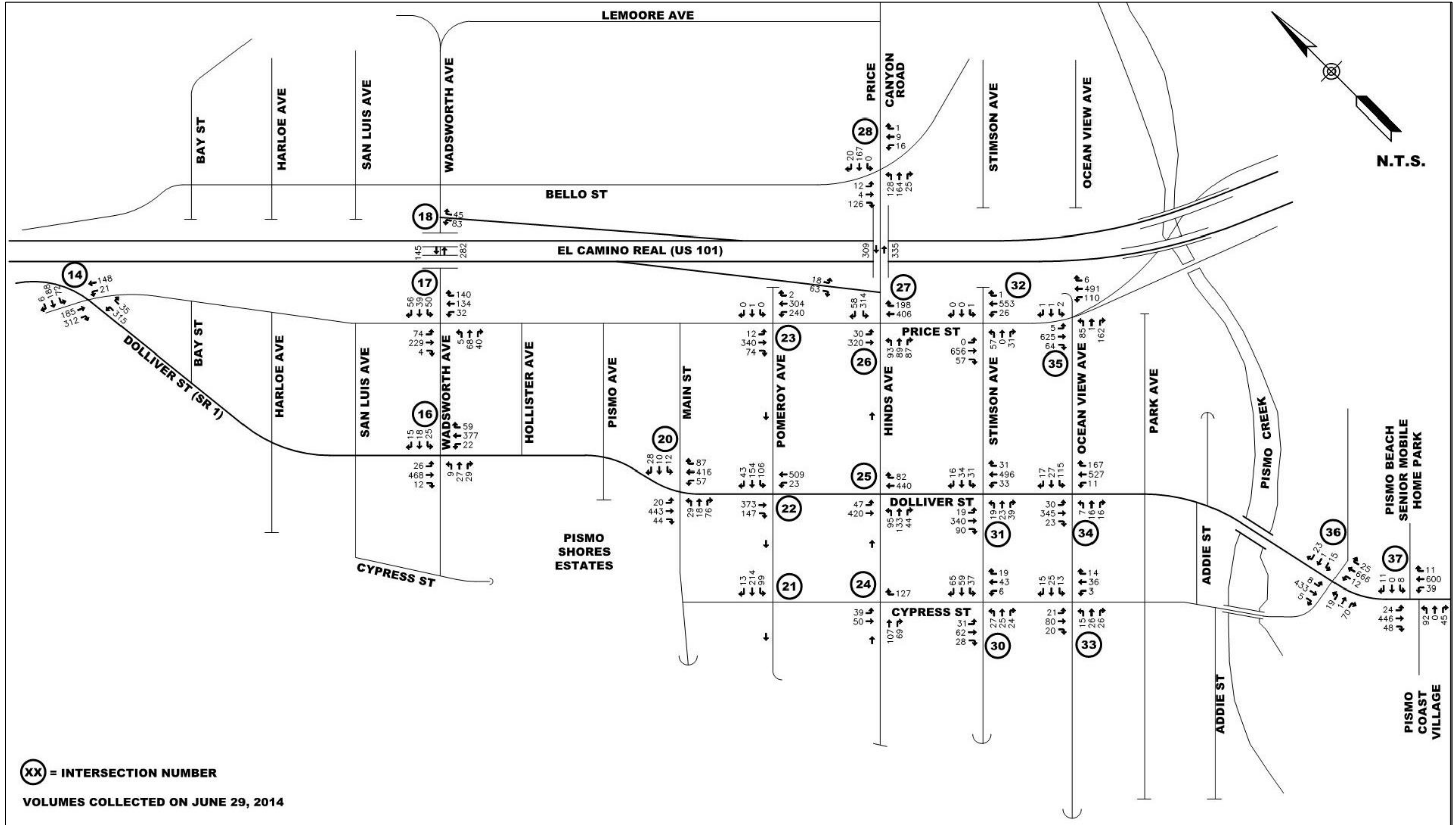

Exhibit 20 – Existing Memorial Day Sunday Midday Peak Hour Volumes

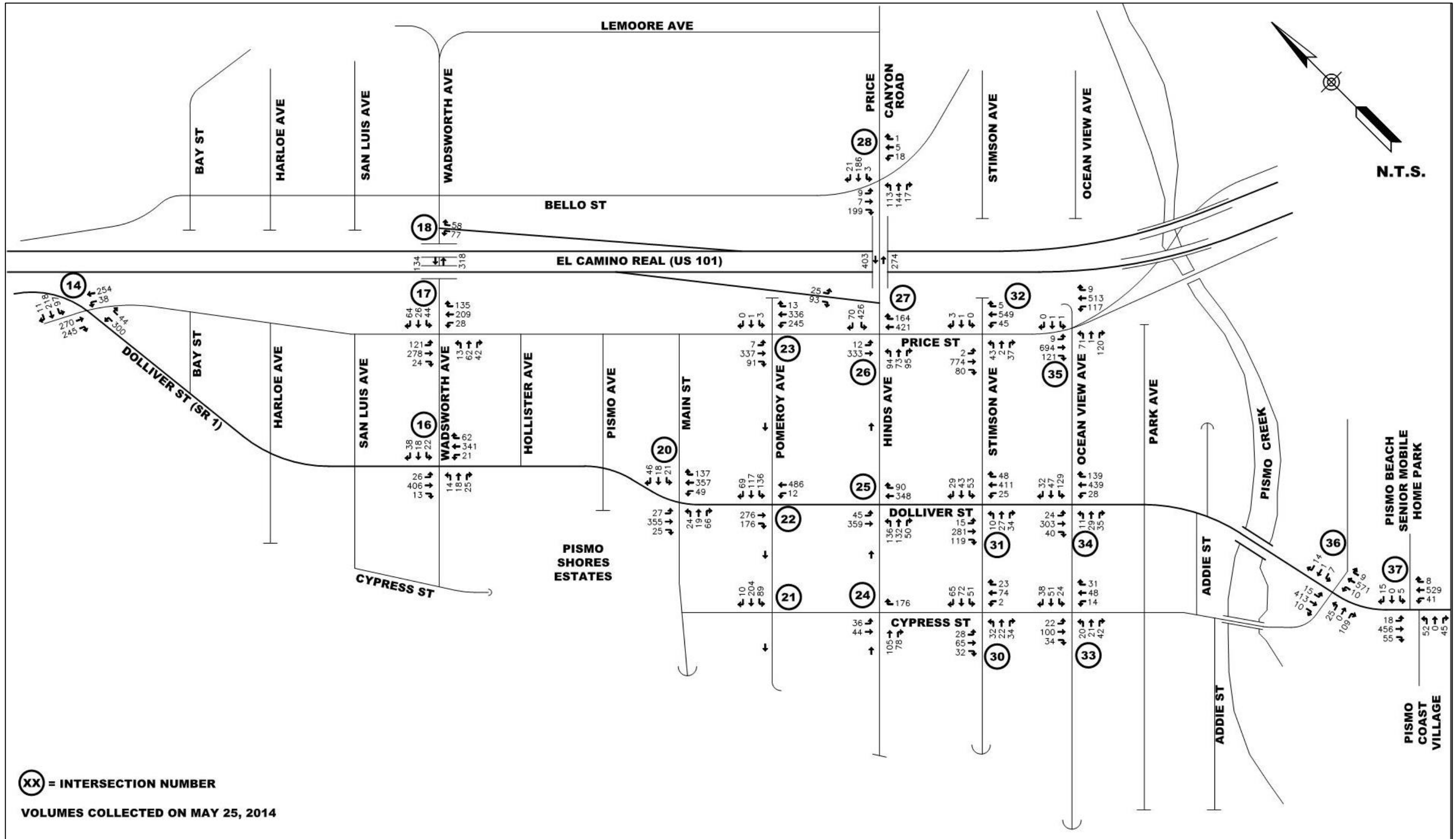

Exhibit 21 – Intersection Levels of Service Existing Conditions

N-S Street	E-W Street	Existing Lane Configuration	Existing Intersection Control	LOS Standard	Existing Conditions						Existing Conditions With Improvements						Proposed Improvement(s)
					Weekday PM Peak Hr		Summer Sunday Mid		Memorial Day Sunday Mid		Weekday PM Peak Hr		Summer Sunday Mid		Memorial Day Sunday Mid		
					Delay (sec)	LOS	Delay (sec)	LOS	Delay (sec)	LOS	Delay (sec)	LOS	Delay (sec)	LOS	Delay (sec)	LOS	
1	Shell Beach Road - US 101 SB Ramps	Avila Beach Drive	NB 1-L/R SB 1-L/T, 1-R EB 1-T/R WB 1-L/T	Two-Way Stop <i>(County)</i>	C/D Side Street	4.2	A	21.3	C								
2	Monte Road	Avila Beach Drive - US 101 NB Ramps	SB 1-R EB 1-L WB 1-T/R	Two-Way Stop <i>(County)</i>	C/D Side Street	3.0	A	9.4	A								
3	Spyglass Drive	US 101 NB Ramps	NB 1-L, 1-T SB 1-T/R EB 1-L, 1-T/R	One-Way Stop	C/D Side Street	8.1	A	14.5	B								
4	Spyglass Drive	US 101 SB Ramps	NB 1-T/R SB 1-L, 1-T WB 1-L/T, 1-R	One-Way Stop	C/D Side Street	5.4	A	12.1	B								
5	Spyglass Drive	Shell Beach Road	NB 1-L/T/R SB 1-L, 1-T, 1-R EB 1-L, 1-T/R WB 1-L, 1-T, 1-R	All-Way Stop	C	13.4	B										
6	Terrace Avenue	Shell Beach Road	NB 1-L/R EB 1-T/R WB 1-L, 1-T	All-Way Stop	C	9.7	A										
7	Vista Del Mar Avenue	Shell Beach Road	NB 1-L/R EB 1-T/R WB 1-L/T	All-Way Stop	C	9.2	A										
8	Esparto Avenue	Shell Beach Road	NB 1-L/R EB 1-T/R WB 1-L/T	All-Way Stop	C	9.3	A										
9	Windward Avenue	Shell Beach Road	NB 1-L/R EB 1-T/R WB 1-L/T	All-Way Stop	C	9.4	A										
10	Mattie Road	US 101 NB Ramps	NB 1-L/T SB 1-T/R EB 1-L, 1-T/R	One-Way Stop	C/D Side Street	7.0	A	12.0	B								

Notes:

1. L, T, R = Left, Through, Right.
2. NB, SB, EB, WB = Northbound, Southbound, Eastbound, Westbound.
3. Analysis performed using 2010 Highway Capacity Manual methodologies.
4. Overall level of service standard for Caltrans is the transition between LOS C and D.
5. Overall level of service standard for the City of Pismo Beach and County of San Luis Obispo is LOS C.
6. Worst approach level of service standard is generally LOS E. Level of service "F" is the level of service at which improvements would be required.
7. * = Delay is over 300 seconds (5 minutes)

Exhibit 21 – Intersection Levels of Service Existing Conditions (Continued)

N-S Street	E-W Street	Existing Lane Configuration	Existing Intersection Control	LOS Standard	Existing Conditions						Existing Conditions With Improvements						Proposed Improvement(s)	
					Weekday PM Peak Hr		Summer Sunday Mid		Memorial Day Sunday Mid		Weekday PM Peak Hr		Summer Sunday Mid		Memorial Day Sunday Mid			
					Delay (sec)	LOS	Delay (sec)	LOS	Delay (sec)	LOS	Delay (sec)	LOS	Delay (sec)	LOS	Delay (sec)	LOS		
11	US 101 SB On-ramp	Price Street	EB 1-L/T WB 1-T/R	None	C Side Street	0.0 0.0	A A											
12	Mattie Road	Price Street	SB 1-L, 1-R EB 1-L/T WB 1-T/R	Signal	C	6.6	A											
13	US 101 SB Off-ramp	Price Street	SB 1-L, 1-R EB 1-T WB 1-T	One-Way Stop	C/D Side Street	2.3 11.6	A B											
14	US 101 SB Off-ramp - Dolliver Street (SR 1)	Price Street	NB 1-L, 1-R SB 1-L, 1-T, 1-R EB 1-T/R WB 1-L/T	All-Way Stop	C/D	14.0	B	43.0	E	48.6	E	7.4	A	12.4	B	16.3	C	Roundabout
15	US 101 NB On-ramp - Bello Street	Bay Street	NB 1-L/T/R EB 1-L/T/R WB 1-L/T/R	Two-Way Stop	C/D Side Street	0.3 9.5	A A											
16	Dolliver Street (SR 1)	Wadsworth Avenue	NB 1-L/T/R SB 1-L/T/R EB 1-L/T/R WB 1-L/T/R	Two-Way Stop	C/D Side Street	2.4 15.1	A C	3.5 32.0	A D	4.0 27.0	A D							
17	Price Street	Wadsworth Avenue	NB 1-L/T/R SB 1-L, 1-T/R EB 1-L/T/R WB 1-L/T/R	All-Way Stop	C	9.4	A	12.0	B	14.1	B							
18	US 101 NB Off-ramp	Wadsworth Avenue	NB 1-L, 1-R EB 1-T WB 1-T	One-Way Stop	C/D Side Street	5.2 9.9	A A	3.0 11.3	A B	3.0 11.4	A B							
19	Bello Street	Wadsworth Avenue	NB 1-L/T/R SB 1-L/T/R EB 1-L/T/R WB 1-L/T/R	All-Way Stop	C	8.4	A											
20	Dolliver Street (SR 1)	Main Street	NB 1-L/T/R SB 1-L/T/R EB 1-L/T/R WB 1-L/T/R	Two-Way Stop	C/D Side Street	1.6 15.2	A C	18.2 146.7	C F	42.4 248.8	E F	1.5 14.8	A B	8.8 60.4	A F	18.4 111.5	C F	Eliminate 1 On-Street Parking Space to Accommodate Right Turn Lane on Westbound Main

Notes:

1. L, T, R = Left, Through, Right.
2. NB, SB, EB, WB = Northbound, Southbound, Eastbound, Westbound.
3. Analysis performed using 2010 Highway Capacity Manual methodologies.
4. Overall level of service standard for Caltrans is the transition between LOS C and D.
5. Overall level of service standard for the City of Pismo Beach and County of San Luis Obispo is LOS C.
6. Worst approach level of service standard is generally LOS E. Level of service "F" is the level of service at which improvements would be required.
7. * = Delay is over 300 seconds (5 minutes)

Exhibit 21 – Intersection Levels of Service Existing Conditions (Continued)

N-S Street	E-W Street	Existing Lane Configuration	Existing Intersection Control	LOS Standard	Existing Conditions						Existing Conditions With Improvements						Proposed Improvement(s)	
					Weekday PM Peak Hr		Summer Sunday Mid		Memorial Day Sunday Mid		Weekday PM Peak Hr		Summer Sunday Mid		Memorial Day Sunday Mid			
					Delay (sec)	LOS	Delay (sec)	LOS	Delay (sec)	LOS	Delay (sec)	LOS	Delay (sec)	LOS	Delay (sec)	LOS		
21	Cypress Street	Pomeroy Avenue	WB 1-L/T/R	One-Way Stop	C Side Street	16.1 16.3	C C	*	F	*	F	5.5	A	4.8	A	5.1	A	Signal with Pedestrian Scramble
22	Dolliver Street (SR 1)	Pomeroy Avenue	NB 1-L/T SB 1-T/R WB 1-L, 1-T/R	Signal	C/D	17.4	B	65.0	E	210.1	F	9.3	A	24.6	C	39.4	D	Eliminate On-Street Parking to Accommodate Right Turn Lane on Southbound Dolliver
23	Price Street	Pomeroy Avenue	NB 1-L, 1-T/R SB 1-L/T/R WB 1-L/T/R	All-Way Stop	C	9.3	A	12.2	B	12.7	B							
24	Cypress Street	Hinds Avenue	NB 1-R SB 1-L,T EB 1-T/R	All-Way Stop	C	7.6	A	8.1	A	8.3	A							
25	Dolliver Street (SR 1)	Hinds Avenue	NB 1-T/R SB 1-L/T EB 1-L/T, 1-T/R	Signal	C/D	5.7	A	35.8	D	144.2	F	6.5	A	19.7	B	26.6	C	Eliminate On-Street Parking to Accommodate Right Turn Lane on Northbound Dolliver
26	Price Street	Hinds Avenue	NB 1-T, 1-T/R SB 1-L/T, 1-T EB 1-L, 1-T/R WB 1-L, 1-L/R	Signal	C	14.1	B	13.2	B	14.8	B	14.1	B	13.2	B	14.8	B	1. Review signal timing to minimize SB Hinds queue 2. Consider widening Hinds bridge over US 101 to mitigate SB Hinds queue
27	US 101 SB Off-ramp	Hinds Avenue	SB 1-L, 1-R EB 1-T WB 2-T	One-Way Stop	C/D Side Street	1.2 30.4	A D	1.2 10.9	A B	1.7 12.0	A B							
28	Bello Street	Price Canyon Road	NB 1-L/T/R SB 1-L/T/R EB 1-L, 1-T/R WB 1-L, 1-T/R	Two-Way Stop	C Side Street	1.6 30.4	A D	4.1 18.1	A C	5.1 19.0	A C							
29	Lemoore Avenue	Price Canyon Road	NB 1-L, 1-T SB 1-T/R EB 1-L/R	One-Way Stop	C Side Street	0.2 16.0	A C											
30	Cypress Street	Stimson Avenue	NB 1-L/T/R SB 1-L/T/R EB 1-L/T/R WB 1-L/T/R	Two-Way Stop	C Side Street	6.2 10.3	A B	12.9 22.6	B C	15.2 28.6	C D	6.5 10.4	A B	14.0 24.2	B C	18.2 33.1	C D	Implement Ocean View - Stimson Couplet

Notes:

1. L, T, R = Left, Through, Right.
2. NB, SB, EB, WB = Northbound, Southbound, Eastbound, Westbound.
3. Analysis performed using 2010 Highway Capacity Manual methodologies.
4. Overall level of service standard for Caltrans is the transition between LOS C and D.
5. Overall level of service standard for the City of Pismo Beach and County of San Luis Obispo is LOS C.
6. Worst approach level of service standard is generally LOS E. Level of service "F" is the level of service at which improvements would be required.
7. * = Delay is over 300 seconds (5 minutes)

Exhibit 21 – Intersection Levels of Service Existing Conditions (Continued)

N-S Street	E-W Street	Existing Lane Configuration	Existing Intersection Control	LOS Standard	Existing Conditions						Existing Conditions With Improvements						Proposed Improvement(s)	
					Weekday PM Peak Hr		Summer Sunday Mid		Memorial Day Sunday Mid		Weekday PM Peak Hr		Summer Sunday Mid		Memorial Day Sunday Mid			
					Delay (sec)	LOS	Delay (sec)	LOS	Delay (sec)	LOS	Delay (sec)	LOS	Delay (sec)	LOS	Delay (sec)	LOS		
31	Dolliver Street (SR 1)	Stimson Avenue	NB 1-L/T/R SB 1-L/T/R EB 1-L/T/R WB 1-L/T/R	Two-Way Stop	C/D Side Street	4.9 32.3	A D	5.0 40.0	A E	8.1 54.9	A F	8.4 7.4	A A	7.4 7.4	A A	8.6 8.6	A A	Implement Ocean View - Stimson Couplet and Signal
32	Price Street	Stimson Avenue	NB 1-L/T/R SB 1-L/T, 1-T/R EB 1-L/T, 1-R WB 1-L/T/R	Two-Way Stop	C Side Street	1.0 23.4	A C	3.9 58.5	A F	4.7 80.5	A F	1.1 9.7	A A	1.0 21.9	A C	1.2 10.7	A B	Implement Ocean View - Stimson Couplet and Price Street Restriping
33	Cypress Street	Ocean View Avenue	NB 1-L/T/R SB 1-L/T/R EB 1-L/T/R WB 1-L/T/R	Two-Way Stop	C Side Street	4.2 9.9	A A	6.5 12.7	A B	7.2 15.0	A B	3.6 10.1	A B	5.4 13.3	A B	6.3 14.9	A B	Implement Ocean View - Stimson Couplet
34	Dolliver Street (SR 1)	Ocean View Avenue	NB 1-L/T/R SB 1-L/T/R EB 1-L/T/R WB 1-L/T/R	Two-Way Stop	C/D Side Street	10.3 52.9	B F	28.3 221.8	D F	45.8 264.1	E F	1.1 17.6	A C	1.3 21.1	A C	2.1 21.1	A C	Implement Ocean View - Stimson Couplet
35	US 101 Ramps - Price Street	Ocean View Avenue	NB 1-L, 1-T/R SB 1-L, 1-T, 1-R EB 1-L/T, 1-R WB 1-L/T/R	Two-Way Stop	C/D Side Street	2.6 30.9	A D	13.1 76.6	B F	11.4 91.2	B F	1.8 18.6	A C	8.1 37.0	A E	6.5 37.3	A E	Implement Ocean View - Stimson Couplet and Price Street Restriping
36	Dolliver Street (SR 1)	Cypress Street - Holiday RV Park Ent.	NB 1-L, 1-T/R SB 1-L, 1-T/R EB 1-L/T/R WB 1-L/T/R	Two-Way Stop	C/D Side Street	1.1 13.0	A B	1.8 18.0	A C	2.2 15.8	A C							
37	Dolliver Street (SR 1)	Pismo Beach Senior MHP - Pismo Coast Village	NB 1-L, 1-T/R SB 1-L, 1-T/R EB 1-L/T/R WB 1-L/T/R	Signal	C/D	7.2	A	11.0	B	9.9	A							
38	US 101 NB On-ramp	James Way	EB 1-T/R WB 1-L, 1-T	None	C/D Side Street	0.0 0.0	A A											
39	Fourth Street - Paseo Ladera Lane	James Way	NB 1-L/T, 1-R SB 1-L/T/R EB 1-L/T, 1-R WB 1-L, 1-T/R	All-Way Stop	C	10.0	A											
40	Fourth Street	US 101 NB Ramps	NB 2-L, 2-T SB 1-T, 1-T/R EB 1-L, 1-T/R	Signal	C/D	12.1	B											

Notes:

1. L, T, R = Left, Through, Right.
2. NB, SB, EB, WB = Northbound, Southbound, Eastbound, Westbound.
3. Analysis performed using 2010 Highway Capacity Manual methodologies.
4. Overall level of service standard for Caltrans is the transition between LOS C and D.
5. Overall level of service standard for the City of Pismo Beach and County of San Luis Obispo is LOS C.
6. Worst approach level of service standard is generally LOS E. Level of service "F" is the level of service at which improvements would be required.
7. * = Delay is over 300 seconds (5 minutes)

Exhibit 21 – Intersection Levels of Service Existing Conditions (Continued)

N-S Street	E-W Street	Existing Lane Configuration	Existing Intersection Control	LOS Standard	Existing Conditions						Existing Conditions With Improvements						Proposed Improvement(s)
					Weekday PM Peak Hr		Summer Sunday Mid		Memorial Day Sunday Mid		Weekday PM Peak Hr		Summer Sunday Mid		Memorial Day Sunday Mid		
					Delay (sec)	LOS	Delay (sec)	LOS	Delay (sec)	LOS	Delay (sec)	LOS	Delay (sec)	LOS	Delay (sec)	LOS	
41	US 101 SB Ramps - Outlets Main Entrance	Five Cities Drive	NB 1-L, 1-T/R SB 1-L, 1-L/T, 1-T/R EB 1-L, 1-T, 1-T/R WB 1-L, 1-T, 1-R	Signal	C/D	27.1	C										
42	Fourth Street	Five Cities Drive	NB 1-L, 1-T, 1-T/R SB 1-L, 1-T, 1-R EB 1-L, 1-T, 1-R WB 1-L, 1-T/R	Signal	C	36.3	D					26.8	C			Add Right Turn Overlap Phase on Eastbound Five Cities Drive	
43	US 101 SB Ramps - Hotel Driveway	Five Cities Drive - El Camino Real	NB 1-L/T/R SB 1-L/T, 1-R EB 1-L/T/R WB 1-L/T/R	All-Way Stop	C/D	13.8	B										
44	Ridge Road	James Way	SB 1-L/R EB 1-L, 1-T WB 1-T/R	All-Way Stop	C	9.0	A										
45	Oak Park Boulevard	James Way	NB 1-L, 1-T, 1-T/R SB 1-L, 1-T, 1-T/R EB 1-L, 1-T, 1-R WB 1-L, 1-T/R	Signal	C	25.7	C										
46	Oak Park Boulevard	US 101 NB On-Ramp - West Branch Street	NB 1-L, 1-T, 1-T/R SB 1-L, 1-T, 1-T/R WB 1-L, 1-L/T, 1-R	Signal	C	11.1	B										
47	Camino Mercado- US 101 NB Ramps	West Branch Street	NB 1-L, 1-T/R SB 1-L, 1-T/R EB 1-L, 1-T, 1-T/R WB 1-L, 1-T	Signal <i>(Arroyo Grande)</i>	C/D	28.3	C										
48	US 101 SB Ramps	El Camino Real	SB 1-L, 1-L/R EB 1-L/T WB 1-T/R	All-Way Stop <i>(Grover Beach)</i>	C/D	33.8	D					10.1	B			Signal	
49	Oak Park Boulevard	El Camino Real	NB 1-L, 1-T, 1-T/R SB 1-L, 2-T, 1-R EB 1-L, 1-L/T, 1-R WB 1-L, 1-T/R	Signal	C	22.3	C										
50	US 101 SB On-ramp	Avila Beach Drive	EB 1-T/R WB 1-L/T	None <i>(County)</i>	C/D Side Street	0.0	A										

Notes:

1. L, T, R = Left, Through, Right.
2. NB, SB, EB, WB = Northbound, Southbound, Eastbound, Westbound.
3. Analysis performed using 2010 Highway Capacity Manual methodologies.
4. Overall level of service standard for Caltrans is the transition between LOS C and D.
5. Overall level of service standard for the City of Pismo Beach and County of San Luis Obispo is LOS C.
6. Worst approach level of service standard is generally LOS E. Level of service "F" is the level of service at which improvements would be required.
7. * = Delay is over 300 seconds (5 minutes)

This page was intentionally left blank
(For Duplex Printing)

Exhibit 22A – Intersection Operations Existing Weekday PM Peak Hour

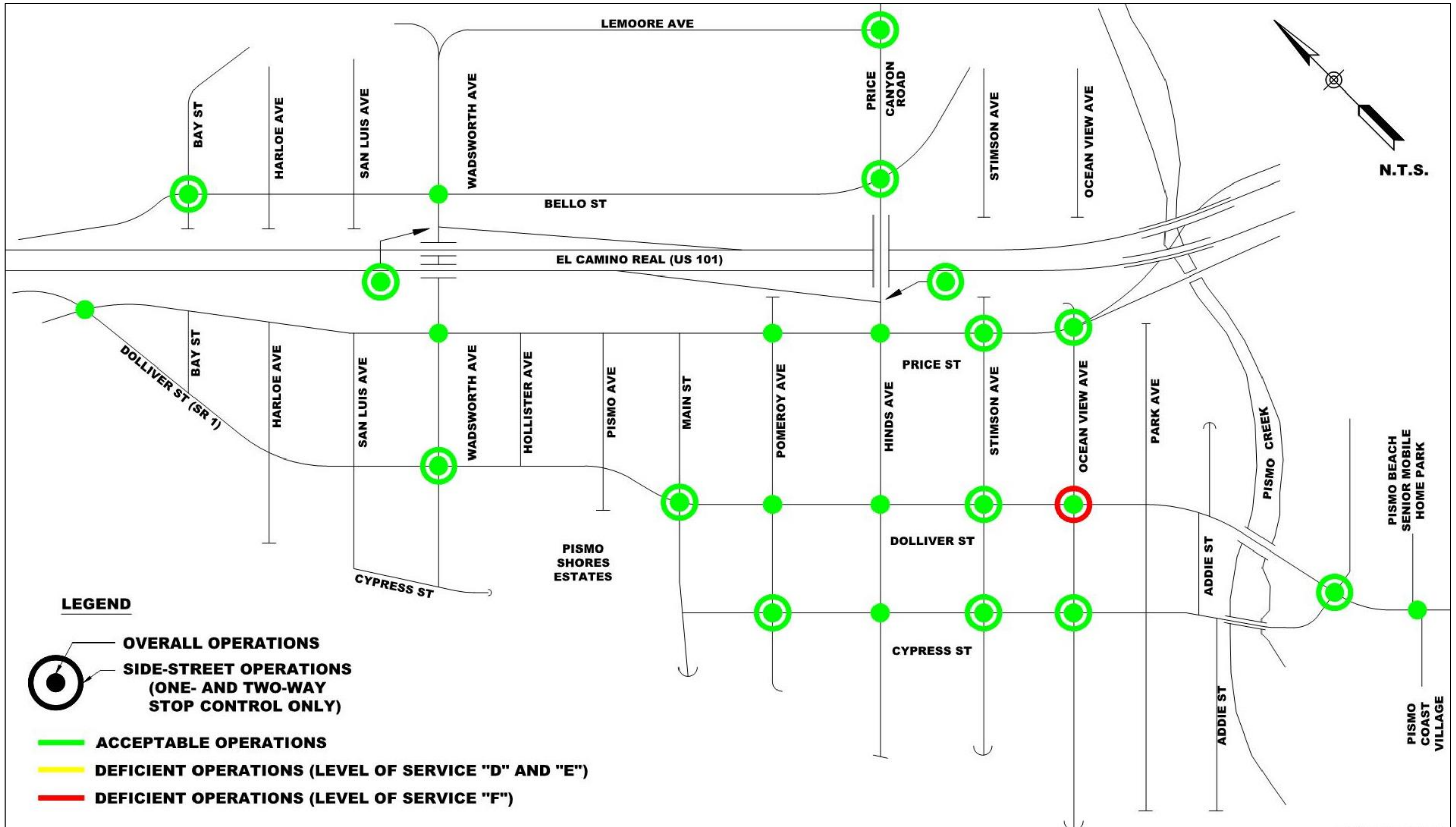

Exhibit 22B – Intersection Operations Existing Weekday PM Peak Hour (Continued)

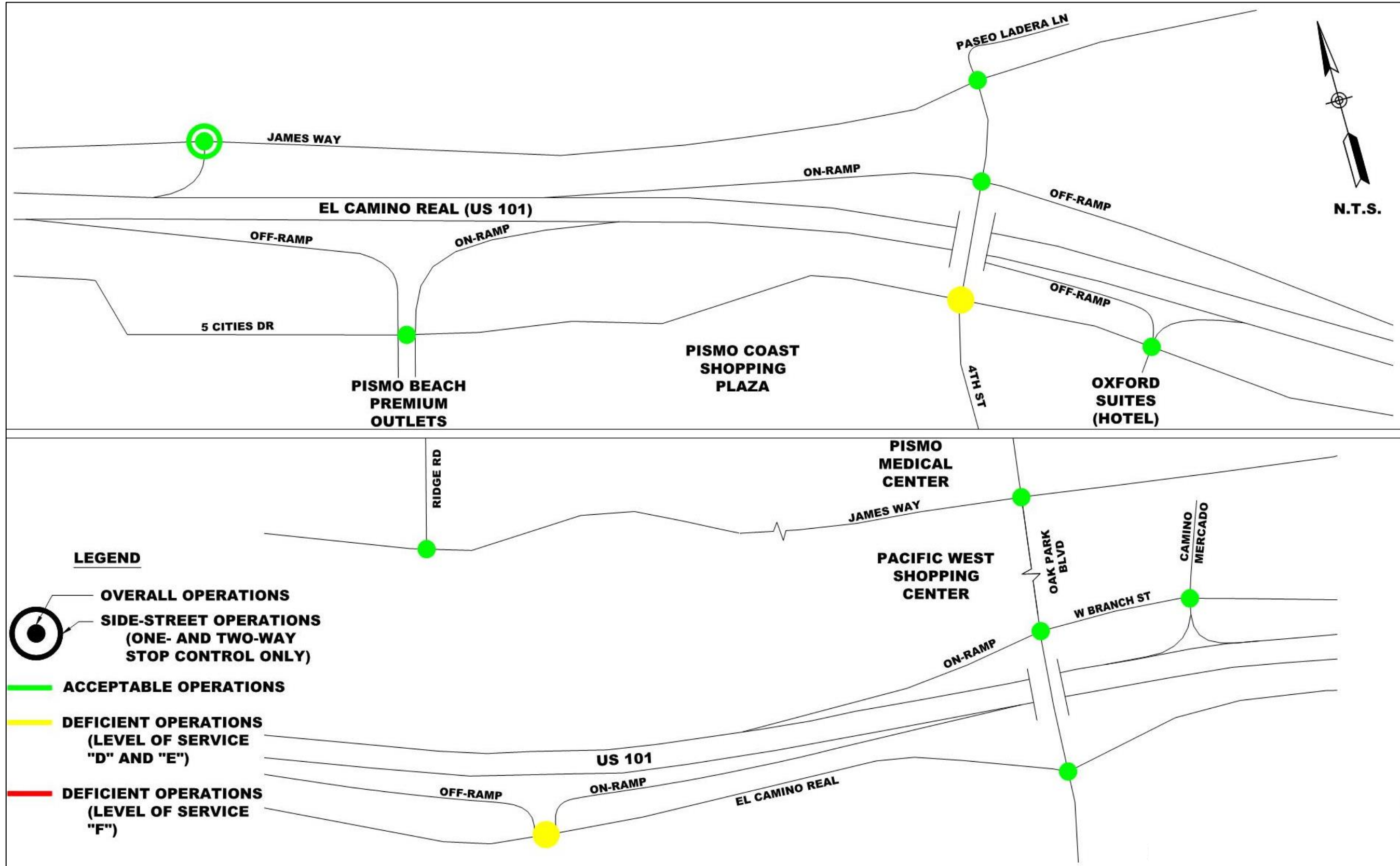

Exhibit 23 – Intersection Operations Existing Summer Sunday Midday Peak Hour

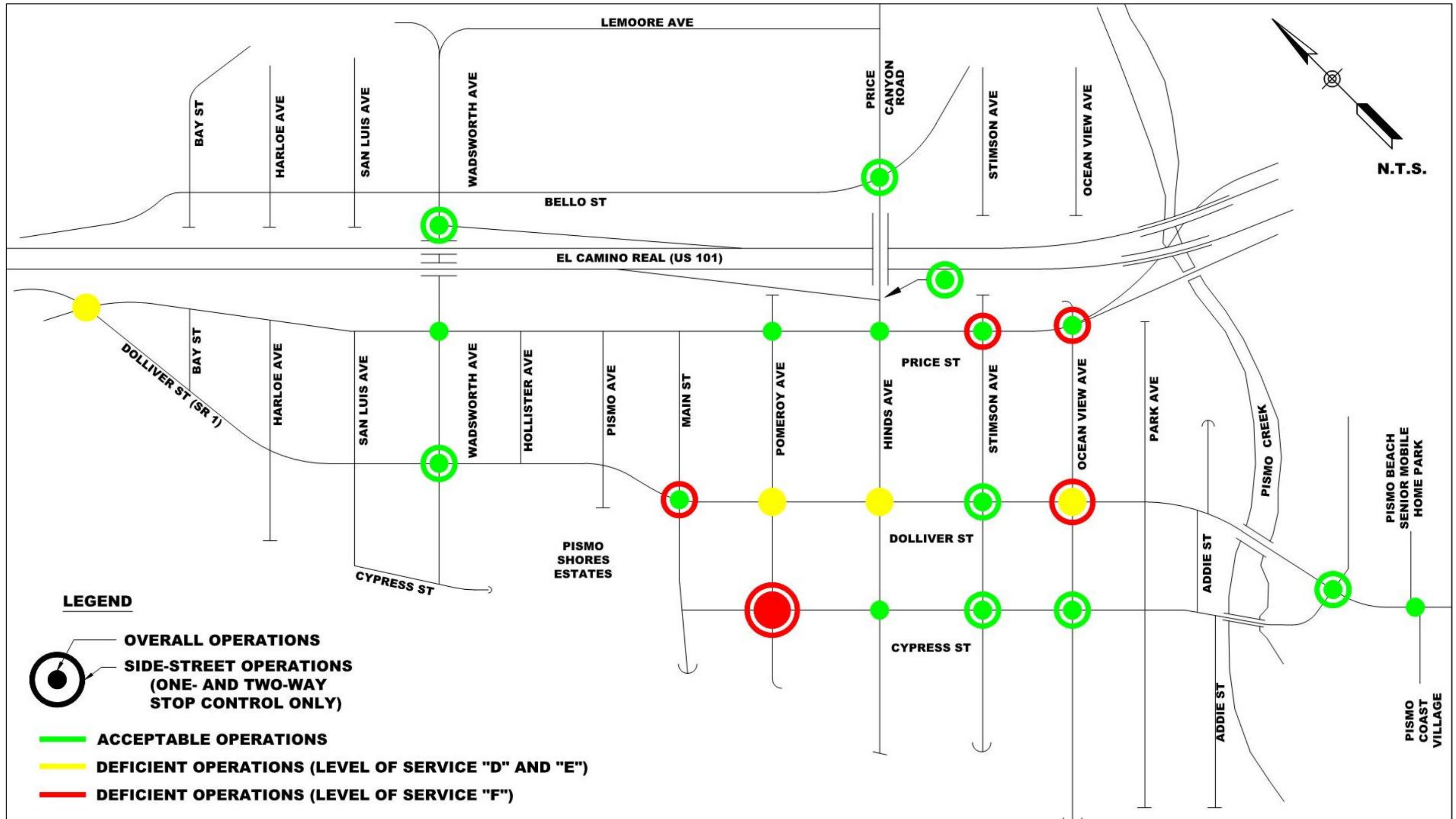
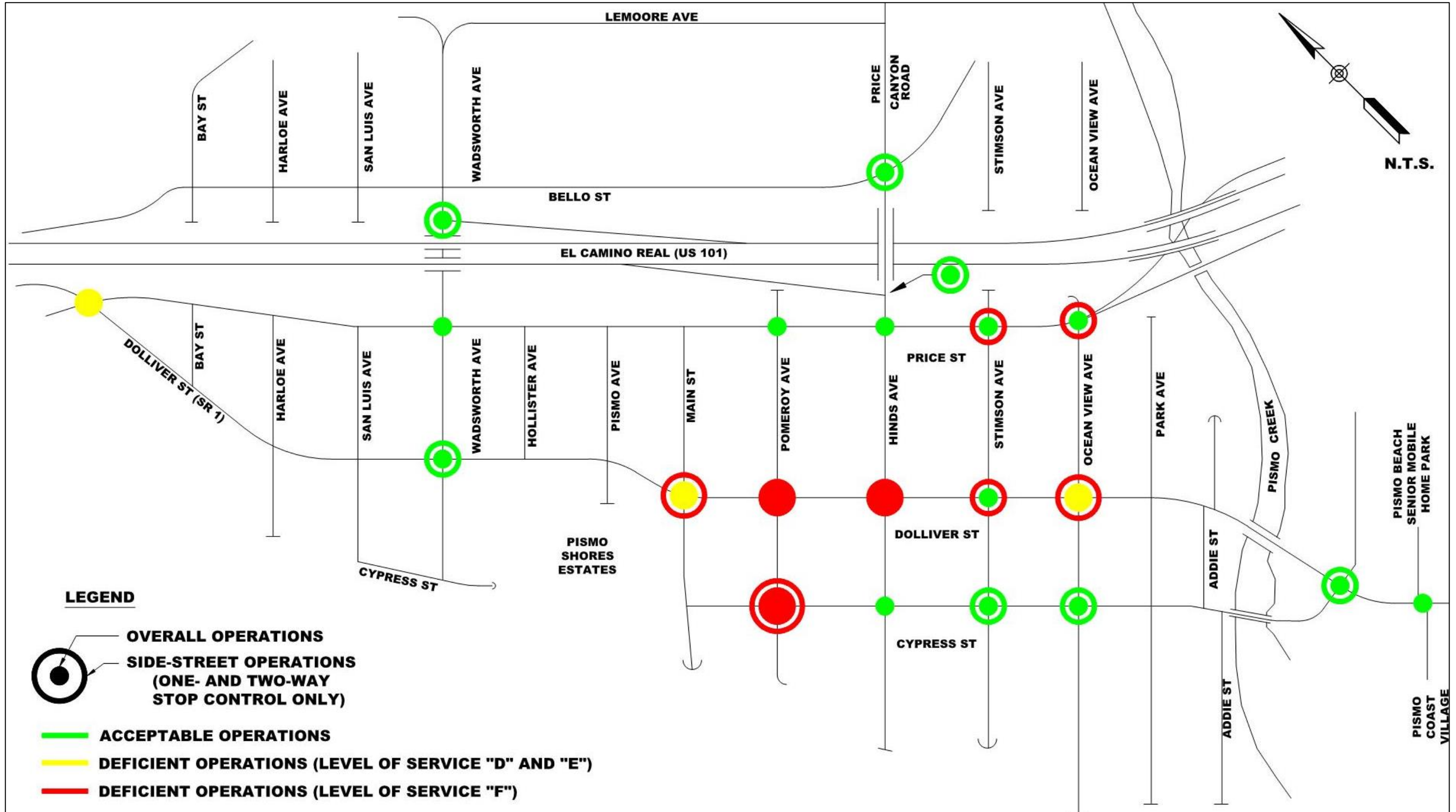

Exhibit 24 – Intersection Operations Existing Memorial Day Sunday Midday Peak Hour



K. Community Participation

Public participation played an essential role in this Study. Public input was solicited especially regarding existing conditions for bicyclists and pedestrians, desired bicycling and walking infrastructure, and types of support facilities or programs needed to improve bicycling in Pismo Beach. Public input was also used to generally develop and prioritize recommended network improvements.

Stakeholders within the community were interviewed, including city staff, the Parking Advisory Committee, the Pismo Beach City Council, the Pismo Beach Chamber of Commerce, and city residents. Other adjacent cities were also contacted, such as the Cities of Arroyo Grande and Grover Beach, as well as other agencies whose jurisdictions are either adjacent to or within portions of Pismo Beach, such as County of San Luis Obispo, Caltrans, and the San Luis Obispo Council of Governments (SLOCOG). A brief summary of the common themes identified by the stakeholders follows below. A full summary of the stakeholder comments is included in **Appendix C**.

Common themes identified by the stakeholders included the following:

1. Parking capacity and circulation demand varies with the peak season, with very high demand during the summer months and little demand during other times of the year.
2. General desire for a new parking structure within the downtown core. However, it was understood that public spending for a parking structure that may only be used for three months out of the year makes this fiscally challenging.
3. The Pomeroy-Hinds one-way couplet had greatly reduced collision rates at the Price Street / Hinds Avenue intersection. Other one-way couplets within the downtown area may be useful.
4. Price Street between Price Canyon Road and the US 101 Ramps at the south side of Downtown is used as a primary thoroughfare for commuters to and from San Luis Obispo. Extending Price Street to Five Cities Drive and adding other frontage roads to US 101 would allow for these and other local trips to avoid using the freeway when traveling between southeastern and downtown Pismo Beach.
5. Strategically placed satellite parking lots (i.e., park and ride lots) are being considered to serve bus routes along US 101. Some of the satellite parking lots are within the City of Pismo Beach.

The City also hosted two public workshops to encourage public feedback on existing circulation issues for all modes of transportation in Pismo Beach. The purpose of the first workshop was to provide an opportunity for members of the public to identify key transportation and circulation issues (including bicycle and pedestrian related issues) throughout the City of Pismo Beach. The second workshop was held to summarize the findings of the analysis, including identifying existing and future circulation problems and corresponding solutions, and physical or operational improvements needed citywide. The workshops were held on:

- Wednesday, September 17, 2014 from 6:00 PM to 8:00 PM – at City Hall (Council Chambers), 760 Mattie Road, Pismo Beach.
- Wednesday, January 7, 2015 from 6:00 PM to 8:00 PM – at City Hall (Council Chambers), 760 Mattie Road, Pismo Beach.

Summaries of each public workshop are provided in **Appendix D**.

The following points of discussion during the first workshop are summarized in **Exhibit 25 (Page 54)**. (A summary of the second workshop can be found in **Chapter 5** of this document.)

Exhibit 25 – Public Comments from September 2014 Workshop

Item No.	Comment
1.	<u>Elevated Pedestrian Boardwalk</u> – Important to construct between Pier and Shell Beach along hotel beach frontage. Would provide safe, attractive alternative to driving. Would alleviate parking demand within the downtown and enhance local connectivity.
2.	<u>Attractive, Clean Streets</u> – Important to provide. Should feature wide sidewalks, visible bicycle facilities, working streetlights, and readable directional signs.
3.	<u>Emphasis Away from Vehicle Level of Service in Downtown</u> – Should instead focus on efficient use of existing and proposed parking facilities, maintaining high-level of pedestrian usability, increase bicycle use, and increase public safety. However, should use criteria to determine investment in future capital projects.
4.	<u>High Visitor Demand to Pismo Beach Area:</u> a. 2.4 million visitors to Pismo Beach each year b. 1+ million visitors to Pismo State Park (specifically the Dunes) each year c. \$600,000 in sales tax generated in Pismo Beach each year from tourist activity d. Hotel Occupancy – an annual average of about 70%, much higher during the peak season and much lower during the off-season
5.	<u>Paid Parking:</u> a. 200,000 cars utilize paid parking facilities annually b. Average length of stay in paid parking – 2 hours c. Visitors within campgrounds, hotels and RV parks park for free
6.	<u>Bus Tour Groups – not common:</u> a. Few areas for buses to stage within downtown b. Hotels within downtown charge more than outside of downtown
7.	<u>Hotels, RV Parks and Vacation Rentals have high occupancy:</u> a. 75% to 80% of Transient Occupancy Tax is generated by hotels, followed by vacation rentals and RV parks b. RV park occupancy never drops below 85% during summer months and approaches 100% during holidays and peak summer periods c. Person Occupancies: i. Hotel – 2.1 person/room (estimated) ii. RV Parks – above 2.1 persons/RV
8.	<u>Tourist Activity Growth:</u> a. Most visitors to Pismo Beach are driving from within a 5-hour radius, including from the Los Angeles, San Francisco, and Central Valley metropolitan areas. Growth in population within those areas will lead to tourist growth within Pismo Beach b. Transient Occupancy Tax is not good measure of past tourist growth, as increase is more tied to increased room rates rather than increased demand c. Building permits and retail sales are up dramatically within the year. Sales tax may be used to project future retail growth in Pismo Beach
9.	<u>Other Traffic Issues:</u> a. Many visitors drive, walk, and bicycle into the downtown from hotels and RV parks located outside of downtown b. Number of surreys and bicycles within downtown are increasing c. Parking demand has remained relatively flat – annual paid parking occupancy changed from 35% to 39% over six years d. More demand for hotel and RV area parking than downtown parking

In addition, a workshop exercise was conducted to discuss specific street network and congestion issues within the greater Pismo Beach region. **Exhibit 26 (Page 55)** summarizes those network issues.

Exhibit 26 – Street Network Issues Discussed at September 2014 Workshop

Item No.	Network Issue
1.	Trail parking at Cave Landing and Shell Beach Road (near Avila Beach) creates potential traffic hazard, as well as parking availability issues on El Portal Drive and Indio Drive (adjacent residential roadways) for trail users.
2.	Southbound US 101 merge from three lanes to two lanes, between Avila Beach Drive and Spyglass Drive and creates traffic congestion on US 101.
3.	Increasing congestion at the Spyglass Drive / Shell Beach Road intersection during peak hours.
4.	<u>Mattie Road sidewalks and bicycle lanes are not connected to the rest of the city:</u> a. Lack of sidewalk or bicycle lanes on Spyglass Drive between Mattie Road and Shell Beach Road. b. No striped bike lane along northbound Mattie Road. c. Lack of sidewalk along Mattie Road between 2400 Mattie Road and just south of Bayview Lane (i.e., Spyglass Drive). d. Lack of sidewalk and bicycle lanes between 1050 Mattie Road and Price Street. e. Bicycle lanes on Price Street near Mattie Road ends abruptly.
5.	Left turn from Price Street onto Wadsworth Avenue is problematic.
6.	Turning movement conflicts at Price Street / Dolliver Street (SR 1) – Southbound US 101 Off-Ramp cause traffic to back up onto southbound US 101.
7.	Lack of crosswalks across Dolliver Street (SR 1) creates pedestrian/vehicle conflicts and a safety hazard, especially during peak hours and peak season.
8.	Lack of surface street connections between north and south Pismo Beach. Extend Price Street to Five Cities Drive to relieve congestion at Five Cities Drive/US 101 interchange and provide direct pedestrian and transit connection to downtown.
9.	<u>Major Perceived Traffic Congestion Locations (outside of downtown):</u> a. Price Street / Hinds Avenue (Price Canyon Road) b. Oak Park Boulevard / US 101 Interchange c. Fourth Street / James Way d. Five Cities Drive / US 101 Interchange
10.	<u>Major Perceived Traffic Congestion Locations (within downtown):</u> a. Dolliver Street (SR 1) / Pomeroy Avenue b. Dolliver Street (SR 1) / Stimson Avenue c. Dolliver Street (SR 1) / Ocean View Avenue d. Price Street / Ocean View Avenue e. Price Street / Stimson Avenue f. Price Street / Hinds Avenue (Price Canyon Road) g. Price Street /Pomeroy Avenue
11.	<u>Consider One-Way Turning Movements and Road Reconfiguration at:</u> a. Ocean View Avenue b. Stimson Avenue c. Hinds Avenue d. Pomeroy Avenue
12.	Provide a pedestrian bridge across the Union Pacific Railroad tracks from James Way/Five Cities Drive to Pismo Beach Sports Complex on Frady Lane.
13.	Replace the US 101 bridge over Frady Lane and Pismo Creek to improve vehicular and emergency travel time for traffic underneath bridge.
14.	Consider converting part of Cypress Street into a bicycle boulevard, including lane configurations with one-way and two-way vehicle travel.

Possible future downtown and recreational parking areas were also suggested. These sites could provide access to the downtown, the future boardwalk promenade extension and the Pismo Preserve trailhead. **Exhibit 27** summarizes these suggestions. Other issues discussed are summarized in **Exhibit 28**.

Exhibit 27 – Suggested Future Parking Areas Discussed at September 2014 Workshop

Item No.	Suggested Future Parking Area
1.	New public parking lot off Terrace Avenue at Shell Beach Elementary School.
2.	Pismo Preserve trailhead at 850 Mattie Road (in addition to paving an existing dirt parking area along Price Street near Mattie Road)
3.	Kon Tiki Inn hotel, Steamers restaurant and Bank of America building near the intersection of Price and Dolliver (SR 1) Streets, including below-grade parking structures.
4.	Pismo Beach Self Storage site on Five Cities Drive.

Exhibit 28 – Other Issues Discussed at September 2014 Workshop

Item No.	Other Item
1.	Southbound US 101 off-ramp to Hinds Avenue – preserve, because it provides direct freeway access to downtown.
2.	Perhaps add signing to direct RV traffic from northbound US 101 to use Price Street, Pomeroy Avenue, and Dolliver Street (SR 1) and avoid Ocean View Avenue. Direct RV traffic bound for southbound US 101 to use Dolliver Street (SR 1), Hinds Avenue, and Price Street to avoid Ocean View Avenue.
3.	Color the existing bike lanes along Dolliver Street (SR 1).
4.	Vehicles utilize the one-lane bridge on Cypress Street over Pismo Creek to exit the downtown during high traffic periods.
5.	Pedestrians and bicyclists also use the Cypress Street bridge.
6.	Optimize downtown parking by adding spaces where possible and removing red curb and consolidating driveways.
7.	Heavy pedestrian traffic along Pomeroy Avenue near pier.
8.	Congestion on Hinds Avenue (Price Canyon Road) between Price Street and Bello Street

3. General Plan Buildout Conditions

A. Weekday PM – Volume Derivation

SLOCOG manages a transportation demand model that forecasts future traffic growth throughout San Luis Obispo County, including Pismo Beach in the Year 2035. This model, updated in 2014, was modified to add additional land use and street network detail in Pismo Beach to create a citywide model for Pismo Beach. The Existing Conditions model (i.e., Year 2010) land use information was updated in Pismo Beach to reflect 2014 conditions (i.e., the Year 2014 model). The resulting existing and 2035 volumes from the Pismo Beach model are included in **Appendix E**, in addition to the documentation of the SLOCOG model modifications.

Appendix F tabulates the net change in land use in the Pismo Beach area between the Existing Year model (Year 2014) and the Future Year model (Year 2035). In total, an additional 476 new homes (286 single family and 190 multi-family) and 690 new jobs are anticipated by both SLOCOG and the Pismo Beach Planning Department in Pismo Beach by the Year 2035. The net change in land use in **Appendix F** has been estimated for each of the 17 Neighborhood Planning Areas defined in the 1992 General Plan. For reference, **Appendix F** also includes the 1992 General Plan Neighborhood Planning Area Map. The Neighborhood Planning Areas where the highest growth in housing is expected include Area N - Oak Park Heights (144 dwelling units-d.u.), Area K - Commercial Core (103 d.u.), Area P - Pismo Heights and Freeway Foothills (101 d.u.) and Area B - South Palisades (48 d.u.). These represent 406 dwelling units, or 85% of the citywide growth. The remaining residential growth is scattered throughout the city. Most of the employment is anticipated in the hospitality and retail industries, primarily in Areas K (future downtown hotels) and N (retail).

The average percentage growth in volume forecasted on city streets from 2014 to 2035 was determined for six distinct regions of the city. This was then applied to forecast the resulting traffic volumes at each intersection in the study area. The future percentage growth will vary by region, ranging from a low of 12% to a high of 28% over existing conditions, averaging about 19% at study intersections citywide. **Appendix G** provides a table summarizing the growth factor for each intersection.

Exhibits 29A-C (Pages 59-62) depict the existing and future Weekday PM peak hour segment traffic volumes in the Pismo Beach region along city streets, the US 101 freeway, and freeway on- and off-ramps. Overall, the Pismo Beach region is projected to experience an overall 15% growth in traffic volumes along all city streets, freeways, and ramps between 2014 and 2035.

This page was intentionally left blank
(For Duplex Printing)

Exhibit 29A – Weekday PM Peak Hour Segment Volumes on Greater Pismo Beach Area – Roadways

Street Name	Limits	Direction	Actual Count (2014)			Existing Model (2014)			Percent Existing	Buildout Model (2035)			Percent Growth
			N or E	S or W	Total	N or E	S or W	Total		N or E	S or W	Total	
Avila Beach Drive	Shell Beach Road - US 101 SB Offramp to US 101 SB Onramp	E-W	516	205	721	363	147	510	71%	393	149	542	6%
Bello Street	Price Canyon Road to Bay Street	N-S	178	68	246	330	85	415	169%	321	88	410	-1%
Cypress Street	Dolliver Street (SR 1) to Ocean View Avenue	N-S	23	72	95	11	148	159	167%	20	194	215	35%
Cypress Street	Ocean View Avenue to Stimson Avenue	N-S	32	66	98	11	155	166	169%	21	203	225	35%
Cypress Street	Stimson Avenue to Hinds Avenue	N-S	60	77	137	2	137	138	101%	2	166	169	22%
Cypress Street	Hinds Avenue to Pomeroy Avenue	N-S	N/A	77	77	N/A	185	185	240%	N/A	232	232	26%
Cypress Street	Pomeroy Avenue to Main Street	N-S	20	N/A	20	47	N/A	47	234%	50	N/A	50	6%
Dolliver Street (SR 1)	South of Pismo Beach Senior MHP - Pismo Coast Village	N-S	370	500	870	174	502	676	78%	219	664	883	31%
Dolliver Street (SR 1)	Pismo Beach Senior MHP - Pismo Coast Village to Cypress Street - Holiday RV Park Ent.	N-S	600	526	1126	215	588	803	71%	261	754	1015	26%
Dolliver Street (SR 1)	Cypress Street - Holiday RV Park Ent. to Ocean View Avenue	N-S	410	502	912	230	470	700	77%	267	591	858	23%
Dolliver Street (SR 1)	Ocean View Avenue to Stimson Avenue	N-S	363	398	761	124	245	369	48%	148	323	471	28%
Dolliver Street (SR 1)	Stimson Avenue to Hinds Avenue	N-S	354	390	744	134	213	347	47%	167	284	451	30%
Dolliver Street (SR 1)	Hinds Avenue to Pomeroy Avenue	N-S	345	382	727	168	210	378	52%	212	284	496	31%
Dolliver Street (SR 1)	Pomeroy Avenue to Main Street	N-S	279	414	693	104	151	254	37%	130	220	350	37%
Dolliver Street (SR 1)	Main Street to Wadsworth Avenue	N-S	253	395	648	117	176	293	45%	140	247	386	32%
Dolliver Street (SR 1)	Wadsworth Avenue to Price Street	N-S	190	337	527	80	140	220	42%	96	203	299	36%
Dolliver Street (SR 1)	North of Price Street	N-S	N/A	247	247	N/A	88	88	36%	N/A	105	105	19%
Esparto Avenue	South of Shell Beach Road	N-S	15	27	42	0	0	0	0%	0	0	0	0%
Five Cities Drive	West of US 101 SB Ramps - Outlets Main Entrance	E-W	175	324	499	49	218	267	53%	57	248	305	14%
Five Cities Drive	US 101 SB Ramps - Outlets Main Entrance to Fourth Street	E-W	950	395	1345	540	307	847	63%	695	355	1050	24%
Five Cities Drive	East of Fourth Street	E-W	473	237	710	161	166	327	46%	271	232	503	54%
Fourth Street	South of Five Cities Drive	N-S	601	863	1464	371	528	899	61%	423	574	996	11%
Fourth Street	Five Cities Drive to US 101 NB Ramps	N-S	646	589	1235	481	379	860	70%	556	401	957	11%
Fourth Street	US 101 NB Ramps to James Way	N-S	338	257	595	356	235	591	99%	408	255	663	12%
Hinds Avenue	West of Cypress Street	E-W	136	N/A	136	173	N/A	173	127%	177	N/A	177	2%
Hinds Avenue	Cypress Street to Dolliver Street (SR 1)	E-W	187	N/A	187	223	N/A	223	119%	245	N/A	245	10%
Hinds Avenue	Dolliver Street (SR 1) to Price Street	E-W	178	N/A	178	187	N/A	187	105%	200	N/A	200	7%
Hinds Avenue	Price Street to US 101 SB Offramp	E-W	294	823	1117	262	682	944	85%	301	721	1022	8%
Hinds Avenue	US 101 SB Offramp to Bello Street	E-W	314	752	1066	279	363	643	60%	319	428	746	16%
James Way	West of US 101 NB Onramp	E-W	229	62	291	237	63	300	103%	262	65	327	9%
James Way	US 101 NB Onramp to Fourth Street - Paseo Ladera Lane	E-W	174	175	349	139	143	282	81%	156	168	324	15%
James Way	Fourth Street - Paseo Ladera Lane to Ridge Road	E-W	277	195	472	246	131	377	80%	278	137	415	10%
James Way	Ridge Road to Oak Park Boulevard	E-W	501	310	811	316	211	527	65%	179	106	285	-46%
James Way	East of Oak Park Boulevard	E-W	296	241	537	177	134	310	58%	195	141	336	8%
Main Street	West of Dolliver Street (SR 1)	E-W	51	34	85	47	0	47	55%	50	0	50	6%
Main Street	Dolliver Street (SR 1) to Price Street	E-W	33	19	52	509	21	530	1019%	485	21	506	-5%
Mattie Road	Price Street to US 101 NB Ramps	N-S	134	263	397	39	162	201	51%	44	199	243	21%
Mattie Road	North of US 101 NB Ramps	N-S	67	53	120	41	52	93	78%	57	68	125	34%
Mattie Road	South of Spyglass Drive	N-S	65	62	127	63	108	171	135%	86	140	226	32%
Oak Park Boulevard	South of El Camino Real	N-S	709	1098	1807	699	910	1609	89%	842	1039	1881	17%
Oak Park Boulevard	El Camino Real to US 101 NB Onramp - West Branch Street	N-S	1096	1099	2195	953	679	1632	74%	1110	835	1945	19%
Oak Park Boulevard	US 101 NB Onramp - West Branch Street to James Way	N-S	729	1043	1772	590	691	1281	72%	692	866	1558	22%
Oak Park Boulevard	North of James Way	N-S	294	439	733	217	204	421	57%	280	319	599	42%

Exhibit 29A – Weekday PM Peak Hour Segment Volumes in Greater Pismo Beach Area – Roadways (Continued)

Street Name	Limits	Direction	Actual Count (2014)			Existing Model (2014)			Percent Existing	Buildout Model (2035)			Percent Growth
			N or E	S or W	Total	N or E	S or W	Total		N or E	S or W	Total	
Ocean View Avenue	West of Cypress Street	E-W	18	35	53	0	0	0	0%	0	0	0	0%
Ocean View Avenue	Cypress Street to Dolliver Street (SR 1)	E-W	20	46	66	145	134	279	422%	149	146	295	6%
Ocean View Avenue	Dolliver Street (SR 1) to Price Street - US 101 Ramps	E-W	100	183	283	330	387	716	253%	257	381	638	-11%
Pomeroy Avenue	West of Cypress Street	E-W	N/A	99	99	N/A	129	129	131%	N/A	136	136	5%
Pomeroy Avenue	Cypress Street to Dolliver Street (SR 1)	E-W	N/A	197	197	N/A	286	286	145%	N/A	330	330	15%
Pomeroy Avenue	Dolliver Street (SR 1) to Price Street	E-W	N/A	121	121	N/A	563	563	466%	N/A	571	571	1%
Price Canyon Road	East of Bello Street	E-W	218	741	959	173	290	463	48%	211	357	568	23%
Price Street	South of Ocean View Avenue	N-S	493	1068	1561	667	1059	1726	111%	752	1135	1887	9%
Price Street	Ocean View Avenue to Stimson Avenue	N-S	401	1062	1463	633	1007	1639	112%	704	1155	1858	13%
Price Street	Stimson Avenue to Hinds Avenue	N-S	386	1078	1464	616	1103	1720	117%	674	1196	1870	9%
Price Street	Hinds Avenue to Pomeroy Avenue	N-S	272	256	528	592	472	1065	202%	601	503	1104	4%
Price Street	Pomeroy Avenue to Main Street	N-S	165	285	450	29	472	501	111%	30	503	533	6%
Price Street	Main Street to Wadsworth Avenue	N-S	131	231	362	254	210	464	128%	234	244	478	3%
Price Street	North of Wadsworth Avenue	N-S	145	257	402	162	276	438	109%	200	319	520	19%
Price Street	South of US 101 SB Offramp - Dolliver Street (SR 1)	N-S	113	222	335	134	249	383	114%	151	282	433	13%
Price Street	North of US 101 SB Offramp - Dolliver Street (SR 1)	N-S	266	295	561	203	291	494	88%	231	356	586	19%
Price Street	South of US 101 SB Offramp	N-S	210	304	514	98	93	191	37%	113	153	266	39%
Price Street	US 101 SB Offramp to Mattie Road	N-S	251	244	495	124	63	188	38%	116	124	241	28%
Price Street	Mattie Road to US 101 SB Onramp	N-S	295	171	466	199	14	213	46%	214	46	260	22%
Price Street	US 101 SB Onramp to Windward Avenue	N-S	233	290	523	148	167	315	60%	179	206	385	22%
Shell Beach Road	West of Avila Beach Drive	E-W	132	N/A	132	95	N/A	95	72%	111	N/A	111	17%
Shell Beach Road	East of Avila Beach Drive	E-W	150	87	237	125	68	193	81%	182	101	283	47%
Shell Beach Road	West of Spyglass Drive	E-W	216	215	431	210	143	353	82%	166	237	403	14%
Shell Beach Road	Spyglass Drive to Terrace Avenue	E-W	401	205	606	291	150	441	73%	294	156	450	2%
Shell Beach Road	Terrace Avenue to Vista Del Mar Avenue	E-W	324	156	480	238	123	361	75%	274	144	419	16%
Shell Beach Road	Vista Del Mar Avenue to Esparto Avenue	E-W	292	222	514	141	73	214	42%	171	88	259	21%
Shell Beach Road	Esparto Avenue to Windward Avenue	E-W	296	238	534	159	133	291	55%	196	161	357	23%
Spyglass Drive	South of Shell Beach Road	N-S	86	100	186	65	73	139	75%	74	82	156	13%
Spyglass Drive	Shell Beach Road to US 101 SB Ramps	N-S	281	490	771	338	420	758	98%	433	541	974	29%
Spyglass Drive	US 101 SB Ramps to US 101 NB Ramps	N-S	188	185	373	249	134	383	103%	293	157	450	17%
Stimson Avenue	West of Cypress Street	E-W	44	57	101	74	61	135	134%	133	105	238	77%
Stimson Avenue	Cypress Street to Dolliver Street (SR 1)	E-W	57	89	146	51	47	98	67%	89	79	167	71%
Stimson Avenue	Dolliver Street (SR 1) to Price Street	E-W	52	92	144	35	73	108	75%	63	109	172	59%
Terrace Avenue	South of Shell Beach Road	N-S	29	26	55	40	30	71	129%	44	35	79	11%
Vista Del Mar Avenue	South of Shell Beach Road	N-S	19	43	62	50	98	148	238%	56	103	159	8%
Wadsworth Avenue	Cypress Street to Dolliver Street (SR 1)	E-W	41	30	71	0	0	0	0%	0	0	0	0%
Wadsworth Avenue	Dolliver Street (SR 1) to Price Street	E-W	77	61	138	38	37	75	55%	51	52	103	37%
Wadsworth Avenue	Price Street to US 101 NB Offramp	E-W	168	136	304	360	179	540	178%	363	225	588	9%
Wadsworth Avenue	US 101 NB Offramp to Bello Street	E-W	234	26	260	457	43	500	192%	470	44	513	3%
Wadsworth Avenue	Bello Street to Lemoore Avenue	E-W	116	63	179	179	75	255	142%	200	87	288	13%
West Branch Street	Oak Park Boulevard to Camino Mercado - US 101 NB Ramps	E-W	616	791	1407	374	385	759	54%	404	361	765	1%
Windward Avenue	South of Shell Beach Road	N-S	23	20	43	0	0	0	0%	0	0	0	0%
Total:			20514	24533	45047	17543	19638	37181	83%	19697	23031	42728	15%

**Exhibit 29B – Daily and Weekend PM Peak Hour
Segment Volumes in Greater Pismo Beach Area – Freeways**

US 101	Caltrans Count (AADT)	PM Peak Hour*			Existing Model (2014)			Percent Existing	Buildout Model (2035)			Percent Growth
		North	South	Total	North	South	Total		North	South	Total	
South of Oak Park Boulevard	57500	2013	3738	5750	2306	3351	5657	98%	2612	3612	6223	10%
Oak Park Boulevard to Fourth Street	62900	2202	4089	6290	2639	3862	6501	103%	3022	4086	7107	9%
Fourth Street to Price Street (South)	69400	2429	4511	6940	2804	4264	7068	102%	3236	4624	7860	11%
Price Street (South) to Price Street (North)	63100	2209	4102	6310	2137	3542	5679	90%	2484	3800	6284	11%
Price Street (North) to Mattie Road	62200	2177	4043	6220	2267	3630	5897	95%	2562	3905	6467	10%
Mattie Road to Spyglass Drive	66450	2326	4319	6645	2156	3664	5820	88%	2418	3937	6355	9%
Spyglass Drive to Avila Beach Drive	67800	2373	4407	6780	2226	3657	5883	87%	2500	3986	6486	10%
North of Avila Beach Drive	64600	2261	4199	6460	2138	3447	5586	86%	2425	3778	6202	11%
Total:		17988	33407	51395	18673	29418	48091	94%	21260	31726	52986	10%

* PM Peak Hour volumes estimated by assuming 10% of daily traffic is in PM Peak Hour and 65% of that is in SB direction

**Exhibit 29C – Daily and Weekend PM Peak Hour
Segment Volumes in Greater Pismo Beach Area – Ramps**

US 101 Ramp Type	Location	Caltrans Count		Actual Count	Existing Model	Percent Existing	Buildout Model	Percent Growth
		ADT	PM Pk Hr*					
NB Offramp	West Branch Street / Camino Mercado	2900	290	332	163	49%	166	2%
NB Onramp	West Branch Street / Camino Mercado	2500	250	227	111	49%	118	6%
NB Onramp	Oak Park Boulevard	6300	630	486	386	79%	459	19%
SB Onramp	El Camino Real	2300	230	270	32	12%	43	34%
SB Offramp	El Camino Real	1800	180	740	543	73%	517	-5%
SB Onramp	Fourth Street (South)	2100	210	245	90	37%	112	25%
NB Offramp	Fourth Street	4500	450	459	267	58%	283	6%
SB Offramp	Fourth Street (South)	6700	670	200	233	116%	272	17%
NB Onramp	Fourth Street	6300	630	435	250	57%	284	14%
NB Onramp	James Way	1600	160	193	182	94%	213	17%
SB Onramp	Five Cities Drive / Premium Outlets	1100	110	135	227	168%	155	-32%
SB Offramp	Five Cities Drive / Premium Outlets	7300	730	791	486	61%	533	10%
NB Offramp	Price Street (South)	5900	590	493	667	135%	752	13%
SB Onramp	Price Street (South)	8400	840	1068	1059	99%	1135	7%
SB Offramp	Hinds Avenue	757	76	91	336	370%	311	-8%
NB Offramp	Wadsworth Avenue	1548	155	176	234	133%	288	23%
NB Onramp	Bello Street	1686	169	175	364	208%	366	0%
SB Offramp	Dolliver Street (SR 1)	2070	207	247	88	36%	105	19%
NB Offramp	Mattie Road	2567	257	258	138	53%	171	24%
SB Offramp	Price Street	810	81	109	34	31%	32	-5%
NB Onramp	Mattie Road	1282	128	115	27	23%	27	1%
SB Onramp	Price Street (North)	1973	197	171	204	119%	195	-4%
SB Onramp	Spyglass Drive	1812	181	143	173	121%	160	-8%
NB Offramp	Spyglass Drive	1717	172	169	112	66%	123	10%
NB Onramp	Spyglass Drive	1877	188	175	182	104%	204	12%
SB Offramp	Spyglass Drive	1988	199	355	370	104%	404	9%
SB Onramp	Avila Beach Drive	2560	256	391	305	78%	319	5%
NB Offramp	Avila Beach Drive	2562	256	210	146	70%	149	2%
SB Offramp	Avila Beach Drive	975	98	132	95	72%	111	17%
NB Onramp	Avila Beach Drive	987	99	125	59	47%	74	25%
	Total:		8687	9116	7563	83%	8081	7%

* PM Peak Hour volumes estimated by
assuming 10% of daily traffic is in PM Peak Hour

B. Summer Sunday and Memorial Day Sunday – Volume Derivation

The SLOCOG model forecasts traffic volume for typical weekdays. It does not forecast traffic volumes during Sundays. Two different methods were used to forecast traffic growth during the Summer Sunday and Memorial Day Sunday analysis periods:

- 1) Downtown Projects – The trip generation was estimated on a Sunday for each of the anticipated development projects in the downtown area. Their trips were assigned to the downtown street system on an intersection-by-intersection basis; and
- 2) Tourist Growth – projected tourist activity traffic growth in the downtown area.

Appendix H includes a trip generation table documenting Sunday peak hour traffic generated by future downtown developments. This was developed using the Institute of Transportation Engineers' publication *Trip Generation Manual*, 9th Edition, 2012. These trips were then distributed throughout the downtown region, using the trip distribution also depicted in **Appendix H**. It was assumed that none of these trips would remain within the downtown; instead, it was assumed that all of these trips would be coming from or going to destinations outside of the downtown. All visitor serving uses such as hotels and rental homes are assumed to be 100% occupied, which represents a worst case condition, but is typical of the busy summer weekends.

Future tourist growth in Downtown Pismo Beach is projected based on two sources. The first is the State of California projections for statewide population growth by county by the Year 2035. **Appendix I** contains those projections, along with calculations of the net percentage population growth in the five metropolitan regions of California from which most tourists to Pismo Beach are anticipated – San Francisco Bay Area, Monterey Bay Area, Central Coast, Southern California (Coastal), and the Southern Central Valley. These growth projections indicate an average population growth of about 1% per year between 2014 and 2035, or 21% total. Assuming that tourist activity in the Pismo Beach region would increase at the same rate as the statewide population growth, tourist activity would also increase by 21% between 2014 and 2035.

The conversion of the increase in tourist activity to an increase in vehicular activity was achieved in part by estimating the net increase in traffic volumes at key intersections in the downtown during the summer season above the off-peak season. This represents the net increase in traffic in Pismo Beach during the summer season created by existing tourist activity. The percentage increase varied by intersection, but was approximately 30% for the Summer Sunday Midday peak hour and 25% for the Memorial Day Sunday Midday peak hour. When applied to the 21% growth in tourist activity anticipated by the Year 2035, they equated to a 6% increase in overall vehicle traffic by the Year 2035 for the Summer Sunday Midday peak hour, and a 5% increase in overall vehicle traffic by the Year 2035 for the Memorial Day Sunday Midday peak hour. These percentages were added to the forecasted traffic growth from increased development at intersections on the major roadways within the downtown that lead to the pier and beach areas.

The total increase in traffic at intersections in the downtown area during the Summer Sunday Midday and Memorial Day Sunday peak hours will range from 9% to 25% above Existing volumes over the next 20 years. For comparative purposes, Dolliver Street (SR 1) volumes have not increased over the past 35 years.

C. Traffic Operations and Recommendations - General Plan Buildout

INTERSECTIONS WITH ACCEPTABLE OPERATIONS

Exhibit 30 (Pages 66-70) summarizes the levels of service at the study intersections under General Plan Buildout Conditions (i.e., Year 2035), while **Exhibits 31A-B, 32, and 33 (Pages 71-74)** graphically depict the levels of service at those same intersections. The level of service calculations can be found in **Appendix J**. Most of the study intersections continue to operate better than the City and County standard of Level of Service (LOS) “C” and the Caltrans standard of the transition between LOS C and LOS D (i.e., LOS C/D). This includes 44 of 50 intersections studied during the Weekday PM peak hour, 11 of the 21 intersections during the Summer Sunday Midday peak hour, and 11 of the 21 intersections studied under the Memorial Day Sunday Midday peak hour.

INTERSECTIONS WITH DEFICIENT OPERATIONS

Exhibit 30 (Pages 66-70) also indicates the study intersections under General Plan Buildout Conditions that would operate at a deficient level of service, as well as the recommended improvements to correct each deficiency and the resulting operations with implementation of the identified roadway improvements. The deficient intersections, their projected operations and their respective improvements are also repeated below, organized by intersection number. More information about the recommended improvements and why they are recommended is provided in the following two sections, **Section 3.D – Improvements Recommended in Previous Studies (Page 75)** and **Section 3.E - Network Alternatives (Page 79)**. The following six (6) intersections will operate deficiently under the Weekday PM peak hour:

- 26. Price Street/Hinds Avenue (Overall LOS B, but long queues on Southbound Hinds) – Review signal timing and consider widening the Hinds bridge over US 101. Vertical clearance about US 101 may be an issue.
- 31. Dolliver Street (SR 1) / Stimson Avenue (Side Street LOS F - Implement Ocean View - Stimson Couplet)
- 34. Dolliver Street (SR 1) / Ocean View Avenue (Side Street LOS F - Implement Ocean View - Stimson Couplet)
- 35. US 101 Ramps - Price Street / Ocean View Avenue (Side Street LOS F - Implement Ocean View - Stimson Couplet)
- 42. Fourth Street / Five Cities Drive (Signal LOS E - Add Right Turn Overlap Phase on Eastbound Five Cities Drive and Optimize Signal Timing)
- 47. Camino Mercado - US 101 Northbound Ramps / West Branch Street (Signal LOS D - Optimize Signal Timing)
- 48. US 101 Southbound Ramps / El Camino Real (All-Way Stop LOS E - Install Signal)

The following ten (10) intersections will operate deficiently under the Summer Sunday Midday peak hour:

- 14. US 101 Southbound Off-ramp - Dolliver Street (SR 1) / Price Street (All-way stop LOS E - Install Roundabout)
- 16. Dolliver Street (SR 1) / Wadsworth Avenue (Side Street LOS F - Eliminate Two On-Street Parking Spaces to Accommodate a Right Turn Lane on Eastbound Wadsworth. Consider left turn pockets as an alternative.)
- 20. Dolliver Street (SR 1) / Main Street (Side Street LOS F - Eliminate One On-Street Parking Space to Accommodate a Right Turn Lane on Westbound Main. Consider left turn pockets as an alternative.)
- 21. Cypress Street / Pomeroy Avenue (Side Street LOS F - Install Signal with Pedestrian Scramble – described in Section 3.5.a – General Plan Buildout Conditions - Network Alternatives – Pier Area Improvements – Cypress Street/Pomeroy)
- 22. Dolliver Street (SR 1) / Pomeroy Avenue (Signal LOS E - Eliminate Three On-Street Parking Spaces to Accommodate a Right Turn Lane on Southbound Dolliver. Consider a northbound left turn pocket as an alternative. Also consider Modifying Signal to include Pedestrian Scramble – described in Section 3.5.b –

General Plan Buildout Conditions - Network Alternatives – Pier Area Improvements – Dolliver Street (State Route 1)/Pomeroy)

- 25. Dolliver Street (SR 1) / Hinds Avenue (Signal LOS F - Eliminate Two On-Street Parking Spaces to Accommodate a Right Turn Lane on Northbound Dolliver. Consider a southbound left turn pocket as an alternative.)
- 31. Dolliver Street (SR 1) / Stimson Avenue (Side Street LOS F - Implement Ocean View - Stimson Couplet)
- 32. Price Street / Stimson Avenue (Side Street LOS F - Implement Ocean View - Stimson Couplet)
- 34. Dolliver Street (SR 1) / Ocean View Avenue (Side Street LOS F - Implement Ocean View - Stimson Couplet)
- 35. US 101 Ramps - Price Street / Ocean View Avenue (Side Street LOS F - Implement Ocean View - Stimson Couplet)

The following ten (10) intersections will operate deficiently under the Memorial Day Midday peak hour:

- 14. US 101 Southbound Off-ramp - Dolliver Street (SR 1) / Price Street (All-way stop LOS F - Install Roundabout)
- 20. Dolliver Street (SR 1) / Main Street (Side Street LOS F - Eliminate One On-Street Parking Space to Accommodate a Right Turn Lane on Westbound Main. Consider left turn pockets as an alternative.)
- 21. Cypress Street / Pomeroy Avenue (Side Street LOS F - Install Signal with Pedestrian Scramble – described in Section 3.5.a – General Plan Buildout Conditions - Network Alternatives – Pier Area Improvements – Cypress Street/Pomeroy)
- 22. Dolliver Street (SR 1) / Pomeroy Avenue (Signal LOS E - Eliminate On-Street Parking to Accommodate Right Turn Lane on Southbound Dolliver. Consider a northbound left turn pocket as an alternative. Also consider Modifying Signal to include Pedestrian Scramble – described in Section 3.5.b – General Plan Buildout Conditions - Network Alternatives – Pier Area Improvements – Dolliver Street (State Route 1)/Pomeroy)
- 25. Dolliver Street (SR 1) / Hinds Avenue (Signal LOS F - Eliminate On-Street Parking to Accommodate Right Turn Lane on Northbound Dolliver. Consider a southbound left turn pocket as an alternative.)
- 30. Cypress Street / Stimson Avenue (Side Street LOS F - Implement Ocean View - Stimson Couplet)
- 31. Dolliver Street (SR 1) / Stimson Avenue (Side Street LOS F - Implement Ocean View - Stimson Couplet)
- 32. Price Street / Stimson Avenue (Side Street LOS F - Implement Ocean View - Stimson Couplet)
- 34. Dolliver Street (SR 1) / Ocean View Avenue (Side Street LOS F - Implement Ocean View - Stimson Couplet)
- 35. US 101 Ramps - Price Street / Ocean View Avenue (Side Street LOS F - Implement Ocean View - Stimson Couplet)

Exhibit 30 (Pages 66-70) also lists the improved levels of service at the deficient intersections resulting from the implementation of the corresponding recommended improvements. In many cases, the improvements are identical to those suggested under Existing conditions (i.e., in **Exhibit 21 (Pages 43-47)**).

Additional considerations for intersection improvements under General Plan Buildout conditions are identical to those described under Existing Conditions on Page 36.

Exhibit 30 – Intersection Levels of Service General Plan Buildout (Year 2035)

N-S Street	E-W Street	Existing Lane Configuration	Existing Intersection Control	LOS Standard	General Plan Buildout						Proposed Improvement(s)			
					General Plan Buildout (Year 2035)			General Plan Buildout With Improvements						
					Weekday PM Peak Hr	Summer Sunday Mid	Memorial Day Sunday Mid	Weekday PM Peak Hr	Summer Sunday Mid	Memorial Day Sunday Mid				
					Delay (sec)	LOS	Delay (sec)	LOS	Delay (sec)	LOS	Delay (sec)	LOS	Delay (sec)	LOS
1	Shell Beach Road - US 101 SB Ramps	Avila Beach Drive	NB 1-L/R SB 1-L/T, 1-R EB 1-T/R WB 1-L/T	Two-Way Stop (County)	C/D Side Street	5.6 A 30.7 D			12.2 B					Roundabout
2	Monte Road	Avila Beach Drive - US 101 NB Ramps	SB 1-R EB 1-L WB 1-T/R	Two-Way Stop (County)	C/D Side Street	3.1 A 9.6 A								
3	Spyglass Drive	US 101 NB Ramps	NB 1-L, 1-T SB 1-T/R EB 1-L, 1-T/R	One-Way Stop	C/D Side Street	9.0 A 16.7 C								
4	Spyglass Drive	US 101 SB Ramps	NB 1-T/R SB 1-L, 1-T WB 1-L/T, 1-R	One-Way Stop	C/D Side Street	5.9 A 13.3 B								
5	Spyglass Drive	Shell Beach Road	NB 1-L/T/R SB 1-L, 1-T, 1-R EB 1-L, 1-T/R WB 1-L, 1-T, 1-R	All-Way Stop	C	16.4 C								
6	Terrace Avenue	Shell Beach Road	NB 1-L/R EB 1-T/R WB 1-L, 1-T	All-Way Stop	C	10.5 B								
7	Vista Del Mar Avenue	Shell Beach Road	NB 1-L/R EB 1-T/R WB 1-L/T	All-Way Stop	C	9.9 A								
8	Esparto Avenue	Shell Beach Road	NB 1-L/R EB 1-T/R WB 1-L/T	All-Way Stop	C	9.9 A								
9	Windward Avenue	Shell Beach Road	NB 1-L/R EB 1-T/R WB 1-L/T	All-Way Stop	C	10.1 B								
10	Mattie Road	US 101 NB Ramps	NB 1-L/T SB 1-T/R EB 1-L, 1-T/R	One-Way Stop	C/D Side Street	7.7 A 13.2 B								

Notes:

1. L, T, R = Left, Through, Right.
2. NB, SB, EB, WB = Northbound, Southbound, Eastbound, Westbound.
3. Analysis performed using 2010 Highway Capacity Manual methodologies.
4. Overall level of service standard for Caltrans is the transition between LOS C and D.
5. Overall level of service standard for the City of Pismo Beach and County of San Luis Obispo is LOS C.
6. Worst approach level of service standard is generally LOS E. Level of service "F" is the level of service at which improvements would be required.
7. * = Delay is over 300 seconds (5 minutes)
8. N/A = Not Applicable. Proposed improvement combines intersections #1 and #50 into a single intersection.

Exhibit 30 – Intersection Levels of Service General Plan Buildout (Year 2035-Continued)

N-S Street	E-W Street	Existing Lane Configuration	Existing Intersection Control	LOS Standard	General Plan Buildout (Year 2035)						General Plan Buildout With Improvements						Proposed Improvement(s)			
					Weekday PM Peak Hr		Summer Sunday Mid		Memorial Day Sunday Mid		Weekday PM Peak Hr		Summer Sunday Mid		Memorial Day Sunday Mid					
					Delay (sec)	LOS	Delay (sec)	LOS	Delay (sec)	LOS	Delay (sec)	LOS	Delay (sec)	LOS	Delay (sec)	LOS				
11	US 101 SB On-ramp	Price Street	EB 1-L/T WB 1-T/R	None	C Side Street	0.0	A	0.0	A											
12	Mattie Road	Price Street	SB 1-L, 1-R EB 1-L/T WB 1-T/R	Signal	C	6.9	A													
13	US 101 SB Off-ramp	Price Street	SB 1-L, 1-R EB 1-T WB 1-T	One-Way Stop	C/D Side Street	2.4	A	12.4	B											
14	US 101 SB Off-ramp - Dolliver Street (SR 1)	Price Street	NB 1-L, 1-R SB 1-L, 1-T, 1-R EB 1-T/R WB 1-L/T	All-Way Stop	C/D	16.8	C	49.8	E	58.7	F	8.9	A	17.3	C	24.4	C	Roundabout		
15	US 101 NB On-ramp - Bello Street	Bay Street	NB 1-L/T/R EB 1-L/T/R WB 1-L/T/R	Two-Way Stop	C/D Side Street	0.3	A	9.7	A											
16	Dolliver Street (SR 1)	Wadsworth Avenue	NB 1-L/T/R SB 1-L/T/R EB 1-L/T/R WB 1-L/T/R	Two-Way Stop	C/D Side Street	2.8	A	18.1	C	5.3	A	5.0	A	2.7	A	4.7	A	43.0	E	Eliminate 2 On-Street Parking Spaces to Accommodate Right Turn Lane on Eastbound Wadsworth
17	Price Street	Wadsworth Avenue	NB 1-L/T/R SB 1-L, 1-T/R EB 1-L/T/R WB 1-L/T/R	All-Way Stop	C	10.2	B	13.5	B	16.4	C									
18	US 101 NB Off-ramp	Wadsworth Avenue	NB 1-L, 1-R EB 1-T WB 1-T	One-Way Stop	C/D Side Street	5.4	A	10.3	B	3.2	A	3.2	A	12.0	B	12.2	B			
19	Bello Street	Wadsworth Avenue	NB 1-L/T/R SB 1-L/T/R EB 1-L/T/R WB 1-L/T/R	All-Way Stop	C	8.9	A													
20	Dolliver Street (SR 1)	Main Street	NB 1-L/T/R SB 1-L/T/R EB 1-L/T/R WB 1-L/T/R	Two-Way Stop	C/D Side Street	1.8	A	17.9	C	40.0	E	85.7	F	1.7	A	17.9	C	37.7	E	Eliminate 1 On-Street Parking Space to Accommodate Right Turn Lane on Westbound Main

Notes:

1. L, T, R = Left, Through, Right.
2. NB, SB, EB, WB = Northbound, Southbound, Eastbound, Westbound.
3. Analysis performed using 2010 Highway Capacity Manual methodologies.
4. Overall level of service standard for Caltrans is the transition between LOS C and D.
5. Overall level of service standard for the City of Pismo Beach and County of San Luis Obispo is LOS C.
6. Worst approach level of service standard is generally LOS E. Level of service "F" is the level of service at which improvements would be required.
7. * = Delay is over 300 seconds (5 minutes)
8. N/A = Not Applicable. Proposed improvement combines intersections #1 and #50 into a single intersection.

Exhibit 30 – Intersection Levels of Service General Plan Buildout (Year 2035-Continued)

N-S Street	E-W Street	Existing Lane Configuration	Existing Intersection Control	LOS Standard	General Plan Buildout (Year 2035)						General Plan Buildout With Improvements						Proposed Improvement(s)	
					Weekday PM Peak Hr		Summer Sunday Mid		Memorial Day Sunday Mid		Weekday PM Peak Hr		Summer Sunday Mid		Memorial Day Sunday Mid			
					Delay (sec)	LOS	Delay (sec)	LOS	Delay (sec)	LOS	Delay (sec)	LOS	Delay (sec)	LOS	Delay (sec)	LOS		
21	Cypress Street	Pomeroy Avenue	WB 1-L/T/R	One-Way Stop	C Side Street	17.7 17.9	C C	* *	F F	* *	F F	4.6	A	4.5	A	4.5	A	Signal with Pedestrian Scramble
22	Dolliver Street (SR 1)	Pomeroy Avenue	NB 1-L/T SB 1-T/R WB 1-L, 1-T/R	Signal	C/D	17.1	B	106.4	F	287.9	F	16.4	B	40.9	D	76.6	E	Eliminate On-Street Parking to Accommodate Right Turn Lane on Southbound Dolliver
25	Dolliver Street (SR 1)	Hinds Avenue	NB 1-T/R SB 1-L/T EB 1-L/T, 1-T/R	Signal	C/D	5.9	A	81.3	F	177.9	F	5.8	A	47.0	D	38.4	D	Eliminate On-Street Parking to Accommodate Right Turn Lane on Northbound Dolliver
26	Price Street	Hinds Avenue	NB 1-T, 1-T/R SB 1-L/T, 1-T EB 1-L, 1-T/R WB 1-L, 1-L/R	Signal	C	18.1	B	16.8	B	18.8	B	18.1	B	16.8	B	18.8	B	1. Review signal timing to minimize SB Hinds queue 2. Consider widening Hinds bridge over US 101 to mitigate SB Hinds queue
27	US 101 SB Off-ramp	Hinds Avenue	SB 1-L, 1-R EB 1-T WB 2-T	One-Way Stop	C/D Side Street	1.4 17.6	A C	1.5 11.3	A B	2.0 11.9	A B							
28	Bello Street	Price Canyon Road	NB 1-L/T/R SB 1-L/T/R EB 1-L, 1-T/R WB 1-L, 1-T/R	Two-Way Stop	C Side Street	2.1 46.9	A E	4.4 23.4	A C	5.3 24.2	A C							
29	Lemoore Avenue	Price Canyon Road	NB 1-L, 1-T SB 1-T/R EB 1-L/R	One-Way Stop	C Side Street	0.3 19.0	A C											
30	Cypress Street	Stimson Avenue	NB 1-L/T/R SB 1-L/T/R EB 1-L/T/R WB 1-L/T/R	Two-Way Stop	C Side Street	6.4 10.6	A B	21.7 34.6	C D	31.1 55.1	D F	7.8	A	9.2	A	9.9	A	Implement Ocean View - Stimson Couplet and All-Way Stop Control

Notes:

1. L, T, R = Left, Through, Right.
2. NB, SB, EB, WB = Northbound, Southbound, Eastbound, Westbound.
3. Analysis performed using 2010 Highway Capacity Manual methodologies.
4. Overall level of service standard for Caltrans is the transition between LOS C and D.
5. Overall level of service standard for the City of Pismo Beach and County of San Luis Obispo is LOS C.
6. Worst approach level of service standard is generally LOS E. Level of service "F" is the level of service at which improvements would be required.
7. * = Delay is over 300 seconds (5 minutes)
8. N/A = Not Applicable. Proposed improvement combines intersections #1 and #50 into a single intersection.

Exhibit 30 – Intersection Levels of Service General Plan Buildout (Year 2035-Continued)

N-S Street	E-W Street	Existing Lane Configuration	Existing Intersection Control	LOS Standard	General Plan Buildout (Year 2035)						General Plan Buildout With Improvements						Proposed Improvement(s)	
					Weekday PM Peak Hr		Summer Sunday Mid		Memorial Day Sunday Mid		Weekday PM Peak Hr		Summer Sunday Mid		Memorial Day Sunday Mid			
					Delay (sec)	LOS	Delay (sec)	LOS	Delay (sec)	LOS	Delay (sec)	LOS	Delay (sec)	LOS	Delay (sec)	LOS		
31	Dolliver Street (SR 1)	Stimson Avenue	NB 1-L/T/R SB 1-L/T/R EB 1-L/T/R WB 1-L/T/R	Two-Way Stop	C/D Side Street	8.2 60.4	A F	16.9 129.5	C F	27.6 194.4	D F	9.2	A	9.7	A	10.5	B	Implement Ocean View - Stimson Couplet and Signal
32	Price Street	Stimson Avenue	NB 1-L/T/R SB 1-L/T, 1-T/R EB 1-L/T, 1-R WB 1-L/T/R	Two-Way Stop	C Side Street	1.5 37.4	A E	7.9 117.3	A F	9.2 155.6	A F	1.3	A	1.1	A	1.3	A	Implement Ocean View - Stimson Couplet
33	Cypress Street	Ocean View Avenue	NB 1-L/T/R SB 1-L/T/R EB 1-L/T/R WB 1-L/T/R	Two-Way Stop	C Side Street	4.3 10.1	A B	7.3 12.6	A B	7.2 16.0	A C	3.6	A	5.3	A	6.3	A	Implement Ocean View - Stimson Couplet
34	Dolliver Street (SR 1)	Ocean View Avenue	NB 1-L/T/R SB 1-L/T/R EB 1-L/T/R WB 1-L/T/R	Two-Way Stop	C/D Side Street	32.7 175.6	D F	50.6 *	F F	82.9 *	F F	1.4	A	1.8	A	2.7	A	Implement Ocean View - Stimson Couplet
35	US 101 Ramps - Price Street	Ocean View Avenue	NB 1-L, 1-T/R SB 1-L, 1-T, 1-R EB 1-L/T, 1-R WB 1-L/T/R	Two-Way Stop	C/D Side Street	4.2 55.5	A F	22.4 147.5	C F	19.7 174.3	C F	2.5	A	14.1	B	10.9	B	Implement Ocean View - Stimson Couplet and Price Street Restriping
36	Dolliver Street (SR 1)	Cypress Street - Holiday RV Park Ent.	NB 1-L, 1-T/R SB 1-L, 1-T/R EB 1-L/T/R WB 1-L/T/R	Two-Way Stop	C/D Side Street	1.3 14.7	A B	2.1 21.5	A C	2.5 17.9	A C							
37	Dolliver Street (SR 1)	Pismo Beach Senior MHP - Pismo Coast Village	NB 1-L, 1-T/R SB 1-L, 1-T/R EB 1-L/T/R WB 1-L/T/R	Signal	C/D	8.3	A	12.9	B	11.1	B							
38	US 101 NB On-ramp	James Way	EB 1-T/R WB 1-L, 1-T	None	C/D Side Street	0.0 0.0	A A											
39	Fourth Street - Paseo Ladera Lane	James Way	NB 1-L/T, 1-R SB 1-L/T/R EB 1-L/T, 1-R WB 1-L, 1-T/R	All-Way Stop	C	10.6	B											
40	Fourth Street	US 101 NB Ramps	NB 2-L, 2-T SB 1-T, 1-T/R EB 1-L, 1-T/R	Signal	C/D	15.1	B											

Notes:

1. L, T, R = Left, Through, Right.
2. NB, SB, EB, WB = Northbound, Southbound, Eastbound, Westbound.
3. Analysis performed using 2010 Highway Capacity Manual methodologies.
4. Overall level of service standard for Caltrans is the transition between LOS C and D.
5. Overall level of service standard for the City of Pismo Beach and County of San Luis Obispo is LOS C.
6. Worst approach level of service standard is generally LOS E. Level of service "F" is the level of service at which improvements would be required.
7. * = Delay is over 300 seconds (5 minutes)
8. N/A = Not Applicable. Proposed improvement combines intersections #1 and #50 into a single intersection.

Exhibit 30 – Intersection Levels of Service General Plan Buildout (Year 2035-Continued)

N-S Street	E-W Street	Existing Lane Configuration	Existing Intersection Control	LOS Standard	General Plan Buildout (Year 2035)						General Plan Buildout With Improvements						Proposed Improvement(s)
					Weekday PM Peak Hr		Summer Sunday Mid		Memorial Day Sunday Mid		Weekday PM Peak Hr		Summer Sunday Mid		Memorial Day Sunday Mid		
					Delay (sec)	LOS	Delay (sec)	LOS	Delay (sec)	LOS	Delay (sec)	LOS	Delay (sec)	LOS	Delay (sec)	LOS	
41	US 101 SB Ramps - Outlets Main Entrance	Five Cities Drive	NB 1-L, 1-T/R SB 1-L, 1-L/T, 1-T/R EB 1-L, 1-T, 1-T/R WB 1-L, 1-T, 1-R	Signal	C/D	29.2	C										
42	Fourth Street	Five Cities Drive	NB 1-L, 1-T, 1-T/R SB 1-L, 1-T, 1-R EB 1-L, 1-T, 1-R WB 1-L, 1-T/R	Signal	C	61.3	E					34.5	C			Add Right Turn Overlap Phase on Eastbound Five Cities Drive and Optimize Signal Timing	
43	US 101 SB Ramps - Hotel Driveway	Five Cities Drive - El Camino Real	NB 1-L/T/R SB 1-L/T, 1-R EB 1-L/T/R WB 1-L/T/R	All-Way Stop	C/D	21.7	C										
44	Ridge Road	James Way	SB 1-L/R EB 1-L, 1-T WB 1-T/R	All-Way Stop	C	9.3	A										
45	Oak Park Boulevard	James Way	NB 1-L, 1-T, 1-T/R SB 1-L, 1-T, 1-T/R EB 1-L, 1-T, 1-R WB 1-L, 1-T/R	Signal	C	34.9	C										
46	Oak Park Boulevard	US 101 NB On-ramp - West Branch Street	NB 1-L, 1-T, 1-T/R SB 1-L, 1-T, 1-T/R WB 1-L, 1-L/T, 1-R	Signal	C	14.8	B					27.6	C			Revise NS Oak Park Blvd. Protected/Permissive Left Turn Phasing to Protected Only	
47	Camino Mercado- US 101 NB Ramps	West Branch Street	NB 1-L, 1-T/R SB 1-L, 1-T/R EB 1-L, 1-T, 1-T/R WB 1-L, 1-T	Signal <i>(Arroyo Grande)</i>	C/D	41.0	D					34.9	C			Optimize Signal Timing	
48	US 101 SB Ramps	El Camino Real	SB 1-L, 1-L/R EB 1-L/T WB 1-T/R	All-Way Stop <i>(Grover Beach)</i>	C/D	43.6	E					12.9	B			Signal	
49	Oak Park Boulevard	El Camino Real	NB 1-L, 1-T, 1-T/R SB 1-L, 2-T, 1-R EB 1-L, 1-L/T, 1-R WB 1-L, 1-T/R	Signal <i>(Arroyo Grande)</i>	C	29.7	C					33.9	C			Revise NS Oak Park Blvd. Protected/Permissive Left Turn Phasing to Protected Only	
50	US 101 SB On-ramp	Avila Beach Drive	EB 1-T/R WB 1-L/T	None <i>(County)</i>	C/D <i>Side Street</i>	0.0	A					N/A				Consolidate with Intersection #1	

Notes:

1. L, T, R = Left, Through, Right.
2. NB, SB, EB, WB = Northbound, Southbound, Eastbound, Westbound.
3. Analysis performed using 2010 Highway Capacity Manual methodologies.
4. Overall level of service standard for Caltrans is the transition between LOS C and D.
5. Overall level of service standard for the City of Pismo Beach and County of San Luis Obispo is LOS C.
6. Worst approach level of service standard is generally LOS E. Level of service "F" is the level of service at which improvements would be required.
7. * = Delay is over 300 seconds (5 minutes)
8. N/A = Not Applicable. Proposed improvement combines intersections #1 and #50 into a single intersection.

Exhibit 31A – Intersection Operations General Plan Buildout Weekday PM Peak Hour

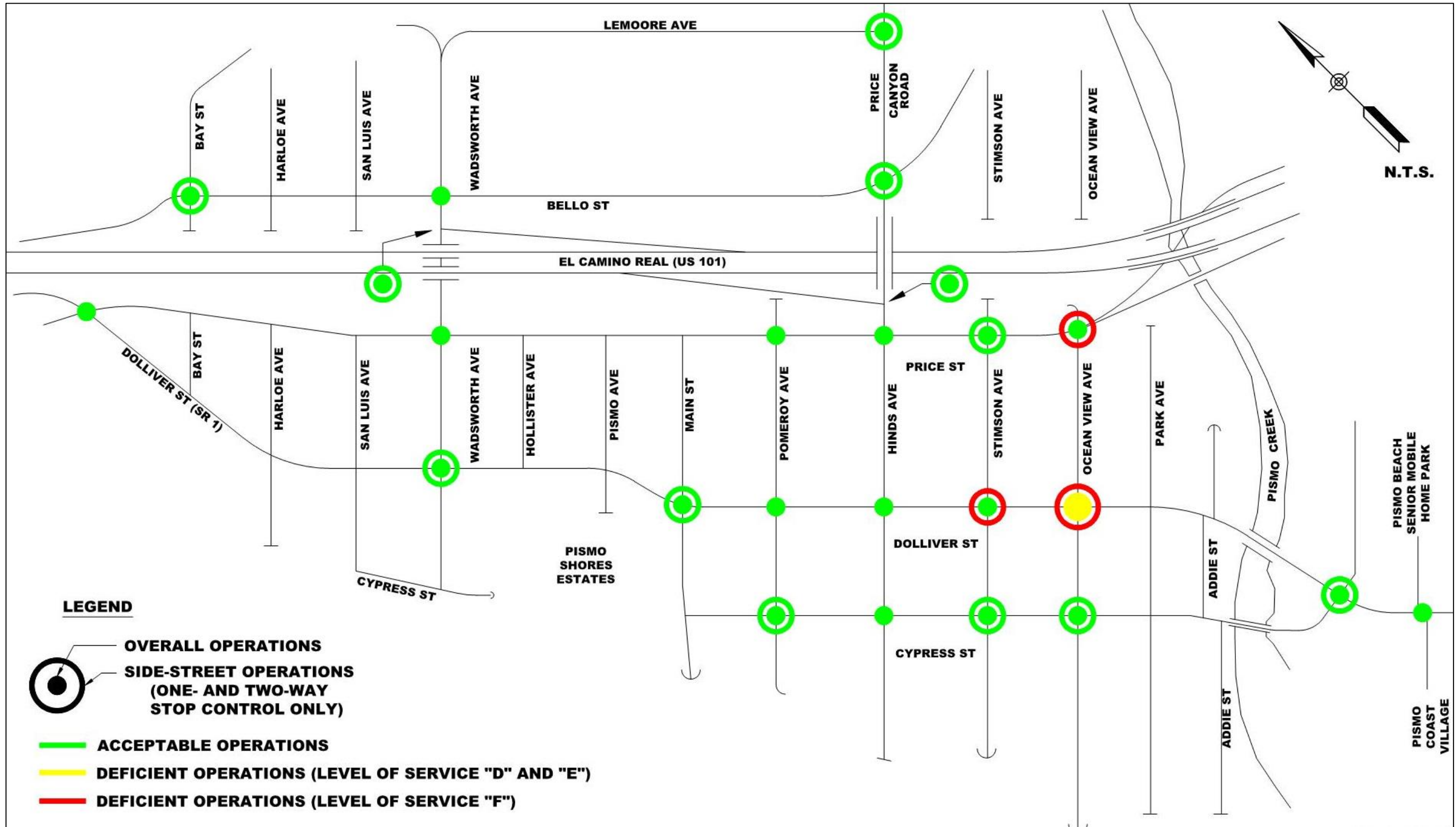

Exhibit 31B – Intersection Operations General Plan Buildout Weekday PM Peak Hour (Continued)

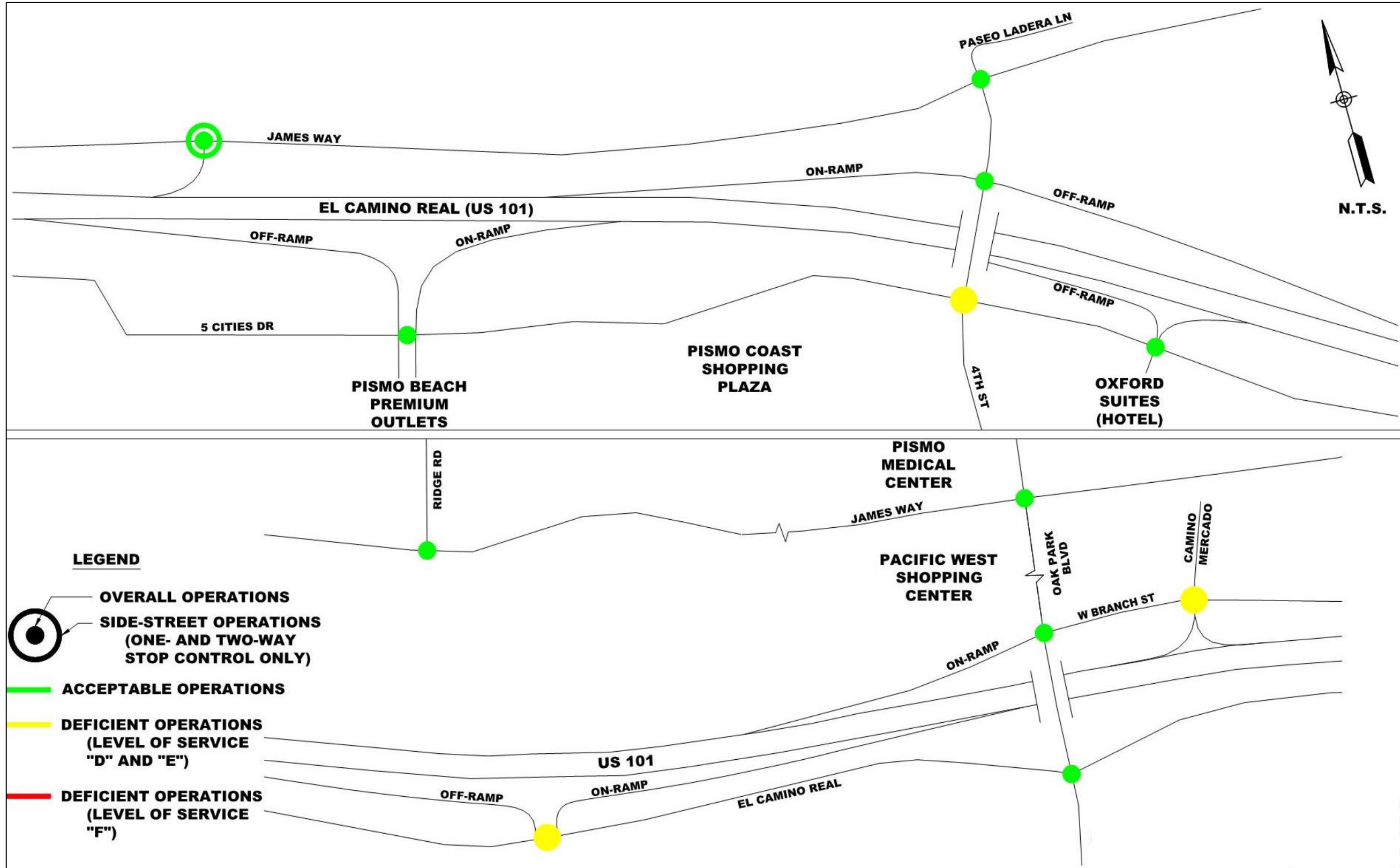

Exhibit 32 – Intersection Operations General Plan Buildout Summer Sunday Midday Peak Hour

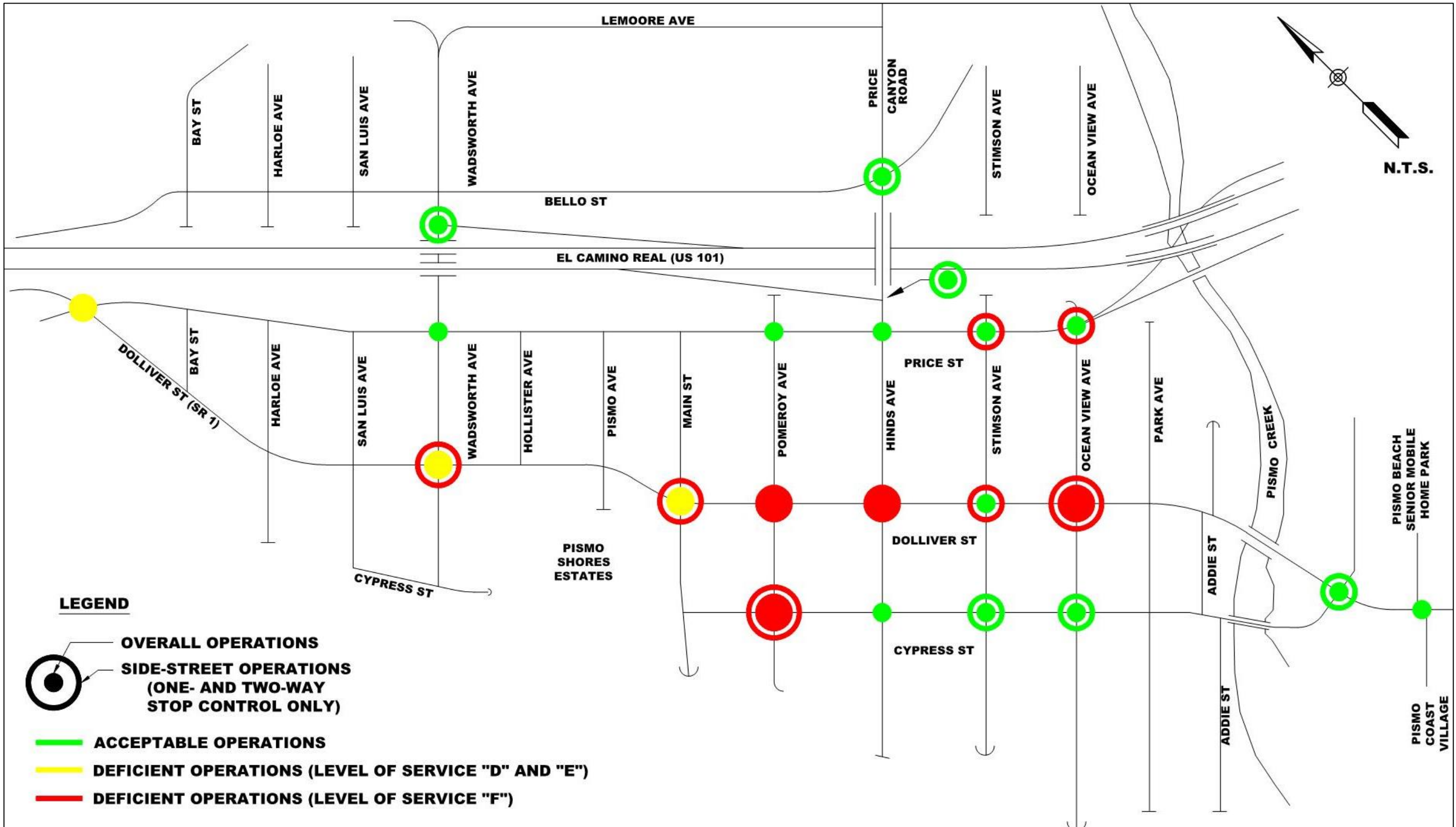
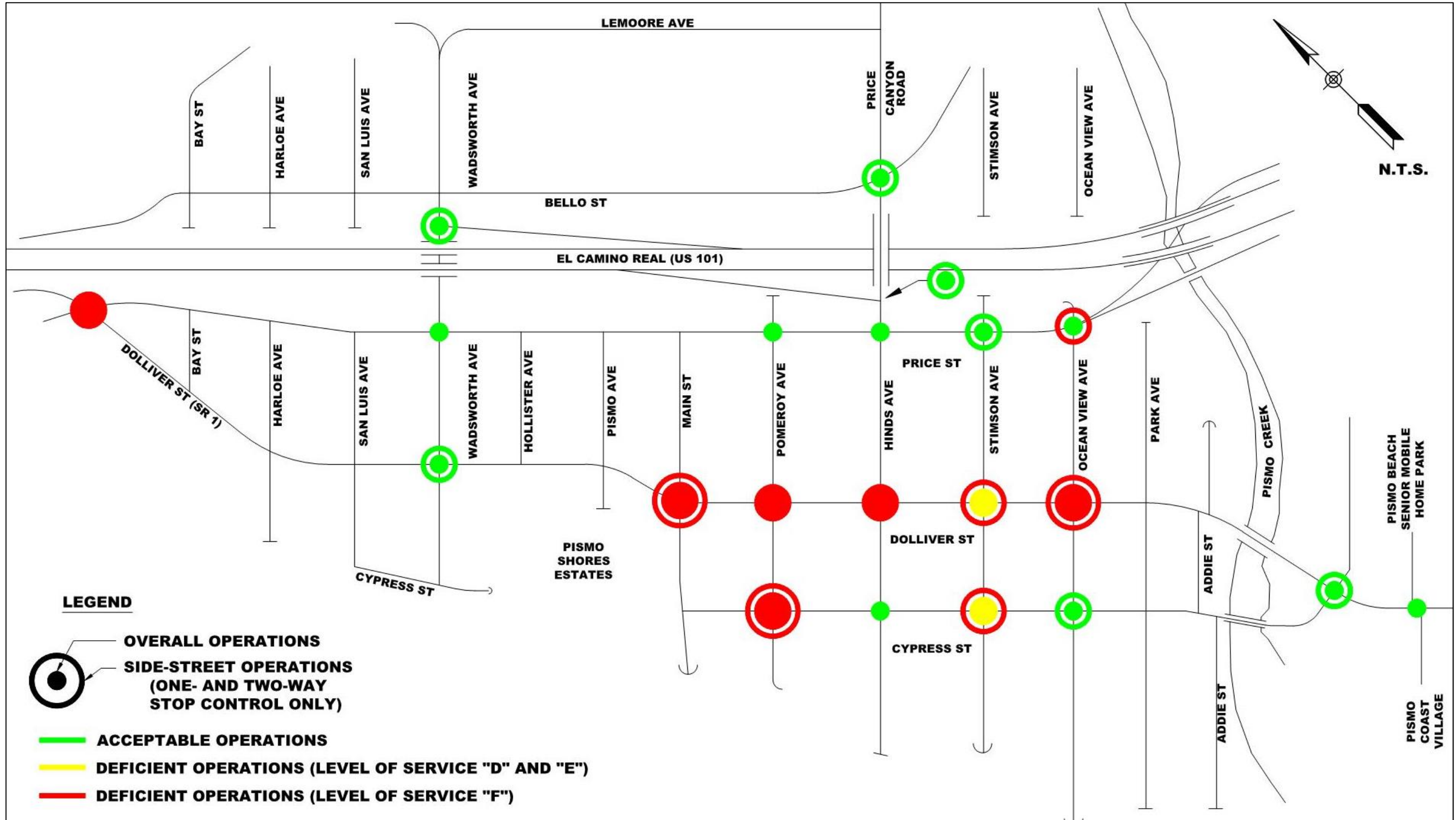

Exhibit 33 – Intersection Operations General Plan Buildout Memorial Day Sunday Midday Peak Hour



D. Improvements Recommended in Previous Studies

A roundabout was recommended at the intersection of the US 101 Southbound Off-ramp – Dolliver Street (SR 1) and Price Street intersection (Intersection No. 14) in the Pismo Beach Complete Street Plan. It is depicted on **Exhibit 34 (Page 77)**. As indicated in the level of service summary table on **Exhibit 30 (Pages 66-70)**, a one-lane roundabout can successfully accommodate Year 2035 traffic demand at Level of Service C.

Caltrans has proposed adding a new southbound on-ramp to US 101 at this intersection. **Exhibit 35 (Page 78)** illustrates how it would connect into the roundabout. It is anticipated that this ramp could be added to the proposed roundabout without requiring major modifications to the physical layout of the roundabout.

This page was intentionally left blank
(For Duplex Printing)

Exhibit 34 – Dolliver St. (SR1) / Price St. Roundabout

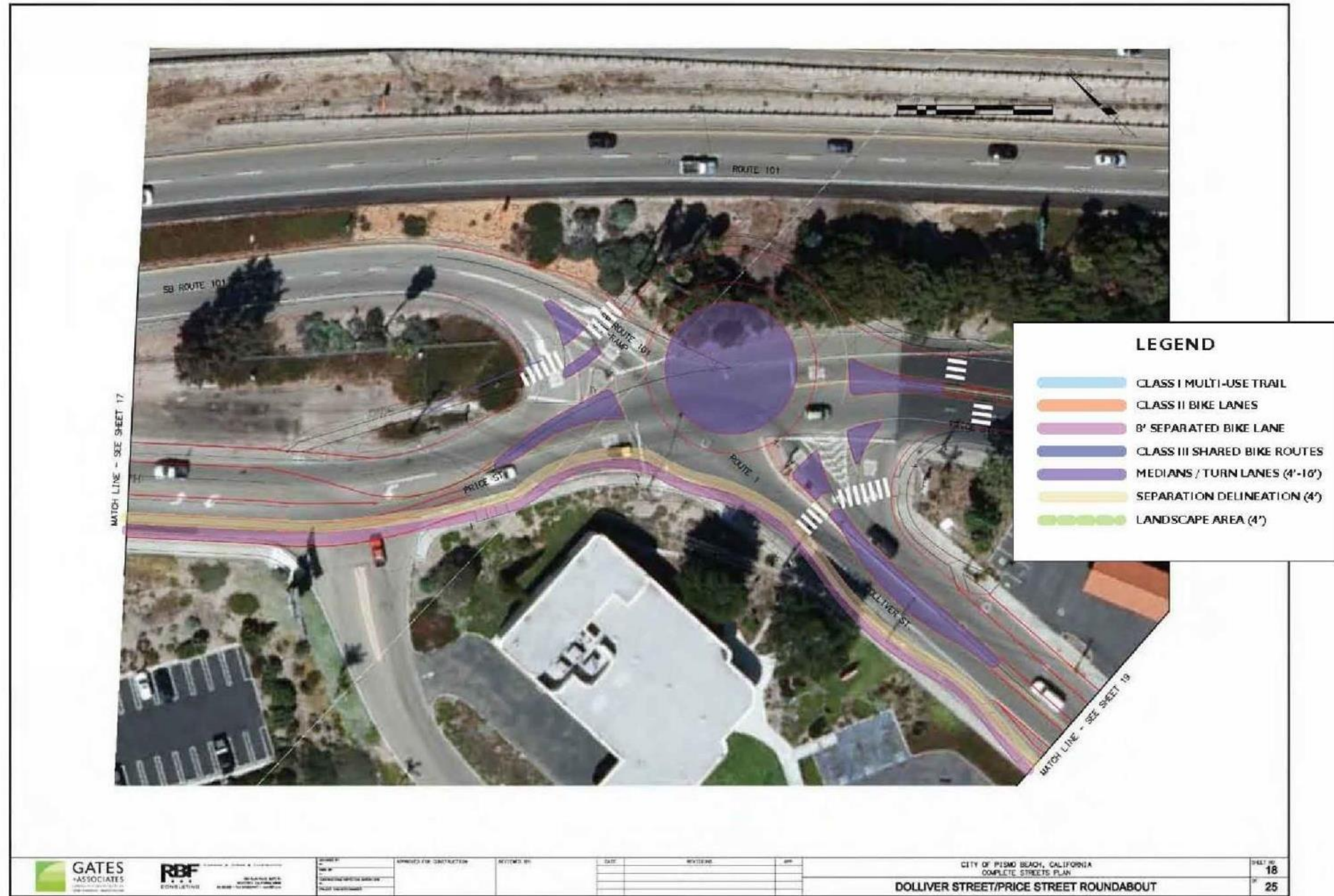

Source: "Pismo Beach Complete Street Plan", Gates + Associates, March 2013, p77

Exhibit 35 – Dolliver St. (SR1) / Price St. Roundabout with Future US 101 SB Onramp

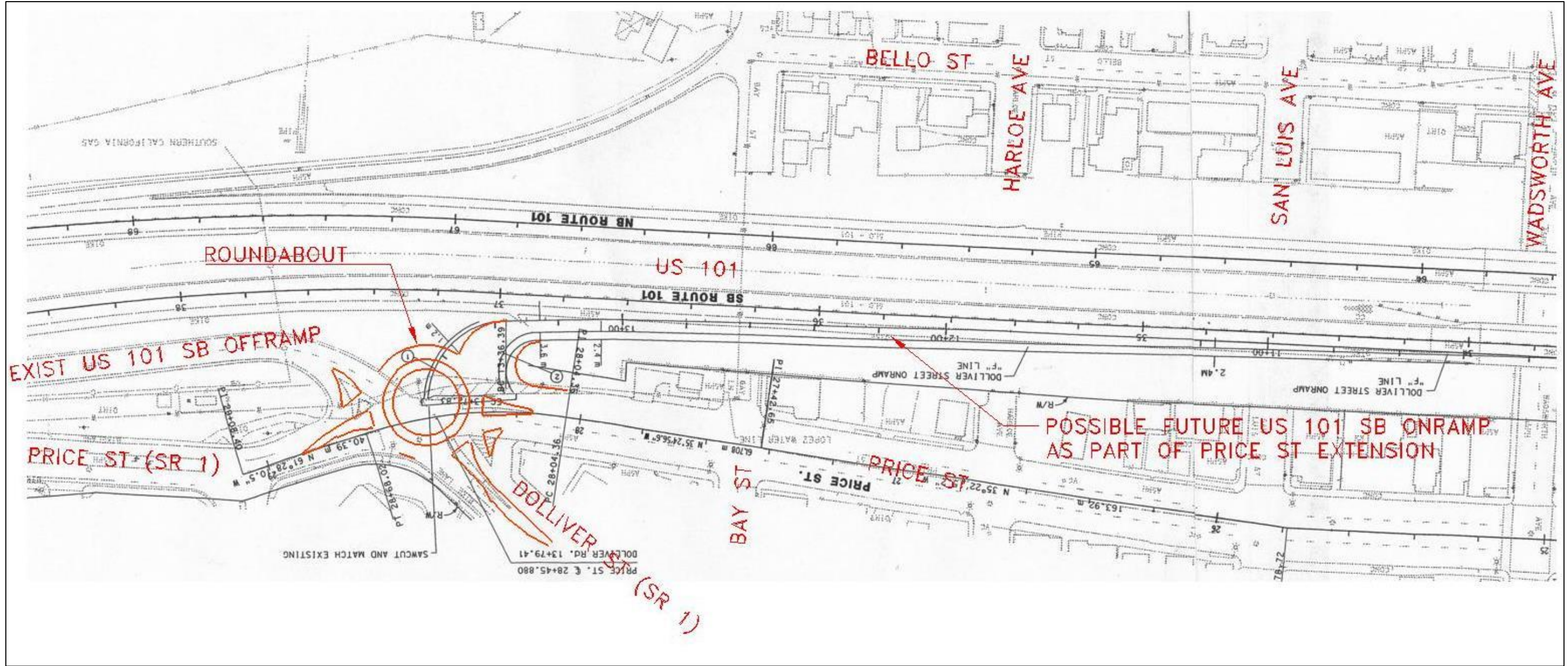

Sources:

1. Roundabout Layout- "Pismo Beach Complete Street Plan", Gates + Associates, March 2013, p77
2. Future Southbound On-Ramp – "Price Street Extension Initial Study with Proposed Mitigated Negative Declaration/Environmental Assessment", Caltrans, September 2004

E. Network Alternatives

In addition to the existing street network, which was considered the base condition, various major network alternatives (i.e., changes to the Pismo Beach street network such as new streets, conversions to one way streets or street realignments) were also evaluated for Year 2035 conditions. This study evaluates their effectiveness in improving operations at the study intersections or achieving other network enhancements. They are in addition to the intersection improvements described in Section 3.C – Traffic Operations and Recommendations – General Plan Buildout. They are listed below and separately described in the following pages.

- 1) Price Street Extension;
- 2) Frady Lane Improvements
- 3) Mattie Road Extension.

The citywide model was used to forecast traffic with these network alternatives. The forecast volumes are included in **Appendix E**.

A number of downtown-specific network alternatives were also evaluated. They include:

- 4) Stimson / Ocean View Couplet and Downtown Price Street Modifications;
- 5) Pier Area Improvements
 - a. Cypress Street/Pomeroy Avenue Pedestrian Scramble Traffic Signal and
 - b. Dolliver Street (State Route 1)/Pomeroy Signal Modification to Pedestrian Scramble
 - c. Dolliver Street Left Turn Pockets
 - d. Restrict Motorized Vehicles on the Cypress Street Bridge
 - e. Cypress Street Bike Boulevard;
 - f. Addie / Park Avenue Couplet; and
 - g. Restrict Motorized Vehicles on Pomeroy Avenue South of Cypress
- 6) Other downtown network modifications were also considered. They include:
 - a. Reverse One-Way on Pomeroy and Hinds;
 - b. Dolliver / Price Couplet; and
 - c. Dolliver / Bello Couplet.

1) Price Street Extension

The Price Street Extension would extend Price Street eastward across Pismo Creek to connect to Five Cities Drive. In 2004, Caltrans prepared an environmental evaluation of the potential design options for this improvement (*Price Street Extension Initial Study with Proposed Mitigated Negative Declaration/ Environmental Assessment*), based on the *James Way/Price Street Frontage Road Project Study Report*, March 1998. The recommended option had the following four components:

1. Extend Price Street over Pismo Creek and over the Union Pacific Railroad to connect with Five Cities Drive. This would be a two-lane road with 6-foot shoulders on each side (suitable for use by bicycle traffic) and a 5-foot sidewalk along the ocean-side of the street.
2. Closure of the existing southbound US 101 on-ramp from southbound Price Street.
3. Closure of the existing southbound US 101 off-ramp at Hinds Avenue.
4. Addition of a new southbound US 101 on-ramp at the Price / Southbound US 101 Off-Ramp – Dolliver intersection.

A schematic layout of this improvement is included as **Exhibit 36 (Page 81)**. This exhibit also illustrates four other alternative alignments analyzed in the 1998 Project Study Report (PSR) for either the Price Street Extension or James Way Extension. The following is a list of the five alternatives.

1. Alternative 1 – James Way Extension to Bello Street
2. Alternative 2 – James Way Extension to Hinds Avenue
3. Alternative 3 – James Way Extension to Price Street
4. Alternative 4 – Northbound James Way to Price Street; Southbound Price Street to Five Cities Drive
5. Alternative 5 – Price Street Extension to Five Cities Drive (Caltrans Preferred Alternative and the recommended alignment described above and analyzed below).

Year 2035 citywide model volume projections for Alternative 5 is included in **Appendix K**. The projected traffic diversions are displayed in **Exhibit 37 (Page 82)**. Total traffic volumes on the Price Street extension are anticipated to be almost 1,100 vehicles in the southbound direction and about 190 vehicles in the northbound direction. Most of this traffic is taken off of US 101 between the Price Street and Fourth Street interchanges. About 140 of the 190 vehicles in the northbound direction would be diverted from that section of freeway. About 1,150 vehicles would be diverted from US 101 in the southbound direction.

Exhibit 36 – Price Street / James Way Extension Alternatives

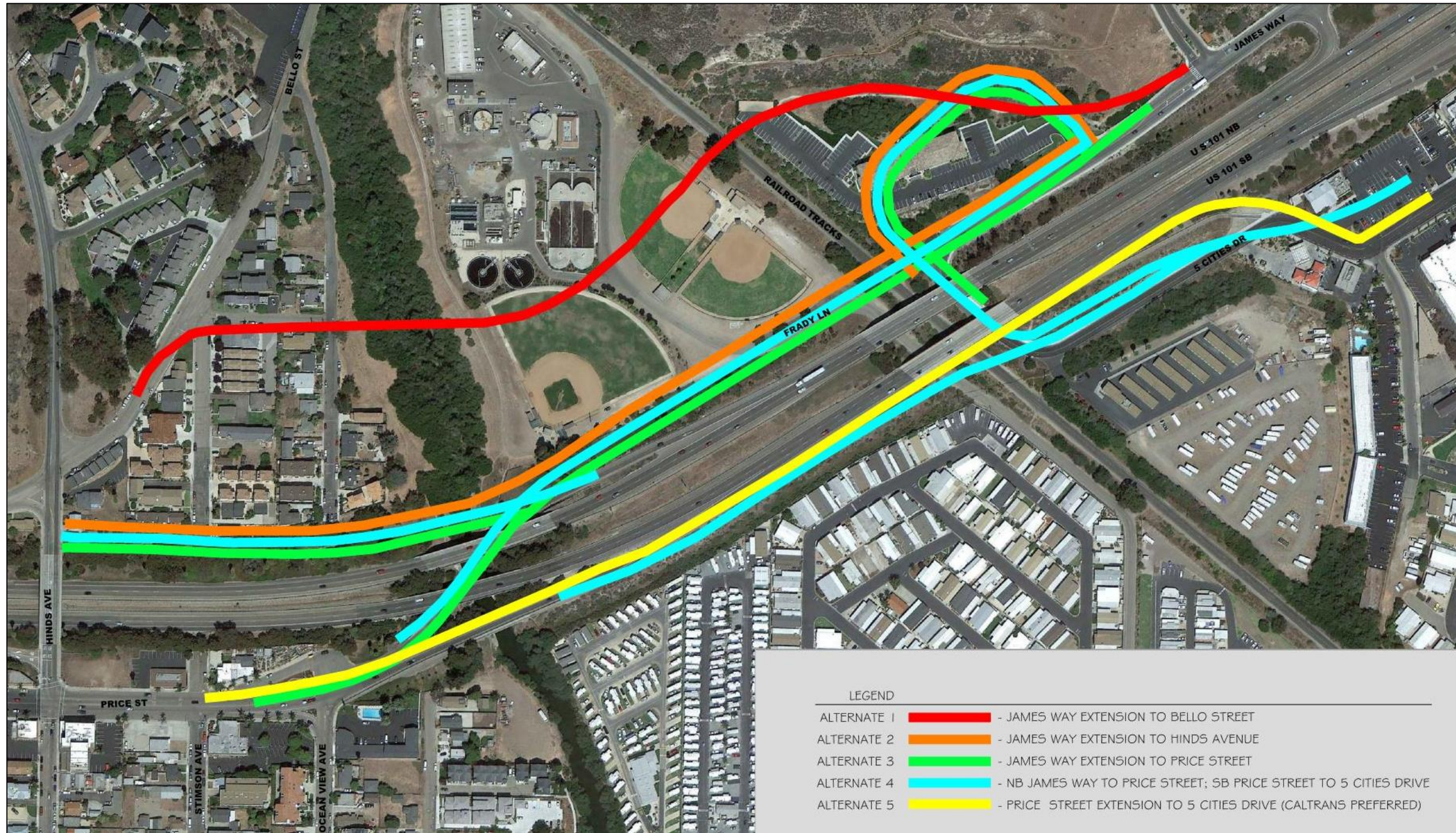

Source of Alternatives: "James Way/Price Street Frontage Road Project Study Report", March 1998 and "Price Street Extension Initial Study with Proposed Mitigation Negative Declaration/Environmental Assessment", September 2004.

Exhibit 37 – Projected Traffic Diversions with Price Street Extension (Year 2035 – PM Peak Hour)

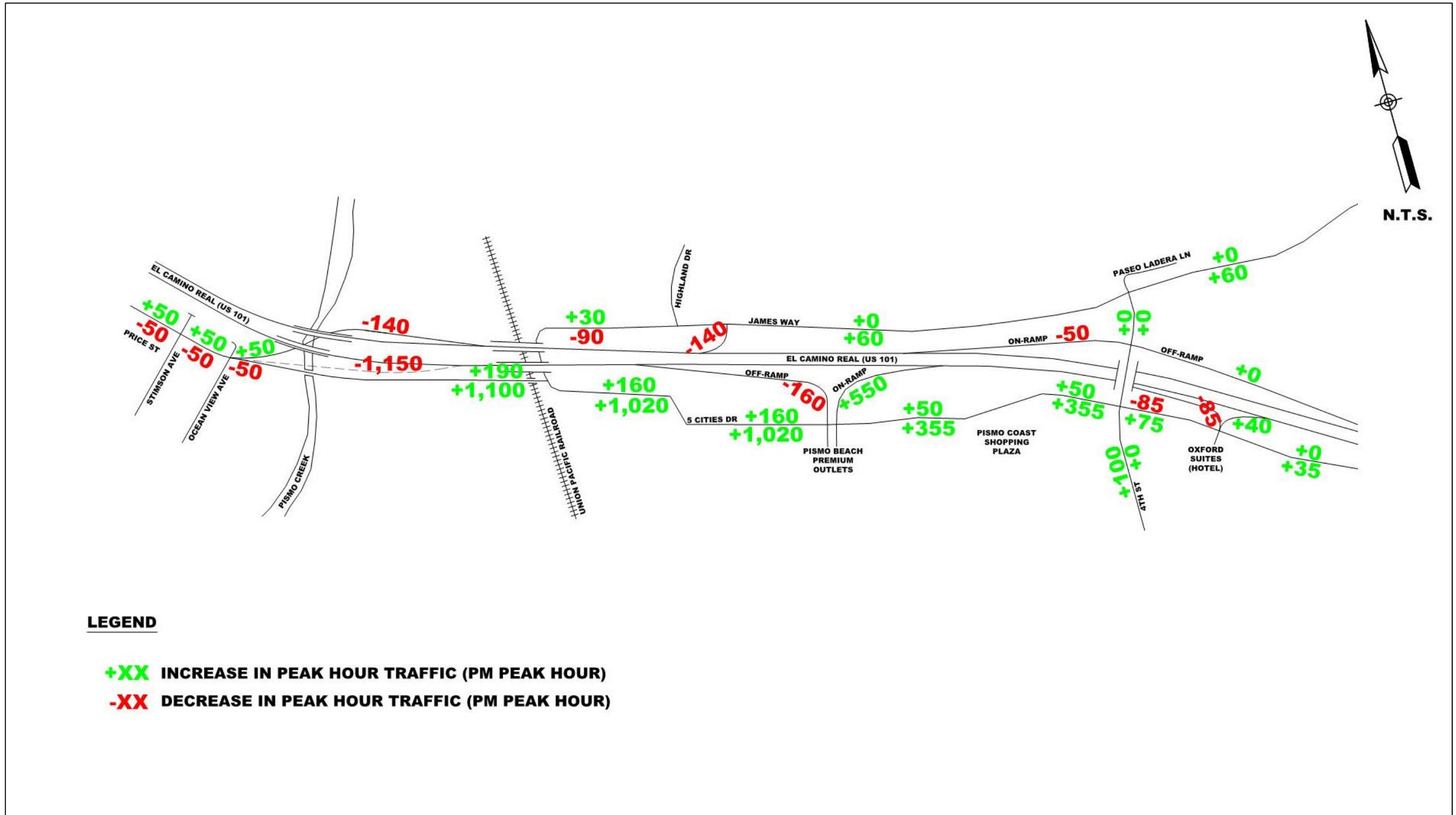

**Exhibit 38 – US 101 SB Ramps – Outlets Main Entrance
Intersection Level of Service – General Plan Buildout
Weekday PM Peak Hour – With Price Street Extension**

N-S Street	E-W Street	Existing Lane Configuration	Existing Intersection Control	LOS Standard	General Plan (Year 2035)		General Plan With Imprvmnts.		Proposed Improvement(s)	
					Weekday PM Peak Hr		Weekday PM Peak Hr			
					Delay (sec)	LOS	Delay (sec)	LOS		
41	US 101 SB Ramps - Outlets Main Entrance	Five Cities Drive	NB 1-L, 1-T/R SB 1-L, 1-L/T, 1-T/R EB 1-L, 1-T, 1-T/R WB 1-L, 1-T, 1-R	Signal	C/D	256.0	F	38.6	D	Add 2nd WB L, 2nd EB L, Change E/W Left Turn Phasing to Protected Phasing, Lag WB L Phase behind EB T Phase, Accept LOS D as Standard

Notes:

1. L, T, R = Left, Through, Right.
2. NB, SB, EB, WB = Northbound, Southbound, Eastbound, Westbound.
3. Analysis performed using 2010 Highway Capacity Manual methodologies.
4. Overall level of service standard for Caltrans is the transition between LOS C and D.
5. Overall level of service standard for the City of Pismo Beach and County of San Luis Obispo is LOS C.

The Price Street Extension would improve southbound freeway operations with the substantial diversion of traffic from US 101. However, it will have an impact that was not addressed in either the 1998 or 2004 Caltrans reports – the diversion of commute traffic on Price Canyon Road that currently uses Hinds Avenue and Price Street to access southbound US 101. With the removal of the southbound US 101 on-ramp at Price Street, this traffic would proceed westward to the Five Cities Drive southbound US 101 on-ramp. In the weekday PM peak hour, almost 1,100 vehicles in the southbound direction and about 190 vehicles in the northbound direction will be added to Five Cities Drive west of the US 101 Ramps / Pismo Beach Premium Outlets intersection. The SLOCOG model projects that an additional 550 vehicles during the weekday PM peak hour will enter US 101 at the Five Cities Drive southbound on-ramp. As noted on **Exhibit 38 (above)**, this increase in hourly traffic would overwhelm the existing westbound Five Cities Drive left turn lane onto southbound US 101, resulting in an F level of service. This left turn movement would need two lanes to accommodate this level of traffic, which in turn would require widening of the southbound US 101 on-ramp. A conceptual design of these improvements is shown in **Exhibit 39 (Page 85)**. Even with this improvement, it may not be possible to achieve acceptable operations at this intersection, with a mitigated level of service “D” during the weekday evening peak hour.

The Caltrans report also did not finalize the design of the merge between the Price Street extension and the existing northbound US 101 off-ramp to Price Street, nor did it finalize the necessary lane configuration along Price Street between Hinds and Ocean View Avenues. The merge between the northbound Price Street extension and the northbound US 101 off-ramp will need to continue along Price Street between Stimson and Ocean View Avenues, to for proper merge length between through lanes. A left turn lane at Ocean View Avenue is thus not recommended, as it would encourage off-ramp traffic to immediately weave directly across Price Street and into the left turn lane that would start only a few feet away from the merge point. This maneuver would not be expected by traffic on the Price Street extension and could result in undesirable safety consequences. The Stimson / Ocean View couplet would also be indispensable to mitigate the short weaving operational problems (see below for more on the Stimson / Ocean View couplet).

The Price Street Extension includes the addition of a southbound US 101 on-ramp at the Price Street / Southbound US 101 Off-Ramp – Dolliver Street (SR 1) intersection. This ramp is expected to only attract a few of the commuters using Price Canyon Road, because accessing an on-ramp at that location would require Price Canyon Road traffic to travel too far out of their way. It would also have a limited attraction from within the downtown area. It is forecasted to attract a total about 110 vehicles during the PM peak hour.

The addition of the US 101 southbound on-ramp at Dolliver Street - Price Street intersection would require the closure of the southbound US 101 off-ramp to Hinds Avenue. This ramp only carries about 90 vehicles in the PM peak hour. However, its closure would also have unintended consequences. It is the primary route for trucks servicing the oil fields along Price Canyon Road north of Pismo Beach. With its closure, those trucks would be forced to travel through the downtown, presumably on Price Street. It is recommended that if the Hinds Avenue off-ramp is closed in the future, that the City of Pismo Beach prohibit through trucks on Price Street, forcing trucks to use Dolliver Street (SR 1) and Hinds Avenue to access Price Canyon Road, which is also through downtown Pismo Beach.

Two other design options for the Price Street extension would be an extension of James Way, the frontage road on the inland side of US 101. The James Way extension options evaluated in the 2004 Caltrans report were:

- i. James Way Extension to Hinds Avenue – This improvement would extend James Way westward along the freeway to Hinds Avenue. It is designated Alternative 2 in the 1998 PSR and on **Exhibit 33 (page 74)**. Five Cities Drive would be rerouted underneath the James Way extension and looped back to James Way near Highland Drive. This option was originally proposed prior to the development of the Pismo Beach Medical Center at the current western end of James Way. The Five Cities Drive loop would now require a larger loop that around the perimeter of that development. Also, the western end of the James Way extension and the northern end of the Five Cities Drive Loop would both be located very close to the Highland Drive intersection. Adequate left turn lane storage may not be able to be provided along this section of James Way.

The effect of the James Way extension on traffic patterns would primarily be regional in nature. Year 2035 citywide model volume projections for this alternative can be found in **Appendix K**, and the projected traffic diversions are displayed in **Exhibit 40 (Page 86)**. The James Way extension would carry about 70 vehicles in the northbound direction and 350 vehicles in the southbound direction. This diversion would be from both commuters along Price Canyon Road and traffic from within the downtown area, some of which would be diverted from the US 101 southbound on- and northbound off-ramp at Price Street. Diversions would also occur from the southbound Five Cities Drive off-ramp.

- ii. James Way Extension to Price Street – This improvement would extend James Way to Price Street on the alignment of the northbound US 101 off-ramp to Price Street. The existing northbound US 101 off-ramp to Price Street would be removed. It is designated Alternative 4 in the PSR and **Exhibit 33 (page 74)**. The primary negative aspect of this improvement would be that it would remove the primary access into the downtown from northbound US 101. During the weekday PM peak hour, approximately 500 vehicles would be forced to divert to either the Wadsworth Avenue or Fourth Street off-ramps to access downtown Pismo Beach.

Exhibit 39 – Five Cities Drive / US101 SB Ramps – Outlets Main Entrance Improvements with Price Street Extension

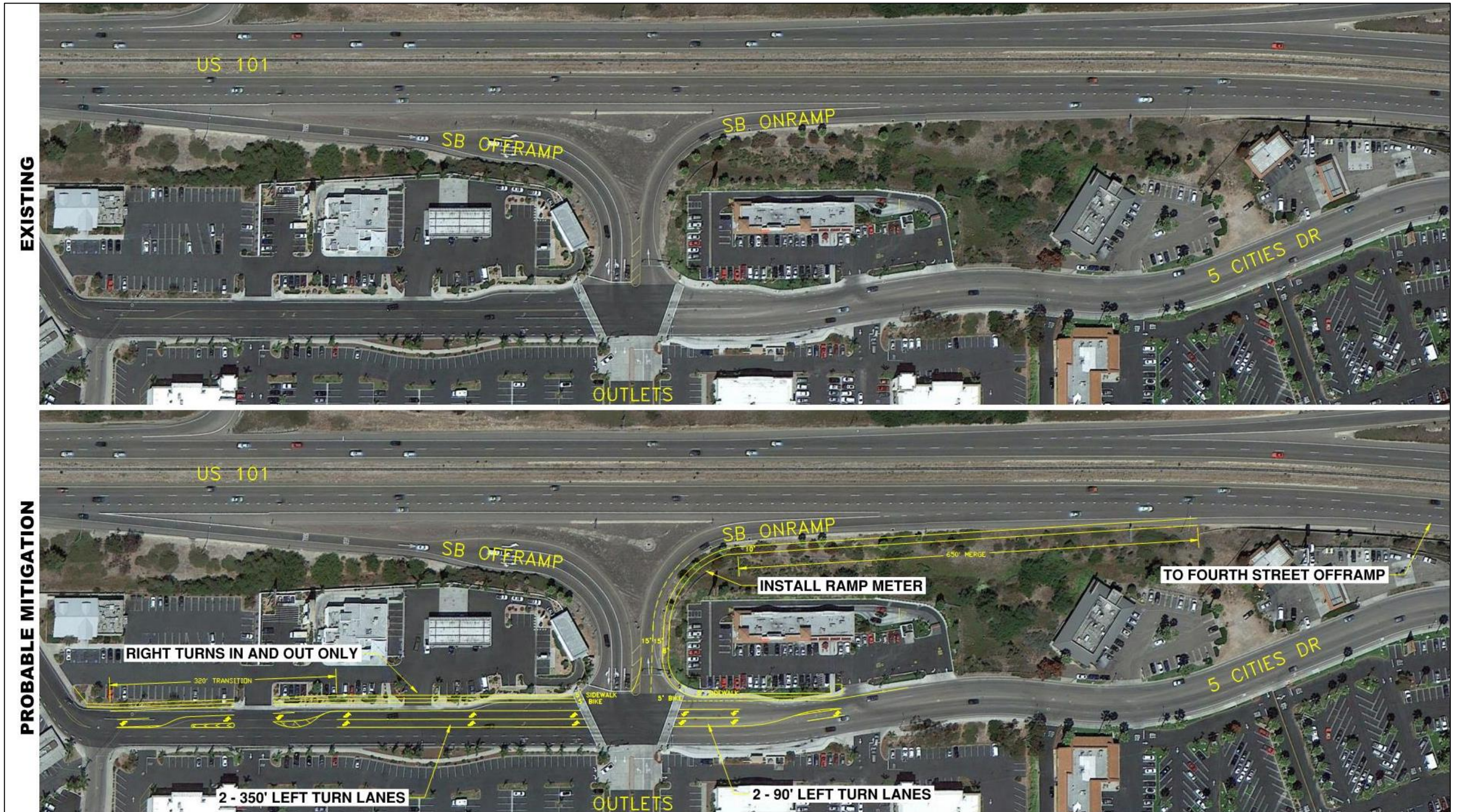
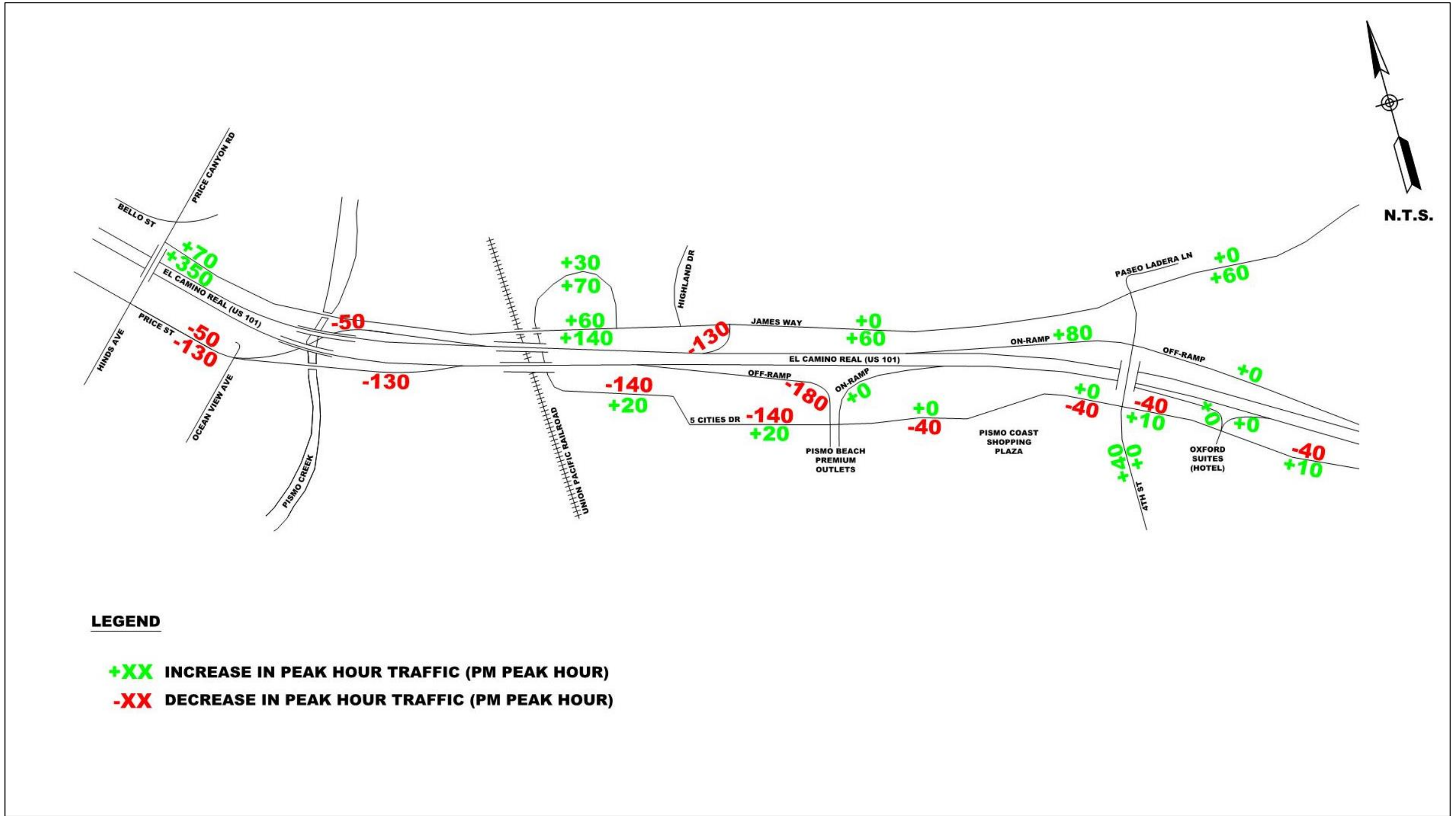

Exhibit 40 – Projected Traffic Diversions with James Way Extension (Year 2013- PM Peak Hour)



2) **Frady Lane Improvements**

The Frady Lane Improvement would realign Frady Lane near the Pismo Beach Sports Complex. **Exhibit 41 (Page 89)** depicts a conceptual design of this improvement. Currently, it meanders between the existing baseball fields, bisecting the Sports Complex. The proposed alignment would be much straighter and be located between the baseball fields and the Union Pacific Railroad tracks. The proposed improvement would provide better pedestrian connectivity between the baseball fields and provide additional onsite parking spaces.

A vehicular bridge over Pismo Creek between Frady Lane and Bello Street is currently being designed that will connect the Sports Complex and Frady lane to Price Canyon Road and the northern area of Pismo Beach. This would provide a secondary access into the Pismo Beach Sports Complex. This improvement would replace the existing bridge that has been closed to vehicular traffic since 1983. It would also improve emergency response times to the sports complex and mobile home parks south of US 101 for police and fire services. It also would improve public works corporation yard access to northern parts of the City and PG&E access to the southern part of the City. Finally, it would serve as an alternate route during incidents involving closure of parallel routes including crossings of Pismo Creek.

Exhibit 42 (Page 90) depicts the projected traffic diversions in the Year 2035 due to the Frady Lane Realignment, including the proposed vehicle bridge, as projected by the citywide model. The projections show that there would be minimal diversion of through traffic onto the Frady Lane corridor. Rather, most of the diversion that would occur will be sports complex traffic from Frady Lane to the new Bello Street access, with a total of 15 trips in and 10 trips out during the PM peak hour. This level of traffic diversion is not anticipated to result in any noticeable effect on the operations of the study network. Midday traffic redistribution will also occur from the City corporation yard and PG&E, although not substantial enough to affect traffic operations elsewhere in the City.

Finally, as illustrated on **Exhibit 41 (Page 89)**, a relatively straightforward method can be implemented to provide a pedestrian and bicycle connection between the downtown, the Pismo Beach Sports Complex, and the eastern portion of Pismo Beach. This improvement would include two connections to the existing pedestrian/bicycle path adjacent to US 101 between Price Street and Five Cities Drive. One connection would be a pedestrian/bicycle ramp connecting the path to Frady Lane, with a new sidewalk along Frady Lane between this ramp and the Pismo Beach Sports Complex. The second would be a stairwell connecting the path to Five Cities Drive.

This page was intentionally left blank
(For Duplex Printing)

Exhibit 41 – Frady Lane Improvements

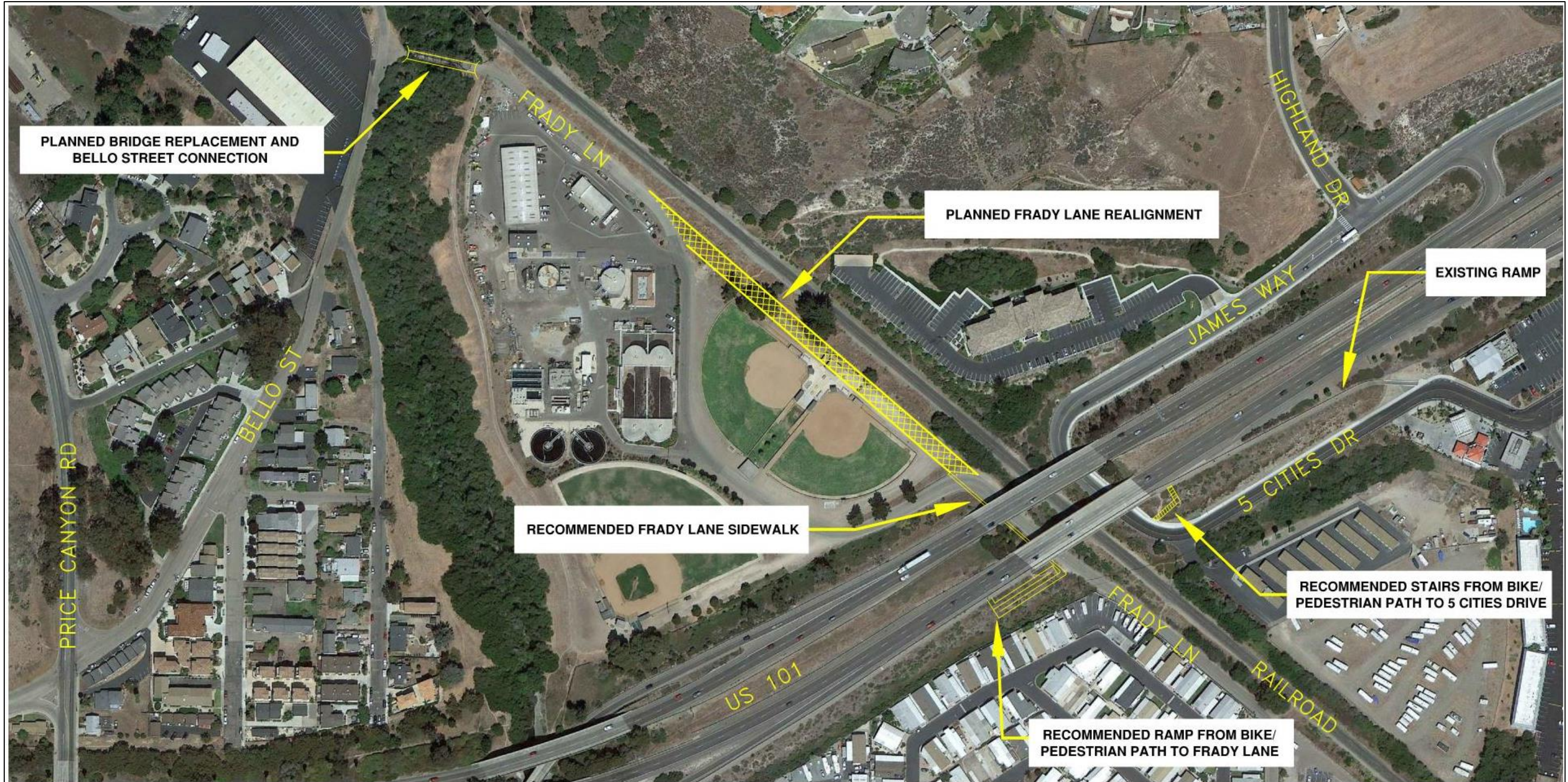
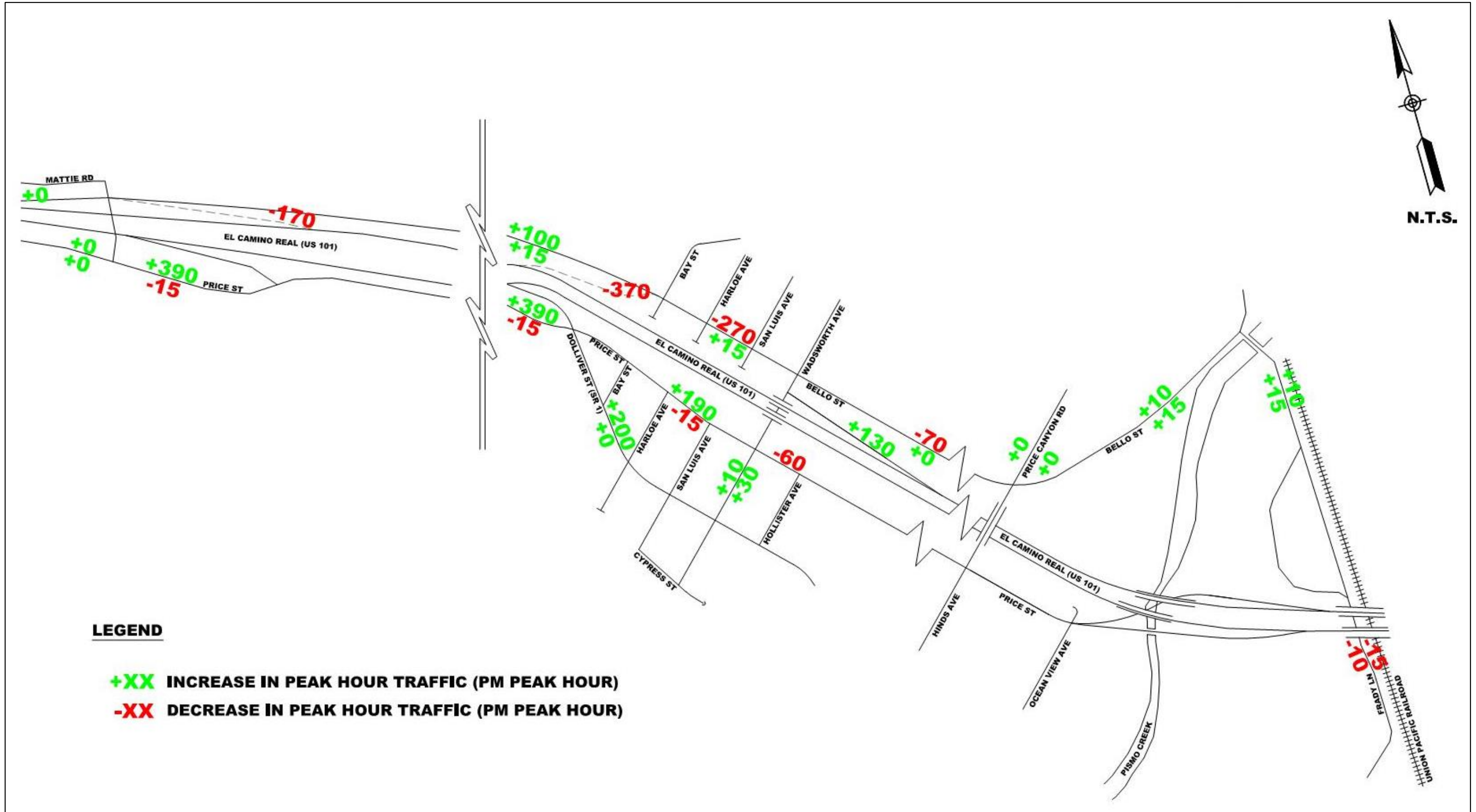

Exhibit 42 – Projected Traffic Diversions with Frady Lane Realignment and Mattie Road Extension (Year 2035 – PM Peak Hour)



3) Mattie Road Extension

The Mattie Road Extension would connect Mattie Road eastward to Bello Street along the northern frontage of US 101. The potential alignment would route it through the southern end of the adjacent Pismo Preserve. The Land Conservancy of San Luis Obispo has indicated it will permit this connection.

A conceptual plan and profile as well as typical cross sections of this extension as a two lane road are included on **Exhibits 43A-C (Pages 93-95)**. The existing topography in this area will make establishing this connection rather expensive due to the need for extensive grading and retaining walls along the route. Therefore, to minimize the expense of constructing this roadway, the improvement may require the complete removal of the existing northbound US 101 on-ramp at Bello Street and the existing northbound US 101 off-ramp at Shell Beach Road / Mattie Road. This will impact the ability to access northbound US 101 from the downtown and Mattie Road from northbound US 101, unless replacement ramps are included.

The projected traffic diversions associated with the Mattie Road extension are also depicted in **Exhibit 42 (Page 90)**. About 100 PM peak hour vehicles are projected on Mattie Road. In the southbound direction on the Mattie Road extension, only 15 PM peak hour vehicles are projected, all attracted from the Price Street corridor. The closure of the northbound US 101 northbound on-ramp at Bello Street and off-ramp at Mattie Road would shift traffic onto Price and Dolliver (SR 1) Streets and away from Bello Street and the Mattie Road extension. South of the existing Mattie Road interchange, Price Street would experience an additional 390 vehicles in the northbound direction during the PM peak hour, more than doubling the current traffic at this location due to the ramp closure.

Exhibit 44 (Page 97) tabulates the levels of service at key study intersections with the Mattie Road extension. Despite the potential diversion of traffic onto Price Street, no additional improvements would be required at the study intersections beyond those already required under either Existing or General Plan Buildout conditions.

This page was intentionally left blank
(For Duplex Printing)

Exhibit 43A – Mattie Road Extension Conceptual Plan/Profile

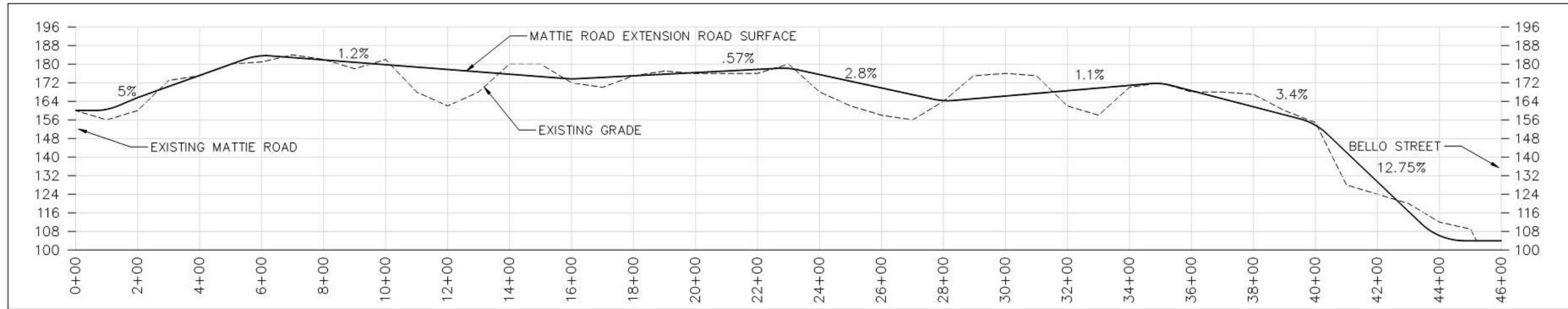

PROFILE

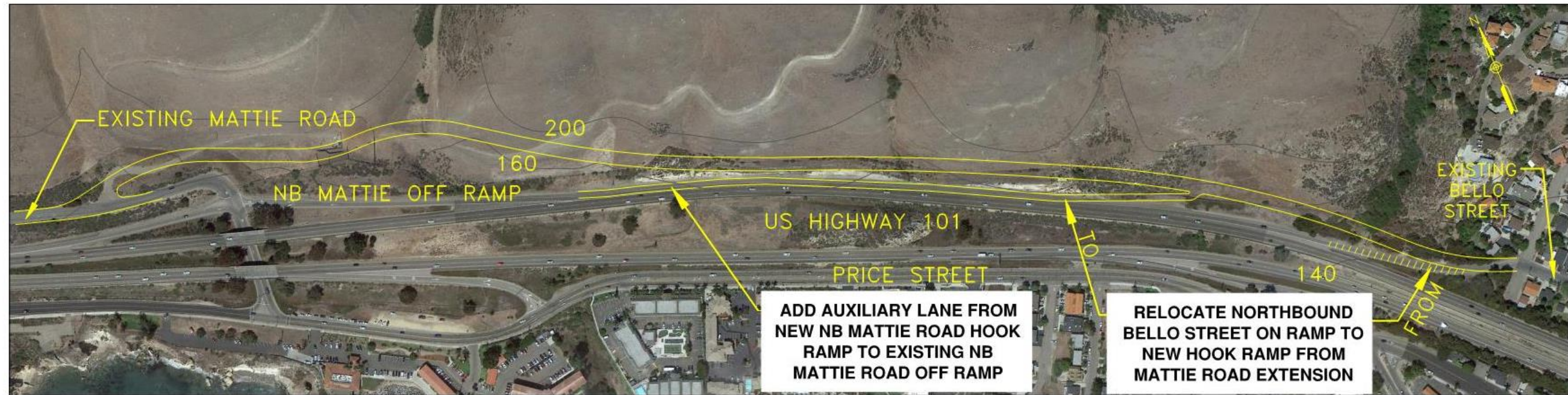

PLAN

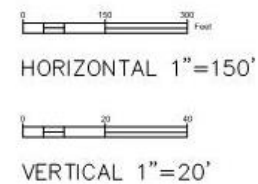

NOTE: MATTIE ROAD EXTENSION AND NORTHBOUND HOOK RAMP ALIGNMENTS MUST ACCOMMODATE FUTURE WIDENING OF US 101 TO SIX LANES

Exhibit 43B – Mattie Road Extension Conceptual Cross Sections STA 5+00 to STA 20+0

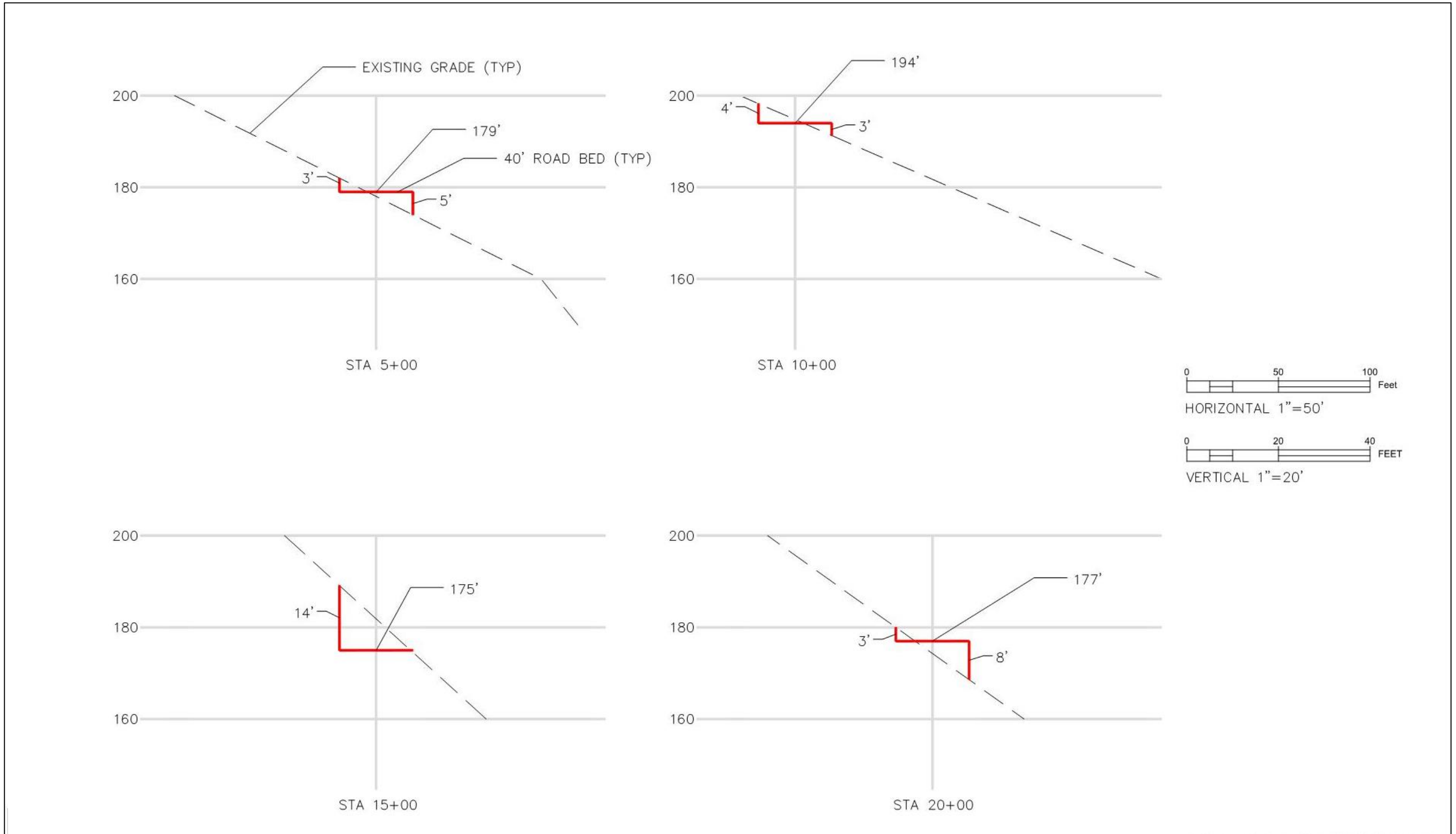
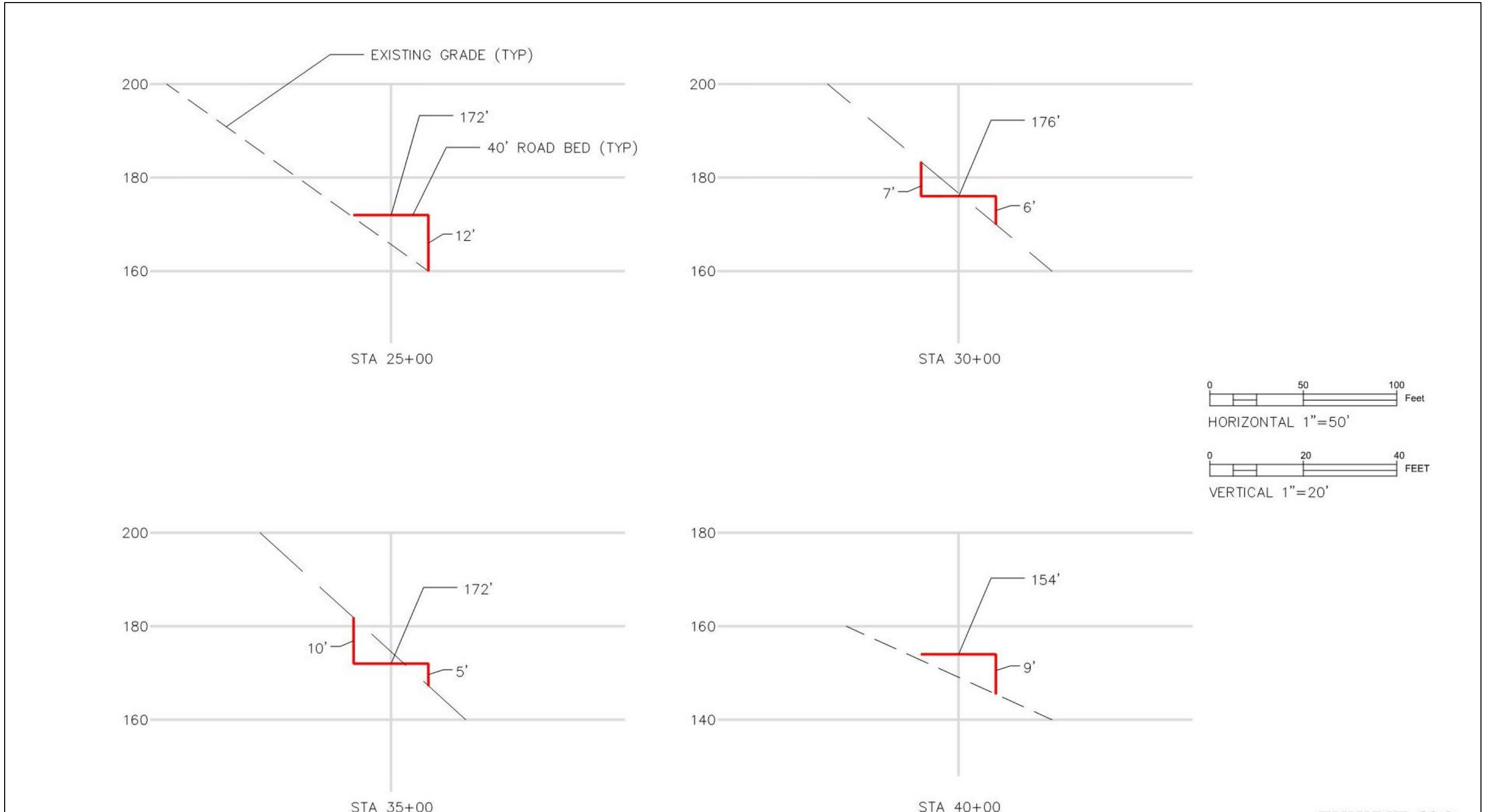

Exhibit 43C– Mattie Road Extension Conceptual Cross Sections STA 25+00 to STA 40+00



This page was intentionally left blank
(For Duplex Printing)

**Exhibit 44 – Mattie Road Area Intersection Levels of Service – General Plan Buildout
Weekday PM Peak Hour – With Mattie Road Extension**

N-S Street	E-W Street	Existing Lane Configuration	Existing Intersection Control	LOS Standard	General Plan Buildout (Year 2035)				Proposed Improvement(s)					
					Without Mattie Rd. Extension		With Mattie Rd. Extension							
					No Imprvmnts.		With Imprvmnts.							
Weekday PM Peak Hr		Weekday PM Peak Hr		Weekday PM Peak Hr		Weekday PM Peak Hr								
Delay (sec)	LOS	Delay (sec)	LOS	Delay (sec)	LOS	Delay (sec)	LOS							
12	Mattie Road	Price Street	SB 1-L, 1-R EB 1-L/T WB 1-T/R	Signal	C	6.9	A							
14	US 101 SB Off-ramp - Dolliver Street (SR 1)	Price Street	NB 1-L, 1-R SB 1-L, 1-T, 1-R EB 1-T/R WB 1-L/T	All-Way Stop	C/D	16.8	C	8.9	A	48.8	E	13.0	B	Roundabout

Notes:

1. L, T, R = Left, Through, Right.
2. NB, SB, EB, WB = Northbound, Southbound, Eastbound, Westbound.
3. Analysis performed using 2010 Highway Capacity Manual methodologies.
4. Overall level of service standard for Caltrans is the transition between LOS C and D.
5. Overall level of service standard for the City of Pismo Beach and County of San Luis Obispo is LOS C.

4) Stimson / Ocean View Couplet and Downtown Price Street Modifications

The Stimson Avenue/Ocean View Avenue Couplet would convert Stimson and Ocean View Avenues into one-way streets between Dolliver (SR 1) and Price Streets. Ocean View Avenue would be one-way eastbound and Stimson Avenue would be one-way westbound. Currently, both streets are two-way streets. The project would also add a two-way bicycle facility along Ocean View Avenue between Dolliver (SR 1) and Price Streets. **Exhibits 45A and 45B (Pages 99 and 100, respectively)** depict this improvement. **Exhibit 45A (Page 99)** includes associated channelization modifications along Price Street through lanes through the Ocean View Avenue intersection. **Exhibit 45B (Page 100)** provides a single southbound through lane from Hinds Avenue, requiring the elimination of westbound left turns from the outside lane (currently and optional left/right lane) on the Price Canyon Road approach.

Exhibit 45A (Page 99) shows the extension of two eastbound lanes on Price Street from Stimson Avenue, where they currently transition into a single lane, to Ocean View Avenue. This will provide additional capacity at the Price Street/Stimson Avenue intersection. It will also improve lane utilization on southbound Price Canyon Road at Price Street, which currently experiences long queues during the evening peak period. It will also include a northbound Price Street left turn lane at Stimson Avenue. However, two parking spaces would be lost on the Price Street frontage of the Pismo Food Store as well as three spaces on the east side of Price Street, north of Stimson. A bike lane also would be provided from Hinds Avenue to Ocean View Avenue.

Exhibit 45B (Page 100) shows the provision of a single through lane on southbound Price Street. This has the advantage of preserving on-street parking with ample room for a protected bike lane (cycle track) and northbound Price Street left turn lane at Stimson Avenue. The disadvantage is that it will reduce the capacity of the Price Street/Price Canyon Road-Hinds Avenue intersections, especially for westbound Price Canyon Road. Queues already are long for the westbound to southbound left turn movement with two lanes available for left turns.

The City will need to determine which alternative is the most beneficial. Additional detailed design alternatives also need to be explored, which would require a more detailed alternatives analysis.

The following are features common to both alternatives.

1. The left turn lane on Price Street at Ocean View Avenue is currently only about 40 feet long. This is not enough storage to accommodate current demand (including recreational vehicles), and the geometrics of the upstream northbound off-ramp preclude the lengthening of the left turn lane. By changing Stimson and Ocean View Avenues into a one-way couplet, left turns can be provided at Stimson Avenue (instead of Ocean View Avenue), which can better accommodate a longer left turn lane. This improvement also works well with the proposed Price Street extension (as noted previously). **Exhibits 21 and 30 (Pages 43-47 and 66-70)** depict operations under Existing and General Plan Buildout with the Stimson / Ocean View couplet in place.
2. The Stimson / Ocean View couplet also eliminates one other potential roadway hazard. At the Dolliver (SR 1) / Ocean View intersection, many RVs make the turn from northbound Dolliver Street (SR 1) onto eastbound Ocean View Avenue. These RVs require a large right turning radius, which can cause these vehicles to encroach into oncoming traffic on westbound Ocean View when making the northbound-to-eastbound right turn. With implementation of the Stimson / Ocean View couplet, there will no longer be an opposing traffic stream on westbound Ocean View east of Dolliver Street (SR 1), thus eliminating this issue.
3. Signalization of the Dolliver (SR 1) / Stimson intersection would be preferred to achieve acceptable operations at this location. While this improvement also may be required without implementation of the Stimson / Ocean View couplet, the couplet would eliminate the need to also signalize the adjacent Dolliver (SR 1) / Ocean View intersection.

Appendix L provides recommended design considerations (i.e., “best practices”) for the proposed two-way bicycle facilities on Ocean View Avenue and Price Street.

A short term alternative that can be easily implemented is to provide wayfinding signs directing large vehicles to continue northbound on Dolliver Street to Hinds Avenue. Hinds Avenue is a two lane, one-way street that can accommodate large right turning vehicles without encroaching into on-coming traffic.

Exhibit 45A – Stimson Ave. / Ocean View Ave. One way Couplet with Two Eastbound Price St. Through Lanes



Exhibit 45B – Stimson Ave. / Ocean View Ave. One way Couplet with Two-Way Cycle Track



5) Pier Area Improvements

The downtown area, especially in the vicinity of the Pismo Beach Pier, is the location of the most severe congestion in the City of Pismo Beach, occurring on nearly all summer weekends and holidays. Downtown is also the location of the highest pedestrian traffic, which is a major contributor to vehicle congestion, due to the requirement of vehicles to yield to pedestrians in crosswalks.

Bicycle traffic is also highest in the downtown area and between the pier area and the RV and camping facilities to the east along Dolliver (SR 1), with about 60 bicyclists (30 bicyclists in each direction) during both the Summer Sunday and Memorial Day Sunday afternoon peak hours. This is more than four times as much as occurs during the Weekday PM peak hour (about 13 bicyclists in each direction). A similar trend also occurs along Dolliver Street (SR 1) within the downtown, with about 40 bicyclists (20 in each direction) on Sundays, versus 10-20 bicyclists during the Weekday PM peak hour.

Recommended improvements in the Pier Area that improve traffic operations, pedestrian and bicycle facilities or provide signal operations that reduce pedestrian impacts on traffic operations are listed below. They are located in **Exhibit 46 (Page 103)**, followed by individual discussions on the subsequent pages.

- a. Cypress Street/Pomeroy Avenue Pedestrian Scramble Traffic Signal and
- d. Dolliver Street (State Route 1)/Pomeroy Signal Modification to Pedestrian Scramble
- e. Dolliver Street Left Turn Pockets
- f. Restrict Motorized Vehicles on the Cypress Street Bridge
- g. Cypress Street Bike Boulevard;
- h. Addie / Park Avenue Couplet; and
- i. Restrict Motorized Vehicles on Pomeroy Avenue South of Cypress

This page was intentionally left blank
(For Duplex Printing)

Exhibit 46 – Recommended Pier Area Improvements

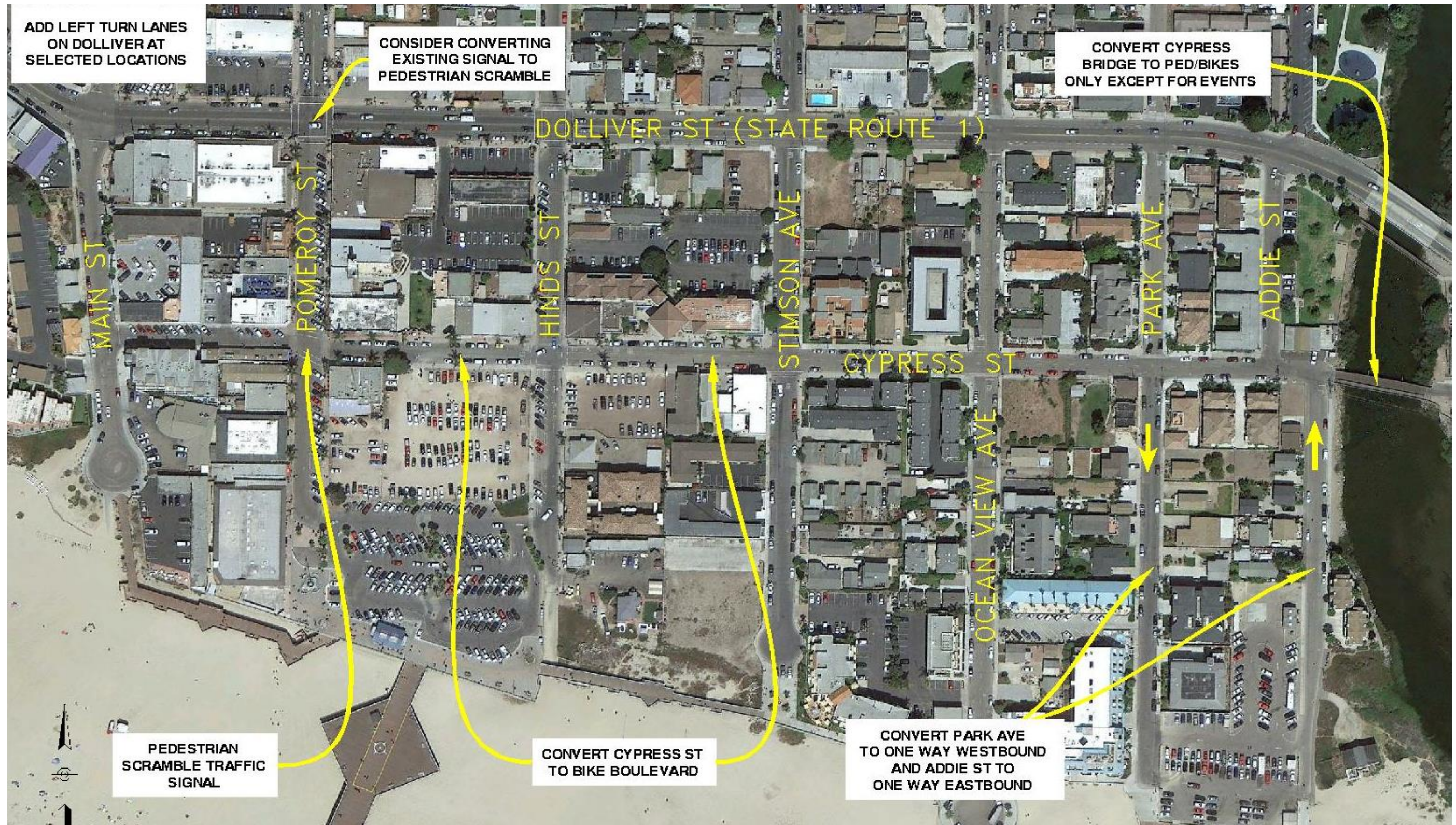

This page was intentionally left blank
(For Duplex Printing)

- a. Cypress Street/Pomeroy Avenue Pedestrian Scramble Traffic Signal and
- b. Dolliver Street (State Route 1)/Pomeroy Signal Modification to Pedestrian Scramble

A total of 257 pedestrians crossed the four legs of the Dolliver (SR 1)/Pomeroy intersection during the weekday evening peak hour, compared with 1,023 crossings on a Summer Sunday afternoon and 1,305 on Memorial Day Sunday afternoon (see Exhibits 8 through 10 (Pages 19-21)). The Pomeroy/Cypress intersection experienced 665 pedestrian crossings on the weekday evening, 2,765 on a summer afternoon and 2,033 on the Memorial Day Sunday afternoon. All of these are extremely high volumes that severely affect intersection operations. Installation of a pedestrian-based signal, also called a “pedestrian scramble”, may be a viable option at both locations. An example of a pedestrian scramble is depicted in **Exhibit 47 (right)**. This signal would provide a pedestrian-only phase at the intersection. During the pedestrian phase, pedestrians would be allowed to cross all of the intersection approaches at once, without vehicular conflicts. Pedestrians would also be allowed to cross diagonally across the intersection, again without any vehicular conflicts.



Exhibit 47 – Example of a Pedestrian Scramble

At the Cypress / Pomeroy intersection, the pedestrian scramble will improve existing congestion levels by organizing the current randomness of pedestrian crossings. This signal would operate as a two-phase signal, alternating between traffic flow and pedestrian crossings. Organizing the pedestrian crossings into a set timeframe (versus the current random timing of the pedestrian crossings) would reduce vehicle queuing on Pomeroy Avenue and reduce the potential for pedestrian collisions. The pedestrian scramble signal could also be turned off during the off season, reverting the intersection back to the stop control that is present today.

The addition of a pedestrian scramble should be investigated at the Dolliver Street (SR 1)/Pomeroy Avenue signal. As noted in **Section 2.J - Traffic Operations and Recommendations – Existing Conditions**, pedestrians are occasionally restricted from crossing Dolliver by vehicular congestion on Sundays during the peak season, which will be more difficult as vehicular and pedestrian traffic increase in the future. The addition of a pedestrian scramble could be a method to improve the capacity of pedestrian crossings at this intersection. This intersection is owned by Caltrans, which has investigated the use of pedestrian scramble phases on state highways in the past. However, it has not pursued or implemented them on any state highways to date.

c. Dolliver Street Left Turn Pockets

The addition of short exclusive left turn pockets (40 foot long by 10 feet wide) on Dolliver Street (SR 1) at key intersections between Wadsworth Avenue and Ocean View Avenue, such as at Pomeroy Avenue and Hinds Avenue, should be considered. Most left-turning vehicles on Dolliver Street (SR 1) would be able to leave the through lane while waiting for gaps in opposing traffic, thus allowing through traffic to flow freely in an adjacent lane. This would help mitigate the current situation, where left-turning vehicles wait in through lanes and block through traffic on Dolliver Street (SR 1). Blocked vehicles can often attempt to bypass these left-turning vehicles via the bicycle lane, potentially endangering passing bicyclists.

However, due to the narrow width of Dolliver Street (SR 1) – 50 feet of pavement – some on-street parking will be lost – up to three spaces on each side of Dolliver where a left turn pocket is provided. Alternatively, the existing bike lane would need to be terminated in the proximity of the left turn lane. However, the beneficial improvement in traffic congestion justifies this improvement. Two alternative left turn pockets are conceptually illustrated on **Exhibit 48** on the following page. Alternative A illustrates a left turn pocket centered on Dolliver Street. Alternative B illustrated a left turn pocket offset to the northbound side of Dolliver Street. Alternative B probably would result in the loss of fewer on-street parking spaces. Dolliver Street is a state highway and any modifications will require Caltrans approval. Also, consideration needs to be given to maintaining continuous northbound and southbound Class II bike lanes as recommended in the *Pismo Beach Complete Street Plan*.

d. Restrict Motorized Vehicles on the Cypress Street Bridge

The Downtown Strategic plan recommended considering the prohibition of vehicle traffic along the Cypress Street bridge over Pismo Creek. The bridge would instead be exclusively used by pedestrians and bicyclists, with the exception of small electric vehicles, emergency vehicles and special event traffic. This closure could be done on a trial basis to better assess the benefits and consequences of this modification.

Exhibit 48 – Left Turn Pocket Alternatives on Dolliver St. (SR1)

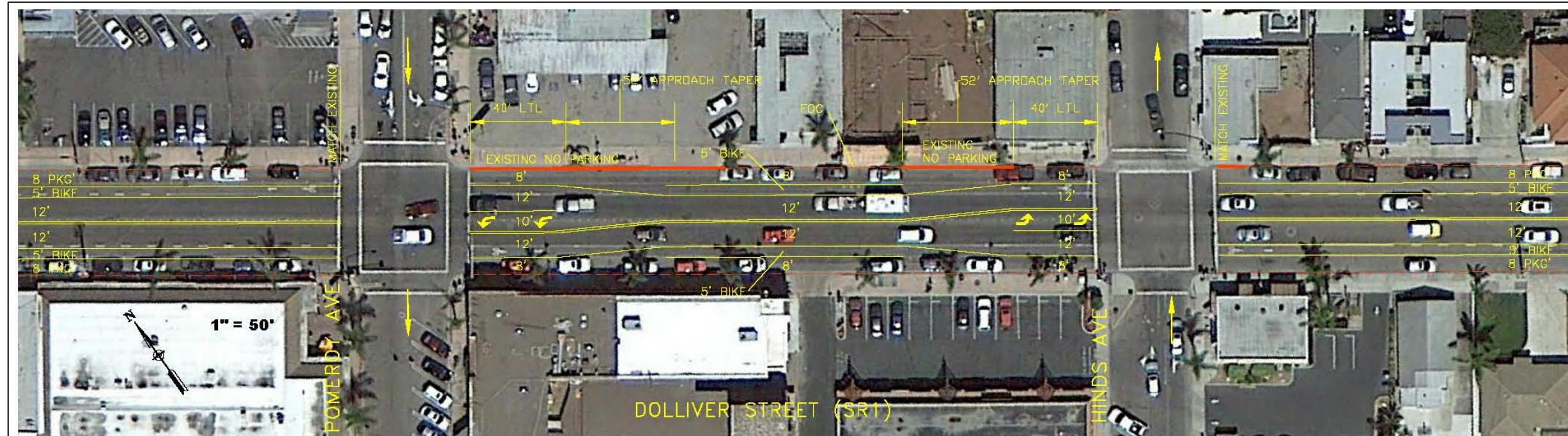

ALTERNATIVE A - LEFT TURN POCKET CENTERED ON DOLLIVER (SR1)

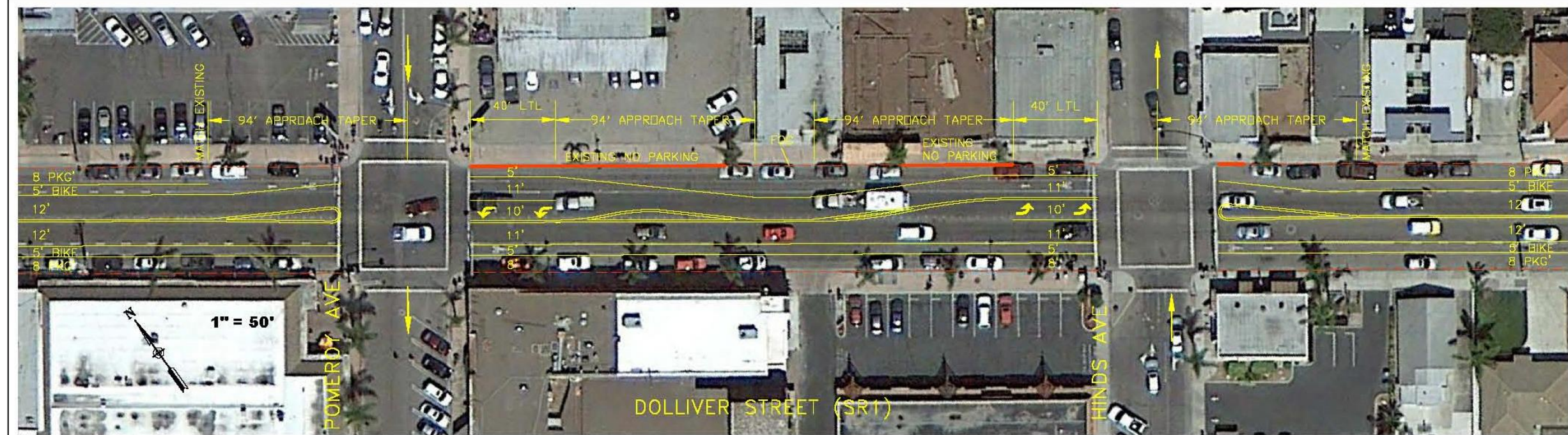

ALTERNATIVE B - LEFT TURN ON NORTHBOUND SIDE OF DOLLIVER (SR1)

This page was intentionally left blank
(For Duplex Printing)

e. **Cypress Street Bike Boulevard**

This improvement was suggested in the Downtown Strategic Plan. It would convert Cypress Street into a bicycle boulevard (i.e., a street where bicycles have the right-of-way over vehicles). The conversion would be similar to that of Morro Street in San Luis Obispo, with pavement striping indicating that Cypress Street is a bicycle boulevard, although unlike Morro Street, no forced vehicle traffic diversions would be implemented on Cypress Street. **Exhibit 49 (right)** depicts a sample roadway pavement striping (similar to striping on Morro Street in San Luis Obispo) that could be added to Cypress Street to indicate that the roadway is a bike boulevard. Cypress Street carries about 200 to 250 vehicles in the peak hour at relatively low speeds. A bike boulevard should be easily implemented. Consideration could also be given to reducing the speed limit to 20 miles per hour, which would reduce the speed differential between motorized vehicles and bicycles.



Exhibit 49 – Example of Bike Boulevard Pavement Striping

f. **Addie Street / Park Avenue Couplet**

Convert Addie Street and Park Avenue into one-way streets between Dolliver Street and the public parking lot along the beachfront. Addie would be one-way westbound (toward the beach) and Park one-way eastbound (toward Dolliver). Both Addie Street and Park Avenue are very narrow for roadways that allow two-way traffic (30 feet wide or less). With parking on both sides of the street, only about 14 feet remains for two-way travel. Most local streets have at least 20 feet for vehicle travel. By converting both roadways into a one-way couplet, only one lane of traffic will be needed on each street and parking can be preserved on both sides of each street.

Converting Addie Street and Park Avenue to one-way streets will require traffic generated from land uses along these streets to travel through the city parking area at the beach end of Addie Street. This parking lot layout should be reconfigured to both improve vehicle throughput and also improve the efficiency of the parking layout.

Neither street experiences a large volume of traffic. The Addie Street / Park Avenue one-way couplet conversion will have little effect on traffic operations in the area during normal traffic conditions, although it may have an effect during special events held in the vicinity of the Addie Street parking lot.

g. Restrict Motorized Vehicles on Pomeroy Avenue South of Cypress

Convert Pomeroy Avenue to pedestrian traffic only between Cypress Street and the pier area. As previously shown on **Exhibits 9 and 10 (Pages 20-21)**, the extreme pedestrian activity crossing both Pomeroy Avenue and Cypress Street on Sundays during the peak season affects the operation of both streets at their intersection. For this reason, Pomeroy Avenue could be converted into a pedestrian walkway between Cypress Street and the pier. This would force all traffic currently using Pomeroy to turn left onto Cypress, eliminating one of the largest pedestrian/vehicle conflicts in the city. In addition, converting Pomeroy Avenue into a pedestrian walkway would be consistent with the long-term vision of the pier plaza as described in the *Pismo Beach Downtown Strategic Plan*. The entrance to the pier would be converted to a pedestrian-only plaza with minimal or no adjacent parking.

One of the major disadvantages of this improvement would be the loss of on-street parking on Pomeroy between Cypress and the pier parking area, although these spaces could be replaced elsewhere in the downtown area.

If the pier parking area were to remain in place (or moved underneath the plaza in front of the pier, as shown in the Strategic Plan concepts of the pier area), the entrance to the pier parking area would need to be relocated to Hinds Avenue. This, in turn, would require the conversion of Hinds Avenue to two-way travel between the pier parking lot and Cypress Street. Inbound traffic would be diverted onto Cypress Street and Hinds Avenue. Both Hinds Avenue and Cypress Street could accommodate the additional traffic.

Consideration should be given to maintaining emergency and evacuation access via the Pomeroy pedestrian facility. If the City of Pismo Beach desires to underground the pier parking area, it could still place the entrance off of Pomeroy Avenue west of Cypress Street, via an access ramp into the parking lot. Pedestrian access to the pier area could be preserved via a widened sidewalk at ground level alongside the existing businesses along the north frontage of Pomeroy Avenue near the pier.

There are many different access and configuration decisions that would need to be made prior to a restriction of motorized vehicles on Pomeroy Avenue south of Cypress Street. It is therefore recommended that this improvement not be implemented until a plan for the pier parking area is completed.

6) Downtown One-Way Couplet Alternatives

Several downtown one-way couplet alternatives were evaluated as a part of this study. They include reversing the existing Pomeroy-Hinds couplet, creating a Dolliver (SR 1)/Price couplet, and creating a Dolliver (SR 1)/Bello couplet. Each is discussed below.

a. Reverse One-Way on Pomeroy and Hinds

Currently, Pomeroy Avenue is one-way westbound (i.e., towards the beach) and Hinds Avenue is one-way eastbound (i.e., away from the beach) between the pier and Price Street. This alternative would reverse the one-way directions of Pomeroy and Hinds Avenues, so that Pomeroy is one-way eastbound and Hinds Avenue is one-way westbound.

The current one-way couplet was created in the 1990s to address the collision history at the Price Street / Hinds Avenue intersection, specifically collisions created by traffic turning from Price Street onto Hinds Avenue. Reversing the one-way directions on Pomeroy and Hinds would re-introduce these movements at the Price / Hinds intersection, and thus may lead to an increase in collisions. For this reason, it is recommended that this improvement not be implemented.

b. Dolliver (SR 1)/ Price Couplet

This alternative would convert Dolliver (SR 1) and Price Streets into one-way streets between the Price/Dolliver intersection and their mutual intersections with Hinds Avenue. Dolliver Street (SR 1) would be one-way southbound and Price one-way northbound. Based upon the volumes on both corridors, Dolliver Street (SR 1) would likely need to have two through lanes. Price Street would operate acceptably with one lane.

This alternative would change the character of the Price Street corridor between Pomeroy and San Luis Avenues, as the roadway would function as a major through street rather than its current function of primarily providing access to adjoining businesses. The existing median on-street parking on Price Street in this area would likely need to be eliminated due to the potential conflicts between pedestrians and the increased through traffic. The resulting parking supply may not be adequate to serve the demand from Price Street businesses.

It is also likely that Caltrans may require that Price Street also be designated as SR 1, in order to provide a state facility in the opposing direction to Dolliver Street. Caltrans encroachment permits would then be required for any work within the Price Street right of way, which could constrain the City's ability to manage traffic operations in the downtown. The through traffic function of a state highway designation for Price Street would likely also conflict with the pedestrian-orientation of Price Street that the City has created in the area, such as the stop sign locations and the 15 miles per hour speed limit, and would likely need to be removed. The designation as a state highway would not be necessary if Caltrans were to relinquish the portion of SR 1 within the downtown, in which case the jurisdiction of the streets would revert to the City of Pismo Beach. However, the typical relinquishment process with Caltrans can take many years to accomplish. For these reasons, this couplet alternative is not recommended for implementation.

c. Dolliver/Bello Couplet

One variant to the Dolliver/Price Couplet is the Dolliver / Bello Couplet. This improvement would be similar to the Dolliver / Price couplet, except that Price Street would be replaced by Bello Street as the westbound one-way street. This variant would not have the same configuration effects upon Price Street as the Dolliver / Price couplet, but would introduce considerable through traffic on Bello Street, which is mostly residential and would still be subject to the probable need to designate Bello Street at SR 1. For these reasons, the Dolliver / Bello couplet is not recommended for implementation.

F. Regional Highway Improvements

SLOCOG is proposing a number of improvements to the US 101 corridor, which connects the Five Cities region to the rest of San Luis Obispo County and beyond. The segment of US 101 within Pismo Beach experiences the largest traffic volume along US 101 in the South County region with approximately 68,000 vehicles per day. The widening of US 101 to six lanes has been proposed through the Five Cities region for many decades (including in the 1992 Pismo Beach General Plan). However, the high expense and limited funding sources for this widening have led SLOCOG to attempt to maximize the capacity of the existing corridor with multi-modal, relatively low cost strategies. This effort began in the early 2000s with the addition of auxiliary lanes (i.e., ramp-to-ramp lanes) between Price Street and Oak Park Boulevard. SLOCOG and RTA (San Luis Obispo Regional Transit Authority) are currently planning Bus Rapid Transit (BRT) service along the US 101 corridor.

The latest plans proposed by SLOCOG are described in the *US 101 Corridor Mobility Master Plan*. They include improvements to the ramps and segments along southbound US 101 between Avila Beach Drive and Hinds Avenue and are listed in **Exhibit 50 (Page 114)**. They include the addition of auxiliary lanes, ramp meters, extensions of the acceleration and deceleration distances on various ramps, extending the climbing lane on southbound US 101 to the Spyglass Drive off-ramp, and other ramp improvements. Many of these improvements are currently being evaluated in more detail by Caltrans staff.

In December 2014, SLOCOG released its draft 2014 Regional Transportation Plan, which identifies its transportation goals for San Luis Obispo County, its preferred regional transportation improvements within the County and how it will fund them. This continues the theme of maximizing the capacity of the existing corridor, as well as increasing the number of transportation mode choices that are available to San Luis Obispo County residents. Proposed improvements in the Pismo Beach region include regional Transportation System Management strategies (such as the establishment of three new park and ride lots within Pismo Beach), the addition of regional transit service at the US 101 / Spyglass Drive interchange, the Price Street/James Way extension, reconstruction of the Hinds Avenue bridge over US 101, and the previously mentioned improvements along US 101 in Pismo Beach. Many of these proposed improvements do not have available funding at this time.

Exhibit 50 – Regional Improvement Concept List in Five Cities Area

ID	Description	Project Location
US 101 Freeway Improvements		
1.1.a	Add General Purpose Lanes	NB/SB 101 - Traffic Way to Avila Beach Drive
1.1.b	Add HOV Lanes	NB/SB 101 - Traffic Way to Avila Beach Drive
1.1.c	Add Auxiliary Lanes *	Various
1.1.d	Add Ramp Meters	NB/SB 101 - On-Ramps Traffic Way to Avila Beach Drive
1.1.e	N/A (see Project 1.5.a)	
1.1.f	N/A (see Project 1.5.b)	
1.1.g	Increase Regional Transit Service	Traffic Way to Avila Beach Drive
1.1.h	Travel Demand Management	Traffic Way to Avila Beach Drive
* US 101 Freeway Auxiliary Lane Improvements		
1.1.c01	1300' Deceleration Lane	NB 101 - Grand Avenue Off-Ramp
1.1.c02	Ramp to Ramp Auxiliary Lane	NB 101 - Brisco Road to Camino Mercado
1.1.c03	Acceleration Lane to N. Oak Park Blvd Overcrossing	NB 101 - Camino Mercado On-Ramp
1.1.c04	Close James Hook On-Ramp. Extend Auxiliary Lane to 4th Street	NB 101 - 4th Street to James Way On-Ramp
1.1.c05	600' Deceleration Lane	NB 101 - Wadsworth Avenue Off-Ramp to Hinds Avenue Overcrossing
1.1.c06	2000' Acceleration Lane	NB 101 - Mattie Road On-Ramp
1.1.c07	1300' Deceleration Lane	NB 101 - Spyglass Drive On-Ramp
1.1.c08	Ramp to Ramp Auxiliary Lane	NB 101 - Spyglass Drive to Avila Beach Drive
1.1.c09	2000' Acceleration Lane	NB 101 - Avila Beach Drive On-Ramp
1.1.c10	1300' Deceleration Lane	SB 101 - Avila Beach Drive Off-Ramp
1.1.c11	Extend Truck Climb Lane	SB 101 - Spyglass Drive Off-Ramp
1.1.c12	Add 3rd Lane (Project 1.1.c11 + 1.1.a or 1.1.b)	SB 101 - Spyglass Drive Off-Ramp
1.1.c13	Extend Auxiliary Lane to Avila Beach On-Ramp	SB 101 - Avila Beach Drive On-Ramp to Project 1.1.c12
1.1.c14	2000' Acceleration Lane	SB 101 - Spyglass Drive On-Ramp
1.1.c15	Ramp to Ramp Auxiliary Lane	SB 101 - Price Street (Dinosaur Cave Park) to Price Street (Mattie Road)
1.1.c16	1300' Deceleration Lane	SB 101 - SB 1 Off-Ramp
1.1.c17	1300' Deceleration Lane	SB 101 - Hinds Avenue Off-Ramp
1.1.c18	2000' Acceleration Lane	SB 101 - El Camino Real (12th Street) On-Ramp
1.1.c19	1300' Deceleration Lane	SB 101 - Halcyon Road Off-Ramp
Fair Oaks Avenue Intersection Improvements		
1.2.a	Add Traffic Signal (Offset Intersection)	Fair Oaks Avenue at Orchard Avenue and SB 101 Off-Ramp
1.2.b	Add Roundabout (Offset Intersection)	Fair Oaks Avenue at Orchard Avenue and SB 101 Off-Ramp
1.2.c	<i>Convert Orchard Avenue to Right In/Out</i>	<i>Fair Oaks Avenue at Orchard Avenue</i>
1.2.d	<i>Close Orchard Avenue Access to Fair Oaks Avenue</i>	<i>Fair Oaks Avenue at Orchard Avenue</i>
1.2.e	Realign SB 101 Ramp Terminal to Orchard Avenue (Signal)	Fair Oaks Avenue at Orchard Avenue and SB 101 Off-Ramp
1.2.e	Realign SB 101 Ramp Terminal to Orchard Avenue (Roundabout)	Fair Oaks Avenue at Orchard Avenue and SB 101 Off-Ramp
Carpool / Vanpool / Transit Access		
1.3.c	Small Park & Ride Lot (Spyglass Drive)	Spyglass Drive at Mattie Road or Shell Beach Road
Price Street Gap Closure		
1.5.a	Extend Price Street to Five Cities Drive	Price Street between Ocean View Avenue & Five Cities Drive
1.5.b	US 101 Collector Distributor Lanes	US 101 - NB/SB between Price Street and 4th Street
Pismo Creek / Anza Trail Improvements		
1.6.a	New Bicycle / Pedestrian Bridge at UP Railroad	James Way to Pismo Beach Sports Complex
1.6.b	Class I Trail along Pismo Creek	Pismo Creek between UP Railroad and Price Street
1.6.c	Class I Trail along the UP Railroad	UP Railroad between Pismo Creek and James Way

Projects shown in *italics* were not carried through full analysis due to other factors that rendered them infeasible or if they have already been programmed for funding through other efforts.

Abridged from: *US 101 Corridor Mobility Master Plan*, Kittleson & Associates, December 2014.

4. Recommendations

Study recommendations are summarized in **Exhibit 51 (Page 116)** and repeated below. The recommendations are organized into the following categories:

- A. Pedestrian and Bicycle
- B. Transit
- C. Rail
- D. Parking
- E. Traffic Operations
- F. Transportation Demand Management

A. Pedestrian and Bicycle

CROSSWALK ENHANCEMENTS

The *Pismo Beach Bicycle and Pedestrian Master Plan*, *Complete Street Plan*, and *Downtown Strategic Plan*, encourage pedestrian activity throughout the City in order to minimize automobile congestion and increase walking, bicycling, and other healthy living practices. In particular, high traffic areas within and adjacent to downtown, local schools, sports facilities, and parking/transit facilities should be areas of focus where enhancement of existing crosswalks or the incorporation of new crosswalks would encourage increased pedestrian activity and/or would improve pedestrian safety. Additional recommendations for crosswalk enhancements in the Pismo Beach Complete Street Plan and Downtown Strategic Plan include:

Complete Street Plan

- At the Terrace Avenue intersection with Shell Beach Road and the Shell Beach Road/Price Street/Cliff Avenue intersection, crosswalks should be highlighted through the incorporation of decorative paving treatments with separate markings for bicycles and pedestrians.
- Within the downtown area, enhancements of existing crosswalks should include decorative pavers and/or markings to enhance the walkability and beautification of the street scene.
- Where appropriate, raised sidewalks, decorative pavers, and ADA crosswalk upgrades should be incorporated to improve and enhance the existing or proposed pedestrian infrastructure and safety throughout the City.

Downtown Strategic Plan

- The City should enhance crosswalks at Main Street, Pomeroy Avenue, Hinds Avenue, and Stimson Avenue with special paving and/or markings.

Exhibit 51 – Summary of Recommendations

Item No.	Recommendations
A. Pedestrian and Bicycle	
1.	Identify locations within Pismo Beach where crosswalks should be added or enhanced
2.	Pursue implementation of recreational trails, as funding becomes available
3.	Convert Cypress Street, between Hinds Avenue and Addie Street, into a bicycle boulevard
4.	Convert the existing Cypress Street bridge over Pismo Creek into primarily bicycle and pedestrian use, but open to one-way vehicle traffic during special events.
5.	Provide additional support facilities for pedestrian and bicycle use throughout the city
6.	Consider establishing a bicycle sharing program
7.	Extend the existing promenade north of Main Street
8.	Increase education, encouragement, and enforcement of bicycle facilities
9.	Implement other recommendations within the Bicycle and Pedestrian Master Plan
10.	Implement other recommendations within Pismo Beach Complete Streets Plan
11.	Implement other recommendations within the Downtown Strategic Plan
B. Transit	
1.	Work with San Luis Obispo Council of Governments (SLOCOG) and San Luis Obispo Regional Transportation Authority (RTA) to improve transit availability and accessibility within Pismo Beach
C. Rail	
1.	Work with RTA, SLOCOG, and the City of Grover Beach to add a shuttle service between the Grover Beach train station and Downtown Pismo Beach
D. Parking	
1.	Develop a Parking Strategy Plan for Downtown Pismo Beach
2.	"Right Size" (i.e. utilize during off-season) the parking inventory within Downtown Pismo Beach
3.	Add both static and dynamic parking wayfinding systems
4.	Study further feasibility of potential parking structure site, including:
	a. Parking structure site analysis
	b. Analyze cost benefit analysis for each site
	c. Prepare financial feasibility for each site
	d. Prioritize development of site ranking; select site and move forward with development plan
5.	Need for downtown parking standards review
6.	Site-Specific parking improvements:
	a. Parking inventory control system (i.e. dynamic system) at pier parking area
	b. Back-in parking in on-street spaces on Pomeroy Avenue between Price Street and pier parking area
	c. Back-in parking in on-street spaces on Hinds Avenue between pier parking area and Price Street
	d. Convert existing parking into back-in parking on Price Street, Pomeroy Avenue, and Hinds Avenue (see Appendix N)
	e. Re-evaluate parking lot layout for Addie Street lot to increase parking inventory and improve flow

(Table continued on next page)

Exhibit 51 – Summary of Recommendations (Continued)

Item No.	Recommendations
E. Traffic Operations	
1.	Implement intersection improvements identified within Exhibits 21 and 30
2.	Implement Stimson/Ocean View one-way couplet, including signal at Dolliver Street (SR 1) / Stimson Avenue and striping improvements along Price Street
3.	Adopt policy that establishes a lower or no level of service standard within the Downtown area
4.	If implement Price Street extension, also implement associated striping improvements along Price Street, Stimson/Ocean View one-way couplet, and improvements at the US 101 Southbound Ramps - Outlets Main Entrance / Five Cities Drive intersection
5.	If the Southbound US 101 Off-Ramp to Hinds Avenue is closed, prohibit through trucks on Price Street [Dolliver Street (SR 1) to Hinds Avenue]
6.	Implement the Addie Street / Park Avenue one-way couplet
7.	Only convert Pomeroy Avenue to pedestrian-only traffic if way(s) to replace lost parking spaces are identified.
8.	Add left turn lanes on Dolliver Street once have identified way(s) to replace any lost parking spaces
9.	Work with San Luis Obispo Council of Governments (SLOCOG) in its efforts to implement the improvements identified within the <i>US 101 Corridor Mobility Master Plan</i> and the <i>2014 Regional Transportation Plan</i>
F. Transportation Demand Management	
1.	Consider establishing a Transportation Demand Management (TDM) plan for the Downtown area

PROPOSED TRAILS

The City of Pismo Beach should pursue recreational trails as funding becomes available. One example is the Pismo Creek Recreational Path, whose alignment is included in **Appendix M**. Both the City of Pismo Beach and San Luis Obispo County have identified the establishment of this trail as a long-term goal.

PROPOSED BIKEWAYS

Bikeway improvements and enhancements recommended in the *Pismo Beach Bicycle and Pedestrian Master Plan*, *Complete Street Plan*, and *Downtown Strategic Plan* include the following, listed individually for each of the three documents.

Bicycle and Pedestrian Master Plan

- Planning and development activities that construct, reconstruct, or reconfigure existing roadways shall, to the extent feasible as determined by the City, provide pedestrian and bicycle facilities as shown on **Exhibits 7 and 8 (Pages 15 and 19)**.
- Future Planning projects and right-of-way dedications will take the existing layout and circulation of bicycle facilities into consideration and make appropriate adjustments for facilities identified in the plan.
- Whenever new development is adjacent to an existing commercial center, school or other community facilities, development should include non-motorized pathways to the center/school/facility.
- The Bike Plan shall be consulted when assembling and updating the Capital Improvement Program.

Complete Street Plan

- Class II bicycle lanes should be extended along both sides of Shell Beach Road from the northern City limits to Spyglass Drive.
- A separate multi-use trail along the west side of Shell Beach Road from the northern City limits to Spyglass Drive should be incorporated to encourage non-motorized transportation and recreational activities within and outside the City limits.
- At the Shell Beach Road and Spyglass Drive intersection, Class II bicycle lane striping should be incorporated east of the intersection with appropriate signage directing cyclists to the Class II bicycle lane on Mattie Road.
- The multi-use trail should continue along the east side of Shell Beach Road from Spyglass Drive to Cliff Avenue.
- Existing Class III travel lanes along Shell Beach Road between Spyglass Drive and Vista Del Mar Avenue should be marked with shared lane markings or other appropriate Class III indicators.
- The City should coordinate with Caltrans to determine the appropriate pavement markings to improve cyclist visibility along Price Street from Cliff Avenue to the Price Street/Dolliver Street/US 101 intersection.
- The City should work with Caltrans to evaluate the configuration and determine the most appropriate alternative for the incorporation of either a Class I multi-use trail or Class II bicycle lanes from Cliff Avenue to the Price Street/Dolliver Street/US 101 intersection.
- The City should consider incorporating a Class I multi-use trail behind the Best Western Hotel that connects with Price Street to the north and south.
- A two-way, separate bicycle lane should be incorporated along the west side of Dolliver Street from Price Street to Main Street.
- Due to high automobile traffic volumes along Dolliver Street south of Main Street, Class III bicycle lanes should be incorporated along Main Street, Pomeroy Avenue, Hinds Avenue, and Addie Avenue to connect with the Class III bicycle routes along Cypress Street and the Promenade.
- The City should consider incorporating a multi-use pathway that would allow casual cyclists to traverse from the Cypress Street Bridge to the intersection of Dolliver Street and Village Drive.
- Where appropriate, bicycle activity enhancements should be considered and incorporated to encourage bicycle use and safety throughout the City.

Downtown Strategic Plan

- The City should designate Cypress Street a bicycle boulevard from Main Street to Dolliver Street (State Route 1), orienting and prioritizing bicycle use along the boulevard but still remaining open to use by automobiles. This closure could be done on a trial basis to better assess the benefits and consequences of this modification.

SUPPORT FACILITIES

Support facilities recommended in the *Pismo Beach Bicycle and Pedestrian Master Plan*, *Complete Street Plan*, and *Downtown Strategic Plan*, listed individually for each of the three documents.

Bicycle and Pedestrian Master Plan

- Future updates to the Municipal Code Section 17.108.020 should consider a ratio of one bike rack for every 10 car spaces for commercial uses and one bike rack for every two car spaces for multi-family residential uses.
- All new City parking lots should provide bicycle parking of not less than 10% of the number of planned parking spaces.
- Long and short-term bicycle parking shall be provided at all park and ride lots and transit centers within the City and the City shall work with SLOCOG and RTA to identify funds for the provision of bicycle parking.
- City staff shall identify locations where additional long and short-term bike parking may be necessary and:
 - May develop a “racks-with-plaques” program to provide for additional bike parking at those locations.
 - Recommend long-term parking facilities including lockers and showers for new developments.

The City should consider placing short-term bicycle parking adjacent to shops, areas lacking automobile parking spaces, and/or in areas of observed needs where appropriate as it has already done in the downtown.

Complete Street Plan

- Consider opportunities to incorporate bicycle parking and seating amenities near view corridors along Shell Beach Road south of El Portal Drive, at Palisades Park, and at coastal access trail connections.
- The City should consider including locations for parking and/or pedestrian bicycle amenities on the east side of Price Street, especially where the available space widens at ramp locations.
- Within the downtown pedestrian core, consider incorporating pedestrian amenities such as benches to enhance walkability.
- Integrate long-term bicycle parking locations to serve people who leave their bicycles at the same location for the day or overnight near transit locations, schools, and places of work.
- Integrate short-term bicycle parking to serve people who leave their bicycles for short periods of time while shopping, recreating, eating, and/or running errands.

Downtown Strategic Plan

- Bicycle racks should be placed in prominent locations or gathering spaces that are easily accessible and, where appropriate, be in the form of public art that is reflective of the character of the downtown.

BIKE SHARING

As noted earlier, the City of Pismo Beach has completed but not adopted a feasibility study to consider establishing a bicycle sharing program within the City. This program would provide bicycle rental stations at key locations around the City. The traffic study encourages the development of this program and is envisioned to provide a range of benefits to the public and local business throughout the City by expanding healthy/active living choices, reducing automobile usage, improving circulation within the City particularly in the summer months, and increasing exposure to local businesses among others. Recommendations for a bike sharing program within the *Pismo Beach Downtown Strategic Plan* include:

The City should continue the process to incorporate a bike share program within the downtown area to encourage bicycle use, reduce automobile usage, and free additional parking spots.

LOCATION-SPECIFIC RECOMMENDATIONS

Recommendations for location-specific enhancements focus on expansion of the existing promenade that currently runs from Addie Street north to Main Street. The promenade expansion would extend north from Main Street to connect neighborhoods and hotels to the downtown. It is envisioned that this would reduce automobile related trips downtown, increase pedestrian mobility, and improve access to the beach. Recommendations for expanding the existing promenade in the *Pismo Beach Bicycle and Pedestrian Master Plan* and the *Downtown Strategic Plan* include (see next page):

Bicycle and Pedestrian Master Plan

- Consistent with the 2005 San Luis Obispo County Regional Transportation Plan (Vision 2025), the City should encourage the development of boardwalks, recreation and multi-use trails, which travel through or connect scenic areas or other destinations to promote walking and equestrian travel where appropriate.

Downtown Strategic Plan

- A new promenade extension should be incorporated north of Main Street to connect the neighborhoods and hotels to the downtown.
- Stairs providing access to and from the beach located at hotels and streets between Dolliver Street and Mattie Road should connect to the extended promenade.

EDUCATION, ENCOURAGEMENT AND ENFORCEMENT

Recommendations for increasing education, encouragement, and enforcement described in the *Pismo Beach Bicycle and Pedestrian Master Plan* include:

- The City shall work with SLO Regional Rideshare to provide Transportation Choices Programs to City employees.
- The City should consider adding the following text to the Municipal Code 12.16.160 Content of Special Event form:
 - *As a condition of the issuance of a Special Event permit, the applicant may be required to provide bicycle parking. Bicycle parking provision may include "Bike Valet" services provided by SLOCBC or by event volunteers.*

- The City may work with the bike coalition to advertise Bicycle Confidence Workshops in Pismo Beach.
- The City should encourage Lucia Mar School District to provide bike and pedestrian safety programs at schools within City limits. The City may participate in bike rodeos or assemblies and organized walk/bike to school day events.

The City may participate in Bicycle Confidence Workshops or another equivalent program, to individuals ticketed for bicycling illegally.

- The City may participate in education programs for motorists on rights/rules of pedestrian and bicyclists.
- The City should promote proper cycling to tourists by providing safe cycling information on the Conference and Visitors Bureau website and at the Chamber of Commerce Building downtown.
- The City will continue its advertisement of the many walking and beach access options within the City by print, on-line advertisement and public access television.
- The City may assist and provide support for organizations and individuals who wish to use pedestrian facilities for social activity and improvement.
- The City encourages school participation with the SLOCOG Safe Routes to School program.
- The City encourages Rideshare Employee Incentive Programs. Helps employers promote bicycling, walking, carpooling, and riding the bus to work. This would reduce the employers' parking demand. This program may provide financial incentives or only promotional materials.
- The City may engage Cal Poly, the San Luis Distance Club, SLO Soles Volkssport and/or other walking/running clubs, SLO County Bicycle Coalition, biking clubs or Regional Rideshare assistance to implement elements of this bicycle/pedestrian plan by doing the following:
 - *Organizing an outreach campaign for International Walk to School Day each October or other similar walking programs.*
 - *Coordination of walking programs for varying segments of the population, including, but not limited to children and seniors.*
 - *Seeking and writing grants for bicycle and pedestrian infrastructure.*
 - *Monitoring success of the implementation procedures identified in this document.*
 - *Developing a safety campaign to reduce car/bike conflicts.*
 - *Liaising between local schools and Rideshare to provide bike education*
 - *Creating or working with the SLOCBC to provide bike valet at events*
 - *Starting a "racks with plaques" and other promotion programs.*
- The City may participate with others to address countywide bicycle and pedestrian access issues.
- The City may provide advertising opportunities through its quarterly recreation guide for walking clubs along City pedestrian trails.
- The City may work collaboratively with others to support events and programs promoting pedestrian/biking/beach access opportunities.

B. Transit

SLOCOG and the San Luis Obispo RTA are both working to improve transit availability and accessibility within San Luis Obispo County. This includes the establishment of a future Bus Rapid Transit (BRT) route in the southern portion of San Luis Obispo County, the goal of which is also to reduce congestion along US 101. It is recommended that the City of Pismo Beach support these efforts.

C. Rail

There is currently no shuttle service between the Grover Beach train station and Downtown Pismo Beach. It is recommended that the City of Pismo Beach work with RTA, SLOCOG and the City of Grover Beach to establish such a service. This would enhance the alternative to travel by train rather than driving to Pismo Beach for visitors from locations along the California coast.

D. Parking

The following are recommendations for the parking program:

1. There is a need for development of a Parking Strategic Plan for Downtown Pismo Beach. The last formal parking study was completed in 2006 which primarily addressed the parking management of existing spaces. A Parking Strategic plan will follow the City's Vision, Mission and Objectives statement. It will define the strategic goals for the parking system and develop the guiding principles which will serve the community to make policy and operational decisions for a 20 -30 year time period. It also will provide the implementation strategy to guide the City through the long time period of development of the program. It is important to note that a parking strategic plan is a long-term guidance document. It will take both time and money to implement all of the plan's recommendations.
2. It is important to "right size" the downtown parking inventory to meet the needs of all seasons. This includes balancing the parking demands by creating year-round destination events which will assist with development and use of the parking inventories. It also creates the opportunity for public parking development in partnership with private developers to provide shared parking resources.
3. There is a need for a parking wayfinding system to assist the public with finding available parking, which allows them to park once and walk through-out the downtown, and reduces the repeated circulating of traffic and queuing of vehicles waiting for parking spaces to become available. The wayfinding system can include both dynamic and static signage and dynamic signage may be activated or de-activated based on seasonal demands. A static wayfinding signage program was implemented in 2015.
4. The Parking Strategic Plan also needs to analyze the potential sites for future parking structures once the "right size" parking system is determined. A parking structure feasibility plan a step-by-step process for development of parking facilities, prioritizes the sites and plan and provides a guiding plan to take advantage of partnering opportunities with private sector developers as they arise during a 20-30 year time frame. The plan includes site analysis for each site, cost benefit analysis, financial feasibility, as well as development of a ranking system for moving forward. Without such a plan, most cities function in a reactionary mode and miss opportunities for timing and forecasting parking needs and often miss opportunities for public- private partnerships in the development of shared facilities.
5. The City should undertake a review of its parking standards and requirements and adjust standards to allow public-private projects and shared parking opportunities. Such plans result in reduced parking requirements for a compact downtown such as that in Downtown Pismo Beach.

6. There are a number of site-specific parking improvements which will not only improve the parking inventory and functional use of parking inventories, they will also improve traffic flow and circulation of the downtown. These options include:
 - a. Implement a parking inventory control system (i.e., dynamic parking guidance system) at the pier parking area which will assist with parking utilization and reduce traffic in a very congested location of downtown.
 - b. Provide two rows of interlocking diagonal parking in the median on Price Street between Wadsworth Avenue and Hinds Avenue. These could be back-in spaces as illustrated on **Exhibit 53A (Page 125)**). Either conventional or back-in spaces will eliminate curb side parking spaces and relocate all parking to the center of the street. Thus, the conflicts of backing out of parking spaces into both moving traffic and curb-side parked vehicles are eliminated. (Note: This improvement could also allow the City to lengthen the left turn lanes on Price Street at Wadsworth Avenue. Although the example in Exhibit 51A matches the length of the existing 50 foot left turn lane, it could be lengthened through the elimination of one or more spaces.)
 - c. Consider development of on-street back-in parking spaces on Pomeroy Avenue between Price Street and Cypress Street. A sample of this type of parking is provided in **Exhibit 53B (Page 126)**.
 - d. Consider development of on-street back-in parking spaces on Hinds Avenue between Price Street and Cypress Street. A sample of this type of parking is provided in **Exhibit 53C (Page 127)**.
 - e. Re-evaluate the parking lot layout for the Addie Street lot to increase the number of parking spaces and improve flow. This coupled with street improvements recommended for Addie and Park Street will increase the parking inventories within the lot.

Although back-in parking would be a relatively new concept to Pismo Beach, it is a concept that has been used successfully in other areas of the state and country for decades. Examples include the cities of Oceanside, California (on Mission Avenue in its main downtown core) and San Francisco (near AT&T Park). One of the major safety benefits of back-in angled parking is that exiting vehicles who have back-in parked into angled spaces have improved visibility of through traffic and bicyclists, compared to standard angled parking.

The “Downtown Parking Enhancements and Opportunities Study” previously cited on page 30 represents the Parking Strategic Plan described in Item 1 above. It makes the following additional recommendations.

1. Implement variable parking rates based on demand. This will encourage more efficient parking utilization.
2. Implement enhanced parking meters, fee collection and enforcement systems.
3. Postpone development of parking structures until parking management strategies have been fully implemented and evaluated. A parking structure is the most expensive means of addressing the peak season parking deficiency. Current and future revenue streams are not adequate to finance this option.
4. The Pier Plaza with underground parking appears to be able to be implemented without negatively impacting local businesses. The concept should be tested with a pilot project to simulate the reduced parking supply before implementing a permanent project.

E. Traffic Operations

The following transportation-related improvements are recommended for implementation:

1. Implement the intersection improvements identified in **Exhibits 21 and 30 (Pages 43-47 and 66-70)**.
2. Implement the Stimson / Ocean View one-way couplet, including a new signal at the Dolliver Street (SR 1) / Stimson Avenue intersection and striping improvements along Price Street at Stimson and Ocean View Avenues as depicted on **Exhibit 45 (Pages 99-100)**.

3. The Pismo Beach City Council should adopt a policy that establishes either a lower level of service standard or no level of service standard in Downtown Pismo Beach. The 1992 General Plan Circulation Element Principle P-1 stated that “A lower standard (than Level of Service C) may be used for the downtown area,” but did not define the level of service, the specific locations it would apply to and how this policy would relate to the applicable Caltrans level of service policy of C/D. This should be clarified.
4. If the Price Street extension to Five Cities Drive is implemented, the improvements described in Improvement 2 above as well as the recommended improvements at the US 101 Southbound Ramps – Outlets Main Entrance / Five Cities Drive intersection (**Exhibit 39 (Page 85)**) will be required.
5. If the southbound US 101 Off-Ramp to Hinds Avenue is closed, adjust approved through truck routes to prohibit through trucks on Price Street [Dolliver Street (SR 1) to Hinds Avenue].
6. Implement the Addie Street / Park Avenue one-way couplet.
7. Consider converting Pomeroy Avenue (Cypress Street to pier) to pedestrian-only traffic only when a method has been determined to replace the lost parking spaces.
8. Add left turn pockets on Dolliver Street (SR 1) at selected intersections in consultation with Caltrans.
9. Work with SLOCOG to maximize throughput along the US 101 corridor in the Five Cities region.

F. Transportation Demand Management

The City of Pismo Beach should also consider a Transportation Demand Management (TDM) plan. This plan would identify measures and policies that can manage or reduce traffic demand within the city, especially during the summer peak season. A preliminary plan is included in **Appendix N** and summarized on **Exhibit 52 (Below)**. Some of the bicycle-related recommendations are also identified in other documents, such as the *Complete Streets Plan*.

Exhibit 52 – Transportation Demand Management Options

Item No.	Potential Transportation Demand Management Measure
1.	Create TDM steering group
2.	Create Pismo Beach TDM program
3.	Review options for a formal park and ride and assess feasibility
4.	Implement a formal park and ride
5.	Increase localized bus stops on existing routes
6.	Add public showers / enhance beach facilities for use by cyclists
7.	Install cycling / walking lockers
8.	Continue the Pismo Beach Rideshare program – www.pismobikeshare.com
9.	Ensure cycle parking provided at key bus stops and other key locations
10.	Ensure that walking and cycling routes are fully linked and fill in any gaps
11.	Develop a dedicated area on city web site with transportation information
12.	Develop a Pismo Beach TDM logo
13.	Develop a TDM marketing campaign to encourage use of non-motorized transportation
14.	Develop walking and cycling maps to promote active travel
15.	Hold specific events that can be a focus for TDM promotion
16.	Free “Dr. Bike sessions” to help residents and visitors maintain their bicycles
17.	“Beat the Streets” challenge
18.	“Drive Less” challenge
19.	Free cycle training to local residents / employees

Exhibit 53A – Price Street from San Luis Ave. to Pomeroy Ave. Possible Double Loaded Median Back-In Angled Parking



MATCHLINE - SEE BELOW



MATCHLINE - SEE ABOVE

Exhibit 53B – Pomeroy Ave. from Cypress St. to Price St. Possible Back-In Angled Parking



Exhibit 53C – Hinds Ave. from Cypress St. to Price St. Possible Back-In Angled Parking



MATCHLINE - SEE BELOW



MATCHLINE - SEE ABOVE

This page was intentionally left blank
(For Duplex Printing)

5. Public Comments on Recommendations

Many of the recommendations identified in Chapter 4 were presented at a public workshop on January 7, 2015 at Pismo Beach City Hall. Below are the primary topics of discussion during that workshop. A summary of the discussion at the second public workshop, including all public comments, is provided in **Appendix D**.

Primary Topics of Discussion:

1. Scope of Work
2. Future Forecasting Methods
3. Recommendations:
 - a. Network Alternatives
 - b. Intersection Alternatives
 - c. Why are improvements necessary?
 - d. Alternatives to identified recommendations
 - e. Public-initiated recommendations
 - f. Cooperation from other jurisdictions (e.g. Caltrans District 5)
4. Parking:
 - a. Parking Structure
 - b. Back-in Parking
 - c. Advantages and Disadvantages of Parklets
 - d. Park and Ride Lots
5. Dissemination of Documents via City Web Page

6. References

1. 2010 US Census, <http://www.census.gov/2010census>, accessed August 26, 2014.
2. AECOM Technical Services, *San Luis Obispo County 2040 Population, Housing & Employment Forecast*, August 11, 2011.
3. Avila Beach Pier, <http://avilabeachpier.com>, accessed January 21, 2015.
4. California Department of Transportation, *Price Street Extension Initial Study with Proposed Mitigated Negative Declaration/Environmental Assessment*, September 2004.
5. California Department of Transportation, Traffic Data Branch, www.dot.ca.gov/hq/traffops/safevesr/trafdata, accessed September 25, 2014.
6. California Department of Transportation, *Guide for the Preparation of Traffic Impact Studies*, December 2002.
7. California Department of Transportation, *Transportation Concept Report for State Route 1 in District 5*, April 2006.
8. City of Grover Beach website, <http://grover.org>, accessed January 19 and 21, 2015.
9. City of Pismo Beach, *Pismo Beach Bicycle & Pedestrian Master Plan*, June 15, 2010.
10. City of Pismo Beach, *City of Pismo Beach General Plan & Local Coastal Plan*, adopted November 24, 1992.
11. City of San Luis Obispo website, <http://www.slocity.org>, accessed January 21, 2015.
12. County of San Luis Obispo, *The Land Use and Circulation Elements of the San Luis Obispo County General Plan – San Luis Bay Coastal Area Plan*, Adopted March 1998, Revised August 2009.
13. DKS Associates, *A Traffic Improvement Strategy for the Oak Park Heights and Five Cities Planning Areas*, April 25, 1988.
14. DKS Associates, *A Traffic Improvement Strategy for the U.S. 101 Study Corridor Oak Park to Grand Avenue*, August 30, 1988.
15. Federal Highway Administration, *FHWA Course on Bicycle and Pedestrian Transportation*, http://safety.fhwa.dot.gov/PED_BIKE/univcourse/pdf/swless19.pdf, accessed January 22, 2015.
16. Fehr & Peers, *San Luis Obispo County Highway 101 Bus Rapid Transit Applications Study*, June 2013.
17. Gates + Associates, *Pismo Beach Complete Street Plan*, March 2013.
18. Joseph Boud & Associates and Firma, *Pismo Creek Recreational Path Project Study Report*, adopted May 16, 2006.
19. Kittelson & Associates, *US 101 Corridor Mobility Master Plan*, December 2014.
20. Korve Engineering, Inc. *Route 101 Major Investment Study*, September 8, 1997.
21. LSC Transportation Consultants, Inc., *South County Transit Plan*, January 2011.
22. Merriam-Fraser Associates, *Environment Impact Report for the Development of Pismo Beach Pier Commercial Project*, July 1986.
23. National Association of City Transportation Officials, *Two-Way Cycle Track*, http://nacto.org/wp-content/gallery/twoway_cycletrack_3d/two-way-cycle-track-plan.jpg, accessed January 22, 2015.
24. Omni-Means, *Grover Beach Lodge Transportation Impact Analysis Report*, October 2010.
25. Omni-Means, *James Way/Price Street Frontage Road Extension Project Study Report*, March 1998.
26. Omni-Means, *San Luis Obispo County in Pismo Beach on and adjacent to Route 101 between KP 25.7 and 26.8 Ramp Work and Frontage Rd Improvements*, March 12, 1998.

27. The Regional and Urban Design Committee of the American Institute of Architects, *Pismo Beach R/UDAT*, no date.
28. RRM Design Group, *Beach Cities Multi-Purpose Trail Feasibility Study*, March 2010.
29. RRM Design Group, *Pismo Beach Downtown Strategic Plan*, 2014.
30. San Luis Obispo Council of Governments, *2013 Park & Ride Lot Study*, August 2013.
31. San Luis Obispo Council of Governments, *2014 Regional Transportation Plan*, December 2014.
32. San Luis Obispo Council of Governments, *San Luis Obispo County Highway 101 Bus Rapid Transit Applications Study*, June 2013.
33. San Luis Obispo Council of Governments, *SLOCOG 2010RTP-PSCS: Chapter 4: Highways, Streets and Roads*, 2010.
34. San Luis Obispo Regional Transit Authority web page, www.slorta.org, accessed December 14, 2015.
35. The (San Luis Obispo) Tribune, “New Stretch of Bob Jones Trail Nearly Finished”, published March 18, 2014, <http://www.sanluisobispo.com>, accessed January 21, 2015.
36. Walker Parking Consultants, *Downtown Parking Enhancements and Opportunities Study*, April 2016.
37. Wilbur Smith Associates, *Downtown Parking Study*, October 10, 2006.

7. Report Preparation

Hatch Mott MacDonald (Transportation)

Chris Metzger, PE, LEED AP

Keith Higgins, PE, TE

Allen Nie, PhD, PE

Jeff Waller, TE

Travis Low, EIT

Ankit Sharma

RRM Design Group (Land Use Public Outreach)

Debbie Rudd, AICP, LEED AP

Paul Kronser

JR Parking Consultants (Parking)

Janis Rhodes