APPENDIX H

PRELIMINARY HYDROLOGY STUDY

THIS PAGE INTENTIONALLY LEFT BLANK

PRELIMINARY HYDROLOGY STUDY

FOR

LEUCADIA 101 MIXED USE

CITY OF ENCINITAS, CA

PREPARED FOR:

ENCINITAS BEACH LAND VENTURE I, LLC
674 Via De La Valle, Suite 310
Solana Beach 92075
858-436-3600

PREPARED BY:

PASCO LARET SUITER & ASSOCIATES, INC.
535 N. HIGHWAY 101, SUITE A
SOLANA BEACH, CA 92075
(858) 259-8212

PREPARED: MAY 2020
REVISED: SEPTEMBER 2020
REVISED: DECEMBER 2020
REVISED: MAY 2021
REVISED: JULY 2021

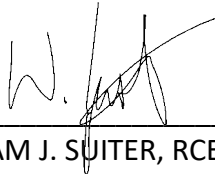

WILLIAM J. SUITER, RCE 68964

7/16/21
DATE

TABLE OF CONTENTS

	<u>SECTION</u>
Executive Summary	1.0
Introduction	1.1
Existing Conditions	1.2
Proposed Project	1.3
Hydrologic Unit Contribution	1.4
Conclusions	1.5
References	1.6
Methodology	2.0
Rational Method	2.1
County of San Diego Criteria	2.2
Hydraulic Calculations	2.3
Hydrologic Analysis	3.0
Existing Condition Hydrologic Calculations	3.1
Proposed Condition Hydrologic Calculations	3.2
Detention Analysis	3.3
Proposed Condition Hydrologic Calculations - Detained	3.4
Hydromodification Analysis	3.5
Storm Water Pollutant Control	3.6
Appendices	
Appendix A: Hydrology Support Material	
Appendix B: Hydraulic Calculations	
Appendix C: Existing and Proposed Hydrology Maps	

1.0 EXECUTIVE SUMMARY

1.1 Introduction

This Hydrology Study for the proposed Leucadia 101 Mixed Use development has been prepared to analyze the hydrologic characteristics of the existing and proposed project site. This report presents both the methodology and the calculations used for determining the storm water runoff from the project site in the existing condition, proposed condition, and the proposed mitigated condition produced by the 100-year, 6-hour storm event.

1.2 Existing Conditions

The subject property is approximately 3.79 acres and is located at 1900 and 1950 North Coast Highway 101 in the City of Encinitas. The existing site is currently developed and consists of commercial buildings, paved access drives and parking, open space, hardscape and landscape.

In the existing condition, storm water runoff from the site generally flows overland and in onsite storm drain easterly to North Coast Highway 101. There is offsite run-on from the hillside along the westerly and southerly boundaries.

An existing high point in North Coast Highway 101 is located approximately at the midpoint of the property's easterly boundary. Surface runoff from the property that enters the right-of-way north of the high point will continue to surface flow northerly and enters the public storm drain system within the La Costa Avenue and North Coast Highway 101 intersection. The storm drain system then conveys captured flows to the east side Carlsbad Boulevard into the Batiquitos Lagoon and ultimately the Pacific Ocean. Surface runoff from the property that enters the right-of-way south of the high point will surface flow southerly and enters a separate public storm drain system that conveys captured flow northerly to an extended detention basin located on the west side of Carlsbad Boulevard which discharges to Batiquitos Lagoon and ultimately the Pacific Ocean. The onsite storm drain connects to the public storm drain located on the west side of North Coast Highway 101 which also drains to the extended detention basin on the west side of Carlsbad Boulevard which discharges to Batiquitos Lagoon and ultimately the Pacific Ocean.

Per the Web Soil Survey application available through the United States Department of Agriculture, the site is categorized to have hydrologic group B soil. Refer to Appendix A for soil information.

Using the Rational Method Procedure outlined in the San Diego County Hydrology Manual dated June 2003 (SDCHM), the 100-year, 6-hour storm event peak flow rate was calculated for the project site in the existing condition. The table below summarizes the existing condition hydrologic analysis.

Summary of Existing Condition 100-Yr Storm Event Hydrologic Analysis

Condition	Area (ac)	Q100 (cfs)
Existing (East of Carlsbad Boulevard) Existing Subareas 1 & 3	0.626	1.03
Existing (West of Carlsbad Boulevard) Existing Subarea 2	3.507	13.62
Existing (Total) Existing Subareas 1, 2 & 3	4.133	14.65

Refer to the existing condition hydrologic calculations included in Section 3.1 of this report.

1.3 Proposed Project

The project proposes to demolish the existing development and construct a new apartment complex with approximately 94 units, boutique hotel, retail units, structured parking, access drive, hardscape and landscape, and associated improvements including storm water biofiltration basins to meet the requirements for pollutant control and an underground storage vault to comply with hydromodification management flow control and to mitigate the 100-year storm event peak discharge rate.

In the proposed condition, storm water runoff will be collected by proposed storm drain and conveyed to biofiltration basins located throughout the site. Discharge from the biofiltration basins will flow to the proposed underground storage vault located in the northeastern corner of the project site. The vault will discharge to a proposed 18" RCP which will connect to the back of the existing curb inlet located north of the project along North Coast Highway 101. The existing curb outlets to an 18" RCP then transitions to a 24" RCP that conveys flows northerly and into the Batiquitos Lagoon on the east side of Carlsbad Boulevard. Offsite storm water that runs onto the site along the westerly boundary will be intercepted via a new concrete ditch and routed to proposed storm drain which runs along the northern boundary of the site and connects to the underground vault outlet pipe and continues as described above. Offsite run-on along the southern boundary will be captured in a new concrete ditch and discharged to North Coast Highway 101 via sidewalk underdrain which will enter the public storm drain system and be conveyed to the extended detention basin on the west side of Carlsbad Boulevard as in the existing condition.

The biofiltration basins and underground storage vault are designed to provide pollutant control treatment and hydromodification management flow control to meet the requirements of the California Regional Water Quality Control Board San Diego Region municipal storm water permit (Order No. R9-2013-0001, referred to as the MS4 Permit). The underground storage vault will also provide mitigation for the site's total 100-year storm event peak discharge rate. Refer to the Storm Water Quality Management Plan (SWQMP) for the project titled "Storm Water Quality Management Plan for Leucadia

101 Mixed Use” dated July 2021 prepared by Pasco Laret Suiter & Associates for the detailed HMP and storm water pollutant control analyses.

The table below summarizes the existing and proposed condition hydrologic analyses.

Summary of 100-yr Storm Event Hydrologic Analyses

Condition	Area (ac)	Q100 (cfs)
Existing (East of Carlsbad Boulevard)	0.626	1.03
Existing (West of Carlsbad Boulevard)	3.507	13.62
Existing (Total)	4.133	14.65
Proposed (East of Carlsbad Boulevard) Proposed Subareas 1 & 2	4.009	19.62
Proposed Detained (East of Carlsbad Blvd) Proposed Subareas 1 & 2		0.89
Proposed (West of Carlsbad Boulevard) Proposed Subarea 3	0.124	0.28
Proposed (Total) Proposed Subareas 1, 2 & 3	4.133	19.90
Proposed (Total) Detained Proposed Subareas 1, 2 & 3	4.133	1.17

Refer to the proposed condition hydrologic calculations and detailed detention analysis included in Sections 3.2, 3.3, and 3.4.

1.4 Hydrologic Unit Contribution

As identified by the San Diego Basin Plan, the proposed project site drains within Carlsbad Hydrologic Unit, specifically the San Marcos Hydrologic Area and Batiquitos Sub Area (904.51).

1.5 Conclusions

Based upon the analyses included in this report, the proposed underground storage vault is sized to accommodate the increase in peak runoff in the proposed condition and the biofiltration basins and storage vault are designed to meet the requirements of the MS4 Permit for both pollutant control and hydromodification management. The peak flow rate resulting from the 100-year, 6-hour storm event will be lower in the proposed mitigated condition (1.17 cfs) than the existing condition (14.65 cfs).

1.6 References

“San Diego County Hydrology Manual”, revised June 2003, County of San Diego, Department of Public Works, Flood Control Section.

“City of Encinitas Engineering Design Manual”, October 28, 2009, City of Encinitas, Engineering Department

Soil Survey Staff, Natural Resources Conservation Service, United States Department of Agriculture. Web Soil Survey. Available online at <http://websoilsurvey.nrcs.usda.gov>.

2.0 METHODOLOGY

2.1 Rational Method

Pursuant to the San Diego County Hydrology Manual dated June 2003 (SDCHM), the Rational Method is recommended for analyzing the runoff response from drainage areas up to approximately 1 square mile in size. The proposed project and associated watershed basins are less than 1 square mile, therefore the Rational Method was used to analyze the project's hydrologic characteristics in the existing and proposed conditions.

The Rational Method (RM) formula estimates the peak rate of runoff based on the variables of area, runoff coefficient, and rainfall intensity. The rainfall intensity (I) is equal to:

$$I = 7.44 \times P_6 \times D^{-0.645}$$

Where:

I = Intensity (in/hr)

P₆ = 6-hour precipitation (in)

D = duration (min – use Tc)

Using the Time of Concentration (Tc) which is the time required for a given element of water that originates at the most remote point of the basin being analyzed to reach the point at which the runoff from the basin is being analyzed, the RM equation determines the storm water runoff rate (Q) for a given basin in terms of flow (typically in cubic feet per second (cfs)). The Tc is calculated pursuant to the methodology described in Section 3.1.4 of the San Diego County Hydrology Manual. The RM equation is as follows:

$$Q = CIA$$

Where:

Q= flow (cfs)

C = runoff coefficient, ratio of rainfall that produces storm water runoff (runoff vs. infiltration/evaporation/absorption/etc)

I = average rainfall intensity for a duration equal to the Tc for the area (in/hr)

A = drainage area contributing to the basin (ac)

The RM equation assumes that the storm event being analyzed delivers precipitation to the entire basin uniformly, and therefore the peak discharge rate will occur when a raindrop that falls at the most remote portion of the basin arrives at the point of analysis. The RM also assumes that the fraction of rainfall that becomes runoff or the runoff coefficient (C) is not affected by the storm intensity (I), or the precipitation zone number.

2.2 County of San Diego Criteria

The County of San Diego has developed tables, nomographs, and methodologies for analyzing storm water runoff for areas within the County. The County has also developed precipitation isopluvial contour maps that show even lines of rainfall anticipated from a given storm event (i.e. 100-year, 6-hour storm). The 100-year 6-hour storm event rainfall isopluvial map is included in Appendix A.

One of the variables of the RM equation is the runoff coefficient (C) which is dependent upon land use and soil type. Table 3-1 Runoff Coefficients for Urban Areas in the SDCHM categorizes the land use, the associated development density (dwelling units per acre) and the percentage of impervious area. Each of the categories listed has an associated runoff coefficient for each soil type class. A composite runoff coefficient can also be calculated for an area based on soil type and impervious percentage using the following equation from Section 3.1.2 of the SDCHM:

$$C = 0.90 \times (\% \text{ Impervious}) + C_p \times (1 - \% \text{ Impervious})$$

Where: C_p = Pervious Coefficient Runoff Value for the soil type (shown in Table 3-1 as Undisturbed Natural Terrain/Permanent Open Space, 0% Impervious)

The calculations contained herein figure a composite runoff coefficient for the onsite project areas based on the percentage of impervious area and the percentage of pervious or landscape area. Refer to Section 3.0 for the composite runoff coefficient calculations.

2.3 Hydraulic Calculations

The proposed Type A ditches were sized using the FHWA Hydraulic Toolbox, v4.4 to convey the 100-year peak discharge offsite run-on.

Refer to Appendix B for detailed calculations.

3.0 HYDROLOGIC ANALYSIS

The table below summarizes the hydrologic calculations provided in Sections 3.1, 3.2 and 3.4.

Summary of 100-yr Storm Event Hydrologic Analyses

Condition	Area (ac)	Q100 (cfs)
Existing (East of Carlsbad Boulevard)	0.626	1.03
Existing (West of Carlsbad Boulevard)	3.507	13.62
Existing (Total)	4.133	14.65
Proposed (East of Carlsbad Boulevard) Proposed Subareas 1 & 2	4.009	19.62
Proposed Detained (East of Carlsbad Blvd) Proposed Subareas 1 & 2		0.89
Proposed (West of Carlsbad Boulevard) Proposed Subarea 3	0.124	0.28
Proposed (Total) Proposed Subareas 1, 2 & 3	4.133	19.90
Proposed (Total) Detained Proposed Subareas 1, 2 & 3	4.133	1.17

3.1 Existing Condition Hydrologic Calculations

3161 Leucadia 101
7/16/2021

Existing Condition - Subarea 1

Q = CIA

P6 (in) 2.5

	Area (sq ft)	C value	A x C value	Weighted C
Impervious	0	0.9	0	
Pervious	17025	0.25	4256.25	
Total (sf)	17025		4256.25	0.25
Total (ac)	0.391			

Tc = 5.0

I(in/hr) = 6.6

Q (cfs) = 0.64

3161 Leucadia 101
7/16/2021

Existing Condition - Subarea 2

Q = CIA

P6 (in) 2.5

	Area (sq ft)	C value	A x C value	Weighted C
Impervious	79773	0.9	71795.7	
Pervious	73013	0.25	18253.25	
Total (sf)	152786		90048.95	0.59
Total (ac)	3.507			

Tc = 5.0

I (in/hr) = 6.6

Q (cfs) = 13.62

3161 Leucadia 101
7/16/2021

Existing Condition - Subarea 3

Q = CIA

P6 (in) 2.5

	Area (sq ft)	C value	A x C value	Weighted C
Impervious	0	0.9	0	
Pervious	10243	0.25	2560.75	
Total (sf)	10243		2560.75	0.25
Total (ac)	0.235			

Tc = 5.0

I (in/hr) = 6.6

Q (cfs) = 0.39

3.2 Proposed Condition Hydrologic Calculations

3161 Leucadia 101
7/16/2021

Proposed Condition - Subarea 1

Q = CIA

P6 (in) 2.5

	Area (sq ft)	C value	A x C value	Weighted C
Impervious	132474	0.9	119226.6	
Pervious	31874	0.25	7968.5	
Total (sf)	164348		127195.1	0.77
Total (ac)	3.773			

Tc = 5.0

I (in/hr) = 6.6

Q (cfs) = 19.23

3161 Leucadia 101
7/16/2021

Proposed Condition - Subarea 2

Q = CIA

P6 (in) 2.5

	Area (sq ft)	C value	A x C value	Weighted C
Impervious	40	0.9	36	
Pervious	10244	0.25	2561	
Total (sf)	10284		2597	0.25
Total (ac)	0.236			

Tc = 5.0

I (in/hr) = 6.6

Q (cfs) = 0.39

3161 Leucadia 101
7/16/2021

Proposed Condition - Subarea 3

Q = CIA

P6 (in) 2.5

	Area (sq ft)	C value	A x C value	Weighted C
Impervious	717	0.9	645.3	
Pervious	4705	0.25	1176.25	
Total (sf)	5422		1821.55	0.34
Total (ac)	0.124			

Tc = 5.0

I (in/hr) = 6.6

Q (cfs) = 0.28

3.3 Detention Analysis

The underground storage vault provides hydromodification management flow control and mitigation of the 100-year storm event peak flow rate. The 100-year storm event detention analysis was performed using HydroCAD Stormwater Modeling software. The inflow runoff hydrograph to the vault was modeled using RatHydro which is a Rational Method Design Storm Hydrograph software that creates a hydrograph using the results of the Rational Method calculations. HydroCAD has the ability to route the 100-year 6-hour storm event inflow hydrograph through the vault and based on the cross sectional geometry, stage storage and outlet structure data, HydroCAD calculates the detained peak flow rate and detained time to peak.

Based on the results of the HydroCAD analysis, the underground storage vault provides mitigation for the 100-year storm event peak flow rate, detaining the proposed condition to 1.17 cfs which is below the existing condition of 14.65 cfs. Refer to Section 3.4 for the vault cross section and HydroCAD proposed detained condition detailed output.

3.4 Proposed Condition Hydrologic Calculations - Detained

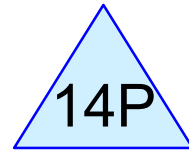
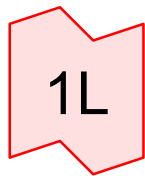

100-yr Inflow to BMP-1

Vault 100-yr and HMP
Alt 1

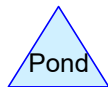
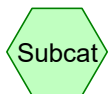

Routing Diagram for 3161

Prepared by Pasco Laret Suiter & Associates, Printed 7/16/2021
HydroCAD® 10.10-6a s/n 10097 © 2020 HydroCAD Software Solutions LLC

Summary for Link 1L: 100-yr Inflow to BMP-1

Inflow = 19.25 cfs @ 4.08 hrs, Volume= 0.601 af
Primary = 19.25 cfs @ 4.08 hrs, Volume= 0.601 af, Atten= 0%, Lag= 0.0 min
Routed to Pond 14P : Vault 100-yr and HMP Alt 1

Primary outflow = Inflow, Time Span= 0.00-96.00 hrs, dt= 0.01 hrs

DISCHARGE Imported from RatHydro adju.csv

Link 1L: 100-yr Inflow to BMP-1

Hydrograph

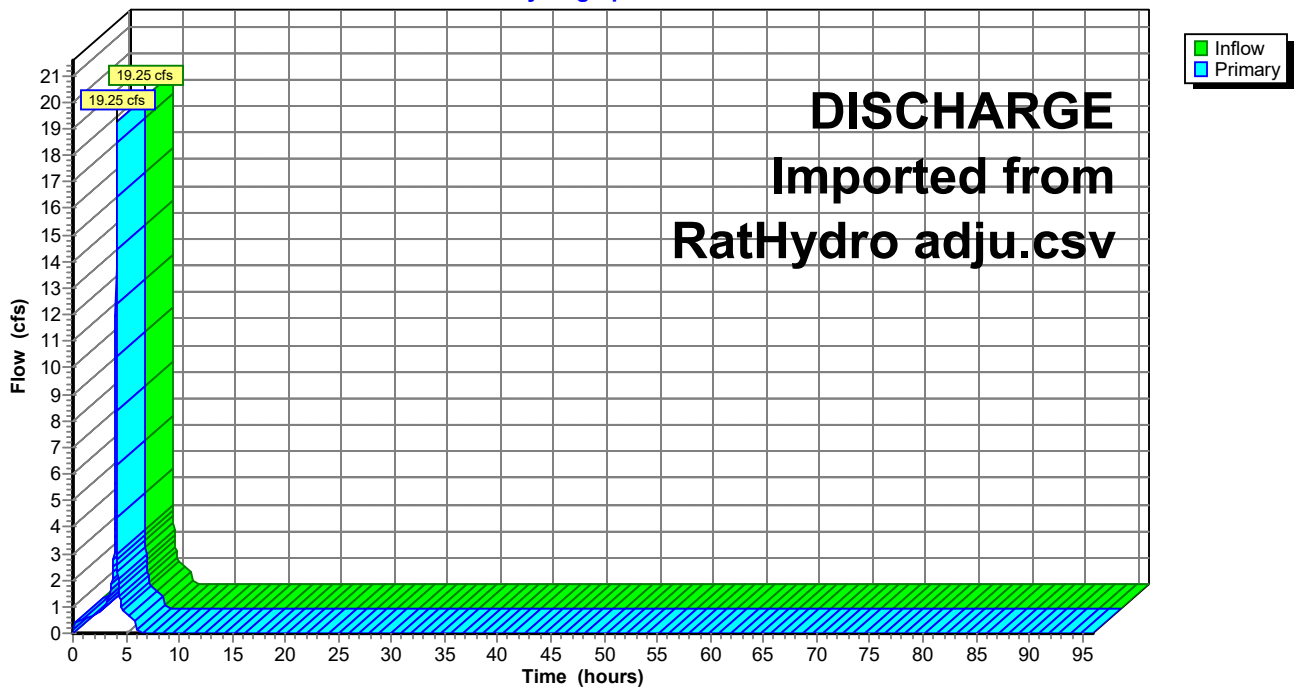

Summary for Pond 14P: Vault 100-yr and HMP Alt 1

Inflow = 19.25 cfs @ 4.08 hrs, Volume= 0.601 af
 Outflow = 0.50 cfs @ 5.91 hrs, Volume= 0.596 af, Atten= 97%, Lag= 109.7 min
 Primary = 0.50 cfs @ 5.91 hrs, Volume= 0.596 af

Routing by Dyn-Stor-Ind method, Time Span= 0.00-96.00 hrs, dt= 0.01 hrs
 Peak Elev= 51.84' @ 5.91 hrs Storage= 23,699 cf

Plug-Flow detention time= 1,814.3 min calculated for 0.596 af (99% of inflow)
 Center-of-Mass det. time= 1,813.2 min (2,025.8 - 212.6)

Volume	Invert	Avail.Storage	Storage Description
#1	44.31'	25,174 cf	Custom Stage Data Listed below

Elevation (feet)	Cum.Store (cubic-feet)
44.31	0
44.56	787
44.81	1,573
45.06	2,360
45.31	3,147
45.56	3,933
45.81	4,720
46.06	5,507
46.31	6,293
46.56	7,080
46.81	7,867
47.06	8,654
47.31	9,440
47.56	10,227
47.81	11,014
48.06	11,800
48.31	12,587
48.56	13,374
48.81	14,160
49.06	14,947
49.31	15,734
49.56	16,520
49.81	17,307
49.99	17,866
50.06	18,094
50.31	18,880
50.56	19,667
50.81	20,454
51.06	21,240
51.31	22,027
51.56	22,814
51.81	23,601
52.06	24,387
52.31	25,174

Device	Routing	Invert	Outlet Devices
#1	Primary	44.31'	18.0" Round Culvert L= 10.0' RCP, groove end projecting, Ke= 0.200 Inlet / Outlet Invert= 44.31' / 44.21' S= 0.0100 ' / Cc= 0.900 n= 0.013, Flow Area= 1.77 sf
#2	Device 1	44.31'	1.4" Vert. Orifice C= 0.600 Limited to weir flow at low heads
#3	Device 1	51.81'	Custom Weir, Cv= 2.62 (C= 3.28) Head (feet) 0.00 0.50 0.50 Width (feet) 20.00 20.00 0.00

Primary OutFlow Max=0.50 cfs @ 5.91 hrs HW=51.84' (Free Discharge)

- 1=Culvert (Passes 0.50 cfs of 27.70 cfs potential flow)
- 2=Orifice (Orifice Controls 0.14 cfs @ 13.16 fps)
- 3=Custom Weir (Weir Controls 0.36 cfs @ 0.58 fps)

Pond 14P: Vault 100-yr and HMP Alt 1

Hydrograph

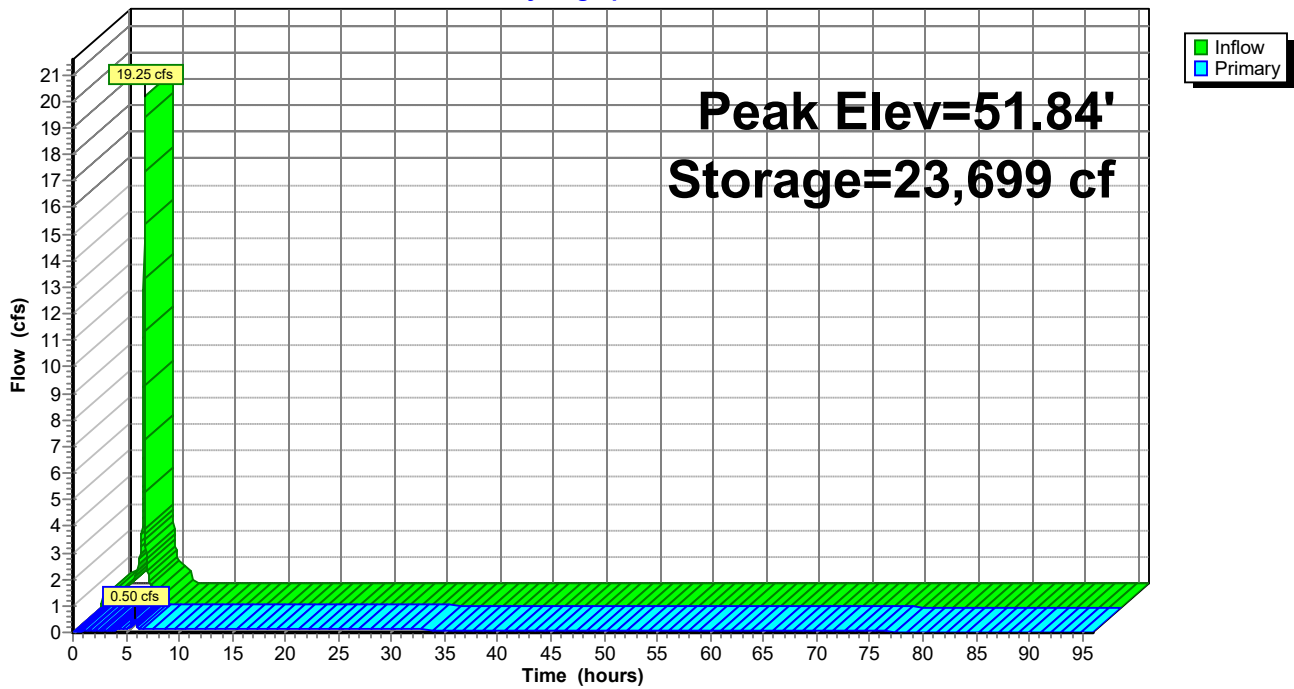

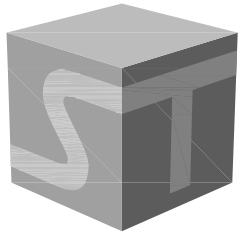

StormTrap®

MODULAR CONCRETE
STORMWATER MANAGEMENT

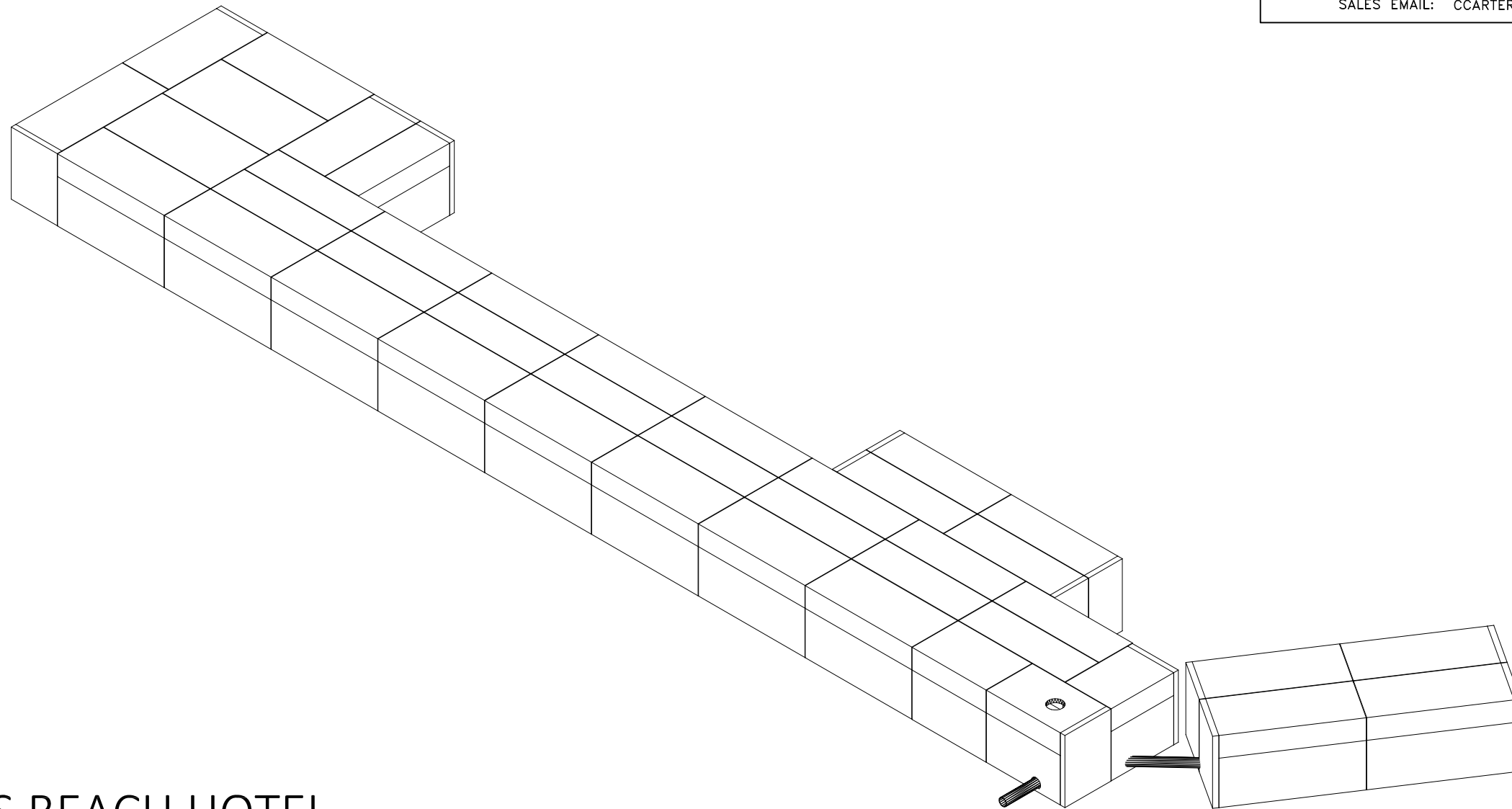

ENCINITAS BEACH HOTEL
LEUCADIA, CA

SHEET INDEX	
PAGE	DESCRIPTION
0.0	COVER SHEET
1.0	SINGLETRAP DESIGN CRITERIA
2.0	SINGLETRAP SYSTEM LAYOUT
2.1	SINGLETRAP FOUNDATION LAYOUT
3.0	SINGLETRAP INSTALLATION SPECIFICATIONS
3.1	SINGLETRAP INSTALLATION SPECIFICATIONS
4.0	SINGLETRAP BACKFILL SPECIFICATIONS
5.0	RECOMMENDED PIPE/ACCESS OPENING SPECIFICATIONS
6.0	SINGLETRAP MODULE TYPES

STORMTRAP CONTACT INFORMATION

STORMTRAP SUPPLIER: STORMTRAP
 CONTACT NAME: CHARLIE CARTER
 CELL PHONE: 760-212-5628
 SALES EMAIL: CCARTER@STORMTRAP.COM

StormTrap®

PATENTS LISTED AT: [HTTP://STORMTRAP.COM/PATENT]

1287 WINDHAM PARKWAY
 ROMEVILLE, IL 60446
 P:815-941-4549 / F:331-318-5347

ENGINEER INFORMATION:

PASCO LARET SUITER
 & ASSOCIATES
 535 NORTH COAST HIGHWAY
 SOLANA BEACH, CA
 858-259-8212

PROJECT INFORMATION:

ENCINITAS BEACH HOTEL

LEUCADIA, CA

CURRENT ISSUE DATE:

7/19/2021

ISSUED FOR:

PRELIMINARY

REV.	DATE:	ISSUED FOR:	DWN BY:
1	7/9/2021	PRELIMINARY	RJL

SCALE:

NTS

SHEET TITLE:

COVER SHEET

SHEET NUMBER:

0.0

STRUCTURAL DESIGN LOADING CRITERIA

LIVE LOADING: **AASHTO HS-20 HIGHWAY LOADING**
 GROUND WATER TABLE: BELOW INVERT OF SYSTEM
 SOIL BEARING PRESSURE: 3000PSF
 SOIL DENSITY: 120 PCF
 EQUIVALENT UNSATURATED
 LATERAL ACTIVE EARTH PRESSURE: 35 PSF / FT.
 EQUIVALENT SATURATED
 LATERAL ACTIVE EARTH PRESSURE: 80 PSF/FT. (IF WATER TABLE PRESENT)
 APPLICABLE CODES: ASTM C857
 ACI-318
 BACKFILL TYPE: SEE SHEET 4.0 FOR BACKFILL OPTIONS

STORMTRAP SYSTEM INFORMATION

TOTAL WATER STORAGE PROV: 25,033.16 CUBIC FEET
 WATER STORAGE PROV: 23,468.58 CUBIC FEET
 ELEV 0.00 - 7.50
 UNIT HEADROOM: 8'-0" DOUBLETRAP
 UNIT QUANTITY: 84 TOTAL PIECES

SITE SPECIFIC DESIGN CRITERIA

1. STORMTRAP UNITS SHALL BE MANUFACTURED AND INSTALLED ACCORDING TO SHOP DRAWINGS APPROVED BY THE INSTALLING CONTRACTOR AND ENGINEER OF RECORD. THE SHOP DRAWINGS SHALL INDICATE SIZE AND LOCATION OF ROOF OPENINGS AND INLET/OUTLET PIPE TYPES, SIZES, INVERT ELEVATIONS AND SIZE OF OPENINGS.
2. COVER RANGE: MIN. 1.00' MAX. 8.00' CONSULT STORMTRAP FOR ADDITIONAL COVER OPTIONS.
3. ALL DIMENSIONS AND SOIL CONDITIONS, INCLUDING BUT NOT LIMITED TO GROUNDWATER AND SOIL BEARING CAPACITY ARE REQUIRED TO BE VERIFIED IN THE FIELD BY OTHERS PRIOR TO STORMTRAP INSTALLATION.
4. FOR STRUCTURAL CALCULATIONS THE GROUND WATER TABLE IS ASSUMED TO BE BELOW INVERT OF SYSTEM IF WATER TABLE IS DIFFERENT THAN ASSUMED, CONTACT STORMTRAP.
5. **SYSTEM DESIGN MAY ALLOW FOR INCIDENTAL LEAKAGE AND WILL NOT BE SUBJECT TO LEAKAGE TESTING.**

StormTrap

PATENTS LISTED AT: [HTTP://STORMTRAP.COM/PATENT]

1287 WINDHAM PARKWAY
 ROMEVILLE, IL 60446
 P: 815-941-4549 / F: 331-318-5347

ENGINEER INFORMATION:

PASCO LARET SUITER
 & ASSOCIATES
 535 NORTH COAST HIGHWAY
 SOLANA BEACH, CA
 858-259-8212

PROJECT INFORMATION:

ENCINITAS BEACH HOTEL

LEUCADIA, CA

CURRENT ISSUE DATE:

7/19/2021

ISSUED FOR:

PRELIMINARY

REV.	DATE:	ISSUED FOR:	DWN BY:
1	7/9/2021	PRELIMINARY	RJL

SCALE:

NTS

SHEET TITLE:

DOUBLETRAP
 DESIGN
 CRITERIA

SHEET NUMBER:

1.0

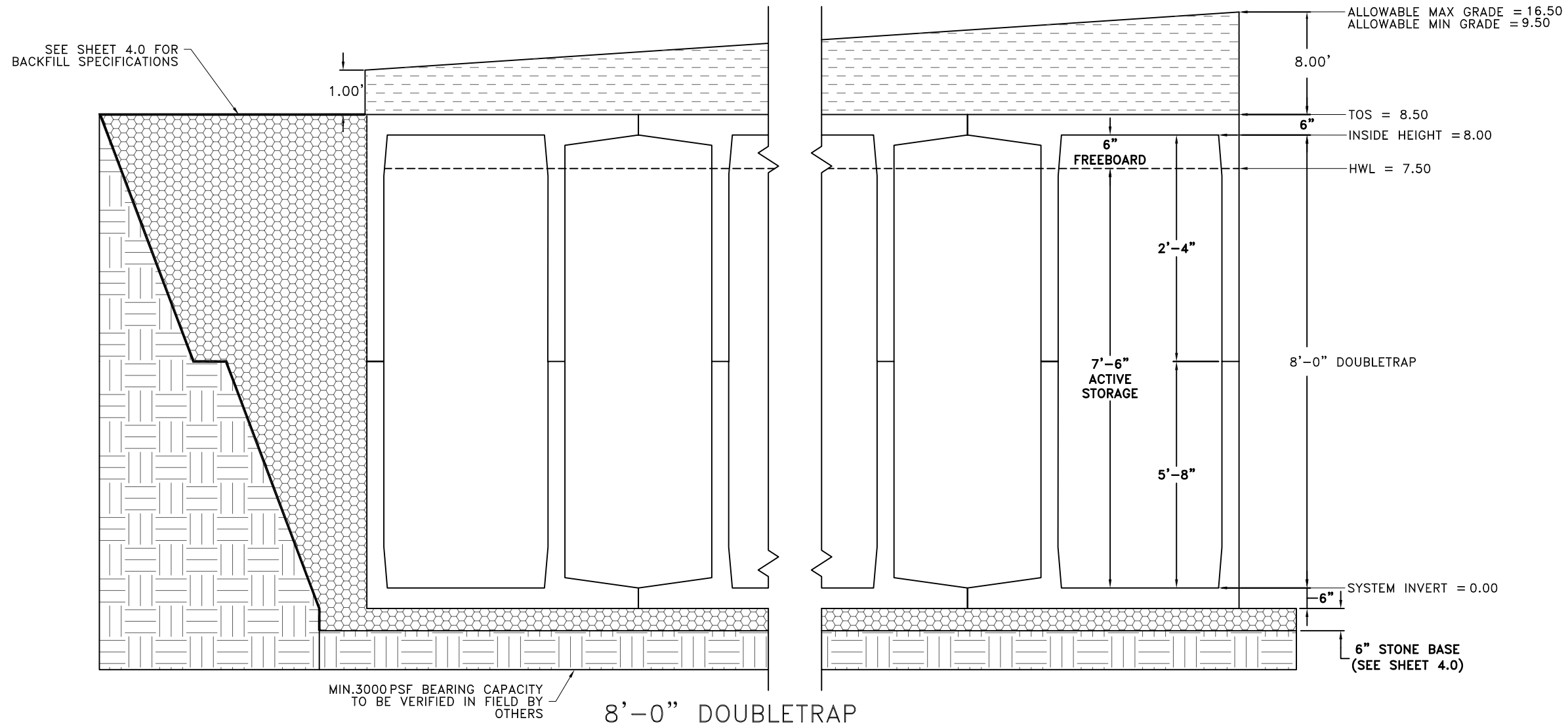

BILL OF MATERIALS

QTY.	UNIT TYPE	DESCRIPTION	TOP WEIGHT	BASE WEIGHT
0	I	8'-0" DOUBLETRAP	0	0
2	II	8'-0" DOUBLETRAP	14286	18560
0	III	8'-0" DOUBLETRAP	0	0
14	IV	8'-0" DOUBLETRAP	12249	17584
0	VII	8'-0" DOUBLETRAP	0	0
11	VII-2	8'-0" DOUBLETRAP	9822	14096
9	VII-4	8'-0" DOUBLETRAP	10017	15352
5	SPIV	8'-0" DOUBLETRAP	VARIES	VARIES
1	SPVII-4	8'-0" DOUBLETRAP	VARIES	VARIES
0	T2 PANEL	8" THICK PANEL		0
9	T4 PANEL	8" THICK PANEL		5963
5	T7 PANEL	8" THICK PANEL		4348
6	JOINT WRAP	150' PER ROLL		
80	JOINT TAPE	14.5' PER ROLL		

LOADING DISCLAIMER:

STORMTRAP IS NOT DESIGNED TO ACCEPT ANY ADDITIONAL LOADINGS FROM NEARBY STRUCTURES NEXT TO OR OVER THE TOP OF STORMTRAP. IF ADDITIONAL LOADING CONSIDERATIONS ARE REQUIRED FOR STRUCTURAL DESIGN OF STORMTRAP, PLEASE CONTACT STORMTRAP IMMEDIATELY.

THE STORMTRAP SYSTEM HAS NOT BEEN DESIGNED TO SUPPORT THE ADDITIONAL WEIGHT OF ANY TREES. FURTHERMORE, THE ROOTS OF THE TREES MUST BE CONTAINED TO PREVENT FUTURE DAMAGE TO THE STORMTRAP SYSTEM. STORMTRAP ACCEPTS NO LIABILITY FOR DAMAGES CAUSED BY TREES OR OTHER VEGETATION PLACE AROUND OR ON TOP OF THE SYSTEM.

DESIGN CRITERIA

ALLOWABLE MAX GRADE = 16.50
 ALLOWABLE MIN GRADE = 9.50
 INSIDE HEIGHT ELEVATION = 8.00
 SYSTEM INVERT = 0.00

NOTES:

- DIMENSIONING OF STORMTRAP SYSTEM SHOWN BELOW ALLOW FOR A 3/4" GAP BETWEEN EACH MODULE.
- ALL DIMENSIONS TO BE VERIFIED IN THE FIELD BY OTHERS.
- SEE SHEET 3.0 FOR INSTALLATION SPECIFICATIONS.
- SP - INDICATES A MODULE WITH MODIFICATIONS.
- P - INDICATES A MODULE WITH A PANEL ATTACHMENT.
- CONTRACTORS RESPONSIBILITY TO ENSURE CONSISTENCY/ACCURACY TO FINAL ENGINEER OF RECORD PLAN SET.
- IF A WATERTIGHT SOLUTION IS REQUIRED FOR THIS OUTLET CONTROL STRUCTURE, ALL EXTERIOR COLD JOINTS, INCLUDING JOINT BETWEEN TOP AND BASE MODULES, BETWEEN TOP AND BASE OF ADJOINING SYMONS WALLS, AND JOINTS BETWEEN MODULE AND ADJACENT END PANELS WILL BE THE SOLE RESPONSIBILITY OF THE INSTALLING CONTRACTOR TO PROVIDE AND INSTALL THE WATERTIGHT APPLICATION PER THE EOR'S SPECIFICATION.

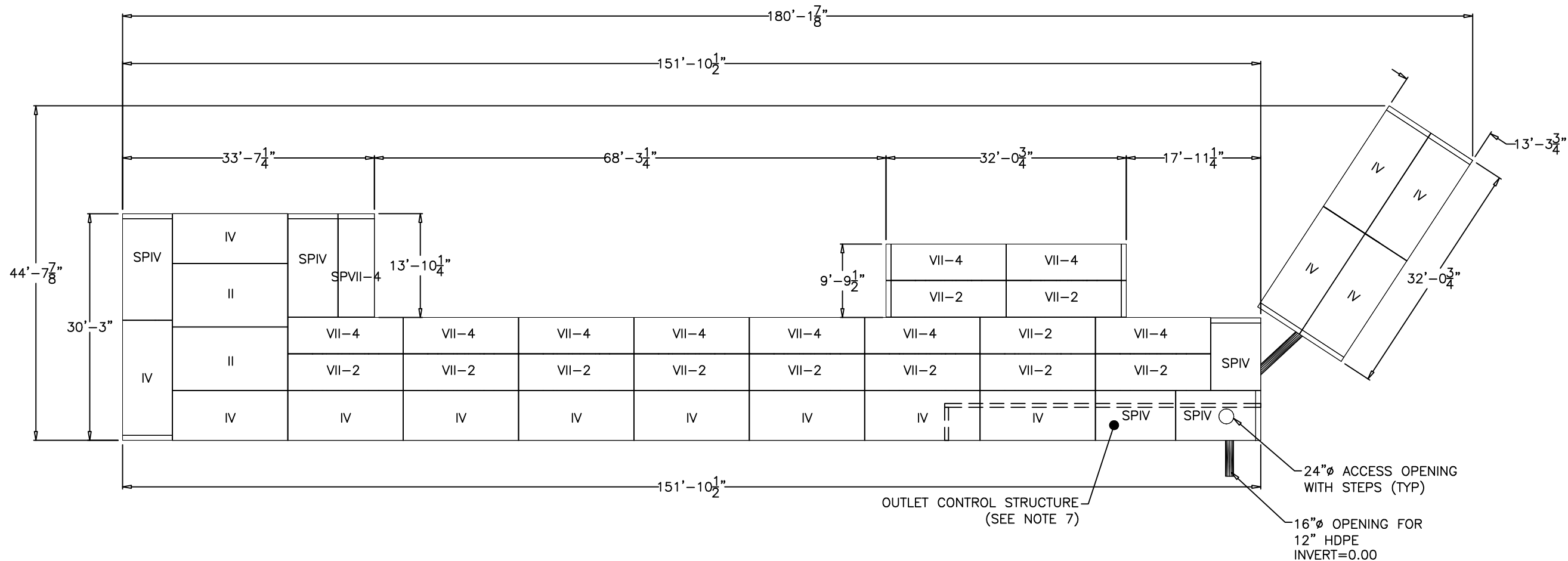

PATENTS LISTED AT: [HTTP://STORMTRAP.COM/PATENT]

1287 WINDHAM PARKWAY
 ROMEVILLE, IL 60446
 P:815-941-4549 / F:331-318-5347

ENGINEER INFORMATION:

PASCO LARET SUITER
 & ASSOCIATES
 535 NORTH COAST HIGHWAY
 SOLANA BEACH, CA
 858-259-8212

PROJECT INFORMATION:

ENCINITAS BEACH HOTEL

LEUCADIA, CA

CURRENT ISSUE DATE:

7/19/2021

ISSUED FOR:

PRELIMINARY

REV.	DATE:	ISSUED FOR:	DWN BY:
1	7/9/2021	PRELIMINARY	RJL

SCALE:

NTS

SHEET TITLE:

DOUBLETRAP SYSTEM LAYOUT

SHEET NUMBER:

2.0

STORMTRAP INSTALLATION SPECIFICATIONS

1. STORMTRAP SHALL BE INSTALLED IN ACCORDANCE WITH ASTM C891, STANDARD FOR INSTALLATION OF UNDERGROUND PRECAST CONCRETE UTILITY STRUCTURES, THE FOLLOWING ADDITIONS AND/OR EXCEPTIONS SHALL APPLY:
2. IT IS THE RESPONSIBILITY OF THE INSTALLING CONTRACTOR TO ENSURE THAT PROPER/ADEQUATE EQUIPMENT IS USED TO SET/INSTALL THE MODULES.
3. STORMTRAP MODULES CAN BE PLACED ON A LEVEL, 6" FOUNDATION OF 3/4" AGGREGATE EXTENDING 2'-0" PAST THE OUTSIDE OF THE SYSTEM (SEE DETAIL 1) AND SHALL BE PLACED ON PROPERLY COMPACTED SOILS (SEE SHEET 1.0 FOR SOIL BEARING CAPACITY REQUIREMENTS), AND IN ACCORDANCE WITH ASTM C891 STANDARD PRACTICE FOR INSTALLATION OF UNDERGROUND PRECAST UTILITY STRUCTURES.
4. THE STORMTRAP MODULES SHALL BE PLACED SUCH THAT THE MAXIMUM SPACE BETWEEN ADJACENT MODULES DOES NOT EXCEED 3/4" (SEE DETAIL 2). IF THE SPACE EXCEEDS 3/4", THE MODULES SHALL BE RESET WITH APPROPRIATE ADJUSTMENT MADE TO LINE AND GRADE TO BRING THE SPACE INTO SPECIFICATION.
5. STORMTRAP MODULES ARE NOT WATERTIGHT. IF A WATERTIGHT SOLUTION IS REQUIRED, CONTACT STORMTRAP FOR RECOMMENDATIONS. THE WATERTIGHT APPLICATION IS TO BE PROVIDED AND IMPLEMENTED BY THE CONTRACTOR. THE CONTRACTOR IS RESPONSIBLE TO ENSURE THAT THE SELECTED WATERTIGHT SOLUTION PERFORMS AS SPECIFIED BY THE MANUFACTURER.
6. THE PERIMETER HORIZONTAL JOINT BETWEEN THE TOP AND BASE LEG CONNECTION OF THE STORMTRAP MODULES SHALL BE SEALED WITH PREFORMED MASTIC JOINT TAPE ACCORDING TO ASTM C891, 8.8 AND 8.12. (SEE DETAIL 3). THE MASTIC JOINT TAPE DOES NOT PROVIDE A WATERTIGHT SEAL.
7. ALL EXTERIOR JOINTS BETWEEN ADJACENT STORMTRAP MODULES SHALL BE SEALED WITH 8" WIDE PRE-FORMED, COLD-APPLIED, SELF-ADHERING ELASTOMERIC RESIN, BONDED TO A WOVEN, HIGHLY PUNCTURE RESISTANT POLYMER WRAP, CONFORMING TO ASTM C891 AND SHALL BE INTEGRATED WITH PRIMER SEALANT AS APPROVED BY STORMTRAP (SEE DETAILS 4 & 5). THE JOINT WRAP DOES NOT PROVIDE A WATERTIGHT SEAL. THE SOLE PURPOSE OF THE JOINT WRAP IS TO PROVIDE A SILT AND SOIL TIGHT SYSTEM. THE ADHESIVE EXTERIOR JOINT WRAP SHALL BE INSTALLED ACCORDING TO THE FOLLOWING INSTALLATION INSTRUCTIONS:
 - 7.1. USE A BRUSH OR WET CLOTH TO THOROUGHLY CLEAN THE OUTSIDE SURFACE AT THE POINT WHERE JOINT WRAP IS TO BE APPLIED.
 - 7.2. A RELEASE PAPER PROTECTS THE ADHESIVE SIDE OF THE JOINT WRAP. PLACE THE ADHESIVE TAPE (ADHESIVE SIDE DOWN) AROUND THE STRUCTURE, REMOVING THE RELEASE PAPER AS YOU GO. PRESS THE JOINT WRAP FIRMLY AGAINST THE STORMTRAP MODULE SURFACE WHEN APPLYING.
8. IF THE CONTRACTOR NEEDS TO CANCEL ANY SHIPMENTS, THEY MUST DO SO 48 HOURS PRIOR TO THEIR SCHEDULED ARRIVAL AT THE JOB SITE. IF CANCELED AFTER THAT TIME, PLEASE CONTACT THE PROJECT MANAGER.
9. IF THE STORMTRAP MODULE(S) IS DAMAGED IN ANY WAY PRIOR, DURING, OR AFTER INSTALL, STORMTRAP MUST BE CONTACTED IMMEDIATELY TO ASSESS THE DAMAGE AND TO DETERMINE WHETHER OR NOT THE MODULE(S) WILL NEED TO BE REPLACED. IF ANY MODULE ARRIVES AT THE JOBSITE DAMAGED DO NOT UNLOAD IT; CONTACT STORMTRAP IMMEDIATELY. ANY DAMAGE NOT REPORTED BEFORE THE TRUCK IS UNLOADED WILL BE THE CONTRACTOR'S RESPONSIBILITY.
10. STORMTRAP MODULES CANNOT BE ALTERED IN ANY WAY AFTER MANUFACTURING WITHOUT WRITTEN CONSENT FROM STORMTRAP.

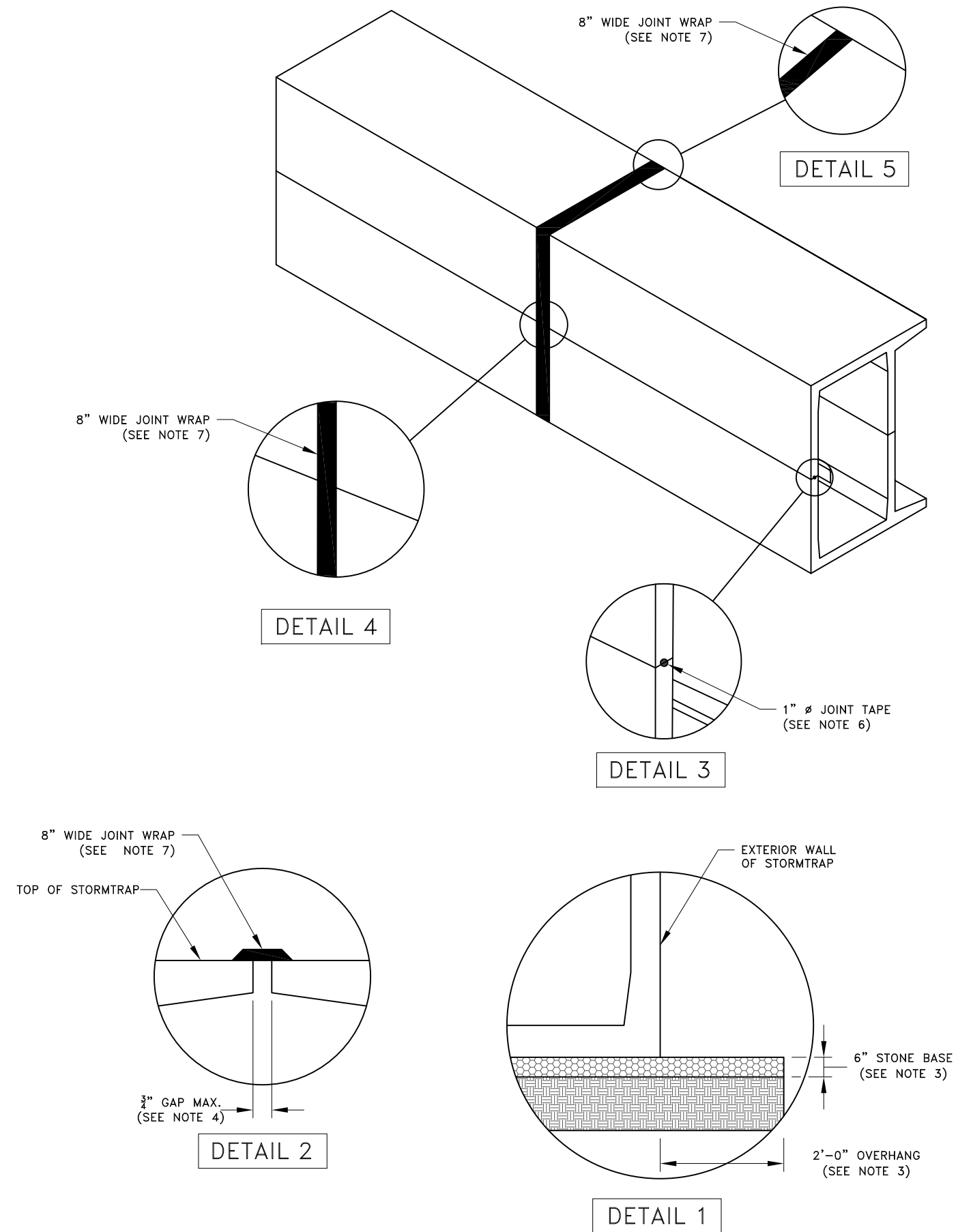

StormTrap
 PATENTS LISTED AT: [HTTP://STORMTRAP.COM/PATENT]
 1287 WINDHAM PARKWAY
 ROMEVILLE, IL 60446
 P:815-941-4549 / F:331-318-5347

ENGINEER INFORMATION:

**PASCO LARET SUITER
 & ASSOCIATES**
 535 NORTH COAST HIGHWAY
 SOLANA BEACH, CA
 858-259-8212

PROJECT INFORMATION:

ENCINITAS BEACH HOTEL

 LEUCADIA, CA

CURRENT ISSUE DATE:

7/19/2021

ISSUED FOR:

PRELIMINARY

REV.	DATE:	ISSUED FOR:	DWN BY:

SCALE:

NTS

SHEET TITLE:

**DOUBLETRAP
 INSTALLATION
 SPECIFICATIONS**

SHEET NUMBER:

3.0

STORMTRAP MODULE LIFTING INSTALLATION NOTES

1. IT IS THE CONTRACTOR'S RESPONSIBILITY TO ENSURE THAT ALL (4) CHAINS/CABLES ARE SECURED PROPERLY TO THE LIFTING ANCHORS AND IN EQUAL TENSION WHEN LIFTING THE STORMTRAP MODULE (SEE RECOMMENDATIONS 2 & 3).
2. MINIMUM 7'-0" CHAIN/CABLE LENGTH TO BE USED TO LIFT STORMTRAP MODULES (SUPPLIED BY CONTRACTOR).
3. CONTRACTOR TO ENSURE MINIMUM LIFTING ANGLE IS 60° FROM TOP SURFACE OF STORMTRAP MODULE. SEE DETAIL.

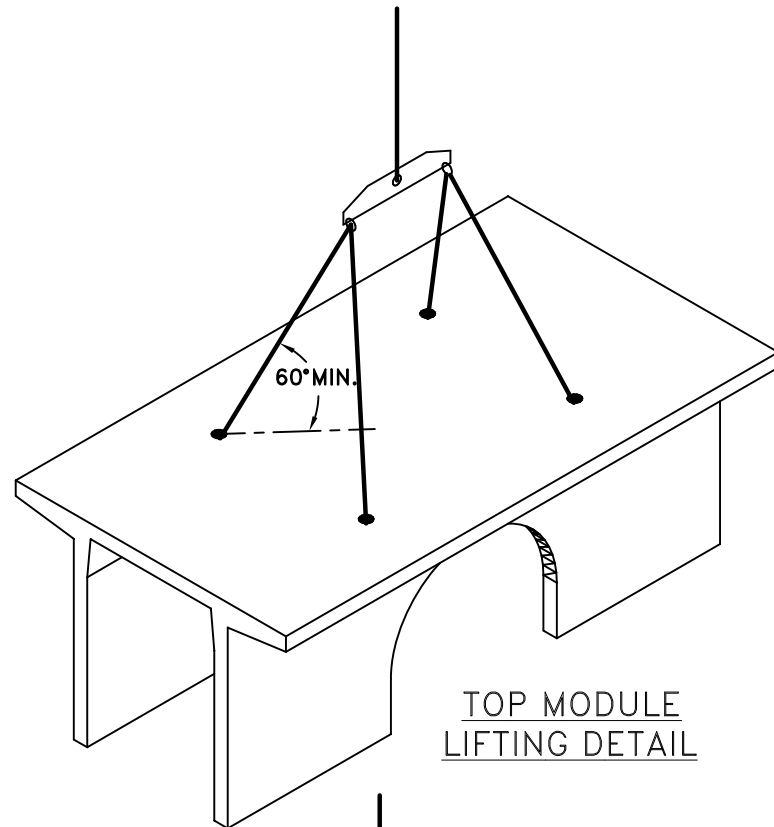

TOP MODULE
LIFTING DETAIL

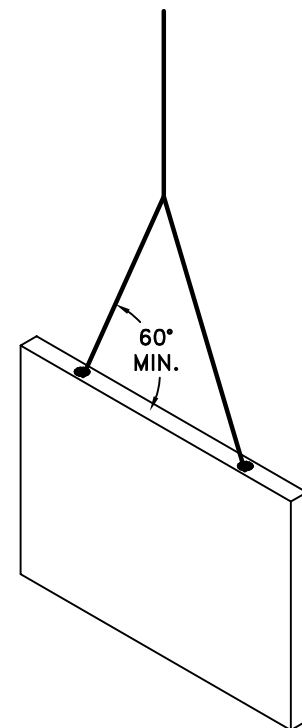

END PANEL
LIFTING DETAIL

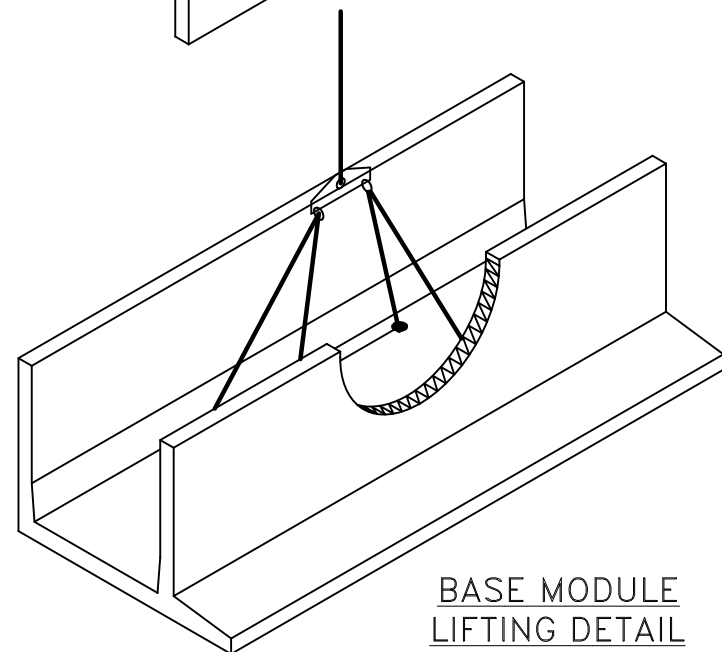

BASE MODULE
LIFTING DETAIL

END PANEL ERECTION/INSTALLATION NOTES

1. END PANELS WILL BE SUPPLIED TO CLOSE OFF OPEN ENDS OF ROWS.
2. PANELS SHALL BE INSTALLED IN A TILT UP FASHION DIRECTLY ADJACENT TO OPEN END OF MODULE (REFER TO SHEET 2.0 FOR END PANEL LOCATIONS).
3. CONNECTION HOOKS WILL BE SUPPLIED WITH END PANELS TO SECURELY CONNECT PANEL TO ADJACENT STORMTRAP MODULE (SEE PANEL CONNECTION ELEVATION VIEW).
4. ONCE CONNECTION HOOK IS ATTACHED, LIFTING CLUTCHES MAY BE REMOVED.
5. JOINT WRAP SHALL BE PLACED AROUND PERIMETER JOINT PANEL (SEE SHEET 3.0).

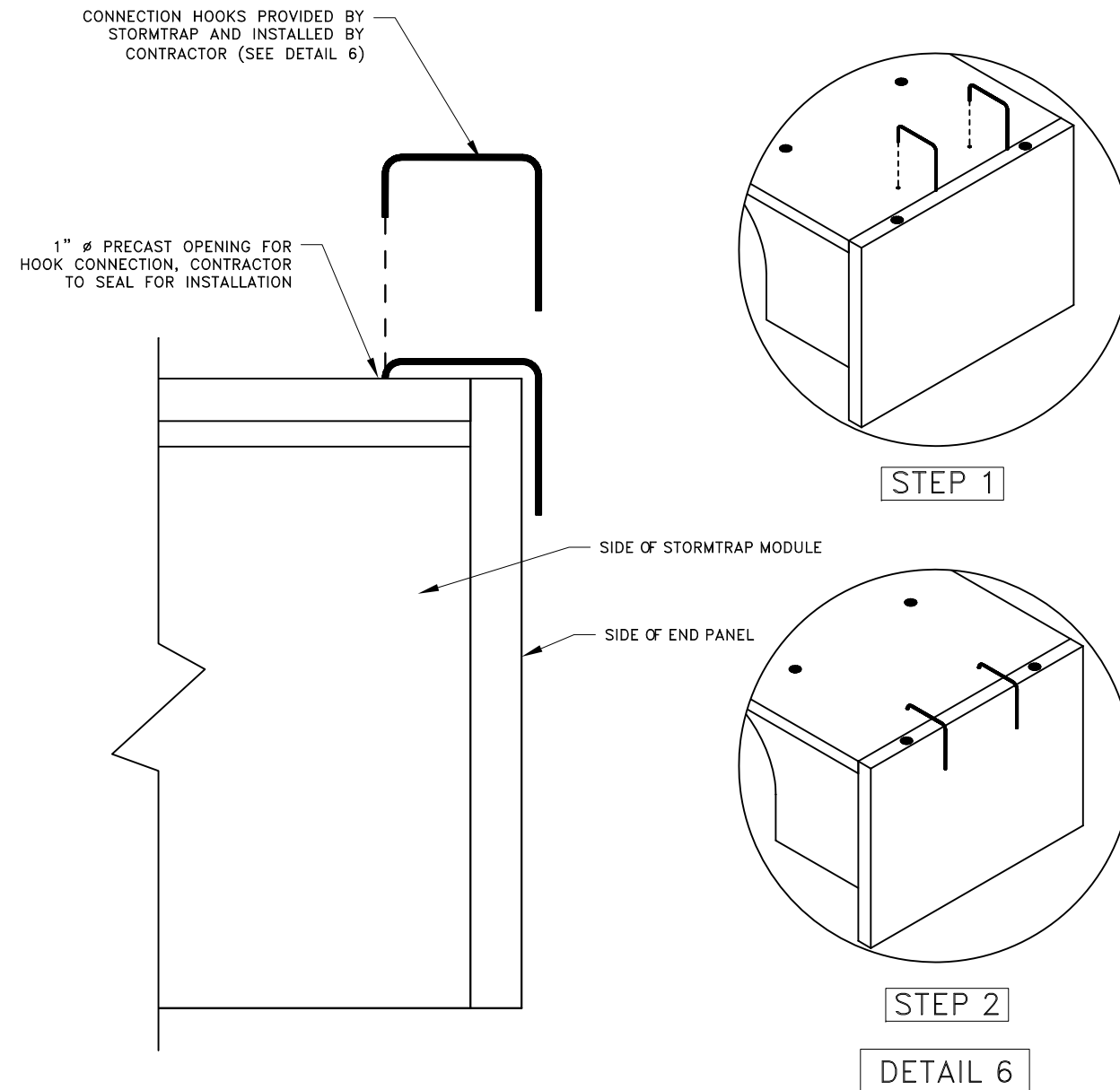

PANEL CONNECTION
ELEVATION VIEW

StormTrap

PATENTS LISTED AT: [\[HTTP://STORMTRAP.COM/PATENT\]](http://stormtrap.com/patent)

1287 WINDHAM PARKWAY
ROMEDEVILLE, IL 60446
P:815-941-4549 / F:331-318-5347

ENGINEER INFORMATION:

PASCO LARET SUITER
& ASSOCIATES
535 NORTH COAST HIGHWAY
SOLANA BEACH, CA
858-259-8212

PROJECT INFORMATION:

ENCINITAS BEACH HOTEL

LEUCADIA, CA

CURRENT ISSUE DATE:

7/19/2021

ISSUED FOR:

PRELIMINARY

REV.	DATE:	ISSUED FOR:	DWN BY:
1	7/9/2021	PRELIMINARY	RJL

SCALE:

NTS

SHEET TITLE:

DOUBLETRAP
INSTALLATION
SPECIFICATIONS

SHEET NUMBER:

3.1

ZONE CHART		
ZONES	ZONE DESCRIPTIONS	REMARKS
ZONE 1	FOUNDATION AGGREGATE	#5 (3/8") STONE AGGREGATE (SEE NOTE 4 FOR DESCRIPTION)
ZONE 2	BACKFILL	UNIFIED SOILS CLASSIFICATION (GW, GP, SW, SP) OR SEE BELOW FOR APPROVED BACKFILL OPTIONS
ZONE 3	FINAL COVER OVERTOP	MATERIALS NOT TO EXCEED 120 PCF

FILL DEPTH	TRACK WIDTH	MAX VEHICLE WEIGHT (KIPS)	MAX GROUND PRESSURE
12"	12"	51.8	1690 psf
	18"	56.1	1219 psf
	24"	68.1	1111 psf
	30"	76.7	1000 psf
	36"	85.0	924 psf

NOTE:
TRACK LENGTH NOT TO EXCEED 15'-4".
ONLY TWO TRACKS PER VEHICLE.

STORMTRAP ZONE INSTALLATION SPECIFICATIONS/PROCEDURES

1. THE FILL PLACED AROUND THE STORMTRAP MODULES MUST BE DEPOSITED ON BOTH SIDES AT THE SAME TIME AND TO APPROXIMATELY THE SAME ELEVATION. AT NO TIME SHALL THE FILL BEHIND ONE SIDE WALL BE MORE THAN 2'-0" HIGHER THAN THE FILL ON THE OPPOSITE SIDE. BACKFILL SHALL EITHER BE COMPACTED AND/OR VIBRATED TO ENSURE THAT BACKFILL AGGREGATE/STONE MATERIAL IS WELL SEATED AND PROPERLY INTER LOCKED. CARE SHALL BE TAKEN TO PREVENT ANY WEDGING ACTION AGAINST THE STRUCTURE, AND ALL SLOPES WITHIN THE AREA TO BE BACKFILLED MUST BE STEPPED OR SERRATED TO PREVENT WEDGING ACTION. CARE SHALL ALSO BE TAKEN AS NOT TO DISRUPT THE JOINT WRAP FROM THE JOINT DURING THE BACKFILL PROCESS. BACKFILL MUST BE FREE-DRAINING MATERIAL. SEE ZONE 2 BACKFILL CHART ON THIS PAGE FOR APPROVED BACKFILL OPTIONS. IF NATIVE EARTH IS SUSCEPTIBLE TO MIGRATION, CONFIRM WITH GEOTECHNICAL ENGINEER AND PROVIDE PROTECTION AS REQUIRED (PROVIDED BY OTHERS).
2. DURING PLACEMENT OF MATERIAL OVERTOP THE SYSTEM, AT NO TIME SHALL MACHINERY BE USED OVERTOP THAT EXCEEDS THE DESIGN LIMITATIONS OF THE SYSTEM. WHEN PLACEMENT OF MATERIAL OVERTOP, MATERIAL SHALL BE PLACED SUCH THAT THE DIRECTION OF PLACEMENT IS PARALLEL WITH THE OVERALL LONGITUDINAL DIRECTION OF THE SYSTEM WHENEVER POSSIBLE.
3. THE FILL PLACED OVERTOP THE SYSTEM SHALL BE PLACED AT A MINIMUM OF 6" LIFTS. AT NO TIME SHALL MACHINERY OR VEHICLES GREATER THAN THE DESIGN HS-20 LOADING CRITERIA TRAVEL OVERTOP THE SYSTEM WITHOUT THE MINIMUM DESIGN COVERAGE. IF TRAVEL IS NECESSARY OVERTOP THE SYSTEM PRIOR TO ACHIEVING THE MINIMUM DESIGN COVER, IT MAY BE NECESSARY TO REDUCE THE ULTIMATE LOAD/BURDEN OF THE OPERATING MACHINERY SO AS TO NOT EXCEED THE DESIGN CAPACITY OF THE SYSTEM. IN SOME CASES, IN ORDER TO ACHIEVE REQUIRED COMPACTION, HAND COMPACTION MAY BE NECESSARY IN ORDER NOT TO EXCEED THE ALLOTTED DESIGN LOADING. SEE CHART FOR TRACKED VEHICLE WIDTH AND ALLOWABLE MAXIMUM PRESSURE PER TRACK.
4. STONE AGGREGATE FOUNDATION IN ZONE 1 IS RECOMMENDED FOR LEVELING PURPOSES ONLY (OPTIONAL).

APPROVED ZONE 2 BACKFILL OPTIONS	
OPTION	REMARKS
3/4" STONE AGGREGATE	THE STONE AGGREGATE SHALL CONSIST OF CLEAN AND FREE DRAINING ANGULAR MATERIAL. THE SIZE OF THIS MATERIAL SHALL HAVE 100% PASSING THE 1" SIEVE WITH 0% TO 5% PASSING THE #8 SIEVE. THIS MATERIAL SHALL BE SEPARATED FROM NATIVE MATERIAL USING GEOFABRIC AROUND THE PERIMETER OF THE BACKFILL (ASTM SIZE #57) AS DETERMINED BY THE GEOTECHNICAL ENGINEER.
SAND	IMPORTED PURE SAND IS PERMITTED TO BE USED AS BACKFILL IF IT IS CLEAN AND FREE DRAINING. THE SAND USED FOR BACKFILLING SHALL HAVE LESS THAN 40% PASSING #40 SIEVE AND LESS THAN 5% PASSING #200 SIEVE. THIS MATERIAL SHALL BE SEPARATED FROM NATIVE MATERIAL USING GEOFABRIC AROUND THE PERIMETER OF THE SAND BACKFILL.
CRUSHED CONCRETE AGGREGATE	CLEAN, FREE DRAINING CRUSHED CONCRETE AGGREGATE MATERIAL CAN BE USED AS BACKFILL FOR STORMTRAP'S MODULES. THE SIZE OF THIS MATERIAL SHALL HAVE 100% PASSING THE 1" SIEVE WITH 0% TO 5% PASSING THE #8 SIEVE. THIS MATERIAL SHALL BE SEPARATED FROM NATIVE MATERIAL USING GEOFABRIC AROUND THE PERIMETER OF THE BACKFILL.
ROAD PACK	STONE AGGREGATE 100% PASSING THE 1-1/2" SIEVE WITH LESS THAN 12% PASSING THE #200 SIEVE (ASTM SIZE #467). GEOFABRIC AS PER GEOTECHNICAL ENGINEER RECOMMENDATION.

StormTrap
 PATENTS LISTED AT: [HTTP://STORMTRAP.COM/PATENT]
 1287 WINDHAM PARKWAY
 ROMEVILLE, IL 60446
 P:815-941-4549 / F:331-318-5347

ENGINEER INFORMATION:
 PASCO LARET SUITER
 & ASSOCIATES
 535 NORTH COAST HIGHWAY
 SOLANA BEACH, CA
 858-259-8212

PROJECT INFORMATION:
 ENCINITAS BEACH HOTEL

 LEUCADIA, CA

CURRENT ISSUE DATE:
 7/19/2021

ISSUED FOR:
 PRELIMINARY

REV.	DATE:	ISSUED FOR:	DWN BY:
1	7/9/2021	PRELIMINARY	RJL

SCALE:
 NTS

SHEET TITLE:
 DOUBLETRAP
 BACKFILL
 SPECIFICATIONS

SHEET NUMBER:
 4.0

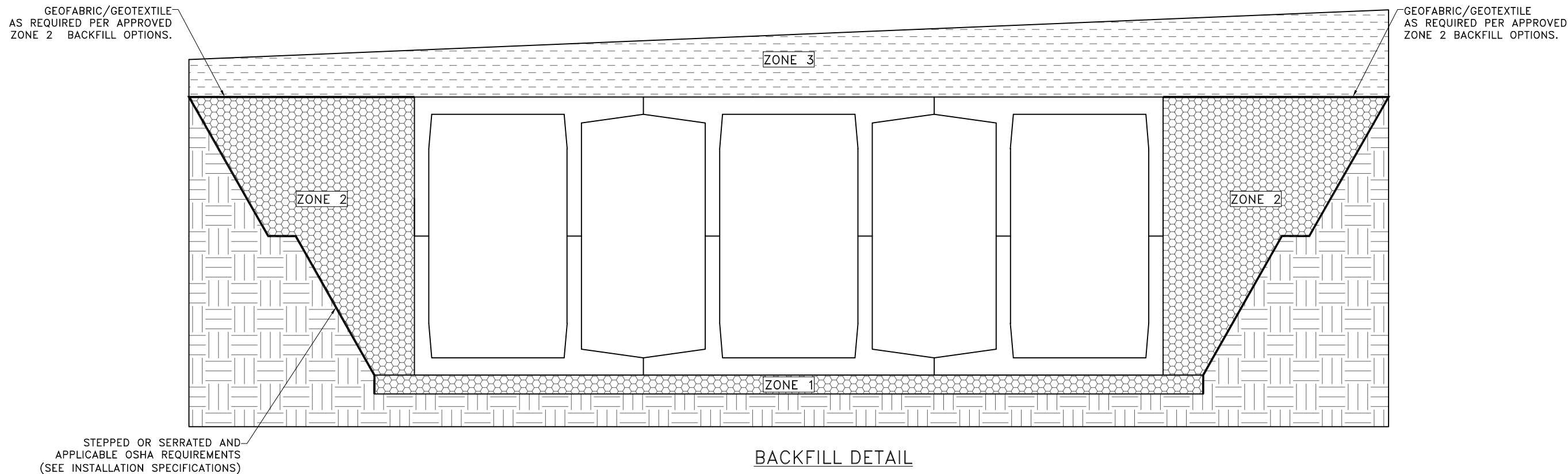

**RECOMMENDED
ACCESS OPENING SPECIFICATION**

1. A TYPICAL ACCESS OPENING FOR THE STORMTRAP SYSTEM ARE 2'-0" IN DIAMETER. ACCESS OPENINGS LARGER THAN 3'-0" IN DIAMETER NEED TO BE APPROVED BY STORMTRAP. ALL OPENINGS MUST RETAIN AT LEAST 1'-0" OF CLEARANCE FROM THE END OF THE STORMTRAP MODULE UNLESS NOTED OTHERWISE. ALL ACCESS OPENINGS TO BE LOCATED ON INSIDE LEG UNLESS OTHERWISE SPECIFIED.
2. PLASTIC COATED STEEL STEPS PRODUCED BY M.A. INDUSTRIES PART #PS3-PFC OR APPROVED EQUAL (SEE STEP DETAIL) ARE PROVIDED INSIDE ANY MODULE WHERE DEEMED NECESSARY. THE HIGHEST STEP IN THE MODULE IS TO BE PLACED A DISTANCE OF 1'-0" FROM THE INSIDE EDGE OF THE STORMTRAP MODULES. ALL ENSUING STEPS SHALL BE PLACED AT A DISTANCE BETWEEN 10" MIN AND 14" MAX BETWEEN THEM. STEPS MAY BE MOVED OR ALTERED TO AVOID OPENINGS OR OTHER IRREGULARITIES IN THE MODULE.
3. STORMTRAP LIFTING INSERTS MAY BE RELOCATED TO AVOID INTERFERENCE WITH ACCESS OPENINGS OR THE CENTER OF GRAVITY OF THE MODULE AS NEEDED.
4. STORMTRAP ACCESS OPENINGS MAY BE RELOCATED TO AVOID INTERFERENCE WITH INLET AND/OR OUTLET PIPE OPENINGS SO PLACEMENT OF STEPS IS ATTAINABLE.
5. ACCESS OPENINGS SHOULD BE LOCATED IN ORDER TO MEET THE APPROPRIATE MUNICIPAL REQUIREMENTS. STORMTRAP RECOMMENDS AT LEAST TWO ACCESS OPENINGS PER SYSTEM FOR ACCESS AND INSPECTION.
6. USE PRECAST ADJUSTING RINGS AS NEEDED TO MEET GRADE. STORMTRAP RECOMMENDS FOR COVER OVER 2' TO USE PRECAST BARREL OR CONE SECTIONS. (PROVIDED BY OTHERS)

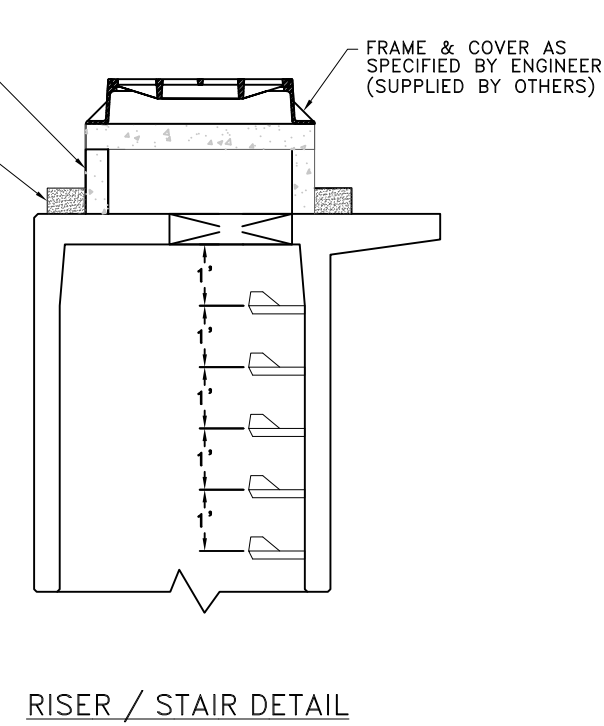
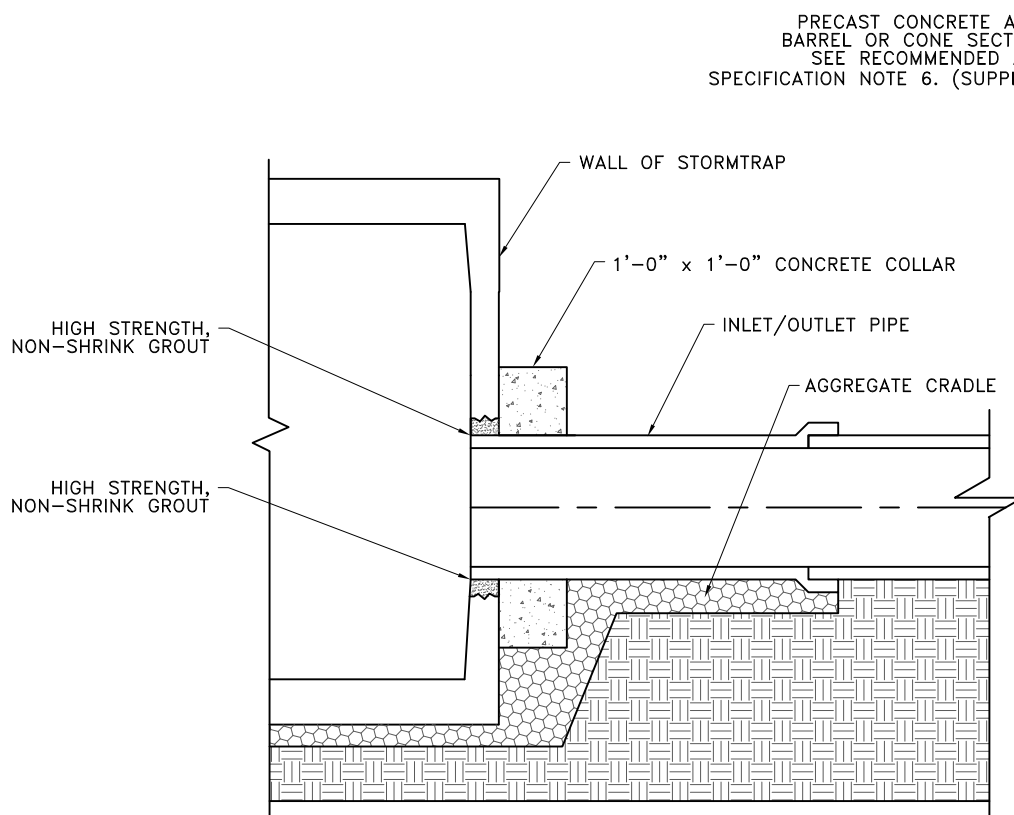

**RECOMMENDED
PIPE OPENING SPECIFICATION**

1. MINIMUM EDGE DISTANCE FOR AN OPENING ON THE OUTSIDE WALL SHALL BE NO LESS THAN 1'-0".
2. MAXIMUM OPENING SIZE TO BE DETERMINED BY THE MODULE HEIGHT. PREFERRED OPENING SIZE \varnothing 36" OR LESS. ANY OPENING NEEDED THAT DOES NOT FIT THIS CRITERIA SHALL BE BROUGHT TO THE ATTENTION OF STORMTRAP FOR REVIEW.
3. CONNECTING PIPES SHALL BE INSTALLED WITH A 1'-0" CONCRETE COLLAR, AND AN AGGREGATE CRADLE FOR AT LEAST ONE PIPE LENGTH (SEE PIPE CONNECTION DETAIL). A STRUCTURAL GRADE CONCRETE OR HIGH STRENGTH, NON-SHRINK GROUT WITH A MINIMUM 28 DAY COMPRESSIVE STRENGTH OF 3000 PSI SHALL BE USED.
4. THE ANNULAR SPACE BETWEEN THE PIPE AND THE HOLE SHALL BE FILLED WITH HIGH STRENGTH NON-SHRINK GROUT.

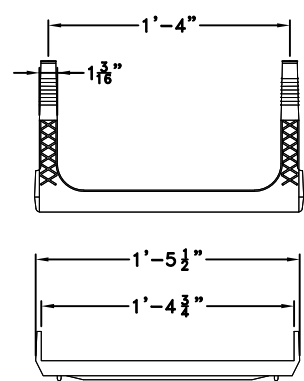
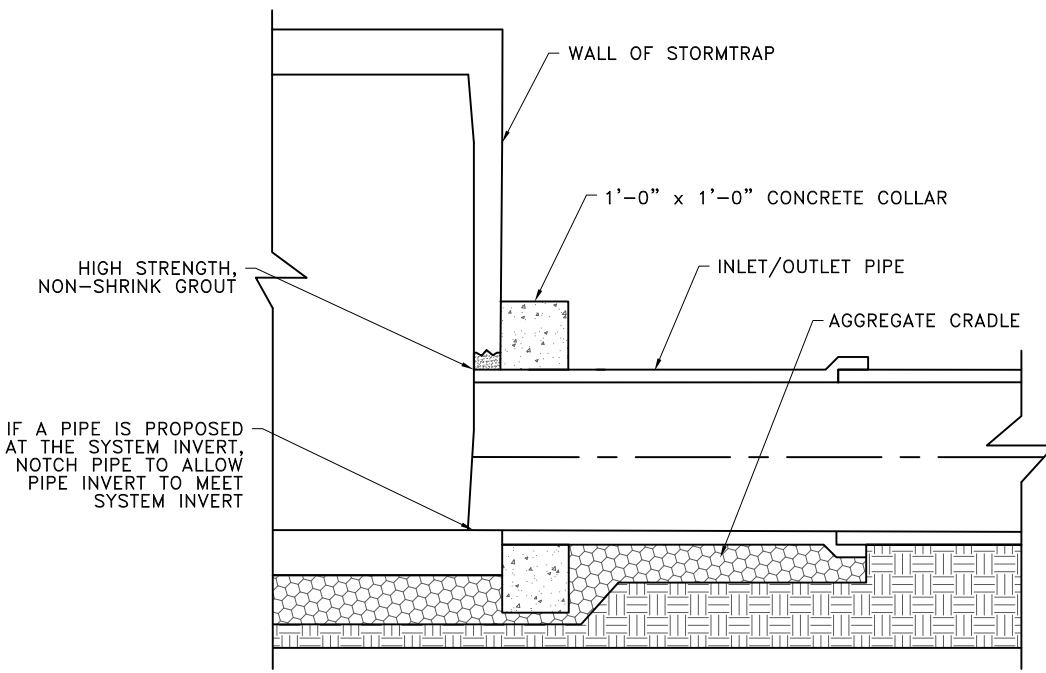

MEETS:
 OPSS 1351.08.02
 BNQ
 ASTM C-478.95a
 ASTM D4-101.95b
 AASHTO M-199
 ASTM 4A-15

STEP DETAIL

**RECOMMENDED PIPE
INSTALLATION INSTRUCTIONS**

1. CLEAN AND LIGHTLY LUBRICATE ALL OF THE PIPE TO BE INSERTED INTO STORMTRAP.
2. IF PIPE IS CUT, CARE SHOULD BE TAKEN TO ALLOW NO SHARP EDGES. BEVEL AND LUBRICATE LEAD END OF PIPE.
3. ALIGN CENTER OF PIPE TO CORRECT ELEVATION AND INSERT INTO OPENING.

NOTE: ALL ANCILLARY PRODUCTS/SPECIFICATIONS RECOMMENDED AND SHOWN ON THIS SHEET ARE RECOMMENDATIONS ONLY AND SUBJECT TO CHANGE PER THE INSTALLING CONTRACTOR AND/OR PER LOCAL MUNICIPAL CODE/REQUIREMENTS.

PIPE CONNECTION DETAIL

StormTrap

PATENTS LISTED AT: [HTTP://STORMTRAP.COM/PATENT]

1287 WINDHAM PARKWAY
 ROMEVILLE, IL 60446
 P:815-941-4549 / F:331-318-5347

ENGINEER INFORMATION:

PASCO LARET SUITER
 & ASSOCIATES
 535 NORTH COAST HIGHWAY
 SOLANA BEACH, CA
 858-259-8212

PROJECT INFORMATION:

ENCINITAS BEACH HOTEL

LEUCADIA, CA

CURRENT ISSUE DATE:

7/19/2021

ISSUED FOR:

PRELIMINARY

REV.	DATE:	ISSUED FOR:	DWN BY:
1	7/9/2021	PRELIMINARY	RJL

SCALE:

NTS

SHEET TITLE:

RECOMMENDED
 PIPE / ACCESS
 OPENING
 SPECIFICATIONS

SHEET NUMBER:

5.0

ENGINEER INFORMATION:

PASCO LARET SUITER
& ASSOCIATES
535 NORTH COAST HIGHWAY
SOLANA BEACH, CA
858-259-8212

PROJECT INFORMATION:

ENCINITAS BEACH HOTEL

LEUCADIA, CA

CURRENT ISSUE DATE:

7/19/2021

ISSUED FOR:

PRELIMINARY

REV.	DATE:	ISSUED FOR:	DWN BY:
1	7/9/2021	PRELIMINARY	RJL

SCALE:

NTS

SHEET TITLE:

DOUBLETRAP
MODULE TYPES

SHEET NUMBER:

6.0

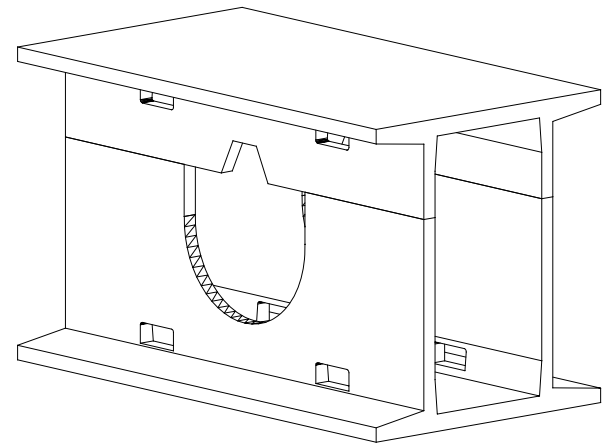

TYPE II

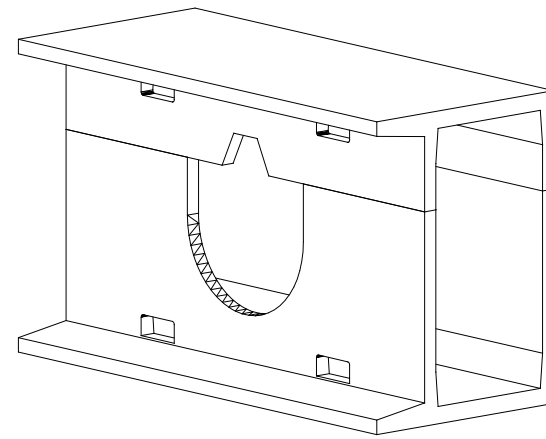

TYPE IV

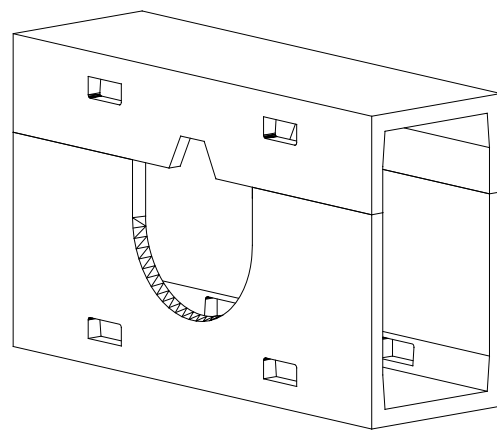

TYPE VII-2

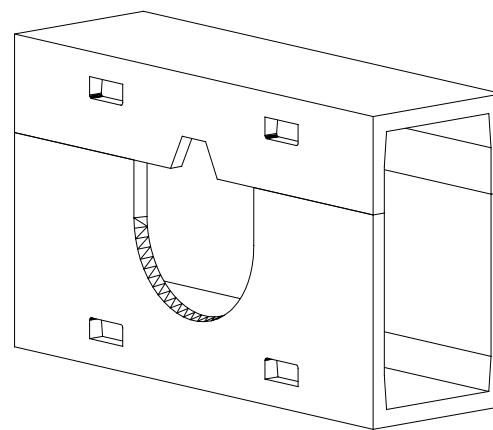

TYPE VII-4

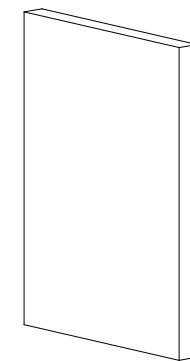

TYPE IV
END PANEL

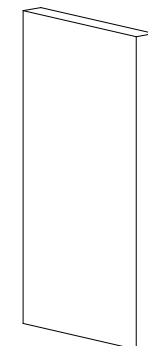

TYPE VII
END PANEL

NOTES:

1. OPENING LOCATIONS AND SHAPES MAY VARY.
2. SP - INDICATES A MODULE WITH MODIFICATIONS.
3. P - INDICATES A MODULE WITH A PANEL ATTACHMENT.
4. POCKET WINDOW OPENINGS ARE OPTIONAL.

StormTrap®

PATENTS LISTED AT: [HTTP://STORMTRAP.COM/PATENT]

1287 WINDHAM PARKWAY
 ROMEVILLE, IL 60446
 P:815-941-4549 / F:331-318-5347

ENGINEER INFORMATION:

PASCO LARET
 SUITER & ASSOCIATES
 535 N COAST HWY
 SOLANA BEACH, CA
 858-259-8212

PROJECT INFORMATION:

ENCINITAS BEACH HOTEL

LEUCADIA, CA

CURRENT ISSUE DATE:

3/9/2021

ISSUED FOR:

PRELIMINARY

REV.	DATE:	ISSUED FOR:	DWN BY:
3	3/9/2021	PRELIMINARY	RJL
2	12/11/2020	PRELIMINARY	RJL
1	8/26/2020	PRELIMINARY	NP

SCALE:

NTS

SHEET TITLE:

OUTLET CONTROL STRUCTURE

SHEET NUMBER:

7.0

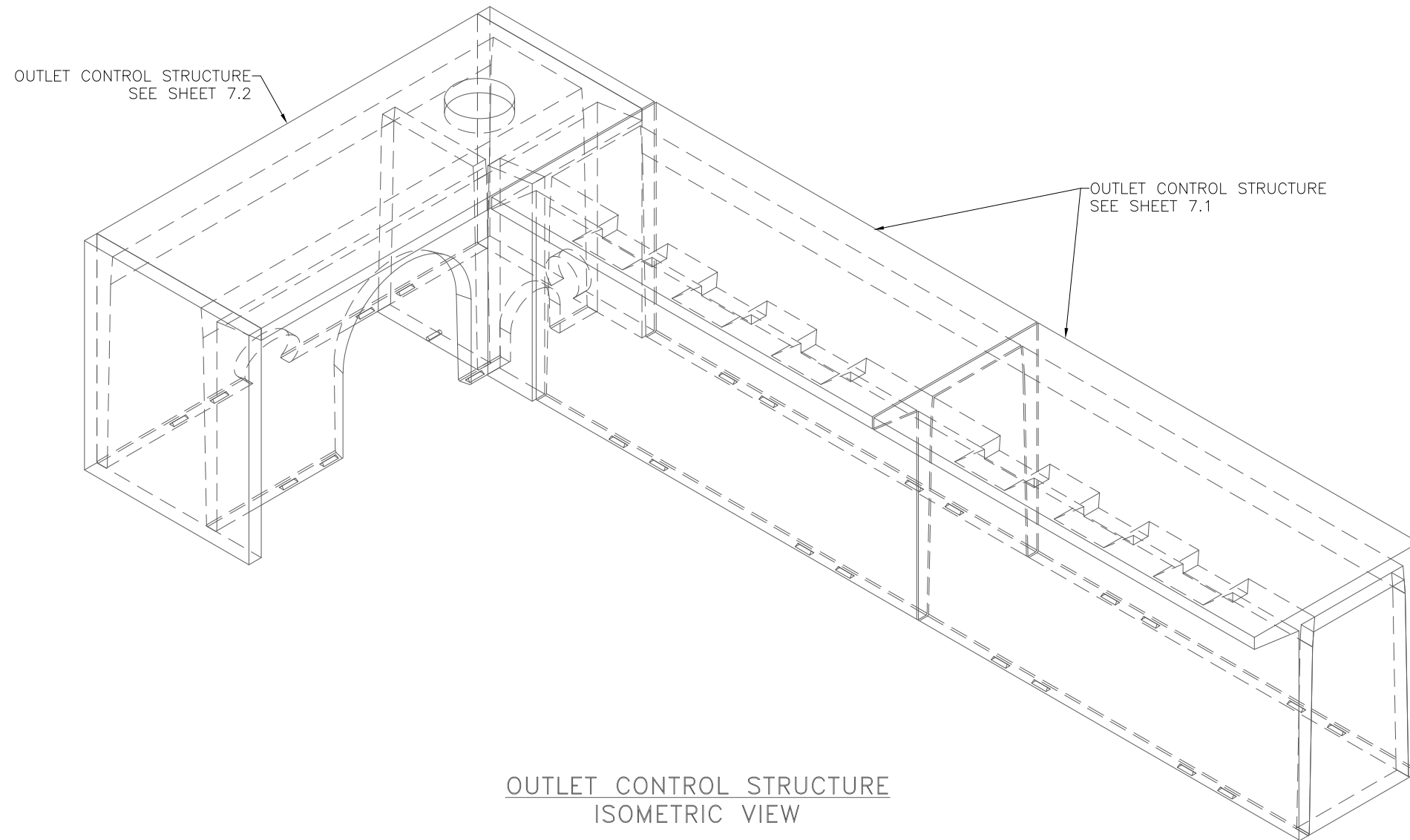

OUTLET CONTROL STRUCTURE
 ISOMETRIC VIEW

StormTrap

PATENTS LISTED AT: [HTTP://STORMTRAP.COM/PATENT]

1287 WINDHAM PARKWAY
 ROMEVILLE, IL 60446
 P:815-941-4549 / F:331-318-5347

ENGINEER INFORMATION:

PASCO LARET
 SUITER & ASSOCIATES
 535 N COAST HWY
 SOLANA BEACH, CA
 858-259-8212

PROJECT INFORMATION:

ENCINITAS BEACH HOTEL

LEUCADIA, CA

CURRENT ISSUE DATE:

3/9/2021

ISSUED FOR:

PRELIMINARY

REV.	DATE:	ISSUED FOR:	DWN BY:
3	3/9/2021	PRELIMINARY	RJL
2	12/11/2020	PRELIMINARY	RJL
1	8/26/2020	PRELIMINARY	NP

SCALE:

NTS

SHEET TITLE:

OUTLET CONTROL
 STRUCTURE

SHEET NUMBER:

7.1

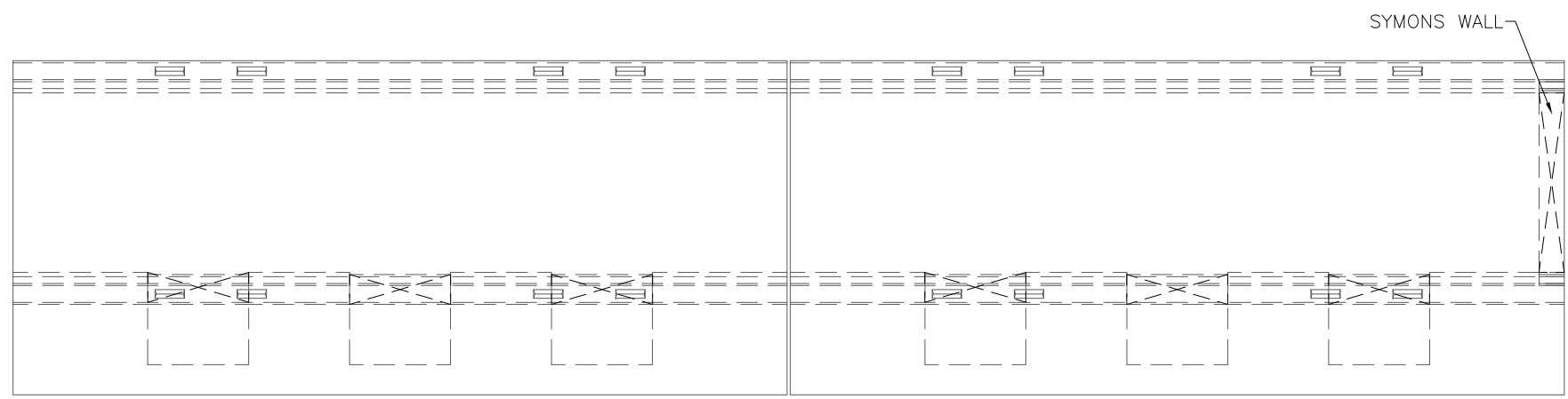

PLAN VIEW

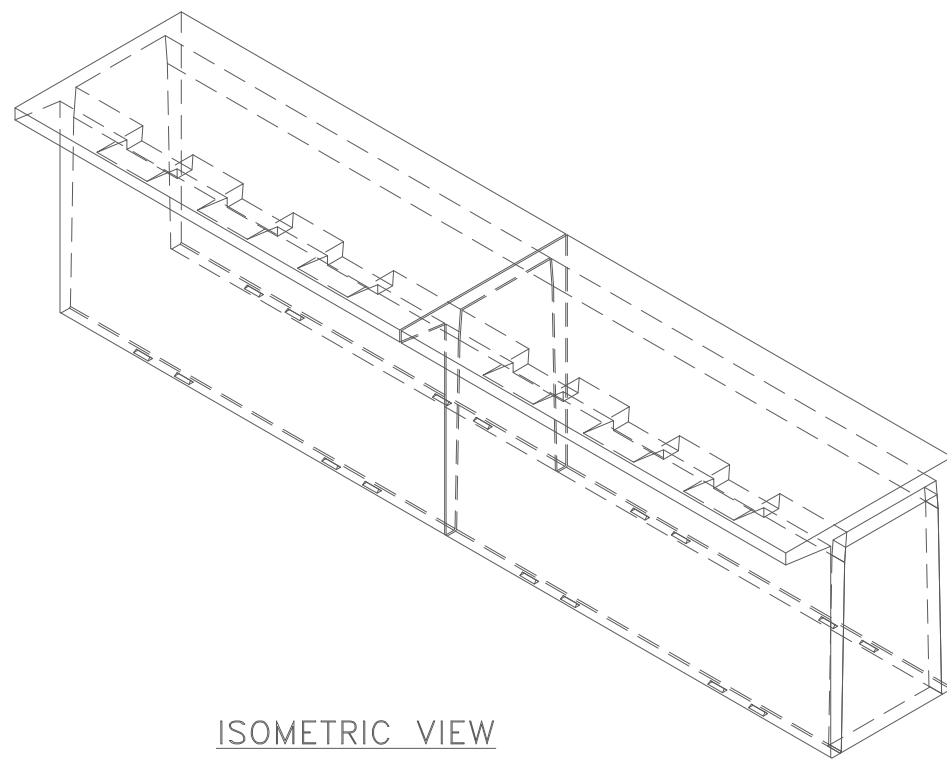

ISOMETRIC VIEW

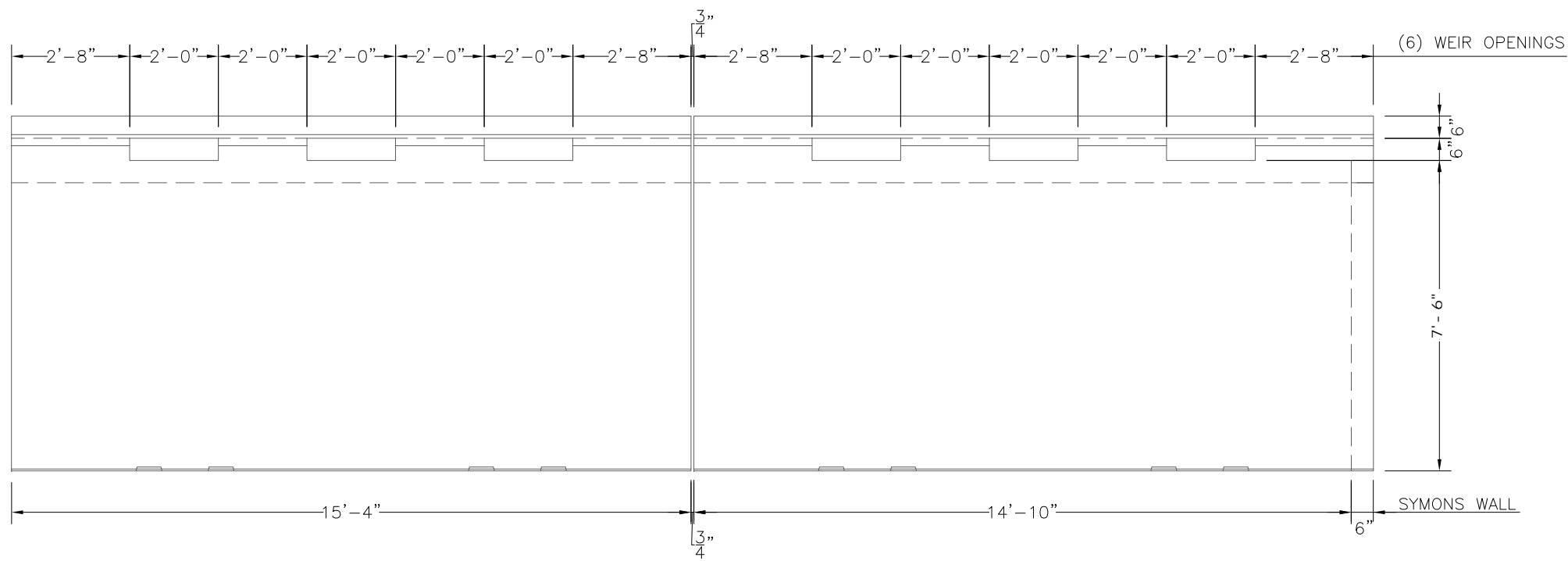

ELEVATION VIEW

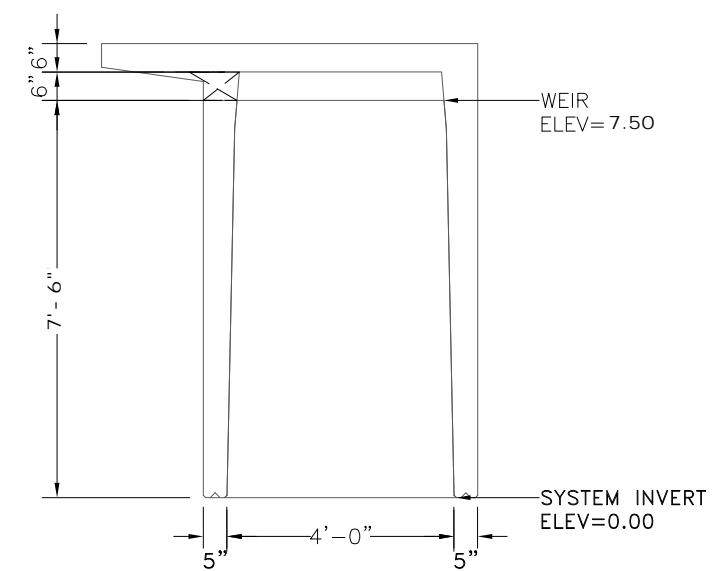

SIDE VIEW

StormTrap

PATENTS LISTED AT: [HTTP://STORMTRAP.COM/PATENT]

1287 WINDHAM PARKWAY
ROMEONVILLE, IL 60446
P:815-941-4549 / F:331-318-5347

ENGINEER INFORMATION:

PASCO LARET
SUITER & ASSOCIATES
535 N COAST HWY
SOLANA BEACH, CA
858-259-8212

PROJECT INFORMATION:

ENCINITAS BEACH HOTEL

LEUCADIA, CA

CURRENT ISSUE DATE:

3/9/2021

ISSUED FOR:

PRELIMINARY

REV.	DATE:	ISSUED FOR:	DWN BY:
3	3/9/2021	PRELIMINARY	RJL
2	12/11/2020	PRELIMINARY	RJL
1	8/26/2020	PRELIMINARY	NP

SCALE:

NTS

SHEET TITLE:

OUTLET CONTROL
STRUCTURE

SHEET NUMBER:

7.2

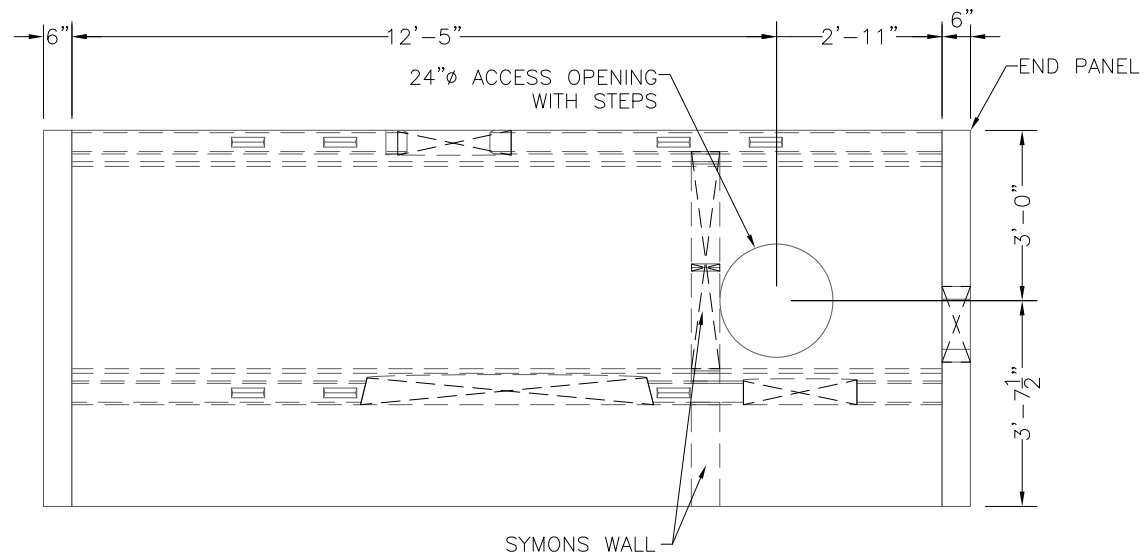

PLAN VIEW

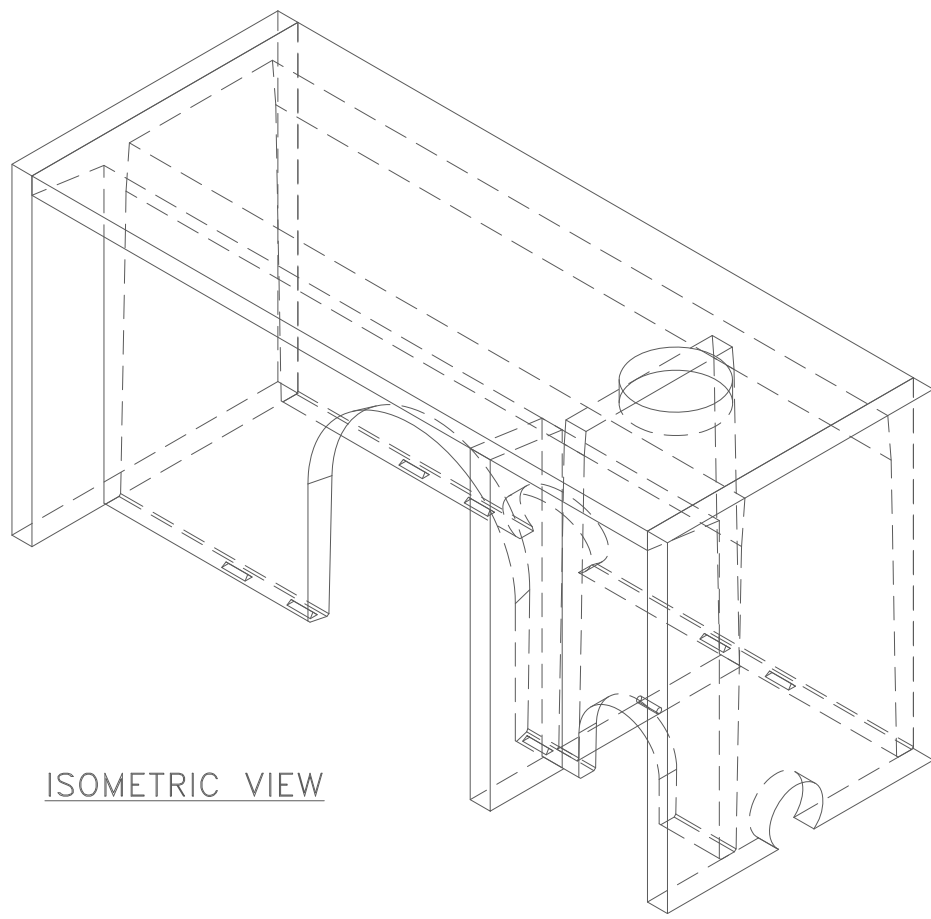

ISOMETRIC VIEW

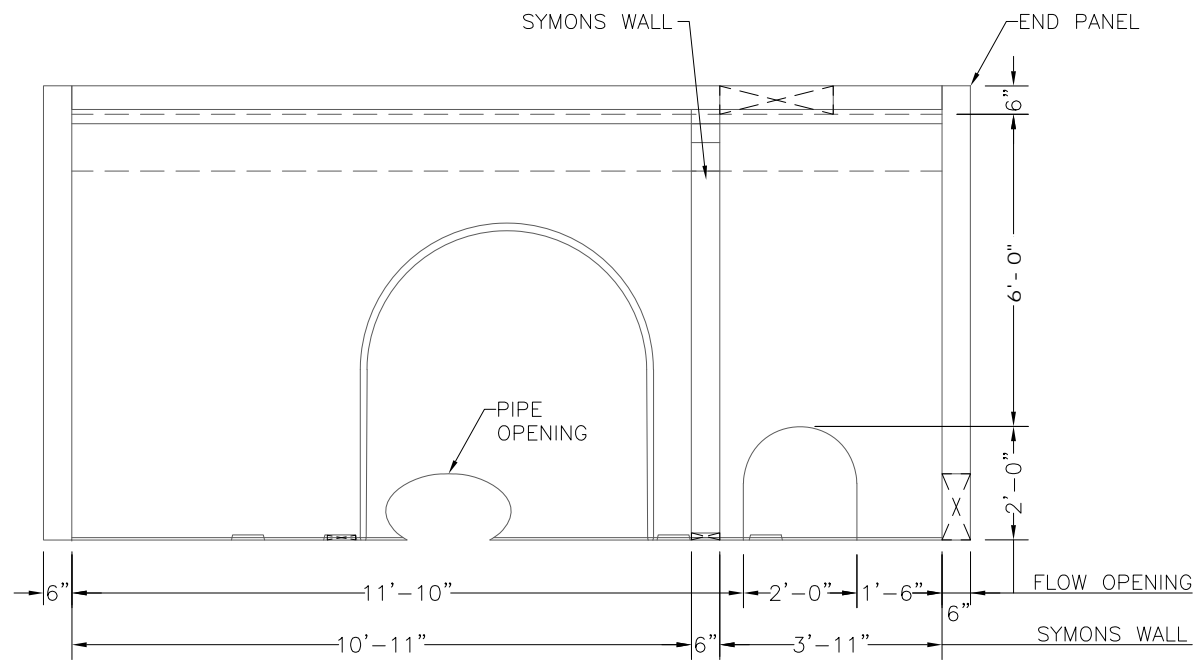

ELEVATION VIEW

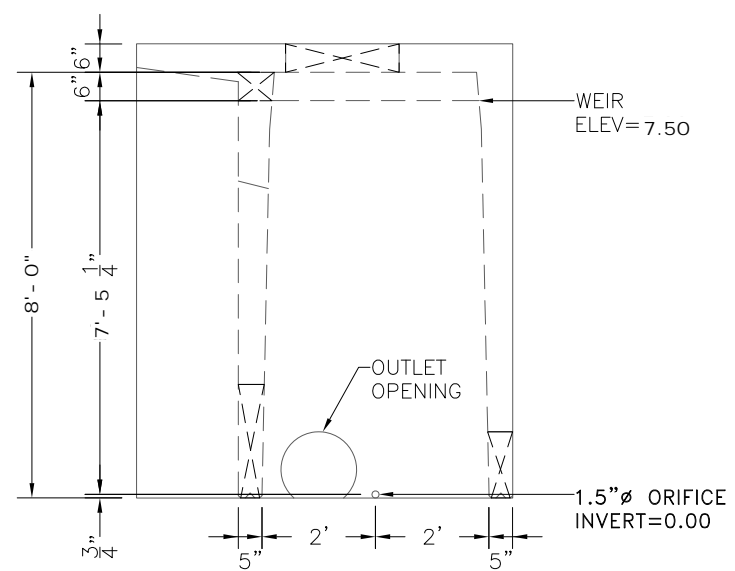

SIDE VIEW

8'-0" STORMTRAP STAGE STORAGE BREAKDOWN

Elevation	Storage (cubic-feet)
44.31	0
44.56	786.68
44.81	1,573.37
45.06	2,360.05
45.31	3,146.74
45.56	3,933.42
45.81	4,720.11
46.06	5,506.79
46.31	6,293.48
46.56	7,080.16
46.81	7,866.85
47.06	8,653.53
47.31	9,440.22
47.56	10,226.90
47.81	11,013.59
48.06	11,800.27
48.31	12,586.96
48.56	13,373.64
48.81	14,160.33
49.06	14,947.01
49.31	15,733.70
49.56	16,520.38
49.81	17,307.07
49.99	17,866.49
50.06	18,093.75
50.31	18,880.44
50.56	19,667.12
50.81	20,453.81
51.06	21,240.49
51.31	22,027.18
51.56	22,813.86
51.81	23,600.55
52.06	24,387.22
52.31	25,173.92

3.5 Hydromodification Analysis

To satisfy the requirements of the MS4 Permit, a hydromodification management strategy has been developed for the project based on the Final Hydromodification Management Plan dated March 2011, (Final HMP). Refer to the Stormwater Quality Management Plan (SWQMP) for the project titled “Stormwater Quality Management Plan for Leucadia 101 Mixed Use” dated July 2021 prepared by Pasco Laret Suiter & Associates for the detailed HMP analysis.

3.6 Storm Water Pollutant Control

To meet the requirements of the MS4 Permit, the project has been designed to treat onsite storm water pollutants contained in the volume of runoff from a 24-hour, 85th percentile storm event by slowly infiltrating runoff through an engineered soil layer and gravel layer. Refer to the Stormwater Quality Management Plan (SWQMP) for the project titled “Stormwater Quality Management Plan for Leucadia 101 Mixed Use” dated July 2021 prepared by Pasco Laret Suiter & Associates for the detailed pollutant control calculations.

APPENDIX A

Hydrology Support Material

County of San Diego Hydrology Manual



Rainfall Isopleths

100 Year Rainfall Event - 6 Hours



THIS MAP IS PROVIDED WITHOUT WARRANTY OF ANY KIND, EITHER EXPRESS OR IMPLIED, INCLUDING BUT NOT LIMITED TO, WARRANTIES OF MERCHANTABILITY AND FITNESS FOR A PARTICULAR PURPOSE. Copyright SanGIS. All Rights Reserved.
This product may contain information from the SANDAG Regional Hydrologic Data System. No part of this product may be reproduced without the written permission of SANDAG.
This product may contain information which has been reproduced with permission granted by Thomas Brothers Maps.

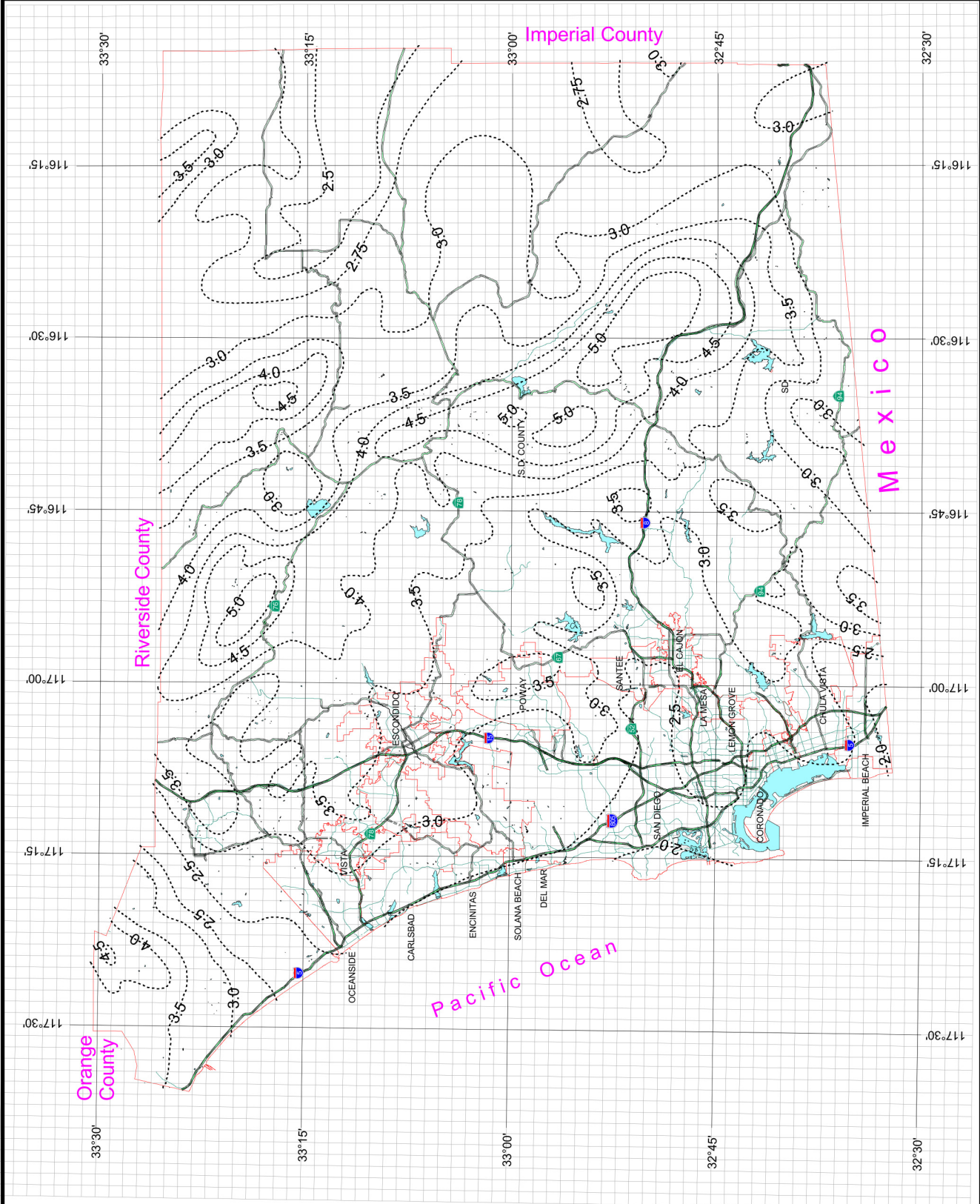

**Table 3-1
RUNOFF COEFFICIENTS FOR URBAN AREAS**

Land Use		Runoff Coefficient "C"				
NRCS Elements	County Elements	% IMPER.	Soil Type			
			A	B	C	D
Undisturbed Natural Terrain (Natural)	Permanent Open Space	0*	0.20	0.25	0.30	0.35
Low Density Residential (LDR)	Residential, 1.0 DU/A or less	10	0.27	0.32	0.36	0.41
Low Density Residential (LDR)	Residential, 2.0 DU/A or less	20	0.34	0.38	0.42	0.46
Low Density Residential (LDR)	Residential, 2.9 DU/A or less	25	0.38	0.41	0.45	0.49
Medium Density Residential (MDR)	Residential, 4.3 DU/A or less	30	0.41	0.45	0.48	0.52
Medium Density Residential (MDR)	Residential, 7.3 DU/A or less	40	0.48	0.51	0.54	0.57
Medium Density Residential (MDR)	Residential, 10.9 DU/A or less	45	0.52	0.54	0.57	0.60
Medium Density Residential (MDR)	Residential, 14.5 DU/A or less	50	0.55	0.58	0.60	0.63
High Density Residential (HDR)	Residential, 24.0 DU/A or less	65	0.66	0.67	0.69	0.71
High Density Residential (HDR)	Residential, 43.0 DU/A or less	80	0.76	0.77	0.78	0.79
Commercial/Industrial (N. Com)	Neighborhood Commercial	80	0.76	0.77	0.78	0.79
Commercial/Industrial (G. Com)	General Commercial	85	0.80	0.80	0.81	0.82
Commercial/Industrial (O.P. Com)	Office Professional/Commercial	90	0.83	0.84	0.84	0.85
Commercial/Industrial (Limited I.)	Limited Industrial	90	0.83	0.84	0.84	0.85
Commercial/Industrial (General I.)	General Industrial	95	0.87	0.87	0.87	0.87

*The values associated with 0% impervious may be used for direct calculation of the runoff coefficient as described in Section 3.1.2 (representing the pervious runoff coefficient, Cp, for the soil type), or for areas that will remain undisturbed in perpetuity. Justification must be given that the area will remain natural forever (e.g., the area is located in Cleveland National Forest).

DU/A = dwelling units per acre

NRCS = National Resources Conservation Service

Hydrologic Soil Group—San Diego County Area, California

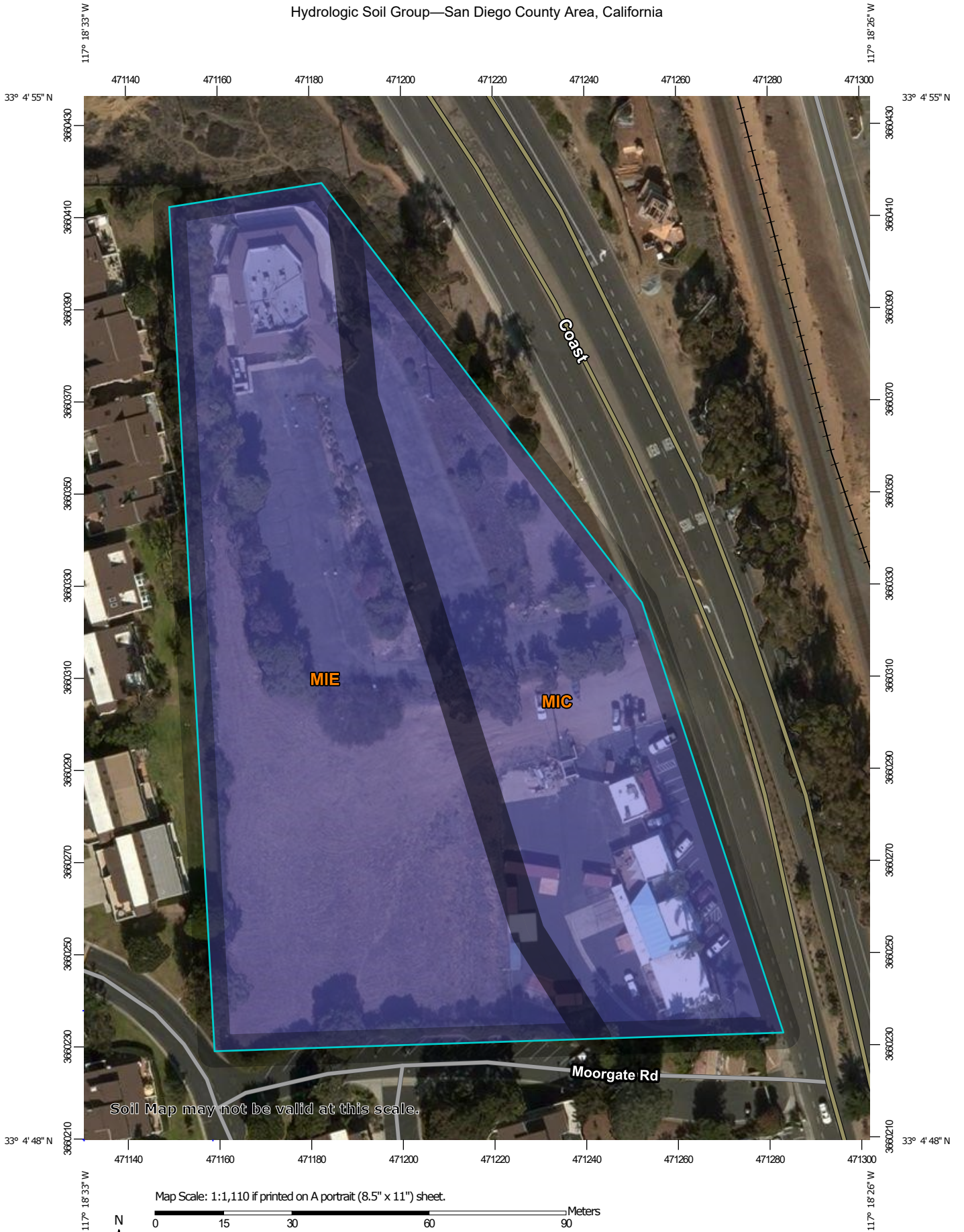

Soil Map may not be valid at this scale.



MAP LEGEND

Area of Interest (AOI)









 Area of Interest (AOI)

Soils

Soil Rating Polygons





 A
 A/D
 B
 B/D
 C
 C/D
 D
 Not rated or not available

Soil Rating Lines

 A
 A/D
 B
 B/D
 C
 C/D
 D
 Not rated or not available

Soil Rating Points





 A
 A/D
 B
 B/D

 C
 C/D
 D
 Not rated or not available

Water Features

 Streams and Canals

Transportation

 Rails
 Interstate Highways
 US Routes
 Major Roads
 Local Roads

Background

 Aerial Photography

MAP INFORMATION

The soil surveys that comprise your AOI were mapped at 1:24,000.

Warning: Soil Map may not be valid at this scale.

Enlargement of maps beyond the scale of mapping can cause misunderstanding of the detail of mapping and accuracy of soil line placement. The maps do not show the small areas of contrasting soils that could have been shown at a more detailed scale.

Please rely on the bar scale on each map sheet for map measurements.

Source of Map: Natural Resources Conservation Service
 Web Soil Survey URL:
 Coordinate System: Web Mercator (EPSG:3857)

Maps from the Web Soil Survey are based on the Web Mercator projection, which preserves direction and shape but distorts distance and area. A projection that preserves area, such as the Albers equal-area conic projection, should be used if more accurate calculations of distance or area are required.

This product is generated from the USDA-NRCS certified data as of the version date(s) listed below.

Soil Survey Area: San Diego County Area, California
 Survey Area Data: Version 14, Sep 16, 2019

Soil map units are labeled (as space allows) for map scales 1:50,000 or larger.

Date(s) aerial images were photographed: Nov 3, 2014—Nov 22, 2014

The orthophoto or other base map on which the soil lines were compiled and digitized probably differs from the background imagery displayed on these maps. As a result, some minor shifting of map unit boundaries may be evident.

Hydrologic Soil Group

Map unit symbol	Map unit name	Rating	Acres in AOI	Percent of AOI
MIC	Marina loamy coarse sand, 2 to 9 percent slopes	B	1.6	40.0%
MIE	Marina loamy coarse sand, 9 to 30 percent slopes	B	2.5	60.0%
Totals for Area of Interest			4.1	100.0%

Description

Hydrologic soil groups are based on estimates of runoff potential. Soils are assigned to one of four groups according to the rate of water infiltration when the soils are not protected by vegetation, are thoroughly wet, and receive precipitation from long-duration storms.

The soils in the United States are assigned to four groups (A, B, C, and D) and three dual classes (A/D, B/D, and C/D). The groups are defined as follows:

Group A. Soils having a high infiltration rate (low runoff potential) when thoroughly wet. These consist mainly of deep, well drained to excessively drained sands or gravelly sands. These soils have a high rate of water transmission.

Group B. Soils having a moderate infiltration rate when thoroughly wet. These consist chiefly of moderately deep or deep, moderately well drained or well drained soils that have moderately fine texture to moderately coarse texture. These soils have a moderate rate of water transmission.

Group C. Soils having a slow infiltration rate when thoroughly wet. These consist chiefly of soils having a layer that impedes the downward movement of water or soils of moderately fine texture or fine texture. These soils have a slow rate of water transmission.

Group D. Soils having a very slow infiltration rate (high runoff potential) when thoroughly wet. These consist chiefly of clays that have a high shrink-swell potential, soils that have a high water table, soils that have a claypan or clay layer at or near the surface, and soils that are shallow over nearly impervious material. These soils have a very slow rate of water transmission.

If a soil is assigned to a dual hydrologic group (A/D, B/D, or C/D), the first letter is for drained areas and the second is for undrained areas. Only the soils that in their natural condition are in group D are assigned to dual classes.

Rating Options

Aggregation Method: Dominant Condition

Component Percent Cutoff: None Specified

Tie-break Rule: Higher

APPENDIX B

Hydraulic Calculations

3161 Leucadia 101
7/16/2021

West Ditch

Q = CIA

P6 (in)

	Area (sq ft)	C value	A x C value	Weighted C
Impervious	40	0.9	36	
Pervious	10244	0.25	2561	
Total (sf)	10284		2597	0.25
Total (ac)	0.24			

Tc =

I (in/hr) =

Q (cfs) =

Hydraulic Analysis Report

Project Data

Project Title: 3161 Leucadia 101

Channel Analysis: West Ditch

Input Parameters

Channel Type: Triangular
Side Slope 1 (Z1): 1.2500 ft/ft
Side Slope 2 (Z2): 1.2500 ft/ft
Longitudinal Slope: 0.2300 ft/ft
Manning's n: 0.0150
Flow: 0.4000 cfs

Result Parameters

Depth: 0.1940 ft
Area of Flow: 0.0470 ft²
Wetted Perimeter: 0.6210 ft
Hydraulic Radius: 0.0757 ft
Average Velocity: 8.5046 ft/s
Top Width: 0.4849 ft
Froude Number: 4.8125
Critical Depth: 0.3637 ft
Critical Velocity: 2.4197 ft/s
Critical Slope: 0.0081 ft/ft
Critical Top Width: 0.91 ft
Calculated Max Shear Stress: 2.7839 lb/ft²
Calculated Avg Shear Stress: 1.0869 lb/ft²

3161 Leucadia 101
7/16/2021

South Ditch

Q = CIA

P6 (in) 2.5

	Area (sq ft)	C value	A x C value	Weighted C
Impervious	717	0.9	645.3	0.34
Pervious	4705	0.25	1176.25	
Total (sf)	5422		1821.55	
Total (ac)	0.12			

Tc = 5.0

I (in/hr) = 6.6

Q (cfs) = 0.3

Channel Analysis: South Ditch

Input Parameters

Channel Type: Triangular
Side Slope 1 (Z1): 1.2500 ft/ft
Side Slope 2 (Z2): 1.2500 ft/ft
Longitudinal Slope: 0.0100 ft/ft
Manning's n: 0.0150
Flow: 0.3000 cfs

Result Parameters

Depth: 0.3135 ft
Area of Flow: 0.1228 ft²
Wetted Perimeter: 1.0036 ft
Hydraulic Radius: 0.1224 ft
Average Velocity: 2.4422 ft/s
Top Width: 0.7837 ft
Froude Number: 1.0871
Critical Depth: 0.3241 ft
Critical Velocity: 2.2844 ft/s
Critical Slope: 0.0084 ft/ft
Critical Top Width: 0.81 ft
Calculated Max Shear Stress: 0.1956 lb/ft²
Calculated Avg Shear Stress: 0.0764 lb/ft²

APPENDIX C

Existing and Proposed Hydrology Maps

EXISTING HYDROLOGY MAP

FENWAY N. HWY 101 - ENCINITAS, CA

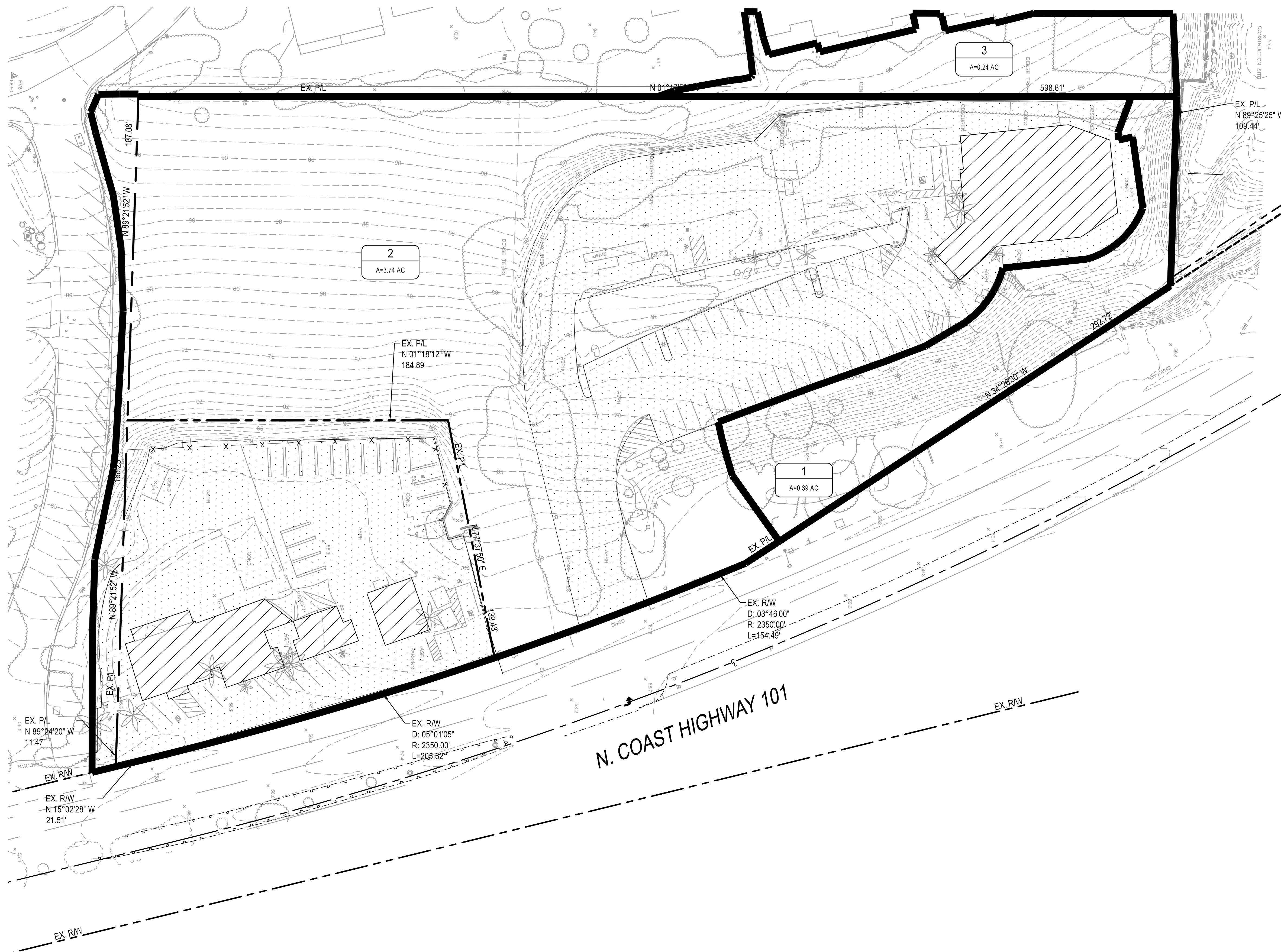

LEGEND	
	LIMITS OF EXISTING BUILDING
	LIMITS OF EXISTING AC PAVEMENT
	STREET CENTERLINE
	RIGHT OF WAY
	PROPERTY BOUNDARY
	BASIN BOUNDARY
	EXISTING CONTOURS

AREA CALCULATIONS

DRAINAGE BASIN 1 TOTAL AREA = 17,025 SF
 IMPERVIOUS AREA = 0 SF
 PERVIOUS AREA = 17,025 SF
 PERCENT IMPERVIOUS = 0%
 SOIL CLASSIFICATION = B
 C_p (PER TABLE 3-1 OF THE SDCHM) = 0.25
 $C = 0.9(0\% \text{ IMPERVIOUS}) + C_p(1\% \text{ IMPERVIOUS}) = 0.9(0.00) + 0.25(1-0.00) = 0.25$

DRAINAGE BASIN 2 TOTAL AREA = 152,786 SF
 IMPERVIOUS AREA = 79,773 SF
 PERVIOUS AREA = 73,013 SF
 PERCENT IMPERVIOUS = 52%
 SOIL CLASSIFICATION = B
 C_p (PER TABLE 3-1 OF THE SDCHM) = 0.25
 $C = 0.9(52\% \text{ IMPERVIOUS}) + C_p(1\% \text{ IMPERVIOUS}) = 0.9(0.52) + 0.25(1-0.52) = 0.59$

DRAINAGE BASIN 3 TOTAL AREA = 10,243 SF
 IMPERVIOUS AREA = 0 SF
 PERVIOUS AREA = 10,243 SF
 PERCENT IMPERVIOUS = 0%
 SOIL CLASSIFICATION = B
 C_p (PER TABLE 3-1 OF THE SDCHM) = 0.25
 $C = 0.9(0\% \text{ IMPERVIOUS}) + C_p(1\% \text{ IMPERVIOUS}) = 0.9(0.00) + 0.25(1-0.00) = 0.25$

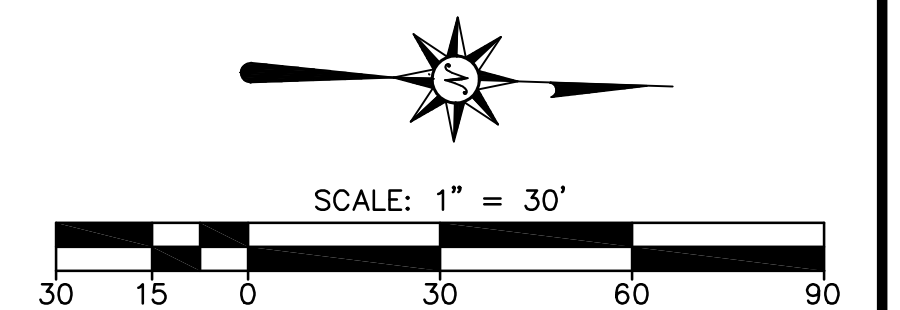

EXISTING HYDROLOGY MAP
 FENWAY N. HWY 101
 CITY OF ENCINITAS
PASCO LARET SUITER
 & ASSOCIATES
 San Diego | Solana Beach | Orange County
 Phone 949.661.6695 | www.pisaengineering.com

PROPOSED HYDROLOGY MAP

FENWAY N. HWY 101 - ENCINITAS, CA

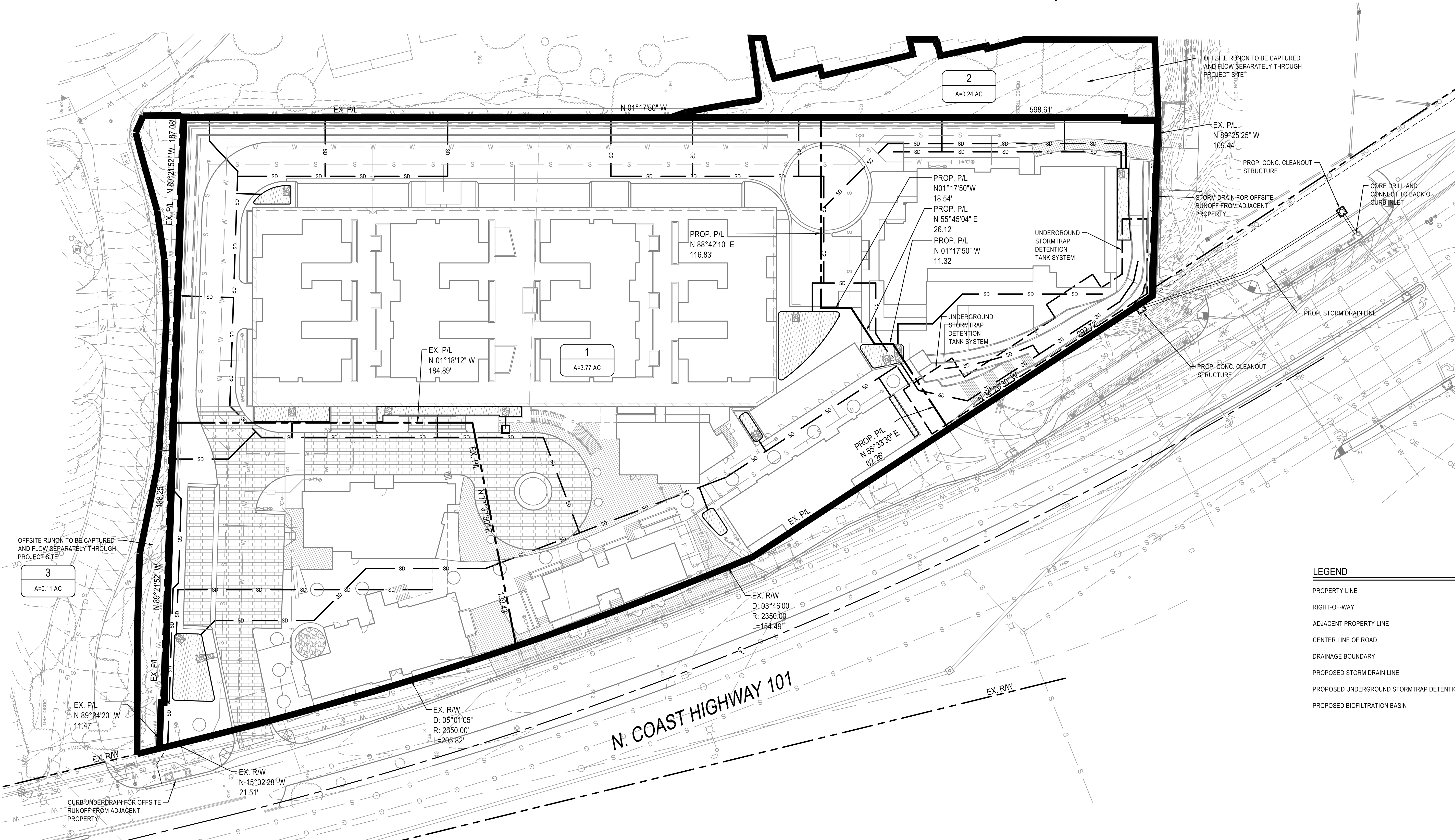

LEGEND

PROPERTY LINE	---
RIGHT-OF-WAY	---
ADJACENT PROPERTY LINE	---
CENTER LINE OF ROAD	---
DRAINAGE BOUNDARY	---
PROPOSED STORM DRAIN LINE	SD
PROPOSED UNDERGROUND STORMTRAP DETENTION SYSTEM	---
PROPOSED BIOFILTRATION BASIN	---

AREA CALCULATIONS

<p>DRAINAGE BASIN 1 TOTAL AREA = 164,348 SF</p> <p>IMPERVIOUS AREA = 132,474 SF</p> <p>PERVIOUS AREA = 31,874 SF</p> <p>PERCENT IMPERVIOUS = 81%</p> <p>SOIL CLASSIFICATION = B</p> <p>C_p (PER TABLE 3-1 OF THE SDCMH) = 0.25</p> <p>C = 0.9(1% IMPERVIOUS) + C_p(1% IMPERVIOUS) = 0.9(0.81)+0.25(1-0.81) = 0.77</p>	<p>DRAINAGE BASIN 2 TOTAL AREA = 10,284 SF</p> <p>IMPERVIOUS AREA = 40 SF</p> <p>PERVIOUS AREA = 10,244 SF</p> <p>PERCENT IMPERVIOUS = 0%</p> <p>SOIL CLASSIFICATION = B</p> <p>C_p (PER TABLE 3-1 OF THE SDCMH) = 0.25</p> <p>C = 0.9(1% IMPERVIOUS) + C_p(1% IMPERVIOUS) = 0.9(0.00)+0.25(1-0.00) = 0.25</p>	<p>DRAINAGE BASIN 3 TOTAL AREA = 5,422 SF</p> <p>IMPERVIOUS AREA = 717 SF</p> <p>PERVIOUS AREA = 4,705 SF</p> <p>PERCENT IMPERVIOUS = 13%</p> <p>SOIL CLASSIFICATION = B</p> <p>C_p (PER TABLE 3-1 OF THE SDCMH) = 0.25</p> <p>C = 0.9(1% IMPERVIOUS) + C_p(1% IMPERVIOUS) = 0.9(0.00)+0.25(1-0.00) = 0.34</p>
---	--	--

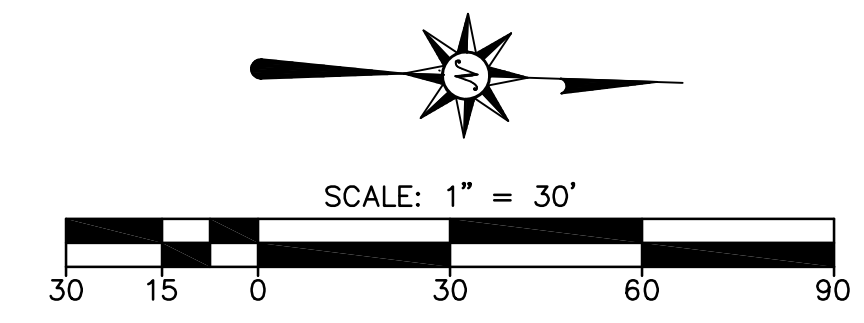

PROPOSED HYDROLOGY MAP
 FENWAY N. HWY 101
 CITY OF ENCINITAS
PASCO LARET SUITER
 & ASSOCIATES
 San Diego | Solana Beach | Orange County
 Phone 949.661.6695 | www.pisaengineering.com

SAVE DATE: 07/13/21 ~ ELOI DATE: 07/16/21 ~ FILE NAME: J:\ACTIVE JOBS\3161 ENCINITAS LEUCADIA 101\CIVIL\REPORTS\HYDROLOGY\APP - Exhibits\3161-Pest Development_Hydrology Map.dwg

THIS PAGE INTENTIONALLY LEFT BLANK