

**Diamond Street Industrial
Technical Appendices**

**Appendix C2
Jurisdictional Delineation**



Melrose and Diamond Industrial Project

Jurisdictional Waters and Wetlands Delineation

prepared for

Holmes Law Group

1030 La Bonita Drive, Suite 314

San Marcos, California 92078

Contact: Rhonda J. Holmes, Esquire

prepared by

Rincon Consultants, Inc.

2215 Faraday Avenue, Suite A

Carlsbad, California 92008

December 2020



RINCON CONSULTANTS, INC.

Environmental Scientists | Planners | Engineers

rinconconsultants.com

Table of Contents

1	Introduction.....	1
	1.1 Project Location	1
	1.2 Project Description	1
2	Methodology	4
	2.1 Literature Review	4
	2.2 Field Survey.....	4
	2.3 Vegetation Communities	6
3	Existing Setting	7
	3.1 Topography, Climate and Land Use.....	7
	3.2 Hydrology.....	7
	3.3 Soils.....	9
	3.4 Vegetation.....	9
4	Delineation Results	15
	4.1 Jurisdictional Features	15
5	Project Impacts	18
6	Conclusions and Recommendations	20
7	References.....	21

Tables

Table 1	Summary of Vegetation Communities and Land Cover Types in the Study Area.....	12
Table 2	Potentially Jurisdictional Areas Delineated within the Study Area	17
Table 3	Anticipated Permanent Impacts to Potentially Jurisdictional Areas	18

Figures

Figure 1	Project Location	2
Figure 2	USGS Topographic Map.....	3
Figure 3	Project Site and Study Area	5
Figure 4	NWI Map	8
Figure 5	Soils	10
Figure 6	Vegetation Communities.....	11
Figure 7	Jurisdictional Delineation	16
Figure 8	Impacts on Jurisdictional Areas	19

Appendices

- Appendix A Tentative Parcel Map
- Appendix B Representative Photographs
- Appendix C Completed Wetland Delineation Forms
- Appendix D Regulatory Framework

1 Introduction

Rincon Consultants, Inc. (Rincon) prepared this report to assist Diamond Street Industrial with the Melrose and Diamond Industrial Project (project). This report delineates jurisdictional waters on the project site. Potentially jurisdictional waters include waters of the United States (U.S.) subject to U.S. Army Corps of Engineers (USACE) jurisdiction under Section 404 of the Clean Water Act; San Diego Regional Water Quality Control Board (RWQCB) jurisdiction under Section 401 of the Clean Water Act and/or the Porter-Cologne Water Quality Control Act (PCWQA); and California Department of Fish and Wildlife (CDFW) jurisdiction under California Fish and Game Code (CFGC) Section 1600 et seq.

1.1 Project Location

The project site is northeast of the intersection of Melrose Drive and Diamond Street in San Marcos, San Diego County, California (Assessor Parcel Numbers 223-341-03 through -014 and -016; Figure 1). The project site can be found on the U.S. Geologic Survey (USGS) 7.5-minute topographic quadrangle *Rancho Santa Fe, California*, as seen in Figure 2. The site is within Township 12 South, Range 3 West, Section 29, San Bernardino baseline and meridian (Earth Point 2020). The approximate center of the project site is at latitude 33.107661° and longitude -117.213930° (WGS84).

1.2 Project Description

The project proposes to split the site into two parcels: A and B. Parcel A would have approximately 16.12 acres and would be developed into an industrial pad with associated 2:1 graded slopes; Parcel B would contain approximately 6.77 acres of designated open space. Project development includes the following:

- An existing Community Facilities District-landscaped slope in the western portion of the site adjacent to Melrose Drive would be reconfigured.
- A private driveway originating from the intersection of Melrose Drive and Diamond Street would be constructed along a portion of the southeast project site boundary.
- A water quality basin would be constructed in the southern corner of the project site adjacent to Melrose Drive.
- A desiltation basin would be constructed in the eastern corner of the site.

Project implementation would also remove the downstream portions of two hydrologic features (i.e., streambeds) on the project site. This would involve the construction of a storm drain inlet which would collect flows from the avoided portions of the features and an associated headwall and riprap. Flows would then be conveyed through a 48-inch reinforced concrete pipe (RCP) under the proposed private driveway along the southeast property boundary. This RCP would connect with an existing 48-inch RCP under the proposed water quality basin in the south corner of the project site, and into the existing underground storm drain system under Melrose Drive and Diamond Street. Please refer to Appendix A for the Tentative Parcel Map.

Periodic fuel modification would also occur in the Parcel A boundary subsequent to project development.

Figure 1 Project Location

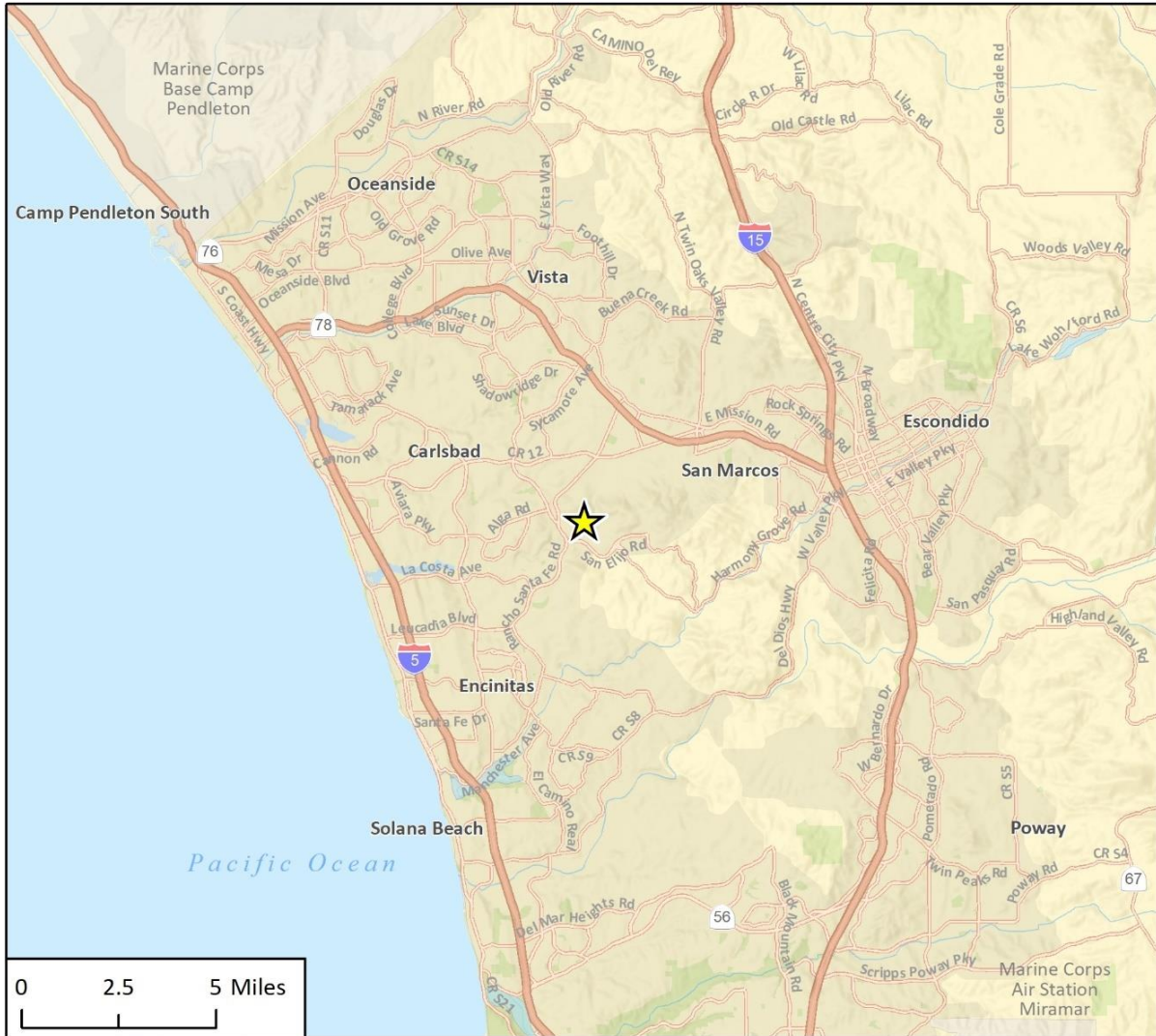

Imagery provided by Esri and its licensors © 2020.

★ Project Location

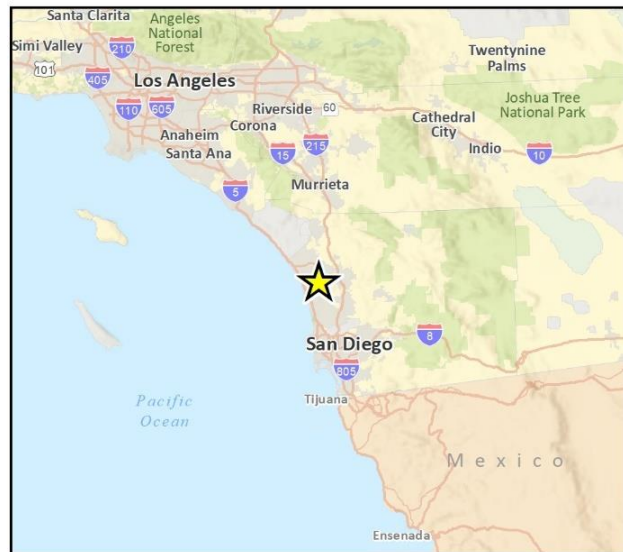
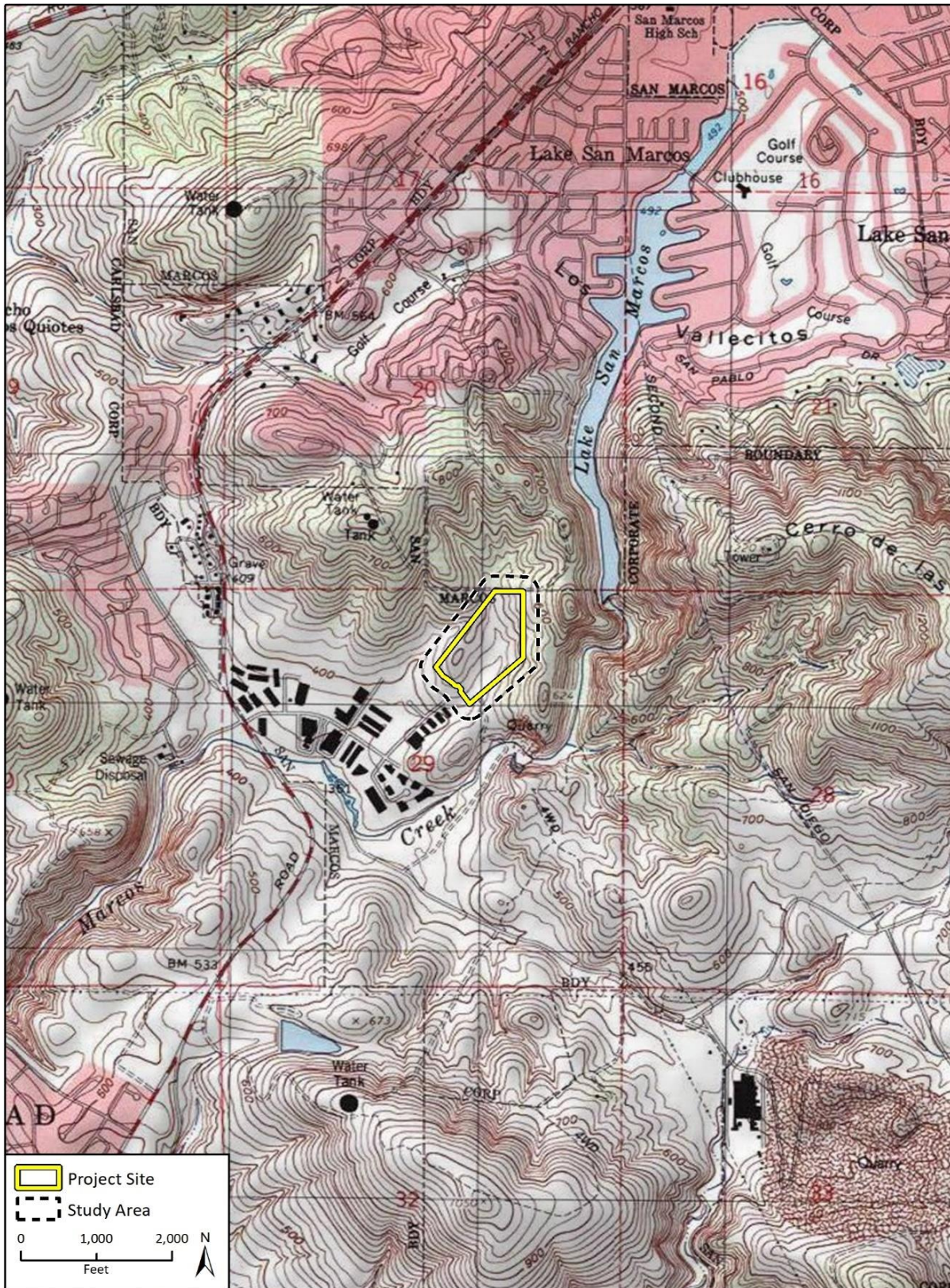

Fig. 1 Regional Location

Figure 2 USGS Topographic Map



Imagery provided by National Geographic Society, Esri and its licensors © 2020. The topographic representation depicted in this map may not portray all of the features currently found in the vicinity today and/or features depicted in this map may have changed since the original topographic map was assembled. BIRAFig 2 USGS Topo Map

2 Methodology

This jurisdictional delineation included a literature review and desktop evaluation of existing studies, maps, aerial imagery, and published datasets, followed by a field survey and delineation to map all potential jurisdictional aquatic features in a study area that consists of the project site plus a 200-foot buffer (Figure 3). Prior to visiting the study area, recent aerial imagery of the site was reviewed (Google Earth Pro 2020).

2.1 Literature Review

To aid in characterizing the nature and extent of jurisdictional waters potentially occurring on the study area, resources were reviewed, including the most recent *Rancho Santa Fe, California* USGS 7.5-minute topographic quadrangle map (2020), and the U.S. Department of Agriculture (USDA), Natural Resources Conservation Service (NRCS) Web Soil Survey (USDA NRCS 2020a). Additionally, the *National Hydrography Dataset* (USGS 2020) and the *National Wetlands Inventory* (NWI) (United States Fish and Wildlife Service 2020a) were reviewed to determine if any potential wetlands and/or other waters had been previously mapped on the project study area or in its vicinity. The *San Diego County Area Hydric Soils List* (USDA NRCS 2020b) was reviewed to determine if any soil map unit types mapped on or near the study area were classified as hydric. Rincon also reviewed precipitation records for the area to understand typical precipitation patterns and average annual precipitation totals.

2.2 Field Survey

A jurisdictional delineation field survey was conducted on June 18, 2020 by Rincon biologists Jared Reed and Emily Kochert to inspect drainage features exhibiting stream characteristics such as a defined bed, banks, or channel, ordinary high water mark (OHWM), or potential wetland indicators. All portions of the study area were surveyed on foot during the field survey.

Data points representing the top of bank, OHWM, and other observation points were mapped using a Trimble Geo7X Global Positioning System with sub-meter accuracy and were plotted on aerial photographs. The data were subsequently transferred to Rincon's geographic information system and used in combination with recent, high-resolution aerial imagery and topographic datasets to map the extent of streams in the study area. Representative photographs of the study area were taken and are presented in Appendix B.

Within the limits of the study area, jurisdictional aquatic features, including wetlands, were delineated in accordance with the following:

- *Wetlands Delineation Manual* (Environmental Laboratory 1987)
- *Regulatory Guidance Letter No. 05-05: Ordinary High Water Mark Identification* (United States Army Corps of Engineers 2005)
- Regional Supplement to the Corps of Engineers Wetland Delineation Manual: Arid West Region (Version 2.0) (United States Army Corps of Engineers 2008a) and
- A Field Guide to the Identification of the Ordinary High Water Mark (OHWM) in the Arid West Region of the Western United States (United States Army Corps of Engineers 2008b)

Figure 3 Project Site and Study Area

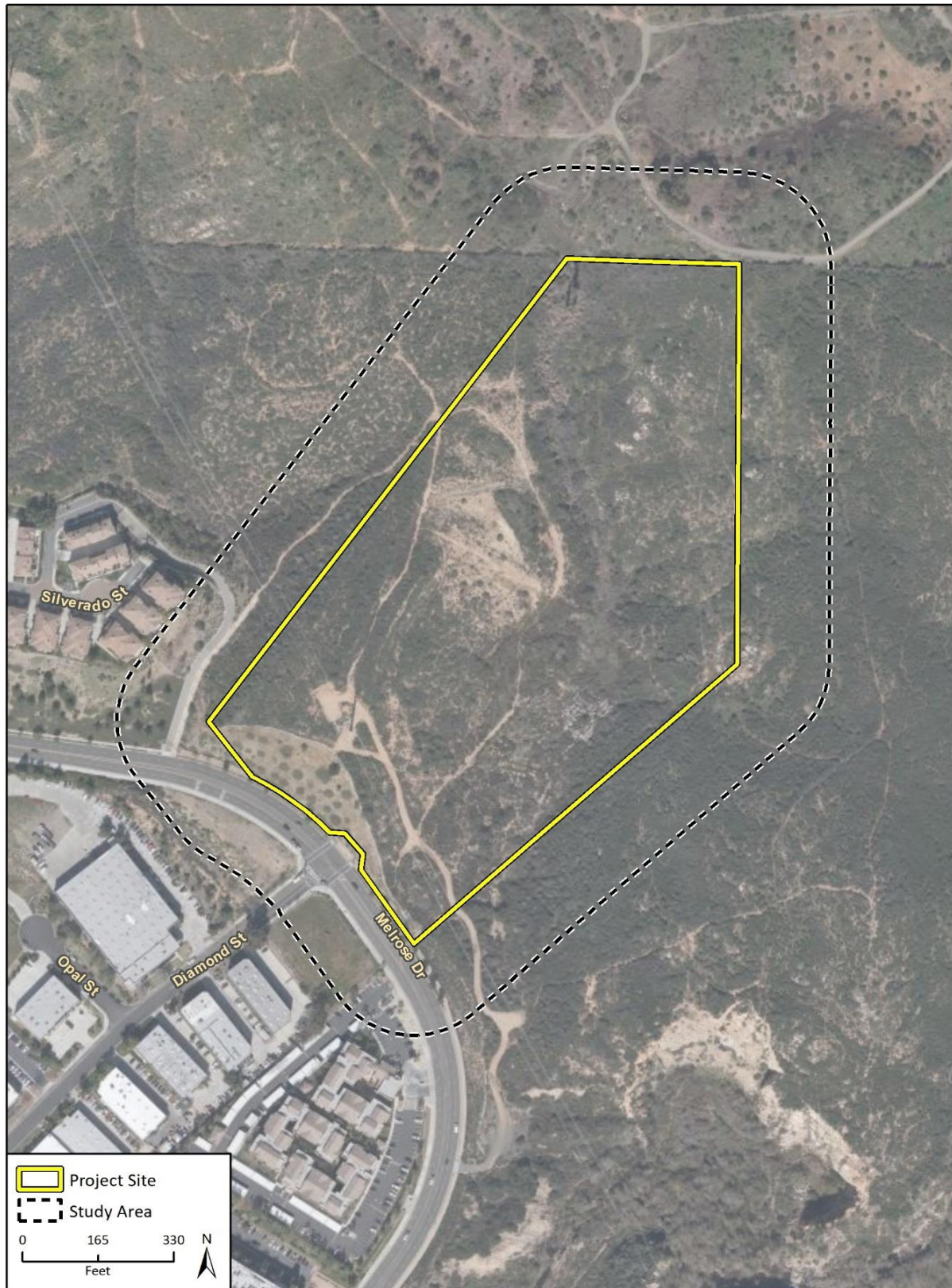

USACE jurisdictional limits were determined based on the lateral extent of the OHWM. Potential wetland features were evaluated for presence of wetland indicators, specifically hydrophytic vegetation, hydric soils, and wetland hydrology, according to routine delineation procedure as described in the Wetlands Delineation Manual (USACE 1987) and Regional Supplement to the Corps of Engineers Wetland Delineation Manual: Arid West Region (USACE 2008a). Completed Wetland Determination Data Forms for the Arid West Region are included in Appendix C. The preliminary determination of presence or absence of USACE jurisdiction was based on the 2020 Navigable Waters Protection Rule.

RWQCB non-wetland waters of the State were determined in accordance with the methodologies previously listed for identifying non-wetland waters of the U.S. Wetland waters of the State were determined using the methods outlined in the State Water Resources Control Board State Wetland Definition and Procedures for Discharges of Dredged or Fill Material to Waters of the State, effective May 28, 2020.

CDFW jurisdiction was delineated in accordance with Section 1602(a) of the CFGC and was bounded by top of the bank or edge of riparian vegetation, whichever was broader. Appendix D presents a discussion of pertinent regulations and definitions pertaining to this jurisdictional delineation.

2.3 Vegetation Communities

Vegetation classification was based on the classification systems provided in the *Draft Vegetation Communities of San Diego County* (Oberbauer et al. 2008) and modified as appropriate to reflect the existing site conditions. Where applicable, vegetation communities were further classified using *A Manual of California Vegetation, Second Edition* (Sawyer et al. 2009), to better identify the species composition and provide consistency with CDFW classifications.

3 Existing Setting

The study area has a history of disturbance and contains fill from prior adjacent land uses including a quarry and the Brookfield Homes residential development. A Final Map (Map No. 12781) for City of San Marcos Tract No. 292 was recorded for the site in the early 1990s encompassing the entire project site with an industrial project. In its General Plan Update in 2012, the City of San Marcos designated a potential wildlife corridor in the approximate northeastern portion of the property. Existing structures on the project site include a utility tower associated with a 150-foot wide San Diego Gas and Electric Easement in the southwestern portion of the site and a number of storm drain pipe pieces in the central portion of the site along the eastern boundary. Multiple dirt trails throughout the site suggest off-road vehicle and pedestrian use. Several open excavations were observed throughout the site. These open excavations were assumed to be geotechnical in origin due to a known geotechnical study prepared by Geocon, Inc. for the site in 2001.

3.1 Topography, Climate and Land Use

The study area is in San Marcos, an area characterized by hot, dry summers and cool, wet winters. Average annual precipitation in this area is approximately 11.84 inches, with most occurring between December and March (U.S. Climate Data 2020).

The site is bounded by the following as seen in Figure 3:

- A citrus grove (designated in San Diego County as permanent open space) to the north
- Designated open space managed by the Center for Natural Lands Management to the northwest, east, and southeast
- Industrial development to the southwest
- Residential development to the west

The project site is approximately 0.5 mile southwest of Lake San Marcos and west of San Marcos Creek, as seen on Figure 2.

The topography of the study area consists of steep to gently sloping rocky hills in the western, northeastern, and eastern portions of the site and an intervening canyon generally running north to south in the central portion of the site. Elevations range from approximately 430 feet above mean sea level in the south corner to approximately 565 feet above mean sea level in the northeast corner.

3.2 Hydrology

The study area is in the Batiqitos Lagoon Watershed (Hydrologic Unit Code 180701090451), which is in the San Marcos Hydrologic Area, within the larger Carlsbad Hydrologic Unit.

Two unnamed streambeds, a primary drainage and a tributary, were observed on site. The primary drainage exhibits indicators of regular flow, bed, and banks. It enters the project site at the north property boundary from the adjacent citrus grove to the north, and traverses south into the central portion of the project site where it dissipates to sheet flow. According to the USFWS NWI, this feature is mapped as a freshwater forested/shrub wetland (USFWS 2020) (Figure 4). The smaller drainage joins the main drainage from the east. These features have clearly defined channels, with bed and banks.

Figure 4 NWI Map

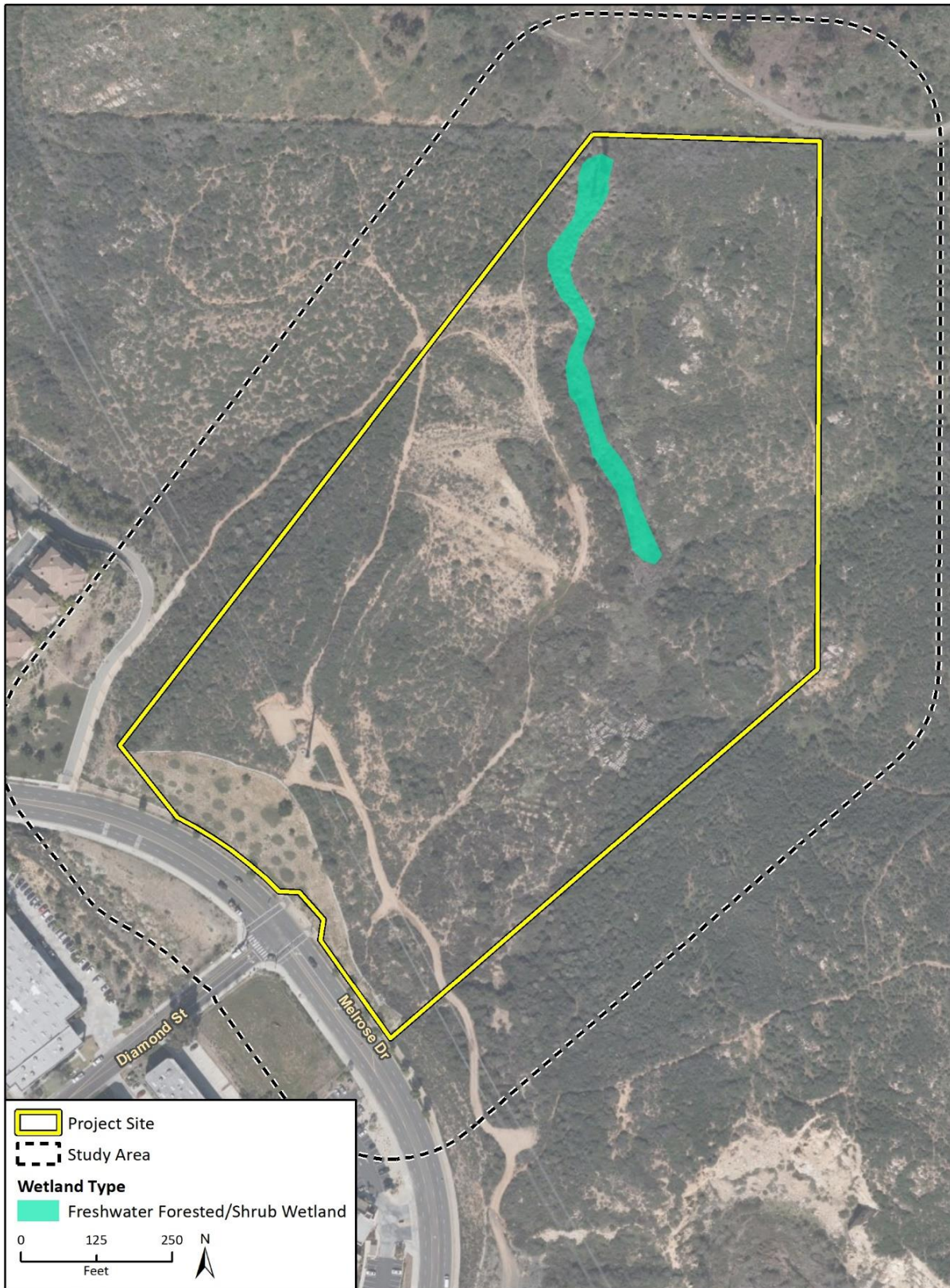

Imagery provided by Microsoft Bing and its licensors © 2020.
Additional data provided by USFWS, 2017.

Fig 4 NWI Map

The study area is in the 53 square mile San Marcos Creek Watershed (HUC 180703030503). The San Marcos Creek watershed originates east of Interstate 15, north of Escondido, includes portions of San Marcos, Encinitas and Carlsbad, and drains into the Batiquitos Lagoon before reaching the Pacific Ocean. The main drainage does not have a clear surface connection to San Marcos Creek.

3.3 Soils

According to the Geotechnical Investigation, the project site contains four surficial soil types and one geologic formation (Geocon 2001). The four surficial soil types consist of undocumented fill, topsoil, colluvium, and alluvium. The geologic formation is comprised of Cretaceous Granitic Rock.

Soils underlying the study area consist of Cieneba rocky coarse sandy loam, 9 to 30 percent slopes, eroded and Exchequer rocky silt loam, 30 to 70 percent slopes (NRCS 2020a) (Figure 5). The following are the official soils series descriptions for each soil series (NRCS 2020c).

Cieneba Series

Cieneba rocky coarse sandy loam, 9 to 30 percent slopes, comprises the entirety of the project site and most of the study area. The Cieneba series consists of very shallow and shallow, somewhat excessively drained soils that formed in material weathered from granitic rock. The soils have low to high runoff, with moderately rapid permeability in the soil and much slower permeability in the weathered bedrock.

Chaparral, sage scrub, and non-native grass vegetation and palm trees are found on this soil type in the study area, as described below. Rock outcrops cover approximately 10 percent of the surface on this soil type in the study area. The USDA NRCS does not identify this soil type as hydric (USDA NRCS 2020b).

Exchequer Series

Exchequer rocky silt loam, 30 to 70 percent slopes, is limited to the north, northeast, and east portions of the study area. The Exchequer series consists of shallow, somewhat excessively drained soils that formed in residuum weathered from hard andesitic breccia, schist, and metamorphosed volcanic rocks. These soils are on undulating to steep uplands and have medium to rapid runoff and moderate permeability. Chaparral and sage scrub vegetation, agriculture and disturbed habitat are present on this soil type in the study area. Dense shrubs are prevalent throughout the study area. The USDA NRCS does not identify this soil type as hydric (USDA NRCS 2020b).

3.4 Vegetation

Eight vegetation communities and three land cover types occur within the study area (Figure 6). Approximate acreages are displayed in Table 1 below.

Figure 5 Soils

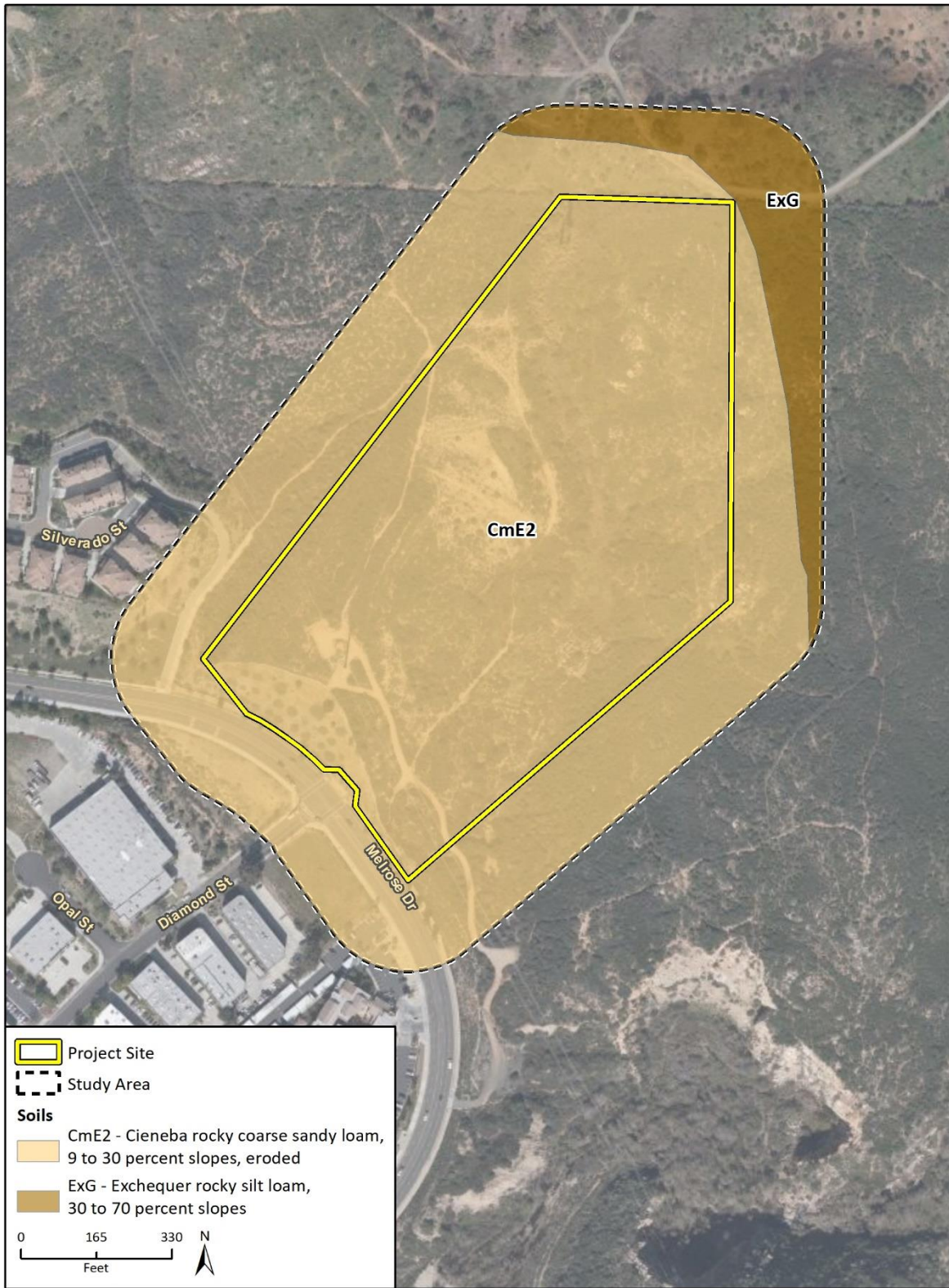

Imagery provided by Microsoft Bing and its licensors © 2020.
Additional data provided by USDA NRCS SSURGO, 2020.

BRAFig 4 Soils

Figure 6 Vegetation Communities

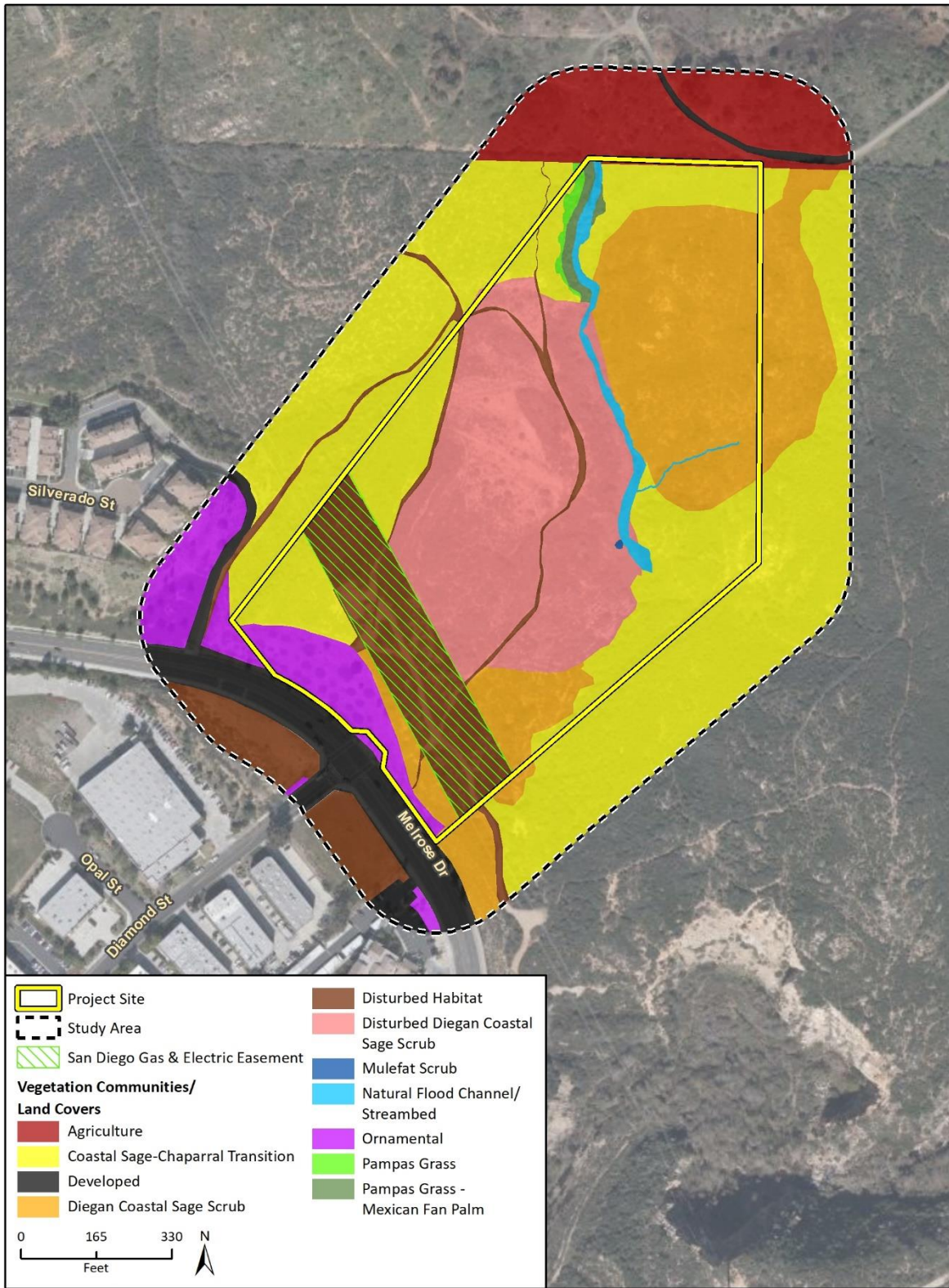

Imagery provided by Microsoft Bing and its licensors © 2020.

Fig 2 Vegetation Communities

Table 1 Summary of Vegetation Communities and Land Cover Types in the Study Area

Vegetation Community/Land Cover Type	Approximate Acreage (acres)
Coastal Sage-Chaparral Transition	15.85
Diegan Coastal Sage Scrub	8.10
Disturbed Diegan Coastal Sage Scrub	7.25
Disturbed Habitat	4.63
Agriculture	3.22
Developed	2.65
Ornamental	2.36
Natural Floodchannel/Streambed	0.44
Pampas Grass – Mexican Fan Palm	0.12
Pampas Grass Patches	0.11
Mulefat Scrub	0.01
Total	44.75

Coastal Sage – Chaparral Transition

This vegetation community is the most prevalent community within the study area and comprises a mix of coastal sage scrub and chaparral species. The shrub layer is dense and dominated by chamise (*Adenostoma fasciculatum*), laurel sumac (*Malosma laurina*), woolly-leaved ceanothus (*Ceanothus tomentosus*), black sage (*Salvia mellifera*), and California buckwheat (*Eriogonum fasciculatum*). Wart-stemmed ceanothus (*Ceanothus verrucosus*) and California sagebrush (*Artemisia californica*) are present as subdominant species. Fascicled tarplant (*Deinandra fasciculata*) and ripgut brome (*Bromus diandrus*) dominate the herbaceous layer.

This vegetation community was further classified using Sawyer et al. (2009), which resulted in the designation of the following four alliances:

Chamise Chaparral

Chamise chaparral (*Adenostoma fasciculatum* Alliance) is concentrated in the central portion of the study area. Chamise is the dominant species.

Chamise – Black Sage Chaparral

Chamise – black sage chaparral (*Adenostoma fasciculatum* – *Salvia mellifera* Alliance) is also concentrated in the central portion of the study area. Dominant species include chamise, California buckwheat, black sage, and California sagebrush.

Hairy Leaf – Woolly Leaf Ceanothus Chaparral

Hairy leaf – woolly leaf ceanothus chaparral (*Ceanothus oliganthus*, *tomentosus* Alliance) is in the north, east, and west portions of the study area. Woolly-leaved ceanothus and chamise are the dominant species.

Wart-stemmed Ceanothus Chaparral

Wart-stemmed ceanothus chaparral (*Ceanothus verrucosus* Alliance) is also located in the north, east, and west portions of the study area. Wart-stemmed ceanothus is the dominant species.

Diegan Coastal Sage Scrub

The shrub layer is dense and dominated by California buckwheat, California sagebrush, and laurel sumac, with black sage, coyote brush (*Baccharis pilularis*), deerweed (*Acmispon glaber*), chaparral mallow (*Malacothamnus fasciculatus*), and broom baccharis (*Baccharis sarothroides*) present as subdominant species. The herbaceous layer is dense and relatively diverse, consisting of fascicled tarplant, chaparral dodder (*Cuscuta californica*), chalk dudleya (*Dudleya pulverulenta*), cliff aster (*Malacothrix saxatilis*), chia (*Salvia columbariae*), dwarf plantain (*Plantago erecta*), common cryptantha (*Cryptantha intermedia*), and sapphire woollystar (*Eriastrum sapphirinum*). Several non-native species including tocalote (*Centaurea melitensis*), black mustard (*Brassica nigra*), slender wild oat (*Avena barbata*), and ripgut brome are also common throughout this community.

The Diegan Coastal Sage Scrub was further classified using Sawyer et al. (2009), which resulted in the designation of the following two alliances:

California Sagebrush-California Buckwheat Scrub

California sagebrush-California buckwheat scrub (*Artemisia californica*-*Eriogonum fasciculatum* Shrubland Alliance) is found throughout the study area. California sagebrush and California buckwheat are codominant.

California Buckwheat Scrub

California buckwheat scrub (*Eriogonum fasciculatum* Shrubland Alliance) is found in more disturbed areas of Diegan coastal sage scrub, where monotypic stands of California buckwheat are present.

Disturbed Diegan Coastal Sage Scrub

This vegetation community is structurally similar to Diegan Coastal Sage Scrub but has been subjected to prior disturbance due to topographic alterations and placement of debris and storm drain pipe pieces. As a result, much of the disturbed Diegan coastal sage scrub is in recovery and contains a high proportion of bare ground and weedy species. Dominant shrub species include California buckwheat, California sagebrush, coyote brush, and broom baccharis, and dominant herbaceous species include fascicled tarplant, fountain grass (*Pennisetum setaceum*), ripgut brome and slender wild oat.

Agriculture

This vegetation community is situated adjacent to the project site and is in the northern portion of the study area. This land cover type is comprised of a citrus grove and contains very little native vegetation.

Developed

This land cover type is directly associated with areas covered by existing development (i.e., buildings and paved roads). It is not officially identified in Sawyer et al. (2009) as a defined vegetation community or land cover type.

Disturbed Habitat

This land cover type generally lacks vegetation and is comprised of dirt roads, trails, and other topographically disturbed areas such as the existing San Diego Gas and Electric easement in the southwest portion of the study area. Dirt roads and trails are located throughout the study area.

Ornamental

This land cover type contains planted ornamental vegetation adjacent to developed areas. It is not officially identified in Sawyer et al. (2009) as a defined vegetation community or land cover type.

Natural Floodchannel/Streambed

This land cover type is directly associated with the primary feature and its tributary in the north, central and eastern portions of the study area. The northern, upstream portion of the primary feature is comprised of dense pampas grass (*Cortaderia selloana*) with a Mexican fan palm (*Washingtonia robusta*) overstory, while the central and downstream portions comprise broad-leaved cattail (*Typha latifolia*), bristly ox-tongue (*Helminthotheca echioides*), Italian thistle (*Carduus pycnocephalus*), slender wild oat, black mustard, tumbleweed (*Amaranthus albus*), rabbitsfoot grass (*Polypogon monspeliensis*), tall flatsedge (*Cyperus eragrostis*), and curly dock (*Rumex crispus*). The tributary contains dense California sagebrush, California buckwheat and tocalote. The lateral extent of Natural floodchannel/streambed is equivalent to that of CDFW-jurisdictional limits.

Pampas Grass – Mexican Fan Palm

This vegetation community is situated in the northern portion of the study area, located in an upland area immediately adjacent to the Natural Floodchannel/Streambed land cover type (Figure 6). Pampas grass and Mexican fan palm are codominant. This community is not officially identified in Sawyer et al. (2009) as a defined vegetation community or land cover type.

Pampas Grass Patches (*Cortaderia jubata, selloana* Semi-Natural Alliance)

Pampas grass patches are in the north portion of the study area. Pampas grass in this portion of the study area is dense and is the dominant species. Pampas grass patches are recognized as a semi-natural alliance in Sawyer et al. (2009).

Mulefat Scrub

A small patch of mulefat (*Baccharis salicifolia*) is in the downstream portion of the primary feature within the central portion of the study area, adjacent to the Natural Floodchannel/Streambed land cover type and is within the CDFW jurisdictional.

4 Delineation Results

4.1 Jurisdictional Features

Two watercourse features, a primary channel and a tributary, were mapped in the study area (Figure 7). Both features are in the northeast portion of the study area.

The OHWM limits in the primary channel was defined by drift deposits, presence of a bed and bank, soil development, and changes in soils and vegetation. This feature has an average OHWM width of six feet and an average bank to bank width of 12 feet and is heavily invaded by non-native vegetation, primarily pampas grass and Italian thistle. Other vegetative species in the channel bed include broad-leaved cattail, bristly ox-tongue, slender wild oat, common sow-thistle (*Sonchus oleraceus*), black mustard, tumbleweed, rabbitsfoot grass, tall flatsedge, mulefat, cocklebur (*Xanthium strumarium*), and curly dock. Vegetative species on the channel banks include laurel sumac, coyote brush, California buckwheat, toyon (*Heteromeles arbutifolia*), wart-stemmed ceanothus, and fennel (*Foeniculum vulgare*). This channel enters the project site at the north property boundary from the adjacent citrus grove to the north, and traverses south into the central portion of the project site where it dissipates to sheet flow.

Surface water was observed in a small area in the midstream portion of the streambed. Saturated soils were observed in the upper five inches in the downstream portion of the streambed during the jurisdictional delineation survey. According to the USFWS NWI, this feature is mapped as a freshwater forested/shrub wetland (USFWS 2020). Our field observations led to the conclusion that this feature does not contain wetlands because the drainage only met one (wetland hydrology) of the three parameters needed to determine presence of a wetland. Photographs of this streambed can be found in Appendix 2 Photographs 1 through 4.

The tributary, a single-thread channel, joins the main watercourse from the east (Figure 7). Photographs of this tributary can be found in Attachment 2 Photographs 5 and 6. The OHWM limits were defined by presence of a bed and bank and changes in vegetation. This tributary has an average OHWM width of three feet and an average bank to bank width of 4.5 feet. Most of this tributary has dense upland vegetation, including California buckwheat, California sagebrush, black sage, and tocalote (*Centaurea melitensis*). There was no evidence of surface water in the drainage during the jurisdictional delineation survey. No wetland characteristics were observed and as a result, no soil test pits were taken.

As described below, both features lack surface water flow contributing to nearby navigable waters in a typical year and thereby do not meet current USACE jurisdictional standards to be considered waters of the U.S. The streambeds in the study area are potentially subject to San Diego RWQCB jurisdiction under the PCWQA, and potentially under the jurisdiction of CDFW per Section 1600 et seq. of the California Fish and Game Code, as discussed below. See Figure 7 for the extent of these jurisdictions.

USACE Jurisdiction

Neither feature meets current USACE standards for waters of the U.S. because they lack surface water flow that contributes to nearby navigable waters in a typical year under the 2020 Navigable Water Protection Rule. Both features are located in the upper San Marcos Creek Watershed, which as described above, is approximately 53 square miles. The primary feature originates off-site in the agricultural property to the north of the project site. Additionally, the project site is approximately 4.5

Figure 7 Jurisdictional Delineation

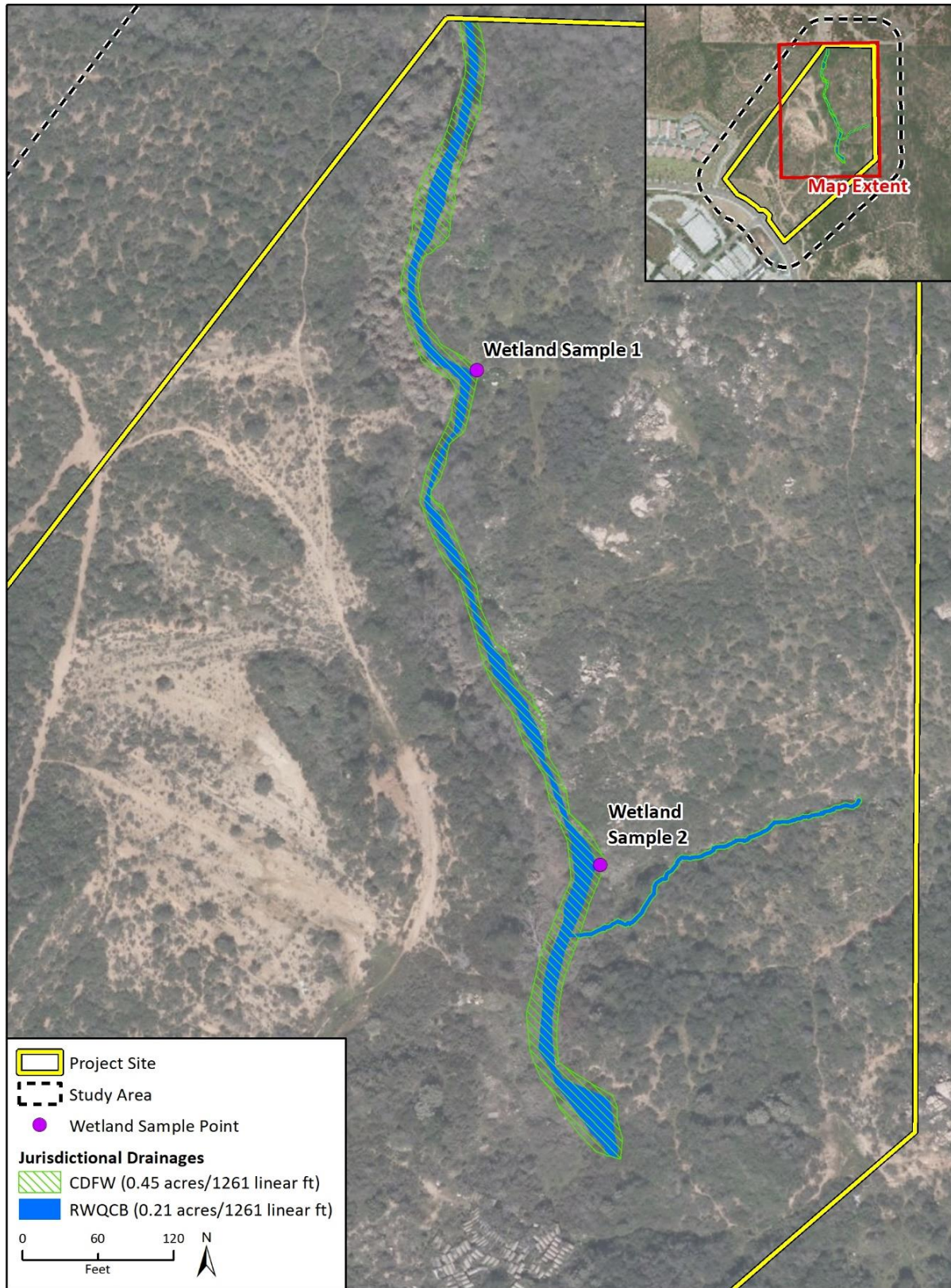

Imagery provided by Microsoft Bing and its licensors © 2020.

Fig 6 Jurisdictional Delineation

river miles from the nearest Traditional Navigable Water. Water dissipates to sheetflow northeast of Melrose Drive, where runoff from other properties are conveyed into the underground storm drain infrastructure under Melrose Drive, Diamond Street, and the industrial developments to the southwest of the project site. No clear surface water connection to San Marcos Creek was observed. It is therefore anticipated that the USACE will not take jurisdiction over the two streambeds on the project site.

RWQCB Jurisdiction

No wetland waters of the State were observed despite the presence of broad-leaved cattail, a wetland obligate species. Only one parameter, wetland hydrology, was observed in the primary feature. It is anticipated that the USACE will not take jurisdiction of these features, therefore the features are likely to be regulated by the RWQCB as non-wetland waters of the State under the PCWQA. The limits of RWQCB jurisdiction were delineated by a clearly defined OHWM identified by changes in vegetation cover, changes in sediment texture (sand in the channel and more developed soils outside the OHWM), and a defined break in slope.

CDFW Jurisdiction

Both watercourses would be subject to CDFW jurisdiction because they both contain banks, and channel, through which waters flow, at least periodically. CDFW jurisdiction was determined by the physical (e.g., top of bank or outer extent of riparian vegetation) and biological (i.e., changes in vegetation communities and bioturbation) evidence.

Table 2 Potentially Jurisdictional Areas Delineated within the Study Area

Feature	Waters of the U.S.		Waters of the State ¹		CDFW Jurisdictional Streambed ² (acres/linear feet)
	Non-wetland Waters of the U.S. (acres/linear feet)	Wetland Waters of the U.S. (acres/linear feet)	Non-wetland Waters of the State ¹ (acres/linear feet)	Wetland Waters of the State (acres/linear feet)	
Unnamed Primary Drainage	-/-	-/-	0.20/985	-/-	0.43/985
Unnamed Ephemeral Tributary Drainage	-/-	-/-	0.01/276	-/-	0.02/276
Total	-/-	-/-	0.21/1,261	-/-	0.45/1,261

¹ Calculated to OHWM

² Calculated to top of bank or outer edge of riparian vegetation as applicable

5 Project Impacts

The project will result in permanent impacts to jurisdictional waters, though no temporary impacts are expected. Project implementation would fill the downstream portions of the streambeds on the project site. This would involve the construction of a storm drain inlet which would collect flows from the avoided portions of the streambeds and an associated headwall and riprap. Flows would then be conveyed through a 48-inch RCP under the proposed private driveway along the southeast property boundary. This RCP would connect with an existing 48-inch RCP under the proposed water quality basin in the south corner of the project site, and into the existing underground storm drain system under Melrose Drive and Diamond Street. Please refer to Appendix A for the Tentative Parcel Map. Refer to Figure 8 and Table 3 for a summary of jurisdictional impacts.

Table 3 Anticipated Permanent Impacts to Potentially Jurisdictional Areas

Feature	Waters of the U.S.		Waters of the State ¹		CDFW Jurisdictional Streambed ² (acres/linear feet)
	Non-wetland Waters of the U.S. (acres/linear feet)	Wetland Waters of the U.S. (acres/linear feet)	Non-wetland Waters of the State ¹ (acres/linear feet)	Wetland Waters of the State (acres/linear feet)	
Primary Channel	-/-	-/-	0.06/207	-/-	0.12/207
Tributary Channel	-/-	-/-	0.00/21	-/-	0.00/21
Total	-/-	-/-	0.06/228	-/-	0.12/228

¹ Calculated to OHWM

² Calculated to top of bank or outer edge of riparian vegetation as applicable

The project would permanently impact approximately 0.06 acre of non-wetland waters of the State. No wetland waters of the State were observed; thus, no impacts to wetland waters would occur. Approximately 0.12 acre of permanent impacts to CDFW-jurisdictional streambed anticipated. The project is not anticipated to result in temporary impacts.

Figure 8 Impacts on Jurisdictional Areas

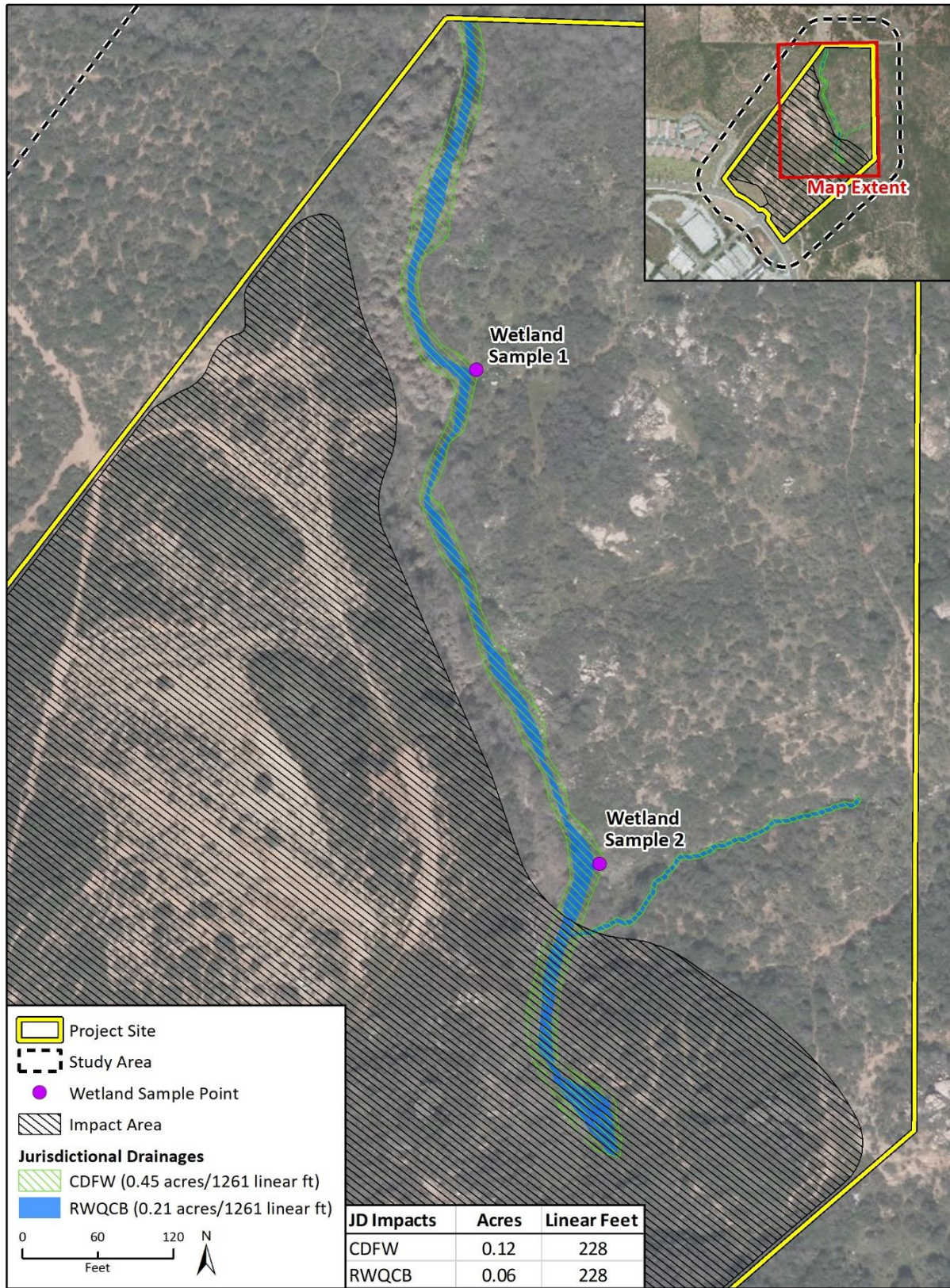

6 Conclusions and Recommendations

If avoidance of jurisdictional resources is not feasible for this project, permits from the RWQCB and CDFW may be required. The PCWQA establishes a comprehensive program to protect water quality and the beneficial uses of water. The PCWQA applies to surface waters, wetlands, and ground water and to both point and nonpoint sources of pollution. Assuming the USACE does not assert its jurisdiction, prior to impacting waters of the State, an application for Waste Discharge Requirements (WDR) coverage must be submitted to the San Diego RWQCB. Acquiring WDR coverage generally takes nine to 12 months. CDFW regulates not only the discharge of dredged or fill material, but all activities that substantially alter streams and lakes and their associated habitat. Prior to diverting, obstructing, or substantially altering CDFW-jurisdictional streams, an application (termed "Notification") must be provided to CDFW. If the agency determines that a fish or wildlife resource could be adversely affected, a Lake and Streambed Alteration Agreement (Agreement) will be required. Terms and conditions are likely to include seasonal work restrictions, measures to protect biological resources and water quality during construction, and compensatory mitigation requirements. Acquiring an Agreement generally takes four to six months. This timeline may be extended due to COVID-19 restrictions.

The findings and conclusions presented in this report, including the location and extent of areas subject to regulatory jurisdiction, represent the professional opinion of the biological consultants. These findings and conclusions should be considered preliminary and at final discretion of the applicable resource agency.

7 References

- Earth Point. 2020. Township and Range. <http://www.earthpoint.us/TownshipsSearchByDescription.aspx>
- Geocon, Inc. 2001. Martin Business Park, City of San Marcos T.S.M. 292 Geotechnical Investigation. December 2001.
- Google LLC. 2020. Google Earth Pro. Version 7.3.3.7786
- Lichvar, R.W. et al. The National Wetland Plant List: 2016 wetland ratings. *Phytoneuron* 2016-30: 1–17. Published 28 April 2016.
- Oberbauer, Thomas, Meghan Kelly, and Jeremy Buegge. 2008. Draft Vegetation Communities of San Diego County. Based on “Preliminary Descriptions of the Terrestrial Natural Communities of California.” Robert F. Holland, Ph.D., October 1986. March 2008.
- Sawyer, J. O., T. Keeler-Wolf, and J.M. Evens. 2009. A Manual of California Vegetation, Second Edition. California Native Plant Society, Sacramento, California.
- United States Army Corps of Engineers (USACE). 1987. Technical Report Y-97-1. Environmental Laboratory. In: United States Army Corps of Engineers Wetlands Delineation Manual. United States Army Corps of Engineers Waterways Experiment Station. Vicksburg, MS.
- _____. 2005. Regulatory Guidance Letter No. 05-05: Ordinary High-Water Mark Identification. U.S. Army Corps of Engineers. Washington, D.C.
- _____. 2008a. Regional Supplement to the Corps of Engineers Wetland Delineation Manual: Arid West Region (Version 2.0). United States Army Corps of Engineers Research and Development Center. Vicksburg, MS. September
- _____. 2008b. A Field Guide to the Identification of the Ordinary High-Water mark (OHWM) in the Arid West Region of the Western United States. Technical Report ERDC/CRREL TR-08-12. U.S. Army Engineer Research and Development Center, Cold Regions Research and Engineering Laboratory. Hanover, New Hampshire.
- U.S. Climate Data. 2020. Weather averages Carlsbad, California. Available at: <https://www.usclimatedata.com/climate/carlsbad/california/united-states/usca1608>
- United States Department of Agriculture, Natural Resources Conservation Service (USDA NRCS). 2020a. Web Soil Survey. <https://websoilsurvey.sc.egov.usda.gov/App/WebSoilSurvey.aspx>. Accessed November 2020.
- _____. 2020b. Lists of Hydric Soils, online database. <https://www.nrcs.usda.gov/wps/portal/nrcs/main/soils/use/hydric/>. Accessed November 2020.
- _____. 2020c. Official Soil Series Descriptions, online database. https://www.nrcs.usda.gov/wps/portal/nrcs/detail/soils/survey/geo/?cid=nrcs142p2_053587. Accessed November 2020.
- United States Fish and Wildlife Service (USFWS). 2020. National Wetlands Inventory. Wetland Mapper V2. <http://wetlands.fws.gov> Accessed July 2020.
- United States Geological Survey (USGS). 2020a. *Rancho Santa Fe, California* 7.5-minute topographic quadrangle, accessed via the National Map. November 2020.

_____. 2020b. National Hydrography Dataset. Accessed via the National Map. July 2020.

This page intentionally left blank.

Appendix A

Tentative Parcel Map

TENTATIVE PARCEL MAP FOR APNs 223-341-03 THROUGH 14 & 16 CITY OF SAN MARCOS

EASEMENTS NOTES:
THE FOLLOWING EASEMENT NOTES ARE FROM PRELIMINARY TITLE REPORT PROVIDED BY CHICAGO TITLE COMPANY, ORDER NUMBER 00119017-005-MDD-TVA, DATED OCTOBER 9, 2019.

- E-01** EXISTING 100' SAN DIEGO GAS AND ELECTRIC COMPANY PUBLIC UTILITIES, INGRESS, EGRESS, EASEMENT, UPON, OVER & ACROSS THE LANDS PER DOC. NO. 53881, BOOK 1073, PAGE 448 OF OFFICIAL RECORDS, RECORDED OCTOBER 14, 1940.
- E-04** EXISTING 50' WIDTH SAN DIEGO GAS AND ELECTRIC COMPANY PUBLIC UTILITIES, INGRESS, EGRESS, EASEMENT UPON, OVER, UNDER & ACROSS THE LANDS TOGETHER WITH THE RIGHT TO TRIM & TOP TREES PER DOC. NO. 192240 OF OFFICIAL RECORDS, RECORDED OCTOBER 22, 1965.
- E-06** EXISTING DRAINAGE EASEMENT PER DOC. NO. 87-448625 OF OFFICIAL RECORDS, RECORDED AUGUST 10, 1987.
- E-08A** EXISTING DRAINAGE EASEMENT PER MAP NO. 12781.
- E-08B** EXISTING SDG&E ROAD ACCESS EASEMENT PER MAP NO. 12781.
- E-08C** EXISTING 5' DRAINAGE EASEMENT PER MAP NO. 12781.
- E-11** EXISTING PUBLIC STREET & DRAINAGE PURPOSES IN FAVOR OF THE CITY OF SAN MARCOS PER DOCUMENT 2004-0999808 OF OFFICIAL RECORDS, RECORDED OCTOBER 21, 2004.

EASEMENTS ABANDONEMENT NOTE:
ALL EASEMENTS OFFERED OR RESERVED WITHIN LOTS 2 THROUGH 14 ON MAP NO. 12781 WILL BE ABANDONED WITH THIS PROPOSED MAP.

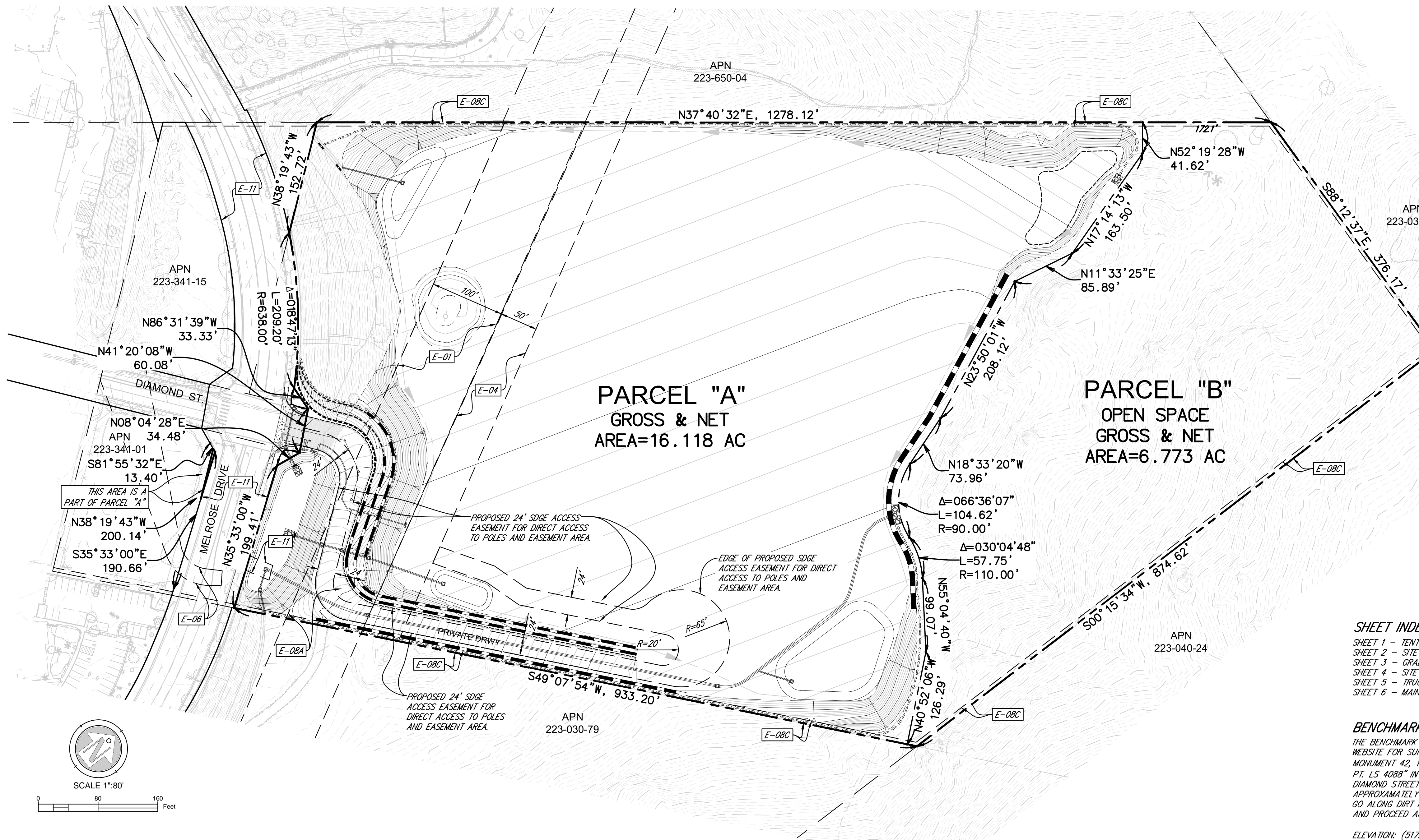

SHEET INDEX
SHEET 1 - TENTATIVE PARCEL MAP
SHEET 2 - SITE EXISTING CONDITION
SHEET 3 - GRADING CONCEPT
SHEET 4 - SITE SECTIONS
SHEET 5 - TRUCK MOTION EXHIBIT
SHEET 6 - MAIN DRIVEY DETAIL & PROFILE

BENCHMARK
THE BENCHMARK FOR THIS PROJECT IS PER THE CITY OF SAN MARCOS'S WEBSITE FOR SURVEY CONTROL NETWORK INTERACTIVE MAP. SURVEY MONUMENT 42, 1/2" X 18" REBAR WITH PLASTIC CAP MARKED "WITNESS PT. LS 4088" IN PLASTIC PANEL. LOCATED FROM INTERSECTION OF DIAMOND STREET AND LA COSTA MEADOWS DRIVE, PROCEED NORTHERLY APPROXIMATELY 0.1 MILE ON DIAMOND STREET TO END OF PAVEMENT, GO ALONG DIRT ROAD APPROXIMATELY 0.1 MILE AT FORK, TURN LEFT AND PROCEED APPROXIMATELY 500 FEET.
ELEVATION: (517.53 NAVD 88)

BASIS OF BEARING
THE BASIS OF BEARINGS FOR THIS SURVEY IS THE CALIFORNIA COORDINATES OF 1983 (CCS83), ZONE VI, (EPOCH 2011.00), BETWEEN STATION NO. 3001, STATION NAME "CLB" AND STATION NO. 3003, STATION NAME "DCSD", AS SHOWN ON CITY OF OCEANSIDE CONTROL SURVEY, ROS 21787 AND BEING NORTH 15° 20' 45" WEST
QUOTED BEARINGS FROM REFERENCE MAPS OR DEEDS MAY OR MAY NOT BE IN TERMS OF SAID SYSTEM.
THE COMBINED FACTOR FOR THIS PROJECT IS BASED ON STATION NO. 3003, STATION NAME "DCSD", BEING 0.99994861 (GROUND = GRID / COMBINED FACTOR)

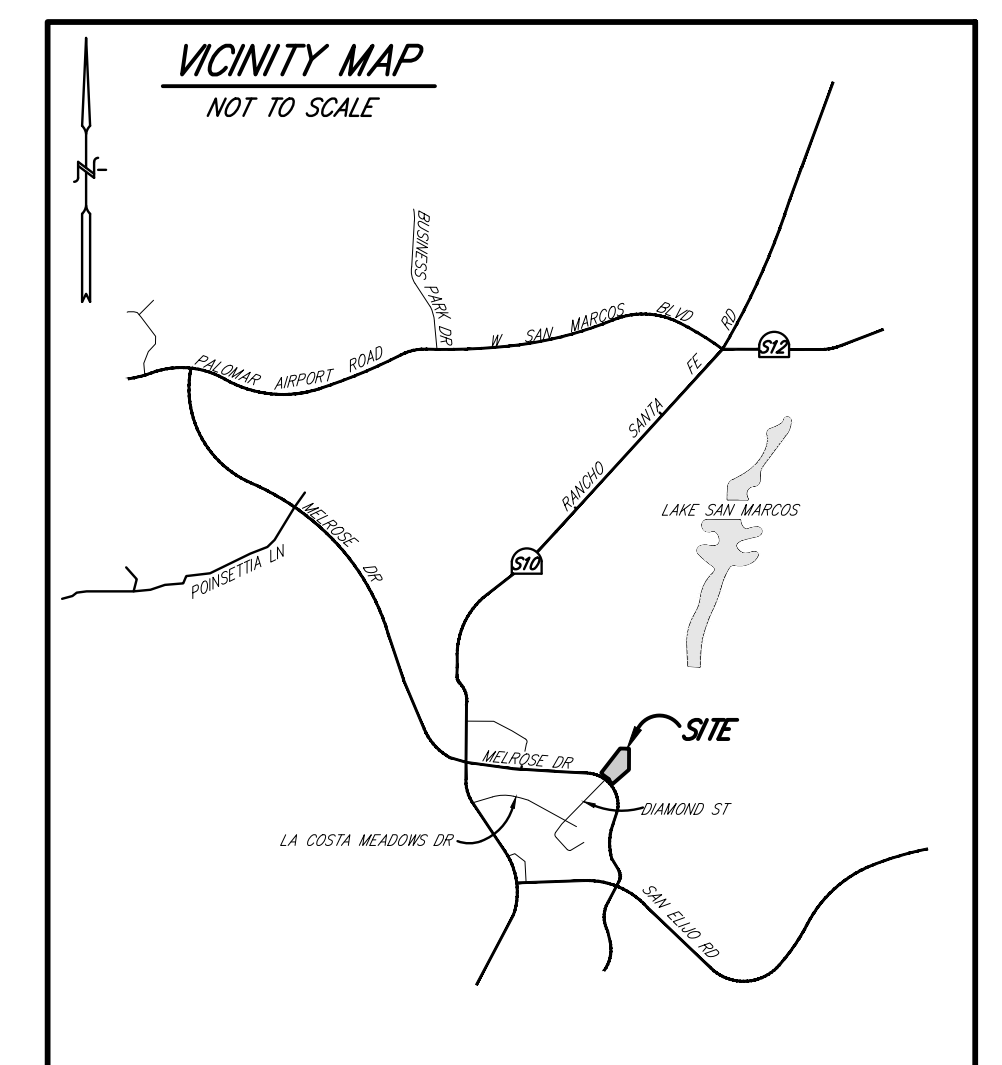

OWNER:
JAMES WILLIAM MARTIN & BONNIE LOU MARTIN
REVOCABLE LIVING TRUST, MARCLAW LP, LAURA LEE
MARTIN CHANCELLOR & LINDA LEE RAMSEY.

DEVELOPER:
JENCO HOLMES FAMILY TRUST
1316 SAN JULIAN LANE
SAN MARCOS, CA 92078

ASSESSORS PARCEL NUMBER
223-341-03 THROUGH 14 & 16

TOTAL ACREAGE:
GROSS = 22.912 ACRES
NET = 22.912 AC

ZONING / LAND USE
EXISTING ZONING: L-1 LIGHT INDUSTRIAL
EXISTING LAND USE: VACANT
PROPOSED ZONING: L-1 LIGHT INDUSTRIAL
PROPOSED LAND USE: LIGHT INDUSTRIAL

LEGAL DESCRIPTION:
THE LAND REFERRED TO HEREIN BELOW IS SITUATED IN THE CITY OF SAN MARCOS, IN THE COUNTY OF SAN DIEGO, STATE OF CALIFORNIA, AND IS DESCRIBED AS FOLLOWS: LOTS 2 THROUGH 14 OF CITY OF SAN MARCOS TRACT NO. 292, IN THE CITY OF SAN MARCOS, COUNTY OF SAN DIEGO, STATE OF CALIFORNIA, ACCORDING TO MAP THEREOF NO. 12781, FILED IN THE OFFICE OF THE COUNTY RECORDER OF SAN DIEGO COUNTY, FEBRUARY 21, 1991.

SOURCE OF TOPOGRAPHY:
AERIAL TOPOGRAPHIC SURVEY CONDUCTED BY AEROTECH MAPPING, INC FLOWN LAST JANUARY 15, 2020.

MAP PREPARED BY:
EXCEL ENGINEERING
440 STATE PLACE
ESCONDIDO, CA 92029
TELEPHONE: (760) 745-8118

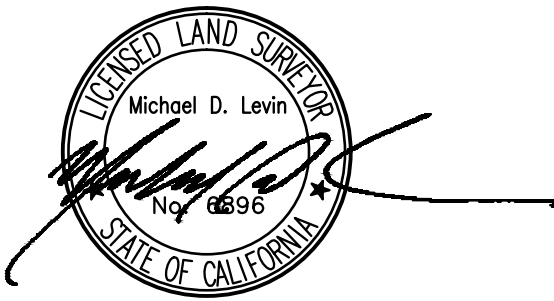

TENTATIVE PARCEL MAP PREPARED:
OCTOBER 2020

GRADING VOLUME
CUT = 122,750 CY
FILL = 236,920 CY
IMPORT = 114,170 CY

EARTHWORK CALCULATED USING THE DIFFERENCE BETWEEN THE EXISTING CONDITION & PROPOSED GRADING. A BULKING FACTOR OF 20% WAS APPLIED TO THE RAW CUT VOLUME.

CONCEPTUAL GRADING PLAN PREPARED BY:
EXCEL ENGINEERING
440 STATE PLACE
ESCONDIDO, CA 92029
TELEPHONE: (760) 745-8118

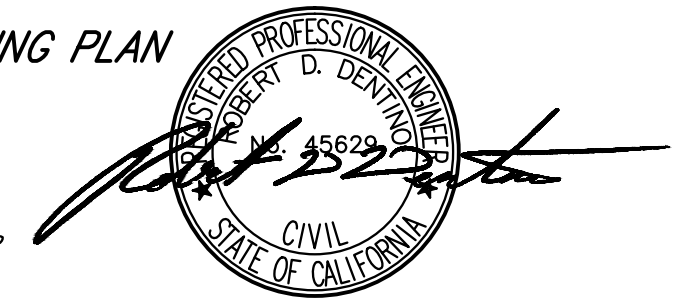

FLOOD ZONE
ZONE X PER FIRM PANEL 06073C1052G EFFECTIVE 05/16/2012.

DISTRICTS & UTILITY AGENCIES
SCHOOL DISTRICT - SAN MARCOS UNIFIED
WATER - VALLECITOS WATER DISTRICT
SEWER - VALLECITOS WATER DISTRICT
GAS - SAN DIEGO GAS & ELECTRIC
ELECTRIC - SAN DIEGO GAS & ELECTRIC

REFERENCES:
MAP 12781
CITY OF SAN MARCOS DWG GP-2161
CITY OF SAN MARCOS DWG IP-3158
CITY OF SAN MARCOS DWG IP-4556



TENTATIVE PARCEL MAP
TENTATIVE PARCEL MAP FOR APNS
223-341-03 THROUGH 14 & 16

c:\191\190209\engineering\preliminary_concepts\120101000_concept\178-cpl1 TENTATIVE PARCEL MAP.dwg 10/17/2020 12:04 PM ORIGINAL PLOT SIZE: 11x17

LEGEND

- RIGHT OF WAY ———-RW———
- PROPERTY LINE ———-PL———
- PROJECT BOUNDARY ———-PB———
- EXIST MAJOR CONTOUR - - - -400- - - -
- EXIST MINOR CONTOUR - - - - - - - -
- EXIST WATER MAIN ———-S———
- EXIST SEWER MAIN ———-W———

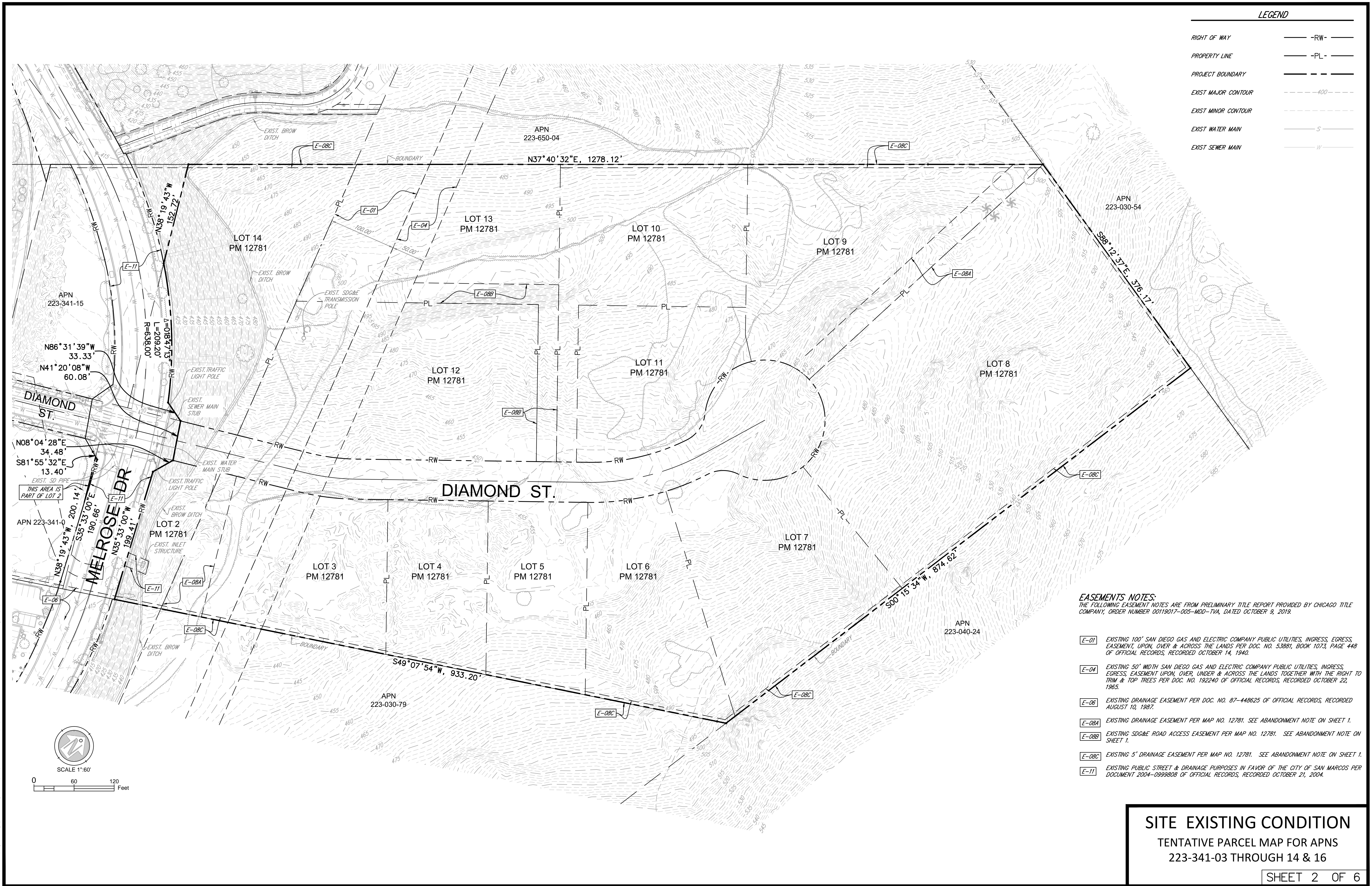

- EASEMENTS NOTES:**
 THE FOLLOWING EASEMENT NOTES ARE FROM PRELIMINARY TITLE REPORT PROVIDED BY CHICAGO TITLE COMPANY, ORDER NUMBER 00119017-005-MDO-TVA, DATED OCTOBER 9, 2019.
- E-01** EXISTING 100' SAN DIEGO GAS AND ELECTRIC COMPANY PUBLIC UTILITIES, INGRESS, EGRESS, EASEMENT, UPON, OVER & ACROSS THE LANDS PER DOC. NO. 53881, BOOK 1073, PAGE 448 OF OFFICIAL RECORDS, RECORDED OCTOBER 14, 1940.
 - E-04** EXISTING 50' WIDTH SAN DIEGO GAS AND ELECTRIC COMPANY PUBLIC UTILITIES, INGRESS, EGRESS, EASEMENT UPON, OVER, UNDER & ACROSS THE LANDS TOGETHER WITH THE RIGHT TO TRIM & TOP TREES PER DOC. NO. 192240 OF OFFICIAL RECORDS, RECORDED OCTOBER 22, 1965.
 - E-06** EXISTING DRAINAGE EASEMENT PER DOC. NO. 87-448625 OF OFFICIAL RECORDS, RECORDED AUGUST 10, 1987.
 - E-08A** EXISTING DRAINAGE EASEMENT PER MAP NO. 12781. SEE ABANDONMENT NOTE ON SHEET 1.
 - E-08B** EXISTING SDG&E ROAD ACCESS EASEMENT PER MAP NO. 12781. SEE ABANDONMENT NOTE ON SHEET 1.
 - E-08C** EXISTING 5' DRAINAGE EASEMENT PER MAP NO. 12781. SEE ABANDONMENT NOTE ON SHEET 1.
 - E-11** EXISTING PUBLIC STREET & DRAINAGE PURPOSES IN FAVOR OF THE CITY OF SAN MARCOS PER DOCUMENT 2004-0999808 OF OFFICIAL RECORDS, RECORDED OCTOBER 21, 2004.

SITE EXISTING CONDITION
 TENTATIVE PARCEL MAP FOR APNS
 223-341-03 THROUGH 14 & 16
 SHEET 2 OF 6

v:19 | 1/2023 | engineering | preliminary | concepts | 12010100 | concept | 17M - CIP 2 - SITE | EXISTING CONDITION.dwg | 10/17/2020 12:04 PM | ORIGINAL | PLOT SIZE:

LEGEND

RIGHT OF WAY	-RW-
PROPERTY LINE	-PL-
PROJECT BOUNDARY	---
EXIST MAJOR CONTOUR	---400---
EXIST MINOR CONTOUR	---
EXIST WATER MAIN	W
EXIST SEWER MAIN	S
GEOGRID TYPE RETAINING	█
SOIL NAIL TYPE RETAINING	█
NEW WATER MAIN	W
NEW SEWER MAIN	S
FLOW LINE	→
PCC BROW DITCH	⇨

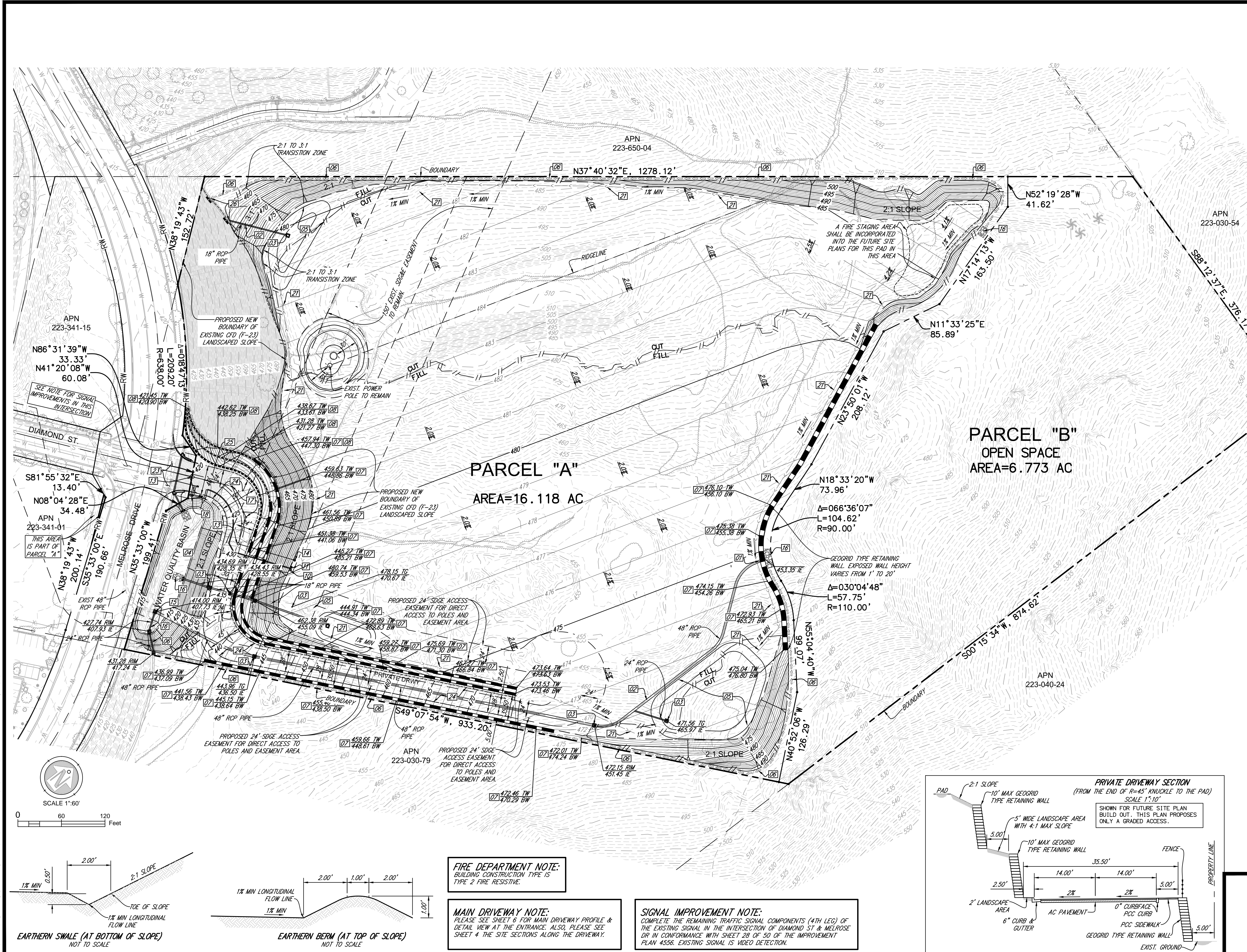

PARCEL "A"
AREA=16.118 AC

PARCEL "B"
OPEN SPACE
AREA=6.773 AC

CONSTRUCTION NOTES

- 01 CONSTRUCT STORM DRAIN HEADWALL
- 02 INSTALL STORM DRAIN PIPE
- 03 CONSTRUCT STORM DRAIN STRUCTURE
- 04 CONSTRUCT DESILTATION BASIN CAN BE CONVERTED INTO A WATER QUALITY BASIN FOR FUTURE SITE DEVELOPMENT PLAN.
- 05 CONSTRUCT DESILTATION BASIN.
- 06 CONSTRUCT PCC BROWDITCH
- 07 CONSTRUCT GEOGRID TYPE RETAINING WALL
- 08 CONSTRUCT SOIL NAIL TYPE RETAINING WALL
- 09 INSTALL FIRELINE MAIN
- 10 INSTALL FIRE SERVICE
- 11 INSTALL WATER LINE SERVICE
- 12 INSTALL SEWER MAIN
- 13 INSTALL SEWER MANHOLE
- 14 INSTALL SEWER SERVICE
- 15 MODIFY EXISTING STORM DRAIN STRUCTURE
- 16 INSTALL RIPRAP
- 17 INSTALL SEWER CLEANOUT
- 18 INSTALL 2" WATER LINE LATERALS FOR DOMESTIC & IRRIGATION
- 19 EXTEND EXISTING WATER MAIN STUB
- 20 CONNECT NEW SEWERLINE TO EXISTING SEWER STUB
- 21 CONSTRUCT EARTHEN BERM/SWALE. SEE DETAILS THIS SHEET.
- 22 FUTURE CURB & GUTTER TO BE PART OF THE FUTURE SITE DEVELOPMENT PLAN.
- 23 CONSTRUCT PCC CROSS GUTTER, PEDESTRIAN RAMPS & 6" PCC CURB RETURN
- 24 FUTURE CURB & GUTTER. PART OF THE FUTURE SITE DEVELOPMENT PLAN.
- 25 INSTALL TEMPORARY GRAVEL SURFACE.
- 26 CONNECT SD PIPE & BROWDITCH TO EXISTING BROWDITCH. INSTALL SPLASH WALL.
- 27 INSTALL PEDESTRIAN RAMP

FIRE DEPARTMENT NOTE:
BUILDING CONSTRUCTION TYPE IS TYPE 2 FIRE RESISTIVE.

MAIN DRIVEWAY NOTE:
PLEASE SEE SHEET 6 FOR MAIN DRIVEWAY PROFILE & DETAIL VIEW AT THE ENTRANCE. ALSO, PLEASE SEE SHEET 4 THE SITE SECTIONS ALONG THE DRIVEWAY.

SIGNAL IMPROVEMENT NOTE:
COMPLETE THE REMAINING TRAFFIC SIGNAL COMPONENTS (4TH LEG) OF THE EXISTING SIGNAL IN THE INTERSECTION OF DIAMOND ST & MELROSE DR IN CONFORMANCE WITH SHEET 28 OF 50 OF THE IMPROVEMENT PLAN 4556. EXISTING SIGNAL IS VIDEO DETECTION.

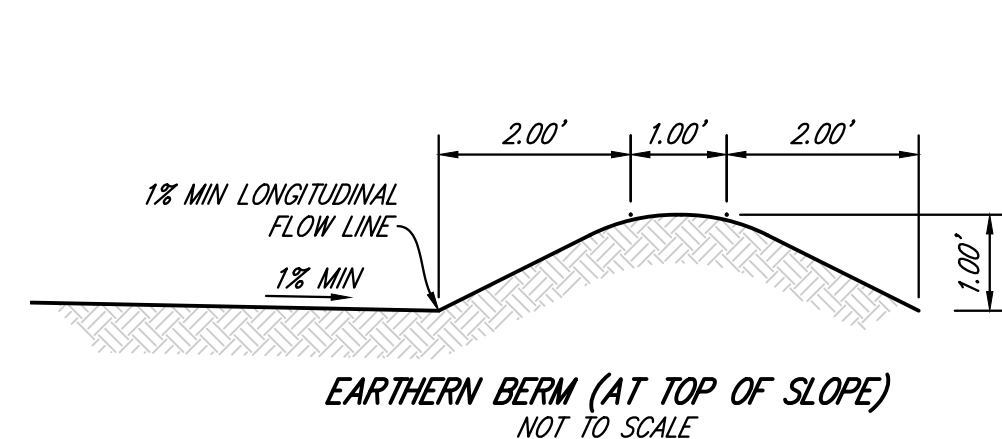
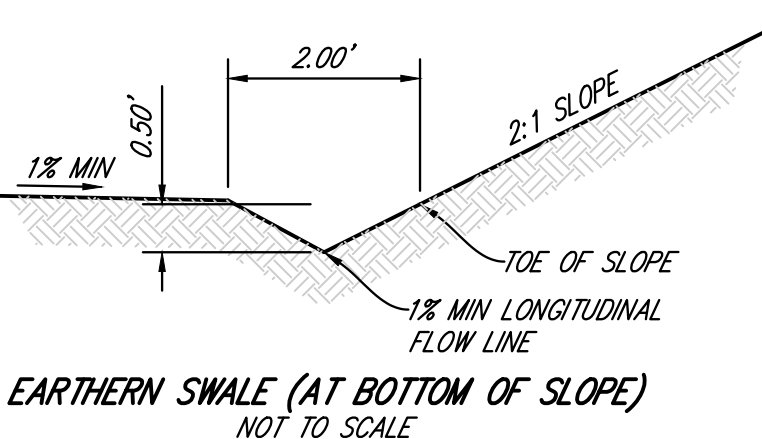
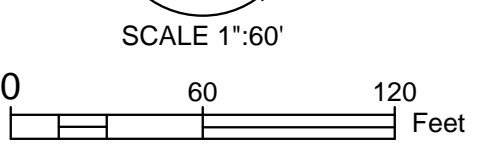
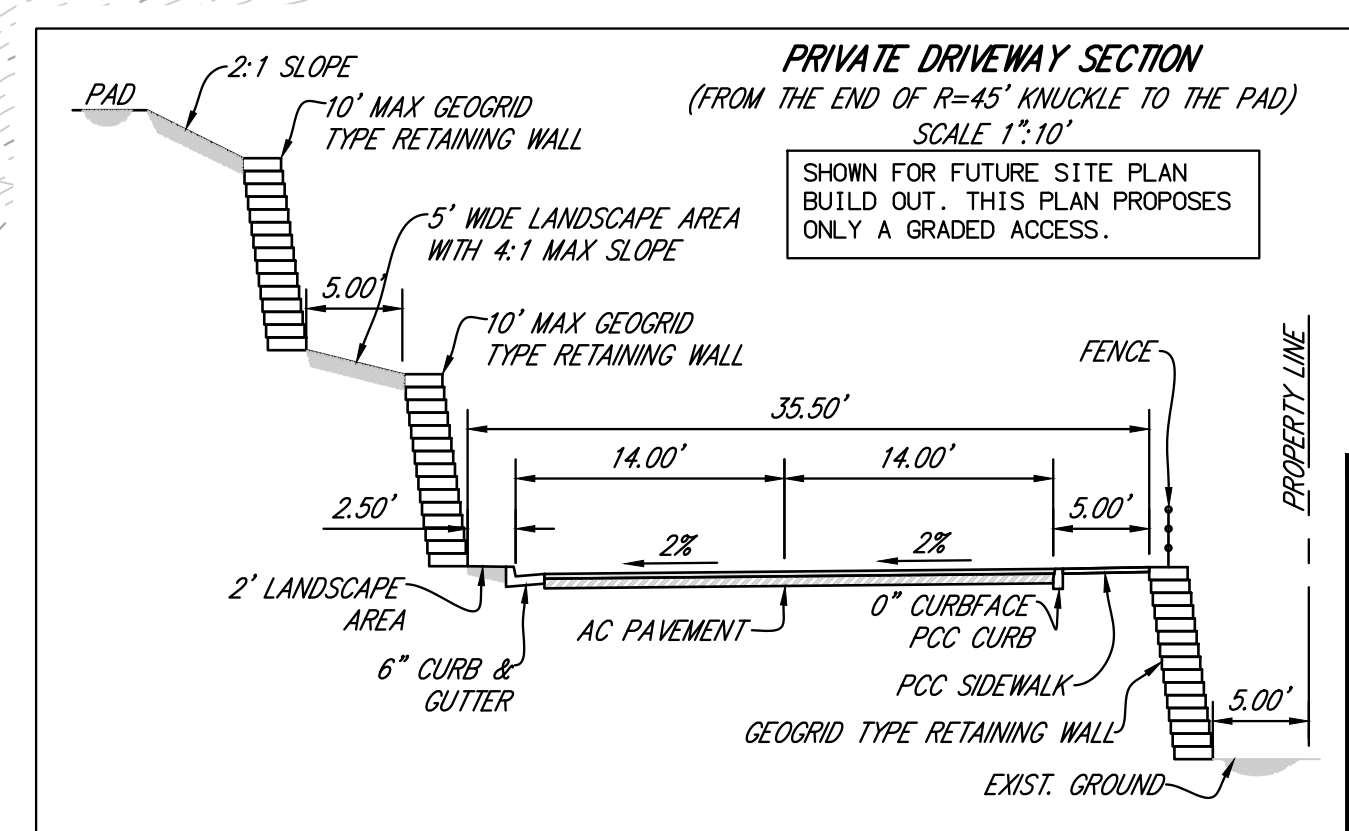

GRADING CONCEPT
TENTATIVE PARCEL MAP FOR APNS
223-341-03 THROUGH 14 & 16

1/19/2023 Engineering preliminary concepts 120101000 concept111M-CPI 3 GRADING CONCEPT.dwg 10/17/2020 12:04 PM ORIGINAL PLOT SIZE.

c:\191\191009\engineering\preliminary_concepts\120101000_concept\17M-GP14_SITE_SECTION.dwg 10/7/2020 12:05 PM ORIGINAL PLOT SIZE: -----

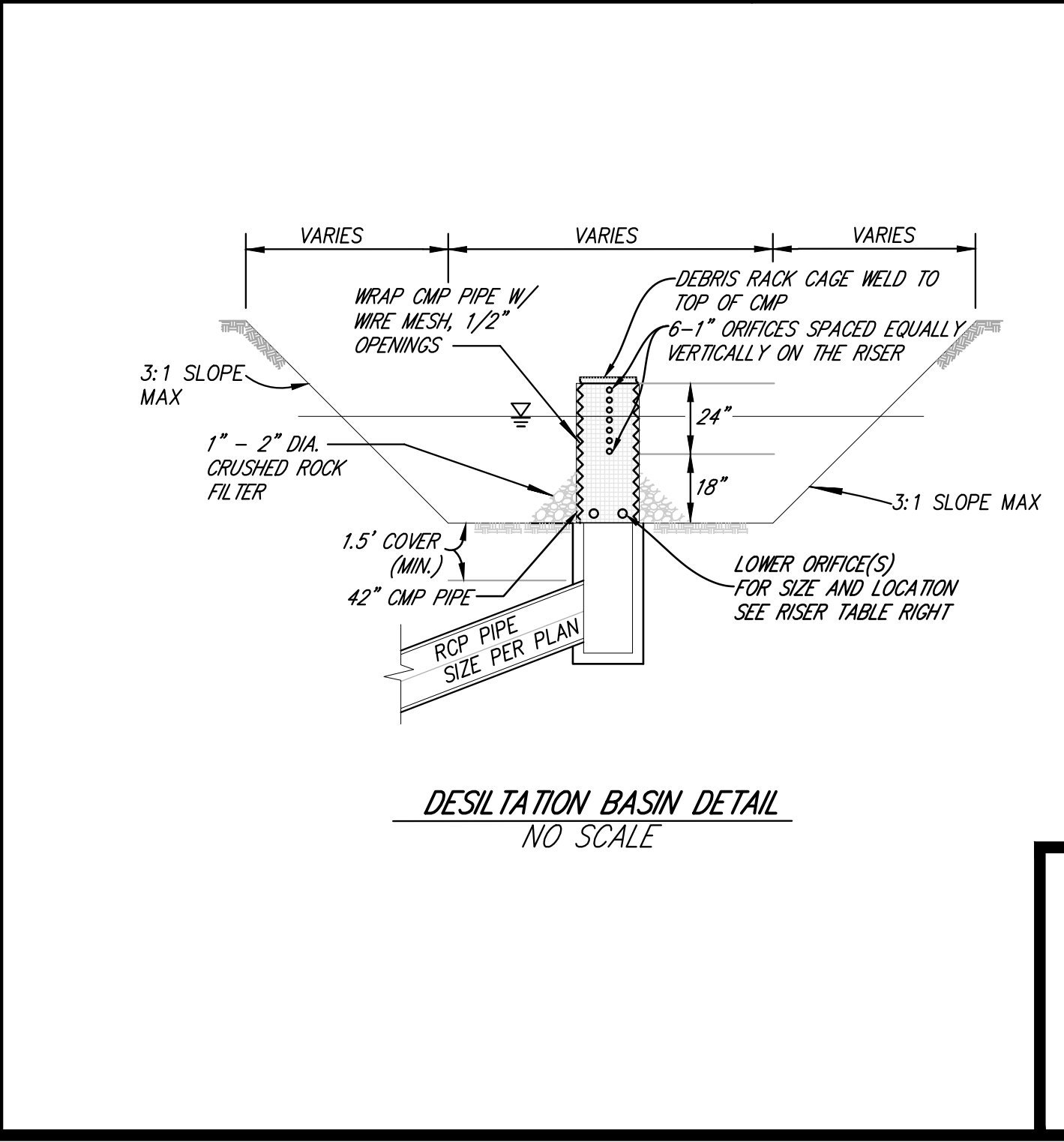
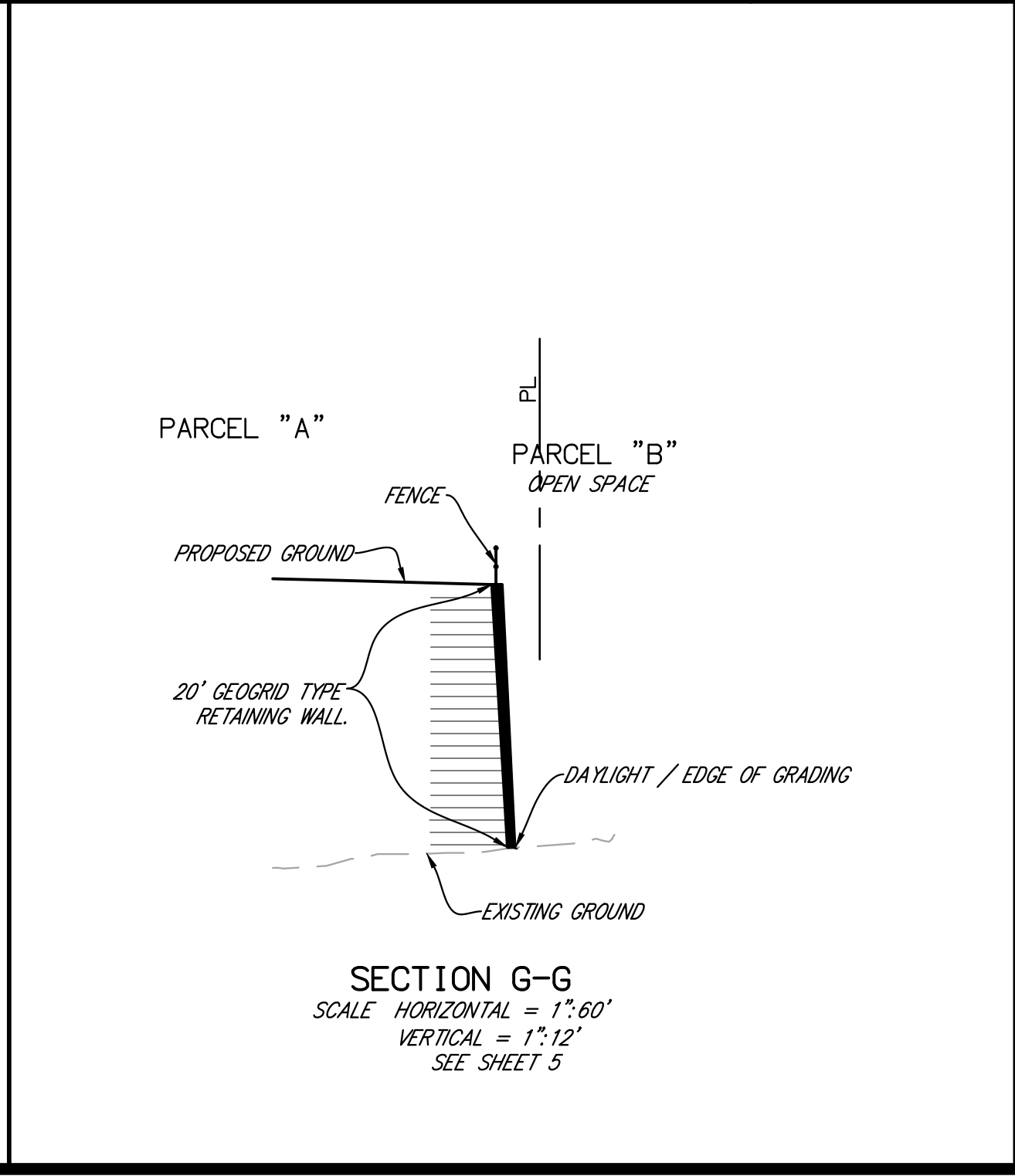
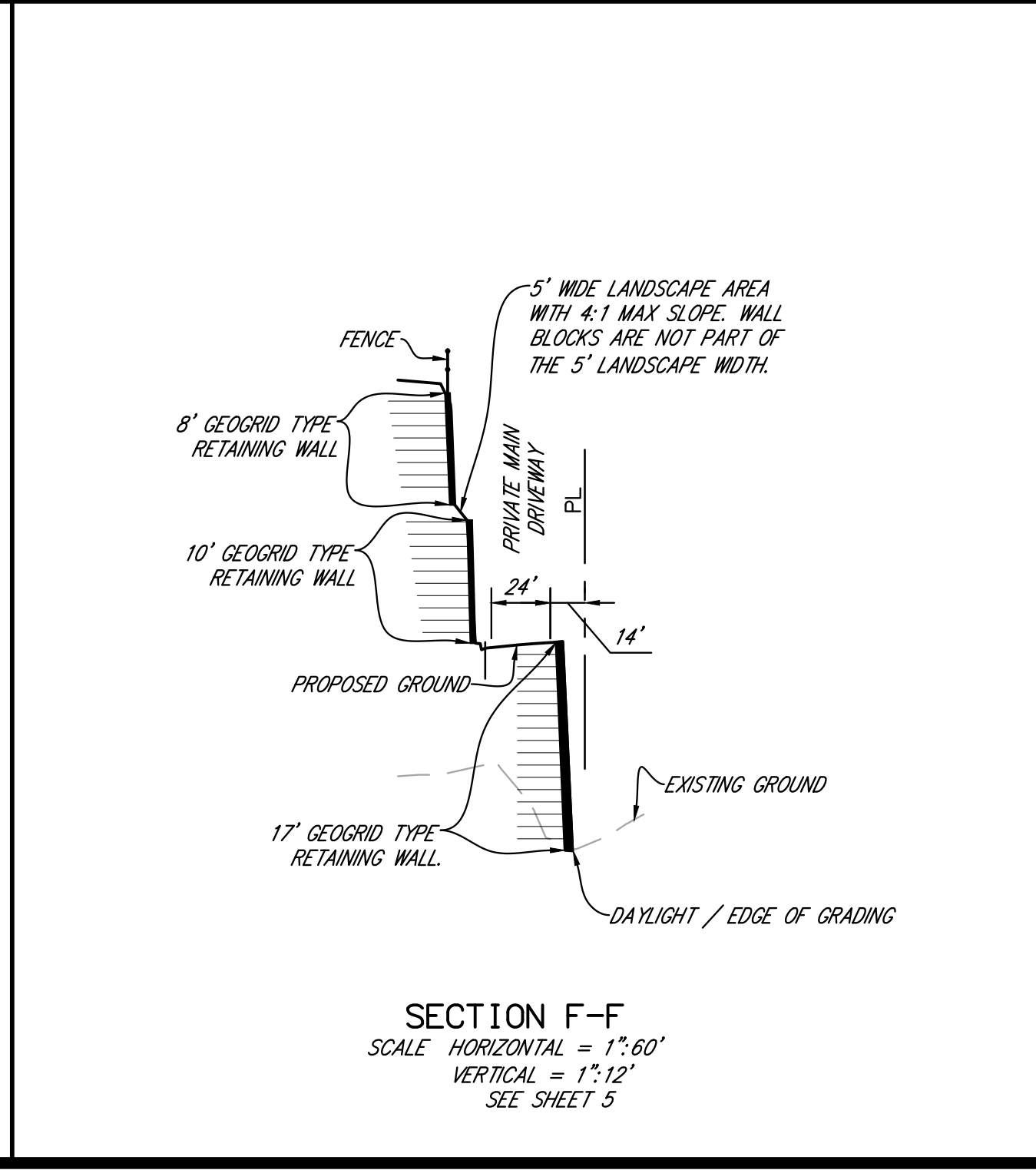
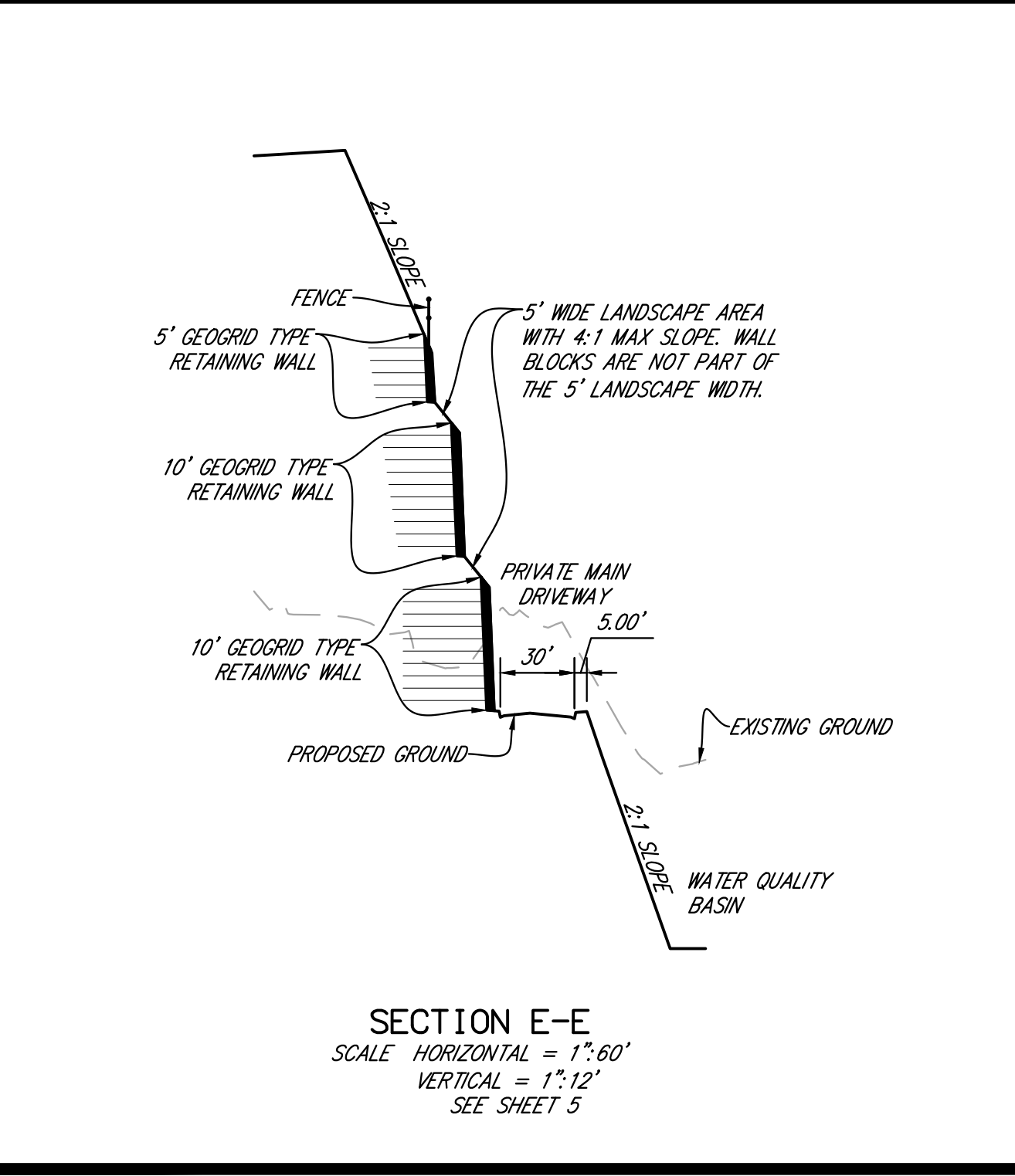
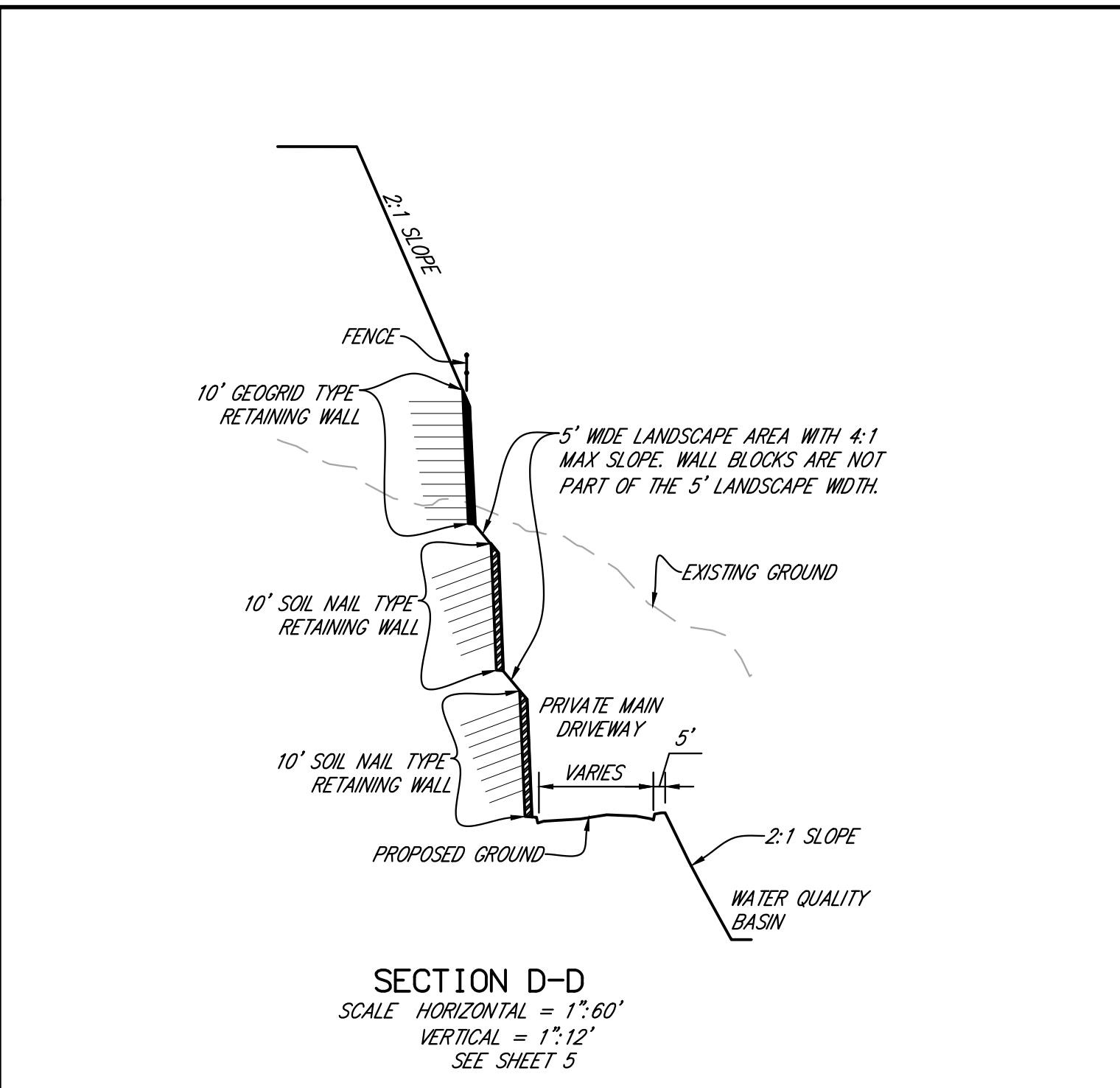
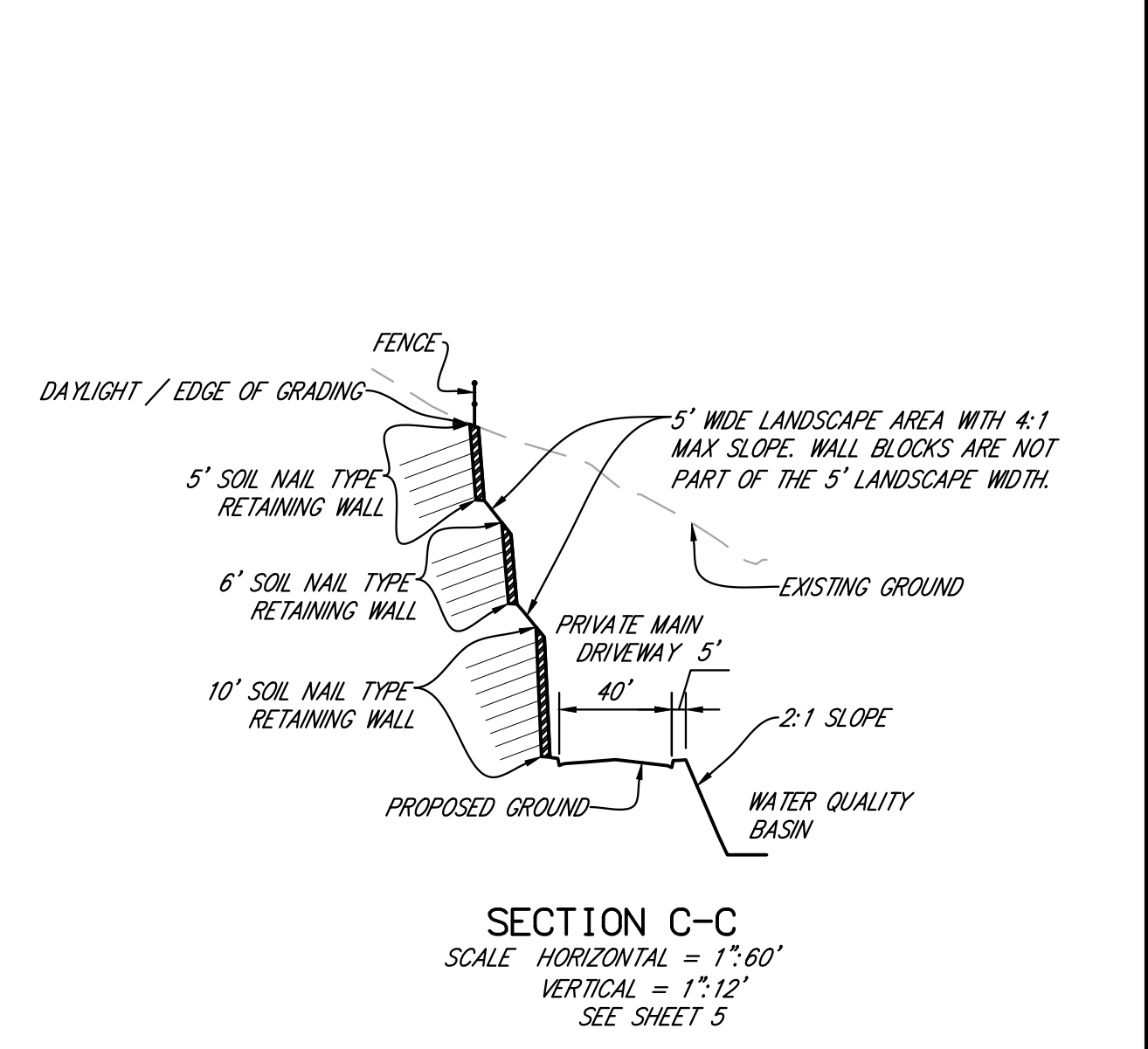
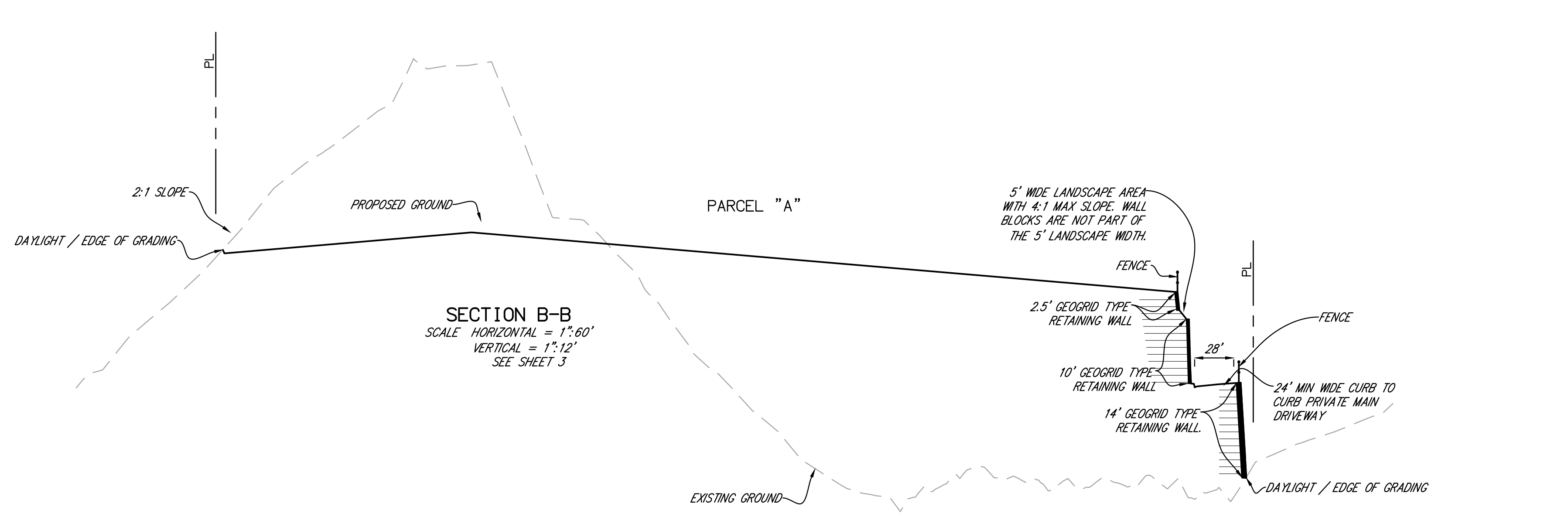
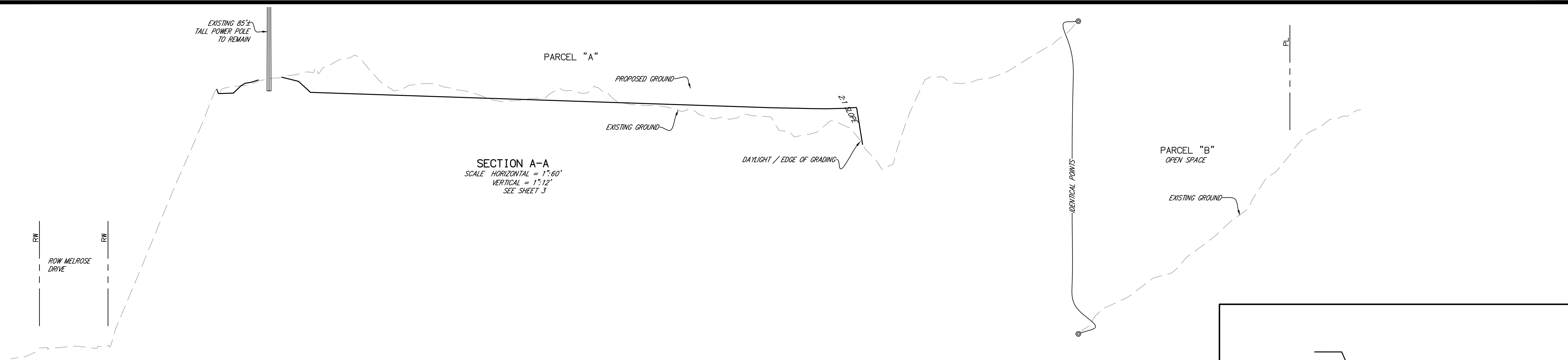

RISER TABLE		
BASIN #	LOW ORIFICE	
	# OF ORIFICES	DIAMETER
503	2	2 INCHES
603	1	1.5 INCHES
406	1	1 INCH

SITE SECTIONS
TENTATIVE PARCEL MAP FOR APNS
223-341-03 THROUGH 14 & 16
SHEET 4 OF 6

PARCEL "A"

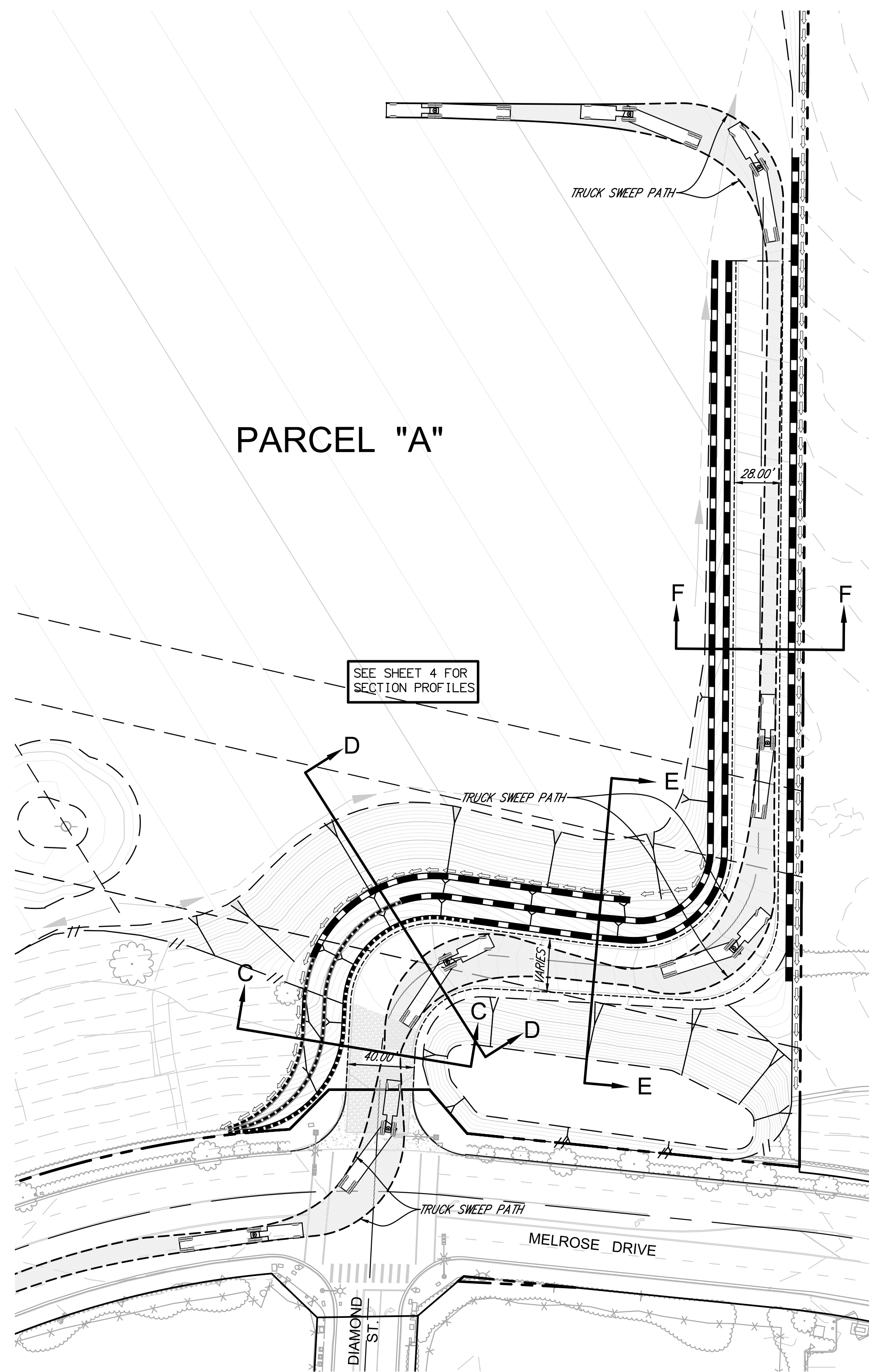

TRUCK MOTION EXHIBIT
(ENTERING THE SITE)

THE TRUCK TURNING ENVELOPE SHOWN HERE IS THE CALTRANS 2008 (US) STAA-LONG. SIMULATION IS DONE IN AUTOTURN VERSION 6.0.

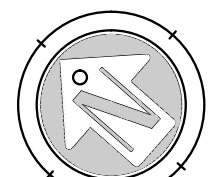

SCALE 1":50'

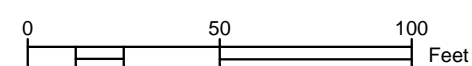

PARCEL "A"

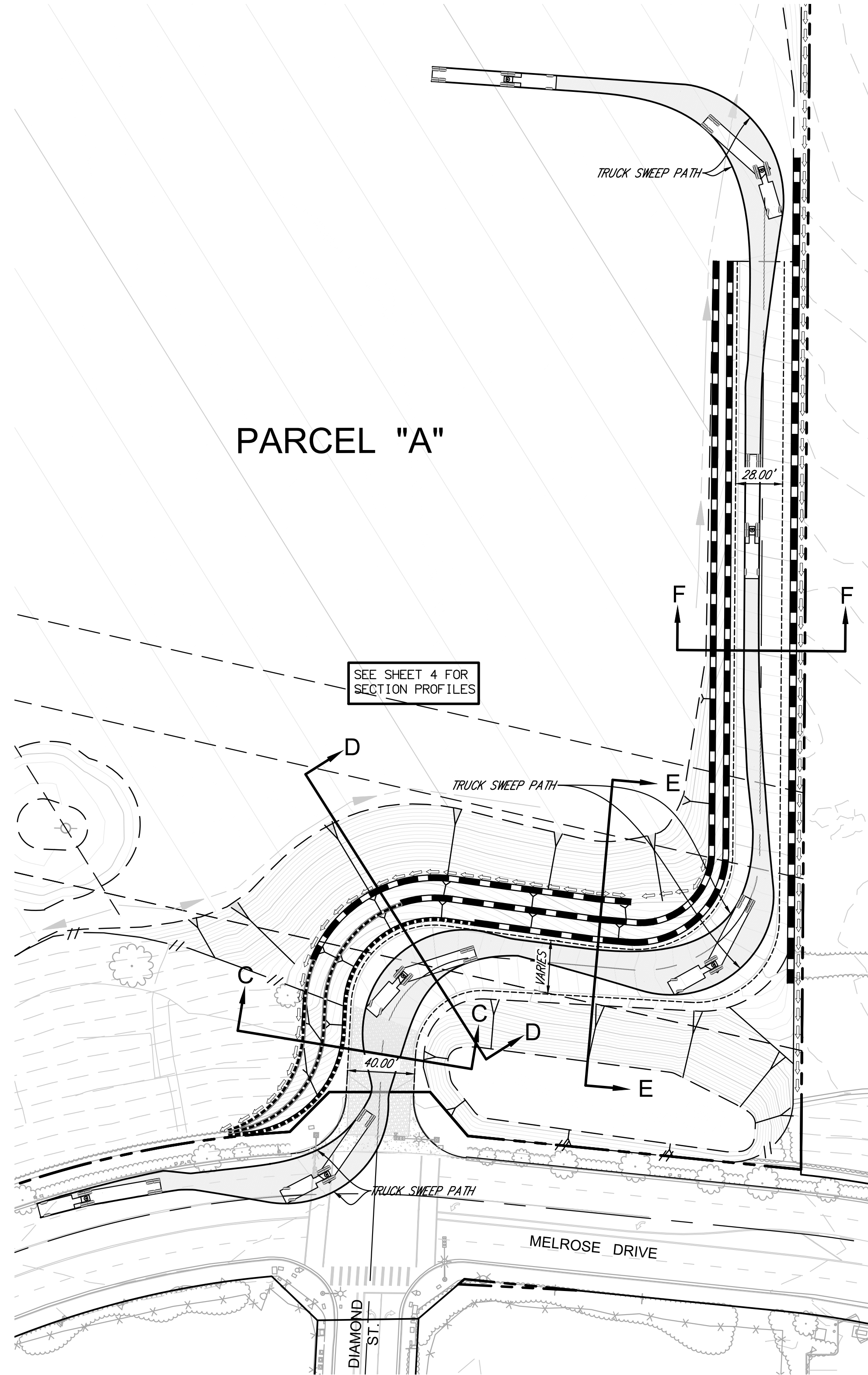

TRUCK MOTION EXHIBIT
(EXITING THE SITE)

THE TRUCK TURNING ENVELOPE SHOWN HERE IS THE CALTRANS 2008 (US) STAA-LONG. SIMULATION IS DONE IN AUTOTURN VERSION 6.0.

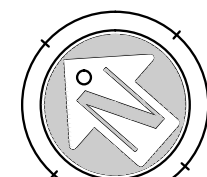

SCALE 1":50'

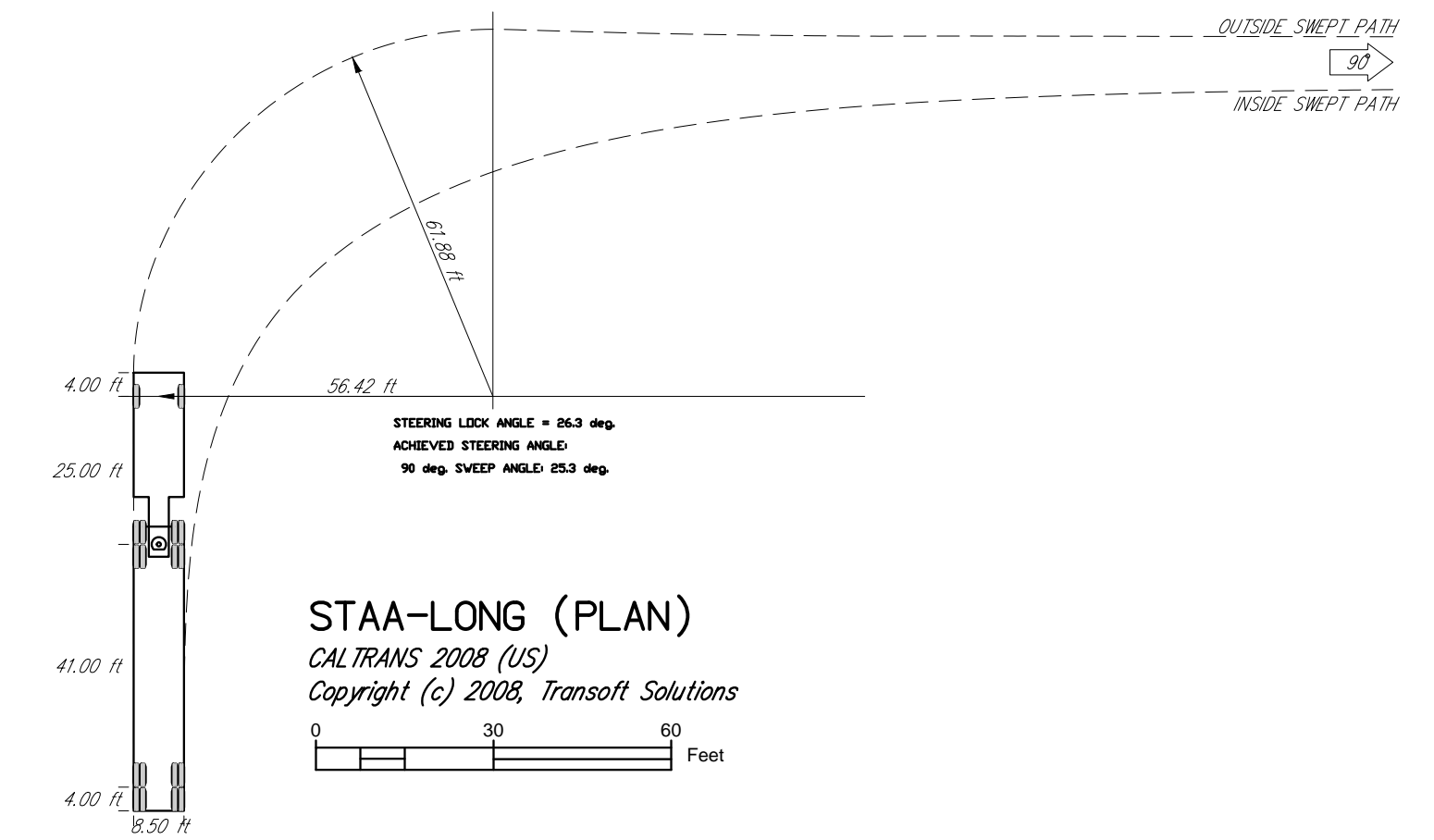
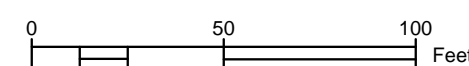

STAA-LONG (PLAN)

CALTRANS 2008 (US)
Copyright (c) 2008, Transoft Solutions

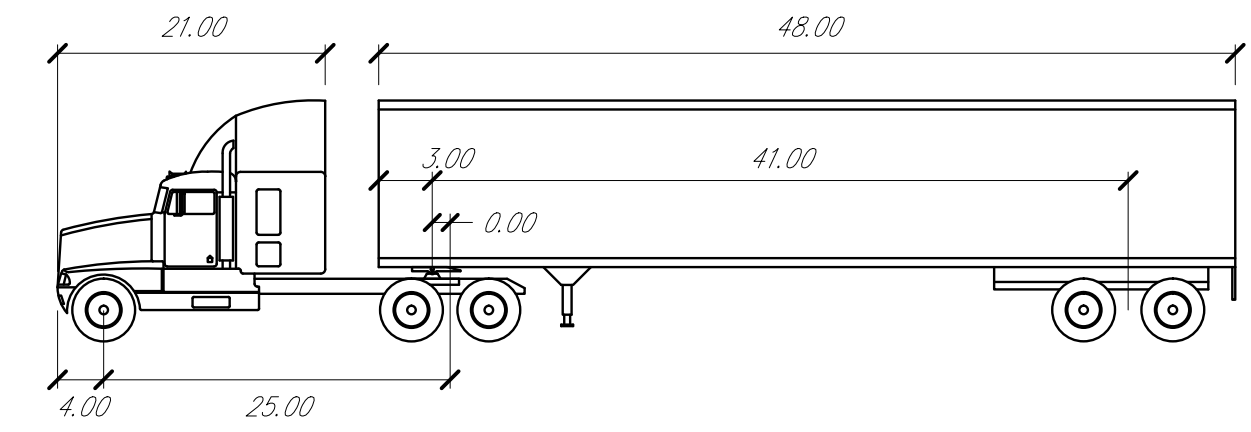
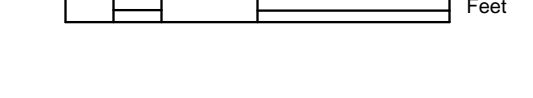

STAA-LONG (PROFILE)

CALTRANS 2008 (US)

TRACTOR WIDTH = 8.50' LOCK TO LOCK TIME = 6.00
TRAILER WIDTH = 8.50' STEERING ANGLE = 26.30
TRACTOR TRACK = 8.50' ARTICULATING ANGLE = 70.0
TRAILER TRACK = 8.50'

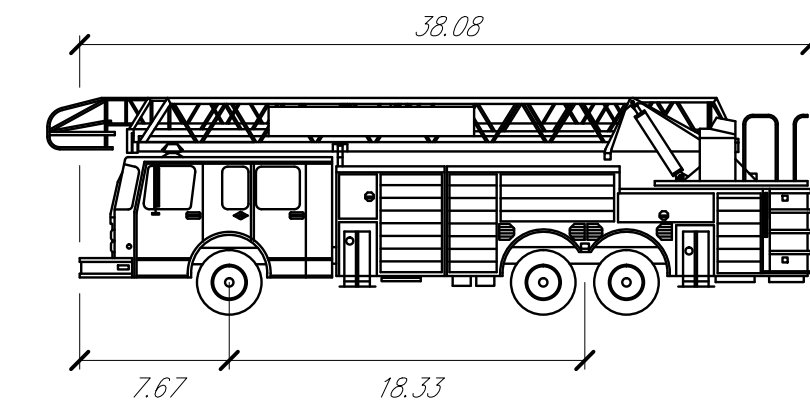
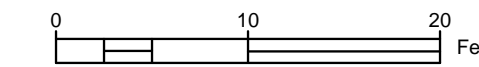

E-ONE G114 100' AERIAL BODY

WIDTH = 8.00'
TRACK = 8.00'
LOCK TO LOCK TIME = 6.00
STEERING ANGLE = 33.3

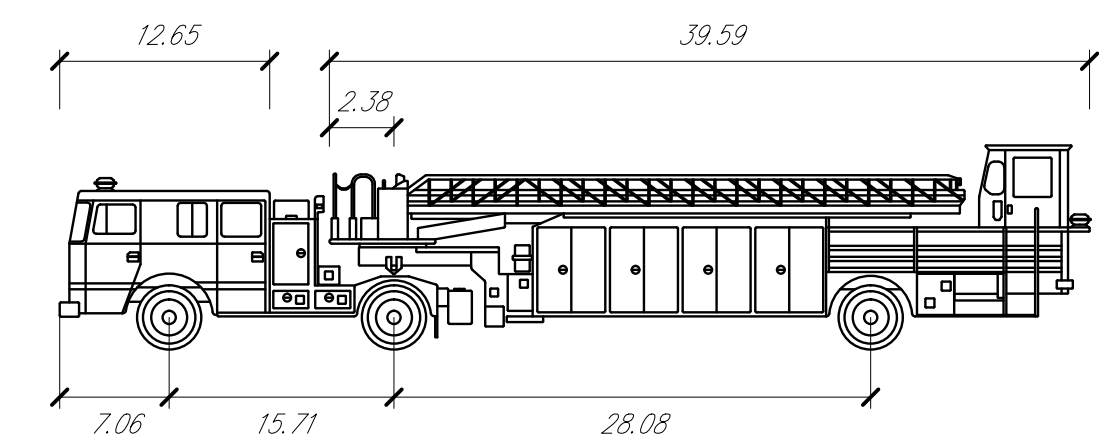

PIERCE 100' MDL TILLER

TRACTOR WIDTH = 8.60' LOCK TO LOCK TIME = 6.00
TRAILER WIDTH = 8.60' STEERING ANGLE = 34.8
TRACTOR TRACK = 6.60' ARTICULATING ANGLE = 70.0
TRAILER TRACK = 6.60'

EMERGENCY VEHICLE NOTE:
THE TRUCK MOTION SIMULATION SHOWN HERE USES THE STAA-LONG TURNING TEMPLATE. THIS VEHICLE IS MORE RESTRICTIVE THAN THE E-ONE G114 AERIAL BODY & THE PIERCE 100' MDL TILLER EMERGENCY VEHICLES.

TRUCK MOTION EXHIBIT
TENTATIVE PARCEL MAP FOR APNS
223-341-03 THROUGH 14 & 16

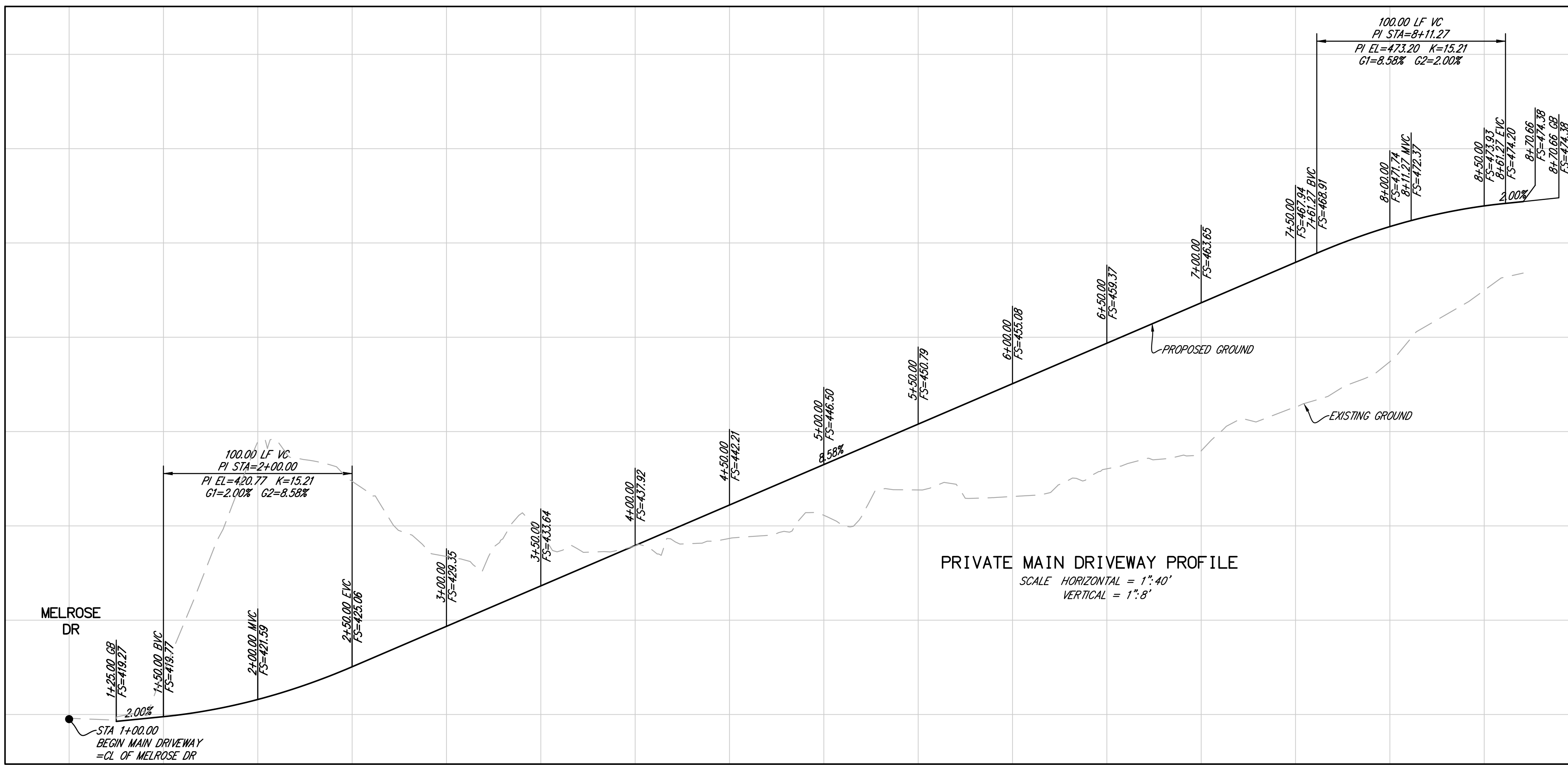

PRIVATE MAIN DRIVEWAY PROFILE
SCALE HORIZONTAL = 1"=40'
VERTICAL = 1"=8'

CONSTRUCTION NOTES

- 01 CONSTRUCT STORM DRAIN HEADWALL
- 02 INSTALL STORM DRAIN PIPE
- 03 CONSTRUCT STORM DRAIN STRUCTURE
- 04 CONSTRUCT DESILTATION BASIN CAN BE CONVERTED INTO A WATER QUALITY BASIN FOR FUTURE SITE DEVELOPMENT PLAN.
- 05 CONSTRUCT DESILTATION BASIN.
- 06 CONSTRUCT PCC BROWDNITCH
- 07 CONSTRUCT GEOGRID TYPE RETAINING WALL
- 08 CONSTRUCT SOIL NAIL TYPE RETAINING WALL
- 09 INSTALL FIRELINE MAIN
- 10 INSTALL FIRE SERVICE
- 11 INSTALL WATER LINE SERVICE
- 12 INSTALL SEWER MAIN
- 13 INSTALL SEWER MANHOLE
- 14 INSTALL SEWER SERVICE
- 15 MODIFY EXISTING STORM DRAIN STRUCTURE
- 16 INSTALL RIPRAP
- 17 INSTALL SEWER CLEANOUT
- 18 INSTALL 2" WATER LINE LATERALS FOR DOMESTIC & IRRIGATION
- 19 EXTEND EXISTING WATER MAIN STUB
- 20 CONNECT NEW SEWERLINE TO EXISTING SEWER STUB
- 21 CONSTRUCT EARTHEN BERM. SEE DETAILS THIS SHEET.
- 22 FUTURE CURB & GUTTER TO BE PART OF THE FUTURE SITE DEVELOPMENT PLAN.
- 23 CONSTRUCT PCC CROSS GUTTER, PEDESTRIAN RAMPS & 6" PCC CURB RETURN
- 24 FUTURE CURB & GUTTER. PART OF THE FUTURE SITE DEVELOPMENT PLAN.
- 25 INSTALL TEMPORARY GRAVEL SURFACE.
- 26 CONNECT SD PIPE & BROWDNITCH TO EXISTING BROWDNITCH. INSTALL SPLASH WALL.
- 27 INSTALL PEDESTRIAN RAMP

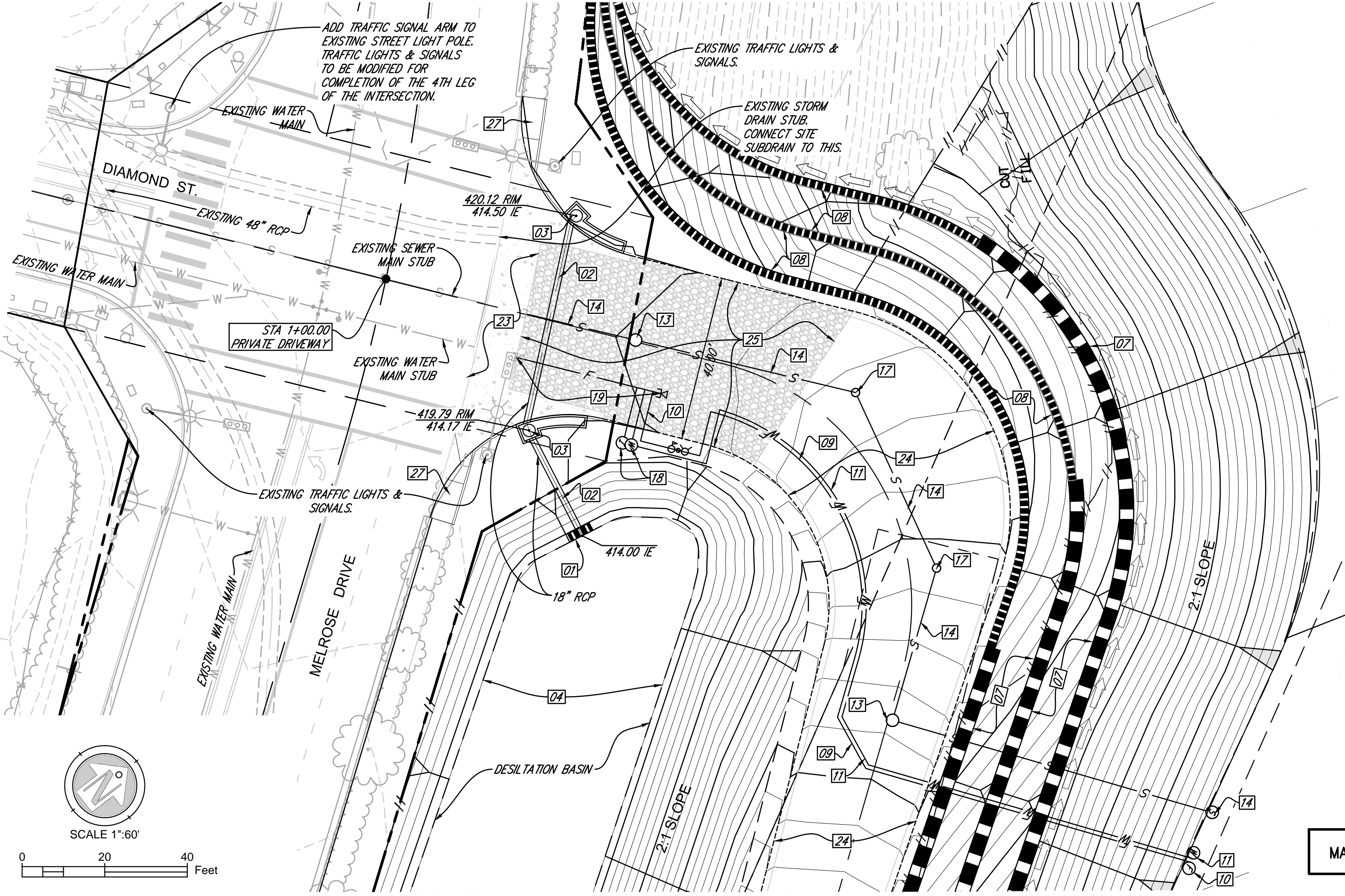

SIGNAL IMPROVEMENT NOTE:
COMPLETE THE REMAINING TRAFFIC SIGNAL COMPONENTS (4TH LEG) OF THE EXISTING SIGNAL IN THE INTERSECTION OF DIAMOND ST & MELROSE DR IN CONFORMANCE WITH SHEET 28 OF 50 OF THE IMPROVEMENT PLAN 4556. EXISTING SIGNAL IS VIDEO DETECTION.

LEGEND

- RIGHT OF WAY ——— -RW———
- PROPERTY LINE ——— -PL———
- PROJECT BOUNDARY ——— -PB———
- EXIST MAJOR CONTOUR - - - - -400- - - - -
- EXIST MINOR CONTOUR - - - - -
- EXIST WATER MAIN ——— W ———
- EXIST SEWER MAIN ——— S ———
- GEOGRID TYPE RETAINING ———
- SOIL NAIL TYPE RETAINING ———
- NEW WATER MAIN ——— W ———
- NEW SEWER MAIN ——— S ———

MAIN DRIVEWAY DETAIL PLAN VIEW

MAIN DRWY DETAIL & PROFILE
TENTATIVE PARCEL MAP FOR APNS
223-341-03 THROUGH 14 & 16

c:\191\0009\engineering\preliminary_concepts\2010.00\concept\178-GP16 MAIN DRIVEY DETAIL & PROFILE.dwg 10/7/2020 12:05 PM ORIGINAL PLOT SIZE: 11x17

Appendix B

Representative Photographs

Appendix B Photograph Location Map

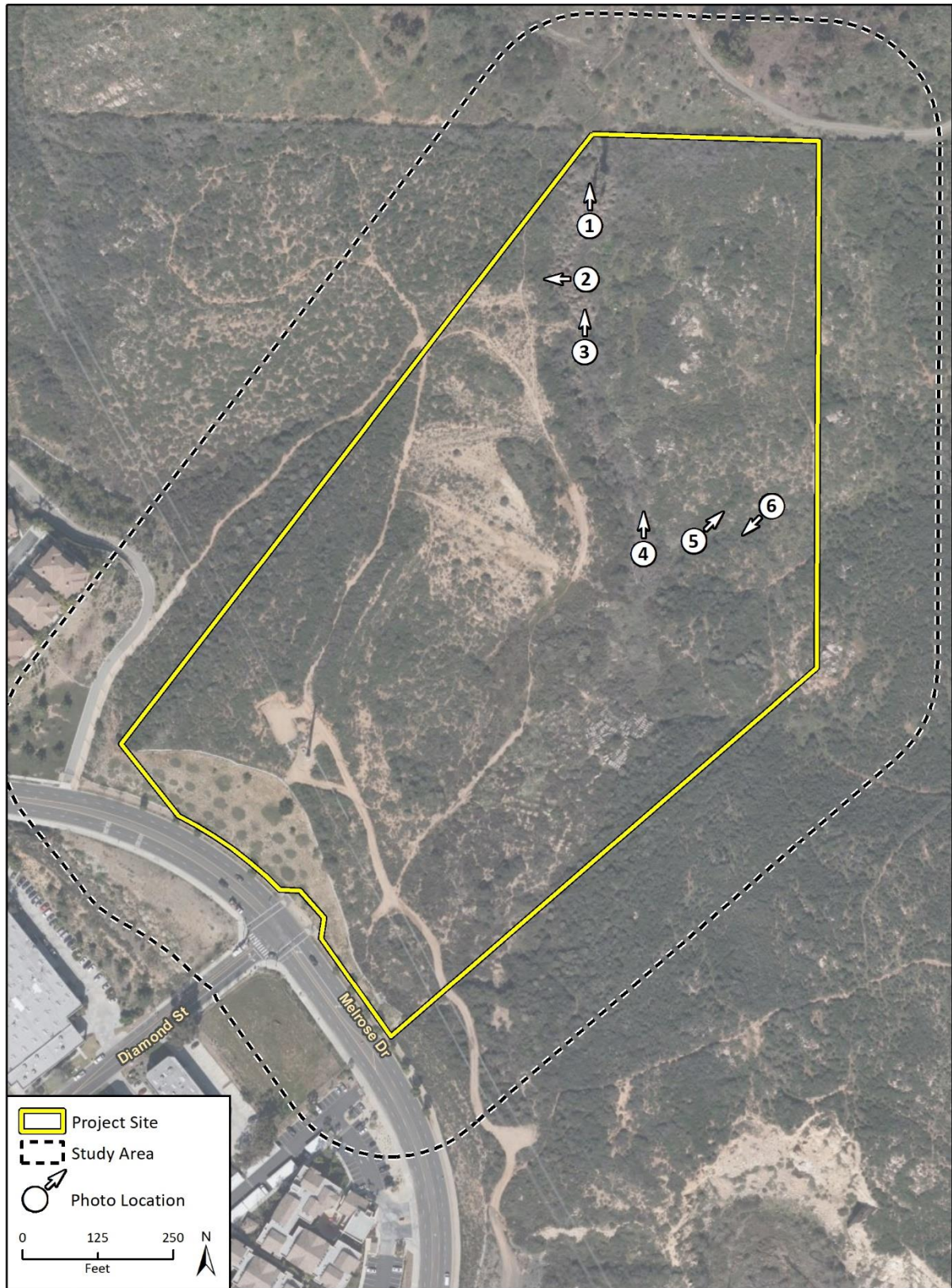

Fig X Photo Location Map



Photograph 1. Upstream view of primary feature, illustrating dense pampas grass and palm trees.



Photograph 2. Side view facing west of the primary feature. The Channel bed is primarily pampas grass.



Photograph 3. Dense broad-leaved cattail, pampas grass and bristly ox-tongue in primary feature.



Photograph 4. Upstream view of herbaceous vegetation in the primary feature. View facing north.



Photograph 5. Upstream view of tributary with dense California sagebrush and California buckwheat.



Photograph 6. Downstream view of origination of tributary drainage with dense upland vegetation.

Appendix C

Completed Wetland Delineation Forms

WETLAND DETERMINATION DATA FORM – Arid West Region

Project Site: Melrose & Diamond Industrial Site City/County: San Marcos/San Diego Sampling Date: 6/18/2020
 Applicant/Owner: Melrose Industrial, LLC State: CA Sampling Point: 1
 Investigator(s): Jared Reed and Emily Kochert Section, Township, Range: 29, 12S, R3W
 Landform (hillslope, terrace, etc.): ravine Local relief (concave, convex, none): concave Slope (%): 2
 Subregion (LRR): C Lat: 34.1088° Long: -117.2137° Datum: NAD83
 Soil Map Unit Name: Cieneba rocky coarse sandy loam, 9 to 30% slopes, eroded NWI classification: Freshwater Forested/Shrub Wetland

Are climatic / hydrologic conditions on the site typical for this time of year? Yes No (If no, explain in Remarks.)
 Are Vegetation , Soil , or Hydrology significantly disturbed? Are "Normal Circumstances" present? Yes No
 Are Vegetation , Soil , or Hydrology naturally problematic? (If needed, explain any answers in Remarks.)

SUMMARY OF FINDINGS – Attach site map showing sampling point locations, transects, important features, etc.

Hydrophytic Vegetation Present?	Yes <input type="checkbox"/>	No <input checked="" type="checkbox"/>	Is the Sampled Area within a Wetland?	Yes <input type="checkbox"/>	No <input checked="" type="checkbox"/>
Hydric Soil Present?	Yes <input type="checkbox"/>	No <input checked="" type="checkbox"/>			
Wetland Hydrology Present?	Yes <input type="checkbox"/>	No <input checked="" type="checkbox"/>			
Remarks: <u>Weak evidence of water flow from north to south. Heavy pampas grass invasion.</u>					

VEGETATION – Use scientific names of plants.

Tree Stratum (Plot size: N/A)	Absolute % Cover	Dominant Species?	Indicator Status	Dominance Test Worksheet:	
1. _____	_____	<u>n/a*</u>	_____	Number of Dominant Species That Are OBL, FACW, or FAC:	1 (A)
2. _____	_____	<u>n/a*</u>	_____	Total Number of Dominant Species Across All Strata:	2 (B)
3. _____	_____	<u>n/a*</u>	_____	Percent of Dominant Species That Are OBL, FACW, or FAC:	50 (A/B)
4. _____	_____	<u>n/a*</u>	_____		
50% = _____, 20% = _____	_____	= Total Cover			
Sapling/Shrub Stratum (Plot size: N/A)	Absolute % Cover	Dominant Species?	Indicator Status	Prevalence Index worksheet:	
1. _____	_____	<u>n/a*</u>	_____		
2. _____	_____	<u>n/a*</u>	_____	OBL species	x1 = _____
3. _____	_____	<u>n/a*</u>	_____	FACW species	x2 = _____
4. _____	_____	<u>n/a*</u>	_____	FAC species	x3 = _____
5. _____	_____	<u>n/a*</u>	_____	FACU species	x4 = _____
50% = _____, 20% = _____	_____	= Total Cover		UPL species	x5 = _____
Herb Stratum (Plot size: 10'x10')	Absolute % Cover	Dominant Species?	Indicator Status	Column Totals: _____ (A) _____ (B)	
1. <u>Typha latifolia</u>	60	yes	OBL	Prevalence Index = B/A = _____	
2. <u>Cortaderia selloana</u>	30	yes	FACU	Hydrophytic Vegetation Indicators: <input type="checkbox"/> Dominance Test is >50% <input type="checkbox"/> Prevalence Index is ≤3.0 ¹ <input type="checkbox"/> Morphological Adaptations ¹ (Provide supporting data in Remarks or on a separate sheet) <input type="checkbox"/> Problematic Hydrophytic Vegetation ¹ (Explain)	
3. <u>Avena barbata</u>	3	no	NL (UPL)		
4. <u>Sonchus oleraceus</u>	2	no	UPL		
5. _____	_____	<u>n/a*</u>	_____		
6. _____	_____	<u>n/a*</u>	_____	Hydrophytic Vegetation Present? Yes <input type="checkbox"/> No <input checked="" type="checkbox"/>	
7. _____	_____	<u>n/a*</u>	_____		
8. _____	_____	<u>n/a*</u>	_____		
50% = <u>47.5</u> , 20% = <u>19</u>	95	= Total Cover			
Woody Vine Stratum (Plot size: N/A)	Absolute % Cover	Dominant Species?	Indicator Status		
1. _____	_____	_____	_____		
2. _____	_____	_____	_____		
50% = _____, 20% = _____	_____	= Total Cover			
% Bare Ground in Herb Stratum <u>5</u>	_____	% Cover of Biotic Crust <u>0</u>			
Remarks: <u>Vegetation dominated by dense broad-leaved cattail and pampas grass.</u>					

SOIL

Sampling Point: 1

Profile Description: (Describe to the depth needed to document the indicator or confirm the absence of indicators.)

Depth (inches)	Matrix		Redox Features					Texture	Remarks
	Color (moist)	%	Color (Moist)	%	Type ¹	Loc ²			
_____	_____	_____	_____	_____	_____	_____	_____	_____	
_____	_____	_____	_____	_____	_____	_____	_____	_____	
_____	_____	_____	_____	_____	_____	_____	_____	_____	
_____	_____	_____	_____	_____	_____	_____	_____	_____	
_____	_____	_____	_____	_____	_____	_____	_____	_____	

¹Type: C= Concentration, D=Depletion, RM=Reduced Matrix, CS=Covered or Coated Sand Grains. ²Location: PL=Pore Lining, M=Matrix.

Hydric Soil Indicators: (Applicable to all LRRs, unless otherwise noted.)		Indicators for Problematic Hydric Soils³:	
<input type="checkbox"/> Histosol (A1)	<input type="checkbox"/> Sandy Redox (S5)	<input type="checkbox"/> 1 cm Muck (A9) (LRR C)	
<input type="checkbox"/> Histic Epipedon (A2)	<input type="checkbox"/> Stripped Matrix (S6)	<input type="checkbox"/> 2 cm Muck (A10) (LRR B)	
<input type="checkbox"/> Black Histic (A3)	<input type="checkbox"/> Loamy Mucky Mineral (F1)	<input type="checkbox"/> Reduced Vertic (F18)	
<input type="checkbox"/> Hydrogen Sulfide (A4)	<input type="checkbox"/> Loamy Gleyed Matrix (F2)	<input type="checkbox"/> Red Parent Material (TF2)	
<input type="checkbox"/> Stratified Layers (A5) (LRR C)	<input type="checkbox"/> Depleted Matrix (F3)	<input type="checkbox"/> Other (Explain in Remarks)	
<input type="checkbox"/> 1 cm Muck (A9) (LRR D)	<input type="checkbox"/> Redox Dark Surface (F6)		
<input type="checkbox"/> Depleted Below Dark Surface (A11)	<input type="checkbox"/> Depleted Dark Surface (F7)		
<input type="checkbox"/> Thick Dark Surface (A12)	<input type="checkbox"/> Redox Depressions (F8)		
<input type="checkbox"/> Sandy Mucky Mineral (S1)	<input type="checkbox"/> Vernal Pools (F9)		
<input type="checkbox"/> Sandy Gleyed Matrix (S4)			

³Indicators of hydrophytic vegetation and wetland hydrology must be present, unless disturbed or problematic.

Restrictive Layer (if present): Type: _____ Depth (Inches): _____	Hydric Soils Present? Yes <input type="checkbox"/> No <input checked="" type="checkbox"/>
--	--

Remarks: Unable to dig test pit due to dense vegetation.

HYDROLOGY

Wetland Hydrology Indicators:	
Primary Indicators (minimum of one required; check all that apply)	Secondary Indicators (2 or more required)
<input type="checkbox"/> Surface Water (A1)	<input type="checkbox"/> Salt Crust (B11)
<input type="checkbox"/> High Water Table (A2)	<input type="checkbox"/> Biotic Crust (B12)
<input type="checkbox"/> Saturation (A3)	<input type="checkbox"/> Aquatic Invertebrates (B13)
<input type="checkbox"/> Water Marks (B1) (Nonriverine)	<input type="checkbox"/> Hydrogen Sulfide Odor (C1)
<input type="checkbox"/> Sediment Deposits (B2) (Nonriverine)	<input type="checkbox"/> Oxidized Rhizospheres along Living Roots (C3)
<input type="checkbox"/> Drift Deposits (B3) (Nonriverine)	<input type="checkbox"/> Presence of Reduced Iron (C4)
<input type="checkbox"/> Surface Soil Cracks (B6)	<input type="checkbox"/> Recent Iron Reduction in Tilled Soils (C6)
<input type="checkbox"/> Inundation Visible on Aerial Imagery (B7)	<input type="checkbox"/> Thin Muck Surface (C7)
<input type="checkbox"/> Water-Stained Leaves (B9)	<input type="checkbox"/> Other (Explain in Remarks)
	<input type="checkbox"/> Water Marks (B1) (Riverine)
	<input type="checkbox"/> Sediment Deposits (B2) (Riverine)
	<input type="checkbox"/> Drift Deposits (B3) (Riverine)
	<input checked="" type="checkbox"/> Drainage Patterns (B10)
	<input type="checkbox"/> Dry-Season Water Table (C2)
	<input type="checkbox"/> Crayfish Burrows (C8)
	<input type="checkbox"/> Saturation Visible on Aerial Imagery (C9)
	<input type="checkbox"/> Shallow Aquitard (D3)
	<input type="checkbox"/> FAC-Neutral Test (D5)

Field Observations: Surface Water Present? Yes <input type="checkbox"/> No <input checked="" type="checkbox"/> Depth (inches): _____ Water Table Present? Yes <input type="checkbox"/> No <input checked="" type="checkbox"/> Depth (inches): _____ Saturation Present? (includes capillary fringe) Yes <input type="checkbox"/> No <input checked="" type="checkbox"/> Depth (inches): _____	Wetland Hydrology Present? Yes <input type="checkbox"/> No <input checked="" type="checkbox"/>
---	---

Describe Recorded Data (stream gauge, monitoring well, aerial photos, previous inspections), if available:

Remarks:

WETLAND DETERMINATION DATA FORM – Arid West Region

Project Site: Melrose & Diamond Industrial Site City/County: San Marcos/San Diego Sampling Date: 6/18/2020
 Applicant/Owner: Melrose Industrial, LLC State: CA Sampling Point: 2
 Investigator(s): Jared Reed and Emily Kochert Section, Township, Range: 29, 12S, R3W
 Landform (hillslope, terrace, etc.): ravine Local relief (concave, convex, none): concave Slope (%): 2
 Subregion (LRR): C Lat: 34.1078° Long: -117.2134° Datum: NAD83
 Soil Map Unit Name: Cieneba rocky coarse sandy loam, 9 to 30% slopes, eroded NWI classification: Freshwater Forested/Shrub Wetland

Are climatic / hydrologic conditions on the site typical for this time of year? Yes No (If no, explain in Remarks.)
 Are Vegetation , Soil , or Hydrology significantly disturbed? Are "Normal Circumstances" present? Yes No
 Are Vegetation , Soil , or Hydrology naturally problematic? (If needed, explain any answers in Remarks.)

SUMMARY OF FINDINGS – Attach site map showing sampling point locations, transects, important features, etc.

Hydrophytic Vegetation Present?	Yes <input type="checkbox"/>	No <input checked="" type="checkbox"/>	Is the Sampled Area within a Wetland?	Yes <input type="checkbox"/>	No <input checked="" type="checkbox"/>
Hydric Soil Present?	Yes <input type="checkbox"/>	No <input checked="" type="checkbox"/>			
Wetland Hydrology Present?	Yes <input checked="" type="checkbox"/>	No <input type="checkbox"/>			
Remarks:					

VEGETATION – Use scientific names of plants.

Tree Stratum (Plot size: N/A)	Absolute % Cover	Dominant Species?	Indicator Status	Dominance Test Worksheet:			
1. <u>N/A</u>	_____	<u>n/a*</u>	_____	Number of Dominant Species That Are OBL, FACW, or FAC:	1 (A)		
2. _____	_____	<u>n/a*</u>	_____	Total Number of Dominant Species Across All Strata:	2 (B)		
3. _____	_____	<u>n/a*</u>	_____	Percent of Dominant Species That Are OBL, FACW, or FAC:	50 (A/B)		
4. _____	_____	<u>n/a*</u>	_____				
50% = _____, 20% = _____	_____	= Total Cover					
Sapling/Shrub Stratum (Plot size: N/A)				Prevalence Index worksheet:			
1. <u>N/A</u>	_____	<u>n/a*</u>	_____	<u>Total % Cover of :</u>	<u>Multiply by:</u>		
2. _____	_____	<u>n/a*</u>	_____	OBL species _____	x1 = _____		
3. _____	_____	<u>n/a*</u>	_____	FACW species _____	x2 = _____		
4. _____	_____	<u>n/a*</u>	_____	FAC species _____	x3 = _____		
5. _____	_____	<u>n/a*</u>	_____	FACU species _____	x4 = _____		
50% = _____, 20% = _____	_____	= Total Cover		UPL species _____	x5 = _____		
Herb Stratum (Plot size: 10'x10')				Column Totals: _____ (A)	_____ (B)		
1. <u>Amaranthus albus</u>	<u>20</u>	<u>yes</u>	<u>FACU</u>	Prevalence Index = B/A = _____			
2. <u>Polypogon monspeliensis</u>	<u>15</u>	<u>yes</u>	<u>FACW</u>	Hydrophytic Vegetation Indicators: <input type="checkbox"/> Dominance Test is >50% <input type="checkbox"/> Prevalence Index is ≤3.0 ¹ <input type="checkbox"/> Morphological Adaptations ¹ (Provide supporting data in Remarks or on a separate sheet) <input type="checkbox"/> Problematic Hydrophytic Vegetation ¹ (Explain)			
3. <u>Cyperus eragrostis</u>	<u>7</u>	<u>no</u>	<u>FACW</u>				
4. <u>Euphorbia polycarpa</u>	<u>5</u>	<u>no</u>	<u>NL (UPL)</u>				
5. <u>Xanthium strumarium</u>	<u>3</u>	<u>no</u>	<u>FAC</u>	¹ Indicators of hydric soil and wetland hydrology must be present, unless disturbed or problematic.			
6. _____	_____	<u>n/a*</u>	_____				
7. _____	_____	<u>n/a*</u>	_____				
8. _____	_____	<u>n/a*</u>	_____	Hydrophytic Vegetation Present?			
50% = <u>25</u> , 20% = <u>10</u>	<u>50</u>	= Total Cover				Yes <input type="checkbox"/>	No <input checked="" type="checkbox"/>
<u>Woody Vine Stratum (Plot size: N/A)</u>							
1. _____	_____	_____	_____				
2. _____	_____	_____	_____				
50% = _____, 20% = _____	_____	= Total Cover					
% Bare Ground in Herb Stratum <u>50</u>		% Cover of Biotic Crust <u>0</u>					
Remarks:							

SOIL

Sampling Point: 2

Profile Description: (Describe to the depth needed to document the indicator or confirm the absence of indicators.)

Depth (inches)	Matrix		Redox Features				Texture	Remarks
	Color (moist)	%	Color (Moist)	%	Type ¹	Loc ²		
0-5	10YR/4/4	100	_____	_____	_____	_____	Sandy	_____
_____	_____	_____	_____	_____	_____	_____	_____	_____
_____	_____	_____	_____	_____	_____	_____	_____	_____
_____	_____	_____	_____	_____	_____	_____	_____	_____
_____	_____	_____	_____	_____	_____	_____	_____	_____

¹Type: C= Concentration, D=Depletion, RM=Reduced Matrix, CS=Covered or Coated Sand Grains. ²Location: PL=Pore Lining, M=Matrix.

Hydric Soil Indicators: (Applicable to all LRRs, unless otherwise noted.)		Indicators for Problematic Hydric Soils³:	
<input type="checkbox"/> Histosol (A1)	<input type="checkbox"/> Sandy Redox (S5)	<input type="checkbox"/> 1 cm Muck (A9) (LRR C)	
<input type="checkbox"/> Histic Epipedon (A2)	<input type="checkbox"/> Stripped Matrix (S6)	<input type="checkbox"/> 2 cm Muck (A10) (LRR B)	
<input type="checkbox"/> Black Histic (A3)	<input type="checkbox"/> Loamy Mucky Mineral (F1)	<input type="checkbox"/> Reduced Vertic (F18)	
<input type="checkbox"/> Hydrogen Sulfide (A4)	<input type="checkbox"/> Loamy Gleyed Matrix (F2)	<input type="checkbox"/> Red Parent Material (TF2)	
<input type="checkbox"/> Stratified Layers (A5) (LRR C)	<input type="checkbox"/> Depleted Matrix (F3)	<input type="checkbox"/> Other (Explain in Remarks)	
<input type="checkbox"/> 1 cm Muck (A9) (LRR D)	<input type="checkbox"/> Redox Dark Surface (F6)		
<input type="checkbox"/> Depleted Below Dark Surface (A11)	<input type="checkbox"/> Depleted Dark Surface (F7)		
<input type="checkbox"/> Thick Dark Surface (A12)	<input type="checkbox"/> Redox Depressions (F8)		
<input type="checkbox"/> Sandy Mucky Mineral (S1)	<input type="checkbox"/> Vernal Pools (F9)		
<input type="checkbox"/> Sandy Gleyed Matrix (S4)			

³Indicators of hydrophytic vegetation and wetland hydrology must be present, unless disturbed or problematic.

Restrictive Layer (if present):
 Type: _____
 Depth (Inches): _____

Hydric Soils Present? Yes No

Remarks: Uniform in color

HYDROLOGY

Wetland Hydrology Indicators:		
Primary Indicators (minimum of one required; check all that apply)		Secondary Indicators (2 or more required)
<input type="checkbox"/> Surface Water (A1)	<input type="checkbox"/> Salt Crust (B11)	<input type="checkbox"/> Water Marks (B1) (Riverine)
<input type="checkbox"/> High Water Table (A2)	<input type="checkbox"/> Biotic Crust (B12)	<input type="checkbox"/> Sediment Deposits (B2) (Riverine)
<input checked="" type="checkbox"/> Saturation (A3)	<input type="checkbox"/> Aquatic Invertebrates (B13)	<input checked="" type="checkbox"/> Drift Deposits (B3) (Riverine)
<input type="checkbox"/> Water Marks (B1) (Nonriverine)	<input type="checkbox"/> Hydrogen Sulfide Odor (C1)	<input checked="" type="checkbox"/> Drainage Patterns (B10)
<input type="checkbox"/> Sediment Deposits (B2) (Nonriverine)	<input type="checkbox"/> Oxidized Rhizospheres along Living Roots (C3)	<input type="checkbox"/> Dry-Season Water Table (C2)
<input type="checkbox"/> Drift Deposits (B3) (Nonriverine)	<input type="checkbox"/> Presence of Reduced Iron (C4)	<input type="checkbox"/> Crayfish Burrows (C8)
<input type="checkbox"/> Surface Soil Cracks (B6)	<input type="checkbox"/> Recent Iron Reduction in Tilled Soils (C6)	<input type="checkbox"/> Saturation Visible on Aerial Imagery (C9)
<input type="checkbox"/> Inundation Visible on Aerial Imagery (B7)	<input type="checkbox"/> Thin Muck Surface (C7)	<input type="checkbox"/> Shallow Aquitard (D3)
<input type="checkbox"/> Water-Stained Leaves (B9)	<input type="checkbox"/> Other (Explain in Remarks)	<input type="checkbox"/> FAC-Neutral Test (D5)

Field Observations:

Surface Water Present? Yes No Depth (inches): _____

Water Table Present? Yes No Depth (inches): N/A

Saturation Present? (includes capillary fringe) Yes No Depth (inches): 5

Wetland Hydrology Present? Yes No

Describe Recorded Data (stream gauge, monitoring well, aerial photos, previous inspections), if available:

Remarks: Saturation in upper 5 inches

Appendix D

Regulatory Framework

Regulatory Framework

The following is a brief summary of the regulatory context under which biological resources are managed at the federal, State, and local levels. A number of federal and State statutes provide a regulatory structure which guide the protection of jurisdictional waters. Agencies with the responsibility for protection of jurisdictional waters within the project site include:

- United States Army Corps of Engineers (non-wetland waters and wetlands of the United States)
- Central Coast Regional Water Quality Control Board (waters of the State)
- California Department Fish and Wildlife (riparian areas, streambeds, and lakes)

United States Army Corps of Engineers Jurisdiction

The USACE, under provisions of Section 404 of the CWA and USACE implementing regulations, has jurisdiction over the placement of dredged or fill material into “waters of the United States.” Congress enacted the CWA “to restore and maintain the chemical, physical, and biological integrity of the Nation’s waters.” In practice, the boundaries of certain waters subject to USACE jurisdiction under Section 404 have not been fully defined. Previous regulations codified in 1986 defined “waters of the United States” as traditional navigable waters, interstate waters, all other waters that could affect interstate or foreign commerce, impoundments of waters of the United States, tributaries, the territorial seas, and adjacent wetlands.

On April 21, 2020, the USACE and U.S. Environmental Protection Agency published the *Navigable Waters Protection Rule to define “Waters of the United States.”* This rule, effective on June 22, 2020, defines four categories of jurisdictional waters, documents certain types of waters that are excluded from jurisdiction, and clarifies some regulatory terms. Under the *Navigable Waters Protection Rule*, “waters of the United States” include:

- (1) Territorial seas and traditional navigable waters;
- (2) Perennial and intermittent tributaries that contribute surface flow to those waters;
- (3) Certain Lakes and ponds, and impoundments of jurisdictional waters, and;
- (4) Wetlands adjacent to jurisdictional waters.

Tributaries are defined as “a river, stream, or similar naturally occurring surface water channel that contributes surface water flow to the territorial seas or traditional navigable waters in a typical year either directly or through one or more tributaries, jurisdictional lakes, ponds, and impoundments of jurisdictional waters, or adjacent wetlands.” The tributary category also includes a ditch that “either relocates a tributary, is constructed in a tributary, or is constructed in an adjacent wetland as long as the ditch is perennial or intermittent and contributes surface water flow to a traditional navigable water or territorial sea in a typical year.”

Adjacent wetlands are defined as wetlands that:

- (i) Abut, meaning to touch at least at one point or side of, a defined Water of the U.S.;
- (ii) Are inundated by flooding from a defined Water of the U.S in a typical year;

Melrose and Diamond Industrial Project

- (iii) Are physically separated from a defined Water of the U.S. by a natural berm, bank, dune, or similar natural features or by artificial dike, barrier or similar artificial structures as long as direct hydrological surface connection to defined Waters of the U.S. are allowed; or,
- (iv) Are impounded of Waters of the U.S. in a typical year through a culvert, flood or tide gate, pump or similar artificial structure.

The Navigable Waters Protection Rule states that the following areas not considered to be jurisdictional waters even where they otherwise meet the definitions described above:

- (1) Groundwater, including groundwater drained through subsurface drainage systems;
- (2) Ephemeral features that flow only in direct response to precipitation including ephemeral streams, swales, gullies, rills and pools;
- (3) Diffuse stormwater runoff and directional sheet flow over uplands;
- (4) Ditches that are not defined Waters of the U.S. and not constructed in adjacent wetlands subject to certain limitations;
- (5) Prior converted cropland;
- (6) Artificially irrigated areas that would revert to upland if artificial irrigation ceases;
- (7) Artificial lakes and ponds that are not jurisdictional impoundments and that are constructed or excavated in upland or non-jurisdictional waters;
- (8) Water-filled depressions constructed or excavated in upland or in non-jurisdictional waters for the purpose of obtaining fill, sand, or gravel;
- (9) Stormwater control features constructed or excavated in uplands or in non-jurisdictional water to convey, treat, infiltrate, or stormwater run-off;
- (10) Groundwater recharge, water reuse, and wastewater recycling structures constructed or excavated in upland or in non-jurisdictional waters; and,
- (11) Waste treatment systems.

USACE jurisdictional limits are typically identified by the OHWM or the landward edge of adjacent wetlands (where present). The OHWM is the “line on the shore established by the fluctuations of water and indicated by physical characteristics such as a clear, natural line impressed on the bank, shelving, changes in the character of soil, destruction of terrestrial vegetation, the presence of litter and debris, or other appropriate means that consider the characteristics of the surrounding area” (33 CFR 328.3).

Wetland Waters of the U.S.

The USACE defines wetlands as “those areas that are inundated or saturated by surface or groundwater at a frequency and duration sufficient to support, and that under normal circumstances do support, a prevalence of vegetation typically adapted for life in saturated soil conditions” (33 CFR 328.3). The USACE’s delineation procedures identify wetlands in the field based on indicators of three wetland parameters: hydrophytic vegetation, hydric soils, and wetland hydrology. The following is a discussion of each of these parameters.

Hydrophytic Vegetation

Hydrophytic vegetation dominates areas where frequency and duration of inundation or soil saturation exerts a controlling influence on the plant species present. Plant species are assigned wetland indicator status according to the probability of their occurring in wetlands. More than fifty percent of the

dominant plant species must have a wetland indicator status to meet the hydrophytic vegetation criterion. The USACE published the National Wetland Plant List (Lichvar 2016), which separates vascular plants into the following four basic categories based on plant species frequency of occurrence in wetlands:

- **Obligate Wetland (OBL).** Almost always occur in wetlands
- **Facultative Wetland (FACW).** Usually occur in wetlands, but occasionally found in non-wetlands
- **Facultative (FAC).** Occur in wetlands or non-wetlands
- **Facultative Upland (FACU).** Usually occur in non-wetlands, but may occur in wetlands
- **Obligate Upland (UPL).** Almost never occur in wetlands

The USACE considers OBL, FACW and FAC species to be indicators of wetlands. An area is considered to have hydrophytic vegetation when greater than 50 percent of the dominant species in each vegetative stratum (tree, shrub, and herb) fall within these categories. Any species not appearing on the United States Fish and Wildlife Service's list is assumed to be an upland species, almost never occurring in wetlands. In addition, an area needs to contain at least 5% vegetative cover to be considered as a vegetated wetland.

Hydric Soils

Hydric soils are saturated or inundated for a sufficient duration during the growing season to develop anaerobic or reducing conditions that favor the growth and regeneration of hydrophytic vegetation. Field indicators of wetland soils include observations of ponding, inundation, saturation, dark (low chroma) soil colors, bright mottles (concentrations of oxidized minerals such as iron), gleying (indicates reducing conditions by a blue-grey color), or accumulation of organic material. Additional supporting information includes documentation of soil as hydric or reference to wet conditions in the local soils survey, both of which must be verified in the field.

Wetland Hydrology

Wetland hydrology is inundation or soil saturation with a frequency and duration long enough to cause the development of hydric soils and plant communities dominated by hydrophytic vegetation. If direct observation of wetland hydrology is not possible (as in seasonal wetlands), or records of wetland hydrology are not available (such as stream gauges), assessment of wetland hydrology is frequently supported by field indicators, such as water marks, drift lines, sediment deposits, or drainage patterns in wetlands.

Regional Water Quality Control Board Jurisdiction

The State Water Resources Control Board (SWRCB) and local RWQCB have jurisdiction over "waters of the State," which are defined as any surface water or groundwater, including saline waters, within the boundaries of the state.

The SWRCB or local RWQCB have not established regulations for field determinations of waters of the State except for wetlands currently. The RWQCB are affected by or shares USACE jurisdiction unless isolated conditions or ephemeral waters are present. Each local RWQCB may delineate their jurisdictions of waters of the State differently based on current interpretations of jurisdiction.

Procedures for defining RWQCB jurisdiction will change when the SWRCB implements its adopted *Wetland Definition and Procedures for Discharges of Dredge and Fill Material to Waters of the State*.

Procedures for defining RWQCB jurisdiction pursuant to the SWRCB's *State Wetland Definition and Procedures for Discharges of Dredged or Fill Material to Waters of the State* effective May 28, 2020. The SWRCB define an area as wetland if, under normal circumstances:

- (i) the area has continuous or recurrent saturation of the upper substrate caused by groundwater, or shallow surface water, or both;
- (ii) the duration of such saturation is sufficient to cause anaerobic conditions in the upper substrate; and
- (iii) the area's vegetation is dominated by hydrophytes or the area lacks vegetation.

The USACE wetland delineation method differs than the federal definition in that a lack of vegetation does not preclude the determination of an area that meets the definition of a wetland and the upper substrate instead of soils that can cause hydric conditions.

Porter-Cologne Water Quality Control Act

The Porter-Cologne Act is the principal law governing water quality regulation in California. It establishes a comprehensive program to protect water quality and the beneficial uses of water. The Porter-Cologne Act applies to surface waters, wetlands, and ground water and to both point and nonpoint sources of pollution. Pursuant to the Porter-Cologne Act (California Water Code section 13000 et seq.), the policy of the State is as follows:

- The quality of all the waters of the State shall be protected
- All activities and factors affecting the quality of water shall be regulated to attain the highest water quality within reason
- The State must be prepared to exercise its full power and jurisdiction to protect the quality of water in the State from degradation

The Porter-Cologne Act established nine Regional Water Quality Control Boards (based on hydrogeologic barriers) and the State Water Resources Control Board, which are charged with implementing its provisions and which have primary responsibility for protecting water quality in California. The State Water Resources Control Board provides program guidance and oversight, allocates funds, and reviews Regional Water Quality Control Boards' decisions. In addition, the State Water Resources Control Board allocates rights to the use of surface water. The Regional Water Quality Control Boards have primary responsibility for individual permitting, inspection, and enforcement actions within each of nine hydrologic regions. The State Water Resources Control Board and Regional Water Quality Control Boards have numerous nonpoint source related responsibilities, including monitoring and assessment, planning, financial assistance, and management.

California Department of Fish and Wildlife Jurisdiction

The CDFW has not defined the term "stream" for the purposes of implementing its regulatory program under Section 1602, and the agency has not promulgated regulations directing how jurisdictional streambeds may be identified, or how their limits should be delineated. Considering this, four sources of information were reviewed and considered in determining the appropriate limits of CDFW jurisdiction within the site, as discussed below. The principles presented in these materials were used to guide the delineation of on-site streams, with consideration given to the relevance (i.e., jurisdiction, applicability) of each source to the project and resources at hand.

- **The plain language of Section 1602 of CFGC** establishes the following general concepts:
 - References “river,” “stream,” and “lake”
 - References “natural flow”
 - References “bed,” “bank,” and “channel”
- **Applicable court decisions**, in particular *Rutherford v. State of California* (188 Cal App. 3d 1276 (1987)), which interpreted Section 1602’s use of “stream” to be as defined in common law. The Court indicated that a “stream” is commonly understood to:
 - Have a source and a terminus
 - Have banks and a channel
 - Convey flow at least periodically, but need not flow continuously and may at times appear outwardly dry
 - Represent the depression between the banks worn by the regular and usual flow of the water
 - Include the area between the opposing banks measured from the foot of the banks from the top of the water at its ordinary stage, including intervening sand bars
 - Include the land that is covered by the water in its ordinary low stage
 - Include lands below the OHWM
- **CDFW regulations** defining “stream” for other purposes, including sport fishing (14 CCR 1.72) and streambed alterations associated with cannabis production (14 CCR 722(c)(21)), which indicate that a stream:
 - Flows at least periodically or intermittently
 - Flows through a bed or channel having banks
 - Supports fish or aquatic life
 - Can be dry for a period of time
 - Includes watercourses where surface or subsurface flow supports or has supported riparian vegetation
- **Guidance documents**, including A Field Guide to Lake and Streambed Alteration Agreements (CDFG 1994) and Methods to Describe and Delineate Episodic Stream Processes on Arid Landscapes for Permitting Utility-Scale Solar Power Plants (Brady and Vyverberg 2013), which suggest the following:
 - A stream may flow perennially or episodically
 - A stream is defined by the course in which water currently flows, or has flowed during the historic hydrologic course regime (approximately the last 200 years)
 - Width of a stream course can reasonably be identified by physical or biological indicators
 - A stream may have one or more channels (single thread vs. compound form)
 - Features such as braided channels, low-flow channels, active channels, banks associated with secondary channels, floodplains, islands, and stream-associated vegetation, are interconnected parts of the watercourse
 - Canals, aqueducts, irrigation ditches, and other means of water conveyance can be considered streams if they support aquatic life, riparian vegetation, or stream-dependent terrestrial wildlife
 - Biologic components of a stream may include aquatic and riparian vegetation, all aquatic wildlife including fish, amphibians, reptiles, invertebrates, and terrestrial species which derive benefits from the stream system

Melrose and Diamond Industrial Project

- The lateral extent of a stream can be measured in different ways depending on the particular situation and the type of fish or wildlife resource at risk

The tenets listed above, among others, are applied in desert environments. Coastal drainages are delineated predominately based on the following factors:

- Areas that exhibited evidence of hydrologic activity, such as scour, formation of banks, and/or deposition of sediment or material
- Areas where the vegetation community was adapted to the presence of elevated soil moisture levels (i.e., contained mostly hydrophytic species)