

# Project Specific Water Quality Management Plan

A Template for Projects located within the **Santa Ana Watershed** Region of Riverside County

**Project Title:** First Rider

**Design Review/Case No:** 19-00016

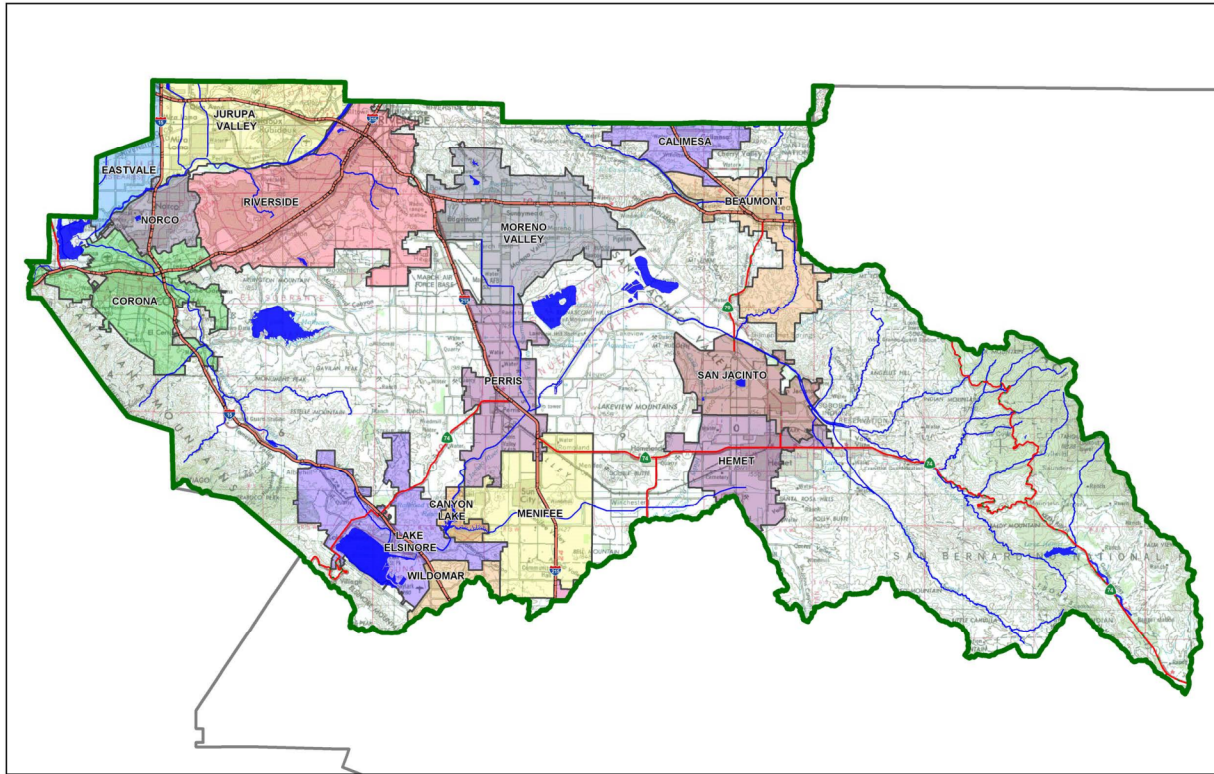

- Preliminary
- Final

**Original Date Prepared:** January 2020

**Revision Date(s):** May 2020, September 2020

*Prepared for Compliance with*

*Regional Board Order No. **R8-2010-0033***

## Contact Information:

### Prepared for:

First Industrial Realty Trust  
Attn: Michael Goodwin  
898 N. Pacific Coast Highway, Suite 175  
El Segundo, CA 90245

### Prepared by:

Albert A. Webb Associates  
3788 McCray St  
Riverside, CA 92506  
(951) 686 – 1070

## A Brief Introduction

This Project-Specific WQMP Template for the **Santa Ana Region** has been prepared to help guide you in documenting compliance for your project. Because this document has been designed to specifically document compliance, you will need to utilize the WQMP Guidance Document as your “how-to” manual to help guide you through this process. Both the Template and Guidance Document go hand-in-hand, and will help facilitate a well prepared Project-Specific WQMP. Below is a flowchart for the layout of this Template that will provide the steps required to document compliance.

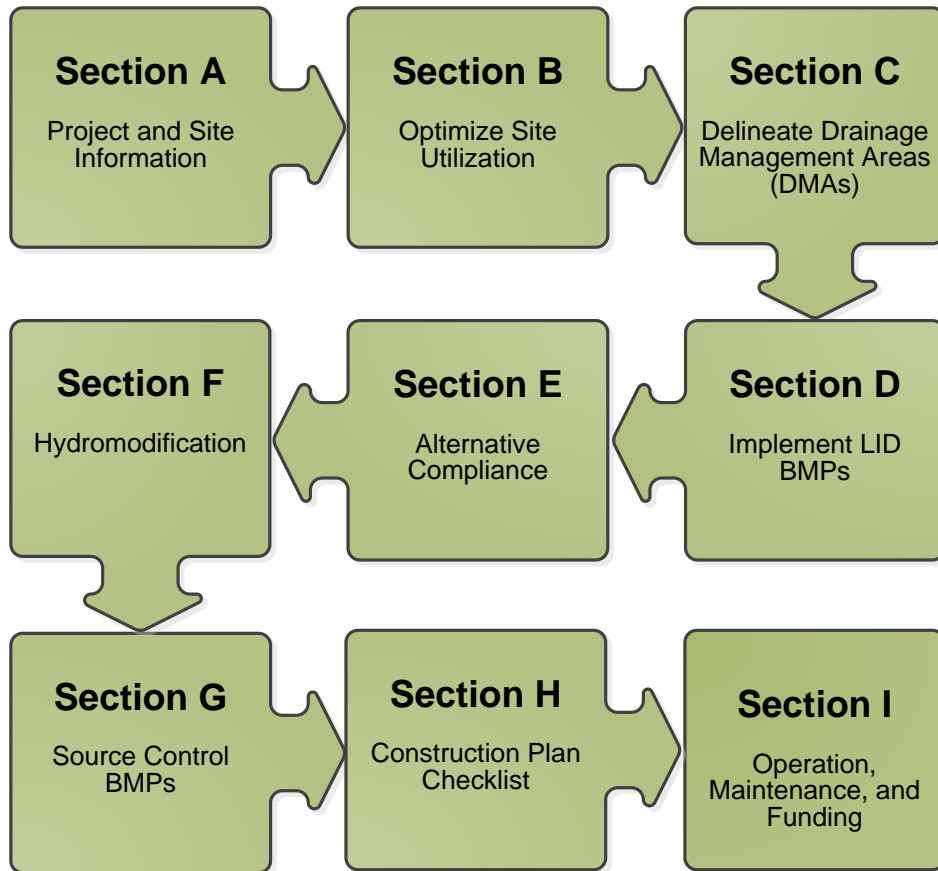



## OWNER'S CERTIFICATION

This Project-Specific Water Quality Management Plan (WQMP) has been prepared for First Industrial Realty Trust by Albert A. Webb Associates for the First Rider project (P19-00016).

This WQMP is intended to comply with the requirements of City of Perris for Water Quality Ordinance 1194 which includes the requirement for the preparation and implementation of a Project-Specific WQMP.

The undersigned, while owning the property/project described in the preceding paragraph, shall be responsible for the implementation and funding of this WQMP and will ensure that this WQMP is amended as appropriate to reflect up-to-date conditions on the site. In addition, the property owner accepts responsibility for interim operation and maintenance of Stormwater BMPs until such time as this responsibility is formally transferred to a subsequent owner. This WQMP will be reviewed with the facility operator, facility supervisors, employees, tenants, maintenance and service contractors, or any other party (or parties) having responsibility for implementing portions of this WQMP. At least one copy of this WQMP will be maintained at the project site or project office in perpetuity. The undersigned is authorized to certify and to approve implementation of this WQMP. The undersigned is aware that implementation of this WQMP is enforceable under City of Perris Water Quality Ordinance (Municipal Code Section 1194).

"I, the undersigned, certify under penalty of law that the provisions of this WQMP have been reviewed and accepted and that the WQMP will be transferred to future successors in interest."

\_\_\_\_\_  
Owner's Signature

\_\_\_\_\_  
Date

\_\_\_\_\_  
Owner's Printed Name

\_\_\_\_\_  
Owner's Title/Position

## PREPARER'S CERTIFICATION

"The selection, sizing and design of stormwater treatment and other stormwater quality and quantity control measures in this plan meet the requirements of Regional Water Quality Control Board Order No. **R8-2010-0033** and any subsequent amendments thereto."

\_\_\_\_\_  
Preparer's Signature

\_\_\_\_\_  
Date

DJ Arellano, P.E.  
\_\_\_\_\_  
Preparer's Printed Name

Senior Engineer  
\_\_\_\_\_  
Preparer's Title/Position

Preparer's Licensure:



## Table of Contents

Section A: Project and Site Information.....	6
A.1 Maps and Site Plans.....	6
A.2 Identify Receiving Waters.....	7
A.3 Additional Permits/Approvals required for the Project: .....	8
Section B: Optimize Site Utilization (LID Principles) .....	9
Section C: Delineate Drainage Management Areas (DMAs).....	10
Section D: Implement LID BMPs .....	12
D.1 Infiltration Applicability .....	12
D.2 Harvest and Use Assessment.....	13
D.3 Bioretention and Biotreatment Assessment .....	15
D.4 Feasibility Assessment Summaries .....	16
D.5 LID BMP Sizing .....	17
Section E: Alternative Compliance (LID Waiver Program) .....	18
E.1 Identify Pollutants of Concern .....	19
E.2 Stormwater Credits .....	20
E.3 Sizing Criteria.....	20
E.4 Treatment Control BMP Selection .....	21
Section F: Hydromodification .....	22
F.1 Hydrologic Conditions of Concern (HCOC) Analysis.....	22
F.2 HCOC Mitigation.....	23
Section G: Source Control BMPs.....	24
Section H: Construction Plan Checklist .....	29
Section I: Operation, Maintenance and Funding.....	30

## List of Tables

Table A.1 Identification of Receiving Waters.....	8
Table A.2 Other Applicable Permits.....	8
Table C.1 DMA Classifications.....	10
Table C.2 Type 'A', Self-Treating Areas.....	10
Table C.3 Type 'B', Self-Retaining Areas.....	11
Table C.4 Type 'C', Areas that Drain to Self-Retaining Areas.....	11
Table C.5 Type 'D', Areas Draining to BMPs.....	11
Table D.1 Infiltration Feasibility.....	12
Table D.2 LID Prioritization Summary Matrix.....	16
Table D.3 DCV Calculations for LID BMPs.....	17
Table E.1 Potential Pollutants by Land Use Type.....	19
Table E.2 Water Quality Credits.....	20
Table E.3 Treatment Control BMP Sizing.....	20
Table E.4 Treatment Control BMP Selection.....	21
Table F.1 Hydrologic Conditions of Concern Summary.....	22
Table G.1 Permanent and Operational Source Control Measures.....	24
Table H.1 Construction Plan Cross-reference.....	29

## List of Appendices

Appendix 1: Maps and Site Plans.....	31
Appendix 2: Construction Plans.....	32
Appendix 3: Soils Information.....	33
Appendix 4: Historical Site Conditions.....	34
Appendix 5: LID Infeasibility.....	35
Appendix 6: BMP Design Details.....	36
Appendix 7: Hydromodification.....	37
Appendix 8: Source Control.....	38
Appendix 9: O&M.....	39
Appendix 10: Educational Materials.....	- 40 -

## Section A: Project and Site Information

PROJECT INFORMATION	
Type of Project:	<i>Commercial/Industrial</i>
Planning Area:	<i>Perris Valley Commerce Center (PVCC) Specific Plan Area</i>
Community Name:	<i>Perris Valley</i>
Development Name:	<i>First Rider</i>
PROJECT LOCATION	
Latitude & Longitude (DMS): 33°49'43.88"N, 117°12'58.18"W	
Project Watershed and Sub-Watershed: Santa Ana, San Jacinto Valley	
APN(s): 300-210-001, 300-210-002, 300-210-003, 300-210-004, 300-210-005	
Map Book and Page No.: Thomas Bros. Map Page 777, Grid H3 & H4	
PROJECT CHARACTERISTICS	
Proposed or Potential Land Use(s)	Commercial/Industrial
Proposed or Potential SIC Code(s) <b>1542</b> (General Contractors-Industrial Buildings & Warehouses) <b>4225</b> (General Warehouse & Storage)	1542, 4225
Area of Impervious Project Footprint (SF)	582,300
Total Area of <u>proposed</u> Impervious Surfaces within the Project Limits (SF)/or Replacement	582,300
Does the project consist of offsite road improvements?	<input type="checkbox"/> Y <input checked="" type="checkbox"/> N
Does the project propose to construct unpaved roads?	<input type="checkbox"/> Y <input checked="" type="checkbox"/> N
Is the project part of a larger common plan of development (phased project)?	<input type="checkbox"/> Y <input checked="" type="checkbox"/> N
EXISTING SITE CHARACTERISTICS	
Total area of <u>existing</u> Impervious Surfaces within the project limits (SF)	176,700
Is the project located within any MSHCP Criteria Cell?	<input type="checkbox"/> Y <input checked="" type="checkbox"/> N
If so, identify the Cell number:	N/A
Are there any natural hydrologic features on the project site?	<input type="checkbox"/> Y <input checked="" type="checkbox"/> N
Is a Geotechnical Report attached?	<input checked="" type="checkbox"/> Y <input type="checkbox"/> N
If no Geotech. Report, list the NRCS soils type(s) present on the site (A, B, C and/or D)	N/A
What is the Water Quality Design Storm Depth for the project?	0.64

### Project Description

The project is proposing a warehouse/industrial building (approximately 320,100 square feet) on approximately 14.9 acres of land on the southeast corner of the Rider Street and Redlands Avenue intersection. The project site is bounded by Rider Street to the north, vacant and sparse residential lots to the east, future RCTC Mid-County Parkway to the south (currently vacant and sparse residential lots), and Redlands Avenue to the west. Majority of the land is vacant with a few existing manufactured homes and a commercial business with pavement occupying approximately 4 acres of existing impervious area. The site is relatively flat and the existing ground slopes at approximately 0.5% in the easterly direction. Existing elevations across the site vary from 1445 at the north west corner to 1442 at the north east corner (NAVD88 datum). Drainage across the site sheet flows from west to east.

The project is located within the Perris Valley Master Drainage Plan (PVMDP) adopted July 1987 and revised June 1991. Approximately 10 acres of this project are tabled to discharge into MDP Line "A-B", which is existing in Rider Street. The remaining area, approximately 5 acres, is tabled to discharge into MDP Line "A-C", which does not currently exist. However, the proposed RCTC Mid County Parkway

(MCP) – currently completing construction package one - runs directly through the Line A-C alignment and surrounding surface draining tributary areas. Because of this, WEBB is proposing that the Line A-C tributary areas impacted by MCP will be redirected to Line A-B, though a smaller area will still drain to Line A-C. This project is proposing to discharge into Line “A-B”. The revised tributary areas allow the entire project to discharge into Line “A-B”, and therefore the project is exempt from HCOC. See appendix 7 for existing and proposed areas of Line “A-B”.

The project is not impacted by off-site flows. The western half of the building, westerly drive aisle, and parking areas will drain to bio-retention facilities “A” and “B” via curb and gutter and curb cuts. Bio-retention facilities “A” and “B” are only designed to treat the water quality volume. The parking area to the north of the building will discharge into a water quality basin “C” along Rider Street; it functions the same as “A” and “B”. For basins “A”, “B”, and “C”, high degree flows will bypass through grated outlet structures who’s top of grate is located at the water quality ponding depth (6-inches). The outlet structures will discharge into the proposed storm drain Line “A”, which will connect to the existing MDP Line “A-B”.

The remainder of the site, DMA-D, will drain to the easterly truck court area through curb and gutter, and ribbon gutter. All water quality runoff generated by the eastern half of the project will be directed into proposed underground storage chambers that are located at the north east corner of the truck court parking stalls. The underground detention chambers are sized only to hold the water quality design capture volume for DMA-D; high flows will be forced out of the chambers at an outlet above the chamber soffit and gravity flow to Line “A-B”. Water quality runoff will be pumped from the chambers into a Contech Filterra unit.

The project contains some amount of self-retaining/self-treating area, and all trash enclosures will be covered.

Project is located within the Hydromodification exemption area based on Riverside County WAP geodatabase approved April 20, 2017. The site is in a blue area which means it is exempt from HCOC design criterion.

## A.1 Maps and Site Plans

When completing your Project-Specific WQMP, include a map of the local vicinity and existing site. In addition, include all grading, drainage, landscape/plant palette and other pertinent construction plans in Appendix 2. At a **minimum**, your WQMP Site Plan should include the following:

- Drainage Management Areas
- Proposed Structural BMPs
- Drainage Path
- Drainage Infrastructure, Inlets, Overflows
- Source Control BMPs
- Buildings, Roof Lines, Downspouts
- Impervious Surfaces
- Standard Labeling

Use your discretion on whether or not you may need to create multiple sheets or can appropriately accommodate these features on one or two sheets. Keep in mind that the Co-Permittee plan reviewer must be able to easily analyze your project utilizing this template and its associated site plans and maps.

## A.2 Identify Receiving Waters

Using Table A.1 below, list in order of upstream to downstream, the receiving waters that the project site is tributary to. Continue to fill each row with the Receiving Water’s 303(d) listed impairments (if any), designated beneficial uses, and proximity, if any, to a RARE beneficial use. Include a map of the receiving waters in Appendix 1.



**Table A.1 Identification of Receiving Waters**

Receiving Waters	EPA Approved 303(d) List Impairments	Designated Beneficial Uses	Proximity to RARE Beneficial Use
Perris Valley Storm Drain	None	None	Not a water body classified as RARE
San Jacinto River (Reach 3)(Hu#802.11)	None	MUN, AGR, GWR, REC1, REC2, WARM, WILD	Not a water body classified as RARE
San Jacinto River (Reach 2)(Hu#802.11)	None	MUN, AGR, GWR, REC1, REC2, WARM, WILD	Not a water body classified as RARE
Canyon Lake (Hu#802.11, 802.12)	Nutrients, Pathogens	MUN, AGR, GWR, REC1, REC2, WARM, WILD	Not a water body classified as RARE
San Jacinto River (Reach 1)(Hu#802.32)	None	MUN, AGR, GWR, REC1, REC2, WARM, WILD	Not a water body classified as RARE
Lake Elsinore (Hu#802.31)	PCBs, (Organic Compounds), Nutrients, Organic Enrichment (Low DO), Sediment Toxicity, Unknown Toxicity	REC1, REC2, WARM, WILD	Not a water body classified as RARE

### A.3 Additional Permits/Approvals required for the Project:

**Table A.2 Other Applicable Permits**

Agency	Permit Required	
State Department of Fish and Game, 1602 Streambed Alteration Agreement	<input type="checkbox"/> Y	<input checked="" type="checkbox"/> N
State Water Resources Control Board, Clean Water Act (CWA) Section 401 Water Quality Cert.	<input type="checkbox"/> Y	<input checked="" type="checkbox"/> N
US Army Corps of Engineers, CWA Section 404 Permit	<input type="checkbox"/> Y	<input checked="" type="checkbox"/> N
US Fish and Wildlife, Endangered Species Act Section 7 Biological Opinion	<input type="checkbox"/> Y	<input checked="" type="checkbox"/> N
Statewide Construction General Permit Coverage	<input checked="" type="checkbox"/> Y	<input type="checkbox"/> N
Statewide Industrial General Permit Coverage <b>(Dependent on Tenant)</b>	<input checked="" type="checkbox"/> Y	<input type="checkbox"/> N
Western Riverside MSHCP Consistency Approval (e.g., JPR, DBESP)	<input type="checkbox"/> Y	<input checked="" type="checkbox"/> N
Other (please list in the space below as required) City of Perris Grading Permit	<input checked="" type="checkbox"/> Y	<input type="checkbox"/> N

If yes is answered to any of the questions above, the Co-Permittee may require proof of approval/coverage from those agencies as applicable including documentation of any associated requirements that may affect this Project-Specific WQMP.

## Section B: Optimize Site Utilization (LID Principles)

Review of the information collected in Section 'A' will aid in identifying the principal constraints on site design and selection of LID BMPs as well as opportunities to reduce imperviousness and incorporate LID Principles into the site and landscape design. For example, **constraints** might include impermeable soils, high groundwater, groundwater pollution or contaminated soils, steep slopes, geotechnical instability, high-intensity land use, heavy pedestrian or vehicular traffic, utility locations or safety concerns. **Opportunities** might include existing natural areas, low areas, oddly configured or otherwise unbuildable parcels, easements and landscape amenities including open space and buffers (which can double as locations for bioretention BMPs), and differences in elevation (which can provide hydraulic head). Prepare a brief narrative for each of the site optimization strategies described below. This narrative will help you as you proceed with your LID design and explain your design decisions to others.

The 2010 Santa Ana MS4 Permit further requires that LID Retention BMPs (Infiltration Only or Harvest and Use) be used unless it can be shown that those BMPs are infeasible. Therefore, it is important that your narrative identify and justify if there are any constraints that would prevent the use of those categories of LID BMPs. Similarly, you should also note opportunities that exist which will be utilized during project design. Upon completion of identifying Constraints and Opportunities, include these on your WQMP Site plan in Appendix 1.

### Site Optimization

The following questions are based upon Section 3.2 of the WQMP Guidance Document. Review of the WQMP Guidance Document will help you determine how best to optimize your site and subsequently identify opportunities and/or constraints, and document compliance.

Did you identify and preserve existing drainage patterns? If so, how? If not, why?

*Yes, the project proposes to maintain existing flow pattern from west to east. Runoff will surface flow to the east where feasible. The western half of the building will drain to bio-retention facilities along Redlands that discharge to storm drain Line "A", which will tie in to the existing RCB Line "A-B" in Rider Street.*

Did you identify and protect existing vegetation? If so, how? If not, why?

*No, most of the site is vacant. Existing buildings and vegetation associated with the existing buildings will be removed. There are no dense areas of vegetation nor well-established trees.*

Did you identify and preserve natural infiltration capacity? If so, how? If not, why?

*Per the attached geotechnical report, infiltration is not feasible.*

Did you identify and minimize impervious area? If so, how? If not, why?

*The site contains the standard impervious area per code for the given land use. The minimum required landscape area is 10% per PVCC-SP Section 13.2.7, this project provides a 10% pervious area including self-retaining/self-treating and media area.*

Did you identify and disperse runoff to adjacent pervious areas? If so, how? If not, why?

*For DMAs -A, -B, and -C, all runoff is directed towards the adjacent landscape/basin area. DMA-D is runoff is directed to underground chambers.*

## Section C: Delineate Drainage Management Areas (DMAs)

Utilizing the procedure in Section 3.3 of the WQMP Guidance Document which discusses the methods of delineating and mapping your project site into individual DMAs, complete Table C.1 below to appropriately categorize the types of classification (e.g., Type A, Type B, etc.) per DMA for your project site. Upon completion of this table, this information will then be used to populate and tabulate the corresponding tables for their respective DMA classifications.

**Table C.1 DMA Classifications**

DMA Name	ID	Surface Type(s) <sup>1</sup>	Area (Sq. Ft.)	DMA Type
DMA-A	L-A	LANDSCAPE	1,100	D
	R-A	ROOF	82,590	D
	H-A	HARDSCAPE	26,740	D
	BMP-A	BIO-RETENTION	4,050	D
	SR-A	SELF-RETAINING	7,000	B
DMA-B	L-B	LANDSCAPE	5,140	D
	R-B	ROOF	82,590	D
	H-B	HARDSCAPE	26,710	D
	BMP-B	BIO-RETENTION	3,000	D
	SR-B	SELF-RETAINING	7,000	B
DMA-C	L-C	LANDSCAPE	740	D
	H-C	HARDSCAPE	36,390	D
	BMP-C	BIO-RETENTION	1,765	D
	SR-C	SELF-RETAINING	1,457	B
DMA-D	L-D	LANDSCAPE	5,105	D
	R-D	ROOF	154,910	D
	H-D	HARDSCAPE	172,285	D
	SR-D	SELF-RETAINING	33,355	B

<sup>1</sup>Reference Table 2-1 in the WQMP Guidance Document to populate this column

**Table C.2 Type 'A', Self-Treating Areas**

DMA Name or ID	Area (Sq. Ft.)	Stabilization Type	Irrigation Type (if any)

**Table C.3 Type 'B', Self-Retaining Areas**

Self-Retaining Area				Type 'C' DMAs that are draining to the Self-Retaining Area		
DMA Name/ ID	Post-project surface type	Area (square feet) [A]	Storm Depth (inches) [B]	DMA Name / ID	[C] from Table C.4 = [C]	Required Retention Depth (inches) [D]
SR-A	LANDSCAPE	7,000	0.64	N/A	N/A	0.64
SR-B	LANDSCAPE	7,000	0.64	N/A	N/A	0.64
SR-C	LANDSCAPE	1,457	0.64	N/A	N/A	0.64
SR-D	LANDSCAPE	33,355	0.64	N/A	N/A	0.64

$$[D] = [B] + \frac{[B] \cdot [C]}{[A]}$$

**Table C.4 Type 'C', Areas that Drain to Self-Retaining Areas**

DMA					Receiving Self-Retaining DMA		
DMA Name/ ID	Area (square feet) [A]	Post-project surface type	Runoff factor [B]	Product [C] = [A] x [B]	DMA name /ID	Area (square feet) [D]	Ratio [C]/[D]
N/A	N/A	N/A	N/A	N/A	N/A	N/A	N/A

**Table C.5 Type 'D', Areas Draining to BMPs**

DMA Name or ID	BMP Name or ID
L-A, R-A, H-A, BMP-A	BMP-A
L-B, R-B, H-B, BMP-B	BMP-B
L-C, H-C, BMP-C	BMP-C
L-D, R-D, H-D	BMP-D

*Note: More than one drainage management area can drain to a single LID BMP, however, one drainage management area may not drain to more than one BMP.*

## Section D: Implement LID BMPs

### D.1 Infiltration Applicability

Is there an approved downstream ‘Highest and Best Use’ for stormwater runoff (see discussion in Chapter 2.4.4 of the WQMP Guidance Document for further details)?  Y  N

If yes has been checked, Infiltration BMPs shall not be used for the site. If no, continue working through this section to implement your LID BMPs. It is recommended that you contact your Co-Permittee to verify whether or not your project discharges to an approved downstream ‘Highest and Best Use’ feature.

### Geotechnical Report

A Geotechnical Report or Phase I Environmental Site Assessment may be required by the Copermitttee to confirm present and past site characteristics that may affect the use of Infiltration BMPs. In addition, the Co-Permittee, at their discretion, may not require a geotechnical report for small projects as described in Chapter 2 of the WQMP Guidance Document. If a geotechnical report has been prepared, include it in Appendix 3. In addition, if a Phase I Environmental Site Assessment has been prepared, include it in Appendix 4.

Is this project classified as a small project consistent with the requirements of Chapter 2 of the WQMP Guidance Document?  Y  N

### Infiltration Feasibility

Table D.1 below is meant to provide a simple means of assessing which DMAs on your site support Infiltration BMPs and is discussed in the WQMP Guidance Document in Chapter 2.4.5. Check the appropriate box for each question and then list affected DMAs as applicable. If additional space is needed, add a row below the corresponding answer.

Table D.1 Infiltration Feasibility

Does the project site...	YES	NO
...have any DMAs with a seasonal high groundwater mark shallower than 10 feet? If Yes, list affected DMAs:		X
...have any DMAs located within 100 feet of a water supply well? If Yes, list affected DMAs:		X
...have any areas identified by the geotechnical report as posing a public safety risk where infiltration of stormwater could have a negative impact? If Yes, list affected DMAs:		X
...have measured in-situ infiltration rates of less than 1.6 inches / hour? If Yes, list affected DMAs: DMA-A, DMA-B, DMA-C, DMA-D	X	
...have significant cut and/or fill conditions that would preclude in-situ testing of infiltration rates at the final infiltration surface? If Yes, list affected DMAs:		X
...geotechnical report identify other site-specific factors that would preclude effective and safe infiltration? Describe here:		X

If you answered “Yes” to any of the questions above for any DMA, Infiltration BMPs should not be used for those DMAs and you should proceed to the assessment for Harvest and Use below.



## D.2 Harvest and Use Assessment

Please check what applies:

- Reclaimed water will be used for the non-potable water demands for the project.
- Downstream water rights may be impacted by Harvest and Use as approved by the Regional Board (verify with the Copermittee).
- The Design Capture Volume will be addressed using Infiltration Only BMPs. In such a case, Harvest and Use BMPs are still encouraged, but it would not be required if the Design Capture Volume will be infiltrated or evapotranspired.

If any of the above boxes have been checked, Harvest and Use BMPs need not be assessed for the site. If neither of the above criteria applies, follow the steps below to assess the feasibility of irrigation use, toilet use and other non-potable uses (e.g., industrial use).

### Irrigation Use Feasibility

Complete the following steps to determine the feasibility of harvesting stormwater runoff for Irrigation Use BMPs on your site:

Step 1: Identify the total area of irrigated landscape on the site, and the type of landscaping used.

*Total Area of Irrigated Landscape: N/A*

*Type of Landscaping (Conservation Design or Active Turf): N/A*

Step 2: Identify the planned total of all impervious areas on the proposed project from which runoff might be feasibly captured and stored for irrigation use. Depending on the configuration of buildings and other impervious areas on the site, you may consider the site as a whole, or parts of the site, to evaluate reasonable scenarios for capturing and storing runoff and directing the stored runoff to the potential use(s) identified in Step 1 above.

*Total Area of Impervious Surfaces: N/A*

Step 3: Cross reference the Design Storm depth for the project site (see Exhibit A of the WQMP Guidance Document) with the left column of Table 2-3 in Chapter 2 to determine the minimum area of Effective Irrigated Area per Tributary Impervious Area (EIATIA).

*Enter your EIATIA factor: N/A*

Step 4: Multiply the unit value obtained from Step 3 by the total of impervious areas from Step 2 to develop the minimum irrigated area that would be required.

*Minimum required irrigated area: N/A*

Step 5: Determine if harvesting stormwater runoff for irrigation use is feasible for the project by comparing the total area of irrigated landscape (Step 1) to the minimum required irrigated area (Step 4).

Minimum required irrigated area (Step 4)	Available Irrigated Landscape (Step 1)
N/A	N/A

## Toilet Use Feasibility

Complete the following steps to determine the feasibility of harvesting stormwater runoff for toilet flushing uses on your site:

Step 1: Identify the projected total number of daily toilet users during the wet season, and account for any periodic shut downs or other lapses in occupancy:

*Projected Number of Daily Toilet Users: N/A*

*Project Type: N/A*

Step 2: Identify the planned total of all impervious areas on the proposed project from which runoff might be feasibly captured and stored for toilet use. Depending on the configuration of buildings and other impervious areas on the site, you may consider the site as a whole, or parts of the site, to evaluate reasonable scenarios for capturing and storing runoff and directing the stored runoff to the potential use(s) identified in Step 1 above.

*Total Area of Impervious Surfaces: N/A*

Step 3: Enter the Design Storm depth for the project site (see Exhibit A) into the left column of Table 2-1 in Chapter 2 to determine the minimum number of toilet users per tributary impervious acre (TUTIA).

*Enter your TUTIA factor: N/A*

Step 4: Multiply the unit value obtained from Step 3 by the total of impervious areas from Step 2 to develop the minimum number of toilet users that would be required.

*Minimum number of toilet users: N/A*

Step 5: Determine if harvesting stormwater runoff for toilet flushing use is feasible for the project by comparing the Number of Daily Toilet Users (Step 1) to the minimum required number of toilet users (Step 4).

<b>Minimum required Toilet Users (Step 4)</b>	<b>Projected number of toilet users (Step 1)</b>
N/A	N/A

## Other Non-Potable Use Feasibility

Are there other non-potable uses for stormwater runoff on the site (e.g. industrial use)? See Chapter 2 of the Guidance for further information. If yes, describe below. If no, write N/A.

N/A

Step 1: Identify the projected average daily non-potable demand, in gallons per day, during the wet season and accounting for any periodic shut downs or other lapses in occupancy or operation.

*Average Daily Demand: N/A*

Step 2: Identify the planned total of all impervious areas on the proposed project from which runoff might be feasibly captured and stored for the identified non-potable use. Depending on the configuration of buildings and other impervious areas on the site, you may consider the site as a whole, or parts of the site, to evaluate reasonable scenarios for capturing and storing runoff and directing the stored runoff to the potential use(s) identified in Step 1 above.

*Total Area of Impervious Surfaces: N/A*

Step 3: Enter the Design Storm depth for the project site (see Exhibit A) into the left column of Table 2-3 in Chapter 2 to determine the minimum demand for non-potable uses per tributary impervious acre.

*Enter the factor from Table 2-3: N/A*

Step 4: Multiply the unit value obtained from Step 4 by the total of impervious areas from Step 3 to develop the minimum number of gallons per day of non-potable use that would be required.

*Minimum required use: N/A*

Step 5: Determine if harvesting stormwater runoff for other non-potable use is feasible for the project by comparing the Number of Daily Toilet Users (Step 1) to the minimum required number of toilet users (Step 4).

<b>Minimum required non-potable use (Step 4)</b>	<b>Projected average daily use (Step 1)</b>
N/A	N/A

If Irrigation, Toilet and Other Use feasibility anticipated demands are less than the applicable minimum values, Harvest and Use BMPs are not required and you should proceed to utilize LID Bioretention and Biotreatment, unless a site-specific analysis has been completed that demonstrates technical infeasibility as noted in D.3 below.

### **D.3 Bioretention and Biotreatment Assessment**

Other LID Bioretention and Biotreatment BMPs as described in Chapter 2.4.7 of the WQMP Guidance Document are feasible on nearly all development sites with sufficient advance planning.

*Select one of the following:*

LID Bioretention/Biotreatment BMPs will be used for some or all DMAs of the project as noted below in Section D.4 (note the requirements of Section 3.4.2 in the WQMP Guidance Document).

A site-specific analysis demonstrating the technical infeasibility of all LID BMPs has been performed and is included in Appendix 5. If you plan to submit an analysis demonstrating the technical infeasibility of LID BMPs, request a pre-submittal meeting with the Copermittee to discuss this option. Proceed to Section E to document your alternative compliance measures.

## D.4 Feasibility Assessment Summaries

From the Infiltration, Harvest and Use, Bioretention and Biotreatment Sections above, complete Table D.2 below to summarize which LID BMPs are technically feasible, and which are not, based upon the established hierarchy.

Table D.2 LID Prioritization Summary Matrix

DMA Name/ID	LID BMP Hierarchy				No LID (Alternative Compliance)
	1. Infiltration	2. Harvest and use	3. Bioretention	4. Biotreatment	
DMA-A	<input type="checkbox"/>	<input type="checkbox"/>	<input checked="" type="checkbox"/>	<input type="checkbox"/>	<input type="checkbox"/>
DMA-B	<input type="checkbox"/>	<input type="checkbox"/>	<input checked="" type="checkbox"/>	<input type="checkbox"/>	<input type="checkbox"/>
DMA-C	<input type="checkbox"/>	<input type="checkbox"/>	<input checked="" type="checkbox"/>	<input type="checkbox"/>	<input type="checkbox"/>
DMA-D	<input type="checkbox"/>	<input type="checkbox"/>	<input type="checkbox"/>	<input checked="" type="checkbox"/>	<input type="checkbox"/>
	<input type="checkbox"/>	<input type="checkbox"/>	<input type="checkbox"/>	<input type="checkbox"/>	<input type="checkbox"/>
	<input type="checkbox"/>	<input type="checkbox"/>	<input type="checkbox"/>	<input type="checkbox"/>	<input type="checkbox"/>

For those DMAs where LID BMPs are not feasible, provide a brief narrative below summarizing why they are not feasible, include your technical infeasibility criteria in Appendix 5, and proceed to Section E below to document Alternative Compliance measures for those DMAs. Recall that each proposed DMA must pass through the LID BMP hierarchy before alternative compliance measures may be considered.

## D.5 LID BMP Sizing

Each LID BMP must be designed to ensure that the Design Capture Volume will be addressed by the selected BMPs. First, calculate the Design Capture Volume for each LID BMP using the  $V_{BMP}$  worksheet in Appendix F of the LID BMP Design Handbook. Second, design the LID BMP to meet the required  $V_{BMP}$  using a method approved by the Copermittee. Utilize the worksheets found in the LID BMP Design Handbook or consult with your Copermittee to assist you in correctly sizing your LID BMPs. Complete Table D.3 below to document the Design Capture Volume and the Proposed Volume for each LID BMP. Provide the completed design procedure sheets for each LID BMP in Appendix 6. You may add additional rows to the table below as needed.

Table D.3 DCV Calculations for LID BMPs

DMA Type/ID	DMA Area (square feet)	Post-Project Surface Type	Effective Impervious Fraction, $f_i$	DMA Runoff Factor	DMA Areas x Runoff Factor	Enter BMP Name / Identifier Here		
	[A]		[B]	[C]	[A] x [C]			
<b>DMA-A</b>	8,100	Landscape	0.1	0.11	894.7	Design Storm Depth (in)	Design Capture Volume, $V_{BMP}$ (cubic feet)	Proposed Volume on Plans (cubic feet)
	82,590	Roofs	1	0.89	73,670.3			
	26,740	Hardscape	1	0.89	23,852.1			
	4,050	Landscape	0.1	0.11	447.4			
<b>DMA-B</b>	9,140	Landscape	0.1	0.11	1,009.6			
	82,590	Roofs	1	0.89	73,670.3			
	26,710	Hardscape	1	0.89	23,825.3			
	3,000	Landscape	0.1	0.11	331.4			
<b>DMA-C</b>	2,275	Landscape	0.1	0.11	251.3			
	36,390	Hardscape	1	0.89	32,459.9			
	1,765	Landscape	0.1	0.11	195			
<b>DMA-D</b>	34,609	Landscape	0.1	0.11	3,822.8			
	154,910	Roofs	1	0.89	138,179.7			
	172,285	Hardscape	1	0.89	153,678.2			
	1,746	Landscape	0.1	0.11	192.9			
	646,900				526,480			
	$A_T = \Sigma[A]$				$\Sigma = [D]$	[E]	$[F] = \frac{[D] \times [E]}{12}$	[G]

[B], [C] is obtained as described in Section 2.3.1 of the WQMP Guidance Document

[E] is obtained from Exhibit A in the WQMP Guidance Document

[G] is obtained from a design procedure sheet, such as in LID BMP Design Handbook and placed in Appendix 6



## Section E: Alternative Compliance (LID Waiver Program)

LID BMPs are expected to be feasible on virtually all projects. Where LID BMPs have been demonstrated to be infeasible as documented in Section D, other Treatment Control BMPs must be used (subject to LID waiver approval by the Copermittee). Check one of the following Boxes:

LID Principles and LID BMPs have been incorporated into the site design to fully address all Drainage Management Areas. No alternative compliance measures are required for this project and thus this Section is not required to be completed.

- Or -

The following Drainage Management Areas are unable to be addressed using LID BMPs. A site-specific analysis demonstrating technical infeasibility of LID BMPs has been approved by the Co-Permittee and included in Appendix 5. Additionally, no downstream regional and/or sub-regional LID BMPs exist or are available for use by the project. The following alternative compliance measures on the following pages are being implemented to ensure that any pollutant loads expected to be discharged by not incorporating LID BMPs, are fully mitigated.

## E.1 Identify Pollutants of Concern

Utilizing Table A.1 from Section A above which noted your project's receiving waters and their associated EPA approved 303(d) listed impairments, cross reference this information with that of your selected Priority Development Project Category in Table E.1 below. If the identified General Pollutant Categories are the same as those listed for your receiving waters, then these will be your Pollutants of Concern and the appropriate box or boxes will be checked on the last row. The purpose of this is to document compliance and to help you appropriately plan for mitigating your Pollutants of Concern in lieu of implementing LID BMPs.

**Table E.1 Potential Pollutants by Land Use Type**

Priority Development Project Categories and/or Project Features (check those that apply)	General Pollutant Categories							
	Bacterial Indicators	Metals	Nutrients	Pesticides	Toxic Organic Compounds	Sediments	Trash & Debris	Oil & Grease
<input type="checkbox"/> Detached Residential Development	P	N	P	P	N	P	P	P
<input type="checkbox"/> Attached Residential Development	P	N	P	P	N	P	P	P <sup>(2)</sup>
<input checked="" type="checkbox"/> Commercial/Industrial Development	P <sup>(3)</sup>	P	P <sup>(1)</sup>	P <sup>(1)</sup>	P <sup>(5)</sup>	P <sup>(1)</sup>	P	P
<input type="checkbox"/> Automotive Repair Shops	N	P	N	N	P <sup>(4, 5)</sup>	N	P	P
<input type="checkbox"/> Restaurants (>5,000 ft <sup>2</sup> )	P	N	N	N	N	N	P	P
<input type="checkbox"/> Hillside Development (>5,000 ft <sup>2</sup> )	P	N	P	P	N	P	P	P
<input type="checkbox"/> Parking Lots (>5,000 ft <sup>2</sup> )	P <sup>(6)</sup>	P	P <sup>(1)</sup>	P <sup>(1)</sup>	P <sup>(4)</sup>	P <sup>(1)</sup>	P	P
<input type="checkbox"/> Retail Gasoline Outlets	N	P	N	N	P	N	P	P
<b>Project Priority Pollutant(s) of Concern</b>	<input type="checkbox"/>	<input type="checkbox"/>	<input type="checkbox"/>	<input type="checkbox"/>	<input type="checkbox"/>	<input type="checkbox"/>	<input type="checkbox"/>	<input type="checkbox"/>

*P = Potential*

*N = Not Potential*

<sup>(1)</sup> A potential Pollutant if non-native landscaping exists or is proposed onsite; otherwise not expected

<sup>(2)</sup> A potential Pollutant if the project includes uncovered parking areas; otherwise not expected

<sup>(3)</sup> A potential Pollutant is land use involving animal waste

<sup>(4)</sup> Specifically petroleum hydrocarbons

<sup>(5)</sup> Specifically solvents

<sup>(6)</sup> Bacterial indicators are routinely detected in pavement runoff

## E.2 Stormwater Credits

Projects that cannot implement LID BMPs but nevertheless implement smart growth principles are potentially eligible for Stormwater Credits. Utilize Table 3-8 within the WQMP Guidance Document to identify your Project Category and its associated Water Quality Credit. If not applicable, write N/A.

Table E.2 Water Quality Credits

Qualifying Project Categories	Credit Percentage <sup>2</sup>
<i>Total Credit Percentage<sup>1</sup></i>	

<sup>1</sup>Cannot Exceed 50%

<sup>2</sup>Obtain corresponding data from Table 3-8 in the WQMP Guidance Document

## E.3 Sizing Criteria

After you appropriately considered Stormwater Credits for your project, utilize Table E.3 below to appropriately size them to the DCV, or Design Flow Rate, as applicable. Please reference Chapter 3.5.2 of the WQMP Guidance Document for further information.

Table E.3 Treatment Control BMP Sizing

DMA Type/ID	DMA Area (square feet)	Post-Project Surface Type	Effective Impervious Fraction, I <sub>f</sub>	DMA Runoff Factor	DMA Area x Runoff Factor	Enter BMP Name / Identifier Here			
	[A]		[B]	[C]	[A] x [C]				
						<i>Design Storm Depth (in)</i> <i>Minimum Design Capture Volume or Design Flow Rate (cubic feet or cfs)</i> <i>Total Storm Water Credit % Reduction</i> <i>Proposed Volume or Flow on Plans (cubic feet or cfs)</i>			
	$A_T = \sum[A]$				$\sum = [D]$	[E]	$[F] = \frac{[D] \times [E]}{[G]}$	$[F] \times (1-[H])$	[I]

[B], [C] is obtained as described in Section 2.3.1 from the WQMP Guidance Document

[E] is obtained from Exhibit A in the WQMP Guidance Document

[G] is for Flow-Based Treatment Control BMPs [G] = 43,560, for Volume-Based Control Treatment BMPs, [G] = 12

[H] is from the Total Credit Percentage as Calculated from Table E.2 above

[I] as obtained from a design procedure sheet from the BMP manufacturer and should be included in Appendix 6

## E.4 Treatment Control BMP Selection

Treatment Control BMPs typically provide proprietary treatment mechanisms to treat potential pollutants in runoff, but do not sustain significant biological processes. Treatment Control BMPs must have a removal efficiency of a medium or high effectiveness as quantified below:

- **High:** equal to or greater than 80% removal efficiency
- **Medium:** between 40% and 80% removal efficiency

Such removal efficiency documentation (e.g., studies, reports, etc.) as further discussed in Chapter 3.5.2 of the WQMP Guidance Document, must be included in Appendix 6. In addition, ensure that proposed Treatment Control BMPs are properly identified on the WQMP Site Plan in Appendix 1.

**Table E.4 Treatment Control BMP Selection**

Selected Treatment Control BMP Name or ID <sup>1</sup>	Priority Pollutant(s) of Concern to Mitigate <sup>2</sup>	Removal Percentage <sup>3</sup>	Efficiency

<sup>1</sup> Treatment Control BMPs must not be constructed within Receiving Waters. In addition, a proposed Treatment Control BMP may be listed more than once if they possess more than one qualifying pollutant removal efficiency.

<sup>2</sup> Cross Reference Table E.1 above to populate this column.

<sup>3</sup> As documented in a Co-Permittee Approved Study and provided in Appendix 6.

# Section F: Hydromodification

## F.1 Hydrologic Conditions of Concern (HCOC) Analysis

Once you have determined that the LID design is adequate to address water quality requirements, you will need to assess if the proposed LID Design may still create a HCOC. Review Chapters 2 and 3 (including Figure 3-7) of the WQMP Guidance Document to determine if your project must mitigate for Hydromodification impacts. If your project meets one of the following criteria which will be indicated by the check boxes below, you do not need to address Hydromodification at this time. However, if the project does not qualify for Exemptions 1, 2 or 3, then additional measures must be added to the design to comply with HCOC criteria. This is discussed in further detail below in Section F.2.

**HCOC EXEMPTION 1:** The Priority Development Project disturbs less than one acre. The Copermitttee has the discretion to require a Project-Specific WQMP to address HCOCs on projects less than one acre on a case by case basis. The disturbed area calculation should include all disturbances associated with larger common plans of development.

Does the project qualify for this HCOC Exemption?       Y     N

If Yes, HCOC criteria do not apply.

**HCOC EXEMPTION 2:** The volume and time of concentration<sup>1</sup> of storm water runoff for the post-development condition is not significantly different from the pre-development condition for a 2-year return frequency storm (a difference of 5% or less is considered insignificant) using one of the following methods to calculate:

- Riverside County Hydrology Manual
- Technical Release 55 (TR-55): Urban Hydrology for Small Watersheds (NRCS 1986), or derivatives thereof, such as the Santa Barbara Urban Hydrograph Method
- Other methods acceptable to the Co-Permittee

Does the project qualify for this HCOC Exemption?       Y     N

If Yes, report results in Table F.1 below and provide your substantiated hydrologic analysis in Appendix 7.

**Table F.1** Hydrologic Conditions of Concern Summary

	2 year – 24 hour		
	Pre-condition	Post-condition	% Difference
<b>Time of Concentration</b>	INSERT VALUE	INSERT VALUE	INSERT VALUE
<b>Volume (Cubic Feet)</b>	INSERT VALUE	INSERT VALUE	INSERT VALUE

<sup>1</sup> Time of concentration is defined as the time after the beginning of the rainfall when all portions of the drainage basin are contributing to flow at the outlet.



**HCOC EXEMPTION 3:** All downstream conveyance channels to an adequate sump (for example, Prado Dam, Lake Elsinore, Canyon Lake, Santa Ana River, or other lake, reservoir or naturally erosion resistant feature) that will receive runoff from the project are engineered and regularly maintained to ensure design flow capacity; no sensitive stream habitat areas will be adversely affected; or are not identified on the Co-Permittees Hydromodification Sensitivity Maps.

Does the project qualify for this HCOC Exemption?       Y       N

If Yes, HCOC criteria do not apply and note below which adequate sump applies to this HCOC qualifier:

## **F.2 HCOC Mitigation**

If none of the above HCOC Exemption Criteria are applicable, HCOC criteria is considered mitigated if they meet one of the following conditions:

- a. Additional LID BMPS are implemented onsite or offsite to mitigate potential erosion or habitat impacts as a result of HCOCs. This can be conducted by an evaluation of site-specific conditions utilizing accepted professional methodologies published by entities such as the California Stormwater Quality Association (CASQA), the Southern California Coastal Water Research Project (SCCRWP), or other Co-Permittee approved methodologies for site-specific HCOC analysis.
- b. The project is developed consistent with an approved Watershed Action Plan that addresses HCOC in Receiving Waters.
- c. Mimicking the pre-development hydrograph with the post-development hydrograph, for a 2-year return frequency storm. Generally, the hydrologic conditions of concern are not significant, if the post-development hydrograph is no more than 10% greater than pre-development hydrograph. In cases where excess volume cannot be infiltrated or captured and reused, discharge from the site must be limited to a flow rate no greater than 110% of the pre-development 2-year peak flow.

Be sure to include all pertinent documentation used in your analysis of the items a, b or c in Appendix 7.

**Project is located within the Hydromodification exemption area based on Riverside County WAP geodatabase approved April 20, 2017. See Appendix 7.**

## Section G: Source Control BMPs

Source control BMPs include permanent, structural features that may be required in your project plans — such as roofs over and berms around trash and recycling areas — and Operational BMPs, such as regular sweeping and “housekeeping”, that must be implemented by the site’s occupant or user. The MEP standard typically requires both types of BMPs. In general, Operational BMPs cannot be substituted for a feasible and effective permanent BMP. Using the Pollutant Sources/Source Control Checklist in Appendix 8, review the following procedure to specify Source Control BMPs for your site:

1. **Identify Pollutant Sources:** Review Column 1 in the Pollutant Sources/Source Control Checklist. Check off the potential sources of Pollutants that apply to your site.
2. **Note Locations on Project-Specific WQMP Exhibit:** Note the corresponding requirements listed in Column 2 of the Pollutant Sources/Source Control Checklist. Show the location of each Pollutant source and each permanent Source Control BMP in your Project-Specific WQMP Exhibit located in Appendix 1.
3. **Prepare a Table and Narrative:** Check off the corresponding requirements listed in Column 3 in the Pollutant Sources/Source Control Checklist. In the left column of Table G.1 below, list each potential source of runoff Pollutants on your site (from those that you checked in the Pollutant Sources/Source Control Checklist). In the middle column, list the corresponding permanent, Structural Source Control BMPs (from Columns 2 and 3 of the Pollutant Sources/Source Control Checklist) used to prevent Pollutants from entering runoff. **Add additional narrative** in this column that explains any special features, materials or methods of construction that will be used to implement these permanent, Structural Source Control BMPs.
4. **Identify Operational Source Control BMPs:** To complete your table, refer once again to the Pollutant Sources/Source Control Checklist. List in the right column of your table the Operational BMPs that should be implemented as long as the anticipated activities continue at the site. Copermittee stormwater ordinances require that applicable Source Control BMPs be implemented; the same BMPs may also be required as a condition of a use permit or other revocable Discretionary Approval for use of the site.

**Table G.1** Permanent and Operational Source Control Measures

Potential Sources of Runoff pollutants	Permanent Structural Source Control BMPs	Operational Source Control BMPs
A. On-site storm drain catch basins and grated inlets. Locations are shown on the FWQMP Exhibit in Appendix 1.	On-site storm drain signage will utilize language, “No Dumping Drains to River”, or equally approved text that is consistent with the City of Perris’ requirements. Landscape area drains surrounded by vegetation will not be signed. Catch Basin Markers may be available from the Riverside County Flood Control and Water District Conservation District, call	Maintain and periodically repaint or replace inlet markings. Provide stormwater pollution prevention information to new site owners, lessees, or operators. See applicable operational BMPs in Fact Sheet SC-44, “Drainage System Maintenance,” in Appendix 10 (CASQA Stormwater Quality Handbook at <a href="http://www.cabmphandbooks.com">http://www.cabmphandbooks.com</a>

	<p>951-955-1200 to verify.</p> <p>On-site drainage structures, including all storm drain clean outs, area drains, inlets, catch basins, inlet &amp; outlet structures, forebays, &amp; water treatment control basins shall be inspected and maintained on a regular basis to insure their operational adequacy.</p>	<p>Include the following in lessee agreements: “Tenants shall not allow anyone to discharge anything to storm drains or to store or deposit materials so as to create a potential discharge to storm drains”</p> <p>Maintenance should include removal of trash, debris, &amp; sediment and the repair of any deficiencies or damage that may impact water quality.</p>
B. Interior floor drains and elevator shaft sump	The interior floor drains and elevator shaft sump pumps will be plumbed to sanitary sewer	Inspect and maintain drains to prevent blockages and overflow.
C. Need for future indoor & structural pest control	Note building design features that discourage entry of pests.	Provide Integrated Pest Management information to owners, lessees, and operators.
D. Landscape/Outdoor Pesticide Use	<p>The final landscape shall be designed to accomplish all of the following:</p> <p>Preserve existing native trees, shrubs and ground cover to the maximum extent possible.</p> <p>Design landscape to minimize irrigation and runoff, to promote surface infiltration where appropriate and to minimize the use of fertilizers and pesticides that can contribute to stormwater pollution.</p> <p>Where landscaped areas are used to retain or detain stormwater, specify plants that are tolerant of saturated soil conditions.</p> <p>Consider using pest-resistant plants, especially adjacent to hardscape.</p> <p>To insure successful establishments, select plants</p>	<p>Maintain landscaping using minimum or no pesticides</p> <p>See applicable operational BMPs in “What you should know for.... Landscape and Gardening” at <a href="http://rcflood.org/stormwater">http://rcflood.org/stormwater</a> and Appendix 10.</p> <p>Provide IPM information to new owners, lessees and operators.</p> <p>Landscape maintenance should include mowing, weeding, trimming, removal of trash &amp; debris, repair of erosion, re-vegetation, and removal of cut &amp; dead vegetation.</p> <p>Irrigation maintenance should include the repair of leaky or broken sprinkler heads, the maintaining of timing apparatus accuracy, and the maintaining of shut off valves in good working order.</p>

	<p>appropriate to site, soils, slopes, climate, sun, wind, rain, land use, air movement, ecological consistency and plant interactions.</p> <p>Pesticide usage should be at a necessary minimum and be consistent with the instructions contained on product labels and with the regulations administered by the State Department of Pesticide Regulation.</p> <p>Pesticides should be used at an absolute minimum or not at all in the retention/infiltration basin. If used, it should not be applied in close proximity to the rainy season.</p>	
<p>E. Refuse Trash Storage areas</p>	<p>Trash container storage areas shall be paved with an impervious surface, designed not to allow run-on from adjoining areas, designed to divert drainage from adjoining roofs and pavements from the surrounding area, and screened or walled to prevent off-site transport of trash.</p> <p>Trash dumpsters (containers) shall be leak proof and have attached covers or lids.</p> <p>Trash enclosures shall be roofed per City standards and the details on the PWQMP Exhibit in Appendix 1.</p> <p>Trash compactors shall be roofed and set on a concrete pad per City standards. The pad shall be a minimum of one foot larger all around than the trash compactor and sloped to drain to a sanitary sewer line. Connection of trash area drains to the MS4 is prohibited.</p> <p>See CASQA SD-32 BMP Fact</p>	<p>Adequate number of receptacles shall be provided. Inspect receptacles regularly; repair or replace leaky receptacles. Keep receptacles covered.</p> <p>Prohibit/prevent dumping of liquid or hazardous wastes. Post “no hazardous materials” signs. Inspect and pick up litter daily and clean up spills immediately. Keep spill control materials available on-site. See Fact Sheet SC-34, in Appendix 10, “Waste Handling and Disposal” in the CASQA Stormwater Quality Handbook at <a href="http://www.cabmphandbooks.com">www.cabmphandbooks.com</a></p>

	<p>Sheets in Appendix 10 for additional information.</p> <p>Signs shall be posted on or near dumpsters with the words “Do not dump hazardous materials here” or similar.</p>	
F. Outdoor storage of equipment or materials.	Concrete bricks will be stored within the paved storage yard.	See the Fact Sheets SC-31, “Outdoor Liquid Container Storage” and SC-33, “Outdoor Storage of Raw Materials” in the CASQA Stormwater Quality Handbooks at <a href="http://www.cabmphandbooks.com">www.cabmphandbooks.com</a>
G. Loading Docks	<p>Loading docks will not be covered and are 4 feet above finished pavement surface.</p> <p>Spill kits are to be kept on-site at all times per SC-11.</p>	<p>Move loaded and unloaded items indoors as soon as possible.</p> <p>Inspect for accumulated trash and debris. Implement good housekeeping procedures on a regular basis. Sweep areas clean instead of using wash water. Loading docks will be kept in a clean and orderly condition, through a regular program of sweeping and litter control, and immediate clean up of any spills or broken containers. Property owner will ensure that loading docks will be swept as needed. Cleanup procedures will not include the use of wash-down water. Property owner will be responsible for implementation of loading dock housekeeping procedures</p> <p>See the Fact Sheet SC-30, in Appendix 10, “Outdoor Loading and Unloading” in the CASQA Stormwater Quality Handbooks at <a href="http://www.cabmphandbooks.com">www.cabmphandbooks.com</a></p>
H. Fire Sprinkler Test Water	Provide a means to drain fire sprinkler test water to the sanitary sewer.	See the note in the Fact Sheet SC-41, in Appendix 10, “Building and Grounds Maintenance”, in the CASQA Stormwater Quality Handbooks at
I. Miscellaneous Drain or Wash Water or Other	Boiler drain lines shall be directly or indirectly connected	

<p>Sources</p> <p>Boiler drain lines</p> <p>Condensate drain lines</p> <p>Rooftop equipment</p> <p>Drainage sumps</p> <p>Roofing, gutters and trim</p>	<p>to the sanitary sewer system and may not discharge to the storm drain system</p> <p>Condensate drain lines may discharge to landscaped areas if the flow is small enough that runoff will not occur.</p> <p>Condensate drain lines may not discharge to the storm drain system.</p> <p>Rooftop equipment with potential to produce pollutants shall be roofed and/or have secondary containment.</p> <p>Any drainage sumps on-site shall feature a sediment sump to reduce the quantity of sediment in pumped water.</p> <p>Avoid roofing, gutters and trim made of copper or other unprotected metals that may leach into runoff.</p> <p>Include controls for other sources as specified by local reviewer.</p>	
<p>J. Plazas, sidewalks, and parking lots</p>	<p>Spill kits are to be kept on-site at all times per SC-11.</p>	<p>Sweep plazas, sidewalks, and parking lots regularly to prevent accumulation of litter and debris. Collect debris from pressure washing to prevent entry into the storm drain system. Collect washwater containing any cleaning agent or degreaser and discharge to the sanitary sewer not to a storm drain.</p>

# Section H: Construction Plan Checklist

Populate Table H.1 below to assist the plan checker in an expeditious review of your project. The first two columns will contain information that was prepared in previous steps, while the last column will be populated with the corresponding plan sheets. This table is to be completed with the submittal of your final Project-Specific WQMP.

Table H.1 Construction Plan Cross-reference

BMP No. or ID	BMP Identifier and Description	Corresponding Plan Sheet(s)
*	*	*

Note that the updated table — or Construction Plan WQMP Checklist — is **only a reference tool** to facilitate an easy comparison of the construction plans to your Project-Specific WQMP. Co-Permittee staff can advise you regarding the process required to propose changes to the approved Project-Specific WQMP.

**\*This section will be completed during Final Engineering Design.**

## Section I: Operation, Maintenance and Funding

The Copermittee will periodically verify that Stormwater BMPs on your site are maintained and continue to operate as designed. To make this possible, your Copermittee will require that you include in Appendix 9 of this Project-Specific WQMP:

1. A means to finance and implement facility maintenance in perpetuity, including replacement cost.
2. Acceptance of responsibility for maintenance from the time the BMPs are constructed until responsibility for operation and maintenance is legally transferred. A warranty covering a period following construction may also be required.
3. An outline of general maintenance requirements for the Stormwater BMPs you have selected.
4. Figures delineating and designating pervious and impervious areas, location, and type of Stormwater BMP, and tables of pervious and impervious areas served by each facility. Geo-locating the BMPs using a coordinate system of latitude and longitude is recommended to help facilitate a future statewide database system.
5. A separate list and location of self-retaining areas or areas addressed by LID Principles that do not require specialized O&M or inspections but will require typical landscape maintenance as noted in Chapter 5, pages 85-86, in the WQMP Guidance. Include a brief description of typical landscape maintenance for these areas.

Your local Co-Permittee will also require that you prepare and submit a detailed Stormwater BMP Operation and Maintenance Plan that sets forth a maintenance schedule for each of the Stormwater BMPs built on your site. An agreement assigning responsibility for maintenance and providing for inspections and certification may also be required.

Details of these requirements and instructions for preparing a Stormwater BMP Operation and Maintenance Plan are in Chapter 5 of the WQMP Guidance Document.

**Maintenance Mechanism:** Owner will privately maintain all BMPs. An Access and maintenance agreement will be provided to the County to ensure maintenance can be provided by the County (at the expense of the owner) if the owner fails to maintain BMPs.

Will the proposed BMPs be maintained by a Home Owners' Association (HOA) or Property Owners Association (POA)?

Y       N

Include your Operation and Maintenance Plan and Maintenance Mechanism in Appendix 9. Additionally, include all pertinent forms of educational materials for those personnel that will be maintaining the proposed BMPs within this Project-Specific WQMP in Appendix 10.

**\*Will be included in Final Report.**



# Appendix 1: Maps and Site Plans

*Location Map, WQMP Site Plan and Receiving Waters Map*

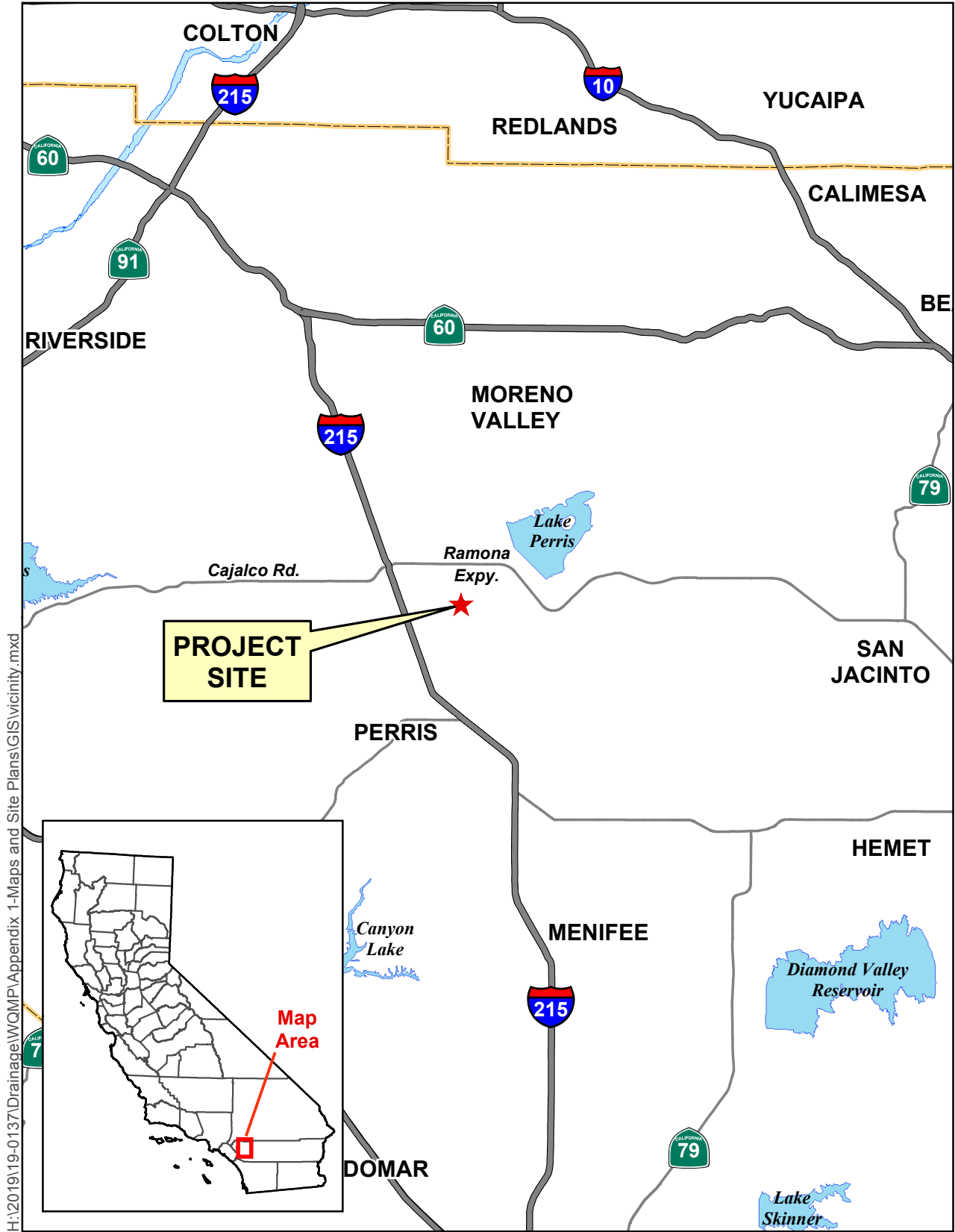

H:\201919-0137\Drainage\WQMP\Appendix 1-Maps and Site Plans\GIS\vicinity.mxd

Figure 1. Vicinity Map

0 2.5 5 Miles



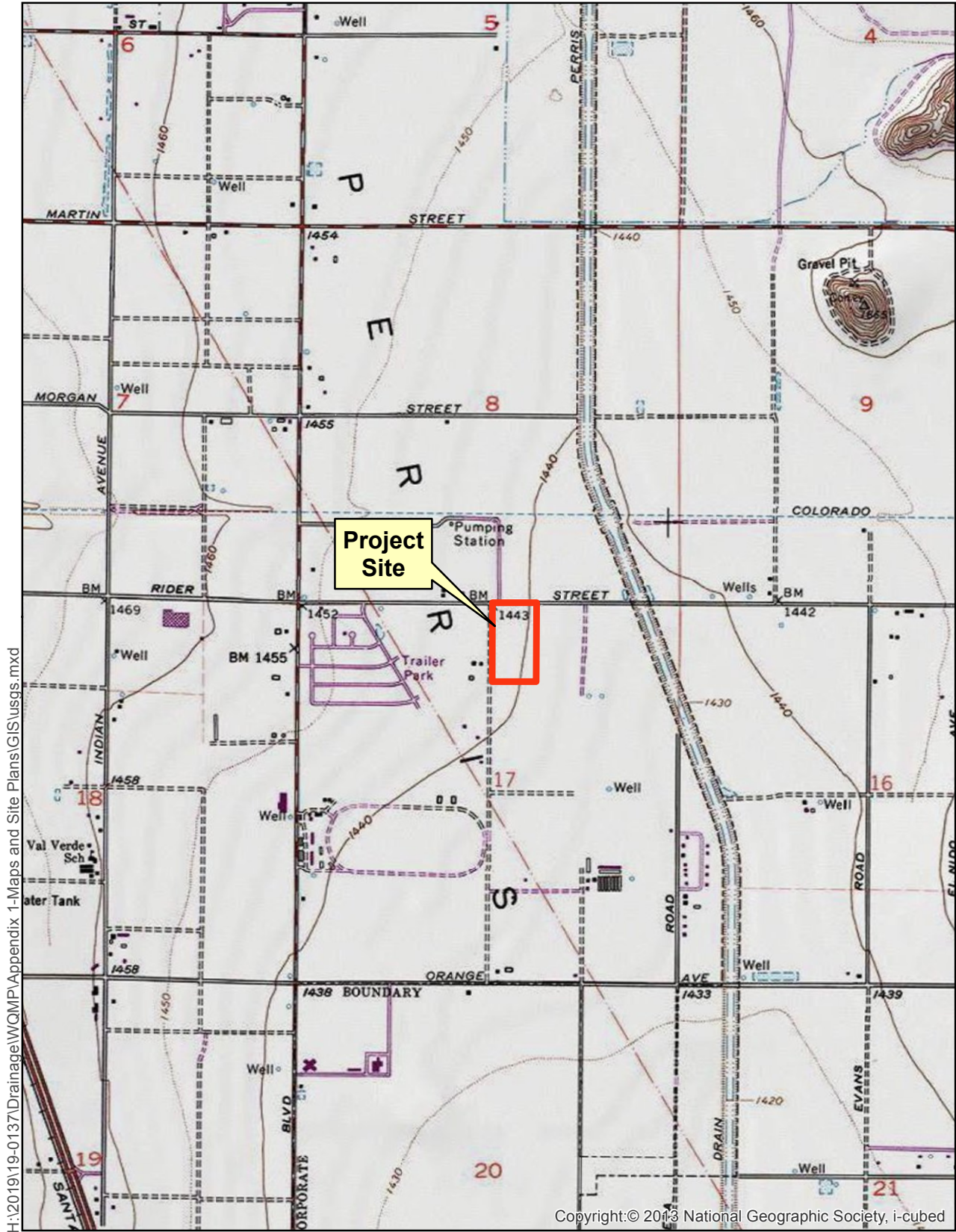

Sources: ESRI / USGS 7.5min Quad  
 DRGs: PERRIS / STEELE PEAK

**Figure 2. USGS Topography Map**

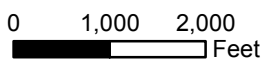



H:\2019\19-0137\Drainage\WQMP\Appendix 1-Maps and Site Plans\GIS\Aerial.mxd



Sources: County of Riverside GIS, 2013;  
Eagle Aerial, April 2012.

Figure 3. Aerial Photograph

0 400 800  
Feet





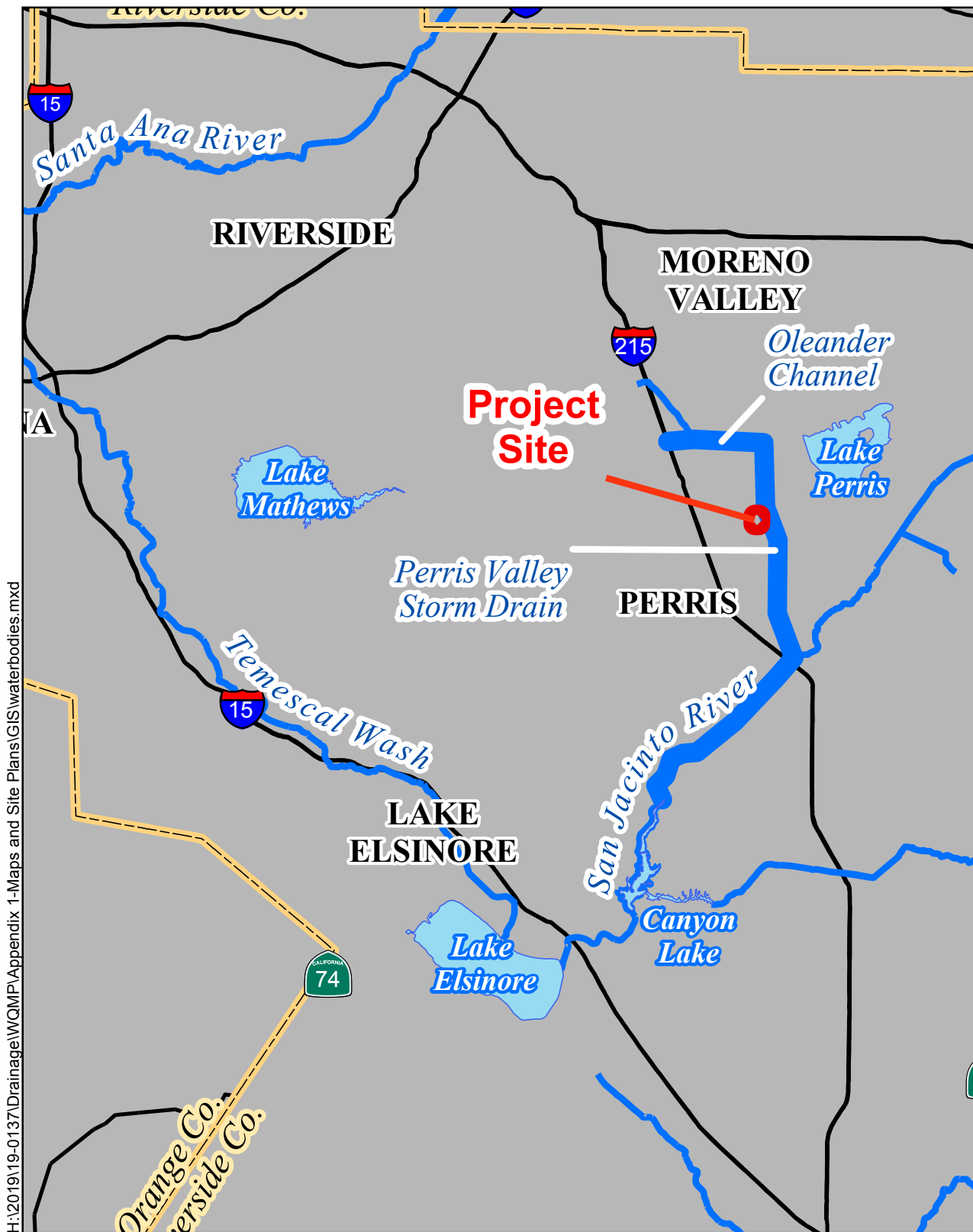

H:\2019\19-0137\Drainage\WQMP\Appendix 1-Maps and Site Plans\GIS\waterbodies.mxd

Sources: USGS 30 Meter DEM;  
USGS Digital Line Graph

**Figure 4. Receiving Waterbodies**

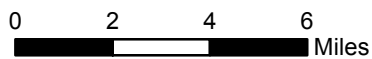

 Flowpath

H:\2019\19-0137\Drainage\WQMP\Appendix 1-Maps and Site Plans\GIS\SOILS MAP.mxd

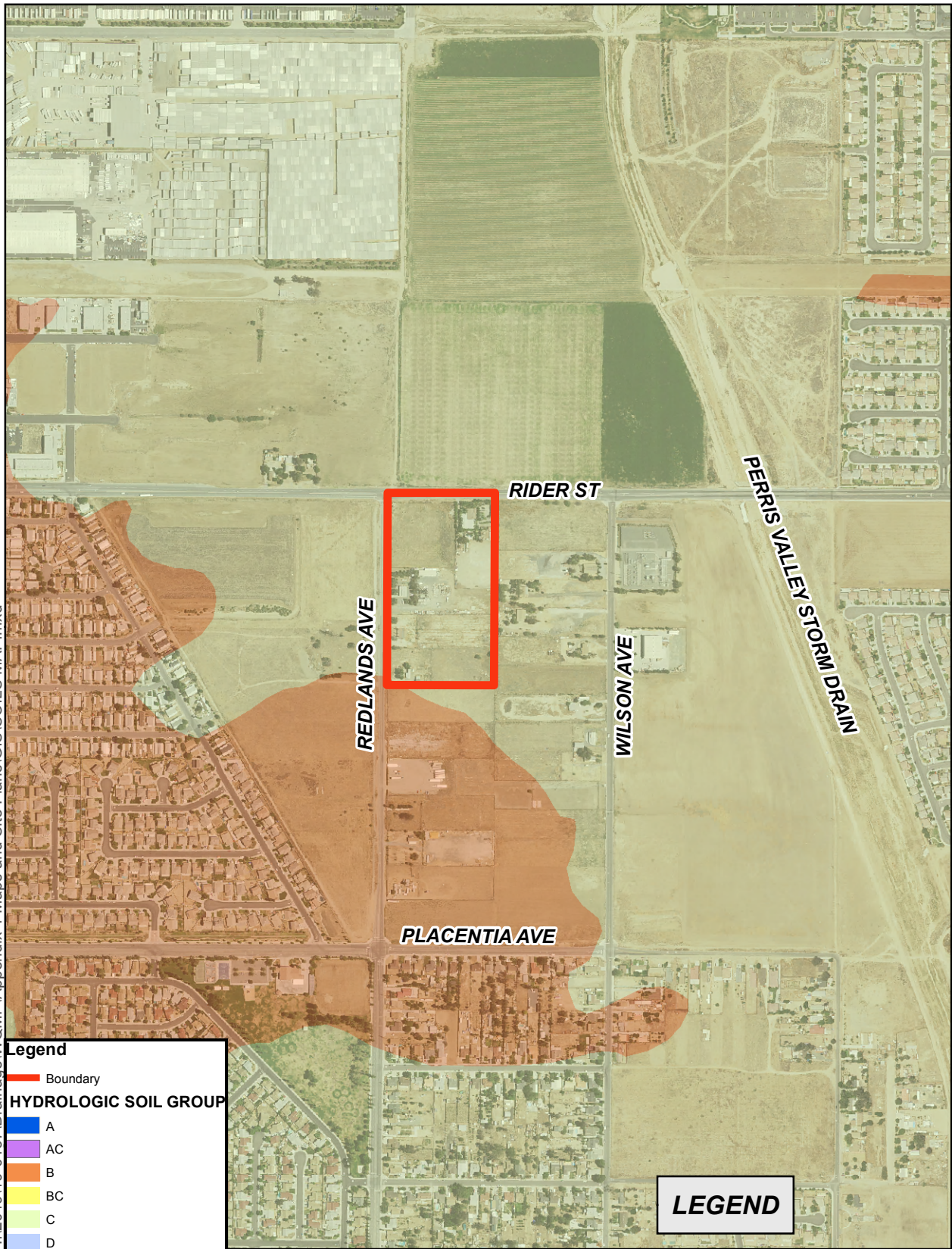

**Legend**

- Boundary

**HYDROLOGIC SOIL GROUP**

- A
- AC
- B
- BC
- C
- D

**LEGEND**

Eagle Aerial, April 2010;  
Riverside County GIS, 2012  
RCFC&WCD Hydology Manual Plate C-1.30

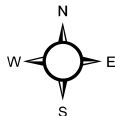

0 500 1,000  
Feet

**Soils Map**  
Perris Valley Logisitc Center



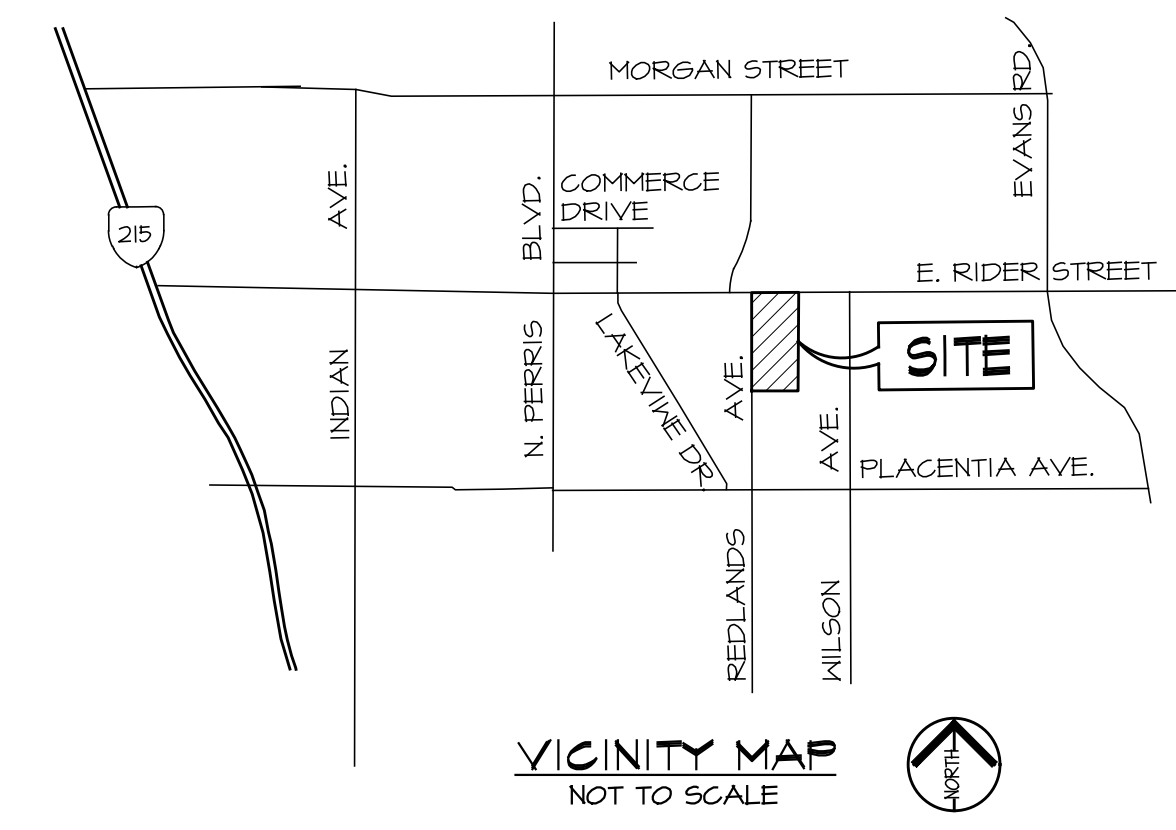
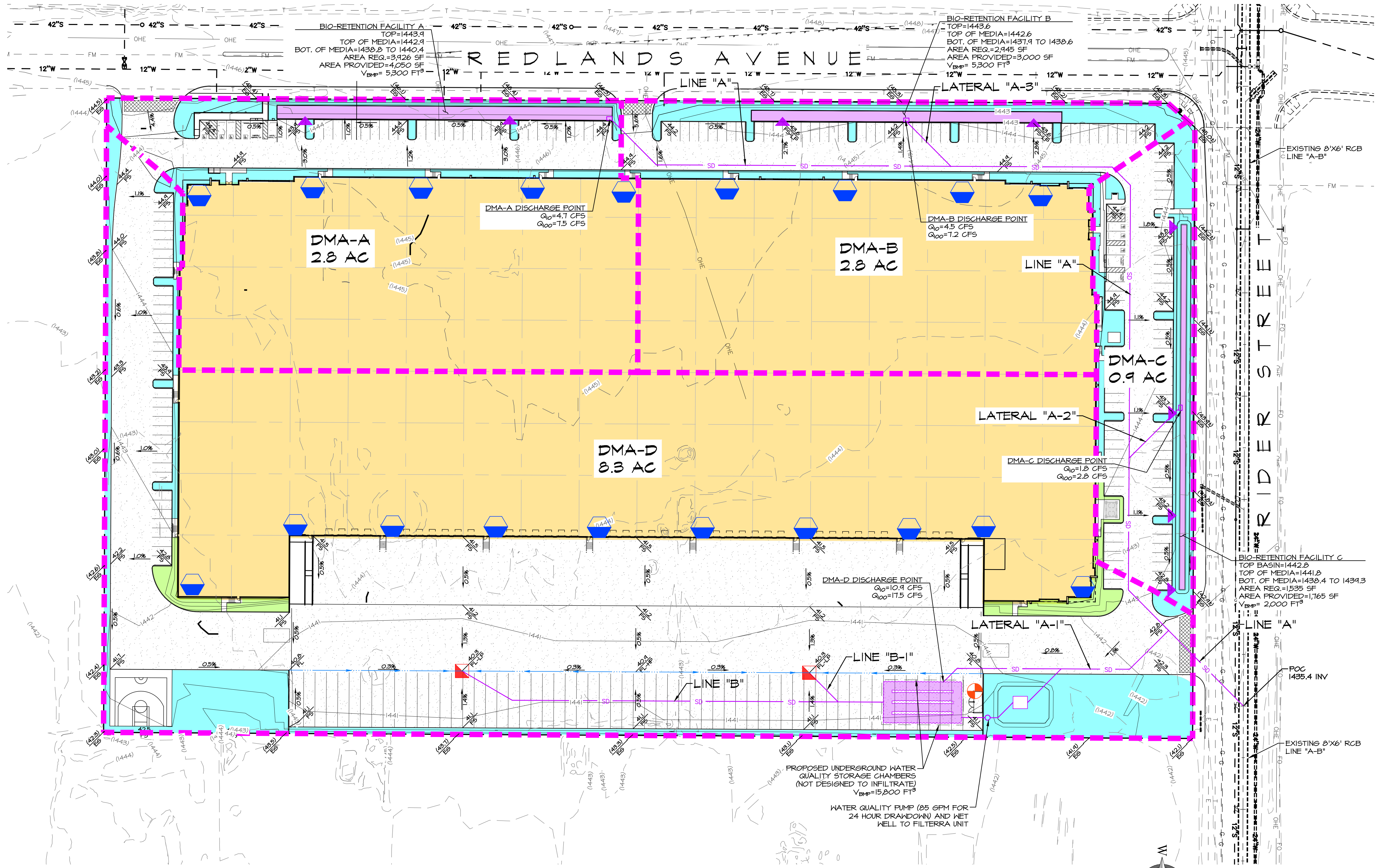

- LEGEND**
- DRAINAGE MANAGEMENT BOUNDARY
  - LANDSCAPED AREA
  - SELF-RETAINING AREA
  - ROOF AREA
  - CONCRETE OR ASPHALT
  - WQ BIORETENTION FACILITY/BASIN
  - FLOW DIRECTION
  - STORM DRAIN PIPE
  - ROOF DRAIN DOWNSPOUT
  - CURB OPENING/CUT
  - STORM INLET
  - TRASH ENCLOSURE

**DRAINAGE MANAGEMENT AREAS (DMA) SUMMARY**

DMA ID	TOTAL AREA (SF)	LANDSCAPE (I=0.10)	SELF-RETAINING	HARDSCAPE (I=1.0)	ROOF (I=1.0)	V <sub>BMP</sub> REQUIRED (CFS)	V <sub>BMP</sub> PROVIDED (CFS)
DMA A	121,480	5,150	7,000	26,740	82,590	5,232	5,300
DMA B	121,440	5,140	7,000	26,710	82,590	5,248	5,300
DMA C	40,352	2,500	1,451	36,390	-	1,746	2,000
DMA D	365,651	51,055	33,355	172,285	154,910	15,545	15,800
<b>TOTAL</b>	<b>648,923</b>	<b>17,845</b>	<b>48,812</b>	<b>262,125</b>	<b>320,090</b>	<b>27,821</b>	<b>28,400</b>

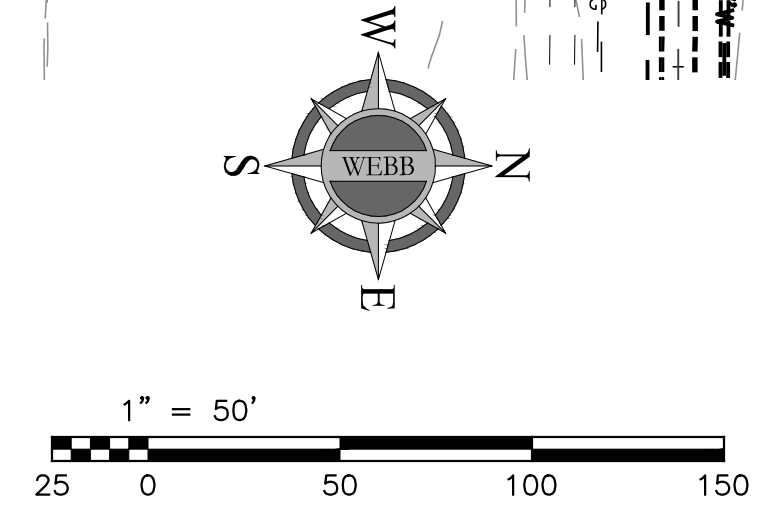

**CITY OF PERRIS**

**POST-CONSTRUCTION BMP SITE PLAN  
P19-0016 FIRST RIDER**

SCALE: 1"=50' DATE: 6/1/20 DESIGNED: CV CHECKED: DJA PLN CK REF: F.B.	<b>ALBERT A. WEBB ASSOCIATES</b> ENGINEERING CONSULTANTS 3738 MCCRAY STREET RIVERSIDE CA 92506 PH. (951) 686-1070 FAX (951) 788-1256	W.O. 19-0197 SHEET 1 OF 3 SHEETS DWG. NO.
--	---	--

H:\2019\19-0137\DRAINAGE\WQMP\DWG DRAWINGS\19-0137-PWQMP.DWG 6/1/2020 11:55:01 AM



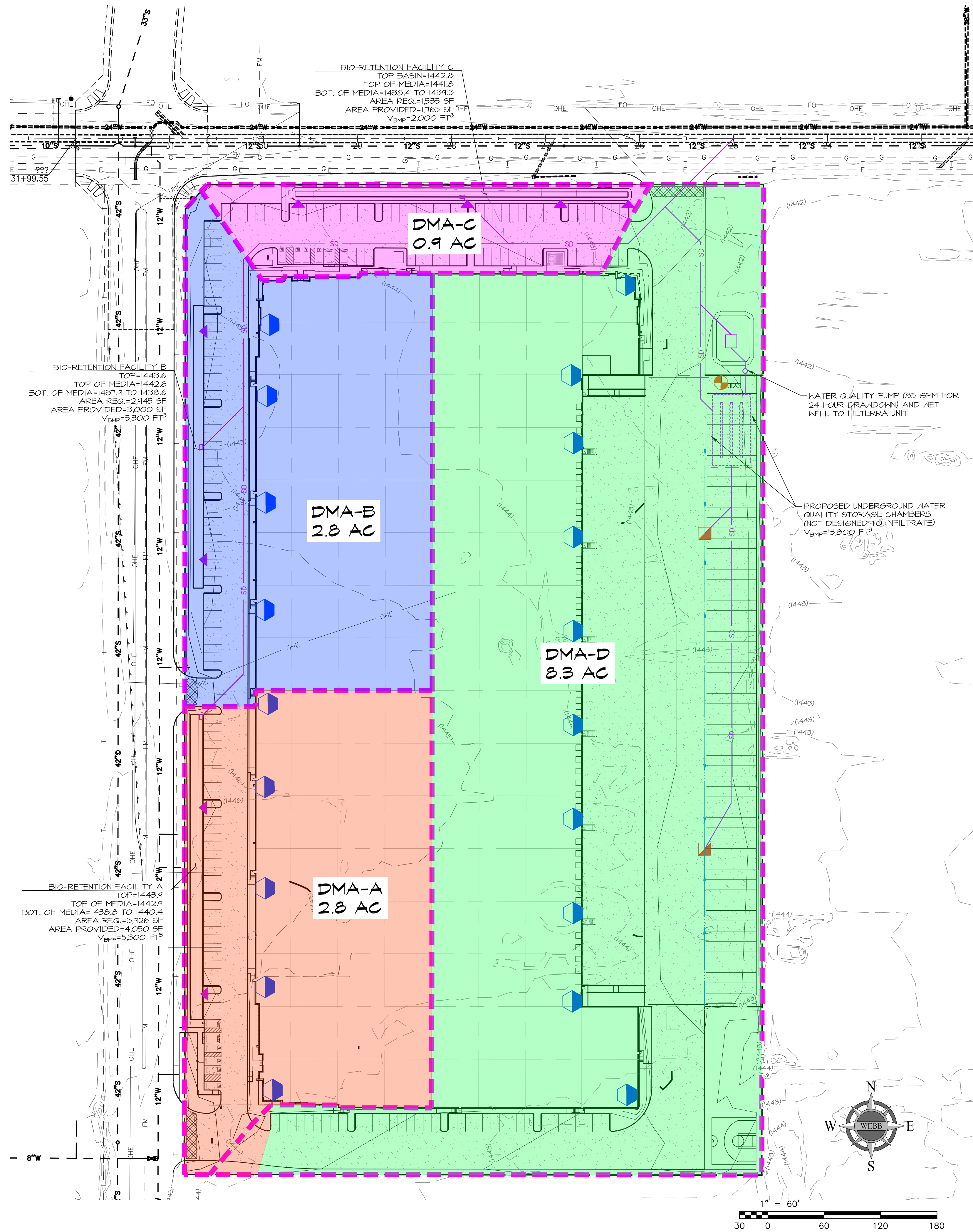

- DMA-A
- DMA-B
- DMA-C
- DMA-D

DRAINAGE MANAGEMENT AREAS (DMA) SUMMARY							
DMA ID	TOTAL AREA (SF)	LANDSCAPE (1=0.10)	SELF-RETAINING	HARDSCAPE (1=1.0)	ROOF (1=1.0)	V <sub>BMP</sub> REQUIRED (CFS)	V <sub>BMP</sub> PROVIDED (CFS)
DMA A	121,480	5,150	7,000	26,740	82,590	5,232	5,300
DMA B	121,440	5,140	7,000	26,710	82,590	5,248	5,300
DMA C	40,352	2,500	1,457	36,390	-	1,746	2,000
DMA D	365,651	5,105	33,355	172,285	154,910	15,595	15,800
<b>TOTAL</b>	<b>648,923</b>	<b>17,895</b>	<b>48,812</b>	<b>262,125</b>	<b>320,090</b>	<b>27,821</b>	<b>28,400</b>

CITY OF PERRIS

POST-CONSTRUCTION DMA PLAN  
 P19-0016 FIRST RIDER

SCALE:		W.O. 19-0197
DATE:	6/1/20	SHEET 2
DESIGNED:	CV	OF 3 SHEETS
CHECKED:	DJA	DWG. NO.
PLN CK REF:		
F.B.		

ALBERT A. ENGINEERING CONSULTANTS  
 3788 MCCRAY STREET  
 RIVERSIDE CA 92506  
 PH. (951) 686-1070  
 FAX (951) 788-1256

WEBB ASSOCIATES

H:\2019\19-0137\DRAWING\WQMP\DWG DRAWINGS\19-0137-PWQMP.DWG 6/1/2020 11:55:01 AM



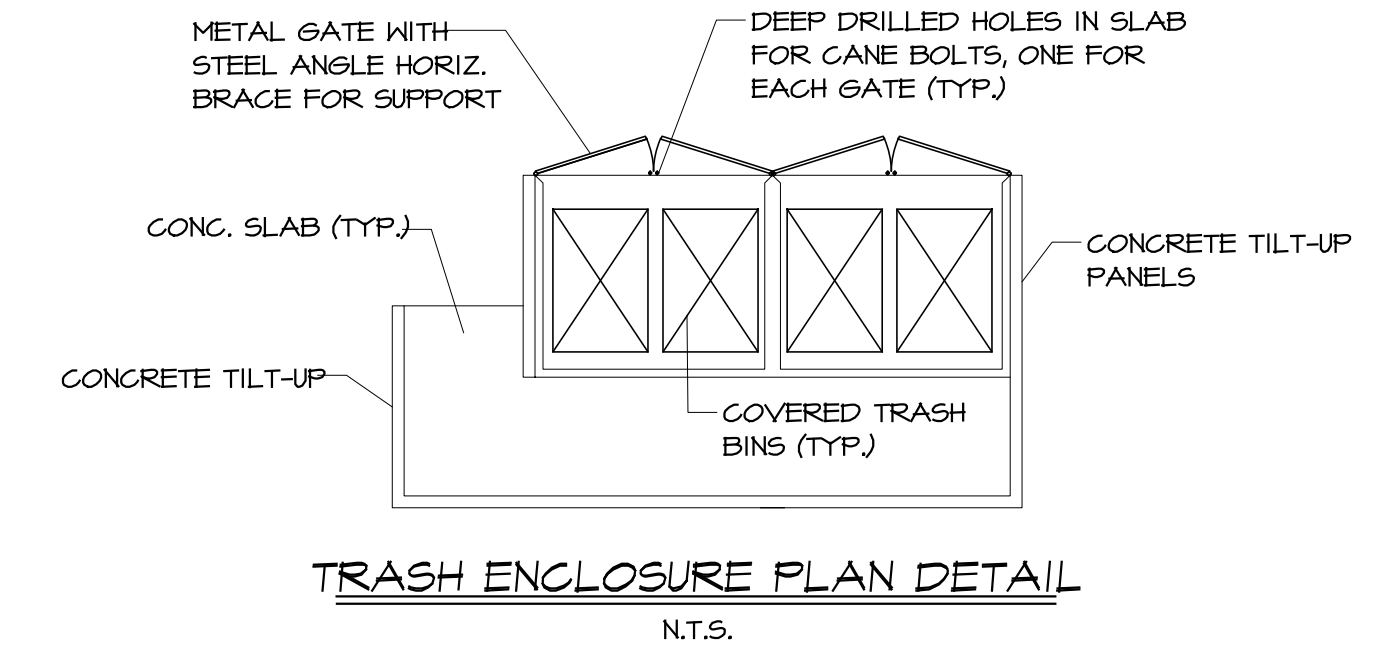
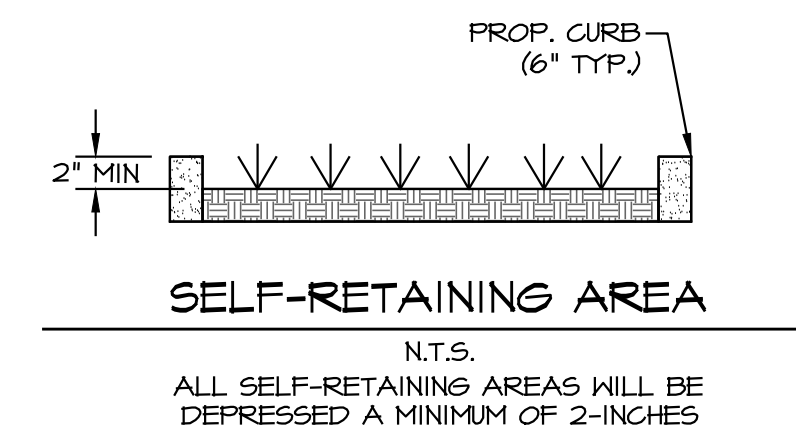
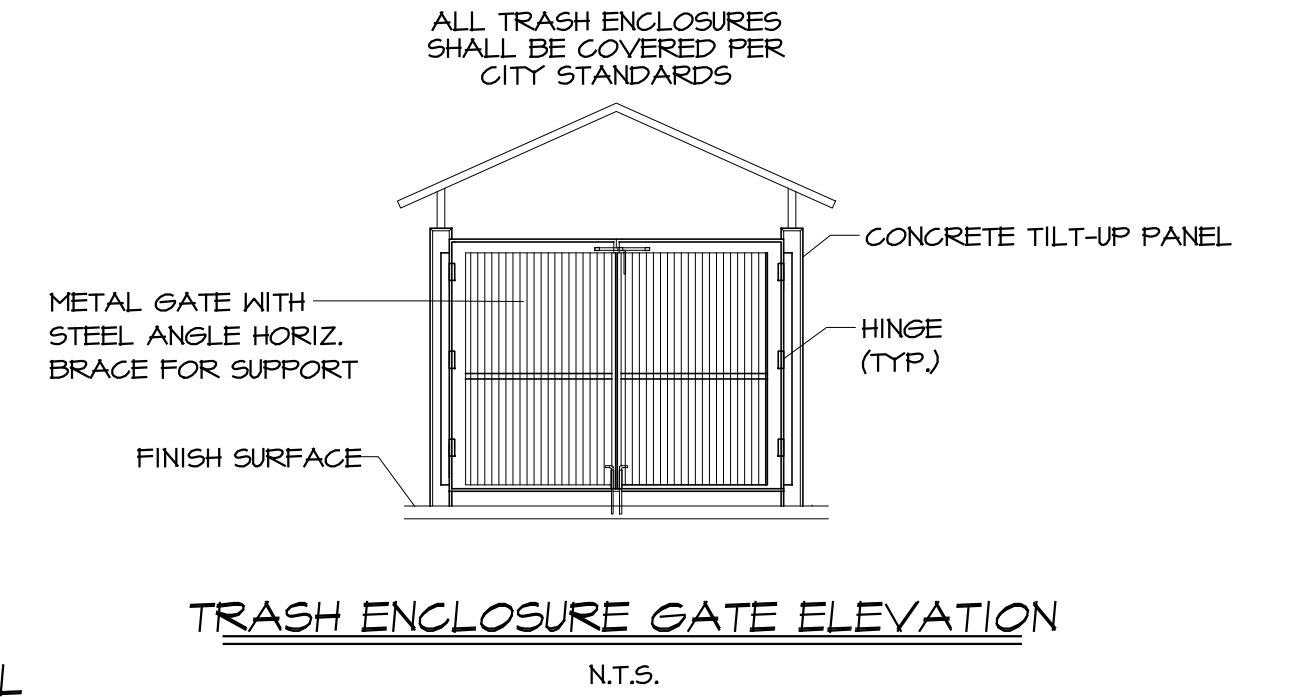
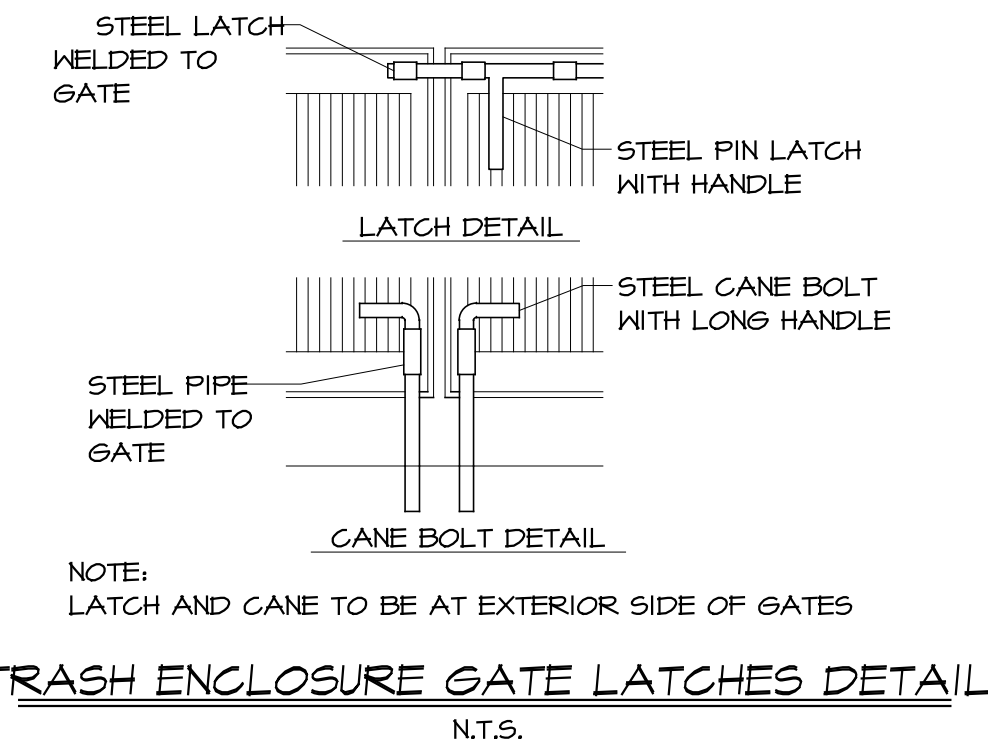
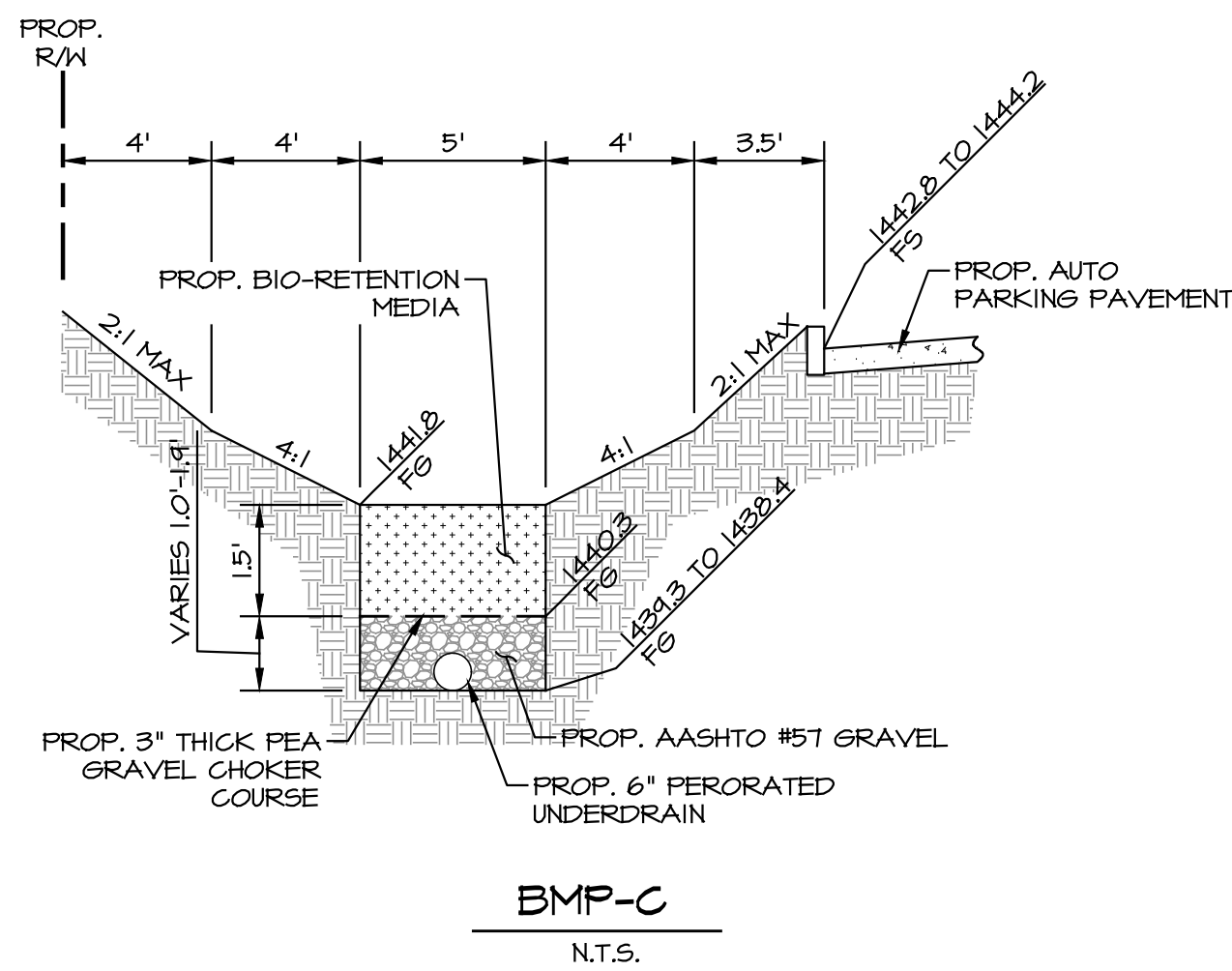
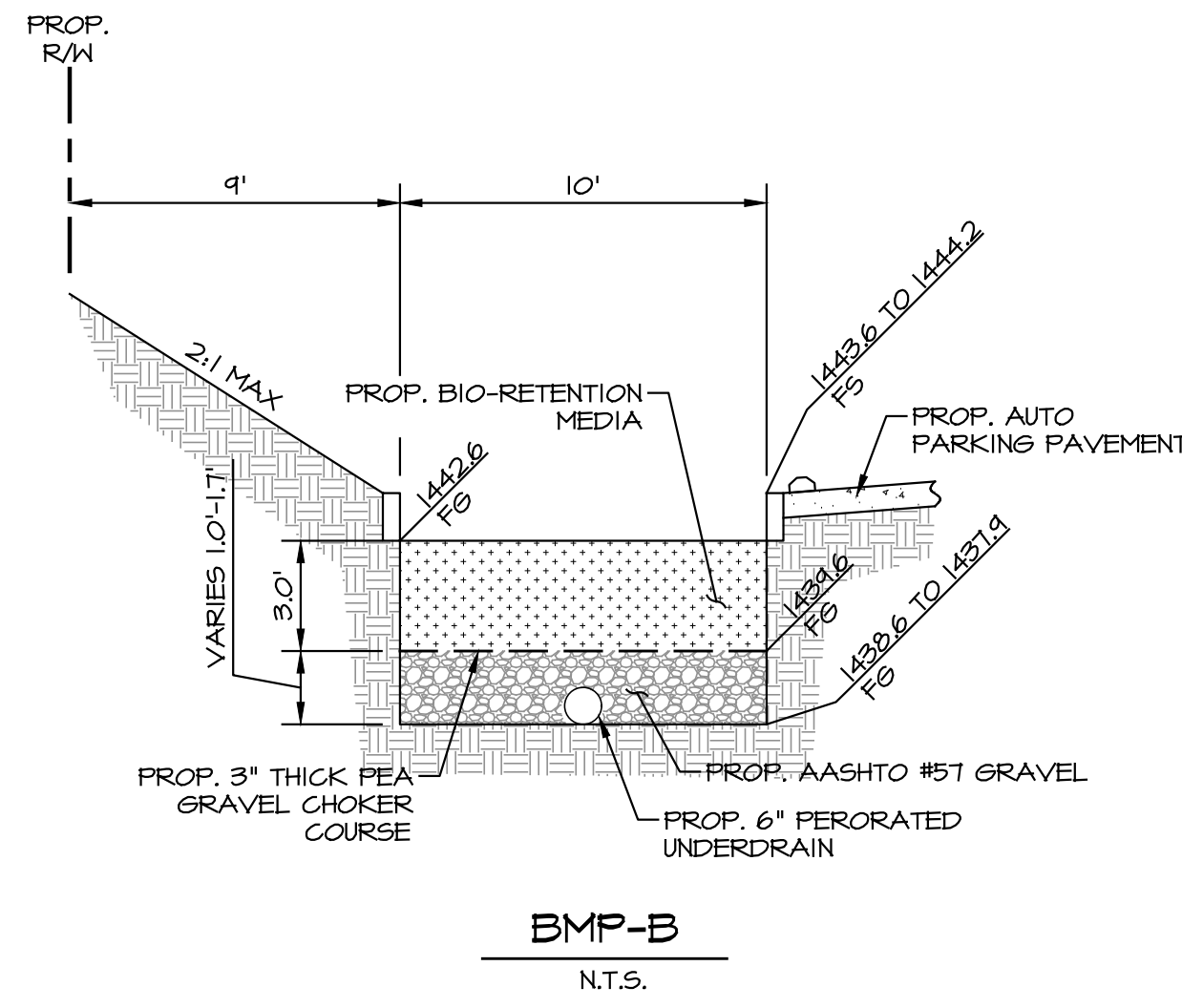
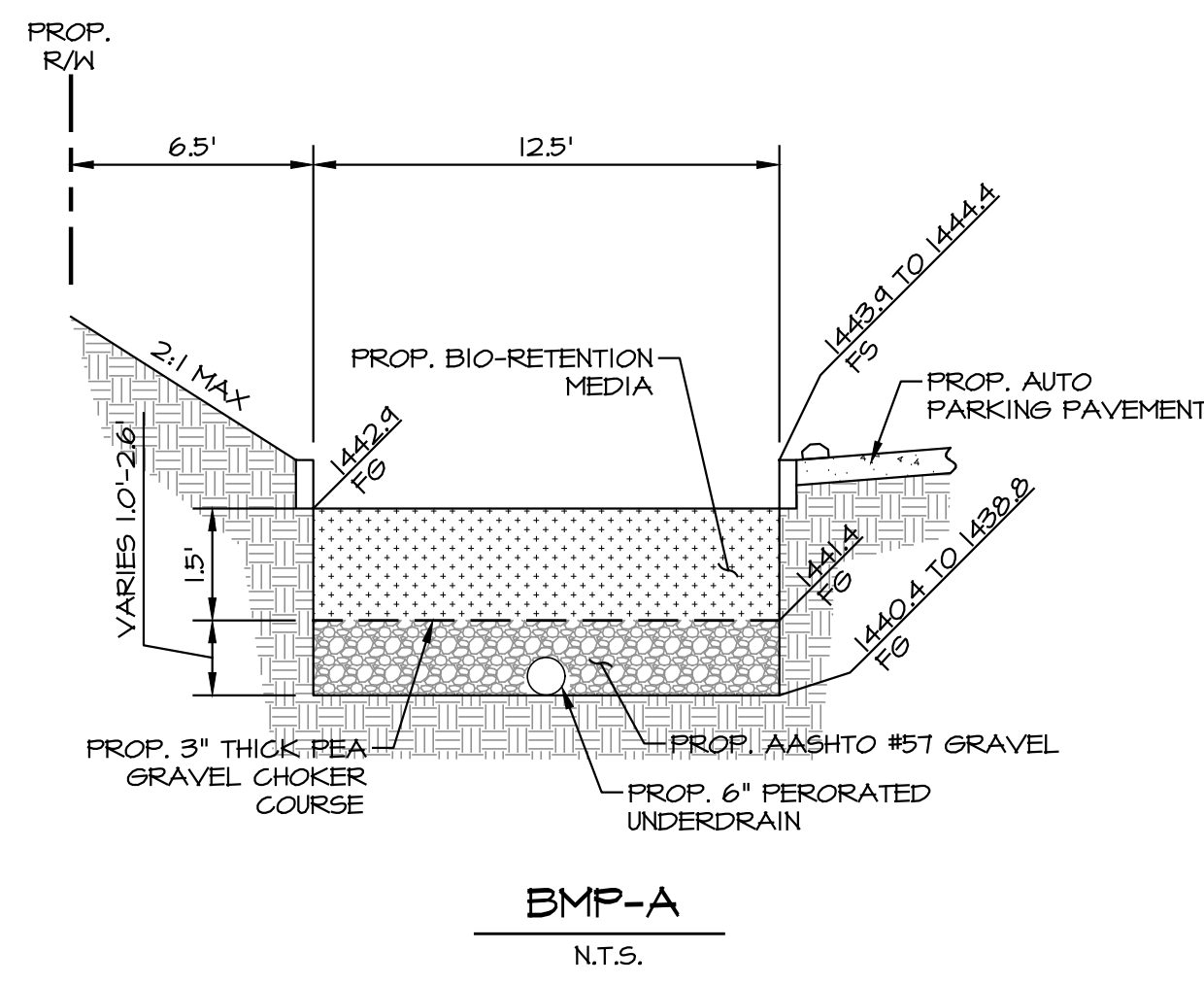

THIS IS A SCHEMATIC LAYOUT ONLY. ACTUAL CONFIGURATION WILL VARY BASED ON THE SITE SPECIFIC CONSIDERATIONS. REFER TO FLOWKIT DRAWINGS FOR ADDITIONAL DETAILS.

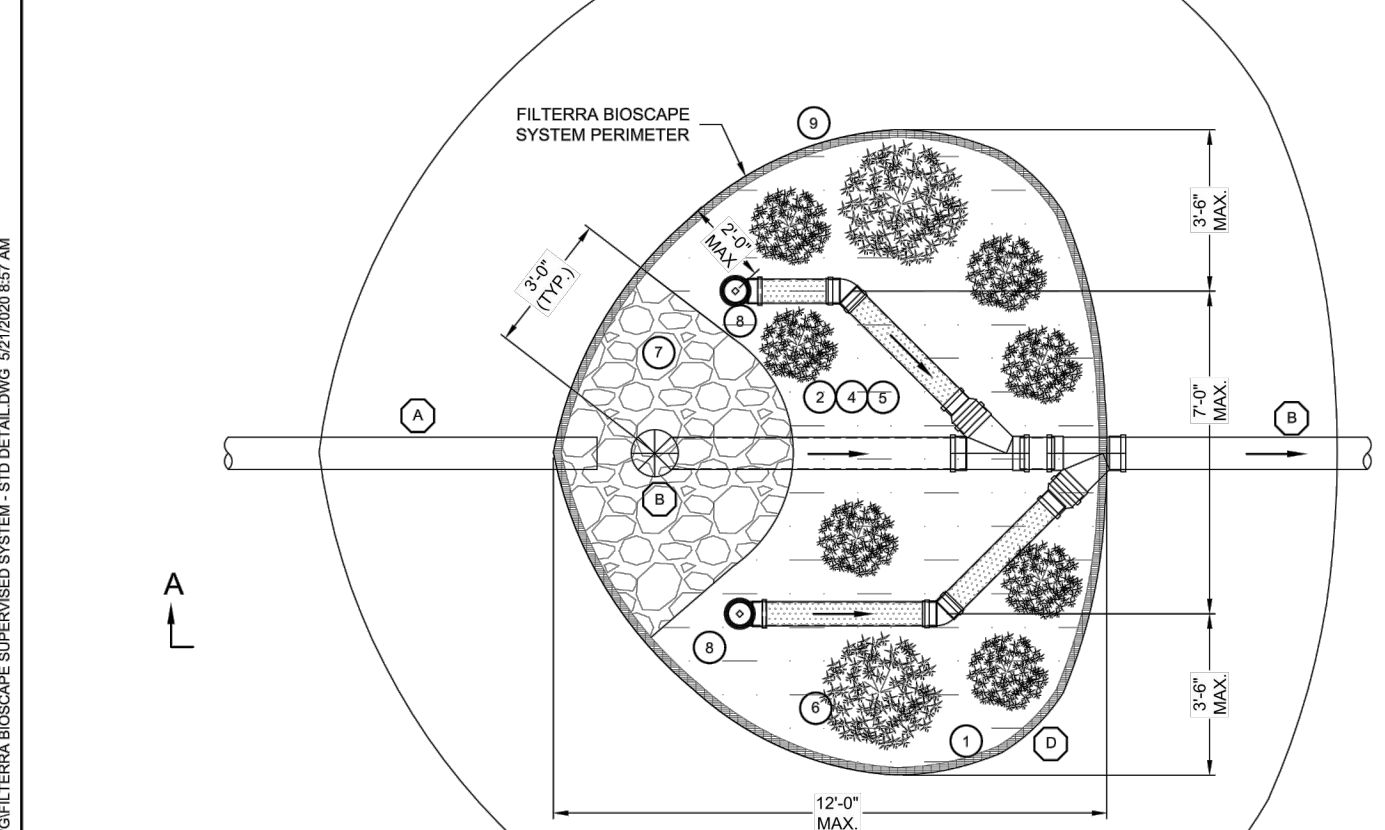

AS WITH ALL OPEN TOP BIORETENTION SYSTEMS, FILTERRA BIOSCAPE SYSTEM IS OPEN TO THE ATMOSPHERE WITH A MEDIA SURFACE RECESSED BELOW FINISHED GRADE. CONTRACTOR OR OWNER IS RESPONSIBLE FOR PROVIDING ANY REQUIRED SAFETY MEASURES AROUND SYSTEM PERIMETER. TO MAINTAIN AESTHETICS, REMOVAL OF HEAVY STORMWATER DEBRIS MAY BE NECESSARY BETWEEN REGULAR FILTERRA SYSTEM MAINTENANCE EVENTS.

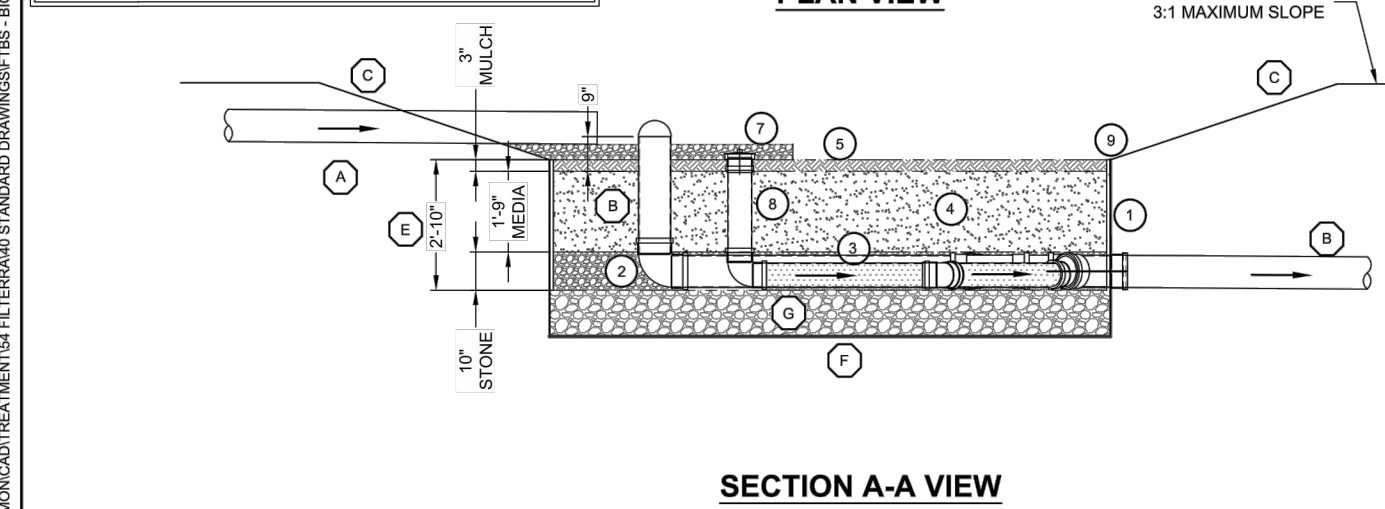

BILL OF MATERIALS			PLANTING SCHEDULE	
COUNT	DESCRIPTION	INSTALLED BY	QUANTITY	NOTE: PLANTS PROVIDED BY OTHERS
X	FILTERRA SURFACE AREA (SF)	CONTRACTOR		FILTERRA BIOSCAPE SYSTEM PLANT PALETTE
X	MULCH VOLUME (CY)	CONTRACTOR		
XX	FILTERRA MEDIA VOLUME (CY)	CONTRACTOR		
X	1/2" R ROUND AGGREGATE UNDERDRAIN STONE (CY)	CONTRACTOR		
X	ENERGY DISSIPATION ROCK (CY)	CONTRACTOR		
X	EROSION CONTROL (LF)	CONTRACTOR		
X	FILTERRA FLOWKIT	CONTRACTOR		

- GENERAL NOTES**
- CONTRACTOR SHALL CONTACT CONTECH TO COORDINATE DELIVERY AND SUPERVISION OF PLACEMENT OF FILTERRA BIOSCAPE SYSTEM COMPONENTS (ACTIVATION). CONTRACTOR SHALL COMPLETE ITEMS IN THE LIST OF CONTRACTOR INSTALLATION RESPONSIBILITIES LISTED ON THIS DETAIL BEFORE CONTECH'S REPRESENTATIVE ATTENDS AND SUPERVISES THE ACTIVATION OF THE BIOSCAPE SYSTEM.
  - PERFORM FILTERRA BIOSCAPE SYSTEM EXCAVATION ONLY AFTER ALL THE CONTRIBUTING DRAINAGE AREAS ARE PERMANENTLY STABILIZED. DO NOT CONSTRUCT FILTERRA BIOSCAPE SYSTEM IN AN AREA USED AS EROSION AND SEDIMENT CONTROL FACILITIES. DO NOT STOCKPILE MATERIALS NOR STORE EQUIPMENT IN THIS AREA.
  - USE METHODS OF EXCAVATION THAT MINIMIZE COMPACTION OF THE UNDERLYING SOIL UNLESS THE SYSTEM IS TO BE LINED.
  - CONTRACTOR SHALL COORDINATE WITH CONTECH BEFORE THE FILTERRA BIOSCAPE SYSTEM AREA IS EXCAVATED TO MINIMIZE TIME BETWEEN EXCAVATION AND DELIVERY AND ACTIVATION OF THE FILTERRA BIOSCAPE SYSTEM. ANY STANDING WATER THAT ACCUMULATES IN THE EXCAVATED AREA MUST BE REMOVED BY THE CONTRACTOR BEFORE CONTECH CAN PROVIDE ACTIVATION OF THE FILTERRA BIOSCAPE SYSTEM. ANY ADDITIONAL EXCAVATION WILL BE THE RESPONSIBILITY OF THE CONTRACTOR. EXCAVATION DIMENSIONS SHOULD BE PROVIDED TO CONTECH IN THE ACTIVATION REQUEST CHECKLIST.
  - CONTRACTOR SHALL PROVIDE ACCESS TO THE EXCAVATED AREA(S) FOR USE DURING THE ACTIVATION OF THE FILTERRA BIOSCAPE SYSTEM(S). ACCESS SHALL NOT PROHIBIT LIGHT DUTY EQUIPMENT THAT MAY BE USED TO INSTALL THE COMPONENTS (STONE, MEDIA, ETC.). THE CONTRACTOR SHALL BE RESPONSIBLE FOR ANY RE-STABILIZATION THAT MAY BE REQUIRED AFTER THE FILTERRA BIOSCAPE SYSTEM ACTIVATION.
  - CONTECH AND/OR ITS REPRESENTATIVES MUST BE SCHEDULED TO BE ON SITE FOR THE LIST ENTITLED CONTRACTOR ACTIVATION RESPONSIBILITIES.

- CONTRACTOR SITE PREPARATION RESPONSIBILITIES AS DENOTED BY (X) ON THIS DETAIL:**
- CONTRACTOR SHALL INSTALL PIPE OR SWALE THAT CONVEYS INFLOWING FLOWS AS WELL AS ANY REQUIRED INLET AND OUTLET STRUCTURES.
  - CONTRACTOR SHALL PROVIDE BYPASS PIPE AND RISER OR OTHER STRUCTURE AS SHOWN ON PLANS. THE BYPASS PIPE SHALL BE INSTALLED WITH WYEB (OR OTHER PIPE FITTINGS) AND WITH REDUCER COUPLINGS FOR CONNECTION OF UNDERDRAIN PIPE PER PLANS. PIPES SHALL BE INSTALLED TO PROMOTE POSITIVE FLOW FROM THE FILTERRA BIOSCAPE SYSTEM.
  - IF REQUIRED, CONTRACTOR TO PROVIDE SHOULDER ACCORDING TO DIMENSION AND SLOPE SHOWN ON PLANS OR AS DESIGNED BY ENGINEER OF RECORD. SLOPE FROM SHOULDER TO FILTERRA BIOSCAPE SYSTEM SURFACE AREA SHALL NOT EXCEED 3:1. SOIL IS REQUIRED TO STABILIZE SIDE SLOPES OR ADJACENT GRADE.
  - CONTRACTOR TO EXCAVATE MEDIA AREA CORRESPONDING TO THE SIZE OF THE FILTERRA BIOSCAPE SYSTEM SURFACE AREA AS SHOWN ON DETAIL AND ON PLAN SHEETS.
  - CONTRACTOR SHALL EXCAVATE VERTICALLY FROM BOTTOM OF UNDERDRAIN STONE, OR DRAINAGE STONE, IF REQUIRED, TO ELEVATION OF MULCH AS SHOWN ON THIS DETAIL.
  - CONTRACTOR TO PROVIDE AND INSTALL ANY GEOTEXTILE OR IMPERMEABLE LINER FOR BOTTOM OF THE FILTERRA BIOSCAPE SYSTEM IF REQUIRED PER THE PLANS.
  - CONTRACTOR TO PROVIDE AND INSTALL ANY ADDITIONAL DRAINAGE STONE BELOW THE FILTERRA BIOSCAPE SYSTEM AS CALLED OUT ON THE PLANS.

- CONTRACTOR ACTIVATION RESPONSIBILITIES AS DENOTED BY (C) ON THIS DETAIL:**
- PLACE GEOTEXTILE FABRIC ALONG THE PERIMETER OF THE FILTERRA BIOSCAPE SYSTEM EXCAVATION.
  - PLACE 1" OF UNDERDRAIN STONE - 2" UNDER THE PIPING, 6" AROUND THE PIPING AND 2" ABOVE THE PIPING USING LIGHT DUTY EQUIPMENT ONLY.
  - PLACE 6" UNDERDRAIN PIPING UNLESS OTHERWISE APPROVED BY CONTECH. ASSOCIATED PIPING AND FITTINGS/ELBOWS TO CONNECT TO THE PIPING/FITTINGS THAT IS PROVIDED BY CONTRACTOR (SEE CONTRACTOR INSTALLATION RESPONSIBILITIES THIS DETAIL).
  - PLACE 2" FILTERRA MEDIA USING LIGHT DUTY EQUIPMENT ONLY. DO NOT COMPACT MEDIA.
  - PLACE 3" DOUBLE SHREDDED HARDWOOD MULCH OVER ENTIRE FILTERRA BIOSCAPE SYSTEM SURFACE AREA USING LIGHT DUTY EQUIPMENT ONLY. DO NOT COMPACT MULCH.
  - PLACE ENERGY DISSIPATION ROCK APRON AS DESIGNED AND INDICATED ON THIS DETAIL OR PER ENGINEER OF RECORD PLANS.
  - PLACE CLEANOUT ADAPTER, PLUG AND PIPING.
  - PLACE ADDITIONAL EROSION CONTROL AROUND FILTERRA BIOSCAPE SYSTEM (IF REQUIRED).

**CONTECH**  
ENGINEERED SOLUTIONS LLC  
www.contechES.com  
2925 Centre Pointe Dr., Suite 400, West Chester, OH 45390  
937-338-1122 937-345-7000 937-345-7993 FAX

**FILTERRA BIOSCAPE™ SYSTEM**  
STANDARD DETAIL

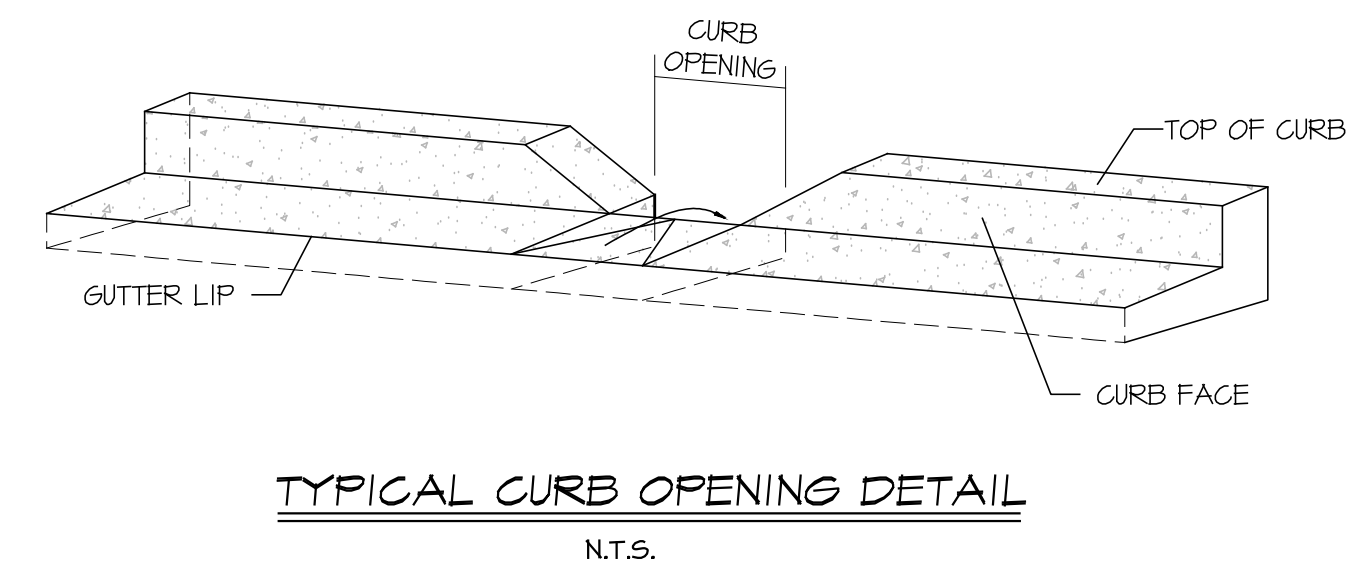
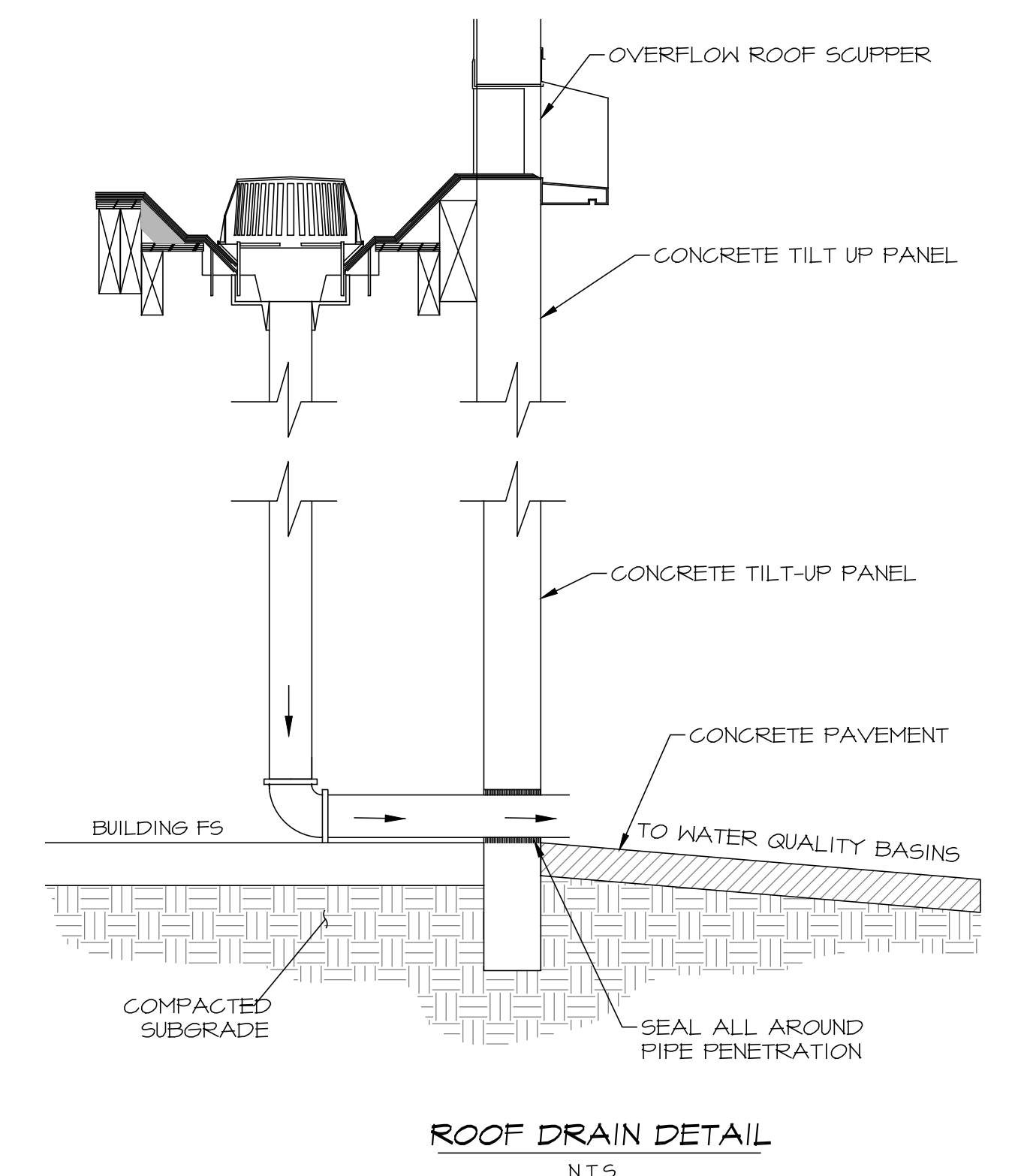
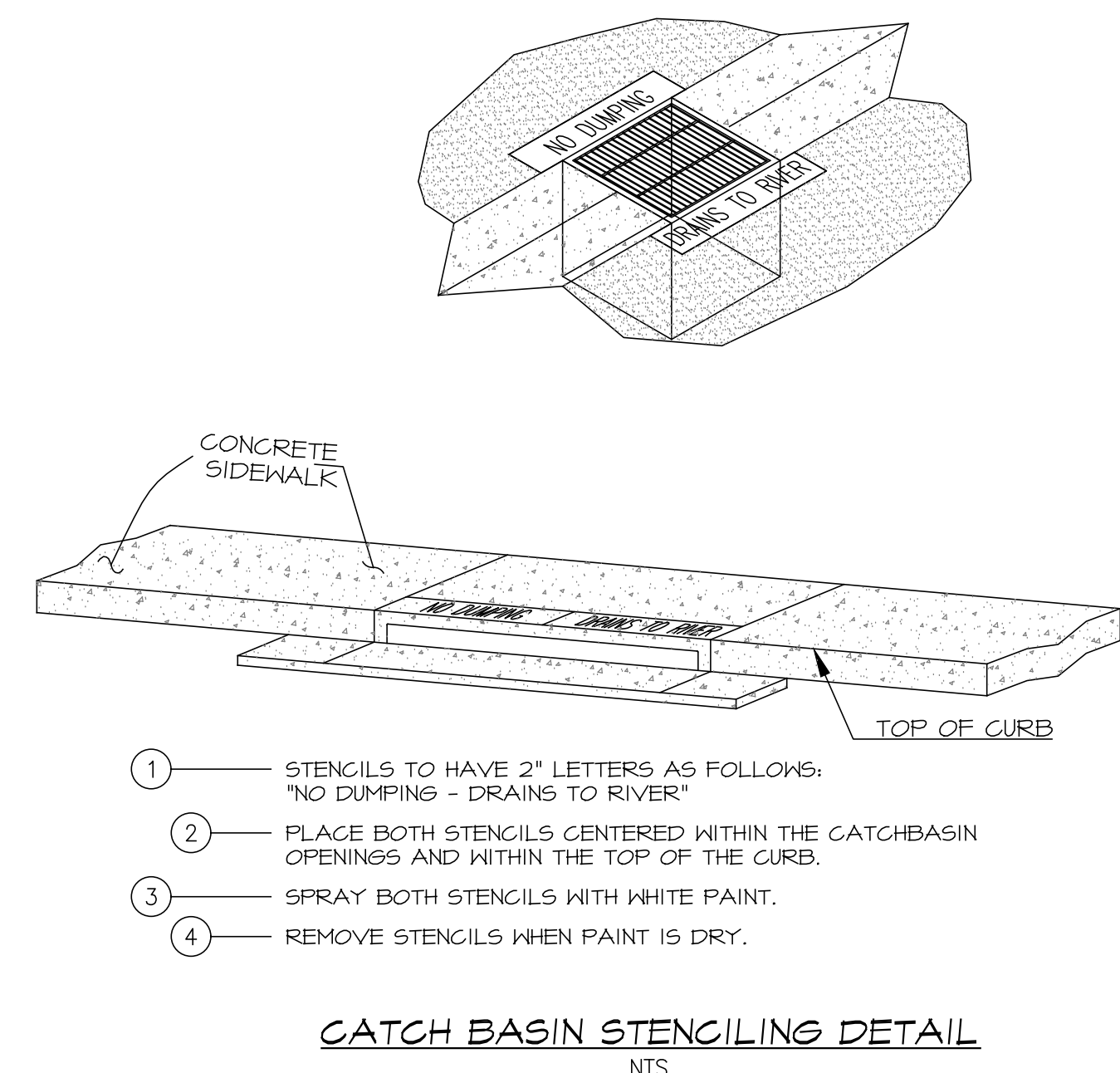

**CITY OF PERRIS**

**POST-CONSTRUCTION DETAILS**  
P19-0016 FIRST RIDER

SCALE:	<b>ALBERTA A.</b>	ENGINEERING CONSULTANTS	W.O.	19-0197
DATE:	6/1/20	3788 MCCRAY STREET	RIVERSIDE CA 92506	SHEET
DESIGNED:	CY	PH. (951) 686-1070		3
CHECKED:	DJA	FAX (951) 788-1256		OF 3 SHEETS
PLN CK REF:				DWG. NO.
F.B.				

# Appendix 2: Construction Plans

*Grading and Drainage Plans*



**OWNER/APPLICANT**  
 FIRST INDUSTRIAL REALTY TRUST  
 ATTN: MICHAEL GOODWIN  
 848 N PACIFIC COAST HWY, SUITE 175  
 EL SEGUNDO, CA 90245  
 TEL: (310) 606-1634

**ENGINEER**  
 ALBERT A. WEBB ASSOCIATES  
 ATTN: DJ ARELLANO  
 3788 MCCRAY STREET  
 RIVERSIDE, CA 92506  
 TEL: (951) 686-1070  
 FAX: (951) 788-1256

**TOPOGRAPHY**  
 INLAND AERIAL SURVEYS, INC  
 ATTN: DEREK C. HOOD  
 7117 ARLINGTON AVENUE, SUITE A  
 RIVERSIDE, CA 92503  
 TEL: (951) 687-4252  
 FAX: (951) 687-4120

**ARCHITECT**  
 RGA  
 ATTN: MIKE GILL  
 15231 ALTON PARKWAY, SUITE 100  
 IRVINE, CA 92618  
 TEL: (414) 341-0420  
 FAX: (414) 341-0422

**DEVELOPMENT PLAN REVIEW NO. \_\_\_\_\_**

**FIRST INDUSTRIAL REALTY - RIDER STREET  
 CONCEPTUAL GRADING & DRAINAGE PLAN**

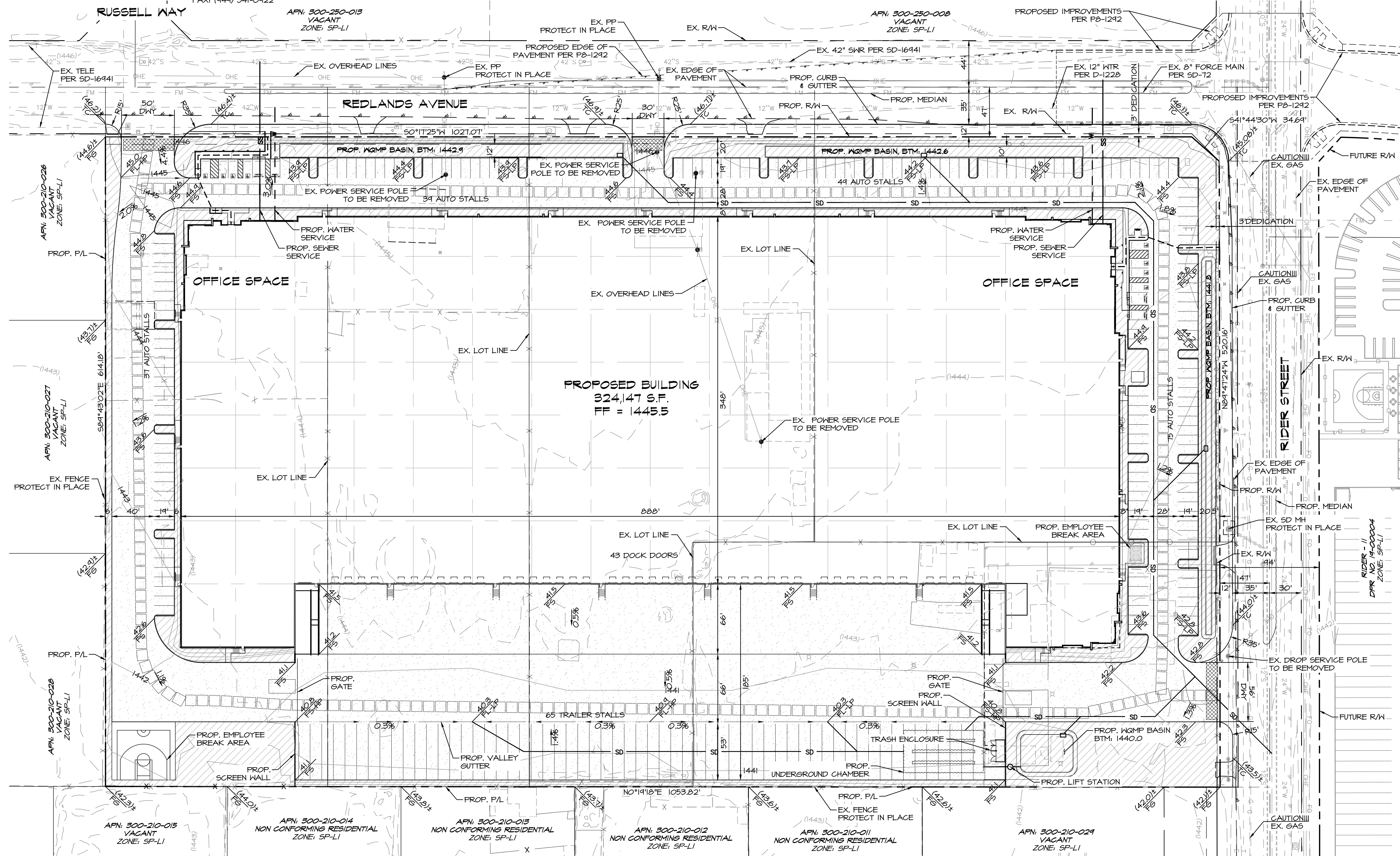
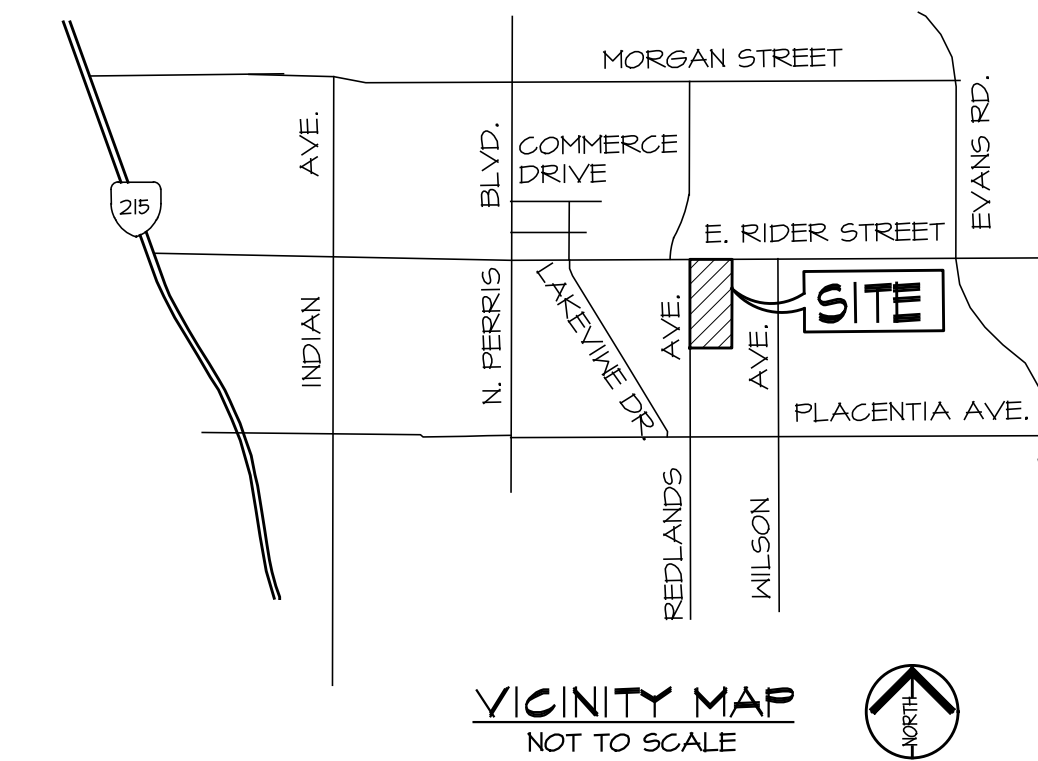

**PROJECT DATA**

ACREAGE			
GROSS SITE AREA:	108,031 S.F.	16.25 A.C.	
STREET DEDICATION:	81,005 S.F.	1.40 A.C.	
NET SITE AREA:	64,102 S.F.	14.85 A.C.	

<b>BUILDING AREA</b>	
OFFICE	8,000 S.F.
WAREHOUSE	312,147 S.F.
MEZZANINE	4,000 S.F.
FOOTPRINT	324,147 S.F.
TOTAL AREA*	324,147 S.F.

LOT COVERAGE, PROPOSED: 44.41% MAX. ALLOWED: 50%

<b>PARKING REQUIREMENTS</b>	
1ST. 20K @ 1/1,000 S.F.	20 STALLS
ABOVE 20K @ 1/2,000 S.F.	81 STALLS
TOTAL PARKING REQUIRED	101 STALLS

<b>PARKING PROVIDED</b>	
AUTO	
STANDARD (9'x14')	192 STALLS
HANDICAP (9'x14')	8 STALLS
TOTAL AUTO:	200 STALLS
TRAILER (10'x53') PROVIDED	65 STALLS

<b>LANDSCAPED AREA</b>	
LANDSCAPED AREA REQUIRED:	12%
LANDSCAPED AREA PROVIDED:	12.6%
LANDSCAPED AREA PROVIDED:	81,804 S.F.

**EARTHWORK ESTIMATE:**

CUT:	82,360 CY
FILL:	86,060 CY
SHRINKAGE:	3,100 CY
NET:	0 CY (BALANCED)

**LEGEND**

PROPOSED CONCRETE PAVEMENT	---(475)---	EXISTING CONTOURS	---(475)---
PROPOSED LANDSCAPE AREA	---(475)---	PROPOSED CONTOURS	---(475)---
PROPOSED DECORATIVE PAVEMENT	---(475)---	EXISTING WATER LINE	---(475)---
FIRE ACCESS LANE	---(475)---	EXISTING SEWER LINE	---(475)---
ADA PATH OF TRAVEL	---(475)---	EXISTING STORM DRAIN	---(475)---
SCREEN WALL	---(475)---	EXISTING GAS LINE	---(475)---
FENCE LINE	---(475)---	EXISTING ELECTRICAL LINE	---(475)---
GRADEBREAK/RIDGELINE	---(475)---	FF	FINISHED FLOOR
FLOWLINE	---(475)---	F6	FINISHED GROUND
FL	FINISHED SURFACE	FL	FLOW LINE
FB	GRADE BREAK	IN	INVERT
IN	LANDSCAPE AREA	LS	LANDSCAPE AREA
LS	LOW POINT	LP	LOW POINT
LP	MAXIMUM	MAX	MAXIMUM
MAX	PROPERTY LINE	PL	PROPERTY LINE
PL	RIGHT OF WAY	R/W	RIGHT OF WAY
R/W	TYPICAL DRIVEWAY	TYP	TYPICAL DRIVEWAY
TYP	RIDGELINE	RL	RIDGELINE

**LEGAL DESCRIPTION**

THIS PROPERTY SURVEYED AND SHOWN HEREON IS THE SAME PROPERTY AS DESCRIBED IN SCHEDULE A OF FIRST AMERICAN TITLE INSURANCE COMPANY COMMITMENT NO. NC5-465175-CH12 WITH COMMITMENT DATE OF JUNE 03, 2019.

THE LAND REFERRED TO HEREIN BELOW IS SITUATED IN THE CITY OF FERRIS, COUNTY OF RIVERSIDE, STATE OF CALIFORNIA, AND IS DESCRIBED AS FOLLOWS:

PARCEL 2 AS SHOWN ON PARCEL MAP 7470, IN THE CITY OF FERRIS, COUNTY OF RIVERSIDE, STATE OF CALIFORNIA, RECORDED JULY 21, 1977 IN BOOK 37, PAGE 54 OF PARCEL MAPS, THE OFFICE OF THE COUNTY RECORDER OF SAID COUNTY.

FOR CONVEYANCING PURPOSES ONLY: APN 300-210-002-4

**PROJECT DESCRIPTION**

DEVELOPMENT PLAN REVIEW FOR A NEW INDUSTRIAL WAREHOUSE BUILDING TOTALING 324,147 SQUARE FEET ON 14.85± NET ACRES.

**LAND USE**

EXISTING/PROPOSED ZONING: SP-LI  
 EXISTING/PROPOSED GENERAL PLAN USE: SP-LI  
 EXISTING LAND USE: LOW DENSITY RESIDENTIAL/VACANT  
 PROPOSED LAND USE: WAREHOUSE DISTRIBUTION

**APN:**  
 300-210-001, 300-210-002,  
 300-210-003, 300-210-004,  
 300-210-005

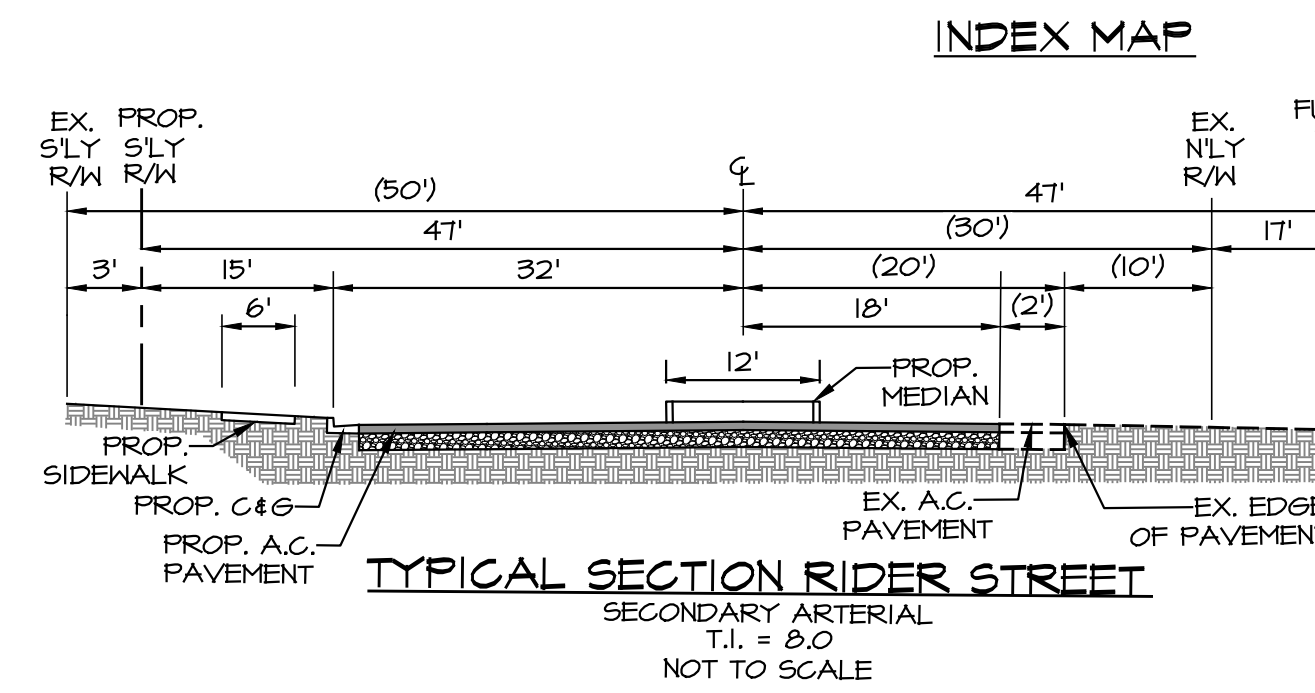
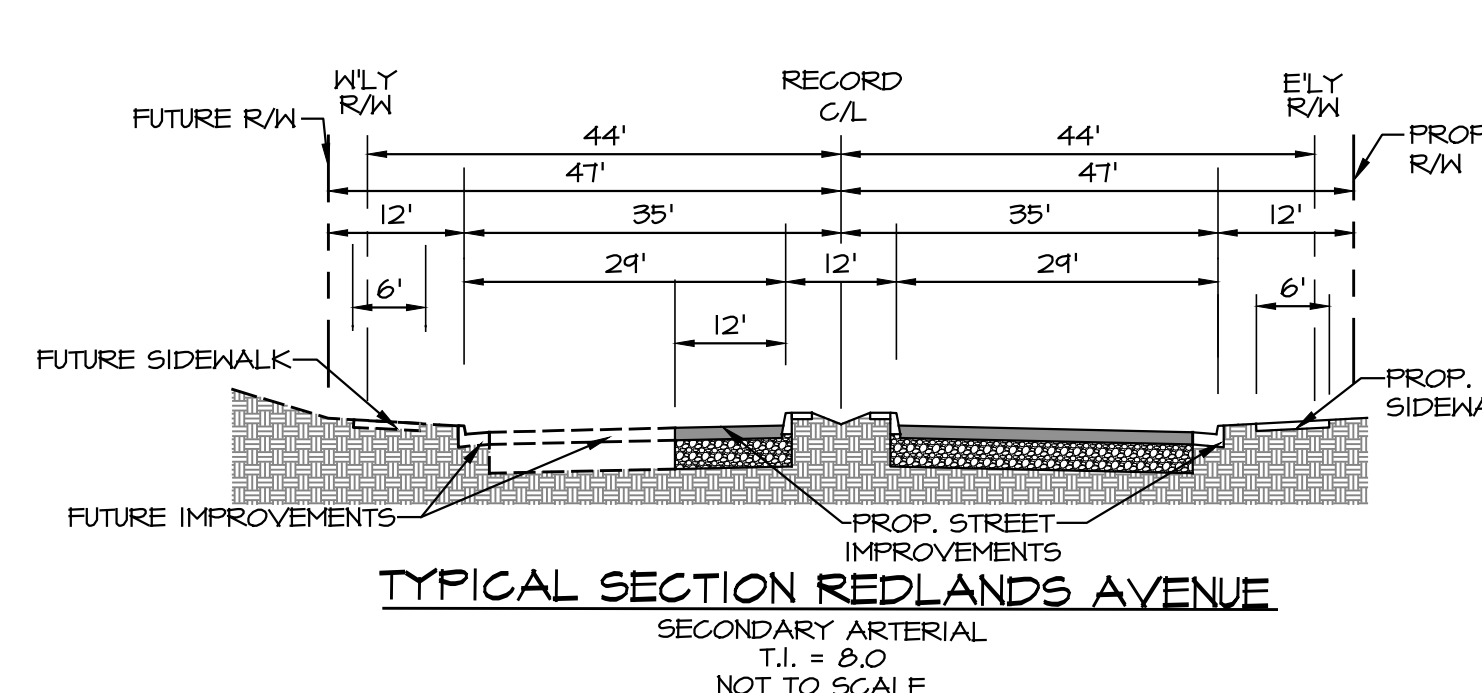
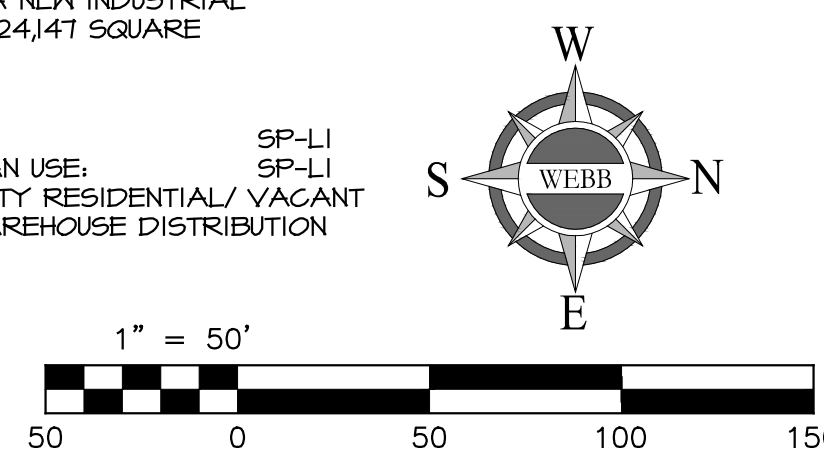

- NOTES:**
- 2005 THOMAS BROTHERS MAP, PAGE T71, GRID H-3 & H-4.
  - THIS AREA IS SUBJECT TO LOW TO MODERATE LIQUEFACTION AND IS SUSCEPTIBLE TO SUBSIDENCE.
  - THIS AREA IS WITHIN THE FERRIS VALLEY COMMERCE SPECIFIC PLAN.
  - THIS PROJECT IS NOT WITHIN A COMMUNITY SERVICES DISTRICT.
  - THIS PROJECT IS WITHIN THE AIRPORT COMPATIBILITY ZONES C-1 & B-2.
  - FEMA COMMUNITY PANEL NO. 06065C1430H, ZONE X.
  - ALL EXISTING STRUCTURES WILL BE DEMOLISHED.

**UTILITY COMPANIES:**

WATER:	EASTERN MUNICIPAL WATER DISTRICT PHONE: (800) 426-3643
SEWER:	EASTERN MUNICIPAL WATER DISTRICT PHONE: (800) 426-3643
ELECTRIC:	SOUTHERN CALIFORNIA EDISON COMPANY PHONE: (800) 684-8123
TELEPHONE:	CHARTER COMMUNICATIONS PHONE: (833) 644-4254
GAS:	SOUTHERN CALIFORNIA GAS COMPANY PHONE: (800) 427-2200
SCHOOL:	VAL VERDE UNIFIED SCHOOL DISTRICT PHONE: (951) 940-6100

ALBERT A. WEBB ASSOCIATES  
 ENGINEERING CONSULTANTS  
 3788 MCCRAY STREET  
 RIVERSIDE, CA 92506  
 PH. (951) 686-1070  
 FAX (951) 788-1256

SCALE AS SHOWN  
 DATE: 1/15/20  
 DESIGNED: EA  
 CHECKED: DJA  
 PLN CK REF:  
 F.B.

PLOT DATE: 16-Jan-20

CITY OF FERRIS  
 DEVELOPMENT PLAN REVIEW NO. \_\_\_\_\_  
 FIRST INDUSTRIAL REALTY - RIDER STREET

W.O. 2019-017  
 SHEET 1  
 OF 1 SHEETS  
 DWG. NO.

# Appendix 3: Soils Information

*Geotechnical Study and Other Infiltration Testing Data*



**ARAGÓN GEOTECHNICAL, INC.**  
Consultants in the Earth & Material Sciences

**PRELIMINARY GEOTECHNICAL INVESTIGATION  
“RIDER STREET AT REDLANDS AVENUE” PROJECT  
CITY OF PERRIS, RIVERSIDE COUNTY, CALIFORNIA**

**FOR  
FIRST INDUSTRIAL REALTY TRUST, INC.  
898 N. PACIFIC COAST HWY., SUITE 175  
EL SEGUNDO, CALIFORNIA 90245**

**PROJECT NO. 4534-SFI  
AUGUST 9, 2019**



**ARAGÓN GEOTECHNICAL, INC.**  
Consultants in the Earth & Material Sciences

August 9, 2019  
Project No. 4534-SFI

**First Industrial Realty Trust, Inc.**  
898 N. Pacific Coast Highway, Suite 175  
El Segundo, California 90245

Attention: Mr. Matt Pioli

Subject: Preliminary Geotechnical Investigation Report  
Proposed "Rider Street at Redlands Avenue" Light Industrial Project  
City of Perris, Riverside County, California.

Mr. Pioli:

In accordance with our proposal dated June 10, 2019 and your authorization, Aragón Geotechnical Inc. (AGI) has completed preliminary geotechnical and geological assessments for the above-referenced project. The attached report presents in detail the findings, opinions, and recommendations developed as a result of surface inspections, subsurface exploration and field tests, laboratory testing, and quantitative analyses. Our scope included an infiltration feasibility study for stormwater BMPs, but excluded environmental research and materials testing for contaminants in soil, groundwater, or air at the site. Infiltration-related findings have been presented in a separate report for the civil designer's use in formulating a required water quality management plan.

Subsurface site characterization was based on eleven exploratory borings arrayed within the proposed construction area. Drilled intervals encountered massive Pleistocene-age alluvial strata comprising sandy silt, silt, clayey silt, and clayey sand as majority classifications within 50 feet of existing grades. A veneer of younger, sometimes low-density silty sand alluvium blanketed almost all of the building site. Mapped floodplain areas in the northeastern project area lacked the silty sand layer. The surficial materials have been loosened by former agricultural tilling, burrowing fauna, and seasonal shrink-swell phenomena. Site soils were classified compressible within 5 to 7 feet of existing grades. AGI did not find evidence for pre-existing fill. Saturated soils were encountered in two borings starting at depths of about 37 feet and 45 feet. Although a static phreatic surface was not measurable in either hole, these depths were consistent with known groundwater depths within a half-mile radius.



Geologic constraints to development will require inclusion of structural measures to mitigate the high likelihood of strong earthquake ground motions at the site. However, risks from other natural hazards including liquefaction, surface fault rupture, excessive settlement, gross instability or landsliding, seiching, induced flooding, and tsunami appear to range from extremely low to zero.

Findings indicate the site should be suitable for a large warehouse-type structure from a geotechnical viewpoint. AGI recommends that loose and porous shallow-depth alluvium be removed and replaced as compacted engineered fill for adequate support of new fills, structures, and new pavements. Acceptable remedial grading "bottoms" below the building outline will generally average between 5 and 7 feet below existing surfaces, deepening slightly toward the north and northeast. All site soils should be acceptable for reuse in compacted fills. AGI guidance is recommended to institute limited selective grading to place non-expansive soils near pad subgrades to the maximum extent feasible.

It is AGI's preliminary conclusion that properly designed and constructed conventional shallow footings should provide adequate building support. Overexcavation is recommended when or if needed to supply at least 36 inches of engineered fill below all shallow spread and continuous footings. On-and off-site pavement areas should be partly stripped and partly processed-in-place to create recompacted depths of approximately 36 inches. Paved areas in cuts deeper than two feet should require only soil processing in place.

In addition to foundation design guidelines, including preliminary recommended design values for both vertical and lateral loads, this report presents recommendations for site earthwork, prescriptive code values for use in seismic groundshaking mitigation, concrete mix designs, and construction observation. It is recommended that grading and foundation plan reviews be performed by AGI prior to construction.

Thank you very much for this opportunity to be of service. Please do not hesitate to call our Riverside office if you should have any questions.

Very truly yours,  
Aragón Geotechnical Inc.



Mark G. Doerschlag, CEG 1752  
Engineering Geologist



C. Fernando Aragón, P.E., M.S.  
Geotechnical Engineer, G.E. No. 2994

MGD/CFA:mma

Distribution: (4) Addressee

**Aragón Geotechnical, Inc.**

## TABLE OF CONTENTS

	<u>Page</u>
1.0 INTRODUCTION .....	1
2.0 PROPOSED CONSTRUCTION .....	3
3.0 FIELD INVESTIGATION AND LABORATORY TESTING .....	3
4.0 SITE GEOTECHNICAL CONDITIONS .....	5
4.1 Previous Site Uses .....	5
4.2 Surface Conditions .....	6
4.3 Subsurface Conditions .....	7
4.4 Groundwater .....	8
5.0 ENGINEERING GEOLOGIC ANALYSES .....	9
5.1 Regional Geologic Setting .....	9
5.2 Local Geologic Conditions .....	10
5.3 Slope Stability .....	12
5.4 Flooding .....	12
5.5 Faulting and Regional Seismicity .....	14
5.5.1 Fault Rupture Potential .....	14
5.5.2 Strong Motion Potential .....	14
5.5.3 Secondary Seismic Hazards .....	19
6.0 CONCLUSIONS AND RECOMMENDATIONS .....	20
6.1 General .....	20
6.2 Site Grading .....	22
6.3 Earthwork Volume Adjustments .....	25
6.4 Slopes .....	26
6.5 Foundation Design .....	27
6.6 Floor Slab Design .....	28
6.7 2016 California Building Code Seismic Criteria .....	30
6.8 Pavements .....	32
6.9 Retaining Walls .....	34
6.10 Temporary Sloped Excavations .....	35
6.11 Trench Backfill .....	36
6.12 Soil Corrosivity .....	36
6.13 Construction Observation .....	37
6.14 Investigation Limitations .....	37
7.0 CLOSURE .....	38
REFERENCES .....	39
Geotechnical Map Explanation & Subsurface Exploration Logs .....	APPENDIX A
Laboratory Testing .....	APPENDIX B



**PRELIMINARY GEOTECHNICAL INVESTIGATION  
PROPOSED LIGHT INDUSTRIAL PROJECT  
RIDER STREET AT REDLANDS AVENUE  
CITY OF PERRIS, RIVERSIDE COUNTY, CALIFORNIA**

## **1.0 INTRODUCTION**

This report presents the results of preliminary soils engineering and geologic evaluations conducted by Aragón Geotechnical, Inc. (AGI) for a proposed logistics warehouse or light manufacturing facility situated southeast of the intersection of Rider Street at Redlands Avenue, Perris, California. The rectangular project site comprises 5 contiguous land parcels (APN 300-210-001 through 300-210-005) and totals 16.26 gross acres. Map coordinates at the northeast project corner are 33.83002°N x 117.21524°W (this coordinate point was selected for seismological analyses based on closest site-to-source distance). Situs per the Public Lands Survey System places the project in the NE¼ of Section 17, Township 4 South, Range 3 West (San Bernardino Baseline and Meridian). The accompanying Site Location Map, Figure 1, depicts the general location of the project on a 1:24,000-scale topographic quadrangle map. Although out-of-date with respect to the rapid urbanization of the surrounding Perris Valley area, the older map series was selected for better depictions of ground slope and drainage patterns.

The primary objectives of our investigation were to determine the nature and engineering properties of the subsurface materials underlying the project area, in order to assess site suitability for the building and to provide *preliminary* foundation design, grading, and construction recommendations. Accordingly, our scope included reconnaissance of the 5 parcels and surrounding acreage, aerial photo interpretation, geologic literature research, subsurface exploration, recovery of representative soil samples, laboratory soils testing, and geotechnical analyses. Authorized services included field tests to characterize water infiltration potential at a pair of prospective water-quality basin sites. An infiltration feasibility report has been issued by AGI under separate cover for the design civil engineer's use in formulating a required water quality management plan.

Geological assessments focused on risks posed by active earthquake faults, strong ground motion, liquefaction or other secondary seismic hazards, and groundwater. These were evaluated using published resources and site-specific qualitative analyses, plus conclusions drawn from field findings and local case-history experience. However, environmental research, Phase I or Phase II environmental site assessments, monitoring well construction, or contaminant testing of air, soil, or groundwater found in the site were beyond the scope of this geotechnical investigation.

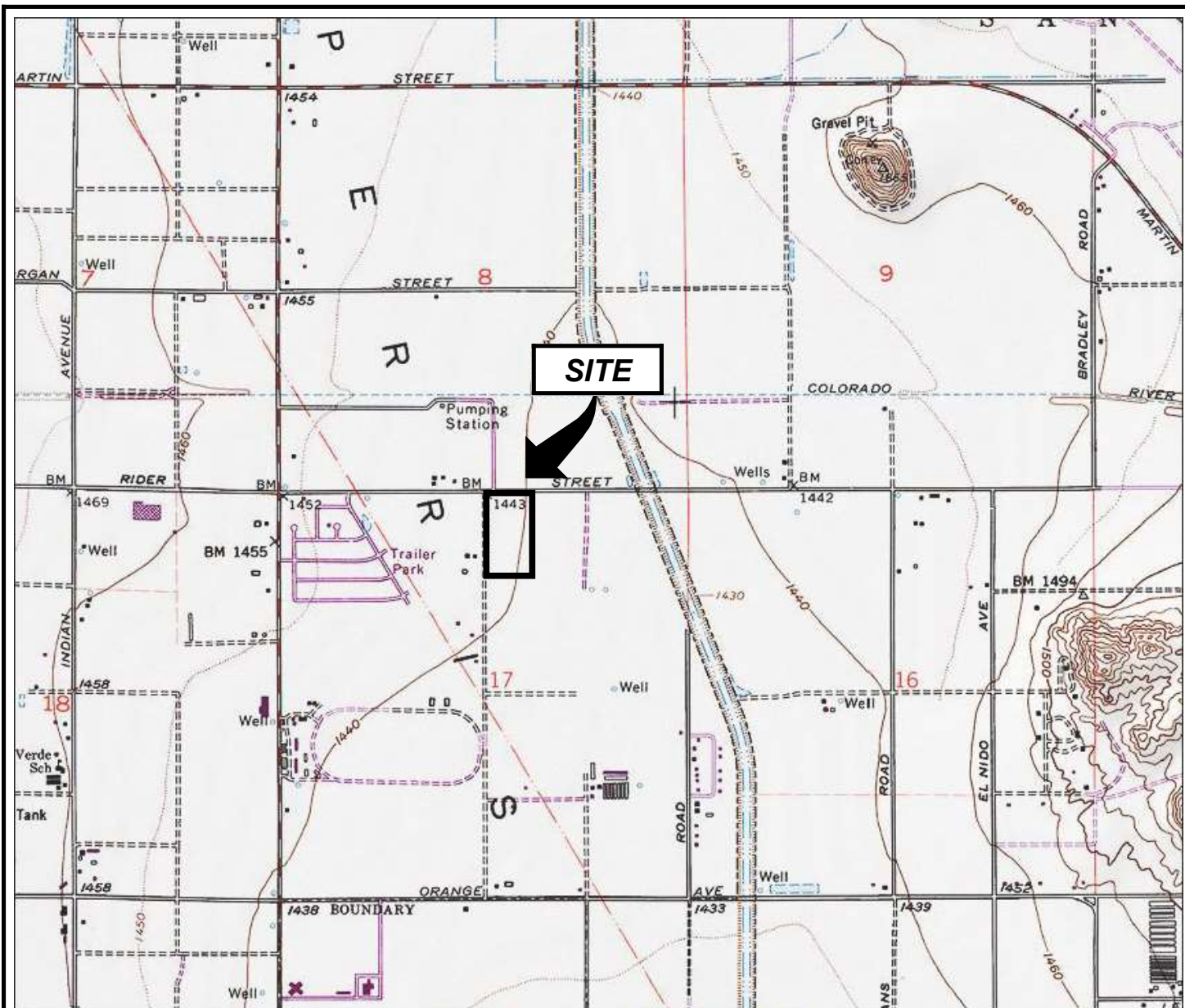

Printed from TOPO! ©2001 National Geographic Holdings (www.topo.com)



0 2000 4000 FT.

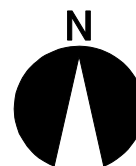

**Reference:** U. S. Geological Survey 7½-Minute Series Topographic Map, Perris Quadrangle (1979).



### SITE LOCATION MAP

RIDER ST. AT REDLANDS AVE SITE, PERRIS, RIVERSIDE COUNTY, CA.

PROJECT NO. 4534-SF1

DATE: 8/9/19

FIGURE 1

## **2.0 PROPOSED CONSTRUCTION**

A conceptual site development plan originating from the Irvine firm of RGA Office of Architectural Design was referenced for property information and borehole locality selection. The scaled drawing (Scheme 01) lacked elevation contours but included the planned envelope of an approximately rectangular 338,110-square-foot industrial building more or less centered in the site. Clearance-under-beam dimensions and finish floor elevations have not been specified. Two office areas, potentially with mezzanine levels, are planned in the northwestern and southwestern building corners. Truck dock doors would be situated on the east side of the structure. Based on regional practices, AGI anticipated that the structural system would feature concrete tilt-up walls with parapet heights of possibly 45 to 60 feet, supported by perimeter shallow foundations. Engineered roof trusses would rest on isolated interior steel columns. Moderate foundation loads would be predicted for walls and columns. Basements or other subterranean construction were not shown on the drawing and would be unlikely. Jurisdiction for development entitlements will be exercised by the City of Perris.

Surrounding the building, concrete paving is expected in truck areas while lighter-duty asphalt sections could be substituted in automobile driveways and stalls. Limited areas for collection, treatment, and disposal of stormwater runoff may exist next to Redlands Avenue and in a pair of prospective BMP basins near the eastern project-area corners. Live sewer, water, and gas utilities exist in street rights-of-way next to the property, and would presumably connect with the new building via buried service laterals.

Future grading would probably be a cut-and-fill operation. We suspect that grading could involve soil imports to help raise industrial floor elevations above general terrain elevations and for flood protection. Raw cut-and-fill quantities can be expected to increase based on ground preparation measures we can foresee for the building pad. Neither earthen slopes nor retaining walls are shown on conceptual plans, but in our view are unlikely to be needed on the very flat site.

## **3.0 FIELD INVESTIGATION AND LABORATORY TESTING**

Subsurface geotechnical site characterization comprising 11 exploratory soil borings was completed by AGI on July 8 and 9, 2019. Four out of five individual properties featured existing structures, landscaping, greenhouses, and storage yards that created some

access impediments. However, enough gaps and vacant lot areas were present to allow creation of a well-spaced soil boring array. AGI-selected drill sites were cleared of utility interference issues by notification to the 811 DigAlert service in advance of AGI's work. Soil borings were preferentially sited to explore possible "least-favorable" locations identified from aerial photos and other geological resources, while also meeting a goal of spanning the building envelope to gauge the degree of geotechnical site variability. Soil boring locations and depths were not fixed, however, and were modified by AGI's field geologist where appropriate to obtain data concerning: (1) Soil material classifications, water contents, in-place densities, and settlement potential in light of local geological interpretations; (2) Presence or absence of groundwater; (3) Continuity of layers or units across the property; and (4) Unit geological origins and a derivation of site "stiffness" for earthquake engineering purposes.

The soil borings were drilled with a truck-mounted hollow-stem auger rig capable of driving and retrieving soil sample barrels. Borehole termination depths ranged from 11.5 to 51.5 feet. None of the borings encountered bedrock or were halted by machine refusal. As expected, all borings encountered deep sediments that were amenable to drive-tube sampling, performed at 2-foot to 5-foot depth increments. At shallow depths where soil bearing capacity and settlement potential would be the main items of concern, relatively undisturbed soil samples were recovered by driving a 3.0-inch-diameter "California modified" split-barrel sampler lined with brass rings. Deeper horizons in most borings included Standard Penetration Tests (SPTs) conducted using an unlined 2.0-inch O.D. split-barrel spoon. All sampler driving was done using rods and a mechanically actuated automatic 140-pound hammer free-falling 30 inches. Bulk samples of auger cuttings representative of shallow native materials found near the northern and southern ends of the proposed building were bagged. All geotechnical samples were brought to AGI's Riverside laboratory for assigned soils testing.

Drill cuttings and each discrete sample were visually/manually examined and classified according to the Unified Soil Classification System, and observations made concerning relative density, constituent grain size, visible macro-porosity, plasticity, and past or present groundwater conditions. Continuous logs of the subsurface conditions encountered were recorded by a senior Engineering Geologist, and the results are presented on the Field

Boring Logs in Appendix A. The approximate locations of the borehole explorations are illustrated on the Geotechnical Map (Plate No. 1 foldout), located at the back of this report.

“Undisturbed” samples were tested for dry density and water content. One-dimensional consolidation tests were conducted on selected barrel samples in order to evaluate settlement or collapse potential. Collapsible soils undergo rapid, irreversible compression when brought close to saturation while also subjected to loads such as from buildings or fill. The recovered bulk soil samples were evaluated for index and engineering properties such as shear strength, compaction criteria, expansion potential, and corrosivity characteristics. Discussions of the laboratory test standards used and the test results are presented in Appendix B.

## **4.0 SITE GEOTECHNICAL CONDITIONS**

### **4.1 Previous Site Uses**

AGI’s scope included limited historical research to ascertain changes to surficial conditions through time, and address known or possible geotechnical impacts to project design or construction. Stereoscopic aerial photographs archived at the Riverside County Flood Control and Water Conservation District headquarters in Riverside, California, were interpreted for evidence of past structures, land use, and for geological assessments of active faulting potential and geomorphic history. Older monoscopic pictures were downloaded from the U.C. Santa Barbara Aerial Collections web application. Finally, the on-line version of the U.S. Geological Survey Historical Map Collection was accessed for digital scans of topographic quadrangle sheets pre-dating the referenced base map used for Figure 1. Reviewed historical sources are listed under “References” at the end of this report.

For decades beginning before 1938 and up until at least the mid-1970's, the site was a single agricultural field used for dry-farmed grain crops and irrigated alfalfa. Buildings were not present within the project limits. A 12-foot-tall concrete irrigation standpipe (still present today) was located in the far northwest site corner next to a large eucalyptus tree. There were no confirmed past uses for stock raising, poultry ranching, feedlot, or dairying operations.

By 1980 the first subdivided lot (“Reyez property”) in the northeast corner had been split from the field and improved with a small mobile home. The rest of the lot was barren. This property over the years acquired additional outbuildings, stored vehicles and equipment, a covered patio, and fairly lush landscaping near the home. An animal pen was installed near the middle of the property. Turkey pens were situated along the southern property line. These were removed more than 10 year ago, however, according to the owner.

Lots fronting onto a then-unimproved dirt Redlands Avenue were developed between 1980 and 1990 with manufactured housing and one commercial site (“Lopez property”). The latter is a plastering business with several shop buildings, storage containers, a storage yard for scaffolding, and a large inventory of EPS architectural foam shapes. Redlands Avenue does not appear to have been completed as a improved paved street until 2007-2009.

#### **4.2 Surface Conditions**

Project limits are defined by Rider Street to the north, Redlands Avenue on the west side, a vacant field to the south, and a mix of rural-residential and commercial lots to the east. Chain-link or simple barbed-wire fences demarcate private property boundaries. None of the constituent parcels seem to have experienced grading or dumping of fill soils. Mobile homes or pre-engineered buildings and some mature trees are present on APNs 300-210-002 through 300-210-005. To date, AGI has not seen any evidence for private wells in the project area. Water mains are present in the neighboring streets. Since the 1980s, vacant APN 300-210-001 in the northwest quadrant has been periodically disced for weed abatement.

The project area features a very low-gradient slope of under a half-percent toward the east-southeast according to Riverside County Flood Control contour maps. Relief within the 16-acre site is estimated to be only about 3 feet. Very soft and disturbed soil surfaces dominate the recently cleared APN 300-210-001. The remaining parcels have variously firm native-soil or crushed-rock surfaces. It appears that most incident rainfall is absorbed by unpaved and disturbed surface horizons, although excess water runoff can move unimpeded as sheetflow through the individual lots eastward toward ultimate interception by improved Wilson Avenue.

#### 4.3 Subsurface Conditions

AGI soil borings penetrated vertically heterogeneous alluvial soil sequences that could be grouped into three general packages:

- (1) A surficial zone dominated by silty sand (Unified Soil Classification System classification SM) with subordinate sandy silt (ML). The zone ranged between 8 and 10 feet thick in borings near the southern project limits. The middle and northern segments of the building envelope had from ~2 to 5 feet of silty sand. The unit was completely absent from the northeast corner area. Surficial soils have been “churned” by burrowing fauna and consistently exhibited visible porosity to depths of 5 to 5½ feet. Mild to moderate soil cementation was noted near 3-foot depths. The surficial silty sand horizons tended to have low *in situ* density and sometimes low penetration resistance for sampling tools. Logged ring sampler penetration resistance ranged from 12 to 66 blows per foot.
- (2) An intermediate-depth interval of alluvial deposits composed mostly of fine-grained soil classifications of sandy silt, clayey silt, and silty clay (USCS ML and CL). These deposits were typically very stiff or hard, non-plastic, and frequently shot through with abundant whitish-colored calcium carbonate as interstitial cement, fracture linings, or laminar precipitates. Where weathered near ground surfaces, fine-grained soils exhibited poor cohesion and soft, punky textures judged to be highly compressible. Deeper horizons *not* subject to weathering were cohesive and proven to have low compressibility in laboratory tests.
- (3) Sequences dominated by coarse-grained soil classifications of clayey sand (SC) and subordinate silty sand (SM) at depths beyond 35 to 37 feet. Logged relative densities ranged from medium dense to very dense. Almost all recovered samples appeared massive, i.e., without distinct stratification, although sample variability implied soil coarse-fine proportions changed over spans of feet.

Laboratory tests corroborated field logs of slightly variable but mostly low clay content in the surficial zone. Near-surface soils collected from the approximate southeast building corner produced an expansion index of only 2 (categorically “very low” expansion potential), while a blended sand + silt sample from the northwest building corner produced an expansion index of 20 (“low” potential). Surficial sandy materials

were also characterized by high achievable maximum dry density on the order of 134 pounds per cubic foot based on modified Proctor methods.

The deeper silty and clayey sequences were interpreted to be far older than the surficial horizons. Pedogenic alteration and concentration of whitish-colored calcium carbonate as interstitial cement, fracture fillings, and laminar hardpans was sometimes more than 10 feet thick. Consolidation tests showed that clay-bearing fine-grained soil types that have been subjected to subaerial weathering and moisture changes may be prone to collapse when saturated under load, even where not described as porous. Vesicular textures and pinhole voids are reliable indicators for detecting collapsible soils in the Inland area. However, testing also demonstrated that soils deeper than 5 to 7 feet, i.e., beyond typical active shrink-swell depths, should normally have very low compressibility. The contact between surficial silty sand zones and hardpan soils was usually fairly abrupt and typical of an erosional surface. Section 5.2 (Local Geologic Conditions) and the drill logs in Appendix A contain considerable additional descriptions and interpretations of soil conditions in the project area.

#### **4.4 Groundwater**

Very slow groundwater inflows were observed in two exploratory borings. Saturated or near-saturated soils were logged beginning at approximately 37 feet deep near the southern building limits. Wet conditions started near 45 feet deep in the north end of the proposed structure. Neither soil boring produced a measurable water pool. Nonetheless, the observed seepage was consistent with our knowledge of the Perris area and groundwater data from nearby properties. Shallower soil samples were not mottled with iron oxide staining, a telltale effect of episodic high groundwater. All other soil borings remained dry.

The project site is within the West San Jacinto groundwater subbasin. According to many years of monitoring well records reviewed through the State CASGEM website, groundwater within a radius of about a half-mile from the property has had minimum measured depths of about 40 feet east of the site, and 57 to 81 feet to the west. The hydrogeologic regime is complex due to the heterogeneity of the alluvial basin fill, substantial erosional relief of the buried bedrock surfaces under the southern Perris



Valley, and municipal groundwater pumping. The seepage zones would be best interpreted as perched water horizons. Close by is the Perris Valley Drain, an unlined flood control channel located a few hundred yards to the east. The channel represents a seasonal line of basin recharge. There has also been a historic tendency for groundwater levels to rise across the valley. Rising water levels are attributed to changing land uses in the Perris Plain vicinity, such as the cessation of formerly widespread agricultural pumping and introduction of irrigated suburban tracts.

Under current and predicted future conditions, we judge that groundwater should remain at or below the minimum-detected 37-foot depth. Shallower unsaturated soils tend to be cemented and/or fine-grained, and will not readily transmit seasonal rainfall as local recharge. Groundwater should not influence building design or construction. Any open excavation or shaft deeper than ~37 feet, however, could encounter saturated ground and water inflows. Future fluctuations in water surface elevations are possible, however, due to variations in precipitation, temperature, consumptive uses, or surrounding land use changes which were not present at the time observations were made.

## 5.0 ENGINEERING GEOLOGIC ANALYSES

### 5.1 Regional Geologic Setting

All of western Riverside County lies within the Peninsular Ranges Physiographic Province, one of 11 continental provinces recognized in California. The physiographic provinces are topographic-geologic groupings of convenience based primarily on landforms, characteristic lithologies, and late Cenozoic structural and geomorphic history. The Peninsular Ranges encompass southwestern California west of the Imperial-Coachella Valley trough and south of the escarpments of the San Gabriel and San Bernardino Mountains. Most of the province lies outside of California, where it comprises much of the Baja California Peninsula. The province is characterized by youthful, steeply sloped, northwest-trending elongated ranges and intervening valleys.

Structurally, the Peninsular Ranges province in California is composed of a number of relatively stable, elongated crustal blocks bounded by active faults of the San Andreas transform system. Although some folding, minor faulting, and random seismic activity can be found within the blocks, intense structural deformation and

large earthquakes are mostly limited to the block margins. Exceptions are most notable approaching the Los Angeles Basin, where compressive stress gives rise to increasing degrees of vertical offset along the transform faults and a change in deformation style that includes young folds and active thrust ramps. Perris is located in the central portion of the Perris tectonic block, the longest sides of which are bounded by the San Jacinto fault zone to the northeast and the Elsinore and Chino fault systems to the southwest.

The Peninsular Ranges structural blocks are dominated by the presence of intrusive granitic rock types similar to those in the Sierra Nevada, although the province additionally contains a diverse array of metamorphic, sedimentary, and extrusive volcanic rocks. In general, the metamorphic rocks represent the highly altered host rocks for the episodic emplacement of Mesozoic-age granitic masses of varying composition. Parts of the province include thick sequences of younger marine and non-marine clastic sedimentary rocks of Mesozoic and Tertiary age, ranging from claystones to conglomerate. Pre-Quaternary sedimentary rocks are conspicuously absent from most of the Perris Block, however, which is dominated by crystalline basement materials.

## **5.2 Local Geologic Conditions**

Bounded by sometimes bold mountainous terrain to the east and west, the Perris Plain is entirely underlain by massive to crudely bedded alluvium. Morton and Miller (2006) assign an early to middle Pleistocene age for very old alluvium (unit Qvof<sub>a</sub>, Figure 2) that composes the majority of the topographical valley floor. The map exhibit also delineates a ribbon-like zone of younger Quaternary alluvium that follows the valley axis and supposedly underlies most of the site. Data from Rider Street and other nearby projects show that younger deposits actually tend to be very thin or absent in valley floodplain areas such as the eastern portions of the project. AGI interprets surficial silty sand in the site to be representative of younger (but probably still pre-Holocene age) alluvium derived from elevated granitic bedrock terrain west of the Interstate 215 freeway. These deposits thicken westward. The regional map is erroneous. The Perris Plain is considered part of the “Paloma” depositional surface

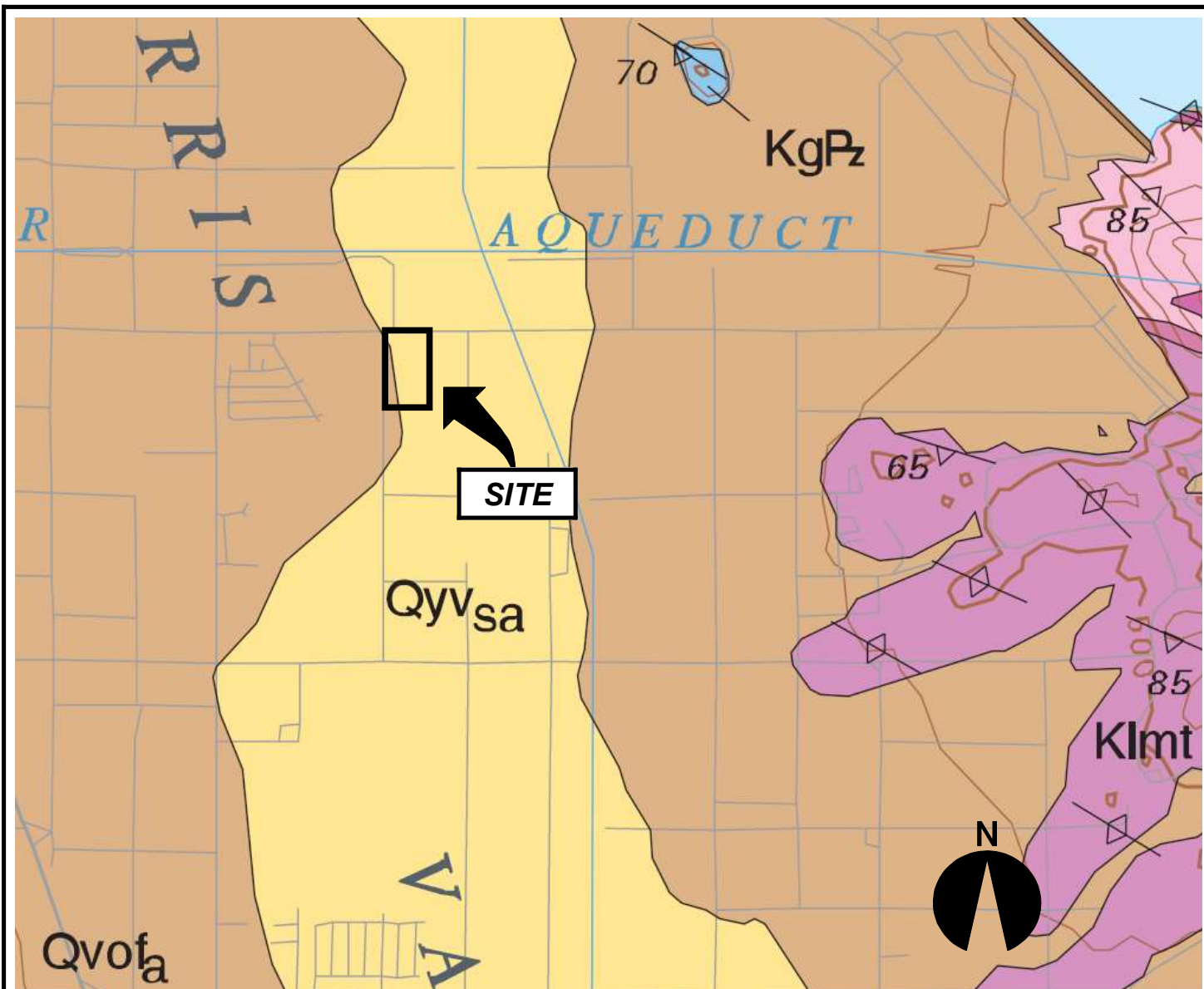

**Selected vicinity units:**

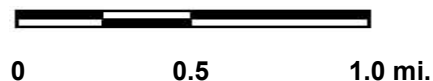

- Qyvs<sub>a</sub>      Young sandy axial-valley alluvial deposits (Holocene and late Pleistocene)
- Qvof<sub>a</sub>      Very old sandy alluvial-fan deposits (middle to early Pleistocene)
  
- KgPz        |      Granitic and mixed intrusive/metamorphic basement rocks composed of tonalite,  
 Klmt        |      granodiorite, and banded gneiss (Cretaceous and older)

**Reference:** Modified after Morton and Miller (2006). Scale is approximate.



**VICINITY GEOLOGIC MAP**

*RIDER ST. AT REDLANDS AVE. SITE, PERRIS, RIVERSIDE COUNTY, CA.*

PROJECT NO. 4534-SFI

DATE: 8/9/19

**FIGURE 2**

of Woodford et al. (1971), typified by fairly strongly developed illuvial clay and calcic horizons atop the older parent materials. The drilling logs hint that the deeper soils grossly describe a fining-up sequence within 35 to 40 feet of existing grade.

The alluvium conceals several deep erosional channels carved into granitic basement bedrock that can be considered tributaries to an ancestral San Jacinto River. The maximum depth of the Qvof<sub>a</sub> unit at the warehouse site is not known with certainty, but based on water well data is inferred to be at least 400 feet. Bedrock contour maps suggest the site is actually over a bedrock valley that angles northeast towards Lake Perris. Granitic bedrock consisting of weakly foliated quartz diorite (Lakeview Mountains tonalite) rises to the surface only about 1¼ miles east of the project site.

### **5.3 Slope Stability**

The almost zero-relief site was found to be free of natural features associated with gross instability of slopes. The property is also distant from mountainous slopes surrounding Perris Valley. We judge landslide risks to be nil.

### **5.4 Flooding**

AGI reviews of Riverside County GIS maps suggested that about 0.5 acres in the far northeast site corner might be in “100-year” floodplain zones close to the Perris Valley Drain. However, according to the official revised (2014) FEMA Flood Insurance Rate Map for the site and vicinity, “100-year” flood volumes should remain closer to the - Perris Valley Drain channel (Figure 3). We suspect the County GIS map is out-of-date.

Per the referenced susceptibility map, certain northeastern-area terrain is zoned for 0.2 percent chance per annum for flood hazard, i.e., “500-year” floodplain. There are normally few restrictions for non-critical facilities developed in 500-year risk management zones, although an owner’s election to protect against flooding by raising the building floor can be considered. We suspect that the maximum 500-year flood depth in the project is under a foot. Maximum water depth would be at the northeast corner.



# National Flood Hazard Layer FIRMette



## Legend

SEE FIS REPORT FOR DETAILED LEGEND AND INDEX MAP FOR FIRM PANEL LAYOUT

SPECIAL FLOOD HAZARD AREAS		Without Base Flood Elevation (BFE) Zone A, V, A99
		With BFE or Depth Zone AE, AO, AH, VE, AR
		Regulatory Floodway
OTHER AREAS OF FLOOD HAZARD		0.2% Annual Chance Flood Hazard, Areas of 1% annual chance flood with average depth less than one foot or with drainage areas of less than one square mile Zone X
		Future Conditions 1% Annual Chance Flood Hazard Zone X
		Area with Reduced Flood Risk due to Levee. See Notes. Zone X
		Area with Flood Risk due to Levee Zone D
OTHER AREAS		Area of Minimal Flood Hazard Zone X
		Effective LOMRs
GENERAL STRUCTURES		Channel, Culvert, or Storm Sewer
		Levee, Dike, or Floodwall
OTHER FEATURES		20.2 Cross Sections with 1% Annual Chance Water Surface Elevation
		17.5 Coastal Transect
		513 Base Flood Elevation Line (BFE)
		Limit of Study
		Jurisdiction Boundary
MAP PANELS		Digital Data Available
		No Digital Data Available
		Unmapped



The pin displayed on the map is an approximate point selected by the user and does not represent an authoritative property location.

This map complies with FEMA's standards for the use of digital flood maps if it is not void as described below. The basemap shown complies with FEMA's basemap accuracy standards

The flood hazard information is derived directly from the authoritative NFHL web services provided by FEMA. This map was exported on 6/8/2019 at 2:07:00 PM and does not reflect changes or amendments subsequent to this date and time. The NFHL and effective information may change or become superseded by new data over time.

This map image is void if the one or more of the following map elements do not appear: basemap imagery, flood zone labels, legend, scale bar, map creation date, community identifiers, FIRM panel number, and FIRM effective date. Map images for unmapped and unmodernized areas cannot be used for regulatory purposes.

Figure 3

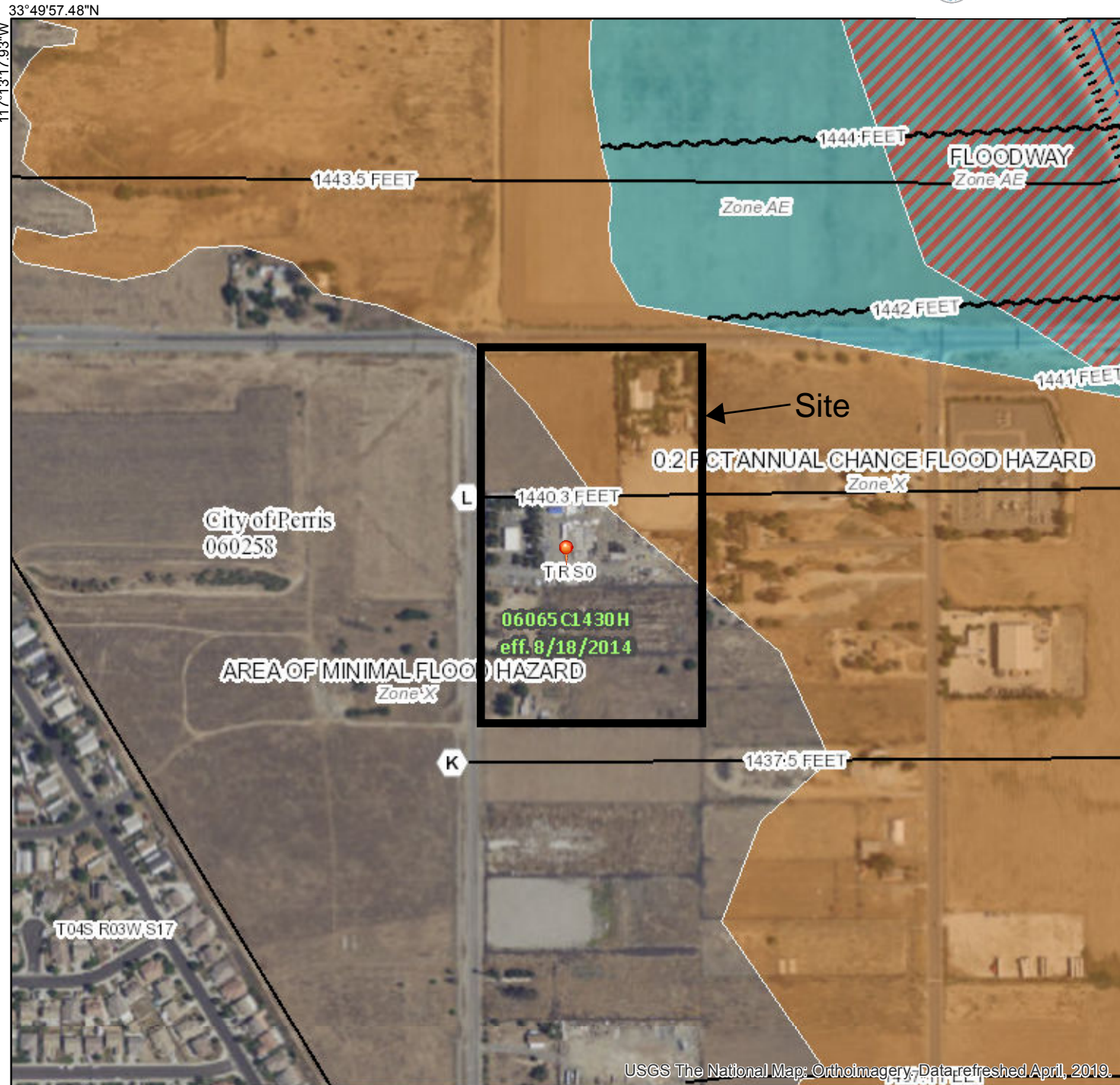

33°49'57.48"N

117°13'17.93"W

USGS The National Map: Orthoimagery, Data refreshed April, 2019.



33°49'27.59"N

117°12'40.47"W

## **5.5 Faulting and Regional Seismicity**

The project is situated in region of active and potentially active faults, as is all of metropolitan Southern California. Active faults present several potential risks to structures and people. Hazards associated with active faults include strong earthquake ground shaking, soil densification and liquefaction, mass wasting (landsliding), and surface rupture along active fault traces. Generally, the following four factors are the principal determinants of seismic risk at a given location:

- Distance to seismogenically capable faults.
- The maximum or “characteristic” magnitude earthquake for a capable fault.
- Seismic recurrence interval, in turn related to tectonic slip rates.
- Nature of earth materials underlying the site.

### **5.5.1 Fault Rupture Potential**

Surface rupture presents a primary or direct potential hazard to structures built across an active fault trace. Reviews of official maps delineating State of California Earthquake Fault Zones and Riverside County Fault Hazard Management zones indicated the project site is not located in a zone of required investigation for active faulting. The closest known active regional fault traces are associated with the San Jacinto Fault east of Moreno Valley, about 8.8 miles away at closest approach. Aerial photographic interpretations did not suggest visible lineaments or manifestations of fault topography related to active fault traces on or adjacent to the site. Accordingly, chances for direct surface fault rupture affecting the project are judged to be extremely low.

### **5.5.2 Strong Motion Potential**

All Southern California construction is considered to be at high risk of experiencing strong ground motion during a structure’s design life. In addition to the previously mentioned San Jacinto fault zone, the San Andreas Fault can be considered a potentially significant sources of lower-frequency and longer-duration shaking at the project. Other, more-distant regional faults are very unlikely to cause shaking as intense as that caused by rupture of one of the two listed faults. Probabilistic risk models for the Perris-Moreno Valley area fundamentally assign the highest seismic risks from large characteristic seismic

events along the San Jacinto fault system. The mode-magnitude event for peak ground acceleration at a 2% in 50-year exceedance risk is a multi-segment  $M_w$ 8.1 earthquake on the San Jacinto fault (U.S. Geological Survey, 2019b; dynamic conterminous U.S. 2014 model).

The searchable ANSS Comprehensive Earthquake Catalog indicates about 176 events of local magnitude M4.5 or greater have occurred within 100 kilometers of the project since instrumented recordings started in 1932 (Figure 4, next page). Clusters of epicenters are associated with the 1992 Landers and triggered Big Bear Lake events. These and other notable historical earthquakes in southern California over the last 30 years (e.g., Northridge, Hector Mine) were far away. They produced estimated peak ground accelerations well under 0.20g in the City of Perris area. Interestingly, earthquakes larger than the selected M4.5 intensity threshold have been rare along the northern San Jacinto fault and the San Andreas fault, even though both have among the fastest slip rates and shortest mean recurrence intervals among all California faults.

*San Jacinto Fault:* The San Jacinto fault constitutes a set of *en-écheleon* or right- and left-stepping fault segments stretching from near Cajon Pass to the Imperial Valley region. The primary sense of slip along the zone is right-lateral, although many individual fault segments show evidence of at least several thousand feet of vertical displacement. The San Jacinto fault zone has been very active, producing possibly eight historical earthquakes of local magnitude 6.0 or greater. The communities of Hemet and San Jacinto were heavily damaged in 1918 and again in 1923 from events on the San Jacinto Fault. Pre-instrumental interpreted magnitudes for these events were  $M_L$ 6.8 and  $M_L$ 6.3, respectively. The historical record suggests each discrete segment *usually* reacts to tectonic stress more or less independently from the others, and to have its own characteristic large earthquake with differing maximum magnitude potential and recurrence interval. Researchers and code development authorities now model the fault with potential for multi-segment rupture, however, with consequent increases in calculated risk to structures.





**Reference:** U. S. Geological Survey (2019c) real-time earthquake epicenter map. Plotted are 176 epicenters of instrument-recorded events from 1932 to present (8/9/19) of local magnitude M4.5 or greater within a radius of ~62 miles (100 kilometers) of the site. Location accuracy varies. The site is indicated by the gold square. The red lines indicate the approximate surface traces of Quaternary active faults. The selected magnitude corresponds to a threshold intensity value where light damage potential begins. These events are also generally widely felt by persons. Notable Southern California historical events with epicenters just beyond the selected search radius would include the Northridge earthquake [San Fernando Valley], and the Hector Mine event in the Mojave Desert north of Yucca Valley.



## SIGNIFICANT EVENT EPICENTER EXHIBIT

RIDER ST. AT REDLANDS AVE. SITE, PERRIS, RIVERSIDE COUNTY, CA.

PROJECT NO. 4534-SFI

DATE: 8/9/19

FIGURE 4



*San Andreas Fault:* For most of its over-550-mile length, the San Andreas Fault can be clearly defined as a narrow, discrete zone of predominantly right-lateral shear. The southern terminus is close to the eastern shore of the Salton Sea, where it joins a crustal spreading center marked by the Brawley Seismic Zone. To the northwest, a major interruption of the otherwise relatively simple slip model for the San Andreas fault is centered in the San Geronio Pass region. Here, structural complexity resulting from a 15-kilometer left step in the fault zone has created (or reactivated) a myriad of separate faults spanning a zone 5 to 7 kilometers wide (Matti, et al., 1985; Sieh and Yule, 1997; 1998). Continuing research is refining speculation that propagation of ruptures from other portions of the San Andreas Fault might not be impeded through the Pass region. New data suggest the San Bernardino and Coachella Valley segments of the fault may experience concurrent rupture roughly once out of every three to four events. Multi-segment cascade rupture is currently considered in all 2008 and later State of California seismic hazard models (Petersen, 2008; Working Group, 2013), and has been adopted as a scenario event for emergency response training such as the annual ShakeOut drill.

Source characteristics for the two regional active fault zones with the highest contributions to site risks are listed in the following table. Fault data have been summarized from WGCEP (2013) as implemented for the latest California fault model. Magnitudes are based on a probabilistic recurrence interval of 2,475 years for each source, binned to nearest 0.05 magnitude decrement. The reference magnitudes usually reflect cascade ruptures.

### Regional Seismic Source Parameters

Fault Name (segment)	Distance from Site (km)	Length (km)	Geologic Slip Rate (mm/yr)	Magnitude @ 2% in 50 Yr. Prob., $M_w$
San Jacinto (w/ stepovers)	14.2	25	14.0	8.1
San Andreas (Coachella → Mojave South)	31.9	302	10.0 to 32.5	8.25

Version 3 of the Uniform California Earthquake Rupture Forecast (UCERF3) will be the reference fault source model for future California building codes and insurance risk analyses. Utilizing knowledge of tectonic slip rates and last historical or constrained paleoseismic event dates, UCERF3 includes *time-dependent* rupture probabilities for many major California faults. For the San Jacinto fault zone (stepovers combined) between Hemet and Moreno Valley, the model ascribed a 13.8% chance for an earthquake of  $M \geq 6.7$  in the next 30 years beginning in 2015 (Field et al., 2015). The conditional probability for an earthquake of magnitude  $M_w \geq 6.7$  somewhere along the southern San Andreas Fault was calculated at 57 percent in 30 years. These probabilities will increase each year for successive 30-year windows. Most researchers peg the southern San Andreas as “overdue” for a very large earthquake.

Earthquake shaking hazards are quantified by deterministic calculation (specified source, specified magnitude, and a distance attenuation function), or probabilistic analysis (chance of intensity exceedance considering all sources and all potential magnitudes for a specified exposure period). With certain special exceptions, today’s engineering codes and practice generally utilize (time-independent) probabilistic hazard analysis. Prescribed parameter values calculated for the latest 2014 U.S. national hazard model indicate the site has a 10 percent risk in 50 years of peak ground accelerations (pga) exceeding approximately 0.53g, and 2 percent chance in 50-year exposure period of exceeding .96g (U.S. Geological Survey, 2019b). The reported pga values were linearly interpolated from 0.01-degree gridded data and include soil correction (NEHRP site class D; local shear wave velocity estimate  $V_{s30} \approx 260$  m/sec). Calculated peak or spectral acceleration values should never be construed as representing exact predictions of site response, however. *Actual* shaking intensities from any seismic source may be substantially higher or lower than estimated for a given earthquake event, due to complex and unpredictable effects from variables such as:

- Near-source directivity of horizontal shaking components
- Fault rupture propagation direction, length, and mode (strike-slip, normal, reverse)
- Depth and consistency of unconsolidated sediments or fill

- Topography
- Geologic structure underlying the site
- Seismic wave reflection, refraction, and interference (basin effects)

### 5.5.3 Secondary Seismic Hazards

Secondary hazards include landsliding or mass wasting, liquefaction, flooding (from ruptured tanks or canals, inundation following dam collapse, surface oscillations in enclosed water bodies, or tsunami), and combined saturated-unsaturated soil subsidence as a result of dynamic soil densification. All of these induced hazards are consequences of earthquake ground motion given the right set of initial conditions.

Flooding. AGI categorically rules out tsunami and seiche hazards. The project site is inland and not adjacent to lakes or open reservoirs. Induced flooding risks from municipal water storage tanks are also absent.

Parts of the Perris Valley including the Rider Street site would be impacted by breaching of the Lake Perris dam. Other reservoirs near Hemet (Lake Hemet; Diamond Valley Lake) do not pose inundation hazard, as the site appears to be passively protected by elevation. In July 2005, the State identified potential seismic safety problems with Perris Dam. Deficiencies with the alluvial foundation soils were addressed by several years of construction to stabilize the downstream embankment and mitigate liquefaction potential. Work was completed in 2018. We believe reservoir loss potential is now extremely remote and is below a level of regulatory concern for ordinary construction.

Liquefaction. Riverside County classifies the site as “low” to “moderate” liquefaction potential. The site is not within State-delineated “Zones of Required Investigation” for either liquefaction potential or landsliding (California Department of Conservation, 2019b). Opportunity is present, as evidenced by interpreted perennial perched-water horizons less than 50 feet deep. However, our investigation findings are that the site lacks liquefaction-susceptible materials. The sedimentary layers are geologically old and have high relative densities. Field tests demonstrated that saturated older alluvium universally has

corrected SPT  $N_{1(60)cs}$  values exceeding 30. Worldwide empirical data have demonstrated that liquefaction triggering is extremely unlikely whenever saturated soils meet a criterion of corrected  $N_{\geq 30}$ . The site passes regulatory screening criteria used to differentiate sites with liquefaction hazard from those that have minimal hazard (California Department of Conservation, 2008). Related permanent ground deformation phenomena such as ground fissuring, ejection of pressurized sand-water mixtures from shallow liquefied layers (sand boils), flow slides, and lateral spreading have also been ruled out as hazards.

Subsidence. AGI finds that surface settlements from saturated and dry-sand volumetric changes should be trivial assuming that very shallow soils are treated by remedial grading for structural support. Calculated total surface settlements from a liquefaction model analysis are of very low magnitude (approximately 0.2 inch). Differential settlements would be even less. We think the tiny calculated differential settlement potentials are reasonable engineering assumptions for this site, and are less than AGI's predicted consolidation settlements from structural loads. Both the total and differential settlements are far lower than typical allowable maximum deflections for concrete panel-wall construction on continuous foundations.

Landslides. Section 5.3 notes that the site is flat and far from steep or boulder-strewn mountain slopes. Earthquake-induced hazards from slope instability or tumbling rocks are believed to be zero.

## 6.0 CONCLUSIONS AND RECOMMENDATIONS

### 6.1 General

Based on the results of our field exploration and laboratory tests, engineering analyses, local experience, and judgment, it is our professional opinion that the project site should be suitable from a geotechnical viewpoint for the proposed project. Geological hazards imposed on the warehouse building appear to be limited to strong ground motion due to earthquake. Geotechnical constraints include surficial lower-density natural materials judged susceptible to hydrocollapse and compression under building loads. Deeper alluvium within zones of near-constant soil moisture is

demonstrably hard, cemented, and has very low compressibility. Some very old alluvium is clayey and categorized as expansive, though.

Prescriptive mitigation for the hazard of strong ground motion is nominally provided structural design adherence to local adopted building codes. Section 6.7 contains recommended short- and long-period design spectral accelerations for the project.

Soil excavation and compaction to create dense engineered fill are recommended to mitigate unsuitable surficial alluvial deposits and disturbed horizons that would otherwise be present below shallow structural foundations, pavements, and planned engineered fills. Listed below are the recommended earthwork actions for existing soil conditions impacting site development:

- (1) Remedial grading should replace the majority of “younger”, typically loose silty sand deposits capping older alluvium, and all active shrink-swell horizons, as compacted engineered fill beside and below the building envelope and attached concrete site walls. Based on the exploration logs, expected structural “removal” depths from existing grades will usually range between a minimum of approximately 5 feet up to about 7 feet. “Active” horizons are mostly in the northern third of the site. The soil types include silt and clayey silt. Active horizons will usually require 6 to 7 feet of removal, and are physically distinguishable by peculiar granulated or “exploded” textures, abundant white carbonate, and visible macro-porosity. There is a fairly abrupt transition from unsuitable materials to competent alluvium. We think this transition should be fairly obvious during mass grading.
- (2) Overexcavations should be deepened, if required, so that at least 36 inches of engineered fill is created beneath all future continuous or spread footings. Concrete site walls not attached to the building should also be founded on a minimum of 36 inches of engineered fill. Lateral excavation limits at final bottom elevations should be at least 5.0 feet beyond footing edges. Bottom elevations should be uniform across the entire building design envelope, i.e., “slot-cutting” for individual column lines or continuous footings without treating unsuitable compressible-soil zones below industrial floors is not recommended.

- (3) At least 24 inches of soil stripping before placement of compacted engineered fill is recommended in all future new pavement areas, including street widening for Rider Street and Redlands Avenue. The remaining 12 inches may be processed and compacted in place. The intent is to recompact loose, heavily bioturbated, and mechanically tilled soils. Should pavement subgrades be planned more than 24 inches below current surfaces, in-place processing is recommended to create at least 12 inches of engineered soil fill below flexible or rigid pavement structural sections.

Careful staging of earthwork is urged to help minimize chances for placing expansive soils in the upper foot of industrial floor slab subgrades. Pre-project consultations between AGI and earthwork contractors would be encouraged to formulate plans for initial stockpiling and “round-robin” excavations and fills. Clay content is much higher in the older, deeper fine-grained soil classifications. Active-zone removals will necessarily produce engineered fill with expansion potential. A goal of planning would be to devise schemes to keep excavated clayey soils only in the deeper portions of fills, and selectively retain shallow non-expansive materials that are thickest in the southern and western portions of the site for use in pad finishing. Alternatively, if import soil is required, proven non-expansive import materials could substitute for local soils when constructing pad subgrades.

## **6.2 Site Grading**

The general guidelines presented below should be included in the project construction specifications to provide a basis for quality control during grading. It is recommended that all compacted fills be placed and compacted under continuous engineering observation and in accordance with the following:

- Demolition and removal of any and all abandoned buried improvements including foundations, slabs, irrigation pipes, tanks, or cables. Any abandoned septic tanks and leach fields should be excavated and removed in their entirety. If domestic water wells are found, they should be properly grouted, sealed, and capped by a C57-licensed drilling contractor in accordance with Riverside County and State DWR regulations. A copy of the well closure report(s) must be submitted to AGI.

- Clearing and disposal of weeds, shrubs, trees, tree roots larger than approximately one inch, and debris should be initiated prior to grading. If necessary in the opinion of the Geotechnical Engineer, the grading contractor must be prepared to supply personnel to pick woody debris or foreign objects from engineered fill during the grading operations.
- Excavation of fill, disturbed or porous native soil, or other unsuitable material as determined at the time of grading by the Geotechnical Engineer shall be performed as discussed in Section 6.1 for support of compacted engineered fill, structures, and improvements. Bottom acceptance will be by geological observation, probing, and density testing in alluvium. Natural soils shall demonstrate in-place dry densities of 85% or greater of the laboratory-determined maximum dry density to be classified competent, and exhibit insignificant macroporosity. All of the site soils appear to be acceptable for re-use in new engineered compacted fill if free from organic debris and trash. Final determinations of removal depths shall be made during grading based upon conditions encountered during earthwork activities.
- Observation and acceptance of all stripped areas by the Geotechnical Engineer and/or Engineering Geologist and/or their designated representative shall be done prior to placing fill.
- Shallow scarification of exposed bottoms to depths of 4 to 6 inches (structural envelope), or to planned processing depths (pavement and other engineered fill areas), moisture-conditioning by adding moisture or drying back to above-optimum moisture contents as described below, and recompaction to at least 90 percent of the maximum dry density as determined by the ASTM D1557-12 test standard.
- Fill soils should be uniformly moisture-conditioned by mixing and blending to optimum water content or higher, and placed in lifts having thicknesses commensurate with the type of compaction equipment used, but generally no greater than 6 to 8 inches. Pre-watering of the site is recommended in advance of earthwork (depending upon seasonal conditions) to moisten the upper 48 to

60 inches of material. This will help reduce fugitive dust, and more importantly allow for easier mixing and clod crushing. Care will be needed to avoid overwatering the deeper clayey horizons and creating sticky, muddy, impassable conditions. Pre-watering is not recommended for the Reyez property (APN 300-210-002) in the northeast corner due to non-existent sand. *Fill water contents below the recommended minimum water content shall constitute a basis for non-acceptance of the fill irrespective of measured relative compaction, and at the discretion of the Geotechnical Engineer may require the fill be reworked to produce uniform water contents at or over the desired 100% of optimum moisture.*

- The contractor should utilize means and methods that result in uniform compaction of engineered fill meeting at least 90 percent of the laboratory maximum dry density determined by the ASTM D1557-12 standard. Sheepsfoot rollers and/or a Rex compactor are recommended for mixing and kneading action that will be needed to distribute water in clayey fill soils and break down cohesive clods. AGI recommends the uppermost 12 inches of pad and pavement subgrade material achieve at least 95 percent relative compaction for all project-site soil classifications except for silty clay (USCS CL). The latter is not anticipated, but would require special recommendations to minimize chances for heave and pavement distress.
- Rocks or other similar irreducible inert particles larger than about 3 inches in diameter should be excluded from engineered structural fills on this site. Rocks should be very rare or absent.
- Field observation and testing shall be performed to verify that the recommended compaction and soil water contents are being uniformly achieved. Where compaction of less than 90 percent is indicated (95 percent in identified subgrade zones as previously noted), additional compaction effort, with adjustment of the water content as necessary, should be made until at least minimum-accepted compaction is obtained. Field density tests should be performed at frequencies not less than one test per 2-foot rise in fill elevation and/or per 1,000 cubic yards of fill placed and compacted at this site.



- Import soils, if required, should consist of predominantly granular material with low or negligible expansion potential and be free of deleterious organic matter and large rocks. Import soils with an expansion index of under 20 are preferred and recommended for selective use in floor slab subgrade should import be part of the design plan. The borrow site and import soils must be reviewed and accepted by the Geotechnical Engineer prior to use. Geotechnical acceptance will only be predicated on meeting certain engineering criteria, and would not address any environmental testing or clearances required by local agencies or by the proposed end use.
- Proper surface drainage should be carefully taken into consideration during site development planning and warehouse construction. Finish surface contours should everywhere result in drainage being directed away from building foundations to swales, area drains, or water quality basins. The use of descending ramps to proposed dock doors should be discouraged; a better approach is an elevated building finish floor and exterior pavement surfaces sloping away from the dock doors. Roof runoff should be directed to LID BMPs at least 15 feet lateral to perimeter building foundations. Landscape beds should not be placed next to structures unless xeriscape and micro-irrigation design practices can be enforced.
- It is recommended that expansion index and soluble sulfate content tests be performed upon completion of rough grading in the building pad. The exact number of tests should be determined by site observations made during grading, but should not be less than one test for every soil type encountered or 8 tests overall, whichever is greater. Atterberg limits testing to help qualify soil activity is recommended in the event expansion indices greater than 20 are calculated.

### **6.3 Earthwork Volume Adjustments**

Removal and recompaction of the unsuitable surficial alluvium will result in material volume loss. The calculation of earth balance factors for the site as a whole is subject to some uncertainty, based on imprecise estimates of shallow soil density from 0 to 2 feet (tilled zone), and the future achieved degrees of compaction. We believe that civil designers should make allowances for at least 12 to 15 percent

shrinkage in the building removal areas. Exterior paved areas may shrink closer to 20 percent from 0 to 2 feet. Bottom subsidence from heavy equipment is predicted to be almost undetectable in the deep cemented soils, but on a site-wide average inclusive of paved areas should fall near 0.1 foot in our estimation.

#### **6.4 Slopes**

Slopes are not shown on the project conceptual drawing. However, low permanent manufactured fill slopes would not be unexpected along the eastern and southern site boundaries. Slope design should in general conform to the following recommendations:

- Cut and fill slopes should be constructed at maximum slope inclinations of 2:1 (horizontal:vertical).
- The surfaces of all fill slopes should be compacted as generally recommended under Site Grading, and should be free of slough or loose soils in their finished condition. The desired result should be 90 percent relative compaction to the slope face.
- The fill portion of any fill-over-cut slopes should maintain a minimum horizontal thickness of 5 feet or one-half the remaining fill slope height (whichever is greater), and be adequately benched into undisturbed competent materials. Cut slopes in local native surficial alluvium are preliminarily judged feasible without needs for stabilization fills.
- Erosion control measures should be implemented for all slopes as soon as practicable after slope completion, per applicable City ordinances.

#### **6.5 Foundation Design**

Although information regarding anticipated foundation loads was not available for this report, the predicted construction type implies moderate imposed soil loads. Foundation plans, once they become available, must be evaluated by this firm for compatibility with the preliminary recommendations presented below.

Conventional shallow continuous or spread footings embedded entirely within compacted engineered fill appear feasible for the light industrial building. Structural loads may be supported on continuous or isolated spread footings at least 18 inches

wide. All footings including site wall foundations should be bottomed a minimum of 24 inches below the lowest adjacent final grade. The recommended maximum allowable bearing value is limited to 3,000 pounds per square foot ( $FS \geq 3.0$ ). Bearing values may be increased by one-third when considering short-duration seismic or wind loads.

Lateral load resistance will be provided by friction between the supporting materials and building support elements, and by passive pressure. A friction coefficient of 0.42 may be utilized for foundations and slabs constructed atop structural fill derived from granular surficial-zone alluvium or granular + fine-grained blended site materials. A passive earth pressure of 250 pounds per square foot, per foot of depth, may be used for the sides of footings. When combining passive pressure and frictional resistance, the passive pressure component should be reduced by one-third.

Any exterior isolated building footings should be tied in at least two perpendicular directions by grade beams or tie beams to reduce the potential for lateral drift or differential distortion. The base of the grade beams should enter the adjoining footings at the same depth as the footings (viewed in profile). The grade beam steel should be continuous at the footing connection. Footings should either be continuous across large openings, such as loading dock doors or main entrances, or be tied with a grade beam or tie beam.

Interior columns should be supported on spread footings or integrated footing and grade beam systems. Column loads should not be supported directly by slabs. When designing the interior building footings, the structural engineer should consider utilizing grade beams to control lateral drift of isolated column footings, if the combination of friction and passive earth pressure will not be sufficient to resist lateral forces.

Minimum foundation reinforcement should consist of four No. 5 bars, two near the top and two near the bottom (viewed in cross-section), or as dictated by loading conditions. However, footing and grade beam reinforcement specified by the project structural engineer shall take precedence over the latter guidelines.

Provided that AGI's recommendations for engineered fill depths below footings are incorporated into final design and construction, foundation settlements should be of low magnitude. Much of the anticipated foundation settlement is expected to occur during construction. Maximum consolidation settlements are not expected to exceed a ½-inch and should occur below the heaviest loaded columns. Differential settlement is not expected to exceed approximately ¼ to ½ of an inch between similarly loaded elements in a 30-foot span.

## **6.6 Floor Slab Design**

Concrete slab-on-grade industrial floor construction is assumed. The following recommendations are presented as options for minimum design parameters for the slabs, accounting for soil expansive pressures and measured soil strengths only. The minimum design parameters do not account for concentrated loads (e.g., machinery, pallet racks, etc.) and/or the installation of freezers or heating boxes.

The information and recommendations presented in these sections are not meant to supersede design by the project structural engineer. We have conceptualized options based on an as-built subgrade having an expansion index of less than 20 and plasticity index of 0, as AGI anticipates for local sandy materials selectively placed during mass grading. Generally, the indicated dimensions or materials may be varied by the structural engineer to produce acceptable performance for heavy or point loads, or to reduce section thicknesses. Final verification of the applicability of these or any modified recommendations must be confirmed by expansion index testing at the conclusion of pad precise grading.

Lightly Loaded Floor Slabs. Commercial/office slabs in areas which will receive relatively light live loads (i.e., less than approximately 125 psf) may be a minimum of 4.5 inches thick if reinforced with No. 3 reinforcing bars at 18 inches on-center in two horizontally perpendicular directions. Reinforcing should be properly supported on chairs or blocks to ensure placement near the vertical midpoint of the slab. "Hooking" of the reinforcement is not considered an acceptable method of positioning the steel. The recommended minimum compressive strength of concrete in this application is 3,000 pounds per square inch (psi).

Transverse and longitudinal control joints are advised to isolate slab cracking due to concrete shrinkage or expansion. If utilized in lieu of added reinforcement or concrete additives, crack control joints should be spaced no more than 12 feet on center and constructed to a minimum depth of  $T/4$ , where "T" equals the slab thickness in inches. Construction joints between pours should utilize dowel baskets to control vertical deflections from either interior loads or soil uplift pressures.

*Highly Loaded Floor Slabs.* The project structural engineer should design slabs in the event of expected high loads (i.e., machinery, forklifts, storage racks, etc.). Designs utilizing the modulus of subgrade reaction (k-value) may be used. A k-value of 150 pounds per square inch per inch may conservatively be used for on-site soils. Recommended R-value tests for final pavement section design, and/or plate load tests, may be used to verify the subgrade modulus after completion of grading.

For live loads of up to 250 psf, plain concrete slabs should be at least 5½ inches thick. The concrete used in slab construction should conform to Class 560-C-3250. Transverse and longitudinal crack control joints (if utilized) should be spaced no more than 12 feet on center and constructed to a minimum depth of  $T/4$ , where "T" equals the slab thickness in inches. Construction joints between pours should utilize dowel baskets to control vertical deflections from either interior loads or soil uplift pressures. These suggested design factors can be altered as long as comparable stiffness and strength objectives can be achieved.

*Moisture Protection.* Ground-floor office portions of the warehouse building slab would be expected to have interior floor finishes (wood, vinyl, carpet) potentially sensitive to subgrade moisture or water vapor. AGI recommends a minimum 6-mil-thick plastic vapor retarder installed per manufacturer and code specifications with all laps/openings sealed. The barrier may be situated atop as-built subgrades if reasonably free of large stones. Optional thicker 10-mil vapor retarders (e.g., StegoWrap®) should be favored due to greater damage resistance and even lower transmissivity. Protected areas should be separated from any areas that are not similarly protected. The separation may be created by a concrete cut-off wall extending at least 24 inches into the subgrade soil.

Subgrade Pre-Saturation. Pre-saturation is recommended for all pad soil and pedestrian walkway subgrades demonstrating post-grading expansion indices exceeding 20. It is our belief that selective grading can minimize chances for code-based categorization as an “expansive” pad. For as-built expansion indices under 20, AGI would recommend that soil water contents at least approach optimum soil water contents determined from ASTM D1557-12 to a depth of at least 12 inches prior to vapor retarder installation or industrial slab concrete placement. Extremely dry soils can pull water from wet concrete by capillary action and potentially affect hydration of cement pastes. Construction sequencing that helps preserve grading water should be encouraged. Pad subgrade soils with as-built expansion indices in the range of 20 to 50 should be at or over 110 percent of optimum water content to a depth of 12 inches. Subgrade soil water contents should be checked and verified as suitable by AGI technical staff no more than 48 hours prior to concrete placement.

#### **6.7 2016 California Building Code Seismic Criteria**

Prescriptive mitigation for the hazard of strong ground motion is nominally provided by structural design adherence to local adopted building codes. The 2016 CBC, based on the 2015 *International Building Code*, maintains a “look-up” code convention for seismic engineering, using as primary inputs the site’s location and the assigned site class. The latter is a measure of soil or rock elastic resistance determined by borehole tests or geophysical methods. For non-critical structures, the 2016 code continues past practice that quantifies seismic risk based on the probabilistic 2008 National Seismic Hazard model and the 2009 NEHRP *Recommended Seismic Provisions*. Design coefficients are ultimately functions of distance to active faults, fault activity, and measured or correlated mean shear wave velocity within 30 meters (~100 feet) of the ground surface. The tabulated criteria presented below were derived in accordance with the rules of Section 1613 of the 2016 CBC and ASCE/SEI Standard 7-10.

**Table 6.7-1**  
**2016 CBC Seismic Design Factors and Coefficients**  
**(Lat. 33.83002, Long. 117.21524)**

2016 CBC Section #	Seismic Parameter	Indicated Value or Classification
1613.3.1	Mapped Acceleration $S_s$	1.500g (Note 1)
	Mapped Acceleration $S_t$	0.600g (Note 1)
1613.2.2	Site Class	D (Note 2)
1613.3.3(1)	Site Coefficient $F_a$	1.0
1613.3.3(2)	Site Coefficient $F_v$	1.5
1613.3.3	Adjusted MCE Spectral Response $S_{MS}$	1.500g
	Adjusted MCE Spectral Response $S_{M1}$	0.900g
1613.3.4	Design Spectral Response $S_{DS}$	1.000g (Note 3)
	Design Spectral Response $S_{D1}$	0.600g (Note 3)

**Notes**

- (1) Interpolated from 0.01-degree gridded data in the probabilistic 2008 National Seismic Hazard Model (SEAOC, 2019), 2% in 50-year exceedance probability.
- (2) Based on minimal site grading, borehole SPT data, and estimated  $V_{s30} \approx 280$  m/sec.
- (3) Defined by 2016 CBC §1613.1 and the statement of ASCE/SEI 7-10 §21.2.3 indicating site-specific MCE response spectral acceleration at any period shall be taken as the lesser of the probabilistic or deterministic spectral response accelerations, with the latter subject to lower-limit values. The design spectral response accelerations are calculated as  $\frac{2}{3}$  of the MCE value.

Based on ASCE 7-10 and CBC §1613.3.5, a Seismic Design Category of **D** for risk category I-III buildings/structures is assigned for buildings sited where  $S_{D1} > 0.20g$  and  $S_1 < 0.75g$ . The option for alternative seismic design category determination based on a structure's fundamental period and CBC Table 1613.3.5(1) is allowed. The site-modified zero-period MCE<sub>R</sub> ground motion estimate  $PGA_M$  is 0.50g. Seismic response coefficients determined by the SEAOC seismic design tool applied to Figures 22-17 and 22-18 of ASCE 7-10 would be:

$$C_{RS} = 1.058$$

$$C_{R1} = 1.027$$

It should be understood that the 2016 CBC and most other building codes define minimum criteria needed to produce acceptable life-safety performance. Code-

compliant structures can still suffer damage. Project owners should be aware that structures can be designed to further limit earthquake damage, sometimes for modest cost premiums. Ultimately, final selection of design coefficients should be made by the structural consultant based on local guidelines and ordinances, expected structural response, and desired performance objectives. Please note that structural engineering approvals after January 1, 2020 will need to conform with the revised 2019 CBC. Seismic demands will change under the new code, and AGI's currently recommended coefficients will not be valid.

## **6.8 Pavements**

Depending upon budget, aesthetics, life-cycle costs, and proposed end use, Portland cement concrete (PCC) pavement or a mix of PCC and lighter-duty asphalt surfaces could be specified for the project. Customarily, truck driveways and trailer stalls use PCC pavement. Conventional asphalt surfaces would be predicted for public roadway improvements, and might be elected for employee auto parking and driveways along Redlands Avenue. It is anticipated that the uppermost porous and mechanically tilled topsoils in areas that will support new asphalt or PCC pavements, curbs and gutter, sidewalks, or other flatwork will be removed and recompacted as recommended in Section 6.1.

For an assumed traffic index of 8.0, equivalent maximum single-axle loads of 13,000 pounds, an estimated R-value of 30 or greater for on-site *granular* soils, and assumed concrete modulus of rupture of 500 psi, the recommended preliminary PCC design section includes 7.0 inches of un-reinforced (plain) concrete over 12 inches of granular site soil compacted to not less than 95 percent relative compaction. Poorer soils exist in the north half of the trailer yard and north entrance. The local R-value may be under 15. Untreated USCS ML subgrades compacted to not less than 95 percent should have thicker unreinforced PCC design sections preliminarily estimated at 9.0 inches. Subgrade treatments such as lime or cement stabilization should be considered for low-strength soil classifications, and would be recommended for heavy-duty pavements resting on clay soils exhibiting plasticity indices greater than 10. Concrete used for pavement should have a minimum 28-day compressive strength  $f_c$  of 3,500 pounds per square inch. The structural engineer may evaluate



alternative sections that include reinforcement or different-strength concrete mixes in the event of a different design traffic index, special conditions including ESALs exceeding 13,000 pounds, or requests for a thinner concrete section.

The following table presents *example* structural sections for street and parking lot hot-mix asphalt pavements based upon Caltrans design methods, a 20-year pavement lifetime, and an estimated soil R-value. The example sections may be useful for development cost estimates. Street traffic indexes are guidelines only. Confirmation of final design traffic indexes must be made with City of Perris Public Works officials. For regular parking lots, the tabulated dimensions are the minimum-recommended structural section for passenger automobile loads. Final recommended sections may change and should be based on expected loading, desired pavement lifetime, and recommended R-value tests on soils collected from as-built subgrades.

**Table 6.8-1**  
**Preliminary Example Asphalt Pavement Designs**

Pavement End Use	Traffic Index	R-Value	A.C. Thickness	Base Thickness
Passenger Auto Parking	5.5	30	3.0"	6.5"
Rider Street & Redlands Avenue	8.0	30	4.0" 5.0"	11.0" 9.5"

It is recommended that concrete curbs and ribbon gutters be poured neat against compacted soil subgrades in advance of pavement subgrade excavation and base course placement. It is especially critical that drainage pathways from tree wells or nearby landscaped areas not be created by inadvertent construction of curbs atop permeable base course layers.

Generally, subexcavation of pavement areas should not exceed that needed to mitigate compressible surficial soils per the protocol in Section 6.1. Subgrades not classified as clay should be processed and compacted to a minimum of 95 percent of the laboratory maximum dry density determined by ASTM D1557-12 to depths of at least 12 inches. Base course should meet materials specifications for Caltrans

Class 2 aggregate base material or better, and should be placed and fully compacted in lifts no greater than 6 inches thick to a minimum dry density of 95 percent of the laboratory maximum dry density per the ASTM D1557-12 standard. Pavement gradients should be designed to allow rapid and unimpaired flows of runoff water, and concrete gutters should be provided at all flow lines.

**6.9 Retaining Walls**

Available plans did not depict retaining walls, and the limited site relief suggests walls may be avoidable except possibly for dock door areas. Preliminary recommended earth pressure values for walls are shown below. AGI assumes that a well-drained, select granular on-site or import material such as locally available decomposed granite sand with a sand equivalent value of 30 or better will be utilized for backfill. Very silty sand or clayey site soils are not recommended for wall backfill. Live loading (e.g., forklifts) must be added to the stated values. Wall pressures from seismic inertial loads must also be included for tall walls (none expected). Seismic loads may be based on a design peak ground acceleration of 0.50g and MCE event magnitude  $M_w$  8.1. Other expected site conditions such as drained, granular backfill soils appear to be consistent with the assumptions of the widely used Mononobe-Okabe method or similar later variations of rigid plastic methods for finding force magnitudes on the wall. Standard reduction factors for pga (e.g., 0.5 for M-O method) may thus be implemented.

**Table 6.9-1  
 Preliminary Retaining Wall Fluid Pressure**

Inclination of Retained Material	Equivalent Fluid Pressure (psf)	
	Unrestrained	Restrained
Level	36	56

AGI recommends reviews of preliminary wall designs to gauge needs for locality-specific modifications and/or supplemental soil tests before construction. The same recommended maximum foundation bearing value of 3,000 psf for structures may also be assumed for retaining walls and site walls founded atop engineered fill.

Granular wall backfill at dock doors should be mechanically compacted to a minimum of 95 percent relative compaction; 90 percent or greater is sufficient where not subject to live loads. Density testing is recommended to verify the adequacy of compaction. Substitution with crushed or pit-run clean rock materials in wall panel backfills is encouraged, but must also be accompanied by mechanical densification with plate compactors, ramming tampers, or concrete vibrators.

Exterior walls retaining more than 3 feet of soil should be provided with a means of drainage to prevent hydrostatic forces. Drainage provisions may be based on the wall height, wall length, and any irrigated land uses next to the improvement. Typical approaches would be a continuous perforated subdrain line embedded in open-graded crushed rock placed at the inside bottom of the wall, or through-the-wall options such as weepholes, or open head joints for CMU structures.

#### **6.10 Temporary Sloped Excavations**

Excavations at the site would be expected to encounter massive, non-raveling sequences of silty or clayey alluvium, and/or engineered fill after mass grading. Excavations up to 5 feet in depth in these materials should stand vertically for temporary periods. Trenches open for any extended period of time, trenches placed in disturbed native ground, and all excavations greater than 5 feet in depth should be properly sloped or shored. Where sufficient space is available for a sloped excavation, the side slopes should be inclined to no steeper than 1:1 (horizontal to vertical) per current rules for excavation material Type B and an excavation depth of 20 feet or less in unsaturated soil. The exposed earth materials in the excavation side slopes should be observed and verified as suitable by a geotechnical engineer or other qualified person. The exposed slope faces should be kept moist and not allowed to dry out.

Surcharge loads should not be permitted within five feet from the top of excavations, unless the cut or trench is properly shored. Contractors are ultimately responsible for verifying that slope height, slope inclination, excavation depths, and shoring design are in compliance with Cal-OSHA safety regulations (Title 8, Section 1540-1543 et seq.), or successor regulations.

### **6.11 Trench Backfill**

All soil-backfilled utility trenches on this site should be backfilled in lifts and mechanically compacted to at least 90 percent of the laboratory maximum dry density. Utility purveyors may specify a greater degree of compaction in streets (e.g., lateral connections into Redlands Avenue or Rider Street) than this stated minimum. Flooded or jetted backfill is not recommended except for densification of select imported granular bedding materials placed directly around utility lines. The local soils are deemed unsuitable to serve as pipe bedding materials. Density testing is recommended to verify the adequacy of compaction efforts.

### **6.12 Soil Corrosivity**

Chemical analyses were performed to provide a general evaluation of the corrosivity of the native soils and included soluble sulfates, soluble chlorides, nitrate, and ammonia in addition to several electrochemical potential tests. Findings indicated the site soils should not be aggressive to concrete, but could be highly corrosive to buried metal. Analytic tests reported soluble sulfate contents were low, quantified at only 0.00074 weight percent and 0.0207 weight percent in two samples from opposite ends of the building envelope. Minimum saturated resistivity ranged from 5,829 to 1,407 ohm-cm in two samples. The test data point to soluble salt enrichment and far higher corrosion potential in older silt and clay deposits toward the north end of the project. We encourage the owner to engage a qualified corrosion engineer for a more in-depth evaluation of risks to buried ferrous objects and for specification of special corrosion protection features that may be required. Metal fire protection lines should be keyed upon.

The categorically “negligible” sulfate concentrations indicate that normal Type I-II cement should be suitable for concrete mix designs utilized for this project, based on American Concrete Institute (ACI) 318 Table 4.3.1. Type V cement may optionally be used for any site concrete mix, and would be mandatory for measured sulfate concentrations exceeding 0.20 weight percent. It is recommended that all concrete which will come in contact with on-site soil materials be selected, batched, and placed in accordance with the latest California Building Code and ACI technical recommendations.

### **6.13 Construction Observation**

The preliminary foundation recommendations presented in this report are based on the assumption that all foundations will bear entirely within properly compacted engineered fill approved by this office. It is recommended that all engineered fill placement operations be performed under continuous engineering observation and testing by AGI personnel. Engineered fill shall constitute any load-bearing soil placements, irrespective of yardage quantity or depth. Continuous observation is a 2016 CBC requirement for engineered fill. Continuous or periodic fill observation and testing may be suitable for trench backfills depending mostly on trench depth and contractor production. Verification testing of completed soil-subgrade expansion potential, soluble sulfate content, soil plasticity index, and pre-saturation (if required) is recommended at appropriate points in the construction time line. All foundation excavations should be observed prior to placing reinforcing steel to verify that foundations are embedded within satisfactory materials and that excavations are free of loose or disturbed soils and made to the recommended depths.

### **6.14 Investigation Limitations**

The present findings and recommendations are based on the results of the field exploration combined with interpolations of soil and groundwater conditions between a limited number of subsurface excavations. The nature and extent of variations beyond or between the explorations may not become evident until construction. If conditions encountered during construction vary significantly from those indicated by this report, then additional geotechnical tests, analyses, and recommendations could be required from this office. Because this report has also incorporated assumed conditions or characteristics of the proposed structure where specific information was not available, foundation plan reviews by this firm are recommended prior to site grading in order to evaluate the proposed facilities from a geotechnical viewpoint and allow modifications to the preliminary recommendations developed to date.

We recommend that the project engineer incorporate this report and subsequent plan review reports into the overall project specification by title and date references on final drawings. Lastly, a pre-construction meeting with the owner, grading contractor, and civil engineer is strongly encouraged to present, explain, and clarify geotechnical concerns, uncertainties, and recommendations for the site.

## 7.0 CLOSURE

This report was prepared for the use of First Industrial Realty Trust, Inc. and their designates, in cooperation with this office. All professional services provided in connection with the preceding report were prepared in accordance with generally accepted professional engineering principles and local practice in the fields of soil mechanics, foundation engineering, and engineering geology, as well as the general requirements of Riverside County and the City of Perris in effect at the time of report issuance. We make no other warranty, either expressed or implied. We cannot guarantee acceptance of the final report by regulating authorities without needs for additional services.

AGI enthusiastically welcomes the opportunity to help engineer the owner's planned business improvements in the Inland Empire. If you should have any questions, please contact the undersigned at our Riverside office at (951) 776-0345.

Respectfully submitted,  
Aragón Geotechnical, Inc.

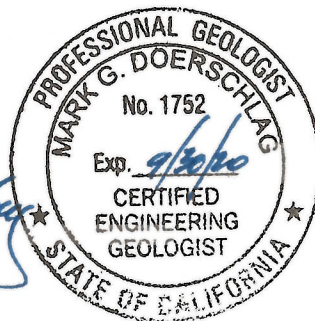

Mark G. Doerschlag, CEG 1752  
Engineering Geologist

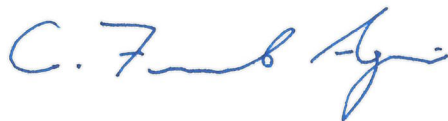

C. Fernando Aragón, P.E., M.S.  
Geotechnical Engineer, G.E. No. 2994

MGD/CFA:mma

Attachments: Appendices A and B  
Geotechnical Map, Plate No. 1 (foldout)

Distribution: (4) Addressee

**Aragón Geotechnical, Inc.**

## REFERENCES

- California Division of Mines and Geology, 2008, *Guidelines for Evaluation and Mitigation of Seismic Hazards in California*: CDMG Special Publication 117 [Rev. September 11, 2008], online version at <http://www.consrv.ca.gov/dmg/pubs/sp/117.htm>
- California Department of Conservation, Division of Mines and Geology, 2019a, Digital images of official maps of Alquist-Priolo Earthquake Fault Zones of California, on-line versions at Internet URL [http://www.quake.ca.gov/gmaps/ap/ap\\_maps.htm](http://www.quake.ca.gov/gmaps/ap/ap_maps.htm)
- California Department of Conservation, California Geological Survey, 2019b, Digital images of official maps of liquefaction and landslide Seismic Hazard Zones, on-line versions at Internet URL <http://www.conservation.ca.gov/cgs/shzp>
- County of Riverside, Transportation and Land Management Agency, 2002, *Technical Guidelines for Review of Geologic and Geotechnical Reports*, 63 p.
- FEMA, 2008, Flood Insurance Rate Map, Community Map No. 06065C1410G, 8-28-2008.
- Field, E.H., and 2014 Working Group on California Earthquake Probabilities, 2015, UCERF3: A new earthquake forecast for California's complex fault system: U.S. Geological Survey 2015-3009, 6 p., <http://dx.doi.org/10.3133/fs20153009>
- Ishihara, K., 1985, Stability of natural deposits during earthquakes, *in Proceedings of the Eleventh International Conference on Soil Mechanics and Foundation Engineering*, San Francisco, CA, vol. 1, p. 321-376.
- Ishihara, K., and Yoshimine, M., 1992, Evaluation of settlements in sand deposits following liquefaction during earthquakes: *Soils and Foundations*, JSSMFE, v. 32, no. 1, March 1992.
- Matti, J.C., Morton, D.M., and Cox, B.F., 1985, Distribution and geologic relations of fault systems in the vicinity of the central Transverse Ranges, southern California: U.S. Geological Survey Open File Report OFR 85-365.
- Morton, D.M., and Miller, F.K., 2006, Geologic map of the San Bernardino and Santa Ana 30' x 60' quadrangles, California [ver. 1.0], U.S. Geological Survey Open File Report 2006-1217, scale 1:100,000.
- Petersen, Mark D., Frankel, Arthur D., Harmsen, Stephen C., Mueller, Charles S., Haller, Kathleen M., Wheeler, Russell L., Wesson, Robert L., Zeng, Yuehua, Boyd, Oliver S., Perkins, David M., Luco, Nicolas, Field, Edward H., Wills, Chris J., and Rukstales, Kenneth S., 2008, *Documentation for the 2008 Update of the United States National Seismic Hazard Maps*: U.S. Geological Survey Open-File Report 2008-1128, 61 p.

- Sieh, K, and Yule, D., 1997, Neotectonic and paleoseismic investigation of the San Andreas fault system, San Gorgonio Pass: Progress report to Southern California Earthquake Center, 4 p.
- Sieh, K., and Yule, D., 1998, Neotectonic and paleoseismic investigation of the San Andreas fault system, San Gorgonio Pass: Southern California Earthquake Center, Annual Report for 1998, 2 p. and figures. <http://www.scec.org/research/98progreports/>
- Sieh, K., and Yule, D., 1999, Neotectonic and paleoseismic investigation of the San Andreas fault system, San Gorgonio Pass: Southern California Earthquake Center, Annual Report for 1999, 4 p. and figures. <http://www.scec.org/research/99progreports/>
- Structural Engineers Association of California [SEAOC], 2019, Seismic Design Map Tool: access date 7/19/19 from Internet URL  
<https://www.seaoc.org/page/seismicdesignmaptool>
- Tokimatsu, K., and Seed, H.B., 1987, Evaluation of settlement in sands due to earthquake shaking: Journal of Geotechnical Engineering, ASCE, vol. 113, no. 8, p. 861-878.
- U.S. Geological Survey, 2019a, Steele Peak (1953 and 1967) 7.5' topographic quadrangle sheets, and Perris (1953) 15' topographic quadrangle sheet, download files at The National Map: Historical Topographical Map Collection, access date 7/12/19 from Internet URL <http://nationalmap.gov/historical/>
- U.S. Geological Survey, 2019b, Unified Hazard Tool: Internet URL  
<https://earthquake.usgs.gov/hazards/interactive/>
- U.S. Geological Survey, 2019c, Worldwide Earthquake Map, with embedded access to Quaternary faults and folds, and ANSS Comprehensive Earthquake Catalog [COMCAT], Internet URL <http://earthquake.usgs.gov/earthquakes/map/>
- Woodford, A.O., Shelton, J.S., Doehring, D.O., and Morton, R.K., 1971, Pliocene-Pleistocene history of the Perris Block, southern California: Geological Society of America Bulletin, v. 82, p. 3421-3448.
- WGCEP, 2013, The uniform California earthquake rupture forecast, Version 3 (UCERF3) – the time-independent model: U.S. Geological Survey Open-File Report 2013-1165, 97 p.



**AERIAL PHOTOGRAPHS**

RCFCWCD Aerial Photography Collection, Riverside

Date Flown	Flight Number	Scale	Frame Numbers
1-28-62	Fairchild #24244	1:24,000	Line 1, Nos.81-82
5-24-74	1974 County	1:24,000	Nos. 380-381
4-10-80	1980 County	1:19,200	Nos. 399-400
2-4-84	1984 County	1:19,200	Nos. 1148-1149
1-21-90	1990 County	1:19,200	Line 8, Nos. 26-27
1-30-95	1995 County	1:19,200	Line 8, Nos. 24-25
3-11-00	2000 County	1:19,200	Line 8, Nos. 26-27
4-14-05	2005 County	1:19,200	Line 8, Nos. 23-24
3-29-10	2010 County	1:19,200	Line 8, Nos. 23-24

U.C. Santa Barbara Aerial Image Collections

Date Flown	Flight Number	Scale	Frame Numbers
6-7-38	AXM-1938A	1:20,000	Line 45, #58
8-28-53	AXM-1953B	1:20,000	Line 2K, #110
5-15-67	AXM-1967	1:12,000	3HH-31
3-8-04	EAG RV 04	1:21,000	616

Google Earth Pro Historical Image Archive

Image dates as shown in application:

6/5/02	1/3/06	2/9/16
5/21/02	4/27/06	10/21/16
12/30/02	5/24/09	2/9/18
10/25/03	11/15/09	8/10/18
12/18/03	3/9/11	8/24/18
1/4/04	6/17/12	
10/10/05	11/12/13	
12/2005	4/27/14	

## ***APPENDIX A***

## **A P P E N D I X A**

### **MAP EXPLANATION & SUBSURFACE EXPLORATION LOGS**

*The Geotechnical Map (Plate No. 1, foldout at the back of this report) was prepared based upon information supplied by the client, or others, along with Aragón Geotechnical's field measurements and observations. Field exploration locations illustrated on the map were derived from taped and paced measurements of distance to existing improvements, and air photo overlays scaled to match the development plan. Locations should be considered approximate. The selected boring locations were deemed sufficient by AGI for characterizing the possible range of subsurface conditions occurring at the site.*

*The Field Boring Logs on the following pages schematically depict and describe the subsurface (soil and groundwater) conditions encountered at the specific exploration locations on the date that the explorations were performed. Unit descriptions reflect predominant soil types; actual variability may be much greater. Unit boundaries may be approximate or gradational. Text information often incorporates the field investigator's interpretations of geologic history, origin, diagenesis, and unit identifiers such as formation name or time-stratigraphic group. Additionally, soil conditions between recovered samples are based in part on judgment. Therefore, the logs contain both factual and interpretive information. Subsurface conditions may differ between exploration locations and within areas of the site that were not explored. The subsurface conditions may also change at the exploration locations over the passage of time.*

*The investigation scope and field operations were conducted in general accordance with the procedures recommended by the American Society for Testing and Materials (ASTM) standard D420-98 entitled "Site Characterization for Engineering Design and Construction Purposes" and/or other relevant specifications. Soil samples were preserved and transported to AGI's Riverside laboratory in general accordance with the procedures recommended by ASTM standard D4220 entitled "Standard Practices for Preserving and Transporting Soil Samples". Brief descriptions of the sampling and testing procedures are presented below:*

#### **Ring-Lined Barrel Sampling – ASTM D3550-01**

*In this procedure, a thick-walled barrel sampler constructed to receive thin-wall liners (either a stack of 1-inch-high brass rings or 6-inch stainless steel tubes for environmental testing) is used to collect soil samples for classification and laboratory tests. Samples were collected from selected depths in all 6 hollow-stem auger borings. The drilling rig was equipped with a 140-pound mechanically actuated automatic driving hammer operated to fall 30 inches, acting on rods. A 12-inch-long sample barrel fitted with 2.50-inch-diameter rings and tubes plus a waste barrel extension was subsequently driven a distance of 18 inches or to practical refusal (considered to be  $\geq 50$  blows for 6 inches). The raw blow counts for each 6-inch increment of penetration (or fraction thereof) were recorded and are shown on the Field Boring Logs. An asterisk (\*) marks refusal within the initial 6-inch seating interval. The hammer weight of 140 pounds and fall of 30 inches allow rough*

*correlations to be made (via conversion factors that normally range from 0.60 to 0.65 in Southern California practice) to uncorrected Standard Penetration Test N-values, and thus approximate descriptions of consistency or relative density could be derived. The method provides relatively undisturbed samples that fit directly into laboratory test instruments without additional handling and disturbance.*

#### **Standard Penetration Tests – ASTM D1586-11**

*In deeper boreholes, Standard Penetration Tests were performed to recover disturbed samples suitable for classification, and to provide baseline data for liquefaction susceptibility analyses and site class assignment for seismic design. A split-barrel sampler with a 2.0-inch outside diameter is driven by successive blows of a 140-pound hammer with a vertical fall of 30 inches, for a distance of 18 inches at the desired depth. The drill rig used for this investigation was equipped with an automatic trip hammer acting on drilling rods. The total number of blows required to drive the sampler the last 12 inches of the 18-inch sample interval is defined as the Standard Penetration Resistance, or “N-value”. Penetration resistance counts for each 6-inch interval and the raw, uncorrected N-value for each test are shown on the Field Boring Logs. Drive efficiencies for automatic hammers are higher than older rope-and-cathead systems, which are disappearing from practice. Where practical refusal was encountered within a 6-inch interval, defined as penetration resistance  $\geq 50$  blows per 6 inches, the raw blow count was recorded for the noted fractional interval; an asterisk (\*) marks refusal within the initial 6-inch seating interval. The N-value represents an index of the relative density for granular soils or comparative consistency for cohesive soils.*

#### **Bulk Sample**

*A relatively large volume of soil is collected with a shovel or trowel. The sample is transported to the materials laboratory in a sealed plastic bag or bucket.*

#### **Classification of Samples**

*Bulk auger cuttings and discrete soil samples were visually-manually classified based on texture and plasticity, utilizing the procedures outlined in the ASTM D2487-11 standard. The assignment of a group name to each of the collected samples was performed according to the Unified Soil Classification System (ASTM D2488-09). The plasticity reported on field logs refers to soil behavior at field moisture content unless noted otherwise. Site material classifications are reported on the Field Boring Logs.*



# FIELD LOG OF BORING B - 1

Sheet 1 of 2

Project: **"RIDER AT REDLANDS" LIGHT INDUSTRIAL PROJECT**

Location: **CITY OF PERRIS, RIVERSIDE COUNTY, CALIF.**

Date(s) Drilled: <b>7/8/19</b>	Logged By: <b>M. Doerschlag</b>
Drilled By: <b>GP Drilling</b>	Total Depth: <b>26.5 Ft.</b>
Rig Make/Model: <b>Mobile B-61</b>	Hammer Type: <b>Automatic trip</b>
Drilling Method: <b>Hollow-Stem Auger</b>	Hammer Weight/Drop: <b>140 Lb./30 In.</b>
Hole Diameter: <b>8 In.</b>	Surface Elevation: <b>± 1443 Ft. AMSL, RCFC NAD 83</b>

Comments: Located at SEC of proposed development site, within possible BMP outline.

DEPTH (ft.)	ELEVATION (MSL DATUM)	SAMPLE INTERVALS		GRAPHIC LOG	USCS	GEOTECHNICAL DESCRIPTION	DRY DENSITY (pcf)	WATER CONTENT (%)	WELL COMPLETION	OTHER TESTS
		BULK DRIVE	TYPE "N" or (Blows/ft.)							
0					ML	Sandy Silt: Brown; mechanically disturbed to around 2 feet, abruptly becoming very stiff below; slightly moist; averages around 40% fine- to medium-grained sand; no clay. Non-plastic even with added water. [Older alluvium]				
1440		SPT 3 5 15	N=20		ML	← Sandy silt, with trace clay and diffuse carbonate, mildly cemented, visibly porous.				
5		SPT 7 7 7	N=14		SM	Silty Sand: Brown; medium dense; slightly moist; fine to medium grained, with ~35-40% fines including trace of clay; massive; crumbly. Upper half with pinhole pores. [Older alluvium]				
1435		SPT 6 7 8	N=15		SM	← Silty sand, as above but with some diffuse carbonate, not visibly porous.				
10		SPT 8 10 14	N=24		ML	Sandy Silt: Brown; very stiff; slightly moist; estimated 30% fine to medium sand and possibly 5-8% clay; mildly cohesive; not visibly porous. [Very old alluvium]				
1430					ML	← Sandy silt, weakly cemented and with few pinhole pores, crumbly. Traces of carbonate increase quickly with depth				
15					ML	Clayey Silt: Brown; hard; moist; cohesive; traces of fine sand. [Very old alluvium]				

Continued on next sheet.



# FIELD LOG OF BORING B - 1

Sheet 2 of 2

Project: **"RIDER AT REDLANDS" LIGHT INDUSTRIAL PROJECT**

Location: **CITY OF PERRIS, RIVERSIDE COUNTY, CALIF.**

DEPTH (ft.)	ELEVATION (MSL DATUM)	SAMPLE INTERVALS		GRAPHIC LOG	USCS	GEOTECHNICAL DESCRIPTION	DRY DENSITY (pcf)	WATER CONTENT (%)	WELL COMPLETION	OTHER TESTS
		BULK DRIVE	TYPE: "N" or (Blows/ft.)							
15		SPT 9 14 19	N=33	ML	ML	Clayey Silt: Brown; hard; moist; moderately cohesive; traces of fine sand. Unit is massive and not visibly porous, with common veils of MnO. Non-plastic. [Very old alluvium]			WELL COMPLETION	
1425										
20		SPT 9 15 20	N=35	ML	ML	← Clayey silt, as above, estimated 15% fine to medium sand, not visibly porous.				
1420						Sandy Silt: Brown to yellowish brown; hard; moist; typical 30-35% fine to medium grained sand; massive; non-plastic; common MnO spots and veils. Crumbly and essentially uncemented. [Very old alluvium]				
25		SPT 6 13 19	N=32	ML	ML	← Sandy silt, as above with a trace of clay, ~30% f-m sand. massive.				

*Bottom of boring at 26.5 ft.  
 No groundwater encountered.  
 Boring backfilled with compacted soil cuttings.*



## FIELD LOG OF BORING B - 2

Sheet 1 of 3

Project: **"RIDER AT REDLANDS" LIGHT INDUSTRIAL PROJECT**

Location: **CITY OF PERRIS, RIVERSIDE COUNTY, CALIF.**

Date(s) Drilled: <b>7/8/19</b>	Logged By: <b>M. Doerschlag</b>
Drilled By: <b>GP Drilling</b>	Total Depth: <b>51.5 Ft.</b>
Rig Make/Model: <b>Mobile B-61</b>	Hammer Type: <b>Automatic trip</b>
Drilling Method: <b>Hollow-Stem Auger</b>	Hammer Weight/Drop: <b>140 Lb./30 In.</b>
Hole Diameter: <b>8 In.</b>	Surface Elevation: <b>± 1444 Ft. AMSL, RCFC NAD 83</b>

Comments: Located at SEC of proposed building

DEPTH (ft.)	ELEVATION (MSL DATUM)	SAMPLE INTERVALS		GRAPHIC LOG	USCS	GEOTECHNICAL DESCRIPTION	DRY DENSITY (pcf)	WATER CONTENT (%)	WELL COMPLETION	OTHER TESTS
		BULK DRIVE	TYPE, "N" or (Blows/ft.)							
0					SM	Silty Sand: Brown; loose to around 2 feet, abruptly becoming medium dense below; slightly moist; fine to medium grained sand and around 40-45% silt; plus trace of clay; massive. [Older alluvium]				BULK: MAX, EI, SHEAR, CORROSION SUITE
		RING 5 17 (41)			SM	← Silty sand, some diffuse carbonate, mildly cemented, visibly porous.	108.7	7.2		
1440		RING 21 22 (44)			SM/ML	← Silty sand, now near 50:50 sand and fines proportions, less cemented and with few fine pores.	122.3	7.4		
5		RING 10 16 (37)			SM	← Silty sand, coarser than above and with ~30% silt plus some clay, continued few fine pores, slightly cemented but friable.	117.7	6.4		
1435		RING 9 16 (47)			ML	Sandy Silt: Brown; very stiff to hard; moist; cemented with fine carbonate clots and threads; moderately cohesive. some clay and estimated ~30% sand. Few fine pores at 10 feet. [Very old alluvium]	119.0	12.2		
10					CL	Silty Clay: Brown; stiff; moist; heavy carbonate precipitates including some hard nodular concretions to 1/2" across; trace of fine sand. Cohesive. [Very old alluvium]				
1430										
15										

Continued on next sheet.



# FIELD LOG OF BORING B - 2

Sheet 2 of 3

Project: **"RIDER AT REDLANDS" LIGHT INDUSTRIAL PROJECT**

Location: **CITY OF PERRIS, RIVERSIDE COUNTY, CALIF.**

DEPTH (ft.)	ELEVATION (MSL DATUM)	SAMPLE INTERVALS		GRAPHIC LOG	USCS	GEOTECHNICAL DESCRIPTION	DRY DENSITY (pcf)	WATER CONTENT (%)	WELL COMPLETION	OTHER TESTS
		BULK DRIVE	TYPE "N" or (Blows/ft.)							
15			SPT 3, 4, 7 N=11		CL	Silty Clay: Brown; stiff; moist; heavy carbonate precipitates including some hard nodular concretions to 1/2" across; trace of fine sand; not visibly porous; non-plastic. Cohesive. [Very old alluvium]				
1425					ML	Clayey Silt: Brown; very stiff; moist; mildly cohesive but crumbly and with common MnO veils; about 20-25% fine to medium sand; massive; non-plastic. [Very old alluvium]				
20			SPT 6, 9, 12 N=21		ML	← Clayey silt, as above, non-plastic.				
1420					ML	Sandy Silt: Brown to yellowish brown; hard; moist; uncemented and friable samples; massive; common stains and spots of metal oxides. No carbonate. [Very old alluvium]				
25			SPT 7, 14, 16 N=30		ML	← Sandy silt with trace of clay, abundant fine MnO spots. Below 27 feet becomes browner color and very stiff drilling.				
1415					ML					
30			SPT 12, 21, 21 N=42		ML	← Sandy silt, traces of clay and coarse sand, massive, not visibly porous.				
1410					ML					
35					ML					

Continued on next sheet.





# FIELD LOG OF BORING B - 2

Sheet 3 of 3

Project: "RIDER AT REDLANDS" LIGHT INDUSTRIAL PROJECT

Location: CITY OF PERRIS, RIVERSIDE COUNTY, CALIF.

DEPTH (ft.)	ELEVATION (MSL DATUM)	SAMPLE INTERVALS		GRAPHIC LOG	USCS	GEOTECHNICAL DESCRIPTION	DRY DENSITY (pcf)	WATER CONTENT (%)	WELL COMPLETION	OTHER TESTS
		BULK DRIVE	TYPE, "N" or (Blows/ft.)							
35		SPT 9, 13, 17	N=30	[Pattern]	ML	Sandy Silt: Brown; hard; moist; uncemented and friable sample at 35 feet, with some clay; massive. No carbonate. Lower unit contact marked by faster auger progress and appearance of wet cuttings. [Very old alluvium]			[Symbol]	
40	1405	SPT 10, 12, 15	N=27	[Pattern]	SC	Clayey Sand: Yellowish brown; medium dense; wet; fine to coarse weathered sand grains; estimated 30% fines; massive, but with some possible thin cleaner-sand beds in uppermost 2-3 feet. [Very old alluvium]				
45	1400	SPT 15, 23, 33	N=53	[Pattern]	SC	← Clayey sand, wet, with slightly sticky matrix composing ~30% of sample, not visibly porous. ↙ Drilling rate slows.				
50	1395	SPT 18, 29, 36	N=65	[Pattern]	SM	← Clayey sand, becomes very dense, matches 40' sample, wet. ← Grades to silty sand with clay, massive, very moist.				

Bottom of boring at 51.5 ft.  
 Limited groundwater seepage noted at ~37-45 ft., no static level achieved.  
 Boring backfilled with compacted soil cuttings.



# FIELD LOG OF BORING B - 3

Sheet 1 of 2

Project: **"RIDER AT REDLANDS" LIGHT INDUSTRIAL PROJECT**

Location: **CITY OF PERRIS, RIVERSIDE COUNTY, CALIF.**

Date(s) Drilled: <b>7/8/19</b>	Logged By: <b>M. Doerschlag</b>
Drilled By: <b>GP Drilling</b>	Total Depth: <b>21.5 Ft.</b>
Rig Make/Model: <b>Mobile B-61</b>	Hammer Type: <b>Automatic trip</b>
Drilling Method: <b>Hollow-Stem Auger</b>	Hammer Weight/Drop: <b>140 Lb./30 In.</b>
Hole Diameter: <b>8 In.</b>	Surface Elevation: <b>± 1445 Ft. AMSL, RCFC NAD 83</b>

Comments: Located close to SWC of proposed building.

DEPTH (ft.)	ELEVATION (MSL DATUM)	SAMPLE INTERVALS		GRAPHIC LOG	USCS	GEOTECHNICAL DESCRIPTION	DRY DENSITY (pcf)	WATER CONTENT (%)	WELL COMPLETION	OTHER TESTS
		BULK DRIVE	TYPE, "N" or (Blows/ft.)							
0	1445			[Graphic Log Pattern]	SM	Silty Sand: Brown; mechanically disturbed to around 1 foot, abruptly becoming medium dense below; slightly moist; fine to coarse grained sand averaging around 30% silt fines (seems clay-free); not stratified. [Older alluvium]			[Well Completion Pattern]	
		RING 12 30 36 (66)		[Graphic Log Pattern]	SM	← Silty sand, dense and slightly cemented with fine carbonate clots and filaments, sample is fine to medium grained, visibly porous.	111.0	6.4	[Well Completion Pattern]	
5	1440	RING 20 20 18 (38)		[Graphic Log Pattern]	SM	← Silty sand, now uncemented and not visibly porous.	114.6	6.5	[Well Completion Pattern]	
		RING 12 14 16 (30)		[Graphic Log Pattern]	SM	← Silty sand, grades yellowish brown and siltier, uncemented, not visibly porous.	114.8	6.7	[Well Completion Pattern]	
10	1435	RING 27 39 44 (83)		[Graphic Log Pattern]	ML	Sandy Silt: Brown; hard; subjectively only slightly moist. Almost pure silt at top, grading to sandy silt with minor clay. Massive; few fine pores at 10 feet; non-plastic. [Very old alluvium]	107.1	17.3	[Well Completion Pattern]	
15	1430			[Graphic Log Pattern]					[Well Completion Pattern]	

Continued on next sheet.



# FIELD LOG OF BORING B - 3

Sheet 2 of 2

Project: **"RIDER AT REDLANDS" LIGHT INDUSTRIAL PROJECT**

Location: **CITY OF PERRIS, RIVERSIDE COUNTY, CALIF.**

DEPTH (ft.)	ELEVATION (MSL DATUM)	SAMPLE INTERVALS		GRAPHIC LOG	USCS	GEOTECHNICAL DESCRIPTION	DRY DENSITY (pcf)	WATER CONTENT (%)	WELL COMPLETION	OTHER TESTS
		BULK DRIVE	TYPE "N" or (Blows/ft.)							
15	1430		SPT 7 12 16 N=28		ML	Clayey Silt: Olive brown; very stiff; slightly moist; traces of fine sand and scattered carbonate filaments plus MnO spots/veils; friable; non-plastic; not visibly porous. [Very old alluvium]				
20	1425		SPT 12 15 20 N=35		ML, SC	← Clayey silt with subordinate coarse "gritty" immature clayey sand, fine carbonate threads.				

*Bottom of boring at 21.5 ft.  
 No groundwater encountered.  
 Boring backfilled with compacted soil cuttings.*



# FIELD LOG OF BORING B - 4

Sheet 1 of 2

Project: **"RIDER AT REDLANDS" LIGHT INDUSTRIAL PROJECT**

Location: **CITY OF PERRIS, RIVERSIDE COUNTY, CALIF.**

Date(s) Drilled: <b>7/8/19</b>	Logged By: <b>M. Doerschlag</b>	
Drilled By: <b>GP Drilling</b>	Total Depth: <b>21.5 Ft.</b>	
Rig Make/Model: <b>Mobile B-61</b>	Hammer Type: <b>Automatic trip</b>	
Drilling Method: <b>Hollow-Stem Auger</b>	Hammer Weight/Drop: <b>140 Lb./30 In.</b>	
Hole Diameter: <b>8 In.</b>	Surface Elevation: <b>± 1444 Ft. AMSL, RCFC NAD 83</b>	

Comments: Located in proposed truck and trailer yard.

DEPTH (ft.)	ELEVATION (MSL DATUM)	SAMPLE INTERVALS		GRAPHIC LOG	USCS	GEOTECHNICAL DESCRIPTION	DRY DENSITY (pcf)	WATER CONTENT (%)	WELL COMPLETION	OTHER TESTS
		BULK	DRIVE							
0					SM	Silty Sand: Brown; medium dense; slightly moist; fine to coarse grained sand averaging around 35% fines including trace of clay; not stratified. [Older alluvium]				
					SM	Silty sand, with sharp lower unit contact.				
	1440		RING 7 (17)		ML	Clayey Silt: Brown; hard; moist; traces of fine sand; massive; cohesive and cemented near top; non-plastic. Sample at 5 feet has few fine pores. [Very old alluvium]	91.2	11.0		
5			RING 18 (57)		ML		108.0	17.1		CONSOL
			RING 10 (34)		ML	← Clayey silt, moist, slightly punky and crumbly texture, about 20% fine sand and abundant pedogenic carbonate.	101.8	12.8		CONSOL
	1435		RING 7 (39)		ML	← Silt, with some soft laminar carbonate and only trace of clay, not visibly porous.	104.1	18.6		
					CL	Silty Clay: Variegated dark brown and lighter olive brown; hard; moist; traces of fine sand. [Very old alluvium]				
15										

Continued on next sheet.



# FIELD LOG OF BORING B - 4

Sheet 2 of 2

Project: **"RIDER AT REDLANDS" LIGHT INDUSTRIAL PROJECT**

Location: **CITY OF PERRIS, RIVERSIDE COUNTY, CALIF.**

DEPTH (ft.)	ELEVATION (MSL DATUM)	SAMPLE INTERVALS		GRAPHIC LOG	USCS	GEOTECHNICAL DESCRIPTION	DRY DENSITY (pcf)	WATER CONTENT (%)	WELL COMPLETION	OTHER TESTS
		BULK DRIVE	TYPE "N" or (Blows/ft.)							
15		SPT 7 12 19	N=31		CL	Silty Clay: Variegated dark brown and lighter olive brown; hard; moist; traces of fine sand. Lighter-colored zones contain abundant clots of carbonate; moderately cohesive; non-plastic; not visibly porous. Firm drilling. [Very old alluvium]				
20	1425	SPT 23 34	N=57		SC/CL	← Borderline clayey sand, fine to coarse weathered grains, massive, moist, massive.				

*Bottom of boring at 21.5 ft.  
 No groundwater encountered.  
 Boring backfilled with compacted soil cuttings.*



# FIELD LOG OF BORING B - 5

Sheet 1 of 2

Project: **"RIDER AT REDLANDS" LIGHT INDUSTRIAL PROJECT**

Location: **CITY OF PERRIS, RIVERSIDE COUNTY, CALIF.**

Date(s) Drilled: <b>7/8/19</b>	Logged By: <b>M. Doerschlag</b>
Drilled By: <b>GP Drilling</b>	Total Depth: <b>21.5 Ft.</b>
Rig Make/Model: <b>Mobile B-61</b>	Hammer Type: <b>Automatic trip</b>
Drilling Method: <b>Hollow-Stem Auger</b>	Hammer Weight/Drop: <b>140 Lb./30 In.</b>
Hole Diameter: <b>8 In.</b>	Surface Elevation: <b>± 1446 Ft. AMSL, RCFC NAD 83</b>

Comments: West-central side of warehouse envelope.

DEPTH (ft.)	ELEVATION (MSL DATUM)	SAMPLE INTERVALS		GRAPHIC LOG	USCS	GEOTECHNICAL DESCRIPTION	DRY DENSITY (pcf)	WATER CONTENT (%)	WELL COMPLETION	OTHER TESTS
		BULK DRIVE	TYPE, "N" or (Blows/ft.)							
0										
1445					SM	Silty Sand: Brown; loose; slightly moist; predominately fine to medium grained sand and very silty (40%); massive. [Older alluvium]				
		RING 5	(13)		SM	← Silty sand, less silty and with traces of coarse sand.	113.1	2.7		
		RING 6			SM	← Silty sand, porous, and with sharp lower contact.				
5		RING 12	(52)		ML	Sandy Silt: Olive brown to brown; very stiff; slightly moist; massive; mildly cemented and abundant carbonate near top plus some clay; non-plastic. [Very old alluvium]	100.1	7.3		
		RING 25			ML	← Sandy silt, slightly cemented with abundant pedogenic carbonate, visibly porous.	112.8	6.0		
		RING 27								
1440		RING 11	(55)		ML, SM	← Sandy silt, indistinctly layered with very silty fine sand. No clay, not visibly porous.	113.8	4.0		
		RING 17								
		RING 18								
10		RING 8	(27)							
		RING 11								
		RING 16								
1435										
15										

Continued on next sheet.



# FIELD LOG OF BORING B - 5

Sheet 2 of 2

Project: **"RIDER AT REDLANDS" LIGHT INDUSTRIAL PROJECT**

Location: **CITY OF PERRIS, RIVERSIDE COUNTY, CALIF.**

DEPTH (ft.)	ELEVATION (MSL DATUM)	SAMPLE INTERVALS		GRAPHIC LOG	USCS	GEOTECHNICAL DESCRIPTION	DRY DENSITY (pcf)	WATER CONTENT (%)	WELL COMPLETION	OTHER TESTS
		BULK DRIVE	TYPE: "N" or (Blows/ft.)							
15	1430	SPT 6 9 12	N=21		ML	Sandy Silt: Brown; very stiff; moist; some clay. Sample at 15 feet with heavy filamentous carbonate (paleosol); massive. [Very old alluvium]				
20	1425	SPT 7 13 19	N=32		CL	← Classifies as silty clay, hard, non-plastic and with 10-15% fine sand, massive, minor filamentous carbonate.				

*Bottom of boring at 21.5 ft.  
 No groundwater encountered.  
 Boring backfilled with compacted soil cuttings.*



# FIELD LOG OF BORING B - 6

Sheet 1 of 2

Project: **"RIDER AT REDLANDS" LIGHT INDUSTRIAL PROJECT**

Location: **CITY OF PERRIS, RIVERSIDE COUNTY, CALIF.**

Date(s) Drilled: <b>7/8/19</b>	Logged By: <b>M. Doerschlag</b>
Drilled By: <b>GP Drilling</b>	Total Depth: <b>21.5 Ft.</b>
Rig Make/Model: <b>Mobile B-61</b>	Hammer Type: <b>Automatic trip</b>
Drilling Method: <b>Hollow-Stem Auger</b>	Hammer Weight/Drop: <b>140 Lb./30 In.</b>
Hole Diameter: <b>8 In.</b>	Surface Elevation: <b>± 1446 Ft. AMSL, RCFC NAD 83</b>

Comments: West-central side of warehouse envelope; drill site in former cultivated field.

DEPTH (ft.)	ELEVATION (MSL DATUM)	SAMPLE INTERVALS		GRAPHIC LOG	USCS	GEOTECHNICAL DESCRIPTION	DRY DENSITY (pcf)	WATER CONTENT (%)	WELL COMPLETION	OTHER TESTS
		BULK DRIVE	TYPE, "N" or (Blows/ft.)							
0					SM	Silty Sand: Brown; loose; slightly moist; predominantly fine to medium grained sand with estimated 35% silt plus trace of clay; massive. Inferred heavily bioturbated; surface has been plowed. [Older alluvium]				
1445					SM	← Silty sand, disturbed and bioturbated, fine to coarse grained.	110.8	6.6		
		RING 4 5 7 (12)			ML	Sandy Silt: Brown; very stiff; moist; massive; mildly cemented and abundant soft carbonate near top; estimated 20% fine sand plus some clay; non-plastic. Sample at 5 feet is visibly porous. [Very old alluvium]	103.5	12.4		
5	1440				ML	← Sandy silt, now 30% sand, slightly cemented, few pinhole pores and carbonate threads.	118.5	9.5		
		RING 10 13 24 (37)			ML	← Clayey silt, becomes moist, still occasional pinhole pores, massive, crumbly or friable.	95.5	19.8		
		RING 12 16 19 (35)								
10	1435									
		RING 9 10 15 (25)								
15										

Continued on next sheet.





# FIELD LOG OF BORING B - 6

Sheet 2 of 2

Project: **"RIDER AT REDLANDS" LIGHT INDUSTRIAL PROJECT**

Location: **CITY OF PERRIS, RIVERSIDE COUNTY, CALIF.**

DEPTH (ft.)	ELEVATION (MSL DATUM)	SAMPLE INTERVALS		GRAPHIC LOG	USCS	GEOTECHNICAL DESCRIPTION	DRY DENSITY (pcf)	WATER CONTENT (%)	WELL COMPLETION	OTHER TESTS
		BULK DRIVE	TYPE "N" or (Blows/ft.)							
15	1430	SPT 8 11 13	N=24	[Graphic Log: Dotted pattern]	ML	Sandy Silt: Brown; very stiff; moist; increased clay versus shallower deposits. Sample at 15 feet with heavy soft clots of carbonate (paleosol?); massive and friable. [Very old alluvium]			[Graphic Log: Wavy pattern]	
20	1425	SPT 14 15 22	N=37	[Graphic Log: Dotted pattern]	SC, ML	← Faintly layered clayey sand and clayey silt, former tending to medium-coarse weathered sand, moist.			[Graphic Log: Wavy pattern]	

*Bottom of boring at 21.5 ft.  
 No groundwater encountered.  
 Boring backfilled with compacted soil cuttings.*



# FIELD LOG OF BORING B - 7

Sheet 1 of 3

Project: **"RIDER AT REDLANDS" LIGHT INDUSTRIAL PROJECT**

Location: **CITY OF PERRIS, RIVERSIDE COUNTY, CALIF.**

Date(s) Drilled: <b>7/9/19</b>	Logged By: <b>M. Doerschlag</b>	
Drilled By: <b>GP Drilling</b>	Total Depth: <b>51.5 Ft.</b>	
Rig Make/Model: <b>Mobile B-61</b>	Hammer Type: <b>Automatic trip</b>	
Drilling Method: <b>Hollow-Stem Auger</b>	Hammer Weight/Drop: <b>140 Lb./30 In.</b>	
Hole Diameter: <b>8 In.</b>	Surface Elevation: <b>± 1445 Ft. AMSL, RCFC NAD 83</b>	

Comments: Located at NWC of proposed building

DEPTH (ft.)	ELEVATION (MSL DATUM)	SAMPLE INTERVALS		GRAPHIC LOG	USCS	GEOTECHNICAL DESCRIPTION	DRY DENSITY (pcf)	WATER CONTENT (%)	WELL COMPLETION	OTHER TESTS
		BULK DRIVE	TYPE: "N" or (Blows/ft.)							
0	1445				SM	Silty Sand: Brown; loose; slightly moist; fine to medium grained sand and very silty; plus trace of clay. Disturbed and bioturbated. [Older alluvium]				BULK: MAX, EI, CORROSION SUITE
		RING 4			ML	Silt: Brown; stiff to very stiff; slightly moist; some very fine sand; visibly porous; spotty pedogenic carbonate. [Older alluvium]	93.8	8.3		
		7 (20)			SM	Silty Sand: Brown to yellowish brown; medium dense; slightly moist; fine to coarse grained, with estimated 40% fines; massive. Persistent pinhole porosity. [Older alluvium]	113.3	9.3		
5	1440	RING 16			SM	Silty Sand: Brown to yellowish brown; medium dense; slightly moist; fine to coarse grained, with estimated 40% fines; massive. Persistent pinhole porosity. [Older alluvium]	113.3	9.3		
		28 (53)			SM	Silty Sand: Brown to yellowish brown; medium dense; slightly moist; fine to coarse grained, with estimated 40% fines; massive. Persistent pinhole porosity. [Older alluvium]	113.3	9.3		
		25 (53)			SM	Silty Sand: Brown to yellowish brown; medium dense; slightly moist; fine to coarse grained, with estimated 40% fines; massive. Persistent pinhole porosity. [Older alluvium]	113.3	9.3		
		RING 10			SM	← Silty sand, slightly cemented, continued fine pores; massive.	115.2	5.1		
		15 (31)			SM	← Silty sand, slightly cemented, continued fine pores; massive.	115.2	5.1		
		16 (31)			SM	← Silty sand, slightly cemented, continued fine pores; massive.	115.2	5.1		
10	1435	RING 9			ML	Clayey Silt: Brown and olive brown; very stiff; moist; massive; traces of fine sand. [Very old alluvium]				
		20 (53)			ML	Clayey Silt: Brown and olive brown; very stiff; moist; massive; traces of fine sand. [Very old alluvium]	96.4	21.0		
		33 (53)			ML	Clayey Silt: Brown and olive brown; very stiff; moist; massive; traces of fine sand. [Very old alluvium]	96.4	21.0		
						} Nodular carbonate zone, hard concretions to 3/4" diameter.				
15	1430									

Continued on next sheet.



# FIELD LOG OF BORING B - 7

Sheet 2 of 3

Project: **"RIDER AT REDLANDS" LIGHT INDUSTRIAL PROJECT**

Location: **CITY OF PERRIS, RIVERSIDE COUNTY, CALIF.**

DEPTH (ft.)	ELEVATION (MSL DATUM)	SAMPLE INTERVALS		GRAPHIC LOG	USCS	GEOTECHNICAL DESCRIPTION	DRY DENSITY (pcf)	WATER CONTENT (%)	WELL COMPLETION	OTHER TESTS
		BULK DRIVE	TYPE "N" or (Blows/ft.)							
15	1430		SPT 12, 13, 16 N=29		ML SP-SM	<p>Clayey Silt: Brown; very stiff; moist; massive. Sandy between previous nodule zone and bottom of subunit. Sharp contact. [Very old alluvium]</p> <p>Sand with Silt: Light brown; medium dense; slightly moist. Composed of low-silt, fine- to coarse-grained, low-cohesion sand from granitic watershed. May grade increasing fines with depth. [Very old alluvium]</p> <p style="text-align: center;">Gradational contact.</p>				
20	1425		SPT 10, 11, 13 N=24		SC, SM	<p>Clayey Sand: Yellowish brown; medium dense; moist; fine to coarse immature sand from granitic source; indistinct 6-8" layering; crumbly and low cohesion. Clay % may increase with depth. [Very old alluvium]</p>				
25	1420		SPT 8, 11, 16 N=27		ML/CL	<p>← Clayey sandy silt, yellowish brown, about 35% weathered sand, non-plastic. Lower unit contact marked by much slower drilling rate and distinctly brown color soil.</p>				
30	1415		SPT 8, 15, 24 N=39		ML, SM	<p>Clayey Silt: Brown; hard; moist; uncemented but moderately cohesive. No carbonate. Firm drilling and tends to squeeze. Coarsens very slowly downward. [Very old alluvium]</p> <p>← Clayey silt, with ~25-30% fine sand, indistinct layering over inches with very silty sand, uncemented but moderate cohesion, no carbonate.</p>				
35	1410									

Continued on next sheet.



# FIELD LOG OF BORING B - 7

Sheet 3 of 3

Project: **"RIDER AT REDLANDS" LIGHT INDUSTRIAL PROJECT**

Location: **CITY OF PERRIS, RIVERSIDE COUNTY, CALIF.**

DEPTH (ft.)	ELEVATION (MSL DATUM)	SAMPLE INTERVALS		GRAPHIC LOG	USCS	GEOTECHNICAL DESCRIPTION	DRY DENSITY (pcf)	WATER CONTENT (%)	WELL COMPLETION	OTHER TESTS
		BULK DRIVE	TYPE, "N" or (Blows/ft.)							
35	1410		SPT 6 12 13 N=25		SM	Silty Sand: Yellowish brown; medium dense; very moist; fine to medium sand. Interpreted as basal part of a 10-foot-thick fining-up sequence. [Very old alluvium]				
					SC	Clayey Sand: Yellowish brown; dense; moist to very moist; fine to coarse "gritty" immature and weathered sand grains, with traces of fine gravel. Matrix slightly plastic. Stiff drilling. [Very old alluvium]				
40	1405		SPT 7 12 19 N=31		SC	← Clayey sand, very moist, slightly sticky plastic matrix, very faint layering and graded beds. About 40% fines. Much easier drilling below 40 feet.				
45	1400		SPT 15 20 30 N=50		SC	← Clayey sand, as at 40'. Sharp contact.				
					SM	Silty Sand: Brown; dense; very moist to wet; fine to coarse grained sand with traces of clay; massive. Easier drill penetration than above. [Very old alluvium]				
50	1395		SPT 10 16 24 N=40		SM	← Silty sand, trace of clay, wet.				

Bottom of boring at 51.5 ft.  
 Limited groundwater seepage between ~45-50 ft., no static level achieved.  
 Boring backfilled with compacted soil cuttings.



# FIELD LOG OF BORING B - 8

Sheet 1 of 2

Project: **"RIDER AT REDLANDS" LIGHT INDUSTRIAL PROJECT**

Location: **CITY OF PERRIS, RIVERSIDE COUNTY, CALIF.**

Date(s) Drilled: <b>7/9/19</b>	Logged By: <b>M. Doerschlag</b>
Drilled By: <b>GP Drilling</b>	Total Depth: <b>21.5 Ft.</b>
Rig Make/Model: <b>Mobile B-61</b>	Hammer Type: <b>Automatic trip</b>
Drilling Method: <b>Hollow-Stem Auger</b>	Hammer Weight/Drop: <b>140 Lb./30 In.</b>
Hole Diameter: <b>8 In.</b>	Surface Elevation: <b>± 1444 Ft. AMSL, RCFC NAD 83</b>

Comments: Northeast quadrant of proposed structure.

DEPTH (ft.)	ELEVATION (MSL DATUM)	SAMPLE INTERVALS		GRAPHIC LOG	USCS	GEOTECHNICAL DESCRIPTION	DRY DENSITY (pcf)	WATER CONTENT (%)	WELL COMPLETION	OTHER TESTS
		BULK DRIVE	TYPE: "N" or (Blows/ft.)							
0					SM	Silty Sand: Brown; loose; slightly moist; predominantly fine to medium grained sand and very silty (40%); massive. Disturbed. [Older alluvium]				
		RING 13			ML	Silt: Light brown and olive brown; hard, grading to stiff; subjectively only slightly moist; massive; cemented and cohesive near top, but quickly decreasing dry strength with depth. Abundant carbonate clots and veils; traces of very fine sand and clay. Porous. [Very old alluvium]	93.3	17.2		
	1440	23 (73)			ML	← Silt, much less cemented but continued visibly porous, friable.	88.3	19.3		CONSOL
		RING 15			ML	← Sandy silt, not visibly porous, heavy interstitial carbonate, friable.	106.6	6.5		CONSOL
	5	16 (33)			ML	← Sandy silt, becomes more brown, subjectively moist, about 35% fine sand and almost no carbonate. Few pinhole pores. [Very old alluvium]	116.5	7.6		
		17 (33)			ML					
		RING 10			ML					
		10 (21)			ML					
	1435				ML					
		RING 8			ML					
		12 (32)			ML					
		20			ML					
	1430				SC	Clayey Sand: Yellowish brown to brown; medium dense; moist; fine to coarse grained sand. [Very old alluvium]				
15										

Continued on next sheet.



# FIELD LOG OF BORING B - 8

Sheet 2 of 2

Project: **"RIDER AT REDLANDS" LIGHT INDUSTRIAL PROJECT**

Location: **CITY OF PERRIS, RIVERSIDE COUNTY, CALIF.**

DEPTH (ft.)	ELEVATION (MSL DATUM)	SAMPLE INTERVALS		GRAPHIC LOG	USCS	GEOTECHNICAL DESCRIPTION	DRY DENSITY (pcf)	WATER CONTENT (%)	WELL COMPLETION	OTHER TESTS
		BULK DRIVE	TYPE, "N" or (Blows/ft.)							
15			SPT 5 10 12 N=22		SC	Clayey Sand: Yellowish brown to brown; medium dense; moist; fine to coarse grained sand. Sample at 15 feet features a few 1/4" hard carbonate nodules. Sand is highly weathered. Easily drilled. [Very old alluvium]				
20	1425		SPT 11 15 19 N=34		SC, ML	← Indistinctly layered clayey sand and sandy silt, dense, uncemented.				

*Bottom of boring at 21.5 ft.  
 No groundwater encountered.  
 Boring backfilled with compacted soil cuttings.*



# FIELD LOG OF BORING B - 9

Sheet 1 of 2

Project: **"RIDER AT REDLANDS" LIGHT INDUSTRIAL PROJECT**

Location: **CITY OF PERRIS, RIVERSIDE COUNTY, CALIF.**

Date(s) Drilled: <b>7/9/19</b>	Logged By: <b>M. Doerschlag</b>	
Drilled By: <b>GP Drilling</b>	Total Depth: <b>26.5 Ft.</b>	
Rig Make/Model: <b>Mobile B-61</b>	Hammer Type: <b>Automatic trip</b>	
Drilling Method: <b>Hollow-Stem Auger</b>	Hammer Weight/Drop: <b>140 Lb./30 In.</b>	
Hole Diameter: <b>8 In.</b>	Surface Elevation: <b>± 1443 Ft. AMSL, RCFC NAD 83</b>	

Comments: Located at NEC of proposed development site, next to possible BMP.

DEPTH (ft.)	ELEVATION (MSL DATUM)	SAMPLE INTERVALS		GRAPHIC LOG	USCS	GEOTECHNICAL DESCRIPTION	DRY DENSITY (pcf)	WATER CONTENT (%)	WELL COMPLETION	OTHER TESTS
		BULK DRIVE	TYPE, "N" or (Blows/ft.)							
0					ML	Silt: Light brown; stiff to very stiff; subjectively only slightly moist; trace of very fine sand; non-plastic. [Very old alluvium]				
4	1440	RING 4-8	(28)		ML	← Silt, variegated colors due to bioturbation, with abundant carbonate, punky texture.	77.8	22.9		
5		RING 10-22	(46)		ML	← Silt, very heavy diffuse carbonate, cemented, visibly porous and with punky texture.	91.7	21.5		
		SPT 5-7	N=16		ML	Sandy Silt: Brown; very stiff; slightly moist; massive; slightly cemented but crumbly and with few pinhole pores. Abundant reticulate carbonate. [Very old alluvium]				
	1435				ML/CL	Clayey Silt: Brown; hard; slightly moist; mildly cohesive; massive; not visibly porous and non-plastic. Sample at 10' features abundant reticulate white-colored carbonate. [Very old alluvium]				
10		SPT 8-13	N=33		ML/CL					
	1430									
15										

Continued on next sheet.



# FIELD LOG OF BORING B - 9

Sheet 2 of 2

Project: **"RIDER AT REDLANDS" LIGHT INDUSTRIAL PROJECT**

Location: **CITY OF PERRIS, RIVERSIDE COUNTY, CALIF.**

DEPTH (ft.)	ELEVATION (MSL DATUM)	SAMPLE INTERVALS		GRAPHIC LOG	USCS	GEOTECHNICAL DESCRIPTION	DRY DENSITY (pcf)	WATER CONTENT (%)	WELL COMPLETION	OTHER TESTS
		BULK DRIVE	TYPE, "N" or (Blows/ft.)							
15		SPT 7 14 21	N=35	[Diagonal hatching pattern]	ML	Clayey Silt: Grades yellowish brown; hard; slightly moist; minor carbonate and some MnO veils; typical 30% fine-grained sand. Non-plastic. Base of unit detected by color and faster drilling rate. [Very old alluvium]			[Wavy line pattern]	
1425				[Horizontal line pattern]		Sandy Silt: Yellowish brown; hard; moist; similar to overlying sediments bu little to no clay and no pedogenic carbonate but common MnO spots and films; friable and crumbly; not visibly porous. [Very old alluvium]			[Wavy line pattern]	
20		SPT 14 23 28	N=51	[Horizontal line pattern]	ML	← Sandy silt, as above, zero carbonate but common coarse MnO spots, estimated 30% fine to medium grained sand. not visibly porous.			[Wavy line pattern]	
1420				[Horizontal line pattern]					[Wavy line pattern]	
25		SPT 10 12 27	N=39	[Horizontal line pattern]	ML	← Sandy silt, no clay, massive and not visibly porous.			[Wavy line pattern]	

*Bottom of boring at 26.5 ft.  
 No groundwater encountered.  
 Boring backfilled with compacted soil cuttings.*





# FIELD LOG OF BORING B - 10

Sheet 1 of 1

Project: **"RIDER AT REDLANDS" LIGHT INDUSTRIAL PROJECT**

Location: **CITY OF PERRIS, RIVERSIDE COUNTY, CALIF.**

Date(s) Drilled: <b>7/9/19</b>	Logged By: <b>M. Doerschlag</b>
Drilled By: <b>GP Drilling</b>	Total Depth: <b>11.5 Ft.</b>
Rig Make/Model: <b>Mobile B-61</b>	Hammer Type: <b>Automatic trip</b>
Drilling Method: <b>Hollow-Stem Auger</b>	Hammer Weight/Drop: <b>140 Lb./30 In.</b>
Hole Diameter: <b>8 In.</b>	Surface Elevation: <b>± 1443 Ft. AMSL, RCFC NAD 83</b>

Comments: North end of prospective truck and trailer yard.

DEPTH (ft.)	ELEVATION (MSL DATUM)	SAMPLE INTERVALS		GRAPHIC LOG	USCS	GEOTECHNICAL DESCRIPTION	DRY DENSITY (pcf)	WATER CONTENT (%)	WELL COMPLETION	OTHER TESTS
		BULK DRIVE	TYPE, "N" or (Blows/ft.)							
0				[Diagonal hatching pattern]	ML	Clayey Silt: Light grayish brown; stiff; subjectively only slightly moist; variable proportions of very fine sand. Active soil horizon is at least 6-7 feet deep. [Very old alluvium]			[Wavy line pattern]	
1440		RING 6-8 (25)		[Diagonal hatching pattern]	ML	← Clayey silt, with active-soil "exploded" textures and some evidence for bioturbation. Cemented blocky granules are visibly porous. Pedogenic Bt horizon.	79.6	19.9	[Wavy line pattern]	
5		RING 15-24 (52)		[Diagonal hatching pattern]	ML	← Silt, shot through with punky, soft carbonate, visibly porous, friable. Clayey at top of sample.	104.9	17.5	[Wavy line pattern]	
1435		RING 11-14 (30)		[Diagonal hatching pattern]	CL, ML	← Silty clay and subordinate clayey silt, reticulate carbonate throughout, pinhole pores, non-plastic, granulated small peds.	103.0	15.1	[Wavy line pattern]	
10		RING 12-20 (44)		[Diagonal hatching pattern]	ML	← Sandy silt, becomes yellowish brown with some clay, moist, massive, non-porous, and almost no carbonate.	105.8	20.2	[Wavy line pattern]	

*Bottom of boring at 11.5 ft.  
 No groundwater encountered.  
 Boring backfilled with compacted soil cuttings.*



# FIELD LOG OF BORING B - 11

Sheet 1 of 2

Project: **"RIDER AT REDLANDS" LIGHT INDUSTRIAL PROJECT**

Location: **CITY OF PERRIS, RIVERSIDE COUNTY, CALIF.**

Date(s) Drilled: <b>7/9/19</b>	Logged By: <b>M. Doerschlag</b>	
Drilled By: <b>GP Drilling</b>	Total Depth: <b>21.5 Ft.</b>	
Rig Make/Model: <b>Mobile B-61</b>	Hammer Type: <b>Automatic trip</b>	
Drilling Method: <b>Hollow-Stem Auger</b>	Hammer Weight/Drop: <b>140 Lb./30 in.</b>	
Hole Diameter: <b>8 in.</b>	Surface Elevation: <b>± 1444 Ft. AMSL, RCFC NAD 83</b>	

Comments: East side dock door area.

DEPTH (ft.)	ELEVATION (MSL DATUM)	SAMPLE INTERVALS		GRAPHIC LOG	USCS	GEOTECHNICAL DESCRIPTION	DRY DENSITY (pcf)	WATER CONTENT (%)	WELL COMPLETION	OTHER TESTS
		BULK DRIVE	TYPE, "N" or (Blows/ft.)							
0					SM	Silty Sand: Brown; loose; slightly moist to moist; fine to coarse grained sand and very silty (40%); massive. Disturbed. [Older alluvium]				
		RING 5			SM	← Silty sand, grayish brown, moist, visibly porous.	100.1	16.4		
	1440	15 (42)			ML	Clayey Silt: Generally brown; stiff; subjectively moist; massive; typical 20% fine to medium sand. Granulated, active-soil textures and usually visibly porous near top. [Very old alluvium]	78.7	24.6		
5		RING 5			ML	← Sandy silt, heavy interstitial carbonate, friable, few macroscopic vesicles/pores.	112.6	14.4		
		5 (12)			ML					
		RING 6			ML					
		9 (21)			ML					
	1435	12			ML					
10		RING 7			SM	Silty Sand: Yellowish brown; medium dense; moist; fine to coarse grained sand. [Very old alluvium]	118.1	7.3		
		12 (24)			SM					
		12			SM					
	1430				CL	Silty Clay: Brown; stiff; moist; plastic with added water and molding; common reticulate carbonate but not visibly porous; massive; cohesive. [Very old alluvium]				
15					CL					

Continued on next sheet.

## ***APPENDIX B***

## ***A P P E N D I X B***

### **LABORATORY TESTING**

#### **Water Content - Dry Density Determinations – ASTM D2216-10**

*The dry unit weight and field moisture content were determined for each of the recovered barrel samples. The moisture-density information provides a gross indication of soil consistency and can assist in delineating local variations. The information can also be used to correlate soils and define units between individual exploration locations on the project site, as well as with units found on other sites in the general area.*

*Measured dry densities ranged from approximately 77.8 to 122.3 pounds per cubic foot. Water contents in ring samples ranged from 2.7 to 24.6 percent of dry unit weight. Sample locations and the corresponding test results are illustrated on the Field Boring Logs.*

#### **Modified Effort Compaction Tests – ASTM D1557-12**

*Bulk soil samples were collected from the northern and southern ends of the prospective building envelope. The representative future fill materials were tested to determine their maximum dry densities and optimum water contents per the Method A procedure in the noted ASTM standard. The test method uses 25 blows of a 10-pound hammer falling 18 inches on each of 5 soil layers in a 1/30 cubic foot cylinder. Soil samples were prepared at varying moisture contents to create a curve illustrating achieved dry density as a function of water content. The test results are listed below and shown graphically on pages B-6 and B-7.*

#### **Maximum Density - Optimum Water Content Determinations**

<b>Soil Description</b>	<b>Location</b>	<b>Maximum Dry Density (pcf)</b>	<b>Optimum Moisture Content (%)</b>
Silty Sand (SM), trace of clay [Older alluvium]	B - 2 @ 0 - 4 ft.	134.0	7.0
Silty Sand (SM), some clay [Older alluvium, silt blend]	B - 7 @ 0 - 4 ft.	129.5	9.5

**Shear Strength Tests – ASTM D3080-11**

Direct shear tests were performed on soils prepared to represent future compacted fill derived from surficial native site alluvium. We expect mass grading operations should produce soil masses with roughly equivalent strengths. "Fill" test samples were remolded to approximately 90 percent of the maximum dry density, at optimum water content as determined from a compaction test. All samples were initially saturated, consolidated and drained of excess moisture, and tested in a direct shear machine of the strain control type. Test samples are initially prepared and/or retained within standard one-inch-high brass rings. Samples were tested at increasing normal loads to determine the Mohr-Coulomb shear strength parameters illustrated on page B-8. Peak and ultimate shear strength values are illustrated on the plot.

**Expansion Index Tests – ASTM D4829-11**

Laboratory clay expansion tests of typical clay materials expected to be incorporated into structural compacted fill were performed in general accordance with the 1994 Uniform Building Code Standard 18-2 and subsequent modern ASTM adoption. A remolded sample is compacted in two layers in a 4-inch I.D. mold to a total compacted thickness of about 1.0 inch, using a 5.5-pound hammer falling 12 inches at 15 blows per layer. The sample is initially at a saturation between 49 and 51 percent. After remolding, the sample is confined under a normal load of 144 pounds per square foot and allowed to soak for 24 hours. The resulting volume change due to increase in moisture content within the sample is recorded and the Expansion Index (EI) calculated.

**Expansion Index Test Results**

Soil Description	Location	Expansion Index	Expansion Classification
Silty Sand (SM), trace of clay [Older alluvium]	B - 2 @ 0 - 4 ft.	2	Very Low
Silty Sand (SM), some clay [Older alluvium, silt blend]	B - 7 @ 0 - 4 ft.	20	Low

**Consolidation Tests – ASTM D2435M-11**

Natural alluvium was checked for collapse susceptibility and overall compressibility within predicted removal intervals and in probable competent materials. Testing imposes a series of cumulative vertical loads to a small, laterally confined soil sample. The apparatus is designed to accept a one-inch-high brass ring containing an undisturbed or remolded soil sample. During each load increment, vertical compression (consolidation) of the sample is measured and recorded at selected time intervals. Porous stones are placed in contact with both sides of the specimen to permit the ready addition or release of water. Undisturbed samples are initially at field moisture content, and are subsequently inundated to determine soil behavior under saturated conditions. The test results are plotted graphically on pages B-9 through B-12.

**Soil Corrosivity**

*Soil samples representative of future mass-graded fill in future contact with concrete or ferrous metals were tested in the laboratories of Project X Corrosion Engineers, Murrieta, California, to determine the tabulated data on the next two pages. The submitted soil samples were tested in general accordance with ASTM and Caltrans Standard Methods listed at the top of the table. Soluble-species quantitative determinations were based on 1:3 water-to-soil extracts.*



### Soil Analysis Lab Results

Client: Aragon Geotechnical Inc  
 Job Name: First Industrial  
 Client Job Number: 4534-SFI  
 Project X Job Number: S190715A  
 July 17, 2019

Bore# / Description	Method	ASTM D4327		ASTM D4327		ASTM G187		ASTM G51	ASTM G200	SM 4500-S2-D	ASTM D4327	ASTM D4327	ASTM D4327	ASTM D4327	ASTM D4327	ASTM D4327	ASTM D4327	ASTM D4327		
		Depth	Sulfates SO <sub>4</sub> <sup>2-</sup>		Chlorides Cl <sup>-</sup>		Resistivity As Rec'd   Minimum (Ohm-cm)   (Ohm-cm)		pH	Redox	Sulfide S <sup>2-</sup>	Nitrate NO <sub>3</sub> <sup>-</sup>	Ammonia H <sub>2</sub> N <sup>+</sup>	Lithium Li <sup>+</sup>	Sodium Na <sup>+</sup>	Potassium K <sup>+</sup>	Magnesium Mg <sup>2+</sup>	Calcium Ca <sup>2+</sup>	Flouride F <sub>2</sub> <sup>-</sup>	Phosphate PO <sub>4</sub> <sup>3-</sup>
	(ft)	(mg/kg)	(wt%)	(mg/kg)	(wt%)	(Ohm-cm)	(Ohm-cm)		(mV)	(mg/kg)	(mg/kg)	(mg/kg)	(mg/kg)	(mg/kg)	(mg/kg)	(mg/kg)	(mg/kg)	(mg/kg)	(mg/kg)	(mg/kg)
B-7 #19-1524	0.0-4.0	207.3	0.0207	169.4	0.0169	7,370	1,407	8.8	157.0	0.5	10.2	ND	0.2	178.0	2.5	11.7	69.1	6.2	2.1	228

Anions and Cations, except Sulfide and Bicarbonate, tested with Ion Chromatography  
 mg/kg = milligrams per kilogram (parts per million) of dry soil weight  
 ND = 0 = Not Detected | NT = Not Tested | Unk = Unknown  
 Chemical Analysis performed on 1:3 Soil-To-Water extract



### Soil Analysis Lab Results

Client: Aragon Geotechnical Inc  
 Job Name: First Industrial  
 Client Job Number: 4534-SFI  
 Project X Job Number: S190710B  
 July 12, 2019

Bore# / Description	Method	ASTM D4327		ASTM D4327		ASTM G187		ASTM G51	ASTM G200	SM 4500-S2-D	ASTM D4327	ASTM D4327	ASTM D4327	ASTM D4327	ASTM D4327	ASTM D4327	ASTM D4327	ASTM D4327	
		Sulfates		Chlorides		Resistivity		pH	Redox	Sulfide	Nitrate	Ammonia	Lithium	Sodium	Potassium	Magnesium	Calcium	Flouride	Phosphate
Depth	(ft)	(mg/kg)	(wt%)	(mg/kg)	(wt%)	As Rec'd (Ohm-cm)	Minimum (Ohm-cm)		(mV)	(mg/kg)	(mg/kg)	(mg/kg)	(mg/kg)	(mg/kg)	(mg/kg)	(mg/kg)	(mg/kg)	(mg/kg)	(mg/kg)
B-2 #19-1503	0.0-4.0	7.4	0.00074	2.3	0.0002	18,090	5,829	8.4	166.0	1.3	12.9	0.4	ND	48.6	3.2	10.5	43.5	3.9	9.2

mg/kg = milligrams per kilogram (parts per million) of dry soil weight  
 ND = 0 = Not Detected | NT = Not Tested | Unk = Unknown  
 Chemical Analysis performed on 1:3 Soil-To-Water extract





# ARAGÓN GEOTECHNICAL, INC.

16801 Van Buren Blvd.  
Riverside, California 92504  
(951) 776-0345

## Maximum Density Test

<b>Client:</b>	First Industrial Realty Trust, Inc. 898 N. Pacific Coast Highway, Suite 175 El Segundo, CA 90245	<b>Project Name:</b>	Rider St. at Redlands Ave. Perris, California
<b>Project No.:</b>	4534-SFI	<b>Report Date:</b>	August 9, 2019
<b>Sampled By:</b>	Mark Doerschlag	<b>Lab ID No.:</b>	19-1503
<b>Date of Sampling:</b>	July 8, 2019		
<b>Information provided by Technician</b>	<input checked="" type="checkbox"/> Performed at Laboratory <input type="checkbox"/> Performed at Jobsite	<input checked="" type="checkbox"/> Moist Preparation <input type="checkbox"/> Dry Preparation	
<b>Tested By:</b>	Cesar Lopez	<b>Date Tested:</b>	July 9, 2019
<b>Sample Location:</b>	B-2	<b>Source:</b>	Native
<b>Sample Description:</b>	Silty sand (SM), fine to medium grained. [Older alluvium]		

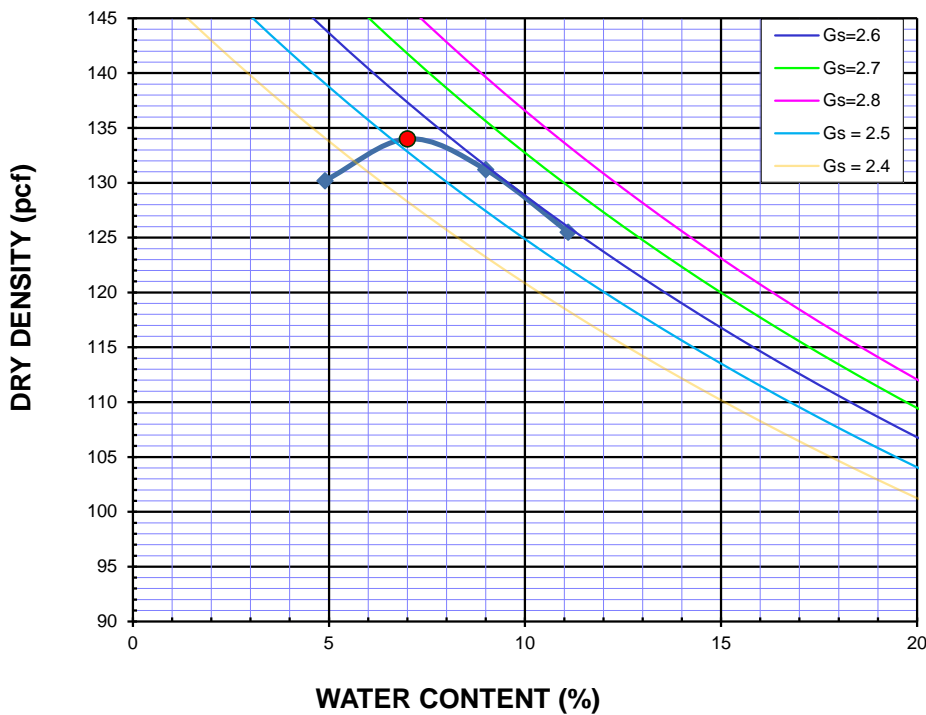

A	METHOD USED (A,B or C)
-	SIEVE NUMBER
Mechanical	TYPE OF RAMMER
4.9%	AS REC'D MOISTURE
-	PERCENT RETAINED
-	OVEN DRY (C127)
134.0	MAXIMUM DENSITY [PCF]
7.0	OPTIMUM MOISTURE [%]
-	CORRECTED MAXIMUM DENSITY [PCF]
-	CORRECTED OPTIMUM MOISTURE [%]

**Remarks:** No modifications made to test method, followed exact test procedure.

**AASHTO/ASTM/CTM Standards Used:** Unless noted, material was sampled in accordance with AASHTO T2/ASTM D75/CTM 125. Sample tested in accordance with ASTM D2216, D1557-C & D4718.

Testing was performed by qualified personnel in accordance with generally accepted industry practice, material testing consultants procedures and the above reference standards. This report is applicable only to the items listed herein. The tests performed and in this report are not intended to be considered as any guarantee or warranty of suitability for service or fitness of use of items tested and it should not be relied on as such. The report has been prepared for the exclusive use of the client and any partial or whole reproduction without the consent of the client is prohibited.



# ARAGÓN GEOTECHNICAL, INC.

16801 Van Buren Blvd.  
Riverside, California 92504  
(951) 776-0345

## Maximum Density Test

<b>Client:</b>	First Industrial Realty Trust, Inc. 898 N. Pacific Coast Highway, Suite 175 El Segundo, CA 90245	<b>Project Name:</b>	Rider St. at Redlands Ave. Perris, California
<b>Project No.:</b>	4534-SFI	<b>Report Date:</b>	August 9, 2019
<b>Sampled By:</b>	Mark Doerschlag	<b>Lab ID No.:</b>	19-1524
<b>Date of Sampling:</b>	July 9, 2019		
<b>Information provided by Technician</b>	<input checked="" type="checkbox"/> Performed at Laboratory <input type="checkbox"/> Performed at Jobsite	<input checked="" type="checkbox"/> Moist Preparation <input type="checkbox"/> Dry Preparation	
<b>Tested By:</b>	Cesar Lopez	<b>Date Tested:</b>	July 12, 2019
<b>Sample Location:</b>	B-7	<b>Source:</b>	Native
<b>Sample Description:</b>	Silty sand (SM) with some clay. [Older alluvium blend]		

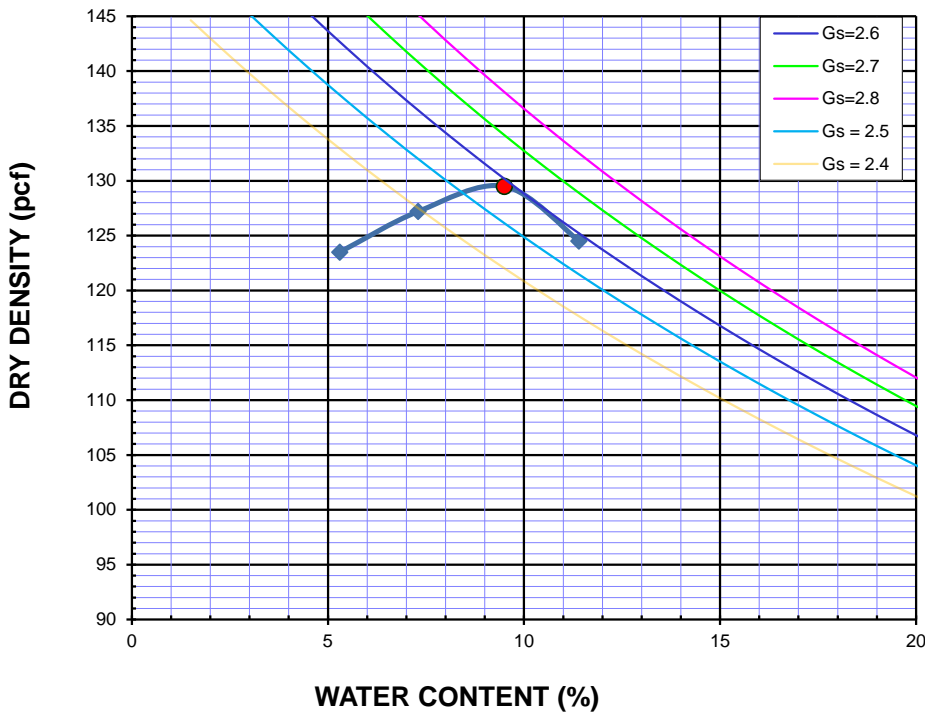

A	METHOD USED (A,B or C)
-	SIEVE NUMBER
Mechanical	TYPE OF RAMMER
5.3%	AS REC'D MOISTURE
-	PERCENT RETAINED
-	OVEN DRY (C127)
129.5	MAXIMUM DENSITY [PCF]
9.5	OPTIMUM MOISTURE [%]
-	CORRECTED MAXIMUM DENSITY [PCF]
-	CORRECTED OPTIMUM MOISTURE [%]

**Remarks:** No modifications made to test method, followed exact test procedure.

**AASHTO/ASTM/CTM Standards Used:** Unless noted, material was sampled in accordance with AASHTO T2/ASTM D75/CTM 125. Sample tested in accordance with ASTM D2216, D1557-C & D4718.

Testing was performed by qualified personnel in accordance with generally accepted industry practice, material testing consultants procedures and the above reference standards. This report is applicable only to the items listed herein. The tests performed and in this report are not intended to be considered as any guarantee or warranty of suitability for service or fitness of use of items tested and it should not be relied on as such. The report has been prepared for the exclusive use of the client and any partial or whole reproduction without the consent of the client is prohibited.



## ARAGÓN GEOTECHNICAL, INC.

16801 Van Buren Blvd., Bldg. B  
Riverside, California 92504  
951-776-0345

### Direct Shear Test Diagram

Project Name:	First Industrial Realty Trust, Inc. - Rider St. at Redlands Ave., Perris, CA		
Project Number:	4534-SFI	Tested by:	Cesar Lopez
Sample Location:	B-2	Date Tested:	7/10/2019
Sampled by:	Mark Doerschlag	Depth (ft):	0.0 - 4.0
Date Sampled:	7/8/2019	Lab I.D. No.:	19-1503
Test Condition:	Remolded, Consolidated, Drained.		
Sample Description:	Silty sand (SM), fine to medium grained. [Older alluvium]		

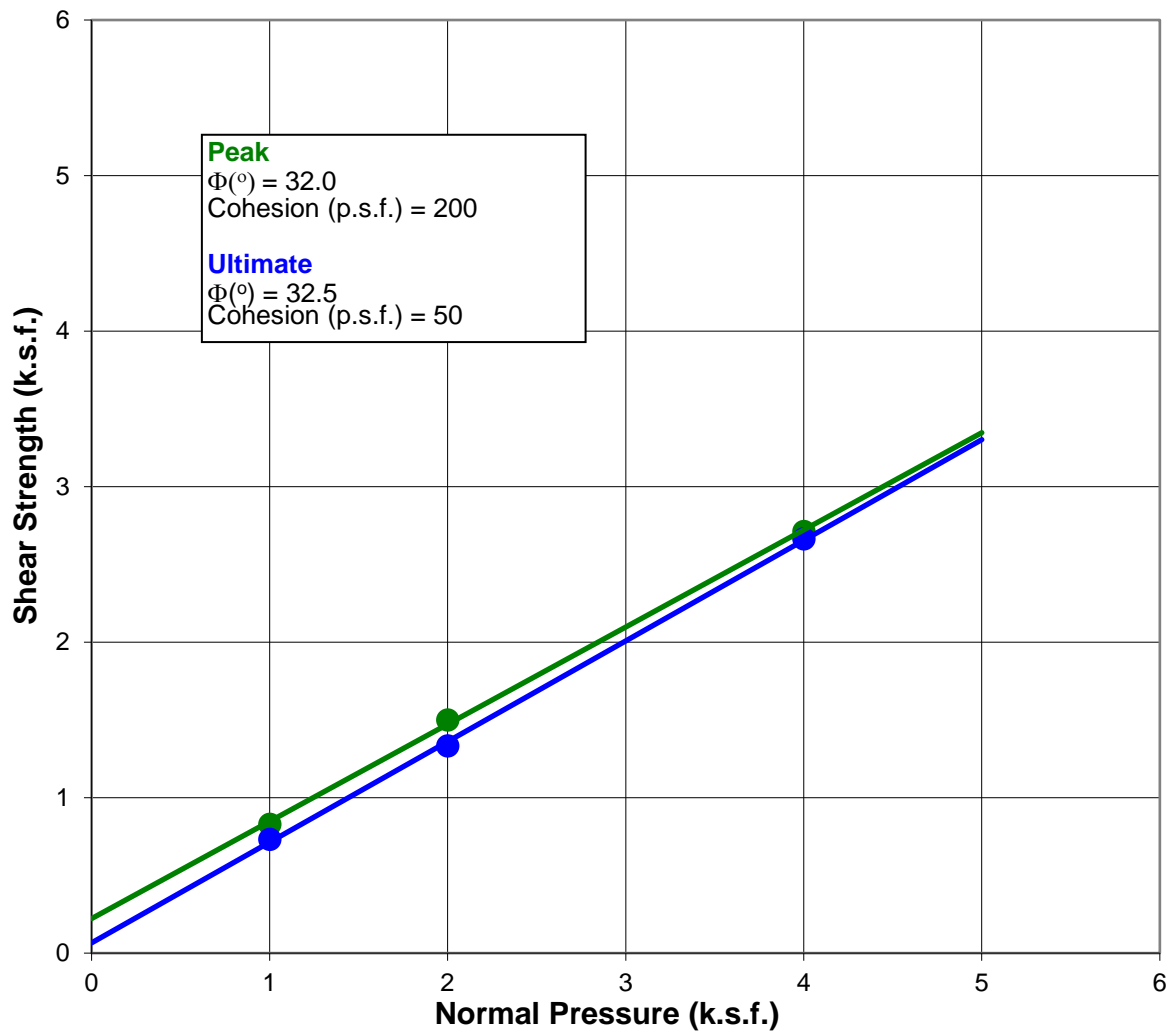



# ARAGÓN GEOTECHNICAL, INC.

16801 Van Buren Blvd., Bldg. B  
Riverside, California 92504  
951-776-0345

## Consolidation Curve

Project Name:	Rider St. at Redlands Ave., Perris, CA		
Project Number:	4534-SFI	Tested by:	Cesar Lopez
Sample Location:	B-4	Date Tested:	7/10/19
Sampled by:	Mark Doerschlag	Depth (ft):	5.0
Date Sampled:	7/8/19	Moisture %:	17.1
Dry Density (pcf):	108.0	Saturation %:	82.3
Sample Description:	Clayey silt (ML), cemented, few fine pores. [Very old alluvium]		

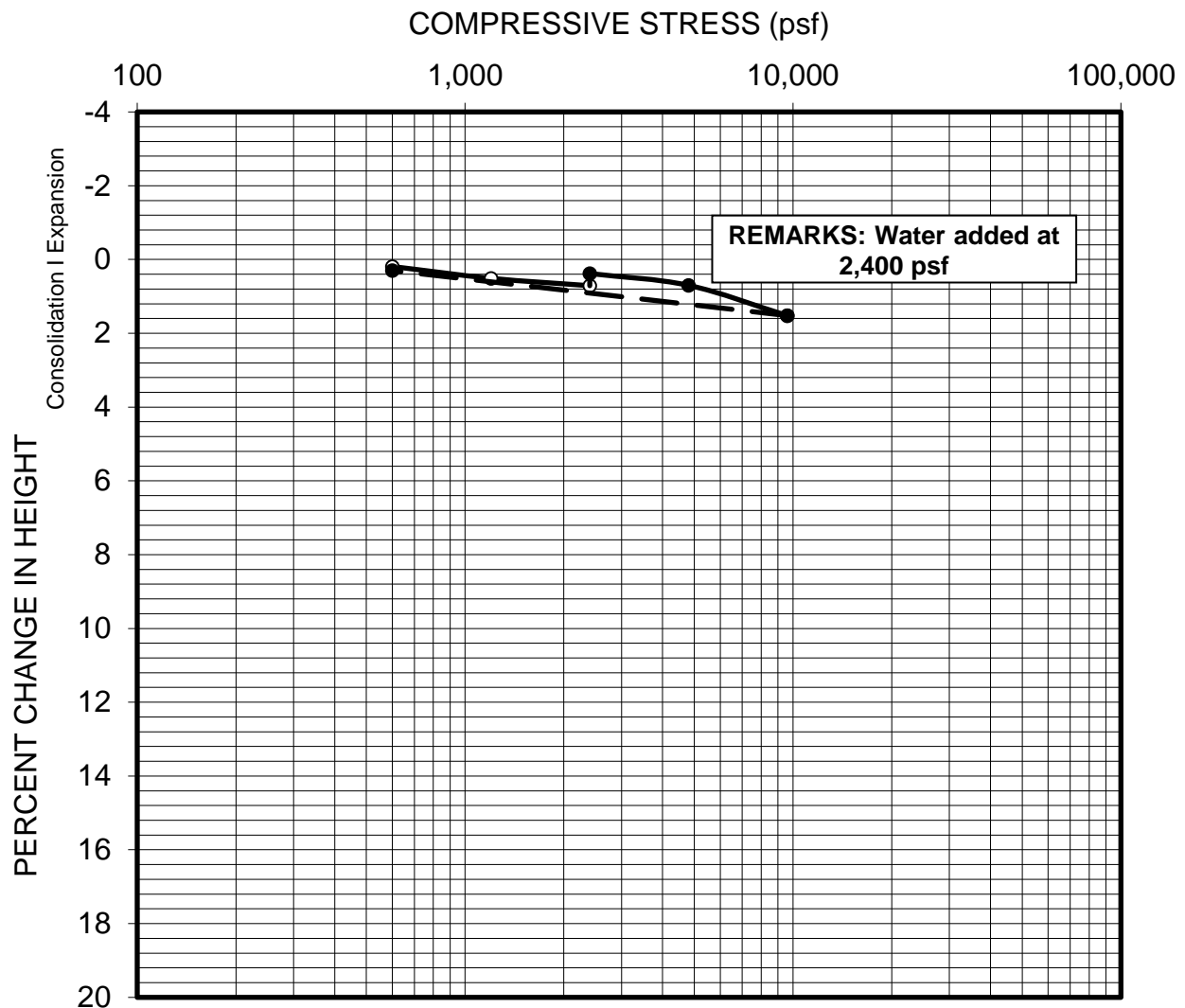



# ARAGÓN GEOTECHNICAL, INC.

16801 Van Buren Blvd., Bldg. B  
Riverside, California 92504  
951-776-0345

## Consolidation Curve

Project Name:	Rider St. at Redlands Ave., Perris, CA		
Project Number:	4534-SFI	Tested by:	Cesar Lopez
Sample Location:	B-4	Date Tested:	7/10/19
Sampled by:	Mark Doerschlag	Depth (ft):	7.0
Date Sampled:	7/8/19	Moisture %:	12.8
Dry Density (pcf):	101.8	Saturation %:	52.7
Sample Description:	Clayey silt (ML), abundant carbonate. [Very old alluvium]		

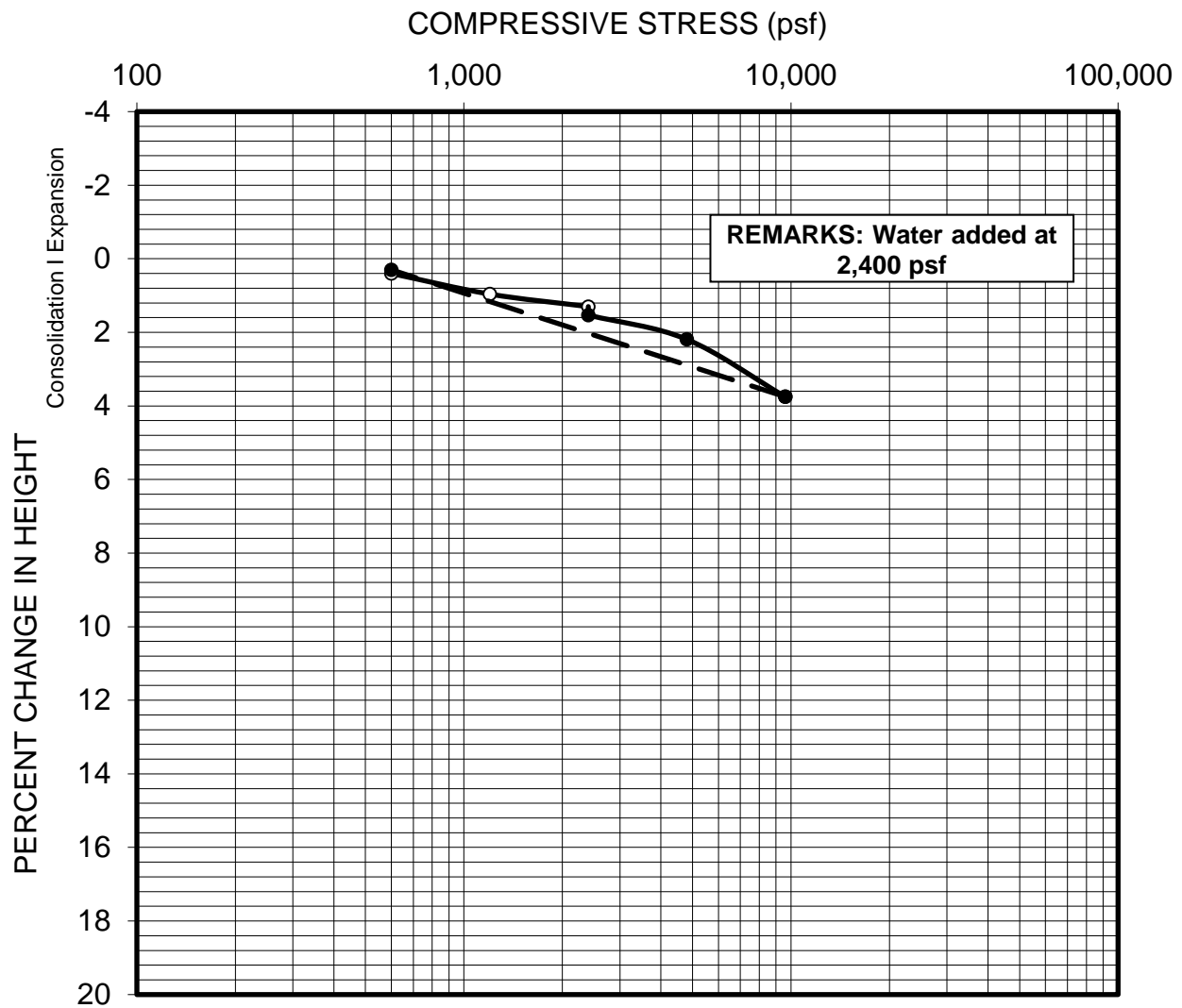



# ARAGÓN GEOTECHNICAL, INC.

16801 Van Buren Blvd., Bldg. B  
Riverside, California 92504  
951-776-0345

## Consolidation Curve

Project Name:	Rider St. at Redlands Ave., Perris, CA		
Project Number:	4534-SFI	Tested by:	Cesar Lopez
Sample Location:	B-8	Date Tested:	7/12/19
Sampled by:	Mark Doerschlag	Depth (ft):	4.0
Date Sampled:	7/9/19	Moisture %:	19.3
Dry Density (pcf):	88.3	Saturation %:	57.3
Sample Description:	Silt (ML), visibly porous. [Very old alluvium]		

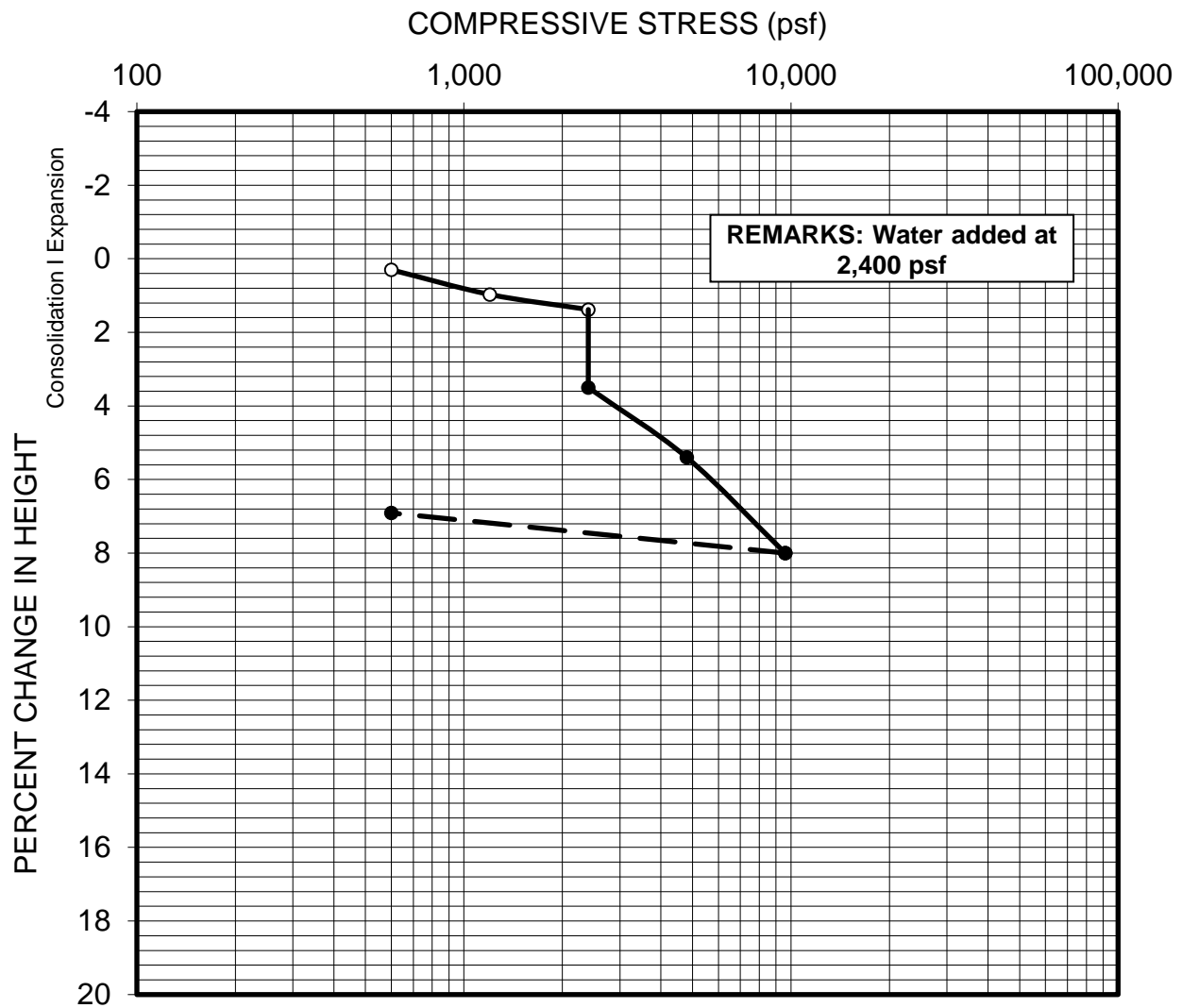



**ARAGÓN GEOTECHNICAL, INC.**

16801 Van Buren Blvd., Bldg. B  
 Riverside, California 92504  
 951-776-0345

**Consolidation Curve**

Project Name:	Rider St. at Redlands Ave., Perris, CA		
Project Number:	4534-SFI	Tested by:	Cesar Lopez
Sample Location:	B-8	Date Tested:	7/12/19
Sampled by:	Mark Doerschlag	Depth (ft):	6.0
Date Sampled:	7/9/19	Moisture %:	6.5
Dry Density (pcf):	106.6	Saturation %:	30.2
Sample Description:	Sandy silt (ML), heavy carbonate, not visibly porous. [Very old alluvium]		

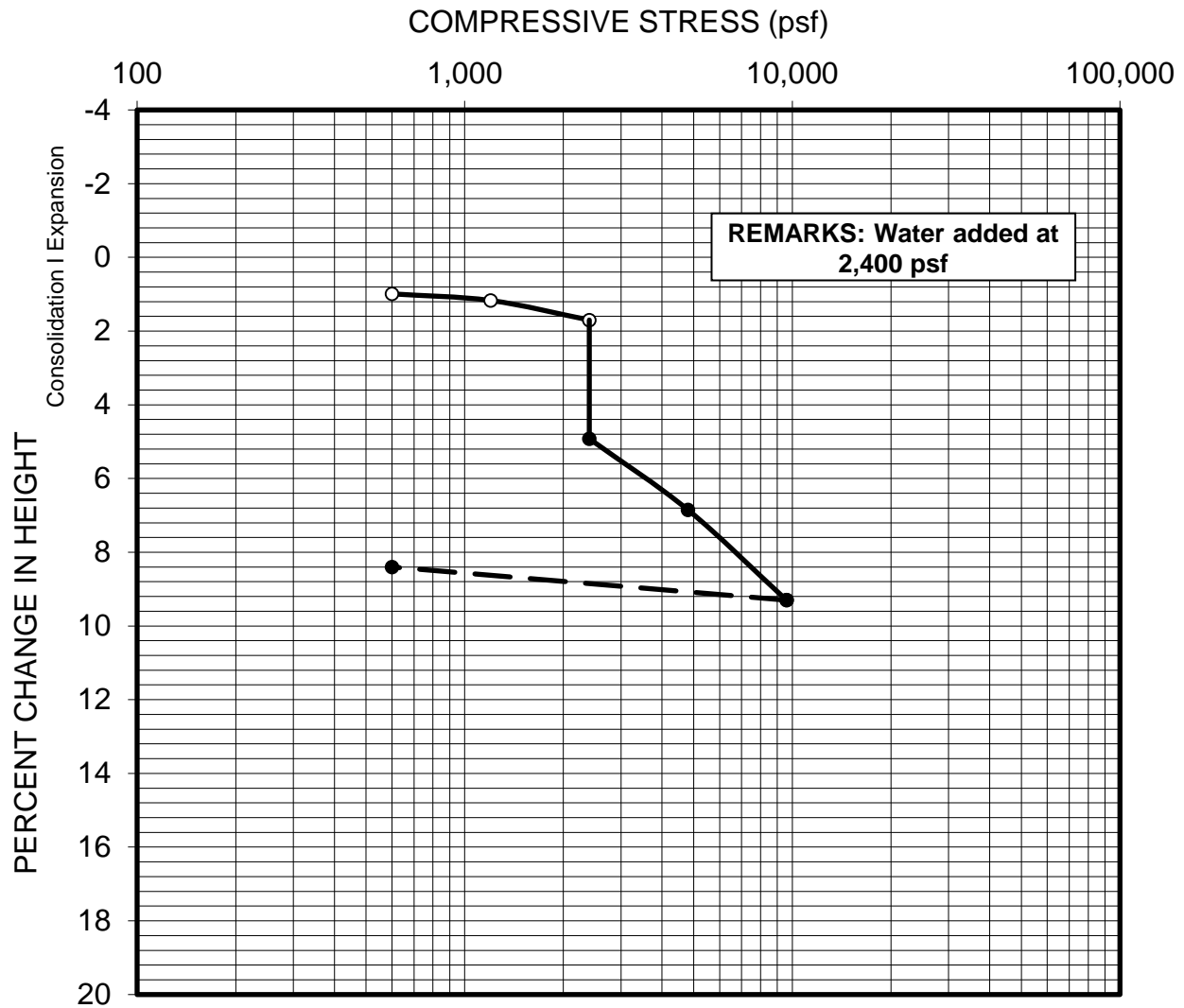

LEGEND

**B-11** Approximate location of exploratory boring

**IN-4** Approximate location of infiltration test

**Qvof** Very old fan alluvium

Not shown: Minor surficial cover of later Pleistocene fan alluvium in south half of site.

**PROJECT DATA:**

APPROX. SITE AREA: 641,631 SF  
14.72 AC

BUILDING AREA: 338,110 SF

COVERAGE: 52.69 %

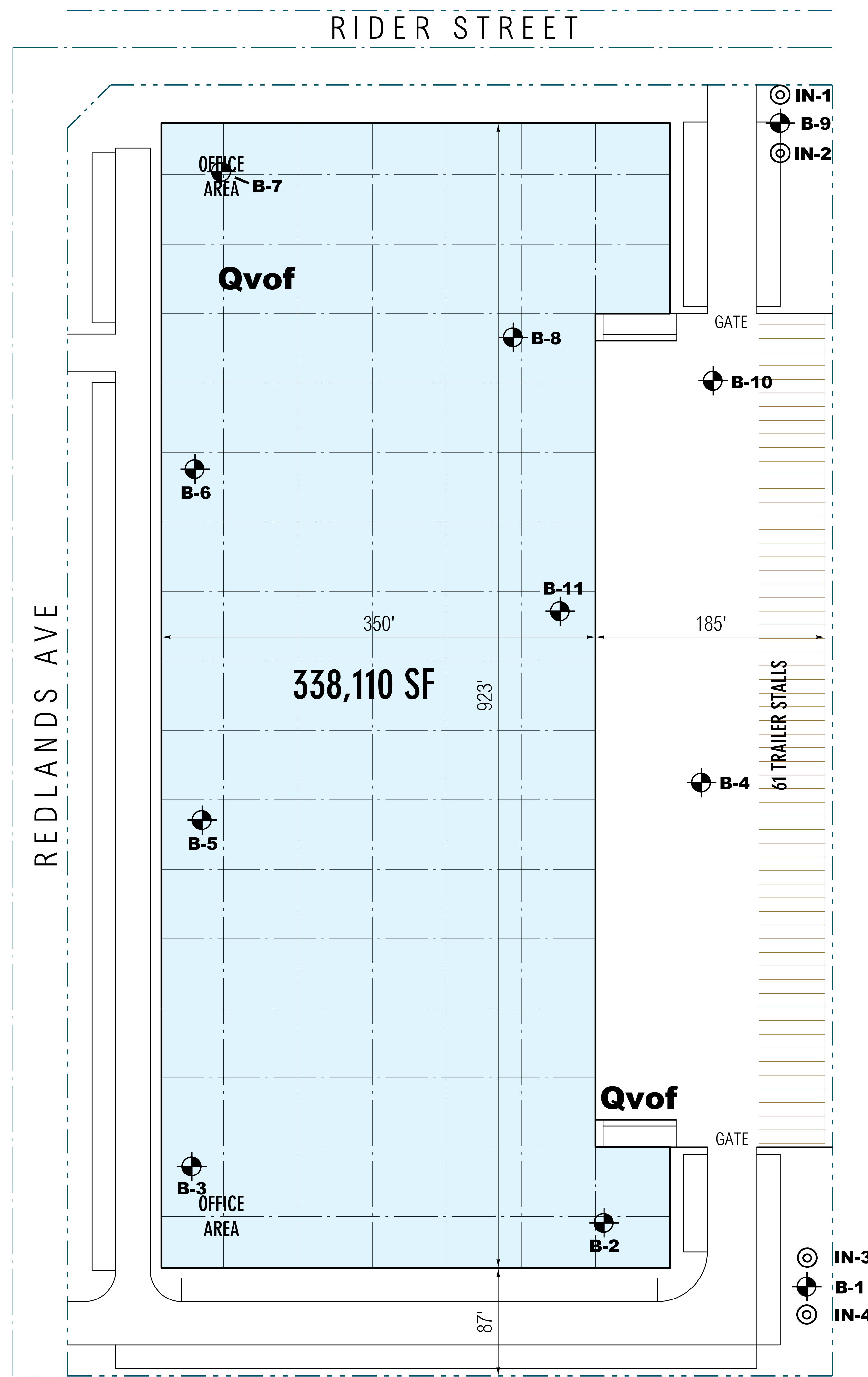

**GEOTECHNICAL MAP**

RIDER STREET AT REDLANDS AVENUE,  
CITY OF PERRIS, CA

PROJECT NO. 4534-SFI	DATE: 8/9/19	PLATE NO. 1
----------------------	--------------	-------------

SCALE: 1" = 40'-0"

0' 10' 20' 50' 100'

**RG**  
Office of Architectural Design

15231 Alton Parkway, Suite 100  
Irvine, CA 92618

T 949-341-0920  
FX 949-341-0922

**PROJECT NAME**

ADDRESS, CITY

PRELIMINARY SITE PLAN - SCHEME 01

XXXXXX	CONCEPTUAL SITE PLAN	
MARK	DATE	DESCRIPTION

RGA PROJECT NO:	15XXX-00
CAD FILE NAME:	15XXX-00-A1-01
DRAWN BY:	CS
CHK'D BY:	CS
COPYRIGHT:	RGA, OFFICE OF ARCHITECTURAL DESIGN
SHEET TITLE:	
<b>A1-01</b>	





**ARAGÓN GEOTECHNICAL, INC.**  
Consultants in the Earth & Material Sciences

August 2, 2019  
Project No. 4534-I

**First Industrial Realty Trust, Inc.**  
898 N. Pacific Coast Highway, Suite 175  
El Segundo, California 90245

Attention: Mr. Matt Pioli

Subject: WQMP Site Assessment & Infiltration Test Results  
"Rider Street at Redlands Avenue" Light Industrial Project  
City of Perris, Riverside County, California.

Dear Mr. Pioli:

In accordance with our proposal dated June 10, 2019, Aragón Geotechnical Inc. (AGI) has completed site testing and analyses of soil infiltration potential. Our conclusions are intended to support the creation of a site-specific water quality management plan (WQMP) and final selection of stormwater best management practices (BMPs) at the listed project. Data and recommendations for BMP engineering design and construction of low impact development (LID), hydromodification, and pollution prevention features are required by the Santa Ana Region (SAR) *Water Quality Management Plan* effective January 1, 2013. AGI services were performed concurrently with a preliminary geotechnical design investigation for the proposed industrial development. Subsurface explorations, geological reconnaissance and research, and characterization of the local groundwater regime were requirements for both of AGI's current studies. Our primary tasks for the infiltration feasibility assessment consisted of (1) Review of local and regional geologic, soil, and groundwater elevation maps plus proprietary data from other nearby AGI investigations; (2) Machine drilling of percolation test borings to estimated elevations of a proposed infiltration system, using a hollow-stem auger drilling rig; (3) Field tests of water absorption rates; and (4) Preparation of this results report. Calculations or recommendations for the design precipitation event intensity or duration, climate coefficients, storm water retention or treatment flow rates, or treatment volumes were outside of AGI's scope.

### **Proposed Construction**

AGI was furnished with an undated conceptual development plan prepared by the Irvine firm of RGA Office of Architectural Design. The scaled drawing (Scheme 01) lacked topographic contours or finish surface elevations, but included the planned envelope of an approximately rectangular 338,110-square-foot logistics or light industrial building more or less centered in the 16.26-acre site. The structure would reasonably comprise concrete tilt-up walls resting on shallow strip footings, with a concrete slab-on-grade industrial floor. Ninety-two dock doors would be included in the building. Concrete pavements are expected, with limited possible exceptions for automobile parking lots. Jurisdiction for development entitlements will be exercised by the City of Perris.

Two potential treatment control BMP sites for stormwater management were evaluated. Rectangular areas shown on the conceptual plans at the northeastern and southeastern project corners were judged candidate sites for simple excavated water quality basins. Estimated infiltration surface elevations were established by AGI at 10 feet below current grade. The slightly deeper-than-average prospective basin floors were selected to maximize possible capture volume, while also assessing what we interpreted as possible water-limiting layers detected during exploration drilling. Overflows or controlled discharges would presumably be directed north, toward Rider Street and a parallel unlined surface swale that flows east to a master drain. Based on City-minimum landscape area guidelines, we would predict up to 88 percent of the site's incident precipitation will intercept impermeable surfaces composed of the building and surrounding pavements.

### **Subsurface Investigation and Permeability Testing**

The project site comprises 5 contiguous land parcels. At the time of AGI's investigations, 4 out of 5 parcels contained structures, outbuildings, greenhouses, or storage yards that constrained our access to certain site areas. Exploration and test borings for the basin locations could be placed coincident with BMP-area outlines, however. The northeastern test area was within a residential compound, surrounded by landscaping. The southeastern test area was in an open weedy lot. All of the project area was noted to be extremely flat and was verified to constitute a single tilled agricultural field many decades ago.

Site-wide, 11 deep exploratory soil borings were drilled on July 8 and 9, 2019 with a truck-mounted hollow-stem auger rig for the paired project investigations. One boring was located in each prospective BMP location. Most other borings were situated within the

building envelope. These borings were nonetheless useful for assessing feasibility for shallow basins or bioswales closer to Redlands Avenue. All exploratory borings were continuously observed by AGI's engineering geologist and logged for materials classifications, interpreted materials origins, relative density as determined from *in situ* penetration tests, presence of groundwater, and other characteristics that can influence water uptake rates. The exploration borings were backfilled with tamped auger cuttings. No permanent wells were created. The Field Boring Logs for the two basin exploration holes are included in the accompanying Appendix. A modified version of the conceptual plan depicting the speculative BMP sites, geotechnical and infiltration-related soil borings, and locations of tests done for this study is presented on Plate No. 1 at the back of this report.

AGI's infiltration determinations were based on technical guidelines for percolation testing in small-diameter boreholes. Most California jurisdictions including co-permittees of the Riverside County master discharge permit accept percolation test results for stormwater BMP design, with the proviso that percolation test data be adjusted to an equivalent one-dimensional (1-D) infiltration velocity. Boreholes of course infiltrate water both vertically and laterally. Considering potential available head in smaller but fairly deep basins, AGI elected to use the constant-head U.S. Bureau of Reclamation Well Permeameter Method (USBR Procedure 7300-89). Measured water takes in units of vol/time are converted by formula into an equivalent infiltration test velocity in units of length/time. All field exploration, percolation testing, and derivations of equivalent infiltration rates were performed by or under direct supervision of the following qualified professionals:

- Fernando Aragón, P.E.: California Registered Civil Engineer and Geotechnical Engineer, with over 15 years of professional experience.
- Mark G. Doerschlag: California Professional Geologist and Certified Engineering Geologist, with over 35 years of professional experience.

The as-built test holes were bottomed at depths of 10.2 to 11.4 feet below ground surfaces (bgs). Approximately 2 to 3 inches of 3/4" gravel was placed in the bottom of each test hole, followed by insertion of a 3¼-inch O.D. PVC perforated pipe encased in filter fabric material. Well bore gravel filter packs were omitted from the annular space between the plastic pipe and hole sidewalls given stable and cohesive soils in the test intervals. Pre-saturation of the test bores was omitted for a constant-head test.

Heads of 6.0 feet (72 inches) were assigned for all 4 tested locations. AGI's intent was to test the roughly 6 feet of materials composing possible bottom and sidewall surfaces. The intended 6.0-foot interval also exceeded the minimum-desired test interval of at least 10 times the 4-inch borehole radius. Regular garden hoses provided pressurized municipal water to each test site. Feed water was introduced at the bottom of infiltration test holes. Maximum-available delivery rates of about 8 gallons per minute were much higher than water-take rates. The soils proved to be relatively impermeable. Water volumes delivered per time-trial increment were directly measured to the nearest 0.1 gallon using a Sensus SR-II magnetic-drive positive displacement water meter. A gate valve downstream of the meter was adjusted as needed to maintain the specified 6.0-foot test head. Absolute water level was monitored with an electric meter probe inserted into the primary perforated pipe. Total input durations of about 2½ hours were sufficient to arrive at near-steady-state water takes. A typical permeameter test would show incremental (constant-head) rates asymptotically approaching a minimum rate. Record sheets with the field measurement data are included in the Appendix.

## **FINDINGS**

### **Local Soil Conditions**

*NE Project Corner.* Surficial soils consisted of light brown-colored and stiff to very stiff silt (Unified Soil Classification System symbol ML). Sandy silt and very clayey silt were logged below 6 feet in depth. Weathering and interstitial concentrations of clay and carbonate were very pronounced beginning only 2 feet below grade. Fine-grained soils typical of very low-energy floodplain sediments continued to the bottom of AGI's exploration boring at 21.5 feet. Vertical variability was interpreted to be gradational in nature, and was not marked by sharp stratigraphic boundaries.

*SE Project Corner.* Soil units in this area would be judged grossly similar to the northeastern corner, although slightly coarser average textures were logged. About 4 feet of sandy silt blanketed a 10-foot-thick zone of very silty sand (SM/ML) and very stiff sandy silt (ML), the latter with some clay at elevations correlating with a predicted basin bottom. Deeper strata from 14 feet bgs to bottom at 26.5 feet were composed of hard sandy silt (ML) below a probable cemented paleosol (= an old weathered surface-soil horizon).

From a soil science viewpoint, the National Resources Conservation Service classifies basin-site surficial materials as Domino silt loam Du. Domino soils characteristically have low water storage capability and indurated duripans at shallow depths. Silt loam Du is assigned to hydrologic soil group D. The saturated hydraulic conductivity of the most limiting layer is given as "0.00" inches per hour. Soil classifications and hydrologic soil groups are usually based on a profile depth of 60 inches or so; thus, we would expect that a basin-type BMP improvement could completely bypass NRCS soil profiles and cannot be qualified or disqualified solely on the basis of a NRCS hydrologic soil group.

AGI's geotechnical studies identified the majority of site materials as early to middle Pleistocene alluvium (unit Qvof<sub>a</sub> of Morton & Miller, 2006). The referenced regional map actually depicts a Holocene-age unit of sandy axial-valley alluvium across the majority of the project site. However, sandy soils were not observed at all in the northeastern project corner. We interpret borderline coarse-grained soil classifications shallower than 8 feet at the southeastern basin site as not technically part of either the Qvof<sub>a</sub> unit or recent floodplain sediments mapped close to the Perris Valley Drain. Instead, soil development and gradations would be consistent with late Pleistocene-age distal fan deposits that compose a thin veneer over the very old alluvium.

Most of the Perris Plain where the Rider Street project is sited is considered part of the "Paloma" depositional surface of Woodford et al. (1971), typified by fairly strongly developed illuvial clay and calcic horizons atop the older parent materials. Detrital sediments have originated from granitic bedrock terrains surrounding the valley east, west, and north of the project. The alluvium buries and conceals several deep erosional channels carved into granitic basement bedrock that can be considered tributaries to an ancestral San Jacinto River. The maximum depth of the Qvof<sub>a</sub> unit at the project site is not known with certainty, but may be approximately 400 feet based on geophysical survey data and some well records (AECOM, 2013; AGI, 2019). Granitic bedrock consisting of weakly foliated quartz diorite (Lakeview Mountains tonalite) rises to the surface only one mile east of the project site.

### **Groundwater**

AGI's BMP exploration borings did not encounter groundwater. Two deep geotechnical borings encountered minor perched-groundwater inflows beginning at depths of about 37 feet (site B-2) and 45 feet (B-7). All other soil borings remained dry.

The project site is within the West San Jacinto groundwater subbasin. According to many years of monitoring well records reviewed through the State CASGEM website, groundwater within a radius of about a half-mile from the property has had minimum measured depths of about 40 feet northeast of the site, and 57 to 81 feet to the west. The hydrogeologic regime is complex due to the heterogeneity of the alluvial basin fill, substantial erosional relief of the buried bedrock surfaces under the southern Perris Valley, and municipal groundwater pumping. Shallower groundwater close to the Perris Valley Drain located ~¼ mile to the east would not be unexpected, as this feature represents a seasonal line of basin recharge. There has been a historic tendency for groundwater levels to rise across the valley. Rising water levels are attributed to changing land uses in the Perris Plain vicinity, such as the cessation of formerly widespread agricultural pumping and introduction of irrigated suburban tracts. Nonetheless, AGI concludes that minimum depths to permanent groundwater at the project site have always been in excess of 30 feet.

Jurisdictional requirements usually mandate a minimum separation between stormwater BMPs and groundwater of at least 10 feet and up to 40 feet (for very permeable soils). Data thus indicate there should be zero limitations on BMP design or construction due to groundwater at the project.

### **Permeameter Test Results**

The table below summarizes the obtained field test results. Based on the drilling logs, the test results are interpreted as representative of longer-duration uptake capacity in the fine-grained soil classifications at the bottom of injection holes. Lateral absorption into thin slightly sandier lenses occurred at IN-4, but was short-lived and limited in volume.

Test Location	Tested Interval (depth below existing ground surface, feet)	Constant-Head Percolation Rate (gal/hr)	Field Test Infiltration Velocity $I_t$ (in/hr)
IN-1	5.2 - 11.2	12.3	0.18
IN-2	4.8 - 10.8	19.5	0.29
IN-3	5.4 - 11.4	5.4	0.08
IN-4	4.2 - 10.2	28.5	0.43

Measured percolation rates were converted to 1-D infiltration velocities by the USBR 7300-89 formula:

$$K_s = \frac{Q[\ln(H/r + (H/r + 1)^{0.5}) - 1](\mu_T/\mu_{20})}{2\pi H^2}$$

Where:

- $K_s$  = saturated hydraulic conductivity (infiltration rate, inches/hour)
- $H$  = height of water in well (inches)
- $Q$  = percolation flow rate from selected time interval (cubic inches/hour)
- $r$  = effective radius of well (inches)
- $\mu_T$  = viscosity of water at water temperature,  $t$
- $\mu_{20}$  = viscosity of water at 20°C

The calculated result  $K_s$  is close to but not exactly the same as an infiltration test velocity  $I_t$  calculated from a ring infiltrometer test. The minor difference is ignored for stormwater BMP design. AGI usually automatically assumes a viscosity coefficient of 1.0 for tests in metro Southern California where piped municipal water supplies and deep soil temperatures are near 20°C [68°F] year-round.

The calculated velocities would be judged very poor for infiltration BMPs. We think the results correctly characterize the hard and somewhat clayey nature of test-area sediments deeper than 8 to 9 feet. We do not think there are better soil conditions above or below the tested intervals.

### **Conclusions, Recommendations, and Advice**

The SAR *Water Quality Management Plan* explicitly requires any infiltration-based BMP to be clear of water in 72 hours or less after the design storm event. Mathematically, for typical volume-based BMP improvements, this requires field infiltration velocities  $I_t$  of roughly 1.6 inches per hour or faster. Achieved Rider Street project test results are far lower. AGI recommends a mean field-test infiltration test velocity of 0.2 inches per hour for either prospective basin site.

We think actual performance may be reduced further once available vadose-zone storage is filled during first-of-the-season storm events and the wetting front encounters deeper clayey strata. Riverside County guidelines for storm water best management practices

specify a factor of safety of 3.0 when calculating the design infiltration velocity  $I_d$  for an infiltration-type BMP, based on the methods and results of this investigation (Appendix A, Table 1, *Design Handbook for Low Impact Development Best Management Practices*). The AGI-recommended average  $I_t$  should be reduced by a factor of 3 to derive final  $I_d$ . Unless the design capture volume is unexpectedly small, it appears that the tested WQMP BMP sites cannot rely on surface infiltration. Hydromodification to reduce peak flows will likely require extended detention, treatment, and thence controlled release to the MS4 system [open ditch or future storm drain next to Rider Street].

Our reviews of geotechnical boring data did not identify any other site areas that could be considered favorable for either shallow open-basin BMPs or subterranean installations. Soils beneath and beside the proposed warehouse were logged as fine-grained, hard, and cemented starting just 5 to 9 feet below grade and extending to depths exceeding 20 feet. It is possible there could be very limited disposal potential in micro-basins along Redlands Avenue, but the input volumes would have to be low. Deep disposal options such as drywells suffer problems with a lack of suitable sandy horizons and inadequate separation to groundwater. Drywells are judged infeasible. At this time, hydromodification with biofiltration “treat and release” appear to be the only viable options for peak-discharge and water quality management.

It is important to note the test velocities were obtained in carefully prepared test holes as free as practicable of surface sealing and boundary-zone compaction. Field performance of any designed LID improvement could be markedly lower than AGI’s achieved results if precautions are not maintained during construction. If incidental infiltration is still designed into the LID BMP, then it will be imperative to specify construction practices for minimizing excavation bottom compaction. Excavations should be made with backhoes, grade-alls, or excavators working from beside the basin bottom. An overall goal of preventing heavy equipment from rolling or tracking any infiltration system excavation bottom should be understood.

Lastly, AGI preliminarily concludes from test and exploration findings that the tested BMP locations should neither cause structural concerns, nor result in significantly increased risks to the proposed building or neighboring properties from slope instability, liquefaction, or settlement. Future grading plan verification reviews are recommended, however.



**Investigation Limitations**

The findings in this report may require modification as a result of later field observations. Our opinions have been based on the results of limited testing within the prospective water-quality BMP sites combined with extrapolations of soil conditions away from the test bores. The nature and extent of variations within or beyond the tested sites may not become evident until construction. If conditions encountered during construction vary significantly from those indicated by this report, or BMP type or location changes are proposed, then additional site testing, preparation recommendations, or as-built tests may be needed to achieve correct designs for the treatment control BMP system(s).

**Closure**

This report was prepared for the use of First Industrial Realty Trust, Inc., their civil engineers, and authorized designates in cooperation with this office. Our findings and recommendations were prepared in accordance with generally accepted professional principles and local practice in the fields of engineering geology and geotechnical engineering. We make no other warranties either expressed or implied. Questions concerning the test results or design advice are invited, and may be directed to the undersigned at our Riverside office at (951) 776-0345.

Respectfully submitted,

**Aragón Geotechnical, Inc**

  
8/7/19

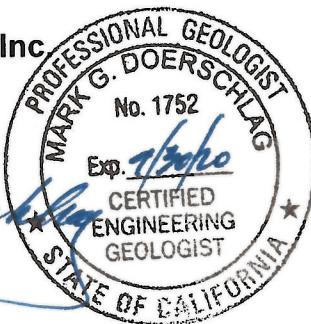

Mark G. Doerschlag, CEG 1752  
Engineering Geologist

  
8/7/19



C. Fernando Aragón, P.E., M.S.  
Geotechnical Engineer, G.E. 2994

MGD/CFA:mma

Attachments: Exploratory Boring Logs, Borings B-1 and B-9  
Permeameter Field Test Data, Sites IN-1 through IN-4  
Plate No. 1, Exploration & Infiltration Test Location Map (foldout)

Distribution: (4) Addressee

**Aragón Geotechnical, Inc.**

## REFERENCES

- AECOM Technical Services, Inc., 2013, *Final 2011-2012 Annual Monitoring Report, Long-Term Groundwater Monitoring Program, March Air Reserve Base, Former March Air Force Base, California*: contractor's report dated December 9, 2013 (Contract No. FA8903-09-D-8547-0007, Project No. 60271680-0009AG), digital download from State of California GeoTracker website, <https://geotracker.waterboards.ca.gov/>
- Aragon Geotechnical, Inc., 2019, *Preliminary Geotechnical Investigation, Proposed Light Industrial Project, APN 300-170-009, City of Perris, Riverside County, California*: consultant's report date January 21, 2019, Project No. 4488-SFLI, 42 p. and appendices.
- Morton, D.M., and Miller, F.K., 2006, Geologic map of the San Bernardino and Santa Ana 30' x 60' quadrangles, California [ver. 1.0], U.S. Geological Survey Open File Report 2006-1217, scale 1:100,000.
- Natural Resources Conservation Service, 2019, Web Soil Survey utility, accessed 7/31/19 from Internet URL <http://websoilsurvey.nrcs.usda.gov/app/HomePage.htm>
- Riverside County Flood Control and Water Conservation District, 2011, *Design Handbook for Low Impact Development Best Management Practices*, Riverside, California, download file at Internet URL [http://rcflood.org/downloads/NPDES/Documents/LIDManual/LID\\_BMP\\_Design\\_Handbook.pdf](http://rcflood.org/downloads/NPDES/Documents/LIDManual/LID_BMP_Design_Handbook.pdf)
- Woodford, A.O., Shelton, J.S., Doehring, D.O., and Morton, R.K., 1971, Pliocene-Pleistocene history of the Perris Block, southern California: Geological Society of America Bulletin, v. 82, p. 3421-3448.



# FIELD LOG OF BORING B - 1

Sheet 1 of 2

Project: **"RIDER AT REDLANDS" LIGHT INDUSTRIAL PROJECT**

Location: **CITY OF PERRIS, RIVERSIDE COUNTY, CALIF.**

Date(s) Drilled: <b>7/8/19</b>	Logged By: <b>M. Doerschlag</b>	
Drilled By: <b>GP Drilling</b>	Total Depth: <b>26.5 Ft.</b>	
Rig Make/Model: <b>Mobile B-61</b>	Hammer Type: <b>Automatic trip</b>	
Drilling Method: <b>Hollow-Stem Auger</b>	Hammer Weight/Drop: <b>140 Lb./30 In.</b>	
Hole Diameter: <b>8 In.</b>	Surface Elevation: <b>± 1442 Ft. AMSL, RCFC NAD 83</b>	

Comments: Located at SEC of proposed development site, within to possible BMP outline.

DEPTH (ft.)	ELEVATION (MSL DATUM)	SAMPLE INTERVALS		GRAPHIC LOG	USCS	GEOTECHNICAL DESCRIPTION	DRY DENSITY (pcf)	WATER CONTENT (%)	WELL COMPLETION	OTHER TESTS
		BULK DRIVE	TYPE, "N" or (Blows/ft.)							
0					ML	Sandy Silt: Brown; mechanically disturbed to around 2 feet, abruptly becoming very stiff below; slightly moist; averages around 40% fine- to medium-grained sand; no clay. Non-plastic even with added water. [Older alluvium]				
1440		SPT 3, 5, 15	N=20		ML	← Sandy silt, with trace clay and diffuse carbonate, mildly cemented, visibly porous.				
5		SPT 7, 7, 7	N=14		SM/ML	Silty Sand: Brown; medium dense; slightly moist; fine to medium grained, with ~35-40% fines including trace of clay; massive; crumbly. Upper half with pinhole pores. [Older alluvium]				
1435		SPT 6, 7, 8	N=15		SM/ML	← Silty sand, as above but with some diffuse carbonate, not visibly porous.				
10		SPT 8, 10, 14	N=24		ML	Sandy Silt: Brown; very stiff; slightly moist; estimated 30% fine to medium sand and possibly 5-8% clay; mildly cohesive; not visibly porous. [Very old alluvium]				
1430					ML	← Sandy silt, weakly cemented and with few pinhole pores, crumbly. Traces of carbonate increase quickly with depth				
15					ML	Clayey Silt: Brown; hard; moist; cohesive; traces of fine sand. [Very old alluvium]				

Continued on next sheet.



# FIELD LOG OF BORING B - 1

Sheet 2 of 2

Project: **"RIDER AT REDLANDS" LIGHT INDUSTRIAL PROJECT**

Location: **CITY OF PERRIS, RIVERSIDE COUNTY, CALIF.**

DEPTH (ft.)	ELEVATION (MSL DATUM)	SAMPLE INTERVALS		GRAPHIC LOG	USCS	GEOTECHNICAL DESCRIPTION	DRY DENSITY (pcf)	WATER CONTENT (%)	WELL COMPLETION	OTHER TESTS
		BULK DRIVE	TYPE, "N" or (Blows/ft.)							
15	1425	SPT 9 14 19	N=33	[Diagonal hatching pattern]	ML	Clayey Silt: Brown; hard; moist; moderately cohesive; traces of fine sand. Unit is massive and not visibly porous, with common veils of MnO. Non-plastic. [Very old alluvium]			[Wavy line pattern]	
20	1420	SPT 9 15 20	N=35	[Diagonal hatching pattern]	ML	← Clayey silt, as above, estimated 15% fine to medium sand, not visibly porous.			[Wavy line pattern]	
25		SPT 6 13 19	N=32	[Diagonal hatching pattern]	ML	← Classifies sandy silt, trace of clay, common MnO spots, ~30% f-m sand. massive.			[Wavy line pattern]	

*Bottom of boring at 26.5 ft.  
 No groundwater encountered..  
 Boring backfilled with compacted soil cuttings.*



# FIELD LOG OF BORING B - 9

Sheet 1 of 2

Project: **"RIDER AT REDLANDS" LIGHT INDUSTRIAL PROJECT**

Location: **CITY OF PERRIS, RIVERSIDE COUNTY, CALIF.**

Date(s) Drilled: <b>7/9/19</b>	Logged By: <b>M. Doerschlag</b>	
Drilled By: <b>GP Drilling</b>	Total Depth: <b>26.5 Ft.</b>	
Rig Make/Model: <b>Mobile B-61</b>	Hammer Type: <b>Automatic trip</b>	
Drilling Method: <b>Hollow-Stem Auger</b>	Hammer Weight/Drop: <b>140 Lb./30 In.</b>	
Hole Diameter: <b>8 In.</b>	Surface Elevation: <b>± 1442 Ft. AMSL, RCFC NAD 83</b>	

Comments: Located at NEC of proposed development site, next to possible BMP.

DEPTH (ft.)	ELEVATION (MSL DATUM)	SAMPLE INTERVALS		GRAPHIC LOG	USCS	GEOTECHNICAL DESCRIPTION	DRY DENSITY (pcf)	WATER CONTENT (%)	WELL COMPLETION	OTHER TESTS
		BULK DRIVE	TYPE, "N" or (Blows/ft.)							
0					ML	Silt: Light brown; stiff to very stiff; subjectively only slightly moist; trace of very fine sand; non-plastic. [Very old alluvium]				
1440		RING 4-8 (28)			ML	← Silt, variegated colors due to bioturbation, with abundant carbonate, punky texture.	77.8	22.9		
5		RING 10-22 (46)			ML	← Silt, very heavy diffuse carbonate, cemented, visibly porous and with punky texture.	91.7	21.5		
1435		SPT 5-7 N=16			ML	Sandy Silt: Brown; very stiff; slightly moist; massive; slightly cemented but crumbly and with few pinhole pores. Abundant reticulate carbonate. [Very old alluvium]				
10		SPT 8-13 N=33			ML/CL	Clayey Silt: Brown; hard; slightly moist; mildly cohesive; massive; not visibly porous and non-plastic. Sample at 10' features abundant reticulate white-colored carbonate. [Very old alluvium]				
1430					ML/CL					
15										

Continued on next sheet.



# FIELD LOG OF BORING B - 9

Sheet 2 of 2

Project: **"RIDER AT REDLANDS" LIGHT INDUSTRIAL PROJECT**

Location: **CITY OF PERRIS, RIVERSIDE COUNTY, CALIF.**

DEPTH (ft.)	ELEVATION (MSL DATUM)	SAMPLE INTERVALS		GRAPHIC LOG	USCS	GEOTECHNICAL DESCRIPTION	DRY DENSITY (pcf)	WATER CONTENT (%)	WELL COMPLETION	OTHER TESTS
		BULK DRIVE	TYPE, "N" or (Blows/ft.)							
15			SPT 7 14 21 N=35		ML	Clayey Silt: Grades yellowish brown; hard; slightly moist; minor carbonate and some MnO veils; typical 30% fine-grained sand. Non-plastic. Base of unit detected by color and faster drilling rate. [Very old alluvium]				
1425						Sandy Silt: Yellowish brown; hard; moist; similar to overlying sediments bu little to no clay and no pedogenic carbonate but common MnO spots and films; friable and crumbly; not visibly porous. [Very old alluvium]				
20			SPT 14 23 28 N=51		ML	← Sandy silt, as above, zero carbonate but common coarse MnO spots, estimated 30% fine to medium grained sand. not visibly porous.				
1420										
25			SPT 10 12 27 N=39		ML	← Sandy silt, no clay, massive and not visibly porous.				

Bottom of boring at 26.5 ft.  
 No groundwater encountered.  
 Boring backfilled with compacted soil cuttings.











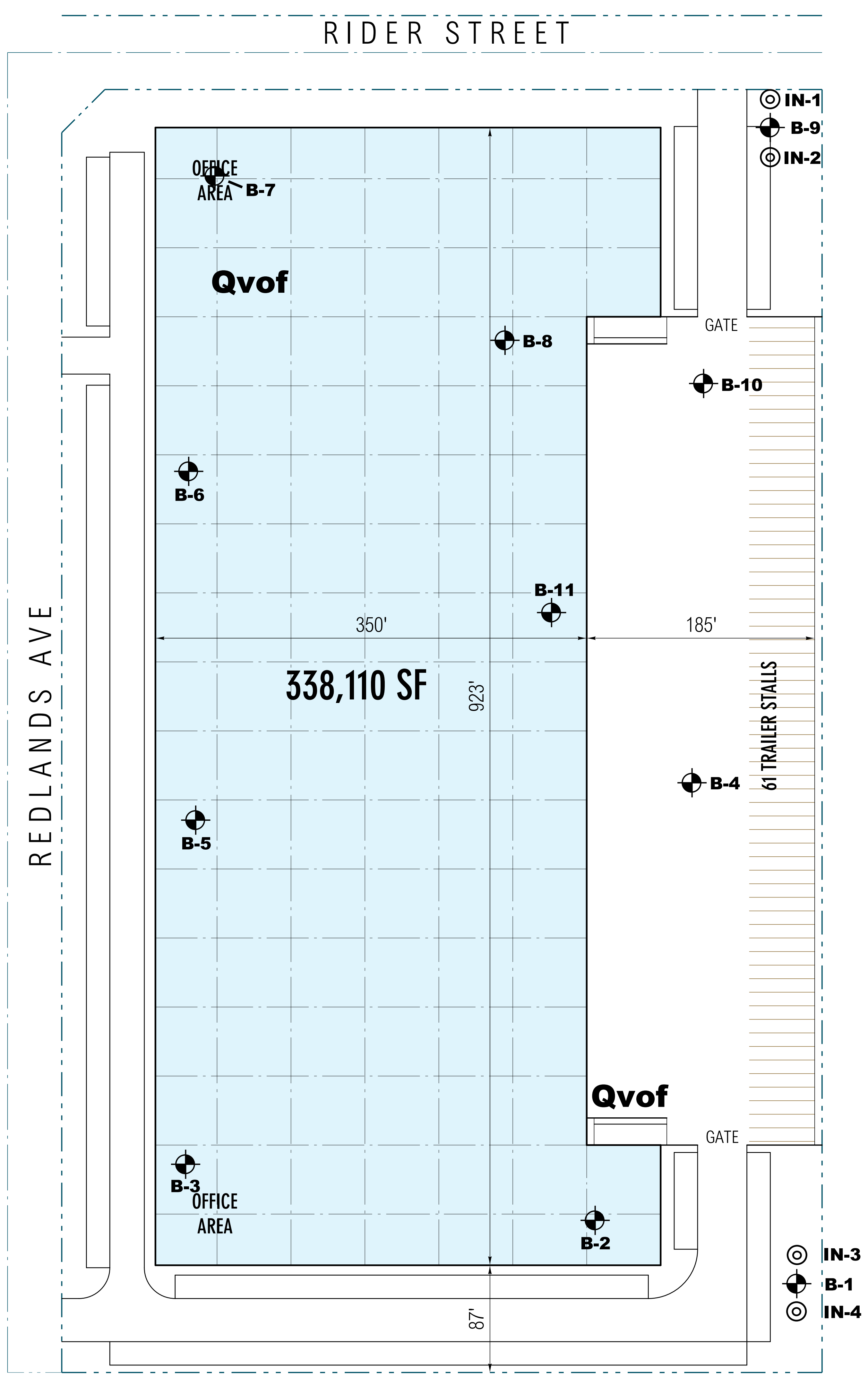

LEGEND	
	<b>B-11</b> Approximate location of exploratory boring
	<b>IN-4</b> Approximate location of infiltration test
	<b>Qvof</b> Very old fan alluvium
Not shown: Minor surficial cover of later Pleistocene fan alluvium in south half of site.	

**PROJECT DATA:**

APPROX. SITE AREA: 641,631 SF  
14.72 AC

BUILDING AREA: 338,110 SF

COVERAGE: 52.69 %

**EXPLORATION & TEST LOCATION MAP**

RIDER STREET AT REDLANDS AVENUE,  
CITY OF PERRIS, CA

PROJECT NO. 4534-1	DATE: 8/2/19	PLATE NO. 1
--------------------	--------------	-------------

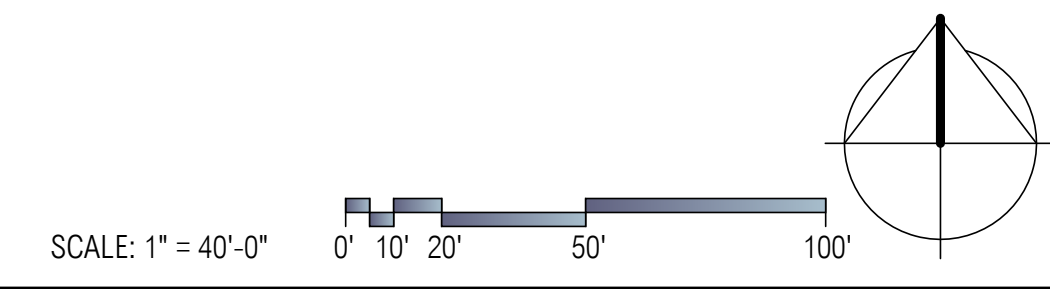

**RG**  
Office of Architectural Design

15231 Alton Parkway, Suite 100  
Irvine, CA 92618

T 949-341-0920  
FX 949-341-0922

# PROJECT NAME

ADDRESS, CITY

PRELIMINARY SITE PLAN - SCHEME 01

RGA PROJECT NO:	15XXX-00
CAD FILE NAME:	15XXX-00-A1-01
DRAWN BY:	CS
CHK'D BY:	CS
COPYRIGHT: RGA, OFFICE OF ARCHITECTURAL DESIGN	
SHEET TITLE	
A1-01	
MARK	DESCRIPTION

# Appendix 4: Historical Site Conditions

*Phase I Environmental Site Assessment or Other Information on Past Site Use*

**N/A**

# Appendix 5: LID Infeasibility

*LID Technical Infeasibility Analysis*

**N/A**

# Appendix 6: BMP Design Details

*BMP Sizing, Design Details and other Supporting Documentation*



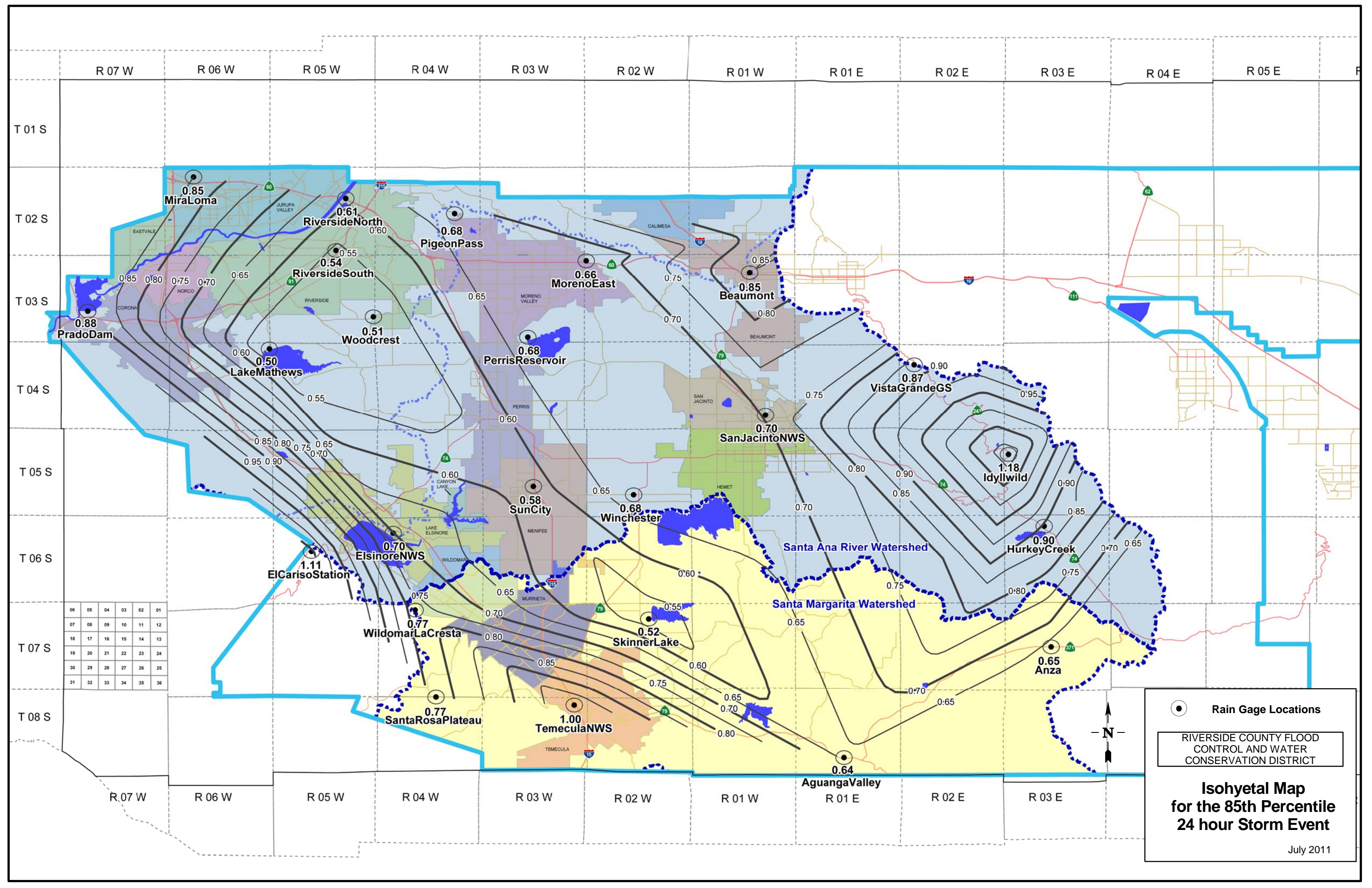

06	05	04	03	02	01
07	08	09	10	11	12
18	17	16	15	14	13
19	20	21	22	23	24
30	29	28	27	26	25
31	32	33	34	35	36

Rain Gage Locations

RIVERSIDE COUNTY FLOOD CONTROL AND WATER CONSERVATION DISTRICT

**Isohyetal Map for the 85th Percentile 24 hour Storm Event**

July 2011



### Santa Ana Watershed - BMP Design Volume, V<sub>BMP</sub>

(Rev. 10-2011)

Legend:

Legend:

Required Entries

Calculated Cells

*(Note this worksheet shall only be used in conjunction with BMP designs from the LID BMP Design Handbook)*

Company Name	Albert A. Webb Associates	Date	1/9/2020
Designed by	Cristina Velgara	Case No	
Company Project Number/Name	19-0137 Rider/Redlands Project		

#### BMP Identification

BMP NAME / ID **WQMP Facility A**

*Must match Name/ID used on BMP Design Calculation Sheet*

#### Design Rainfall Depth

85th Percentile, 24-hour Rainfall Depth, from the Isohyetal Map in Handbook Appendix E D<sub>85</sub> = **0.64** inches

#### Drainage Management Area Tabulation

*Insert additional rows if needed to accommodate all DMAs draining to the BMP*

DMA Type/ID	DMA Area (square feet)	Post-Project Surface Type	Effective Imperivous Fraction, I <sub>f</sub>	DMA Runoff Factor	DMA Areas x Runoff Factor	Design Storm Depth (in)	Design Capture Volume, V <sub>BMP</sub> (cubic feet)	Proposed Volume on Plans (cubic feet)
L-A	1,100	<i>Ornamental Landscaping</i>	0.1	0.11	121.5			
R-A	82,590	<i>Roofs</i>	1	0.89	73670.3			
H-A	26,740	<i>Concrete or Asphalt</i>	1	0.89	23852.1			
BMP-A	4050	<i>Ornamental Landscaping</i>	0.1	0.11	447.4			
SR-A	7000	<i>Ornamental Landscaping</i>						
<b>121480</b>		<b>Total</b>			<b>98091.3</b>	<b>0.64</b>	<b>5231.5</b>	<b>5300</b>

Notes:



Bioretention Facility - Design Procedure		BMP ID	Legend:	Required Entries
				Calculated Cells
Company Name:	Albert A. Webb Associates		Date:	1/14/2020
Designed by:	Cristina Velgara		County/City Case No.:	
Design Volume				
Enter the area tributary to this feature			$A_T =$	2.8 acres
Enter $V_{BMP}$ determined from Section 2.1 of this Handbook			$V_{BMP} =$	5,300 ft <sup>3</sup>
Type of Bioretention Facility Design				
<input type="radio"/> Side slopes required (parallel to parking spaces or adjacent to walkways) <input checked="" type="radio"/> No side slopes required (perpendicular to parking space or Planter Boxes)				
Bioretention Facility Surface Area				
Depth of Soil Filter Media Layer			$d_S =$	1.5 ft
Top Width of Bioretention Facility, excluding curb			$w_T =$	12.0 ft
Total Effective Depth, $d_E$				
$d_E = [(0.3) \times d_S + (0.4) \times 1] + 0.5$			$d_E =$	1.35 ft
Minimum Surface Area, $A_m$				
$A_M (ft^2) = \frac{V_{BMP} (ft^3)}{d_E (ft)}$			$A_M =$	3,926 ft <sup>2</sup>
Proposed Surface Area			$A =$	4,050 ft <sup>2</sup>
Minimum Required Length of Bioretention Facility, L			$L =$	327.2 ft
Bioretention Facility Properties				
Side Slopes in Bioretention Facility			$z =$	0 :1
Diameter of Underdrain				6 inches
Longitudinal Slope of Site (3% maximum)				0.5 %
6" Check Dam Spacing				0 feet
Describe Vegetation:				
Notes:				

**Santa Ana Watershed - BMP Design Volume,  $V_{BMP}$**

(Rev. 10-2011)

Legend:

Required Entries

Calculated Cells

*(Note this worksheet shall **only** be used in conjunction with BMP designs from the **LID BMP Design Handbook**)*

Company Name	Albert A. Webb Associates	Date	1/9/2020
Designed by	Cristina Velgara	Case No	
Company Project Number/Name	19-0137 Rider/Redlands Project		

**BMP Identification**

BMP NAME / ID	WQMP Facility B
<i>Must match Name/ID used on BMP Design Calculation Sheet</i>	

**Design Rainfall Depth**

85th Percentile, 24-hour Rainfall Depth, from the Isohyetal Map in Handbook Appendix E  $D_{85} =$  0.64 inches

**Drainage Management Area Tabulation**

*Insert additional rows if needed to accommodate all DMAs draining to the BMP*

DMA Type/ID	DMA Area (square feet)	Post-Project Surface Type	Effective Imperivous Fraction, $I_f$	DMA Runoff Factor	DMA Areas x Runoff Factor	Design Storm Depth (in)	Design Capture Volume, $V_{BMP}$ (cubic feet)	Proposed Volume on Plans (cubic feet)
L-B	5,140	Ornamental Landscaping	0.1	0.11	567.8			
R-B	82,590	Roofs	1	0.89	73670.3			
H-B	26,710	Concrete or Asphalt	1	0.89	23825.3			
BMP-B	3000	Ornamental Landscaping	0.1	0.11	331.4			
SR-B	7000	Ornamental Landscaping						
	<b>124440</b>		<b>Total</b>		<b>98394.8</b>	<b>0.64</b>	<b>5247.7</b>	<b>5,300</b>

Notes:

Bioretention Facility - Design Procedure		BMP ID	Legend:	Required Entries
				Calculated Cells
Company Name:	Albert A. Webb Associates		Date:	1/9/2020
Designed by:	Cristina Velgara		County/City Case No.:	
Design Volume				
Enter the area tributary to this feature			$A_T =$	2.8 acres
Enter $V_{BMP}$ determined from Section 2.1 of this Handbook			$V_{BMP} =$	5,300 ft <sup>3</sup>
Type of Bioretention Facility Design				
<input type="radio"/> Side slopes required (parallel to parking spaces or adjacent to walkways) <input checked="" type="radio"/> No side slopes required (perpendicular to parking space or Planter Boxes)				
Bioretention Facility Surface Area				
Depth of Soil Filter Media Layer			$d_S =$	3.0 ft
Top Width of Bioretention Facility, excluding curb			$w_T =$	10.0 ft
Total Effective Depth, $d_E$				
$d_E = [(0.3) \times d_S + (0.4) \times 1] + 0.5$			$d_E =$	1.80 ft
Minimum Surface Area, $A_m$				
$A_M (ft^2) = \frac{V_{BMP} (ft^3)}{d_E (ft)}$			$A_M =$	2,945 ft <sup>2</sup>
Proposed Surface Area			$A =$	3,000 ft <sup>2</sup>
Minimum Required Length of Bioretention Facility, L			$L =$	294.5 ft
Bioretention Facility Properties				
Side Slopes in Bioretention Facility			$z =$	0 :1
Diameter of Underdrain				6 inches
Longitudinal Slope of Site (3% maximum)				0.5 %
6" Check Dam Spacing				0 feet
Describe Vegetation:				
Notes:				

**Santa Ana Watershed - BMP Design Volume,  $V_{BMP}$**

(Rev. 10-2011)

Legend:

Required Entries

Calculated Cells

*(Note this worksheet shall **only** be used in conjunction with BMP designs from the **LID BMP Design Handbook**)*

Company Name	Albert A. Webb Associates	Date	1/9/2020
Designed by	Cristina Velgara	Case No	
Company Project Number/Name	19-0137 Rider/Redlands Project		

**BMP Identification**

BMP NAME / ID	WQMP Facility C
---------------	-----------------

*Must match Name/ID used on BMP Design Calculation Sheet*

**Design Rainfall Depth**

85th Percentile, 24-hour Rainfall Depth, from the Isohyetal Map in Handbook Appendix E  $D_{85} =$  0.64 inches

**Drainage Management Area Tabulation**

*Insert additional rows if needed to accommodate all DMAs draining to the BMP*

DMA Type/ID	DMA Area (square feet)	Post-Project Surface Type	Effective Imperivous Fraction, $I_p$	DMA Runoff Factor	DMA Areas x Runoff Factor	Design Storm Depth (in)	Design Capture Volume, $V_{BMP}$ (cubic feet)	Proposed Volume on Plans (cubic feet)
L-C	740	Ornamental Landscaping	0.1	0.11	81.7			
H-C	36,390	Concrete or Asphalt	1	0.89	32459.9			
BMP-C	1,765	Ornamental Landscaping	0.1	0.11	195			
SR-C	1457	Ornamental Landscaping						
	<b>40352</b>	<b>Total</b>			<b>32736.6</b>	<b>0.64</b>	<b>1746</b>	<b>2,000</b>

Notes:

Bioretention Facility - Design Procedure		BMP ID	Legend:	Required Entries
				Calculated Cells
Company Name:	Albert A. Webb Associates		Date:	1/9/2020
Designed by:	Cristina Velgara		County/City Case No.:	
Design Volume				
Enter the area tributary to this feature			$A_T =$	0.93 acres
Enter $V_{BMP}$ determined from Section 2.1 of this Handbook			$V_{BMP} =$	2,000 ft <sup>3</sup>
Type of Bioretention Facility Design				
<input checked="" type="radio"/> Side slopes required (parallel to parking spaces or adjacent to walkways) <input type="radio"/> No side slopes required (perpendicular to parking space or Planter Boxes)				
Bioretention Facility Surface Area				
Depth of Soil Filter Media Layer			$d_S =$	1.5 ft
Top Width of Bioretention Facility, excluding curb			$w_T =$	15.0 ft
Total Effective Depth, $d_E$ $d_E = (0.3) \times d_S + (0.4) \times 1 - (0.7/w_T) + 0.5$			$d_E =$	1.30 ft
Minimum Surface Area, $A_m$ $A_M (ft^2) = \frac{V_{BMP} (ft^3)}{d_E (ft)}$			$A_M =$	1,535 ft <sup>2</sup>
Proposed Surface Area			$A =$	1,765 ft <sup>2</sup>
Bioretention Facility Properties				
Side Slopes in Bioretention Facility			$z =$	4 :1
Diameter of Underdrain				6 inches
Longitudinal Slope of Site (3% maximum)				0.5 %
6" Check Dam Spacing				0 feet
Describe Vegetation:				
Notes:				

**Santa Ana Watershed - BMP Design Volume,  $V_{BMP}$**

(Rev. 10-2011)

Legend:

Required Entries

Calculated Cells

*(Note this worksheet shall **only** be used in conjunction with BMP designs from the **LID BMP Design Handbook**)*

Company Name	Albert A. Webb Associates	Date	1/9/2020
Designed by	Cristina Velgara	Case No	
Company Project Number/Name	19-0137 Rider/Redlands Project		

**BMP Identification**

BMP NAME / ID **WQMP Basin D**

*Must match Name/ID used on BMP Design Calculation Sheet*

**Design Rainfall Depth**

85th Percentile, 24-hour Rainfall Depth, from the Isohyetal Map in Handbook Appendix E  $D_{85} =$  **0.64** inches

**Drainage Management Area Tabulation**

*Insert additional rows if needed to accommodate all DMAs draining to the BMP*

DMA Type/ID	DMA Area (square feet)	Post-Project Surface Type	Effective Imperivous Fraction, $I_f$	DMA Runoff Factor	DMA Areas x Runoff Factor	Design Storm Depth (in)	Design Capture Volume, $V_{BMP}$ (cubic feet)	Proposed Volume on Plans (cubic feet)
L-D	5,105	Ornamental Landscaping	0.1	0.11	563.9			
R-D	154,910	Roofs	1	0.89	138179.7			
H-D	172,285	Concrete or Asphalt	1	0.89	153678.2			
SR-D	33,355	Ornamental Landscaping						
	<b>365655</b>		<b>Total</b>		<b>292421.8</b>	<b>0.64</b>	<b>15595.8</b>	<b>15,800</b>

Notes:



**Project Summary**

Date:	1/14/2020
Project Name:	First Rider
City / County:	City of Perris
State:	CA
Designed By:	CV
Company:	Albert A. Webb Associates
Telephone:	(951) 686-1070

Enter Information in  
Blue Cells

**Corrugated Metal Pipe Calculator**

Storage Volume Required (cf):	15,800	50.27 ft <sup>2</sup> Pipe Area
Limiting Width (ft):	50.00	
Invert Depth Below Asphalt (ft):	10.00	
Solid or Perforated Pipe:	Solid	
Shape Or Diameter (in):	96	
Number Of Headers:	2	
Spacing between Barrels (ft):	2.50	
Stone Width Around Perimeter of System (ft):	2	
Depth A: Porous Stone Above Pipe (in):	6	
Depth C: Porous Stone Below Pipe (in):	6	
Stone Porosity (0 to 40%):	40	

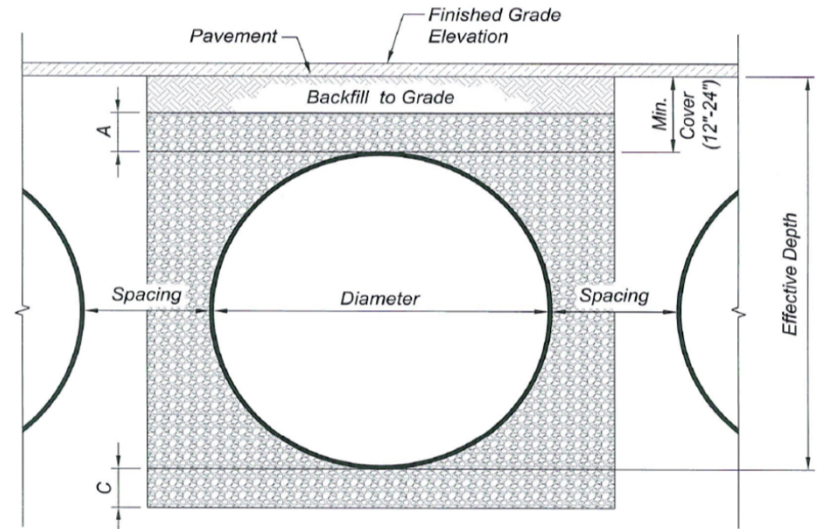

**System Sizing**

Pipe Storage:	15,834 cf	
Porous Stone Storage:	0 cf	
Total Storage Provided:	15,834 cf	100.2% Of Required Storage
Number of Barrels:	4 barrels	
Length per Barrel:	59.0 ft	
Length Per Header:	39.5 ft	
Rectangular Footprint (W x L):	43.5 ft x 79. ft	

**System Layout**

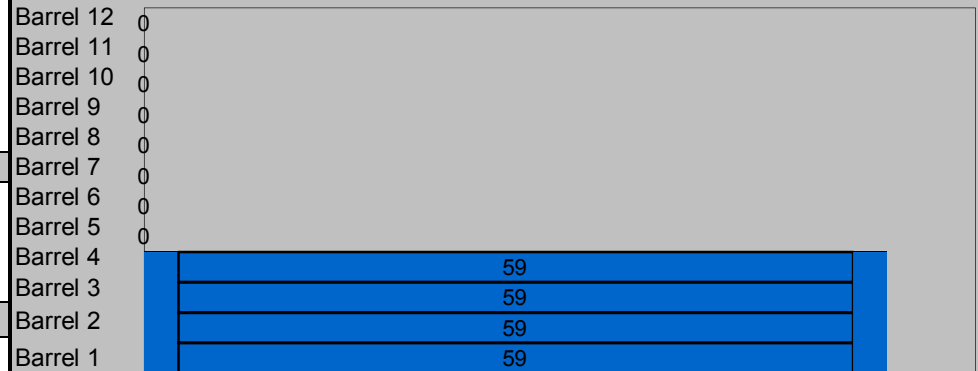

Barrel Footage (w/o headers)

**CONTECH Materials**

Total CMP Footage:	315 ft
Approximate Total Pieces:	16 pcs
Approximate Coupling Bands:	18 bands
Approximate Truckloads:	8 trucks

**Construction Quantities\*\***

Total Excavation:	1273 cy
Porous Stone Backfill For Storage:	0 cy stone
Backfill to Grade Excluding Stone:	687 cy fill

\*\*Construction quantities are approximate and should be verified upon final design

THIS IS A SCHEMATIC LAYOUT ONLY. ACTUAL CONFIGURATION WILL VARY BASED ON THE SITE SPECIFIC CONSIDERATIONS. REFER TO FLOWKIT DRAWINGS FOR ADDITIONAL DETAILS.

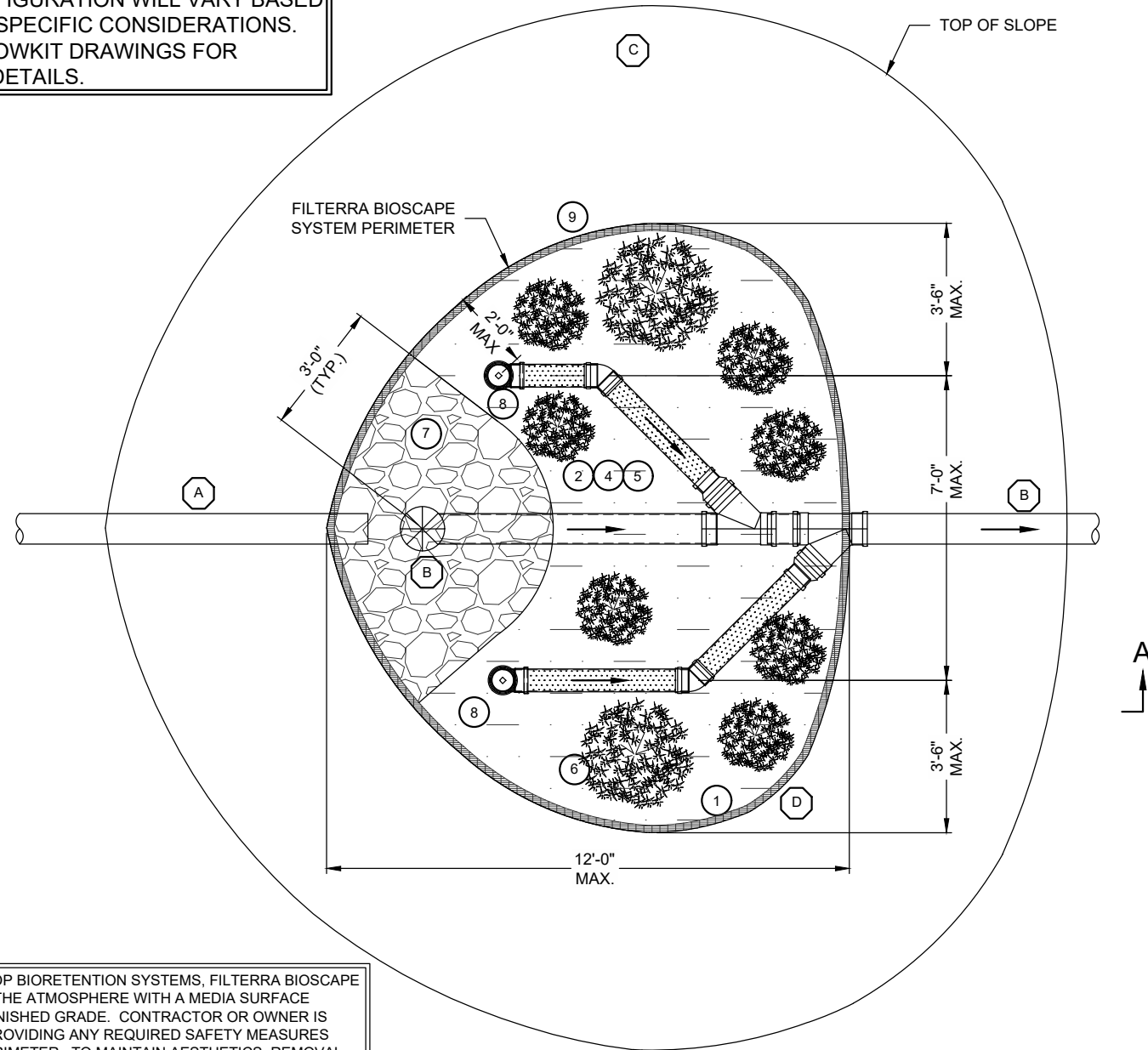

**PLAN VIEW**

AS WITH ALL OPEN TOP BIORETENTION SYSTEMS, FILTERRA BIOSCAPE SYSTEM IS OPEN TO THE ATMOSPHERE WITH A MEDIA SURFACE RECESSED BELOW FINISHED GRADE. CONTRACTOR OR OWNER IS RESPONSIBLE FOR PROVIDING ANY REQUIRED SAFETY MEASURES AROUND SYSTEM PERIMETER. TO MAINTAIN AESTHETICS, REMOVAL OF HEAVY STORMWATER DEBRIS MAY BE NECESSARY BETWEEN REGULAR FILTERRA SYSTEM MAINTENANCE EVENTS.

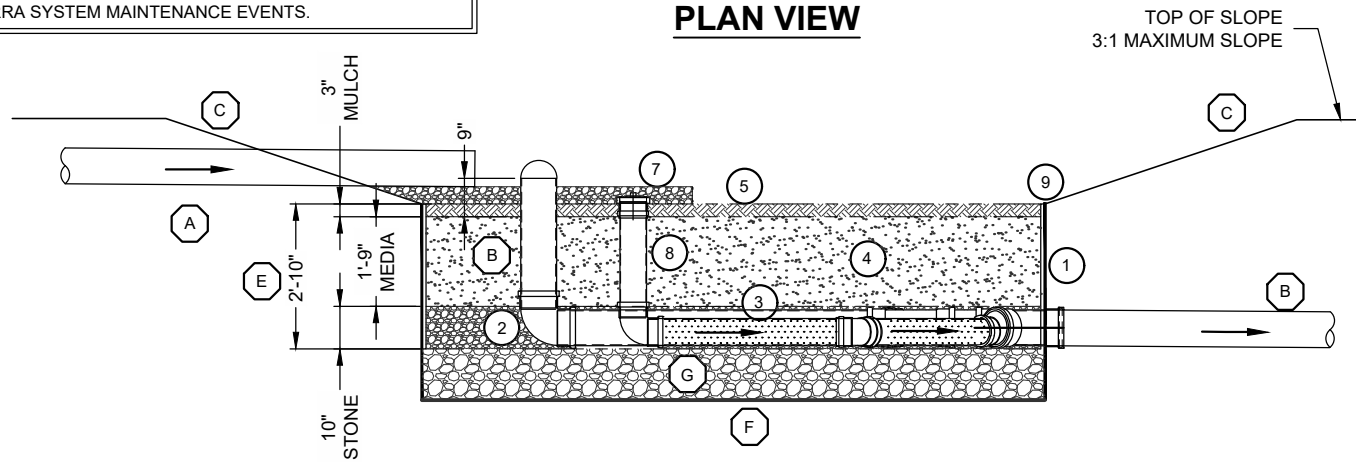

**SECTION A-A VIEW**

**BILL OF MATERIALS**

COUNT	DESCRIPTION	INSTALLED BY
X	FILTERRA SURFACE AREA (SF)	CONTRACTOR
X	MULCH VOLUME (CY)	CONTRACTOR
XX	FILTERRA MEDIA VOLUME (CY)	CONTRACTOR
X	1/2" #4 ROUND AGGREGATE UNDERDRAIN STONE (CY)	CONTRACTOR
X	ENERGY DISSIPATION ROCK (CY)	CONTRACTOR
X	EROSION CONTROL (LF)	CONTRACTOR
X	FILTERRA FLOWKIT	CONTRACTOR

**PLANTING SCHEDULE**

\*NOTE: PLANTS PROVIDED BY OTHERS

QUANTITY	FILTERRA BIOSCAPE SYSTEM PLANT PALETTE

**GENERAL NOTES**

- CONTRACTOR SHALL CONTACT CONTECH TO COORDINATE DELIVERY AND SUPERVISION OF PLACEMENT OF FILTERRA BIOSCAPE SYSTEM COMPONENTS (ACTIVATION). CONTRACTOR SHALL COMPLETE ITEMS IN THE LIST OF CONTRACTOR INSTALLATION RESPONSIBILITIES LISTED ON THIS DETAIL BEFORE CONTECH'S REPRESENTATIVE ATTENDS AND SUPERVISES THE ACTIVATION OF THE BIOSCAPE SYSTEM.
- PERFORM FILTERRA BIOSCAPE SYSTEM EXCAVATION ONLY AFTER ALL THE CONTRIBUTING DRAINAGE AREAS ARE PERMANENTLY STABILIZED. DO NOT CONSTRUCT FILTERRA BIOSCAPE SYSTEM IN AN AREA USED AS EROSION AND SEDIMENT CONTROL FACILITIES. DO NOT STOCKPILE MATERIALS NOR STORE EQUIPMENT IN THIS AREA.
- USE METHODS OF EXCAVATION THAT MINIMIZE COMPACTION OF THE UNDERLYING SOIL UNLESS THE SYSTEM IS TO BE LINED.
- CONTRACTOR SHALL COORDINATE WITH CONTECH BEFORE THE FILTERRA BIOSCAPE SYSTEM AREA IS EXCAVATED TO MINIMIZE TIME BETWEEN EXCAVATION AND DELIVERY AND ACTIVATION OF THE FILTERRA BIOSCAPE SYSTEM. ANY STANDING WATER THAT ACCUMULATES IN THE EXCAVATED AREA MUST BE REMOVED BY THE CONTRACTOR BEFORE CONTECH CAN PROVIDE ACTIVATION OF THE FILTERRA BIOSCAPE SYSTEM. ANY ADDITIONAL EXCAVATION WILL BE THE RESPONSIBILITY OF THE CONTRACTOR. EXCAVATION DIMENSIONS SHOULD BE PROVIDED TO CONTECH IN THE ACTIVATION REQUEST CHECKLIST.
- CONTRACTOR SHALL PROVIDE ACCESS TO THE EXCAVATED AREA(S) FOR USE DURING THE ACTIVATION OF THE FILTERRA BIOSCAPE SYSTEM(S). ACCESS SHALL NOT PROHIBIT LIGHT DUTY EQUIPMENT THAT MAY BE USED TO INSTALL THE COMPONENTS (STONE, MEDIA, ETC). THE CONTRACTOR SHALL BE RESPONSIBLE FOR ANY RE-STABILIZATION THAT MAY BE REQUIRED AFTER THE FILTERRA BIOSCAPE SYSTEM ACTIVATION.
- CONTECH AND/OR ITS REPRESENTATIVES MUST BE SCHEDULED TO BE ON SITE FOR THE LIST ENTITLED CONTRACTOR ACTIVATION RESPONSIBILITIES.

**CONTRACTOR SITE PREPARATION RESPONSIBILITIES AS DENOTED BY (X) ON THIS DETAIL:**

- (A) CONTRACTOR SHALL INSTALL PIPE OR SWALE THAT CONVEYS INFLUENT FLOWS AS WELL AS ANY REQUIRED INLET AND OUTLET STRUCTURES.
- (B) CONTRACTOR SHALL PROVIDE BYPASS PIPE AND RISER OR OTHER STRUCTURE AS SHOWN ON PLANS. THE BYPASS PIPE SHALL BE INSTALLED WITH WYE(S), OR OTHER PIPE FITTINGS, AND WITH REDUCER COUPLING(S) FOR CONNECTION OF UNDERDRAIN PIPE, PER PLANS. PIPES SHALL BE INSTALLED TO PROMOTE POSITIVE FLOW FROM THE FILTERRA BIOSCAPE SYSTEM.
- (C) IF REQUIRED, CONTRACTOR TO PROVIDE SHOULDER ACCORDING TO DIMENSION AND SLOPE SHOWN ON PLANS OR AS DESIGNED BY ENGINEER OF RECORD. SLOPE FROM SHOULDER TO FILTERRA BIOSCAPE SYSTEM SURFACE AREA SHALL NOT EXCEED 3:1. SOIL IS REQUIRED TO STABILIZE SIDE SLOPES OR ADJACENT GRADE.
- (D) CONTRACTOR TO EXCAVATE MEDIA AREA CORRESPONDING TO THE SIZE OF THE FILTERRA BIOSCAPE SYSTEM SURFACE AREA AS SHOWN ON DETAIL AND ON PLAN SHEETS.
- (E) CONTRACTOR SHALL EXCAVATE VERTICALLY FROM BOTTOM OF UNDERDRAIN STONE, OR DRAINAGE STONE, IF REQUIRED, TO ELEVATION OF MULCH AS SHOWN ON THIS DETAIL.
- (F) CONTRACTOR TO PROVIDE AND INSTALL ANY GEOTEXTILE OR IMPERMEABLE LINER FOR BOTTOM OF THE FILTERRA BIOSCAPE SYSTEM IF REQUIRED PER THE PLANS.
- (G) CONTRACTOR TO PROVIDE AND INSTALL ANY ADDITIONAL DRAINAGE STONE BELOW THE FILTERRA BIOSCAPE SYSTEM AS CALLED OUT ON THE PLANS.

**CONTRACTOR ACTIVATION RESPONSIBILITIES AS DENOTED BY (#) ON THIS DETAIL:**

- (1) PLACE GEOTEXTILE FABRIC ALONG THE PERIMETER OF THE FILTERRA BIOSCAPE SYSTEM EXCAVATION.
- (2) PLACE 10" OF UNDERDRAIN STONE - 2" UNDER THE PIPING, 6" AROUND THE PIPING AND 2" ABOVE THE PIPING USING LIGHT DUTY EQUIPMENT ONLY.
- (3) PLACE 6" UNDERDRAIN PIPING UNLESS OTHERWISE APPROVED BY CONTECH, ASSOCIATED PIPING AND FITTINGS/ELBOWS TO CONNECT TO THE PIPING/FITTING(S) THAT IS PROVIDED BY CONTRACTOR (SEE CONTRACTOR INSTALLATION RESPONSIBILITIES THIS DETAIL).
- (4) PLACE 21" FILTERRA MEDIA USING LIGHT DUTY EQUIPMENT ONLY. DO NOT COMPACT MEDIA.
- (5) PLACE 3" DOUBLE SHREDDED HARDWOOD MULCH OVER ENTIRE FILTERRA BIOSCAPE SYSTEM SURFACE AREA USING LIGHT DUTY EQUIPMENT ONLY. DO NOT COMPACT MULCH.
- (6) PROVIDE AND PLANT VEGETATION AS INDICATED IN TABLE ON THIS DETAIL OR ON SITE PLANS.
- (7) PLACE ENERGY DISSIPATION ROCK APRON AS DESIGNED AND INDICATED ON THIS DETAIL OR PER ENGINEER OF RECORD PLANS.
- (8) PLACE CLEANOUT ADAPTER, PLUG AND PIPING.
- (9) PLACE ADDITIONAL EROSION CONTROL AROUND FILTERRA BIOSCAPE SYSTEM (IF REQUIRED).

I:\COMMON\CAD\TREATMENT\64 FILTERRA\40 STANDARD DRAWINGS\FTBS - BIOSCAPE SYSTEM (BOXLESS)\DWG\FILTERRA BIOSCAPE SUPERVISED SYSTEM - STD DETAIL.DWG 5/21/2020 8:57 AM



www.ContechES.com  
9025 Centre Pointe Dr., Suite 400, West Chester, OH 45069  
800-338-1122 513-645-7000 513-645-7993 FAX

**FILTERRA BIOSCAPE™ SYSTEM  
STANDARD DETAIL**



# Appendix 7: Hydromodification

*Supporting Detail Relating to Hydrologic Conditions of Concern*

**Riverside County WAP Hydromodification Geodatabase**  
approved April 20, 2017

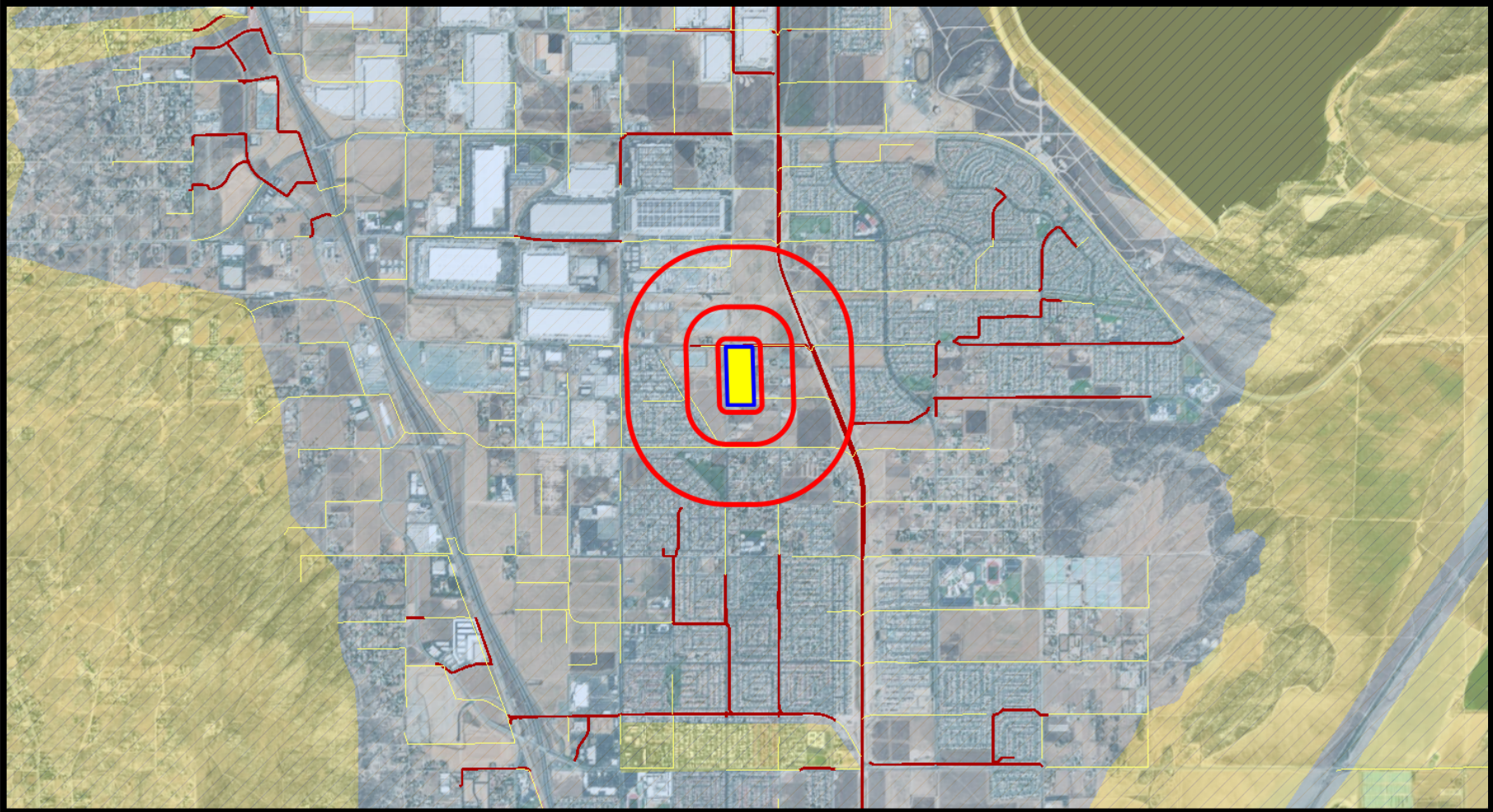

# Appendix 8: Source Control

*Pollutant Sources/Source Control Checklist*

**\*To be provided during final engineering**

# Appendix 9: O&M

*Operation and Maintenance Plan and Documentation of Finance, Maintenance and Recording Mechanisms*

**\*To be provided during final engineering**

# Appendix 10: Educational Materials

*BMP Fact Sheets, Maintenance Guidelines and Other End-User BMP Information*

**\*To be provided during final engineering**