

# Project Specific Water Quality Management Plan

A Template for Projects located within the **Santa Ana Watershed** Region of Riverside County

**Project Title:** Rider Business Center

**Design Review/Case No:** P20-00011

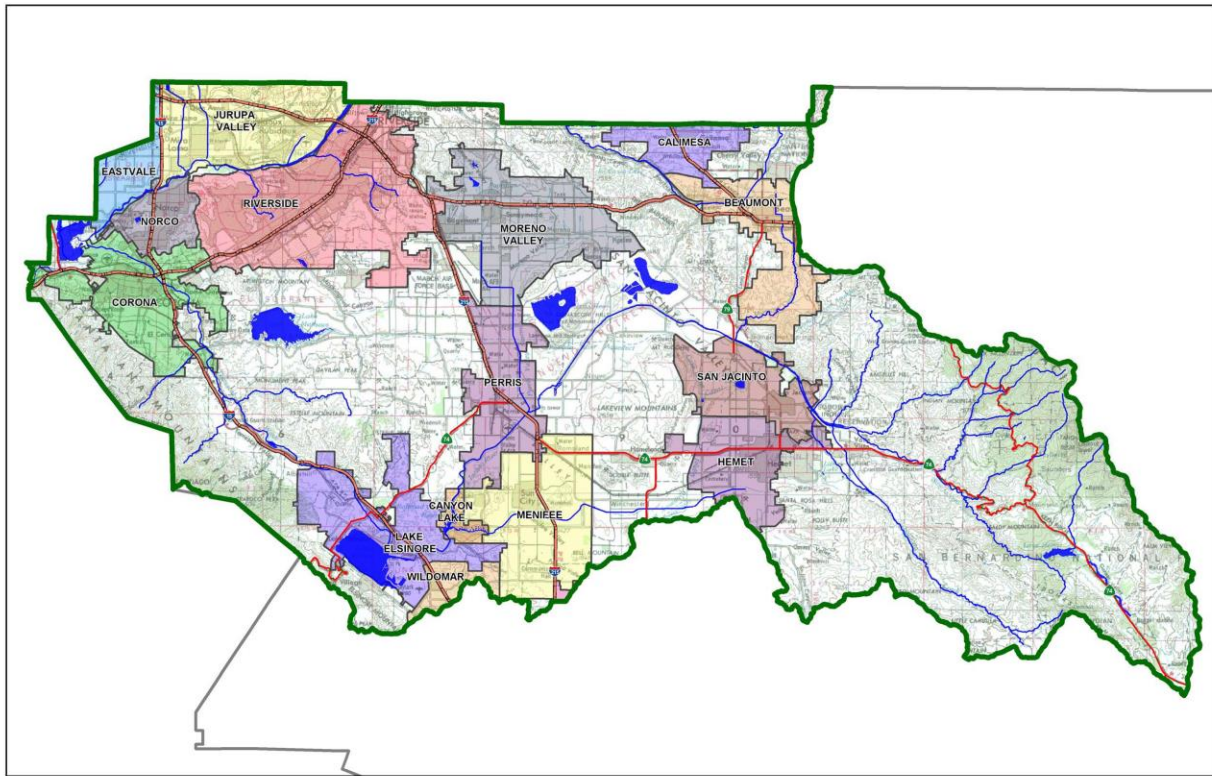

## Contact Information:

### Prepared for:

Core 5 Industrial Partners  
Attn: Jon Kelly  
300 Spectrum Center Drive, Suite 880  
Irvine, CA 92618

### Prepared by:

Albert A. Webb Associates  
3788 McCray St  
Riverside, CA 92506  
(951) 686 – 1070

- Preliminary
- Final

**Original Date Prepared:** August 2020

**Revision Date(s):** December 2020

*Prepared for Compliance with*

*Regional Board Order No. **R8-2010-0033***

## A Brief Introduction

This Project-Specific WQMP Template for the **Santa Ana Region** has been prepared to help guide you in documenting compliance for your project. Because this document has been designed to specifically document compliance, you will need to utilize the WQMP Guidance Document as your “how-to” manual to help guide you through this process. Both the Template and Guidance Document go hand-in-hand, and will help facilitate a well prepared Project-Specific WQMP. Below is a flowchart for the layout of this Template that will provide the steps required to document compliance.

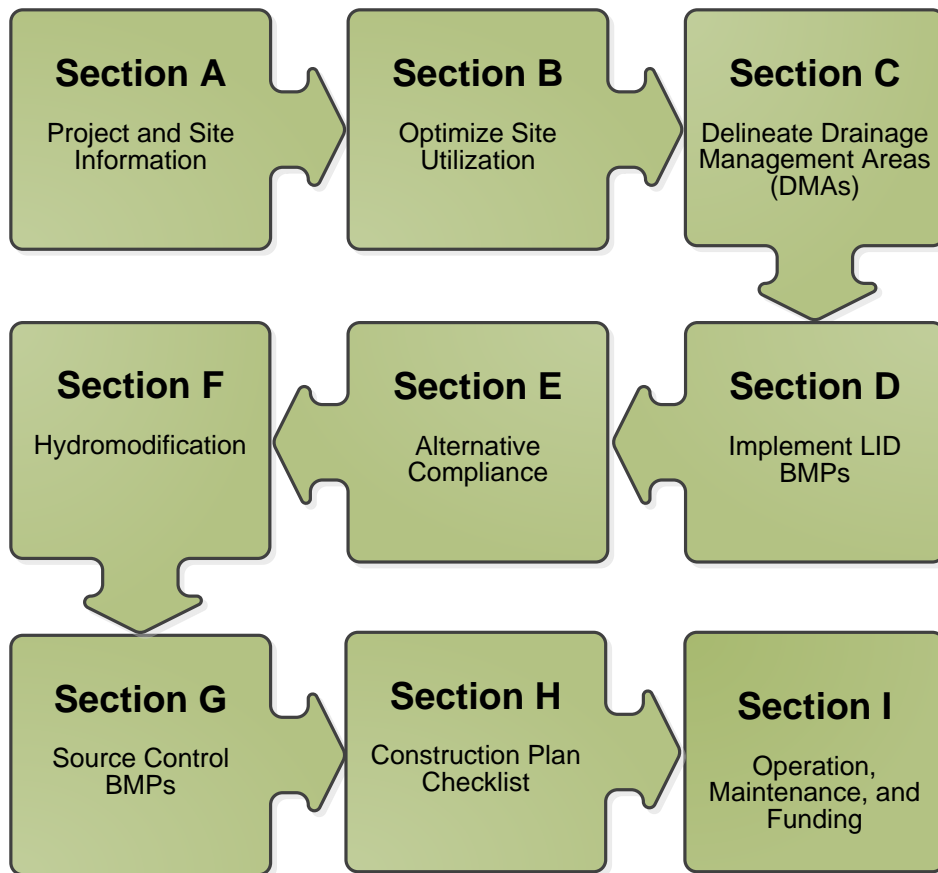

## OWNER'S CERTIFICATION

This Project-Specific Water Quality Management Plan (WQMP) has been prepared for Core 5 Industrial Partners by Albert A. Webb Associates for the Rider Business Center project (P20-00011).

This WQMP is intended to comply with the requirements of City of Perris for Water Quality Ordinance 1194 which includes the requirement for the preparation and implementation of a Project-Specific WQMP.

The undersigned, while owning the property/project described in the preceding paragraph, shall be responsible for the implementation and funding of this WQMP and will ensure that this WQMP is amended as appropriate to reflect up-to-date conditions on the site. In addition, the property owner accepts responsibility for interim operation and maintenance of Stormwater BMPs until such time as this responsibility is formally transferred to a subsequent owner. This WQMP will be reviewed with the facility operator, facility supervisors, employees, tenants, maintenance and service contractors, or any other party (or parties) having responsibility for implementing portions of this WQMP. At least one copy of this WQMP will be maintained at the project site or project office in perpetuity. The undersigned is authorized to certify and to approve implementation of this WQMP. The undersigned is aware that implementation of this WQMP is enforceable under City of Perris Water Quality Ordinance (Municipal Code Section 1194).

"I, the undersigned, certify under penalty of law that the provisions of this WQMP have been reviewed and accepted and that the WQMP will be transferred to future successors in interest."

  
\_\_\_\_\_  
Owner's Signature

JON C KELLY  
\_\_\_\_\_  
Owner's Printed Name

12.21.20  
\_\_\_\_\_  
Date

VP DEVELOPMENT  
\_\_\_\_\_  
Owner's Title/Position

## PREPARER'S CERTIFICATION

"The selection, sizing and design of stormwater treatment and other stormwater quality and quantity control measures in this plan meet the requirements of Regional Water Quality Control Board Order No. **R8-2010-0033** and any subsequent amendments thereto."

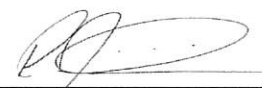
  
\_\_\_\_\_  
Preparer's Signature

DJ Arellano, P.E.  
\_\_\_\_\_  
Preparer's Printed Name

Preparer's Licensure:

12/11/2020  
\_\_\_\_\_  
Date

Senior Engineer  
\_\_\_\_\_  
Preparer's Title/Position



**CALIFORNIA ALL-PURPOSE ACKNOWLEDGMENT**

**CIVIL CODE § 1189**

A notary public or other officer completing this certificate verifies only the identity of the individual who signed the document to which this certificate is attached, and not the truthfulness, accuracy, or validity of that document.

State of California )  
County of Orange )  
On December 21, 2020 before me, Brandon G. Wolfe, Notary Public,  
Date Here Insert Name and Title of the Officer  
personally appeared Jon C Kelly  
Name(s) of Signer(s)

who proved to me on the basis of satisfactory evidence to be the person(s) whose name(s) is/are subscribed to the within instrument and acknowledged to me that he/she/they executed the same in his/her/their authorized capacity(ies), and that by his/her/their signature(s) on the instrument the person(s), or the entity upon behalf of which the person(s) acted, executed the instrument.

I certify under PENALTY OF PERJURY under the laws of the State of California that the foregoing paragraph is true and correct.

WITNESS my hand and official seal.



Signature [Handwritten Signature]  
Signature of Notary Public

Place Notary Seal Above

**OPTIONAL**

Though this section is optional, completing this information can deter alteration of the document or fraudulent reattachment of this form to an unintended document.

**Description of Attached Document**

Title or Type of Document: WQMP owner's Certification  
Document Date: \_\_\_\_\_ Number of Pages: \_\_\_\_\_  
Signer(s) Other Than Named Above: \_\_\_\_\_

**Capacity(ies) Claimed by Signer(s)**

Signer's Name: \_\_\_\_\_  
 Corporate Officer — Title(s): \_\_\_\_\_  
 Partner —  Limited  General  
 Individual  Attorney in Fact  
 Trustee  Guardian or Conservator  
 Other: \_\_\_\_\_  
Signer Is Representing: \_\_\_\_\_

Signer's Name: \_\_\_\_\_  
 Corporate Officer — Title(s): \_\_\_\_\_  
 Partner —  Limited  General  
 Individual  Attorney in Fact  
 Trustee  Guardian or Conservator  
 Other: \_\_\_\_\_  
Signer Is Representing: \_\_\_\_\_

## Table of Contents

Section A: Project and Site Information.....	6
A.1 Maps and Site Plans.....	6
A.2 Identify Receiving Waters.....	7
A.3 Additional Permits/Approvals required for the Project: .....	8
Section B: Optimize Site Utilization (LID Principles) .....	9
Section C: Delineate Drainage Management Areas (DMAs).....	10
Section D: Implement LID BMPs .....	11
D.1 Infiltration Applicability .....	11
D.2 Harvest and Use Assessment.....	13
D.3 Bioretention and Biotreatment Assessment .....	15
D.4 Feasibility Assessment Summaries .....	16
D.5 LID BMP Sizing .....	16
Section E: Alternative Compliance (LID Waiver Program) .....	17
E.1 Identify Pollutants of Concern .....	18
E.2 Stormwater Credits .....	19
E.3 Sizing Criteria.....	19
E.4 Treatment Control BMP Selection .....	20
Section F: Hydromodification .....	21
F.1 Hydrologic Conditions of Concern (HCOC) Analysis.....	21
F.2 HCOC Mitigation.....	22
Section G: Source Control BMPs.....	23
Section H: Construction Plan Checklist .....	28
Section I: Operation, Maintenance and Funding.....	29

## List of Tables

Table A.1 Identification of Receiving Waters.....	8
Table A.2 Other Applicable Permits.....	8
Table C.1 DMA Classifications.....	10
Table C.2 Type 'A', Self-Treating Areas.....	10
Table C.3 Type 'B', Self-Retaining Areas.....	10
Table C.4 Type 'C', Areas that Drain to Self-Retaining Areas.....	11
Table C.5 Type 'D', Areas Draining to BMPs.....	11
Table D.1 Infiltration Feasibility.....	12
Table D.2 LID Prioritization Summary Matrix.....	16
Table D.3 DCV Calculations for LID BMPs.....	16
Table E.1 Potential Pollutants by Land Use Type.....	18
Table E.2 Water Quality Credits.....	19
Table E.3 Treatment Control BMP Sizing.....	19
Table E.4 Treatment Control BMP Selection.....	20
Table F.1 Hydrologic Conditions of Concern Summary.....	21
Table G.1 Permanent and Operational Source Control Measures.....	23
Table H.1 Construction Plan Cross-reference.....	28

## List of Appendices

Appendix 1: Maps and Site Plans.....	30
Appendix 2: Construction Plans.....	31
Appendix 3: Soils Information.....	32
Appendix 4: Historical Site Conditions.....	33
Appendix 5: LID Infeasibility.....	34
Appendix 6: BMP Design Details.....	35
Appendix 7: Hydromodification.....	36
Appendix 8: Source Control.....	37
Appendix 9: O&M.....	38
Appendix 10: Educational Materials.....	- 39 -

## Section A: Project and Site Information

PROJECT INFORMATION	
Type of Project:	<i>Commercial/Industrial</i>
Planning Area:	<i>Perris Valley Commerce Center (PVCC) Specific Plan Area</i>
Community Name:	<i>Perris Valley</i>
Development Name:	<i>Rider Business Center</i>
PROJECT LOCATION	
Latitude & Longitude (DMS): 33°49'43"N, 117°12'50"W	
Project Watershed and Sub-Watershed: Santa Ana, San Jacinto Valley	
Gross Acres: 11.2 acres	
APN(s): 300-210-011, 300-210-012, 300-210-013, 300-210-029	
Map Book and Page No.: Thomas Bros. Map Page 777, Grid H3, H4, J3, 7 J4	
PROJECT CHARACTERISTICS	
Proposed or Potential Land Use(s)	Commercial/Industrial
Proposed or Potential SIC Code(s) <b>1542</b> (General Contractors-Industrial Buildings & Warehouses) <b>4225</b> (General Warehouse & Storage)	1542, 4225
Area of Impervious Project Footprint (SF)	436,300
Total Area of <u>proposed</u> Impervious Surfaces within the Project Limits (SF)/or Replacement	436,300
Does the project consist of offsite road improvements?	<input type="checkbox"/> Y <input checked="" type="checkbox"/> N
Does the project propose to construct unpaved roads?	<input type="checkbox"/> Y <input checked="" type="checkbox"/> N
Is the project part of a larger common plan of development (phased project)?	<input type="checkbox"/> Y <input checked="" type="checkbox"/> N
EXISTING SITE CHARACTERISTICS	
Total area of <u>existing</u> Impervious Surfaces within the project limits (SF)	14,600
Is the project located within any MSHCP Criteria Cell?	<input type="checkbox"/> Y <input checked="" type="checkbox"/> N
If so, identify the Cell number:	N/A
Are there any natural hydrologic features on the project site?	<input type="checkbox"/> Y <input checked="" type="checkbox"/> N
Is a Geotechnical Report attached?	<input checked="" type="checkbox"/> Y <input type="checkbox"/> N
If no Geotech. Report, list the NRCS soils type(s) present on the site (A, B, C and/or D)	D
What is the Water Quality Design Storm Depth for the project?	0.64

### Project Description

The project is proposing a warehouse/industrial building (approximately 248,442 square feet) on approximately 11.2 acres of land on the southwest corner of the Rider Street and Wilson Avenue intersection. The project site is bounded by Rider Street to the north, vacant and sparse residential lots to the west, future RCTC Mid-County Parkway to the south (currently vacant and sparse residential lots), and Wilson Avenue to the east. Majority of the land is vacant with a few existing manufactured homes and a commercial business with pavement occupying approximately a third of an acre of existing impervious area. The site is relatively flat and the existing ground slopes at approximately 0.3% in the easterly direction. Existing elevations across the site vary from 1443 along the western property line to 1441 along the eastern property line (NAVD88 datum). Drainage across the site sheet flows from west to east.

The project is located within the Perris Valley Master Drainage Plan (PVMDP) adopted July 1987 and revised June 1991. Approximately 10 acres of this project are tabled to discharge into MDP Line "A-B",

which is existing in Rider Street. The remaining area, approximately 1.2 acres, is tabled to discharge into MDP Line "A-C", which does not currently exist. However, the proposed RCTC Mid County Parkway (MCP) – currently completing construction package one - runs directly through the Line A-C alignment and surrounding surface draining tributary areas. Because of this, WEBB is proposing that the Line A-C tributary areas impacted by MCP will be redirected to Line A-B. See the Reallocation Memo in the project specific Drainage Report for more information.

The project is not impacted by off-site flows. All runoff from the project will be directed to the north east corner of the project where it will be collected in an open storage basing and underground chambers. The open storage basin will be hydraulically connected to the underground chambers to act as a single system and will only be sized to store the water quality design capture volume. Water quality runoff will be pumped from the storage basin into a Contech Filterra Unit. High flows will bypass the Filterra Unit and exit the basin via a grated outlet structure, with grates located a foot below the top of the basin, and gravity flow to Line "A-B".

The project contains some amount of self-retaining/self-treating area that will be further analyzed during final engineering, and all trash enclosures will be covered.

This site is located within the Hydromodification exemption area based on Riverside County WAP geodatabase approved April 20, 2017. The site is in a blue area which means it is exempt from HCOC design criterion.

## A.1 Maps and Site Plans

When completing your Project-Specific WQMP, include a map of the local vicinity and existing site. In addition, include all grading, drainage, landscape/plant palette and other pertinent construction plans in Appendix 2. At a **minimum**, your WQMP Site Plan should include the following:

- Drainage Management Areas
- Proposed Structural BMPs
- Drainage Path
- Drainage Infrastructure, Inlets, Overflows
- Source Control BMPs
- Buildings, Roof Lines, Downspouts
- Impervious Surfaces
- Standard Labeling

Use your discretion on whether or not you may need to create multiple sheets or can appropriately accommodate these features on one or two sheets. Keep in mind that the Co-Permittee plan reviewer must be able to easily analyze your project utilizing this template and its associated site plans and maps.

## A.2 Identify Receiving Waters

Using Table A.1 below, list in order of upstream to downstream, the receiving waters that the project site is tributary to. Continue to fill each row with the Receiving Water's 303(d) listed impairments (if any), designated beneficial uses, and proximity, if any, to a RARE beneficial use. Include a map of the receiving waters in Appendix 1.



**Table A.1 Identification of Receiving Waters**

Receiving Waters	EPA Approved 303(d) List Impairments	Designated Beneficial Uses	Proximity to RARE Beneficial Use
Perris Valley Storm Drain	None	None	Not a water body classified as RARE
San Jacinto River (Reach 3)(Hu#802.11)	None	MUN, AGR, GWR, REC1, REC2, WARM, WILD	Not a water body classified as RARE
San Jacinto River (Reach 2)(Hu#802.11)	None	MUN, AGR, GWR, REC1, REC2, WARM, WILD	Not a water body classified as RARE
Canyon Lake (Hu#802.11, 802.12)	Nutrients, Pathogens	MUN, AGR, GWR, REC1, REC2, WARM, WILD	Not a water body classified as RARE
San Jacinto River (Reach 1)(Hu#802.32)	None	MUN, AGR, GWR, REC1, REC2, WARM, WILD	Not a water body classified as RARE
Lake Elsinore (Hu#802.31)	PCBs, (Organic Compounds), Nutrients, Organic Enrichment (Low DO), Sediment Toxicity, Unknown Toxicity	REC1, REC2, WARM, WILD	Not a water body classified as RARE

### A.3 Additional Permits/Approvals required for the Project:

**Table A.2 Other Applicable Permits**

Agency	Permit Required	
State Department of Fish and Game, 1602 Streambed Alteration Agreement	<input type="checkbox"/> Y	<input checked="" type="checkbox"/> N
State Water Resources Control Board, Clean Water Act (CWA) Section 401 Water Quality Cert.	<input type="checkbox"/> Y	<input checked="" type="checkbox"/> N
US Army Corps of Engineers, CWA Section 404 Permit	<input type="checkbox"/> Y	<input checked="" type="checkbox"/> N
US Fish and Wildlife, Endangered Species Act Section 7 Biological Opinion	<input type="checkbox"/> Y	<input checked="" type="checkbox"/> N
Statewide Construction General Permit Coverage	<input checked="" type="checkbox"/> Y	<input type="checkbox"/> N
Statewide Industrial General Permit Coverage ( <b>Dependent on Tenant</b> )	<input checked="" type="checkbox"/> Y	<input type="checkbox"/> N
Western Riverside MSHCP Consistency Approval (e.g., JPR, DBESP)	<input type="checkbox"/> Y	<input checked="" type="checkbox"/> N
Other ( <i>please list in the space below as required</i> ) City of Perris Grading Permit	<input checked="" type="checkbox"/> Y	<input type="checkbox"/> N

If yes is answered to any of the questions above, the Co-Permittee may require proof of approval/coverage from those agencies as applicable including documentation of any associated requirements that may affect this Project-Specific WQMP.

## Section B: Optimize Site Utilization (LID Principles)

Review of the information collected in Section 'A' will aid in identifying the principal constraints on site design and selection of LID BMPs as well as opportunities to reduce imperviousness and incorporate LID Principles into the site and landscape design. For example, **constraints** might include impermeable soils, high groundwater, groundwater pollution or contaminated soils, steep slopes, geotechnical instability, high-intensity land use, heavy pedestrian or vehicular traffic, utility locations or safety concerns. **Opportunities** might include existing natural areas, low areas, oddly configured or otherwise unbuildable parcels, easements and landscape amenities including open space and buffers (which can double as locations for bioretention BMPs), and differences in elevation (which can provide hydraulic head). Prepare a brief narrative for each of the site optimization strategies described below. This narrative will help you as you proceed with your LID design and explain your design decisions to others.

The 2010 Santa Ana MS4 Permit further requires that LID Retention BMPs (Infiltration Only or Harvest and Use) be used unless it can be shown that those BMPs are infeasible. Therefore, it is important that your narrative identify and justify if there are any constraints that would prevent the use of those categories of LID BMPs. Similarly, you should also note opportunities that exist which will be utilized during project design. Upon completion of identifying Constraints and Opportunities, include these on your WQMP Site plan in Appendix 1.

### Site Optimization

The following questions are based upon Section 3.2 of the WQMP Guidance Document. Review of the WQMP Guidance Document will help you determine how best to optimize your site and subsequently identify opportunities and/or constraints, and document compliance.

Did you identify and preserve existing drainage patterns? If so, how? If not, why?

*Yes, the project proposes to maintain existing flow pattern from west to east. Runoff will surface flow to the east and will be conveyed to a storage basin and underground chambers on the east side of the project via underground storm drain pipes.*

Did you identify and protect existing vegetation? If so, how? If not, why?

*No, most of the site is vacant. Existing buildings and vegetation associated with the existing buildings will be removed. There are no dense areas of vegetation nor well-established trees.*

Did you identify and preserve natural infiltration capacity? If so, how? If not, why?

*Infiltration is not expected to be feasible in this area.*

Did you identify and minimize impervious area? If so, how? If not, why?

*The site contains the standard impervious area per code for the given land use. The minimum required landscape area is 10% per PVCC-SP Section 13.2.7, this project provides a 10% pervious area including self-retaining/self-treating area.*

Did you identify and disperse runoff to adjacent pervious areas? If so, how? If not, why?

*All runoff is conveyed to the open storage basin and underground storage chambers located at the north east corner of the building. Runoff was not dispersed to adjacent pervious areas because it is not feasible to add water quality treatment facilities within adjacent landscape areas due to the grading of the site.*

# Section C: Delineate Drainage Management Areas (DMAs)

Utilizing the procedure in Section 3.3 of the WQMP Guidance Document which discusses the methods of delineating and mapping your project site into individual DMAs, complete Table C.1 below to appropriately categorize the types of classification (e.g., Type A, Type B, etc.) per DMA for your project site. Upon completion of this table, this information will then be used to populate and tabulate the corresponding tables for their respective DMA classifications.

**Table C.1 DMA Classifications**

DMA Name	ID	Surface Type(s) <sup>1</sup>	Area (Sq. Ft.)	DMA Type
DMA-A	L-A	LANDSCAPE	20,200	D
	R-A	ROOF	243,442	D
	H-A	HARDSCAPE	192,879	D
	SR-A	SELF-RETAINING	30,200	B

<sup>1</sup>Reference Table 2-1 in the WQMP Guidance Document to populate this column

**Table C.2 Type 'A', Self-Treating Areas**

DMA Name or ID	Area (Sq. Ft.)	Stabilization Type	Irrigation Type (if any)

**Table C.3 Type 'B', Self-Retaining Areas**

Self-Retaining Area				Type 'C' DMAs that are draining to the Self-Retaining Area		
DMA Name/ ID	Post-project surface type	Area (square feet) [A]	Storm Depth (inches) [B]	DMA Name / ID	[C] from Table C.4 = [C]	Required Retention Depth (inches) [D]
SR-A	LANDSCAPE	30,200	0.64	N/A	N/A	0.64

$$[D] = [B] + \frac{[B] \cdot [C]}{[A]}$$

**Table C.4 Type 'C', Areas that Drain to Self-Retaining Areas**

DMA					Receiving Self-Retaining DMA		
DMA Name/ ID	Area (square feet)	Post-project surface type	Runoff factor	Product	DMA name /ID	Area (square feet)	Ratio
	[A]		[B]	[C] = [A] x [B]		[D]	[C]/[D]
N/A	N/A	N/A	N/A	N/A	N/A	N/A	N/A

**Table C.5 Type 'D', Areas Draining to BMPs**

DMA Name or ID	BMP Name or ID
L-A, R-A, H-A, SR-A	BMP-A

*Note: More than one drainage management area can drain to a single LID BMP, however, one drainage management area may not drain to more than one BMP.*

## Section D: Implement LID BMPs

### D.1 Infiltration Applicability

Is there an approved downstream 'Highest and Best Use' for stormwater runoff (see discussion in Chapter 2.4.4 of the WQMP Guidance Document for further details)?  Y  N

If yes has been checked, Infiltration BMPs shall not be used for the site. If no, continue working through this section to implement your LID BMPs. It is recommended that you contact your Co-Permittee to verify whether or not your project discharges to an approved downstream 'Highest and Best Use' feature.

### Geotechnical Report

A Geotechnical Report or Phase I Environmental Site Assessment may be required by the Copermitttee to confirm present and past site characteristics that may affect the use of Infiltration BMPs. In addition, the Co-Permittee, at their discretion, may not require a geotechnical report for small projects as described in Chapter 2 of the WQMP Guidance Document. If a geotechnical report has been prepared, include it in Appendix 3. In addition, if a Phase I Environmental Site Assessment has been prepared, include it in Appendix 4.

Is this project classified as a small project consistent with the requirements of Chapter 2 of the WQMP Guidance Document?  Y  N

## Infiltration Feasibility

Table D.1 below is meant to provide a simple means of assessing which DMAs on your site support Infiltration BMPs and is discussed in the WQMP Guidance Document in Chapter 2.4.5. Check the appropriate box for each question and then list affected DMAs as applicable. If additional space is needed, add a row below the corresponding answer.

Table D.1 Infiltration Feasibility

Does the project site...	YES	NO
...have any DMAs with a seasonal high groundwater mark shallower than 10 feet?		X
If Yes, list affected DMAs:		
...have any DMAs located within 100 feet of a water supply well?		X
If Yes, list affected DMAs:		
...have any areas identified by the geotechnical report as posing a public safety risk where infiltration of stormwater could have a negative impact?		X
If Yes, list affected DMAs:		
...have measured in-situ infiltration rates of less than 1.6 inches / hour?	X	
If Yes, list affected DMAs: DMA-A, DMA-B, DMA-C, DMA-D		
...have significant cut and/or fill conditions that would preclude in-situ testing of infiltration rates at the final infiltration surface?		X
If Yes, list affected DMAs:		
...geotechnical report identify other site-specific factors that would preclude effective and safe infiltration?		X
Describe here:		

If you answered “Yes” to any of the questions above for any DMA, Infiltration BMPs should not be used for those DMAs and you should proceed to the assessment for Harvest and Use below.

## D.2 Harvest and Use Assessment

Please check what applies:

- Reclaimed water will be used for the non-potable water demands for the project.
- Downstream water rights may be impacted by Harvest and Use as approved by the Regional Board (verify with the Copermittee).
- The Design Capture Volume will be addressed using Infiltration Only BMPs. In such a case, Harvest and Use BMPs are still encouraged, but it would not be required if the Design Capture Volume will be infiltrated or evapotranspired.

If any of the above boxes have been checked, Harvest and Use BMPs need not be assessed for the site. If neither of the above criteria applies, follow the steps below to assess the feasibility of irrigation use, toilet use and other non-potable uses (e.g., industrial use).

### Irrigation Use Feasibility

Complete the following steps to determine the feasibility of harvesting stormwater runoff for Irrigation Use BMPs on your site:

Step 1: Identify the total area of irrigated landscape on the site, and the type of landscaping used.

*Total Area of Irrigated Landscape: N/A*

*Type of Landscaping (Conservation Design or Active Turf): N/A*

Step 2: Identify the planned total of all impervious areas on the proposed project from which runoff might be feasibly captured and stored for irrigation use. Depending on the configuration of buildings and other impervious areas on the site, you may consider the site as a whole, or parts of the site, to evaluate reasonable scenarios for capturing and storing runoff and directing the stored runoff to the potential use(s) identified in Step 1 above.

*Total Area of Impervious Surfaces: N/A*

Step 3: Cross reference the Design Storm depth for the project site (see Exhibit A of the WQMP Guidance Document) with the left column of Table 2-3 in Chapter 2 to determine the minimum area of Effective Irrigated Area per Tributary Impervious Area (EIATIA).

*Enter your EIATIA factor: N/A*

Step 4: Multiply the unit value obtained from Step 3 by the total of impervious areas from Step 2 to develop the minimum irrigated area that would be required.

*Minimum required irrigated area: N/A*

Step 5: Determine if harvesting stormwater runoff for irrigation use is feasible for the project by comparing the total area of irrigated landscape (Step 1) to the minimum required irrigated area (Step 4).

Minimum required irrigated area (Step 4)	Available Irrigated Landscape (Step 1)
N/A	N/A

## Toilet Use Feasibility

Complete the following steps to determine the feasibility of harvesting stormwater runoff for toilet flushing uses on your site:

Step 1: Identify the projected total number of daily toilet users during the wet season, and account for any periodic shut downs or other lapses in occupancy:

*Projected Number of Daily Toilet Users: N/A*

*Project Type: N/A*

Step 2: Identify the planned total of all impervious areas on the proposed project from which runoff might be feasibly captured and stored for toilet use. Depending on the configuration of buildings and other impervious areas on the site, you may consider the site as a whole, or parts of the site, to evaluate reasonable scenarios for capturing and storing runoff and directing the stored runoff to the potential use(s) identified in Step 1 above.

*Total Area of Impervious Surfaces: N/A*

Step 3: Enter the Design Storm depth for the project site (see Exhibit A) into the left column of Table 2-1 in Chapter 2 to determine the minimum number of toilet users per tributary impervious acre (TUTIA).

*Enter your TUTIA factor: N/A*

Step 4: Multiply the unit value obtained from Step 3 by the total of impervious areas from Step 2 to develop the minimum number of toilet users that would be required.

*Minimum number of toilet users: N/A*

Step 5: Determine if harvesting stormwater runoff for toilet flushing use is feasible for the project by comparing the Number of Daily Toilet Users (Step 1) to the minimum required number of toilet users (Step 4).

<b>Minimum required Toilet Users (Step 4)</b>	<b>Projected number of toilet users (Step 1)</b>
N/A	N/A

## Other Non-Potable Use Feasibility

Are there other non-potable uses for stormwater runoff on the site (e.g. industrial use)? See Chapter 2 of the Guidance for further information. If yes, describe below. If no, write N/A.

N/A

Step 1: Identify the projected average daily non-potable demand, in gallons per day, during the wet season and accounting for any periodic shut downs or other lapses in occupancy or operation.

*Average Daily Demand: N/A*

Step 2: Identify the planned total of all impervious areas on the proposed project from which runoff might be feasibly captured and stored for the identified non-potable use. Depending on the configuration of buildings and other impervious areas on the site, you may consider the site as a whole, or parts of the site, to evaluate reasonable scenarios for capturing and storing runoff and directing the stored runoff to the potential use(s) identified in Step 1 above.

*Total Area of Impervious Surfaces: N/A*

Step 3: Enter the Design Storm depth for the project site (see Exhibit A) into the left column of Table 2-3 in Chapter 2 to determine the minimum demand for non-potable uses per tributary impervious acre.

*Enter the factor from Table 2-3: N/A*

Step 4: Multiply the unit value obtained from Step 4 by the total of impervious areas from Step 3 to develop the minimum number of gallons per day of non-potable use that would be required.

*Minimum required use: N/A*

Step 5: Determine if harvesting stormwater runoff for other non-potable use is feasible for the project by comparing the Number of Daily Toilet Users (Step 1) to the minimum required number of toilet users (Step 4).

<b>Minimum required non-potable use (Step 4)</b>	<b>Projected average daily use (Step 1)</b>
N/A	N/A

If Irrigation, Toilet and Other Use feasibility anticipated demands are less than the applicable minimum values, Harvest and Use BMPs are not required and you should proceed to utilize LID Bioretention and Biotreatment, unless a site-specific analysis has been completed that demonstrates technical infeasibility as noted in D.3 below.

### **D.3 Bioretention and Biotreatment Assessment**

Other LID Bioretention and Biotreatment BMPs as described in Chapter 2.4.7 of the WQMP Guidance Document are feasible on nearly all development sites with sufficient advance planning.

*Select one of the following:*

LID Bioretention/Biotreatment BMPs will be used for some or all DMAs of the project as noted below in Section D.4 (note the requirements of Section 3.4.2 in the WQMP Guidance Document).

A site-specific analysis demonstrating the technical infeasibility of all LID BMPs has been performed and is included in Appendix 5. If you plan to submit an analysis demonstrating the technical infeasibility of LID BMPs, request a pre-submittal meeting with the Copermittee to discuss this option. Proceed to Section E to document your alternative compliance measures.



## D.4 Feasibility Assessment Summaries

From the Infiltration, Harvest and Use, Bioretention and Biotreatment Sections above, complete Table D.2 below to summarize which LID BMPs are technically feasible, and which are not, based upon the established hierarchy.

Table D.2 LID Prioritization Summary Matrix

DMA Name/ID	LID BMP Hierarchy				No LID (Alternative Compliance)
	1. Infiltration	2. Harvest and use	3. Bioretention	4. Biotreatment	
DMA-A	<input type="checkbox"/>	<input type="checkbox"/>	<input type="checkbox"/>	<input checked="" type="checkbox"/>	<input type="checkbox"/>
	<input type="checkbox"/>	<input type="checkbox"/>	<input type="checkbox"/>	<input type="checkbox"/>	<input type="checkbox"/>
	<input type="checkbox"/>	<input type="checkbox"/>	<input type="checkbox"/>	<input type="checkbox"/>	<input type="checkbox"/>

For those DMAs where LID BMPs are not feasible, provide a brief narrative below summarizing why they are not feasible, include your technical infeasibility criteria in Appendix 5, and proceed to Section E below to document Alternative Compliance measures for those DMAs. Recall that each proposed DMA must pass through the LID BMP hierarchy before alternative compliance measures may be considered.

## D.5 LID BMP Sizing

Each LID BMP must be designed to ensure that the Design Capture Volume will be addressed by the selected BMPs. First, calculate the Design Capture Volume for each LID BMP using the  $V_{BMP}$  worksheet in Appendix F of the LID BMP Design Handbook. Second, design the LID BMP to meet the required  $V_{BMP}$  using a method approved by the Copermittee. Utilize the worksheets found in the LID BMP Design Handbook or consult with your Copermittee to assist you in correctly sizing your LID BMPs. Complete Table D.3 below to document the Design Capture Volume and the Proposed Volume for each LID BMP. Provide the completed design procedure sheets for each LID BMP in Appendix 6. You may add additional rows to the table below as needed.

Table D.3 DCV Calculations for LID BMPs

DMA Type/ID	DMA Area (square feet)	Post-Project Surface Type	Effective Impervious Fraction, $I_f$	DMA Runoff Factor	DMA Areas x Runoff Factor	Enter BMP Name / Identifier Here		
	[A]		[B]	[C]	[A] x [C]			
<b>DMA-A</b>	20,200	Landscape	0.1	0.11	2,231.3	Design Storm Depth (in)	Design Capture Volume, $V_{BMP}$ (cubic feet)	Proposed Volume on Plans (cubic feet)
	243,442	Roofs	1	0.89	217,150.3			
	192,879	Hardscape	1	0.89	172,048.1			
	30,200	Landscape	0.1					
	486,721				391,440.2	0.64	20,876.8	20,900
	$A_T = \Sigma[A]$				$\Sigma = [D]$	[E]	$[F] = \frac{[D] \times [E]}{12}$	[G]

[B], [C] is obtained as described in Section 2.3.1 of the WQMP Guidance Document

[E] is obtained from Exhibit A in the WQMP Guidance Document

[G] is obtained from a design procedure sheet, such as in LID BMP Design Handbook and placed in Appendix 6

## Section E: Alternative Compliance (LID Waiver Program)

LID BMPs are expected to be feasible on virtually all projects. Where LID BMPs have been demonstrated to be infeasible as documented in Section D, other Treatment Control BMPs must be used (subject to LID waiver approval by the Copermittee). Check one of the following Boxes:

LID Principles and LID BMPs have been incorporated into the site design to fully address all Drainage Management Areas. No alternative compliance measures are required for this project and thus this Section is not required to be completed.

- Or -

The following Drainage Management Areas are unable to be addressed using LID BMPs. A site-specific analysis demonstrating technical infeasibility of LID BMPs has been approved by the Co-Permittee and included in Appendix 5. Additionally, no downstream regional and/or sub-regional LID BMPs exist or are available for use by the project. The following alternative compliance measures on the following pages are being implemented to ensure that any pollutant loads expected to be discharged by not incorporating LID BMPs, are fully mitigated.

## E.1 Identify Pollutants of Concern

Utilizing Table A.1 from Section A above which noted your project's receiving waters and their associated EPA approved 303(d) listed impairments, cross reference this information with that of your selected Priority Development Project Category in Table E.1 below. If the identified General Pollutant Categories are the same as those listed for your receiving waters, then these will be your Pollutants of Concern and the appropriate box or boxes will be checked on the last row. The purpose of this is to document compliance and to help you appropriately plan for mitigating your Pollutants of Concern in lieu of implementing LID BMPs.

**Table E.1 Potential Pollutants by Land Use Type**

Priority Development Project Categories and/or Project Features (check those that apply)	General Pollutant Categories							
	Bacterial Indicators	Metals	Nutrients	Pesticides	Toxic Organic Compounds	Sediments	Trash & Debris	Oil & Grease
<input type="checkbox"/> Detached Residential Development	P	N	P	P	N	P	P	P
<input type="checkbox"/> Attached Residential Development	P	N	P	P	N	P	P	P <sup>(2)</sup>
<input checked="" type="checkbox"/> Commercial/Industrial Development	P <sup>(3)</sup>	P	P <sup>(1)</sup>	P <sup>(1)</sup>	P <sup>(5)</sup>	P <sup>(1)</sup>	P	P
<input type="checkbox"/> Automotive Repair Shops	N	P	N	N	P <sup>(4, 5)</sup>	N	P	P
<input type="checkbox"/> Restaurants (>5,000 ft <sup>2</sup> )	P	N	N	N	N	N	P	P
<input type="checkbox"/> Hillside Development (>5,000 ft <sup>2</sup> )	P	N	P	P	N	P	P	P
<input checked="" type="checkbox"/> Parking Lots (>5,000 ft <sup>2</sup> )	P <sup>(6)</sup>	P	P <sup>(1)</sup>	P <sup>(1)</sup>	P <sup>(4)</sup>	P <sup>(1)</sup>	P	P
<input type="checkbox"/> Retail Gasoline Outlets	N	P	N	N	P	N	P	P
<b>Project Priority Pollutant(s) of Concern</b>	<input checked="" type="checkbox"/>	<input type="checkbox"/>	<input checked="" type="checkbox"/>	<input type="checkbox"/>	<input checked="" type="checkbox"/>	<input type="checkbox"/>	<input type="checkbox"/>	<input type="checkbox"/>

P = Potential

N = Not Potential

<sup>(1)</sup> A potential Pollutant if non-native landscaping exists or is proposed onsite; otherwise not expected

<sup>(2)</sup> A potential Pollutant if the project includes uncovered parking areas; otherwise not expected

<sup>(3)</sup> A potential Pollutant is land use involving animal waste

<sup>(4)</sup> Specifically petroleum hydrocarbons

<sup>(5)</sup> Specifically solvents

<sup>(6)</sup> Bacterial indicators are routinely detected in pavement runoff

## E.2 Stormwater Credits

Projects that cannot implement LID BMPs but nevertheless implement smart growth principles are potentially eligible for Stormwater Credits. Utilize Table 3-8 within the WQMP Guidance Document to identify your Project Category and its associated Water Quality Credit. If not applicable, write N/A.

Table E.2 Water Quality Credits

Qualifying Project Categories	Credit Percentage <sup>2</sup>
N/A	
Total Credit Percentage <sup>1</sup>	

<sup>1</sup>Cannot Exceed 50%

<sup>2</sup>Obtain corresponding data from Table 3-8 in the WQMP Guidance Document

## E.3 Sizing Criteria

After you appropriately considered Stormwater Credits for your project, utilize Table E.3 below to appropriately size them to the DCV, or Design Flow Rate, as applicable. Please reference Chapter 3.5.2 of the WQMP Guidance Document for further information.

Table E.3 Treatment Control BMP Sizing

DMA Type/ID	DMA Area (square feet)	Post-Project Surface Type	Effective Impervious Fraction, I <sub>f</sub>	DMA Runoff Factor	DMA Area x Runoff Factor	Enter BMP Name / Identifier Here					
	[A]		[B]	[C]	[A] x [C]						
N/A						Design Storm Depth (in)	Minimum Design Capture Volume or Design Flow Rate (cubic feet or cfs)	Total Storm Water Credit % Reduction	Proposed Volume or Flow on Plans (cubic feet or cfs)		
	$A_T = \sum[A]$				$\Sigma = [D]$	[E]	$[F] = \frac{[D] \times [E]}{[G]}$	$[F] \times (1-[H])$	[I]		

[B], [C] is obtained as described in Section 2.3.1 from the WQMP Guidance Document

[E] is obtained from Exhibit A in the WQMP Guidance Document

[G] is for Flow-Based Treatment Control BMPs [G] = 43,560, for Volume-Based Control Treatment BMPs, [G] = 12

[H] is from the Total Credit Percentage as Calculated from Table E.2 above

[I] as obtained from a design procedure sheet from the BMP manufacturer and should be included in Appendix 6

## E.4 Treatment Control BMP Selection

Treatment Control BMPs typically provide proprietary treatment mechanisms to treat potential pollutants in runoff, but do not sustain significant biological processes. Treatment Control BMPs must have a removal efficiency of a medium or high effectiveness as quantified below:

- **High:** equal to or greater than 80% removal efficiency
- **Medium:** between 40% and 80% removal efficiency

Such removal efficiency documentation (e.g., studies, reports, etc.) as further discussed in Chapter 3.5.2 of the WQMP Guidance Document, must be included in Appendix 6. In addition, ensure that proposed Treatment Control BMPs are properly identified on the WQMP Site Plan in Appendix 1.

**Table E.4 Treatment Control BMP Selection**

Selected Treatment Control BMP Name or ID <sup>1</sup>	Priority Pollutant(s) of Concern to Mitigate <sup>2</sup>	Removal Efficiency Percentage <sup>3</sup>
Contech Filterra Bioscape (BMP-A)	TSS/TOC	66% - 85%
	Nutrients	73%

<sup>1</sup> Treatment Control BMPs must not be constructed within Receiving Waters. In addition, a proposed Treatment Control BMP may be listed more than once if they possess more than one qualifying pollutant removal efficiency.

<sup>2</sup> Cross Reference Table E.1 above to populate this column.

<sup>3</sup> As documented in a Co-Permittee Approved Study and provided in Appendix 6.

# Section F: Hydromodification

## F.1 Hydrologic Conditions of Concern (HCOC) Analysis

Once you have determined that the LID design is adequate to address water quality requirements, you will need to assess if the proposed LID Design may still create a HCOC. Review Chapters 2 and 3 (including Figure 3-7) of the WQMP Guidance Document to determine if your project must mitigate for Hydromodification impacts. If your project meets one of the following criteria which will be indicated by the check boxes below, you do not need to address Hydromodification at this time. However, if the project does not qualify for Exemptions 1, 2 or 3, then additional measures must be added to the design to comply with HCOC criteria. This is discussed in further detail below in Section F.2.

**HCOC EXEMPTION 1:** The Priority Development Project disturbs less than one acre. The Copermitttee has the discretion to require a Project-Specific WQMP to address HCOCs on projects less than one acre on a case by case basis. The disturbed area calculation should include all disturbances associated with larger common plans of development.

Does the project qualify for this HCOC Exemption?       Y     N

If Yes, HCOC criteria do not apply.

**HCOC EXEMPTION 2:** The volume and time of concentration<sup>1</sup> of storm water runoff for the post-development condition is not significantly different from the pre-development condition for a 2-year return frequency storm (a difference of 5% or less is considered insignificant) using one of the following methods to calculate:

- Riverside County Hydrology Manual
- Technical Release 55 (TR-55): Urban Hydrology for Small Watersheds (NRCS 1986), or derivatives thereof, such as the Santa Barbara Urban Hydrograph Method
- Other methods acceptable to the Co-Permittee

Does the project qualify for this HCOC Exemption?       Y     N

If Yes, report results in Table F.1 below and provide your substantiated hydrologic analysis in Appendix 7.

**Table F.1** Hydrologic Conditions of Concern Summary

	2 year – 24 hour		
	Pre-condition	Post-condition	% Difference
<b>Time of Concentration</b>	INSERT VALUE	INSERT VALUE	INSERT VALUE
<b>Volume (Cubic Feet)</b>	INSERT VALUE	INSERT VALUE	INSERT VALUE

<sup>1</sup> Time of concentration is defined as the time after the beginning of the rainfall when all portions of the drainage basin are contributing to flow at the outlet.

**HCOC EXEMPTION 3:** All downstream conveyance channels to an adequate sump (for example, Prado Dam, Lake Elsinore, Canyon Lake, Santa Ana River, or other lake, reservoir or naturally erosion resistant feature) that will receive runoff from the project are engineered and regularly maintained to ensure design flow capacity; no sensitive stream habitat areas will be adversely affected; or are not identified on the Co-Permittees Hydromodification Sensitivity Maps.

Does the project qualify for this HCOC Exemption?       Y       N

If Yes, HCOC criteria do not apply and note below which adequate sump applies to this HCOC qualifier:

## F.2 HCOC Mitigation

If none of the above HCOC Exemption Criteria are applicable, HCOC criteria is considered mitigated if they meet one of the following conditions:

- a. Additional LID BMPS are implemented onsite or offsite to mitigate potential erosion or habitat impacts as a result of HCOCs. This can be conducted by an evaluation of site-specific conditions utilizing accepted professional methodologies published by entities such as the California Stormwater Quality Association (CASQA), the Southern California Coastal Water Research Project (SCCRWP), or other Co-Permittee approved methodologies for site-specific HCOC analysis.
- b. The project is developed consistent with an approved Watershed Action Plan that addresses HCOC in Receiving Waters.
- c. Mimicking the pre-development hydrograph with the post-development hydrograph, for a 2-year return frequency storm. Generally, the hydrologic conditions of concern are not significant, if the post-development hydrograph is no more than 10% greater than pre-development hydrograph. In cases where excess volume cannot be infiltrated or captured and reused, discharge from the site must be limited to a flow rate no greater than 110% of the pre-development 2-year peak flow.

Be sure to include all pertinent documentation used in your analysis of the items a, b or c in Appendix 7.

**Project is located within the Hydromodification exemption area based on Riverside County WAP geodatabase approved April 20, 2017. See Appendix 7.**

## Section G: Source Control BMPs

Source control BMPs include permanent, structural features that may be required in your project plans — such as roofs over and berms around trash and recycling areas — and Operational BMPs, such as regular sweeping and “housekeeping”, that must be implemented by the site’s occupant or user. The MEP standard typically requires both types of BMPs. In general, Operational BMPs cannot be substituted for a feasible and effective permanent BMP. Using the Pollutant Sources/Source Control Checklist in Appendix 8, review the following procedure to specify Source Control BMPs for your site:

1. **Identify Pollutant Sources:** Review Column 1 in the Pollutant Sources/Source Control Checklist. Check off the potential sources of Pollutants that apply to your site.
2. **Note Locations on Project-Specific WQMP Exhibit:** Note the corresponding requirements listed in Column 2 of the Pollutant Sources/Source Control Checklist. Show the location of each Pollutant source and each permanent Source Control BMP in your Project-Specific WQMP Exhibit located in Appendix 1.
3. **Prepare a Table and Narrative:** Check off the corresponding requirements listed in Column 3 in the Pollutant Sources/Source Control Checklist. In the left column of Table G.1 below, list each potential source of runoff Pollutants on your site (from those that you checked in the Pollutant Sources/Source Control Checklist). In the middle column, list the corresponding permanent, Structural Source Control BMPs (from Columns 2 and 3 of the Pollutant Sources/Source Control Checklist) used to prevent Pollutants from entering runoff. **Add additional narrative** in this column that explains any special features, materials or methods of construction that will be used to implement these permanent, Structural Source Control BMPs.
4. **Identify Operational Source Control BMPs:** To complete your table, refer once again to the Pollutant Sources/Source Control Checklist. List in the right column of your table the Operational BMPs that should be implemented as long as the anticipated activities continue at the site. Copermittee stormwater ordinances require that applicable Source Control BMPs be implemented; the same BMPs may also be required as a condition of a use permit or other revocable Discretionary Approval for use of the site.

**Table G.1** Permanent and Operational Source Control Measures

Potential Sources of Runoff pollutants	Permanent Structural Source Control BMPs	Operational Source Control BMPs
A. On-site storm drain catch basins and grated inlets. Locations are shown on the FWQMP Exhibit in Appendix 1.	On-site storm drain signage will utilize language, “No Dumping Drains to River”, or equally approved text that is consistent with the City of Perris’ requirements. Landscape area drains surrounded by vegetation will not be signed. Catch Basin Markers may be available from the Riverside County Flood Control and Water District Conservation District, call	Maintain and periodically repaint or replace inlet markings. Provide stormwater pollution prevention information to new site owners, lessees, or operators. See applicable operational BMPs in Fact Sheet SC-44, “Drainage System Maintenance,” in Appendix 10 (CASQA Stormwater Quality Handbook at <a href="http://www.cabmphandbooks.com">http://www.cabmphandbooks.com</a>



	<p>951-955-1200 to verify.</p> <p>On-site drainage structures, including all storm drain clean outs, area drains, inlets, catch basins, inlet &amp; outlet structures, forebays, &amp; water treatment control basins shall be inspected and maintained on a regular basis to insure their operational adequacy.</p>	<p>Include the following in lessee agreements: "Tenants shall not allow anyone to discharge anything to storm drains or to store or deposit materials so as to create a potential discharge to storm drains"</p> <p>Maintenance should include removal of trash, debris, &amp; sediment and the repair of any deficiencies or damage that may impact water quality.</p>
B. Interior floor drains and elevator shaft sump	The interior floor drains and elevator shaft sump pumps will be plumbed to sanitary sewer	Inspect and maintain drains to prevent blockages and overflow.
C. Need for future indoor & structural pest control	Note building design features that discourage entry of pests.	Provide Integrated Pest Management information to owners, lessees, and operators.
D. Landscape/Outdoor Pesticide Use	<p>The final landscape shall be designed to accomplish all of the following:</p> <p>Preserve existing native trees, shrubs and ground cover to the maximum extent possible.</p> <p>Design landscape to minimize irrigation and runoff, to promote surface infiltration where appropriate and to minimize the use of fertilizers and pesticides that can contribute to stormwater pollution.</p> <p>Where landscaped areas are used to retain or detain stormwater, specify plants that are tolerant of saturated soil conditions.</p> <p>Consider using pest-resistant plants, especially adjacent to hardscape.</p> <p>To insure successful establishments, select plants</p>	<p>Maintain landscaping using minimum or no pesticides</p> <p>See applicable operational BMPs in "What you should know for.... Landscape and Gardening" at <a href="http://rcflood.org/stormwater">http://rcflood.org/stormwater</a> and Appendix 10.</p> <p>Provide IPM information to new owners, lessees and operators.</p> <p>Landscape maintenance should include mowing, weeding, trimming, removal of trash &amp; debris, repair of erosion, re-vegetation, and removal of cut &amp; dead vegetation.</p> <p>Irrigation maintenance should include the repair of leaky or broken sprinkler heads, the maintaining of timing apparatus accuracy, and the maintaining of shut off valves in good working order.</p>

	<p>appropriate to site, soils, slopes, climate, sun, wind, rain, land use, air movement, ecological consistency and plant interactions.</p> <p>Pesticide usage should be at a necessary minimum and be consistent with the instructions contained on product labels and with the regulations administered by the State Department of Pesticide Regulation.</p> <p>Pesticides should be used at an absolute minimum or not at all in the retention/infiltration basin. If used, it should not be applied in close proximity to the rainy season.</p>	
<p>E. Refuse Trash Storage areas</p>	<p>Trash container storage areas shall be paved with an impervious surface, designed not to allow run-on from adjoining areas, designed to divert drainage from adjoining roofs and pavements from the surrounding area, and screened or walled to prevent off-site transport of trash.</p> <p>Trash dumpsters (containers) shall be leak proof and have attached covers or lids.</p> <p>Trash enclosures shall be roofed per City standards and the details on the PWQMP Exhibit in Appendix 1.</p> <p>Trash compactors shall be roofed and set on a concrete pad per City standards. The pad shall be a minimum of one foot larger all around than the trash compactor and sloped to drain to a sanitary sewer line. Connection of trash area drains to the MS4 is prohibited.</p> <p>See CASQA SD-32 BMP Fact</p>	<p>Adequate number of receptacles shall be provided. Inspect receptacles regularly; repair or replace leaky receptacles. Keep receptacles covered.</p> <p>Prohibit/prevent dumping of liquid or hazardous wastes. Post “no hazardous materials” signs. Inspect and pick up litter daily and clean up spills immediately. Keep spill control materials available on-site. See Fact Sheet SC-34, in Appendix 10, “Waste Handling and Disposal” in the CASQA Stormwater Quality Handbook at <a href="http://www.cabmphandbooks.com">www.cabmphandbooks.com</a></p>

	<p>Sheets in Appendix 10 for additional information.</p> <p>Signs shall be posted on or near dumpsters with the words “Do not dump hazardous materials here” or similar.</p>	
F. Outdoor storage if equipment or materials.	Concrete bricks will be stored within the paved storage yard.	See the Fact Sheets SC-31, “Outdoor Liquid Container Storage” and SC-33, “Outdoor Storage of Raw Materials” in the CASQA Stormwater Quality Handbooks at <a href="http://www.cabmphandbooks.com">www.cabmphandbooks.com</a>
G. Loading Docks	<p>Loading docks will not be covered and are 4 feet above finished pavement surface.</p> <p>Spill kits are to be kept on-site at all times per SC-11.</p>	<p>Move loaded and unloaded items indoors as soon as possible.</p> <p>Inspect for accumulated trash and debris. Implement good housekeeping procedures on a regular basis. Sweep areas clean instead of using wash water. Loading docks will be kept in a clean and orderly condition, through a regular program of sweeping and litter control, and immediate clean up of any spills or broken containers. Property owner will ensure that loading docks will be swept as needed. Cleanup procedures will not include the use of wash-down water. Property owner will be responsible for implementation of loading dock housekeeping procedures</p> <p>See the Fact Sheet SC-30, in Appendix 10, “Outdoor Loading and Unloading” in the CASQA Stormwater Quality Handbooks at <a href="http://www.cabmphandbooks.com">www.cabmphandbooks.com</a></p>
H. Fire Sprinkler Test Water	Provide a means to drain fire sprinkler test water to the sanitary sewer.	See the note in the Fact Sheet SC-41, in Appendix 10, “Building and Grounds Maintenance”, in the CASQA Stormwater Quality Handbooks at
I. Miscellaneous Drain or Wash Water or Other	Boiler drain lines shall be directly or indirectly connected	

<p>Sources</p> <p>Boiler drain lines</p> <p>Condensate drain lines</p> <p>Rooftop equipment</p> <p>Drainage sumps</p> <p>Roofing, gutters and trim</p>	<p>to the sanitary sewer system and may not discharge to the storm drain system</p> <p>Condensate drain lines may discharge to landscaped areas if the flow is small enough that runoff will not occur.</p> <p>Condensate drain lines may not discharge to the storm drain system.</p> <p>Rooftop equipment with potential to produce pollutants shall be roofed and/or have secondary containment.</p> <p>Any drainage sumps on-site shall feature a sediment sump to reduce the quantity of sediment in pumped water.</p> <p>Avoid roofing, gutters and trim made of copper or other unprotected metals that may leach into runoff.</p> <p>Include controls for other sources as specified by local reviewer.</p>	
<p>J. Plazas, sidewalks, and parking lots</p>	<p>Spill kits are to be kept on-site at all times per SC-11.</p>	<p>Sweep plazas, sidewalks, and parking lots regularly to prevent accumulation of litter and debris. Collect debris from pressure washing to prevent entry into the storm drain system. Collect washwater containing any cleaning agent or degreaser and discharge to the sanitary sewer not to a storm drain.</p>

# Section H: Construction Plan Checklist

Populate Table H.1 below to assist the plan checker in an expeditious review of your project. The first two columns will contain information that was prepared in previous steps, while the last column will be populated with the corresponding plan sheets. This table is to be completed with the submittal of your final Project-Specific WQMP.

Table H.1 Construction Plan Cross-reference

BMP No. or ID	BMP Identifier and Description	Corresponding Plan Sheet(s)
*	*	*

Note that the updated table — or Construction Plan WQMP Checklist — is **only a reference tool** to facilitate an easy comparison of the construction plans to your Project-Specific WQMP. Co-Permittee staff can advise you regarding the process required to propose changes to the approved Project-Specific WQMP.

**\*This section will be completed during Final Engineering Design.**

## Section I: Operation, Maintenance and Funding

The Copermittee will periodically verify that Stormwater BMPs on your site are maintained and continue to operate as designed. To make this possible, your Copermittee will require that you include in Appendix 9 of this Project-Specific WQMP:

1. A means to finance and implement facility maintenance in perpetuity, including replacement cost.
2. Acceptance of responsibility for maintenance from the time the BMPs are constructed until responsibility for operation and maintenance is legally transferred. A warranty covering a period following construction may also be required.
3. An outline of general maintenance requirements for the Stormwater BMPs you have selected.
4. Figures delineating and designating pervious and impervious areas, location, and type of Stormwater BMP, and tables of pervious and impervious areas served by each facility. Geo-locating the BMPs using a coordinate system of latitude and longitude is recommended to help facilitate a future statewide database system.
5. A separate list and location of self-retaining areas or areas addressed by LID Principles that do not require specialized O&M or inspections but will require typical landscape maintenance as noted in Chapter 5, pages 85-86, in the WQMP Guidance. Include a brief description of typical landscape maintenance for these areas.

Your local Co-Permittee will also require that you prepare and submit a detailed Stormwater BMP Operation and Maintenance Plan that sets forth a maintenance schedule for each of the Stormwater BMPs built on your site. An agreement assigning responsibility for maintenance and providing for inspections and certification may also be required.

Details of these requirements and instructions for preparing a Stormwater BMP Operation and Maintenance Plan are in Chapter 5 of the WQMP Guidance Document.

**Maintenance Mechanism:** Owner will privately maintain all BMPs. An Access and maintenance agreement will be provided to the County to ensure maintenance can be provided by the County (at the expense of the owner) if the owner fails to maintain BMPs.

Will the proposed BMPs be maintained by a Home Owners' Association (HOA) or Property Owners Association (POA)?

Y       N

Include your Operation and Maintenance Plan and Maintenance Mechanism in Appendix 9. Additionally, include all pertinent forms of educational materials for those personnel that will be maintaining the proposed BMPs within this Project-Specific WQMP in Appendix 10.

**\*Will be included in Final Report.**

# Appendix 1: Maps and Site Plans

*Location Map, WQMP Site Plan and Receiving Waters Map*

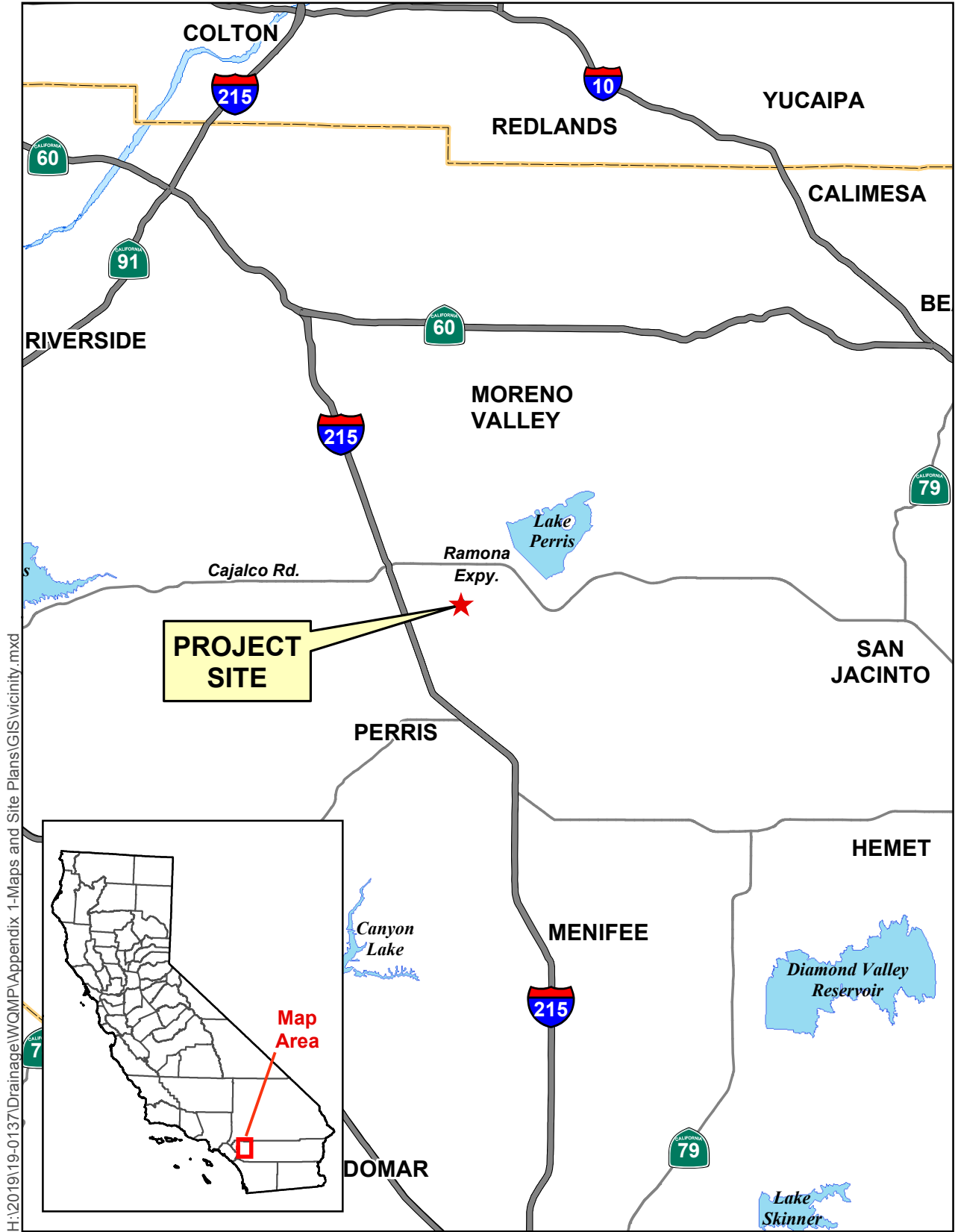

H:\2019\19-0137\Drainage\WQMP\Appendix 1-Maps and Site Plans\GIS\vicinity.mxd

Figure 1. Vicinity Map

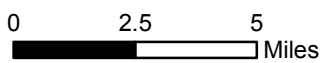



H:\2019\19-0207\Drainage\WQMP\Appendix 1-Maps and Site Plans\GIS\usgs.mxd

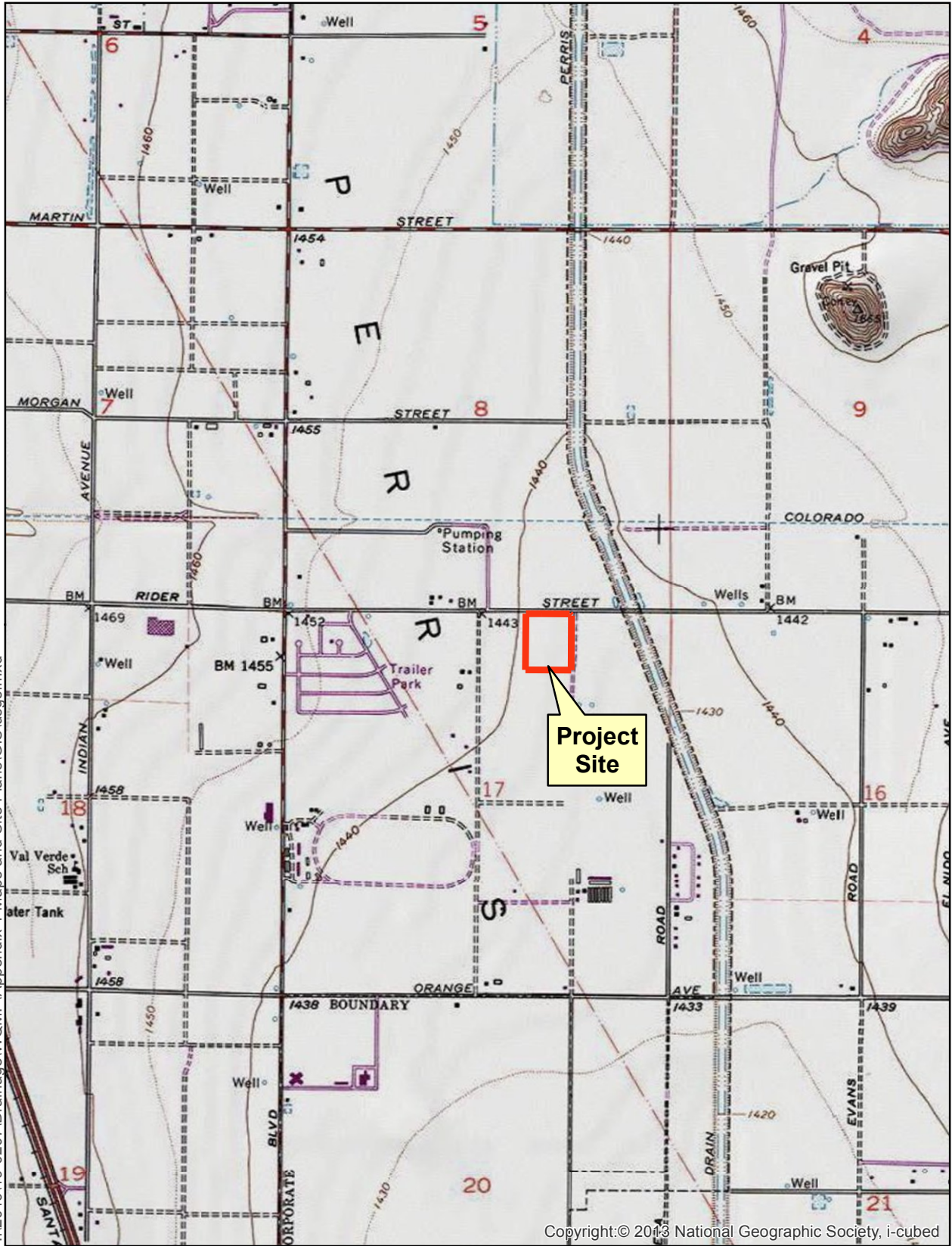

Sources: ESRI / USGS 7.5min Quad  
DRGs: PERRIS / STEELE PEAK

**Figure 2. USGS Topography Map**

0 1,000 2,000  
Feet



H:\201919-0207\Drainage\WQMP\Appendix 1-Maps and Site Plans\GIS\Aerial.mxd



Sources: County of Riverside GIS, 2013; Eagle Aerial, April 2012.

Figure 3. Aerial Photograph

0 400 800 Feet



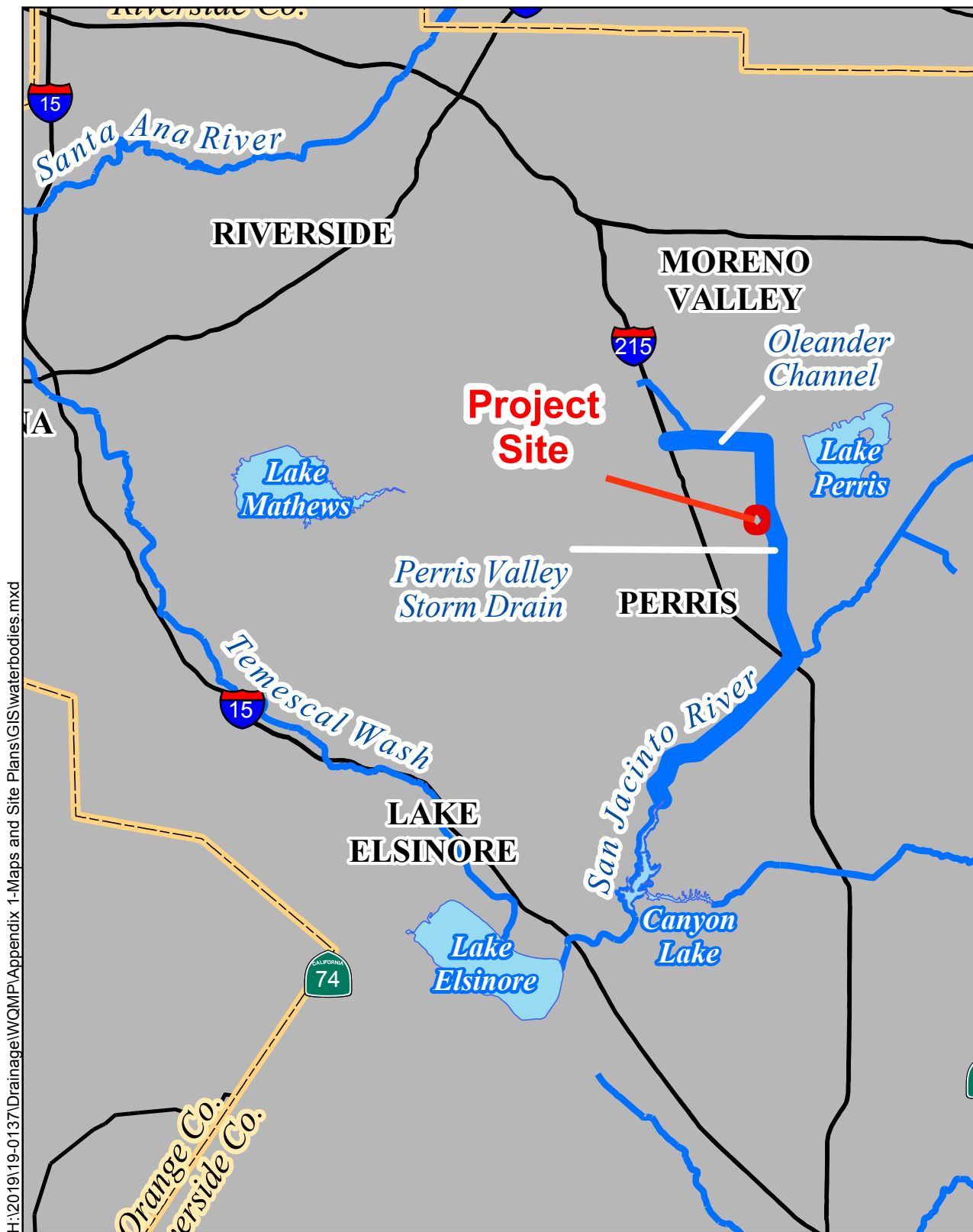

H:\2019\19-0137\Drainage\WQMP\Appendix 1-Maps and Site Plans\GIS\waterbodies.mxd

Sources: USGS 30 Meter DEM;  
USGS Digital Line Graph

**Figure 4. Receiving Waterbodies**

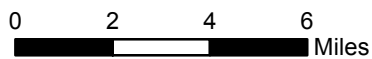

 Flowpath

H:\201919-0207\Drainage\WQMP\Appendix 1-Maps and Site Plans\GIS\SOILS MAP.mxd

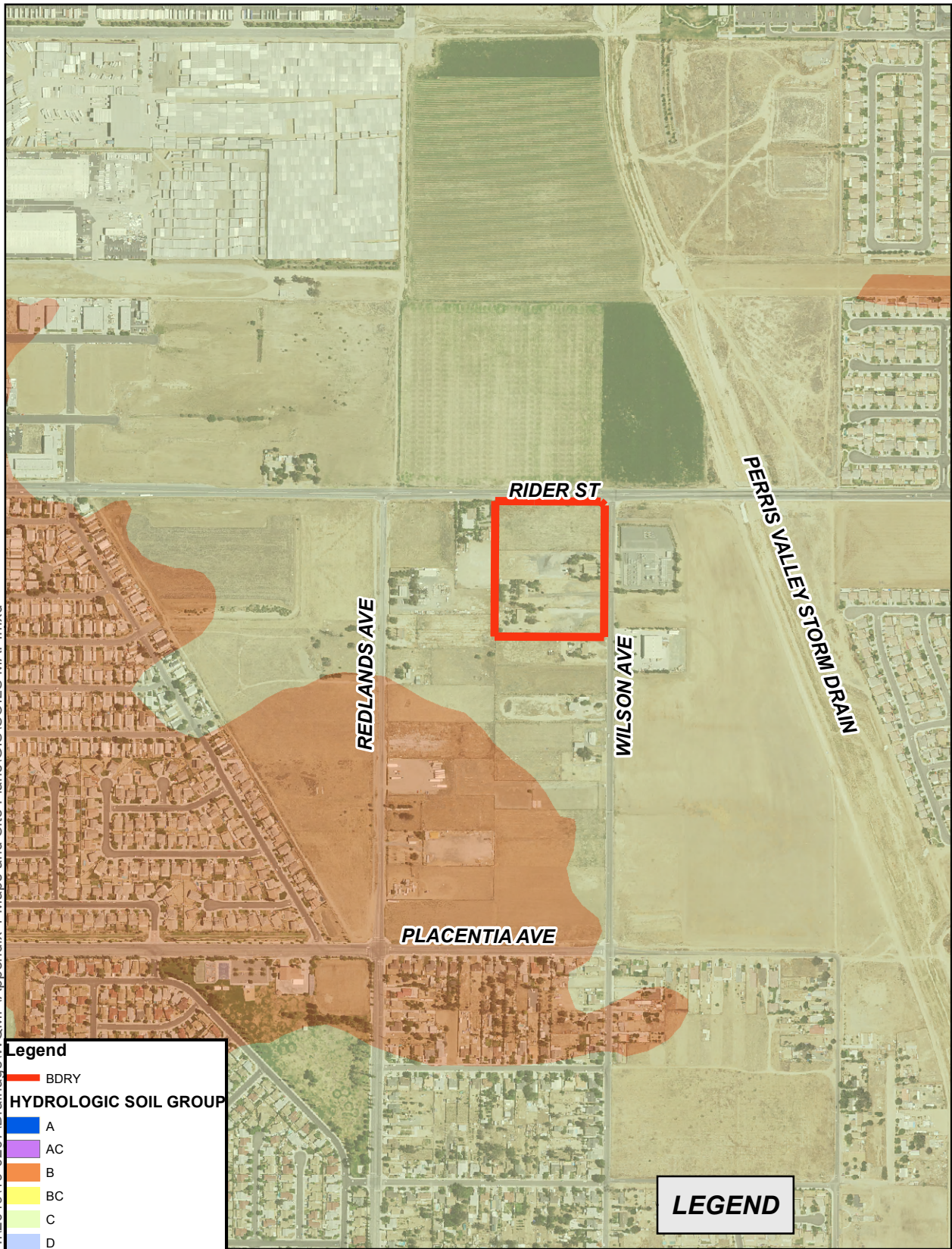

**Legend**

- BDRY
- HYDROLOGIC SOIL GROUP**
- A
- AC
- B
- BC
- C
- D

**LEGEND**

Eagle Aerial, April 2010;  
Riverside County GIS, 2012  
RCFC&WCD Hydology Manual Plate C-1.30

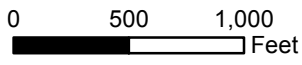
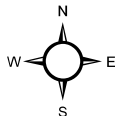

**Soils Map**  
Perris Valley Logisitic Center

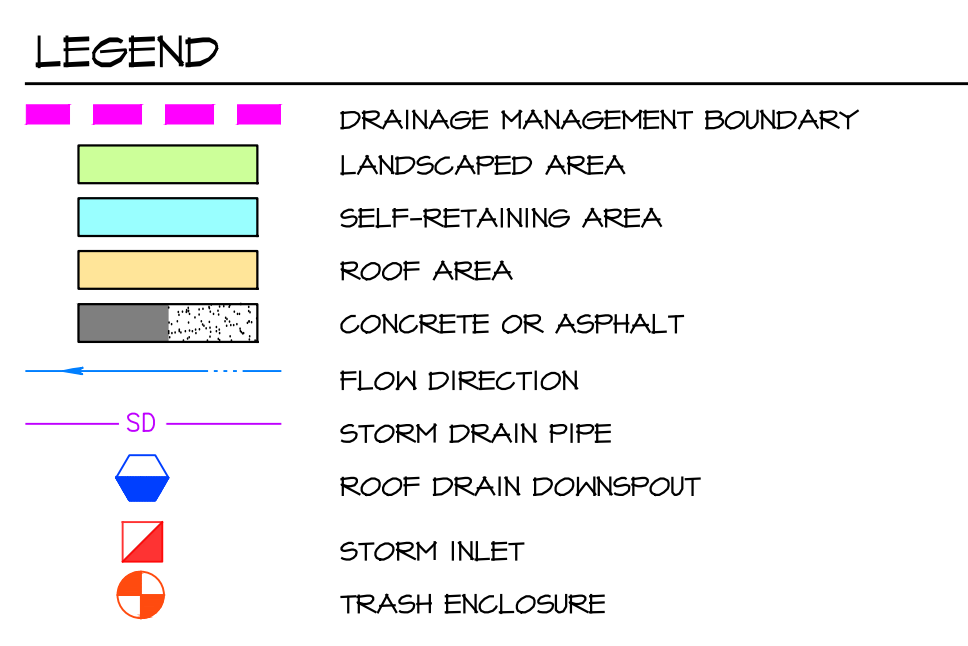
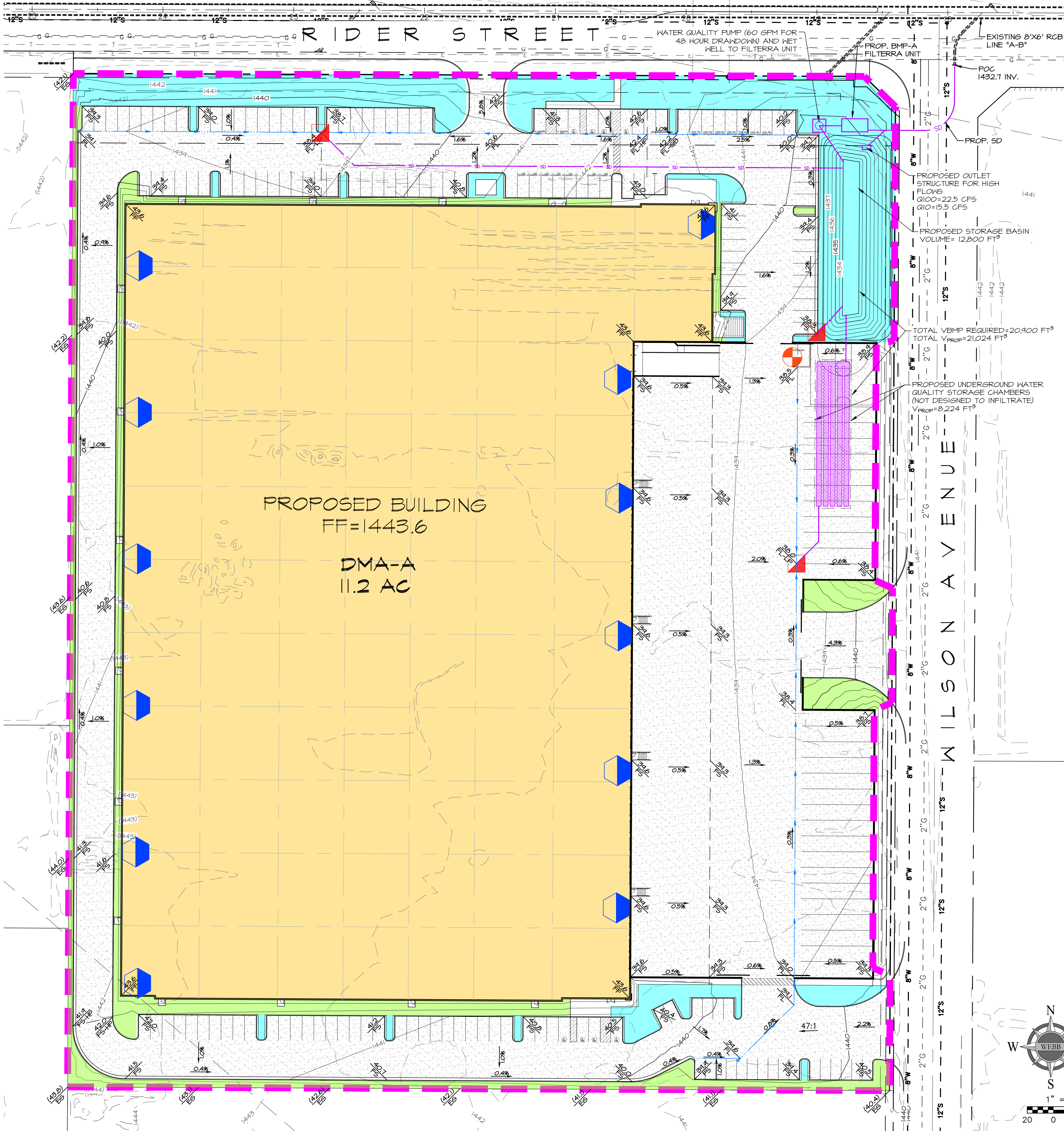

**DRAINAGE MANAGEMENT AREA "A"**

LEGEND	DMA-ID	TYPE	AREA (SF)
[Green Box]	L-A	LANDSCAPE	20,200
[Cyan Box]	SR-A	LANDSCAPE	30,200
[Yellow Box]	R-A	ROOF	243,442
[Grey Box]	H-A	HARDSCAPE	192,874

**SOURCE CONTROL NOTES**

- ALL INLETS SHALL BE MARKED WITH THE WORDS "NO DUMPING - DRAINS TO RIVER".
- INTERIOR FLOOR PLANS AND ELEVATOR SHAFT SUMP PUMPS WILL BE PLUMBED TO SANITARY SEWER.
- MAINTAIN LANDSCAPING USING MINIMUM OR NO PESTICIDES.
- TRASH ENCLOSURE AREA SHALL BE CONNECTED TO SANITARY SEWER AND SHALL HAVE A SIGN THAT STATES "DO NOT DUMP HAZARDOUS MATERIALS HERE".
- ALL INDUSTRIAL PROCESS ACTIVITIES ARE TO BE PERFORMED INDOORS. NO PROCESSES SHALL DRAIN TO EXTERIOR STORM DRAIN SYSTEM.
- ROOF DOWNSPOUTS SHALL BE POSITIONED TO DIRECT STORMWATER AWAY FROM LOADING AREA. PROVIDE ROOF OVERHANG OVER THE LOADING AREA OR INSTALL DOOR SKIRTS AT EACH BAY THAT ENCLOSE THE END OF THE TRAILER.
- PROVIDE A MEANS TO DRAIN FIRE SPRINKLER WATER TO SANITARY SEWER SYSTEM.
- BOILER DRAIN LINES AND CONDENSATE DRAIN LINES SHALL BE DIRECTLY OR INDIRECTLY CONNECTED TO THE SANITARY SEWER SYSTEM AND MAY NOT DISCHARGE TO THE STORM DRAIN SYSTEM.
- ROOFTOP EQUIPMENT WITH POTENTIAL TO PRODUCE POLLUTANTS SHALL BE ROOFED OR HAVE A SECONDARY CONTAINMENT.
- ANY DRAINAGE SUMPS ON-SITE SHALL BE FEATURE SEDIMENT SUMP TO REDUCE THE QUANTITY OF SEDIMENT IN PUMPED WATER.

**SITE PLAN RESTRICTION**

- THE USE OF OUTDOOR STORAGE OF EQUIPMENT AND MATERIALS ARE NOT PERMITTED.
- VEHICLE AND EQUIPMENT CLEANING ARE NOT PERMITTED ON-SITE.
- NO VEHICLE/EQUIPMENT REPAIR OR MAINTENANCE WILL BE DONE OUTDOORS.
- NO TANKS, CONTAINERS, OR SINKS ARE TO BE USED FOR PARTS CLEANING OR RINSING.
- NO FUELING AREAS ARE PERMITTED ON-SITE.
- OWNER MUST IMPLEMENT THESE ACTIVITY RESTRICTIONS.

**ADDITIONAL NOTE**

THE PROJECT IS NOT AFFECTED BY OFF-SITE RUNOFF

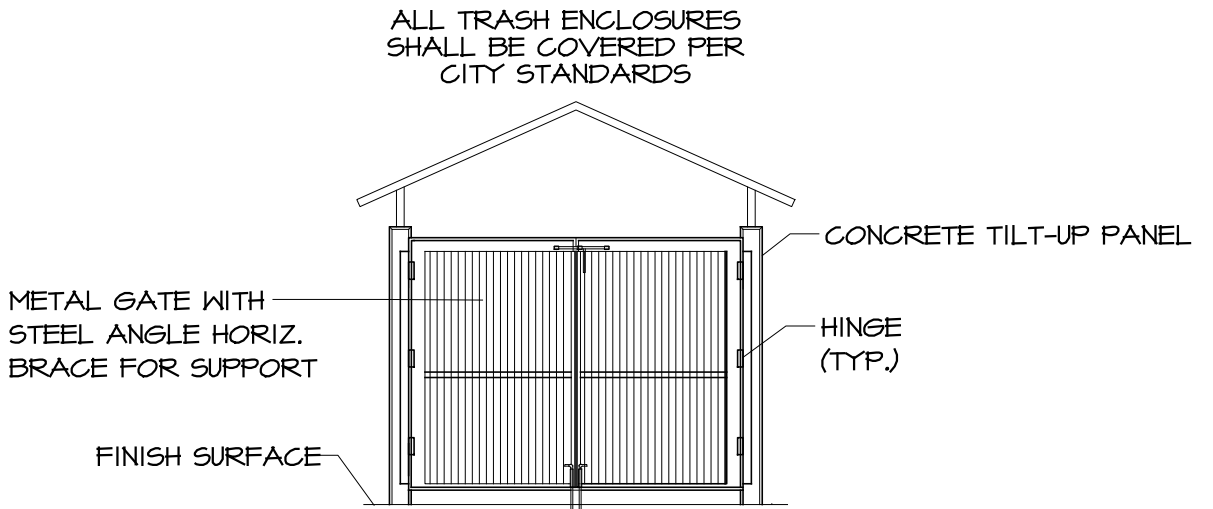

**TRASH ENCLOSURE GATE ELEVATION**  
N.T.S.

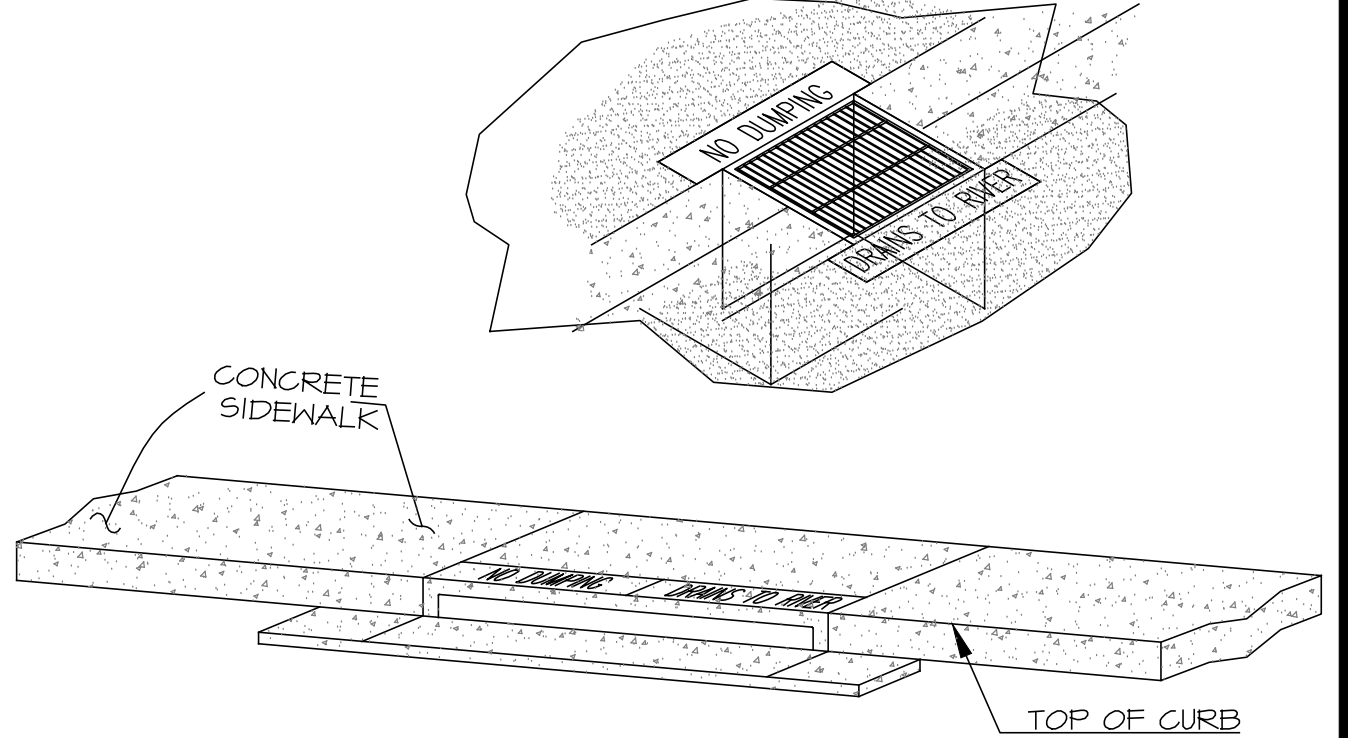
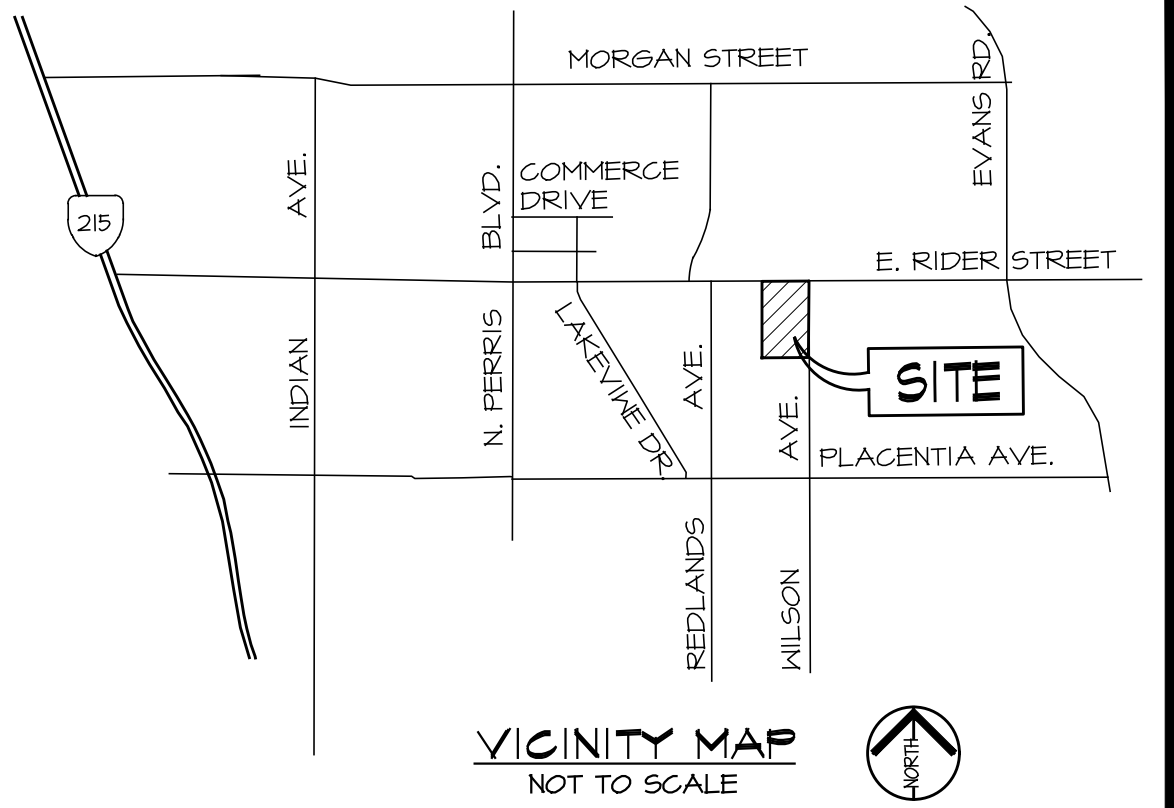
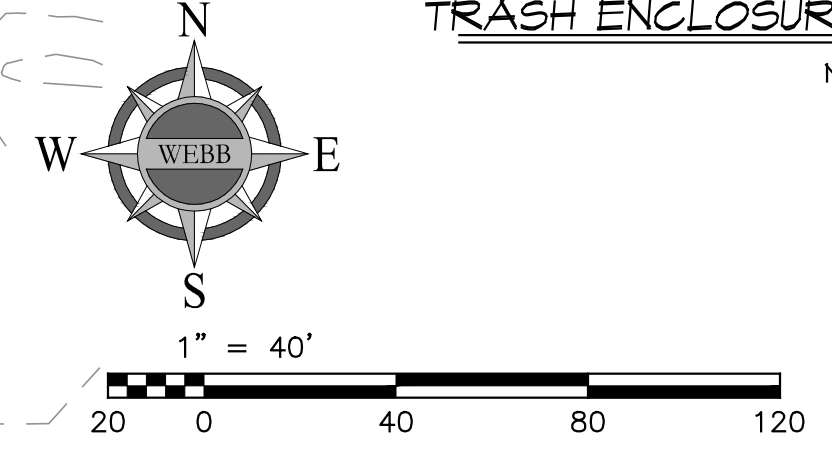

- STENCILS TO HAVE 2" LETTERS AS FOLLOWS: "NO DUMPING - DRAINS TO RIVER"
- PLACE BOTH STENCILS CENTERED WITHIN THE CATCHBASIN OPENINGS AND WITHIN THE TOP OF THE CURB.
- SPRAY BOTH STENCILS WITH WHITE PAINT.
- REMOVE STENCILS WHEN PAINT IS DRY.

**CATCH BASIN STENCILING DETAIL**  
N.T.S.

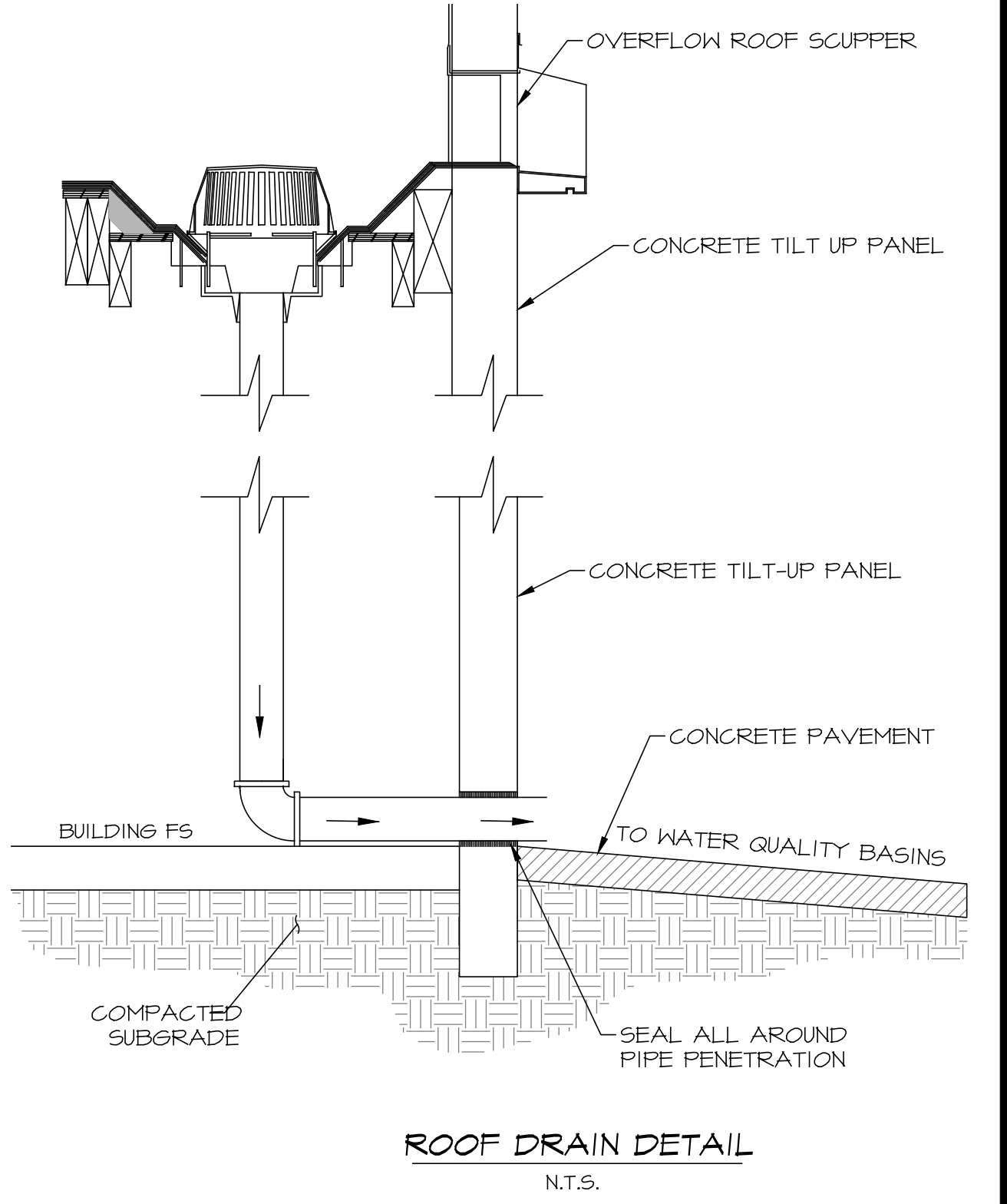

**ROOF DRAIN DETAIL**  
N.T.S.

**CITY OF PERRIS**

POST-CONSTRUCTION BMP SITE PLAN  
CORE 5 - RIDER BUSINESS CENTER  
P20-00011

SCALE: 1"=50'  
DATE: 12/04/2020  
DESIGNED: CV  
CHECKED: DJA  
PLN CK REF: F.B.

**ALBERTA A. ENGINEERING CONSULTANTS**  
3788 MCCRAY STREET  
RIVERSIDE CA 92506  
PH. (951) 686-1070  
FAX (951) 788-1256

W.O. 19-0207  
SHEET 1  
OF 2 SHEETS  
DWG. NO.

H:\2019\19-0207\DRAINAGE\WQMP\DWG DRAWINGS\19-0207-PWQMP.DWG 12/10/2020 8:33:08 AM

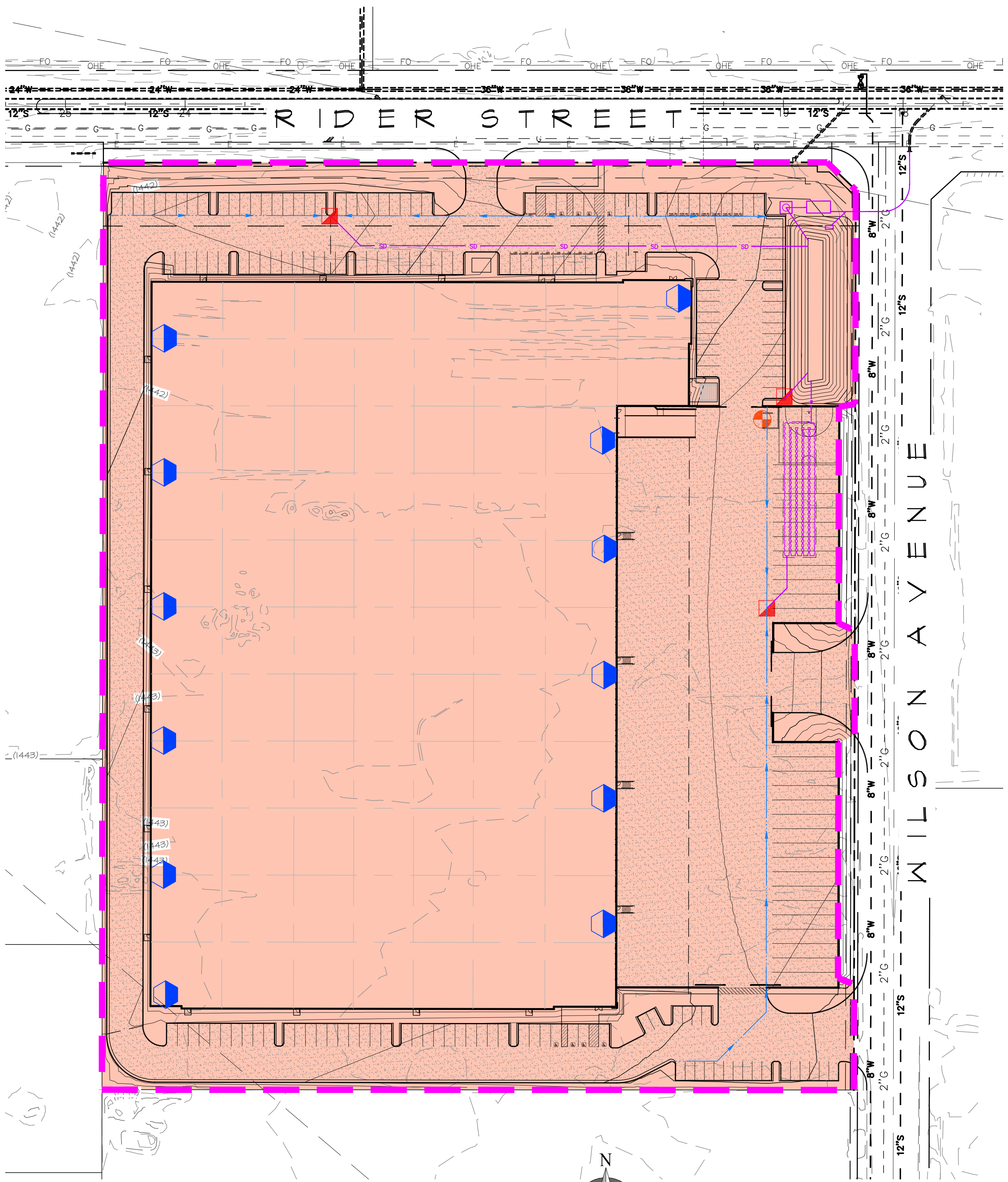

THIS IS A SCHEMATIC LAYOUT ONLY. ACTUAL CONFIGURATION WILL VARY BASED ON THE SITE SPECIFIC CONSIDERATIONS. REFER TO FLOWKIT DRAWINGS FOR ADDITIONAL DETAILS.

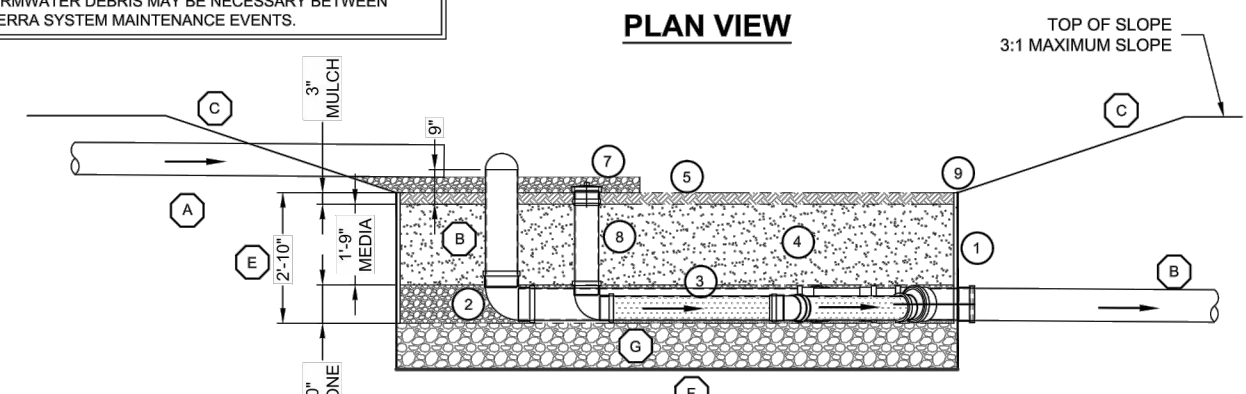
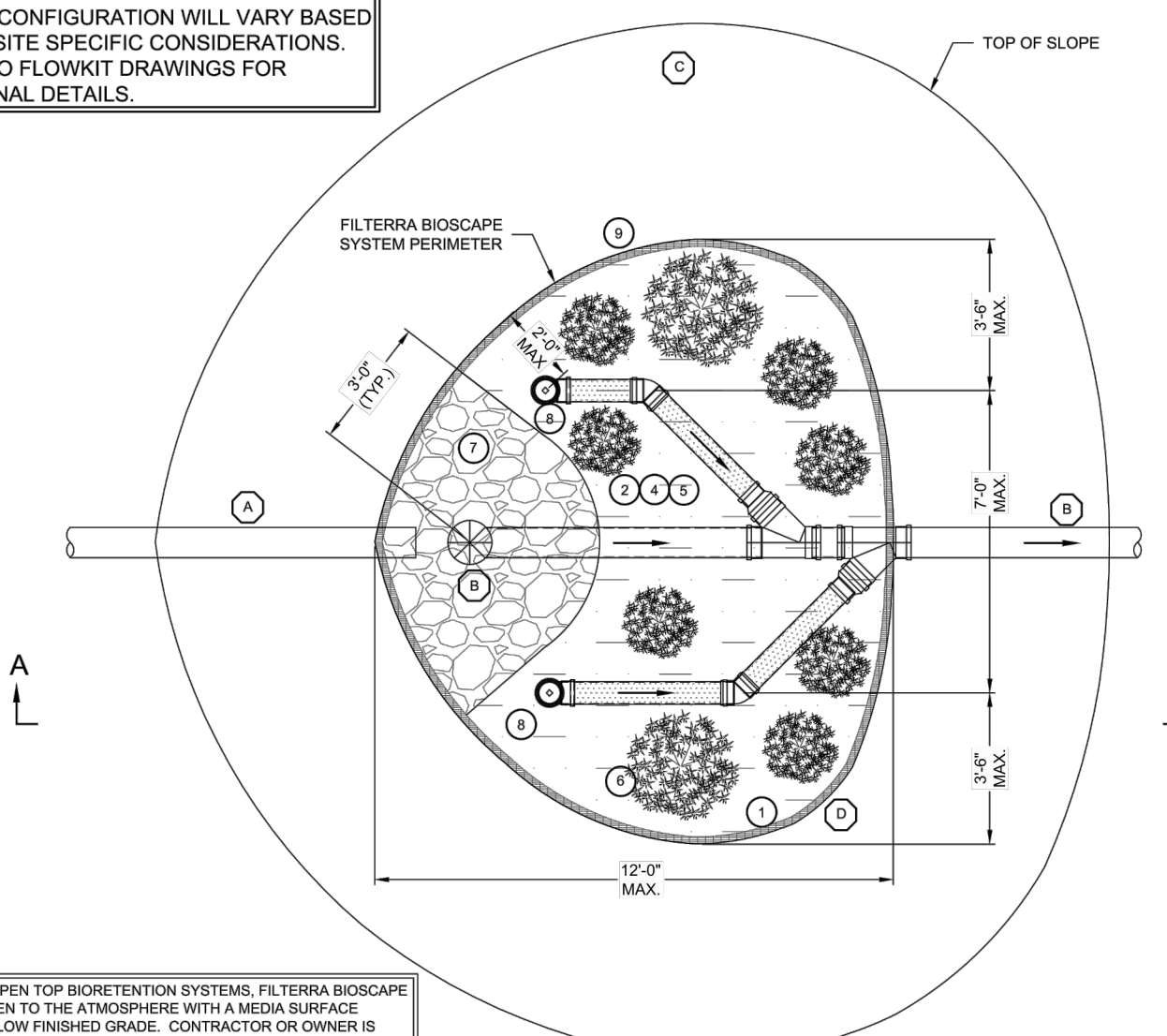

BILL OF MATERIALS		
COUNT	DESCRIPTION	INSTALLED BY
X	FILTERRA SURFACE AREA (SF)	CONTRACTOR
X	MULCH VOLUME (CY)	CONTRACTOR
XX	FILTERRA MEDIA VOLUME (CY)	CONTRACTOR
X	1/2" #4 ROUND AGGREGATE UNDERDRAIN STONE (CY)	CONTRACTOR
X	ENERGY DISSIPATION ROCK (CY)	CONTRACTOR
X	EROSION CONTROL (LF)	CONTRACTOR
X	FILTERRA FLOWKIT	CONTRACTOR

PLANTING SCHEDULE	
NOTE: PLANTS PROVIDED BY OTHERS	
QUANTITY	FILTERRA BIOSCAPE SYSTEM PLANT PALETTE

- GENERAL NOTES**
- CONTRACTOR SHALL CONTACT CONTECH TO COORDINATE DELIVERY AND SUPERVISION OF PLACEMENT OF FILTERRA BIOSCAPE SYSTEM COMPONENTS (ACTIVATION). CONTRACTOR SHALL COMPLETE TERMS IN THE LIST OF CONTRACTOR INSTALLATION RESPONSIBILITIES LISTED ON THIS DETAIL BEFORE CONTECH'S REPRESENTATIVE ATTENDS AND SUPERVISES THE ACTIVATION OF THE BIOSCAPE SYSTEM.
  - PERFORM FILTERRA BIOSCAPE SYSTEM EXCAVATION ONLY AFTER ALL THE CONTRIBUTING DRAINAGE AREAS ARE PERMANENTLY STABILIZED. DO NOT CONSTRUCT FILTERRA BIOSCAPE SYSTEM IN AN AREA USED AS EROSION AND SEDIMENT CONTROL FACILITIES. DO NOT STOCKPILE MATERIALS NOR STORE EQUIPMENT IN THIS AREA.
  - USE METHODS OF EXCAVATION THAT MINIMIZE COMPACTION OF THE UNDERLYING SOIL. UNLESS THE SYSTEM IS TO BE LINED, CONTRACTOR SHALL COORDINATE WITH CONTECH BEFORE THE FILTERRA BIOSCAPE SYSTEM AREA IS EXCAVATED TO MINIMIZE TIME BETWEEN EXCAVATION AND DELIVERY AND ACTIVATION OF THE FILTERRA BIOSCAPE SYSTEM. ANY STANDING WATER THAT ACCUMULATES IN THE EXCAVATED AREA MUST BE REMOVED BY THE CONTRACTOR BEFORE CONTECH CAN PROVIDE ACTIVATION OF THE FILTERRA BIOSCAPE SYSTEM. ANY ADDITIONAL EXCAVATION WILL BE THE RESPONSIBILITY OF THE CONTRACTOR.
  - EXCAVATION DIMENSIONS SHOULD BE PROVIDED TO CONTECH IN THE ACTIVATION REQUEST CHECKLIST.
  - CONTRACTOR SHALL PROVIDE ACCESS TO THE EXCAVATED AREAS FOR USE DURING THE ACTIVATION OF THE FILTERRA BIOSCAPE SYSTEMS. ACCESS SHALL NOT PROHIBIT LIGHT DUTY EQUIPMENT THAT MAY BE USED TO INSTALL THE COMPONENTS (STONE, MEDIA, ETC.). THE CONTRACTOR SHALL BE RESPONSIBLE FOR ANY RE-STABILIZATION THAT MAY BE REQUIRED AFTER THE FILTERRA BIOSCAPE SYSTEM ACTIVATION.
  - CONTECH AND/OR ITS REPRESENTATIVES MUST BE SCHEDULED TO BE ON SITE FOR THE LIST ENTITLED CONTRACTOR ACTIVATION RESPONSIBILITIES.
- CONTRACTOR SITE PREPARATION RESPONSIBILITIES AS DENOTED BY (X) ON THIS DETAIL:**
- CONTRACTOR SHALL INSTALL PIPE OR SWALE THAT CONVEYS INFLUENT FLOWS AS WELL AS ANY REQUIRED INLET AND OUTLET STRUCTURES.
  - CONTRACTOR SHALL PROVIDE BYPASS PIPE AND RISER OR OTHER STRUCTURE AS SHOWN ON PLANS. THE BYPASS PIPE SHALL BE INSTALLED WITH WYES, OR OTHER PIPE FITTINGS, AND WITH REDUCER COUPLINGS FOR CONNECTION OF UNDERDRAIN PIPE. PER PLANS. PIPES SHALL BE INSTALLED TO PROMOTE POSITIVE FLOW FROM THE FILTERRA BIOSCAPE SYSTEM.
  - IF REQUIRED, CONTRACTOR TO PROVIDE SHOULDER ACCORDING TO DIMENSION AND SLOPE SHOWN ON PLANS OR AS DESIGNED BY ENGINEER OF RECORD. SLOPE FROM SHOULDER TO FILTERRA BIOSCAPE SYSTEM SURFACE AREA SHALL NOT EXCEED 3:1. SOO IS REQUIRED TO STABILIZE SIDE SLOPES OR ADJACENT GRADE.
  - CONTRACTOR SHALL EXCAVATE MEDIA AREA CORRESPONDING TO THE SIZE OF THE FILTERRA BIOSCAPE SYSTEM SURFACE AREA AS SHOWN ON DETAIL AND ON PLAN SHEETS.
  - CONTRACTOR SHALL EXCAVATE VERTICALLY FROM BOTTOM OF UNDERDRAIN STONE, OR DRAINAGE STONE, IF REQUIRED, TO ELEVATION OF MULCH AS SHOWN ON THIS DETAIL.
  - CONTRACTOR TO PROVIDE AND INSTALL ANY GEOTEXTILE OR IMPERMEABLE LINER FOR BOTTOM OF THE FILTERRA BIOSCAPE SYSTEM IF REQUIRED PER THE PLANS.
  - CONTRACTOR TO PROVIDE AND INSTALL ANY ADDITIONAL DRAINAGE STONE BELOW THE FILTERRA BIOSCAPE SYSTEM AS CALLED OUT ON THE PLANS.
- CONTRACTOR ACTIVATION RESPONSIBILITIES AS DENOTED BY (O) ON THIS DETAIL:**
- PLACE GEOTEXTILE FABRIC ALONG THE PERIMETER OF THE FILTERRA BIOSCAPE SYSTEM EXCAVATION.
  - PLACE 12" OF UNDERDRAIN STONE - 2" UNDER THE PIPING AND 2" ABOVE THE PIPING USING LIGHT DUTY EQUIPMENT ONLY.
  - PLACE 6" UNDERDRAIN PIPING UNLESS OTHERWISE APPROVED BY CONTECH. ASSOCIATED PIPING AND FITTINGS/BELLOWS TO CONNECT TO THE PIPING/FITTINGS THAT IS PROVIDED BY CONTRACTOR (SEE CONTRACTOR INSTALLATION RESPONSIBILITIES THIS DETAIL).
  - PLACE 2" FILTERRA MEDIA USING LIGHT DUTY EQUIPMENT ONLY. DO NOT COMPACT MEDIA.
  - PLACE 3" DOUBLE SHREDDED HARDWOOD MULCH OVER ENTIRE FILTERRA BIOSCAPE SYSTEM SURFACE AREA USING LIGHT DUTY EQUIPMENT ONLY. DO NOT COMPACT MULCH.
  - PROVIDE AND PLANT VEGETATION AS INDICATED IN TABLE ON THIS DETAIL OR ON SITE PLANS.
  - PLACE ENERGY DISSIPATION ROCK APRON AS DESIGNED AND INDICATED ON THIS DETAIL OR PER ENGINEER OF RECORD PLANS.
  - PLACE CLEANOUT ADAPTER, FLUG AND PIPING.
  - PLACE ADDITIONAL EROSION CONTROL AROUND FILTERRA BIOSCAPE SYSTEM (IF REQUIRED).



FILTERRA BIOSCAPE™ SYSTEM STANDARD DETAIL

BMP-A  
N.T.S.

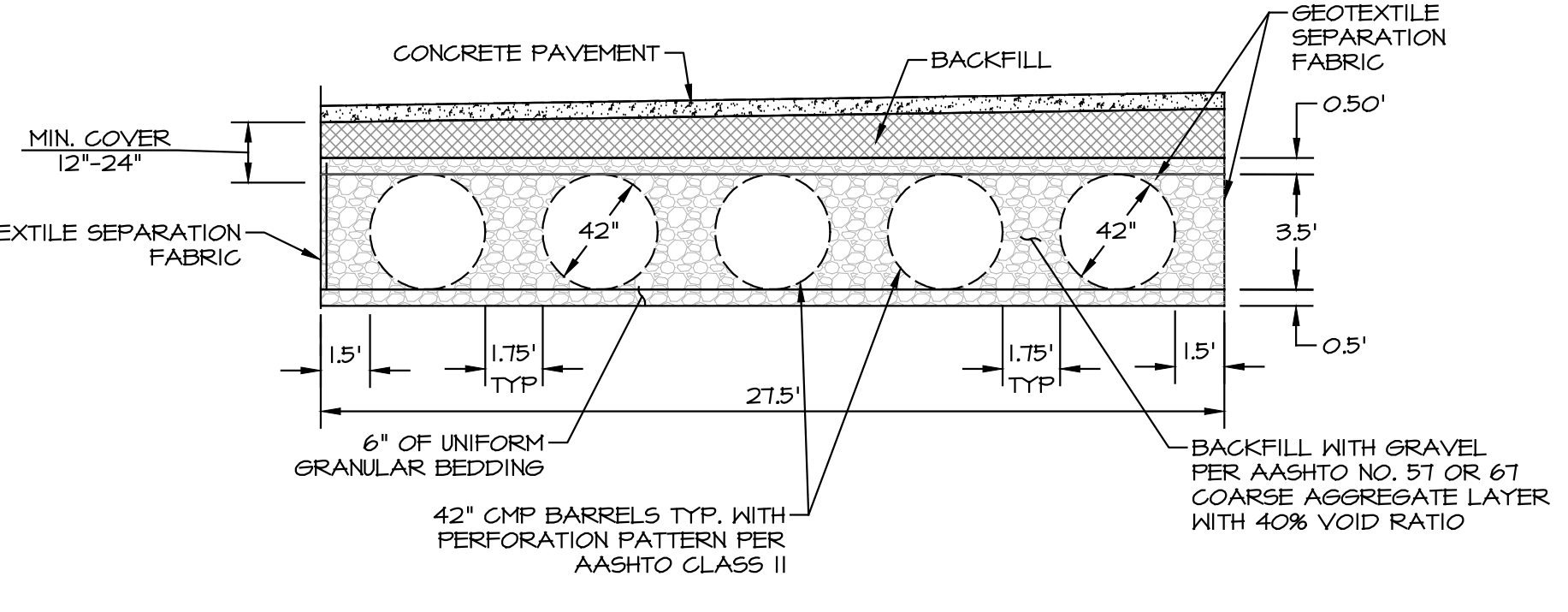

CMP DETENTION SYSTEM A TYPICAL DETAIL  
NOT TO SCALE

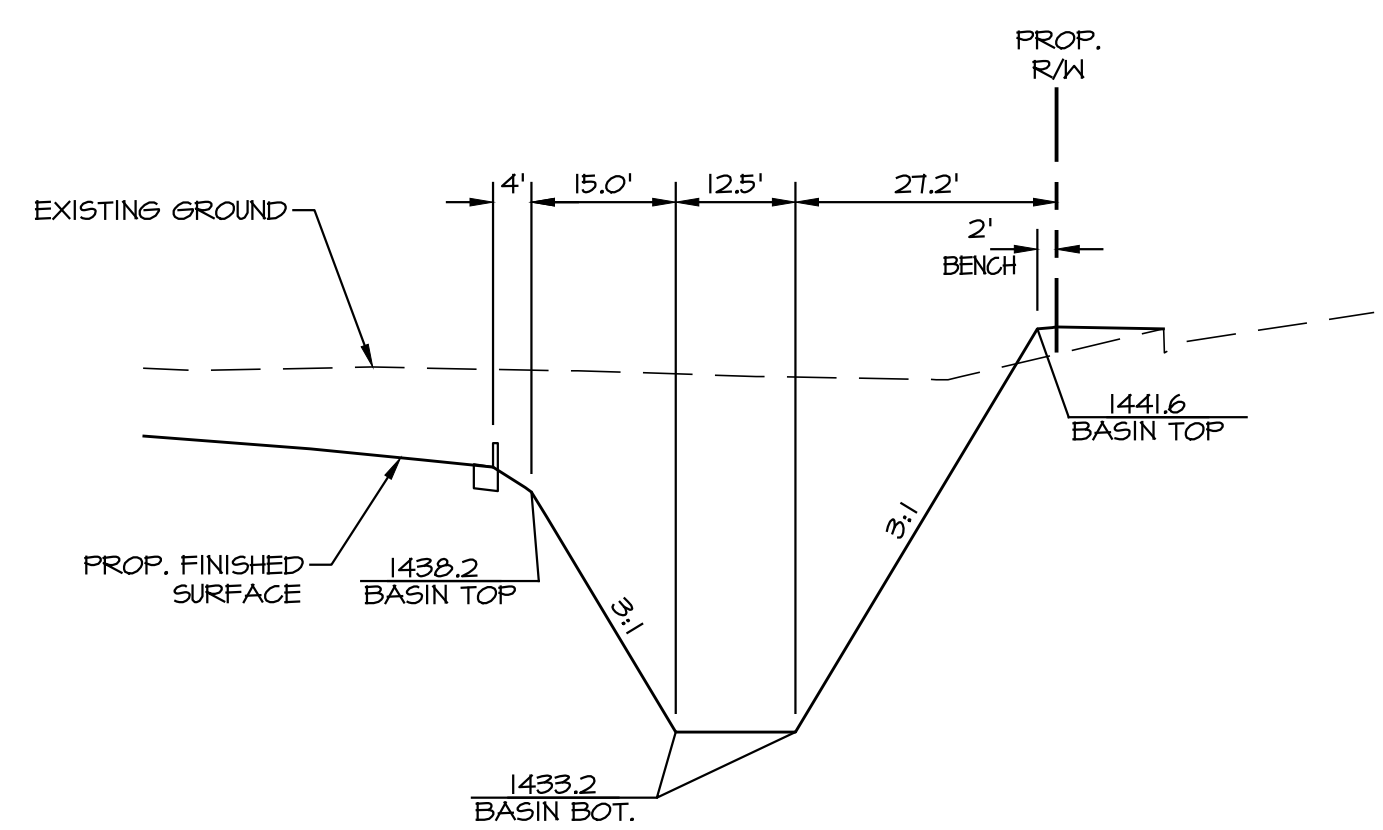

OPEN STORAGE BASIN TYPICAL SECTION  
N.T.S.

DMA-A

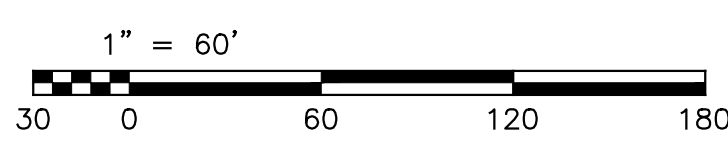
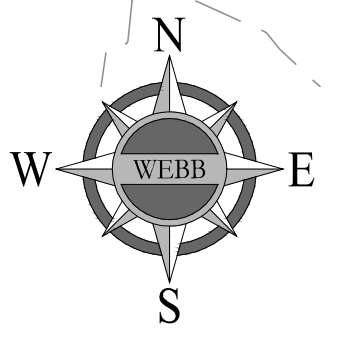

CITY OF PERRIS

POST-CONSTRUCTION DMA PLAN & DETAILS  
CORE 5 - RIDER BUSINESS CENTER  
P20-00011

SCALE:	ALBERT A. ENGINEERING CONSULTANTS	W.O. 19-0207
DATE: 12/04/2020	3788 MCCRAY STREET	SHEET 2
DESIGNED: CV	RIVERSIDE CA 92506	OF 2 SHEETS
CHECKED: DJA	PH. (951) 686-1070	DWG. NO.
PLN CK REF:	FAX (951) 788-1256	
F.B.		

H:\2019\19-0207\DRAINAGE\WQMP\DWG DRAWINGS\19-0207-PWQMP.DWG 12/10/2020 8:33:08 AM

# Appendix 2: Construction Plans

*Grading and Drainage Plans*

**PROPERTY OWNERS**

APN: 300-210-024  
KIRIT PATEL & KRISHNAKANT PATEL  
21744 CHESWOLD AVENUE  
SAUGUS, CA 91350

APN: 300-210-011 & 300-210-012  
FEDERICO ESCOBEDO & PASCUALA  
ESCOBEDO  
3545 CHESTERFIELD DRIVE  
PERRIS, CA 92571

APN: 300-210-013  
FABIO LOPEZ & MARIA VAQUERO  
21433 MARTIN STREET  
PERRIS, CA 92570

**DEVELOPMENT PLAN REVIEW NO. \_\_\_\_\_**  
**CORE 5 - RIDER BUSINESS CENTER**  
**CONCEPTUAL GRADING & DRAINAGE PLAN**

RIDER - II DPR NO. 19-00004  
APN(S): 303-170-004, 303-170-005,  
303-170-011, 303-170-014, 303-130-022  
ZONE: SP-L1

**APPLICANT**  
CORE 5 INDUSTRIAL PARTNERS, LLC  
ATTN: JON KELLY  
300 SPECTRUM CENTER DRIVE, SUITE 880  
IRVINE, CA 92618  
TEL: (949) 467-3281

**A.P.N(S)**  
300-210-024,  
300-210-011,  
300-210-012,  
300-210-013

**ACREAGE**  
11.2 AC

**LEGAL DESCRIPTION**

APN: 300-210-024  
PARCEL I TOGETHER WITH LOT C AS SHOWN BY PARCEL MAP NO. 12170, ON FILE IN BOOK 63 PAGE 24 OF PARCEL MAPS, RECORDS OF RIVERSIDE COUNTY, CALIFORNIA;  
EXCEPTING THEREFROM THAT PORTION THEREOF CONVEYED TO THE CITY OF PERRIS, CALIFORNIA BY DOCUMENT RECORDED MARCH 3, 1988 AS INSTRUMENT NO. 56391 AND RE-RECORDED MARCH 19, 1988 AS INSTRUMENT NO. 12086 BOTH OF OFFICIAL RECORDS OF RIVERSIDE COUNTY, CALIFORNIA.

APN: 300-210-011 & 300-210-012  
PARCELS 2 AND 3, LOTS A AND B OF PARCEL MAP NO. 12170, AS SHOWN BY MAP ON FILE IN BOOK 63 PAGE 24 OF PARCEL MAPS, RECORDS OF RIVERSIDE COUNTY, CALIFORNIA.

APN: 300-210-013  
PARCEL I AND LETTERED LOT "D" OF PARCEL MAP 11480, AS SHOWN BY MAP ON FILE IN BOOK 63 PAGE 28 OF PARCEL MAPS, RECORDS OF RIVERSIDE COUNTY, CALIFORNIA.

**LAND USE**  
EXISTING/PROPOSED ZONING: SP-L1  
EXISTING/PROPOSED GENERAL PLAN USE: SP-L1  
EXISTING LAND USE: LOW DENSITY RESIDENTIAL/VACANT  
PROPOSED LAND USE: WAREHOUSE DISTRIBUTION

**PROJECT DESCRIPTION:**  
DEVELOPMENT PLAN REVIEW FOR A DISTRIBUTION WAREHOUSE FACILITY CONSISTING OF 1 BUILDING TOTALING 248,360 SQUARE FEET ON 11.2+ NET ACRES.

**UTILITY COMPANIES:**  
WATER: EASTERN MUNICIPAL WATER DISTRICT  
PHONE: (800) 426-3643  
SEWER: EASTERN MUNICIPAL WATER DISTRICT  
PHONE: (800) 426-3643  
ELECTRIC: SOUTHERN CALIFORNIA EDISON COMPANY  
PHONE: (800) 684-8123  
TELEPHONE: TIME WARNER CABLE  
PHONE: (887) 475-3121  
GAS: SOUTHERN CALIFORNIA GAS COMPANY  
PHONE: (800) 427-2200  
SCHOOL: VAL VERDE UNIFIED SCHOOL DISTRICT  
PHONE: (951) 940-6100

**EARTHWORK ESTIMATE:**  
CUT: 49,600 CY  
FILL: 44,200 CY  
SHRINKAGE: 5,400 CY  
NET: 0 CY (BALANCED)

- NOTES:**
- 2005 THOMAS BROTHERS MAP: PAGE TTI, GRID H-3, H-4, J3 & J4
  - THIS AREA IS SUBJECT TO LOW LIQUEFACTION.
  - THIS AREA IS WITHIN THE PERRIS VALLEY COMMERCE SPECIFIC PLAN.
  - THIS PROJECT IS NOT WITHIN A COMMUNITY SERVICES DISTRICT.
  - THIS PROJECT IS WITHIN THE AIRPORT COMPATIBILITY ZONE C-1.
  - PROJECT BOUNDARY WILL BE CREATED VIA PARCEL MERGER.
  - ALL PARCELS WITHIN PROJECT BOUNDARY TO BE COMBINED VIA FUTURE CERTIFICATE OF PARCEL MERGER.

- EASEMENTS**
- AN EASEMENT FOR TEMPORARY EASEMENT AND RIGHT OF WAY TO CONSTRUCT A PIPELINE OR PIPELINES AND INCIDENTAL PURPOSES, RECORDED MARCH 26, 1992 AS INSTRUMENT NO. 149210572 OF OFFICIAL RECORDS, IN FAVOR OF EASTERN MUNICIPAL WATER DISTRICT, A MUNICIPAL WATER DISTRICT. EASEMENT TO BE QUITCLAIMED.
  - AN EASEMENT FOR EITHER OR BOTH POLE LINES, CONDUITS OR UNDERGROUND FACILITIES AND INCIDENTAL PURPOSES, RECORDED DECEMBER 11, 1978 AS INSTRUMENT NO. 1978-260146 OF OFFICIAL RECORDS, IN FAVOR OF SOUTHERN CALIFORNIA EDISON CO.
  - AN EASEMENT FOR EITHER OR BOTH POLE LINES, UNDERGROUND CONDUITS AND INCIDENTAL PURPOSES, RECORDED DECEMBER 11, 1978 AS INSTRUMENT NO. 260146 OF OFFICIAL RECORDS, IN FAVOR OF SOUTHERN CALIFORNIA EDISON CO.
  - AN EASEMENT FOR POLE LINES AND UNDERGROUND CONDUITS AND INCIDENTAL PURPOSES, RECORDED DECEMBER 15, 1978 AS INSTRUMENT NO. 264981 OF OFFICIAL RECORDS, IN FAVOR OF SO. CAL. EDISON.

**LEGEND**

	PROP. CONCRETE PAVEMENT		EXISTING CONTOURS
	PROP. AC PAVEMENT		PROPOSED CONTOURS
	PROP. LANDSCAPE AREA		EXISTING WATER LINE
	PROP. DECORATIVE PAVEMENT		EXISTING SEWER LINE
	FIRE LANE		EXISTING STORM DRAIN
	ADA PATH OF TRAVEL		EXISTING GAS LINE
	SCREEN WALL		EXISTING ELECTRICAL LINE
	FENCE LINE		FINISHED FLOOR
	GRADEBREAK/RIDGELINE		FINISHED GROUND
	FLOWLINE		FINISHED SURFACE
	WATER LINE		FLOW LINE
	STORM DRAIN LINE		GRADE BREAK
	SEWER LINE		INVERT
			LANDSCAPE AREA
			LOW POINT
			MAXIMUM PROPERTY LINE
			RIGHT OF WAY
			TYPICAL

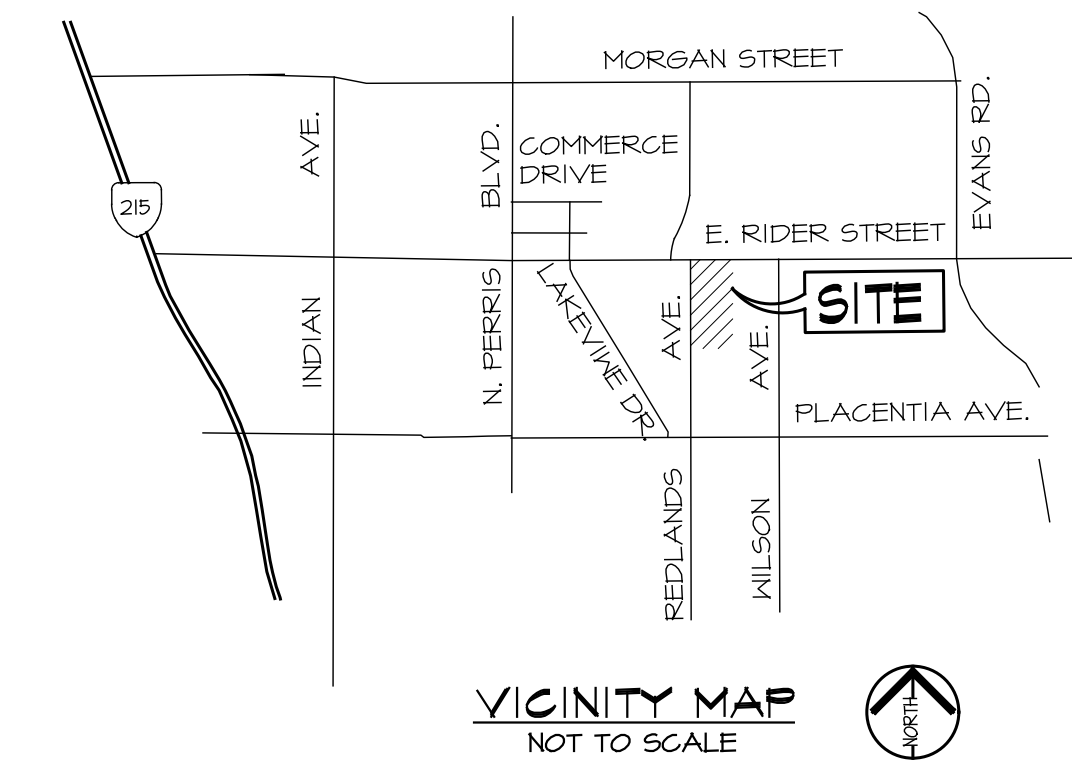
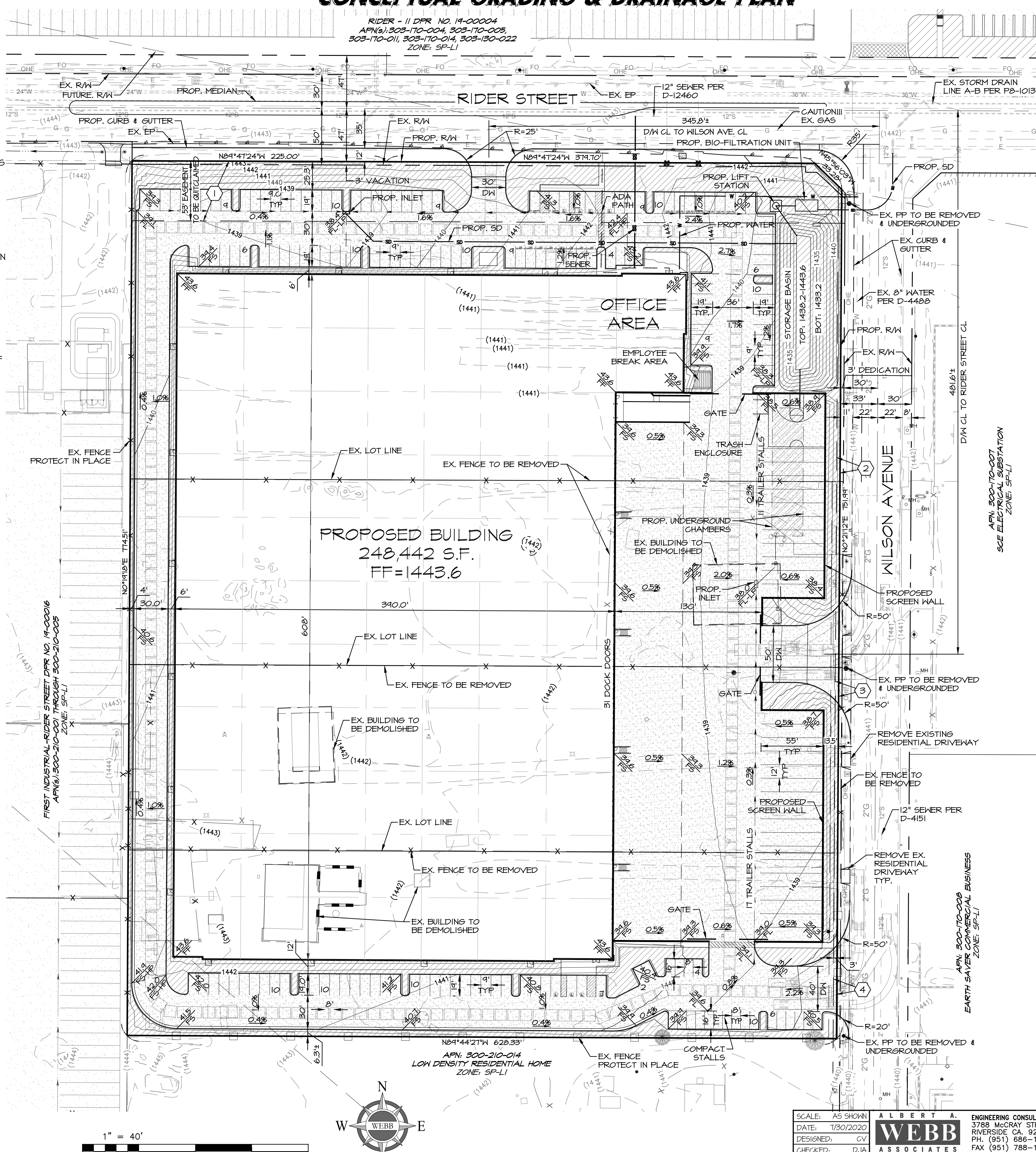

**PROJECT DATA**

<b>ACREAGE</b>		
GROSS SITE AREA:	486,945 S.F.	11.18 AC.
R/W DEDICATION (WILSON AVE):	2,235 S.F.	0.05 AC.
R/W VACATION (PERRY ST.):	2,011 S.F.	0.04 AC.
NET SITE AREA:	486,721 S.F.	11.17 AC.
<b>BUILDING AREA</b>		
1ST FLOOR OFFICE:		5,000 S.F.
MEZZANINE:		5,000 S.F.
WAREHOUSE:		238,360 S.F.
TOTAL AREA:		248,360 S.F.
<b>LOT COVERAGE, PROPOSED:</b>	50% MAX. ALLOWED:	50%
<b>PARKING REQUIREMENTS</b>		
OFFICE @ 1/250 S.F.:		40 STALLS
1ST. 20K @ 11,000 S.F.:		2 STALLS
ABOVE 20K @ 1/2,000 S.F.:		101 STALLS
TOTAL PARKING REQUIRED:		149 STALLS
<b>PARKING PROVIDED</b>		
AUTO:		
STANDARD (9'X19'):		137 STALLS
COMPACT (8'X16'):		25 STALLS
HANDICAP (9'X19'):		8 STALLS
TOTAL AUTO:		170 STALLS
TRAILER (10'X55') PROVIDED:		28 STALLS
<b>LANDSCAPED AREA</b>		
LANDSCAPED AREA REQUIRED:		12%
LANDSCAPED AREA PROVIDED:		12.7%
LANDSCAPED AREA PROVIDED:		62,024 S.F.

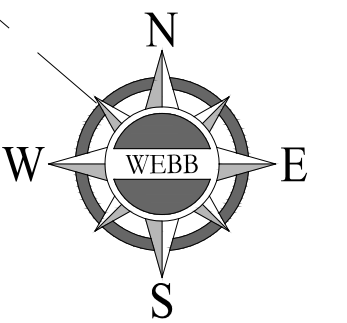
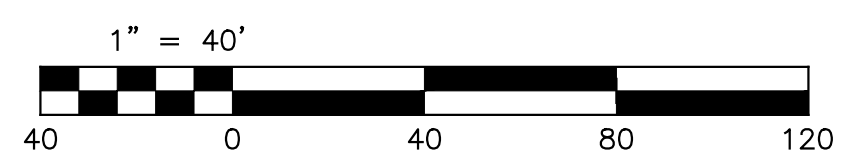
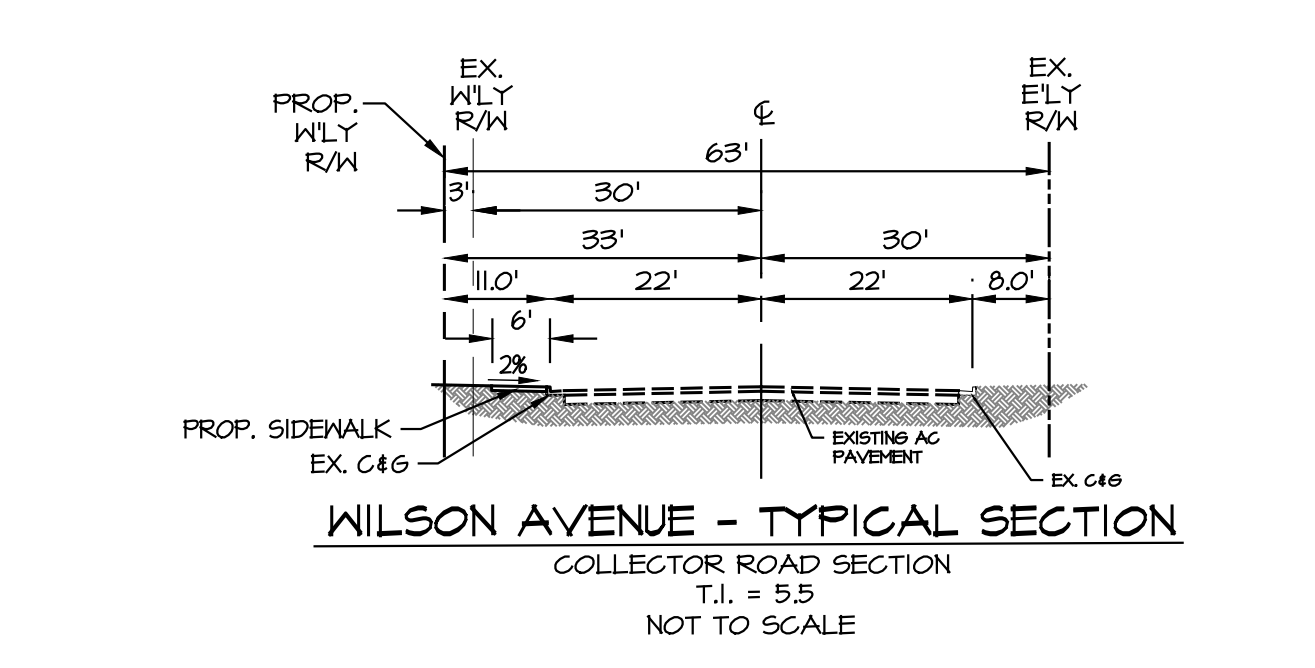
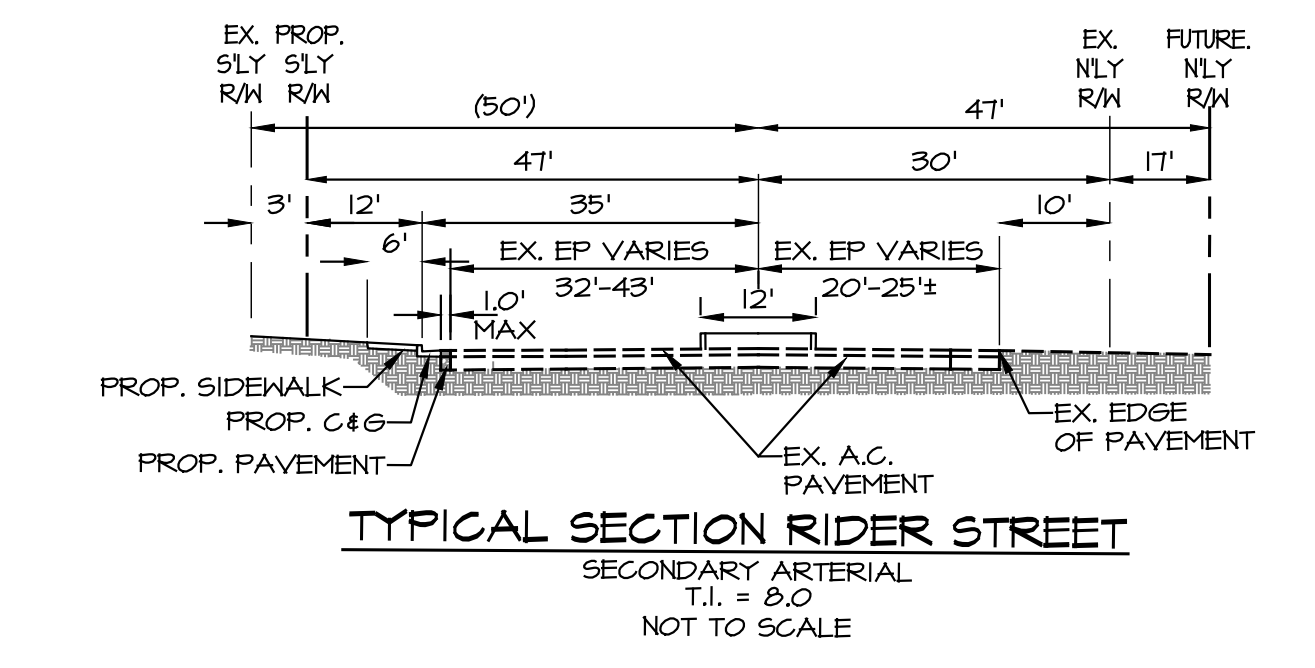

SCALE: AS SHOWN  
DATE: 7/30/2020  
DESIGNED: CV  
CHECKED: DJA  
PLN CK REF: FB

**WEBB ASSOCIATES**

ENGINEERING CONSULTANTS  
3788 MCCRAY STREET  
RIVERSIDE CA, 92506  
PH. (951) 686-1070  
FAX (951) 788-1256

PLOT DATE: 7/30/2020

CITY OF PERRIS  
DEVELOPMENT PLAN REVIEW NO. \_\_\_\_\_  
CORE 5-RIDER BUSINESS CENTER

W.O. 19-0207  
SHEET 1  
OF 1 SHEETS  
DWG. NO.

HE:\2019\19-0207\DRAWINGS\ENTIREMENTS\19-0207.DPR.DWG 7/30/2020 4:44:23 PM



# Appendix 3: Soils Information

*Geotechnical Study and Other Infiltration Testing Data*

September 17, 2020

Core5 Industrial Partners  
300 Spectrum Center Drive, Suite 880  
Irvine, California 92618



**SOUTHERN  
CALIFORNIA  
GEOTECHNICAL**  
*A California Corporation*

Attention: Mr. Jon Kelly  
Vice President Development

Project No.: **20G186-2**

Subject: **Results of Infiltration Testing**  
Proposed Warehouse  
SWC Rider Avenue and Wilson Avenue  
Perris, California

Reference: Geotechnical Investigation, Proposed Warehouse, SWC Rider Avenue and Wilson Avenue, Perris, California, prepared by Southern California Geotechnical, Inc. (SCG), prepared for Core5 Industrial Partners, SCG project No. 20G186-1, dated September 15, 2020.

Mr. Kelly:

In accordance with your request, we have conducted infiltration testing at the subject site. We are pleased to present this report summarizing the results of the infiltration testing and our design recommendations.

### **Scope of Services**

The scope of services performed for this project was in general accordance with our Proposal No. 20P311, dated August 12, 2020. The scope of services included site reconnaissance, subsurface exploration, field testing, and engineering analysis to determine the infiltration rates of the on-site soils. The infiltration testing was performed in general accordance with the Riverside County – Low Impact Development BMP Design Handbook – Section 2.3 of Appendix A, prepared for the Riverside County Department of Environmental Health (RCDEH), dated December 2013 and the ASTM test method D-3385-03, Standard Test Method for Infiltration Rate of Soils in Field Using Double-Ring Infiltrometer.

### **Site and Project Description**

The subject site is located at the southwest corner of Rider Avenue and Wilson Avenue in Perris, California. The site is bounded to the north by Rider Avenue, to the east by Wilson Avenue, to the south and west by single-family residences. The general location of the site is illustrated on the Site Location Map, included as Plate 1 of this report.

The subject site consists of several rectangular-shaped parcels which total 11.17± acres in size. Based on observations made during site visitation, the site is currently developed with residential parcels and one (1) vacant lot. The residential structures are of wood frame and stucco construction, presumably supported on conventional shallow foundations with concrete slab-on-

grade floors. The ground surface surrounding the residences appear to consist of exposed soil with moderate to heavy grass and weed growth with some areas of several large trees. However, parking and drive areas for truck parkin are developed with aggregate base.

Detailed topographic information was obtained from a conceptual site plan prepared Albert A. Webb & Associates (WEBB). Based on this map, the overall site topography slopes gently to the southeast at a gradient of less than 1± percent. The maximum site elevation is 1443± feet mean sea level (msl), in the southwestern corner of the site. The minimum site elevation is 1439± feet msl in the northeastern corner of the site.

### **Proposed Development**

Based on the conceptual site plan prepared by WEBB, the site will be developed with a warehouse, 248,422± ft<sup>2</sup> in size. The building will be located in the west-central area of the site and will be constructed with dock-high doors along the east building wall. The building will be surrounded by asphaltic concrete pavements in the automobile parking and drive lane areas with Portland cement concrete pavements in the loading dock areas. We expect the new development will also include areas of concrete flatwork and landscape planters.

The proposed development will include on-site infiltration to dispose of storm water. The infiltration system will consist of a below-grade chamber system located in the northeastern area of the site.

### **Concurrent Study**

Southern California Geotechnical, Inc. (SCG) recently performed a geotechnical investigation at the subject site, referenced above. As part of this investigation, SCG performed a total of six (6) borings advanced to depths of 15 to 50± feet below the existing site grades. Artificial fill soils were encountered at the ground surface of Boring No. B-5. The artificial fill soils consist of loose clayey fine to medium sands. Native young alluvium was encountered at the ground surface of all boring locations, except Boring No. B-5, extending to at least the maximum depth explored of 50± feet. The near surface native alluvial soils generally consist of loose to medium dense fine sandy silts, silty fine to coarse sands, clayey fine sands and silts with little fine sand. Occasional layers of stiff to very stiff clayey silts and silty clays were encountered near the surface. The near surface alluvium generally possesses trace to extensive amounts of calcareous veining and nodules. Deeper native young alluvial soils generally consist of medium dense to dense fine sandy silts, clayey fine sands, and very stiff to hard fine sandy clays. Occasional layers of dense fine to coarse sand were encountered. These deeper alluvial soils occasionally possess trace to some iron oxide staining and calcareous veining and nodules. Native older alluvial soils were encountered beneath the native alluvium at Boring Nos. B-1 and B-5, extending to at least the maximum depth explored of 50± feet below ground surface. The older alluvium generally consists of medium dense to very dense fine sandy silts, silty fine to coarse sands and clayey fine to coarse sands.

## Groundwater

Free water was encountered during drilling at Boring Nos. B-1 and B-5 between depths of 28½ to 33½± feet below ground surface. A delayed groundwater level reading was taken at Boring No. B-1, 1½ hours after completion. The water level reading indicated the groundwater table is 28± feet below ground surface. Due to caving at the time of completion, a second delayed reading at Boring No. B-5 was not possible. Based on the moisture contents of the recovered soil samples and the delayed water measurement taken within the open borehole, the static groundwater table is considered to have been present at a depth of 28± feet below the existing site grades at the time of subsurface exploration.

Recent water level data was obtained from the California State Water Resources Control Board, GeoTracker, website, <http://geotracker.waterboards.ca.gov/>. The nearest monitoring well on record is located approximately 1.23 miles northwest of the site. Water level readings within this monitoring well indicate a groundwater level of 79± feet below the ground surface in January 2009.

## **Subsurface Exploration**

### Scope of Exploration

The subsurface exploration for the infiltration testing consisted of two (2) backhoe-excavated trenches, extending to a depth of 10± feet below existing site grades. The trenches were logged during excavation by a member of our staff. The approximate locations of the infiltration trenches (identified as I-1 and I-2) are indicated on the Infiltration Test Location Plan, enclosed as Plate 2 of this report.

### Geotechnical Conditions

Native alluvial soils were encountered beneath the ground surface at both infiltration trench locations, extending to at least the maximum explored depth of 10± feet. The near-surface alluvial soils, extending 4± feet below the ground surface, consist of soft to very stiff silty clays with trace little fine sand and some porosity. The alluvial soils beneath 4± feet which extend to the maximum explored depth of 10± feet below existing site grades consist of stiff to very stiff silty clays with trace to little fine to medium sands and extensive calcareous nodules.

The Trench Logs, which illustrate the conditions encountered at the infiltration test locations, are included with this report.

## **Infiltration Testing – Double Ring Infiltrometer**

The infiltration testing was performed in general accordance with the ASTM test method D-3385-03, Standard Test Method for Infiltration Rate of Soils in Field Using Double-Ring Infiltrometer.

Two stainless steel infiltration rings were used for the infiltration testing. The outer infiltration ring is 2 feet in diameter and 20 inches in height. The inner infiltration ring is 1 foot in diameter and 20 inches in height. At each test location, a trench was excavated to the proposed depth of the infiltration system and the outer ring was driven 3± inches into the soil at the base of each

trench. The inner ring was centered inside the outer ring and subsequently driven 3± inches into the soil at the base of the trench. The rings were driven into the soil using a sixteen-pound sledge hammer. The soil surrounding the wall of the infiltration rings was only slightly disturbed during the driving process.

Infiltration Testing Procedure

Infiltration testing was performed at both of the infiltration trench locations. The infiltration testing consisted of filling the inner ring and the annular space (the space between the inner and outer rings) with water, approximately 3 to 4 inches above the soil. To prevent the flow of water from one ring to the other, the water level in both the inner ring and the annular space between the rings was maintained using constant-head float valves. The volume of water that was added to maintain a constant head in the inner ring and the annular space during each time interval was determined and recorded. A cap was placed over the rings to minimize the evaporation of water during the tests.

The schedule for readings was determined based on the observed soil type at the base of each backhoe-excavated trench. Based on the existing soils at the trench locations, the volumetric measurements were made at 30-minute increments. The water volume measurements are presented on the spreadsheets enclosed with this report. The infiltration rates for each of the timed intervals are also tabulated on these spreadsheets

**Infiltration Results**

The infiltration rates from the tests are tabulated in inches per hour. In accordance with the typically accepted practice, it is recommended that the most conservative reading from the latter part of the infiltration tests be used as the design infiltration rate. The rates are summarized below:

<b><u>Infiltration Test No.</u></b>	<b><u>Test Depth (feet)</u></b>	<b><u>Soil Description</u></b>	<b><u>Infiltration Rate (inches/hour)</u></b>
I-1	10	Brown Silty Clay, little fine to medium Sand	0.7
I-2	10	Light Brown Silty Clay, little fine to medium Sand	0.6

**Laboratory Testing**

Moisture Content

The moisture contents for the recovered soil samples within the borings were determined in accordance with ASTM D-2216 and are expressed as a percentage of the dry weight. These test results are presented on the Trench Logs.

Grain Size Analysis

The grain size distribution of selected soils collected from the base of each infiltration test boring have been determined using a range of wire mesh screens. These tests were performed in general

accordance with ASTM D-422 and/or ASTM D-1140. The weight of the portion of the sample retained on each screen is recorded and the percentage finer or coarser of the total weight is calculated. The results of these tests are presented on Plates C-1 through C-2 of this report.

### **Design Recommendations**

Two (2) infiltration tests were performed at the subject site. As noted above, the infiltration rates at these locations vary from 0.7 to 0.6 inches per hour. **Based on the results of infiltration testing, we recommend an infiltration rate of 0.6 inches per hour to be used for the infiltration system located in the northeastern area of the site.**

We recommend that a representative from the geotechnical engineer be on-site during the construction of the proposed infiltration system to identify the soil classification at the base of the system. It should be confirmed that the soils at the base of the proposed infiltration system correspond with those presented in this report to ensure that the performance of the system will be consistent with the rates reported herein.

The design of the storm water infiltration systems should be performed by the project civil engineer, in accordance with the City of Perris and/or County of Riverside guidelines. It is recommended that the system be constructed so as to facilitate removal of silt and clay, or other deleterious materials from any water that may enter the system. The presence of such materials would decrease the effective infiltration rates. **It is recommended that the project civil engineer apply an appropriate factor of safety. The infiltration rate recommended above is based on the assumption that only clean water will be introduced to the subsurface profile. Any fines, debris, or organic materials could significantly impact the infiltration rate.** It should be noted that the recommended infiltration rates are based on infiltration testing at two (2) discrete locations and that the overall infiltration rates of the proposed infiltration system could vary considerably.

### **Construction Considerations**

The infiltration rates presented in this report are specific to the tested locations and tested depths. Infiltration rates can be significantly reduced if the soils are exposed to excessive disturbance or compaction during construction. Therefore, the subgrade soils within proposed infiltration system areas should not be over-excavated, undercut or compacted in any significant manner. **It is recommended that a note to this effect be added to the project plans and/or specifications.**

### **Infiltration versus Permeability**

Infiltration rates are based on unsaturated flow. As water is introduced into soils by infiltration, the soils become saturated and the wetting front advances from the unsaturated zone to the saturated zone. Once the soils become saturated, infiltration rates become zero, and water can only move through soils by hydraulic conductivity at a rate determined by pressure head and soil permeability. The infiltration rates presented herein were determined in accordance with the Riverside County guidelines and are considered valid for the time and place of the actual tests. Changes in soil moisture content will affect the infiltration rate. Infiltration rates should be expected to decrease until the soils become saturated. Soil permeability values will then govern

groundwater movement. Permeability values may be on the order of 10 to 20 times less than infiltration rates. The system designer should incorporate adequate factors of safety and allow for overflow design into appropriate traditional storm drain systems, which would transport storm water off-site.

### **Location of Infiltration System**

The use of on-site storm water infiltration system carries a risk of creating adverse geotechnical conditions. Increasing the moisture content of the soil can cause the soil to lose internal shear strength and increase its compressibility, resulting in a change in the designed engineering properties. Overlying structures and pavements in the infiltration area could potentially be damaged due to saturation of subgrade soils. **The proposed infiltration system for this site should be located at least 25 feet away from any structures, including retaining walls.** Even with this provision of locating the infiltration system at least 25 feet from the building, it is possible that infiltrating water into the subsurface soils could have an adverse effect on the proposed or existing structures. It should also be noted that utility trenches which happen to collect storm water can also serve as conduits to transmit storm water toward the structure, depending on the slope of the utility trench. Therefore, consideration should also be given to the proposed locations of underground utilities which may pass near the proposed infiltration system.

### **General Comments**

This report has been prepared as an instrument of service for use by the client in order to aid in the evaluation of this property and to assist the architects and engineers in the design and preparation of the project plans and specifications. This report may be provided to the contractor(s) and other design consultants to disclose information relative to the project. However, this report is not intended to be utilized as a specification in and of itself, without appropriate interpretation by the project architect, structural engineer, and/or civil engineer. The design of the proposed storm water infiltration system is the responsibility of the civil engineer. The role of the geotechnical engineer is limited to determination of infiltration rate only. By using the design infiltration rate contained herein, the civil engineer agrees to indemnify, defend, and hold harmless the geotechnical engineer for all aspects of the design and performance of the proposed storm water infiltration system. The reproduction and distribution of this report must be authorized by the client and Southern California Geotechnical, Inc. Furthermore, any reliance on this report by an unauthorized third party is at such party's sole risk, and we accept no responsibility for damage or loss which may occur.

The analysis of this site was based on a subsurface profile interpolated from limited discrete soil samples. While the materials encountered in the project area are considered to be representative of the total area, some variations should be expected between boring locations and testing depths. If the conditions encountered during construction vary significantly from those detailed herein, we should be contacted immediately to determine if the conditions alter the recommendations contained herein.

This report has been based on assumed or provided characteristics of the proposed development. It is recommended that the owner, client, architect, structural engineer, and civil engineer carefully review these assumptions to ensure that they are consistent with the characteristics of the proposed development. If discrepancies exist, they should be brought to our attention to

verify that they do not affect the conclusions and recommendations contained herein. We also recommend that the project plans and specifications be submitted to our office for review to verify that our recommendations have been correctly interpreted. The analysis, conclusions, and recommendations contained within this report have been promulgated in accordance with generally accepted professional geotechnical engineering practice. No other warranty is implied or expressed.

### **Closure**

We sincerely appreciate the opportunity to be of service on this project. We look forward to providing additional consulting services during the course of the project. If we may be of further assistance in any manner, please contact our office.

Respectfully Submitted,

SOUTHERN CALIFORNIA GEOTECHNICAL, INC.



Ryan Bremer  
Staff Geologist



Robert G. Trazo, GE 2655  
Principal Engineer



Distribution: (1) Addressee

Enclosures: Plate 1 - Site Location Map  
Plate 2 - Infiltration Test Location Plan  
Trench Logs (2 pages)  
Infiltration Test Results Spreadsheets (2 pages)  
Grain Size Distribution Results (2 pages)



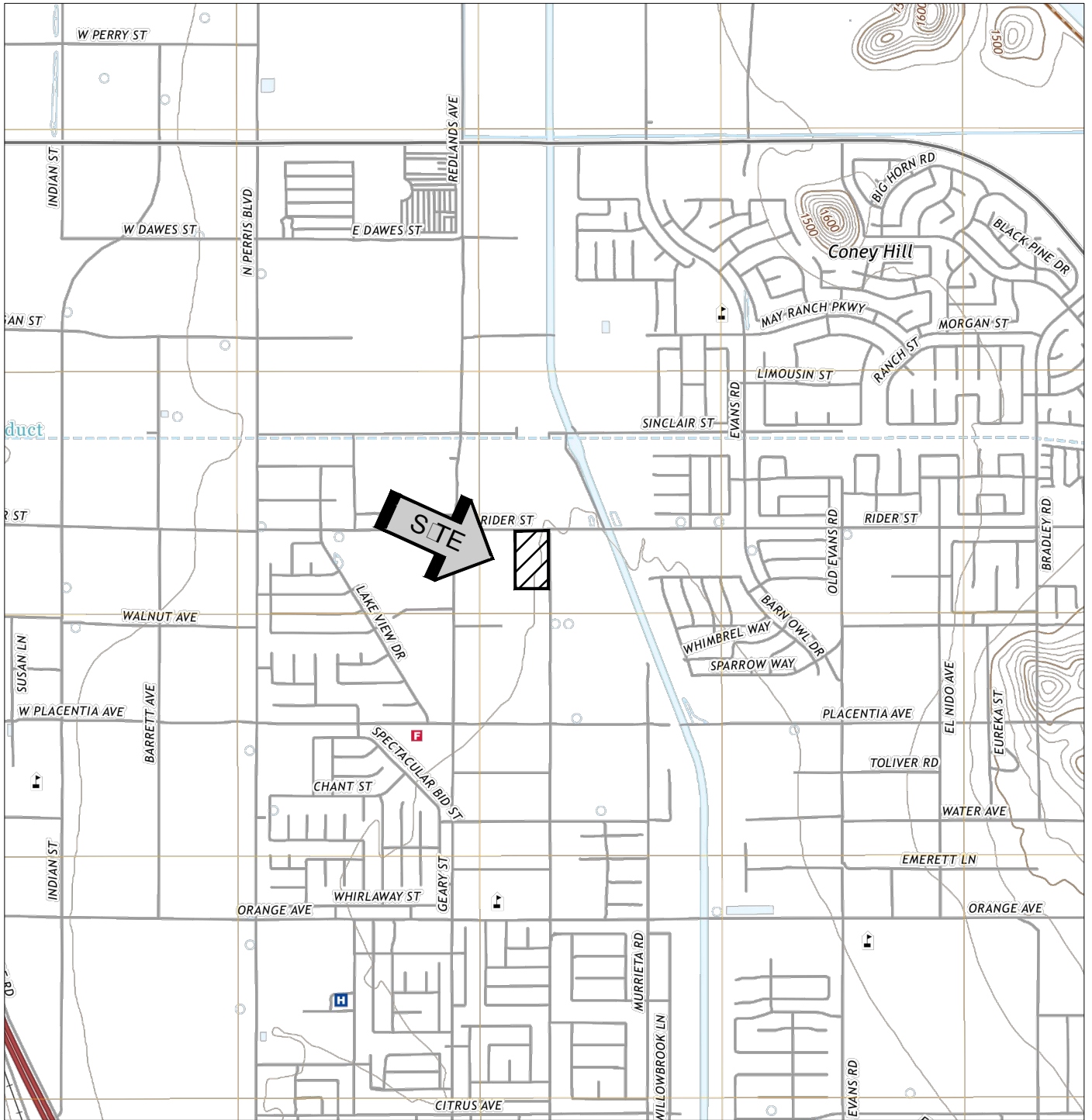

SO...E...SGS TO...OG...H...M...OF THE  
 E...S...G...E...E...SE  
 O...T...FO...2...18



**SITE LOCATION MAP**

□□□□OSE □W□□EHO□SE

□E□□S□□□□FO□□□□

S□□□E□□"□2□□'

□□W□□□□H  
 □H□□□GT

S□G□□□O□E□T  
 2□G186.2

PLATE 1



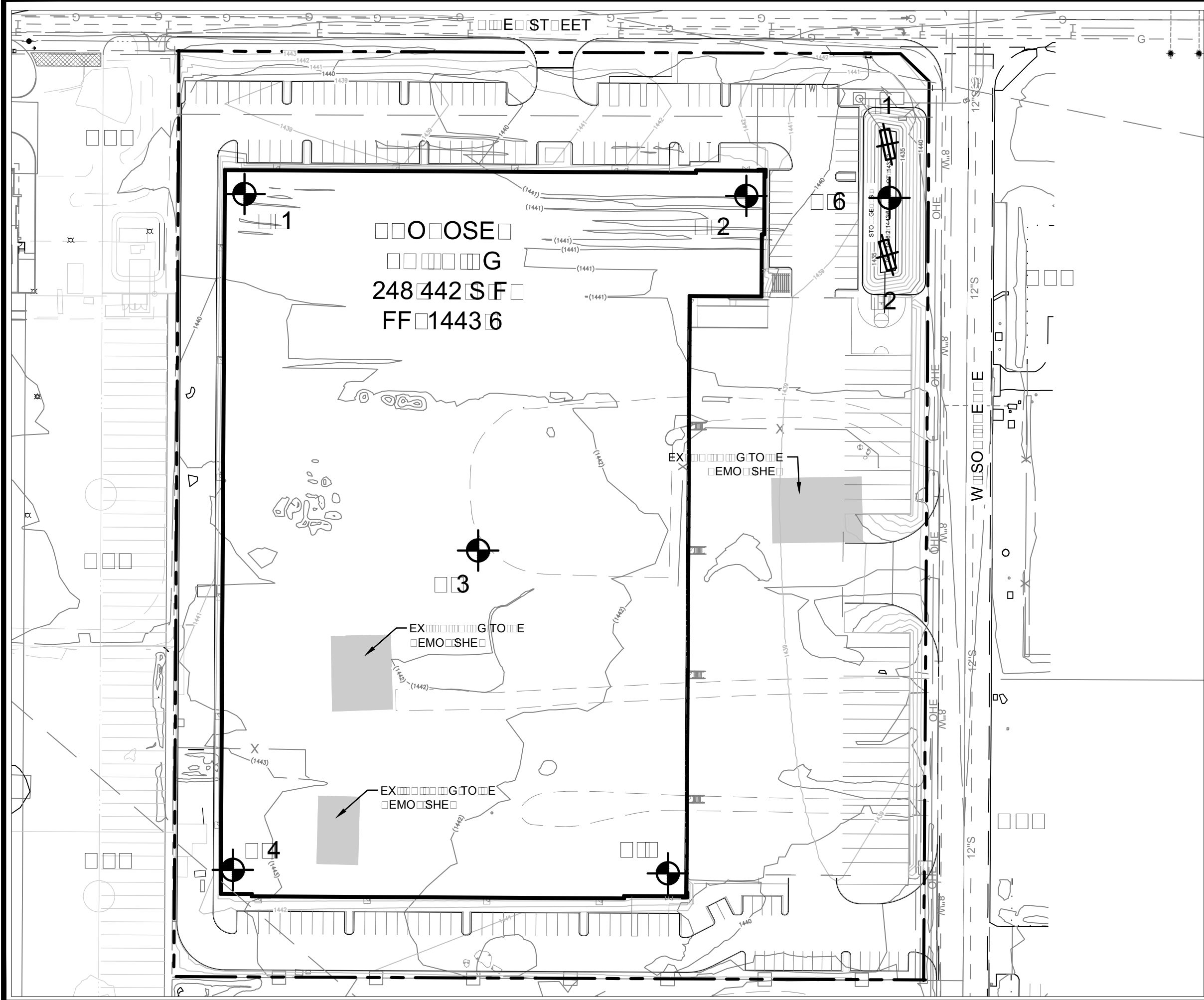

**SOUTHERN  
 CALIFORNIA  
 GEOTECHNICAL**



OOSE  
 G  
 248 442 SF  
 FF 1443 6

GEOTECHNICAL ENGINEERING

- 
 EXISTING FOOTING TO BE REMOVED
- 
 EXISTING STRUCTURE TO BE REMOVED
- 
 EXISTING STRUCTURE TO BE REMOVED

NOTE: CONCEPTUAL SITE PLAN PROVIDED BY ALBERT A. WEBB ASSOCIATES.

<b>INFILTRATION TEST LOCATION PLAN</b>	
OOSE WHESE	
ESFO	
Scale: 1" = 8'	 <b>SOUTHERN CALIFORNIA GEOTECHNICAL</b>
WHESE	
SGOET 2:G186.2	
PLATE 2	

# SOUTHERN CALIFORNIA GEOTECHNICAL

**TRENCH NO.  
I-1**

O O O 2 G186.2	E O O M E T S E O O O O O O	W O T E O O E O T H O O r O
O O E O T O O O O O d W O O O O O O	O O G G E O O O O O O O O r O O O	S E E O O G E O O E O T H O O r O
O O O T O O O O O O O O O O O O	O O E O T O T O O O S 12 E	O O E O O G S T O O E O O O O O O O O O
O O T E O 8/21/2 O 2 O	E O E O O T O O O 1441 O O O O O O	

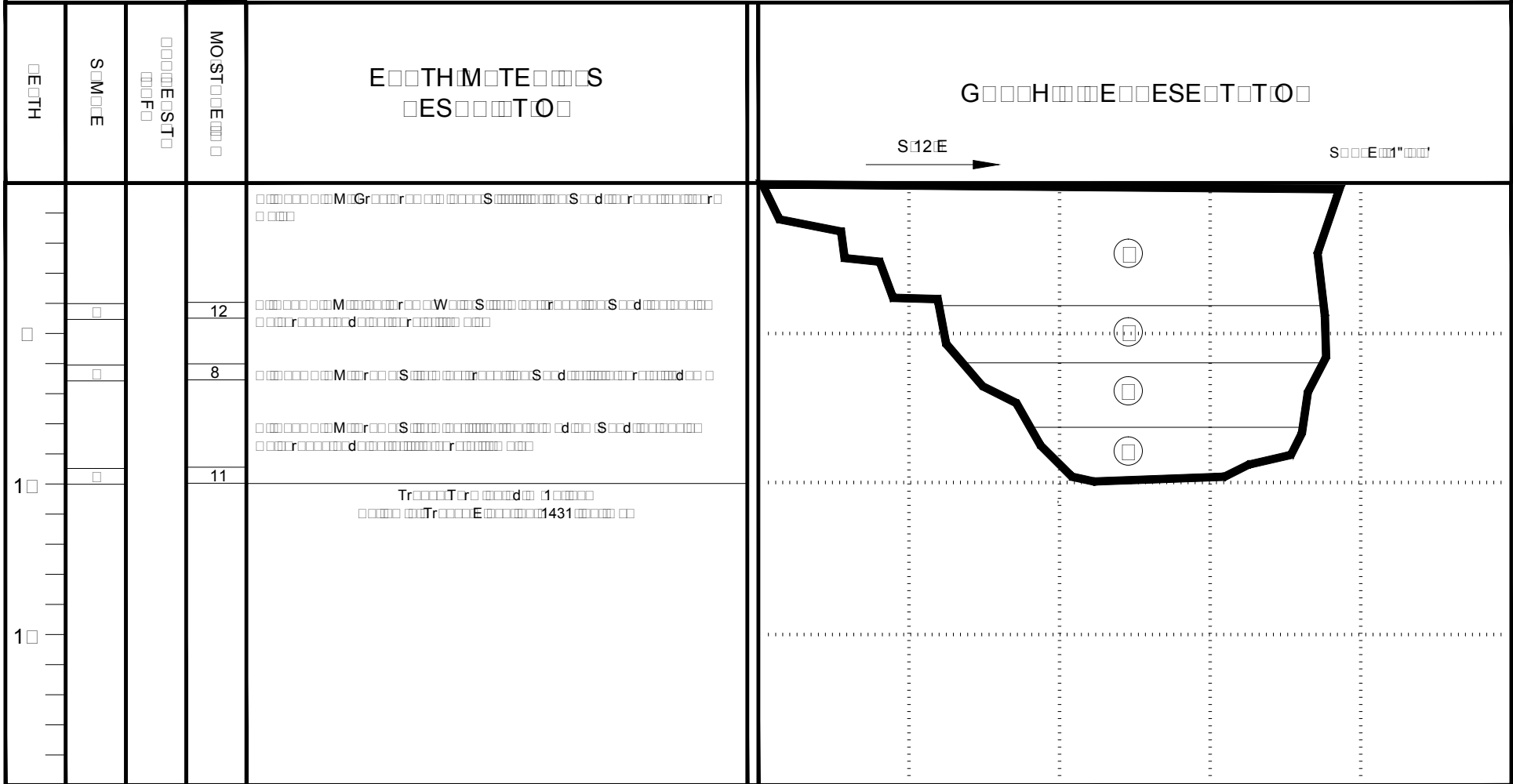

O O T O S M O E T O E S  
 O O O S M O E O T O O E O  
 O O O G S M O E 2 1/2 O O M E T E O  
 O O O E O T O E O O O O T O O E O

**TRENCH LOG**

**PLATE B-1**

# SOUTHERN CALIFORNIA GEOTECHNICAL

TRENCH NO.  
I-2

PROJECT NO. 21G186.2

ENCLOSURE SE

WATER EARTH

DATE OF TEST

LOGGERS

SEE GEOTECH

TEST LOCATION

DATE OF TEST 16W

ENGINEERING

TEST DATE 8/21/20

ENCLOSURE 1441

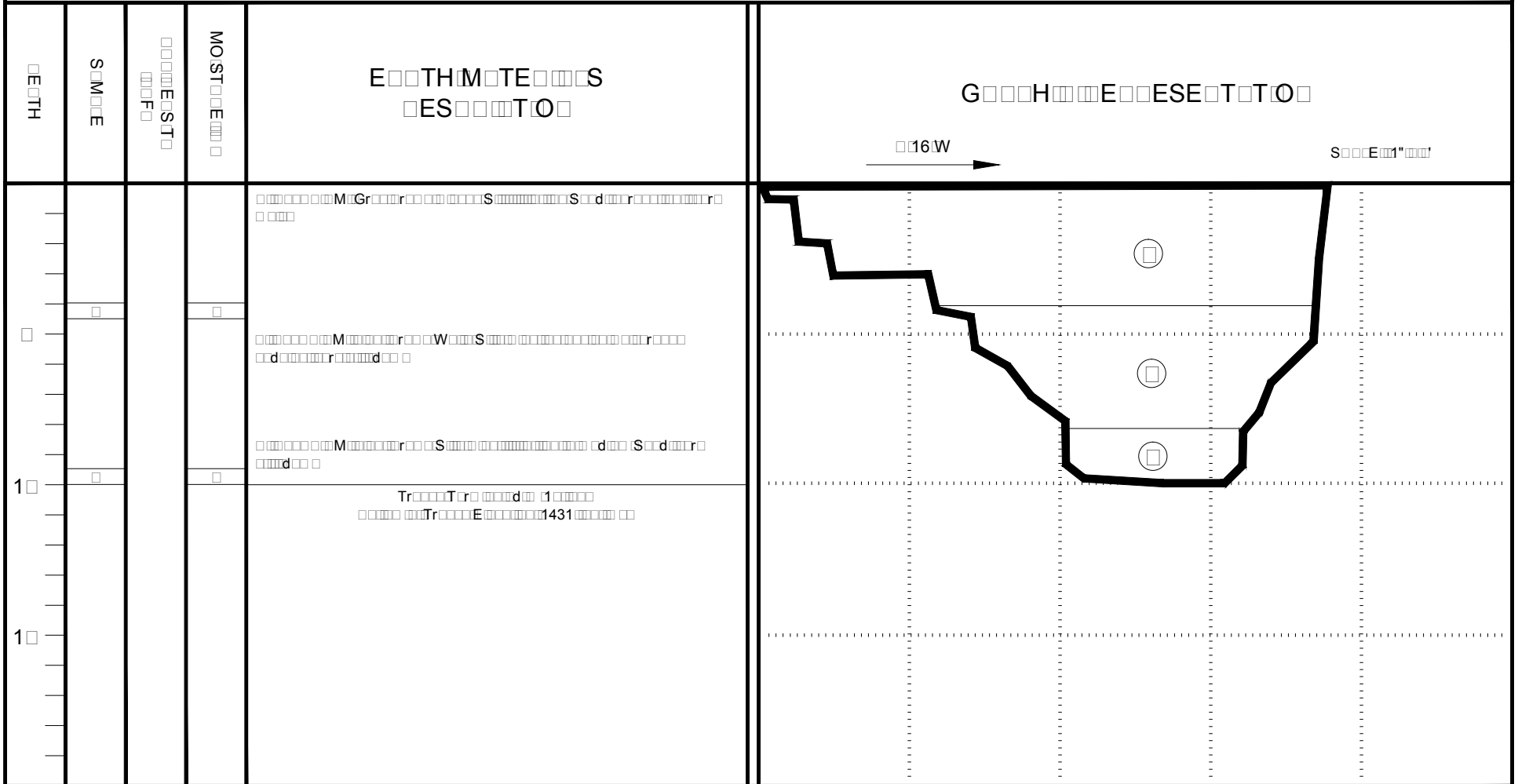

TESTS

SAMPLES

ENGINEERING

DATE OF TEST

TRENCH LOG

PLATE B-2

### INFILTRATION CALCULATIONS

Project Name	Proposed Warehouse
Project Location	Perris, California
Project Number	20G186-2
Engineer	LA

Infiltration Test No I-1

Constants			
	Diameter (ft)	Area (ft <sup>2</sup> )	Area (cm <sup>2</sup> )
Inner	1	0.79	730
Anlr. Spac	2	2.36	2189

\*Note: The infiltration rate was calculated based on current time interval

Test Interval		Time (hr)	Interval Elapsed (min)	Flow Readings				Infiltration Rates			
				Inner Ring (ml)	Ring Flow (cm <sup>3</sup> )	Annular Ring (ml)	Space Flow (cm <sup>3</sup> )	Inner Ring* (cm/hr)	Annular Space* (cm/hr)	Inner Ring* (in/hr)	Annular Space* (in/hr)
1	Initial	10:28 AM	30	0	700	1000	5000	1.92	4.57	0.76	1.80
	Final	10:58 AM	<b>30</b>	700		6000					
2	Initial	11:17 AM	30	0	700	0	2800	1.92	2.56	0.76	1.01
	Final	11:47 AM	<b>79</b>	700		2800					
3	Initial	11:49 AM	30	0	700	0	2800	1.92	2.56	0.76	1.01
	Final	12:19 PM	<b>111</b>	700		2800					
4	Initial	12:20 PM	30	0	650	0	2700	1.78	2.47	0.70	0.97
	Final	12:50 PM	<b>142</b>	650		2700					

## INFILTRATION CALCULATIONS

Project Name	Proposed Warehouse
Project Location	Perris, California
Project Number	20G186-2
Engineer	LA

Infiltration Test No I-2

Constants			
	Diameter (ft)	Area (ft <sup>2</sup> )	Area (cm <sup>2</sup> )
Inner	1	0.79	730
Anlr. Spac	2	2.36	2189

\*Note: The infiltration rate was calculated based on current time interval

Test Interval		Time (hr)	Interval Elapsed (min)	Flow Readings				Infiltration Rates			
				Inner Ring (ml)	Ring Flow (cm <sup>3</sup> )	Annular Ring (ml)	Space Flow (cm <sup>3</sup> )	Inner Ring* (cm/hr)	Annular Space* (cm/hr)	Inner Ring* (in/hr)	Annular Space* (in/hr)
1	Initial	1:55 AM	30	0	700	0	3500	1.92	3.20	0.76	1.26
	Final	2:25 AM	<b>30</b>	700		3500					
2	Initial	2:29 AM	30	0	600	0	3400	1.64	3.11	0.65	1.22
	Final	2:59 AM	<b>64</b>	600		3400					
3	Initial	3:00 AM	30	0	600	0	3400	1.64	3.11	0.65	1.22
	Final	3:30 AM	<b>95</b>	600		3400					
4	Initial	3:32 AM	30	0	550	0	3300	1.51	3.02	0.59	1.19
	Final	4:02 AM	<b>127</b>	550		3300					

# Grain Size Distribution

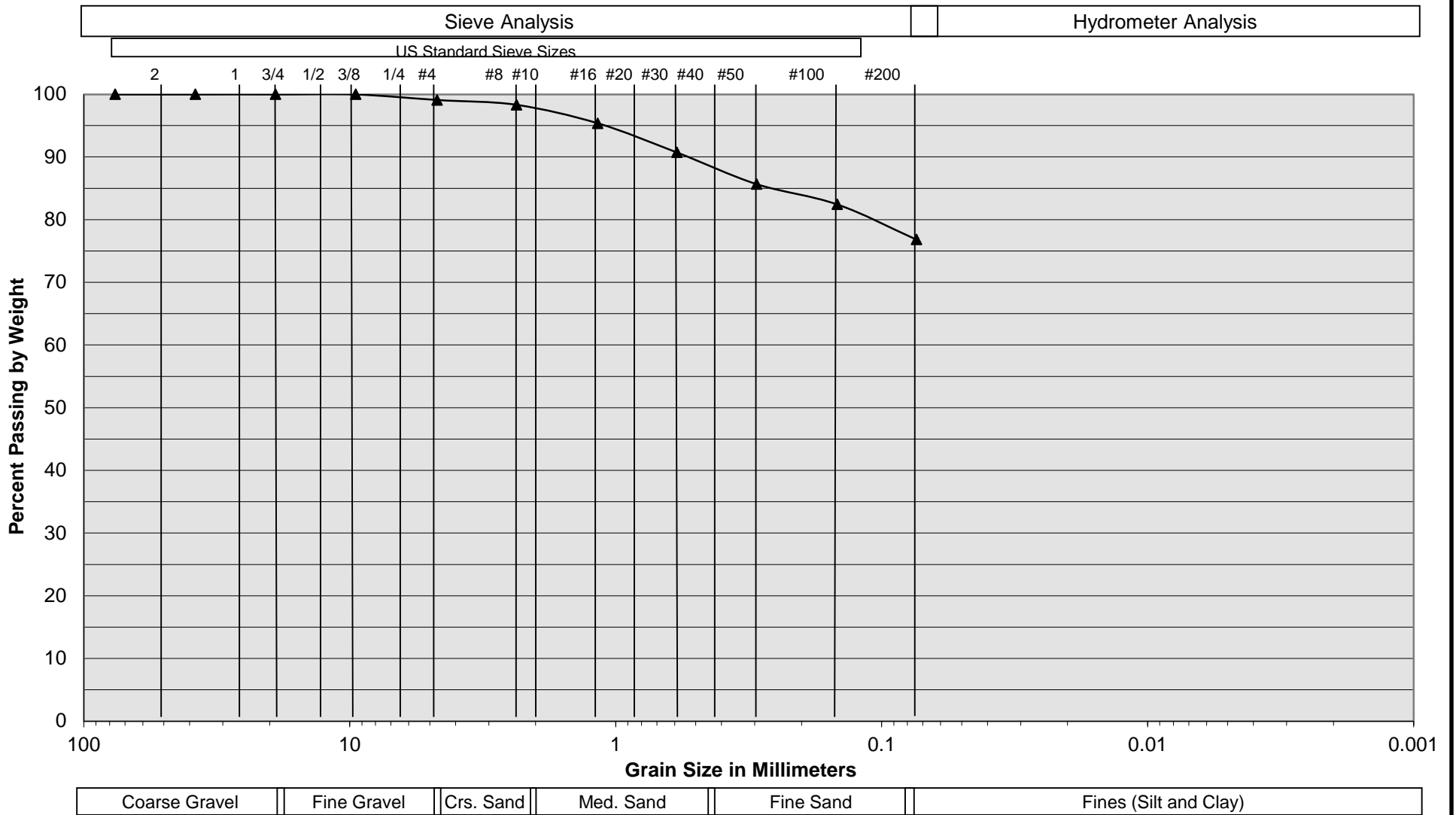

Sample Description	Brown Silty Clay, little fine to medium Sand
Soil Classification	I-1 @ 10'

Proposed Warehouse  
 Perris, California  
 Project No. 20G186-2  
**PLATE C- 1**



**SOUTHERN CALIFORNIA GEOTECHNICAL**  
*A California Corporation*

# Grain Size Distribution

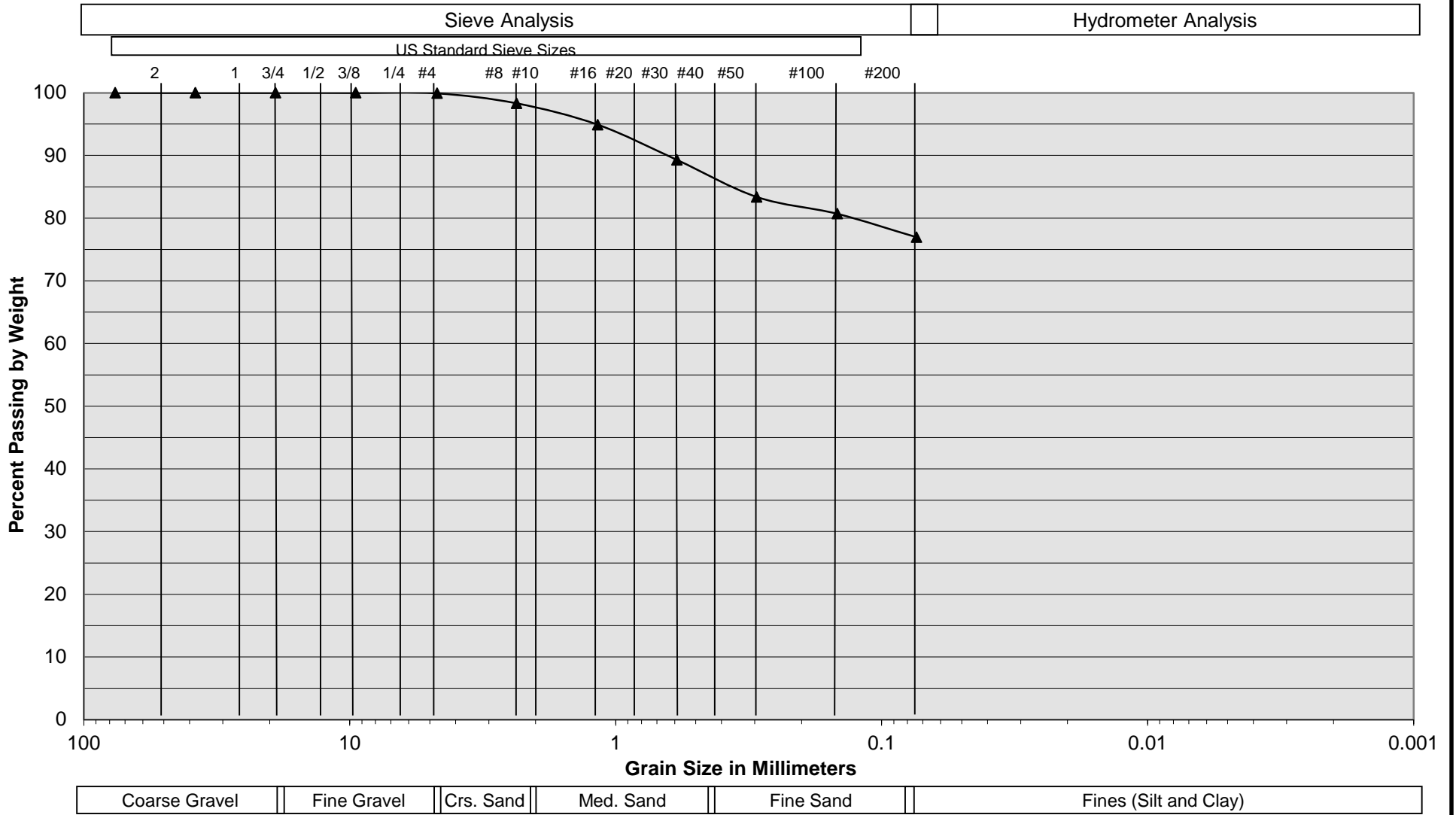

Sample Description	Light Brown Silty Clay, little fine to medium Sand
Soil Classification	I-2 @ 10'

Proposed Warehouse  
 Perris, California  
 Project No. 20G186-2  
**PLATE C- 2**



**SOUTHERN CALIFORNIA GEOTECHNICAL**  
A California Corporation



# Appendix 4: Historical Site Conditions

*Phase I Environmental Site Assessment or Other Information on Past Site Use*

**N/A**

# Appendix 5: LID Infeasibility

*LID Technical Infeasibility Analysis*

**N/A**

# Appendix 6: BMP Design Details

*BMP Sizing, Design Details and other Supporting Documentation*

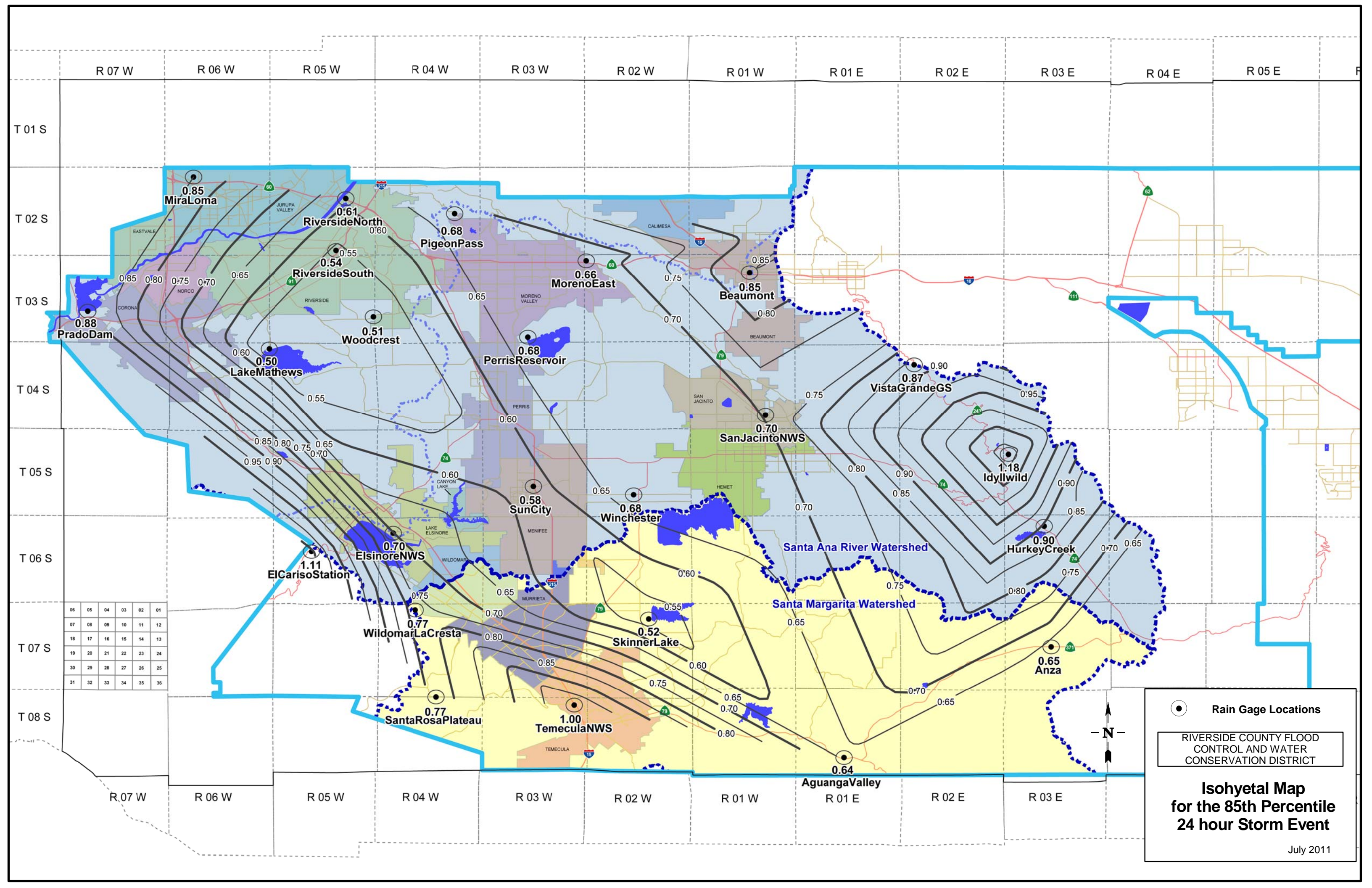

06	05	04	03	02	01
07	08	09	10	11	12
18	17	16	15	14	13
19	20	21	22	23	24
30	29	28	27	26	25
31	32	33	34	35	36

Rain Gage Locations

RIVERSIDE COUNTY FLOOD CONTROL AND WATER CONSERVATION DISTRICT

**Isohyetal Map for the 85th Percentile 24 hour Storm Event**

July 2011

**Santa Ana Watershed - BMP Design Volume,  $V_{BMP}$**

(Rev. 10-2011)

Legend:

Required Entries

Calculated Cells

*(Note this worksheet shall **only** be used in conjunction with BMP designs from the **LID BMP Design Handbook**)*

Company Name Albert A. Webb Associates

Date 7/28/2020

Designed by Cristina Velgara

Case No

Company Project Number/Name 19-0207 Rider Distribution Center

**BMP Identification**

BMP NAME / ID WQMP Facility A

*Must match Name/ID used on BMP Design Calculation Sheet*

**Design Rainfall Depth**

85th Percentile, 24-hour Rainfall Depth,  
from the Isohyetal Map in Handbook Appendix E

$D_{85}$  = 0.64 inches

**Drainage Management Area Tabulation**

*Insert additional rows if needed to accommodate all DMAs draining to the BMP*

DMA Type/ID	DMA Area (square feet)	Post-Project Surface Type	Effective Imperivous Fraction, $I_f$	DMA Runoff Factor	DMA Areas x Runoff Factor	Design Storm Depth (in)	Design Capture Volume, $V_{BMP}$ (cubic feet)	Proposed Volume on Plans (cubic feet)
L-A	20,200	Ornamental Landscaping	0.1	0.11	2231.3			
R-A	243,442	Roofs	1	0.89	217150.3			
H-A	192,879	Concrete or Asphalt	1	0.89	172048.1			
SR-A	30,200	Ornamental Landscaping						
	<b>486721</b>				<b>391429.7</b>	<b>0.64</b>	<b>20876.3</b>	<b>20,900</b>

Notes:



**Project Summary**

Date:	7/28/2020
Project Name:	Core 5 Rider Business Center
City / County:	City of Perris
State:	CA
Designed By:	CV
Company:	Albert A. Webb Associates
Telephone:	(951) 686-1070

Enter Information in  
Blue Cells

**Corrugated Metal Pipe Calculator**

Storage Volume Required (cf):	8,100	9.62 ft <sup>2</sup> Pipe Area
Limiting Width (ft):	32.00	
Invert Depth Below Asphalt (ft):	5.00	
Solid or Perforated Pipe:	Perforated	
Shape Or Diameter (in):	42	
Number Of Headers:	1	
Spacing between Barrels (ft):	1.75	
Stone Width Around Perimeter of System (ft):	1.5	
Depth A: Porous Stone Above Pipe (in):	6	
Depth C: Porous Stone Below Pipe (in):	0	
Stone Porosity (0 to 40%):	40	

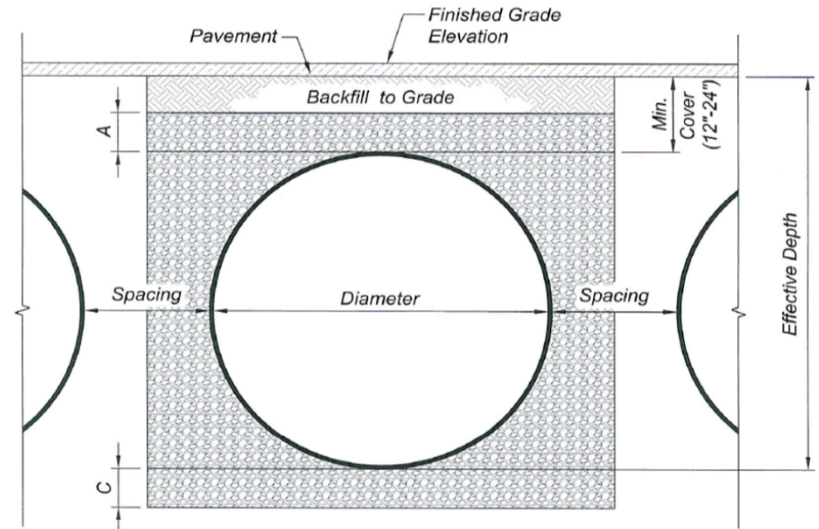

**System Sizing**

Pipe Storage:	5,383 cf	
Porous Stone Storage:	2,841 cf	
Total Storage Provided:	8,224 cf	101.5% Of Required Storage
Number of Barrels:	5 barrels	
Length per Barrel:	107.0 ft	
Length Per Header:	24.5 ft	
Rectangular Footprint (W x L):	27.5 ft x 113.5 ft	

**System Layout**

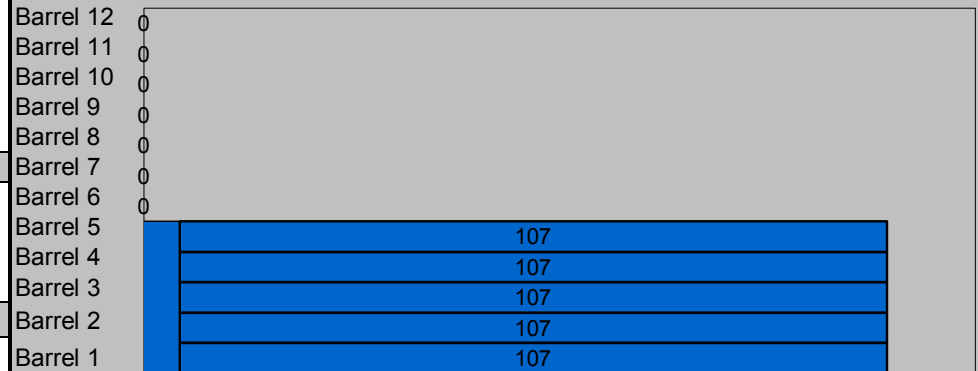

Barrel Footage (w/o headers)

**Construction Quantities\*\***

Total Excavation:	579 cy
Porous Stone Backfill For Storage:	263 cy stone
Backfill to Grade Excluding Stone:	117 cy fill

\*\*Construction quantities are approximate and should be verified upon final design

THIS IS A SCHEMATIC LAYOUT ONLY. ACTUAL CONFIGURATION WILL VARY BASED ON THE SITE SPECIFIC CONSIDERATIONS. REFER TO FLOWKIT DRAWINGS FOR ADDITIONAL DETAILS.

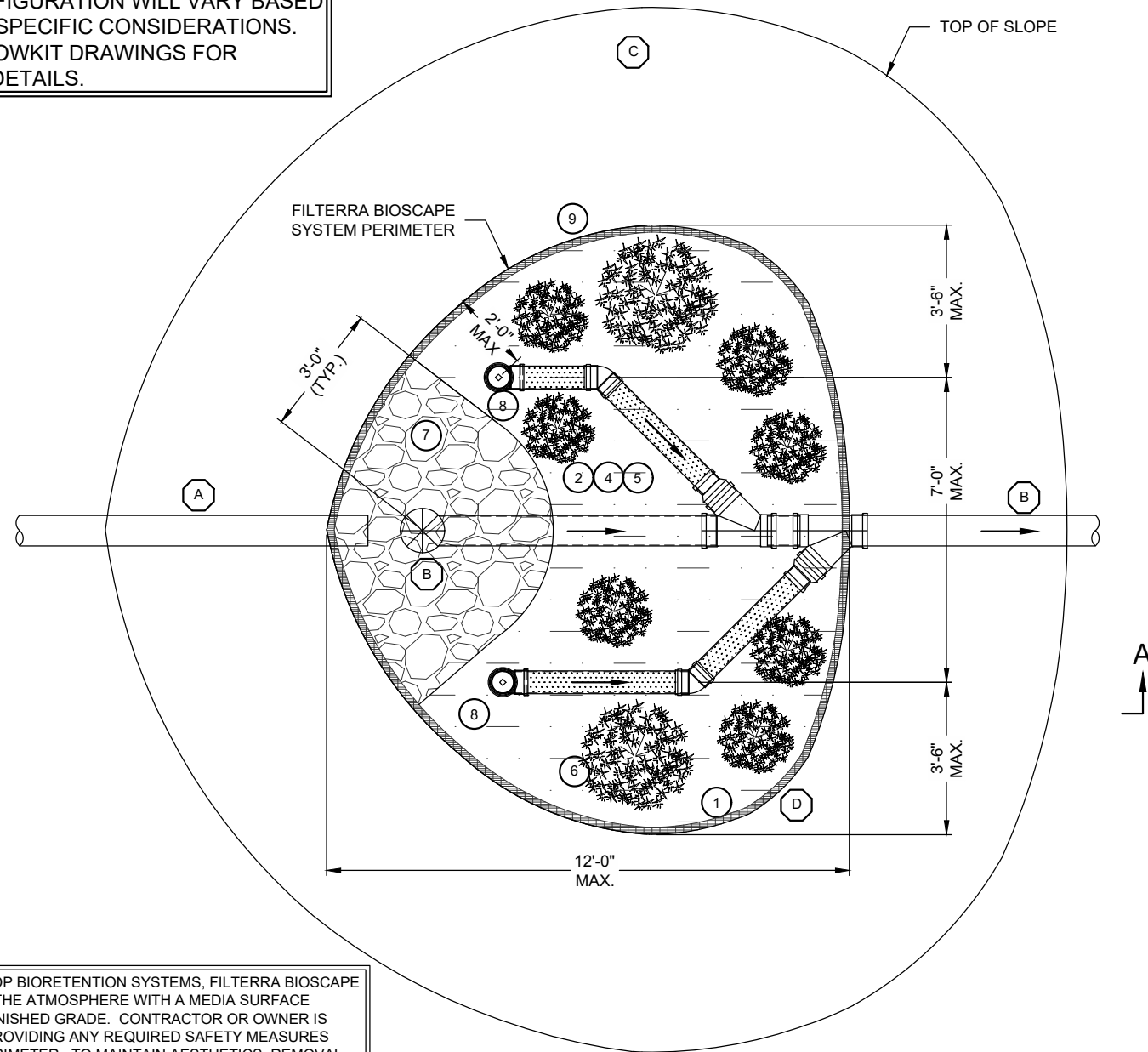

PLAN VIEW

AS WITH ALL OPEN TOP BIORETENTION SYSTEMS, FILTERRA BIOSCAPE SYSTEM IS OPEN TO THE ATMOSPHERE WITH A MEDIA SURFACE RECESSED BELOW FINISHED GRADE. CONTRACTOR OR OWNER IS RESPONSIBLE FOR PROVIDING ANY REQUIRED SAFETY MEASURES AROUND SYSTEM PERIMETER. TO MAINTAIN AESTHETICS, REMOVAL OF HEAVY STORMWATER DEBRIS MAY BE NECESSARY BETWEEN REGULAR FILTERRA SYSTEM MAINTENANCE EVENTS.

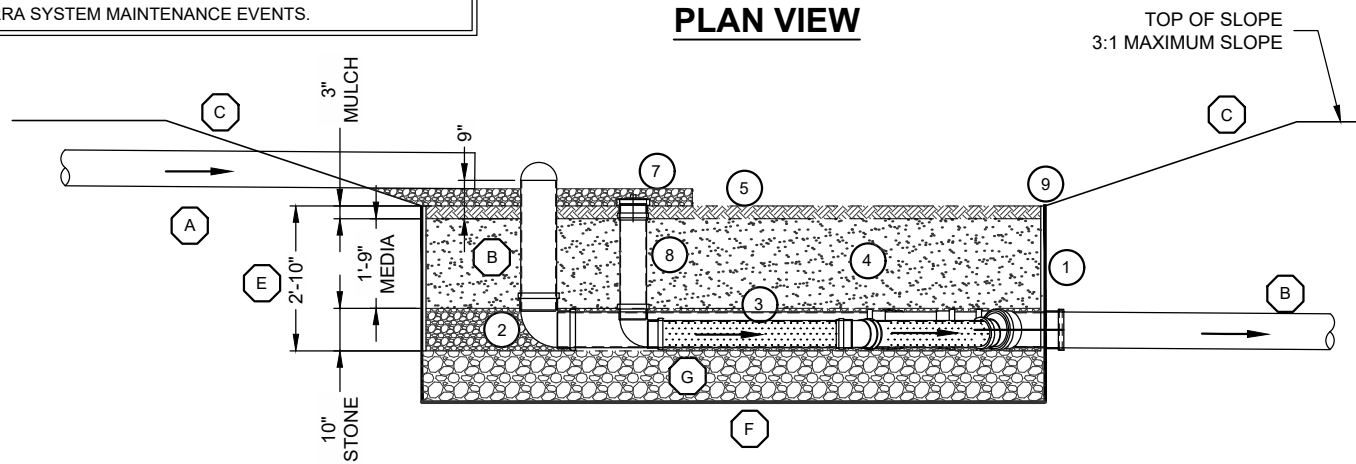

SECTION A-A VIEW

**BILL OF MATERIALS**

COUNT	DESCRIPTION	INSTALLED BY
X	FILTERRA SURFACE AREA (SF)	CONTRACTOR
X	MULCH VOLUME (CY)	CONTRACTOR
XX	FILTERRA MEDIA VOLUME (CY)	CONTRACTOR
X	1/2" #4 ROUND AGGREGATE UNDERDRAIN STONE (CY)	CONTRACTOR
X	ENERGY DISSIPATION ROCK (CY)	CONTRACTOR
X	EROSION CONTROL (LF)	CONTRACTOR
X	FILTERRA FLOWKIT	CONTRACTOR

**PLANTING SCHEDULE**

\*NOTE: PLANTS PROVIDED BY OTHERS

QUANTITY	FILTERRA BIOSCAPE SYSTEM PLANT PALETTE

**GENERAL NOTES**

- CONTRACTOR SHALL CONTACT CONTECH TO COORDINATE DELIVERY AND SUPERVISION OF PLACEMENT OF FILTERRA BIOSCAPE SYSTEM COMPONENTS (ACTIVATION). CONTRACTOR SHALL COMPLETE ITEMS IN THE LIST OF CONTRACTOR INSTALLATION RESPONSIBILITIES LISTED ON THIS DETAIL BEFORE CONTECH'S REPRESENTATIVE ATTENDS AND SUPERVISES THE ACTIVATION OF THE BIOSCAPE SYSTEM.
- PERFORM FILTERRA BIOSCAPE SYSTEM EXCAVATION ONLY AFTER ALL THE CONTRIBUTING DRAINAGE AREAS ARE PERMANENTLY STABILIZED. DO NOT CONSTRUCT FILTERRA BIOSCAPE SYSTEM IN AN AREA USED AS EROSION AND SEDIMENT CONTROL FACILITIES. DO NOT STOCKPILE MATERIALS NOR STORE EQUIPMENT IN THIS AREA.
- USE METHODS OF EXCAVATION THAT MINIMIZE COMPACTION OF THE UNDERLYING SOIL UNLESS THE SYSTEM IS TO BE LINED.
- CONTRACTOR SHALL COORDINATE WITH CONTECH BEFORE THE FILTERRA BIOSCAPE SYSTEM AREA IS EXCAVATED TO MINIMIZE TIME BETWEEN EXCAVATION AND DELIVERY AND ACTIVATION OF THE FILTERRA BIOSCAPE SYSTEM. ANY STANDING WATER THAT ACCUMULATES IN THE EXCAVATED AREA MUST BE REMOVED BY THE CONTRACTOR BEFORE CONTECH CAN PROVIDE ACTIVATION OF THE FILTERRA BIOSCAPE SYSTEM. ANY ADDITIONAL EXCAVATION WILL BE THE RESPONSIBILITY OF THE CONTRACTOR. EXCAVATION DIMENSIONS SHOULD BE PROVIDED TO CONTECH IN THE ACTIVATION REQUEST CHECKLIST.
- CONTRACTOR SHALL PROVIDE ACCESS TO THE EXCAVATED AREA(S) FOR USE DURING THE ACTIVATION OF THE FILTERRA BIOSCAPE SYSTEM(S). ACCESS SHALL NOT PROHIBIT LIGHT DUTY EQUIPMENT THAT MAY BE USED TO INSTALL THE COMPONENTS (STONE, MEDIA, ETC). THE CONTRACTOR SHALL BE RESPONSIBLE FOR ANY RE-STABILIZATION THAT MAY BE REQUIRED AFTER THE FILTERRA BIOSCAPE SYSTEM ACTIVATION.
- CONTECH AND/OR ITS REPRESENTATIVES MUST BE SCHEDULED TO BE ON SITE FOR THE LIST ENTITLED CONTRACTOR ACTIVATION RESPONSIBILITIES.

**CONTRACTOR SITE PREPARATION RESPONSIBILITIES AS DENOTED BY (X) ON THIS DETAIL:**

- (A) CONTRACTOR SHALL INSTALL PIPE OR SWALE THAT CONVEYS INFLUENT FLOWS AS WELL AS ANY REQUIRED INLET AND OUTLET STRUCTURES.
- (B) CONTRACTOR SHALL PROVIDE BYPASS PIPE AND RISER OR OTHER STRUCTURE AS SHOWN ON PLANS. THE BYPASS PIPE SHALL BE INSTALLED WITH WYE(S), OR OTHER PIPE FITTINGS, AND WITH REDUCER COUPLING(S) FOR CONNECTION OF UNDERDRAIN PIPE, PER PLANS. PIPES SHALL BE INSTALLED TO PROMOTE POSITIVE FLOW FROM THE FILTERRA BIOSCAPE SYSTEM.
- (C) IF REQUIRED, CONTRACTOR TO PROVIDE SHOULDER ACCORDING TO DIMENSION AND SLOPE SHOWN ON PLANS OR AS DESIGNED BY ENGINEER OF RECORD. SLOPE FROM SHOULDER TO FILTERRA BIOSCAPE SYSTEM SURFACE AREA SHALL NOT EXCEED 3:1. SOD IS REQUIRED TO STABILIZE SIDE SLOPES OR ADJACENT GRADE.
- (D) CONTRACTOR TO EXCAVATE MEDIA AREA CORRESPONDING TO THE SIZE OF THE FILTERRA BIOSCAPE SYSTEM SURFACE AREA AS SHOWN ON DETAIL AND ON PLAN SHEETS.
- (E) CONTRACTOR SHALL EXCAVATE VERTICALLY FROM BOTTOM OF UNDERDRAIN STONE, OR DRAINAGE STONE, IF REQUIRED, TO ELEVATION OF MULCH AS SHOWN ON THIS DETAIL.
- (F) CONTRACTOR TO PROVIDE AND INSTALL ANY GEOTEXTILE OR IMPERMEABLE LINER FOR BOTTOM OF THE FILTERRA BIOSCAPE SYSTEM IF REQUIRED PER THE PLANS.
- (G) CONTRACTOR TO PROVIDE AND INSTALL ANY ADDITIONAL DRAINAGE STONE BELOW THE FILTERRA BIOSCAPE SYSTEM AS CALLED OUT ON THE PLANS.

**CONTRACTOR ACTIVATION RESPONSIBILITIES AS DENOTED BY (#) ON THIS DETAIL:**

- (1) PLACE GEOTEXTILE FABRIC ALONG THE PERIMETER OF THE FILTERRA BIOSCAPE SYSTEM EXCAVATION.
- (2) PLACE 10" OF UNDERDRAIN STONE - 2" UNDER THE PIPING, 6" AROUND THE PIPING AND 2" ABOVE THE PIPING USING LIGHT DUTY EQUIPMENT ONLY.
- (3) PLACE 6" UNDERDRAIN PIPING UNLESS OTHERWISE APPROVED BY CONTECH, ASSOCIATED PIPING AND FITTINGS/ELBOWS TO CONNECT TO THE PIPING/FITTING(S) THAT IS PROVIDED BY CONTRACTOR (SEE CONTRACTOR INSTALLATION RESPONSIBILITIES THIS DETAIL).
- (4) PLACE 21" FILTERRA MEDIA USING LIGHT DUTY EQUIPMENT ONLY. DO NOT COMPACT MEDIA.
- (5) PLACE 3" DOUBLE SHREDDED HARDWOOD MULCH OVER ENTIRE FILTERRA BIOSCAPE SYSTEM SURFACE AREA USING LIGHT DUTY EQUIPMENT ONLY. DO NOT COMPACT MULCH.
- (6) PROVIDE AND PLANT VEGETATION AS INDICATED IN TABLE ON THIS DETAIL OR ON SITE PLANS.
- (7) PLACE ENERGY DISSIPATION ROCK APRON AS DESIGNED AND INDICATED ON THIS DETAIL OR PER ENGINEER OF RECORD PLANS.
- (8) PLACE CLEANOUT ADAPTER, PLUG AND PIPING.
- (9) PLACE ADDITIONAL EROSION CONTROL AROUND FILTERRA BIOSCAPE SYSTEM (IF REQUIRED).

I:\COMMON\CAD\TREATMENT\64 FILTERRA\40 STANDARD DRAWINGS\FTBS - BIOSCAPE SYSTEM (BOXLESS)\DWG\FILTERRA BIOSCAPE SUPERVISED SYSTEM - STD DETAIL.DWG 5/21/2020 8:57 AM

## Pump Rate Calculation

$$\frac{V_{BMP}}{t_{drain}} = Area * i = Q_{pump}$$

$$\frac{V_{BMP}}{t_{drain}} = Q_{pump}$$

$$Q_{pump} = \frac{ft^3}{hr} * \frac{1 hr}{3600 sec} * \frac{449 gpm}{1 \frac{ft^3}{sec}}$$

$$Q_{pump} = \frac{20,900 ft^3}{48 hr} * \frac{449 gpm}{3600 \frac{ft^3}{hr}} = 54.3 gpm$$

$$Q_{pump} = 55 gpm$$





June 2020

## GENERAL USE LEVEL DESIGNATION FOR BASIC (TSS), ENHANCED, PHOSPHORUS & OIL TREATMENT

For

### CONTECH Engineered Solutions Filterra®

#### **Ecology's Decision:**

Based on Contech's submissions, including the Final Technical Evaluation Reports, dated August 2019, March 2014, December 2009, and additional information provided to Ecology dated October 9, 2009, Ecology hereby issues the following use level designations:

1. A General Use Level Designation for Basic, Enhanced, Phosphorus, and Oil Treatment for the Filterra® system constructed with a minimum media thickness of 21 inches (1.75 feet), at the following water quality design hydraulic loading rates:

Treatment	Infiltration Rate (in/hr) for use in Sizing
Basic	175
Phosphorus	100
Oil	50
Enhanced	175

2. The Filterra is not appropriate for oil spill-control purposes.
3. Ecology approves Filterra systems for treatment at the hydraulic loading rates listed above, and sized based on the water quality design flow rate for an off-line system. Calculate the water quality design flow rates using the following procedures:

- Western Washington: for treatment installed upstream of detention or retention, the water quality design flow rate is the peak 15-minute flow rate as calculated using the latest version of the Western Washington Hydrology Model or other Ecology-approved continuous runoff model.
- Eastern Washington: For treatment installed upstream of detention or retention, the water quality design flow rate is the peak 15-minute flow rate as calculated using one of the three flow rate based methods described in Chapter 2.7.6 of the Stormwater Management Manual for Eastern Washington (SWMMEW) or local manual.
- Entire State: For treatment installed downstream of detention, the water quality design flow rate is the full 2-year release rate of the detention facility.

4. This General Use Level Designation has no expiration date, but Ecology may revoke or amend the designation, and is subject to the conditions specified below.

**Ecology's Conditions of Use:**

Filtterra systems shall comply with these conditions shall comply with the following conditions:

1. Design, assemble, install, operate, and maintain the Filtterra systems in accordance with applicable Contech Filtterra manuals and this Ecology Decision.
2. The minimum size filter surface-area for use in Washington is determined by using the design water quality flow rate (as determined in this Ecology Decision, Item 3, above) and the Infiltration Rate from the table above (use the lowest applicable Infiltration Rate depending on the level of treatment required). Calculate the required area by dividing the water quality design flow rate (cu-ft/sec) by the Infiltration Rate (converted to ft/sec) to obtain required surface area (sq-ft) of the Filtterra unit.
3. Each site plan must undergo Contech Filtterra review before Ecology can approve the unit for site installation. This will ensure that design parameters including site grading and slope are appropriate for use of a Filtterra unit.
4. Filtterra media shall conform to the specifications submitted to and approved by Ecology and shall be sourced from Contech Engineered Solutions, LLC with no substitutions.
5. Maintenance includes removing trash, degraded mulch, and accumulated debris from the filter surface and replacing the mulch layer. Use inspections to determine the site-specific maintenance schedules and requirements. Follow maintenance procedures given in the most recent version of the Filtterra Operation and Maintenance Manual.
6. Maintenance: The required maintenance interval for stormwater treatment devices is often dependent upon the degree of pollutant loading from a particular drainage basin. Therefore, Ecology does not endorse or recommend a "one size fits all" maintenance cycle for a particular model/size of manufactured treatment device.
  - Contech designs Filtterra systems for a target maintenance interval of 6 months in the Pacific Northwest. Maintenance includes removing and replacing the mulch layer above the media along with accumulated sediment, trash, and captured organic materials therein, evaluating plant health, and pruning the plant if deemed necessary.
  - Conduct maintenance following manufacturer's guidelines.
7. Filtterra systems come in standard sizes.
8. Install the Filtterra in such a manner that flows exceeding the maximum Filtterra operating rate are conveyed around the Filtterra mulch and media and will not resuspend captured sediment.
9. Discharges from the Filtterra units shall not cause or contribute to water quality standards violations in receiving waters.

## **Approved Alternate Configurations**

### **Filtterra Internal Bypass - Pipe (FTIB-P)**

1. The Filtterra® Internal Bypass – Pipe allows for piped-in flow from area drains, grated inlets, trench drains, and/or roof drains. Design capture flows and peak flows enter the structure through an internal slotted pipe. Filtterra® inverted the slotted pipe to allow design flows to drop through to a series of splash plates that then disperse the design flows over the top surface of the Filtterra® planter area. Higher flows continue to bypass the slotted pipe and convey out the structure.
2. To select a FTIB-P unit, the designer must determine the size of the standard unit using the sizing guidance described above.

### **Filtterra Internal Bypass – Curb (FTIB-C)**

1. The Filtterra® Internal Bypass –Curb model (FTIB-C) incorporates a curb inlet, biofiltration treatment chamber, and internal high flow bypass in one single structure. Filtterra® designed the FTIB-C model for use in a “Sag” or “Sump” condition and will accept flows from both directions along a gutter line. An internal flume tray weir component directs treatment flows entering the unit through the curb inlet to the biofiltration treatment chamber. Flows in excess of the water quality treatment flow rise above the flume tray weir and discharge through a standpipe orifice; providing bypass of untreated peak flows. Americast manufactures the FTIB-C model in a variety of sizes and configurations and you may use the unit on a continuous grade when a single structure providing both treatment and high flow bypass is preferred. The FTIB-C model can also incorporate a separate junction box chamber to allow larger diameter discharge pipe connections to the structure.
2. To select a FTIB-C unit, the designer must determine the size of the standard unit using the sizing guidance described above.

### **Filtterra® Shallow**

1. The Filtterra Shallow provides additional flexibility for design engineers and designers in situations where various elevation constraints prevent application of a standard Filtterra configuration. Engineers can design this system up to six inches shallower than any of the previous Filtterra unit configurations noted above.
2. Ecology requires that the Filtterra Shallow provide a media contact time equivalent to that of the standard unit. This means that with a smaller depth of media, the surface area must increase.
3. To select a Filtterra Shallow System unit, the designer must first identify the size of the standard unit using the modeling guidance described above.
4. Once the size of the standard Filtterra unit is established using the sizing technique described above, use information from the following table to select the appropriate size Filtterra Shallow System unit.

Shallow Unit Basic, Enhanced, Phosphorus, and Oil Treatment Sizing

Standard Depth	Equivalent Shallow Depth
4x4	4x6 or 6x4
4x6 or 6x4	6x6
4x8 or 8x4	6x8 or 8x6
6x6	6x10 or 10x6
6x8 or 8x6	6x12 or 12x6
6x10 or 10x6	13x7

Notes:

1. Shallow Depth Boxes are less than the standard depth of 3.5 feet but no less than 3.0 feet deep (TC to INV).

**Applicant:** Contech Engineered Solutions, LLC.

**Applicant's Address:** 11815 NE Glenn Widing Drive  
Portland, OR 97220

**Application Documents:**

- State of Washington Department of Ecology Application for Conditional Use Designation, Americast (September 2006)
- Quality Assurance Project Plan Filterra® Bioretention Filtration System Performance Monitoring, Americast (April 2008)
- Quality Assurance Project Plan Addendum Filterra® Bioretention Filtration System Performance Monitoring, Americast (June 2008)
- Draft Technical Evaluation Report Filterra® Bioretention Filtration System Performance Monitoring, Americast (August 2009)
- Final Technical Evaluation Report Filterra® Bioretention Filtration System Performance Monitoring, Americast (December 2009)
- Technical Evaluation Report Appendices Filterra® Bioretention Filtration System Performance Monitoring, Americast, (August 2009)
- Memorandum to Department of Ecology Dated October 9, 2009 from Americast, Inc. and Herrera Environmental Consultants
- Quality Assurance Project Plan Filterra® Bioretention System Phosphorus treatment and Supplemental Basic and Enhanced Treatment Performance Monitoring, Americast (November 2011)
- Filterra® letter August 24, 2012 regarding sizing for the Filterra® Shallow System.
- University of Virginia Engineering Department Memo by Joanna Crowe Curran, Ph. D dated March 16, 2013 concerning capacity analysis of Filterra® internal weir inlet tray.
- Terraphase Engineering letter to Jodi Mills, P.E. dated April 2, 2013 regarding Terrafume Hydraulic Test, Filterra® Bioretention System and attachments.
- Technical Evaluation Report, Filterra® System Phosphorus Treatment and Supplemental Basic Treatment Performance Monitoring. March 27<sup>th</sup>, 2014.
- State of Washington Department of Ecology Application for Conditional Use Level Designation, Contech Engineered Solutions (May 2015)

- Quality Assurance Project Plan Filterra® Bioretention System, Contech Engineered Solutions (May 2015)
- Filterra Bioretention System Armco Avenue General Use Level Designation Technical Evaluation Report, Contech Engineered Solutions (August 2019)

**Applicant’s Use Level Request:**

General Level Use Designation for Basic (175 in/hr), Enhanced (175 in/hr), Phosphorus (100 in/hr), and Oil Treatment (50 in/hr).

**Applicant’s Performance Claims:**

Field-testing and laboratory testing show that the Filterra® unit is promising as a stormwater treatment best management practice and can meet Ecology’s performance goals for basic, enhanced, phosphorus, and oil treatment.

**Findings of Fact:**

Field Testing 2015-2019

1. Contech completed field testing of a 4 ft. x 4 ft. Filterra® unit at one site in Hillsboro, Oregon from September 2015 to July 2019. Throughout the monitoring period a total of 24 individual storm events were sampled, of which 23 qualified for TAPE sampling criteria.
2. Contech encountered several unanticipated events and challenges that prevented them from collecting continuous flow and rainfall data. An analysis of the flow data from the sampled events, including both the qualifying and non-qualifying events, demonstrated the system treated over 99 % of the influent flows. Peak flows during these events ranged from 25 % to 250 % of the design flow rate of 29 gallons per minute.
3. Of the 23 TAPE qualified sample events, 13 met requirements for TSS analysis. Influent concentrations ranged from 20.8 mg/L to 83 mg/L, with a mean concentration of 46.3 mg/L. The UCL95 mean effluent concentration was 15.9 mg/L, meeting the 20 mg/L performance goal for Basic Treatment.
4. All 23 TAPE qualified sample events met requirements for dissolved zinc analysis. Influent concentrations range from 0.0384 mg/L to 0.2680 mg/L, with a mean concentration of 0.0807 mg/L. The LCL 95 mean percent removal was 62.9 %, meeting the 60 % performance goal for Enhanced Treatment.
5. Thirteen of the 23 TAPE qualified sample events met requirements for dissolved copper analysis. Influent concentrations ranged from 0.00543 mg/L to 0.01660 mg/L, with a mean concentration of 0.0103 mg/L. The LCL 95 mean percent removal was 41.2 %, meeting the 30 % performance goal for Enhanced Treatment.
6. Total zinc concentrations were analyzed for all 24 sample events. Influent EMCs for total zinc ranged from 0.048 mg/L to 5.290 mg/L with a median of 0.162 mg/L. Corresponding effluent EMCs for total zinc ranged from 0.015 mg/L to 0.067 mg/L with a median of

0.029 mg/L. Total event loadings for the study for total zinc were 316.85 g at the influent and 12.92 g at the effluent sampling location, resulting in a summation of loads removal efficiency of 95.9 %.

7. Total copper concentrations were analyzed for all 24 sample events. Influent EMCs for total copper ranged from 0.003 mg/L to 35.600 mg/L with a median value of 0.043 mg/L. Corresponding effluent EMCs for total copper ranged from 0.002 mg/L to 0.015 mg/L with a median of 0.004 mg/L. Total event loadings for total copper for the study were 1,810.06 g at the influent and 1.90 g at the effluent sampling location, resulting in a summation of loads removal efficiency of 99.9 %.

### Field Testing 2013

1. Filterra completed field-testing of a 6.5 ft x 4 ft. unit at one site in Bellingham, Washington. Continuous flow and rainfall data collected from January 1, 2013 through July 23, 2013 indicated that 59 storm events occurred. Water quality data was obtained from 22 storm events. Not all the sampled storms produced information that met TAPE criteria for storm and/or water quality data.
2. The system treated 98.9 % of the total 8-month runoff volume during the testing period. Consequently, the system achieved the goal of treating 91 % of the volume from the site. Stormwater runoff bypassed Filterra treatment during four of the 59 storm events.
3. Of the 22 sampled events, 18 qualified for TSS analysis (influent TSS concentrations ranged from 25 to 138 mg/L). The data were segregated into sample pairs with influent concentration greater than and less than 100 mg/L. The UCL95 mean effluent concentration for the data with influent less than 100 mg/L was 5.2 mg/L, below the 20-mg/L threshold. Although the TAPE guidelines do not require an evaluation of TSS removal efficiency for influent concentrations below 100 mg/L, the mean TSS removal for these samples was 90.1 %. Average removal of influent TSS concentrations greater than 100 mg/L (three events) was 85 %. In addition, the system consistently exhibited TSS removal greater than 80 % at flow rates equivalent to a 100 in/hr infiltration rate and was observed at 150 in/hr.
4. Ten of the 22 sampled events qualified for TP analysis. Americast augmented the dataset using two sample pairs from previous monitoring at the site. Influent TP concentrations ranged from 0.11 to 0.52 mg/L. The mean TP removal for these twelve events was 72.6 %. The LCL95 mean percent removal was 66.0, well above the TAPE requirement of 50 %. Treatment above 50 % was evident at 100 in/hr infiltration rate and as high as 150 in/hr. Consequently, the Filterra test system met the TAPE Phosphorus Treatment goal at 100 in/hr. Influent ortho-P concentrations ranged from 0.005 to 0.012 mg/L; effluent ortho-P concentrations ranged from 0.005 to 0.013 mg/L. The reporting limit/resolution for the ortho-P test method is 0.01 mg/L, therefore the influent and effluent ortho-P concentrations were both at and near non-detect concentrations.

## Field Testing 2008-2009

1. Filtterra completed field-testing at two sites at the Port of Tacoma. Continuous flow and rainfall data collected during the 2008-2009 monitoring period indicated that 89 storm events occurred. The monitoring obtained water quality data from 27 storm events. Not all the sampled storms produced information that met TAPE criteria for storm and/or water quality data.
2. During the testing at the Port of Tacoma, 98.96 to 99.89 % of the annual influent runoff volume passed through the POT1 and POT2 test systems respectively. Stormwater runoff bypassed the POT1 test system during nine storm events and bypassed the POT2 test system during one storm event. Bypass volumes ranged from 0.13 % to 15.3% of the influent storm volume. Both test systems achieved the 91 % water quality treatment-goal over the 1-year monitoring period.
3. Consultants observed infiltration rates as high as 133 in/hr during the various storms. Filtterra did not provide any paired data that identified percent removal of TSS, metals, oil, or phosphorus at an instantaneous observed flow rate.
4. The maximum storm average hydraulic loading rate associated with water quality data is <40 in/hr, with the majority of flow rates < 25 in/hr. The average instantaneous hydraulic loading rate ranged from 8.6 to 53 in/hr.
5. The field data showed a removal rate greater than 80 % for TSS with an influent concentration greater than 20 mg/L at an average instantaneous hydraulic loading rate up to 53 in/hr (average influent concentration of 28.8 mg/L, average effluent concentration of 4.3 mg/L).
6. The field data showed a removal rate generally greater than 54 % for dissolved zinc at an average instantaneous hydraulic loading rate up to 60 in/hr and an average influent concentration of 0.266 mg/L (average effluent concentration of 0.115 mg/L).
7. The field data showed a removal rate generally greater than 40 % for dissolved copper at an average instantaneous hydraulic loading rate up to 35 in/hr and an average influent concentration of 0.0070 mg/L (average effluent concentration of 0.0036 mg/L).
8. The field data showed an average removal rate of 93 % for total petroleum hydrocarbon (TPH) at an average instantaneous hydraulic loading rate up to 53 in/hr and an average influent concentration of 52 mg/L (average effluent concentration of 2.3 mg/L). The data also shows achievement of less than 15 mg/L TPH for grab samples. Filtterra provided limited visible sheen data due to access limitations at the outlet monitoring location.
9. The field data showed low percentage removals of total phosphorus at all storm flows at an average influent concentration of 0.189 mg/L (average effluent concentration of 0.171 mg/L). We may relate the relatively poor treatment performance of the Filtterra system at this location to influent characteristics for total phosphorus that are unique to the Port of Tacoma site. It appears that the Filtterra system will not meet the 50 % removal performance goal when the majority of phosphorus in the runoff is expected to be in the dissolved form.

### Laboratory Testing

1. Filterra performed laboratory testing on a scaled down version of the Filterra unit. The lab data showed an average removal from 83-91 % for TSS with influents ranging from 21 to 320 mg/L, 82-84 % for total copper with influents ranging from 0.94 to 2.3 mg/L, and 50-61 % for orthophosphate with influents ranging from 2.46 to 14.37 mg/L.
2. Filterra conducted permeability tests on the soil media.
3. Lab scale testing using Sil-Co-Sil 106 showed removals ranging from 70.1 % to 95.5 % with a median removal of 90.7 %, for influent concentrations ranging from 8.3 to 260 mg/L. Filterra ran these laboratory tests at an infiltration rate of 50 in/hr.
4. Supplemental lab testing conducted in September 2009 using Sil-Co-Sil 106 showed an average removal of 90.6 %. These laboratory tests were run at infiltration rates ranging from 25 to 150 in/hr for influent concentrations ranging from 41.6 to 252.5 mg/L. Regression analysis results indicate that the Filterra system's TSS removal performance is independent of influent concentration in the concentration range evaluated at hydraulic loading rates of up to 150 in/hr.

### **Contact Information:**

Applicant: Jeremiah Lehman  
Contech Engineered Solutions, LLC.  
11815 Glenn Widing Dr  
Portland, OR 97220  
(503) 258-3136  
[jlehman@conteches.com](mailto:jlehman@conteches.com)

Applicant's Website: <http://www.conteches.com>

Ecology web link: <http://www.ecy.wa.gov/programs/wq/stormwater/newtech/index.html>

Ecology: Douglas C. Howie, P.E.  
Department of Ecology  
Water Quality Program  
(360) 407-6444  
[douglas.howie@ecy.wa.gov](mailto:douglas.howie@ecy.wa.gov)

<b>Date</b>	<b>Revision</b>
December 2009	GULD for Basic, Enhanced, and Oil granted, CULD for Phosphorus
September 2011	Extended CULD for Phosphorus Treatment
September 2012	Revised design storm discussion, added Shallow System.
January 2013	Revised format to match Ecology standards, changed Filterra contact information
February 2013	Added FTIB-P system
March 2013	Added FTIB-C system
April 2013	Modified requirements for identifying appropriate size of unit



June 2013	Modified description of FTIB-C alternate configuration
March 2014	GULD awarded for Phosphorus Treatment. GULD updated for a higher flow-rate for Basic Treatment.
June 2014	Revised sizing calculation methods
March 2015	Revised Contact Information
June 2015	CULD for Basic and Enhanced at 100 in/hr infiltration rate
September 2019	GULD for Basic and Enhanced at 175 in/hr infiltration rate
February 2020	Revised sizing language to note sizing based on off-line calculations
June 2020	Added Phosphorus to Filterra Shallow sizing table

# Appendix 7: Hydromodification

*Supporting Detail Relating to Hydrologic Conditions of Concern*



PROJECT SITE

100m  
300ft

Site Address: rivco.permitrack.com

Riverside County  
SWCTT  
Stormwater Map

# Appendix 8: Source Control

*Pollutant Sources/Source Control Checklist*

**\*To be provided during final engineering**

# Appendix 9: O&M

*Operation and Maintenance Plan and Documentation of Finance, Maintenance and Recording Mechanisms*

**\*To be provided during final engineering**

# Appendix 10: Educational Materials

*BMP Fact Sheets, Maintenance Guidelines and Other End-User BMP Information*

**\*To be provided during final engineering**