

**Priority Development Project (PDP)
Storm Water Quality Management Plan (SWQMP)**

Foxhill Residence & Boundary Adjustment

PTS. NO. 508125

SDP NO. 1790091 / TENTATIVE PLAN NO. 2330219 / CDP NO. 2330222

Check if electing for offsite alternative compliance

Engineer of Work:



A handwritten signature in blue ink that reads "Son P. Nguyen".

Son P. Nguyen RCE 86249

Provide Wet Signature and Stamp Above Line

Prepared For:

Manchester Foxhill, LLC

7007 Country Club Drive

La Jolla, CA. 92037

(619) 446-5000

Prepared By:

Snipes-Dye Associates

8348 Center Drive, Suite G

La Mesa, CA 91942

(619) 697-9234

Date:

September 23, 2020

SDA NO. LJ4742

Approved by: City of San Diego

Date



THIS PAGE INTENTIONALLY LEFT BLANK FOR DOUBLE-SIDED PRINTING



Project Name:

Table of Contents

- Acronyms
- Certification Page
- Submittal Record
- Project Vicinity Map
- FORM DS-560: Storm Water Applicability Checklist
- FORM I-1: Applicability of Permanent, Post-Construction Storm Water BMP Requirements
- HMP Exemption Exhibit (for all hydromodification management exempt projects)
- FORM I-3B: Site Information Checklist for PDPs
- FORM I-4B: Source Control BMP Checklist for PDPs
- FORM I-5B: Site Design BMP Checklist PDPs
- FORM I-6: Summary of PDP Structural BMPs
- Attachment 1: Backup for PDP Pollutant Control BMPs
 - Attachment 1a: DMA Exhibit
 - Attachment 1b: Tabular Summary of DMAs (Worksheet B-1 from Appendix B) and Design Capture Volume Calculations
 - Attachment 1c: FORM I-7 : Worksheet B.3-1 Harvest and Use Feasibility Screening
 - Attachment 1d: Infiltration Feasibility Information(One or more of the following):
 - FORM I-8A: Worksheet C.4-1 Categorization of Infiltration Feasibility Condition based on Geotechnical Conditions
 - Form I-8B: Worksheet C.4-2 Categorization of Infiltration Feasibility Condition based on Groundwater and Water Balance Conditions
 - Infiltration Feasibility Condition Letter
 - Worksheet C.4-3: Infiltration and Groundwater Protection for Full Infiltration BMPs
 - FORM I-9: Worksheet D.5-1 Factor of Safety and Design Infiltration Rate
 - Attachment 1e: Pollutant Control BMP Design Worksheets / Calculations
- Attachment 2: Backup for PDP Hydromodification Control Measures
 - Attachment 2a: Hydromodification Management Exhibit
 - Attachment 2b: Management of Critical Coarse Sediment Yield Areas
 - Attachment 2c: Geomorphic Assessment of Receiving Channels
 - Attachment 2d: Flow Control Facility Design

Project Name:

- Attachment 3: Structural BMP Maintenance Plan
 - Maintenance Agreement (Form DS-3247) (when applicable)
- Attachment 4: Copy of Plan Sheets Showing Permanent Storm Water BMPs
- Attachment 5: Project's Drainage Report
- Attachment 6: Project's Geotechnical and Groundwater Investigation Report

Project Name:

Acronyms

APN	Assessor's Parcel Number
ASBS	Area of Special Biological Significance
BMP	Best Management Practice
CEQA	California Environmental Quality Act
CGP	Construction General Permit
DCV	Design Capture Volume
DMA	Drainage Management Areas
ESA	Environmentally Sensitive Area
GLU	Geomorphic Landscape Unit
GW	Ground Water
HMP	Hydromodification Management Plan
HSG	Hydrologic Soil Group
HU	Harvest and Use
INF	Infiltration
LID	Low Impact Development
LUP	Linear Underground/Overhead Projects
MS4	Municipal Separate Storm Sewer System
N/A	Not Applicable
NPDES	National Pollutant Discharge Elimination System
NRCS	Natural Resources Conservation Service
PDP	Priority Development Project
PE	Professional Engineer
POC	Pollutant of Concern
SC	Source Control
SD	Site Design
SDRWQCB	San Diego Regional Water Quality Control Board
SIC	Standard Industrial Classification
SWPPP	Stormwater Pollutant Protection Plan
SWQMP	Storm Water Quality Management Plan
TMDL	Total Maximum Daily Load
WMAA	Watershed Management Area Analysis
WPCP	Water Pollution Control Program
WQIP	Water Quality Improvement Plan

Certification Page

Project Name: Foxhill Residence & Boundary Adjustment
Permit Application PTS. NO. 508125

I hereby declare that I am the Engineer in Responsible Charge of design of storm water BMPs for this project, and that I have exercised responsible charge over the design of the project as defined in Section 6703 of the Business and Professions Code, and that the design is consistent with the requirements of the Storm Water Standards, which is based on the requirements of SDRWQCB Order No. R9-2013-0001 as amended by R9-2015-0001 and R9-2015-0100 (MS4 Permit).

I have read and understand that the City Engineer has adopted minimum requirements for managing urban runoff, including storm water, from land development activities, as described in the Storm Water Standards. I certify that this PDP SWQMP has been completed to the best of my ability and accurately reflects the project being proposed and the applicable source control and site design BMPs proposed to minimize the potentially negative impacts of this project's land development activities on water quality. I understand and acknowledge that the plan check review of this PDP SWQMP by the City Engineer is confined to a review and does not relieve me, as the Engineer in Responsible Charge of design of storm water BMPs for this project, of my responsibilities for project design.

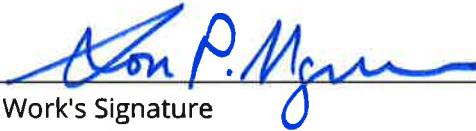

Engineer of Work's Signature

86249

3-31-2021

PE#

Expiration Date

Son P. Nguyen

Print Name

Snipes-Dye Associates

Company

September 23, 2020

Date



Engineer's Stamp

Project Name:

Submittal Record

Use this Table to keep a record of submittals of this PDP SWQMP. Each time the PDP SWQMP is re-submitted, provide the date and status of the project. In last column indicate changes that have been made or indicate if response to plancheck comments is included. When applicable, insert response to plancheck comments.

Submittal Number	Date	Project Status	Changes
1		Preliminary Design/Planning/CEQA Final Design	Initial Submittal
2		Preliminary Design/Planning/CEQA Final Design	
3		Preliminary Design/Planning/CEQA Final Design	
4		Preliminary Design/Planning/CEQA Final Design	

Project Name:

Project Vicinity Map

Project Name:
Permit Application

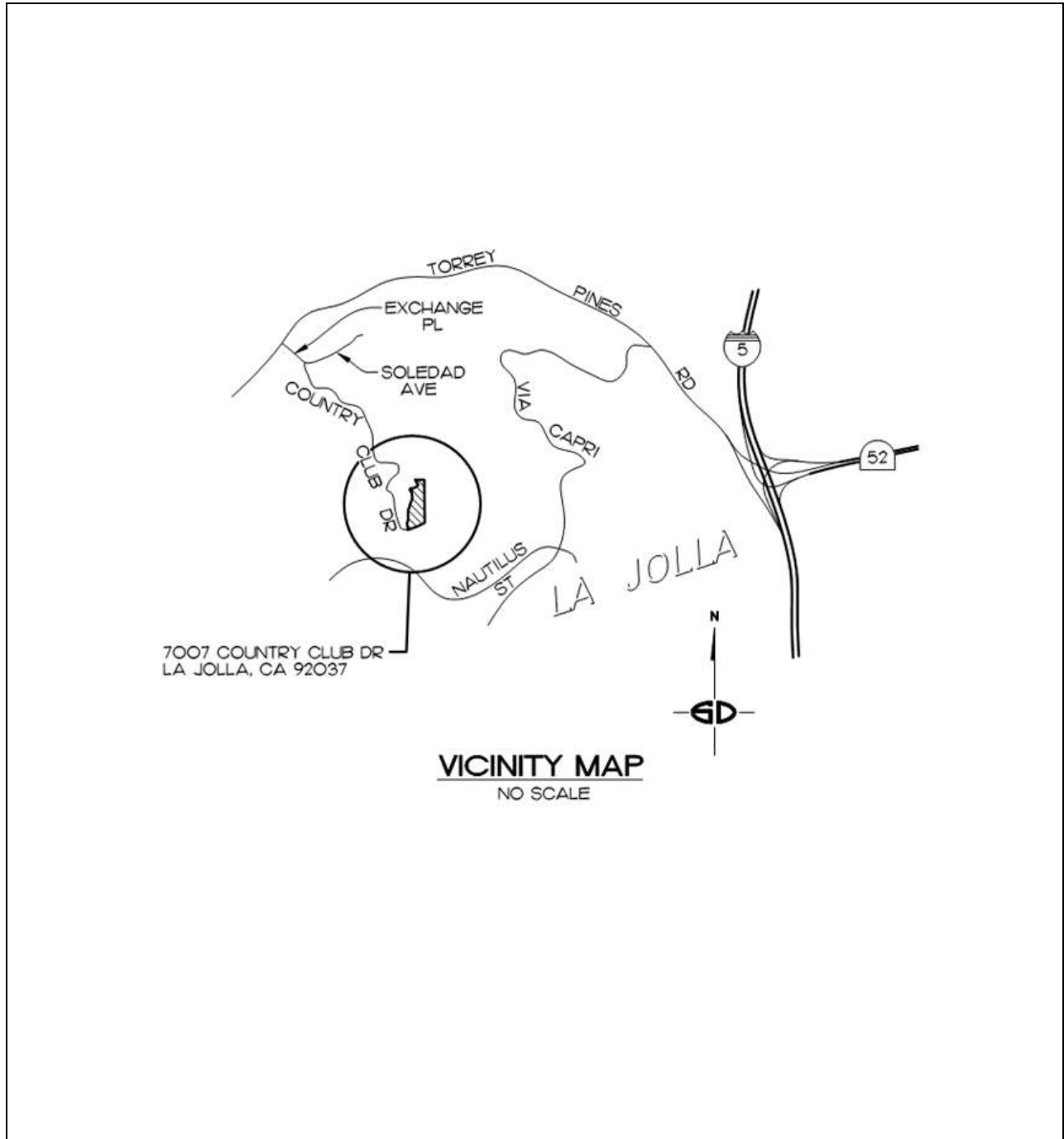

Project Name:

City of San Diego Form DS-560 Storm Water Requirements Applicability Checklist

Attach DS-560 form.

Project Name:

THIS PAGE INTENTIONALLY LEFT BLANK FOR DOUBLE-SIDED PRINTING





City of San Diego
 Development Services
 1222 First Ave., MS-302
 San Diego, CA 92101
 (619) 446-5000

Storm Water Requirements Applicability Checklist

**FORM
 DS-560**
 November 2018

Project Address:	Project Number:
------------------	-----------------

SECTION 1. Construction Storm Water BMP Requirements:

All construction sites are required to implement construction BMPs in accordance with the performance standards in the [Storm Water Standards Manual](#). Some sites are additionally required to obtain coverage under the State Construction General Permit (CGP)¹, which is administered by the State Regional Water Quality Control Board.

For all projects complete PART A: If project is required to submit a SWPPP or WPCP, continue to PART B.

PART A: Determine Construction Phase Storm Water Requirements.

1. Is the project subject to California's statewide General NPDES permit for Storm Water Discharges Associated with Construction Activities, also known as the State Construction General Permit (CGP)? (Typically projects with land disturbance greater than or equal to 1 acre.)

- Yes; SWPPP required, skip questions 2-4 No; next question

2. Does the project propose construction or demolition activity, including but not limited to, clearing, grading, grubbing, excavation, or any other activity resulting in ground disturbance and/or contact with storm water?

- Yes; WPCP required, skip questions 3-4 No; next question

3. Does the project propose routine maintenance to maintain original line and grade, hydraulic capacity, or original purpose of the facility? (Projects such as pipeline/utility replacement)

- Yes; WPCP required, skip question 4 No; next question

4. Does the project only include the following Permit types listed below?

- Electrical Permit, Fire Alarm Permit, Fire Sprinkler Permit, Plumbing Permit, Sign Permit, Mechanical Permit, Spa Permit.
- Individual Right of Way Permits that exclusively include only ONE of the following activities: water service, sewer lateral, or utility service.
- Right of Way Permits with a project footprint less than 150 linear feet that exclusively include only ONE of the following activities: curb ramp, sidewalk and driveway apron replacement, pot holing, curb and gutter replacement, and retaining wall encroachments.

- Yes; no document required

Check one of the boxes below, and continue to PART B:

- If you checked "Yes" for question 1, **a SWPPP is REQUIRED. Continue to PART B**
- If you checked "No" for question 1, and checked "Yes" for question 2 or 3, **a WPCP is REQUIRED.** If the project proposes less than 5,000 square feet of ground disturbance AND has less than a 5-foot elevation change over the entire project area, a Minor WPCP may be required instead. **Continue to PART B.**
- If you checked "No" for all questions 1-3, and checked "Yes" for question 4 **PART B does not apply and no document is required. Continue to Section 2.**

1. More information on the City's construction BMP requirements as well as CGP requirements can be found at: www.sandiego.gov/stormwater/regulations/index.shtml

PART B: Determine Construction Site Priority

This prioritization must be completed within this form, noted on the plans, and included in the SWPPP or WPCP. The city reserves the right to adjust the priority of projects both before and after construction. Construction projects are assigned an inspection frequency based on if the project has a "high threat to water quality." The City has aligned the local definition of "high threat to water quality" to the risk determination approach of the State Construction General Permit (CGP). The CGP determines risk level based on project specific sediment risk and receiving water risk. Additional inspection is required for projects within the Areas of Special Biological Significance (ASBS) watershed. **NOTE:** The construction priority does **NOT** change construction BMP requirements that apply to projects; rather, it determines the frequency of inspections that will be conducted by city staff.

Complete PART B and continued to Section 2

1. **ASBS**
 - a. Projects located in the ASBS watershed.
2. **High Priority**
 - a. Projects that qualify as Risk Level 2 or Risk Level 3 per the Construction General Permit (CGP) and not located in the ASBS watershed.
 - b. Projects that qualify as LUP Type 2 or LUP Type 3 per the CGP and not located in the ASBS watershed.
3. **Medium Priority**
 - a. Projects that are not located in an ASBS watershed or designated as a High priority site.
 - b. Projects that qualify as Risk Level 1 or LUP Type 1 per the CGP and not located in an ASBS watershed.
 - c. WPCP projects (>5,000sf of ground disturbance) located within the Los Penasquitos watershed management area.
4. **Low Priority**
 - a. Projects not subject to a Medium or High site priority designation and are not located in an ASBS watershed.

SECTION 2. Permanent Storm Water BMP Requirements.

Additional information for determining the requirements is found in the [Storm Water Standards Manual](#).

PART C: Determine if Not Subject to Permanent Storm Water Requirements.

Projects that are considered maintenance, or otherwise not categorized as "new development projects" or "redevelopment projects" according to the [Storm Water Standards Manual](#) are not subject to Permanent Storm Water BMPs.

If "yes" is checked for any number in Part C, proceed to Part F and check "Not Subject to Permanent Storm Water BMP Requirements".

If "no" is checked for all of the numbers in Part C continue to Part D.

1. Does the project only include interior remodels and/or is the project entirely within an existing enclosed structure and does not have the potential to contact storm water? Yes No
2. Does the project only include the construction of overhead or underground utilities without creating new impervious surfaces? Yes No
3. Does the project fall under routine maintenance? Examples include, but are not limited to: roof or exterior structure surface replacement, resurfacing or reconfiguring surface parking lots or existing roadways without expanding the impervious footprint, and routine replacement of damaged pavement (grinding, overlay, and pothole repair). Yes No

PART D: PDP Exempt Requirements.

PDP Exempt projects are required to implement site design and source control BMPs.

If “yes” was checked for any questions in Part D, continue to Part F and check the box labeled “PDP Exempt.”

If “no” was checked for all questions in Part D, continue to Part E.

1. Does the project ONLY include new or retrofit sidewalks, bicycle lanes, or trails that:

- **Are designed and constructed to direct storm water runoff to adjacent vegetated areas, or other non-erodible permeable areas? Or;**
- **Are designed and constructed to be hydraulically disconnected from paved streets and roads? Or;**
- **Are designed and constructed with permeable pavements or surfaces in accordance with the Green Streets guidance in the City’s Storm Water Standards manual?**

Yes; PDP exempt requirements apply No; next question

2. Does the project ONLY include retrofitting or redeveloping existing paved alleys, streets or roads designed and constructed in accordance with the Green Streets guidance in the [City’s Storm Water Standards Manual](#)?

Yes; PDP exempt requirements apply No; project not exempt.

PART E: Determine if Project is a Priority Development Project (PDP).

Projects that match one of the definitions below are subject to additional requirements including preparation of a Storm Water Quality Management Plan (SWQMP).

If “yes” is checked for any number in PART E, continue to PART F and check the box labeled “Priority Development Project”.

If “no” is checked for every number in PART E, continue to PART F and check the box labeled “Standard Development Project”.

1. New Development that creates 10,000 square feet or more of impervious surfaces collectively over the project site. This includes commercial, industrial, residential, mixed-use, and public development projects on public or private land. Yes No

2. Redevelopment project that creates and/or replaces 5,000 square feet or more of impervious surfaces on an existing site of 10,000 square feet or more of impervious surfaces. This includes commercial, industrial, residential, mixed-use, and public development projects on public or private land. Yes No

3. New development or redevelopment of a restaurant. Facilities that sell prepared foods and drinks for consumption, including stationary lunch counters and refreshment stands selling prepared foods and drinks for immediate consumption (SIC 5812), and where the land development creates and/or replace 5,000 square feet or more of impervious surface. Yes No

4. New development or redevelopment on a hillside. The project creates and/or replaces 5,000 square feet or more of impervious surface (collectively over the project site) and where the development will grade on any natural slope that is twenty-five percent or greater. Yes No

5. New development or redevelopment of a parking lot that creates and/or replaces 5,000 square feet or more of impervious surface (collectively over the project site). Yes No

6. New development or redevelopment of streets, roads, highways, freeways, and driveways. The project creates and/or replaces 5,000 square feet or more of impervious surface (collectively over the project site). Yes No

7. **New development or redevelopment discharging directly to an Environmentally Sensitive Area.** The project creates and/or replaces 2,500 square feet of impervious surface (collectively over project site), and discharges directly to an Environmentally Sensitive Area (ESA). "Discharging directly to" includes flow that is conveyed overland a distance of 200 feet or less from the project to the ESA, or conveyed in a pipe or open channel any distance as an isolated flow from the project to the ESA (i.e. not commingled with flows from adjacent lands). Yes No

8. **New development or redevelopment projects of a retail gasoline outlet (RGO) that create and/or replaces 5,000 square feet of impervious surface.** The development project meets the following criteria: (a) 5,000 square feet or more or (b) has a projected Average Daily Traffic (ADT) of 100 or more vehicles per day. Yes No

9. **New development or redevelopment projects of an automotive repair shops that creates and/or replaces 5,000 square feet or more of impervious surfaces.** Development projects categorized in any one of Standard Industrial Classification (SIC) codes 5013, 5014, 5541, 7532-7534, or 7536-7539. Yes No

10. **Other Pollutant Generating Project.** The project is not covered in the categories above, results in the disturbance of one or more acres of land and is expected to generate pollutants post construction, such as fertilizers and pesticides. This does not include projects creating less than 5,000 sf of impervious surface and where added landscaping does not require regular use of pesticides and fertilizers, such as slope stabilization using native plants. Calculation of the square footage of impervious surface need not include linear pathways that are for infrequent vehicle use, such as emergency maintenance access or bicycle pedestrian use, if they are built with pervious surfaces of if they sheet flow to surrounding pervious surfaces. Yes No

PART F: Select the appropriate category based on the outcomes of PART C through PART E.

- 1. The project is **NOT SUBJECT TO PERMANENT STORM WATER REQUIREMENTS.**
- 2. The project is a **STANDARD DEVELOPMENT PROJECT.** Site design and source control BMP requirements apply. See the [Storm Water Standards Manual](#) for guidance.
- 3. The project is **PDP EXEMPT.** Site design and source control BMP requirements apply. See the [Storm Water Standards Manual](#) for guidance.
- 4. The project is a **PRIORITY DEVELOPMENT PROJECT.** Site design, source control, and structural pollutant control BMP requirements apply. See the [Storm Water Standards Manual](#) for guidance on determining if project requires a hydromodification plan management

Ramon Esquer

Design Engineer

Name of Owner or Agent (Please Print)

Title



06/01/2020

Signature

Date

Project Name:

Applicability of Permanent, Post-Construction Storm Water BMP Requirements		Form I-1
Project Identification		
Project Name:		
Permit Application Number:		Date:
Determination of Requirements		
<p>The purpose of this form is to identify permanent, post-construction requirements that apply to the project. This form serves as a short <u>summary</u> of applicable requirements, in some cases referencing separate forms that will serve as the backup for the determination of requirements.</p> <p>Answer each step below, starting with Step 1 and progressing through each step until reaching "Stop". Refer to the manual sections and/or separate forms referenced in each step below.</p>		
Step	Answer	Progression
Step 1: Is the project a "development project"? See Section 1.3 of the manual (Part 1 of Storm Water Standards) for guidance.	<input type="checkbox"/> Yes	Go to Step 2 .
	<input type="checkbox"/> No	Stop. Permanent BMP requirements do not apply. No SWQMP will be required. Provide discussion below.
Discussion / justification if the project is <u>not</u> a "development project" (e.g., the project includes <i>only</i> interior remodels within an existing building):		
Step 2: Is the project a Standard Project, PDP, or PDP Exempt? To answer this item, see Section 1.4 of the manual in its entirety for guidance AND complete Form DS-560, Storm Water Requirements Applicability Checklist.	<input type="checkbox"/> Standard Project	Stop. Standard Project requirements apply
	<input type="checkbox"/> PDP	PDP requirements apply, including PDP SWQMP. Go to Step 3 .
	PDP Exempt	Stop. Standard Project requirements apply. Provide discussion and list any additional requirements below.
Discussion / justification, and additional requirements for exceptions to PDP definitions, if applicable:		



Project Name:

Form I-1 Page 2 of 2		
Step	Answer	Progression
Step 3. Is the project subject to earlier PDP requirements due to a prior lawful approval? See Section 1.10 of the manual (Part 1 of Storm Water Standards) for guidance.	<input type="checkbox"/> Yes	Consult the City Engineer to determine requirements. Provide discussion and identify requirements below. Go to Step 4.
	<input type="checkbox"/> No	BMP Design Manual PDP requirements apply. Go to Step 4.
Discussion / justification of prior lawful approval, and identify requirements (<u>not required if prior lawful approval does not apply</u>):		
Step 4. Do hydromodification control requirements apply? See Section 1.6 of the manual (Part 1 of Storm Water Standards) for guidance.	<input type="checkbox"/> Yes	PDP structural BMPs required for pollutant control (Chapter 5) and hydromodification control (Chapter 6). Go to Step 5.
	<input type="checkbox"/> No	Stop. PDP structural BMPs required for pollutant control (Chapter 5) only. Provide brief discussion of exemption to hydromodification control below.
Discussion / justification if hydromodification control requirements do <u>not</u> apply:		
Step 5. Does protection of critical coarse sediment yield areas apply? See Section 6.2 of the manual (Part 1 of Storm Water Standards) for guidance.	<input type="checkbox"/> Yes	Management measures required for protection of critical coarse sediment yield areas (Chapter 6.2). Stop.
	<input type="checkbox"/> No	Management measures not required for protection of critical coarse sediment yield areas. Provide brief discussion below. Stop.
Discussion / justification if protection of critical coarse sediment yield areas does <u>not</u> apply:		



Project Name:

HMP Exemption Exhibit

Attach a HMP Exemption Exhibit that shows direct storm water runoff discharge from the project site to HMP exempt area. Include project area, applicable underground storm drain line and/or concrete lined channels, outfall information and exempt waterbody.
Reference applicable drawing number(s).

Exhibit must be provided on 11"x17" or larger paper.

NOT APPLICABLE

Project Name:

THIS PAGE INTENTIONALLY LEFT BLANK FOR DOUBLE-SIDED PRINTING



Project Name:

Site Information Checklist For PDPs		Form I-3B
Project Summary Information		
Project Name		
Project Address		
Assessor's Parcel Number(s) (APN(s))		
Permit Application Number		
Project Watershed	Select One: <input type="checkbox"/> San Dieguito River <input type="checkbox"/> Penasquitos <input type="checkbox"/> Mission Bay <input type="checkbox"/> San Diego River <input type="checkbox"/> San Diego Bay <input type="checkbox"/> Tijuana River	
Hydrologic subarea name with Numeric Identifier up to two decimal places (9XX.XX)		
Project Area (total area of Assessor's Parcel(s) associated with the project or total area of the right-of-way)	_____ Acres (_____ Square Feet)	
Area to be disturbed by the project (Project Footprint)	_____ Acres (_____ Square Feet)	
Project Proposed Impervious Area (subset of Project Footprint)	_____ Acres (_____ Square Feet)	
Project Proposed Pervious Area (subset of Project Footprint)	_____ Acres (_____ Square Feet)	
Note: Proposed Impervious Area + Proposed Pervious Area = Area to be Disturbed by the Project. This may be less than the Project Area.		
The proposed increase or decrease in impervious area in the proposed condition as compared to the pre-project condition	_____ %	



Project Name:

Form I-3B Page 2 of 11	
Description of Existing Site Condition and Drainage Patterns	
Current Status of the Site (select all that apply): <input type="checkbox"/> Existing development <input type="checkbox"/> Previously graded but not built out <input type="checkbox"/> Agricultural or other non-impervious use <input type="checkbox"/> Vacant, undeveloped/natural Description / Additional Information:	
Existing Land Cover Includes (select all that apply): <input type="checkbox"/> Vegetative Cover <input type="checkbox"/> Non-Vegetated Pervious Areas <input type="checkbox"/> Impervious Areas Description / Additional Information:	
Underlying Soil belongs to Hydrologic Soil Group (select all that apply): <input type="checkbox"/> NRCS Type A <input type="checkbox"/> NRCS Type B <input type="checkbox"/> NRCS Type C <input type="checkbox"/> NRCS Type D	
Approximate Depth to Groundwater: <input type="checkbox"/> Groundwater Depth < 5 feet <input type="checkbox"/> 5 feet < Groundwater Depth < 10 feet <input type="checkbox"/> 10 feet < Groundwater Depth < 20 feet <input type="checkbox"/> Groundwater Depth > 20 feet	
Existing Natural Hydrologic Features (select all that apply): <input type="checkbox"/> Watercourses <input type="checkbox"/> Seeps <input type="checkbox"/> Springs <input type="checkbox"/> Wetlands <input type="checkbox"/> None Description / Additional Information:	



Project Name:

Form I-3B Page 3 of 11

Description of Existing Site Topography and Drainage

How is storm water runoff conveyed from the site? At a minimum, this description should answer:

1. Whether existing drainage conveyance is natural or urban;
2. If runoff from offsite is conveyed through the site? If yes, quantification of all offsite drainage areas, design flows, and locations where offsite flows enter the project site and summarize how such flows are conveyed through the site;
3. Provide details regarding existing project site drainage conveyance network, including storm drains, concrete channels, swales, detention facilities, storm water treatment facilities, and natural and constructed channels;
4. Identify all discharge locations from the existing project along with a summary of the conveyance system size and capacity for each of the discharge locations. Provide summary of the pre-project drainage areas and design flows to each of the existing runoff discharge locations.

Descriptions/Additional Information

SUMMARY OF 100-YEAR, 6-HOUR STORM EVENT

Basin ID	Pre-Development		Post-Development		Post-Development With Mitigation	
	<i>Area (acres)</i>	<i>Discharge Q₁₀₀ (cfs)</i>	<i>Area (acres)</i>	<i>Discharge Q₁₀₀ (cfs)</i>	<i>Area (acres)</i>	<i>Discharge Q₁₀₀ (cfs)</i>
1	0.16	0.36	0.49	1.59	0.49	0.02
2	1.24	2.77	1.15	2.57	1.15	2.57
3	0.18	0.41	0.15	0.34	0.15	0.10
4	0.72	1.61	0.44	1.05	0.44	1.05
5	-	-	0.07	0.16	0.07	0.16
TOTAL	2.30 ac.	5.15 cfs	2.30 ac.	5.44 cfs	2.30 ac.	3.91 cfs



Project Name:

Form I-3B Page 4 of 11	
Description of Proposed Site Development and Drainage Patterns	
Project Description / Proposed Land Use and/or Activities:	
List/describe proposed impervious features of the project (e.g., buildings, roadways, parking lots, courtyards, athletic courts, other impervious features):	
List/describe proposed pervious features of the project (e.g., landscape areas):	
Does the project include grading and changes to site topography? <input type="checkbox"/> Yes <input type="checkbox"/> No	
Description / Additional Information:	



Project Name:

Form I-3B Page 5 of 11

Does the project include changes to site drainage (e.g., installation of new storm water conveyance systems)?

- Yes
- No

If yes, provide details regarding the proposed project site drainage conveyance network, including storm drains, concrete channels, swales, detention facilities, storm water treatment facilities, natural and constructed channels, and the method for conveying offsite flows through or around the proposed project site. Identify all discharge locations from the proposed project site along with a summary of the conveyance system size and capacity for each of the discharge locations. Provide a summary of pre and post-project drainage areas and design flows to each of the runoff discharge locations. Reference the drainage study for detailed calculations.

Description / Additional Information:



Project Name:

Form I-3B Page 6 of 11

Identify whether any of the following features, activities, and/or pollutant source areas will be present (select all that apply):

- Onsite storm drain inlets
- Interior floor drains and elevator shaft sump pumps
- Interior parking garages
- Need for future indoor & structural pest control
- Landscape/outdoor pesticide use
- Pools, spas, ponds, decorative fountains, and other water features
- Food service
- Refuse areas
- Industrial processes
- Outdoor storage of equipment or materials
- Vehicle and equipment cleaning
- Vehicle/equipment repair and maintenance
- Fuel dispensing areas
- Loading docks
- Fire sprinkler test water
- Miscellaneous drain or wash water
- Plazas, sidewalks, and parking lots

Description/Additional Information:

Project Name:

Form I-3B Page 7 of 11	
Identification and Narrative of Receiving Water	
Narrative describing flow path from discharge location(s), through urban storm conveyance system, to receiving creeks, rivers, and lagoons and ultimate discharge location to Pacific Ocean (or bay, lagoon, lake or reservoir, as applicable)	
Provide a summary of all beneficial uses of receiving waters downstream of the project discharge locations	
Identify all ASBS (areas of special biological significance) receiving waters downstream of the project discharge locations	
Provide distance from project outfall location to impaired or sensitive receiving waters	
Summarize information regarding the proximity of the permanent, post-construction storm water BMPs to the City's Multi-Habitat Planning Area and environmentally sensitive lands	



Project Name:

Form I-3B Page 8 of 11			
Identification of Receiving Water Pollutants of Concern			
List any 303(d) impaired water bodies within the path of storm water from the project site to the Pacific Ocean (or bay, lagoon, lake or reservoir, as applicable), identify the pollutant(s)/stressor(s) causing impairment, and identify any TMDLs and/or Highest Priority Pollutants from the WQIP for the impaired water bodies:			
303(d) Impaired Water Body (Refer to Appendix K)	Pollutant(s)/Stressor(s) (Refer to Appendix K)	TMDLs/WQIP Highest Priority Pollutant (Refer to Table 1-4 in Chapter 1)	
Identification of Project Site Pollutants*			
*Identification of project site pollutants is only required if flow-thru treatment BMPs are implemented onsite in lieu of retention or biofiltration BMPs (note the project must also participate in an alternative compliance program unless prior lawful approval to meet earlier PDP requirements is demonstrated)			
Identify pollutants anticipated from the project site based on all proposed use(s) of the site (see Appendix B.6):			
Pollutant	Not Applicable to the Project Site	Anticipated from the Project Site	Also a Receiving Water Pollutant of Concern
Sediment			
Nutrients			
Heavy Metals			
Organic Compounds			
Trash & Debris			
Oxygen Demanding Substances			
Oil & Grease			
Bacteria & Viruses			
Pesticides			



Project Name:

Form I-3B Page 9 of 11

Hydromodification Management Requirements

Do hydromodification management requirements apply (see Section 1.6)?

- Yes, hydromodification management flow control structural BMPs required.
- No, the project will discharge runoff directly to existing underground storm drains discharging directly to water storage reservoirs, lakes, enclosed embayments, or the Pacific Ocean.
- No, the project will discharge runoff directly to conveyance channels whose bed and bank are concrete-lined all the way from the point of discharge to water storage reservoirs, lakes, enclosed embayments, or the Pacific Ocean.
- No, the project will discharge runoff directly to an area identified as appropriate for an exemption by the WMAA for the watershed in which the project resides.

Description / Additional Information (to be provided if a 'No' answer has been selected above):

Note: If "No" answer has been selected the SWQMP must include an exhibit that shows the storm water conveyance system from the project site to an exempt water body. The exhibit should include details about the conveyance system and the outfall to the exempt water body.

Critical Coarse Sediment Yield Areas*

*This Section only required if hydromodification management requirements apply

Based on Section 6.2 and Appendix H does CCSYA exist on the project footprint or in the upstream area draining through the project footprint?

- Yes
- No

Discussion / Additional Information:



Project Name:

Form I-3B Page 10 of 11	
Flow Control for Post-Project Runoff*	
*This Section only required if hydromodification management requirements apply	
List and describe point(s) of compliance (POCs) for flow control for hydromodification management (see Section 6.3.1). For each POC, provide a POC identification name or number correlating to the project's HMP Exhibit and a receiving channel identification name or number correlating to the project's HMP Exhibit.	
Has a geomorphic assessment been performed for the receiving channel(s)? <input type="checkbox"/> No, the low flow threshold is $0.1Q_2$ (default low flow threshold) <input type="checkbox"/> Yes, the result is the low flow threshold is $0.1Q_2$ <input type="checkbox"/> Yes, the result is the low flow threshold is $0.3Q_2$ <input type="checkbox"/> Yes, the result is the low flow threshold is $0.5Q_2$ If a geomorphic assessment has been performed, provide title, date, and preparer:	
Discussion / Additional Information: (optional)	



Project Name:

Form I-3B Page 11 of 11

Other Site Requirements and Constraints

When applicable, list other site requirements or constraints that will influence storm water management design, such as zoning requirements including setbacks and open space, or local codes governing minimum street width, sidewalk construction, allowable pavement types, and drainage requirements.

Optional Additional Information or Continuation of Previous Sections As Needed

This space provided for additional information or continuation of information from previous sections as needed.



Project Name:

Source Control BMP Checklist for PDPs		Form I-4B		
Source Control BMPs				
All development projects must implement source control BMPs where applicable and feasible. See Chapter 4 and Appendix E of the BMP Design Manual (Part 1 of the Storm Water Standards) for information to implement source control BMPs shown in this checklist.				
Answer each category below pursuant to the following.				
<ul style="list-style-type: none"> • "Yes" means the project will implement the source control BMP as described in Chapter 4 and/or Appendix E of the BMP Design Manual. Discussion / justification is not required. • "No" means the BMP is applicable to the project but it is not feasible to implement. Discussion / justification must be provided. • "N/A" means the BMP is not applicable at the project site because the project does not include the feature that is addressed by the BMP (e.g., the project has no outdoor materials storage areas). Discussion / justification may be provided. 				
Source Control Requirement		Applied?		
4.2.1 Prevention of Illicit Discharges into the MS4		<input type="checkbox"/> Yes	<input type="checkbox"/> No	<input type="checkbox"/> N/A
Discussion / justification if 4.2.1 not implemented:				
4.2.2 Storm Drain Stenciling or Signage		<input type="checkbox"/> Yes	<input type="checkbox"/> No	<input type="checkbox"/> N/A
Discussion / justification if 4.2.2 not implemented:				
4.2.3 Protect Outdoor Materials Storage Areas from Rainfall, Run-On, Runoff, and Wind Dispersal		<input type="checkbox"/> Yes	<input type="checkbox"/> No	<input type="checkbox"/> N/A
Discussion / justification if 4.2.3 not implemented:				
4.2.4 Protect Materials Stored in Outdoor Work Areas from Rainfall, Run-On, Runoff, and Wind Dispersal		<input type="checkbox"/> Yes	<input type="checkbox"/> No	<input type="checkbox"/> N/A
Discussion / justification if 4.2.4 not implemented:				
4.2.5 Protect Trash Storage Areas from Rainfall, Run-On, Runoff, and Wind Dispersal		<input type="checkbox"/> Yes	<input type="checkbox"/> No	<input type="checkbox"/> N/A
Discussion / justification if 4.2.5 not implemented:				



Project Name:

Form I-4B Page 2 of 2			
Source Control Requirement	Applied?		
4.2.6 Additional BMPs Based on Potential Sources of Runoff Pollutants (must answer for each source listed below)			
On-site storm drain inlets	<input type="checkbox"/> Yes	<input type="checkbox"/> No	<input type="checkbox"/> N/A
Interior floor drains and elevator shaft sump pumps	<input type="checkbox"/> Yes	<input type="checkbox"/> No	<input type="checkbox"/> N/A
Interior parking garages	<input type="checkbox"/> Yes	<input type="checkbox"/> No	<input type="checkbox"/> N/A
Need for future indoor & structural pest control	<input type="checkbox"/> Yes	<input type="checkbox"/> No	<input type="checkbox"/> N/A
Landscape/Outdoor Pesticide Use	<input type="checkbox"/> Yes	<input type="checkbox"/> No	<input type="checkbox"/> N/A
Pools, spas, ponds, decorative fountains, and other water features	<input type="checkbox"/> Yes	<input type="checkbox"/> No	<input type="checkbox"/> N/A
Food service	<input type="checkbox"/> Yes	<input type="checkbox"/> No	<input type="checkbox"/> N/A
Refuse areas	<input type="checkbox"/> Yes	<input type="checkbox"/> No	<input type="checkbox"/> N/A
Industrial processes	<input type="checkbox"/> Yes	<input type="checkbox"/> No	<input type="checkbox"/> N/A
Outdoor storage of equipment or materials	<input type="checkbox"/> Yes	<input type="checkbox"/> No	<input type="checkbox"/> N/A
Vehicle/Equipment Repair and Maintenance	<input type="checkbox"/> Yes	<input type="checkbox"/> No	<input type="checkbox"/> N/A
Fuel Dispensing Areas	<input type="checkbox"/> Yes	<input type="checkbox"/> No	<input type="checkbox"/> N/A
Loading Docks	<input type="checkbox"/> Yes	<input type="checkbox"/> No	<input type="checkbox"/> N/A
Fire Sprinkler Test Water	<input type="checkbox"/> Yes	<input type="checkbox"/> No	<input type="checkbox"/> N/A
Miscellaneous Drain or Wash Water	<input type="checkbox"/> Yes	<input type="checkbox"/> No	<input type="checkbox"/> N/A
Plazas, sidewalks, and parking lots	<input type="checkbox"/> Yes	<input type="checkbox"/> No	<input type="checkbox"/> N/A
SC-6A: Large Trash Generating Facilities	<input type="checkbox"/> Yes	<input type="checkbox"/> No	<input type="checkbox"/> N/A
SC-6B: Animal Facilities	<input type="checkbox"/> Yes	<input type="checkbox"/> No	<input type="checkbox"/> N/A
SC-6C: Plant Nurseries and Garden Centers	<input type="checkbox"/> Yes	<input type="checkbox"/> No	<input type="checkbox"/> N/A
SC-6D: Automotive Facilities	<input type="checkbox"/> Yes	<input type="checkbox"/> No	<input type="checkbox"/> N/A
Discussion / justification if 4.2.6 not implemented. Clearly identify which sources of runoff pollutants are discussed. Justification must be provided for <u>all</u> "No" answers shown above.			



Project Name:

Site Design BMP Checklist for PDPs		Form I-5B	
Site Design BMPs			
<p>All development projects must implement site design BMPs where applicable and feasible. See Chapter 4 and Appendix E of the BMP Design Manual (Part 1 of Storm Water Standards) for information to implement site design BMPs shown in this checklist.</p> <p>Answer each category below pursuant to the following.</p> <ul style="list-style-type: none"> • "Yes" means the project will implement the site design BMP as described in Chapter 4 and/or Appendix E of the BMP Design Manual. Discussion / justification is not required. • "No" means the BMP is applicable to the project but it is not feasible to implement. Discussion / justification must be provided. • "N/A" means the BMP is not applicable at the project site because the project does not include the feature that is addressed by the BMP (e.g., the project site has no existing natural areas to conserve). Discussion / justification may be provided. <p>A site map with implemented site design BMPs must be included at the end of this checklist.</p>			
Site Design Requirement		Applied?	
4.3.1 Maintain Natural Drainage Pathways and Hydrologic Features		<input type="checkbox"/> Yes	<input type="checkbox"/> No <input type="checkbox"/> N/A
Discussion / justification if 4.3.1 not implemented:			
1-1 Are existing natural drainage pathways and hydrologic features mapped on the site map?		<input type="checkbox"/> Yes	<input type="checkbox"/> No <input type="checkbox"/> N/A
1-2 Are trees implemented? If yes, are they shown on the site map?		<input type="checkbox"/> Yes	<input type="checkbox"/> No <input type="checkbox"/> N/A
1-3 Implemented trees meet the design criteria in 4.3.1 Fact Sheet (e.g. soil volume, maximum credit, etc.)?		<input type="checkbox"/> Yes	<input type="checkbox"/> No <input type="checkbox"/> N/A
1-4 Is tree credit volume calculated using Appendix B.2.2.1 and SD-1 Fact Sheet in Appendix E?		<input type="checkbox"/> Yes	<input type="checkbox"/> No <input type="checkbox"/> N/A
4.3.2 Have natural areas, soils and vegetation been conserved?		<input type="checkbox"/> Yes	<input type="checkbox"/> No <input type="checkbox"/> N/A
Discussion / justification if 4.3.2 not implemented:			



Project Name:

Form I-5B Page 2 of 4			
Site Design Requirement	Applied?		
4.3.3 Minimize Impervious Area	<input type="checkbox"/> Yes	<input type="checkbox"/> No	<input type="checkbox"/> N/A
Discussion / justification if 4.3.3 not implemented:			
4.3.4 Minimize Soil Compaction	<input type="checkbox"/> Yes	<input type="checkbox"/> No	<input type="checkbox"/> N/A
Discussion / justification if 4.3.4 not implemented:			
4.3.5 Impervious Area Dispersion	<input type="checkbox"/> Yes	<input type="checkbox"/> No	<input type="checkbox"/> N/A
Discussion / justification if 4.3.5 not implemented:			
5-1	Is the pervious area receiving runoff from impervious area identified on the site map?	<input type="checkbox"/> Yes	<input type="checkbox"/> No <input type="checkbox"/> N/A
5-2	Does the pervious area satisfy the design criteria in 4.3.5 Fact Sheet in Appendix E (e.g. maximum slope, minimum length, etc.)	<input type="checkbox"/> Yes	<input type="checkbox"/> No <input type="checkbox"/> N/A
5-3	Is impervious area dispersion credit volume calculated using Appendix B.2.1.1 and 4.3.5 Fact Sheet in Appendix E?	<input type="checkbox"/> Yes	<input type="checkbox"/> No <input type="checkbox"/> N/A



Project Name:

Form I-5B Page 3 of 4			
Site Design Requirement	Applied?		
4.3.6 Runoff Collection	<input type="checkbox"/> Yes	<input type="checkbox"/> No	<input type="checkbox"/> N/A
Discussion / justification if 4.3.6 not implemented:			
6a-1 Are green roofs implemented in accordance with design criteria in 4.3.6A Fact Sheet? If yes, are they shown on the site map?	<input type="checkbox"/> Yes	<input type="checkbox"/> No	<input type="checkbox"/> N/A
6a-2 Is the green roof credit volume calculated using Appendix B.2.1.2 and 4.3.6A Fact Sheet in Appendix E?	<input type="checkbox"/> Yes	<input type="checkbox"/> No	<input type="checkbox"/> N/A
6b-1 Are permeable pavements implemented in accordance with design criteria in 4.3.6B Fact Sheet? If yes, are they shown on the site map?	<input type="checkbox"/> Yes	<input type="checkbox"/> No	<input type="checkbox"/> N/A
6b-2 Is the permeable pavement credit volume calculated using Appendix B.2.1.3 and 4.3.6B Fact Sheet in Appendix E?	<input type="checkbox"/> Yes	<input type="checkbox"/> No	<input type="checkbox"/> N/A
4.3.7 Landscaping with Native or Drought Tolerant Species	<input type="checkbox"/> Yes	<input type="checkbox"/> No	<input type="checkbox"/> N/A
Discussion / justification if 4.3.7 not implemented:			
4.3.8 Harvest and Use Precipitation	<input type="checkbox"/> Yes	<input type="checkbox"/> No	<input type="checkbox"/> N/A
Discussion / justification if 4.3.8 not implemented:			
8-1 Are rain barrels implemented in accordance with design criteria in 4.3.8 Fact Sheet? If yes, are they shown on the site map?	<input type="checkbox"/> Yes	<input type="checkbox"/> No	<input type="checkbox"/> N/A
8-2 Is the rain barrel credit volume calculated using Appendix B.2.2.2 and 4.3.8 Fact Sheet in Appendix E?	<input type="checkbox"/> Yes	<input type="checkbox"/> No	<input type="checkbox"/> N/A



Project Name:

Form I-5B Page 4 of 4

Insert Site Map with all site design BMPs identified:

Refer to DMA Exhibit in Attachment 1

Project Name:

THIS PAGE INTENTIONALLY LEFT BLANK FOR DOUBLE-SIDED PRINTING

Project Name:

(Continued from page 1)



Project Name:

Form I-6 Page of (Copy as many as needed)	
Structural BMP Summary Information	
Structural BMP ID No.	
Construction Plan Sheet No.	
Type of Structural BMP: <input type="checkbox"/> Retention by harvest and use (e.g. HU-1, cistern) <input type="checkbox"/> Retention by infiltration basin (INF-1) <input type="checkbox"/> Retention by bioretention (INF-2) <input type="checkbox"/> Retention by permeable pavement (INF-3) <input type="checkbox"/> Partial retention by biofiltration with partial retention (PR-1) <input type="checkbox"/> Biofiltration (BF-1) <input type="checkbox"/> Flow-thru treatment control with prior lawful approval to meet earlier PDP requirements (provide BMP type/description in discussion section below) <input type="checkbox"/> Flow-thru treatment control included as pre-treatment/forebay for an onsite retention or biofiltration BMP (provide BMP type/description and indicate which onsite retention or biofiltration BMP it serves in discussion section below) <input type="checkbox"/> Flow-thru treatment control with alternative compliance (provide BMP type/description in discussion section below) <input type="checkbox"/> Detention pond or vault for hydromodification management <input type="checkbox"/> Other (describe in discussion section below)	
Purpose: <input type="checkbox"/> Pollutant control only <input type="checkbox"/> Hydromodification control only <input type="checkbox"/> Combined pollutant control and hydromodification control <input type="checkbox"/> Pre-treatment/forebay for another structural BMP <input type="checkbox"/> Other (describe in discussion section below)	
Who will certify construction of this BMP? Provide name and contact information for the party responsible to sign BMP verification form DS-563	
Who will be the final owner of this BMP?	
Who will maintain this BMP into perpetuity?	
What is the funding mechanism for maintenance?	



Project Name:

Form I-6 Page of (Copy as many as needed)
Structural BMP ID No.
Construction Plan Sheet No.
Discussion (as needed; must include worksheets showing BMP sizing calculations in the SWQMPs):



Project Name:

Form I-6 Page of (Copy as many as needed)	
Structural BMP Summary Information	
Structural BMP ID No.	
Construction Plan Sheet No.	
Type of Structural BMP: <input type="checkbox"/> Retention by harvest and use (e.g. HU-1, cistern) <input type="checkbox"/> Retention by infiltration basin (INF-1) <input type="checkbox"/> Retention by bioretention (INF-2) <input type="checkbox"/> Retention by permeable pavement (INF-3) <input checked="" type="checkbox"/> Partial retention by biofiltration with partial retention (PR-1) <input type="checkbox"/> Biofiltration (BF-1) <input type="checkbox"/> Flow-thru treatment control with prior lawful approval to meet earlier PDP requirements (provide BMP type/description in discussion section below) <input type="checkbox"/> Flow-thru treatment control included as pre-treatment/forebay for an onsite retention or biofiltration BMP (provide BMP type/description and indicate which onsite retention or biofiltration BMP it serves in discussion section below) <input type="checkbox"/> Flow-thru treatment control with alternative compliance (provide BMP type/description in discussion section below) <input type="checkbox"/> Detention pond or vault for hydromodification management <input type="checkbox"/> Other (describe in discussion section below)	
Purpose: <input type="checkbox"/> Pollutant control only <input type="checkbox"/> Hydromodification control only <input checked="" type="checkbox"/> Combined pollutant control and hydromodification control <input type="checkbox"/> Pre-treatment/forebay for another structural BMP <input type="checkbox"/> Other (describe in discussion section below)	
Who will certify construction of this BMP? Provide name and contact information for the party responsible to sign BMP verification form DS-563	
Who will be the final owner of this BMP?	
Who will maintain this BMP into perpetuity?	
What is the funding mechanism for maintenance?	



Project Name:

Form I-6 Page of (Copy as many as needed)
Structural BMP ID No.
Construction Plan Sheet No.
Discussion (as needed; must include worksheets showing BMP sizing calculations in the SWQMPs):



Project Name:

Attachment 1

Backup For PDP Pollutant Control BMPs

This is the cover sheet for Attachment 1.

Project Name:

THIS PAGE INTENTIONALLY LEFT BLANK FOR DOUBLE-SIDED PRINTING

Project Name:

Indicate which Items are Included:

Attachment Sequence	Contents	Checklist
Attachment 1a	DMA Exhibit (Required) See DMA Exhibit Checklist.	<input checked="" type="checkbox"/> Included
Attachment 1b	Tabular Summary of DMAs Showing DMA ID matching DMA Exhibit, DMA Area, and DMA Type (Required)* *Provide table in this Attachment OR on DMA Exhibit in Attachment 1a	<input type="checkbox"/> Included on DMA Exhibit in Attachment 1a <input type="checkbox"/> Included as Attachment 1b, separate from DMA Exhibit
Attachment 1c	Form I-7, Harvest and Use Feasibility Screening Checklist (Required unless the entire project will use infiltration BMPs) Refer to Appendix B.3-1 of the BMP Design Manual to complete Form I-7.	<input type="checkbox"/> Included <input type="checkbox"/> Not included because the entire project will use infiltration BMPs
Attachment 1d	Infiltration Feasibility Information. Contents of Attachment 1d depend on the infiltration condition: <ul style="list-style-type: none">• No Infiltration Condition:<ul style="list-style-type: none">○ Infiltration Feasibility Condition Letter (<i>Note: must be stamped and signed by licensed geotechnical engineer</i>)○ Form I-8A (optional)○ Form I-8B (optional)• Partial Infiltration Condition:<ul style="list-style-type: none">○ Infiltration Feasibility Condition Letter (<i>Note: must be stamped and signed by licensed geotechnical engineer</i>)○ Form I-8A○ Form I-8B• Full Infiltration Condition:<ul style="list-style-type: none">○ Form I-8A○ Form I-8B○ Worksheet C.4-3○ Form I-9 Refer to Appendices C and D of the BMP Design Manual for guidance.	<input type="checkbox"/> Included <input type="checkbox"/> Not included because the entire project will use harvest and use BMPs
Attachment 1e	Pollutant Control BMP Design Worksheets / Calculations (Required) Refer to Appendices B and E of the BMP Design Manual for structural pollutant control BMP design guidelines and site design credit calculations	<input type="checkbox"/> Included



Project Name:

Use this checklist to ensure the required information has been included on the DMA Exhibit:

The DMA Exhibit must identify:

- Underlying hydrologic soil group
- Approximate depth to groundwater
- Existing natural hydrologic features (watercourses, seeps, springs, wetlands)
- Critical coarse sediment yield areas to be protected
- Existing topography and impervious areas
- Existing and proposed site drainage network and connections to drainage offsite
- Proposed grading
- Proposed impervious features
- Proposed design features and surface treatments used to minimize imperviousness
- Drainage management area (DMA) boundaries, DMA ID numbers, and DMA areas (square footage or acreage), and DMA type (i.e., drains to BMP, self-retaining, or self-mitigating)
- Potential pollutant source areas and corresponding required source controls (see Chapter 4, Appendix E.1, and Form I-3B)
- Structural BMPs (identify location, type of BMP, size/detail, and include cross-section)

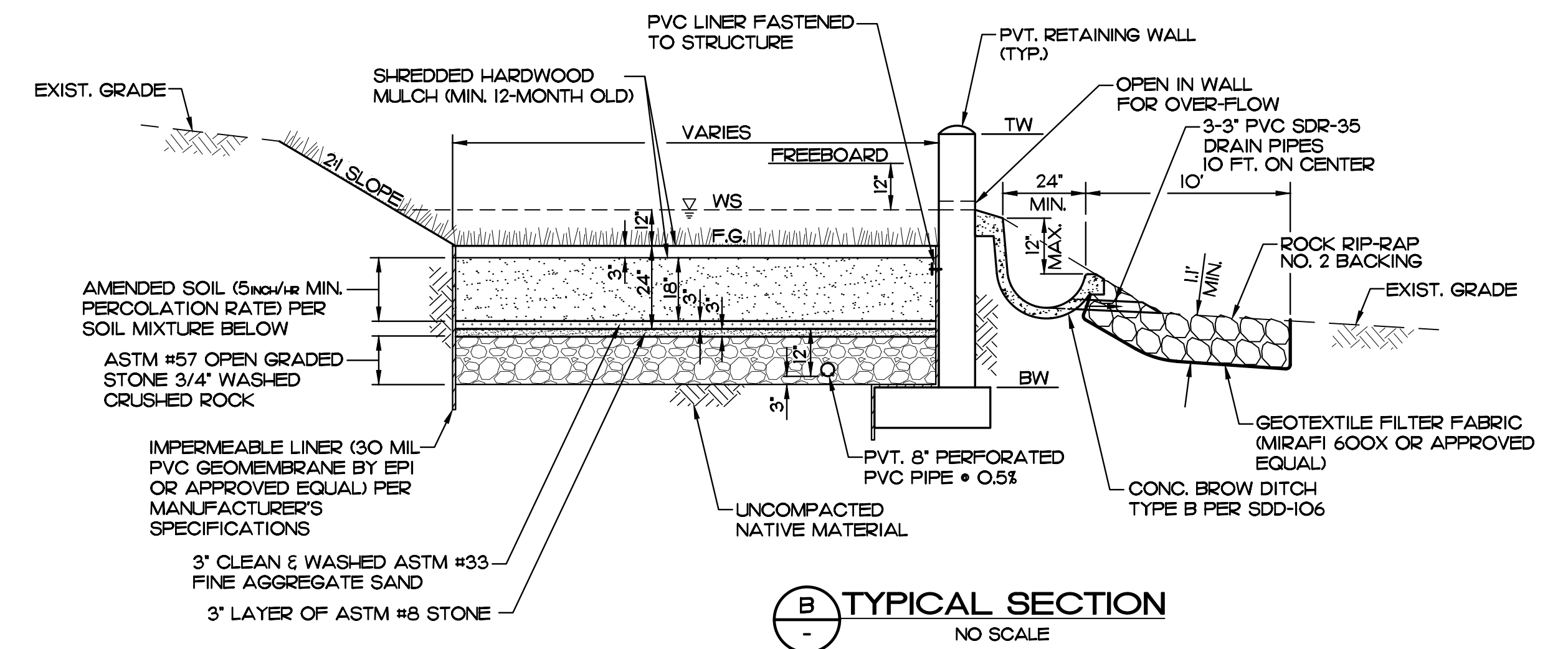
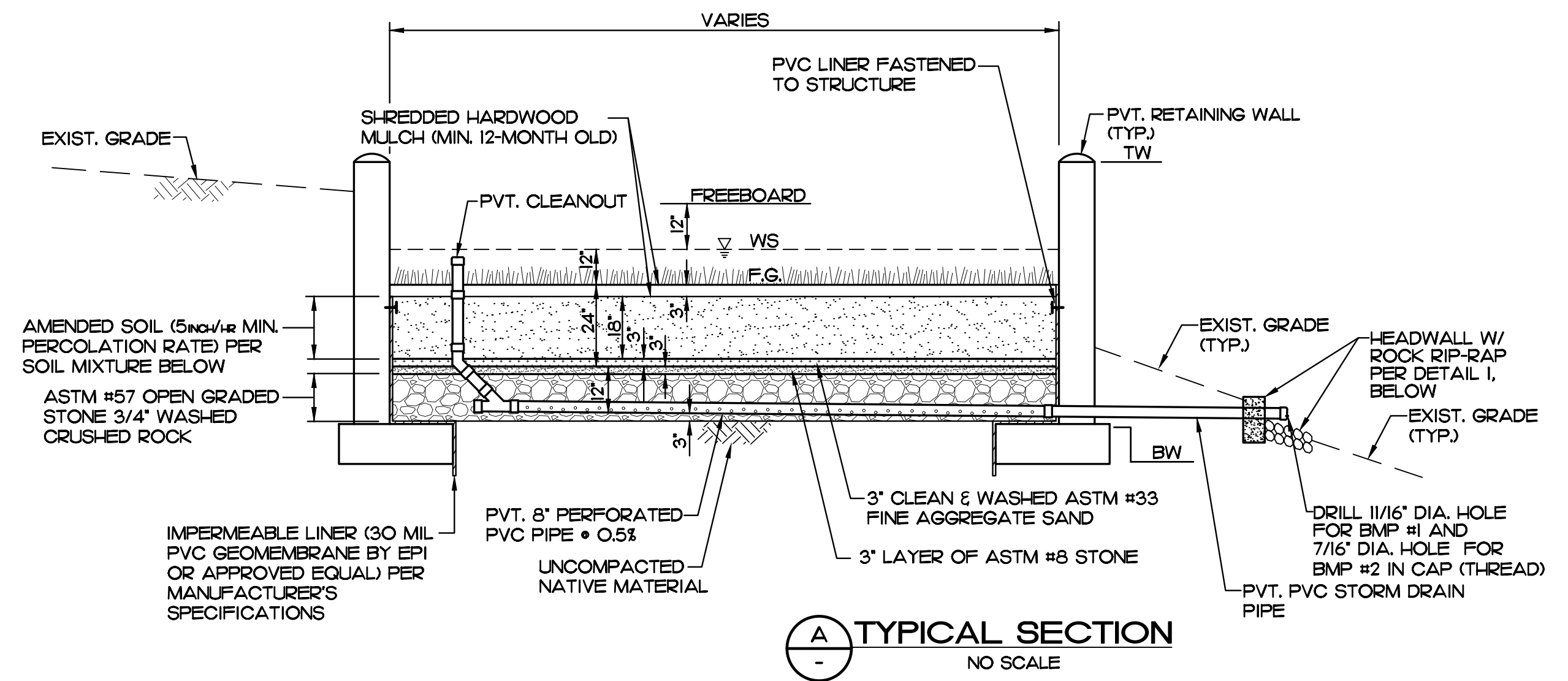
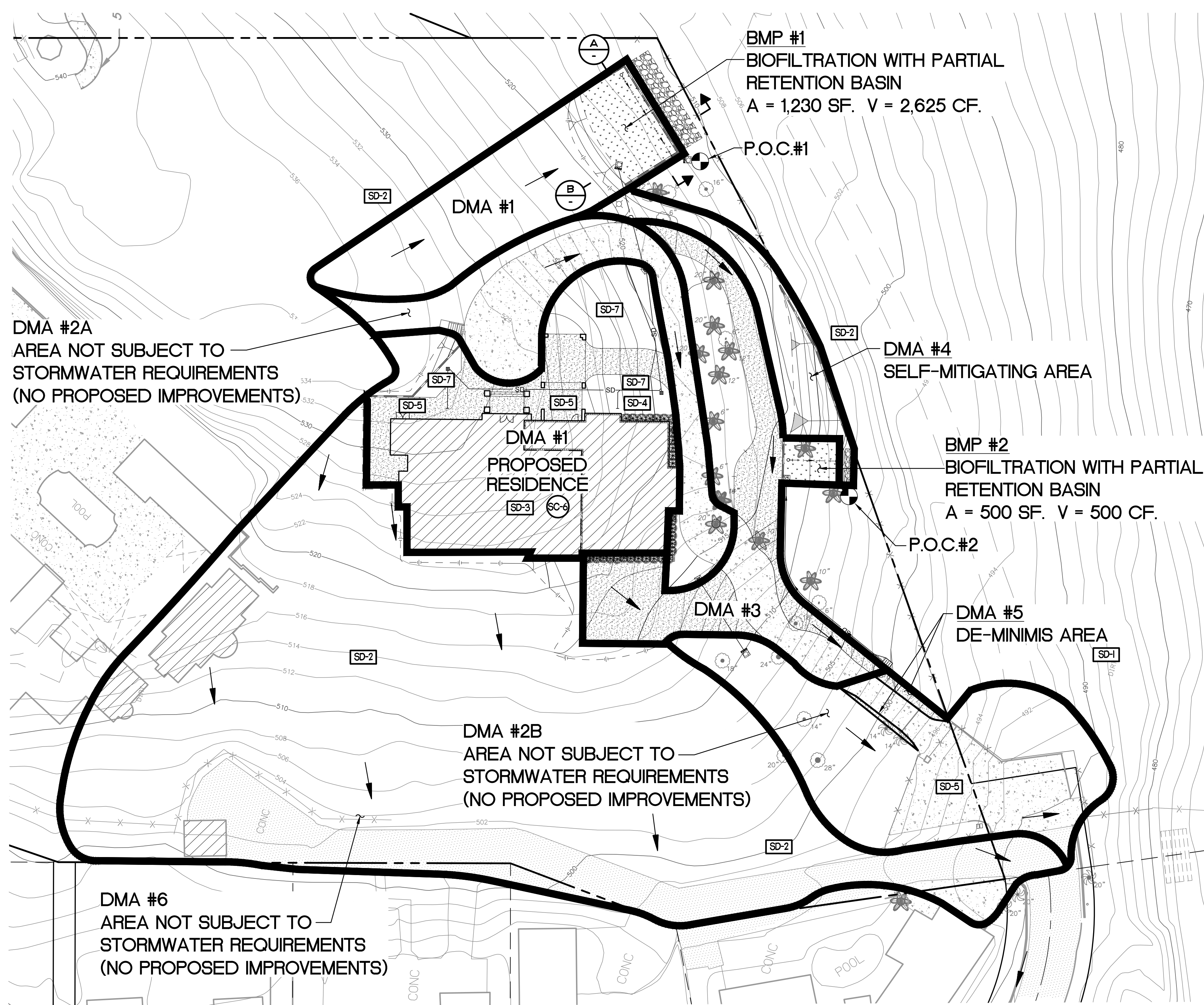

SOIL MIXTURE:
85% WASHED SAND, 10% FINES (SILT & CLAY), 5% ORGANIC MATTER.
(SEE CITY OF SAN DIEGO STORM WATER STANDARDS, APPENDIX F.)

PVT. BIOFILTRATION W/ PARTIAL RETENTION
NO SCALE

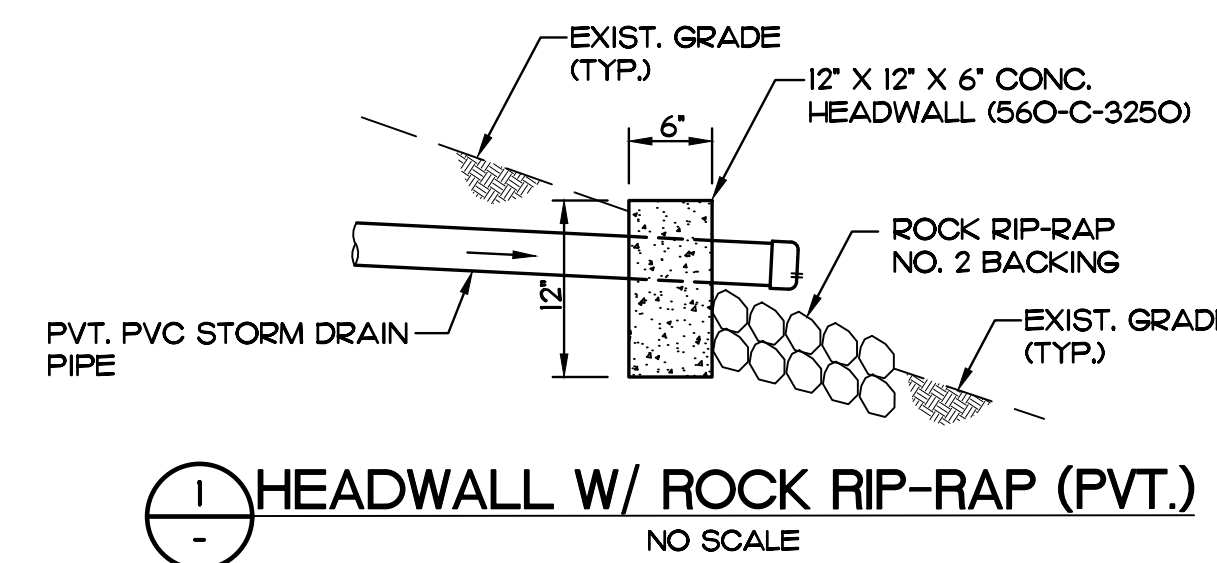

DRAINAGE MANAGEMENT AREAS										
DESCRIPTION	TRIBUTARY TO BMP	BMP TYPE	SOIL TYPE	DEPTH TO GROUNDWATER	PRE-PROJECT SLOPE	IMPERVIOUS DMA'S		PERVIOUS DMA'S		TOTAL AREA (SF.)
						POST-PROJECT SURFACE TYPE	POST-PROJECT SURFACE AREA IMPERVIOUS (SF.)	POST-PROJECT SURFACE TYPE PERVIOUS	POST-PROJECT SURFACE AREA PERVIOUS (SF.)	
DMA #1	BMP #1	BIOFILTRATION WITH PARTIAL RETENTION (PR-1)	D	> 20 FEET	STEEP (> 15%)	ROOFS / CONCRETE	10,721	LANDSCAPING	10,692	21,413
DMA #2A	N/A	NOT SUBJECT TO STORMWATER REQ.	D	> 20 FEET	STEEP (> 15%)	CONCRETE	4,914	LANDSCAPING	1,837	6,751
DMA #2B	N/A	NOT SUBJECT TO STORMWATER REQ.	D	> 20 FEET	STEEP (> 15%)	CONCRETE	3,672	LANDSCAPING	6,990	10,662
DMA #3	BMP #2	BIOFILTRATION WITH PARTIAL RETENTION (PR-1)	D	> 20 FEET	STEEP (> 15%)	CONCRETE	6,786	LANDSCAPING	2,705	9,491
DMA #4	N/A	SELF-MITIGATING	D	> 20 FEET	STEEP (> 15%)	N/A	0	LANDSCAPING	2,997	2,997
DMA #5	N/A	DE-MINIMIS	D	> 20 FEET	STEEP (> 15%)	CONCRETE	250	N/A	0	250
DMA #6	N/A	NOT SUBJECT TO STORMWATER REQ.	D	> 20 FEET	STEEP (> 15%)	ROOFS / PAVEMENT	10,677	LANDSCAPING	38,298	48,975
TOTAL	---	---	---	---	---	---	37,020	---	63,519	100,539

SITE DESIGN BMP'S

- (SD-1)** MAINTAIN NATURAL DRAINAGE PATHWAYS & HYDROLOGIC FEATURES.
- (SD-2)** CONSERVE NATURAL AREAS, SOILS, AND VEGETATION.
- (SD-3)** MINIMIZE IMPERVIOUS AREA.
- (SD-4)** MINIMIZE SOIL COMPACTION.
- (SD-5)** IMPERVIOUS AREA DISPERSION.
- (SD-7)** LANDSCAPING WITH NATIVE OR DROUGHT TOLERANT SPECIES.

SOURCE CONTROL BMP'S

- (SC-1)** PREVENTION OF ILLICIT DISCHARGES INTO MS4.
- (SC-6)** ADDITIONAL BMP'S TO MINIMIZE POLLUTANT GENERATION

- FUTURE INDOOR & PEST CONTROL.
- LANDSCAPE/OUTDOOR PESTICIDE USE SHALL BE KEPT TO A MINIMUM.
- FIRE SPRINKLER TEST WATER SHALL BE PLUMBED TO THE SANITARY SEWER.
- MISCELLANEOUS DRAIN OR WASH WATER SHALL BE PLUMBED TO THE SANITARY SEWER.

NOTES

1. SITE IS LOCATED WITHIN OCEANSIDE RAIN GAUGE BASIN.
2. UNDERLYING HYDROLOGIC SOIL GROUP D.
3. SITE HAS MODERATE SLOPE.
4. CHANNEL ASSESSMENT WAS NOT CONDUCTED, LOW FLOW THRESHOLD ASSUMED 10% OF Q₂ (O.I.Q.).
5. TWO PROPOSED TCBMPS ARE BIOFILTRATION WITH PARTIAL RETENTION FACILITIES.
6. COUNTY OF SAN DIEGO'S 85TH PERCENTILE ISOPLEUVIAL MAP WAS UTILIZED FOR SIZING TCBMP WHICH WILL COMPLY FOR COMBINED POLLUTANT CONTROL AND HYDROMODIFICATION FLOW CONTROL.
7. GROUNDWATER LEVEL HAS NOT BEEN DETERMINED.
8. CRITICAL COURSE SEDIMENT YIELD AREAS (CCSYAS) WERE NOT IDENTIFIED ONSITE OR UPSTREAM OF THE SITE.

HYDROMODIFICATION MANAGEMENT

THIS DMA EXHIBIT IS ALSO A HYDROMODIFICATION EXHIBIT AS ALL STRUCTURAL BMP'S ACT AS COMBINED POLLUTANT CONTROL AND HYDROMODIFICATION CONTROL BMP'S.

LEGEND

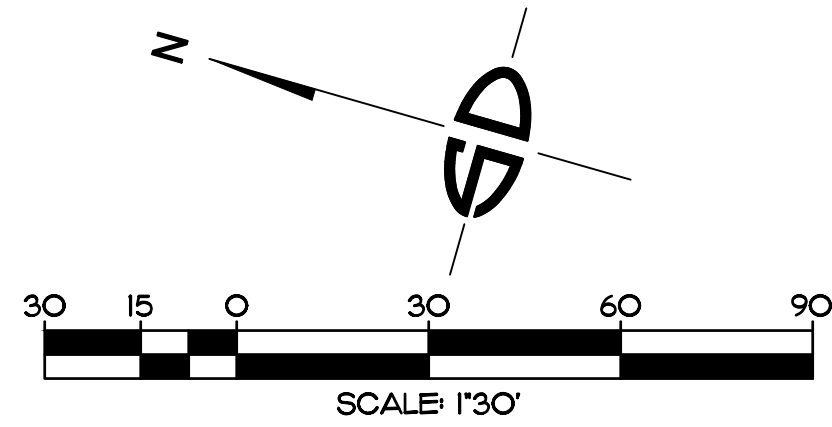
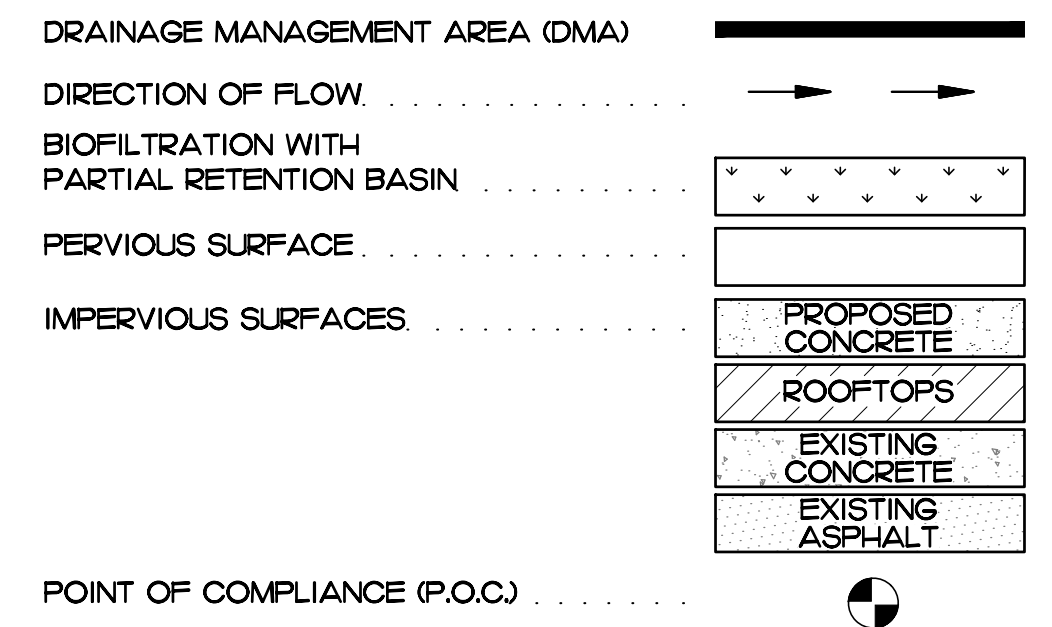

Project Name:

Tabular Summary of DMAs							Worksheet B-1		
DMA Unique Identifier	Area (acres)	Impervious Area (acres)	% Imp	HSG	Area Weighted Runoff Coefficient	DCV (cubic feet)	Treated By (BMP ID)	Pollutant Control Type	Drains to (POC ID)
Summary of DMA Information (Must match project description and SWQMP Narrative)									
No. of DMAs	Total DMA Area (acres)	Total Impervious Area (acres)	% Imp		Area Weighted Runoff Coefficient	Total DCV (cubic feet)	Total Area Treated (acres)		No. of POCs

Where: DMA = Drainage Management Area; Imp = Imperviousness; HSG = Hydrologic Soil Group; DCV= Design Capture Volume; BMP = Best Management Practice; POC = Point of Compliance; ID = identifier; No. = Number



DMA#1

Design Capture Volume		Worksheet B.2-1		
1	85 th percentile 24-hr storm depth from Figure B.1-1	d=		inches
2	Area tributary to BMP (s)	A=		acres
3	Area weighted runoff factor (estimate using Appendix B.1.1 and B.2.1)	C=		unitless
4	Trees Credit Volume Note: In the SWQMP list the number of trees, size of each tree, amount of soil volume installed for each tree, contributing area to each tree and the inlet opening dimension for each tree.	TCV=		cubic-feet
5	Rain barrels Credit Volume Note: In the SWQMP list the number of rain barrels, size of each rain barrel and the use of the captured storm water runoff.	RCV=		cubic-feet
6	Calculate DCV = (3630 x C x d x A) – TCV - RCV	DCV=		cubic-feet

DMA#3

Design Capture Volume		Worksheet B.2-1		
1	85 th percentile 24-hr storm depth from Figure B.1-1	d=		inches
2	Area tributary to BMP (s)	A=		acres
3	Area weighted runoff factor (estimate using Appendix B.1.1 and B.2.1)	C=		unitless
4	<p>Trees Credit Volume</p> <p>Note: In the SWQMP list the number of trees, size of each tree, amount of soil volume installed for each tree, contributing area to each tree and the inlet opening dimension for each tree.</p>	TCV=		cubic-feet
5	<p>Rain barrels Credit Volume</p> <p>Note: In the SWQMP list the number of rain barrels, size of each rain barrel and the use of the captured storm water runoff.</p>	RCV=		cubic-feet
6	Calculate DCV = (3630 x C x d x A) – TCV - RCV	DCV=		cubic-feet

1. Is there a demand for harvested water (check all that apply) at the project site that is reliably present during the wet season?

Toilet and urinal flushing

Landscape irrigation

Other: _____

2. If there is a demand; estimate the anticipated average wet season demand over a period of 36 hours. Guidance for planning level demand calculations for toilet/urinal flushing and landscape irrigation is provided in Section B.3.2.
[Provide a summary of calculations here]

3. Calculate the DCV using worksheet B-2.1.
DCV = _____ (cubic feet)
[Provide a summary of calculations here]

<p>3a. Is the 36-hour demand greater than or equal to the DCV?</p> <p style="text-align: center;">Yes / No ⇒</p> <p style="text-align: center;">↓</p>	<p>3b. Is the 36-hour demand greater than 0.25DCV but less than the full DCV?</p> <p style="text-align: center;"><input type="checkbox"/> Yes / No ⇒</p> <p style="text-align: center;">↓</p>	<p>3c. Is the 36-hour demand less than 0.25DCV?</p> <p style="text-align: center;">Yes</p> <p style="text-align: center;">↓</p>
----------------------------------------------------------------------------------------------------------------------------------------------------------	--------------------------------------------------------------------------------------------------------------------------------------------------------------------------------------------------	---------------------------------------------------------------------------------------------------------------------------------

<p>Harvest and use appears to be feasible. Conduct more detailed evaluation and sizing calculations to confirm that DCV can be used at an adequate rate to meet drawdown criteria.</p>	<p>Harvest and use may be feasible. Conduct more detailed evaluation and sizing calculations to determine feasibility. Harvest and use may only be able to be used for a portion of the site, or (optionally) the storage may need to be upsized to meet long term capture targets while draining in longer than 36 hours.</p>	<p>Harvest and use is considered to be infeasible.</p>
----------------------------------------------------------------------------------------------------------------------------------------------------------------------------------------	--------------------------------------------------------------------------------------------------------------------------------------------------------------------------------------------------------------------------------------------------------------------------------------------------------------------------------	--------------------------------------------------------

Is harvest and use feasible based on further evaluation?
 Yes, refer to Appendix E to select and size harvest and use BMPs.
 No, select alternate BMPs.

Categorization of Infiltration Feasibility Condition based on Geotechnical Conditions ¹		Worksheet C.4-1: Form I-8A ²
Part 1 - Full Infiltration Feasibility Screening Criteria		
DMA(s) Being Analyzed:		Project Phase:
Criteria 1: Infiltration Rate Screening		
1A	<p>Is the mapped hydrologic soil group according to the NRCS Web Soil Survey or UC Davis Soil Web Mapper Type A or B and corroborated by available site soil data³?</p> <p><input type="checkbox"/> Yes; the DMA may feasibly support full infiltration. Answer “Yes” to Criteria 1 Result or continue to Step 1B if the applicant elects to perform infiltration testing.</p> <p><input type="checkbox"/> No; the mapped soil types are A or B but is not corroborated by available site soil data (continue to Step 1B).</p> <p><input type="checkbox"/> No; the mapped soil types are C, D, or “urban/unclassified” and is corroborated by available site soil data. Answer “No” to Criteria 1 Result.</p> <p><input type="checkbox"/> No; the mapped soil types are C, D, or “urban/unclassified” but is not corroborated by available site soil data (continue to Step 1B).</p>	
1B	<p>Is the reliable infiltration rate calculated using planning phase methods from Table D.3-1?</p> <p><input type="checkbox"/> Yes; Continue to Step 1C.</p> <p><input type="checkbox"/> No; Skip to Step 1D.</p>	
1C	<p>Is the reliable infiltration rate calculated using planning phase methods from Table D.3-1 greater than 0.5 inches per hour?</p> <p><input type="checkbox"/> Yes; the DMA may feasibly support full infiltration. Answer “Yes” to Criteria 1 Result.</p> <p><input type="checkbox"/> No; full infiltration is not required. Answer “No” to Criteria 1 Result.</p>	
1D	<p>Infiltration Testing Method. Is the selected infiltration testing method suitable during the design phase (see Appendix D.3)? Note: Alternative testing standards may be allowed with appropriate rationales and documentation.</p> <p><input type="checkbox"/> Yes; continue to Step 1E.</p> <p><input type="checkbox"/> No; select an appropriate infiltration testing method.</p>	

¹ Note that it is not required to investigate each and every criterion in the worksheet, a single “no” answer in Part 1, Part 2, Part 3, or Part 4 determines a full, partial, or no infiltration condition.

² This form must be completed each time there is a change to the site layout that would affect the infiltration feasibility condition. Previously completed forms shall be retained to document the evolution of the site storm water design.

³ Available data includes site-specific sampling or observation of soil types or texture classes, such as obtained from borings or test pits necessary to support other design elements.



Categorization of Infiltration Feasibility Condition based on Geotechnical Conditions		Worksheet C.4-1: Form I-8A ²
1E	<p>Number of Percolation/Infiltration Tests. Does the infiltration testing method performed satisfy the minimum number of tests specified in Table D.3-2?</p> <input type="checkbox"/> Yes; continue to Step 1F. <input type="checkbox"/> No; conduct appropriate number of tests.	
1F	<p>Factor of Safety. Is the suitable Factor of Safety selected for full infiltration design? See guidance in D.5; Tables D.5-1 and D.5-2; and Worksheet D.5-1 (Form I-9).</p> <input type="checkbox"/> Yes; continue to Step 1G. <input type="checkbox"/> No; select appropriate factor of safety.	
1G	<p>Full Infiltration Feasibility. Is the average measured infiltration rate divided by the Factor of Safety greater than 0.5 inches per hour?</p> <input type="checkbox"/> Yes; answer “Yes” to Criteria 1 Result. <input type="checkbox"/> No; answer “No” to Criteria 1 Result.	
Criteria 1 Result	<p>Is the estimated reliable infiltration rate greater than 0.5 inches per hour within the DMA where runoff can reasonably be routed to a BMP?</p> <input type="checkbox"/> Yes; the DMA may feasibly support full infiltration. Continue to Criteria 2. <input type="checkbox"/> No; full infiltration is not required. Skip to Part 1 Result.	
<p>Summarize infiltration testing methods, testing locations, replicates, and results and summarize estimates of reliable infiltration rates according to procedures outlined in D.5. Documentation should be included in project geotechnical report.</p>		



Criteria 2: Geologic/Geotechnical Screening

2A	<p>If all questions in Step 2A are answered “Yes,” continue to Step 2B.</p> <p>For any “No” answer in Step 2A answer “No” to Criteria 2, and submit an “Infiltration Feasibility Condition Letter” that meets the requirements in Appendix C.1.1. The geologic/geotechnical analyses listed in Appendix C.2.1 do not apply to the DMA because one of the following setbacks cannot be avoided and therefore result in the DMA being in a no infiltration condition. The setbacks must be the closest horizontal radial distance from the surface edge (at the overflow elevation) of the BMP.</p>		
2A-1	Can the proposed full infiltration BMP(s) avoid areas with existing fill materials greater than 5 feet thick below the infiltrating surface?	<input type="checkbox"/> Yes	<input type="checkbox"/> No
2A-2	Can the proposed full infiltration BMP(s) avoid placement within 10 feet of existing underground utilities, structures, or retaining walls?	<input type="checkbox"/> Yes	<input type="checkbox"/> No
2A-3	Can the proposed full infiltration BMP(s) avoid placement within 50 feet of a natural slope (>25%) or within a distance of 1.5H from fill slopes where H is the height of the fill slope?	<input type="checkbox"/> Yes	<input type="checkbox"/> No
2B	<p>When full infiltration is determined to be feasible, a geotechnical investigation report must be prepared that considers the relevant factors identified in Appendix C.2.1.</p> <p>If all questions in Step 2B are answered “Yes,” then answer “Yes” to Criteria 2 Result. If there are “No” answers continue to Step 2C.</p>		
2B-1	<p>Hydroconsolidation. Analyze hydroconsolidation potential per approved ASTM standard due to a proposed full infiltration BMP.</p> <p>Can full infiltration BMPs be proposed within the DMA without increasing hydroconsolidation risks?</p>	<input type="checkbox"/> Yes	<input type="checkbox"/> No
2B-2	<p>Expansive Soils. Identify expansive soils (soils with an expansion index greater than 20) and the extent of such soils due to proposed full infiltration BMPs.</p> <p>Can full infiltration BMPs be proposed within the DMA without increasing expansive soil risks?</p>	<input type="checkbox"/> Yes	<input type="checkbox"/> No



Categorization of Infiltration Feasibility Condition based on Geotechnical Conditions		Worksheet C.4-1: Form I-8A ²	
2B-3	<p>Liquefaction. If applicable, identify mapped liquefaction areas. Evaluate liquefaction hazards in accordance with Section 6.4.2 of the City of San Diego's Guidelines for Geotechnical Reports (2011 or most recent edition). Liquefaction hazard assessment shall take into account any increase in groundwater elevation or groundwater mounding that could occur as a result of proposed infiltration or percolation facilities.</p> <p>Can full infiltration BMPs be proposed within the DMA without increasing liquefaction risks?</p>	<input type="checkbox"/> Yes	<input type="checkbox"/> No
2B-4	<p>Slope Stability. If applicable, perform a slope stability analysis in accordance with the ASCE and Southern California Earthquake Center (2002) Recommended Procedures for Implementation of DMG Special Publication 117, Guidelines for Analyzing and Mitigating Landslide Hazards in California to determine minimum slope setbacks for full infiltration BMPs. See the City of San Diego's Guidelines for Geotechnical Reports (2011) to determine which type of slope stability analysis is required.</p> <p>Can full infiltration BMPs be proposed within the DMA without increasing slope stability risks?</p>	<input type="checkbox"/> Yes	<input type="checkbox"/> No
2B-5	<p>Other Geotechnical Hazards. Identify site-specific geotechnical hazards not already mentioned (refer to Appendix C.2.1).</p> <p>Can full infiltration BMPs be proposed within the DMA without increasing risk of geologic or geotechnical hazards not already mentioned?</p>	<input type="checkbox"/> Yes	<input type="checkbox"/> No
2B-6	<p>Setbacks. Establish setbacks from underground utilities, structures, and/or retaining walls. Reference applicable ASTM or other recognized standard in the geotechnical report.</p> <p>Can full infiltration BMPs be proposed within the DMA using established setbacks from underground utilities, structures, and/or retaining walls?</p>	<input type="checkbox"/> Yes	<input type="checkbox"/> No



Categorization of Infiltration Feasibility Condition based on Geotechnical Conditions		Worksheet C.4-1: Form I-8A ²	
2C	<p>Mitigation Measures. Propose mitigation measures for each geologic/geotechnical hazard identified in Step 2B. Provide a discussion of geologic/geotechnical hazards that would prevent full infiltration BMPs that cannot be reasonably mitigated in the geotechnical report. See Appendix C.2.1.8 for a list of typically reasonable and typically unreasonable mitigation measures.</p> <p>Can mitigation measures be proposed to allow for full infiltration BMPs? If the question in Step 2 is answered “Yes,” then answer “Yes” to Criteria 2 Result.</p> <p>If the question in Step 2C is answered “No,” then answer “No” to Criteria 2 Result.</p>	<input type="checkbox"/> Yes	<input type="checkbox"/> No
Criteria 2 Result	Can infiltration greater than 0.5 inches per hour be allowed without increasing risk of geologic or geotechnical hazards that cannot be reasonably mitigated to an acceptable level?	<input type="checkbox"/> Yes	<input type="checkbox"/> No
Summarize findings and basis; provide references to related reports or exhibits.			
Part 1 Result – Full Infiltration Geotechnical Screening⁴		Result	
<p>If answers to both Criteria 1 and Criteria 2 are “Yes”, a full infiltration design is potentially feasible based on Geotechnical conditions only.</p> <p>If either answer to Criteria 1 or Criteria 2 is “No”, a full infiltration design is not required.</p>		<input type="checkbox"/> Full infiltration Condition <input type="checkbox"/> Complete Part 2	

⁴ To be completed using gathered site information and best professional judgement considering the definition of MEP in the MS4 Permit. Additional testing and/or studies may be required by City Engineer to substantiate findings.



Categorization of Infiltration Feasibility Condition based on Geotechnical Conditions		Worksheet C.4-1: Form I-8A ²
Part 2 – Partial vs. No Infiltration Feasibility Screening Criteria		
DMA(s) Being Analyzed:		Project Phase:
Criteria 3 : Infiltration Rate Screening		
3A	<p>NRCS Type C, D, or “urban/unclassified”: Is the mapped hydrologic soil group according to the NRCS Web Soil Survey or UC Davis Soil Web Mapper is Type C, D, or “urban/unclassified” and corroborated by available site soil data?</p> <p><input type="checkbox"/> Yes; the site is mapped as C soils and a reliable infiltration rate of 0.15 in/hr. is used to size partial infiltration BMPS. Answer “Yes” to Criteria 3 Result.</p> <p><input type="checkbox"/> Yes; the site is mapped as D soils or “urban/unclassified” and a reliable infiltration rate of 0.05 in/hr. is used to size partial infiltration BMPS. Answer “Yes” to Criteria 3 Result.</p> <p><input type="checkbox"/> No; infiltration testing is conducted (refer to Table D.3-1), continue to Step 3B.</p>	
3B	<p>Infiltration Testing Result: Is the reliable infiltration rate (i.e. average measured infiltration rate/2) greater than 0.05 in/hr. and less than or equal to 0.5 in/hr?</p> <p><input type="checkbox"/> Yes; the site may support partial infiltration. Answer “Yes” to Criteria 3 Result.</p> <p><input type="checkbox"/> No; the reliable infiltration rate (i.e. average measured rate/2) is less than 0.05 in/hr., partial infiltration is not required. Answer “No” to Criteria 3 Result.</p>	
Criteria 3 Result	<p>Is the estimated reliable infiltration rate (i.e., average measured infiltration rate/2) greater than or equal to 0.05 inches/hour and less than or equal to 0.5 inches/hour at any location within each DMA where runoff can reasonably be routed to a BMP?</p> <p><input type="checkbox"/> Yes; Continue to Criteria 4.</p> <p><input type="checkbox"/> No: Skip to Part 2 Result.</p>	
<p>Summarize infiltration testing and/or mapping results (i.e. soil maps and series description used for infiltration rate).</p>		



Categorization of Infiltration Feasibility Condition based on Geotechnical Conditions		Worksheet C.4-1: Form I-8A ²	
Criteria 4: Geologic/Geotechnical Screening			
4A	<p>If all questions in Step 4A are answered “Yes,” continue to Step 2B.</p> <p>For any “No” answer in Step 4A answer “No” to Criteria 4 Result, and submit an “Infiltration Feasibility Condition Letter” that meets the requirements in Appendix C.1.1. The geologic/geotechnical analyses listed in Appendix C.2.1 do not apply to the DMA because one of the following setbacks cannot be avoided and therefore result in the DMA being in a no infiltration condition. The setbacks must be the closest horizontal radial distance from the surface edge (at the overflow elevation) of the BMP.</p>		
4A-1	Can the proposed partial infiltration BMP(s) avoid areas with existing fill materials greater than 5 feet thick?	<input type="checkbox"/> Yes	<input type="checkbox"/> No
4A-2	Can the proposed partial infiltration BMP(s) avoid placement within 10 feet of existing underground utilities, structures, or retaining walls?	<input type="checkbox"/> Yes	<input type="checkbox"/> No
4A-3	Can the proposed partial infiltration BMP(s) avoid placement within 50 feet of a natural slope (>25%) or within a distance of 1.5H from fill slopes where H is the height of the fill slope?	<input type="checkbox"/> Yes	<input type="checkbox"/> No
4B	<p>When full infiltration is determined to be feasible, a geotechnical investigation report must be prepared that considers the relevant factors identified in Appendix C.2.1.</p> <p>If all questions in Step 4B are answered “Yes,” then answer “Yes” to Criteria 4 Result. If there are any “No” answers continue to Step 4C.</p>		
4B-1	<p>Hydroconsolidation. Analyze hydroconsolidation potential per approved ASTM standard due to a proposed full infiltration BMP.</p> <p>Can partial infiltration BMPs be proposed within the DMA without increasing hydroconsolidation risks?</p>	<input type="checkbox"/> Yes	<input type="checkbox"/> No
4B-2	<p>Expansive Soils. Identify expansive soils (soils with an expansion index greater than 20) and the extent of such soils due to proposed full infiltration BMPs.</p> <p>Can partial infiltration BMPs be proposed within the DMA without increasing expansive soil risks?</p>	<input type="checkbox"/> Yes	<input type="checkbox"/> No
4B-3	<p>Liquefaction. If applicable, identify mapped liquefaction areas. Evaluate liquefaction hazards in accordance with Section 6.4.2 of the City of San Diego's Guidelines for Geotechnical Reports (2011). Liquefaction hazard assessment shall take into account any increase in groundwater elevation or groundwater mounding that could occur as a result of proposed infiltration or percolation facilities.</p> <p>Can partial infiltration BMPs be proposed within the DMA without increasing liquefaction risks?</p>	<input type="checkbox"/> Yes	<input type="checkbox"/> No



Categorization of Infiltration Feasibility Condition based on Geotechnical Conditions		Worksheet C.4-1: Form I-8A ²	
4B-4	<p>Slope Stability. If applicable, perform a slope stability analysis in accordance with the ASCE and Southern California Earthquake Center (2002) Recommended Procedures for Implementation of DMG Special Publication 117, Guidelines for Analyzing and Mitigating Landslide Hazards in California to determine minimum slope setbacks for full infiltration BMPs. See the City of San Diego's Guidelines for Geotechnical Reports (2011) to determine which type of slope stability analysis is required.</p> <p>Can partial infiltration BMPs be proposed within the DMA without increasing slope stability risks?</p>	<input type="checkbox"/> Yes	<input type="checkbox"/> No
4B-5	<p>Other Geotechnical Hazards. Identify site-specific geotechnical hazards not already mentioned (refer to Appendix C.2.1).</p> <p>Can partial infiltration BMPs be proposed within the DMA without increasing risk of geologic or geotechnical hazards not already mentioned?</p>	<input type="checkbox"/> Yes	<input type="checkbox"/> No
4B-6	<p>Setbacks. Establish setbacks from underground utilities, structures, and/or retaining walls. Reference applicable ASTM or other recognized standard in the geotechnical report.</p> <p>Can partial infiltration BMPs be proposed within the DMA using recommended setbacks from underground utilities, structures, and/or retaining walls?</p>	<input type="checkbox"/> Yes	<input type="checkbox"/> No
4C	<p>Mitigation Measures. Propose mitigation measures for each geologic/geotechnical hazard identified in Step 4B. Provide a discussion on geologic/geotechnical hazards that would prevent partial infiltration BMPs that cannot be reasonably mitigated in the geotechnical report. See Appendix C.2.1.8 for a list of typically reasonable and typically unreasonable mitigation measures.</p> <p>Can mitigation measures be proposed to allow for partial infiltration BMPs? If the question in Step 4C is answered "Yes," then answer "Yes" to Criteria 4 Result. If the question in Step 4C is answered "No," then answer "No" to Criteria 4 Result.</p>	<input type="checkbox"/> Yes	<input type="checkbox"/> No
Criteria 4 Result	Can infiltration of greater than or equal to 0.05 inches/hour and less than or equal to 0.5 inches/hour be allowed without increasing the risk of geologic or geotechnical hazards that cannot be reasonably mitigated to an acceptable level?	<input type="checkbox"/> Yes	<input type="checkbox"/> No



Summarize findings and basis; provide references to related reports or exhibits.

Part 2 – Partial Infiltration Geotechnical Screening Result⁵

Result

If answers to both Criteria 3 and Criteria 4 are “Yes”, a partial infiltration design is potentially feasible based on geotechnical conditions only.

If answers to either Criteria 3 or Criteria 4 is “No”, then infiltration of any volume is considered to be infeasible within the site.

Partial Infiltration Condition

No Infiltration Condition

⁵ To be completed using gathered site information and best professional judgement considering the definition of MEP in the MS4 Permit. Additional testing and/or studies may be required by City Engineer to substantiate findings.



Categorization of Infiltration Feasibility Condition based on Groundwater and Water Balance Conditions		Worksheet C.4-2: Form I-8B ²
Part 1 - Full Infiltration Feasibility Screening Criteria		
DMA(s) Being Analyzed:		Project Phase:
Criteria 1: Groundwater Screening		
1A	<p>Groundwater Depth. Is the depth to seasonally high groundwater tables (normal high depth during the wet season) beneath the base of any full infiltration BMP greater than 10 feet?</p> <p><input type="checkbox"/> Yes; continue to Step 1B.</p> <p><input type="checkbox"/> No; The depth to groundwater is less than or equal to 10 feet, but site layout changes or reasonable mitigation measures can be proposed to support full infiltration BMPs. Continue to step 1B.</p> <p><input type="checkbox"/> No; The depth to groundwater is less than or equal to 10 feet and site layout changes or reasonable mitigation measures cannot be proposed to support full infiltration BMPs. Answer “No” for Criteria 1 Result.</p>	
1B	<p>Contaminated Soil/Groundwater. Are proposed full infiltration BMPs at least 250 feet away from contaminated soil or groundwater sites? This can be confirmed using GeoTracker (geotracker.waterboards.ca.gov) to identify open contaminated sites. The setbacks must be the closest horizontal radial distance from the surface edge (at the overflow elevation) of the BMP.</p> <p><input type="checkbox"/> Yes; continue to Step 1C.</p> <p><input type="checkbox"/> No; However, site layout changes or reasonable mitigation measures can be proposed to support full infiltration BMPs. Continue to Step 1C.</p> <p><input type="checkbox"/> No; Site layout changes or reasonable mitigation measures cannot be proposed to support full infiltration BMPs. Answer “No” to Criteria 1 Result.</p>	

¹ Note that it is not required to investigate each and every criterion in the worksheet, a single “no” answer in Part 1, Part 2, part 3, or Part 4 determines a full, partial, or no infiltration condition.

² This form must be completed each time there is a change to the site layout that would affect the infiltration feasibility condition. Previously completed forms shall be retained to document the evolution of the site storm water design.



Categorization of Infiltration Feasibility Condition based on Groundwater and Water Balance Conditions		Worksheet C.4-2: Form I-8B ²
1C	<p>Inadequate Soil Treatment Capacity. Are full infiltration BMPs proposed in DMA soils that have adequate soil treatment capacity?</p> <p>The DMA has adequate soil treatment capacity if ALL of the following criteria (detailed in C.2.2.1) for all soil layers beneath the infiltrating surface are met:</p> <ul style="list-style-type: none"> • USDA texture class is sandy loam or loam or silt loam or silt or sandy clay loam or clay loam or silty clay loam or sandy clay or silty clay or clay; and • Cation Exchange Capacity (CEC) greater than 5 milliequivalents/100g; and • Soil organic matter is greater than 1%; and • Groundwater table is equal to or greater than 10 feet beneath the base of the full infiltration BMP. <p><input type="checkbox"/> Yes; continue to Step 1D.</p> <p><input type="checkbox"/> No; However, site layout changes or reasonable mitigation measures can be proposed to support full infiltration BMPs. Continue to Step 1D.</p> <p><input type="checkbox"/> No; Site layout changes or reasonable mitigation measures cannot be proposed to support full infiltration BMPs. Answer “No” to Criteria 1 Result.</p>	
1D	<p>Other Groundwater Contamination Hazards. Are there site-specific groundwater contamination hazards not already mentioned (refer to Appendix C.2.2) that can be reasonably mitigated to support full infiltration BMPs?</p> <p><input type="checkbox"/> Yes; there are other contamination hazards identified that can be mitigated. Answer “Yes” to Criteria 1 Result.</p> <p><input type="checkbox"/> No; there are other contamination hazards identified that cannot be mitigated. Answer “No” to Criteria 1 Result.</p> <p><input type="checkbox"/> N/A; no contamination hazards are identified. Answer “Yes” to Criteria 1 Result.</p>	
Criteria 1 Result	<p>Can infiltration greater than 0.5 inches per hour be allowed without increasing risk of groundwater contamination that cannot be reasonably mitigated to an acceptable level? See Appendix C.2.2.8 for a list of typically reasonable and typically unreasonable mitigation measures.</p> <p><input type="checkbox"/> Yes; Continue to Part 1, Criteria 2.</p> <p><input type="checkbox"/> No; Continue to Part 1 Result.</p>	



Summarize groundwater quality and any mitigation measures proposed. Documentation should focus on groundwater table, mapped soil types and contaminated site locations.



Categorization of Infiltration Feasibility Condition based on Groundwater and Water Balance Conditions		Worksheet C.4-2: Form I-8B ²
Criteria 2: Water Balance Screening		
2A	<p>Ephemeral Stream Setback. Does the proposed full infiltration BMP meet both the following?</p> <ul style="list-style-type: none"> The full infiltration BMP is located at least 250 feet away from an ephemeral stream; AND The bottom surface of the full infiltration BMP is at a depth 20 feet or greater from seasonally high groundwater tables. <p><input type="checkbox"/> Yes; Answer “Yes” to Criteria 2 Result.</p> <p><input type="checkbox"/> No; Continue to Step 2B.</p>	
2B	<p>Mitigation Measures. Can site layout changes be proposed to support full infiltration BMPs?</p> <p><input type="checkbox"/> Yes; the site can be reconfigured to mitigate potential water balance issues. Answer “Yes” to Criteria 2 Result.</p> <p><input type="checkbox"/> No; the site cannot be reconfigured to mitigate potential water balance issues. Continue to Step 2C and provide discussion.</p>	
2C	<p>Additional studies. Do additional studies support full infiltration BMPs?</p> <p>In the event that water balance effects are used to reject full infiltration (anticipated to be rare), additional analysis shall be completed and documented by a qualified professional indicating the site-specific information evaluated and the technical basis for this finding.</p> <p><input type="checkbox"/> Yes; Answer “Yes” to Criteria 2 Result.</p> <p><input type="checkbox"/> No; Answer “No” to Criteria 2 Result.</p>	
Criteria 2 Result	<p>Can infiltration greater than 0.5 inches per hour be allowed without causing potential water balance issues such as change of seasonality of ephemeral streams?</p> <p><input type="checkbox"/> Yes; Continue to Part 1 Result.</p> <p><input type="checkbox"/> No; Continue to Part 1 Result.</p>	



Summarize potential water balance effects. Documentation should focus on mapping and soil data regarding proximity to ephemeral streams and groundwater depth.

Part 1 – Full Infiltration Groundwater and Water Balance Screening Result³

Result

If answers to Criteria 1 and 2 are “Yes”, a full infiltration design is potentially feasible. The feasibility screening category is Full Infiltration based on groundwater conditions.

If answer to Criteria 1 or Criteria 2 is “No”, infiltration may be possible to some extent but would not generally be feasible or desirable to achieve a “full infiltration” design based on groundwater conditions. Proceed to Part 2.

- Full Infiltration
- Complete Part 2

³ To be completed using gathered site information and best professional judgement considering the definition of MEP in the MS4 Permit. Additional testing and/or studies may be required by City Engineer to substantiate findings.



Categorization of Infiltration Feasibility Condition based on Groundwater and Water Balance Conditions	Worksheet C.4-2: Form I-8B ²
Part 2 – Partial vs. No Infiltration Feasibility Screening Criteria	
DMA(s) Being Analyzed:	Project Phase:
Criteria 3: Groundwater Screening	
<p>Contaminated Soil/Groundwater. Are partial infiltration BMPs proposed at least 100 feet away from contaminated soil or groundwater sites? This can be confirmed using GeoTracker (geotracker.waterboards.ca.gov) to identify open contaminated sites. This criterion is intentionally a smaller radius than full infiltration, as the potential quantity of infiltration from partial infiltration BMPs is smaller.</p> <p><input type="checkbox"/> Yes; Answer “Yes” to Criteria 3 Result.</p> <p><input type="checkbox"/> No; However, site layout changes can be proposed to avoid contaminated soils or soils that lack adequate treatment capacity. Select “Yes” to Criteria 3 Result. It is a requirement for the SWQMP preparer to identify potential mitigation measures.</p> <p><input type="checkbox"/> No; Contaminated soils or soils that lack adequate treatment capacity cannot be avoided and partial infiltration BMPs are not feasible. Select “No” to Criteria 3 Result.</p>	
<p>Criteria 3 Result: Can infiltration of greater than or equal to 0.05 inches/hour and less than or equal to 0.5 inches/hour be allowed without increasing risk of groundwater contamination that cannot be reasonably mitigated to an acceptable level?</p> <p><input type="checkbox"/> Yes; Continue to Part 2, Criteria 4.</p> <p><input type="checkbox"/> No; Skip to Part 2 Result.</p>	
<p>Summarize findings and basis. Documentation should focus on mapped soil types and contaminated site locations.</p>	



Categorization of Infiltration Feasibility Condition based on Groundwater and Water Balance Conditions	Worksheet C.4-2: Form I-8B ²
<p>Criteria 4: Water Balance Screening</p>	
<p>Additional studies. In the event that water balance effects are used to reject partial infiltration (anticipated to be rare), a qualified professional must provide an analysis of the incremental effects of partial infiltration BMPs on the water balance compared to incidental infiltration under a no infiltration scenario (e.g. precipitation, irrigation, etc.).</p>	
<p>Criteria 4 Result: Can infiltration of greater than or equal to 0.05 inches/hour and less than or equal to 0.5 inches/hour be allowed without causing potential water balance issues such as change of seasonality of ephemeral streams?</p> <p><input type="checkbox"/> Yes: Continue to Part 2 Result.</p> <p><input type="checkbox"/> No: Continue to Part 2 Result.</p>	
<p>Summarize potential water balance effects. Documentation should focus on mapping and soil data regarding proximity to ephemeral streams and groundwater depth.</p>	
Part 2 – Partial Infiltration Groundwater and Water Balance Screening Result ⁴	Result
<p>If answers to Criteria 3 and Criteria 4 are “Yes”, a partial infiltration design is potentially feasible. The feasibility screening category is Partial Infiltration based on groundwater and water balance conditions.</p> <p>If answer to Criteria 3 or Criteria 4 is “No”, then infiltration of any volume is considered to be infeasible within the site. The feasibility screening category is No Infiltration based on groundwater or water balance condition.</p>	<p><input type="checkbox"/> Partial Infiltration Condition</p> <p><input type="checkbox"/> No Infiltration Condition</p>

⁴ To be completed using gathered site information and best professional judgement considering the definition of MEP in the MS4 Permit. Additional testing and/or studies may be required by City Engineer to substantiate findings.



		Project Name	Foxhill Residence & Boundary Adjustment	
		BMP ID	BMP #1	
Sizing Method for Pollutant Removal Criteria			Worksheet B.5-1	
1	Area draining to the BMP		21413	sq. ft.
2	Adjusted runoff factor for drainage area (Refer to Appendix B.1 and B.2)		0.5	
3	85 th percentile 24-hour rainfall depth		0.51	inches
4	Design capture volume [Line 1 x Line 2 x (Line 3/12)]		455	cu. ft.
BMP Parameters				
5	Surface ponding [6 inch minimum, 12 inch maximum]		12	inches
6	Media thickness [18 inches minimum], also add mulch layer and washed ASTM 33 fine aggregate sand thickness to this line for sizing calculations		24	inches
7	Aggregate storage (also add ASTM No 8 stone) above underdrain invert (12 inches typical) – use 0 inches if the aggregate is not over the entire bottom surface area		12	inches
8	Aggregate storage below underdrain invert (3 inches minimum) – use 0 inches if the aggregate is not over the entire bottom surface area		3	inches
9	Freely drained pore storage of the media		0.2	in/in
10	Porosity of aggregate storage		0.4	in/in
11	Media filtration rate to be used for sizing (maximum filtration rate of 5 in/hr. with no outlet control; if the filtration rate is controlled by the outlet use the outlet controlled rate (includes infiltration into the soil and flow rate through the outlet structure) which will be less than 5 in/hr.)		0.84	in/hr.
Baseline Calculations				
12	Allowable routing time for sizing		6	hours
13	Depth filtered during storm [Line 11 x Line 12]		5.04	inches
14	Depth of Detention Storage [Line 5 + (Line 6 x Line 9) + (Line 7 x Line 10) + (Line 8 x Line 10)]		22.8	inches
15	Total Depth Treated [Line 13 + Line 14]		27.84	inches
Option 1 – Biofilter 1.5 times the DCV				
16	Required biofiltered volume [1.5 x Line 4]		683	cu. ft.
17	Required Footprint [Line 16/ Line 15] x 12		294	sq. ft.
Option 2 - Store 0.75 of remaining DCV in pores and ponding				
18	Required Storage (surface + pores) Volume [0.75 x Line 4]		341	cu. ft.
19	Required Footprint [Line 18/ Line 14] x 12		180	sq. ft.
Footprint of the BMP				
20	BMP Footprint Sizing Factor (Default 0.03 or an alternative minimum footprint sizing factor from Line 11 in Worksheet B.5-4)		0.03	
21	Minimum BMP Footprint [Line 1 x Line 2 x Line 20]		321	sq. ft.
22	Footprint of the BMP = Maximum(Minimum(Line 17, Line 19), Line 21)		321	sq. ft.
23	Provided BMP Footprint		1230	sq. ft.
24	Is Line 23 ≥ Line 22?	Yes, Performance Standard is Met		

		Project Name	Foxhill Residence & Boundary Adjustment	
		BMP ID	BMP #2	
Sizing Method for Pollutant Removal Criteria			Worksheet B.5-1	
1	Area draining to the BMP		9491	sq. ft.
2	Adjusted runoff factor for drainage area (Refer to Appendix B.1 and B.2)		0.67	
3	85 th percentile 24-hour rainfall depth		0.51	inches
4	Design capture volume [Line 1 x Line 2 x (Line 3/12)]		270	cu. ft.
BMP Parameters				
5	Surface ponding [6 inch minimum, 12 inch maximum]		12	inches
6	Media thickness [18 inches minimum], also add mulch layer and washed ASTM 33 fine aggregate sand thickness to this line for sizing calculations		24	inches
7	Aggregate storage (also add ASTM No 8 stone) above underdrain invert (12 inches typical) – use 0 inches if the aggregate is not over the entire bottom surface area		12	inches
8	Aggregate storage below underdrain invert (3 inches minimum) – use 0 inches if the aggregate is not over the entire bottom surface area		3	inches
9	Freely drained pore storage of the media		0.2	in/in
10	Porosity of aggregate storage		0.4	in/in
11	Media filtration rate to be used for sizing (maximum filtration rate of 5 in/hr. with no outlet control; if the filtration rate is controlled by the outlet use the outlet controlled rate (includes infiltration into the soil and flow rate through the outlet structure) which will be less than 5 in/hr.)		0.86	in/hr.
Baseline Calculations				
12	Allowable routing time for sizing		6	hours
13	Depth filtered during storm [Line 11 x Line 12]		5.16	inches
14	Depth of Detention Storage [Line 5 + (Line 6 x Line 9) + (Line 7 x Line 10) + (Line 8 x Line 10)]		22.8	inches
15	Total Depth Treated [Line 13 + Line 14]		27.96	inches
Option 1 – Biofilter 1.5 times the DCV				
16	Required biofiltered volume [1.5 x Line 4]		405	cu. ft.
17	Required Footprint [Line 16/ Line 15] x 12		174	sq. ft.
Option 2 - Store 0.75 of remaining DCV in pores and ponding				
18	Required Storage (surface + pores) Volume [0.75 x Line 4]		203	cu. ft.
19	Required Footprint [Line 18/ Line 14] x 12		107	sq. ft.
Footprint of the BMP				
20	BMP Footprint Sizing Factor (Default 0.03 or an alternative minimum footprint sizing factor from Line 11 in Worksheet B.5-4)		0.03	
21	Minimum BMP Footprint [Line 1 x Line 2 x Line 20]		191	sq. ft.
22	Footprint of the BMP = Maximum(Minimum(Line 17, Line 19), Line 21)		191	sq. ft.
23	Provided BMP Footprint		500	sq. ft.
24	Is Line 23 ≥ Line 22?	Yes, Performance Standard is Met		

BIOFILTRATION
MEDIA FILTRATION RATE CALCULATIONS

(Input for Item 11 on Worksheet B.5-1)

Job No: LJ4741

Date: 9/23/2020

Project: Foxhill Residence

Calculated By: RE

$$\text{Media Filtration Rate (M.F.R.)} = \frac{\text{Avg. Orifice Outflow (Q}_0\text{) During Surface Ponding}}{\text{BMP Footprint (A}_{\text{BMP}}\text{)}} \times \frac{3600 \text{ sec.}}{1 \text{ Hour}} \times \frac{12 \text{ in.}}{1 \text{ ft.}}$$

BMP #1:

$Q_0 = \underline{0.024} \text{ CFS}$ $A_{\text{BMP}} = \underline{1230} \text{ ft}^2$ M.F.R. (in./hr) = 0.84 in./hr

BMP #2:

$Q_0 = \underline{0.01} \text{ CFS}$ $A_{\text{BMP}} = \underline{500} \text{ ft}^2$ M.F.R. (in./hr) = 0.86 in./hr

Prepared By:

SNIPES - DYE
ASSOCIATES
8348 CENTER DRIVE, SUITE "G"
LA MESA, CA 91942-2910

Runoff Factor

Storm Water Pollutant Control Hydrologic Calculations and Sizing Methods

Runoff Factor

Equation B.1-2: Estimating Runoff Factor for Area

$$C = \frac{\sum C_x A_x}{\sum A_x}$$

where:

C_x = Runoff factor for area

A_x = Tributary area X

These runoff factors apply to areas receiving direct rainfall only. For conditions in which runoff is routed onto a surface from an adjacent surface, see Section B.2 for determining composite runoff factors for these areas.

Table B.1-1: Runoff factors for surfaces draining to BMPs – Pollutant Control BMPs

Surface	Runoff Factor
Roofs	0.90
Concrete or Asphalt	0.90
Unit Pavers (grouted)	0.90
Decomposed Granite	0.30
Cobbles or Crushed Aggregate	0.30
Amended, Mulched Soils or Landscape	0.10
Compacted Soil (e.g., unpaved parking)	0.30
Natural (A Soil)	0.10
Natural (B Soil)	0.14
Natural (C Soil)	0.23
Natural (D Soil)	0.30

DMA ID.	Pervious Surface	$C_{pervious}$	$A_{pervious}$ (SF)	Impervious Surface	$C_{impervious}$	$A_{impervious}$ (SF)	$C = \frac{\sum C_x A_x}{\sum A_x}$
1	Landscape	0.10	10,692	Roofs / Concrete	0.90	10,721	0.50
2A	Landscape	0.10	1,837	Concrete	0.90	4,914	0.68
2B	Landscape	0.10	6,990	Concrete	0.90	3,672	0.38
3	Landscape	0.10	2,705	Concrete	0.90	6,786	0.67
4	Landscape	0.10	2,997	N/A	0.90	0	0.10
5	Landscape	0.10	0	Concrete	0.90	250	0.90
6	Landscape	0.10	38,298	Roofs / Concrete	0.90	10,677	0.27
Total	Landscape	0.10	63,519	Roofs / Pavement	0.90	37,020	0.39

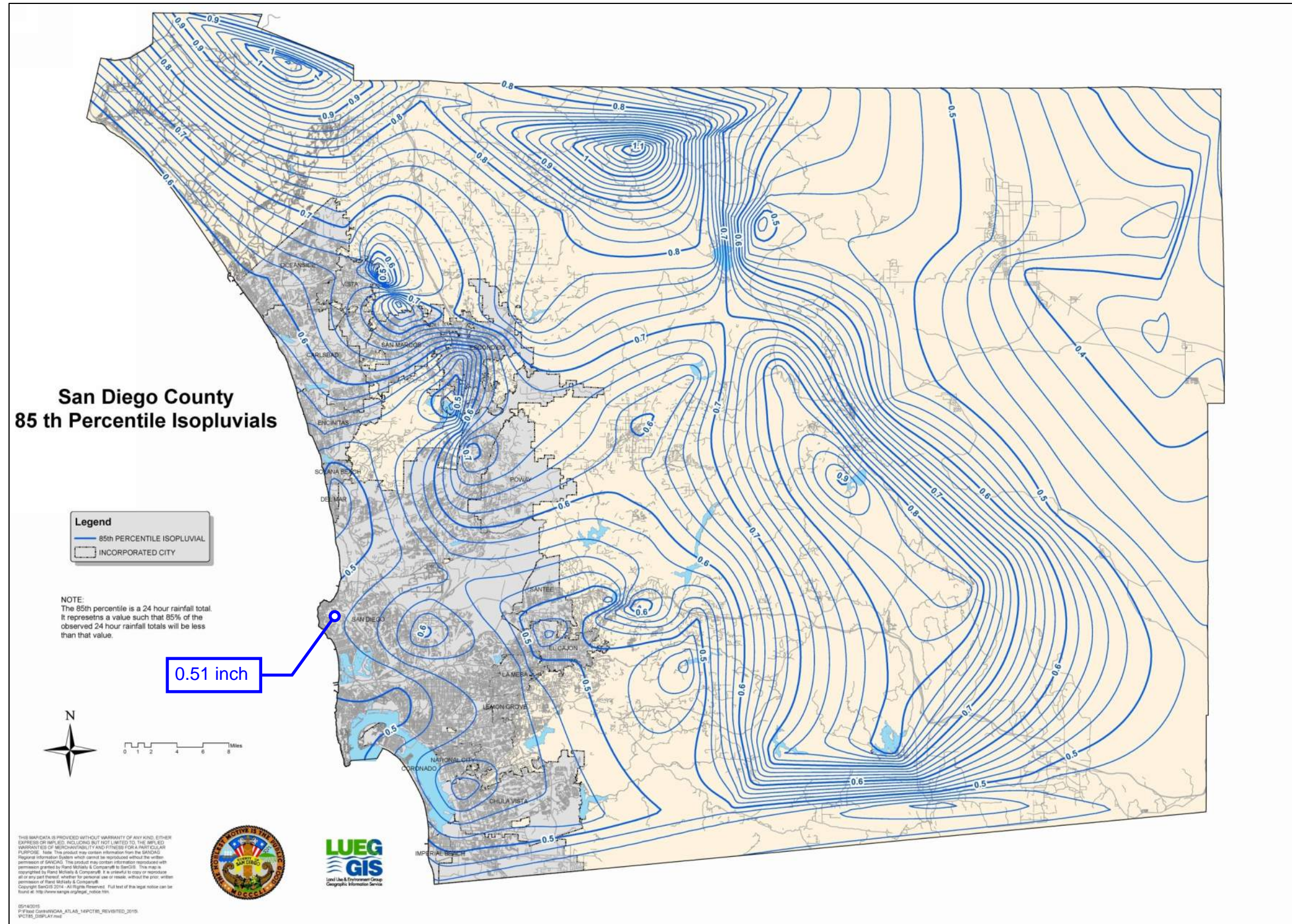
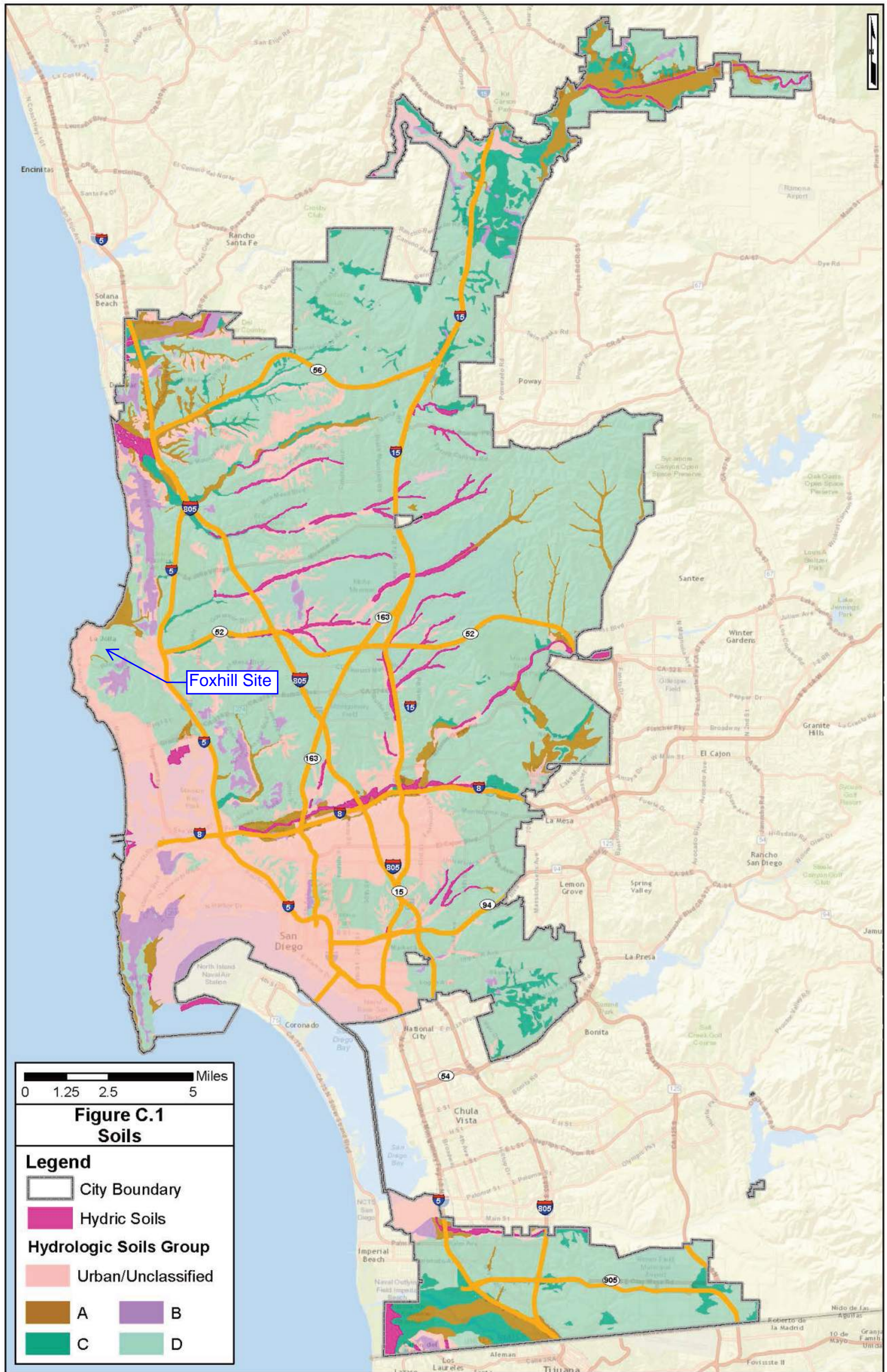

Figure B.1-1: 85th Percentile 24-hour Isopluvial Map



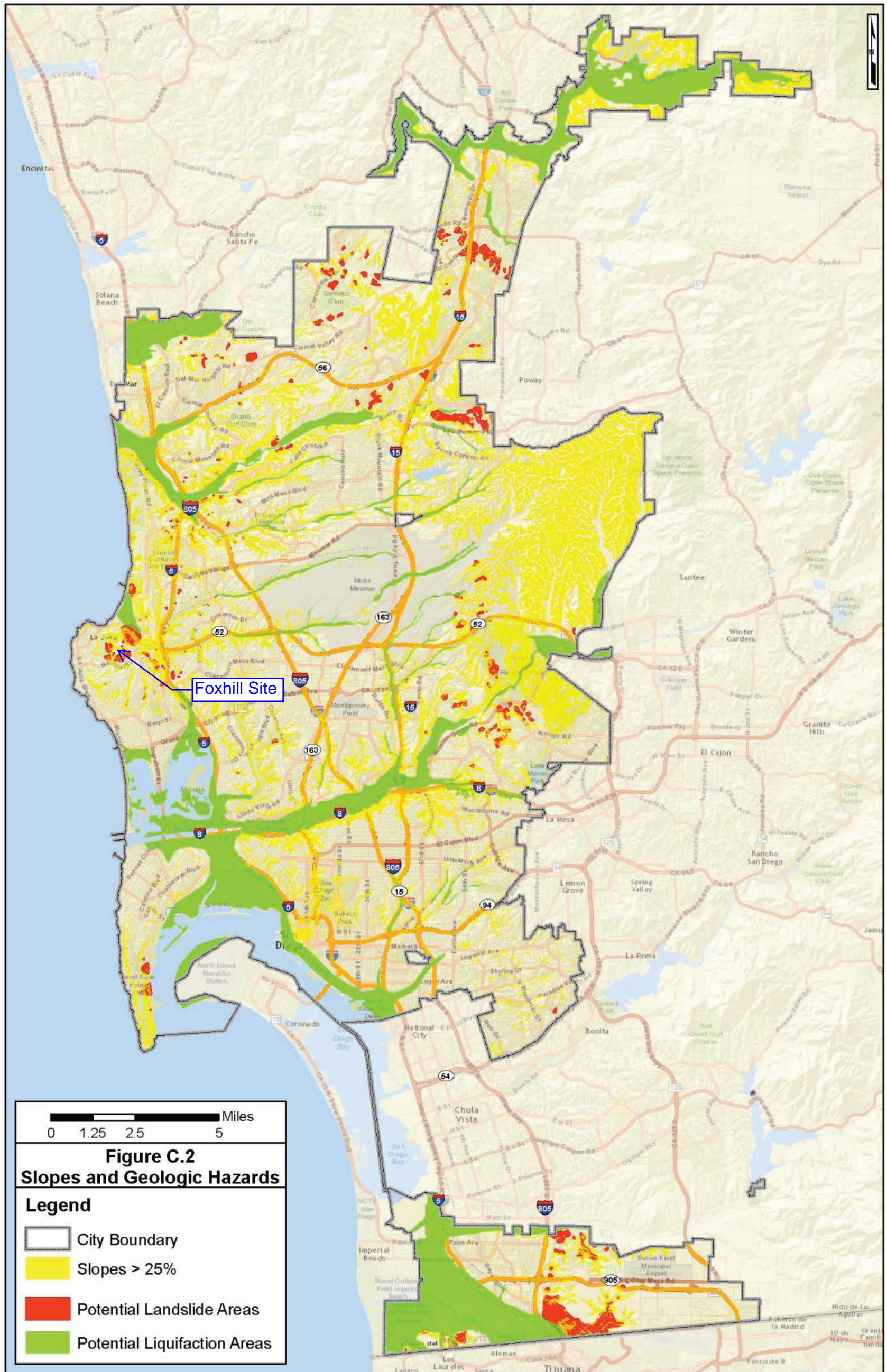

Figure C.4-2 : Slopes and Geologic Hazards Exhibit

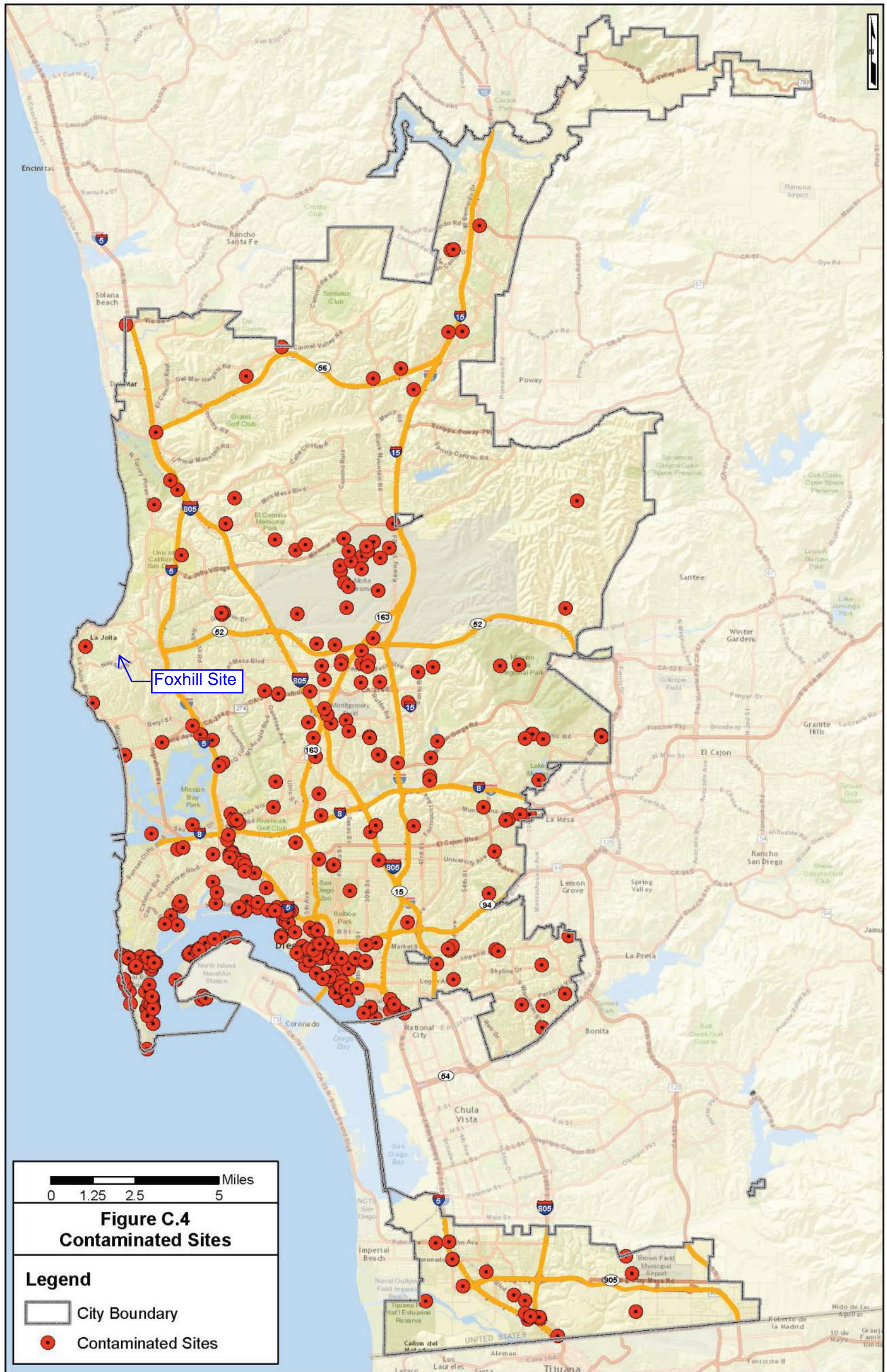
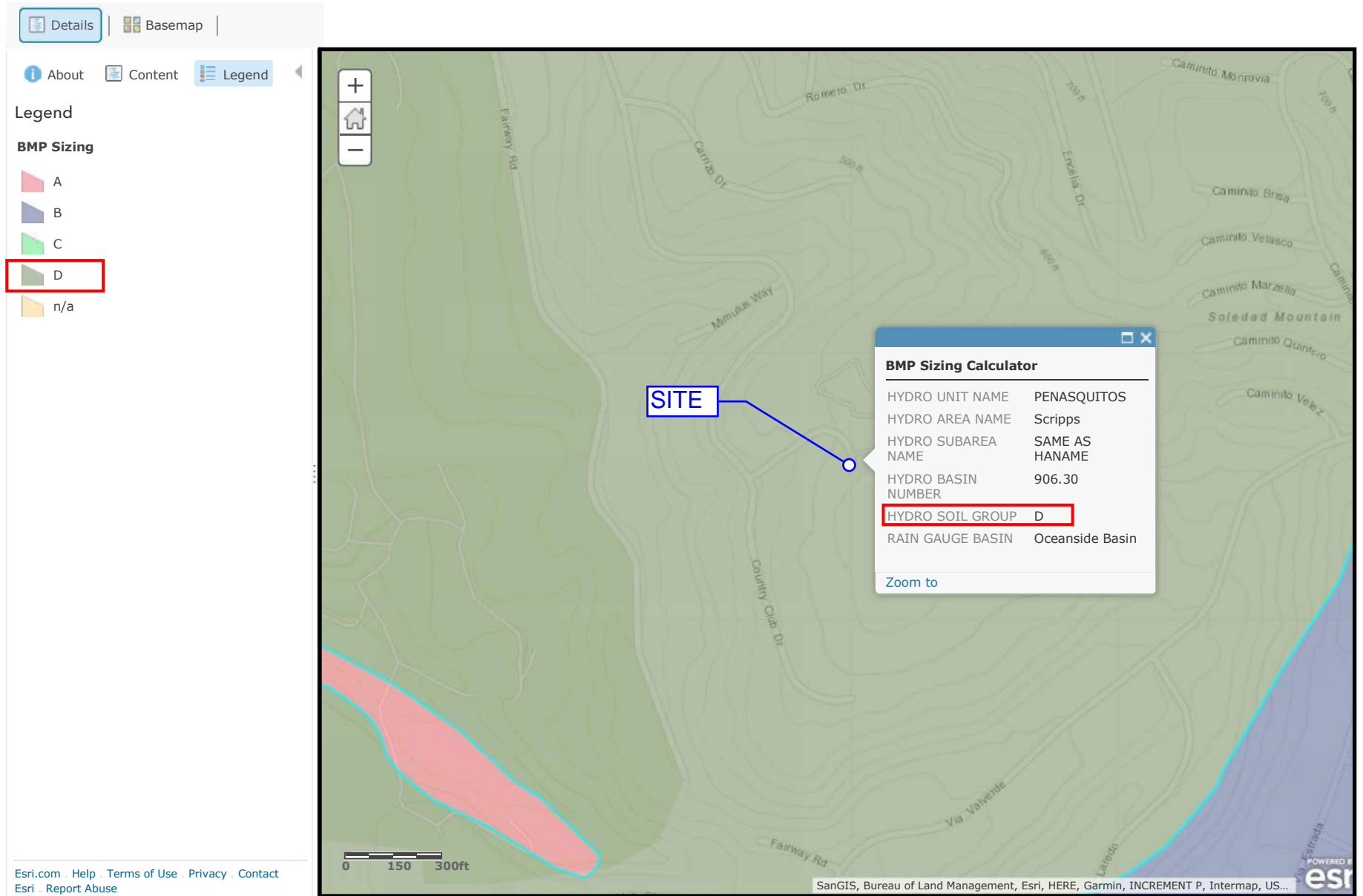

Figure C.4-4 : Contaminated Sites Exhibit

SOIL TYPE FOXHILL RESIDENCE

ArcGIS ▾ BMP Sizing Calculator



Final 2014/2016 California Integrated Report (Clean Water Act Section 303(d) List / 305(b) Report)

2014 and 2016 Integrated Report

Map

303(d) List

References

Data Download

Contact Us

2014 AND 2016 INTEGRATED REPORT — ALL ASSESSED WATERS

Zoom to county:

San Diego

Zoom to Regional Board:

All

Map Help

Show county

Show Regional Board

Zoom to water body: (Filter: All)

Filter list by:

Reset list

Change basemap

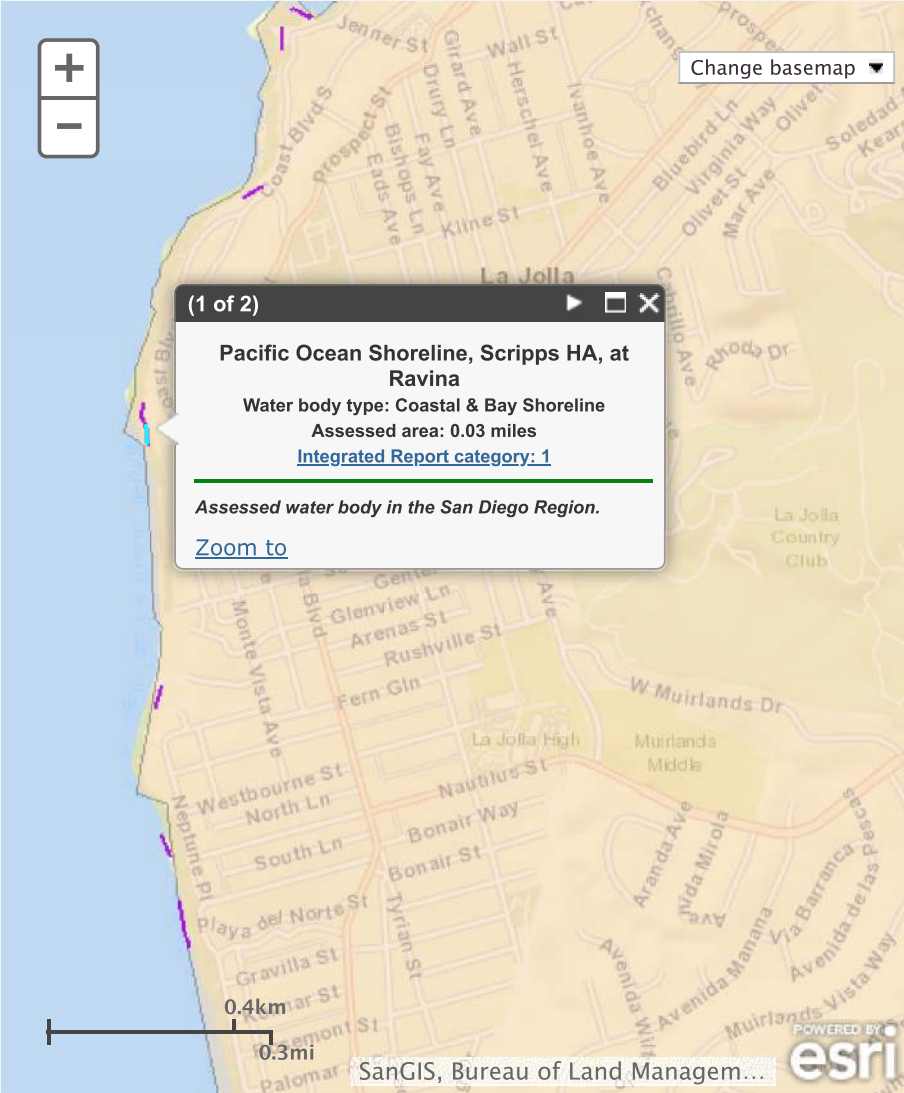

Pacific Ocean Shoreline, Scripps HA, at Ravina
Pollutant assessments

	Listing Decision
Pollutants	Report Link
	Potential Sources
	Schedule
	Comments
Indicator Bacteria	Delist from 303(d) list (being addressed by USEPA approved TMDL)
	43594
	n/a
	USEPA TMDL approval: 2011

Project Name:

Attachment 2

Backup for PDP Hydromodification Control Measures

This is the cover sheet for Attachment 2.

Mark this box if this attachment is empty because the project is exempt from PDP hydromodification management requirements.

Project Name:

THIS PAGE INTENTIONALLY LEFT BLANK FOR DOUBLE-SIDED PRINTING

Project Name:

Indicate which Items are Included:

Attachment Sequence	Contents	Checklist
Attachment 2a	Hydromodification Management Exhibit (Required)	<input type="checkbox"/> Included See Hydromodification Management Exhibit Checklist. SEE DMA EXHIBIT
Attachment 2b	<p>Management of Critical Coarse Sediment Yield Areas (WMAA Exhibit is required, additional analyses are optional)</p> <p>See Section 6.2 of the BMP Design Manual.</p>	<input type="checkbox"/> Exhibit showing project drainage boundaries marked on WMAA Critical Coarse Sediment Yield Area Map (Required) Optional analyses for Critical Coarse Sediment Yield Area Determination <input type="checkbox"/> 6.2.1 Verification of Geomorphic Landscape Units Onsite <input type="checkbox"/> 6.2.2 Downstream Systems Sensitivity to Coarse Sediment <input type="checkbox"/> 6.2.3 Optional Additional Analysis of Potential Critical Coarse Sediment Yield Areas Onsite
Attachment 2c	<p>Geomorphic Assessment of Receiving Channels (Optional)</p> <p>See Section 6.3.4 of the BMP Design Manual.</p>	<input type="checkbox"/> Not Performed <input type="checkbox"/> Included <input type="checkbox"/> Submitted as separate stand-alone document
Attachment 2d	<p>Flow Control Facility Design and Structural BMP Drawdown Calculations (Required)</p> <p>Overflow Design Summary for each structural BMP</p> <p>See Chapter 6 and Appendix G of the BMP Design Manual</p>	<input type="checkbox"/> Included <input type="checkbox"/> Submitted as separate stand-alone document



Project Name:

Use this checklist to ensure the required information has been included on the Hydromodification Management Exhibit:

The Hydromodification Management Exhibit must identify:

- Underlying hydrologic soil group
- Approximate depth to groundwater
- Existing natural hydrologic features (watercourses, seeps, springs, wetlands)
- Critical coarse sediment yield areas to be protected OR provide a separate map showing that the project site is outside of any critical coarse sediment yield areas
- Existing topography
- Existing and proposed site drainage network and connections to drainage offsite
- Proposed grading
- Proposed impervious features
- Proposed design features and surface treatments used to minimize imperviousness
- Point(s) of Compliance (POC) for Hydromodification Management
Existing and proposed drainage boundary and drainage area to each POC (when necessary, create separate exhibits for pre-development and post-project conditions)
- Structural BMPs for hydromodification management (identify location, type of BMP, and size/detail).

FOXHILL RESIDENCE & BOUNDARY ADJUSTMENT



Google Earth



CRITICAL COARSE SEDIMENT AREAS 



BMP Sizing Spreadsheet V3.1

Project Name:	Foxhill Guest Quarters TPM	Hydrologic Unit:	906.3
Project Applicant:	Manchester Foxhill, LLC	Rain Gauge:	Oceanside
Jurisdiction:	City of San Diego	Total Project Area:	100,254
Parcel (APN):	352-300-04 & -09	Low Flow Threshold:	0.1Q2
BMP Name:	BMP #1	BMP Type:	Biofiltration w/ Partial Retention
BMP Native Soil Type:	D	BMP Infiltration Rate (in/hr):	0.025

Areas Draining to BMP						HMP Sizing Factors	Minimum BMP Size
DMA Name	Area (sf)	Pre Project Soil Type	Pre-Project Slope	Post Project Surface Type	Area Weighted Runoff Factor (Table G.2-1) ¹	Surface Area	Surface Area (SF)
DMA #1	10,721	D	Moderate	Roofs	1.0	0.07	750
DMA #1	10,692	D	Moderate	Landscape	0.1	0.07	75
						0	0
						0	0
						0	0
						0	0
						0	0
						0	0
						0	0
						0	0
						0	0
						0	0
						0	0
						0	0
						0	0
						0	0
						0	0
						0	0
						0	0
						0	0
						0	0
BMP Tributary Area	21,413						
						Minimum BMP Size	825
						Proposed BMP Size*	1230

* Assumes standard configuration

Surface Ponding Depth	12.00	in
Bioretention Soil Media Depth	18.00	in
Filter Course	6.00	in
Gravel Storage Layer Depth	12	in
Underdrain Offset	3.0	in

Notes:

1. Runoff factors which are used for hydromodification management flow control (Table G.2-1) are different from the runoff factors used for pollutant control BMP sizing (Table B.1-1). Table references are taken from the San Diego Region Model BMP Design Manual.

Describe the BMP's in sufficient detail in your PDP SWQMP to demonstrate the area, volume, and other criteria can be met within the constraints of the site.

BMP's must be adapted and applied to the conditions specific to the development project such as unstable slopes or the lack of available head.

Designated Staff have final review and approval authority over the project design.

This BMP Sizing Spreadsheet has been updated in conformance with the San Diego Region Model BMP Design Manual, May 2018. For questions or concerns please contact the jurisdiction in which your project is located.

BMP Sizing Spreadsheet V3.1

Project Name:	Foxhill Guest Quarters TPM	Hydrologic Unit:	906.3
Project Applicant:	Manchester Foxhill, LLC	Rain Gauge:	Oceanside
Jurisdiction:	City of San Diego	Total Project Area:	382,579
Parcel (APN):	352-300-04 & -09	Low Flow Threshold:	0.1Q2
BMP Name:	BMP #2	BMP Type:	Biofiltration w/ Partial Retention
BMP Native Soil Type:	D	BMP Infiltration Rate (in/hr):	0.025

Areas Draining to BMP						HMP Sizing Factors	Minimum BMP Size
DMA Name	Area (sf)	Pre Project Soil Type	Pre-Project Slope	Post Project Surface Type	Area Weighted Runoff Factor (Table G.2-1) ¹	Surface Area	Surface Area (SF)
DMA #3	6,786	D	Moderate	Roofs	1.0	0.07	475
DMA #3	2,705	D	Moderate	Landscape	0.1	0.07	19
						0	0
						0	0
						0	0
						0	0
						0	0
						0	0
						0	0
						0	0
						0	0
						0	0
						0	0
						0	0
						0	0
						0	0
						0	0
						0	0
						0	0
						0	0
						0	0
						0	0
BMP Tributary Area	9,491						
						Minimum BMP Size	494
						Proposed BMP Size*	500

* Assumes standard configuration

Surface Ponding Depth	12.00	in
Bioretention Soil Media Depth	18.00	in
Filter Course	6.00	in
Gravel Storage Layer Depth	12	in
Underdrain Offset	3.0	in

Notes:

1. Runoff factors which are used for hydromodification management flow control (Table G.2-1) are different from the runoff factors used for pollutant control BMP sizing (Table B.1-1). Table references are taken from the San Diego Region Model BMP Design Manual.

Describe the BMP's in sufficient detail in your PDP SWQMP to demonstrate the area, volume, and other criteria can be met within the constraints of the site.

BMP's must be adapted and applied to the conditions specific to the development project such as unstable slopes or the lack of available head.

Designated Staff have final review and approval authority over the project design.

This BMP Sizing Spreadsheet has been updated in conformance with the San Diego Region Model BMP Design Manual, May 2018. For questions or concerns please contact the jurisdiction in which your project is located.

Project Name:

Attachment 3 Structural BMP Maintenance Information

This is the cover sheet for Attachment 3.

Project Name:

THIS PAGE INTENTIONALLY LEFT BLANK FOR DOUBLE-SIDED PRINTING

Project Name:

Indicate which Items are Included:

Attachment Sequence	Contents	Checklist
Attachment 3	Maintenance Agreement (Form DS-3247) (when applicable)	<input type="checkbox"/> Included <input type="checkbox"/> Not applicable

Project Name:

Use this checklist to ensure the required information has been included in the Structural BMP Maintenance Information Attachment:

Attachment 3: For private entity operation and maintenance, Attachment 3 must include a Storm Water Management and Discharge Control Maintenance Agreement (Form DS-3247). The following information must be included in the exhibits attached to the maintenance agreement:

- Vicinity map
- Site design BMPs for which DCV reduction is claimed for meeting the pollutant control obligations.
- BMP and HMP location and dimensions
- BMP and HMP specifications/cross section/model
- Maintenance recommendations and frequency
- LID features such as (permeable paver and LS location, dim, SF).

OPERATION AND MAINTENANCE PLAN

for

Biofiltration with Partial Retention Basins

I. Introduction

The proposed development consists of the construction of a two-story guest house with an access concrete paved driveway. Based on the uses of the site, the anticipated pollutants generated by the project consist of sediment, nutrients, heavy metals, organic compounds, trash & debris, oxygen demanding substances, oil & grease, bacteria & viruses, and pesticides.

The selected structural BMPs for this project consists of two biofiltration with partial retention basins which were selected based on the feasibility analysis of the site conditions. The anticipated pollutants shall be removed from runoff by filtration through the vegetation, sedimentation and absorption to soil particles, and infiltration through the engineered soil.

The biofiltration basins with partial retention consist of the excavated detention basin which is backfilled with 18-inches of engineered soil with underlying subdrain system and vegetation over the surface. The three biofiltration basins with partial retention are designed to pond runoff after rainfall events; gradually allowing water to infiltrate into the soil and control discharges offsite through the subdrain system. The engineered soil is designed to have an infiltration rate of 5 inches per hour minimum, as well as providing an appropriate planting medium. Vegetation pretreats the runoff by capturing and removing larger sediment particles or debris.

This facility will need adequate maintenance to function as designed.

II. Responsibility for Maintenance

The responsibilities of maintenance for the structural BMP is the Owner or Tenant.

III. Inspection and Maintenance Checklist

Inspection and Maintenance Checklists and Report Form for the BMPs are attached in Attachment A. The Source Control BMP fact sheets in Attachment B provide information for the Tenant to train the care-takers.

IV. Inspection and Maintenance Schedule

At the minimum, the BMPs shall be inspected monthly, after major rain event, pre-rainy season and after rainy season. Below is Table 7-2 from the City of San Diego Storm Water Standards (October 2018 Edition) which lists the maintenance indicators and the required actions for the selected structural BMP.

Table 7-2. Maintenance Indicators and Actions for Vegetated BMPs

Typical Maintenance Indicator(s) for Vegetated BMPs	Maintenance Actions
Accumulation of sediment, litter, or debris	Remove and properly dispose of accumulated materials, without damage to the vegetation.
Poor vegetation establishment	Re-seed, re-plant, or re-establish vegetation per original plans.
Overgrown vegetation	Mow or trim as appropriate, but not less than the design height of the vegetation per original plans when applicable (e.g. a vegetated swale may require a minimum vegetation height).
Erosion due to concentrated irrigation flow	Repair/re-seed/re-plant eroded areas and adjust the irrigation system.
Erosion due to concentrated storm water runoff flow	Repair/re-seed/re-plant eroded areas, and make appropriate corrective measures such as adding erosion control blankets, adding stone at flow entry points, or minor re-grading to restore proper drainage according to the original plan. If the issue is not corrected by restoring the BMP to the original plan and grade, the City Engineer shall be contacted prior to any additional repairs or reconstruction.
Standing water in vegetated swales	Make appropriate corrective measures such as adjusting irrigation system, removing obstructions of debris or invasive vegetation, loosening or replacing top soil to allow for better infiltration, or minor re-grading for proper drainage. If the issue is not corrected by restoring the BMP to the original plan and grade, the City Engineer shall be contacted prior to any additional repairs or reconstruction.
Standing water in bioretention, biofiltration with partial retention, or biofiltration areas, or flow-through planter boxes for longer than 96 hours following a storm event*	Make appropriate corrective measures such as adjusting irrigation system, removing obstructions of debris or invasive vegetation, clearing underdrains (where applicable), or repairing/replacing clogged or compacted soils.
Obstructed inlet or outlet structure	Clear obstructions.
Damage to structural components such as weirs, inlet or outlet structures	Repair or replace as applicable.
*These BMPs typically include a surface ponding layer as part of their function which may take 96 hours to drain following a storm event.	

V. Records

Each owner shall maintain records of the self certification forms for a minimum of 5-year period, excepting the initial year, the period of warranty.

ATTACHMENT A

ANNUAL REPORT FORM

INSPECTION AND MAINTENANCE CHECKLIST:

1. BIOFILTRATION WITH PARTIAL RETENTION (PR-1)
2. BIOFILTRATION WITH PARTIAL RETENTION BMP MAINTENANCE
FACT SHEET

Project Name:

THIS PAGE INTENTIONALLY LEFT BLANK FOR DOUBLE-SIDED PRINTING

E.17 PR-1 Biofiltration with Partial Retention



Location: 805 and Bonita Road, Chula Vista, CA.

MS4 Permit Category
NA
Manual Category
Partial Retention
Applicable Performance Standard
Pollutant Control
Flow Control
Primary Benefits
Volume Reduction
Treatment
Peak Flow Attenuation

Description

Biofiltration with partial retention (partial infiltration and biofiltration) facilities are vegetated surface water systems that filter water through vegetation, and soil or engineered media prior to infiltrating into native soils, discharge via underdrain, or overflow to the downstream conveyance system. Where feasible, these BMPs have an elevated underdrain discharge point that creates storage capacity in the aggregate storage layer. Biofiltration with partial retention facilities are commonly incorporated into the site within parking lot landscaping, along roadsides, and in open spaces. They can be constructed in ground or partially aboveground, such as planter boxes with open bottoms to allow infiltration. Treatment is achieved through filtration, sedimentation, sorption, infiltration, biochemical processes and plant uptake.

Typical biofiltration with partial retention components include:

- Inflow distribution mechanisms (e.g. perimeter flow spreader or filter strips)
- Energy dissipation mechanism for concentrated inflows (e.g., splash blocks or riprap)
- Shallow surface ponding for captured flows
- Side Slope and basin bottom vegetation selected based on climate and ponding depth
- Non-floating mulch layer
- Media layer (planting mix or engineered media) capable of supporting vegetation growth
- Filter course layer (aka choking layer) consisting of aggregate to prevent the migration of fines into uncompacted native soils or the optional aggregate storage layer
- Aggregate storage layer with underdrain(s)
- Uncompacted native soils at the bottom of the facility
- Overflow structure

Appendix E: BMP Design Fact Sheets

Design Adaptations for Project Goals

Partial infiltration BMP with biofiltration treatment for storm water pollutant control.

Biofiltration with partial retention can be designed so that a portion of the DCV is infiltrated by providing infiltration storage below the underdrain invert. The infiltration storage depth should be determined by the volume that can be reliably infiltrated within drawdown time limitations. Water discharged through the underdrain is considered biofiltration treatment. Storage provided above the underdrain within surface ponding, media, and aggregate storage is included in the biofiltration treatment volume.

Integrated storm water flow control and pollutant control configuration. The system can be designed to provide flow rate and duration control by primarily providing increased surface ponding and/or having a deeper aggregate storage layer. This will allow for significant detention storage, which can be controlled via inclusion of an orifice in an outlet structure at the downstream end of the underdrain.

Recommended Siting Criteria

Siting Criteria	Intent/Rationale
<ul style="list-style-type: none"> □ Placement observes geotechnical recommendations regarding potential hazards (e.g., slope stability, landslides, liquefaction zones) and setbacks (e.g., slopes, foundations, utilities). 	<p>Must not negatively impact existing site geotechnical concerns.</p>
<ul style="list-style-type: none"> □ Selection and design of basin is based on infiltration feasibility criteria and appropriate design infiltration rate (See Appendix C and D). 	<p>Must operate as a partial infiltration design and must be supported by drainage area and in-situ infiltration rate feasibility findings.</p>
<ul style="list-style-type: none"> □ Contributing tributary area shall be ≤ 5 acres (≤ 1 acre preferred). 	<p>Bigger BMPs require additional design features for proper performance. Contributing tributary area greater than 5 acres may be allowed at the discretion of the City Engineer if the following conditions are met: 1) incorporate design features (e.g. flow spreaders) to minimizing short circuiting of flows in the BMP and 2) incorporate additional design features requested by the City Engineer for proper performance of the regional BMP.</p>
<ul style="list-style-type: none"> □ Finish grade of the facility is $\leq 2\%$. 	<p>Flatter surfaces reduce erosion and channelization within the facility.</p>

Example Schematic Design – Plan and Section View

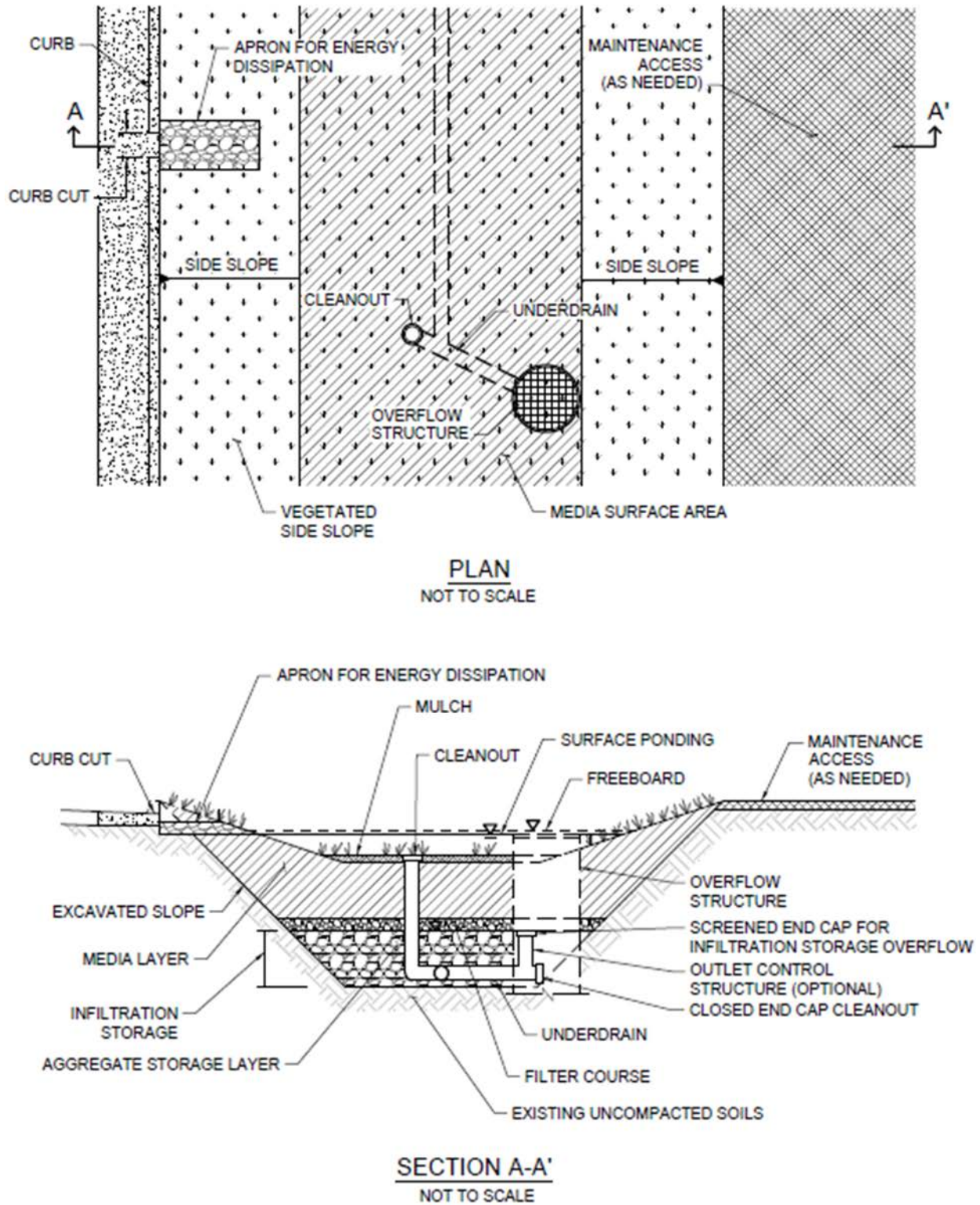

Figure E.17-1 : Typical Plan and Section View of a Biofiltration with Partial Retention BMP

Recommended BMP Component Dimensions

Appendix E: BMP Design Fact Sheets

BMP Component	Dimension	Intent/Rationale
Freeboard	≥ 2 inches	Freeboard provides room for head over overflow structures and minimizes risk of uncontrolled surface discharge.
Surface Ponding	≥ 6 and ≤ 12 inches	<p>The minimum ponding depth is required so that the runoff is uniformly spread throughout the basin (minimizes the likelihood of short circuiting). Deep surface ponding raises safety concerns.</p> <p>When the BMP is adjoining walkways the minimum surface ponding depth can be reduced to 4 inches.</p> <p>Surface ponding depth greater than 12 inches (for additional pollutant control or surface outlet structures or flow-control orifices) may be allowed at the discretion of the City Engineer if the following conditions are met: 1) surface ponding depth drawdown time is less than 24 hours; and 2) safety issues and fencing requirements are considered (typically ponding greater than 18" will require a fence) and 3) potential for elevated clogging risk is evaluated (Worksheet B.5.4).</p>
Ponding Area Side Slopes	3H:1V or shallower	Gentler side slopes are safer, less prone to erosion, able to establish vegetation more quickly and easier to maintain.
Mulch	≥3 inches	Mulch will suppress weeds and maintain moisture for plant growth.
Media Layer	≥ 18 inches	A deep media layer provides additional filtration and supports plants with deeper roots. Where the minimum of 18 inches is used, only shallow-rooted species shall be planted. A minimum 24-inch media layer depth is recommended to support vegetation, with a minimum 36-inch media layer depth recommended for trees.
Filter Course	6 inches	To reduce clogging potential, a two-layer filter course (aka choking stone system) is used consisting of one 3" layer of clean and washed ASTM 33 Fine Aggregate Sand overlying a 3" layer of ASTM No 8 Stone (Appendix F.4). This specification has been developed to maintain permeability while limiting the migration of media material into the stone reservoir and underdrain system.
Underdrain Diameter	≥ 8 inches	Minimum diameter required for maintenance by City crews. For privately maintained BMPs, a minimum underdrain diameter of 6 inches is allowed.
Cleanout Diameter	≥ 8 inches	Facilitates simpler cleaning, when needed. For privately maintained BMPs, cleanout diameter of 6 inches is allowed.

Deviations to the recommended BMP component dimensions may be approved at the discretion of the City Engineer if it is determined to be appropriate.

Design Criteria and Considerations

Appendix E: BMP Design Fact Sheets

Biofiltration with partial retention must meet the following design criteria and considerations. Deviations from the below criteria may be approved at the discretion of the City Engineer if it is determined to be appropriate:

Design Criteria	Intent/Rationale
Surface Ponding	
<ul style="list-style-type: none"> □ Surface ponding is limited to a 24-hour drawdown time. 	<p>Surface ponding limited to 24 hours for plant health.</p> <p>Surface ponding drawdown time greater than 24-hours but less than 96 hours may be allowed at the discretion of the City Engineer if certified by a landscape architect or agronomist.</p>
Vegetation	
<ul style="list-style-type: none"> □ Plantings are suitable for the climate and expected ponding depth. A plant list to aid in selection can be found in Appendix E.26 	<p>Plants suited to the climate and ponding depth are more likely to survive.</p>
<ul style="list-style-type: none"> □ An irrigation system with a connection to water supply should be provided as needed. 	<p>Seasonal irrigation might be needed to keep plants healthy.</p>
Mulch	
<ul style="list-style-type: none"> □ A minimum of 3 inches of well-aged, shredded hardwood mulch that has been stockpiled or stored for at least 12 months is provided. Mulch must be non-floating to avoid clogging of overflow structure. 	<p>Mulch will suppress weeds and maintain moisture for plant growth. Aging mulch kills pathogens and weed seeds and allows the beneficial microbes to multiply.</p>
Media Layer	
<ul style="list-style-type: none"> □ Media maintains a minimum filtration rate of 5 in/hr over lifetime of facility. Additional Criteria for media hydraulic conductivity described in the bioretention soil media model specification (Appendix F.3) 	<p>A filtration rate of at least 5 inches per hour allows soil to drain between events, and allows flows to relatively quickly enter the aggregate storage layer, thereby minimizing bypass. The initial rate should be higher than long term target rate to account for clogging over time. However an excessively high initial rate can have a negative impact on treatment performance, therefore an upper limit is needed.</p>

Appendix E: BMP Design Fact Sheets

Design Criteria	Intent/Rationale
<p>Media shall be a minimum 18 inches deep for filtration purposes, with a minimum 24-inch media layer depth recommended to support vegetation and a minimum 36-inch media layer depth recommended for trees. Media shall meet the following specifications:</p> <ul style="list-style-type: none"> □ Model bioretention soil media specification provided in Appendix F.3 <u>or</u> County of San Diego Low Impact Development Handbook: Appendix G - Bioretention Soil Specification (June 2014, unless superseded by more recent edition). Alternatively, for proprietary designs and custom media mixes not meeting the media specifications, the media meets the pollutant treatment performance criteria in Section F.1. 	<p>A deep media layer provides additional filtration and supports plants with deeper roots.</p> <p>Standard specifications shall be followed.</p> <p>For non-standard or proprietary designs, compliance with Appendix F.1 ensures that adequate treatment performance will be provided.</p>
<ul style="list-style-type: none"> □ Media surface area is 3% of contributing area times adjusted runoff factor or greater. Unless demonstrated that the BMP surface area can be smaller than 3%. 	<p>Greater surface area to tributary area ratios: a) maximizes volume retention as required by the MS4 Permit and b) decrease loading rates per square foot and therefore increase longevity.</p> <p>Adjusted runoff factor is to account for site design BMPs implemented upstream of the BMP (such as rain barrels, impervious area dispersion, etc.). Refer to Appendix B.2 guidance.</p> <p>Refer to Appendix B.5 for guidance to support use of smaller than 3% footprint.</p>
<ul style="list-style-type: none"> □ Where receiving waters are impaired or have a TMDL for nutrients, the system is designed with nutrient sensitive media design (see fact sheet BF-2). 	<p>Potential for pollutant export is partly a function of media composition; media design must minimize potential for export of nutrients, particularly where receiving waters are impaired for nutrients.</p>
<p>Filter Course Layer</p>	
<ul style="list-style-type: none"> □ A filter course is used to prevent migration of fines through layers of the facility. Filter fabric is not used. 	<p>Migration of media can cause clogging of the aggregate storage layer void spaces or subgrade and can result in poor water quality performance for turbidity and suspended solids. Filter fabric is more likely to clog.</p>
<ul style="list-style-type: none"> □ Filter course is washed and free of fines. 	<p>Washing aggregate will help eliminate fines that could clog the facility</p>
<ul style="list-style-type: none"> □ To reduce clogging potential, a two-layer filter course (aka choking stone system) is used consisting of one 3" layer of clean and washed ASTM 33 Fine Aggregate Sand overlying a 3" layer of ASTM No 8 Stone (Appendix F.4) 	<p>This specification has been developed to maintain permeability while limiting the migration of media material into the stone reservoir and underdrain system.</p>

Design Criteria	Intent/Rationale
Aggregate Storage Layer	
<ul style="list-style-type: none"> □ ASTM #57 open graded stone is used for the storage layer and a two layer filter course (detailed above) is used above this layer 	<p>This layer provides additional storage capacity. ASTM #8 stone provides an acceptable choking/bridging interface with the particles in ASTM #57 stone.</p>
Inflow, Underdrain, and Outflow Structures	
<ul style="list-style-type: none"> □ Inflow, underdrains and outflow structures are accessible for inspection and maintenance. 	<p>Maintenance will prevent clogging and ensure proper operation of the flow control structures.</p>
<ul style="list-style-type: none"> □ Inflow velocities are limited to 3 ft/s or less or use energy dissipation methods. (e.g., riprap, level spreader) for concentrated inflows. 	<p>High inflow velocities can cause erosion, scour and/or channeling.</p>
<ul style="list-style-type: none"> □ Curb cut inlets are at least 18 inches wide, have a 4-6 inch reveal (drop) and an apron and energy dissipation as needed. 	<p>Inlets must not restrict flow and apron prevents blockage from vegetation as it grows in. Energy dissipation prevents erosion.</p>
<ul style="list-style-type: none"> □ Underdrain outlet elevation should be a minimum of 3 inches above the bottom elevation of the aggregate storage layer. 	<p>A minimal separation from subgrade or the liner lessens the risk of fines entering the underdrain and can improve hydraulic performance by allowing perforations to remain unblocked.</p>
<ul style="list-style-type: none"> □ Minimum underdrain diameter is 8 inches. 	<p>Minimum diameter required for maintenance by City crews. For privately maintained BMPs, a minimum underdrain diameter of 6 inches is allowed.</p>
<ul style="list-style-type: none"> □ Underdrains are made of slotted, PVC pipe conforming to ASTM D 3034 or equivalent or corrugated, HDPE pipe conforming to AASHTO 252M or equivalent. 	<p>Slotted underdrains provide greater intake capacity, clog resistant drainage, and reduced entrance velocity into the pipe, thereby reducing the chances of solids migration.</p>
<ul style="list-style-type: none"> □ An underdrain cleanout with a minimum 8-inch diameter and lockable cap is placed every 50 feet as required based on underdrain length. 	<p>Properly spaced cleanouts will facilitate underdrain maintenance. For privately maintained BMPs, cleanout diameter of 6 inches is allowed.</p>
<ul style="list-style-type: none"> □ Overflow is safely conveyed to a downstream storm drain system or discharge point. Size overflow structure to pass 100-year peak flow for on-line infiltration basins and water quality peak flow for off-line basins. 	<p>Planning for overflow lessens the risk of property damage due to flooding.</p>



Appendix E: BMP Design Fact Sheets

Conceptual Design and Sizing Approach for Storm Water Pollutant Control Only

To design biofiltration with partial retention and an underdrain for storm water pollutant control only (no flow control required), the following steps should be taken:

1. Verify that siting and design criteria have been met, including placement requirements, contributing tributary area, maximum side and finish grade slopes, and the recommended media surface area tributary ratio.
2. Calculate the DCV per **Appendix B** based on expected site design runoff for tributary areas.
3. Generalized sizing procedure is presented in **Appendix B.5**. The surface ponding should be verified to have a maximum 24-hour drawdown time. Surface ponding drawdown time greater than 24-hours but less than 96 hours may be allowed at the discretion of the City Engineer if certified by a landscape architect or agronomist.

Conceptual Design and Sizing Approach when Storm Water Flow Control is Applicable

Control of flow rates and/or durations will typically require significant surface ponding and/or aggregate storage volumes, and therefore the following steps should be taken prior to determination of storm water pollutant control design. Pre-development and allowable post-project flow rates and durations should be determined as discussed in **Chapter 6** of the manual.

1. Verify that siting and design criteria have been met, including placement requirements, contributing tributary area, maximum side and finish grade slopes, and the recommended media surface area tributary ratio.
2. Iteratively determine the facility footprint area, surface ponding and/or aggregate storage layer depth required to provide detention and/or infiltration storage to reduce flow rates and durations to allowable limits. Flow rates and durations can be controlled from detention storage by altering outlet structure orifice size(s) and/or water control levels. Multi-level orifices can be used within an outlet structure to control the full range of flows.
3. If biofiltration with partial retention cannot fully provide the flow rate and duration control required by this manual, an upstream or downstream structure with significant storage volume such as an underground vault can be used to provide remaining controls.
4. After biofiltration with partial retention has been designed to meet flow control requirements, calculations must be completed to verify if storm water pollutant control requirements to treat the DCV have been met.

Biofiltration with Partial Retention

BMP MAINTENANCE FACT SHEET

FOR

STRUCTURAL BMP PR-1 BIOFILTRATION WITH PARTIAL RETENTION

Biofiltration with partial retention facilities are vegetated surface water systems that filter water through vegetation and soil or engineered media prior to infiltrating into native soils, discharge via underdrain, or overflow to the downstream conveyance system. These BMPs have an elevated underdrain discharge point that creates storage capacity in the aggregate storage layer. Typical biofiltration with partial retention components include:

- Inflow distribution mechanisms (e.g., perimeter flow spreader or filter strips)
- Energy dissipation mechanism for concentrated inflows (e.g., splash blocks or riprap)
- Shallow surface ponding for captured flows
- Side slope and basin bottom vegetation selected based on climate and ponding depth
- Non-floating mulch layer
- Media layer (planting mix or engineered media) capable of supporting vegetation growth
- Filter course layer consisting of aggregate to prevent the migration of fines into uncompacted native soils or the aggregate storage layer
- Aggregate storage layer with underdrain(s)
- Uncompacted native soils at the bottom of the facility
- Overflow structure

Normal Expected Maintenance

Biofiltration with partial retention requires routine maintenance to: remove accumulated materials such as sediment, trash or debris; maintain vegetation health; maintain infiltration capacity of the media layer; replenish mulch; and maintain integrity of side slopes, inlets, energy dissipators, and outlets. A summary table of standard inspection and maintenance indicators is provided within this Fact Sheet.

Non-Standard Maintenance or BMP Failure

If any of the following scenarios are observed, the BMP is not performing as intended to protect downstream waterways from pollution and/or erosion. Corrective maintenance, increased inspection and maintenance, BMP replacement, or a different BMP type will be required.

- The BMP is not drained between storm events. Surface ponding longer than approximately 24 hours following a storm event may be detrimental to vegetation health, and surface ponding longer than approximately 96 hours following a storm event poses a risk of vector (mosquito) breeding. Poor drainage can result from clogging of the media layer, filter course, aggregate storage layer, underdrain, or outlet structure. The specific cause of the drainage issue must be determined and corrected.
- Sediment, trash, or debris accumulation greater than 25% of the surface ponding volume within one month. This means the load from the tributary drainage area is too high, reducing BMP function or clogging the BMP. This would require pretreatment measures within the tributary area draining to the BMP to intercept the materials. Pretreatment components, especially for sediment, will extend the life of components that are more expensive to replace such as media, filter course, and aggregate layers.

Biofiltration with Partial Retention

- Erosion due to concentrated storm water runoff flow that is not readily corrected by adding erosion control blankets, adding stone at flow entry points, or minor re-grading to restore proper drainage according to the original plan. If the issue is not corrected by restoring the BMP to the original plan and grade, the [City Engineer] shall be contacted prior to any additional repairs or reconstruction.

Other Special Considerations

Biofiltration with partial retention is a vegetated structural BMP. Vegetated structural BMPs that are constructed in the vicinity of, or connected to, an existing jurisdictional water or wetland could inadvertently result in creation of expanded waters or wetlands. As such, vegetated structural BMPs have the potential to come under the jurisdiction of the United States Army Corps of Engineers, SDRWQCB, California Department of Fish and Wildlife, or the United States Fish and Wildlife Service. This could result in the need for specific resource agency permits and costly mitigation to perform maintenance of the structural BMP. Along with proper placement of a structural BMP, **routine maintenance is key to preventing this scenario.**

PR-1 Biofiltration with Partial Retention

SUMMARY OF STANDARD INSPECTION AND MAINTENANCE FOR PR-1 BIOFILTRATION WITH PARTIAL RETENTION		
<p>The property owner is responsible to ensure inspection, operation and maintenance of permanent BMPs on their property unless responsibility has been formally transferred to an agency, community facilities district, homeowners association, property owners association, or other special district.</p> <p>Maintenance frequencies listed in this table are average/typical frequencies. Actual maintenance needs are site-specific, and maintenance may be required more frequently. Maintenance must be performed whenever needed, based on maintenance indicators presented in this table. The BMP owner is responsible for conducting regular inspections to see when maintenance is needed based on the maintenance indicators. During the first year of operation of a structural BMP, inspection is recommended at least once prior to August 31 and then monthly from September through May. Inspection during a storm event is also recommended. After the initial period of frequent inspections, the minimum inspection and maintenance frequency can be determined based on the results of the first year inspections.</p>		
Threshold/Indicator	Maintenance Action	Typical Maintenance Frequency
Accumulation of sediment, litter, or debris	Remove and properly dispose of accumulated materials, without damage to the vegetation or compaction of the media layer.	<ul style="list-style-type: none"> • Inspect monthly. If the BMP is 25% full* or more in one month, increase inspection frequency to monthly plus after every 0.1-inch or larger storm event. • Remove any accumulated materials found at each inspection.
Obstructed inlet or outlet structure	Clear blockage.	<ul style="list-style-type: none"> • Inspect monthly and after every 0.5-inch or larger storm event. • Remove any accumulated materials found at each inspection.
Damage to structural components such as weirs, inlet or outlet structures	Repair or replace as applicable.	<ul style="list-style-type: none"> • Inspect annually. • Maintenance when needed.
Poor vegetation establishment	Re-seed, re-plant, or re-establish vegetation per original plans.	<ul style="list-style-type: none"> • Inspect monthly. • Maintenance when needed.
Dead or diseased vegetation	Remove dead or diseased vegetation, re-seed, re-plant, or re-establish vegetation per original plans.	<ul style="list-style-type: none"> • Inspect monthly. • Maintenance when needed.
Overgrown vegetation	Mow or trim as appropriate.	<ul style="list-style-type: none"> • Inspect monthly. • Maintenance when needed.
2/3 of mulch has decomposed, or mulch has been removed	Remove decomposed fraction and top off with fresh mulch to a total depth of 3 inches.	<ul style="list-style-type: none"> • Inspect monthly. • Replenish mulch annually, or more frequently when needed based on inspection.

*"25% full" is defined as ¼ of the depth from the design bottom elevation to the crest of the outflow structure (e.g., if the height to the outflow opening is 12 inches from the bottom elevation, then the materials must be removed when there is 3 inches of accumulation – this should be marked on the outflow structure).

PR-1

Biofiltration with Partial Retention

SUMMARY OF STANDARD INSPECTION AND MAINTENANCE FOR PR-1 BIOFILTRATION WITH PARTIAL RETENTION (Continued from previous page)		
Threshold/Indicator	Maintenance Action	Typical Maintenance Frequency
Erosion due to concentrated irrigation flow	Repair/re-seed/re-plant eroded areas and adjust the irrigation system.	<ul style="list-style-type: none"> Inspect monthly. Maintenance when needed.
Erosion due to concentrated storm water runoff flow	Repair/re-seed/re-plant eroded areas, and make appropriate corrective measures such as adding erosion control blankets, adding stone at flow entry points, or minor re-grading to restore proper drainage according to the original plan. If the issue is not corrected by restoring the BMP to the original plan and grade, the [City Engineer] shall be contacted prior to any additional repairs or reconstruction.	<ul style="list-style-type: none"> Inspect after every 0.5-inch or larger storm event. If erosion due to storm water flow has been observed, increase inspection frequency to after every 0.1-inch or larger storm event. Maintenance when needed. If the issue is not corrected by restoring the BMP to the original plan and grade, the [City Engineer] shall be contacted prior to any additional repairs or reconstruction.
Standing water in BMP for longer than 24 hours following a storm event Surface ponding longer than approximately 24 hours following a storm event may be detrimental to vegetation health	Make appropriate corrective measures such as adjusting irrigation system, removing obstructions of debris or invasive vegetation, clearing underdrains, or repairing/replacing clogged or compacted soils.	<ul style="list-style-type: none"> Inspect monthly and after every 0.5-inch or larger storm event. If standing water is observed, increase inspection frequency to after every 0.1-inch or larger storm event. Maintenance when needed.
Presence of mosquitos/larvae For images of egg rafts, larva, pupa, and adult mosquitos, see http://www.mosquito.org/biology	If mosquitos/larvae are observed: first, immediately remove any standing water by dispersing to nearby landscaping; second, make corrective measures as applicable to restore BMP drainage to prevent standing water. If mosquitos persist following corrective measures to remove standing water, or if the BMP design does not meet the 96-hour drawdown criteria due to release rates controlled by an orifice installed on the underdrain, the [City Engineer] shall be contacted to determine a solution. A different BMP type, or a Vector Management Plan prepared with concurrence from the County of San Diego Department of Environmental Health, may be required.	<ul style="list-style-type: none"> Inspect monthly and after every 0.5-inch or larger storm event. If mosquitos are observed, increase inspection frequency to after every 0.1-inch or larger storm event. Maintenance when needed.
Underdrain clogged	Clear blockage.	<ul style="list-style-type: none"> Inspect if standing water is observed for longer than 24-96 hours following a storm event. Maintenance when needed.

PR-1

Biofiltration with Partial Retention

References

- American Mosquito Control Association. <http://www.mosquito.org/>
- California Storm Water Quality Association (CASQA). 2003. Municipal BMP Handbook. <https://www.casqa.org/resources/bmp-handbooks/municipal-bmp-handbook>
- County of San Diego. 2014. Low Impact Development Handbook. <http://www.sandiegocounty.gov/content/sdc/dpw/watersheds/susmp/lid.html>
- San Diego County Copermittees. 2016. Model BMP Design Manual, Appendix E, Fact Sheet PR-1. http://www.projectcleanwater.org/index.php?option=com_content&view=article&id=250&Itemid=220

PR-1 Biofiltration with Partial Retention

Page Intentionally Blank for Double-Sided Printing

PR-1 Biofiltration with Partial Retention

Date:	Inspector:	BMP ID No.:	
Permit No.:	APN(s):		
Property / Development Name:		Responsible Party Name and Phone Number:	
Property Address of BMP:		Responsible Party Address:	

INSPECTION AND MAINTENANCE CHECKLIST FOR PR-1 BIOFILTRATION WITH PARTIAL RETENTION PAGE 1 of 5			
Threshold/Indicator	Maintenance Recommendation	Date	Description of Maintenance Conducted
Accumulation of sediment, litter, or debris Maintenance Needed? <input type="checkbox"/> YES <input type="checkbox"/> NO <input type="checkbox"/> N/A	<input type="checkbox"/> Remove and properly dispose of accumulated materials, without damage to the vegetation <input type="checkbox"/> If sediment, litter, or debris accumulation exceeds 25% of the surface ponding volume within one month (25% full*), add a forebay or other pre-treatment measures within the tributary area draining to the BMP to intercept the materials. <input type="checkbox"/> Other / Comments:		
Poor vegetation establishment Maintenance Needed? <input type="checkbox"/> YES <input type="checkbox"/> NO <input type="checkbox"/> N/A	<input type="checkbox"/> Re-seed, re-plant, or re-establish vegetation per original plans <input type="checkbox"/> Other / Comments:		

*"25% full" is defined as ¼ of the depth from the design bottom elevation to the crest of the outflow structure (e.g., if the height to the outflow opening is 12 inches from the bottom elevation, then the materials must be removed when there is 3 inches of accumulation – this should be marked on the outflow structure).

PR-1 Biofiltration with Partial Retention

Date:	Inspector:	BMP ID No.:
Permit No.:	APN(s):	

INSPECTION AND MAINTENANCE CHECKLIST FOR PR-1 BIOFILTRATION WITH PARTIAL RETENTION PAGE 2 of 5		
Threshold/Indicator	Maintenance Recommendation	Date Description of Maintenance Conducted
Dead or diseased vegetation Maintenance Needed? <input type="checkbox"/> YES <input type="checkbox"/> NO <input type="checkbox"/> N/A	<input type="checkbox"/> Remove dead or diseased vegetation, re-seed, re-plant, or re-establish vegetation per original plans <input type="checkbox"/> Other / Comments:	
Overgrown vegetation Maintenance Needed? <input type="checkbox"/> YES <input type="checkbox"/> NO <input type="checkbox"/> N/A	<input type="checkbox"/> Mow or trim as appropriate <input type="checkbox"/> Other / Comments:	
2/3 of mulch has decomposed, or mulch has been removed Maintenance Needed? <input type="checkbox"/> YES <input type="checkbox"/> NO <input type="checkbox"/> N/A	<input type="checkbox"/> Remove decomposed fraction and top off with fresh mulch to a total depth of 3 inches <input type="checkbox"/> Other / Comments:	

PR-1 Biofiltration with Partial Retention

Date:	Inspector:	BMP ID No.:
Permit No.:	APN(s):	

INSPECTION AND MAINTENANCE CHECKLIST FOR PR-1 BIOFILTRATION WITH PARTIAL RETENTION PAGE 3 of 5		
Threshold/Indicator	Maintenance Recommendation	Date
<p>Erosion due to concentrated irrigation flow</p> <p>Maintenance Needed?</p> <p><input type="checkbox"/> YES <input type="checkbox"/> NO <input type="checkbox"/> N/A</p>	<p><input type="checkbox"/> Repair/re-seed/re-plant eroded areas and adjust the irrigation system</p> <p><input type="checkbox"/> Other / Comments:</p>	
<p>Erosion due to concentrated storm water runoff flow</p> <p>Maintenance Needed?</p> <p><input type="checkbox"/> YES <input type="checkbox"/> NO <input type="checkbox"/> N/A</p>	<p><input type="checkbox"/> Repair/re-seed/re-plant eroded areas, and make appropriate corrective measures such as adding erosion control blankets, adding stone at flow entry points, or minor re-grading to restore proper drainage according to the original plan</p> <p><input type="checkbox"/> If the issue is not corrected by restoring the BMP to the original plan and grade, the [City Engineer] shall be contacted prior to any additional repairs or reconstruction</p> <p><input type="checkbox"/> Other / Comments:</p>	
		Description of Maintenance Conducted

PR-1 Biofiltration with Partial Retention

Date:	Inspector:	BMP ID No.:	
Permit No.:	APN(s):		

INSPECTION AND MAINTENANCE CHECKLIST FOR PR-1 BIOFILTRATION WITH PARTIAL RETENTION PAGE 4 of 5			
Threshold/Indicator	Maintenance Recommendation	Date	Description of Maintenance Conducted
<p>Obstructed inlet or outlet structure</p> <p>Maintenance Needed?</p> <p><input type="checkbox"/> YES</p> <p><input type="checkbox"/> NO</p> <p><input type="checkbox"/> N/A</p>	<p><input type="checkbox"/> Clear blockage</p> <p><input type="checkbox"/> Other / Comments:</p>		
<p>Underdrain clogged (inspect underdrain if standing water is observed for longer than 24-96 hours following a storm event)</p> <p>Maintenance Needed?</p> <p><input type="checkbox"/> YES</p> <p><input type="checkbox"/> NO</p> <p><input type="checkbox"/> N/A</p>	<p><input type="checkbox"/> Clear blockage</p> <p><input type="checkbox"/> Other / Comments:</p>		
<p>Damage to structural components such as weirs, inlet or outlet structures</p> <p>Maintenance Needed?</p> <p><input type="checkbox"/> YES</p> <p><input type="checkbox"/> NO</p> <p><input type="checkbox"/> N/A</p>	<p><input type="checkbox"/> Repair or replace as applicable</p> <p><input type="checkbox"/> Other / Comments:</p>		

PR-1

Biofiltration with Partial Retention

Date:	Inspector:	BMP ID No.:
Permit No.:	APN(s):	

INSPECTION AND MAINTENANCE CHECKLIST FOR PR-1 BIOFILTRATION WITH PARTIAL RETENTION PAGE 5 of 5		
Threshold/Indicator	Maintenance Recommendation	Date
<p>Standing water in BMP for longer than 24 hours following a storm event*</p> <p>Surface ponding longer than approximately 24 hours following a storm event may be detrimental to vegetation health</p> <p>Maintenance Needed?</p> <p><input type="checkbox"/> YES <input type="checkbox"/> NO <input type="checkbox"/> N/A</p>	<p><input type="checkbox"/> Make appropriate corrective measures such as adjusting irrigation system, removing obstructions of debris or invasive vegetation, clearing underdrains, or repairing/replacing clogged or compacted soils</p> <p><input type="checkbox"/> Other / Comments:</p>	
<p>Presence of mosquitos/larvae</p> <p>For images of egg rafts, larva, pupa, and adult mosquitos, see http://www.mosquito.org/biology.</p> <p>Maintenance Needed?</p> <p><input type="checkbox"/> YES <input type="checkbox"/> NO <input type="checkbox"/> N/A</p>	<p><input type="checkbox"/> Apply corrective measures to remove standing water in BMP when standing water occurs for longer than 24-96 hours following a storm event.**</p> <p><input type="checkbox"/> Other / Comments:</p>	

*Surface ponding longer than approximately 24 hours following a storm event may be detrimental to vegetation health, and surface ponding longer than approximately 96 hours following a storm event poses a risk of vector (mosquito) breeding. Poor drainage can result from clogging of the media layer, filter course, aggregate storage layer, underdrain, or outlet structure. The specific cause of the drainage issue must be determined and corrected.

**If mosquitos persist following corrective measures to remove standing water, or if the BMP design does not meet the 96-hour drawdown criteria due to release rates controlled by an orifice installed on the underdrain, the [City Engineer] shall be contacted to determine a solution. A different BMP type, or a Vector Management Plan prepared with concurrence from the County of San Diego Department of Environmental Health, may be required.

Project Name:

THIS PAGE INTENTIONALLY LEFT BLANK FOR DOUBLE-SIDED PRINTING

ATTACHMENT B

SOURCE CONTROL BMP FACT SHEETS: (OBTAINED FROM THE CALIFORNIA STORMWATER BMP HANDBOOK)

3. NON-STORMWATER DISCHARGES SC-10
4. SPILL PREVENTION, CONTROL & CLEANUP SC-11
5. BUILDING AND GROUNDS MAINTENANCE SC-41
6. DRAINAGE SYSTEM MAINTENANCE SC-44
7. LANDSCAPE MAINTENANCE SC-73

Project Name:

THIS PAGE INTENTIONALLY LEFT BLANK FOR DOUBLE-SIDED PRINTING

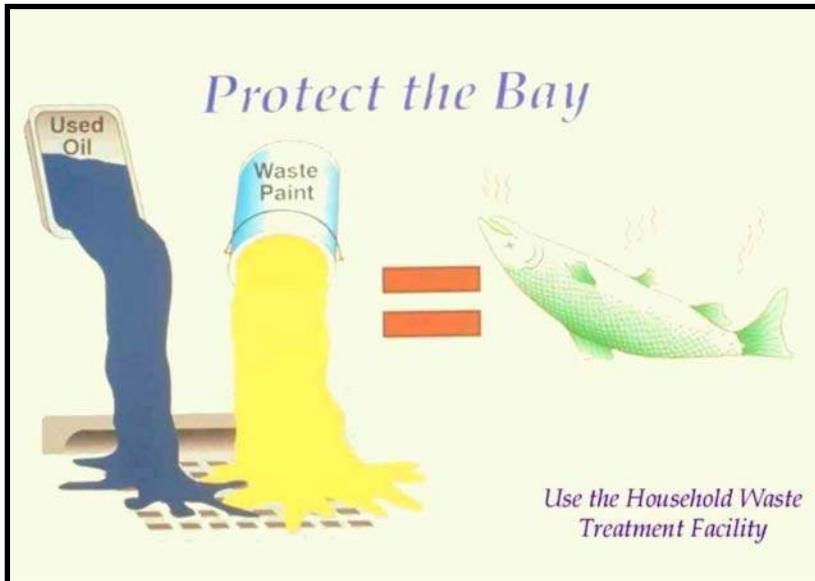

Graphic by: Margie Winter

Description

Non-stormwater discharges are those flows that do not consist entirely of stormwater. For municipalities non-stormwater discharges present themselves in two situations. One is from fixed facilities owned and/or operated by the municipality. The other situation is non-stormwater discharges that are discovered during the normal operation of a field program. Some non-stormwater discharges do not include pollutants and may be discharged to the storm drain. These include uncontaminated groundwater and natural springs. There are also some non-stormwater discharges that typically do not contain pollutants and may be discharged to the storm drain with conditions. These include car washing, and surface cleaning. However, there are certain non-stormwater discharges that pose environmental concern. These discharges may originate from illegal dumping or from internal floor drains, appliances, industrial processes, sinks, and toilets that are connected to the nearby storm drainage system. These discharges (which may include: process waste waters, cooling waters, wash waters, and sanitary wastewater) can carry substances (such as paint, oil, fuel and other automotive fluids, chemicals and other pollutants) into storm drains. The ultimate goal is to effectively eliminate non-stormwater discharges to the stormwater drainage system through implementation of measures to detect, correct, and enforce against illicit connections and illegal discharges.

Approach

The municipality must address non-stormwater discharges from its fixed facilities by assessing the types of non-stormwater discharges and implementing BMPs for the discharges determined to pose environmental concern. For field programs

Objectives

- Contain
- Educate
- Reduce/Minimize

Targeted Constituents

Sediment	<input checked="" type="checkbox"/>
Nutrients	<input checked="" type="checkbox"/>
Trash	<input checked="" type="checkbox"/>
Metals	<input checked="" type="checkbox"/>
Bacteria	<input checked="" type="checkbox"/>
Oil and Grease	<input checked="" type="checkbox"/>
Organics	<input checked="" type="checkbox"/>
Oxygen Demanding	<input checked="" type="checkbox"/>



the field staff must be trained to now what to look for regarding non-stormwater discharges and the procedures to follow in investigating the detected discharges.

Suggested Protocols

Fixed Facility

General

- Post “No Dumping” signs with a phone number for reporting dumping and disposal. Signs should also indicate fines and penalties for illegal dumping.
- Stencil storm drains, where applicable, to prevent illegal disposal of pollutants. Storm drain inlets should have messages such as “Dump No Waste Drains to Stream” stenciled next to them to warn against ignorant or intentional dumping of pollutants into the storm drainage system.
- Landscaping and beautification efforts of hot spots might also discourage future dumping, as well as provide open space and increase property values.
- Lighting or barriers may also be needed to discourage future dumping.

Illicit Connections

- Locate discharges from the fixed facility drainage system to the municipal storm drain system through review of “as-built” piping schematics.
- Use techniques such as smoke testing, dye testing and television camera inspection (as noted below) to verify physical connections.
- Isolate problem areas and plug illicit discharge points.

Visual Inspection and Inventory

- Inventory and inspect each discharge point during dry weather.
- Keep in mind that drainage from a storm event can continue for several days following the end of a storm and groundwater may infiltrate the underground stormwater collection system. Also, non-stormwater discharges are often intermittent and may require periodic inspections.

Review Infield Piping

- Review the “as-built” piping schematic as a way to determine if there are any connections to the stormwater collection system.
- Inspect the path of floor drains in older buildings.

Smoke Testing

- Smoke testing of wastewater and stormwater collection systems is used to detect connections between the two systems.

- During dry weather the stormwater collection system is filled with smoke and then traced to sources. The appearance of smoke at the base of a toilet indicates that there may be a connection between the sanitary and the stormwater system.

Dye Testing

- A dye test can be performed by simply releasing a dye into either your sanitary or process wastewater system and examining the discharge points from the stormwater collection system for discoloration.

TV Inspection of Storm Sewer

- TV Cameras can be employed to visually identify illicit connections to the fixed facility storm drain system.

Illegal Dumping

- Regularly inspect and clean up hot spots and other storm drainage areas where illegal dumping and disposal occurs.
- Clean up spills on paved surfaces with as little water as possible. Use a rag for small spills, a damp mop for general cleanup, and absorbent material for larger spills. If the spilled material is hazardous, then the used cleanup materials are also hazardous and must be sent to a certified laundry (rags) or disposed of as hazardous waste.
- Never hose down or bury dry material spills. Sweep up the material and dispose of properly.
- Use adsorbent materials on small spills rather than hosing down the spill. Remove the adsorbent materials promptly and dispose of properly.
- For larger spills, a private spill cleanup company or Hazmat team may be necessary.
- See fact sheet SC-11 Spill Prevention, Control, and Clean Up.

Field Program

General

- Develop clear protocols and lines of communication for effectively prohibiting non-stormwater discharges, especially ones that involve more than one jurisdiction and those that are not classified as hazardous, which are often not responded to as effectively as they need to be.
- Stencil storm drains, where applicable, to prevent illegal disposal of pollutants. Storm drain inlets should have messages such as “Dump No Waste Drains to Stream” stenciled next to them to warn against ignorant or intentional dumping of pollutants into the storm drainage system.
- See SC-74 Stormwater Drainage System Maintenance for additional information.

Field Inspection

- Regularly inspect and clean up hot spots and other storm drainage areas where illegal dumping and disposal occurs.
- During routine field program maintenance field staff should look for evidence of illegal discharges or illicit connection:
 - Is there evidence of spills such as paints, discoloring, etc.
 - Are there any odors associated with the drainage system
 - Record locations of apparent illegal discharges/illicit connections and notify appropriate investigating agency.
- If trained, conduct field investigation of non-stormwater discharges to determine whether they pose a threat to water quality.

Recommended Complaint Investigation Equipment

- Field Screening Analysis
 - pH paper or meter
 - Commercial stormwater pollutant screening kit that can detect for reactive phosphorus, nitrate nitrogen, ammonium nitrogen, specific conductance, and turbidity
 - Sample jars
 - Sample collection pole
 - A tool to remove access hole covers
- Laboratory Analysis
 - Sample cooler
 - Ice
 - Sample jars and labels
 - Chain of custody forms.
- Documentation
 - Camera
 - Notebook
 - Pens
 - Notice of Violation forms

- Educational materials

Reporting

- A database is useful for defining and tracking the magnitude and location of the problem.
- Report prohibited non-stormwater discharges observed during the course of normal daily activities so they can be investigated, contained and cleaned up or eliminated.
- Document that non-stormwater discharges have been eliminated by recording tests performed, methods used, dates of testing, and any onsite drainage points observed.
- Maintain documentation of illicit connection and illegal dumping incidents, including significant conditionally exempt discharges that are not properly managed.

Enforcement

- Educate the responsible party if identified on the impacts of their actions, explain the stormwater requirements, and provide information regarding Best Management Practices (BMP), as appropriate. Initiate follow-up and/or enforcement procedures.
- If an illegal discharge is traced to a commercial, residential or industrial source, conduct the following activities or coordinate the following activities with the appropriate agency:
 - Contact the responsible party to discuss methods of eliminating the non-stormwater discharge, including disposal options, recycling, and possible discharge to the sanitary sewer (if within POTW limits).
 - Provide information regarding BMPs to the responsible party, where appropriate.
 - Begin enforcement procedures, if appropriate.
 - Continue inspection and follow-up activities until the illicit discharge activity has ceased.
- If an illegal discharge is traced to a commercial or industrial activity, coordinate information on the discharge with the jurisdiction's commercial and industrial facility inspection program.

Training

- Train technical staff to identify and document illegal dumping incidents.
- Well-trained employees can reduce human errors that lead to accidental releases or spills. The employee should have the tools and knowledge to immediately begin cleaning up a spill if one should occur. Employees should be familiar with the Spill Prevention Control and Countermeasure Plan.
- Train employees to identify non-stormwater discharges and report them to the appropriate departments.
- Train staff who have the authority to conduct surveillance and inspections, and write citations for those caught illegally dumping.

- Train municipal staff responsible for surveillance and inspection in the following:
 - OSHA-required Health and Safety Training (29 CFR 1910.120) plus annual refresher training (as needed).
 - OSHA Confined Space Entry training (Cal-OSHA Confined Space, Title 8 and federal OSHA 29 CFR 1910.146).
 - Procedural training (field screening, sampling, smoke/dye testing, TV inspection).
- Educate the identified responsible party on the impacts of his or her actions.

Spill Response and Prevention

- See SC-11 Spill Prevention Control and Clean Up

Other Considerations

- The elimination of illegal dumping is dependent on the availability, convenience, and cost of alternative means of disposal. The cost of fees for dumping at a proper waste disposal facility are often more than the fine for an illegal dumping offense, thereby discouraging people from complying with the law. The absence of routine or affordable pickup service for trash and recyclables in some communities also encourages illegal dumping. A lack of understanding regarding applicable laws or the inadequacy of existing laws may also contribute to the problem.
- Municipal codes should include sections prohibiting the discharge of soil, debris, refuse, hazardous wastes, and other pollutants into the storm drain system.
- Many facilities do not have accurate, up-to-date schematic drawings.
- Can be difficult to locate illicit connections especially if there is groundwater infiltration.

Requirements

Costs

- Eliminating illicit connections can be expensive especially if structural modifications are required such re-plumbing cross connections under an existing slab.
- Minor cost to train field crews regarding the identification of non-stormwater discharges. The primary cost is for a fully integrated program to identify and eliminate illicit connections and illegal dumping. However, by combining with other municipal programs (i.e. pretreatment program) cost may be lowered.
- Municipal cost for containment and disposal may be borne by the discharger.

Maintenance

Not applicable

Supplemental Information

Further Detail of the BMP

What constitutes a “non-stormwater” discharge?

- Non-stormwater discharges are discharges not made up entirely of stormwater and include water used directly in the manufacturing process (process wastewater), air conditioning condensate and coolant, non-contact cooling water, cooling equipment condensate, outdoor secondary containment water, vehicle and equipment wash water, landscape irrigation, sink and drinking fountain wastewater, sanitary wastes, or other wastewaters.

Permit Requirements

- Current municipal NPDES permits require municipalities to effectively prohibit non-stormwater discharges unless authorized by a separate NPDES permit or allowed in accordance with the current NPDES permit conditions. Typically the current permits allow certain non-stormwater discharges in the storm drain system as long as the discharges are not significant sources of pollutants. In this context the following non-stormwater discharges are typically allowed:
 - Diverted stream flows;
 - Rising found waters;
 - Uncontaminated ground water infiltration (as defined at 40 CFR 35.2005(20));
 - Uncontaminated pumped ground water;
 - Foundation drains;
 - Springs;
 - Water from crawl space pumps;
 - Footing drains;
 - Air conditioning condensation;
 - Flows from riparian habitats and wetlands;
 - Water line and hydrant flushing ;
 - Landscape irrigation;
 - Planned and unplanned discharges from potable water sources;
 - Irrigation water;
 - Individual residential car washing; and
 - Lawn watering.

Municipal facilities subject to industrial general permit requirements must include a certification that the stormwater collection system has been tested or evaluated for the presence of non-stormwater discharges. The state's General Industrial Stormwater Permit requires that non-stormwater discharges be eliminated prior to implementation of the facility's SWPPP.

Illegal Dumping

- Establish a system for tracking incidents. The system should be designed to identify the following:
 - Illegal dumping hot spots
 - Types and quantities (in some cases) of wastes
 - Patterns in time of occurrence (time of day/night, month, or year)
 - Mode of dumping (abandoned containers, "midnight dumping" from moving vehicles, direct dumping of materials, accidents/spills)
 - Responsible parties

Outreach

One of the keys to success of reducing or eliminating illegal dumping is increasing the number of people on the street who are aware of the problem and who have the tools to at least identify the incident, if not correct it. There are a number of ways of accomplishing this:

- Train municipal staff from all departments (public works, utilities, street cleaning, parks and recreation, industrial waste inspection, hazardous waste inspection, sewer maintenance) to recognize and report the incidents.
- Deputize municipal staff who may come into contact with illegal dumping with the authority to write illegal dumping tickets for offenders caught in the act (see below).
- Educate the public. As many as 3 out of 4 people do not understand that in most communities the storm drain does not go to the wastewater treatment plant. Unfortunately, with the heavy emphasis in recent years on public education about solid waste management, including recycling and household hazardous waste, the sewer system (both storm and sanitary) has been the likely recipient of cross-media transfers of waste.
- Provide the public with a mechanism for reporting incidents such as a hot line and/or door hanger (see below).
- Help areas where incidents occur more frequently set up environmental watch programs (like crime watch programs).
- Train volunteers to notice and report the presence and suspected source of an observed pollutant to the appropriate public agency.

What constitutes a “non-stormwater” discharge?

- Non-stormwater discharges are discharges not made up entirely of stormwater and include water used directly in the manufacturing process (process wastewater), air conditioning condensate and coolant, non-contact cooling water, cooling equipment condensate, outdoor secondary containment water, vehicle and equipment wash water, landscape irrigation, sink and drinking fountain wastewater, sanitary wastes, or other wastewaters.

Permit Requirements

- Current municipal NPDES permits require municipalities to effectively prohibit non-stormwater discharges unless authorized by a separate NPDES permit or allowed in accordance with the current NPDES permit conditions. Typically the current permits allow certain non-stormwater discharges in the storm drain system as long as the discharges are not significant sources of pollutants. In this context the following non-stormwater discharges are typically allowed:
 - Diverted stream flows;
 - Rising found waters;
 - Uncontaminated ground water infiltration (as defined at 40 CFR 35.2005(20));
 - Uncontaminated pumped ground water;
 - Foundation drains;
 - Springs;
 - Water from crawl space pumps;
 - Footing drains;
 - Air conditioning condensation;
 - Flows from riparian habitats and wetlands;
 - Water line and hydrant flushing ;
 - Landscape irrigation;
 - Planned and unplanned discharges from potable water sources;
 - Irrigation water;
 - Individual residential car washing; and
 - Lawn watering.

Municipal facilities subject to industrial general permit requirements must include a certification that the stormwater collection system has been tested or evaluated for the presence

of non-stormwater discharges. The state's General Industrial Stormwater Permit requires that non-stormwater discharges be eliminated prior to implementation of the facility's SWPPP.

Storm Drain Stenciling

- Stencil storm drain inlets with a message to prohibit illegal dumpings, especially in areas with waste handling facilities.
- Encourage public reporting of improper waste disposal by a HOTLINE number stenciled onto the storm drain inlet.
- See Supplemental Information section of this fact sheet for further detail on stenciling program approach.

Oil Recycling

- Contract collection and hauling of used oil to a private licensed used oil hauler/recycler.
- Comply with all applicable state and federal regulations regarding storage, handling, and transport of petroleum products.
- Create procedures for collection such as; collection locations and schedule, acceptable containers, and maximum amounts accepted.
- The California Integrated Waste Management Board has a Recycling Hotline, (800) 553-2962, that provides information and recycling locations for used oil.

Household Hazardous Waste

- Provide household hazardous waste (HHW) collection facilities. Several types of collection approaches are available including permanent, periodic, or mobile centers, curbside collection, or a combination of these systems.

Training

- Train municipal employees and contractors in proper and consistent methods for waste disposal.
- Train municipal employees to recognize and report illegal dumping.
- Train employees and subcontractors in proper hazardous waste management.

Spill Response and Prevention

- Refer to SC-11, Spill Prevention, Control & Cleanup
- Have spill cleanup materials readily available and in a known location.
- Cleanup spills immediately and use dry methods if possible.
- Properly dispose of spill cleanup material.

Other Considerations

- Federal Regulations (RCRA, SARA, CERCLA) and state regulations exist regarding the disposal of hazardous waste.
- Municipalities are required to have a used oil recycling element and a HHW element within their integrated waste management plan.
- Significant liability issues are involved with the collection, handling, and disposal of HHW.

Examples

The City of Palo Alto has developed a public participation program for reporting dumping violations. When a concerned citizen or public employee encounters evidence of illegal dumping, a door hanger (similar in format to hotel “Do Not Disturb” signs) is placed on the front doors in the neighborhood. The door hanger notes that a violation has occurred in the neighborhood, informs the reader why illegal dumping is a problem, and notes that illegal dumping carries a significant financial penalty. Information is also provided on what citizens can do as well as contact numbers for more information or to report a violation.

The Port of Long Beach has a state of the art database incorporating storm drain infrastructure, potential pollutant sources, facility management practices, and a pollutant tracking system.

The State Department of Fish and Game has a hotline for reporting violations called CalTIP (1-800-952-5400). The phone number may be used to report any violation of a Fish and Game code (illegal dumping, poaching, etc.).

The California Department of Toxic Substances Control’s Waste Alert Hotline, 1-800-69TOXIC, can be used to report hazardous waste violations.

References and Resources

<http://www.stormwatercenter.net/>

California’s Nonpoint Source Program Plan <http://www.co.clark.wa.us/pubworks/bmpman.pdf>

King County Stormwater Pollution Control Manual - <http://dnr.metrokc.gov/wlr/dss/spcm.htm>

Orange County Stormwater Program,
http://www.ocwatersheds.com/stormwater/swp_introduction.asp

San Diego Stormwater Co-permittees Jurisdictional Urban Runoff Management Program
(<http://www.projectcleanwater.org>)

Santa Clara Valley Urban Runoff Pollution Prevention Program
http://www.scvurppp-w2k.com/pdf%20documents/PS_ICID.PDF

Spill Prevention, Control & Cleanup SC-11



Objectives

- Cover
- Contain
- Educate
- Reduce/Minimize
- Product Substitution

Description

Spills and leaks, if not properly controlled, can adversely impact the storm drain system and receiving waters. Due to the type of work or the materials involved, many activities that occur either at a municipal facility or as a part of municipal field programs have the potential for accidental spills and leaks. Proper spill response planning and preparation can enable municipal employees to effectively respond to problems when they occur and minimize the discharge of pollutants to the environment.

Approach

- An effective spill response and control plan should include:
 - Spill/leak prevention measures;
 - Spill response procedures;
 - Spill cleanup procedures;
 - Reporting; and
 - Training
- A well thought out and implemented plan can prevent pollutants from entering the storm drainage system and can be used as a tool for training personnel to prevent and control future spills as well.

Pollution Prevention

- Develop and implement a Spill Prevention Control and Response Plan. The plan should include:

Targeted Constituents

Sediment	
Nutrients	☑
Trash	
Metals	☑
Bacteria	
Oil and Grease	☑
Organics	☑
Oxygen Demanding	☑



SC-11 Spill Prevention, Control & Cleanup

- A description of the facility, the address, activities and materials involved
- Identification of key spill response personnel
- Identification of the potential spill areas or operations prone to spills/leaks
- Identification of which areas should be or are bermed to contain spills/leaks
- Facility map identifying the key locations of areas, activities, materials, structural BMPs, etc.
- Material handling procedures
- Spill response procedures including:
 - Assessment of the site and potential impacts
 - Containment of the material
 - Notification of the proper personnel and evacuation procedures
 - Clean up of the site
 - Disposal of the waste material and
 - Proper record keeping
- Product substitution – use less toxic materials (i.e. use water based paints instead of oil based paints)
- Recycle, reclaim, or reuse materials whenever possible. This will reduce the amount of materials that are brought into the facility or into the field.

Suggested Protocols

Spill/Leak Prevention Measures

- If possible, move material handling indoors, under cover, or away from storm drains or sensitive water bodies.
- Properly label all containers so that the contents are easily identifiable.
- Berm storage areas so that if a spill or leak occurs, the material is contained.
- Cover outside storage areas either with a permanent structure or with a seasonal one such as a tarp so that rain can not come into contact with the materials.
- Check containers (and any containment sumps) often for leaks and spills. Replace containers that are leaking, corroded, or otherwise deteriorating with containers in good condition. Collect all spilled liquids and properly dispose of them.

Spill Prevention, Control & Cleanup SC-11

- Store, contain and transfer liquid materials in such a manner that if the container is ruptured or the contents spilled, they will not discharge, flow or be washed into the storm drainage system, surface waters, or groundwater.
- Place drip pans or absorbent materials beneath all mounted taps and at all potential drip and spill locations during the filling and unloading of containers. Any collected liquids or soiled absorbent materials should be reused/recycled or properly disposed of.
- For field programs, only transport the minimum amount of material needed for the daily activities and transfer materials between containers at a municipal yard where leaks and spill are easier to control.
- If paved, sweep and clean storage areas monthly, do not use water to hose down the area unless all of the water will be collected and disposed of properly.
- Install a spill control device (such as a tee section) in any catch basins that collect runoff from any storage areas if the materials stored are oil, gas, or other materials that separate from and float on water. This will allow for easier cleanup if a spill occurs.
- If necessary, protect catch basins while conducting field activities so that if a spill occurs, the material will be contained.

Training

- Educate employees about spill prevention, spill response and cleanup on a routine basis.
- Well-trained employees can reduce human errors that lead to accidental releases or spills:
 - The employees should have the tools and knowledge to immediately begin cleaning up a spill if one should occur.
 - Employees should be familiar with the Spill Prevention Control and Countermeasure Plan if one is available.
- Training of staff from all municipal departments should focus on recognizing and reporting potential or current spills/leaks and who they should contact.
- Employees responsible for aboveground storage tanks and liquid transfers for large bulk containers should be thoroughly familiar with the Spill Prevention Control and Countermeasure Plan and the plan should be readily available.

Spill Response and Prevention

- Identify key spill response personnel and train employees on who they are.
- Store and maintain appropriate spill cleanup materials in a clearly marked location near storage areas; and train employees to ensure familiarity with the site's spill control plan and/or proper spill cleanup procedures.
- Locate spill cleanup materials, such as absorbents, where they will be readily accessible (e.g. near storage and maintenance areas, on field trucks).

SC-11 Spill Prevention, Control & Cleanup

- Follow the Spill Prevention Control and Countermeasure Plan if one is available.
- If a spill occurs, notify the key spill response personnel immediately. If the material is unknown or hazardous, the local fire department may also need to be contacted.
- If safe to do so, attempt to contain the material and block the nearby storm drains so that the area impacted is minimized. If the material is unknown or hazardous wait for properly trained personnel to contain the materials.
- Perform an assessment of the area where the spill occurred and the downstream area that it could impact. Relay this information to the key spill response and clean up personnel.

Spill Cleanup Procedures

- Small non-hazardous spills
 - Use a rag, damp cloth or absorbent materials for general clean up of liquids
 - Use brooms or shovels for the general clean up of dry materials
 - If water is used, it must be collected and properly disposed of. The wash water can not be allowed to enter the storm drain.
 - Dispose of any waste materials properly
 - Clean or dispose of any equipment used to clean up the spill properly
- Large non-hazardous spills
 - Use absorbent materials for general clean up of liquids
 - Use brooms, shovels or street sweepers for the general clean up of dry materials
 - If water is used, it must be collected and properly disposed of. The wash water can not be allowed to enter the storm drain.
 - Dispose of any waste materials properly
 - Clean or dispose of any equipment used to clean up the spill properly
- For hazardous or very large spills, a private cleanup company or Hazmat team may need to be contacted to assess the situation and conduct the cleanup and disposal of the materials.
- Chemical cleanups of material can be achieved with the use of absorbents, gels, and foams. Remove the adsorbent materials promptly and dispose of according to regulations.
- If the spilled material is hazardous, then the used cleanup materials are also hazardous and must be sent to a certified laundry (rags) or disposed of as hazardous waste.

Reporting

- Report any spills immediately to the identified key municipal spill response personnel.

Spill Prevention, Control & Cleanup SC-11

- Report spills in accordance with applicable reporting laws. Spills that pose an immediate threat to human health or the environment must be reported immediately to the Office of Emergency Service (OES)
- Spills that pose an immediate threat to human health or the environment may also need to be reported within 24 hours to the Regional Water Quality Control Board.
- Federal regulations require that any oil spill into a water body or onto an adjoining shoreline be reported to the National Response Center (NRC) at 800-424-8802 (24 hour)
- After the spill has been contained and cleaned up, a detailed report about the incident should be generated and kept on file (see the section on Reporting below). The incident may also be used in briefing staff about proper procedures

Other Considerations

- A Spill Prevention Control and Countermeasure Plan (SPCC) is required for facilities that are subject to the oil pollution regulations specified in Part 112 of Title 40 of the Code of Federal Regulations or if they have a storage capacity of 10,000 gallons or more of petroleum. (Health and Safety Code 6.67)
- State regulations also exist for storage of hazardous materials (Health & Safety Code Chapter 6.95), including the preparation of area and business plans for emergency response to the releases or threatened releases.
- Consider requiring smaller secondary containment areas (less than 200 sq. ft.) to be connected to the sanitary sewer, if permitted to do so, prohibiting any hard connections to the storm drain.

Requirements

Costs

- Will vary depending on the size of the facility and the necessary controls.
- Prevention of leaks and spills is inexpensive. Treatment and/or disposal of wastes, contaminated soil and water is very expensive

Maintenance

- This BMP has no major administrative or staffing requirements. However, extra time is needed to properly handle and dispose of spills, which results in increased labor costs

Supplemental Information

Further Detail of the BMP

Reporting

Record keeping and internal reporting represent good operating practices because they can increase the efficiency of the response and containment of a spill. A good record keeping system helps the municipality minimize incident recurrence, correctly respond with appropriate containment and cleanup activities, and comply with legal requirements.

SC-11 Spill Prevention, Control & Cleanup

A record keeping and reporting system should be set up for documenting spills, leaks, and other discharges, including discharges of hazardous substances in reportable quantities. Incident records describe the quality and quantity of non-stormwater discharges to the storm drain.

These records should contain the following information:

- Date and time of the incident
- Weather conditions
- Duration of the spill/leak/discharge
- Cause of the spill/leak/discharge
- Response procedures implemented
- Persons notified
- Environmental problems associated with the spill/leak/discharge

Separate record keeping systems should be established to document housekeeping and preventive maintenance inspections, and training activities. All housekeeping and preventive maintenance inspections should be documented. Inspection documentation should contain the following information:

- The date and time the inspection was performed
- Name of the inspector
- Items inspected
- Problems noted
- Corrective action required
- Date corrective action was taken

Other means to document and record inspection results are field notes, timed and dated photographs, videotapes, and drawings and maps.

Examples

The City of Palo Alto includes spill prevention and control as a major element of its highly effective program for municipal vehicle maintenance shops.

References and Resources

King County Stormwater Pollution Control Manual - <http://dnr.metrokc.gov/wlr/dss/spcm.htm>

Orange County Stormwater Program

http://www.ocwatersheds.com/stormwater/swp_introduction.asp

Spill Prevention, Control & Cleanup SC-11

San Diego Stormwater Co-permittees Jurisdictional Urban Runoff Management Program
(URMP)

<http://www.projectcleanwater.org/pdf/Model%20Program%20Municipal%20Facilities.pdf>



Objectives

- Cover
- Contain
- Educate
- Reduce/Minimize
- Product Substitution

Description

Stormwater runoff from building and grounds maintenance activities can be contaminated with toxic hydrocarbons in solvents, fertilizers and pesticides, suspended solids, heavy metals, and abnormal pH. Utilizing the following protocols will prevent or reduce the discharge of pollutants to stormwater from building and grounds maintenance activities by washing and cleaning up with as little water as possible, following good landscape management practices, preventing and cleaning up spills immediately, keeping debris from entering the storm drains, and maintaining the stormwater collection system.

Approach

Pollution Prevention

- Switch to non-toxic chemicals for maintenance when possible.
- Choose cleaning agents that can be recycled.
- Encourage proper lawn management and landscaping, including use of native vegetation.
- Encourage use of Integrated Pest Management techniques for pest control.
- Encourage proper onsite recycling of yard trimmings.
- Recycle residual paints, solvents, lumber, and other material as much as possible.

Targeted Constituents

Sediment	<input checked="" type="checkbox"/>
Nutrients	<input checked="" type="checkbox"/>
Trash	<input checked="" type="checkbox"/>
Metals	<input checked="" type="checkbox"/>
Bacteria	<input checked="" type="checkbox"/>
Oil and Grease	<input checked="" type="checkbox"/>
Organics	<input checked="" type="checkbox"/>
Oxygen Demanding	<input checked="" type="checkbox"/>



SC-41 Building & Grounds Maintenance

Suggested Protocols

Pressure Washing of Buildings, Rooftops, and Other Large Objects

- In situations where soaps or detergents are used and the surrounding area is paved, pressure washers must use a waste water collection device that enables collection of wash water and associated solids. A sump pump, wet vacuum or similarly effective device must be used to collect the runoff and loose materials. The collected runoff and solids must be disposed of properly.
- If soaps or detergents are not used, and the surrounding area is paved, wash water runoff does not have to be collected but must be screened. Pressure washers must use filter fabric or some other type of screen on the ground and/or in the catch basin to trap the particles in wash water runoff.
- If you are pressure washing on a grassed area (with or without soap), runoff must be dispersed as sheet flow as much as possible, rather than as a concentrated stream. The wash runoff must remain on the grass and not drain to pavement. Ensure that this practice does not kill grass.

Landscaping Activities

- Do not apply any chemicals (insecticide, herbicide, or fertilizer) directly to surface waters, unless the application is approved and permitted by the state.
- Dispose of grass clippings, leaves, sticks, or other collected vegetation as garbage, or by composting. Do not dispose of collected vegetation into waterways or storm drainage systems.
- Use mulch or other erosion control measures on exposed soils.
- Check irrigation schedules so pesticides will not be washed away and to minimize non-stormwater discharge.

Building Repair, Remodeling, and Construction

- Do not dump any toxic substance or liquid waste on the pavement, the ground, or toward a storm drain.
- Use ground or drop cloths underneath outdoor painting, scraping, and sandblasting work, and properly dispose of collected material daily.
- Use a ground cloth or oversized tub for activities such as paint mixing and tool cleaning.
- Clean paint brushes and tools covered with water-based paints in sinks connected to sanitary sewers or in portable containers that can be dumped into a sanitary sewer drain. Brushes and tools covered with non-water-based paints, finishes, or other materials must be cleaned in a manner that enables collection of used solvents (e.g., paint thinner, turpentine, etc.) for recycling or proper disposal.

- Use a storm drain cover, filter fabric, or similarly effective runoff control mechanism if dust, grit, wash water, or other pollutants may escape the work area and enter a catch basin. The containment device(s) must be in place at the beginning of the work day, and accumulated dirty runoff and solids must be collected and disposed of before removing the containment device(s) at the end of the work day.
- If you need to de-water an excavation site, you may need to filter the water before discharging to a catch basin or off-site. In which case you should direct the water through hay bales and filter fabric or use other sediment filters or traps.
- Store toxic material under cover with secondary containment during precipitation events and when not in use. A cover would include tarps or other temporary cover material.

Mowing, Trimming, and Planting

- Dispose of leaves, sticks, or other collected vegetation as garbage, by composting or at a permitted landfill. Do not dispose of collected vegetation into waterways or storm drainage systems.
- Use mulch or other erosion control measures when soils are exposed.
- Place temporarily stockpiled material away from watercourses and drain inlets, and berm or cover stockpiles to prevent material releases to the storm drain system.
- Consider an alternative approach when bailing out muddy water; do not put it in the storm drain, pour over landscaped areas.
- Use hand or mechanical weeding where practical.

Fertilizer and Pesticide Management

- Follow all federal, state, and local laws and regulations governing the use, storage, and disposal of fertilizers and pesticides and training of applicators and pest control advisors.
- Follow manufacturers' recommendations and label directions. Pesticides must never be applied if precipitation is occurring or predicted. Do not apply insecticides within 100 feet of surface waters such as lakes, ponds, wetlands, and streams.
- Use less toxic pesticides that will do the job, whenever possible. Avoid use of copper-based pesticides if possible.
- Do not use pesticides if rain is expected.
- Do not mix or prepare pesticides for application near storm drains.
- Use the minimum amount needed for the job.
- Calibrate fertilizer distributors to avoid excessive application.
- Employ techniques to minimize off-target application (e.g. spray drift) of pesticides, including consideration of alternative application techniques.

SC-41 Building & Grounds Maintenance

- Apply pesticides only when wind speeds are low.
- Work fertilizers into the soil rather than dumping or broadcasting them onto the surface.
- Irrigate slowly to prevent runoff and then only as much as is needed.
- Clean pavement and sidewalk if fertilizer is spilled on these surfaces before applying irrigation water.
- Dispose of empty pesticide containers according to the instructions on the container label.
- Use up the pesticides. Rinse containers, and use rinse water as product. Dispose of unused pesticide as hazardous waste.
- Implement storage requirements for pesticide products with guidance from the local fire department and County Agricultural Commissioner. Provide secondary containment for pesticides.

Inspection

- Inspect irrigation system periodically to ensure that the right amount of water is being applied and that excessive runoff is not occurring. Minimize excess watering, and repair leaks in the irrigation system as soon as they are observed.

Training

- Educate and train employees on use of pesticides and in pesticide application techniques to prevent pollution.
- Train employees and contractors in proper techniques for spill containment and cleanup.
- Be sure the frequency of training takes into account the complexity of the operations and the nature of the staff.

Spill Response and Prevention

- Refer to SC-11, Spill Prevention, Control & Cleanup
- Keep your Spill Prevention Control and countermeasure (SPCC) plan up-to-date, and implement accordingly.
- Have spill cleanup materials readily available and in a known location.
- Cleanup spills immediately and use dry methods if possible.
- Properly dispose of spill cleanup material.

Other Considerations

- Alternative pest/weed controls may not be available, suitable, or effective in many cases.

Requirements

Costs

- Overall costs should be low in comparison to other BMPs.

Maintenance

- Sweep paved areas regularly to collect loose particles, and wipe up spills with rags and other absorbent material immediately, do not hose down the area to a storm drain.

Supplemental Information

Further Detail of the BMP

Fire Sprinkler Line Flushing

Building fire sprinkler line flushing may be a source of non-stormwater runoff pollution. The water entering the system is usually potable water though in some areas it may be non-potable reclaimed wastewater. There are subsequent factors that may drastically reduce the quality of the water in such systems. Black iron pipe is usually used since it is cheaper than potable piping but it is subject to rusting and results in lower quality water. Initially the black iron pipe has an oil coating to protect it from rusting between manufacture and installation; this will contaminate the water from the first flush but not from subsequent flushes. Nitrates, poly-phosphates and other corrosion inhibitors, as well as fire suppressants and antifreeze may be added to the sprinkler water system. Water generally remains in the sprinkler system a long time, typically a year, between flushes and may accumulate iron, manganese, lead, copper, nickel and zinc. The water generally becomes anoxic and contains living and dead bacteria and breakdown products from chlorination. This may result in a significant BOD problem and the water often smells. Consequently dispose fire sprinkler line flush water into the sanitary sewer. Do not allow discharge to storm drain or infiltration due to potential high levels of pollutants in fire sprinkler line water.

References and Resources

California's Nonpoint Source Program Plan <http://www.swrcb.ca.gov/nps/index.html>

King County - <ftp://dnr.metrokc.gov/wlr/dss/spcm/Chapter%203.PDF>

Orange County Stormwater Program

http://www.ocwatersheds.com/StormWater/swp_introduction.asp

Mobile Cleaners Pilot Program: Final Report. 1997. Bay Area Stormwater Management Agencies Association (BASSMA) <http://www.basmaa.org/>

Pollution from Surface Cleaning Folder. 1996. Bay Area Stormwater Management Agencies Association (BASMAA) <http://www.basmaa.org/>

San Diego Stormwater Co-permittees Jurisdictional Urban Runoff Management Program (URMP) -

<http://www.projectcleanwater.org/pdf/Model%20Program%20Municipal%20Facilities.pdf>



Objectives

- Cover
- Contain
- Educate
- Reduce/Minimize

Description

As a consequence of its function, the stormwater conveyance system collects and transports urban runoff and stormwater that may contain certain pollutants. The protocols in this fact sheet are intended to reduce pollutants reaching receiving waters through proper conveyance system operation and maintenance.

Approach

Pollution Prevention

Maintain catch basins, stormwater inlets, and other stormwater conveyance structures on a regular basis to remove pollutants, reduce high pollutant concentrations during the first flush of storms, prevent clogging of the downstream conveyance system, restore catch basins' sediment trapping capacity, and ensure the system functions properly hydraulically to avoid flooding.

Suggested Protocols

Catch Basins/Inlet Structures

- Staff should regularly inspect facilities to ensure compliance with the following:
 - Immediate repair of any deterioration threatening structural integrity.
 - Cleaning before the sump is 40% full. Catch basins should be cleaned as frequently as needed to meet this standard.
 - Stenciling of catch basins and inlets (see SC34 Waste Handling and Disposal).

Targeted Constituents

Sediment	✓
Nutrients	
Trash	✓
Metals	
Bacteria	✓
Oil and Grease	
Organics	



SC-44 Drainage System Maintenance

- Clean catch basins, storm drain inlets, and other conveyance structures before the wet season to remove sediments and debris accumulated during the summer.
- Conduct inspections more frequently during the wet season for problem areas where sediment or trash accumulates more often. Clean and repair as needed.
- Keep accurate logs of the number of catch basins cleaned.
- Store wastes collected from cleaning activities of the drainage system in appropriate containers or temporary storage sites in a manner that prevents discharge to the storm drain.
- Dewater the wastes if necessary with outflow into the sanitary sewer if permitted. Water should be treated with an appropriate filtering device prior to discharge to the sanitary sewer. If discharge to the sanitary sewer is not allowed, water should be pumped or vacuumed to a tank and properly disposed. Do not dewater near a storm drain or stream.

Storm Drain Conveyance System

- Locate reaches of storm drain with deposit problems and develop a flushing schedule that keeps the pipe clear of excessive buildup.
- Collect and pump flushed effluent to the sanitary sewer for treatment whenever possible.

Pump Stations

- Clean all storm drain pump stations prior to the wet season to remove silt and trash.
- Do not allow discharge to reach the storm drain system when cleaning a storm drain pump station or other facility.
- Conduct routine maintenance at each pump station.
- Inspect, clean, and repair as necessary all outlet structures prior to the wet season.

Open Channel

- Modify storm channel characteristics to improve channel hydraulics, increase pollutant removals, and enhance channel/creek aesthetic and habitat value.
- Conduct channel modification/improvement in accordance with existing laws. Any person, government agency, or public utility proposing an activity that will change the natural (emphasis added) state of any river, stream, or lake in California, must enter into a Stream or Lake Alteration Agreement with the Department of Fish and Game. The developer-applicant should also contact local governments (city, county, special districts), other state agencies (SWRCB, RWQCB, Department of Forestry, Department of Water Resources), and Federal Corps of Engineers and USFWS.

Illicit Connections and Discharges

- Look for evidence of illegal discharges or illicit connections during routine maintenance of conveyance system and drainage structures:
 - Is there evidence of spills such as paints, discoloring, etc?

- Are there any odors associated with the drainage system?
- Record locations of apparent illegal discharges/illicit connections?
- Track flows back to potential dischargers and conduct aboveground inspections. This can be done through visual inspection of upgradient manholes or alternate techniques including zinc chloride smoke testing, fluorometric dye testing, physical inspection testing, or television camera inspection.
- Eliminate the discharge once the origin of flow is established.
- Stencil or demarcate storm drains, where applicable, to prevent illegal disposal of pollutants. Storm drain inlets should have messages such as “Dump No Waste Drains to Stream” stenciled next to them to warn against ignorant or intentional dumping of pollutants into the storm drainage system.
- Refer to fact sheet SC-10 Non-Stormwater Discharges.

Illegal Dumping

- Inspect and clean up hot spots and other storm drainage areas regularly where illegal dumping and disposal occurs.
- Establish a system for tracking incidents. The system should be designed to identify the following:
 - Illegal dumping hot spots
 - Types and quantities (in some cases) of wastes
 - Patterns in time of occurrence (time of day/night, month, or year)
 - Mode of dumping (abandoned containers, “midnight dumping” from moving vehicles, direct dumping of materials, accidents/spills)
 - Responsible parties
- Post “No Dumping” signs in problem areas with a phone number for reporting dumping and disposal. Signs should also indicate fines and penalties for illegal dumping.
- Refer to fact sheet SC-10 Non-Stormwater Discharges.

Training

- Train crews in proper maintenance activities, including record keeping and disposal.
- Allow only properly trained individuals to handle hazardous materials/wastes.
- Have staff involved in detection and removal of illicit connections trained in the following:
 - OSHA-required Health and Safety Training (29 CFR 1910.120) plus annual refresher training (as needed).

- OSHA Confined Space Entry training (Cal-OSHA Confined Space, Title 8 and Federal OSHA 29 CFR 1910.146).
- Procedural training (field screening, sampling, smoke/dye testing, TV inspection).

Spill Response and Prevention

- Investigate all reports of spills, leaks, and/or illegal dumping promptly.
- Clean up all spills and leaks using “dry” methods (with absorbent materials and/or rags) or dig up, remove, and properly dispose of contaminated soil.
- Refer to fact sheet SC-11 Spill Prevention, Control, and Cleanup.

Other Considerations (Limitations and Regulations)

- Clean-up activities may create a slight disturbance for local aquatic species. Access to items and material on private property may be limited. Trade-offs may exist between channel hydraulics and water quality/riparian habitat. If storm channels or basins are recognized as wetlands, many activities, including maintenance, may be subject to regulation and permitting.
- Storm drain flushing is most effective in small diameter pipes (36-inch diameter pipe or less, depending on water supply and sediment collection capacity). Other considerations associated with storm drain flushing may include the availability of a water source, finding a downstream area to collect sediments, liquid/sediment disposal, and prohibition against disposal of flushed effluent to sanitary sewer in some areas.
- Regulations may include adoption of substantial penalties for illegal dumping and disposal.
- Local municipal codes may include sections prohibiting discharge of soil, debris, refuse, hazardous wastes, and other pollutants into the storm drain system.

Requirements***Costs***

- An aggressive catch basin cleaning program could require a significant capital and O&M budget.
- The elimination of illegal dumping is dependent on the availability, convenience, and cost of alternative means of disposal. The primary cost is for staff time. Cost depends on how aggressively a program is implemented. Other cost considerations for an illegal dumping program include:
 - Purchase and installation of signs.
 - Rental of vehicle(s) to haul illegally-disposed items and material to landfills.
 - Rental of heavy equipment to remove larger items (e.g., car bodies) from channels.
 - Purchase of landfill space to dispose of illegally-dumped items and material.

- Methods used for illicit connection detection (smoke testing, dye testing, visual inspection, and flow monitoring) can be costly and time-consuming. Site-specific factors, such as the level of impervious area, the density and ages of buildings, and type of land use will determine the level of investigation necessary.

Maintenance

- Two-person teams may be required to clean catch basins with vacuum trucks.
- Teams of at least two people plus administrative personnel are required to identify illicit discharges, depending on the complexity of the storm sewer system.
- Arrangements must be made for proper disposal of collected wastes.
- Technical staff are required to detect and investigate illegal dumping violations.

Supplemental Information

Further Detail of the BMP

Storm Drain Flushing

Flushing is a common maintenance activity used to improve pipe hydraulics and to remove pollutants in storm drainage systems. Flushing may be designed to hydraulically convey accumulated material to strategic locations, such as an open channel, another point where flushing will be initiated, or the sanitary sewer and the treatment facilities, thus preventing resuspension and overflow of a portion of the solids during storm events. Flushing prevents “plug flow” discharges of concentrated pollutant loadings and sediments. Deposits can hinder the designed conveyance capacity of the storm drain system and potentially cause backwater conditions in severe cases of clogging.

Storm drain flushing usually takes place along segments of pipe with grades that are too flat to maintain adequate velocity to keep particles in suspension. An upstream manhole is selected to place an inflatable device that temporarily plugs the pipe. Further upstream, water is pumped into the line to create a flushing wave. When the upstream reach of pipe is sufficiently full to cause a flushing wave, the inflated device is rapidly deflated with the assistance of a vacuum pump, thereby releasing the backed up water and resulting in the cleaning of the storm drain segment.

To further reduce impacts of stormwater pollution, a second inflatable device placed well downstream may be used to recollect the water after the force of the flushing wave has dissipated. A pump may then be used to transfer the water and accumulated material to the sanitary sewer for treatment. In some cases, an interceptor structure may be more practical or required to recollect the flushed waters.

It has been found that cleansing efficiency of periodic flush waves is dependent upon flush volume, flush discharge rate, sewer slope, sewer length, sewer flow rate, sewer diameter, and population density. As a rule of thumb, the length of line to be flushed should not exceed 700 feet. At this maximum recommended length, the percent removal efficiency ranges between 65-75% for organics and 55-65% for dry weather grit/inorganic material. The percent removal efficiency drops rapidly beyond that. Water is commonly supplied by a water truck, but fire hydrants can also supply water. To make the best use of water, it is recommended that reclaimed water be used or that fire hydrant line flushing coincide with storm sewer flushing.

SC-44 Drainage System Maintenance

References and Resources

California's Nonpoint Source Program Plan <http://www.swrcb.ca.gov/nps/index.html>

Clark County Storm Water Pollution Control Manual
<http://www.co.clark.wa.us/pubworks/bmpman.pdf>

Ferguson, B.K. 1991. Urban Stream Reclamation, p. 324-322, Journal of Soil and Water Conservation.

King County Storm Water Pollution Control Manual <http://dnr.metrokc.gov/wlr/dss/spcm.htm>

Oregon Association of Clean Water Agencies. Oregon Municipal Stormwater Toolbox for Maintenance Practices. June 1998.

Santa Clara Valley Urban Runoff Pollution Prevention Program <http://www.scvurppp.org>

The Storm Water Managers Resource Center <http://www.stormwatercenter.net>

United States Environmental Protection Agency (USEPA). 2002. Pollution Prevention/Good Housekeeping for Municipal Operations Storm Drain System Cleaning. On line:
http://www.epa.gov/npdes/menuofbmps/poll_16.htm



Objectives

- Contain
- Educate
- Reduce/Minimize
- Product Substitution

Targeted Constituents

Sediment	<input checked="" type="checkbox"/>
Nutrients	<input checked="" type="checkbox"/>
Trash	<input checked="" type="checkbox"/>
Metals	
Bacteria	
Oil and Grease	
Organics	
Oxygen Demanding	<input checked="" type="checkbox"/>

Description

Landscape maintenance activities include vegetation removal; herbicide and insecticide application; fertilizer application; watering; and other gardening and lawn care practices. Vegetation control typically involves a combination of chemical (herbicide) application and mechanical methods. All of these maintenance practices have the potential to contribute pollutants to the storm drain system. The major objectives of this BMP are to minimize the discharge of pesticides, herbicides and fertilizers to the storm drain system and receiving waters; prevent the disposal of landscape waste into the storm drain system by collecting and properly disposing of clippings and cuttings, and educating employees and the public.

Approach

Pollution Prevention

- Implement an integrated pest management (IPM) program. IPM is a sustainable approach to managing pests by combining biological, cultural, physical, and chemical tools.
- Choose low water using flowers, trees, shrubs, and groundcover.
- Consider alternative landscaping techniques such as naturescaping and xeriscaping.
- Conduct appropriate maintenance (i.e. properly timed fertilizing, weeding, pest control, and pruning) to help preserve the landscapes water efficiency.



- Consider grass cycling (grass cycling is the natural recycling of grass by leaving the clippings on the lawn when mowing. Grass clippings decompose quickly and release valuable nutrients back into the lawn).

Suggested Protocols

Mowing, Trimming, and Weeding

- Whenever possible use mechanical methods of vegetation removal (e.g. mowing with tractor-type or push mowers, hand cutting with gas or electric powered weed trimmers) rather than applying herbicides. Use hand weeding where practical.
- Avoid loosening the soil when conducting mechanical or manual weed control, this could lead to erosion. Use mulch or other erosion control measures when soils are exposed.
- Performing mowing at optimal times. Mowing should not be performed if significant rain events are predicted.
- Mulching mowers may be recommended for certain flat areas. Other techniques may be employed to minimize mowing such as selective vegetative planting using low maintenance grasses and shrubs.
- Collect lawn and garden clippings, pruning waste, tree trimmings, and weeds. Chip if necessary, and compost or dispose of at a landfill (see waste management section of this fact sheet).
- Place temporarily stockpiled material away from watercourses, and berm or cover stockpiles to prevent material releases to storm drains.

Planting

- Determine existing native vegetation features (location, species, size, function, importance) and consider the feasibility of protecting them. Consider elements such as their effect on drainage and erosion, hardiness, maintenance requirements, and possible conflicts between preserving vegetation and the resulting maintenance needs.
- Retain and/or plant selected native vegetation whose features are determined to be beneficial, where feasible. Native vegetation usually requires less maintenance (e.g., irrigation, fertilizer) than planting new vegetation.
- Consider using low water use groundcovers when planting or replanting.

Waste Management

- Compost leaves, sticks, or other collected vegetation or dispose of at a permitted landfill. Do not dispose of collected vegetation into waterways or storm drainage systems.
- Place temporarily stockpiled material away from watercourses and storm drain inlets, and berm or cover stockpiles to prevent material releases to the storm drain system.
- Reduce the use of high nitrogen fertilizers that produce excess growth requiring more frequent mowing or trimming.

- Avoid landscape wastes in and around storm drain inlets by either using bagging equipment or by manually picking up the material.

Irrigation

- Where practical, use automatic timers to minimize runoff.
- Use popup sprinkler heads in areas with a lot of activity or where there is a chance the pipes may be broken. Consider the use of mechanisms that reduce water flow to sprinkler heads if broken.
- Ensure that there is no runoff from the landscaped area(s) if re-claimed water is used for irrigation.
- If bailing of muddy water is required (e.g. when repairing a water line leak), do not put it in the storm drain; pour over landscaped areas.
- Irrigate slowly or pulse irrigate to prevent runoff and then only irrigate as much as is needed.
- Apply water at rates that do not exceed the infiltration rate of the soil.

Fertilizer and Pesticide Management

- Utilize a comprehensive management system that incorporates integrated pest management (IPM) techniques. There are many methods and types of IPM, including the following:
 - Mulching can be used to prevent weeds where turf is absent, fencing installed to keep rodents out, and netting used to keep birds and insects away from leaves and fruit.
 - Visible insects can be removed by hand (with gloves or tweezers) and placed in soapy water or vegetable oil. Alternatively, insects can be sprayed off the plant with water or in some cases vacuumed off of larger plants.
 - Store-bought traps, such as species-specific, pheromone-based traps or colored sticky cards, can be used.
 - Slugs can be trapped in small cups filled with beer that are set in the ground so the slugs can get in easily.
 - In cases where microscopic parasites, such as bacteria and fungi, are causing damage to plants, the affected plant material can be removed and disposed of (pruning equipment should be disinfected with bleach to prevent spreading the disease organism).
 - Small mammals and birds can be excluded using fences, netting, tree trunk guards.
 - Beneficial organisms, such as bats, birds, green lacewings, ladybugs, praying mantis, ground beetles, parasitic nematodes, trichogramma wasps, seed head weevils, and spiders that prey on detrimental pest species can be promoted.
- Follow all federal, state, and local laws and regulations governing the use, storage, and disposal of fertilizers and pesticides and training of applicators and pest control advisors.

- Use pesticides only if there is an actual pest problem (not on a regular preventative schedule).
- Do not use pesticides if rain is expected. Apply pesticides only when wind speeds are low (less than 5 mph).
- Do not mix or prepare pesticides for application near storm drains.
- Prepare the minimum amount of pesticide needed for the job and use the lowest rate that will effectively control the pest.
- Employ techniques to minimize off-target application (e.g. spray drift) of pesticides, including consideration of alternative application techniques.
- Fertilizers should be worked into the soil rather than dumped or broadcast onto the surface.
- Calibrate fertilizer and pesticide application equipment to avoid excessive application.
- Periodically test soils for determining proper fertilizer use.
- Sweep pavement and sidewalk if fertilizer is spilled on these surfaces before applying irrigation water.
- Purchase only the amount of pesticide that you can reasonably use in a given time period (month or year depending on the product).
- Triple rinse containers, and use rinse water as product. Dispose of unused pesticide as hazardous waste.
- Dispose of empty pesticide containers according to the instructions on the container label.

Inspection

- Inspect irrigation system periodically to ensure that the right amount of water is being applied and that excessive runoff is not occurring. Minimize excess watering, and repair leaks in the irrigation system as soon as they are observed.
- Inspect pesticide/fertilizer equipment and transportation vehicles daily.

Training

- Educate and train employees on use of pesticides and in pesticide application techniques to prevent pollution. Pesticide application must be under the supervision of a California qualified pesticide applicator.
- Train/encourage municipal maintenance crews to use IPM techniques for managing public green areas.
- Annually train employees within departments responsible for pesticide application on the appropriate portions of the agency's IPM Policy, SOPs, and BMPs, and the latest IPM techniques.

- Employees who are not authorized and trained to apply pesticides should be periodically (at least annually) informed that they cannot use over-the-counter pesticides in or around the workplace.
- Use a training log or similar method to document training.

Spill Response and Prevention

- Refer to SC-11, Spill Prevention, Control & Cleanup
- Have spill cleanup materials readily available and in a known location
- Cleanup spills immediately and use dry methods if possible.
- Properly dispose of spill cleanup material.

Other Considerations

- The Federal Pesticide, Fungicide, and Rodenticide Act and California Title 3, Division 6, Pesticides and Pest Control Operations place strict controls over pesticide application and handling and specify training, annual refresher, and testing requirements. The regulations generally cover: a list of approved pesticides and selected uses, updated regularly; general application information; equipment use and maintenance procedures; and record keeping. The California Department of Pesticide Regulations and the County Agricultural Commission coordinate and maintain the licensing and certification programs. All public agency employees who apply pesticides and herbicides in “agricultural use” areas such as parks, golf courses, rights-of-way and recreation areas should be properly certified in accordance with state regulations. Contracts for landscape maintenance should include similar requirements.
- All employees who handle pesticides should be familiar with the most recent material safety data sheet (MSDS) files.
- Municipalities do not have the authority to regulate the use of pesticides by school districts, however the California Healthy Schools Act of 2000 (AB 2260) has imposed requirements on California school districts regarding pesticide use in schools. Posting of notification prior to the application of pesticides is now required, and IPM is stated as the preferred approach to pest management in schools.

Requirements

Costs

Additional training of municipal employees will be required to address IPM techniques and BMPs. IPM methods will likely increase labor cost for pest control which may be offset by lower chemical costs.

Maintenance

Not applicable

Supplemental Information***Further Detail of the BMP******Waste Management***

Composting is one of the better disposal alternatives if locally available. Most municipalities either have or are planning yard waste composting facilities as a means of reducing the amount of waste going to the landfill. Lawn clippings from municipal maintenance programs as well as private sources would probably be compatible with most composting facilities

Contractors and Other Pesticide Users

Municipal agencies should develop and implement a process to ensure that any contractor employed to conduct pest control and pesticide application on municipal property engages in pest control methods consistent with the IPM Policy adopted by the agency. Specifically, municipalities should require contractors to follow the agency's IPM policy, SOPs, and BMPs; provide evidence to the agency of having received training on current IPM techniques when feasible; provide documentation of pesticide use on agency property to the agency in a timely manner.

References and Resources

King County Stormwater Pollution Control Manual. Best Management Practices for Businesses. 1995. King County Surface Water Management. July. On-line: <http://dnr.metrokc.gov/wlr/dss/spcm.htm>

Los Angeles County Stormwater Quality Model Programs. Public Agency Activities http://ladpw.org/wmd/npdes/model_links.cfm

Model Urban Runoff Program: A How-To Guide for Developing Urban Runoff Programs for Small Municipalities. Prepared by City of Monterey, City of Santa Cruz, California Coastal Commission, Monterey Bay National Marine Sanctuary, Association of Monterey Bay Area Governments, Woodward-Clyde, Central Coast Regional Water Quality Control Board. July. 1998.

Orange County Stormwater Program

http://www.ocwatersheds.com/StormWater/swp_introduction.asp

Santa Clara Valley Urban Runoff Pollution Prevention Program. 1997 Urban Runoff Management Plan. September 1997, updated October 2000.

United States Environmental Protection Agency (USEPA). 2002. Pollution Prevention/Good Housekeeping for Municipal Operations Landscaping and Lawn Care. Office of Water. Office of Wastewater Management. On-line: http://www.epa.gov/npdes/menuofbmps/poll_8.htm

Project Name:

Attachment 4

Copy of Plan Sheets Showing Permanent Storm Water BMPs

This is the cover sheet for Attachment 4.

**NOT APPLICABLE -
WILL PROVIDE AS PART
OF GRADING PERMIT**

Project Name:

THIS PAGE INTENTIONALLY LEFT BLANK FOR DOUBLE-SIDED PRINTING

Project Name:

Use this checklist to ensure the required information has been included on the plans:

The plans must identify:

- Structural BMP(s) with ID numbers matching Form I-6 Summary of PDP Structural BMPs
- The grading and drainage design shown on the plans must be consistent with the delineation of DMAs shown on the DMA exhibit
- Details and specifications for construction of structural BMP(s)
- Signage indicating the location and boundary of structural BMP(s) as required by the City Engineer
- How to access the structural BMP(s) to inspect and perform maintenance
- Features that are provided to facilitate inspection (e.g., observation ports, cleanouts, silt posts, or other features that allow the inspector to view necessary components of the structural BMP and compare to maintenance thresholds)
- Manufacturer and part number for proprietary parts of structural BMP(s) when applicable
- Maintenance thresholds specific to the structural BMP(s), with a location-specific frame of reference (e.g., level of accumulated materials that triggers removal of the materials, to be identified based on viewing marks on silt posts or measured with a survey rod with respect to a fixed benchmark within the BMP)
- Recommended equipment to perform maintenance
- When applicable, necessary special training or certification requirements for inspection and maintenance personnel such as confined space entry or hazardous waste management
- Include landscaping plan sheets showing vegetation requirements for vegetated structural BMP(s)
- All BMPs must be fully dimensioned on the plans
- When proprietary BMPs are used, site specific cross section with outflow, inflow and model number shall be provided. Broucher photocopies are not allowed.

Project Name:

THIS PAGE INTENTIONALLY LEFT BLANK FOR DOUBLE-SIDED PRINTING

Project Name:

Attachment 5

Drainage Report

Attach project's drainage report. Refer to Drainage Design Manual to determine the reporting requirements.

Project Name:

THIS PAGE INTENTIONALLY LEFT BLANK FOR DOUBLE-SIDED PRINTING

**PRELIMINARY
HYDROLOGY/DRAINAGE STUDY**

For

**FOXHILL RESIDENCE
& BOUNDARY ADJUSTMENT**

*7007 Country Club Drive
La Jolla, CA 92037
Portion of Lot 1263 of MM 36 & Parcel 1 of PM 21506*

City of San Diego
*SDP No. 1790091 / TM No. 2330219 / CDP No. 2330222
PTS No. 508125*

Applicant/Developer:
Manchester Foxhill, LLC
*7007 County Club Drive
La Jolla, CA 92037
Contact: Robert Aguilar*

Snipes-Dye Associates
civil engineers and land surveyors

*8348 Center Drive, Suite G
La Mesa, CA 91942-2910
(619) 697-9234, Fax (619) 460-2033
SDA No. LJ4742*

*Dated: June 7, 2019
Revised: June 2, 2020*

Project Name:

Attachment 6

Geotechnical and Groundwater Investigation Report

Attach project's geotechnical and groundwater investigation report. Refer to Appendix C.4 to determine the reporting requirements.

Project Name:

THIS PAGE INTENTIONALLY LEFT BLANK FOR DOUBLE-SIDED PRINTING



Geotechnical Exploration, Inc.

SOIL AND FOUNDATION ENGINEERING • GROUNDWATER • ENGINEERING GEOLOGY

20 April 2017

Mr. Robert Aguilar
La Jolla Reserve, LLC
10452 Coyote Hill Glen
Escondido, CA 92026

Job No. 16-11251

Subject: **Report of Limited Geotechnical Investigation**
Proposed Storm Water Infiltration BMPs
Proposed Foxhill Estate Guest House
Country Club Drive
La Jolla, California

Dear Mr. Aguilar:

In accordance with your request, and our proposal dated February 06, 2017, we herein provide this limited geotechnical investigation report to allow evaluation of the feasibility of proposed storm water infiltration BMP's at the location of your proposed two-story, detached guest house on the Foxhill Estate property in La Jolla. On February 10, 2017, we placed two test pits on the lot for evaluation of subsurface soil infiltration, per the requirements of the City of San Diego's BMP Design Manual in accordance with Appendix C of their Guidelines for Geotechnical Reports, and Appendix D, Approved Infiltration Rate Assessment Methods.

I. PROJECT SUMMARY AND SCOPE OF SERVICES

It is our understanding that the existing property will be developed to receive a new two-story, detached guest house structure and associated improvements. The property is currently developed with a 20,683 square foot, two-story single family residence, a detached garage, greenhouse, fitness studio, pavilion, tennis court, swimming pool, pool house and garden. We have reviewed a topographic map of

the property provided by Coston Architects Incorporated, dated March 6, 2017. In addition, we have also reviewed our "*Report of Preliminary Geotechnical and Geologic Investigation*" of the subject site dated October 25, 2016.

The scope of work performed for this investigation included a site reconnaissance and subsurface exploration program, laboratory testing, simple open pit falling head testing within the location of the proposed bio-retention basins, and the preparation of this report. The data obtained and the analyses were performed to allow evaluation of the feasibility of storm water infiltration BMPs.

II. SITE DESCRIPTION

The project is located on Country Club Drive in the La Jolla area of the City of San Diego. The subject site is known as Assessor's Parcel No. 352-300-04-00, a portion of Pueblo Lot 1263, according to Miscellaneous Map No. MM36 recorded November 14, 1921, in the La Jolla area of the City and County of San Diego, State of California. It is currently addressed as 7007 Country Club Drive. Refer to the Vicinity Map, Figure No. I, for the location of the site.

The guesthouse is proposed to the south of the existing residential structure, on the southern portion of the property. The lot consists of a relatively broad, north-south trending ridgeline bounded on the south by easterly to southwesterly descending slopes with elevations ranging from approximately 535 to 510 feet above Mean Sea Level (MSL). The guesthouse project is planned for the upper portion of these slopes between elevation 535 and 525 feet above MSL.

The guesthouse area will be accessed by a new concrete-paved driveway which originates at the southwest property corner of the Foxhill Estate property from an



unpaved road on the Reserve property. The Reserve property is accessed from the southern terminus of Country Club Drive.

III. FIELD INVESTIGATION

Our prior exploratory work at the site, as described in our referenced report, included advancement of three exploratory trenches across the lot ranging from 2.5 to 3 feet in depth, and advancement of 6 exploratory borings 41 to 86 feet in depth.

The recent limited field investigation consisted of a surface reconnaissance and a subsurface exploration program using hand tools to investigate, sample and perform infiltration testing of the subsurface soils. Two exploratory hand-dug pits were excavated in the proposed bio-retention basin area on March 10, 2017. The pits were advanced to depths of 36 and 33 inches with a diameter of 2 feet. The soils encountered in the exploratory excavations were continuously logged in the field by our representatives and described in accordance with the Unified Soil Classification System. The approximate locations of the exploratory excavations and simple open pit testing (INF-1 and INF-2) are shown on the Site Plan, Figure No. II.

Representative samples were obtained from the exploratory excavations at selected depths appropriate to the investigation. All samples were returned to our laboratory for evaluation and testing.

IV. SOIL DESCRIPTION

Our recent subsurface exploration program (INF-1 and INF-2) revealed that the storm water bio-retention basin area, proposed near the southwest property corner, are underlain by Quaternary Very Old Paralic Deposits. The encountered materials



consisted of loose to medium dense silty sand topsoil to approximately 2 feet, and medium dense to dense silty sand formational materials to approximately 3 feet below existing grade. Soil conditions encountered in both excavations were similar. Refer to the Excavation Logs, Figure No. III.

These recently dug pits and related information depict subsurface conditions only at the specific locations shown on the site plan and on the particular date of the investigation. The passage of time may result in changes in the subsurface conditions due to environmental changes.

IV. LABORATORY TESTS AND SOIL INFORMATION

The following test was conducted on the sampled soils:

*1. Determination of Percentage of Particles Passing #200 Sieve
(ASTM D1140-06)*

The particle size smaller than a No. 200 sieve analysis aids in classifying the tested soils in accordance with the Unified Soil Classification System and provides qualitative information related to engineering characteristics such as expansion potential, permeability, and shear strength. Based on our laboratory test results at infiltration test locations INF-1 and INF-2, 19 and 16 percent of the soils passed the #200 sieve, respectively.



V. GROUNDWATER

Free groundwater was not encountered in the exploratory excavations at the time of excavation. Our prior exploratory excavations did not encounter significant groundwater to a maximum depth of exploration of 86 feet below the ground surface elevations. It must be noted, however, that fluctuations in the level of groundwater may occur due to extended periods of rainfall, variations in ground surface topography, subsurface stratification, and other possible factors that may not have been evident at the time of our field investigations.

VI. CONCLUSIONS AND RECOMMENDATIONS

The following conclusions and recommendations are based on the field investigation conducted by our firm, our laboratory test results, infiltration test results, and our experience with soils similar to those at the site.

We performed simple open pit falling head testing at two locations within the proposed bio-retention basin at a depth of 36 inches at INF-1, and 33 inches at INF-2, per the requirements of the City of San Diego's Storm Water Standards, BMP Design Manual, in accordance with Appendix D. Testing at both locations, (INF-1 and INF-2), revealed falling head rates of 480 and 0.0 (head did not fall) minutes/inch, respectively. The simple open pit test rate results for INF-1 and INF-2 have been converted to infiltration rates, using the Porchet Method and indicate infiltration rates of 0.063 and 0.000 inch/hour, respectively. Refer to Appendix A for simple open pit test rate results and simple open pit infiltration rate calculations. Based on the results of our simple open pit testing and review of USDA soil maps, the site has been assigned to hydrologic soil group (HSG) D. As part of our geologic/geotechnical site evaluation, we considered the following issues:



1. The site is **not** subject to high groundwater conditions (within 10 feet of the base of the bioretention facility).
2. The site is **not** in close proximity to a known contaminated soil site.
3. The site does **not** have any significant thicknesses of artificial fill believed to exist in the area of the currently planned project. Most of the site consists of Very Old Paralac deposits near the ground surface. Per our referenced report existing fill soils are to be removed and recompacted (if required) as part of the new site development.
4. The site **has** an infiltration rates of 0.063 and 0.000-inch/hour, without a factor of safety applied.
5. Based on our "*Report of Preliminary Geologic and Geotechnical Investigation*" for the subject site dated October 25, 2016 the laboratory soil testing and our experience suggest indicate expansion indices ranging from very low to medium for the encountered site formational soils.
6. The site **is not** located within 100 feet from a drinking water well.
7. The site **is not** located within 100 feet from an on-site septic system or designated expansion area.
8. The site **is** located adjacent to a slope steeper than 25 percent.



9. The site *is* located within hazard category 22, possible or conjectured landslide, however, the questionable landslide was not encountered during our geotechnical investigation on October 25, 2016.

Based on the results of our simple open pit falling head testing and evaluation of the infiltration rates, it is our professional opinion that the proposed bio-retention basin do not have appreciable infiltration rates for the design of full infiltration BMPs on the southwestern portion of the lot. However, the geotechnical and geologic conditions along with the recorded infiltration rates do allow for the design of partial infiltration. Therefore, we recommend the recorded infiltration rates with appropriate factors of safety be applied and incorporated into the bio-retention basin design.

LIMITATIONS

The findings, opinions, and conclusions presented herein have been made in accordance with generally accepted principles and practice in the field of expressed or implied, is made.

We have reviewed our "*Report of Preliminary Geotechnical and Geologic Investigation*" for the subject site dated October 25, 2016 and our findings and opinions are based in part on the information provided therein. Our findings, opinions and conclusions are specifically limited to the scope of services described herein, for the evaluation and feasibility of storm water infiltration, within and immediately adjacent to, the proposed bio-retention basin.



If you have any questions regarding this letter, please contact our office. Reference to our **Job No. 16-11251** will help expedite a response to your inquiry.

Respectfully submitted,

GEOTECHNICAL EXPLORATION, INC.



Jonathan A. Browning
P.G. 9012/C.E.G. 2615
Senior Project Geologist

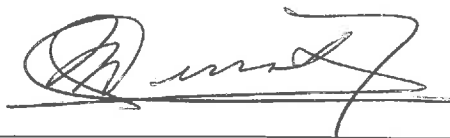

Jaime A. Cerros, P.E.
R.C.E.34422/G.E.2007
Senior Geotechnical Engineer

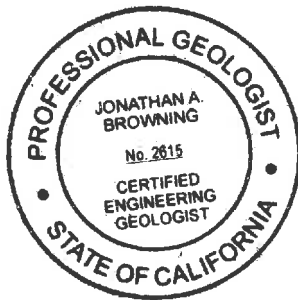

VICINITY MAP

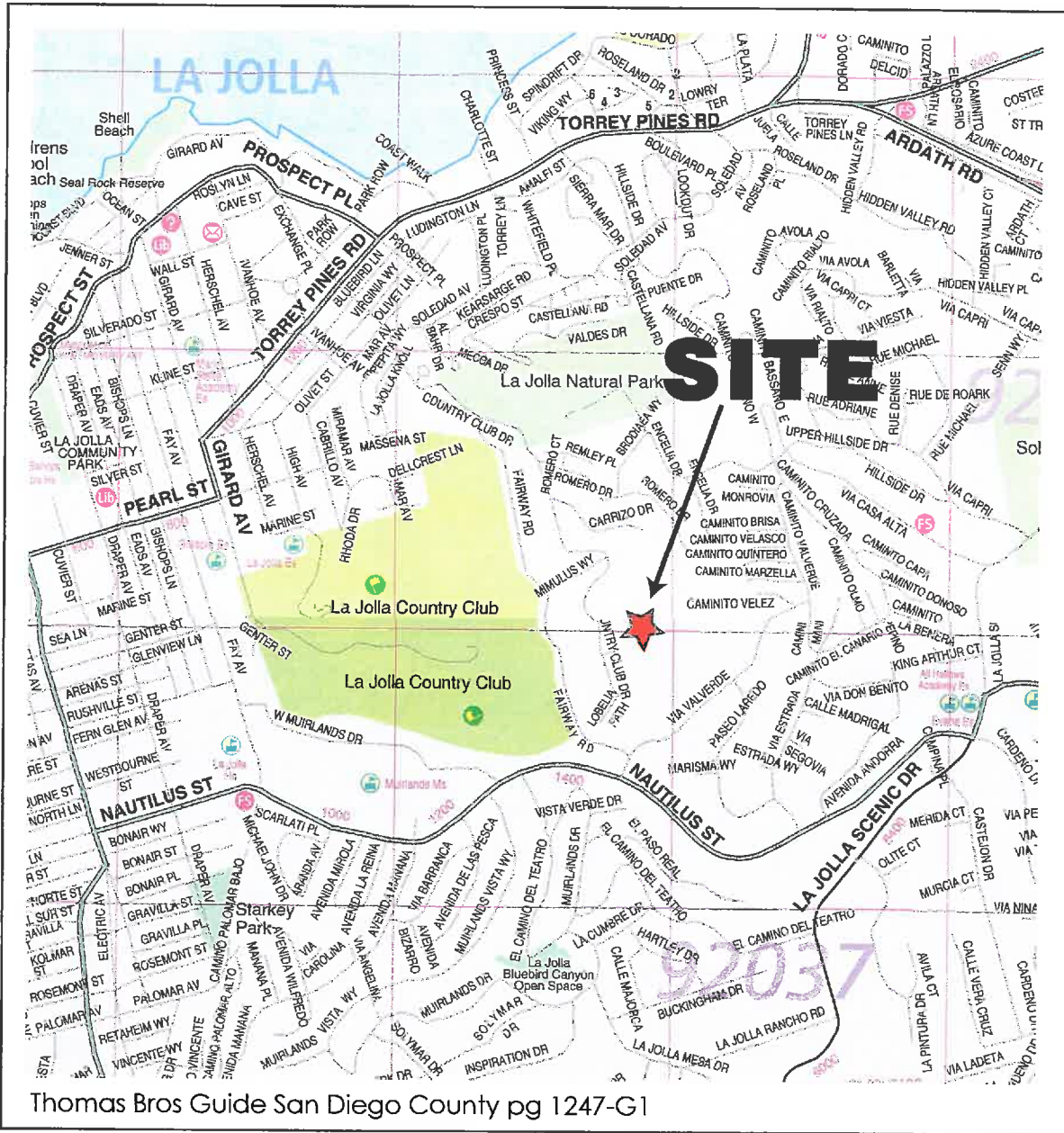

Foxhill Estates Guesthouse
 7007 Country Club Drive
 La Jolla, CA.

Figure No. 1
 Job No. 16-11251



NOTE: This Plot Plan is not to be used for legal purposes. Locations and dimensions are approximate. Actual property dimensions and locations of utilities may be obtained from the Approved Building Plans or the "As-Built" Grading Plans.

LEGEND

● INF-2 Approximate Location of Infiltration Test



Scale: 1" = 60' (approximate)

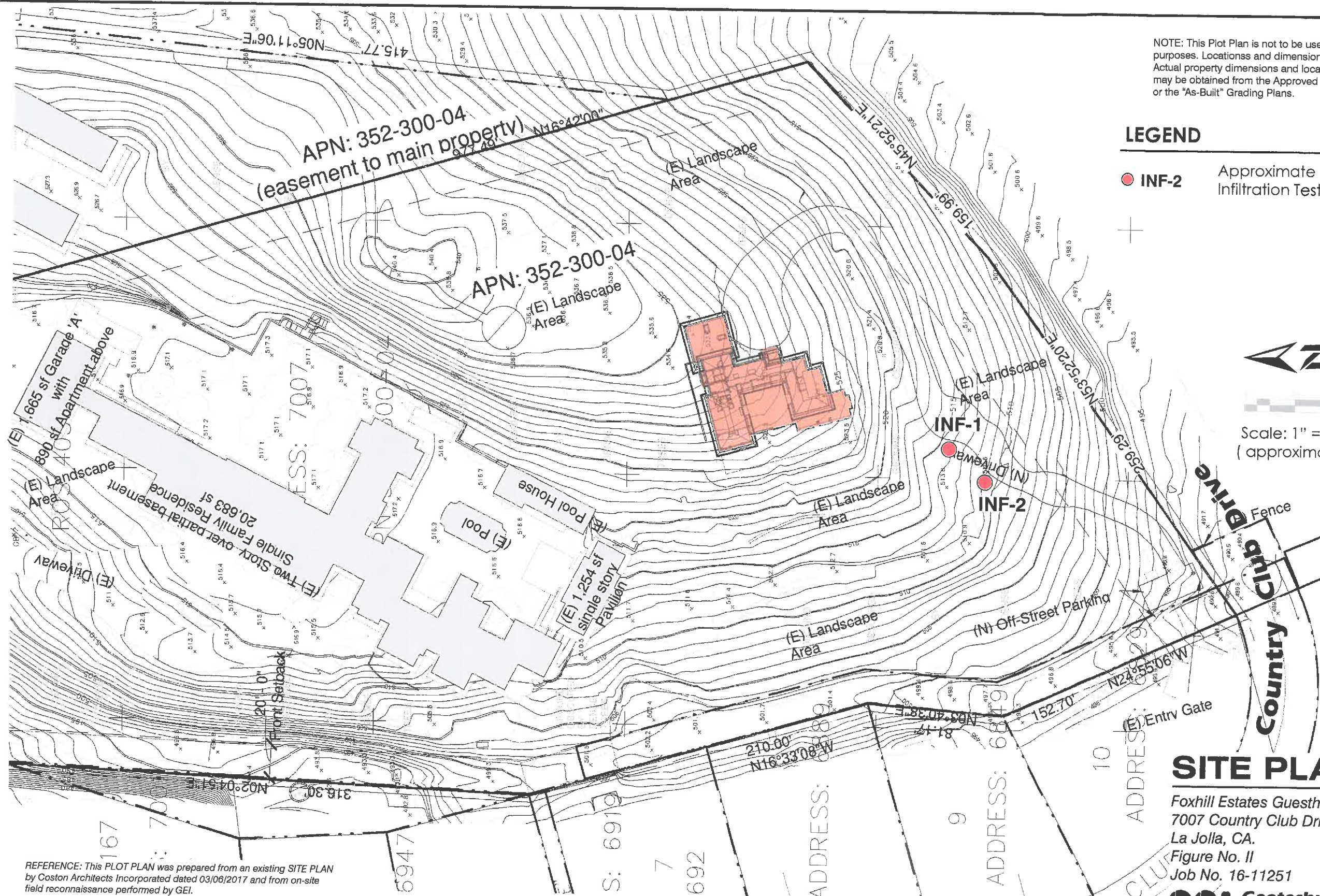

REFERENCE: This PLOT PLAN was prepared from an existing SITE PLAN by Coston Architects Incorporated dated 03/06/2017 and from on-site field reconnaissance performed by GEI.

SITE PLAN

Foxhill Estates Guesthouse
7007 Country Club Drive
La Jolla, CA.
Figure No. II
Job No. 16-11251

GEI Geotechnical Exploration, Inc.

(April 2017)

EQUIPMENT Hand Tools	DIMENSION & TYPE OF EXCAVATION 24-inch diameter Pit	DATE LOGGED 3-10-17
SURFACE ELEVATION ± 514' Mean Sea Level	GROUNDWATER/ SEEPAGE DEPTH Not Encountered	LOGGED BY JM

DEPTH (feet)	SYMBOL	SAMPLE	FIELD DESCRIPTION AND CLASSIFICATION		U.S.C.S.	IN-PLACE MOISTURE (%)	IN-PLACE DRY DENSITY (pcf)	OPTIMUM MOISTURE (%)	MAXIMUM DRY DENSITY (pcf)	DENSITY (% of M.D.D.)	EXPAN. + CONSOL. (%)	BLOW COUNTS/FT.	SAMPLE O.D. (INCHES)
			DESCRIPTION AND REMARKS (Grain size, Density, Moisture, Color)										
1			SILTY SAND , fine- to medium-grained. Loose. Damp. Dark brown.		SM								
			FILL/ TOPSOIL (Qaf)										
2			CLAYEY SAND , fine- to medium-grained. Very dense. Dry. Red-brown.		SC								
			VERY OLD PARALIC DEPOSITS (Qvop) -- 19% passing #200 sieve.			11.2							
3			Bottom @ 3'										
4													
5													

EXPLORATION LOG 11251 FOXHILL.GPJ GEO_EXPL.GDT 4/17/17

PERCHED WATER TABLE BULK BAG SAMPLE IN-PLACE SAMPLE MODIFIED CALIFORNIA SAMPLE NUCLEAR FIELD DENSITY TEST STANDARD PENETRATION TEST	JOB NAME Foxhill Estate Guesthouse	SITE LOCATION Country Club Drive, La Jolla, CA	
	JOB NUMBER 16-11251	REVIEWED BY JAB/LDR	LOG No. INF-1
	FIGURE NUMBER IIIa	Geotechnical Exploration, Inc.	

EQUIPMENT Hand Tools	DIMENSION & TYPE OF EXCAVATION 24-inch diameter Pit	DATE LOGGED 3-10-17
SURFACE ELEVATION ± 511' Mean Sea Level	GROUNDWATER/ SEEPAGE DEPTH Not Encountered	LOGGED BY JM

DEPTH (feet)	SYMBOL	SAMPLE	FIELD DESCRIPTION AND CLASSIFICATION		U.S.C.S.	IN-PLACE MOISTURE (%)	IN-PLACE DRY DENSITY (pcf)	OPTIMUM MOISTURE (%)	MAXIMUM DRY DENSITY (pcf)	DENSITY (% of M.D.D.)	EXPAN. + CONSOL. (%)	BLOW COUNTS/FT.	SAMPLE O.D. (INCHES)
			DESCRIPTION AND REMARKS (Grain size, Density, Moisture, Color)										
1			SILTY SAND , fine- to medium-grained. Loose. Moist. Dark brown.		SM								
			FILL/ TOPSOIL (Qaf)										
2			CLAYEY SAND , fine- to medium-grained. Very dense. Dry. Red-brown.		SC								
			VERY OLD PARALIC DEPOSITS (Qvop) -- 16% passing #200 sieve.			10.1							
3			Bottom @ 2.75'										
4													
5													

EXPLORATION LOG 11251 FOXHILL.GPJ GEO_EXPL.GDT 4/17/17

PERCHED WATER TABLE BULK BAG SAMPLE IN-PLACE SAMPLE MODIFIED CALIFORNIA SAMPLE NUCLEAR FIELD DENSITY TEST STANDARD PENETRATION TEST	JOB NAME Foxhill Estate Guesthouse	SITE LOCATION Country Club Drive, La Jolla, CA	
	JOB NUMBER 16-11251	REVIEWED BY JAB/LDR	LOG No. INF-2
	FIGURE NUMBER IIIb	Geotechnical Exploration, Inc.	

APPENDIX A

SIMPLE OPEN PIT TEST RESULTS AND INFILTRATION RATE CONVERSIONS

Appendix C: Geotechnical and Groundwater Investigation Requirements

Foxhill Guesthouse 16-11251

Worksheet C.4-1: Categorization of Infiltration Feasibility Condition

Categorization of Infiltration Feasibility Condition		Worksheet C.4-1	
Part 1 - Full Infiltration Feasibility Screening Criteria Would infiltration of the full design volume be feasible from a physical perspective without any undesirable consequences that cannot be reasonably mitigated?			
Criteria	Screening Question	Yes	No
1	Is the estimated reliable infiltration rate below proposed facility locations greater than 0.5 inches per hour? The response to this Screening Question shall be based on a comprehensive evaluation of the factors presented in Appendix C.2 and Appendix D.		X
Provide basis: The infiltration test results below the proposed facility location at (INF-1) was 0.032 inches per hour, and at (INF-2) was 0.000 inches per hour with a minimum factor of safety of 2 applied at both locations. Simple open pit testing was performed at 2 locations on the site within or adjacent to the proposed infiltration basins in accordance with Appendix D of the City of San Diego BMP design manual. In addition, a comprehensive evaluation of the site was conducted in accordance with Appendix C.2. Please refer to our "Report of Limited Geotechnical Investigation Proposed Storm Water Infiltration BMP's" dated April 20, 2017 for details of the comprehensive evaluation and investigation conducted, simple open pit test rates and simple open pit rate to infiltration rate calculations and maps representative of the study.			
Summarize findings of studies; provide reference to studies, calculations, maps, data sources, etc. Provide narrative discussion of study/data source applicability.			
2	Can infiltration greater than 0.5 inches per hour be allowed without increasing risk of geotechnical hazards (slope stability, groundwater mounding, utilities, or other factors) that cannot be mitigated to an acceptable level? The response to this Screening Question shall be based on a comprehensive evaluation of the factors presented in Appendix C.2.		X
Provide basis: Our infiltration test results below the proposed facility location range from 0.000 to 0.032 inches per hour with a minimum factor of safety of 2 applied. Infiltration rates greater than 0.5 inches per hour were not encountered, therefore, the question is not applicable. Please refer to our "Report of Limited Geotechnical Investigation Proposed Storm Water Infiltration BMP's" dated April 20, 2017 for details of the comprehensive evaluation and investigation conducted, simple open pit test rates and simple open pit rate to infiltration rate calculations and maps representative of the study.			
Summarize findings of studies; provide reference to studies, calculations, maps, data sources, etc. Provide narrative discussion of study/data source applicability.			

Appendix C: Geotechnical and Groundwater Investigation Requirements

Foxhill Guesthouse 16-11251

Worksheet C.4-1 Page 2 of 4			
Criteria	Screening Question	Yes	No
3	Can infiltration greater than 0.5 inches per hour be allowed without increasing risk of groundwater contamination (shallow water table, storm water pollutants or other factors) that cannot be mitigated to an acceptable level? The response to this Screening Question shall be based on a comprehensive evaluation of the factors presented in Appendix C.3.		X
<p>Provide basis: Our infiltration test results below the proposed facility location range from 0.000 to 0.032 inches per hour with a minimum factor of safety of 2 applied. Infiltration rates greater than 0.5 inches per hour were not encountered, therefore, the question is not applicable. Please refer to our "Report of Limited Geotechnical Investigation Proposed Storm Water Infiltration BMP's" dated April 20, 2017 for details of the comprehensive evaluation and investigation conducted, simple open pit test rates and simple open pit rate to infiltration rate calculations and maps representative of the study.</p> <p>Summarize findings of studies; provide reference to studies, calculations, maps, data sources, etc. Provide narrative discussion of study/data source applicability.</p>			
4	Can infiltration greater than 0.5 inches per hour be allowed without causing potential water balance issues such as change of seasonality of ephemeral streams or increased discharge of contaminated groundwater to surface waters? The response to this Screening Question shall be based on a comprehensive evaluation of the factors presented in Appendix C.3.		
<p>Provide basis: Question to be answered by the design engineer.</p> <p>Summarize findings of studies; provide reference to studies, calculations, maps, data sources, etc. Provide narrative discussion of study/data source applicability.</p>			
Part 1 Result*	If all answers to rows 1 - 4 are "Yes" a full infiltration design is potentially feasible. The feasibility screening category is Full Infiltration If any answer from row 1-4 is "No", infiltration may be possible to some extent but would not generally be feasible or desirable to achieve a "full infiltration" design. Proceed to Part 2		

*To be completed using gathered site information and best professional judgment considering the definition of MEP in the MS4 Permit. Additional testing and/or studies may be required by City Engineer to substantiate findings.

Appendix C: Geotechnical and Groundwater Investigation Requirements

Foxhill Guesthouse 16-11251

Worksheet C.4-1 Page 3 of 4			
Part 2 – Partial Infiltration vs. No Infiltration Feasibility Screening Criteria Would infiltration of water in any appreciable amount be physically feasible without any negative consequences that cannot be reasonably mitigated?			
Criteria	Screening Question	Yes	No
5	Do soil and geologic conditions allow for infiltration in any appreciable rate or volume? The response to this Screening Question shall be based on a comprehensive evaluation of the factors presented in Appendix C.2 and Appendix D.	X	
Provide basis: The City of San Diego BMP Design Manual, Appendix C and Appendix D, do not provide values considered for appreciable rates. However, the City of San Diego geology reviewer for other projects has indicated that partial infiltration is feasible with infiltration rates between 0.01 to 0.5 inches/hour. Measured infiltration rates ranged from 0.000 to 0.032 inches per hour with a minimum factor of safety of 2 applied. Please refer to our "Report of Limited Geotechnical Investigation Proposed Storm Water Infiltration BMP's" dated April 20, 2017 for details of the comprehensive evaluation and investigation conducted, simple open pit test rates and simple open pit rate to infiltration rate calculations and maps representative of the study.			
Summarize findings of studies; provide reference to studies, calculations, maps, data sources, etc. Provide narrative discussion of study/data source applicability and why it was not feasible to mitigate low infiltration rates.			
6	Can Infiltration in any appreciable quantity be allowed without increasing risk of geotechnical hazards (slope stability, groundwater mounding, utilities, or other factors) that cannot be mitigated to an acceptable level? The response to this Screening Question shall be based on a comprehensive evaluation of the factors presented in Appendix C.2.	X	
Provide basis: In our opinion, we do not anticipate that long term infiltration at the site will result in geotechnical hazards which cannot be reasonable mitigated to an acceptable level. Please refer to our "Report of Limited Geotechnical Investigation Proposed Storm Water Infiltration BMP's" dated April 20, 2017 for details of the comprehensive evaluation and investigation conducted, simple open pit test rates and simple open pit rate to infiltration rate calculations and maps representative of the study.			
Summarize findings of studies; provide reference to studies, calculations, maps, data sources, etc. Provide narrative discussion of study/data source applicability and why it was not feasible to mitigate low infiltration rates.			

Appendix C: Geotechnical and Groundwater Investigation Requirements

Foxhill Guesthouse 16-11251

Worksheet C.4-1 Page 4 of 4			
Criteria	Screening Question	Yes	No
7	Can Infiltration in any appreciable quantity be allowed without posing significant risk for groundwater related concerns (shallow water table, storm water pollutants or other factors)? The response to this Screening Question shall be based on a comprehensive evaluation of the factors presented in Appendix C.3.	X	
<p>Provide basis: In our opinion, we do not anticipate that long term infiltration at the site will result in groundwater related concerns. Please refer to our "Report of Limited Geotechnical Investigation Proposed Storm Water Infiltration BMP's" dated April 20, 2017 for details of the comprehensive evaluation and investigation conducted, simple open pit test rates and simple open pit rate to infiltration rate calculations and maps representative of the study.</p> <p>Summarize findings of studies; provide reference to studies, calculations, maps, data sources, etc. Provide narrative discussion of study/data source applicability and why it was not feasible to mitigate low infiltration rates.</p>			
8	Can infiltration be allowed without violating downstream water rights? The response to this Screening Question shall be based on a comprehensive evaluation of the factors presented in Appendix C.3.		
<p>Provide basis: Question to be answered by the design engineer.</p> <p>Summarize findings of studies; provide reference to studies, calculations, maps, data sources, etc. Provide narrative discussion of study/data source applicability and why it was not feasible to mitigate low infiltration rates.</p>			
Part 2 Result*	If all answers from row 1-4 are yes then partial infiltration design is potentially feasible. The feasibility screening category is Partial Infiltration. If any answer from row 5-8 is no, then infiltration of any volume is considered to be infeasible within the drainage area. The feasibility screening category is No Infiltration.		

*To be completed using gathered site information and best professional judgment considering the definition of MEP in the MS4 Permit. Additional testing and/or studies may be required by City Engineer to substantiate findings

Appendix D: Approved Infiltration Rate Assessment Methods

Foxhill Estate Guesthouse 16-11251

Worksheet D.5-1: Factor of Safety and Design Infiltration Rate Worksheet

Factor of Safety and Design Infiltration Rate Worksheet		Worksheet D.5-1			
Factor Category		Factor Description	Assigned Weight (w)	Factor Value (v)	Product (p) $p = w \times v$
A	Suitability Assessment	Soil assessment methods	0.25	2	0.5
		Predominant soil texture	0.25	3	0.75
		Site soil variability	0.25	2	0.5
		Depth to groundwater / impervious layer	0.25	2	0.5
		Suitability Assessment Safety Factor, $S_A = \Sigma p$			
B	Design	Level of pretreatment/ expected sediment loads	0.5		
		Redundancy/resiliency	0.25		
		Compaction during construction	0.25		
		Design Safety Factor, $S_B = \Sigma p$			
Combined Safety Factor, $S_{total} = S_A \times S_B$					
Observed Infiltration Rate, inch/hr, $K_{observed}$ (corrected for test-specific bias)					
Design Infiltration Rate, in/hr, $K_{design} = K_{observed} / S_{total}$					
Supporting Data					
<p>Briefly describe infiltration test and provide reference to test forms: Simple open pit testing was performed at 2 locations within or adjacent to the proposed facility per the requirements of the City of San Diego Storm Water Standards, BMP Design Manual, in accordance with Appendix D. Please refer to our "Report of Limited Geotechnical Investigation Proposed Storm Water Infiltration BMP's" dated April 20, 2017 for details of the comprehensive evaluation and investigation conducted, simple open pit test results and converted simple open pit test results to infiltration rate calculations, and maps representative of the study.</p>					



United States
Department of
Agriculture

NRCS

Natural
Resources
Conservation
Service

A product of the National
Cooperative Soil Survey,
a joint effort of the United
States Department of
Agriculture and other
Federal agencies, State
agencies including the
Agricultural Experiment
Stations, and local
participants

Custom Soil Resource Report for San Diego County Area, California

7007 Country Club Dr., La Jolla



Preface

Soil surveys contain information that affects land use planning in survey areas. They highlight soil limitations that affect various land uses and provide information about the properties of the soils in the survey areas. Soil surveys are designed for many different users, including farmers, ranchers, foresters, agronomists, urban planners, community officials, engineers, developers, builders, and home buyers. Also, conservationists, teachers, students, and specialists in recreation, waste disposal, and pollution control can use the surveys to help them understand, protect, or enhance the environment.

Various land use regulations of Federal, State, and local governments may impose special restrictions on land use or land treatment. Soil surveys identify soil properties that are used in making various land use or land treatment decisions. The information is intended to help the land users identify and reduce the effects of soil limitations on various land uses. The landowner or user is responsible for identifying and complying with existing laws and regulations.

Although soil survey information can be used for general farm, local, and wider area planning, onsite investigation is needed to supplement this information in some cases. Examples include soil quality assessments (<http://www.nrcs.usda.gov/wps/portal/nrcs/main/soils/health/>) and certain conservation and engineering applications. For more detailed information, contact your local USDA Service Center (<https://offices.sc.egov.usda.gov/locator/app?agency=nrcs>) or your NRCS State Soil Scientist (http://www.nrcs.usda.gov/wps/portal/nrcs/detail/soils/contactus/?cid=nrcs142p2_053951).

Great differences in soil properties can occur within short distances. Some soils are seasonally wet or subject to flooding. Some are too unstable to be used as a foundation for buildings or roads. Clayey or wet soils are poorly suited to use as septic tank absorption fields. A high water table makes a soil poorly suited to basements or underground installations.

The National Cooperative Soil Survey is a joint effort of the United States Department of Agriculture and other Federal agencies, State agencies including the Agricultural Experiment Stations, and local agencies. The Natural Resources Conservation Service (NRCS) has leadership for the Federal part of the National Cooperative Soil Survey.

Information about soils is updated periodically. Updated information is available through the NRCS Web Soil Survey, the site for official soil survey information.

The U.S. Department of Agriculture (USDA) prohibits discrimination in all its programs and activities on the basis of race, color, national origin, age, disability, and where applicable, sex, marital status, familial status, parental status, religion, sexual orientation, genetic information, political beliefs, reprisal, or because all or a part of an individual's income is derived from any public assistance program. (Not all prohibited bases apply to all programs.) Persons with disabilities who require

alternative means for communication of program information (Braille, large print, audiotape, etc.) should contact USDA's TARGET Center at (202) 720-2600 (voice and TDD). To file a complaint of discrimination, write to USDA, Director, Office of Civil Rights, 1400 Independence Avenue, S.W., Washington, D.C. 20250-9410 or call (800) 795-3272 (voice) or (202) 720-6382 (TDD). USDA is an equal opportunity provider and employer.

Contents

Preface	2
How Soil Surveys Are Made	5
Soil Map	8
Soil Map.....	9
Legend.....	10
Map Unit Legend.....	11
Map Unit Descriptions.....	11
San Diego County Area, California.....	13
GaF—Gaviota fine sandy loam, 30 to 50 percent slopes.....	13
OhF—Olivenhain cobbly loam, 30 to 50 percent slopes.....	14
References	16

How Soil Surveys Are Made

Soil surveys are made to provide information about the soils and miscellaneous areas in a specific area. They include a description of the soils and miscellaneous areas and their location on the landscape and tables that show soil properties and limitations affecting various uses. Soil scientists observed the steepness, length, and shape of the slopes; the general pattern of drainage; the kinds of crops and native plants; and the kinds of bedrock. They observed and described many soil profiles. A soil profile is the sequence of natural layers, or horizons, in a soil. The profile extends from the surface down into the unconsolidated material in which the soil formed or from the surface down to bedrock. The unconsolidated material is devoid of roots and other living organisms and has not been changed by other biological activity.

Currently, soils are mapped according to the boundaries of major land resource areas (MLRAs). MLRAs are geographically associated land resource units that share common characteristics related to physiography, geology, climate, water resources, soils, biological resources, and land uses (USDA, 2006). Soil survey areas typically consist of parts of one or more MLRA.

The soils and miscellaneous areas in a survey area occur in an orderly pattern that is related to the geology, landforms, relief, climate, and natural vegetation of the area. Each kind of soil and miscellaneous area is associated with a particular kind of landform or with a segment of the landform. By observing the soils and miscellaneous areas in the survey area and relating their position to specific segments of the landform, a soil scientist develops a concept, or model, of how they were formed. Thus, during mapping, this model enables the soil scientist to predict with a considerable degree of accuracy the kind of soil or miscellaneous area at a specific location on the landscape.

Commonly, individual soils on the landscape merge into one another as their characteristics gradually change. To construct an accurate soil map, however, soil scientists must determine the boundaries between the soils. They can observe only a limited number of soil profiles. Nevertheless, these observations, supplemented by an understanding of the soil-vegetation-landscape relationship, are sufficient to verify predictions of the kinds of soil in an area and to determine the boundaries.

Soil scientists recorded the characteristics of the soil profiles that they studied. They noted soil color, texture, size and shape of soil aggregates, kind and amount of rock fragments, distribution of plant roots, reaction, and other features that enable them to identify soils. After describing the soils in the survey area and determining their properties, the soil scientists assigned the soils to taxonomic classes (units). Taxonomic classes are concepts. Each taxonomic class has a set of soil characteristics with precisely defined limits. The classes are used as a basis for comparison to classify soils systematically. Soil taxonomy, the system of taxonomic classification used in the United States, is based mainly on the kind and character of soil properties and the arrangement of horizons within the profile. After the soil

Custom Soil Resource Report

scientists classified and named the soils in the survey area, they compared the individual soils with similar soils in the same taxonomic class in other areas so that they could confirm data and assemble additional data based on experience and research.

The objective of soil mapping is not to delineate pure map unit components; the objective is to separate the landscape into landforms or landform segments that have similar use and management requirements. Each map unit is defined by a unique combination of soil components and/or miscellaneous areas in predictable proportions. Some components may be highly contrasting to the other components of the map unit. The presence of minor components in a map unit in no way diminishes the usefulness or accuracy of the data. The delineation of such landforms and landform segments on the map provides sufficient information for the development of resource plans. If intensive use of small areas is planned, onsite investigation is needed to define and locate the soils and miscellaneous areas.

Soil scientists make many field observations in the process of producing a soil map. The frequency of observation is dependent upon several factors, including scale of mapping, intensity of mapping, design of map units, complexity of the landscape, and experience of the soil scientist. Observations are made to test and refine the soil-landscape model and predictions and to verify the classification of the soils at specific locations. Once the soil-landscape model is refined, a significantly smaller number of measurements of individual soil properties are made and recorded. These measurements may include field measurements, such as those for color, depth to bedrock, and texture, and laboratory measurements, such as those for content of sand, silt, clay, salt, and other components. Properties of each soil typically vary from one point to another across the landscape.

Observations for map unit components are aggregated to develop ranges of characteristics for the components. The aggregated values are presented. Direct measurements do not exist for every property presented for every map unit component. Values for some properties are estimated from combinations of other properties.

While a soil survey is in progress, samples of some of the soils in the area generally are collected for laboratory analyses and for engineering tests. Soil scientists interpret the data from these analyses and tests as well as the field-observed characteristics and the soil properties to determine the expected behavior of the soils under different uses. Interpretations for all of the soils are field tested through observation of the soils in different uses and under different levels of management. Some interpretations are modified to fit local conditions, and some new interpretations are developed to meet local needs. Data are assembled from other sources, such as research information, production records, and field experience of specialists. For example, data on crop yields under defined levels of management are assembled from farm records and from field or plot experiments on the same kinds of soil.

Predictions about soil behavior are based not only on soil properties but also on such variables as climate and biological activity. Soil conditions are predictable over long periods of time, but they are not predictable from year to year. For example, soil scientists can predict with a fairly high degree of accuracy that a given soil will have a high water table within certain depths in most years, but they cannot predict that a high water table will always be at a specific level in the soil on a specific date.

After soil scientists located and identified the significant natural bodies of soil in the survey area, they drew the boundaries of these bodies on aerial photographs and

Custom Soil Resource Report

identified each as a specific map unit. Aerial photographs show trees, buildings, fields, roads, and rivers, all of which help in locating boundaries accurately.

Soil Map

The soil map section includes the soil map for the defined area of interest, a list of soil map units on the map and extent of each map unit, and cartographic symbols displayed on the map. Also presented are various metadata about data used to produce the map, and a description of each soil map unit.

Custom Soil Resource Report Soil Map

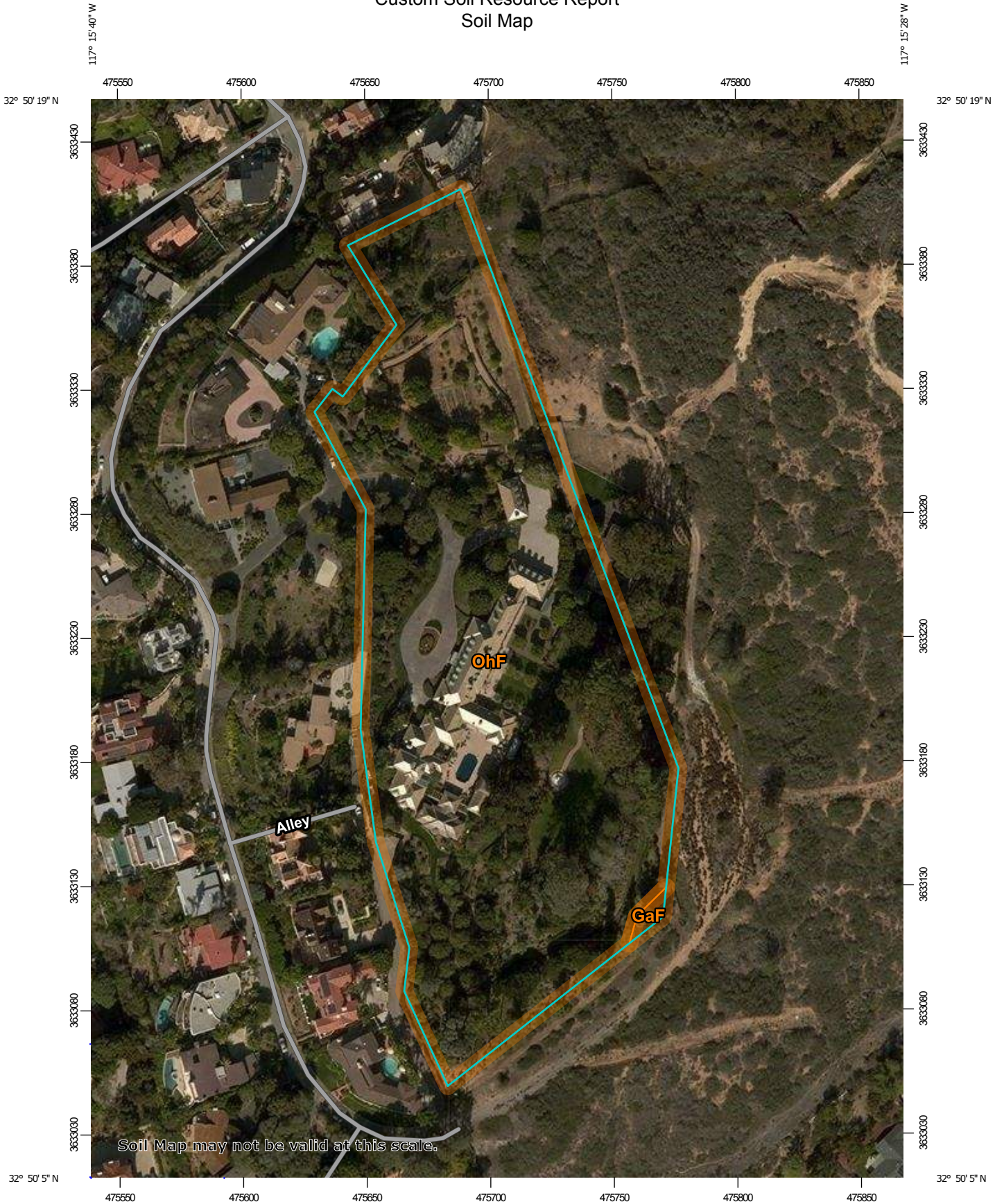

Soil Map may not be valid at this scale.

Map Scale: 1:2,120 if printed on A portrait (8.5" x 11") sheet.



Map projection: Web Mercator Corner coordinates: WGS84 Edge tics: UTM Zone 11N WGS84

MAP LEGEND

Area of Interest (AOI)		Spoil Area
Area of Interest (AOI)		Stony Spot
Soils		Very Stony Spot
Soil Map Unit Polygons		Wet Spot
Soil Map Unit Lines		Other
Soil Map Unit Points		Special Line Features
Special Point Features		Water Features
Blowout		Streams and Canals
Borrow Pit		Transportation
Clay Spot		Rails
Closed Depression		Interstate Highways
Gravel Pit		US Routes
Gravelly Spot		Major Roads
Landfill		Local Roads
Lava Flow		Background
Marsh or swamp		Aerial Photography
Mine or Quarry		
Miscellaneous Water		
Perennial Water		
Rock Outcrop		
Saline Spot		
Sandy Spot		
Severely Eroded Spot		
Sinkhole		
Slide or Slip		
Sodic Spot		

MAP INFORMATION

The soil surveys that comprise your AOI were mapped at 1:24,000.

Warning: Soil Map may not be valid at this scale.

Enlargement of maps beyond the scale of mapping can cause misunderstanding of the detail of mapping and accuracy of soil line placement. The maps do not show the small areas of contrasting soils that could have been shown at a more detailed scale.

Please rely on the bar scale on each map sheet for map measurements.

Source of Map: Natural Resources Conservation Service
 Web Soil Survey URL:
 Coordinate System: Web Mercator (EPSG:3857)

Maps from the Web Soil Survey are based on the Web Mercator projection, which preserves direction and shape but distorts distance and area. A projection that preserves area, such as the Albers equal-area conic projection, should be used if more accurate calculations of distance or area are required.

This product is generated from the USDA-NRCS certified data as of the version date(s) listed below.

Soil Survey Area: San Diego County Area, California
 Survey Area Data: Version 10, Sep 12, 2016

Soil map units are labeled (as space allows) for map scales 1:50,000 or larger.

Date(s) aerial images were photographed: Dec 7, 2014—Jan 4, 2015

The orthophoto or other base map on which the soil lines were compiled and digitized probably differs from the background imagery displayed on these maps. As a result, some minor shifting of map unit boundaries may be evident.

Map Unit Legend

San Diego County Area, California (CA638)			
Map Unit Symbol	Map Unit Name	Acres in AOI	Percent of AOI
GaF	Gaviota fine sandy loam, 30 to 50 percent slopes	0.0	0.4%
OhF	Olivenhain cobbly loam, 30 to 50 percent slopes	7.5	99.6%
Totals for Area of Interest		7.5	100.0%

Map Unit Descriptions

The map units delineated on the detailed soil maps in a soil survey represent the soils or miscellaneous areas in the survey area. The map unit descriptions, along with the maps, can be used to determine the composition and properties of a unit.

A map unit delineation on a soil map represents an area dominated by one or more major kinds of soil or miscellaneous areas. A map unit is identified and named according to the taxonomic classification of the dominant soils. Within a taxonomic class there are precisely defined limits for the properties of the soils. On the landscape, however, the soils are natural phenomena, and they have the characteristic variability of all natural phenomena. Thus, the range of some observed properties may extend beyond the limits defined for a taxonomic class. Areas of soils of a single taxonomic class rarely, if ever, can be mapped without including areas of other taxonomic classes. Consequently, every map unit is made up of the soils or miscellaneous areas for which it is named and some minor components that belong to taxonomic classes other than those of the major soils.

Most minor soils have properties similar to those of the dominant soil or soils in the map unit, and thus they do not affect use and management. These are called noncontrasting, or similar, components. They may or may not be mentioned in a particular map unit description. Other minor components, however, have properties and behavioral characteristics divergent enough to affect use or to require different management. These are called contrasting, or dissimilar, components. They generally are in small areas and could not be mapped separately because of the scale used. Some small areas of strongly contrasting soils or miscellaneous areas are identified by a special symbol on the maps. If included in the database for a given area, the contrasting minor components are identified in the map unit descriptions along with some characteristics of each. A few areas of minor components may not have been observed, and consequently they are not mentioned in the descriptions, especially where the pattern was so complex that it was impractical to make enough observations to identify all the soils and miscellaneous areas on the landscape.

The presence of minor components in a map unit in no way diminishes the usefulness or accuracy of the data. The objective of mapping is not to delineate pure taxonomic classes but rather to separate the landscape into landforms or landform segments that have similar use and management requirements. The delineation of such segments on the map provides sufficient information for the

Custom Soil Resource Report

development of resource plans. If intensive use of small areas is planned, however, onsite investigation is needed to define and locate the soils and miscellaneous areas.

An identifying symbol precedes the map unit name in the map unit descriptions. Each description includes general facts about the unit and gives important soil properties and qualities.

Soils that have profiles that are almost alike make up a *soil series*. Except for differences in texture of the surface layer, all the soils of a series have major horizons that are similar in composition, thickness, and arrangement.

Soils of one series can differ in texture of the surface layer, slope, stoniness, salinity, degree of erosion, and other characteristics that affect their use. On the basis of such differences, a soil series is divided into *soil phases*. Most of the areas shown on the detailed soil maps are phases of soil series. The name of a soil phase commonly indicates a feature that affects use or management. For example, Alpha silt loam, 0 to 2 percent slopes, is a phase of the Alpha series.

Some map units are made up of two or more major soils or miscellaneous areas. These map units are complexes, associations, or undifferentiated groups.

A *complex* consists of two or more soils or miscellaneous areas in such an intricate pattern or in such small areas that they cannot be shown separately on the maps. The pattern and proportion of the soils or miscellaneous areas are somewhat similar in all areas. Alpha-Beta complex, 0 to 6 percent slopes, is an example.

An *association* is made up of two or more geographically associated soils or miscellaneous areas that are shown as one unit on the maps. Because of present or anticipated uses of the map units in the survey area, it was not considered practical or necessary to map the soils or miscellaneous areas separately. The pattern and relative proportion of the soils or miscellaneous areas are somewhat similar. Alpha-Beta association, 0 to 2 percent slopes, is an example.

An *undifferentiated group* is made up of two or more soils or miscellaneous areas that could be mapped individually but are mapped as one unit because similar interpretations can be made for use and management. The pattern and proportion of the soils or miscellaneous areas in a mapped area are not uniform. An area can be made up of only one of the major soils or miscellaneous areas, or it can be made up of all of them. Alpha and Beta soils, 0 to 2 percent slopes, is an example.

Some surveys include *miscellaneous areas*. Such areas have little or no soil material and support little or no vegetation. Rock outcrop is an example.

San Diego County Area, California

GaF—Gaviota fine sandy loam, 30 to 50 percent slopes

Map Unit Setting

National map unit symbol: hbc7
Elevation: 100 to 4,000 feet
Mean annual precipitation: 20 inches
Mean annual air temperature: 61 degrees F
Frost-free period: 280 to 320 days
Farmland classification: Not prime farmland

Map Unit Composition

Gaviota and similar soils: 85 percent
Minor components: 15 percent
Estimates are based on observations, descriptions, and transects of the mapunit.

Description of Gaviota

Setting

Landform: Hillslopes
Landform position (two-dimensional): Backslope
Landform position (three-dimensional): Side slope
Down-slope shape: Convex
Across-slope shape: Convex
Parent material: Residuum weathered from calcareous sandstone

Typical profile

H1 - 0 to 16 inches: fine sandy loam
H2 - 16 to 20 inches: unweathered bedrock

Properties and qualities

Slope: 30 to 50 percent
Depth to restrictive feature: 10 to 20 inches to lithic bedrock
Natural drainage class: Well drained
Runoff class: Medium
Capacity of the most limiting layer to transmit water (Ksat): High (1.98 to 5.95 in/hr)
Depth to water table: More than 80 inches
Frequency of flooding: None
Frequency of ponding: None
Available water storage in profile: Very low (about 1.9 inches)

Interpretive groups

Land capability classification (irrigated): None specified
Land capability classification (nonirrigated): 6e
Hydrologic Soil Group: D
Ecological site: SHALLOW LOAMY (1975) (R019XD060CA)
Hydric soil rating: No

Minor Components

Linne

Percent of map unit: 10 percent
Hydric soil rating: No

Diablo

Percent of map unit: 3 percent
Hydric soil rating: No

Huerhuero

Percent of map unit: 2 percent
Hydric soil rating: No

OhF—Olivenhain cobbly loam, 30 to 50 percent slopes

Map Unit Setting

National map unit symbol: hbfd
Elevation: 100 to 600 feet
Mean annual precipitation: 14 inches
Mean annual air temperature: 63 degrees F
Frost-free period: 290 to 330 days
Farmland classification: Not prime farmland

Map Unit Composition

Olivenhain and similar soils: 85 percent
Minor components: 15 percent
Estimates are based on observations, descriptions, and transects of the mapunit.

Description of Olivenhain

Setting

Landform: Marine terraces
Landform position (three-dimensional): Riser
Down-slope shape: Concave
Across-slope shape: Concave
Parent material: Gravelly alluvium derived from mixed sources

Typical profile

H1 - 0 to 10 inches: cobbly loam
H2 - 10 to 27 inches: very cobbly clay, very cobbly clay loam
H2 - 10 to 27 inches: cobbly loam, cobbly clay loam
H3 - 27 to 45 inches:
H3 - 27 to 45 inches:

Properties and qualities

Slope: 30 to 50 percent
Depth to restrictive feature: About 10 inches to abrupt textural change
Natural drainage class: Well drained
Runoff class: Very high
Capacity of the most limiting layer to transmit water (Ksat): Very low to moderately low (0.00 to 0.06 in/hr)
Depth to water table: More than 80 inches
Frequency of flooding: None
Frequency of ponding: None
Available water storage in profile: Very low (about 1.3 inches)

Custom Soil Resource Report

Interpretive groups

Land capability classification (irrigated): None specified

Land capability classification (nonirrigated): 7e

Hydrologic Soil Group: D

Ecological site: CLAYPAN (1975) (R019XD061CA)

Hydric soil rating: No

Minor Components

Huerhuero

Percent of map unit: 5 percent

Hydric soil rating: No

Diablo

Percent of map unit: 5 percent

Hydric soil rating: No

Linne

Percent of map unit: 5 percent

Hydric soil rating: No

References

- American Association of State Highway and Transportation Officials (AASHTO). 2004. Standard specifications for transportation materials and methods of sampling and testing. 24th edition.
- American Society for Testing and Materials (ASTM). 2005. Standard classification of soils for engineering purposes. ASTM Standard D2487-00.
- Cowardin, L.M., V. Carter, F.C. Golet, and E.T. LaRoe. 1979. Classification of wetlands and deep-water habitats of the United States. U.S. Fish and Wildlife Service FWS/OBS-79/31.
- Federal Register. July 13, 1994. Changes in hydric soils of the United States.
- Federal Register. September 18, 2002. Hydric soils of the United States.
- Hurt, G.W., and L.M. Vasilas, editors. Version 6.0, 2006. Field indicators of hydric soils in the United States.
- National Research Council. 1995. Wetlands: Characteristics and boundaries.
- Soil Survey Division Staff. 1993. Soil survey manual. Soil Conservation Service. U.S. Department of Agriculture Handbook 18. http://www.nrcs.usda.gov/wps/portal/nrcs/detail/national/soils/?cid=nrcs142p2_054262
- Soil Survey Staff. 1999. Soil taxonomy: A basic system of soil classification for making and interpreting soil surveys. 2nd edition. Natural Resources Conservation Service, U.S. Department of Agriculture Handbook 436. http://www.nrcs.usda.gov/wps/portal/nrcs/detail/national/soils/?cid=nrcs142p2_053577
- Soil Survey Staff. 2010. Keys to soil taxonomy. 11th edition. U.S. Department of Agriculture, Natural Resources Conservation Service. http://www.nrcs.usda.gov/wps/portal/nrcs/detail/national/soils/?cid=nrcs142p2_053580
- Tiner, R.W., Jr. 1985. Wetlands of Delaware. U.S. Fish and Wildlife Service and Delaware Department of Natural Resources and Environmental Control, Wetlands Section.
- United States Army Corps of Engineers, Environmental Laboratory. 1987. Corps of Engineers wetlands delineation manual. Waterways Experiment Station Technical Report Y-87-1.
- United States Department of Agriculture, Natural Resources Conservation Service. National forestry manual. http://www.nrcs.usda.gov/wps/portal/nrcs/detail/soils/home/?cid=nrcs142p2_053374
- United States Department of Agriculture, Natural Resources Conservation Service. National range and pasture handbook. <http://www.nrcs.usda.gov/wps/portal/nrcs/detail/national/landuse/rangepasture/?cid=stelprdb1043084>

Custom Soil Resource Report

United States Department of Agriculture, Natural Resources Conservation Service. National soil survey handbook, title 430-VI. http://www.nrcs.usda.gov/wps/portal/nrcs/detail/soils/scientists/?cid=nrcs142p2_054242

United States Department of Agriculture, Natural Resources Conservation Service. 2006. Land resource regions and major land resource areas of the United States, the Caribbean, and the Pacific Basin. U.S. Department of Agriculture Handbook 296. http://www.nrcs.usda.gov/wps/portal/nrcs/detail/national/soils/?cid=nrcs142p2_053624

United States Department of Agriculture, Soil Conservation Service. 1961. Land capability classification. U.S. Department of Agriculture Handbook 210. http://www.nrcs.usda.gov/Internet/FSE_DOCUMENTS/nrcs142p2_052290.pdf