

VICINITY MAP

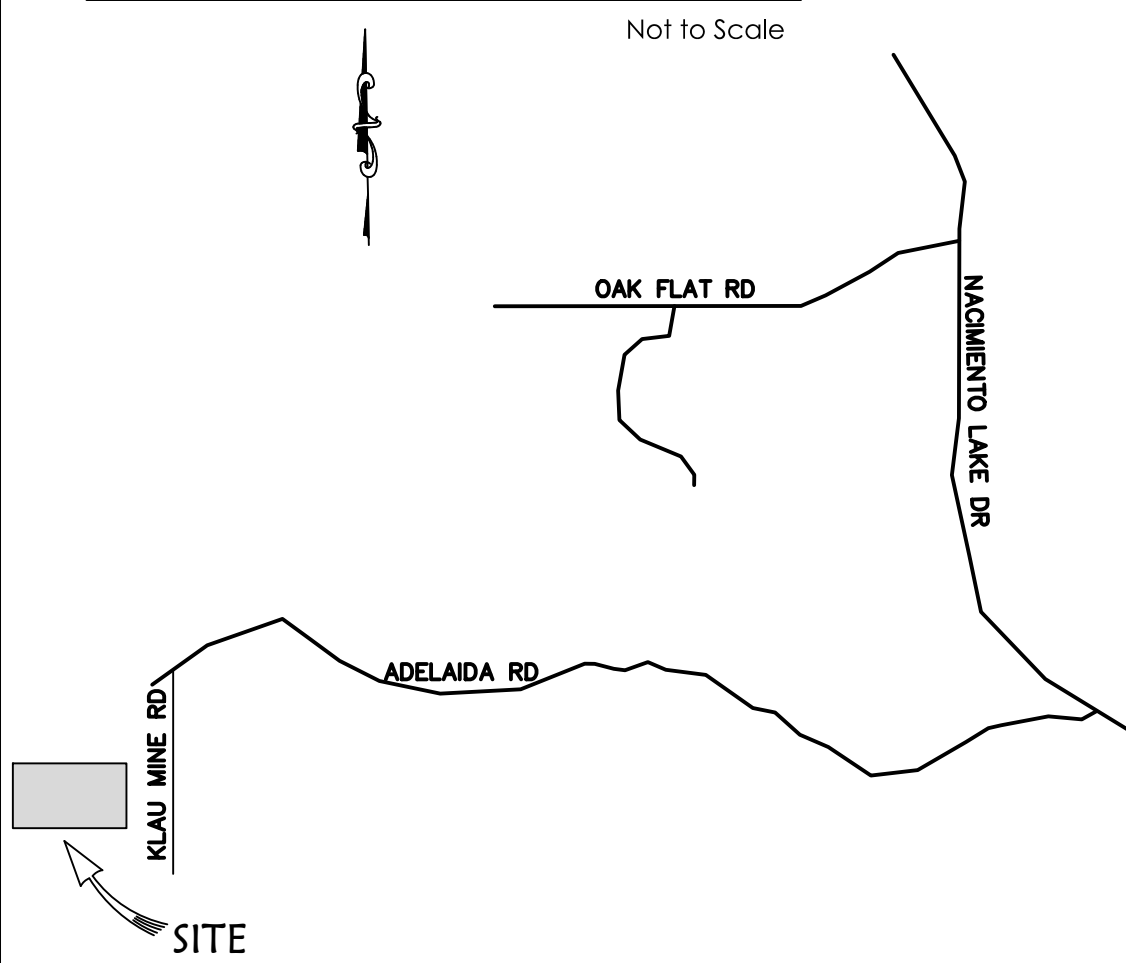

BASIS OF BEARINGS

THE BASIS OF BEARINGS FOR THIS SURVEY IS GRID NORTH, CALIFORNIA STATE PLANE COORDINATE SYSTEM, ZONE 5, ACCORDING TO GPS OBSERVATION AND POST PROCESSING CALCULATION PROVIDED BY NATIONAL GEODETIC SURVEY OPUS SOFTWARE.

BENCH MARK

THE BASIS OF ELEVATIONS FOR THIS SURVEY IS NAVD88, ACCORDING TO GPS OBSERVATION AND POST PROCESSING CALCULATION PROVIDED BY NATIONAL GEODETIC SURVEY OPUS SOFTWARE.

SURVEYOR

DAKOS LAND SURVEYS
7600 MORRO ROAD
ATASCADERO, CA 93422
(805) 466-2445

OWNER

DR. KIRK AZEVEDO
1375 KLAU MINE ROAD
PASO ROBLES, CA 93446

APPLICABLE CODES

- 2019 Building Standards Codes
 - California Energy Code
 - California Building Code, Vols 1 & 2
 - California Electrical Code
 - California Fire Code
 - California Green Building Code
 - California Mechanical Code
 - California Plumbing Code
 - California Reference Standards Code
 - California Residential Code County Building and Construction Ordinance - Title 19
 - County Coastal Zone Land Use Ordinance - Title 23
 - County Fire Code Ordinance - Title 16
 - County Land Use Ordinance - Title 22

PROJECT STATISTICS 1375 KLAU MINE RD (PARCEL A)

Cut 4428 CY± * , Fill 3650 CY± * , Total 8078 CY±
Max. cut = 9 ft, Max. fill = 7 ft
Average slope > 10%
Parcel Area = 50.50 ac±
Pre-Project (sf ±)
Impervious Area = 0 , Total Project Area = 215464
Post-Project (sf ±)
Total Impervious Area = 33,000, Pervious Area = 182464
New Imp. Area = 33,000, Removed Imp. Area = 0
Replaced Imp. Surface = 0
Total Site Disturbance = 215464

PROJECT STATISTICS 1385 KLAU MINE RD (PARCEL B)

Cut 7,035 CY± * , Fill 5,635 CY± * , Total 12,760 CY±
Max. cut = 16 ft, Max. fill = 8 ft
Average slope > 10%
Parcel Area = 149.75 ac±
Pre-Project (sf ±)
Impervious Area = 0 , Total Project Area = 91,390
Post-Project (sf ±)
Total Impervious Area = 30,230, Pervious Area = 61,160
New Imp. Area = 30,230, Removed Imp. Area = 0
Replaced Imp. Surface = 0
Total Site Disturbance = 91,390

* Quantities shown are unadjusted. When subsidence and losses are considered, the earthwork will balance on site.

4/14/2021 11:29 AM

Azevedo - 1375 Klau Mine Road, Paso Robles - Grading, Drainage, & Erosion Control Plan

SITE MAP

SCALE: 1" = 250'

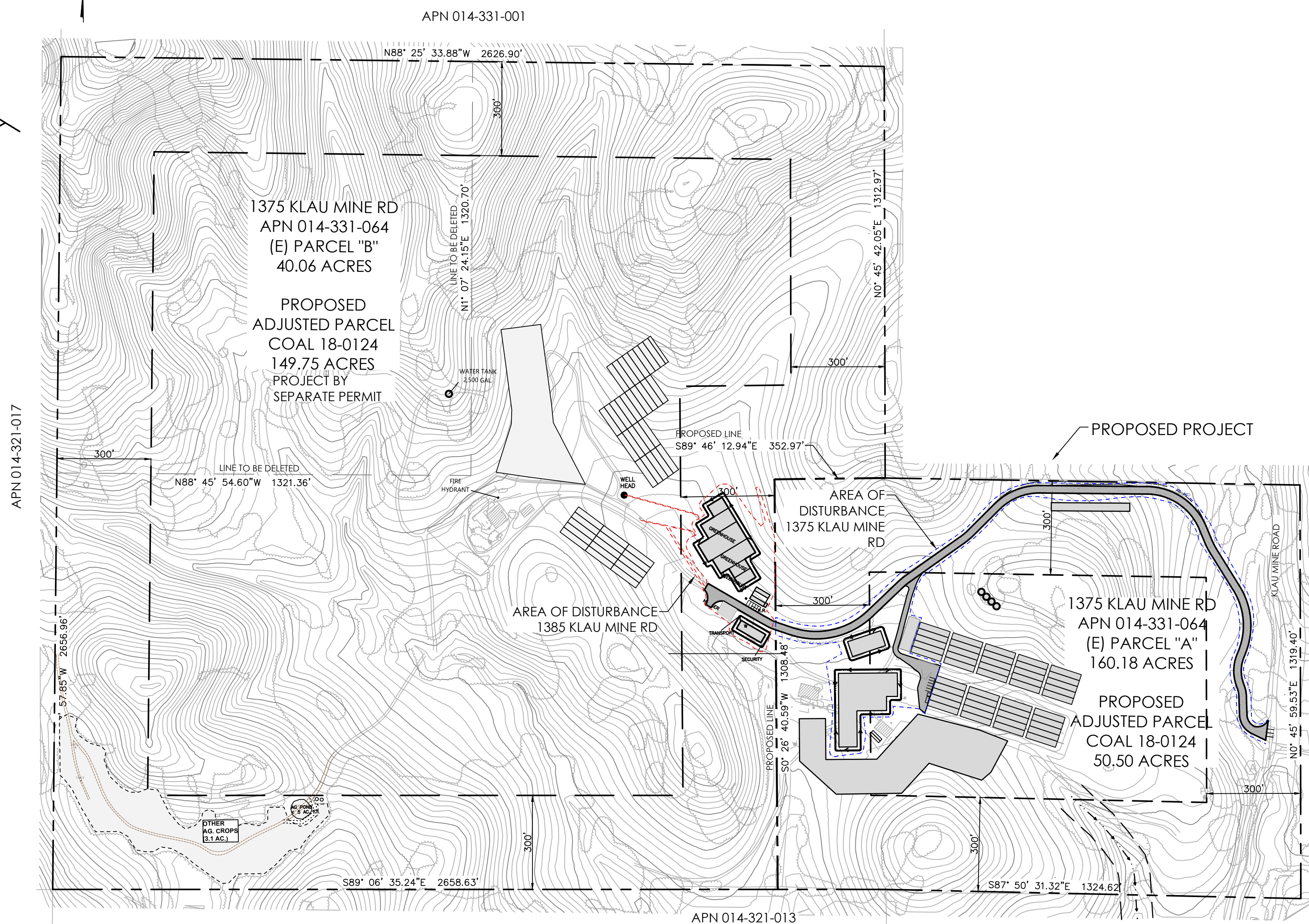

ABBREVIATIONS

AC	Asphalt Concrete Paving
AP	Angle Point
CO	Clean-out
CL	Centerline
CONC	Concrete
CONST	Construction
DIA & Ø	Diameter
ELEV	Elevation
(E) & (I)	Existing
FF	Finished Floor
FS	Finished Surface
FH	Fire Hydrant
FL	Flow Line
G	Gas
GB	Grade Break
GR	Finished Grade
HDPE	High-density Polyethylene
HP	High Point
INV	Invert Elevation
LT	Left
LF	Linear Feet
LP	Low Point
MH	Manhole
P	Power
PC	Point Of Curvature
PL	Property Line
PRC	Point Of Reverse Curvature
PT	Point Of Tangency
PUE	Public Utility Easement
PVC	Polyvinyl Chloride
R	Radius
RT	Right
RP	Radius Point
RW	Right-of-way
S	Slope
SD	Storm Drain
SS	Sanitary Sewer
STA	Station
T	Telephone
TW	Top Of Wall
TYP	Typical
W	Water

LEGEND

---	Property Line
---	Centerline
---	Existing Ground Contour
---	Finish Grade Contour
---	Concrete
---	Edge of Pavement
---	Water Line
---	Water Valve
---	Fire Hydrant
---	Sanitary Sewer Main
---	Electrical Line
---	Overhead Line
---	Utility Pole
---	Guy Anchor
---	Elec. Vault / Pedestal / Pull Box
---	Telephone Line
---	Tele. Vault / Pedestal / Pull Box
---	Fence
---	Gas Main
---	Flowline
---	Proposed Grade & Direction
---	Construction Note Reference
---	Spot Elevation
---	Proposed Slope
---	Area of Disturbance 1375 Klau Mine Road
---	Area of Disturbance 1385 Klau Mine Road

GENERAL NOTES

- No construction shall be started without plans approved by the County Building Department. The Building Department shall be notified of least 24 hours prior to starting of construction and of the time location of the preconstruction conference. Any construction performed without approved plans or prior notification to the Building Department will be rejected and will be of the contractor's and/or owner's risk.
- For any construction performed that is not in compliance with plans or permits approved for the project the Building Department may revoke all active permits and recommend that County Code Enforcement provide a written notice or stop work order in accordance with Section 22.52.140 [23.10] of the Land Use Ordinance.
- All construction work and installations shall conform to the most current County of San Luis Obispo Public Improvement Standards and all work shall be subject to the approval of the Building Department.
- The project owner and contractor shall be responsible for providing and/or maintaining all weather access at all times to existing properties located in the vicinity of work. Additionally, they shall be responsible for maintaining all existing services, including utility, garbage collection, mail distribution, etc., to all existing properties located in the vicinity of work.
- On-site hazards to public safety shall be shielded by construction fencing. Fencing shall be maintained by the project owner and contractor until such time that the project is completed and occupied. Potential hazards have been mitigated, or alternative protective measures have been installed.
- Soils tests shall be done in accordance with the County Public Improvement Standards, Section 3.2.3. All tests must be made within 15 days prior to the placing material. The test results shall clearly indicate the location and source of the material.
- Roadway compaction tests shall be made on subgrade material, aggregate base material, and material as specified by the Soils Engineer. Said tests shall be made prior to the placement of the next material lift.
- Subgrade material shall be compacted to a relative compaction of 95% in the zone between finished subgrade elevation and a minimum of 1-foot below. All material in fill sections below the zone mentioned above shall be compacted to 90% relative compaction.
- A registered civil engineer shall certify that the improvements when completed are in accordance with the plans prior to the request for a final inspection. Record Drawings shall be prepared after construction is completed. The civil engineer certifying the improvements and preparing as-built plans may be present when the final inspection is made by the County.
- An Engineer of Work Agreement and an Engineer Checking and Inspection Agreement are required prior to the start of construction. The Building Department shall be notified in writing of any changes to the Engineer of Work Agreement. Construction shall not proceed without an Engineer of Work.
- All utility companies shall be notified prior to the start of construction.
- A County Encroachment Permit is required for all work done within the County right-of-way. The Encroachment Permit may establish additional construction, utility and traffic control requirements.
- The County Inspector acting on behalf of the County Building Department may require revisions in the plans to solve unforeseen problems that may arise in the field. All revisions shall be subject to the approval of the Developer's Engineer of Work.
- The structural section shall be based on soils tests taken at the time of construction and using a Traffic Index of for (road name). The structural section shall be approved by the Building Department prior to road construction.
- Hydro-seeding or other permanent erosion control shall be placed and established with 90% coverage on all disturbed surfaces (other than paved or gravel surfaces) prior to the final inspection.
- For any public improvements to be maintained by the County, if environmental permits from the U.S. Army Corps of Engineers, the California Regional Water Quality Control Board/State Water Resources Control Board, or the California Department of Fish & Game are required, the Developer shall: a. submit a copy of all such completed permits to the County Building Department OR, b. document that the regulatory agencies determined that said permit is not required; prior to acceptance of the completed improvements for County maintenance and release of improvement security. Any mitigation monitoring required by said permits will remain the responsibility of the Developer.
- When the project site earthwork is not intended to balance then a separate grading permit for the sending or receiving property may be required. A copy of the permit/s or evidence that no permits are required shall be submitted to the Department prior to commencing project earthwork.
- A final report from the designing engineer is required for the engineered leach field design.

GRADING NOTES

- All grading construction shall conform to the applicable codes as noted under "Applicable Codes" heading.
- The developer shall be responsible for scheduling a pre-construction meeting with the County and other affected agencies. The contractor shall notify the County Building Department at least 24 hours prior to any work being performed, and arrange for inspection.
- Grading shall comply with the recommendations of the preliminary soils report by: TBD.
- Estimated earth quantities:
Cut: 4428 CY± Fill: 3650 CY±
Note: exact shrinkage, consolidation, and subsidence factors and losses due to clearing operations are not included. Estimated earthwork quantities are based upon the difference between existing ground surface and proposed finish grades, or sub grades as shown on the plan, and should vary according to these factors. The contractor shall be responsible for site inspection and quantity take off, and shall bid accordingly.
- Soils engineer to determine the soil is suitable to support the intended structure. Such report including progress and/or compaction reports shall be submitted to the field inspector prior to final inspection when a soils report is obtained. The County policy regarding pad certification shall be followed. When applicable the engineer shall observe the grading operation(s) and provide the field inspector with required compaction reports and a report stating that the grading performed has been observed and is in conformance with the UBC and County ordinances.
- No cut or fill slopes will be constructed steeper than two horizontal to one vertical (2:1).
- Dust control is to be maintained at all times during construction.
- Areas of fill shall be scarified, benched and recompact prior to replacing fill and observed by a soil or civil engineer.
- Fill material will be recompact to 90% of maximum density.
- Remove any deleterious material encountered before placing fill.
- All disturbed areas shall be hydro seeded or planted with approved erosion control vegetation as soon as practical after construction is complete.
- Minimum setback to creeks and bluffs shall be maintained. Minimum setback of two feet from all property lines will be maintained for all grading.
- Minimum slope away from buildings shall be 5% for the first ten feet around perimeter.
- The contractor shall be responsible for the protection of all existing survey markers during construction. All such monuments or markers disturbed shall be reset at the contractor's expense.
- All contractors and subcontractors working within the right of way shall have an appropriate contractor's license, a local business license, and shall obtain an encroachment permit.
- Engineering reports for cut or fill slope steeper than 2:1 shall be submitted to the field inspector.

UNDERGROUND UTILITY NOTES

- An effort has been made to define the location of underground facilities within the job site. However, all existing utility and other underground structures may not be shown on this plan and their location where shown is approximate. The construction contractor agrees that he shall assume sole and complete responsibility for locating or having located all underground utilities and other facilities and for protecting them during construction.
- All utility companies must be notified prior to the start of construction. The construction contractor shall contact underground service alert (USA) at 811 two to ten days prior to the start of excavation and shall verify the location of any known utilities and whether or not a representative of each company will be present during excavation.



Roberts Engineering, Inc.		
Azevedo - 1375 Klau Mine Road, Paso Robles		
Title Sheet		
Design/Drawn TR / SEB	County Plan Checker	Approved for County Requirements
Job # 20-77	County W.O. No.	Development Services Engineer Date
California Coordinates (CCS83, Zone 5)	County Road #	Date 4/14/2021 11:29 AM
2431561 N 5689484 E		Timothy P. Roberts, RCE 35366 exp 10/21/21 Date
		1 of 11

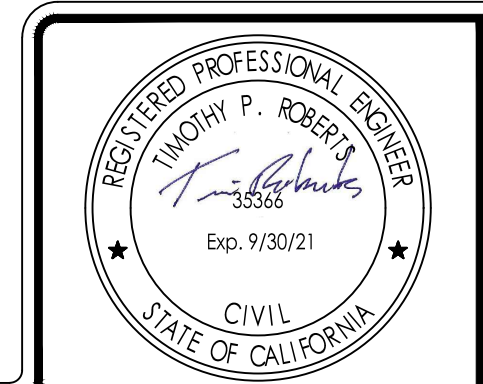

Roberts Engineering
Timothy P. Roberts
Civil Engineer - RCE 35366
2015 Vista de la Vina
Templeton, CA 93465
Phone (805) 239-0664
Fax (805) 238-6148
Email tim@robertsenginc.com
Website.robertsenginc.com

Record Drawings

Timothy P. Roberts, RCE 35366 exp 09/30/21	Date
Revisions This Sheet:	
1	
2	
3	
4	
5	
6	

EROSION CONTROL NOTES

- The site shall be maintained as to prevent flow of sediments from the project.
- All areas over 5% grade which are disturbed by grading activities shall be hydroseeded with an approved perennial mix prior to final acceptance. Areas with established growth at the time of final acceptance need not be hydroseeded.
- Erosion control and sediment control measures shall be provided for any site work.
- Erosion control and sediment control measures shall be provided after construction is completed until permanent measures are in place.
- During rainy season, all paved areas shall be kept clear of soil and debris.
- All erosion protection measures shall be inspected and repaired as necessary at the end of each work day, and after each rainfall event.
- An erosion control plan shall be prepared and approved by the County Engineer.
- All projects involving site disturbance of one acre or greater shall comply with the requirements of the National Pollutant Discharge Elimination System (NPDES). The Developer shall submit a Notice of Intent (NOI) to comply with the General Permit for Construction Activity with the Regional Water Quality Control Board (RWQCB). The Developer shall provide the County with the Waste Discharge Identification Number (WDID #) or with verification that an exemption has been granted by RWQCB.

WDID: TBD

Person to contact 24 hours a day in the event there is an erosion control/sedimentation problem (Storm Water Compliance Officer):
Name: Helios Dayspring

- Hydro Seeding Specifications:

Seed Mix:
20 LB/AC BROMUS CARINATUS CUCAMONGA SEED MIX
8 LB/AC FESTUCA MICROSTACHYS SEED MIX
3 LB/AC TRIFOLIUM WILDENOVII SEED MIX

Mulch/Fertilizer/Binder:
1500 LB/AC WOOD FIBER MULCH
300 LB/AC 15/15/15 FERTILIZER
100 LB/AC ECOLOGY CONTROL M-BINDER TACKIFIER

SPECIAL INSPECTIONS

- All construction & inspections shall conform to 2019 California Building Code (CBC) Chapter 17.
- Special inspection requirements are required for this project, the owner or registered design professional in responsible charge acting as the owner's agent shall employ one or more special inspectors to provide inspections during construction on all tasks identified below.
- Special inspectors shall be a qualified person who shall demonstrate competence, to the satisfaction of the County Building Department. Names and qualifications of special inspector(s) shall be submitted to the County Building Department for approval.
- Each contractor responsible for the construction of components listed in the special inspections shall submit a written statement of responsibility to the County Building Department and the owner prior to the commencement of work. The statement shall contain the items listed in CBC 1706.1.
- A final report prepared by a soil or civil engineer shall be submitted to the field inspector stating the work performed is in substantial conformance with the approved plans, applicable codes, and is found to be suitable to support the intended structure. Such report shall include any field progress reports, compaction data etc.

Section 1705. Statement of Special Inspections:

- 1705.1 General. Where special inspection or testing is required by Section 1704, 1707 or 1708, the registered design professional in responsible charge shall prepare a statement of special inspections in accordance with Section 1705 for submittal by the permit application (see Section 1704.1.1).
- 1705.2 Content of statement of special inspections. The statement of special inspections shall identify the following:
 - The materials, systems, components and work required to have special inspection or testing by the building official or by the registered design professional responsible for each portion of the work.
 - The type and extent of each special inspection.
 - The type and extent of each test.
 - Additional requirements for special inspection or testing for seismic or wind resistance as specified in Section 1705.3, 1705.4, 1707 or 1708.
 - For each type of special inspection, identification as to whether it will be continuous special inspection or periodic special inspection.

Section (Table) 1705.6 Required Verification and Inspection of Soils:

- Verify materials below footings are adequate to achieve the design bearing capacity shall be performed periodically during task.
- Verify excavations are extended to proper depth and have reached proper material, shall be performed periodically during task.
- Perform classification and testing of controlled fill materials, shall be performed periodically during task.
- Verify use of proper materials, densities and lift thicknesses during placement and compaction of controlled fill, shall be performed continuously during task.
- Prior to placement of controlled fill, observe subgrade and verify that site had been prepared properly, shall be performed periodically during task.

Observation & Testing Program.

The project soils engineer shall perform the inspection & testing for the following tasks:

- Final plans
- Stripping and clearing of vegetation
- Recompaction of scarification soils
- Fill placement and compaction
- Over excavating
- Verification of soils type & depth
- Final report

The soil engineer of work shall be TBD

Soils Report # TBD

The project engineer of work shall perform the inspection for the following tasks:

- Rough grading & site preparation
- Final grading inspection prior to final County inspection

The project engineer of work shall be Tim Roberts of Roberts Engineering, Inc., RCE 35366, 2015 Vista de la Vina, Templeton, CA 93465, phone (805) 239-0664

The Engineer or work shall state in writing the work is in substantial conformance with the approved plans.

The person responsible for BMP inspection is:
Helios Dayspring

TREE PROTECTION NOTES

- Trees within 20 feet of grading or trenching shall be protected by placement of protective fencing as indicated.
- Protective fencing shall be four feet high chain link or safety fence, and shall be placed at the dripline unless otherwise indicated
- Trenching and excavation within tree driplines shall be hand dug or bored to minimize root disturbance. Any root encountered 1" diameter or greater, shall be hand cut and appropriately treated.
- Pruning of lower limbs in the construction area shall occur prior to construction activities to minimize damage.
- Tree protection fencing shall remain in place until the completion of construction.
- No vehicle parking or storage of materials under oak canopies.

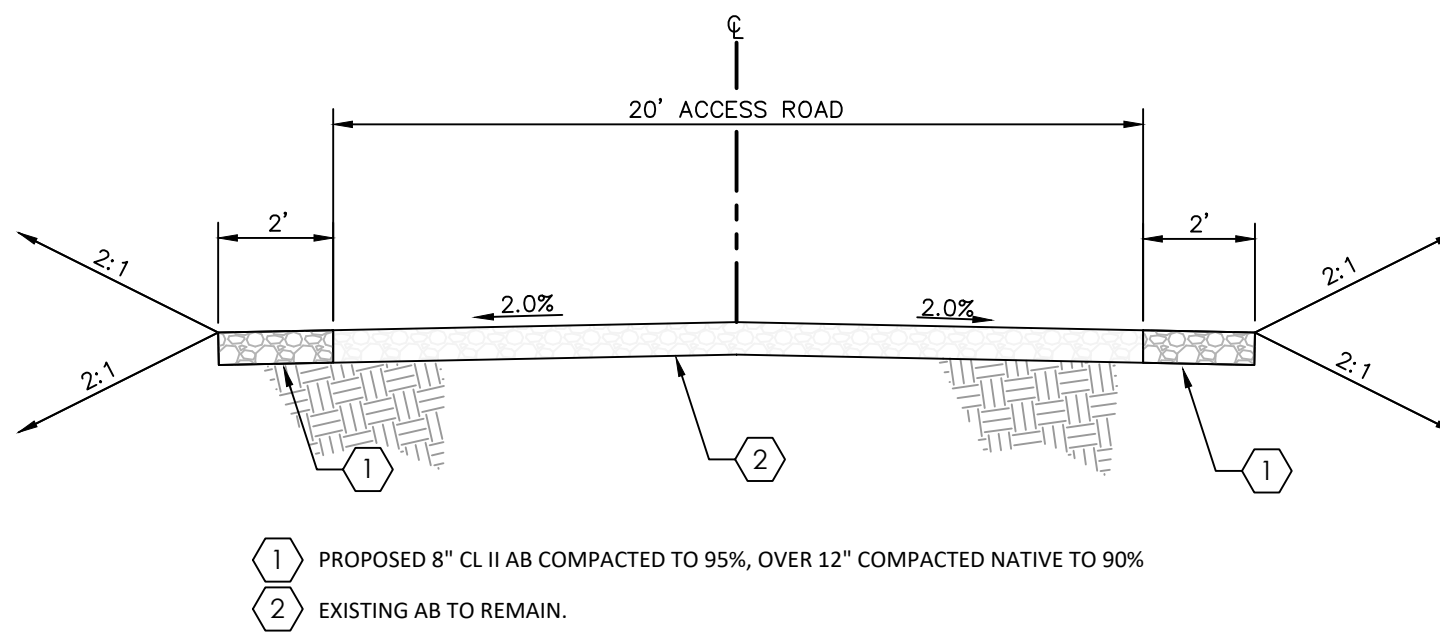

20' ACCESS ROAD TYPICAL SECTION

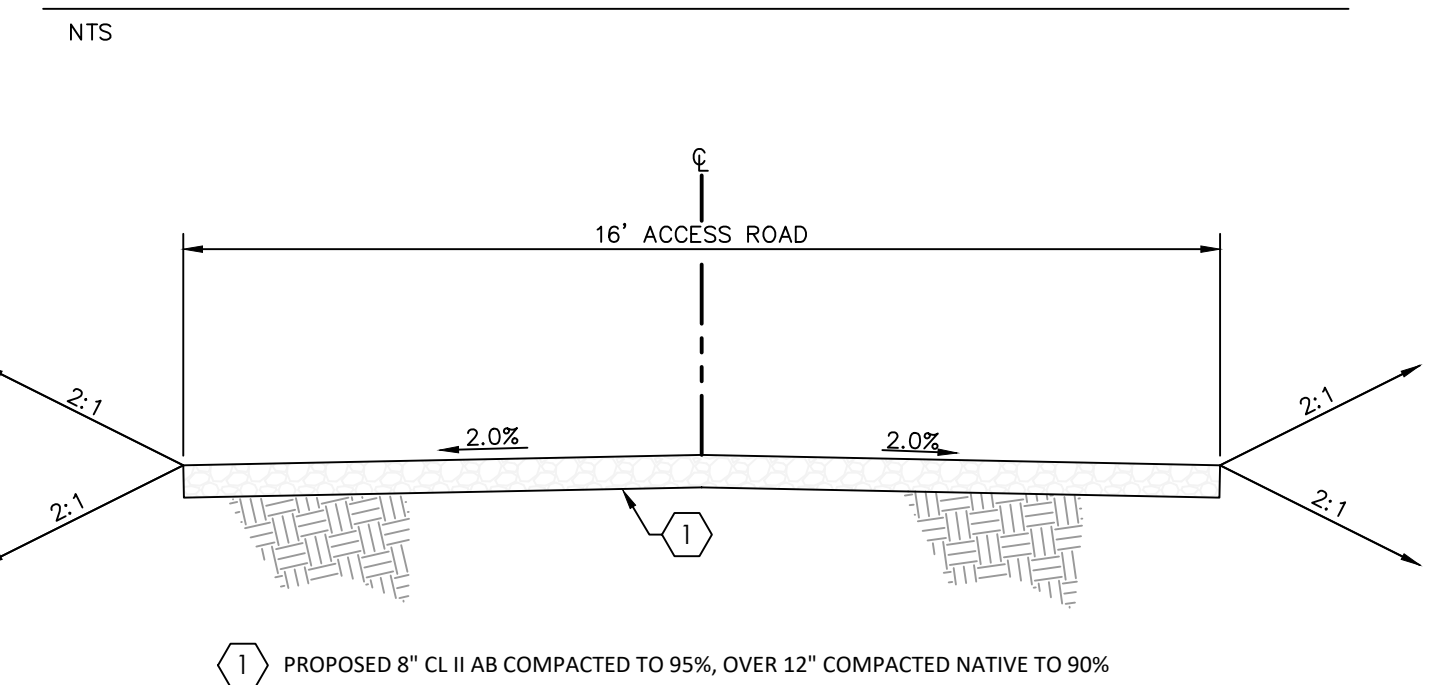

16' ACCESS ROAD TYPICAL SECTION

Hydroseeding

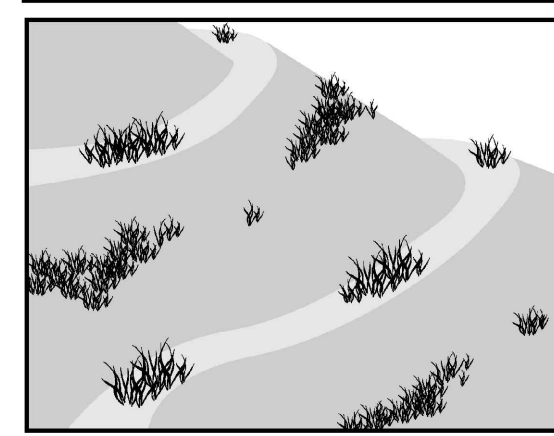

Description and Purpose
Hydroseeding typically consists of applying a mixture of a hydraulic mulch, seed, fertilizer, and stabilizing emulsion with a hydraulic mulcher, to temporarily protect exposed soils from erosion by water and wind. Hydraulic seeding, or hydroseeding, is simply the method by which temporary or permanent seed is applied to the soil surface.

Suitable Applications
Hydroseeding is suitable for disturbed areas requiring temporary protection until permanent stabilization is established, for disturbed areas that will be re-disturbed following an extended period of inactivity, or to apply permanent stabilization measures. Hydroseeding without mulch or other cover (e.g., EC-5, Erosion Control Blanket) is not a stand-alone erosion control BMP and should be combined with additional measures until vegetation establishment.

- Typical applications for hydroseeding include:
- Disturbed soil/graded areas where permanent stabilization or continued earthwork is not anticipated prior to seed germination.
 - Cleared and graded areas exposed to seasonal rains or temporary irrigation.
 - Areas not subject to heavy wear by construction equipment or high traffic.

EC-4

Categories	
EC	Erosion Control <input checked="" type="checkbox"/>
SE	Sediment Control <input type="checkbox"/>
TC	Tracking Control <input type="checkbox"/>
WE	Wind Erosion Control <input checked="" type="checkbox"/>
NS	Non-Stormwater Management Control <input type="checkbox"/>
WM	Waste Management and Materials Pollution Control <input type="checkbox"/>

Legend:
 Primary Category
 Secondary Category

Targeted Constituents	
Sediment	<input checked="" type="checkbox"/>
Nutrients	<input type="checkbox"/>
Trash	<input type="checkbox"/>
Metals	<input type="checkbox"/>
Bacteria	<input type="checkbox"/>
Oil and Grease	<input type="checkbox"/>
Organics	<input type="checkbox"/>

Potential Alternatives	
EC-3 Hydraulic Mulch	<input type="checkbox"/>
EC-5 Soil Binders	<input type="checkbox"/>
EC-6 Straw Mulch	<input type="checkbox"/>
EC-7 Geotextiles and Mats	<input type="checkbox"/>
EC-8 Wood Mulching	<input type="checkbox"/>
EC-14 Compost Blanket	<input type="checkbox"/>
EC-16 Non-Vegetative Stabilization	<input type="checkbox"/>

If User/Subscriber modifies this fact sheet in any way, the CASQA nomenclature and footer below must be removed from each page and not appear on the modified version.



Storm Drain Inlet Protection SE-10

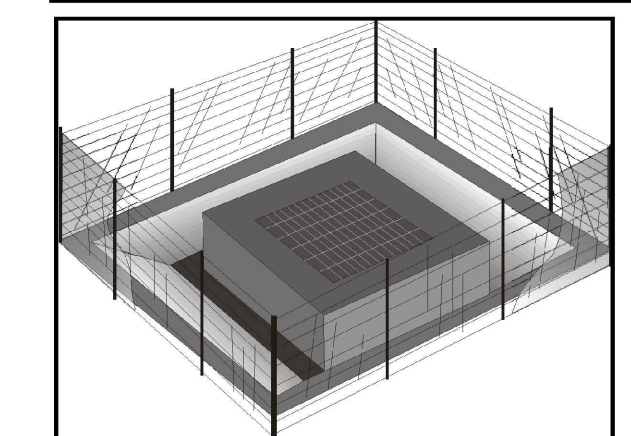

Description and Purpose
Storm drain inlet protection consists of a sediment filter or an impounding area in, around or upstream of a storm drain, drop inlet, or curb inlet. Storm drain inlet protection measures temporarily pond runoff before it enters the storm drain, allowing sediment to settle. Some filter configurations also remove sediment by filtering, but usually the ponding action results in the greatest sediment reduction. Temporary geotextile storm drain inserts attach underneath storm drain grates to capture and filter storm water.

Suitable Applications
Every storm drain inlet receiving runoff from unstabilized or otherwise active work areas should be protected. Inlet protection should be used in conjunction with other erosion and sediment controls to prevent sediment-laden stormwater and non-stormwater discharges from entering the storm drain system.

- Limitations**
- Drainage areas should not exceed a acre.
 - In general straw bales should not be used as inlet protection.
 - Requires an adequate area for water to pond without encroaching into portions of the roadway subject to traffic.
 - Sediment removal may be inadequate to prevent sediment discharges in high flow conditions or if runoff is heavily sediment laden. If high flow conditions are expected, use

Categories	
EC	Erosion Control <input type="checkbox"/>
SE	Sediment Control <input checked="" type="checkbox"/>
TC	Tracking Control <input type="checkbox"/>
WE	Wind Erosion Control <input type="checkbox"/>
NS	Non-Stormwater Management Control <input type="checkbox"/>
WM	Waste Management and Materials Pollution Control <input type="checkbox"/>

Legend:
 Primary Category
 Secondary Category

Targeted Constituents	
Sediment	<input checked="" type="checkbox"/>
Nutrients	<input type="checkbox"/>
Trash	<input type="checkbox"/>
Metals	<input type="checkbox"/>
Bacteria	<input type="checkbox"/>
Oil and Grease	<input type="checkbox"/>
Organics	<input type="checkbox"/>

Potential Alternatives	
SE-13 Filter Fences	<input type="checkbox"/>
SE-15 Straw Bales	<input type="checkbox"/>
SE-4 Gravel Bag Berms	<input type="checkbox"/>
SE-8 Sandbag Berms	<input type="checkbox"/>
SE-14 Baffle Bags	<input type="checkbox"/>
SE-13 Compost Socks and Berms	<input type="checkbox"/>

If User/Subscriber modifies this fact sheet in any way, the CASQA nomenclature and footer below must be removed from each page and not appear on the modified version.



Concrete Waste Management WM-8

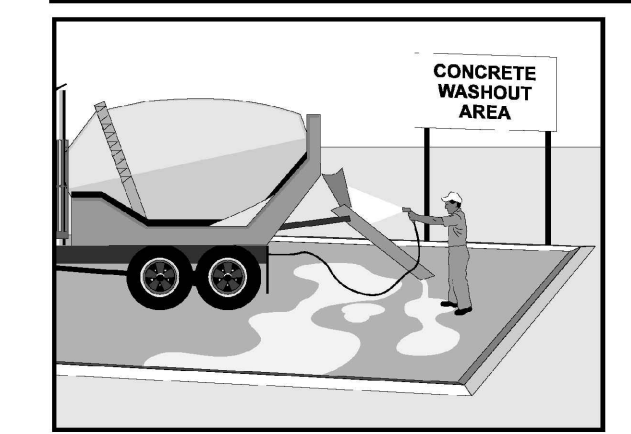

Description and Purpose
Prevent the discharge of pollutants to stormwater from concrete waste by conducting washout onsite or offsite in a designated area, and by employee and subcontractor training. The General Permit incorporates Numeric Action Levels (NAL) for pH (See Section 2 of this handbook to determine your project's risk level and if you are subject to these requirements).

Many types of construction materials, including mortar, concrete, stucco, cement and block and their associated wastes have basic chemical properties that can raise pH levels outside of the permitted range. Additional care should be taken when managing these materials to prevent them from coming into contact with stormwater flows and raising pH to levels outside the accepted range.

- Suitable Applications**
Concrete waste management procedures and practices are implemented on construction projects where:
- Concrete is used as a construction material or where concrete dust and debris result from demolition activities.
 - Slurries containing portland cement concrete (PCC) are generated, such as from saw cutting, coring, grinding, grooving, and hydro-concrete demolition.
 - Concrete trucks and other concrete-coated equipment are washed onsite.

Categories	
EC	Erosion Control <input type="checkbox"/>
SE	Sediment Control <input type="checkbox"/>
TC	Tracking Control <input type="checkbox"/>
WE	Wind Erosion Control <input type="checkbox"/>
NS	Non-Stormwater Management Control <input type="checkbox"/>
WM	Waste Management and Materials Pollution Control <input checked="" type="checkbox"/>

Legend:
 Primary Category
 Secondary Category

Targeted Constituents	
Sediment	<input checked="" type="checkbox"/>
Nutrients	<input type="checkbox"/>
Trash	<input type="checkbox"/>
Metals	<input checked="" type="checkbox"/>
Bacteria	<input type="checkbox"/>
Oil and Grease	<input type="checkbox"/>
Organics	<input type="checkbox"/>

Potential Alternatives	
None	<input type="checkbox"/>

If User/Subscriber modifies this fact sheet in any way, the CASQA nomenclature and footer below must be removed from each page and not appear on the modified version.

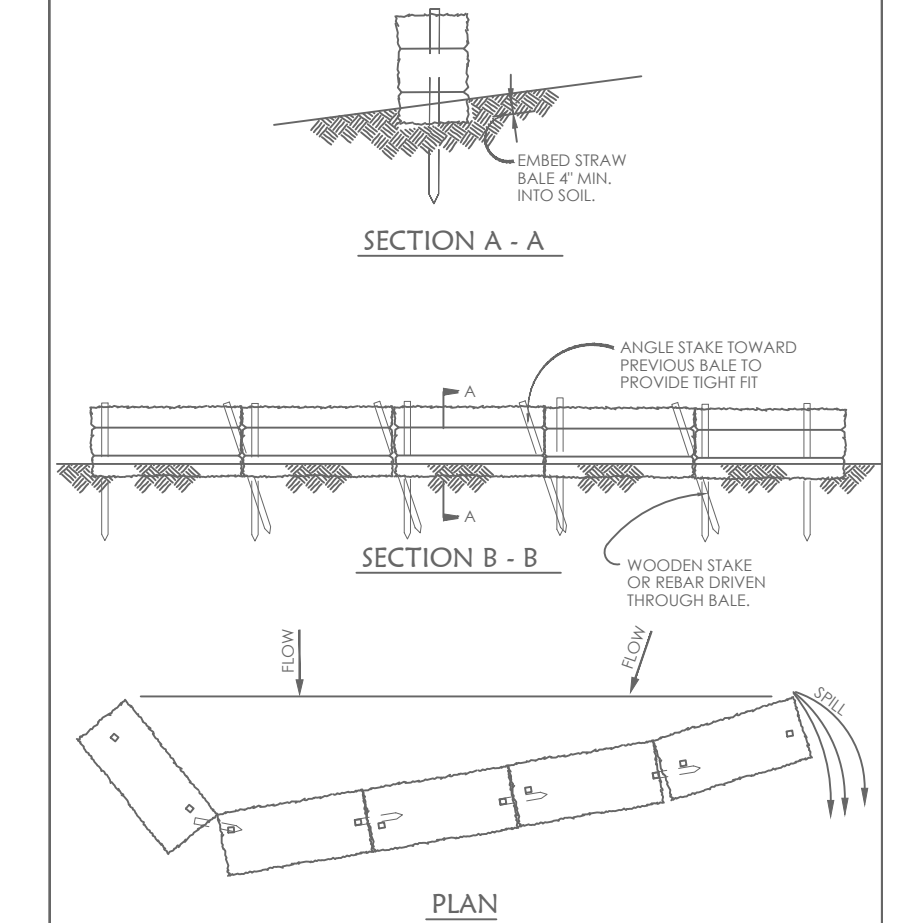

STRAW BALE DIKE

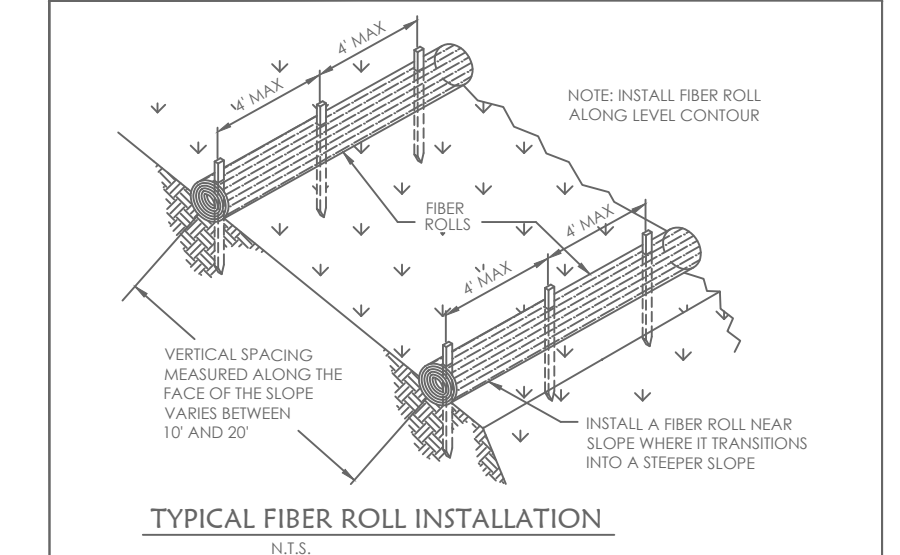

TYPICAL FIBER ROLL INSTALLATION



ENTRENCHMENT DETAIL

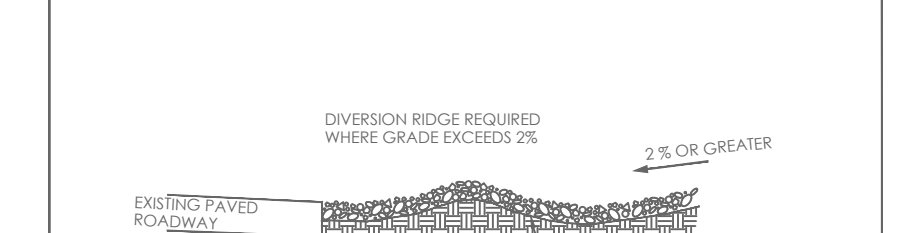

FIBER ROLLS

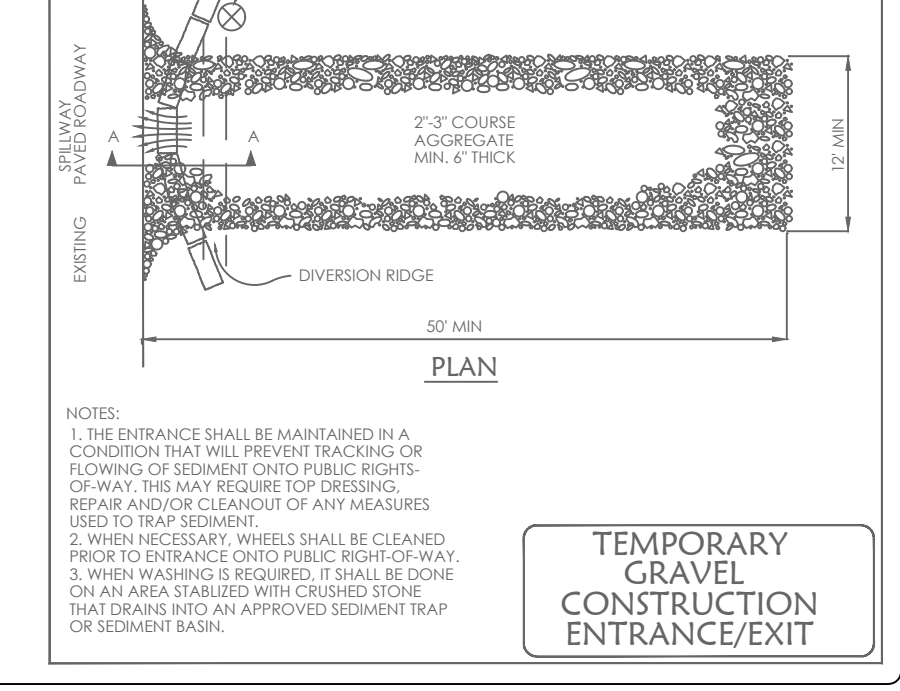

TEMPORARY GRAVEL CONSTRUCTION ENTRANCE/EXIT

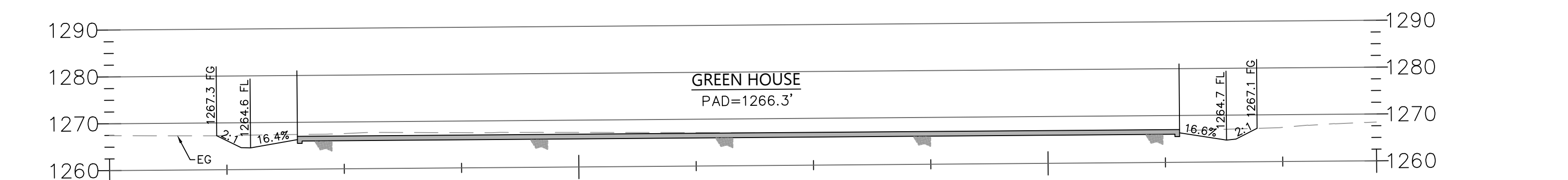

SECTION A-A

HORIZONTAL AND VERTICAL SCALE: 1"=20'

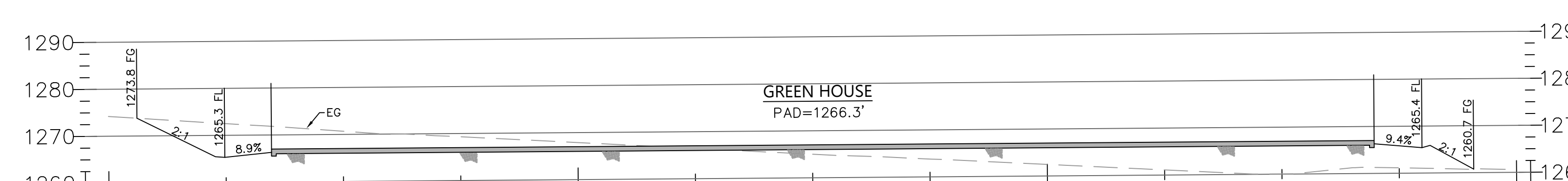

SECTION B-B

HORIZONTAL AND VERTICAL SCALE: 1"=20'

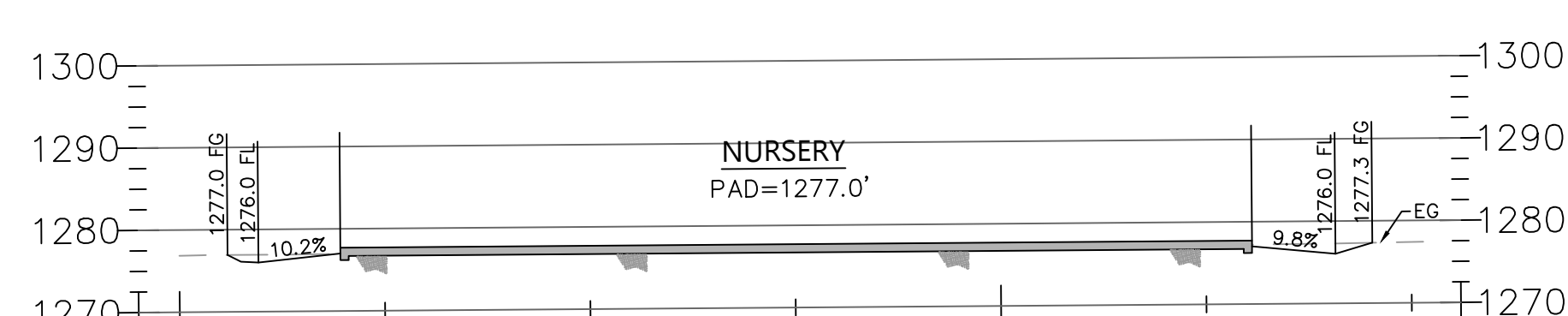

SECTION C-C

HORIZONTAL AND VERTICAL SCALE: 1"=20'

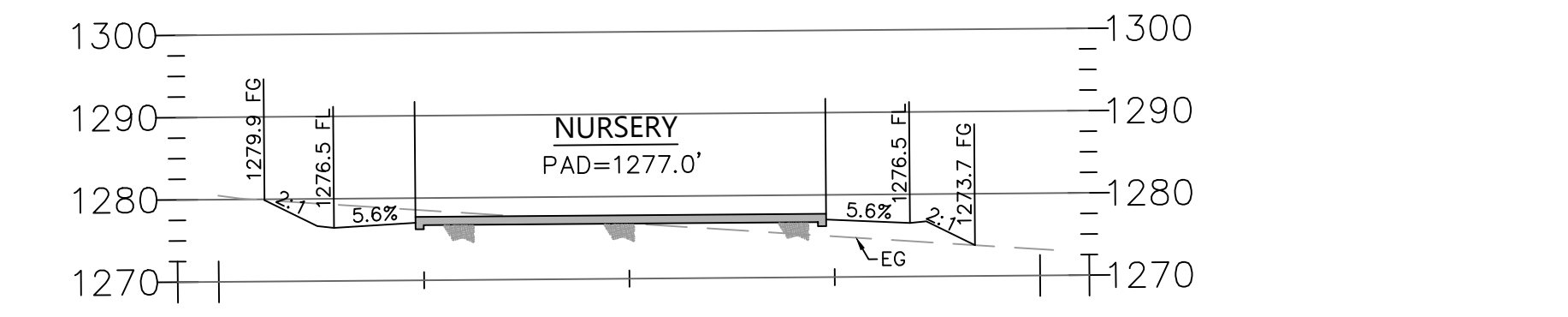

SECTION D-D

HORIZONTAL AND VERTICAL SCALE: 1"=20'

4/14/2021 11:29 AM

		<p>Roberts Engineering Timothy P. Roberts Civil Engineer - RCE 35366 2015 Vista de la Vina Templeton, CA 93465 Phone (805) 239-0664 Fax (805) 238-6148 Email tim@robertsenginc.com Website robertsenginc.com</p>		<p>Record Drawings Timothy P. Roberts, RCE 35366 exp 09/30/21 Date Revisions This Sheet: 1 2 3 4 5</p>	
<p>Roberts Engineering, Inc. Azevedo - 1375 Klau Mine Road, Paso Robles</p>		<p>Notes & Details</p>		<p>Design/Drawn: TR / SEB County Plan Checker: [Signature] Approved for County Requirements: [Signature] Development Services Engineer: [Signature] Date: 7/11/2020 Job #: 20-77 County W.O. No.: [Signature] California Coordinates (CCS83, Zone 5): 2431561 N 5689484 E County Road #: [Signature] of 11</p>	

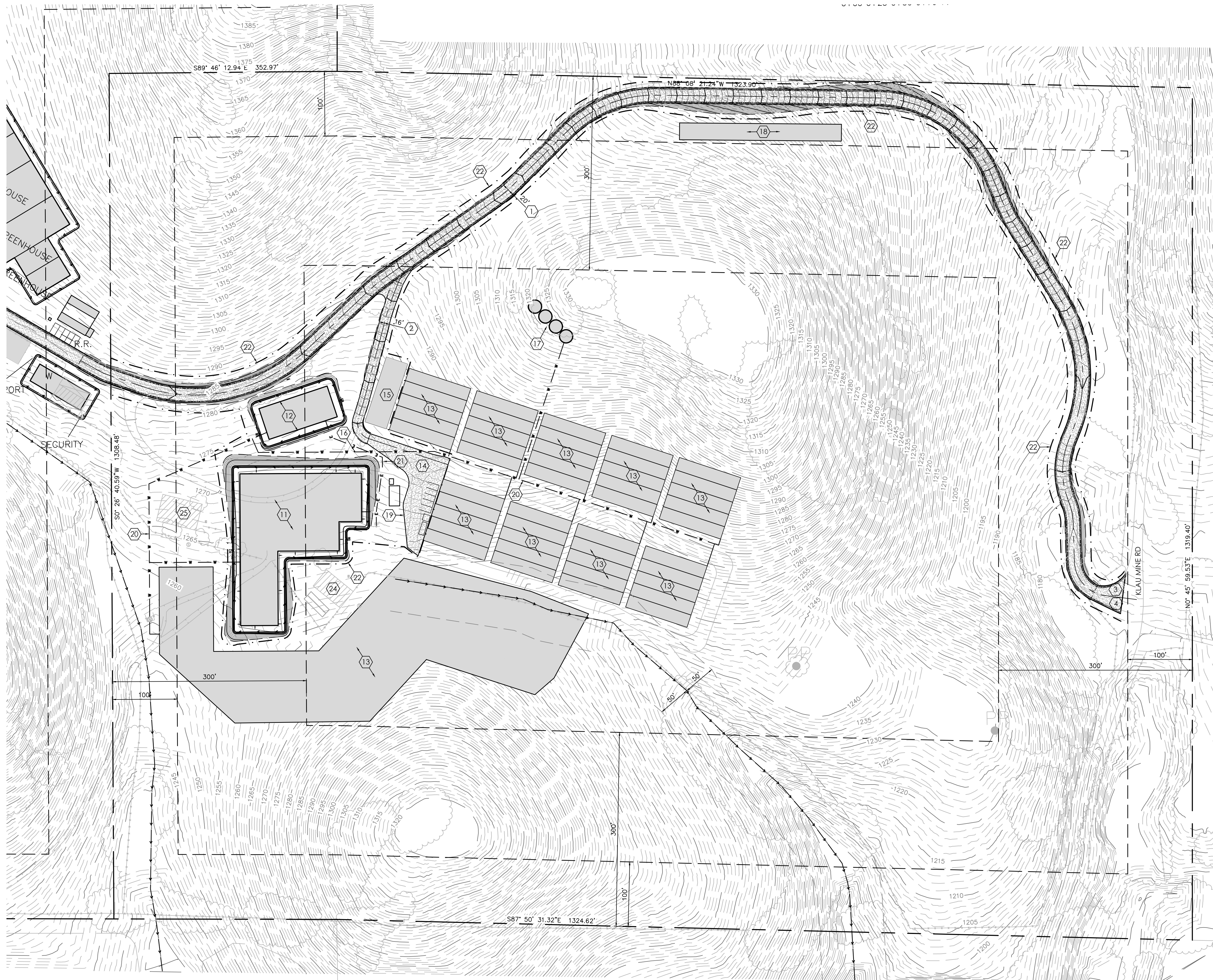

CONSTRUCTION NOTES

- 1 CONSTRUCT 20' WIDE ACCESS ROAD PER CAL FIRE STANDARDS, 8" CLASS II AB COMPACTED TO 95% OVER 12" SCARIFIED NATIVE COMPACTED TO 90%. SEE TYPICAL SECTION ON SHEET 2.
 - 2 CONSTRUCT 16' WIDE ACCESS ROAD PER CAL FIRE STANDARDS, 8" CLASS II AB COMPACTED TO 95% OVER 12" SCARIFIED NATIVE COMPACTED TO 90%. SEE TYPICAL SECTION ON SHEET 2.
 - 3 EXISTING DRIVE APPROACH TO REMAIN.
 - 4 CONSTRUCT TEMPORARY CONSTRUCTION ENTRANCE, SEE DETAIL ON SHEET 2.
 - 5 CONSTRUCT 6" THICK PCC V-GUTTER, (2' WIDE BY 0.2' DEEP).
 - 6 INSTALL STRAW WATTLES, TYPICAL.
 - 7 GRADE TO DRAIN AWAY FROM PROPOSED STRUCTURE AT 5:5% FOR 10 FEET MIN. TYPICAL.
 - 8 CONSTRUCT CONCRETE WASHOUT STRUCTURE PER DETAIL SHEET 2.
 - 9 CONSTRUCT TEMPORARY MATERIAL STORAGE AREA PER DETAIL SHEET 2. INSTALL 10 LF - 4" PVC PIPE AT 5 = 1% ±.
 - 10 HYDROSEED ALL CUT AND FILL SLOPES, SEE EROSION CONTROL NOTE #9 ON SHEET 2.
 - 11 CONSTRUCT NEW 27,500 SF GREENHOUSE, PLAN BY OTHERS.
 - 12 CONSTRUCT NEW 5,500 SF NURSERY, PLAN BY OTHERS.
 - 13 INSTALL HOOP HOUSES ON EXISTING GRADE.
 - 14 CALFIRE TURN AROUND AREA.
 - 15 CONSTRUCT A NEW LOADING ZONE, 8" CLASS II AB COMPACTED TO 95% OVER 12" SCARIFIED NATIVE COMPACTED TO 90%.
 - 16 INSTALL NEW WHARF HEAD HYDRANT PER CAL FIRE STANDARDS.
 - 17 INSTALL (4) 9,100 GALLON WATER TANKS OVER 8" CLASS II AB COMPACTED TO 95% OVER 12" SCARIFIED NATIVE COMPACTED TO 90%.
 - 18 COMPOST AREA, 6500 SF.
 - 19 CONSTRUCT PARKING AREA WITH 8" CLASS II AB COMPACTED TO 95% OVER 12" SCARIFIED NATIVE COMPACTED TO 90%.
 - 20 INSTALL WATER SERVICE FROM EXISTING WELL, SIZE PER IRRIGATION DESIGNER.
 - 21 CONSTRUCT ELECTRICAL SERVICE PER PG&E SERVICE TRENCH STANDARDS.
 - 22 AREA OF DISTURBANCE, SEE SITE STATISTICS, SHEET 1.
 - 23 CONSTRUCT ROCK RIP RAP ENERGY DISSIPATER PER CALTRANS STANDARD 72. USE BACKING NO. 3 TYPE ROCK, TYPE B PLACEMENT OVER GEOTEXTILE FABRIC. W = 5', L = 5', D = 0.75
 - 24 NOT A PART, EXISTING GARAGE/SHOP WITH EXISTING RESTROOM INSIDE. (VERIFY LEACH FIELD AND SEPTIC TANK LOCATION PRIOR TO OCCUPANCY WITH BUILDING PERMIT.)
 - 25 EXISTING RESIDENCE.
- NOTE - NOT ALL CONSTRUCTION NOTES SHOWN ON THE SITE MAP FOR CLARITY. REFER TO FOLLOWING SHEETS FOR ADDITIONAL DETAIL.

Roberts Engineering, Inc.
Azevedo - 1375 Klau Mine Road, Paso Robles

Site Plan

Design/Drawn TR / SEB	County Plan Checker	Approved for County Requirements Development Services Engineer
Job # 20-77	County W.O. No.	Date 4/14/2021 11:30 AM
California Coordinates (CCS83, Zone 5)	County Road #	Date Timothy P. Roberts, RCE 35366 exp 09/30/21
2431561 N 5689484 E		3 of 11

Roberts Engineering
Timothy P. Roberts
Civil Engineer - RCE 35366
2015 Vista de la Vina
Templeton, CA 93465
Phone (805) 239-0664
Fax (805) 238-6148
Email tim@robertsenginc.com
Website robertsenginc.com

Record Drawings

Timothy P. Roberts, RCE 35366 exp 09/30/21	Date
Revisions This Sheet:	
1	
2	
3	
4	
5	
6	

4/14/2021 11:38 AM

MATCHLINE, SEE SHEET 6



MATCHLINE, SEE SHEET 8

MATCHLINE, SEE SHEET 5

CONSTRUCTION NOTES

- 1 CONSTRUCT 20' WIDE ACCESS ROAD PER CAL FIRE STANDARDS, 8" CLASS II AB COMPACTED TO 95% OVER 12" SCARIFIED NATIVE COMPACTED TO 90%. SEE TYPICAL SECTION ON SHEET 2.
- 2 CONSTRUCT 16' WIDE ACCESS ROAD PER CAL FIRE STANDARDS, 8" CLASS II AB COMPACTED TO 95% OVER 12" SCARIFIED NATIVE COMPACTED TO 90%. SEE TYPICAL SECTION ON SHEET 2.
- 3 EXISTING DRIVE APPROACH TO REMAIN.
- 4 CONSTRUCT TEMPORARY CONSTRUCTION ENTRANCE, SEE DETAIL ON SHEET 2.
- 5 CONSTRUCT 6" THICK PCC V-GUTTER, (2' WIDE BY 0.2' DEEP).
- 6 INSTALL STRAW WATTLES, TYPICAL.
- 7 GRADE TO DRAIN AWAY FROM PROPOSED STRUCTURE AT 5:5% FOR 10 FEET MIN. TYPICAL.
- 8 CONSTRUCT CONCRETE WASHOUT STRUCTURE PER DETAIL SHEET 2.
- 9 CONSTRUCT TEMPORARY MATERIAL STORAGE AREA PER DETAIL SHEET 2. INSTALL 10 LF - 4" PVC PIPE AT 5 = 1% ±.
- 10 HYDROSEED ALL CUT AND FILL SLOPES, SEE EROSION CONTROL NOTE #9 ON SHEET 2.
- 11 CONSTRUCT NEW 27,500 SF GREENHOUSE, PLAN BY OTHERS.
- 12 CONSTRUCT NEW 5,500 SF NURSERY, PLAN BY OTHERS.
- 13 INSTALL HOOP HOUSES ON EXISTING GRADE.
- 14 CALFIRE TURN AROUND AREA.
- 15 CONSTRUCT A NEW LOADING ZONE, 8" CLASS II AB COMPACTED TO 95% OVER 12" SCARIFIED NATIVE COMPACTED TO 90%.
- 16 INSTALL NEW WHARF HEAD HYDRANT PER CAL FIRE STANDARDS.
- 17 INSTALL (4) 9,100 GALLON WATER TANKS OVER 8" CLASS II AB COMPACTED TO 95% OVER 12" SCARIFIED NATIVE COMPACTED TO 90%.
- 18 COMPOST AREA, 6500 SF.
- 19 CONSTRUCT PARKING AREA WITH 8" CLASS II AB COMPACTED TO 95% OVER 12" SCARIFIED NATIVE COMPACTED TO 90%.
- 20 INSTALL WATER SERVICE FROM EXISTING WELL, SIZE PER IRRIGATION DESIGNER.
- 21 CONSTRUCT ELECTRICAL SERVICE PER PG&E SERVICE TRENCH STANDARDS.
- 22 AREA OF DISTURBANCE, SEE SITE STATISTICS, SHEET 1.
- 23 CONSTRUCT ROCK RIP RAP ENERGY DISSIPATOR PER CALTRANS STANDARD 72. USE BACKING NO. 3 TYPE ROCK, TYPE B PLACEMENT OVER GEOTEXTILE FABRIC. W = 5', L = 5', D = 0.75
- 24 NOT A PART, EXISTING GARAGE/SHOP WITH EXISTING RESTROOM INSIDE. (VERIFY LEACH FIELD AND SEPTIC TANK LOCATION PRIOR TO OCCUPANCY WITH BUILDING PERMIT.)
- 25 EXISTING RESIDENCE.

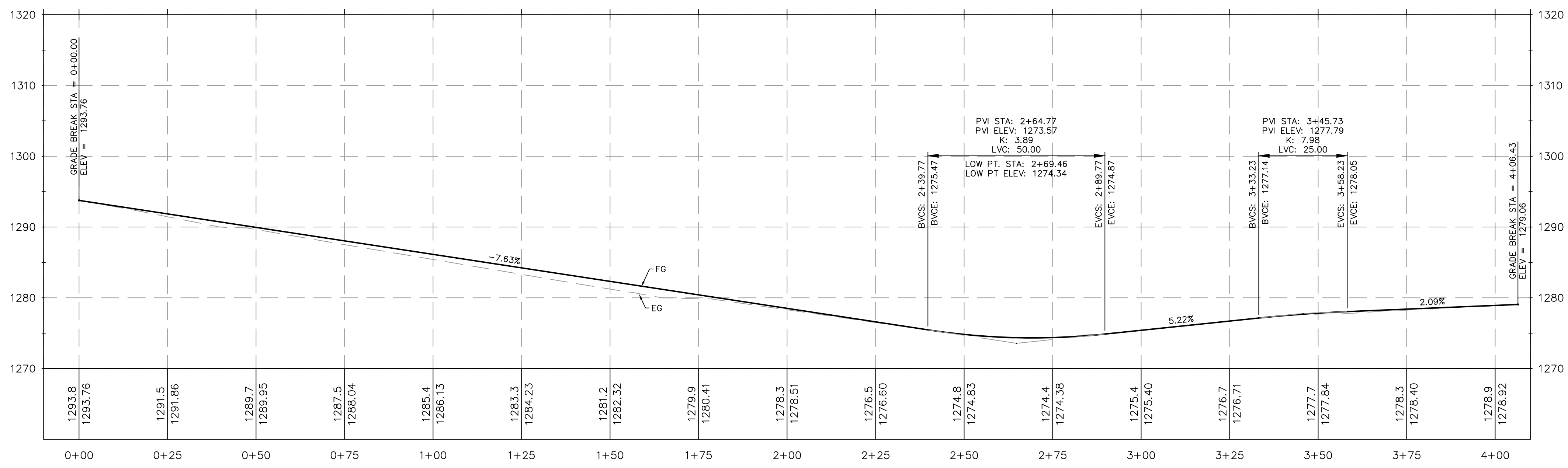

DRIVEWAY PROFILE
 HORIZONTAL SCALE: 1"=20'
 VERTICAL SCALE: 1"=10'

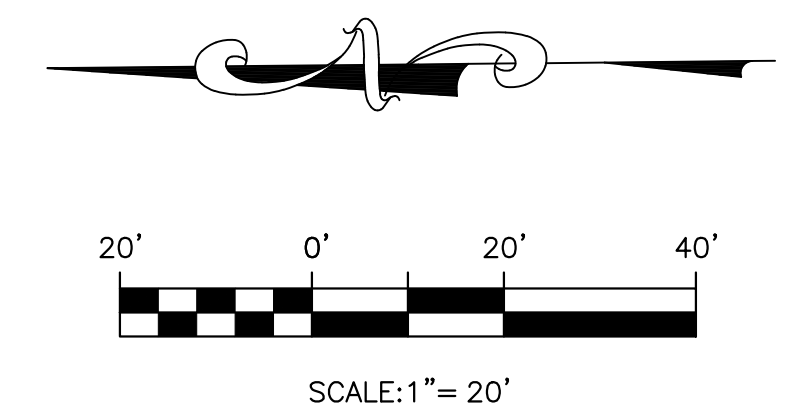

Roberts Engineering, Inc.		
Azevedo - 1375 Klau Mine Road, Paso Robles		
Grading, Drainage, and Erosion Control Plan		
Design/Draw TR / SEB	County Plan Checker	Approved for County Requirements
Job # 20-77	County W.O. No.	Development Services Engineer Date
California Coordinates (CCS83, Zone 5)	County Road #	4/14/2021 11:30 AM Timothy P. Roberts, RCE 35366 exp 09/30/21 Date
2431561 N 5689484 E		4 of 11

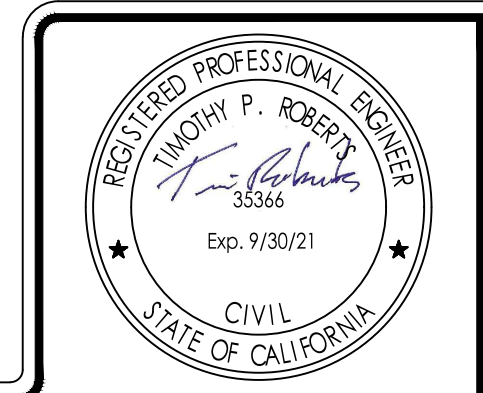

Roberts Engineering
 Timothy P. Roberts
 Civil Engineer - RCE 35366
 2015 Vista de la Vina
 Tempton, CA 93465
 Phone (805) 239-0664
 Fax (805) 238-6148
 Email tim@robertsenginc.com
 Website robertsenginc.com

Record Drawings	
Timothy P. Roberts, RCE 35366 exp 09/30/21	Date
Revisions This Sheet:	
1	
2	
3	
4	
5	
6	

4/14/2021 11:38 AM

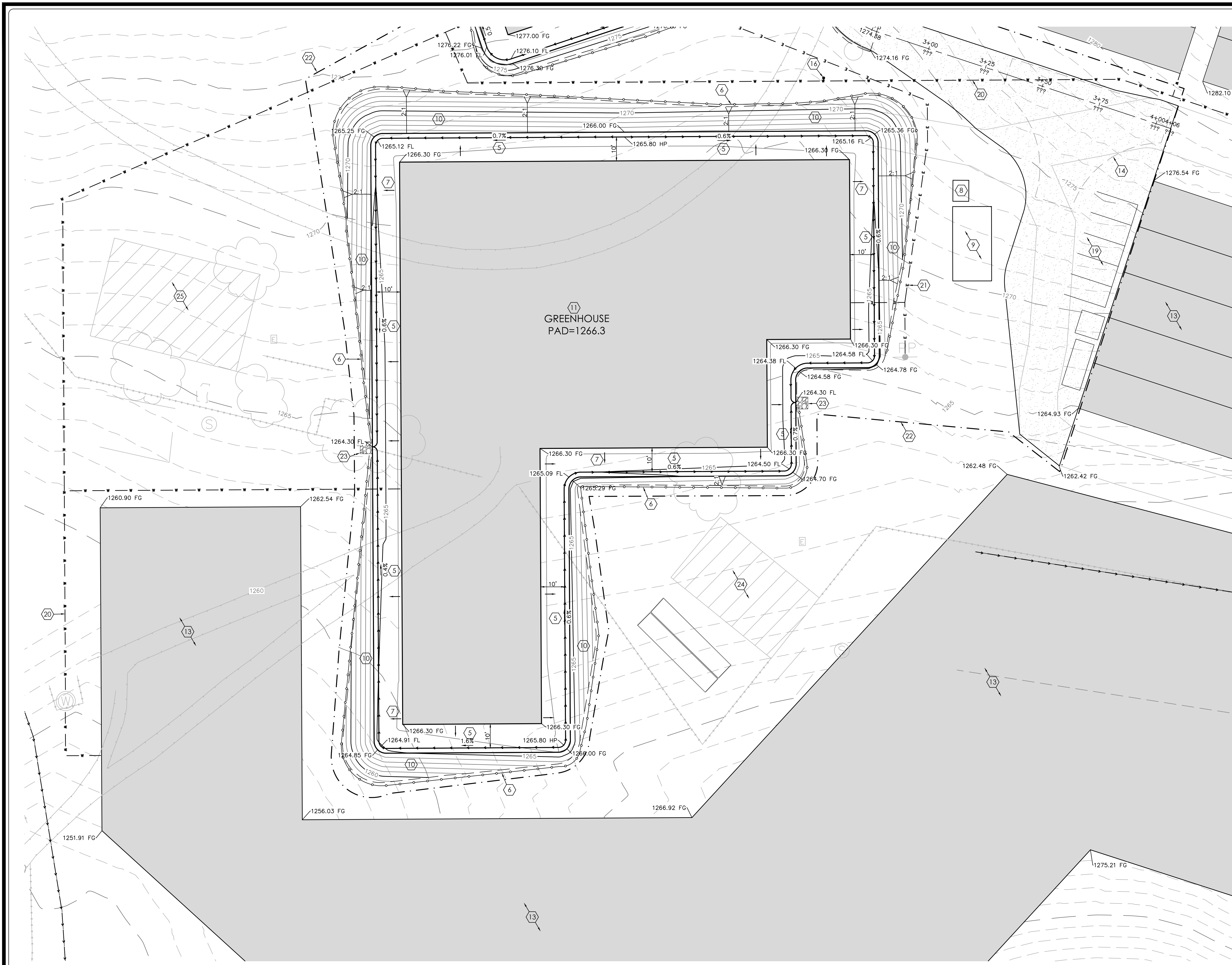

CONSTRUCTION NOTES

- 1 CONSTRUCT 20' WIDE ACCESS ROAD PER CAL FIRE STANDARDS, 8" CLASS II AB COMPACTED TO 95% OVER 12" SCARIFIED NATIVE COMPACTED TO 90%. SEE TYPICAL SECTION ON SHEET 2.
- 2 CONSTRUCT 16' WIDE ACCESS ROAD PER CAL FIRE STANDARDS, 8" CLASS II AB COMPACTED TO 95% OVER 12" SCARIFIED NATIVE COMPACTED TO 90%. SEE TYPICAL SECTION ON SHEET 2.
- 3 EXISTING DRIVE APPROACH TO REMAIN.
- 4 CONSTRUCT TEMPORARY CONSTRUCTION ENTRANCE, SEE DETAIL ON SHEET 2.
- 5 CONSTRUCT 6" THICK PCC V-GUTTER, (2' WIDE BY 0.2' DEEP).
- 6 INSTALL STRAW WATTLES, TYPICAL.
- 7 GRADE TO DRAIN AWAY FROM PROPOSED STRUCTURE AT 5=5% FOR 10 FEET MIN. TYPICAL.
- 8 CONSTRUCT CONCRETE WASHOUT STRUCTURE PER DETAIL SHEET 2.
- 9 CONSTRUCT TEMPORARY MATERIAL STORAGE AREA PER DETAIL SHEET 2. INSTALL 10 LF - 4" PVC PIPE AT S = 1% ±.
- 10 HYDROSEED ALL CUT AND FILL SLOPES, SEE EROSION CONTROL NOTE #9 ON SHEET 2.
- 11 CONSTRUCT NEW 27,500 SF GREENHOUSE, PLAN BY OTHERS.
- 12 CONSTRUCT NEW 5,500 SF NURSERY, PLAN BY OTHERS.
- 13 INSTALL HOOP HOUSES ON EXISTING GRADE.
- 14 CALFIRE TURN AROUND AREA.
- 15 CONSTRUCT A NEW LOADING ZONE, 8" CLASS II AB COMPACTED TO 95% OVER 12" SCARIFIED NATIVE COMPACTED TO 90%.
- 16 INSTALL NEW WHARF HEAD HYDRANT PER CAL FIRE STANDARDS.
- 17 INSTALL (4) 9,100 GALLON WATER TANKS OVER 8" CLASS II AB COMPACTED TO 95% OVER 12" SCARIFIED NATIVE COMPACTED TO 90%.
- 18 COMPOST AREA, 6500 SF.
- 19 CONSTRUCT PARKING AREA WITH 8" CLASS II AB COMPACTED TO 95% OVER 12" SCARIFIED NATIVE COMPACTED TO 90%.
- 20 INSTALL WATER SERVICE FROM EXISTING WELL, SIZE PER IRRIGATION DESIGNER.
- 21 CONSTRUCT ELECTRICAL SERVICE PER PG&E SERVICE TRENCH STANDARDS.
- 22 AREA OF DISTURBANCE, SEE SITE STATISTICS, SHEET 1.
- 23 CONSTRUCT ROCK RIP RAP ENERGY DISSIPATER PER CALTRANS STANDARD 72. USE BACKING NO. 3 TYPE ROCK, TYPE B PLACEMENT OVER GEOTEXTILE FABRIC. W = 5', L = 5', D = 0.75
- 24 NOT A PART, EXISTING GARAGE/SHOP WITH EXISTING RESTROOM INSIDE. (VERIFY LEACH FIELD AND SEPTIC TANK LOCATION PRIOR TO OCCUPANCY WITH BUILDING PERMIT.)
- 25 EXISTING RESIDENCE.

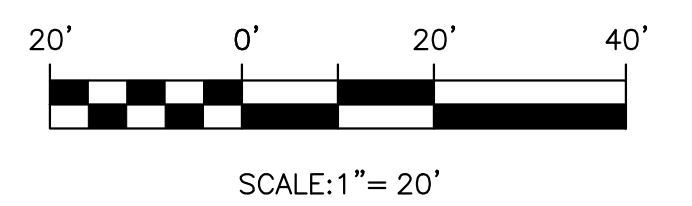

Roberts Engineering, Inc.		
Azevedo - 1375 Klau Mine Road, Paso Robles		
Grading, Drainage, and Erosion Control Plan		
Design/Draw <i>TR / SEB</i>	County Plan Checker	Approved for County Requirements
Job # 20-77	County W.O. No.	Development Services Engineer <i>[Signature]</i> Date 4/14/2021 11:30 AM
California Coordinates (CCS83, Zone 5)	County Road #	Date Timothy P. Roberts, RCE 35366 exp 09/30/21
2431561 N 5689484 E		5 of 11

Roberts Engineering
 Timothy P. Roberts
 Civil Engineer - RCE 35366
 2015 Vista de la Vina
 Templeton, CA 93465
 Phone (805) 239-0664
 Fax (805) 238-6148
 Email tim@robertsenginc.com
 Website robertsenginc.com

Record Drawings

Timothy P. Roberts, RCE 35366 exp 09/30/21	Date
Revisions This Sheet:	
1	
2	
3	
4	
5	
6	

4/14/2021 11:38 AM

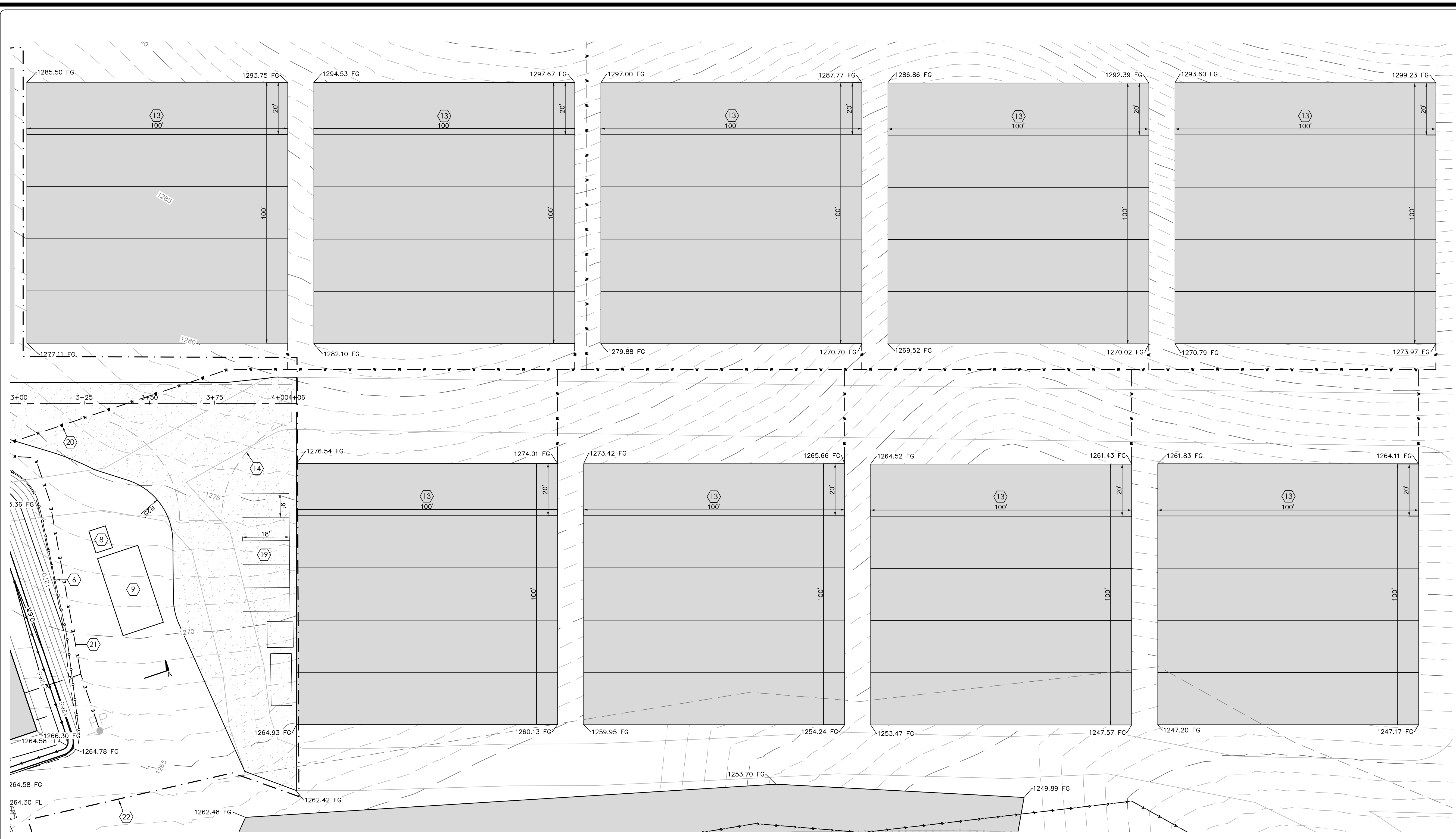

CONSTRUCTION NOTES

- 1 CONSTRUCT 20' WIDE ACCESS ROAD PER CAL FIRE STANDARDS, 8" CLASS II AB COMPACTED TO 95% OVER 12" SCARIFIED NATIVE COMPACTED TO 90%. SEE TYPICAL SECTION ON SHEET 2.
- 2 CONSTRUCT 16' WIDE ACCESS ROAD PER CAL FIRE STANDARDS, 8" CLASS II AB COMPACTED TO 95% OVER 12" SCARIFIED NATIVE COMPACTED TO 90%. SEE TYPICAL SECTION ON SHEET 2.
- 3 EXISTING DRIVE APPROACH TO REMAIN.
- 4 CONSTRUCT TEMPORARY CONSTRUCTION ENTRANCE, SEE DETAIL ON SHEET 2.
- 5 CONSTRUCT 6" THICK PCC V-GUTTER, (2' WIDE BY 0.2' DEEP).
- 6 INSTALL STRAW WATTLES, TYPICAL.
- 7 GRADE TO DRAIN AWAY FROM PROPOSED STRUCTURE AT S=5% FOR 10 FEET MIN. TYPICAL.
- 8 CONSTRUCT CONCRETE WASHOUT STRUCTURE PER DETAIL SHEET 2.
- 9 CONSTRUCT TEMPORARY MATERIAL STORAGE AREA PER DETAIL SHEET 2
INSTALL 10 LF - 4" PVC PIPE AT S = 1% ±.
- 10 HYDROSEED ALL CUT AND FILL SLOPES, SEE EROSION CONTROL NOTE #9 ON SHEET 2.
- 11 CONSTRUCT NEW 27,500 SF GREENHOUSE, PLAN BY OTHERS.
- 12 CONSTRUCT NEW 5,500 SF NURSERY, PLAN BY OTHERS.
- 13 INSTALL HOOP HOUSES ON EXISTING GRADE.
- 14 CALFIRE TURN AROUND AREA.
- 15 CONSTRUCT A NEW LOADING ZONE, 8" CLASS II AB COMPACTED TO 95% OVER 12" SCARIFIED NATIVE COMPACTED TO 90%.
- 16 INSTALL NEW WHARF HEAD HYDRANT PER CAL FIRE STANDARDS.
- 17 INSTALL (4) 9,100 GALLON WATER TANKS OVER 8" CLASS II AB COMPACTED TO 95% OVER 12" SCARIFIED NATIVE COMPACTED TO 90%.
- 18 COMPOST AREA, 6500 SF.
- 19 CONSTRUCT PARKING AREA WITH 8" CLASS II AB COMPACTED TO 95% OVER 12" SCARIFIED NATIVE COMPACTED TO 90%.
- 20 INSTALL WATER SERVICE FROM EXISTING WELL, SIZE PER IRRIGATION DESIGNER.
- 21 CONSTRUCT ELECTRICAL SERVICE PER PG&E SERVICE TRENCH STANDARDS.
- 22 AREA OF DISTURBANCE, SEE SITE STATISTICS, SHEET 1.
- 23 CONSTRUCT ROCK RIP RAP ENERGY DISSIPATER PER CALTRANS STANDARD 72. USE BACKING NO. 3 TYPE ROCK, TYPE B PLACEMENT OVER GEOTEXTILE FABRIC. W = 5', L = 5', D = 0.75
- 24 NOT A PART, EXISTING GARAGE/SHOP WITH EXISTING RESTROOM INSIDE. (VERIFY LEACH FIELD AND SEPTIC TANK LOCATION PRIOR TO OCCUPANCY WITH BUILDING PERMIT.)
- 25 EXISTING RESIDENCE.

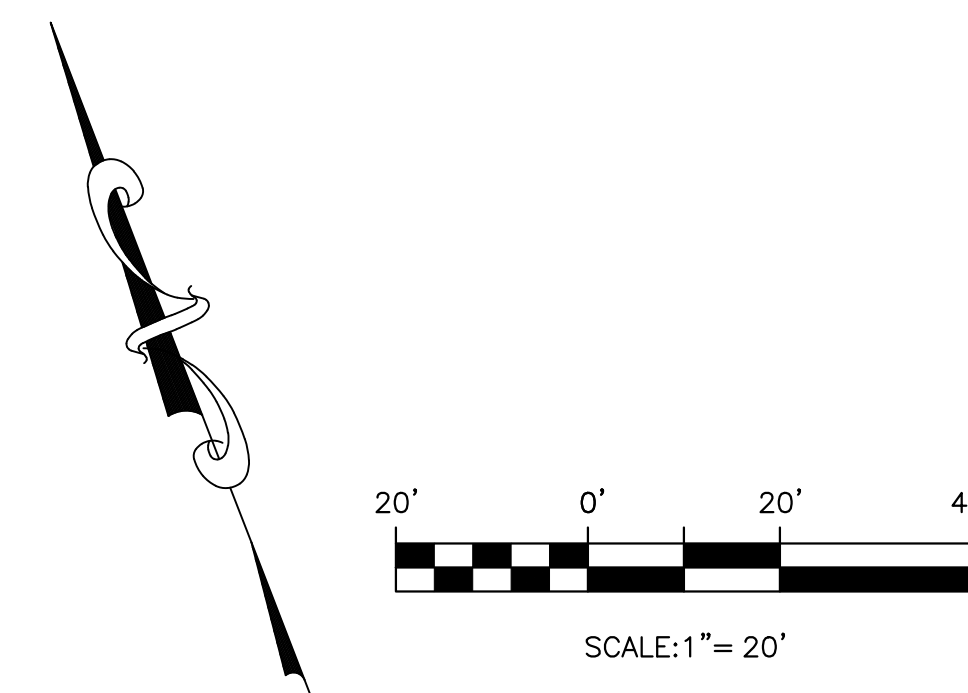

4/14/2021 11:30 AM



Roberts Engineering
 Timothy P. Roberts
 Civil Engineer - RCE 35366
 2015 Vista de la Vina
 Templeton, CA 93465
 Phone (805) 239-0664
 Fax (805) 238-6148
 Email tim@robertsenginc.com
 Website robertsenginc.com

Record Drawings

Timothy P. Roberts, RCE 35366 exp 09/30/21	Date
Revisions This Sheet:	
1	
2	
3	
4	
5	
6	

Roberts Engineering, Inc.
 Azevedo - 1375 Klau Mine Road, Paso Robles

Grading, Drainage, and Erosion Control Plan

Design/Drawn TR / SEB	County Plan Checker	Approved for County Requirements
Job # 20-77	County W.O. No.	Development Services Engineer Date
California Coordinates (CCS83, Zone 5)	County Road #	Date 4/14/2021 11:30 AM Timothy P. Roberts, RCE 35366 exp 09/30/21
2431561 N 5689484 E		6 of 11

MATCHLINE, STATION 4+00, SEE SHEET 8

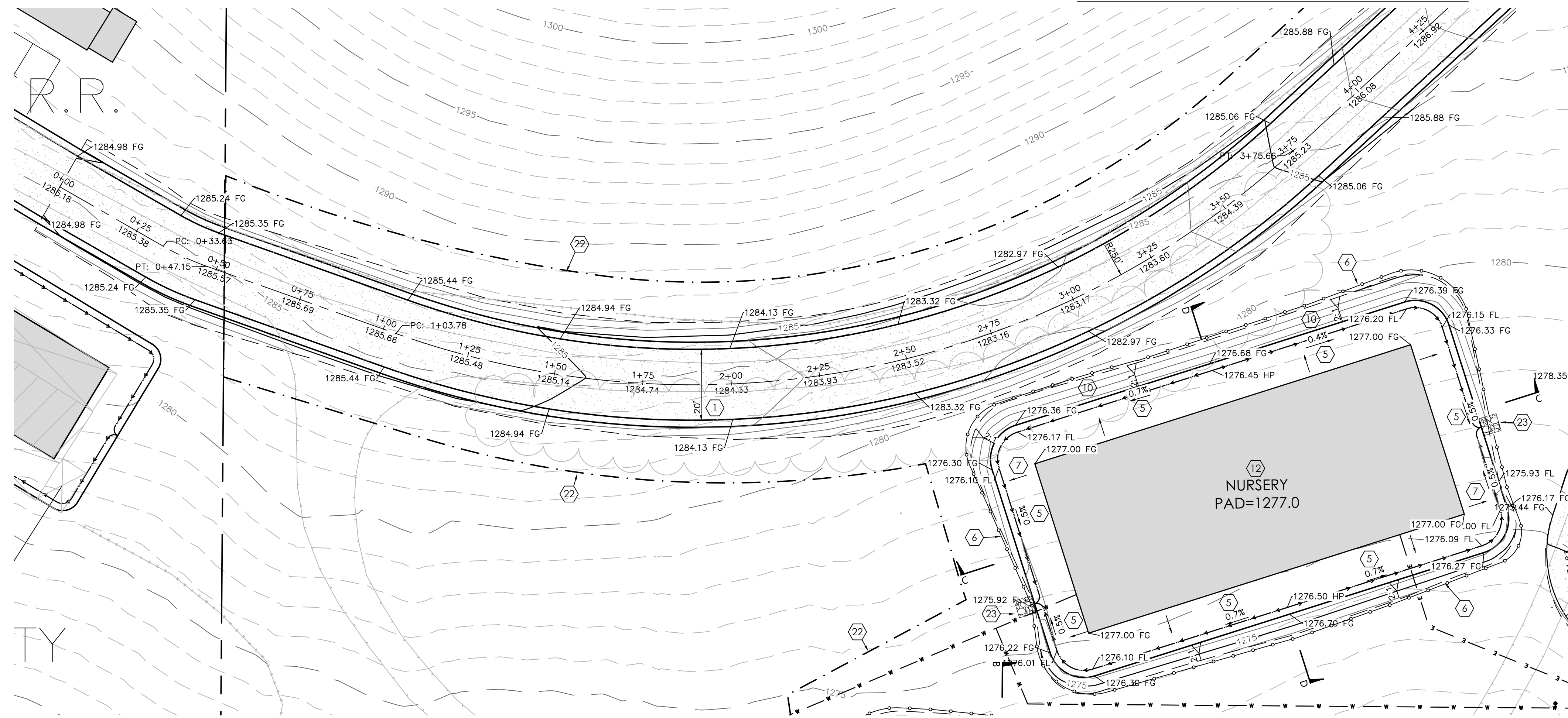

CONSTRUCTION NOTES

- 1 CONSTRUCT 20' WIDE ACCESS ROAD PER CAL FIRE STANDARDS, 8" CLASS II AB COMPACTED TO 95% OVER 12" SCARIFIED NATIVE COMPACTED TO 90%. SEE TYPICAL SECTION ON SHEET 2.
- 2 CONSTRUCT 16' WIDE ACCESS ROAD PER CAL FIRE STANDARDS, 8" CLASS II AB COMPACTED TO 95% OVER 12" SCARIFIED NATIVE COMPACTED TO 90%. SEE TYPICAL SECTION ON SHEET 2.
- 3 EXISTING DRIVE APPROACH TO REMAIN.
- 4 CONSTRUCT TEMPORARY CONSTRUCTION ENTRANCE, SEE DETAIL ON SHEET 2.
- 5 CONSTRUCT 6" THICK PCC V-GUTTER, (2' WIDE BY 0.2' DEEP).
- 6 INSTALL STRAW WATTLES, TYPICAL.
- 7 GRADE TO DRAIN AWAY FROM PROPOSED STRUCTURE AT 5% FOR 10 FEET MIN. TYPICAL.
- 8 CONSTRUCT CONCRETE WASHOUT STRUCTURE PER DETAIL SHEET 2.
- 9 CONSTRUCT TEMPORARY MATERIAL STORAGE AREA PER DETAIL SHEET 2
INSTALL 10 LF - 4" PVC PIPE AT 5 = 1% ±.
- 10 HYDROSEED ALL CUT AND FILL SLOPES, SEE EROSION CONTROL NOTE #9 ON SHEET 2.
- 11 CONSTRUCT NEW 27,500 SF GREENHOUSE, PLAN BY OTHERS.
- 12 CONSTRUCT NEW 5,500 SF NURSERY, PLAN BY OTHERS.
- 13 INSTALL HOOP HOUSES ON EXISTING GRADE.
- 14 CALFIRE TURN AROUND AREA.
- 15 CONSTRUCT A NEW LOADING ZONE, 8" CLASS II AB COMPACTED TO 95% OVER 12" SCARIFIED NATIVE COMPACTED TO 90%.
- 16 INSTALL NEW WHARF HEAD HYDRANT PER CAL FIRE STANDARDS.
- 17 INSTALL (4) 9,100 GALLON WATER TANKS OVER 8" CLASS II AB COMPACTED TO 95% OVER 12" SCARIFIED NATIVE COMPACTED TO 90%.
- 18 COMPOST AREA, 6500 SF.
- 19 CONSTRUCT PARKING AREA WITH 8" CLASS II AB COMPACTED TO 95% OVER 12" SCARIFIED NATIVE COMPACTED TO 90%.
- 20 INSTALL WATER SERVICE FROM EXISTING WELL, SIZE PER IRRIGATION DESIGNER.
- 21 CONSTRUCT ELECTRICAL SERVICE PER PG&E SERVICE TRENCH STANDARDS.
- 22 AREA OF DISTURBANCE, SEE SITE STATISTICS, SHEET 1.
- 23 CONSTRUCT ROCK RIP RAP ENERGY DISSIPATER PER CALTRANS STANDARD 72.
USE BACKING NO. 3 TYPE ROCK, TYPE B PLACEMENT OVER GEOTEXTILE FABRIC.
W = 5', L = 5', D = 0.75
- 24 NOT A PART, EXISTING GARAGE/SHOP WITH EXISTING RESTROOM INSIDE.
(VERIFY LEACH FIELD AND SEPTIC TANK LOCATION PRIOR TO OCCUPANCY WITH BUILDING PERMIT.)
- 25 EXISTING RESIDENCE.

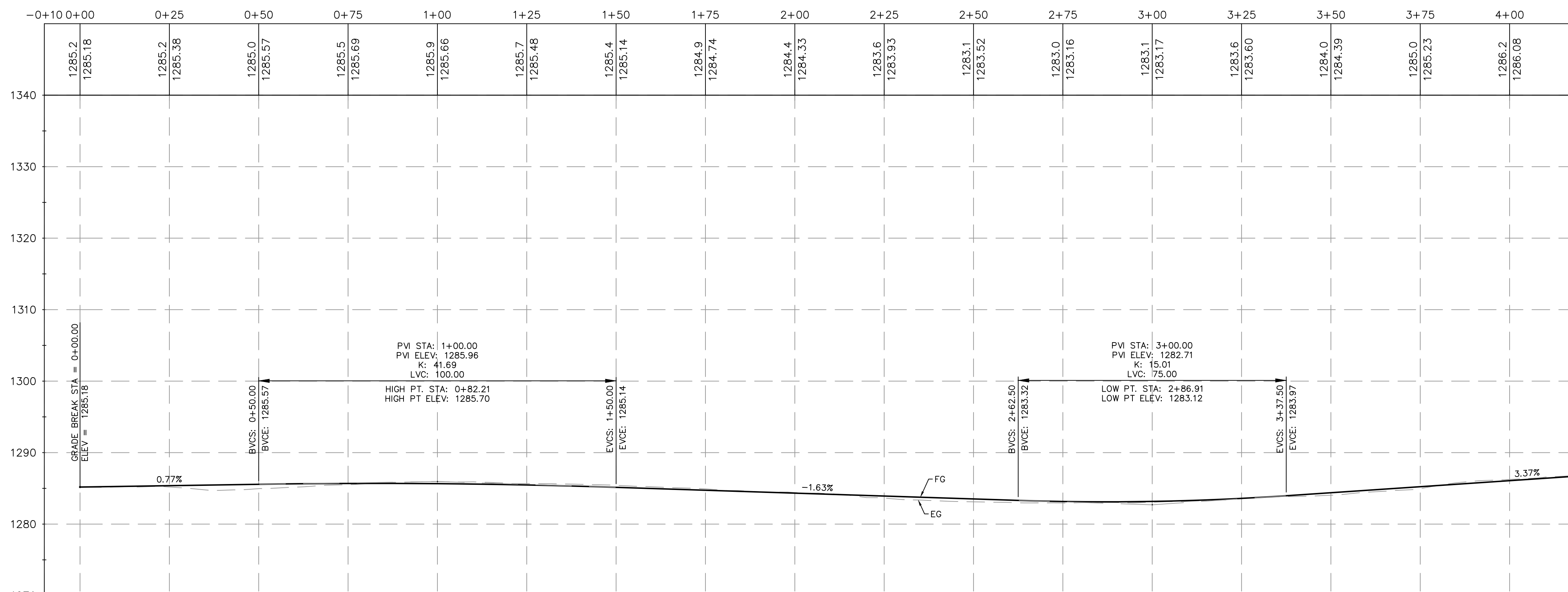

DRIVEWAY PROFILE
HORIZONTAL SCALE: 1"=20'
VERTICAL SCALE: 1"=10'

MATCHLINE, STATION 4+00, SEE SHEET 8

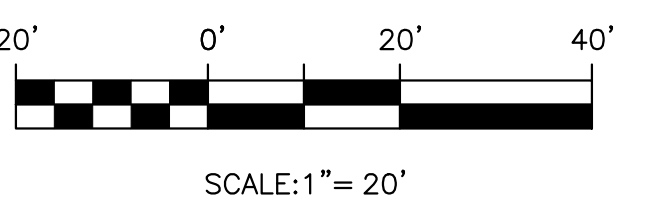

Roberts Engineering, Inc.		
Azevedo - 1375 Klau Mine Road, Paso Robles		
Grading, Drainage, and Erosion Control Plan		
Design/Drawn TR / SEB	County Plan Checker	Approved for County Requirements
Job # 20-77	County W.O. No.	Development Services Engineer Date
California Coordinates (CCS83, Zone 5)	County Road #	Date 4/14/2021 11:30 AM
2431561 N 5689484 E		7 of 11

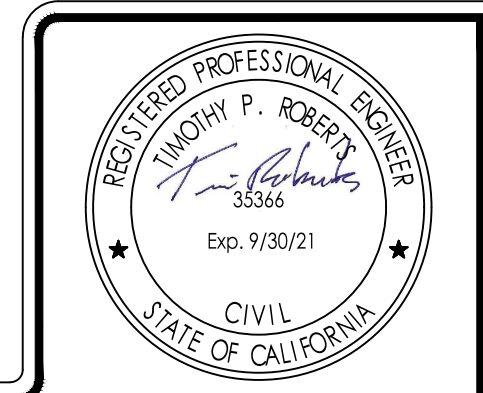

Roberts Engineering
Timothy P. Roberts
Civil Engineer - RCE 35366
2015 Vista de la Vina
Templeton, CA 93465
Phone (805) 239-0664
Fax (805) 238-6148
Email tim@robertsenginc.com
Website robertsenginc.com

Record Drawings	
Timothy P. Roberts, RCE 35366 exp 09/30/21	Date
Revisions This Sheet:	
1	
2	
3	
4	
5	
6	

4/14/2021 11:38 AM

MATCHLINE, STATION 4+00, SEE SHEET 7

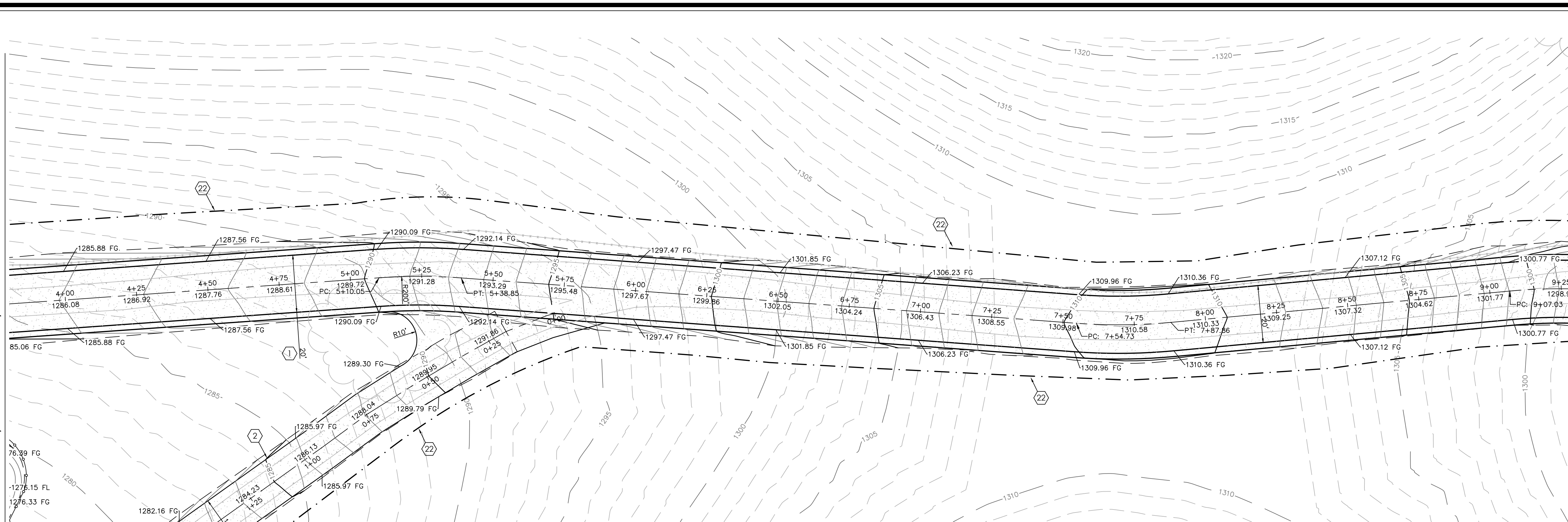

- ### CONSTRUCTION NOTES
- 1 CONSTRUCT 20' WIDE ACCESS ROAD PER CAL FIRE STANDARDS, 8" CLASS II AB COMPACTED TO 95% OVER 12" SCARIFIED NATIVE COMPACTED TO 90%. SEE TYPICAL SECTION ON SHEET 2.
 - 2 CONSTRUCT 16' WIDE ACCESS ROAD PER CAL FIRE STANDARDS, 8" CLASS II AB COMPACTED TO 95% OVER 12" SCARIFIED NATIVE COMPACTED TO 90%. SEE TYPICAL SECTION ON SHEET 2.
 - 3 EXISTING DRIVE APPROACH TO REMAIN.
 - 4 CONSTRUCT TEMPORARY CONSTRUCTION ENTRANCE, SEE DETAIL ON SHEET 2.
 - 5 CONSTRUCT 6" THICK PCC V-GUTTER, (2' WIDE BY 0.2' DEEP).
 - 6 INSTALL STRAW WATTLES, TYPICAL.
 - 7 GRADE TO DRAIN AWAY FROM PROPOSED STRUCTURE AT 5% FOR 10 FEET MIN. TYPICAL.
 - 8 CONSTRUCT CONCRETE WASHOUT STRUCTURE PER DETAIL SHEET 2.
 - 9 CONSTRUCT TEMPORARY MATERIAL STORAGE AREA PER DETAIL SHEET 2. INSTALL 10 LF - 4" PVC PIPE AT S = 1%.
 - 10 HYDROSEED ALL CUT AND FILL SLOPES, SEE EROSION CONTROL NOTE #9 ON SHEET 2.
 - 11 CONSTRUCT NEW 27,500 SF GREENHOUSE, PLAN BY OTHERS.
 - 12 CONSTRUCT NEW 5,500 SF NURSERY, PLAN BY OTHERS.
 - 13 INSTALL HOOP HOUSES ON EXISTING GRADE.
 - 14 CALFIRE TURN AROUND AREA.
 - 15 CONSTRUCT A NEW LOADING ZONE, 8" CLASS II AB COMPACTED TO 95% OVER 12" SCARIFIED NATIVE COMPACTED TO 90%.
 - 16 INSTALL NEW WHARF HEAD HYDRANT PER CAL FIRE STANDARDS.
 - 17 INSTALL (4) 9,100 GALLON WATER TANKS OVER 8" CLASS II AB COMPACTED TO 95% OVER 12" SCARIFIED NATIVE COMPACTED TO 90%.
 - 18 COMPOST AREA, 6500 SF.
 - 19 CONSTRUCT PARKING AREA WITH 8" CLASS II AB COMPACTED TO 95% OVER 12" SCARIFIED NATIVE COMPACTED TO 90%.
 - 20 INSTALL WATER SERVICE FROM EXISTING WELL, SIZE PER IRRIGATION DESIGNER.
 - 21 CONSTRUCT ELECTRICAL SERVICE PER PG&E SERVICE TRENCH STANDARDS.
 - 22 AREA OF DISTURBANCE, SEE SITE STATISTICS, SHEET 1.
 - 23 CONSTRUCT ROCK RIP RAP ENERGY DISSIPATOR PER CALTRANS STANDARD 72. USE BACKING NO. 3 TYPE ROCK, TYPE B PLACEMENT OVER GEOTEXTILE FABRIC. W = 5', L = 5', D = 0.75
 - 24 NOT A PART, EXISTING GARAGE/SHOP WITH EXISTING RESTROOM INSIDE. (VERIFY LEACH FIELD AND SEPTIC TANK LOCATION PRIOR TO OCCUPANCY WITH BUILDING PERMIT.)
 - 25 EXISTING RESIDENCE.

MATCHLINE, STATION 9+00, SEE SHEET 9

MATCHLINE, STATION 4+00, SEE SHEET 7

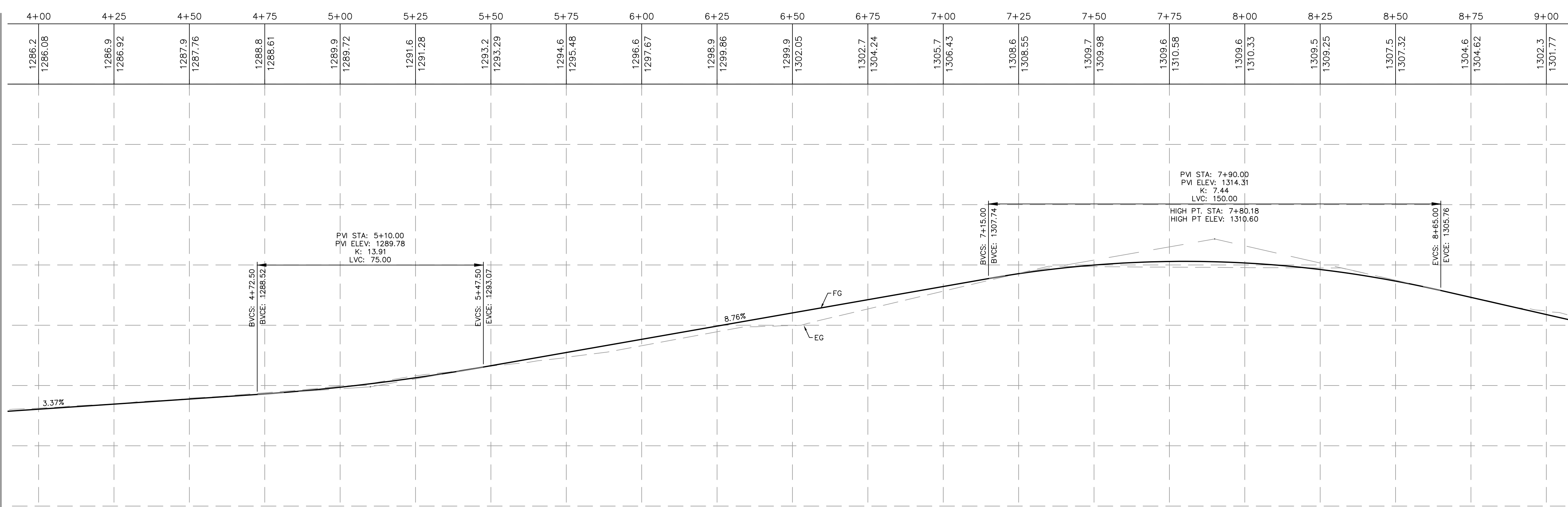

MATCHLINE, STATION 9+00, SEE SHEET 9

DRIVEWAY PROFILE
 HORIZONTAL SCALE: 1"=20'
 VERTICAL SCALE: 1"=10'

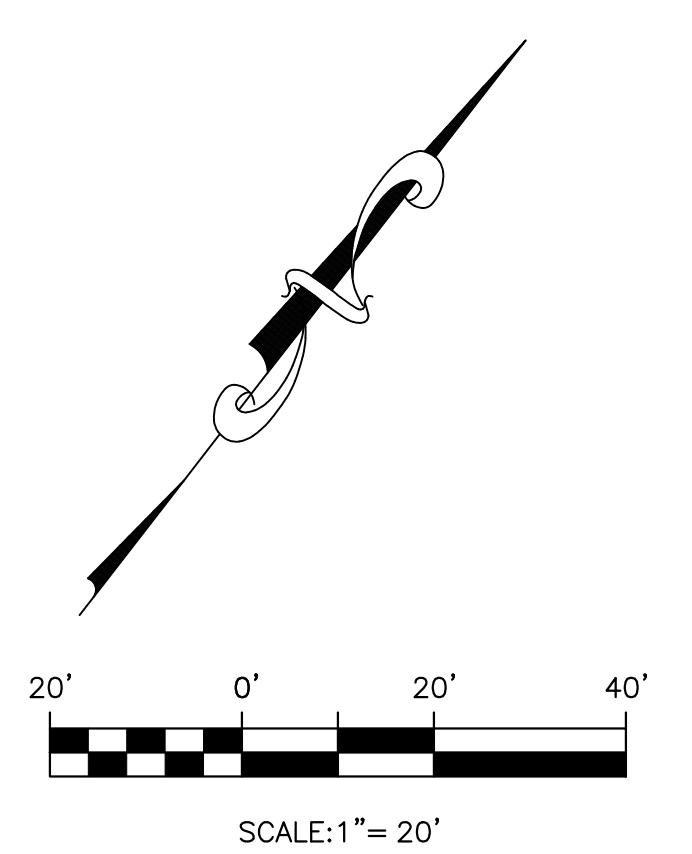

Roberts Engineering, Inc.		
Azevedo - 1375 Klau Mine Road, Paso Robles		
Grading, Drainage, and Erosion Control Plan		
Design/Draw TR / SEB	County Plan Checker	Approved for County Requirements
Job # 20-77	County W.O. No.	Development Services Engineer Date
California Coordinates (CCS83, Zone 5)	County Road #	Date 4/14/2021 11:30 AM
2431561 N 5689484 E		Timothy P. Roberts, RCE 35366 exp 09/30/21
		8 of 11

REGISTERED PROFESSIONAL ENGINEER
 TIMOTHY P. ROBERTS
 35366
 Exp. 9/30/21
 CIVIL
 STATE OF CALIFORNIA

Roberts Engineering

Timothy P. Roberts
 Civil Engineer - RCE 35366

2015 Vista de la Vina
 Templeton, CA 93465
 Phone (805) 239-0664
 Fax (805) 238-6148
 Email tim@robertsenginc.com
 Website robertsenginc.com

Record Drawings	
Timothy P. Roberts, RCE 35366 exp 09/30/21	Date
Revisions This Sheet:	
1	
2	
3	
4	
5	
6	

MATCHLINE, STATION 9+00, SEE SHEET 8

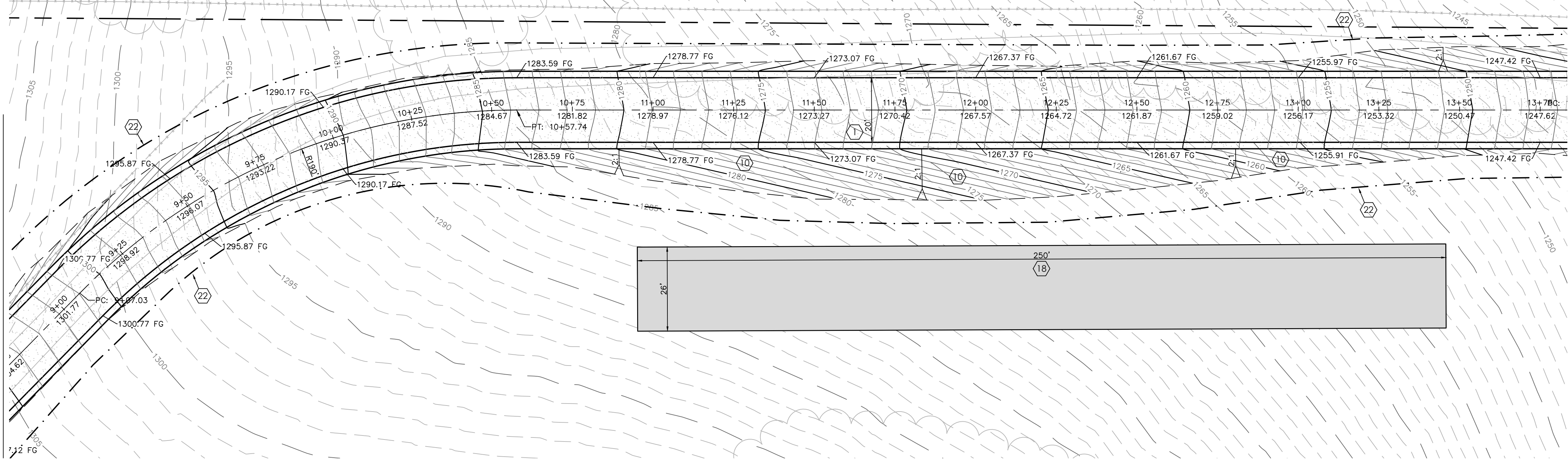

MATCHLINE, STATION 13+75, SEE SHEET 10

CONSTRUCTION NOTES

- 1 CONSTRUCT 20' WIDE ACCESS ROAD PER CAL FIRE STANDARDS, 8" CLASS II AB COMPACTED TO 95% OVER 12" SCARIFIED NATIVE COMPACTED TO 90%. SEE TYPICAL SECTION ON SHEET 2.
- 2 CONSTRUCT 16' WIDE ACCESS ROAD PER CAL FIRE STANDARDS, 8" CLASS II AB COMPACTED TO 95% OVER 12" SCARIFIED NATIVE COMPACTED TO 90%. SEE TYPICAL SECTION ON SHEET 2.
- 3 EXISTING DRIVE APPROACH TO REMAIN.
- 4 CONSTRUCT TEMPORARY CONSTRUCTION ENTRANCE, SEE DETAIL ON SHEET 2.
- 5 CONSTRUCT 6" THICK PCC V-GUTTER, (2' WIDE BY 0.2' DEEP).
- 6 INSTALL STRAW WATTLES, TYPICAL.
- 7 GRADE TO DRAIN AWAY FROM PROPOSED STRUCTURE AT 5-5% FOR 10 FEET MIN. TYPICAL.
- 8 CONSTRUCT CONCRETE WASHOUT STRUCTURE PER DETAIL SHEET 2.
- 9 CONSTRUCT TEMPORARY MATERIAL STORAGE AREA PER DETAIL SHEET 2. INSTALL 10 LF - 4" PVC PIPE AT 5 = 1% ±.
- 10 HYDROSEED ALL CUT AND FILL SLOPES, SEE EROSION CONTROL NOTE #9 ON SHEET 2.
- 11 CONSTRUCT NEW 27,500 SF GREENHOUSE, PLAN BY OTHERS.
- 12 CONSTRUCT NEW 5,500 SF NURSERY, PLAN BY OTHERS.
- 13 INSTALL HOOP HOUSES ON EXISTING GRADE.
- 14 CALFIRE TURN AROUND AREA.
- 15 CONSTRUCT A NEW LOADING ZONE, 8" CLASS II AB COMPACTED TO 95% OVER 12" SCARIFIED NATIVE COMPACTED TO 90%.
- 16 INSTALL NEW WHARF HEAD HYDRANT PER CAL FIRE STANDARDS.
- 17 INSTALL (4) 9,100 GALLON WATER TANKS OVER 8" CLASS II AB COMPACTED TO 95% OVER 12" SCARIFIED NATIVE COMPACTED TO 90%.
- 18 COMPOST AREA, 6500 SF.
- 19 CONSTRUCT PARKING AREA WITH 8" CLASS II AB COMPACTED TO 95% OVER 12" SCARIFIED NATIVE COMPACTED TO 90%.
- 20 INSTALL WATER SERVICE FROM EXISTING WELL, SIZE PER IRRIGATION DESIGNER.
- 21 CONSTRUCT ELECTRICAL SERVICE PER PG&E SERVICE TRENCH STANDARDS.
- 22 AREA OF DISTURBANCE, SEE SITE STATISTICS, SHEET 1.
- 23 CONSTRUCT ROCK RIP RAP ENERGY DISSIPATER PER CALTRANS STANDARD 72. USE BACKING NO. 3 TYPE ROCK, TYPE B PLACEMENT OVER GEOTEXTILE FABRIC. W = 5', L = 5', D = 0.75
- 24 NOT A PART, EXISTING GARAGE/SHOP WITH EXISTING RESTROOM INSIDE. (VERIFY LEACH FIELD AND SEPTIC TANK LOCATION PRIOR TO OCCUPANCY WITH BUILDING PERMIT.)
- 25 EXISTING RESIDENCE.

9+00	9+25	9+50	9+75	10+00	10+25	10+50	10+75	11+00	11+25	11+50	11+75	12+00	12+25	12+50	12+75	13+00	13+25	13+50	13+75
1302.3 1301.77	1299.6 1298.92	1296.8 1296.07	1293.8 1293.22	1290.6 1290.37	1288.0 1287.52	1285.3 1284.67	1282.9 1281.82	1280.1 1278.97	1278.9 1276.12	1276.7 1273.27	1272.4 1270.42	1270.5 1267.57	1266.3 1264.72	1262.0 1261.87	1259.9 1259.02	1255.5 1256.17	1251.6 1253.32	1249.3 1250.47	1244.7 1247.62

MATCHLINE, STATION 9+00, SEE SHEET 8

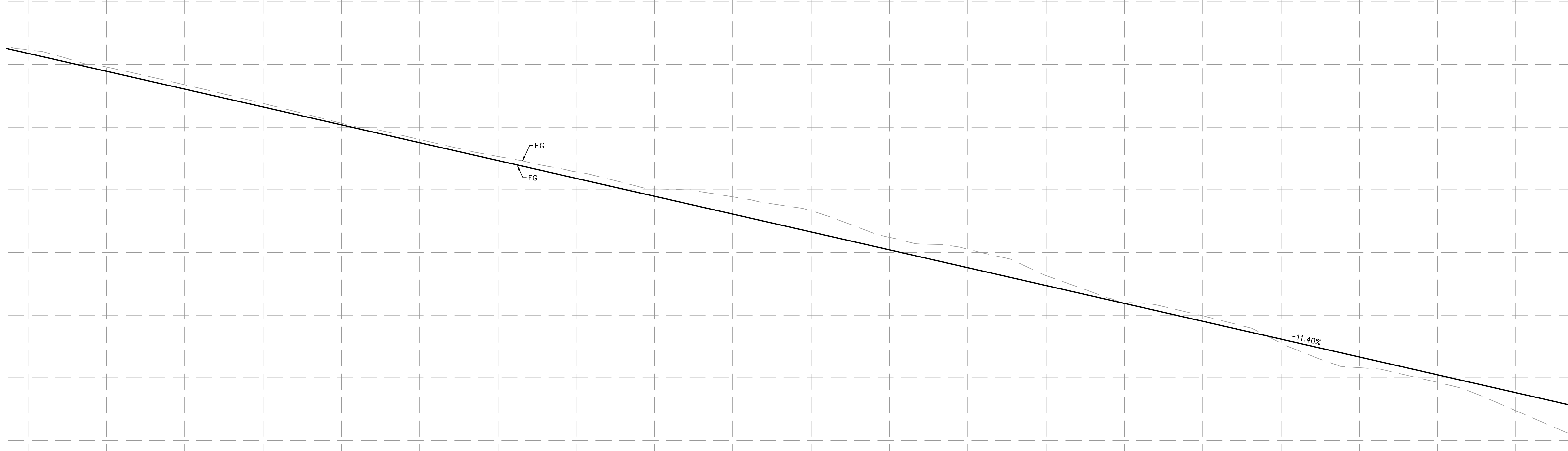

MATCHLINE, STATION 13+75, SEE SHEET 10

DRIVEWAY PROFILE
HORIZONTAL SCALE: 1"=20'
VERTICAL SCALE: 1"=10'

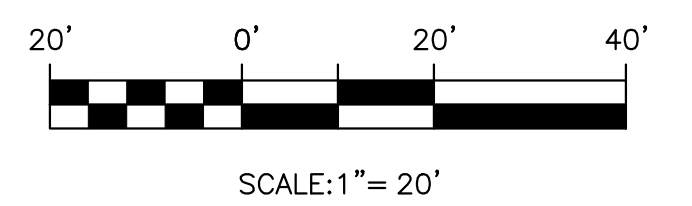

Roberts Engineering, Inc.		
Azevedo - 1375 Klau Mine Road, Paso Robles		
Grading, Drainage, and Erosion Control Plan		
Design/Drawn TR / SEB	County Plan Checker	Approved for County Requirements
Job # 20-77	County W.O. No.	Development Services Engineer <i>Timothy P. Roberts</i> Date: 4/14/2021 11:30 AM
California Coordinates (CCS83, Zone 5) 2431561 N 5689484 E	County Road #	9



Roberts Engineering
Timothy P. Roberts
Civil Engineer - RCE 35366
2015 Vista de la Vina
Templeton, CA 93465
Phone (805) 239-0664
Fax (805) 238-6148
Email tim@robertsenginc.com
Website robertsenginc.com

Record Drawings	
Timothy P. Roberts, RCE 35366 exp 09/30/21	Date
Revisions This Sheet:	
1	
2	
3	
4	
5	
6	

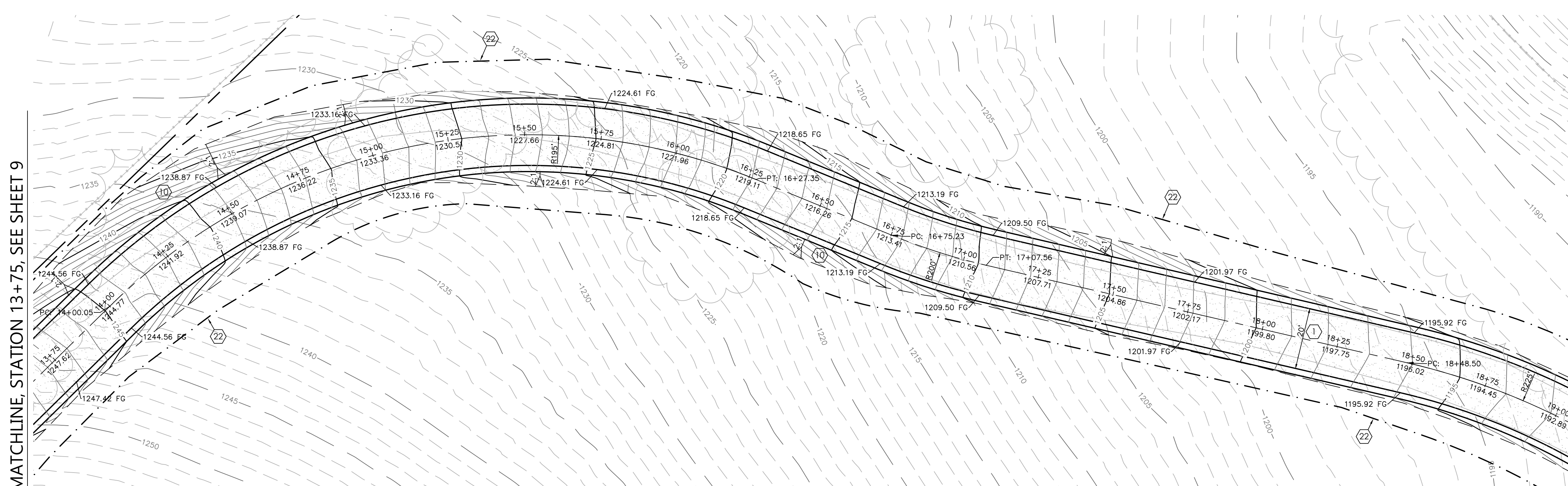

MATCHLINE, STATION 13+75, SEE SHEET 9

MATCHLINE, STATION 19+00, SEE SHEET 11

- ### CONSTRUCTION NOTES
- 1 CONSTRUCT 20' WIDE ACCESS ROAD PER CAL FIRE STANDARDS, 8" CLASS II AB COMPACTED TO 95% OVER 12" SCARIFIED NATIVE COMPACTED TO 90%. SEE TYPICAL SECTION ON SHEET 2.
 - 2 CONSTRUCT 16' WIDE ACCESS ROAD PER CAL FIRE STANDARDS, 8" CLASS II AB COMPACTED TO 95% OVER 12" SCARIFIED NATIVE COMPACTED TO 90%. SEE TYPICAL SECTION ON SHEET 2.
 - 3 EXISTING DRIVE APPROACH TO REMAIN.
 - 4 CONSTRUCT TEMPORARY CONSTRUCTION ENTRANCE, SEE DETAIL ON SHEET 2.
 - 5 CONSTRUCT 6" THICK PCC V-GUTTER, (2' WIDE BY 0.2' DEEP).
 - 6 INSTALL STRAW WATTLES, TYPICAL.
 - 7 GRADE TO DRAIN AWAY FROM PROPOSED STRUCTURE AT S=5% FOR 10 FEET MIN. TYPICAL.
 - 8 CONSTRUCT CONCRETE WASHOUT STRUCTURE PER DETAIL SHEET 2.
 - 9 CONSTRUCT TEMPORARY MATERIAL STORAGE AREA PER DETAIL SHEET 2
INSTALL 10 LF - 4" PVC PIPE AT S = 3%.
 - 10 HYDROSEED ALL CUT AND FILL SLOPES, SEE EROSION CONTROL NOTE #9 ON SHEET 2.
 - 11 CONSTRUCT NEW 27,500 SF GREENHOUSE, PLAN BY OTHERS.
 - 12 CONSTRUCT NEW 5,500 SF NURSERY, PLAN BY OTHERS.
 - 13 INSTALL HOOP HOUSES ON EXISTING GRADE.
 - 14 CALFIRE TURN AROUND AREA.
 - 15 CONSTRUCT A NEW LOADING ZONE, 8" CLASS II AB COMPACTED TO 95% OVER 12" SCARIFIED NATIVE COMPACTED TO 90%.
 - 16 INSTALL NEW WHARF HEAD HYDRANT PER CAL FIRE STANDARDS.
 - 17 INSTALL (4) 9,100 GALLON WATER TANKS OVER 8" CLASS II AB COMPACTED TO 95% OVER 12" SCARIFIED NATIVE COMPACTED TO 90%.
 - 18 COMPOST AREA, 6500 SF.
 - 19 CONSTRUCT PARKING AREA WITH 8" CLASS II AB COMPACTED TO 95% OVER 12" SCARIFIED NATIVE COMPACTED TO 90%.
 - 20 INSTALL WATER SERVICE FROM EXISTING WELL, SIZE PER IRRIGATION DESIGNER.
 - 21 CONSTRUCT ELECTRICAL SERVICE PER PG&E SERVICE TRENCH STANDARDS.
 - 22 AREA OF DISTURBANCE, SEE SITE STATISTICS, SHEET 1.
 - 23 CONSTRUCT ROCK RIP RAP ENERGY DISSIPATOR PER CALTRANS STANDARD 72.
USE BACKING NO. 3 TYPE ROCK, TYPE B PLACEMENT OVER GEOTEXTILE FABRIC.
W = 5', L = 5', D = 0.75
 - 24 NOT A PART, EXISTING GARAGE/SHOP WITH EXISTING RESTROOM INSIDE.
(VERIFY LEACH FIELD AND SEPTIC TANK LOCATION PRIOR TO OCCUPANCY WITH BUILDING PERMIT.)
 - 25 EXISTING RESIDENCE.

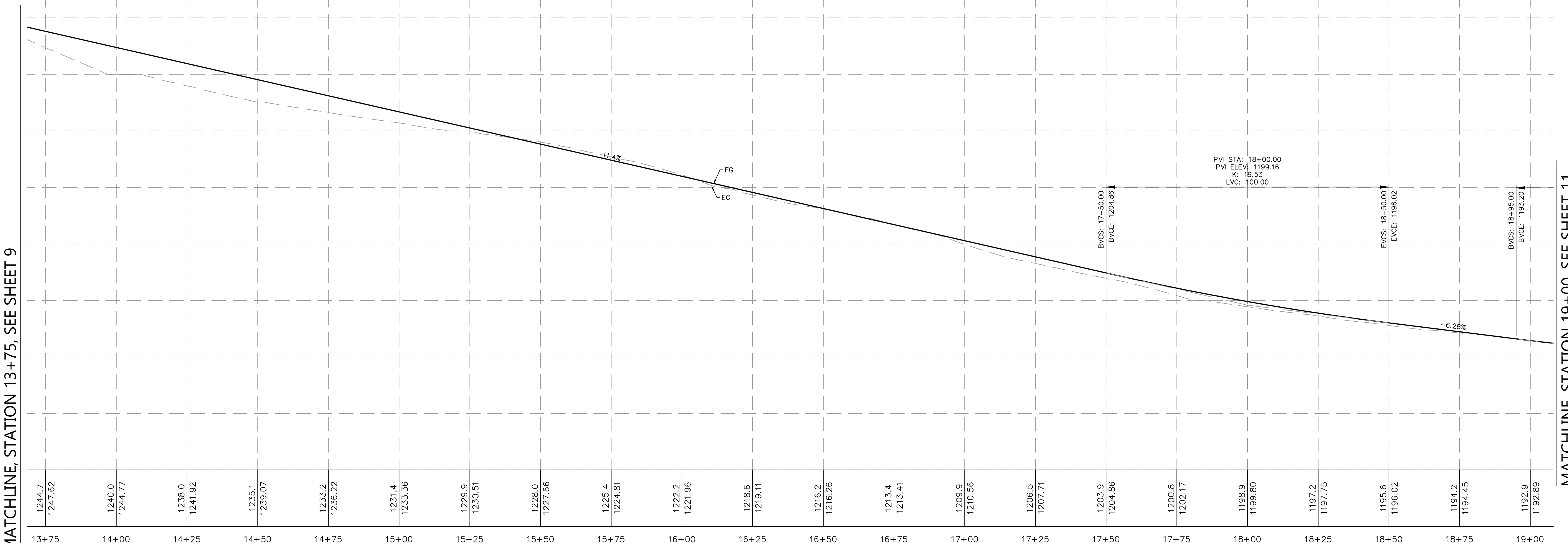

MATCHLINE, STATION 13+75, SEE SHEET 9

MATCHLINE, STATION 19+00, SEE SHEET 11

DRIVEWAY PROFILE
HORIZONTAL SCALE: 1"=20'
VERTICAL SCALE: 1"=10'

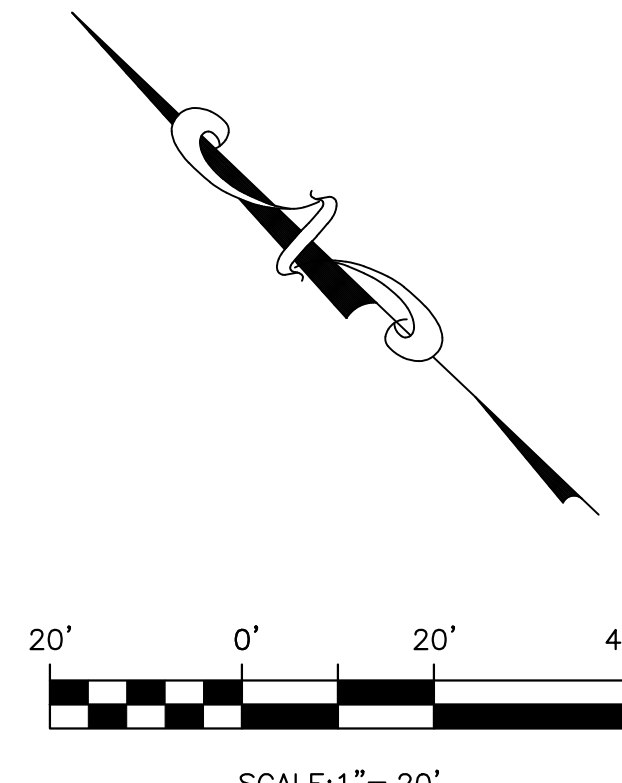

4/14/2021 11:31 AM

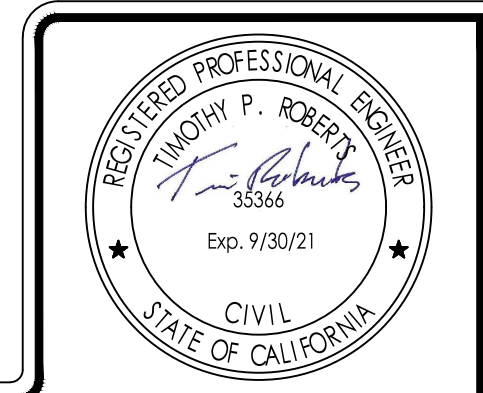

Roberts Engineering
Timothy P. Roberts
Civil Engineer - RCE 35366
2015 Vista de la Vina
Templeton, CA 93465
Phone (805) 239-0664
Fax (805) 238-6148
Email tim@robtsenginc.com
Website: robertsenginc.com

Record Drawings	
Timothy P. Roberts, RCE 35366 exp 09/30/21	Date
1	Revisions This Sheet:
2	
3	
4	
5	
6	

Roberts Engineering, Inc.		
Azevedo - 1375 Klau Mine Road, Paso Robles		
Grading, Drainage, and Erosion Control Plan		
Design/Draw TR / SEB	County Plan Checker	Approved for County Requirements
Job # 20-77	County W.O. No.	Development Services Engineer Date
California Coordinates (CCS83, Zone 5)	County Road #	4/14/2021 11:31 AM Timothy P. Roberts, RCE 35366 exp 09/30/21 Date
2431561 N 5689484 E		10 of 11

MATCHLINE, STATION 19+00, SEE SHEET 10

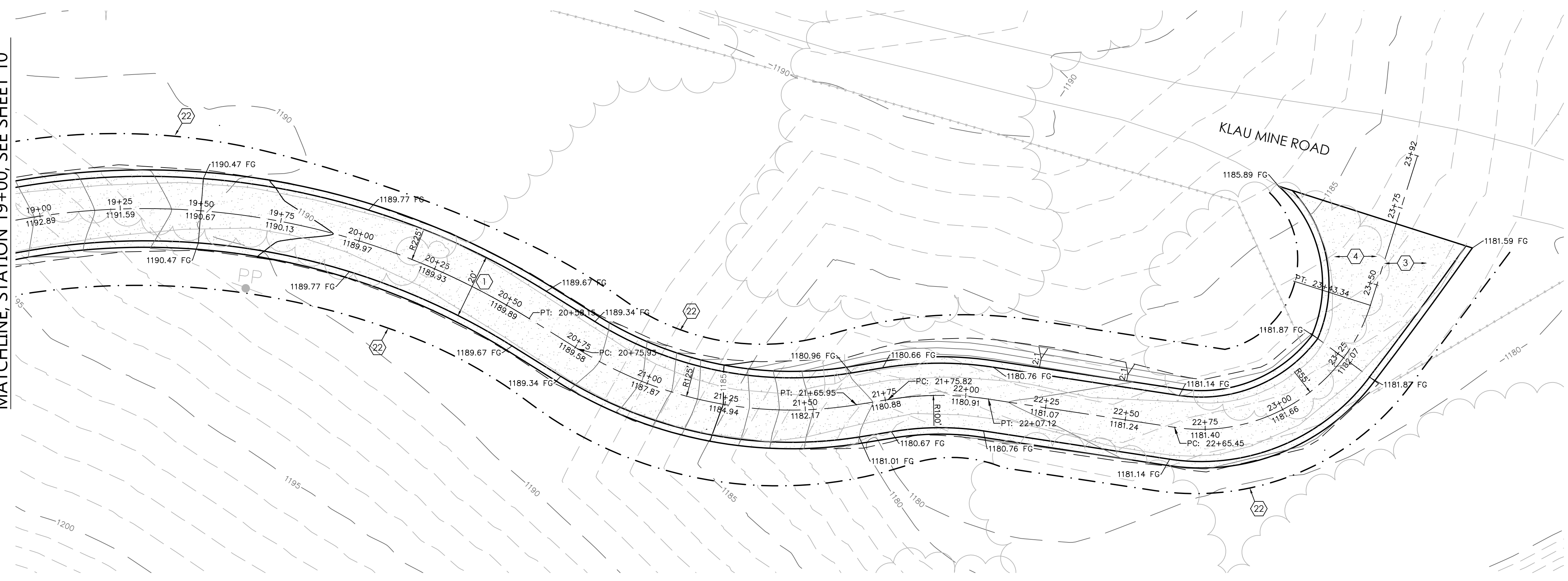

CONSTRUCTION NOTES

- 1 CONSTRUCT 20' WIDE ACCESS ROAD PER CAL FIRE STANDARDS, 8" CLASS II AB COMPACTED TO 95% OVER 12" SCARIFIED NATIVE COMPACTED TO 90%. SEE TYPICAL SECTION ON SHEET 2.
- 2 CONSTRUCT 16' WIDE ACCESS ROAD PER CAL FIRE STANDARDS, 8" CLASS II AB COMPACTED TO 95% OVER 12" SCARIFIED NATIVE COMPACTED TO 90%. SEE TYPICAL SECTION ON SHEET 2.
- 3 EXISTING DRIVE APPROACH TO REMAIN.
- 4 CONSTRUCT TEMPORARY CONSTRUCTION ENTRANCE, SEE DETAIL ON SHEET 2.
- 5 CONSTRUCT 6" THICK PCC V-GUTTER, (2' WIDE BY 0.2' DEEP).
- 6 INSTALL STRAW WATTLES, TYPICAL.
- 7 GRADE TO DRAIN AWAY FROM PROPOSED STRUCTURE AT 5% FOR 10 FEET MIN. TYPICAL.
- 8 CONSTRUCT CONCRETE WASHOUT STRUCTURE PER DETAIL SHEET 2.
- 9 CONSTRUCT TEMPORARY MATERIAL STORAGE AREA PER DETAIL SHEET 2
INSTALL 10 LF - 4" PVC PIPE AT 5 = 1% ±.
- 10 HYDROSEED ALL CUT AND FILL SLOPES, SEE EROSION CONTROL NOTE #9 ON SHEET 2.
- 11 CONSTRUCT NEW 27,500 SF GREENHOUSE, PLAN BY OTHERS.
- 12 CONSTRUCT NEW 5,500 SF NURSERY, PLAN BY OTHERS.
- 13 INSTALL HOOP HOUSES ON EXISTING GRADE.
- 14 CALFIRE TURN AROUND AREA.
- 15 CONSTRUCT A NEW LOADING ZONE, 8" CLASS II AB COMPACTED TO 95% OVER 12" SCARIFIED NATIVE COMPACTED TO 90%.
- 16 INSTALL NEW WHARF HEAD HYDRANT PER CAL FIRE STANDARDS.
- 17 INSTALL (4) 9,100 GALLON WATER TANKS OVER 8" CLASS II AB COMPACTED TO 95% OVER 12" SCARIFIED NATIVE COMPACTED TO 90%.
- 18 COMPOST AREA, 6500 SF.
- 19 CONSTRUCT PARKING AREA WITH 8" CLASS II AB COMPACTED TO 95% OVER 12" SCARIFIED NATIVE COMPACTED TO 90%.
- 20 INSTALL WATER SERVICE FROM EXISTING WELL, SIZE PER IRRIGATION DESIGNER.
- 21 CONSTRUCT ELECTRICAL SERVICE PER PG&E SERVICE TRENCH STANDARDS.
- 22 AREA OF DISTURBANCE, SEE SITE STATISTICS, SHEET 1.
- 23 CONSTRUCT ROCK RIP RAP ENERGY DISSIPATER PER CALTRANS STANDARD 72.
USE BACKING NO. 3 TYPE ROCK, TYPE B PLACEMENT OVER GEOTEXTILE FABRIC.
W = 5', L = 5', D = 0.75
- 24 NOT A PART. EXISTING GARAGE/SHOP WITH EXISTING RESTROOM INSIDE.
(VERIFY LEACH FIELD AND SEPTIC TANK LOCATION PRIOR TO OCCUPANCY WITH BUILDING PERMIT.)
- 25 EXISTING RESIDENCE.

MATCHLINE, STATION 19+00, SEE SHEET 10

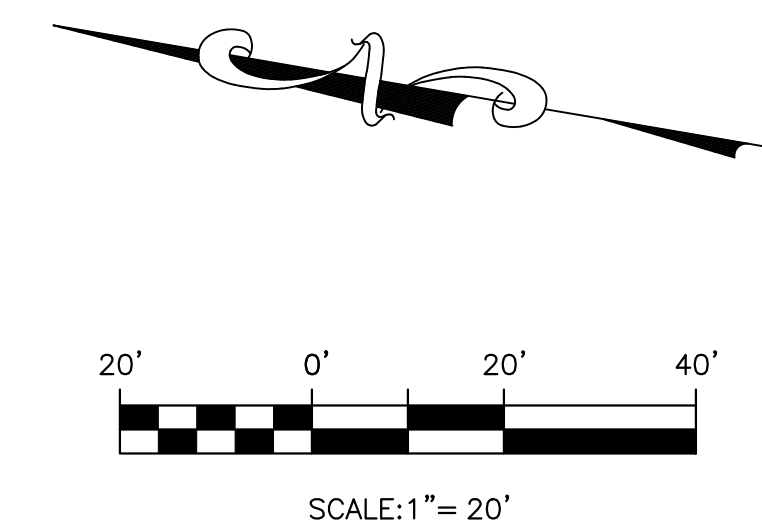
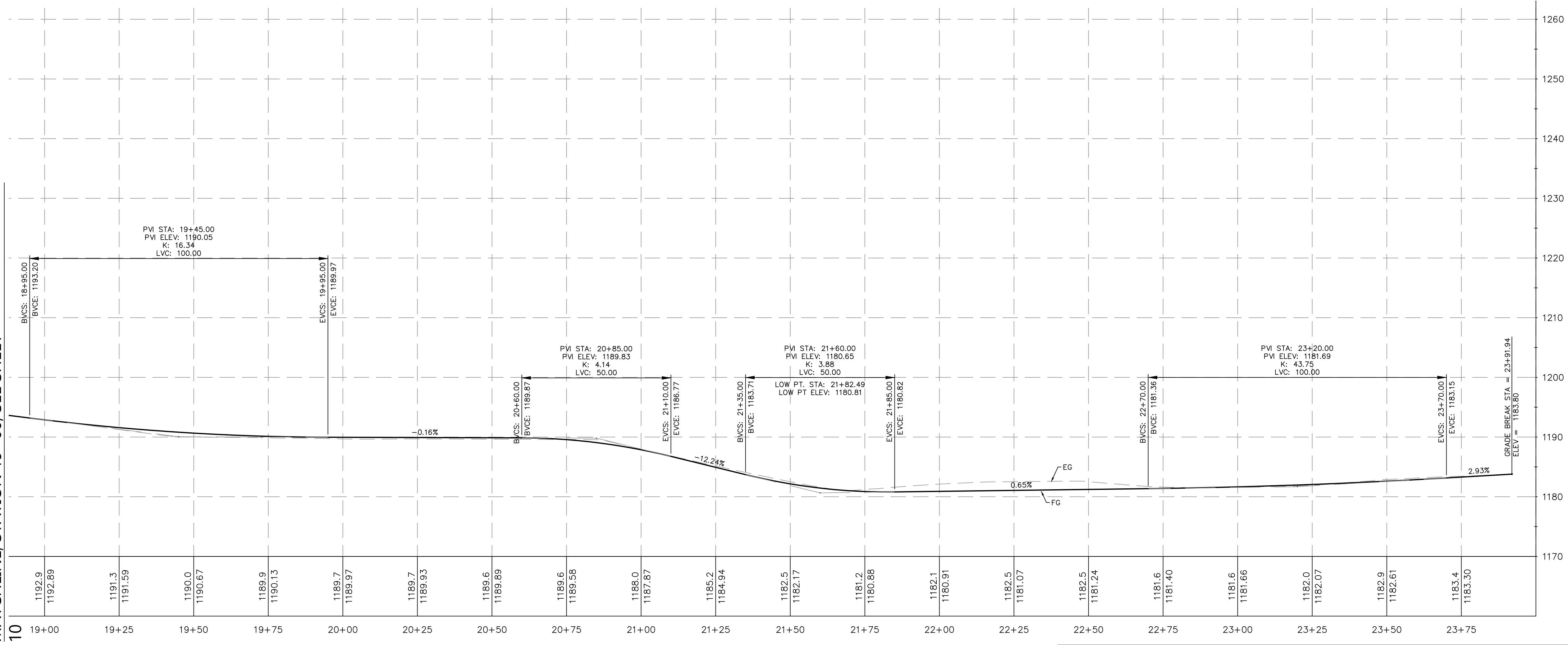

DRIVEWAY PROFILE
HORIZONTAL SCALE: 1"=20'
VERTICAL SCALE: 1"=10'

Roberts Engineering, Inc.		
Azevedo - 1375 Klau Mine Road, Paso Robles		
Grading, Drainage, and Erosion Control Plan		
Design/Drawn <i>TR / SEB</i>	County Plan Checker	Approved for County Requirements
Job # 20-77	County W.O. No.	Development Services Engineer <i>T. Roberts</i> Date: 4/14/2021 11:31 AM
California Coordinates (CCS83, Zone 5)	County Road #	Date: Timothy P. Roberts, RCE 35366 exp 09/30/21
2431561 N 5689484 E		11 of 11

Roberts Engineering
Timothy P. Roberts
Civil Engineer - RCE 35366
2015 Vista de la Vina
Templeton, CA 93465
Phone (805) 239-0664
Fax (805) 238-6148
Email tim@robertsenginc.com
Website robertsenginc.com

Record Drawings

Timothy P. Roberts, RCE 35366 exp 09/30/21	Date
Revisions This Sheet:	
1	
2	
3	
4	
5	
6	

4/14/2021 11:31 AM