



**CHRISTIAN WHEELER  
ENGINEERING**

**REPORT OF PRELIMINARY GEOTECHNICAL INVESTIGATION**

**SINGLE-FAMILY RESIDENCE**

**8455 EL PASEO GRANDE**

**LA JOLLA, CALIFORNIA**

**PREPARED FOR**

**MR. JEFFREY HARPER**

**8455 EL PASEO GRANDE**

**LA JOLLA, CALIFORNIA 92037**

**PREPARED BY**

**CHRISTIAN WHEELER ENGINEERING**

**3980 HOME AVENUE**

**SAN DIEGO, CALIFORNIA 92105**



CHRISTIAN WHEELER  
ENGINEERING

July 13, 2020

Mr. Jeffrey Harper  
8455 El Paseo Grande  
La Jolla, California 92037

CWE 2190610.01

**Subject: Report of Preliminary Geotechnical Investigation  
Single-Family Residence, 8455 El Paseo Grande, La Jolla, California**

Dear Mr. Harper,

In accordance with your request and our proposal dated May 19, 2020, we have completed a preliminary geotechnical investigation for the subject project. We are presenting herewith our findings and recommendations.

In general, it is our opinion that the subject site is suitable to support the proposed residence provided the recommendations presented herein are incorporated into the design and construction. The main geotechnical and geologic condition that will impact the proposed construction is the presence of potentially liquefiable soils below the foundation level of the home. As discussed in the attached report, the life-safety hazards associated with this condition can be mitigated by designing the foundations in accordance with current building standards.

If you have any questions after reviewing this report, please do not hesitate to contact our office. This opportunity to be of professional service is sincerely appreciated.

Respectfully submitted,

**CHRISTIAN WHEELER ENGINEERING**

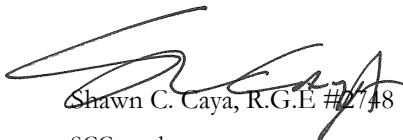
  
Shawn C. Caya, R.G.E. #2748  
SCC:scc;dr

email: Jeffrey Harper



  
David R. Russell, C.E.G. #2215



## TABLE OF CONTENTS

	PAGE
Introduction and Project Description.....	1
Scope of Services.....	1
Findings.....	2
Site Description.....	2
General Geology and Subsurface Conditions .....	3
Geologic Setting and Soil Description .....	3
Alluvium.....	3
Old Paralic Deposits .....	3
Ardath Shale .....	3
Groundwater .....	3
Tectonic Setting .....	4
Geologic Hazards.....	5
Geologic Hazards Category .....	5
Landslide Potential and Slope Stability.....	5
Seismic Hazard.....	5
Flooding .....	6
Tsunamis .....	6
Liquefaction .....	7
General .....	7
Description of Analysis.....	7
Earthquake Parameters .....	8
Potential for Liquefaction.....	8
Post Liquefaction Reconsolidation Settlement .....	8
Lateral Spreading.....	8
Conclusions .....	9
Recommendations.....	9
Grading and Earthwork .....	9
General .....	9
Observation of Grading.....	9
Clearing and Grubbing.....	9
Site Preparation .....	10
Excavation Characteristics .....	10
Dewatering.....	10
Processing of Removal Bottom.....	10
Compaction and Method of Filling .....	11
Imported Fill Material .....	11
Temporary Cut Slopes .....	11
Surface Drainage.....	11
Grading Plan Review.....	12
Temporary Shoring.....	12
General .....	12
Shoring Design and Lateral Pressures .....	12
Design of Soldier Piles.....	12
Lagging .....	12
Deflections.....	12
Monitoring.....	13
Foundations .....	13

**TABLE OF CONTENTS (Continued)**

	PAGE
General.....	13
Mat Foundations.....	13
Conventional Shallow Footings.....	13
Lateral Load Resistance.....	14
Settlement Characteristics.....	14
Expansive Characteristics.....	14
Foundation Plan Review.....	14
Foundation Excavation Observation.....	14
Corrosivity.....	15
On-Grade Slabs.....	15
General.....	15
Basement Slab.....	15
Under-Slab Vapor Retarders.....	15
Exterior Concrete Flatwork.....	15
Earth Retaining Walls.....	16
Foundations.....	16
Active Pressures.....	16
Passive Pressures.....	17
Waterproofing and Subdrains.....	17
Backfill.....	17
Limitations.....	17
Uniformity of Conditions.....	17
Change in Scope.....	17
Time Limitations.....	18
Professional Standard.....	18
Field Explorations.....	18

**TABLES**

Table I: Proximal Fault Zones .....5  
Table II: CBC 2019/ASCE 7-16 – Seismic Design Parameters .....6

**FIGURES**

Figure 1 Site Vicinity Map, Follows Page 1

**PLATES**

Plate 1 Existing Site Plan and Geotechnical Map  
Plate 2 Proposed Site Plan and Geotechnical Map  
Plate 3 Geologic Cross-Section  
Plate 4 Suggested Retaining Wall Subdrain Detail

**APPENDICES**

Appendix A Boring Log  
Appendix B Laboratory Test Results  
Appendix C Previous Field Data and Lab Test Results (CWE, 2008)  
Appendix D Liquefaction Analyses  
Appendix E References



CHRISTIAN WHEELER  
ENGINEERING

**REPORT OF PRELIMINARY GEOTECHNICAL INVESTIGATION**

SINGLE-FAMILY RESIDENCE

8455 EL PASEO GRANDE

LA JOLLA, CALIFORNIA

**INTRODUCTION AND PROJECT DESCRIPTION**

This report presents the results of our preliminary geotechnical investigation for a planned single-family residence to be constructed at 8455 El Paseo Grande, in the La Jolla neighborhood of the city of San Diego, California. The following Figure No. 1 presents a vicinity map showing the location of the site.

To augment our understanding of the proposed project, we were provided with topographic site plan prepared by Hale Engineering and conceptual floor plans prepared by Design Lead. We understand that it is proposed to raze the existing structure at the site and to construct a new residence in its place. The new structure will have three levels, including a basement. We anticipate that the residence will be of concrete or masonry construction for the basement and of conventional, wood-frame construction for the remaining portions. We also anticipate that the structure will be supported by conventional shallow foundations with a slab-on-ground floor or by a structural mat foundation. Grading to accommodate the proposed improvements is expected to be limited to the excavation for the proposed basement.

This report has been prepared for the exclusive use of Mr. Jeffrey Harper and his design consultants for specific application to the project described herein. Should the project be changed in any way, the modified plans should be submitted to Christian Wheeler Engineering for review to determine their conformance with our recommendations and to determine whether any additional subsurface investigation, laboratory testing and/or recommendations are necessary. Our professional services have been performed, our findings obtained and our recommendations prepared in accordance with generally accepted engineering principles and practices. This warranty is in lieu of all other warranties, express or implied.

**SCOPE OF SERVICES**

Our geotechnical investigation generally consisted of surface reconnaissance, subsurface exploration, review of previous subsurface explorations, analysis of the previous field data, laboratory testing, and review of relevant readily available geologic literature. More specifically, our services included the following items.

# SITE VICINITY

© OpenStreetMap contributors



PROPOSED SINGLE-FAMILY RESIDENCE  
8455 EL PASEO GRANDE  
LA JOLLA, CALIFORNIA



CHRISTIAN WHEELER  
ENGINEERING

DATE: JUNE 2020

JOB NO.: 2190610.01

BY: SRD

FIGURE NO.: 1

- Obtaining a boring permit from the County of San Diego Department of Environmental Health to conduct the proposed subsurface investigation.
- Drilling one small-diameter boring with a limited access, track-mounted drill rig at the front of the lot to explore the subsurface conditions and to obtain samples for laboratory testing.
- Backfilling the boring hole using a grout or a grout/bentonite mix as required by the County of San Diego Department of Environmental Health.
- Evaluating, by laboratory testing and our past experience within the vicinity of the site, the engineering properties of the various soil strata that may influence the proposed construction, including bearing capacities and settlement potential.
- Describing the general geology at the site, including possible geologic hazards that could have an effect on the proposed construction, and provide the seismic design parameters as required by the 2019 edition of the California Building Code.
- Addressing potential construction difficulties that may be encountered due to soil conditions, groundwater or geologic hazards, and provide geotechnical recommendations to deal with these difficulties.
- Quantitatively addressing the potential for soil liquefaction and dynamic settlement at the site in the event of a major, proximal seismic event.
- Providing site preparation and remedial grading recommendations for the anticipated work.
- Providing foundation recommendations for the type of construction anticipated and developing soil engineering design criteria for the recommended foundation designs.
- Providing this geotechnical report presenting the results of our evaluation, including a plot plan showing the locations of current and previous subsurface explorations, excavation logs, and our conclusions and recommendations for the proposed project.

## **FINDINGS**

### **SITE DESCRIPTION**

The subject site is a developed residential lot that is located at the address of 8455 El Paseo Grande in the La Jolla area of San Diego, California. The lot is bordered by El Paseo Grande to the west and by developed residential properties on the remaining sides. The site currently supports a two- and three-story, single-family residence that includes a partial basement and open carport level. Topographically, the site is relatively level with elevations ranging from approximately 19 to 22 feet around the main level to just over 12 feet in the carport area according to the provided topographic plan.



## GENERAL GEOLOGY AND SUBSURFACE CONDITIONS

**GEOLOGIC SETTING AND SOIL DESCRIPTION:** The subject site is located in the Coastal Plains Physiographic Province of San Diego County. In order to evaluate the subsurface conditions at the project area, we have drilled a small-diameter boring at the subject site as well as reviewed boring information obtained by our firm for the neighboring site to the south (CWE, 2008). Based on this information, our experience in the area, and our analysis of other readily available, pertinent geologic and geotechnical literature, we have determined that the site is underlain by alluvial deposits that are underlain by Quaternary-age old paralic deposits and Tertiary-age sedimentary deposits of the Ardath Shale. These materials are described below:

**ALLUVIUM (Qal):** Alluvial deposits were encountered near the ground surface with our boring B-1 drilled on-site as well as the explorations performed on the adjacent lot. The alluvium had a thickness of 12 feet within our boring B-1. In general, the alluvial material was noted to consist of light brown, moist to very moist, soft to medium stiff, sandy silt (ML). Based on our visual classification, the alluvium was judged to have a low expansion index.

**OLD PARALIC DEPOSITS (Qop):** Below the alluvium are late to middle Pleistocene-age, old paralic deposits. Within our boring B-1, the encountered old paralic deposits consisted of a 7-foot-thick layer of medium grayish-brown, clayey sand (SC) that was underlain by a 13-foot-thick layer of light gray, poorly graded sand-silty sand (SP-SM). These deposits were generally moist above the water table, and saturated below the water table. These materials were medium dense to dense in the upper clayey sand (SC) layer and medium dense in the lower, poorly graded sand-silty sand (SP-SM) layer.

**ARDATH SHALE (Ta):** Tertiary-age sedimentary deposits of the Ardath Shale were encountered below the old paralic deposits within our boring at a depth of approximately 32 feet below existing site grades, and are expected to underlie the entire site at depth. In general, the Ardath Shale consisted of light yellowish-brown to light gray, moist, hard, silty clay (CL).

**GROUNDWATER:** Groundwater was measured in our boring B-1 at an approximate depth of 17½ feet below the existing grade, which corresponds to an elevation of roughly 1 foot based on the topographic plan prepared by Hale Engineering. Variations in subsurface water (including perched water zones and seepage) may result from fluctuations in the ground surface topography, subsurface stratification, precipitation, irrigation, sea level rise, and other factors that may not have been evident at the time of the investigation. It should also be recognized that minor groundwater seepage problems might occur after development of a site even where none were present

before development. These are usually minor phenomena and are often the result of an alteration in drainage patterns and/or an increase in irrigation water. It is further our opinion that these problems can be most effectively corrected on an individual basis if and when they occur.

Based on our findings, free groundwater is anticipated at depths of 8 to 10 feet below the elevation of the proposed home's subterranean, lower level. As such, site grading will not impact groundwater flow or quality in the area and the need for pumping of free groundwater is not anticipated.

**TECTONIC SETTING:** It should be noted that much of Southern California, including the San Diego County area, is characterized by a series of Quaternary-age fault zones that consist of several individual, en echelon faults that generally strike in a northerly to northwesterly direction. Some of these fault zones (and the individual faults within the zones) are classified as “active” according to the criteria of the California Division of Mines and Geology. Active fault zones are those that have shown conclusive evidence of faulting during the Holocene Epoch (the most recent 11,000 years).

The Division of Mines and Geology used the term “potentially active” on Earthquake Fault Zone maps until 1988 to refer to all Quaternary-age faults for the purpose of evaluation for possible zonation in accordance with the Alquist-Priolo Earthquake Fault Zoning Act. The Alquist-Priolo Act requires the State Geologist to zone faults that are “sufficiently active” and “well-defined” to have a relatively high potential for ground rupture. The Division of Mines and Geology no longer uses the term “potentially active.” However, the City of San Diego has elected to continue to use the term “potentially active” to refer to certain faults that demonstrated movement during the Pleistocene epoch (11,000 to 1.6 million years before the present) but that do not have substantiated Holocene movement. It should be recognized that the Alquist-Priolo Act (Division 2, Chapter 7.5, Section 2624) authorizes individual cities and counties to establish policies and criteria that are stricter than those established by the Alquist-Priolo Act.

A review of available geologic maps indicates that the nearest active fault within the Rose Canyon Fault Zone is located approximately 0.5 mile south of the site. Other active fault zones in the region that could possibly affect the site include the Coronado Bank Fault Zone to the west, the Newport-Inglewood Fault Zone to the northwest, and the Elsinore and Earthquake Valley Fault Zones to the northeast. In addition, the potentially active, northeast/southwest trending Scripps Fault is mapped as being approximately 450 feet north of the subject site. The following Table I presents the proximal faults that are anticipated to most significantly contribute to the ground-motion hazard at the site.

**TABLE I: PROXIMAL FAULT ZONES**

<b>Fault Zone</b>	<b>Distance</b>
Rose Canyon	0.5 mile
Coronado Bank	13 miles
Newport-Inglewood	23 miles
Elsinore	37 miles
Earthquake Valley	45 miles
San Clemente	47 miles
San Jacinto	61 miles
San Andreas	88 miles

## **GEOLOGIC HAZARDS**

**GEOLOGIC HAZARDS CATEGORY:** A review of the City of San Diego Seismic Safety Study (Sheet 29) indicates that the site is located in Geologic Hazards Category 52. Hazard Category 52 is assigned to level, gently sloping to steep terrain with favorable geologic structure, where the risks are also classified as low. Although not mapped as such, the site is located within an area that possesses a low to moderate potential for soil liquefaction due to such factors as shallow groundwater and the presence of loose to medium dense, cohesionless sediments. Discussion of the geologic hazards associated with seismically induced soil liquefaction at the subject site is presented in the Liquefaction section of this report.

**LANDSLIDE POTENTIAL AND SLOPE STABILITY:** As part of this investigation we reviewed the publication, “Landslide Hazards in the Southern Part of the San Diego Metropolitan Area” by Tan, 1995. This reference is a comprehensive study that classifies San Diego County into areas of relative landslide susceptibility. The subject site is located in Area 2. Land within Area w is considered to be marginally susceptible to slope failures. Based on the absence of significant slopes within the vicinity of the subject site, the potential for slope failures can be considered negligible.

**SEISMIC HAZARD:** A likely geologic hazard to affect the site is ground shaking as a result of movement along one of the major active fault zones mentioned in the “Tectonic Setting” section of this report. Seismic design parameters were determined in accordance with Chapter 16 of the *2019 California Building Code (CBC)* and the applicable sections of *ASCE/SEI 7-16 Minimum Design Loads and Associated Criteria for Buildings and Other Structures*. For the subject site, field blow counts measured/estimated in our boring B-1 indicate that the upper 100 feet of geologic subgrade has a  $N_{30}$  value of 31 and can be characterized as Soil Site Class D.

In accordance with Section 11.4.8 of *ASCE/SEI 7-16*, structures on Soil Site Class D or E sites that have a mapped  $MCE_R$  spectral response acceleration parameter ( $S_1$ ) value greater than or equal to 0.2 require a site-

specific ground motion hazard analysis or the seismic response coefficient ( $C_s$ ) must be adjusted to adequately characterize the site response (Exception 2). The following Table II presents the seismic design parameters based on Exception 2 in Section 11.4.8.

**TABLE II: CBC 2019/ASCE 7-16 – SEISMIC DESIGN PARAMETERS**

CBC – Chapter 16 Section	Seismic Design Parameter	Recommended Value
Section 1613.2.2	Soil Site Class	D
Figure 1613.2.1 (1)	$MCE_R$ Acceleration for Short Periods (0.2 sec), $S_s$	1.401 g
Figure 1613.2.1 (2)	$MCE_R$ Acceleration for 1.0 Sec Periods (1.0 sec), $S_1$	0.491 g
Table 1613.2.3 (1)	Site Coefficient, $F_a$	1.000
Table 1613.3.3 (2)	Site Coefficient, $F_v$	1.809
Section 1613.2.3	$S_{MS} = MCE_R$ Spectral Response at 0.2 sec. = $(S_s)(F_a)$	1.401 g
Section 1613.2.3	$S_{M1} = MCE_R$ Spectral Response at 1.0 sec. = $(S_1)(F_v)$	0.888 g
Section 1613.2.4	$S_{DS} =$ Design Spectral Response at 0.2 sec. = $2/3(S_{MS})$	0.934 g
Section 1613.2.4	$S_{D1} =$ Design Spectral Response at 1.0 sec. = $2/3(S_{M1})$	0.592 g
Section 1613.2.5	Seismic Design Category	D
ASCE 7-16 Fig. 22-14	Mapped Long-Period Transition Period, $T_L$	8 sec
ASCE 7-16 Eq 12.8-3	Adjustment to Seismic Response Coefficient, $C_s$	Multiply by 1.5
Section 1803.2.12	$PGA_M$ per Section 11.8.3 of ASCE 7	0.74 g

It can be noted that sites underlain by liquefaction-susceptible soils should be designated as Soil Site Class F, requiring a site response analysis. However, as discussed in Section 20.3.1 of ASCE/SEI 7-16, for structures having fundamental periods of vibration equal to or less than 0.5 second, it is not required to perform a site response analysis. We understand that the proposed structure will have fundamental periods less than 0.5 second and can therefore be designed using Soil Site Class D as described above.

**FLOODING:** As delineated on the Flood Insurance Rate Map (Panel 1582H) prepared by the Federal Emergency Management Agency, the site is located within an area labeled as “Area of Minimal Flooding-Zone X.”

**TSUNAMIS:** Tsunamis are great sea waves produced by a submarine earthquake or volcanic eruption. Historically, the San Diego area has been relatively free of tsunami-related hazards and tsunamis reaching San Diego have generally been well within the normal tidal range. It is thought that the wide continental margin off the coast acts to diffuse and reflect the wave energy of remotely generated tsunamis. The largest historical tsunami to reach San Diego's coast was 4.6 feet high, generated by the 1960 earthquake in Chile.

The site is adjacent to, however not within the projected tsunami inundation area presented on the La Jolla Quadrangle of the Tsunami Inundation Map for Emergency Planning (CEMA, 2009). The site has also been

mapped adjacent to, but just inland of the maximum tsunami projected runup area in the San Diego County Multi-Jurisdictional Hazard Mitigation Plan (URS, 2004 and 2010). Additionally, a lack of knowledge about the offshore fault systems makes it difficult to assess the risk due to locally generated tsunamis. However, the risk associated with tsunamis at the site is considered to be comparable to nearby, similarly developed sites.

The County of San Diego and the City of San Diego have developed a tsunami alert and evacuation plan. The City has posted signs throughout the community showing routes of evacuation in the event of a tsunami warning, evacuation center locations, and the limits of tsunami hazard areas.

**SEICHES:** Seiches are periodic oscillations in large bodies of water such as lakes, harbors, bays or reservoirs. Although the site is located on the La Jolla Shores area, due to the size and configuration of the La Jolla Cove and Shores area, it is our opinion that the risk potential for damage caused by seiches is very low.

## **LIQUEFACTION**

**GENERAL:** In order to be subject to liquefaction, three conditions must be present: loose sandy or cohesionless silty deposits of a relatively young geologic age, shallow groundwater, and earthquake shaking of sufficient magnitude and duration. Based on our site-specific study, it appears that shallow groundwater is present at the site and strong earthquake shaking may affect the site. Additionally, as described in the Geologic Setting and Soil Description section of this report above, the paralic deposits below the shallow water table in the project area include a layer of poorly-graded sand (SP) with soil properties conducive to liquefaction. Though this material has been estimated to be from the middle to late Pleistocene-age, which is much older than the Holocene-age material that is typically susceptible to liquefaction, this material was evaluated to assess the potential for soil liquefaction and the associated risks.

It should be noted that the following discussion is in no way a guarantee that the analysis will accurately predict the liquefaction potential at the site. The analysis provides general information only on the site liquefaction potential. It should be noted that many of the parameters used in liquefaction evaluations are subjective and open to interpretation, and that much is yet unknown about both the seismicity of the San Diego area and the phenomenon of liquefaction.

**DESCRIPTION OF ANALYSIS:** Our analysis was performed in general accordance with the procedure recommended by the National Center For Earthquake Engineering Research – *NCEER-97-0022, Proceedings of the NCEER Workshop on Evaluation of Liquefaction Resistance of Soils*. The methodology for Standard Penetration Testing (SPT) was used in conjunction with the field blow counts (N) measured in our

exploratory boring B-1. The analysis was limited to the sandy layer of the old paralic deposits as the remaining material is not considered to be susceptible to liquefaction.

**EARTHQUAKE PARAMETERS:** As permitted in Section 1803.5.12 of the California Building Code, our calculations were performed using a peak ground acceleration ( $PGA_M = 0.70g$ ) as determined using the procedures set forth in Section 11.8.3 of ASCE 7-16. We have also performed a seismic hazard deaggregation using the interactive program available on the U. S. Geological Survey website. Within the USGS program, the site coordinates were entered and a deaggregation was performed based on the peak ground acceleration with 2 percent probability of exceedance in 50 years ( $0.66g$ ) for soil with  $V_s^{30} = 260$  m/s (Soil Site Class D). For the subject site, this yielded a modal earthquake magnitude of 6.9. Based on this result and the proximity of the site to the Rose Canyon (7.2 Magnitude) and Coronado Bank (7.6 Magnitude) Fault Zones, this result was used in our analyses.

**POTENTIAL FOR LIQUEFACTION:** Using the parameters described above, the results of our liquefaction analyses indicate that sandy portion of the old paralic deposits below the site possess factors-of-safety against soil liquefaction of less than 1.0 and are therefore considered potentially liquefiable. A complete report of our analysis is presented in Appendix C of this report.

**POST LIQUEFACTION RECONSOLIDATION SETTLEMENT:** The potential amount of total vertical settlement due to reconsolidation of the liquefied soils was estimated using the methods presented by Seed et al, 1985. The estimated settlement within our boring was about 3 inches. It can be noted that, for sites with relatively small lateral displacement (i.e. less than one foot), predicted settlements are typically within a factor of two relative to those observed (Seed et al, 2003).

In terms of differential settlement, CGS Special Publication 117 notes that considerable difficulty exists in trying to “reliably estimate” the amount of differential settlement at a site caused by soil liquefaction. As such, a conservative estimate of differential settlement at any given site can be assumed to be one-half to two-thirds of the total liquefaction-induced settlement. Using this criterion and based on the age of the paralic deposits, the subject project area may be assumed to be subject to approximately 1½ inches of liquefaction-induced, differential settlement. This estimated differential settlement can be assumed to occur over a horizontal distance of 40 feet, which equates to an angular distortion of 0.003L.

**LATERAL SPREADING:** Another concern is the possible lateral ground spreading that could occur at the site. Lateral ground spreading can occur when the viscous liquefied soils flow downslope, usually towards a river channel or shoreline. The project area is located approximately 200 feet from the shoreline and is gently

sloping. Based on this condition, the relatively level hydraulic gradient that is expected across the project area, and the shallow depth of the Ocean shelf, it is our opinion that if liquefaction were to occur during an earthquake, the site will likely experience only minor lateral movement towards the Pacific Ocean.

## CONCLUSIONS

In general, it is our opinion that the subject site is suitable to support the proposed residence; however, special consideration will be required in the design of foundations based on the presence of potentially liquefiable soils. Based on our evaluation, we estimate that a potential differential settlement of approximately 1.5 inches could occur over a horizontal distance of 40 feet (0.003L) as a result of the design-level seismic event. In order to be supported by a shallow foundation system, the estimated differential settlement cannot exceed the thresholds given in Table 12.3-3 of ASCE/SEI 7-16. For this project, which is presumed to include concrete or masonry basement walls, the table specifies that “multistory structures with concrete or masonry wall systems” in Risk Category II have a limiting differential settlement of 2.5 inches over a distance of approximately 40 feet (0.005L). Since the estimated differential settlement does not exceed the threshold, the proposed residence can be supported by shallow foundation systems that are designed in accordance with Section 12.13.9.2 of ASCE/SEI 7-16.

## RECOMMENDATIONS

### GRADING AND EARTHWORK

**GENERAL:** All grading should conform to the guidelines presented in Appendix J of the California Building Code and the minimum requirements of the City of San Diego except where specifically superseded in the text of this report. Prior to grading, a representative of Christian Wheeler Engineering should be present at the pre-construction meeting to provide additional grading guidelines, if necessary, and to review the earthwork schedule.

**OBSERVATION OF GRADING:** Continuous observation by the Geotechnical Consultant is essential during the grading operation to confirm conditions anticipated by our investigation, to allow adjustments in design criteria to reflect actual field conditions exposed, and to determine that the grading proceeds in general accordance with the recommendations contained herein.

**CLEARING AND GRUBBING:** Site preparation should begin with demolition and removal of the existing improvements and the stripping and removal of vegetation, construction debris and other deleterious materials

from the site. This should include all significant root material. The resulting materials should be disposed of off-site in a legal dumpsite.

**SITE PREPARATION:** Site grading is expected to be limited to making cuts of up to about 12 feet for the proposed basement. We anticipate that the cuts for the basement will expose generally competent paralitic deposits. No special site preparation is anticipated for the basement level other than preparing the subgrade in accordance with the Processing of Fill Areas section of this report.

Site preparation in the areas to support the driveway, exterior flatwork, and other light exterior improvements should consist of removing the upper one foot of the existing soils, as well as any soil disturbed soils from the demolition of the existing improvements, and replacing these removed soils as structural fill.

The Geotechnical Consultant should observe the bottom of removal areas prior to either filling or the construction of improvements. Once the Geotechnical Consultant has observed the removal bottom, it should be prepared in accordance with the “Processing of Fill Areas” section of this report. Once the bottom has been prepared, the removed soils may be replaced as properly compacted fill. All fill should be placed in accordance with the “Compaction and Method of Filling” section of this report.

**EXCAVATION CHARACTERISTICS:** Based on our exploratory excavations, the subsurface materials at the site appear to be excavatable to the anticipated excavation depths with conventional heavy-duty earthmoving equipment in good operating condition. Significant caving of the exploratory excavations was not encountered above the water table at the time of our subsurface explorations.

**DEWATERING:** Perched groundwater or localized zones of seepage may be encountered near the proposed basement level, which may necessitate localized, temporary dewatering. If necessary, a contractor specializing in construction dewatering should be retained to design and perform the necessary localized dewatering. It is recommended that if dewatering is needed, it be performed as much as possible on a localized basis in order to minimize its impact on adjacent improvements.

**PROCESSING OF REMOVAL BOTTOM:** Prior to placing any new fill soils or constructing any new improvements in areas that have been excavated and approved by the geotechnical consultant, the exposed soils should be scarified to a depth of 12 inches, moisture conditioned, and compacted to at least 90 percent relative compaction.



**COMPACTION AND METHOD OF FILLING:** All structural fill and backfill material placed at the site should be compacted to a relative compaction of at least 90 percent of maximum dry density as determined by ASTM Laboratory Test D1557. Fills should be placed at or slightly above optimum moisture content, in lifts six to eight inches thick, with each lift compacted by mechanical means. Fills should consist of approved earth material, free of trash or debris, roots, vegetation, or other materials determined to be unsuitable by our soil technicians or project geologist. Fill material should be free of rocks or lumps of soil in excess of twelve inches in maximum dimension; however, this should be reduced to six inches within four feet of finish grade.

**IMPORTED FILL MATERIAL:** Soils to be imported to the site should be evaluated and approved by the Geotechnical Consultant prior to being imported. At least five working days-notice of a potential import source should be given to the Geotechnical Consultant so that appropriate testing can be accomplished. The type of material considered most desirable for import is granular material containing some silt or clay binder, which has an Expansion Index of less than 50. Less than 25 percent of the material should be larger than the Standard #4 sieve, and less than 25 percent finer than the Standard # 200 sieve. Soils not meeting these criteria should not be used for structural fill or backfill.

**TEMPORARY CUT SLOPES:** The contractor is solely responsible for designing and constructing stable, temporary excavations and will need to shore, slope, or bench the sides of trench excavations as required to maintain the stability of the excavation sides. The contractor's "competent person", as defined in the OSHA Construction Standards for Excavations, 29 CFR, Part 1926, should evaluate the soil exposed in the excavations as part of the contractor's safety process. We anticipate that the existing on-site soils will consist of Type C material. Our firm should be contacted to observe all temporary cut slopes during grading to ascertain that no unforeseen adverse conditions exist. No surcharge loads such as foundation loads, or soil or equipment stockpiles, vehicles, etc. should be allowed within a distance from the top of temporary slopes equal to half the slope height.

**SURFACE DRAINAGE:** The ground around the proposed structure should be graded so that surface water flows rapidly away from the structure without ponding. In general, we recommend that the ground adjacent to structure slope away at a gradient of at least 5 percent for a minimum distance of 10 feet. If the minimum distance of 10 feet cannot be achieved, an alternative method of drainage runoff away from the building at the termination of the 5 percent slope will need to be used. Swales and impervious surfaces that are located within 10 feet of the building should have a minimum slope of 2 percent. Rain gutters with downspouts that discharge runoff away from the structure into controlled drainage devices are also recommended.

**GRADING PLAN REVIEW:** The final grading plans should be submitted to this office for review in order to ascertain that the recommendations of this report have been implemented, and that no additional recommendations are needed due to changes in the anticipated development plans.

## **TEMPORARY SHORING**

**GENERAL:** Where it is not possible to construct temporary cut slopes in accordance with the previously recommended criteria, it will be necessary to use temporary shoring to support the proposed excavations. For shoring systems, we considered the use of cantilevered soldier pile walls. We recommend that a specialty contractor with experience in shoring design provide the shoring recommendations and plans. It is recommended that a “survey” be made of adjacent properties and structures prior to the start of grading and excavation in order to establish the existing condition of existing neighboring structures and to reduce the possibility of potential damage claims as a result of site grading.

**SHORING DESIGN AND LATERAL PRESSURES:** For design of cantilevered shoring, a triangular distribution of lateral earth pressure may be used. It may be assumed that retained soils having a level surface behind the cantilevered shoring will exert a lateral pressure equal to that developed by a fluid with a density of 35 pounds per cubic foot.

**DESIGN OF SOLDIER PILES:** Soldier piles should be spaced no closer than two diameters on center. The ultimate lateral bearing value (passive value) of the soils below the level of excavation may be assumed to be 300 pounds per square foot per foot of depth from the excavated surface, up to a maximum of 4,500 pounds per square foot. The lateral bearing can be applied over a horizontal distance equal to twice the pile diameter. To develop the full lateral value, provisions should be made to assure firm contact between the soldier piles and the undisturbed soils. The concrete placed in the soldier pile excavations should be of sufficient strength to adequately transfer the imposed loads to the surrounding soils.

**LAGGING:** Continuous lagging will be required between the soldier piles. The soldier piles and anchors should be designed for the full anticipated lateral pressure. However, the pressure on the lagging will likely be somewhat less due to arching in the soils. We recommend that the lagging be designed for a semi-circular distribution of earth pressure where the maximum pressure is 400 pounds per square foot at the mid-point between soldier piles, and zero pounds per square foot at the soldier piles. This value does not include any surcharge pressures.

**DEFLECTIONS:** We recommend from a geotechnical standpoint that the deflection at the top of the shoring not exceed about one inch. If greater deflection occurs during construction, additional bracing may be necessary.

If desired to reduce the deflection of the shoring, a greater lateral earth pressure could be used in the shoring design.

**MONITORING:** Some means of monitoring the performance of the shoring system is recommended. The monitoring should consist of periodic surveying of the lateral and vertical locations of the tops of the soldier piles approximately every 50 lineal feet. We will be pleased to discuss this further with the design consultants and the contractor when the design of the shoring system has been finalized.

## FOUNDATIONS

**GENERAL:** We expect that the proposed residence will be supported by a mat foundation or conventional spread footings with tie beams per ASCE/SEI 7-16 Section 12.13.9.2. We recommend that the design ground water elevation be taken as 3 feet (datum unknown) based on the previously referenced topographic plan by Hale Engineering. The following design recommendations are considered the minimum based on anticipated soil conditions and are not intended to be lieu of structural considerations. All foundations should be designed by a qualified structural engineer.

**MAT FOUNDATIONS:** The thickness and reinforcement of mat foundations should be in accordance with the specifications of the project structural engineer. The mat can be designed using an allowable bearing pressure of 1,500 pounds per square foot for dead plus live load conditions. This bearing pressure may be increased by up to one-third when considering loads of a short duration such as wind or seismic forces.

Mat foundations typically experience some deflection due to loads placed on the mat and the reaction of the soils underlying the mat. A design coefficient of subgrade reaction,  $K_{v1}$ , of 100 pounds per cubic inch (pci) may be used for evaluating such deflections at the site. This value is based on the anticipated soil conditions and is considered as applied to a unit square foot area. The value should be adjusted for the design mat size. The coefficient of subgrade reaction,  $K_b$ , for a mat of a specific width may be evaluated using the following equation:

$$K_b = K_{v1} [(b+1)/2b]^2$$

Where **b** is the least width of the foundation in feet

**CONVENTIONAL SHALLOW FOOTINGS:** Shallow footings should have a minimum embedment depth of 18 inches below the lowest adjacent grade. Continuous and isolated footings should have a minimum width of 12 and 24 inches, respectively. The allowable bearing pressure for foundations with such

dimensions is 2,500 pounds per square foot for dead plus live load conditions. The bearing pressure may be increased by one-third for combinations of temporary loads such as those due to wind or seismic.

**LATERAL LOAD RESISTANCE:** Lateral loads against foundations may be resisted by friction between the bottom of the footing and the supporting soil, and by the passive pressure against the footing. The coefficient of friction between concrete and soil may be considered to be 0.35. The passive resistance may be considered to be equal to an equivalent fluid weight of 300 pounds per cubic foot. These values are based on the assumption that the footings are poured tight against undisturbed soil. If a combination of the passive pressure and friction is used, the friction value should be reduced by one-third.

**SETTLEMENT CHARACTERISTICS:** The anticipated total and differential foundation settlement for the static condition is expected to be less than one inch and  $\frac{3}{4}$  inch in forty feet, respectively, provided the recommendations presented in this report are followed. It should be recognized that minor cracks normally occur in concrete slabs and foundations due to shrinkage during curing or redistribution of stresses, therefore some cracks should be anticipated. Such cracks are not necessarily an indication of excessive vertical movements.

**EXPANSIVE CHARACTERISTICS:** The foundation soils are expected to have a “low” expansion index. The site preparation and foundation recommendations reflect this condition.

**FOUNDATION PLAN REVIEW:** The final foundation plan and accompanying details and notes should be submitted to this office for review. The intent of our review will be to verify that the plans used for construction reflect the minimum dimensioning and reinforcing criteria presented in this section and that no additional criteria are required due to changes in the foundation type or layout. It is not our intent to review structural plans, notes, details, or calculations to verify that the design engineer has correctly applied the geotechnical design values. It is the responsibility of the design engineer to properly design/specify the foundations and other structural elements based on the requirements of the structure and considering the information presented in this report.

**FOUNDATION EXCAVATION OBSERVATION:** All foundation excavations should be observed by the Geotechnical Consultant prior to placing reinforcing steel or formwork in order to determine if the foundation recommendations presented herein are followed. All footing excavations should be excavated neat, level, and square. All loose or unsuitable material should be removed prior to the placement of concrete.

## **CORROSIVITY**

The water-soluble sulfate content was determined in accordance with California Test Method 417 for a representative soil sample from the site. The result of this test indicates that the foundation soils may be categorized as  $S_0$  per *ACI 318: Building Code Requirements for Structural Concrete*.

It should be understood Christian Wheeler Engineering does not practice corrosion engineering. If such an analysis is considered necessary, we recommend that the client retain an engineering firm that specializes in this field to consult with them on this matter. The results of our tests should only be used as a guideline to determine if additional testing and analysis is necessary.

## **ON-GRADE SLABS**

**GENERAL:** It is our understanding that the basement level will have a concrete slab-on-grade floor if conventional shallow foundations are used. The following recommendations are considered the minimum slab requirements based on the soil conditions and are not intended to be in lieu of structural considerations.

**BASEMENT SLAB:** We recommend that the basement slab-on-grade be at least 6 inches thick and be reinforced with at least No. 3 bars spaced at 18 inches on center each way. The reinforcing bars should extend at least six inches into the foundations and should be supported by chairs and be positioned in the center of the slab. The owner and the project structural engineer should determine if the on-grade slabs need to be designed for special loading conditions. For such cases, a subgrade modulus of 100 pounds per cubic inch can be assumed for the subgrade provided it is prepared as recommended in this report. The allowable bearing pressure for the subgrade is 1,500 pounds per square foot.

**UNDER-SLAB VAPOR RETARDERS:** Steps should be taken to minimize the transmission of moisture vapor from the subsoil through the interior slabs where it can potentially damage the interior floor coverings. We recommend that the owner/contractor follow national standards for the installation of vapor retarders below interior slabs as presented in currently published standards including ACI 302, "Guide to Concrete Floor and Slab Construction" and ASTM E1643, "Standard Practice for Installation of Water Vapor Retarder Used in Contact with Earth or Granular Fill Under Concrete Slabs".

**EXTERIOR CONCRETE FLATWORK:** Exterior slabs not subject to vehicular traffic should have a minimum thickness of 4 inches. Slabs that will be support vehicular traffic should have a minimum thickness of 6 inches. Reinforcement can be placed in exterior concrete flatwork to reduce the potential for cracking and

movement. Control joints should be placed in exterior concrete flatwork to help control the location of shrinkage cracks. Spacing of control joints should be in accordance with the American Concrete Institute specifications.

Special attention should be paid to the method of concrete curing to reduce the potential for excessive shrinkage and resultant random cracking. It should be recognized that minor cracks occur normally in concrete slabs due to shrinkage. Some shrinkage cracks should be expected and are not necessarily an indication of excessive movement or structural distress.

## **EARTH RETAINING WALLS**

**FOUNDATIONS:** Foundations for retaining walls can be designed in accordance with the foundation recommendations previously presented.

**ACTIVE PRESSURES:** The active soil pressure for the design of unrestrained earth retaining structures with level backfill surface may be assumed to be equivalent to the pressure of a fluid weighing 35 and 80 pounds per cubic foot for drained and undrained conditions, respectively. In the design of walls restrained from movement at the top (non-yielding walls) with a level backfill surface, the at-rest soil pressure may be assumed to be equivalent to the pressure of a fluid weighing 55 and 90 pounds per cubic foot for drained and undrained conditions, respectively.

Thirty percent of any area surcharge placed adjacent to the retaining wall may be assumed to act as a uniform horizontal pressure against the wall. Where vehicles will be allowed within ten feet of the retaining wall, a uniform horizontal pressure of 100 pounds per square foot should be added to the upper 10 feet of the retaining wall to account for the effects of adjacent traffic. Special cases such as a combination of shored and sloping temporary slopes, or other surcharge loads not described above, may require an increase in the design values recommended above. These conditions should be evaluated by the project geotechnical engineer on a case-by-case basis. If any other loads are anticipated, the Geotechnical Consultant should be contacted for the necessary increase in soil pressure.

For load combinations including earthquake, the seismic increment may be assumed to be equivalent to the pressure of a fluid weighing 17 pounds per cubic foot. For restrained basement walls, this value should be added to the active pressure as if the walls are unrestrained.

**PASSIVE PRESSURES:** The passive pressure for the prevailing soil conditions may be considered to be 300 pounds per square foot per foot of depth for foundations in fill soil. This pressure may be increased one-third for seismic loading. The coefficient of friction for concrete to soil may be assumed to be 0.35 for the resistance to lateral movement. When combining frictional and passive resistance, the friction should be reduced by one-third

**WATERPROOFING AND SUBDRAINS:** The project architect should provide (or coordinate) waterproofing details for the retaining walls. The design values presented above are based on both drained and undrained backfill conditions. Wall drainage will need to be coordinated with the temporary shoring and should be detailed by others. Outlet points for the retaining wall subdrains should be coordinated by the project civil engineer. For subterranean walls, it may be necessary to collect the subdrain water in sumps and then pump it to an appropriate outlet.

**BACKFILL:** All retaining wall backfill should be compacted to at least 90 percent relative compaction. It is anticipated that the on-site soils are suitable for use as backfill material provided the design parameters given herein are used in the wall design. Retaining walls should not be backfilled until the masonry/concrete has reached an adequate strength.

## LIMITATIONS

### UNIFORMITY OF CONDITIONS

The recommendations and opinions expressed in this report reflect our best estimate of the project requirements based on an evaluation of the subsurface soil conditions encountered at the subsurface exploration locations and on the assumption that the soil conditions do not deviate appreciably from those encountered. It should be recognized that the performance of the foundations and/or cut and fill slopes may be influenced by undisclosed or unforeseen variations in the soil conditions that may occur in the intermediate and unexplored areas. Any unusual conditions not covered in this report that may be encountered during site development should be brought to the attention of the Geotechnical Engineer so that he may make modifications if necessary.

### CHANGE IN SCOPE

This office should be advised of any changes in the project scope or proposed site grading so that we may determine if the conclusions contained herein are appropriate. It should be verified in writing if the

recommendations are found to be appropriate for the proposed changes or our recommendations should be modified by a written addendum.

### **TIME LIMITATIONS**

The findings of this report are valid as of this date. Changes in the condition of a property can, however, occur with the passage of time, whether they are due to natural processes or the work of man on this or adjacent properties. In addition, changes in the Standards-of-Practice and/or Government Codes may occur. Due to such changes, the findings of this report may be invalidated wholly or in part by changes beyond our control. Therefore, this report should not be relied upon after a period of two years without a review by us verifying the suitability of the conclusions and recommendations.

### **PROFESSIONAL STANDARD**

In the performance of our professional services, we comply with that level of care and skill ordinarily exercised by members of our profession currently practicing under similar conditions and in the same locality. The client recognizes that subsurface conditions may vary from those encountered at the locations where our borings, surveys, and explorations are made, and that our data, interpretations, and recommendations are based solely on the information obtained by us. We will be responsible for those data, interpretations, and recommendations, but shall not be responsible for the interpretations by others of the information developed. Our services consist of professional consultation and observation only, and no warranty of any kind whatsoever, express or implied, is made or intended in connection with the work performed or to be performed by us, or by our proposal for consulting or other services, or by our furnishing of oral or written reports or findings.

### **FIELD EXPLORATIONS**

One subsurface exploration was made on June 4, 2020 at the location indicated on the Site Plan and Geotechnical Map included herewith as Plate Number 1. This exploration consisted of a small-diameter, hollow-stem auger advanced using a limited access drill rig. The fieldwork was conducted under the observation and direction of our engineering geology personnel.

The boring was carefully logged when made. The boring log is presented in the attached Appendix A. The soils are described in accordance with the Unified Soils Classification. In addition, a verbal textural description, the wet color, the apparent moisture and the density or consistency are provided. The density of granular soils is given as either very loose, loose, medium dense, dense or very dense. The consistency of silts or clays is given as



either very soft, soft, medium stiff, stiff, very stiff, or hard. Undisturbed samples of typical and representative soils were obtained and returned to the laboratory for testing. The undisturbed samples were obtained by driving a 2 3/8-inch inside diameter split-tube sampler ahead of the auger using a 140-pound weight free-falling a distance of 30 inches. The number of blows required to drive the sampler each foot was recorded and this value is presented on the attached boring logs as "Penetration Resistance." Bulk samples of disturbed soil were also collected in bags from the auger cuttings during the advancement of the borings and transported to the laboratory for testing.

### **LABORATORY TESTING**

Laboratory tests were performed in accordance with the generally accepted American Society for Testing and Materials (ASTM) test methods or suggested procedures. A brief description of the tests performed and the subsequent results are presented in Appendix B.

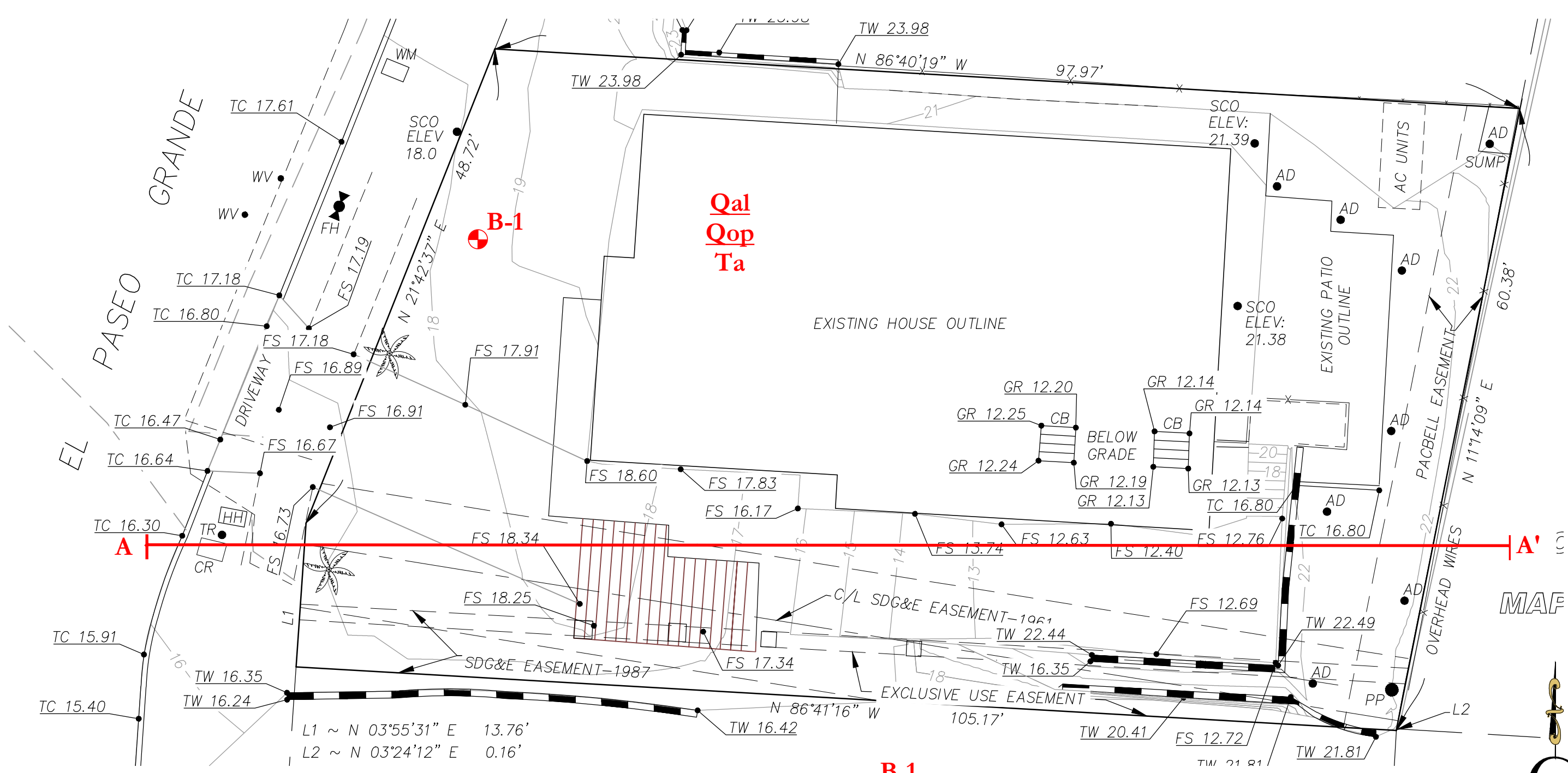

**CWE LEGEND**

**B-1** APPROXIMATE BORING LOCATION

**B-1** APPROXIMATE BORING LOCATION (CWE, 2008)

**A-A'** GEOLOGIC CROSS-SECTION

**Qal**  
**Qop**  
**Ta** ALLUVIUM OVER  
OLD PARALIC DEPOSITS OVER  
ARDATH SHALE

EXHIBIT FOR:  
**HARPER RESIDENCE**  
LOT 3, MAP 5396  
SHEET 1 OF 1

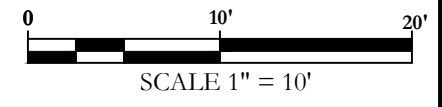

**EXISTING SITE PLAN AND GEOTECHNICAL MAP**

<b>PROPOSED SINGLE-FAMILY RESIDENCE</b> 8455 EL PASEO GRANDE, LA JOLLA, CA	
DATE: JULY 2020	REPORT NO.: 2190610.01
BY: SCC	PLATE NO.: 1

**CHRISTIAN WHEELER**  
ENGINEERING

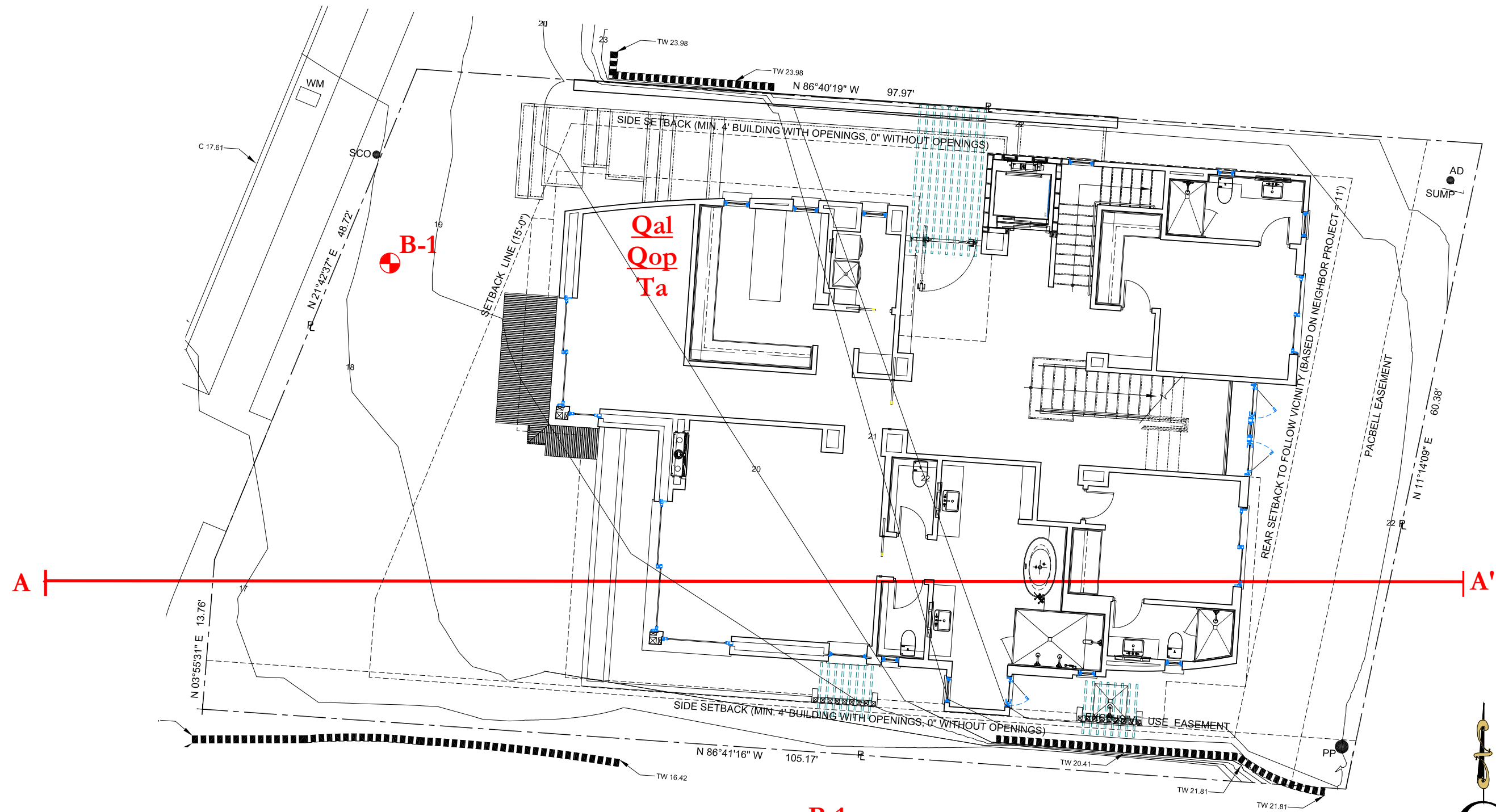

**CWE LEGEND**

**B-1** APPROXIMATE BORING LOCATION

**B-1** APPROXIMATE BORING LOCATION (CWE, 2008)

**A** **A'** GEOLOGIC CROSS-SECTION

**Qal**  
**Qop**  
**Ta** ALLUVIUM OVER  
OLD PARALIC DEPOSITS OVER  
ARDATH SHALE

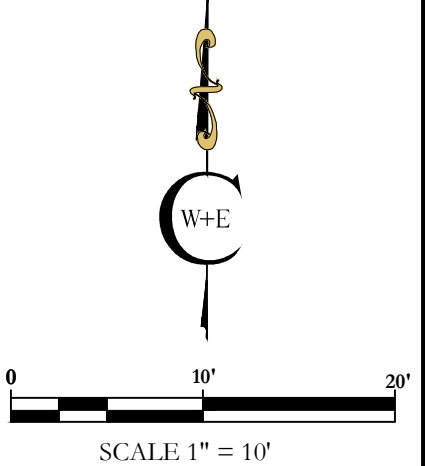
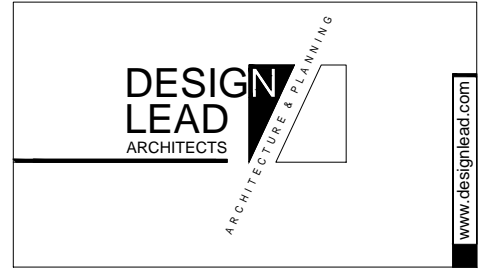

**PROPOSED SITE PLAN AND GEOTECHNICAL MAP**

**PROPOSED SINGLE-FAMILY RESIDENCE**  
8455 EL PASEO GRANDE, LA JOLLA, CA

DATE: JULY 2020	REPORT NO.: 2190610.01
BY: SCC	PLATE NO.: 2



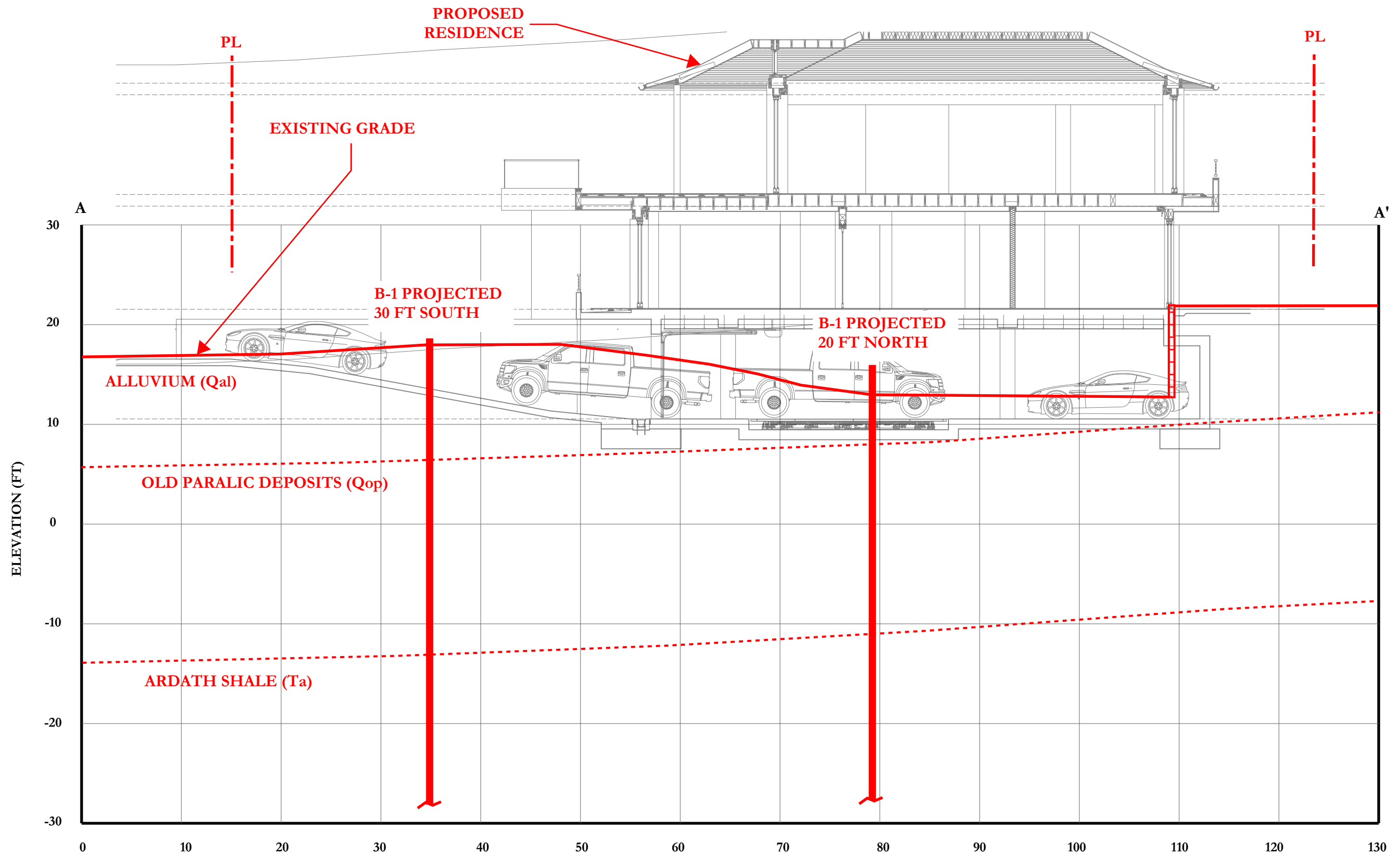

SCALE 1" = 10'

**GEOLOGIG CROSS-SECTION A-A'**

<b>PROPOSED SINGLE-FAMILY RESIDENCE</b> 8455 EL PASEO GRANDE, LA JOLLA, CA	
DATE: JULY 2020	REPORT NO.: 2190610.01
BY: SCC	PLATE NO.: 3



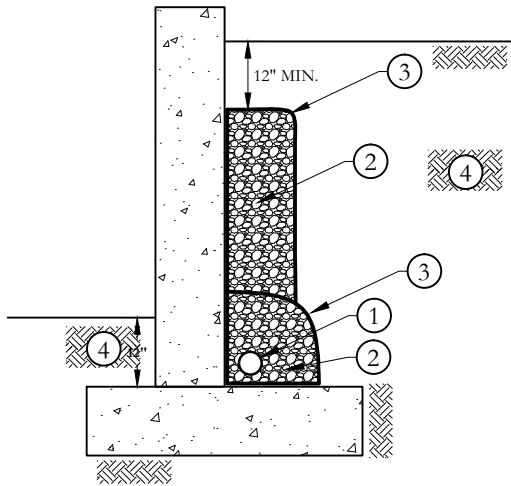

**1** DETAIL

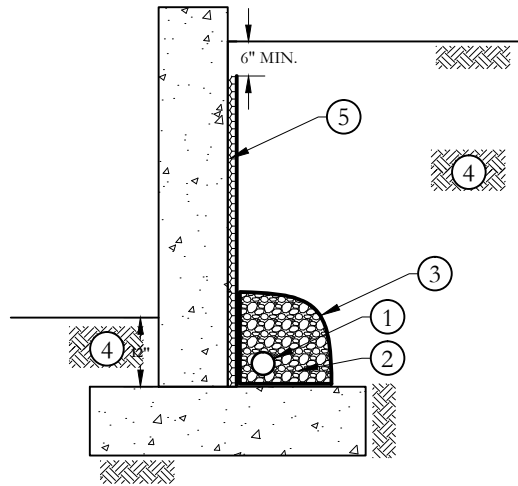

**2** DETAIL

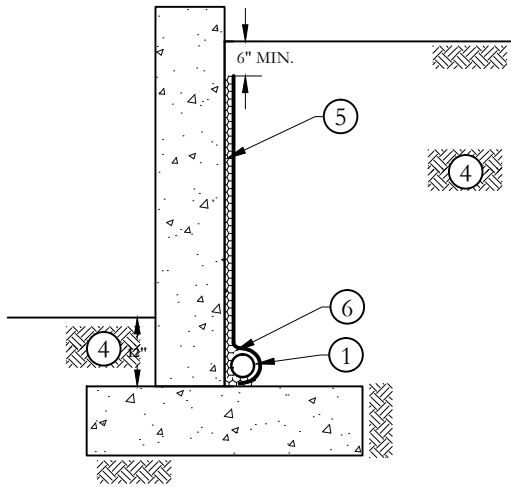

**3** DETAIL

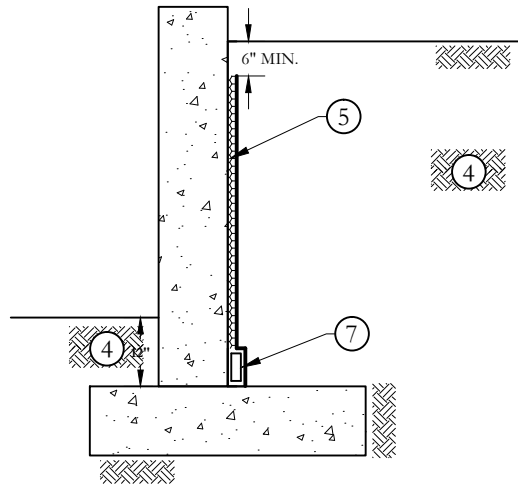

**4** DETAIL

**NOTES AND DETAILS**

**GENERAL NOTES:**

- 1) THE NEED FOR WATERPROOFING SHOULD BE EVALUATED BY OTHERS.
- 2) WATERPROOFING TO BE DESIGNED BY OTHERS (CWE CAN PROVIDE A DESIGN IF REQUESTED).
- 3) EXTEND DRAIN TO SUITABLE DISCHARGE POINT PER CIVIL ENGINEER.
- 4) DO NOT CONNECT SURFACE DRAINS TO SUBDRAIN SYSTEM.

**DETAILS:**

- |   |   |
|---|---|
| <ul style="list-style-type: none"> <li>① 4-INCH PERFORATED PVC PIPE ON TOP OF FOOTING, HOLES POSITIONED DOWNWARD (SDR 35, SCHEDULE 40, OR EQUIVALENT).</li> <li>② ¾ INCH OPEN-GRADED CRUSHED AGGREGATE.</li> <li>③ GEOFABRIC WRAPPED COMPLETELY AROUND ROCK.</li> <li>④ PROPERLY COMPACTED BACKFILL SOIL.</li> <li>⑤ WALL DRAINAGE PANELS (MIRADRAIN OR EQUIVALENT) PLACED PER MANUFACTURER'S REC'S.</li> </ul> | <ul style="list-style-type: none"> <li>⑥ UNDERLAY SUBDRAIN WITH AND CUT FABRIC BACK FROM DRAINAGE PANELS AND WRAP FABRIC AROUND PIPE.</li> <li>⑦ COLLECTION DRAIN (TOTAL DRAIN OR EQUIVALENT) LOCATED AT BASE OF WALL DRAINAGE PANEL PER MANUFACTURER'S RECOMMENDATIONS.</li> </ul> |
|---|---|

**CANTILEVER RETAINING WALL  
DRAINAGE SYSTEMS**

PROPOSED SINGLE-FAMILY RESIDENCE  
8455 EL. PASEO GRANDE  
LA JOLLA, CALIFORNIA

DATE: JUNE 2020

JOB NO.: 2190610.01

BY: SRD

PLATE NO.: 4



CHRISTIAN WHEELER  
ENGINEERING

# Appendix A

---

Boring Log

# LOG OF TEST BORING B-1

## Sample Type and Laboratory Test Legend





Cal	Modified California Sampler	CK	Chunk
SPT	Standard Penetration Test	DR	Drive Ring
ST	Shelby Tube		
MD	Max Density	DS	Direct Shear
SO4	Soluble Sulfates	Con	Consolidation
SA	Sieve Analysis	EI	Expansion Index
HA	Hydrometer	R-Val	Resistance Value
SE	Sand Equivalent	Chl	Soluble Chlorides
PI	Plasticity Index	Res	pH & Resistivity
CP	Collapse Potential	SD	Sample Density

Date Logged: 6/4/20      Equipment: Frasta Limited Access  
 Logged By: DJF      Auger Type: 6 inch Hollow Stem  
 Existing Elevation: 18.5'      Drive Type: 140lbs/30 inches  
 Proposed Elevation: Unknown      Depth to Water: Unknown

DEPTH (ft)	ELEVATION (ft)	GRAPHIC LOG	USCS SYMBOL	SUMMARY OF SUBSURFACE CONDITIONS (based on Unified Soil Classification System)	PENETRATION (blows per foot)	SAMPLE TYPE	BULK	MOISTURE CONTENT (%)	DRY DENSITY (pcf)	RELATIVE COMPACTION (%)	LABORATORY TESTS
0				Lawn and Associated Topsoil.							
			ML	<b>Alluvium (Qal):</b> Light brown, moist, medium stiff, SANDY SILT with clay, upper 24" disturbed.							SA MD SO4 Chl
				Trace rootlets.	9	Cal					Res DS
				Very moist, soft, trace Hematite nodules, reddish iron staining.	6	Cal					DS
			SC	<b>Old Paralic Deposits (Qop):</b> Grayish-brown, moist, medium dense, very fine- to medium-grained, CLAYEY SAND with reddish iron staining.	23	Cal					
				Reddish-brown to grayish-brown, dense.	37	Cal					SA
				Saturated, medium dense. Groundwater at 17' 2".							
			SP	Light gray, saturated, medium dense, very fine- to medium-grained, very fine- to medium-grained, poorly graded SAND, flowing sands.	14	Cal*					
					13	SPT					SA
					14	SPT					SA
30				Continues on A-2							

### Notes:

### Symbol Legend

-  Groundwater Level During Drilling
-  Groundwater Level After Drilling
-  Apparent Seepage
-  No Sample Recovery
-  Non-Representative Blow Count (rocks present)

PROPOSED SINGLE-FAMILY RESIDENCE  
 8455 EL PASEO GRANDE  
 LA JOLLA, CALIFORNIA

DATE:	JULY 2020	JOB NO.:	2190610.01
BY:	SRD	APPENDIX:	A-1



CHRISTIAN WHEELER  
 ENGINEERING

# LOG OF TEST BORING B-1 (Cont.)

## Sample Type and Laboratory Test Legend

Cal	Modified California Sampler	CK	Chunk
SPT	Standard Penetration Test	DR	Drive Ring
ST	Shelby Tube		
MD	Max Density	DS	Direct Shear
SO4	Soluble Sulfates	Con	Consolidation
SA	Sieve Analysis	EI	Expansion Index
HA	Hydrometer	R-Val	Resistance Value
SE	Sand Equivalent	Cbl	Soluble Chlorides
PI	Plasticity Index	Res	pH & Resistivity
CP	Collapse Potential	SD	Sample Density

Date Logged: 6/4/20      Equipment: Frasta Limited Access  
 Logged By: DJF      Auger Type: 6 inch Hollow Stem  
 Existing Elevation: 18.5'      Drive Type: 140lbs/30 inches  
 Proposed Elevation: Unknown      Depth to Water: Unknown

DEPTH (ft)	ELEVATION (ft)	GRAPHIC LOG	USCS SYMBOL	SUMMARY OF SUBSURFACE CONDITIONS (based on Unified Soil Classification System)	PENETRATION (blows per foot)	SAMPLE TYPE	BULK	MOISTURE CONTENT (%)	DRY DENSITY (pcf)	RELATIVE COMPACTION (%)	LABORATORY TESTS
30			SP	<b>Old Paralac Deposits (Qop):</b> Light gray, saturated, medium dense, very fine- to medium-grained, poorly graded SAND.							
35			CL	<b>Ardath Shale (Ta):</b> Yellowish-brown to light gray, moist, hard, SILTY CLAY.	67	SPT					
40					50/4"	SPT					
45				Possible concretion at 43'. Practical refusal at 43'. Groundwater at 17' 2".	50/1"	SPT*					
50											
55											
60											

### Notes:

### Symbol Legend

- Groundwater Level During Drilling
- Groundwater Level After Drilling
- Apparent Seepage
- \* No Sample Recovery
- \*\* Non-Representative Blow Count (rocks present)

PROPOSED SINGLE-FAMILY RESIDENCE  
 8455 EL PASEO GRANDE  
 LA JOLLA, CALIFORNIA

DATE: JULY 2020      JOB NO.: 2190610.01  
 BY: SRD      APPENDIX: A-2



CHRISTIAN WHEELER  
 ENGINEERING



# Appendix B

---

## Laboratory Test Results

Laboratory tests were performed in accordance with the generally accepted American Society for Testing and Materials (ASTM) test methods or suggested procedures. Brief descriptions of the tests performed are presented below:

- a) **CLASSIFICATION:** Field classifications were verified in the laboratory by visual examination. The final soil classifications are in accordance with the Unified Soil Classification System and are presented on the exploration logs in Appendix A.
- b) **MOISTURE-DENSITY:** In-place moisture contents and dry densities were determined for representative soil samples. This information was an aid to classification and permitted recognition of variations in material consistency with depth. The dry unit weight is determined in pounds per cubic foot, and the in-place moisture content is determined as a percentage of the soil's dry weight. The results of these tests are summarized in the exploration logs presented in Appendix A.
- c) **DIRECT SHEAR:** Direct shear tests were performed to determine the failure envelope of selected soils based on yield shear strength. The shear box was designed to accommodate a sample having a diameter of 2.375 inches or 2.50 inches and a height of 1.0 inch. Samples were tested at different vertical loads and a saturated moisture content. The shear stress was applied at a constant rate of strain of approximately 0.05 inch per minute.
- d) **GRAIN SIZE DISTRIBUTION:** The grain size distributions of selected samples were determined in accordance with ASTM C136 and/or ASTM D422.
- e) **MAXIMUM DENSITY & OPTIMUM MOISTURE CONTENT:** The maximum dry density and optimum moisture content of typical soils were determined in the laboratory in accordance with ASTM Standard Test D-1557, Method A.
- f) **SOLUBLE SULFATES:** The soluble sulfate content was determined for samples of soil likely to be present at the foundation level. The soluble sulfate content was determined in accordance with California Test Method 417.

 CHRISTIAN WHEELER ENGINEERING	<b>LABORATORY TEST RESULTS</b>	PROJECT NO. 2190610
		DATE 07/2020
	<b>PROPOSED SINGLE-FAMILY RESIDENCE</b> 8455 EL PASEO GRANDE, LA JOLLA, CALIFORNIA	FIGURE <b>1</b>

# DIRECT SHEAR TEST (ASTM D3080)

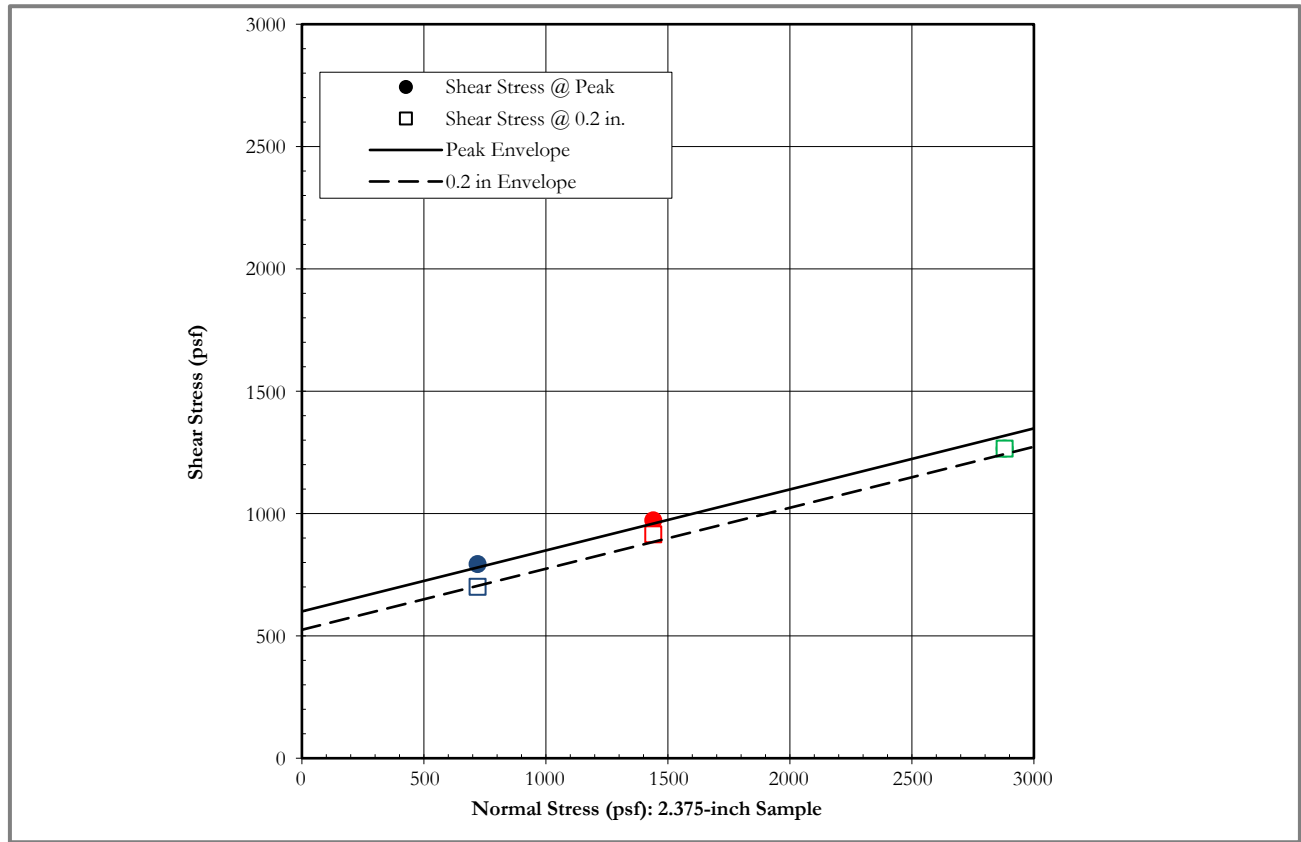
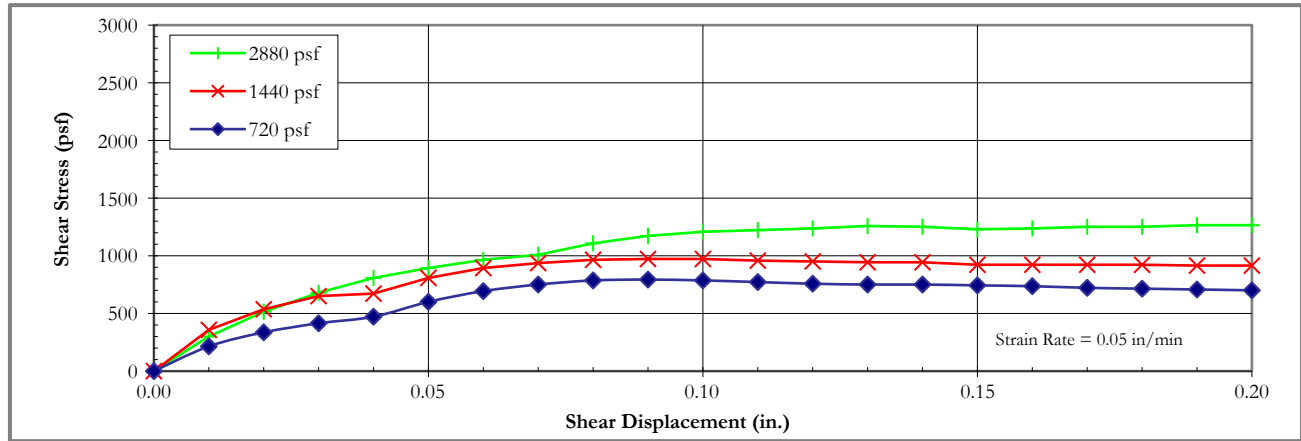

Sample No. **B-1 @ 4½'**

Sample Type: Undisturbed (Ring)

Normal Stress (psf)	<b>720</b>	<b>1440</b>	<b>2880</b>
Peak Shear Stress (psf)	794	972	1266
Shear Stress at 0.2 in (psf)	701	915	1266
Initial Dry Density (pcf)	93.7	93.8	93.2
Initial Moisture Content (%)	26.4	27.1	26.8

	<b>Peak</b>	<b>at 0.2 in Displacement</b>
Friction Angle, $\phi$ (deg):	14	14
Cohesion Intercept, $c$ (psf):	600	525



CHRISTIAN WHEELER  
ENGINEERING

## LABORATORY TEST RESULTS

PROPOSED SINGLE-FAMILY RESIDENCE  
8455 EL PASEO GRANDE, LA JOLLA, CALIFORNIA

PROJECT NO. 2190610

DATE 07/2020

FIGURE

**2**

# DIRECT SHEAR TEST (ASTM D3080)

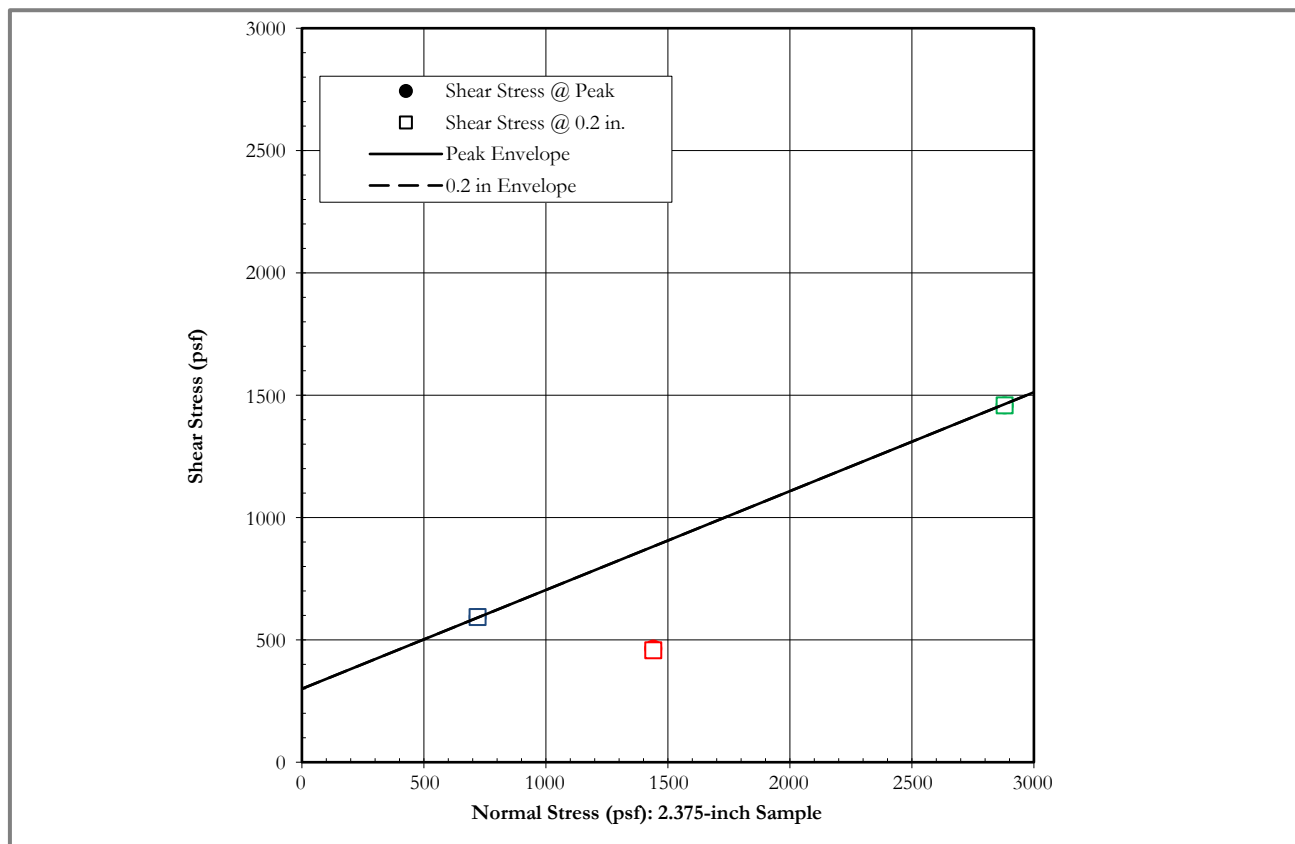
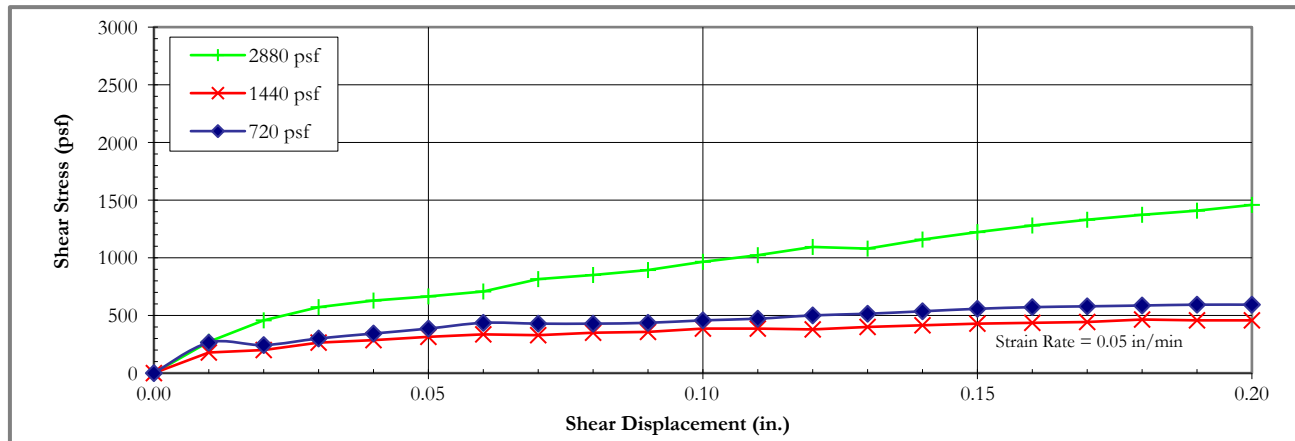

Sample No. **B-1 @ 9½'**

Sample Type: Undisturbed (Ring)

Normal Stress (psf)	<b>720</b>	<b>1440</b>	<b>2880</b>
Peak Shear Stress (psf)	593	465	1459
Shear Stress at 0.2 in (psf)	593	458	1459
Initial Dry Density (pcf)	102.9	95.9	104
Initial Moisture Content (%)	21.8	25.7	22.4

	<b>Peak</b>	<b>at 0.2 in Displacement</b>
Friction Angle, $\phi$ (deg):	22	22
Cohesion Intercept, $c$ (psf):	300	300



CHRISTIAN WHEELER  
ENGINEERING

## LABORATORY TEST RESULTS

PROPOSED SINGLE-FAMILY RESIDENCE  
8455 EL PASEO GRANDE, LA JOLLA, CALIFORNIA

PROJECT NO. 2190610

DATE 07/2020

FIGURE

**3**

# GRAIN SIZE DISTRIBUTION (ASTM D422)

Cobble

Cobble		Gravel		Sand			Silt and Clay
		Coarse	Fine	Coarse	Medium	Fine	

U.S. Standard Sieves

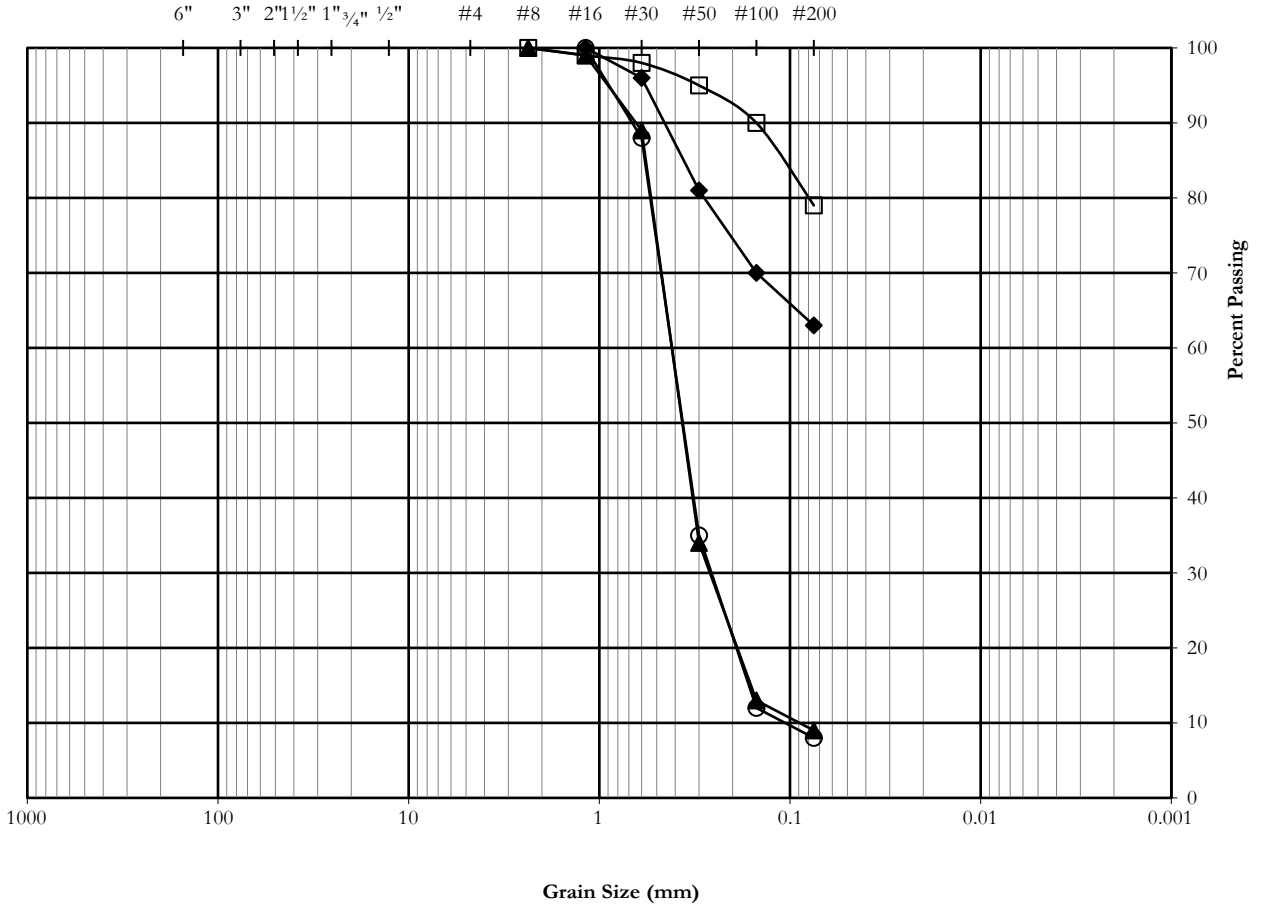

Symbol	Sample No.	Liquid Limit	Plastic Limit	Plasticity Index	D <sub>10</sub>	D <sub>30</sub>	D <sub>60</sub>	C <sub>u</sub>	C <sub>c</sub>	USCS
□	B-1 @ 1½'-5'									ML
♦	B-1 @ 16½'									CL
○	B-1 @ 22½'-23½'									SP-SM
▲	B-1 @ 28½'-29½'									SP-SM



## LABORATORY TEST RESULTS

**PROPOSED SINGLE-FAMILY RESIDENCE**  
8455 EL PASEO GRANDE, LA JOLLA, CALIFORNIA

PROJECT NO. 2190610
DATE 07/2020
FIGURE

**MAXIMUM DENSITY AND OPTIMUM MOISTURE CONTENT (ASTM D1557)**

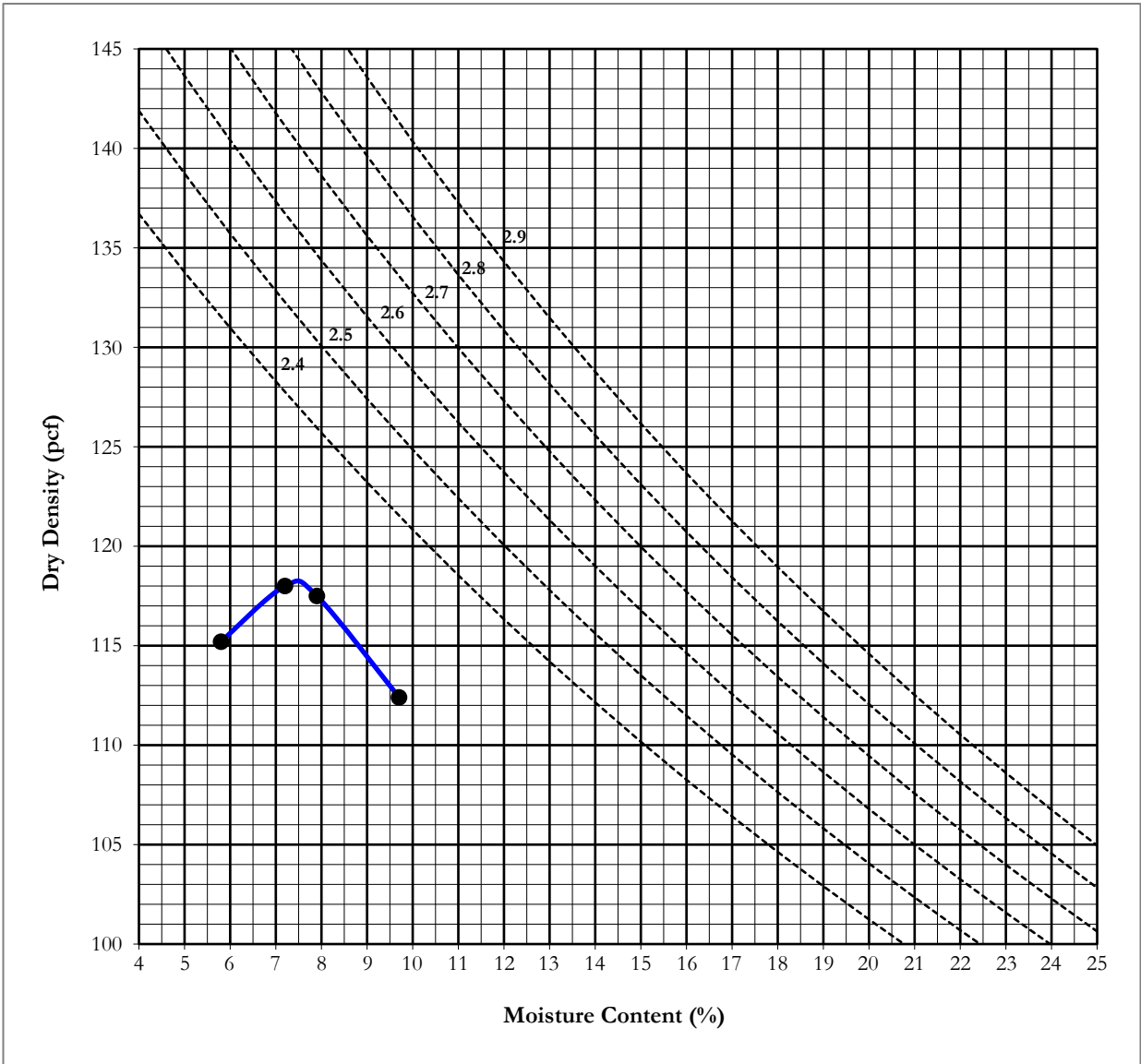

Sample No	Sample Description	Method	Maximum Dry Density (pcf)	Optimum Moisture Content (%)
B-1 @ 1/2'-5'	Light brown, sandy silt (ML) w/clay	A	118.0	7.2



CHRISTIAN WHEELER  
ENGINEERING

**LABORATORY TEST RESULTS**

PROPOSED SINGLE-FAMILY RESIDENCE  
8455 EL. PASEO GRANDE, LA JOLLA, CALIFORNIA

PROJECT NO. 2190610

DATE 07/2020

FIGURE

**5**

## CORROSIVITY TESTS

Sample No.	Caltest 417	Caltest 643		Caltest 422
	Sulfate Content (% SO <sub>4</sub> )	pH	Resistivity (ohm-cm)	Chloride Content (%)
B-2 @ 1½'-5'	0.008	8.2	1,100	0.004



CHRISTIAN WHEELER  
ENGINEERING

### LABORATORY TEST RESULTS

**PROPOSED SINGLE-FAMILY RESIDENCE**  
8455 EL PASEO GRANDE, LA JOLLA, CALIFORNIA

PROJECT NO. 2190610

DATE 07/2020

FIGURE

6

# Appendix C

---

**Boring Log and Laboratory Test Results (CWE, 2008)**



## LOG OF TEST BORING NUMBER B-1

Date Excavated:	12/19/2007	Logged by:	DF
Equipment:	CME 55 Drill Rig	Project Manager:	CHC
Existing Elevation:	16 feet	Depth to Water:	15'
Finish Elevation:	5 feet	Drive Weight:	140 lbs.

DEPTH (feet)	GRAPHIC LOG	SUMMARY OF SUBSURFACE CONDITIONS	SAMPLES						
			SAMPLE TYPE	BULK	PENETRATION (blows/foot)	MOISTURE (%)	DRY UNIT WT. (pcf)	LABORATORY TESTS	
		4 inches of concrete.							
2		<b>Sloewash (Qsw):</b> Medium grayish-brown, moist, medium stiff to stiff, SILTY CLAY (CL), with organics, moderatley porous. Contact at 3½ feet	Cal	15	21.0	102.3			
4		Light brown, moist, loose, CLAYEY SAND (SC), very fine to fine-grained, porous.	Cal	11	19.8	102.3			
8		<b>Bay Point Formation (Qbp):</b> Medium grayish-brown, moist, very stiff, SILTY CLAY (CL), with sand. Expansion Index = 36 (low).	Cal	31					SA DS E.I. SO <sub>4</sub>
14		Ground water table at 15 feet. Becomes saturated.	Cal	45	14.1	120.4			
18		Light brown, saturated, loose to medium dense, POORLY GRADED SAND-SILTY SAND (SP-SM), very fine to medium-grained, micaceous.	Cal	12					

Boring continued on Plate No. 4.



### PROPOSED SINGLE-FAMILY RESIDENCE 8449 El Paseo Grande, La Jolla, California

BY:	WM	DATE:	January 2008
JOB NO. :	2060605	PLATE NO.:	3

## LOG OF TEST BORING NUMBER B-1 (Continued)

Date Excavated:	12/19/2007	Logged by:	DF
Equipment:	CME 55 Drill Rig	Project Manager:	CHC
Existing Elevation:	16 feet	Depth to Water:	15'
Finish Elevation:	5 feet	Drive Weight:	140 lbs.

DEPTH (feet)	GRAPHIC LOG	SUMMARY OF SUBSURFACE CONDITIONS					SAMPLES		MOISTURE (%)	DRY UNIT WT. (pcf)	LABORATORY TESTS
		SAMPLE TYPE	BULK	PENETRATION (blows/foot)							
22		<p><b>Bay Point Formation (Qbp):</b> Light brown, saturated, loose to medium dense, POORLY GRADED SAND-SILTY SAND (SP-SM), very fine to medium-grained.</p> <p>Becomes dense at 24 feet.</p>	SPT		41					SA	
24											
26											
28		<p><b>Ardath Shale (Ta):</b> Light grayish-brown to light brown, moist, hard, SILTY CLAY (CL), well bedded.</p>	SPT		49						
30											
32											
34											
36		<p>Boring terminated at 36 feet. Groundwater at 17 feet.</p>	SPT		59						
36			Cal		50-5"	22.4	103.5				
38											
40											



CHRISTIAN WHEELER  
Engineering

**PROPOSED SINGLE-FAMILY RESIDENCE**  
**8449 El Paseo Grande, La Jolla, California**

BY:	WM	DATE:	January 2008
JOB NO. :	2060605	PLATE NO.:	4

# LABORATORY TEST RESULTS

## PROPOSED SINGLE-FAMILY HOME

8449 EL PASEO GRANDE

SAN DIEGO, CALIFORNIA

### MAXIMUM DRY DENSITY AND OPTIMUM MOISTURE CONTENT (ASTM D1557)

**Sample Location:** Test Pit P-1 @ 1.5'-5.5'  
Sample Description: Grayish brown, CL  
Maximum Density: 119.2 pcf  
Optimum Moisture: 8.9 %

### DIRECT SHEAR (ASTM D3080)

**Sample Location:** Boring B-1 @ 10'  
Sample Type: Natural  
Friction Angle: 18 °  
Cohesion: 1200 psf

### GRAIN SIZE DISTRIBUTION (ASTM D422/C136)

<b>Sample Location</b>	<b>Boring B-1 @ 8'-12'</b>	<b>Boring B-1 @ 24'-25'</b>
<i>Sieve Size</i>	<i>Percent Passing</i>	<i>Percent Passing</i>
#4	100	--
#8	100	100
#16	99	100
#30	95	92
#50	80	34
#100	67	12
#200	56	7
0.05 mm	50	--
0.005 mm	26	--
0.001 mm	23	--

### EXPANSION INDEX (ASTM D4829)

<b>Sample Location:</b>	<b>Boring B-1 @ 8'-12'</b>	<b>Test Pit P-1 @ 1.5'-5.5'</b>
Initial Moisture:	9.2 %	10.5 %
Initial Dry Density:	111.1 pcf	104.9 pcf
Final Moisture:	20.4 %	23.8 %
Expansion Index:	36 (medium)	43 (medium)

### SOLUBLE SULFATE

<b>Sample Location:</b>	<b>Boring B-1 @ 8'-12'</b>	<b>Test Pit P-1 @ 1.5'-5.5'</b>
Soluble Sulfate:	0.020 % (SO <sub>4</sub> )	0.013 % (SO <sub>4</sub> )

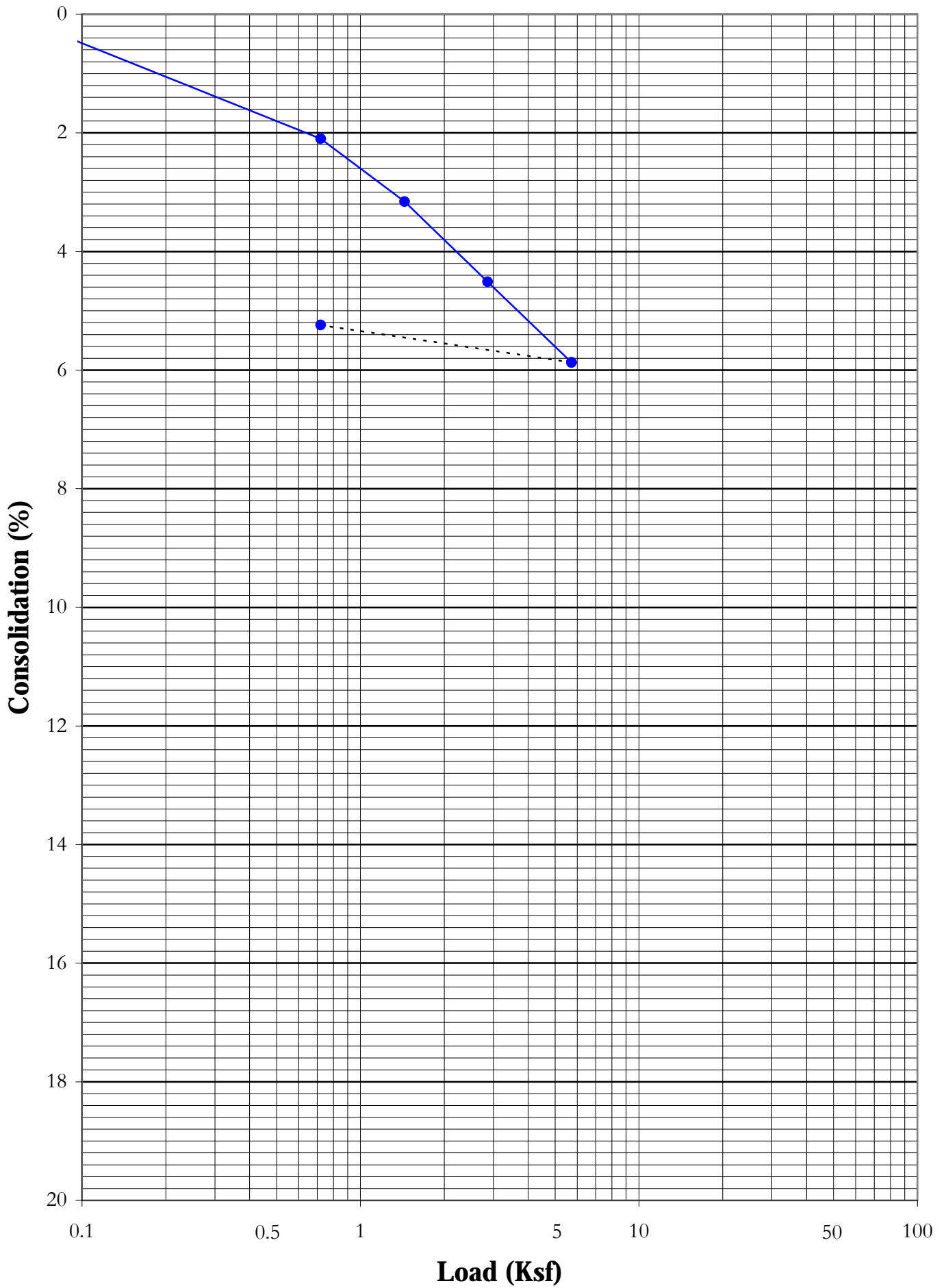

# Appendix D

---

Liquefaction Analyses

**LIQUEFACTION ANALYSIS (NCEER-97-0022, Proceedings of the NCEER Workshop on Evaluation of Liquefaction Resistance of Soils)**

Field Measurements					Soil Classification					Cyclic Stress Ratio, CSR						Cyclic Resistance Ratio, CRR						CRR/CSR	
Layer No.	Bottom Elev. (ft)	ΔH (ft)	SPT Depth (ft)	Field N	Soil Type (USCS)	Fines Content (%)	LL	PI	Assumed Non Liquefiable Layer	γ (lb/ft <sup>3</sup> )	γ <sub>w</sub> (lb/ft <sup>3</sup> )	σ <sub>v</sub> (lb/ft <sup>2</sup> )	σ' <sub>v</sub> (lb/ft <sup>2</sup> )	r <sub>d</sub>	CSR	C <sub>N</sub>	C <sub>R</sub>	N <sub>1,60</sub>	N <sub>1,60,CS</sub>	MSF	CRR <sub>7.5, 1 atm</sub>	CRR	Factor of Safety
1	17.0	17	6.0	9	SM	30			yes	128	0	768	768	0.986	0.449	1.658	0.75	14.1	21.0	--	0.228	--	--
2	19.0	2	17.0	20	SC	35				128	62.4	2176	2176	0.961	0.437	0.985	0.85	21.1	30.3	1.14	2.000	2.000	2.00
3	26.0	7	23.0	13	SP	3				128	62.4	2944	2569.6	0.947	0.494	0.906	0.95	14.1	14.1	1.14	0.153	0.174	0.35
4	32.0	6	29.0	14	SP	3				128	62.4	3712	2963.2	0.933	0.532	0.844	0.95	14.1	14.1	1.14	0.153	0.175	0.33
5	43.0	11	36.0	67	CL	85				128	62.4	4608	3422.4	0.883	0.541	0.785	1	66.3	84.5	1.14	2.000	2.000	2.00
6																							
7																							
8																							
9																							
10																							
11																							
12																							
13																							

**INPUT PARAMETERS**

Earthquake Magnitude, M <sub>w</sub>	7
PGA <sub>M</sub> (g)	0.7
Depth to Groudwater (ft)	17
Sampler Correction Factor, C <sub>s</sub>	1
Borehole Diameter Correction Factor, C <sub>B</sub>	1.05
Energy Ratio Correction Factor, C <sub>E</sub>	1.2

**VERTICAL RECONSOLIDATION (Seed et al, 1985)**

Layer No.	CSR	N <sub>1,60,CS</sub>	Tokumatsu Vertical Strain (%)	ΔSi (in)
1	0.449	21.0	0.000	0.000
2	0.437	30.3	0.000	0.000
3	0.494	14.1	2.000	1.680
4	0.532	14.1	2.000	1.440
5	0.541	84.5	0.000	0.000
6				
7				
8				
9				
10				
11				
12				
13				

**Total Settlement = 3.12**

**B-1 LIQUEFACTION ANALYSIS**

**PROPOSED SINGLE-FAMILY RESIDENCE**  
8455 EL PASEO GRANDE, LA JOLLA, CALIFORNIA

DATE: JULY 2020

JOB NO.: 2190610

BY: SCC

FIGURE: D-1



**CHRISTIAN WHEELER**  
ENGINEERING

# Appendix E

---

References

**REFERENCES**

Anderson, J.G.; Rockwell, R.K. and Agnew, D.C., 1989, Past and Possible Future Earthquakes of Significance to the San Diego Region, Earthquake Spectra, Volume 5, No. 2, 1989.

American Society of Civil Engineers, ASCE 7 Hazard Tool, <https://asce7hazardtool.online>

Bartlett, S.F. and Youd, T.L., 1995, Empirical Prediction of Liquefaction-Induced Lateral Spread, American Society of Civil Engineers, Journal of Geotechnical Engineers, v. 121, no. 4, p. 316-329.

Bowles, Joseph E., 1988, Foundation Analysis and Design: New York, McGraw-Hill, Inc.

Bryant, W. A. (compiler), 2005, Digital Database of Quaternary and Younger Faults from the Fault Activity Map of California, version 2.0: California Geological Survey Web Page, [http://www.consrv.ca.gov/CGS/information/publications/QuaternaryFaults\\_ver2.htm](http://www.consrv.ca.gov/CGS/information/publications/QuaternaryFaults_ver2.htm)

California Division of Mines and Geology, 2008, Guidelines for Evaluating and Mitigating Seismic Hazards in California, Special Publication 117A.

California Division of Mines and Geology, 2003, State of California Earthquake Fault Studies Zones, Point Loma Quadrangle, scale 1:24,000, adopted May 1, 2003.

California Division of Mines and Geology, 1999, Recommended Procedures for Implementation of DMG Special Publication 117 Guidelines for Analyzing and Mitigating Liquefaction Hazards in California, organized through the Southern California Earthquake Center, University of Southern California.

California Emergency Management Agency – California Geological Society – University of Southern California, 2009, Tsunami Inundation Map for Emergency Planning, La Jolla Quadrangle, scale 1:24,000, dated June 1, 2009.

Christian Wheeler Engineering, 2008, Report of Preliminary Geotechnical Investigation, Proposed Single-Family Home, 8449 El Paseo Grande, La Jolla, California, Report No. 2060605.02, dated January 17, 2008.

City of San Diego, 2008, SEISMIC HAZARD STUDY, Geologic Hazards and Faults, Sheet 29, Scale 1" = 800'.

Federal Emergency Management Agency, 2019, San Diego County, California and Incorporated Areas Flood Insurance Rate Map, Panel 1614 of 2375, Map Number 06073C1614 H.



Hart, E.W., 1994, Fault-Rupture Hazard Zones in California, California Division of Mines and Geology Special Publication 42.

Historic Aerials, NETR Online, [historicaerials.com](http://historicaerials.com)

Ishihara, K., 1985, "Stability of Natural Deposits During Earthquakes," Theme Lecture, Proceeding of the XI ICSMFE, Vol. 2, pp. 321-376

Jennings, C.W. and Bryant, W. A., 2010, Fault Activity Map, California Geological Survey, Geologic Data Map No. 6, <http://www.quake.ca.gov/gmaps/FAM/faultactivitymap.html>

Kennedy, Michael P., 1975, Geology of the San Diego Metropolitan Area, California, California Division of Mines and Geology, Bulletin 200.

Kennedy, Michael P. and Tan, Siang S., 2008, Geologic Map of the San Diego 30'x60' Quadrangle, California, California Geologic Survey, Map No. 3.

Kern, P., 1989, Earthquakes and Faults in San Diego County, Pickle Press, 73 pp.

Tan, S.S., 1995, Landslide Hazards in the Southern Part of the San Diego Metropolitan Area, San Diego County, California, California Division of Mines and Geology Open-File Report 95-03.

U.S. Geological Survey, Quaternary Faults in Google Earth, <http://earthquake.usgs.gov/hazards/qfaults/google.php>

URS Corporation, 2004, San Diego County Multi-Jurisdictional Hazard Mitigation Plan San Diego County California, URS Project No. 27653042.00500, dated March 15, 2004.

Zhang, G., Robertson, P.K., Brachman, R., 2002, Estimating Liquefaction Induced Ground Settlements from the CPT, Canadian Geotechnical Journal, 39: pp 1168-1180.

Zhang, G., Robertson, P.K., Brachman, R., 2004, Estimating Liquefaction Induced Lateral Displacements Using the SPT and CPT, ASCE, Journal of Geotechnical & Environmental Engineering, Vol. 130, No. 8, 861-871.