

California Environmental Quality Act  
Initial Study and Negative Declaration  
for the  
East Weaver Creek Dam Removal  
and Intake Relocation Project



Weaverville, CA  
July 15, 2021

*Prepared for:*  
Weaverville Community Services District  
716 Main Street  
Weaverville, California 96093  
(530) 623-5051

*Prepared by:*  
Northwest California Resource Conservation & Development Council  
Five Counties Salmonid Conservation Program  
40 Horseshoe Lane  
Weaverville, California 96093  
(530) 623-3967

Table of Contents

LIST OF TABLES ..... 4

LIST OF FIGURES..... 4

1.0 INTRODUCTION ..... 6

    1.1 Project Brief ..... 6

    1.2 Purpose of Initial Study..... 8

    1.3 Project Background..... 9

    1.4 Environmental Evaluation Checklist Terminology..... 10

    1.5 Summary of Environmental Effects and Mitigation Measures..... 10

    1.6 Project and General Area Environmental Studies..... 13

    1.7 Review Process ..... 15

2.0 PROJECT DETAILS ..... 16

    2.1 Project Location ..... 16

    2.2 Project Purpose and Need ..... 19

    2.2 Project Description..... 21

    2.3 Dam Repair and Removal Regulation and Permitting..... 28

3.0 ENVIRONMENTAL EVALUATION CHECKLIST..... 31

    3.1 Aesthetics ..... 31

    3.2 Agriculture and Forestry Resources..... 32

    3.3 Air Quality..... 33

    3.4 Biological Resources..... 34

    3.5 Cultural Resources ..... 61

    3.6 Energy ..... 62

    3.7 Geology and Soils ..... 63

    3.8 Greenhouse Gas Emissions ..... 66

    3.9 Hazards and Hazardous Materials..... 66

    3.10 Hydrology and Water Quality ..... 68

    3.11 Land Use and Planning ..... 71

    3.12 Mineral Resources..... 71

    3.13 Noise..... 72

    3.14 Population and Housing ..... 73

    3.15 Public Services ..... 73

    3.16 Recreation..... 74

3.17	Transportation and Traffic .....	75
3.18	Tribal Cultural Resources.....	75
3.19	Utilities and Service Systems.....	76
3.20	Wildfire .....	77
3.21	Mandatory Findings of Significance .....	78
4.0	REFERENCES .....	81
	END NOTES .....	84
	Appendices.....	85

## LIST OF TABLES

Table 1-1	Summary of Environmental Effects and Mitigation Measures
Table 3-1	eWRIMS reported water right records for East Weaver Creek
Table 3-2	Federal and state Threatened Endangered, or Fully Protected species excluded from further analysis
Table 3-3	CDFW SSC or Watch List species excluded from further analysis
Table 3-4	California Endangered, Threatened, or SSC species with the potential for occurrence within or near the project area

## LIST OF FIGURES

Figure 1-1	Alternative-2 (Multiphase Removal) flow chart
Figure 1-2	CEQA review process
Figure 2-1	Project area and EWD location
Figure 2-2	Weaver Creek watershed and the project location
Figure 2-3	EWD concrete cap and EWF stilling basin
Figure 2-4	Conceptual design for the WCSD screened diversion, intake, and piping infrastructure
Figure 2-5	Screened intake and grade structure design
Figure 2-6	Phase I intake and grade structure placement
Figure 2-7	Phase II (A) grade structure placement and installation and excavation of Streambed material
Figure 2-8	Phase II (B) placement of chop and drop trees, grade structures, and streambed material
Figure 3-1	CNDDDB Map of Project & Surrounding Areas
Figure 3-2	East Weaver Creek sediment transport, deposition, and scour reaches
Figure 3-3	East Weaver Creek reference reach pebble count
Figure 3-4	<i>Smilax jamesii</i> observations in the APE
Figure 3-5	CDWR Landslide mapping near the EWD

## LIST OF ACRONYMS AND ABBREVIATIONS USED IN THIS DOCUMENT

APE	area of potential effect
BLM	Bureau of Land Management
BMPs	Best Management Practices
BO	Biological Opinion
CDFG	California Department of Fish and Game
CDFW	California Department of Fish and Wildlife
CDWR	California Department of Water Resources
CEQA	California Environmental Quality Act
cfs	cubic feet per second
CNDDDB	California Natural Diversity Database
CNPS	California Native Plant Society Database
CRPR	California Rare Plant Rank
CWA	Clean Water Act
DBH	diameter at breast height
EFH	Essential Fish Habitat
EWC	East Weaver Campground
EWD	East Weaver Creek Dam
EWF	East Weaver Creek Treatment Facilities
eWRIMS	Electronic Water Rights Information Management System
FEMA	Federal Emergency Management Agency
IS	Initial Study
LOP	Limited Operating Period
LSA	Lake and Streambed Alteration Agreement
LWD	Large Woody Debris
NCRWQCB	North Coast Regional Water Quality Control Board
NMFS	National Marine Fisheries Service
NOAA	National Oceanic and Atmospheric Administration
NSO	Northern Spotted Owl ( <i>Strix occidentalis caurina</i> )
ODFW	Oregon Department of Fish and Wildlife
RC&DC	Northwest California Resource Conservation & Development Council
RSL	Redwood Sciences Lab
SCADA	supervisory control and data acquisition
SCI	Stream Condition Inventory
SONCC	Southern Oregon/Northern California Coast
SPI	Sierra Pacific Industries
SSC	Species of Special Concern
USFS	U.S. Forest Service
USFWS	U.S. Fish and Wildlife Service
USGS	U.S. Geological Survey
WCSD	Weaverville Community Services District
5C	Five Counties Salmonid Conservation Program

## 1.0 INTRODUCTION

### 1.1 Project Brief

---

This document is an Initial Study (IS) and draft Negative Declaration, prepared pursuant to the California Environmental Quality Act (CEQA) process, for the East Weaver Creek Dam Removal and Intake Relocation Project. The purpose of the IS is to evaluate the potential environmental impacts of the proposed action and determine if the project is Categorical Exempt from further CEQA review or if it requires preparation of a Negative Declaration or Environmental Impact Report. The CEQA Lead Agency is the Weaverville Community Services District (WCSD) located in Weaverville, California.

In February 2016, the East Weaver Dam Design Alternatives and Assessment Report was completed (Appendix 1)<sup>1</sup>. Under that assessment, three action alternatives were examined: Alternative-1 (Dam Removal and Channel Rehab), Alternative-2 (Multiphase Removal), and Alternative-3 (Single-phase Dam Removal). A Do Nothing Alternative was considered as well. In March 2016, the WCSD Board of Directors evaluated the Alternatives and selected Alternative-2 (Multiphase Removal) as the proposed action (Figure 1-1).

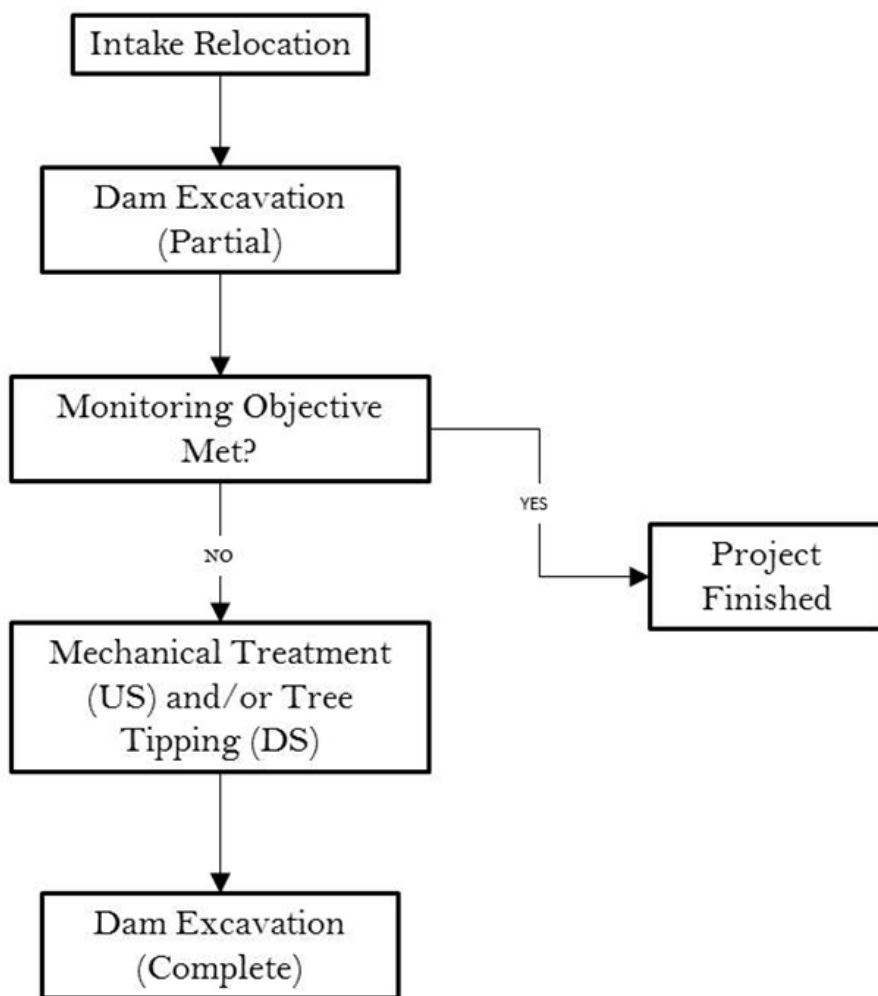
The selected alternative to remove the East Weaver Creek Dam (EWD) relies on using the natural stream hydraulics in lieu of excavators and bulldozers where possible to reach the desired stream bed conditions. Once the dam is removed, channel incision would adjust the upstream channel to the natural 5.7% slope. The process of channel formation can take a year to a decade following dam removal, depending on flow conditions. The process would mimic debris jam formation processes that can locally accelerate or retard channel bed and bank erosion and/or deposition, create sites for significant sediment storage, and produce a stepped channel profile. The selected alternative for dam removal could involve adaptive management techniques including the use of a series of tree and boulder clusters to simulate natural jam conditions. This design spreads out impacts over the course of several years, minimizing construction traffic and negative impacts to the residents of the East Weaver neighborhood.

The expected results of the proposed action will have short-term impacts to aquatic habitats from temporary increases in suspended sediment loads into the water column as the stream channel adjusts and the eventual transport and deposition of sediment onto fisheries habitat that exist immediately downstream. The long-term impacts would be beneficial, improving water reliability and security for the WCSD by replacing the aging dam and intake with a new intake system that is not dependent on damming the stream. In the process, the project will restore natural bedload, debris transport, and access to ~2.5 miles of high-quality, cold-water salmonid habitat in the upstream reaches of East Weaver Creek. The project will eliminate or reduce mortality to aquatic species migrating downstream or that are currently directed into the unscreened intake and treatment plant. The project would also affirm the quantified water right of the WCSD as 1.73 cubic feet per second (cfs) and include monitoring of intake flows.

---

<sup>1</sup> The assessment was completed by the Northwest CA Resource Conservation and Development Council's (RC&DC) Five Counties Salmonid Conservation Program (5C) using state and federal grant funds.

Prior to this project, four major habitat restoration projects were initiated and/or completed within a 1-mile radius of the EWD. These projects resulted or will result in immediate benefit by increasing streamflow and provide long-term benefits that offset the short term effects of the project's dam removal. The projects within or proximal to EWD are: Schofield Gulch Channel Restoration and Sediment Reduction Project located on WCSD property upstream of EWD; McKnight Ditch Water Conservation Project (located 1 mile downstream of EWD); Hansen Ditch Water Conservation Project (located 0.75 miles downstream of EWD) and East Branch Migration Barrier Removal Project (located 0.75 miles downstream of EWD). An additional six stream restoration projects have been completed in the past 20 years in the greater Weaver Creek watershed and seven more are in design or permitting stages.



**Figure 1-1.** Alternative-2 (Multiphase Removal) flow chart of the project's phases.

## 1.2 Purpose of Initial Study

---

CEQA requires that public agencies document and consider the potential environmental effects of the agency's actions that meet CEQA's definition of a "project"<sup>2</sup>. Provided that a project is not exempt from CEQA, the first step in the agency's consideration of its potential environmental effects is the preparation of an Initial Study. The purpose of an Initial Study is to determine whether the project as described would involve "significant" environmental effects, as defined by CEQA. Where potentially significant effects may occur, the Initial Study would describe feasible mitigation measures that would avoid significant effects or reduce them to a level that is less than significant.

If the Initial Study does not identify significant effects, then the agency prepares a Categorical Exemption or Negative Declaration. If the Initial Study notes significant effects but also identifies mitigation measures that would reduce these significant effects to a level that is less than significant, then the agency prepares a Mitigated Negative Declaration. If a project would involve significant effects that cannot be readily mitigated, then the agency must prepare an Environmental Impact Report. The agency may also decide to proceed directly with the preparation of an Environmental Impact Report without an Initial Study.

The East Weaver Creek Dam Removal and Intake Relocation Project is a "project" as defined by CEQA and is not exempt from a preparation of an Initial Study. This Initial Study describes the proposed project and its environmental setting, discusses the potential environmental effects of the project, and identifies feasible mitigation measures that would reduce any effects to a level that would be less than significant. The Initial Study considers the project's potential for significant environmental effects in the following subject areas:

- Aesthetics
- Agricultural Resources
- Air Quality
- Biological Resources
- Cultural Resources
- Energy
- Geology and Soils
- Greenhouse Gas Emissions
- Hazards and Hazardous Waste Materials
- Hydrology and Water Quality
- Land Use and Planning
- Mineral Resources
- Noise
- Population and Housing
- Public Services
- Recreation
- Transportation/Traffic
- Tribal Cultural Resources
- Utilities and Service Systems
- Wildfire
- Mandatory Findings of Significance

This IS concludes that the project would have less than significant environmental effects to no environmental impacts.

---

<sup>2</sup> Briefly summarized, a "project" is an action that has the potential to result in direct or indirect physical changes in the environment. A project includes the agency's direct activities and activities that involve public agency approvals or funding. Guidelines for an agency's implementation of CEQA are found in the "CEQA Guidelines" (Title 14, Chapter 3 of the California Code of Regulations).



### 1.3 Project Background

---

The *Recovery Strategy for California Coho Salmon*, prepared by the California Department of Fish and Game<sup>3</sup> (CDFG), includes a recommendation to remove dams on Weaver Creek and its tributaries that prevent migration of salmon (CDFG, 2004). In February 2016, the WCSD adopted the East Weaver Dam Design Alternatives and Assessment Report (Appendix 1). Under that assessment three action alternatives were examined: Alternative-1 (Dam Removal and Channel Rehab), Alternative-2 (Multiphase Removal), and Alternative-3 (Single-phase Dam Removal). A Do Nothing Alternative was considered as well.

Under all three action alternatives the project would convert the existing <0.1 acre surface area reservoir to a run of the river facility, which would restore the original channel behind the dam. Under all three alternatives, the intake for the WCSD facility would be relocated upstream. Alternative intake locations and designs were considered, but all alternatives selected for analysis utilized a cone screen intake located on the east bank of the stream ~270' upstream of the WCSD East Weaver Creek Treatment Facilities (EWF). Under any of the Action Alternatives, restoration grant funding is available to relocate the WCSD intake and remove the dam, restoring access to 2.5 miles of habitat for the threatened Coho salmon (*Oncorhynchus kisutch*) and other special status aquatic species.

The Do Nothing Alternative would retain the dam and WCSD intake structure in the current location until such time as: 1) the dam fails and an emergency intake repair or relocation is done; 2) maintenance of the dam is required and WCSD obtains permits to maintain and perpetuate the current intake; 3) maintenance of the dam is required and WCSD is denied permits to make repairs without mitigation; and 4) state or federal agencies implement "Take" proceeding to remove the dam as a migration barrier to threatened Coho salmon. Under the Do Nothing Alternative, the cost of restoring the East Weaver intake could be the responsibility of the WCSD rate payers.

In March 2016, the WCSD Board of Directors evaluated the Alternatives and selected Alternative-2 (Multiphase Removal) as the proposed action (Figure 1-1). In May 2017, Water Works Engineering completed an "East Weaver Creek Dam Intake/Pipeline Assessment Conceptual Design Report" (Appendix 2) for the new intake system and fish screen. Between 2017 and 2018, the Five Counties Salmonid Conservation Program (5C) obtained grants to complete design, conduct environmental analysis, initiate permitting, and partial funding of implementation<sup>4</sup>. In 2019, the intake screen design was completed (Appendix 3). Between 2017 and 2020, the 5C in coordination with WCSD and other partners undertook a number of restoration projects in the watershed which increased salmonid habitat and resiliency for salmonids.

---

<sup>3</sup> The CA Department of Fish and Game has been renamed the CA Department of Fish and Wildlife

<sup>4</sup> The California Coastal Conservancy, US Fish and Wildlife Service, National Fish and Wildlife Foundation, and the Trinity River Restoration Program provided grants to complete design, environmental planning, permitting, and partial funding for the construction of a new WCSD intake structure, removal of EWD and installation of grade structures necessary to maintain and restore channel gradient and protect the new intake.

## 1.4 Environmental Evaluation Checklist Terminology

---

The project’s potential environmental effects are evaluated and explained in the Environmental Evaluation Checklist<sup>5</sup> presented in Chapter 3.0 of this Initial Study. The checklist includes a list of environmental considerations against which the project is evaluated. For each question, the lead agency determines whether the project would involve a Potentially Significant Impact, a Less Than Significant Impact with Mitigation Incorporated, a Less Than Significant Impact, or No Impact.

A Potentially Significant Impact occurs when there is substantial evidence that the project would involve a substantial adverse change to the physical environment, i.e., the environmental effect may be significant, and mitigation measures have not been defined that would reduce the impact to a level that would be less than significant. If there is a Potentially Significant Impact entry in the Initial Study, then an EIR is required.

An environmental effect that is Less Than Significant with Mitigation Incorporated is a Potentially Significant Impact that can be avoided or reduced to a level that is less than significant with the application of defined mitigation measures.

A Less Than Significant Impact occurs when the project would involve an environmental impact, but the impact would not cause a substantial adverse change to the physical environment that would require mitigation.

A determination of No Impact has no impacts to the environment.

Any potentially significant environmental effects identified in the Initial Study would be avoided or reduced to a level that would be less than significant with recommended mitigation measures. For all other issues, the project would have no impact or less than significant impacts.

## 1.5 Summary of Environmental Effects and Mitigation Measures

---

**Table 1-1.** A summary of the environmental effects and their mitigation measures are presented below. The abbreviations within the column reference the levels of significance previously explained in Section 1.4. PS – Potentially Significant. LS – Less Than Significant. NI – No Impact.

Potential Impact	Significance Before Mitigation Measures	Mitigation Measures	Significance After Mitigation Measures
<b>3.1 AESTHETICS</b>			
a) Scenic Vistas	NI	None Required	-
b) Scenic Routes and Resources	NI	None Required	-
c) Visual Character and Quality	LS	None Required	-
d) Light and Glare	NI	None Required	-

<sup>5</sup> Appendix G of the 2021 CEQA Statute and Guidelines

3.2 AGRICULTURE AND FORESTRY RESOURCES				
a)	Agricultural Land Conversion	NI	None Required	-
b)	Agricultural Zoning and Williamson Act	NI	None Required	-
c)	Forest Land Zoning	NI	None Required	-
d)	Forest Land Conversion	NI	None Required	-
e)	Indirect Conversion of Farmland and Forest Land	NI	None Required	-
3.3 AIR QUALITY				
a)	Air Quality Plan Consistency	NI	None Required	-
b)	Cumulative Emissions	NI	None Required	-
c)	Exposure of Sensitive Receptors	NI	None Required	-
d)	Odors	NI	None Required	-
3.4 BIOLOGICAL RESOURCES				
a)	Special-Status Species	LS	None Required	-
b)	Riparian and Other Sensitive Habitats	LS	None Required	-
c)	Wetlands and Waters of the U.S.	NI	None Required	-
d)	Fish and Wildlife Movement	NI	None Required	-
e)	Local Biological Requirements	NI	None Required	-
f)	Conflict with Habitat Conservation Plans	NI	None Required	-
3.5 CULTURAL RESOURCES				
a)	Historical Resources	LS	None Required	-
b)	Archaeological Resources	LS	None Required	-
c)	Human Burials	LS	None Required	-
3.6 ENERGY				
a)	Project Energy Consumption and Consistency	NI	None Required	-
b)	Renewable energy	NI	None Required	-
3.7 GEOLOGY AND SOILS				
a-i)	Fault Rapture Hazards	NI	None Required	-
a-ii)	Seismic Ground Shaking	NI	None Required	-
a-iii)	Other Seismic Hazards	NI	None Required	-
a-iv)	Landslides	NI	None Required	-
b)	Soil Erosion	NI	None Required	-
c)	Unstable Soils	LS	None Required	-
d)	Expansive Soils	NI	None Required	-
e)	Adequacy of Soils for Wastewater Disposal	NI	None Required	-
f)	Paleontological Resources and Unique Geologic Features	NI	None Required	-
3.8 GREENHOUSE GAS EMISSIONS				
a)	Project GHG Emissions	LS	None Required	-
b)	Consistency with GHG Reduction Plans	NI	None Required	-
3.9 HAZARDS AND HAZARDOUS MATERIALS				
a)	Hazardous Material Transport, Use, and Storage	NI	None Required	-

b)	Release of Hazardous Materials by Upset or Accident	NI	None Required	-
c)	Hazardous Materials Releases near Schools	NI	None Required	-
d)	Hazardous Materials Sites	NI	None Required	-
e)	Airport Vicinity	NI	None Required	-
f)	Emergency Response and Evacuation	NI	None Required	-
g)	Wildland Fire Hazards	NI	None Required	-
<b>3.10 HYDROLOGY AND WATER QUALITY</b>				
a)	Violation of Water Quality Standards	LS	None Required. Dewatering, reconstruction of scoured areas, jetting and compaction of fine sediment, compliance with NMFS 2012 BO minimization measures.	LS
b)	Groundwater Supplies and Recharge	NI	None Required	-
c-i)	Erosion and Siltation	LS	None Required	-
c-ii)	Surface Runoff	NI	None Required	-
c-iii)	Stormwater Drainage	NI	None Required	-
c-iv)	Flood Flows	NI	None Required	-
c)	Release of Pollutants in Flood Zone	NI	None Required	-
e)	Conflict with Water Quality or Sustainable Groundwater Plans	NI	None Required	-
<b>3.11 LAND USE AND PLANNING</b>				
a)	Division of Established Communities	NI	None Required	-
b)	Conflict with Applicable Plans, Policies, and Regulations	NI	None Required	-
<b>3.12 MINERAL RESOURCES</b>				
a, b)	Loss of Mineral Resource Availability	NI	None Required	-
<b>3.13 NOISE</b>				
a)	Exposure to Noise Exceeding Local Standards	NI	None Required	-
b)	Groundborne Vibrations	NI	None Required	-
c)	Permanent Increase	NI	None Required	-
d)	Exposure to Airport/Airstrip Noise	NI	None Required	-
<b>3.14 POPULATION AND HOUSING</b>				
a)	Population Growth Inducement	NI	None Required	-
b)	Displacement of Housing and People	NI	None Required	-
<b>3.15 PUBLIC SERVICES</b>				
a-i)	Fire Protection	NI	None Required	-
a-ii)	Police Protection	NI	None Required	-
a-iii)	Schools	NI	None Required	-
a-iv)	Parks	NI	None Required	-
a-v)	Other Public Facilities	NI	None Required	-
<b>3.16 RECREATION</b>				
a, b)	Recreational Facilities	NI	None Required	-

3.17 TRANSPORTATION AND TRAFFIC				
a)	Conflict with Transportation Plans, Ordinances and Policies	NI	None Required	-
b)	Conflict with CEQA Guidelines Section 15064.3(b)	NI	None Required	-
c)	Traffic Hazards	NI	None Required	-
d)	Emergency Access	NI	None Required	-
3.18 TRIBAL CULTURAL RESOURCES				
a)	CA Register of Historical Resources	NI	None Required	-
b)	Significance of resource to a CA Native American tribe	NI	None Required	-
3.19 UTILITIES AND SERVICE SYSTEMS				
a)	Construction or Relocation of Infrastructure	LS	None Required	-
b)	Water Supply	NI	None Required	-
c)	Wastewater Systems	NI	None Required	-
d, e)	Solid Waste Services	NI	None Required	-
3.20 WILDFIRE				
a)	Impair an Adopted Emergency Plan	NI	None Required	-
b)	Exposure of Wildfire Pollutants	LS	None Required	-
c)	Installation/Maintenance of Infrastructure	NI	None Required	-
d)	Exposure to Significant Risks	NI	None Required	-
3.21 MANDATORY FINDINGS OF SIGNIFICANCE				
a)	Degradation	LS	None Required	-
b)	Cumulative Impacts	LS	None Required	-
c)	Direct/Indirect Effects on Humans	NI	None Required	-

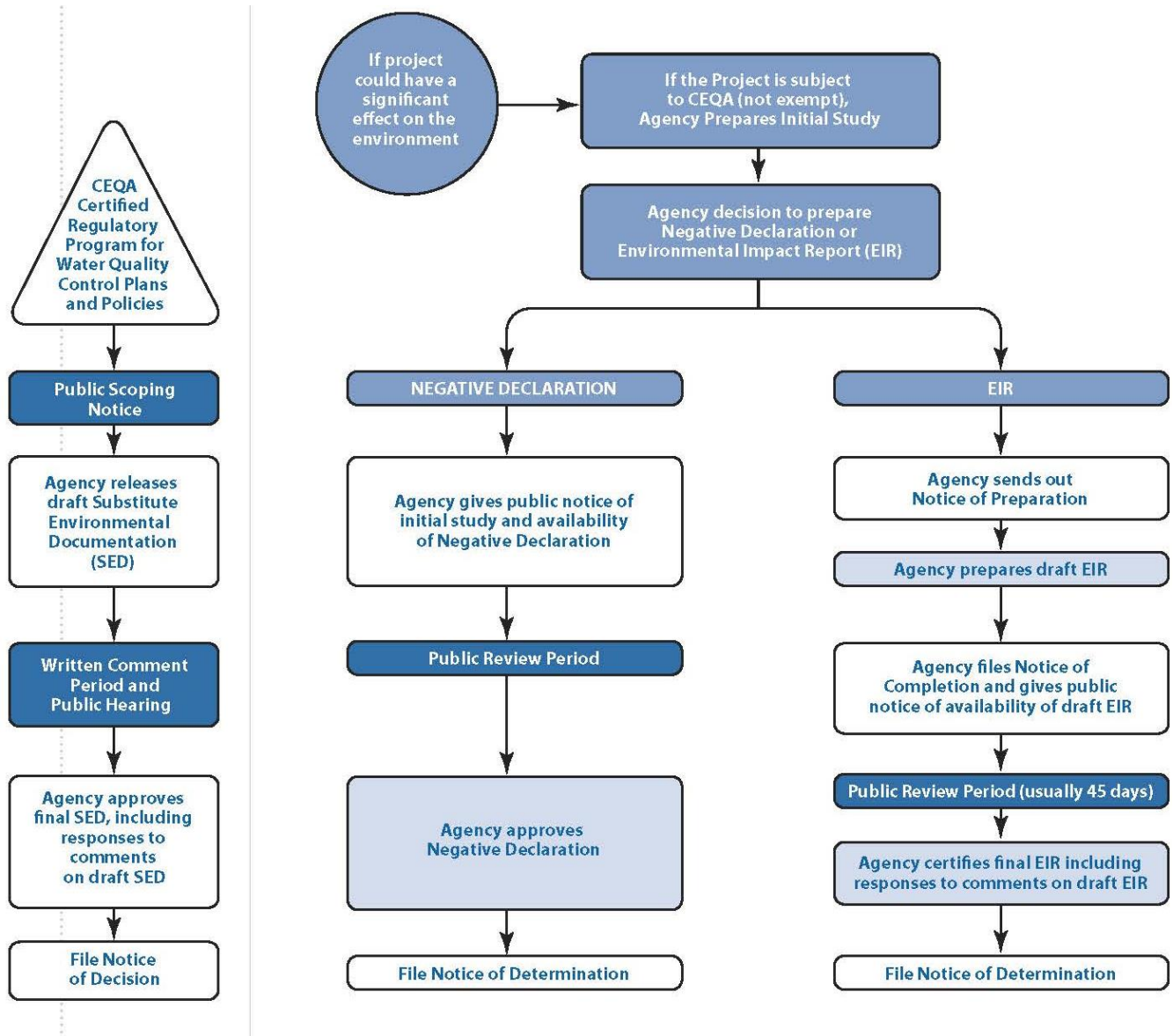
## 1.6 Project and General Area Environmental Studies

- Arnold, Mark. 2018. *Cultural Resources Survey of East Weaver Dam including Site Records*. (Unpublished)
- California Native Plant Society Inventory of Rare and Endangered Plants of California (CNPS) Record Check (2012, 2016, 2021)
- California Natural Diversity Database (CNDDB) Record Check (2012, 2016, 2021)
- DeJuillo, Carla. 2018, 2019, & 2020. Memo: East Weaver Dam Single Pass Frog Survey. (Unpublished)
- Department of Water Resources. 1980. Main Stem Trinity River Watershed Erosion Investigation
- Intake Screen Inc. 2013. Self-Cleaning Intake Screen Typical Design
- Lancaster, et al. 2016. East Weaver Dam Design Alternatives and Assessment Report (Unpublished)

- Lindstrand, Clare. 2017. East Weaver Creek Stream and Temperature Data Summary for 2014 and 2015 For 3 Locations (Unpublished)
- Mounivong, Leslie. 2020. Memo: Review of East Weaver Dam Site for English Peak greenbrier and Wetland Obligate Plant Species (Unpublished)
- Mounivong, L. and Manka, M. 2021. *East Weaver Dam and Intake Effects on Stream Temperature and Flow in Relation to Endangered or Threatened Salmonid Species*. (Unpublished)
- Natural Resources Conservation Service. 1990. Soil Survey Trinity County, CA
- Reiss, Joe. 2016. East Weaver Creek Dam Intake/Pipeline Assessment Conceptual Design Report (Unpublished)
- Sierra Pacific Industries. 2000. Timber Harvest Plan 2-00-026
- Sierra Pacific Industries. 2007. Timber Harvest Plan 2-07-061
- Wiseman, Eric. 2013. Memo: US Forest Service Stream Condition Survey Summary Of Site Changes Over Time (2002 and 2001) (Unpublished)
- Wiseman, Eric. 2013. Memo: US Forest Service TRMU Juvenile Fish Survey Multi-Year Summary (Unpublished)
- Wiseman, Eric. 2015. Memo: East Weaver Creek LWD Assessments (Unpublished)
- Yamasaki, Keiki. 2015. Memo: 850 meters Snorkel Survey of East Weaver Creek Upstream of Dam (Unpublished)

1.7 Review Process

This Initial Study is being circulated for public and agency review as required by CEQA (Figure 1-2).



**Figure 1-2.** CEQA review process.

## 2.0 PROJECT DETAILS

### 2.1 Project Location

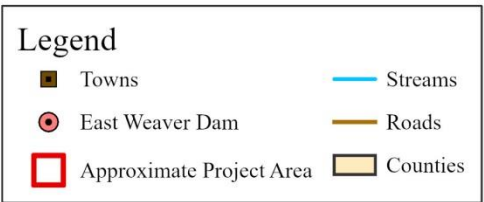
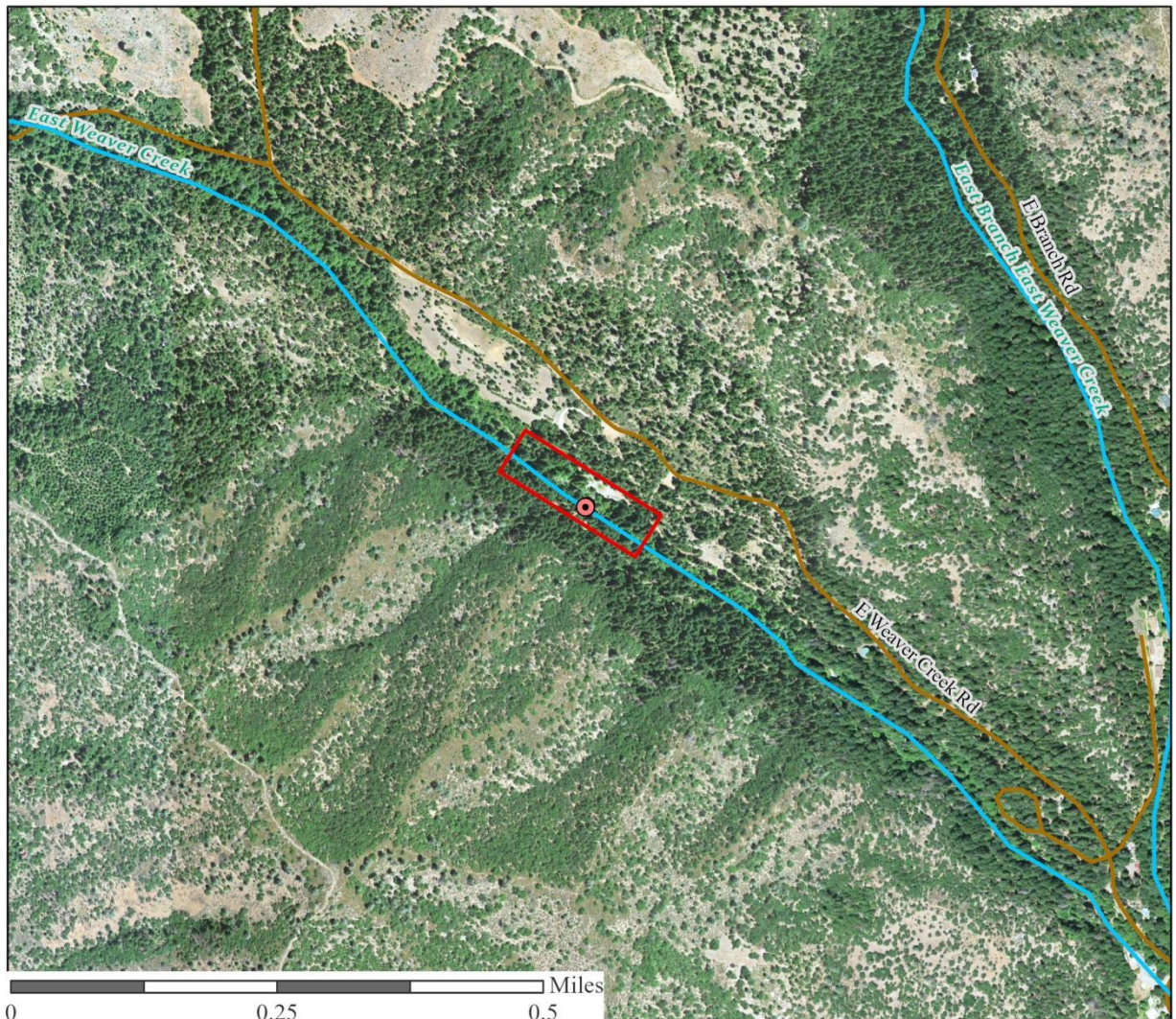
---

The project is located in Section 30, Township 34N, Range 9W, MDB&M (40.73525, -122.93026) (Figure 2-1). It is accessible by traveling north on Highway 3 from Weaverville to East Weaver Creek Road. At East Weaver Creek Road, turn left from Highway 3 and proceed 2.5 miles to the access road to the WCSD's EWF. This road's access is controlled with a gate. The facilities are 0.2 miles down this access road.

Easter Weaver Creek is a tributary to Weaver Creek and the Trinity River. The East Weaver Creek watershed encompasses 8,300 acres and represents ~25% of the Weaver Creek watershed (Figure 2-2). The upper 30% of the East Weaver watershed is within the Trinity Alps Wilderness and the East Weaver Dam is located ~0.5 miles downstream of the Wilderness boundary. The National Oceanic and Atmospheric Administration's (NOAA) National Marine Fisheries Service (NMFS) *Final Recovery Plan for the Southern Oregon/ Northern California Coast (SONCC) Evolutionarily Significant Unit of Coho Salmon (Oncorhynchus kisutch)* lists Weaver Creek and its tributaries as having a high Intrinsic Potential for Coho (NMFS, 2014). Intrinsic Potential is defined as the "potential of the landscape to support a population. The Intrinsic Potential of a watershed or stream reach, is used to evaluate the likelihood of the area to support fish, and is used when population characteristics are unknown" (NMNFS, 2014).

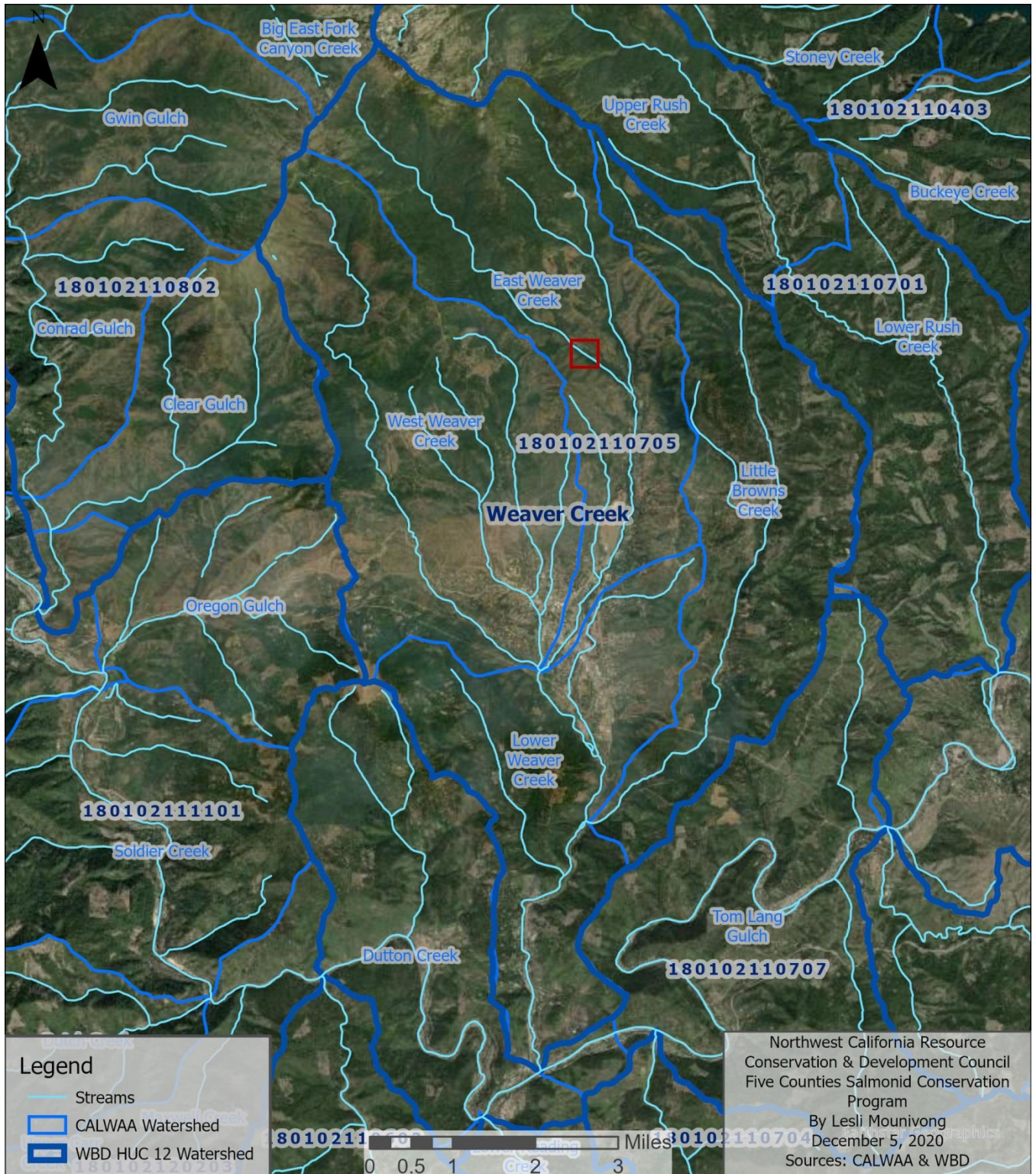


# EAST WEAVER CREEK DAM REMOVAL AND INTAKE RELOCATION PROJECT



Northwest California Resource  
Conservation & Development  
Council  
Five Counties Salmonid  
Conservation Program  
Created by: Lesli Mounivong  
NAD 1983 UTM Zone 10  
Sources: Esri, USGS, TCR CDC,  
TCDOT

**Figure 2-1.** Project area and EWD location.



**Figure 2-2.** Map of the greater Weaver Creek watershed and its sub-watersheds. Approximate project size is given in relation to the watershed.

## 2.2 Project Purpose and Need

---

The project will remove the East Weaver Creek Dam, install a screened intake, and allow fish passage while maintaining water reliability to the community of Weaverville. The first action is to determine if the EWD is a regulated dam. A regulatory dam is defined as “any artificial barrier, together with appurtenant works, which does or may impound or divert water, and which either (a) is or will be 25 feet or more in height... or (b) has or will have an impounding capacity of 50 acre-feet or more”; a structure is not considered a dam if “any such barrier which is or will be not in excess of six feet in height, regardless of storage capacity, or which has or will have a storage capacity not in excess of 15 acre-feet, regardless of height...” (Clean Water Code, 1965).

The East Weaver Creek Dam is not classified as a regulatory dam due to its 12’ hydraulic height with less than 0.5 acre-feet storage capacity. The EWD structure is considered a minor dam and is located in a seismically low risk area.

A dam condition assessment was completed using the Bureau of Land Management (BLM) Dam Condition Assessment Checklist (BLM, 2006). The EWD is rated in poor condition due to repairs or modifications required to maintain the structure operationally. Deficiencies are evident on visual inspection of the dam including: loss of concrete apron segments, concrete spalling, exposed rebar, water flows interstitially through the dam’s rock structure, sediment filling upstream, and bed scour below the base of the dam (Figure 2-3). Major repairs to the dam will be necessary in the reasonably foreseeable future.

The EWD is a complete barrier to aquatic species including the threatened Coho salmon (*Oncorhynchus kisutch*). It is recognized as the only complete barrier to upstream fish migration for all life stages of all fish species in East Weaver Creek. The NMFS *Final Recovery Plan for the SONCC Coho Salmon* lists barriers and diversions as “very high” threats to the survival of all life stages of Coho, except the egg stage. It also lists migration barriers as a “key limiting factor” to salmonid recovery in the Upper Trinity River basin for adult life stages and ranks them as “high” stressors for Coho. Dams and diversions contribute to factors affecting habitat destruction, modification, or curtailment, disease and predation, and inadequate regulatory mechanisms for Coho (NMFS, 2014). NMFS *Final Recovery Plan for the SONCC* includes the following discussion:

“East Weaver Creek supplies the town of Weaverville with its water. The town’s municipal diversion dam creates a barrier to salmon migration and to gravel movement in the creek, which degrades habitat below the dam in addition to blocking fish passage” (NMFS, 2014 pp. 39-20).

Given the fish mortality and passage issues, it is questionable whether the California Department of Fish and Wildlife (CDFW) and/or NMFS would provide the required agreement and Biological Opinion (BO) needed for repairs to the dam without addressing fish passage as part of the repair design.

The habitat upstream of EWD is cold water habitat capable of providing critical summer salmon rearing habitat in the Weaver Creek watershed. Downstream of the East Weaver Campground

(EWC), the stream provides marginal summer rearing habitat due to the high amount of diversions, lack of cover, and limited pools. This portion of the stream is entrenched with narrow floodplains and riparian bands as a result of roads, bridges, houses, maintained lawns, and levees. The entrenched portions lack critical habitat elements such as large wood components, pools, and overbank habitat elements. Water diversion for domestic, agricultural, and industrial uses further reduce summer rearing habitat opportunities below EWD. Restoring access to habitat upstream of EWD provides significant opportunities in the stream reaches with the least level of human impacts.



**Figure 2-3.** Dam showing concrete cap (left) and stilling basin to the EWF (right).

## 2.2 Project Description<sup>6</sup>

---

The WCSD Board of Directors selected Alternative-2 (Multiphase Removal) as the preferred alternative. The proposed project relies on using the natural stream hydraulics in lieu of excavators and bulldozers where possible to reach the desired stream bed conditions. The adaptive management approach allows for modifications in response to channel adjustments and identifies the modification as use of “chop and drop” tree felling techniques to adjust sediment transport rates. The process of channel formation can take a year to a decade following dam removal, depending on flow conditions. Once the dam is removed, channel incision would adjust the upstream channel to the natural 5.7% slope. The process would mimic debris jam formation processes that can locally accelerate or retard channel bed and bank erosion and/or deposition, create sites for significant sediment storage, and produce a stepped channel profile. This alternative could involve a series of tree and boulder clusters to simulate jam conditions. The design spreads out impacts over the course of several years.

The project incorporates in its design adaptive management options and utilizes the following Best Management Practices (BMPs) and minimization measures (Appendix 4) from the following documents: the 5C’s *A Water Quality and Habitat Protection Manual for County Road Maintenance*, Natural Resource Conservation Service’s *Field Office Technical Guide*, and NOAA’s Biological Opinion (BO) under the NMFS’s Final BO and Essential Fish Habitat (EFH) consultation for restoration projects within the NMFS Northern California Office jurisdictional area.

The selected alternative (Alternative-2) is separated into 2-3 phases based on monitoring and performance indicators (refer to Figure 1-1). The phases and work are as follows and shown in the design drawings and details in Appendix 5 of this Initial Study:

### **Phase I**

In the summer to fall of Year 1, Phase I will install new intake screens, pipes, and infrastructure approximately 270’ upstream and on the east bank of East Weaver Creek. The water system will continue to operate while retaining the existing intake system through a winter period in order to assess performance. Phase I will consist of:

---

<sup>6</sup> A project description is a brief summary of the proposed project and its consequences in sufficient detail as to describe the project being contemplated and provide the focus for the environmental review. The term "project" means the whole of the action which has the potential for resulting in either a direct physical change in the environment or a reasonably foreseeable indirect physical change in the environment. It does not mean each separate governmental approval. The language of the project description should be clear and as simple as is reasonably practical. It is usually prepared by the [lead agency](#) and may be any of the following: 1) an activity directly undertaken by any [public agency](#); 2) an activity undertaken by a person which is supported, in whole or in part, through contracts, grants, subsidies, loans or other forms of assistance from one or more public agencies; or, 3) an activity that involves the issuance to a person of a lease, permit, license, certificate or other entitlement for use by one or more public agencies.

References: 14 CCR Sections [15378](#), [15071](#), and [15124](#)

#### Pre-Construction Tasks:

- Implementation of a Limited Operating Period (LOP) - All ground disturbing work shall be limited to August 15<sup>th</sup> through November 15<sup>th</sup> of any year;
- Implement the BMPs listed in Appendix 4 throughout construction;
- Installation of 3/32" mesh exclusion fencing for aquatic and terrestrial aquatic species including fish and amphibians within any wetted areas where work is to occur;
- Survey terrestrial work areas for amphibians and western pond turtles and, if found, relocate outside the work area.

#### Streambank Construction Tasks:

- Upgrade the existing trail route from the EWF to the new inlet location to temporarily accommodate heavy equipment. Most work will consist of trimming branches of trees and removal of sapling to pole diameter trees as necessary;
- Installation of an approved screened intake (Figure 2-4 and Figure 2-5) approximately 270' upstream of the existing EWD inlet. The inlet structure is designed to direct 1.73 cfs into the EWT<sup>7</sup>;
- Installation of a 40' long elevated walkway from the stream bank to the inlet structure (refer to Appendix 5);
- Optional installation of a supervisory control and data acquisition (SCADA) system to monitor operations;
- Installation of buried utilities (power, communications) from the existing EWF to the new inlet structure within the existing road/trail;
- Installation of ~450' of 10" water main, vaults and valves from the screened inlet to the contact basin in the existing EWF.

#### Instream Construction Tasks:

- Installation of 3/32" mesh exclusion fencing across the stream;
- Installation of rock weirs/grade structures at inlet channel elevation (Figure 2-5);
- Removal of netting and restoration of stream flows.

#### Post Construction Tasks:

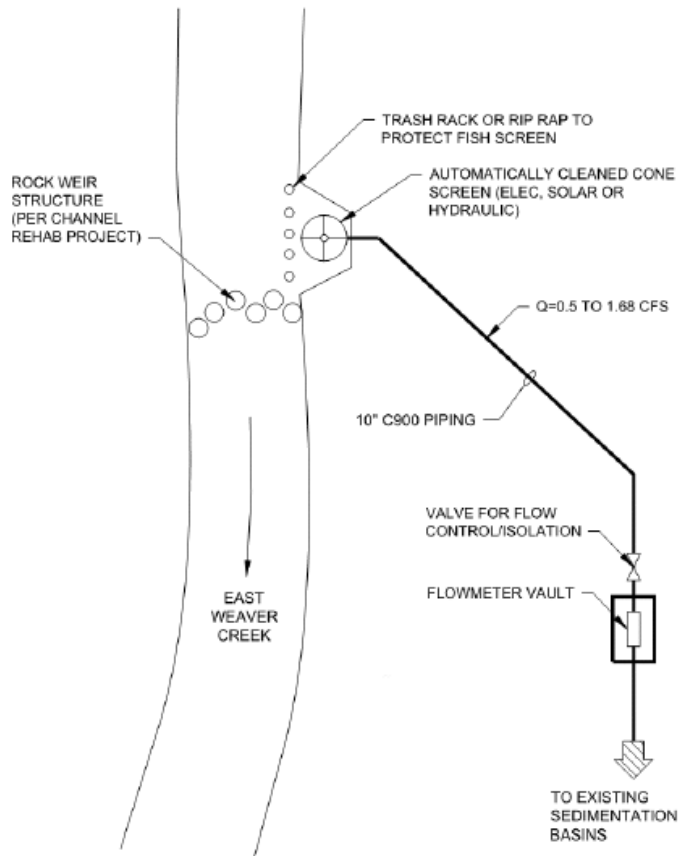
- Installation of certified weed free mulch (straw or wood), native annual and perennial grasses, shrubs, and trees in disturbed areas in excess of 100 ft<sup>2</sup>;
- Restore surface and tread on the Weaver Basin Trail to the same pre-project condition;
- Monitor intake performance for at least 6 months before initiating Phase II (A).

#### Performance Measures for Phase I:

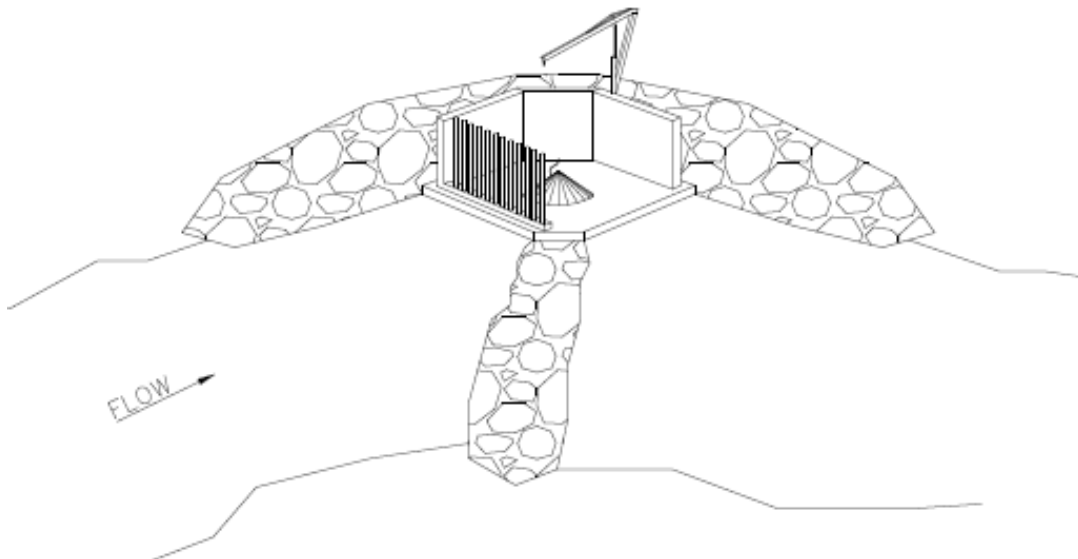
- Successfully operate intake from winter to early summer, confirming reliable performance;
  - If performance is reliable, proceed to Phase II (A).
  - If performance is not reliable, adjust inlet elements to improve reliability.
- Proceed to Phase II(A) when reliable flow is achieved.

---

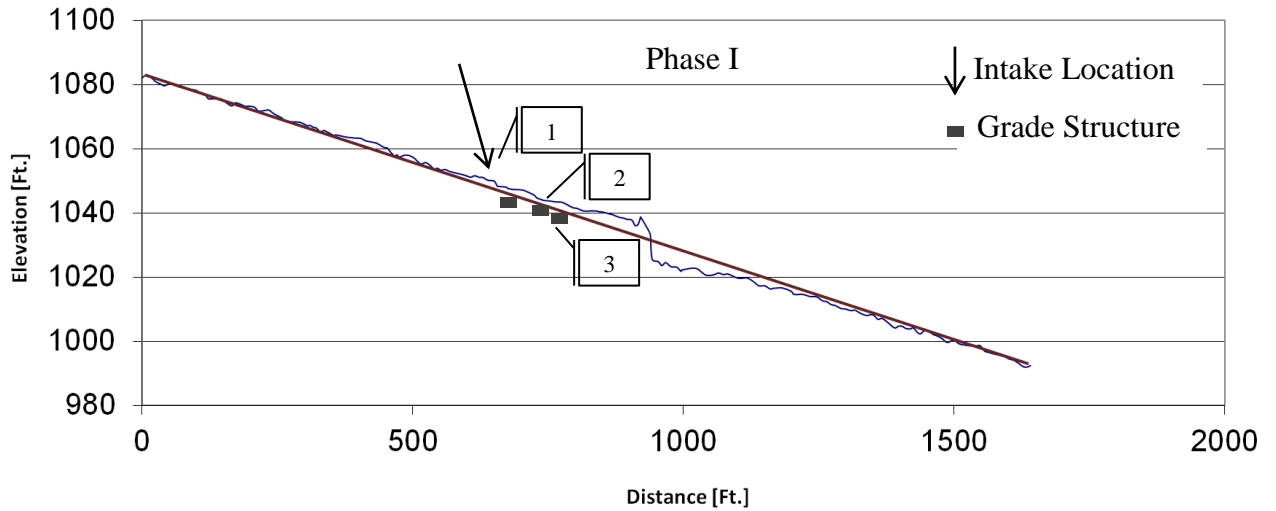
<sup>7</sup> See Section 3.4 Discussion



**Figure 2-4.** Conceptual design for the WCSD screened diversion, intake, and piping infrastructure.

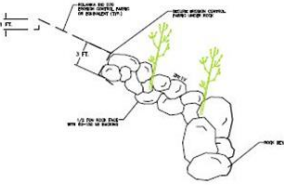


**Figure 2-5.** Screened intake and grade structure design.

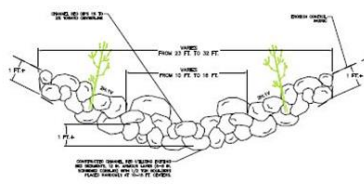


**Figure 2-6.** Placement of the intake and grade structures on the east bank of East Weaver Creek (above). Phase I will install the intake structure, 3-4 channel spanning subsurface grade weirs (#1-3 above), and temporary upgrade access road to the new intake. Grade structures designs are below.

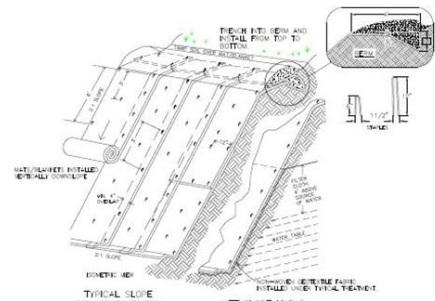
**PLANTED ROCK SLOPE PROTECTION**  
NTS



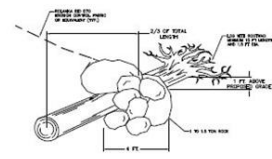
**CONSTRUCTED CHANNEL BED - TYPICAL**  
NTS



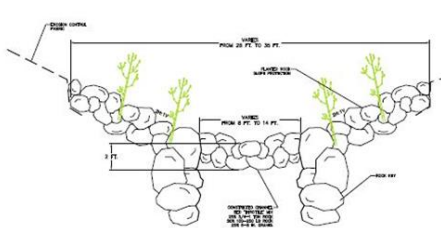
**ROLLED EROSION CONTROL DETAIL - TYPICAL**  
NTS



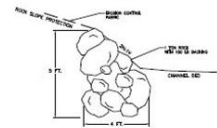
**LARGE WOOD BANK DEFLECTOR**  
NTS



**CONSTRICTED CHANNEL - 'THROTTLE' AREA PROTECTION**  
NTS



**ROCK KEY**  
NTS



**Phase II (A)**

In the summer to fall of Year 2, Phase II(A) will install channel grade control structures (embedded rock weirs) upstream of EWD, remove the upper 6' of concrete apron, reposition the underlying boulder fill in the scour reach of the channel downstream of the dam, and redistribute



accumulated bedload stored upstream of EWD into the scour reach downstream. Once completed, the channel and intake will be monitored for a winter period. If channel adjustment is excessive, the project would implement Phase II(B) the following summer. Phase II(A) will be completed the summer following the successful completion of Phase I and consist of:

Pre-Construction Tasks:

- Implementation of a LOP – All ground disturbing work shall be limited to August 15<sup>th</sup> through November 15<sup>th</sup> of any year;
- Implement the BMPs listed in Appendix 4 throughout construction;
- Installation of 3/32” mesh exclusion fencing for aquatic and terrestrial aquatic species including amphibians within any wetted areas where work is to occur;
- Survey terrestrial work areas for amphibians and western pond turtles and, if found, relocate outside the work area.

In-Stream Construction Tasks:

- Placement of fish exclusion netting (3/32” mesh) and relocation of aquatic species consistent with CDFW permitting requirements. Fish relocation will be conducted using both net and electro-fish passes by a qualified fisheries biologist with a Section 10 permit and consistent with the General Conditions for all Fish Capture and Relocation Activities (NMFS, 2016 p. 18-21);
- Dewater ~600’ of East Weaver Creek (300’ upstream and 300’ downstream of EWD) and relocation of aquatic species. All work will be done consistent with the Requirements for Fish Relocation and Dewatering Activities (NMFS, 2016 p. 16-21);
- Removal of the upper 6’ of concrete cap/apron of the dam and 1-3 ton boulders located beneath the concrete cap;
- Excavation of ~300 yd<sup>3</sup> (30’ wide channel x 1.3’ average depth x 200’ length) of the accumulated sediments and bedload materials from upstream of the dam;
- Placement of the excavated materials in the sediment deficit (scoured) reach of the stream immediately downstream of the dam;
- Placement of up to 6 grade structures within 300’ either upstream or downstream of the dam site to stabilize channel gradient (Figure 2-7);
- Jetting fines into the placed materials downstream of the channel<sup>8</sup>;
- Restoration of channel flows and removal of barrier nets;
- Thalweg and cross section surveys of ~1000’ of channel at conclusion of operations.

Post Construction Tasks:

- Installation of weed free certified mulch (straw or wood), native annual and perennial grasses, shrubs, and trees in disturbed areas in excess of 100 ft<sup>2</sup>;
- Restore the surface and tread on the Weaver Basin Trail to same pre-project condition;

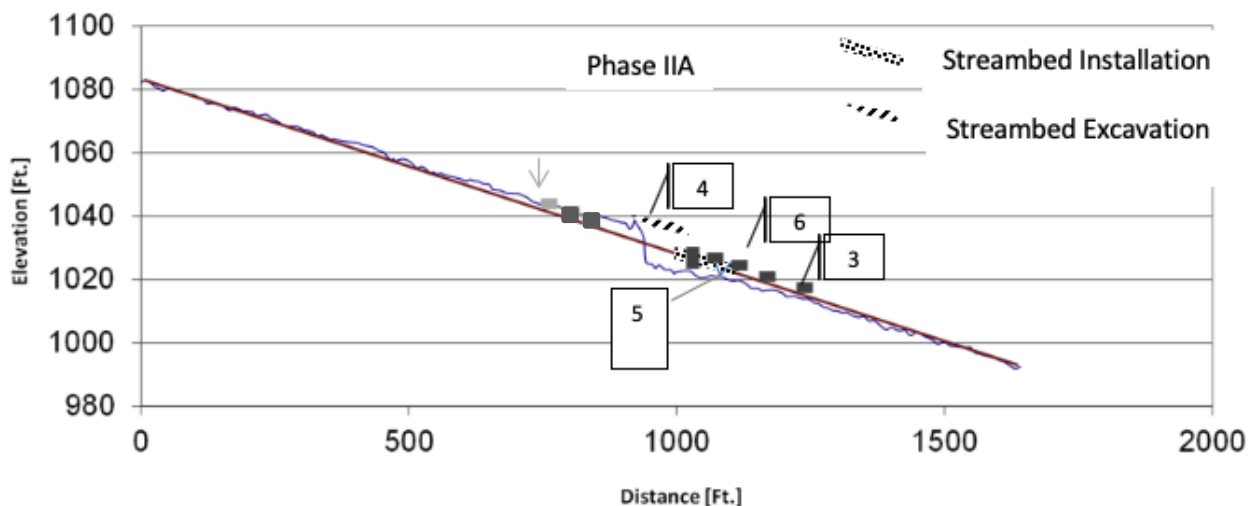
---

<sup>8</sup> Jetting consists of using high pressure water to force fine sediments into voids between gravels, cobble and boulder. A series of recirculating pumps are used to move water from the lower end of a jetted segment back up into the upper end of a jetted stream segment to reuse the turbid water again. A sump pump at the lowest point of a jetted channel segment removes excess turbid water and discharges it on a bank or other suitable area where it will not flow back into the creek. The discharged water percolates into the ground trapping fine particles.

- Monitor intake performance for at least 6-18 months before initiating Phase II(B) if necessary.

Performance Measures for Phase II(A):

- Survey thalweg for 1000' during winter flow (receding limb of flows) to determine if channel incision upstream is exceeding the targeted natural channel gradient of 6% or if downstream recruitment is insufficient to restore a natural channel gradient of 6%;
- Survey cross sections for 1000' during winter flow (receding limb of flows) to determine if channel or bank scour is occurring outside the expected normal scour and erosion processes;
- If excess scour, aggradation, or a combination occurs, implement Phase II (B).



**Figure 2-7.** Placement of grade structures and streambed installation and excavation. Phase II(A) will install six channel spanning subsurface grade structures/weirs (#3) and remove the top 6' of EWD (#4) (~300 yd<sup>3</sup> of streambed) to the scour reach downstream of the dam (#5).

**Phase II (B)**

If necessary, Phase II(B) may be implemented. In the summer to fall of Year 3, Phase II(B) will mechanically reposition the remaining dam fill boulders and upstream bedload sediments to achieve a 5.7% gradient for 600' of the project reach. Phase II(B) (Figure 2-8) consists of:

Pre-Construction Tasks:

- Implementation of a LOP- All ground disturbing work shall be limited to August 15<sup>th</sup> through November 15<sup>th</sup> of any year;
- Implement the BMPs listed in Appendix 4 throughout construction;

Stream Bank Chop and Drop, if needed:

- “Chop and Drop” tree placement of up to twenty trees 12”- 24” diameter at breast height (DBH) in order to create complex habitat elements within the project reaches and encourage bedload entrainment. This will reduce incision in the upstream reach and increase entrainment of bedload in the downstream reach.

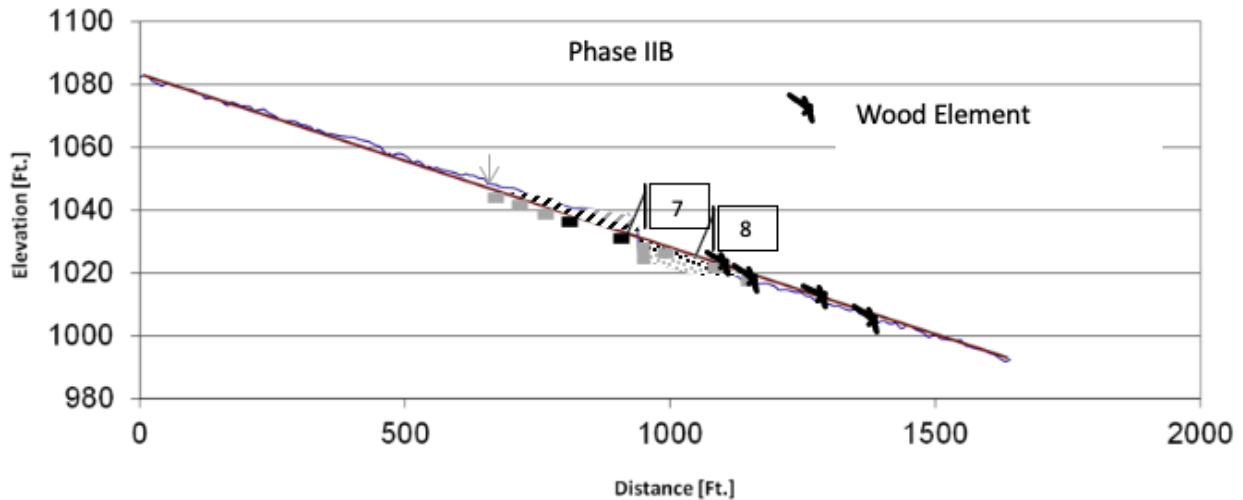
- Streambank vegetation modification will be limited to a maximum of 125' linear distance on either stream bank within the 600 linear feet project area.
- Monitor channel gradient performance for at least 6-18 months before implementing In-Stream Construction Tasks.

In-Stream Construction Tasks, if implemented:

- Placement of fish exclusion netting (3/32" mesh) and relocation of aquatic species consistent with CDFW permitting requirements. Fish relocation will be conducted using both net and electro-fish passes by a qualified fisheries biologist with an Section 10 permit and consistent with the General Conditions for all Fish Capture and Relocation Activities (NMFS, 2016 p. 18-21);
- Dewatering ~100' to 600' of East Weaver Creek (within 300' upstream and 300' downstream of EWD) and relocation of aquatic species. All work will be consistent with the Requirements for Fish Relocation and Dewatering Activities (NMFS, 2016 p. 16-21);
- Removal of the lower 3' of residual 1-3 ton boulders to the extent needed (i.e. if jumps exceed 1', the natural jump height within the reference reach);
- Excavation of ~300 yd<sup>3</sup> of accumulated sediments and bedload materials from upstream of the dam;
- Placement of the excavated materials in the sediment deficit (scoured) reach of the stream immediately downstream of the dam;
- Placement of up to six grade structures within 300' either upstream or downstream of the dam site to stabilize channel gradient;
- Jetting fines into the placed materials downstream of the channel;
- Restoration of channel flows and removal of barrier nets;
- Thalweg and cross section surveys of ~1000' of channel at the conclusion of operations.

Post Construction Tasks:

- Installation of weed free certified mulch (straw or wood), native annual and perennial grasses, shrubs, and trees in disturbed areas in excess of 100 ft<sup>2</sup>;
- Restore the surface and tread on the Weaver Basin Trail to the same pre-project condition;
- Monitor intake performance for at least 6-18 months after Phase II (B).



**Figure 2-8.** Phase II (B) placement of chop and drop trees, grade structures, and streambed material. Phase II (B) consists of monitoring the stream after Phase II (A) and installing supplemental channel spanning subsurface grade structures/weirs (#7), wood elements (“chop and drop”), and streambed materials (#8) if necessary.

### 2.3 Dam Repair and Removal Regulation and Permitting

The federal government requires coordination with U.S. Geological Survey (USGS) for any regulated dam, i.e. structure 25’ high or higher or will have a capacity of 50 acre-feet or more that will be built or modified (Public Law 92-367). The East Weaver Creek Dam does not meet the size or storage capacity criteria necessary for USGS coordination. No federal permits are required for EWD repair or removal; however, federal Clean Water Act (CWA) Certifications are required (discussed below).

California Water Code, Division 3, Section 6002 defines a “Dam” as:

“any artificial barrier, together with appurtenant works, which does or may impound or divert water, and which either (a) is or will be 25 feet or more in height from the natural bed of the stream or watercourse at the downstream toe of the barrier, as determined by the department, or from the lowest elevation of the outside limit of the barrier, as determined by the department, if it is not across a stream channel or watercourse, to the maximum possible water storage elevation or (b) has or will have an impounding capacity of 50 acre-feet or more.”

Section 6003 further defines what does not constitute a structure as a “Dam”. It is as follows: “[a]ny such barrier which is or will be not in excess of 6 feet in height, regardless of storage capacity, or which has or will have a storage capacity not in excess of 15 acre-feet, regardless of height, shall not be considered a dam”.

The East Weaver Creek Dam does not meet the size or storage capacity criteria of a state regulated dam. No state permits are required for dam repair or removal; however, a CDFW Lake

and Streambed Alteration Agreement (LSA) is required (discussed below). The CDFW requires a LSA before any work in a stream can be done, including dam repair or removal. The LSA will have to be signed by the WCSD and CDFW before repairs or removal of EWD can be done.

While the North Coast Regional Water Quality Control Board (NCRWQCB) does not regulate dams, they are required to issue a CWA Section 401 Certification for projects that have a threat to discharge into waters of the U.S.<sup>9</sup>

A U.S. Army Corp of Engineers Nationwide Permit 53 – Removal of Low-Head Dams will be submitted. Because the removal of the low-head dam will result in a net increase in ecological functions and services provided by the stream, as a general rule, compensatory mitigation is not required for activities authorized by this Nationwide Permit. However, the district engineer may determine for a particular low-head dam removal activity that compensatory mitigation is necessary to ensure the authorized activity results in no more than minimal adverse environmental effects. Both CWA 401 and 404 Certification and Nationwide Permit 53 must be obtained for any dam repairs or removal.

The NMFS must be consulted for impacts to Coho salmon. The U.S. Fish and Wildlife Service (USFWS) have been consulted for impacts to other listed species, in this case the northern spotted owl (NSO) or *Strix occidentalis caurina*.

The NOAA BO related to Coho salmon may be programmatically covered under the NMFS's Final BO and EFH consultation for restoration projects within the NMFS Northern California Office jurisdictional area. To be eligible for the BO, small dam removals must meet the following criteria listed in the 2012 NMFS's Final BO and EFH consultation for restoration projects within the NMFS Northern California Office jurisdictional area:

“... form a channel at natural grade and shape upstream of the dam, naturally or with excavation, in order to minimize negative effects on downstream habitat. Dam removal projects will (1) have a relatively small volume of sediment available for release, that when released by storm flows, will have minimal effects on downstream habitat, or (2) are designed to remove sediment trapped by the dam down to the elevation of the target thalweg including design channel and floodplain dimensions. This can be accomplished by estimating the natural thalweg using an adequate longitudinal profile (CDFG California Salmonid Stream Habitat Restoration Manual Part XII: Fish Passage Design and Implementation) and designing a natural shaped channel that provides the same hydraulic conditions and habitat for listed fish that is provided by the natural channel and has the capacity to accommodate flows up to a 2-year flood.

#### *b. Minimization Measures*

---

<sup>9</sup> The NCRWQCB Executive Director addressed small dam removals in a letter to the State Water Board on the draft North Coast Instream Water Policy (August 25, 2005) as follows:“...it is critical that the entire dam fill and any related structures are removed, all the way down to the “original grade” of the stream bed. Some sites may require the excavation below “original grade” and placement of large rock to stabilize the streambed. In addition, all stored sediment should be removed and all previously inundated land should be stabilized with vegetation or rock to limit soil movement. Also, release of stored waters should be done to limit pulse flows...”

- All construction will take place out of the wetted channel either by implementing the project from the bank and out of the channel or by constructing coffer dams, removing aquatic species located within the project reach, and dewatering the channel.
- No more than 250 linear feet (125 feet on each side of the channel) of riparian vegetation will be removed. All disturbed areas will be re-vegetated with native grasses, trees, or shrubs.
- All dewatering efforts associated with small dam removal will abide by the applicable minimization measures (Section D. Sideboards, Minimization Measures, and Other Requirements).

*c. Data Requirements and Analysis*

- A longitudinal profile of the stream channel thalweg for at least a distance equal to 20 channel widths upstream and downstream of the structure and long enough to establish the natural channel grade, whichever is farther, shall be used to determine the potential for channel degradation (as described in the CDFG Manual).
- A minimum of five cross-sections: one downstream of the structure, three roughly evenly spaced through the reservoir area upstream of the structure, and one upstream of the reservoir area outside of the influence of the structure to characterize the channel morphology and quantify the stored sediment.
- Sediment characterization within the reservoir and within a reference reach of a similar channel to determine the proportion of coarse sediment (>2mm) in the reservoir area and target sediment composition.
- A habitat typing survey (DFG Manual Part III, Habitat Inventory Methods) that maps and quantifies all downstream spawning areas that may be affected by sediment released by removal of the water control structure.

Projects will be deemed ineligible for the program if: (1) sediments stored behind dam have a reasonable potential to contain environmental contaminants [dioxins, chlorinated pesticides, polychlorinated biphenyls (PCB's), or mercury] beyond the freshwater probable effect levels (PELs) summarized in the NOAA Screening Quick Reference Table guidelines or (2) the risk of significant loss or degradation of downstream spawning or rearing areas by sediment deposition is considered to be such that the project requires more detailed analysis. Sites shall be considered to have a reasonable potential to contain contaminants of concern if they are downstream of historical contamination sources such as lumber or paper mills, industrial sites, or intensive agricultural production going back several decades (i.e., since chlorinated pesticides were legal to purchase and use)" (pp. 9-11).

The project is not within a Federal Emergency Management Agency (FEMA) mapped floodplain, not zoned Flood Hazard or Flood Hazard Overlay, and does not require a Trinity County Floodplain Development Permit. The County may require a grading permit for dam removal. The Trinity County Building Department does not regulate or permit dams but relies on the state to "permit" them via the CDFW LSA. A building permit for the construction of a safety walkway at the inlet structure and for electrical service will be necessary.

### 3.0 ENVIRONMENTAL EVALUATION CHECKLIST

#### 3.1 Aesthetics

Except as provided in Public Resources Code Section 21099, would the project:	Potentially Significant Impact	Less Than Significant with Mitigation	Less Than Significant Impact	No Impact
a) Have a substantial adverse effect on a scenic vista?				X
b) Substantially damage scenic resources, including, but not limited to, trees, rock outcroppings, and historic buildings within a state scenic highway?				X
c) In non-urbanized areas, substantially degrade the existing visual character or quality of public views of the site and its surroundings? (Public views are those that are experienced from publicly accessible vantage point). If the project is in an urbanized area, would the project conflict with applicable zoning and other regulations governing scenic quality?			X	
d) Create a new source of substantial light or glare which would adversely affect day or nighttime views in the area?				X

#### DISCUSSION

a – d) The project area and facilities are not visible from public roads, state scenic highways, scenic vistas, or viewing areas. The project will not create new sources of light or glare. The project area of effect for visual resource analysis consists of the project work area as viewed from the Weaver Basin Trail, a publicly accessible trail which bisects the project work area (refer to the discussion in Recreation Section 3.16 for additional information). The visual area of effect is defined by East Weaver Creek to the west and mixed conifer forest in all directions. Within the project area a wooden and cinder block water treatment facility, concrete stilling basin, concrete and boulder dam, settling ponds, stored sediments, stored wood, fences and access road define the area (refer to Figure 2-1 and 2-3). At the completion of the project these features will remain unchanged, except the boulder dam which will be replaced with a natural channel bottom.

The Weaver Basin Trail crosses through the EWF adjacent to East Weaver Creek. The removal of the dam and installation of a new intake approximately 270' upstream will maintain views, land uses, or visual patterns similar to and consistent with the existing view scape and values. The project design includes provisions for revegetating and reforesting disturbed areas.

The contrast in viewsheds resulting from the project are consistent with the existing viewsheds. No mitigations are necessary.

### 3.2 Agriculture and Forestry Resources

In determining whether impacts to agricultural resources are significant environmental effects, lead agencies may refer to the CA Agricultural Land Evaluation and Site Assessment Model (1997) prepared by the CA Dept. of Conservation as an optional model to use in assessing impacts on agriculture and farmland. In determining whether impacts to forest resources, including timberland, are significant environmental effects, lead agencies may refer to information compiled by the CA Dept. of Forestry and Fire Protection regarding the state’s inventory of forest land, including the Forest and Range Assessment Project and the Forest Legacy Assessment project; and forest carbon measurement methodology provided in Forest Protocols adopted by the CA Air Resources Board.

Would the project:

	Potentially Significant Impact	Less Than Significant with Mitigation	Less Than Significant Impact	No Impact
a) Convert Prime Farmland, Unique Farmland, or Farmland of Statewide Importance (Farmland), as shown on the maps prepared pursuant to the Farmland Mapping and Monitoring Program of the California Resources Agency, to non-agricultural use?				X
b) Conflict with existing zoning for agricultural use, or a Williamson Act contract?				X
c) Conflict with existing zoning for, or cause rezoning of, forest land (as defined in Public Resources Code Section 12220(g)), timberland (as defined by Public Resources Code Section 4526), or timberland zoned Timberland Production (as defined by Government Code Section 51104(g))?				X
d) Result in the loss of forest land or conversion of forest land to non-forest use?				X
e) Involve other changes in the existing environment, which, due to their location or nature, could result in conversion of Farmland to non-agricultural use or conversion of forest land to non-forest use?				X

### DISCUSSION

a – e) The project area is managed for watershed resources, timber production, and Wilderness values. It is not considered Prime or Unique Farmland. The WCSD 160 acre property is managed for water quality and watershed resources. It is designated and zoned as Open Space lands in the



Trinity County General Plan. The adjacent private timberlands are zoned as Timber Production and managed for timber growth and yield. The adjacent National Forest lands are managed for recreation, fuels reduction, and other watershed values. Areas north of the WCSD property transition into Wilderness lands.

The replacement of the dam and relocation of the intake will not impact agricultural resources, timber, or result in changes in forest lands to non-forest uses. Failure of the dam would adversely impact agricultural and forestry management by reducing water supply and reliability to all users of the WCSD, which includes forest product and agricultural industries.

### 3.3 Air Quality

Where available, the significance criteria established by the applicable air quality management district or air pollution control district may be relied upon to make the following determinations. Would the project:

- a) Conflict with or obstruct implementation of the applicable Air Quality Attainment Plan?
- b) Result in a cumulatively considerable net increase of any criteria pollutant for which the project region is nonattainment under an applicable federal or state ambient air quality standard?
- c) Expose sensitive receptors to substantial pollutant concentrations?
- d) Result in other emissions (such as those leading to odors) adversely affecting a substantial number of people?

Potentially Significant Impact	Less Than Significant with Mitigation	Less Than Significant Impact	No Impact
			X
			X
			X
			X

### DISCUSSION

a – d) The project will not conflict or obstruct with a the Air Quality Attainment Plan, result in a cumulatively considerable net increase of any criteria pollutant or other emissions, expose sensitive receptors to substantial pollutant concentrations, or result in other emissions that will adversely affect a substantial number to people. The replacement of the failing dam and upstream relocation of the water system intake will allow for the continued use of gravity fed water to the community. Gravity fed water systems do not require electrical power to deliver water. Relocation of the water source out of the East Weaver Creek intake location would require pumping and increased electrical power sources. This project avoids that need. The East Weaver water system is the primary portion of the system that does not rely on pumps to distribute water. Relocation to an alternative location would reduce reliability; but, Trinity County’s reliance on hydroelectric power generation would not increase air emissions to meet water demand.

The project will generate minimal amounts of fugitive dust during excavation and removal of the boulder dam, concrete cover, and earthwork to reconstruct ~300' of stream channel. There are no public areas that would be exposed to construction dust. The project description includes BMPs to deal with short term fugitive dust including watering to prevent dust and tarping of soil piles where wind can result in dust migration (Appendix 4). Tarping spoils piles will reduce the potential for non-native seed sources to contaminate the spoils and prevents fugitive dust during windy periods.

### 3.4 Biological Resources

Would the project:	Potentially Significant Impact	Less Than Significant with Mitigation	Less Than Significant Impact	No Impact
a) Adversely impact, either directly or through habitat modifications, any endangered, rare, or threatened species, as listed in Title 14 of the California Code of Regulations (Sections 670.2 or 670.5) or in Title 50, Code of Federal Regulations (Sections 17.11 or 17.12)?			X	
b) Have a substantial adverse effect on any riparian habitat or other sensitive natural community identified in local or regional plans, policies, or regulations, or by the California Department of Fish and Wildlife or US Fish and Wildlife Service?			X	
c) Have a substantial adverse effect on state or federally protected wetlands (including, but not limited to, marsh, vernal pool, coastal, etc.) through direct removal, filling, hydrological interruption, or other means?				X
d) Interfere substantially with the movement of any native resident or migratory fish or wildlife species or with established native resident or migratory wildlife corridors, or impede the use of native wildlife nursery sites?				X
e) Conflict with any local policies or ordinances protecting biological resources, such as a tree preservation policy or ordinance?				X
f) Conflict with the provisions of an adopted Habitat Conservation Plan,				X

Natural Conservation Community Plan, or other approved local, regional, or state habitat conservation plan?

--	--	--	--

## DISCUSSION

### a) Threatened Species

Reviews of the following records were completed prior to field surveys: CNDDDB (2020, 2021), CNPS (2020, 2021), and CDFW Wildlife Habitat Relationships habitat communities mapping (2020). Previous biological work included: U.S. Forest Service (USFS) fisheries stream condition surveys (2002, 2011; Wiseman, pers. comm. 2017), NSO surveys (Sierra Pacific Industries (SPI), pers. comm. 2018-2020), USFS wildlife surveys and atlas reviews (Rogers, pers. comm. 2017; DeJuillo, pers. comm. 2020), Timber Harvest Plan biological and botanical surveys (2-16-054-TRI, 2-07-061-TRI, 2-06-026-TRI), and fisheries and water temperature surveys (Appendix 6).

Based on database record checks and existing biological surveys, two state and federally listed threatened species are known to occur within a 3 mile radius of the project area: Coho salmon (*Oncorhynchus kisutch*) and northern spotted owl (*Strix occidentalis caurina*). Coho salmon are presumed to utilize habitat immediately downstream of EWD, but fisheries surveys have not found them within the area of potential effect (APE). The project APE contains suitable NSO foraging habitat<sup>10</sup> within an area designed as critical NSO habitat (Figure 3-1).

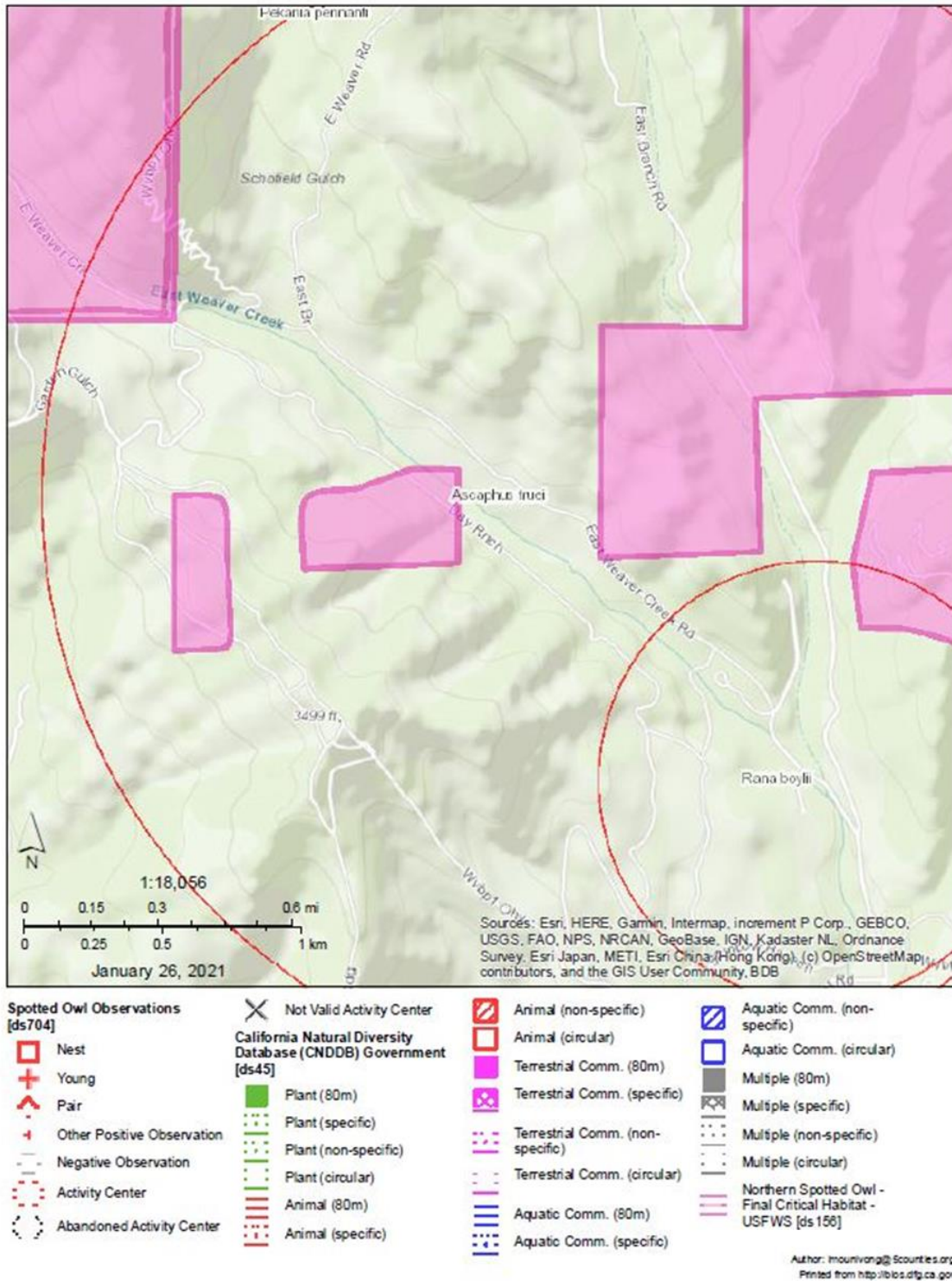
Two California or federal Species of Special Concern (SSC) were located within the APE: English Peak greenbrier (*Smilax jamesii*) and foothill yellow-legged frog (*Rana boylei*). The CNDDDB lists populations of English Peak greenbrier (*Smilax jamesii*), a California Rare Plant Rank (CRPR) 4.2 species, within 2 miles of the project area. Four observations of *Smilax jamesii* were recorded within the project area near highly trafficked areas. A single yellow-legged frog was observed in the project reach in 2020 (DeJuillio, pers. comm. 2020).

Refer to the following discussion on known and potential SSC utilization of the project reach.

---

<sup>10</sup> “Nest-Roost habitat in California is generally defined as 60-90% canopy closure, multi-layered/species canopy with trees >30 inches diameter, trees with deformities, woody debris on ground and open space below canopy to allow spotted owls to fly” (USFWS, 2011 pg. III-61).

## CNDDDB Map of EWD Removal & Intake Relocation Project Area



**Figure 3-1.** CNDDDB map of the project area. The only SSC that could potentially occur in the project site are the Pacific tailed frog (*Ascaphus truei*) and the foothill yellow-legged frog (*Rana boylii*). NSO critical habitat can be found within 0.5 miles from the project site.

## A. Salmonid Species of Special Concern

Review of fisheries surveys by USFS and 5C fisheries staff determined that the project area is utilized by the state and federally listed threatened species: *Oncorhynchus kisutch* (Coho salmon). East Weaver Creek from the confluence with West Weaver Creek has been monitored for salmon and steelhead for more than 50 years. In 1964, LaFaunce counted 89 steelhead redds near the confluence (LaFaunce, 1964). In 1971, Rogers surveyed the same area and found no redds (Rogers, 1971). In 1972, Rogers found 3 redds in the lower 2 miles (Rogers, 1972). CDFG biologists, Boberg and Kenyon noted the presence of Chinook salmon and steelhead trout among seven fish species in the stream near the confluence (Boberg and Kenyon, 1979). Ebasco Environmental conducted a Habitat Assessment of East Weaver Creek and found steelhead in the project reach (Ebasco, 1990). U.S. Department of Agriculture Natural Resources Conservation Service fisheries biologist, Tim Veil, observed young of the year Coho in East Weaver at Horseshoe Lane (pers. comm., 2011). CDFG completed steelhead redd surveys in the lower reaches of East Weaver Creek and found 2 redds and 8 redds respectively (CDFG, 2009; CDFG, 2010). Fisheries biologist, Ross Taylor, found a female Coho carcass below the confluence of East and West Weaver Creeks in 2011 (pers. comm., 2011). The Northwest California Resource Conservation & Development Council (RC&DC) staff found an adult steelhead female in 2012 just upstream of the confluence of the two streams. According to E. Wiseman, USFS has monitored the upper reaches (EWC to EWD) between 2010 and 2015 finding juvenile Coho and rainbow trout in this reach each summer (pers. comm., 2015). In July 2015, a snorkel survey by K. Yamasaki followed the creek upstream of EWD and found several rainbow trout (*Oncorhynchus mykiss*) exhibiting physiological changes associated with smoltification, a physiological change in which juveniles adapt from living in fresh water to living in seawater by altering body shape and increasing skin reflectance (pers. comm., 2015).

The project will enhance Coho, steelhead, rainbow trout, Pacific lamprey, and other aquatic species habitat by restoring access to ~2.5 miles of high quality habitat currently blocked by EWD. Habitat upstream of EWD consists of high quality spawning and rearing habitat, which includes deep pools, thermal refugia, and adequate cover. The project will also protect young of the year fisheries by installing a fish screen on the inlet of the EWF water diversion. Currently, the inlet to the water system is unscreened and fish entering the stilling basin are forced through the treatment plant or bypass pipe system, increasing mortality. The removal of the dam will also allow for natural bedload and debris movement, which will allow for deposition reaches of the channel downstream of the dam.

### 1. *Temperature Effects of EWD Removal in Relation to Salmonids*

Over summer rearing habitat in Weaver Creek is among the most critical limiting factor to salmonid survival in the watershed. Low flows and high water temperatures result in fish mortality in most years in the lower 2/3<sup>rd</sup> of the Weaver Creek watershed. Lethal summer water temperatures are the result of drought, reduced canopy cover, water diversions, channel lining and straightening (including levee construction), simplified habitats, anthropogenic sediment sources, and legacy mining impacts. All of these factors can affect water temperature.

As part of the planning for the removal of the EWD, temperature data was analyzed above and below EWD. Water temperature and stage monitoring began by 5C in 2014 to determine

baseline water quality prior to removing the EWD and relocating the WCSD water intake. Prior and ongoing monitoring was also performed by USFS and Redwoods Sciences Lab (RSL). Stream temperature monitoring by USFS, USGS, RSL, and 5C provides data at several points within a 1-2 mile range of EWD. Appendix 6 (*East Weaver Dam and Intake Effects on Stream Temperature and Flow in Relation to Endangered or Threatened Salmonid Species*) of this Initial Study summarizes the 5C data of the effects of the EWD and intake on temperature and flow in relation to salmonids.

The water study, *East Weaver Dam and Intake Effects on Stream Temperature and Flow in Relation to Endangered or Threatened Salmonid Species* (Appendix 6) indicates that the East Weaver Creek below EWC can reach temperatures that preclude Coho and steelhead migration. Lethal temperatures in low summer flows can increase mortality for salmonids of all life stages. Downstream of EWC (below the Lance Gulch Road Bridge) the stream provides little summer rearing habitat, as summer flows tend to decrease. Within these reaches the stream dries up completely in some years. Monitoring upstream of Butterfield Bridge (location of the RSL flow, barometric pressure, and temperature gauges) shows year round flows; but, late summer temperatures can reach at, or near, lethal levels for salmonids. Upstream of the EWD, USFS temperature data shows reduced temperatures compared to the EWC or the RSL monitoring sites.

EWD removal will substantially improve over summer rearing salmonid survival in East Weaver Creek by opening access to 2.5 miles of year round flows with sub-lethal and cooler water temperatures. The limited extent of stream reaches with summer rearing habitat and sub-lethal water temperatures are limited to the upper reaches of East Weaver Creek, West Weaver Creek and Little Browns Creek.

## 2. *Water Quantity (Water Diversion) Effects of Dam Removal in Relation to Salmonids*

The WCSD holds a “pre-1914” water right on East Weaver Creek and is the uppermost diversion in the stream. The water right was not quantified in state records at the time as it began as an open ditch flow in the late 1890’s. The East Weaver Creek Treatment Facilities were installed in 1958. It utilizes a dam and stilling basin for diversion into a series of contact basins, sand filters, and storage tanks. The intake consists of a 3’ x 3’ concrete stilling basin set approximately 0.5’ below the top elevation of EWD. At the bottom of the stilling basin, a 12” diameter pipe moves water from the stilling basin to the contact basin. At the stilling basin, a baffle pushes water either into the contact basin or into an overflow and stream return pipe. Debris, grates, and turbulence reduce the capacity of the stilling basin inlet to some degree; but, it is still capable of diverting far more water than the EWF can treat.

As part of the East Weaver Creek Dam Removal and Intake Relocation Project, Waterworks Engineering was retained to design a new inlet for the EWF. As part of the inlet design, the WCSD had to determine its water usage and underlying quantified water right. The intake flow capacity for the new intake, and the quantified water use, was determined based on review of the existing treatment plant capacity. The existing stilling basin pipe has a theoretical capacity of diverting 6.87 cfs through the pipe to the contact basin (flowing into the stilling basin in excess of 6.87 cfs, backfills the basin and overflows the top of the dam). Flows in excess of 1.73 cfs that move from the stilling basin to the contact basin are returned to the creek via the bypass pipe

that discharges approximately 100 feet downstream of the dam. While the WCSD uses 1.73 cfs, the intake diverts 100% of the stream flow into the unscreened stilling basin when the stream flow drops to ~2.5 cfs at the dam crest. Flow monitoring indicates that even when the stream is fully diverted into the stilling basin, interstitial leakage and return flows downstream of the dam were ~0.8 - 1 cfs in the driest summer periods.

The sand filters, located downstream of the contact basin, are a limiting factor for the EWF capacity. The sand filters can treat 1.73 cfs and monitoring indicates that WCSD operates at that level for much of the year. The sand filters have been in operation for more than 60 years and provides additional basis to quantify the WCSD diversion rate at 1.73 cfs. Prior to 1958, the predecessor utility company to WCSD relied on an open ditch flow for water needs and most likely exceeded the current diversion rate; however, the rate was never quantified.

Review of filed water rights from the California Water Resources Control Board Electronic Water Rights Information Management System (eWRIMS) show that there are a total of 16 recorded diversions reporting to a total of 2.92 cfs per day on East Weaver Creek (Table 3-1). The diversions do not include unreported riparian diversions, excess diversions to perfect a water right, or illegal diversions. There is no flow monitoring upstream of the diversions to determine the percentage of flow diverted; however, interviews with long term residents indicate that the stream typically has perennial flow at least to the Lance Gulch Road bridge (approximately 4 miles downstream of EWD).

**Table 3-1.** Water right records for East Weaver Creek obtained from eWRIMS.

Applicant ID	Name	Entity Type	Reported Direct Diversion	
			cfs/day	gal/day
A015472	Daniel Powers	Individual	0.006	4000
A016510	Gay Butler	Individual	0.050	32316
S000361	Weaverville Community Services District	Corporation	1.730	1118124
S004681	Trinity River Lumber Co.	Corporation	1.000	646315
S008683	Bertha Loving	Individual	0.000	0
S008684	Eric Peterson	Individual	0.006	4200
S008691	Robert Thomas	Individual	0.000	0
S008800	Jerry Main	Individual	0.020	12672
S009042	Willis Norman	Individual	0.000	50
S009043	Michael McFadin	Individual	0.000	0
S009044	William Wardall	Individual	0.001	750
S009053	Lowain Hatfield	Individual	0.000	0
S009121	Patricia Kraus	Individual	0.001	900
S009156	Florence Burroughs	Individual	0.001	730
S012481	Jerry Brasuell	Individual	0.090	58168
S020366	Brandt Gutermuth	Individual	0.010	6463
Total			2.92	1884688

The new intake design will only divert 1.73 cfs compared to the existing EWF diversion, which diverts significantly higher flows and returns excess flows to the creek downstream of the dam

via a bypass pipe. The new intake design will more accurately monitor the diversion rate. The design incorporates a NMFS approved cone fish exclusion screen that prevents fish and other species from entering the treatment plant and will have a minimum 1 cfs bypass flow. Because the WCSD already reduces its EWF diversion in summers by increasing pumping from its Trinity River plant as the creek flow drops, the revised intake will have minimal impacts to the WCSD operations. While the new intake will result in significant improvements to fish mortality due to the addition of fish screens, the most significant benefit is opening access to 2.5 miles of cold-water salmonid habitat in the Weaver Creek watershed and providing reliable operations for WCSD.

The proposed project is not a water capacity project; and, will not result in increased demand for water use or change in water demand. The project will result in increase of critical summer rearing habitat in the Weaver Creek watershed.

In conjunction with the dam removal, the 5C with WCSD participation undertook a voluntary program to increase stream flow. In 2015, the McKnight Ditch water right holders reduced their diversion to avoid the take<sup>11</sup> of salmonids. Over the next five years, the water right holders were supplied water from the WCSD and 5C to determine water use and alternatives to the existing ditch system. In 2019, the 5C and water right holders completed a new water line placement<sup>12</sup> and fish screen to replace the unscreened, open flow ditch. The new system, which is 1.5 miles downstream of EWD, reduces the diversion rate from approximately 2.13 cfs<sup>13</sup> to 0.06 cfs. A second ditch water conservation project (Hansen Ditch) is in development on the East Branch of East Weaver Creek, approximately 1 mile downstream of EWD. If and when implemented, the Hansen Ditch project will return an estimated 0.5 cfs to East Branch East Weaver Creek and East Weaver Creek.

The most significant diversion in East Weaver Creek remains as the unscreened Howe Ditch. There are no recorded water rights for this ditch, which moves an estimated 10% to 40% of East Weaver Creek's flow out of the stream to Five Cent Gulch via a series of old mining ditches. Howe Ditch is a significant source to fish mortality as well as impacts to water temperatures. The Howe Ditch mortality and fisheries impacts are known to the USFS (where the diversion is located without a use permit), CDFW (which typically requires fish exclusion screens on diversions), and the Department of Water Resources (which regulates water rights and inter-basin water transfers). None of the regulating agencies has interceded in the Howe Ditch operations, suggesting that agencies are not significantly concerned with temperatures and flows in East Weaver Creek.

When fully implemented, the McKnight, Hansen, and Howe Ditch conservation projects could increase summer flows by 2.5 to 3.5 cfs as well as a reduction to fish mortality from unscreened diversions.

---

<sup>11</sup> The term 'take' means to harass, harm, pursue, hunt, shoot, wound, kill, trap, capture, or collect, or attempt to engage in any such conduct to a Federally listed species.

<sup>12</sup> The water conservation project was funded by the Trinity River Restoration Programs Watershed Restoration grant program, North Coast Regional Partners Prop 84 Water Bond grant, Water Right holders, 5C, and WCSD.

<sup>13</sup> Refer to Endnote #3



No mitigation measures for water temperature or quantity are needed as the project will not result in increases in water temperature or diversion rates. The project designs will quantify the WCSD water right, establish a minimum bypass flow, and eliminate the dry portion of the stream created by late summer diversion at the dam to the return flow pipe downstream of the dam. Water conservation projects have already been implemented downstream that will increase streamflow compared to the baseline condition (refer to discussion above).

### 3. *Channel Dewatering*

Channel dewatering and fish relocation will only occur during construction periods. Dewatering is necessary to install the new intake structure or pipeline to the existing contact basin and for the removal of EWD (Phase I and II (A)). Minimal dewatering is necessary for Phase I.

Prior to dewatering the wetted channel at both upstream and downstream ends of project reaches will be spanned with 3' high, 3/32" mesh fish exclusion netting. The netting will be set into the gravels to prevent migration into the work area. Once the nets are installed fish and other aquatic vertebrates will be removed by a qualified fisheries biologist and assistants. An approximate 1' high temporary dam will be constructed at the upper end of the fish excluded reach and a 12" diameter pipe will be installed in the temporary dam to divert the flow into the EWF intake. The intake will bypass the work area, returning flows at the bottom of the project.

Approximately 30' of the eastern streambank length and 3' of width of the stream will be dewatered for one week during Phase I work. Dewatering will consist of constructing an approximately 15' long deflecting weir of gravel and engineering fabric at the upstream end of the work area. The weir will deflect the minimal summer flows to the west side of the channel. Minor manual manipulation of the west side of the channel will occur to contain the summer flows away from the work area. A silt and exclusion fence will be installed around the work area to keep the deflected flows and aquatic species away from the work area. A small gas or electric pump will be used to dewater interstitial flows as needed. Pumped water will be discharged in an existing swale that is not connected to East Weaver Creek. Under Phase II, approximately 600' of the channel will be dewatered and fish relocated to adjust channel elevation and install grade structures. During Phase II, flows will be diverted into the new WCSD intake that was installed in Phase I.

The in-channel work is expected to take 4-5 days for each phase during the late summer (August 15 – October 15) when flows are lowest. It is anticipated that approximately 95% of flows will be diverted through the diversion culvert (Phase II) but subsurface flows may be encountered during channel excavation. If that occurs, a sump with a gas pump will be installed to pump water out of the construction area and into a swale clear of the project. The temporary dam will be constructed out of plastic sand bags, rocks, and plastic sheeting at the downstream side of a natural pool below the upper fish exclusion screen. Once channel work is completed, the dam and fish screen nets will be removed. All work will be done consistent with the Requirements for Fish Relocation and Dewatering Activities (NMFS, 2016 p. 16-17).

### 4. *Fish and Aquatic Vertebrate Relocation*

Fish relocation will be conducted using both net and electro-fish passes by a qualified fisheries biologist with a Section 10 permit and consistent with the Guidelines for Fish Capture and Relocation Activities (NMFS, 2016 p. 18-21). There is suitable habitat for releasing captured fish and amphibians both above and below the work areas. Due to complex fish habitat features including large and small woody debris, pools and overhung banks, the project reaches may not be electro-fished to depletion. After installation of the stream diversion and the gradual dewatering of pools, resident trout will be removed with small nets and buckets with appropriate aerators and relocated above or below the fish exclusion fencing. Relocation will be timed for periods when water temperatures are within safe limits for salmonids, typically early morning.

##### 5. *Short Term Turbidity Effects of Dam Removal*

Short term increases in sediment and turbidity may occur from construction activities including: pipeline excavation outside of the channel; excavating aggraded channel materials in the depositional reach of the channel (Figure 3-2); reconstruction of the existing scour channel reaches; and installation of grade structures. Short-term increases in sediment and turbidity may also occur as minor channel adjustments occur upstream of the project.

Increases in suspended particles and turbidity are expected to be relatively low as the work area will be dewatered and jetting reconstructed channel fines will be incorporated to entrain fines between gravels and boulders. The use of jetting to “lock” fines into voids in gravels, cobbles, and boulders is similar to the effect of sediment transport on channel forming flows<sup>14</sup>. Sediment enters the water column during naturally turbid conditions and increases are expected to occur for short periods and short distances downstream, settling out quickly. The impacts would be minimal and short term. Discharged sediment volumes are expected to be within the seasonal variability amount of sediment and water carried by the East Weaver Creek watershed over an annual cycle. Sediment dissemination from material existing behind the dam is expected to distribute in accordance with water velocities of the course of a normal flood and non-flood season<sup>15</sup>.

Impacts to current patterns and water circulation would be realized as the material re-contours the current sediment starved and scoured sections of the downstream channels. These impacts are expected to be temporary and short-lived. The loss of environmental characteristics and values is not considered significant; and, the material is expected to be beneficial to in-stream habitats. Compliance with project designs ensure, to the extent practical, aquatic based resource impacts are below significant levels. The project description includes dewatering of the work areas, reconstructing scour regions during the project, and use of jetting and compaction techniques to entrain fine sediments during low flows. In addition, the project incorporates compliance with the NMFS 2012 BO for the NOAA’s Restoration Center’s Minimization Measures (refer to Section 2.2).

---

<sup>14</sup> Similar jetting practices on more than 20 previous barrier removal projects completed by the 5C and its partners indicate that less than 5 yd<sup>3</sup> of fines would be released in storm flows. Due to the project’s practices, siltation will be significantly less than would normally occur as a result of the dam deteriorating and the rapid mobilization of stored materials.

<sup>15</sup> Refer to <https://www.nae.usace.army.mil/Portals/74/docs/Topics/NBLConversion/CWActSection404b1Eval.pdf>

Channel excavation of approximately 300' of the depositional upstream channel reach will occur in Phase II (A). The excavation will increase the channel gradient to ~4.5% from the current ~2%. Additional natural channel adjustment is anticipated to occur over the first 1-3 years following the implementation of Phase II (A) to bring the channel back to natural gradient of ~5.7%. The composition of the material in the depositional reach is consistent with the natural bedload particle composition (Figure 3-3). The mechanical relocation of the bed materials will result in some increase in fine sediments becoming transportable; however, the area will be washed with water to mobilize these fines downstream into the reach being reconstructed. Once loose fines have been washed down to the reconstructed "scour" reach they will be incorporated into a final erosion control and reconstruction process known as "jetting". Reconstruction of scour reaches consist of building up the channel gradient using natural bedload materials of particles sizes that mimic natural routing processes as well as relocating the larger grade rocks that form the dam.

Turbid water collected at the bottom of the jetted reach will be pumped out of the channel and into basins located outside the stream. Channel reconstruction, including "jetting" of fine sediments (<6mm in diameter), will be used to rapidly compact fine sediments in the interstices between cobble, gravel, and boulder features.

The fine sediment, while highly mobile in suspension form, creates a "glue" between the larger particles holding them in place and mobilizes only on high flows when natural bedload replaces particles in a similar fashion as those mobilized. Following the initial storms, the sediment transport balance (sediment routing) will replenish mobilized sediment and mimic natural turbidity levels over time. Properly jetting fine sediments minimizes short term increases in turbidity. The 5C's Project Managers have extensive experience with jetting and water quality compliance when reintroducing fine sediment particles into channel reconstruction. The project designs include erosion control and jetting plans.

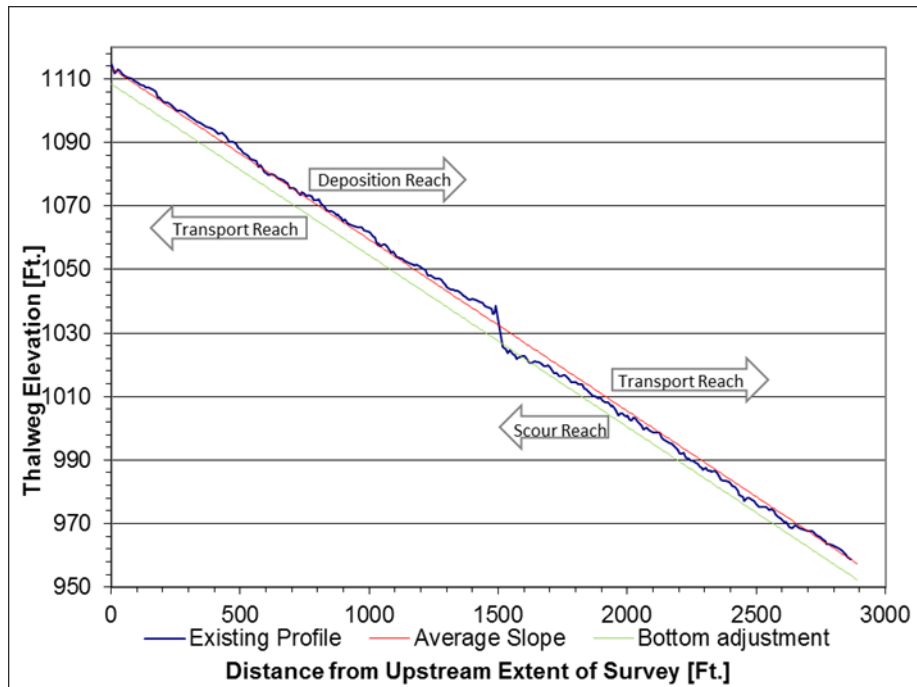
No mitigation measures for fish relocation or channel dewatering are required as the project description includes participation and compliance with the NOAA/NMFS 2012 BO and EFH consultation for the NOAA's Restoration Center's proposed funding and the U.S. Army Corps of Engineers proposed permitting of restoration projects within the NMFS BO. The NMFS's BO includes design criteria and Minimization Measures to protect listed Coho salmon:

#### "Minimization Measures

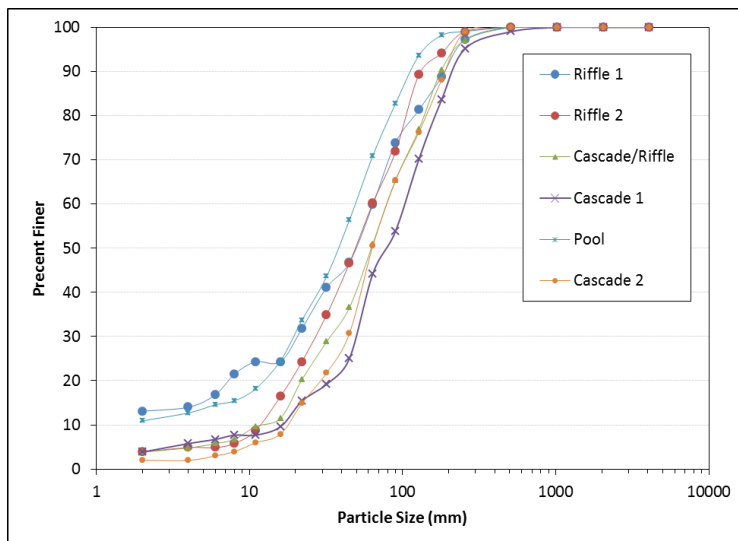
- All construction will take place out of the wetted channel either by implementing the project from the bank and out of the channel or by constructing coffer dams, removing aquatic species located within the project reach, and dewatering the channel.
- No more than 250 linear feet (125 feet on each side of the channel) of riparian vegetation will be removed. All disturbed areas will be re-vegetated with native grasses, trees, or shrubs.
- All dewatering efforts associated with small dam removal will abide by the applicable minimization measures (Section D. Sideboards, Minimization Measures, and Other Requirements).

## Data Requirements and Analysis

- A longitudinal profile of the stream channel thalweg for at least a distance equal to 20 channel widths upstream and downstream of the structure and long enough to establish the natural channel grade, whichever is farther, shall be used to determine the potential for channel degradation (as described in the CDFG California Salmonid Stream Habitat Restoration Manual).
- A minimum of five cross-sections: one downstream of the structure, three roughly evenly spaced through the reservoir area upstream of the structure, and one upstream of the reservoir area outside of the influence of the structure to characterize the channel morphology and quantify the stored sediment.
- Sediment characterization within the reservoir and within a reference reach of a similar channel to determine the proportion of coarse sediment (>2mm) in the reservoir area and target sediment composition.
- A habitat typing survey (CDFG California Salmonid Stream Habitat Restoration Manual Part III: Habitat Inventory Methods) that maps and quantifies all downstream spawning areas that may be affected by sediment released by removal of the water control structure (Flosi, et al. 2010).
- Projects will be deemed ineligible for the program if: (1) sediments stored behind dam have a reasonable potential to contain environmental contaminants [dioxins, chlorinated pesticides, 11 polychlorinated biphenyls (PCB's), or mercury] beyond the freshwater probable effect levels (PELs) summarized in the NOAA Screening Quick Reference Table guidelines or (2) the risk of significant loss or degradation of downstream spawning or rearing areas by sediment deposition is considered to be such that the project requires more detailed analysis. Sites shall be considered to have a reasonable potential to contain contaminants of concern if they are downstream of historical contamination sources such as lumber or paper mills, industrial sites, or intensive agricultural production going back several decades (i.e., since chlorinated pesticides were legal to purchase and use). In these cases, preliminary sediment sampling is advisable” (NMFS, 2012 p. 10-11).



**Figure 3-2.** Long profile of East Weaver Creek including the average slope, adjustment grade (bottom adjustment), and reach description in terms of sediment transport/deposition.



**Figure 3-3.** Results of six pebble count samples in the reference reach of East Weaver Creek.

### 6. Large Woody Debris

Stream Condition Inventories (SCI) of East Weaver Creek were completed by the USFS in 2002 and 2011 including assessments of Large Woody Debris (LWD). The objective of the LWD inventory is to characterize the woody debris influencing the stream channel. The survey above EWD found 8 pieces of LWD that met the minimum debris length of 7 feet in 2002. In 2011, there were 31 pieces of LWD counted, nearly a 400% increase compared to the 2002 survey. The

2002 SCI data shows that the diameters of 50% (n=4) of the LWD that met the minimum debris length were small and ~4” to 8” in diameter. The 2011 data shows that the diameters of 61% (n=19) of the LWD that met the minimum debris length were small and ~4” to 8” in diameter. In summary, the 2011 SCI survey showed a marked increase in the numbers of LWD counted but that most pieces for both the 2002 and 2011 SCI’s were small diameter logs. According to E. Wiseman, the most plausible explanation for the increases in LWD counted within the Upper East Weaver Creek SCI site is due to an increase in recruitment from the surrounding riparian area and not due to changes in the stream channel geometry (personal communication, 2015).

The data downstream of EWD shows that in 2002 there were 57 pieces of LWD that met the minimum debris length of 7 feet compared to only 25 pieces of LWD counted in 2011, a 56% decrease over the 2002 survey. The 2002 SCI data shows that the diameters of 54% (n=31) of the LWD that met the minimum debris length were small (~4” to 8” in diameter). The 2011 data indicate that the diameters of 52% (n=13) of the LWD that met the minimum debris length were moderately sized (8” to 16”). The 2002 survey still had more pieces of LWD (n=21) between 8” to 16” in diameter than the 2011 survey (n=13). In 2002, there were no observed root wads and only five woody aggregates (log jams) tallied, which included 21 pieces of wood that met the minimum length requirements. In 2011, there were no aggregates tallied; but, there were two root wads noted in the SCI survey. In summary and observed by E. Wiseman, the 2011 SCI survey showed a marked decrease in the overall numbers of LWD pieces counted including the loss of five wood aggregates that had a total of 21 pieces of suitably sized LWD (personal communication, 2015).

The project will improve the LWD elements if Phase II (B) is implemented, especially by adding larger woody elements to the system. If Phase II (B) is not implemented, the project will not increase LWD upstream but will improve debris routing down the channel.

## **B. Northern Spotted Owl**

The NSO is found in a mix of old and younger conifer forest types in the Klamath region. The APE consists of suitable foraging and roosting habitat used by the NSO. Review of the CNDDB shows no historic NSO activity centers within ~1.3 miles of the project area (Figure 3-1). SPI maintains a continuous NSO survey and inventory program in coordination with USFWS and tracks nesting and habitat utilization in the project area. SPI shares data on owl presence and habitat with qualified biologists and forestry professionals as necessary to assess project effects on owl habitat. SPI 2018 and 2019 NSO surveys within 1.3 miles of EWD found no NSO responses. Other known NSO activity centers and/or detections occur more than 1.3 miles from EWD. It is unlikely that NSO would nest within the project area due to its proximity to East Weaver Road, the daily operations performed by WCSD staff and equipment, residents, and hiking trails used by people and dogs daily.

Three potential activities from the EWD removal are analyzed for impacts to NSO from the project: construction noise, construction activities, and removal of habitat. Noise and construction activities could impact nesting and foraging behavior for short periods of time. Tree removal could reduce overall habitat slightly.

## *1. Construction Noise and Construction Activities*

A LOP for the project (August 15 to November 15) was established in the project description to minimize noise and construction impacts. The selected LOP will also time instream work for the lowest flow periods. During the LOP, ground disturbing activities will not occur. These limitations will restrict operations until the young owls will be fledged and no longer rely on the nest.

## *2. Removal of Habitat*

No suitable nesting or roosting trees will be removed under Phase I or II(A) of the project. If Phase II(B) is implemented, up to 20 trees ranging from 12” to 24” DBH could be felled into and across East Weaver Creek, utilizing either equipment to tip trees with root wads intact or to hire professional timber fellers to “chop and drop” trees. Chop and drop directs trees into specific locations to provide stable LWD spanning the channel. All tree placement will be consistent with techniques specified in the Oregon Department of Fish and Wildlife’s (ODFW) “Guide to Placement of Wood, Boulders and Gravel for Habitat Restoration” (ODFW, 2010). The chop and drop method allows for the placement of large wood elements in channel reaches that are inaccessible with wheel or track equipment. The woody structures provide salmonid habitat and improve channel bedload movement and gravel sorting. Under Phase II(B) up to six log cluster habitat features would be incorporated into the channel.

The tree tipping would resemble natural tree recruitment along the channel. Selected trees will primarily be existing dead trees and/or trees with a high probability of falling into the channel (i.e. leaning towards channel, exposed roots). If tree tipping is utilized, approximately 0.2 acres of potentially suitable NSO roosting habitat would be affected; however, the project area is not within the home range of known NSO nests. No trees will be selected within 1.3 miles of a historic or active NSO nest site. These trees will be used to create root wad and LWD habitat in the stream channel. The effect of removing ~20 trees over ~600 linear feet of stream bank (actual application of “chop and drop” techniques will be limited to no more than 125’ on either side of the channel within the 600’ treatment area) will have minimal change in tree canopy cover or density at any one location. Given the proximity of the project to the Wilderness area and adjacent National Forest lands, the reduction of ~0.2 acres of potential suitable habitat outside of known home ranges for NSO will likely not result in take of NSO due to loss of habitat.

## **C. Federal or State Listed or Special Status Species**

The APE for other federal or state listed or special status species is based on the species being evaluated. For most species, the habitat within the approximately 600’ of channel, bank, and floodplain (~0.68 acres) physical footprint of the project is analyzed. The majority of the APE will not be impacted by earth moving activities; but, restoration of natural flow and bedload movement will result in the restoration of natural gradient and floodplains as well as the channel thalweg over time. The removal of the dam will restore aquatic habitats and increase habitat for federal or state listed species (SONCC Coho salmon) and species of special concern (steelhead, Pacific lamprey). Federal and state listed species that are excluded from further analysis are

listed and explained in Table 3-2 (CDFW, 2021). The species chosen for analysis were based on the USFS Database or CNDDDB observations within Trinity County.

**Table 3-2.** Federal or California Threatened, Endangered, and Fully Protected species excluded from further analysis.

Species	Status		Effects/Rationale
	ESA	CESA	
Western yellow-billed cuckoo ( <i>Coccyzus americanus occidentalis</i> )	Threatened	Endangered	No effect. No suitable habitat present. Outside known or expected range. No confirmed observations in Trinity County.
Bald eagle ( <i>Haliaeetus leucocephalus</i> )	Delisted	Endangered	No effect. No suitable nesting habitat. No water bodies present that would provide an adequate food supply. Trinity River and Lake are over 6 miles away. A visual inspection did not detect nests.
Golden eagle ( <i>Aquila chrysaetos</i> )	N/A	Fully Protected	No effect. Not known or expected to occur. No suitable nesting habitat. No large cliffs present. There are no recorded nests or known occurrences within the assessment area. A visual inspection of the area did not detect nests.
American peregrine falcon ( <i>Falco peregrinus anatum</i> )	Delisted	Delisted; Fully Protected	No effect. Not known or expected to occur. No suitable nesting habitat. No large cliffs present.
California wolverine ( <i>Gulo gulo</i> )	N/A	Threatened; Fully Protected	No effect. Outside known or expected range. This area lacks persistent snow pack through the spring and human disturbance is high.
Humboldt marten ( <i>Martes caurina humboldtensis</i> )	Threatened	Endangered; SSC	No effect. Not known or expected to occur. Outside known or expected range (North Coast fog belt), warming and dry years have reduced habitat range.
Trinity bristle snail ( <i>Monadenia infumata setosa</i> )	N/A	Threatened	No effect. Not known or expected to occur. Outside known or expected range. APE is substantially east of the nearest known Trinity Bristle population with extreme topography between the APE and observed population.



Both the CDFW list of SSC, obtained from the CDFW website (updated July 2021), and CNDDDB were reviewed to determine if species have potential ranges within or near the project area. The species chosen for analysis were based on the CNDDDB observations within Trinity County. The SSC or CDFW Watch List species included in Table 3-3 either have a distribution range that is outside of the project area or not known or expected to occur near the area due to a lack of suitable habitat. They are excluded from further analysis as it has been determined that the proposed project will have no effect on them. Table 3-4 lists California endangered, threatened, or SSC that have a potential to occur within or near the project area (refer to Figure 3-1). The effects, rationale, and determination for these species are discussed in the following paragraphs.

**Table 3-3. CDFW SSC or Watch List species excluded from further analysis.**

Species	State Status	Effects/Rationale
Southern long-toed salamander ( <i>Ambystoma macrodactylum sigillatum</i> )	SSC	No effect. Not known or expected to occur. Typically found at high elevation meadows and lakes in the Sierra Nevada, Cascade, and Klamath mountains.
Southern torrent salamander ( <i>Rhyacotriton variegatus</i> )	SSC	No effect. Not known or expected to occur. No observations in USFS Database or CNDDDB near Weaverville, CA
Cascades frog ( <i>Rana cascadae</i> )	SSC	Standing water is required for reproduction, and typically occurs in waters lacking predatory fish. In addition the project is in the lower elevation range for this species.
Black swift ( <i>Cypseloides niger</i> )	CDFW Watch List	No effect. Not known or expect to occur. Outside known or expected range and no suitable breeding habitat present, such as cliffs near waterfalls, deep canyons, or sea-bluffs.
Cooper’s Hawk ( <i>Accipiter cooperii</i> )	CDFW Watch List	No effect. Not known or expected to occur. No confirmed observation within assessment area.
osprey ( <i>Pandion haliaetus</i> )	SSC	No effect. Not known or expected to occur. No water bodies present that would provide an adequate food supply. Trinity River and Lake are over 6 miles away. No confirmed observation within assessment area.
sharp-shinned hawk ( <i>Accipiter striatus</i> )	CDFW Watch List	No effect. Not known or expected to occur. Not identified in the CNDDDB record check within the assessment area. No confirmed observation within assessment area.
Townsend’s big-eared bat ( <i>Corynorhinus townsendii</i> )	SSC	No effect. Not known or expected to occur. No suitable roosting habitat present, such as mines, caves, rock outcrops, or cliffs. Extremely sensitive to human disturbance, the project’s close proximity to East Weaver Trail and neighborhood does not make this suitable habitat.

Pallid bat ( <i>Antrozous pallidus</i> )	SSC	No effect. Not known or expected to occur. No suitable roosting habitat present, such as mines, caves, rock outcrops, or cliffs.
Oregon snowshoe hare ( <i>Lepus americanus klamathensis</i> )	SSC	No effect. Not known or expected to occur. Typically found at higher elevations. No observations in USFS Database in Trinity County. One observation from 1922 in the CNDDDB.
American badger ( <i>Taxidea taxus</i> )	SSC	No effect. Not known or expected to occur. Outside known or expected range. No observations in USFS Database in Trinity County. CNDDDB observations in the west of Trinity County.

**Table 3-4.** California Endangered, Threatened, or SSC species with the potential for occurrence within or near the project area. PS – Potentially Significant. LS – Less Than Significant. NI – No Impact.

Common Name	Scientific Name	California Status	Potential Impact
Pacific fisher	<i>Pekania pennanti</i>	SSC	LS
Ring-tailed cat	<i>Bassariscus astutus</i>	Fully Protected	LS
Northern goshawk	<i>Accipiter gentilis</i>	SSC	LS
Willow flycatcher	<i>Empidonax traillii</i>	Endangered	LS
Olive-sided flycatcher	<i>Contopus cooperi</i>	SSC	LS
Yellow warbler	<i>Setophaga petechia</i>	SSC	LS
Yellow-breasted chat	<i>Icteria virens</i>	SSC	LS
Purple martin	<i>Progne subis</i>	SSC	LS
Pacific tailed frog	<i>Ascaphus truei</i>	SSC	LS
Foothill yellow-legged frog	<i>Rana boylei</i>	Endangered	LS
Western pond turtle	<i>Emys marmorata</i>	SSC	LS

**Pacific fisher (*Pekania pennanti*)**

Pacific fishers are most commonly associated with late-successional, old growth, and mature forests exhibiting high canopy closure, large trees and snags, large woody debris, large hardwoods, and multiple canopy layers (USFW, 2016). This species are also closely tied to drainage bottoms and riparian areas. They prey on squirrels, rabbits, skunks, other small mammals and birds and eat carrion when available. The project lacks significant patches of late successional habitat associated with denning; however, few patches are within a mile of the project. Residential areas with dogs tend to discourage these species from using the area.

A range of canopy cover suitable for dispersal can be found on and adjacent to the project area post-treatment, as well as the surrounding National Forest lands. This will maintain connectivity to other suitable patches of habitat and provide dispersal for fishers. These late successional habitats on the Shasta-Trinity National Forest are managed with the intent to support obligate species as typically represented by the NSO.

Suitable habitat for travel corridors occurs along East Weaver Creek in the project area. The removal of the dam and implementation of the project will have short term disruption to travel (most likely requiring animal to use slopes and cover ~100' upslope of the work area for a few weeks during construction). The dense cover adjacent to the project work zone will allow fishers to migrate up and down the stream corridor during work periods. The LOP from August 15th to November 15th will avoid or minimize the potential impacts during the breeding season (February to May) for Pacific fishers (Frost, 1997). The LOP for construction will occur after denning and fledging of the young. The placement of large wood in the channel would provide limited beneficial habitat elements, but overall the small area affected by the project is not anticipated to result in take of fishers. The project is not likely to adversely affect Pacific fisher population levels.

#### **Ring-tailed cat (*Bassariscus astutus*)**

Suitable habitat for the ring-tailed cat consists of a mixture of forest and shrubland, in close association with rocky and riparian areas. They are usually found within 0.6 miles of permanent water (Grinnell et al., 1937; Schempf and White, 1977). This nocturnal species uses hollow trees, logs, snags, rock recesses, abandoned burrows, and woodrat nests for cover and denning. Young are typically born in May or June (Walker et al., 1968).

Suitable habitat is present for this species. The LOP from August 15<sup>th</sup> to November 15<sup>th</sup> will avoid potential impacts during the breeding season for ring-tailed cats and most other species addressed in this study. No snags or logs will be removed during this LOP time period; therefore, breeding ring-tailed cats will not be affected. The placement of large wood in the channel would provide limited beneficial habitat elements. Overall, the small area affected by the project is not anticipated to result in take of ring-tailed cats. The area will remain as suitable habitat for ring-tailed cats following project completion.

#### **Northern goshawk (*Accipiter gentilis*)**

The northern goshawk is a larger raptor which is normally found in mature dense Douglas-fir stands with high canopy cover, a scattered hardwood component, and light understory/shrub layer (Stone, 2013). The species ranges throughout the state with most observations from inland to the coast. This species tends to nest on north slopes near bodies of water (Stone, 2013). The nearest northern goshawk observation reported in the Forest Service Database is approximately 0.4 mile northeast of the project, on Forest Service land. It is associated with Territory #309 Schofield Ditch and was last active in 1993.

Habitat within ¼ mile of the project area was analyzed to determine its suitability for use by the northern goshawk. The project is located within suitable northern goshawk nesting and foraging habitat. Higher quality nesting habitat is located on the south side of East Weaver Creek and

further upstream (northwest). Noise-generating activities above ambient levels will occur during the construction period. The incorporated LOP (August 15 – November 15) will avoid or minimize any potential impacts to nesting northern goshawks during the breeding season (mid-April through July).

It is unlikely that northern goshawks would nest within the project area due to noise and human activities. The project is proximal to East Weaver Road with daily operations by WCSD staff at the site and hiking trails used daily by humans and dogs. Northern goshawks are highly territorial and typically become very vocal and agitated when intruders, including humans, enter their nesting territory. However, due to the presence of suitable habitat, there is potential for this species to nest near the project area. The proposed project could result in short- or long-term indirect effects if trees are tipped under Phase II(B) because of degradation, downgrading, or removal of <0.2 acres of northern goshawk habitat. The loss of 0.2 acres of low value habitat will not impact habitat levels to a significant degree.

The project area may contain or be within 0.25 miles of potential habitat for bald eagles, ospreys, peregrine falcons, Cooper's hawks, northern goshawks, golden eagles, NSOs, and sharp-shinned hawks. Visual inspections of the area did not detect nests. The project description includes direction to retain pre-dominant and old growth trees. The LOPs minimize operations during the incubation period through fledging for all these species. The project's Phase II (A) will not modify potential habitat. Phase II (B) may modify potential habitat. The suitable habitat within the project area is significantly reduced by the presence of roads, pets, noise, and other disturbance activities that discourage reclusive species. Considering the physical condition of the project area and the extent of surrounding National Forest habitats there will not be any significant negative impacts to these species as a result of the project.

#### **Willow flycatcher (*Empidonax traillii*)**

Willow flycatcher habitat typically consists of riparian habitat dominated by willows (*Salix* spp.) and/or alder (*Alnus* spp.) and permanent water often in the form of low gradient watercourses, ponds, lakes, wet meadows, marshes, and seeps within and adjacent to forested landscapes (Craig et al., 1998). Grinnell and Miller described the California breeding habitat of this species as "...strikingly restricted to thickets of willows..." generally in a riparian situation (Grinnell and Miller, 1944). Riparian deciduous shrubs or trees, such as willow or alder, are essential elements in willow flycatcher territories (Sanders and Flett, 1989; Harris et al., 1988). In mountain meadows, willow thickets interspersed with open space are typically utilized while large, contiguous willow thickets are avoided. However, in lowland riverine habitats, contiguous willow thickets are used, due to the linear nature of these areas. They provide sufficient edge and/or the tree-like willows typically found in these areas provide sufficient openings within the willow canopy (Harris, 1991).

Egg laying often starts between June 25 and July 5, rarely beginning as early as the second week of June. Young typically fledge from the nest from late July through late August (Stafford and Valentine, 1985). Adults depart from breeding territories as early as mid-August but may stay until mid-September if they fledged young late in the season (Stafford and Valentine, 1985). It is likely that fledglings leave the breeding area a week or two after adults, but few details are known (Sogge et al., 1997).

There are no willow flycatcher observations reported in the CNDDDB within Trinity County. While this project may remove an occasional alder or cottonwood, the project is in a relatively low elevation area that is not considered potential breeding habitat for willow flycatchers. The LOP will protect migrating birds moving upslope to suitable breeding habitat in the Trinity Alps Wilderness. There is the potential for migrating individuals to pass through the area during the spring and fall. The project will not have significant effect on this species or its habitat.

#### **Olive-sided flycatcher (*Contopus cooperi*)**

These species occur in a wide variety of forest and woodland habitats; however, breeding typically occurs in late-successional conifer forests with open canopies (e.g., 0%–39% canopy cover) (Verner and Boss, 1980). Olive-sided flycatchers are mostly associated with edges, openings, and natural and human-created clearings in otherwise relatively dense forests (Altman and Sallabanks, 2000).

Nests are most commonly found in large live coniferous. This species typically uses short-needled conifers (e.g., Douglas-fir [*Pseudotsuga menziesii*]) more frequently than long-needled trees (e.g., ponderosa pine [*Pinus ponderosa*]) (Altman, 1998; Kotliar and Clouse, 2000). Lofty perches, which are usually the apical tips of snags or uppermost branches of the tallest trees in the area, are important for singing and foraging (Grinnell and Miller, 1944). Breeding locations range from sea level to timberline but usually are at mid- to high elevations (3,018 – 6,988 feet) (Altman and Sallabanks, 2000).

The olive-sided flycatcher breeding season in California extends from early May to late August (Bent, 1942; Altman and Sallabanks 2000). The peak of egg-laying is in June and incubation lasts about 14 days. Nestlings fledge 15-19 days after hatching (Bent, 1942). This species typically departs its breeding area in August, migrating to Central or South America for the winter. The LOP will protect nesting habitats and allow birds to fledge before operations occur.

Under Phase II(B) if implemented, approximately 0.2 acres of suitable habitat will be affected with the tipping over of approximately 10-20 12"-24" DBH trees. These trees will be used to create root wad/LWD habitat in the stream channel and entrain bedload. Given the proximity of the project to the Wilderness area and adjacent National Forest lands, the reduction of ~0.2 acres will likely not result in take of olive-sided flycatcher due to loss of habitat.

#### **Yellow warbler (*Setophaga petechia*)**

The yellow warbler generally occupies riparian vegetation in close proximity to water along streams and in wet meadows (Lowther et al., 1999). Throughout their range, they are found in willows (*Salix* spp.) and cottonwoods (*Populus* spp.). In northern California, willow cover and Oregon ash (*Fraxinus latifolia*) are important predictors of high yellow warbler abundance (Alexander, 1999). Although breeding typically occurs in riparian woodlands, it can also occur in montane chaparral, open ponderosa pine, and mixed conifer habitats with substantial amounts of brush. The yellow warbler breeds from mid-April to late July, with peak activity in June (Dunn and Garrett, 1997). Eggs are incubated for 11 days and nestlings fledge after 9-12 days (Harrison, 1978). Most members of this species have left California by October.

Surveys have not been conducted for this species; however, the nearest yellow warbler observation reported in the Forest Service Database is approximately 18 miles west of the project, near the Trinity River in Big Bar. There is limited suitable nesting habitat along East Weaver Creek.

This species typically departs its breeding area in July or early August. The LOP will protect nesting habitats and allow birds to fledge before operations occur. Under Phase II(B), if implemented, approximately 0.2 acres of suitable habitat will be affected with tree tipping of approximately 10-20 12"-24" DBH trees. These trees will be used to create root wad/LWD habitat in the stream channel. Given the proximity of the project to the Wilderness area and adjacent National Forest lands, the reduction of ~0.2 acres will likely not result in take of yellow warbler due to loss of habitat.

### **Yellow-breasted chat (*Icteria virens*)**

During the breeding season, the yellow-breasted chat occupies early successional riparian habitats with a well-developed shrub layer and an open canopy (Eckerle and Thompson, 2001). This species is typically found near water; nesting habitat is usually restricted to the narrow border of streams, creeks, sloughs, and rivers. Blackberry (*Rubus* spp.), wild grape (*Vitis* spp.), willow (*Salix* spp.), and other plants that form dense thickets and tangles are frequently selected as nesting strata (Grinnell and Miller, 1944). Taller trees, such as cottonwood (*Populus* spp.) and alder (*Alnus* spp.), are required for song perches (Dunn and Garrett, 1997). This species usually arrives on its breeding grounds in April and departs by late September for wintering grounds in Mexico and Guatemala (Gaines, 1977). Breeding occurs from early May to early August, with peak egg laying in June (Ehrlich et al., 1988). Incubation lasts for 11-15 days and chicks fledge 8-11 days after hatching (Harrison, 1978). This species typically fledges its young in July or early August.

Surveys have not been conducted for this species; however, the nearest yellow-breasted chat observation reported in the Forest Service Database is approximately 18 miles west of the project, near the Trinity River in Big Bar. There is limited suitable nesting habitat along East Weaver Creek.

The LOP will protect nesting habitats and allow birds to fledge before operations occur. Under Phase II (B), if implemented, approximately 0.2 acres of suitable habitat will be affected with tree tipping of approximately 10-20 12"-24" DBH trees. These trees will be used to create root wad/LWD habitat in the stream channel. Given the proximity of the project to the Wilderness area and adjacent National Forest lands, the reduction of ~0.2 acres will likely not result in take of yellow-breasted chat due to loss of habitat.

### **Purple martin (*Progne subis*)**

The purple martin breeds in a wide variety of habitats; however suitable nesting cavities must be present. This species is typically found in open areas where old, tall, large diameter trees occur. They are also typically found near bodies of water (Grinnell and Miller, 1944). This species of martins is one of the largest cavity nesters in California, requiring cavities with relatively large entrances. Over 70% of the purple martins in California nest in large conifer snags, although other natural and man-made structures, including bridges and rarely nest boxes, have been reported (Grinnell and Miller, 1944; Lund, 1978). In one study, the average DBH of 17 nesting

snags was 47 inches and the average snag height was 80 ft. Nest cavities are typically located within the top 15 feet of the snag (Williams, 1998). In California, purple martins begin arriving at their breeding grounds in March and may continue to arrive through mid-May (Williams, 1998). Egg laying typically begins in April or May (Williams, 1998). The incubation period typically lasts for 15 days, and hatched nestlings are usually in the nest for about 28 days before fledging (Brown, 1997). Purple martins begin to depart their nesting sites within a few days of fledging, usually in late July (Williams, 1998).

Surveys have not been conducted for this species but there is suitable purple martin habitat present. There have been no purple martin observations in Trinity County reported in the CNDDDB or the USFS Database; therefore, it is unlikely that this species would occur here. There are several large snags within the project area with visible cavities that could potentially be used by purple martins for nesting. The LOP will be implemented such that no trees (including snags) will be removed during this time period.

Under Phase II (B), if implemented, approximately 0.2 acres of suitable habitat will be affected with tree tipping of approximately 10-20 12"-24" DBH trees. These trees will be used to create root wad/LWD habitat in the stream channel. Given the proximity of the project to the Wilderness area and adjacent National Forest lands, the reduction of ~0.2 acres will likely not result in take of purple martin due to loss of habitat.

#### **Pacific tailed frog (*Ascaphus truei*)**

In California, the range of this species is from sea level to approximately 6,500' above sea level. The specific habitats of this species include flowing waters in lower montane/north coast coniferous forests, redwoods, and riparian forests. A rocky streambed is important in providing hiding places for larvae, attaching eggs, and cover for adults. This species is mostly aquatic, although the adult is known to forage on land during cool and wet conditions. Permanent water is critical to this species because the aquatic larvae require one to four years to transform. This species is nocturnal, spending days under submerged rocks and logs within the stream. At night, movements away from water are rare except during wet periods such as during or just after a rain.

Stream characteristics seem to be a better predictor of Pacific tailed frog abundance than landscape characteristics (Bull and Carter, 1996). This suggests the possibility that other factors of habitat suitability, such as water temperature, may be more important than forest age and observations of this species in young growth stands corroborates this. This species has also been found in suitable habitat in the Turwar Creek (Klamath River) drainage following intense fires, which removed essentially all stream side vegetation and woody instream cover. It was also able to quickly reestablish itself on the treeless terrain created by the Mt. St. Helen eruption (Hawkins et al., 1988).

Habitat within the project area was analyzed to determine its suitability for use by the Pacific tailed frog. Portions of East Weaver Creek are considered suitable for this species. As observed by C. DeJuillo, no tailed frogs or juveniles were observed in a 2018, 2019 and 2020 survey of the project area (personal communication, 2020). An unknown number of individuals were observed on September 9, 1963. According to the CNDDDB, the project area is within presumed

extent of Pacific tailed frogs (Figure 3-1). Pacific tailed frogs are presumed to exist in watercourse segments having substrates of consolidated parent material. The project will restore bedload transport, allowing scoured regions to be replenished and improve habitat for the species downstream. Preventive measures including relocation of aquatic dependent species during construction are included in the project design. While the project may impact individual Pacific tailed frogs not captured during relocation efforts, it would not cause a trend towards federal listing or a loss of viability. The potential impact to the Pacific tailed frogs is so small as to be discountable.

### **Foothill yellow-legged frog (*Rana boylei*)<sup>16</sup>**

The foothill yellow-legged frog is a highly aquatic amphibian, spending most or all of its life in or near streams utilizing pools, riffles, and runs in rivers and tributary streams. The foothill yellow-legged frog habitat includes clean water, gravel and cobble substrates, and lush riparian vegetation. Adults are found along the mainstem of rivers during spring when they are breeding in pools then return to basking and foraging sites at stream tributaries. Depending on local water conditions, between mid-April and late June, egg masses are deposited on the downstream side of cobbles and boulders over which a relatively thin, gentle flow of water exists. Metamorphosis of tadpoles takes three to four months to complete between late July and early September. Juvenile frogs tend to migrate to upstream tributaries in late summer and early fall. High flows and seasonal flooding from storm events and dam releases can wash egg masses downstream. Suitable foothill yellow-legged frog habitat occurs along East Weaver Creek. Biologist C. DeJuillo surveyed the project area for amphibians in spring 2018, 2019 and 2020 and found a single foothill yellow-legged frog in 2020. No other amphibians were observed in the project area (personal communication, 2020).

Preventive measures including the relocation of aquatic dependent species during construction are included in the project design. While the project may impact individual foothill yellow-legged frogs not captured during relocation efforts, it would not cause a trend towards federal listing or a loss of viability. The potential impact to the foothill yellow-legged is so small as to be discountable.

### **Western pond turtle (*Emys marmorata*)**

Western pond turtles occur in a variety of habitat types associated with permanent or nearly permanent water and are often concentrated in low flow regions of rivers and creeks, such as side channels and backwater areas (Holland, 1991). They prefer habitats with large areas for cover (logs, algae, vegetation) and basking sites (boulders or other substrates). They have been observed to avoid areas of open water lacking these habitat features (Holland, 1994). These species typically inhabits permanent water bodies and adjacent mud banks. However, female pond turtles often climb hillsides, sometimes moving 1,500 feet or more from the stream side to nest during the spring or early summer (Holland, 1991; Zeiner et al. 1990).

Nesting occurs in upland habitats consisting of dry grassy areas with a predominantly south or southwest aspect. Suitable habitat includes appropriate soils, thermal conditions, and basking

---

<sup>16</sup> The Southern Sierra, Central Coast and South Coast clades are listed as endangered under CESA. The Feather River and Northern Sierra clades are listed as threatened under CESA. The North Coast clade is not warranted at this time. The project is within the North Coast clade.



sites. Nest sites typically occur in open areas dominated by grasses or herbaceous annuals, on dry, well-drained soils with high clay/silt content, and low (less than 15%) slopes (Holland, 1994). Nests are constructed 4” below ground in moist areas in sandy to very hard soil types. Nests and burrows are usually found in undisturbed areas of duff or mud. Nesting benches are usually located on flat benches on the banks of rivers in close proximity to rearing habitat (shallow water and riparian vegetation). Eggs are laid from March to August and take 73 to 80 days to incubate. Western pond turtles leave the water in late September and spend the winter in burrows up to 500 feet away from the stream (Holland, 1991; Zeiner et al., 1990).

During field investigations, habitat within ¼ mile of the project was analyzed to determine its suitability for use by western pond turtles. Perennial water sources like East Weaver Creek provides suitable habitat. Suitable nesting habitat occurs approximately 0.2 miles upstream of the EWD in the meadows on the north side of the creek and bounded by East Weaver Creek Road.

Preventive measures including relocation of aquatic dependent species during construction are included in the project design. While the project may impact individual western pond turtles not captured during relocation efforts, it would not cause a trend towards federal listing or a loss of viability. The potential impact to the northwestern pond turtle is so small as to be discountable.

#### **D. Botanical Resources**

A botanical reconnaissance was completed by the Trinity County Resource Conservation District staff botanist in the summer of 2015. The inventory did not identify any populations of state or federally listed plant species in the project area or along East Weaver Creek for 0.5 miles upstream. Another botanical survey was completed June 2020 by 5C botanist Lesli Mounivong and did not identify any populations of state or federally listed plant species in the project area or along East Weaver Creek for 300 feet upstream and downstream of the EWD (personal communication, 2020). Four specimens of English Peak greenbrier were found within or adjacent to the project. The CNDDDB lists other populations of English peak greenbrier (*Smilax jamesii*), a CRPR 4.2 ranked species, within 1.3 miles of the project area.

English peak greenbrier grows in moist areas such as lakesides and streambanks in mountain coniferous forest habitat. This is a rhizomatous perennial herb taking the form of a vine, climbing and branching to maximum lengths of 2 to 3 meters. The dark green leaves have blades up to 8 centimeters long by 7 cm wide, triangular to pointed oval in shape. There are numerous tendrils. The mature fruit is a blue berry just under a centimeter wide which turns maroon in color as it dries.

English Peak greenbrier is listed as a rare plant under the basis of declining trends, recent taxonomic information, or other factors. It is tracked by CNPS as a CRPR of 4.2. According to the CNPS website English Peak greenbrier was “[p]reviously CRPR 1B.3; more common than originally known. Potentially threatened by logging and associated road usage. Possibly threatened by vehicles, recreational activities, foot traffic, grazing, trampling, alteration of fire regimes, hydrological alterations, and non-native plants”. English Peak greenbrier is not listed, proposed, or a candidate for possible future listing as threatened or endangered under the ESA

(50 C.F.R. Sec. 17.12) nor listed or listing candidate by the State of California as threatened or endangered under CESA (Fish & G. Code Sec. 2050 et seq.).

The recorded occurrences of *Smilax jamesii* were located near heavily trafficked areas, a popular hiking trail, and a road commonly used by the WCSD (Figure 3-4). It is assumed that these individuals were tracked into the project area by hikers or vehicles since no other individuals were observed in the project area. The observed individuals were in the vegetative state occurring in low densities of the overall project area. The populations within the project area are relatively new. It is possible that there could be more populations of this plant species throughout the area, increasing its range and population size.



**Figure 3-4.** Map showing the locations of the observed *Smilax jamesii*.

#### *Potential Impacts to English Peak Greenbrier*

The project will most likely impact three individuals of *Smilax jamesii* due to their location near a heavily trafficked road and underneath a spoils site. The spoils material will be cleared or incorporated into the downstream reconstruction design due to its large quantity, proximity to East Weaver Creek, and optimal landing for equipment. Regardless if the project does not incorporate the spoils pile into the design, it will have to be removed from the site. If left untouched, the pile will eventually wash out into East Weaver Creek or the East Weaver Creek Trail and disrupt or degrade habitat for migratory salmonids. The project will improve downstream hydrologic and habitat conditions and create optimal habitat for this species to establish.

The project's direct, indirect, or cumulative impacts will not cause a significant decline of *Smilax jamesii* towards a higher CRPR, federal, or state rank.

### **E. Invasive Species**

Dam removal activities have the potential to result in producing environmental conditions favorable for invasive plant species. These conditions may arise by two different means. First, by its very nature, a dam removal project is not unlike other construction projects which results in earth disturbance, intentional and inadvertent vegetation removal, exposure of the ground surface to sunlight and higher ambient temperatures, and the transport of seeds and plant fragments from one area to another.

b-c) There are no marsh, vernal pool, coastal, or wetland habitats within the project area. The creek within the project reach is a high gradient, perennial mountain stream with a dense canopy of mature mixed conifers and hardwoods in the overstory and an understory of common species (*Maianthemum racemosum*, *Claytonia perfoliata*, *Lysimachia latifolia*, *Rubus parviflorus*, *Equisetum sp.*, *Toxicodendron diversilobum*, and various other common riparian species). The project reach (600 linear feet) represents approximately 0.1 percent of East Weaver Creek and less than 0.05 percent of floodplain habitat for East Weaver Creek watershed. Changes in the floodplain as a result of restoration of the channel will enhance habitat for most aquatic dependent species and degrade habitat for other species. The short-term modifications of ~0.68 acre of channel, bank and floodplain will not significantly reduce any habitat type levels to a point that it would affect a species population. Given the slope position, aspect, and minimal affected area the project will not have a substantial effect on federally protected wetland through direct removal, filling, hydrological interruption, or other means.

The project will reverse currently degraded habitat elements occurring within 1000' of the East Weaver Creek channel including scoured stream segments downstream of the dam and approximately 250' of aggraded reach upstream of the dam. Removal of the dam will improve bedload restoration by routing gravels and boulders currently trapped upstream of the dam. Channel restoration will primarily occur during channel forming flows (e.g. Q<sub>5</sub> and larger storms). Upstream of the existing dam, the currently aggraded channel will downcut after the dam is removed. The channel adjustments will extend approximately 300' downstream and 300' upstream of the dam until the natural channel gradient of ~6% is stabilized in this reach. Natural and dynamic channel, bank, and floodplain modifications downstream of the APE will occur in response to channel forming flows regardless of the project.

d) The project occurs within the winter range for a portion of the Weaverville deer herd but the project will not modify winter range habitat. The project construction is scheduled for mid-August to mid-October and will not impact deer winter utilization of the area.

The specific requirements of the "Final Biological Opinion and Essential Fish Habitat Consultation for Restoration Projects within the NMFS Northern California Office Jurisdictional Area" (Section 2.3) are incorporated into the project description and provides protection and post-project monitoring measures that would otherwise have been included as Mitigation Measures. These include:

#### “Minimization Measures

- All construction will take place out of the wetted channel either by implementing the project from the bank and out of the channel or by constructing coffer dams, removing aquatic species located within the project reach, and dewatering the channel;
- No more than 250 linear feet (125 feet on each side of the channel) of riparian vegetation will be removed. All disturbed areas will be re-vegetated with native grasses, trees, or shrubs;
- All dewatering efforts associated with small dam removal will abide by the applicable minimization measures (Section D. Sideboards, Minimization Measures, and Other Requirements)” (NMFS, 2012).

Long-term, the project will re-establish the natural bedload, debris transport, channel gradient, and step pools to allow migratory fish to move both upstream and downstream. The project will restore access to some of the best spawning and rearing habitat upstream and provide cold water refugia during summer periods. Short-term impacts include temporary dewatering of the channel, fish and aquatic vertebrate relocation, and temporary increases in turbidity. During Phase I (new intake and fish screen installation, pipeline construction, and grade control installation) approximately 30’ of the eastern streambank length and 3’ of width of the stream will be dewatered for one week. Under Phase II (A) (partial dam removal and channel adjustment), approximately 300’ of the channel downstream of the dam and 300’ upstream of the dam will be dewatered to allow adjustment of ~300yd<sup>3</sup> of the channel bedload. If Phase II (B) is implemented (additional dam lowering, channel adjustment, and large wood placement), the impacts would be similar to Phase II (A).

Removing the dam will open access to the upper watershed and result in significant improvement in summer rearing habitat when temperatures are critical. Retention of the dam will continue to confine salmonids to stream segments where stream temperatures can reach sub-critical to lethal conditions, especially below East Weaver Creek campground.

The project will restore approximately 2.5 miles of fisheries habitat currently blocked by the EWD. The project will relocate and modify the WCSD EWF intake to add a fish screen to prevent juveniles from being drawn into the stilling basin. The project will include a minimum bypass flow of 1 cfs at the EWF inlet which is considered a high flow rather than what occurs in the lowest flow portions of the summer currently. The short-term modifications of ~0.34 acre of channel, bank, and floodplain will not significantly reduce any habitat type levels to a point that it would affect a species population. The long term benefits of re-establishment of natural bedload movement and aggradation downstream of the EWD will enhance riparian and floodplain habitats.

The project will not increase the WCSD water rights or diversion rates. Water conservation projects have been initiated downstream to increase flows (refer to Section 3.4.A.2 *Water Quantity (Water Diversion) Effects of Dam Removal in Relation to Salmonids* above). The implementation of any, or all, of the projects will have significant beneficial effects on stream flows.

e, f) There are no local policies or ordinances protecting biological resources, such as a tree preservation policy or ordinance. The county has not adopted a Habitat Conservation Plan, Natural Community Conservation Plan, or other approved local, regional, or state habitat conservation plan for the project area.

### 3.5 Cultural Resources

Would the project:	Potentially Significant Impact	Less Than Significant with Mitigation	Less Than Significant Impact	No Impact
a) Cause a substantial adverse change in the significance of a historical resource pursuant to Section 15064.5?			X	
b) Cause a substantial adverse change in the significance of an archaeological resource pursuant to Section 15064.5?			X	
c) Disturb any human remains, including those interred outside of formal cemeteries?			X	

### DISCUSSION

a – c) The APE is the work areas and roads to be used to reach the construction areas. The entire area has been disturbed in the past 50 years with logging, roads, and water facilities defining the project area landscape. A cultural survey including a record check of the Northwest Information Center at Chico State University was completed for the APE and surrounding areas. The project site occurs within a steep stream channel within an active floodplain subject to periodic scour of flows and bedload transport Review of Trinity County Historic Sites (1981) finds only one mention of the area of the EWD (Trinity, 1981). The EWD area was part of the Day Ranch. In 1914, William Clement moved his home off of the Day Ranch and relocated it to 806 Mill Street in Weaverville. There are no other mentions of the ranch. Remnants of the Day Ranch can still be found on the WCSD property but not within the area of potential effect. Remaining remnants include old wood lathe fence and telephone wire and insulators. None of these features are within the project area.

The EWD was constructed in 1958 and is more than 50 years old. Fifty years is a general estimate of the time needed to develop historical perspective and to evaluate significance. This consideration guards against the listing of properties of passing contemporary interest and ensures that the National Register is a list of truly historic places. The National Register Criteria for Evaluation exclude properties that achieved significance within the last fifty years unless they are of exceptional importance. Significance criteria focuses on the importance of the site to people or events, what extent, amount, and duration were people affected by the site, and how much does the site contribute to historic or scientific understanding or meaning of sites or events.

The EWD is one of an estimated 84,000 dams in the United States, impounding 600,000 miles (970,000 km) of river or about 17% of rivers in the nation. The EWD lacks relations to historic events, places, or has a significant meaning that is unique or special. The function of the facility and the location will remain intact even if the structure is removed. The dam is not unique, represents the best of its type, or contains physical characteristics that must be preserved to answer historic or scientific questions, or understand answers to such questions. A cultural site record was prepared for the dam; however, the dam is not a significant cultural site. No other cultural sites have been mapped, recorded, or observed within the project area of potential effect.

Upslope of the project area, and outside of the area of potential effect, early European settlement consisted of gold mining then farming. The general area (upslope of the project area) was part of the Day Ranch which included an orchard and fencing, portions of it remain.

No historic or pre-historic artifacts were located in the project area during cultural surveys. If they had, they would lack context to site. Artifacts located in the stream would represent displaced, relocated features from further reaches but would provide clues to upstream or upslope sites. In that instance, the sites would not be affected by this project. No mitigation is required for cultural resources.

### 3.6 Energy

Would the project:	Potentially Significant Impact	Less Than Significant with Mitigation	Less Than Significant Impact	No Impact
a) Result in potentially significant environmental impacts due to wasteful, inefficient, or unnecessary consumption of energy resources during project construction or operation?				X
b) Conflict with or obstruct a state or local plan for renewable energy or energy efficiency?				X

### DISCUSSION

a) The project will not result in potentially significant environmental impact due to wasteful, inefficient, or unnecessary consumption of energy resources during project construction. The entire construction process will take less than two weeks to complete utilizing an excavator, loader, and dump truck. The design will maintain the gravity flow operations and require less than one household electrical equivalent to operate monitoring equipment and motors to maintain fish screen effectiveness.

b) The project does not conflict with or obstruct a state or local plan for renewable energy or energy efficiency.

### 3.7 Geology and Soils

Would the project:

- a) Directly or indirectly cause potential substantial adverse effects, including the risk of loss, injury, or death involving:
- i. Rupture of a known earthquake fault, as delineated on the most recent Alquist-Priolo Earthquake Fault Zoning Map issued by the State Geologist for the area or based on other substantial evidence of a known fault? Refer to Division of Mines and Geology Special Publication 42.
  - ii. Strong seismic ground shaking?
  - iii. Seismic-related ground failure, including liquefaction?
  - iv. Landslides?
- b. Result in substantial soil erosion or the loss of topsoil?
- c. Be located on strata or soil that is unstable, or that would become unstable as a result of the project, and potentially result in on- or off-site landslide, lateral spreading, subsidence, liquefaction or collapse?
- d. Be located on expansive soil, as defined in Table 18-1-B of the Uniform Building Code, creating substantial direct or indirect risks to life or property?
- e. Have soils incapable of adequately supporting the use of septic tanks or alternative wastewater disposal systems where sewers are not available for the disposal of wastewater?
- f. Directly or indirectly destroy a unique paleontological resource or site or unique geologic feature?

Potentially Significant Impact	Less Than Significant with Mitigation	Less Than Significant Impact	No Impact
			X
			X
			X
			X
		X	
			X
			X
			X

#### DISCUSSION

a: i-iii) There are no known earthquake faults as delineated on the most recent Alquist-Priolo Earthquake Fault Zoning Map issued by the State Geologist. The project is located in a steep inner gorge of a perennial stream.

b) The project will not result in significant erosion. Channel adjustments as a result of dam removal will not increase sediment but will restore natural sediment movements. Increases in suspended particles and turbidity are expected to be relatively low as the work area will be dewatered and jetting and compaction of reconstructed channel fines will be done to entrain

finer. The use of jetting to “lock” fines into voids in gravels, cobbles, and boulders is similar to the effect of sediment transport on channel forming flows. Sediment enters the water column during naturally turbid conditions. Increases are expected to occur for short periods and short distances downstream, settling out quickly. The impacts would be minimal and short term. Sediment volumes from discharge are expected to be within the seasonal variability of the amount of sediment and water carried by the East Weaver Creek watershed over an annual cycle.

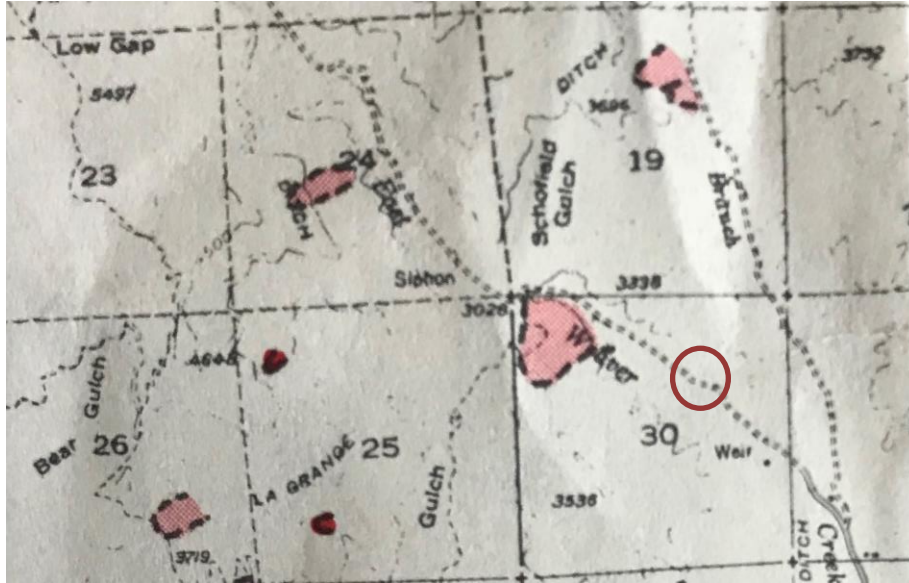
Impacts to current patterns and water circulation would be realized as the material re-contours, current sediment starved, and scour sections of the channel downstream of the dam. These impacts are expected to be temporary and short-lived. The project description includes dewatering of the work areas, reconstructing scour regions during the project, and use of jetting and compaction techniques to entrain fine sediments during low flows. In addition, the project incorporates compliance with NMFS 2012 BO for the NOAA’s Restoration Center’s minimization measures (refer to Section 3.4.A discussion).

In 2013, the 5C completed the Schofield Creek channel restoration project on the WCSD property which reduced anthropogenic sediment sources contributing to East Weaver Creek. That project is estimated to prevent more than 1500 yd<sup>3</sup> of future sediment. Refer to Hydrology and Water Quality discussion (Section 3.10). Additional restoration projects in the watershed have reduced other anthropogenic sediment sources.

a: iv, c) The stream channel is incised downstream and aggraded upstream of the dam for ~300’ as a result of the dam. Several minor stream bank segments within 1000’ upstream and downslope of the project site have over steepened slopes with downed trees, rock jumbles, and raw eroding slopes. The bank erosion rates are consistent with other reaches within a mile of the project area.

The 1980 California Department of Water Resources (CDWR) Main Stem Trinity River Watershed Erosion Investigation does not map any active or inactive landslide features within the project area. The CDWR mapping indicates an inactive landslide ~0.25 miles upstream of the EWD (Figure 3-5). This project will reduce the potential for road failure and channel scour. It will include the installation of grade and energy dissipating rock slope protection which will lessen the potential for downstream scour and incision in the mapped unstable area.





**Figure 3-5.** CDWR Landslide Mapping of the Mainstem Trinity River, 1980. Landslides are mapped as red. The approximate APE is outlined in red.

The USFS has completed SCI assessments of East Weaver Creek above and below the EWC in 2002 and 2011. Observed by E. Wiseman, the pebble count data shows a coarsening of the streambed below the diversion at the campground (compared to the same site in 2002) while the site above the diversion remained relatively unchanged (personal communication, 2015).

While the Upper East Weaver SCI site remained fairly stable between 2002 and 2011, the Lower East Weaver SCI site showed an increase in entrenchment evolving from a slight to a moderately entrenched channel, approaching fully entrenched conditions. Besides the increasing entrenchment, the width to depth ratio also increased (i.e. the channel became smaller) between 2002 and 2011. The width to depth ratio is a key to understanding the distribution of available energy within a channel, and the ability of various discharges occurring within the channel to move sediment. Higher width to depth values are indicative of wider and shallower stream channels with lower shear stress values associated with them. Lower width to depth values are indicative of narrower and deeper stream channels with higher shear stress values associated with them. E. Wiseman's evidence for the Lower East Weaver SCI site indicates that the stream channel here is subject to higher shear stress due to persistent entrenchment (personal communication, 2015).

- d) Based on site review, the project soils fill materials are not located on expansive soil, as defined in Table 18-1-B of the Uniform Building Code.
- e) The project site is not designated for use of septic tanks or alternative waste water disposal systems where sewers are not available for the disposal of waste water.
- f) Review of cutbanks and exposed soils show no signs of unique paleontological resources, sites, or unique geologic features.

### 3.8 Greenhouse Gas Emissions

Would the project:	Potentially Significant Impact	Less Than Significant with Mitigation	Less Than Significant Impact	No Impact
a) Generate greenhouse gas emissions, either directly or indirectly, that may have a significant impact on the environment?			X	
b) Conflict with an applicable plan, policy or regulation adopted for the purpose of reducing the emissions of greenhouse gases?				X

### DISCUSSION

a) The project will not change land uses, length road mileage, create attractive uses to the area or other changes that could increase traffic use or resulting greenhouse gas. If the EWD is not repaired or relocated and failed, the alternative pumping needed to provide water to the community would result in greater electrical consumption. However, the WCSD obtains its power from Trinity Public Utilities District which receives its power from hydro-electric production. The increased pumping would not increase greenhouse gas emissions.

b) The project does not conflict with plans, polices, or regulations for the purpose of reducing greenhouse gas emissions.

### 3.9 Hazards and Hazardous Materials

Would the project:	Potentially Significant Impact	Less Than Significant with Mitigation	Less Than Significant Impact	No Impact
a) Create a significant hazard to the public or the environment through the routine transport, use, or disposal of hazardous materials?				X
b) Create a significant hazard to the public or the environment through reasonably foreseeable upset and accident conditions involving the release of hazardous materials into the environment?				X
c) Emit hazardous emissions or handle hazardous or acutely hazardous materials, substances, or waste within one-quarter mile of an existing or proposed school?				X
d) Be located on a site which is				X

included on a list of hazardous materials sites compiled pursuant to Government Code Section 65962.5 and, as a result, would it create a significant hazard to the public or the environment?			
e) For a project located within an airport land use plan, or where such a plan has not been adopted, within two miles of a public airport or public use airport, would the project result in a safety hazard or excessive noise for people residing or working in the project area?			X
f) Impair implementation of or physically interfere with an adopted emergency response plan or emergency evacuation plan?			X
g) Expose people or structures, either directly or indirectly, to a significant risk of loss, injury or death involving wildland fires?			X

**DISCUSSION**

a) The project is located in an area zoned Open Space, which precludes incompatible land use to forestry. The project will not alter land uses or generate uses that would result in the routine transport or disposal of hazardous materials.

b) The project description includes BMPs for the storage of fuels away from stream, requires daily inspecting equipment for leaks and repairing all equipment that would work in or near a stream, requires spill contingency kits to be on-site during equipment operations, and requires the placement of oil absorption booms at the downstream end of stream projects.

c, e) The project is not within a quarter mile of an existing or proposed school. It is within a two mile radius of a public airport or private airship; however, the project will not result in a safety hazard or excessive noise. It will not pose a safety hazard or emit hazardous emissions or hazardous materials, substances, or waste within a quarter mile of a school. Refer to discussion under Section 3.9a.

d) The project site is not on a list of hazardous materials sites compiled pursuant to Government Code Section 65962.5.

f) The project will not interfere or impair an adopted emergency response plan or emergency evacuation plan. If the EWD is not upgraded or removed, a catastrophic dam failure would result in scour and debris movements downstream of the site. However, the nearest home is approximately 0.68 miles downstream of the dam. Channel incision and debris movement upstream of the dam would be expected to extend approximately 300' downstream of the dam in an incised reach. Existing log jams, aggraded reaches, and incised reaches would adjust in response to larger storm flows; but, the project would only have a limited effect on bedload

transport. There are no improvements within 6 to 15 meander bends in the stream and meander bends. Islands and point bars all tend to slow and accumulate large wood metering the flow of wood downstream.

g) The project is within an area mapped as high wildland fire risk by CalFire. To minimize impacts to water quality and aquatic resources, the project construction period is timed to occur at the periods of lowest stream flow. These same time periods correlate to moderate to high fire danger periods. The project is in the bottom of a valley surrounded by mixed conifer forest stands where, if a fire started, could move upslope rapidly under high or extreme fire danger periods. The probability of a fire start at the project site is low to moderate as relative humidity of the perennial stream bottom is higher than adjacent slopes. The fuel moisture content of live and dead vegetation in the stream bottom is also higher than upslope vegetation. If a fire started, the higher moisture level in the vegetation at the stream bottom reduces the rate of fire spread. Slower fire spread rates allow for rapid containment if detected at incipient stages of the fire. Typical fire behavior would be for a fire to move upslope, but wind patterns can result in erratic fire behavior.

The project description indicates that the contractor will adhere to the following fire BMPs: 1) all internal combustion equipment will have USFS approved spark arrestors; 2) maintain a water truck for rapid fire attack; 3) maintain a fire suppression cache on-site; 4) maintain a fire watch after all mechanical operations are completed; 5) restrict welding and other activities that generate sparks; and 6) will not conduct mechanical operations after 1 pm on days with a fire or extreme fire danger rating. The combination of location of the project and implementation of fire BMPs will reduce the potential for a wildland fire start and allow for rapid detection and suppression if a fire started.

### 3.10 Hydrology and Water Quality

Would the project:	Potentially Significant Impact	Less Than Significant with Mitigation	Less Than Significant Impact	No Impact
a) Violate any water quality standards or waste discharge requirements or otherwise substantially degrade surface or ground water quality?			X	
b) Substantially decrease groundwater supplies or interfere substantially with groundwater recharge such that the project may impede sustainable groundwater management of the basin?				X
c) Substantially alter the existing drainage pattern of the site or area, including through the alteration of the course of a stream or river or through the addition of impervious surfaces, in a manner which would: i) Result in substantial erosion or			X	

siltation on- or off-site?				
ii) Substantially increase the rate or amount of surface runoff in a manner which would result in flooding on- or off-site?				X
iii) Create or contribute runoff water which would exceed the capacity of existing or planned stormwater drainage systems or provide substantial additional sources of polluted runoff to a significant risk of loss, injury or death involving wildland fires?				X
iv) Impede or redirect flood flows?				X
d) In flood hazard, tsunami, or seiche zones, risk release of pollutants due to project inundation?				X
e) Conflict with or obstruct implementation of a water quality control plan or sustainable groundwater management plan?				X

## DISCUSSION

a) The project will not violate any water quality standards, waste discharge requirements, or otherwise substantially degrade surface or ground water. Temporary impacts to the streambed from downstream sediment migration may be realized with the removal of the dam and channel reconstruction. Approximately 300-500 yd<sup>3</sup> of accumulated stream sediment within 200' upstream of the dam would be mechanically transported to immediately downstream of the dam to rebuild scour locations (Phase II (A)). Similar volumes of material will be moved in Phase II (B) if needed. Stored sediment upstream of the dam consists of material already existing within the waterbody and does not represent new material being placed into wetlands or waterbodies of the United States. Impacts from the downstream distribution of this material are expected to be minor, temporary, and recover quickly as natural events re-distribute the material within the stream bed. See Section 3.4.A Discussion.

Impacts to current patterns and water circulation would be realized as the material re-contours, current sediment starved, and scour sections of the channel downstream of the dam. These impacts are expected to be temporary and short-lived. The loss of environmental characteristics and values is not considered significant and the material is expected to be beneficial to in-stream habitats. Compliance with project designs ensure, to the extent practical, aquatic based resource impacts are below significant levels. The project description includes dewatering of the work areas, reconstructing scour regions during the project, and use of jetting and compaction techniques to entrain fine sediments during low flows. In addition, the project incorporates compliance with NMFS 2012 BO for the NOAA's Restoration Center's minimization measures (refer to Section 2.2).

The project will restore the historic channel gradient upstream and downstream of the dam.

b) The project will not alter existing groundwater or surface water recharge rates. The project will not substantially decrease groundwater supplies or interfere substantially with groundwater recharge. The project will have no impact to sustainable groundwater management of the basin.

c) The project will not substantially alter the existing drainage pattern of the site or area, including through the alteration of the course of a stream or river. A number of past watershed restoration projects in the Weaver Creek watershed have contributed to improving watershed conditions and restoring natural drainage patterns of the area.

In 2013, the Schofield Gulch stream (located ~0.5 miles upstream of the dam) was restored to its natural channel location, eliminating a 2000' long ditch that had diverted Schofield Gulch around the EWD facilities. The ditch was a significant source of sediment to East Weaver Creek, delivering approximately 120 yd<sup>3</sup> of sediment per year on average between 1977 and 2013. Schofield Gulch was often the first tributary to deliver turbid water to the East Weaver Creek watershed in any storm and the turbidity was the direct result of erosion in the diverted ditch segment of the stream. The restored channel now tends to deliver turbid water well after other stream systems have activated flows and Schofield exhibits minimal erosion.

An additional six restoration projects in the greater Weaver Creek watershed have been completed in the past 20 years including removal of three migration barriers (Oregon St at West Weaver Creek, Roundy Road at Little Browns Creek, and Bally View Road at Sidney Gulch) and three road sediment reduction programs (China Gulch Road and Browns Mountain Road in Little Browns Creek and Weaver Bally Road in Sidney Gulch). The East Branch East Weaver Creek at East Weaver Road Culvert Replacement and Migration Barrier Removal Project is in design to restore access to this tributary and to restore hydrologic functions of that tributary stream.

This project will relocate the WCSD intake ~270 feet upstream of the current location and remove the EWD which will restore natural channel grade, bedload transport, and debris routing. The existing artificially scoured reach downstream of the dam will be reduced as bedload is repositioned. The artificially aggraded reach upstream of the dam will adjust to the downstream scour reach and the channel grade will adjust one the dam is removed.

The new intake is located on the north edge of the active channel of the stream but will not impede flow in the channel. The new intake will not increase diversion or alter the stream course. The project will not alter the course of the channel through the addition of impervious surfaces nor increase the rate or amount of surface runoff in a manner which would result in flooding on- or offsite. The project will not create or contribute runoff water which would exceed the capacity of existing or planned stormwater drainage systems or provide substantial additional sources of polluted runoff (refer to Section 3.4(A) discussion).

d) The project will restore natural channel conditions which will reduce the potential to impede or redirect flood flows compared to the existing EWD facilities. The project has no risk to release of pollutants due to project inundation during flood, tsunami, or seiche.

e) The project does not conflict with or obstruct implementation of a water quality control plan or sustainable groundwater management plan.

### 3.11 Land Use and Planning

Would the project:	Potentially Significant Impact	Less Than Significant with Mitigation	Less Than Significant Impact	No Impact
a) Physically divide an established community?				X
b) Cause a significant environmental impact due to a conflict with any land use plan, policy, or regulation adopted for the purpose of avoiding or mitigating an environmental effect?				X

#### DISCUSSION

a – b) The project does not change circulation patterns or divide a community. The project improves water reliability and security by removing the marginally functioning dam and providing fish protection measures that reduce conflicts between the WCSD water rights and compliance with the Endangered Species Act. The project implements the Coho Recovery Strategy Recommendations of the CDFW and implements the federal SONCC Coho Recovery Plan. The project does not impact deer winter range. There are no Habitat Conservation Plans or Community Conservation Plans associated with the property.

### 3.12 Mineral Resources

Would the project:	Potentially Significant Impact	Less Than Significant with Mitigation	Less Than Significant Impact	No Impact
a) Result in the loss of availability of a known mineral resource that would be of value to the region and the residents of the state?				X
b) Result in the loss of availability of a locally-important mineral resource recovery site delineated on a local general plan, specific plan or other land use plan?				X

#### DISCUSSION

a – b) The project will not impact mineral resource that would be of value to the region and the residents of the state or result in the loss of availability of locally-important mineral resource sites delineated in the General Plan, Specific Plan, or other adopted land use plan.

### 3.13 Noise

Would the project result in:	Potentially Significant Impact	Less Than Significant with Mitigation	Less Than Significant Impact	No Impact
a) Generation of a substantial temporary or permanent increase in ambient noise levels in the vicinity of the project in excess of standards established in the local general plan or noise ordinance, or applicable standards of other agencies?				X
b) Generation of excessive groundborne vibration or groundborne noise levels?				X
c) A substantial permanent increase in ambient noise levels in the project vicinity above levels existing without the project?				X
d) For a project located within the vicinity of a private airstrip or an airport land use plan or, where such a plan has not been adopted, within two miles of a public airport or public use airport, would the project expose people residing or working in the project area to excessive noise levels?				X

#### DISCUSSION

a, c) The project will temporarily increase in ambient noise levels but not in excess of standards established in the local general plan or ordinance.

b) The project site is not located near any noise (including ground borne vibration) receptors (homes, schools, airports, etc.). The short time frame of the operation and use of construction equipment is consistent with logging, forestry, and agricultural equipment used in areas zoned Timber Production. The project has a short duration time frame and will not result in permanent increases in ambient noise levels.

d) The project is not within a quarter mile of an existing or proposed school. It is within a two mile radius of a public airport or private airship; however, the project will not result in a safety hazard or excessive noise levels.



### 3.14 Population and Housing

Would the project:	Potentially Significant Impact	Less Than Significant with Mitigation	Less Than Significant Impact	No Impact
a) Induce substantial unplanned population growth in an area, either directly (for example, by proposing new homes and businesses) or indirectly (for example, through extension of roads or other infrastructure)?				X
b) Displace substantial numbers of existing people or housing, necessitating the construction of replacement housing elsewhere?				X

### DISCUSSION

a - b) The project is located in an area zoned Timber Production and Open Space which does not allow for residential or other community growth activities. The project will not induce population growth in an area, either directly or indirectly.

### 3.15 Public Services

	Potentially Significant Impact	Less Than Significant with Mitigation	Less Than Significant Impact	No Impact
a) Would the project result in substantial adverse physical impacts associated with the provision of new or physically altered governmental facilities, need for new or physically altered governmental facilities, the construction of which could cause significant environmental impacts, in order to maintain acceptable service ratios, response times or other performance objectives for any of the public services:				
i) Fire protection?				X
ii) Police protection?				X
iii) Schools?				X
iv) Parks?				X
v) Other public facilities?				X

DISCUSSION

a) The project will not result in substantial adverse physical impacts or require expansion of police protection, schools, parks, fire, or other public facilities. The failure of the dam could result in significant environmental impacts. The closure of the road leading to the EWF would have minor impacts on public services if responders have to take alternative roads to perform their work. However, the road is gated and restricted to vehicles.

3.16 Recreation

	Potentially Significant Impact	Less Than Significant with Mitigation	Less Than Significant Impact	No Impact
a) Would the project increase the use of existing neighborhood and regional parks or other recreational facilities such that substantial physical deterioration of the facility would occur or be accelerated?				X
b) Does the project include recreational facilities or require the construction or expansion of recreational facilities which might have an adverse physical effect on the environment?				X

DISCUSSION

a – b) The project is not a recreational attraction and will not increase the use of existing neighborhood, regional parks, or other recreational facilities such that substantial physical deterioration of the facility would occur or be accelerated.

The project area includes a short segment of the Weaver Basin Trail system<sup>17</sup>. The trail is a tourist attraction for mountain biking. An annual bike race, the LaGrange Classic, is held on the trail in June of each year. The race attracts dozens to hundreds of riders from out of the region. The project’s LOP will not conflict with the June race.

The project will temporarily close a portion of the trail during construction. The closure will be short term and will not result in changes in the location or long-term use of the trail. Closing a short segment of the trail will not preclude users from completing looped trail segments or to

<sup>17</sup> The Weaver Basin Trail system is managed by the Trinity County Resource Conservation District in coordination with the USFS and BLM for portions on National Forest and BLM managed lands. On private lands and non-federal lands a citizen based trail committee provides direction. The trail is maintained by funds from the USFS, BLM, and state grants as well as volunteer labor and equipment. The trail is a tourist attraction for mountain biking. An ‘annual’ bike race (the LaGrange Classic) is held on the trail in June of each year. The race attracts dozens to hundreds of riders from out of the region.

hike around the construction zone via roads and other routes. The trail route within the project reach will be restored and reopened within two weeks of start of construction.

### 3.17 Transportation and Traffic

Would the project:	Potentially Significant Impact	Less Than Significant with Mitigation	Less Than Significant Impact	No Impact
a) Conflict with an applicable program, plan, ordinance or policy addressing the circulation system, including transit, roadway, bicycle and pedestrian facilities?				X
b) Conflict or be inconsistent with CEQA Guidelines Section 15064.3, subdivision (b)?				X
c) Substantially increase hazards to a geometric design feature (e.g., sharp curves or dangerous intersections) or incompatible uses (e.g., farm equipment)?				X
d) Result in inadequate emergency access?				X

### DISCUSSION

a-d) The project does not affect the road capacity, air traffic patterns, or increase hazards due to a design feature. The project will not change road surface width or grade, alter existing public transit, bicycle, or pedestrian facilities, or decrease the performance or safety of such facilities.

### 3.18 Tribal Cultural Resources

Would the project cause a substantial adverse change in the significance of a tribal cultural resource, defined in Public Resources Code Sec. 21074 as either a site, feature, place, cultural landscape that is geographically defined in terms of the size and scope of the landscape, sacred place, or object with cultural value to California Native American tribe, and that is:	Potentially Significant Impact	Less Than Significant with Mitigation	Less Than Significant Impact	No Impact
a) Listed or eligible for listing in the California Register of Historical Resources, or in a local register of historical resources as defined in Public Resources Code Sec. 5020.1 (k)				X

- b) A resource determined by the lead agency, in its discretion and supported by substantial evidence, to be pursuant to criteria set forth in subdivision © of Public Resources Code Sec. 5024.1. In applying the criteria set forth in subdivision © of Public Resource Code Sec. 5024.1, the lead agency shall consider the significance of the resource to a California Native American tribe.

			X
--	--	--	---

**DISCUSSION**

a-b) This feature does not have significant association with local historical events or persons. The diversion does not have design and engineering elements that makes it historically significant. Finally, this feature does not have the information potential to contribute significantly to local or state history.

**3.19 Utilities and Service Systems**

Would the project:	Potentially Significant Impact	Less Than Significant with Mitigation	Less Than Significant Impact	No Impact
a) Require or result in the relocation or construction of new or expanded water, wastewater treatment facilities or storm drainage, electric power, natural gas, or telecommunications facilities, the construction or relocation of which could cause significant environmental effects?			X	
b) Have sufficient water supplies available to serve the project and reasonably foreseeable future development during normal, dry, and multiple dry years?				X
c) Result in a determination by the wastewater treatment provider which serves or may serve the project determined that it has adequate capacity to serve the project's projected demand in addition to the provider's existing commitments?				X
d) Generate solid waste in excess of State or local standards, or in excess of the capacity of local infrastructure, or otherwise impair				X

- the attainment of solid waste reduction goals?
- e) Comply with federal, state and local management and reduction statutes and regulations related to solid waste?

			X

## DISCUSSION

a, c, e) The project is located in an area zoned Open Space, Timber Production, and Wilderness which precludes new development. Replacing the WCSD inlet will not increase demand for wastewater, stormwater, water treatment, or solid waste facilities or change demand for such services.

b, d) The project will not require construction of new water or waste water facilities nor will expand existing facilities. The project will relocate the intake of an existing water facility but maintain the current capacity. The project will enhance fisheries habitat and reduce potential juvenile fish mortality. The project will improve water reliability for WCSD by relocating the EWF intake off of the EWD, which is in poor condition.

### 3.20 Wildfire

If located in or near state responsibility areas or lands classified as very high fire hazard severity zones, would the project:	Potentially Significant Impact	Less Than Significant with Mitigation	Less Than Significant Impact	No Impact
a) Substantially impair an adopted emergency response plan or emergency evacuation plan?				X
b) Due to slope, prevailing winds, and other factors, exacerbate wildfire risks, and thereby expose project occupants to pollutant concentrations from a wildfire or the uncontrolled spread of a wildfire?			X	
c) Require the installation or maintenance of associated infrastructure (such as roads, fuel breaks, emergency water sources, power lines or other utilities) that may exacerbate fire risk or that may result in temporary or ongoing impacts to the environment?				X
d) Expose people or structures to significant risks, including downslope or downstream flooding or landslides, as a result of runoff, post-fire slope instability, or drainage changes?				X

## DISCUSSION

a) The project will not substantially impair an adopted emergency response plan or emergency evacuation plan.

b) The project is within an area mapped as high wildland fire risk by CalFire. To minimize impacts to water quality and aquatic resources, the project construction period is timed to occur at the periods of lowest stream flow. These same time periods correlate to moderate to high fire danger periods. The project is in the bottom of a valley surrounded by mixed conifer forest stands where a fire started could move upslope rapidly under high or extreme fire danger periods. The probability of a fire start at the project site is low to moderate as relative humidity of the perennial stream bottom is higher than adjacent slopes. The fuel moisture content of live and dead vegetation in the stream bottom is also higher than upslope vegetation. The higher moisture levels in vegetation in the stream bottom reduces the rate of fire spread should a fire start. Slower fire spread rates allow for rapid containment if detected at incipient stages of the fire. Typical fire behavior would be for a fire to move upslope, but wind patterns can result in erratic fire behavior.

The project description indicates that the contractor will adhere to the following fire BMPs: 1) all internal combustion equipment will have USFS approved spark arrestors; 2) maintain a water truck for rapid fire attack; 3) maintain a fire suppression cache on-site; 4) maintain a fire watch after all mechanical operations are completed; 5) restrict welding and other activities that generate sparks; and 6) will not conduct mechanical operations after 1 pm on days with a high or extreme fire danger rating.

The combination of location of the project and implementation of fire BMPs will reduce the potential for a wildland fire start and allow for rapid detection and suppression if a fire started

c) The project will not require the installation or maintenance of associated infrastructure (such as roads, fuel breaks, emergency water sources, power lines or other utilities) that may exacerbate fire risk or that may result in temporary or ongoing impacts to the environment.

d) The project will reduce exposure of people or structures to significant risks, including downslope or downstream flooding or landslides, as a result of runoff, post-fire slope instability, or drainage changes

### 3.21 Mandatory Findings of Significance

	Potentially Significant Impact	Less Than Significant with Mitigation	Less Than Significant Impact	No Impact
a. Does the project have the potential to substantially degrade the quality of the environment, substantially reduce the habitat of a fish or wildlife species, cause a fish or wildlife population to drop below self-sustaining levels, threaten to eliminate a plant or animal			X	

community, substantially reduce the number or restrict the range of a rare or endangered plant or animal or eliminate important examples of the major periods of California history or prehistory?

- b. Does the project have impacts that are individually limited, but cumulatively considerable? (“Cumulatively considerable” means that the incremental effects of a project are considerable when viewed in connection with the effects of past projects, the effects of other current projects, and the effects of probable future projects.)
- c. Does the project have environmental effects which will cause substantial adverse effects on human beings, directly or indirectly?

		X	
			X

## Clarification Based on IS/ND Public Scoping

### California Department of Fish and Wildlife

During dewatering, fish relocation, electrofishing, and all other matters concerning the potential harm in fish, the 5C will follow CDFW guidelines and measures to protect fish in addition to NOAA NMFS guidelines as stated previously. This clarification reinforces the discussion on page 25:

#### In-Stream Construction Tasks:

- Placement of fish exclusion netting (3/32" mesh) and relocation of aquatic species consistent with CDFW permitting requirements. Fish relocation will be conducted using both net and electro-fish passes by a qualified fisheries biologist with a Section 10 permit and consistent with the General Conditions for all Fish Capture and Relocation Activities (NMFS, 2016 p. 18-21);



## 4.0 REFERENCES

- Alexander, J. D. 1999. *Bird-habitat relationships in the Klamath/Siskiyou Mountains* (Master's thesis, Southern Oregon University).
- Altman, B. 1998. Productivity of the Olive-sided Flycatcher in the Cascade Mountains of Northern Oregon: a pilot project to assess nesting success as a potential factor in population declines. *Unpublished report submitted to US Fish and Wildlife Service. USDI, Fish and Wildlife Office, Oregon State Office, Portland, USA.*
- Altman, B. and R. Sallabanks. 2000. Olive-sided Flycatcher (*Contopus cooperi*). The birds of North America. Number 502.
- Bent, A.C. 1942. Life Histories of North American Flycatchers, Larks, Swallows, and Their Allies. U.S. National Museum, Bulletin 179.
- Boberg, J. and C. Kenyon. 1979. Department of Fish and Game Stream Inventory: Trinity County. California Department of Fish and Game. Sacramento, CA.
- Brown, C. R. 1997. *Purple Martin: Progne Subis*. American Ornithologists' Union.
- Bull, E. L., & Carter, B. E. (1996). Tailed frogs: distribution, ecology, and association with timber harvest in northeastern Oregon. *Res. Pap. PNW-RP-497. Portland, OR: US Department of Agriculture, Forest Service, Pacific Northwest Research Station. 11 p, 497.*
- Bureau of Land Management (BLM). 2006. Maintenance and Safety of Dams. BLM Manual 9177. Denver, Colorado, Release x-xxxx. 7 sheets.
- California Department of Fish and Game (CDFG). 2004. Recovery Strategy for California Coho Salmon. Report to the California Fish and Game Commission. 594 pp. Sacramento, CA.
- California Department Fish and Game (CDFG). 2009. 2009 Report Trinity River Tributaries Steelhead Spawning Survey Report. California Department Fish and Game, Northern Region.
- California Department Fish and Game (CDFG). 2010. 2010 Report Trinity River Tributaries Steelhead Spawning Survey Report. California Department Fish and Game, Northern Region.
- California Department of Fish and Wildlife (CDFW). 2021. California Natural Diversity Database. Special Animals List. Periodic publication. 95 pp.
- California Department of Water Resources (CDWR). 1980. Mainstem Trinity River Watershed Erosion Investigation.
- California Water Code. 1965. §6000-6009.
- Craig, D. and P. L. Williams. 1998. Willow Flycatcher (*Empidonax traillii*). The Riparian Bird Conservation Plan: a strategy for reversing the decline of riparian-associated birds in California. California Partners in Flight. [http://www.prbo.org/calpif/htmldocs/riparian\\_v2.html](http://www.prbo.org/calpif/htmldocs/riparian_v2.html).
- Dunn, J. L., & Garrett, K. 1997. *A field guide to warblers of North America* (Vol. 49). Houghton Mifflin Harcourt.
- Ebasco Environmental. 1990. Trinity River basin restoration program - Weaver Creek fish habitat assessment. Report for Bureau of Reclamation, Sacramento, California.
- Eckerle, K. P., & Thompson, C. F. 2001. Yellow-breasted Chat (*Icteria virens*). No. 575 in. *The Birds of North America. Edited by A. Poole and F. Gill. Academy of Natural Sciences, Philadelphia, and American Ornithologists' Union, Washington.*
- Ehrlich, P. R., Dobkin, D. S., and Wheye, D. 1988. The Birder's Handbook: A Field Guide to the

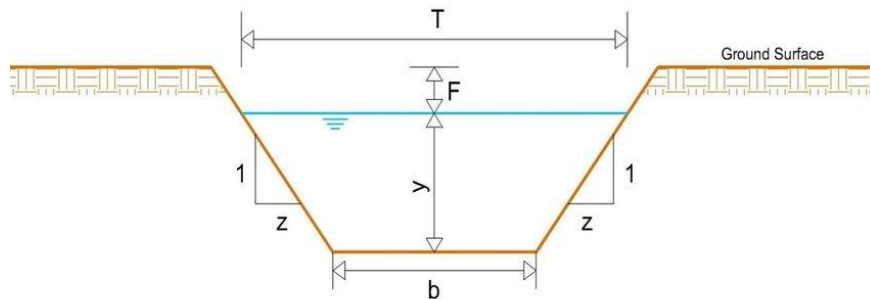
- Natural History of North American Birds. Simon & Schuster, New York.
- Frost, H.C., W.B. Krohn, and C.R. Wallace. 1997. Age-specific reproductive characteristics in fishers. *Journal of Mammalogy* 78(2):598–612.
- Gaines, D. 1977. *Birds of the Yosemite Sierra*. California Syllabus, Oakland.
- Grinnell, J., J.S. Dixon, & J.M. Linsdale. 1937. *Fur-bearing mammals of California*. Berkeley, California. University of California Press 1, 375 pp.
- Grinnell, J., & Miller, A. H. 1944. *The Distribution of the Birds of California*. Pacific Coast Avifauna Number 27. Copper Ornithological Club, Berkeley.
- Harris, J.H. 1991. Effects of brood parasitism by Brown-headed Cowbirds on Willow Flycatcher nesting success along the Kern River, California. *Western Birds* 22:13-26.
- Harris, J. H., Sanders, S. D., & Flett, M. A. 1988. *The status and distribution of the willow flycatcher in California, 1986*. State of California, the Resources Agency, Department of Fish and Game.
- Harrison, C. 1978. *A Field guide to the nests, eggs and nestlings of North American birds*. W. Collins Sons and Co., Cleveland, OH. 416pp.
- Hawkins, C. P., Gottschalk, L. J., & Brown, S. S. 1988. Densities and habitat of tailed frog tadpoles in small streams near Mt. St. Helens following the 1980 eruption. *Journal of the North American Benthological Society*, 7(3), 246-252.
- Holland, D.C. 1991. A synopsis of the ecology and status of the western pond turtle (*Clemmys marmorata*) in 1991. Unpublished report prepared for the U.S. Fish and Wildlife Service. 141 pp.
- Holland, D.C. 1994. *The western pond turtle: habitat and history*. Portland, OR: U.S. Department of Energy, Bonneville Power Administration.
- Kotliar, N.B. and L.A. Clouse. 2000. Olive-sided Flycatcher nest success in stand-replacement and prescribed-understory burns. Unpublished annual report prepared for U.S. Fish and Wildlife Service, USGS, Fort Collins, CO.
- LaFauce, D.A. 1964. *A Steelhead Spawning Survey of the Upper Trinity River System*. Marine Resources Administrative Report No. 65-4. California Department of Fish and Game, Region 1, Inland Fisheries Branch.
- Lowther, P. E., Celada, C., Klein, N. K., Rimmer, C. C., & Spector, D. A. 1999. Yellow Warbler (*Dendroica petechia*). *The birds of North America*, (454), 32.
- Lund, T. 1978. The Purple Martin in the western United States, part two: it's a question of holes. *Oregon Birds* 4(2): 1-9.
- National Marine Fisheries Service (NMFS). 2012. Endangered Species Act (ESA) Section 7(a)(2) Biological Opinion and Magnuson-Stevens Fishery Conservation and Management Act Essential Fish Habitat Consultation. Arcata, CA.
- National Marine Fisheries Service (NMFS). 2014. Final Recovery Plan for the Southern Oregon/Northern California Coast Evolutionarily Significant Unit of Coho Salmon (*Oncorhynchus kisutch*). National Marine Fisheries Service. Arcata, CA.
- National Marine Fisheries Service (NMFS). 2016. Endangered Species Act (ESA) Section 7(a)(2) Biological Opinion and Magnuson-Stevens Fishery Conservation and Management Act Essential Fish Habitat Consultation. Arcata, CA.
- Oregon Department of Fish and Wildlife (ODFW). 2010. Guide to Placement of Wood, Boulders and Gravel for Habitat Restoration. *Oregon Department of Forestry & Oregon Department of Fish and Wildlife*.
- Rogers, D.W. 1971. *A Steelhead Spawning Survey of the Tributaries of the Upper Trinity River*

- and Upper Hayfork Creek Drainage. California Department of Fish and Game, Region 1, Inland\ Fisheries Branch.
- Rogers, D.W. 1972. A Steelhead Spawning Survey of the Tributaries of the Upper Trinity River and Upper Hayfork Creek Drainage. California Department of Fish and Game, Region 1, Inland Fisheries Branch.
- Sanders, S. D., & Flett, M. A. 1989. Montane Riparian Habitat And Willow Flycatchers: Threats To A Sensitive Environment And Species. In *California Riparian Systems Conference* (p. 262).
- Schempf, P. P., & White, M. 1977. Status of six furbearer populations in the mountains of northern California. USDA Forest Service, California Region, San Francisco, 51 pp.
- Stafford, M.D., Valentine, B.E. 1985. A preliminary report on the biology of the Willow Flycatcher in the central Sierra Nevada. *Cal-Neva Wildlife Transactions* 1985: 66-67.
- Sogge, M. K., Marshall, R. M., Sferra, S. J., & Tibbitts, T. J. 1997. *A southwestern willow flycatcher natural history summary and survey protocol*. Technical Report NPS/NAUCPRS/NRTR-97/12. USGS Colorado Plateau Research Station, Northern Arizona University, Flagstaff, AZ.
- Stone, K.R. 2013. *Accipiter gentilis*. In: Fire Effects Information System, [Online]. U.S. Department of Agriculture, Forest Service, Rocky Mountain Research Station, Fire Sciences Laboratory (Producer). Available: [www.fs.fed.us/database/feis/animals/bird/acge/all.html](http://www.fs.fed.us/database/feis/animals/bird/acge/all.html).
- Trinity County Historical Society. 1981. Trinity County Historic Sites.
- U.S. Fish and Wildlife Service (USFWS). 2011. Revised Recovery Plan for the Northern Spotted Owl (*Strix occidentalis caurina*). U.S. Fish and Wildlife Service, Portland, Oregon. xvi + 258 pp.
- U.S. Fish and Wildlife Service (USFWS). 2016. Fisher (*Pekania pennanti*), West Coast Population Final Report. U.S. Fish and Wildlife Service, Pacific Southwest Region. 332 pp.
- Verner, J., & Boss, A. S. 1980. California wildlife and their habitats: western Sierra Nevada. *Gen. Tech. Rep. PSW-GTR-37*. Berkeley, CA: Pacific Southwest Forest and Range Exp. Stn., Forest Service, US Department of Agriculture: 43.
- Walker, E. P., F. Warnick, and S. E. Hamlet. 1968. *Mammals of the World*. 2nd ed. 2 Vols. Johns Hopkins Press, Baltimore, MD. 1500 pp.
- Williams, B.D.C. 1998. Distribution, Habitat Associations, and Conservation of Purple Martins Breeding in California (Thesis). California State University, Sacramento. (California Department of Fish and Game, Bird and Mammal Conservation Program Report 98-14).
- Zeiner, D. C., Laudenslayer Jr, W. F., Mayer, K. E., & White, M. 1990. California's Wildlife, Volume III: Mammals. *California Department of Fish and Game, Sacramento, CA*.

## END NOTES

### End Note #3

Baseline water diversion volume for the McKnight Ditch was determined by taking cross sectional area of the ditch and using multiple readings on a flowmeter against that area to get an average flow volume. Flow was measured ~500 ft downstream (at East Weaver Road) of the ditch intake on August 9<sup>th</sup>, 2013. The flow velocity was measured at ~3.2 ft/sec based on a repeated sampling of a 10 ft long length of the stream. The dimensions of the wetted surface were measured consistent with the open channel flow calculator variables for a trapezoid channel (below). A Manning's "n" roughness co-efficient of 0.025 was estimated for the channel bottom. The channel values  $z_1$ ,  $z_2$ ,  $y$ ,  $T$  and  $b$  for a trapezoid channel were  $z_1$ - 1/1.25;  $z_2$ - 1/1.25;  $y$ -0.5;  $T$ -2.0;  $b$ -1.25.



The open channel flow calculator results were consistent with the observed flows. The observed flow velocity was 3.2 ft/sec and the calculated flow velocity was 2.8 ft/sec. Based on the open channel calculations the flows at the measurement point were 2.13 cfs.

## Appendices

## Appendix 1

### East Weaver Dam Designs Alternatives and Assessment Report



## EAST WEAVER DAM DESIGN ALTERNATIVES AND ASSESSMENT REPORT

Prepared By:

Mark Lancaster, Registered Professional Forester

Dustin Revel, Engineer

Jerry Hauke, Professional Engineer

# Table of Contents

Table of Figures .....	5
Table of Tables .....	7
1 Introduction.....	1
1.1 Contract.....	1
1.2 Location .....	2
1.3 Purpose of Study .....	2
1.4 East Weaver Facilities.....	3
1.4.1 Water Right and Reliability .....	3
1.4.2 East Weaver Water Treatment Facilities.....	3
1.4.3 East Weaver Dam.....	4
1.5 Design Considerations .....	7
1.5.1 Water Diversions/Intake Design .....	7
2 Project Background.....	8
2.1 General Description .....	8
2.2 Fish Passage Barrier.....	9
2.3 Climatic Effects .....	10
3 Field Surveying and Mapping.....	11
3.1 Topographic, Thalweg, and Impoundment Surveys .....	11
3.2 Flow and Temperature Monitoring .....	12
3.2.1 Monitoring Sites.....	12
3.2.2 Temperature Monitoring .....	15
3.2.3 Water Temperature, Turbidity and Flow Conclusion .....	16
3.3 Reference Reach Surveys.....	16
3.4 Water Right Search .....	17
3.5 Existing Conditions Plans .....	17
3.6 Downstream Water Utilization .....	17
4 Historic Resource Assessment.....	17
5 Sediment Sampling .....	19
5.1 Introduction.....	19
5.2 Background .....	20
5.3 Sampling .....	20
6 Biological Resources .....	23
6.1 Fisheries .....	23
6.1.1 Fish Presence .....	23
6.1.2 Instream Habitat Assessment .....	24



6.1.3	Large Wood Debris.....	24
6.1.4	Upper East Weaver Creek SCI: 2002 vs. 2011 .....	25
6.1.5	Lower East Weaver Creek SCI: 2002 vs. 2011.....	25
6.2	Wildlife Species .....	25
6.2.1	Pacific Fisher .....	28
6.2.2	Ring-tailed cat.....	28
6.2.3	Northern Spotted Owl .....	28
6.2.4	Northern goshawk.....	29
6.2.5	Willow flycatcher.....	29
6.2.6	Olive-sided flycatcher .....	29
6.2.7	Yellow warbler.....	30
6.2.8	Yellow-Breasted Chat .....	30
6.2.9	Purple martin.....	31
6.2.10	Pacific Tailed Frog.....	32
6.2.11	Foothill yellow-legged frog .....	32
6.2.12	Western pond turtle.....	32
6.3	Botanical Resources.....	33
6.4	Invasive Species.....	33
6.5	Infrastructure.....	33
6.6	Recreational Usage .....	34
6.7	Other Socio-Economic and Political Issues .....	35
7	DAM REMOVAL ALTERNATIVES.....	36
7.1	ALTERNATIVE 1 Dam Removal and Channel Rehab .....	37
7.1.1	Construction.....	39
7.2	ALTERNATIVE 2 Multiphase Removal .....	41
7.3	ALTERNATIVE 3 Single-phase Dam Removal .....	42
7.4	Alternatives Considered and Rejected for Detailed Analysis .....	43
8	Hydrology .....	44
8.1.1	Regression Methodology .....	44
8.1.2	Rush Creek Correlation.....	45
9	Hydraulics .....	46
9.1	Water Surface Profiles .....	46
9.1.1	Evaluation of Alternatives for Removal of the East Weaver Dam .....	48
9.2	Roughened Channel Design.....	48
9.2.1	Channel Profile and Shape.....	48
9.2.2	Engineered Streambed Material.....	49

9.2.3	Fish Passage Analysis:.....	51
9.3	Conclusion .....	51
10	Sediment Transport and Channel Stability .....	52
10.1	Steady HEC-RAS Simulation Results .....	52
10.1.1	Channel Shear Stress.....	52
10.1.2	Channel Velocity.....	52
10.2	Long-Term Streambed Stability.....	53
10.2.1	Channel Stability Indications .....	53
10.2.2	Summary .....	54
10.3	Bridge Elevation and Channel Flow .....	54
10.4	Conclusions.....	57
11	Recommended Alternative.....	58
12	References.....	59

## Table of Figures

Figure 1-1: East Weaver Creek Watershed and East Weaver Dam location .....	2
Figure 1-2: East Weaver Creek upstream of the East Weaver Dam .....	8
Figure 2-1: Global average temperature since 1880. This graph from NOAA shows the annual trend in average global air temperature in degrees Celsius, through December 2013. For each year, the range of uncertainty is indicated by the gray vertical bars. The blue line represents a moving average. ....	10
Figure 3-1: Long Profile of East Weaver Creek .....	11
Figure 3-2: Map of Flow & Temperature Monitoring sites, bridge sites and stream reference reach site..	14
Figure 3-3: Daily maximum water temperature collected between August and November 2014 at three sites below East Weaver Dam.....	15
Figure 3-4: Daily maximum water temperature data collected between June and November 2015 for three sites in and around the project reach.....	16
Figure 5-1 Long profile of East Weaver Creek including the average slope, adjustment grade (lowest), and reach description in terms of sediment transport/deposition.....	20
Figure 5-2: Reference reach cross section used for sediment sampling. ....	21
Figure 5-3: Results of six pebble count samples.....	21
Figure 6-1: An adult steelhead carcass found in the lower portion of East Weaver Creek in 2012. ....	24
Figure 6-2: Engineered large wood installed in the lower reaches of East Weaver Creek in November 2014. ....	25
Figure 6-3: Engineered large wood installed in the lower reaches of East Weaver Creek in November 2014 during an approximately Q <sub>7</sub> flow in January 2016. ....	25
Figure 7-1: Longitudinal view of Alternative-1, dam removal and channel rehab, showing the existing, average, and proposed grade as well as rock weir and intake locations. ....	37
Figure 7-2: Plan view of typical Rock U-weir .....	38
Figure 7-3: the roughened channel portion of the channel rehab will resemble a cascade morphology creating a series of steps at low flows and a rough cascade during higher flow (Love and Bates 2009). ...	38
Figure 7-4: A section of Little Browns Creek dewatered, aggraded materials removed and excavation below the channel grade in order to install streambed materials and grade control structures. The excavation provided mechanical access to the stream reach. ....	39
Figure 7-5: Installation of stream bed materials. ....	39
Figure 7-6: Construction of grade control veins into the banks and below channel grade (note: grade control boulders and willow plantings materials in background). ....	39
Figure 7-7: Grade control veins are buried every 25’ and the channel bottom bedload materials in place (final jetting and washing fines has not been done at this stage). ....	39
Figure 7-8: Willow mattresses before soil is added to them.....	40
Figure 7-9: Willow walls and bed.....	40
Figure 7-10: Channel with grade structures buried and channel bottom before final jetting.....	40
Figure 7-11: First year channel flows .....	40
Figure 7-12: Multiphase dam removal flow chart. ....	41
Figure 8-1: Project Assessment Area and East Weaver Creek Dam location.....	44
Figure 9-1: Resulting water surface profile from HEC-RAS model under existing conditions during a 100-year flow event. ....	47
Figure 9-2: Resulting water surface profile from HEC-RAS model under Alternative-1 (Dam Removal and Channel Rehab).....	47
Figure 9-3: Roughened channel design process (Love and Bates 2009) .....	48
Figure 9-4: Typical roughened channel cross section for curved reaches. ....	49
Figure 9-5: Typical roughened channel cross section for straight reaches. ....	49
Figure 9-6: Engineered streambed material particle size distribution.....	50
Figure 10-1: The cross section area for bridges within the assessment area.....	55

Figure 10-2: East Weaver Campground Pedestrian Bridge Spans the entire floodplain of East Weaver Creek..... 56

Figure 10-3: Hansen Mine Bridge spans the entire floodplain of East Weaver Creek ..... 56

Figure 10-4: Butterfield Private Road Bridge shown in December 2015 is the most undersized crossing.56

Figure 10-5: Butterfield Private Road Bridge in December 2015(Above Left) and in January 2016 during an estimated Q2-Q4 storm flow. .... 56

Figure 10-6: The Butterfield Pedestrian Bridge immediately downstream of the Butterfield Road Bridge in December 2015 and upstream of the Bonar Bridge (note the Bonar Bridge can be seen downstream of this bridge in the photo). .... 56

Figure 10-7: Storm flows from Butterfield Pedestrian Bridge in January 2016. The Bonar Bridge is visible..... 56

Figure 10-8: Bonar Private Road Bridge in December 2015. .... 57

## Table of Tables

Table 5-1: Particle size and aggregate class descriptions .....	22
Table 6-1: Federal and California Threatened, Endangered, and Fully Protected Species excluded from further analysis.....	26
Table 6-2: California Species of Special Concern (SSC) excluded from further analysis.....	27
Table 6-3: Species of Special Concern (SSC) with the potential for occurrence within or near the project area includes: .....	27
Table 8-1: Pertinent basin and climatic characteristics of the portion of East Weaver Creek upstream of the Dam site (StreamStats).....	44
Table 8-2: Summary of recurrence flows calculated from regression equations presented by Gotvald et al. (2012) as well as Wannanen and Crippen (1977). .....	45
Table 8-3: Basin characteristics of East Weaver Creek above and Rush Creek (StreamStats). .....	45
Table 9-1: Engineered streambed material particle size distribution. ....	50
Table 9-2: Minimum water depth and maximum water velocities for salmonids at different life stages. .	51
Table 10-1: Summary of channel shear stress generated from HEC-RAS model of the existing conditions and Alternative-1 (dam removal and channel rehab) for all storms investigated in the hydrology study. .	52
Table 10-2: Summary of channel shear stress generated from HEC-RAS model of the existing conditions and Alternative-1 (dam removal and channel rehab) for all storms investigated in the hydrology study. .	53
Table 10-3: Storm Discharge to Intersect the Bottom of Beam for Downstream Bridges .....	55

## **LIST OF ABBREVIATIONS:**

5C- Five Counties Salmonid Conservation Program  
ACOE- Army Corps of Engineers  
CDFW- CA Dept. of Fish and Wildlife  
CWA- Clean Water Act  
EWD- East Weaver Creek Dam  
EWF- East Weaver Creek WCSD Treatment Facilities  
FIRM- Flood Insurance Rate Map  
HECRAS- Hydrologic Engineering Centers River Analysis System  
LWD- Large Wood Debris  
NCRWQCB- North Coast Regional Water Quality Control Board  
NEIC- North East Information Center<sup>1</sup>  
NMFS- National Marine Fisheries Service RC&DC-  
RC&DC- Northwest California Resource Conservation and Development Council  
RSL- Redwood Science Lab, US Forest Service Southwest Forest and Range Station, Arcata CA  
SCI- Stream Condition Inventory  
SLAA- Streambed and Lake Alteration Agreement  
SONCC- Southern Oregon Northern California Coastal  
SWE- Snow water equivalent  
TRRP- Trinity River Restoration Program  
USFS- United States Forest Service  
WCSD- Weaverville Community Services District  
WWE- Water Works Engineering Inc.

---

<sup>1</sup> Department of Anthropology, California State University Chico



**i:** East Weaver Dam- integrity of the structure has been compromised by undercutting.



**ii:** East Weaver Dam- photo taken from the intake structure near the crest of the dam, looking downstream.



iii: Exposed bed rock is common in the reach directly downstream of East Weaver Dam is a result of scour since the dam was constructed

## 1 Introduction

### 1.1 Contract

This report has been prepared by the Five Counties Salmonid Conservation Program (**5C**) a program of the nonprofit Northwest California Resource Conservation and Development Council (**RC&DC**), in consultation with Weaverville Community Services District (**WCSD**) and Water Works Engineering, Inc. (**WWE**). Funding for the project came from the U.S. Bureau of Reclamation's Trinity River Restoration Program's (**TRRP**) Watershed Restoration Grant Program and the CA Coastal Conservancy. This report addresses the design components included in the TRRP agreement and portions of the Coastal Conservancy agreement. A supplemental report will address the additional components included in the Coastal Conservancy agreement.

All design work was done under the direction and supervision of Jerome Hauke, Professional Engineer and Mark Lancaster (Registered Professional Forester). Water Works Engineering was retained to work on the design of the East Weaver Creek Water Treatment Facilities intertie and inlet designs. Property line boundaries were delineated by Brian Howard (Licensed Land Surveyor) of Omni Means Ltd. Wes Scribner (Professional Engineer, WCSD) provided oversight in all aspects of the design and reporting processes.

This report summarizes the investigation of the feasibility of removing the East Weaver Creek, Dam (**EWD**).

This report is laid out with the intent of examining physical design constraints and options as well as physical environmental factors (cultural resources, wildlife resources, botanical resources, floodplain developments) that should be factored into designs. The feasibility study, while not identifying all



impacts does identify critical items that will need additional action before a final design and permitting can be completed.

## 1.2 Location

The project is located in the headwater reach of East Weaver Creek, one of the largest tributary streams to Weaver Creek, in Weaverville, Trinity County in Section 30, T34N, R9W, MDB&M (40.7769889° 122.9298083° NAD83) (Figure 1-1). The project is located approximately 11.75 miles upstream of the confluence of Weaver Creek and the Trinity River. The project site can be reached by traveling to approximately mile post 2.5 on East Weaver Creek Road, a county maintained road. At mile 2.5 vehicles can park at the WCSD access control gate. If the gate is closed the site can be reached by walking the ~0.25 mile road to the EWF.

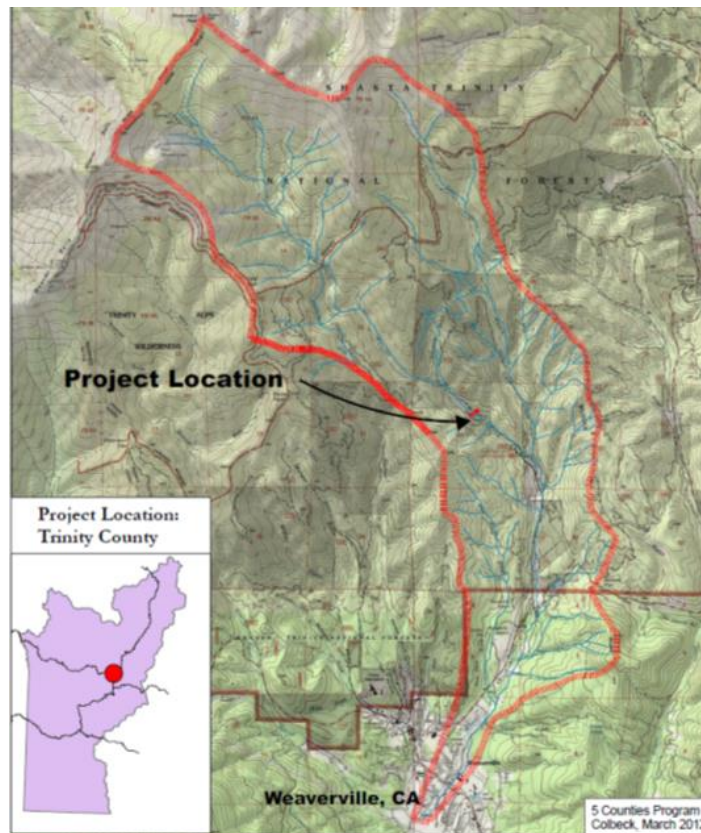


Figure 1-1: East Weaver Creek Watershed and East Weaver Dam location

## 1.3 Purpose of Study

The EWD is an integral part of the community of Weaverville's water supply supplying the majority of water to the community throughout most of the year. While integral to the community, the dam is a migration barrier to endangered Coho salmon and other migrating anadromous fish species (steelhead, Pacific lamprey) and resident trout. The EWD is the only complete migration barrier on East Weaver Creek and the dam is in poor condition and will require repairs that may be hindered until fish passage is addressed.

This study is intended to assess options for the WCSD to economically allow fish to migrate upstream of the EWF while maintaining its EWF operations. The objectives of this project are to: 1) to develop a plan and design options for the removal of the East Weaver Creek Dam while assuring a reliable water supply to the community of Weaverville California; 2) open up to 2.5 miles of anadromous salmonid habitat and

restore natural gravel and bedload routing down the channel; 3) assure that the WCSD East Weaver Creek Water Treatment Facilities (**EWF**) intake functions effectively with any design alternative; 4) assess downstream water diversions for opportunities to improve instream flows while preserving private water rights.

The downstream water use assessments are addressed in a separate report from this feasibility study.

Designs options could range from retaining the dam to removing it entirely. In addition to the objective of dam removal the operations of the EWF must be maintained and any design must recognize the future needs of the WCSD for this site including the possibility of:

- Relocating the EWF filtration system and storage tanks onto their property and off of the National Forest;
- Replacing the existing 400,000 gallon water storage tank as it is nearing the end of its effective life span. Replacement tank(s) should be considered in the siting criteria for this project;
- Moving the sand filtration plant away from East Weaver Creek Campground to reduce conflicts and trespass concerns;
- Any new intake system should be designed as a gravity fed with screens. The gravity intake substantially reduces the loss of stream side vegetation compared to an infiltration system. The mitigation costs to replace riparian/wetlands habitat is both pragmatically difficult to do and very expensive. Minimizing riparian loss becomes a design objective;
- All new designs have to allow for gravity flow of from intake to filtration and storage. Elevation change from the intakes will have to consider future water tank heights in siting considerations.

## 1.4 East Weaver Facilities

### 1.4.1 Water Right and Reliability

The WCSD holds a “pre-1914” water right for its East Weaver Creek diversion<sup>2</sup> although the quantity of that right has never had to show cause at a water right hearing. The District recognizes that both of its East and West Weaver Creek diversions will not be increased and that future water increases will be the result of water conservation and increased use of its Trinity River water right. The District is also aware of public trust doctrine water needs for the protection of public uses of fishing and the environment that could affect the amount of water the district uses in some seasons.

While designs for EWD and EWF operations were based on assumptions of reliable stream flows climatic changes over the past 50 years have influenced water reliability, especially during summer low flow periods. Changes in precipitation patterns and declining snow packs have impacted water reliability for the WCSD East and West Weaver Creek intakes (refer to Climatic Effects in Section 2 for addition discussion).

Even before those changes were fully recognized the WCSD had to implement water hook up restrictions because of seasonal flow constraints<sup>3</sup>. The addition of the Trinity River treatment plant finally eliminated the restrictions in 2000, but the listing of coho salmon has increased the need for the WCSD to consider minimum bypass flows for fisheries particularity in summer.

### 1.4.2 East Weaver Water Treatment Facilities

The EWF is one of three water treatment facilities the WCSD operates. The 60+ year old water treatment facility includes a dam, contact basin, settling ponds, sand filtration building and filters, stadia monitoring

---

<sup>2</sup> CA State Water Resources Control Board’s Electronic Water Rights Information Management System #S000361\_01.

<sup>3</sup> Between 1980 and 2000 the District had a water hook up moratorium and a bond measure to improved water reliability. The completion of the Trinity River treatment facility finally eliminated the hook up moratorium.

equipment, 400,000 gallon storage tank and piping and valves. The sand filter and building as well as the storage tank are located on National Forest lands, while the dam, contact basin and settling (backwash) ponds are on WCSD lands. The other two water treatment plants are West Weaver Creek and Trinity River. The EWF is the highest elevation intake and can serve all ~1850 household equivalents hookups in Weaverville (population 4,000). The other two plants cannot serve the East Weaver Creek neighborhoods.

The EWF does not meet the most recent water quality regulations for water treatment facilities but continues to operate under the regulations that were in place when it was constructed. The water generally remains of the highest quality, but additional filtration requirements have been included in the WCSD long range capital improvement plans.

The EWF is gravity operated and requires minimal electricity and can operate even in periods of power outages. The West Weaver facilities are also gravity operated, but being lower in elevation cannot service the whole community. The Trinity River plant requires significant electricity to pump to the community but is a constant reliable water source. East Weaver Creek alone cannot provide all of the water for the community and the WCSD has the flexibility to bring the West Weaver and Trinity River treatment plants online and offline as needed for maintenance and other needs, but these facilities cannot service the higher elevations parts of the district which means that the EWF system can only be offline as long as there is adequate reserve water in its 400,000 storage tank.

To maintain relatively low water costs and because the water quality is high, the WCSD relies on the EWF for as much of its water needs as is possible. The limiting constraint on EWF is the total water flow in the stream and complying with applicable fisheries and water quality regulations. The WCSD has indicated a strong desire to work on improving fisheries resources and meeting its water needs. To that end the District has already upgraded its infiltration galleries in the Trinity River to increase the amount of water it can pump and has improved leak detection and repairs to pipes and water storage tanks. The district continues to look for power generation opportunities to offset some of its Trinity River pumping costs.

### 1.4.3 East Weaver Dam

The EWD components include a concrete apron and sill over top a boulder dam with a concrete stilling basin for diverting the stream into the East Weaver Water Treatment Facility. The dam is 12 feet high, 33 feet wide and spans the Q<sub>2</sub> width of East Weaver Creek. The dam has a 25 feet long concrete and boulder spillway. The downstream end of the spillway is about 6 feet above the “original grade”, or normal downstream tail water elevation and the crest is about 18 feet above the bottom of the downstream stream channel. The EWD does not have gates or low flow outlets.

The concrete apron covering the rip rap boulder and concrete structure has spalled and broken (refer to attached photos) and some water flows interstitially through the dam's rock structure. The area behind the dam is filled with bedload material and provides no water storage capacity. Upstream of the dam the creek has trapped and stored mid to large bedload material and immediately downstream the channel has scoured and incised down to a weak bedrock layer consisting of dense, compressed clay of the Weaverville geologic formation. The scour at the base of the dam increases the potential for long term maintenance issues of the dam.

The dam has one function, diverting water into the Weaverville Community Services District's East Weaver stilling basin. From the stilling basin the water flows into a contact/settling basin and then to the sand filters system. The treated water then gravity flows to the 400,000 gallon storage tank. There are no

plans for increased water diversion from East Weaver Creek and WCSD system expansion is focused on improving treatment, delivery, storage capacity, and safety of its water to customers.

#### 1.4.3.1 Dam Integrity

East Weaver Dam is classified as a minor dam (<25' hydraulic height) with less than 15 acre feet of storage capacity (EWD has less than 0.1 acre feet of storage capacity) with a low hazard potential within a seismically low risk area. The dam is rated as in poor condition due to repairs or modifications required to maintain the structure operationally. A number of deficiency are evident on visual inspection of the dam including: loss of concrete apron segments, concrete spalling, exposed rebar, water flows interstitially through the dam's rock structure, sediment filling upstream and bed scour below the base of the dam. Repairs to the dam will be necessary in the reasonably foreseeable future.

Given the fish mortality and passage issues it is questionable whether CDFW and/or NMFS would provide the required agreement and Biological Opinion needed for repairs to the dam without addressing fish passage as part of the repair design.

#### 1.4.3.2 Dam Repair and Dam Removal Regulation

The federal government requires coordination with USGS for any structure 25 feet high or higher or that will have a capacity of 50 acre-feet or more that will be built or modified (Public Law 92-367). East Weaver Dam does not meet the size or storage capacity criteria necessary for USGS coordination. No federal permits are required for EWD repair or removal, however federal Clean Water Act Certifications are required (discussed below).

California Water Code, Division 3, Section 6002 defines a "Dam" as *"any artificial barrier, together with appurtenant works, which does or may impound or divert water, and which either (a) is or will be 25 feet or more in height from the natural bed of the stream or watercourse at the downstream toe of the barrier, as determined by the department, or from the lowest elevation of the outside limit of the barrier, as determined by the department, if it is not across a stream channel or watercourse, to the maximum possible water storage elevation or (b) has or will have an impounding capacity of 50 acre-feet or more.*

Section 6003 further defines what constitutes a "Dam" is not as follows: *"Any such barrier which is or will be not in excess of 6 feet in height, regardless of storage capacity, or which has or will have a storage capacity not in excess of 15 acre-feet, regardless of height, shall not be considered a dam.*

East Weaver Dam does not meet the size or storage capacity criteria of a state regulated dam. No state permits are required for dam repair or removal, however a Streambed and Lake Alteration Agreement (**SLAA**) is required (discussed below).

Trinity County Building Department does not regulate or permit dams but relies on the state to "permit" them via Streambed Alteration Agreements. The County will not require a permit for dam repair or removal.

The CA Department of Fish and Wildlife (**CDFW**) requires a SLAA before any work in a stream can be done, including dam repair or removal. A SLAA will have to be signed by WCSD and CDFW before repairs or removal of EWD can be done.

While the North Coast Regional Water Quality Control Board (**NCRWQCB**) does not regulate dams, they are required to issue a Clean Water Act (**CWA**) Section 401 Certification for projects that have a threat to discharge into waters of the U.S.

The NCRWQCB Executive Director addressed small dam removals in a letter to the State Water Board on the draft North Coast Instream Water Policy (August 25, 2005) as follows: “...it is critical that the entire dam fill and any related structures are removed, all the way down to the “original grade” of the stream bed. Some sites may require the excavation below “original grade” and placement of large rock to stabilize the streambed. In addition, all stored sediment should be removed and all previously inundated land should be stabilized with vegetation or rock to limit soil movement. Also, release of stored waters should be done to limit pulse flows...”

The US Army Corp of Engineers will be required to issue a CWA Section 404 Discharge of Dredged or Fill Material Certification for the project as well. Under the Section 404 review the National Marine Fisheries Service is consulted for impacts to coho salmon and the US Fish and Wildlife Service is consulted for impacts to other listed species (in this case northern spotted owl).

Both CWA 401 and 404 Certifications must be obtained for any dam repairs or removal.

The project requirements for Section 401 and 404 certifications related to coho salmon may be programmatically covered under the National Marine Fisheries Service's (NMFS) “*Final Biological Opinion and Essential Fish Habitat Consultation for Restoration Projects within the NMFS Northern California Office Jurisdictional Area (2014)*”. To be eligible for the Biological Opinion small dam removals must meet the following criteria:

*“form a channel at natural grade and shape upstream of the dam, naturally or with excavation, in order to minimize negative effects on downstream habitat. Dam removal projects will (1) have a relatively small volume of sediment available for release, that when released by storm flows, will have minimal effects on downstream habitat, or (2) are designed to remove sediment trapped by the dam down to the elevation of the target thalweg including design channel and floodplain dimensions. This can be accomplished by estimating the natural thalweg using an adequate longitudinal profile (CDFG Manual Part XII Fish Passage Design and Implementation) and designing a natural shaped channel that provides the same hydraulic conditions and habitat for listed fish that is provided by the natural channel and has the capacity to accommodate flows up to a 2-year flood.*

*b. Minimization Measures*

*All construction will take place out of the wetted channel either by implementing the project from the bank and out of the channel or by constructing coffer dams, removing aquatic species located within the project reach, and dewatering the channel.*

- No more than 250 linear feet (125 feet on each side of the channel) of riparian vegetation will be removed. All disturbed areas will be re-vegetated with native grasses, trees, or shrubs.*
- All dewatering efforts associated with small dam removal will abide by the applicable minimization measures (Section D. Sideboards, Minimization Measures, and Other Requirements).*

*c. Data Requirements and Analysis*

- A longitudinal profile of the stream channel thalweg for at least a distance equal to 20 channel widths upstream and downstream of the structure and long enough to establish the natural channel grade, whichever is farther, shall be used to determine the potential for channel degradation (as described in the CDFG Manual).*

- *A minimum of five cross-sections: one downstream of the structure, three roughly evenly spaced through the reservoir area upstream of the structure, and one upstream of the reservoir area outside of the influence of the structure to characterize the channel morphology and quantify the stored sediment.*
- *Sediment characterization within the reservoir and within a reference reach of a similar channel to determine the proportion of coarse sediment (>2mm) in the reservoir area and target sediment composition.*
- *A habitat typing survey (DFG Manual Part III, Habitat Inventory Methods) that maps and quantifies all downstream spawning areas that may be affected by sediment released by removal of the water control structure.*

*Projects will be deemed ineligible for the program if: (1) sediments stored behind dam have a reasonable potential to contain environmental contaminants [dioxins, chlorinated pesticides, polychlorinated biphenyls (PCB's), or mercury] beyond the freshwater probable effect levels (PELs) summarized in the NOAA Screening Quick Reference Table guidelines or (2) the risk of significant loss or degradation of downstream spawning or rearing areas by sediment deposition is considered to be such that the project requires more detailed analysis. Sites shall be considered to have a reasonable potential to contain contaminants of concern if they are downstream of historical contamination sources such as lumber or paper mills, industrial sites, or intensive agricultural production going back several decades (i.e., since chlorinated pesticides were legal to purchase and use)."*

## 1.5 Design Considerations

The WCSD has identified design considerations for any project that repairs or removes EWD including:

- The WCSD would like to relocate their facilities (filtration system and storage tanks) onto their property and off of the National Forest;
- The existing 400,000 gallon water storage tank is nearing the end of its effective life span and replacement tank(s) should be considered in the siting criteria for this project;
- Moving the plant away from the public campground reduces conflicts and trespass concern;
- New intakes should be designed as gravity fed with screens (maybe similar to West Weaver WCSD intakes). The gravity intake substantially reduces the loss of stream side vegetation compared to an infiltration system. The mitigation costs to replace riparian/wetlands habitat is both pragmatically difficult to do and very expensive. Minimizing riparian loss becomes a design objective;

All new designs have to allow for gravity flow of from intake to filtration and storage. Elevation change from the intakes will have to consider future water tank heights in siting considerations.

### 1.5.1 Water Diversions/Intake Design

Under the design alternatives a new intake location and design was required. Water Works Engineering was contracted to design the intake and intertie to the existing EWF. The design was done in consultation with WCSD General Manager and Registered Engineer Wes Scribner.



Figure 1-2: East Weaver Creek upstream of the East Weaver Dam

## 2 Project Background

### 2.1 General Description

East Weaver Creek is a tributary to Weaver Creek and the Trinity River. The East Weaver Creek watershed encompasses 8,300 acres and represents ~25% of the Weaver Creek watershed. Elevations range from 7762 feet (Monument Peak) to 1968 feet at its confluence with West Weaver Creek. The upper 30% of the watershed is within the Trinity Alps Wilderness and the East Weaver Dam is located ~0.5 miles downstream of the Wilderness boundary. Approximately 95% of the watershed upstream of the dam is either wilderness or timber production zoned (Figure 1-2). Sierra Pacific Industries (SPI) owns 684 acres intermixed with the National Forest lands in the upper end of the watershed. The Weaverville Community Services District (WCSD) owns the 160-acre project area.

The upper 70% of the East Weaver Creek watershed consists of alpine and Klamath Mixed Conifer forests with pockets of Montane Hardwood woodlands on south facing slopes and areas of shallow soils. Approximately 59% of the watershed is within the Trinity National Forest. The lower watershed includes semi-urban Weaverville (population 4,000) and rural residential uses intermixed within mixed conifer forests.

There are 10 bridges on East Weaver Creek five upstream of Highway 3 and 5 downstream of Highway 3. There are approximately 6 homes mapped within the Flood Insurance Rate Map (FIRM) 100 year floodplain of the stream, but FIRM floodplain mapping only extends to the end of the Weaverville Airport (FEMA, 2010). We estimate that there are approximately four homes or other structures

potentially within the 100 year floodplain upstream of the FIRM floodplain mapping (based on Google Earth views).

## 2.2 Fish Passage Barrier

The EWD is recognized as the only complete barrier to upstream fish migration for all life stages of all fish species in East Weaver Creek<sup>4</sup>. The Federal “Final Recovery Plan for the Southern Oregon/Northern California Coast (**SONCC**) Evolutionarily Significant Unit of Coho Salmon (*Oncorhynchus kisutch*)” (NMFS, 2014) includes the following discussion “*East Weaver Creek supplies the town of Weaverville with its water. The town’s municipal diversion dam creates a barrier to salmon migration and to gravel movement in the creek, which degrades habitat below the dam in addition to blocking fish passage. (NMNFS, 2014 p. 39-20)*”.

The EWD blocks access to ~2.5 miles of habitat. In addition to being an upstream migration barrier, the dam and intake system for the EWF results in mortality of some resident trout during summer downstream migration. Downstream migration is known to occur during smoltification in resident rainbow. During June 2015 snorkel surveys of the stream upstream of the dam a significant number of trout exhibited physiological changes as they transition from living in fresh water to living in seawater. Physiological changes during smoltification include altered body shape and increased skin reflectance. Smoltification requires these fish to migrate to salt water for their survival.

When all stream flow is diverted into the EWF stilling well, fish migrating downstream are forced into the inlet pipes and either into the contact basin or are flushed around the plant via an overflow piping system. There is a presumed low probability of survival for fish entering the stilling basin. Even migration over the dam face presents hazards to downstream migration fish. There is no known studies to quantify the effects of fish falling the ~12’ from the edge of the apron to the channel below.

The SONCC coho plan set out recovery actions for this species that includes a task for the Trinity River including to, “*assess highest priority road-stream and diversion related barriers. Develop a plan for removal*”. The plan indicates that Weaver Creek and its tributaries have a high intrinsic potential for coho<sup>5</sup>. Intrinsic Potential is defined as the “*potential of the landscape to support a population. The Intrinsic Potential of a watershed or stream reach, is used to evaluate the likelihood of the area to support fish, and is used when population characteristics are unknown*”.

The SONCC coho recovery plan lists barriers as a “key limiting factor” to salmonid recovery in the Upper Trinity River basin for adult life stages and ranks them as “high” stressors for coho. Barriers and diversions are also “very high” threats to the survival of all life stages of coho, except the egg stage<sup>6</sup>.

Projects that restore coho habitat also benefit all other anadromous species (steelhead and Pacific lamprey). The coho salmon has the most at risk characteristics (live longest in tributary streams, “weakest” jump capabilities and lowest tolerance range for stream temperatures) of the salmonids in CA. Designs that benefit coho also benefit all other fish species.

---

<sup>4</sup> Highway 3 crossing of East Weaver Creek is a partial fish passage barrier (velocity). At the highway crossing, adult fish can move upstream on the receding limb of storm flows and downstream floodplains provide resting habitat during higher flows. Adult and juvenile steelhead and coho salmon have been documented upstream of the Highway 3 crossing on numerous occasions (refer to fisheries section). A partial barrier is also located on East Fork of East Weaver Creek.

<sup>5</sup> Federal SONCC Coho Recovery Plan, Table 39-1, page 39-5 (Appendix G-7)

<sup>6</sup> Federal SONCC Coho Recovery Plan Table 39-5, page 39-16)



### 2.3 Climatic Effects

The Klamath Mountain range, in which the project area occurs, is a Mediterranean climate characterized by cool wet winters and hot dry summers. Average rainfall in the project area is ~38” of rain equivalent precipitation with a significant portion of that falling as snow in the highest elevations.

The WCSD water system does not have a reservoir to store water during the dry summer period but rather relies on a relative constant stream recharge from annual precipitation augmented by snow melt running into the spring and early summer. However, shifts in timing of precipitation over the past 50 years in the Trinity and Klamath Mountains (Asarian and Walker, 2015, Mote 2005) may be as important water reliability planning issue as drought conditions.

There has been a decrease in winter precipitation and snow water equivalent (**SWE**) storage in the Klamath Mountains over the past 50+ years. The overall rate of SWE loss in the Pacific Northwest, including northwest California has averaged 30% for the period 1950–2000 (Mote, 2003). This contrasts with only a 1% SWE loss in the remainder of California. The difference between northwest California and the remainder of the state is due in part to weakening and offshore shifts of the Pacific winter storm track (Minobe, 1997) and “the anomalously strong El Nino–Southern Oscillation events in the past 20 years, which strengthen winter storms, resulting in more precipitation in California” (Piechota, et al, 1997). Howat and Tulaczyk (2005) summarize this difference as follows:

*“Such a contrast should not be completely unexpected, as previous researchers have found an anti-correlation between the climates of California and the Pacific Northwest, largely driven by the relative forcing of tropical and northern Pacific climate modes (Dettinger and Cayan, 1995; Cayan, 1996; Cayan et al, 1998)....In addition to a trend of drier and warmer winters in the recent past, snow pact levels have declined. The amount of snow water equivalent (SWE) storage trends is dependent on both latitude and elevation of the mountain range being measures.”<sup>7</sup>*

In addition to, or contributing to, the reduced SWE in the region is the rise in air temperatures both globally (Figure 2-1) and within California (Groisman et al, 2005; Lund et al, 2001).

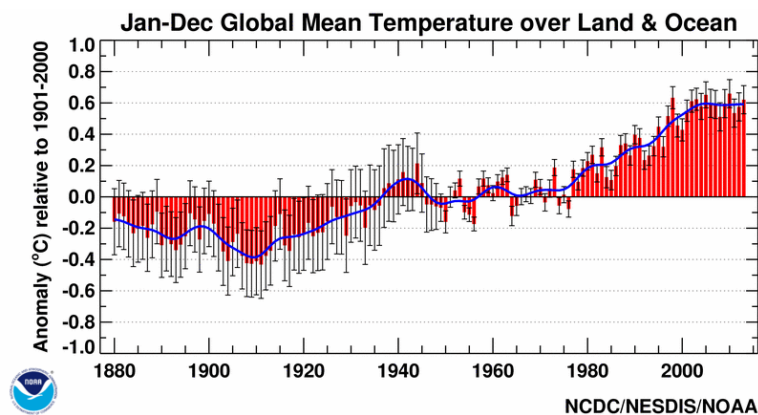


Figure 2-1: Global average temperature since 1880. This graph from NOAA shows the annual trend in average global air temperature in degrees Celsius, through December 2013. For each year, the range of uncertainty is indicated by the gray vertical bars. The blue line represents a moving average.

<sup>7</sup> Howat and Tulaczyk (2005) found that snow gauge stations below 2300m elevation lost, on average, 13% SWE while higher-altitude stations gained 12%. This spatial distinction was also found between northern and southern stations, averaging –15% and 10% respectively.

### 3 Field Surveying and Mapping

#### 3.1 Topographic, Thalweg<sup>8</sup>, and Impoundment Surveys

The design objective was to collect sufficient data to develop the hydraulic model discussed in later sections of this report, calculate cut and fill quantities, establish channel elevations and grades, and design modifications to EWF as a result of each alternative and to assess downstream impacts of alternatives.

The RC&DC conducted topographic and thalweg surveying using a Nikon DTM A20LG Total Station. A total of 3,000' of the East Weaver Creek thalweg was surveyed as shown in Figure 3-1. A total of 10 cross sections were installed within this reach. Additional surveying of potential pipeline routes was completed to ensure feasibility. Thalweg and cross section surveys were made for the Schofield Ditch channel and conforming reaches as part of the evaluation of installing a fishway and Dam Retention (Alternatives Considered and Eliminated).

In addition to the total station surveys, five cross sections were installed downstream of the project reach at five bridges: East Weaver Creek Campground Pedestrian Bridge, Hansen Private Road Bridge, Butterfield Private Road Bridge, Butterfield Pedestrian Bridge, and Bonar Private Road Bridge. The bridge cross section surveys consisted of stadia rod measurements and stations to capture changes in slope from bank to bank.

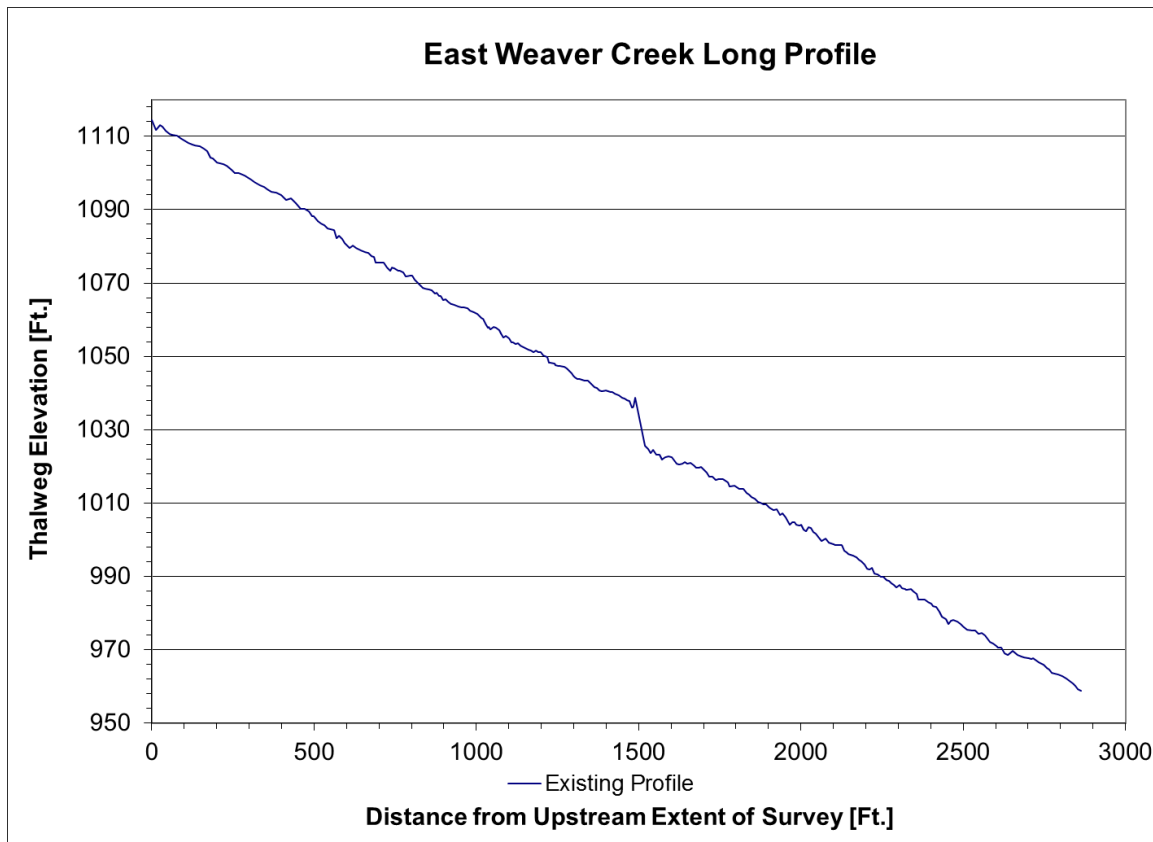


Figure 3-1: Long Profile of East Weaver Creek

<sup>8</sup> Thalweg can be defined as a line connecting the lowest points in a stream channel

Because of the shallow depth (<2') and minimal surface area (<0.025 ac.) of the water impoundment upstream of EWD, a bathymetric survey of the impoundment area was not needed.

AutoCAD Civil 3D software was used to create topographic contours and design drawings. Excel software was used to plot thalweg profiles and calculate fill estimates. Survey data was imported into flow models to predict changes in stage under different alternatives.

At the onset of the project it was anticipated that LiDAR (Light Detection and Ranging) topographic data for the project reach might be available to fill in the topography for the surrounding areas. Unfortunately, Lidar flights in the East Weaver Creek area did not extend far enough up stream to be used for this project.

## 3.2 Flow and Temperature Monitoring

A number of monitoring efforts have been on-going in East Weaver Creek for the past 3 years. Redwood Science Lab (RSL) has been monitoring water quality and quantity since 2011 at the Butterfield Bridge stream crossing site (0.75 miles downstream of dam. The Forest Service has been monitoring temperature ~0.5 miles upstream of the dam for the past few years, but records for the summer of 2014 were lost. Redwood Science Lab data for 2015 has not been obtained.

### 3.2.1 Monitoring Sites

Three flow monitoring stations were established in East Weaver Creek by the RC&DC as shown in Figure 3-2. These sites complement a gage installed downstream at the Butterfield Bridge site by the Pacific Southwest Research Station- Redwood Sciences Lab (RSL) in 2011. The three new locations extended from the Forest Service Campground upstream to the Weaverville Community Services District Dam site. At each site an Onset Data Logger - U20L-04 was installed to record absolute pressure and temperature at 15 minute increments set on the hour (PST). Periodic discharge measurements were made at each of the sites at established cross sections in order to establish a rating curve. A USGS Style A Staff Gage was installed at the two upstream sites. Barometric (atmospheric) pressure monitoring for all sites utilized pressure transducers at the RSL Butterfield Bridge site on East Weaver Creek above the water surface; subtracting these measurements from those recorded by the submerged transducers gives the pressure created by the water column above the transducer (gauge pressure).

The 5 Counties monitoring sites were established at the following three locations:

1. **Dam:** Instream just above the dam. The cross section for this site was set approximately 30 feet upstream of the dam where the channel is straight. The data logger for this site was mounted on the bottom rung of the access ladder in the water intake structure placed in the Onset U2X Protective Housing.
2. **Water Tank:** Instream below the water tank. The cross section for this site was located at the rebar currently located at this site. The data logger was mounted inside a galvanized pipe modeled after the RSL set up at the Butterfield Bridge site and buried in the substrate on the right bank (facing downstream). This site had a staff gage installed.
3. **Campground:** Instream below the Five Cent Gulch Ditch and the foot bridge. The cross section for this site is located approximately 50 feet downstream of the footbridge in a straight section of channel accessible from the trail and then heading slightly downstream. The data logger was mounted inside a galvanized pipe modeled after the RSL set up at the Butterfield Bridge site and buried in the substrate on the right bank (facing downstream). This site did not have a staff gage installed.

These sites were selected to address the question of the quantity of water being diverted in the portion of East Weaver Creek above the residential area. By establishing these three sites, diversion rates at the dam and ditch can be calculated assuming lateral inflow/infiltration is negligible through the reaches.

# East Weaver Dam Removal Project 5 Counties Program

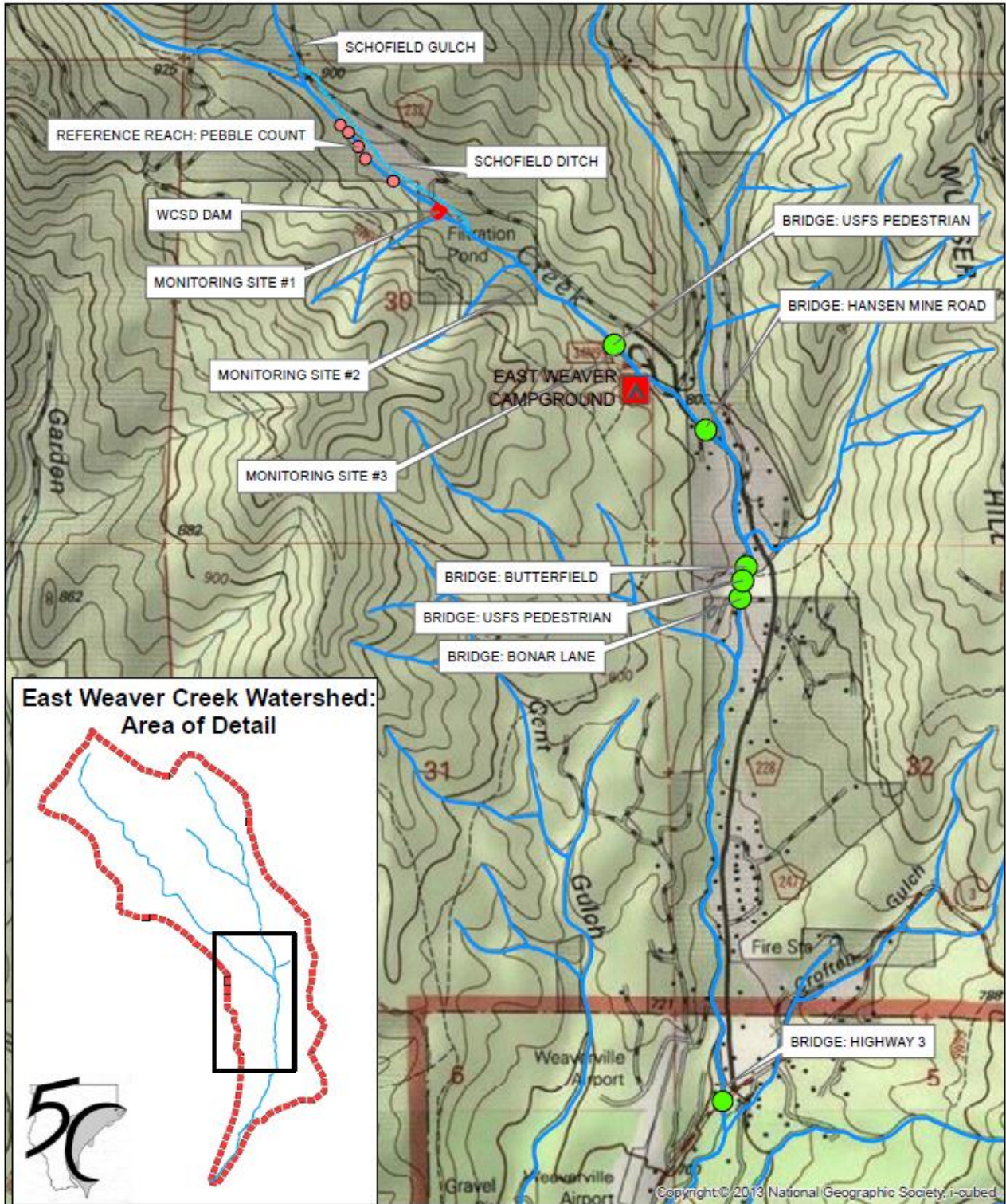
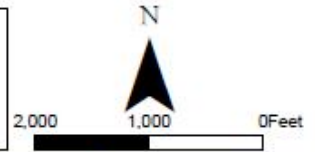


Figure 3-2: Map of Flow & Temperature Monitoring sites, bridge sites and stream reference reach site.

Water levels were recorded above and below the WCSD dam and above and below the Five Cent Gulch (Hansen Ditch) diversion. Flow data collected at these sites were correlated to 3 years of flow data collected by RSL at the Butterfield Bridge site, downstream of these gages. The RSL has correlated its East Weaver flows to gaged flows on Rush Creek, approximately 6 miles north of this watershed.

### 3.2.2 Temperature Monitoring

Water temperature measurements were taken at three points on East Weaver Creek ranging from the RSL site at HWY 3 to a site below EWD during late summer to fall of 2014 (Figure 3-3). At these sites, Hobo U22-001 Water Temp Pro v2 were installed. In addition to these sites, 5 Counties operated three more monitoring sites in the vicinity of the project at the three sites described in Monitoring Sites. The results of the 5 Counties monitoring sites are shown in Figure 3-4. Onset Data Loggers - U20L-04 were installed at these sites.

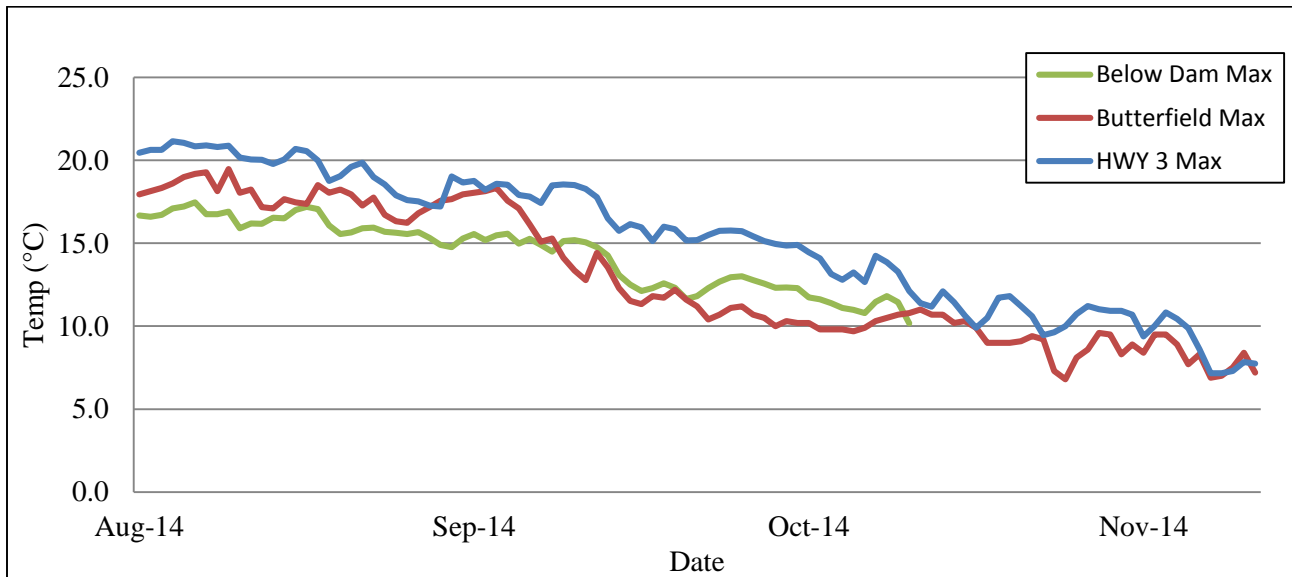


Figure 3-3: Daily maximum water temperature collected between August and November 2014 at three sites below East Weaver Dam.

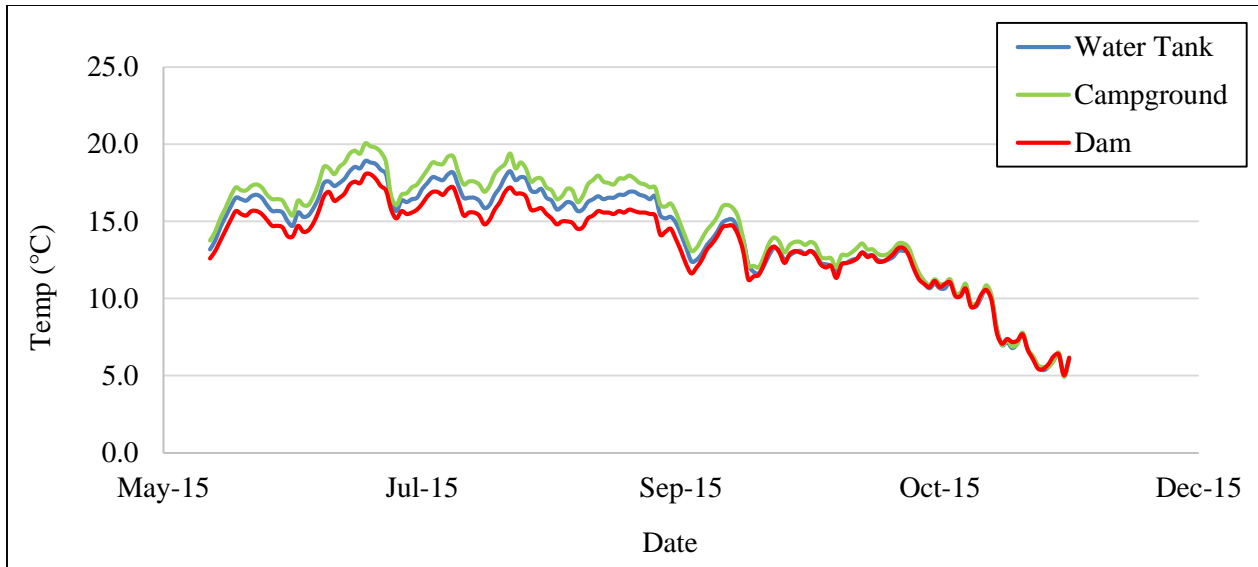


Figure 3-4: Daily maximum water temperature data collected between June and November 2015 for three sites in and around the project reach.

### 3.2.3 Water Temperature, Turbidity and Flow Conclusion

A number of monitoring efforts have been on-going in East Weaver Creek for at least the past 3 years. Redwood Science Lab (RSL) has been monitoring water quality and quantity since 2011 at the Butterfield Bridge stream crossing site (0.75 miles downstream of dam). The Forest Service has been monitoring temperature ~0.5 miles upstream of the dam for the past few years, but records for the summer of 2014 were lost. Data for 2015 has not been obtained yet.

Water temperature was monitored immediately upstream of the dam as well as immediately downstream and ~0.1 mile downstream of the dam site in 2014 and 2015 as part of this project. Water temperatures rise the further downstream of EWD one goes. The temperature rises are due to a number of natural factors (ambient temperature, canopy closure, soils and bedrock color, evapo-transpiration rates, and other factors) as well as human factors (stream diversion). Flow monitoring at the dam site indicates that the stream at the WCSD intake had a low flow of approximately 1.5 cfs in the summer period of 2015 and the WCSD diverted approximately 1 cfs. WCSD records for the EWF facilities and flow monitoring above and below the diversion were consistent, indicating a fairly reliable understanding of the summer water balance in the project reach. It appears that during periods of lowest summer flows (i.e. less than 1.5 cfs) the combination of interstitial flows in the channel substrate and inherent losses in the EWF prevents the WCSD from using more than 1cfs. During higher flows they are able to use up to 2 cfs based on the capacity of the sand filter system.

### 3.3 Reference Reach Surveys

A stream channel reference reach was selected using General Technical Report RM-245- *Stream Channel Reference Sites: An Illustrated Guide to Field Technique* (Harrelson, Rawlins, and Potyond). The reference reach was located ~200' upstream of the EWD and outside of the backwater influence of the dam. A cross section of the reference reach was surveyed to assist in channel design (refer to Figure 5-2). Within the reference reach a pebble count was conducted based on Bevenger and King (1995). A Manning's Roughness Coefficient for the Natural Channel and Flood Plain was determined using Yochom and Bledsoe (2010) *Guide for Flow Resistance Estimation in High-Gradient Streams*.

#### Dam Structure Topographic Survey

The EWD structure was surveyed as part of the overall site survey.

### 3.4 Water Right Search

The WCSD holds a “pre-1914” California water right for its East Weaver Creek diversion and is documented in the CA State Water Resources Control Board’s Electronic Water Rights Information Management System as #S000361\_01. The WCSD has never quantified its diversion under its “senior” water right and does not report its water use to the CA State Water Resources Control Board. Historical and anecdotal evidence exists to suggest that the right is up to 2 cfs in high flows<sup>9</sup>. Changes in state regulations regarding reporting of senior water rights could result in the WCSD reporting diversion rates in the future.

### 3.5 Existing Conditions Plans

Using the data collected, the following plans were developed. These large-size plans are attached to this report and are referenced in other sections of this report.

1. Plan of Study Area (Plate 1): This plan presents the general limits of the study area which are the Easter Weaver Creek watershed upstream of Butterfield Bridge. This plan includes the following planimetric information:
  - stream channel
  - dam structure
  - roads
  - parcel layout
  - 100-year floodplain lines
2. Hydraulic Model Sections and Sediment Sampling. The plan also shows the locations of the reference reach

### 3.6 Downstream Water Utilization

Reference data collected for downstream water use and conservation is addressed in a separate report.

## 4 Historic Resource Assessment

The WCSD completed an Archaeological Records Check with the North East Information Center<sup>10</sup> (**NEIC**) in 1988 as part of a timber harvest operation. The record check reply from the NEIC indicated that the combination of southern aspect, flatter topography, proximity to perennial water, and other recorded historic sites within a mile, makes the project area highly sensitive for possible undiscovered cultural resources.

The NEIC identified one historic site within the WCSD ownership (CA-TRI-1047H). The site is a combination of historic road segment (East Weaver Creek Road) and a telephone line. The road and telephone line were constructed to access several mining claims, ditch tenders cabins and the Weaver Bally Lookout. It is likely that the telephone line was installed as part of the LaGrange Ditch system in the early 1890’s. Remnant ceramic insulators can occasionally be found in standing or downed trees along the old phone line route.

Early Government Land Office maps of Trinity County show that the road was constructed prior to 1883. The road is now a County maintained road.

This project occurs in a portion of an early homestead known as the Day Ranch. The majority of the Day Ranch buildings and artifacts were located in a separate part of the ranch in the East Branch of East

---

<sup>9</sup> The capacity of the EWF sand filtration plant is limited to 2 cfs capability.

<sup>10</sup> Department of Anthropology, California State University Chico



Weaver Creek watershed. There are no physical features of the ranch in the project area, except for a former orchard area. The orchard site was cleared and was bulldozed in 1977 as part of a failed effort to construct a reservoir near the EWD site. Repetitive Arbor Day plantings of the abandoned reservoir site has resulted in a young ponderosa pine stand developing in the field.

As part of the 1988 timber harvest planning, a cultural survey of the area was done by registered professional forester Clarence Rose<sup>11</sup>. That survey effort did not locate any new cultural sites. A phone call with US Forest Service archaeologist Mark Arnold determined that there have been no additional sites recorded on the project area since site CA-TRI-1047H was recorded.

During the course of work for this project an historic era fence segment was observed outside of the project area and on National Forest lands. This fence segment would not be affected by the project and the location was relayed to US Forest Service Archaeologist Mark Arnold. The fence segment was not recorded as a part of this project.

Trinity County Historic Society President Jim French lives in the East Weaver neighborhood and was interviewed about possible historic features of the project area including the Day Ranch. Mr French indicated he was aware of a number of ditches in the area, but was not aware of any farm building or other improvements in the vicinity of the EWD. He indicated that there may be information on the Day Ranch at the J. Jake Jackson Museum.

The project area while being in a sensitive area for potentially unknown cultural sites or features has a low probability for discovery of new features, artifacts, or information. The project area for the EWD would be disturbed is within the 100 year floodplain of East Weaver Creek and flooding would have likely impacted any features or artifacts. Access areas, storage sites, and road segments to be used have been heavily disturbed as a result of historic grading and road building. There is a very low probability that features would remain as a result of these past entries.

At the time of construction funding (as part of the final environmental review for the project) an additional cultural resources survey will be completed either by a professional archaeologist and/or a certified archaeological surveyor if a CalFire project is included in the project.

---

<sup>11</sup> Registered professional foresters that have completed a certified archaeological surveyor course pursuant to 14 CCR Section 949.4 may conduct limited archaeological records, survey and site protection work supporting CalFire regulated projects provided that such work is overseen, reviewed, and approved by a professional CalFire archaeologist.



## 5 Sediment Sampling

### 5.1 Introduction

East Weaver Creek is a high gradient, steep channel flowing out of its headwaters high in the Trinity Alps Wilderness. The steep channel transports large amounts of cobble during high flows. Piles of native material stored along the banks of East Weaver Creek immediately upstream of the dam provides evidence of aggradation of material for several hundred feet upstream of the dam. This area is referred to as a deposition reach. Below the dam, the stream has scoured- exposing intermittent bedrock with small sediment deposits. This zone is referred to as a scour reach. Downstream of the scour reach, the stream channel reach returns to a transport reach, albeit below original channel grade. Figure 5-1 offers a graphical representation of each reach in relation to one another.

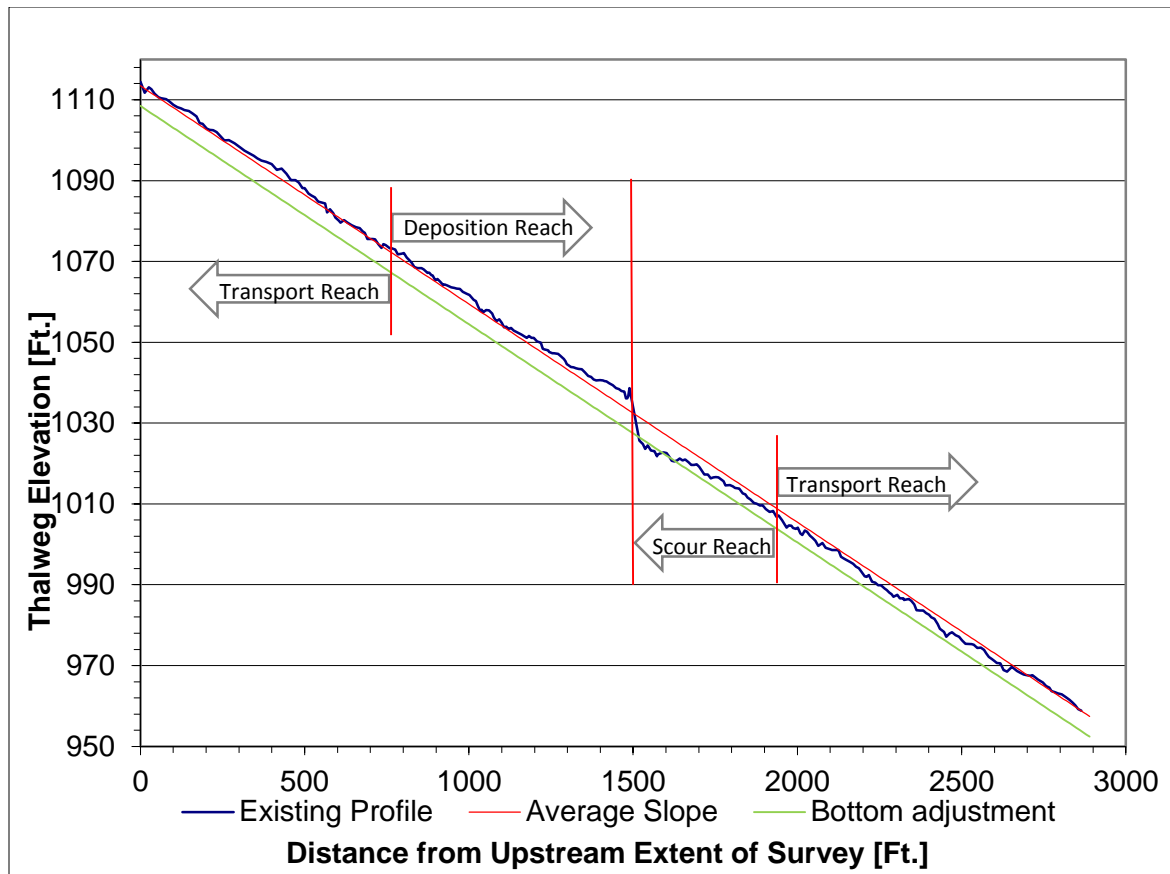


Figure 5-1 Long profile of East Weaver Creek including the average slope, adjustment grade (lowest), and reach description in terms of sediment transport/deposition.

## 5.2 Background

The objectives of the sediment sampling and testing for this Feasibility Study focus on assessing the characteristics of the sediment upstream of the dam.

Specifically, there are two objectives for sediment sampling and testing:

- Physical Testing: Determine the physical characteristics of the materials in the stream channel for use in evaluating the long-term stability of the stream bed if the dam is removed.
- Analytical Testing: Determine if there are any potential pollutants in the sediment that may be present upstream of the two feeder dams. Such data will be used to evaluate sediment management options if sediment is to be removed with the dam removal.

## 5.3 Sampling

A stream channel reference reach was selected using General Technical Report RM-245- *Stream Channel Reference Sites: An Illustrated Guide to Field Technique* (Harrelson, Rawlins, and Potyond). The reference reach was located approximately 200 feet upstream of the EWD and outside of the backwater influence of the dam. A cross section of the reference reach was surveyed to assist in channel design (refer to Figure 5-2). Within the reference reach a pebble count was conducted based on Bevenger and King (1995). Particle size distributions were created for each pebble count- these results are shown in Figure 5-3. A Manning's Roughness Coefficient for the Natural Channel and Flood Plain was determined using Yochom and Bledsoe (2010) *Guide for Flow Resistance Estimation in High-Gradient Streams*.

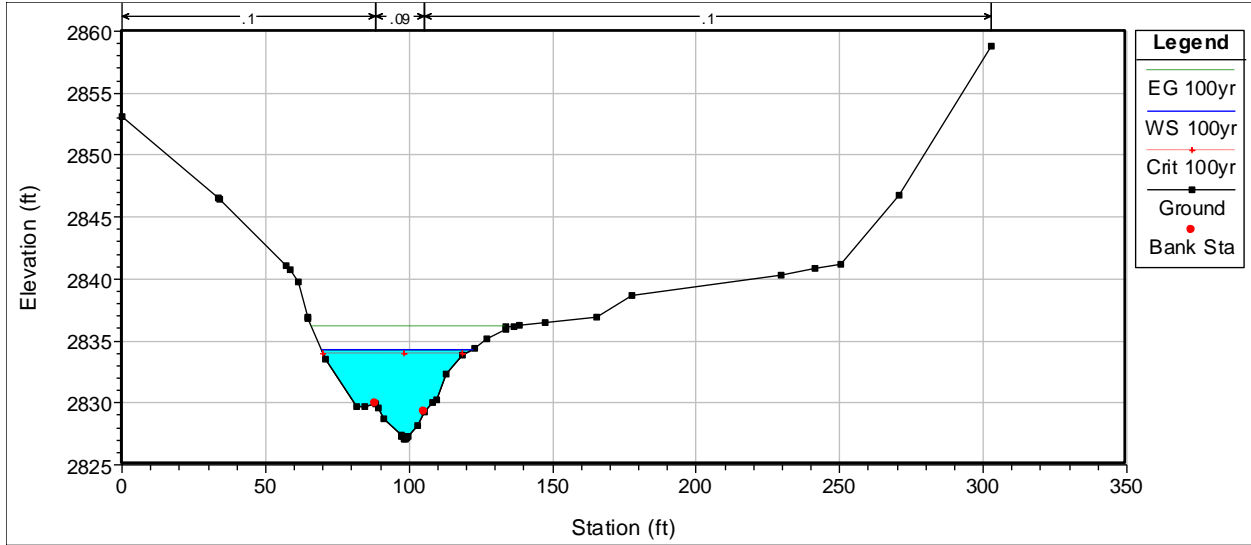


Figure 5-2: Reference reach cross section used for sediment sampling.

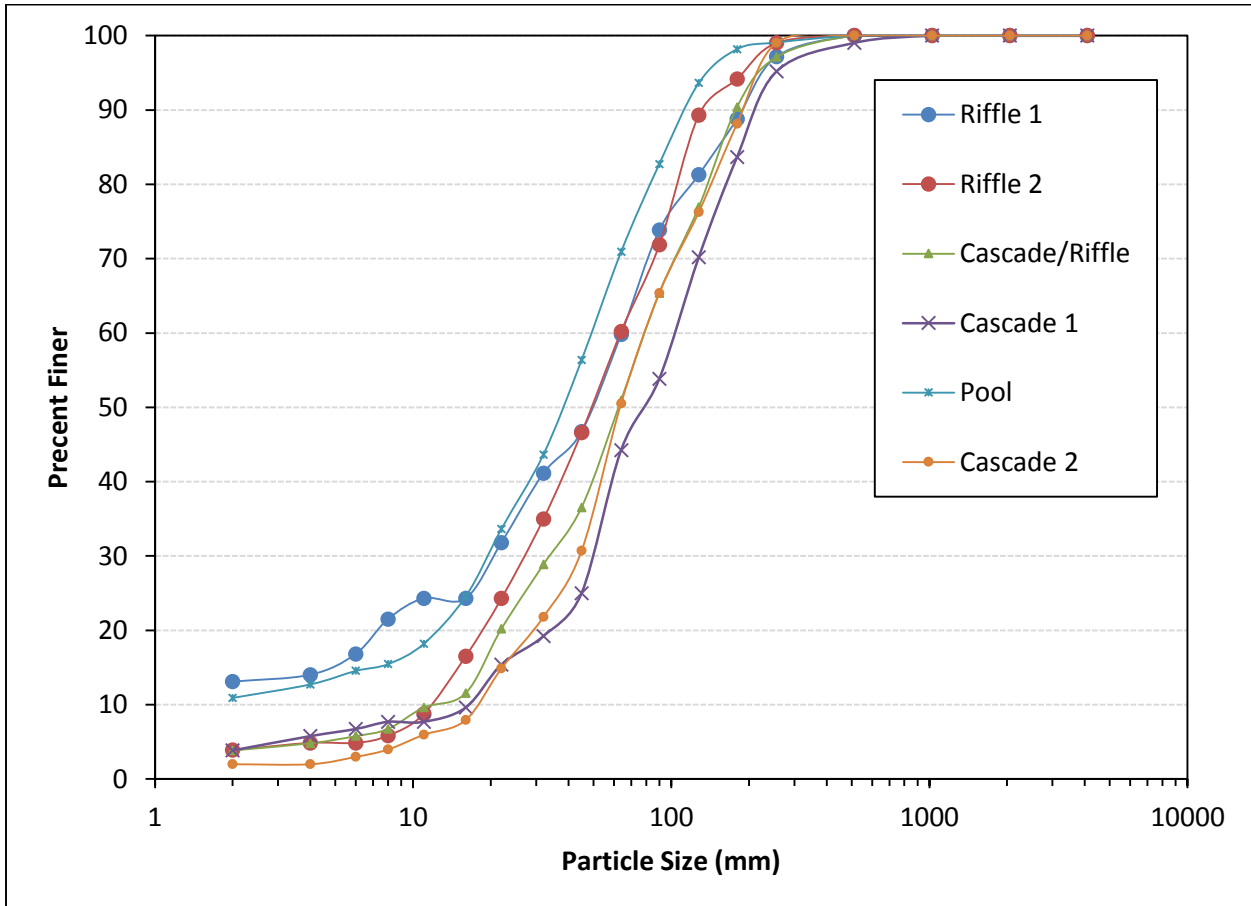


Figure 5-3: Results of six pebble count samples

The results showed that the bed is well-graded gravel and cobbles with some sand and boulders (refer to Table 5-1 for particle size summaries). The visual observations in the stream along with the particle size data indicate that the sediment are generally gravels and cobbles with little fine grained material.

Examination of approximately 100 cubic yards of stored sediments on the river right bank provide a good example of sediment transported in storm flows. This material was removed from the channel at the dam following the 2006 storm flows.

Table 5-1: Particle size and aggregate class descriptions

<b>Particle Size and Aggregate Class Size range (metric)</b>	<b>Size range (approx. inches)</b>	<b>Aggregate name (Wentworth class)</b>	<b>Other names</b>
<b>&gt;256 mm</b>	>10.1 in	<u>Boulder</u>	
<b>64–256 mm</b>	2.5–10.1 in	<u>Cobble</u>	
<b>32–64 mm</b>	1.26–2.5 in	Very coarse gravel	<u>Pebble</u>
<b>16–32 mm</b>	0.63–1.26 in	Coarse gravel	Pebble
<b>8–16 mm</b>	0.31–0.63 in	Medium gravel	Pebble
<b>4–8 mm</b>	0.157–0.31 in	Fine gravel	Pebble
<b>2–4 mm</b>	0.079–0.157 in	Very fine gravel	<u>Granule</u>
<b>1–2 mm</b>	0.039–0.079 in	Very coarse sand	
<b>0.5–1 mm</b>	0.020–0.039 in	Coarse sand	
<b>0.25–0.5 mm</b>	0.010–0.020 in	Medium sand	
<b>125–250 <math>\mu\text{m}</math></b>	0.0049–0.010 in	Fine sand	
<b>62.5–125 <math>\mu\text{m}</math></b>	0.0025–0.0049 in	Very fine sand	
<b>3.9–62.5 <math>\mu\text{m}</math></b>	0.00015–0.0025 in	<u>Silt</u>	<u>Mud</u>
<b>0.98–3.9 <math>\mu\text{m}</math></b>	$3.8 \times 10^{-5}$ – 0.00015 in	<u>Clay</u>	Mud
<b>0.95–977 <u>nm</u></b>	$3.8 \times 10^{-8}$ – $3.8 \times 10^{-5}$ in	<u>Colloid</u>	Mud

It was determined that analytical testing of sediments was not needed for this project. Analytical testing is done to determine contaminants that may be contained in sediments stored behind dams. Several factors contribute to the determination that sampling is not needed:

- 95% of the upstream area is within a designated Wilderness area;
- The remaining 5% of watershed area runoff located upstream of the EWD, but downstream of the Wilderness area, was intercepted and transported downstream of EWD via a man-made ditch (Schofield Ditch channel) that ran parallel to East Weaver Creek and emptied back into the creek downstream of EWD.
- There is less than 0.1 acre of impoundment area behind the EWD and less than 150 yd<sup>3</sup> of stored bedload material within the impoundment area.



## 6 Biological Resources

### 6.1 Fisheries

#### 6.1.1 Fish Presence

The lower 1.5 miles of East Weaver Creek has been monitored for salmon and steelhead for more than 50 years. In 1964, LaFaunce counted 89 steelhead redds. In 1971 Rogers surveyed the same area and found no redds. In 1972 Rogers found 3 redds in the lower 2 miles. Department of Fish and Game biologists Boberg and Kenyon conducted a survey in 1979 and noted the presence of Chinook salmon and steelhead trout among seven fish species in the stream. Ebasco, Inc. conducted a Habitat Assessment of East Weaver Creek in 1992.

USDA Natural Resources Conservation Service fisheries biologist Tim Veil has observed young of the year coho in East Weaver at Horseshoe Lane (pers comm. 2011). California Department of Fish and Game completed steelhead redd surveys in the lower reaches of the stream in 2009 and 2010 and found 2 redds and 8 redds respectively. They did not survey upstream of that reach. The RC&DC staff found an adult steelhead female in 2012 (Figure 6-1). The Forest Service has monitored the upper reaches (East Weaver Campground to the dam) between 2010 and 2015 finding juvenile coho and rainbow trout in this reach each summer (E. Wiseman, personal communication, December 8, 2015).

On July 2, 2015, East Weaver Creek upstream of the dam was snorkel dived for approximately 850 meters (up to the pedestrian trail bridge). Observed aquatic species were rainbow trout (*Oncorhynchus mykiss*) and Pacific giant salamanders (*Dicamptodon tenebrosus*). During the survey a majority of the 3” to 5” long rainbow trout were exhibiting smolt characteristics (K. Yamasaki, 2015 field notes). Trout exhibit physiological changes when juveniles adapt from living in fresh water to living in seawater including altered body shape and increased skin reflectance.



Figure 6-1: An adult steelhead carcass found in the lower portion of East Weaver Creek in 2012.

### 6.1.2 Instream Habitat Assessment

The Forest Service has completed Stream Condition Inventory (**SCI**) assessments of East Weaver Creek above and below the East Weaver Creek Campground in 2002 and 2011. The pebble count data shows a coarsening of the streambed below the diversion at the campground (compared to the same site in 2002) while the site above the diversion remained relatively unchanged (Wiseman, 2015 pers comm).

While the Upper East Weaver SCI site remained fairly stable between 2002 and 2011, the Lower East Weaver SCI site showed an increase in entrenchment evolving from a slightly entrenched channel to a moderately entrenched channel approaching fully entrenched conditions. Besides the increasing entrenchment measured, the width/depth ratio also increased (got smaller) between 2002 and 2011 at the Lower East Weaver SCI site. The width/depth ratio is a key to understanding the distribution of available energy within a channel, and the ability of various discharges occurring within the channel to move sediment. Higher W/D values are indicative of wider and shallower stream channels with lower sheer stress values associated with them, while lower W/D values are indicative of narrower and deeper stream channels with higher sheer stress values associated with them. The empirical evidence for the Lower East Weaver SCI site indicates that the stream channel here is subject to higher sheer stress values due to persistent entrenchment (Wiseman, 2015 pers comm).

### 6.1.3 Large Wood Debris

A component of the SCI is a Large Woody Debris (**LWD**) inventory. The objective of the LWD inventory is to characterize the woody debris influencing the stream channel. This is accomplished by counting all pieces of wood within the SCI reach that has any portion within the bankfull width of the channel and includes logs suspended above the channel. Only those pieces of LWD that are longer than  $\frac{1}{2}$  bankfull width are counted (examples are shown in Figures 6.2 and 6.3).



Figure 6-2: Engineered large wood installed in the lower reaches of East Weaver Creek in November 2014.



Figure 6-3: Engineered large wood installed in the lower reaches of East Weaver Creek in November 2014 during an approximately  $Q_7$  flow in January 2016.

#### 6.1.4 Upper East Weaver Creek SCI: 2002 vs. 2011

In 2002 there were 8 pieces of LWD that met the minimum debris length of 17 feet. In 2011 there were 31 pieces of LWD counted, nearly a 300% increase over the 2002 survey. The 2002 data shows that the diameters of 50% (n=4) of the LWD that met the minimum debris length were small and ~4" to 8" in diameter. The 2011 data shows that the diameters of 61% (n=19) of the LWD that met the minimum debris length were small and ~4" to 8" in diameter. In summary, the 2011 SCI survey showed a marked increase in the numbers of LWD counted but that most pieces for both the 2002 and 2011 SCI's were small diameter logs. The most plausible explanation for the increases in LWD counted within the Upper East Weaver Creek SCI site is most likely due to an increase in recruitment from the surrounding riparian area and not due to changes in the stream channel geometry. (Wiseman, 2015 pers comm.)

#### 6.1.5 Lower East Weaver Creek SCI: 2002 vs. 2011

The data shows that in 2002 there were 57 pieces of LWD that met the minimum debris length of 7 feet compared to only 25 pieces of LWD counted in 2011, a 56% decrease over the 2002 survey. The 2002 data shows that the diameters of 54% (n=31) of the LWD that met the minimum debris length were small (~4" to 8" in diameter). The 2011 data shows that the diameters of 52% (n=13) of the LWD that met the minimum debris length were moderately sized (8" to 16"). The 2002 survey still had more pieces of LWD (n=21) between 8" to 16" in diameter than the 2011 survey (n=13). In 2002 there were no root wads and five wood aggregates (log jams) tallied, which included 21 pieces of wood that met the minimum length requirements. In 2011 there were no aggregates tallied but there were two rootwads noted in the LWD survey. In summary, the 2011 SCI survey showed a marked decrease in the overall numbers of LWD pieces counted including the loss of five wood aggregates that had a total of 21 pieces of suitably sized LWD (Wiseman, 2015 pers comm.)

## 6.2 Wildlife Species

A search of the CA Natural Diversity Database indicates a number of state or federally listed Species of Special Concern, Candidate for Listing, Rare, Threatened or Endangered within a 6 mile radius of the project as shown in Table 6-1-Table 6-3 below.



Table 6-1: Federal and California Threatened, Endangered, and Fully Protected Species excluded from further analysis.

Species	Status		Effects/Rationale
	ESA	CESA	
Western yellow-billed cuckoo ( <i>Coccyzus americanus</i> )	Candidate	Endangered	No effect. No suitable habitat present. Outside known or expected range. No confirmed observations in Trinity County.
Bald eagle ( <i>Haliaeetus leucocephalus</i> )	Delisted	Endangered	No effect. No suitable nesting habitat. No water bodies present that would provide an adequate food supply. Trinity River and Lake are over 6 miles away.
Golden eagle ( <i>Aquila chrysaetos</i> )	N/A	Full Protection	No effect. Not known or expected to occur. No suitable nesting habitat. No large cliffs present.
American peregrine falcon ( <i>Falco peregrinus anatum</i> )	N/A	Full Protection	No effect. Not known or expected to occur. No suitable nesting habitat. No large cliffs present.
Wolverine ( <i>Gulo gulo</i> )	Proposed	Threatened	No effect. Outside known or expected range. This area lacks persistent snow pack through the spring and human disturbance is high.
Trinity bristle snail ( <i>Monadenia setosa</i> )	N/A	Threatened	No effect. Not known or expected to occur. Outside known or expected range. No observations in USFS Database east of Junction City.

The California wildlife list of Species of Special Concern (SSC) was obtained from the California Department of Fish and Wildlife (CDFW), via their website (updated January 2011) and was reviewed to determine if species have potential ranges within or near the Project (Table 6-2 & Table 6-3).

The SSC species included in Table 6-2 either have a distribution range that is outside of the project area or are not known or expected to occur there due to a lack of suitable habitat. They are excluded from further analysis as it has been determined that the proposed project will have no effect on them.

Table 6-2: California Species of Special Concern (SSC) excluded from further analysis.

Species	State Status	Effects/Rationale
Oregon snowshoe hare ( <i>Lepus americanus</i> )	SSC	No effect. Not known or expected to occur. Typically found at higher elevations. No observations in USFS Database in Trinity County.
American badger ( <i>Taxidea taxus</i> )	SSC	No effect. Not known or expected to occur. Outside known or expected range. No observations in USFS Database in Trinity County.
Townsend's big-eared bat ( <i>Corynorhinus townsendii</i> )	SSC	No effect. Not known or expected to occur. No suitable roosting habitat present, such as mines, caves, rock outcrops, or cliffs
Pallid bat ( <i>Antrozous pallidus</i> )	SSC	No effect. Not known or expected to occur. No suitable roosting habitat present, such as mines, caves, rock outcrops, or cliffs.
Cascades frog ( <i>Rana cascadae</i> )	SSC	Standing water is required for reproduction, and typically occurs in waters lacking predatory fish. In addition the project is in the lower elevation range for this species.
Southern torrent salamander ( <i>Rhyacotriton variegatus</i> )	SSC	No effect. Not known or expected to occur. No observations in USFS Database or CNDDB in Trinity County.

Table 6-3: Species of Special Concern (SSC) with the potential for occurrence within or near the project area includes:

Common Name	Scientific Name	State Status
Pacific fisher	( <i>Martes pennanti</i> )	
Ring-tailed cat	<i>Bassariscus astutus</i>	Full Protection
Northern spotted owl	<i>Strix occidentalis caurina</i>	
Northern goshawk	( <i>Accipiter gentilis</i> )	
Willow flycatcher	( <i>Empidonax traillii</i> )	Endangered
Olive-sided flycatcher	<i>Contopus cooperi</i>	SSC
Yellow warbler	<i>Dendroica petechia brewsteri</i>	SSC
Yellow-breasted chat	<i>Icteria virens</i>	SSC

Purple martin	<i>Progne subis</i>	SSC
Pacific tailed frog	<i>(Ascaphus truei)</i>	SSC
Foothill yellow-legged frog	<i>Rana boylei</i>	SSC
Western pond turtle	<i>Emys marmorata</i>	SSC

### 6.2.1 Pacific Fisher

The fisher is associated with mature and late-successional forests exhibiting high canopy closure, large trees and snags, large woody debris, large hardwoods, and multiple canopy layers. This species is also closely tied to drainage bottoms and riparian areas.

Suitable habitat for travel corridors may occur along East Weaver Creek preferring large areas of contiguous interior forest.

The removal of the dam and implementation of the project will have short term impacts to travel, limited to a few weeks during construction. The placement of large wood in the channel would provide limited beneficial habitat elements, but overall the small area affected by the project is not anticipated to result in take of fishers.

### 6.2.2 Ring-tailed cat

Suitable habitat for the ring-tailed cat consists of a mixture of forest and shrubland, in close association with rocky and riparian areas. They are usually found within 0.6 miles of permanent water (Grinnell et al. 1937, Schempf and White 1977). This nocturnal species uses hollow trees, logs, snags, rock recesses, abandoned burrows, and woodrat nests for cover and denning. Young are typically born in May or June (Walker et al. 1968).

Suitable habitat is present for this species. A limited operating period (LOP) from March 1-August 15 will avoid or minimize the potential impacts during the breeding season for ring-tailed cats and most other species addressed in this study. No snags or logs will be removed during this LOP time period, therefore breeding ring-tailed cats will not be affected. The placement of large wood in the channel would provide limited beneficial habitat elements, but overall the small area affected by the project is not anticipated to result in take of ring-tailed cats. The area will remain suitable habitat for ring-tailed cats following project completion.

### 6.2.3 Northern Spotted Owl

The northern spotted owl (NSO) lives in conifer forest habitats. Review of the CA NDDB shows that there are two recorded historic NSO activity centers within ~1.2 miles of the project area. While these sites may not currently be occupied by owls, they indicate the probability of NSO utilization of areas within 1.3 miles of the project. Year over year surveys of suitable NSO habitat have been done for the project area by Sierra Pacific Industries and nest sites and activity centers are well documented. Sierra Pacific Ind. cost shares survey and habitat data and at the time of construction funding (as part of the final environmental review for the project) SPI survey data will be purchased to determine nesting locations, limited operating periods and will be used to prepare a Biological Assessment to assist the USFWS in completing its Biological Opinion.

Under Alternative 1 minimal changes in habitat will occur as no large trees will be removed. Owl surveying and/or limited operating periods will be implemented to avoid disturbance to nesting pairs.

Under Alternative 2 approximately 0.2 acres of suitable roosting habitat will be affected with the tipping over of approximately 10-20 small to large (4"-24" diameter) trees with root wads. These trees will be used to create root wad/LWD habitat in the stream channel. Given the proximity of the project to the Wilderness area and adjacent National Forest lands, the reduction of ~0.2 acres will likely not result in take of NSO due to loss of habitat.

#### 6.2.4 Northern goshawk

The nearest northern goshawk observation reported in the Forest Service Database is approximately 0.4 mile northeast of the project, on Forest Service land. It is associated with Territory #309 Schofield Ditch which is approximately and was last active in 1993.

Habitat within ¼ mile of the project area was analyzed to determine its suitability for use by the northern goshawk. The project is located within suitable northern goshawk nesting and foraging habitat. Higher quality nesting habitat is located on the opposite (south) side of East Weaver Creek and further upstream (northwest). Depending on the amount of water present at the time of construction, East Weaver Creek noise would likely drown out some of the construction noise.

It is unlikely that northern goshawks would nest within the project area due to its close proximity to East Weaver Road and hiking trails used daily by humans and dogs. This species is highly territorial and typically becomes very vocal and agitated when intruders, including humans, enter their nesting territory. However, due to the presence of suitable habitat, there is potential for this species to nest near the project area. The proposed project could result in short- or long-term indirect effects because it will degrade, downgrade, or remove <0.1 acres of northern goshawk habitat. Noise-generating activities above ambient levels will occur during the construction period, however the incorporated LOP (March 1-August 15), will avoid or minimize any potential impacts to nesting northern goshawks during the breeding season (mid-April through July).

#### 6.2.5 Willow flycatcher

In California, breeding habitat is typically moist meadows with perennial streams; lowland riparian woodlands dominated by willows (*Salix* spp.), primarily in tree form, and cottonwoods (*Populus* spp.); or smaller spring-fed or boggy areas with willow or alders (*Alnus* spp.) (Serena 1982, Harris et al. 1988, Whitfield et al. 1997). Riparian deciduous shrubs or trees, such as willow or alder, are essential elements on Willow Flycatcher territories (Sanders and Flett 1989, Harris et al. 1988). In mountain meadows, willow thickets interspersed with open space are typically utilized, while large, contiguous willow thickets are avoided (Ibid). However, in lowland riverine habitats, contiguous willow thickets are used, possibly because the linear nature of these areas provide sufficient edge and/or the tree-like willows typically found in these areas provide sufficient openings within the willow canopy (Harris 1991, R. Wilson, pers. comm.).

While this project may remove an occasional alder or cottonwood, this would only be done where equipment limitations prevent avoidance. The project is in a relatively low elevation area that is not breeding habitat for willow flycatchers. The LOP will protect migrating birds moving upslope to suitable breeding habitat in the Trinity Alps Wilderness.

#### 6.2.6 Olive-sided flycatcher

The olive-sided flycatcher occurs in a wide variety of forest and woodland habitats, however, breeding typically occurs in late-successional conifer forests with open canopies (e.g., 0%–39% canopy cover; Verner 1980). This species is mostly associated with edges, openings, and natural and human-created clearings in otherwise relatively dense forests (Altman and Sallabanks 2000).

Nests are most commonly found in large coniferous trees that are alive (Altman 1998), and this species typically uses short-needled conifers [e.g., Douglas-fir (*Pseudotsuga menziesii*)] more frequently than long-needled trees (e.g., ponderosa pine) (Kotliar and Clouse 2000). Lofty perches, which are usually the apical tips of snags or uppermost branches of the tallest trees in the area, are important for singing and foraging (Grinnell and Miller 1944). Breeding locations range from sea level to timberline but usually are at mid to high elevations (3018–6988 ft); Altman and Sallabanks 2000).

The olive-sided flycatcher breeding season in California extends from early May to late August (Bent 1942, Altman and Sallabanks 2000). The peak of egg-laying is in June and incubation lasts about 14 days. Nestlings fledge 15-19 days after hatching (Bent 1942). This species typically departs its breeding area in August, migrating to Central or South America for the winter. The LOP will protect nesting habitats and allow birds to fledge before operations occur.

Under Alternative 1 minimal changes in habitat will occur as no large trees will be removed. Under Alternative 2 approximately 0.2 acres of suitable habitat will be affected with the tipping over of approximately 10-20 small to large (4"-24" diameter) trees with root wads. These trees will be used to create root wad/LWD habitat in the stream channel. Given the proximity of the project to the Wilderness area and adjacent National Forest lands, the reduction of ~0.2 acres will likely not result in take of olive-sided flycatcher due to loss of habitat.

#### 6.2.7 Yellow warbler

The yellow warbler generally occupies riparian vegetation in close proximity to water along streams and in wet meadows (Lowther et al. 1999). Throughout their range, they are found in willows (*Salix* spp.) and cottonwoods (*Populus* spp.), and in northern California, willow cover and Oregon ash (*Fraxinus latifolia*) are important predictors of high yellow warbler abundance (Alexander 1999). Although breeding typically occurs in riparian woodlands, it can also occur in montane chaparral, and in open ponderosa pine and mixed conifer habitats with substantial amounts of brush.

The yellow warbler breeds from mid-April to late July, with peak activity in June (Dunn and Garrett 1997). Eggs are incubated for 11 days and nestlings fledge after 9-12 days (Harrison 1978). Most members of this species have left California by October.

Surveys have not been conducted for this species; however the nearest yellow warbler observation reported in the Forest Service Database is approximately 18 miles west of the project, near the Trinity River in Big Bar. There is limited suitable nesting habitat along East Weaver Creek.

This species typically departs its breeding area in July or early August. The LOP will protect nesting habitats and allow birds to fledge before operations occur.

Under Alternative 1 minimal changes in habitat will occur as no large trees will be removed. Under Alternative 2 approximately 0.2 acres of suitable habitat will be affected with the tipping over of approximately 10-20 small to large (4"-24" diameter) trees with root wads. These trees will be used to create root wad/LWD habitat in the stream channel. Given the proximity of the project to the Wilderness area and adjacent National Forest lands, the reduction of ~0.2 acres will likely not result in take of yellow warbler due to loss of habitat.

#### 6.2.8 Yellow-Breasted Chat

During the breeding season, the yellow-breasted chat occupies early successional riparian habitats with a well-developed shrub layer and an open canopy (Eckerle and Thompson 2001). This species is typically found near water, and nesting habitat is usually restricted to the narrow border of streams, creeks, sloughs,

and rivers. Blackberry (*Rubus* spp.), wild grape (*Vitis* spp.), willow, and other plants that form dense thickets and tangles are frequently selected as nesting strata (Grinnell and Miller 1944). Taller trees, such as cottonwood (*Populus* spp.) and alder (*Alnus* spp.), are required for song perches (Dunn and Garrett 1997).

This species usually arrives on its breeding grounds in April and departs by late September for wintering grounds in Mexico and Guatemala (Gaines 1977). Breeding occurs from early May to early August, with peak egg laying in June (Ehrlich et al. 1988). Incubation lasts for 11-15 days and chicks fledge 8-11 days after hatching (Harrison 1978).

Surveys have not been conducted for this species; however the nearest yellow-breasted chat observation reported in the Forest Service Database is approximately 18 miles west of the project, near the Trinity River in Big Bar. There is limited suitable nesting habitat along East Weaver Creek.

This species typically fledges its young in July or early August. The LOP will protect nesting habitats and allow birds to fledge before operations occur.

Under Alternative 1 minimal changes in habitat will occur as no large trees will be removed. Under Alternative 2 approximately 0.2 acres of suitable habitat will be affected with the tipping over of approximately 10-20 small to large (4"-24" diameter) trees with root wads. These trees will be used to create root wad/LWD habitat in the stream channel. Given the proximity of the project to the Wilderness area and adjacent National Forest lands and the implementation of the LOP the reduction of ~0.2 acres will likely not result in take of yellow warbler due to loss of habitat.

### 6.2.9 Purple martin

The Purple martin breeds in a wide variety of habitats, however suitable nesting cavities must be present. This species is typically found in open areas where old, tall, large diameter trees occur. They are also typically found near bodies of water (Grinnell and Miller 1944). This species of swallow is one of the largest cavity nesters in California, requiring cavities with relatively large entrances. Over 70% of the purple martins in California nest in large conifer snags, although other natural and man-made structures, including bridges and rarely nest boxes, have been reported (Grinnell and Miller 1944, Lund 1978). In one study, the average diameter at breast height (DBH) of 17 nesting snags was 47 inches and the average snag height was 80 ft. Nest cavities are typically located within the top 15 feet of the snag (Williams 1998).

In California, purple martins begin arriving at their breeding grounds in March and may continue to arrive through mid-May (Williams 1998). Egg laying typically begins in April or May (Williams 1998). The incubation period typically lasts for 15 days, and hatched nestlings are usually in the nest for about 28 days before fledging (Brown 1997). Purple martins begin to depart their nesting sites within a few days of fledging, usually in late July (Williams 1998).

Surveys have not been conducted for this species but there is suitable purple martin habitat present. There have been no purple martin observations in Trinity County reported in the CNDDDB or the Forest Database, therefore it is unlikely that this species would occur here. There are several large snags within the project area with visible cavities that could potentially be used by purple martin for nesting. The LOP will be implemented such that no trees (including snags) will be removed during this time period.

Under Alternative 1 minimal changes in habitat will occur as no large trees will be removed. Under Alternative 2 approximately 0.2 acres of suitable habitat will be affected with the tipping over of approximately 10-20 small to large (4"-24" diameter) trees with root wads. These trees will be used to

create root wad/LWD habitat in the stream channel. Given the proximity of the project to the Wilderness area and adjacent National Forest lands and the implementation of the LOP the reduction of ~0.2 acres will likely not result in take of purple martins due to loss of habitat.

#### 6.2.10 Pacific Tailed Frog

The nearest Pacific tailed frog observation reported in the CNDDDB is 0.5 miles southeast (downstream) of the project area, in East Weaver Creek, just downstream of the campground. An unknown number of individuals were observed on September 9, 1963.

Habitat within the project area was analyzed to determine its suitability for use by the Pacific tailed frog. The project is not located within suitable Pacific tailed frog habitat, however East Weaver Creek is considered suitable for this species.

Permanent water is critical because the aquatic larvae require 1 to 4 years to transform. This species is nocturnal, spending days under submerged rocks and logs within the stream. At night, movements away from water are rare except during wet periods such as during or just after a rain. The project includes a Limited Operating Period (LOP), restricting work to the dry season. The project includes specific Resource Protection and Conservation Measures and Best Management Practices (BMPs) to minimize effects to fish, aquatic and terrestrial wildlife, plants, water quality and soils. BMPs will control potential runoff and erosion at the project site. This would benefit the Pacific tailed frog over the long term. In conclusion, the proposed action will have no effect on the Pacific tailed frog.

#### 6.2.11 Foothill yellow-legged frog

The foothill yellow-legged frog is a highly aquatic amphibian, spending most or all of its life in or near streams (Seltenrich and Pool 2002) using pools, riffles and runs in rivers and tributary streams. Foothill yellow-legged frog habitat includes clean water, gravel and cobble substrates and lush riparian vegetation. Adults are found along the mainstem of rivers during spring when they are breeding in pools and then return to basking and foraging sites at stream tributaries. Between mid-April and late June, depending on local water conditions, egg masses are deposited on the downstream side of cobbles and boulders over which a relatively thin, gentle flow of water exists (Seltenrich and Pool 2002). Metamorphosis of tadpoles takes three to four months, with completion occurring between late July and early September. Juvenile frogs tend to migrate to upstream tributaries in late summer and early fall. High flows and seasonal flooding from storm events and dam releases can wash egg masses downstream (Zeiner et al 1990). Suitable foothill yellow legged frog habitat occurs along East Weaver Creek.

Preventive measures including relocation of aquatic dependent species during construction are included in the project design. While the project may impact individual foothill yellow-legged frogs not captured during relocation efforts, it would not cause a trend towards federal listing or a loss of viability. The potential impact to the foothill yellow-legged is so small as to be discountable.

#### 6.2.12 Western pond turtle

The Western pond turtle occurs in a variety of habitat types associated with permanent or nearly permanent water (Holland 1991) and is often concentrated in low flow regions of rivers and creeks, such as side channels and backwater areas. They prefer habitats with large areas for cover (logs, algae, vegetation) and basking sites (boulders or other substrates) and have been observed to avoid areas of open water lacking these habitat features (Holland 1994). The species typically inhabits permanent water bodies and adjacent mud banks. However, female pond turtles often climb hillsides, sometimes moving 1,500 feet or more from the stream side to nest during the spring or early summer (Holland 1991, Zeiner et al. 1990).

Nesting occurs in upland habitats consisting of dry grassy areas with a predominantly south or southwest aspect and including appropriate soils, thermal conditions, and basking sites. Nest sites typically occur in open areas dominated by grasses or herbaceous annuals on dry, well-drained soils with high clay/silt content and low (less than 15%) slope (Holland 1994). Nests are constructed four inches below ground in moist areas in sandy to very hard soil types. Nests and burrows are usually found in undisturbed areas of duff or mud. Nesting benches are usually located on flat benches on the banks of rivers in close proximity to rearing habitat (shallow water and riparian vegetation). Eggs are laid from March to August, and take 73 to 80 days to incubate. Turtles leave the water in late September and spend the winter in burrows up to 500 feet away from the stream (Holland 1991, Zeiner et al. 1990).

During field investigations, habitat within 1/4 mile of the project was analyzed to determine its suitability for use by Western pond turtles. Perennial water sources, including East Weaver Creek provide suitable habitat.

Preventive measures including relocation of aquatic dependent species during construction are included in the project design. While the project may impact individual western pond turtles not captured during relocation efforts, it would not cause a trend towards federal listing or a loss of viability. The potential impact to the northwestern pond turtle is so small as to be discountable.

### 6.3 Botanical Resources

A botanical reconnaissance was completed by the Trinity County Resource Conservation District staff botanist in the summer of 2015. The inventory did not identify any populations of state or federally listed plant species in the project area or along East Weaver Creek for 0.5 miles upstream.

The CA NDDDB lists populations of English peak greenbrier (*Smilax jamesii*), a California Rare Plant Rank 1B.3 ranked species, within 1.3 miles but none were found within the survey area. English peak greenbrier grows in moist areas such as lakesides and streambanks in mountain coniferous forest habitat. This is a rhizomatous perennial herb taking the form of a vine, climbing and branching to maximum lengths of 2 to 3 meters. The dark green leaves have blades up to 8 centimeters long by 7 wide, triangular to pointed oval in shape. There are numerous tendrils. The mature fruit is a blue berry just under a centimeter wide which turns maroon in color as it dries.

### 6.4 Invasive Species

Dam removal activities have the potential to result in producing environmental conditions favorable for invasive plant species. These conditions may arise by two different means. First, by its very nature, a dam removal project is not unlike other construction projects which result in earth disturbance, intentional and inadvertent vegetation removal, exposure of the ground surface to sunlight and higher ambient temperatures, and the transport of seeds and plant fragments from one area to another.

The Trinity County RCD in its botanical survey of the project site identified several non-native invasive species and recommended actions will be incorporated in the final design and contract stage of the project.

### 6.5 Infrastructure

There are no infrastructure/developments downstream of the project for 0.5 miles. The East Weaver Creek Campground and WCSD sand filtration building are the first downstream improvements, but they are located on a terrace well outside of the 100 year floodplain. Downstream of the campground there are



two homes that would appear to be outside of the 100 year floodplain<sup>12</sup> but possibly within the 500 year floodplain. No analysis of effect was done for these homes as they are outside of the 100 year floodplain of the stream.

There are five bridges within 1.1 miles downstream of the project area: East Weaver Pedestrian (Figure 10-2), Hansen Mine Road (Figure 10-3), Butterfield Private Road (Figure 10-4), Butterfield Pedestrian (Figure 10-6), and Bonar Private Road (Figure 10-8).

There are five additional bridges on East Weaver Creek downstream of East Weaver Creek Road, four public and one on private (Highway 3, Squires Lane (private), Lance Gulch Road, Browns Ranch Road, and Highway 299). All except Highway 3 span or nearly span the Q<sub>100</sub> floodplain of East Weaver Creek (FEMA, 2010) and all five are deemed far enough downstream to not be significantly affected by this project.

While there are approximately five structures within the Q<sub>100</sub> year floodplain downstream of the Highway 3 crossing, they are located in the outer floodplains areas (Squires Avenue, Browns Ranch Road area) subject to slow water and ponding where large wood transport would not occur. Downstream of these reaches is a floodway (levee) that would not be affected by this project.

Downstream of East Branch of East Weaver Creek this project will not adversely affect flood conditions as the contributory watersheds are sufficiently sized to activate large wood movement well in advance (i.e. lower flows) of mobilization of engineered large wood structures. Any at risk infrastructure will have already been affected by naturally occurring large wood movement in the stream system before engineered wood would begin moving.

While all homes within the assessment area are served by the WCSD, there are an unknown number of individual water diversions in East Weaver Creek serving individual parcels downstream of the East Weaver Campground. There is the potential concern that sediment could become mobilized during dam removal which could impact the quality of the pumped water. This water is untreated and not used for domestic consumption and is typically used only during the low flow season. The project will incorporate diversion and bypass systems to de-water the channel in the construction reach, minimizing the potential for construction related sediment mobilization in the period that water is being pumped. East Weaver Creek is sufficiently turbid during even small storm flows and owners do not pump in these periods. Any short term sediment and turbidity during the first flush period will occur during higher flows when pumps are not operating.

## 6.6 Recreational Usage

A community forest trail (Day Ranch Trail) runs parallel to the creek throughout the project area. The trail is well used by pedestrians, horseback riders and mountain bikers. A series of mountain bike races, including nationally renowned races, occur on this trail. The East Weaver Creek Road also accesses a trailhead for the Trinity Alps Wilderness. Downstream from the project approximately 0.5 miles is the East Weaver Creek Campground, a ten site campground that receives moderate use, primarily in summer.

During any construction portions of the Day Ranch Trail will need to be closed or rerouted. The project will not impact the campground or other recreation activities.

---

<sup>12</sup> The FIRM floodplain maps for East Weaver Creek do not extend upstream of Weaverville Airport, but both homes were constructed after 1990 and were required to either be outside of the 100 year floodplain or be a minimum of 1 foot above the 100 year floodplain.

## 6.7 Other Socio-Economic and Political Issues

The 5C acknowledges that any project in this area will have impacts to residents of the East Weaver Creek neighborhood. These impacts include: traffic delays, dust, wear on roads, and noise. For these reasons, the 5C recommends the alternative that minimizes construction duration and intensity while also achieving the design objectives (improving community water infrastructure and improving fish/sediment passage).

The downstream communities of the EWD are likely to have concerns that should the dam be removed the stream would experience changes which may impact their residents, bridges, roads, and/or summer water systems.



## 7 DAM REMOVAL ALTERNATIVES

Three alternatives for dam removal are described in this section. Alternative-1 (Dam Removal and Channel Rehab) aims to restore the form of the stream thereby restoring the natural function of the stream. Conversely, Alternative-2 (Multiphase Removal) and Alternative-3 (Single-phase Dam Removal) aim to restore the function of the stream thereby restoring the form of the stream through natural processes.

During construction (under any alternative) stream flow would be routed both into the WCSD intake and excess/bypass flows around the construction site via the Schofield Ditch runoff channel. At the lower end of the former Schofield Gulch channel piping and a coffer dam will be installed to carry channel flow below the project reach. Fish exclusion fencing and aquatic species relocation would be done at part of the de-watering effort.

The new EWF intake structure will be constructed approximately 270 feet upstream of the current intake to allow WCSD greater flexibility in future system upgrades. The intake will consist of a diversion above one weir and returned above the next rock weir. From this diversion, water will be metered by an adjustable gate and conveyed via a conduit to the EWF. The diversion channel will be designed to convey the entirety of flows during periods of low water and maintain fish passage for juveniles and would have an approved fish screen system in place.

## 7.1 ALTERNATIVE 1 Dam Removal and Channel Rehab

Alternative-1 consists of dam removal and setting the channel grade at 5.8% extending 280 feet upstream (to the Forest Service property boundary) and 200 feet downstream of the current dam crest. The current grade for this same reach is a similar 5.7% but has an 18' jump at the dam site. The channel upstream of the dam will be cut to achieve this grade while the downstream portion will be filled. The grade will be tied into the existing channel elevation 200 feet below the crest of the dam. At the completion of the project there will be an approximate 2' jump or cascade at the upstream terminus of work. This jump will create a headcut that will supply sediment to downstream scoured reaches, providing material needed to rebuild the channel in those areas. A longitudinal view of this alternative is shown in Figure 7-1.

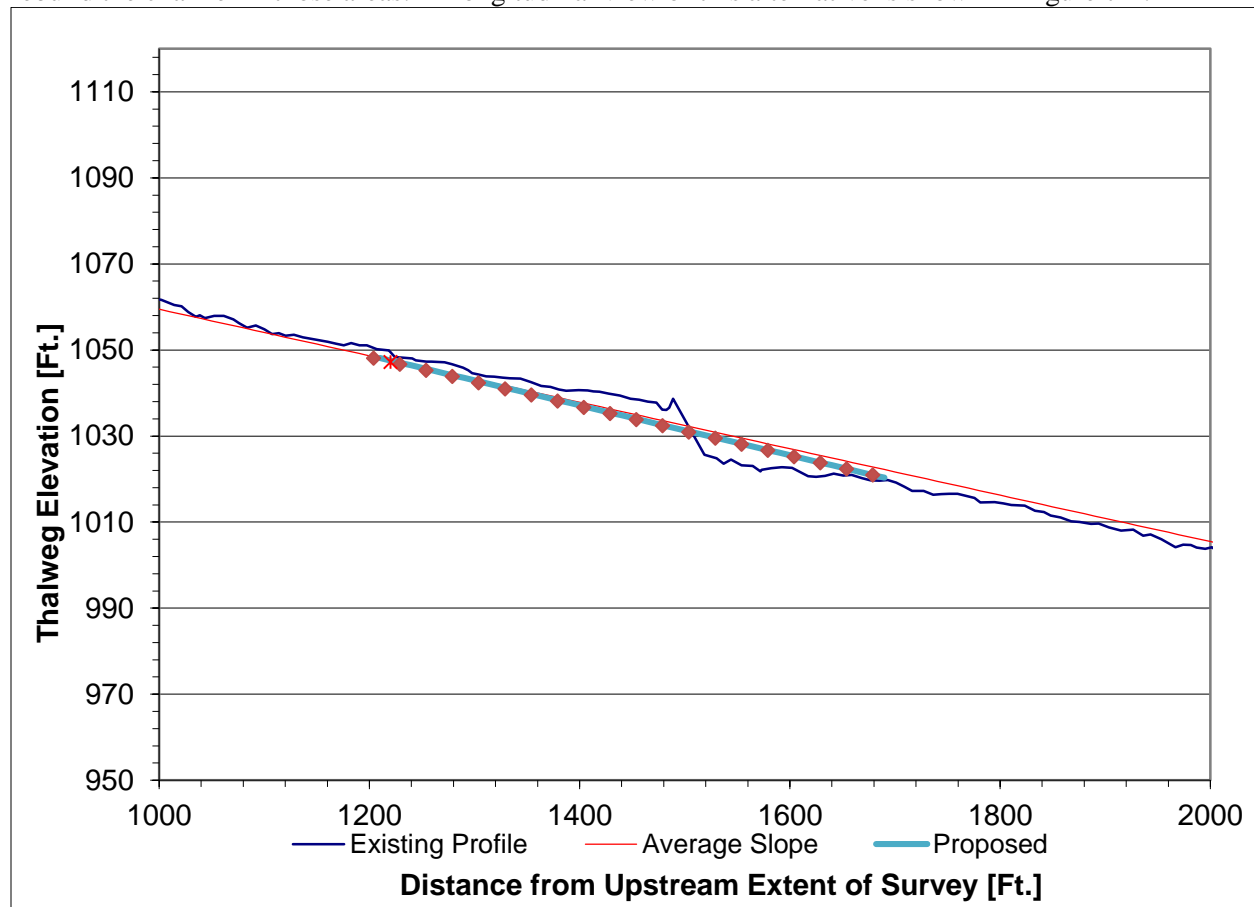


Figure 7-1: Longitudinal view of Alternative-1, dam removal and channel rehab, showing the existing, average, and proposed grade as well as rock weir and intake locations.

The long term channel adjustment (which could occur in a single large flow event or over a long period of smaller events) will contribute approximately 550 yd<sup>3</sup> of bedload material to the channel. This material will contribute to the scoured reaches below the dam, including near the Butterfield Road Bridge and downstream.

A series of 20 grade control rock ribbons would be installed at 25 foot intervals throughout the 480-foot reach. The intermediate areas between the rock weirs will include a scour pool followed by a 15 foot long section of roughened channel. Figure 7-2 shows the plan view of a typical rock weir. Figure 9-4 and Figure 9-5 show typical cross sections for curved reaches and straight reaches respectively. The boulders used for the rock weirs and larger pieces of the roughened channel (D<sub>84</sub>-D<sub>100</sub>) will be sized according to Bates et al 2003, and based on the ACOE rip rap equations (Army Corps of Engineers 1994). The channel bed would be compacted utilizing a mix of mechanical and water jetting methods. For more information

regarding the engineered streambed material refer to Section 9.2. Stream banks downstream of the dam site would not be altered while banks within 100' upstream of the dam site upstream would be reconstructed to a 1:5 slope where possible.

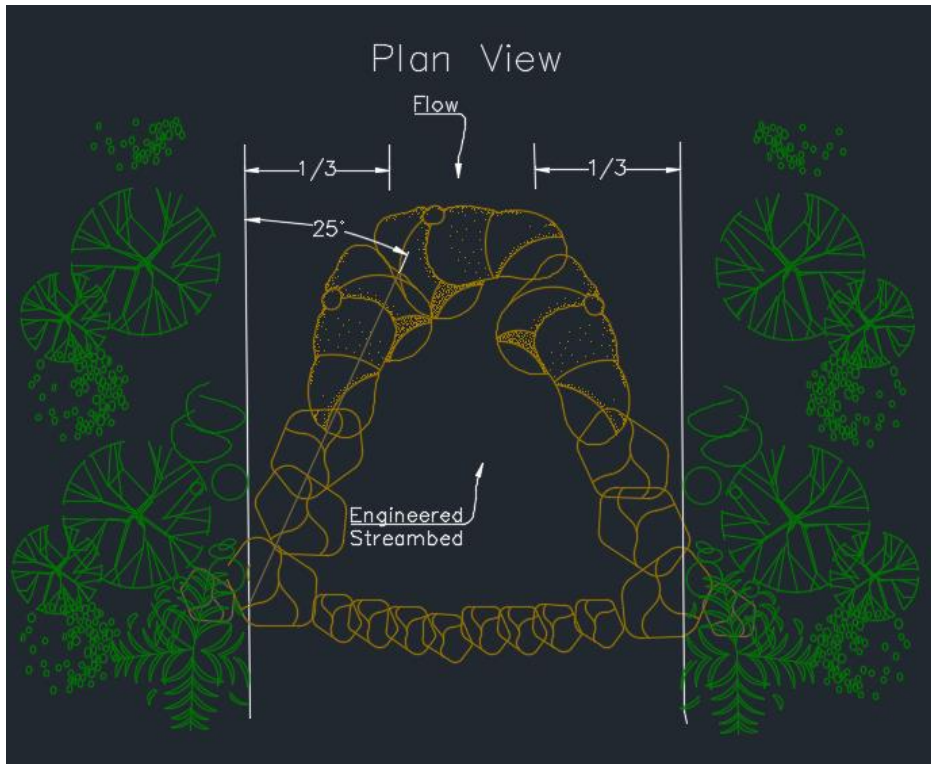


Figure 7-2: Plan view of typical Rock U-weir

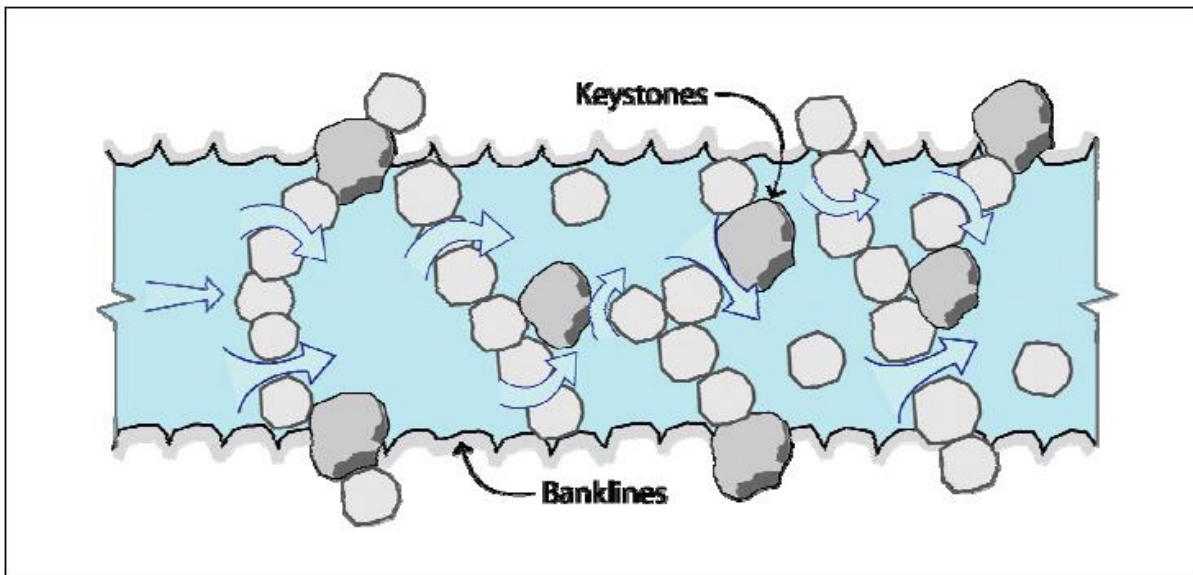


Figure 7-3: the roughened channel portion of the channel rehab will resemble a cascade morphology creating a series of steps at low flows and a rough cascade during higher flow (Love and Bates 2009).

### 7.1.1 Construction

Once the channel is dewatered, bedload materials will be repositioned via a trail cut into the channel to allow loaders to transport materials from excessive sediment reaches upstream, to sediment starved reaches downstream. Two similar projects have been designed and constructed in the Weaver Creek watershed (Little Browns Creek at Roundy Road and Sidney Gulch at Bally Loop Road) in the past decade. These projects have provided valuable knowledge in designing channel reconstruction projects in this stream system. Figure 7-4 through Figure 7-11 illustrate the type of construction practices utilized under this alternative.



Figure 7-4: A section of Little Browns Creek dewatered, aggraded materials removed and excavation below the channel grade in order to install streambed materials and grade control structures. The excavation provided mechanical access to the stream reach.



Figure 7-5: Installation of stream bed materials.



Figure 7-6: Construction of grade control veins into the banks and below channel grade (note: grade control boulders and willow plantings materials in background).



Figure 7-7: Grade control veins are buried every 25' and the channel bottom bedload materials in place (final jetting and washing fines has not been done at this stage).



Figure 7-8: Willow mattresses before soil is added to them.



Figure 7-9: Willow walls and bed



Figure 7-10: Channel with grade structures buried and channel bottom before final jetting.



Figure 7-11: First year channel flows

## 7.2 ALTERNATIVE 2 Multiphase Removal

Removal of the dam under this alternative will occur in a series of phases (Figure 7-12) and rely on natural channel forming processes over time. Similar to the previous alternative, the first phase will be relocating the intake structure 270 feet upstream of the dam crest.

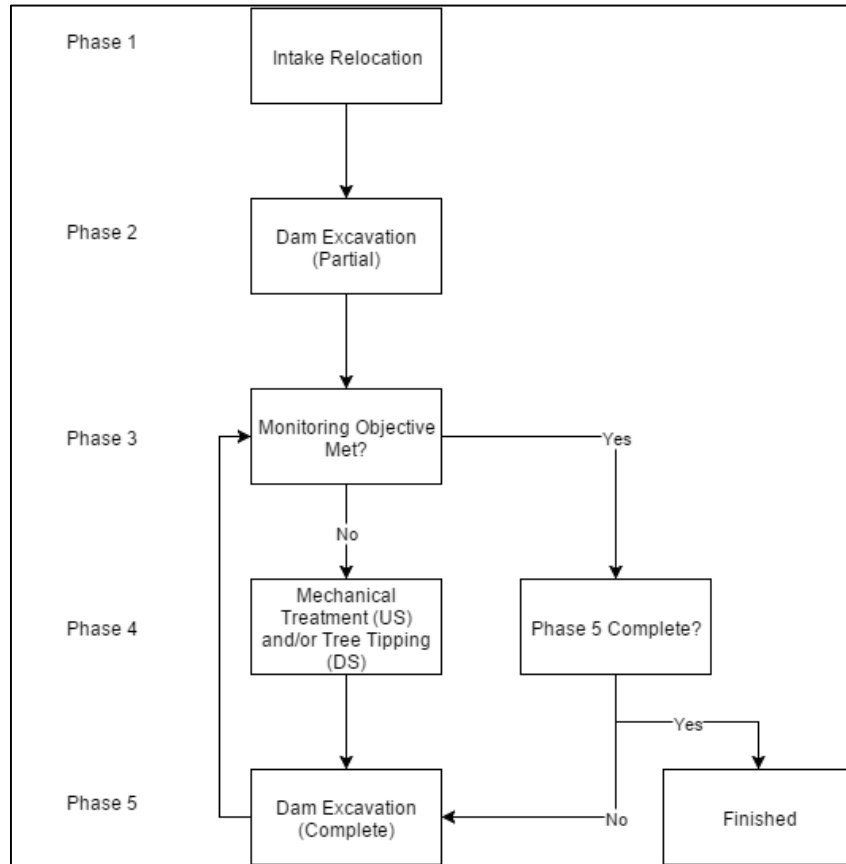


Figure 7-12: Multiphase dam removal flow chart.

The second phase of this alternative is to remove a portion of the dam and fill the scour pool. The removed portion of the dam will be approximately six feet in depth and span the width of the dam crest and wing walls. This will result in lower shear stress in the channel downstream of the dam, which will result in sediment deposition.

The third phase of this alternative takes place the following spring and will include channel elevation monitoring upstream and downstream of the dam. If downstream sediment deposition is not satisfactory at the edge of the scour/transport interface, sediment retention methods will be the next phase (4). If upstream sediment processes result in a barrier forming above the dam crest mechanical removal of the barrier will be included in the next phase (4). Otherwise, if channel response in both the upstream and downstream directions is satisfactory, complete dam removal will be the next phase (5).



Phase four- Downstream, if required, will include the addition of a downstream roughened channel and rock-weirs at the scour/transport interface. Below the rock-weir tree tipping<sup>13</sup> will be implemented to ensure a jump does not form below the weir.

Natural pieces of wood provide a variety of ecosystem functions in streams including habitat, organic matter retention, increased hyporheic exchange and transient storage, and enhanced hydraulic and geomorphic heterogeneity. Tree tipping can be used to rebuild scoured channels in lieu of or to accentuate natural wood recruitment. Under this alternative engineered wood structures would be placed to remain stable in  $>Q_{50}$  flows. Wood mobilization under natural conditions is a complex function of both mechanical factors (burial, length ratio, bracing, rootwad presence, draft ratio) and hydraulic factors (effective depth, downstream force ratio). Designs to retain wood for stream management include partial burial, placement at low effective depths, high length relative to channel width, bracing against other objects (e.g., stream banks, trees, rocks, or larger wood pieces), and rootwad presence (Merten, 2010).

Phase four- Upstream, if required, will remove any present barriers that have formed upstream of the dam after dam removal during the period of channel grade adjustment. The barriers will be removed mechanically using an excavator, and accessed by minimum impact routes.

Phase five- Dam removal completion will include removing the remaining portions of the dam structure and filling any remaining scour pool that may have formed in the time since phase two. At this point, phase three will be repeated.

The process of channel formation can take a few years to a decade depending on flow conditions. Once the dam is removed, channel adjustments (incision) would adjust the upstream channel to the natural 5.7% slope. The process would mimic debris jam formation processes that can locally accelerate or retard channel bed and bank erosion and/or deposition; create sites for significant sediment storage; and produce a stepped channel profile (Keller and Swanson, 2007). This alternative would involve a series of tree and boulder clusters to simulate jam conditions.

Under this alternative significantly more sediment material would be allowed to migrate downstream compared to alternative-1, but much of it would be entrained in the channel reaches that are currently scoured out and within the channel features constructed in phase 4.

### 7.3 ALTERNATIVE 3 Single-phase Dam Removal

This alternative consists of relocating the EWF intake structure 270 feet upstream of the dam crest, dam excavation, and scour pool fill (using the same techniques as discussed in Alternative 1). This alternative would remove the 12' tall boulder and concrete structure and allow head cutting processes to proceed upstream during storm flows. In these flows bedload, sediment and debris would be redistributed downstream in an unconfined condition. Short term flushes of sediment and turbidity would exceed state water quality standards as the channel down-cut and adjusted. The flushes would continue until the channel stabilized which could range from 1-10 years depending on flows.

Similar dam removal methods have been used over the past 10 years in all size of watersheds including small systems like East Weaver Creek (Whites Gulch, Siskiyou County- 2008), moderate sized river systems (Elwha River, Washington- 2012), and similar plan have been proposed for large river systems (Klamath River, Siskiyou County CA).

---

<sup>13</sup>Tree-tipping is a low impact method used to create log jams similar to those found in natural streams

This alternative, while the least expensive, has the most uncertain impacts to downstream channel reaches, the risk of flooding and debris jams to downstream residents and the risk of unanticipated head cutting impacting the intake structure for the EWF.

Downstream of East Weaver Creek campground the floodplain of East Weaver Creek has been straightened and confined by both roads and housing development. One bridge (Butterfield Road) could be impacted by bedload and debris accumulations.

This alternative would allow for significant sediment movement as the channel gradient stabilizes in response to storm flows.

#### 7.4 Alternatives Considered and Rejected for Detailed Analysis

In addition to the alternatives considered one additional alternative was considered and rejected for further consideration:

- 1) Bypass the dam with a fishway located within the former Schofield Gulch stream channel and construct ~500' of new fishway channel back into East Weaver Creek. This ~1,000' long fishway would allow fish to migrate around the EWD. This channel would be set at a maximum 6% grade and a series of 6" jump pools and designed to maintain a sufficient bypass flow in the fishway for year round migration.

This alternative would retain the existing EWD and EWF intake system.

This alternative was rejected because it was felt that maintaining the fishway to allow year round passage would be both expensive and labor intensive. The fishway would not address the dilapidated condition of the dam which ultimately will need maintenance to be maintained. Based on past dam maintenance precedents, there is a likelihood that either CDFW or NMFS would not issue permits necessary to repair the dam. If the dam cannot be maintained it will eventually fail and the resulting channel head-cutting would disrupt the EWF operations. The timing of dam failure could be dependent on storm flows even within a single year. Once the dam fails the effects would be similar to Alternative 4 discussed below.

## 8 Hydrology

This study focuses on the East Weaver Creek watershed (Table 8-1) upstream of East Weaver Dam as well as the 100-year floodplain downstream to Butterfield Bridge. The upstream watershed area is 5.5 mi<sup>2</sup> and elevations range from 7,762 at Monument Peak to 2,500 feet at Butterfield Bridge. Precipitation is a mix of rain and snow with snow tending to accumulate above 5,000 and typically melting out from March-May. In some years rain on snow weather events can result in rapid melt and runoff. The watershed upstream of EWD is undeveloped with 95% being in Wilderness or forest management (Schofield Gulch subwatershed).

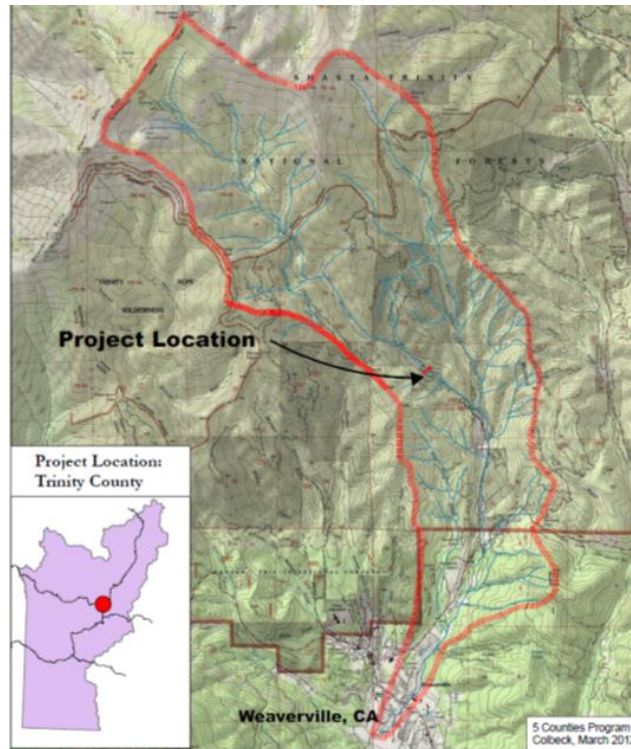


Figure 8-1: Project Assessment Area and East Weaver Creek Dam location.

Basin and climatic characteristics were gathered from the StreamStats web interface- these characteristics are displayed by Table 8-1. The basin characteristics were used to calculate recurrence flows based on the regional regression equations defined by Gotvald et al. (2012) as well as the regression equations given by Waananen and Crippen (1977). The resulting recurrence flows are displayed by Table 8-2.

Table 8-1: Pertinent basin and climatic characteristics of the portion of East Weaver Creek upstream of the Dam site (StreamStats).

<i>Site</i>	<b>Mean Annual Precip. (in)</b>	<b>Average Basin Elevation (ft)</b>	<b>Drainage Area (mi<sup>2</sup>)</b>
<i>East Weaver Creek Dam</i>	52.5	5005	5.5

### 8.1.1 Regression Methodology

The recurrence flows derived from the Gotvald et al 2012 equations are greater in magnitude than the flows derived by Waananen and Crippen 1977 equations. The difference increases with storm frequency, and the sets of regression equations converge near the 100-year return interval. This can be explained by

the data used to create each set of regression equations. Waananen and Crippin used peak discharge data from 1958 to 1973, which included the 1964 flood. Gotvald et al used an additional 30 years of peak discharge data when available and incorporated more robust regionalization and station skew techniques. For these reasons, the flows calculated from the Gotvald et al. (2012) regression equations will be assumed to be more accurate than the recurrence flows calculated from the Waananen and Crippin regression equations.

### 8.1.1.1 Flood Events Investigated

Six simulated events representing a range in flows were modeled and analyzed. These six events include the 2-year, 5-year, 10-year, 25-year, 50-year, and 100-year. For each flood event, the peak water surface elevation, channel velocity, total flow, and channel shear stress in each stream reach was evaluated under the alternatives.

Table 8-2: Summary of recurrence flows calculated from regression equations presented by Gotvald et al. (2012) as well as Waananen and Crippin (1977).

<i>Equation</i>	<b>2-year flow (cfs)</b>	<b>5-year flow (cfs)</b>	<b>10-year flow (cfs)</b>	<b>25-year flow (cfs)</b>	<b>50-year flow (cfs)</b>	<b>100-year flow (cfs)</b>
<i>Gotvald et al. 2012</i>	417	782	1044	1387	1648	1920
<i>Waananen and Crippin, 1977</i>	284	513	754	1090	1510	1900

### 8.1.2 Rush Creek Correlation

The discharge of East Weaver Creek was estimated using a correlation to the flow gage located in the Rush Creek watershed. The basin characteristics, including drainage area, mean annual precipitation, and altitude index, were gathered from StreamStats for East Weaver Creek and Rush Creek. Similarity in basin characteristics (Table 8-3) was used as justification for correlation of discharge.

Table 8-3: Basin characteristics of East Weaver Creek above and Rush Creek (StreamStats).

<i>Watershed</i>	<b>Drainage Area (mi<sup>2</sup>)</b>	<b>Mean Annual Precipitation (in)</b>	<b>Altitude Index (thousand feet)</b>
<i>East Weaver Creek</i>	5.5	52.5	4.19
<i>Rush Creek</i>	9.9	49.6	3.81

The USGS daily discharge of Rush Creek was plotted against the daily discharge of East Weaver Creek measured at Butterfield Bridge by the Redwood Sciences Lab. The discharge of East Weaver Creek at the Butterfield Bridge can be estimated as a function of the reported gage stage height of Rush Creek (White, 2015):

$$EWC = 2.13 * Rush - 3.07$$

Where:

EWC = discharge of East Weaver Creek in cubic meters per second  
 Rush = stage height in feet

The results of this correlation will not be applicable until after the data loggers are downloaded in the spring of 2016.



## 9 Hydraulics

The hydrology portion of the analysis will investigate several flow events- these events will be analyzed in a hydraulic backwater model (HEC-RAS) to evaluate the alternatives effects on channel formation, floodplain elevations, scour potential, bedload designs and large wood designs. The hydraulic model will include 2,100 feet of the existing channel and the channel conditions under alternatives (where appropriate). A separate analysis for five bridges downstream of the survey area is also included.

### 9.1 Water Surface Profiles

The US Army Corps of Engineers (USACE) HEC-RAS Steady Flow backwater model was used to determine downstream water surface elevations during various flood events for the existing condition as well as Alternative-1 (Dam Removal and Channel Rehab). The resulting water surface profile with the dam intact can be seen in Figure 9-1 and the water surface profile for Alternative-1 (dam removal and channel rehab) can be seen in Figure 9-2. The rock-weir and roughened channel combination does not lend itself to 1-D modeling, and the water surface profile is not expected to exactly match what the HEC-RAS generated profile. The model provides an estimate of cross sectional area and channel flow that is important for engineered streambed material calculations and fish passage analysis.

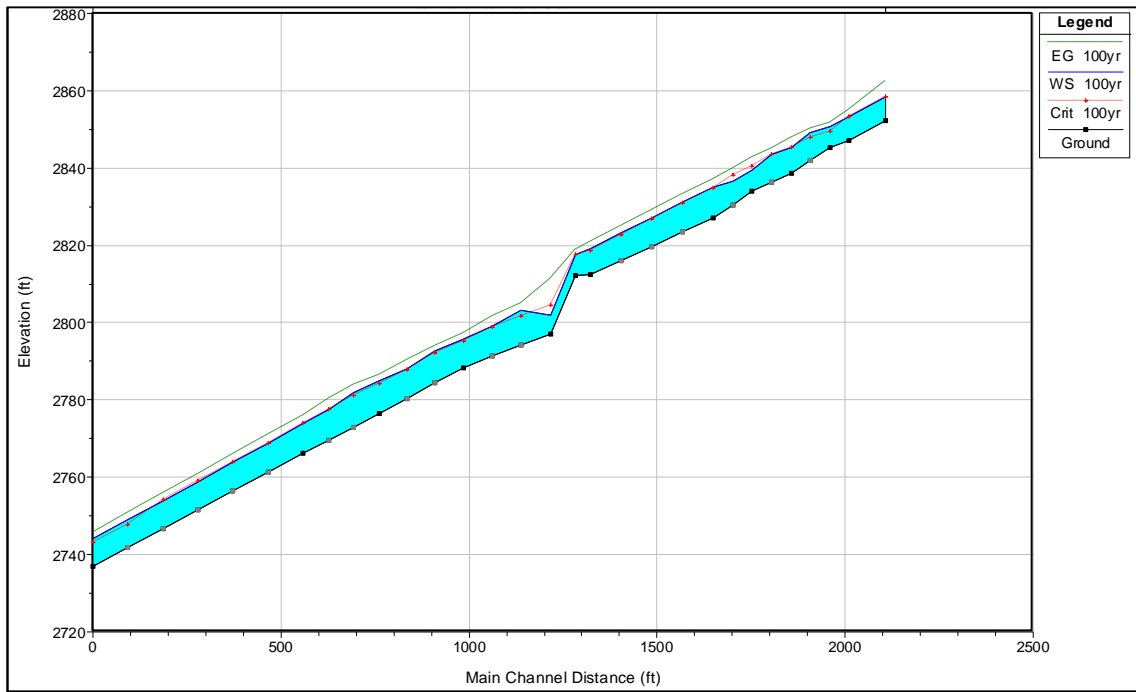


Figure 9-1: Resulting water surface profile from HEC-RAS model under existing conditions during a 100-year flow event.

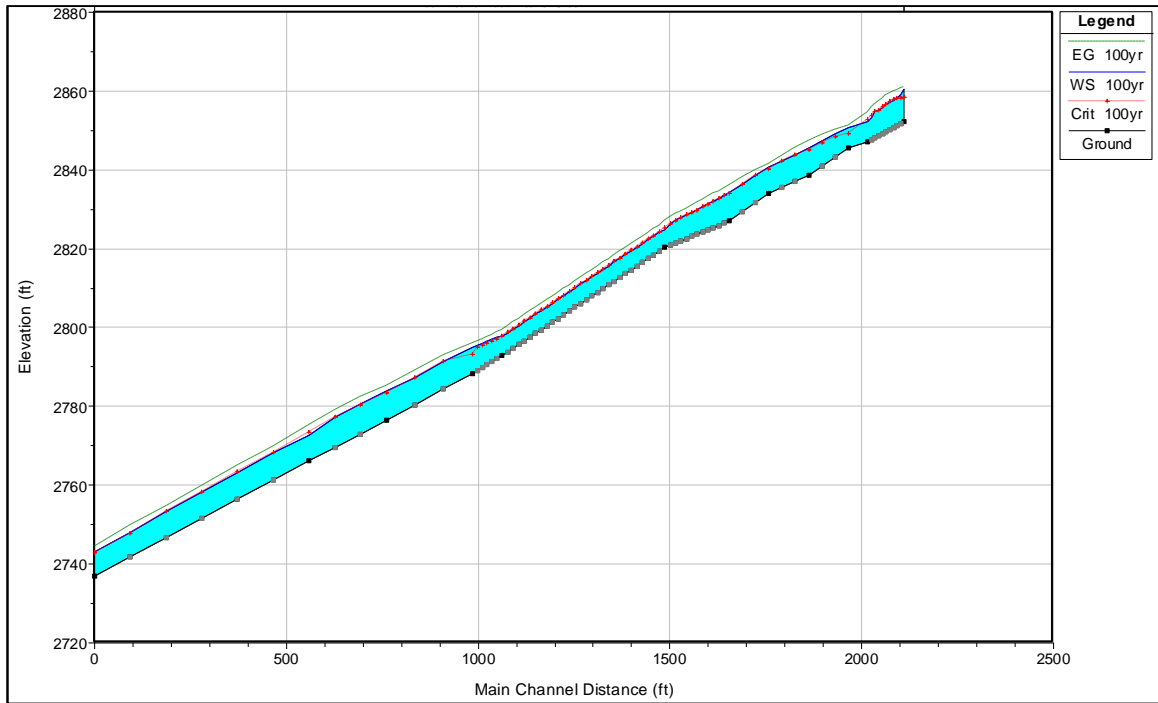


Figure 9-2: Resulting water surface profile from HEC-RAS model under Alternative-1 (Dam Removal and Channel Rehab)

### 9.1.1 Evaluation of Alternatives for Removal of the East Weaver Dam

For each alternative, the peak water surface elevation, channel velocity, total flow, and channel shear stress for a number of stations (cross sections) was compared and evaluated under the flood events discussed above. In all instances there was no noticeable difference in the flood elevations outside of the modified stream channel. Similarities in water surface profiles are caused by changes between subcritical and super critical flow (downstream control to upstream control), which occur in this high gradient stream. The model also showed no significant difference in flood elevations between the action alternatives and the do nothing alternative. The result is not surprising given the minimal impoundment area above EWD.

## 9.2 Roughened Channel Design

Roughened channel design is an iterative process. The process begins by selecting a channel profile and shape to best fit the project objectives. The next requires bed stability analysis, which leads to the gradation of streambed material. At this point, fish passage is assessed. If fish passage is satisfactory, hydraulic transitions are addressed and a final design is created. If fish passage is not satisfactory, changes to channel profile and shape must be made to begin the next iteration of design (Figure 9-3).

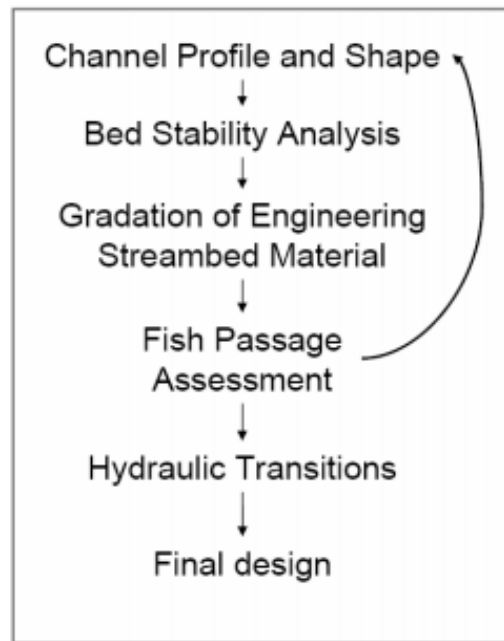


Figure 9-3: Roughened channel design process (Love and Bates 2009)

### 9.2.1 Channel Profile and Shape

Surveying a longitudinal profile through the project site is essential for developing successful channel designs. The RC&DC conducted a topographic survey of the project site and stream channel. The survey included 1,500 feet of channel downstream and 1,500 feet upstream of the dam. There is 18 feet of vertical drop that needs to be accounted for at the dam location.

Each proposed roughened channel slope is 5.7% and is 15 feet in length. This provides a balance between (1) minimizing the length of the roughened channel and (2) maintaining suitable fish passage and bed stability within the constructed channel.

The channel must be stable at the design flow ( $Q_{100}$ ) of 1920 cfs while maintaining fish passage at lower flows. This requires a relatively wide channel to accommodate such large flows at a low enough unit discharge to source suitable  $D_{100}$  boulders that are not disproportionately large in relation to the stream channel. Figure 9-4 and Figure 9-5 show typical cross sections in bending and straight reaches respectively. The active channel is relatively shallow (1.7 feet) to promote flood plain activation during annual storms. Sediment deposits are expected to form behind the  $D_{84}$ - $D_{100}$  rocks in the roughened channel creating confined low flow channels during periods of low. Flow the channel is expected to weave in a series of meanders through the roughened channel as has been observed in past projects.

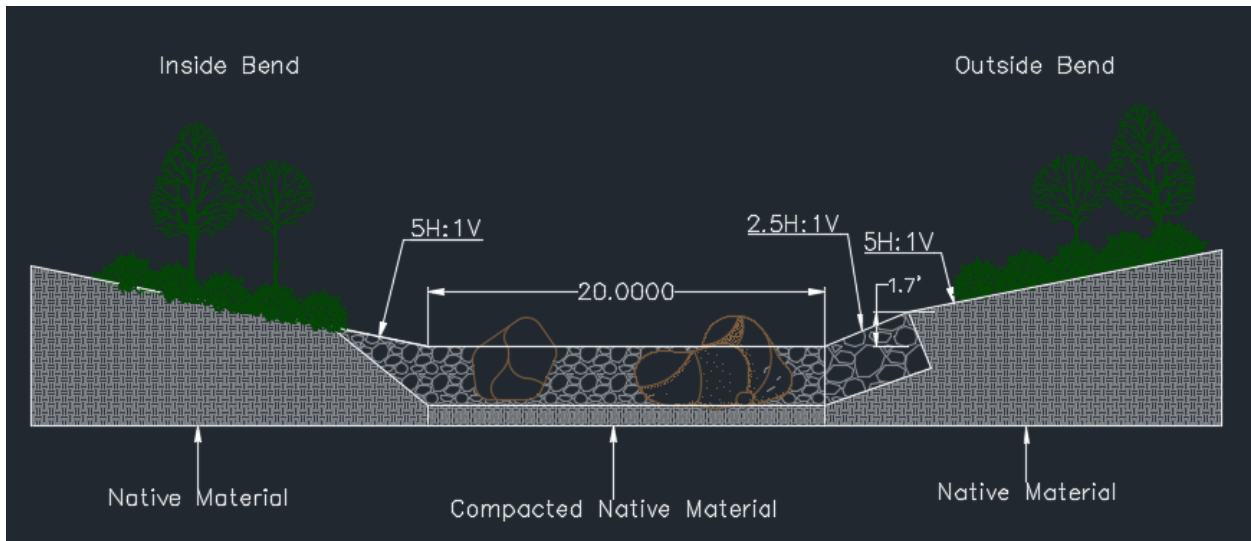


Figure 9-4: Typical roughened channel cross section for curved reaches.

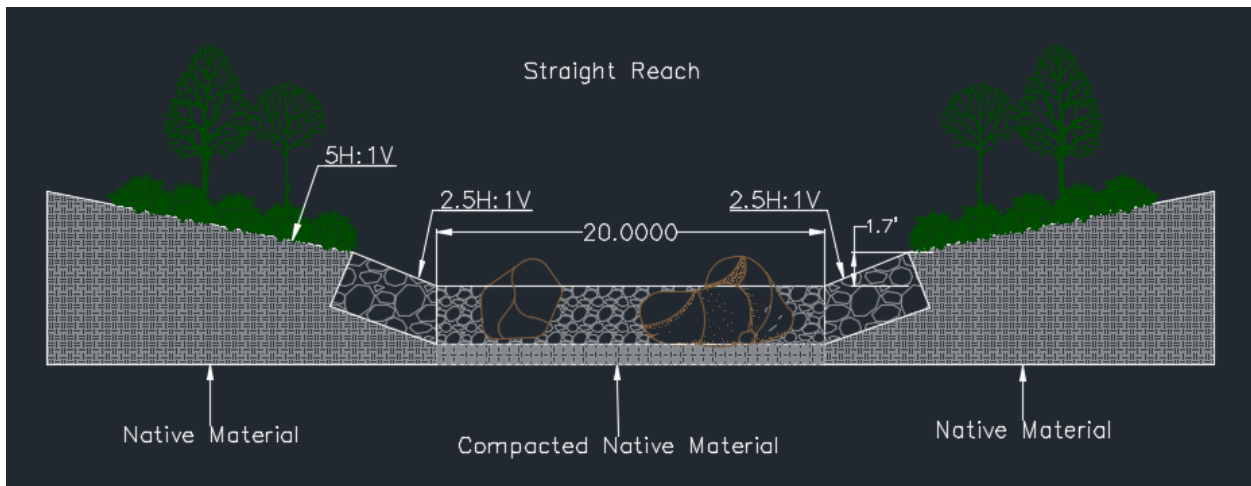


Figure 9-5: Typical roughened channel cross section for straight reaches.

### 9.2.2 Engineered Streambed Material

The stability analysis determines the minimum rock sizing necessary to maintain a stable channel bed and banks during a particular peak flow event. For this analysis, we used the 100-year peak flow of 1920 cfs. No explicit design equations or regulatory criteria exist specifically for roughened channel designs, but there are generally accepted methods used to determine stable particle sizes. For the analysis the US Army Corps of Engineers Modified Critical Shear Stress Method for Incipient Motion for the  $D_{30}$  particle (ACOE, 1994) was used. Calculating  $D_{30}$  (ACOE) requires use of unit discharge- unit discharge



was calculated from HEC-RAS model results. Using Bates et al (2003) methodology for calculating particle diameters for roughened channels, the D84, D8, D16, D50, and D100 were determined to define the engineered streambed material to be used in construction of the roughened channel bed. The D100/D84 ratio was decreased from 2.5 to 1.5- common practice for high gradient streams. It is expected that the engineered mixture will stay in place through the design flood with only minor adjustments to channel shape. For the stability analysis, we assumed the water surface slope during the 100-year peak flow would be equal to the overall slope of the roughened channel (5.7%), with the high flow drowning-out individual large boulders.

Based on the stability analysis and channel geometry, the streambed material for the new roughened channel shall be comprised of the distributions presented by Table 9-1 & Figure 9-6. These specifications can be used in combination with gradations of different materials available by local suppliers, and with the existing channel bed, to develop an appropriate mixture for the engineered streambed material.

Table 9-1: Engineered streambed material particle size distribution.

Percent Finer	Diameter (ft)	Diameter (mm)
7	0.01	2
8	0.09	28.20
16	0.25	75.91
50	1.27	386.59
84	3.17	966.47
100	4.76	1449.70

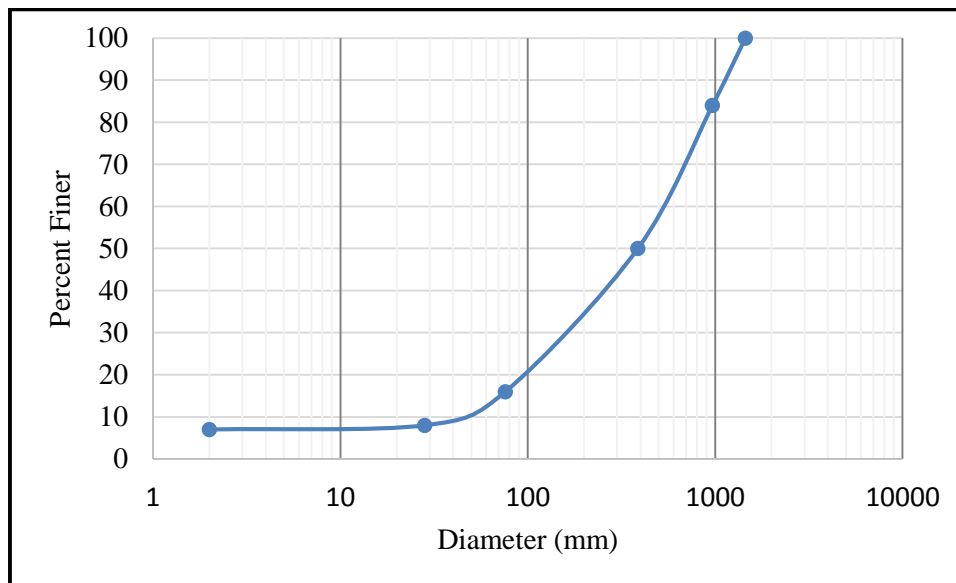


Figure 9-6: Engineered streambed material particle size distribution.

### 9.2.3 Fish Passage Analysis:

The fish passage and stability analysis of the roughened channel (described above) were interrelated, using an iterative process that converged on a final preferred design. The final roughened channel design provides hydraulic conditions that should allow passage of all size classes of salmonids at the same rate the natural stream channel would allow for passage.

The CDFG and NOAA fish passage guidelines prescribe minimum water depths and maximum average water velocities for adult and juvenile fish passage at stream crossings. To provide unimpeded adult and juvenile passage, depth and velocity criteria should be satisfied between the lower and upper fish passage design flows. CDFG and NOAA Fisheries guidelines do recognize that the criteria cannot always be satisfied, and suggest they be applied as a project goal instead of a strict requirement.

Using the Thorne and Zevenbergen equations (1985) to predict roughness coefficients based on particle size, model-predicted water velocities and depths at the upper and lower fish passage design flows are presented in Table 9-2. Based on results from the stability analysis, we used a stable D84 particle of 3.17 feet.

Table 9-2: Minimum water depth and maximum water velocities for salmonids at different life stages.

<b>Species and Life stage</b>	<b>Minimum Water Depth</b>	<b>Max. Water Velocity (distance 60-100 ft)</b>
Juvenile Salmonids	0.50 ft	1 ft/sec
Resident Trout	0.50 ft	3 ft/sec
Adult Salmonids	1.0 ft	4 ft/sec

#### 9.2.3.1 Water Depth

The natural stream channel does not meet the depth criteria given above throughout much of the year. The alternatives presented above closely mimic the natural stream, and fish passage is assumed to be equal to that of the natural channel.

#### 9.2.3.2 Water Velocities

The natural stream channel often exceeds the velocity criteria given in Table 9-2. The alternatives presented above closely mimic the natural stream, and fish passage is assumed to be equal to that of the natural channel.

### 9.3 Conclusion

To provide fish passage equal to that of the natural stream channel, we are proposing a 480 foot long roughened rock channel and rock weir combination similar to a pool and chute morphology. The channel would be constructed at a 5.7% slope, overcoming 18 feet of vertical drop. The channel design is such that a low flow channel is constructed within a 20 foot wide channel with 2.5:1 slopes and streambank slopes of 5:1. The bed of the roughened rock channel is an engineered mixture of different rock sizes intended to be stable up to the 100-year flow of 1920 cfs and provides sufficient roughness and complexity to provide for passage of fish and other aquatic species. The streambanks will be stabilized with bioengineering techniques in critical stream meander locations that will eventually also create shade and more complex habitat for aquatic species.

# 10 Sediment Transport and Channel Stability

Changes in sediment transport conditions due to the alternatives were analyzed based on the results of the steady HEC-RAS simulations, other surveys and empirical observations.

## 10.1 Steady HEC-RAS Simulation Results

### 10.1.1 Channel Shear Stress

The existing condition creates very large shear stress at the base of the dam and downstream reach with values ranging from 42.74 lb/ft<sup>2</sup> during a 2 year event to 97.06 lb/ft<sup>2</sup> during a 100 year event. Above the dam shear stress values range from 11.28 lb/ft<sup>2</sup> during a 2 year event to 26.07 lb/ft<sup>2</sup> during a 50 year event. After completion of Alternative-1 (dam removal and channel rehab), shear stress values range from 8.43 lb/ft<sup>2</sup> during a 2 year event to 19.07 lb/ft<sup>2</sup> during a 100 year event. Table 10-1 presents a summary of shear stress values generated by the HEC-RAS model. In general, the alternative provides a continuous reach with shear stress values that allow for natural sediment deposition, mobilization, and transport of sediments entering the reach from the upstream watershed.

Table 10-1: Summary of channel shear stress generated from HEC-RAS model of the existing conditions and Alternative-1 (dam removal and channel rehab) for all storms investigated in the hydrology study.

Freq.	Shear Stress (lb/ft <sup>2</sup> )				
	Existing Condition		Alternative-1		
	Above Dam	Below Dam	Above	Middle	Below
2yr	11.28	42.74	8.46	8.43	9.13
5yr	15.09	56.07	11.86	11.84	12.05
10yr	16.26	65.8	13.81	13.8	13.72
25yr	19.15	68.5	15.89	15.89	17.5
50yr	26.07	59.71	16.36	17.26	18.34
100yr	14.36	97.06	17.33	19.07	17.25

### 10.1.2 Channel Velocity

The existing condition creates very large average channel velocities at the base of the dam and downstream reach with values ranging from 14.65 ft/s during a 2 year event to 25.67 ft/s during a 100 year event. Above the dam average channel velocities range from 5.03 ft/s during a 2 year event to 12.07 ft/s during a 50 year event. After completion of Alternative-1 (dam removal and channel rehab), average channel velocity values range from 6.86 ft/s during a 2 year event to 12.00 ft/s during a 100 year event. Table 10-2 presents a summary of average channel velocity values generated by the HEC-RAS model. In general, the alternative provides a continuous reach with average channel velocity values that are similar to stream reaches that are outside the influence of the dam.

Table 10-2: Summary of channel shear stress generated from HEC-RAS model of the existing conditions and Alternative-1 (dam removal and channel rehab) for all storms investigated in the hydrology study.

Freq.	Average Channel Velocity (ft/s)				
	Existing		Alt 1		
	Above Dam	Below Dam	Above	Middle	Below
2yr	5.03	14.65	6.95	6.86	7.56
5yr	6.71	17.95	8.73	8.60	9.20
10yr	9.30	20.01	9.57	9.52	10.04
25yr	10.15	21.14	10.47	10.47	11.58
50yr	12.07	20.37	11.05	11.07	12.00
100yr	11.65	25.67	11.69	11.76	11.81

Both shear stress and average channel velocities are improved by completion of Alternative-1 (Dam Removal and Channel Rehab). Alternative-2 (Multiphase Dam Removal) and Alternative-3 (Single-phase Dam Removal) are expected to have similar effects; however the effects will take time to materialize as natural stream processes reshape the channel.

## 10.2 Long-Term Streambed Stability

Stage-discharge rating curves were evaluated in order to understand the long term stability of the study area. It is important to evaluate sedimentation in the channels, since excessive sedimentation may lead to increased flood heights and potential for downstream flooding.

A change in the stage-discharge relationship for a channel is a good indication of a response to a disturbance, such as an increase or decrease in sediment. For instance, if the stage elevation in a channel for a particular discharge has a downward trend, it is possible that the channel-bed elevation may be declining with time because of sediment erosion. Similarly, the stage elevation in a channel for a particular discharge may rise due to sediment deposition. If there are no observable trends in the rating curves, it is likely that the sediment load in the channel is stable.

### 10.2.1 Channel Stability Indications

Examination of the streambed downstream and upstream of the EWD was done to locate grade structures that can be indicators of grade control. Both hardpan and bedrock were observed downstream of EWD with a compressed grey clay layer of the Weaverville Formation exposed immediately below the dam and extending ~200'. The scour reach ends at a large rock recruitment reach. At this point the creek cuts through a boulder glacial or slide deposit consisting of a matrix of clay and rocks ranging up to 3.5' in diameter. A large number of 1.5' to 3' diameter<sup>14</sup> rocks form a roughened riffle in the stream from this point downstream for ~200'. Empirical observations of channel conditions in this location demonstrate the effects of this feature. Upstream the channel is scoured to a clay hardpan to the dam, while downstream particle distribution is consistent with reference reach conditions. The roughened riffle acts as an effective grade structure within the channel.

Additional indicators of channel stability are evident from the Forest Service Stream Condition Inventories of two reaches downstream of the project. The inventories in 2002 and 2011 measured changes in the channels. The Lower East Weaver SCI site (downstream of the East Weaver Creek

<sup>14</sup> Rocks 1.5' to 3' in diameter are within the D<sub>95</sub> to D<sub>100+</sub> particle size for this stream

campground) had an increasing entrenchment ratio (2.12 to 1.4) between 2002 and 2011. Ratios of 1-1.4 represent entrenched streams; 1.41-2.2 represent moderately entrenched streams; and ratios greater than 2.2 indicate rivers only slightly entrenched in a well-developed floodplain. Therefore, the Lower East Weaver Creek SCI site evolved from having a channel that was only slightly entrenched at 2.12 to a channel that was 1.43, which is right about at the numerical threshold between moderately entrenched and fully entrenched. Besides the increasing entrenchment ratio, the width/depth ratio also increased between 2002 and 2011. The width/depth ratio is key to understanding the distribution of available energy within a channel, and the ability of various discharges occurring within the channel to move sediment. Higher W/D values are indicative of wider and shallower stream channels and have lower shear stress values associated with them, while lower W/D values are indicative of narrower and deeper stream channels with higher shear stress values associated with them. The empirical evidence for the Lower East Weaver SCI site all indicate that the stream channel here is subject to higher shear stress values due to persistent entrenchment.

In comparison the upper inventory site (near the WCSD water tank) found that the width/depth and entrenchment ratios remained relatively static. Bankfull widths for the 2002 and 2011 surveys were 5.2 and 5.4 meters, respectively further indicating a relatively stable reach.

### 10.2.2 Summary

East Weaver Creek appears to be relatively stable with no appreciable sediment erosion or sediment deposition in the stream channel that would cause any detrimental effects within the stream system. Based on flow data, stream shear stress and velocity assessments; empirical monitoring and observed grade controls (bedrock and boulder reaches) indicate helps to explain the consistent channel gradient for the 3,000' of thalweg surveyed as part of this study. It also suggests that the overall channel gradient is well controlled by large boulders and bedrock.

### 10.3 Bridge Elevation and Channel Flow

There are five bridges within 1.1 miles downstream of the project area: East Weaver Pedestrian (Figure 10-2), Hansen Mine Road (Figure 10-3), Butterfield Private Road (Figure 10-4), Butterfield Pedestrian (Figure 10-6), and Bonar Private Road (Figure 10-8).

While analysis shows that there will be no significant changes in channel shear and velocities under all alternatives (refer to discussion above) an assessment of each bridge crossing was done to estimate the stage discharge (Q) at which channel flows could intersect the bottom beam of each bridge. At these flows large wood could begin to jam against the beam and racking against the bridge could increase the shear stress on the bridge. A survey using a stadia rod and tape was done to determine the Q discharge needed to contact the bottom beam of each bridge. Figure 10-1 shows the cross sectional area for each bridge based on that survey.

A maximum discharge velocity for each crossing was then calculated. The storm Q's were then compared to the storm Q at EWD needed to mobilize naturally occurring large wood stored in the channel/floodplain. The Q for natural wood mobilization (refer to discussion in Section 6 above) was then compared to the design Q needed to mobilize engineered large wood. With these flows it was possible to describe potential bridge effects from wood movement with or without a project.

Table 10-3 shows the surface area, velocity and flows at which point the bottom of the bridge beam contacts the flow. Large wood debris<sup>15</sup> would contact the beam prior to the stream surface contact and racking of material could occur depending on the size of material.

Table 10-3: Storm Discharge to Intersect the Bottom of Beam for Downstream Bridges

Location	Dist to EWD (mi)	Under Bridge Area(ft <sup>2</sup> )	Average Channel Velocity (ft/s)*	Flow At Bottom of Beam (cfs)	Overtopping freq. (yrs)
East Weaver Campground Trail	0.5	192	10.4	2000	100
Hansen Mine Road	0.75	176	11.3	2000	100
Butterfield Pvt Road#	1.1	120	10.4	1390	8
Butterfield Ped. Trail#	1.1	271	11.4	3090	100
Bonner Pvt Road#	1.1	273	11.3	3090	100

\* Mountain streams, no vegetation in channel, banks usually steep, trees and brush along banks submerged at high stages. Channel bottom: cobbles with large boulders (Chow, 1959)

#- East Branch East Weaver Creek flows into East Weaver Creek upstream of this crossing

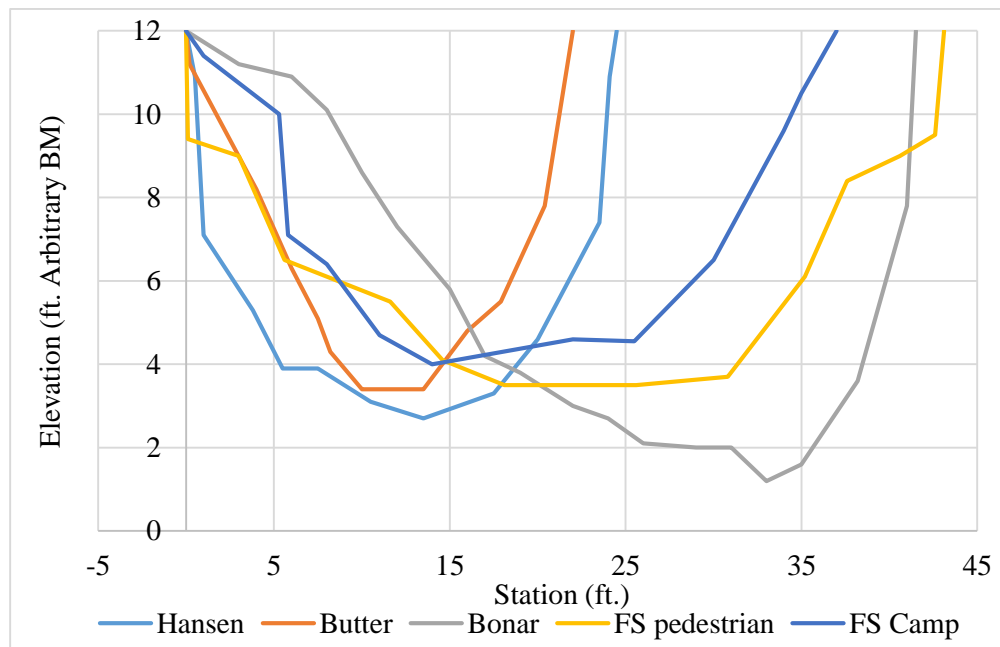


Figure 10-1: The cross section area for bridges within the assessment area.

<sup>15</sup> Large wood debris is defined as logs greater than 10” in diameter and 30’, or long enough to span the Q<sub>2</sub> channel whichever is shorter.



Figure 10-2: East Weaver Campground Pedestrian Bridge Spans the entire floodplain of East Weaver Creek.



Figure 10-3: Hansen Mine Bridge spans the entire floodplain of East Weaver Creek

Downstream of these two bridges, but upstream of the other three bridges, the East Fork of East Weaver Creek joins East Weaver Creek increasing flow substantially.



Figure 10-4: Butterfield Private Road Bridge shown in December 2015 is the most undersized crossing.



Figure 10-5: Butterfield Private Road Bridge in December 2015 (Above Left) and in January 2016 during an estimated Q2-Q4 storm flow.



Figure 10-6: The Butterfield Pedestrian Bridge immediately downstream of the Butterfield Road Bridge in December 2015 and upstream of the Bonar Bridge (note the Bonar Bridge can be seen downstream of this bridge in the photo).

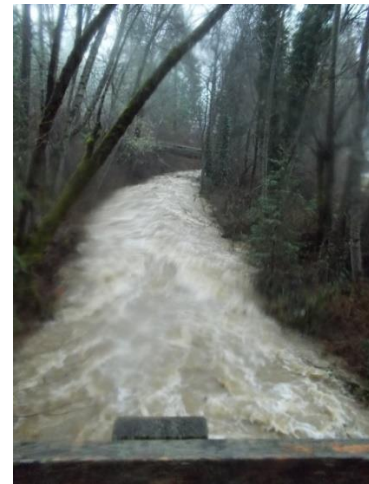


Figure 10-7: Storm flows from Butterfield Pedestrian Bridge in January 2016. The Bonar Bridge is visible.



Figure 10-8: Bonar Private Road Bridge in December 2015.

## 10.4 Conclusions

Based on the sediment transport evaluations and the long-term bed stability analysis, we believe that the proposed alternatives for the dam removal will have minimal effects on the existing stream bed stability and sediment transport characteristics in East Weaver Creek. Specifically, there is minimal change in channel velocities in the study reaches during all storm events under all alternative conditions, and almost no change in channel shear stress observed for all conditions.

The lack of changes in velocity and shear stress within the stream sections also means that structures will not be subject to changes in scouring or structural problems with implementation of Alternative 1.

The evaluation of the effects of large wood movement and downstream impact potential under Alternative 2 focuses on the peak water surface elevations during various storm events since this parameter determines flooding impacts and potential benefits.

The Forest Service SCI inventory found nearly a 300% increase in LWD in 2011 (compared to 2002) for the reach they studied upstream of East Weaver Creek campground. In 2002 there were 8 pieces of LWD but that increased by 23 pieces to a total of 31 in 2011. The inventory indicates that there 40 pieces of LWD per mile of river for this reach. The opposite is true for the reach downstream of the campground where the number of LWD pieces dropped from 57 in 2002 to 25 in 2011. The inventory indicates that there 70 pieces of LWD per mile of river for this reach (dropping from 156 pieces/ river mile). The number of log jams also changed. In the downstream reach there were 5 log jams in 2002 and none in 2011 while in the upstream reach there were no log jams in 2002 and 2 in 2011.

The Upper East Weaver SCI site showed a significant increase in the number of pieces of LWD counted between 2002 and 2011 while the width/depth and entrenchment ratios remained relatively static. The most plausible explanation for the increases in LWD counted within the Upper East Weaver Creek SCI site is most likely due to an increase in recruitment from the surrounding riparian area and not due to changes in the stream channel geometry.

In contrast to the Upper East Weaver SCI site, the Lower East Weaver SCI site showed a significant decrease in the number of pieces of LWD counted between 2002 and 2011. The channel in this reach also



became more entrenched. The empirical evidence for the Lower East Weaver SCI site indicates that the stream channel here is subject to higher shear stress values due to persistent entrenchment. Therefore, the most plausible explanation for the decrease in the amount of LWD counted here is that the wood was mobilized out of the reach by high flows and LWD recruitment did not keep pace with it.

All wood installed under Alternative 2 would be anchored using engineered logjam techniques (Abbe et al. 2003) that will actually retain these structures in place in higher flows than would occur for the natural large wood debris patterns found along East Weaver Creek. The engineered wood would not contribute new wood to the lower reaches where entrenchment increases were noted in the 2011 survey based on the same flows ( $<Q_{10}$ ) that occurred between the 2 survey periods. The increase in wood in the upper reach found in the 2011 survey will continue to route downstream, but may not be sufficiently sized to offset entrenchment in lower reaches of the stream.

The Butterfield Private Road Bridge is at risk of flow and debris stresses at flows that are well below what would be necessary to mobilize any engineered wood structures. There may be both fish passage and bedload routing benefits to replacing this bridge with a structure capable of spanning the 100 year floodplain. While this would not be required as part of this project, the opportunity to work with the landowner could be investigated concurrent with this project.

All other bridges have sufficient clearance to allow mobilized debris to flow pass under the structure, except in all but the most devastating storms.

## 11 Recommended Alternative

The 5 Counties Program recommends Alternative-2 (Multiphase Removal) be implemented to address the issues presented by the current stream condition. Several factors make this alternative more attractive than the others. The cost of this alternative is greater than Alternative-3 (Single-phase Dam Removal), but far less than Alternative-1 (Dam Removal and Channel Rehab). This alternative balances construction impacts to the adjacent riparian zone with desired stream results (fish and sediment passage). The recommended alternative utilizes natural stream processes instead of mechanical processes to create the desired stream function. The recommended alternative provides adaptive management capability that Alternative-3 (Single-phase Dam Removal) is lacking- ensuring improved conditions in the event of barrier formation above the current dam site or sediment deposition failure in the downstream reach. For these reasons, Alternative-2 (Multiphase Removal) is the recommended alternative.

The selected alternative relies on the stream for labor, using natural hydraulics in lieu of excavators and bulldozers where possible to reach the desired stream conditions. This design spreads out impacts over the course of several years- minimizing construction traffic and negative impacts to the residents of the East Weaver neighborhood.

## 12 References

- Abbe, T.B., Pess, G., Montgomery, D.R. and Fetherston, K.L., 2003. Integrating engineered log jam technology into river rehabilitation.
- Alexander, J. D. 1999. Bird-habitat relationships in the Klamath/Siskiyou Mountains. M.S. thesis, Southern Oregon Univ., Ashland.
- Altman, B. 1998. Productivity of the Olive-sided Flycatcher in the Cascade Mountains of northern Oregon: a pilot project to assess nesting success as a potential factor in population declines. Unpublished report submitted to U.S. Fish and Wildlife Service Oregon State Office, Portland, OR.
- Altman, B., and Sallabanks, R. 2000. Olive-sided Flycatcher (*Contopus cooperi*), in *The Birds of North America* (A. Poole and F. Gill, eds.), no. 502. Birds N. Am., Philadelphia.
- Army Corps of Engineers. 1994. "Hydraulic design of flood control channels," Engineer Manual 1110-2-1601, Washington, DC.
- Asarian, J.E. and J.D. Walker, 2016. Long-Term Trends in Streamflow and Precipitation in Northwest California and Southwest Oregon, 1953-2012. JAWRA Journal of the American Water Resources Association:n/a–n/a. doi: 10.1111/1752-1688.12381.
- Bates, K., B. Bernard, B. Heiner, J.P. Klavas, and P.D. Powers. 2003. Design of Road Culverts for Fish Passage. Washington Department of Fish and Wildlife, Olympia, WA.
- Bathurst, J.C. 1978. Flow Resistance of Large-Scale Roughness. *Journal of the Hydraulics Division, A M. Soc. Civil Engr.*, Vol. 104, No. HY12, pp. 1587-1603
- Bent, A. C. 1942. Life histories of North American flycatchers, larks, swallows, and their allies. U.S. Natl. Mus. Bull. 179.
- Bevenger, G.S. and King, R.M., 1995. A pebble count procedure for assessing watershed cumulative effects. *Research paper RM (USA)*.
- Blakesley, J.A., A.B. Franklin, and R.J. Gutierrez. 1992. Spotted owl roost and nest site selection in northwestern California. 1992. *Journal of Wildlife Management*, 56 (2): 388-392.
- Brown, Charles R. 1997. Purple Martin (*Progne subis*). In *The Birds of North America*, No. 287 (A. Poole and F. Gill, eds.). The Academy of Natural Sciences, Philadelphia, PA, and The American Ornithologists' Union, Washington, D.C.
- Brown, Herbert A. et al. 1993. *Amphibians of Washington and Oregon*. Seattle Audubon Society. Seattle, Washington.
- Bunte K and Abt S (2001) Sampling Surface and Subsurface Particle-Size Distributions in Wadable Gravel- and Cobble-Bed Streams for Analyses in Sediment Transport, Hydraulics, and Streambed Monitoring. USDA USFS Rocky Mountain Research Station General Technical Report RMRS-GTR-74

Buskirk, S. G., C. Mullis, A. S. Mossman, I. Show and C. Coolahan. 1994. Habitat ecology of American martens and fishers. In S. W. Buskirk, A. S. Harestad, M. G. Raphael, and R. A. Powell (Eds.), *Martens, sables and fishers: biology and conservation*. Ithaca, NY: Cornell University Press. pp. 368-376

California Natural Diversity Database (CNDDB). December 2013. CNDDB and Spotted Owl Observations Database (BIOS layer ds704). Sacramento, California, USA.

CDFW. 2016. State & Federally Listed Endangered & Threatened Animals in California. January 2016. Available: <http://www.dfg.ca.gov/biogeodata/cnddb/pdfs/TEAnimals.pdf>

Chow, V.T., 1959, *Open-channel hydraulics*: New York, McGraw-Hill, 680 p.

Copeland, J.P., K.S. McKelvey, K.B. Aubry, A. Landa, J. Persson, R.M. Inman, J. Krebs, E. Lofroth, H. Golden, J.R. Squires, A. Magoun, M.K. Schwartz, J. Wilmot, C.L. Copeland, R.E. Yates, I. Kojola, and R. May. 2010. The bioclimatic envelope of the wolverine (*Gulo gulo*): do climatic constraints limit its geographic distribution? *Canadian Journal of Zoology* 88: 233-246.

Courtney, S.P., J.A. Blakesley, R.E. Bigley, Cody, M.L., Dumbacher, J.P., Fleisher, R.C., Franklin, A.B., Franklin J.F., Gutierrez R.J., Marzluff, J.M., and L. Sztukowski. 2004. Scientific evaluation of the status of the northern spotted owl. Sustainable Ecosystems Institute. Portland, OR. September

Dark, S. J. 1997. A landscape-scale analysis of mammalian carnivore distribution and habitat use by fisher. Unpublished Masters Thesis, Humboldt State University, Arcata, CA.

Detrich, P.J. 1980. Pit 3, 4, 5 bald eagle study. USDA, Forest Service, Redding, CA. Unpublished manuscript. 21 pp.

Dunn, J. L., and Garrett, K. L. 1997. *A Field Guide to Warblers of North America*. Houghton Mifflin, Boston.

Eckerle, K. P., and Thompson, C. F. 2001. Yellow-breasted Chat (*Icteria virens*), in *The Birds of North America* (A. Poole and F. Gill, eds.), no. 575. Birds N. Am., Philadelphia.

Ehrlich, P. R., D. S. Dobkin, and D. Wheye. 1988. *The birder's handbook*. Simon and Schuster, New York. 785pp.

Federal Emergency Management Agency. 2010. Flood Insurance Rate Map Panel 06105C1035E

Forsman, E.D., E.C. Meslow, and H.M. Wight. 1984. Distribution and biology of the spotted owl in Oregon. *Wildlife Monographs* 87:1-64.

Fowler, C., B. Valentine, S. Sanders, and M. Stafford. 1991. Habitat Suitability Index Model: Willow Flycatcher (*Empidonax traillii*). USDA Forest Service, Tahoe National Forest.

Gaines, D. 1977. *Birds of the Yosemite Sierra*. California Syllabus, Oakland. 153pp.

Grinnell, J., J. S. Dixon, and J. M. Linsdale. 1937. *Fur-bearing mammals of California*. 2 Vols. Univ. California Press, Berkeley. 777pp.

Grinnell, J., and A. H. Miller. 1944. The distribution of the birds of California. *Pac. Coast Avifauna* No. 27. 608pp.

Harrison, C. 1978. A Field guide to the nests, eggs and nestlings of North American birds. W. Collins Sons and Co., Cleveland, OH. 416pp.

Holland, D.C. 1991. A synopsis of the ecology and status of the western pond turtle (*Clemmys marmorata*) in 1991. Unpublished report prepared for the U.S. Fish and Wildlife Service. 141 pp.

Holland, D.C. 1994. *The western pond turtle: habitat and history*. Portland, OR: U.S. Department of Energy, Bonneville Power Administration.

Hunt, W.G., R.E. Jackman, J.M. Jenkins, C.G. Thelander and R.N. Lehman. 1992. Northward post-fledging migration of California bald eagles. *J. Raptor Res.* 26:19-23.

Jepson Manual: Higher Plants of California" by James C. Hickman, Rudolf Schmid, Taxon, Vol. 42, No. 2 (May, 1993) and updates.

Keller, E. And Swanson, F (2007). Effects of large organic material on channel form and fluvial processes. 2007. DOI: 10.1002/esp.3290040406

Kotliar, N.B. and L.A. Clouse. 2000. Olive-sided Flycatcher nest success in stand-replacement and prescribed-understory burns. Unpublished annual report prepared for U.S. Fish and Wildlife Service, USGS, Fort Collins, CO.

Love, M. and Bates, K., 2009. Part XII: Fish Passage Design and Implementation. California Salmonid.

Lowther, P. E., Celada, C., Klein, N. K., Rimmer, C. C., and Spector, D. A. 1999. Yellow Warbler (*Dendroica petechia*), in *The Birds of North America* (A. Poole and F. Gill, eds.), no. 454. Birds N. Am., Philadelphia.

Merten, E., J. Finlay, L. Johnson, R. Newman, H. Stefan, and B. Vondracek (2010), Factors influencing wood mobilization in streams, *Water Resour. Res.*, 46, W10514, doi:10.1029/2009WR008772.

Mote, P.W. 2003. Trends in snow water equivalent in the Pacific Northwest and their climatic causes. *Geophysical Research Letters* 30(12) 1601, doi:10.1029/2003GL017258, 2003.

Pavel Ya Groisman, Richard W. Knight, David R. Easterling, Thomas R. Karl, Gabriele C. Hegerl, and Vyacheslav N. Razuvaev, 2005: Trends in Intense Precipitation in the Climate Record. *J. Climate*, 18, 1326–1350.

Schempf, P. F., and M. White. 1977. Status of six furbearer populations in the mountains of northern California. U.S. Dep. Agric., For. Serv., San Francisco, Calif. 51pp.

Seltenrich, C.P. and A.C. Pool. 2002. A Standardized Approach for Habitat Assessments and Visual Encounter Surveys for the Foothill Yellow-Legged Frog (*Rana boylei*). Appendix A Foothill Yellow-Legged Frog (*Rana boylei*): Life History and Habitat Information. Technical Report for Pacific Gas and Electric Company. May 2002.

Verner, J. 1980. Bird communities of mixed-conifer forests of the Sierra Nevada, in *Management of western forests and grasslands for nongame birds* (R. M. DeGraff, tech. coord.), pp. 198–223. Gen. Tech. Rep. INT-86, U.S. Forest Serv., Intermountain Forest and Range Exp. Station, Ogden, UT.

Walker, E. P., F. Warnick, and S. E. Hamlet. 1968. Mammals of the world. 2nd ed. 2 Vols. Johns Hopkins Press, Baltimore, MD. 1500pp.

Williams, B.D.C. 1998. Distribution, Habitat Associations, and Conservation of Purple Martins Breeding in California (Thesis). California State University, Sacramento. (California Department of Fish and Game, Bird and Mammal Conservation Program Report 98-14).

Wiseman, E. 2015. East Weaver Creek LWD Assessments. Fisheries Division, Trinity River Management Unit, Shasta-Trinity National Forest, Unpublished paper via email on 12/21/2015

Yager, E. M., J. W. Kirchner, and W. E. Dietrich (2007), Calculating bed load transport in steep boulder bed channels, Water Resour. Res.43, W07418, doi:10.1029/2006WR005432.

Yamasaki, K. 2015 field notes for snorkel survey of East Weaver Creek upstream of dam. Northwest CA RC&DC, Weaverville CA

Yochum, S. and Bledsoe, B., 2010, June. Flow resistance estimation in high-gradient streams. In *2nd Joint Federal Interagency Conference, Las Vegas, NV, June*.

Zeiner, D.C., W.F. Laudenslayer, Jr., K.E. Mayer, and M. White, eds. 1988-1990. California's Wildlife. Vol. I-III. California Depart. of Fish and Game, Sacramento, California.

## Appendix 2

# East Weaver Creek Dam Intake/Pipeline Assessment Conceptual Design Report

# EAST WEAVER CREEK DAM INTAKE/PIPELINE ASSESSMENT CONCEPTUAL DESIGN REPORT

---

Date: May 31, 2017  
 Prepared by: Joe Riess, PE  
 Gilbert Fuentes, PE



## Contents

Purpose .....	1
Existing System .....	2
Design Flows .....	3
Diversion System Overview .....	4
Weir Alternatives .....	5
Permanent Weirs .....	5
Adjustable Weirs .....	6
Weir Comparison .....	1
Weir Design Recommendation .....	1
Headgate Alternatives .....	1
Types of Headgates .....	1
Fish Screen Alternatives .....	3
Fish Screening Requirements .....	4
Horizontal Flat-Plate Screen .....	5
Brushed Cone Screen .....	7
Bypass System .....	8
Connection to Existing Water Treatment System .....	9
Comparison of Alternatives .....	10
Alternative 1-Horizontal Flat-Plate Screen .....	10
Alternative 2-Brushed Cone Screen .....	11
Conceptual Design Cost Estimates .....	12
References .....	13

## Tables

Table 1. Diversion, EWTP, and Bypass Design Flows .....	3
Table 2. Weir Comparison .....	1
Table 3. NMFS Bypass Design Guideline .....	8
Table 4: Conceptual Cost Estimate (Alternative 1-Horizontal Flat-Plate Screen) .....	12
Table 5: Conceptual Cost Estimate (Alternative 2-Brushed Cone Screen) .....	12

## Figures

Figure 1: Location Map .....	1
Figure 2: Comparison of East Weaver Creek Flows, EWTP Demand and Total CSD Water Demand .....	4
Figure 3. Typical Diversion System Overview (USDA, 2013).....	5
Figure 4. Submerged Orifice Gate (A) and Overflow Weir Gate (B) (USDA, 2013). .....	2
Figure 5. Typical Fish Screen and Bypass Layout (NMFS, 2015) .....	4
Figure 6: Overview of Farmers Screen™ (From FCA’s website) .....	5
Figure 7: Schematic view of cone screen.....	7
Figure 8: Conceptual Layout of Horizontal Flat-Plate Fish Screen (Alternative 1).....	10
Figure 9: Conceptual Layout of Brushed Cone Screen (Alternative 2).....	11



## Purpose

The Five Counties Salmonid Restoration Program (5Cs) is planning a project to remove an existing concrete diversion dam on East Weaver Creek to provide passage for salmonids, specifically Coho Salmon, and to rehabilitate the creek to improve conditions to allow for long term recovery of salmon and steelhead. With the removal of the diversion dam, however, the Weaverville Community Services District’s (WCSD) East Weaver Treatment Plant (EWTP) intake structure must be relocated farther upstream. Since the existing intake structure is not equipped with a fish screen (the diversion dam functions as an effective barrier to upstream salmonid migration), an appropriate fish screening system will be required at the new intake facility.

This report serves as the conceptual design for the new intake and fish screening facility that can be used for budgeting and planning purposes. Note that although this document provides discussion and recommendations for the in-channel grade control (e.g. weirs, riffles), the focus is primarily on the intake structure, fish screen, and interconnections with the WCSD’s existing water supply system. At the time this report was prepared, the stream restoration design was in development and the exact placement (horizontally and vertically) of the intake is to be determined during final design. However, the information provided in this report should be readily adapted to the final channel configuration once available.

A map of the existing EWTP system and property ownership is shown in Figure 1.



Figure 1: Location Map

## Existing System

The Weaverville Community Services District is a water utility located in Weaverville, California and has three separate water sources; the Trinity River at Douglas City, West Weaver Creek, and East Weaver Creek. The focus of this report is the East Weaver Creek diversion and intake structure. The existing East Weaver Creek diversion consists of an aging concrete diversion dam (~EL 2812.4) that backs water up into a concrete diversion box. The diversion box has a stationary bar screen and isolation gate. Water flows from the diversion box to a bypass box, then to two sedimentation basins, and then to the EWTP. Excess water that is not conveyed to the EWTP flows over a weir in the bypass box and is returned to the creek. Sediment accumulation in front of the intake is periodically removed with a backhoe from the bank.

The two concrete sedimentation basins are each approximately 8 feet wide by 30 feet long by 10 feet deep, for a total volume of 36,000 gallons (water level approx. EL 2811.2). The basins are covered with wood planks, and typically capture large debris, pine cones, and leaves. Coagulant and, at times chlorine for pre-chlorination, are added at the inlet of each sedimentation basin. From these basins, water travels by gravity approximately 2,800 feet through a buried 10-inch diameter PVC pipeline to the EWTP near the East Weaver Campground.

The EWTP has two pressure filters (~EL 2662.5). Each filter vessel is divided into 4 cells, with a total surface area of 126 ft<sup>2</sup>. The media reportedly consists of 10 inches of anthracite over 18 inches of sand supported by 14 inches of graded gravel. The maximum allowable filter-loading rate for the EWTP filters is 3 gpm/ft<sup>2</sup>. Based on a total surface area of 252 ft<sup>2</sup> and a maximum filter-loading rate of 3 gpm/ft<sup>2</sup>, the treatment plant is capable of producing 756 gpm (1.68 cfs). Reportedly, the system normally operates between 700 and 725 gpm. Static pressure at the filters is approximately 64 psi.

Chlorine is injected into the water after the filters, and water flows back uphill 950 feet to the East Weaver Storage Tank. The bolted steel tank has a 0.42 million-gallon (MGal) capacity and has a floor elevation of 2729.1.

Water to backwash the filters is provided by gravity from the storage tank, and is collected in a redwood backwash waste tank adjacent to the filters. The backwash waste is pumped back to two backwash settling ponds (~EL 2815) adjacent to the sedimentation basins near the stream diversion. Water from the backwash ponds is recycled back to the treatment process, via the bypass box and then to the sedimentation basins.

The facilities at the diversion location are on Weaverville CSD property. The EWTP and East Weaver Storage Tank are both located on USFS property.

## Design Flows

The Weaverville CSD has pre-1914 appropriative water rights (Permit ID S000361) from East Weaver Creek. The permit does not state the amount of the water right: the amount of the right is fixed by the amount that can be shown to be actually beneficially used as to both amount and season of diversion. In this case, the water right is currently limited to 1.68 cfs since that is the maximum capacity of the EWTP filtration system. However, to allow for potential future growth, a 50% factor of safety is recommended, resulting in a future flow to the EWTP of 2.5 cfs (1.68 cfs x 150% = 2.5 cfs). During low flow and high demand periods, the entire creek has historically been diverted to the sedimentation basins with no flow passing over the dam. Flow in excess of that required by the EWTP is bypassed at the sedimentation basin entrance, and is returned to the creek via a pipe into an existing diversion ditch.

The highest water demands occur in the summer, when creek flows are low. Stream flow measurements were taken by the 5Cs between July and November 2015 and compared to production records from the EWTP (e.g. water demand). Measurements were taken at the upstream of the diversion at the dam, adjacent to the water storage tank, and near the campground. During this period, the stream flow ranged from a low of 1.44 cfs (October 2, 2015) to a high of 2.86 cfs (October 28, 2015). During the same period, the water demand at EWTP ranged from a low of 0.69 cfs (11/20/2015) to 1.37 cfs (July 2, 2015). The amount diverted by the EWTP and not returned to the creek ranged from a low of 38% (11/20/2015) to a high of 69% (9/9/2015).

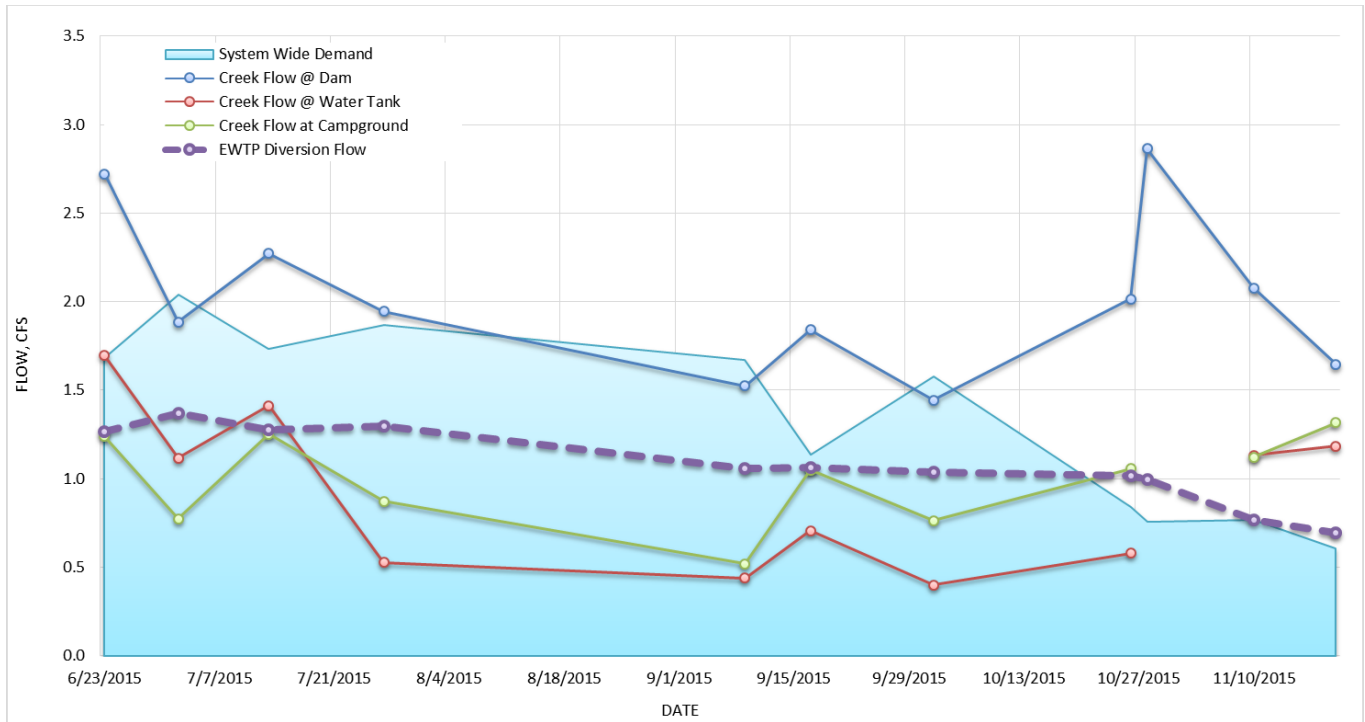
On 9/9/2015 when 69% of the creek flow was diverted to the EWTP, the flow upstream of the dam was 1.52 cfs, 1.06 was diverted to the EWTP, and 0.46 cfs remained in the creek. Data from this day can be viewed as nearly worst-case due to prolonged drought conditions. For the purposes of this report and unless new data become available, the new diversion system should be designed for the following scenarios.

**Table 1. Diversion, EWTP, and Bypass Design Flows**

Scenario	Diversion Flow, cfs	Flow to EWTP, cfs	Bypass Flow, cfs
Low Creek Flow, High Demand	1.5	1.0	0.5
Peak Future Flow	3.0	2.5	0.5

Details of the diversion and bypass are discussed in subsequent sections.

See Figure 2 for a comparison of East Weaver Creek flow, EWTP diversion flow (demand) and total CSD system demand. Note that in the fall, the EWTP system may supply the entire CSD with water (Trinity WTP and West Weaver WTP offline).



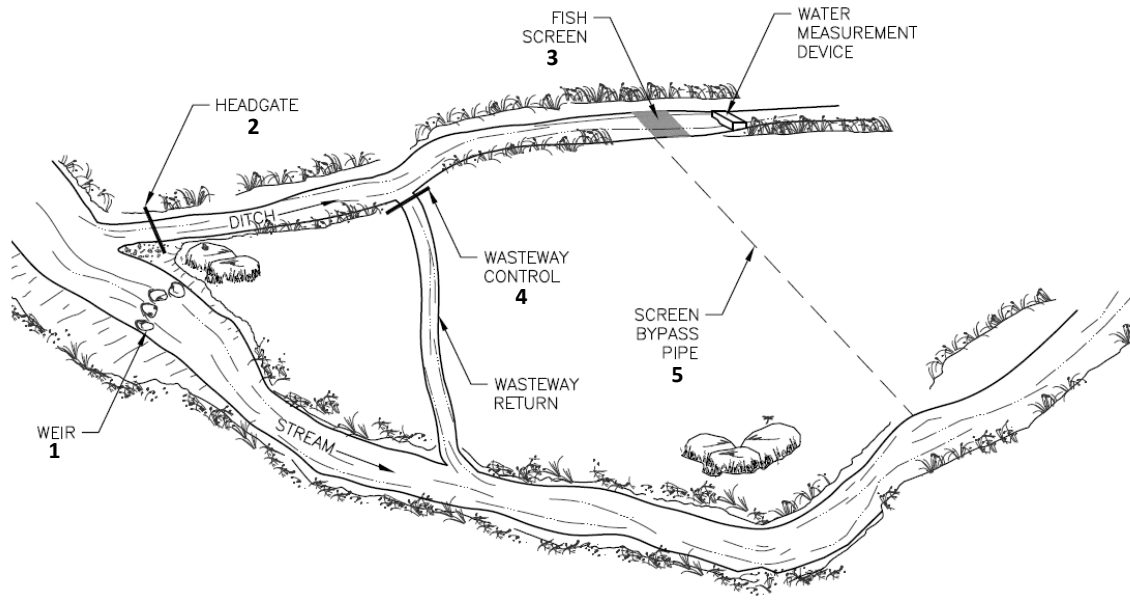
**Figure 2: Comparison of East Weaver Creek Flows, EWTP Demand and Total CSD Water Demand**

## Diversion System Overview

Many surface water diversions are located on streams within the boundaries of the US Department of Agriculture (USDA). The USDA - Forest Service provides a very useful guidance document to assist water users in diversion system planning while protecting aquatic and riparian habitats and organisms to the greatest possible degree. The USDA document entitled, "Planning and Layout of Small Stream Diversions", dated March 2013 (USDA, 2013) was utilized in preparing this report.

The USDA lists the following as the major components of a typical diversion system (see Figure 3):

1. Weir
2. Headgate
3. Fish Screen
4. Overflow / Wasteway System
5. Bypass System



**Figure 3. Typical Diversion System Overview (USDA, 2013).**

Many diversion systems include some or all of the above components to divert water from the main source to the user and provide a safe means for fish passage in the diversion system. Some systems utilize fish screens installed directly in, or slightly off, the main channel and do not require headgates, wasteways, or bypass returns. Due to the steep nature of the creek and high amount of bedload and debris transported during storms, an in-channel fish screen is not recommended. However, a system with a fish screen slightly off channel or a variation of a system as described above is recommended. The major components of the proposed system were evaluated as described below.

## Weir Alternatives

Diversion structures, which typically consist of weirs, are designed to raise and protect the upstream water surface elevation (WSE), forcing water to rise up and into the diversion structure through the headgate. They can be permanent or adjustable, and full span (crossing the entire channel width) or partial span (USDA, 2013). The USDA document provides comparisons and guidelines on various types of weirs. The two main types of weirs consist of permanent and adjustable weirs.

Alternative means such as infiltration galleries and pump station are also available options for diversion structures. Infiltration galleries and pump stations were not considered for this project due to limited space available for an infiltration gallery on Weaverville CSD property and the desire to have a gravity flow system over a pumped system (similar to the existing system).

## Permanent Weirs

Permanent weirs raise the water level upstream of the weir, and force some or all of the water in the channel to flow over the structure throughout the year. Permanent weirs cannot be readily adjusted without using heavy equipment or machinery. The following are the most common types of permanent weirs:

- Rock weirs:

- A channel-spanning structure constructed of large rock sized to be immobile during the design flow (usually 12-inch to 48-inch or larger rock). Rock weirs used in diversion applications are intended to be permanent and the largest rocks may be larger than in the natural channel. Rocks may also be more angular than the natural streambed sediments. Rock weirs should be designed as passable for local aquatic species.
- Rock weirs are typically used in step pool and pool riffle channels. Streams utilizing rock weirs should be moderately well confined so that as weirs are added the WSE does not raise to beyond a tolerable point, especially on the bank edge.
- Some rocks are non-porous but most are porous raising the minimum WSE while allowing some flow between the rocks. Because of leakage, the minimum WSE may be lower than intended.
- Water flowing around or under the structure may cause erosion of the embedment soils. Structures must be constructed to effectively dissipate energy and limit downstream scour.
- Rock Riffles:
  - A channel-spanning structure constructed of large rock sized to be immobile in the design flow (usually 12-inch to 48-inch rock). The rock is placed as a sloping blanket along the length and width of the streambed downstream of the point of diversion, with the goal of raising the WSE at the point of diversion.
  - Rock riffles are typically used where the WSE does not have to be raised very much to force water into the diversion. A rock riffle might be considered a desirable control structure in channels with low banks and channel slopes up to about 4 percent.
  - Streambed erosion is a potential risk with rock riffles even though the water does not plunge over the structure. Structures must be constructed to effectively dissipate energy and limit downstream scour.
- Rock Barbs/Vanes:
  - A rock structure that spans only part of the channel cross section. Rock barbs raise the WSE in the vicinity of the bank where the diversion is located and permit free flow and aquatic species passage across the rest of the channel. They are usually constructed pointing upstream at an angle from the bank and sloping down from the bank in order to help keep water from overflowing the barb away.
  - Barbs are typically used where the amount of water diverted is small compared with instream flow and a relatively small increase in WSE in the bank is needed to supply the diversion. Barbs are best utilized on mildly sloping streams (<0.5%) with relatively high seasonal flows. They are not useful where a diversion takes all or most of the flow. Barbs are best used on wider streams where the vane will not deflect water into the opposite bank at moderate to high flows.

## Adjustable Weirs

Adjustable weirs can be manipulated to achieve variable minimum water surface elevations. Adjustable weirs may be constructed of rock riprap, logs/timbers, or concrete and steel with the adjustable portion consisting of:

- Stoplog weirs (Adjustable Log Dams):
  - Short stoplogs (2-foot to 12-foot logs/boards) are placed in slots or stanchions attached to the floor of the weirs. Adding or removing boards/logs adjusts the WSE (typical elevation change is 2 to 6 inches).
  - Typically, stoplogs are used where it is not possible or desirable to construct a permanent bed elevation control high enough to divert water through the diversion season. Adjustable dams allow raising the minimum water surface elevations as flows decrease over the summer to continue delivering water to the diversion. Stop dams do not require power or automation so they are useful in remote locations without power or automation. Low cost installation especially with surplus of wood materials, however dam adjustment is dangerous during high flows and not typically conducted in a timely manner.
  - Construction includes installation of slab and walls and stoplog slots which typically requires dewatering and bed and bank excavation.
  - Dam boards require adjustments frequently during high fluctuation seasons. Operators will be required to respond in timely manners.
- Air-bladder weirs:
  - Rubber air bladders are placed on concrete or wood floor slabs and are protected by hinged steel panels that cover the air bladder at all flows. The air is supplied by an air compressor raising the steel panels that control the water surface elevation. Minute changes in WSE can be made with air bladders.
  - Air dams are typically desired when it is not possible to construct a permanent bed elevation high enough to divert water throughout the entire season. Adjustable dams allow you to raise the water surface elevation significantly as flows decrease over the summer. Air bladders can be raised on-site by the operator or remotely. The inflation system requires electrical power at the site.
  - Installation requires dewatering and bed and bank excavation. Air dams are also susceptible to air leaks in the supply lines.
- Adjustable weir gates:
  - Adjustable slide gates:
    - A slide gate that moves up and down between vertical walls on either side of the channel. It might be on tracks, or simply set against concrete walls. Hydraulics or cylinders, lead screws or winches might move the gate
    - Adjustable gate weirs that slide vertically are more appropriate for taller check structures where there is enough fall to keep it clear of sediment that would prevent the gate from closing
  - Tilting weirs:

- A weir consisting of a panel that is hinged or attached to a tube that rotates. The hinge or tube is attached to the floor of the structure. The panel is raised or lowered by means of a cable winch or torque tube to change the WSE.
- Tilting weirs are susceptible to hinge damage from fine sediment and require problematic synchronized lifters on both sides of the channel.
- Tilting weirs are rarely used.
- Radial Gates:
  - Curved plates that rotate around a hinge on the weir sidewall are raised by cable winch.
  - Highly undesirable for fish who are migrating upstream and get stuck in the gate shelves/bars.



## Weir Comparison

A comparison of each weir type is presented in Table 2 (adapted from 2013 USDA guidance document).

**Table 2. Weir Comparison**

Diversion Structure Alternative	Description	Pros	Cons
<i>Permanent Weirs</i>			
Rock Weirs	A channel-spanning structure constructed of large rock sizes (12-inch to 48-inch). Rock weirs are typically designed as passable for local aquatic species.	<ul style="list-style-type: none"> <li>Rock structures are more likely to permit aquatic species passage than smoother concrete or metal structures because the rougher rock surface may provide some slower flow pathways near the banks or between rocks. The height of a rock weir can be limited to the jump height achievable by a target fish. In steeper channels, one or a series of rock weirs can be designed to mimic the structure and height of rock steps in the natural channel so that aquatic species are likely able to move upstream through them.</li> <li>Water leaking through the rocks may permit smaller organisms to swim or crawl between rocks.</li> <li>Bank vegetation can grow in and between the rocks, and help stabilize the structure. It may also help to moderate water temperature.</li> <li>Inexpensive if rock is locally available.</li> </ul>	<ul style="list-style-type: none"> <li>Nonadjustable: Like any structure that raises streambed elevation permanently, may cause streamflow to overtop the banks at lower flows.</li> <li>Consequences might include increased bank erosion, flooding the diversion works, eroding the ditch.</li> <li>Water leaking between the rocks can reduce efficiency of the diversion and the amount of water available for any fish screen and bypass. This problem can be managed by sealing the structure and maintaining it regularly.</li> <li>Leakage also can deter larger fish from swimming upstream if water depth over the weir crest is low.</li> </ul>
Rock Riffles	A permanent channel-spanning structure constructed of large rock sizes (usually 12-inch to 48-inch). The rock is placed as a sloping blanket along the length and width of the	<ul style="list-style-type: none"> <li>Depending on the degree of similarity to natural streambed structures in the channel, may pass a variety of endemic aquatic organisms. Like rock weirs, engineered riffles can be designed (using hydraulic methods) to pass a target fish within a certain flow range.</li> <li>Inexpensive if rock is available locally and the site has good access for equipment. With your own</li> </ul>	<ul style="list-style-type: none"> <li>Nonadjustable: Like any structure that raises streambed elevation permanently, may cause streamflow to overtop the banks at lower flows.</li> <li>Consequences might include increased bank erosion, flooding the diversion works, eroding the ditch.</li> <li>Water leaking between the rocks can</li> </ul>

	streambed downstream of the point of diversion. A series of engineered riffles is often needed to raise the water surface sufficiently.	<p>equipment, a rock riffle on a small stream can be built in a couple of hours. Strict precision with elevations is not necessary.</p> <ul style="list-style-type: none"> <li>• Bank vegetation can grow in the rocks, and help stabilize the structure. It may also help to moderate water temperature.</li> <li>• Water leaking through the rocks may permit smaller organisms to swim or crawl between</li> </ul>	<p>reduce efficiency of the diversion and the amount of water available for any fish screen and bypass. This problem can be managed by sealing the structure and maintaining it regularly. Leakage also can deter larger fish from swimming upstream if water depth over the crest is low.</p>
Rock Vanes	Similar to rock weirs however rock structures span only part of the channel cross section. When used as diversion checks, they raise the water surface in the vicinity of the bank where the diversion is located, and permit free flow and aquatic species passage across the rest of the channel	<ul style="list-style-type: none"> <li>• Does not block entire channel cross section, and provides free upstream aquatic organism passage as well as downstream sediment and debris movement.</li> <li>• Bank vegetation can grow in the rocks, and help stabilize the structure. Angled construction helps avoid bank erosion downstream.</li> </ul>	<ul style="list-style-type: none"> <li>• Nonadjustable: Like any structure that raises streambed elevation permanently, may cause streamflow to overtop the banks at lower flows than normal. This is less likely than for rock weirs and riffles because the structure spans only part of the channel.</li> <li>• Like other rock structures, must be keyed into the bed and banks for stability. Keying rocks in to bankfull elevation requires substantial bank disturbance</li> </ul>
<i>Adjustable Weirs</i>			
Stoplog Weirs	Short stoplogs (2-foot to 12-foot boards or tubes) are placed in slots or stanchions attached to the floor of the weir.	<ul style="list-style-type: none"> <li>• Water surface elevation does not have to be permanently raised, and flow during much of the year can be nearer normal than is possible non-adjustable weirs.</li> <li>• These are common, easily understandable structures. It is relatively easy for landowners to understand and approve modifications, such as leaving out one or two logs for fish passage.</li> <li>• Can be constructed with readily available sometimes leftover materials with them inexpensive.</li> </ul>	<ul style="list-style-type: none"> <li>• Due to the difficulty of removing saturated boards with water pressure against them, boards are sometimes not removed in the fall. The resulting overflow can cause scour and sediment deposition during the next flood event, creating an additional maintenance need.</li> <li>• Notches may not provide adequate passage for fish or other aquatic species.</li> <li>• When dam boards are finally removed, a concentrated wave of sediment may be</li> </ul>

			released to settle out on the streambed somewhere downstream.
Air bladder Weirs	Rubber air bladders are placed on concrete or wood floor slabs, and are protected by hinged steel panels that cover the air bladder. The air bladder is inflated using an air compressor, raising the steel panels that control water surface elevation.	<ul style="list-style-type: none"> <li>• Water surface elevation does not have to be permanently raised, and flow during much of the year can be nearer normal than is possible with nonadjustable weirs.</li> <li>• Less dangerous than handplaced stoplogs and more likely to adjust in a timely way, because no manual manipulation is needed.</li> <li>• Compared to stoplog weirs, more likely to seal tightly, allowing more water to be sent through a constructed fish ladder and/or a fish screen/bypass system.</li> </ul>	<ul style="list-style-type: none"> <li>• Grid electricity or a generator and engine are required onsite to run the air compressor. Solar panels do not generate enough power. Power is not required all the times not to change the surface elevation needs to be changed.</li> <li>• Upstream fish passage requires an off-stream facility: a fishway, such as a ladder or a side channel.</li> <li>• If construction is not done well, experience shows that pipes running to the bladder develop small leaks, creating the need to run the air compressor frequently.</li> </ul>
Adjustable Weir Gates	This category includes several types of adjustable weirs including adjustable slide gate, tilting weirs and rotating gates.	<ul style="list-style-type: none"> <li>• Mechanically adjustable.</li> <li>• Like other weir styles, flow over the crest increases rapidly with increasing upstream head. Therefore, these are good for maintaining a relatively constant upstream water surface elevation and ditch flow even when instream flow increases greatly.</li> <li>• Radial gates are well-balanced and easy to lift. They work well with high sediment loads because the hinges are out of the water.</li> <li>• Radial gates can be moved easily using a hoist setup.</li> </ul>	<ul style="list-style-type: none"> <li>• Poor in streams with high sediment loads because sediment resting on weir floor can prevent gate from closing. Fine sediment can bind hinges of tilting weirs.</li> <li>• Radial gates are quite dangerous for upstream migrating fish because they attract fish and encourage them to jump at the back of the gate.</li> </ul>

## Weir Design Recommendation

The diversion design is contingent upon the channel restoration design and selected diversion location. However, to allow maximum flexibility to divert low flows and pass high flows and bedload, a rock weir structure is most likely the preferred alternative.

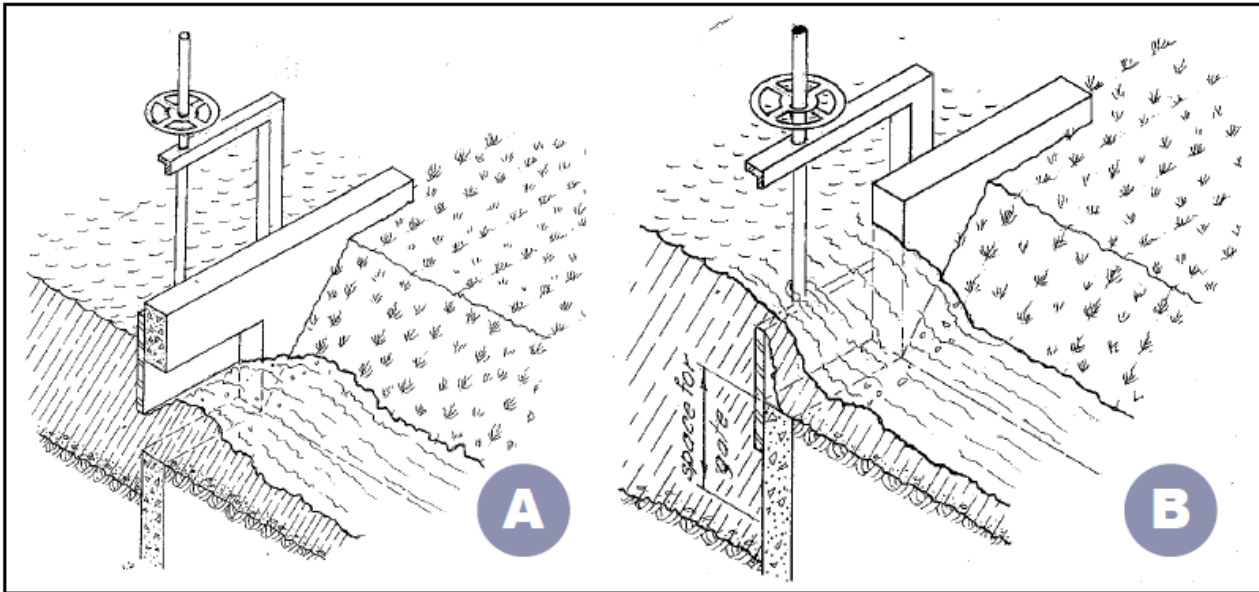
## Headgate Alternatives

A headgate structure will be required to control the amount of flow, and limit the amount of sediment and debris that enters the diversion structure and flows to the fish screen. The headgate should be located at the entrance to the diversion system and be selected to allow a steady rate of flow in to the diversion system. Headgate structures can also be used to measure the flow rate entering the diversion system using integral weirs. Alternatively, an orifice, weir or flowmeter can be located downstream of the headgate to measure flow. The headgate can be automated to maintain a set water surface elevation (and corresponding flow rate) in the in the diversion system, and respond automatically when diversion flow changes (USDA, 2013). However, most headgates on small diversion systems such as the WCSD's are manually controlled, and are not automated. During steady flow seasons headgate adjustment is anticipated to be minimal. However, if water levels in the creek fluctuate significantly, then daily adjustment may be required.

### Types of Headgates

There are two main types of headgates used for water diversion systems: submerged orifice gates and weirs. Most headgates used at stream diversions are submerged orifice gates where the inlet is below the water surface, such as at the existing EWTP diversion. These usually consist of a wall opening with rectangular or circular slide gate that slides on rails or pivots around a hinge point to allow water in through the wall. An advantage of submerged orifice gates is that the through-flow increases slowly with increases in upstream water surface elevation.

Weirs are overflow structures that are used commonly as diversion structures in the main channel. With a weir gate, the amount of water flowing over the weir increases rapidly as upstream water surface elevation rises. Weirs are uncommon as headgates because keeping the diversion flow as consistent as possible is usually a high priority for operators. Additionally, weirs result in additional headloss and may actually become barriers to fish passage. Figure 4 shows the differences between an orifice gate and a weir gate.



**Figure 4. Submerged Orifice Gate (A) and Overflow Weir Gate (B) (USDA, 2013).**

An orifice gate with an upstream bar screen (aka “trash rack”) is recommended for the headgate entrance for the diversion structure, similar to at the existing diversion. Orifice structures provide better flow control than weirs. Flow through an orifice gate increases slowly with increases in water surface level which can create better flow regulation during a peak flow event. This steady flow regulation will provide protection to the downstream fish screen and bypass systems. The water surface variation at the diversion is dependent upon the final channel restoration design. However, it is anticipated the minimal to moderate fluctuations in water level can be expected. Therefore, an automated system for the orifice gate is not warranted. The orifice gate will be sized to accommodate the full diversion flow range of 1.5 to 3 cfs.

Depending on the final channel configuration, the area in front of the headgate may be prone to sediment deposition such as is the case at the existing diversion dam. Additionally, if there is not sufficient sweep velocity in front of the diversion at low flows (particularly in the fall), floating debris such as leaves will tend to accumulate in front of the diversion. To mitigate these maintenance issues, a low spot in front of the orifice gate should be graded to allow construction equipment to periodically remove sediment and floating debris.

When sizing the headgate, the headloss across the entrance must be considered. Minimal headloss is preferred across the orifice gate to leave as much head as possible to convey water down to EWTP. In addition, limiting velocity across the orifice gate is recommended to limit the sediment and debris from entering the ditch. These objectives typically control orifice sizing. For this project, a 15-inch square opening is recommended to minimize headloss across the diversion flow rate range, and results in 1.0 fps to 1.9 feet per second (fps) from low to high flow. This low velocity range is ideal in order to aide in sediment and debris control through the headgate.

A fabricated stainless steel slide gate is recommended for the orifice gate, for flow control and diversion structure isolation for maintenance. The slide gate would be installed on the inside face of the structure, to allow room for a bar rack or trash rack to be installed on the outside face of the structure. The slide gate would be manually operated with a lockable handwheel, similar to at the existing headgate.

A bar rack (trash rack) will be needed to keep large debris from entering the structure. A bar rack can be constructed from structural steel and should be designed to withstand impact from debris, and minimize headloss yet still allow fish passage.

The diversion box should also be provided with a side outlet, isolation gate, and bypass piping to allow the structure to be flushed clean. A 12-inch square, flush-floor mounted slide gate is recommended, along with 12-inch bypass piping that returns to the creek downstream of the control weir. This bypass pipe would be periodically used to flush the diversion box clean of floating debris and fine sediment.

## Fish Screen Alternatives

The new diversion system and intake structure at EWTP will require a fish screen to prevent salmonids from entering into the EWTP intake pipe. Fish screens are structures that physically prevent fish from moving into the diversion system. Screens are designed to have a large total open area that is large enough that as water accelerates through the screen openings, fish will not be pinned against the screen. As debris clogs the screen, the water accelerates more to get through the restricted area and increase the risk of fish pinning (USDA, 2013).

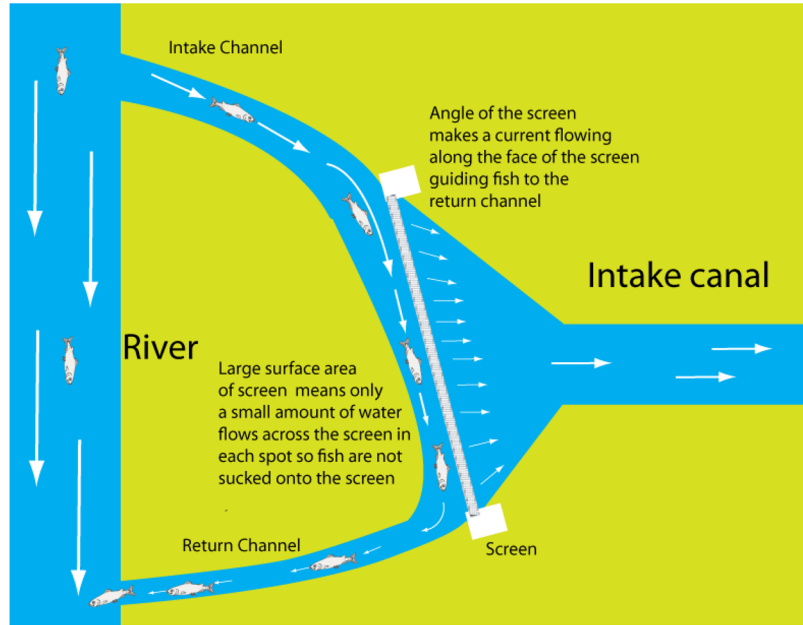
Fish screens are either fixed in place, or they move as part of the cleaning process. A fixed screen is sealed in place and does not move, although brushes or other cleaning components may move over it. In a moving screen, seals and brushes close gaps between the moving screen and its housing, preventing fish from entering the diversion through those gaps. Fixed screens include:

- Plate, cone or drum screens cleaned by air burst or water backwash.
- Plate, cone or drum screens cleaned by brushes.
- Plate screens cleaned by water flowing over and off the screen.

Moving screens include:

- Rotary drum.
- Traveling-belt screens.

Screens without a mechanical cleaning mechanism can be utilized. However, they must be properly designed to allow effective cleaning and bypass flows. If passive screens are utilized a high sweeping velocity is typically required to keep it clear and debris in the creek is minimal (USDA, 2013). Typically, the fish screen is installed parallel with the bypass system to guide fish along the face of the screen to an exit downstream which will return them to the creek (NMFS, 2015). See Figure 5 for a typical diversion layout with fish screen.



**Figure 5. Typical Fish Screen and Bypass Layout (NMFS, 2015)**

### Fish Screening Requirements

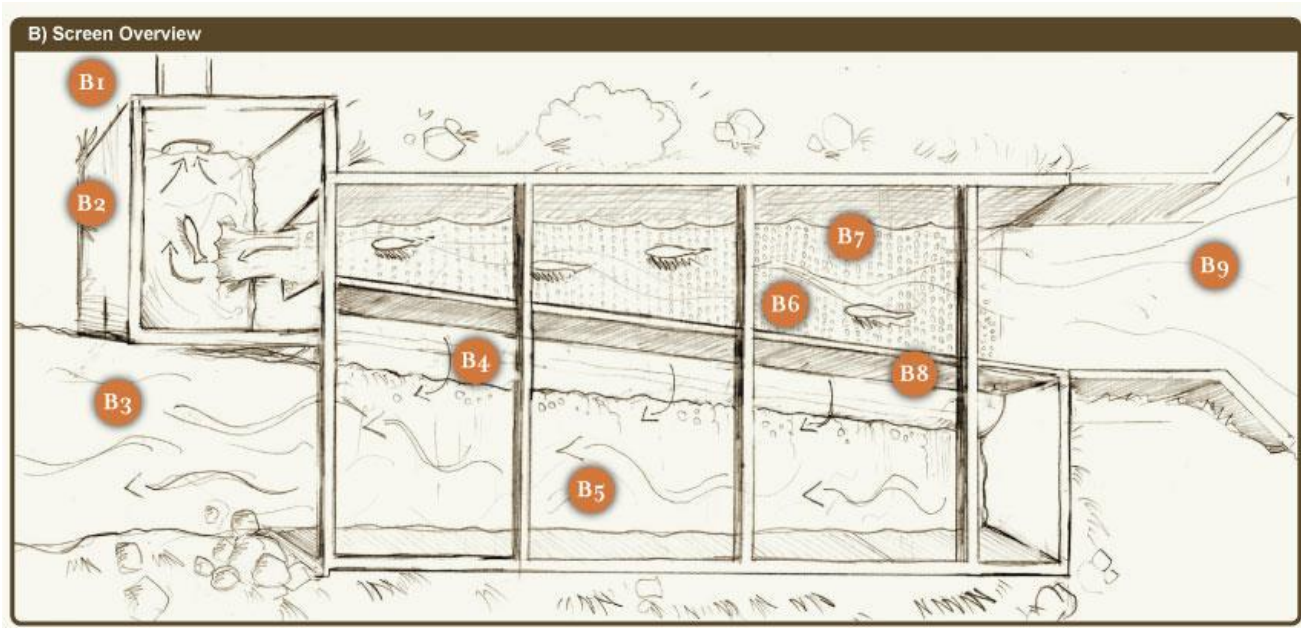
The Coho salmon is a fish regulated at the State and Federal level, therefore the California Department of Fish and Wildlife (CDFW) and National Marine Fisheries Service (NMFS) have design requirements on the approach and sweeping velocity of the screen, screen size and material and cleaning requirements. These design requirements were reviewed and the major criteria are summarized below (CDFW, 2015) (NMFS, 2011):

- The screen face is to be installed parallel to the flow.
- The upstream and downstream transitions of the screen structure shall be designed and constructed to match the bankline, minimizing eddies upstream of, in front of and downstream of, the screen.
- The design of the screen shall distribute the approach velocity uniformly across the face of the screen.
- The design approach velocity (velocity perpendicular to screen face) shall not exceed:
  - For self-cleaning screen (active screens): 0.33 feet per second (fps),
  - For non-self-cleaning screen: one-fourth the velocity of self-cleaning screen (0.08 fps).
  - The required wetted screen area shall be determined by dividing the maximum diverted flow by the allowable approach velocity.
- The sweeping velocity (velocity component parallel to screen face) should be at least two times the allowable approach velocity. It is recommended that the sweeping velocity is between 0.8 and 3 fps.
- The screen surface shall have a minimum open area of 27 percent. In addition, the openings in the screen shall not exceed the following:
  - Round: 5/32 in.
  - Square: 5/32 in. (measured diagonally)
  - Slotted: 3/32 in width
- Screens should be constructed of corrosion-resistant material and care should be taken to avoid the use of material with sharp edges or projections which could harm fish.

Due to the remote location of the diversion and desire to keep the system relatively simple to operate and maintain, two types of screens were considered: horizontal flat-plate screens and brushed cone screens.

### Horizontal Flat-Plate Screen

The horizontal flat-plate screen considered for this project is the Farmers Screen™ by Farmers Conservation Alliance (FCA). The following description of the Farmers Screen is excerpted from the FCA website, <http://farmerscreen.org/>. The Farmers Screen™ is a passive, horizontal, flat-plate fish and debris screen. Designed to be installed in an off-stream channel, water, fish, and debris pass quickly over the Farmers Screen and return to the channel. Inside the screen, the screening material lies parallel to the water's surface. Diverted water travels slowly downward through the screen material while the water carrying fish and debris moves quickly across the screen surface, cleaning it as it returns to the channel. This combination of minimal downward velocity and high sweeping velocity is what manages debris and protects fish. A tapered channel design and weir walls ensure uniform water depths and velocities. See Figure 6 for an overview of the Farmers Screen.



**Figure 6: Overview of Farmers Screen™ (From FCA's website)**

The components labeled in the above figure are as follows:

- B1=Bypass return
- B2=Fish return plenum or flume
- B3=Screened water
- B4=Weir wall
- B5=Attenuation bay
- B6=Screen material
- B7=Cleaning water
- B8=Taper Wall
- B9=Inlet



The Farmers Screen is different from traditional screening technologies in several ways. First, the screen material itself is horizontal as opposed to vertical, allowing debris and fish to be carried above and over the surface of the screen material. Second, the Farmers Screen has no moving parts, eliminating the need for a power supply and greatly reducing the maintenance associated with the screen. Third, the Farmers Screen is substantially self-cleaning, meaning that under normal operating conditions the screen will not accumulate debris on the screen surface which again reduces maintenance requirements and provides consistent fish protection. Finally, to operate correctly, the Farmers Screen requires by-pass flow, which provides protection from both injury and delay for fish as well as effective debris management.

All of the installed Farmers Screens are located off-channel and behind a functioning head gate that controls the rate of flow into the screen system. The Farmers Screen received federal approval in 2011 from the NMFS, and is marketed by the nonprofit Farmers Conservation Alliance (FCA), based in Hood River.

The Farmers Screen can either be provided as modular pre-fabricated steel sections or constructed in the field out of concrete. Typically, modular systems are most cost effective for diversions less than 15 cfs and are relatively quick to install in the field and do not require specialized construction equipment.

The required site conditions for the Farmers Screen are as follows:

- **Screen Location:** The site must be off-channel with flow to the screen regulated by a head gate. There must be adequate space to accommodate the screen structure in a place that is protected from high flow events.
- **Adequate Flow:** There must be adequate flow in the source river or stream to ensure that the proper amount of by-pass flow (flow returning to the river or stream along with fish and debris) in addition to the screened flow and any necessary in-stream flow is available 100% of the time that the screen is operating. The necessary by-pass flow quantity is a function of screen design and is determined during the design process.
- **Elevation Differential:** Also referred to as required head or fall. The Farmers Screen™ requires a drop in elevation from the point of diversion to the end of the screen structure. Typically, a total of 1 foot in elevation differential from the point of diversion to the end of the screen structure is more than adequate. The head generated by the elevation differential is needed in two places: the entrance to the flume, and at the leading edge of the screen. Head is required to drive the water into the flume, and more head is required as water volume increases. There must be enough head to induce velocities of 3 to 7 feet per second in the flume. Head is also required to drive water through the screen structure itself. Approximately 0.3 feet is necessary to overcome the head loss through the screen (measured from the flume water surface elevation to the attenuation bay water surface elevation).
- **Stream or River Gradient:** The slope of the source river or stream must exceed the slope of the diverted water conveyance such that the elevation differential between the screen surface elevation and the stream (at the point where the by-pass water return pipe enters the stream) is sufficient to prevent any backwater influence in the pipe and to meet NMFS criteria regarding by-pass flow hydraulics.

It appears that all of the above conditions would met for the East Weaver Creek diversion following the channel rehabilitation. Therefore, the Farmers Screen should be a viable alternative for this project.

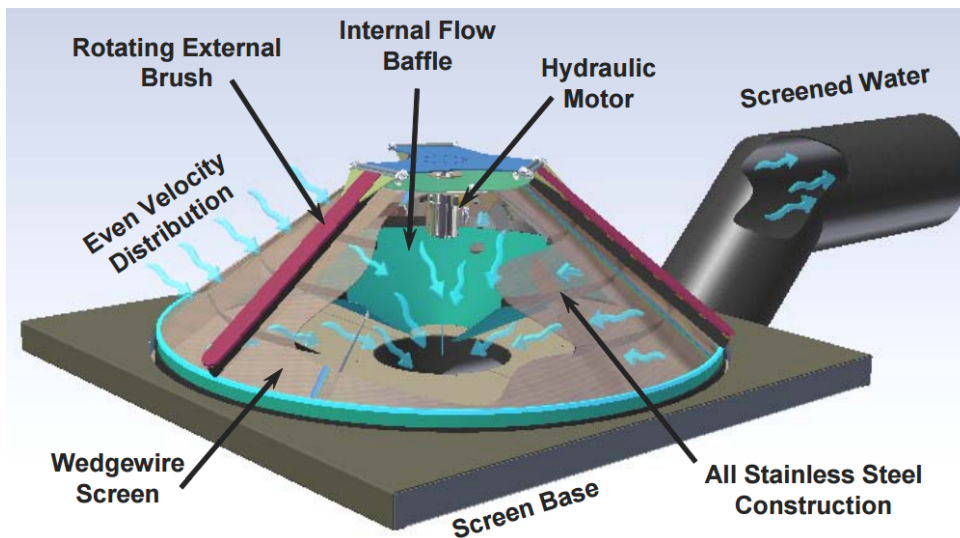
For passive screens the recommended fish screen area by the USDA is 15 to 20 square feet (sf) per cfs. Based on this guideline a fish screen size of at least 45 sf is recommended for this project. This sizing is based on a future flow rate of 3.0 cfs and complies with the minimum fish screen size of approximately 30 sf required by the CDFW.

Due to the relatively small diversion flow, a modular screen would be most practical versus a concrete screen structure.

### Brushed Cone Screen

The brushed cone screen considered for this project is by Intake Screens, Inc. (ISI) (<http://intakescreensinc.com/brushed-cone/>). The cone screen is designed for shallow water, tidal estuaries and silty conditions. The screen is comprised of stainless steel wedgewire screen in a cone shape to provide a large screen area in shallow applications, even if not fully submerged. Internal baffles distribute flow evenly across the screen surface to ensure approach velocities are uniform. The screen includes an automatic cleaning system that is hydraulically operated, either via standard line voltage, solar power, or an internal propeller drive. The drive system rotates an external brush assembly that to prevent debris buildup, sedimentation and biofouling.

The screen can be installed directly in the creek or stream, slightly off channel and protected by a trash rack, or completely off channel (such as in a separate structure downstream of the headgate). Screened water flows through a connecting discharge pipe. Typical screen sizes range from 5.5 to 12 feet in diameter for flows ranging from 5.4 to 43.2 cfs, depending on the slot and approach velocity requirements. Smaller screens can be manufactured, down to approximately 4 ft diameter. See Figure 7 for a schematic view of a cone screen.



**Figure 7: Schematic view of cone screen**

Several brushed cone screen screens have been installed in Siskiyou County by the Siskiyou RCD and have been in operation for more than 10 years with good success. Some of these installations are on small, steep creeks similar in nature to East Weaver Creek.

One of the primary advantages the cone screen has over other screens is that it can be installed directly in the channel or in an alcove, the screen is designed to handle high sediment and debris loads, and there is no bypass flow requirement across the screen and back to the creek.

## Bypass System

Diversions can directly affect fish movement in both upstream and downstream directions. Depending on the selected fish screen type (specifically, the horizontal flat-plate screen described earlier), a bypass system may be required to bypass any excess water and fish back to the creek. Fish bypass design has been standardized for anadromous fish screens meeting NOAA NMFS criteria for Coho Salmon. The bypass design parameters include the minimum conduit size, bend radii, maximum velocity, water depth and other hydraulic features that protect fish as they approach and travel through the bypass (USDA, 2013). The two main components of the bypass system are the bypass entrance and the bypass conveyance system.

From the design bypass flows developed earlier, the bypass flow rate of 0.44 cfs will be required. The bypass entrance will also need to account for a complete 100% bypass system of 3 cfs. The bypass conveyance system typically consists of either open channels or pipes. Whatever conveyance structure is used, the bypass is required by the NMFS to be a non-pressurized system (NMFS, 2011). Pipes are the most common bypass system since they are inexpensive and allow equipment and people easier access to the area while also protecting fish from above predation.

Due to the low flow rate of the bypass system (0.44 to 3 cfs), a pipe is recommended for the bypass conveyance system. A pipe will be easier to install compared to constructing a ditch and will most likely be cheaper. The NMFS provide design guidelines for selecting a bypass pipe diameter based on the diverted flow. The NMFS bypass flow pipe size guideline is presented in the following table.

**Table 3. NMFS Bypass Design Guideline**

Diverted Flow (cfs)	Recommended Bypass Flow (cfs)	Bypass Pipe Diameter (in.)	Bypass Flow Depth <sup>b</sup> (in.)
<6	5%	10	2 1/2

a. Source (NMFS, 2011). Table assumes the following: 1) Slope of 1.3%, 2) Manning’s coefficient of 0.009 3) other bypass criteria of NMFS document are met.

b. Bypass flow depth is recommended to be 40% of the bypass pipe diameter.

c. Bypass velocity is recommended to be between 6 and 12 fps and have a minimum velocity of 2 fps.

Based on preliminary hydraulics and the NMFS guidelines a 10-inch pipe is the minimum size that can account for the flow design bypass flow range of 0.44 cfs to 3 cfs. Utilizing a PVC pipe and assuming an average slope of 1.3% the flow depth at 0.44 cfs would be approximately 2.3 inches, the flow depth at 3 cfs would be approximately 7 inches. A more detailed hydraulic assessment would need to be conducted once the exact bypass alignment and profile is selected.

## Connection to Existing Water Treatment System

Currently, diverted water continuously flows from the EWTP intake and diversion structure to a diversion box upstream of two parallel sedimentation basins adjacent to the diversion dam. Settled water is then conveyed through approximately 2,800 feet in a 10-inch PVC main to the East Weaver WTP. Treated water then flows back uphill (under pressure) to the water storage tank. Water in excess of that required by the WTP flows over a weir at the sedimentation basins and is returned back to the creek, downstream of the dam. The existing 10-inch pipe from the sedimentation basins to the WTP is reportedly in good condition and would not need to be replaced as part of this project. However, new piping would need to be installed from the outlet of the fish screen structure to the inlet to the sedimentation basins.

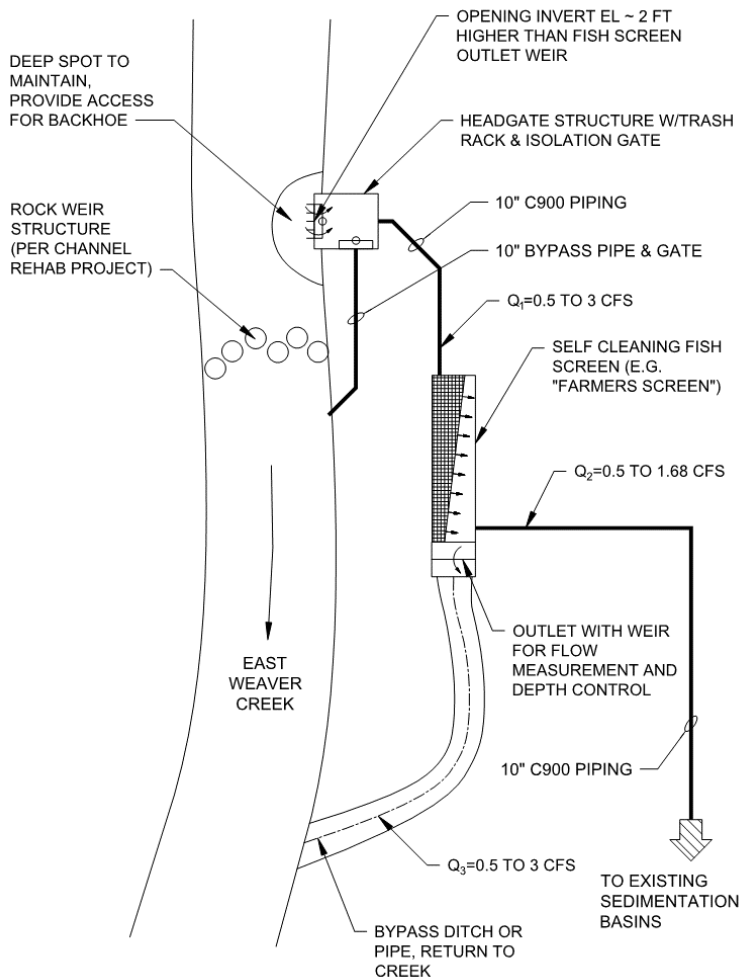
From the survey data, it appears that the ground surface elevation near where the fish screen would likely be located is EL 2818. The ground surface elevation near the inlet box at the sedimentation basins is EL 2811. The preliminary pipe length from the outlet of the fish screen to the inlet box is approximately 200 ft. Therefore, the pipe slope would be approximately 0.035 ft/ft. For a 10-inch diameter pipe flowing full at this slope, the maximum capacity is estimated at 1,993 gpm, or 4.44 cfs which is greater than the maximum expected future diversion flow of 3 cfs. Therefore, the recommended pipe size is at least 10-inch diameter. A detailed hydraulic analysis should be performed during final design activities to confirm pipe sizing and routing.

## Comparison of Alternatives

The primary difference between the two diversion system alternatives developed for this report is the type of fish screen that will be utilized, and the related headgate and bypass requirements. These two options are as described below.

### Alternative 1-Horizontal Flat-Plate Screen

Under this alternative, the diversion system would include a new headgate structure, self-cleaning horizontal flat-plate fish screen, bypass piping (or ditch), and interconnecting from the headgate to fish screen, and from fish screen to existing water treatment system. This alternative is shown conceptually in Figure 8.

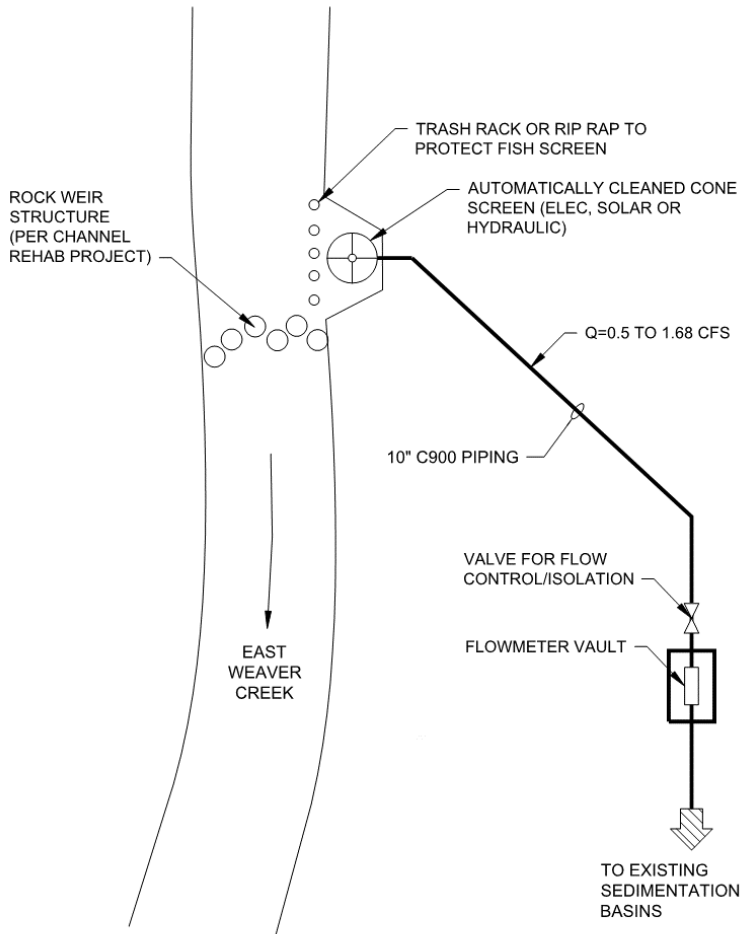


**Figure 8: Conceptual Layout of Horizontal Flat-Plate Fish Screen (Alternative 1)**

The primary advantage of this alternative is that there are no moving parts so maintenance is relatively simple. The primary disadvantage of this alternative is that a relatively high bypass flow is required at all times for screen cleaning and fish passage.

## Alternative 2-Brushed Cone Screen

Under this alternative, the diversion system would include a new automatically cleaned brushed cone screen, a buried valve for flow control and isolation, a flowmeter in a vault, and interconnecting piping to existing water treatment system. This alternative is shown conceptually in Figure 9.



**Figure 9: Conceptual Layout of Brushed Cone Screen (Alternative 2)**

The primary advantages of this alternative are that no bypass flow is required and no headgate is required. The new valve would be used to control flow to the existing sedimentation basins, so the diverted flow would only need to be equal to the amount required to meet water system demands. The primary disadvantage of this alternative is that special care must be taken during design and construction of the fish screen to protect it from sediment and debris during storms. If desired, the screen could be installed in a protected concrete structure adjacent to the creek such as a large headgate structure.

## Conceptual Design Cost Estimates

Conceptual level construction cost estimates were prepared for the two alternatives described above. Note that it was assumed that construction of this project would be in conjunction with the larger channel rehabilitation

project. Therefore, design and environmental permitting costs were not included in these cost estimates, nor were any costs associated with the diversion weir. These two costs estimates should be considered order-of-magnitude and used primarily for alternative evaluation and general budgeting purposes. See Table 4 and Table 5, below.

**Table 4: Conceptual Cost Estimate (Alternative 1-Horizontal Flat-Plate Screen)**

Item		Unit	Quantity	Unit Cost	Installation Cost	Total Cost *
1	Mobilization	LS	1	\$2,000	included	\$2,000
2	Permits (not incl, part of channel rehab project)	-	n/a	n/a	n/a	-
3	Clearing and Grubbing	LS	1	\$3,000	included	\$3,000
4	Excavation for Headgate Structure	LS	1	\$3,000	included	\$3,000
5	Pre-cast Concrete Headgate Structure	LS	1	\$18,000	included	\$18,000
6	Trash Rack	LS	1	\$5,000	included	\$5,000
7	Fabricated Slide Gates	LS	2	\$8,000	included	\$16,000
8	10" C900 Piping	LF	300	\$80	included	\$24,000
9	Farmers Screen (incl excavation and placement)	LS	1	\$30,000	\$15,000	\$45,000
10	Bypass Ditch/Pipe	LS	1	\$10,000	included	\$10,000
* (ROUNDED TO \$1,000)						
<b>Subtotal</b>						<b>\$126,000</b>
<b>Design Contingency</b>				30%		<b>\$38,000</b>
<b>Contractor Overhead and Profit</b>				15%		<b>\$19,000</b>
<b>Contractor Bonds and Insurance</b>				4%		<b>\$6,000</b>
<b>TOTAL ESTIMATED CONSTRUCTION COST</b>						<b>\$189,000</b>

**Table 5: Conceptual Cost Estimate (Alternative 2-Brushed Cone Screen)**

Item		Unit	Quantity	Unit Cost	Installation Cost	Total Cost *
1	Mobilization	LS	1	\$2,000	included	\$2,000
2	Permits (not incl, part of channel rehab project)	-	n/a	n/a	n/a	-
3	Clearing and Grubbing	LS	1	\$3,000	included	\$3,000
4	Excavation for Cone Screen Structure	LS	1	\$5,000	included	\$5,000
5	Concrete Base for Cone Screen	LS	1	\$5,000	included	\$5,000
6	Trash Rack or Rip Rap	LS	1	\$5,000	included	\$5,000
7	10" C900 Piping	LF	250	\$80	included	\$20,000
8	Brushed Cone Screen	LS	1	\$10,000	\$10,000	\$20,000
9	Flowmeter and Vault	LS	1	\$8,000	included	\$8,000
<i>* (ROUNDED TO \$1,000)</i>						
<b>Subtotal</b>						<b>\$68,000</b>
<b>Design Contingency</b>				30%		<b>\$21,000</b>
<b>Contractor Overhead and Profit</b>				15%		<b>\$11,000</b>
<b>Contractor Bonds and Insurance</b>				4%		<b>\$3,000</b>
<b>TOTAL ESTIMATED CONSTRUCTION COST</b>						<b>\$103,000</b>

As seen in Table 4 and Table 5, the estimated construction cost for the brushed cone screen alternative (Alternative 2) is approximately \$86,000 less than that of the horizontal flat-plate screen alternative (Alternative 2).

## Conclusions and Recommendations

In addition to being less costly, the brushed cone screen alternative appears to have some significant advantages over the other technologies, most significantly being the lack of bypass water flow requirement. Therefore, the brushed cone screen alternative is the recommended fish screening technology. The recommended project is therefore as described under Alternative 2-Brushed Cone Screen.

## References

CDFW (California Department of Fish and Wildlife), 2015, Fish Screening Criteria

NMFS (National Marine Fisheries Service), 2011, Anadromous Salmonid Passage Facility Design, National Marine Fisheries Service Northwest Region, dated July 2011.

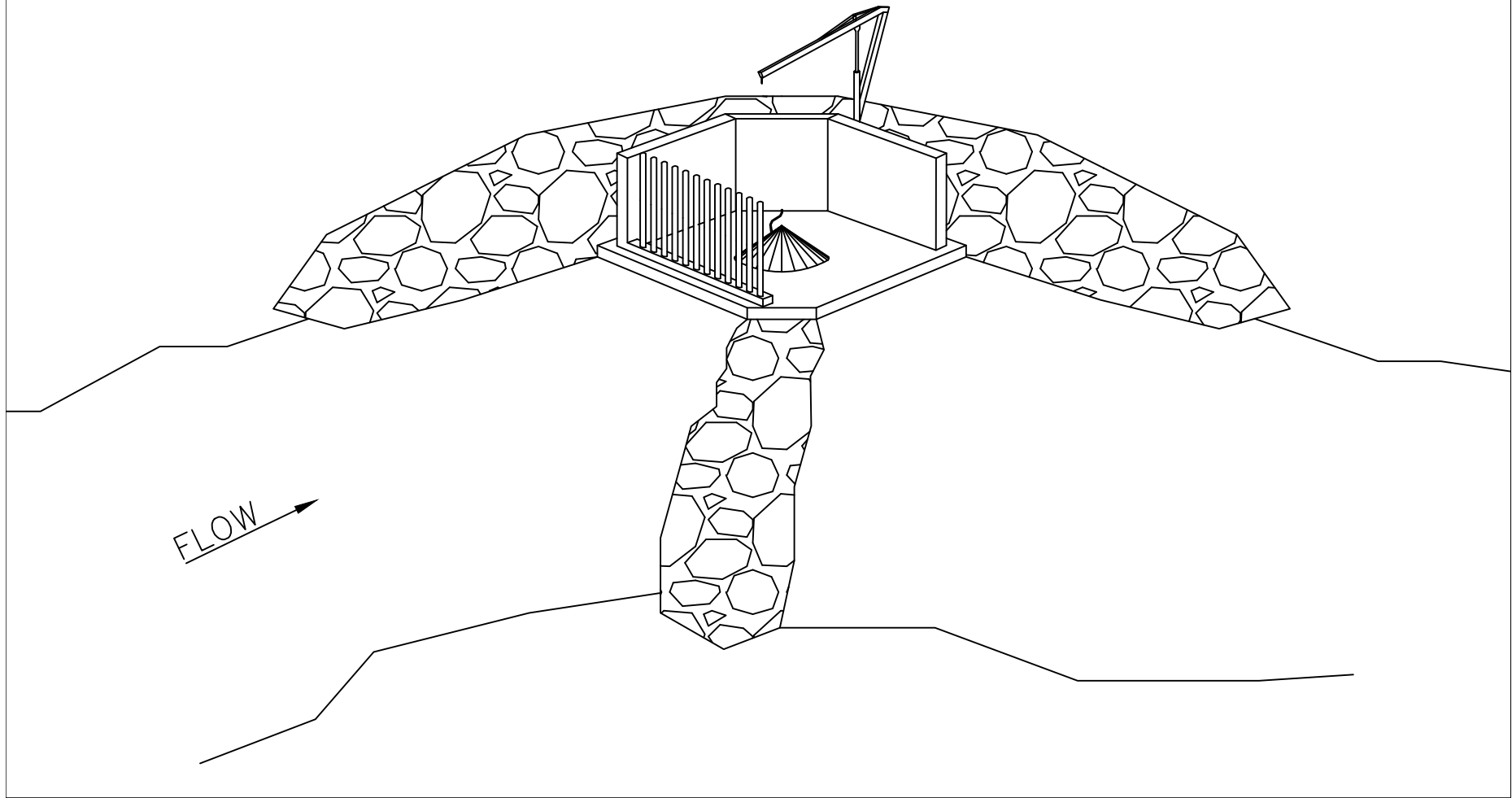
USDA (United States Department of Agriculture), 2013, Planning and Layout of Small-Stream Diversions, Dan Axness and Kim Clarkin, Boise ID and San Dimas, CA.



## Appendix 3

### East Weaver Creek Dam Intake/Pipeline Conceptual Design

EAST WEAVER CREEK DAM  
CONCEPTUAL DESIGN



Appendix 4  
Best Management Practices

# Best Management Practices

## For the

### East Weaver Creek Dam Removal and Intake Relocation Project

Best Management Practices (BMPs) will be utilized throughout the East Weaver Creek Dam Removal and Intake Relocation Project. The project incorporates BMPs from the following documents: the Five Counties Salmonid Conservation Program's *A Water Quality and Stream Habitat Protection Manual for County Road Maintenance in Northwestern California Watersheds*, the California Department of Fish and Game's *California Salmonid Stream Habitat Restoration Manual*, the Natural Resources Conservation Service's *Field Office Technical Guide*, CDFW Minimization and Avoidance Measures, and the National Marine Fisheries Service's 2012 and 2016 *Final Biological Opinion and Essential Fish Habitat consultation for restoration projects within the NMFS Northern California Office jurisdictional area*.

#### **A. Channel Maintenance**

1. During replacement of significant sections of riprap within drainage channels acting as streams, employ bioengineering solutions where the structures are stable and not cost-prohibitive [See *A Water Quality and Stream Habitat Protection Manual for County Road Maintenance in Northwestern California Watersheds* Appendix B-7].
2. Remove any excess material from channels after maintenance actions are completed and place in locations that will not reenter the drainage system, away from channel banks, riparian areas, wetlands, and waterways [See Section T: Spoils Site Selection].
3. Within stream systems supporting sensitive fish species, perform work during the window of time that will have the smallest impact.
4. During any in-water work, minimize sediment impacts and ensure that fish stranding does not occur.
5. Use clean rock sources for channel maintenance work.

#### **B. Dam Diversion**

1. All materials to be used in constructing the diversion dam and appurtenances shall have the strength, durability, and workability required to meet the installation and service conditions of the site.
2. If part of the flow is to be diverted, the outlet works must provide for positive control of both maximum and minimum diversions consistent with the purpose for which the diversion is made. If all the flow is to be diverted, the outlet works must provide for safe diversion of all expected flows, depending on site conditions.
3. The bypass works must be capable of passing all flows needed to satisfy downstream priorities and all flows in excess of diversion requirements, including expected flood flows. This may require a combination of orifices, weirs, and gates designed to meet the requirements of the site.

### **C. Dewatering and Temporary Stream Diversions**

All work will comply with the Requirements for Fish Relocation and Dewatering Activities of the National Marine Fisheries Service 2016 Endangered Species Act (ESA) Section 7(a)(2) Biological Opinion and Magnuson-Stevens Fishery Conservation and Management Act Essential Fish Habitat Consultation, Central Coast) and CDFW requirements:

1. In those specific cases where it is deemed necessary to dewater a work site that is located in aquatic habitat, the work area shall be isolated and all the flowing water upstream of the work site shall be temporarily diverted around the work site to maintain downstream flows during construction. Prior to dewatering, determine the best means to bypass flow through the work area to minimize disturbance to the channel and avoid direct mortality of fish and other aquatic vertebrates [See Section H: Fish Exclusion].
  - a. Make sure the temporary diversion channel is capable of carrying the anticipated streamflows during the construction period.
  - b. Complete the diversion before or after typical upstream fish migration periods. If this is not possible, install a diversion pipe capable of passing fish or other method approved by DFG.
2. Fish will be excluded from reentering the work area by blocking the stream channel above and below the work area with fine-meshed net or screens. Mesh will be no greater than 1/8-inch diameter. The bottom of the seine must be completely secured to the channel bed to prevent fish from reentering the work area. Exclusion screening must be placed in areas of low water velocity to minimize fish impingement. Upstream and downstream screens must be checked daily (prior to, during, and after instream activities) and cleaned of debris to permit free flow of water. Block nets shall be placed and maintained throughout the construction period at the upper and lower extent of the areas where fish will be removed. Block net mesh shall be sized to ensure salmonids upstream or downstream does not enter the areas proposed for dewatering between passes with the electro-fisher or seine.
3. Coordinate project site dewatering with a qualified biologist to perform fish and amphibian relocation activities. The qualified biologist(s) will possess all valid state and federal permits needed for fish relocation and will be familiar with the life history and identification of salmonids, state-listed fish, and listed amphibians within the action area.
4. Prior to dewatering a construction site, qualified individuals will capture and relocate fish and amphibians to avoid direct mortality and minimize take. This is especially important if listed species are present within the project site.
5. Bypass stream flow around the work area, but maintain the stream flow to channel below the construction site. The bypass works must be capable of passing all flows needed to satisfy downstream priorities and all flows in excess of diversion requirements, including expected flood flows
6. Minimize the length of the dewatered stream channel and duration of dewatering.
7. Any temporary dam or other artificial obstruction constructed shall only be built from materials such as sandbags or clean gravel that will cause little or no siltation. Impenetrable material shall be placed over sandbags used for construction of cofferdams construction to

minimize water seepage into the construction areas. The impenetrable material shall be firmly anchored to the streambed to minimize water seepage. Cofferdams and the stream diversion systems shall remain in place and fully functional throughout the construction period.

8. When cofferdams with bypass pipes are installed, debris racks will be placed at the bypass pipe inlet. Bypass pipes will be monitored a minimum of two times per day, seven days a week, during the construction period. The contractor or project applicant shall remove all accumulated debris.
9. Bypass pipe diameter will be sized to accommodate, at a minimum, twice the existing summer baseflow.
10. The work area may need to be periodically pumped dry of seepage. Place pumps in flat areas, well away from the stream channel. Secure pumps by tying off to a tree or stake in place to prevent movement by vibration. Refuel in an area well away from the stream channel and place fuel absorbent mats under pump while refueling. Pump intakes shall be covered with appropriate sized screening material to prevent potential entrainment of fish or amphibians that failed to be removed. Check intake periodically for impingement of fish or amphibians.
11. If pumping is necessary to dewater the work site, procedures for pumped water shall include requiring a temporary siltation basin for treatment of all water prior to entering any waterway and not allowing oil or other greasy substances originating from the contractor or project applicants operations to enter or be placed where they could enter a wetted channel. Projects will adhere to currently approved CDFW and NMFS Fish Screening Criteria (NMFS 2011).
12. Discharge wastewater from construction area to an upland location where it will not drain sediment-laden water back to the stream channel.
13. When construction is completed, the flow diversion structure shall be removed as soon as possible in a manner that will allow flow to resume with the least disturbance to the substrate. Cofferdams will be removed so surface elevations of water impounded above the cofferdam will not be reduced at a rate greater than one inch per hour. This will minimize the risk of beaching and stranding of fish as the area upstream becomes dewatered.
14. Isolate the diversion channel from the natural channel during excavation.
15. When diverting the flow into the temporary channel, first remove the downstream plug of the temporary channel, followed by the upstream plug. Next, close the upstream end of the natural channel and then close the downstream end.
16. To restore flow to the natural channel, first remove the downstream and then the upstream plug of the natural channel. Next, close the upstream end and then the downstream end of the diversion channel.
17. For each job site where equipment is used:
  - a. Install oil absorbent materials downstream of in-water work sites to trap accidental spills or leaks into streams from equipment. Store excavated spoils and equipment to prevent sediment delivery to watercourses [See Section S: Spoil Disposal Maintenance].

- b. Ensure spill contingency resources to contain a small to moderate spill (1-10 gallons) are in place.

**D. Dust Abatement**

1. Treat unpaved roads and staging areas with water, chemicals, soil stabilizers, mulch, or other cover during heavy use to reduce dust.
2. Treatment shall minimize mud sticking to equipment tires.
3. Apply methods and materials in a manner that is not detrimental to either water or vegetation. See *A Water Quality and Stream Habitat Protection Manual for County Road Maintenance in Northwestern California Watersheds* Table 3-B-2.1 for selection criteria and recommended application rates.
4. Use environmentally friendly dust palliatives where warranted.
5. Carry adequate spill protection materials when applying chemicals.
6. Use environmentally sensitive cleaning agents.
7. Dispose of excess materials at appropriate sites. Never dispose of materials in the riparian area or the floodplain.
8. Avoid applying excessive amounts of water onto road surface to prevent sediment runoff into ditches and the stream system.

**E. Electrofishing**

All electrofishing procedures will comply with Electrofishing Guidelines of the National Marine Fisheries Service 2016 Endangered Species Act (ESA) Section 7(a)(2) Biological Opinion and Magnuson-Stevens Fishery Conservation and Management Act Essential Fish Habitat Consultation:

1. All electrofishing will be conducted according to NMFS’ Guidelines for Electrofishing Waters Containing Salmonids Listed Under the Endangered Species Act (NMFS 2000).
2. The backpack electro-fisher shall be set as follows when capturing fish: Voltage setting on the electro-fisher shall not exceed 300 volts.

	Initial	Maximum
A) Voltage:	100 Volts	300 Volts
B) Duration:	500 microseconds	5 milliseconds
C) Frequency:	30 Hertz	30 Hetz

3. A minimum of three passes with the electro-fisher shall be utilized to ensure maximum capture probability of salmonids within the area proposed for dewatering.
4. Water temperature, dissolved oxygen, and conductivity shall be recorded in an electrofishing log book, along with electrofishing settings.
5. A minimum of one assistant shall aid the fisheries biologist by netting stunned fish and other aquatic vertebrates.

**F. Erosion Repair and Control**

1. Dispose of removed material at appropriate sites. For example, stable locations outside the maintenance area, or if within the maintenance area, where the material won't be washed into wetlands or waterways. [See Section T: Spoil Site Selection].
2. Apply appropriate erosion control BMPs based on the standard designs and procedures described for each practice. [See *A Water Quality and Stream Habitat Protection Manual for County Road Maintenance in Northwestern California Watersheds* Appendix B Sec. 4 and 9].
3. Apply erosion control measures in a timely manner. Treating sources by anticipating erosion from existing or potential problem sites before the rainy season is best.
4. Check temporary measures during and after storms, and remove sediment as needed (such as with silt fences, sandbags, and sediment traps). Materials used as temporary measures may need to be removed once the source of the erosion is stopped. Permanent measures, such as seeding, planting, and rocking, are preferred once the source of any runoff problem is corrected.
5. Coordinate any erosion repair activities (responses and cleanup of erosion problems, not the erosive action itself) which cause significant changes in the topography or vegetation within the riparian management area with the regulatory agencies.

#### **G. Fire Risk**

1. All internal combustion equipment will have USFS approved spark arrestors;
2. Maintain a water truck for rapid fire attack;
3. Maintain a fire suppression cache on-site;
4. Maintain a fire watch after all mechanical operations are completed;
5. Restrict welding and other activities that generate sparks;
6. Do not conduct mechanical operations after 1 pm on days with a fire or extreme fire danger rating.

#### **H. Fish Exclusion**

Fish Exclusion procedures complies with the Guidelines for Fish Capture and Relocation Activities of the National Marine Fisheries Service 2016 Endangered Species Act (ESA) Section 7(a)(2) Biological Opinion and Magnuson-Stevens Fishery Conservation and Management Act Essential Fish Habitat Consultation, Central Coast General Conditions for all Fish Capture and Relocation Activities, and any CDFW requirements:

1. Fish relocation and dewatering activities shall only occur between June 15 and October 31 of each year. If precipitation sufficient to produce runoff is forecast to occur while construction is underway, work will cease and erosion control measures will be put in place sufficient to prevent significant sediment runoff from occurring. Exceptions on the fish relocation/dewatering time period will be considered on a case-by-case basis only if justified and if precipitation sufficient to produce runoff is not forecast to occur during any of the above activities, and if approved by the RC, Corps and NMFS. If the channel is expected to be seasonally dry during this period, construction should be scheduled so that fish relocation and dewatering are not necessary.
2. A qualified fisheries biologist shall perform all seining, electrofishing, and fish relocation activities. The qualified fisheries biologist shall capture and relocate salmonids and other



native fish prior to construction of the water diversion structures (e.g., cofferdams). The qualified fisheries biologist shall note the number of salmonids observed in the affected area, the number of salmonids relocated, and the date and time of collection and relocation. The qualified fisheries biologist shall have a minimum of three years of field experience in the identification and capture of salmonids, including juvenile salmonids. The qualified biologist will adhere to the following requirements for capture and transport of salmonids:

- a. Determine the most efficient means for capturing fish. Complex stream habitat generally requires the use of electrofishing equipment, whereas in outlet pools, fish may be concentrated by pumping down the pool and then seining or dip netting fish.
  - b. Notify the RC one week prior to capture and relocation of salmonids to provide RC or NMFS staff an opportunity to attend.
  - c. Initial fish relocation efforts will be conducted several days prior to the start of construction. This provides the fisheries biologist an opportunity to return to the work area and perform additional electrofishing passes immediately prior to construction if there is water in the isolated construction area. In these instances, additional fish could be captured that eluded the previous day's efforts. If water is left in the construction area, dissolved oxygen levels sufficient for salmonid survival must be maintained.
  - d. At project sites with high summer water temperatures, perform relocation activities during morning periods.
  - e. Prior to capturing fish, determine the most appropriate release location(s). Consider the following when selecting release site(s):
    - f Similar water temperature as capture location
    - f Ample habitat for captured fish
    - f Low likelihood of fish reentering work site or becoming impinged on exclusion net or screen.
  - f. Periodically measure air and water temperatures and monitor captured fish. Temperatures will be measured at the head of riffle tail of pool interface. Cease activities if health of fish is compromised owing to high water temperatures, or if mortality exceeds three percent of captured salmonids.
3. Fish will be excluded from reentering the work area by blocking the stream channel above and below the work area with fine-meshed net or screens. Mesh will be no greater than 1/8-inch diameter. The bottom of the seine must be completely secured to the channel bed to prevent fish from reentering the work area. Exclusion screening must be placed in areas of low water velocity to minimize fish impingement. Upstream and downstream screens must be checked daily (prior to, during, and after instream activities) and cleaned of debris to permit free flow of water. Block nets shall be placed and maintained throughout the construction period at the upper and lower extent of the areas where fish will be removed. Block net mesh shall be sized to ensure salmonids upstream or downstream does not enter the areas proposed for dewatering between passes with the electro-fisher or seine.

#### Best Management Practices:

1. Consult with a qualified fishery biologist with an Incidental Taking Permit from NMFS and CDFG. A copy of the permit must be in possession of the person(s) authorized to collect the fish at the time of the fish exclusion activity.
2. Obtain any needed training from the qualified fishery biologist.

3. Only assist the supervising fishery biologist in the officially approved “incidental take permit” procedures when requested.
4. Help clean fish screens twice a day of leaves and debris, and report any dead fish to the supervising biologist.
5. Do not “harass, harm, pursue, hunt, shoot, wound, kill, trap, capture, or collect” a threatened or endangered species (i.e., “take”) without the above procedure.

What NOT to do:

- Do not “harass, harm, pursue, hunt, shoot, wound, kill, trap, capture, or collect” a threatened or endangered species (i.e., “take”) without the above procedure.

### **I. Fish Relocation**

Fish Relocation procedures complies with the Guidelines for Relocation of Salmonids of the National Marine Fisheries Service 2016 Endangered Species Act (ESA) Section 7(a)(2) Biological Opinion and Magnuson-Stevens Fishery Conservation and Management Act Essential Fish Habitat Consultation, Central Coast General Conditions for all Fish Capture and Relocation Activities, and any CDFW requirements:

1. Fish shall not be overcrowded into buckets, allowing no more than 150 0+ fish (approximately six cubic inches per 0+ individuals) per 5 gallon bucket and fewer individuals per bucket for larger/older fish.
2. Every effort shall be made not to mix 0+ salmonids with larger steelhead, or other potential predators, that may consume the smaller salmonids. Have at least two containers and segregate young-of-year (0+) fish from larger age classes. Place larger amphibians in the container with larger fish.
3. Salmonid predators, including other fishes and amphibians, collected and relocated during electrofishing or seining activities shall not be relocated so as to concentrate them in one area. Particular emphasis shall be placed on avoiding relocation of predators into the salmonid relocation pools. To minimize predation of salmonids, these species shall be distributed throughout the wetted portion of the stream to avoid concentrating them in one area.
4. All captured salmonids shall be relocated, preferably upstream, of the proposed construction project and placed in suitable habitat. Captured fish shall be placed into a pool, preferably with a depth of greater than two feet with available instream cover.
5. All captured salmonids will be processed and released prior to conducting a subsequent electrofishing or seining pass.
6. All native captured fish will be allowed to recover from electrofishing before being returned to the stream.
7. Minimize handling of salmonids. However, when handling is necessary, always wet hands or nets prior to touching fish. Handlers will not wear insect repellants containing the chemical N,N-Diethyl-meta-toluamide (DEET).
8. Temporarily hold fish in cool, shaded, aerated water in a container with a lid. Provide aeration with a battery-powered external bubbler. Protect fish from jostling and noise and do not remove fish from this container until time of release.

9. Place a thermometer in holding containers and, if necessary, periodically conduct partial water changes to maintain a stable water temperature. If water temperature reaches or exceeds those allowed by CDFW and NMFS, fish shall be released and rescue operations ceased.
10. In areas where aquatic vertebrates are abundant, periodically cease capture, and release at predetermined locations.
11. Visually identify species and estimate year-classes of fish at time of release. Count and record the number of fish captured. Avoid anesthetizing or measuring fish. Also identify hatchery (clipped adipose fin) and wild fish.
12. If more than 3 percent of the salmonids captured are killed or injured, the project permittee shall contact the NMFS California North Coast office.
13. The purpose of the contact is to review the activities resulting in take and to determine if additional protective measures are required. All salmonid mortalities must be retained, placed in an appropriately sized, zip-sealed bag, labeled with the date and time of collection, fork length, location of capture, and frozen as soon as possible. Frozen samples must be retained until specific instructions are provided by NMFS.

#### **J. Hazardous Materials**

1. Store hazardous materials under cover and away from areas that might drain into the storm water drainage system or watercourses, where feasible. Store granular materials at least 10 feet from waterways, storm drains, curbs, and gutters and under cover.
2. Keep labels on containers and ensure that covers or caps are secure.
3. Maintain an ample inventory of appropriate spill clean-up materials near the storage area. Keep absorbent and baking soda on hand to soak up spilled fluids and to neutralize spilled acid from cracked batteries.
4. Attend to any spills immediately.
5. Inspect storage areas regularly or weekly and before and after rainfall events. Ensure all containers are properly labeled, covered, securely fastened, and in good condition. Check for external corrosion or other signs of wear of material containers (CCR Title 22 Section 66265.174).

#### **K. Instream Bank Erosion Control**

1. Any installation of material that exceeds the material removed by bank erosion (below bankfull stage) will constitute significant action. Increases in the material profile will require additional coordination with regulating agencies, and are not covered in this document.
2. Replacement of riprap will follow DFG and NMFS in-water work periods, in non-emergency situations.
3. Use bioengineering solutions where practicable. Practicable use areas include areas not shaded by bridge elements, and where success is probable and safety of the structural elements is assured. [See *A Water Quality and Stream Habitat Protection Manual for County Road Maintenance in Northwestern California Watersheds* Appendix B Sec. B-7.1 to 7.7].

4. In large fluvial systems where in-water replacement of riprap is required, attempt to increase backwater areas, where appropriate, practical, and feasible.
5. Follow one of the standard practices and procedures for streambank protection and channel improvement. [See *A Water Quality and Stream Habitat Protection Manual for County Road Maintenance in Northwestern California Watersheds* Appendix B-7].

#### **L. Mulching**

1. Various types and sizes of mulch are available.
  - a. When mulching with straw, use at least 4,000 pounds of cereal grain straw or grass hay per acre to be evenly distributed over the area to be treated and anchored sufficiently to hold it on the site.
  - b. When mulching with wood fiber, use at least 2,000 pounds of wood fiber mulch per acre.
  - c. When mulching with other wood products (chips, bark, shavings) or other material, they must be applied in an amount that will provide at least 80% ground cover.
2. Apply over areas already seeded or planted to provide soil protection and insulation.
3. Cover soil sufficiently to allow seeds to germinate but thicker where seeding germination is not an issue.
4. Nets and matting may be used in combination with mulch, and can help keep mulch from blowing away.
5. Apply additional mulch where erosion or scouring occurs.
6. Repair if a tear in the cover netting or matting occurs.
7. Inspect weekly during construction or immediately after rainstorms.
8. Do not use on slopes steeper than 2 horizontal to 1 vertical, in watercourses and streams, and in ditches where water flow is continuous.

#### **M. Outdoor Loading & Unloading of Raw Materials**

1. Conduct outdoor loading and unloading on paved surfaces, where feasible.
2. Store an ample supply of spill clean-up materials in readily accessible locations in the vicinity of the loading/unloading area.
3. Limit exposure of the materials to precipitation. [See *A Water Quality and Stream Habitat Protection Manual for County Road Maintenance in Northwestern California Watersheds* Ch. 6-D-4].
4. Regularly check loading and unloading equipment for leaks before and after use.
5. Contain any leaks that occur during the transfer of materials.
6. If practical, place drip pans under hoses when making connections and during liquid material transfer. Promptly remove drip pan after use.
7. Inspect loading/unloading areas before and after precipitation events, and as needed during other times to promote good housekeeping.
8. Repair and replace perimeter controls, containment structures, and covers as needed to keep them properly functioning.

## **N. Outdoor Storage of Raw Materials**

1. Store materials away from areas that might drain into the storm water drainage system or other watercourse. Route stormwater run-on away from material storage areas through grading or sloping of the site, where feasible.
2. Cover the storage areas with a canopy or roof that is designed to direct run-on away from the storage area, where feasible.
3. Cover (tarp) dry materials that are not under a roof or canopy to prevent water intrusion during the winter season, where practical.
4. Protect storm drain inlets with sand bags, geotextile dams, filtration socks, berms, hay bales, etc. [See *A Water Quality and Stream Habitat Protection Manual for County Road Maintenance in Northwestern California Watersheds* Ch. 3-A-2; Appendix B-8 & B-9].
5. Inspect storage areas regularly.

## **O. Planting**

1. Correct choice of plant species and proper planting technique are critical to good plant survival.
2. Obtain container-grown or bare-root stock of native species found in the vicinity of the planting site from a nursery in the region. Large quantities (>100 plants of 1 species) may need to be special ordered (grown under contract) with the nursery at least 6-12 months in advance.
3. For moist areas, an option is to collect willow sprigs from a grove of willows near the area when dormant: sprigs should be at least ½ inch in diameter and 18 inches long, with 2-3 inches diameter and 3-4 feet long being the best.
4. Handle seedlings carefully and ensure they are kept sufficiently watered (soil mixture is damp, not dry or soggy) and shaded until site is ready to plant. In cool, damp weather, seedlings are vulnerable to mold. Plant willow sprigs same day as cut.
5. Clear away loose organic material, such as leaves and grasses, from the planting spot to expose mineral soil.
6. Dig hole with shovel or hoedad to be deep and wide enough for the roots to be fully extended. Fill hole, being sure soil falls around roots, and tamp soil firmly around base of plant with heel. Willow sprigs need to be 75-80% buried into the soil.
7. Add slow-release fertilizer tablet into hole, especially on poor soils.
8. Water site - if possible – immediately after planting and weekly during dry periods of the first year. An attachment from a water truck can be used to hand irrigate near roads.
9. DO NOT plant trees within the safety clear zone areas that could become hazardous, willows sprigs upside down, in the summer months, and where watering is unavailable.

## **P. Recreation Trail and Walkway**

1. Special attention shall be given to saving and maintaining key trees and other vegetation that have scenic value, provide shade, reduce erosion and runoff, provide den and food for wildlife, or add to the visual quality of the area.

2. Sustained grades shall be dictated by good judgment for the purpose intended, considering the topography, and shall not exceed 10 percent.
3. Generally the minimum treat width shall be 4 ft.
4. Equestrian and pedestrian trails may vary from specific grades, widths, and clearing requirements if so dictated by location and topography.
5. Adequate drainage shall be provided. A raised or elevated trail or walkway may be required for wet sites that cannot be drained.

#### **Q. Seeding**

1. Prepare site by removing weeds and debris, then loosening and roughening seedbed with a rake to 2-4" deep, if possible. Follow by raking smooth to a depth of ½ inch.
2. Select seed mix carefully. Species or variety selection should be based on:
  - a. Performance (high survival rate) under local climate conditions
  - b. Protection of native grass communities
  - c. No tendency to spread (be "non-invasive") or become a weed if an exotic
  - d. Need for annual (short-term) and/ or perennial (long-term) mix of species
  - e. Commercial availability of seed
  - f. Examples of Effective Native Seed Mixes: (a) Blue wildrye, California Brome, Idaho fescue, Squirreltail – for hot, dry sites; (b) Slender hairgrass, tufted hairgrass, red fescue, and California meadow barley – for moist sites
3. Spread seed at appropriate time of year (Sept. 1- Oct. 15 best) and application rates (ranging from 15-80 lbs/acre). A hand-seeding device can apply more uniformly than hand broadcasting. Hydromulch may be better for applying to steeper slopes.
4. Apply a slow-release fertilizer (such as ammonium phosphate 16-20-0) at recommended rate (e.g., 100 lb/acre). Re-apply in the second growing season to get full establishment.
5. Rake lightly after seeding to cover seeds with a ½ to 1 inch layer of soil.
6. Cover with certified weed-free (see County Agriculture Commissioner) straw (rye, barley, rice) mulch as needed to protect the surface during germination. [Note: "Organic" straw mulch is not the same thing and may contain many weed seeds.] Application rate varies at 2,000 -3,000 lbs/acre. See B-4.4 Mulching
7. Only use tackifiers on very steep slopes, if needed to hold down mulch. Be sure the type selected is non-toxic (e.g., not the asphalt-type).
8. Irrigate if rainfall is insufficient to keep soil moist during seed germination and establishment.
9. Re-seed if established grass cover is inadequate after one growing season.

#### **R. Spoil Site Disposal Closure**

1. Do not add excess unusable material to permanently closed sites.
2. Spread material not to be re-used in compacted layers, generally conforming to the local topography.
3. Design the final disposal site reclamation topography to minimize the discharge of concentrated surface water and sediment off the site and into nearby watercourses.
4. Cover the compacted surfaces with a 6-inch layer of organic or fine-grained soil, if feasible.

5. After placement of the soil layer, track walk the slopes perpendicular to the contour to stabilize the soil until vegetation is established. Track walking creates indentations that trap seed and decrease erosion of the reclaimed surfaces.
6. Revegetate the disposal site with a mix of native plant species. Cover the seeded and planted areas with straw compost, mulched with straw at a rate of 1 to 1 ½ tons per acre. Apply jute netting or similar erosion control fabric on slopes greater than 2:1 if site is erosive.

### **S. Spoil Site Disposal Maintenance**

1. Avoid placing excess spoils into stream courses and adjacent riparian zones where it could potentially result in sediment delivery to streams.
2. Drain spoil piles to prevent the concentration of flow and to prevent rill and gully erosion.
3. Spread material not to be re-used in compacted layers and generally conforming to the local topography.
4. Separate organic material (e.g., roots, stumps) from the dirt fill and store separately. Place this material in long-term, upland storage sites, as it cannot be used for fill. Leave all organic material that can safely remain in adjacent riparian zones. Make stored woody debris available to others as large wood for placement in streams for habitat improvement.
5. Store “clean” material in a short-term disposal site (stockpile) if it will likely be re-used for fill or shoulder widening projects. Verify if material can be used for shoulder widening. [See Sec. T: Spoil Site Selection].
6. Encourage stockpiling and reusing concrete materials when possible.

### **T. Spoil Site Selection**

1. Determine the location of existing disposal sites and potential disposal sites.
  - a. Conduct site investigations of existing and potentially suitable disposal sites. Site investigations should include the disposal area size, distance to watercourses, potential slope instabilities, listed species habitat, archaeological sites, nearby residential areas, access, and other limiting factors.
  - b. Prepare a map and data set indicating sites (existing and potential) with acceptable site characteristics (see below). Prioritize acceptable sites and initiate the permitting process.
  - c. Develop site plans for sites adjacent to or near riparian areas or streams to identify erosion and sediment control needs, and to ensure stability of the material.
2. Follow these acceptable site characteristics in the site election & design process:
  - a. Seek a stable site where sediment cannot reach the stream during any high water event.
  - b. Avoid adjacent riparian corridors or any area within the 100-year floodplain.
  - c. Avoid all wetland sites as these sites are protected from disposal activities and permits will be required and may not be granted.
  - d. Avoid placing spoil on unstable slopes, where the added weight could trigger a land movement. Excessive loading of clay or silt soils could also trigger a failure.

- e. Use wide, stable locations such as rock pits, ridges, and benches as places to dispose of fill. Avoid locations where ground water emerges or a thick organic layer is present.
- f. Avoid sites with endangered or threatened plant species, and avoid any unnecessary destruction of riparian habitat. Search the California Natural Diversity Database [<https://wildlife.ca.gov/Data/CNDDDB/Maps-and-Data>] for any known listed plant sites in the area. Seek site evaluations by qualified botanists during the appropriate season before selecting a new site.

#### **U. Stockpile Maintenance**

1. Keep temporary disposal sites out of wetlands, adjacent riparian corridors, and ordinary high water areas as well as high risk zones, such as 100-year floodplain and unstable slopes.
2. Anticipate sufficient storage area with no risk for sediment delivery for piles that may slump. Stress cracks indicate that the pile is at risk of slumping. See figure below.
3. Follow BMPs in Section N: Outdoor Storage of Raw Materials, where possible.
4. Reuse and recycle concrete, asphalt, and other construction waste when possible.

#### **V. Vegetation and Tree Removal**

1. Leave cut brush in riparian areas in place to minimize erosion, where doing so does not interfere with sight distance, create safety issues, cause fire hazards, involve noxious weeds or impair the proper functioning of road features, such as drainage.
2. Maintain shade trees along streams and rivers, unless those trees are hazard trees, could potentially impact bridge structures, or could impact line of sight. If trees provide shade or bank stabilization and are determined to be danger trees that must be removed, coordinate tree removal with DFG, CDF or other regulatory agency.
  - a. If Phase II (B)'s "Chop and Drop" is utilized, tree placement of up to twenty trees 12"- 24" diameter at breast height (DBH) in order to create complex habitat elements within the project reaches and encourage bedload entrainment. This will reduce incision in the upstream reach and increase entrainment of bedload in the downstream reach;
  - b. Streambank vegetation modification will be limited to a maximum of 125' linear distance on either stream bank within the 600 linear feet project area.
3. When removing mature trees in riparian areas, replant two native, site-appropriate trees for every tree removed. Ensure that the replanted trees will not pose a future threat to county structures. Leave the downed tree in the riparian corridor for recruitment as large woody debris, as long as it does not pose an immediate threat to infrastructure or property downstream.

#### **W. Vehicle & Equipment Maintenance & Repair**

1. Perform vehicle and equipment maintenance in a designated covered facility, where feasible.
2. When maintenance occurs onsite, the contractor shall select and designate an area to be used, subject to approval of the RE and implement appropriate controls for the activities to be performed.



3. Dedicated maintenance areas shall be on level ground and protected from storm water runoff and runoff, and shall be located at least 50 ft from downstream drainage facilities and receiving waters.
4. Absorbent spill clean-up materials and spill kits shall be available in maintenance areas and used on small spills instead of hosing down or burying techniques. Affected absorbent material and spill kits should be removed promptly and disposed of properly after use.
5. Drip pans or absorbent pads shall be placed under vehicles and equipment when performing maintenance work that involves fluids. Vehicles and equipment maintenance areas shall not be left unattended during maintenance activities.
6. Use drip pans or absorbent material under leaking vehicles and equipment to capture fluids. Promptly remove absorbent material or drip pan after use and dispose properly.
7. Vehicles and equipment shall be inspected on each day of use for leaks. Leaks shall be repaired immediately or removed from the project site.
8. Ensure that any spill can be diked and contained immediately by having necessary materials on-site and appropriate training. Clean up all smaller spills using absorbent material or a dry mop method. Place absorbent material collected by sweeping into a waste container. Dispose of the contents according to approved disposal procedures. Large spills may require a private company or Hazmat (Hazardous Materials) team for complete clean-up.
9. Use safer alternative housekeeping products to minimize the potential discharge of toxic products to storm water drainage systems or watercourses, where practical and effective.

#### **W. Waste Minimization, Handling & Disposal**

1. Methods for reducing the discharge of potential pollutants in waste include source reduction, reuse and recycling, tracking of waste generation, safe storage and disposal practices, and minimizing contact between storm water and waste.
2. Purchase or order supplies in smaller quantities to minimize excess or expired materials, when possible.
3. Closely evaluate waste streams: processes generating waste, chemical spill records, shelf life expiration, and product or raw material inventory records.
4. Inspect waste storage areas to ensure that materials stored in the area are not leaking, and if they do leak, take immediate measures to repair the leak.
5. Train staff to minimize wastes (e.g., use all paint, stop leaks and spills, and recycle all oil). Allow empty paint containers to evaporate prior to disposal.
6. Reduce or minimize waste handling activities when it is raining, the ground is frozen, or the ground is saturated.

## Appendix 5- Designs

# EAST WEAVER CREEK DAM REMOVAL AND INTAKE RELOCATION PROJECT

## GENERAL NOTES:

- Source of Topography:** 2013 and 2018 SURVEY BY FIVE COUNTIES SALMONID CONSERVATION PROGRAM 40 Horseshoe Lane Weaverville, CA 96093
- Datums:**  
HORIZONTAL ASSUMED  
VERTICAL ASSUMED
- Design Intent:** These drawings represent the general design intent to be implemented and contractor is responsible for all terms shown on these Plans. Contractor shall be responsible for contacting Engineer for any clarifications or further details necessary to accommodate actual site conditions. Any deviation from these Plans without the Engineer's approval are at the contractor's own risk and expense. Notify Engineer immediately of any unexpected and changed conditions, safety hazards, and environmental problems encountered.
- Pre-construction Meeting:** A pre-construction meeting will be held at the job site(s) to be attended by the Engineer and the Construction Site Foreman and key contractor work personnel. The purpose of the meeting is to go over the work, provide clarifications, and discuss conditions of the permits. Special attention will be paid to Fisheries and Endangered Species issues and protection requirements. Provide Engineer with minimum 72 hours notice prior to meeting. Notice to proceed will be provided at completion of Pre-construction meeting.
- Completion Schedule:** Provide Engineer with project construction completion schedule within 72 hours of award of contract. All work within stream channels must be completed by October 15, 2020 and all erosion control measures must be in place by October 15, 2020. All contract work must be completed by and contractor demobilized by November 15, 2020.
- Clarifications, Change Orders, and Additional Work:** The Engineer, acting on behalf of the Northwest California Resource Conservation and Development Council (Northwest California RC&D Council), may require revisions in the Plans due to unforeseen circumstances and problems that may arise in the field. Extra Work will be that as defined in the most recent State of California Caltrans Standard Specifications. Contractor is to promptly notify the Project Manager of all work considered Extra. Written cost estimates will be required for all Extra Work and written change orders will be executed upon the recommendation of the Engineer by the Northwest California RC&D Council.
- Materials and Workmanship:** All materials, workmanship, and construction shall conform to the most recent State of California Caltrans Standard Specifications unless otherwise noted.
- Job Site Conditions and Contractor Responsibility:** Contractor shall assume sole and complete responsibility for site conditions during the course of the construction of this project, including the safety of all persons and property, and all environmental protection elements, whether shown on these Drawings or not. Contractor shall follow all applicable construction and safety regulations. These requirements shall apply continuously and will not be limited to normal working hours. The Contractor shall defend, indemnify, and hold Northwest California RC&D Council and the project engineer harmless from any and all liability, real or alleged, in the connection with the performance of work on this project, except from liability arising from the sole negligence of the Owner or Engineer.
- Damage:** Contractor shall exercise care to avoid damage to existing public and private property, including ornamental and native trees and shrubs, and other property improvements. If contractor causes damages to such items, he shall be responsible for repair or replacement in like number, kind, condition, and size. Any such cost may be deducted by Northwest California RC&D Council from monies due Contractor under this contract.
- Limits of Work, Access, Staging and Mobilization Areas:** The approximate Limits of Work are shown on the Drawings. Exact Limits of Work, points of ingress-egress, creek channel access, mobilization, staging, and work areas will be flagged in the field by the Project Manager or Engineer. All materials, excess soil, demolition debris and rubble and equipment and equipment storage must occur within the staging and mobilization area. Equipment maintenance and fueling must occur within the staging and mobilization areas.
- Utilities:** Prior to commencing construction, the contractor is required to contact the utility companies involved and request a visual verification of the location of their underground facilities. It shall be the responsibility of the contractor to identify, locate, and protect all underground utilities. The utility companies are thought to be members of the Underground Service Alert (USA) On-call program. The contractor shall notify USA 48 hours in advance of performing excavation work by calling toll-free 1-800-642-2444.
- Erosion Control:** Contractor is responsible for all erosion control as part of the work. Install silt fence and/or hay bale barrier at downslope end of all channel grading projects prior to initiation of creek grading work. Hydroseed or broadcast seed, rake and straw mulch all disturbed areas upon job completion as shown on Drawings.
- Work in Stream Channels and Stream Diversions:** All work involving use of heavy equipment must be completed from top of bank unless a specific point of creek channel access has been approved and is shown on the plans, and then only in non-live water as defined by the Calif. Dept of Fish and Wildlife. The Contractor shall be responsible for following the Stream Diversion and Water Control Plan. All stream diversion and water control work is assumed to be part of the mobilization and/or earthwork job requirements for payment purposes.

At or before the Pre-construction meeting, the contractor shall submit written and/or graphic descriptions of how the project site work areas will be dewatered, including but not limited to bypassing low flows around the work site to a point downstream of a silt trap (if deemed necessary), constructing of such a silt trap, necessary holding facilities, upstream or downstream cofferdams, pumps or pipe conveyance systems. In general, sandbag and geotextile filter fabric diversion structures and creek lining are preferred. Contractor is responsible for removal and disposal of all water control structures.

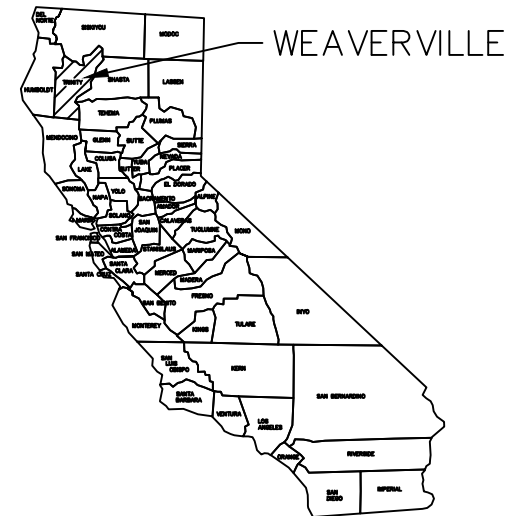
The contractor shall furnish, install and operate all necessary machinery, appliances and equipment to divert flowing water around work areas, and to keep excavations and trenches reasonably free from water during construction. Contractor shall dispose of the water so as not to cause injury to public or private property, or to cause a nuisance or a menace to the public, or to degrade water quality. The contractor shall at all times have on hand sufficient pumping equipment and machinery in good working condition for all ordinary emergencies and shall have available at all times competent mechanics for the operation of all pumping equipment. If the contractor chooses to use a pumping system for any portion of the water control work he shall have adequate back-up equipment to ensure the continuous operation of the equipment.

The Contractor shall at times provide for the adequate return flow of diversions below the project site. The Contractor may temporarily divert water during construction as outlined in their approved Stream Diversion and Water Control Plan. This may include for instance, visqueen and straw bale or sandbag diversion dikes and piping systems.

Turbid dewatering flows shall be pumped into a holding facility or sprayed over a large area outside the stream channel to allow for natural filtration of sediments. At no time shall turbid water be allowed back into the stream channel until water is clear of silt.

All heavy equipment must have a supply of sorbent pads available to clean-up grease, oil, or fuel that drips or spills into the stream channel. Used pads and booms are to be disposed of properly at Contractor's expense.

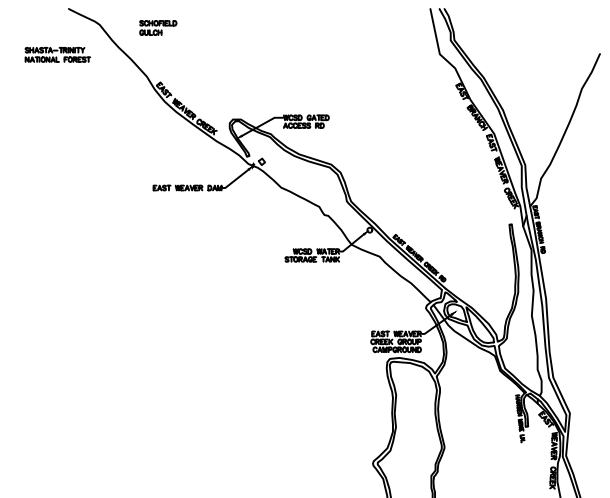
- Endangered Species May Be Present In Work Areas:** The regulatory agencies including the California Dept. of Fish and Wildlife, the U.S. Fish and Wildlife Service, and the National Marine Fisheries Service will issue terms and conditions and other permit requirements related to work in or near the stream channel. This will likely require periodic inspections, monitoring, and capturing and moving fish and other aquatic organisms. Northwest California RC&D Council will be responsible for providing a Biological Monitor to perform the required inspections, monitoring, and capture and move work tasks. Contractor is to coordinate with Engineer and Biologist in meeting these conditions of approval. The Biologist will have the authority to shut down the job site if in their opinion, Contractor is violating conditions of the permits, or if there is a significant threat to the safety of Endangered Species.
- Earthwork and Grading:** All earthwork and grading shall be done in conformance with Chapter 33 of the UBC, the grading ordinance of Trinity County, and as shown on these Drawings. Grading work will be completed under the direct supervision of the Engineer. Contractor is to provide a smooth or uniform slope as shown on the Drawings, and uniform transition to adjacent natural grades. Clearing for earthwork and grading shall be narrowly confined to only that absolutely necessary to complete the work, within the Limits of Work. Additional, unauthorized grading outside of the Limits of Work will not be compensated for and must be restored and repaired by Contractor. The final grade must be approved by the Engineer.
- Earthwork Quantities:** Contractor is responsible for all earthwork, including grading, provision and placement of rock meeting size limits, as shown on Drawings, and off-haul and legal disposal of all excess soil and rubble. Earthwork quantities, including grading, placed rock rip-rap and off-haul quantity estimates provided by Engineer is for purposes of estimating permit fees and for bid comparison only. Contractor is responsible for pre-bid job site inspection and independent estimation of all quantities. Northwest California RC&D Council and Engineer do not, expressly or otherwise by implication, extend any warranty to earthwork calculations.
- Archaeological Resources:** If Archaeological or Cultural Resources are identified during the work, then all work will halt in the affected area until a qualified professional is brought in to determine the significance of the resources, assess the situation and make recommendations.  
  
The Northwest California RC&D Council will be responsible for developing and implementing a plan for dealing with the resources.
- Permits:**  
*Sec. 404 permit issued by US Army Corps of Engineers*  
*1602/1603 Streambed Alteration Agreement issued by CA Dept. Fish & Wildlife*  
*NPDES Storm Water Discharge permit and Water Quality Certification, by North Coast Regional Water Quality Control Board*  
*US Fish and Wildlife Service Consultation and Implementation Recommendations*  
*National Marine Fisheries Services Consultation and Implementation Recommendations*
- Telephone Numbers:**  
  
Project Lead: Northwest California RC&D Council  
Contact: Mark Lancaster (530) 623-3967 ext. 111



**REGIONAL VICINITY**  
NTS

## SHEET LEGEND:

- TITLE SHEET
- STAGING AND SURVEY CONTROL PLAN
- DEMOLITION AND DEWATERING PLAN
- GRADING PLAN AND PROFILE
- IMPROVEMENTS PLAN
- CROSS SECTIONS
- PIPELINE PROFILE
- PIPELINE TIE IN DETAIL
- PIPELINE DETAILS
- INTAKE STRUCTURAL PLANS
- ACCESS RAMP STRUCTURAL PLANS
- ELECTRICAL DETAILS
- CONE SCREEN PLANS
- CONE SCREEN FLOW RATES
- FLOW CALCULATOR



**PROJECT VICINITY**  
NTS



## EAST WEAVER CREEK DAM REMOVAL AND INTAKE RELOCATION PROJECT



NORTHWEST CALIFORNIA RESOURCE  
CONSERVATION AND DEVELOPMENT COUNCIL  
FIVE COUNTIES SALMONID CONSERVATION  
PROGRAM

P.O. Box 2571 • 40 HORSESHOE LANE • WEAVERVILLE, CA 96093



Sh't	Rev	Date	By	Description	App'r'd	Design	OR, AR

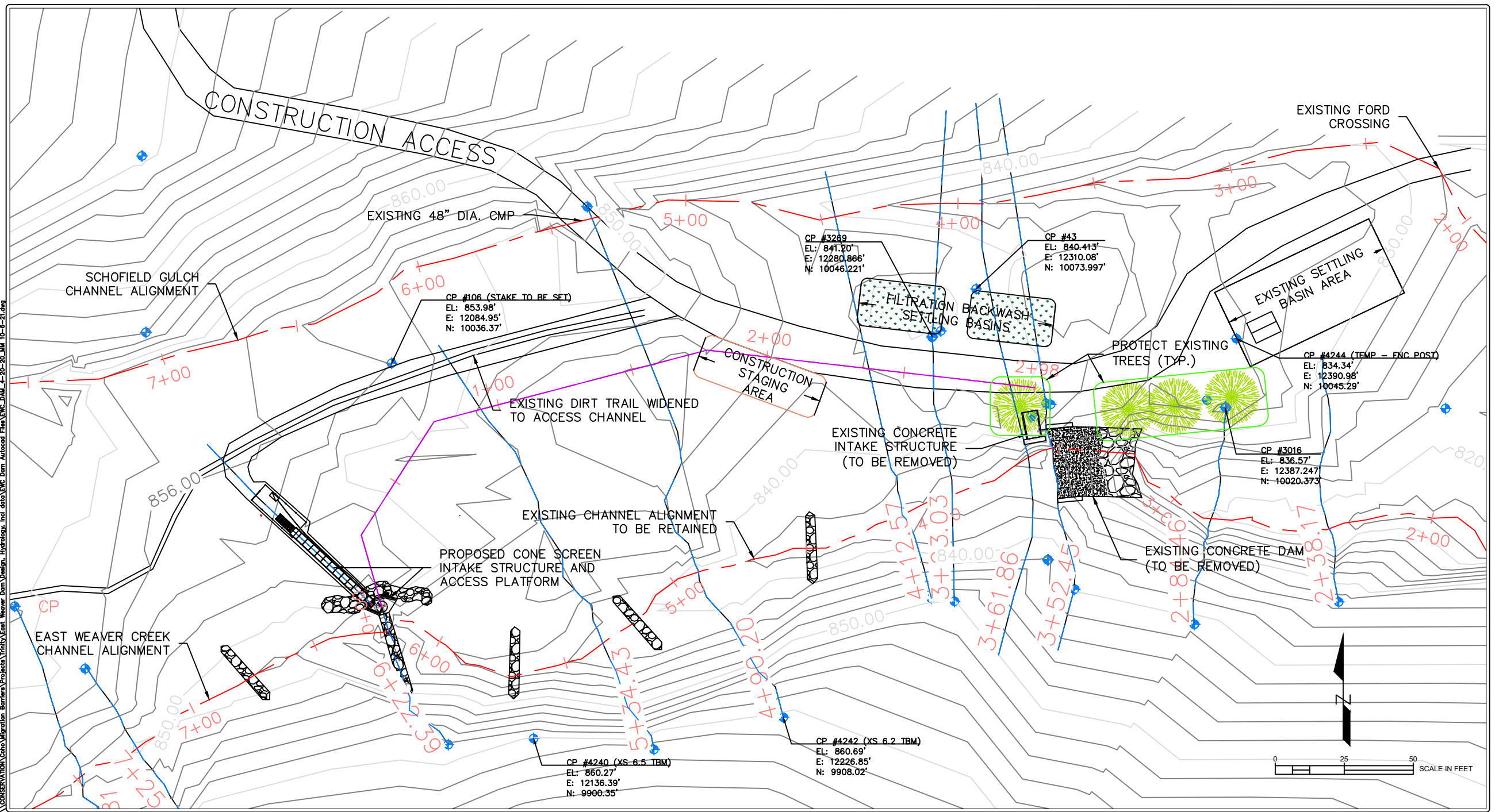
Design	OR, AR
Drawn	OR
Checked	AR
App'r'd	

TITLE SHEET

EAST WEAVER DAM  
WEAVERVILLE, CALIFORNIA

Size	Project No.	Rev
Scale	AS SHOWN	
Date	10/18/21	
Sheet	1 of 15	

CONSERVATION\Conservation\Projects\Trinity\East\_Weaver\_Dam\Design\_Hydrology\Info\DWG\DWG\_10-18-21.dwg



**EAST WEAVER CREEK DAM REMOVAL AND INTAKE RELOCATION PROJECT**



NORTHWEST CALIFORNIA RESOURCE CONSERVATION AND DEVELOPMENT COUNCIL  
FIVE COUNTIES SALMONID CONSERVATION PROGRAM  
P.O. Box 2571 • 40 HORSESHOE LANE • WEAVERVILLE, CA 96093



Sht	Rev	Date	By	Description	Appr'd

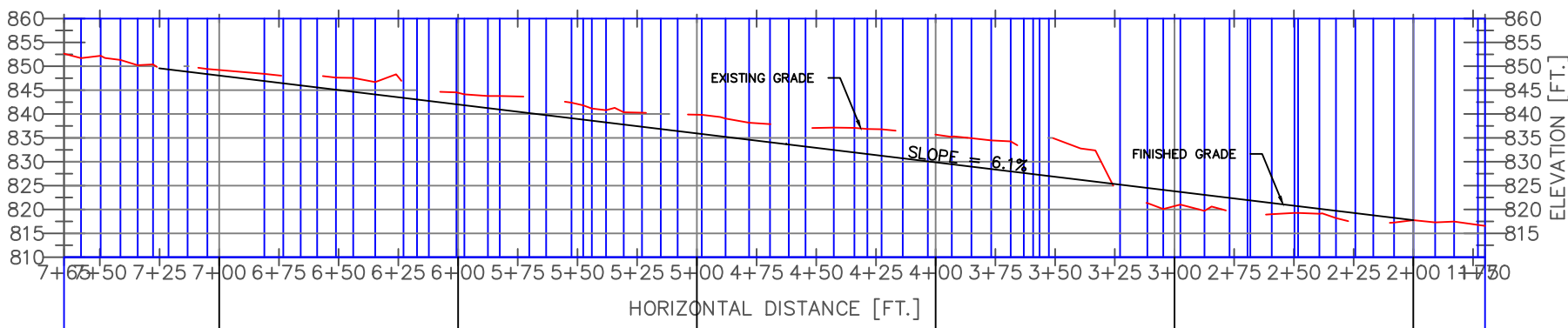
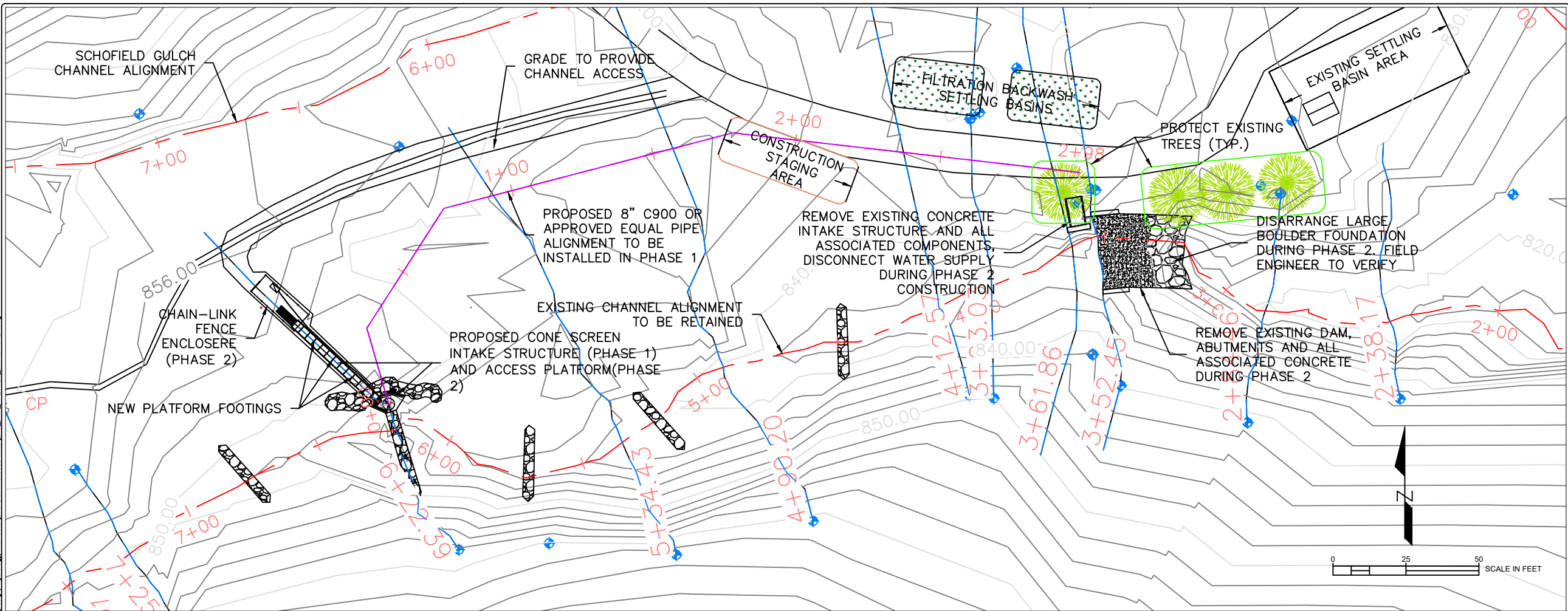
Design	OR, AR
Drawn	OR
Checked	AR
Appr'd	

**STAGING AND SURVEY CONTROL PLAN**  
EAST WEAVER DAM  
WEAVERVILLE, CALIFORNIA

Size	Project No.	Rev
Scale	AS SHOWN	
Date	10/18/21	
Sheet	2 of 15	



CONSERVATION\Cono\Migration\_Barriers\Projects\Trinity\East\_Weaver\_Dam\_Design\_Hydrology\_10-18-21.dwg



**NOTE:**  
 EXCESS SEDIMENTS MAY BE USED FOR CONSTRUCTION DOWNSTREAM ON THE EAST BRANCH EAST WEAVER CREEK CULVERT REPLACEMENT PROJECT. EXCESS SEDIMENTS MAY ALSO BE SPREAD DOWNSTREAM OF THE DAM REMOVAL AT THE DIRECTION OF SUPERVISING ENGINEER.  
 ALL OVER-MATERIAL MUST BE HAULED OFF.

**EAST WEAVER CREEK DAM REMOVAL AND INTAKE RELOCATION PROJECT**



NORTHWEST CALIFORNIA RESOURCE CONSERVATION AND DEVELOPMENT COUNCIL  
 FIVE COUNTIES SALMONID CONSERVATION PROGRAM  
 P.O. Box 2571 • 40 HORSESHOE LANE • WEAVERVILLE, CA 96093



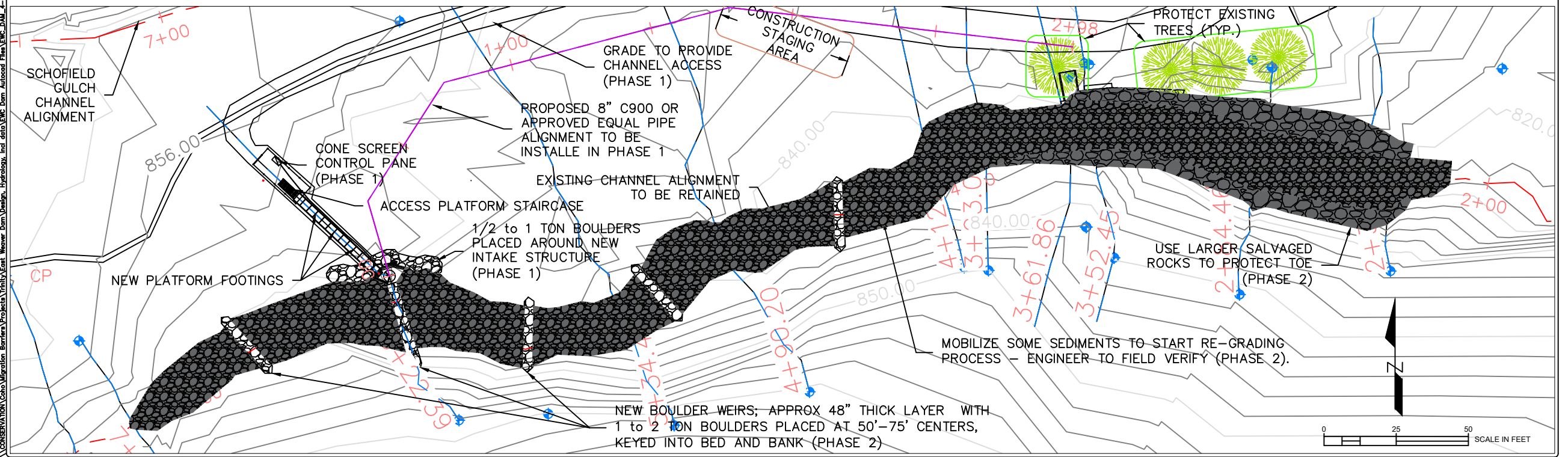
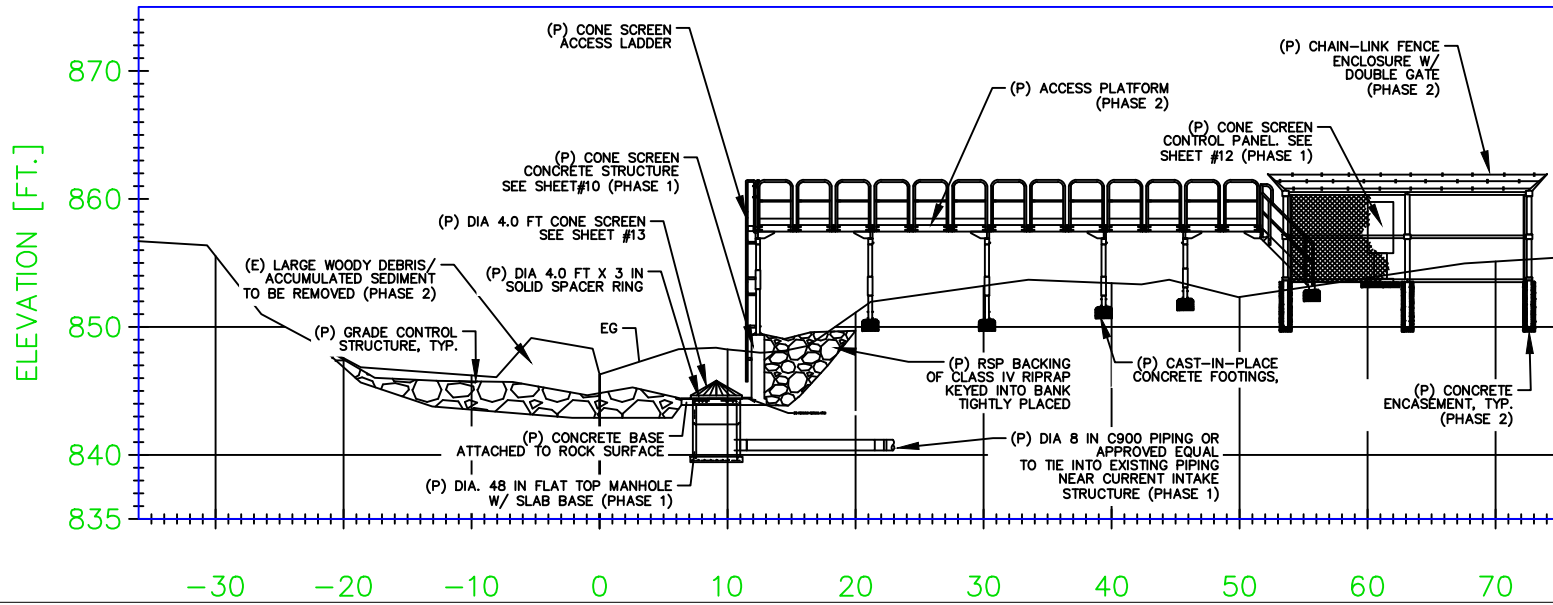
Sht	Rev	Date	By	Description	Appr'd

Design	OR, AR
Drawn	OR
Checked	AR
Appr'd	----

**GRADING PLAN AND PROFILE**  
**EAST WEAVER DAM**  
**WEAVERVILLE, CALIFORNIA**

Size	Project No.	Rev
Scale	AS SHOWN	
Date	10/18/21	
Sheet	4 of 15	





CONSERVATION\Cons\Migration\_Borders\Projects\Trinity\East\_Weaver Dam\Design\_Hydrology\10-10-21.dwg

**EAST WEAVER CREEK DAM REMOVAL AND INTAKE RELOCATION PROJECT**



NORTHWEST CALIFORNIA RESOURCE CONSERVATION AND DEVELOPMENT COUNCIL  
 FIVE COUNTIES SALMONID CONSERVATION PROGRAM  
 P.O. Box 2571 • 40 HORSESHOE LANE • WEAVERVILLE, CA 96093



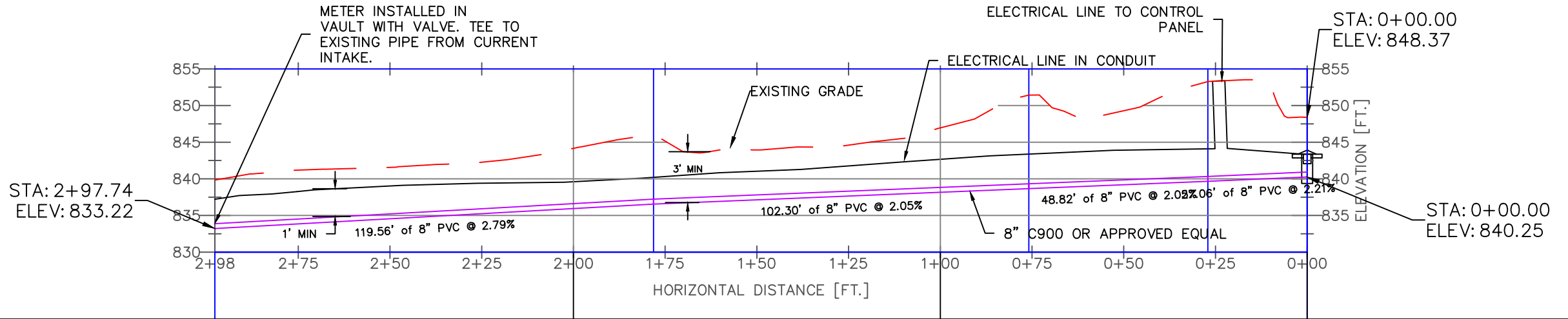
Sht	Rev	Date	By	Description	Appr'd	Design	OR, AR

**CROSS-SECTIONS**

EAST WEAVER DAM  
WEAVERVILLE, CALIFORNIA

Size	Project No.	Rev
Scale	AS SHOWN	
Date	10/18/21	
Sheet	6	of 15





INTAKE PIPELINE PROFILE

\\CONSERVATION\Cono\Migration\_Barriers\Projects\Trinity\East\_Weaver\_Dam\_Design\_Hydrology\In\_data\ENC\_DAM\_1-20-20\_JM\_10-8-21.dwg

**EAST WEAVER CREEK DAM REMOVAL AND INTAKE RELOCATION PROJECT**



NORTHWEST CALIFORNIA RESOURCE CONSERVATION AND DEVELOPMENT COUNCIL  
 FIVE COUNTIES SALMONID CONSERVATION PROGRAM

P.O. Box 2571 · 40 HORSESHOE LANE · WEAVERVILLE, CA 96093



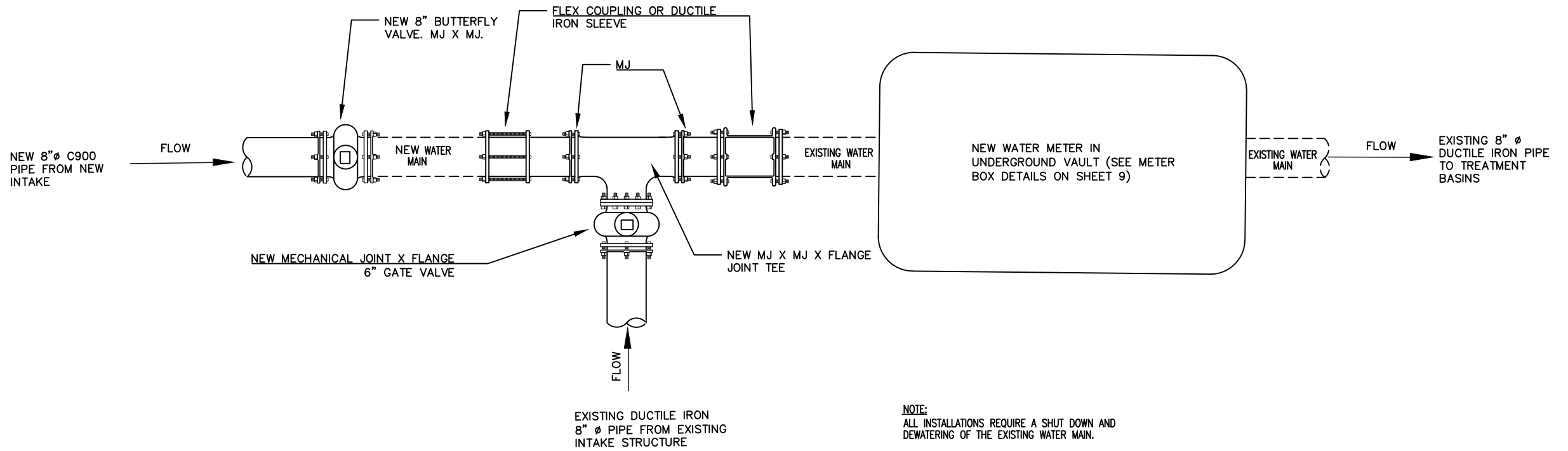
Sht	Rev	Date	By	Description	Appr'd

Design	OR, AR
Drawn	OR
Checked	AR
Appr'd	----

PIPELINE PROFILE  
 EAST WEAVER DAM  
 WEAVERVILLE, CALIFORNIA

Size	Project No.	Rev
Scale	AS SHOWN	
Date	10/18/21	
Sheet	7	of 15

CONSERVATION\Conservation\Projects\Trinity\East Weaver Dam\Design\_Hydrology\In\_data\ENC Dam\_Autocad Files\ENC\_DAM\_4-20-20\_MM\_10-8-21.dwg



**NOTE:**  
ALL INSTALLATIONS REQUIRE A SHUT DOWN AND DEWATERING OF THE EXISTING WATER MAIN.

**PIPE TIE IN DETAIL**  
NTS

**EAST WEAVER CREEK DAM REMOVAL AND INTAKE RELOCATION PROJECT**



NORTHWEST CALIFORNIA RESOURCE CONSERVATION AND DEVELOPMENT COUNCIL  
FIVE COUNTIES SALMONID CONSERVATION PROGRAM  
P.O. Box 2571 · 40 HORSESHOE LANE · WEAVERVILLE, CA 96093



Sht	Rev	Date	By	Description	Appr'd

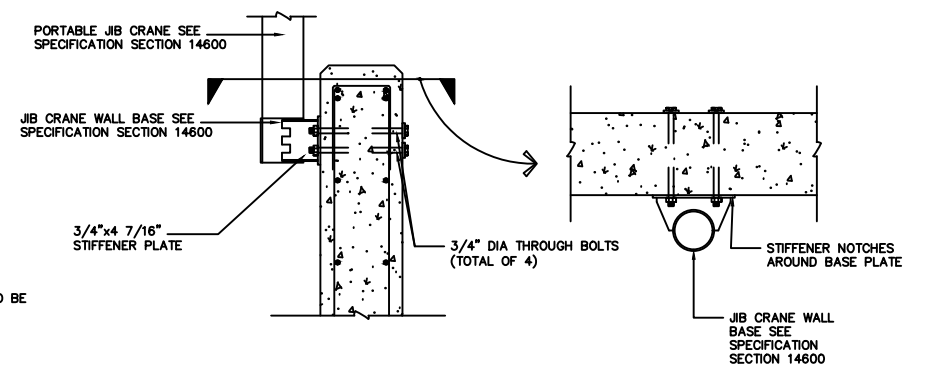
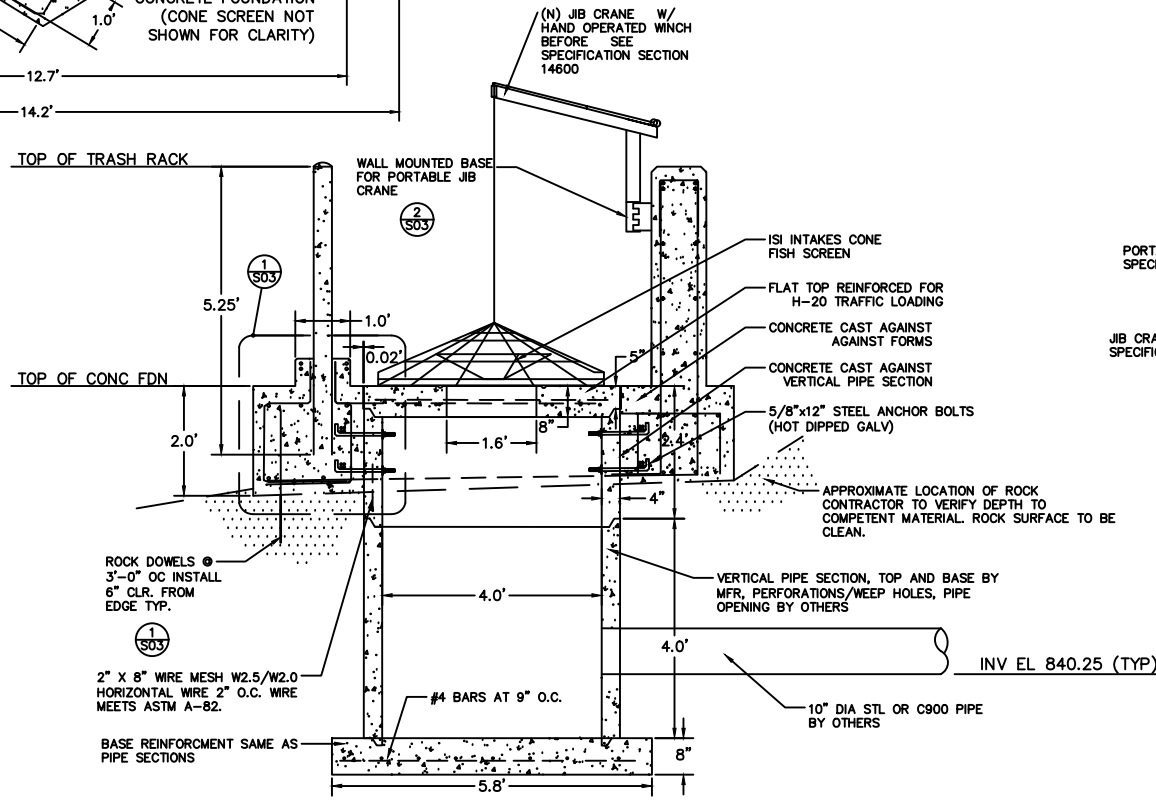
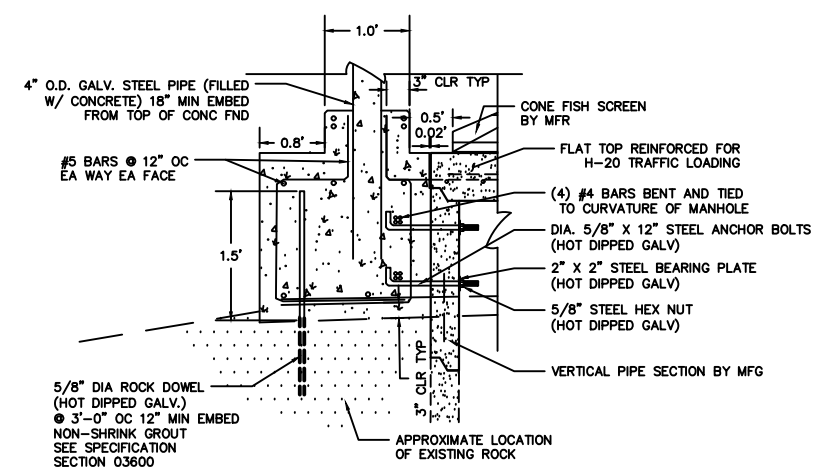
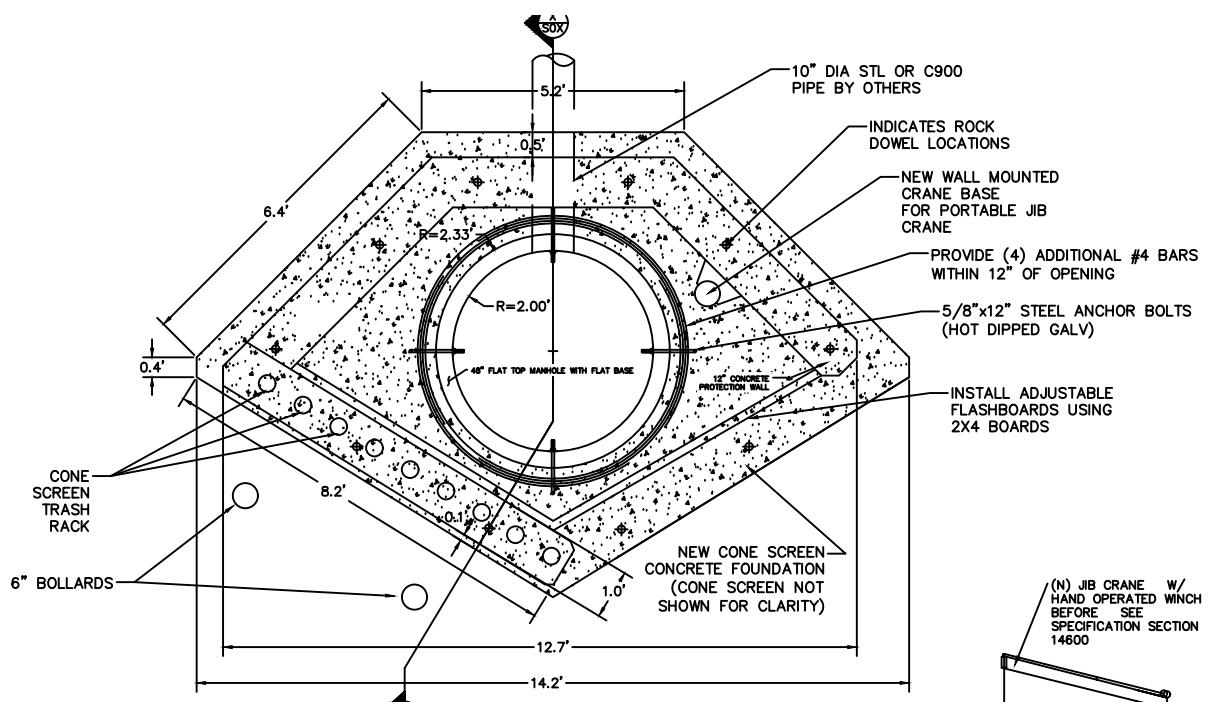
Design	MM, AR
Drawn	MM
Checked	AR
Appr'd	----

**PIPELINE TIE IN DETAIL**  
EAST WEAVER DAM  
WEAVERVILLE, CALIFORNIA

Size	Project No.	Rev
Scale	AS SHOWN	
Date	10/18/21	
Sheet	8	of 15



CONSERVATION\Cono\Migration\Barriers\Projects\Trinity\East\_Weaver\_Dam\_Design\_Hydrology\10-18-21.dwg



PLAN

NOTE: ALL STEEL AND HARDWARE SHALL BE HOT DIPPED GALVANIZED AS PROVIDED BY THE MANUFACTURER.

**EAST WEAVER CREEK DAM REMOVAL AND INTAKE RELOCATION PROJECT**



NORTHWEST CALIFORNIA RESOURCE CONSERVATION AND DEVELOPMENT COUNCIL  
FIVE COUNTIES SALMONID CONSERVATION PROGRAM  
P.O. Box 2571 • 40 HORSESHOE LANE • WEAVERVILLE, CA 96093

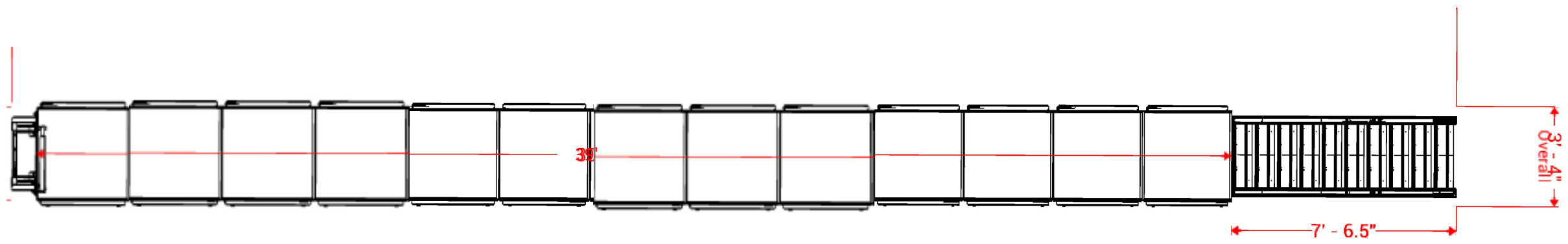
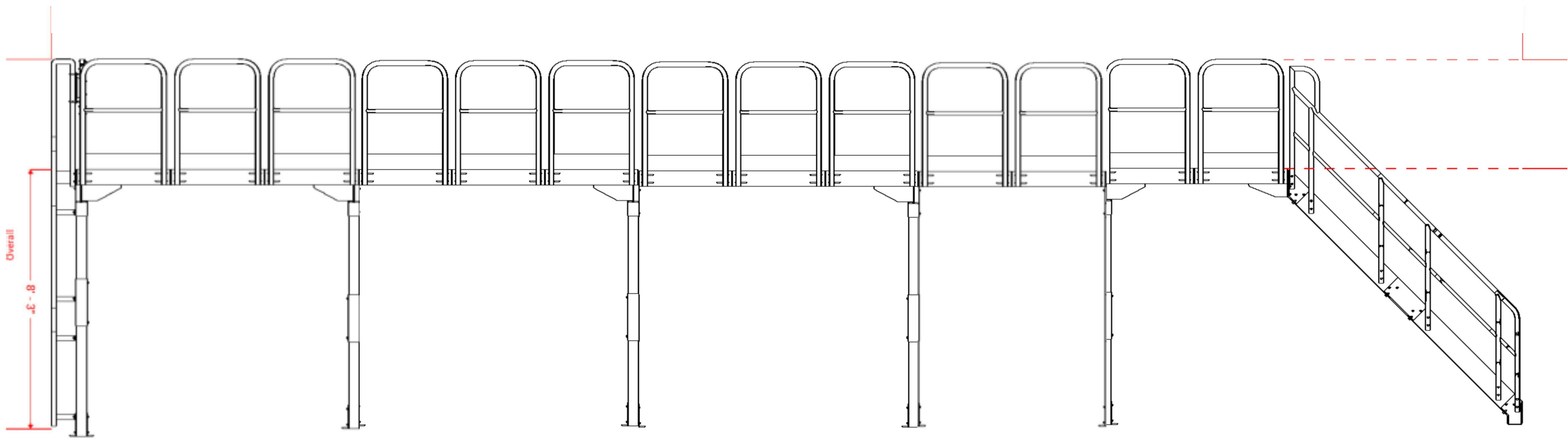


Sht	Rev	Date	By	Description	Appr'd	Design	OR, AR

Design OR, AR  
Drawn OR  
Checked AR  
Appr'd

**INTAKE STRUCTURAL PLANS**  
EAST WEAVER DAM  
WEAVERVILLE, CALIFORNIA

Size	Project No.	Rev
Scale	AS SHOWN	
Date	10/18/21	
Sheet	10	of 15



**EAST WEAVER CREEK DAM REMOVAL AND INTAKE RELOCATION PROJECT**



NORTHWEST CALIFORNIA RESOURCE CONSERVATION AND DEVELOPMENT COUNCIL  
 FIVE COUNTIES SALMONID CONSERVATION PROGRAM  
 P.O. Box 2571 · 40 HORSESHOE LANE · WEAVERVILLE, CA 96093



Sht	Rev	Date	By	Description	Appr'd

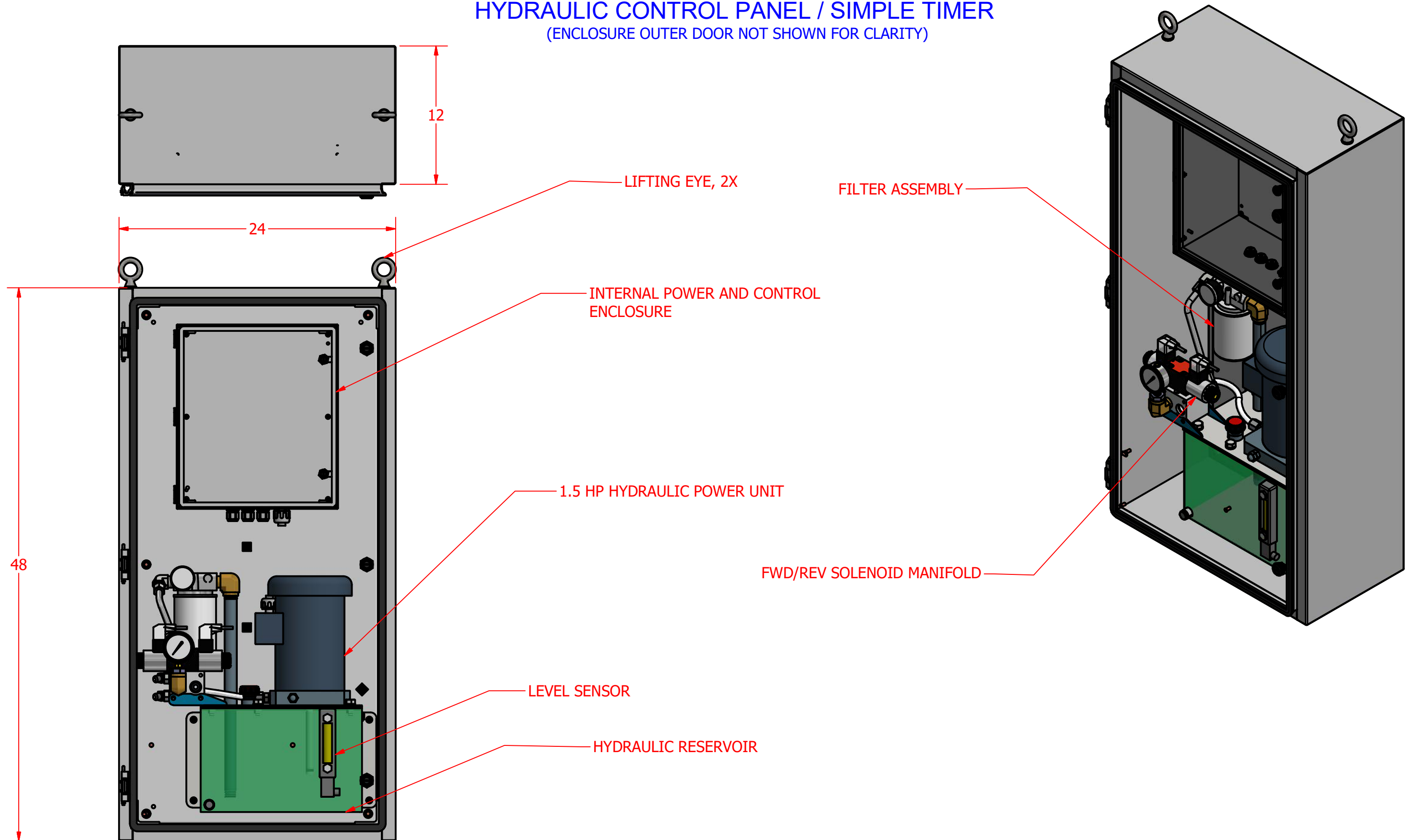
Design ----  
 Drawn ----  
 Checked ----  
 Appr'd ----

**ACCESS RAMP STRUCTURAL PLANS**  
 EAST WEAVER DAM  
 WEAVERVILLE, CALIFORNIA

Size	Project No.	Rev
Scale	AS SHOWN	
Date	4/22/20	
Sheet	11	of 14

# HYDRAULIC CONTROL PANEL / SIMPLE TIMER

(ENCLOSURE OUTER DOOR NOT SHOWN FOR CLARITY)



ALL DIMENSIONS IN INCHES UNLESS NOTED			
REV	DESCRIPTION	DATE	APPROVED
Designs are property of INTAKE SCREENS INC, and are subject to change without notice.		Fractional Dimensions ± 1/32 Decimal Dimensions ± 0.005	

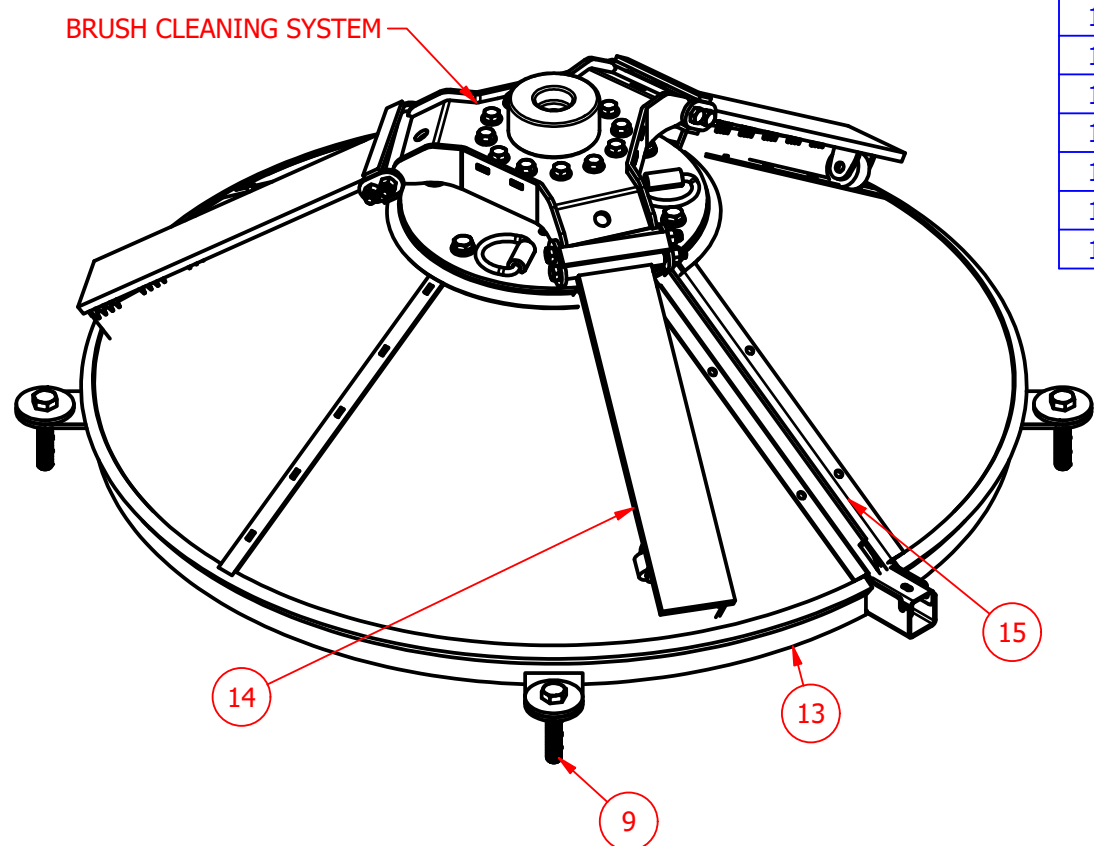
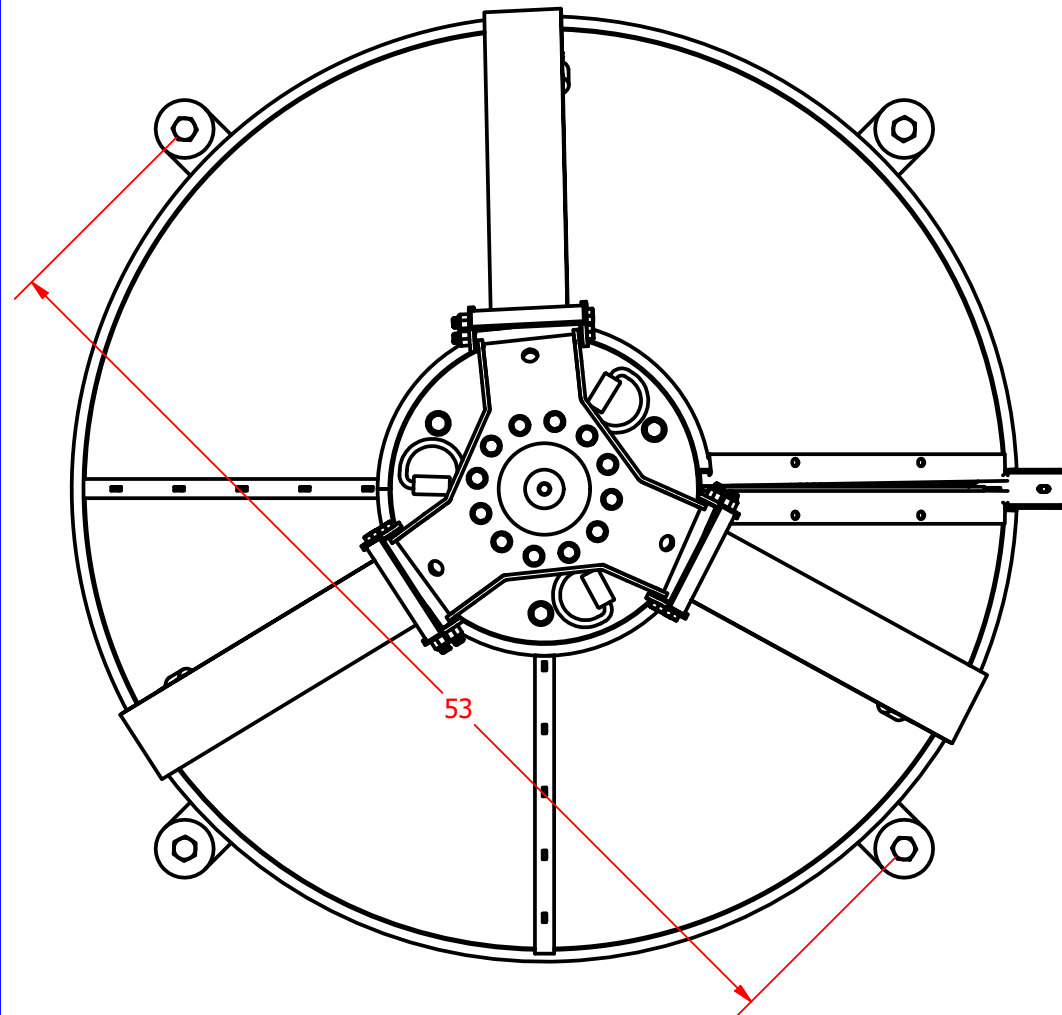
www.intakescreensinc.com  
CA CL. 796197

Intake Screens, Inc.  
8417 River Road - Sacramento, California 95832  
(916) 665-2727 (916) 665-2729 FAX

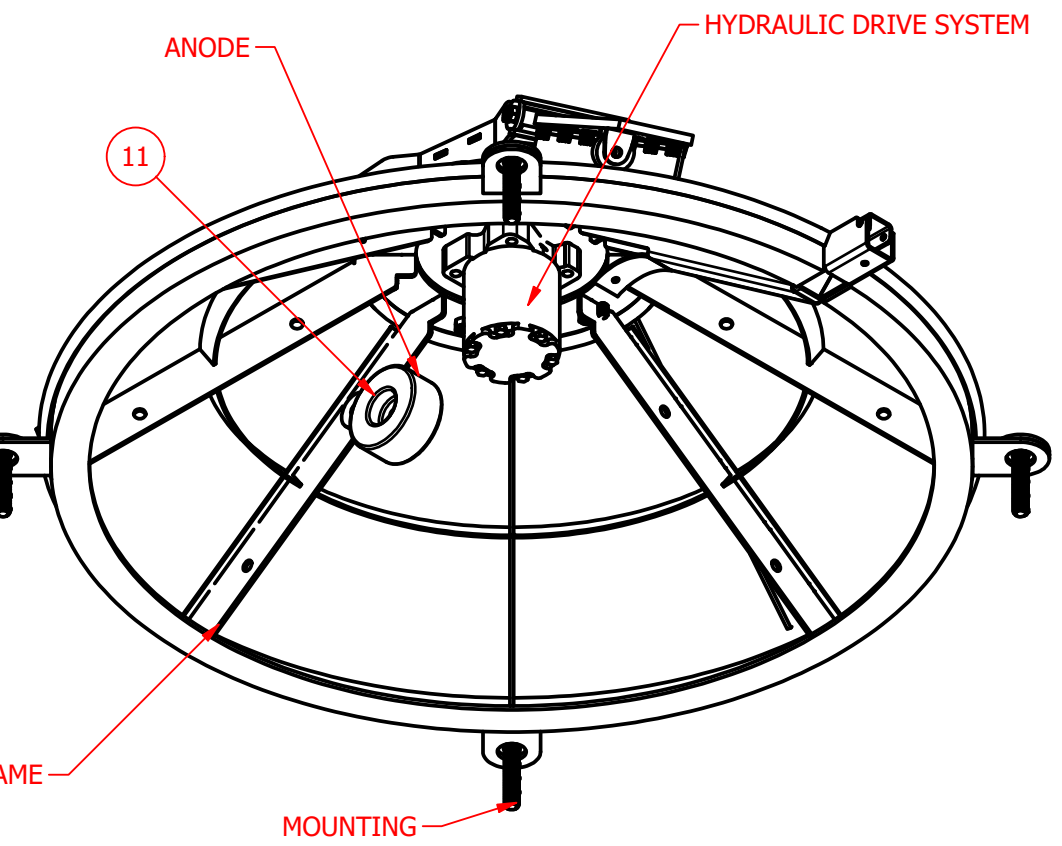
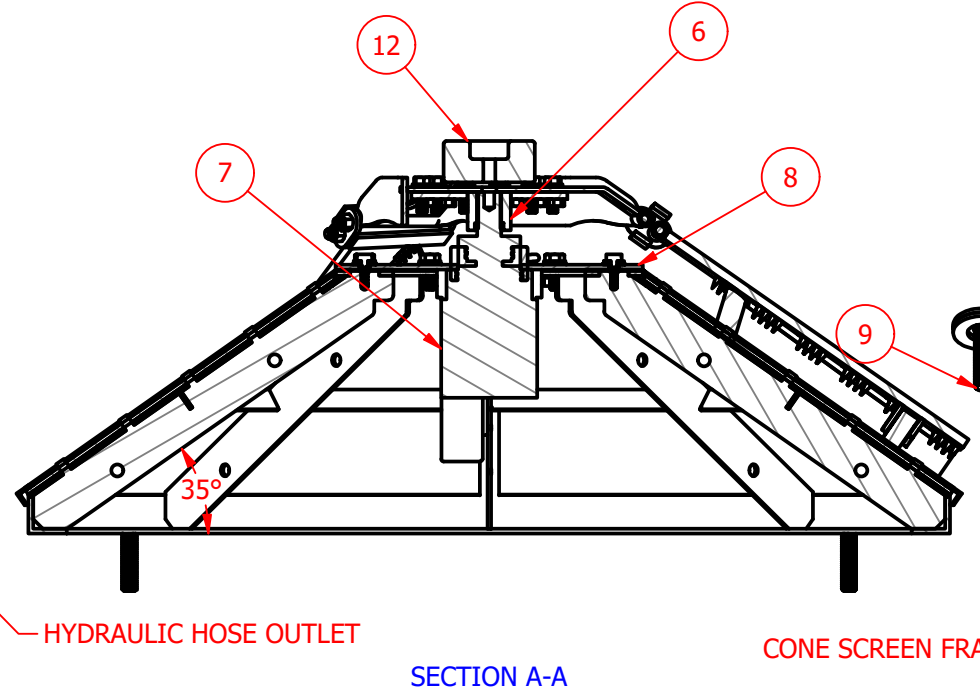
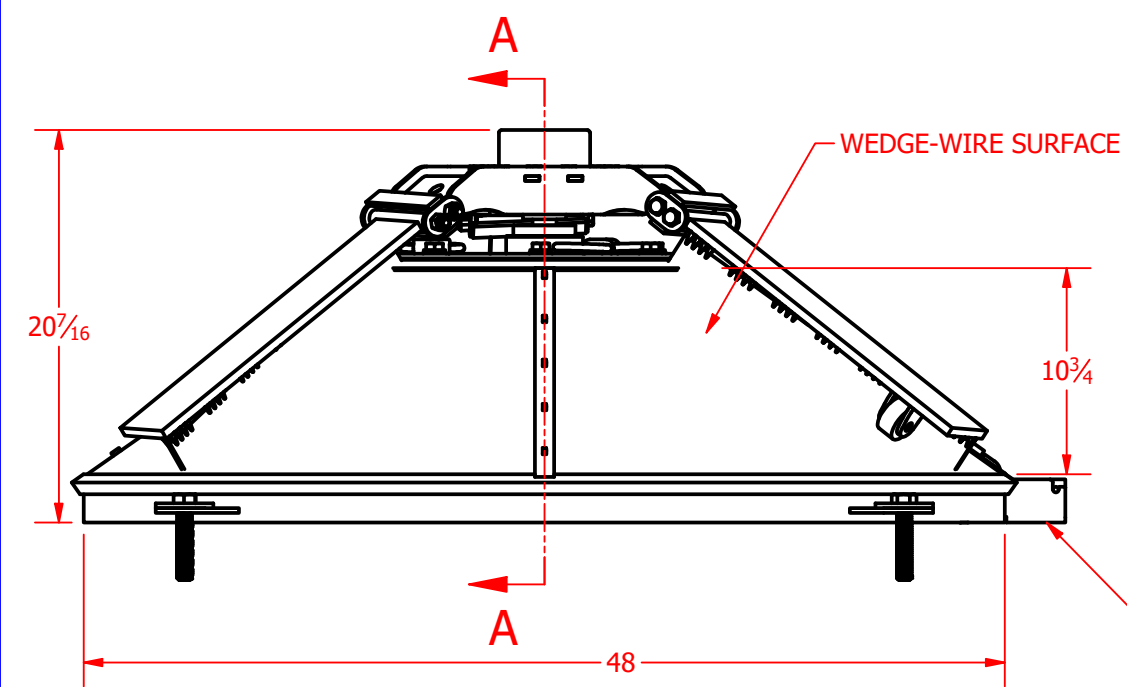
DATE 4/12/2018	PROJECT YELLOW JACKET
APP'D BY DARRYL HAYES	DESCRIPTION Simple Timer Panel
DRAWN BY JACOB CHAPIN	
"B" SHEET SCALE	MATERIAL Painted Steel

DRAWING NUMBER Simple Timer Panel
MASS 350 lbmass

SHEET NUMBER 12 of 15
--------------------------



ITEM	QTY	PART NUMBER	DESCRIPTION
1	1	Motor Mount Gasket-66	66" Cone Motor Mount Gasket
6	1	Assembly5	HUB SPLINED
7	1	500750W3123ZAAAA	HYDRAULIC MOTOR
8	1	MMP-12-WELDMENT	MOTOR MOUNT PLATE WELDMENT
9	4	ISI-66-S	SCREEN HOLD DOWN
10	1	66-SEAL	MOTOR SEAL
11	1	ANODE-HOLD	ANODE HOLD
12	2	anode	Mag Anode, 5" x 2", 1/2" pipe case
13	1	48-CONE-SCREEN-A	CONE FRAME 48
14	1	BRUSH-48	BRUSH ARMS, 48" CONE
15	1	ISI-48-COVT	V TROUGH COVER
16	6	BOLT-GROUP-ISO-HALFINCH	ISOLATED BOLT GROUP



REV	DESCRIPTION	DATE	APPROVED

Designs are property of INTAKE SCREENS INC; and are subject to change without notice.

www.intakescreensinc.com  
CA CL. 796197

8417 River Road - Sacramento, California 95832  
(916) 665-2727 (916) 665-2729 FAX

DATE 8/22/2013  
APP'D BY DARRYL HAYES  
DRAWN BY JACOB CHAPIN  
"B" SHEET SCALE

PROJECT  
48" CONE

DESCRIPTION  
48" CONE SCREEN  
MATERIAL  
304 STAINLESS ASSEMBLY

DRAWING NUMBER  
48-CONE-SCREEN  
MASS  
337 lbmass

SHEET NUMBER  
13 of 15

**ISI C48-12 SELF CLEANING INTAKE SCREEN**

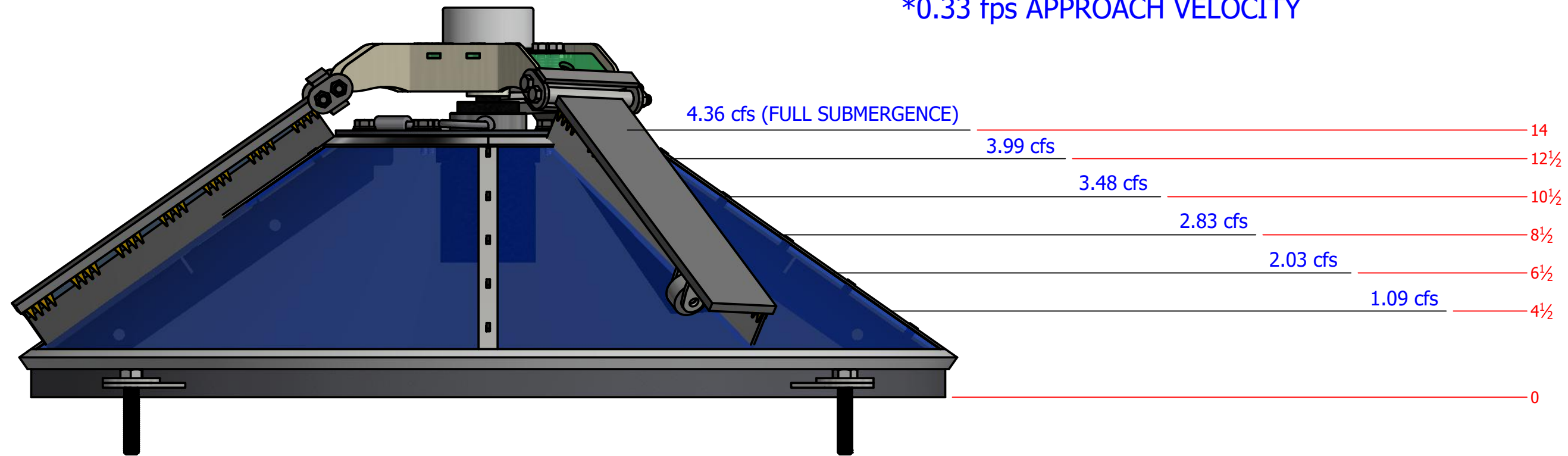
**WEIGHT: 337 lb**


**FRAME MATERIAL: 304 SS**

**MOTOR FRAME / DRIVE PLATE MATERIAL: EPOXY COATED ASTM A36 CARBON STEEL**

**69V WEDGEWIRE, .069" SLOT SIZE, 50% OPEN AREA**

**FLOW RATES BASED ON SUBMERGENCE:  
\*0.33 fps APPROACH VELOCITY**



ALL DIMENSIONS IN INCHES UNLESS NOTED		 <p>www.intakescreensinc.com CA C.L. 796197 Intake Screens, Inc. 8417 River Road - Sacramento, California 95832 (916) 665-2727 (916) 665-2729 FAX</p>	DATE 8/22/2013	PROJECT	DESCRIPTION	DRAWING NUMBER	SHEET NUMBER
Designs are property of INTAKE SCREENS INC; and are subject to change without notice.			APP'D BY DARRYL HAYES DRAWN BY JACOB CHAPIN "B" SHEET SCALE	48" CONE	48" CONE SCREEN	48-CONE-SCREEN	14 of 15
STANDARD TOLERANCES Fractional Dimensions ± 1/32 Decimal Dimensions ± 0.005				MATERIAL 304 STAINLESS ASSEMBLY	MASS 337 lbmass		



## CONE SCREEN CALCULATOR

Minimum Design Flow Rate =	<b>2.5</b>	cfs
Approach Velocity Criteria =	<b>0.33</b>	fps
Slot Velocity Criteria = <i>(Recommended if under 1mm slot)</i>	<b>0.66</b>	fps
Open Area =	50.00	percent
Minimum Water Depth =	<b>5</b>	inches

### APPROACH VELOCITY METHOD

Approach Velocity Criteria =	<b>0.33</b>	ft/sec
Wedgewire Width =	<b>1.75</b>	mm
Opening Slot =	<b>1.75</b>	mm
Percent Open Area =	50.00	%
SV Equivalent =	0.66	ft/sec

### SLOT VELOCITY METHOD

Slot Velocity Criteria =	<b>0.66</b>	ft/sec
Wedgewire Width =	<b>1.75</b>	mm
Opening Slot =	<b>1.75</b>	mm
Percent Open Area =	50.00	%
AV Equivalent =	0.33	ft/sec

$$s = \sqrt{[(R-r)^2 + h^2]}$$

$$S = \pi(r+R)s$$

Where:  
*h*=Height;  
*R, r*=Radius of bases;  
*s*=Slant Height;  
*S*=Lateral Surface Area

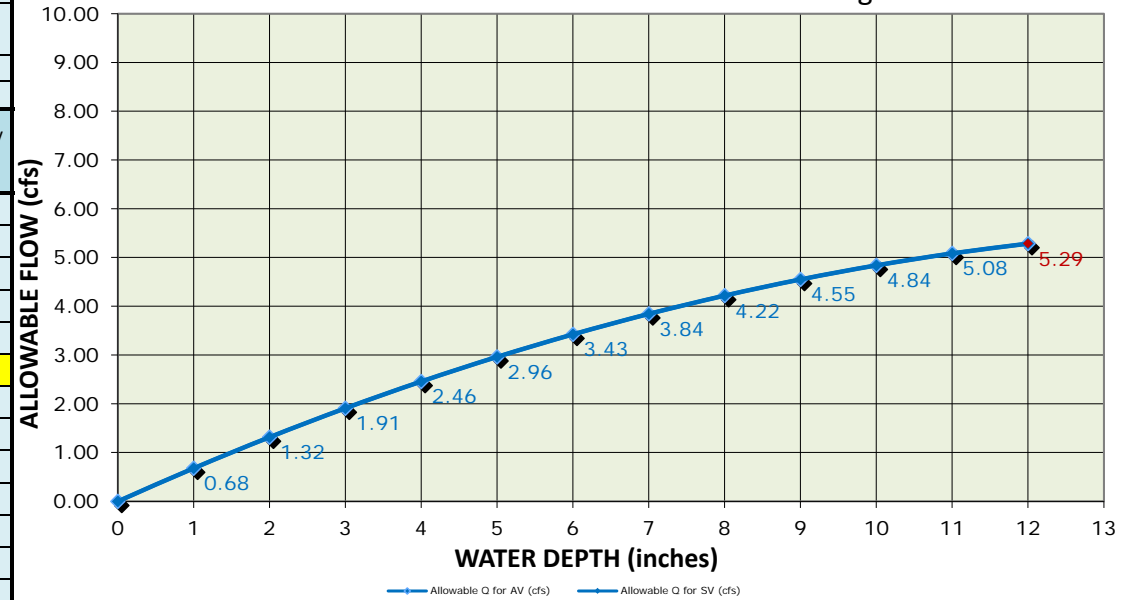
## ISI C48-12

Screen Angle =	35	degrees	Base Radius of Screen =	24	inches	
COS (Screen Angle) =	0.819152044		Screen Diameter at Base =	47	inches	
TAN (Screen Angle) =	0.700207538		Screen Height =	12	inches	
SIN (Screen Angle) =	0.573576436		Top Diameter =	12	inches	
Water Depth Over Screen (in.)	Screen Surface Area (in <sup>2</sup> )	Screen Surface Area (ft <sup>2</sup> )	Allowable Q for AV (cfs)	Allowable Q for SV (cfs)	Actual AV (fps)	Actual SV (fps)
0	0	0.00	0.00	0.00	0.00	0.00
1	245	1.70	0.68	0.68	0.00	0.00
2	474	3.29	1.32	1.32	0.00	0.00
3	687	4.77	1.91	1.91	0.00	0.00
4	885	6.14	2.46	2.46	0.00	0.00
5	1067	7.41	2.96	2.96	0.00	0.00
6	1233	8.56	3.43	3.43	0.00	0.00
7	1384	9.61	3.84	3.84	0.00	0.00
8	1519	10.55	4.22	4.22	0.00	0.00
9	1638	11.38	4.55	4.55	0.00	0.00
10	1742	12.10	4.84	4.84	0.00	0.00
11	1830	12.71	5.08	5.08	0.00	0.00
12	1903	13.21	5.29	5.29	0.00	0.00

<b>MAX FLOW (cfs)</b>	<b>5.29</b>	<b>5.29</b>
<b>MAX FLOW (gpm)</b>	<b>2379</b>	<b>2372</b>

## ISI C48-12

Allowable Flows at Various Levels of Submergence



C:\FISH\HW\DATA\Removable Disk\BROTHER\TheCountiesSalmonidConservationProgram\Projects\East Weaver Dam\ENC\_DAM\_4-20-20.png

**EAST WEAVER CREEK DAM REMOVAL AND INTAKE RELOCATION PROJECT**



NORTHWEST CALIFORNIA RESOURCE CONSERVATION AND DEVELOPMENT COUNCIL  
 FIVE COUNTIES SALMONID CONSERVATION PROGRAM  
 P.O. Box 2571 · 40 HORSESHOE LANE · WEAVERVILLE, CA 96093



Sht	Rev	Date	By	Description	Appr'd

Design ----  
 Drawn ----  
 Checked ----  
 Appr'd ----

**FLOW CALCULATOR**  
 EAST WEAVER DAM  
 WEAVERVILLE, CALIFORNIA

Size	Project No.	Rev
Scale	AS SHOWN	
Date	4/22/20	
Sheet	15 of 15	

## Appendix 6- Water Study

East Weaver Creek Dam and Intake Effects on  
Stream Temperature and Flow  
In Relation to Endangered or Threatened Salmonid Species

Northwest California Resource Conservation & Development Council  
Five Counties Salmonid Conservation Program

Muriel Manka and Leslie Mounivong

December 15, 2020

## **Abstract**

This study summarizes water quality data collected on East Weaver Creek surrounding the East Weaver Creek Dam (EWD) area. Water quality monitoring evaluated the baseline water quality in East Weaver Creek prior to the proposed removal of the EWD. The current water quality of East Weaver Creek was also evaluated for its current habitat quality in relation to salmonid species. Water stage and temperature monitoring in this study showed that the habitat upstream of the EWD has never been observed to dry up and stream temperature data shows that the creek is capable of supporting salmonids even in drought periods. Thus, upstream conditions has optimal habitat for salmonid species of all life cycles. However, downstream of EWD, the water temperatures and flows decrease, in some areas reaching lethal conditions for salmonid. Retention of the EWD will continue to confine salmonids to stream segments where water quality is not adequate to support them.

## **I. Introduction**

This study examines water temperature data that has been collected on East Weaver Creek at several points in a 1-2 mile range of East Weaver Creek Dam (EWD). Stream temperature data was collected by the United States Forest Service (USFS), Redwood Sciences Lab (RSL), and Five Counties Salmonid Conservation Program (5C). The Weaverville Community Services District (WCSD) dam and intake system is affecting downstream conditions and salmonids at various life stages. The purpose of water temperature monitoring is to determine the effects of EWD on water temperature and water stage and use it as a baseline prior to a proposed restoration project: East Weaver Creek Dam Removal and Intake Relocation Project (Appendix A). The water temperature data is also analyzed to determine whether the water temperature ranges exceed the maximum temperatures tolerated by salmonid species during the summer months, when water levels are lower.

Dams and structures are present in nearly all watersheds and are well known to alter the sediment regime, hydrology, geomorphology, aquatic organisms, and ecosystem of a water system (Null et al., 2014; Nilsson et al., 2005; NMFS, 2014; Ock and Kondolf, 2012; Poff et al., 1997). There are very few rivers that are not impeded by such structures and recent studies have focused on the effects of dams and dam removal on migrating salmonids. The effects of low flows or altered hydrologic regimes downstream can affect winter rearing salmonids with increased water temperatures. During the summer months, low flows can disconnect stream habitats, greatly increase stream temperatures, reduce habitat diversity, water quality, and thermal refugia (NMFS, 2014). Although dams have great socioeconomic benefits such as hydroelectric power, flood control, irrigation, and act as a water source for urban areas, they can have great impacts to aquatic organisms and upstream riverine conditions (Moyle, 1998; NMFS, 2014; Reisner, 1993). According to recent studies, dam removal in conjunction with habitat restoration is likely to improve ecosystem functions and resiliency, result in net benefits to salmonids, freshwater mussels, and native vegetation, and increase socioeconomic benefits downriver (Quinones, 2015; Null, 2014) .

A dam is defined as “any artificial barrier, together with appurtenant works, which does or may impound or divert water, and which either (a) is or will be 25 feet or more in height... or (b) has or will have an impounding capacity of 50 acre-feet or more”; a structure is not considered a dam if “any such barrier which is or will be not in excess of six feet in height, regardless of storage capacity, or which has or will have a storage capacity not in excess of 15 acre-feet, regardless of height...” (CWC, 1965). The East Weaver Creek Dam is not classified as

a dam due to its 12' hydraulic height, less than 0.5 acre-feet storage capacity, and location in a low seismically low risk area. Other state definitions can classify the EWD structure as a minor dam. Following the Bureau of Land Management (BLM) Dam Condition Assessment Checklist (Public), EWD is rated in poor condition due to repairs or modifications required to maintain the structure operationally (BLM, 2006).

The EWD is a complete barrier to aquatic species including the threatened coho salmon and recognized as the only complete barrier to upstream fish migration for all life stages of all fish species in East Weaver Creek (NMNFS, 2014). The National Oceanic and Atmospheric Administration's (NOAA) National Marine Fisheries Service (NMFS) Final Recovery Plan for the Southern Oregon/ Northern California Coast Evolutionarily Significant Unit of Coho Salmon (*Oncorhynchus kisutch*) (SONCC) Table 39-5 lists barriers and diversions as "very high" threats to the survival of all life stages of Coho, except the egg stage. It also lists migration barriers as a "key limiting factor" to salmonid recovery in the Upper Trinity River basin for adult life stages and ranks them as "high" stressors for coho. Dams and diversions contribute to factors affecting habitat destruction, modification, or curtailment, disease and predation, and inadequate regulatory mechanisms for coho (NMFS, 2014).

The number and extent of water diversions can also adversely impact aquatic species by reducing the amount of available habitat, increasing stream temperatures, reducing oxygen, disrupting flows, and even drying up stream reaches. In addition to being a migration barrier, the dam and intake system for the WCSD East Weaver Treatment Facilities results in altered flow regimes downstream of the EWD. The intake system can harm and/or increase mortality to resident salmonids upstream of the dam during summer downstream migration. When all stream flow is diverted into the stilling well, fish migrating downstream are forced into the inlet pipes, either into the contact basin or flushed around the plant via an overflow piping system. Presumably, there is a low survival for fish entering the stilling basin. Even migration over the dam face presents hazards to downstream migration fish. There are no known studies to quantify the effects of fish falling the ~12' from the edge of the apron to the channel below.

Review of the California Natural Diversity Database, California Native Plant Society database, existing fisheries/wildlife/botanical surveys by USFS, LanMark, and 5C, habitat assessments by California Department of Fish and Wildlife (CDFW) and Wildlife Habitat Relationship (WHR), and site inventories determined that the project area is utilized by the state listed threatened species: *Oncorhynchus kisutch* (coho salmon). East Weaver Creek from the confluence with West Weaver Creek has been monitored for salmon and steelhead for more than 50 years. In 1964, LaFaunce counted 89 steelhead redds near the confluence (LaFaunce, 1964). In 1971, Rogers surveyed the same area and found no redds (Rogers, 1971). In 1972, Rogers found 3 redds in the lower 2 miles (Rogers, 1972). California Department of Fish and Game (CDFG) biologists, Boberg and Kenyon noted the presence of Chinook salmon and steelhead trout among seven fish species in the stream (Boberg and Kenyon, 1979). Ebasco Environmental conducted a Habitat Assessment of East Weaver Creek and found steelhead in the project reach (Ebasco, 1990). U.S. Department of Agriculture Natural Resources Conservation Service fisheries biologist, Tim Veil, has observed young of the year coho in East Weaver Creek at Horseshoe Lane (personal communication, 2011). CDFG completed steelhead redd surveys in the lower reaches of East Weaver Creek and found 2 redds and 8 redds respectively (CDFG, 2009; CDFG, 2010). Fisheries biologist, Ross Taylor, found a female Coho carcass below the confluence of East and West Weaver Creeks in 2011 (personal communication, 2011). The Northwest California Resource Conservation & Development Council (RC&DC) staff found an

adult steelhead female in 2012 just upstream of the confluence of the two streams. According to E. Wiseman, USFS has monitored the upper reaches (East Weaver Campground to EWD) between 2010 and 2015 finding juvenile Coho and rainbow trout in this reach each summer (personal communication, 2015). In July 2015, a snorkel survey by K. Yamasaki followed the creek upstream of EWD and found several rainbow trout (*Oncorhynchus mykiss*) exhibiting physiological changes associated with smoltification, a physiological change in which juveniles adapt from living in fresh water to living in seawater by altering body shape and increasing skin reflectance (personal communication, 2015).

The U.S. Environmental Protection Agency (USEPA) document, *EPA Region 10 Guidance for Pacific Northwest State and Tribal Water Quality Standards*, state that a summer maximum weekly maximum water temperature (MWMWT) of approximately 21-26°C (70-79°F) create lethal conditions for rearing juvenile and migrating adult salmonids (USEPA, 2003). The USEPA recommends that the seven-day average of the daily maximum temperatures (7-DADM) should not exceed 18°C (64°F) in waters where both adult salmonid migration and “non-core” juvenile rearing occur during the period of summer maximum temperatures. The USEPA believes that this temperature recommendation will protect against lethal conditions, prevent migration blockage, provide optimal or near optimal juvenile growth conditions, and prevent high disease risk (USEPA, 2003). For rearing juveniles in environments with limited food, optimal growth temperatures should average 10-14°C (50°F – 57°F) (NMFS, 2014; USEPA, 2003). According to SONCC, an indicator for good coho aquatic habitat is a MWMWT of 16-17°C (61 - 63°F); the habitat is considered very good when temperatures are less than 16°C (61°F) (NMFS, 2014).

For waterbodies that are used exclusively for migration during the period of summer maximum temperatures, the EPA recommends a 7-DADM temperature of 20°C (68°F):

*“EPA believes that a 20 °C criterion would protect migrating juveniles and adults from lethal temperatures and would prevent migration blockage conditions. However, EPA is concerned that rivers with significant hydrologic alterations (e.g., rivers with dams and reservoirs, water withdrawals, and /or significant river channelization) may experience a loss of temperature diversity in the river, such that maximum temperatures occur for an extended period of time and there is little cold water refugia available for fish to escape maximum temperatures. In this case, even if the river meets a 20 °C criterion for maximum temperatures, the duration of exposure to 20 °C temperatures may cause adverse effects in the form of increased disease and decreased swimming performance in adults, and increased disease, impaired smoltification, reduced growth, and increased predation for late emigrating juveniles...” (USEPA, 2003, p. 29)*

Therefore, the USEPA recommends a narrative provision to protect and, if possible, restore the natural thermal regime to accompany the 7-DADM 20°C (68°F) criterion for rivers with significant hydrologic alterations.

In a discussion paper and literature summary evaluating temperature criteria for fish species including salmonids and trout, the Washington State Department of Ecology (WDOE) cites studies showing that steelhead were observed spawning in temperatures ranging from 3.9 - 21.1°C (39 - 70°F), and preferred temperatures for steelhead spawning range from 4.4 - 12.8°C (40 - 55°F) (WDOE, 2002). In another review of various studies, researchers concluded that steelhead spawning occurs at water temperatures ranging from 3.9 - 9.4°C (39 – 49°F) (Bell, 1986). Steelhead and rainbow trout eggs had the highest survival rates ranging 5-10°C (41 – 50°F), tolerate temperatures as low as 2°C (35.6°F) or as high as 15°C (59°F), and mortality is

increased at these temperatures (Myrick and Cech, 2001). WDOE concluded for the survival of steelhead and rainbow trout embryos and alevins that the average water temperature should not exceed 7-10°C (45 - 50°F) throughout development and the maximum daily average temperature should be below 11-12°C (52 – 54°F) at the time of hatching. WDOE also suggests that the Maximum Weekly Mean Temperature (MWMT) should not exceed 17-18°C (63 – 64°F), and daily maximum temperatures should not exceed 21-22°C (70 – 72°F) to fully protect adult steelhead migration. In a review of numerous studies, WDOE concluded that daily average temperatures of 21-24°C (70 – 76°F) are associated with avoidance behavior and migration blockage in steelhead trout (WDOE, 2002).

## **II. Methods**

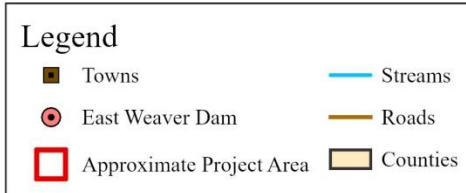
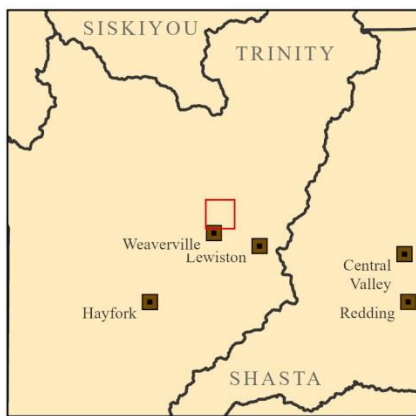
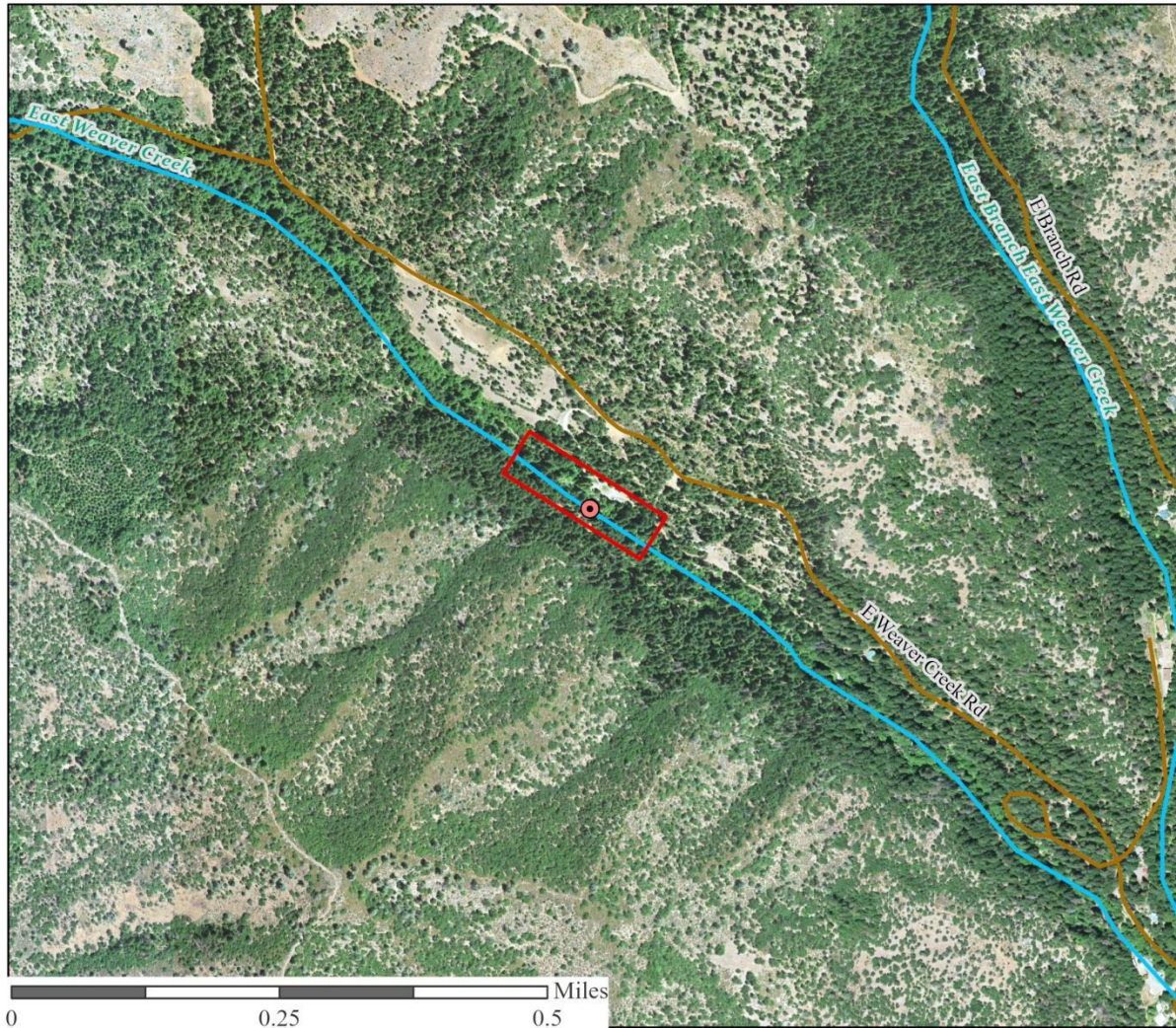
### *Study Location and Background*

This study focused on East Weaver Creek at and around East Weaver Creek Dam. The EWD is located in Section 30, Township 34N, Range 9W, MDB&M (Figure 1). It is accessible by traveling north on Highway 3 from Weaverville to East Weaver Creek Road. At East Weaver Creek Road, turn left from Highway 3, and proceed 2.5 miles to the access road to the EWD facilities. This road's access is controlled with a gate. The facilities are 0.2 miles down this access road.

East Weaver Creek is a tributary to Weaver Creek and the Trinity River. The East Weaver Creek watershed encompasses 8,300 acres and represents ~25% of the Weaver Creek watershed (HUC 180102110705) (Figure 2). The upper 30% of the watershed is within the Trinity Alps Wilderness and the East Weaver Creek Dam is located ~0.5 miles downstream of the Wilderness boundary. Weaver Creek and its tributaries have a high Intrinsic Potential for Coho (NMFS, 2014). Intrinsic Potential is defined as the “potential of the landscape to support a population. The Intrinsic Potential of a watershed or stream reach, is used to evaluate the likelihood of the area to support fish, and is used when population characteristics are unknown” (NMNFS, 2014). The habitat upstream of the East Weaver Creek Dam is cold water habitat capable of providing critical summer salmon rearing habitat in the Weaver Creek watershed. Downstream of the East Weaver Creek Campground (EWC), the stream provides marginal summer rearing habitat due to diversions, lack of cover, and limited pools.

This portion of the stream is entrenched with narrow floodplains and riparian bands as a result of roads, bridges, houses, maintained lawns, and levees. The entrenched portions lack critical habitat elements such as large wood components, pools, and overbank habitat elements. East Weaver Creek temperatures increase with distance from the snowpack headwater sources and can reach critical limits for fisheries approximately 4 miles downstream of EWD at the East Weaver Creek Levee. The primary sources for temperature increases are naturally warming factors; but, these are exacerbated by confined floodplains, historic mine tailing, water diversions, levees, and narrow riparian bands.

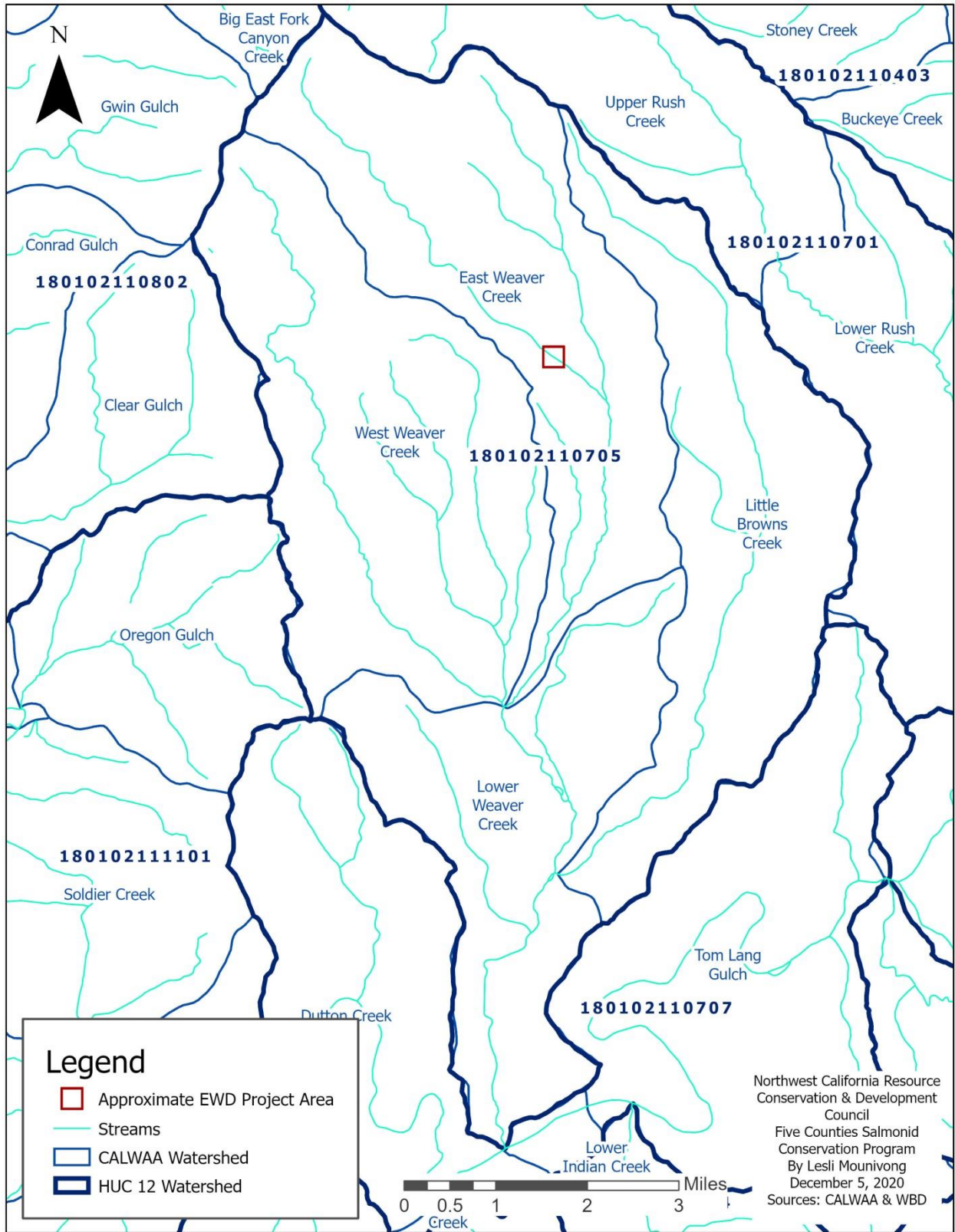
# EAST WEAVER CREEK DAM REMOVAL AND INTAKE RELOCATION PROJECT



Northwest California Resource  
Conservation & Development  
Council  
Five Counties Salmonid  
Conservation Program  
Created by: Lesli Mounivong  
NAD 1983 UTM Zone 10  
Sources: Esri, USGS, TCRCDC,  
TCDOT

**Figure 1.** EWD and project area location.





**Figure 2.** East Weaver Creek watershed and the greater Weaver Creek watershed.

## *Procedure*

Data from various sources and locations on the East Weaver Creek were used to analyze stream data and assess water quality (Figure 3). The U.S. Geological Survey (USGS) installed a Style-A Staff Gage at two sites downstream of the EWD. RSL has been monitoring water quality, water quantity, and barometric pressure since 2011 at the Butterfield Bridge stream crossing site (0.75 miles downstream of EWD). RSL utilized pressure transducers above the water surface. Their barometric pressure data was used to calibrate with the 5C's flow data by subtracting these measurements from those recorded by the submerged transducers. The calculations will give the pressure created by the water column above the transducer. The USFS has been continuously monitoring temperature at the Schofield Gulch (approx. 1 mile upstream of EWD). In 2016, the 5C installed three HOBO Onset Data Loggers - U20L-04 in East Weaver Creek at three monitoring points (Figure 2). Monitoring site #1 (EWD) is located within the WCSD intake stilling basin, directly above the EWD. Monitoring site #2 (Water Tank) is located instream, downstream of the EWC water tank. Monitoring site #3 (East Weaver Campground) is located instream at the EWC. The use of HOBOs to monitor temperature and flow continues today. The data loggers were set to record absolute pressure and temperature at 15 minute increments set on the hour (PST). Periodic discharge measurements were made at each of the sites at established cross sections in order to establish a rating curve.

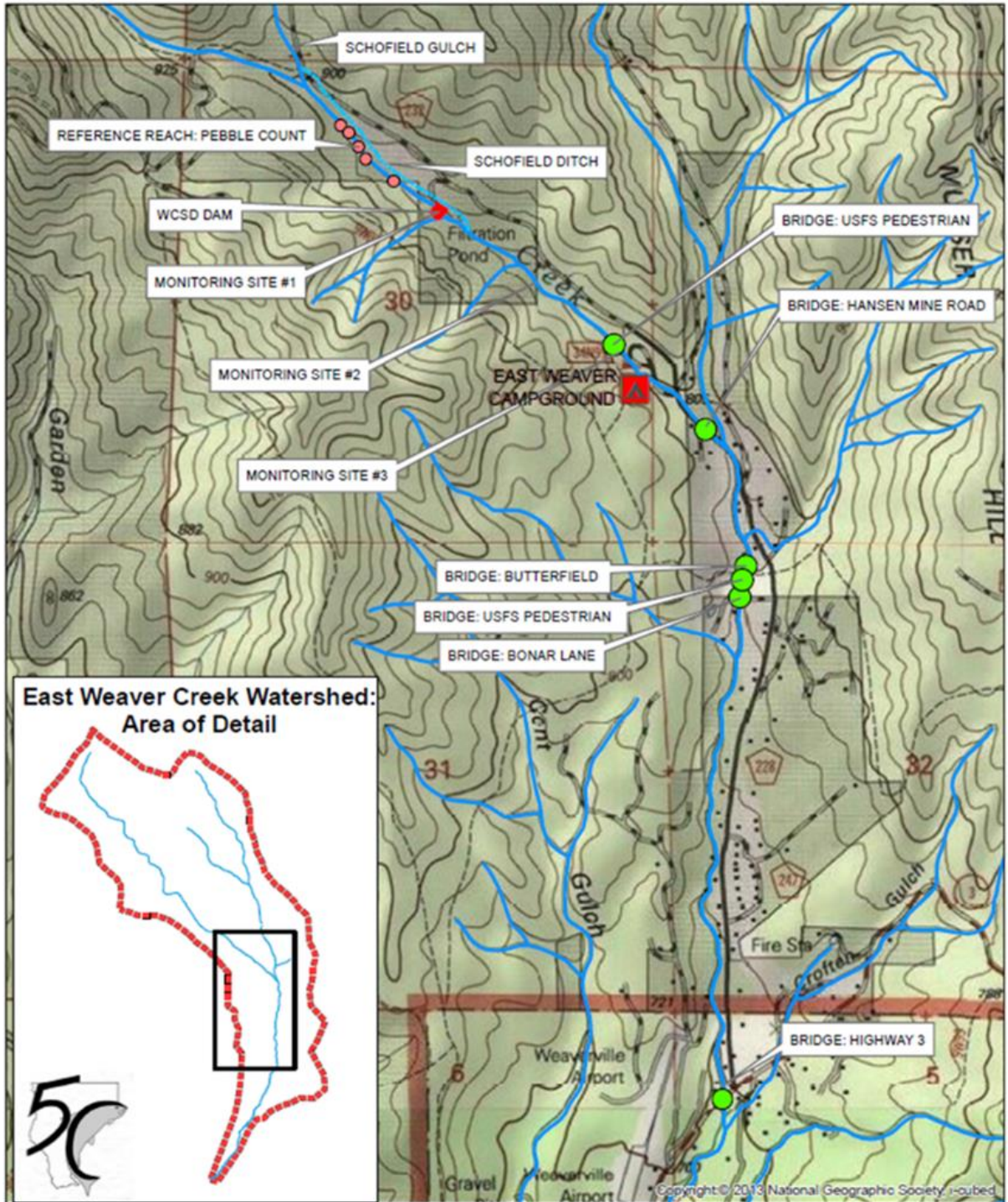
Ideally, data loggers will be placed in the creek after the last of the spring rains and will be retrieved in the fall, before winter storms. The reason for this is to be able to capture the peak summer temperatures and to reduce the likelihood of losing a datalogger during high flows. To ensure yearly accurate readings, find a suitable pool to place the data loggers in. The pool will need to be deep enough so that the logger will remain under water for the duration of the summer. It will need to be well mixed and out of the thalweg and direct sunlight. Due to the high storm volumes and pedestrian traffic, the HOBOs were deployed and stationed differently than most data loggers. Rather than using a rebar or a large rock, HOBOs at the water tank and the EWC were placed inside a 3" metal pipe and topped with a steel cap (Figure 4). The bottom of the steel cap is attached a vertical metal rod with a loop at the end of it and the data logger is zip-tied to the loop. Ensure the data loggers will not be damaged or removed by others. At the EWD, the HOBO was deployed differently as well to capture the difference in temperature and flow of the stilling basin. This HOBO is located within the stilling basin, on the bottom rung of the ladder. The HOBO is contained within a PVC pipe dotted with holes. The PVC is fastened to the rung by metal fasteners and zip-ties.

GPS points were taken at each location so that the placement of the logger can be accurately displayed on a map and this will help in retrieval. Photographs of the logger placement are also important to document the location of the logger. Hang flagging near the datalogger placement to identify the location of the datalogger to assist with retrieval. If the datalogger is being placed somewhere accessible to the public, try and hide it as much as possible and post a sign, or include information nearby letting the public know what it is and to please help us with our study by leaving it alone (or something to that effect).

The HOBO devices constantly measure water temperature and flow for about four months before needing to be read and cleared of data. These data loggers are programmed to log the water temperature at 15 minute intervals. When taking the devices out of the water to download data, make sure to write down the time and day. There is a possibility that the devices are still reading the environment and could skew the data when taken out.

The devices should be brought back a safe and dry station. The data loggers require the program, HOBOWare, to read, download, and re-launch the loggers. After downloading the data of all devices, clear the device and re-launch the HOBO for a later date. The HOBO data loggers were also programmed to measure absolute pressure. The absolute pressure data collected was converted to water stage using the barometric pressure data collected by Redwood Sciences Lab. The daily average water temperature data was graphed with the sensor depth (water stage) for each monitoring point as well as the maximum and minimum daily water temperature. Additional data at other locations on East Weaver Creek are included in this report for a more comprehensive water quality study.

The document does not define what constitutes the “summer” period. Non-core juvenile Coho rearing is defined as moderate to low density salmon and trout rearing usually occurring in the mid or lower part of the basin, as opposed to areas of high density rearing which are termed “core” rearing areas. This criterion is derived from analysis and synthesis of past laboratory and field research.



**Figure 3.** Water quality monitoring locations on East Weaver Creek. The map includes monitoring locations used by the 5C, USFS, USGS, and RSL.



**Figure 4.** HOBO container for Monitoring Sites #2 and #3.

### **III. Results**

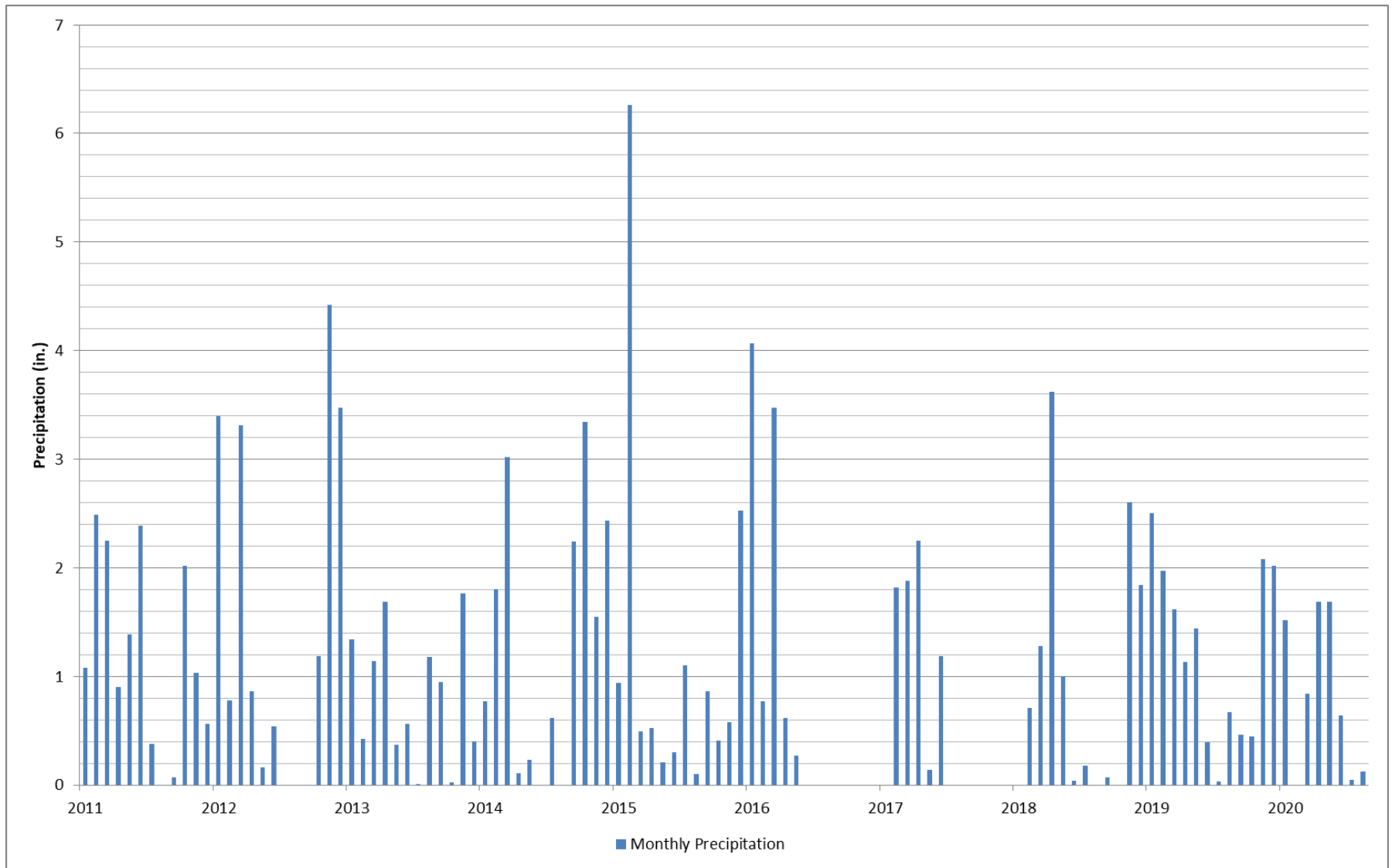
Water temperature and stage monitoring began by 5C in 2014 to determine baseline water quality prior to removing the EWD and relocating the WCSD water intake. Prior and ongoing monitoring was also performed by USFS and RSL. Stream temperature monitoring by USFS, USGS, RSL, and 5C provides a range of data at several points within a 1-2 mile range of EWD. A series of temperature and flow monitors were located within the project area providing data during record low flow periods. Temperature monitors also recorded stream temperatures in normal and above average precipitation years as well. The graphical results of the water quality monitoring on East Weaver Creek are shown below, from the earliest data collected (2011-2012) to the latest data collected (summer of 2020). Graphs include the daily maximum, average, and minimum temperatures and daily stage for various monitoring points on East Weaver Creek. Precipitation data was acquired from the NOAA's National Centers for Environmental Information Local Climatological Dataset (Figure 5). Information regarding records for water rights holders for East Weaver Creek was obtained through the California Water Resources Control Board Electronic Water Rights Information Management System (eWRIMS) (Table 1). The WCSD diversion quantity was determined based on the maximum capacity of the sand filters components of the East Weaver Creek facilities, which are the limiting factor for the facility.

Upstream from the EWD at Schofield Gulch, USFS data shows the temperature ranges from 40 - 58°F in the summer to 32 - 44°F in the winter of 2011-2012 (Figure 6). Later years (2013-2014), the same monitoring point displays temperature ranging from 48°F - 63°F in the summer and 32-47°F in the winter (Figure 7). Data from just above the WCSD intake diversions shows temperatures remaining below 60°F during the summer and dropping to a minimum of 32°F in the winter (Figure 8). At the end of East Weaver Road (HWY 3 monitoring site) temperatures reached 70°F in the late summer and slowly decline, but temperatures remained above 60°F in the early fall (Figure 9). The Butterfield Bridge monitoring site, just upstream of HWY 3, also had high temperatures (Figure 9).

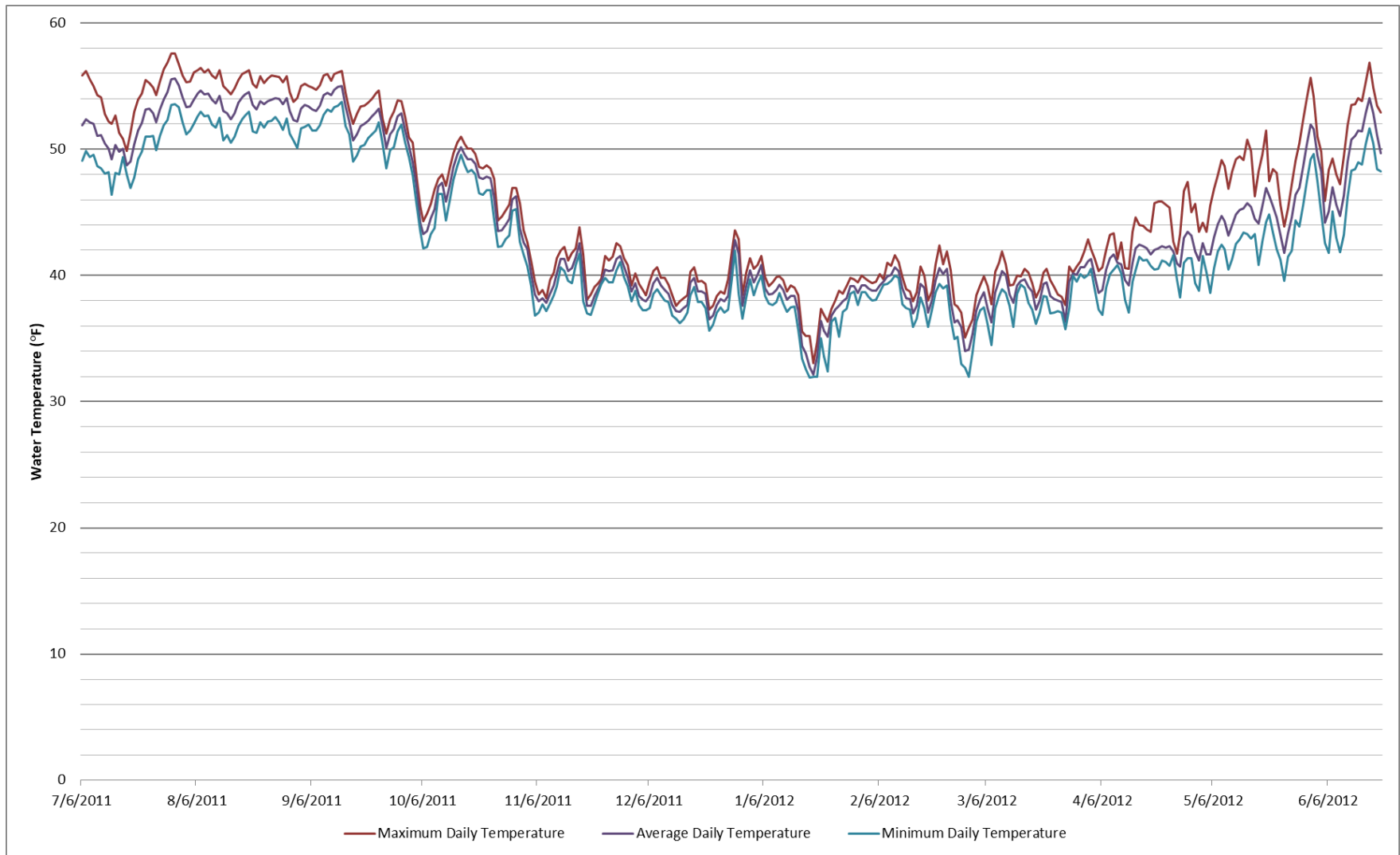
The next set of graphs (Figures 10-19) display the daily average stage and minimum, average, and maximum temperatures at the three 5C monitoring locations surrounding the EWD (EWD, Water Tank, and EWC). Data errors in calculating average stage are apparent in Figures 12 and 16. EWD stage flow drastically drops in multiple areas due to environmental conditions, calculation errors, or other factors. Some of the daily maximum and minimum temperature graphs included in this report are not accompanied by the stage flow calculations (Figures 14-15). This is due to a recording error when reading out the data loggers; the data for the specific time periods are not compatible with the software used to recalibrate the data with the RSL barometric data.

**Table 1.** Reported direct diversion from East Weaver Creek.

Applicant ID	Name	Entity Type	Reported Direct Diversion	
			cfs/day	gal/day
A015472	Daniel Powers	Individual	0.006	4000
A016510	Gay Butler	Individual	0.050	32316
S000361	Weaverville Community Services District	Corporation	1.730	1118124
S004681	Trinity River Lumber Co.	Corporation	1.000	646315
S008683	Bertha Loving	Individual	0.000	0
S008684	Eric Peterson	Individual	0.006	4200
S008691	Robert Thomas	Individual	0.000	0
S008800	Jerry Main	Individual	0.020	12672
S009042	Willis Norman	Individual	0.000	50
S009043	Michael McFadin	Individual	0.000	0
S009044	William Wardall	Individual	0.001	750
S009053	Lowain Hatfield	Individual	0.000	0
S009121	Patricia Kraus	Individual	0.001	900
S009156	Florence Burroughs	Individual	0.001	730
S012481	Jerry Brasuell	Individual	0.090	58168
S020366	Brandt Gutermuth	Individual	0.010	6463
Total			2.92	1884688

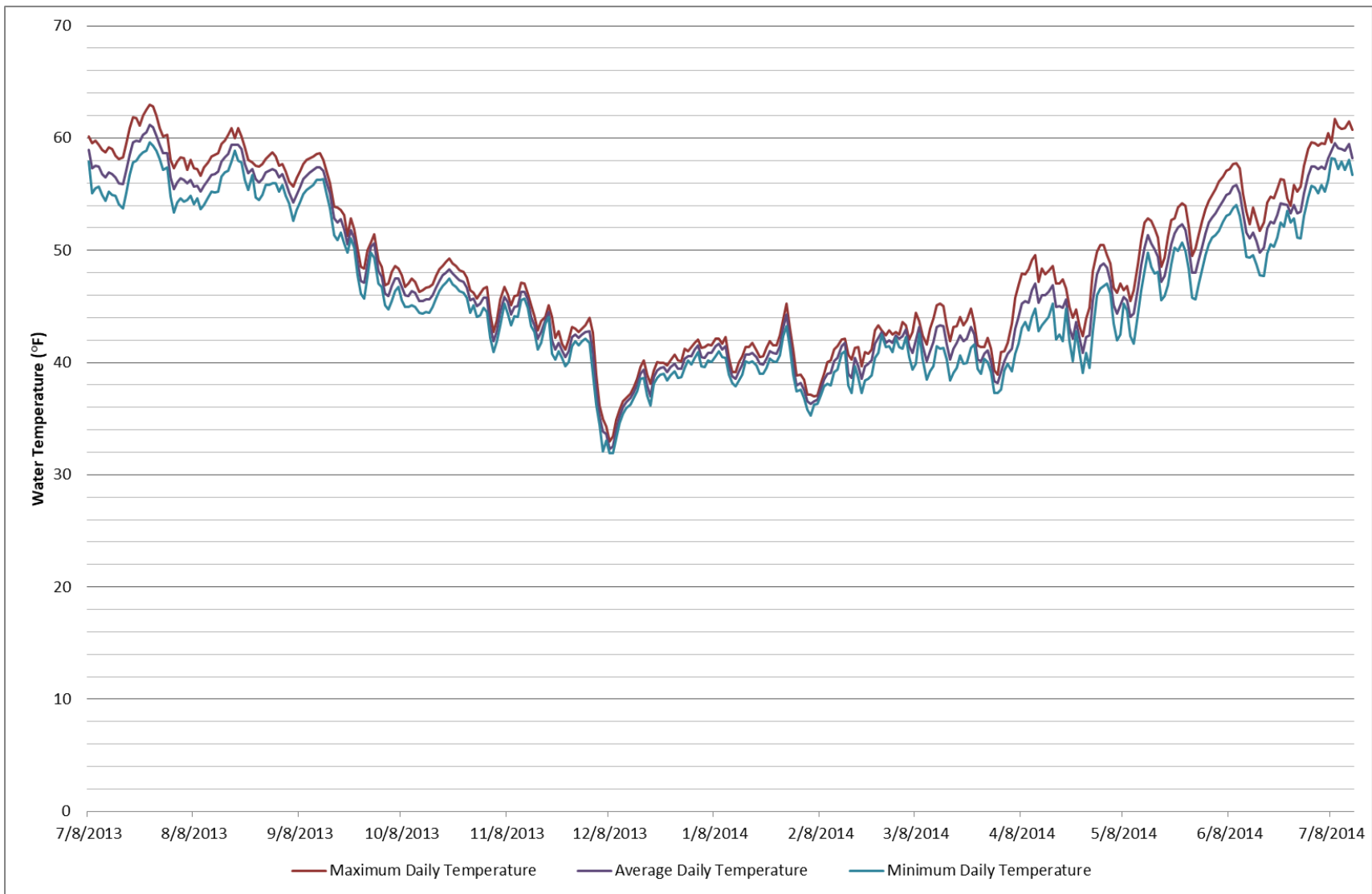


**Figure 5.** Monthly precipitation totals in Weaverville, CA. Data was acquired from NOAA’s National Centers for Environmental Information Local Climatological Dataset.

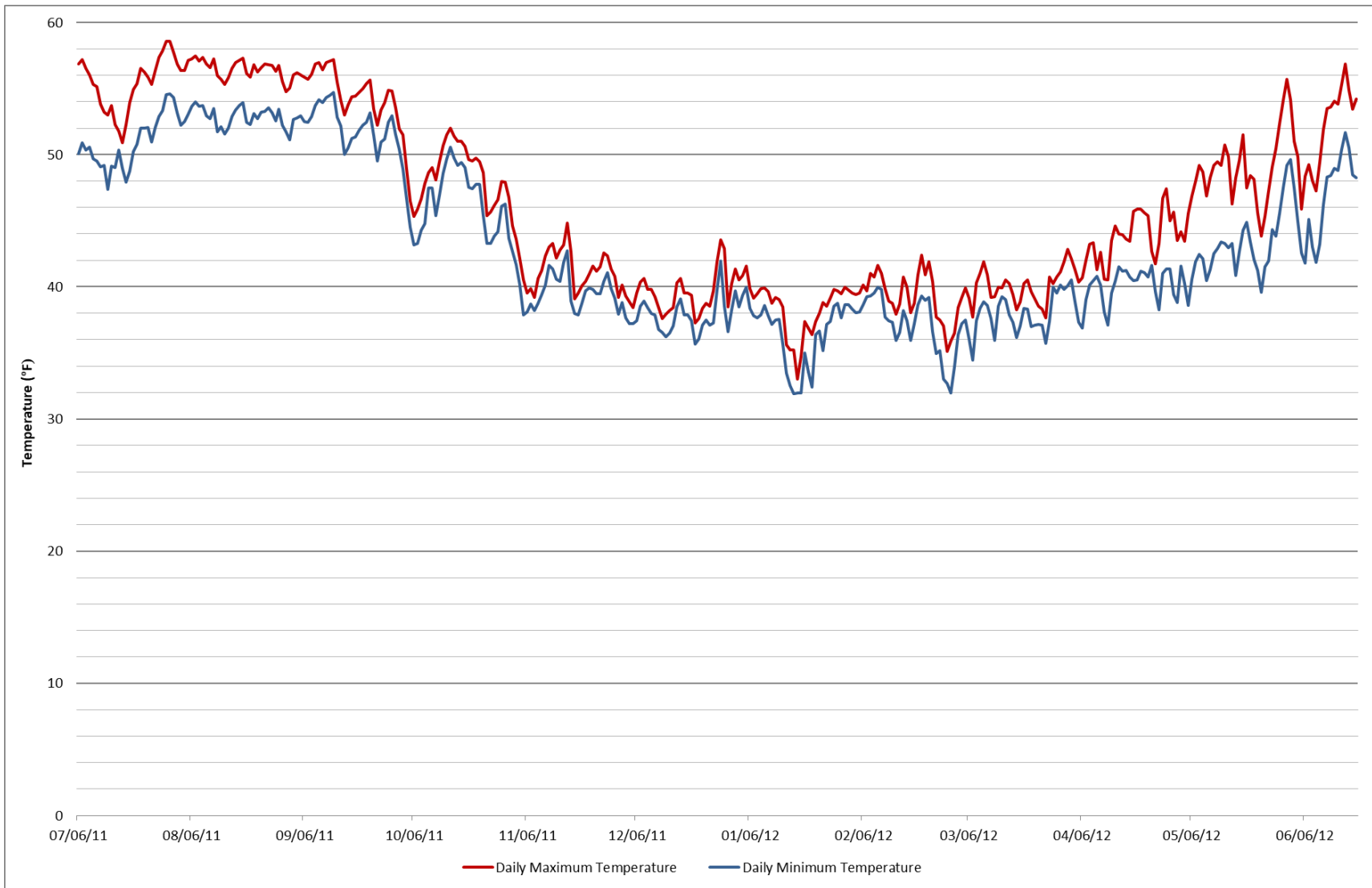


**Figure 6.** Daily maximum, average, and minimum water temperature at Schofield Gulch. Data was collected from 7/6/2011 to 6/20/2012 by USFS. Schofield Gulch is approximately one mile upstream of the EWD.

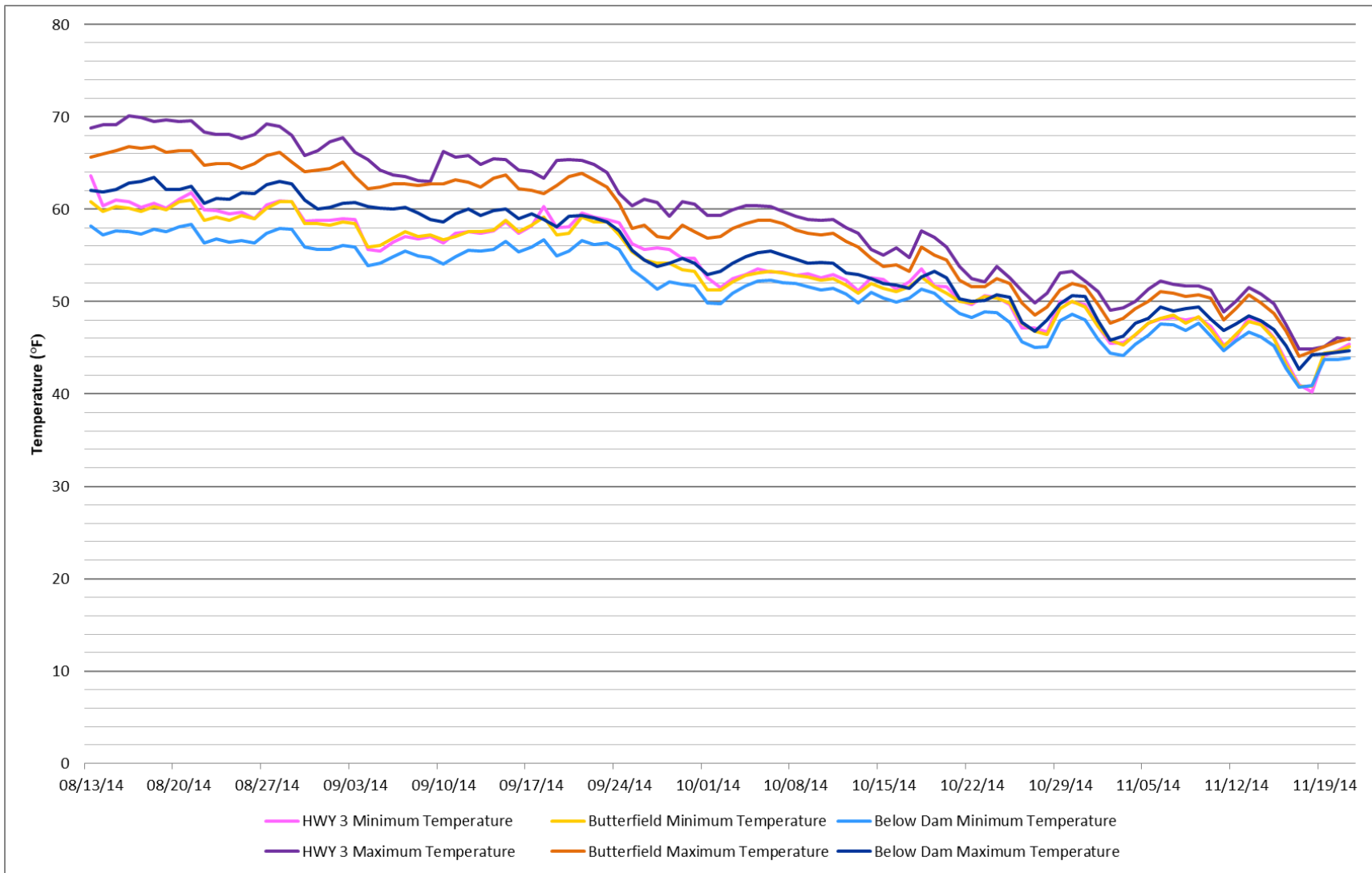




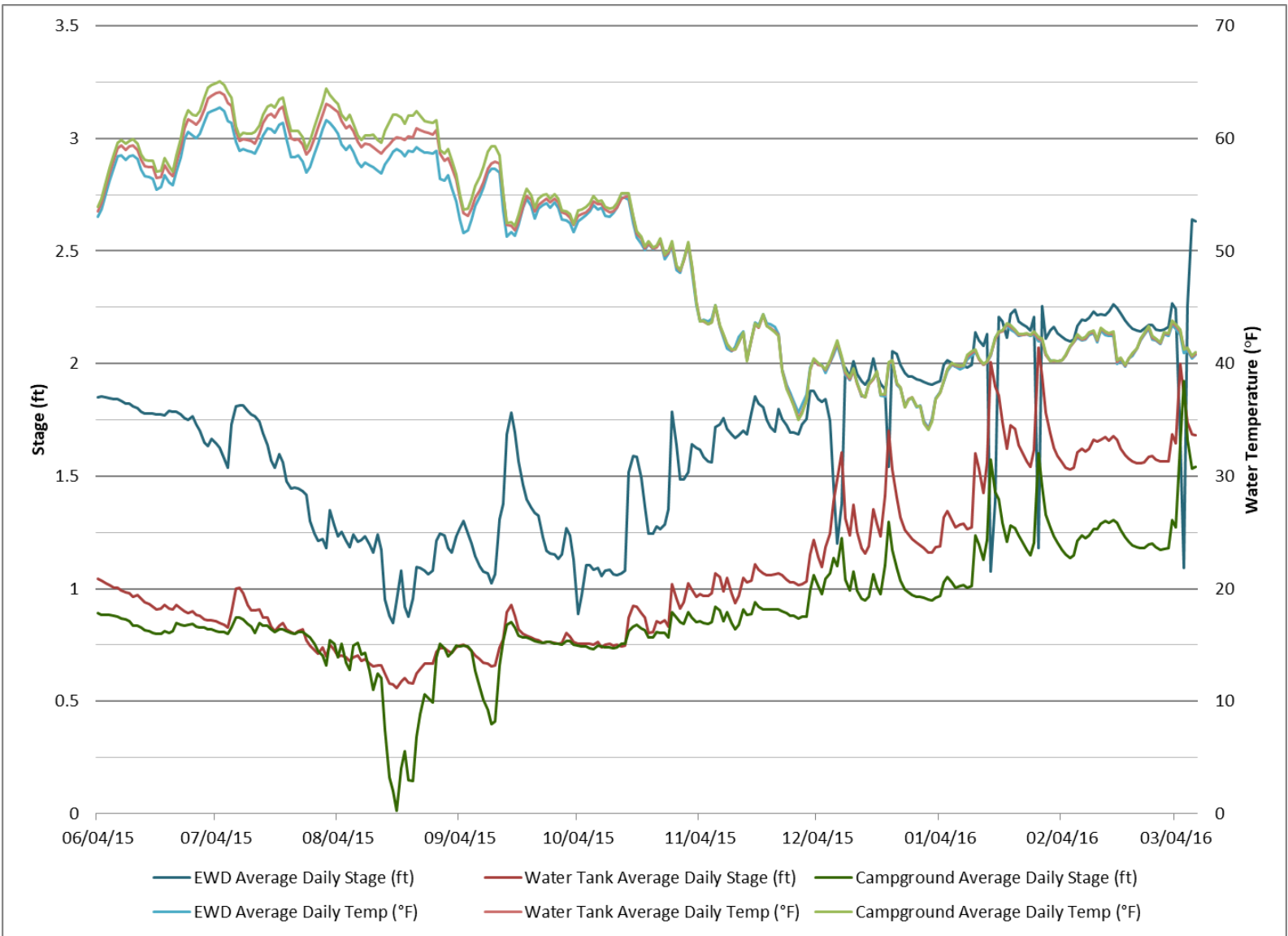
**Figure 7.** Daily maximum, average, and minimum water temperature at Schofield Gulch. Data was collected from 7/8/2013 to 7/14/2014 by USFS. Schofield Gulch is approximately one mile upstream of the EWD.



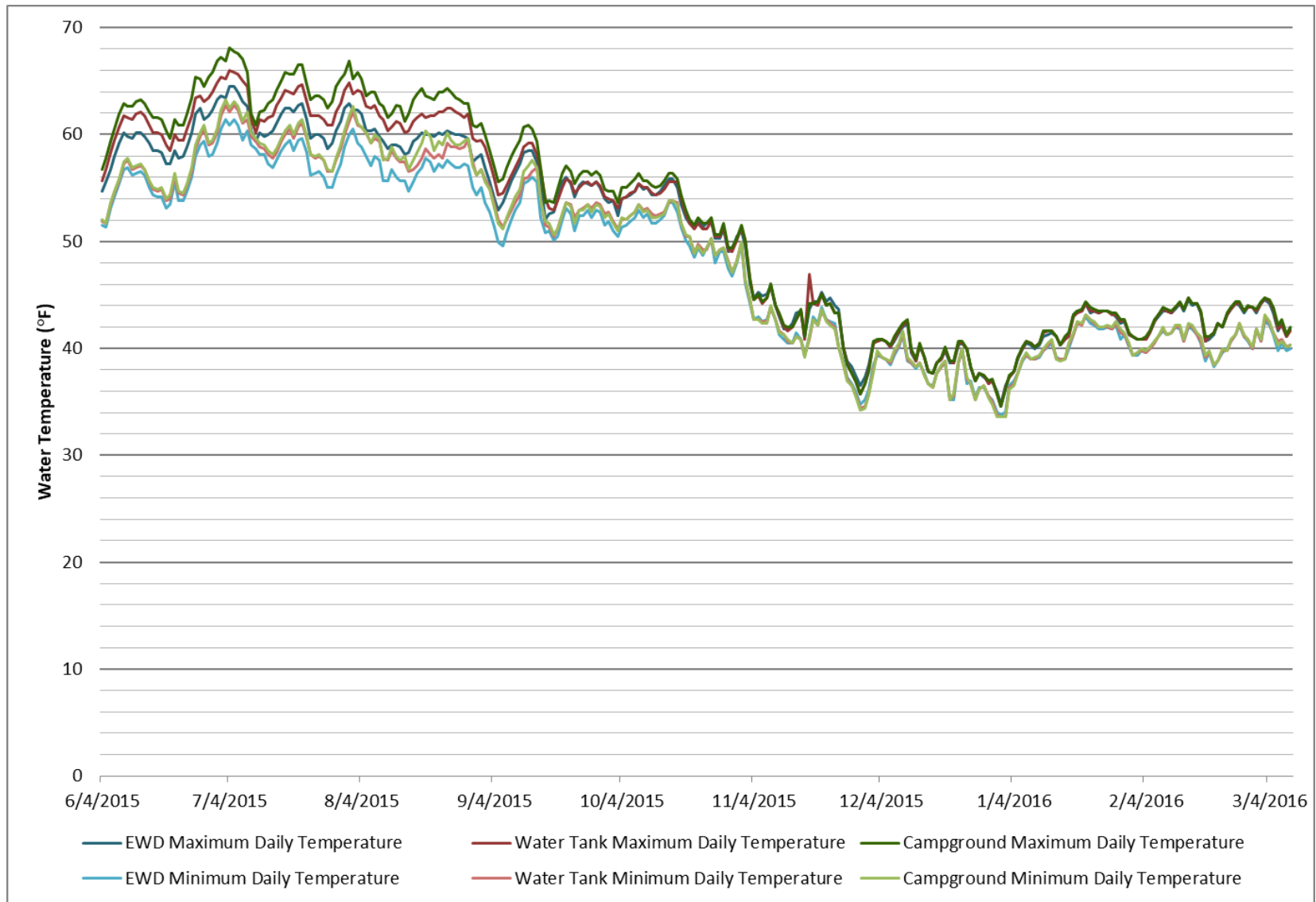
**Figure 8.** USFS daily water temperature above the WCSD intake diversion. Daily maximum and minimum water temperature data was collected from 7/6/2011 to 6/20/2012. Data was acquired by the USFS directly above the WCSD EWD intake.



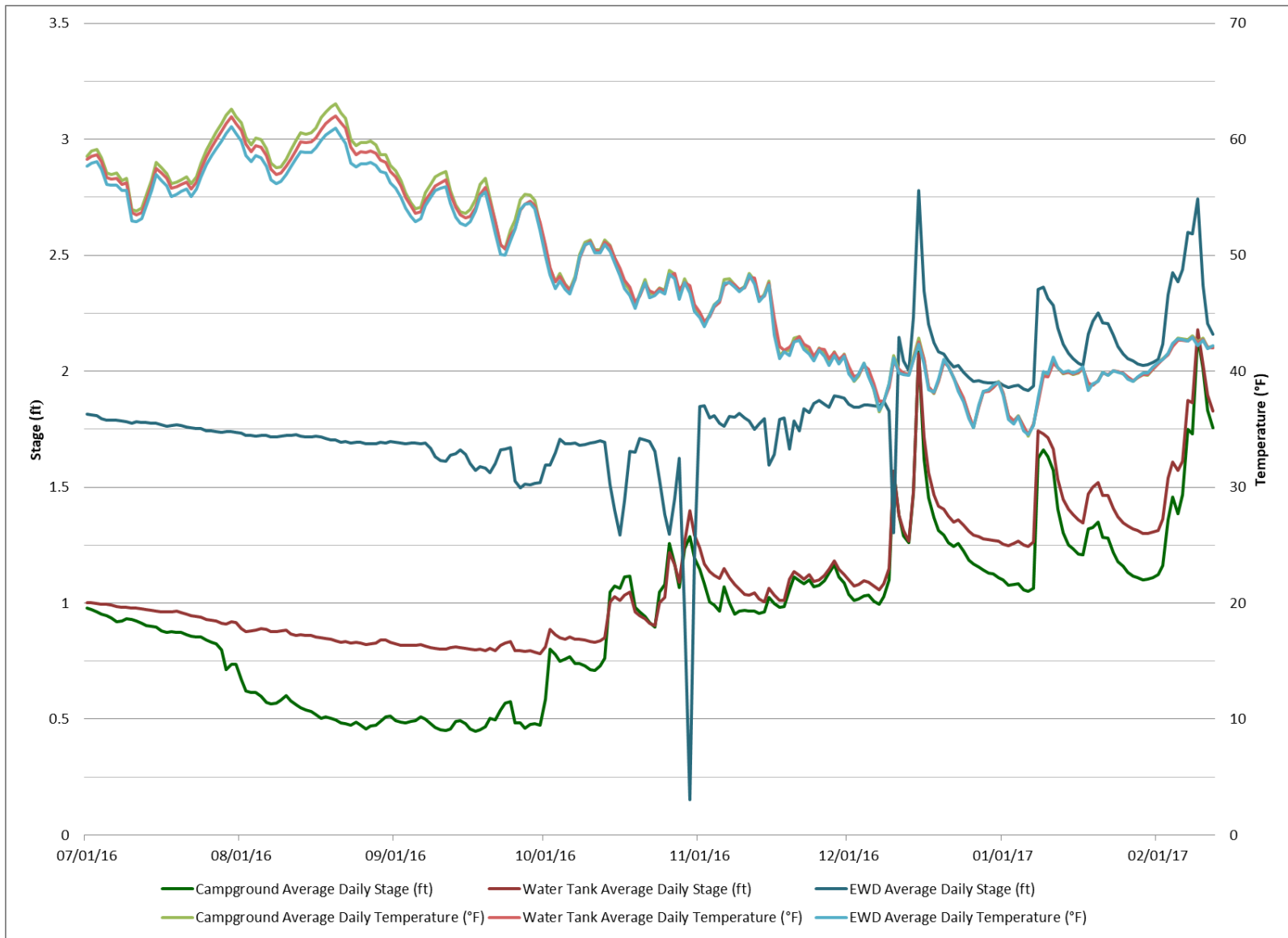
**Figure 9.** Daily minimum and maximum water temperature data. Data was collected at three locations (HWY 3 Bridge, Butterfield Bridge, and below EWD) between 8/13/14 and 11/21/14. The “Below Dam” data logger is located downstream of the return flow from the WCD water treatment facility.



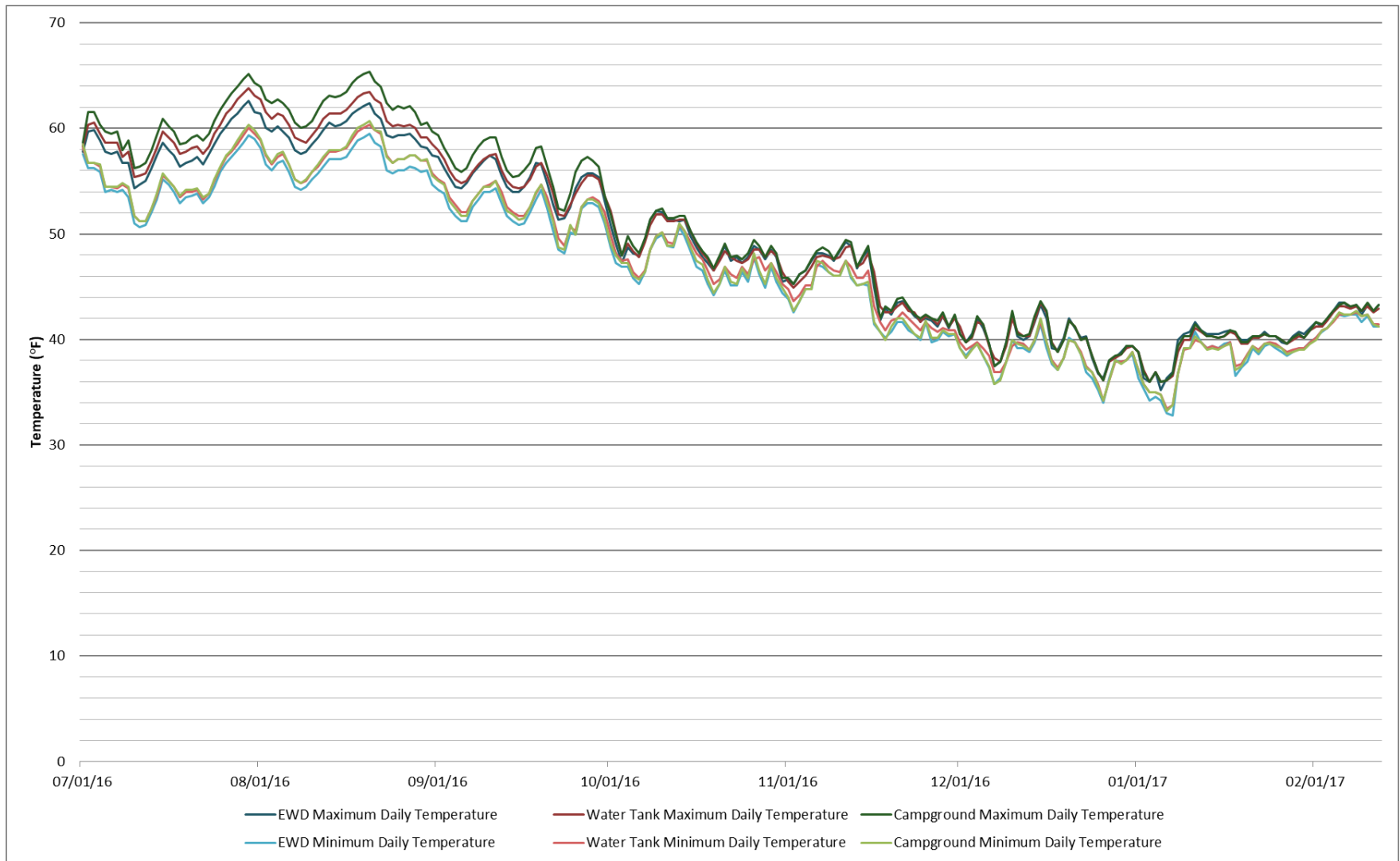
**Figure 10.** Daily average stage and water temperature for summer 2015 to spring 2016 (06/04/2015 to 03/09/2016). Data was taken at the EWD, EWC, and the Water Tank by 5C staff.



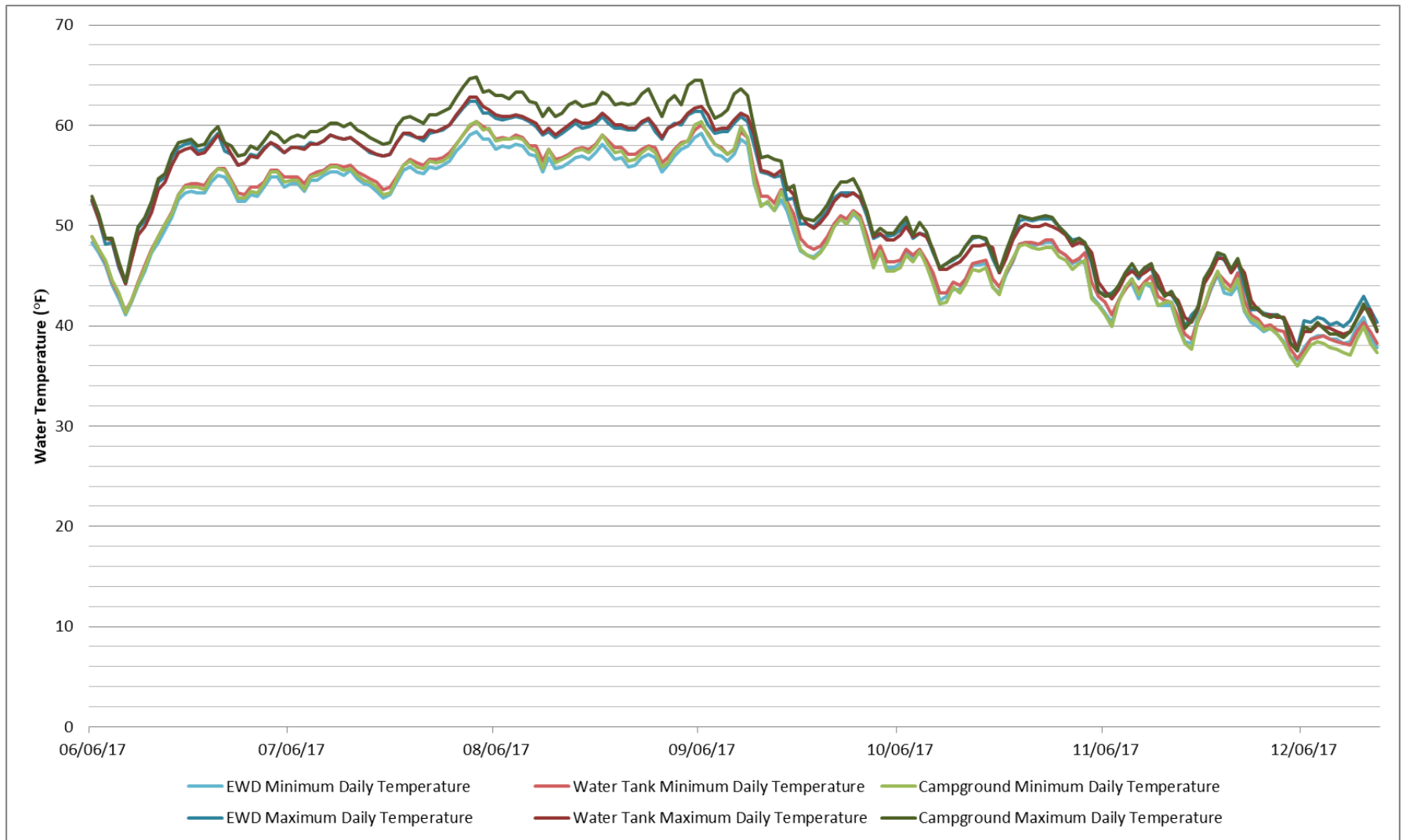
**Figure 11.** Maximum and minimum daily temperatures at EWD, Water Tank, and EWC monitoring sites. Data was collected from 06/04/2015 to 03/09/2016 by 5C staff.



**Figure 12.** Daily averages of water temperature and flow data at EWD, Water Tank, and EWC. Data was collected from 07/01/2016 to 02/12/2017 by 5C staff.

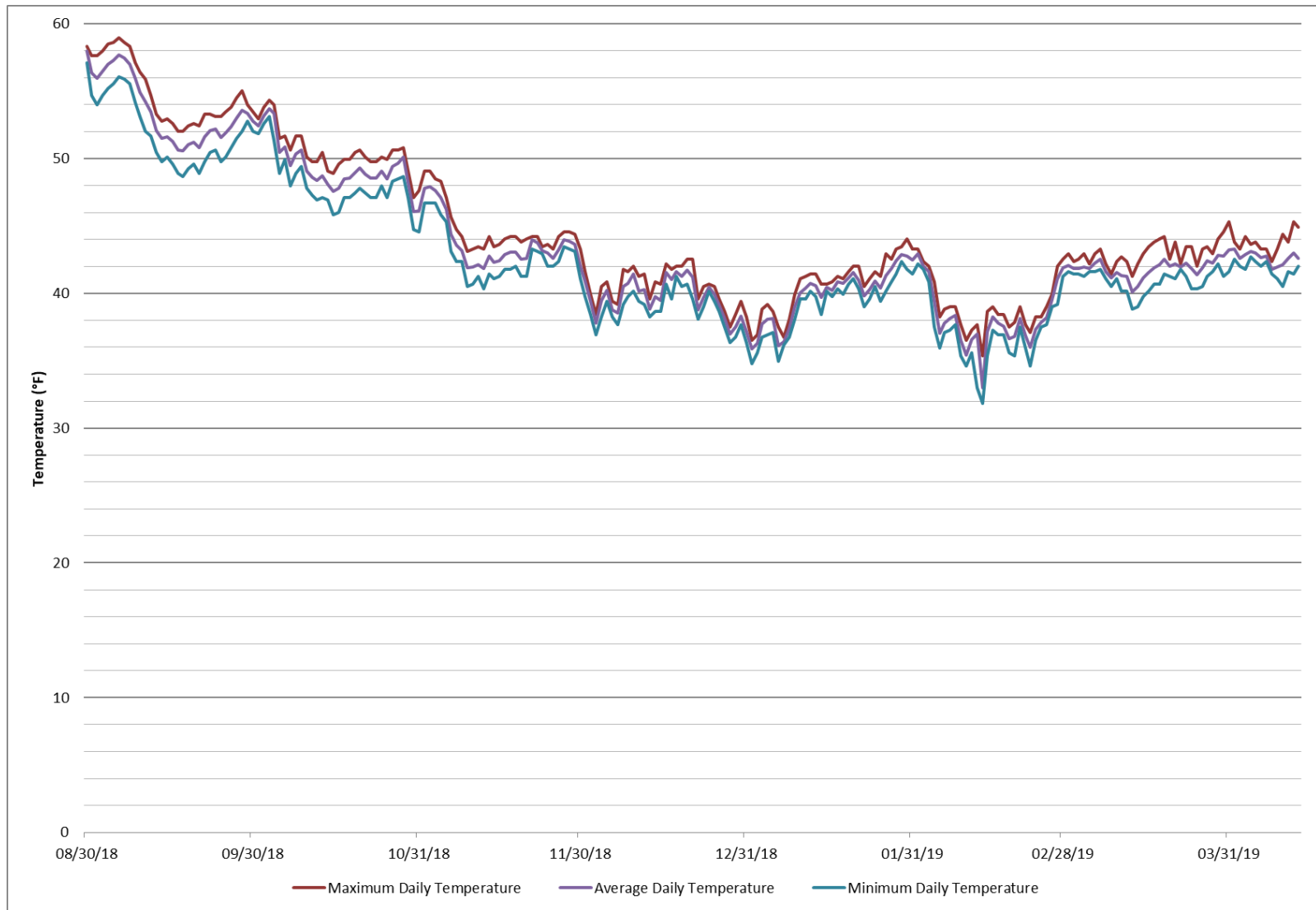


**Figure 13.** Daily maximum and minimum water temperature. Data was collected by 5C staff at three locations on East Weaver Creek in 2016 and 2017.

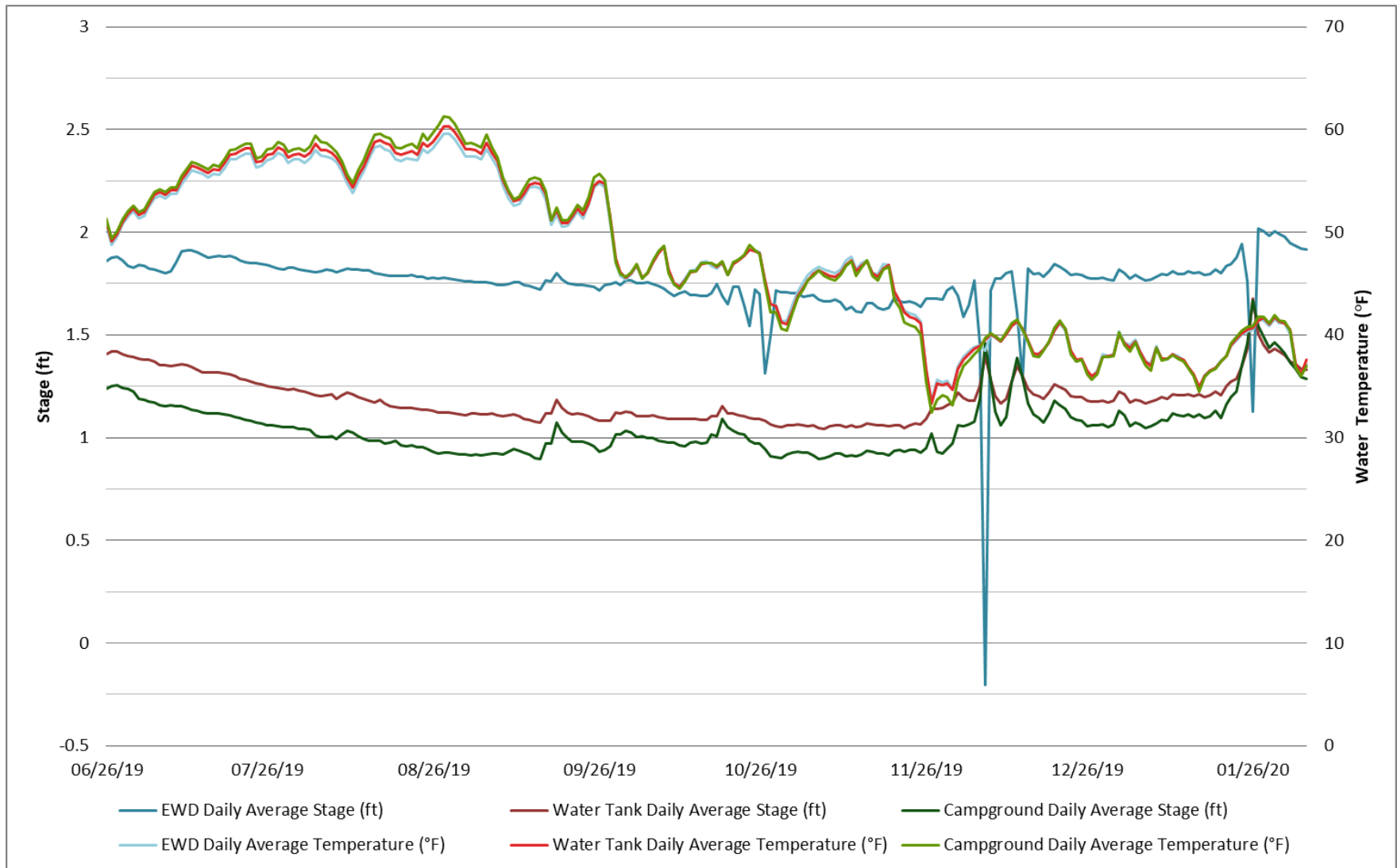


**Figure 14.** EWD, Water Tank, and EWC maximum and minimum daily temperatures. The graph displays daily maximum and minimum stream temperature data from 06/06/17 to 12/17/17. Data was collected by 5C staff. The data is not accompanied with an additional graph of stream flow due to data file errors.

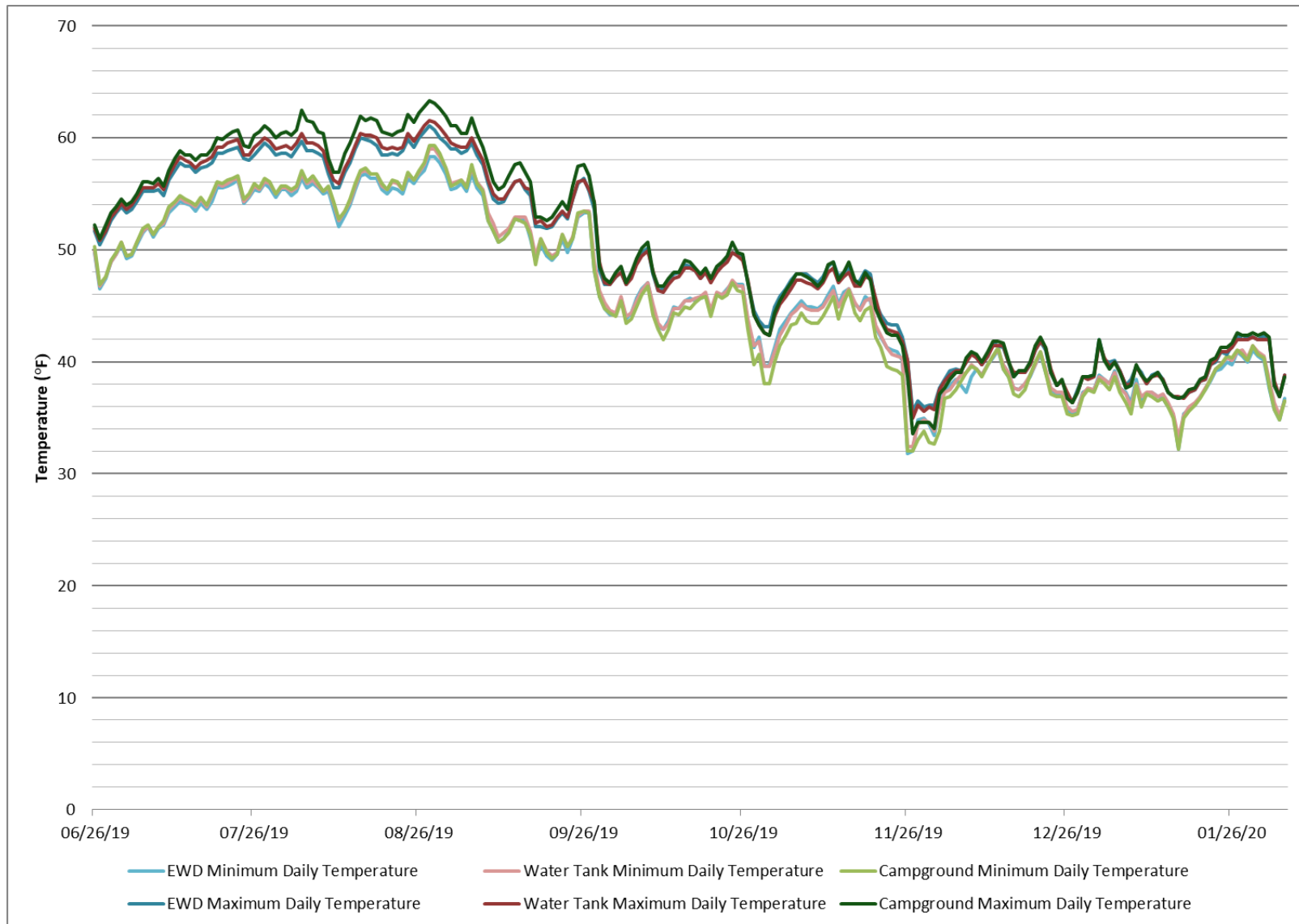




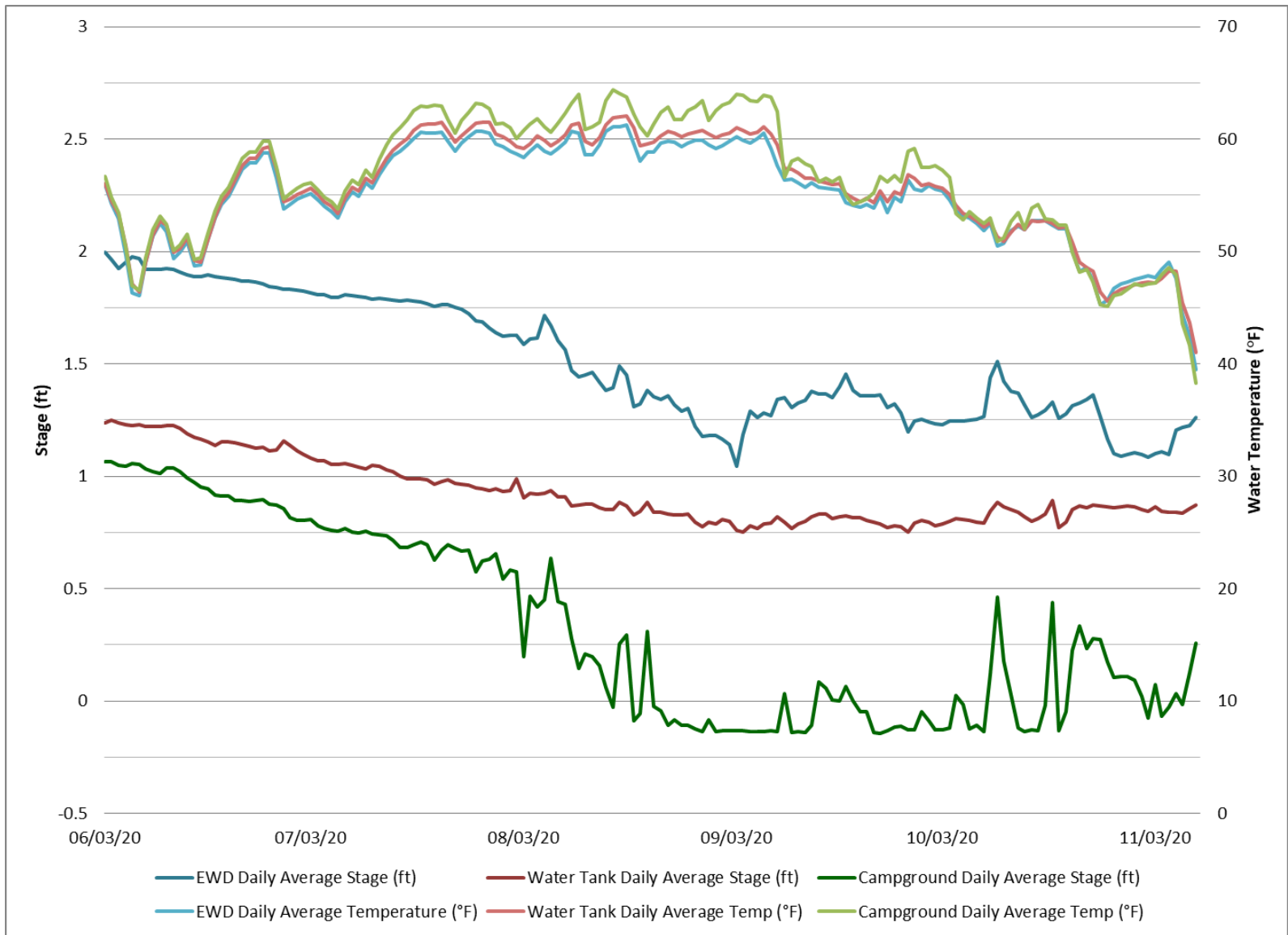
**Figure 15.** EWD maximum, average, and minimum daily temperatures. Stream temperature data was collected from 08/30/18 to 04/13/2019 by 5C staff. The data is not accompanied with an additional graph of average stream flow due to data file errors.



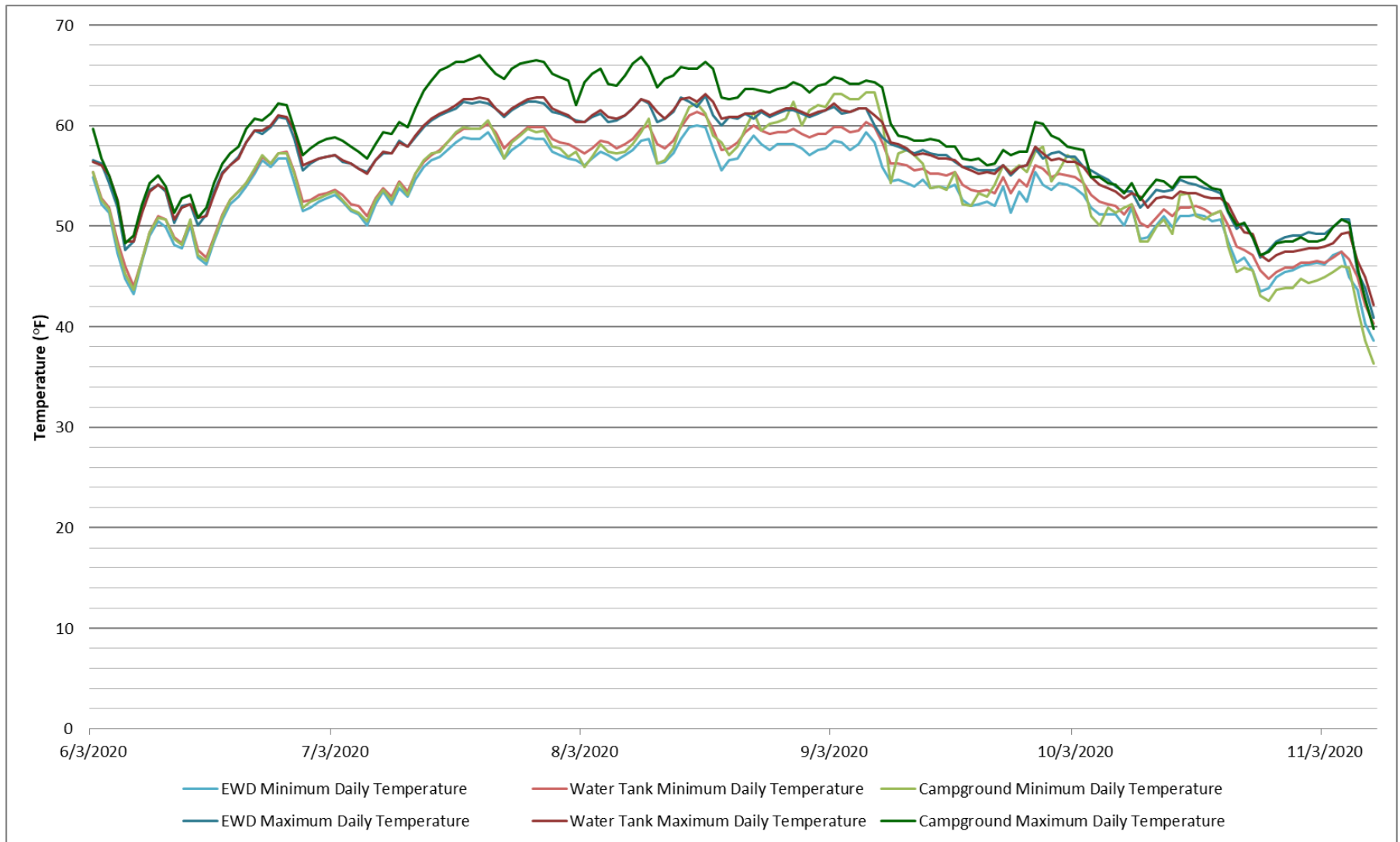
**Figure 16.** Daily average water temperature and stage data. Data was collected at monitoring points #1-3 (EWD, Water Tank, and EWC). Data displays daily average stream stage and temperature from 6/26/19 to 2/7/20. Data was collected by 5C staff.



**Figure 17.** Maximum and minimum daily water temperature. Data was collected at monitoring points #1-3 (EWD, Water Tank, and EWC) by 5C staff. Graph displays daily temperatures from 6/26/19 to 2/5/20.



**Figure 18.** Daily average water temperature and flow data at EWD, Water Tank, and EWC. Data was collected from 6/3/20 to 11/9/20 by 5C staff.



**Figure 19.** Maximum and minimum daily water temperature data collected at EWD, Water Tank, and EWC. Data was collected from 6/3/20 to 11/9/20 by 5C staff.

## Discussion

East Weaver Creek is an important habitat for threatened coho salmon and other aquatic species. Based on the assembled temperature data it appears that stream temperatures above the dam typically remain below thresholds for coho and steelhead survival, even in drought years. The habitat upstream of the EWD is cold water habitat capable of providing critical summer salmon rearing habitat in the Weaver Creek watershed. Favorable topographic and riparian cover from EWC upstream to the headwaters reduce direct summer sun from reach the stream, helping moderate peak daily temperatures in the stream. The stream above EWD has never been observed to dry up and upstream temperature monitoring shows the creek is capable of supporting salmonids even in drought periods (Figures 6-8). In Figures 6 & 7, the highest recorded summer temperatures (62-63°F) for three summers do not exceed the USEPA 7DADM recommendation for salmonids of all life cycles. Upstream temperatures do not exceed 63°F 7DADM, making habitat upstream of the EWD optimal summer habitat for migrating and rearing salmonids. The habitat upstream of the EWD indicates “good” habitat environments for coho even during the summer months and “very good” habitat almost year round (Figures 6-8) (NMFS, 2014). Re-establishing connection to upstream habitat and increasing flows downstream will encourage salmonids to spawn earlier in the year, maintain low summer temperatures, and provide thermal refugia.

### *Reservoir Effects*

Reservoirs can affect water temperature, depending on the design of the reservoir; however, the “reservoir” behind the EWD is less than 0.5 acre feet of storage capacity and is filled with stream bedload, making the “reservoir” act as a run of the river facility. The minimal retention time in storage minimizes the potential effects of water storage on temperature. Upstream of the EWD, favorable topographic shading and riparian cover reduce direct sunlight from reaching the stream, helping moderate peak daily temperatures. This can be seen in the moderated temperatures and preferable coho conditions upstream of the EWD (Figures 6-8).

### *Baseline Stream Temperatures*

Downstream of EWC, the stream provides little summer rearing habitat due to diversions, lack of cover, and limited pools. The entrenched portions lack critical habitat elements such as large wood components, pools, and overbank habitat elements. East Weaver Creek stream temperatures increase with distance from the snowpack headwater sources and can reach critical limits for fisheries approximately 4 miles downstream of EWD at the East Weaver Creek Levee (located at the intersection of Levee Road and Main Street). Water temperatures below the East Weaver Levee can reach lethal temperatures in summer. In some reaches, the stream dries up entirely. Water diversion for domestic, agricultural, and industrial uses further reduce summer rearing habitat opportunities below EWD. The primary sources for temperature increases are naturally warming factors; but, these are exacerbated by confined floodplains, historic mine tailing, water diversions, levees, and narrow riparian bands. Compared to upstream, stream temperatures downstream of the EWD differ greatly and increase to conditions unsuitable for coho. As flows in East Weaver Creek decline around mid-June, temperatures begin increasing as a result. According to the data, as summer flows tend to decrease, temperatures rise towards lethal levels for coho and steelhead.

The data also shows a correlation between distance from EWD and stream temperature; as water moves downstream and flows decrease, stream temperatures gradually raise. The

maximum temperature at HWY 3, approximately 2 miles downstream of the EWD, exhibit the effects of the low flows of East Weaver Creek (Figure 9). Almost a month after the last USFS upstream data collected in 2014, stream temperatures continue to increase further away from EWD (Figure 8). By HWY 3, stream temperatures raised 8°F. The temperature stays in the 69-70°F range for more than 7 days in the summer, which are considered lethal and exceeds the USEPA recommendations of 64.4°F 7DADM (NMFS 2014; USEPA, 2003). Even with added streamflow from the conjunction with East Branch East Weaver Creek, the environment is not adequate for all life cycles of both coho and steelhead. The temperature differences at HWY 3, Butterfield Bridge, and below the dam decrease and range from 40°F to 50°F during the winter months of 2014 (Figure 9). In conjunction with higher precipitation and typically low winter temperatures, the difference in temperature between the three monitoring sites decreased (Figure 5).

Analysis of stream data at EWD, Water Tank, and EWC, can conclude that East Weaver Creek downstream of EWC at its current state is not suitable for salmonid species of all life stages. During the winter, East Weaver Creek meets the USEPA minimum daily average temperature recommendations of 57°F during Coho and steelhead spawning and incubation in November through April. During spring, East Weaver Creek can usually support spawning steelhead ranges. However, in 2020, an exceptionally dry year, spring had higher temperatures that can increase steelhead egg mortality (Figure 19). Stream data shows that areas downstream of the EWC do not support rearing juveniles. The stream also does not meet the USEPA summer 7DADM of 64.4°F, especially at the HWY 3 monitoring site (Figures 9).

Stream temperature data for the summer of 2020 provides worst case data for the stream, due to the record low snow pack, high fire danger, and driest hydrologic year for Weaverville (Figure 18-19). A series of temperature and flow monitors were located within the project area providing data during this record low flow period. Temperature monitors also recorded stream temperatures in normal and above average precipitation years as well.

### *Water Diversion*

The WCSD EWD water right is 1.73 cfs and is the uppermost diversion in the stream. The WCSD holds a “pre-1914” water right for its East Weaver Creek diversion (eWRIMS #S000361); although, the quantity of that right has never had to show cause at a water right hearing. The quantity was determined based on the maximum capacity of the sand filters components of the East Weaver Creek facilities which are the limiting factor for the facility. The sand filters have been in operation since the 1950’s and provide the documented water withdrawal. Review of filed water rights from eWRIMS show that there is a total of 16 recorded diversions reporting a total of 2.92 cfs (refer to Table 1). The diversions do not include unreported riparian diversions, excess diversions, and illegal diversions. There is no flow monitoring upstream of the diversions to determine the percentage of flow diverted; however, interviews with long term residents indicate that the stream has perennial flow at least to the East Weaver Levee (approximately 4 miles downstream of EWD).

While the WCSD uses 1.73 cfs, the intake diverts 100% of the stream flow into the unscreened stilling basin when the stream flow drops to ~2.5 cfs at the dam crest. The complete stream diversion occurs in the summer of drought years, observed by 5C staff and displayed by the figures above. Water entering the stilling basin travels to a contact basin, where excess flows are returned to the stream via a bypass flow pipe. Flow monitoring indicates that even when the

stream is fully diverted into the stilling basin, interstitial leakage and return flows downstream of the dam were ~0.8 - 1 cfs in the driest summer recorded since 1890 (Figures 9, 11, 12, 14).

In the summer of 2020 daily average stage data shows that East Weaver Creek became dry for most of the late summer and early fall at monitoring location #3 at EWC (Figure 14). Water levels at monitoring location #2 (Water Tank) shows the average daily stage to be within previously expected ranges. However, there is usually a drastic drop in water level at the EWC (approximately 0.2 miles downstream). This change of stream flow could be due to the Howe Ditch diverting water out of East Weaver Creek causing the large difference in water level between monitoring location #2 and #3 not previously observed.

### **Conclusion and Recommendation**

Downstream of EWC water temperatures, especially in drought years, reach temperatures not recommended for salmonids. Stream conditions reach temperatures that preclude coho from entering the stream or increase mortality for salmonids of all life stages. Removing the dam will open access to the upper watershed, result in significant improvement in summer rearing habitat and cold water refugia when temperatures are critical, and restore access to some of the best spawning and rearing habitat upstream. If implemented, the proposed project will re-establish the natural bedload and debris transport, the channel gradient, and step pools allowing fish to migrate both upstream and downstream. Retention of the dam will continue to confine salmonids to stream segments where stream temperatures can reach sub-critical to lethal conditions, especially below East Weaver Creek campground. Removing EWD is highly recommended as it will access to upstream access and optimal salmonid habitat.



## References

- Bell, M.C. 1986. Fisheries handbook of engineering requirements and biological criteria. Fish Passage Development and Evaluation Program. U.S. Army Corps of Engineers.
- Boberg, J. and C. Kenyon. 1979. Department of Fish and Game Stream Inventory: Trinity County. California Department of Fish and Game. Sacramento, CA.
- Bureau of Land Management (BLM). 2006. Maintenance and Safety of Dams. BLM Manual 9177. Denver, Colorado, Release x-xxxx. 7 sheets.
- California Department Fish and Game (CDFG). 2009. 2009 Report Trinity River Tributaries Steelhead Spawning Survey Report. California Department Fish and Game, Northern Region.
- California Department Fish and Game (CDFG). 2010. 2010 Report Trinity River Tributaries Steelhead Spawning Survey Report. California Department Fish and Game, Northern Region.
- California Water Code §6000-6009. 1965.
- Ebasco Environmental. 1990. Trinity River basin restoration program - Weaver Creek fish habitat assessment. Report for Bureau of Reclamation, Sacramento, California.
- LaFaunce, D.A. 1964. A Steelhead Spawning Survey of the Upper Trinity River System, 1964. Marine Resources Administrative Report No. 65-4. California Department of Fish and Game, Region 1, Inland Fisheries Branch.
- Myrick C.A., and J.J. Cech. 2001. Temperature Effects on Chinook Salmon and Steelhead: a Review Focusing on California's Central Valley Populations. Bay-Delta ModelingForum. Technical Publication 01-1.
- National Marine Fisheries Service (NMFS). 2014. Final Recovery Plan for the Southern Oregon/Northern California Coast Evolutionarily Significant Unit of Coho Salmon (*Oncorhynchus kisutch*). National Marine Fisheries Service. Arcata, CA.
- Nilsson, C., Reidy, C.A., Dynesius, M., Revenga, C., 2005 April 15. Fragmentation and flow regulation of the World's large river systems. *Science* 308 (5720), 405e 408. <http://dx.doi.org/10.1126/science.1107887>.
- Null, S. E., Medellín-Azuara, J., Escrivá-Bou, A., Lent, M., & Lund, J. R. (2014). Optimizing the dammed: Water supply losses and fish habitat gains from dam removal in California. *Journal of Environmental Management*, 136, 121-131.
- Ock, G., Takemon, Y., Sumi, T., & Kondolf, G. M. (2012). Ecological significance of riverine gravel bars in regulated river reaches below dams. *AGUFM*, 2012, EP23C-0827.
- Poff, N., et al. 1997. The Natural Flow Regime. *BioScience*. 47 (11), 769-784. <https://doi.org/10.2307/1313099>.
- Power, M.E., Dietrich, W.E., Finlay, J.C., 1996. Dams and downstream aquatic biodiversity: potential food web consequences of hydrologic and geomorphic change. *Environ. Manag.* 20 (6), 887e895. <http://dx.doi.org/10.1007/BF01205969>.
- Quinones, R. M., Grantham, T. E., Harvey, B. N., Kiernan, J. D., Klasson, M., Wintzer, A. P., & Moyle, P. B. (2015). Dam removal and anadromous salmonid (*Oncorhynchus* spp.) conservation in California. *Reviews in Fish Biology and Fisheries*, 25(1), 195-215.
- Rogers, D.W. 1971. *A Steelhead Spawning Survey of the Tributaries of the Upper Trinity River and Upper Hayfork Creek Drainage*. California Department of Fish and Game, Region 1, Inland Fisheries Branch.
- Rogers, D.W. 1972. *A Steelhead Spawning Survey of the Tributaries of the Upper Trinity River*

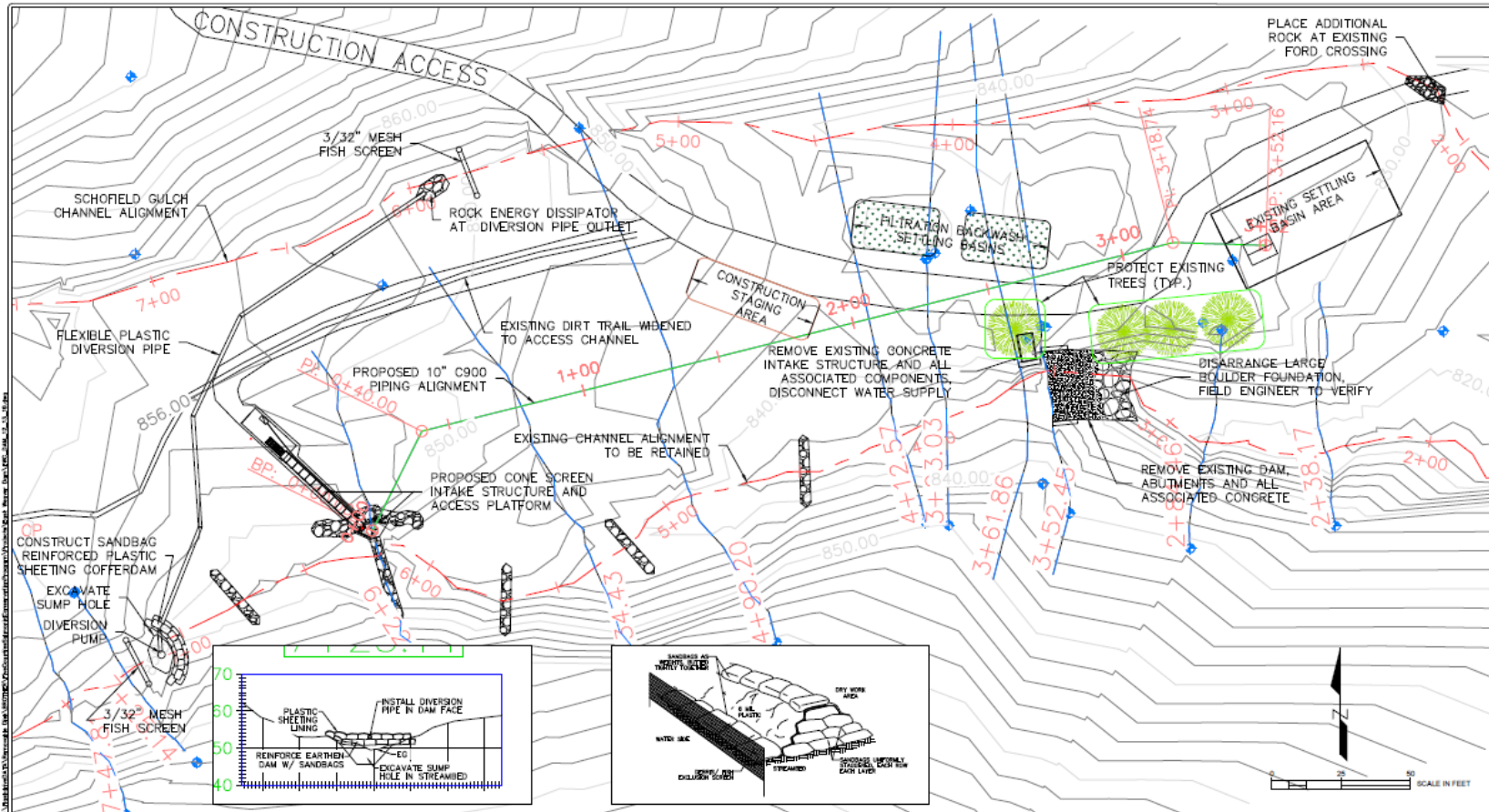
*and Upper Hayfork Creek Drainage.* California Department of Fish and Game, Region 1, Inland Fisheries Branch.

US Environmental Protection Agency (USEPA). (2003). *EPA Region 10 Guidance for Pacific Northwest State and Tribal Temperature Water Quality Standards.* EPA 910-B-03-002. Region 10 Office of Water, Seattle, WA.

Washington Department of Ecology (WDOE). December 2002. Evaluating Standards for Protection Aquatic Life in Washington's Surface Water Quality Standards, Temperature Criteria, Draft Discussion Paper and Literature Summary.

# Appendix A

## EWD Design



**EAST WEAVER DAM REMOVAL AND WCSD WATER INTAKE MODIFICATION PROJECT**  
 SHASTA-TRINITY NATIONAL FOREST - WEAVERVILLE, CALIFORNIA



**NORTHWEST CALIFORNIA RESOURCE CONSERVATION AND DEVELOPMENT COUNCIL**  
 FIVE COUNTIES SALMONID CONSERVATION PROGRAM  
 P.O. Box 2571 43 HORSBURG LANE WEAVERVILLE, CA 95953



Rev	Date	By	Description	App'd

Design: \_\_\_\_\_  
 Drawn: \_\_\_\_\_  
 Checked: \_\_\_\_\_  
 App'd: \_\_\_\_\_

**DEMOLITION AND DEWATERING PLAN**  
 EAST WEAVER DAM  
 WEAVERVILLE, CALIFORNIA

Rev	Project No.	Rev

Scale: AS SHOWN  
 Date: 4/1/20  
 Sheet: 3 of 15