APPENDIX C

HEALTH RISK ASSESSMENT

Health Risk Assessment

1065 South Winchester Boulevard Mixed Use Project

July 19, 2021

Prepared by
EMC Planning Group

HEALTH RISK ASSESSMENT

1065 SOUTH WINCHESTER BOULEVARD
MIXED USE PROJECT

PREPARED FOR

Henry Cord, Cord Associates

401 Fieldcrest Drive, San Jose, CA 95123

Tel 408.283.7292

PREPARED BY

EMC Planning Group Inc.

301 Lighthouse Avenue, Suite C

Monterey, CA 93940

Tel 831.649.1799

Fax 831.649.8399

David Craft, Senior Planner

craft@emcplanning.com

www.emcplanning.com

July 19, 2021

This document was produced on recycled paper.



TABLE OF CONTENTS

1.0	INTRODUCTION.....	1-1
1.1	Purpose.....	1-1
1.2	Project Description	1-1
2.0	SETTING	2-1
2.1	Environmental Setting	2-1
2.2	Regulatory Setting	2-7
3.0	SIGNIFICANCE CRITERIA AND METHODOLOGY.....	3-1
3.1	Significance Thresholds	3-1
3.2	Methodology and Approach.....	3-2
4.0	ANALYSIS.....	4-1
4.1	Construction Health Risks.....	4-1
4.2	Cumulative Health Risks.....	4-6
5.0	SOURCES	5-1

Appendices

Appendix A	Project Plans
Appendix B	Roadway Assessment (Illingworth and Rodkin)
Appendix C	Stationary Source Results
Appendix D	CalEEMod Results
Appendix E	AERMOD Construction Health Risk Calculations

Figures

Figure 1-1	Location Map	1-3
Figure 2-1	Existing Sources of TAC Emissions.....	2-5
Figure 2-2	Sensitive Receptors Within 1,000 Feet.....	2-9

Tables

Table 2-1	Typical Non-road Engine Emissions Standards.....	2-8
Table 3-1	Bay Area Air Quality Management District Community Risk Significance Thresholds	3-1
Table 3-2	Health Risk Parameters.....	3-5
Table 4-1	Unmitigated Construction DPM and PM _{2.5} Emissions	4-1
Table 4-2	Unmitigated Diesel Exhaust Particulate Matter Cancer Risks, PM _{2.5} Concentrations and the Hazard Index at the MEI	4-3
Table 4-3	Mitigated Construction Health Risks at the MEI	4-4
Table 4-4	Cumulative Health Risks at Construction MEIs	4-7

1.0 Introduction

1.1 PURPOSE

The purpose of this report is to address community health risk impacts associated with the proposed 1065 South Winchester Boulevard Mixed Use Project located in the City of San José. Construction activities associated with the project, including demolition of the existing uses at the site, would generate air pollutant emissions, which were predicted using models. Community health risk assessments typically look at all substantial sources of toxic air contaminants (TACs) that can affect sensitive receptors located within 1,000 feet of a project site (i.e., influence area). These sources include rail lines, highways, busy surface streets, and stationary sources. The potential health risk impacts to nearby sensitive receptors from exposure to emissions generated by project demolition and construction activity were evaluated in combination with exposures to existing toxic air contaminant emissions from stationary sources and high-traffic volume roadways. The impact analysis is based on the guidance provided by the Bay Area Air Quality Management District (hereinafter “BAAQMD”).

This introductory section provides a description of the project. Section 2 describes the existing environmental setting including air quality conditions, and the regulatory setting for addressing emissions-related health risks. Section 3 identifies thresholds of significance and describes the analysis methodology. Section 4 presents an assessment of project-related health risks related to emissions generated by construction of the project, and Section 5 identifies references cited and includes a list of persons who prepared this technical report.

1.2 PROJECT DESCRIPTION

The proposed project is the demolition of an existing 2,200 square-foot single-family residence, barn and accessory structures (approximately 2,530 square feet) and the construction of a new six-story commercial and residential mixed-use building on a 0.93-acre project site located at 1065 South Winchester Boulevard in the City of San José. The project plans are included in Appendix A. [Figure 1-1, Location Map](#), presents the regional location of the project site.

1.0 Introduction

The proposed mixed-use building would consist of 70 residential condominiums and 20,410 square feet of commercial office uses. A residential lobby, gym, office lobby, three office units, and parking would be located on the ground floor. The second floor would include seven residential units, seating areas, office lobby, and six office units. Floors three through six would consist of the remaining 62 residential units. A total of 104 vehicle parking spaces are provided in two levels of garage parking; 25 parking spaces covering an area of 18,038 square feet would be tucked under the building on the ground floor; the remaining 79 parking spaces would be located on a subgrade level below the ground floor (3, 214 square feet).

Project demolition and construction activity is estimated to occur over a 20-month period. Grading for the proposed project includes excavation of 14,114 cubic yards of soil to accommodate the proposed underground parking garage level and importing 600 cubic yards of fill. Approximately 14,114 cubic yards of excavated soils would be disposed of off-site.

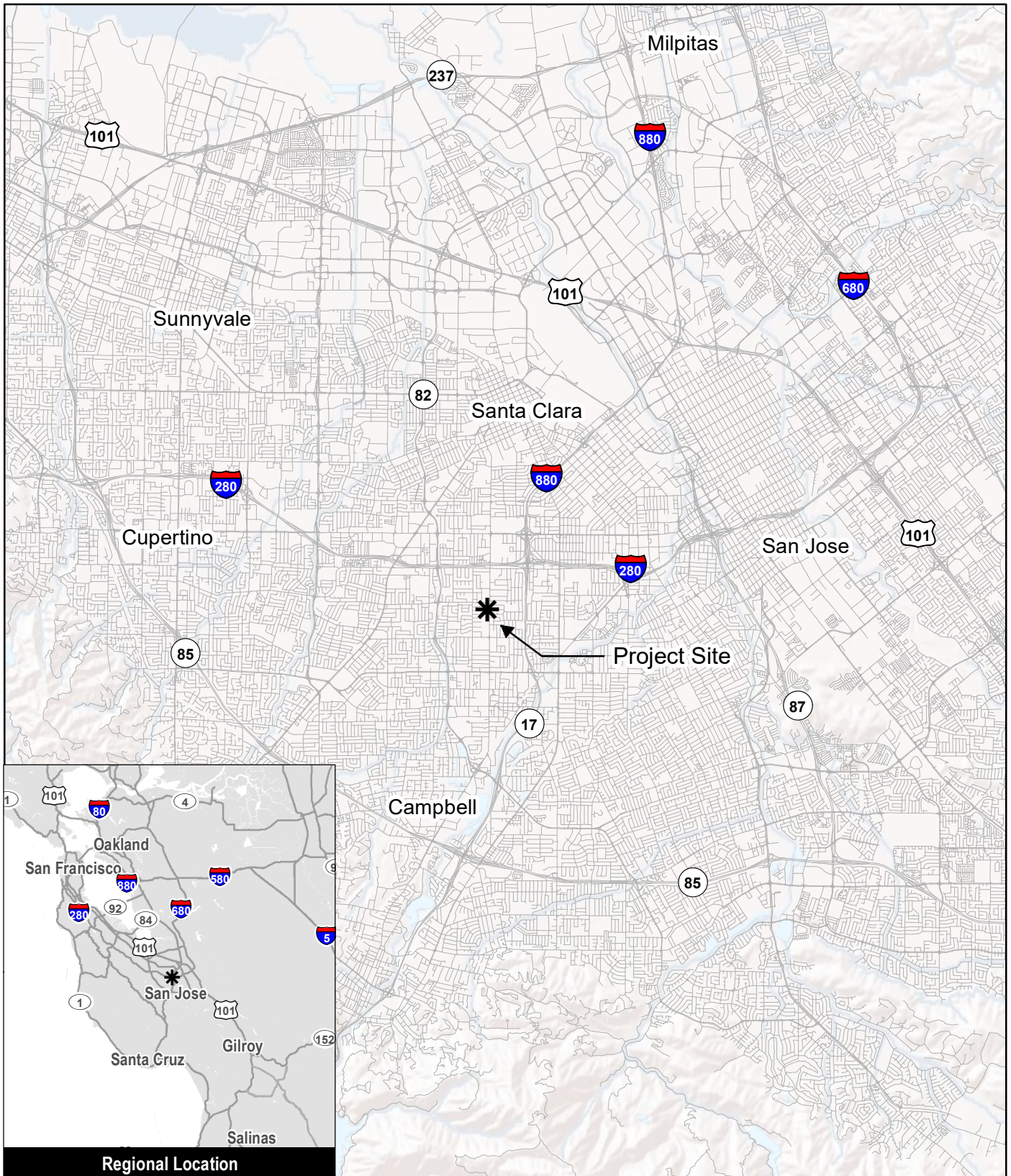

Source: ESRI 2019

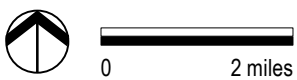

Figure 1-1

Location Map



This side intentionally left blank.

2.0 Setting

2.1 ENVIRONMENTAL SETTING

Regional Climate and Topography

The project is located in Santa Clara County, which is in the San Francisco Bay Area Air Basin (air basin). The air basin encompasses all of Alameda, Contra Costa, Marin, Napa, San Francisco, San Mateo, and Santa Clara Counties, and the southern portions of Solano and Sonoma counties.

The topography of the air basin is characterized by complex terrain, consisting of coastal mountain ranges, inland valleys and bays. This complex terrain, especially the higher elevations, distorts the normal wind flow patterns in the air basin. The greatest distortion occurs when low-level inversions are present and the air beneath the inversion flows independently of air above the inversion, a condition that is common in the summer time.

The climate of the air basin is determined largely by a high-pressure system that is usually present over the eastern Pacific Ocean off the west coast of North America. During winter, the Pacific high-pressure system shifts southward, allowing more storms to pass through the region. During summer and early fall, when few storms pass through the region, emissions generated within the Bay Area can combine with abundant sunshine under the restraining influences of topography and subsidence inversions to create conditions that are conducive to the formation of photochemical pollutants, such as ozone, and secondary particulates, such as nitrates and sulfates.

Temperature inversions can often occur during the summer and winter months. An inversion is a layer of warmer air over a layer of cooler air that traps and concentrates pollutants near the ground. As such, the highest air pollutant concentrations in the air basin generally occur during inversions (Bay Area Air Quality Management District 2017).

The project site is located in the Santa Clara Valley climatological subregion. The Santa Clara Valley subregion is bounded by the Bay to the north and by mountains to the east, south and west. Temperatures are warm on summer days and cool on summer nights, and winter temperatures are fairly mild. At the northern end of the valley, mean maximum temperatures are in the low-80's degrees Fahrenheit (°F) during the summer and the high-50's °F during the winter, and mean minimum temperatures range from the high-50's °F in the summer to the low-40's °F in the winter. Winds in the valley are greatly influenced by the

terrain, resulting in a prevailing flow that roughly parallels the valley's northwest-southeast axis. A north-northwesterly sea breeze flows through the valley during the afternoon and early evening, and a light south-southeasterly drainage flow occurs during the late evening and early morning. In the summer the southern end of the valley sometimes becomes a "convergence zone," when air flowing from the Monterey Bay gets channeled northward into the southern end of the valley and meets with the prevailing north-northwesterly winds. Wind speeds are greatest in the spring and summer and weakest in the fall and winter. Nighttime and early morning hours frequently have calm winds in all seasons, while summer afternoons and evenings are quite breezy. Strong winds are rare, associated mostly with the occasional winter storm (Bay Area Air Quality Management District 2017).

The air pollution potential of the Santa Clara Valley is high. High summer temperatures, stable air and mountains surrounding the valley combine to promote ozone formation. In addition to the many local sources of pollution, ozone precursors from San Francisco, San Mateo and Alameda counties are carried by prevailing winds to the Santa Clara Valley. The valley tends to channel pollutants to the southeast. In addition, on summer days with low level inversions, ozone can be recirculated by southerly drainage flows in the late evening and early morning and by the prevailing north-westerly winds in the afternoon. A similar recirculation pattern occurs in the winter, affecting levels of carbon monoxide and particulate matter. This movement of the air up and down the valley increases the impact of the pollutants significantly (Bay Area Air Quality Management District 2017).

Air Pollutants of Concern

The air basin is currently designated as a non-attainment area for state and national ozone standards, for state and national fine particulate matter (PM_{2.5}) standards, and state respirable particulate matter (PM₁₀) standards.

Ground-level ozone is caused by the cumulative emissions of reactive organic gases (ROG) and nitrogen oxides (NO_x). These precursor pollutants react under certain meteorological conditions to form ground-level ozone. Controlling the emissions of these precursor pollutants is the focus of the Bay Area's attempts to reduce ozone levels. The highest ozone levels in the Bay Area occur in the eastern and southern inland valleys that are downwind of air pollutant sources. High ozone levels aggravate respiratory and cardiovascular diseases, reduced lung function, and increase coughing and chest discomfort.

Particulate matter is another problematic air pollutant in the Bay Area. Particulate matter is assessed and measured in terms of respirable particulate matter or particles that have a diameter of 10 micrometers or less or PM₁₀ and fine particulate matter where particles have a diameter of 2.5 micrometers or less PM_{2.5}. Elevated concentrations of PM₁₀ and PM_{2.5} are the result of both region-wide (or cumulative) emissions and localized emissions. High particulate matter levels aggravate respiratory and cardiovascular diseases, reduce lung function, increase mortality (e.g., lung cancer), and result in reduced lung function growth in children.

Toxic Air Contaminants

TACs have the potential to cause adverse health effects in humans, including increasing the risk of cancer upon exposure or acute (short-term) and/or chronic (long-term) non-cancer health effects. Examples of TACs include certain aromatic and chlorinated hydrocarbons, diesel particulate matter (DPM), certain metals, and asbestos. TACs are generated by a number of sources, including stationary sources such as dry cleaners, gas stations, combustion sources, and laboratories; mobile sources, such as automobiles; and area sources, such as landfills. Adverse health effects associated with exposure to TACs may include carcinogenic (i.e., cancer-causing) and non-carcinogenic effects. Non-carcinogenic effects typically affect one or more target organ systems and may be experienced through either acute or chronic exposure to a given TAC.

Construction activity on the project site would generate emissions of TACs from equipment and trucks that could affect nearby sensitive receptors. The project site is located close to two high volume roadways: South Winchester Boulevard and Williams Road (Illingworth and Rodkin 2020). Typically, for residential projects located near high-volume roadways, the primary TAC of concern with non-cancer health effects is DPM. Vehicle traffic on South Winchester Boulevard and Williams Road would generate DPM volumes that could negatively affect the health of nearby sensitive receptors.

Construction Emissions

Construction emissions are typically generated by the use of heavy equipment, the transport of materials, and construction employee commute trips. Construction-related emissions consist primarily of ROG, NO_x, carbon monoxide, and particulate matter (PM₁₀ and PM_{2.5}). Emissions of ROG, NO_x, carbon monoxide, and exhaust particulate matter are generated primarily by the operation of gas and diesel-powered motor vehicles, asphalt paving activities, and the application of architectural coatings. Fugitive particulate matter emissions are generated primarily by wind erosion of exposed graded surfaces.

Existing Sources of TAC Emissions Near the Project Site

Existing sources of TAC emissions near the site include mobile sources and stationary sources. The locations of existing sources are shown on [Figure 2-1, Existing Sources of TAC Emissions](#).

Mobile-source (Roadway) Emissions

The BAAQMD guidance for high-volume roadways is that roadways with traffic counts greater than 10,000 vehicles per day need to be included in a cumulative risk assessment (BAAQMD 2017). Typically, for residential projects located near high-volume roadways, the primary TAC of concern with non-cancer health effects is DPM.

South Winchester Boulevard and Williams Road are located within 1,000 feet of the project site (refer to Figure 2-1) and are high-volume roadways. Vehicle traffic on South Winchester Boulevard and Williams Road generate DPM volumes that can negatively affect the health of nearby sensitive receptors. The background emissions for these roadways were modeled for a health risk assessment prepared for a similar project proposal located at 1073 South Winchester Boulevard, which adjoins the site (Illingworth and Rodkin 2020) (roadway assessment). According to the Illingworth and Rodkin report, Average Daily Travel (ADT) along South Winchester Boulevard is 24,470 vehicles per day, while the ADT along Williams Road is 10,820 ADT. In the analysis of potential health impacts from vehicle traffic on South Winchester Boulevard and Williams Road the roadway assessment involved predicting emissions for the traffic volume and mix of vehicle types on the roadways near the project site and using an atmospheric dispersion model to predict exposure to TACs. The associated cancer risks were then computed based on the modeled exposures. The roadway assessment is included as Appendix B.

Stationary Source Emissions

A stationary source consists of a single emission source with an identified emission point, such as a stack at an industrial facility. Facilities can have multiple emission point sources located on-site and sometimes the facility as a whole is referred to as a stationary source. Examples of BAAQMD-permitted stationary sources include refineries, gasoline dispensing stations, dry cleaning establishments, back-up diesel generators, boilers, heaters, flares, cement kilns, and other types of combustion equipment, as well as non-combustion sources such as coating or printing operations.

According to the BAAQMD's Permitted Stationary Source Risks and Hazards geographic information systems (GIS) map tool, one stationary source is located within 1,000 feet of the project site (SOURCE). The stationary source is a gasoline dispensing station located at 1025 South Winchester Boulevard in San José, approximately 250 feet north of the project site. Background information on this stationary source is included in Appendix C.

1073 South Winchester Boulevard Construction Emissions

A similar project by the same applicant is currently proposed on the property adjoining the south property line of the project site. It is possible that construction of the adjoining parcel would occur concurrently with the proposed project. Construction emissions and corresponding health risks were calculated in the *1073-1087 S. Winchester Blvd. Mixed Use – Health Risk Assessment* (EMC Planning Group 2020). The health risks associated with construction of this adjacent project are included in the analysis of cumulative community health risks, Section 4.2.

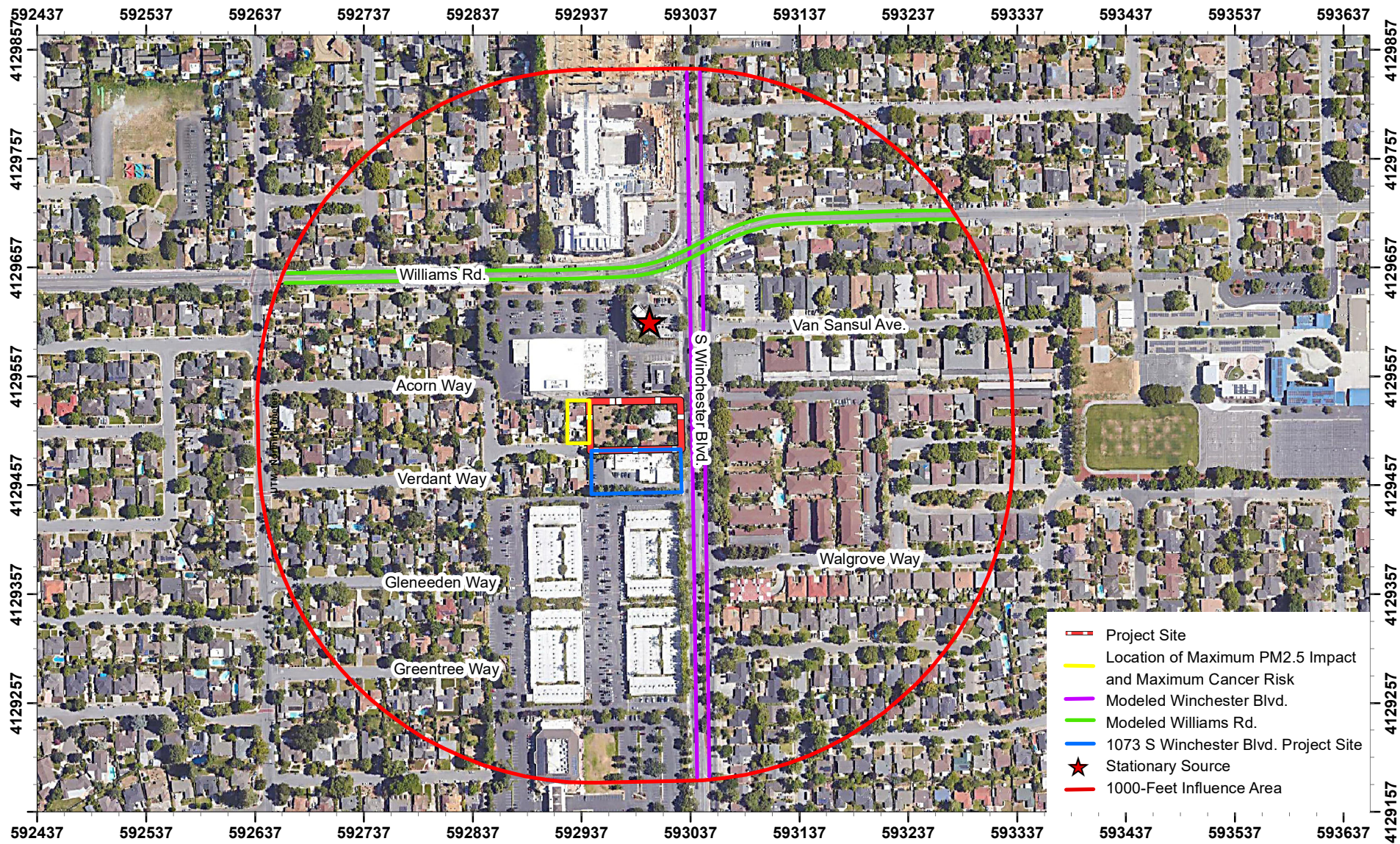

- Project Site
- Location of Maximum PM2.5 Impact and Maximum Cancer Risk
- Modeled Winchester Blvd.
- Modeled Williams Rd.
- 1073 S Winchester Blvd. Project Site
- Stationary Source
- 1000-Foot Influence Area

UTM - Easting (meters)



Source: ESRI 2020, Google Earth 2018, Monterey County GIS 2016



Figure 2-1
Existing Sources of TAC Emissions
 1065 South Winchester Boulevard Mixed Use Project HRA

This side intentionally left blank.

Sensitive Receptors

There are groups of people more affected by air pollution than others. Children, the elderly, and people with illnesses are especially vulnerable to the effects of air pollution. These groups are classified as sensitive receptors. Locations that may contain a high concentration of these sensitive population groups include residential areas, hospitals, daycare facilities, elder care facilities, and elementary schools. For cancer risk assessments, children are the most sensitive receptors, since they are more susceptible to cancer-causing TACs. Residential locations are assumed to include infants and small children.

The closest sensitive receptors to the project site are single-family homes adjacent to the western boundary of the project site, to the south, and to the east (Google 2021). There are additional residences to the east of the project site, and an assisted living facility located at 3065 Van Sansul Avenue, approximately 390 feet northeast of the site. Sensitive receptors within 1,000 feet of the project site are shown on [Figure 2-2, Sensitive Receptors Within 1,000 Feet](#).

2.2 REGULATORY SETTING

Federal

United States Environmental Protection Agency

The United States Environmental Protection Agency (EPA) was established on December 2, 1970 to create a single agency that covered several agency concerns: federal research, monitoring, standard-setting and enforcement.

The EPA regulates diesel engine design and has implemented a series of measures since 1996 to reduce NO_x and particulate emissions from off-road and highway diesel equipment. EPA Tier 1 non-road diesel engine standards were introduced in 1996, Tier 2 in 2001, Tier 3 in 2006, with final Tier 4 in 2014 (DieselNet 2017). [Table 2-1, Typical Non-road Engine Emissions Standards](#), compares emissions standards for NO_x and particulate matter from non-road engine Tier 1 through Tier 4 for typical engine sizes. As illustrated in the table, emissions for these pollutants have decreased significantly for construction equipment manufactured over the past 20 years, and especially for construction equipment manufactured in the past five years.

State

California Air Resources Board

The California Air Resources Board (CARB) oversees regional BAAQMD activities and regulates air quality at the state level. CARB has adopted and implemented a number of

regulations for stationary and mobile sources to reduce emissions of DPM. Several of these regulatory programs affect medium and heavy-duty diesel trucks that represent the bulk of DPM emissions from California highways.

Table 2-1 Typical Non-road Engine Emissions Standards

Engine Tier and Year Introduced	NO _x Emissions ¹			Particulate Emissions ¹		
	100-175 HP	175-300 HP	300-600 HP	100-175 HP	175-300 HP	300-600 HP
Tier 1 (1996)	6.90	6.90	6.90	--	0.40	0.40
Tier 2 (2001)	-- ²	-- ²	-- ²	0.22	0.15	0.15
Tier 3 (2006)	-- ²	-- ²	-- ²	-- † ³	-- † ³	-- † ³
Tier 4 (2014)	0.30	0.30	0.30	0.015	0.015	0.015

SOURCE: DieselNet 2017

NOTES:

1. Expressed in g/bhp-hr, where g/bhp-hr stands for grams per brake horsepower-hour.
2. Tier 1 standards for NO_x remained in effect.
3. † - Not adopted, engines must meet Tier 2 PM standard.

California Air Toxics Program

The Toxic Air Contaminant Identification and Control Act of 1983 or Assembly Bill 1807 established the California Air Toxics Program that was designed to reduce exposure to air toxics. The program involves a two-step process: risk identification and risk management. In the risk identification step, upon CARB's request, the Office of Environmental Health Hazard Assessment evaluates the health effects of substances other than pesticides and their pesticidal uses. Substances with the potential to be emitted or are currently being emitted into the ambient air may be identified as a TAC. Once a substance is identified as a TAC, and with the participation of local BAAQMDs, industry, and interested public, CARB prepares a report that outlines the need and degree to regulate the TAC through a control measure (California Air Resources Board 2020a).

The Air Toxics Hot Spots Information and Assessment Act or AB 2588 was enacted in 1987, and requires stationary sources to report the types and quantities of certain substances their facilities routinely release into the air. The goals of AB 2588 are to collect emission data, to identify facilities having localized impacts, to ascertain health risks, to notify nearby residents of significant risks, and to reduce those significant risks to acceptable levels (California Air Resources Board 2020b).

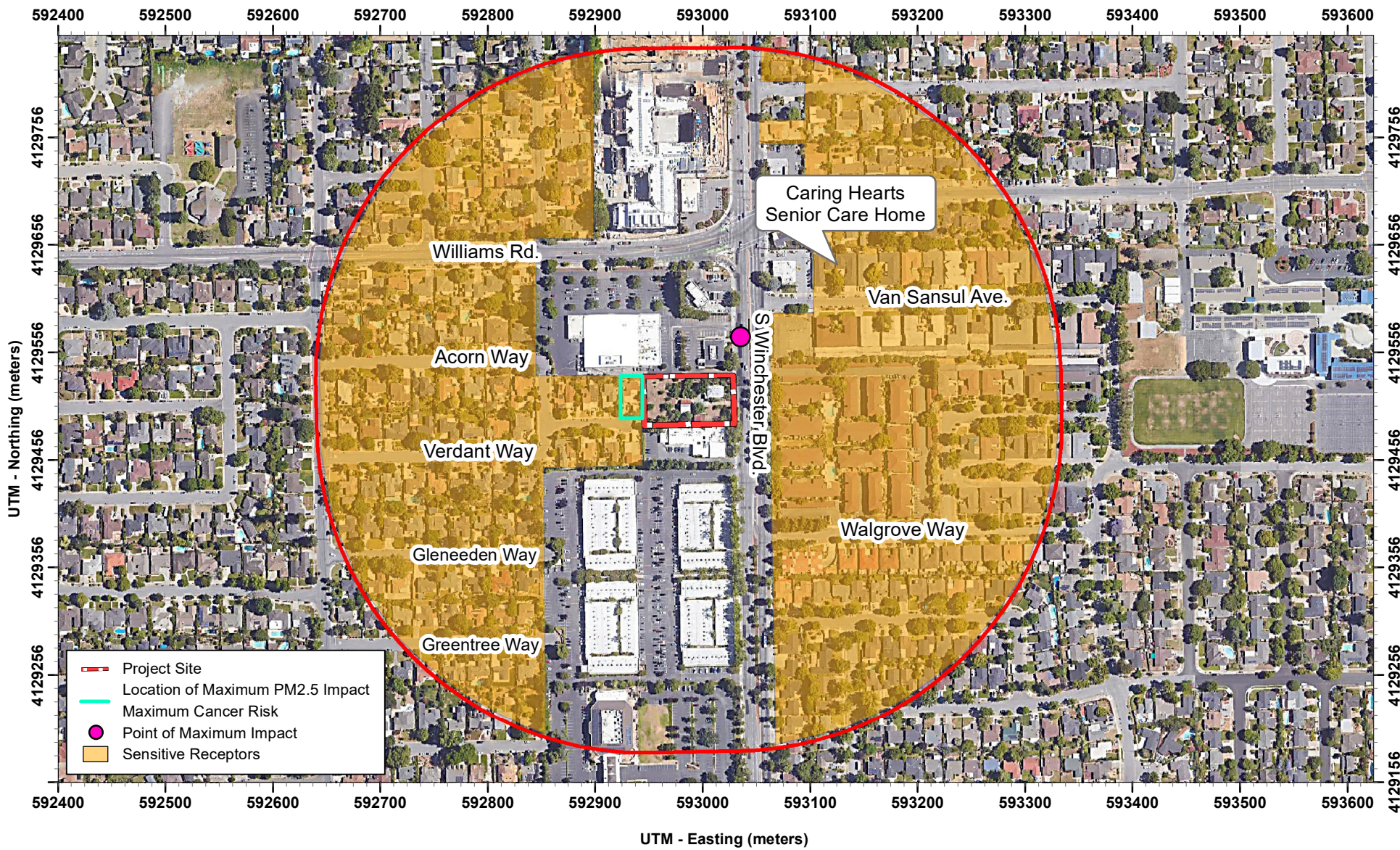

Source: ESRI 2020, Google Earth 2018, Monterey County GIS 2016

Figure 2-2
Sensitive Receptors Within 1,000 Feet



This side intentionally left blank.

Truck and Bus Regulation

As heavy-duty on-road vehicles are a significant source of TACs, the Truck and Bus Regulation is one of the most far-reaching and important tools to reduce smog-forming and toxic emissions and protect public health in disadvantaged communities. The Truck and Bus Regulation requires all trucks and buses, by January 1, 2023, to have 2010 or newer model year engines to reduce DPM and NO_x emissions (California Air Resources Board 2020c). To help ensure that the benefits of this regulation are achieved, starting January 1, 2020, only vehicles compliant with this regulation will be registered by the California Department of Motor Vehicles.

In-Use Off-Road Diesel Vehicle Regulation

The goal of the In-Use Off-Road Diesel-Fueled Fleets Regulation is to reduce DPM and NO_x emissions from in-use (existing) off-road heavy-duty diesel vehicles in California (e.g., loaders, tractors, bulldozers, backhoes, off-highway trucks, etc.) (California Air Resources Board 2020d). This regulation applies to all diesel-powered off-road vehicles with engines 25 horsepower or greater. The regulations are intended to reduce DPM and NO_x exhaust emissions by requiring owners to turn over their fleet (replace older equipment with newer equipment) or retrofit existing equipment in order to achieve specified fleet averaged emission rates.

Regional/Local

Bay Area 2017 Clean Air Plan: Spare the Air, Cool the Climate (2017 Clean Air Plan)

The Clean Air Plan is implemented by the BAAQMD and includes measures to minimize ozone precursor emissions and halt the movement of ozone and its precursors into nearby air basins, and builds upon the air district's determination to minimize the emissions of fine particulate matter and toxic air contaminants (Bay Area Air Quality Management District 2017a).

A primary goal of the Clean Air Plan is to reduce population exposure to pollutants and protect public health in the Bay Area. This is considered to have been accomplished if there are no project-level significant impacts, or if significant project-level impacts are mitigated to a less-than-significant level. Policy TR16, Indirect Source Review, reduces emissions of key ozone precursors, ROG and NO_x, particulate matter, toxic air contaminants and GHGs by reducing construction and operational emissions associated with new or modified land uses. On-road and off-road mobile emission sources are the main source categories targeted by this measure to reduce localized and region-wide population exposures to air pollutants.

Bay Area Air Quality Management District

The BAAQMD is charged with regulatory authority over stationary sources of air emissions, monitoring air quality within the air basin, providing guidelines for analysis of air quality impacts pursuant to California Environmental Quality Act (CEQA), and preparing an air quality management plan to maintain or improve air quality in the air basin. The BAAQMD's 2017 CEQA Air Quality Guidelines (2017 CEQA Guidelines) contain instructions on how to evaluate, measure, and mitigate air quality impacts generated from land development construction and operation activities.

The BAAQMD recommends that all receptors located within a 1,000-foot radius of the project's fence line be assessed for potentially significant impacts from the incremental increase in risks or hazards that would result from exposures to construction emissions (BAAQMD 2017).

San José 2040 General Plan

The *Envision San José 2040 General Plan* includes goals, policies, and actions to reduce exposure of the City's sensitive population to exposure of air pollution and TACs. The following goals, policies, and actions are applicable to the proposed project:

Goal MS-10: Minimize emissions from new development.

Policy MS-10.1 Assess projected air emissions from new development in conformance with air district CEQA Guidelines and relative to state and federal standards. Identify and implement feasible air emission reduction measures.

Policy MS-10.2 Consider the cumulative air quality impacts from proposed developments for proposed land use designation changes and new development, consistent with the region's Clean Air Plan and state law.

Policy MS-10.3 Promote the expansion and improvement of public transportation services and facilities, where appropriate, to both encourage energy conservation and reduce air pollution.

Goal MS-11: Minimize exposure of people to air pollution and toxic air contaminants such as ozone, carbon monoxide, lead, and particulate matter.

Policy MS-11.2 For projects that emit toxic air contaminants, require project proponents to prepare health risk assessments in accordance with air district-recommended procedures as part of environmental review and employ effective mitigation to reduce possible health risks to a less than significant level. Alternatively, require new projects (such

as, but not limited to, industrial, manufacturing, and processing facilities) that are sources of TACs to be located an adequate distance from residential areas and other sensitive receptors.

Policy MS-11.5 Encourage the use of pollution absorbing trees and vegetation in buffer areas between substantial sources of TACs and sensitive land uses.

City of San José Standard Conditions of Approval

The City has adopted BAAQMD requirements for implementation of best management practices during construction to reduce fugitive dust emissions. The following best management practices are required as standard conditions of approval for all phases of construction.

Standard Permit Conditions

1. All exposed surfaces (e.g., parking areas, staging areas, soil piles, graded areas, and unpaved access roads) shall be watered two times per day;
2. All haul trucks transporting soil, sand, debris, or other loose material off-site shall be covered;
3. All visible mud or dirt track-out onto adjacent public roads shall be removed using wet power vacuum street sweepers at least once per day. The use of dry power sweeping is prohibited;
4. All vehicle speeds on unpaved roads shall be limited to 15 miles per hour;
5. All roadways, driveways, and sidewalks to be paved shall be completed as soon as possible. Building pads shall be laid as soon as possible after grading unless seeding or soil binders are used;
6. Idling times shall be minimized either by shutting equipment off when not in use or reducing the maximum idling time to 5 minutes (as required by the California airborne toxics control measure Title 13, Section 2485 of California Code of Regulations [CCR]). Clear signage shall be provided for construction workers at all access points;
7. All construction equipment shall be maintained and properly tuned in accordance with manufacturer's specifications. All equipment shall be checked by a certified mechanic and determined to be running in proper condition prior to operation; and
8. Post a publicly visible sign with telephone number and person to contact at the Lead Agency regarding dust complaints. This person shall respond and take corrective action within 48 hours. The BAAQMD's phone number shall also be visible to ensure compliance with applicable regulations.

This side intentionally left blank.

Significance Criteria and Methodology

3.1 SIGNIFICANCE THRESHOLDS

The BAAQMD's 2017 CEQA Guidelines provide cancer and non-cancer thresholds to establish the level at which TACs would cause significant health risks in sensitive receptors. A summary of the BAAQMD's community risk significance thresholds is presented in [Table 3-1, Bay Area Air Quality Management District Community Risk Significance Thresholds](#).

Table 3-1 Bay Area Air Quality Management District Community Risk Significance Thresholds

Pollutant	Construction	Operational
Risk and Hazards for new sources and receptors (Individual Project)	Same as Operational Thresholds	Compliance with Qualified Community Risk Reduction Plan OR Increased cancer risk of >10.0 in a million Increased non-cancer risk of >1.0 Hazard Index (Chronic or Acute) Ambient PM _{2.5} increase >0.3 micrograms per cubic meter (µg/m ³) annual average <u>Zone of Influence:</u> 1,000-foot radius from property line of source or receptor
Risk and Hazards for new sources and receptors (Cumulative Threshold)	Same as Operational Thresholds	Compliance with Qualified Community Risk Reduction Plan OR Cancer risk of >100 in a million (from all local sources) Noncancer risk of >10.0 Hazard Index (chronic, from all local sources) Ambient PM _{2.5} >0.8 µg/m ³ annual average (from all local sources) <u>Zone of Influence:</u> 1,000-foot radius from property line of source or receptor

SOURCE: Bay Area Air Quality Management District 2017

3.2 METHODOLOGY AND APPROACH

CalEEMod Modeling

The California Emissions Estimator Model (CalEEMod) Version 2016.3.2 was used to estimate emissions from construction of the site assuming full build-out of the project. The model output from CalEEMod is included as [Appendix D](#).

CalEEMod provided annual emissions for both on- and off-site construction activities. On-site activities are primarily made up of construction equipment emissions, while off-site activity includes worker, hauling, and vendor traffic. The on-road emissions are a result of haul truck travel during demolition and grading activities, worker travel, and vendor deliveries during construction. A trip length of one mile was used to represent vehicle travel while at or near the construction site. It was assumed that these emissions from on-road vehicles traveling at or near the site would occur at the construction site. Based on information provided by the project applicant, construction would begin in January 2023 and occur over approximately 20 months. Project-specific construction information was entered into CalEEMod based on information provided by the applicants and derived from the project plans. Assumptions and methodology for modeling the construction emissions are described in greater detail in the memorandum: *1065 South Winchester Boulevard Mixed Use Project – Criteria Air Pollutant Emissions Assessment Assumptions and Methodology* prepared by EMC Planning Group (2021). The memorandum and model results are included in [Appendix D](#).

Dispersion Modeling

For short-term construction, a dispersion modeling analysis was conducted of DPM emitted from diesel vehicles and construction equipment on the proposed project site for the health risk assessment to assess the health risk impacts of the project's construction on nearby off-site sensitive receptors. The dispersion modeling was performed using the American Meteorological Society/Environmental Protection Agency Regulatory Model (AERMOD), which is an BAAQMD-recommended model for modeling atmospheric dispersion of emissions. Principal parameters of AERMOD for the project included the following:

- The 5-year meteorological data set (2013-2017) from the San José International Airport provided by the BAAQMD;
- Construction emissions were modeled as occurring daily between 7:00 a.m. to 4:00 p.m. from Monday through Friday;
- Combustion equipment exhaust emissions (DPM) were modeled as an area source with an emission release height of 3.4 meters. The elevated source height reflects the height of the equipment exhaust pipes plus an additional distance for the height of the exhaust plume above the exhaust pipes to account for plume rise of the exhaust gases;

- Construction fugitive dust emissions (PM_{2.5}) were modeled as an area source with a near-ground level release height of 2 meters; and
- Receptor height of 1.5 meters were used to represent the breathing heights of residents in the nearby homes and senior care home.

Health Risk Calculations

The State of California Office of Environmental Health Hazard Assessment (OEHHA) and California Air Resources Board (CARB) have developed recommended methods for conducting health risk assessments. The *Air Toxics Hot Spots Program Risk Assessment Guidelines: Guidance Manual for Preparation of Health Risk Assessments* (2015 risk assessment guidelines) published in February 2015 are the most recent OEHHA risk assessment guidelines. These guidelines incorporate substantial changes designed to provide for enhanced protection of children, as required by State law, compared to previous published risk assessment guidelines. The BAAQMD has adopted recommended procedures for applying the 2015 risk assessment guidelines as part of Regulation 2, Rule 5: New Source Review of Toxic Air Contaminants, and in the Clean Air Plan policy. Exposure parameters from OEHHA's 2015 risk assessment guidelines and the *BAAQMD Air Toxics NSR Program Health Risk Assessment Guidelines* were used in this report.

Cancer Risk

Potential increased cancer risk from inhalation of TACs are calculated based on the TAC concentration over the period of exposure, inhalation dose, the TAC cancer potency factor, and an age sensitivity factor to reflect the greater sensitivity of infants and children to cancer causing TACs. The inhalation dose depends on a person's breathing rate, exposure time and frequency and duration of exposure. These parameters vary depending on the age, or age range, of the persons being exposed and whether the exposure is considered to occur at a residential location or other sensitive receptor location.

The 2015 risk assessment guidelines recommend that cancer risk be calculated by age groups to account for different breathing rates and sensitivity to TACs. Specifically, they recommend evaluating risks for the third trimester of pregnancy to age zero, ages zero to less than two (infant exposure), ages two to less than 16 (child exposure), and ages 16 to 70 (adult exposure). Age sensitivity factors (ASF) associated with the different types of exposure include: ASF of 10 for the third trimester and infant exposures, ASF of 3 for a child exposure, and ASF of 1 for an adult exposure. Also associated with each exposure type are different breathing rates, expressed as liters per kilogram of body weight per day (L/kg-day). As recommended by the BAAQMD for residential exposures, 95th percentile breathing rates are used for the third trimester and infant exposures, and 80th percentile breathing rates for child and adult exposures. For children at schools and daycare facilities, the BAAQMD

recommends using the 95th percentile breathing rates. Additionally, CARB and the BAAQMD recommend the use of a residential exposure duration of 30 years for sources with long-term emissions (e.g., roadways). For workers, assumed to be adults, a 25-year exposure period is recommended by the BAAQMD.

Under previous OEHHA and BAAQMD guidance, residential receptors were assumed to be at their home 24 hours a day, or 100 percent of the time. In the 2015 risk assessment guidelines, OEHHA includes adjustments to exposure duration to account for the fraction of time at home (FAH), which can be less than 100 percent of the time, based on updated population and activity statistics. The FAH factors are age-specific and are: 0.85 for third trimester of pregnancy to less than 2 years old, 0.72 for ages 2 to less than 16 years, and 0.73 for ages 16 to 70 years. Use of the FAH factors is allowed by the BAAQMD if there are no schools in the project vicinity that would have a cancer risk of one in a million or greater assuming 100 percent exposure (FAH = 1.0).

Functionally, cancer risk is calculated using the following parameters and formulas:

$$\text{Cancer Risk (per million)} = \text{CPF} \times \text{Inhalation Dose} \times \text{ASF} \times \text{ED/AT} \times \text{FAH} \times 10^6$$

Where;

- CPF is Cancer potency factor (mg/kg-day)⁻¹;
- ASF is Age sensitivity factor for specified age group;
- ED is Exposure duration (years);
- AT is Averaging time for lifetime cancer risk (years);
- FAH is Fraction of time spent at home (unitless); and
- Inhalation Dose = $C_{\text{air}} \times \text{DBR} \times A \times (\text{EF}/365) \times 10^{-6}$.

Where;

- C_{air} is Concentration in air ($\mu\text{g}/\text{m}^3$);
- DBR is Daily breathing rate (L/kg body weight-day);
- A is Inhalation absorption factor;
- EF is Exposure frequency (days/year); and
- 10^{-6} is Conversion factor.

A summary of the health risk parameters used in this evaluation are presented in [Table 3-2, Health Risk Parameters](#).

Table 3-2 Health Risk Parameters

Parameter	Exposure Type →	Infant		Child		Adult
	Age Range →	3 rd Trimester	0<2	2<9	9<16	16-30
DPM Cancer Potency Factor (mg/kg-day) ⁻¹		1.10E+00	1.10E+00	1.10E+00	1.10E+00	1.10E+00
Daily Breathing Rate (L/kg-day) 80 th Percentile Rate		273	758	631	572	261
Daily Breathing Rate (L/kg-day) 95 th Percentile Rate		361	1,090	861	745	335
Inhalation Absorption Factor		1	1	1	1	1
Averaging Time (years)		70	70	70	70	70
Exposure Duration (years)		0.25	2	14	14	14
Exposure Frequency (days/year)		350	350	350	350	350
Age Sensitivity Factor		10	10	3	3	1
Fraction of Time at Home		0.85-1.0	0.85-1.0	0.72-1.0	0.72-1.0	0.73

SOURCES: Bay Area Air Quality Management District 2016 and Office of Environmental Health Hazard Assessment 2015

Non-Cancer Hazards

Potential non-cancer health hazards from TAC exposure are expressed in terms of a hazard index, which is the ratio of the TAC concentration to a reference exposure level. OEHHA has defined acceptable concentration levels for contaminants that pose non-cancer health hazards. TAC concentrations below the reference exposure level are not expected to cause adverse health impacts, even for sensitive individuals. The total hazard index is calculated as the sum of the hazard indexes for each TAC evaluated and the total hazard index is compared to the BAAQMD's significance thresholds to determine whether a significant non-cancer health impact from a project would occur. Typically, for residential projects located near roadways with substantial TAC emissions, the primary TAC of concern with non-cancer health effects is DPM. For DPM, the chronic inhalation reference exposure level is 5 µg/m³.

Annual PM_{2.5} Concentrations

While not a TAC, PM_{2.5} has been identified by the BAAQMD as a pollutant with potential non-cancer health effects that should be included when evaluating potential community health impacts under CEQA. The thresholds of significance for PM_{2.5} (project-level and cumulative) are in terms of an increase in the annual average concentration. When considering PM_{2.5} impacts, the contribution from all sources of PM_{2.5} emissions should be included. For projects with potential impacts from nearby local roadways, the PM_{2.5} impacts should include those from vehicle exhaust emissions, PM_{2.5} generated from vehicle tire and brake wear, and fugitive emissions from re-suspended dust on the roads.

This side intentionally left blank.

4.1 CONSTRUCTION HEALTH RISKS

Cancer Risk from Diesel Particulate Emissions

Construction of the proposed project would increase lifetime cancer risk (cancer risk) for sensitive receptors within 1,000 feet of the project site who are exposed to the project's temporary construction DPM and PM_{2.5} emissions. Construction emissions were modeled using the CalEEMod software. Downwind concentrations of DPM were calculated using AERMOD. The location of the Maximally Exposed Individual (MEI) and the Point of Maximum Impact (PMI) were also determined. The PMI is a commercial building (restaurant) located on the north side of the project site. The MEI is located at a single-family home adjacent and to the west of the project site. The MEI, PMI, and sensitive receptors located within a 1000-foot radius of proposed construction activity, are shown in [Figure 2-2, Nearest Sensitive and Worker Receptor Locations, MEI and PMI](#), presented previously. The annual cancer risks for the years 2023 and 2024 were determined. Detailed health risk calculations and AERMOD model results are included in [Appendix B](#).

Unmitigated Cancer Risks

CalEEMod modeled emission rates for unmitigated construction DPM and PM_{2.5} emissions are presented in [Table 4-1, Unmitigated Construction DPM and PM_{2.5} Emissions](#).

Table 4-1 Unmitigated Construction DPM and PM_{2.5} Emissions

Emissions Year	Unmitigated Exhaust DPM PM ₁₀	Unmitigated Total PM _{2.5}
2023 Annual Emissions (tons/year)	0.058	0.16
2024 Annual Emissions (tons/year)	0.012	0.016

SOURCE: EMC Planning Group 2021

NOTES:

1. Results may vary due to rounding.
2. CalEEMod estimates construction criteria air pollutant emissions in tons per year.

Downwind concentrations of DPM were calculated using AERMOD and using the DPM and PM_{2.5} emissions modeled by CalEEMod. The location of the Maximally Exposed Individual (MEI) and the Point of Maximum Impact (PMI) were also determined. The maximum modeled annual DPM and PM_{2.5} concentrations, which includes both the DPM and total

PM_{2.5} concentrations at nearby sensitive receptors, were used to identify the maximally exposed individuals (MEIs). Results of the dispersion modeling indicate that the exhaust PM₁₀ and total PM_{2.5} residential MEI is located at a house west and adjacent to the project site. The PMI is located to the north of the project site (refer to Figure 2-2). The annual cancer risks during construction were determined. The CalEEMod emissions estimate is included in Appendix D. Detailed health risk calculations and AERMOD model results are included in Appendix E.

A senior care home is located at 3065 Van Sansul Avenue (UTM coordinates 593105 meters Easting and 4129619 meters Northing) (see also Figure 2-2). Residents will be exposed to project emissions, but at a concentration lower than at the MEI. The risks at the senior care home will be less than the risks at the MEI, as the senior care center is further from the project emissions allowing for more dispersion of emissions and lower concentrations in the air. A health risk assessment prepared for the adjacent project at 1073 South Winchester Boulevard (Illingworth and Rodkin 2020) indicated a cancer risk of 0.2 (adult) per million at the senior care center. This is far below the mitigated MEI cancer risk of 10 (infant/child) per million for the proposed project. Therefore, the increased cancer risk at the senior care center would not be a significant impact.

Unmitigated Health Risks

The maximum cancer risks, PM_{2.5} concentrations, and hazard index for project-related construction activities affecting the residential MEI are summarized in [Table 4-2, Unmitigated Diesel Exhaust Particulate Matter Cancer Risks, PM_{2.5} Concentrations and the Hazard Index at the MEI](#). Detailed health risk calculations are included in [Appendix E](#).

The unmitigated cancer risk for adults at the MEI would be 0.52 cases per million and the unmitigated hazard index would be 0.03, both of which are below the BAAQMD threshold of significance and are less than significant. The unmitigated cancer risk for infants and children at the MEI it would be 32 cases per million and the maximum PM_{2.5} concentrations would be 0.42, both of which exceed BAAQMD single-source thresholds. This is a significant impact and emissions reductions are necessary to reduce the cancer and health risks from exposures to project construction DPM emissions and PM_{2.5} concentrations.

Mitigated Construction Health Risks

Adherence to the City's standard permit conditions for the control of fugitive dust and construction equipment exhaust would reduce cancer risks and other health risks associated with exposures to DPM and PM_{2.5} emissions, but not to a less-than-significant level. To determine the extent of additional emissions reduction measures that would be required to reduce significant cancer risks and PM_{2.5} exposures below the BAAQMD thresholds, the modeled construction equipment inputs were modified using EPA Tier 4 standards equipped with CARB-certified Level 3 Diesel Particulate Filters. The CalEEMod results are described as "mitigated" and are included in [Appendix D](#).

Table 4-2 Unmitigated Diesel Exhaust Particulate Matter Cancer Risks, PM_{2.5} Concentrations and the Hazard Index at the MEI

Construction Year	DPM PM ₁₀ Concentration at the MEI ^{1,2} (ug/m ³)	Infant Child Cancer Risk (per million)	Adult Cancer Risk (per million)	Hazard Index at the MEI	PM _{2.5} Concentration (ug/m ³)
2023 ³ (0.25 years during pregnancy)	0.15	2	-	0.03	0.42
2023	0.15	25	0.43	0.03	0.42
2024	0.03	5	0.09	0.01	0.04
Total Project Cancer Risk	-	32	0.52	0.03 max	0.42 max
Air District Single-Source Threshold	-	10.0	10.0	1.0	0.3
<i>Exceeds Thresholds?</i>	-	<i>YES</i>	<i>NO</i>	<i>NO</i>	<i>YES</i>

SOURCES: EMC Planning Group 2021 and Bay Area Air Quality Management District 2017.

NOTES:

1. Results have been rounded, and may, therefore, vary slightly.
2. The MEI is located at a house located to the west and adjacent to the project site. The UTM coordinates are approximately 592931.30 meters Easting and 4129513.40 meters Northing (Refer to Figure 2-2).
3. Per OEHHA and air district direction, pregnancies are included in the first-year calculations.

Table 4-3, [Mitigated Construction Health Risks at the MEI](#), illustrates the reduced cancer risks at the location of the MEI that would result from the use of the equipment emissions reduction strategy described above. The modeling results show that project construction exhaust DPM emissions would be reduced by 85 percent and would meet the BAAQMD cancer threshold for adults, infants and children. AERMOD calculations are included in [Appendix E](#).

Mitigated Cancer Risks

Most of the reductions would result from the use of construction vehicle engines that can meet Tier 4 standards and be outfitted with diesel particulate filters. However, adherence to the BAAQMD's best management practices for the control of equipment exhaust PM₁₀, such as limiting engine idling and reducing speeds on unpaved roads, would also reduce DPM emissions. Other options for reducing DPM concentrations at any given time include the use of alternative fuels and the use of electrical equipment.

Table 4-3 Mitigated Construction Health Risks at the MEI

Construction Year	DPM PM ₁₀ Concentration (ug/m ³) ¹	Infant Child Cancer Risk (per million) ¹	Adult Cancer Risk (per million) ¹	Hazard Index ¹	PM _{2.5} Concentration (ug/m ³) ¹
2023 ³ (0.25 years during pregnancy) ²	0.033	0.45	0.095	0.007	0.25
2023	0.033	5.42	0.095	0.007	0.25
2024	0.025	4.18	0.073	0.005	0.025
Total Project Cancer Risk		10.0	0.17	0.007 max	0.25 max
Air District Single-Source Threshold	-	10.0	10.0	1.0	0.3
<i>Exceeds Thresholds?</i>	-	<i>NO</i>	<i>NO</i>	<i>NO</i>	<i>NO</i>

SOURCES: EMC Planning Group 2021 and Bay Area Air Quality Management District 2017.

NOTES:

1. Results have been rounded, and may, therefore, vary slightly.
2. Per OEHHA and air district direction, pregnancies are included in the first-year calculations.

Mitigated Construction PM_{2.5} Health Risks

The mitigated results illustrate the reduction in PM_{2.5} that would result from adherence to the City’s standard permit conditions and use of the emissions reduction strategy described previously. The CalEEMod modeling results (Appendix D) show that project construction PM_{2.5} emissions would be reduced by 59 percent through the use of Tier 3 engines, diesel particulate filters, an increase in the frequency of watering bare soils, and reducing speeds on unpaved areas. The 59 percent reduction in PM_{2.5} emissions is more than necessary to reduce PM_{2.5} emissions below the BAAQMD single-source threshold for health risks.

Discussion Summary

The unmitigated adult cancer risk and the chronic DPM hazard index would not exceed the BAAQMD thresholds and are less than significant. However, the proposed project’s construction equipment exhaust DPM emissions and Total PM_{2.5} emissions would result in increased infant child cancer risk and PM_{2.5} concentrations exceeding the BAAQMD single source thresholds.

Adherence to the City’s standard permit conditions for the control of fugitive dust and construction equipment exhaust would reduce cancer risks and other health risks associated with exposures to DPM and PM_{2.5} emissions, but not to a less-than-significant level. This is a significant impact and mitigation is required.

Construction DPM emissions would need to be reduced by about 85 percent to achieve compliance with the BAAQMD single-source cancer and health risk thresholds. DPM emissions reductions were modeled using Tier 4 engines using level 3 diesel particulate

filters on construction equipment, by reducing speeds on paved roads, and watering exposed soils more frequently than required by the City's standard conditions. Both DPM and PM_{2.5} emissions would be reduced. The mitigated modeled emissions results using this strategy results in emissions that would be below the BAAQMD single-source thresholds.

Implementation of the following mitigation measures would reduce the project's single-source impacts to less than significant. Cumulative PM_{2.5} health risks impacts and mitigation are discussed in the next section.

Mitigation Measures

In addition to compliance with the City of San José standard permit conditions for construction projects, implementation of mitigation measures AQ-1 and AQ-2 would reduce cancer risk and PM_{2.5} health risks to a less-than-significant level.

- AQ-1 Prior to the issuance of any demolition, grading or building permits, the project applicant shall submit project plans containing the requirements listed below to the City of San Jose Planning Director or Director's designee. During construction, the project contractor shall implement the following measures to reduce emissions of fugitive dust and engine exhaust DPM. These measures shall be included in the project plans, prior to issuance of a demolition permit, grading, or building permit:
- a. All exposed surfaces (e.g., parking areas, staging areas, soil piles, graded areas, and unpaved access roads) shall be watered three (3) times per day and at a frequency adequate to maintain minimum soil moisture of 12 percent. Moisture content can be verified by lab samples or moisture probe; and
 - b. All vehicle speeds on unpaved roads shall be limited to five (5) mph.
- AQ-2 Prior to issuance of a demolition or grading permit, whichever comes first, the project developer shall prepare and the project contractor shall implement a plan demonstrating an 85 percent reduction in DPM emissions that corresponds with an infant/child cancer risk of 10 or fewer cases per million, and a reduction of PM_{2.5} emissions of 59 percent.

The plan shall be prepared prior to the issuance of a demolition permit and shall be reviewed and approved by the City of San Jose Director of Planning or Director's designee. The plan shall be accompanied by a letter signed by a qualified air quality specialist, verifying the equipment included in the plan meets the standards set forth in this mitigation measure. The plan shall include the following measures:

- a. All construction equipment larger than 25 horsepower used at the site for more than two continuous days or 20 hours total shall utilize diesel engines that are EPA certified “Tier 4 final” emission standards for particulate matter and be equipped with CARB-certified Level 3 Diesel Particulate Filters. Prior to the issuance of any demolition permits, the project applicant shall submit specifications of the equipment to be used during construction and confirm this requirement is met;
- b. Use alternatively fueled equipment or equipment with zero emissions (i.e., electrical equipment);
- c. Provide line power to the site during the early phases of construction to minimize the use of diesel-powered stationary equipment, such as generators; and
- d. Other demonstrable measures identified by the developer that reduce emissions and avoid or minimize exposures to the affected sensitive receptors.

Implementation of these mitigation measures would reduce project construction health risks to or below the BAAQMD single-source thresholds.

4.2 CUMULATIVE HEALTH RISKS

Background Community Health Risks

As noted in Section 2.1, a roadway assessment (Illingworth and Rodkin 2020) was prepared to analyze existing health risks from exposures to vehicle emissions on two high-volume roadways: South Winchester Boulevard and Williams Road (refer also to Figure 2-1). The cumulative emissions analysis assumes that the MEI concentrations and health risks from roadway vehicle emissions are the same for the proposed project. Also reported earlier is the presence of one stationary source, a gas station located approximately 250 feet from the project site. In addition, the mitigated construction health risks from the adjacent project at 1073 South Winchester Boulevard, are included in the background cumulative health risks, to account for the potential concurrent construction of that project and the proposed project.

Cumulative Community Health Risks

Health risks from exposures to existing mobile and stationary source TACs emissions sources and mitigated construction emissions from the adjacent project at 1073 South Winchester Boulevard (refer to Section 2.1 are summarized in [Table 4-4, Cumulative Health Risks at Construction MEIs](#)).

Table 4-4 Cumulative Health Risks at Construction MEIs

Source	Cancer Risk (per million) ¹	Annual PM _{2.5} Concentration (µg/m ³) ¹	Hazard Index ¹
Air District Cumulative-Source Threshold	100.0	0.80	10.0
S. Winchester Blvd. (24,470 ADT)	4.4	0.07	<0.01
Williams Road (10,820 ADT)	0.3	0.03	<0.01
Shell Gas Station (Facility ID: 112466)	0.01	0.0	-
1073 Winchester Blvd Construction Emissions (mitigated)	7.5 (infant)	0.18	<0.01
Cumulative Without the Project	12	0.28	<0.01
Project Construction (Unmitigated)	32 (infant)	0.42	0.03
Cumulative With Project (Unmitigated) ²	42	0.70	0.03
Exceeds Thresholds? (Unmitigated)	NO	NO	NO

SOURCE: EMC Planning Group 2021, Illingworth and Rodkin 2020

NOTES:

1. Results have been rounded, and may, therefore, vary slightly.
2. Includes reductions due to implementation of mitigation measures AQ-1 and AQ-2.

The modeled cumulative community health risks would not exceed BAAQMD cumulative thresholds of significance with or without the project and are less than cumulatively considerable.

Conclusion

The modeled cumulative community health risks would not exceed BAAQMD cumulative thresholds of significance with or without the project and are less than cumulatively considerable. The addition of unmitigated project emissions would not exceed the BAAQMD cumulative thresholds of significance. Therefore, the project's contribution to cumulative community health risks is less than cumulatively considerable with or without mitigation.

New Sensitive Receptors

The proposed project would introduce new residential receptors to the site that would be exposed to existing sources of TACs, which may increase health risks. Future residents of the project that drive would contribute to vehicle traffic and subsequent emissions exposures at the project site from vehicles on South Winchester Boulevard and Williams Road. According to the traffic report prepared for the project (Hexagon 2021), the proposed project would add a net average of approximately 499 trips to the circulation network. According to the Illingworth and Rodkin report, Average Daily Travel (ADT) along South Winchester Boulevard is 24,470 vehicles per day, while the ADT along Williams Road is 10,820 ADT. The addition of project traffic to South Winchester Boulevard and Williams Road represents a less than 0.10 percent increase to ADT. The increase in emissions and exposures to them from the addition of project traffic to the two roadways would be negligible and the increase in cancer risks and other health risks to future residents on the project site would be less than cumulatively considerable. In addition, the cumulative background risks and concentrations are far below the cumulative thresholds, and the single-source thresholds.

5.0 Sources

- Bay Area Air Quality Management District. "Permitted Stationary Sources Risk and Hazards." Last modified March 16, 2020. Accessed April 13, 2021.
<https://baaqmd.maps.arcgis.com/apps/webappviewer/index.html?id=2387ae674013413f987b1071715daa65>
- . May 2017. *California Environmental Quality Act Air Quality Guidelines*.
http://www.baaqmd.gov/~media/files/planning-and-research/ceqa/ceqa_guidelines_may2017-pdf.pdf?la=en
- . December 2016. *BAAQMD Air Toxics NSR Program Health Risk Assessment Guidelines*.
https://www.baaqmd.gov/~media/files/planning-and-research/permit-modeling/hra_guidelines_12_7_2016_clean-pdf.pdf?la=en
- . April 3, 2020. *BAAQMD Risks and Hazards Emissions Screening Calculator*. Appendix C.
- California Air Resources Board. "AB 1807 – Toxics Air Contaminant Identification and Control." Accessed September 15, 2020a.
<https://ww2.arb.ca.gov/resources/documents/ab-1807-toxics-air-contaminant-identification-and-control>
- . "Air Toxics Hot Spots Information and Assessment Act (AB 2588)." Accessed September 15, 2020b. <https://ww2.arb.ca.gov/resources/documents/air-toxics-hot-spots-information-and-assessment-act-ab-2588>
- . "Truck and Bus Regulation." Accessed September 15, 2020c.
<https://ww2.arb.ca.gov/our-work/programs/truck-and-bus-regulation/about>
- . "In-Use Off-Road Diesel-Fueled Fleets Regulation." Accessed September 15, 2020d.
<https://ww2.arb.ca.gov/our-work/programs/use-road-diesel-fueled-fleets-regulation>
- City of San José. November 1, 2011. *Envision San José 2040 General Plan*. San José, CA.
<https://www.sanjoseca.gov/home/showdocument?id=22359>
- DieselNet. "United States: Nonroad Diesel Engines." Last modified December 2017.
<https://www.dieselnet.com/standards/us/nonroad.php>
- EMC Planning Group. June 28, 2021. *CalEEMod Results*. Appendix D.

5.0 Sources

———. June 28, 2021. “1065 South Winchester Boulevard Mixed Use Project – Criteria Air Pollutant Emissions Assessment Assumptions and Methodology”. Appendix D.

———. September 22, 2020. “Health Risk Assessment. 1073-1087 South Winchester Boulevard Mixed Use Project.”

———. June 2021. *AERMOD Results*. Appendix E.

Carpira Design Group. April 2021. Project Plans. Concord, CA.

FEMA, 2010, Debris Estimating Field Guide, Accessed April 13, 2021.

https://www.fema.gov/sites/default/files/2020-07/fema_329_debris-estimating_field-guide_9-1-2010.pdf

Google, Inc. 2021. Google Earth.

Hexagon Transportation Consultants. *1065 South Winchester Mixed-Use Development Transportation Analysis*. June 21, 2021. Gilroy, CA.

Illingworth and Rodkin. September 17, 2020. *1073 S. Winchester Boulevard, San José, CA – Air Quality Roadway Assessment*. Cotati, CA. Appendix B.

Office of Environmental Health Hazard Assessment (OEHHA). February 2015. *Air Toxics Hot Spots Program Risk Assessment Guidelines: Guidance Manual for Preparation of Health Risk Assessments*. <https://oehha.ca.gov/media/downloads/crn/2015guidancemanual.pdf>

APPENDIX A

PROJECT PLANS

WINCHESTER MIXED USE PROJECT

1065 S WINCHESTER BOULEVARD

San Jose , California

APN: 299-25-037

TABLE OF CONTENTS

OWNER :

A & Z DEVELOPMENT
2881 HEMLOCK AVE, SAN JOSE, CA 95128
E-MAIL : DRADAMASKARI@GMAIL.COM
PH: 408-921-1882

000-IDX	SHEET INDEX
001-TS	TITLE SHEET (PROJECT DESCRIPTION)
002-TS	TITLE SHEET (PROJECT INFORMATION & TABLES)

SITE

003-S	EXISTING SITE PLAN (SURVEY MAP)
004-S	PROPOSED SITE PLAN
005-S	SITE PHOTOS

APPLICANT:

HENRY CORD
CORD ASSOCIATES
REAL ESTATE SERVICES
CA BROKER LIC. 01176923
401 FIELDCREST DRIVE, SAN JOSE, CA 95123
PH: 408-283-7292
FAX: 408-307-0166

ARCHITECTURAL

006-A	BASEMENT(-1) FLOOR PLAN
007-A	1ST FLOOR PLAN
008-A	2ND FLOOR PLAN
009-A	3RD FLOOR PLAN
010-A	4TH FLOOR PLAN
011-A	5TH FLOOR PLAN
012-A	6TH FLOOR PLAN
013-A	ROOF PLAN
014-A	BUILDING ELEVATIONS (NORTH&SOUTH)
015-A	BUILDING ELEVATIONS (EAST&WEST)
016-A	BUILDING SECTION A-A
017-A	BUILDING SECTION B-B, C-C
018-A	MATERIAL BOARD
019-A	BIRD VIEW RENDERING
020-A	BUILDING RENDERING
021-A	BUILDING RENDERING
022-A	BUILDING RENDERING
023-A	BUILDING RENDERING
024-A	BUILDING RENDERING
025-A	BUILDING RENDERING
026-A	BUILDING RENDERING
027-A	SHADOW STUDY
028-A	SHADOW STUDY
029-A	OPEN SPACE STUDY

DESIGNER :

SAM MONFARED MASOUMI
30025 ALICIA PKWY
LAGUNA NIGUEL - CA 92677
E-MAIL : SAMCARPIRA@GMAIL.COM
PH: 310-795-4009
FAX: 949-553-0548

CIVIL ENGINEER:

KIER+WRIGHT
3350 Scott Blvd. , Bldg. 22,
Santa Clara, CA 95054
www.kierwright.com
PH: 408-727-6665
408-591-8801

LANDSCAPE ARCHITECTURE

030-L	FIRST FLOOR LANDSCAPE PLAN
031-L	SECOND FLOOR LANDSCAPE PLAN
032-L	PLANT PALETTE AND IMAGERY
033-L	SITE IMAGERY
034-L	TREE DISPOSITION

LANDSCAPE ENGINEER :

SHILA YASMEH
628 N. MAPLE DR.
BEVERLY HILLS - CA 90210
E-MAIL : SHILA.YASMEH@GMAIL.COM
PH : (650) 492-3249

CIVIL ENGINEERING

035-C	COVER SHEET
036-C	TOPOGRAPHIC SURVEY
037-C	PRELIMINARY GRADING, DRAINAGE & SECTIONS PLAN
038-C	PRELIMINARY UTILITY PLAN
039-C	STORM WATER QUALITY CONTROL PLAN
040-C	STORM WATER QUALITY CO

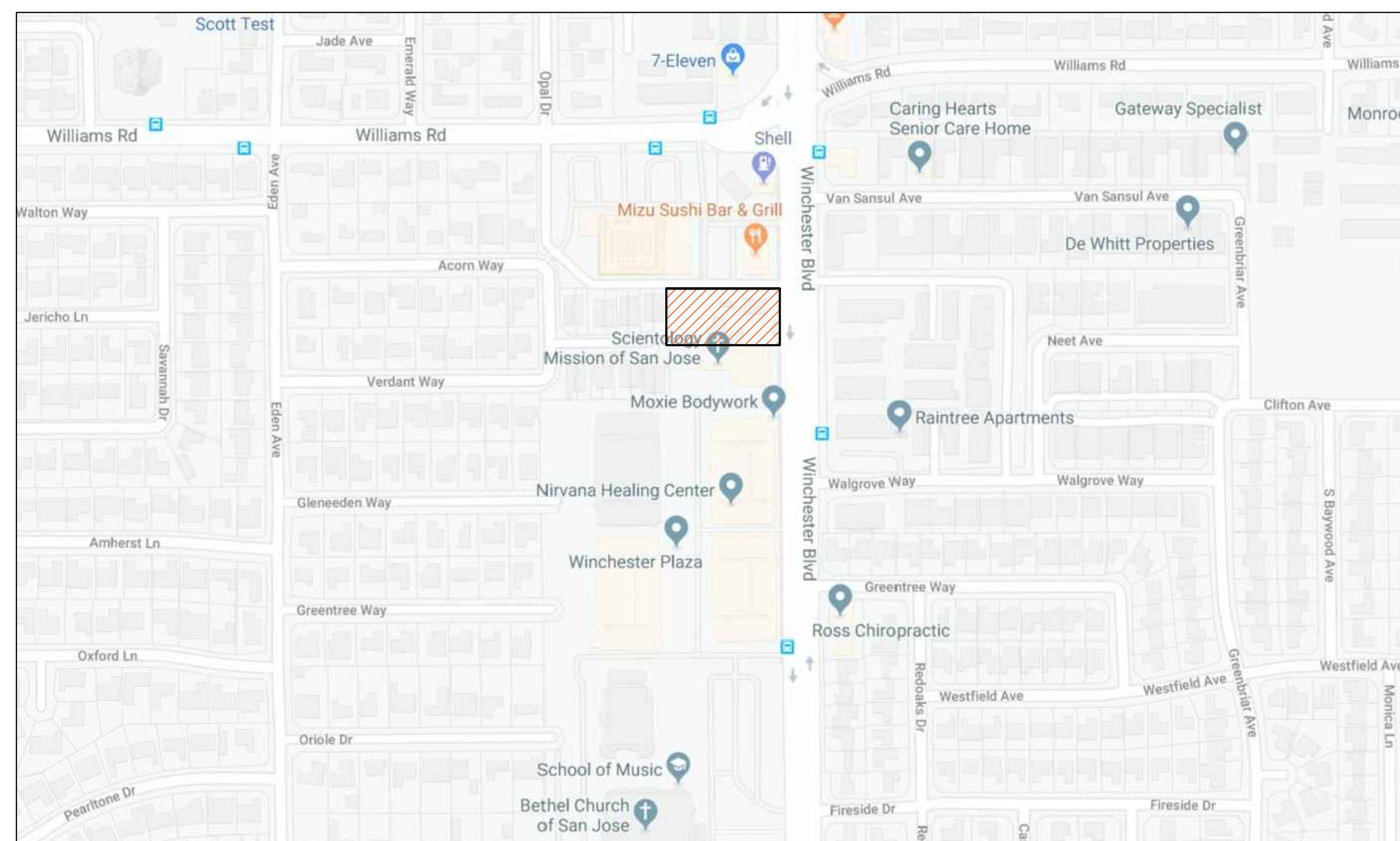

SCALE : 1" = 500'

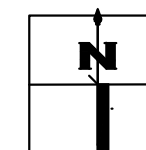

OWNER

A & Z DEVELOPMENT
2881 Hemlock Ave. San Jose
TEL: (408) 921-1882
Dradamaskari@GMAIL.COM

CIVIL ENGINEER



3350 Scott Blvd., Bldg. 22,
Santa Clara, CA 95054
TEL: (408) 727-6665
(408) 591-8801
www.kierwright.com

LANDSCAPE DESIGNER

SHILA YASMEH
628 N. MAPLE DR.
BEVERLY HILLS - CA 90210
SHILA.YASMEH@GMAIL.COM
TEL : (650) 492-3249

REVISIONS

REV.1 06/14/2021

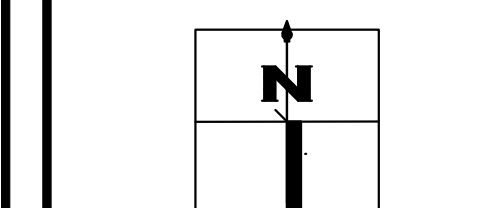

SCALE : 1" = 500'

SHEET INDEX

000-IDX

SP 21 - 006

■ WINCHESTER MIXED USE PROJECT ■

1065 S WINCHESTER BOULEVARD

San Jose , California

APN: 299-25-037



PROJECT DESCRIPTION

The proposed project is a Special Use Permit application to allow a six-story mixed use development up to a height of 65feet.

Proposed project includes the demolition of Single family house,barn,shed and the construction of a 6-story, mixed-used building consisting of 70 condominiums totaling 130,840.1 square feet, 20,410 square feet of commercial space, and 104 vehicle parking spaces; and tentative map to subdivide one parcel for condominium purposes.

The project will contain 70 condominium units (40 one-bedroom -17 two-bedrooms 13- three-bedrooms) and 20,410 square feet of commercial space with up to 9commercial condominium units.

The first floor contains residential lobby,trash cans,residential common open space (GYM), commercial spaces and 25 parking spaces.

The second floor contains both residential and commercial uses.

Floors 3through 6are all residential apartment units.

Parking is provided by one underground level with 79spaces and 25 spaces on first floor justified by TDM measures, and accessed from Winchester Avenue.

A 20foot rear setback is provided ,and 20foot sidewalk along S. Winchester Avenue.

OWNER

A & Z DEVELOPMENT
2881 Hemlock Ave. San Jose
TEL: (408) 921-1882
Dradamaskari@GMAIL.COM

CIVIL ENGINEER



3350 Scott Blvd., Bldg. 22,
Santa Clara, CA 95054
TEL: (408) 727-6665
(408) 591-8801
www.kierwright.com

LANDSCAPE DESIGNER

SHILA YASMEH
628 N. MAPLE DR.
BEVERLY HILLS - CA 90210
SHILA.YASMEH@GMAIL.COM
TEL : (650) 492-3249

REVISIONS

△ REV.1	06/14/2021
△	
△	
△	
△	
△	
△	
△	
△	
△	
△	
△	
△	
△	
△	
△	
△	
△	
△	

TITLE SHEET

001-TS

DETAILS:

OWNER : _____ A & Z DEVELOPMENT
 PROJECT ADDRESS : _____ 1065 S WINCHESTER BOULEVARD SAN JOSE, CA 95128
 BUILDING CLASSIFICATION : _____ RESIDENTIAL (103440 SQ.FT.) & COMMERCIAL (17970 SQ.FT.) & PARKING (44112.2 SQ.FT.)
 TYPE OF CONSTRUCTION : _____ TYPE I-A & III-A
 ALLOWABLE HEIGHT : _____ 65'-0"
 ALLOWABLE AREA : _____ UL
 OCCUPANCY GROUP : _____ R2
 GOVERNMENT BODY : _____ CITY OF SAN JOSE
 LOT SIZE : _____ 40657.34 SQ.FT/ 0.93 ACRES
 DENSITY : _____ 70 / 0.93= 75 UNITS/ACRES
 LEGAL DESCRIPTION : _____ PARCEL NO. 2 OF MAPS MB 415/47

SETBACK TABULATION

FRONT SETBACK	----
SOUTH SIDE YARD SETBACK	15'-0"
NORTH SIDE YARD SETBACK	8'-5"
REAR SETBACK	20'-0"

CONSTRUCTION TYPE SUMMARY

TYPE OF CONSTRUCTION	IIIA	IA
OCCUPANCY	R-2	S-2
NO. OF STORIES	5 (2ND-6TH FLOOR)	1+1BASEMENT
HEIGHT (ALLOWABLE)	65'	UNLIMITED

PARKING SPACE TABLE

RESIDENTIAL	LIVING UNIT SIZE	RATIO	REQUIRED
RESIDENTIAL	1 BEDROOM (40 UNITS)	1.25 PER UNITS	50 SPACES
	2 BEDROOM (13 UNITS)	1.7 PER UNITS	23 SPACES
	3 BEDROOM (17 UNITS)	2 PER UNITS	34 SPACES
* rounded up per code			107 SPACES
COMMERCIAL 0.5 FAR	@ 0.85 factor	1 PER 250 sq.ft.	70 SPACES
20410 sq.ft.	17348.5 sq.ft.		
CLEAN AIR VEHICLE PARKING			10 SPACES
TOTAL PROJECT REQUIREMENT			177 SPACES
PARKING PROVIDED			104 SPACES
EV PARKING (30%)			104 * 30% = 32 SPACES
EVCS			4 SPACES
PARKING REDUCTION			73 SPACES
TDM REDUCTION			41.2%

BICYCLE & MOTORCYCLE TABLE

		RATIO	REQUIRED
70 UNITS RESIDENTIAL	BICYCLE	1 PER 4 UNITS	18 SPACES
	MOTORCYCLE	1 PER 4 UNITS	18 SPACES
COMMERCIAL OFFICE 20410 sq.ft.	BICYCLE	1 PER 4000 sq.ft.	6 SPACES
	MOTORCYCLE	1 PER 20 PARKING SPACE	6 SPACES
SHORT TERM BICYCLE RACK (FIRST FLOOR)			4 SPACES
CARGO BICYCLE			4 SPACES
TOTAL PROJECT REQUIREMENT			24 SPACE BICYCLE 24 SPACE MOTORCYCLE
PROVIDED			59 SPACE BICYCLE 24 SPACE MOTORCYCLE
TDM REDUCTION			0%

	1BEDROOM UNIT	2BEDROOM UNIT	3BEDROOM UNIT	RESIDENTIAL AREA	COMMERCIAL UNIT	COMMERCIAL AREA	PARKING AREA	PARKING SPACES	FLOOR AREA
PARKING LEVEL -1	---	---	---	---	---	---	30214 sq.ft.	79	30214 sq.ft.
1st FLOOR	---	---	---	3966 sq.ft.	3	8029 sq.ft.	18038 sq.ft.	28	30033 sq.ft.
2nd FLOOR	4	3	1	11701.5 sq.ft.	6	12381 sq.ft.	---	---	22325.5 sq.ft.
3rd FLOOR	8	5	3	22389.1 sq.ft.	---	---	---	---	22389.1 sq.ft.
4th FLOOR	8	5	3	22225.4 sq.ft.	---	---	---	---	22225.4 sq.ft.
5th FLOOR	9	5	2	21283.2 sq.ft.	---	---	---	---	21283.2 sq.ft.
6th FLOOR	7	3	4	20083.2 sq.ft.	---	---	---	---	20083.2 sq.ft.
TOTAL	36 UNITS	21 UNITS	13 UNITS	101648.4 sq.ft.	9 UNITS	20410 sq.ft.	48252 sq.ft.	107 SPACES	168553.4 sq.ft.
70 UNITS									



LOT SIZE : 40657.34 SQ.FT/ 0.93 ACRES
 SITE COVERAGE & PARKING & LOADING : 36220.04 SQ.FT (89.1%)
 LANDSCAPE : 4437.30 SQ.FT (10.9%)

REVISIONS

REV.1	06/14/2021

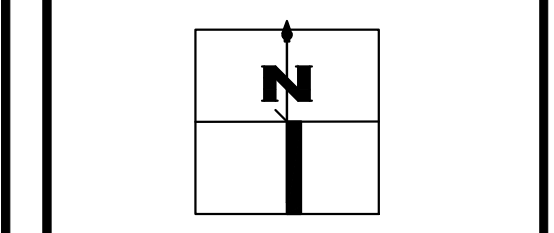

SCALE : 1/16"=1'-0"

FILE NAME: 1065 S WINCHESTER CONDOMINIUM 06 14 2021 REV.1

NO.	DESCRIPTION

TOPOGRAPHIC MAP

1065 S WINCHESTER BOULEVARD SAN JOSE, CALIFORNIA

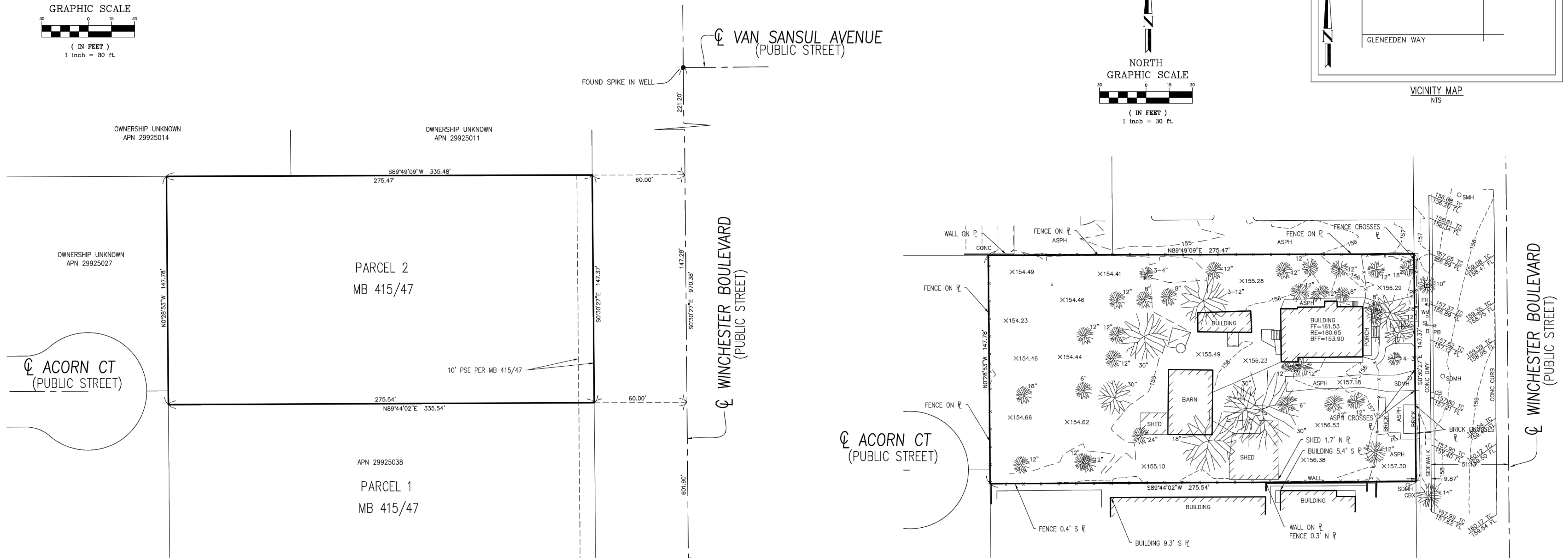
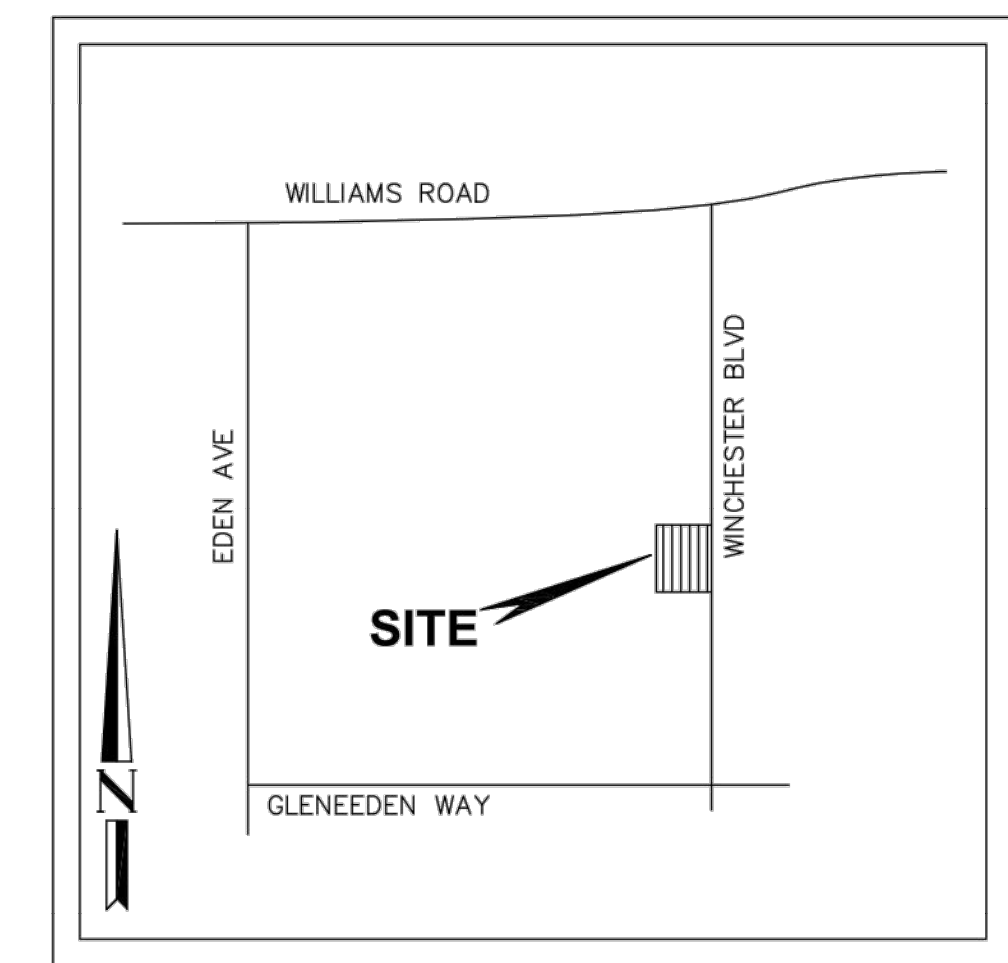
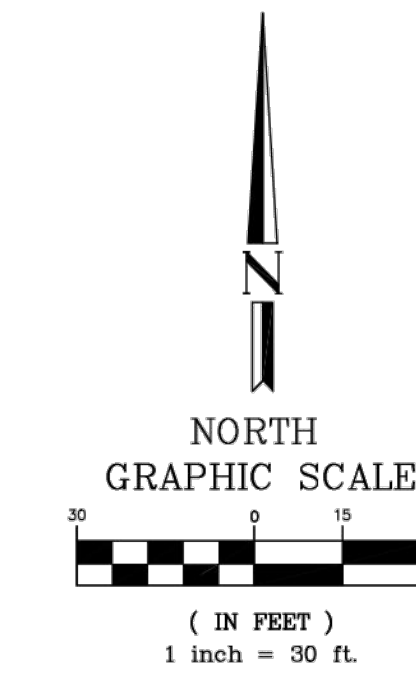
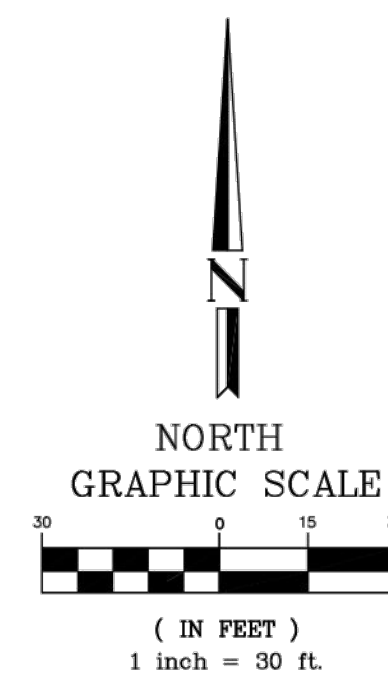

SURVEYOR'S NOTES

- DISTANCES SHOWN ARE IN FEET AND DECIMALS THEREOF.
- NO DISTANCES OR ANGLES SHOWN HEREON MAY BE ASSUMED BY SCALING.
- NO EVIDENCE OF EARTHMOVING WORK, BUILDING CONSTRUCTION, OR BUILDING ADDITIONS WERE OBSERVED ON THIS SITE.

UNLESS THIS PLAN HAS THE SEAL AND SIGNATURE OF THE SURVEYOR RESPONSIBLE FOR ITS PREPARATION, THIS IS NOT AN AUTHENTIC COPY OF THE ORIGINAL SURVEY AND SHALL NOT BE DEEMED RELIABLE.

TAX ASSESSOR'S PARCEL NO.
APN: 299-25-037

AREA
40,657.34 SQ. FT. OR 0.93 ACRES±

LEGAL DESCRIPTION
PARCEL NO. 2 OF MAPS MB 415/47

OWNERS
KATHLEEN A. CAVENEY, TRUSTEE OF THE KATHLEEN A. CAVENEY REVOCABLE TRUST, DATED JUNE 27, 2013, AS TO AN UNDIVIDED 25% INTEREST; MARIANNE RAGER, TRUSTEE OF THE MARIANNE RAGER REVOCABLE TRUST, DATED JUNE 26, 2013, AS TO AN UNDIVIDED 25% INTEREST; AND MARIANNE M. RAGER AND KATHLEEN A. CAVENEY, TRUSTEES OF THE ANTHONY AND GERALDINE BAN FAMILY TRUST, DATED DECEMBER 18, 2017, AS TO AN UNDIVIDED 50% INTEREST

BASIS OF BEARINGS
BASIS OF BEARINGS IS THE CENTERLINE OF WINCHESTER AVENUE PER MB 415/47, RECORDS OF SANTA CLARITA COUNTY, CALIFORNIA

BEING: NORTH 00°30'27" WEST

BENCHMARK
CITY OF SAN JOSE, CALIFORNIA BENCHMARK POINT NO. 538 DESCRIBED AS: THE LETTER "O" IN THE WORD "OAKLAND" ON TOP OF CATCH BASIN SOUTHEAST RETURN OF GREENTREE WAY AND WINCHESTER BLVD, ER ON GREENTREE WAY FD 774,PG 50

ELEVATION =160.97' NAVD '88

- LEGEND**
- CL CENTERLINE
 - PL PROPERTY LINE
 - CONG CONCRETE
 - ASPH ASPHALT
 - DWY DRIVEWAY
 - CB CATCH BASIN
 - CBX CABLE BOX
 - FH FIRE HYDRANT
 - FL FLOWLINE
 - GM GAS METER
 - PB STREET LIGHT PULLBOX
 - PP POWERPOLE
 - SDMH STORMDRAIN MANHOLE
 - SMH SEWER MANHOLE
 - SL STREET LIGHT
 - TC TOP OF CURB
 - WM WATER METER
 - x—x— FENCE

SURVEYOR'S NOTE
THIS SURVEY WAS PREPARED UNDER MY DIRECTION AND IS A CORRECT REPRESENTATION OF THE PROPERTY DESCRIBED HEREON.

Ty E. Thomas
TY E. THOMAS
P.L.S. 9309 EXP. 9/30/2022
DATE 10-12-2020



REVISIONS		
REV	DATE	DESCRIPTION

PREPARED BY:
MFKessler
Civil Engineering, Land Planning, Surveying
ONE VENTURE, SUITE 130
IRVINE, CA 92618
(949) 339-5330
MFKESSLER.COM

TOPOGRAPHIC MAP
**1065 S WINCHESTER BLVD
SAN JOSE, CALIFORNIA**

PROJECT NO. 228-006
SHEET 1
OF 1

EXISTING SITE PLAN (SURVEY MAP)
003-S

FILE NAME: 1985 WINCHESTER CONDOMINIUM 06/09/2021 REV.1

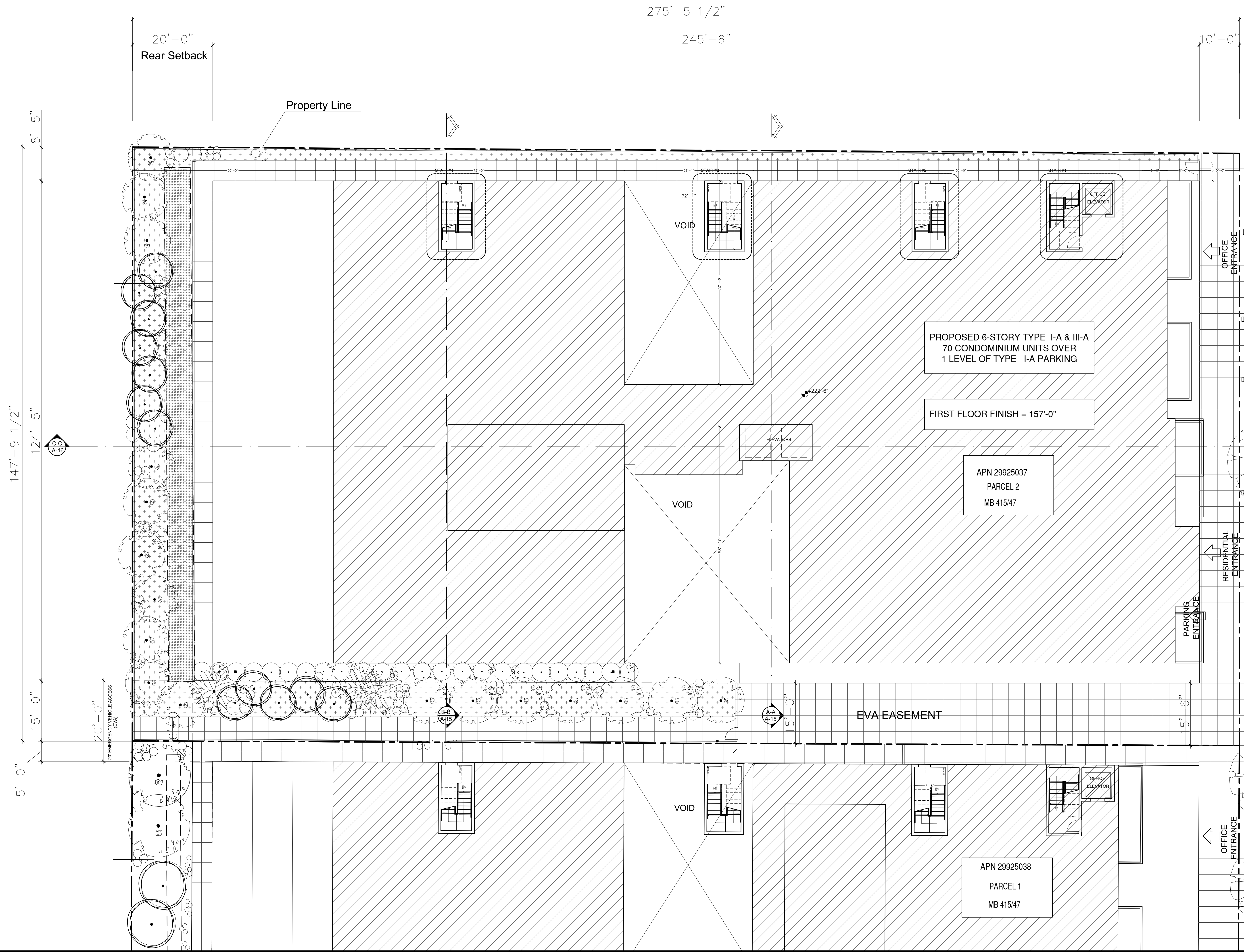

REVISIONS

REV.1	06/14/2021

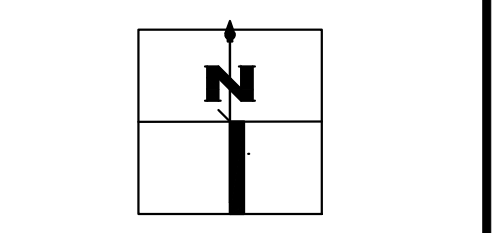

SCALE : 3/32" = 1'-0"

**PROPOSED
SITE
PLAN**

004-S

SP 21 - 006



**CARPIRA
DESIGN
GROUP
PC
COMPANY**

CARPIRA DESIGN GROUP

30025 ALICIA PKWY
LAGUNA NIGUEL - CA 92677
TEL: (310) 795-4009
SAMCARPIRA@GMAIL.COM

OWNER

A & Z DEVELOPMENT
2881 Hemlock Ave. San Jose
TEL: (408) 921-1882
Dradamaskari@GMAIL.COM

CIVIL ENGINEER



3350 Scott Blvd., Bldg. 22,
Santa Clara, CA 95054
TEL: (408) 727-6665
(408) 591-8801
www.kierwright.com

LANDSCAPE DESIGNER

SHILA YASMEH
628 N. MAPLE DR.
BEVERLY HILLS - CA 90210
SHILA.YASMEH@GMAIL.COM
TEL: (650) 492-3249

REVISIONS

△	REV.1	06/14/2021
△		
△		
△		
△		
△		
△		
△		
△		
△		
△		

**SITE
PHOTOS**

005-S

SP 21 - 006

OWNER

A & Z DEVELOPMENT
2881 Hemlock Ave. San Jose
TEL: (408) 921-1882
Dradamaskari@GMAIL.COM

CIVIL ENGINEER

 KIER+WRIGHT
3350 Scott Blvd., Bldg. 22,
Santa Clara, CA 95054
TEL: (408) 727-6665
(408) 591-8801
www.kierwright.com

LANDSCAPE DESIGNER

SHILA YASMEH
628 N. MAPLE DR.
BEVERLY HILLS - CA 90210
SHILA.YASMEH@GMAIL.COM
TEL: (650) 492-3249

REVISIONS

REV.1	06/14/2021

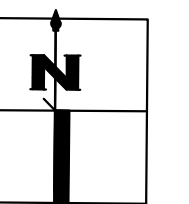

SCALE : 3/32" = 1'-0"

**BASEMENT
FLOOR PLAN**

006-A

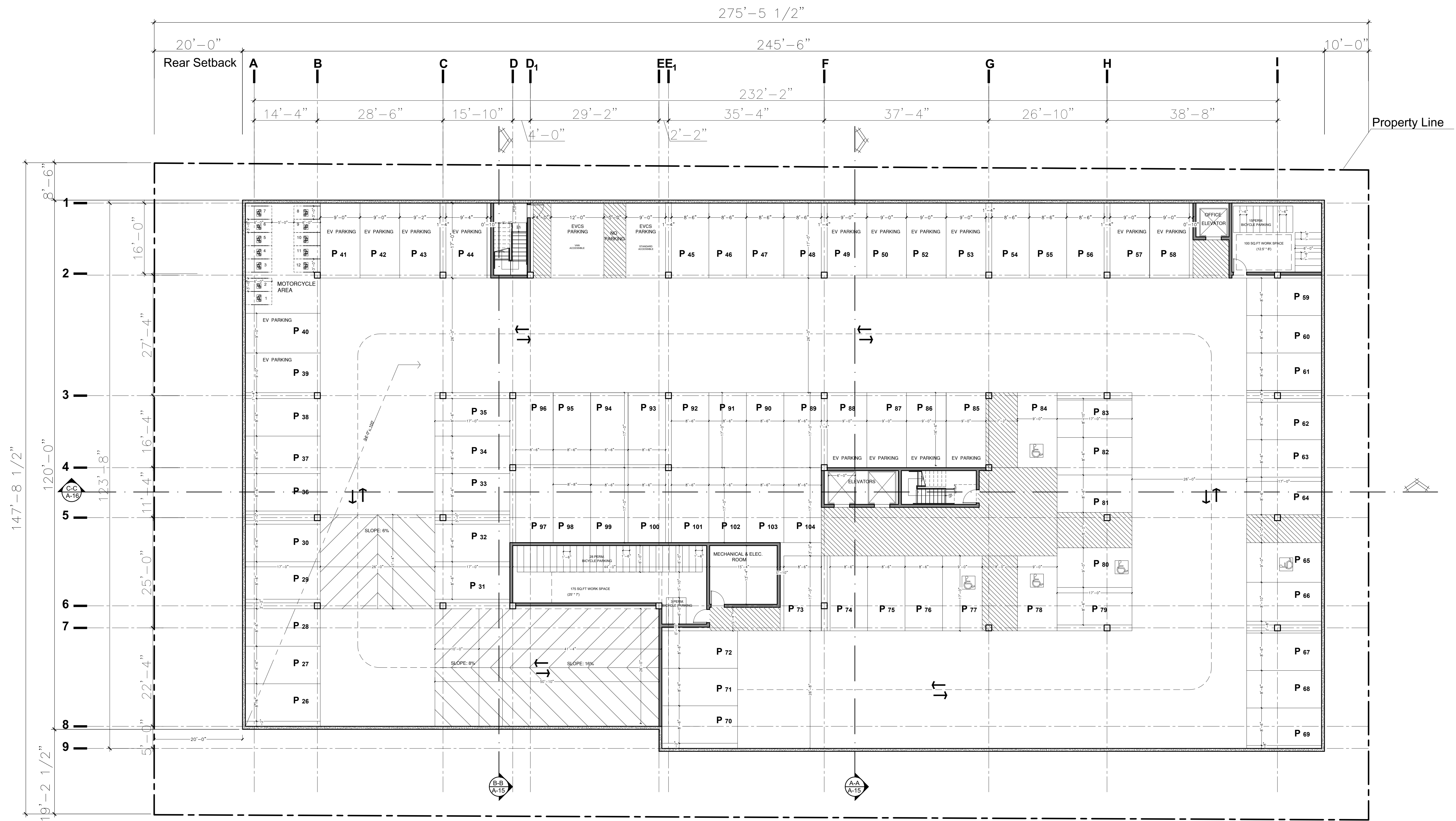

	LIVING UNIT SIZE	RATIO	REQUIRED
RESIDENTIAL	1 BEDROOM (40 UNITS)	1.25 PER UNITS	50 SPACES
	2 BEDROOM (13 UNITS)	1.7 PER UNITS	23 SPACES
	3 BEDROOM (17 UNITS)	2 PER UNITS	34 SPACES
		* rounded up per code	107 SPACES
COMMERCIAL 0.5 FAR 20410 sq.ft.	@ 0.85 factor 17348.5 sq.ft.	1 PER 250 sq.ft.	70 SPACES
CLEAN AIR VEHICLE PARKING			10 SPACES
TOTAL PROJECT REQUIREMENT			177 SPACES
PARKING PROVIDED			104 SPACES
EV PARKING (30%)			104 * 30 = 32 SPACES
EVCS			4 SPACES
PARKING REDUCTION			73 SPACES
TDM REDUCTION			41.2%

		RATIO	REQUIRED
70 UNITS RESIDENTIAL	BICYCLE	1 PER 4 UNITS	18 SPACES
	MOTORCYCLE	1 PER 4 UNITS	18 SPACES
COMMERCIAL OFFICE 20410 sq.ft.	BICYCLE	1 PER 4000 sq.ft.	6 SPACES
	MOTORCYCLE	1 PER 20 PARKING SPACE	6 SPACES
SHORT TERM BICYCLE RACK (FIRST FLOOR)			4 SPACES
CARGO BICYCLE			4 SPACES
TOTAL PROJECT REQUIREMENT			24 SPACE BICYCLE 24 SPACE MOTORCYCLE
PROVIDED			59 SPACE BICYCLE 24 SPACE MOTORCYCLE
TDM REDUCTION			0 %

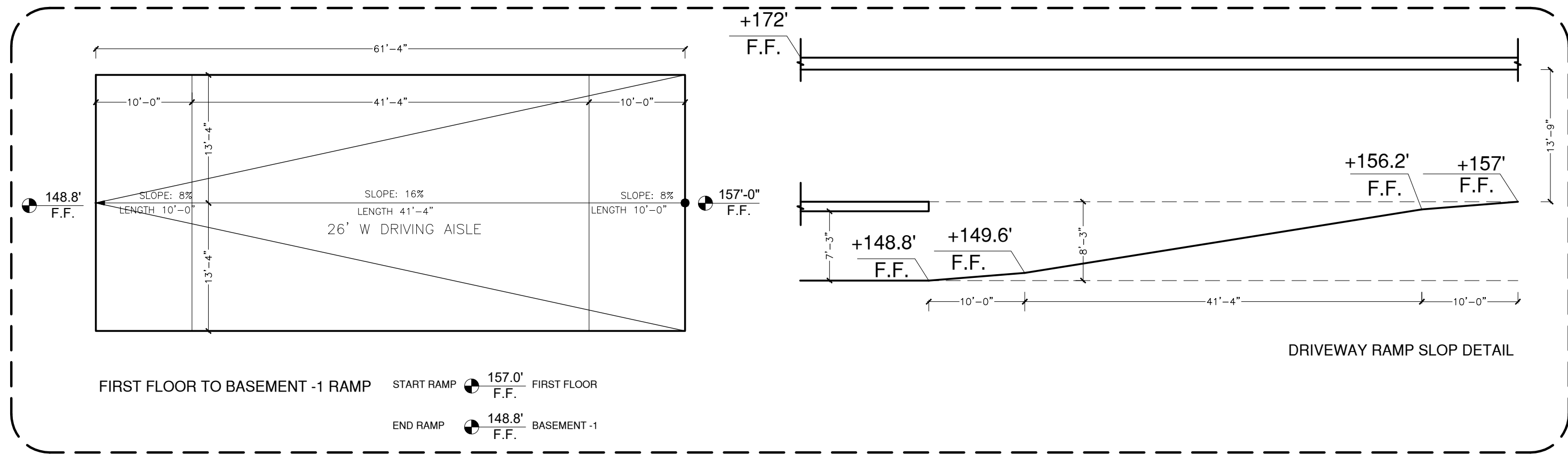
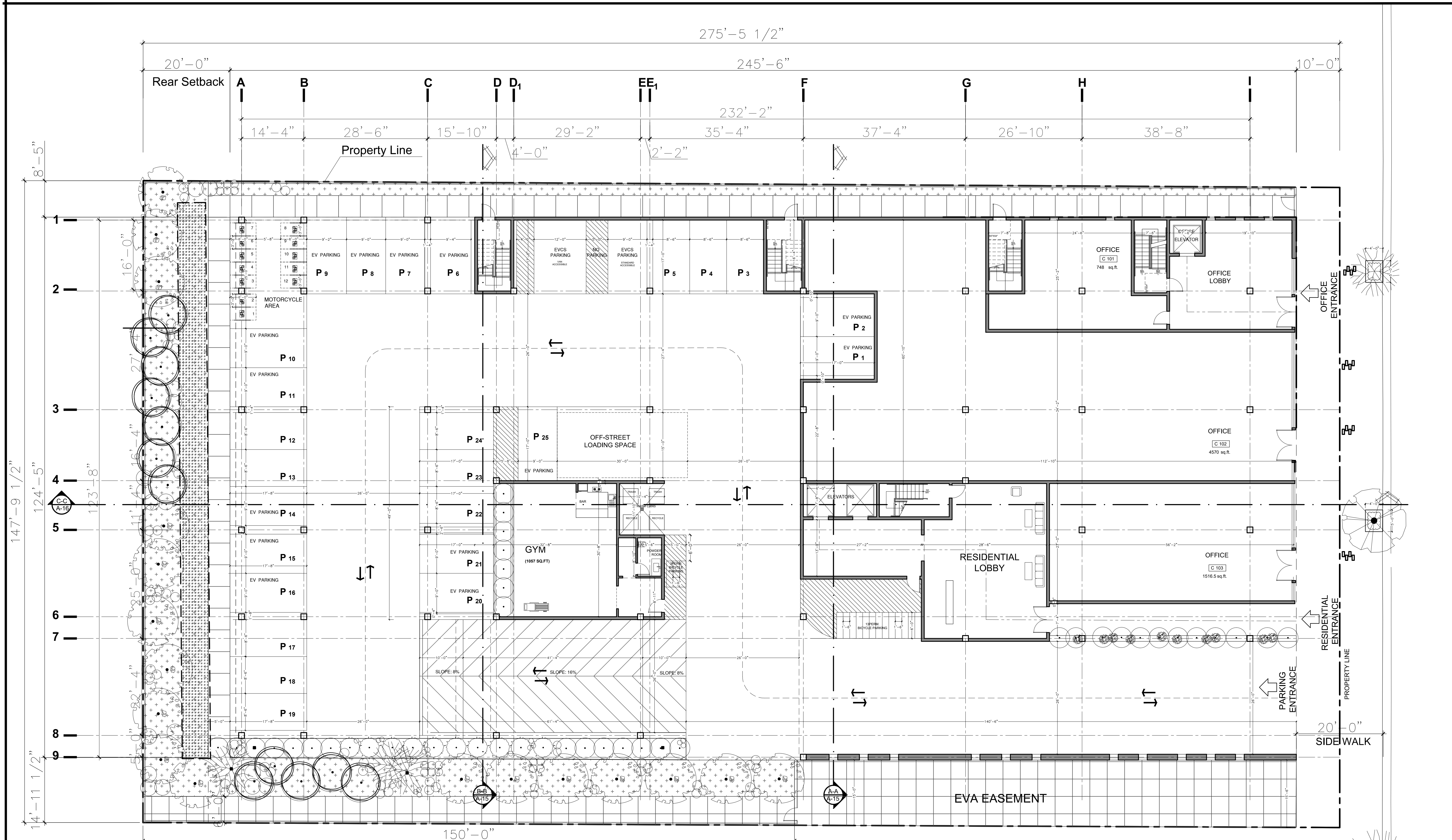

	LIVING UNIT SIZE	RATIO	REQUIRED
RESIDENTIAL	1 BEDROOM (40 UNITS)	1.25 PER UNITS	50 SPACES
	2 BEDROOM (13 UNITS)	1.7 PER UNITS	23 SPACES
	3 BEDROOM (17 UNITS)	2 PER UNITS	34 SPACES
* rounded up per code			107 SPACES
COMMERCIAL 0.5 FAR	@ 0.85 factor	1 PER 250 sq.ft.	70 SPACES
CLEAN AIR VEHICLE PARKING			10 SPACES
TOTAL PROJECT REQUIREMENT			177 SPACES
PARKING PROVIDED			104 SPACES
EV PARKING (30%)			104' %30 = 32 SPACES
EVCS			4 SPACES
PARKING REDUCTION			73 SPACES
TDM REDUCTION			41.2%

		RATIO	REQUIRED
70 UNITS RESIDENTIAL	BICYCLE	1 PER 4 UNITS	18 SPACES
	MOTORCYCLE	1 PER 4 UNITS	18 SPACES
COMMERCIAL OFFICE	BICYCLE	1 PER 4000 sq.ft.	6 SPACES
	MOTORCYCLE	1 PER 20 PARKING SPACE	6 SPACES
SHORT TERM BICYCLE RACK (FIRST FLOOR)			4 SPACES
CARGO BICYCLE			4 SPACES
TOTAL PROJECT REQUIREMENT			24 SPACE BICYCLE 24 SPACE MOTORCYCLE
PROVIDED			59 SPACE BICYCLE 24 SPACE MOTORCYCLE
TDM REDUCTION			0%

FILE NAME: 1065 WINCHESTER CONDOMINIUM 06 14 2021 REV.1

OWNER

A & Z DEVELOPMENT
2881 Hemlock Ave. San Jose
TEL: (408) 921-1882
Dradamaskari@GMAIL.COM

CIVIL ENGINEER



3350 Scott Blvd., Bldg. 22,
Santa Clara, CA 95054
TEL: (408) 727-6665
(408) 591-8801
www.kierwright.com

LANDSCAPE DESIGNER

SHILA YASMEH
628 N. MAPLE DR.
BEVERLY HILLS - CA 90210
SHILA.YASMEH@GMAIL.COM
TEL: (650) 492-3249

REVISIONS

REV.1 06/14/2021

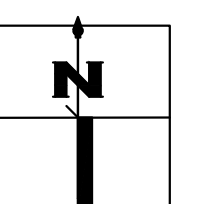

SCALE : 3/32" = 1'-0"

3RD FLOOR
PLAN

009-A

SP 21 - 006



	1BEDROOM UNIT	2BEDROOM UNIT	3BEDROOM UNIT	RESIDENTIAL NET AREA	RESIDENTIAL GROSS AREA	COMMERCIAL UNIT	COMMERCIAL NET AREA	COMMERCIAL GROSS AREA	PARKING AREA	PARKING SPACES	FLOOR AREA
PARKING LEVEL -1	---	---	---	---	---	---	---	---	30214 sq.ft.	79	30214.0 sq.ft.
1st FLOOR	---	---	---	---	3966 sq.ft.	3	6835.0 sq.ft.	8029 sq.ft.	18038 sq.ft.	25	30033.0 sq.ft.
2nd FLOOR	4	3	1	9284.6 sq.ft.	29659.9 sq.ft.	6	9953.2 sq.ft.	12381 sq.ft.	---	---	29659.9 sq.ft.
3rd FLOOR	9	4	3	18860.5 sq.ft.	24926.8 sq.ft.	---	---	---	---	---	24926.8 sq.ft.
4th FLOOR	9	4	3	18692.0 sq.ft.	24758.4 sq.ft.	---	---	---	---	---	24758.4 sq.ft.
5th FLOOR	10	4	2	17808.0 sq.ft.	24299.0 sq.ft.	---	---	---	---	---	24299.0 sq.ft.
6th FLOOR	8	2	4	16679.0 sq.ft.	23230.0 sq.ft.	---	---	---	---	---	23230.0 sq.ft.
TOTAL	40 UNITS	17 UNITS	13 UNITS	81324.1 sq.ft.	130840.1 sq.ft.	9 UNITS	16788.2 sq.ft.	20410 sq.ft.	48252 sq.ft.	104 SPACES	187121.1 sq.ft.
		70 UNITS									

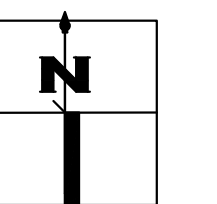

	1BEDROOM UNIT	2BEDROOM UNIT	3BEDROOM UNIT	RESIDENTIAL NET AREA	RESIDENTIAL GROSS AREA	COMMERCIAL UNIT	COMMERCIAL NET AREA	COMMERCIAL GROSS AREA	PARKING AREA	PARKING SPACES	FLOOR AREA
PARKING LEVEL -1									30214 sq.ft.	79	30214.0 sq.ft.
1st FLOOR					3966 sq.ft.	3	6835.0 sq.ft.	8029 sq.ft.	18038 sq.ft.	25	30033.0 sq.ft.
2nd FLOOR	4	3	1	9284.6 sq.ft.	29659.9 sq.ft.	6	9953.2 sq.ft.	12381 sq.ft.			29659.9 sq.ft.
3rd FLOOR	9	4	3	18860.5 sq.ft.	24926.8 sq.ft.						24926.8 sq.ft.
4th FLOOR	9	4	3	18692.0 sq.ft.	24758.4 sq.ft.						24758.4 sq.ft.
5th FLOOR	10	4	2	17808.0 sq.ft.	24299.0 sq.ft.						24299.0 sq.ft.
6th FLOOR	8	2	4	16679.0 sq.ft.	23230.0 sq.ft.						23230.0 sq.ft.
TOTAL	40 UNITS	17 UNITS	13 UNITS	81324.1 sq.ft.	130840.1 sq.ft.	9 UNITS	16788.2 sq.ft.	20410 sq.ft.	48252 sq.ft.	104 SPACES	187121.1 sq.ft.
		70 UNITS									

OWNER

A & Z DEVELOPMENT
2881 Hemlock Ave. San Jose
TEL: (408) 921-1882
Dradamaskari@GMAIL.COM

CIVIL ENGINEER



3350 Scott Blvd., Bldg. 22,
Santa Clara, CA 95054
TEL: (408) 727-6665
(408) 591-8801
www.kierwright.com

LANDSCAPE DESIGNER

SHILA YASMEH
628 N. MAPLE DR.
BEVERLY HILLS - CA 90210
SHILA.YASMEH@GMAIL.COM
TEL: (650) 492-3249

REVISIONS

REV.1 06/14/2021

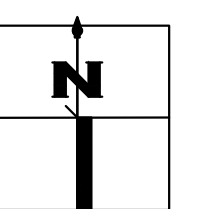

SCALE : 3/32" = 1'-0"

5TH FLOOR
PLAN

011-A

SP 21 - 006



	1BEDROOM UNIT	2BEDROOM UNIT	3BEDROOM UNIT	RESIDENTIAL NET AREA	RESIDENTIAL GROSS AREA	COMMERCIAL UNIT	COMMERCIAL NET AREA	COMMERCIAL GROSS AREA	PARKING AREA	PARKING SPACES	FLOOR AREA
PARKING LEVEL -1	---	---	---	---	---	---	---	---	30214 sq.ft.	79	30214.0 sq.ft.
1st FLOOR	---	---	---	---	3966 sq.ft.	3	6835.0 sq.ft.	8029 sq.ft.	18038 sq.ft.	25	30033.0 sq.ft.
2nd FLOOR	4	3	1	9284.6 sq.ft.	29659.9 sq.ft.	6	9953.2 sq.ft.	12381 sq.ft.	---	---	29659.9 sq.ft.
3rd FLOOR	9	4	3	18860.5 sq.ft.	24926.8 sq.ft.	---	---	---	---	---	24926.8 sq.ft.
4th FLOOR	9	4	3	18692.0 sq.ft.	24758.4 sq.ft.	---	---	---	---	---	24758.4 sq.ft.
5th FLOOR	10	4	2	17808.0 sq.ft.	24299.0 sq.ft.	---	---	---	---	---	24299.0 sq.ft.
6th FLOOR	8	2	4	16679.0 sq.ft.	23230.0 sq.ft.	---	---	---	---	---	23230.0 sq.ft.
TOTAL	40 UNITS	17 UNITS	13 UNITS	81324.1 sq.ft.	130840.1 sq.ft.	9 UNITS	16788.2 sq.ft.	20410 sq.ft.	48252 sq.ft.	104 SPACES	187121.1 sq.ft.
		70 UNITS									

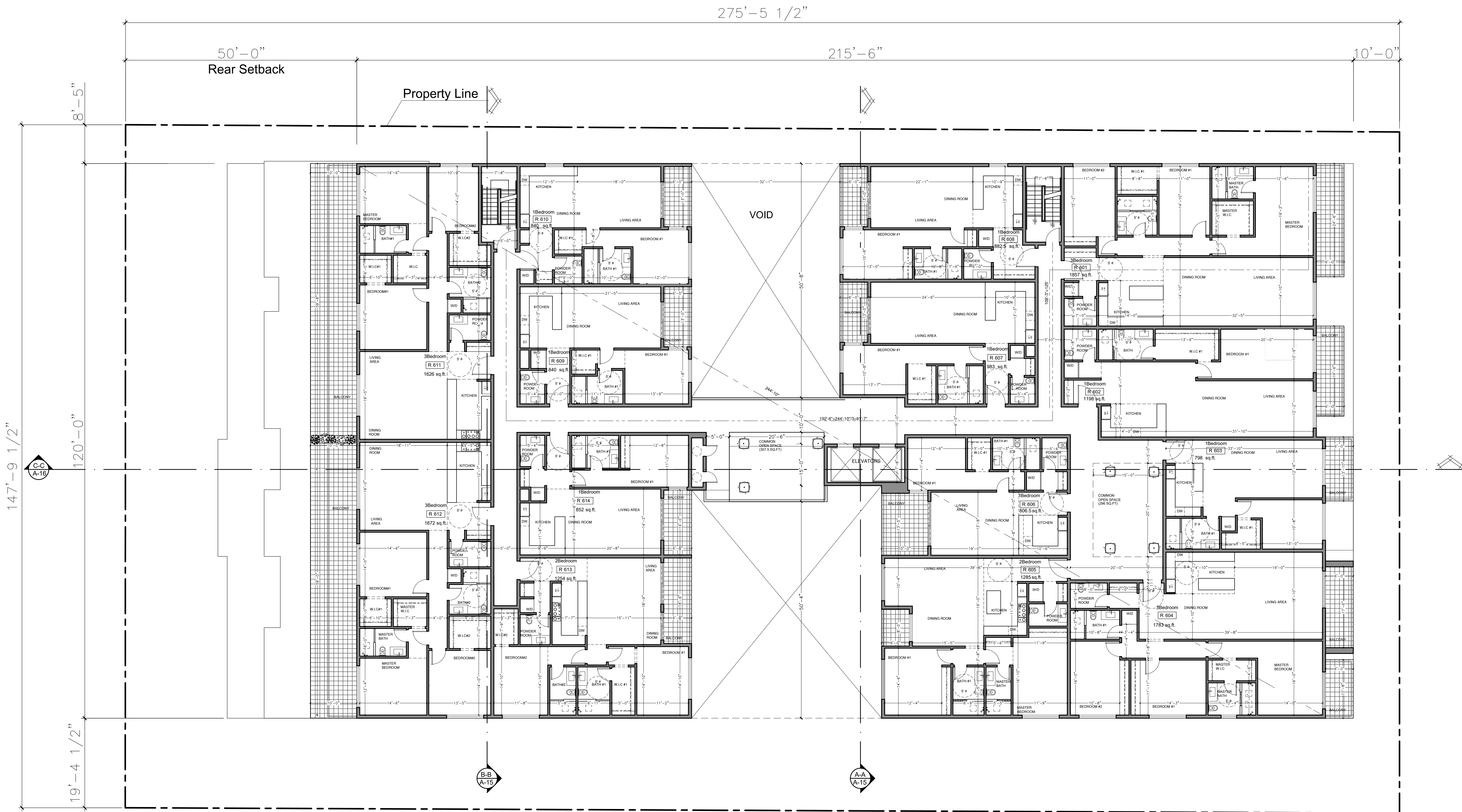
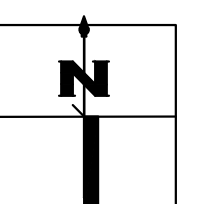

	1BEDROOM UNIT	2BEDROOM UNIT	3BEDROOM UNIT	RESIDENTIAL NET AREA	RESIDENTIAL GROSS AREA	COMMERCIAL UNIT	COMMERCIAL NET AREA	COMMERCIAL GROSS AREA	PARKING AREA	PARKING SPACES	FLOOR AREA
PARKING LEVEL -1	---	---	---						30214 sq.ft.	79	30214.0 sq.ft.
1st FLOOR	---	---	---		3966 sq.ft.	3	6835.0 sq.ft.	8029 sq.ft.	18038 sq.ft.	25	30033.0 sq.ft.
2nd FLOOR	4	3	1	9284.6 sq.ft.	29659.9 sq.ft.	6	9953.2 sq.ft.	12381 sq.ft.			29659.9 sq.ft.
3rd FLOOR	9	4	3	18860.5 sq.ft.	24926.8 sq.ft.						24926.8 sq.ft.
4th FLOOR	9	4	3	18692.0 sq.ft.	24758.4 sq.ft.						24758.4 sq.ft.
5th FLOOR	10	4	2	17808.0 sq.ft.	24299.0 sq.ft.						24299.0 sq.ft.
6th FLOOR	8	2	4	16679.0 sq.ft.	23230.0 sq.ft.						23230.0 sq.ft.
TOTAL	40 UNITS	17 UNITS	13 UNITS	81324.1 sq.ft.	130840.1 sq.ft.	9 UNITS	16788.2 sq.ft.	20410 sq.ft.	48252 sq.ft.	104 SPACES	187121.1 sq.ft.
		70 UNITS									

OWNER

A & Z DEVELOPMENT
2881 Hemlock Ave. San Jose
TEL: (408) 921-1882
Dradamaskari@GMAIL.COM

CIVIL ENGINEER



3350 Scott Blvd., Bldg. 22,
Santa Clara, CA 95054
TEL: (408) 727-6665
(408) 591-8801
www.kierwright.com

LANDSCAPE DESIGNER

SHILA YASMEH
628 N. MAPLE DR.
BEVERLY HILLS - CA 90210
SHILA.YASMEH@GMAIL.COM
TEL: (650) 492-3249

REVISIONS

▲	REV.1	06/14/2021
▲		
▲		
▲		
▲		
▲		
▲		
▲		
▲		
▲		

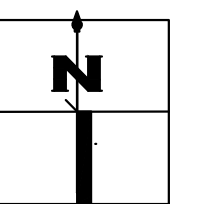

SCALE : 3/32" = 1'-0"

ROOF PLAN

013-A

SP 21 - 006

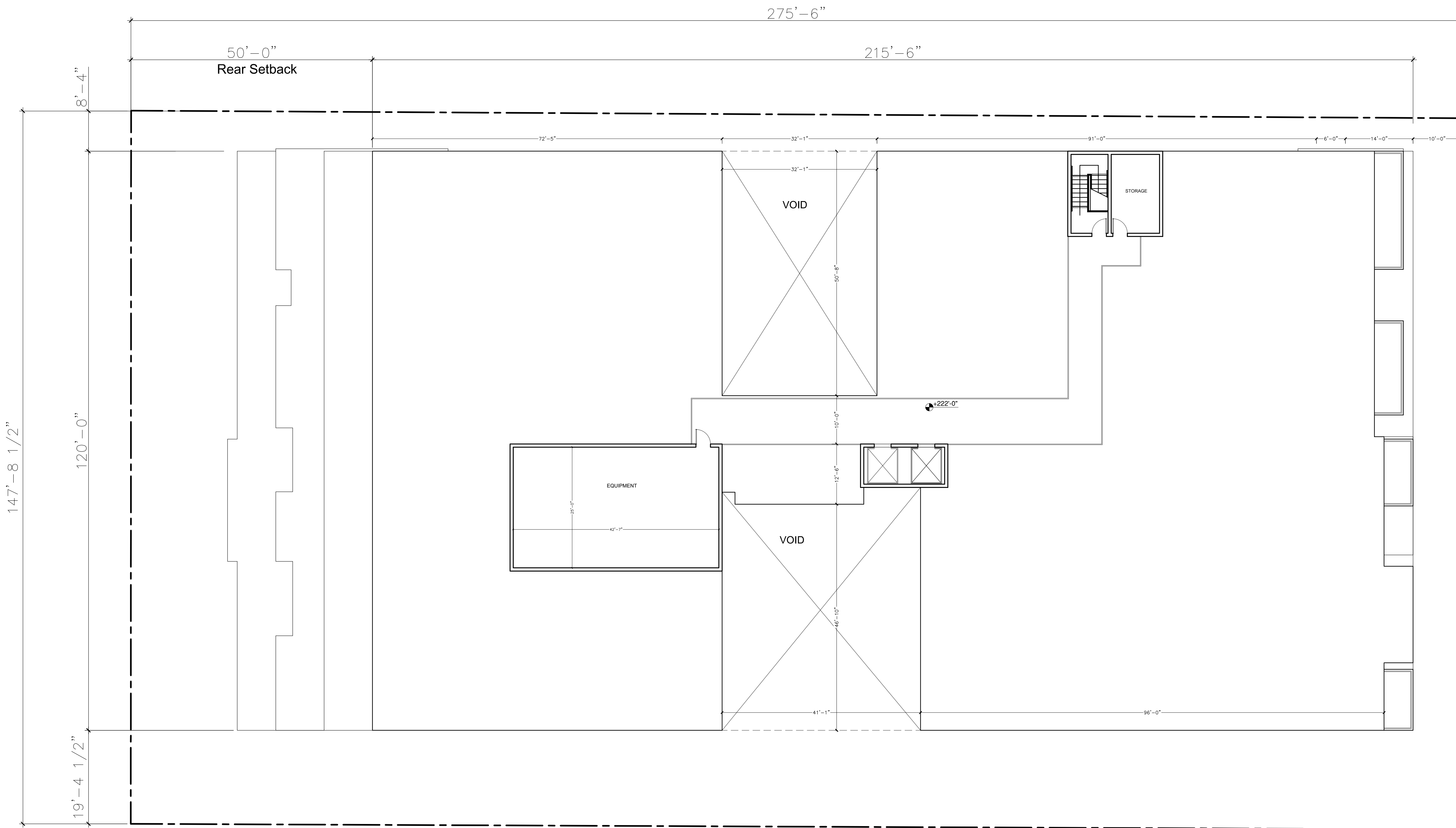

OWNER

A & Z DEVELOPMENT
2881 Hemlock Ave. San Jose
TEL: (408) 921-1882
Dradamaskari@GMAIL.COM

CIVIL ENGINEER



3350 Scott Blvd., Bldg. 22,
Santa Clara, CA 95054
TEL: (408) 727-6665
(408) 591-8801
www.kierwright.com

LANDSCAPE DESIGNER

SHILA YASMEH
628 N. MAPLE DR.
BEVERLY HILLS - CA 90210
SHILA.YASMEH@GMAIL.COM
TEL: (650) 492-3249

REVISIONS

▲	REV.1	06/14/2021
▲		
▲		
▲		
▲		
▲		
▲		
▲		
▲		
▲		

SCALE : 3/32" = 1'-0"

**FRONT&REAR
ELEVATION**

014-A

SP 21 - 006

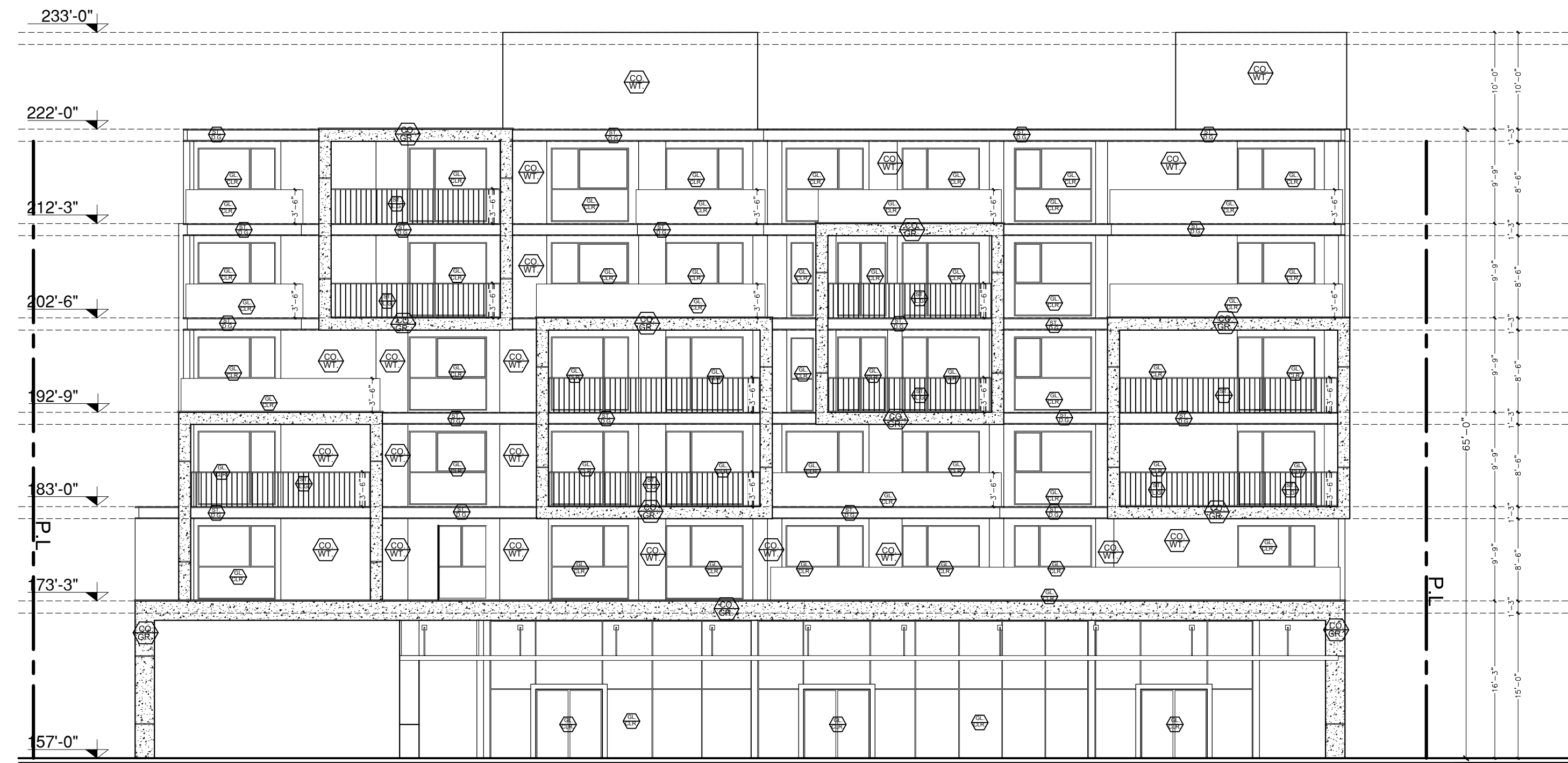

FRONT ELEVATION

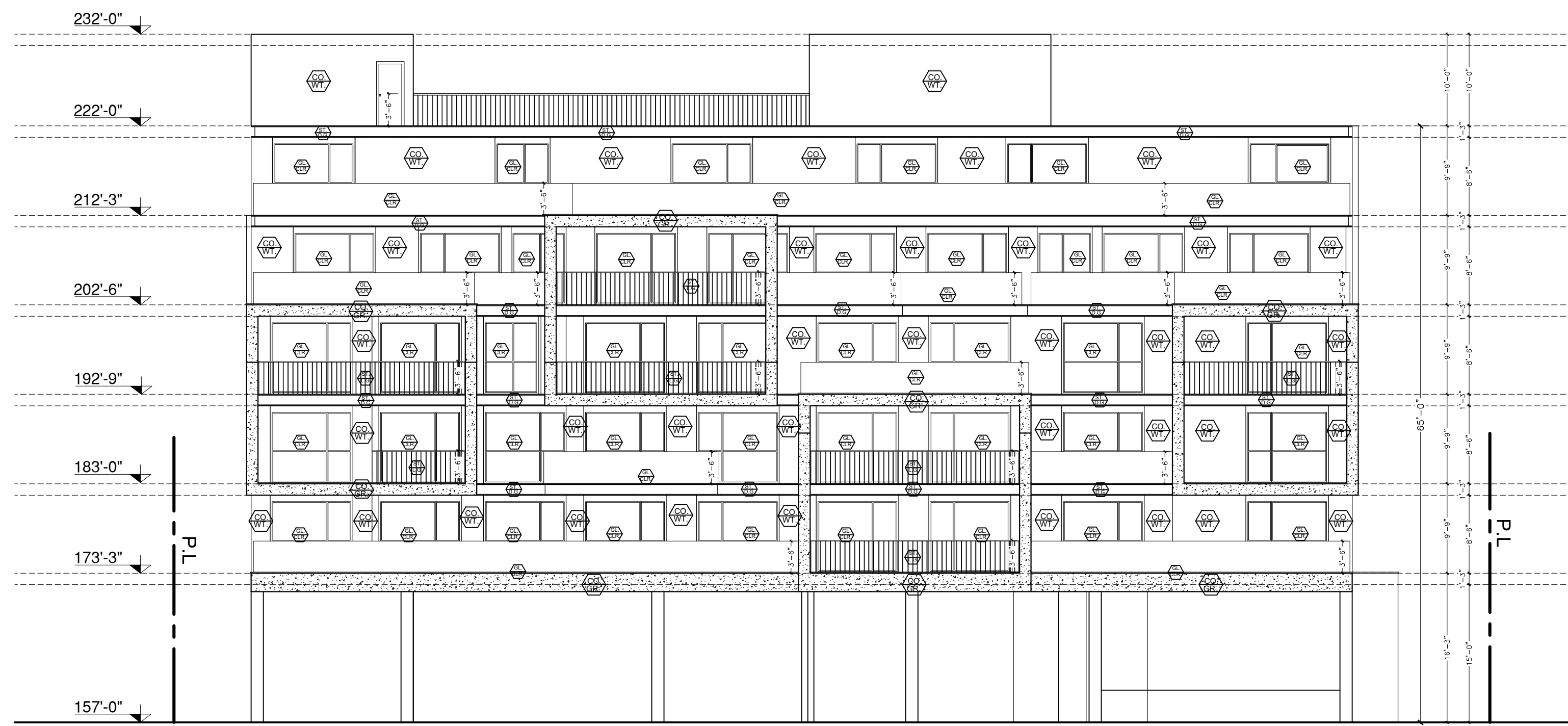

REAR ELEVATION

LEGEND:

MATERIAL	COLOR	ABBREVIATION
WOOD PANEL	BROWN	WD BR
CONCRETE	WHITE	CO WT
GLASS	CLEAR	GL CLR
CONCRETE	GRAY	CO GT
STEEL	LIGHT GRAY	ST LG
STEEL	DARK GRAY	ST DG

OWNER

A & Z DEVELOPMENT
2881 Hemlock Ave. San Jose
TEL: (408) 921-1882
Dradamaskari@GMAIL.COM

CIVIL ENGINEER



3350 Scott Blvd., Bldg. 22,
Santa Clara, CA 95054
TEL: (408) 727-6665
(408) 591-8801
www.kierwright.com

LANDSCAPE DESIGNER

SHILA YASMEH
628 N. MAPLE DR.
BEVERLY HILLS - CA 90210
SHILA.YASMEH@GMAIL.COM
TEL: (650) 492-3249

REVISIONS

REV.1 06/14/2021

SCALE : 3/32" = 1'-0"

RIGHT & LEFT
ELEVATION

015-A

SP 21 - 006

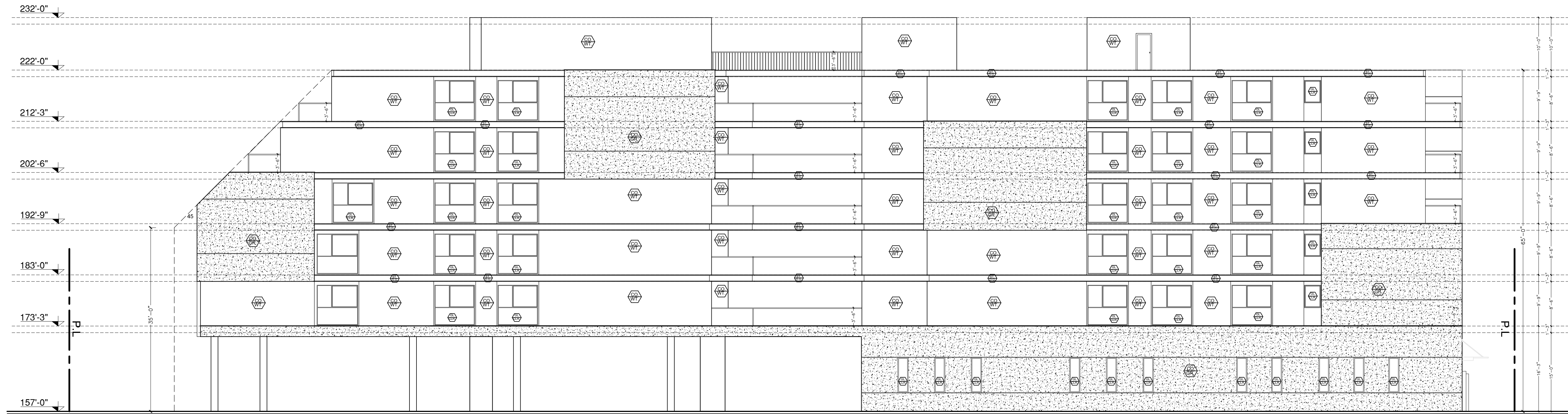

LEFT ELEVATION

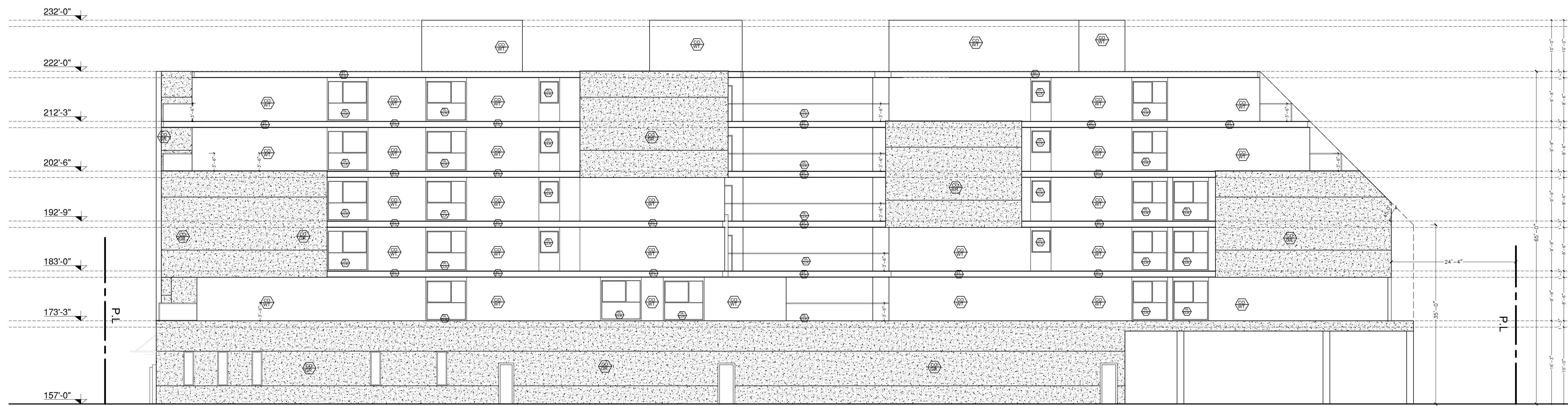

RIGHT ELEVATION

LEGEND:

MATERIAL	COLOR	ABBREVIATION
WOOD PANEL	BROWN	WD BR
CONCRETE	WHITE	CO WT
GLASS	CLEAR	GL CLR
CONCRETE	GRAY	CO GR
STEEL	LIGHT GRAY	ST LG
STEEL	DARK GRAY	ST DG

▲	REV.1	06/14/2021
▲		
▲		
▲		
▲		
▲		
▲		
▲		
▲		



SECTION A-A

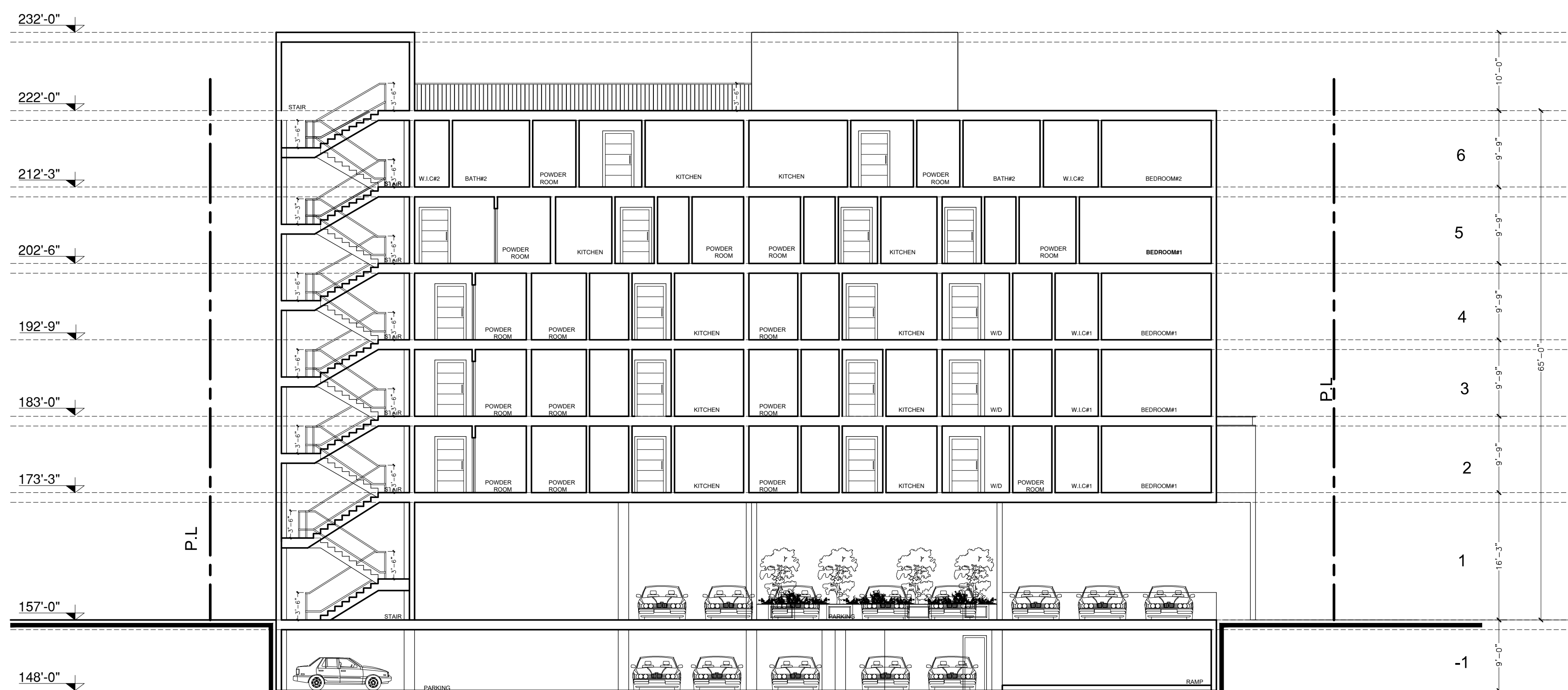

SECTION B-B

△	REV.1	06/14/2021
△		
△		
△		
△		
△		
△		
△		
△		
△		
△		

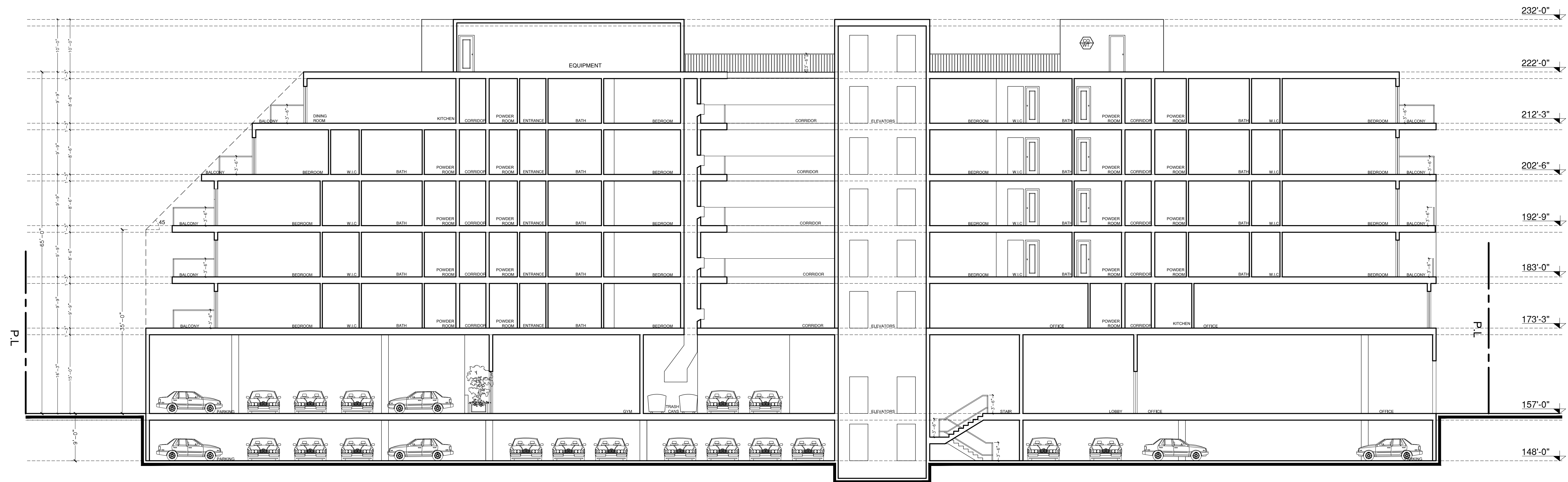

SECTION C-C

OWNER

A & Z DEVELOPMENT
2881 Hemlock Ave. San Jose
TEL: (408) 921-1882
Dradamaskari@GMAIL.COM

CIVIL ENGINEER



3350 Scott Blvd., Bldg. 22,
Santa Clara, CA 95054
TEL: (408) 727-6665
(408) 591-8801
www.kierwright.com

LANDSCAPE DESIGNER

SHILA YASMEH
628 N. MAPLE DR.
BEVERLY HILLS - CA 90210
SHILA.YASMEH@GMAIL.COM
TEL: (650) 492-3249

REVISIONS

REV.	DATE	DESCRIPTION
REV.1	06/14/2021	

MATERIAL BOARD

018-A

SP 21 - 006

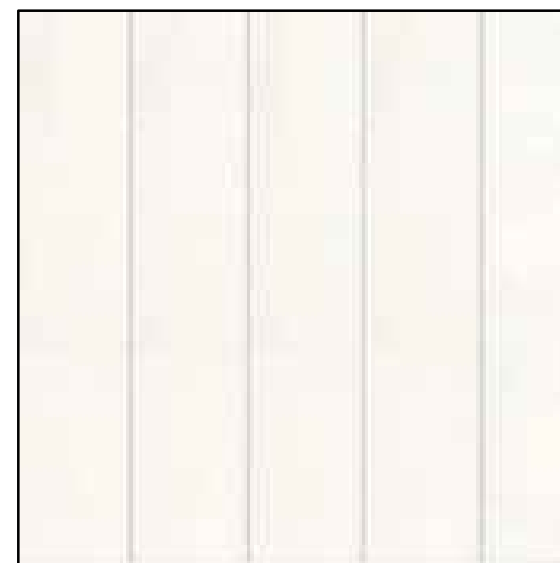

**CONCRETE
COLOR: WHITE**

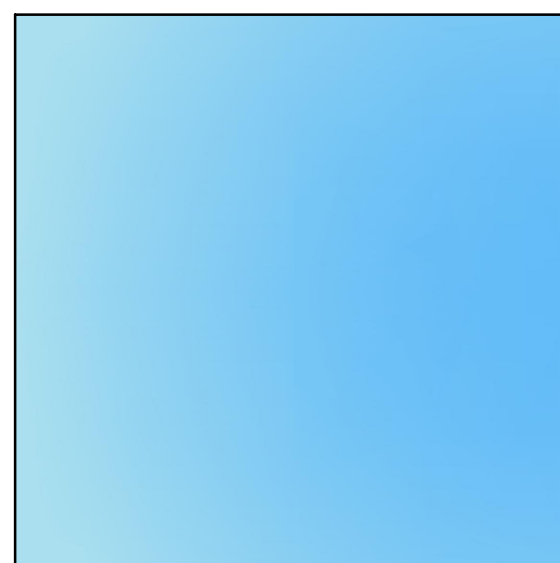

ARCHITECTURAL GLAZING

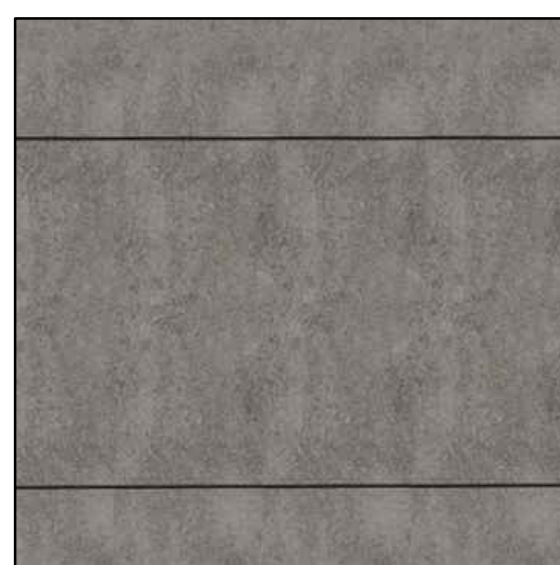

WOOD PANELS

**EXPOSED CONCRETE
COLOR: GRAY**

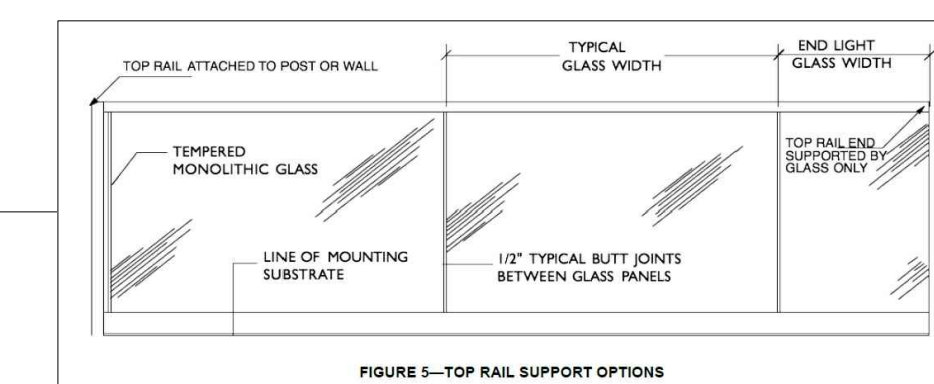
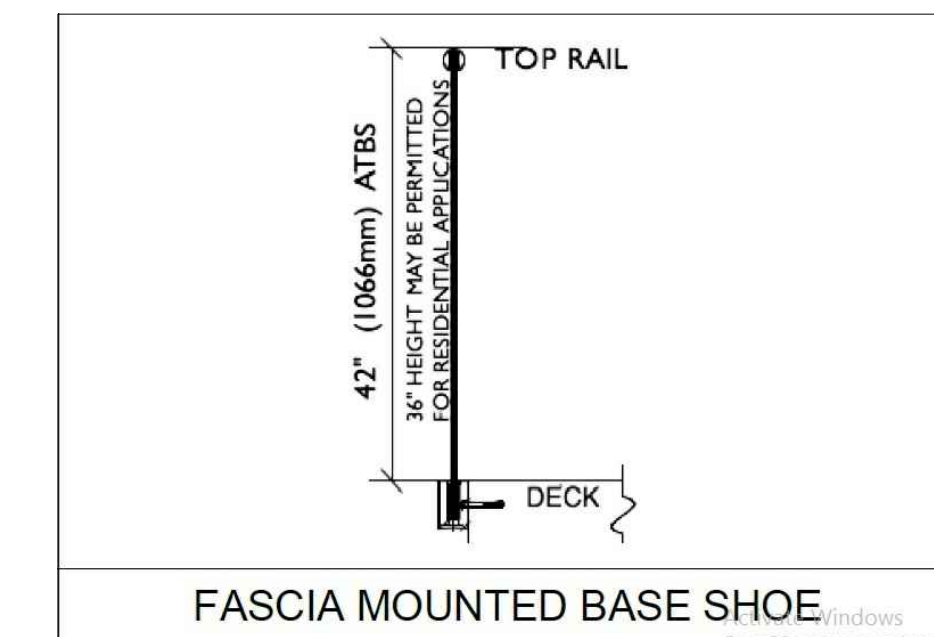

RAILING DETAILS

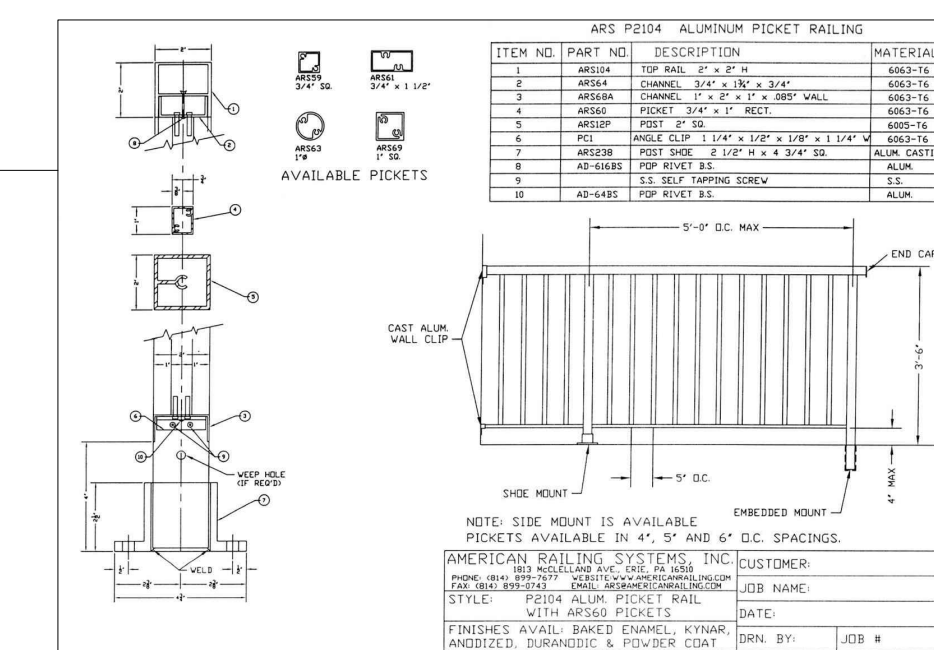

RAILING DETAILS

FILE NAME: 19053 WINCHESTER CONDOMINIUM 06 09 2021 REV.1



CARPIRA DESIGN GROUP

30025 ALICIA PKWY
LAGUNA NIGUEL - CA 92677
TEL: (310) 795-4009
SAMCARPIRA@GMAIL.COM

OWNER

A & Z DEVELOPMENT
2881 Hemlock Ave. San Jose
TEL: (408) 921-1882
Dradamaskari@GMAIL.COM

CIVIL ENGINEER



3350 Scott Blvd., Bldg. 22,
Santa Clara, CA 95054
TEL: (408) 727-6665
(408) 591-8801
www.kierwright.com

LANDSCAPE DESIGNER

SHILA YASMEH
628 N. MAPLE DR.
BEVERLY HILLS - CA 90210
SHILA.YASMEH@GMAIL.COM
TEL: (650) 492-3249

REVISIONS

▲	REV.1	06/14/2021
▲		
▲		
▲		
▲		
▲		
▲		
▲		
▲		
▲		

**BIRD VIEW
RENDERING**

019-A

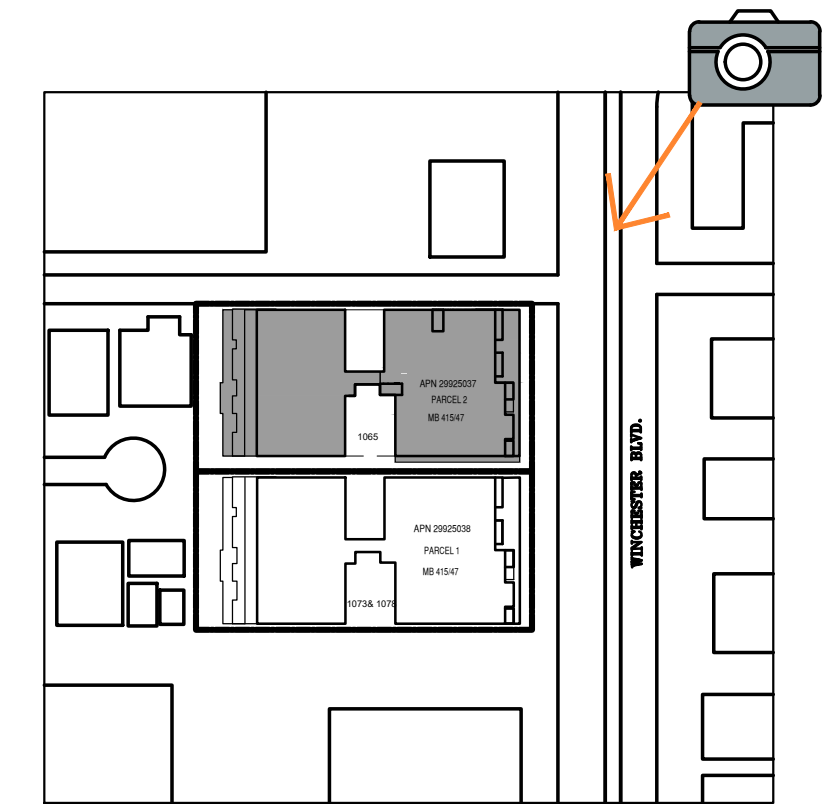

CARPIRA DESIGN GROUP
 30025 ALICIA PKWY
 LAGUNA NIGUEL - CA 92677
 TEL: (310) 795-4009
 SAMCARPIRA@GMAIL.COM

OWNER
 A & Z DEVELOPMENT
 2881 Hemlock Ave. San Jose
 TEL: (408) 921-1882
 Dradamaskari@GMAIL.COM

CIVIL ENGINEER
 **KIER+WRIGHT**
 3350 Scott Blvd., Bldg. 22,
 Santa Clara, CA 95054
 TEL: (408) 727-6665
 (408) 591-8801
 www.kierwright.com

LANDSCAPE DESIGNER
 SHILA YASMEH
 628 N. MAPLE DR.
 BEVERLY HILLS - CA 90210
 SHILA.YASMEH@GMAIL.COM
 TEL: (650) 492-3249

REVISIONS

△ REV.1	06/14/2021
△	
△	
△	
△	
△	
△	
△	
△	
△	
△	

CARPIRA DESIGN GROUP

30025 ALICIA PKWY
LAGUNA NIGUEL - CA 92677
TEL: (310) 795-4009
SAMCARPIRA@GMAIL.COM

OWNER

A & Z DEVELOPMENT
2881 Hemlock Ave. San Jose
TEL: (408) 921-1882
Dradamaskari@GMAIL.COM

CIVIL ENGINEER



3350 Scott Blvd., Bldg. 22,
Santa Clara, CA 95054
TEL: (408) 727-6665
(408) 591-8801
www.kierwright.com

LANDSCAPE DESIGNER

SHILA YASMEH
628 N. MAPLE DR.
BEVERLY HILLS - CA 90210
SHILA.YASMEH@GMAIL.COM
TEL : (650) 492-3249

REVISIONS

REV.	DATE
△ REV.1	06/14/2021
△	
△	
△	
△	
△	
△	
△	
△	
△	
△	
△	
△	
△	
△	
△	
△	
△	
△	
△	
△	
△	
△	

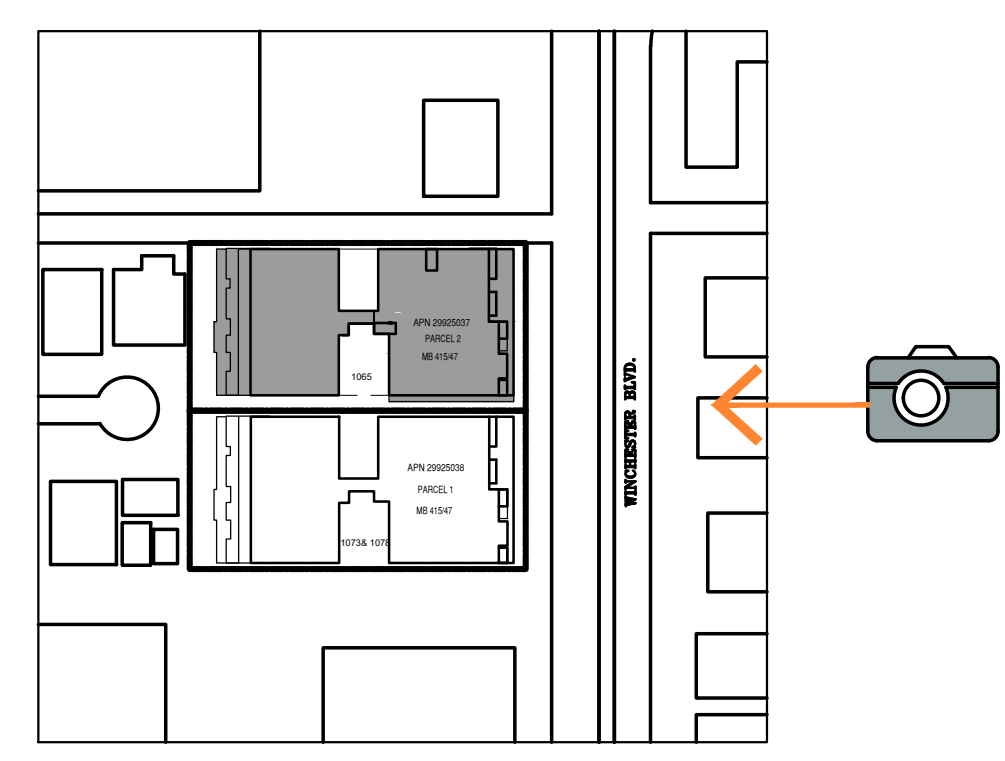

**BUILDING
RENDERING**

021-A

CARPIRA DESIGN GROUP

30025 ALICIA PKWY
LAGUNA NIGUEL - CA 92677
TEL: (310) 795-4009
SAMCARPIRA@GMAIL.COM

OWNER

A & Z DEVELOPMENT
2881 Hemlock Ave. San Jose
TEL: (408) 921-1882
Dradamaskari@GMAIL.COM

CIVIL ENGINEER



3350 Scott Blvd., Bldg. 22,
Santa Clara, CA 95054
TEL: (408) 727-6665
(408) 591-8801
www.kierwright.com

LANDSCAPE DESIGNER

SHILA YASMEH
628 N. MAPLE DR.
BEVERLY HILLS - CA 90210
SHILA.YASMEH@GMAIL.COM
TEL : (650) 492-3249

REVISIONS

△	REV.1	06/14/2021
△		
△		
△		
△		
△		
△		
△		
△		

**BUILDING
RENDERING**

022-A

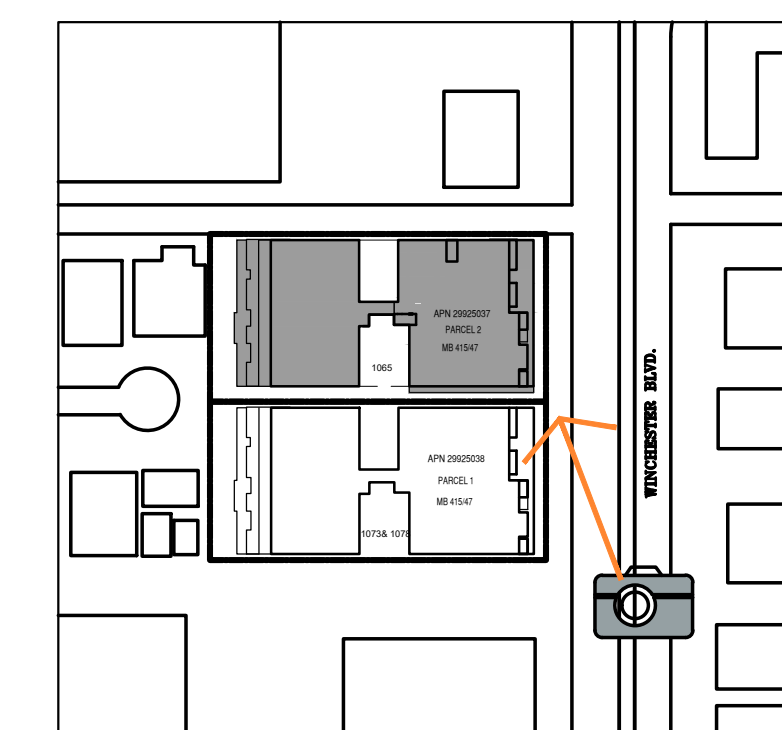

CARPIRA DESIGN GROUP

30025 ALICIA PKWY
LAGUNA NIGUEL - CA 92677
TEL: (310) 795-4009
SAMCARPIRA@GMAIL.COM

OWNER

A & Z DEVELOPMENT
2881 Hemlock Ave. San Jose
TEL: (408) 921-1882
Dradamaskari@GMAIL.COM

CIVIL ENGINEER



3350 Scott Blvd., Bldg. 22,
Santa Clara, CA 95054
TEL: (408) 727-6665
(408) 591-8801
www.kierwright.com

LANDSCAPE DESIGNER

SHILA YASMEH
628 N. MAPLE DR.
BEVERLY HILLS - CA 90210
SHILA.YASMEH@GMAIL.COM
TEL: (650) 492-3249

REVISIONS

▲	REV.1	06/14/2021
▲		
▲		
▲		
▲		
▲		
▲		
▲		
▲		
▲		

**BUILDING
RENDERING**

023-A

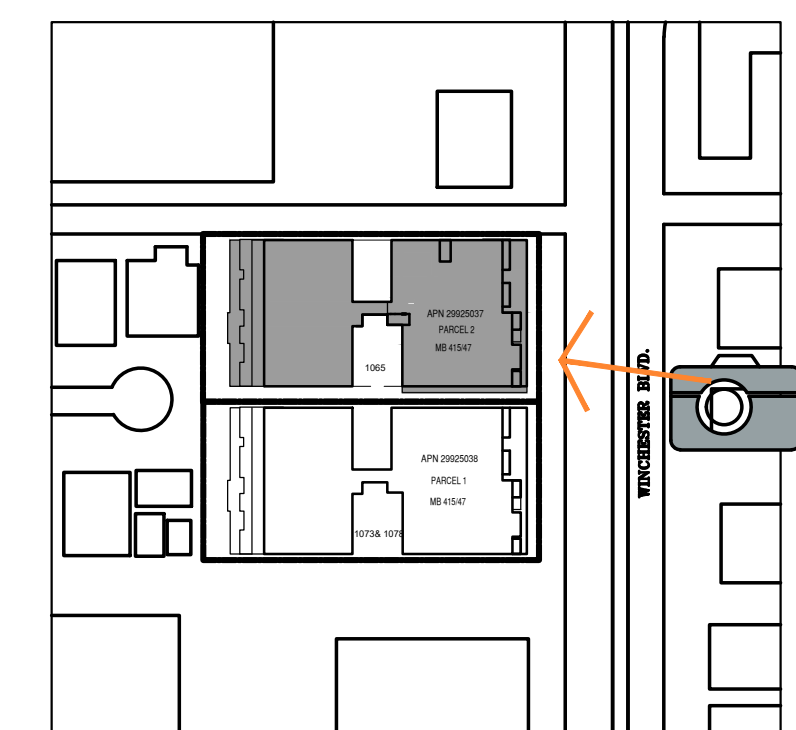



CARPIRA DESIGN GROUP COMPANY

CARPIRA DESIGN GROUP
 30025 ALICIA PKWY
 LAGUNA NIGUEL - CA 92677
 TEL: (310) 795-4009
 SAMCARPIRA@GMAIL.COM

OWNER
 A & Z DEVELOPMENT
 2881 Hemlock Ave. San Jose
 TEL: (408) 921-1882
 Dradamaskari@GMAIL.COM

CIVIL ENGINEER
 **KIER+WRIGHT**
 3350 Scott Blvd., Bldg. 22,
 Santa Clara, CA 95054
 TEL: (408) 727-6665
 (408) 591-8801
 www.kierwright.com

LANDSCAPE DESIGNER
 SHILA YASMEH
 628 N. MAPLE DR.
 BEVERLY HILLS - CA 90210
 SHILA.YASMEH@GMAIL.COM
 TEL : (650) 492-3249

REVISIONS

△	REV.1	06/14/2021
△		
△		
△		
△		
△		
△		
△		
△		
△		
△		
△		

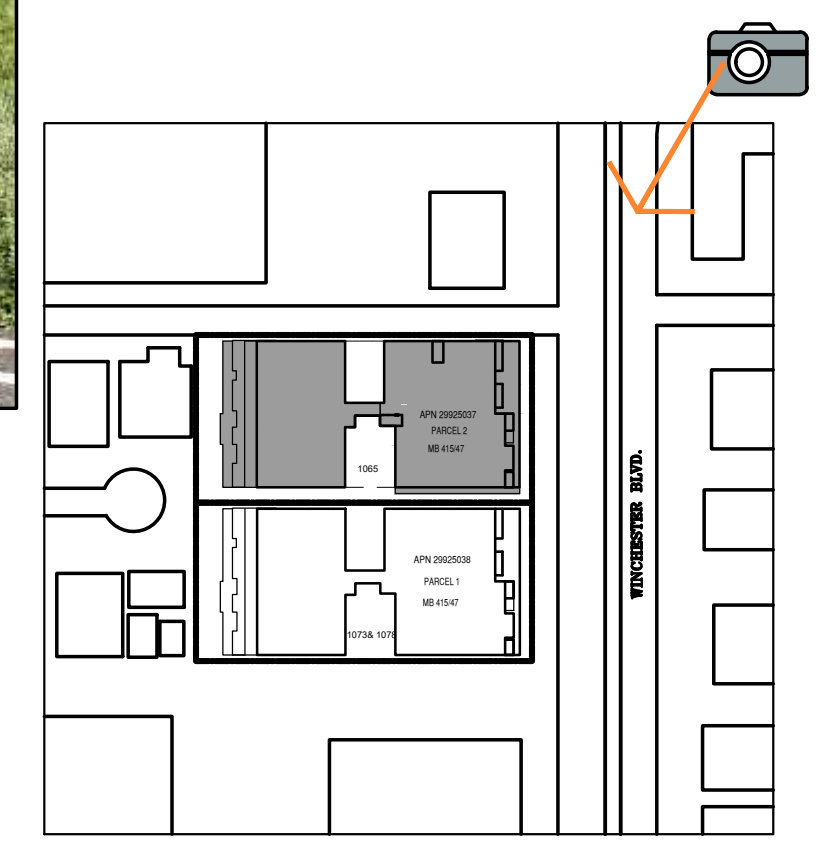

**BUILDING
RENDERING**
024-A

SP 21 - 006

FILE NAME: 19065 WINCHESTER CONDOMINIUM 06 09 2021 REV.1



CARPIRA DESIGN GROUP

30025 ALICIA PKWY
LAGUNA NIGUEL - CA 92677
TEL: (310) 795-4009
SAMCARPIRA@GMAIL.COM

OWNER

A & Z DEVELOPMENT
2881 Hemlock Ave. San Jose
TEL: (408) 921-1882
Dradamaskari@GMAIL.COM

CIVIL ENGINEER



3350 Scott Blvd., Bldg. 22,
Santa Clara, CA 95054
TEL: (408) 727-6665
(408) 591-8801
www.kierwright.com

LANDSCAPE DESIGNER

SHILA YASMEH
628 N. MAPLE DR.
BEVERLY HILLS - CA 90210
SHILA.YASMEH@GMAIL.COM
TEL : (650) 492-3249

REVISIONS

△	REV.1	06/14/2021
△		
△		
△		
△		
△		
△		
△		
△		
△		

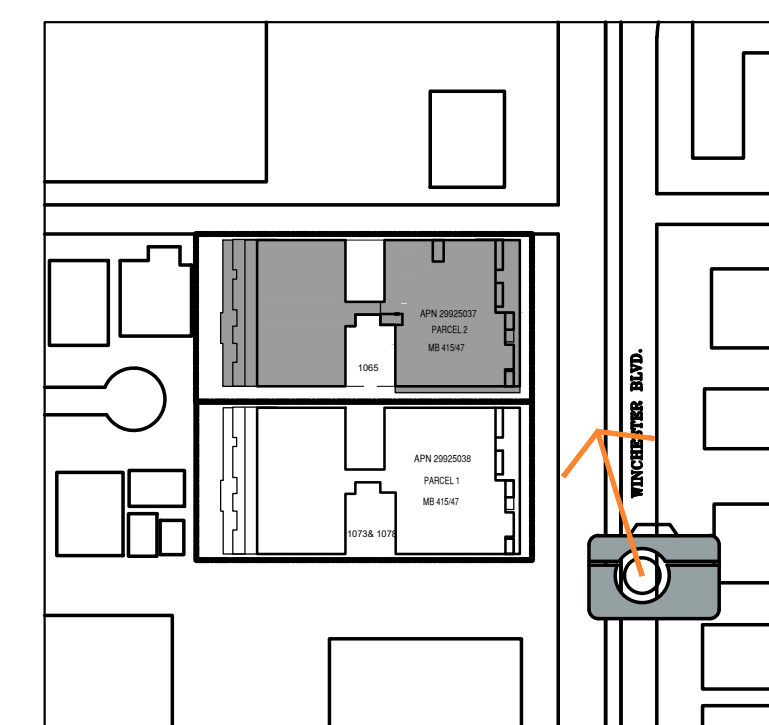

**BUILDING
RENDERING**

025-A

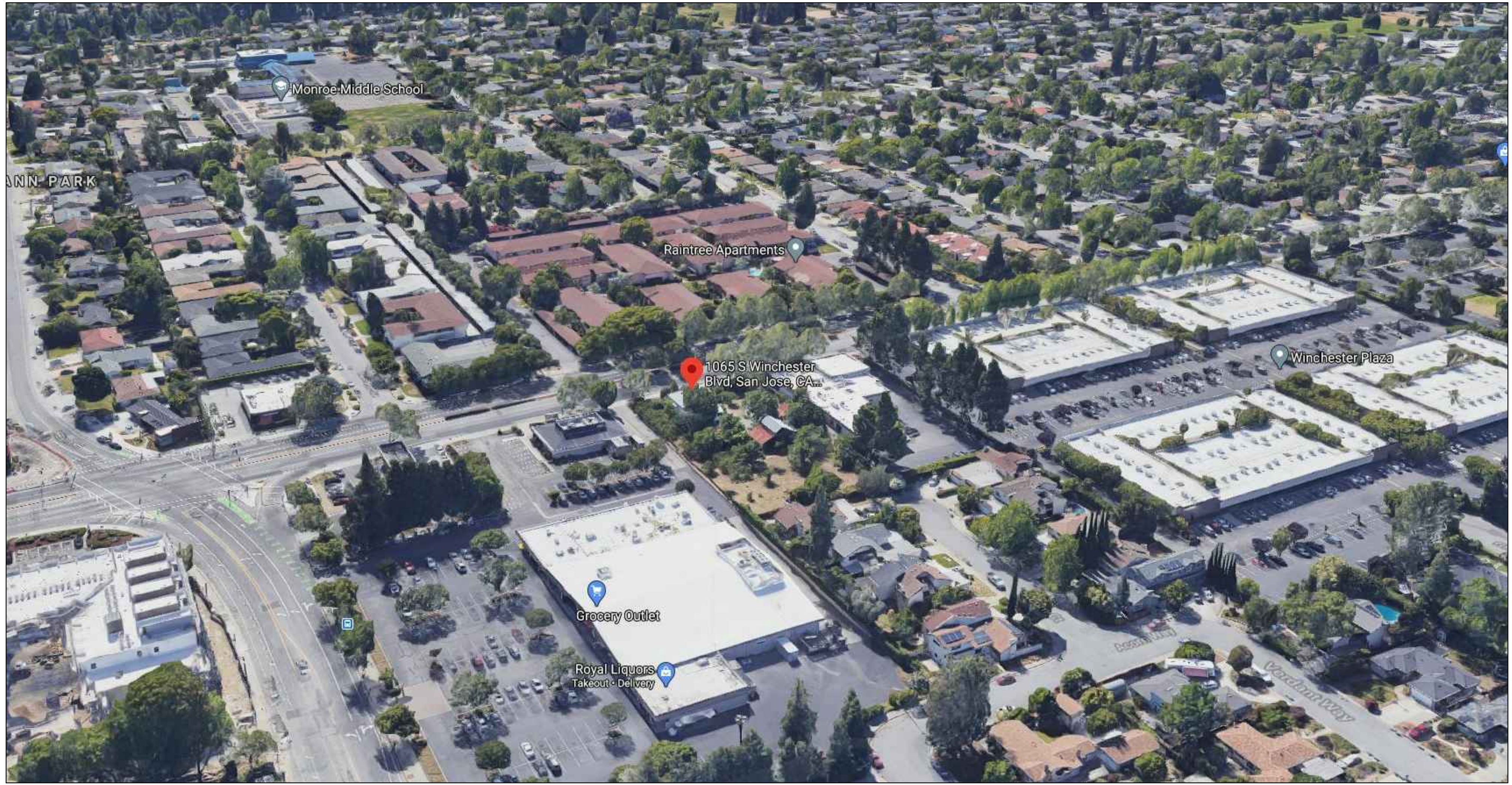

BEFORE



AFTER

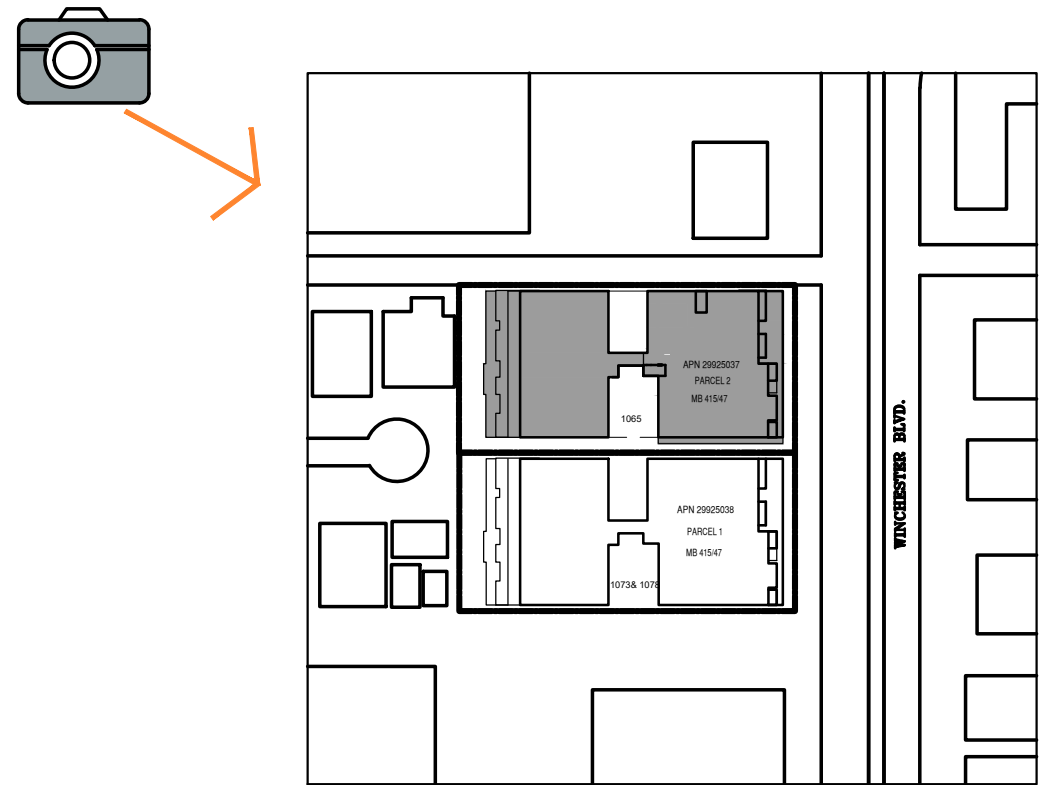

AFTER

REVISIONS

△ REV.1	06/14/2021
△	
△	
△	
△	
△	
△	
△	
△	
△	
△	

OWNER

A & Z DEVELOPMENT
2881 Hemlock Ave. San Jose
TEL: (408) 921-1882
Dradamaskari@GMAIL.COM

CIVIL ENGINEER



3350 Scott Blvd., Bldg. 22,
Santa Clara, CA 95054
TEL: (408) 727-6665
(408) 591-8801
www.kierwright.com

LANDSCAPE DESIGNER

SHILA YASMEH
628 N. MAPLE DR.
BEVERLY HILLS - CA 90210
SHILA.YASMEH@GMAIL.COM
TEL: (650) 492-3249

REVISIONS

△	REV.1	06/14/2021
△		
△		
△		
△		
△		
△		
△		
△		
△		
△		
△		
△		
△		
△		

SHADOW STUDY

027-A



1 SPRING 8 AM

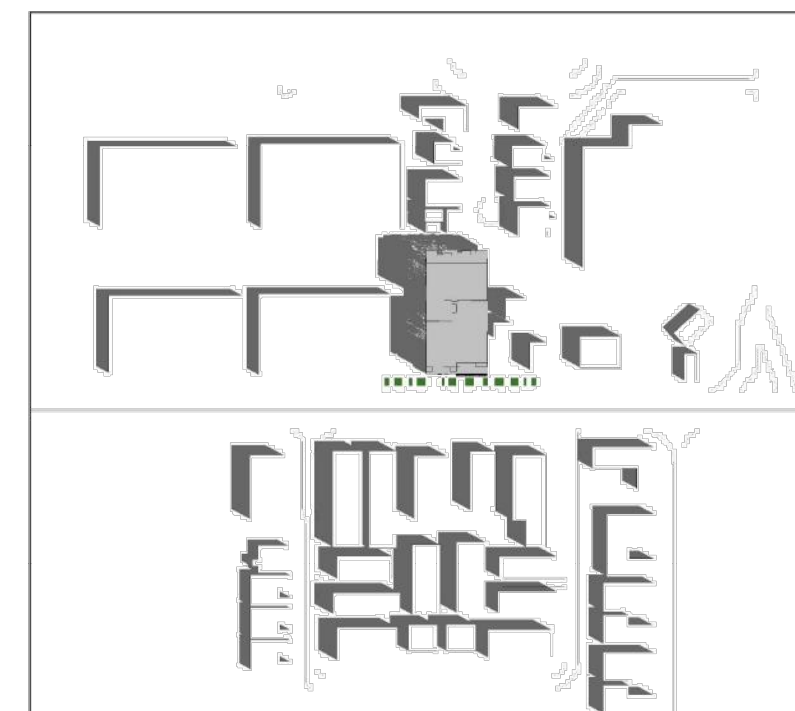

2 SPRING 10 AM

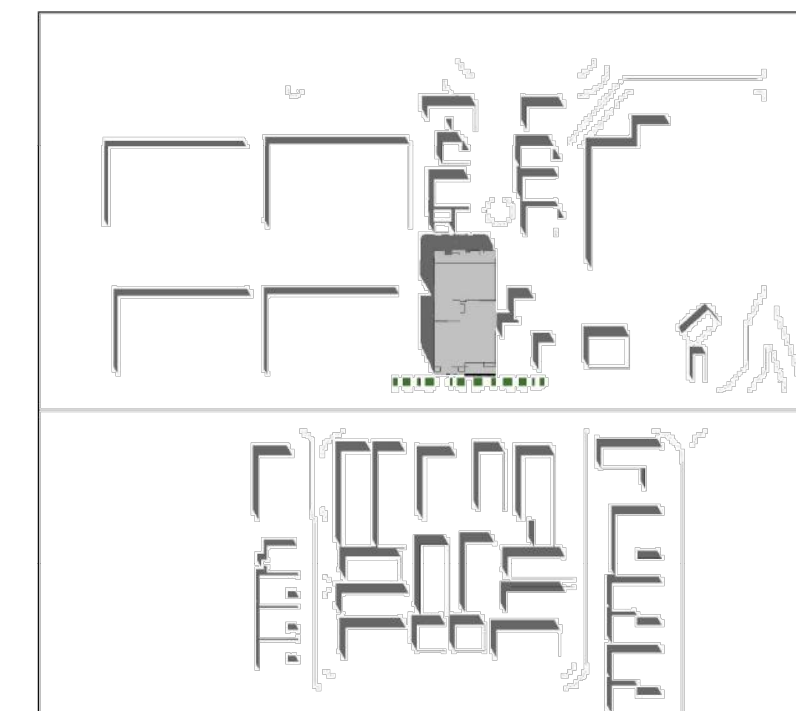

3 SPRING 12 PM



4 SPRING 2 PM

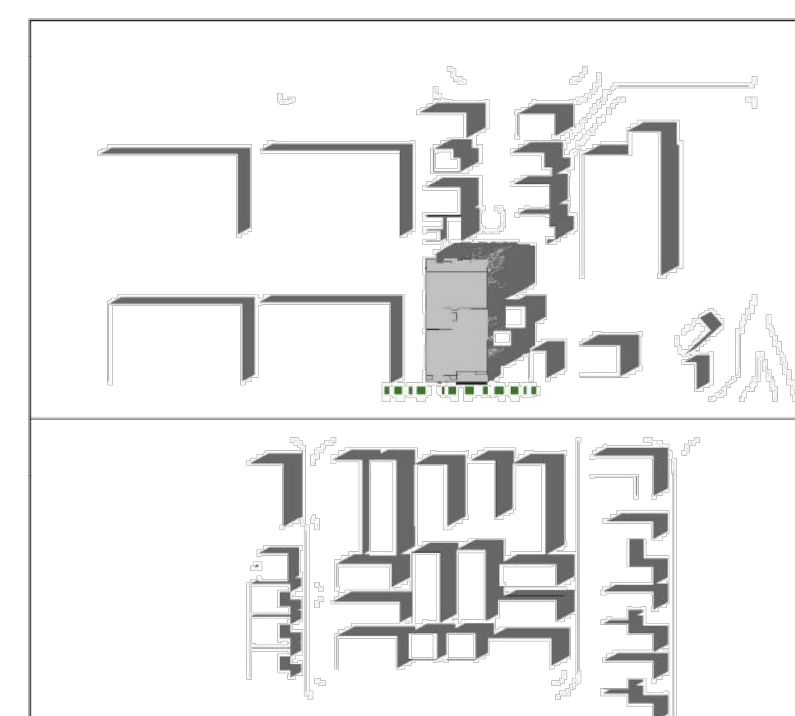

5 SPRING 4:30 AM

SPRING



1 SUMMER 8 AM



2 SUMMER 10 AM



3 SUMMER 12 PM

SUMMER



4 SUMMER 2 PM



5 SUMMER 4:30 AM

OWNER

A & Z DEVELOPMENT
2881 Hemlock Ave. San Jose
TEL: (408) 921-1882
Dradamaskari@GMAIL.COM

CIVIL ENGINEER



3350 Scott Blvd., Bldg. 22,
Santa Clara, CA 95054
TEL: (408) 727-6665
(408) 591-8801
www.kierwright.com

LANDSCAPE DESIGNER

SHILA YASMEH
628 N. MAPLE DR.
BEVERLY HILLS - CA 90210
SHILA.YASMEH@GMAIL.COM
TEL : (650) 492-3249

REVISIONS

△	REV.1	06/14/2021
△		
△		
△		
△		
△		
△		
△		
△		
△		
△		
△		
△		
△		
△		
△		
△		
△		
△		

SHADOW STUDY

028-A

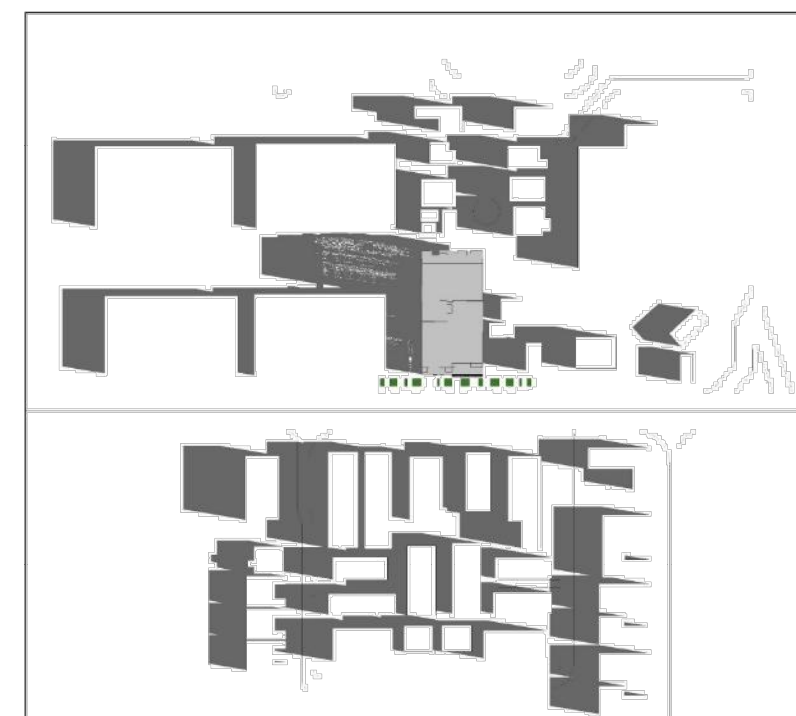

① AUTUMN 8 AM →



② AUTUMN 10 AM →

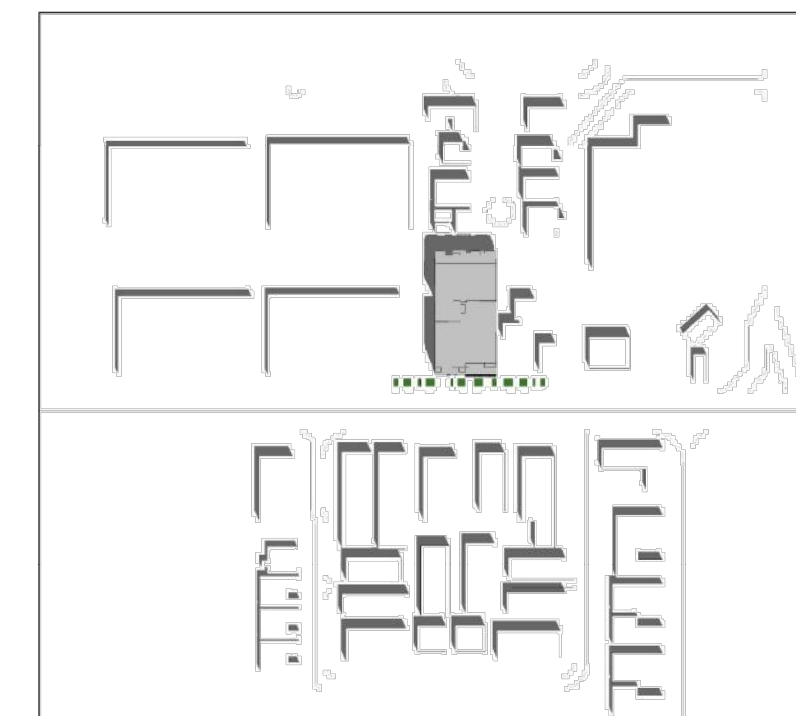

③ AUTUMN 12 PM →

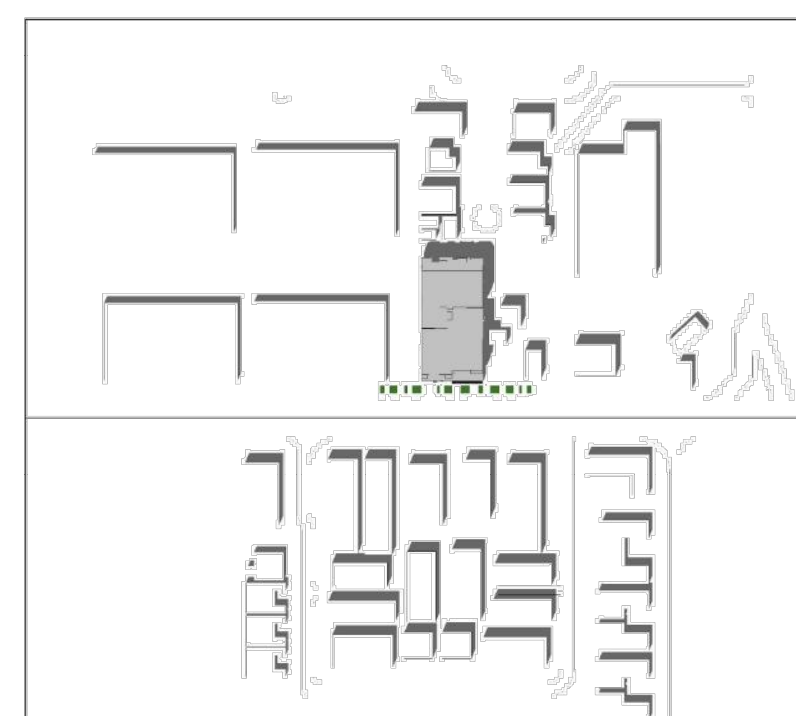

④ AUTUMN 2 PM →

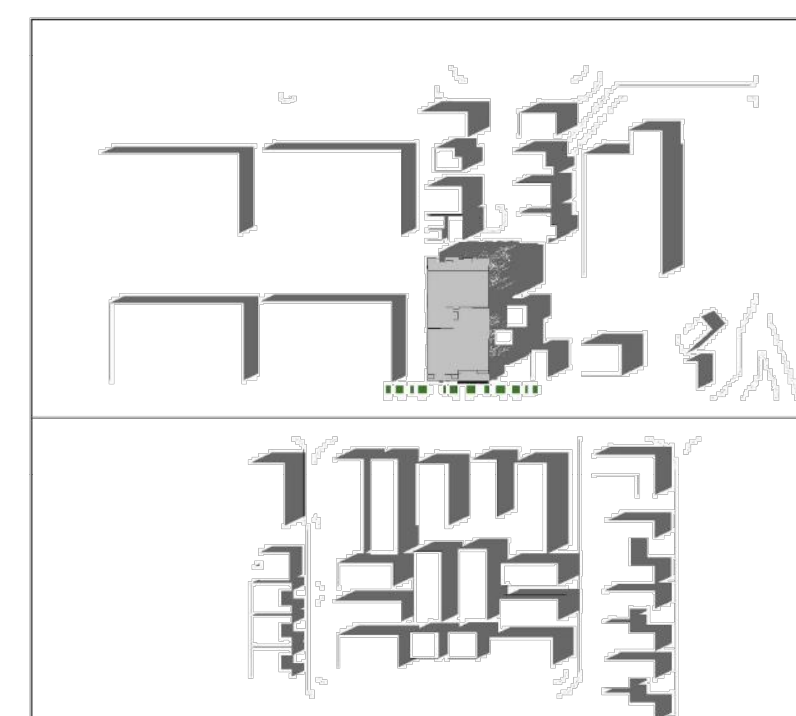

⑤ AUTUMN 4:30 AM →

AUTUMN



① WINTER 8 AM →

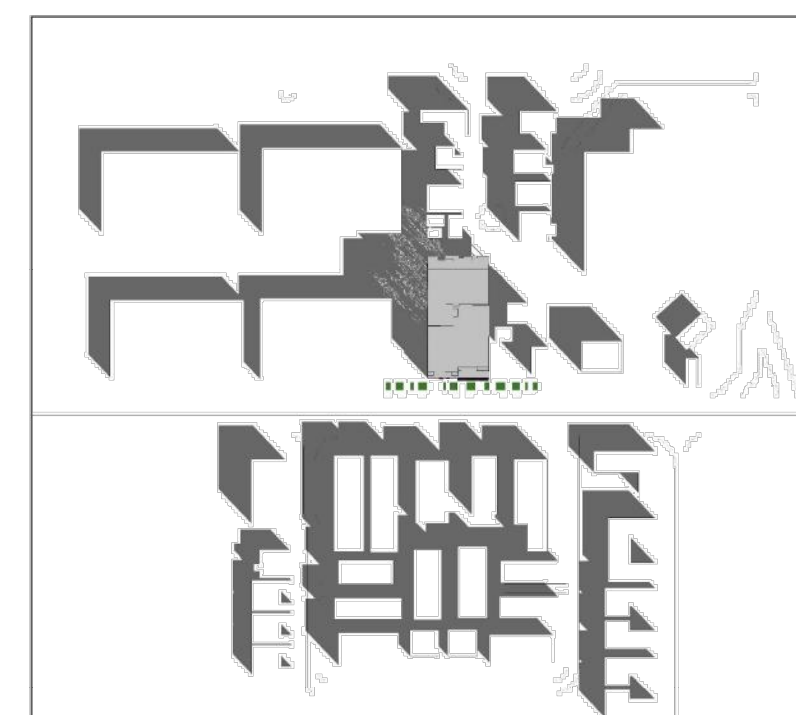

② WINTER 10 AM →

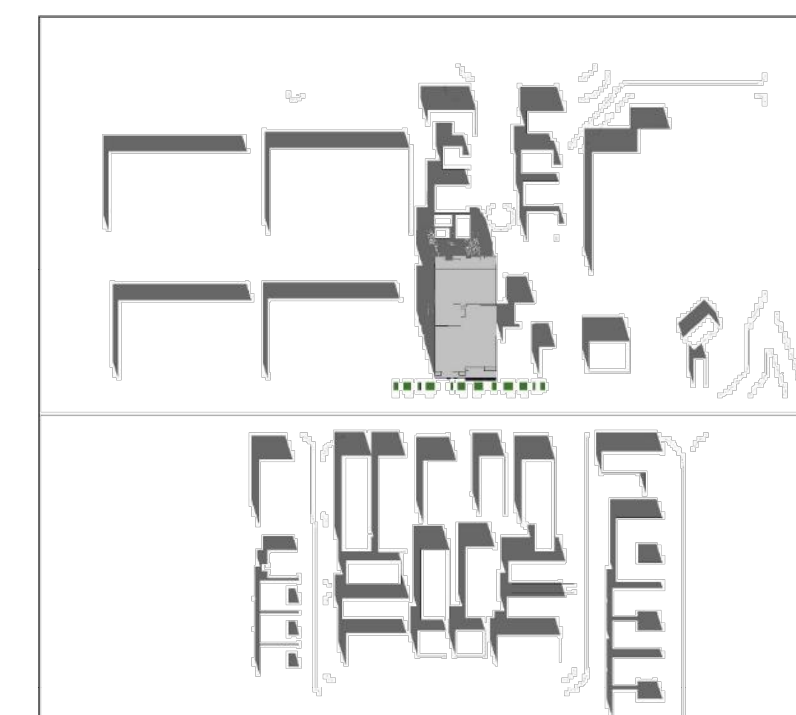

③ WINTER 12 PM →

WINTER



④ WINTER 2 PM →

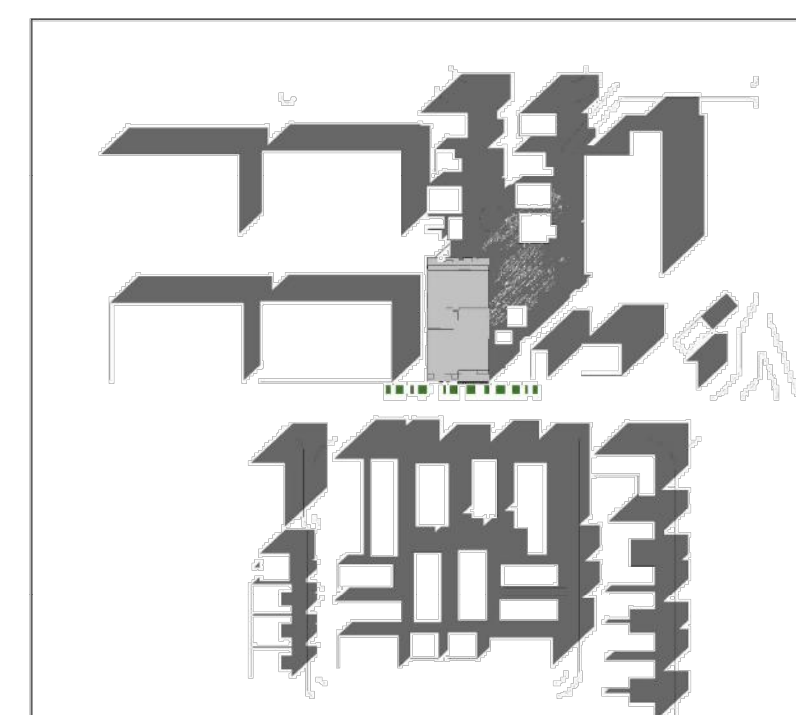

⑤ WINTER 4:30 AM →

OWNER

A & Z DEVELOPMENT
2881 Hemlock Ave. San Jose
TEL: (408) 921-1882
Dradamaskari@GMAIL.COM

CIVIL ENGINEER

3350 Scott Blvd., Bldg. 22,
Santa Clara, CA 95054
TEL: (408) 727-6665
(408) 591-8801
www.kierwright.com

LANDSCAPE DESIGNER

SHILA YASMEH
628 N. MAPLE DR.
BEVERLY HILLS - CA 90210
SHILA.YASMEH@GMAIL.COM
TEL: (650) 492-3249

REVISIONS

REV.	DATE
REV.1	06/14/2021

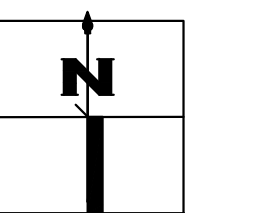

SCALE : 1/32" = 1'-0"

OPEN SPACE
STUDY

029-A

SP 21 - 006

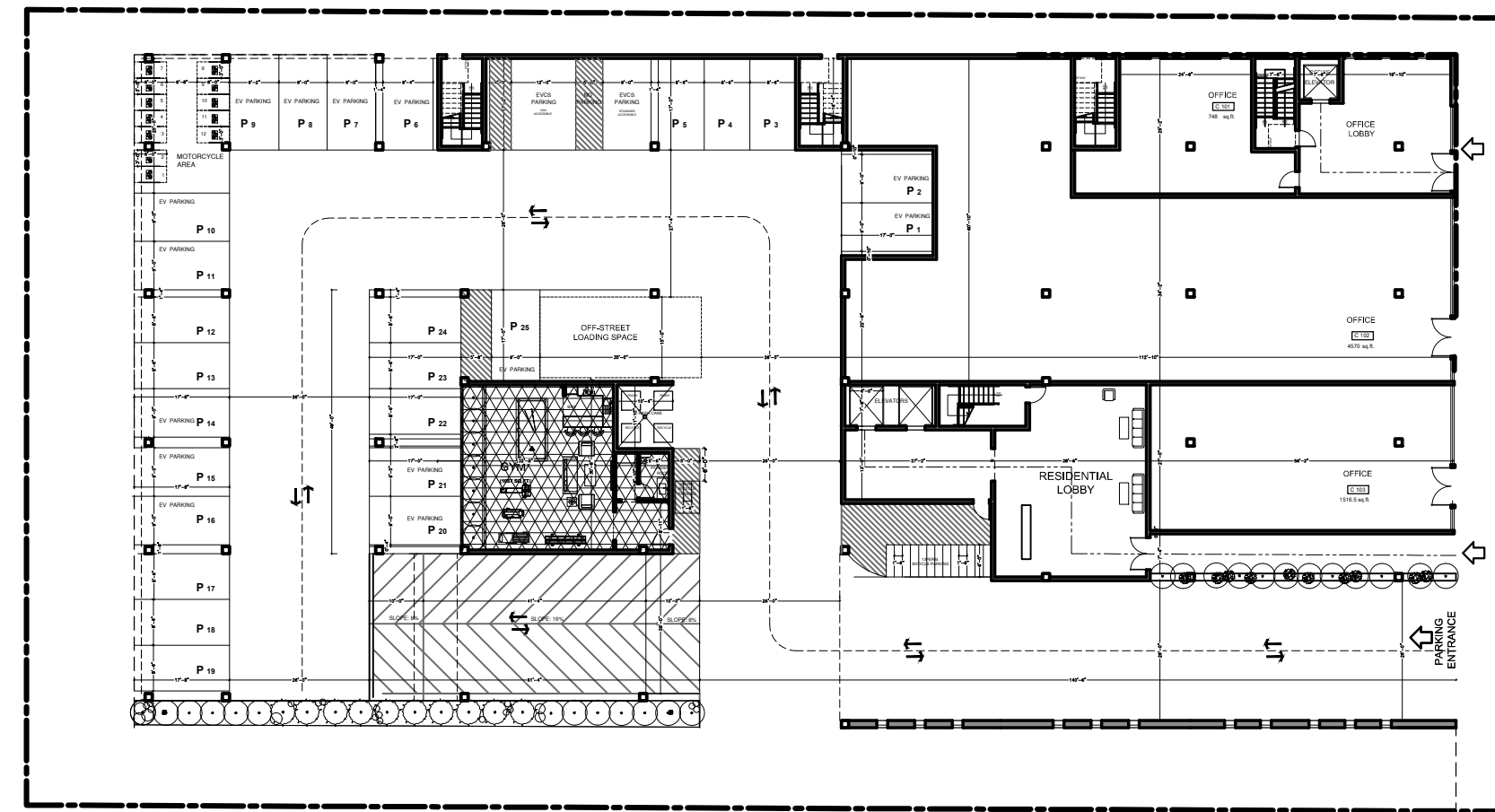

FIRST FLOOR PLAN

PRIVATE OPEN SPACE 1057.0 sq.ft.
COMMON OPEN SPACE

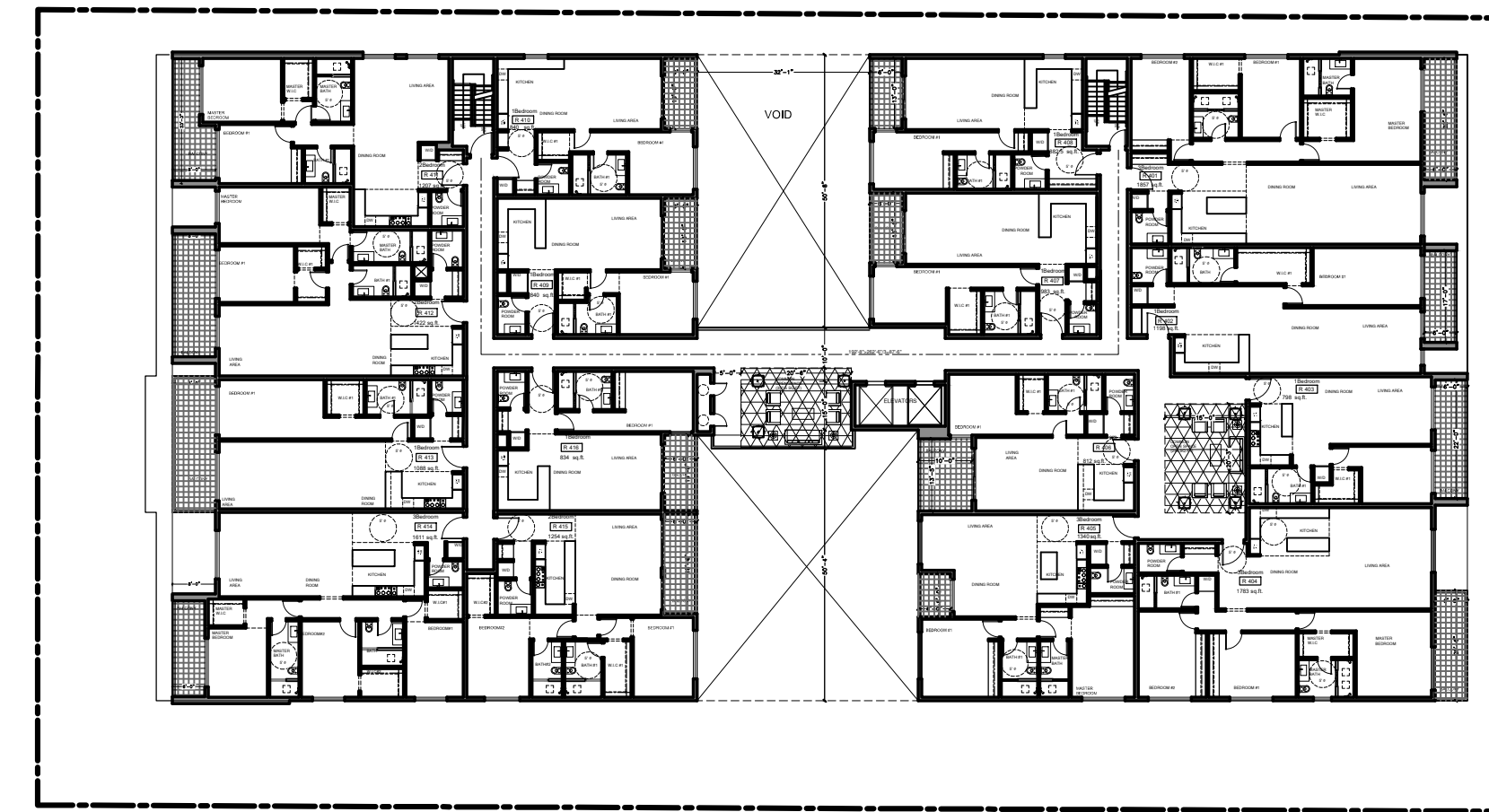

4TH FLOOR PLAN

PRIVATE OPEN SPACE 1694.0 sq.ft.
COMMON OPEN SPACE 611.25 sq.ft.

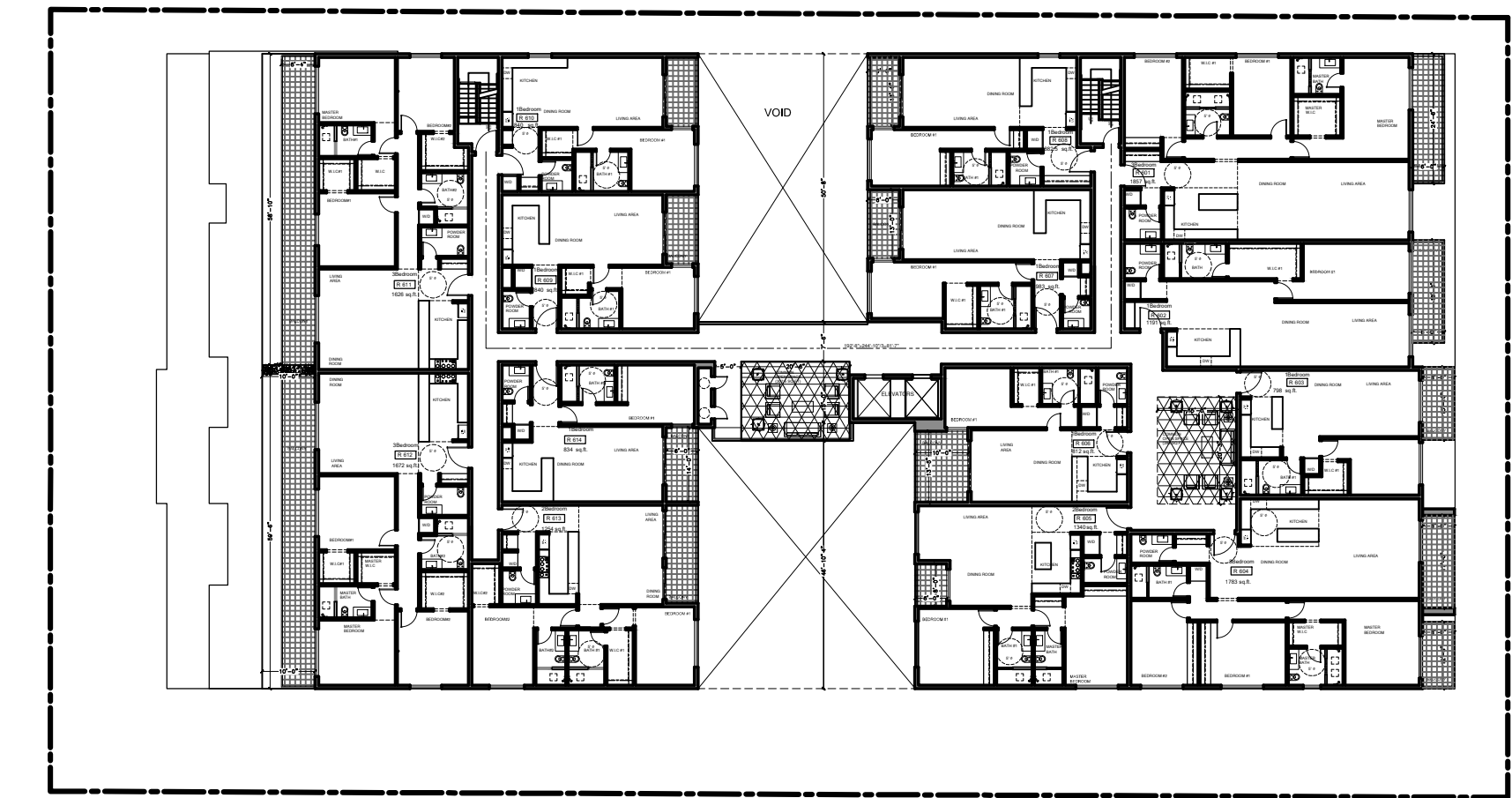

6TH FLOOR PLAN

PRIVATE OPEN SPACE 1944 sq.ft.
COMMON OPEN SPACE 611.25 sq.ft.

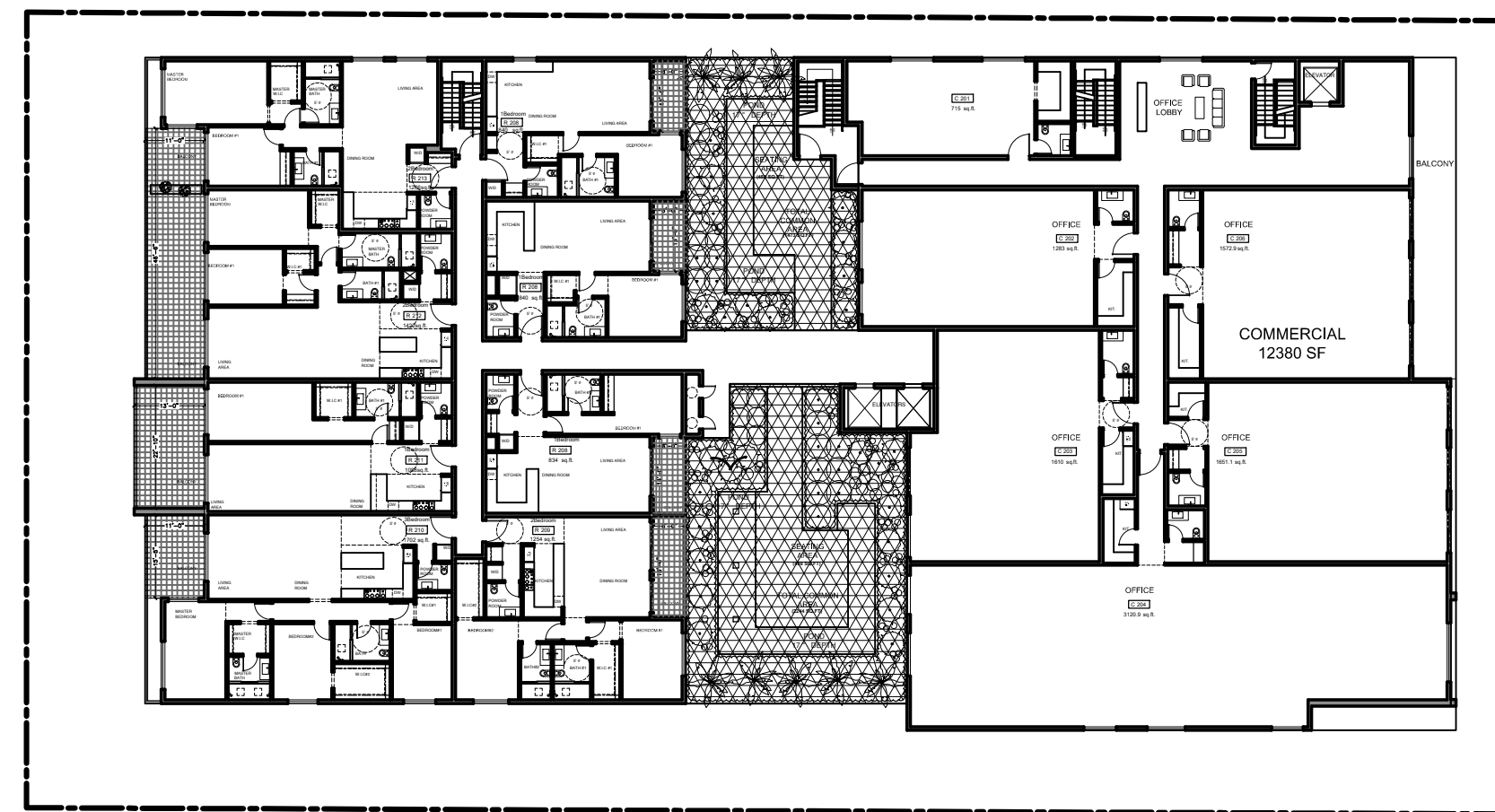

2ND FLOOR PLAN

PRIVATE OPEN SPACE 1329 sq.ft.
COMMON OPEN SPACE 3610 sq.ft.

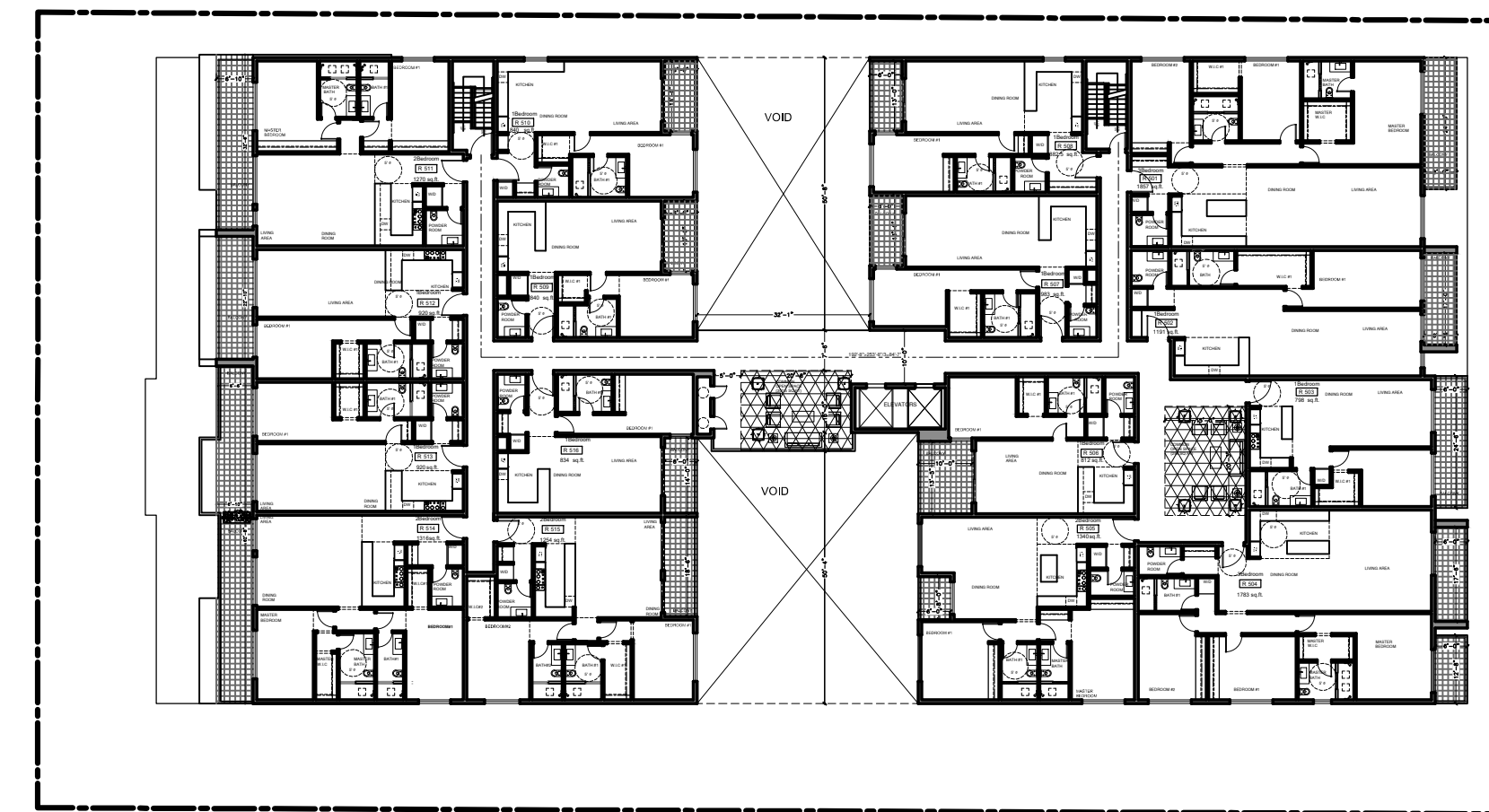

5TH FLOOR PLAN

PRIVATE OPEN SPACE 2063 sq.ft.
COMMON OPEN SPACE 611.25 sq.ft.

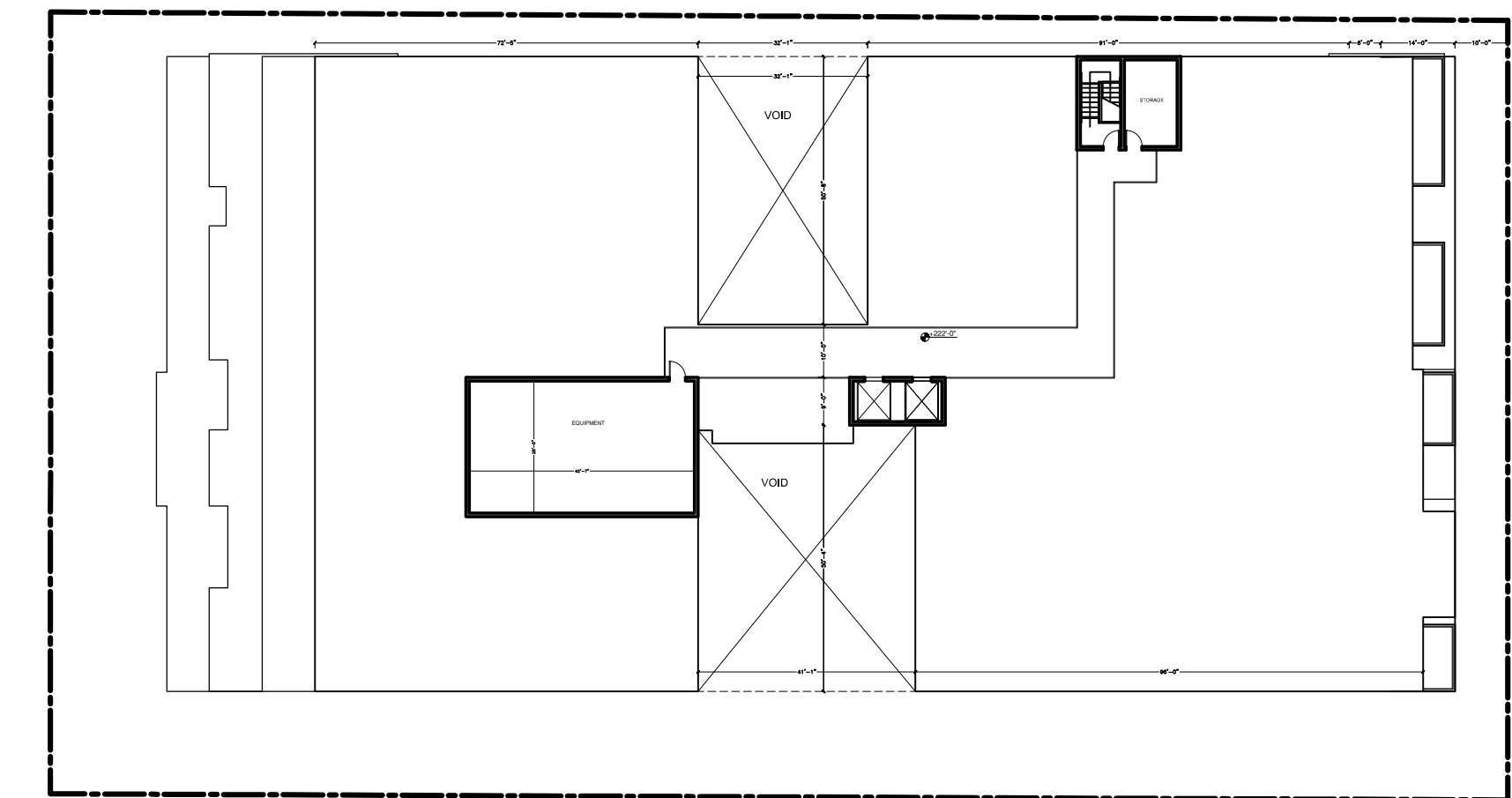

ROOF PLAN

PRIVATE OPEN SPACE
COMMON OPEN SPACE

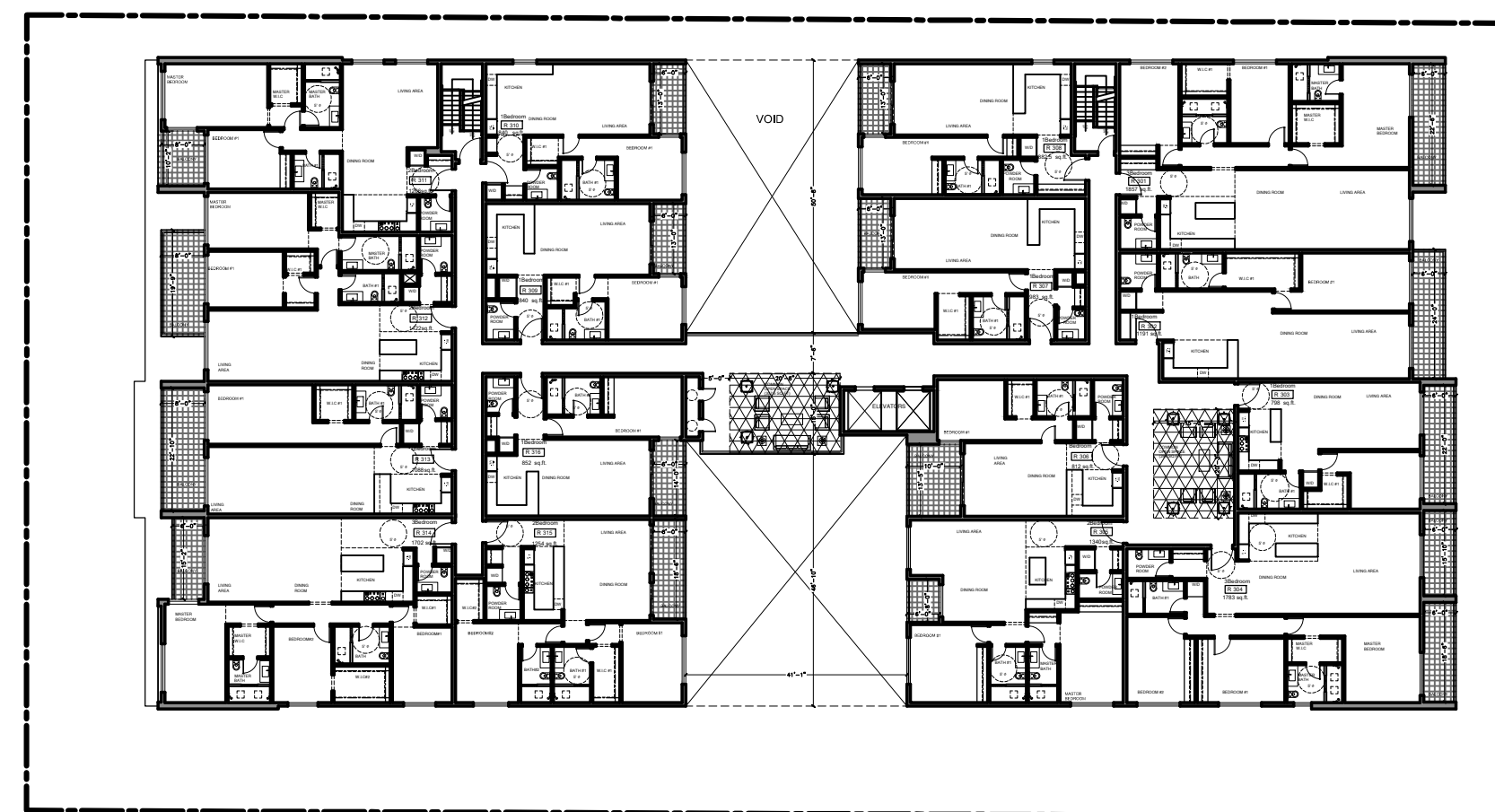

3RD FLOOR PLAN

PRIVATE OPEN SPACE 1825 sq.ft.
COMMON OPEN SPACE 611.25 sq.ft.

COMMON AREA TABLE (70 UNITS RESIDENTIAL)

	RATIO	UNITS	REQUIRED	PROVIDED
PRIVATE OPEN SPACE	60 sq.ft. PER 1 UNIT	70	4200 sq.ft.	8855.0 sq.ft.
COMMON OPEN SPACE	100 sq.ft. PER 1 UNIT	70	7000 sq.ft.	7112.0 sq.ft.
UNITS WITH PRIVATE OPEN SPACE = 70				

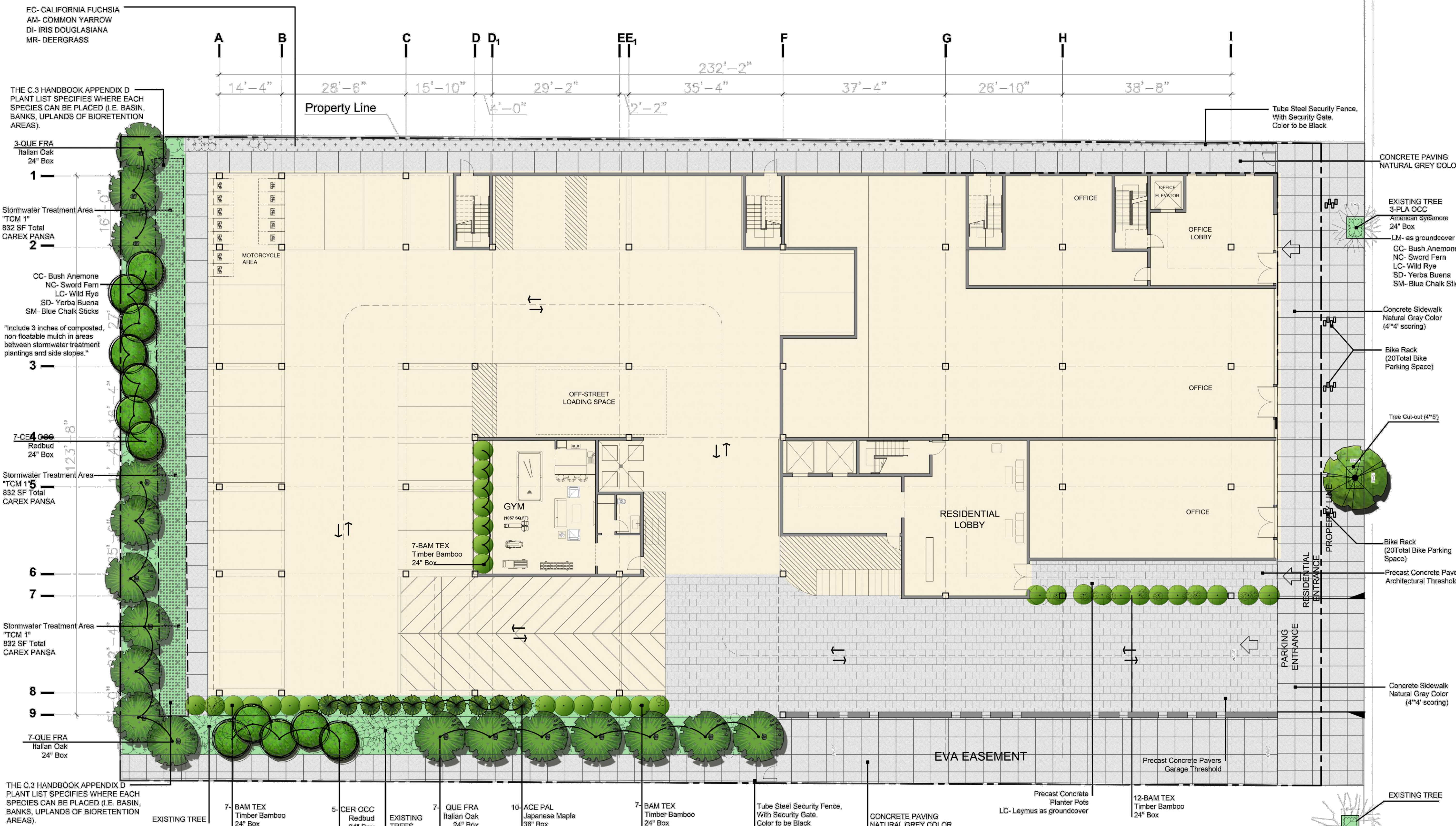

EC- CALIFORNIA FUCHSIA
AM- COMMON YARROW
DI- IRIS DOUGLASIANA
MR- DEERGRASS

THE C.3 HANDBOOK APPENDIX D
PLANT LIST SPECIFIES WHERE EACH
SPECIES CAN BE PLACED (I.E. BASIN,
BANKS, UPLANDS OF BIORETENTION
AREAS).

3-QUE FRA
Italian Oak
24" Box

Stormwater Treatment Area
"TCM 1"
832 SF Total
CAREX PANSA

CC- Bush Anemone
NC- Sword Fern
LC- Wild Rye
SD- Yerba Buena
SM- Blue Chalk Sticks

"Include 3 inches of composted,
non-floatable mulch in areas
between stormwater treatment
plantings and side slopes."

7-CER OCC
Redbud
24" Box

Stormwater Treatment Area
"TCM 1"
832 SF Total
CAREX PANSA

7-BAM TEX
Timber Bamboo
24" Box

Stormwater Treatment Area
"TCM 1"
832 SF Total
CAREX PANSA

7-QUE FRA
Italian Oak
24" Box

Stormwater Treatment Area
"TCM 1"
832 SF Total
CAREX PANSA

7-QUE FRA
Italian Oak
24" Box

Stormwater Treatment Area
"TCM 1"
832 SF Total
CAREX PANSA

7-QUE FRA
Italian Oak
24" Box

Stormwater Treatment Area
"TCM 1"
832 SF Total
CAREX PANSA

7-QUE FRA
Italian Oak
24" Box

Stormwater Treatment Area
"TCM 1"
832 SF Total
CAREX PANSA

7-QUE FRA
Italian Oak
24" Box

Stormwater Treatment Area
"TCM 1"
832 SF Total
CAREX PANSA

7-QUE FRA
Italian Oak
24" Box

THE C.3 HANDBOOK APPENDIX D
PLANT LIST SPECIFIES WHERE EACH
SPECIES CAN BE PLACED (I.E. BASIN,
BANKS, UPLANDS OF BIORETENTION
AREAS).

EXISTING TREE

7- BAM TEX
Timber Bamboo
24" Box

5-CER OCC
Redbud
24" Box

EXISTING TREES

7- QUE FRA
Italian Oak
24" Box

10- ACE PAL
Japanese Maple
36" Box

7- BAM TEX
Timber Bamboo
24" Box

Tube Steel Security Fence,
With Security Gate.
Color to be Black

CONCRETE PAVING
NATURAL GREY COLOR

Precast Concrete
Planter Pots
LC- Leymus as groundcover

12-BAM TEX
Timber Bamboo
24" Box

EXISTING TREE

Tree Cut-out (4"x5")



CAREX PANSA

* Flow-Through Planter Boxes can only accept "basin" planting zone species since they do not have bank or upland planting zones.

** "Project will not locate trees within the basin or bank planting zones of Bioretention Areas, per Appendix D of the SCVURP PP C. 3 Stormwater Handbook. Trees will also not be located directly in line with or next to stormwater inlets (curb openings, bubble box emitters, etc.) and will offset or relocate trees where necessary outside of the Bioretention Area basin and bank planting zones to maximize runoff dispersal throughout Bioretention Areas."

*** "Street trees shown in the public right-of-way are for information only. The Planning Permit does not authorize the installation or removal of trees in the public right of way. Actual street tree location will be determined by Public Works at the implementation stage on the Public Improvement plan. The installation or removal of the street trees requires a permit from the Department of Transportation. The City Arborist will specify the species."

OWNER

A & Z DEVELOPMENT
2881 Hemlock Ave. San Jose
TEL: (408) 921-1882
Dradamaskari@GMAIL.COM

CIVIL ENGINEER

 KIER+WRIGHT
3350 Scott Blvd., Bldg. 22,
Santa Clara, CA 95054
TEL: (408) 727-6665
(408) 591-8801
www.kierwright.com

LANDSCAPE DESIGNER

SHILA YASMEH
628 N. MAPLE DR.
BEVERLY HILLS - CA 90210
SHILA.YASMEH@GMAIL.COM
TEL: (650) 492-3249

REVISIONS

REV.1	06/14/2021

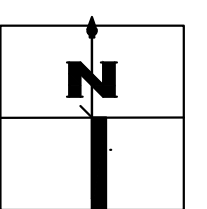

SCALE : 3/32" = 1'-0"

SECOND FLOOR
LANDSCAPE PLAN

031-L

SP 21 - 006

CC- Bush Anemone
NC- Sword Fern
LC- Wild Rye
SD- Yerba Buena
SM- Blue Chalk Sticks

3- SYA ROM
Syagrus romanzoffiana
18' trunk ht.

3- ACE PAL
Japanese Maple
36" Box

4- ARB MAR
Arbutus marina
24" Box

5- ARB MAR
Arbutus marina
24" Box

4- BAM TEX
Timber Bamboo
24" Box

4- ACE PAL
Japanese Maple
36" Box

9- BAM TEX
Timber Bamboo
24" Box

5- ARB MAR
Arbutus marina
24" Box

5- ACE PAL
Japanese Maple
36" Box

8- ARB MAR
Arbutus marina
24" Box

5- SYA ROM
Syagrus romanzoffiana
18' trunk ht.

7- ARB MAR
Arbutus marina
24" Box

3- ACE PAL
Japanese Maple
36" Box

- Architectural Guardrail
- Outdoor Sofa Seating and Table
- Slat Wood Decking on Podium
- (3) Bollard Lights

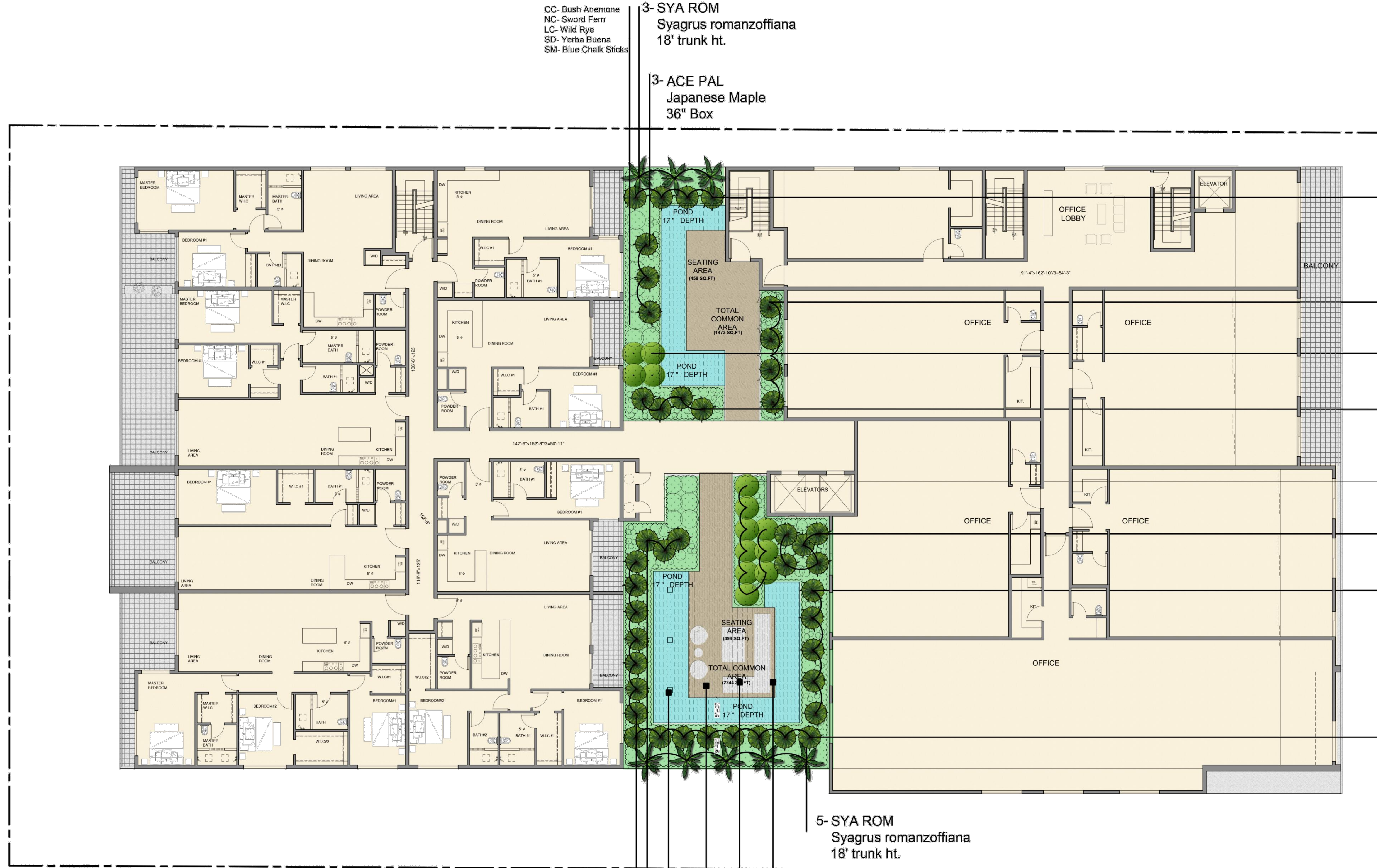

OWNER

A & Z DEVELOPMENT
2881 Hemlock Ave. San Jose
TEL: (408) 921-1882
Dradamaskari@GMAIL.COM

CIVIL ENGINEER



3350 Scott Blvd., Bldg. 22,
Santa Clara, CA 95054
TEL: (408) 727-6665
(408) 591-8801
www.kierwright.com

LANDSCAPE DESIGNER

SHILA YASMEH
628 N. MAPLE DR.
BEVERLY HILLS - CA 90210
SHILA.YASMEH@GMAIL.COM
TEL: (650) 492-3249

REVISIONS

REV.1 06/14/2021

PLANTING IMAGERY

032-L

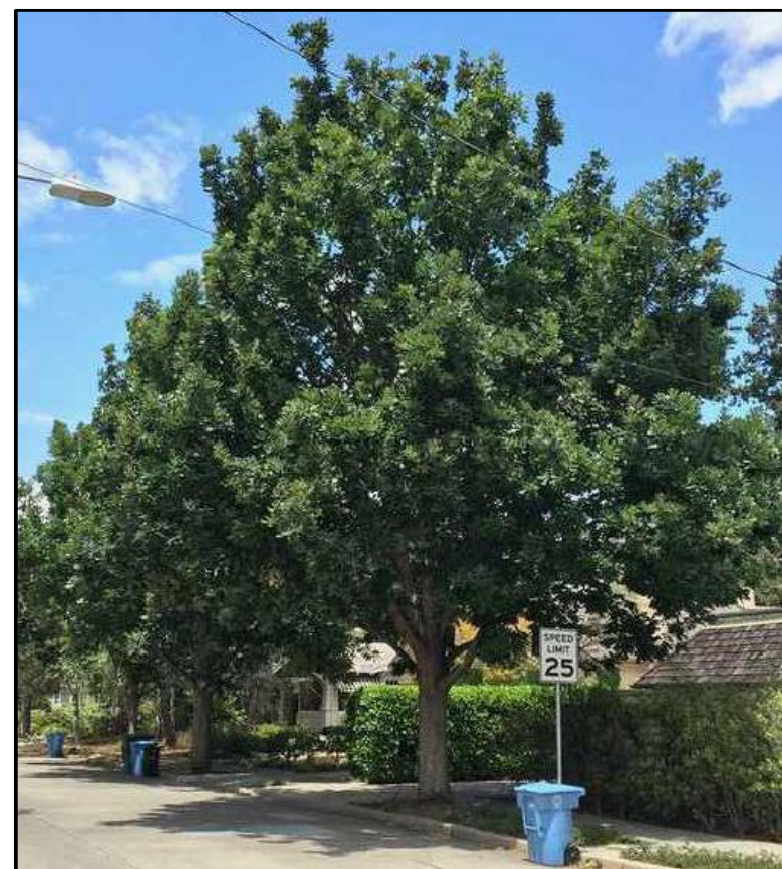

1



2



3



4

NOTE:
THE ABOVE PLANTS HAVE BEEN SELECTED AS BEING REPRESENTATIVE OF THE OVERALL PLANTING DESIGN INTENT. THIS PLANT PALETTE IS BEING SUGGESTED FOR USE, BUT SHOULD NOT PRECLUDE USE OF OTHER APPROPRIATE PLANT MATERIAL. OTHER COMPATIBLE VARIETIES OF TREES, SHRUBS AND GROUND COVERS SHOULD BE SELECTED TO COMPLEMENT THE CHARACTER OF THE PROJECT.



5



6



7

TREES						COMMENTS/ SPACING	CALIFORNIA NATIVE	WUCOLS RATING
KEY	SIZE	BOTANICAL NAME	COMMON NAME	QUANTITY				
1	QUE FRA	24" BOX	QUERCUS FRAINETTO	ITALIAN OAK	17			
2	CER OCC	24" BOX	CERCIS OCCIDENTALIS	WESTERN REDBUD	12		NATIVE	
3	SYA ROM	18' Trunk	SYAGRUS ROMANZOFFIANA	QUEEN PALM	8		NATIVE	MEDIUM
4	BAM TEX	15 GAL	BAMBUSA 'TEXTILIS'	TIMBER BAMBOO	46			
5	ACE PLA	36" BOX	ACER PALMATUM	JAPANESE MAPLE	25			
6	MAR ARB	24" BOX	ARBUTUS U 'MARINA'	STRAWBERRY TREE	29	MULTI		
7	PLA OCC	24" BOX	PLATANUS OCCIDENTALIS	AMERICAN SYCAMORE	3			

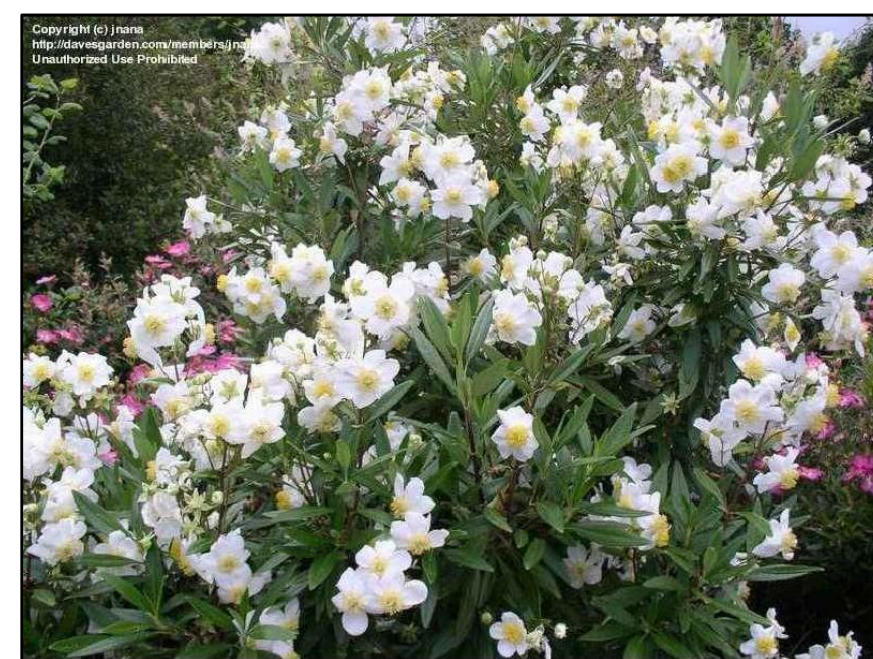
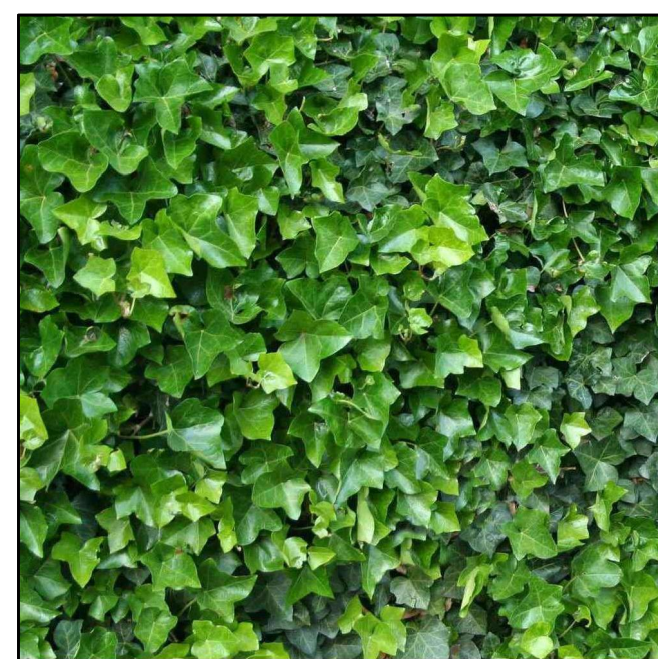

SHURBS						
KEY	SIZE	BOTANICAL NAME	COMMON NAME	COMMENTS/ SPACING	CALIFORNIA NATIVE	WUCOLS RATING
CP	1 GAL	CAREX PANSA	SAND DUNE SEDGE		NATIVE	LOW
NC	1 GAL	NEPHROLEPIS CORDIFOLIA	SWORD FERN			
CC	5 GAL	CARPENTERIA CALIFORNICA	BUSH ANEMONE		NATIVE	LOW
RT	5 GAL	ROSEMARINUS OFFICIANALIS 'TUSCAN BLUE'	TUSCAN BLUE ROSEMARY			
AM		ACHILLEA MILLEFOLIUM	COMMON YARROW			LOW
EC	1 GAL	EPILOBIUM CANUM	CALIFORNIA FUCHSIA			VERY LOW
DI	1 GAL	DOUGLAS IRIS	IRIS DOUGLASIANA		NATIVE	LOW
GRASSES						
LC	1 GAL	LEYMUS CONDENSATUS	CANYON PRINCE WILD RYE			
JP	1 GAL	JUNCUS PATENS	CALIFORNIA GRAY RUSH	18" O.C.	NATIVE	LOW
MR	1 GAL	MUHLENBERGIA RIGENS	DEERGRASS			LOW
GROUND COVER						
SD	1 GAL	SATUREJA DOUGLASII	YERBA BUENA			
SM	1 GAL	SENECIO MANDRALISCAE	BLUE CHALK STICKS			
VINES						
BO	1 GAL	BOUGANVILLEA 'CALIFORNIA GOLD'	BOUGANVILLEA			
CC	1 GAL	CLYTOSTOMA CALESTOIGES	TRUMPET VINE			

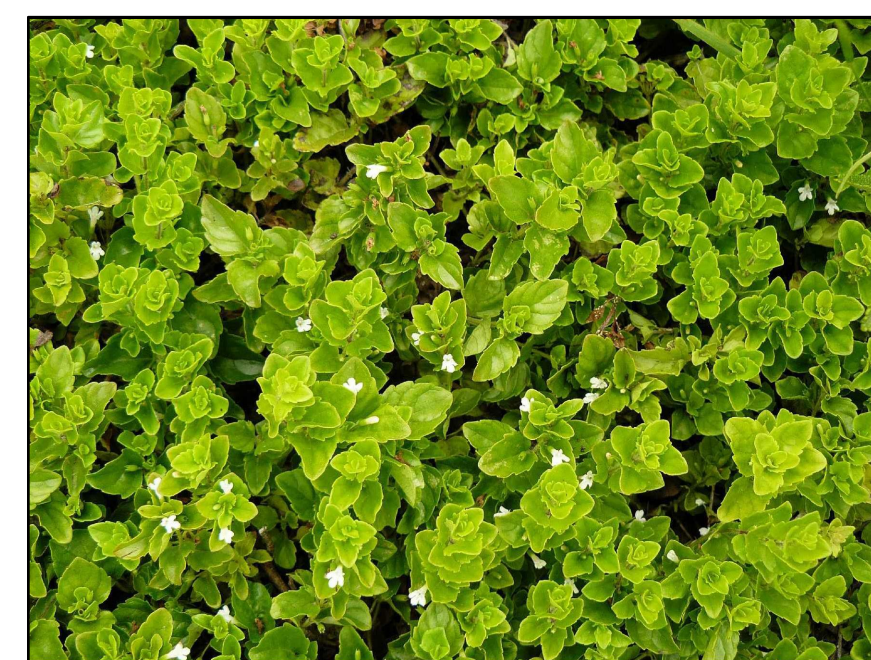

*5 GALLON UNLESS NOTED OTHERWISE

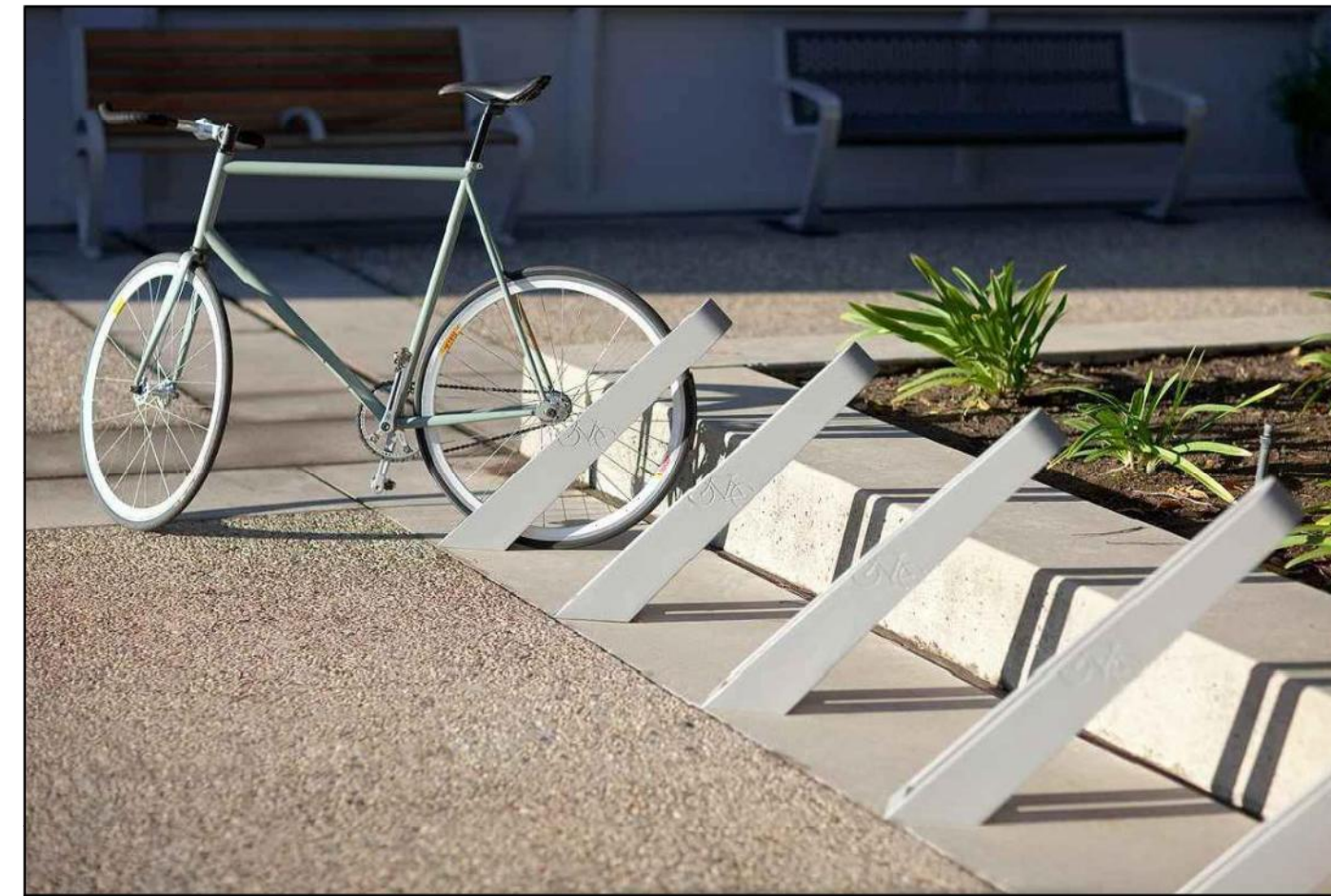

CARPIRA DESIGN GROUP PC OMPANY

CARPIRA DESIGN GROUP

30025 ALICIA PKWY
LAGUNA NIGUEL - CA 92677
TEL: (310) 795-4009
SAMCARPIRA@GMAIL.COM

OWNER

A & Z DEVELOPMENT
2881 Hemlock Ave. San Jose
TEL: (408) 921-1882
Dradamaskari@GMAIL.COM

CIVIL ENGINEER



3350 Scott Blvd., Bldg. 22,
Santa Clara, CA 95054
TEL: (408) 727-6665
(408) 591-8801
www.kierwright.com

LANDSCAPE DESIGNER

SHILA YASMEH
628 N. MAPLE DR.
BEVERLY HILLS - CA 90210
SHILA.YASMEH@GMAIL.COM
TEL : (650) 492-3249

REVISIONS

△	REV.1	06/14/2021
△		
△		
△		
△		
△		
△		
△		
△		

**PROPOSED
SITE IMAGERY**

033-L

FILE NAME: 19065 WINCHESTER CONDOMINIUM_06_14_2021_REV.1

SP 21 - 006

OWNER

A & Z DEVELOPMENT
2881 Hemlock Ave. San Jose
TEL: (408) 921-1882
Dradamaskari@GMAIL.COM

CIVIL ENGINEER



3350 Scott Blvd., Bldg. 22,
Santa Clara, CA 95054
TEL: (408) 727-6665
(408) 591-8801
www.kierwright.com

LANDSCAPE DESIGNER

SHILA YASMEH
628 N. MAPLE DR.
BEVERLY HILLS - CA 90210
SHILA.YASMEH@GMAIL.COM
TEL: (650) 492-3249

REVISIONS

REV.1 06/14/2021

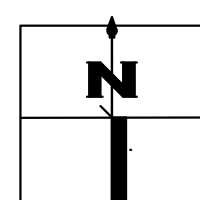

SCALE : 1/192" = 1'-0"

**TREE
DISPOSITION**

034-L

SP 21 - 006

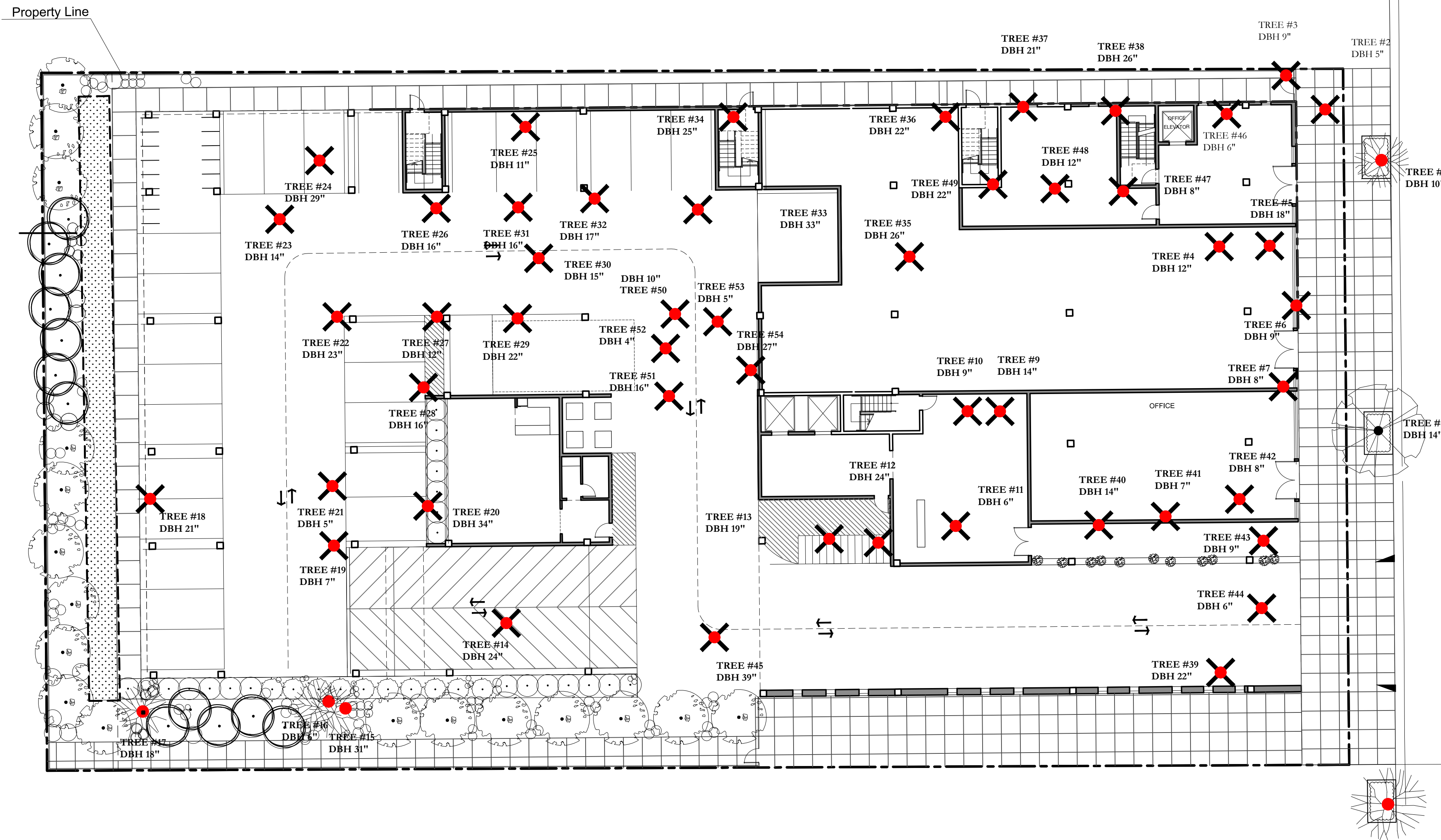

160

TREE MITIGATION ANALYSIS/ PROGRAM

Using the chart below, there are a total of 156 mitigation trees required.

3-Native 38"+ trees	15
2-Native 19"-38" trees	6
3-Native <19" trees	3
27-Non-Native 38"+ trees	108
10-Non-Native 19"-38" trees	20
4-Non-Native<19" trees	4
Mitigation Requirement	156

The project proposes 140 new trees total, meeting the mitigation requirement.

Tree Replacement Ratios

Circumference of Tree to be Removed	Type of Tree to be Removed			Minimum Size of Each Replacement Tree
	Native	Non-Native	Orchard	
38 inches or more	5:1	4:1	3:1	15-gallon
19 to 38 inches	3:1	2:1	None	15-gallon
Less than 19" inches	1:1	1:1	None	15-gallon

xx = tree replacement to tree loss ratio
Note: Trees greater than or equal to 38-inch circumference shall not be removed unless a Tree Removal Permit, or equivalent, has been approved for the removal of such trees. For Multi-Family residential, Commercial and Industrial properties, a permit is required for removal of trees of any size.
A 38-inch tree equals 12.1 inches in diameter.
A 24-inch box tree = two 15-gallon trees
Single Family and Two-dwelling properties may be mitigated at a 1:1 ratio.

TREE DISPOSITION LEGEND

- EXISTING TREE TO REMAIN
- EXISTING TREE TO BE REMOVED
- TREE #N TREE NUMBER PER ARBORIST REPORT
- PROPOSED TREE

TREE NO.	BOTANICAL NAME	CALIFORNIA Native	DBH (at 54" above grade)	Tree Health (1 to 5)	Tree Height (Feet)	REMAIN
1	Platanus racemosa	Native	10"	4	35	REMAIN
2	Prunus spp		5"	3	6	REMOVED
3	Prunus spp		9"	3	9	REMOVED
4	Citrus X sinensis		12"	3	12	REMOVED
5	Olea europaea		18"	3	20	REMOVED
6	Picea spp		9"	3	20	REMOVED
7	Celtis occidentalis	Native	8"	3	10	REMOVED
8	Platanus racemosa	Native	14"	4	35	REMAIN
9	Eriobotrya japonica		14"	3	25	REMOVED
10	Citrus X limon		9"	3	16	REMOVED
11	Aesculus californica	Native	6"	3	8	REMOVED
12	Prunus serotina		24"	3	35	REMOVED
13	Prunus serotina		19"	3	25	REMOVED
14	Prunus serotina		24"	2	25	REMOVED
15	Prunus serotina		31"	2	30	REMAIN
16	Quercus agrifolia	Native	6"	3	11	REMAIN
17	Prunus serotina		18"	2	15	REMAIN
18	Prunus serotina		21"	2	13	REMOVED
19	Prunus serotina		7"	2	7	REMOVED
20	Prunus serotina		34"	2	16	REMOVED

TREE NO.	BOTANICAL NAME	CALIFORNIA Native	DBH (at 54" above grade)	Tree Health (1 to 5)	Tree Height (Feet)	REMOVED
21	Prunus serotina		5"	2	9	REMOVED
22	Prunus serotina		23"	2	8	REMOVED
23	Prunus serotina		14"	1	5	REMOVED
24	Prunus serotina		29"	2	11	REMOVED
25	Prunus serotina		11"	2	8	REMOVED
26	Prunus serotina		16"	2	12	REMOVED
27	Prunus serotina		12"	2	6	REMOVED
28	Prunus serotina		16"	2	10	REMOVED
29	Prunus serotina		22"	2	30	REMOVED
30	Prunus spp		15"	2	9	REMOVED
31	Prunus spp		16"	2	13	REMOVED
32	Prunus spp		17"	2	13	REMOVED
33	Prunus serotina		33"	2	33	REMOVED
34	Prunus spp		25"	2	12	REMOVED
35	Prunus serotina		26"	2	40	REMOVED
36	Prunus spp		22"	2	13	REMOVED
37	Prunus spp		21"	2	14	REMOVED
38	Prunus spp		26"	2	18	REMOVED
39	Aesculus californica	Native	22"	2	17	REMOVED
40	Prunus spp		14"	3	16	REMOVED

TREE NO.	BOTANICAL NAME	CALIFORNIA Native	DBH (at 54" above grade)	Tree Health (1 to 5)	Tree Height (Feet)	REMOVED
41	Prunus spp		7"	3	7	REMOVED
42	Prunus spp		8"	2	12	REMOVED
43	Prunus spp		9"	2	13	REMOVED
44	Prunus spp		6"	2	14	REMOVED
45	Umbellularia californica	Native	39"	3	40	REMOVED
46	Prunus spp		6"	2	8	REMOVED
47	Citrus X limon		8"	3	22	REMOVED
48	Citrus X sinensis		12"	3	17	REMOVED
49	Prunus spp		22"	2	11	REMOVED
50	Ligustrum lucidum	Native	10"	3	15	REMOVED
51	Ligustrum lucidum	Native	16"	3	15	REMOVED
52	Ligustrum lucidum	Native	4"	3	12	REMOVED
53	Ligustrum lucidum	Native	5"	3	12	REMOVED
54	Prunus serotina		27"	2	25	REMOVED

NOTE : SEE ARBORIST REPORT FOR TREE PROTECTION NOTES

PRELIMINARY SITE IMPROVEMENT PLANS

OF

1065 SOUTH WINCHESTER BOULEVARD

FOR

ADAM ASKARI

SAN JOSE,

CALIFORNIA

GENERAL NOTES

- ALL WORK SHALL BE IN CONFORMANCE WITH THE CITY OF SAN JOSE DEPARTMENT OF PUBLIC WORKS' STANDARD SPECIFICATIONS AND DETAILS. ALL WORK SHALL BE SUBJECT TO APPROVAL OF AND INSPECTION BY THE CITY ENGINEER.
- AT LEAST ONE SET OF APPROVED PLANS SHALL BE ON THE SITE AT ALL TIMES FOR INSPECTION. ANY DEVIATION FROM THE APPROVED PLANS DURING CONSTRUCTION WILL REQUIRE 48 HOURS PRIOR NOTICE AND APPROVAL OF THE CITY ENGINEER.
- THE PERMITTEE/CONTRACTOR SHALL NOTIFY THE CITY OF SAN JOSE ENGINEERING DIVISION TWO (2) BUSINESS DAYS PRIOR TO THE START OF ANY WORK.
- IT SHALL BE THE CONTRACTOR'S RESPONSIBILITY TO ASCERTAIN THE EXISTENCE OF ANY AND ALL UNDERGROUND FACILITIES, WHICH MAY BE SUBJECT TO DAMAGE BY REASON OF HIS OPERATIONS. THE CONTRACTOR SHALL NOTIFY UNDERGROUND SERVICE ALERT (USA) AT (800) 642-2444, 48 HOURS PRIOR TO ANY EXCAVATION. WORK SHALL START WITHIN 5 DAYS AFTER THE ISSUANCE OF A USA INQUIRY IDENTIFICATION NUMBER. COMPLETE REMOVAL OF THE USA MARKINGS SHALL BE WITHIN 2 WORKING DAYS AFTER COMPLETION OF THE EXCAVATION, BACKFILL AND SURFACE REPLACEMENT OR FOURTEEN (14) CALENDAR DAYS FOLLOWING THE ISSUANCE OF THE INQUIRY IDENTIFICATION NUMBER WHICHEVER IS EARLIER.
- CONTACTING USA DOES NOT RELIEVE THE CONTRACTOR FROM HIS RESPONSIBILITY TO DETERMINE LOCATION AND DEPTH OF BURIED UTILITIES OR REPAIR OF BURIED UTILITIES DAMAGED BY HIS OPERATION.
- ALL GRADING, SITE PREPARATION, PLACING AND COMPACTION OF FILL SHALL BE DONE IN ACCORDANCE WITH THE CITY OF SAN JOSE STANDARDS, SPECIFICATIONS, SPECIFIC NOTES, DETAIL DRAWINGS AND PER THE RECOMMENDATIONS SPECIFIED IN THE "GEOTECHNICAL INVESTIGATION".
- A GRADING PERMIT IS REQUIRED PRIOR TO COMMENCEMENT OF GRADING. A COPY OF THE GRADING PERMIT IS REQUIRED TO BE ON SITE AT ALL TIMES.
- GRADING OPERATIONS SHALL BE CONDUCTED IN ACCORDANCE WITH THE RECOMMENDATIONS CONTAINED IN THE SOILS INVESTIGATION REPORT. THE SOILS ENGINEER WILL BE RESPONSIBLE FOR THE ON SITE INSPECTION AND QUALITY CONTROL FOR THE GRADING OPERATION. PLAN REQUIREMENTS AND CONSTRUCTION CONTROL WITH RESPECT TO EARTHWORK, SLOPE STABILITY, SETTLEMENT, COMPACTION, ETC., AS SHOWN HEREIN ARE PROVIDED BY THE SOILS ENGINEER. THE CONTRACTOR SHALL READ AND BE FULLY AWARE OF THE SOILS REPORT BEFORE STARTING WORK. ALL WORK SHALL MEET THE APPROVAL OF THE CITY OF SAN JOSE.
- SUBSEQUENT TO THE COMPLETION OF THE WORK, THE SOILS/GEOTECHNICAL ENGINEER SHALL SUBMIT A REPORT TO THE CITY ENGINEER STATING THAT ALL WORK HAS BEEN DONE IN ACCORDANCE WITH THE "GEOTECHNICAL INVESTIGATION".
- NOISE-PRODUCING CONSTRUCTION AND GRADING OPERATIONS SHALL BE LIMITED TO WEEKDAYS (MONDAY THROUGH FRIDAY) EXCEPT CITY HOLIDAYS AND FROM THE HOURS OF 7:30 A.M. TO 6:00 P.M. ALL EQUIPMENT SHALL BE ADEQUATELY MUFFLED AND MAINTAINED. NO CHANGES SHALL BE ALLOWED WITHOUT PRIOR WRITTEN CONSENT OF THE CITY. ALL REQUESTS FOR CHANGE MUST BE MADE A MINIMUM OF 72 HOURS PRIOR TO THE REQUEST FOR CHANGE.
- IT SHALL BE UNDERSTOOD THAT THE TERM "CITY ENGINEER" AS USED HEREIN IS THE CITY ENGINEER OF THE CITY OF SAN JOSE OR HIS AUTHORIZED REPRESENTATIVE.
- A PRE-CONSTRUCTION CONFERENCE SHALL BE SCHEDULED AT LEAST TWO WORKING DAYS IN ADVANCE OF COMMENCEMENT OF ANY CONSTRUCTION WORK FOR THE IMPROVEMENTS DELINEATED WITHIN THIS SET OF PLANS. THE FOLLOWING INDIVIDUALS SHALL BE IN ATTENDANCE: OWNER/DEVELOPER, CONTRACTOR (S), CITY ENGINEER, ENGINEER, SOILS ENGINEER, CONSTRUCTION INSPECTOR, OR THEIR AUTHORIZED REPRESENTATIVES.
- THE CONTRACTOR SHALL SUBMIT A SCHEDULE OF ALL GRADING OPERATIONS AND RECEIVE APPROVAL OF SAID SCHEDULE FROM THE CITY ENGINEER PRIOR TO OR THE DAY OF THE PRE-CONSTRUCTION CONFERENCE.
- THE CONSTRUCTION CONTRACTOR AGREES, THAT IN ACCORDANCE WITH GENERALLY ACCEPTED CONSTRUCTION PRACTICES, TO ASSUME SOLE AND COMPLETE RESPONSIBILITY FOR THE JOB SITE CONDITIONS DURING THE COURSE OF CONSTRUCTION OF THE PROJECT, INCLUDING SAFETY OF ALL PERSONS AND PROPERTY; THAT THIS REQUIREMENT SHALL BE MADE TO APPLY CONTINUOUSLY AND NOT BE LIMITED TO NORMAL WORKING HOURS.
- THE CONTRACTOR SHALL PROVIDE EMERGENCY TELEPHONE NUMBERS FOR PUBLIC WORKS, AMBULANCE, POLICE, AND FIRE DEPARTMENTS AT THE JOB SITE.
- THE CONTRACTOR SHALL NOT DISTURB OR DESTROY ANY PERMANENT SURVEY POINTS WITHOUT THE CONSENT OF THE CITY ENGINEER. IN THE EVENT IT BECOMES NECESSARY TO REMOVE OR DISTURB A MONUMENT, THE PERSON SO DOING SHALL FIRST OBTAIN PERMISSION, IN WRITING, FROM THE CITY ENGINEER AND SHALL DEPOSIT WITH THE CITY ENGINEER A SUFFICIENT AMOUNT, BASED UPON THE CITY ENGINEER'S ESTIMATE, TO COVER THE COST OF PRELIMINARY REFERENCING AND FINAL RELOCATION OF THE MONUMENTS.
- ALL CONSTRUCTION STAKING SHALL BE DONE BY A REGISTERED CIVIL ENGINEER OR LICENSED LAND SURVEYOR. UPON COMPLETION OF GRADING, THE CONTRACTOR SHALL REQUEST THE LICENSED LAND SURVEYOR TO CHECK THE GRADES AND CERTIFY THAT THE PADS ARE GRADED TO WITHIN ± 0.10 FOOT OF FINISH PAD GRADE.
- THE CONTRACTOR SHALL PROVIDE FOR INGRESS AND EGRESS FOR PRIVATE PROPERTY ADJACENT TO THE WORK AREA THROUGHOUT THE PERIOD OF CONSTRUCTION.
- THE CONTRACTOR IS RESPONSIBLE FOR MATCHING EXISTING STREETS, SURROUNDING LANDSCAPE AND OTHER IMPROVEMENTS, WITH A SMOOTH TRANSITION IN GRADE AVOIDING ANY ABRUPT OR APPARENT CHANGES IN GRADE OR CROSS SLOPE, LOW SPOTS OR HAZARDOUS CONDITIONS.
- EXISTING CURB AND SIDEWALK WITHIN THE PROJECT LIMITS THAT ARE DAMAGED OR DISPLACED, EVEN THOUGH THEY WERE NOT TO BE REMOVED, SHALL BE REPAIRED OR REPLACED, EVEN IF THE DAMAGE OR DISPLACEMENT OCCURRED PRIOR TO ANY WORK PERFORMED BY THE CONTRACTOR. CONTRACTOR SHALL DOCUMENT CONDITION VIA PHOTOGRAPHS PRIOR TO START OF CONSTRUCTION.
- THE CONTRACTOR SHALL CONTROL DUST BY WATERING EXPOSED SURFACES AS NEEDED. INCREASED WATERING SHALL BE REQUIRED WHEN WIND SPEEDS EXCEED 10 MPH OR WHEN DIRECTED BY THE CITY.
- NO PERSON SHALL, WHEN HAULING ANY EARTH, SAND, GRAVEL, STONE, DEBRIS, PAPER, OR ANY OTHER SUBSTANCE OVER ANY PUBLIC STREETS OR OTHER PUBLIC PLACE, ALLOW MATERIAL TO BLOW OR SPILL OVER AND UPON SAID PUBLIC OR ADJACENT PRIVATE PROPERTY. ALL LOADS LEAVING THE SITE SHALL BE COVERED.
- THE CONTRACTOR SHALL PROVIDE STABILIZED CONSTRUCTION ENTRANCE TO PREVENT THE TRACKING OF SOIL, DUST, MUD, OR CONSTRUCTION DEBRIS ON PUBLIC STREETS.
- MUD TRACKED ONTO STREETS OR ADJACENT PROPERTIES SHALL BE REMOVED IMMEDIATELY. STREET SHALL BE SWEEPED WITH A POWER SWEEPER (NOT PRESSURE WASHED) AS DIRECTED BY THE CITY.
- A DISPOSAL SITE FOR ANY OFF-SITE HAUL OF DIRT MATERIALS SHALL BE APPROVED BY THE CITY PRIOR TO APPROVAL OF THE GRADING PERMIT. THE OFF-SITE HAUL ROUTE FOR EXCESS DIRT OR CONSTRUCTION DEBRIS IS SUBJECT TO APPROVAL OF THE CITY ENGINEER.
- EXCAVATIONS SHALL BE ADEQUATELY SHORED, BRACED AND SHEETED SO THAT THE EARTH WILL NOT SLIDE OR SETTLE AND SO THAT ALL EXISTING IMPROVEMENTS OF ANY KIND WILL BE FULLY PROTECTED FROM DAMAGE. ANY DAMAGE RESULTING FROM A LACK OF ADEQUATE SHORING, BRACING AND SHEETING, SHALL BE THE RESPONSIBILITY OF THE CONTRACTOR AND THE CONTRACTOR SHALL EFFECT NECESSARY REPAIRS OR RECONSTRUCTION AT HIS OWN EXPENSE. WHERE THE EXCAVATION FOR A TRENCH, STRUCTURE AND/OR BORING OR JACKING PIT IS FIVE FEET OR MORE IN DEPTH THE CONTRACTOR SHALL CONFORM TO THE APPLICABLE CONSTRUCTION SAFETY ORDERS OF THE DIVISION OF INDUSTRIAL SAFETY OF THE STATE OF CALIFORNIA.
- ALL TRENCHES IN EXISTING CITY STREETS SHALL BE BACKFILLED AND PAVED WITHIN 24 HOURS OF EXCAVATION. STEEL PLATES MAY BE PLACED OVER UNBACKFILLED TRENCHES BEYOND THE 24 HOUR PERIOD WITH THE SPECIFIC APPROVAL OF THE CITY ENGINEER.
- ALL REINFORCED CONCRETE PIPE SHALL BE CLASS III OR BETTER, UNLESS OTHERWISE NOTED.
- OPERATION OF VALVES ON THE SAN JOSE WATER COMPANY WATER SYSTEM SHALL BE PERFORMED BY WATER BUREAU PERSONNEL ONLY.

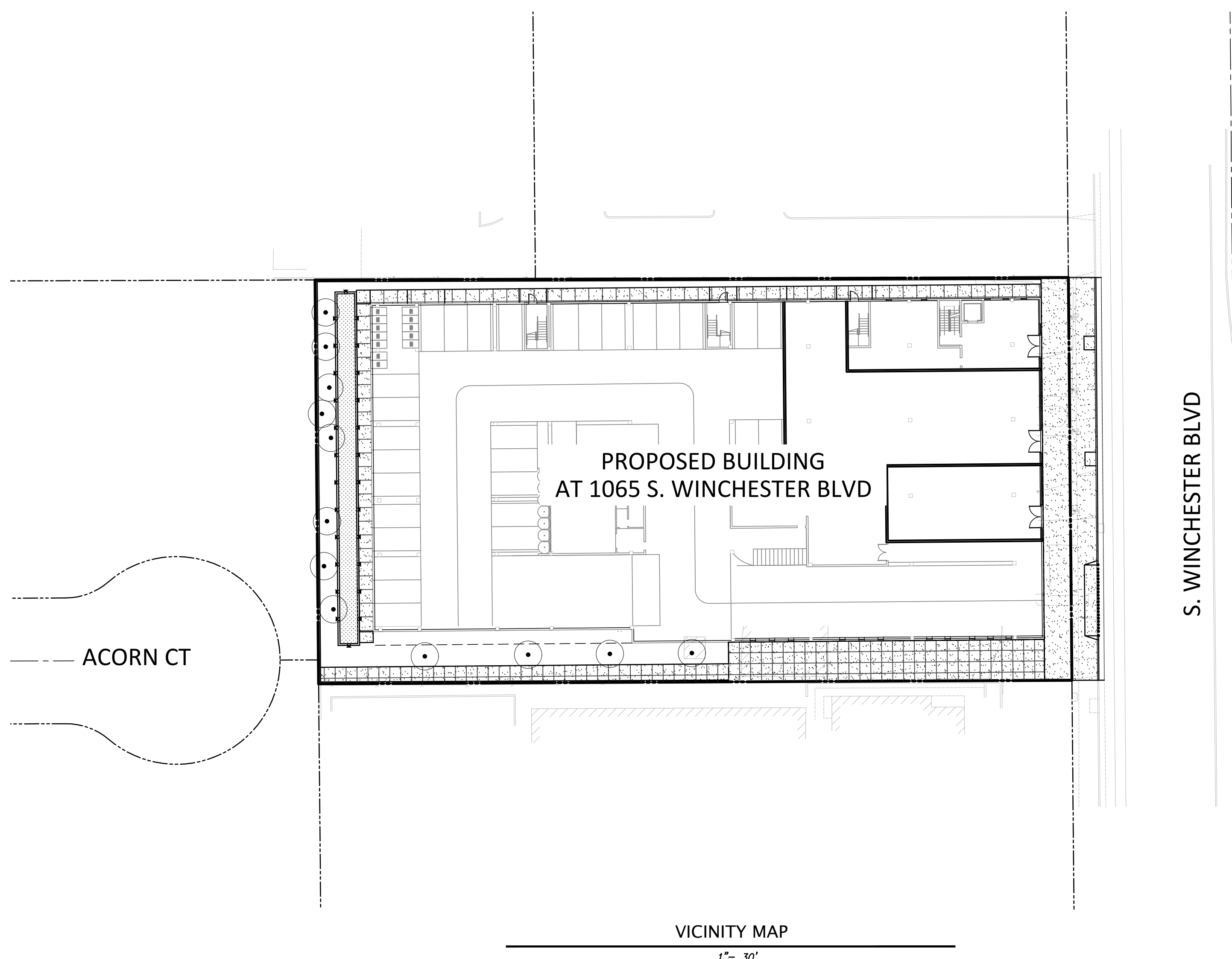

VICINITY MAP
1" = 30'

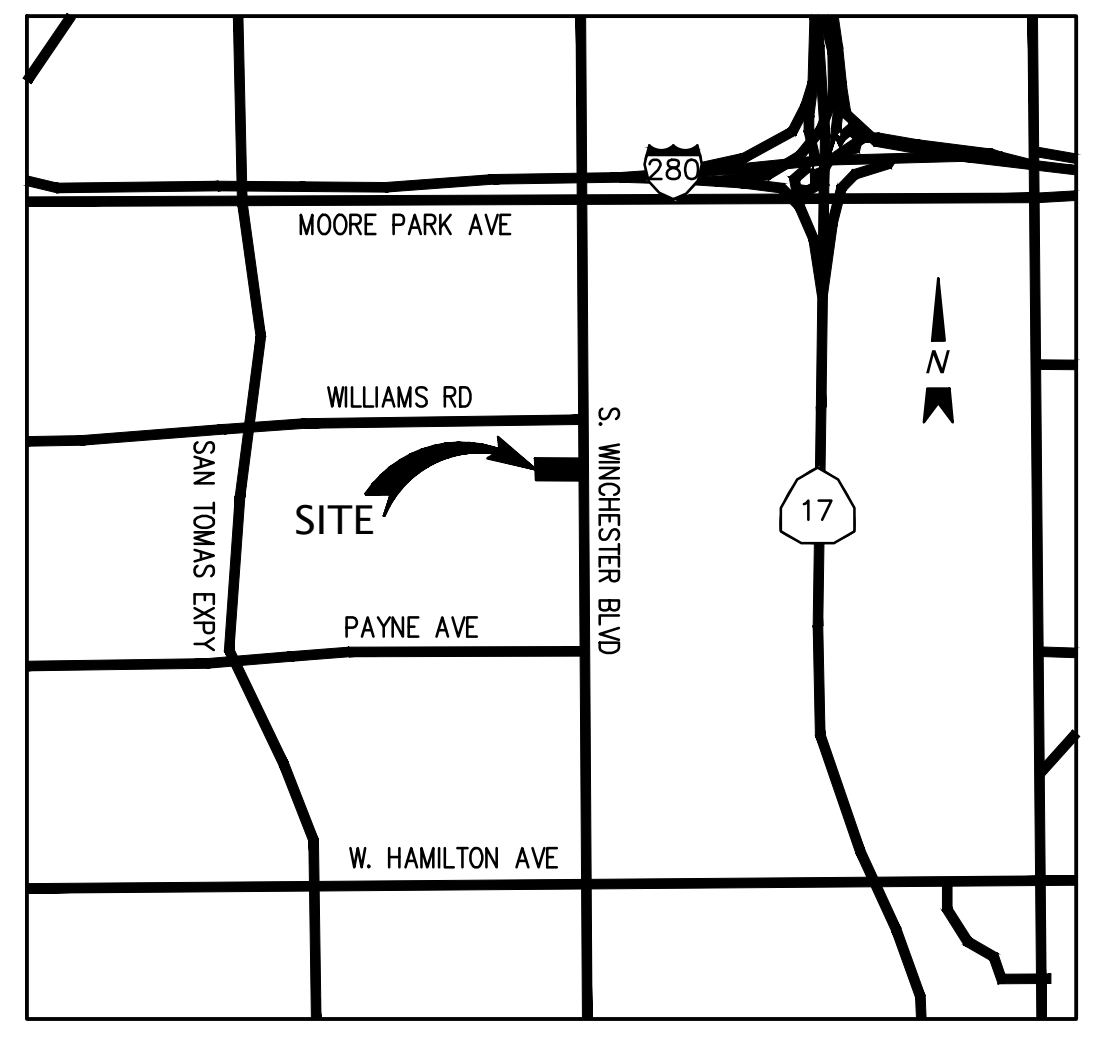

VICINITY MAP
NOT TO SCALE

SHEET INDEX

SHEET	DESCRIPTION
CIVIL	
036-C	COVER SHEET
037-C	TOPOGRAPHIC SURVEY
038-C	PRELIMINARY GRADING, DRAINAGE & SECTIONS PLAN
039-C	PRELIMINARY UTILITY PLAN
040-C	STORM WATER QUALITY CONTROL PLAN
041-C	STORM WATER QUALITY CONTROL PLAN

DEVELOPER

ATTN: ADAM ASKARI
2881 HEMLOCK AVENUE
SAN JOSE, CA 95128
(408) 921-1882

CIVIL ENGINEER

KIER & WRIGHT CIVIL ENGINEERS & SURVEYORS, INC.
ATTN: ANDREW MECKLER, P.E.
3350 SCOTT BOULEVARD, BUILDING 22
SANTA CLARA, CA 95054
(408) 727-6665

ARCHITECT

CARPIRA DESIGN GROUP
ATTN: SAM MONFARÉ
30025 ALICIA PARKWAY, #198
LAGUNA NIGUEL, CA 92677
(310) 795-4009

LANDSCAPE

LANDSCAPE DESIGNER
ATTN: SHILA YASMEH
628 NORTH MAPLE DRIVE
BEVERLY HILLS, CA 90210
(650) 492-3249



CARPIRA DESIGN GROUP
30025 ALICIA PKWY
LAGUNA NIGUEL - CA 92677
TEL: (310) 795-4009
SAMCARPIRA@GMAIL.COM

OWNER
Adam Askari
2881 Hemlock Ave. San Jose
TEL: (408) 921-1882
Dradamaskari@GMAIL.COM

CIVIL ENGINEER
KIER + WRIGHT
3350 SCOTT BLVD., BUILDING 22
Santa Clara, CA 95054
TEL: (408) 727-6665
ameckler@kierwright.com

LANDSCAPE DESIGNER
SHILA YASMEH
628 N. MAPLE DR.
BEVERLY HILLS - CA 90210
SHILA.YASMEH@GMAIL.COM
TEL: (650) 492-3249

REVISIONS

NO.	DESCRIPTION

COVER SHEET
036-C



Know what's below.
Call before you dig.

SP20 - 002

DATE PLOTTED: 10/23/2018 10:45:00 AM

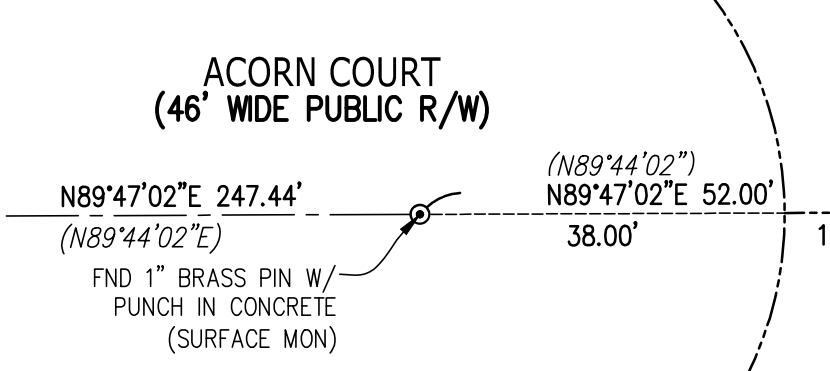
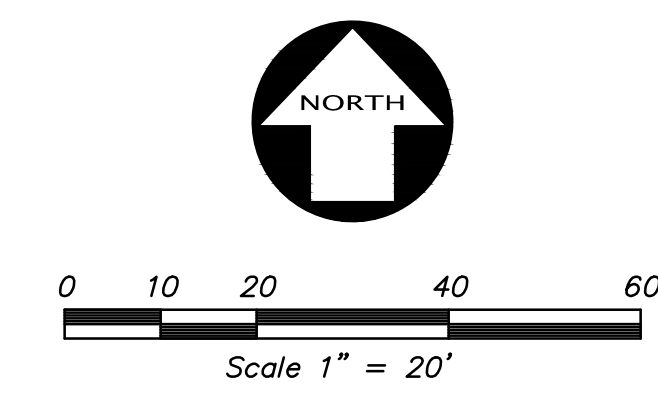
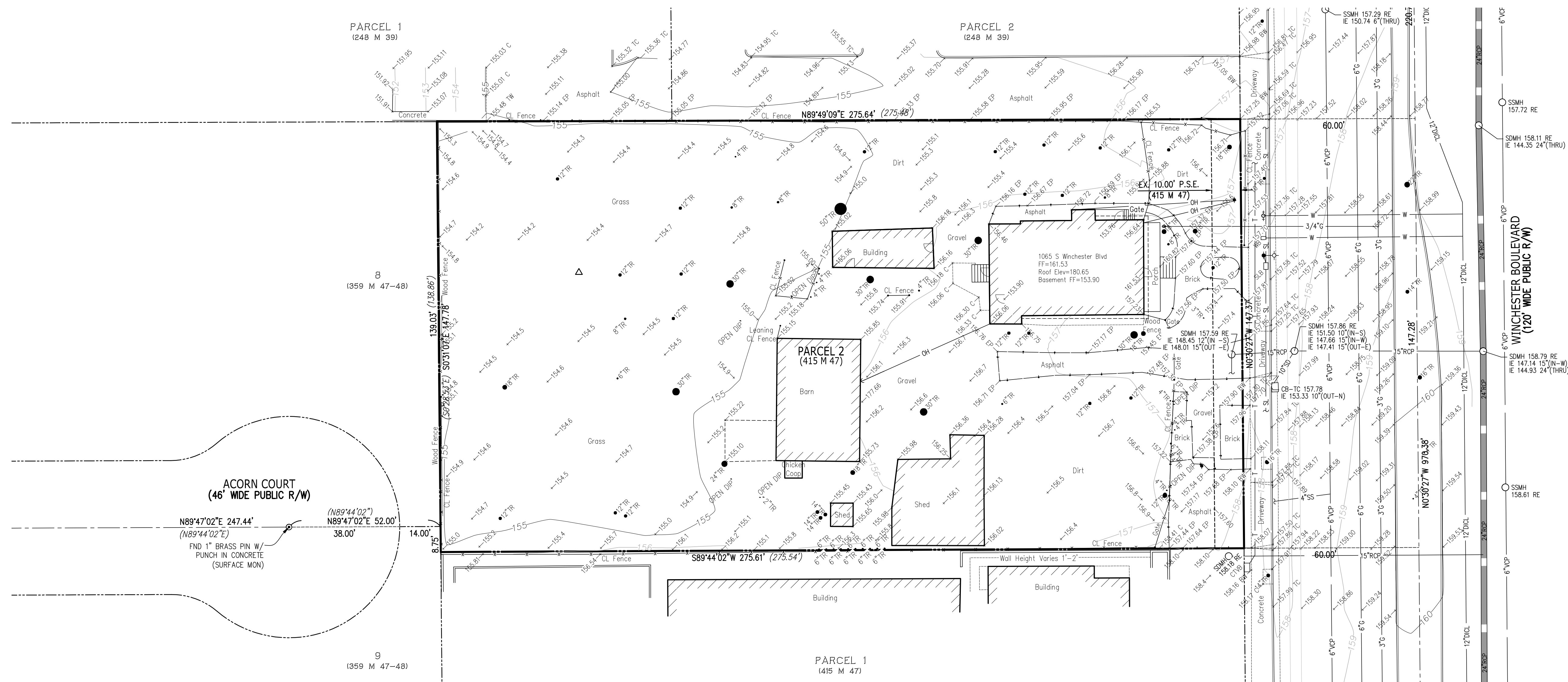

NOTES

- THIS PLOT WAS PREPARED FROM INFORMATION FURNISHED IN A PRELIMINARY TITLE REPORT, PREPARED BY FIRST AMERICAN TITLE INSURANCE COMPANY, DATED JANUARY 26, 2021, NUMBER NCS-1000933-SC. NO LIABILITY IS ASSUMED FOR MATTERS OF RECORD NOT STATED IN SAID PRELIMINARY TITLE REPORT THAT MAY AFFECT THE TITLE LINES, OR EXCEPTIONS, OR EASEMENTS OF THE PROPERTY.
EASEMENTS AND OTHER ENCUMBRANCES, IF ANY, ARE NOT SHOWN.
- ALL DISTANCES AND ELEVATIONS SHOWN HEREON ARE IN FEET AND DECIMALS THEREOF.
- THE TYPES, LOCATIONS, SIZES AND/OR DEPTHS OF EXISTING UNDERGROUND UTILITIES AS SHOWN ON THIS TOPOGRAPHIC SURVEY WERE OBTAINED FROM SOURCES OF VARYING RELIABILITY. THE CONTRACTOR IS CAUTIONED THAT ONLY ACTUAL EXCAVATION WILL REVEAL THE TYPES, EXTENT, SIZES, LOCATIONS AND DEPTHS OF SUCH UNDERGROUND UTILITIES. (A REASONABLE EFFORT HAS BEEN MADE TO LOCATE AND DELINEATE ALL KNOWN UNDERGROUND UTILITIES). HOWEVER, THE ENGINEER CAN ASSUME NO RESPONSIBILITY FOR THE COMPLETENESS OR ACCURACY OF ITS DELINEATION OF SUCH UNDERGROUND UTILITIES WHICH MAY BE ENCOUNTERED, BUT WHICH ARE NOT SHOWN ON THESE DRAWINGS.
- PHYSICAL ITEMS SHOWN ON THIS SURVEY ARE LIMITED TO THOSE ITEMS VISIBLE AS OF THE DATE OF THIS SURVEY. SUBSURFACE STRUCTURES, IF ANY, ARE NOT SHOWN. SAID SUBSURFACE OBJECTS MAY INCLUDE, BUT ARE NOT LIMITED TO, CONCRETE FOOTINGS, SLABS, SHORING, STRUCTURAL PILES, UTILITY VAULTS, PIPING, UNDERGROUND TANKS, AND ANY OTHER SUBSURFACE STRUCTURES NOT REVEALED BY A SURFACE INSPECTION.

FEMA BASE FLOOD ELEVATIONS ARE BASED ON NAVD88 DATUM.
- CITY OF SAN JOSE BENCHMARK 643-K: THE LETTER "O" IN THE WORD "OAKLAND" ON TOP OF CATCH BASIN, SOUTHEAST RETURN OF GREEN TREE WAY AND WINCHESTER BOULEVARD.
ELEV = 160.97 (NGVD29 DATUM)
- BASIS OF BEARINGS:
THE BEARING OF SOUTH 00° 30' 27" EAST TAKEN ON THE MONUMENT LINE OF WINCHESTER BOULEVARD AS SHOWN ON THAT CERTAIN PARCEL MAP FILED FOR RECORD ON MARCH 29, 1978, IN BOOK 415 OF MAPS AT PAGE 47, OFFICIAL RECORDS OF SANTA CLARA COUNTY WAS TAKEN AS THE BASIS FOR ALL BEARINGS SHOWN HEREON.
- CORNER RECORD NOTE:
THE DEVELOPER AND/OR CONTRACTOR SHALL BE RESPONSIBLE FOR THE PREPARATION AND FILING OF PRE-CONSTRUCTION AND POST-CONSTRUCTION CORNER RECORDS FOR ANY MONUMENTS OR PROPERTY CORNERS SHOWN HEREON THAT MAY BE DESTROYED DURING IMPROVEMENTS TO THE SUBJECT PROPERTY AS DEFINED IN SECTION 8771(B) OF THE PROFESSIONAL LAND SURVEYORS ACT.

LEGEND

	BUILDING LINE
	CENTERLINE
	CONCRETE CURB & GUTTER
	CONTOUR LINE
	DRIVEWAY
	EASEMENT LINE
	EDGE OF PAVEMENT
	FENCE LINE
	GAS VALVE & METER
	LOT LINE
	MONUMENT/MONUMENT LINE
	PROPERTY LINE
	SANITARY SEWER LINE-MANHOLE & CLEANOUT
	SANITARY SEWER LINE OVER 24\"/>
	SANITARY SEWER FORCE MAIN LINE
	SIDEWALK
	SPOT ELEVATION
	STORM DRAIN LINE-MANHOLE & CATCH BASIN
	STORM DRAIN LINE-MANHOLE & CATCH BASIN
	STORM DRAIN LINE OVER 24\"/>
	ELECTROLINER
	FIRE HYDRANT
	GAS METER
	POWER POLE/JOINT POLE
	SANITARY SEWER CLEANOUT
	TRANSFORMER
	TRAFFIC SIGN
	TREE
	UTILITY BOX
	UTILITY LINE MARKER
	WATER VALVE

ABBREVIATIONS

CL	CHAIN LINK
CONC	CONCRETE
DICL	DUCTILE IRON CEMENT LINED
DIP	DUCTILE IRON PIPE
E	EAST
EB	ELECTRIC BOX
EP	EDGE OF PAVEMENT
FND	FOUND
FF	FINISH FLOOR
FL	FLOW LINE
GV	GAS VALVE
IP	IRON PIPE
LIP	LIP OF GUTTER
MON	MONUMENT
N	NORTH
PGE	PACIFIC GAS & ELECTRIC
PP	POWER POLE
RCP	REINFORCED CONCRETE PIPE
RE	RIGHT OF WAY
ROW	RIGHT OF WAY
S	SOUTH
SSOD	SANITARY SEWER CLEANOUT
TC	TOP OF CURB
TMH	TELEPHONE MANHOLE
TB	TELEPHONE BOX
TYP	TYPICAL
VCP	VITRIFIED CLAY PIPE
W	WEST
WB	WATER BOX
WM	WATER METER
W/	WITH

CARPIRA DESIGN GROUP
30025 ALICIA PKWY
LAGUNA NIGUEL - CA 92677
TEL: (310) 795-4009
SAMCARPIRA@GMAIL.COM

OWNER

Adam Askari
2881 Hemlock Ave. San Jose
TEL: (408) 921-1882
Dradamaskari@GMAIL.COM

CIVIL ENGINEER

KIER + WRIGHT
3350 SCOTT BLVD., BUILDING 22
Santa Clara, CA 95054
TEL: (408) 727-6665
ameckler@kierwright.com

LANDSCAPE DESIGNER

SHILA YASMEH
628 N. MAPLE DR.
BEVERLY HILLS - CA 90210
SHILA.YASMEH@GMAIL.COM
TEL: (650) 492-3249

REVISIONS

TOPOGRAPHIC SURVEY

037-C

SP 20 - 002

OWNER

Adam Askari
 2881 Hemlock Ave. San Jose
 TEL: (408) 921-1882
 Dradamaskari@GMAIL.COM

CIVIL ENGINEER

KIER + WRIGHT
 3350 SCOTT BLVD., BUILDING 22
 Santa Clara, CA 95054
 TEL: (408) 727-6665
 ameckler@kierwright.com

LANDSCAPE DESIGNER

SHILA YASMEH
 628 N. MAPLE DR.
 BEVERLY HILLS - CA 90210
 SHILA.YASMEH@GMAIL.COM
 TEL: (650) 492-3249

REVISIONS

NO.	DESCRIPTION

**GRADING,
DRAINAGE &
SECTIONS PLAN**
038-C

SP20 - 002

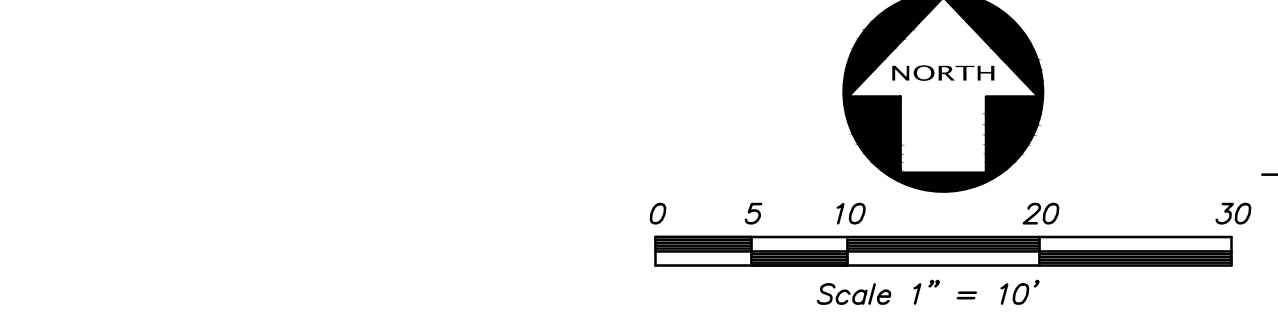
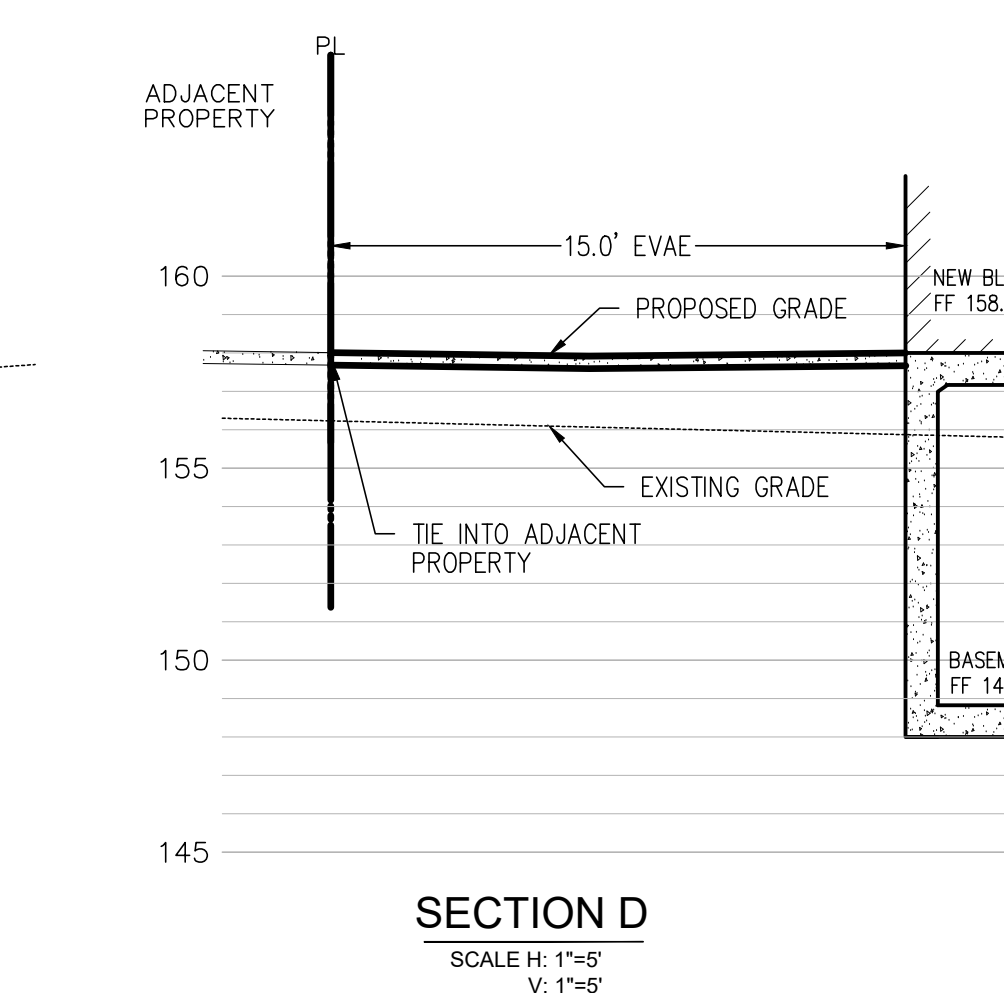
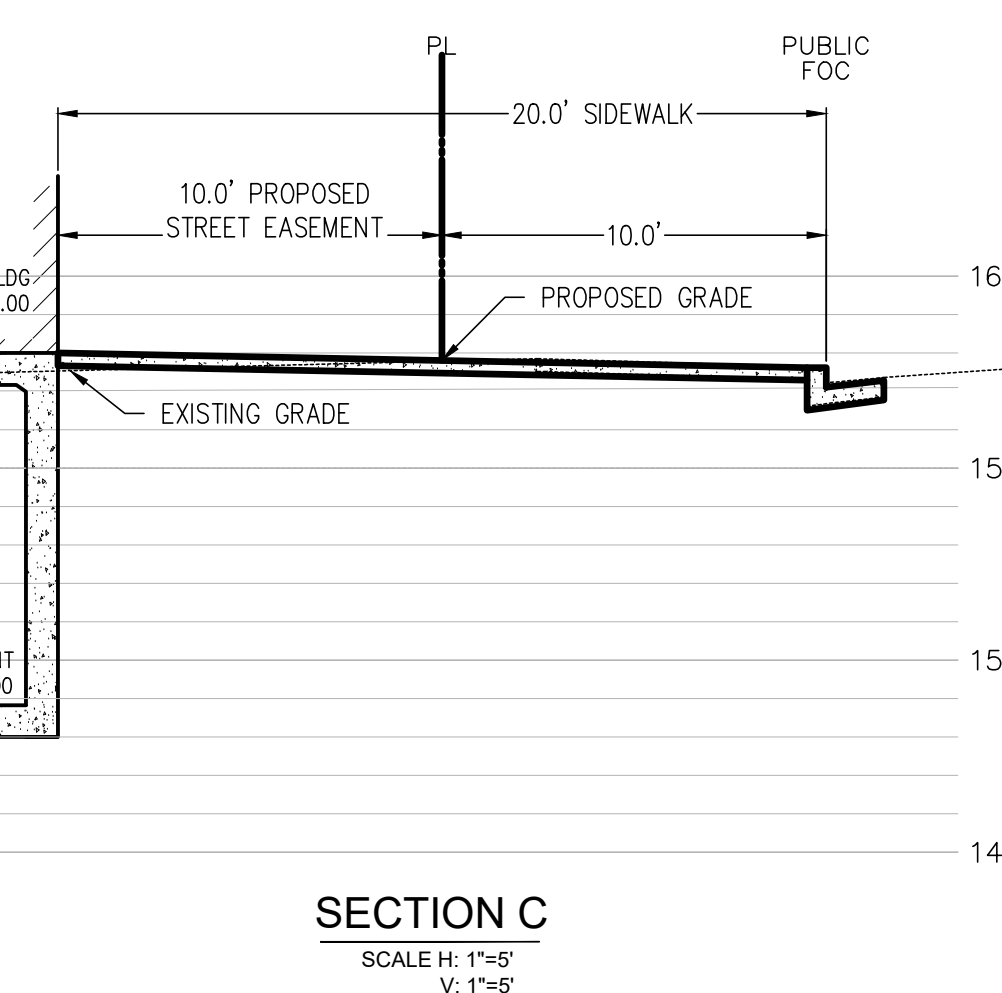
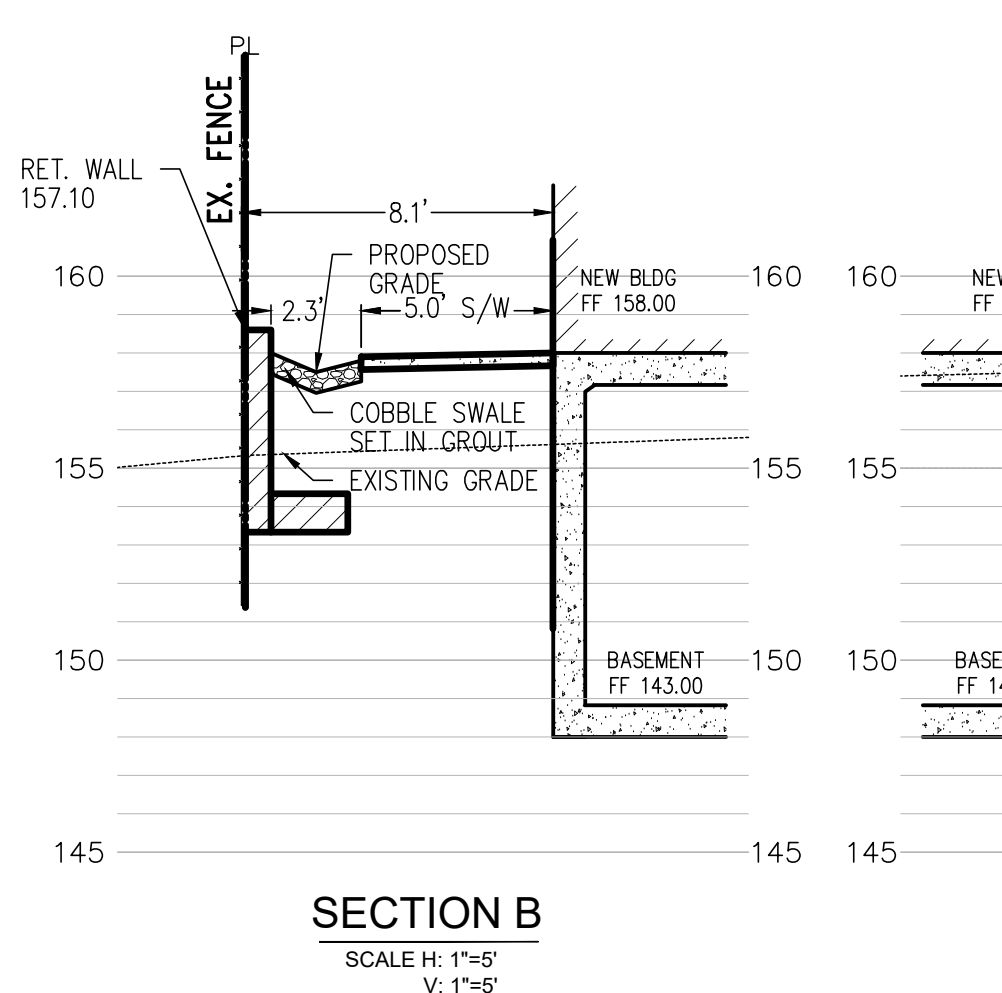
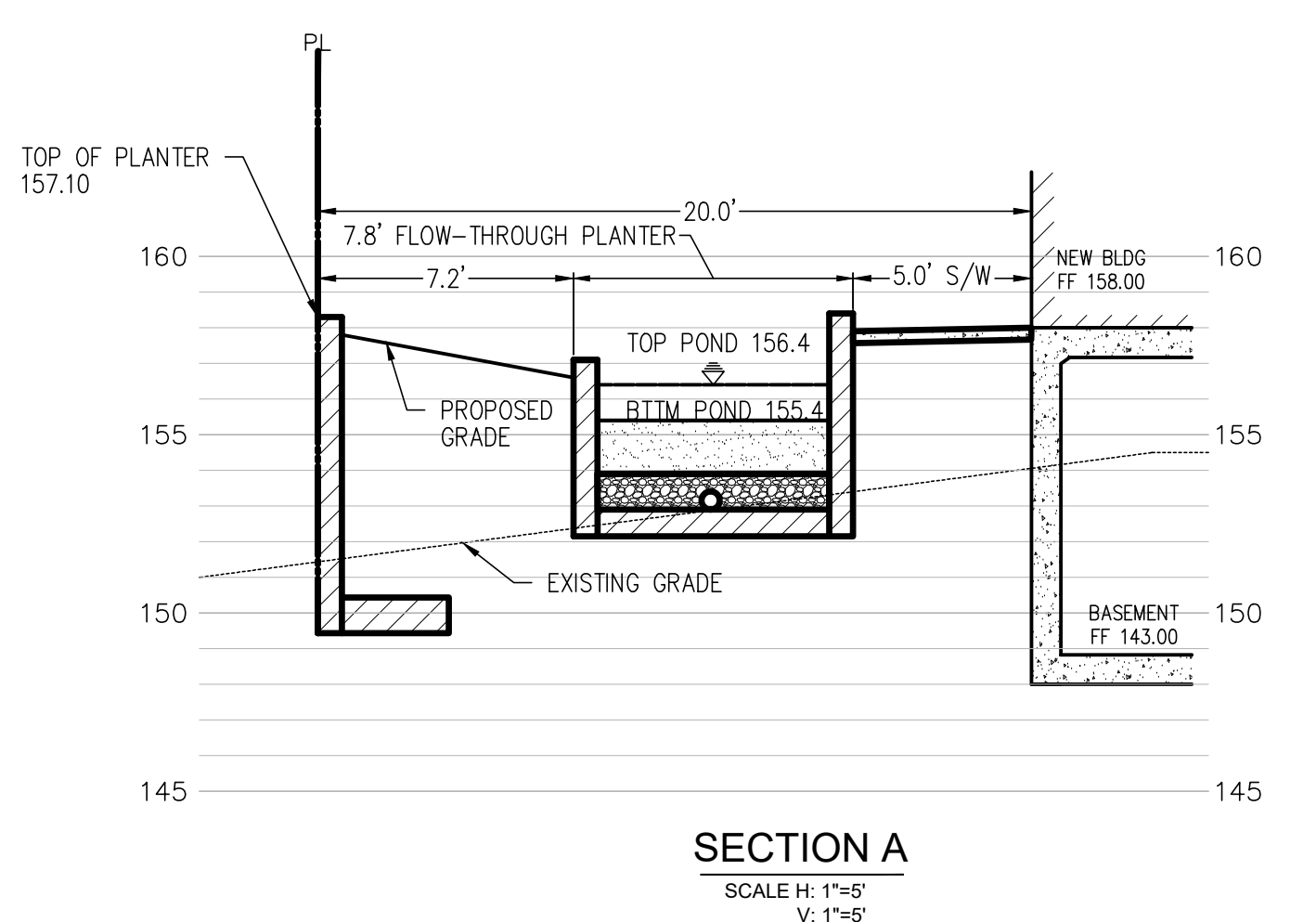
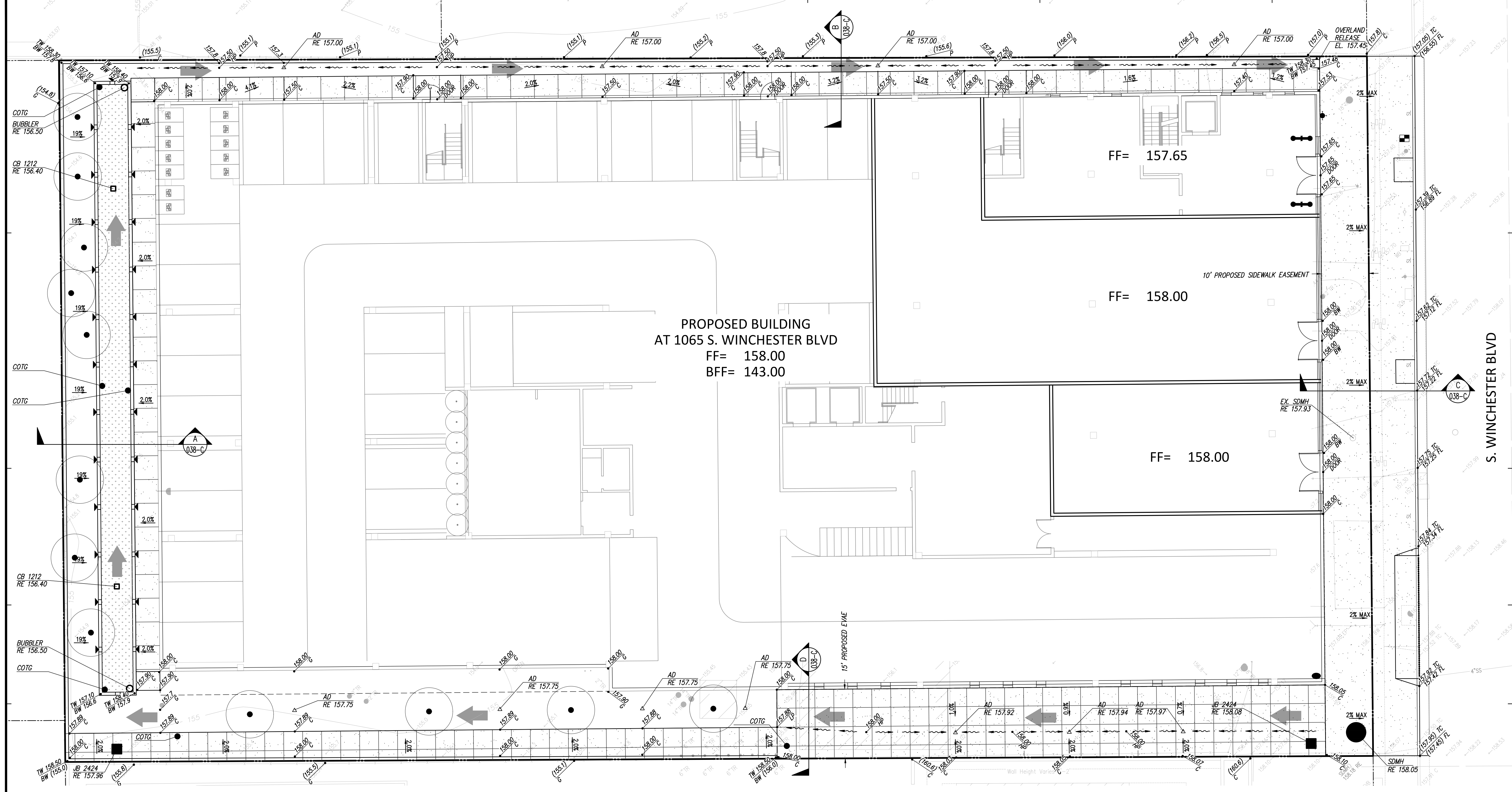

LEGEND

- ▲ AREA DRAIN
- ◻ STORM DRAIN CATCH BASIN
- STORM DRAIN JUNCTION BOX
- STORM DRAIN MANHOLE
- FLOW LINE
- FF FINISH FLOOR
- C CONCRETE
- RE RIM ELEVATION
- 23.B SPOT ELEVATION
- (23.B) EXISTING SPOT ELEVATION
- TC TOP OF CURB
- HP HIGH POINT
- G GROUND
- TW TOP OF WALL
- BW BOTTOM OF WALL
- P PAVEMENT
- COTG CLEAN OUT TO GRADE
- BTTM BOTTOM
- OVERLAND RELEASE

APPENDIX B

ROADWAY ASSESSMENT
(ILLINGWORTH AND RODKIN)

ILLINGWORTH & RODKIN, INC.
Acoustics • Air Quality

429 East Cotati Avenue
Cotati, California 94931

Tel: 707-794-0400
www.illingworthrodkin.com

Fax: 707-794-0405
illro@illingworthrodkin.com

MEMO

Date: September 17, 2020

To: Polaris Kinison Brown
Principal Planner
EMC Planning Group, Inc.
301 Lighthouse Avenue, Suite C
Monterey, CA 93940

From: Casey Divine &
James Reyff
Illingworth & Rodkin, Inc.
429 East Cotati Avenue
Cotati, CA 94931

Via E-mail: kinisonbrown@emcplanning.com

**SUBJECT: 1073 S. Winchester Boulevard, San José, CA –
Air Quality Roadway Assessment I&R Job# 20-118**

This memo reports the community risk impacts from nearby roadways of the mixed-use project proposed at 1073 S. Winchester Boulevard in San José, California. Illingworth & Rodkin, Inc. (I&R) understands that the project proposes to demolish the existing uses located on the site and to construct a 6-story, mixed-use building consisting of 61 condo units, 17,970-sf of commercial use, and 115 parking spaces. EMC Planning Group (EMC) conducted the air quality construction health risk assessment and identified the maximally exposed individual (MEI) where the maximum cancer risk, non-cancer risk, and PM_{2.5} concentrations occurred from project construction activities. I&R analyzed the project's traffic data and calculated the community risk impacts at the MEI and at the new project sensitive receptors (residents) from any roadway within 1,000-ft of the project site with average daily traffic that exceeded 10,000 vehicles. Two roadways were identified for analysis: S. Winchester Boulevard and Williams Road.

Local Roadways Analysis

A refined analysis of potential health impacts from vehicle traffic on S. Winchester Boulevard and Williams Road was conducted. The refined analysis involved predicting emissions for the traffic volume and mix of vehicle types on both roadways near the project site and using an atmospheric dispersion model to predict exposure to TACs. The associated cancer risks are then computed based on the modeled exposures. *Attachment 1* includes a description of how community risk

impacts, including cancer risk are computed.

Traffic Emissions Modeling

This analysis involved the development of DPM, organic TACs, and PM_{2.5} emissions for traffic on both roadways using the Caltrans version of the CARB Emission FACTors 2017 (EMFAC2017) emissions model, known as CT-EMFAC2017. CT-EMFAC2017 provides emission factors for mobile source criteria pollutants and TACs, including DPM. Emission processes modeled include running exhaust for DPM, PM_{2.5} and total organic compounds (e.g., TOG), running evaporative losses for TOG, and tire and brake wear and fugitive road dust for PM_{2.5}. All PM_{2.5} emissions from all vehicles were used, rather than just the PM_{2.5} fraction from diesel powered vehicles, because all vehicle types (i.e., gasoline and diesel powered) produce PM_{2.5}. Additionally, PM_{2.5} emissions from vehicle tire and brake wear and from re-entrained roadway dust were included in these emissions. DPM emissions are projected to decrease in the future and are reflected in the CT-EMFAC2017 emissions data. Inputs to the model include region (i.e., Santa Clara County), type of road, truck percentage (CT-EMFAC2017 Santa Clara County default truck percentages), traffic mix assigned by CT-EMFAC2017 for the county, year of analysis, and season. The CT-EMFAC2017 model was used to develop vehicle emission factors for the year 2024. Year 2024 emissions were conservatively assumed as being representative of conditions over the time period that cancer risks are evaluated (30 years).

The ADTs on S. Winchester Boulevard and Williams Road were based on the AM and PM peak-hour background plus project traffic volumes data provided in the project's traffic report.¹ Traffic volumes were then assumed to increase one percent per year from the year of volumes counts to the operational year. The estimated ADT on S. Winchester Boulevard would be 24,470 vehicles and the estimated ADT on Williams Road would be 10,820 vehicles. Average hourly traffic distributions for Santa Clara County roadways were developed using the EMFAC model,² which were then applied to the ADT volumes to obtain estimated hourly traffic volumes and emissions for both roadways. Average travel speeds of 40 miles per hour (mph) on S. Winchester Boulevard and 30-mph on Williams Road were used for all hours of the day. The S. Winchester Boulevard speed was based on posted speed limit signs. The Williams Road speed was based on the average of the two posted speed limits on each side of the roadway intersection at S. Winchester Boulevard. The first year of occupation was assumed to be 2024.

Dispersion Modeling

Dispersion modeling of TAC and PM_{2.5} emissions was conducted using the EPA AERMOD model. TAC and PM_{2.5} emissions from traffic on S. Winchester Boulevard and Williams Road within about 1,000 feet of the project site were evaluated. Vehicle traffic on the roadways was modeled using a series of adjacent volume sources along a line (line volume sources); with line segments used for on northbound and southbound travel on S. Winchester Boulevard and

¹ Hexagon Transportation Consultants, Inc. *1073 South Winchester Mixed-Use Development Transportation Analysis*. May 26, 2020.

² The Burden output from EMFAC2007, a previous version of CARB's EMFAC model, was used for this since the current web-based version of EMFAC2017 does not include Burden type output with hour by hour traffic volume information.

eastbound and westbound travel on Williams Road. The modeled roadway segments are shown in Figure 1.

A five-year data set (2013-2017) of hourly meteorological data from the San José International Airport was used for the modeling. Other inputs to the model included road geometries and elevations, hourly traffic emissions, and the MEI and project site receptor locations. Concentrations were calculated at the construction MEIs with receptor heights of 5 feet (1.5 meters) to represent the breathing heights of residents on the first floor. Concentrations were calculated at the project site residents with receptor heights of 20 feet (6.1 meters) and 30 feet (9.1 meters) to represent the breathing heights of the first level that residential units were located on the second and third floors.

Results from risk impacts from S. Winchester Boulevard and Williams Road are listed in Table 1 for the construction MEI receptors and Table 2 for the new on-site project sensitive receptors. Figure 1 shows the nearby roadway sources, MEI locations, and location of the on-site residential sensitive receptors that would be introduced by the project. Details of the roadway emission calculations, dispersion modeling, and cancer risk calculations are contained in *Attachment 2*.

Table 1. Roadway Risk Impacts at Construction MEIs

Source	Maximum Cancer Risk* (per million)	Annual PM _{2.5} Concentration* (µg/m ³)	Hazard Index
S. Winchester Boulevard, ADT 24,470	4.4	0.07	<0.01
Williams Road, ADT 10,820	0.3	0.03	<0.01

* Maximum cancer risk and maximum PM_{2.5} concentration occur at different receptor locations.

Table 2. Roadway Risk Impacts at On-site Sensitive Receptors

Source	Maximum Cancer Risk (per million)	Annual PM _{2.5} Concentration (µg/m ³)	Hazard Index
S. Winchester Boulevard, ADT 24,470*	1.4	0.08	<0.01
Williams Road, ADT 10,820*	0.3	0.02	<0.01
<i>BAAQMD Single-Source Threshold</i>	>10.0	>0.3	>1.0
<i>Exceed Threshold?</i>	<i>No</i>	<i>No</i>	<i>No</i>

*Receptor on second floor

Figure 1. Construction MEI Locations, On-site Project Sensitive Receptor Locations, Modeled Roadways, and Maximum Roadway TAC Impacts

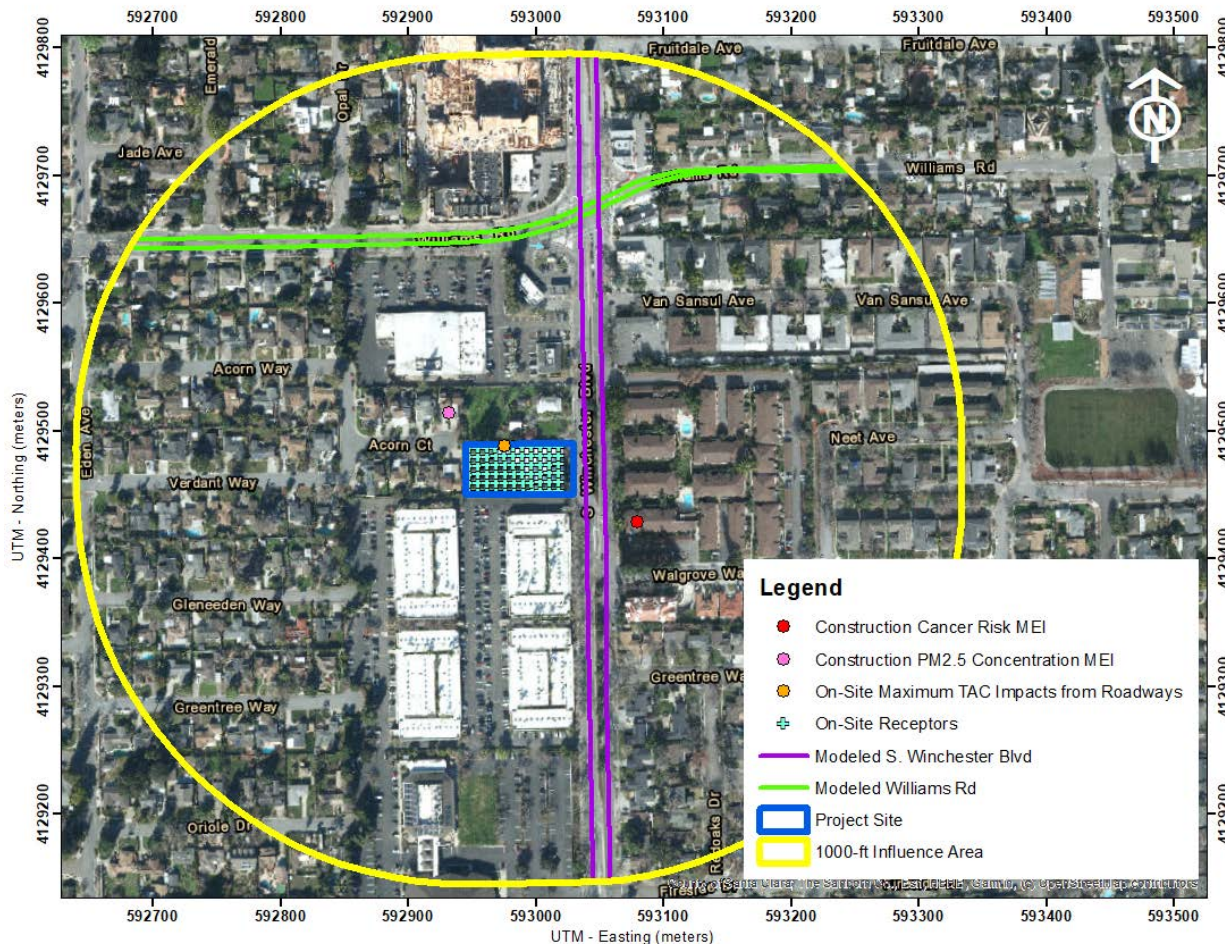

Supporting Documentation

Attachment 1 is the methodology used to compute community risk impacts, including the methods to compute lifetime cancer risk from exposure to project emissions.

Attachment 2 includes the community risk calculations, modeling results, and health risk calculations from roadway sources affecting the project and construction MEIs, including refined roadway modeling. AERMOD dispersion modeling files for this assessment, which are quite voluminous, are available upon request and would be provided in digital format.

Attachment 1: Health Risk Calculation Methodology

A health risk assessment (HRA) for exposure to Toxic Air Contaminates (TACs) requires the application of a risk characterization model to the results from the air dispersion model to estimate potential health risk at each sensitive receptor location. The State of California Office of Environmental Health Hazard Assessment (OEHHA) and California Air Resources Board (CARB) develop recommended methods for conducting health risk assessments. The most recent OEHHA risk assessment guidelines were published in February of 2015.³ These guidelines incorporate substantial changes designed to provide for enhanced protection of children, as required by State law, compared to previous published risk assessment guidelines. CARB has provided additional guidance on implementing OEHHA's recommended methods.⁴ This HRA used the 2015 OEHHA risk assessment guidelines and CARB guidance. The BAAQMD has adopted recommended procedures for applying the newest OEHHA guidelines as part of Regulation 2, Rule 5: New Source Review of Toxic Air Contaminants.⁵ Exposure parameters from the OEHHA guidelines and the recent BAAQMD HRA Guidelines were used in this evaluation.

Cancer Risk

Potential increased cancer risk from inhalation of TACs is calculated based on the TAC concentration over the period of exposure, inhalation dose, the TAC cancer potency factor, and an age sensitivity factor to reflect the greater sensitivity of infants and children to cancer causing TACs. The inhalation dose depends on a person's breathing rate, exposure time and frequency and duration of exposure. These parameters vary depending on the age, or age range, of the persons being exposed and whether the exposure is considered to occur at a residential location or other sensitive receptor location.

The current OEHHA guidance recommends that cancer risk be calculated by age groups to account for different breathing rates and sensitivity to TACs. Specifically, they recommend evaluating risks for the third trimester of pregnancy to age zero, ages zero to less than two (infant exposure), ages two to less than 16 (child exposure), and ages 16 to 70 (adult exposure). Age sensitivity factors (ASFs) associated with the different types of exposure are an ASF of 10 for the third trimester and infant exposures, an ASF of 3 for a child exposure, and an ASF of 1 for an adult exposure. Also associated with each exposure type are different breathing rates, expressed as liters per kilogram of body weight per day (L/kg-day) or liters per kilogram of body weight per 8-hour period for the case of worker or school child exposures. As recommended by the BAAQMD for residential exposures, 95th percentile breathing rates are used for the third trimester and infant exposures, and 80th percentile breathing rates for child and adult exposures. For children at schools and daycare facilities, BAAQMD recommends using the 95th percentile 8-hour breathing rates. Additionally, CARB and the BAAQMD recommend the use of a residential exposure duration of

3 OEHHA, 2015. *Air Toxics Hot Spots Program Risk Assessment Guidelines, The Air Toxics Hot Spots Program Guidance Manual for Preparation of Health Risk Assessments*. Office of Environmental Health Hazard Assessment. February.

4 CARB, 2015. *Risk Management Guidance for Stationary Sources of Air Toxics*. July 23.

5 BAAQMD, 2016. *BAAQMD Air Toxics NSR Program Health Risk Assessment (HRA) Guidelines*. December 2016.

30 years for sources with long-term emissions (e.g., roadways). For workers, assumed to be adults, a 25-year exposure period is recommended by the BAAQMD. For school children a 9-year exposure period is recommended by the BAAQMD.

Under previous OEHHA and BAAQMD HRA guidance, residential receptors are assumed to be at their home 24 hours a day, or 100 percent of the time. In the 2015 Risk Assessment Guidance, OEHHA includes adjustments to exposure duration to account for the fraction of time at home (FAH), which can be less than 100 percent of the time, based on updated population and activity statistics. The FAH factors are age-specific and are: 0.85 for third trimester of pregnancy to less than 2 years old, 0.72 for ages 2 to less than 16 years, and 0.73 for ages 16 to 70 years. Use of the FAH factors is allowed by the BAAQMD if there are no schools in the project vicinity have a cancer risk of one in a million or greater assuming 100 percent exposure (FAH = 1.0).

Functionally, cancer risk is calculated using the following parameters and formulas:

$$\text{Cancer Risk (per million)} = CPF \times \text{Inhalation Dose} \times ASF \times ED/AT \times FAH \times 10^6$$

Where:

CPF = Cancer potency factor (mg/kg-day)⁻¹

ASF = Age sensitivity factor for specified age group

ED = Exposure duration (years)

AT = Averaging time for lifetime cancer risk (years)

FAH = Fraction of time spent at home (unitless)

$$\text{Inhalation Dose} = C_{\text{air}} \times DBR^* \times A \times (EF/365) \times 10^{-6}$$

Where:

C_{air} = concentration in air (µg/m³)

DBR = daily breathing rate (L/kg body weight-day)

8HrBR = 8-hour breathing rate (L/kg body weight-8 hours)

A = Inhalation absorption factor

EF = Exposure frequency (days/year)

10⁻⁶ = Conversion factor

* An 8-hour breathing rate (8HrBR) is used for worker and school child exposures.

The health risk parameters used in this evaluation are summarized as follows:

Parameter	Exposure Type →	Infant		Child	Adult
	Age Range →	3 rd Trimester	0<2	2 < 16	16 - 30
DPM Cancer Potency Factor (mg/kg-day) ⁻¹		1.10E+00	1.10E+00	1.10E+00	1.10E+00
Daily Breathing Rate (L/kg-day) 80 th Percentile Rate		273	758	572	261
Daily Breathing Rate (L/kg-day) 95 th Percentile Rate		361	1,090	745	335
8-hour Breathing Rate (L/kg-8 hours) 95 th Percentile Rate		-	1,200	520	240
Inhalation Absorption Factor		1	1	1	1
Averaging Time (years)		70	70	70	70
Exposure Duration (years)		0.25	2	14	14*
Exposure Frequency (days/year)		350	350	350	350*
Age Sensitivity Factor		10	10	3	1
Fraction of Time at Home (FAH)		0.85-1.0	0.85-1.0	0.72-1.0	0.73*

Non-Cancer Hazards

Non-cancer health risk is usually determined by comparing the predicted level of exposure to a chemical to the level of exposure that is not expected to cause any adverse effects (reference exposure level), even to the most susceptible people. Potential non-cancer health hazards from TAC exposure are expressed in terms of a hazard index (HI), which is the ratio of the TAC concentration to a reference exposure level (REL). OEHHA has defined acceptable concentration levels for contaminants that pose non-cancer health hazards. TAC concentrations below the REL are not expected to cause adverse health impacts, even for sensitive individuals. The total HI is calculated as the sum of the HIs for each TAC evaluated and the total HI is compared to the BAAQMD significance thresholds to determine whether a significant non-cancer health impact from a project would occur.

Typically, for residential projects located near roadways with substantial TAC emissions, the primary TAC of concern with non-cancer health effects is diesel particulate matter (DPM). For DPM, the chronic inhalation REL is 5 micrograms per cubic meter ($\mu\text{g}/\text{m}^3$).

Annual PM_{2.5} Concentrations

While not a TAC, fine particulate matter (PM_{2.5}) has been identified by the BAAQMD as a pollutant with potential non-cancer health effects that should be included when evaluating potential community health impacts under the California Environmental Quality Act (CEQA). The thresholds of significance for PM_{2.5} (project level and cumulative) are in terms of an increase in the annual average concentration. When considering PM_{2.5} impacts, the contribution from all sources of PM_{2.5} emissions should be included. For projects with potential impacts from nearby local roadways, the PM_{2.5} impacts should include those from vehicle exhaust emissions, PM_{2.5} generated from vehicle tire and brake wear, and fugitive emissions from re-suspended dust on the roads.

Attachment 2: Roadway Risk Calculations

S. Winchester Boulevard Traffic Emissions and Health Risk Calculations

File Name: 1073 S Winchester Blvd Santa Clara (SF) - 2024 - Annual.EF
 CT-EMFAC2017 Version: 1.0.2.27401
 Run Date: 9/15/2020 13:48
 Area: Santa Clara (SF)
 Analysis Year: 2024
 Season: Annual

Vehicle Category	VMT Fraction Across Category	Diesel VMT	Gas VMT
		Fraction Within Category	Fraction Within Category
Truck 1	0.026	0.495	0.505
Truck 2	0.036	0.937	0.048
Non-Truck	0.938	0.014	0.955

Road Type: Major/Collector
 Silt Loading Factor: CARB 0.032 g/m2
 Precipitation Correction: CARB P = 64 days N = 365 days

Fleet Average Running Exhaust Emission Factors (grams/veh-mile)

Pollutant Name	<= 5 mph	10 mph	15 mph	20 mph	25 mph	30 mph	35 mph	40 mph	45 mph
PM2.5	0.009055	0.005937	0.004059	0.002926	0.002242	0.001833	0.001603	0.001499	0.001493
TOG	0.187931	0.123609	0.082483	0.057954	0.043756	0.034879	0.029177	0.025607	0.023582
Diesel PM	0.001252	0.001022	0.000793	0.000637	0.00055	0.000516	0.000522	0.000565	0.000641

Fleet Average Running Loss Emission Factors (grams/veh-hour)

Pollutant Name	Emission Factor
TOG	1.314612

Fleet Average Tire Wear Factors (grams/veh-mile)

Pollutant Name	Emission Factor
PM2.5	0.002189

Fleet Average Brake Wear Factors (grams/veh-mile)

Pollutant Name	Emission Factor
PM2.5	0.017344

Fleet Average Road Dust Factors (grams/veh-mile)

Pollutant Name	Emission Factor
PM2.5	0.016811

=====END=====

**1073 S. Winchester Blvd - On- and Off-site Residential
Cumulative Operation - S. Winchester Boulevard
DPM Modeling - Roadway Links, Traffic Volumes, and DPM Emissions
Year = 2024**

Road Link	Description	Direction	No. Lanes	Link Length (m)	Link Length (mi)	Link Width (m)	Link Width (ft)	Release Height (m)	Average Speed (mph)	Average Vehicles per Day
DPM_SB_WIN	S. Winchester Boulevard Southbound	SB	3	650.2	0.40	17.0	55.7	3.4	40	12,235
DPM_NB_WN	S. Winchester Boulevard Northbound	NB	2	647.8	0.40	13.3	43.7	3.4	40	12,235
									Total	24,470

Emission Factors

Speed Category Travel Speed (mph) Emissions per Vehicle (g/VMT)	1	2	3	4
	40 0.00057			

Emission Factors from CT-EMFAC2017

2024 Hourly Traffic Volumes and DPM Emissions - DPM_SB_WIN

Hour	% Per Hour	VPH	g/s	Hour	% Per Hour	VPH	g/s	Hour	% Per Hour	VPH	g/s
1	3.90%	477	3.02E-05	9	6.42%	785	4.98E-05	17	5.62%	687	4.36E-05
2	2.58%	316	2.00E-05	10	7.34%	897	5.69E-05	18	3.27%	400	2.53E-05
3	2.87%	351	2.22E-05	11	6.42%	785	4.98E-05	19	2.35%	287	1.82E-05
4	3.32%	407	2.58E-05	12	6.88%	841	5.34E-05	20	0.86%	105	6.67E-06
5	2.18%	266	1.69E-05	13	6.25%	764	4.85E-05	21	3.09%	379	2.40E-05
6	3.38%	414	2.62E-05	14	6.19%	757	4.80E-05	22	4.13%	505	3.20E-05
7	6.02%	736	4.67E-05	15	5.10%	624	3.96E-05	23	2.52%	309	1.96E-05
8	4.64%	568	3.60E-05	16	3.78%	463	2.93E-05	24	0.92%	112	7.11E-06
Total										12,235	

2024 Hourly Traffic Volumes Per Direction and DPM Emissions - DPM_NB_WN

Hour	% Per Hour	VPH	g/mile	Hour	% Per Hour	VPH	g/mile	Hour	% Per Hour	VPH	g/mile
1	3.90%	477	3.01E-05	9	6.42%	785	4.96E-05	17	5.62%	687	4.34E-05
2	2.58%	316	1.99E-05	10	7.34%	897	5.67E-05	18	3.27%	400	2.52E-05
3	2.87%	351	2.21E-05	11	6.42%	785	4.96E-05	19	2.35%	287	1.82E-05
4	3.32%	407	2.57E-05	12	6.88%	841	5.32E-05	20	0.86%	105	6.64E-06
5	2.18%	266	1.68E-05	13	6.25%	764	4.83E-05	21	3.09%	379	2.39E-05
6	3.38%	414	2.61E-05	14	6.19%	757	4.78E-05	22	4.13%	505	3.19E-05
7	6.02%	736	4.65E-05	15	5.10%	624	3.94E-05	23	2.52%	309	1.95E-05
8	4.64%	568	3.59E-05	16	3.78%	463	2.92E-05	24	0.92%	112	7.09E-06
Total										12,235	

**1073 S. Winchester Blvd - On- and Off-site Residential
 Cumulative Operation - S. Winchester Boulevard
 PM2.5 Modeling - Roadway Links, Traffic Volumes, and PM2.5 Emissions
 Year = 2024**

Road Link	Description	Direction	No. Lanes	Link Length (m)	Link Length (mi)	Link Width (m)	Link Width (ft)	Release Height (m)	Average Speed (mph)	Average Vehicles per Day
PM2.5_SB_WIN	S. Winchester Boulevard Southbound	SB	3	650.2	0.40	17.0	56	1.3	40	12,235
PM2.5_NB_WIN	S. Winchester Boulevard Northbound	NB	2	647.8	0.40	13.3	44	1.3	40	12,235
									Total	24,470

Emission Factors - PM2.5

Speed Category Travel Speed (mph)	1	2	3	4
	40	0.001499		
Emissions per Vehicle (g/VMT)				

Emission Factors from CT-EMFAC2017

2024 Hourly Traffic Volumes and PM2.5 Emissions - PM2.5_SB_WIN

Hour	% Per Hour	VPH	g/s	Hour	% Per Hour	VPH	g/s	Hour	% Per Hour	VPH	g/s
1	1.15%	141	2.37E-05	9	7.11%	870	1.46E-04	17	7.39%	904	1.52E-04
2	0.42%	51	8.60E-06	10	4.39%	537	9.03E-05	18	8.18%	1000	1.68E-04
3	0.41%	50	8.36E-06	11	4.66%	571	9.60E-05	19	5.70%	697	1.17E-04
4	0.26%	32	5.38E-06	12	5.89%	720	1.21E-04	20	4.27%	523	8.80E-05
5	0.50%	61	1.03E-05	13	6.15%	753	1.27E-04	21	3.26%	399	6.70E-05
6	0.90%	111	1.86E-05	14	6.04%	739	1.24E-04	22	3.30%	403	6.79E-05
7	3.79%	464	7.80E-05	15	7.01%	858	1.44E-04	23	2.46%	301	5.07E-05
8	7.76%	950	1.60E-04	16	7.14%	873	1.47E-04	24	1.87%	228	3.84E-05
Total										12,235	

2024 Hourly Traffic Volumes Per Direction and PM2.5 Emissions - PM2.5_NB_WIN

Hour	% Per Hour	VPH	g/mile	Hour	% Per Hour	VPH	g/mile	Hour	% Per Hour	VPH	g/mile
1	1.15%	141	2.36E-05	9	7.11%	870	1.46E-04	17	7.39%	904	1.51E-04
2	0.42%	51	8.57E-06	10	4.39%	537	8.99E-05	18	8.18%	1000	1.68E-04
3	0.41%	50	8.33E-06	11	4.66%	571	9.57E-05	19	5.70%	697	1.17E-04
4	0.26%	32	5.36E-06	12	5.89%	720	1.21E-04	20	4.27%	523	8.77E-05
5	0.50%	61	1.02E-05	13	6.15%	753	1.26E-04	21	3.26%	399	6.68E-05
6	0.90%	111	1.85E-05	14	6.04%	739	1.24E-04	22	3.30%	403	6.76E-05
7	3.79%	464	7.77E-05	15	7.01%	858	1.44E-04	23	2.46%	301	5.05E-05
8	7.76%	950	1.59E-04	16	7.14%	873	1.46E-04	24	1.87%	228	3.83E-05
Total										12,235	

**1073 S. Winchester Blvd - On- and Off-site Residential
Cumulative Operation - S. Winchester Boulevard
TOG Exhaust Modeling - Roadway Links, Traffic Volumes, and TOG Exhaust Emissions
Year = 2024**

Road Link	Description	Direction	No. Lanes	Link Length (m)	Link Length (mi)	Link Width (m)	Link Width (ft)	Release Height (m)	Average Speed (mph)	Average Vehicles per Day
TEXH_SB_WIN	S. Winchester Boulevard Southbound	SB	3	650.2	0.40	17.0	56	1.3	40	12,235
TEXH_NB_WIN	S. Winchester Boulevard Northbound	NB	2	647.8	0.40	13.3	44	1.3	40	12,235
									Total	24,470

Emission Factors - TOG Exhaust

Speed Category	1	2	3	4
Travel Speed (mph)	40			
Emissions per Vehicle (g/VMT)	0.02561			

Emission Factors from CT-EMFAC2017

2024 Hourly Traffic Volumes and TOG Exhaust Emissions - TEXH_SB_WIN

Hour	% Per Hour	VPH	g/s	Hour	% Per Hour	VPH	g/s	Hour	% Per Hour	VPH	g/s
1	1.15%	141	4.05E-04	9	7.11%	870	2.50E-03	17	7.39%	904	2.60E-03
2	0.42%	51	1.47E-04	10	4.39%	537	1.54E-03	18	8.18%	1000	2.87E-03
3	0.41%	50	1.43E-04	11	4.66%	571	1.64E-03	19	5.70%	697	2.00E-03
4	0.26%	32	9.20E-05	12	5.89%	720	2.07E-03	20	4.27%	523	1.50E-03
5	0.50%	61	1.76E-04	13	6.15%	753	2.16E-03	21	3.26%	399	1.15E-03
6	0.90%	111	3.18E-04	14	6.04%	739	2.12E-03	22	3.30%	403	1.16E-03
7	3.79%	464	1.33E-03	15	7.01%	858	2.47E-03	23	2.46%	301	8.65E-04
8	7.76%	950	2.73E-03	16	7.14%	873	2.51E-03	24	1.87%	228	6.56E-04
Total										12,235	

2024 Hourly Traffic Volumes Per Direction and TOG Exhaust Emissions - TEXH_NB_WIN

Hour	% Per Hour	VPH	g/mile	Hour	% Per Hour	VPH	g/mile	Hour	% Per Hour	VPH	g/mile
1	1.15%	141	4.03E-04	9	7.11%	870	2.49E-03	17	7.39%	904	2.59E-03
2	0.42%	51	1.46E-04	10	4.39%	537	1.54E-03	18	8.18%	1000	2.86E-03
3	0.41%	50	1.42E-04	11	4.66%	571	1.63E-03	19	5.70%	697	2.00E-03
4	0.26%	32	9.16E-05	12	5.89%	720	2.06E-03	20	4.27%	523	1.50E-03
5	0.50%	61	1.75E-04	13	6.15%	753	2.16E-03	21	3.26%	399	1.14E-03
6	0.90%	111	3.17E-04	14	6.04%	739	2.11E-03	22	3.30%	403	1.15E-03
7	3.79%	464	1.33E-03	15	7.01%	858	2.46E-03	23	2.46%	301	8.62E-04
8	7.76%	950	2.72E-03	16	7.14%	873	2.50E-03	24	1.87%	228	6.54E-04
Total										12,235	

**1073 S. Winchester Blvd - On- and Off-site Residential
 Cumulative Operation - S. Winchester Boulevard
 TOG Evaporative Emissions Modeling - Roadway Links, Traffic Volumes, and TOG Evaporative Emissions
 Year = 2024**

Road Link	Description	Direction	No. Lanes	Link Length (m)	Link Length (mi)	Link Width (m)	Link Width (ft)	Release Height (m)	Average Speed (mph)	Average Vehicles per Day
TEVAP_SB_WIN	S. Winchester Boulevard Southbound	SB	3	650.2	0.40	17.0	56	1.3	40	12,235
TEVAP_NB_WIN	S. Winchester Boulevard Northbound	NB	2	647.8	0.40	13.3	44	1.3	40	12,235
									Total	24,470

Emission Factors - PM2.5 - Evaporative TOG

Speed Category Travel Speed (mph)	1	2	3	4
Emissions per Vehicle per Hour (g/hour)	1.31461			
Emissions per Vehicle per Mile (g/VMI)	0.03287			

Emission Factors from CT-EMFAC2017

2024 Hourly Traffic Volumes and TOG Evaporative Emissions - TEVAP_SB_WIN

Hour	% Per Hour	VPH	g/s	Hour	% Per Hour	VPH	g/s	Hour	% Per Hour	VPH	g/s
1	1.15%	141	5.20E-04	9	7.11%	870	3.21E-03	17	7.39%	904	3.33E-03
2	0.42%	51	1.88E-04	10	4.39%	537	1.98E-03	18	8.18%	1000	3.69E-03
3	0.41%	50	1.83E-04	11	4.66%	571	2.11E-03	19	5.70%	697	2.57E-03
4	0.26%	32	1.18E-04	12	5.89%	720	2.66E-03	20	4.27%	523	1.93E-03
5	0.50%	61	2.25E-04	13	6.15%	753	2.78E-03	21	3.26%	399	1.47E-03
6	0.90%	111	4.08E-04	14	6.04%	739	2.72E-03	22	3.30%	403	1.49E-03
7	3.79%	464	1.71E-03	15	7.01%	858	3.17E-03	23	2.46%	301	1.11E-03
8	7.76%	950	3.50E-03	16	7.14%	873	3.22E-03	24	1.87%	228	8.42E-04
Total										12,235	

2024 Hourly Traffic Volumes Per Direction and TOG Evaporative Emissions - TEVAP_NB_WIN

Hour	% Per Hour	VPH	g/mile	Hour	% Per Hour	VPH	g/mile	Hour	% Per Hour	VPH	g/mile
1	1.15%	141	5.18E-04	9	7.11%	870	3.20E-03	17	7.39%	904	3.32E-03
2	0.42%	51	1.88E-04	10	4.39%	537	1.97E-03	18	8.18%	1000	3.68E-03
3	0.41%	50	1.83E-04	11	4.66%	571	2.10E-03	19	5.70%	697	2.56E-03
4	0.26%	32	1.18E-04	12	5.89%	720	2.65E-03	20	4.27%	523	1.92E-03
5	0.50%	61	2.25E-04	13	6.15%	753	2.77E-03	21	3.26%	399	1.46E-03
6	0.90%	111	4.06E-04	14	6.04%	739	2.71E-03	22	3.30%	403	1.48E-03
7	3.79%	464	1.70E-03	15	7.01%	858	3.15E-03	23	2.46%	301	1.11E-03
8	7.76%	950	3.49E-03	16	7.14%	873	3.21E-03	24	1.87%	228	8.39E-04
Total										12,235	

**1073 S. Winchester Blvd - On- and Off-site Residential
 Cumulative Operation - S. Winchester Boulevard
 Fugitive Road PM2.5 Modeling - Roadway Links, Traffic Volumes, and Fugitive Road PM2.5 Emissions
 Year = 2024**

Road Link	Description	Direction	No. Lanes	Link Length (m)	Link Length (mi)	Link Width (m)	Link Width (ft)	Release Height (m)	Average Speed (mph)	Average Vehicles per Day
FUG_SB_WIN	S. Winchester Boulevard Southbound	SB	3	650.2	0.40	17.0	56	1.3	40	12,235
FUG_NB_WIN	S. Winchester Boulevard Northbound	NB	2	647.8	0.40	13.3	44	1.3	40	12,235
									Total	24,470

Emission Factors - Fugitive PM2.5

Speed Category	1	2	3	4
Travel Speed (mph)	40			
Tire Wear - Emissions per Vehicle (g/VMT)	0.00219			
Brake Wear - Emissions per Vehicle (g/VMT)	0.01734			
Road Dust - Emissions per Vehicle (g/VMT)	0.01681			
Total Fugitive PM2.5 - Emissions per Vehicle (g/VMT)	0.03634			

Emission Factors from CT-EMFAC2017

2024 Hourly Traffic Volumes and Fugitive PM2.5 Emissions - FUG_SB_WIN

Hour	% Per Hour	VPH	g/s	Hour	% Per Hour	VPH	g/s	Hour	% Per Hour	VPH	g/s
1	1.15%	141	5.75E-04	9	7.11%	870	3.55E-03	17	7.39%	904	3.69E-03
2	0.42%	51	2.08E-04	10	4.39%	537	2.19E-03	18	8.18%	1000	4.08E-03
3	0.41%	50	2.03E-04	11	4.66%	571	2.33E-03	19	5.70%	697	2.84E-03
4	0.26%	32	1.31E-04	12	5.89%	720	2.94E-03	20	4.27%	523	2.13E-03
5	0.50%	61	2.49E-04	13	6.15%	753	3.07E-03	21	3.26%	399	1.63E-03
6	0.90%	111	4.51E-04	14	6.04%	739	3.01E-03	22	3.30%	403	1.65E-03
7	3.79%	464	1.89E-03	15	7.01%	858	3.50E-03	23	2.46%	301	1.23E-03
8	7.76%	950	3.87E-03	16	7.14%	873	3.56E-03	24	1.87%	228	9.31E-04
Total										12,235	

2024 Hourly Traffic Volumes Per Direction and Fugitive PM2.5 Emissions - FUG_NB_WIN

Hour	% Per Hour	VPH	g/mile	Hour	% Per Hour	VPH	g/mile	Hour	% Per Hour	VPH	g/mile
1	1.15%	141	5.73E-04	9	7.11%	870	3.54E-03	17	7.39%	904	3.67E-03
2	0.42%	51	2.08E-04	10	4.39%	537	2.18E-03	18	8.18%	1000	4.07E-03
3	0.41%	50	2.02E-04	11	4.66%	571	2.32E-03	19	5.70%	697	2.83E-03
4	0.26%	32	1.30E-04	12	5.89%	720	2.93E-03	20	4.27%	523	2.13E-03
5	0.50%	61	2.48E-04	13	6.15%	753	3.06E-03	21	3.26%	399	1.62E-03
6	0.90%	111	4.49E-04	14	6.04%	739	3.00E-03	22	3.30%	403	1.64E-03
7	3.79%	464	1.88E-03	15	7.01%	858	3.49E-03	23	2.46%	301	1.22E-03
8	7.76%	950	3.86E-03	16	7.14%	873	3.55E-03	24	1.87%	228	9.28E-04
Total										12,235	

**1073 S. Winchester Blvd, San Jose, CA - S. Winchester Blvd Traffic - TACs & PM2.5
 AERMOD Risk Modeling Parameters and Maximum Concentrations
 at Construction Cancer Risk and PM2.5 Concentration MEI Receptors**

Emission Year 2024
Receptor Information Construction Cancer Risk & PM2.5 Concentration MEI receptor
 Number of Receptors 2 at construction MEI locations
 Receptor Height 1.5 meters for both
 Receptor Distances At Construction MEI locations

Meteorological Conditions
 BAAQMD San Jose Airport Met Data 2013-2017
 Land Use Classification Urban
 Wind Speed Variable
 Winf Direction Variable

Construction Cancer Risk MEI - Maximum Concentrations

Meteorological Data Years	Concentration (µg/m3)*		
	DPM	Exhaust TOG	Evaporative TOG
2013-2017	0.0044	0.2564	0.32819

* Concentrations at construction cancer risk MEI receptor

Construction PM2.5 Concentration MEI - Maximum Concentrations

Meteorological Data Years	PM2.5 Concentration (µg/m3)*		
	Total PM2.5	Fugitive PM2.5	Vehicle PM2.5
2013-2017	0.06692	0.06426	0.00266

* Concentrations at construction PM2.5 MEI receptor

**1073. S. Winchester Blvd, San Jose, CA - S. Winchester Blvd Traffic Cancer Risk
Impacts at Construction Cancer Risk MEI - 1.5 meter receptor height
30 Year Residential Exposure**

Cancer Risk Calculation Method

Cancer Risk (per million) = CPF x Inhalation Dose x ASF x ED/AT x FAH x 1.0E6

Where: CPF = Cancer potency factor (mg/kg-day)⁻¹
ASF = Age sensitivity factor for specified age group
ED = Exposure duration (years)
AT = Averaging time for lifetime cancer risk (years)
FAH = Fraction of time spent at home (unitless)

Inhalation Dose = C_{air} x DBR x A x (EF/365) x 10⁻⁶

Where: C_{air} = concentration in air (µg/m³)
DBR = daily breathing rate (L/kg body weight-day)
A = Inhalation absorption factor
EF = Exposure frequency (days/year)
10⁻⁶ = Conversion factor

Cancer Potency Factors (mg/kg-day)⁻¹

TAC	CPF
DPM	1.10E+00
Vehicle TOG Exhaust	6.28E-03
Vehicle TOG Evaporative	3.70E-04

Values

Age --> Parameter	Infant/Child			Adult
	3rd Trimester	0 - 2	2 - 16	16 - 30
ASF =	10	10	3	1
DBR* =	361	1090	572	261
A =	1	1	1	1
EF =	350	350	350	350
AT =	70	70	70	70
FAH =	1.00	1.00	1.00	0.73

* 95th percentile breathing rates for infants and 80th percentile for children and adults

Construction Cancer Risk by Year - Maximum Impact Receptor Location

Exposure Year	Maximum - Exposure Information				Concentration (ug/m3)			Cancer Risk (per million)			TOTAL
	Exposure Duration (years)	Age	Year	Age Sensitivity Factor	DPM	Exhaust TOG	Evaporative TOG	DPM	Exhaust TOG	Evaporative TOG	
0	0.25	-0.25 - 0*	2024	10	0.0044	0.2564	0.3282	0.060	0.020	0.0015	0.08
1	1	0 - 1	2024	10	0.0044	0.2564	0.3282	0.723	0.240	0.0181	0.98
2	1	1 - 2	2025	10	0.0044	0.2564	0.3282	0.723	0.240	0.0181	0.98
3	1	2 - 3	2026	3	0.0044	0.2564	0.3282	0.114	0.038	0.0029	0.15
4	1	3 - 4	2027	3	0.0044	0.2564	0.3282	0.114	0.038	0.0029	0.15
5	1	4 - 5	2028	3	0.0044	0.2564	0.3282	0.114	0.038	0.0029	0.15
6	1	5 - 6	2029	3	0.0044	0.2564	0.3282	0.114	0.038	0.0029	0.15
7	1	6 - 7	2030	3	0.0044	0.2564	0.3282	0.114	0.038	0.0029	0.15
8	1	7 - 8	2031	3	0.0044	0.2564	0.3282	0.114	0.038	0.0029	0.15
9	1	8 - 9	2032	3	0.0044	0.2564	0.3282	0.114	0.038	0.0029	0.15
10	1	9 - 10	2033	3	0.0044	0.2564	0.3282	0.114	0.038	0.0029	0.15
11	1	10 - 11	2034	3	0.0044	0.2564	0.3282	0.114	0.038	0.0029	0.15
12	1	11 - 12	2035	3	0.0044	0.2564	0.3282	0.114	0.038	0.0029	0.15
13	1	12 - 13	2036	3	0.0044	0.2564	0.3282	0.114	0.038	0.0029	0.15
14	1	13 - 14	2037	3	0.0044	0.2564	0.3282	0.114	0.038	0.0029	0.15
15	1	14 - 15	2038	3	0.0044	0.2564	0.3282	0.114	0.038	0.0029	0.15
16	1	15 - 16	2039	3	0.0044	0.2564	0.3282	0.114	0.038	0.0029	0.15
17	1	16-17	2040	1	0.0044	0.2564	0.3282	0.013	0.004	0.0003	0.02
18	1	17-18	2041	1	0.0044	0.2564	0.3282	0.013	0.004	0.0003	0.02
19	1	18-19	2042	1	0.0044	0.2564	0.3282	0.013	0.004	0.0003	0.02
20	1	19-20	2043	1	0.0044	0.2564	0.3282	0.013	0.004	0.0003	0.02
21	1	20-21	2044	1	0.0044	0.2564	0.3282	0.013	0.004	0.0003	0.02
22	1	21-22	2045	1	0.0044	0.2564	0.3282	0.013	0.004	0.0003	0.02
23	1	22-23	2046	1	0.0044	0.2564	0.3282	0.013	0.004	0.0003	0.02
24	1	23-24	2047	1	0.0044	0.2564	0.3282	0.013	0.004	0.0003	0.02
25	1	24-25	2048	1	0.0044	0.2564	0.3282	0.013	0.004	0.0003	0.02
26	1	25-26	2049	1	0.0044	0.2564	0.3282	0.013	0.004	0.0003	0.02
27	1	26-27	2050	1	0.0044	0.2564	0.3282	0.013	0.004	0.0003	0.02
28	1	27-28	2051	1	0.0044	0.2564	0.3282	0.013	0.004	0.0003	0.02
29	1	28-29	2052	1	0.0044	0.2564	0.3282	0.013	0.004	0.0003	0.02
30	1	29-30	2053	1	0.0044	0.2564	0.3282	0.013	0.004	0.0003	0.02
Total Increased Cancer Risk								3.27	1.090	0.082	4.4

* Third trimester of pregnancy

Maximum
Hazard Index 0.001
Fugitive PM2.5 0.06
Total PM2.5 0.07

**1073 S. Winchester Blvd, San Jose, CA - S. Winchester Blvd Traffic - TACs & PM2.5
 AERMOD Risk Modeling Parameters and Maximum Concentrations
 On-Site 2nd Floor Residential Receptors (6.1 meter receptor height)**

Emission Year 2024
Receptor Information Maximum On-Site Receptor
 Number of Receptors 66
 Receptor Height 6.1 meters
 Receptor Distances 7 meter grid spacing in residential areas

Meteorological Conditions
 BAAQMD San Jose Airport Met Data 2013-2017
 Land Use Classification Urban
 Wind Speed Variable
 Winf Direction Variable

MEI Maximum Concentrations

Meteorological Data Years	Concentration (µg/m3)*		
	DPM	Exhaust TOG	Evaporative TOG
2013-2017	0.00161	0.05402	0.06913

Meteorological Data Years	PM2.5 Concentration (µg/m3)*		
	Total PM2.5	Fugitive PM2.5	Vehicle PM2.5
2013-2017	0.07966	0.0765	0.00316

**1073. S. Winchester Blvd, San Jose, CA - S. Winchester Blvd Traffic Cancer Risk Impacts at On-Site 3rd Floor Residential Receptors - 6.1 meter receptor height
30 Year Residential Exposure**

Cancer Risk Calculation Method

Cancer Risk (per million) = CPF x Inhalation Dose x ASF x ED/AT x FAH x 1.0E6

Where: CPF = Cancer potency factor (mg/kg-day)⁻¹
 ASF = Age sensitivity factor for specified age group
 ED = Exposure duration (years)
 AT = Averaging time for lifetime cancer risk (years)
 FAH = Fraction of time spent at home (unitless)

Inhalation Dose = C_{air} x DBR x A x (EF/365) x 10⁻⁶

Where: C_{air} = concentration in air (µg/m³)
 DBR = daily breathing rate (L/kg body weight-day)
 A = Inhalation absorption factor
 EF = Exposure frequency (days/year)
 10⁻⁶ = Conversion factor

Cancer Potency Factors (mg/kg-day)⁻¹

TAC	CPF
DPM	1.10E+00
Vehicle TOG Exhaust	6.28E-03
Vehicle TOG Evaporative	3.70E-04

Values

Age --> Parameter	Infant/Child			Adult
	3rd Trimester	0 - 2	2 - 16	16 - 30
ASF =	10	10	3	1
DBR* =	361	1090	572	261
A =	1	1	1	1
EF =	350	350	350	350
AT =	70	70	70	70
FAH =	1.00	1.00	1.00	0.73

* 95th percentile breathing rates for infants and 80th percentile for children and adults

Construction Cancer Risk by Year - Maximum Impact Receptor Location

Exposure Year	Maximum - Exposure Information				Concentration (ug/m3)			Cancer Risk (per million)			TOTAL
	Exposure Duration (years)	Age	Year	Age Sensitivity Factor	DPM	Exhaust TOG	Evaporative TOG	DPM	Exhaust TOG	Evaporative TOG	
0	0.25	-0.25 - 0*	2024	10	0.0016	0.0540	0.0691	0.022	0.004	0.0003	0.03
1	1	0 - 1	2024	10	0.0016	0.0540	0.0691	0.264	0.051	0.0038	0.32
2	1	1 - 2	2025	10	0.0016	0.0540	0.0691	0.264	0.051	0.0038	0.32
3	1	2 - 3	2026	3	0.0016	0.0540	0.0691	0.042	0.008	0.0006	0.05
4	1	3 - 4	2027	3	0.0016	0.0540	0.0691	0.042	0.008	0.0006	0.05
5	1	4 - 5	2028	3	0.0016	0.0540	0.0691	0.042	0.008	0.0006	0.05
6	1	5 - 6	2029	3	0.0016	0.0540	0.0691	0.042	0.008	0.0006	0.05
7	1	6 - 7	2030	3	0.0016	0.0540	0.0691	0.042	0.008	0.0006	0.05
8	1	7 - 8	2031	3	0.0016	0.0540	0.0691	0.042	0.008	0.0006	0.05
9	1	8 - 9	2032	3	0.0016	0.0540	0.0691	0.042	0.008	0.0006	0.05
10	1	9 - 10	2033	3	0.0016	0.0540	0.0691	0.042	0.008	0.0006	0.05
11	1	10 - 11	2034	3	0.0016	0.0540	0.0691	0.042	0.008	0.0006	0.05
12	1	11 - 12	2035	3	0.0016	0.0540	0.0691	0.042	0.008	0.0006	0.05
13	1	12 - 13	2036	3	0.0016	0.0540	0.0691	0.042	0.008	0.0006	0.05
14	1	13 - 14	2037	3	0.0016	0.0540	0.0691	0.042	0.008	0.0006	0.05
15	1	14 - 15	2038	3	0.0016	0.0540	0.0691	0.042	0.008	0.0006	0.05
16	1	15 - 16	2039	3	0.0016	0.0540	0.0691	0.042	0.008	0.0006	0.05
17	1	16-17	2040	1	0.0016	0.0540	0.0691	0.005	0.001	0.0001	0.01
18	1	17-18	2041	1	0.0016	0.0540	0.0691	0.005	0.001	0.0001	0.01
19	1	18-19	2042	1	0.0016	0.0540	0.0691	0.005	0.001	0.0001	0.01
20	1	19-20	2043	1	0.0016	0.0540	0.0691	0.005	0.001	0.0001	0.01
21	1	20-21	2044	1	0.0016	0.0540	0.0691	0.005	0.001	0.0001	0.01
22	1	21-22	2045	1	0.0016	0.0540	0.0691	0.005	0.001	0.0001	0.01
23	1	22-23	2046	1	0.0016	0.0540	0.0691	0.005	0.001	0.0001	0.01
24	1	23-24	2047	1	0.0016	0.0540	0.0691	0.005	0.001	0.0001	0.01
25	1	24-25	2048	1	0.0016	0.0540	0.0691	0.005	0.001	0.0001	0.01
26	1	25-26	2049	1	0.0016	0.0540	0.0691	0.005	0.001	0.0001	0.01
27	1	26-27	2050	1	0.0016	0.0540	0.0691	0.005	0.001	0.0001	0.01
28	1	27-28	2051	1	0.0016	0.0540	0.0691	0.005	0.001	0.0001	0.01
29	1	28-29	2052	1	0.0016	0.0540	0.0691	0.005	0.001	0.0001	0.01
30	1	29-30	2053	1	0.0016	0.0540	0.0691	0.005	0.001	0.0001	0.01
Total Increased Cancer Risk								1.20	0.230	0.017	1.4

* Third trimester of pregnancy

Maximum
 Hazard Index 0.0003
 Fugitive PM2.5 0.08
 Total PM2.5 0.08

Williams Road Traffic Emissions and Health Risk Calculations

File Name: 1073 S Winchester Blvd Santa Clara (SF) - 2024 - Annual.EF
 CT-EMFAC2017 Version: 1.0.2.27401
 Run Date: 9/15/2020 13:48
 Area: Santa Clara (SF)
 Analysis Year: 2024
 Season: Annual

Vehicle Category	VMT Fraction	Diesel VMT	Gas VMT
		Fraction	Fraction
		Within	Within
Across Category		Category	Category
Truck 1	0.026	0.495	0.505
Truck 2	0.036	0.937	0.048
Non-Truck	0.938	0.014	0.955

Road Type: Major/Collector
 Silt Loading Factor: CARB 0.032 g/m2
 Precipitation Correction: CARB P = 64 days N = 365 days

Fleet Average Running Exhaust Emission Factors (grams/veh-mile)

Pollutant Name	<= 5 mph	10 mph	15 mph	20 mph	25 mph	30 mph	35 mph	40 mph	45 mph
PM2.5	0.009055	0.005937	0.004059	0.002926	0.002242	0.001833	0.001603	0.001499	0.001493
TOG	0.187931	0.123609	0.082483	0.057954	0.043756	0.034879	0.029177	0.025607	0.023582
Diesel PM	0.001252	0.001022	0.000793	0.000637	0.00055	0.000516	0.000522	0.000565	0.000641

Fleet Average Running Loss Emission Factors (grams/veh-hour)

Pollutant Name	Emission Factor
TOG	1.314612

Fleet Average Tire Wear Factors (grams/veh-mile)

Pollutant Name	Emission Factor
PM2.5	0.002189

Fleet Average Brake Wear Factors (grams/veh-mile)

Pollutant Name	Emission Factor
PM2.5	0.017344

Fleet Average Road Dust Factors (grams/veh-mile)

Pollutant Name	Emission Factor
PM2.5	0.016811

=====
 =====END=====

**1073 S. Winchester Blvd - On- and Off-site Residential
Cumulative Operation - Williams Road
DPM Modeling - Roadway Links, Traffic Volumes, and DPM Emissions
Year = 2024**

Road Link	Description	Direction	No. Lanes	Link Length (m)	Link Length (mi)	Link Width (m)	Link Width (ft)	Release Height (m)	Average Speed (mph)	Average Vehicles per Day
DPM_EB_WIL	Williams Road Eastbound	EB	1	575.0	0.36	9.7	31.7	3.4	30	5,410
DPM_WB_WL	Williams Road Westbound	WB	1	567.1	0.35	9.7	31.7	3.4	30	5,410
									Total	10,820

Emission Factors

Speed Category Travel Speed (mph) Emissions per Vehicle (g/VMT)	1	2	3	4
	30 0.00052			

Emission Factors from CT-EMFAC2017

2024 Hourly Traffic Volumes and DPM Emissions - DPM_EB_WIL

Hour	% Per Hour	VPH	g/s	Hour	% Per Hour	VPH	g/s	Hour	% Per Hour	VPH	g/s
1	3.90%	211	1.08E-05	9	6.42%	347	1.78E-05	17	5.62%	304	1.56E-05
2	2.58%	140	7.14E-06	10	7.34%	397	2.03E-05	18	3.27%	177	9.05E-06
3	2.87%	155	7.94E-06	11	6.42%	347	1.78E-05	19	2.35%	127	6.51E-06
4	3.32%	180	9.21E-06	12	6.88%	372	1.91E-05	20	0.86%	47	2.38E-06
5	2.18%	118	6.03E-06	13	6.25%	338	1.73E-05	21	3.09%	167	8.57E-06
6	3.38%	183	9.37E-06	14	6.19%	335	1.71E-05	22	4.13%	223	1.14E-05
7	6.02%	326	1.67E-05	15	5.10%	276	1.41E-05	23	2.52%	136	6.99E-06
8	4.64%	251	1.29E-05	16	3.78%	205	1.05E-05	24	0.92%	50	2.54E-06
Total										5,410	

2024 Hourly Traffic Volumes Per Direction and DPM Emissions - DPM_WB_WL

Hour	% Per Hour	VPH	g/mile	Hour	% Per Hour	VPH	g/mile	Hour	% Per Hour	VPH	g/mile
1	3.90%	211	1.06E-05	9	6.42%	347	1.75E-05	17	5.62%	304	1.53E-05
2	2.58%	140	7.05E-06	10	7.34%	397	2.00E-05	18	3.27%	177	8.93E-06
3	2.87%	155	7.83E-06	11	6.42%	347	1.75E-05	19	2.35%	127	6.42E-06
4	3.32%	180	9.08E-06	12	6.88%	372	1.88E-05	20	0.86%	47	2.35E-06
5	2.18%	118	5.95E-06	13	6.25%	338	1.71E-05	21	3.09%	167	8.46E-06
6	3.38%	183	9.24E-06	14	6.19%	335	1.69E-05	22	4.13%	223	1.13E-05
7	6.02%	326	1.64E-05	15	5.10%	276	1.39E-05	23	2.52%	136	6.89E-06
8	4.64%	251	1.27E-05	16	3.78%	205	1.03E-05	24	0.92%	50	2.51E-06
Total										5,410	

1073 S. Winchester Blvd - On- and Off-site Residential
Cumulative Operation - Williams Road
PM2.5 Modeling - Roadway Links, Traffic Volumes, and PM2.5 Emissions
Year = 2024

Road Link	Description	Direction	No. Lanes	Link Length (m)	Link Length (mi)	Link Width (m)	Link Width (ft)	Release Height (m)	Average Speed (mph)	Average Vehicles per Day
PM2.5_EB_WIL	Williams Road Eastbound	EB	1	575.0	0.36	9.7	32	1.3	30	5,410
PM2.5_WB_WIL	Williams Road Westbound	WB	1	567.1	0.35	9.7	32	1.3	30	5,410
									Total	10,820

Emission Factors - PM2.5

Speed Category	1	2	3	4
Travel Speed (mph)	30			
Emissions per Vehicle (g/VMT)	0.001833			

Emission Factors from CT-EMFAC2017

2024 Hourly Traffic Volumes and PM2.5 Emissions - PM2.5_EB_WIL

Hour	% Per Hour	VPH	g/s	Hour	% Per Hour	VPH	g/s	Hour	% Per Hour	VPH	g/s
1	1.15%	62	1.13E-05	9	7.11%	385	7.00E-05	17	7.39%	400	7.27E-05
2	0.42%	23	4.11E-06	10	4.39%	237	4.32E-05	18	8.18%	442	8.05E-05
3	0.41%	22	4.00E-06	11	4.66%	252	4.59E-05	19	5.70%	308	5.61E-05
4	0.26%	14	2.57E-06	12	5.89%	319	5.80E-05	20	4.27%	231	4.21E-05
5	0.50%	27	4.92E-06	13	6.15%	333	6.05E-05	21	3.26%	176	3.21E-05
6	0.90%	49	8.89E-06	14	6.04%	327	5.94E-05	22	3.30%	178	3.24E-05
7	3.79%	205	3.73E-05	15	7.01%	380	6.90E-05	23	2.46%	133	2.42E-05
8	7.76%	420	7.64E-05	16	7.14%	386	7.02E-05	24	1.87%	101	1.84E-05
									Total	5,410	

2024 Hourly Traffic Volumes Per Direction and PM2.5 Emissions - PM2.5_WB_WIL

Hour	% Per Hour	VPH	g/mile	Hour	% Per Hour	VPH	g/mile	Hour	% Per Hour	VPH	g/mile
1	1.15%	62	1.12E-05	9	7.11%	385	6.90E-05	17	7.39%	400	7.17E-05
2	0.42%	23	4.05E-06	10	4.39%	237	4.26E-05	18	8.18%	442	7.94E-05
3	0.41%	22	3.94E-06	11	4.66%	252	4.53E-05	19	5.70%	308	5.53E-05
4	0.26%	14	2.54E-06	12	5.89%	319	5.72E-05	20	4.27%	231	4.15E-05
5	0.50%	27	4.85E-06	13	6.15%	333	5.97E-05	21	3.26%	176	3.16E-05
6	0.90%	49	8.77E-06	14	6.04%	327	5.86E-05	22	3.30%	178	3.20E-05
7	3.79%	205	3.68E-05	15	7.01%	380	6.81E-05	23	2.46%	133	2.39E-05
8	7.76%	420	7.54E-05	16	7.14%	386	6.93E-05	24	1.87%	101	1.81E-05
									Total	5,410	

1073 S. Winchester Blvd - On- and Off-site Residential
Cumulative Operation - Williams Road
TOG Exhaust Modeling - Roadway Links, Traffic Volumes, and TOG Exhaust Emissions
Year = 2024

Road Link	Description	Direction	No. Lanes	Link Length (m)	Link Length (mi)	Link Width (m)	Link Width (ft)	Release Height (m)	Average Speed (mph)	Average Vehicles per Day
TEXH_EB_WIL	Williams Road Eastbound	EB	1	575.0	0.36	9.7	32	1.3	30	5,410
TEXH_WB_WIL	Williams Road Westbound	WB	1	567.1	0.35	9.7	32	1.3	30	5,410
									Total	10,820

Emission Factors - TOG Exhaust

Speed Category Travel Speed (mph) Emissions per Vehicle (g/VMT)	1	2	3	4
	30	0.03488		

Emission Factors from CT-EMFAC2017

2024 Hourly Traffic Volumes and TOG Exhaust Emissions - TEXH_EB_WIL

Hour	% Per Hour	VPH	g/s	Hour	% Per Hour	VPH	g/s	Hour	% Per Hour	VPH	g/s
1	1.15%	62	2.16E-04	9	7.11%	385	1.33E-03	17	7.39%	400	1.38E-03
2	0.42%	23	7.82E-05	10	4.39%	237	8.21E-04	18	8.18%	442	1.53E-03
3	0.41%	22	7.60E-05	11	4.66%	252	8.74E-04	19	5.70%	308	1.07E-03
4	0.26%	14	4.90E-05	12	5.89%	319	1.10E-03	20	4.27%	231	8.01E-04
5	0.50%	27	9.36E-05	13	6.15%	333	1.15E-03	21	3.26%	176	6.10E-04
6	0.90%	49	1.69E-04	14	6.04%	327	1.13E-03	22	3.30%	178	6.17E-04
7	3.79%	205	7.10E-04	15	7.01%	380	1.31E-03	23	2.46%	133	4.61E-04
8	7.76%	420	1.45E-03	16	7.14%	386	1.34E-03	24	1.87%	101	3.49E-04
									Total	5,410	

2024 Hourly Traffic Volumes Per Direction and TOG Exhaust Emissions - TEXH_WB_WIL

Hour	% Per Hour	VPH	g/mile	Hour	% Per Hour	VPH	g/mile	Hour	% Per Hour	VPH	g/mile
1	1.15%	62	2.13E-04	9	7.11%	385	1.31E-03	17	7.39%	400	1.36E-03
2	0.42%	23	7.71E-05	10	4.39%	237	8.10E-04	18	8.18%	442	1.51E-03
3	0.41%	22	7.50E-05	11	4.66%	252	8.62E-04	19	5.70%	308	1.05E-03
4	0.26%	14	4.83E-05	12	5.89%	319	1.09E-03	20	4.27%	231	7.90E-04
5	0.50%	27	9.23E-05	13	6.15%	333	1.14E-03	21	3.26%	176	6.02E-04
6	0.90%	49	1.67E-04	14	6.04%	327	1.12E-03	22	3.30%	178	6.09E-04
7	3.79%	205	7.00E-04	15	7.01%	380	1.30E-03	23	2.46%	133	4.55E-04
8	7.76%	420	1.43E-03	16	7.14%	386	1.32E-03	24	1.87%	101	3.45E-04
									Total	5,410	

**1073 S. Winchester Blvd - On- and Off-site Residential
 Cumulative Operation - Williams Road
 TOG Evaporative Emissions Modeling - Roadway Links, Traffic Volumes, and TOG Evaporative Emissions
 Year = 2024**

Road Link	Description	Direction	No. Lanes	Link Length (m)	Link Length (mi)	Link Width (m)	Link Width (ft)	Release Height (m)	Average Speed (mph)	Average Vehicles per Day
TEVAP_EB_WIL	Williams Road Eastbound	EB	1	575.0	0.36	9.7	32	1.3	30	5,410
TEVAP_WB_WIL	Williams Road Westbound	WB	1	567.1	0.35	9.7	32	1.3	30	5,410
									Total	10,820

Emission Factors - PM2.5 - Evaporative TOG

Speed Category	1	2	3	4
Travel Speed (mph)	30			
Emissions per Vehicle per Hour (g/hour)	1.31461			
Emissions per Vehicle per Mile (g/VMT)	0.04382			

Emission Factors from CT-EMFAC2017

2024 Hourly Traffic Volumes and TOG Evaporative Emissions - TEVAP_EB_WIL

Hour	% Per Hour	VPH	g/s	Hour	% Per Hour	VPH	g/s	Hour	% Per Hour	VPH	g/s
1	1.15%	62	2.71E-04	9	7.11%	385	1.67E-03	17	7.39%	400	1.74E-03
2	0.42%	23	9.83E-05	10	4.39%	237	1.03E-03	18	8.18%	442	1.92E-03
3	0.41%	22	9.55E-05	11	4.66%	252	1.10E-03	19	5.70%	308	1.34E-03
4	0.26%	14	6.15E-05	12	5.89%	319	1.39E-03	20	4.27%	231	1.01E-03
5	0.50%	27	1.18E-04	13	6.15%	333	1.45E-03	21	3.26%	176	7.66E-04
6	0.90%	49	2.13E-04	14	6.04%	327	1.42E-03	22	3.30%	178	7.76E-04
7	3.79%	205	8.92E-04	15	7.01%	380	1.65E-03	23	2.46%	133	5.79E-04
8	7.76%	420	1.83E-03	16	7.14%	386	1.68E-03	24	1.87%	101	4.39E-04
Total										5,410	

2024 Hourly Traffic Volumes Per Direction and TOG Evaporative Emissions - TEVAP_WB_WIL

Hour	% Per Hour	VPH	g/mile	Hour	% Per Hour	VPH	g/mile	Hour	% Per Hour	VPH	g/mile
1	1.15%	62	2.67E-04	9	7.11%	385	1.65E-03	17	7.39%	400	1.71E-03
2	0.42%	23	9.69E-05	10	4.39%	237	1.02E-03	18	8.18%	442	1.90E-03
3	0.41%	22	9.42E-05	11	4.66%	252	1.08E-03	19	5.70%	308	1.32E-03
4	0.26%	14	6.07E-05	12	5.89%	319	1.37E-03	20	4.27%	231	9.92E-04
5	0.50%	27	1.16E-04	13	6.15%	333	1.43E-03	21	3.26%	176	7.56E-04
6	0.90%	49	2.10E-04	14	6.04%	327	1.40E-03	22	3.30%	178	7.65E-04
7	3.79%	205	8.80E-04	15	7.01%	380	1.63E-03	23	2.46%	133	5.71E-04
8	7.76%	420	1.80E-03	16	7.14%	386	1.66E-03	24	1.87%	101	4.33E-04
Total										5,410	

**1073 S. Winchester Blvd - On- and Off-site Residential
Cumulative Operation - Williams Road
Fugitive Road PM2.5 Modeling - Roadway Links, Traffic Volumes, and Fugitive Road PM2.5 Emissions
Year = 2024**

Road Link	Description	Direction	No. Lanes	Link Length (m)	Link Length (mi)	Link Width (m)	Link Width (ft)	Release Height (m)	Average Speed (mph)	Average Vehicles per Day
FUG_EB_WIL	Williams Road Eastbound	EB	1	575.0	0.36	9.7	32	1.3	30	5,410
FUG_WB_WIL	Williams Road Westbound	WB	1	567.1	0.35	9.7	32	1.3	30	5,410
									Total	10,820

Emission Factors - Fugitive PM2.5

Speed Category Travel Speed (mph)	1	2	3	4
Tire Wear - Emissions per Vehicle (g/VMT)	0.00219			
Brake Wear - Emissions per Vehicle (g/VMT)	0.01734			
Road Dust - Emissions per Vehicle (g/VMT)	0.01681			
Total Fugitive PM2.5 - Emissions per Vehicle (g/VMT)	0.03634			

Emission Factors from CT-EMFAC2017

2024 Hourly Traffic Volumes and Fugitive PM2.5 Emissions - FUG_EB_WIL

Hour	% Per Hour	VPH	g/s	Hour	% Per Hour	VPH	g/s	Hour	% Per Hour	VPH	g/s
1	1.15%	62	2.25E-04	9	7.11%	385	1.39E-03	17	7.39%	400	1.44E-03
2	0.42%	23	8.15E-05	10	4.39%	237	8.56E-04	18	8.18%	442	1.60E-03
3	0.41%	22	7.92E-05	11	4.66%	252	9.10E-04	19	5.70%	308	1.11E-03
4	0.26%	14	5.10E-05	12	5.89%	319	1.15E-03	20	4.27%	231	8.34E-04
5	0.50%	27	9.75E-05	13	6.15%	333	1.20E-03	21	3.26%	176	6.36E-04
6	0.90%	49	1.76E-04	14	6.04%	327	1.18E-03	22	3.30%	178	6.43E-04
7	3.79%	205	7.40E-04	15	7.01%	380	1.37E-03	23	2.46%	133	4.80E-04
8	7.76%	420	1.52E-03	16	7.14%	386	1.39E-03	24	1.87%	101	3.64E-04
Total										5,410	

2024 Hourly Traffic Volumes Per Direction and Fugitive PM2.5 Emissions - FUG_WB_WIL

Hour	% Per Hour	VPH	g/mile	Hour	% Per Hour	VPH	g/mile	Hour	% Per Hour	VPH	g/mile
1	1.15%	62	2.22E-04	9	7.11%	385	1.37E-03	17	7.39%	400	1.42E-03
2	0.42%	23	8.04E-05	10	4.39%	237	8.44E-04	18	8.18%	442	1.57E-03
3	0.41%	22	7.81E-05	11	4.66%	252	8.98E-04	19	5.70%	308	1.10E-03
4	0.26%	14	5.03E-05	12	5.89%	319	1.13E-03	20	4.27%	231	8.23E-04
5	0.50%	27	9.62E-05	13	6.15%	333	1.18E-03	21	3.26%	176	6.27E-04
6	0.90%	49	1.74E-04	14	6.04%	327	1.16E-03	22	3.30%	178	6.34E-04
7	3.79%	205	7.30E-04	15	7.01%	380	1.35E-03	23	2.46%	133	4.74E-04
8	7.76%	420	1.49E-03	16	7.14%	386	1.37E-03	24	1.87%	101	3.59E-04
Total										5,410	

**1073 S. Winchester Blvd, San Jose, CA - Williams Rd Traffic - TACs & PM2.5
 AERMOD Risk Modeling Parameters and Maximum Concentrations
 at Construction Cancer Risk and PM2.5 Concentration MEI Receptors**

Emission Year 2024
Receptor Information Construction Cancer Risk & PM2.5 Concentration MEI receptor
 Number of Receptors 2 at construction MEI locations
 Receptor Height 1.5 meters for both
 Receptor Distances At Construction MEI locations

Meteorological Conditions
 BAAQMD San Jose Airport Met Data 2013-2017
 Land Use Classification Urban
 Wind Speed Variable
 Winf Direction Variable

Construction Cancer Risk MEI - Maximum Concentrations

Meteorological Data Years	Concentration (µg/m3)*		
	DPM	Exhaust TOG	Evaporative TOG
2013-2017	0.00025	0.01706	0.02143

* Concentrations at construction cancer risk MEI receptor

Construction PM2.5 Concentration MEI - Maximum Concentrations

Meteorological Data Years	PM2.5 Concentration (µg/m3)*		
	Total PM2.5	Fugitive PM2.5	Vehicle PM2.5
2013-2017	0.03189	0.03036	0.00153

* Concentrations at construction PM2.5 Concentration MEI receptor

**1073. S. Winchester Blvd, San Jose, CA - Williams Rd Traffic Cancer Risk
Impacts at Construction Cancer Risk MEI - 1.5 meter receptor height
30 Year Residential Exposure**

Cancer Risk Calculation Method

Cancer Risk (per million) = CPF x Inhalation Dose x ASF x ED/AT x FAH x 1.0E6

Where: CPF = Cancer potency factor (mg/kg-day)⁻¹
ASF = Age sensitivity factor for specified age group
ED = Exposure duration (years)
AT = Averaging time for lifetime cancer risk (years)
FAH = Fraction of time spent at home (unitless)

Inhalation Dose = C_{air} x DBR x A x (EF/365) x 10⁻⁶

Where: C_{air} = concentration in air (µg/m³)
DBR = daily breathing rate (L/kg body weight-day)
A = Inhalation absorption factor
EF = Exposure frequency (days/year)
10⁻⁶ = Conversion factor

Cancer Potency Factors (mg/kg-day)⁻¹

TAC	CPF
DPM	1.10E+00
Vehicle TOG Exhaust	6.28E-03
Vehicle TOG Evaporative	3.70E-04

Values

Age --> Parameter	Infant/Child			Adult
	3rd Trimester	0 - 2	2 - 16	16 - 30
ASF =	10	10	3	1
DBR* =	361	1090	572	261
A =	1	1	1	1
EF =	350	350	350	350
AT =	70	70	70	70
FAH =	1.00	1.00	1.00	0.73

* 95th percentile breathing rates for infants and 80th percentile for children and adults

Construction Cancer Risk by Year - Maximum Impact Receptor Location

Exposure Year	Maximum - Exposure Information				Concentration (ug/m3)			Cancer Risk (per million)			TOTAL
	Exposure Duration (years)	Age	Year	Age Sensitivity Factor	DPM	Exhaust TOG	Evaporative TOG	DPM	Exhaust TOG	Evaporative TOG	
1	1	0 - 1	2024	10	0.0003	0.0171	0.0214	0.041	0.016	0.0012	0.06
2	1	1 - 2	2025	10	0.0003	0.0171	0.0214	0.041	0.016	0.0012	0.06
3	1	2 - 3	2026	3	0.0003	0.0171	0.0214	0.006	0.003	0.0002	0.01
4	1	3 - 4	2027	3	0.0003	0.0171	0.0214	0.006	0.003	0.0002	0.01
5	1	4 - 5	2028	3	0.0003	0.0171	0.0214	0.006	0.003	0.0002	0.01
6	1	5 - 6	2029	3	0.0003	0.0171	0.0214	0.006	0.003	0.0002	0.01
7	1	6 - 7	2030	3	0.0003	0.0171	0.0214	0.006	0.003	0.0002	0.01
8	1	7 - 8	2031	3	0.0003	0.0171	0.0214	0.006	0.003	0.0002	0.01
9	1	8 - 9	2032	3	0.0003	0.0171	0.0214	0.006	0.003	0.0002	0.01
10	1	9 - 10	2033	3	0.0003	0.0171	0.0214	0.006	0.003	0.0002	0.01
11	1	10 - 11	2034	3	0.0003	0.0171	0.0214	0.006	0.003	0.0002	0.01
12	1	11 - 12	2035	3	0.0003	0.0171	0.0214	0.006	0.003	0.0002	0.01
13	1	12 - 13	2036	3	0.0003	0.0171	0.0214	0.006	0.003	0.0002	0.01
14	1	13 - 14	2037	3	0.0003	0.0171	0.0214	0.006	0.003	0.0002	0.01
15	1	14 - 15	2038	3	0.0003	0.0171	0.0214	0.006	0.003	0.0002	0.01
16	1	15 - 16	2039	3	0.0003	0.0171	0.0214	0.006	0.003	0.0002	0.01
17	1	16-17	2040	1	0.0003	0.0171	0.0214	0.001	0.000	0.0000	0.00
18	1	17-18	2041	1	0.0003	0.0171	0.0214	0.001	0.000	0.0000	0.00
19	1	18-19	2042	1	0.0003	0.0171	0.0214	0.001	0.000	0.0000	0.00
20	1	19-20	2043	1	0.0003	0.0171	0.0214	0.001	0.000	0.0000	0.00
21	1	20-21	2044	1	0.0003	0.0171	0.0214	0.001	0.000	0.0000	0.00
22	1	21-22	2045	1	0.0003	0.0171	0.0214	0.001	0.000	0.0000	0.00
23	1	22-23	2046	1	0.0003	0.0171	0.0214	0.001	0.000	0.0000	0.00
24	1	23-24	2047	1	0.0003	0.0171	0.0214	0.001	0.000	0.0000	0.00
25	1	24-25	2048	1	0.0003	0.0171	0.0214	0.001	0.000	0.0000	0.00
26	1	25-26	2049	1	0.0003	0.0171	0.0214	0.001	0.000	0.0000	0.00
27	1	26-27	2050	1	0.0003	0.0171	0.0214	0.001	0.000	0.0000	0.00
28	1	27-28	2051	1	0.0003	0.0171	0.0214	0.001	0.000	0.0000	0.00
29	1	28-29	2052	1	0.0003	0.0171	0.0214	0.001	0.000	0.0000	0.00
30	1	29-30	2053	1	0.0003	0.0171	0.0214	0.001	0.000	0.0000	0.00
Total Increased Cancer Risk								0.19	0.072	0.005	0.3

* Third trimester of pregnancy

Maximum
Hazard Index 0.0001
Fugitive PM2.5 0.03
Total PM2.5 0.03

**1073 S. Winchester Blvd, San Jose, CA - Williams Rd Traffic - TACs & PM2.5
 AERMOD Risk Modeling Parameters and Maximum Concentrations
 On-Site 2nd Floor Residential Receptors (6.1 meter receptor height)**

Emission Year 2024
Receptor Information Maximum On-Site Receptor
 Number of Receptors 66
 Receptor Height 6.1 meters
 Receptor Distances 7 meter grid spacing in residential areas

Meteorological Conditions
 BAAQMD San Jose Airport Met Data 2013-2017
 Land Use Classification Urban
 Wind Speed Variable
 Winf Direction Variable

MEI Maximum Concentrations

Meteorological Data Years	Concentration (µg/m3)*		
	DPM	Exhaust TOG	Evaporative TOG
2013-2017	0.00029	0.0204	0.02562

Meteorological Data Years	PM2.5 Concentration (µg/m3)*		
	Total PM2.5	Fugitive PM2.5	Vehicle PM2.5
2013-2017	0.02233	0.02126	0.00107

**1073. S. Winchester Blvd, San Jose, CA - Williams Rd Traffic Cancer Risk
Impacts at On-Site 3rd Floor Residential Receptors - 6.1 meter receptor height
30 Year Residential Exposure**

Cancer Risk Calculation Method

Cancer Risk (per million) = CPF x Inhalation Dose x ASF x ED/AT x FAH x 1.0E6

Where: CPF = Cancer potency factor (mg/kg-day)⁻¹
ASF = Age sensitivity factor for specified age group
ED = Exposure duration (years)
AT = Averaging time for lifetime cancer risk (years)
FAH = Fraction of time spent at home (unitless)

Inhalation Dose = C_{air} x DBR x A x (EF/365) x 10⁻⁶

Where: C_{air} = concentration in air (µg/m³)
DBR = daily breathing rate (L/kg body weight-day)
A = Inhalation absorption factor
EF = Exposure frequency (days/year)
10⁻⁶ = Conversion factor

Cancer Potency Factors (mg/kg-day)⁻¹

TAC	CPF
DPM	1.10E+00
Vehicle TOG Exhaust	6.28E-03
Vehicle TOG Evaporative	3.70E-04

Values

Age --> Parameter	Infant/Child			Adult
	3rd Trimester	0 - 2	2 - 16	16 - 30
ASF =	10	10	3	1
DBR* =	361	1090	572	261
A =	1	1	1	1
EF =	350	350	350	350
AT =	70	70	70	70
FAH =	1.00	1.00	1.00	0.73

* 95th percentile breathing rates for infants and 80th percentile for children and adults

Construction Cancer Risk by Year - Maximum Impact Receptor Location

Exposure Year	Maximum - Exposure Information				Concentration (ug/m3)			Cancer Risk (per million)			TOTAL
	Exposure Duration (years)	Age	Year	Age Sensitivity Factor	DPM	Exhaust TOG	Evaporative TOG	DPM	Exhaust TOG	Evaporative TOG	
1	1	0 - 1	2024	10	0.0003	0.0204	0.0256	0.048	0.019	0.0014	0.07
2	1	1 - 2	2025	10	0.0003	0.0204	0.0256	0.048	0.019	0.0014	0.07
3	1	2 - 3	2026	3	0.0003	0.0204	0.0256	0.007	0.003	0.0002	0.01
4	1	3 - 4	2027	3	0.0003	0.0204	0.0256	0.007	0.003	0.0002	0.01
5	1	4 - 5	2028	3	0.0003	0.0204	0.0256	0.007	0.003	0.0002	0.01
6	1	5 - 6	2029	3	0.0003	0.0204	0.0256	0.007	0.003	0.0002	0.01
7	1	6 - 7	2030	3	0.0003	0.0204	0.0256	0.007	0.003	0.0002	0.01
8	1	7 - 8	2031	3	0.0003	0.0204	0.0256	0.007	0.003	0.0002	0.01
9	1	8 - 9	2032	3	0.0003	0.0204	0.0256	0.007	0.003	0.0002	0.01
10	1	9 - 10	2033	3	0.0003	0.0204	0.0256	0.007	0.003	0.0002	0.01
11	1	10 - 11	2034	3	0.0003	0.0204	0.0256	0.007	0.003	0.0002	0.01
12	1	11 - 12	2035	3	0.0003	0.0204	0.0256	0.007	0.003	0.0002	0.01
13	1	12 - 13	2036	3	0.0003	0.0204	0.0256	0.007	0.003	0.0002	0.01
14	1	13 - 14	2037	3	0.0003	0.0204	0.0256	0.007	0.003	0.0002	0.01
15	1	14 - 15	2038	3	0.0003	0.0204	0.0256	0.007	0.003	0.0002	0.01
16	1	15 - 16	2039	3	0.0003	0.0204	0.0256	0.007	0.003	0.0002	0.01
17	1	16-17	2040	1	0.0003	0.0204	0.0256	0.001	0.000	0.0000	0.00
18	1	17-18	2041	1	0.0003	0.0204	0.0256	0.001	0.000	0.0000	0.00
19	1	18-19	2042	1	0.0003	0.0204	0.0256	0.001	0.000	0.0000	0.00
20	1	19-20	2043	1	0.0003	0.0204	0.0256	0.001	0.000	0.0000	0.00
21	1	20-21	2044	1	0.0003	0.0204	0.0256	0.001	0.000	0.0000	0.00
22	1	21-22	2045	1	0.0003	0.0204	0.0256	0.001	0.000	0.0000	0.00
23	1	22-23	2046	1	0.0003	0.0204	0.0256	0.001	0.000	0.0000	0.00
24	1	23-24	2047	1	0.0003	0.0204	0.0256	0.001	0.000	0.0000	0.00
25	1	24-25	2048	1	0.0003	0.0204	0.0256	0.001	0.000	0.0000	0.00
26	1	25-26	2049	1	0.0003	0.0204	0.0256	0.001	0.000	0.0000	0.00
27	1	26-27	2050	1	0.0003	0.0204	0.0256	0.001	0.000	0.0000	0.00
28	1	27-28	2051	1	0.0003	0.0204	0.0256	0.001	0.000	0.0000	0.00
29	1	28-29	2052	1	0.0003	0.0204	0.0256	0.001	0.000	0.0000	0.00
30	1	29-30	2053	1	0.0003	0.0204	0.0256	0.001	0.000	0.0000	0.00
Total Increased Cancer Risk								0.22	0.087	0.006	0.3

* Third trimester of pregnancy

Maximum
Hazard Index 0.0001
Fugitive PM2.5 0.02
Total PM2.5 0.02

APPENDIX C

STATIONARY SOURCE RESULTS



Stationary Source Data Request



Instructions

Please provide all contact and project information and submit this form with a printout of the Stationary Source Risk and Hazards Screening Report (instructions below) available via the [Permitted Stationary Source Risk and Hazards GIS map](#) to Areana Flores at aflores@baaqmd.gov. **This form is not applicable for school projects.** Please submit a [Public Records Request](#) for all data requests related to school projects.

Information

Contact Name		Project Name	
Affiliation		Address	
Phone		City	
Email		County	
Date		Type (residential, commercial, mixed use, industrial, etc.)	

Fill in requested data parameters and additional comments below:

Process for retrieving screening report:

1. Go to [GIS map](#)
2. Click on the "screening" widget (top left)
3. Click on "draw"
4. Select draw mode
5. Draw parcel of interest
6. Click "report"
7. Download CSV and print pdf

Winchester Shell Emissions

Facility ID	Facility Name	Period Start Date	Period End Date	Device ID	Device Name	Material Type	Density	Material Usage	Usage Units	Pollutant I	Pollutant	Factor	Factor Units	Unabated Daily Emissions
112466	Winchester Shell	1/31/2019	1/31/2020	S1	Gasoline Dispensing Operation	Gasoline - Unleaded	5.1	599999	Gallons	41	Benzene	0.00284	lbs/1,000 gallons	4.68E-03
112466	Winchester Shell	1/31/2019	1/31/2020	S1	Gasoline Dispensing Operation	Gasoline - Unleaded	5.1	599999	Gallons	148	Hexane	0.0112	lbs/1,000 gallons	1.85E-02
112466	Winchester Shell	1/31/2019	1/31/2020	S1	Gasoline Dispensing Operation	Gasoline - Unleaded	5.1	599999	Gallons	293	Toluene	0.0272	lbs/1,000 gallons	4.48E-02
112466	Winchester Shell	1/31/2019	1/31/2020	S1	Gasoline Dispensing Operation	Gasoline - Unleaded	5.1	599999	Gallons	307	Xylene	0.0227	lbs/1,000 gallons	3.74E-02
112466	Winchester Shell	1/31/2019	1/31/2020	S1	Gasoline Dispensing Operation	Gasoline - Unleaded	5.1	599999	Gallons	333	Ethylbenzene	0.00405	lbs/1,000 gallons	6.68E-03
112466	Winchester Shell	1/31/2019	1/31/2020	S1	Gasoline Dispensing Operation	Gasoline - Unleaded	5.1	599999	Gallons	10007	Precursor Organic Compounds (POC)	0.67	lbs/1,000 gallons	1.10E+00



Step 1:
Enter Facility Data

Plant Name	Winchester Shell
Plant No.	112466

Step 4:
Specify Source Type

Does facility have only diesel backup generators?	no
Is this analysis for a gas station?	yes

Note: Default generic distance multiplier used if source is not a generator or gas station.

Step 2:
Estimate Distance

What is the distance (m) from the facility boundary to the MEI?

105

Step 5:
Read Estimates

Total Cancer Risk	0.055	per 1,000,000
Total Chronic Hazard	0.000	
Total PM2.5 Concentration	0.000	µg/m ³

Step 3:
Enter Emissions Data

Chemical Name	CAS No.	Rate (lb/day)	Risk (W / 1,000,000)	Hazard (Index)	Concentration (µg/m ³)
Fine Particulate Matter (PM2.5)					
1,1,1-Trichloroethane	71556	0.00E+00			
1,1,2-Tetrachloroethane	79345	0.00E+00			
1,1,2-Trichloroethane	79005	0.00E+00			
1,1-Dichloroethane	75343	0.00E+00			
1,1-Dichloroethylene	75354	0.00E+00			
1,2,3,4,6,7,8-Septachlorodibenzo-p-dioxin	338879	0.00E+00			
1,2,3,4,6,7,8-Septachlorodibenzofuran	3900100	0.00E+00			
1,2,3,4,6,7,8-Heptachlorodibenzo-p-dioxin	35822469	0.00E+00			
1,2,3,4,6,7,8-Heptachlorodibenzofuran	67562394	0.00E+00			
1,2,3,4,7,8,9-Heptachlorodibenzofuran	55673897	0.00E+00			
1,2,3,4,7,8-Hexachlorodibenzo-p-dioxin	39227286	0.00E+00			
1,2,3,4,7,8-Hexachlorodibenzofuran	79648269	0.00E+00			
1,2,3,6,7,8-Hexachlorodibenzo-p-dioxin	57653857	0.00E+00			
1,2,3,6,7,8-Hexachlorodibenzofuran	57117449	0.00E+00			
1,2,3,7,8,9-Hexachlorodibenzo-p-dioxin	19408743	0.00E+00			
1,2,3,7,8,9-Hexachlorodibenzofuran	72912119	0.00E+00			
1,2,3,7,8-Pentachlorodibenzo-p-dioxin	40321764	0.00E+00			
1,2,3,7,8-Pentachlorodibenzofuran	57117416	0.00E+00			
1,2-Dibromo-3-chloropropane	96128	0.00E+00			
1,2-Dibromoethane	106634	0.00E+00			
1,2-Dichloroethane	107062	0.00E+00			
1,2-Epoxybutane	106887	0.00E+00			
1,3-Butadiene	106990	0.00E+00			
1,3-Propane sulfone	1120714	0.00E+00			
1,4-Dichlorobenzene	106467	0.00E+00			
1,4-Dioxane	123911	0.00E+00			
1,6-Dinitropropylene	42397648	0.00E+00			
1,8-Dinitropropylene	42397659	0.00E+00			
1-Nitropropylene	5522430	0.00E+00			
2,3,4,4',5'-PeCB	65510443	0.00E+00			
2,3,4,4',5',5'-HxCB	52663726	0.00E+00			
2,3,4,4',5'-PeCB	31508006	0.00E+00			
2,3,3',4,4',5'-HxCB	69929207	0.00E+00			
2,3,3',4,4',5,5'-HxCB	39635319	0.00E+00			
2,3,3',4,4',5-HxCB	38380084	0.00E+00			
2,3,3',4,4'-PeCB	32598144	0.00E+00			
2,3,4,4',5'-PeCB	74472370	0.00E+00			
2,3,4,6,7,8-hexachlorodibenzofuran	60851345	0.00E+00			
2,3,4,7,8-Pentachlorodibenzofuran	57117314	0.00E+00			
2,3,7,8-Tetrachlorodibenzo-p-dioxin and related comp	1746016	0.00E+00			
2,3,7,8-Tetrachlorodibenzofuran	51207319	0.00E+00			
2,4,6-Trichlorophenol	88062	0.00E+00			
2,4-Diaminobenzene	615054	0.00E+00			
2,4-Diaminotoluene	95307	0.00E+00			
2,4-Dinitrotoluene	121142	0.00E+00			
2-Aminoanthraquinone	117793	0.00E+00			
2-Nitrofluorene	607578	0.00E+00			
3,3',4,4',5,5'-HxCB	32774166	0.00E+00			
3,3',4,4',5'-PeCB	57465288	0.00E+00			
3,3',4,4'-TCB	32598133	0.00E+00			
3,3-Dichlorobenzidine	91941	0.00E+00			
3,4,4',5-TCB	70362504	0.00E+00			
3-Methylcholanthrene	56495	0.00E+00			
4,4-Methylenebis(2-chloroaniline)	101144	0.00E+00			
4,4-Methylenedianiline	101779	0.00E+00			
4-Chloro-ortho-phenylenediamine	95330	0.00E+00			
4-Dimethylaminobenzene	69117	0.00E+00			
4-Nitropropylene	57835924	0.00E+00			
5-Methylchrysenes	3697243	0.00E+00			
5-Nitroacenaphthene	602879	0.00E+00			
6-Nitrochrysenes	7496028	0.00E+00			
7,12-Dimethylbenz(a)anthracene	57976	0.00E+00			
7H-dibenzo(c,g)carbazole	194592	0.00E+00			
Acetaldehyde	75070	0.00E+00			
Acetamide	60355	0.00E+00			
Acrolein	107028	0.00E+00			
Acrylamide	79061	0.00E+00			
Acrylic Acid	79107	0.00E+00			
Acrylonitrile	107131	0.00E+00			
Alyl chloride	107051	0.00E+00			
Ammonia	7664417	0.00E+00			
Aniline	62531	0.00E+00			
Arsenic	7440382	0.00E+00			
Arsine	7784421	0.00E+00			
Asbestos [1/[100 PCM fibers/m ³]] ⁻¹	1332214	0.00E+00			
Benz(a)anthracene	56553	0.00E+00			
Benzene	71432	4.68E-03	5.98E-01	2.95E-03	
Benzenidine	92875	0.00E+00			
Benzo(a)pyrene	50328	0.00E+00			
Benzo(b)fluoranthene	205992	0.00E+00			
Benzo(g)fluoranthene	205823	0.00E+00			
Benzo(k)fluoranthene	207089	0.00E+00			
Benzyl Chloride	100447	0.00E+00			
Beryllium	7440417	0.00E+00			
Bis(2-chloroethyl) Ether	111444	0.00E+00			
Bis(2-chloromethyl) Ether	542881	0.00E+00			
Cadmium	7440439	0.00E+00			
Caprolactam	105602	0.00E+00			
Carbon Disulfide	75150	0.00E+00			
Carbon Monoxide	630080	0.00E+00			
Carbon Tetrachloride	56235	0.00E+00			
Carbonyl Sulfide	463581	0.00E+00			
Chlorinated paraffins (Avg. chain length C12; approx. 6)	108171262	0.00E+00			
Chlorine	7782505	0.00E+00			
Chlorine Dioxide	10049044	0.00E+00			
Charite	7758192	0.00E+00			
Chlorobenzene	108907	0.00E+00			
Chlorodibromomethane	124481	0.00E+00			
Chloroethane (Ethyl Chloride)	75003	0.00E+00			
Chloroform	67663	0.00E+00			
Chloropicrin	76062	0.00E+00			
Chromic Trioxide	1333820	0.00E+00			
Chromium-hexavalent	18540299	0.00E+00			
Barium chromate2	1029403	0.00E+00			

Calcium chromate2	13765190	0.00E+00
Lead chromate2	7758976	0.00E+00
Sodium dichromate2	10588019	0.00E+00
Strontium chromate2	7789062	0.00E+00
CHROMIC TRIOXIDE (as chromic acid mist)	1333820	0.00E+00
Chrysene	218019	0.00E+00
Copper	7440508	0.00E+00
Copper and Copper Compounds	7440508	0.00E+00
Cresol Mixtures	1338973	0.00E+00
Cupferron	135206	0.00E+00
Cyanide	57125	0.00E+00
Di(2-ethylhexyl)phthalate	117817	0.00E+00
Dibenz(a-h)acridine	226368	0.00E+00
Dibenz(a-h)anthracene	53703	0.00E+00
Dibenz(a-j)acridine	224420	0.00E+00
Dibenzo(a-e)pyrene	192654	0.00E+00
Dibenzo(a-h)pyrene	189640	0.00E+00
Dibenzo(a-i)pyrene	189559	0.00E+00
Dibenzo(a-l)pyrene	191300	0.00E+00
Diesel Exhaust Particulate	85105	0.00E+00
Diethanolamine	111422	0.00E+00
Dimethylformamide	68123	0.00E+00
Direct Black 38 (Technical Grade)	1937377	0.00E+00
Direct Blue 6 (Technical Grade)	2602462	0.00E+00
Direct Brown 95 (Technical Grade)	16071866	0.00E+00
Epichlorohydrin	106888	0.00E+00
Ethylbenzene	100414	6.68E-03
Ethylene Glycol	107211	0.00E+00
Ethylene Glycol Monoethyl Ether	111762	0.00E+00
Ethylene Glycol Monoethyl Ether	110805	0.00E+00
Ethylene Glycol Monoethyl Ether Acetate	111159	0.00E+00
Ethylene Glycol Monomethyl Ether	109864	0.00E+00
Ethylene Glycol Monomethyl Ether Acetate	111496	0.00E+00
Ethylene Oxide	75218	0.00E+00
Ethylene Thiourea	96457	0.00E+00
Fluorides	1101	0.00E+00
Formaldehyde (gas)	50000	0.00E+00
Glutaraldehyde	111308	0.00E+00
Hexachlorobenzene	118741	0.00E+00
Hexachlorocyclohexane (Technical Grade)	608731	0.00E+00
Hexachlorocyclohexane- Alpha Isomer	319846	0.00E+00
Hexachlorocyclohexane- Beta Isomer	319857	0.00E+00
Hexachlorocyclohexane- Gamma Isomer	58899	0.00E+00
Hydrazine	302012	0.00E+00
Hydrogen Chloride	7647010	0.00E+00
Hydrogen Cyanide	74908	0.00E+00
Hydrogen Fluoride	7664393	0.00E+00
Hydrogen Selenide	7783075	0.00E+00
Hydrogen Sulfide	7783064	0.00E+00
Indeno(1,2,3-c-d)pyrene	193395	0.00E+00
Isoflorone	78591	0.00E+00
Isopropyl Alcohol	67630	0.00E+00
Lead Acetate	301042	0.00E+00
Lead and Lead Compounds	7439921	0.00E+00
Lead Phosphate	7446277	0.00E+00
Lead Subacetate	1335326	0.00E+00
m-CRESOL	108394	0.00E+00
m-XYLENE	108383	0.00E+00
Maleic Anhydride	108316	0.00E+00
Manganese & Manganese Compounds	7439965	0.00E+00
Mercury (Inorganic)	7439976	0.00E+00
Mercuric chloride	7487547	0.00E+00
Methanol	67561	0.00E+00
Methyl bromide	74839	0.00E+00
Methyl Ethyl Ketone	78933	0.00E+00
Methyl isocyanate	624830	0.00E+00
Methyl Tertiary Butyl Ether	1634044	0.00E+00
Methylene Chloride (Dichloromethane)	75092	0.00E+00
Methylene Diphenyl isocyanate (MDI)	101688	0.00E+00
Michlers Ketone	90948	0.00E+00
n-Hexane	110543	1.85E-02
n-Nitroso-n-methylethylamine	10595956	0.00E+00
n-Nitrosodi-n-Butylamine	924163	0.00E+00
n-Nitrosodi-n-Propylamine	621647	0.00E+00
n-Nitrosodimethylamine	55185	0.00E+00
n-Nitrosodiphenylamine	62759	0.00E+00
n-Nitrosodiphenylamine	86306	0.00E+00
n-Nitrosomorpholine	59803	0.00E+00
n-Nitrosopiperidine	100754	0.00E+00
n-Nitrosopyrrolidine	930552	0.00E+00
Naphthalene	91203	0.00E+00
Nickel and Nickel Compounds	7440020	0.00E+00
Nickel acetate	373024	0.00E+00
Nickel carbonate	3333673	0.00E+00
Nickel carbonyl	13463393	0.00E+00
Nickel hydroxide	12054487	0.00E+00
Nickelocene	1271289	0.00E+00
Nickel Oxide	1313991	0.00E+00
Nickel Refinery Dust	11446	0.00E+00
Nickel subsulfide	12035732	0.00E+00
Nitric Acid	7687372	0.00E+00
Nitrogen Dioxide	10102440	0.00E+00
o-CRESOL	95487	0.00E+00
o-XYLENE	95476	0.00E+00
Oilum	8014957	0.00E+00
Ozone	10028156	0.00E+00
p-Chloro-o-toluidine	95692	0.00E+00
p-Cresidine	120718	0.00E+00
p-CRESOL	106445	0.00E+00
p-Nitrosodiphenylamine	156105	0.00E+00
p-XYLENE	106423	0.00E+00
Pentachlorophenol	87865	0.00E+00
Perchloroethylene	127184	0.00E+00
Phenol	108952	0.00E+00
Phosgene	75445	0.00E+00
Phosphine	7803512	0.00E+00
Phosphoric Acid	7664382	0.00E+00
Phthalic Anhydride	85449	0.00E+00
Polychlorinated Biphenyls	1336363	0.00E+00
Potassium Bromate	7758012	0.00E+00
Propylene	115071	0.00E+00
Propylene Glycol Monomethyl Ether	107982	0.00E+00
Propylene oxide	75569	0.00E+00
Selenium	7782492	0.00E+00
Selenium sulfide	7446346	0.00E+00
Silica (crystalline, respirable)	7631869	0.00E+00
Sodium hydroxide	1310732	0.00E+00
Styrene	100425	0.00E+00
Sulfates	9960	0.00E+00
Sulfur Dioxide	7446095	0.00E+00
Sulfuric Acid	7664939	0.00E+00
Sulfur Trioxide	7446719	0.00E+00

7.43E-02

6.31E-06

4.99E-06

Tertiary-butyl acetate	540885	0.00E+00	
Tetrachloroethylene	127184	0.00E+00	
Thioacetamide	62555	0.00E+00	
Toluene	108883	4.48E-02	2.82E-04
Toluene Diisocyanates	26471625	0.00E+00	
Toluene Diisocyanates (2,4 and 2, 6)	584849	0.00E+00	
Toluene Diisocyanates (2,4 and 2, 6)	91087	0.00E+00	
Trichloroethylene	79016	0.00E+00	
Triethylamine	121448	0.00E+00	
Urethane	51796	0.00E+00	
Vanadium pentoxide	1314621	0.00E+00	
Vinyl acetate	108054	0.00E+00	
Vinyl chloride	75014	0.00E+00	
Xylenes (technical mixture of m, o, p-isomers)	1330207	3.74E-03	1.01E-05
Vanadium	7440622	0.00E+00	

TOTAL UNADJUSTED Risk Values 0.673 0.003 0.000

Gasoline Dispensing Facility (GDF) Distance Multiplier Tool: This distance multiplier tool refines the screening values for cancer risk and chronic hazard index found in the District's Stationary Source Screening Analysis Tool for GDF's, to represent adjusted risk and hazard impacts that can be expected with farther distances from the source of emissions.

Gas Station				
Distance (meters)	Distance (feet)	Distance adjustment multiplier	Enter Risk or Hazard	Adjusted Risk or Hazard
0	0.0	1.000		0.0000
5	16.4	1.000		0.0000
10	32.8	1.000		0.0000
15	49.2	1.000		0.0000
20	65.6	1.000		0.0000
25	82.0	0.728		0.0000
30	98.4	0.559		0.0000
35	114.8	0.445		0.0000
40	131.2	0.365		0.0000
45	147.6	0.305		0.0000
50	164.0	0.260		0.0000
55	180.4	0.225		0.0000
60	196.9	0.197		0.0000
65	213.3	0.174		0.0000
70	229.7	0.155		0.0000
75	246.1	0.139		0.0000
80	262.5	0.126		0.0000
85	278.9	0.114		0.0000
90	295.3	0.104		0.0000
95	311.7	0.096		0.0000
100	328.1	0.088		0.0000
105	344.5	0.082	0.055	0.0045
110	360.9	0.076		0.0000
115	377.3	0.071		0.0000
120	393.7	0.066		0.0000
125	410.1	0.062		0.0000
130	426.5	0.058		0.0000
135	442.9	0.055		0.0000
140	459.3	0.052		0.0000
145	475.7	0.049		0.0000
150	492.1	0.046		0.0000
155	508.5	0.044		0.0000
160	524.9	0.042		0.0000
165	541.3	0.040		0.0000
170	557.7	0.038		0.0000
175	574.1	0.036		0.0000
180	590.6	0.034		0.0000
185	607.0	0.033		0.0000
190	623.4	0.031		0.0000
195	639.8	0.030		0.0000
200	656.2	0.029		0.0000
205	672.6	0.028		0.0000
210	689.0	0.027		0.0000
215	705.4	0.026		0.0000
220	721.8	0.025		0.0000
225	738.2	0.024		0.0000
230	754.6	0.023		0.0000
235	771.0	0.022		0.0000
240	787.4	0.022		0.0000
245	803.8	0.021		0.0000
250	820.2	0.020		0.0000
255	836.6	0.020		0.0000
260	853.0	0.019		0.0000
265	869.4	0.018		0.0000
270	885.8	0.018		0.0000
275	902.2	0.017		0.0000
280	918.6	0.017		0.0000
285	935.0	0.016		0.0000
290	951.4	0.016		0.0000
295	967.8	0.015		0.0000
300	984.3	0.015		0.0000

Diesel Internal Combustion (IC) Engine Distance Multiplier Tool: This distance multiplier tool refines the screening values for cancer risk and PM_{2.5} concentrations found in the District's Stationary Source Screening Analysis Tool for permitted facilities which contain only diesel IC engines, to represent adjusted risk and hazard impacts that can be expected with farther distances from the source of emissions.

Diesel Backup Generator						
Distance (meters)	Distance (feet)	Distance adjustment multiplier	Enter Risk or Hazard	Adjusted Risk or Hazard	Enter PM _{2.5} Concentration	Adjusted PM _{2.5} Concentration
0	0.0	1.000		0		0
5	16.4	1.000		0		0
10	32.8	1.000		0		0
15	49.2	1.000		0		0
20	65.6	1.000		0		0
25	82.0	0.85		0		0
30	98.4	0.73		0		0
35	114.8	0.64		0		0
40	131.2	0.58		0		0
50	164.0	0.5		0		0
60	196.9	0.41		0		0
70	229.7	0.31		0		0
80	262.5	0.28		0		0
90	295.3	0.25		0		0
100	328.1	0.22		0		0
110	360.9	0.18		0		0
120	393.7	0.16		0		0
130	426.5	0.15		0		0
140	459.3	0.14		0		0
150	492.1	0.12		0		0
160	524.9	0.1		0		0
180	590.6	0.09		0		0
200	656.2	0.08		0		0
220	721.8	0.07		0		0
240	787.4	0.06		0		0
260	853.0	0.05		0		0
280	918.6	0.04		0		0

Generic Distance Multiplier Tool: This distance multiplier tool refines the screening values to represent adjusted risk and hazard impacts that can be expected with farther distances from the source of emissions.

Generic Case						
Distance (meters)	Distance (feet)	Multiplier	Enter Risk or Hazard	Adjusted Risk or Hazard	Enter PM2.5 Concentration	Adjusted PM2.5 Concentration
0	0.0	1.000		0		0
5	16.4	1.000		0		0
10	32.8	0.883		0		0
15	49.2	0.855		0		0
20	65.6	0.827		0		0
25	82.0	0.801		0		0
30	98.4	0.775		0		0
35	114.8	0.750		0		0
40	131.2	0.726		0		0
45	147.6	0.702		0		0
50	164.0	0.679		0		0
55	180.4	0.658		0		0
60	196.9	0.636		0		0
65	213.3	0.616		0		0
70	229.7	0.596		0		0
75	246.1	0.577		0		0
80	262.5	0.558		0		0
85	278.9	0.540		0		0
90	295.3	0.523		0		0
95	311.7	0.506		0		0
100	328.1	0.489		0		0
105	344.5	0.474		0		0
110	360.9	0.458		0		0
115	377.3	0.444		0		0
120	393.7	0.429		0		0
125	410.1	0.415		0		0
130	426.5	0.402		0		0
135	442.9	0.389		0		0
140	459.3	0.376		0		0
145	475.7	0.364		0		0
150	492.1	0.353		0		0
155	508.5	0.341		0		0
160	524.9	0.330		0		0
165	541.3	0.319		0		0
170	557.7	0.309		0		0
175	574.1	0.299		0		0
180	590.6	0.290		0		0
185	607.0	0.280		0		0
190	623.4	0.271		0		0
195	639.8	0.262		0		0
200	656.2	0.254		0		0
205	672.6	0.246		0		0
210	689.0	0.238		0		0
215	705.4	0.230		0		0
220	721.8	0.223		0		0
225	738.2	0.216		0		0
230	754.6	0.209		0		0
235	771.0	0.202		0		0
240	787.4	0.195		0		0
245	803.8	0.189		0		0
250	820.2	0.183		0		0
255	836.6	0.177		0		0
260	853.0	0.171		0		0
265	869.4	0.166		0		0
270	885.8	0.160		0		0
275	902.2	0.155		0		0
280	918.6	0.150		0		0
285	935.0	0.145		0		0
290	951.4	0.141		0		0
295	967.8	0.136		0		0
300	984.3	0.132		0		0

APPENDIX D

CALEEMOD RESULTS



EMC PLANNING GROUP INC.
A LAND USE PLANNING & DESIGN FIRM

301 Lighthouse Avenue Suite C Monterey California 93940
Tel 831-649-1799 Fax 831-649-8399 www.emcplanning.com

To: Teri Wissler Adam Principal in Charge
From: David Craft, Senior Planner
Cc: File
Date: June 28, 2021

Re: 1065 South Winchester Boulevard Mixed Use Project – Criteria Air Pollutant Emissions Assessment Assumptions and Methodology

PROJECT DESCRIPTION

The project is the demolition of an existing residence, barn, ancillary structures and pavement and construction of a six-story, mixed residential condominium and commercial use on a 0.93-acre project site located at 1065 South Winchester Boulevard in the City of San José. According to the project plans (Carpira Design Group Company 2021) the proposed mixed use consists of 70 condominium units (101,648 square feet) and 20,410 square feet of commercial space).

Commercial uses, common residential open space, and 25 parking spaces (13,898 square feet) would be located on the ground level; residential and commercial uses would be located on the second level; residential uses only are proposed on levels three and above. The proposed project includes 79 parking spaces in a single level of underground parking garage on one level (30,214 square feet).

Construction data inputs are derived from information provided by the applicant (Henry Cord, email to Consultant June 20, 2021) and from the project plans (Carpira Design Group Company 2021; Kier and Wright Civil Engineers 2021; Shila Yasmeh Landscape Designer 2021).

MEMORANDUM

The project site is located within the San Francisco Bay Area Air Basin, which is within the jurisdiction of the Bay Area Air Quality Management District (air district). An initial study is being prepared to evaluate the environmental impacts of the proposed project.

SCOPE OF ASSESSMENT

This assessment provides an estimate of the proposed project's construction and operational criteria air pollutants using the California Emissions Estimator Model (CalEEMod) version 2016.3.2 software, a modeling platform recommended by the California Air Resources Board (CARB) and accepted by the air district. Model results are attached to this assessment. Unless otherwise noted, data inputs to the model take into account the type and size of existing and proposed uses utilizing CalEEMod default land uses based on the size metrics provided in the project plans (Carpira Design Group Company 2021; Kier and Wright Civil Engineers 2021; Shila Yasmeh Landscape Designer 2021) and trip generation information provided in the transportation analysis prepared for the proposed project (Hexagon Transportation Consultants 2021).

Emissions Model

The CalEEMod software utilizes emissions models USEPA AP-42 emission factors, CARB vehicle emission models studies and studies commissioned by other California agencies such as the California Energy Commission and CalRecycle. The CalEEMod platform allows calculations of both construction and operational criteria pollutant emissions from land use projects. The model also calculates indirect emissions from processes "downstream" of the proposed project such as criteria air pollutant emissions from energy use and solid waste disposal.

Existing and Proposed Emissions Sources

The size and type of the existing and proposed sources of criteria air pollutants emissions on the project site and their respective CalEEMod land use default categories are presented in [Table 1, Project Characteristics](#).

Table 1 Project Characteristics

Project Components	CalEEMod Land Use ¹	Existing ²	Proposed ²
Commercial	General Office Building	9,762	20,410
Single-family Residence	Single-family use	1 unit	-
Condominiums	Condo/Townhouse High Rise	-	70 units
Parking	Enclosed Parking with Elevator	-	104 spaces
Sidewalks/hardscapes	Other Non-Asphalt Surfaces	-	3,000
Landscaping ³	Other Non-Asphalt Surfaces	-	4,437 ³
Diesel Emergency Engine Generator	-	-	75 Bhp
Natural Gas Boiler	-	-	2.44 MMBTU/Hour

SOURCE: EMC Planning Group 2021, Carpira Design Group 2021.

NOTES:

1. CalEEMod default land use subtype. Descriptions of the model default land use categories and subtypes are found in the User's Guide for CalEEMod Version 2020.4.0 available online at: <http://www.aqmd.gov/caleemod/user's-guide>
2. Expressed in units of square feet unless otherwise noted.
3. See project plans Sheet 002-TS.

METHODOLOGY

Unless otherwise noted, the calculated emissions estimates are based primarily on model default emissions factors for construction and operations of the project. Construction emissions estimates and existing and proposed operational criteria air pollutant emissions estimates are based on the size metrics presented in Table 1.

Modeling Scenarios

Two modeling scenarios were conducted for the proposed project: Baseline (Existing) Emissions and Proposed Project Emissions.

Baseline (Existing) Emissions Scenario

This scenario consists of unmitigated criteria pollutant emissions volumes that are generated by the existing single-family residential dwelling unit on the project site (refer to Table 1).

Adjustments are made to the model to account for low carbon intensity efficiencies that are explained in greater detail under the Operational Data Inputs discussion.

Proposed Project Emissions Scenario

This scenario estimates unmitigated emissions anticipated through compliance with state regulations. This scenario includes model adjustments to account for mandatory compliance with State requirements for Model Water Efficient Landscape Ordinance (MWELO) and the current Title 24 Building Energy Efficiency Standards (BEES). These model adjustments are explained in greater detail under the Operational Data Inputs discussion.

Assumptions

Unless otherwise noted, data inputs for the model scenarios are based on the following primary assumptions:

1. Operational emissions generated by the existing residential building and out building at the project site are estimated using the CalEEMod default land use subtype “Single Family Housing”, which is defined as all single family detached homes on individual lots typical of a suburban subdivision;
2. Construction of the proposed project is expected to begin in January 15, 2023;
3. Buildout is expected by August 15, 2024;
4. For modeling purposes operational emissions are estimated in 2025;
5. Construction and operational emissions for proposed conditions were estimated as follows:
 - a. Emissions generated by the proposed residential units are assumed to be similar to emissions that would be generated by the CalEEMod default land use subtype “Condo/Townhouse”, which are defined as Ownership units that have at least one other owned unit within the same building structure. The model default trip generation rate for “Condo/Townhouse” has been modified based

on information provided in the transportation analysis prepared for the proposed project (Hexagon Transportation Consultants 2021);

- b. Emissions generated by the proposed office spaces are assumed to be similar to emissions that would be generated by the CalEEMod default land use subtype “General Office Building”. The model default trip generation rate for “General Office Building” has been modified based on information provided in the transportation analysis prepared for the proposed project (Hexagon Transportation Consultants 2021);
- c. Emissions generated by the proposed underground parking garage are assumed to be similar to emissions that would be generated by the CalEEMod default land use subtype “Enclosed Parking with Elevator”, which is defined as an enclosed parking structure that may be above or below the ground, is not covered in asphalt, includes an elevator, and will require lighting and ventilation;
- d. The proposed project includes an emergency generator and a boiler room. Operational emissions associated with these features were also estimated using information provided by the applicant (Henry Cord, email communication with consultant, June 21,2021); and
- e. Emissions generated by construction and curing of the proposed sidewalks and landscaping are assumed to be similar to emissions that would be generated by the CalEEMod default land use subtype “Other Non-Asphalt Surfaces”.

Operational Emissions Data Input

The following adjustments were made to the model inputs:

- Each air district (or county) assigns trip lengths for urban and rural settings, which are incorporated into the CalEEMod defaults. Based on the site’s location, the model defaults were set to “urban.”
- The model’s default CO₂ intensity factor was adjusted to 203 pounds/megawatt hour to reflect Pacific Gas & Electric (PG&E) energy intensity during 2019, the most current data

year. The intensity factor has been falling, in significant part due to the increasing percentage of Pacific Gas & Electric's energy portfolio obtained from renewable energy.

- As noted previously, the model default trip generation rates for the proposed residential condominiums and office spaces are adjusted based on information provided in the transportation analysis prepared for the proposed project (Hexagon Transportation Consultants 2021).
- The Title 24 building energy efficiency defaults in CalEEMod Version 2016.3.2 are the 2016 Title 24 standards. Title 24 standards are updated every three years. The 2019 Title 24 standards were recently adopted and become effective on January 1, 2020 (California Energy Commission 2018). Projects that buildout after January 1, 2020 will be required to comply with the 2019 Title 24 standards. An adjustment of 30 percent was made to the energy mitigation screen under the proposed project scenario to account for reductions in energy demand from increased building energy efficiencies above the 2016 Title 24 standards due to compliance with the 2019 Title 24 standards (California Energy Commission 2021).

Construction Emissions Data Inputs

CalEEMod default construction parameters allow estimates of short-term construction emissions based upon empirical data collected and analyzed by CARB. CalEEMod estimates construction emissions associated with land use development projects and allows for the input of project-specific construction information including phasing and equipment information, if known. Project construction is estimated to occur over a 20-month period. Grading for the proposed project includes excavation and off-site disposal of 14,144 cubic yards of soil, and import of 600 cubic yards of fill. Proposed demolition includes disposal of 4,954 square feet of building material and 262 tons of pavement/concrete. Estimates of the number, type, and size of construction equipment, and vendor trips (concrete delivery) was derived from information provided by the applicant (Henry Cord, email communication to consultant, June 21, 2021).

The model default construction data inputs were modified to reflect compliance with the air district best management practices of watering exposed soils three times per day and reducing speeds on unpaved surfaces to five miles per hour. The modeling results for unmitigated construction emissions volumes are attached to this assessment.

RESULTS

Detailed model results for criteria air pollutants emissions are included as attachments to this assessment.

Construction Emissions

The highest year unmitigated criteria air pollutant emissions resulting from project construction are summarized in [Table 2, Unmitigated Construction Criteria Air Pollutant Emissions](#). The highest year represents a worst-case scenario for annual construction emissions and is applied to the entire construction period.

Table 2 Unmitigated Construction Criteria Air Pollutant Emissions

Emissions	Reactive Organic Gases (ROG)	Nitrogen Oxides (NO _x)	Diesel Exhaust PM ₁₀	Total PM ₁₀	Total PM _{2.5}
Highest Annual Emissions (2024) ^{1,2}	0.27	0.29	0.12	0.03	0.02
Highest year Average Daily Emissions ^{1,3}	1.39	1.59	0.62	0.15	0.10

SOURCE: EMC Planning Group 2021

NOTES:

1. Results may vary due to rounding.
2. Tons per year
3. CalEEMod estimates construction criteria air pollutant emissions in **tons per year**. A U.S. ton is equal to 2,000 pounds. The emissions estimates in ton per year are multiplied by 2,000 pounds to arrive at emissions volume in pounds per year. CalEEMod estimates a total of 390 construction days (see Section 3.0 of the attached CalEEMod results). Highest year average daily emissions (in pounds per day) are computed by dividing the annual construction emissions (in pounds per year) by the number of construction days.

Operational Emissions

Unmitigated operational criteria air pollutant emissions generated by the proposed project are summarized in [Table 3, Unmitigated Operational Criteria Air Pollutant Emissions](#).

Table 3 Unmitigated Operational Criteria Air Pollutant Emissions

Emissions	Reactive Organic Gases (ROG) ¹	Nitrogen Oxides (NO _x) ¹	Respirable Particulate Matter (Total PM ₁₀) ¹	Fine Particulate Matter (Total PM _{2.5}) ¹
Existing Annual Emissions ²	0.04	0.01	0.01	<0.01

Proposed Annual Emissions ²	0.75	0.68	0.55	0.21
Net Operational Emissions ²	0.71	0.67	0.54	0.21
Net Average Daily Emissions	3.89	3.67	3.01	1.15

SOURCE: EMC Planning Group 2021

NOTES:

1. Results may vary due to rounding.
 2. Reported in tons per year.
 3. CalEEMod estimates operational criteria air pollutant emissions in tons per year. A U.S. ton is equal to 2,000 pounds. The emissions estimates in ton per year are multiplied by 2,000 pounds to arrive at emissions volume in pounds per year. Average daily emissions (in pounds per day) are computed by dividing the annual operational emissions (in pounds per year) by the number of operational days (assuming 365 days of operation).
-

SOURCES

1. Trinity Consultants. November 2021. *California Emissions Estimator (CalEEMod) Version 2020.4.0*. Available online at: <http://www.aqmd.gov/caleemod/home>
2. Trinity Consultants. November 2021. *CalEEMod User's Guide (Version 2020.4.0)*. Available online at: <http://www.aqmd.gov/caleemod/user's-guide>
3. Bay Area Air Quality Management District. May 2017. *California Environmental Quality Act Air Quality Guidelines*. http://www.baaqmd.gov/~media/files/planning-and-research/ceqa/ceqa_guidelines_may2017-pdf.pdf?la=en
4. Carpira Design Group. April 2021. *Project Plans*. Concord, CA.
5. Hexagon Transportation Consultants. *1065 South Winchester Mixed-Use Development Transportation Analysis*. June 21, 2021. Gilroy, CA.

Trinity Consultants

1065 South Winchester Blvd Mixed Use_Proposed Conditions- Bay Area AQMD Air District, Annual

**1065 South Winchester Blvd Mixed Use Project - Proposed Conditions
Bay Area AQMD Air District, Annual**

1.0 Project Characteristics

1.1 Land Usage

Land Uses	Size	Metric	Lot Acreage	Floor Surface Area	Population
General Office Building	20.41	1000sqft	0.00	20,410.00	0
Enclosed Parking with Elevator	104.00	Space	0.69	44,112.00	0
Other Non-Asphalt Surfaces	2.60	1000sqft	0.14	3,000.00	0
Other Non-Asphalt Surfaces	4.41	1000sqft	0.10	4,437.00	0
Condo/Townhouse	70.00	Dwelling Unit	0.00	101,648.00	200

1.2 Other Project Characteristics

Urbanization	Urban	Wind Speed (m/s)	2.2	Precipitation Freq (Days)	64
Climate Zone	4	Operational Year	2025		
Utility Company	Pacific Gas & Electric Company				
CO2 Intensity (lb/MW hr)	203	CH4 Intensity (lb/MW hr)	0.029	N2O Intensity (lb/MW hr)	0.006

1.3 User Entered Comments & Non-Default Data

Project Characteristics - Adjusted PG&E CO2 Intensity Factor represents the most current data available, 2019

Land Use - from site plans

Construction Phase - adjusted for 20-month construction period

Off-road Equipment - From Construction Info Request.

Off-road Equipment - From Construction Info Data Request

Off-road Equipment - From Construction Info Data Request

Off-road Equipment - From Construction info request.

Off-road Equipment - From Construction Info Data Request. Concrete will be used for paving.

Off-road Equipment - From Construction Info Data Request

Off-road Equipment - From Construction info request.

Trips and VMT - 720 round trips, cement trucks

Demolished pavement is include in the demolition estimate.

On-road Fugitive Dust - Assume 5 mph onsite because site is too small to go faster than 5 mph.

Demolition - Based on FEMA estimates.

Construction Off-road Equipment Mitigation - 5 Tier 4 engines, only mitigation for DPM PM10

Table Name	Column Name	Default Value	New Value
tblConstEquipMitigation	DPF	No Change	Level 3
tblConstEquipMitigation	DPF	No Change	Level 3
tblConstEquipMitigation	DPF	No Change	Level 3
tblConstEquipMitigation	DPF	No Change	Level 3
tblConstEquipMitigation	DPF	No Change	Level 3
tblConstEquipMitigation	DPF	No Change	Level 3
tblConstEquipMitigation	DPF	No Change	Level 3
tblConstEquipMitigation	DPF	No Change	Level 3
tblConstEquipMitigation	DPF	No Change	Level 3
tblConstEquipMitigation	NumberOfEquipmentMitigated	0.00	1.00
tblConstEquipMitigation	NumberOfEquipmentMitigated	0.00	1.00
tblConstEquipMitigation	NumberOfEquipmentMitigated	0.00	2.00
tblConstEquipMitigation	NumberOfEquipmentMitigated	0.00	3.00
tblConstEquipMitigation	NumberOfEquipmentMitigated	0.00	1.00
tblConstEquipMitigation	NumberOfEquipmentMitigated	0.00	4.00
tblConstEquipMitigation	NumberOfEquipmentMitigated	0.00	2.00
tblConstEquipMitigation	NumberOfEquipmentMitigated	0.00	2.00
tblConstEquipMitigation	NumberOfEquipmentMitigated	0.00	1.00
tblConstEquipMitigation	NumberOfEquipmentMitigated	0.00	1.00
tblConstEquipMitigation	NumberOfEquipmentMitigated	0.00	3.00
tblConstEquipMitigation	NumberOfEquipmentMitigated	0.00	12.00
tblConstEquipMitigation	Tier	No Change	Tier 4 Final
tblConstEquipMitigation	Tier	No Change	Tier 4 Final

tblConstEquipMitigation	Tier	No Change	Tier 4 Final
tblConstEquipMitigation	Tier	No Change	Tier 4 Final
tblConstEquipMitigation	Tier	No Change	Tier 4 Final
tblConstEquipMitigation	Tier	No Change	Tier 4 Final
tblConstEquipMitigation	Tier	No Change	Tier 4 Final
tblConstEquipMitigation	Tier	No Change	Tier 4 Final
tblConstEquipMitigation	Tier	No Change	Tier 4 Final
tblConstructionPhase	NumDays	5.00	100.00
tblConstructionPhase	NumDays	100.00	200.00
tblConstructionPhase	NumDays	2.00	40.00
tblConstructionPhase	NumDays	5.00	10.00
tblConstructionPhase	NumDays	1.00	10.00
tblGrading	AcresOfGrading	20.00	0.93
tblGrading	AcresOfGrading	5.00	0.93
tblGrading	MaterialExported	0.00	14,144.00
tblGrading	MaterialImported	0.00	600.00
tblLandUse	LandUseSquareFeet	41,600.00	44,112.00
tblLandUse	LandUseSquareFeet	2,600.00	3,000.00
tblLandUse	LandUseSquareFeet	4,410.00	4,437.00
tblLandUse	LandUseSquareFeet	70,000.00	101,648.00
tblLandUse	LotAcreage	0.47	0.00
tblLandUse	LotAcreage	0.94	0.69
tblLandUse	LotAcreage	0.06	0.14
tblLandUse	LotAcreage	4.38	0.00
tblOffRoadEquipment	OffRoadEquipmentUnitAmount	4.00	2.00
tblOffRoadEquipment	OffRoadEquipmentUnitAmount	1.00	2.00
tblOffRoadEquipment	OffRoadEquipmentUnitAmount	2.00	1.00
tblOffRoadEquipment	OffRoadEquipmentUnitAmount	2.00	3.00
tblOffRoadEquipment	OffRoadEquipmentUnitAmount	1.00	2.00
tblOffRoadEquipment	OffRoadEquipmentUnitAmount	1.00	3.00
tblOffRoadEquipment	UsageHours	1.00	8.00
tblOffRoadEquipment	UsageHours	6.00	8.00

tblOffRoadEquipment	UsageHours	1.00	8.00
tblOffRoadEquipment	UsageHours	6.00	8.00
tblOffRoadEquipment	UsageHours	4.00	8.00
tblOffRoadEquipment	UsageHours	6.00	8.00
tblOffRoadEquipment	UsageHours	6.00	8.00
tblOffRoadEquipment	UsageHours	6.00	8.00
tblOffRoadEquipment	UsageHours	7.00	8.00
tblOnRoadDust	MeanVehicleSpeed	40.00	5.00
tblOnRoadDust	MeanVehicleSpeed	40.00	5.00
tblOnRoadDust	MeanVehicleSpeed	40.00	5.00
tblOnRoadDust	MeanVehicleSpeed	40.00	5.00
tblOnRoadDust	MeanVehicleSpeed	40.00	5.00
tblOnRoadDust	MeanVehicleSpeed	40.00	5.00
tblOnRoadDust	MeanVehicleSpeed	40.00	5.00
tblOnRoadDust	MeanVehicleSpeed	40.00	5.00
tblProjectCharacteristics	CO2IntensityFactor	641.35	203
tblRoadDust	MeanVehicleSpeed	40	5
tblTripsAndVMT	HaulingTripNumber	0.00	720.00
tblTripsAndVMT	WorkerTripNumber	15.00	10.00

2.0 Emissions Summary

2.1 Overall Construction

Unmitigated Construction

	ROG	NOx	CO	SO2	Fugitive PM10	Exhaust PM10	PM10 Total	Fugitive PM2.5	Exhaust PM2.5	PM2.5 Total	Bio- CO2	NBio- CO2	Total CO2	CH4	N2O	CO2e
Year	tons/yr										MT/yr					
2023	0.1502	1.5669	1.3637	4.0000e-003	0.2503	0.0576	0.3078	0.1084	0.0533	0.1617	0.0000	364.5919	364.5919	0.0629	0.0000	366.1642
2024	0.8679	0.2861	0.3778	7.9000e-004	0.0198	0.0117	0.0315	5.3200e-003	0.0111	0.0164	0.0000	70.2840	70.2840	0.0117	0.0000	70.5767
Maximum	0.8679	1.5669	1.3637	4.0000e-003	0.2503	0.0576	0.3078	0.1084	0.0533	0.1617	0.0000	364.5919	364.5919	0.0629	0.0000	366.1642

Mitigated Construction

	ROG	NOx	CO	SO2	Fugitive PM10	Exhaust PM10	PM10 Total	Fugitive PM2.5	Exhaust PM2.5	PM2.5 Total	Bio- CO2	NBio- CO2	Total CO2	CH4	N2O	CO2e
Year	tons/yr										M1/yr					
2023	0.0630	0.5320	1.5378	4.0000e-003	0.1517	5.9100e-003	0.1576	0.0569	5.8500e-003	0.0628	0.0000	364.5917	364.5917	0.0629	0.0000	366.1640
2024	0.8571	0.1751	0.4085	7.9000e-004	0.0198	4.5500e-003	0.0244	5.3200e-003	4.5400e-003	9.8600e-003	0.0000	70.2839	70.2839	0.0117	0.0000	70.5766
Maximum	0.8571	0.5320	1.5378	4.0000e-003	0.1517	5.9100e-003	0.1576	0.0569	5.8500e-003	0.0628	0.0000	364.5917	364.5917	0.0629	0.0000	366.1640

	ROG	NOx	CO	SO2	Fugitive PM10	Exhaust PM10	PM10 Total	Fugitive PM2.5	Exhaust PM2.5	PM2.5 Total	Bio- CO2	NBio- CO2	Total CO2	CH4	N2O	CO2e
Percent Reduction	9.63	61.84	-11.76	0.00	36.51	84.89	46.38	45.27	83.85	59.21	0.00	0.00	0.00	0.00	0.00	0.00

Quarter	Start Date	End Date	Maximum Unmitigated ROG + NOX (tons/quarter)	Maximum Mitigated ROG + NOX (tons/quarter)
1	1-15-2023	4-14-2023	0.8033	0.3084
2	4-15-2023	7-14-2023	0.3153	0.1277
3	7-15-2023	10-14-2023	0.3222	0.0857
4	10-15-2023	1-14-2024	0.3205	0.0870
5	1-15-2024	4-14-2024	0.3206	0.2474
6	4-15-2024	7-14-2024	0.6222	0.6360
7	7-15-2024	9-30-2024	0.1592	0.1344
		Highest	0.8033	0.6360

3.0 Construction Detail

Construction Phase

Phase Number	Phase Name	Phase Type	Start Date	End Date	Num Days Week	Num Days	Phase Description
1	Demolition	Demolition	1/15/2023	1/27/2023	5	10	
2	Site Preparation	Site Preparation	2/1/2023	2/14/2023	5	10	
3	Grading	Grading	2/15/2023	4/11/2023	5	40	
4	Trenching	Trenching	4/15/2023	5/14/2023	5	20	
5	Building Construction	Building Construction	5/15/2023	2/16/2024	5	200	
6	Architectural Coating	Architectural Coating	3/15/2024	8/1/2024	5	100	

7	Paving	Paving	8/1/2024	8/14/2024	5	10
---	--------	--------	----------	-----------	---	----

Acres of Grading (Site Preparation Phase): 0.93

Acres of Grading (Grading Phase): 0.93

Acres of Paving: 0.93

Residential Indoor: 205,837; Residential Outdoor: 68,612; Non-Residential Indoor: 30,615; Non-Residential Outdoor: 10,205; Striped

OffRoad Equipment

Phase Name	Offroad Equipment Type	Amount	Usage Hours	Horse Power	Load Factor
Demolition	Concrete/Industrial Saws	2	8.00	81	0.73
Demolition	Excavators	1	8.00	158	0.38
Demolition	Rubber Tired Dozers	1	8.00	247	0.40
Demolition	Tractors/Loaders/Backhoes	3	8.00	97	0.37
Site Preparation	Graders	1	8.00	187	0.41
Site Preparation	Rubber Tired Dozers	1	8.00	247	0.40
Site Preparation	Tractors/Loaders/Backhoes	3	8.00	97	0.37
Grading	Concrete/Industrial Saws	1	8.00	81	0.73
Grading	Excavators	2	8.00	158	0.38
Grading	Graders	1	8.00	187	0.41
Grading	Rubber Tired Dozers	1	8.00	247	0.40
Grading	Tractors/Loaders/Backhoes	2	8.00	97	0.37
Trenching	Excavators	1	8.00	158	0.38
Trenching	Tractors/Loaders/Backhoes	1	8.00	97	0.37
Building Construction	Cranes	1	8.00	231	0.29
Building Construction	Forklifts	2	8.00	89	0.20
Building Construction	Tractors/Loaders/Backhoes	1	8.00	97	0.37
Architectural Coating	Aerial Lifts	1	8.00	63	0.31
Architectural Coating	Air Compressors	1	8.00	78	0.48
Paving	Cement and Mortar Mixers	2	8.00	9	0.56
Paving	Pavers	1	7.00	130	0.42
Paving	Rollers	1	7.00	80	0.38

Paving	Tractors/Loaders/Backhoes	2	8.00	97	0.37
--------	---------------------------	---	------	----	------

Trips and VMT

Phase Name	Offroad Equipment Count	Worker Trip Number	Vendor Trip Number	Hauling Trip Number	Worker Trip Length	Vendor Trip Length	Hauling Trip Length	Worker Vehicle Class	Vendor Vehicle Class	Hauling Vehicle Class
Demolition	7	18.00	0.00	86.00	10.80	7.30	20.00	LD_Mix	HDT_Mix	HHDT
Site Preparation	5	13.00	0.00	0.00	10.80	7.30	20.00	LD_Mix	HDT_Mix	HHDT
Grading	7	18.00	0.00	1,843.00	10.80	7.30	20.00	LD_Mix	HDT_Mix	HHDT
Trenching	2	5.00	0.00	720.00	10.80	7.30	20.00	LD_Mix	HDT_Mix	HHDT
Building Construction	4	79.00	19.00	0.00	10.80	7.30	20.00	LD_Mix	HDT_Mix	HHDT
Architectural Coating	2	16.00	0.00	0.00	10.80	7.30	20.00	LD_Mix	HDT_Mix	HHDT
Paving	6	10.00	0.00	0.00	10.80	7.30	20.00	LD_Mix	HDT_Mix	HHDT

3.1 Mitigation Measures Construction

Use Cleaner Engines for Construction Equipment

Use DPF for Construction Equipment

Water Exposed Area

3.2 Demolition - 2023

Unmitigated Construction On-Site

	ROG	NOx	CO	SO2	Fugitive PM10	Exhaust PM10	PM10 Total	Fugitive PM2.5	Exhaust PM2.5	PM2.5 Total	Bio- CO2	NBio- CO2	Total CO2	CH4	N2O	CO2e
Category	tons/yr										MT/yr					
Fugitive Dust					9.2600e-003	0.0000	9.2600e-003	1.4000e-003	0.0000	1.4000e-003	0.0000	0.0000	0.0000	0.0000	0.0000	0.0000
Off-Road	9.9700e-003	0.0923	0.1019	1.8000e-004		4.4000e-003	4.4000e-003		4.1500e-003	4.1500e-003	0.0000	15.5000	15.5000	3.5400e-003	0.0000	15.5885
Total	9.9700e-003	0.0923	0.1019	1.8000e-004	9.2600e-003	4.4000e-003	0.0137	1.4000e-003	4.1500e-003	5.5500e-003	0.0000	15.5000	15.5000	3.5400e-003	0.0000	15.5885

Unmitigated Construction Off-Site

	ROG	NOx	CO	SO2	Fugitive PM10	Exhaust PM10	PM10 Total	Fugitive PM2.5	Exhaust PM2.5	PM2.5 Total	Bio- CO2	NBio- CO2	Total CO2	CH4	N2O	CO2e
Category	tons/yr										MT/yr					
Hauling	2.2000e-004	7.1300e-003	2.2000e-003	3.0000e-005	7.3000e-004	1.0000e-005	7.4000e-004	2.0000e-004	1.0000e-005	2.1000e-004	0.0000	3.0865	3.0865	1.5000e-004	0.0000	3.0902
Vendor	0.0000	0.0000	0.0000	0.0000	0.0000	0.0000	0.0000	0.0000	0.0000	0.0000	0.0000	0.0000	0.0000	0.0000	0.0000	0.0000
Worker	2.4000e-004	1.5000e-004	1.7100e-003	1.0000e-005	7.1000e-004	0.0000	7.2000e-004	1.9000e-004	0.0000	1.9000e-004	0.0000	0.5570	0.5570	1.0000e-005	0.0000	0.5572
Total	4.6000e-004	7.2800e-003	3.9100e-003	4.0000e-005	1.4400e-003	1.0000e-005	1.4600e-003	3.9000e-004	1.0000e-005	4.0000e-004	0.0000	3.6435	3.6435	1.6000e-004	0.0000	3.6474

Mitigated Construction On-Site

	ROG	NOx	CO	SO2	Fugitive PM10	Exhaust PM10	PM10 Total	Fugitive PM2.5	Exhaust PM2.5	PM2.5 Total	Bio- CO2	NBio- CO2	Total CO2	CH4	N2O	CO2e
Category	tons/yr										MT/yr					
Fugitive Dust					3.6100e-003	0.0000	3.6100e-003	5.5000e-004	0.0000	5.5000e-004	0.0000	0.0000	0.0000	0.0000	0.0000	0.0000
Off-Road	4.7500e-003	0.0320	0.1105	1.8000e-004		1.3800e-003	1.3800e-003		1.3800e-003	1.3800e-003	0.0000	15.5000	15.5000	3.5400e-003	0.0000	15.5885
Total	4.7500e-003	0.0320	0.1105	1.8000e-004	3.6100e-003	1.3800e-003	4.9900e-003	5.5000e-004	1.3800e-003	1.9300e-003	0.0000	15.5000	15.5000	3.5400e-003	0.0000	15.5885

Mitigated Construction Off-Site

	ROG	NOx	CO	SO2	Fugitive PM10	Exhaust PM10	PM10 Total	Fugitive PM2.5	Exhaust PM2.5	PM2.5 Total	Bio- CO2	NBio- CO2	Total CO2	CH4	N2O	CO2e
Category	tons/yr										MT/yr					

Hauling	2.2000e-004	7.1300e-003	2.2000e-003	3.0000e-005	7.3000e-004	1.0000e-005	7.4000e-004	2.0000e-004	1.0000e-005	2.1000e-004	0.0000	3.0865	3.0865	1.5000e-004	0.0000	3.0902
Vendor	0.0000	0.0000	0.0000	0.0000	0.0000	0.0000	0.0000	0.0000	0.0000	0.0000	0.0000	0.0000	0.0000	0.0000	0.0000	0.0000
Worker	2.4000e-004	1.5000e-004	1.7100e-003	1.0000e-005	7.1000e-004	0.0000	7.2000e-004	1.9000e-004	0.0000	1.9000e-004	0.0000	0.5570	0.5570	1.0000e-005	0.0000	0.5572
Total	4.6000e-004	7.2800e-003	3.9100e-003	4.0000e-005	1.4400e-003	1.0000e-005	1.4600e-003	3.9000e-004	1.0000e-005	4.0000e-004	0.0000	3.6435	3.6435	1.6000e-004	0.0000	3.6474

3.3 Site Preparation - 2023

Unmitigated Construction On-Site

	ROG	NOx	CO	SO2	Fugitive PM10	Exhaust PM10	PM10 Total	Fugitive PM2.5	Exhaust PM2.5	PM2.5 Total	Bio- CO2	NBio- CO2	Total CO2	CH4	N2O	CO2e
Category	tons/yr										MT/yr					
Fugitive Dust					0.0306	0.0000	0.0306	0.0166	0.0000	0.0166	0.0000	0.0000	0.0000	0.0000	0.0000	0.0000
Off-Road	7.6100e-003	0.0819	0.0575	1.2000e-004		3.5000e-003	3.5000e-003		3.2200e-003	3.2200e-003	0.0000	10.7619	10.7619	3.4800e-003	0.0000	10.8489
Total	7.6100e-003	0.0819	0.0575	1.2000e-004	0.0306	3.5000e-003	0.0341	0.0166	3.2200e-003	0.0198	0.0000	10.7619	10.7619	3.4800e-003	0.0000	10.8489

Unmitigated Construction Off-Site

	ROG	NOx	CO	SO2	Fugitive PM10	Exhaust PM10	PM10 Total	Fugitive PM2.5	Exhaust PM2.5	PM2.5 Total	Bio- CO2	NBio- CO2	Total CO2	CH4	N2O	CO2e
Category	tons/yr										MT/yr					
Hauling	0.0000	0.0000	0.0000	0.0000	0.0000	0.0000	0.0000	0.0000	0.0000	0.0000	0.0000	0.0000	0.0000	0.0000	0.0000	0.0000
Vendor	0.0000	0.0000	0.0000	0.0000	0.0000	0.0000	0.0000	0.0000	0.0000	0.0000	0.0000	0.0000	0.0000	0.0000	0.0000	0.0000
Worker	1.7000e-004	1.1000e-004	1.2300e-003	0.0000	5.1000e-004	0.0000	5.2000e-004	1.4000e-004	0.0000	1.4000e-004	0.0000	0.4023	0.4023	1.0000e-005	0.0000	0.4025
Total	1.7000e-004	1.1000e-004	1.2300e-003	0.0000	5.1000e-004	0.0000	5.2000e-004	1.4000e-004	0.0000	1.4000e-004	0.0000	0.4023	0.4023	1.0000e-005	0.0000	0.4025

Mitigated Construction On-Site

	ROG	NOx	CO	SO2	Fugitive PM10	Exhaust PM10	PM10 Total	Fugitive PM2.5	Exhaust PM2.5	PM2.5 Total	Bio- CO2	NBio- CO2	Total CO2	CH4	N2O	CO2e
Category	tons/yr										MT/yr					
Fugitive Dust					0.0119	0.0000	0.0119	6.4800e-003	0.0000	6.4800e-003	0.0000	0.0000	0.0000	0.0000	0.0000	0.0000
Off-Road	1.5000e-003	6.4900e-003	0.0692	1.2000e-004		9.0000e-005	9.0000e-005		9.0000e-005	9.0000e-005	0.0000	10.7619	10.7619	3.4800e-003	0.0000	10.8489
Total	1.5000e-003	6.4900e-003	0.0692	1.2000e-004	0.0119	9.0000e-005	0.0120	6.4800e-003	9.0000e-005	6.5700e-003	0.0000	10.7619	10.7619	3.4800e-003	0.0000	10.8489

Mitigated Construction Off-Site

	ROG	NOx	CO	SO2	Fugitive PM10	Exhaust PM10	PM10 Total	Fugitive PM2.5	Exhaust PM2.5	PM2.5 Total	Bio- CO2	NBio- CO2	Total CO2	CH4	N2O	CO2e
Category	tons/yr										MT/yr					
Hauling	0.0000	0.0000	0.0000	0.0000	0.0000	0.0000	0.0000	0.0000	0.0000	0.0000	0.0000	0.0000	0.0000	0.0000	0.0000	0.0000
Vendor	0.0000	0.0000	0.0000	0.0000	0.0000	0.0000	0.0000	0.0000	0.0000	0.0000	0.0000	0.0000	0.0000	0.0000	0.0000	0.0000
Worker	1.7000e-004	1.1000e-004	1.2300e-003	0.0000	5.1000e-004	0.0000	5.2000e-004	1.4000e-004	0.0000	1.4000e-004	0.0000	0.4023	0.4023	1.0000e-005	0.0000	0.4025
Total	1.7000e-004	1.1000e-004	1.2300e-003	0.0000	5.1000e-004	0.0000	5.2000e-004	1.4000e-004	0.0000	1.4000e-004	0.0000	0.4023	0.4023	1.0000e-005	0.0000	0.4025

3.4 Grading - 2023

Unmitigated Construction On-Site

	ROG	NOx	CO	SO2	Fugitive PM10	Exhaust PM10	PM10 Total	Fugitive PM2.5	Exhaust PM2.5	PM2.5 Total	Bio- CO2	NBio- CO2	Total CO2	CH4	N2O	CO2e
--	-----	-----	----	-----	---------------	--------------	------------	----------------	---------------	-------------	----------	-----------	-----------	-----	-----	------

Category	tons/yr										MT/yr					
Fugitive Dust					0.1218	0.0000	0.1218	0.0664	0.0000	0.0664	0.0000	0.0000	0.0000	0.0000	0.0000	0.0000
Off-Road	0.0416	0.4107	0.3887	7.6000e-004		0.0181	0.0181		0.0168	0.0168	0.0000	66.4764	66.4764	0.0186	0.0000	66.9402
Total	0.0416	0.4107	0.3887	7.6000e-004	0.1218	0.0181	0.1398	0.0664	0.0168	0.0832	0.0000	66.4764	66.4764	0.0186	0.0000	66.9402

Unmitigated Construction Off-Site

	ROG	NOx	CO	SO2	Fugitive PM10	Exhaust PM10	PM10 Total	Fugitive PM2.5	Exhaust PM2.5	PM2.5 Total	Bio- CO2	NBio- CO2	Total CO2	CH4	N2O	CO2e
Category	tons/yr										MT/yr					
Hauling	4.6800e-003	0.1529	0.0472	6.8000e-004	0.0156	2.7000e-004	0.0158	4.2800e-003	2.6000e-004	4.5400e-003	0.0000	66.1452	66.1452	3.1300e-003	0.0000	66.2234
Vendor	0.0000	0.0000	0.0000	0.0000	0.0000	0.0000	0.0000	0.0000	0.0000	0.0000	0.0000	0.0000	0.0000	0.0000	0.0000	0.0000
Worker	9.6000e-004	6.1000e-004	6.8300e-003	2.0000e-005	2.8400e-003	2.0000e-005	2.8600e-003	7.6000e-004	2.0000e-005	7.7000e-004	0.0000	2.2279	2.2279	4.0000e-005	0.0000	2.2290
Total	5.6400e-003	0.1535	0.0540	7.0000e-004	0.0184	2.9000e-004	0.0187	5.0400e-003	2.8000e-004	5.3100e-003	0.0000	68.3731	68.3731	3.1700e-003	0.0000	68.4524

Mitigated Construction On-Site

	ROG	NOx	CO	SO2	Fugitive PM10	Exhaust PM10	PM10 Total	Fugitive PM2.5	Exhaust PM2.5	PM2.5 Total	Bio- CO2	NBio- CO2	Total CO2	CH4	N2O	CO2e
Category	tons/yr										MT/yr					
Fugitive Dust					0.0475	0.0000	0.0475	0.0259	0.0000	0.0259	0.0000	0.0000	0.0000	0.0000	0.0000	0.0000
Off-Road	0.0145	0.0854	0.4597	7.6000e-004		2.8900e-003	2.8900e-003		2.8900e-003	2.8900e-003	0.0000	66.4764	66.4764	0.0186	0.0000	66.9401
Total	0.0145	0.0854	0.4597	7.6000e-004	0.0475	2.8900e-003	0.0504	0.0259	2.8900e-003	0.0288	0.0000	66.4764	66.4764	0.0186	0.0000	66.9401

Mitigated Construction Off-Site

	ROG	NOx	CO	SO2	Fugitive PM10	Exhaust PM10	PM10 Total	Fugitive PM2.5	Exhaust PM2.5	PM2.5 Total	Bio- CO2	NBio- CO2	Total CO2	CH4	N2O	CO2e
Category	tons/yr										MT/yr					
Hauling	4.6800e-003	0.1529	0.0472	6.8000e-004	0.0156	2.7000e-004	0.0158	4.2800e-003	2.6000e-004	4.5400e-003	0.0000	66.1452	66.1452	3.1300e-003	0.0000	66.2234
Vendor	0.0000	0.0000	0.0000	0.0000	0.0000	0.0000	0.0000	0.0000	0.0000	0.0000	0.0000	0.0000	0.0000	0.0000	0.0000	0.0000
Worker	9.6000e-004	6.1000e-004	6.8300e-003	2.0000e-005	2.8400e-003	2.0000e-005	2.8600e-003	7.6000e-004	2.0000e-005	7.7000e-004	0.0000	2.2279	2.2279	4.0000e-005	0.0000	2.2290
Total	5.6400e-003	0.1535	0.0540	7.0000e-004	0.0184	2.9000e-004	0.0187	5.0400e-003	2.8000e-004	5.3100e-003	0.0000	68.3731	68.3731	3.1700e-003	0.0000	68.4524

3.5 Trenching - 2023

Unmitigated Construction On-Site

	ROG	NOx	CO	SO2	Fugitive PM10	Exhaust PM10	PM10 Total	Fugitive PM2.5	Exhaust PM2.5	PM2.5 Total	Bio- CO2	NBio- CO2	Total CO2	CH4	N2O	CO2e
Category	tons/yr										MT/yr					
Off-Road	3.4000e-003	0.0308	0.0549	8.0000e-005		1.5200e-003	1.5200e-003		1.3900e-003	1.3900e-003	0.0000	7.2727	7.2727	2.3500e-003	0.0000	7.3315
Total	3.4000e-003	0.0308	0.0549	8.0000e-005		1.5200e-003	1.5200e-003		1.3900e-003	1.3900e-003	0.0000	7.2727	7.2727	2.3500e-003	0.0000	7.3315

Unmitigated Construction Off-Site

	ROG	NOx	CO	SO2	Fugitive PM10	Exhaust PM10	PM10 Total	Fugitive PM2.5	Exhaust PM2.5	PM2.5 Total	Bio- CO2	NBio- CO2	Total CO2	CH4	N2O	CO2e
--	-----	-----	----	-----	---------------	--------------	------------	----------------	---------------	-------------	----------	-----------	-----------	-----	-----	------

Category	tons/yr										MT/yr					
Hauling	1.8300e-003	0.0597	0.0184	2.7000e-004	6.0800e-003	1.1000e-004	6.1900e-003	1.6700e-003	1.0000e-004	1.7800e-003	0.0000	25.8408	25.8408	1.2200e-003	0.0000	25.8713
Vendor	0.0000	0.0000	0.0000	0.0000	0.0000	0.0000	0.0000	0.0000	0.0000	0.0000	0.0000	0.0000	0.0000	0.0000	0.0000	0.0000
Worker	1.3000e-004	9.0000e-005	9.5000e-004	0.0000	4.0000e-004	0.0000	4.0000e-004	1.1000e-004	0.0000	1.1000e-004	0.0000	0.3094	0.3094	1.0000e-005	0.0000	0.3096
Total	1.9600e-003	0.0598	0.0194	2.7000e-004	6.4800e-003	1.1000e-004	6.5900e-003	1.7800e-003	1.0000e-004	1.8900e-003	0.0000	26.1502	26.1502	1.2300e-003	0.0000	26.1809

Mitigated Construction On-Site

	ROG	NOx	CO	SO2	Fugitive PM10	Exhaust PM10	PM10 Total	Fugitive PM2.5	Exhaust PM2.5	PM2.5 Total	Bio- CO2	NBio- CO2	Total CO2	CH4	N2O	CO2e
Category	tons/yr										MT/yr					
Off-Road	1.0200e-003	4.4000e-003	0.0626	8.0000e-005		6.0000e-005	6.0000e-005		6.0000e-005	6.0000e-005	0.0000	7.2727	7.2727	2.3500e-003	0.0000	7.3315
Total	1.0200e-003	4.4000e-003	0.0626	8.0000e-005		6.0000e-005	6.0000e-005		6.0000e-005	6.0000e-005	0.0000	7.2727	7.2727	2.3500e-003	0.0000	7.3315

Mitigated Construction Off-Site

	ROG	NOx	CO	SO2	Fugitive PM10	Exhaust PM10	PM10 Total	Fugitive PM2.5	Exhaust PM2.5	PM2.5 Total	Bio- CO2	NBio- CO2	Total CO2	CH4	N2O	CO2e
Category	tons/yr										MT/yr					
Hauling	1.8300e-003	0.0597	0.0184	2.7000e-004	6.0800e-003	1.1000e-004	6.1900e-003	1.6700e-003	1.0000e-004	1.7800e-003	0.0000	25.8408	25.8408	1.2200e-003	0.0000	25.8713
Vendor	0.0000	0.0000	0.0000	0.0000	0.0000	0.0000	0.0000	0.0000	0.0000	0.0000	0.0000	0.0000	0.0000	0.0000	0.0000	0.0000
Worker	1.3000e-004	9.0000e-005	9.5000e-004	0.0000	4.0000e-004	0.0000	4.0000e-004	1.1000e-004	0.0000	1.1000e-004	0.0000	0.3094	0.3094	1.0000e-005	0.0000	0.3096

Total	1.9600e-003	0.0598	0.0194	2.7000e-004	6.4800e-003	1.1000e-004	6.5900e-003	1.7800e-003	1.0000e-004	1.8900e-003	0.0000	26.1502	26.1502	1.2300e-003	0.0000	26.1809
--------------	--------------------	---------------	---------------	--------------------	--------------------	--------------------	--------------------	--------------------	--------------------	--------------------	---------------	----------------	----------------	--------------------	---------------	----------------

3.6 Building Construction - 2023

Unmitigated Construction On-Site

	ROG	NOx	CO	SO2	Fugitive PM10	Exhaust PM10	PM10 Total	Fugitive PM2.5	Exhaust PM2.5	PM2.5 Total	Bio- CO2	NBio- CO2	Total CO2	CH4	N2O	CO2e
Category	tons/yr										MT/yr					
Off-Road	0.0584	0.5998	0.5243	9.9000e-004		0.0292	0.0292		0.0269	0.0269	0.0000	86.5524	86.5524	0.0280	0.0000	87.2523
Total	0.0584	0.5998	0.5243	9.9000e-004		0.0292	0.0292		0.0269	0.0269	0.0000	86.5524	86.5524	0.0280	0.0000	87.2523

Unmitigated Construction Off-Site

	ROG	NOx	CO	SO2	Fugitive PM10	Exhaust PM10	PM10 Total	Fugitive PM2.5	Exhaust PM2.5	PM2.5 Total	Bio- CO2	NBio- CO2	Total CO2	CH4	N2O	CO2e
Category	tons/yr										MT/yr					
Hauling	0.0000	0.0000	0.0000	0.0000	0.0000	0.0000	0.0000	0.0000	0.0000	0.0000	0.0000	0.0000	0.0000	0.0000	0.0000	0.0000
Vendor	3.4800e-003	0.1196	0.0344	4.1000e-004	0.0103	1.4000e-004	0.0104	2.9700e-003	1.3000e-004	3.1000e-003	0.0000	39.1254	39.1254	1.6300e-003	0.0000	39.1661
Worker	0.0174	0.0111	0.1236	4.5000e-004	0.0515	3.2000e-004	0.0518	0.0137	3.0000e-004	0.0140	0.0000	40.3340	40.3340	7.8000e-004	0.0000	40.3536
Total	0.0209	0.1307	0.1580	8.6000e-004	0.0618	4.6000e-004	0.0622	0.0167	4.3000e-004	0.0171	0.0000	79.4594	79.4594	2.4100e-003	0.0000	79.5197

Mitigated Construction On-Site

	ROG	NOx	CO	SO2	Fugitive PM10	Exhaust PM10	PM10 Total	Fugitive PM2.5	Exhaust PM2.5	PM2.5 Total	Bio- CO2	NBio- CO2	Total CO2	CH4	N2O	CO2e
Category	tons/yr										MT/yr					
Off-Road	0.0121	0.0524	0.5993	9.9000e-004		6.0000e-004	6.0000e-004		6.0000e-004	6.0000e-004	0.0000	86.5523	86.5523	0.0280	0.0000	87.2522
Total	0.0121	0.0524	0.5993	9.9000e-004		6.0000e-004	6.0000e-004		6.0000e-004	6.0000e-004	0.0000	86.5523	86.5523	0.0280	0.0000	87.2522

Mitigated Construction Off-Site

	ROG	NOx	CO	SO2	Fugitive PM10	Exhaust PM10	PM10 Total	Fugitive PM2.5	Exhaust PM2.5	PM2.5 Total	Bio- CO2	NBio- CO2	Total CO2	CH4	N2O	CO2e
Category	tons/yr										MT/yr					
Hauling	0.0000	0.0000	0.0000	0.0000	0.0000	0.0000	0.0000	0.0000	0.0000	0.0000	0.0000	0.0000	0.0000	0.0000	0.0000	0.0000
Vendor	3.4800e-003	0.1196	0.0344	4.1000e-004	0.0103	1.4000e-004	0.0104	2.9700e-003	1.3000e-004	3.1000e-003	0.0000	39.1254	39.1254	1.6300e-003	0.0000	39.1661
Worker	0.0174	0.0111	0.1236	4.5000e-004	0.0515	3.2000e-004	0.0518	0.0137	3.0000e-004	0.0140	0.0000	40.3340	40.3340	7.8000e-004	0.0000	40.3536
Total	0.0209	0.1307	0.1580	8.6000e-004	0.0618	4.6000e-004	0.0622	0.0167	4.3000e-004	0.0171	0.0000	79.4594	79.4594	2.4100e-003	0.0000	79.5197

3.6 Building Construction - 2024

Unmitigated Construction On-Site

	ROG	NOx	CO	SO2	Fugitive PM10	Exhaust PM10	PM10 Total	Fugitive PM2.5	Exhaust PM2.5	PM2.5 Total	Bio- CO2	NBio- CO2	Total CO2	CH4	N2O	CO2e
Category	tons/yr										MT/yr					
Off-Road	0.0116	0.1176	0.1101	2.1000e-004		5.5000e-003	5.5000e-003		5.0600e-003	5.0600e-003	0.0000	18.3624	18.3624	5.9400e-003	0.0000	18.5109
Total	0.0116	0.1176	0.1101	2.1000e-004		5.5000e-003	5.5000e-003		5.0600e-003	5.0600e-003	0.0000	18.3624	18.3624	5.9400e-003	0.0000	18.5109

Unmitigated Construction Off-Site

	ROG	NOx	CO	SO2	Fugitive PM10	Exhaust PM10	PM10 Total	Fugitive PM2.5	Exhaust PM2.5	PM2.5 Total	Bio- CO2	NBio- CO2	Total CO2	CH4	N2O	CO2e
Category	tons/yr										MT/yr					
Hauling	0.0000	0.0000	0.0000	0.0000	0.0000	0.0000	0.0000	0.0000	0.0000	0.0000	0.0000	0.0000	0.0000	0.0000	0.0000	0.0000
Vendor	7.1000e-004	0.0251	7.0200e-003	9.0000e-005	2.1800e-003	3.0000e-005	2.2100e-003	6.3000e-004	3.0000e-005	6.6000e-004	0.0000	8.2433	8.2433	3.4000e-004	0.0000	8.2518
Worker	3.4800e-003	2.1300e-003	0.0243	9.0000e-005	0.0109	7.0000e-005	0.0110	2.9100e-003	6.0000e-005	2.9700e-003	0.0000	8.2171	8.2171	1.5000e-004	0.0000	8.2208
Total	4.1900e-003	0.0272	0.0313	1.8000e-004	0.0131	1.0000e-004	0.0132	3.5400e-003	9.0000e-005	3.6300e-003	0.0000	16.4604	16.4604	4.9000e-004	0.0000	16.4726

Mitigated Construction On-Site

	ROG	NOx	CO	SO2	Fugitive PM10	Exhaust PM10	PM10 Total	Fugitive PM2.5	Exhaust PM2.5	PM2.5 Total	Bio- CO2	NBio- CO2	Total CO2	CH4	N2O	CO2e
Category	tons/yr										MT/yr					
Off-Road	2.5600e-003	0.0111	0.1271	2.1000e-004		1.3000e-004	1.3000e-004		1.3000e-004	1.3000e-004	0.0000	18.3624	18.3624	5.9400e-003	0.0000	18.5109
Total	2.5600e-003	0.0111	0.1271	2.1000e-004		1.3000e-004	1.3000e-004		1.3000e-004	1.3000e-004	0.0000	18.3624	18.3624	5.9400e-003	0.0000	18.5109

Mitigated Construction Off-Site

Worker	2.0100e-003	1.2300e-003	0.0141	5.0000e-005	6.3200e-003	4.0000e-005	6.3600e-003	1.6800e-003	4.0000e-005	1.7200e-003	0.0000	4.7549	4.7549	9.0000e-005	0.0000	4.7571
Total	2.0100e-003	1.2300e-003	0.0141	5.0000e-005	6.3200e-003	4.0000e-005	6.3600e-003	1.6800e-003	4.0000e-005	1.7200e-003	0.0000	4.7549	4.7549	9.0000e-005	0.0000	4.7571

Mitigated Construction On-Site

	ROG	NOx	CO	SO2	Fugitive PM10	Exhaust PM10	PM10 Total	Fugitive PM2.5	Exhaust PM2.5	PM2.5 Total	Bio- CO2	NBio- CO2	Total CO2	CH4	N2O	CO2e
Category	tons/yr										MT/yr					
Archit. Coating	0.8327					0.0000	0.0000		0.0000	0.0000	0.0000	0.0000	0.0000	0.0000	0.0000	0.0000
Off-Road	0.0141	0.1284	0.1844	2.8000e-004		4.0800e-003	4.0800e-003		4.0800e-003	4.0800e-003	0.0000	24.3980	24.3980	3.3400e-003	0.0000	24.4816
Total	0.8468	0.1284	0.1844	2.8000e-004		4.0800e-003	4.0800e-003		4.0800e-003	4.0800e-003	0.0000	24.3980	24.3980	3.3400e-003	0.0000	24.4816

Mitigated Construction Off-Site

	ROG	NOx	CO	SO2	Fugitive PM10	Exhaust PM10	PM10 Total	Fugitive PM2.5	Exhaust PM2.5	PM2.5 Total	Bio- CO2	NBio- CO2	Total CO2	CH4	N2O	CO2e
Category	tons/yr										MT/yr					
Hauling	0.0000	0.0000	0.0000	0.0000	0.0000	0.0000	0.0000	0.0000	0.0000	0.0000	0.0000	0.0000	0.0000	0.0000	0.0000	0.0000
Vendor	0.0000	0.0000	0.0000	0.0000	0.0000	0.0000	0.0000	0.0000	0.0000	0.0000	0.0000	0.0000	0.0000	0.0000	0.0000	0.0000
Worker	2.0100e-003	1.2300e-003	0.0141	5.0000e-005	6.3200e-003	4.0000e-005	6.3600e-003	1.6800e-003	4.0000e-005	1.7200e-003	0.0000	4.7549	4.7549	9.0000e-005	0.0000	4.7571
Total	2.0100e-003	1.2300e-003	0.0141	5.0000e-005	6.3200e-003	4.0000e-005	6.3600e-003	1.6800e-003	4.0000e-005	1.7200e-003	0.0000	4.7549	4.7549	9.0000e-005	0.0000	4.7571

3.8 Paving - 2024

Unmitigated Construction On-Site

	ROG	NOx	CO	SO2	Fugitive PM10	Exhaust PM10	PM10 Total	Fugitive PM2.5	Exhaust PM2.5	PM2.5 Total	Bio- CO2	NBio- CO2	Total CO2	CH4	N2O	CO2e
Category	tons/yr										MT/yr					
Off-Road	3.4700e-003	0.0325	0.0462	7.0000e-005		1.5200e-003	1.5200e-003		1.4100e-003	1.4100e-003	0.0000	6.0111	6.0111	1.8400e-003	0.0000	6.0571
Paving	0.0000					0.0000	0.0000		0.0000	0.0000	0.0000	0.0000	0.0000	0.0000	0.0000	0.0000
Total	3.4700e-003	0.0325	0.0462	7.0000e-005		1.5200e-003	1.5200e-003		1.4100e-003	1.4100e-003	0.0000	6.0111	6.0111	1.8400e-003	0.0000	6.0571

Unmitigated Construction Off-Site

	ROG	NOx	CO	SO2	Fugitive PM10	Exhaust PM10	PM10 Total	Fugitive PM2.5	Exhaust PM2.5	PM2.5 Total	Bio- CO2	NBio- CO2	Total CO2	CH4	N2O	CO2e
Category	tons/yr										MT/yr					
Hauling	0.0000	0.0000	0.0000	0.0000	0.0000	0.0000	0.0000	0.0000	0.0000	0.0000	0.0000	0.0000	0.0000	0.0000	0.0000	0.0000
Vendor	0.0000	0.0000	0.0000	0.0000	0.0000	0.0000	0.0000	0.0000	0.0000	0.0000	0.0000	0.0000	0.0000	0.0000	0.0000	0.0000
Worker	1.3000e-004	8.0000e-005	8.8000e-004	0.0000	4.0000e-004	0.0000	4.0000e-004	1.1000e-004	0.0000	1.1000e-004	0.0000	0.2972	0.2972	1.0000e-005	0.0000	0.2973
Total	1.3000e-004	8.0000e-005	8.8000e-004	0.0000	4.0000e-004	0.0000	4.0000e-004	1.1000e-004	0.0000	1.1000e-004	0.0000	0.2972	0.2972	1.0000e-005	0.0000	0.2973

Mitigated Construction On-Site

	ROG	NOx	CO	SO2	Fugitive PM10	Exhaust PM10	PM10 Total	Fugitive PM2.5	Exhaust PM2.5	PM2.5 Total	Bio- CO2	NBio- CO2	Total CO2	CH4	N2O	CO2e
Category	tons/yr										MT/yr					
Off-Road	1.3600e-003	7.0300e-003	0.0508	7.0000e-005		2.0000e-004	2.0000e-004		2.0000e-004	2.0000e-004	0.0000	6.0111	6.0111	1.8400e-003	0.0000	6.0571

Paving	0.0000					0.0000	0.0000		0.0000	0.0000	0.0000	0.0000	0.0000	0.0000	0.0000	0.0000
Total	1.3600e-003	7.0300e-003	0.0508	7.0000e-005		2.0000e-004	2.0000e-004		2.0000e-004	2.0000e-004	0.0000	6.0111	6.0111	1.8400e-003	0.0000	6.0571

Mitigated Construction Off-Site

	ROG	NOx	CO	SO2	Fugitive PM10	Exhaust PM10	PM10 Total	Fugitive PM2.5	Exhaust PM2.5	PM2.5 Total	Bio- CO2	NBio- CO2	Total CO2	CH4	N2O	CO2e
Category	tons/yr										MT/yr					
Hauling	0.0000	0.0000	0.0000	0.0000	0.0000	0.0000	0.0000	0.0000	0.0000	0.0000	0.0000	0.0000	0.0000	0.0000	0.0000	0.0000
Vendor	0.0000	0.0000	0.0000	0.0000	0.0000	0.0000	0.0000	0.0000	0.0000	0.0000	0.0000	0.0000	0.0000	0.0000	0.0000	0.0000
Worker	1.3000e-004	8.0000e-005	8.8000e-004	0.0000	4.0000e-004	0.0000	4.0000e-004	1.1000e-004	0.0000	1.1000e-004	0.0000	0.2972	0.2972	1.0000e-005	0.0000	0.2973
Total	1.3000e-004	8.0000e-005	8.8000e-004	0.0000	4.0000e-004	0.0000	4.0000e-004	1.1000e-004	0.0000	1.1000e-004	0.0000	0.2972	0.2972	1.0000e-005	0.0000	0.2973

APPENDIX E

AERMOD CONSTRUCTION HEALTH RISK CALCULATIONS

CONVERSION CHART

CalEEMod Output -->AERMOD Input

CalEEMod OUTPUT (Tons per Year) to AERMOD Input (Grams per Second per area)

Convert Tons/Year to Grams/Second Formula:

(X tons/year)(2000 lb/ton)(454 grams/lb)(1 year/365 days)(1 day/24 hours)(1 hour/3600 seconds)
= X grams per second

AREA is calculated in m². One acre equals 4,046.86 m²

PROJECT NAME: 1065 Winchester Blvd, San Jose

Project Site Area:	Acres	m²
	0.93	3,764

PM10					@ House #15 (MEI)		INFANT	ADULT	
YEAR	CALEEMOD	EMISSION	AERMOD	AERMOD	CANCER	CANCER			
EMITTED	OUTPUT	RATE	INPUT	OUTPUT	RISK	RISK	HAZARD		
UNMITIGATED DPM	Tons/YR	g/sec	g/sec/area	ug/m3	per million	per million	INDEX		
2023	0.0576	0.00166	4.407E-07	0.14949	31.57	0.52	0.030		
2024	0.0117	0.00034	8.951E-08	0.03036			0.006		
Total =	0.0693								

		CALEEMOD	EMISSION	AERMOD	AERMOD	INFANT	ADULT		
		OUTPUT	RATE	INPUT	OUTPUT	CANCER	CANCER	HAZARD	
		Tons/YR	g/sec	g/sec/area	ug/m3	per million	per million	INDEX	
85% MITIGATED DPM	2023	0.00591	0.00017	4.521E-08	0.03302	10	0.17	0.006604	
	2024	0.00455	0.00013	3.481E-08	0.02542			0.005084	

PM2.5		CALEEMOD	EMISSION	AERMOD	AERMOD	Project	Is project
YEAR	EMITTED	OUTPUT	RATE	INPUT	OUTPUT	Threshold	conc. >
		Tons/YR	g/sec	g/sec/area	ug/m3	ug/m3	Threshold
UNMITIGATED PM_{2.5}	2023	0.1617	0.00466	1.237E-06	0.41962	0.3	Yes
	2024	0.0164	0.00047	1.255E-07	0.04257	0.3	No
	Total =	0.1781					

YEAR	EMITTED	CALEEMOD	EMISSION	AERMOD	AERMOD	Project	Is project
		OUTPUT	RATE	INPUT	OUTPUT	Threshold	conc. >
		Tons/YR	g/sec	g/sec/area	ug/m3	ug/m3	Threshold
59% MITIGATED PM_{2.5}	2023	0.0628	0.00181	4.804E-07	0.16296	0.3	No
	2024	0.00986	0.00028	7.543E-08	0.02559	0.3	No

BREEZE AERMOD

Sensitive Receptor Results

2024 DPM PM10 Construction

0.0117 TPY and 8.951e-8 g/s-m²

Pollutant: PM10, Type: CONC (ug/m3) 5 YEAR AVG., Group: ALL**

Sen. Rcpt. #	Dsc. Rcpt. #	Description	UTM		Conc.
			East(m)	North(m)	
1	1	1	593014.00	4129520.20	0.08004
2	2	2	592933.90	4129471.20	0.00424
3	3	3	592917.40	4129470.60	0.00361
4	4	4	592897.00	4129470.60	0.00323
5	5	5	592877.50	4129470.90	0.00297
6	6	6	592869.70	4129467.00	0.00264
7	7	7	592832.50	4129490.30	0.00301
8	8	8	592814.00	4129489.70	0.0026
9	9	9	592810.70	4129442.00	0.00143
10	10	10	592840.80	4129444.30	0.00158
11	11	11	592875.90	4129512.70	0.00711
12	12	12	592866.50	4129513.00	0.00622
13	13	13	592892.40	4129511.70	0.00921
14	14	14	592909.90	4129512.70	0.01428
15	15	15	592931.30	4129513.40	0.03036
16	16	16	593072.70	4129584.00	0.00585
17	17	17	593072.70	4129573.00	0.00654
18	18	18	593072.40	4129563.90	0.00719
19	19	19	593072.10	4129554.50	0.00795
20	20	20	593086.00	4129584.40	0.00525
21	21	21	593111.70	4129585.00	0.00429
22	22	22	593111.60	4129576.20	0.00453
23	23	23	593112.60	4129566.20	0.00476
24	24	24	593123.00	4129566.50	0.00433
25	25	25	593131.40	4129565.90	0.00404
26	26	26	593138.80	4129566.90	0.00378
27	27	27	593138.20	4129575.60	0.00366

28	28	28	593138.20	4129584.70	0.00351
29	29	29	593152.50	4129586.00	0.00315
30	30	30	593152.80	4129577.60	0.00324
31	31	31	593152.80	4129569.50	0.00335
32	32	32	593160.90	4129569.10	0.00315
33	33	33	593171.30	4129568.20	0.00294
34	34	34	593179.40	4129569.10	0.00277
35	35	35	593179.00	4129576.90	0.0027
36	36	36	593178.40	4129586.00	0.00264
37	37	37	593178.40	4129625.50	0.0023
38	38	38	593177.80	4129634.30	0.00222
39	39	39	593178.10	4129642.70	0.00214
40	40	40	593169.00	4129643.70	0.00222
41	41	41	593159.90	4129643.70	0.00232
42	42	42	593150.50	4129643.10	0.00243
43	43	43	593149.90	4129633.30	0.00256
44	44	44	593149.90	4129622.90	0.00271
45	45	45	593139.50	4129622.90	0.00286
46	46	46	593139.80	4129632.40	0.00271
47	47	47	593139.50	4129645.00	0.00253
48	48	48	593127.80	4129643.70	0.00268
49	49	49	593119.10	4129643.40	0.00279
50	50	50	593108.70	4129644.70	0.00289
51	51	51	593108.40	4129633.00	0.00314
52	52	52	593109.30	4129622.90	0.00336
53	53	53	593078.20	4129517.60	0.01252
54	54	54	593089.20	4129517.90	0.01018
55	55	55	593099.00	4129517.90	0.00871
56	56	56	593078.20	4129486.80	0.02348
57	57	57	593088.60	4129487.40	0.01889
58	58	58	593098.60	4129487.10	0.01566
59	59	59	593077.60	4129458.90	0.02465
60	60	60	593088.90	4129458.60	0.0217
61	61	61	593100.90	4129458.90	0.01876
62	62	62	593079.50	4129428.70	0.01664
63	63	63	593089.90	4129429.10	0.01619
64	64	64	593100.30	4129428.70	0.01535
65	65	65	593109.00	4129429.40	0.01472

66	66	66	593136.30	4129526.70	0.00499
67	67	67	593136.60	4129518.90	0.00537
68	68	68	593136.30	4129509.80	0.00601
69	69	69	593135.90	4129501.40	0.0068
70	70	70	593132.40	4129482.20	0.00962
71	71	71	593142.10	4129482.60	0.00832
72	72	72	593152.80	4129482.20	0.00725
73	73	73	593133.00	4129456.60	0.01257
74	74	74	593143.10	4129456.30	0.0111
75	75	75	593156.00	4129456.00	0.00948
76	76	76	593137.90	4129435.90	0.01234
77	77	77	593137.50	4129426.50	0.01196
78	78	78	593138.20	4129417.10	0.01125

<http://www.breeze-software.com/>

BREEZE AERMOD
Sensitive Receptor Results
2023 DPM PM10 Construction
0.0576 TPY and 4.407e-7 g/s-m²

Pollutant: PM10, Type: CONC (ug/m3) 5 YEAR AVG., Group: ALL**

Sen. Rcpt. #	Dsc. Rcpt. #	Description	UTM		Conc.
			East(m)	North(m)	
1	1	1	593014.00	4129520.20	0.39407
2	2	2	592933.90	4129471.20	0.02087
3	3	3	592917.40	4129470.60	0.01777
4	4	4	592897.00	4129470.60	0.01592
5	5	5	592877.50	4129470.90	0.0146
6	6	6	592869.70	4129467.00	0.01299
7	7	7	592832.50	4129490.30	0.01482
8	8	8	592814.00	4129489.70	0.0128
9	9	9	592810.70	4129442.00	0.00702
10	10	10	592840.80	4129444.30	0.00777
11	11	11	592875.90	4129512.70	0.03498
12	12	12	592866.50	4129513.00	0.03063
13	13	13	592892.40	4129511.70	0.04536
14	14	14	592909.90	4129512.70	0.07031
15	15	15	592931.30	4129513.40	0.14949
16	16	16	593072.70	4129584.00	0.02879
17	17	17	593072.70	4129573.00	0.03219
18	18	18	593072.40	4129563.90	0.03541
19	19	19	593072.10	4129554.50	0.03912
20	20	20	593086.00	4129584.40	0.02587
21	21	21	593111.70	4129585.00	0.0211
22	22	22	593111.60	4129576.20	0.02229
23	23	23	593112.60	4129566.20	0.02342
24	24	24	593123.00	4129566.50	0.02131
25	25	25	593131.40	4129565.90	0.01988

26	26	26	593138.80	4129566.90	0.01861
27	27	27	593138.20	4129575.60	0.018
28	28	28	593138.20	4129584.70	0.01729
29	29	29	593152.50	4129586.00	0.0155
30	30	30	593152.80	4129577.60	0.01597
31	31	31	593152.80	4129569.50	0.01648
32	32	32	593160.90	4129569.10	0.01553
33	33	33	593171.30	4129568.20	0.01446
34	34	34	593179.40	4129569.10	0.01362
35	35	35	593179.00	4129576.90	0.0133
36	36	36	593178.40	4129586.00	0.01298
37	37	37	593178.40	4129625.50	0.01132
38	38	38	593177.80	4129634.30	0.01094
39	39	39	593178.10	4129642.70	0.01054
40	40	40	593169.00	4129643.70	0.01094
41	41	41	593159.90	4129643.70	0.01141
42	42	42	593150.50	4129643.10	0.01196
43	43	43	593149.90	4129633.30	0.01263
44	44	44	593149.90	4129622.90	0.01333
45	45	45	593139.50	4129622.90	0.01409
46	46	46	593139.80	4129632.40	0.01334
47	47	47	593139.50	4129645.00	0.01244
48	48	48	593127.80	4129643.70	0.01321
49	49	49	593119.10	4129643.40	0.01374
50	50	50	593108.70	4129644.70	0.01424
51	51	51	593108.40	4129633.00	0.01546
52	52	52	593109.30	4129622.90	0.01653
53	53	53	593078.20	4129517.60	0.06162
54	54	54	593089.20	4129517.90	0.05011
55	55	55	593099.00	4129517.90	0.04289
56	56	56	593078.20	4129486.80	0.11561
57	57	57	593088.60	4129487.40	0.09298
58	58	58	593098.60	4129487.10	0.07711
59	59	59	593077.60	4129458.90	0.12137
60	60	60	593088.90	4129458.60	0.10682
61	61	61	593100.90	4129458.90	0.09237
62	62	62	593079.50	4129428.70	0.08194
63	63	63	593089.90	4129429.10	0.0797

64	64	64	593100.30	4129428.70	0.07557
65	65	65	593109.00	4129429.40	0.07248
66	66	66	593136.30	4129526.70	0.02456
67	67	67	593136.60	4129518.90	0.02645
68	68	68	593136.30	4129509.80	0.02961
69	69	69	593135.90	4129501.40	0.03347
70	70	70	593132.40	4129482.20	0.04736
71	71	71	593142.10	4129482.60	0.04095
72	72	72	593152.80	4129482.20	0.0357
73	73	73	593133.00	4129456.60	0.06189
74	74	74	593143.10	4129456.30	0.05463
75	75	75	593156.00	4129456.00	0.04669
76	76	76	593137.90	4129435.90	0.06074
77	77	77	593137.50	4129426.50	0.0589
78	78	78	593138.20	4129417.10	0.0554

<http://www.breeze-software.com/>

BREEZE AERMOD

Sensitive Receptor Results

2023 Unmitigated PM_{2.5} Construction

0.1617 TPY and 1.237e-6 g/s-m²

Pollutant: PM25, Type: CONC (ug/m3) 5 YEAR AVG., Group: ALL**

Sen. Rcpt. #	Dsc. Rcpt. #	Description	UTM		Conc.
			East(m)	North(m)	
1	1	1	593014.00	4129520.20	1.10611
2	2	2	592933.90	4129471.20	0.05858
3	3	3	592917.40	4129470.60	0.04987
4	4	4	592897.00	4129470.60	0.04468
5	5	5	592877.50	4129470.90	0.04099
6	6	6	592869.70	4129467.00	0.03645
7	7	7	592832.50	4129490.30	0.0416
8	8	8	592814.00	4129489.70	0.03592
9	9	9	592810.70	4129442.00	0.0197
10	10	10	592840.80	4129444.30	0.02181
11	11	11	592875.90	4129512.70	0.0982
12	12	12	592866.50	4129513.00	0.08599
13	13	13	592892.40	4129511.70	0.12731
14	14	14	592909.90	4129512.70	0.19736
15	15	15	592931.30	4129513.40	0.41962
16	16	16	593072.70	4129584.00	0.08082
17	17	17	593072.70	4129573.00	0.09035
18	18	18	593072.40	4129563.90	0.09939
19	19	19	593072.10	4129554.50	0.1098
20	20	20	593086.00	4129584.40	0.07261
21	21	21	593111.70	4129585.00	0.05923
22	22	22	593111.60	4129576.20	0.06256
23	23	23	593112.60	4129566.20	0.06574
24	24	24	593123.00	4129566.50	0.05981
25	25	25	593131.40	4129565.90	0.05581
26	26	26	593138.80	4129566.90	0.05223
27	27	27	593138.20	4129575.60	0.05051

28	28	28	593138.20	4129584.70	0.04853
29	29	29	593152.50	4129586.00	0.04352
30	30	30	593152.80	4129577.60	0.04482
31	31	31	593152.80	4129569.50	0.04625
32	32	32	593160.90	4129569.10	0.04359
33	33	33	593171.30	4129568.20	0.04058
34	34	34	593179.40	4129569.10	0.03823
35	35	35	593179.00	4129576.90	0.03733
36	36	36	593178.40	4129586.00	0.03644
37	37	37	593178.40	4129625.50	0.03179
38	38	38	593177.80	4129634.30	0.03072
39	39	39	593178.10	4129642.70	0.02957
40	40	40	593169.00	4129643.70	0.03071
41	41	41	593159.90	4129643.70	0.03204
42	42	42	593150.50	4129643.10	0.03357
43	43	43	593149.90	4129633.30	0.03544
44	44	44	593149.90	4129622.90	0.03741
45	45	45	593139.50	4129622.90	0.03956
46	46	46	593139.80	4129632.40	0.03745
47	47	47	593139.50	4129645.00	0.03493
48	48	48	593127.80	4129643.70	0.03707
49	49	49	593119.10	4129643.40	0.03857
50	50	50	593108.70	4129644.70	0.03997
51	51	51	593108.40	4129633.00	0.0434
52	52	52	593109.30	4129622.90	0.04639
53	53	53	593078.20	4129517.60	0.17296
54	54	54	593089.20	4129517.90	0.14065
55	55	55	593099.00	4129517.90	0.12039
56	56	56	593078.20	4129486.80	0.3245
57	57	57	593088.60	4129487.40	0.26099
58	58	58	593098.60	4129487.10	0.21645
59	59	59	593077.60	4129458.90	0.34068
60	60	60	593088.90	4129458.60	0.29984
61	61	61	593100.90	4129458.90	0.25927
62	62	62	593079.50	4129428.70	0.23001
63	63	63	593089.90	4129429.10	0.2237
64	64	64	593100.30	4129428.70	0.21212
65	65	65	593109.00	4129429.40	0.20345

66	66	66	593136.30	4129526.70	0.06894
67	67	67	593136.60	4129518.90	0.07425
68	68	68	593136.30	4129509.80	0.0831
69	69	69	593135.90	4129501.40	0.09394
70	70	70	593132.40	4129482.20	0.13295
71	71	71	593142.10	4129482.60	0.11495
72	72	72	593152.80	4129482.20	0.1002
73	73	73	593133.00	4129456.60	0.17372
74	74	74	593143.10	4129456.30	0.15334
75	75	75	593156.00	4129456.00	0.13106
76	76	76	593137.90	4129435.90	0.17048
77	77	77	593137.50	4129426.50	0.16532
78	78	78	593138.20	4129417.10	0.15551

<http://www.breeze-software.com/>

BREEZE AERMOD

Sensitive Receptor Results

2024 Unmitigated PM_{2.5} Construction

0.0164 TPY and 1.255e-7 g/s-m²

Pollutant: PM25, Type: CONC (ug/m3) 5 YEAR AVG., Group: ALL**

Sen. Rcpt. #	Dsc. Rcpt. #	Description	UTM		Conc.
			East(m)	North(m)	
1	1	1	593014.00	4129520.20	0.11222
2	2	2	592933.90	4129471.20	0.00594
3	3	3	592917.40	4129470.60	0.00506
4	4	4	592897.00	4129470.60	0.00453
5	5	5	592877.50	4129470.90	0.00416
6	6	6	592869.70	4129467.00	0.0037
7	7	7	592832.50	4129490.30	0.00422
8	8	8	592814.00	4129489.70	0.00364
9	9	9	592810.70	4129442.00	0.002
10	10	10	592840.80	4129444.30	0.00221
11	11	11	592875.90	4129512.70	0.00996
12	12	12	592866.50	4129513.00	0.00872
13	13	13	592892.40	4129511.70	0.01292
14	14	14	592909.90	4129512.70	0.02002
15	15	15	592931.30	4129513.40	0.04257
16	16	16	593072.70	4129584.00	0.0082
17	17	17	593072.70	4129573.00	0.00917
18	18	18	593072.40	4129563.90	0.01008
19	19	19	593072.10	4129554.50	0.01114
20	20	20	593086.00	4129584.40	0.00737
21	21	21	593111.70	4129585.00	0.00601
22	22	22	593111.60	4129576.20	0.00635
23	23	23	593112.60	4129566.20	0.00667
24	24	24	593123.00	4129566.50	0.00607
25	25	25	593131.40	4129565.90	0.00566
26	26	26	593138.80	4129566.90	0.0053
27	27	27	593138.20	4129575.60	0.00512

28	28	28	593138.20	4129584.70	0.00492
29	29	29	593152.50	4129586.00	0.00442
30	30	30	593152.80	4129577.60	0.00455
31	31	31	593152.80	4129569.50	0.00469
32	32	32	593160.90	4129569.10	0.00442
33	33	33	593171.30	4129568.20	0.00412
34	34	34	593179.40	4129569.10	0.00388
35	35	35	593179.00	4129576.90	0.00379
36	36	36	593178.40	4129586.00	0.0037
37	37	37	593178.40	4129625.50	0.00322
38	38	38	593177.80	4129634.30	0.00312
39	39	39	593178.10	4129642.70	0.003
40	40	40	593169.00	4129643.70	0.00312
41	41	41	593159.90	4129643.70	0.00325
42	42	42	593150.50	4129643.10	0.00341
43	43	43	593149.90	4129633.30	0.0036
44	44	44	593149.90	4129622.90	0.0038
45	45	45	593139.50	4129622.90	0.00401
46	46	46	593139.80	4129632.40	0.0038
47	47	47	593139.50	4129645.00	0.00354
48	48	48	593127.80	4129643.70	0.00376
49	49	49	593119.10	4129643.40	0.00391
50	50	50	593108.70	4129644.70	0.00405
51	51	51	593108.40	4129633.00	0.0044
52	52	52	593109.30	4129622.90	0.00471
53	53	53	593078.20	4129517.60	0.01755
54	54	54	593089.20	4129517.90	0.01427
55	55	55	593099.00	4129517.90	0.01221
56	56	56	593078.20	4129486.80	0.03292
57	57	57	593088.60	4129487.40	0.02648
58	58	58	593098.60	4129487.10	0.02196
59	59	59	593077.60	4129458.90	0.03456
60	60	60	593088.90	4129458.60	0.03042
61	61	61	593100.90	4129458.90	0.0263
62	62	62	593079.50	4129428.70	0.02334
63	63	63	593089.90	4129429.10	0.0227
64	64	64	593100.30	4129428.70	0.02152
65	65	65	593109.00	4129429.40	0.02064

66	66	66	593136.30	4129526.70	0.00699
67	67	67	593136.60	4129518.90	0.00753
68	68	68	593136.30	4129509.80	0.00843
69	69	69	593135.90	4129501.40	0.00953
70	70	70	593132.40	4129482.20	0.01349
71	71	71	593142.10	4129482.60	0.01166
72	72	72	593152.80	4129482.20	0.01017
73	73	73	593133.00	4129456.60	0.01762
74	74	74	593143.10	4129456.30	0.01556
75	75	75	593156.00	4129456.00	0.0133
76	76	76	593137.90	4129435.90	0.0173
77	77	77	593137.50	4129426.50	0.01677
78	78	78	593138.20	4129417.10	0.01578

<http://www.breeze-software.com/>

BREEZE AERMOD
Sensitive Receptor Results
2023 85% Mitigated DPM PM10
0.00591 TPY and 4.521e-8 g/s-m²

Pollutant: PM10, Type: CONC (ug/m3) 5 YEAR AVG., Group: ALL**

Sen. Rcpt. #	Dsc. Rcpt. #	Description	UTM		Conc.
			East(m)	North(m)	
1	1	1	593014.00	4129520.20	0.06366
2	2	2	592933.90	4129471.20	0.00383
3	3	3	592917.40	4129470.60	0.00323
4	4	4	592897.00	4129470.60	0.00282
5	5	5	592877.50	4129470.90	0.00251
6	6	6	592869.70	4129467.00	0.00221
7	7	7	592832.50	4129490.30	0.00247
8	8	8	592814.00	4129489.70	0.0021
9	9	9	592810.70	4129442.00	0.00113
10	10	10	592840.80	4129444.30	0.0013
11	11	11	592875.90	4129512.70	0.0061
12	12	12	592866.50	4129513.00	0.0053
13	13	13	592892.40	4129511.70	0.00798
14	14	14	592909.90	4129512.70	0.01234
15	15	15	592931.30	4129513.40	0.02542
16	16	16	593072.70	4129584.00	0.00484
17	17	17	593072.70	4129573.00	0.00543
18	18	18	593072.40	4129563.90	0.006
19	19	19	593072.10	4129554.50	0.00666
20	20	20	593086.00	4129584.40	0.00429
21	21	21	593111.70	4129585.00	0.00341
22	22	22	593111.60	4129576.20	0.00362
23	23	23	593112.60	4129566.20	0.00382
24	24	24	593123.00	4129566.50	0.00345
25	25	25	593131.40	4129565.90	0.0032
26	26	26	593138.80	4129566.90	0.00297
27	27	27	593138.20	4129575.60	0.00286

28	28	28	593138.20	4129584.70	0.00274
29	29	29	593152.50	4129586.00	0.00243
30	30	30	593152.80	4129577.60	0.00251
31	31	31	593152.80	4129569.50	0.00261
32	32	32	593160.90	4129569.10	0.00245
33	33	33	593171.30	4129568.20	0.00226
34	34	34	593179.40	4129569.10	0.00212
35	35	35	593179.00	4129576.90	0.00207
36	36	36	593178.40	4129586.00	0.00201
37	37	37	593178.40	4129625.50	0.00173
38	38	38	593177.80	4129634.30	0.00167
39	39	39	593178.10	4129642.70	0.00161
40	40	40	593169.00	4129643.70	0.00168
41	41	41	593159.90	4129643.70	0.00176
42	42	42	593150.50	4129643.10	0.00186
43	43	43	593149.90	4129633.30	0.00196
44	44	44	593149.90	4129622.90	0.00208
45	45	45	593139.50	4129622.90	0.00221
46	46	46	593139.80	4129632.40	0.00209
47	47	47	593139.50	4129645.00	0.00194
48	48	48	593127.80	4129643.70	0.00208
49	49	49	593119.10	4129643.40	0.00218
50	50	50	593108.70	4129644.70	0.00227
51	51	51	593108.40	4129633.00	0.00248
52	52	52	593109.30	4129622.90	0.00265
53	53	53	593078.20	4129517.60	0.01043
54	54	54	593089.20	4129517.90	0.00843
55	55	55	593099.00	4129517.90	0.00715
56	56	56	593078.20	4129486.80	0.01808
57	57	57	593088.60	4129487.40	0.01461
58	58	58	593098.60	4129487.10	0.01215
59	59	59	593077.60	4129458.90	0.01826
60	60	60	593088.90	4129458.60	0.01596
61	61	61	593100.90	4129458.90	0.01374
62	62	62	593079.50	4129428.70	0.01247
63	63	63	593089.90	4129429.10	0.01201
64	64	64	593100.30	4129428.70	0.01128
65	65	65	593109.00	4129429.40	0.01073

66	66	66	593136.30	4129526.70	0.00394
67	67	67	593136.60	4129518.90	0.00425
68	68	68	593136.30	4129509.80	0.00477
69	69	69	593135.90	4129501.40	0.0054
70	70	70	593132.40	4129482.20	0.00746
71	71	71	593142.10	4129482.60	0.00647
72	72	72	593152.80	4129482.20	0.00563
73	73	73	593133.00	4129456.60	0.00915
74	74	74	593143.10	4129456.30	0.00809
75	75	75	593156.00	4129456.00	0.00695
76	76	76	593137.90	4129435.90	0.00876
77	77	77	593137.50	4129426.50	0.0085
78	78	78	593138.20	4129417.10	0.00804

<http://www.breeze-software.com/>

BREEZE AERMOD
Sensitive Receptor Results
2024 85% Mitigated DPM PM10
0.00455 TPY and 3.481e-8 g/s-m²

Pollutant: PM10, Type: CONC (ug/m3) 5 YEAR AVG., Group: ALL**

Sen. Rcpt. #	Dsc. Rcpt. #	Description	UTM		Conc.
			East(m)	North(m)	
1	1	1	593014.00	4129520.20	0.08267
2	2	2	592933.90	4129471.20	0.00498
3	3	3	592917.40	4129470.60	0.0042
4	4	4	592897.00	4129470.60	0.00366
5	5	5	592877.50	4129470.90	0.00326
6	6	6	592869.70	4129467.00	0.00287
7	7	7	592832.50	4129490.30	0.0032
8	8	8	592814.00	4129489.70	0.00273
9	9	9	592810.70	4129442.00	0.00147
10	10	10	592840.80	4129444.30	0.00169
11	11	11	592875.90	4129512.70	0.00792
12	12	12	592866.50	4129513.00	0.00689
13	13	13	592892.40	4129511.70	0.01037
14	14	14	592909.90	4129512.70	0.01603
15	15	15	592931.30	4129513.40	0.03302
16	16	16	593072.70	4129584.00	0.00629
17	17	17	593072.70	4129573.00	0.00705
18	18	18	593072.40	4129563.90	0.00779
19	19	19	593072.10	4129554.50	0.00864
20	20	20	593086.00	4129584.40	0.00557
21	21	21	593111.70	4129585.00	0.00443
22	22	22	593111.60	4129576.20	0.0047
23	23	23	593112.60	4129566.20	0.00496
24	24	24	593123.00	4129566.50	0.00447
25	25	25	593131.40	4129565.90	0.00415

26	26	26	593138.80	4129566.90	0.00386
27	27	27	593138.20	4129575.60	0.00372
28	28	28	593138.20	4129584.70	0.00355
29	29	29	593152.50	4129586.00	0.00315
30	30	30	593152.80	4129577.60	0.00327
31	31	31	593152.80	4129569.50	0.00339
32	32	32	593160.90	4129569.10	0.00318
33	33	33	593171.30	4129568.20	0.00294
34	34	34	593179.40	4129569.10	0.00276
35	35	35	593179.00	4129576.90	0.00268
36	36	36	593178.40	4129586.00	0.0026
37	37	37	593178.40	4129625.50	0.00224
38	38	38	593177.80	4129634.30	0.00217
39	39	39	593178.10	4129642.70	0.00209
40	40	40	593169.00	4129643.70	0.00218
41	41	41	593159.90	4129643.70	0.00229
42	42	42	593150.50	4129643.10	0.00241
43	43	43	593149.90	4129633.30	0.00255
44	44	44	593149.90	4129622.90	0.0027
45	45	45	593139.50	4129622.90	0.00287
46	46	46	593139.80	4129632.40	0.00271
47	47	47	593139.50	4129645.00	0.00252
48	48	48	593127.80	4129643.70	0.0027
49	49	49	593119.10	4129643.40	0.00283
50	50	50	593108.70	4129644.70	0.00295
51	51	51	593108.40	4129633.00	0.00322
52	52	52	593109.30	4129622.90	0.00345
53	53	53	593078.20	4129517.60	0.01354
54	54	54	593089.20	4129517.90	0.01094
55	55	55	593099.00	4129517.90	0.00929
56	56	56	593078.20	4129486.80	0.02348
57	57	57	593088.60	4129487.40	0.01898
58	58	58	593098.60	4129487.10	0.01579
59	59	59	593077.60	4129458.90	0.02372
60	60	60	593088.90	4129458.60	0.02073
61	61	61	593100.90	4129458.90	0.01784
62	62	62	593079.50	4129428.70	0.01619
63	63	63	593089.90	4129429.10	0.01559

64	64	64	593100.30	4129428.70	0.01465
65	65	65	593109.00	4129429.40	0.01393
66	66	66	593136.30	4129526.70	0.00511
67	67	67	593136.60	4129518.90	0.00552
68	68	68	593136.30	4129509.80	0.0062
69	69	69	593135.90	4129501.40	0.00701
70	70	70	593132.40	4129482.20	0.00969
71	71	71	593142.10	4129482.60	0.0084
72	72	72	593152.80	4129482.20	0.00732
73	73	73	593133.00	4129456.60	0.01189
74	74	74	593143.10	4129456.30	0.01051
75	75	75	593156.00	4129456.00	0.00902
76	76	76	593137.90	4129435.90	0.01137
77	77	77	593137.50	4129426.50	0.01104
78	78	78	593138.20	4129417.10	0.01044

<http://www.breeze-software.com/>

BREEZE AERMOD
Sensitive Receptor Results
2023 85% Mitigated PM_{2.5}
0.0628 TPY and 4.804e-7 g/s-m²

Pollutant: PM25, Type: CONC (ug/m3) 5 YEAR AVG., Group: ALL**

Sen. Rcpt. #	Dsc. Rcpt. #	Description	UTM		Conc.
			East(m)	North(m)	
1	1	1	593014.00	4129520.20	0.42957
2	2	2	592933.90	4129471.20	0.02275
3	3	3	592917.40	4129470.60	0.01937
4	4	4	592897.00	4129470.60	0.01735
5	5	5	592877.50	4129470.90	0.01592
6	6	6	592869.70	4129467.00	0.01416
7	7	7	592832.50	4129490.30	0.01616
8	8	8	592814.00	4129489.70	0.01395
9	9	9	592810.70	4129442.00	0.00765
10	10	10	592840.80	4129444.30	0.00847
11	11	11	592875.90	4129512.70	0.03813
12	12	12	592866.50	4129513.00	0.03339
13	13	13	592892.40	4129511.70	0.04944
14	14	14	592909.90	4129512.70	0.07665
15	15	15	592931.30	4129513.40	0.16296
16	16	16	593072.70	4129584.00	0.03139
17	17	17	593072.70	4129573.00	0.03509
18	18	18	593072.40	4129563.90	0.0386
19	19	19	593072.10	4129554.50	0.04264

20	20	20	593086.00	4129584.40	0.0282
21	21	21	593111.70	4129585.00	0.023
22	22	22	593111.60	4129576.20	0.0243
23	23	23	593112.60	4129566.20	0.02553
24	24	24	593123.00	4129566.50	0.02323
25	25	25	593131.40	4129565.90	0.02167
26	26	26	593138.80	4129566.90	0.02028
27	27	27	593138.20	4129575.60	0.01962
28	28	28	593138.20	4129584.70	0.01885
29	29	29	593152.50	4129586.00	0.0169
30	30	30	593152.80	4129577.60	0.01741
31	31	31	593152.80	4129569.50	0.01796
32	32	32	593160.90	4129569.10	0.01693
33	33	33	593171.30	4129568.20	0.01576
34	34	34	593179.40	4129569.10	0.01485
35	35	35	593179.00	4129576.90	0.0145
36	36	36	593178.40	4129586.00	0.01415
37	37	37	593178.40	4129625.50	0.01234
38	38	38	593177.80	4129634.30	0.01193
39	39	39	593178.10	4129642.70	0.01148
40	40	40	593169.00	4129643.70	0.01193
41	41	41	593159.90	4129643.70	0.01244
42	42	42	593150.50	4129643.10	0.01304
43	43	43	593149.90	4129633.30	0.01376
44	44	44	593149.90	4129622.90	0.01453
45	45	45	593139.50	4129622.90	0.01536
46	46	46	593139.80	4129632.40	0.01454
47	47	47	593139.50	4129645.00	0.01356

48	48	48	593127.80	4129643.70	0.0144
49	49	49	593119.10	4129643.40	0.01498
50	50	50	593108.70	4129644.70	0.01552
51	51	51	593108.40	4129633.00	0.01685
52	52	52	593109.30	4129622.90	0.01802
53	53	53	593078.20	4129517.60	0.06717
54	54	54	593089.20	4129517.90	0.05462
55	55	55	593099.00	4129517.90	0.04675
56	56	56	593078.20	4129486.80	0.12602
57	57	57	593088.60	4129487.40	0.10136
58	58	58	593098.60	4129487.10	0.08406
59	59	59	593077.60	4129458.90	0.13231
60	60	60	593088.90	4129458.60	0.11645
61	61	61	593100.90	4129458.90	0.10069
62	62	62	593079.50	4129428.70	0.08933
63	63	63	593089.90	4129429.10	0.08688
64	64	64	593100.30	4129428.70	0.08238
65	65	65	593109.00	4129429.40	0.07901
66	66	66	593136.30	4129526.70	0.02677
67	67	67	593136.60	4129518.90	0.02884
68	68	68	593136.30	4129509.80	0.03227
69	69	69	593135.90	4129501.40	0.03648
70	70	70	593132.40	4129482.20	0.05163
71	71	71	593142.10	4129482.60	0.04464
72	72	72	593152.80	4129482.20	0.03891
73	73	73	593133.00	4129456.60	0.06747
74	74	74	593143.10	4129456.30	0.05955
75	75	75	593156.00	4129456.00	0.0509

76	76	76	593137.90	4129435.90	0.06621
77	77	77	593137.50	4129426.50	0.06421
78	78	78	593138.20	4129417.10	0.06039

<http://www.breeze-software.com/>

BREEZE AERMOD
Sensitive Receptor Results
2024 85% Mitigated PM_{2.5}
0.00986 TPY and 7.543e-8 g/s-m²

Pollutant: PM25, Type: CONC (ug/m3) 5 YEAR AVG., Group: ALL**

Sen. Rcpt. #	Dsc. Rcpt. #	Description	UTM		Conc.
			East(m)	North(m)	
1	1	1	593014.00	4129520.20	0.06745
2	2	2	592933.90	4129471.20	0.00357
3	3	3	592917.40	4129470.60	0.00304
4	4	4	592897.00	4129470.60	0.00272
5	5	5	592877.50	4129470.90	0.0025
6	6	6	592869.70	4129467.00	0.00222
7	7	7	592832.50	4129490.30	0.00254
8	8	8	592814.00	4129489.70	0.00219
9	9	9	592810.70	4129442.00	0.0012
10	10	10	592840.80	4129444.30	0.00133
11	11	11	592875.90	4129512.70	0.00599
12	12	12	592866.50	4129513.00	0.00524
13	13	13	592892.40	4129511.70	0.00776
14	14	14	592909.90	4129512.70	0.01203
15	15	15	592931.30	4129513.40	0.02559
16	16	16	593072.70	4129584.00	0.00493
17	17	17	593072.70	4129573.00	0.00551
18	18	18	593072.40	4129563.90	0.00606
19	19	19	593072.10	4129554.50	0.0067

20	20	20	593086.00	4129584.40	0.00443
21	21	21	593111.70	4129585.00	0.00361
22	22	22	593111.60	4129576.20	0.00381
23	23	23	593112.60	4129566.20	0.00401
24	24	24	593123.00	4129566.50	0.00365
25	25	25	593131.40	4129565.90	0.0034
26	26	26	593138.80	4129566.90	0.00319
27	27	27	593138.20	4129575.60	0.00308
28	28	28	593138.20	4129584.70	0.00296
29	29	29	593152.50	4129586.00	0.00265
30	30	30	593152.80	4129577.60	0.00273
31	31	31	593152.80	4129569.50	0.00282
32	32	32	593160.90	4129569.10	0.00266
33	33	33	593171.30	4129568.20	0.00247
34	34	34	593179.40	4129569.10	0.00233
35	35	35	593179.00	4129576.90	0.00228
36	36	36	593178.40	4129586.00	0.00222
37	37	37	593178.40	4129625.50	0.00194
38	38	38	593177.80	4129634.30	0.00187
39	39	39	593178.10	4129642.70	0.0018
40	40	40	593169.00	4129643.70	0.00187
41	41	41	593159.90	4129643.70	0.00195
42	42	42	593150.50	4129643.10	0.00205
43	43	43	593149.90	4129633.30	0.00216
44	44	44	593149.90	4129622.90	0.00228
45	45	45	593139.50	4129622.90	0.00241
46	46	46	593139.80	4129632.40	0.00228
47	47	47	593139.50	4129645.00	0.00213

48	48	48	593127.80	4129643.70	0.00226
49	49	49	593119.10	4129643.40	0.00235
50	50	50	593108.70	4129644.70	0.00244
51	51	51	593108.40	4129633.00	0.00265
52	52	52	593109.30	4129622.90	0.00283
53	53	53	593078.20	4129517.60	0.01055
54	54	54	593089.20	4129517.90	0.00858
55	55	55	593099.00	4129517.90	0.00734
56	56	56	593078.20	4129486.80	0.01979
57	57	57	593088.60	4129487.40	0.01591
58	58	58	593098.60	4129487.10	0.0132
59	59	59	593077.60	4129458.90	0.02077
60	60	60	593088.90	4129458.60	0.01828
61	61	61	593100.90	4129458.90	0.01581
62	62	62	593079.50	4129428.70	0.01403
63	63	63	593089.90	4129429.10	0.01364
64	64	64	593100.30	4129428.70	0.01293
65	65	65	593109.00	4129429.40	0.01241
66	66	66	593136.30	4129526.70	0.0042
67	67	67	593136.60	4129518.90	0.00453
68	68	68	593136.30	4129509.80	0.00507
69	69	69	593135.90	4129501.40	0.00573
70	70	70	593132.40	4129482.20	0.00811
71	71	71	593142.10	4129482.60	0.00701
72	72	72	593152.80	4129482.20	0.00611
73	73	73	593133.00	4129456.60	0.01059
74	74	74	593143.10	4129456.30	0.00935
75	75	75	593156.00	4129456.00	0.00799

76	76	76	593137.90	4129435.90	0.0104
77	77	77	593137.50	4129426.50	0.01008
78	78	78	593138.20	4129417.10	0.00948

<http://www.breeze-software.com/>

1065 Winchester Blvd - Unmitigated Construction Cancer Risk

Maximum DPM PM10 Cancer Risk from Construction

Impacts at MEI - 1.5 meter receptor height

(Using San Jose Airport Met Data)

Cancer Risk (per million) = CPF x Inhalation Dose x ASF x ED/AT x FAH x 1.0E+06

- Where: CPF = Cancer Potency Factor (mg/kg-day)⁻¹
 ASF = Age Sensitivity Factor for specified age group
 ED = Exposure Duration (years)
 AT = Averaging Time for lifetime cancer risk (years)
 FAH = Fraction of time spent at home (unitless)

Inhalation Dose = C_{air} x DBR x A x (EF/365) x 10⁻⁶

- Where: C_{air} = Concentration in air (µg/m³)
 DBR = Daily Breathing Rate (L/kg body weight-day)
 A = Inhalation Absorption Factor
 EF = Exposure Frequency (days/year)
 10⁻⁶ = Conversion Factor

Age --> Parameter	Infant/Child				Adult
	3rd Trimester	0 - 2	2 - 9	2 - 16	16 - 30
ASF=	10	10	3	3	1
CPF=	1.1	1.1	1.1	1.1	1.1
DBR*=	361	1090	631	572	261
A=	1	1	1	1	1
EF=	350	350	350	350	350
AT=	70	70	70	70	70
FAH=	1	1	1	1	0.73

*95th percentile breathing rates for infants and 80th percentile for children and adults

Cancer Risk by Year - Maximum Emissions Impact (MEI) at a residence southeast of the project (H16) UTM 578484, 4136856											
Exposure Year	Exposure Duration (years)	Age	Infant/Child - Exposure Information				Infant/Child Cancer Risk (per million)	Adult - Exposure Information			Adult Cancer Risk (per million)
			DPM Conc (µg/m ³)		Age Sensitivity Factor	DPM Conc (µg/m ³)		Age Sensitivity Factor			
			Year	Annual		Year			Annual		
0	0.25	-0.25 - 0*	2023	0.14949	10	2.03	2022	0.14949	-	-	
1	1	0 - 1	2023	0.14949	10	24.55	2022	0.14949	1	0.429	
2	1	1 - 2	2024	0.03036	10	4.99	2023	0.03036	1	0.087	
3	1	2 - 3	0	0.0000	3	0.00	0	0.0000	1	0.000	
4	1	3 - 4	0	0.0000	3	0.00	0	0.0000	1	0.00	
5	1	4 - 5	0	0.0000	3	0.00	0	0.0000	1	0.00	
6	1	5 - 6	0	0.0000	3	0.00	0	0.0000	1	0.00	
7	1	6 - 7	0	0.0000	3	0.00	0	0.0000	1	0.00	
8	1	7 - 8	0	0.0000	3	0.00	0	0.0000	1	0.00	
9	1	8 - 9	0	0.0000	3	0.00	0	0.0000	1	0.00	
10	1	9 - 10	0	0.0000	3	0.00	0	0.0000	1	0.00	
11	1	10 - 11	0	0.0000	3	0.00	0	0.0000	1	0.00	
12	1	11 - 12	0	0.0000	3	0.00	0	0.0000	1	0.00	
13	1	12 - 13	0	0.0000	3	0.00	0	0.0000	1	0.00	
14	1	13 - 14	0	0.0000	3	0.00	0	0.0000	1	0.00	
15	1	14 - 15	0	0.0000	3	0.00	0	0.0000	1	0.00	
16	1	15 - 16	0	0.0000	3	0.00	0	0.0000	1	0.00	
17	1	16 - 17	0	0.0000	1	0.00	0	0.0000	1	0.00	
18	1	17 - 18	0	0.0000	1	0.00	0	0.0000	1	0.00	
19	1	18 - 19	0	0.0000	1	0.00	0	0.0000	1	0.00	
20	1	19 - 20	0	0.0000	1	0.00	0	0.0000	1	0.00	
21	1	20 - 21	0	0.0000	1	0.00	0	0.0000	1	0.00	
22	1	21 - 22	0	0.0000	1	0.00	0	0.0000	1	0.00	
23	1	22 - 23	0	0.0000	1	0.00	0	0.0000	1	0.00	
24	1	23 - 24	0	0.0000	1	0.00	0	0.0000	1	0.00	
25	1	24 - 25	0	0.0000	1	0.00	0	0.0000	1	0.00	
26	1	25 - 26	0	0.0000	1	0.00	0	0.0000	1	0.00	
27	1	26 - 27	0	0.0000	1	0.00	0	0.0000	1	0.00	
28	1	27 - 28	0	0.0000	1	0.00	0	0.0000	1	0.00	
29	1	28 - 29	0	0.0000	1	0.00	0	0.0000	1	0.00	
30	1	29 - 30	0	0.0000	1	0.00	0	0.0000	1	0.00	
Total Increased Cancer Risk						31.57				0.52	

* Third Trimester of Pregnancy

1065 Winchester Blvd - **Mitigated Construction Cancer Risk**

Maximum DPM PM10 Cancer Risk from Construction

Impacts at MEI - 1.5 meter receptor height

(Using San Jose Airport Met Data)

Cancer Risk (per million) = CPF x Inhalation Dose x ASF x ED/AT x FAH x 1.0E+06

- Where: CPF = Cancer Potency Factor (mg/kg-day)⁻¹
 ASF = Age Sensitivity Factor for specified age group
 ED = Exposure Duration (years)
 AT = Averaging Time for lifetime cancer risk (years)
 FAH = Fraction of time spent at home (unitless)

Inhalation Dose = C_{air} x DBR x A x (EF/365) x 10⁻⁶

- Where: C_{air} = Concentration in air (µg/m³)
 DBR = Daily Breathing Rate (L/kg body weight-day)
 A = Inhalation Absorption Factor
 EF = Exposure Frequency (days/year)
 10⁻⁶ = Conversion Factor

Age --> Parameter	Infant/Child				Adult
	3rd Trimester	0 - 2	2 - 9	2 - 16	16 - 30
ASF=	10	10	3	3	1
CPF=	1.1	1.1	1.1	1.1	1.1
DBR*=	361	1090	631	572	261
A=	1	1	1	1	1
EF=	350	350	350	350	350
AT=	70	70	70	70	70
FAH=	1	1	1	1	0.73

*95th percentile breathing rates for infants and 80th percentile for children and adults

Cancer Risk by Year - Maximum Emissions Impact (MEI) at a residence southeast of the project (H16) UTM's 578484, 4136856

Exposure Year	Exposure Duration (years)	Age	Infant/Child - Exposure Information				Adult - Exposure Information			Adult Cancer Risk (per million)
			DPM Conc (µg/m ³)		Age Sensitivity Factor	Infant/Child Cancer Risk (per million)	DPM Conc (µg/m ³)		Age Sensitivity Factor	
			Year	Annual			Year	Annual		
0	0.25	-0.25 - 0*	2023	0.03302	10	0.45	2023	0.03302	-	-
1	1	0 - 1	2023	0.03302	10	5.42	2023	0.03302	1	0.095
2	1	1 - 2	2024	0.02542	10	4.18	2024	0.02542	1	0.073
3	1	2 - 3	0	0.0000	3	0.00	0	0.0000	1	0.000
4	1	3 - 4	0	0.0000	3	0.00	0	0.0000	1	0.00
5	1	4 - 5	0	0.0000	3	0.00	0	0.0000	1	0.00
6	1	5 - 6	0	0.0000	3	0.00	0	0.0000	1	0.00
7	1	6 - 7	0	0.0000	3	0.00	0	0.0000	1	0.00
8	1	7 - 8	0	0.0000	3	0.00	0	0.0000	1	0.00
9	1	8 - 9	0	0.0000	3	0.00	0	0.0000	1	0.00
10	1	9 - 10	0	0.0000	3	0.00	0	0.0000	1	0.00
11	1	10 - 11	0	0.0000	3	0.00	0	0.0000	1	0.00
12	1	11 - 12	0	0.0000	3	0.00	0	0.0000	1	0.00
13	1	12 - 13	0	0.0000	3	0.00	0	0.0000	1	0.00
14	1	13 - 14	0	0.0000	3	0.00	0	0.0000	1	0.00
15	1	14 - 15	0	0.0000	3	0.00	0	0.0000	1	0.00
16	1	15 - 16	0	0.0000	3	0.00	0	0.0000	1	0.00
17	1	16 - 17	0	0.0000	1	0.00	0	0.0000	1	0.00
18	1	17 - 18	0	0.0000	1	0.00	0	0.0000	1	0.00
19	1	18 - 19	0	0.0000	1	0.00	0	0.0000	1	0.00
20	1	19 - 20	0	0.0000	1	0.00	0	0.0000	1	0.00
21	1	20 - 21	0	0.0000	1	0.00	0	0.0000	1	0.00
22	1	21 - 22	0	0.0000	1	0.00	0	0.0000	1	0.00
23	1	22 - 23	0	0.0000	1	0.00	0	0.0000	1	0.00
24	1	23 - 24	0	0.0000	1	0.00	0	0.0000	1	0.00
25	1	24 - 25	0	0.0000	1	0.00	0	0.0000	1	0.00
26	1	25 - 26	0	0.0000	1	0.00	0	0.0000	1	0.00
27	1	26 - 27	0	0.0000	1	0.00	0	0.0000	1	0.00
28	1	27 - 28	0	0.0000	1	0.00	0	0.0000	1	0.00
29	1	28 - 29	0	0.0000	1	0.00	0	0.0000	1	0.00
30	1	29 - 30	0	0.0000	1	0.00	0	0.0000	1	0.00
Total Increased Cancer Risk						10.0				0.2

* Third Trimester of Pregnancy