

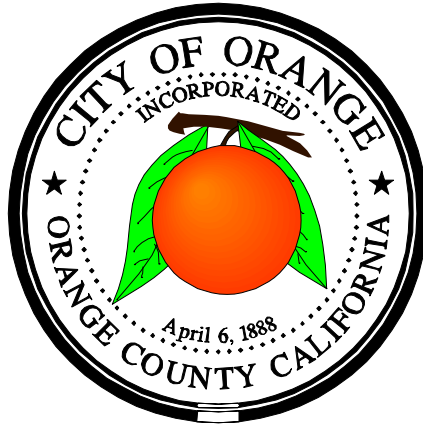

# Appendix I1

## Priority Water Quality Management Plan



**PRIORITY  
WATER QUALITY MANAGEMENT PLAN  
(WQMP)**

**For:**

**534 W. Struck Ave Redevelopment Project  
Major Site Plan Review No. 1039-21  
Design Review No. 5012-20  
Environmental Review No. 1870-20**

**Prepared for:**

**Prologis**

**Attn: Maggie Xu**

**17777 Center Court Dr. N, Suite 100  
Cerritos, CA 90703  
(310) 338-3273**

**Prepared by:**

**Albert A. Webb Associates  
Joshua S. Lesinski, P.E. C92605  
3788 McCray St  
Riverside, CA 92506  
(951) 686-1070**

**Original Date: November 2021**

**Current Revision Date:**



\_\_\_\_\_  
**Public Works Director**

\_\_\_\_\_  
**Date**

\_\_\_\_\_  
**City Engineer**

\_\_\_\_\_  
**Date**

**OWNER'S CERTIFICATION**  
**WATER QUALITY MANAGEMENT PLAN**  
**FOR**

**534 W. STRUCK AVENUE REDEVELOPMENT**

This Water Quality Management Plan (WQMP) for the **534 W. Struck Avenue Redevelopment Project** has been prepared for **Prologis**. This WQMP is intended to comply with the requirements of the City of Orange's **Land Use Project Application: Major Site Plan Review No. 1039-21, Design Review No. 5012-20, and Environmental Review No. 1870-20** requiring the preparation of a Water Quality Management Plan.

The undersigned, while it owns the subject property, is responsible for the implementation of the provisions of this plan and will ensure that this plan is amended as appropriate to reflect up-to-date conditions on the site consistent with the City of Orange Local Implementation Plan (LIP), and the intent of NPDES Permit and Waste Discharge Requirements for the City of Orange, County of Orange, Orange County Flood Control District and the incorporated Cities of Orange County within the Santa Ana Region.

This WQMP will be reviewed with the facility operator, facility supervisors, employees, tenants, maintenance and service contractors, or any other party having responsibility for implementing portions of this WQMP. Maintenance requirements within Section V and Appendix D will be adhered to with particular emphasis on maintaining the BMPs described within Sections IV and V. The Owner's Annual Self Certification Statement along with a BMP maintenance implementation table will be submitted by June 30<sup>th</sup> every year following project completion. At least one copy of the approved WQMP shall be available on the subject property in perpetuity.

Once the undersigned transfers its interest in the property, its successors-in-interest shall bear the aforementioned responsibility to implement and amend the WQMP. The City of Orange will be notified of the change of ownership and the new owner will submit a new certification.

Signature: \_\_\_\_\_ Date: \_\_\_\_\_

Name: Maggie Xu

Title: Director, Project Mangement

Company: Prologis

Address: 17777 Center Ct Dr N, Suite 100, Cerritos, CA 90703

Telephone Number: (310) 338-3273

**Notice of Transfer of Responsibility**

**Water Quality Management Plan (WQMP)**

WQMP Number – As assigned by the City of Orange: \_\_\_\_\_

Submission of this Notice of Transfer of Responsibility constitutes notice to the City that responsibility for the Water Quality Management Plan (WQMP) for the subject property identified below, and implementation of that plan, is being transferred from the Previous Owner (and his/her agent) of the site (or portion thereof) to the New Owner, as further described below.

**I. Owner/ Responsible Party Information**

Company/ Individual: Prologis Contact Person: Maggie Xu  
Street Address: 17777 Center Ct Dr N, Suite 100 Title: Director, Project Management  
City: Cerritos State: CA Zip: 90703 Phone: (310) 338-3273

**II. Information about Site Relevant to WQMP**

Name of Project: 534 W. Struck Ave Redevelopment Project  
Title of WQMP applicable to site: WQMP for 534 W. Struck Ave Redevelopment Project  
Street Address of the site: 534 W. Struck Avenue  
Date of Transfer of Responsibility: \_\_\_\_\_

**III. New Owner (Upon Transfer)/ Responsible Party Information**

Company/ Individual: \_\_\_\_\_ Contact Person: \_\_\_\_\_  
Street Address: \_\_\_\_\_ Title: \_\_\_\_\_  
City \_\_\_\_\_ State \_\_\_\_\_ Zip \_\_\_\_\_ Phone: \_\_\_\_\_

## Table of Contents

I.	Discretionary Permit Number(s), Water Quality Condition Number(s) and Conditions.....	1
II.	Project Description.....	4
III.	Site Description.....	8
IV.	Best Management Practices.....	10
IV.1	Site Design BMPs.....	10
IV.2	Source Control BMPs.....	11
IV.3	Low Impact Development BMP Selection.....	16
IV.4	Water Quality Credits.....	20
IV.5	Alternative Compliance Plan.....	20
IV.6	Vector Control.....	20
IV.7	Drainage Management Areas.....	20
IV.8	Calculations.....	20
V.	Implementation, Maintenance and Inspection Responsibility for BMPs (O&M Plan).....	21
VI.	Location Map, Site Plan, and BMP Details.....	30
VII.	Educational Materials.....	31

### Appendices

- A. Conditions of Approval – to be provided upon approval
- B. Educational Material
- C. BMP Details
- D. BMP Maintenance Information
- E. Geotechnical Infiltration Testing (for reference only)
- F. Hydrology Information (Q2 – Two-year frequency storm evaluation)

### List of Tables

Table 1	Site Design BMPs.....	10
Table 2	Routine Non-Structural BMPs.....	11
Table 3	Routine Structural BMPs.....	14
Table 4	Hydrologic Source Control BMPs.....	16
Table 5	Infiltration BMPs.....	17
Table 6	Evapotranspiration, Rainwater Harvesting.....	18
Table 7	Biotreatment BMPs.....	19
Table 8	Frequency Inspection Matrix.....	21

**I. Discretionary Permit Number(s), Water Quality Condition Number(s) and Conditions of Approval**

Tract No. N/A                      Lot No. N/A                      APN 375-331-04

GPS Coordinates: 33°48'19"N                      117°51'32"W

**Water Quality Conditions (WQMP conditions listed below)**

A complete copy of the signed Conditions of Approval, Resolution Number \_\_\_\_\_ dated \_\_\_\_\_ are included as Appendix A  
(To be provided upon approval)

**Conditions of Approval:**

(To be provided upon approval)

1. Prior to the issuance of any grading permits the applicant shall submit a Priority Project WQMP for review and approval to the Public Works Department that:
  - a. Prioritizes the use of Low Impact Development principles as follows: preserves natural features; minimizes runoff and reduces impervious surfaces; and utilizes infiltration of runoff as the method of pollutant treatment. Infiltration BMPs to be considered include the use of permeable materials such as concrete and concrete pavers, infiltration trenches, infiltration planters, and other infiltration BMPs as applicable,
  - b. Incorporates the applicable Routine Source and Structural Control BMPs as defined in the Drainage Area Management Plan (DAMP),
  - c. Maintains the hydrologic characteristics of the site by matching time of concentration, runoff, velocity, volume and hydrograph for a 2-year storm event,
  - d. Minimizes the potential increase in downstream erosion and avoids downstream impacts to physical structures, aquatic and riparian habitat,
  - e. Generally describes the long-term operation and maintenance requirements for structural and Treatment Control BMPs,
  - f. Identifies the entity or employees that will be responsible for long-term operation, maintenance, repair and or replacement of the structural and Treatment Control BMPs and the training that qualifies them to operate and maintain the BMPs,

- g. Describes the mechanism for funding the long-term operation and maintenance of all structural and Treatment Control BMPs,
    - h. Includes a copy of the forms to be used in conducting maintenance and inspection activities,
    - i. Meets recordkeeping requirements (forms to be kept for 5 years),
    - j. Includes a copy of the form to be submitted annually by the project owner to the Public Works Department that certifies that the project's structural and treatment BMPs are being inspected and maintained in accordance with the project's WQMP.
2. Prior to the issuance of certificates for use of occupancy, the applicant shall demonstrate the following to the Public Works Department:
  - a. That all structural and treatment control best management practices (BMPs) described in the Project WQMP have been constructed and installed in conformance with the approved plans and specifications,
  - b. That the applicant is prepared to implement all non-structural BMPs described in the Project WQMP,
  - c. That an adequate number of copies of the project's approved final Project WQMP are available for the future occupiers.
3. Prior to the issuance of certificates for use of occupancy or final signoff by the Public Works Department, the applicant shall demonstrate to the satisfaction of Public Works, that the preparer of the WQMP has reviewed the BMP maintenance requirements in Section V of the WQMP with the responsible person and that a copy of the WQMP has been provided to that person. A certification letter from the WQMP preparer may be used to satisfy this condition.
4. Prior to issuance of building permits, the applicant shall review the approved Water Quality Management Plan (WQMP) and grading plan to ensure the structure's downspouts or drainage outlet locations are consistent with those documents. Copies of the building or architectural plans specifically showing the downspouts and drainage outlets shall be submitted to the Public Works Department for review.
5. The project applicant shall maintain all structural, treatment and low impact development BMPs at the frequency specified in the approved WQMP. Upon transfer of ownership or management responsibilities for the project site, the applicant shall notify the City of Orange Public Works Department of the new person(s) or entity responsible for maintenance of the BMPs.
6. For those projects requiring coverage under the State of California's General Construction Permit: Prior to the issuance of a grading permit (including *grubbing, clearing, surface mining or paving permits as appropriate*) the applicant shall demonstrate that coverage has been obtained under the State's General Permit for Stormwater Discharges Associated with Construction Activity (General Construction Permit) by providing a copy of the Notice of Intent (NOI) submitted

to the State Water Resources Control Board and a copy of the subsequent notification of the issuance of a Waste Discharge Identification (WDID) Number or other proof of filing. A copy of the current SWPPP required by the General Permit shall be kept at the project site and be available for review by the City representatives upon request.

7. For those projects requiring coverage by the State of California's General Industrial Permit: Prior to the issuance of certificates for use and occupancy, the applicant shall demonstrate that coverage under the State's General Permit for Stormwater Discharges Associated with Industrial Activity has been obtained by providing a copy of the Notice of Intent (NOI) submitted to the State Water Resources Control Board and a copy of the notification of the issuance of a Waste Discharge Identification (WDID) Number or other proof of filing.



## **II. Project Description**

Planning Area (Location): Industrial Areas

Project Site Area (ac): 10.0 acres

Project Disturbed Area (ac): 10.0 acres

Percent Change in Impermeable Surfaces: 1%

SIC Code 1541 – General Contractors – Industrial Buildings and Warehouses

### **Project Description**

The 534 W. Struck Ave Redevelopment Project is located in the industrial area within the City of Orange. The existing site consists of a single manufacturing building, parking, and trailer parking areas that also are used for storage of manufactured goods. The land use is Light Industrial, and the zoning is M-2 Industrial. These designations are not proposed to be changed with the development of the project. At this time, no water quality measures are implemented within the project limits.

The elevations on the existing site range from 190 (NAVD88) in the southeastern corner to 180 in the northwestern corner. The site generally drains from east to west where existing ribbon gutters pick up flows and convey them north into Struck Avenue. Existing flows drain into Struck Avenue and surface flow until flows drain into existing catch basins at the intersection of Struck Avenue and Batavia Street. The flows eventually discharge into the existing 30" storm drain within Struck Avenue and ultimately into the Collins Channel before entering into the Santa Ana River.

### **Project Purpose and Activities**

The 534 W. Struck Ave Redevelopment Project is proposed as an industrial warehouse redevelopment. At this time, the future tenants of the building are unknown and therefore it is unknown what the contents of the warehouse facility will include. However, the project will include warehouse storage within the building limits, loading docks for the loading and unloading of supplies, and employee circulation within the parking areas. No outdoor storage facilities are proposed for warehouse items. However, parking areas are proposed onsite for the truck trailers. Only routine outdoor activities related to loading and unloading trucks are proposed for the project. Any activities that will introduce additional pollutants to the site runoff that are not included to be treated in the project specific WQMP will be prohibited.

The proposed project plans to remove the existing building and outdoor storage in order to build and accommodate a larger industrial warehouse building (52,900 square feet) with a single-story office (5,000 square feet) and a maintenance building (5,400 square feet). This will include realigning drive aisles and removing the existing railroad facilities within the project site boundary. The proposed warehouse building will include loading docks along the western and eastern side of the building. The loading docks will be above ground and slope away for the building to allow flows to drain to the proposed ribbon gutters onsite. Proposed parking for both automobiles and transport trucks will be included around the facility and will meet minimum parking requirements. Landscape areas will be included where applicable with the project site constraints.

The proposed project will implement water quality treatment through a set of Modular Wetland Systems located in the northwestern corner of the project site. The Modular Wetland Systems are proposed due to the lack of infiltration of the underlying clayey soils. Hydromodification is not required for this site since all downstream flows discharge into a regularly maintained facilities. Water quality flows will discharge into the Modular Wetland systems and then get pumped out to a u-channel that transitions into a parkway drain on Struck Avenue. Higher flows will bypass the Modular Wetland Systems and surface drain into Struck Avenue. For more information regarding the onsite hydrology and hydraulics, please see the corresponding hydrology report.

Below is a table summarizing the proposed land uses:

Propose Land Use Areas		
Roofs (sf)	63,296	100% Impervious
Landscape (sf)	42,487	0% Impervious
Impervious (sf)	332,098	90% Impervious
Total Area (sf)	434,883	

**Potential Storm Water Pollutants**

The site is zoned for industrial use. Expected pollutants include: suspended solids and sediments, nutrients, and pesticides from the proposed onsite landscaping, heavy metals from the truck trailers both active and stored, oil & grease, toxic organic compounds, and trash& debris from all vehicular traffic (automobile and truck) that is expected throughout the project site. From these expected pollutants, only Pathogens (Bacteria/Virus) are listed as impaired on the 303(d) list.

Table 2.1: Anticipated and Potential Pollutants Generated by Land Use Type

Priority Project Categories and/or Project Features	General Pollutant Categories							
	Suspended Solid/ Sediments	Nutrients	Heavy Metals	Pathogens (Bacteria/ Virus)	Pesticides	Oil & Grease	Toxic Organic Compounds	Trash & Debris
Detached Residential Development	E	E	N	E	E	E	N	E
Attached Residential Development	E	E	N	E	E	E <sup>(2)</sup>	N	E
Commercial/ Industrial Development	E <sup>(1)</sup>	E <sup>(1)</sup>	E <sup>(5)</sup>	E <sup>(3)</sup>	E <sup>(1)</sup>	E	E	E
Automotive Repair Shops	N	N	E	N	N	E	E	E
Restaurants	E <sup>(1)(2)</sup>	E <sup>(1)</sup>	E <sup>(2)</sup>	E	E <sup>(1)</sup>	E	N	E
Hillside Development >5,000 ft <sup>2</sup>	E	E	N	E	E	E	N	E
Parking Lots	E	E <sup>(1)</sup>	E	E <sup>(4)</sup>	E <sup>(1)</sup>	E	E	E
Streets, Highways, & Freeways	E	E <sup>(1)</sup>	E	E <sup>(4)</sup>	E <sup>(1)</sup>	E	E	E
Retail Gasoline Outlets	N	N	E	N	N	E	E	E

E = expected to be of concern  
N = not expected to be of concern

- (1) Expected pollutant if landscaping exists on-site, otherwise not expected.
- (2) Expected pollutant if the project includes uncovered parking areas, otherwise not expected.
- (3) Expected pollutant if land use involves food or animal waste products, otherwise not expected.
- (4) Bacterial indicators are routinely detected in pavement runoff.
- (5) Expected if outdoor storage or metal roofs, otherwise not expected.

**Hydrologic Conditions of Concern**

The redevelopment of the project site is only expected to produce a Hydrologic Condition of Concern if either the 2-year 24-hour developed condition volume or time of concentration exceed the existing condition volume or time of concentration by more than 5 percent and the downstream channels are potentially susceptible to hydromodification impacts.

Based upon the “Susceptibility Analysis – Santa Ana River” exhibit located in Appendix F – Hydrology Information, the project does not drain to downstream facilities that are considered susceptible to hydromodification impacts. The site will drain to an existing storm drain facility within Struck Avenue before discharging to the Collins Channel and ultimately the Santa Ana River Reach 2, which are all stabilized facilities. Therefore, no HCOC mitigation measures are proposed onsite.

### **Post Development Drainage Characteristics**

In the post development condition, the site will be redeveloped to ensure that the onsite flows are directed to storm drain facilities that will convey flows to treatment devices prior to discharging offsite.

The majority of the site will surface flow to ribbon gutters that are proposed along the sides of the drive aisles to direct flows to proposed storm drain inlets. The proposed building will drain east into the proposed drive aisles and ribbon gutters. Some ponding is expected to occur within the parking limits, however additional storm drain inlets have been proposed along the ribbon gutters to reduce the ponding to acceptable levels. The proposed storm drain will convey flows to the Modular Wetland Systems for treatment prior to discharging offsite into Struck Avenue and ultimately into the existing storm drain facilities.

### **Industrial Projects**

The project redevelopment proposes to construct a new warehouse facility with an office space and maintenance building, parking areas for both truck trailers and automobiles, and drive aisles to ensure circulation throughout the project site. At this time, the future tenant is not known and therefore, the ultimate use of the warehouse is unknown.

Loading docks are proposed along the western and eastern sides of the warehouse building. No outside storage areas are proposed onsite. Other activities which would contribute additional pollutants to the downstream waters shall be prohibited.

### **Site Ownership and any Easements**

The existing site currently has easements dedicated to Southern California Edison that run from Struck Avenue to the center of the project site as shown on the site plan in Section VI.

### **III. Site Description**

**Reference Location Map:** APN 375-331-04, Parcel Map 194-5

**Site Address:** 534 W. Struck Avenue, Orange, CA 92867

**Zoning:** M-2 Industrial

**Predominant Soil type:** D

**Pre-project percent pervious: 8%      Post-project percent pervious: 9%**

**Pre-project percent impervious: 92%      Post-project percent impervious: 91%**

#### **Site Characteristics**

The 534 W. Struck Ave Redevelopment Project is located in the industrial area within the City of Orange. It is surrounded on the north, west, and south by industrial facilities and the east by the Santa Fe Railroad. The existing site is developed and consists of a single manufacturing building, parking, and trailer parking areas that also are used for storage of manufactured goods. The land use is Light Industrial and the zoning is M-2 Industrial. These designations are not proposed to be changed with the development of the project. At this time, no water quality measures are implemented within the project limits.

The elevations on the existing site range from 190 (NAVD88) in the southeastern corner to 180 in the northwestern corner. The site generally drains from east to west where existing ribbon gutters pick up flows and convey them north into Struck Avenue. Flows will drain to the existing 33" storm drain within Struck Avenue and ultimately into the Collins Channel before entering into the Santa Ana River. The downstream storm drain facilities are maintained and owned by the City. The Collins Channel and the Santa Ana River are maintained by Orange County Flood Control as shown on the "Basemap of Drainage Facilities in Orange County" provided in Appendix C. All downstream facilities are fully functioning stabilized drainage facilities and are not susceptible to hydromodification impacts.

The underlying soils for the site are Type D soils that do not promote infiltration as shown on the "NRCS Hydrologic Soils Group" exhibit (Figure XVI-2a) included in Appendix C. The geotechnical report prepared by Geotek on March 31, 2021 shows that the onsite soils were mainly stiff to very stiff clayey silt with infiltration rates of 0.02 inches per hour prior to the incorporation of a safety factor. Medium dense to very dense sand was also encountered on site. The borings were completed to depths of 6'-30' and were located throughout the project site. Therefore infiltration BMPs have been excluded from the project.

The groundwater for the site is approximately 30' below the finished surface based on the geotechnical report dated March 31, 2021 prepared by Geotek. This dept is deeper than what is shown on the "North Orange County Mapped Depth to First Groundwater" exhibit in Appendix C. Therefore it is not listed on the "North Orange County Mapped Shallow Groundwater" exhibit since the shallow groundwater is defined as groundwater encountered within 10' from finished surface.

The project site is not susceptible to potential landslides as shown in Figure XVI-2c in Appendix C.

### **Watershed Characteristics**

Watershed: Santa Ana River Watershed (Susceptibility Analysis for Newport Bay-Newport Coastal Streams Figure 4)

Downstream Receiving Waters: Collins Channel, Santa Ana River Reach 2 and 1

Water Quality Impairments (if applicable): Reach 2 of the Santa Ana River was 303(d) listed for Indicator Bacteria but it was delisted through 2016 303(d) update.

Identify hydromodification susceptibility: None

Identify watershed management priorities: N/A

## IV. Best Management Practices

### IV.1 Site Design and Drainage Characteristics

**Table 1  
Site Design BMPs**

Technique	Included?		If no, state justification.
	Yes	No	
Minimize Directly Connected Impervious Areas (DCIAs) (C-Factor Reduction)		x	The proposed site layout will require the landscaping to be provided outside the vehicular limits which are directly connected to the proposed building. However, this mimics the existing condition of the previously developed site.
Create Reduced or "Zero Discharge" Areas (Runoff Volume Reduction) <sup>1</sup>		x	The project site is not proposed to create HCOCs and therefore will not require volume reductions. The underlying soils will not allow infiltration which will prohibit the amount of volume reduction that can happen upstream of any BMP facilities.
Minimize Impervious Area/Maximize Permeability (C-Factor Reduction) <sup>2</sup>	x		
Conserve Natural Areas (C-Factor Reduction)		x	A portion of the existing project site has been used by the railroad in the past. This portion shall be removed and redeveloped into a drive aisle and landscaping. However, additional landscaping is proposed throughout the site that was impervious area in the existing condition. The landscape areas adjacent to Struck Avenue shall also remain.

1 Detention and retention areas incorporated into landscape design provide areas for retaining and detaining stormwater flows, resulting in lower runoff rates and reductions in volume due to limited infiltration and evaporation. Such Site Design BMPs may reduce the size of Treatment Control BMPs.

2 The "C Factor" is a representation of the ability of a surface to produce runoff. Surfaces that produce higher volumes of runoff are represented by higher C Factors. By incorporating more pervious, lower C Factor surfaces into a development, lower volumes of runoff will be produced. Lower volumes and rates of runoff translate directly to lowering treatment requirements.

#### **Minimize Impervious Area/Maximize Permeability (C-factor Reduction):**

Landscaping areas are provided where available within the site layout. The landscaping areas are proposed in locations that will not interfere with the site flow and safety of traffic throughout the project. The onsite landscape areas shall be recessed approximately 1-inch from adjacent finished surface to allow capture of smaller storm events.

**IV.2 Source Control BMPs**

**IV.2.1 Routine Non-Structural BMPs**

**Table 2**

**Routine Non-Structural BMPs**

<b>BMP No.</b>	<b>Name</b>	<b>Check One</b>		<b>If not applicable, state brief reason.</b>
		<b>Included</b>	<b>Not Applicable</b>	
N1	Education for Property Owners, Tenants and Occupants	<b>x</b>		
N2	Activity Restriction	<b>x</b>		
N3	Common Area Landscape Management	<b>x</b>		
N4	BMP Maintenance	<b>x</b>		
N5	Title 22 CCR Compliance		<b>x</b>	Although building use is unknown at this time, hazardous waste is not anticipated.
N6	Local Water Quality Permit Compliance		<b>X</b>	This BMP is not applicable. The City of Orange does not issue water quality permits.
N7	Spill Contingency Plan	<b>x</b>		
N8	Underground Storage Tank Compliance		<b>x</b>	Although building use is unknown at this time, underground storage tanks are not anticipated.
N9	Hazardous Materials Disclosure Compliance		<b>x</b>	Although building use is unknown at this time, use of hazardous materials is not anticipated.
N10	Uniform Fire Code Implementation	<b>x</b>		
N11	Common Area Litter Control	<b>X</b>		
N12	Employee Training	<b>X</b>		
N13	Housekeeping of Loading Docks	<b>X</b>		
N14	Common Area Catch Basin Inspection	<b>X</b>		
N15	Street Sweeping Private Streets and Parking Lots	<b>x</b>		

**N1: Education for Property Owners, Tenants, and Occupants**

Informational materials shall be provided to all future property owners, tenants, and occupants. This includes brochures and related educational materials on how to help reduce and restrict pollutants from being discharged from the project site. Examples of



educational materials are watershed fact sheets, landscaping information, good housekeeping information, and BMP maintenance and fact sheets. Please see Appendix B for applicable educational materials. Additional educational resources may be found here: <https://h2oc.org/resources/view-order-brochures/business-brochures/>

**N2: Activity Restriction**

It is unknown at this time what the proposed use will be for the warehouse facility. However, any future activities that adversely affect the water quality treatment of the project site shall be restricted. This may include, but is not limited to, vehicle maintenance, unauthorized pesticide use, and discharge of hazardous materials and contaminants offsite.

**N3: Common Area Landscape Management**

On-going landscape maintenance shall be required for the duration of the project lifetime. This shall include proper trimming and removals required for the upkeep of the onsite landscaping. The project shall propose to limit the pesticide use to a minimum, preferably using no pesticides onsite. All fertilizer and pesticide use shall conform to Section 5 – Municipal Activities of the latest Orange County Drainage Area Management Plan.

**N4: BMP Maintenance**

BMP maintenance shall be implemented as required by the BMP educational materials and/or the manufacturer's specifications for upkeep. The responsibility of the BMP maintenance shall be coordinated between the tenant and owner.

**N7: Spill Contingency Plan**

A Spill Contingency Plan is required to address any concerns regarding how the tenant and/or owner shall handle or prepare for onsite spills. This plan is created by the tenant or owner or other appointed person with knowledge of the site. The plan shall address procedures and preparations to mitigate any spills. However, at this time, hazardous waste materials are not expected onsite.

**N10: Uniform Fire Code Implementation**

The site must abide by all regulations stated in the latest Uniform Fire Code and as issued by the City. This includes regular maintenance of test facilities, access points, and inspections.

**N11: Common Area Litter Control**

The owner and/or tenant shall be required to provide adequate trash/recycling receptacles throughout the project site, specifically in common areas such as outdoor break areas. All trash receptacles shall be maintained to proper working condition to reduce the amount of spills, trash, and debris onsite. This includes regular removal of garbage from receptacle and replacement of receptacles that may be damaged.

**N12: Employee Training**

The owner and/or tenant shall be required to provide adequate training to appropriate employees regarding applicable water quality treatment devices. Training shall be conducted upon hire and shall continue throughout the employee's tenure. Examples of employee training are educating the employees on the proper use of pesticides and fertilizer or what to do in the case of a spill on the project site.

**N13: Housekeeping of Loading Docks**

Loading docks shall be designed to ensure that they drain away from the proposed building to minimize run-on within the loading dock areas. When available, loading docks shall provide roof coverings. Loading and unloading of items shall promptly be completed to minimize chances of pollutants entering the storm drain system. Loading docks shall be cleaned regularly, including sweeping, litter control, and mitigating spills.

**N14: Common Area Catch Basin Inspection**

The owner and/or tenant are required to ensure yearly inspections are done for 100% of the private drainage systems. The drainage facilities shall be inspected and cleaned prior to the rainy season. Catch basin stenciling or markings shall be maintained and replaced as necessary. Any and all inlets into basins shall also be inspected and maintained prior to the rainy season. Any defect within the drainage facilities shall promptly be fixed to ensure facilities are operating as designed.

**N15: Street Sweeping Private Streets and Parking Lots**

Private drive aisles and parking areas for both truck trailers and automobiles shall be swept regularly to prevent a buildup of pollutants including oil, grease, trash, and debris. Parking areas and drive aisles must be visually inspected weekly to determine the need for hand broom sweep, mechanical sweep, or vacuum sweep. Special attention shall be paid to the site's conveyance and discharge points prior to October 1<sup>st</sup> and after each rain event. This will include potential street sweeping and cleaning shall occur before the rainy season. Any waste water collected during the sweeping shall be properly disposed of.

**IV.2.2 Routine Structural BMPs**

Complete Table 3.

**Table 3**

**Routine Structural BMPs**

Name	Check One		If not applicable, state brief reason
	Included	Not Applicable	
Provide storm drain system stenciling and signage- "No Dumping – Drains to Ocean"	X		
Design and construct outdoor material storage areas to reduce pollution introduction		X	At this time, no outdoor storage is proposed onsite. If outdoor storage is required onsite, the project shall implement covered facilities.
Design and construct trash and waste storage areas to reduce pollution introduction	X		
Use efficient irrigation systems & landscape design	X		
Protect slopes and channels and provide energy dissipation		X	No slopes or channels are proposed onsite that would require energy dissipation.
Incorporate requirements applicable to individual project features			
a. Dock areas	X		
b. Maintenance bays		X	No maintenance bays are proposed onsite.
c. Vehicle or community wash areas		X	No community wash areas are proposed onsite.
d. Outdoor processing areas		X	No outdoor processing areas are proposed onsite.
e. Equipment wash areas		X	
f. Fueling areas		X	
g. Hillside landscaping		X	
h. Wash water control for food preparation areas		X	

**SD-13: Storm Drain Signage**

All inlets shall be stenciled with "NO DUMPING! DRAINS TO OCEAN" as required by the City. The stenciling and signage shall be regularly maintained in order to retain awareness on downstream facilities that can be contaminated with pollutants from unauthorized dumping.

**SD-32: Trash Storage Areas**

All trash enclosures shall be designed to prevent run-on water from adjacent areas such as buildings or pavement. The trash enclosure shall be an impervious area closed off in

some fashion (walls, fences, etc), including a roof or awning directly over the enclosure. Any dumpsters or bins shall have lids.

**SD-12: Efficient Irrigation Systems and Landscape Design**

The owner and/or developer shall be responsible for installing efficient irrigation and landscape systems within the proposed landscaping areas onsite. The systems shall incorporate, but are not limited to, shutoff devices activated by precipitation, shutoff valves for pressure drops, drought tolerant plants consistent with the City's landscaping guidelines, and landscaping clusters of plants with similar water demands. Other systems should be incorporated to reduce inefficiencies within the irrigation lines. The owner shall ensure that the regular maintenance is performed on the irrigation and landscape systems, and specifically before the start of the rainy season.

**SD-31: Loading Docks**

Loading docks shall be designed to ensure that they drain away from the proposed building to minimize run-on within the loading dock areas. When available, loading docks shall provide roof coverings. Loading and unloading of items shall promptly be completed to minimize chances of pollutants entering the storm drain system. Loading docks shall be cleaned regularly, including sweeping, litter control, and mitigating spills.

**IV.3 Low Impact Development BMP Selection**

**IV.3.1 Hydrologic Source Controls**

Due to site layout constraints and underlying soil infiltration infeasibility, Hydrologic Source Controls are not implemented with the project. This remains consistent with the existing site layout as well. However, to reduce the imperviousness of the project site, landscaping areas have been provided.

**Table 4  
Hydrologic Source Control BMPs**

Name	Check If Used
Localized on-lot infiltration	<input type="checkbox"/>
Impervious area dispersion (e.g. roof top disconnection)	<input type="checkbox"/>
Street trees (canopy interception)	<input type="checkbox"/>
Residential rain barrels (not actively managed)	<input type="checkbox"/>
Green roofs/Brown roofs	<input type="checkbox"/>
Blue roofs	<input type="checkbox"/>
Other:	<input type="checkbox"/>
Other:	<input type="checkbox"/>
Other:	<input type="checkbox"/>
Other:	<input type="checkbox"/>
Other:	<input type="checkbox"/>
Other:	<input type="checkbox"/>
Other:	<input type="checkbox"/>
Other:	<input type="checkbox"/>

**IV.3.2 Infiltration BMPs**

Due to the extremely low underlying soil infiltration rates, infiltration BMPs are not proposed on the project site.

**Table 5  
Infiltration BMPs**

Name	Check If Used
Bioretention without underdrains	<input type="checkbox"/>
Rain gardens	<input type="checkbox"/>
Porous landscaping	<input type="checkbox"/>
Infiltration planters	<input type="checkbox"/>
Retention swales	<input type="checkbox"/>
Infiltration trenches	<input type="checkbox"/>
Infiltration basins	<input type="checkbox"/>
Drywells	<input type="checkbox"/>
Subsurface infiltration galleries	<input type="checkbox"/>
French drains	<input type="checkbox"/>
Permeable asphalt	<input type="checkbox"/>
Permeable concrete	<input type="checkbox"/>
Permeable concrete pavers	<input type="checkbox"/>
Other:	<input type="checkbox"/>
Other:	<input type="checkbox"/>

**Table 2.7: Infiltration BMP Feasibility Worksheet**

	<b>Infeasibility Criteria</b>	<b>Yes</b>	<b>No</b>
1	<b>Would Infiltration BMPs pose significant risk for groundwater related concerns?</b> Refer to <a href="#">Appendix VIII</a> (Worksheet I) for guidance on groundwater-related infiltration feasibility criteria.		X
<p><b>Provide basis:</b> Worksheet I was completed based on known information regarding the underlying conditions of the project site. Since it is known that the infiltration rates are poor within the site boundary, it is assumed infiltration BMPs are not feasible and no further studies for groundwater data were analyzed.</p> <p>Summarize findings of studies provide reference to studies, calculations, maps, data sources, etc. Provide narrative discussion of study/data source applicability.</p>			
2	<p><b>Would Infiltration BMPs pose significant risk of increasing risk of geotechnical hazards that cannot be mitigated to an acceptable level?</b> (Yes if the answer to any of the following questions is yes, as established by a geotechnical expert):</p> <ul style="list-style-type: none"> <li>• The BMP can only be located less than 50 feet away from slopes steeper than 15 percent</li> <li>• The BMP can only be located less than eight feet from building foundations or an alternative setback.</li> <li>• A study prepared by a geotechnical professional or an available watershed study substantiates that stormwater infiltration would potentially result in significantly increased risks of geotechnical hazards that cannot be mitigated to an acceptable level.</li> </ul>		X
<p><b>Provide basis:</b> The geotechnical and infiltration evaluation for the proposed site dated March 31, 2020 found no risk of increased geotechnical hazards due to the development of the project site.</p> <p>Summarize findings of studies provide reference to studies, calculations, maps, data sources, etc. Provide narrative discussion of study/data source applicability.</p>			
3	<b>Would infiltration of the DCV from drainage area violate downstream water rights?</b>		X
<p><b>Provide basis:</b> Since it is known that the infiltration rates are poor within the site boundary, it is assumed infiltration BMPs are not feasible and no further studies for downstream water rights data were analyzed.</p> <p>Summarize findings of studies provide reference to studies, calculations, maps, data sources, etc. Provide narrative discussion of study/data source applicability.</p>			

**Table 2.7: Infiltration BMP Feasibility Worksheet (continued)**

	<b>Partial Infeasibility Criteria</b>	<b>Yes</b>	<b>No</b>
4	Is proposed infiltration facility <b>located on HSG D soils</b> or the site geotechnical investigation identifies presence of soil characteristics which support categorization as D soils?	X	
<p><b>Provide basis:</b>                      Figure XVI-2a from the Orange County Technical Guidance Document was used to determine the underlying hydrologic soil group. It was determined from this figure that the site is located on type D soils. Therefore infiltration is not determined to be feasible. Summarize findings of studies provide reference to studies, calculations, maps, data sources, etc. Provide narrative discussion of study/data source applicability.</p>			
5	Is <b>measured infiltration rate below proposed facility less than 0.3 inches per hour?</b> This calculation shall be based on the methods described in <a href="#">Appendix VII</a> .	X	
<p><b>Provide basis:</b>                      The geotechnical and infiltration evaluation for the proposed site dated March 31, 2020 found infiltration rates of 0.02 in/hr throughout the project site. This infiltration rate does not include a safety factor. Therefore, infiltration is not determined to be feasible. Summarize findings of studies provide reference to studies, calculations, maps, data sources, etc. Provide narrative discussion of study/data source applicability.</p>			
6	Would <b>reduction of over predeveloped conditions cause impairments to downstream beneficial uses, such as change of seasonality of ephemeral washes or increased discharge of contaminated groundwater to surface waters?</b>		X
<p><b>Provide citation to applicable study and summarize findings relative to the amount of infiltration that is permissible:</b>                      Based upon previous criteria, infiltration is not feasible for the project. In the existing condition, the site is developed industrial land. This land use will be kept for the developed condition. No significant change to offsite flows through infiltration measures will occur. Summarize findings of studies provide reference to studies, calculations, maps, data sources, etc. Provide narrative discussion of study/data source applicability.</p>			
7	Would <b>an increase in infiltration over predeveloped conditions cause impairments to downstream beneficial uses, such as change of seasonality of ephemeral washes or increased discharge of contaminated groundwater to surface waters?</b>		X
<p><b>Provide citation to applicable study and summarize findings relative to the amount of infiltration that is permissible:</b>                      Based upon previous criteria, infiltration is not feasible for the project. In the existing condition, the site is developed industrial land. This land use will be kept for the developed condition. No significant change to offsite flows through infiltration measures will occur. Summarize findings of studies provide reference to studies, calculations, maps, data sources, etc. Provide narrative discussion of study/data source applicability.</p>			



Table 2.7: Infiltration BMP Feasibility Worksheet (continued)

Infiltration Screening Results (check box corresponding to result):		
8	<p>Is there substantial evidence that infiltration from the project would result in a significant increase in I&amp;I to the sanitary sewer that cannot be sufficiently mitigated? (See <a href="#">Appendix XVII</a>)</p> <p>Provide narrative discussion and supporting evidence:                      Infiltration is not feasible for the project site. Therefore not adverse impacts will be created to the sanitary sewer system. All storm water will drain to the proposed storm drain and be transported offsite.                      Summarize findings of studies provide reference to studies, calculations, maps, data sources, etc. Provide narrative discussion of study/data source applicability.</p>	No
9	<p>If any answer from row 1-3 is yes: infiltration of any volume is <b>not feasible</b> within the DMA or equivalent.</p> <p>Provide basis:                      No adverse affects are proposed to the project site due to infiltration of runoff. All downstream facilities are developed and are designed to handle full runoff from the project site since the site is currently developed as an industrial site.                      Summarize findings of infeasibility screening</p>	No
10	<p>If any answer from row 4-7 is yes, infiltration is <b>permissible but is not presumed to be feasible for the entire DCV</b>. Criteria for designing biotreatment BMPs to achieve the maximum feasible infiltration and ET shall apply.</p> <p>Provide basis:                      The geotechnical investigation shows that the infiltration rates are 0.02 in/hr without a safety factor. This rate is not able to adequately infiltrate water without causing vector issues onsite. Therefore infiltration is not feasible for the project.                      Summarize findings of infeasibility screening</p>	Yes
11	<p>If all answers to rows 1 through 11 are no, infiltration of the full DCV is potentially feasible, BMPs must be designed to infiltrate the full DCV to the maximum extent practicable.</p>	No

**Worksheet I: Summary of Groundwater-related Feasibility Criteria**

1	Is project large or small? (as defined by <a href="#">Table VIII.2</a> ) circle one	<b>Large</b>	Small	
2	What is the tributary area to the BMP?	A	10.0	acres
3	What type of BMP is proposed?	Bio-treatment - Modular Wetland Systems		
4	What is the infiltrating surface area of the proposed BMP?	A <sub>BMP</sub>	0	sq-ft
5	What land use activities are present in the tributary area (list all) The project site proposes to redevelop the industrial land. The redevelopment would build a new industrial building, parking for trucks and automobiles, and drive aisles. Landscaping areas would also be provided onsite.			
6	What land use-based risk category is applicable?	L	<b>M</b>	H
7	If M or H, what pretreatment and source isolation BMPs have been considered and are proposed (describe all): Based upon Table VIII.1, the proposed redeveloped site falls into the Moderate Runoff Contamination Potential Category as "Light Industrial that does not include usage of chemicals that are mobile in stormwater and groundwater". At this time, it is unknown what type of storage the warehouse facility will accommodate. However it is proposed that there are no outside storage facilities and therefore no contaminated runoff.			
8	What minimum separation to mounded seasonally high groundwater applies to the proposed BMP? See Section <a href="#">VIII.2</a> (circle one)	5 ft	<b>10 ft</b>	
9	Provide rationale for selection of applicable minimum separation to seasonally high mounded groundwater: The geotechnical and infiltration evaluation report dated March 31, 2020 states: <i>Groundwater was not encountered within our test borings to depths up to about 30 feet below grade. Based on a review of the Seismic Hazard Zone Report for the Orange Quadrangle, historic high groundwater at the site is estimated to be greater than 40 feet below grade.</i>			
10	What is separation from the infiltrating surface to seasonally high groundwater?	SHGWT	40+	ft
11	What is separation from the infiltrating surface to mounded seasonally high groundwater?	Mounded SHGWT	unknown	ft
12	Describe assumptions and methods used for mounding analysis: Infiltration BMPs are not proposed for the project site due to poor underlying soils. Therefore the analysis for the mounded seasonally high groundwater was not performed. Based upon the geotechnical investigation mentioned above, the historic high groundwater is estimated to be 40+ feet below the surface.			
13	Is the site within a plume protection boundary (See <a href="#">Figure</a>	Y	<b>N</b>	N/A

**Worksheet I: Summary of Groundwater-related Feasibility Criteria**

	VIII.2)?	
14	Is the site within a selenium source area or other natural plume area (See Figure VIII.2)?	Y    N    N/A
15	Is the site within 250 feet of a contaminated site?	Y    N    N/A
16	If site-specific study has been prepared, provide citation and briefly summarize relevant findings:	
17	Is the site within 100 feet of a water supply well, spring, septic system?	Y    N    N/A
18	Is infiltration feasible on the site relative to groundwater-related criteria?	Y    N
<p>Provide rationale for feasibility determination:</p> <p>The geotechnical and infiltration evaluation report dated March 31, 2020 determined that the underlying soils have very poor infiltration rates. Infiltration rates are also affected due to compaction required during construction of the existing facilities. Therefore it was determined that infiltration is infeasible. Additional studies specifically for groundwater-related criteria were not analyzed due to the poor infiltration rates onsite.</p>		

Note: if a single criterion or group of criteria would render infiltration infeasible, it is not necessary to evaluate every question in this worksheet.

**IV.3.3 Evapotranspiration, Rainwater Harvesting BMPs**

Harvest and use BMPs are not feasible for the project site. Table X.6: Harvested Water Demand Thresholds for Minimum Partial Capture of the Technical Guidance Document shows that the minimum capture needed for the site is 650 gpd. Based upon the calculations in Appendix C, the site will produce 482 gpd and does not meet the minimum threshold. Therefore, no further analysis was done on harvest and use for the project site.

**Table 6  
Evapotranspiration, Rainwater Harvesting BMP**

Name	Check If Used
All HSCs; <i>See Section IV.3.1</i>	<input type="checkbox"/>
Surface-based infiltration BMPs	<input type="checkbox"/>
Biotreatment BMPs	<input type="checkbox"/>
Above-ground cisterns and basins	<input type="checkbox"/>
Underground detention	<input type="checkbox"/>
Other:	<input type="checkbox"/>
Other:	<input type="checkbox"/>
Other:	<input type="checkbox"/>

**IV.3.4 Biotreatment BMPs**

**Table 7  
Biotreatment BMPs**

Bioretention with underdrains	<input type="checkbox"/>
Storm water planter boxes with underdrains	<input type="checkbox"/>
Rain gardens with underdrains	<input type="checkbox"/>
Constructed wetlands	<input type="checkbox"/>
Vegetated swales	<input type="checkbox"/>
Vegetated filter strips	<input type="checkbox"/>
Proprietary vegetated biotreatment systems	<input checked="" type="checkbox"/>
Wet extended detention basin	<input type="checkbox"/>
Dry extended detention basins	<input type="checkbox"/>
Other:	<input type="checkbox"/>
Other:	<input type="checkbox"/>

As previously mentioned, the infiltration rate of the project site precludes the use of infiltration BMPs within the project boundaries. Harvest and use was deemed infeasible since the project site does not meet the minimum demand threshold. Therefore the project is required to utilize biotreatment BMPs to treat the proposed runoff. Due to site layout constraints, including parking minimums and drive aisle minimums, proprietary biotreatment systems are proposed onsite.

The low flows from the project site will drain through the treatment devices prior to outletting into the existing storm drain. The required treatment flow rate was analyzed as directed in Section III.3.3. of the Technical Guidance Document and determined to be a minimum of 2.0 cfs. However, since there are no proposed upstream HSCs, the biotreatment facilities are proposed to treat the full design flowrate.

The Modular Wetland System has been proven to treat for a variety of pollutants, including bacteria (identified pollutant of concern). The Modular Wetland System proposed for the project site is capable of treating up to 2.3 cfs of runoff. The Modular Wetland System is proven to have a medium removal effectiveness of bacteria. Additional information regarding the Modular Wetland System efficiencies can be found in Appendix C: BMP Details.

**IV.3.5 Hydromodification Control BMPs**

The project site is not considered to create Hydrologic Conditions of Concern. Therefore no hydromodification controls are required.

**IV.3.6 Regional/Sub-Regional LID BMPs**

N/A

**IV.3.7 Treatment Control BMPs**

N/A – All required water quality treatment shall be performed in proprietary biotreatment devices.

**IV. 4 Water Quality Credits**

N/A

**IV.5 Alternative Compliance Plan**

N/A

**IV.6 Vector Control**

No BMPs are proposed that shall create standing water. The Modular Wetlands Systems treat water underground and do not propose ponded water upstream.

**IV.7 Drainage Management Area (DMA)**

Describe each DMA used in project, the BMPs in each DMA and the area treated.

DMA Number	BMPs	Area Treated
1	Modular Wetland System	10.0 acres
<b>Total Area</b>		

Total Project Area=10.0 acres

The full design flow rate is treated by the Modular Wetland Systems. No additional BMPs are required.

**IV.8 Calculations**

The following BMPs were selected based upon the Orange County Technical Guidance Document Figure 2.1: LID BMP Selection Flow Chart:

The infiltration capacities within the boundaries of the project site eliminate infiltration BMPs from being implemented to treat runoff per the water quality standards. The site also does not meet the minimum requirements to utilize Harvest and Reuse onsite. Therefore the project proposes biotreatment facilities to treat the site runoff. To ensure proper parking counts and drive aisle widths, the site shall implement Proprietary Vegetated Biotreatment Systems to treat the full design flowrate as calculated on the

following page. Since the Proprietary System treats the full design flowrate, the project is in compliance with the LID BMP selection and sizing requirements.

**Worksheet D: Capture Efficiency Method for Flow-Based BMPs**

<b>Step 1: Determine the design capture storm depth used for calculating volume</b>				
1	Enter the time of concentration, $T_c$ (min) (See <b>Appendix IV.2</b> )	$T_c =$	<b>10</b>	<b>min</b>
2	Using <b>Figure III.4</b> , determine the design intensity at which the estimated time of concentration ( $T_c$ ) achieves 80% capture efficiency, $I_1$	$I_1 =$	<b>0.23</b>	in/hr
3	Enter the effect depth of provided HSCs upstream, $d_{HSC}$ (inches) ( <b>Worksheet A</b> )	$d_{HSC} =$		inches
4	Enter capture efficiency corresponding to $d_{HSC}$ , $Y_2$ ( <b>Worksheet A</b> )	$Y_2 =$		%
5	Using <b>Figure III.4</b> , determine the design intensity at which the time of concentration ( $T_c$ ) achieves the upstream capture efficiency ( $Y_2$ ), $I_2$	$I_2 =$		
6	Determine the design intensity that must be provided by BMP, $I_{design} = I_1 - I_2$	$I_{design} =$	<b>0.23</b>	
<b>Step 2: Calculate the design flowrate</b>				
1	Enter Project area tributary to BMP (s), $A$ (acres)	$A =$	<b>10.0</b>	acres
2	Enter Project Imperviousness, $imp$ (unitless)	$imp =$	<b>90.2%</b>	
3	Calculate runoff coefficient, $C = (0.75 \times imp) + 0.15$	$C =$	<b>0.827</b>	
4	Calculate design flowrate, $Q_{design} = (C \times I_{design} \times A)$	$Q_{design} =$	<b>1.9</b>	cfs
<b>Supporting Calculations</b>				
Describe system: <b>Proposed Modular Wetland System (4- 8' x 20' units) is capable of treating up to 2.3 cfs of runoff generated within the project boundary.</b>				
Provide time of concentration assumptions: <b><math>T_c</math> was derived from the 2-Year rational method calculations.</b>				



Figure III.4. Capture Efficiency Nomograph for Off-line Flow-based Systems in Orange County

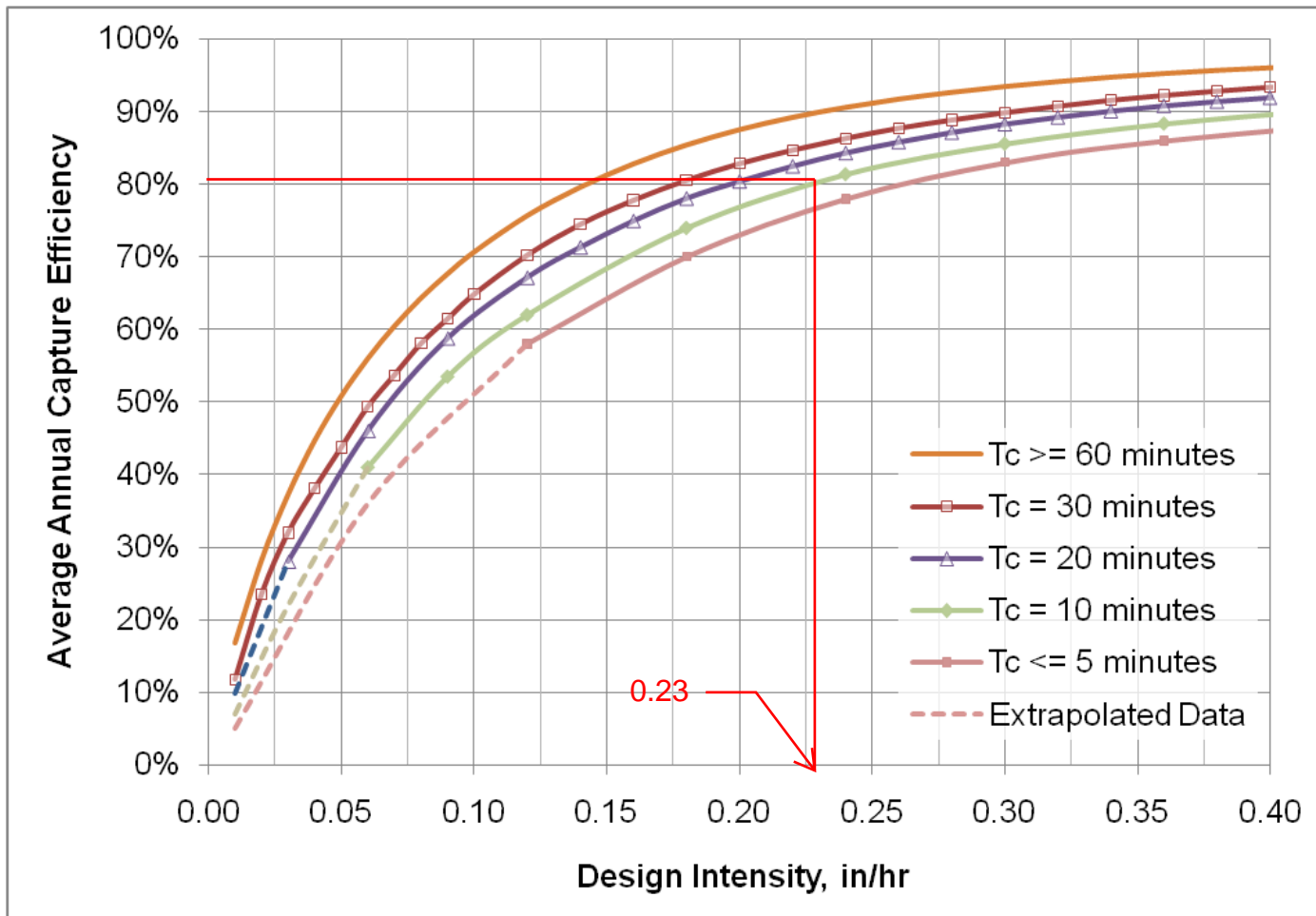

# SPECIFICATIONS

## FLOW-BASED DESIGNS

The Modular Wetlands® System Linear can be used in stand-alone applications to meet treatment flow requirements, and since it is the only biofiltration system that can accept inflow pipes several feet below the surface, it can be used not only in decentralized design applications but also as a large central end-of-the-line application for maximum feasibility.

MODEL #	DIMENSIONS	WETLAND MEDIA SURFACE AREA (sq. ft.)	TREATMENT FLOW RATE (cfs)
MWS-L-4-4	4' x 4'	23	0.052
MWS-L-4-6	4' x 6'	32	0.073
MWS-L-4-8	4' x 8'	50	0.115
MWS-L-4-13	4' x 13'	63	0.144
MWS-L-4-15	4' x 15'	76	0.175
MWS-L-4-17	4' x 17'	90	0.206
MWS-L-4-19	4' x 19'	103	0.237
MWS-L-4-21	4' x 21'	117	0.268
MWS-L-6-8	7' x 9'	64	0.147
MWS-L-8-8	8' x 8'	100	0.230
MWS-L-8-12	8' x 12'	151	0.346
MWS-L-8-16	8' x 16'	201	0.462
MWS-L-8-20	9' x 21'	252	0.577
MWS-L-8-24	9' x 25'	302	0.693
MWS-L-10-20	10' x 20'	302	0.693

Four (4) MWS-L-8-20 Models proposed onsite.

**V. Implementation, Maintenance and Inspection Responsibility for BMPs (O&M Plan)**

Responsible Party Information (Local Contact Information)

Name: Maggie Xu Title: Director, Project Management

Company: Prologis Phone Number: (310) 338-3273

Complete frequency matrix. Expand or increase each cell box to provide the information required.

Table 8 - Frequency Inspection Matrix

BMP	Responsible Party	*Maintenance Activity	*Inspection/Maintenance Frequency
<b>Source Control BMPs (Structural and Non-structural)</b>			
N1: Education for Property Owners, Tenants and Occupants	Owner	Replace educational materials Conduct training sessions for employees	Yearly or upon transfer to new owner or tenant
N2: Activity Restriction	Owner and/or Tenant	Ensure prohibited activities are not conducted onsite	Daily
N3: Common Area Landscape Management	Owner and/or Tenant	Regulate landscaping through regular trimming, weeding, removals, or replanting as needed to maintain healthy landscaping Regularly remove trash and debris in the landscape areas	Weekly or as needed for healthy plant growth Specifically before and after rain events
N4: BMP Maintenance	Owner and/or Tenant	Per manufacturer's specifications. See information in Appendix D.	Every 6 months and before the beginning of the rainy season. Or as needed.
N7: Spill Contingency Plan	Owner and/or Tenant	Educate appropriate personnel on standard procedures in the event of a spill onsite Maintain Plan and ensure Plan is readily available	Yearly or upon transfer to new owner or tenant

**FINAL WQMP for  
534 W. Struck Ave Redevelopment Project**

		Review and update Plan for inconsistencies or updates based on industrial processes within the facility	
N10: Uniform Fire Code Implementation	Owner and/or Tenant	Ensure the site is up to date with the latest Uniform Fire Code  Regularly test and maintain facilities, access points, and conduct inspections	Yearly or as required by the City
N11: Common Area Litter Control	Owner and/or Tenant	Provide adequate trash and recycling receptacles within common areas  All trash receptacles shall be kept in working condition  Replace damaged receptacles	Daily
N12: Employee Training	Owner and/or Tenant	Provide training to employees regarding good housekeeping measures  Ensure appropriate personnel are trained regarding maintenance of applicable water quality treatment devices  Ensure appropriate personnel are trained regarding use of pesticides and fertilizer for landscape maintenance	Upon employee hire and as required to adequately maintain facility
N13: Housekeeping of Loading Docks	Owner and/or Tenant	Regularly clean docks, including sweeping, litter control, and mitigating spills  Promptly unload and load items to minimize pollutants  Ensure positive drainage away from the loading docks is maintained	Daily
N14: Common Area Catch Basin Inspection	Owner and/or Tenant	Regularly inspect and clean out catch basins, including removals of trash and debris	Yearly  Specifically before rainy season

**FINAL WQMP for  
534 W. Struck Ave Redevelopment Project**

		<p>Stenciling or markings shall be maintained or replaced as necessary</p> <p>Replace or fix damaged drainage facilities promptly</p>	
N15: Street Sweeping Private Streets and Parking Lots	Owner and/or Tenant	<p>Regularly sweep drive aisles and parking lots</p> <p>Remove oil, grease, trash, and debris</p> <p>Properly dispose of waste water collected during sweeping</p>	<p>Bi-monthly</p> <p>Specifically before rainy season</p>
SD-13: Storm Drain Signage	Owner and/or Tenant	<p>Stenciling or markings shall be maintained or replaced as necessary</p>	Yearly
SD-32: Trash Storage Areas	Owner and/or Tenant	<p>Regularly maintain trash enclosures including litter control and removing trash and debris</p> <p>Ensure bins have lids</p> <p>Regularly inspect bins and ensure they are fully functioning without cracks or leaks</p>	Daily
SD-12: Efficient Irrigation Systems and Landscape Design	Owner and/or Developer	<p>Install efficient irrigation systems including: shutoff devices, shutoff valves, drought tolerant plants, and grouping of plants with similar water demands</p> <p>Regular maintenance shall be performed to ensure all systems are functioning adequately</p> <p>Damaged devices shall be fixed or replaced</p>	<p>Monthly or as needed</p> <p>Specifically before rainy season</p>
SD-31: Loading Docks	Owner and/or Tenant	<p>Regularly clean docks, including sweeping, litter control, and mitigating spills</p> <p>Promptly unload and load items to minimize pollutants</p> <p>Ensure positive drainage away from the loading</p>	Daily

**FINAL WQMP for  
534 W. Struck Ave Redevelopment Project**

---

		docks is maintained	
<b>Low Impact Development and Treatment BMPs</b>			
Modular Wetland Systems		Per manufacturer's specifications. See information in Appendix D.	Every 6 months and before the beginning of the rainy season. Or as needed.

\*Attach in appendix additional inspection, maintenance and operations information if required.

**Regulatory Permits**

N/A

**Funding**

The installation of the BMPs shall be the responsibility of the developer. Any ongoing maintenance will be the responsibility of the owner/tenant.

**OWNER SELF CERTIFICATION STATEMENT**

As the owner representative of the 534 W. Struck Ave Redevelopment Project for which a Water Quality Management Plan (WQMP) was approved by the City, I hereby certify under penalty of law that all Best Management Practices contained within the approved Project WQMP have been maintained and inspected in accordance with the schedule and frequency outlined in the approved WQMP Maintenance Table.

The maintenance activities and inspections conducted are shown in the attached table and have been performed by qualified and knowledgeable individuals. Structural Treatment BMPs have been inspected and certified by a licensed professional engineer.

To the best of my knowledge, the information submitted is true and accurate and complete. I am aware that there are significant penalties for submitting false information, including the possibility of fines and citations for violating water quality regulations.

Signed: \_\_\_\_\_

Name: Maggie Xu

Title: Director, Project Management

Company: Prologis

Address: 17777 Center Court Dr. N, Suite 100, Cerritos, CA 90703

Telephone Number: (310) 338-3273

Date: \_\_\_\_\_



**BMP Implementation Tracking Table**

BMP	Activity	Completion Dates or Frequency	Initial
<b>Source Control BMPs (Structural and Nonstructural)</b>			
N1: Education for Property Owners, Tenants and Occupants	Replace educational materials Conduct training sessions for employees		
N2: Activity Restriction	Ensure prohibited activities are not conducted onsite		
N3: Common Area Landscape Management	Regulate landscaping through regular trimming, weeding, removals, or replanting as needed to maintain healthy landscaping Regularly remove trash and debris in the landscape areas		
N4: BMP Maintenance	Per manufacturer's specifications. See information in Appendix D.		
N7: Spill Contingency Plan	Educate appropriate personnel on standard procedures in the event of a spill onsite Maintain Plan and ensure Plan is readily available Review and update Plan for inconsistencies or updates based on industrial processes within the facility		
N10: Uniform Fire Code Implementation	Ensure the site is up to date with the latest Uniform Fire Code Regularly test and maintain facilities, access points, and conduct inspections		
N11: Common Area Litter Control	Provide adequate trash and recycling receptacles within common areas All trash receptacles shall be kept in working condition Replace damaged receptacles		
N12: Employee Training	Provide training to employees regarding good housekeeping measures Ensure appropriate personnel are trained regarding maintenance of applicable water quality treatment devices Ensure appropriate personnel are trained regarding use of pesticides and fertilizer for landscape maintenance		

**FINAL WQMP for  
534 W. Struck Ave Redevelopment Project**

N13: Housekeeping of Loading Docks	<p>Regularly clean docks, including sweeping, litter control, and mitigating spills</p> <p>Promptly unload and load items to minimize pollutants</p> <p>Ensure positive drainage away from the loading docks is maintained</p>		
N14: Common Area Catch Basin Inspection	<p>Regularly inspect and clean out catch basins, including removals of trash and debris</p> <p>Stenciling or markings shall be maintained or replaced as necessary</p> <p>Replace or fix damaged drainage facilities promptly</p>		
N15: Street Sweeping Private Streets and Parking Lots	<p>Regularly sweep drive aisles and parking lots</p> <p>Remove oil, grease, trash, and debris</p> <p>Properly dispose of waste water collected during sweeping</p>		
SD-13: Storm Drain Signage	<p>Stenciling or markings shall be maintained or replaced as necessary</p>		
SD-32: Trash Storage Areas	<p>Regularly maintain trash enclosures including litter control and removing trash and debris</p> <p>Ensure bins have lids</p> <p>Regularly inspect bins and ensure they are fully functioning without cracks or leaks</p>		
SD-12: Efficient Irrigation Systems and Landscape Design	<p>Install efficient irrigation systems including: shutoff devices, shutoff valves, drought tolerant plants, and grouping of plants with similar water demands</p> <p>Regular maintenance shall be performed to ensure all systems are functioning adequately</p> <p>Damaged devices shall be fixed or replaced</p>		
SD-31: Loading Docks	<p>Regularly clean docks, including sweeping, litter control, and mitigating spills</p> <p>Promptly unload and load items to minimize pollutants</p> <p>Ensure positive drainage away from the loading docks is maintained</p>		

**FINAL WQMP for  
534 W. Struck Ave Redevelopment Project**

---

Low Impact Development and Treatment BMPs			
Modular Wetland Systems	Per manufacturer's specifications. See information in Appendix D.		

\* This sheet is to be submitted annually with the Owner Self Certification Statement.

\*\* Structural Treatment BMPs should be certified by a Licensed Professional Engineer.

## **VI. Location Map, Site Plan, and BMP Details**

Include a location map that identifies project location and proximity to nearby water bodies. In an 11X17 sheet Identify land use, cover, feasibility constraints, structures, buildings, number of units, landscape areas, storm drain inlets, storm drain facilities, drainage flow direction, structural and treatment BMP locations, dumpsters, trash enclosures, wash areas, etc.

Delineate drainage management areas showing limits (acreage) of each drainage area for all structural, treatment and Low Impact Development BMPs used and provide BMP details on plan or in Appendix C.

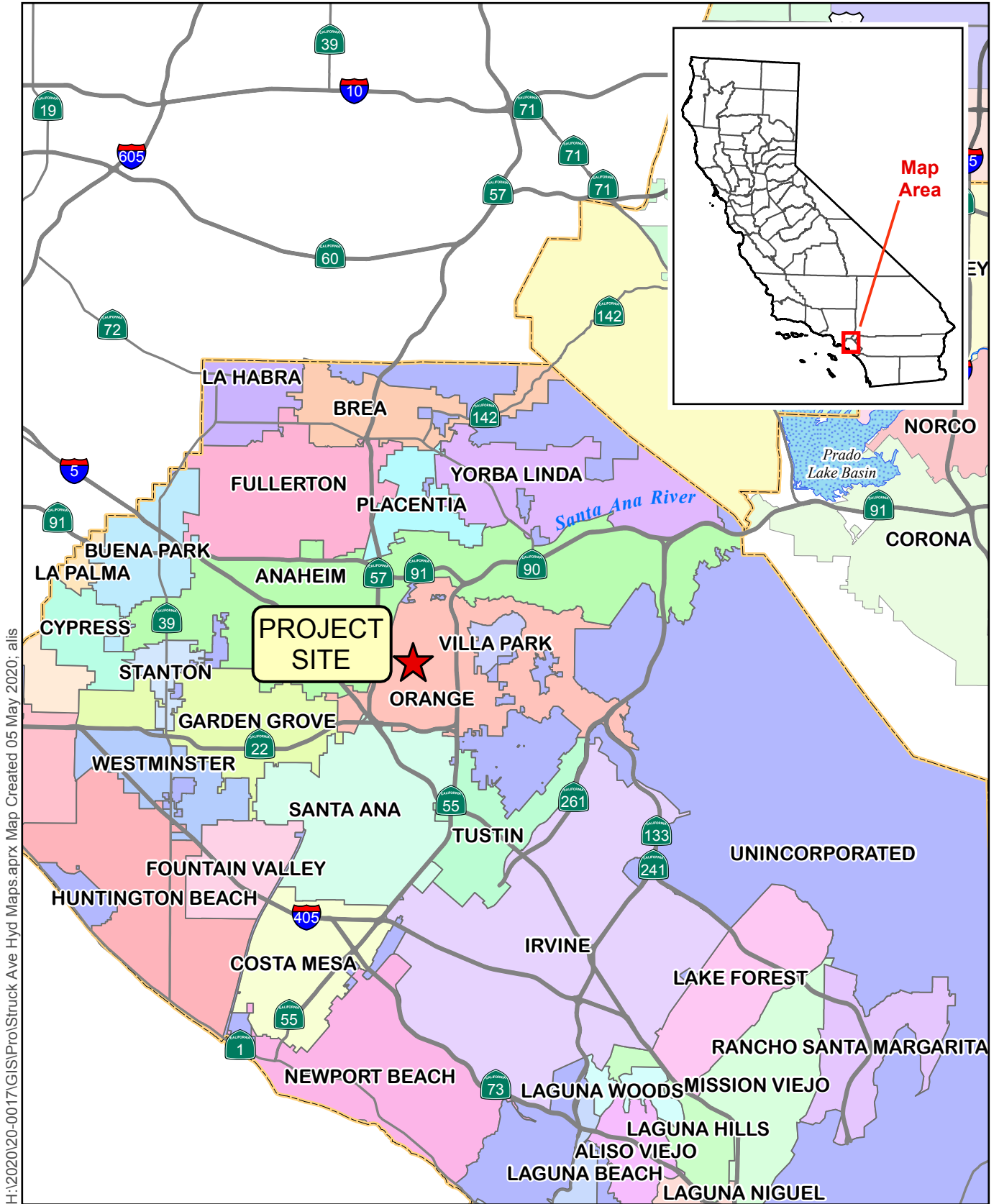

H:\2020\20-0017\GIS\Pro\Struck Ave Hyd Maps.aprx Map Created 05 May 2020; alis

Source: Orange County GIS, 2019



0 2 4 6  
Miles

### Figure 1 – Vicinity Map

20-0017 W. Struck Ave Redevelopment



H:\2020\20-0017\GIS\Pro\Struck Ave Hyd Maps.aprx; Map created 05 May 2020; alis

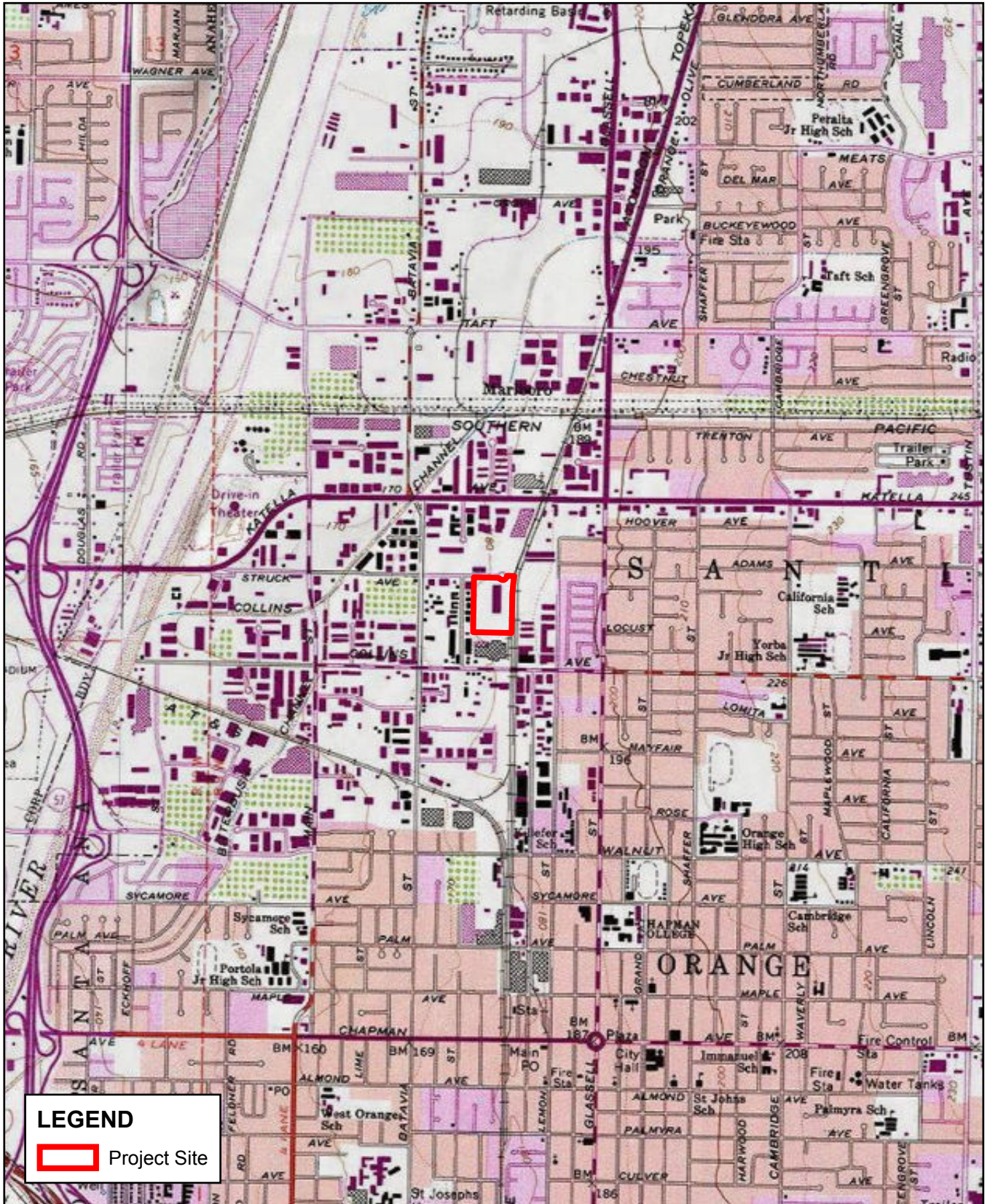

Sources: ESRI / USGS 7.5min Quad  
DRGs: ANAHEIM / ORANGE

**Figure 2 - USGS Map**

20-0017 W. Struck Ave Redevelopment

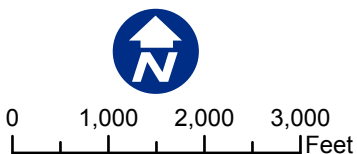

F:\2020\20-0017\GIS\Pro\Struck Ave Hyd Maps.aprx; Map created 05 May 2020

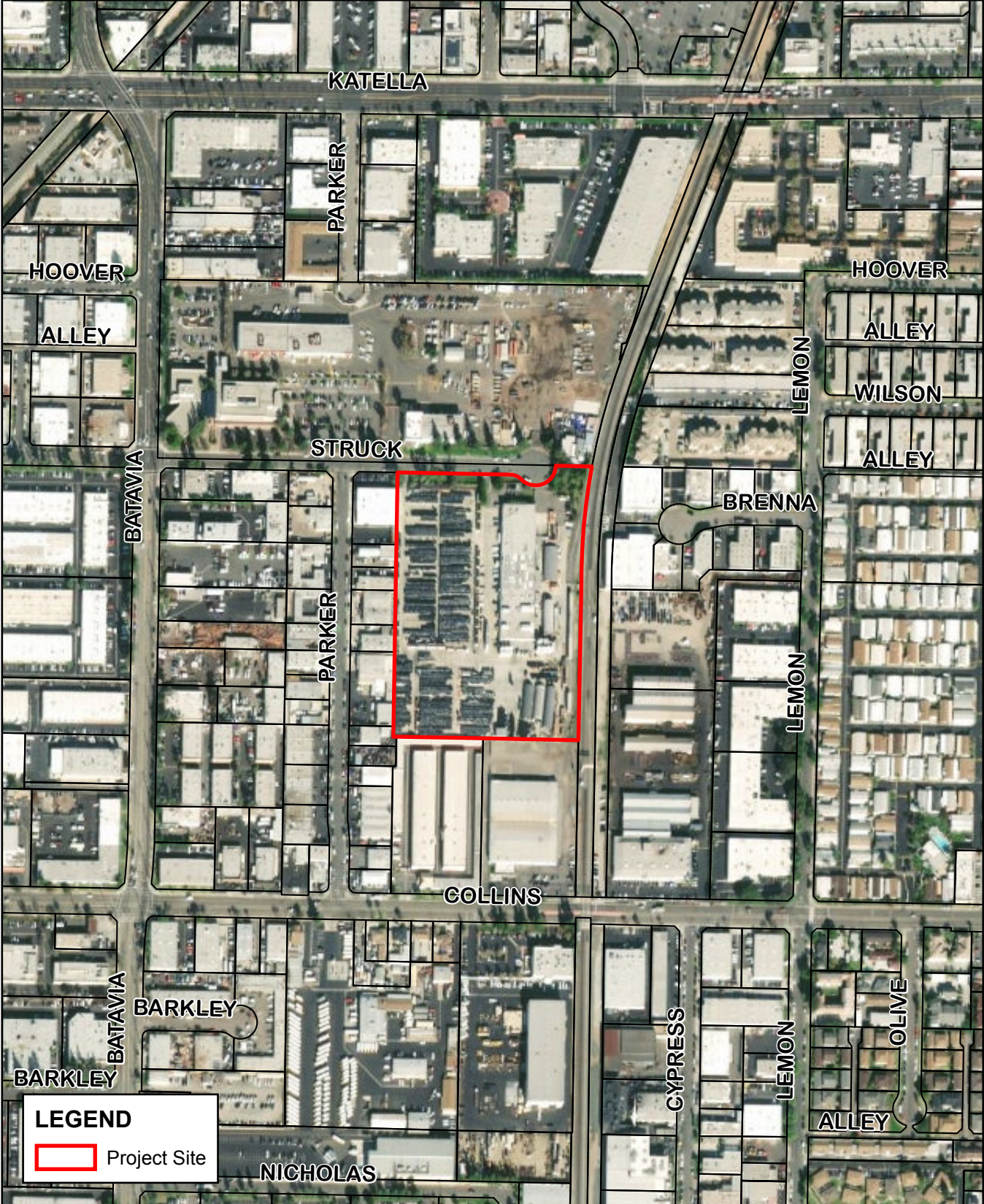

**LEGEND**

 Project Site

Sources: ESRI / Orange County GIS, 2019; USDA NAIP, 2016.

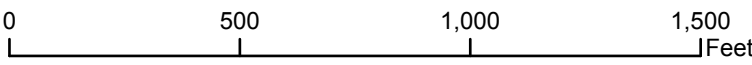
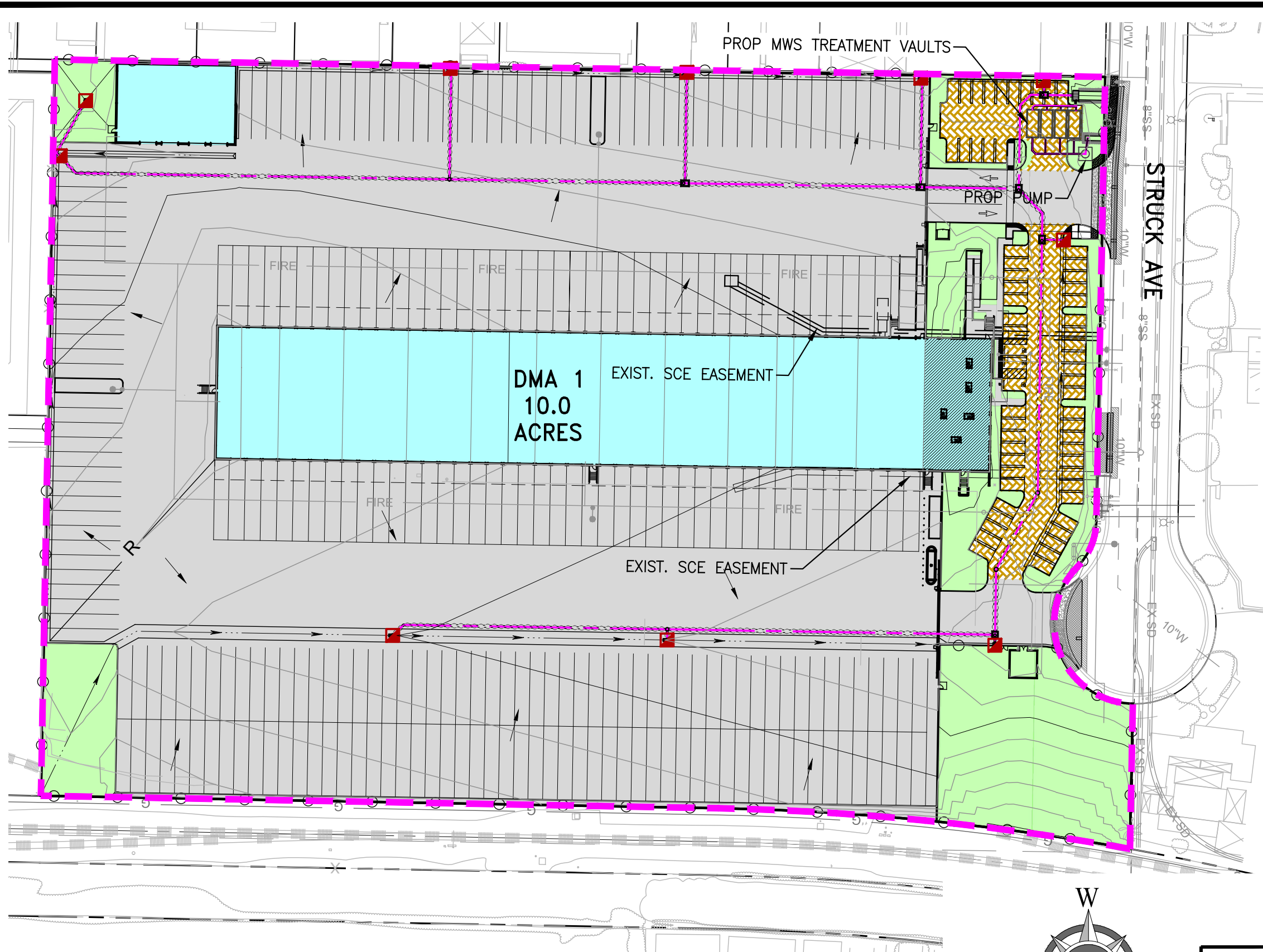

**Figure 3 - Aerial Map**  
20-0017 W. Struck Ave Redevelopment









**LEGEND**

- PROPOSED LANDSCAPE AREA
- PROPOSED ROOF AREA
- PROPOSED IMPERVIOUS AREA
- PROPOSED AUTO PARKING
- SD INLET/CB [STENCILING]
- PROPOSED SD
- DMA BOUNDARY
- DRAINAGE FLOW DIRECTION

**DMA AREAS**

DMA 1 - 10.0 AC

VBMP TABLE	
	PROPOSED AREAS
ROOFS (SF)	63,298
LANDSCAPE (SF)	42,487
HARDSCAPE (SF)	332,098
TOTAL	437883
IMPERVIOUS %	90.3

**LAND USE**  
LIGHT INDUSTRIAL

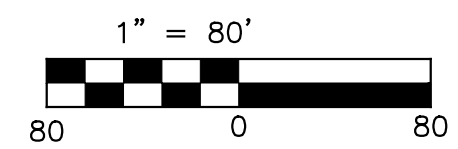
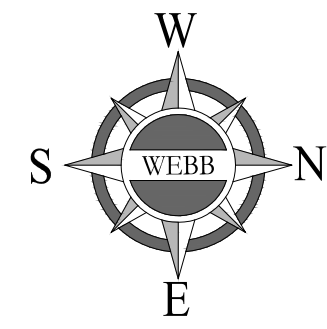

**ALBERT A. WEBB ASSOCIATES**  
ENGINEERING CONSULTANTS  
3788 McCRAY STREET  
RIVERSIDE CA. 92506  
PH. (951) 686-1070  
FAX (951) 788-1256

W.O. 21-0201  
SHEET  
**1**  
OF 3 SHEETS

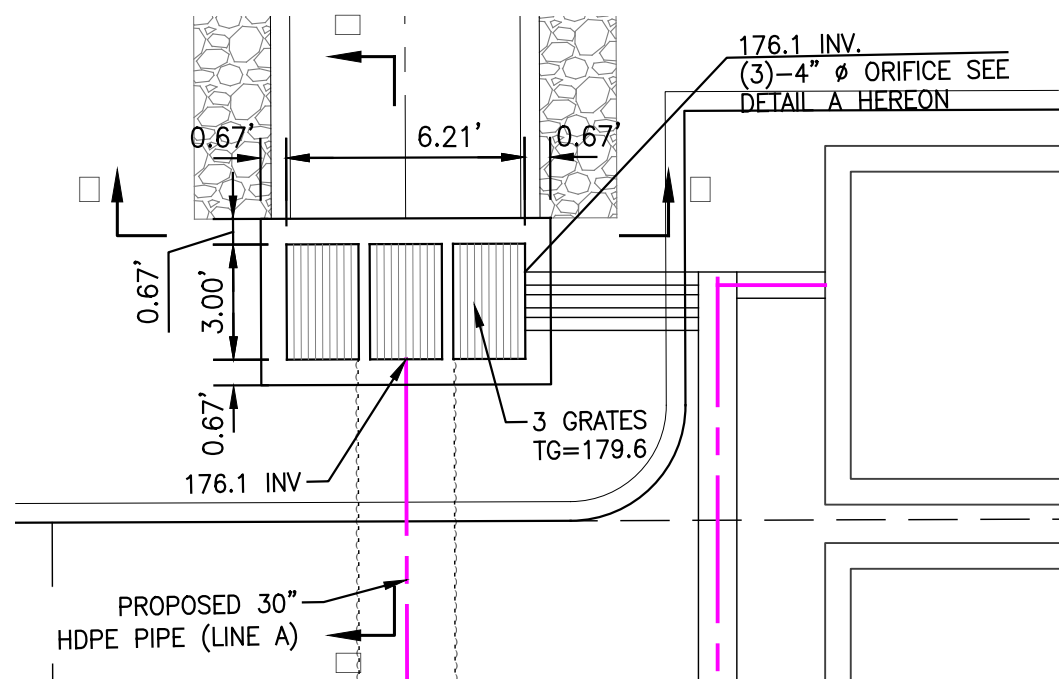
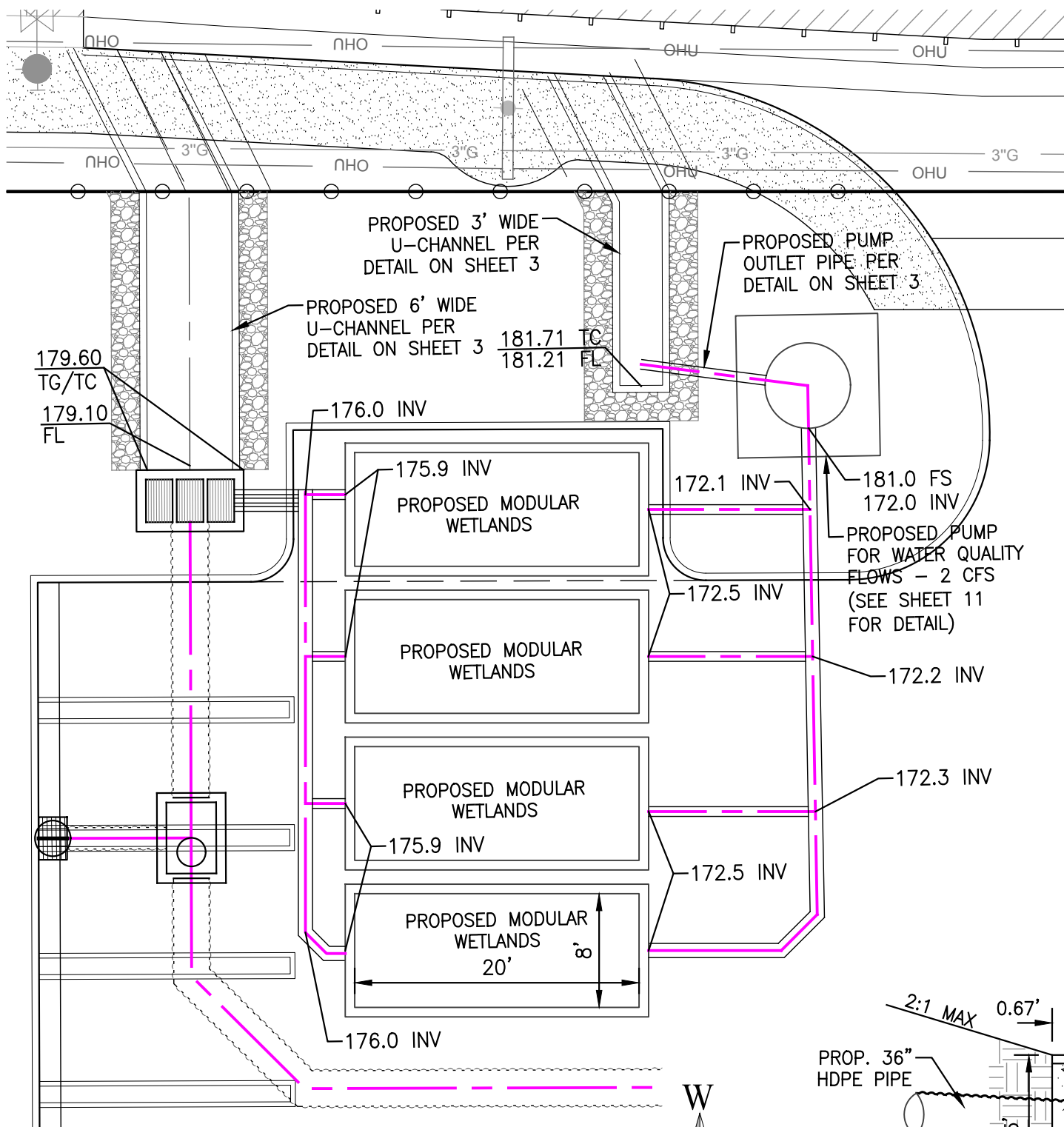

**GRATING CATCH BASIN DETAIL**  
 STRUCTURE DETAIL PER SPPWC STD.  
 DWG. 305-4, MODIFIED AS SHOWN

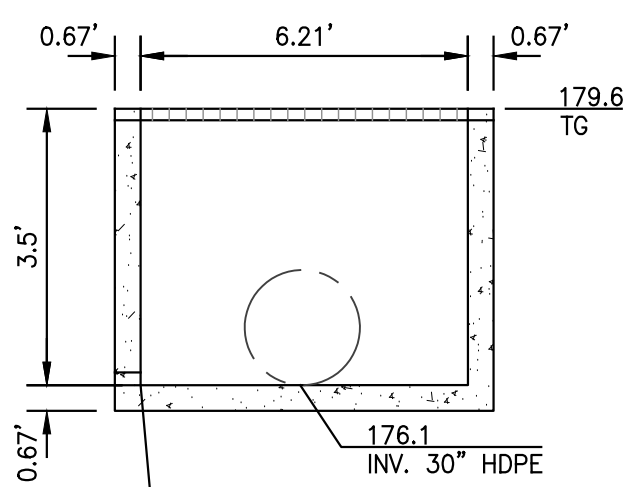

**SECTION A-A**  
 NTS

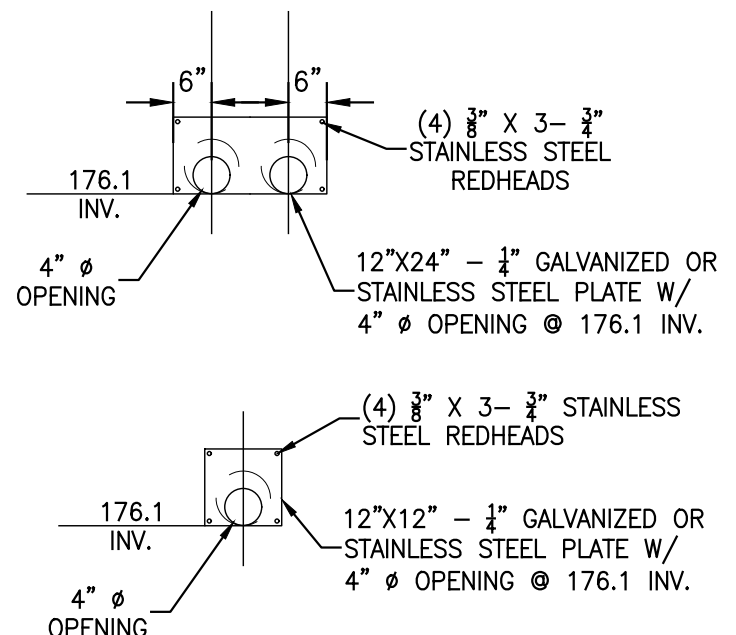

**DETAIL A**  
 NTS

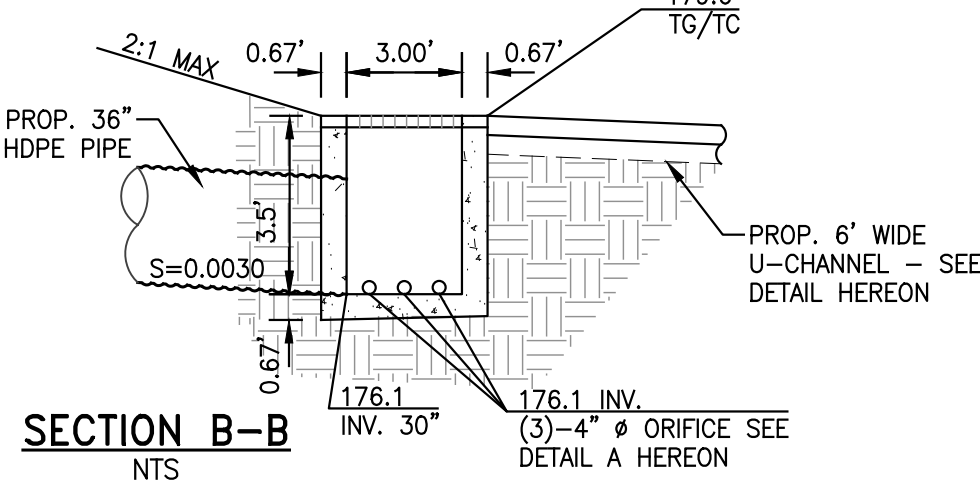

**SECTION B-B**  
 NTS

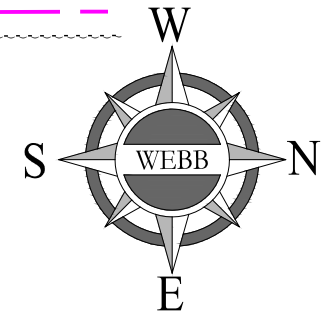
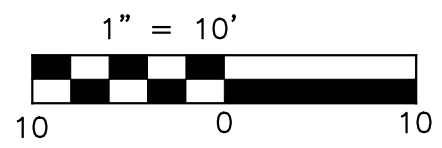

<b>ALBERT A. WEBB ASSOCIATES</b>	ENGINEERING CONSULTANTS 3788 McCRAY STREET RIVERSIDE CA. 92506 PH. (951) 686-1070 FAX (951) 788-1256	W.O. 21-0201 SHEET
		<b>2</b>
		OF 3 SHEETS

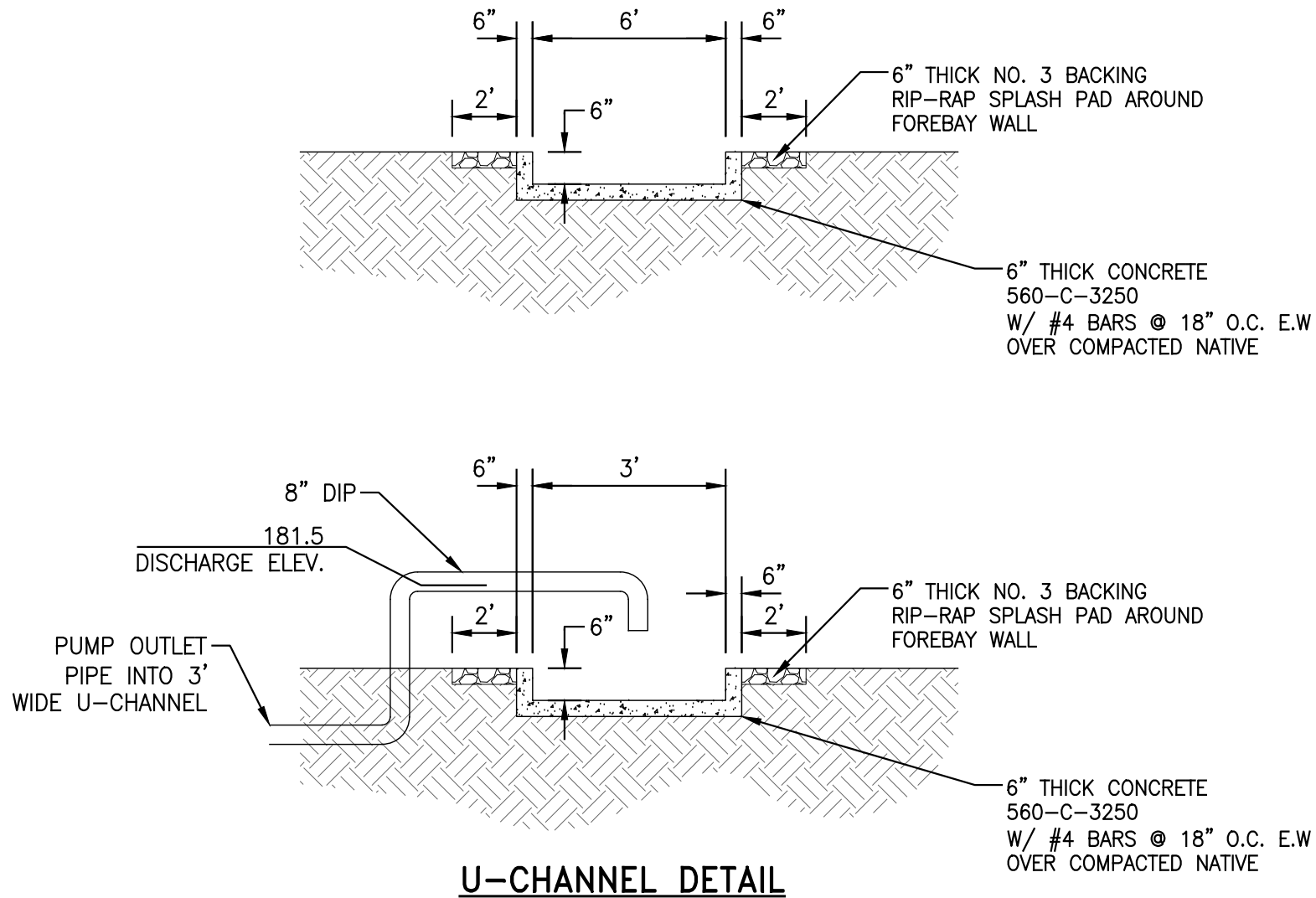

<b>ALBERT A.</b> <b>WEBB</b> ASSOCIATES	ENGINEERING CONSULTANTS 3788 McCRAY STREET RIVERSIDE CA. 92506 PH. (951) 686-1070 FAX (951) 788-1256	W.O. 21-0201
		SHEET <div style="font-size: 2em; text-align: center;">3</div> OF 3 SHEETS

**VII. Educational Materials**

Refer to the City’s website [www.cityoforange.org](http://www.cityoforange.org) or the Orange County Stormwater Program ([ocwatersheds.com](http://ocwatersheds.com)) for a library of materials available. Attach *only* the educational materials specifically applicable to the project.

<b>Education Materials</b>			
<b>Residential Material (<a href="http://www.ocwatersheds.com">http://www.ocwatersheds.com</a>)</b>	<b>Check If Applicable</b>	<b>Business Material (<a href="http://www.ocwatersheds.com">http://www.ocwatersheds.com</a>)</b>	<b>Check If Applicable</b>
The Ocean Begins at Your Front Door	<input checked="" type="checkbox"/>	Tips for the Automotive Industry	<input type="checkbox"/>
Tips for Car Wash Fund-raisers	<input type="checkbox"/>	Tips for Using Concrete and Mortar	<input type="checkbox"/>
Tips for the Home Mechanic	<input type="checkbox"/>	Tips for the Food Service Industry	<input type="checkbox"/>
Homeowners Guide for Sustainable Water Use	<input type="checkbox"/>	Proper Maintenance Practices for Your Business	<input checked="" type="checkbox"/>
Household Tips	<input type="checkbox"/>	<b>Other Material</b>	<b>Check If Attached</b>
Proper Disposal of Household Hazardous Waste	<input type="checkbox"/>		
Recycle at Your Local Used Oil Collection Center (North County)	<input type="checkbox"/>		<input type="checkbox"/>
Recycle at Your Local Used Oil Collection Center (Central County)	<input type="checkbox"/>		<input type="checkbox"/>
Recycle at Your Local Used Oil Collection Center (South County)	<input type="checkbox"/>		<input type="checkbox"/>
Tips for Maintaining a Septic Tank System	<input type="checkbox"/>		<input type="checkbox"/>
Responsible Pest Control	<input checked="" type="checkbox"/>		<input type="checkbox"/>
Sewer Spill Response	<input checked="" type="checkbox"/>		<input type="checkbox"/>
Tips for the Home Improvement Projects	<input type="checkbox"/>		<input type="checkbox"/>
Tips for Horse Care	<input type="checkbox"/>		<input type="checkbox"/>
Tips for Landscaping and Gardening	<input checked="" type="checkbox"/>		<input type="checkbox"/>
Tips for Pet Care	<input type="checkbox"/>		<input type="checkbox"/>
Tips for Pool Maintenance	<input type="checkbox"/>		<input type="checkbox"/>
Tips for Residential Pool, Landscape and Hardscape Drains	<input type="checkbox"/>		<input type="checkbox"/>
Tips for Projects Using Paint	<input checked="" type="checkbox"/>		<input type="checkbox"/>

**Appendix A:**

**Conditions of Approval**

**Resolution Number \_\_\_\_\_ dated \_\_\_\_\_**

**Appendix B:**

**Educational Material**



***Preventing water pollution at your commercial/industrial site***

Clean beaches and healthy creeks, rivers, bays and ocean are important to Orange County. However, many landscape and building maintenance activities can lead to water pollution if you're not careful. Paint, chemicals, plant clippings and other materials can be blown or washed into storm drains that flow to the ocean. Unlike water in sanitary sewers (from sinks and toilets), water in storm drains is not treated before entering our waterways.

You would never pour soap or fertilizers into the ocean, so why would you let them enter the storm drains? Follow these easy tips to help prevent water pollution.

Some types of industrial facilities are required to obtain coverage under the State General Industrial Permit. For more information visit: [www.swrcb.ca.gov/stormwater/industrial.html](http://www.swrcb.ca.gov/stormwater/industrial.html)

For more information, please call the **Orange County Stormwater Program** at **1-877-89-SPILL** (1-877-897-7455) or visit [www.ocwatersheds.com](http://www.ocwatersheds.com)

To report a spill, call the **Orange County 24-Hour Water Pollution Problem Reporting Hotline** at **1-877-89-SPILL** (1-877-897-7455).

**For emergencies, dial 911.**



RECYCLE  
USED OIL



Printed on Recycled Paper

Help Prevent Ocean Pollution:

**Proper Maintenance Practices for Your Business**



**The Ocean Begins at Your Front Door**



# Proper Maintenance Practices for your Business

## *Landscape Maintenance*

- Compost grass clippings, leaves, sticks and other vegetation, or dispose of it at a permitted landfill or in green waste containers. Do not dispose of these materials in the street, gutter or storm drain.
- Irrigate slowly and inspect the system for leaks, overspraying and runoff. Adjust automatic timers to avoid overwatering.
- Follow label directions for the use and disposal of fertilizers and pesticides.
- Do not apply pesticides or fertilizers if rain is expected within 48 hours or if wind speeds are above 5 mph.
- Do not spray pesticides within 100 feet of waterways.
- Fertilizers should be worked into the soil rather than dumped onto the surface.
- If fertilizer is spilled on the pavement or sidewalk, sweep it up immediately and place it back in the container.

## *Building Maintenance*

- Never allow washwater, sweepings or sediment to enter the storm drain.
- Sweep up dry spills and use cat litter, towels or similar materials to absorb wet spills. Dispose of it in the trash.
- If you wash your building, sidewalk or parking lot, you **must** contain the water. Use a shop vac to collect the water and contact your city or sanitation agency for proper disposal information. Do not let water enter the street, gutter or storm drain.
- Use drop cloths underneath outdoor painting, scraping, and sandblasting work, and properly dispose of materials in the trash.
- Use a ground cloth or oversized tub for mixing paint and cleaning tools.
- Use a damp mop or broom to clean floors.
- Cover dumpsters to keep insects, animals, rainwater and sand from entering. Keep the area around the dumpster clear of trash and debris. Do not overfill the dumpster.

- Call your trash hauler to replace leaking dumpsters.
- Do not dump any toxic substance or liquid waste on the pavement, the ground, or near a storm drain. Even materials that seem harmless such as latex paint or biodegradable cleaners can damage the environment.
- Recycle paints, solvents and other materials. For more information about recycling and collection centers, visit [www.oclandfills.com](http://www.oclandfills.com).
- Store materials indoors or under cover and away from storm drains.
- Use a construction and demolition recycling company to recycle lumber, paper, cardboard, metals, masonry, carpet, plastic, pipes, drywall, rocks, dirt, and green waste. For a listing of construction and demolition recycling locations in your area, visit [www.ciwmb.ca.gov/recycle](http://www.ciwmb.ca.gov/recycle).
- Properly label materials. Familiarize employees with Material Safety Data Sheets.

NEVER DISPOSE  
OF ANYTHING  
IN THE STORM  
DRAIN.



Help Prevent Ocean Pollution:

Tips for

Landscape & Gardening



**C**lean beaches and healthy creeks, rivers, bays and ocean are important to Orange County. However, many common activities can lead to water pollution if you're not careful. Fertilizers, pesticides and other chemicals that are left on yards or driveways can be blown or washed into storm drains that flow to the ocean. Overwatering lawns can also send materials into storm drains. Unlike water in sanitary sewers (from sinks and toilets), water in storm drains is not treated before entering our waterways.

You would never pour gardening products into the ocean, so don't let them enter the storm drains. Follow these easy tips to help prevent water pollution.

The tips contained in this brochure provide useful information to help prevent water pollution while landscaping or gardening.

Additional detailed information is available from the

**UCCE Master Gardener Hotline:**  
(714) 708-1646

To report a spill during normal business hours, please call the

**City of Orange  
Public Works Department**  
at (714) 532-6480  
or visit

[www.cityoforange.org](http://www.cityoforange.org).

To report a spill after normal business hours,

or on weekends, please call the  
**City of Orange 24-Hour  
Water Pollution Problem  
Reporting Hotline** at  
(714) 538-1961.

For emergencies, dial 911.



Printed on Recycled Paper

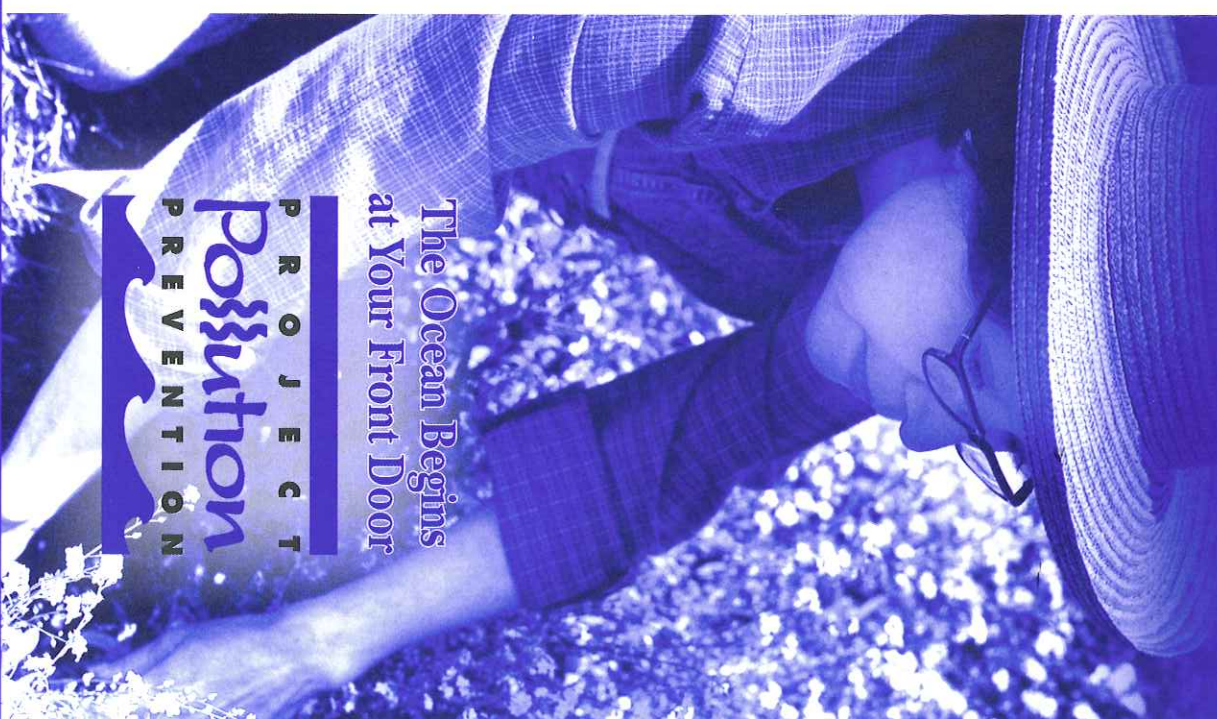

The Ocean Begins  
at Your Front Door

**P R O J E C T  
Pollution  
P R E V E N T I O N**

# Tips for Landscape & Gardening

Never allow gardening products or polluted water to enter the street, gutter or storm drain.

## General Landscaping Tips

■ Protect stockpiles and materials from wind and rain by storing them under tarps or secured plastic sheeting.

■ Prevent erosion of slopes by planting fast-growing, dense ground covering plants. These will shield and bind the soil.

■ Plant native vegetation to reduce the amount of water, fertilizers, and pesticide applied to the landscape.



■ Never apply pesticides or fertilizers when rain is predicted within the next 48 hours.

## Garden & Lawn Maintenance

■ Do not overwater. Use irrigation practices such as drip irrigation, soaker hoses or micro spray systems. Periodically inspect and fix leaks and misdirected sprinklers.

■ Do not rake or blow leaves, clippings or pruning waste into the street, gutter or storm drain. Instead, dispose of green waste by composting, hauling it to a permitted landfill, or recycling it.



■ Use slow-release fertilizers to minimize leaching, and use organic fertilizers.

■ Read labels and use only as directed. Do not over-apply pesticides or fertilizers. Apply to spots as needed, rather than blanketing an entire area.

■ Store pesticides, fertilizers and other chemicals in a dry covered area to prevent exposure that may result in the deterioration of containers and packaging.



■ Rinse empty pesticide containers and re-use rinse water as you would use the product. Do not dump rinse water

down storm drains. Dispose of empty containers in the trash.

■ When available, use non-toxic alternatives to traditional pesticides, and use pesticides specifically designed to control the pest you are targeting. For more information, visit [www.jpnm.ucdavis.edu](http://www.jpnm.ucdavis.edu).

■ If fertilizer is spilled, sweep up the spill before irrigating. If the spill is liquid, apply an absorbent material such as cat litter, and then sweep it up and dispose of it in the trash.

■ Take unwanted pesticides to a Household Hazardous Waste Collection Center to be recycled. Locations are provided below.

## Household Hazardous Waste Collection Centers

Anaheim: 1071 N. Blue Gum St.  
Huntington Beach: 17121 Nichols St.  
Irvine: 6411 Oak Canyon  
San Juan Capistrano: 32250 La Pata Ave.

For more information, call (714) 834-6752  
or visit [www.oclandfills.com](http://www.oclandfills.com)



**C**lean beaches and healthy creeks, rivers, bays and ocean are important to Orange County. However, many common activities such as painting can lead to water pollution if you're not careful. Paint must be used, stored and disposed of properly to ensure that it does not enter the street, gutter or storm drain. Unlike water in sanitary sewers (from sinks and toilets), water in storm drains is not treated before entering our waterways.

You would never dump paint into the ocean, so don't let it enter the storm drains. Follow these easy tips to help prevent water pollution.

For more information, please call the **Orange County Stormwater Program** at **1-877-89-SPILL** (1-877-897-7455) or visit [www.ocwatersheds.com](http://www.ocwatersheds.com)

To report a spill, call the **Orange County 24-Hour Water Pollution Problem Reporting Hotline** at **1-877-89-SPILL** (1-877-897-7455).

**For emergencies, dial 911.**

The tips contained in this brochure provide useful information to help prevent water pollution while using, storing and disposing of paint. If you have other suggestions, please contact your city's stormwater representatives or call the Orange County Stormwater Program.



Printed on Recycled Paper

Help Prevent Ocean Pollution:

## Tips for Projects Using Paint



The Ocean Begins at Your Front Door

PROJECT  
**Pollution**  
PREVENTION

# Tips for Projects Using Paint

Paint can cause significant damage to our environment. Whether you hire a contractor or do it yourself, it is important to follow these simple tips when purchasing, using, cleaning, storing and disposing of paint.

## Purchasing Paint

- Measure the room or object to be painted, then buy only the amount needed.
- Whenever possible, use water-based paint since it usually does not require hazardous solvents such as paint thinner for cleanup.

## Painting

- Use only one brush or roller per color of paint to reduce the amount of water needed for cleaning.
- Place open paint containers or trays on a stable surface and in a position that is unlikely to spill.
- Always use a tarp under the area or object being painted to collect paint drips and contain spills.

## Cleaning

- Never clean brushes or rinse paint containers in the street, gutter or storm drain.
- For oil-based products, use as much of the paint on the brushes as possible. Clean brushes with thinner. To reuse thinner, pour it through a fine filter (e.g. nylon, metal gauze or filter paper) to remove solids such as leftover traces of paint.
- For water-based products, use as much of the paint on the brushes as possible, then rinse in the sink.
- Collect all paint chips and dust. Chips and dust from marine paints or paints containing lead, mercury or tributyl tin are hazardous waste. Sweep up and dispose of at a Household Hazardous Waste Collection Center (HHWCC).

## Storing Paint

- Store paint in a dry location away from the elements.
- Store leftover water-based paint, oil-based paint and solvents separately in original or clearly marked containers.
- Avoid storing paint cans directly on cement floors. The bottom of the can will rust much faster on cement.
- Place the lid on firmly and store the paint can upside-down to prevent air from entering. This will keep the paint usable longer. Oil-based paint is usable for up to 15 years. Water-based paint remains usable for up to 10 years.

## Alternatives to Disposal

- Use excess paint to apply another coat, for touch-ups, or to paint a closet, garage, basement or attic.
- Give extra paint to friends or family. Extra paint can also be donated to a local theatre group, low-income housing program or school.
- Take extra paint to an exchange program such as the “**Stop & Swap**” that allows you to drop off or pick up partially used home care products free of charge. “**Stop & Swap**” programs are available at most HHWCCs.
- For HHWCC locations and hours, call (714) 834-6752 or visit [www.oilandfills.com](http://www.oilandfills.com).



## Disposing of Paint

- Never put wet paint in the trash.

### For water-based paint:

- If possible, brush the leftover paint on cardboard or newspaper. Otherwise, allow the paint to dry in the can with the lid off in a well-ventilated area protected from the elements, children and pets. Stirring the paint every few days will speed up the drying.
- Large quantities of extra paint should be taken to a HHWCC.
- Once dried, paint and painted surfaces may be disposed of in the trash. When setting a dried paint can out for trash collection, leave the lid off so the collector will see that the paint has dried.

### For oil-based paint:

- Oil-based paint is a household hazardous waste. All leftover paint should be taken to a HHWCC.

### Aerosol paint:

- Dispose of aerosol paint cans at a HHWCC.

## Spills

- Never hose down pavement or other impermeable surfaces where paint has spilled.
- Clean up spills immediately by using an absorbent material such as cat litter. Cat litter used to clean water-based paint spills can be disposed of in the trash. When cleaning oil-based paint spills with cat litter, it must be taken to a HHWCC.
- Immediately report spills that have entered the street, gutter or storm drain to the County's 24-Hour Water Pollution Problem Reporting Hotline at (714) 567-6363 or visit [www.ocwatersheds.com](http://www.ocwatersheds.com) to fill out an incident reporting form.



**C**lean beaches and healthy creeks, rivers, bays and ocean are important to Orange County. However, many common activities such as pest control can lead to water pollution if you're not careful. Pesticide treatments must be planned and applied properly to ensure that pesticides do not enter the street, gutter or storm drain. Unlike water in sanitary sewers (from sinks and toilets), water in storm drains is not treated before entering our waterways.

You would never dump pesticides into the ocean, so don't let it enter the storm drains. Pesticides can cause significant damage to our environment if used improperly. If you are thinking of using a pesticide to control a pest, there are some important things to consider.

For more information,  
please call  
University of California Cooperative  
Extension Master Gardeners at  
(714) 708-1646  
or visit these Web sites:  
[www.uccemg.org](http://www.uccemg.org)  
[www.ipm.ucdavis.edu](http://www.ipm.ucdavis.edu)

For instructions on collecting a specimen  
sample visit the Orange County  
Agriculture Commissioner's website at:  
[http://www.ocagcomm.com/ser\\_lab.asp](http://www.ocagcomm.com/ser_lab.asp)

To report a spill, call the  
**Orange County 24-Hour  
Water Pollution Problem  
Reporting Hotline**  
at 1-877-89-SPILL (1-877-897-7455).

**For emergencies, dial 911.**

Information From:  
Cheryl Wilen, Area IPM Advisor; Darren Haver,  
Watershed Management Advisor; Mary  
Louise Flint, IPM Education and Publication  
Director; Pamela M. Geisel, Environmental  
Horticulture Advisor; Carolyn L. Unruh,  
University of California Cooperative  
Extension staff writer. Photos courtesy of  
the UC Statewide IPM Program and  
Darren Haver.

Funding for this brochure has been provided in full  
or in part through an agreement with the State Water  
Resources Control Board (SWRCB) pursuant to the  
Costa-Machado Water Act of 2000 (Prop. 13).



Printed on Recycled Paper

Help Prevent Ocean Pollution:

## Responsible Pest Control



The Ocean Begins  
at Your Front Door



# Tips for Pest Control

## Key Steps to Follow:

**Step 1:** Correctly identify the pest (insect, weed, rodent, or disease) and verify that it is actually causing the problem.



This is important because beneficial insects are often mistaken for pests and sprayed with pesticides needlessly.

Consult with a Certified Nursery Professional at a local nursery or garden center or send a sample of the pest to the Orange County Agricultural Commissioner's Office.

Determine if the pest is still present – even though you see damage, the pest may have left.

**Step 2:** Determine how many pests are present and causing damage.



Small pest populations may be controlled more safely using non-pesticide techniques. These include removing food sources, washing off leaves with a strong stream of water, blocking entry into the home using caulking and replacing problem plants with ones less susceptible to pests.

Integrated Pest Management (IPM) usually combines several least toxic pest control methods for long-term prevention and management of pest problems without harming you, your family, or the environment.



**Step 3:** If a pesticide must be used, choose the least toxic chemical.

Obtain information on the least toxic pesticides that are effective at controlling the target pest from the UC Statewide Integrated Pest Management (IPM) Program's Web site at [www.ipm.ucdavis.edu](http://www.ipm.ucdavis.edu).

Seek out the assistance of a Certified Nursery Professional at a local nursery or garden center when selecting a pesticide. Purchase the smallest amount of pesticide available.

Apply the pesticide to the pest during its most vulnerable life stage. This information can be found on the pesticide label.

**Step 4:** Wear appropriate protective clothing.

Follow pesticide labels regarding specific types of protective equipment you should wear. Protective clothing should always be washed separately from other clothing.

**Step 5:** Continuously monitor external conditions when applying pesticides such as weather, irrigation, and the presence of children and animals.

Never apply pesticides when rain is predicted within the next 48 hours. Also, do not water after applying pesticides unless the directions say it is necessary.

Apply pesticides when the air is still; breezy conditions may cause the spray or dust to drift away from your targeted area.

In case of an emergency call 911 and/or the regional poison control number at (714) 634-5988 or (800) 544-4404 (CA only).

For general questions you may also visit [www.calpoison.org](http://www.calpoison.org).

**Step 6:** In the event of accidental spills, sweep up or use an absorbent agent to remove any excess pesticides. Avoid the use of water.

Be prepared. Have a broom, dust pan, or dry absorbent material, such as cat litter, newspapers or paper towels, ready to assist in cleaning up spills.

Contain and clean up the spill right away. Place contaminated materials in a doubled plastic bag. All materials used to clean up the spill should be properly disposed of according to your local Household Hazardous Waste Disposal site.

**Step 7:** Properly store and dispose of unused pesticides.

Purchase Ready-To-Use (RTU) products to avoid storing large concentrated quantities of pesticides.



Store unused chemicals in a locked cabinet.

Unused pesticide chemicals may be disposed of at a Household Hazardous Waste Collection Center.

Empty pesticide containers should be triple rinsed prior to disposing of them in the trash.

Household Hazardous Waste  
Collection Center  
(714) 834-6752  
[www.oilandfills.com](http://www.oilandfills.com)



# Sewage Spill Regulatory Requirements

Allowing sewage to discharge to a gutter or storm drain may subject you to penalties and/or out-of-pocket costs to reimburse cities or public agencies for clean-up efforts.

Here are the pertinent codes, fines, and agency contact information that apply.

## Orange County Stormwater Program

24 Hour Water Pollution Reporting Hotline

1-877-89-SPILL (1-877-897-7455)

- County and city water quality ordinances prohibit discharges containing pollutants.

## Orange County Health Care Agency Environmental Health

(714) 433-6419

California Health and Safety Code, Sections 5410-5416

- No person shall discharge raw or treated sewage or other waste in a manner that results in contamination, pollution or a nuisance.
- Any person who causes or permits a sewage discharge to any state waters:
  - must immediately notify the local health agency of the discharge.
  - shall reimburse the local health agency for services that protect the public's health and safety (water-contact receiving waters).
  - who fails to provide the required notice to the local health agency is guilty of a misdemeanor and shall be punished by a fine (between \$500-\$1,000) and/or imprisonment for less than one year.

## Regional Water Quality Control Board Santa Ana Region San Diego Region

(951) 782-4130

(858) 467-2952

- Requires the prevention, mitigation, response to and reporting of sewage spills.

## California Office of Emergency Services

(800) 852-7550

California Water Code, Article 4, Chapter 4, Sections 13268-13271  
California Code of Regulations, Title 23, Division 3, Chapter 9.2, Article 2, Sections 2250-2260

- Any person who causes or permits sewage in excess of 1,000 gallons to be discharged to state waters shall immediately notify the Office of Emergency Services.
- Any person who fails to provide the notice required by this section is guilty of a misdemeanor and shall be punished by a fine (less than \$20,000) and/or imprisonment for not more than one year.

# Sewage Spill Reference Guide

## Your Responsibilities as a Private Property Owner

Residences  
Businesses  
Homeowner/Condominium Associations  
Federal and State Complexes  
Military Facilities



Orange County  
Sanitation District



Health Care Agency  
Environmental Health



www.ocwatersheds.com

# What is a Sewage Spill?

Sewage spills occur when the wastewater being transported via underground pipes overflows through a manhole, cleanout or broken pipe. Sewage spills can cause health hazards, damage to homes and businesses, and threaten the environment, local waterways and beaches.

## Common Causes of Sewage Spills

**Grease** builds up inside and eventually blocks sewer pipes. Grease gets into the sewer from food establishments, household drains, as well as from poorly maintained commercial grease traps and interceptors.

**Structure problems** caused by tree roots in the lines, broken/cracked pipes, missing or broken cleanout caps or undersized sewers can cause blockages.

**Infiltration and inflow (I/I)** impacts pipe capacity and is caused when groundwater or rainwater enters the sewer system through pipe defects and illegal connections.

## You Are Responsible for a Sewage Spill Caused by a Blockage or Break in Your Sewer Lines!

Time is of the essence in dealing with sewage spills. You are required to **immediately**:

**Control and minimize the spill.** Keep spills contained on private property and out of gutters, storm drains and public waterways by shutting off or not using the water.

**Use sandbags, dirt and/or plastic sheeting** to prevent sewage from entering the storm drain system.

**Clear the sewer blockage.** Always wear gloves and wash your hands. It is recommended that a plumbing professional be called for clearing blockages and making necessary repairs.

**Always notify your city sewer/public works department or public sewer district of sewage spills.** If the spill enters the storm drains also notify the Health Care Agency. In addition, if it exceeds 1,000 gallons notify the Office of Emergency Services. Refer to the numbers listed in this brochure.

Overflowing  
cleanout pipe  
located on  
private property



## You Could Be Liable

Allowing sewage from your home, business or property to discharge to a gutter or storm drain may subject you to penalties and/or out-of-pocket costs to reimburse cities or public agencies for clean-up and enforcement efforts. See Regulatory Codes & Fines section for pertinent codes and fines that apply.

## What to Look For

Sewage spills can be a very noticeable gushing of water from a manhole or a slow water leak that may take time to be noticed. Don't dismiss unaccounted-for wet areas.

Look for:

- Drain backups inside the building.
- Wet ground and water leaking around manhole lids onto your street.
- Leaking water from cleanouts or outside drains.
- Unusual odorous wet areas: sidewalks, external walls or ground/landscape around a building.

## Caution

Keep people and pets away from the affected area. Untreated sewage has high levels of disease-causing viruses and bacteria. Call your local health care agency listed on the back for more information.

**If You See a Sewage Spill Occurring,  
Notify Your City Sewer/Public Works  
Department or Public Sewer District  
IMMEDIATELY!**

# How a Sewer System Works

A property owner's sewer pipes are called service laterals and are connected to larger local main and regional trunk lines. Service laterals run from the connection at the home to the connection with the public sewer (including the area under the street). These laterals are the responsibility of the property owner and must be maintained by the property owner. Many city agencies have adopted ordinances requiring maintenance of service laterals. Check with your city sewer/local public works department for more information.

Operation and maintenance of **local and regional sewer lines** are the responsibility of the city sewer/public works departments and public sewer districts.

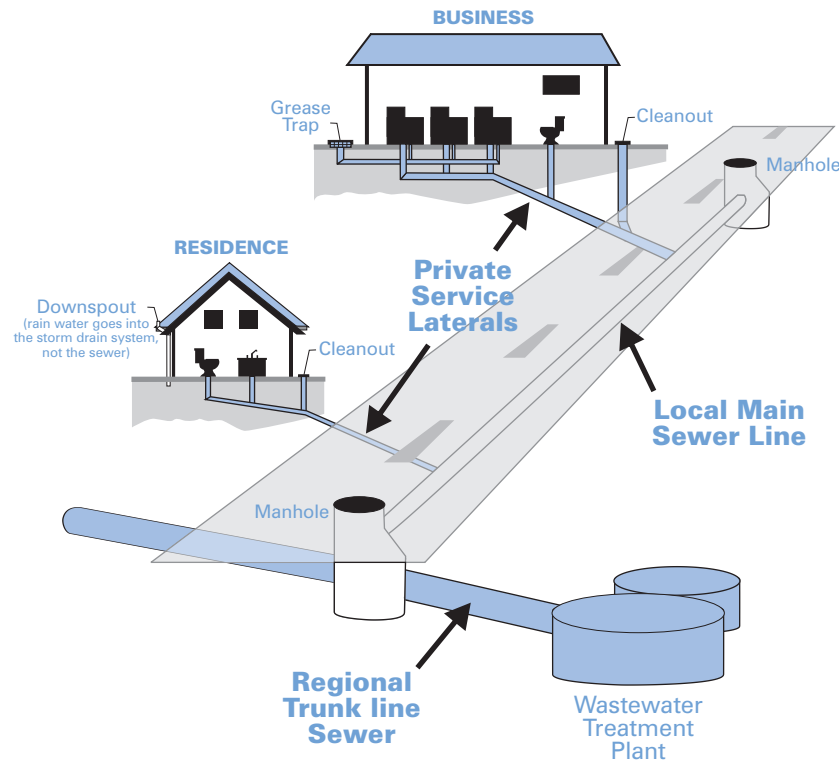

## Preventing Grease Blockages

The drain is not a dump! Recycle or dispose of grease properly and never pour grease down the drain.

Homeowners should mix fats, oils and grease with absorbent waste materials such as paper, coffee grounds, or kitty litter and place it in the trash. Wipe food scraps from plates and pans and dump them in the trash.

Restaurants and commercial food service establishments should always use "Kitchen Best Management Practices." These include:

- Collecting all cooking grease and liquid oil from pots, pans and fryers in covered grease containers for recycling.
- Scraping or dry-wiping excess food and grease from dishes, pots, pans and fryers into the trash.
- Installing drain screens on all kitchen drains.
- Having spill kits readily available for cleaning up spills.
- Properly maintaining grease traps or interceptors by having them serviced regularly. Check your local city codes.

### How You Can Prevent Sewage Spills

- 1 Never put grease down garbage disposals, drains or toilets.**
- 2 Perform periodic cleaning to eliminate grease, debris and roots in your service laterals.**
- 3 Repair any structural problems in your sewer system and eliminate any rainwater infiltration/inflow leaks into your service laterals.**

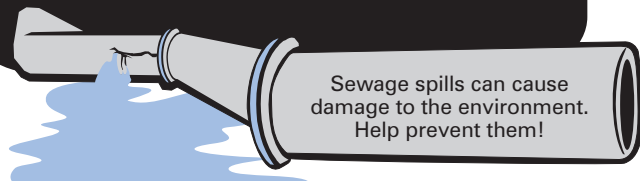

# Orange County Agency Responsibilities

- **City Sewer/Public Works Departments**— Responsible for protecting city property and streets, the local storm drain system, sewage collection system and other public areas.
- **Public Sewer/Sanitation District**— Responsible for collecting, treating and disposing of wastewater.
- **County of Orange Health Care Agency**— Responsible for protecting public health by closing ocean/bay waters and may close food-service businesses if a spill poses a threat to public health.
- **Regional Water Quality Control Boards**— Responsible for protecting State waters.
- **Orange County Stormwater Program**— Responsible for preventing harmful pollutants from being discharged or washed by stormwater runoff into the municipal storm drain system, creeks, bays and the ocean.

### You Could Be Liable for Not Protecting the Environment

Local and state agencies have legal jurisdiction and enforcement authority to ensure that sewage spills are remedied.

They may respond and assist with containment, relieving pipe blockages, and/or clean-up of the sewage spill, especially if the spill is flowing into storm drains or onto public property.

**A property owner may be charged for costs incurred by these agencies responding to spills from private properties.**

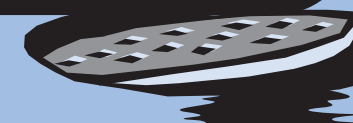

# Report Sewage Spills!

## City Sewer/Public Works Departments

Aliso Viejo	(949) 425-2500
Anaheim	(714) 765-6860
Brea	(714) 990-7691
Buena Park	(714) 562-3655
Costa Mesa	(949) 645-8400
Cypress	(714) 229-6760
Dana Point	(949) 248-3562
Fountain Valley	(714) 593-4600
Fullerton	(714) 738-6897
Garden Grove	(714) 741-5375
Huntington Beach	(714) 536-5921
Irvine	(949) 453-5300
Laguna Beach	(949) 497-0765
Laguna Hills	(949) 707-2650
Laguna Niguel	(949) 362-4337
Laguna Woods	(949) 639-0500
La Habra	(562) 905-9792
Lake Forest	(949) 461-3480
La Palma	(714) 690-3310
Los Alamitos	(562) 431-3538
Mission Viejo	(949) 831-2500
Newport Beach	(949) 644-3011
Orange	(714) 532-6480
Orange County	(714) 567-6363
Placentia	(714) 993-8245
Rancho Santa Margarita	(949) 635-1800
San Clemente	(949) 366-1553
San Juan Capistrano	(949) 443-6363
Santa Ana	(714) 647-3380
Seal Beach	(562) 431-2527
Stanton	(714) 379-9222
Tustin	(714) 962-2411
Villa Park	(714) 998-1500
Westminster	(714) 893-3553
Yorba Linda	(714) 961-7170

## Public Sewer/Water Districts

Costa Mesa Sanitary District	(714) 393-4433/ (949) 645-8400
El Toro Water District	(949) 837-0660
Emerald Bay Service District	(949) 494-8571
Garden Grove Sanitary District	(714) 741-5375
Irvine Ranch Water District	(949) 453-5300
Los Alamitos/Rossmoor Sewer District	(562) 431-2223
Midway City Sanitary District (Westminster)	(714) 893-3553
Moulton Niguel Water District	(949) 831-2500
Orange County Sanitation District	(714) 962-2411
Santa Margarita Water District	(949) 459-6420
South Coast Water District	(949) 499-4555
South Orange County Wastewater Authority	(949) 234-5400
Sunset Beach Sanitary District	(562) 493-9932
Trabuco Canyon Sanitary District	(949) 858-0277
Yorba Linda Water District	(714) 777-3018

## Other Agencies

Orange County Health Care Agency	(714) 433-6419
Office of Emergency Services	(800) 852-7550



# The Ocean Begins at Your Front Door



PROJECT  
**Possution**  
PREVENTION

Follow these simple steps to help reduce water pollution:

### *Household Activities*

- Do not rinse spills with water. Use dry cleanup methods such as applying cat litter or another absorbent material, sweep and dispose of in the trash. Take items such as used or excess batteries, oven cleaners, automotive fluids, painting products and cathode ray tubes, like TVs and computer monitors, to a Household Hazardous Waste Collection Center (HHWCC).
- For a HHWCC near you call (714) 834-6752 or visit [www.oilandfills.com](http://www.oilandfills.com).
- Do not hose down your driveway, sidewalk or patio to the street, gutter or storm drain. Sweep up debris and dispose of it in the trash.

### *Automotive*

- Take your vehicle to a commercial car wash whenever possible. If you wash your vehicle at home, choose soaps, cleaners, or detergents labeled non-toxic, phosphate-free or biodegradable. Vegetable and citrus-based products are typically safest for the environment.
- Do not allow washwater from vehicle washing to drain into the street, gutter or storm drain. Excess washwater should be disposed of in the sanitary sewer (through a sink or toilet) or onto an absorbent surface like your lawn.
- Monitor your vehicles for leaks and place a pan under leaks. Keep your vehicles well maintained to stop and prevent leaks.
- Never pour oil or antifreeze in the street, gutter or storm drain. Recycle these substances at a service station, a waste oil collection center or used oil recycling center. For the nearest Used Oil Collection Center call 1-800-CLEANUP or visit [www.1800cleanup.org](http://www.1800cleanup.org).

### *Pool Maintenance*

- Pool and spa water must be dechlorinated and free of excess acid, alkali or color to be allowed in the street, gutter or storm drain.
- When it is not raining, drain dechlorinated pool and spa water directly into the sanitary sewer.
- Some cities may have ordinances that do not allow pool water to be disposed of in the storm drain. Check with your city.

### *Landscape and Gardening*

- Do not over-water. Water your lawn and garden by hand to control the amount of water you use or set irrigation systems to reflect seasonal water needs. If water flows off your yard onto your driveway or sidewalk, your system is over-watering. Periodically inspect and fix leaks and misdirected sprinklers.
- Do not rake or blow leaves, clippings or pruning waste into the street, gutter or storm drain. Instead, dispose of waste by composting, hauling it to a permitted landfill, or as green waste through your city's recycling program.
- Follow directions on pesticides and fertilizer, (measure, do not estimate amounts) and do not use if rain is predicted within 48 hours.
- Take unwanted pesticides to a HHWCC to be recycled. For locations and hours of HHWCC, call (714) 834-6752 or visit [www.oilandfills.com](http://www.oilandfills.com).

### *Trash*

- Place trash and litter that cannot be recycled in securely covered trash cans.
- Whenever possible, buy recycled products.
- Remember: Reduce, Reuse, Recycle.

### *Pet Care*

- Always pick up after your pet. Flush waste down the toilet or dispose of it in the trash. Pet waste, if left outdoors, can wash into the street, gutter or storm drain.
- If possible, bathe your pets indoors. If you must bathe your pet outside, wash it on your lawn or another absorbent/permeable surface to keep the washwater from entering the street, gutter or storm drain.
- Follow directions for use of pet care products and dispose of any unused products at a HHWCC.

### *Common Pollutants*

#### *Home Maintenance*

- Detergents, cleaners and solvents
- Oil and latex paint
- Swimming pool chemicals
- Outdoor trash and litter

#### *Lawn and Garden*

- Pet and animal waste
- Pesticides
- Clippings, leaves and soil
- Fertilizer

#### *Automobile*

- Oil and grease
- Radiator fluids and antifreeze
- Cleaning chemicals
- Brake pad dust

# The Ocean Begins at Your Front Door



*Never allow pollutants to enter the street, gutter or storm drain!*

## Did You Know?

- Most people believe that the largest source of water pollution in urban areas comes from specific sources such as factories and sewage treatment plants. In fact, the largest source of water pollution comes from city streets, neighborhoods, construction sites and parking lots. This type of pollution is sometimes called “non-point source” pollution.
- There are two types of non-point source pollution: stormwater and urban runoff pollution.
- Stormwater runoff results from rainfall. When rainstorms cause large volumes of water to rinse the urban landscape, picking up pollutants along the way.
- Urban runoff can happen any time of the year when excessive water use from irrigation, vehicle washing and other sources carries trash, lawn clippings and other urban pollutants into storm drains.

## Where Does It Go?

- Anything we use outside homes, vehicles and businesses – like motor oil, paint, pesticides, fertilizers and cleaners – can be blown or washed into storm drains.
- A little water from a garden hose or rain can also send materials into storm drains.
- Storm drains are separate from our sanitary sewer systems; unlike water in sanitary sewers (from sinks or toilets), water in storm drains is not treated before entering our waterways.

## Sources of Non-Point Source Pollution

- Automotive leaks and spills.
- Improper disposal of used oil and other engine fluids.
- Metals found in vehicle exhaust, weathered paint, rust, metal plating and tires.
- Pesticides and fertilizers from lawns, gardens and farms.
- Improper disposal of cleaners, paint and paint removers.
- Soil erosion and dust debris from landscape and construction activities.
- Litter, lawn clippings, animal waste, and other organic matter.
- Oil stains on parking lots and paved surfaces.



## The Effect on the Ocean



Non-point source pollution can have a serious impact on water quality in Orange County. Pollutants from the storm drain system can harm marine life

as well as coastal and wetland habitats. They can also degrade recreation areas such as beaches, harbors and bays.

Stormwater quality management programs have been developed throughout Orange County to educate and encourage the public to protect water quality, monitor runoff in the storm drain system, investigate illegal dumping and maintain storm drains.

Support from Orange County residents and businesses is needed to improve water quality and reduce urban runoff pollution. Proper use and disposal of materials will help stop pollution before it reaches the storm drain and the ocean.



# For More Information

## Orange County Stormwater Program

### California Environmental Protection Agency

[www.calepa.ca.gov](http://www.calepa.ca.gov)

- **Air Resources Board**  
[www.arb.ca.gov](http://www.arb.ca.gov)
- **Department of Pesticide Regulation**  
[www.cdpr.ca.gov](http://www.cdpr.ca.gov)
- **Department of Toxic Substances Control**  
[www.dtsc.ca.gov](http://www.dtsc.ca.gov)
- **Integrated Waste Management Board**  
[www.ciwmb.ca.gov](http://www.ciwmb.ca.gov)
- **Office of Environmental Health Hazard Assessment**  
[www.oehha.ca.gov](http://www.oehha.ca.gov)
- **State Water Resources Control Board**  
[www.waterboards.ca.gov](http://www.waterboards.ca.gov)

**Earth 911** - Community-Specific Environmental Information 1-800-cleanup or visit [www.1800cleanup.org](http://www.1800cleanup.org)

**Health Care Agency's Ocean and Bay Water Closure and Posting Hotline**  
(714) 433-6400 or visit [www.ocbeachinfo.com](http://www.ocbeachinfo.com)

**Integrated Waste Management Dept. of Orange County** (714) 834-6752 or visit [www.oclandfills.com](http://www.oclandfills.com) for information on household hazardous waste collection centers, recycling centers and solid waste collection

**O.C. Agriculture Commissioner**  
(714) 447-7100 or visit [www.ocagcomm.com](http://www.ocagcomm.com)

**Stormwater Best Management Practice Handbook**  
Visit [www.cabmphandbooks.com](http://www.cabmphandbooks.com)

**UC Master Gardener Hotline**  
(714) 708-1646 or visit [www.uccemg.com](http://www.uccemg.com)

The Orange County Stormwater Program has created and moderates an electronic mailing list to facilitate communications, take questions and exchange ideas among its users about issues and topics related to stormwater and urban runoff and the implementation of program elements. To join the list, please send an email to [ocstormwaterinfo-join@list.ocwatersheds.com](mailto:ocstormwaterinfo-join@list.ocwatersheds.com)

Aliso Viejo . . . . .	(949)	425-2535
Anaheim Public Works Operations . . . . .	(714)	765-6860
Brea Engineering . . . . .	(714)	990-7666
Buena Park Public Works . . . . .	(714)	562-3655
Costa Mesa Public Services . . . . .	(714)	754-5323
Cypress Public Works . . . . .	(714)	229-6740
Dana Point Public Works . . . . .	(949)	248-3584
Fountain Valley Public Works . . . . .	(714)	593-4441
Fullerton Engineering Dept. . . . .	(714)	738-6853
Garden Grove Public Works . . . . .	(714)	741-5956
Huntington Beach Public Works . . . . .	(714)	536-5431
Irvine Public Works . . . . .	(949)	724-6315
La Habra Public Services . . . . .	(562)	905-9792
La Palma Public Works . . . . .	(714)	690-3310
Laguna Beach Water Quality . . . . .	(949)	497-0378
Laguna Hills Public Services . . . . .	(949)	707-2650
Laguna Niguel Public Works . . . . .	(949)	362-4337
Laguna Woods Public Works . . . . .	(949)	639-0500
Lake Forest Public Works . . . . .	(949)	461-3480
Los Alamitos Community Dev. . . . .	(562)	431-3538
Mission Viejo Public Works . . . . .	(949)	470-3056
Newport Beach, Code & Water Quality Enforcement . . . . .	(949)	644-3215
Orange Public Works . . . . .	(714)	532-6480
Placentia Public Works . . . . .	(714)	993-8245
Rancho Santa Margarita . . . . .	(949)	635-1800
San Clemente Environmental Programs . . . . .	(949)	361-6143
San Juan Capistrano Engineering . . . . .	(949)	234-4413
Santa Ana Public Works . . . . .	(714)	647-3380
Seal Beach Engineering . . . . .	(562)	431-2527 x317
Stanton Public Works . . . . .	(714)	379-9222 x204
Tustin Public Works/Engineering . . . . .	(714)	573-3150
Villa Park Engineering . . . . .	(714)	998-1500
Westminster Public Works/Engineering . . . . .	(714)	898-3311 x446
Yorba Linda Engineering . . . . .	(714)	961-7138
Orange County Stormwater Program . . . . .	(877)	897-7455
Orange County 24-Hour Water Pollution Problem Reporting Hotline 1-877-89-SPILL (1-877-897-7455)		

On-line Water Pollution Problem Reporting Form

[www.ocwatersheds.com](http://www.ocwatersheds.com)



## **Appendix C:**

### **BMP Details**

SITE SPECIFIC DATA			
PROJECT NUMBER			
PROJECT NAME			
PROJECT LOCATION			
STRUCTURE ID			
TREATMENT REQUIRED			
VOLUME BASED (CF)		FLOW BASED (CFS)	
N/A			
PEAK BYPASS REQUIRED (CFS) – IF APPLICABLE			
PIPE DATA	I.E.	MATERIAL	DIAMETER
INLET PIPE 1			
INLET PIPE 2			
OUTLET PIPE			
	PRETREATMENT	BIOFILTRATION	DISCHARGE
RIM ELEVATION			
SURFACE LOAD			
FRAME & COVER	3EA Ø30"		Ø24"
NOTES:			

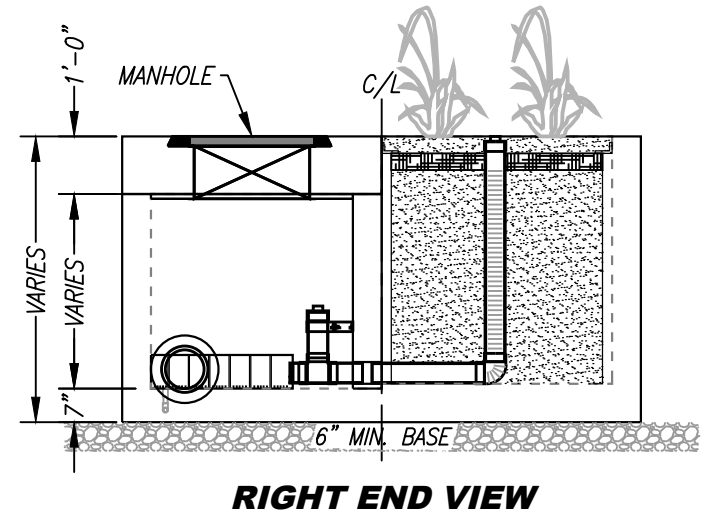
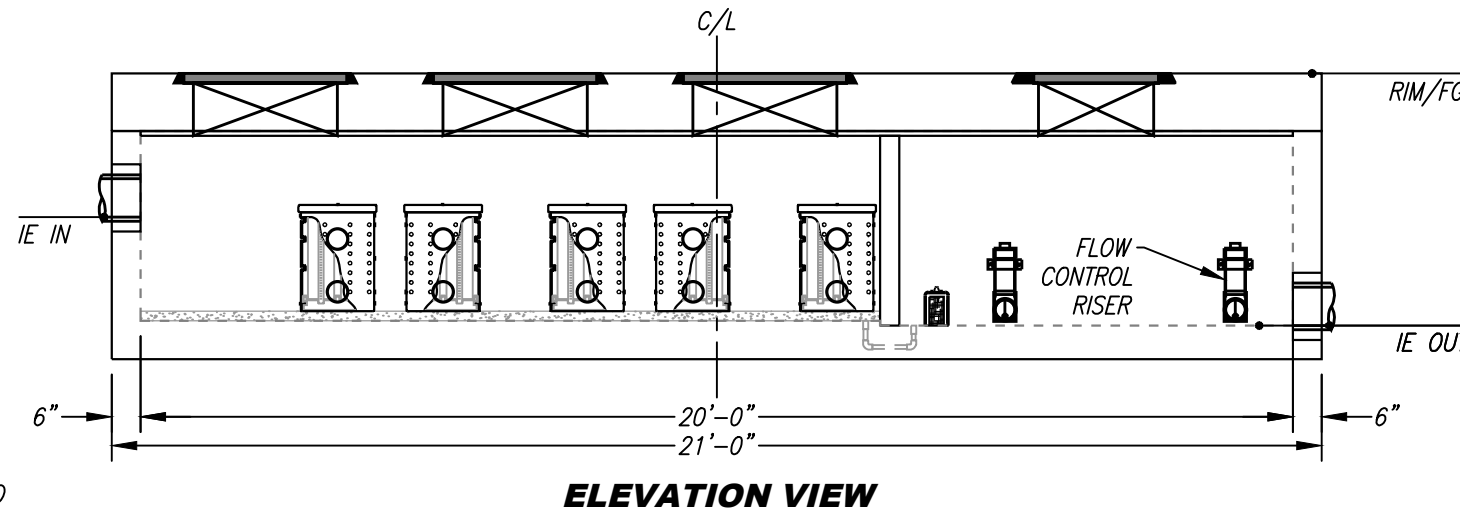
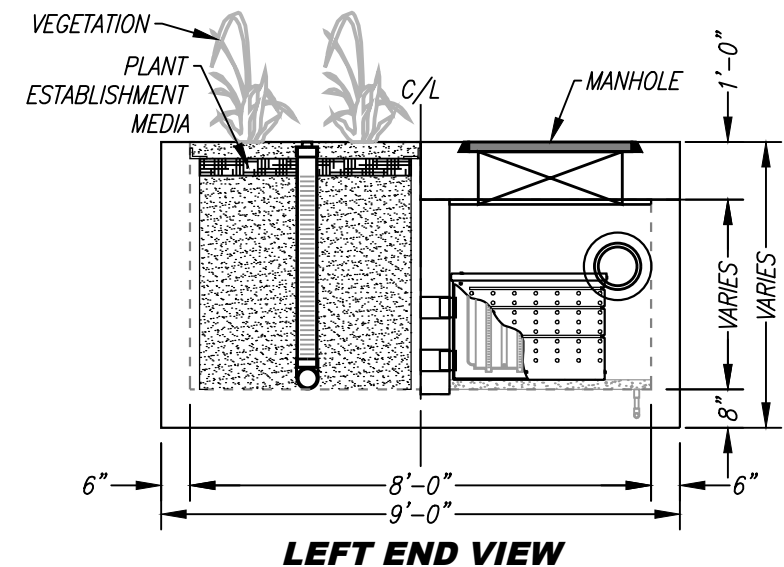
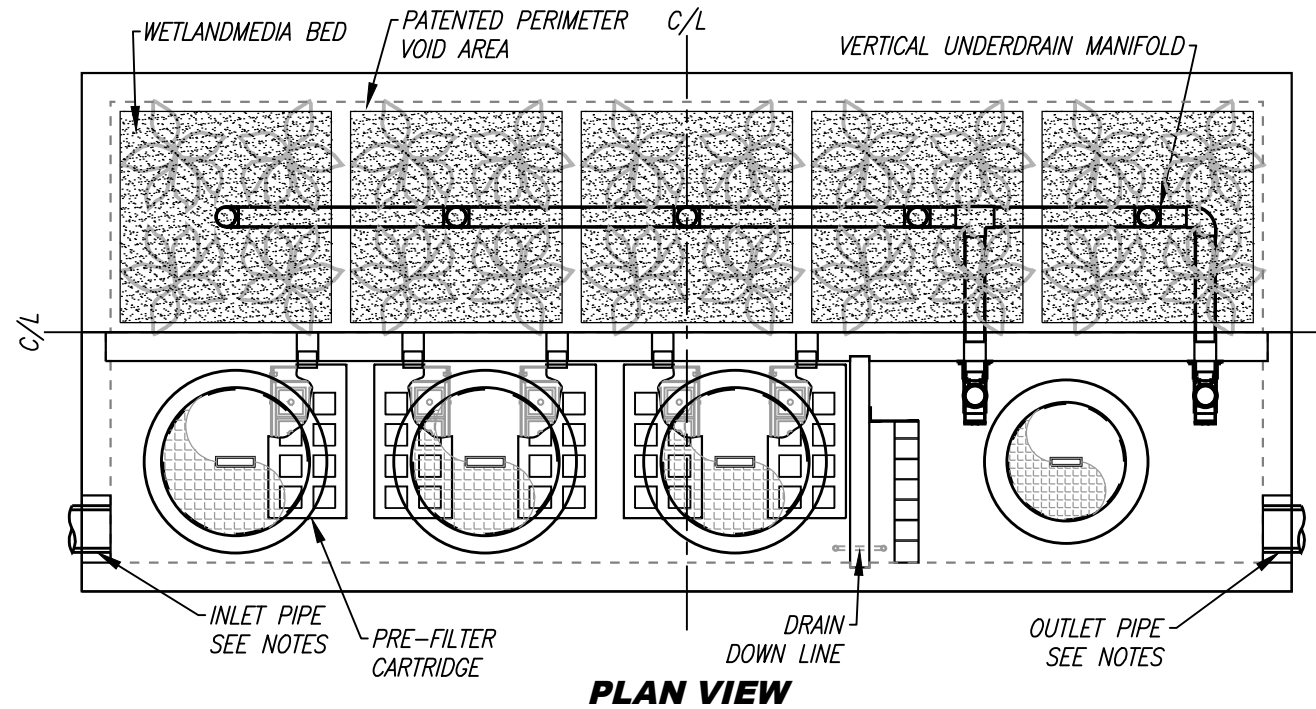

**INSTALLATION NOTES**

1. CONTRACTOR TO PROVIDE ALL LABOR, EQUIPMENT, MATERIALS AND INCIDENTALS REQUIRED TO OFFLOAD AND INSTALL THE SYSTEM AND APPURTENANCES IN ACCORDANCE WITH THIS DRAWING AND THE MANUFACTURERS SPECIFICATIONS, UNLESS OTHERWISE STATED IN MANUFACTURERS CONTRACT.
2. UNIT MUST BE INSTALLED ON LEVEL BASE. MANUFACTURER RECOMMENDS A MINIMUM 6" LEVEL ROCK BASE UNLESS SPECIFIED BY THE PROJECT ENGINEER. CONTRACTOR IS RESPONSIBLE TO VERIFY PROJECT ENGINEERS RECOMMENDED BASE SPECIFICATIONS.
4. CONTRACTOR TO SUPPLY AND INSTALL ALL EXTERNAL CONNECTING PIPES. ALL PIPES MUST BE FLUSH WITH INSIDE SURFACE OF CONCRETE. (PIPES CANNOT INTRUDE BEYOND FLUSH). INVERT OF OUTFLOW PIPE MUST BE FLUSH WITH DISCHARGE CHAMBER FLOOR. ALL PIPES SHALL BE SEALED WATER TIGHT PER MANUFACTURERS STANDARD CONNECTION DETAIL.
5. CONTRACTOR RESPONSIBLE FOR INSTALLATION OF ALL RISERS, MANHOLES, AND HATCHES. CONTRACTOR TO GROUT ALL MANHOLES AND HATCHES TO MATCH FINISHED SURFACE UNLESS SPECIFIED OTHERWISE.
6. VEGETATION SUPPLIED AND INSTALLED BY OTHERS. ALL UNITS WITH VEGETATION MUST HAVE DRIP OR SPRAY IRRIGATION SUPPLIED AND INSTALLED BY OTHERS.
7. CONTRACTOR RESPONSIBLE FOR CONTACTING BIO CLEAN FOR ACTIVATION OF UNIT. MANUFACTURERS WARRANTY IS VOID WITH OUT PROPER ACTIVATION BY A BIO CLEAN REPRESENTATIVE.

**GENERAL NOTES**

1. MANUFACTURER TO PROVIDE ALL MATERIALS UNLESS OTHERWISE NOTED.
2. ALL DIMENSIONS, ELEVATIONS, SPECIFICATIONS AND CAPACITIES ARE SUBJECT TO CHANGE. FOR PROJECT SPECIFIC DRAWINGS DETAILING EXACT DIMENSIONS, WEIGHTS AND ACCESSORIES PLEASE CONTACT BIO CLEAN.

TREATMENT FLOW (CFS)	
OPERATING HEAD (FT)	
PRETREATMENT LOADING RATE (GPM/SF)	
WETLAND MEDIA LOADING RATE (GPM/SF)	

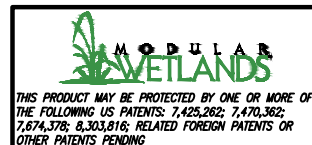

PROPRIETARY AND CONFIDENTIAL:  
THE INFORMATION CONTAINED IN THIS DOCUMENT IS THE SOLE PROPERTY OF FORTERRA AND ITS COMPANIES. THIS DOCUMENT, NOR ANY PART THEREOF, MAY BE USED, REPRODUCED OR MODIFIED IN ANY MANNER WITH OUT THE WRITTEN CONSENT OF FORTERRA.



**MWS-L-8-20-V**  
**STORMWATER BIOFILTRATION SYSTEM**  
**STANDARD DETAIL**



# Modular Wetlands<sup>®</sup> System Linear

A Stormwater Biofiltration Solution





# OVERVIEW

The Bio Clean Modular Wetlands® System Linear (MWS Linear) represents a pioneering breakthrough in stormwater technology as the only biofiltration system to utilize patented horizontal flow, allowing for a smaller footprint, higher treatment capacity, and a wide range of versatility. While most biofilters use little or no pretreatment, the Modular Wetlands System Linear incorporates an advanced pretreatment chamber that includes separation and pre-filter cartridges. In this chamber, sediment and hydrocarbons are removed from runoff before entering the biofiltration chamber, reducing maintenance costs and improving performance.

Horizontal flow also gives the system the unique ability to adapt to the environment through a variety of configurations, bypass orientations, and diversion applications.

## The Urban Impact

For hundreds of years, natural wetlands surrounding our shores have played an integral role as nature's stormwater treatment system. But as cities grow and develop, our environment's natural filtration systems are blanketed with impervious roads, rooftops, and parking lots.

Bio Clean understands this loss and has spent years re-establishing nature's presence in urban areas, and rejuvenating waterways with the MWS Linear.

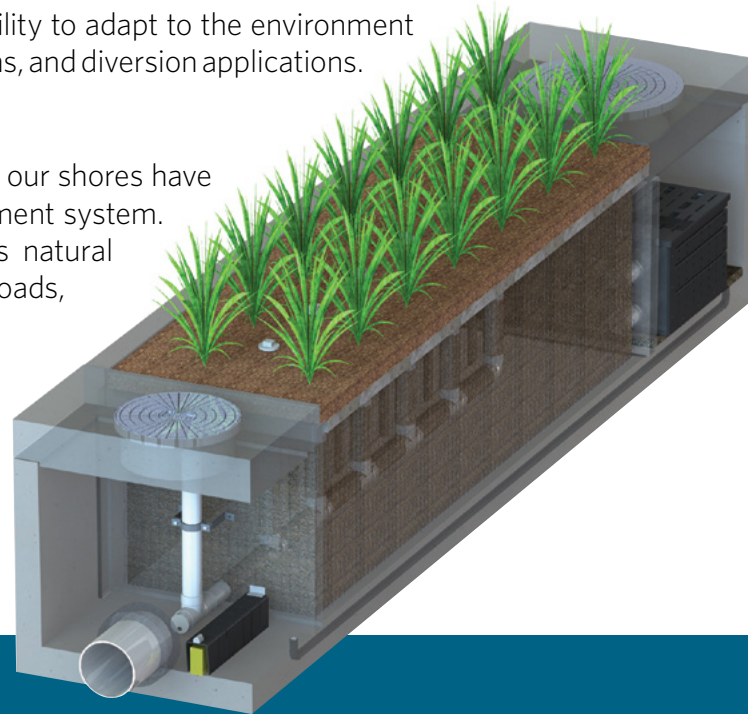

# PERFORMANCE

The Modular Wetlands® System Linear continues to outperform other treatment methods with superior pollutant removal for TSS, heavy metals, nutrients, hydrocarbons, and bacteria. Since 2007 the MWS Linear has been field tested on numerous sites across the country and is proven to effectively remove pollutants through a combination of physical, chemical, and biological filtration processes. In fact, the MWS Linear harnesses some of the same biological processes found in natural wetlands in order to collect, transform, and remove even the most harmful pollutants.

<b>66%</b> REMOVAL OF DISSOLVED ZINC	<b>69%</b> REMOVAL OF TOTAL ZINC	<b>38%</b> REMOVAL OF DISSOLVED COPPER	<b>64%</b> REMOVAL OF TOTAL PHOSPHORUS	
<b>45%</b> REMOVAL OF NITROGEN	<b>50%</b> REMOVAL OF TOTAL COPPER	<b>95%</b> REMOVAL OF MOTOR OIL	<b>67%</b> REMOVAL OF ORTHO PHOSPHORUS	<b>85%</b> REMOVAL OF TSS

# APPROVALS

The Modular Wetlands® System Linear has successfully met years of challenging technical reviews and testing from some of the most prestigious and demanding agencies in the nation and perhaps the world. Here is a list of some of the most high-profile approvals, certifications, and verifications from around the country.



## Washington State Department of Ecology TAPE Approved

The MWS Linear is approved for General Use Level Designation (GULD) for Basic, Enhanced, and Phosphorus treatment at 1 gpm/ft<sup>2</sup> loading rate. The highest performing BMP on the market for all main pollutant categories.



## California Water Resources Control Board, Full Capture Certification

The Modular Wetlands® System is the first biofiltration system to receive certification as a full capture trash treatment control device.



## Virginia Department of Environmental Quality, Assignment

The Virginia Department of Environmental Quality assigned the MWS Linear the highest phosphorus removal rating for manufactured treatment devices to meet the new Virginia Stormwater Management Program (VSMP) regulation technical criteria.



## Maryland Department of the Environment, Approved ESD

Granted Environmental Site Design (ESD) status for new construction, redevelopment, and retrofitting when designed in accordance with the design manual.



## MASTEP Evaluation

The University of Massachusetts at Amherst - Water Resources Research Center issued a technical evaluation report noting removal rates up to 84% TSS, 70% total phosphorus, 68.5% total zinc, and more.



## Rhode Island Department of Environmental Management, Approved BMP

Approved as an authorized BMP and noted to achieve the following minimum removal efficiencies: 85% TSS, 60% pathogens, 30% total phosphorus, and 30% total nitrogen.



## Texas Commission on Environmental Quality



## Atlanta Regional Commission

# ADVANTAGES

- HORIZONTAL FLOW BIOFILTRATION
- GREATER FILTER SURFACE AREA
- PRETREATMENT CHAMBER
- PATENTED PERIMETER VOID AREA
- FLOW CONTROL
- NO DEPRESSED PLANTER AREA
- AUTO DRAINDOWN MEANS NO MOSQUITO VECTOR

# OPERATION

The Modular Wetlands® System Linear is the most efficient and versatile biofiltration system on the market, and it is the only system with horizontal flow which:

- Improves performance
- Reduces footprint
- Minimizes maintenance

Figure 1 & Figure 2 illustrate the invaluable benefits of horizontal flow and the multiple treatment stages.

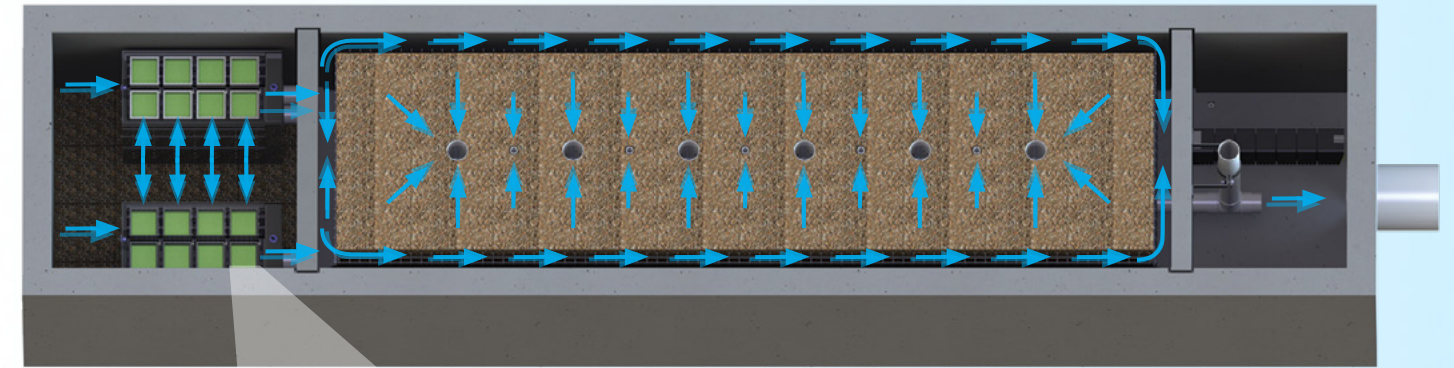

Figure 2,  
Top View

2x to 3x more surface area than traditional downward flow bioretention systems.

## 1 PRETREATMENT

### SEPARATION

- Trash, sediment, and debris are separated before entering the pre-filter boxes
- Designed for easy maintenance access

### PRE-FILTER BOXES

- Over 25 sq. ft. of surface area per box
- Utilizes BioMediaGREEN™ filter material
- Removes over 80% of TSS and 90% of hydrocarbons
- Prevents pollutants that cause clogging from migrating to the biofiltration chamber

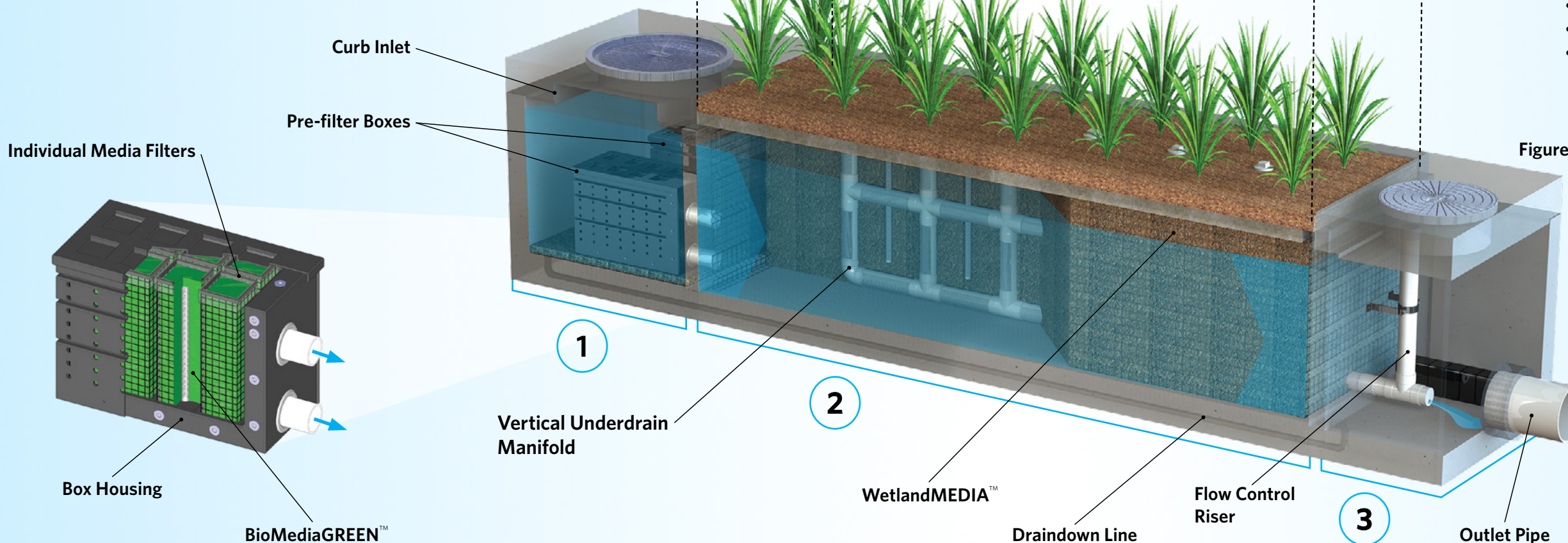

Figure 1

## 2 BIOFILTRATION

### HORIZONTAL FLOW

- Less clogging than downward flow biofilters
- Water flow is subsurface
- Improves biological filtration

### PATENTED PERIMETER VOID AREA

- Vertically extends void area between the walls and the WetlandMEDIA™ on all four sides
- Maximizes surface area of the media for higher treatment capacity

### WETLANDMEDIA

- Contains no organics and removes phosphorus
- Greater surface area and 48% void space
- Maximum evapotranspiration
- High ion exchange capacity and lightweight

## 3 DISCHARGE

### FLOW CONTROL

- Orifice plate controls flow of water through WetlandMEDIA™ to a level lower than the media's capacity
- Extends the life of the media and improves performance

### DRAINDOWN FILTER

- The draindown is an optional feature that completely drains the pretreatment chamber
- Water that drains from the pretreatment chamber between storm events will be treated



# CONFIGURATIONS

The Modular Wetlands® System Linear is the preferred biofiltration system of civil engineers across the country due to its versatile design. This highly versatile system has available “pipe-in” options on most models, along with built-in curb or grated inlets for simple integration into your storm drain design.

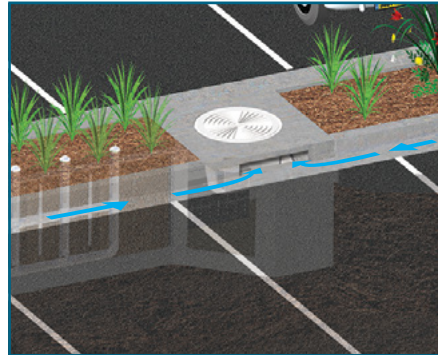

## CURB TYPE

The Curb Type configuration accepts sheet flow through a curb opening and is commonly used along roadways and parking lots. It can be used in sump or flow-by conditions. Length of curb opening varies based on model and size.

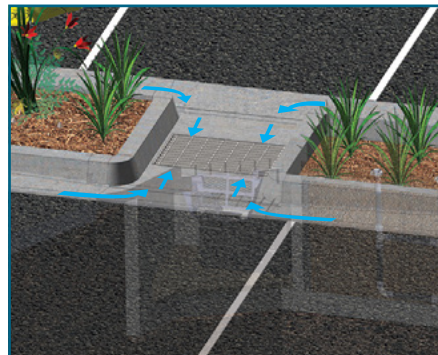

## GRATE TYPE

The Grate Type configuration offers the same features and benefits as the Curb Type but with a grated/drop inlet above the systems pretreatment chamber. It has the added benefit of allowing pedestrian access over the inlet. ADA-compliant grates are available to assure easy and safe access. The Grate Type can also be used in scenarios where runoff needs to be intercepted on both sides of landscape islands.

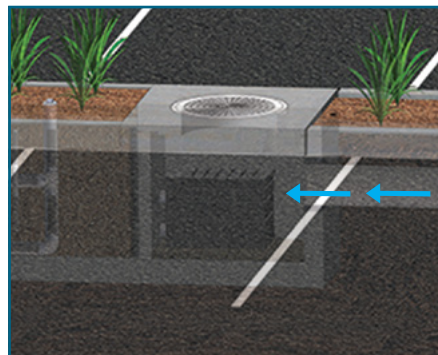

## VAULT TYPE

The system’s patented horizontal flow biofilter is able to accept inflow pipes directly into the pretreatment chamber, meaning the Modular Wetlands® can be used in end-of-the-line installations. This greatly improves feasibility over typical decentralized designs that are required with other biofiltration/bioretenion systems. Another benefit of the “pipe-in” design is the ability to install the system downstream of underground detention systems to meet water quality volume requirements.



## DOWNSPOUT TYPE

The Downspout Type is a variation of the Vault Type and is designed to accept a vertical downspout pipe from rooftop and podium areas. Some models have the option of utilizing an internal bypass, simplifying the overall design. The system can be installed as a raised planter, and the exterior can be stuccoed or covered with other finishes to match the look of adjacent buildings.

# ORIENTATIONS

## SIDE-BY-SIDE

The Side-By-Side orientation places the pretreatment and discharge chamber adjacent to one another with the biofiltration chamber running parallel on either side. This minimizes the system length, providing a highly compact footprint. It has been proven useful in situations such as streets with directly adjacent sidewalks, as half of the system can be placed under that sidewalk. This orientation also offers internal bypass options as discussed below.

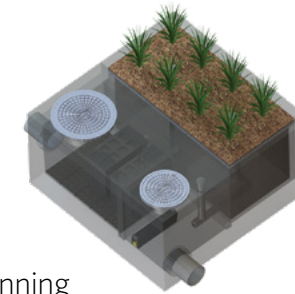

## END-TO-END

The End-To-End orientation places the pretreatment and discharge chambers on opposite ends of the biofiltration chamber, therefore minimizing the width of the system to 5 ft. (outside dimension). This orientation is perfect for linear projects and street retrofits where existing utilities and sidewalks limit the amount of space available for installation. One limitation of this orientation is that bypass must be external.

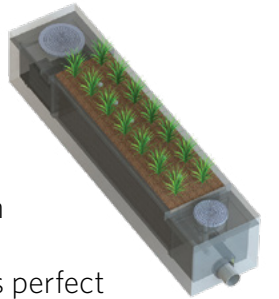

# BYPASS

## INTERNAL BYPASS WEIR (SIDE-BY-SIDE ONLY)

The Side-By-Side orientation places the pretreatment and discharge chambers adjacent to one another allowing for integration of internal bypass. The wall between these chambers can act as a bypass weir when flows exceed the system’s treatment capacity, thus allowing bypass from the pretreatment chamber directly to the discharge chamber.

## EXTERNAL DIVERSION WEIR STRUCTURE

This traditional offline diversion method can be used with the Modular Wetlands® System Linear in scenarios where runoff is being piped to the system. These simple and effective structures are generally configured with two outflow pipes. The first is a smaller pipe on the upstream side of the diversion weir - to divert low flows over to the MWS Linear for treatment. The second is the main pipe that receives water once the system has exceeded treatment capacity and water flows over the weir.

## FLOW-BY-DESIGN

This method is one in which the system is placed just upstream of a standard curb or grate inlet to intercept the first flush. Higher flows simply pass by the MWS Linear and into the standard inlet downstream.

## DVERT LOW FLOW DIVERSION

This simple yet innovative diversion trough can be installed in existing or new curb and grate inlets to divert the first flush to the Modular Wetlands® System Linear via pipe. It works similar to a rain gutter and is installed just below the opening into the inlet. It captures the low flows and channels

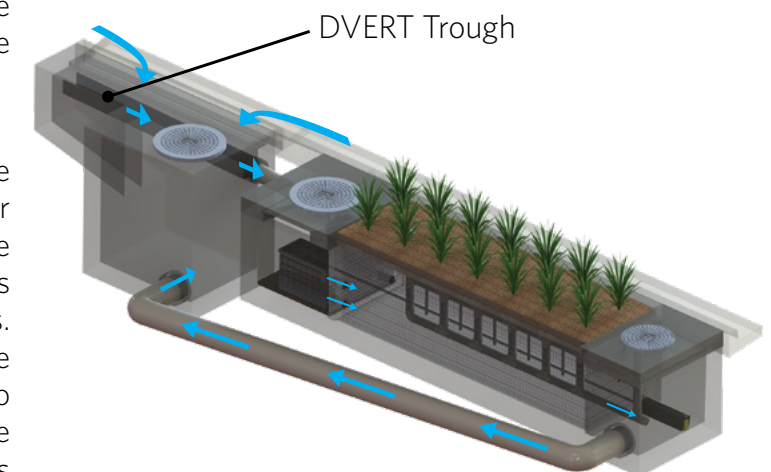

them over to a connecting pipe exiting out the wall of the inlet and leading to the MWS Linear. The DVERT is perfect for retrofit and green street applications that allow the system to be installed anywhere space is available.

# SPECIFICATIONS

## FLOW-BASED DESIGNS

The Modular Wetlands® System Linear can be used in stand-alone applications to meet treatment flow requirements, and since it is the only biofiltration system that can accept inflow pipes several feet below the surface, it can be used not only in decentralized design applications but also as a large central end-of-the-line application for maximum feasibility.

MODEL #	DIMENSIONS	WETLAND MEDIA SURFACE AREA (sq. ft.)	TREATMENT FLOW RATE (cfs)
MWS-L-4-4	4' x 4'	23	0.052
MWS-L-4-6	4' x 6'	32	0.073
MWS-L-4-8	4' x 8'	50	0.115
MWS-L-4-13	4' x 13'	63	0.144
MWS-L-4-15	4' x 15'	76	0.175
MWS-L-4-17	4' x 17'	90	0.206
MWS-L-4-19	4' x 19'	103	0.237
MWS-L-4-21	4' x 21'	117	0.268
MWS-L-6-8	7' x 9'	64	0.147
MWS-L-8-8	8' x 8'	100	0.230
MWS-L-8-12	8' x 12'	151	0.346
MWS-L-8-16	8' x 16'	201	0.462
MWS-L-8-20	9' x 21'	252	0.577
MWS-L-8-24	9' x 25'	302	0.693
MWS-L-10-20	10' x 20'	302	0.693

# VOLUME-BASED DESIGNS

## HORIZONTAL FLOW BIOFILTRATION ADVANTAGE



### MODULAR WETLANDS® SYSTEM LINEAR WITH URBANPOND™ PRESTORAGE

In the example above, the Modular Wetlands® System Linear is installed downstream of the UrbanPond storage system. The MWS Linear is designed for the water quality volume and will treat and discharge the required volume within local draindown time requirements. The MWS Linear's unique horizontal flow design, gives it benefits no other biofilter has - the ability to be placed downstream of detention ponds, extended dry detention basins, underground storage systems and permeable paver reservoirs. The system's horizontal flow configuration and built-in orifice control allows it to be installed with just 6" of fall between inlet and outlet pipe for a simple connection to projects with shallow downstream tie-in points.

UrbanPond  
Single and Double Modules

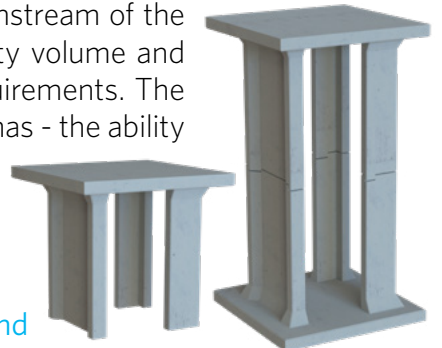

### DESIGN SUPPORT

Bio Clean engineers are trained to provide you with superior support for all volume sizing configurations throughout the country. Our vast knowledge of state and local regulations allow us to quickly and efficiently size a system to maximize feasibility. Volume control and hydromodification regulations are expanding the need to decrease the cost and size of your biofiltration system. Bio Clean will help you realize these cost savings with the MWS Linear, the only biofilter than can be used downstream of storage BMPs.

## ADVANTAGES

- LOWER COST THAN FLOW-BASED DESIGN
- BUILT-IN ORIFICE CONTROL STRUCTURE
- MEETS LID REQUIREMENTS
- WORKS WITH DEEP INSTALLATIONS

# APPLICATIONS

The Modular Wetlands® System Linear has been successfully used on numerous new construction and retrofit projects. The system's superior versatility makes it beneficial for a wide range of stormwater and waste water applications - treating rooftops, streetscapes, parking lots, and industrial sites.



## INDUSTRIAL

Many states enforce strict regulations for discharges from industrial sites. The MWS Linear has helped various sites meet difficult EPA-mandated effluent limits for dissolved metals and other pollutants.



## RESIDENTIAL

Low to high density developments can benefit from the versatile design of the MWS Linear. The system can be used in both decentralized LID design and cost-effective end-of-the-line configurations.

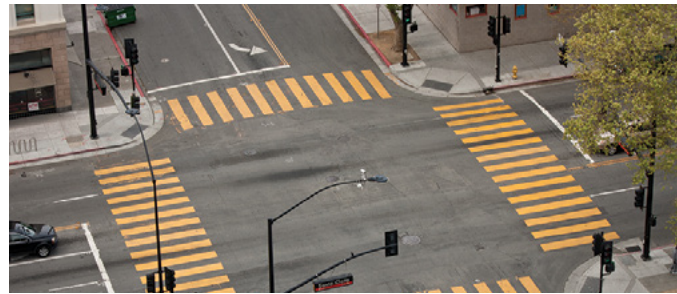

## STREETS

Street applications can be challenging due to limited space. The MWS Linear is very adaptable, and it offers the smallest footprint to work around the constraints of existing utilities on retrofit projects.



## PARKING LOTS

Parking lots are designed to maximize space and the Modular Wetlands® 4 ft. standard planter width allows for easy integration into parking lot islands and other landscape medians.



## COMMERCIAL

Compared to bioretention systems, the MWS Linear can treat far more area in less space, meeting treatment and volume control requirements.



## MIXED USE

The MWS Linear can be installed as a raised planter to treat runoff from rooftops or patios, making it perfect for sustainable "live-work" spaces.

### More applications include:

- Agriculture
- Reuse
- Low Impact Development
- Waste Water

# PLANT SELECTION

Abundant plants, trees, and grasses bring value and an aesthetic benefit to any urban setting, but those in the Modular Wetlands® System Linear do even more - they increase pollutant removal. What's not seen, but very important, is that below grade, the stormwater runoff/flow is being subjected to nature's secret weapon: a dynamic physical, chemical, and biological process working to break down and remove non-point source pollutants. The flow rate is controlled in the MWS Linear, giving the plants more contact time so that pollutants are more successfully decomposed, volatilized, and incorporated into the biomass of the Modular Wetlands® micro/macro flora and fauna.



A wide range of plants are suitable for use in the Modular Wetlands®, but selections vary by location and climate. View suitable plants by visiting [biocleanenvironmental.com/plants](http://biocleanenvironmental.com/plants).

# INSTALLATION



The Modular Wetlands® System Linear is simple, easy to install, and has a space-efficient design that offers lower excavation and installation costs compared to traditional tree-box type systems. The structure of the system resembles precast catch basin or utility vaults and is installed in a similar fashion.

The system is delivered fully assembled for quick installation. Generally, the structure can be unloaded and set in place in 15 minutes. Our experienced team of field technicians is available to supervise installations and provide technical support.

# MAINTENANCE



Reduce your maintenance costs, man hours, and materials with the Modular Wetlands® System Linear. Unlike other biofiltration systems that provide no pretreatment, the MWS Linear is a self-contained treatment train which incorporates simple and effective pretreatment.

Maintenance requirements for the biofilter itself are almost completely eliminated, as the pretreatment chamber removes and isolates trash, sediments, and hydrocarbons. What's left is the simple maintenance of an easily accessible pretreatment chamber that can be cleaned by hand or with a standard vac truck. Only periodic replacement of low-cost media in the pre-filter boxes is required for long-term operation, and there is absolutely no need to replace expensive biofiltration media.



**Bio  Clean**  
A Forterra Company

5796 Armada Drive Suite 250  
Carlsbad, CA 92008  
855.566.3938  
stormwater@forterrabp.com  
biocleanenvironmental.com



**Modular Wetland Systems, Inc.**  
**MWS LINEAR Scale Model**  
**Bacteria Removal Testing**

Prepared for  
**Modular Wetland Systems, Inc.**  
September 2007

Prepared By  
**Waves Environmental**

P.O. Box 462290  
Escondido, CA 92046-2290  
Phone: 760-743-6720  
[www.wavesenv.com](http://www.wavesenv.com)

Testing Laboratory

**Test America**

1014 E. Cooley Dr, Suite A  
Colton, CA 92324  
Phone: 909-377-4667

## Table of Contents

<u>SECTION</u>	<u>PAGE</u>
Scope of Work	3
Description of Testing Apparatus	3
Test Set Up	4
Testing Procedure	4
Results	6
Summary	7
Appendix A	8



## Reference: Bacteria Removal Testing

MWS LINEAR Hybrid Stormwater Treatment System

Waves Environmental is pleased to submit this report to Modular Wetland Systems, Inc. This report includes the laboratory analysis and photo documentation of testing procedures. The conclusions and recommendations are not part of this report since they are not part of the scope of work with Waves Environmental.

## Scope of Work

Waves Environmental measured the percentage removal of bacteria retained/captured by a Modular Wetland System – Linear (MWS-LINEAR). Laboratory testing was accomplished by the design of an exact ¼ scale model of the MWS - LINEAR. The dimensions (I.D.) of a MWS – LINEAR are 21' x 4' x 4'. The dimensions of the scale model are 5.5' x 1' x 1'. A local stormwater discharge point was identified as having consistent levels of bacteria over several weeks. This source was used to gather water to test for the systems ability of bacteria removal. Numerous grab samples were taken from the influent and effluent ends of the test unit. Grab samples were taken to the lab for analysis. A summary of the resulting data is presented in the report.

## Description of Testing Apparatus

On July 27, 2007 Waves Environmental arrived at a Bio Clean Environmental testing and maintenance facility on San Luis Rey Road, in Oceanside, CA. The quarter scale model of the MWS-LINEAR was contracted to be built by Bio Clean Environmental. An exact quarter scale model was constructed using a wood frame and fiberglass coating. Following are pictures of the construction of the model.



Specifications of the model are as follows (inside dimensions): 5.5 ft. in length, 1 ft. wide and 1 ft. tall. All internal piping was also sized to scale. The model was then water tested to ensure no leaks between chambers or piping joints. The sub surface flow wetland chamber was filled with a specific mixture of pre-washed 3-5mm pea gravel and BioMediaGREEN. The wetland chamber was then planted with various wetland plants.

To catalyze the plants rate of growth the entire model was placed under a constructed vegetative lighting system and a programmable recirculating watering system. The plants were placed in the test unit on May 1, 2007. This would allow for adequate time for the plant roots to establish throughout the gravel and media. This maturation process is an important aspect of a natural filtration system allowing for time for numerous biological functions and cycles to establish. A recirculating drip irrigation system was used to provide a continuous flow of water and nutrients in 15 minute per hour intervals 24 hours a day. Light was provided by two high powered 1000 watt high pressure sodium light bulbs mounted in a glass cooling tube and hooked up to a high powered exhaust fan. Two weeks prior to testing low nutrient water was used to water the plants, as to remove any excess nutrient accumulation that may have occurred by high doses of nutrients during the catalyzed establishment of the plants. It is expected that accumulated nutrients may have an effect on the effluent concentrations of dissolved nutrients, specifically phosphorus and nitrate. Future testing for nutrient removal will be performed after a few months to allow for the phosphorus and nitrogen cycles to regulate and accumulation to subside as plants and test unit will be moved to a natural low nutrient growing environment.

## **Test Set Up**

A test was designed to simulate a rainfall event and measure the ability of a MWS-LINEAR to remove pathogens that are commonly found in stormwater runoff. A local source of stormwater discharge high in bacteria was identified the prior week. A pump truck arrived on at the source at 1:45 PM on July 27<sup>th</sup>, 2007. 55 gallons of polluted stormwater was pulled from the source and loaded into a clean 55 gallon drum. The drum was completely filled by 2 PM. Due to time sensitivity issues the sample was immediately taken to the test facility. Testing of the model commenced at 2:14 PM.

Once the drum arrived a forklift raised the drum approximately 5.5 feet to allow for the water to discharge from the bottom of the drum to the influent top end of the MWS-LINEAR. A valve was used to regulate the flow into the system. Discharged water was collected into a container placed at the outflow of the test unit.

## **Testing Procedure**

Michael Alberson a CPESC, CPSWQ and REA from Waves Environmental performed the testing, measurements, and pollutant sampling. The forklift with a 55 gallon tank was positioned over the influent end of the testing model and was allowed to discharge through a 2" valve used to regulate the flow of the discharged batch water into the test model at a rate of 1.8 gpm. This flow rate was determined by scaling down the peak flow

rate of 120 gpm for a full size system. This is done by dividing by 64, since the capacity is one 1/64<sup>th</sup> that of a full size system. This scaling will allow for similar residence times.

Once mixed thoroughly a grab sample was taken from the drum (CQG1010-01). This sample provided the background (influent) levels in the drum to be compared to the five grab samples that were gathered from the effluent end of the MWS-LINEAR test unit. A second influent grab sample (CQG1010-03) was taken to statistically verify the result of the first influent grab sample.

Each grab sample was composed of equal portion of three separate grabs taken at the 3<sup>rd</sup>, 4<sup>th</sup>, and 5<sup>th</sup> minute of a five minute run time. This ensures an accurate average of effluent concentrations over a run time of five minutes. Water was allowed to flow through the test unit for 3 minutes, and then one third of the sample water was collected in a clean vessel and poured into the pathogen sampling bottle. The second and third sample was taken at 4 minutes of flow and the final portion of the sample was taken at approximately 5 minutes as the final amount of contaminated water from the test was flowing through the MWS-LINEAR test model.

Following are photographs of the procedure.



Testing Setup



Test Model



Inflowing Stormwater



Discharge Containment



Grab Sample Collection

## Results

Following are the results.

# MWS LINEAR Scale Model Testing

Run	Pollutant	Influent (MPN/100mL)	Effluent (MPN/100mL)	Percent Reduction
<b>1</b>	Total Coliform	>1600	>1600	n/d
	Fecal Coliform	>1600	170	>89.3%
	E. coli	>1600	110	>93.1%
<b>2</b>	Total Coliform	>1600	>1600	n/d
	Fecal Coliform	>1600	900	>43.75%
	E. coli	>1600	900	>43.75%
<b>3</b>	Total Coliform	>1600	>1600	n/d
	Fecal Coliform	>1600	>1600	n/d
	E. coli	>1600	1600	n/d
<b>4</b>	Total Coliform	>1600	>1600	n/d
	Fecal Coliform	>1600	1600	n/d
	E. coli	>1600	900	>43.75%
<b>5</b>	Total Coliform	>1600	>1600	n/d
	Fecal Coliform	>1600	1600	n/d
	E. coli	>1600	1600	n/d

## Summary of Results

Following is a summary of the results

## Summary

Pollutant	Influent (MPN/100mL)	Effluent (MPN/100mL)	Percent Reduction
Total Coliform	>1600	>1600	n/d
Fecal Coliform	>1600	535	>66.65%
E. coli	>1600	636.6	>60.2%

n/d = non determinable

## Summary

A total of five runs were performed to provide verifiable removal efficiencies. After five 5 minute runs through the MWS – LINEAR stormwater filtration system the effluent concentrations coming out of the system were analyzed and compared to influent concentrations. An influent concentration was sampled at the influent end of the system, prior to entering the systems filter processes. The MWS-LINEAR demonstrated some substantial reductions in the concentrations of fecal Coliform and E.coli. Following is a summary of the effluent concentrations and resulting removal efficiencies.

Unfortunately, certified testing has a concentration limit of 1600 MPN/100mL. All influent concentrations were over this limit; therefore making impossible to determine the actual concentration. Two days prior, samples pulled from the same source had counts of >2,419 MPN/100mL for Total Coliform and 2,419 MPN/100mL for E. coli. Local officials do ongoing sampling at this location and usually report even higher concentrations. Further testing will need to be performed to allow for more accurate analysis for the system performance.

On test runs which effluent concentrations were less than the limit, a few minimum removal efficiencies can be quantified. For two samples of Fecal Coliform there was an average effluent concentration of 890 MPN/100mL. Therefore there was a reduction of at least 44.4%. For three samples of E. coli there was an average effluent concentration of 636.6 MPN/100mL. Therefore there was a reduction of at least 60.2%.

# Appendix A

## LABORATORY REPORT

Prepared For: Bio Clean - Environmental Services, Inc.  
 2972 San Luis Rey Road  
 Oceanside, CA 92054  
 Attention: Zack Kent

Project: Bacterial Analysis  
 Bacterial Analysis

Sampled: 07/27/07  
 Received: 07/27/07  
 Issued: 08/02/07 07:09

*The results listed within this Laboratory Report pertain only to the samples tested in the laboratory. The analyses contained in this report were performed in accordance with the applicable certifications as noted. All soil samples are reported on a wet weight basis unless otherwise noted in the report. This Laboratory Report is confidential and is intended for the sole use of TestAmerica and its client. This report shall not be reproduced, except in full, without written permission from TestAmerica. The Chain of Custody, 1 page, is included and is an integral part of this report.  
 This entire report was reviewed and approved for release.*

### CASE NARRATIVE

**SAMPLE RECEIPT:** Samples were received intact, at 0°C, on ice and with chain of custody documentation.

**HOLDING TIMES:** All samples were analyzed within prescribed holding times and/or in accordance with the TestAmerica Sample Acceptance Policy unless otherwise noted in the report.

**PRESERVATION:** Samples requiring preservation were verified prior to sample analysis.

**QA/QC CRITERIA:** All analyses met method criteria, except as noted in the report with data qualifiers.

**COMMENTS:** No significant observations were made.

**SUBCONTRACTED:** No analyses were subcontracted to an outside laboratory.

LABORATORY ID	CLIENT ID	MATRIX
CQG1010-01	1-	Water
CQG1010-02	2-	Water
CQG1010-03	3-	Water
CQG1010-04	4-	Water
CQG1010-05	5-	Water
CQG1010-06	6-	Water
CQG1010-07	7-	Water

Reviewed By:



**TestAmerica - Ontario, CA**

John Stuart Styles  
 Project Manager

Bio Clean - Environmental Services, Inc.  
 2972 San Luis Rey Road  
 Oceanside, CA 92054  
 Attention: Zack Kent

Project ID: Bacterial Analysis  
 Bacterial Analysis  
 Report Number: CQG1010

Sampled: 07/27/07  
 Received: 07/27/07

## COLIFORMS BY MULTIPLE TUBE FERMENTATION - MPN (SM9221/40 CFR 141.21(f)(6)(i))

Analyte	Method	Batch	Reporting Limit	Sample Result	Dilution Factor	Date Extracted	Date Analyzed	Data Qualifiers
<b>Sample ID: CQG1010-01 (1 - - Water)</b>								
Reporting Units: MPN/100 ml								
Total Coliform	SM9221 A,B,C,E	C7G2719	2.0	> or = 1600	1	7/27/2007	7/30/2007	
Fecal Coliform	SM9221 A,B,C,E	C7G2719	2.0	> or = 1600	1	7/27/2007	7/30/2007	
E. Coli	SM9221 A,B,C,E	C7G2719	2.0	> or = 1600	1	7/27/2007	7/30/2007	
<b>Sample ID: CQG1010-02 (2 - - Water)</b>								
Reporting Units: MPN/100 ml								
Total Coliform	SM9221 A,B,C,E	C7G2719	2.0	> or = 1600	1	7/27/2007	7/30/2007	
Fecal Coliform	SM9221 A,B,C,E	C7G2719	2.0	170	1	7/27/2007	7/30/2007	
E. Coli	SM9221 A,B,C,E	C7G2719	2.0	110	1	7/27/2007	7/30/2007	
<b>Sample ID: CQG1010-03 (3 - - Water)</b>								
Reporting Units: MPN/100 ml								
Total Coliform	SM9221 A,B,C,E	C7G2719	2.0	> or = 1600	1	7/27/2007	7/30/2007	
Fecal Coliform	SM9221 A,B,C,E	C7G2719	2.0	> or = 1600	1	7/27/2007	7/30/2007	
E. Coli	SM9221 A,B,C,E	C7G2719	2.0	> or = 1600	1	7/27/2007	7/30/2007	
<b>Sample ID: CQG1010-04 (4 - - Water)</b>								
Reporting Units: MPN/100 ml								
Total Coliform	SM9221 A,B,C,E	C7G2719	2.0	> or = 1600	1	7/27/2007	7/30/2007	
Fecal Coliform	SM9221 A,B,C,E	C7G2719	2.0	900	1	7/27/2007	7/30/2007	
E. Coli	SM9221 A,B,C,E	C7G2719	2.0	900	1	7/27/2007	7/30/2007	
<b>Sample ID: CQG1010-05 (5 - - Water)</b>								
Reporting Units: MPN/100 ml								
Total Coliform	SM9221 A,B,C,E	C7G2719	2.0	> or = 1600	1	7/27/2007	7/30/2007	
Fecal Coliform	SM9221 A,B,C,E	C7G2719	2.0	> or = 1600	1	7/27/2007	7/30/2007	
E. Coli	SM9221 A,B,C,E	C7G2719	2.0	1600	1	7/27/2007	7/30/2007	
<b>Sample ID: CQG1010-06 (6 - - Water)</b>								
Reporting Units: MPN/100 ml								
Total Coliform	SM9221 A,B,C,E	C7G2719	2.0	> or = 1600	1	7/27/2007	7/30/2007	
Fecal Coliform	SM9221 A,B,C,E	C7G2719	2.0	1600	1	7/27/2007	7/30/2007	
E. Coli	SM9221 A,B,C,E	C7G2719	2.0	900	1	7/27/2007	7/30/2007	
<b>Sample ID: CQG1010-07 (7 - - Water)</b>								
Reporting Units: MPN/100 ml								
Total Coliform	SM9221 A,B,C,E	C7G2719	2.0	> or = 1600	1	7/27/2007	7/30/2007	
Fecal Coliform	SM9221 A,B,C,E	C7G2719	2.0	1600	1	7/27/2007	7/30/2007	
E. Coli	SM9221 A,B,C,E	C7G2719	2.0	1600	1	7/27/2007	7/30/2007	

TestAmerica - Ontario, CA

John Stuart Styles  
 Project Manager



Bio Clean - Environmental Services, Inc.  
 2972 San Luis Rey Road  
 Oceanside, CA 92054  
 Attention: Zack Kent

Project ID: Bacterial Analysis  
 Bacterial Analysis  
 Report Number: CQG1010

Sampled: 07/27/07  
 Received: 07/27/07

## SHORT HOLD TIME DETAIL REPORT

	Hold Time (in days)	Date/Time Sampled	Date/Time Received	Date/Time Extracted	Date/Time Analyzed
<b>Sample ID: 1- (CQG1010-01) - Water</b> SM9221 A,B,C,E	0	07/27/2007 14:14	07/27/2007 16:51	07/27/2007 17:20	07/30/2007 11:00
<b>Sample ID: 2- (CQG1010-02) - Water</b> SM9221 A,B,C,E	0	07/27/2007 14:17	07/27/2007 16:51	07/27/2007 17:20	07/30/2007 11:00
<b>Sample ID: 3- (CQG1010-03) - Water</b> SM9221 A,B,C,E	0	07/27/2007 14:23	07/27/2007 16:51	07/27/2007 17:20	07/30/2007 11:00
<b>Sample ID: 4- (CQG1010-04) - Water</b> SM9221 A,B,C,E	0	07/27/2007 14:27	07/27/2007 16:51	07/27/2007 17:20	07/30/2007 11:00
<b>Sample ID: 5- (CQG1010-05) - Water</b> SM9221 A,B,C,E	0	07/27/2007 14:28	07/27/2007 16:51	07/27/2007 17:20	07/30/2007 11:00
<b>Sample ID: 6- (CQG1010-06) - Water</b> SM9221 A,B,C,E	0	07/27/2007 14:32	07/27/2007 16:51	07/27/2007 17:20	07/30/2007 11:00
<b>Sample ID: 7- (CQG1010-07) - Water</b> SM9221 A,B,C,E	0	07/27/2007 14:36	07/27/2007 16:51	07/27/2007 17:20	07/30/2007 11:00

TestAmerica - Ontario, CA

John Stuart Styles  
 Project Manager

*The results pertain only to the samples tested in the laboratory. This report shall not be reproduced, except in full, without written permission from TestAmerica.*

**CQG1010 <Page 3 of 5>**

Bio Clean - Environmental Services, Inc.  
2972 San Luis Rey Road  
Oceanside, CA 92054  
Attention: Zack Kent

Project ID: Bacterial Analysis  
Bacterial Analysis  
Report Number: CQG1010

Sampled: 07/27/07  
Received: 07/27/07

### DATA QUALIFIERS AND DEFINITIONS

**ND** Analyte NOT DETECTED at or above the reporting limit or MDL, if MDL is specified.  
**RPD** Relative Percent Difference

**TestAmerica - Ontario, CA**

John Stuart Styles  
Project Manager

*The results pertain only to the samples tested in the laboratory. This report shall not be reproduced,  
except in full, without written permission from TestAmerica.*

**CQG1010 <Page 4 of 5>**

Bio Clean - Environmental Services, Inc.  
2972 San Luis Rey Road  
Oceanside, CA 92054  
Attention: Zack Kent

Project ID: Bacterial Analysis  
Bacterial Analysis  
Report Number: CQG1010

Sampled: 07/27/07  
Received: 07/27/07

## Certification Summary

### TestAmerica - Ontario, CA

Method	Matrix	Nelac	California
SM9221 A,B,C,E	Water	X	X

### TestAmerica - Ontario, CA

John Stuart Styles  
Project Manager

*The results pertain only to the samples tested in the laboratory. This report shall not be reproduced, except in full, without written permission from TestAmerica.*

**Appendix D:**

**BMP Maintenance Information**

## Maintenance Guidelines for Modular Wetland System - Linear

### Maintenance Summary

- Remove Trash from Screening Device – average maintenance interval is 6 to 12 months.
  - *(5 minute average service time).*
- Remove Sediment from Separation Chamber – average maintenance interval is 12 to 24 months.
  - *(10 minute average service time).*
- Replace Cartridge Filter Media – average maintenance interval 12 to 24 months.
  - *(10-15 minute per cartridge average service time).*
- Replace Drain Down Filter Media – average maintenance interval is 12 to 24 months.
  - *(5 minute average service time).*
- Trim Vegetation – average maintenance interval is 6 to 12 months.
  - *(Service time varies).*

### System Diagram

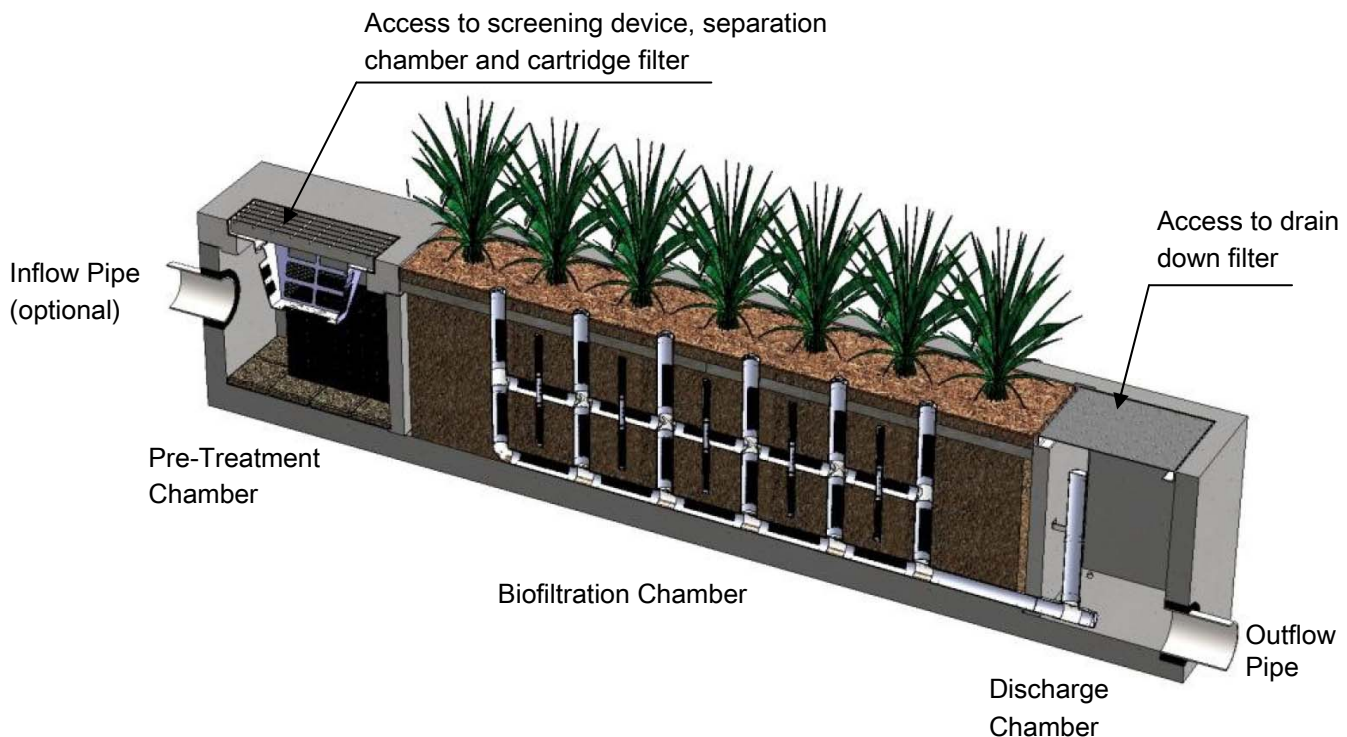

# Maintenance Procedures

## Screening Device

1. Remove grate or manhole cover to gain access to the screening device in the Pre-Treatment Chamber. Vault type units do not have screening device. Maintenance can be performed without entry.
2. Remove all pollutants collected by the screening device. Removal can be done manually or with the use of a vacuum truck. The hose of the vacuum truck will not damage the screening device.
3. Screening device can easily be removed from the Pre-Treatment Chamber to gain access to separation chamber and media filters below. Replace grate or manhole cover when completed.

## Separation Chamber

1. Perform maintenance procedures of screening device listed above before maintaining the separation chamber.
2. With a pressure washer spray down pollutants accumulated on walls and cartridge filters.
3. Vacuum out Separation Chamber and remove all accumulated pollutants. Replace screening device, grate or manhole cover when completed.

## Cartridge Filters

1. Perform maintenance procedures on screening device and separation chamber before maintaining cartridge filters.
2. Enter separation chamber.
3. Unscrew the two bolts holding the lid on each cartridge filter and remove lid.
4. Remove each of 4 to 8 media cages holding the media in place.
5. Spray down the cartridge filter to remove any accumulated pollutants.
6. Vacuum out old media and accumulated pollutants.
7. Reinstall media cages and fill with new media from manufacturer or outside supplier. Manufacturer will provide specification of media and sources to purchase.
8. Replace the lid and tighten down bolts. Replace screening device, grate or manhole cover when completed.

## Drain Down Filter

1. Remove hatch or manhole cover over discharge chamber and enter chamber.
2. Unlock and lift drain down filter housing and remove old media block. Replace with new media block. Lower drain down filter housing and lock into place.
3. Exit chamber and replace hatch or manhole cover.



## Maintenance Notes

1. Following maintenance and/or inspection, it is recommended the maintenance operator prepare a maintenance/inspection record. The record should include any maintenance activities performed, amount and description of debris collected, and condition of the system and its various filter mechanisms.
2. The owner should keep maintenance/inspection record(s) for a minimum of five years from the date of maintenance. These records should be made available to the governing municipality for inspection upon request at any time.
3. Transport all debris, trash, organics and sediments to approved facility for disposal in accordance with local and state requirements.
4. Entry into chambers may require confined space training based on state and local regulations.
5. No fertilizer shall be used in the Biofiltration Chamber.
6. Irrigation should be provided as recommended by manufacturer and/or landscape architect. Amount of irrigation required is dependent on plant species. Some plants may require irrigation.

## Maintenance Procedure Illustration

### Screening Device

The screening device is located directly under the manhole or grate over the Pre-Treatment Chamber. It's mounted directly underneath for easy access and cleaning. Device can be cleaned by hand or with a vacuum truck.



### Separation Chamber

The separation chamber is located directly beneath the screening device. It can be quickly cleaned using a vacuum truck or by hand. A pressure washer is useful to assist in the cleaning process.

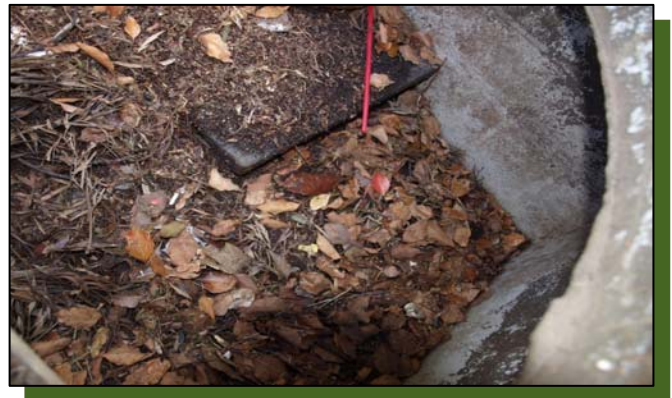



### Cartridge Filters

The cartridge filters are located in the Pre-Treatment chamber connected to the wall adjacent to the biofiltration chamber. The cartridges have removable tops to access the individual media filters. Once the cartridge is open media can be easily removed and replaced by hand or a vacuum truck.



### Drain Down Filter

The drain down filter is located in the Discharge Chamber. The drain filter unlocks from the wall mount and hinges up. Remove filter block and replace with new block.



### Trim Vegetation

Vegetation should be maintained in the same manner as surrounding vegetation and trimmed as needed. No fertilizer shall be used on the plants. Irrigation per the recommendation of the manufacturer and or landscape architect. Different types of vegetation requires different amounts of irrigation.





## Inspection Form

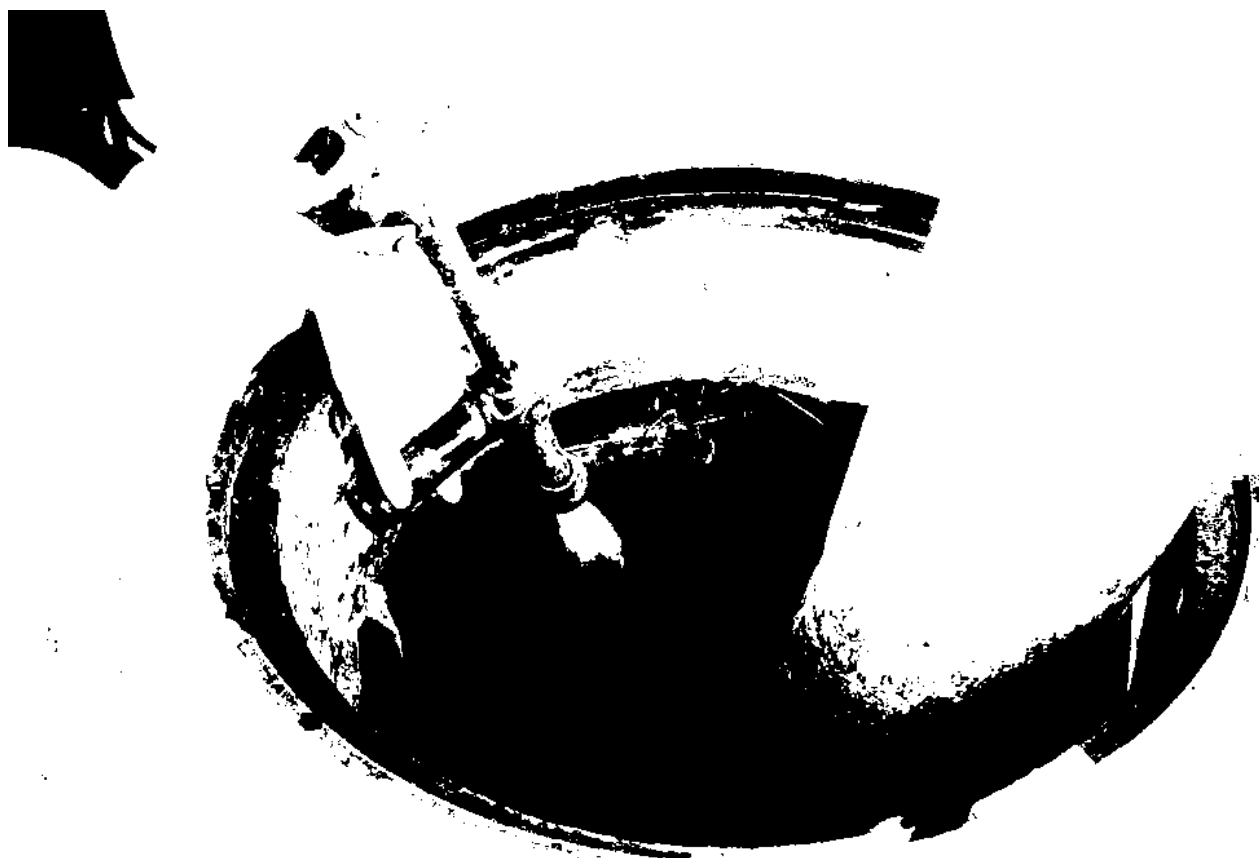

Modular Wetland System, Inc.

P. 760.433-7640

F. 760-433-3176

E. [Info@modularwetlands.com](mailto:Info@modularwetlands.com)

[www.modularwetlands.com](http://www.modularwetlands.com)



# Inspection Report Modular Wetlands System



Project Name \_\_\_\_\_

Project Address \_\_\_\_\_ (city) (Zip Code)

Owner / Management Company \_\_\_\_\_

Contact \_\_\_\_\_

Phone ( ) -

Inspector Name \_\_\_\_\_

Date \_\_\_\_ / \_\_\_\_ / \_\_\_\_

Time \_\_\_\_\_ AM / PM

Type of Inspection  Routine  Follow Up  Complaint

Storm

Storm Event in Last 72-hours?  No  Yes

Weather Condition \_\_\_\_\_

Additional Notes \_\_\_\_\_

For Office Use Only

---

(Reviewed By) \_\_\_\_\_

---

(Date) \_\_\_\_\_  
Office personnel to complete section to the left.

## Inspection Checklist

Modular Wetland System Type (Curb, Grate or UG Vault): \_\_\_\_\_ Size (22', 14' or etc.): \_\_\_\_\_

Structural Integrity:	Yes	No	Comments
Damage to pre-treatment access cover (manhole cover/grate) or cannot be opened using normal lifting pressure?			
Damage to discharge chamber access cover (manhole cover/grate) or cannot be opened using normal lifting pressure?			
Does the MWS unit show signs of structural deterioration (cracks in the wall, damage to frame)?			
Is the inlet/outlet pipe or drain down pipe damaged or otherwise not functioning properly?			
<b>Working Condition:</b>			
Is there evidence of illicit discharge or excessive oil, grease, or other automobile fluids entering and clogging the unit?			
Is there standing water in inappropriate areas after a dry period?			
Is the filter insert (if applicable) at capacity and/or is there an accumulation of debris/trash on the shelf system?			
Does the depth of sediment/trash/debris suggest a blockage of the inflow pipe, bypass or cartridge filter? If yes, specify which one in the comments section. Note depth of accumulation in in pre-treatment chamber.			Depth:
Does the cartridge filter media need replacement in pre-treatment chamber and/or discharge chamber?			Chamber:
Any signs of improper functioning in the discharge chamber? Note issues in comments section.			
<b>Other Inspection Items:</b>			
Is there an accumulation of sediment/trash/debris in the wetland media (if applicable)?			
Is it evident that the plants are alive and healthy (if applicable)? Please note Plant Information below.			
Is there a septic or foul odor coming from inside the system?			

Waste:	Yes	No
Sediment / Silt / Clay		
Trash / Bags / Bottles		
Green Waste / Leaves / Foliage		

Recommended Maintenance	
No Cleaning Needed	
Schedule Maintenance as Planned	
Needs Immediate Maintenance	

Plant Information	
Damage to Plants	
Plant Replacement	
Plant Trimming	

Additional Notes: \_\_\_\_\_

## Maintenance Report



Modular Wetland System, Inc.

P. 760.433-7640

F. 760-433-3176

E. [Info@modularwetlands.com](mailto:Info@modularwetlands.com)

[www.modularwetlands.com](http://www.modularwetlands.com)



# Cleaning and Maintenance Report Modular Wetlands System



Project Name \_\_\_\_\_

Project Address \_\_\_\_\_  
(city) (Zip Code)

Owner / Management Company \_\_\_\_\_

Contact \_\_\_\_\_ Phone (      )      -

Inspector Name \_\_\_\_\_ Date \_\_\_\_ / \_\_\_\_ / \_\_\_\_ Time \_\_\_\_\_ AM / PM

Type of Inspection     Routine     Follow Up     Complaint     Storm    Storm Event in Last 72-hours?     No     Yes

Weather Condition \_\_\_\_\_ Additional Notes \_\_\_\_\_

For Office Use Only

---

(Reviewed By) \_\_\_\_\_

---

(Date) \_\_\_\_\_  
 Office personnel to complete section to the left.

Site Map #	GPS Coordinates of Insert	Manufacturer / Description / Sizing	Trash Accumulation	Foliage Accumulation	Sediment Accumulation	Total Debris Accumulation	Condition of Media 25/50/75/100 (will be changed @ 75%)	Operational Per Manufactures' Specifications (If not, why?)
	Lat: Long:	MWS Catch Basins						
		MWS Sedimentation Basin						
		Media Filter Condition						
		Plant Condition						
		Drain Down Media Condition						
		Discharge Chamber Condition						
		Drain Down Pipe Condition						
		Inlet and Outlet Pipe Condition						

Comments:

---



---

**Appendix E:**

**Geotechnical Information**

**(Storm water infiltration BMP evaluation)**

**GEOTECHNICAL AND INFILTRATION EVALUATION  
PROPOSED WAREHOUSE FACILITY  
534 WEST STRUCK AVENUE  
ORANGE, ORANGE COUNTY, CALIFORNIA**

**PREPARED FOR**

**PROLOGIS  
11777 CENTER COURT DRIVE NORTH, SUITE 100  
CERRITOS, CALIFORNIA 90703**

**PREPARED BY**

**GEOTEK, INC.  
1548 NORTH MAPLE STREET  
CORONA, CALIFORNIA 92880**

**PROJECT No. 2361-CR**

**MARCH 31, 2020**

---







**GeoTek, Inc.**  
1548 North Maple Street, Corona, California 92880  
(951) 710-1160 Office (951) 710-1167 Fax [www.geotekusa.com](http://www.geotekusa.com)

March 31, 2020  
Project No. 2361-CR

**ProLogis**

11777 Center Court Drive North, Suite 100  
Cerritos, California 90703

Attention: Mr. John Carter

Subject: Geotechnical and Infiltration Evaluation  
Proposed Warehouse Facility  
534 West Struck Avenue  
Orange, Orange County, California

Dear Mr. Carter:

We are pleased to provide the results of our geotechnical and infiltration evaluation for the proposed warehouse facility that will be constructed on the subject site in the city of Orange, Orange County. This report presents a discussion of our evaluation and provides preliminary geotechnical recommendations for site preparation, foundation design, infiltration rates and construction.

Based on the results of our evaluation, development of the property appears feasible from a geotechnical viewpoint provided that the recommendations presented in this report and in future reports are incorporated into design and construction.

The opportunity to be of service is sincerely appreciated. If you have any questions, please do not hesitate to contact our office.

Respectfully submitted,  
**GeoTek, Inc.**



Robert R. Russell  
GE 2042, Exp. 12/31/20  
Senior Project Engineer



Edward H. LaMont  
CEG 1892, Exp. 07/31/20  
Principal Geologist

Anna M. Scott  
Project Geologist

Distribution: (1) Addressee via email (one PDF file)

G:\Projects\2351 to 2400\2361CR ProLogis 534 West Struck Avenue Orange\Geotechnical and Infiltration Evaluation\2361CR Geotechnical and Infiltration Evaluation Orange.docx

## TABLE OF CONTENTS

<b>1. PURPOSE AND SCOPE OF SERVICES .....</b>	<b>1</b>
<b>2. SITE DESCRIPTION AND PROPOSED DEVELOPMENT .....</b>	<b>2</b>
2.1 SITE DESCRIPTION .....	2
2.1 PROPOSED DEVELOPMENT .....	2
<b>3. FIELD EXPLORATION AND LABORATORY TESTING .....</b>	<b>3</b>
3.1 FIELD EXPLORATION .....	3
3.2 LABORATORY TESTING .....	4
<b>4. GEOLOGIC AND SOILS CONDITIONS .....</b>	<b>4</b>
4.1 REGIONAL SETTING .....	4
4.2 GENERAL SOIL/GEOLOGIC CONDITIONS .....	5
4.2.1 Undocumented Fill .....	5
4.2.2 Older Alluvial Fan Deposits .....	5
4.3 SURFACE AND GROUNDWATER .....	5
4.3.1 Surface Water .....	5
4.3.2 Groundwater .....	6
4.4 FAULTING AND SEISMICITY .....	6
4.4.1 Seismic Design Parameters .....	6
4.5 LIQUEFACTION ANALYSIS .....	7
4.6 OTHER SEISMIC HAZARDS .....	8
<b>5. CONCLUSIONS AND RECOMMENDATIONS .....</b>	<b>8</b>
5.1 GENERAL .....	8
5.2 EARTHWORK CONSIDERATIONS .....	8
5.2.1 Site Clearing & Demolition .....	8
5.2.2 Remedial Grading .....	9
5.2.3 Preparation of Excavation Bottoms .....	9
5.2.4 Engineered Fills .....	9
5.2.5 Excavation Characteristics .....	9
5.2.6 Shrinkage and Subsidence .....	9
5.3 DESIGN RECOMMENDATIONS .....	10
5.3.1 Foundation Design Criteria .....	10
5.3.2 Miscellaneous Foundation Recommendations .....	13
5.3.3 Foundation Setbacks .....	14
5.3.4 Soil Corrosivity .....	14
5.3.5 Soil Sulfate Content .....	14
5.3.6 Import Soils .....	14
5.3.7 Concrete Flatwork .....	15
5.4 RETAINING WALL DESIGN AND CONSTRUCTION .....	16
5.5 INFILTRATION TEST RESULTS .....	18
5.6 PRELIMINARY PAVEMENT DESIGN .....	19
5.7 POST CONSTRUCTION CONSIDERATIONS .....	21
5.7.1 Landscape Maintenance and Planting .....	21

## TABLE OF CONTENTS

5.7.2 Drainage .....	21
5.8 PLAN REVIEW AND CONSTRUCTION OBSERVATIONS .....	22
<b>6. INTENT .....</b>	<b>22</b>
<b>7. LIMITATIONS .....</b>	<b>23</b>
<b>8. SELECTED REFERENCES .....</b>	<b>23</b>

### ENCLOSURES

Figure 1 – Site Location and Topography Map

Figures 2 – Exploration Location Map

Appendix A – Geophysical Survey and Logs of Exploratory Borings

Appendix B – Laboratory Test Results

Appendix C – Infiltration Test Data

Appendix D – General Grading Guidelines

## I. PURPOSE AND SCOPE OF SERVICES

The purpose of this study was to evaluate the geotechnical conditions for the proposed development. Services provided for this study included the following:

- Research and review of available geologic data and general information pertinent to the site,
- A site reconnaissance,
- A geophysical survey, performed by SubSurface Surveys & Associates, Inc., to locate and identify the existence of any pipes, conduits, utilities and other underground obstructions within the vicinity of our 12 borings,
- Excavation and logging of eight (8) geotechnical exploratory borings,
- Logging and infiltration testing of an additional four (4) hollow stem auger borings in the vicinity of the planned storm water treatment areas,
- Collection of soil samples,
- Laboratory testing of selected soil samples,
- Review and evaluation of site seismicity, and;
- Compilation of this geotechnical report which presents our preliminary recommendations for site development.

The intent of this report is to aid in the evaluation of the site for future proposed development from a geotechnical perspective. The professional opinions and geotechnical information contained in this report may need to be updated based upon our review of the final site development plans. These plans should be provided to GeoTek, Inc. for review when available.

## 2. SITE DESCRIPTION AND PROPOSED DEVELOPMENT

### 2.1 SITE DESCRIPTION

The approximately 10-acre site is located on the south side of Struck Avenue near its eastern terminus in the city of Orange, Orange County. The site is currently developed with an approximate 40,000 square foot 1-story building, several canopy structures, storage areas, parking/drive areas and landscaping. Several silos exist near the southern limits of the existing 1-story building. Topographically, the site is relatively level sloping down gently to the west. The site location is presented on Figure 1.

Based on a review of aerial photographs flown between 1938 and 2016, the site was undeveloped and used for agricultural purposes until between 1966 to 1972. Since that time, the site has been developed and used for industrial purposes. As noted in the CERCLA Screening Report (Ecology and Environment, Inc., 1990), six or seven (conflicting information) underground storage tanks (USTs) were previously present on the site. The USTs appear to have ranged in storage capacity from about 3,500 to 50,000 gallons. Reportedly, six of the USTs were removed in 1983. However, the report only obtained documentation for the removal of three of the USTs.

The site is bounded by Struck Avenue to the north, a railroad right-of-way to the east and commercial/industrial properties to the west and south.

### 2.1 PROPOSED DEVELOPMENT

We understand that the existing improvements on the site are to be demolished and a new 216,860 square foot warehouse building and associated surface parking and drive areas are to be constructed. The new building will include 34 dock doors along the east side of the building.

The structure is anticipated to be a single-story concrete tilt-up (or similar) building and maximum column and wall loads of about 150 kips and 6 kips per foot have been estimated for the purpose of this report. Once actual structural loading information is known, that information should be provided to GeoTek to determine if modifications to the recommendations presented in this report are warranted.

Due to the relatively level nature of the site, we anticipate that the maximum depth of cut and fill will be less than about 5 feet, not including any remedial grading.

### 3. FIELD EXPLORATION AND LABORATORY TESTING

#### 3.1 FIELD EXPLORATION

Prior to our subsurface explorations, a geophysical survey was performed at the site by SurbSurface Surveys & Associates, Inc. in order to locate and identify the existence of any pipes, conduits, utilities and other underground obstructions within the vicinity of our proposed borings. A copy of the report is included in Appendix A.

Our field exploration was conducted on March 9, 2019 and consisted of eight (8) geotechnical test borings which were excavated with a hollow-stem auger drill rig to a maximum depth of 30-½ feet below ground surface (bgs). A hollow-stem auger with an outside diameter of 8 inches was utilized. The inside diameter of the auger was 4.5 inches. A geologist from GeoTek, Inc. logged the exploratory borings. The boring locations are presented on Figure 2. Logs of the exploratory borings are included in Appendix A.

The exploration logs show subsurface conditions at the dates and locations indicated and may not be representative of other locations and times. The stratification lines presented on the logs represent the approximate boundaries between soil types and the transitions may be gradual.

Relatively undisturbed soil samples were recovered at various intervals in the geotechnical borings with a California sampler. The California sampler is a 3-inch outside diameter, 2.4-inch inside diameter, split barrel sampler lined with brass rings. The sampler was 18 inches long. The sampler conformed to the requirements of ASTM D 3550. A 140-pound automatic trip hammer was utilized, dropping 30 inches for each blow. The relatively undisturbed samples, together with bulk samples of representative soil types, were returned to the laboratory for testing and evaluation. The California Ring sampler data are presented on the boring logs.

Four borings were also excavated in the vicinity of the proposed stormwater infiltration areas to depths of about six to eight feet. The locations and depths of the infiltration borings were as requested by the civil engineer. Infiltration testing was conducted in these borings in general accordance with the requirements of the County of Orange. The infiltration tests consisted of drilling eight-inch diameter test holes to the desired depth and installing approximately two inches of gravel in the bottom of the hole. A three-inch diameter perforated PVC pipe, wrapped in a filter sock, was placed in the excavations and the annular space was filled with gravel to prevent caving within the boring. Water was then placed in the borings to presoak the holes overnight and percolation testing was performed the following day.

### **3.2 LABORATORY TESTING**

Laboratory testing was performed on selected soil samples obtained during our field exploration. The purpose of the laboratory testing was to confirm the field classification of the soils encountered and to evaluate the physical properties of the soils for use in engineering design and analysis.

Included in our laboratory testing were moisture-density determinations on undisturbed samples. Gradation (percent passing #200 sieve) testing was performed on selected samples. Collapse testing was performed on representative undisturbed samples to evaluate the collapse and settlement potential of the site soils. Optimum moisture content-maximum dry density relationships were established for typical soil types so that the relative compaction of the subsoils could be determined. Direct shear testing was performed on a selected sample to help evaluate the bearing capacity of the soils. Expansion index and Atterberg Limit testing was performed on selected samples to evaluate the expansion potential and plasticity of the on-site soils. Chemical testing comprised of pH, soluble sulfate, chloride and resistivity testing was conducted on selected samples. Resistance value (R-Value) testing was performed on two selected samples to help determine a preliminary pavement design section for the project. The moisture-density, Atterberg Limits and gradation data are presented on the exploration logs in Appendix A. The maximum density, direct shear, expansion index, chemical test and R-Value data are presented in Appendix B.

## **4. GEOLOGIC AND SOILS CONDITIONS**

### **4.1 REGIONAL SETTING**

The subject property is situated in the Peninsular Ranges geomorphic province. The Peninsular Ranges province is one of the largest geomorphic units in western North America. It extends approximately 975 miles south of the Transverse Ranges geomorphic province to the tip of Baja California. This province varies in width from about 30 to 100 miles. It is bounded on the west by the Pacific Ocean, on the south by the Gulf of California and on the east by the Colorado Desert Province.

The Peninsular Ranges are essentially a series of northwest-southeast oriented fault blocks. Several major fault zones are found in this province. The Elsinore Fault zone and the San Jacinto



Fault zone trend northwest-southeast and are found near the middle of the province. The San Andreas Fault zone borders the northeasterly margin of the province.

More specific to the subject property, the site is located in an area geologically mapped to be underlain by older alluvial fan deposits (Morton, D.M. and Miller, F.K., 2006).

## **4.2 GENERAL SOIL/GEOLOGIC CONDITIONS**

A brief description of the soils encountered on the site is presented in the following sections. Based on our field exploration and observations, the site is generally underlain by undocumented fill and older alluvial fan deposits.

### **4.2.1 Undocumented Fill**

Undocumented fill soils were encountered within ten of the test borings to depths ranging from about 3 to 5 feet below existing grade. As encountered, the undocumented fill consisted of medium dense to dense silty sand, very dense/hard clayey sand to sandy clay, clayey silt and silty clay.

Expansion index testing reveals that the near-surface soils exhibit a “medium” expansion potential.

### **4.2.2 Older Alluvial Fan Deposits**

Older alluvial fan deposits generally consisting of medium dense to very dense sand and silty and clayey sands and stiff to very stiff sandy silts, clayey silts and sandy clays were encountered below the undocumented fill and/or the existing ground surface and extended to the maximum depths explored.

## **4.3 SURFACE AND GROUNDWATER**

### **4.3.1 Surface Water**

Surface water was not observed during our site visit. If encountered during earthwork construction, surface water on this site is the result of precipitation or possibly some minor surface run-off from immediately surrounding properties. Overall site area drainage is generally in a westerly direction, as directed by site topography. Provisions for surface drainage will need to be accounted for by the project civil engineer.

### 4.3.2 Groundwater

Groundwater was not encountered within our test borings to depths up to about 30 feet below grade. Based on a review of the Seismic Hazard Zone Report for the Orange Quadrangle, historic high groundwater at the site is estimated to be greater than 40 feet below grade.

## 4.4 FAULTING AND SEISMICITY

The geologic structure of the entire southern California area is dominated mainly by northwest-trending faults associated with the San Andreas system. The site is in a seismically active region. The site is not situated within a State of California "Alquist-Priolo" Earthquake Fault Zone (CGS, 1980). A review of the Earthquake Zones of Required Investigation Map (Orange Quadrangle, CGS, 1998), the site is not located within a fault or liquefaction hazard area. The nearest known active faults are the San Joaquin Hills and Elsinore fault zones, located about 7.5 miles to the south and 8.3 miles to the northeast, respectively.

### 4.4.1 Seismic Design Parameters

The site is located at approximately  $33.8052^{\circ}$  Latitude and  $-117.8580^{\circ}$  Longitude. Site spectral accelerations ( $S_a$  and  $S_1$ ), for 0.2 and 1.0 second periods for a Class "D" site, was determined from the SEAOC/OSHPD web interface that utilizes the USGS web services and retrieves the seismic design data and presents that information in a report format. As noted using the ASCE 7-16 option on the SEAOC/OSHPD website, the values for  $S_{M1}$  and  $S_{D1}$  are reported as "null-See Section 11.4.8 (of ASCE 7-16). As noted in ASCE 7-16, Section 11.4.8, a site-specific ground motion procedure is recommended for Site Class D when the value  $S_1$  exceeds 0.2. The value  $S_1$  for the subject site exceeds 0.2.

For a site Class D, an exception to performing a site-specific ground motion analysis is allowed in ASCE 7-16 where  $S_1$  exceeds 0.2 provided the value of the seismic response coefficient,  $C_s$ , is conservatively calculated by Eq 12.8-2 of ASCE 7-16 for values of  $T \leq 1.5T_L$  and taken as equal to 1.5 times the value computed in accordance with either Eq. 12.8-3 for  $T_L \geq T > 1.5T_L$  or Eq. 12.8-4 for  $T > T_L$ .

Assuming that the  $C_s$  value calculated by and used by the structural engineer allows for the exclusion per ASCE 7-16, noted above, then a site-specific ground motion analysis is not required. For this assumption and condition, the following seismic design parameters, based on the 2015 National Earthquake Hazards Reduction Program (NEHRP), are presented on the following table:

<b>SITE SEISMIC PARAMETERS</b>	
Mapped 0.2 sec Period Spectral Acceleration, $S_s$	1.405g
Mapped 1.0 sec Period Spectral Acceleration, $S_1$	0.499g
Site Coefficient for Site Class "D," $F_a$	1.0
Site Coefficient for Site Class "D," $F_v$	1.801
Maximum Considered Earthquake Spectral Response Acceleration for 0.2 Second, $S_{MS}$	1.405g
Maximum Considered Earthquake Spectral Response Acceleration for 1.0 Second, $S_{M1}$	0.899g
5% Damped Design Spectral Response Acceleration Parameter at 0.2 Second, $S_{DS}$	0.937g
5% Damped Design Spectral Response Acceleration Parameter at 1 second, $S_{D1}$	0.599g
$PGA_M$	0.649g
Seismic Design Category	D

Final selection of the appropriate seismic design coefficients should be made by the project structural engineer based upon the local practices and ordinances, expected building response and desired level of conservatism.

#### **4.5 LIQUEFACTION ANALYSIS**

Liquefaction describes a phenomenon in which cyclic stresses, produced by earthquake-induced ground motion, create excess pore pressures in relatively cohesionless soils. These soils may thereby acquire a high degree of mobility, which can lead to lateral movement, sliding, settlement of loose sediments, sand boils and other damaging deformations. This phenomenon occurs only below the water table, but, after liquefaction has developed, the effects can propagate upward into overlying non-saturated soil as excess pore water dissipates.

The factors known to influence liquefaction potential include soil type and grain size, relative density, groundwater level, soil plasticity, confining pressures, and both intensity and duration of ground shaking. In general, materials that are susceptible to liquefaction are loose, saturated granular soils having low fines content and some low plastic silts and clays under low confining pressures.

The project site is not located within an area mapped by the State of California for liquefaction potential. Based on the current map designation and the estimated depth to historic high groundwater (+40 feet) and the density of the materials encountered, it is our opinion that the site possesses a very low potential for liquefaction during a seismic event.



## **4.6 OTHER SEISMIC HAZARDS**

Evidence of ancient landslides or slope instability at this site was not observed during our investigation and the project site is relatively flat. Thus, the potential for landslides is considered negligible for design purposes.

# **5. CONCLUSIONS AND RECOMMENDATIONS**

## **5.1 GENERAL**

The anticipated site development appears feasible from a geotechnical viewpoint provided that the following recommendations, and those provided by this firm at a later date are incorporated into the design and construction phases of development. Site development and grading plans should be reviewed by GeoTek, Inc. when they become available.

The on-site soils exhibit “very low” to “medium” expansion potentials. Expansion index testing for near-surface soils should be conducted at the completion of earthwork operations to verify.

## **5.2 EARTHWORK CONSIDERATIONS**

Earthwork and grading should be performed in accordance with the applicable grading ordinances of the City of Orange, the 2019 California Building Code (CBC) and recommendations contained in this report. The Grading Guidelines included in Appendix D outline general procedures and do not anticipate all site-specific situations. In the event of conflict, the recommendations presented in the text of this report should supersede those contained in Appendix D.

### **5.2.1 Site Clearing & Demolition**

In areas of planned grading and improvements, the site should be cleared of vegetation and other deleterious materials. Demolition of the existing buildings and improvements should include removal of their floor slabs, foundations, pavements and any other below-grade construction. Existing utilities should be properly capped off at the property boundaries and removed or be re-routed around the new building. All debris resulting from site clearing and demolition should be properly disposed of off-site. Voids resulting from site clearing should be replaced with engineered fill following proper preparation as described in the following report sections.

### 5.2.2 Remedial Grading

Subsequent to site clearing and lowering of site grades, where necessary, all existing undocumented fill and the upper 1 foot of alluvium should be removed beneath and extending at least 5 feet beyond the planned building limits. As previously noted, USTs were previously present on-site and were reportedly removed in about 1983. No documentation has been provided to indicate that the UST excavations were backfilled with compacted engineered fill. Some localized deeper over-excavations should be expected. As a minimum, all foundations should be underlain by at least 3 feet of newly placed properly compacted engineered fill.

In other areas of the site to support new improvements, we recommend that following site clearing and prior to fill placement, the exposed soil should then be proof rolled with a heavy rubber-tired piece of construction equipment approved by and in the presence of GeoTek. The proof roll equipment should possess a minimum weight of 15 tons and proof rolling should include at least four passes, 2 in each perpendicular direction. Any soil that ruts or excessively deflects during proof rolling should be removed as recommended by the GeoTek representative.

### 5.2.3 Preparation of Excavation Bottoms

A representative of this firm should observe the bottom of all excavations. Upon approval, the exposed soils and all soils in areas to receive engineered fill should be scarified to a depth of approximately 12 inches, moistened to at least the optimum moisture content and compacted to a minimum relative compaction of 90 percent (ASTM D 1557).

### 5.2.4 Engineered Fills

The on-site soils are generally considered suitable for reuse as engineered fill provided that they are free from vegetation, debris and other deleterious material. Engineered fill should be placed in loose lifts with a thickness of eight inches or less, moisture conditioned to at least the optimum moisture content and compacted to a minimum relative compaction of 90 percent (ASTM D-1557).

### 5.2.5 Excavation Characteristics

Excavation in the on-site soils is expected to be feasible utilizing heavy-duty grading equipment in good operating condition. All temporary excavations for grading purposes and installation of underground utilities should be constructed in accordance with local and Cal-OSHA guidelines. Temporary excavations within the on-site materials should be stable at 1:1 (horizontal: vertical) inclinations for cuts less than ten feet in height.

### 5.2.6 Shrinkage and Subsidence

Several factors will impact earthwork balancing on the site, including shrinkage, subsidence, trench spoil from utilities and footing excavations, as well as the accuracy of topography.

Shrinkage and subsidence are primarily dependent upon the degree of compactive effort achieved during construction. For planning purposes, a shrinkage factor of about 5 to 15 percent may be considered for undocumented fill materials requiring removal and recompaction. A shrinkage factor of about 0 to 10 percent may be considered for excavation and recompaction of the native soils. Site balance areas should be available in order to adjust project grades, depending on actual field conditions at the conclusion of earthwork. Subsidence on the order of up to 0.10 foot may be anticipated resulting from preparation of the underlying soils.

## 5.3 DESIGN RECOMMENDATIONS

### 5.3.1 Foundation Design Criteria

Foundation design criteria for a conventional foundation system, in general conformance with the 2019 CBC, are presented below. Based on laboratory test results and the recommendations provided in this report, subsequent to earthwork operations it is anticipated that the as-graded near-surface soils may have a “very low” to “medium” expansion potential.

Additional expansion index and soluble sulfate testing of the soils should be performed during construction to evaluate the as-graded conditions. Final recommendations should be based upon the as-graded soils conditions.

A summary of our foundation design recommendations is presented in the following table:

<b>Design Parameter</b>	<b>“Very Low” to “Low” Expansion Potential</b>	<b>“Medium” Expansion Potential</b>
Foundation Depth or Minimum Perimeter Beam Depth (inches below lowest adjacent grade)	12	18
Minimum Foundation Width (Inches)*	12	12
Minimum Slab Thickness (actual) <sup>1</sup>	4 – Actual	4 – Actual
Sand Blanket and Moisture Retardant Membrane Below On-Grade Building Slabs	2 inches of sand** overlying moisture vapor retardant membrane overlying 2 inches of sand**	2 inches of sand** overlying moisture vapor retardant membrane overlying 2 inches of sand**
Minimum Slab Reinforcing	6” x 6” – W1.4/W1.4 welded wire fabric placed in middle of slab or No. 3 bars at 24 inch centers	6” x 6” – W2.9/W2.9 welded wire fabric placed in middle of slab or No. 3 bars at 18 inch centers.
Minimum Footing Reinforcement	Two No. 4 reinforcing bars, one placed near the top and one near the bottom	Four No. 4 reinforcing bars, two placed near the top and two near the bottom
Effective Plasticity Index***	N/A	18
Presaturation of Subgrade Soil (Percent of Optimum)	Minimum of 110% of the optimum moisture content to a depth of at least 12 inches prior to placing concrete	Minimum of 120% of the optimum moisture content to a depth of at least 12 inches prior to placing concrete

\* Code minimums per Table 1809.7 of the 2019 CBC.

\*\* Sand should have a sand equivalent of at least 30.

\*\*\* Effective plasticity index should be verified at the completion of rough grading.

- I. Slab thickness and reinforcement should be determined necessary by the structural engineer.

It should be noted that the criteria provided are based on soil support characteristics only. The structural engineer should design the slab and beam reinforcement based on actual loading conditions.

The following criteria for design of foundations are preliminary and should be re-evaluated based on the results of additional laboratory testing of samples obtained near finish pad grade.

An allowable bearing capacity of 2,800 pounds per square foot (psf) may be used for design of footings 12 inches deep and 12 inches wide. This value may be increased by 400 pounds per square foot for each additional 12 inches in depth and 150 pounds per square foot for each additional 12 inches in width to a maximum value of 3,500 psf. An increase of one-third may be applied when considering short-term live loads (e.g. seismic and wind loads).

Structural foundations may be designed in accordance with the 2019 CBC, and to withstand a total static settlement of 1 inch and maximum differential static settlement of one-half of the total settlement over a horizontal distance of 40 feet.

The passive earth pressure may be computed as an equivalent fluid having a density of 210 psf per foot of depth, to a maximum earth pressure of 3,000 psf for footings founded on engineered fill. A coefficient of friction between soil and concrete of 0.3 may be used with dead load forces. When combining passive pressure and frictional resistance, the passive pressure component should be reduced by one-third.

If desired, the building floor slab may be designed using an estimated subgrade modulus of 125 pci, which is based on a value typically obtained from a 1 foot by 1 foot plate bearing test. Depending on how the floor slab is loaded, the subgrade modulus may need to be geometrically modified.

A moisture and vapor retarding system should be placed below slabs-on-grade where moisture migration through the slab is undesirable. Guidelines for these are provided in the 2019 California Green Building Standards Code (CALGreen) Section 4.505.2, the 2019 CBC Section 1907.1 and ACI 360R-10. The vapor retarder design and construction should also meet the requirements of ASTM E 1643. A portion of the vapor retarder design should be the implementation of a moisture vapor retardant membrane.

It should be realized that the effectiveness of the vapor retarding membrane can be adversely impacted as a result of construction related punctures (e.g. stake penetrations, tears, punctures from walking on the vapor retarder placed on the underlying aggregate layer, etc.). These occurrences should be limited as much as possible during construction. Thicker membranes are generally more resistant to accidental puncture than thinner ones. Products specifically designed for use as moisture/vapor retarders may also be more puncture resistant. Although the CBC specifies a 6-mil vapor retarder membrane, a minimum 10 mil thick membrane with joints properly overlapped and sealed should be considered, unless otherwise specified by the slab design professional. The membrane should consist of Stego wrap or the equivalent.

A two-inch layer of clean sand with a sand equivalent of at least 30 should be placed over the moisture vapor retardant membrane to promote setting of the concrete. The moisture in the sand should not exceed two percent below the optimum moisture content.

Moisture and vapor retarding systems are intended to provide a certain level of resistance to vapor and moisture transmission through the concrete, but do not eliminate it. The acceptable level of moisture transmission through the slab is to a large extent based on the type of flooring



used and environmental conditions. Ultimately, the vapor retarding system should be comprised of suitable elements to limit migration of water and reduce transmission of water vapor through the slab to acceptable levels. The selected elements should have suitable properties (i.e. thickness, composition, strength, and permeability) to achieve the desired performance level.

Moisture retarders can reduce, but not eliminate, moisture vapor rise from the underlying soils up through the slab. Moisture retarder systems should be designed and constructed in accordance with applicable American Concrete Institute, Portland Cement Association, Post-Tensioning Concrete Institute, ASTM and California Building Code requirements and guidelines.

GeoTek recommends that a qualified person, such as a flooring contractor, structural engineer, architect, and/or other experts specializing in moisture control within the buildings be consulted to evaluate the general and specific moisture and vapor transmission paths and associated potential impact on the proposed construction. That person should provide recommendations relative to the slab moisture and vapor retarder systems and for migration of potential adverse impact of moisture vapor transmission on various components of the structures, as deemed appropriate.

In addition, the recommendations in this report and our services in general are not intended to address mold prevention, since we, along with geotechnical consultants in general, do not practice in the area of mold prevention. If specific recommendations addressing potential mold issues are desired, then a professional mold prevention consultant should be contacted.

We recommend that control joints be placed in two directions spaced approximately 24 to 36 times the thickness of the slab in inches. These joints are a widely accepted means to control cracks and should be reviewed by the project structural engineer.

### **5.3.2 Miscellaneous Foundation Recommendations**

To minimize moisture penetration beneath the slab-on-grade areas, utility trenches should be backfilled with engineered fill, lean concrete or concrete slurry where they intercept the perimeter footing or thickened slab edge.

Soils from the footing excavations should not be placed in the slab-on-grade areas unless properly compacted and tested. The excavations should be free of loose/sloughed materials and be neatly trimmed at the time of concrete placement.

### 5.3.3 Foundation Setbacks

Minimum setbacks for all foundations should comply with the 2019 CBC or City of Orange requirements, whichever is more stringent. Improvements not conforming to these setbacks are subject to the increased likelihood of excessive lateral movement and/or differential settlement. If large enough, these movements can compromise the integrity of the improvements.

- The outside top edge of all footings should be set back a minimum of  $H/3$  (where H is the slope height) from the face of any descending slope. The setback should be at least five feet and need not exceed 40 feet.
- The bottom of any proposed foundations should be deepened so as to extend below a 1:1 upward projection from the bottom edge of the nearest excavation and the bottom edge of the closest footing.

### 5.3.4 Soil Corrosivity

Based on the chemical test results presented in Appendix B, the corrosivity test results indicate that the on-site soils are “highly corrosive” to “corrosive” to buried ferrous metal. This corrosion classification is obtained from “Corrosion Basics: An Introduction,” by Pierre R. Roberge, 2<sup>nd</sup> Edition, 2000. Recommendations for protection of buried ferrous metal should be provided by a corrosion engineer. Additional corrosion testing should be performed at the time of site grading to assess the corrosion of potential of the as-graded soils.

### 5.3.5 Soil Sulfate Content

The results of chemical testing performed on three representative samples of the site soils indicate soluble sulfate contents less than 0.1 percent by weight. Soluble sulfate contents of this level would be in the range of “not applicable” per Table 4.2.1 of ACI 318. Based on the test results and Table 4.3.1 of ACI 318, special concrete mix design is not anticipated to be necessary to resist sulfate attack. Additional soluble sulfate testing should be performed during site grading to further evaluate the as-grade sulfate exposure.

### 5.3.6 Import Soils

Import soils should consist of soils similar or better than the on-site soils and should be tested for expansion and corrosivity potential prior to their use. GeoTek, Inc. should be notified a minimum of 72 hours prior to importing so that appropriate sampling and laboratory testing can be performed.

### **5.3.7 Concrete Flatwork**

#### **5.3.7.1 Exterior Concrete Slabs, Sidewalks and Driveways**

Exterior concrete slabs, sidewalks and driveways should be designed using a four-inch minimum thickness. Some shrinkage and cracking of the concrete should be anticipated as a result of typical mix designs and curing practices typically utilized in construction.

Sidewalks and driveways may be under the jurisdiction of the governing agency. If so, jurisdictional design and construction criteria would apply, if more restrictive than the recommendations presented in this report.

Subgrade soils should be pre-moistened prior to placing concrete. The subgrade soils below exterior slabs, sidewalks, driveways, etc. should be pre-saturated to a minimum of 110 percent (for “low”) or 120 percent (for “medium”) of the optimum moisture content to a depth of 12 inches.

All concrete installation, including preparation and compaction of subgrade, should be done in accordance with the City of Orange specifications, and under the observation and testing of GeoTek, Inc. and a City inspector, if necessary.

#### **5.3.7.2 Concrete Performance**

Concrete cracks should be expected. These cracks can vary from sizes that are essentially unnoticeable to more than 1/8 inch in width. Most cracks in concrete, while unsightly, do not significantly impact long-term performance. While it is possible to take measures (proper concrete mix, placement, curing, control joints, etc.) to reduce the extent and size of cracks that occur, some cracking will occur despite the best efforts to minimize it. Concrete undergoes chemical processes that are dependent on a wide range of variables, which are difficult, at best, to control. Concrete, while seemingly a stable material, is subject to internal expansion and contraction due to external changes over time.

One of the simplest means to control cracking is to provide weakened control joints for cracking to occur along. These do not prevent cracks from developing; they simply provide a relief point for the stresses that develop. These joints are a widely accepted means to control cracks but are not always effective. Control joints are more effective the more closely spaced they are. GeoTek, Inc. suggests that control joints be placed in two directions and located a distance apart approximately equal to 24 to 36 times the slab thickness.

## 5.4 RETAINING WALL DESIGN AND CONSTRUCTION

### 5.4.1 General Design Criteria

Recommendations presented in this report apply to typical masonry or concrete vertical retaining walls. These are typical design criteria and are not intended to supersede the design by the structural engineer.

Retaining wall foundations should be designed in accordance with *Section 5.3.1* of this report. A minimum foundation embedment of 12 inches into engineered compacted fill with “very low” to “low” expansion potential and 18 inches below grade for footings underlain by “medium” expansive soil is recommended. Structural needs may govern and should be evaluated by the project structural engineer.

All earth retention structure plans, as applicable, should be reviewed by this office prior to finalization.

The backfill material placement for all earth retention structures should meet the requirement of *Section 5.4.4* in this report.

In general, cantilever earth retention structures, which are designed to yield at least  $0.001H$ , where  $H$  is equal to the height of the wall to the base of the footing, may be designed using the active condition. Rigid earth retention structures (including but not limited to rigid walls, and walls braced at top, such as typical basement walls) should be designed using the at-rest condition.

In addition to the design lateral forces due to retained earth, surcharges due to improvements, such as an adjacent building or traffic loading, should be considered in the design of the earth retention structures. Loads applied within a 1:1 (h:v) projection from the surcharge on the stem of the earth retention structure should be considered in the design.

Final selection of the appropriate design parameters should be made by the designer of the earth retention structures.

### 5.4.2 Cantilevered Walls

The recommendations presented below are for cantilevered retaining walls. Active earth pressure may be used for retaining wall design, provided the top of the wall is not restrained from minor deflections. An equivalent fluid pressure approach may be used to compute the

horizontal pressure against the wall. Appropriate fluid unit weights are given below for specific slope gradients of the retained material. These do not include other superimposed loading conditions such as traffic, structures, seismic events, or adverse geologic conditions.

<b>ACTIVE EARTH PRESSURES</b>		
Surface Slope of Retained Materials (h:v)	Equivalent Fluid Pressure (pcf) Native Backfill*	Equivalent Fluid Pressure (pcf) Select Backfill**
Level	45	35
2:1	65	55

\* The design pressures assume the backfill material has an expansion index less than or equal to 50. Backfill zone includes area between the back of the wall and footing to a plane (1:1 h:v) up from the bottom of the wall foundation to the ground surface.

\*\* Select backfill to consist of soil with angle of internal friction of at least 34 degree and a very low expansion potential.

### 5.4.3 Restrained Retaining Walls

Retaining walls that will be restrained prior to placing and compacting backfill material, or that have reentrant or male corners, should be designed for an at-rest equivalent fluid pressure of 70 pcf, plus any applicable surcharge loading, for native backfill (EI<50) and level back slope condition. If backfilled with select soil (EI<20), the walls may be designed for an at-rest pressure of 55 pcf. For areas of male or reentrant corners, the restrained wall design should extend a minimum distance of twice the height of the wall laterally from the corner, or a distance otherwise determined by the project structural engineer.

### 5.4.4 Retaining Wall Backfill and Drainage

Retaining wall backfill should consist of materials with expansion index (EI) ≤ 20 or <50, dependent upon what design value is used, and free of deleterious and/or oversized materials. The wall backfill should also include a minimum one-foot wide section of ¾- to 1-inch clean crushed rock (or approved equivalent). The rock should be placed immediately adjacent to the back of wall and extend up from the back drain to within approximately 12 inches of finish grade. The upper 12 inches should consist of compacted onsite materials. Presence of other materials might necessitate revision to the parameters provided and modification of wall designs. The backfill materials should be placed in lifts no greater than 8-inches in thickness and compacted to a minimum of 90 percent relative compaction in accordance with ASTM Test Method D 1557. Proper surface drainage needs to be provided and maintained. Bracing of the walls during backfilling and compaction may also be necessary.

All earth retention structures should be provided with an adequate pipe and gravel back drain system to reduce the potential for hydrostatic pressure build up. As a minimum, backdrains should consist of a four-inch diameter perforated collector pipe (Schedule 40, SDR 35, or approved equivalent) embedded in a minimum of one cubic foot per lineal foot of ¾- to 1-inch clean crushed rock or equivalent, wrapped in filter fabric (Mirafi 140N or approved equivalent). The drain system should be connected to a suitable outlet, as determined by the civil engineer. Drain outlets should be maintained over the life of the project and should not be obstructed or plugged by adjacent improvements. Waterproofing of site walls should be performed where moisture migration through the wall is undesirable.

Proper surface drainage needs to be provided and maintained. Water should not be allowed to pond behind retaining walls. Waterproofing of site walls should be performed where moisture migration through the wall is undesirable.

## 5.5 INFILTRATION TEST RESULTS

Field percolation testing was performed on March 10 and 11, 2020. Percolation rates obtained from the infiltration testing were converted to a field infiltration rate using the Porchet Method. The field infiltration rates calculated are indicated in the following table:

<b>SUMMARY OF FIELD INFILTRATION RATES</b>			
Boring/Area	Depth of Test (Feet)	Material Encountered at Depth of Test	Field Infiltration Rate (Inches per Hour)
I-1	6	Clayey Silt to Silty Clay	0.02
I-2	7	Clayey Silt	0.02
I-3	8	Clayey Silt	0.02
I-4	6	Clayey Silt	0.02

The percolation data sheets and infiltration conversion worksheets are presented in Appendix C. The field infiltration rates presented above do not incorporate a safety factor. The civil engineer should assign a suitable safety factor to these values prior to determining the design infiltration rate.

In addition, over the lifetime of the detention or retention basin, the infiltration rates may be affected by silt build up and biological activities, as well as local variations in near surface soil conditions. A suitable factor of safety should be applied to the field rates to design the infiltration system.

It should be noted that the infiltration rates provided above were performed in relatively undisturbed native soils. Infiltration rates will vary and are mostly dependent on the underlying consistency of the site soils and relative density. Infiltration rates will be impacted by weight of equipment travelling over the soils, placement of engineered fill and other various factors. GeoTek, Inc. assumes no responsibility or liability for the ultimate design or performance of the storm water facility.

## 5.6 PRELIMINARY PAVEMENT DESIGN

### Asphalt Pavements

Preliminary pavement design for areas to receive new asphalt pavements was conducted per Caltrans *Highway Design Manual* guidelines for flexible pavements. Two representative samples of the near surface subgrade in the future pavement improvement areas were collected and submitted to our subconsultant (LaBelle•Marvin) to determine the resistance value (R-value) of the collected samples. These tests were performed in accordance with California Test Method 301 and those results are provided in Appendix B. Assumed Traffic Indices (TIs) of 5.0, 8.0 and 10.0 were utilized for light, medium and heavy-duty pavement areas, respectively.

The R-value results indicated an R-value for the silty sand soils of 71 and an R-value for the clayey silt soils of 13. Since it is not currently known what soils will be present at the subgrade elevation following site grading, we have provided preliminary pavement thickness recommendations based on the R-value of 13. Based on these preliminary assumptions, the following preliminary sections were calculated:

<b>GEOTECHNICAL RECOMMENDATION FOR MINIMUM PAVEMENT SECTION</b>		
Traffic Index	Thickness of Asphalt Concrete (inches)	Thickness of Aggregate Base (inches)
5.0	3	8-½
8.0	5	15-½
10.0	5	22-½

All base material and the upper 12 inches of subgrade should be compacted to at least 95 percent of the material's maximum dry density, per ASTM D-1557.

Traffic Indices (TIs) used in our preliminary pavement design are considered reasonable values for the proposed pavement areas and should provide a pavement life of approximately 20 years with a normal amount of flexible pavement maintenance. Irrigation adjacent to pavements, without a deep curb or other cutoff to separate landscaping from the paving may result in premature pavement failure. Traffic parameters used for preliminary design were selected based

upon engineering judgment and not upon information furnished to us such as an equivalent wheel load analysis or a traffic study. We recommend that final pavement design be based on R-value testing of the subgrade soils along with the assigned TI values for the planned pavement areas.

Asphalt concrete and aggregate base should conform to current Caltrans Standard Specifications Section 39 and 26-1.02, respectively. As an alternative, asphalt concrete can conform to Section 203-6 of the current Standard Specifications for Public Work (Green Book). Crushed aggregate base or crushed miscellaneous base can conform to Section 200-2.2 and 200-2.4 of the Green Book, respectively.

All pavement installation, including preparation and compaction of subgrade, compaction of base material, placement and rolling of asphaltic concrete, should be done in accordance with the City of Orange specifications, and under the observation and testing of GeoTek and a City Inspector where required. Jurisdictional minimum compaction requirements in excess of the aforementioned minimums may govern.

Concrete Pavements

We understand that Portland Cement concrete (PCC) pavements will also be used for select pavement areas for the site. For this preliminary design we have utilized a subgrade modulus of 75 kci, which is considered to be approximately equivalent to an R-value of 13. PCC design is based on equivalent 18-kip single axle loads (ESAL). In our analysis we have utilized ESAL values of 8,000, 380,000 and 2,500,000 ESAL for light duty, medium duty and heavy-duty pavement areas. The ESAL values noted are approximately equivalent to TI values of 5.0, 8.0 and 10.0, respectively. The design thicknesses presented below are also based on design procedures from the Portland Cement Association (PCA, 1966). Based on these assumptions, the following preliminary PCC pavement thickness are recommended.

<b>Light Duty Pavement (PCC/AB)</b>	<b>Medium Duty Pavement (PCC/AB)</b>	<b>Heavy Duty Pavement (PCC/AB)</b>
6”/4”	7”/4”	7-½”/4”
6-½”/no base	7-½”/no base	8”/no base

PCC-Portland Cement Concrete

AB-Aggregate Base

We have based this preliminary analysis on a minimum 28-day concrete compressive strength of 4,000 psi. All base material and the upper 12 inches of subgrade should be compacted to at least 95% of the material/s maximum dry density, per ASTM D 1557.





PCC pavements can be designed as jointed plain (unreinforced), with or without dowels for load transfer, or as jointed reinforced pavement. In general, the use of reinforcement typically allows for a wider, or longer, joint spacing, but the reinforcement does not increase the structural capacity of the pavement. In accordance with AASHTO design procedures, the maximum joint spacing for unreinforced pavement is two times the thickness of the pavement (i.e. for a 6-inch thick pavement, the maximum joint spacing is 12 feet). It should be noted that a larger joint spacing is possible for concrete with maximum aggregate sizes of  $\frac{3}{4}$ -inch and larger and for concrete with slumps less than 4 to 6 inches. Traffic should not be allowed on the finished pavement until the concrete has attained the minimum compressive strength. Final PCC design should be provided upon completion of rough grading based on R-value tests on the as-graded soils and the assigned TI (or ESAL) values determined by others.

## **5.7 POST CONSTRUCTION CONSIDERATIONS**

### **5.7.1 Landscape Maintenance and Planting**

Water has been shown to weaken the inherent strength of soil, and slope stability is significantly reduced by overly wet conditions. Positive surface drainage away from graded slopes should be maintained and only the amount of irrigation necessary to sustain plant life should be provided for planted slopes. Controlling surface drainage and runoff and maintaining a suitable vegetation cover can minimize erosion. Plants selected for landscaping should be lightweight, deep-rooted types that require little water and are capable of surviving the prevailing climate.

Overwatering should be avoided. An abatement program to control ground-burrowing rodents should be implemented and maintained. Burrowing rodents can decrease the long-term performance of slopes.

It is common for planting to be placed adjacent to structures in planter or lawn areas. This will result in the introduction of water into the ground adjacent to the foundations. This type of landscaping should be avoided.

### **5.7.2 Drainage**

Positive site drainage should be maintained at all times. Drainage should not flow uncontrolled down any descending slope. Water should be directed away from foundations and not allowed to pond or seep into the ground adjacent to the footings and floor-slabs. Pad drainage should be directed toward approved areas and not be blocked by other improvements.

Roof gutters should be installed that will direct the collected water at least 20 feet from the buildings.

## 5.8 PLAN REVIEW AND CONSTRUCTION OBSERVATIONS

We recommend that specifications and foundation plans be reviewed by this office prior to construction to check for conformance with the recommendations of this report. We also recommend that GeoTek, Inc. representatives be present during site grading and foundation construction to observe and document proper implementation of the geotechnical recommendations. The owner/developer should verify that GeoTek, Inc. representatives perform at least the following duties:

- Observe site clearing and grubbing operations for proper removal of unsuitable materials.
- Observe and test bottom of removals prior to fill placement.
- Evaluate the suitability of on-site and import materials for fill placement and collect soil samples for laboratory testing where necessary.
- Observe the fill for uniformity during placement, including utility trench backfill. Also, perform field density testing of the fill materials.
- Observe and probe foundation excavations to confirm suitability of bearing materials with respect to density.

If requested, a construction observation and compaction report can be provided by GeoTek, Inc. which can comply with the requirements of the governmental agencies having jurisdiction over the project. We recommend that these agencies be notified prior to commencement of construction so that necessary grading permits can be obtained.

## 6. INTENT

It is the intent of this report to aid in the design and construction of the proposed development. Implementation of the advice presented in this report is intended to reduce risk associated with construction projects. The professional opinions and geotechnical advice contained in this report are not intended to imply total performance of the project or guarantee that unusual or variable conditions will not be discovered during or after construction.

The scope of our evaluation is limited to the boundaries of the subject property. This review does not and should in no way be construed to encompass any areas beyond the specific area of the proposed construction as indicated to us by the client. Further, no evaluation of any existing



site improvements is included. The scope is based on our understanding of the project and geotechnical engineering standards normally used on similar projects in this locality.

## **7. LIMITATIONS**

Our findings are based on site conditions observed and the stated sources. Thus, our comments are professional opinions that are limited to the extent of the available data.

GeoTek has prepared this report in a manner consistent with that level of care and skill ordinarily exercised by members of the engineering and science professions currently practicing under similar conditions in the jurisdiction in which the services are provided, subject to the time limits and physical constraints applicable to this report.

Since our recommendations are based on the site conditions observed and encountered, and laboratory testing, our conclusions and recommendations are professional opinions that are limited to the extent of the available data. Observations during construction are important to allow for any change in recommendations found to be warranted. These opinions have been derived in accordance with current standards of practice and no warranty of any kind is expressed or implied. Standards of care/practice are subject to change with time.

## **8. SELECTED REFERENCES**

American Concrete Institute (ACI), 2006, Publication 302.2R-06, Guide for Concrete Slabs That Receive Moisture Sensitive Flooring Materials.

\_\_\_\_\_, 2010, Publications 360R-10, Guide to Design of Slabs-On-Ground.

American Society of Civil Engineers (ASCE), 2013, "Minimum Design Loads for Buildings and Other Structures," ASCE/SEI 7-10, Third Printing, Errata Incorporated through March 15.

Bowles, J. E., 1977, "Foundation Analysis and Design", Second Edition.

Bryant, W.A., and Hart, E.W., 2007, "Fault Rupture Hazard Zones in California, Alquist-Priolo Earthquake Fault Zoning Act with Index to Earthquake Fault Zones Maps," California Geological Survey: Special Publication 42.

California Code of Regulations, Title 24, 2019, Part 2, “California Building Code,” 2 volumes.

CGS, 1997, “Seismic Hazard Zone Report for the Orange Quadrangle”, January 1.

Department of the Navy, 1982, “Foundations and Earth Structures”, Design Manual 7.2.

GeoTek, Inc., In-house proprietary information.

Morton, D.M. and Miller, F.K., 2006, “Geologic Map of the San Bernardino and Santa Ana 30’ x 60’ Quadrangles, California,” U.S. Geological Survey OF-2006-1217, scale 1:100,000.

Portland Cement Association (PCA), 1966, “Thickness Design for Concrete Pavements”.

Roberge, P. R., 2000, “Corrosion Basics: An Introduction”, second edition.

SEA/OSHPD web service, “Seismic Design Maps” (<https://seismicmaps.org>)

Southern California Earthquake Center (SCEC), 1999, Martin, G. R., and Lew, M., ed., “Recommended Procedures for Implementation of DMG Special Publication 117, Guidelines for Analyzing and Mitigating Liquefaction Hazards in California,”, dated March 1999.

State of California, California Geological Survey (CGS, formerly referred to as the California Division of Mines and Geology), 2008, “Guidelines for Evaluating and Mitigating Seismic Hazards in California,” Special Publication 117A.

Terzaghi, K and Peck, R. B., 1967, “Soil Mechanics in Engineering Practice”, second edition.

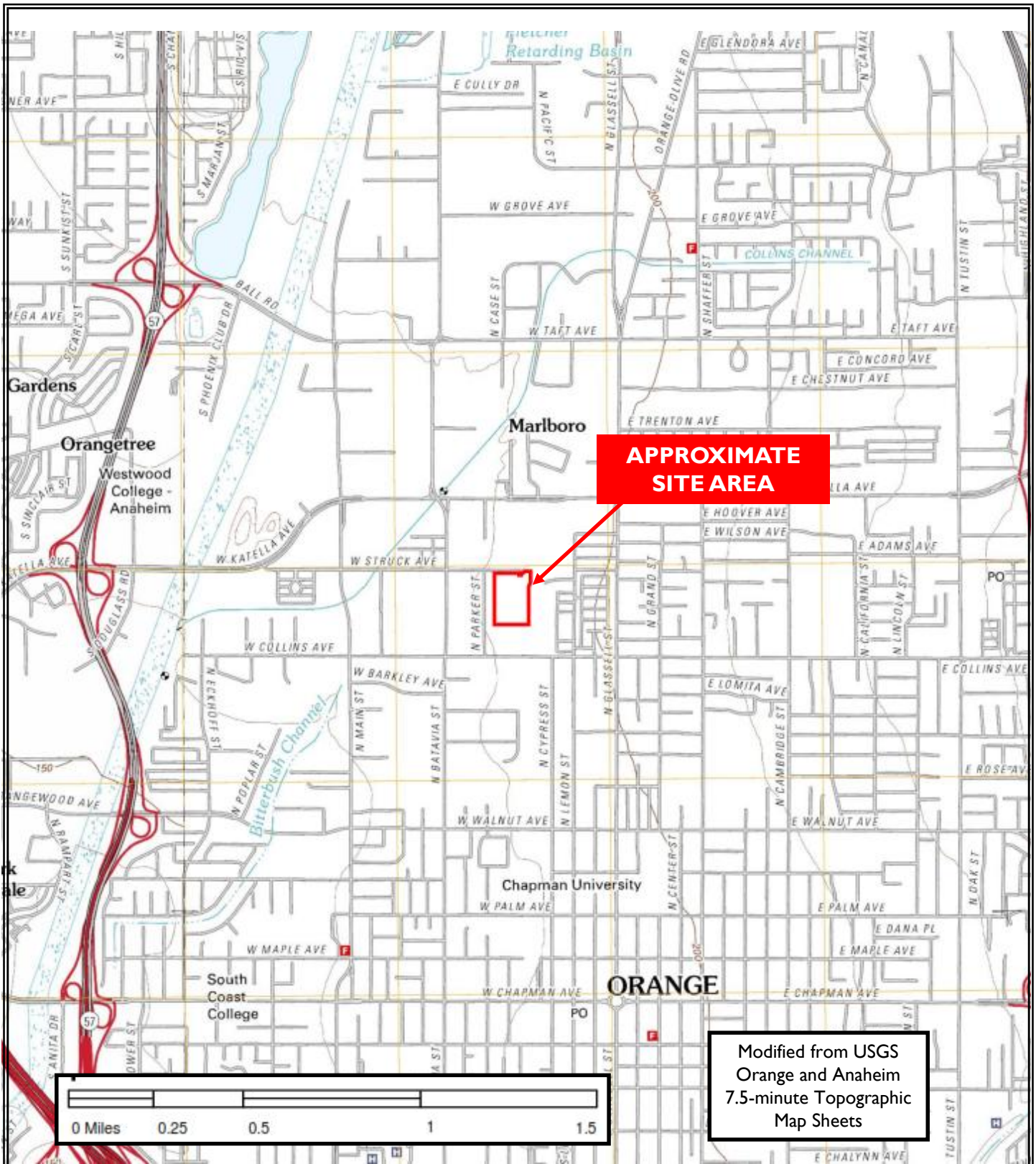

**ProLogis**  
 534 West Struck Street  
 Orange, Orange County, California

Project No. 2361-CR



**Figure 1**

**Site Location  
 and  
 Topography  
 Map**



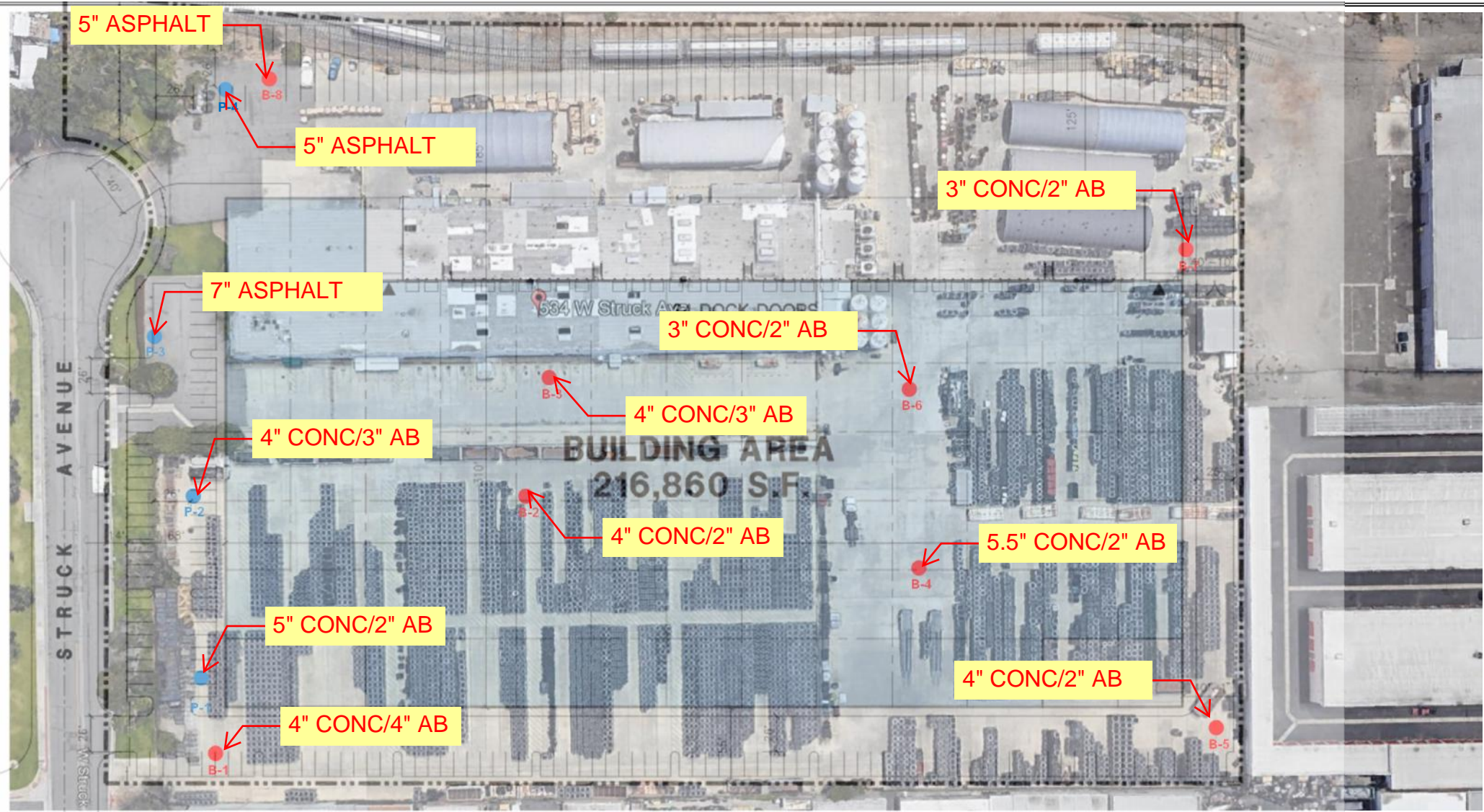

- B-8 - Exploratory Boring
- P-4 - Percolation Boring



Prologis  
534 West Struck Avenue  
Oraneg, Orange County, California

Project No. 2361-CR



**Plate I**  
Exploration Location  
Map

# **APPENDIX A**

## **GEOPHYSICAL SURVEY AND LOGS OF EXPLORATORY BORINGS**

**Proposed Warehouse Facility  
City of Orange, Orange County, California  
Project No. 2361-CR**



## A - FIELD TESTING AND SAMPLING PROCEDURES

### The Modified Split-Barrel Sampler (Ring)

The Ring sampler is driven into the ground in accordance with ASTM Test Method D 3550. The sampler, with an external diameter of 3.0 inches, is lined with 1-inch long, thin brass rings with inside diameters of approximately 2.4 inches. The sampler is typically driven into the ground 12 or 18 inches with a 140-pound hammer free falling from a height of 30 inches. Blow counts are recorded for every 6 inches of penetration as indicated on the log of boring. The samples are removed from the sample barrel in the brass rings, sealed, and transported to the laboratory for testing.

### Bulk Samples (Large)

These samples are normally large bags of earth materials over 20 pounds in weight collected from the field by means of hand digging or exploratory cuttings.

### Bulk Samples (Small)

These are plastic bag samples which are normally airtight and contain less than 5 pounds in weight of earth materials collected from the field by means of hand digging or exploratory cuttings. These samples are primarily used for determining natural moisture content and classification indices.

## B – BORING/TRENCH LOG LEGEND

The following abbreviations and symbols often appear in the classification and description of soil and rock on the logs of borings/trenches:

### SOILS

USCS	Unified Soil Classification System
f-c	Fine to coarse
f-m	Fine to medium

### GEOLOGIC

B: Attitudes      Bedding: strike/dip

J: Attitudes      Joint: strike/dip

C: Contact line

.....	Dashed line denotes USCS material change
————	Solid Line denotes unit / formational change
————	Thick solid line denotes end of boring/trench

(Additional denotations and symbols are provided on the log of borings/trenches)





March 8, 2020

**GeoTek, Inc.**  
1548 North Maple Street  
Corona, CA 90501

Project No. 20-120

Attn: Kyle R. McHargue, P.G.

Re: Geophysical Investigation, Nursery Supplies Plant, 534 Struck Avenue, Orange, California

This report is to present the results of our geophysical survey carried out over the Nursery Supplies Plant property located at 534 Struck Avenue in Orange, California (Figure 1). The survey was performed on March 5, 2020, and its purpose was to locate and identify, insofar as possible, the existence of any pipes, conduits, utilities, and other underground obstructions within the vicinity of twelve (12) proposed boreholes scheduled for drilling.

A combination of electromagnetic induction (EM), magnetometry, and ground penetrating radar (GPR) were brought to the field with anticipation of use. Utility locators with line tracing capabilities were also used where applicable.

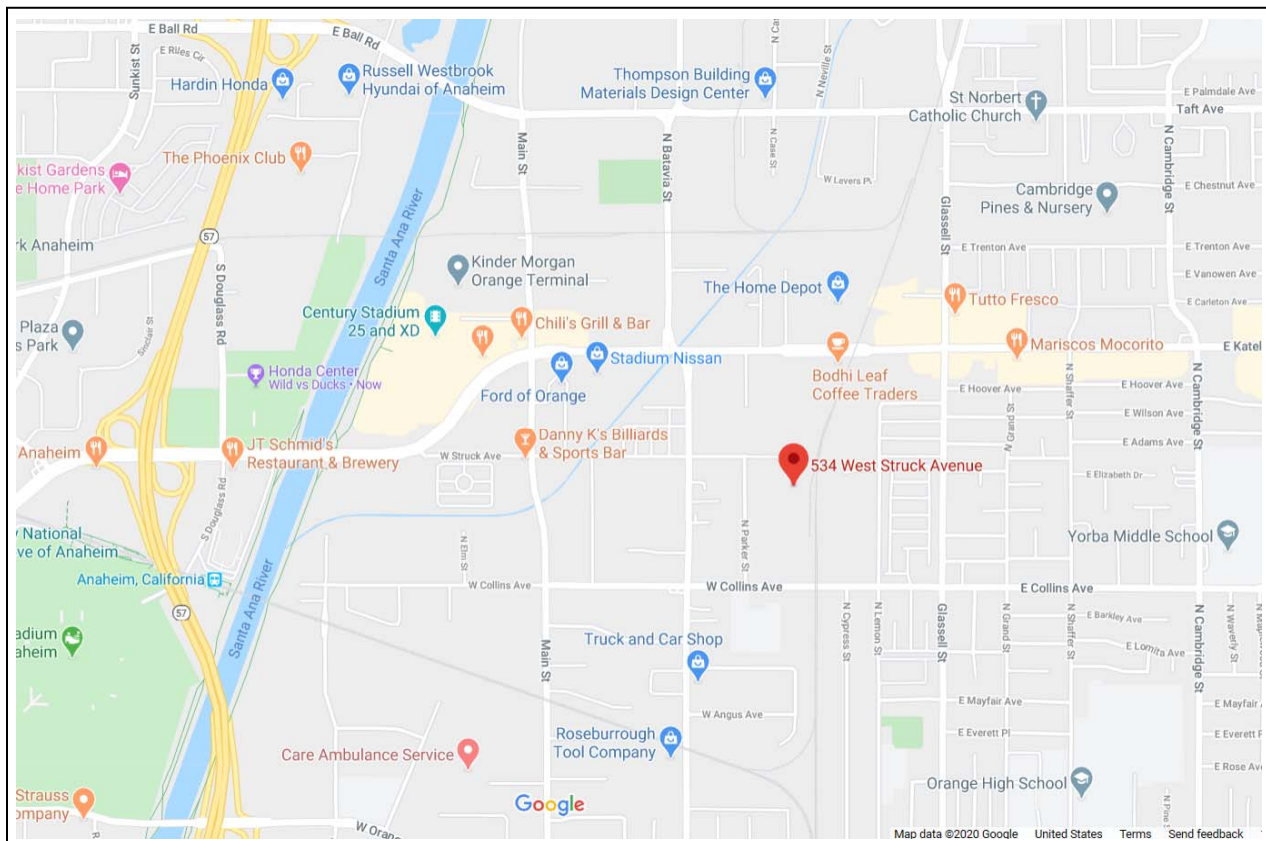

**FIGURE 1 – Site location map**

**Survey Design** – The areas to be surveyed were identified in the field by the client. It included twelve (12) proposed boreholes placed in various locations on an asphalt/concrete surfaced parking lot and landscaping.

In site situations and survey objectives such as this, the best use of time is achieved by systematically free-traversing with the instruments while monitoring them continuously to determine which responses are significant and due to true subsurface targets, and which are due to other non-target or above-ground features and must be ignored. Where applicable, the EM devices, magnetic gradiometer, and GPR were traversed systematically over the survey areas in multiple, organized directions. Other traverses were taken for detailing and confirmation where anomalous conditions were found.

In addition, the line tracers were used to impress signals onto pipes, generally through accessible risers and tracer wires when present, to delineate the lines' locations and orientations. The instruments were also used in passive mode, configured to detect 60 Hz electrical signals and other common radio-frequency signals.

Hard copy of the EM data was not acquired, that is, discrete readings on the nodes of a grid were not recorded that could be put into a contoured map format. Rather, the instruments' meters were read continuously, and in real-time, during each traverse. This free-traversing method allowed for immediate detection of anomalous objects and facilitated the opportunity to investigate them further, without the need to first download and process data in the office. The lack of hard copy for EM data sets does not degrade the quality of the survey in any way. Hard copy merely provides a basis for report documentation of these geophysical fields, if such documentation is needed.

A Fischer M-Scope was used for the EM sampling and a Sensors & Software Noggin Ground Penetrating Radar unit with a 500 MHz antenna produced the radar images. A Metrotech 9890 and RIDGID SR-60 SeekTech utility locator rounded out the tools applied.

**Brief Description of the Geophysical Methods Applied** – The M-Scope device energizes the ground by producing an alternating primary magnetic field with AC current in a transmitting coil. If conducting materials are within the area of influence of the primary field, AC eddy currents are induced to flow in the conductors. A receiving coil senses the secondary magnetic field produced by these eddy currents, and outputs the response as anomalous conditions. The strength of the secondary field is a function of the conductivity of the object, say a pipe, tank or cluster of drums, its size, and its depth and position relative to the instrument's two coils. Conductive objects, to a depth of approximately 7 feet below ground surface (bgs) for the M-Scope are sensed. The device is also somewhat focused; that is, it is more sensitive to conductors below the instrument than they are to conductors off to the side.

The line locator is used to passively detect energized high voltage electric lines and electrical conduit (50-60 Hz), VLF signals (14-22 kHz), as well as to actively trace other utilities. Where risers are present, the utility locator transmitter can be connected directly to the object, and a signal (9.8-82 kHz) is sent traveling along the conductor, pipe, conduit, etc. In the absence of a riser, the transmitter can be used to impress an input signal on the utility by induction. In either case, the receiver unit is tuned to the input signal, and is used to actively trace the signal along the pipe's surface projection.

The GPR instrument beams energy into the ground from its transducer/antenna, in the form of electromagnetic waves. A portion of this energy is reflected back to the antenna at a boundary in the subsurface across which there is an electrical contrast. The instrument produces a continuous record of the reflected energy as the antenna is traversed across the ground surface. The greater the electrical

contrast, the higher the amplitude of the returned energy. The radar wave travels at a velocity unique to the material properties of the ground being investigated, and when these velocities are known, the two-way travel times can be converted to depth. The depth of penetration and image resolution produced are a function of ground electrical conductivity and dielectric constant.

**Interpretation and Conclusions** - The interpretation took place in real time as the survey progressed, and accordingly, the findings of our investigation were verbally relayed to the client, and further documented with site photographs (Figures 2-13).

Utilities detected were marked out in chalk spray paint using red for electric and white for rebar and unknown piping.

Once completed, the proposed boreholes were spray painted white with a white circle and a yellow "SSS" to indicate they had been investigated by Subsurface Surveys personnel. Please refer to the attached photos for location and orientation of items detected in the survey.

**Limitations and Further Recommendations** - It should be understood that limitations inherent in geophysical instruments and/or surveying techniques exist at all sites, and nearly all sites exhibit conditions under which such might not perform optimally. Consequently, the detection of buried objects in all circumstances **cannot be guaranteed**. Such limitations are numerous and include, but are not limited to, rebar-reinforced ground cover, abrupt changes in ground cover type, above-ground obstacles preventing full traverses or traverses in one direction only, above-ground conductive objects interfering with instrument signal, nearby power lines or EM transmitters, highly conductive background soil conditions, limited GPR penetration, non-metallic targets, shallower or larger objects shielding deeper or smaller targets, tracing signal jumping from one line to another, and inaccessible risers, cleanouts, valve boxes, and manholes. If one or more geophysical instrument is rendered ineffective and cannot be utilized, the quality of the survey can be somewhat degraded.

For the above reasons, and in the interest of maximum safety, we encourage our clients to take advantage of Underground Service Alert (USA), Dig Alert, or other similar services, when possible. Furthermore, we recommend hand auguring and the use of a drilling method known as air knifing or vacuum extraction, when feasible or if applicable to this project. These methods may significantly limit damage to underground pipes, conduits, and utilities that might not have been detectable during the course of this survey. Please bear in mind, that geophysical surveying is only one of several levels of protection that is available to our clients.

SubSurface Surveys may include maps in some reports. While they are an accurate general representation of the site and our findings, they are not of engineering quality (i.e., measured and mapped by a licensed land surveyor).

SubSurface Surveys and Associates makes no guarantee either expressed or implied regarding the accuracy of the findings and interpretations present. And, in no event will SubSurface Surveys and Associates be liable for any direct, indirect, special, incidental, or consequential damages resulting from interpretations and opinions presented herewith.

All data generated on this project are in confidential file in this office and are available for review by authorized persons at any time. The opportunity to participate in this investigation is very much appreciated. Please call, if there are questions.



Daniel L. Matticks, MS  
Staff Geophysicist



Travis Crosby, GP# 1044  
Senior Geophysicist

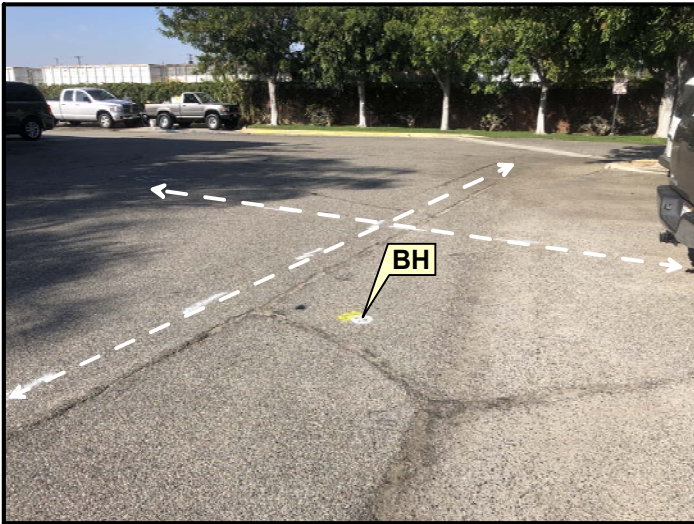

Figure 2

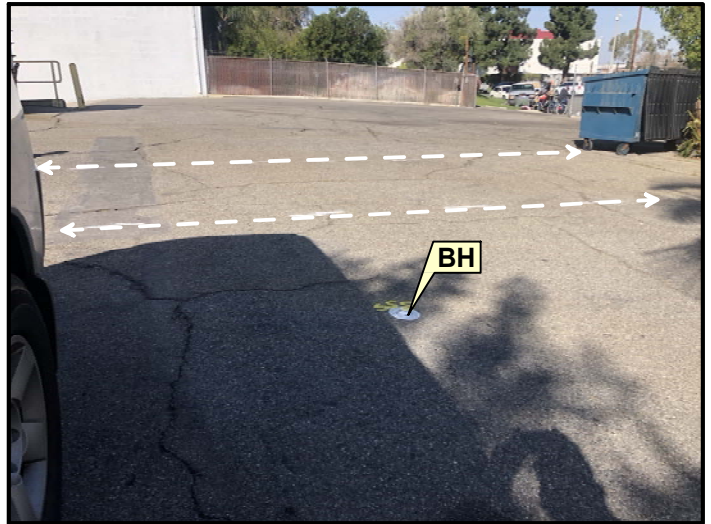

Figure 3



Figure 4

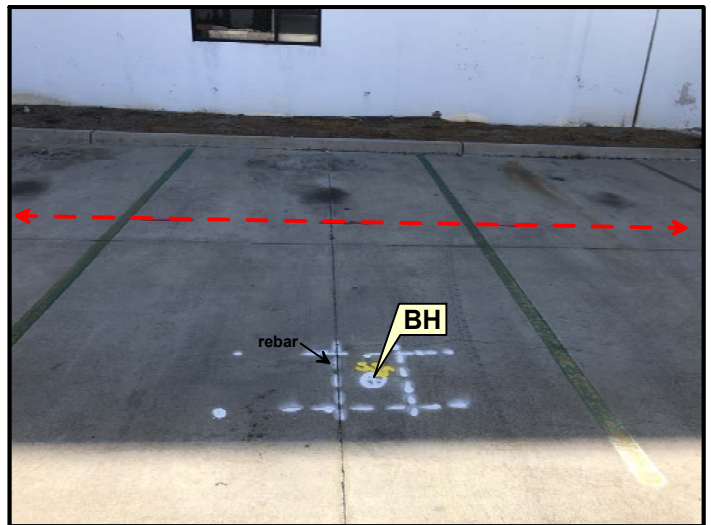

Figure 5



Figure 6

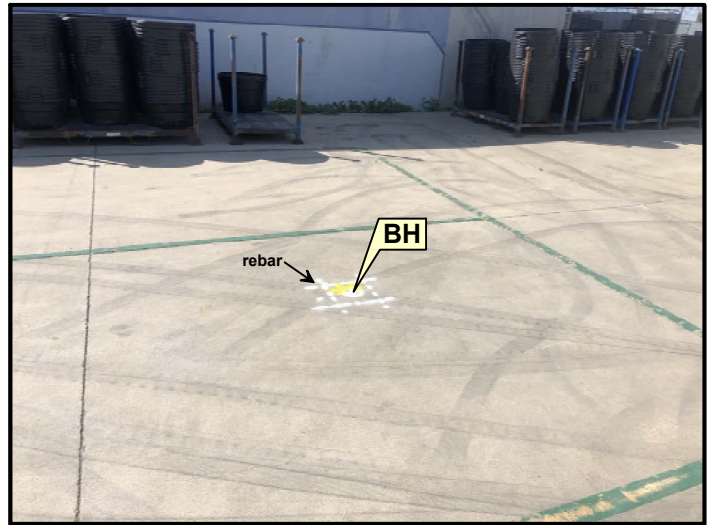

Figure 7



SITE:  
Nursery Supplies Plant  
534 Struck Avenue  
Orange, California

TITLE:  
Borehole Photographs  
PREPARED FOR:  
GeoTek, Inc

SURVEY DATE:  
March 5, 2020  
SSS PROJECT NO:  
20-120

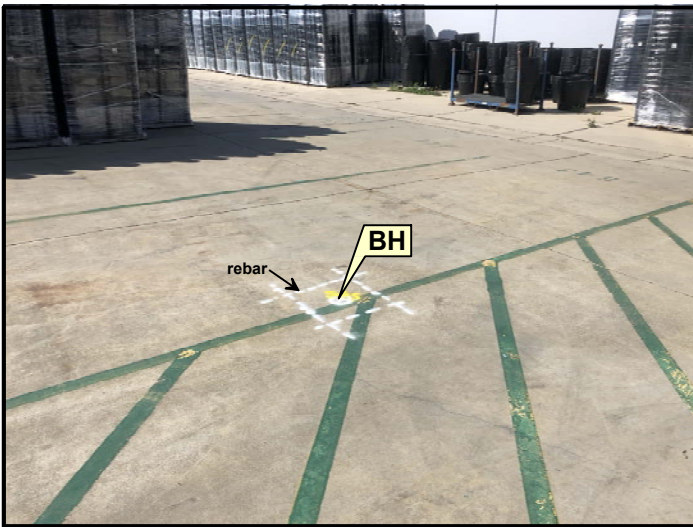

**Figure 8**

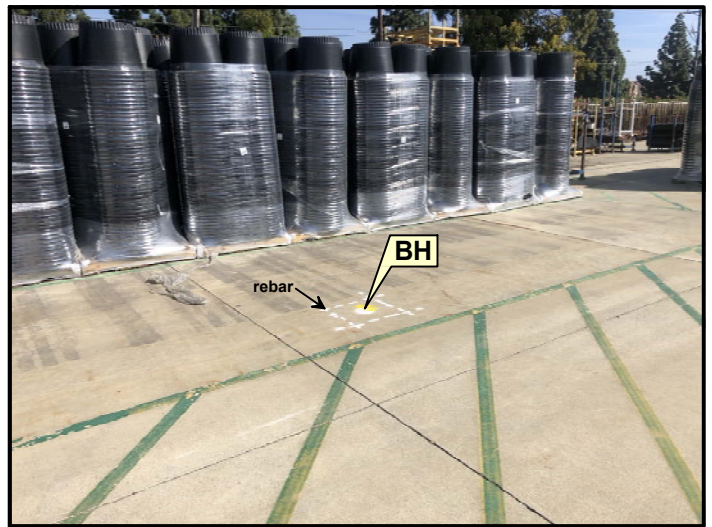

**Figure 9**

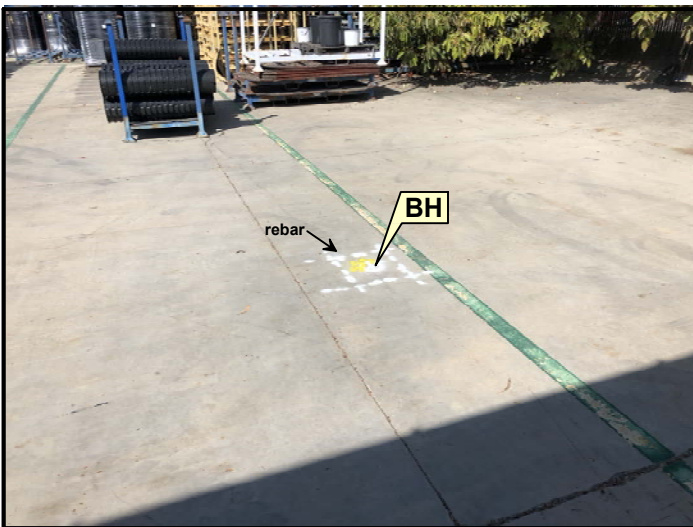

**Figure 10**

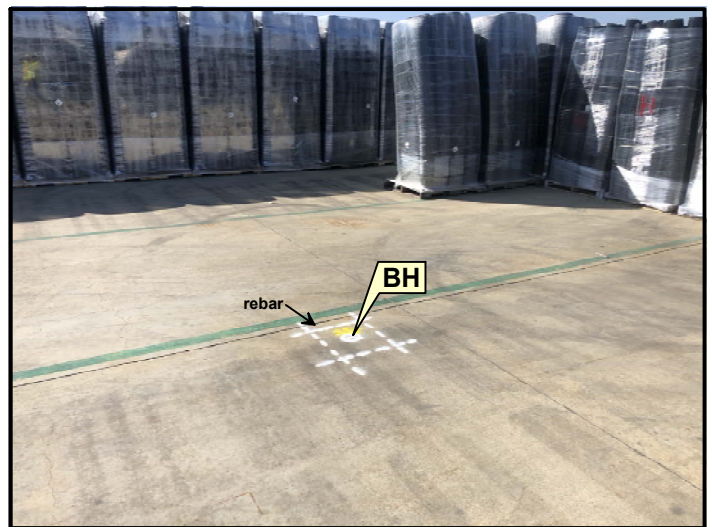

**Figure 11**

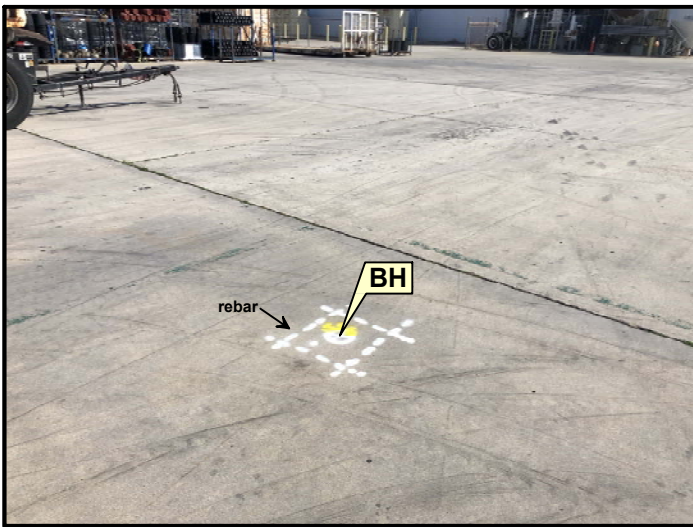

**Figure 12**



**Figure 13**



SITE:  
**Nursery Supplies Plant**  
**534 Struck Avenue**  
**Orange, California**

TITLE:  
**Borehole Photographs**

PREPARED FOR:  
**GeoTek, Inc**

SURVEY DATE:  
**March 5, 2020**

SSS PROJECT NO:  
**20-120**

**GeoTek, Inc.**  
**LOG OF EXPLORATORY BORING**

**CLIENT:** ProLogis  
**PROJECT NAME:** 534 Struck Avenue  
**PROJECT NO.:** 2361-CR  
**LOCATION:** See Boring Location Map

**DRILLER:** 2R Drilling Inc.  
**DRILL METHOD:** Hollow stem Auger  
**HAMMER:** 140lbs/30in.

**LOGGED BY:** DRW  
**OPERATOR:** Miguel  
**RIG TYPE:** CME 75  
**DATE:** 3/9/2020

Depth (ft)	SAMPLES			USCS Symbol	<b>BORING NO.: B-1</b>	Laboratory Testing		
	Sample Type	Blows / 6 in	Sample Number			Water Content (%)	Dry Density (pcf)	Others
<b>MATERIAL DESCRIPTION AND COMMENTS</b>								
					<b>4" Concrete over 4" CAB</b>			
				ML	<b>Undocumented fill:</b> Clayey SILT, dark brown, moist, trace fine to coarse grained sand	16.0	119.0	SH, EI, MD, SR EI = 59
				CL/ML	<b>Older Alluvial Fan Deposits:</b> Silty CLAY to clayey SILT, light reddish brown, moist, stiff			
5		11 15 16		CL	F sandy CLAY, light brown, moist, very stiff, trace coarse grained sand	13.4	124.8	Collapse
		7 11 12			Sandy CLAY, light reddish brown, slightly moist to moist, stiff			
10		12 17 20			Same as above, very stiff	13.3	121.4	AL LL=35; PL=17; PI=18
15		7 9 8			Clayey SILT, light brown, moist, stiff, trace very fine to fine grained sand			
					Silty CLAY, brown, moist to very moist, very stiff			
20		50/6"		SC	Clayey f-c SAND, grayish brown, moist, very dense, few gravel			
					<b>BORING TERMINATED AT 20.5 FEET</b>			
					No groundwater encountered Boring backfilled with soil cuttings			
25								
30								

<b>LEGEND</b>	<b>Sample type:</b>	---Ring	---SPT	---Small Bulk	---Large Bulk	---No Recovery	---Water Table	
	<b>Lab testing:</b>	AL = Atterberg Limits	EI = Expansion Index	SA = Sieve Analysis	RV = R-Value Test	SR = Sulfate/Resistivity Test	SH = Shear Test	HC = Consolidation

**GeoTek, Inc.**  
**LOG OF EXPLORATORY BORING**

**CLIENT:** ProLogis  
**PROJECT NAME:** 534 Struck Avenue  
**PROJECT NO.:** 2361-CR  
**LOCATION:** See Boring Location Map

**DRILLER:** 2R Drilling Inc.  
**DRILL METHOD:** Hollw stem Auger  
**HAMMER:** 140lbs/30in.

**LOGGED BY:** DRW  
**OPERATOR:** Miguel  
**RIG TYPE:** CME 75  
**DATE:** 3/9/2020

Depth (ft)	SAMPLES			USCS Symbol	<b>BORING NO.: B-2</b>	Laboratory Testing		
	Sample Type	Blows / 6 in	Sample Number			Water Content (%)	Dry Density (pcf)	Others
<b>MATERIAL DESCRIPTION AND COMMENTS</b>								
					<b>4" Concrete over 2" CAB</b>			
					<b>Undocumented fill:</b>			
		5 10 20		SC	Clayey f-c SAND, dark brown, moist, medium dense, few gravel	8.1	121.6	
					<b>Older Alluvial Fan Deposits:</b>			
5		22 50/5"		SP	Gravelly f-c SAND, dark reddish brown, moist, very dense, trace clay	8.0		
		35 50/6"			Same as above	5.2		
10		40 50/2"		SP/GP	Gravelly f-c SAND to f-c sandy GRAVEL, grayish brown, slightly moist to moist, very dense, some cobbles			
					<b>BORING TERMINATED AT 11 FEET (REFUSAL)</b>			
					No groundwater encountered Boring backfilled with soil cuttings			
15								
20								
25								
30								

<b>LEGEND</b>	<b>Sample type:</b>	---Ring	---SPT	---Small Bulk	---Large Bulk	---No Recovery	---Water Table	
	<b>Lab testing:</b>	AL = Atterberg Limits	SR = Sulfate/Resistivity Test	EI = Expansion Index	SH = Shear Test	SA = Sieve Analysis	HC = Consolidation	RV = R-Value Test



**GeoTek, Inc.**  
**LOG OF EXPLORATORY BORING**

**CLIENT:** ProLogis  
**PROJECT NAME:** 534 Struck Avenue  
**PROJECT NO.:** 2361-CR  
**LOCATION:** See Boring Location Map

**DRILLER:** 2R Drilling Inc.  
**DRILL METHOD:** Hollow stem Auger  
**HAMMER:** 140lbs/30in.

**LOGGED BY:** DRW  
**OPERATOR:** Miguel  
**RIG TYPE:** CME 75  
**DATE:** 3/9/2020

Depth (ft)	SAMPLES			USCS Symbol	BORING NO.: B-3	Laboratory Testing		
	Sample Type	Blows / 6 in	Sample Number			Water Content (%)	Dry Density (pcf)	Others
MATERIAL DESCRIPTION AND COMMENTS								
					<b>4" Concrete over 3" CAB</b>			
					<b>Undocumented fill:</b>			MD, SR
		10 14 19		SC	Clayey f-c SAND, dark brown, moist, medium dense, some gravel, trace plastic debris			
					<b>Older Alluvial Fan Deposits:</b>			
5		20 30 40		SP	Gravelly f-c SAND, brown to grayish brown, moist, dense, trace clay	3.7	129.8	
		26 38 50		GC	Clayey sandy GRAVEL, brown, moist, very dense	4.2	114.8	
10		38 50/5"		SP	Gravelly f-c SAND, grayish brown, moist, very dense, trace clay			
15		33 50/5"		GP	F-c sandy GRAVEL, grayish brown, moist, very dense			
20		7 15 22		CL	Silty CLAY, dark reddish brown, moist, very stiff			
				GC	Clayey sandy GRAVEL, grayish brown, moist			
25		50/2"		GP	F-c sandy GRAVEL, grayish brown, slightly moist to moist, very dense, some cobbles			
30		50/4"		SC	Clayey f-c SAND, brown, moist, very dense, some gravel, few cobbles			
					<b>BORING TERMINATED AT 30.5 FEET</b>			
					No groundwater encountered Boring backfilled with soil cuttings			

<b>LEGEND</b>	<b>Sample type:</b>	---Ring	---SPT	---Small Bulk	---Large Bulk	---No Recovery	---Water Table	
	<b>Lab testing:</b>	AL = Atterberg Limits	SR = Sulfate/Resistivity Test	EI = Expansion Index	SH = Shear Test	SA = Sieve Analysis	HC = Consolidation	RV = R-Value Test

**GeoTek, Inc.**  
**LOG OF EXPLORATORY BORING**

**CLIENT:** ProLogis  
**PROJECT NAME:** 534 Struck Avenue  
**PROJECT NO.:** 2361-CR  
**LOCATION:** See Boring Location Map

**DRILLER:** 2R Drilling Inc.  
**DRILL METHOD:** Hollw stem Auger  
**HAMMER:** 140lbs/30in.

**LOGGED BY:** DRW  
**OPERATOR:** Miguel  
**RIG TYPE:** CME 75  
**DATE:** 3/9/2020

Depth (ft)	SAMPLES			USCS Symbol	BORING NO.: B-4	Laboratory Testing		
	Sample Type	Blows/ 6 in	Sample Number			Water Content (%)	Dry Density (pcf)	Others
<b>MATERIAL DESCRIPTION AND COMMENTS</b>								
					<b>5.5" Concrete over 2" CAB</b>			
		3 10 17		SM	<b>Undocumented Fill:</b> Silty clayey f-c SAND, reddish brown, moist, medium dense, some gravel, trace cobbles			
5		19 40 23		SM	<b>Older Alluvial Fan Deposits:</b>  Gravelly silty f-c SAND, grayish brown, moist, dense, some cobbles	3.2	125.5	SA % Passing #200 = 14.9
		16 20 21			Gravelly silty f-c SAND, grayish brown, moist, dense, some cobbles	5.3	125.0	
10		16 36 38		SC	Clayey f-c SAND, brown, moist to very moist, dense, some gravel, trace cobble			
		24 34 40		SP	Gravelly f-c SAND, brown to orangish brown, moist, dense			
15					<b>BORING TERMINATED AT 16 FEET (REFUSAL)</b>  No groundwater encountered Boring backfilled with soil cuttings			
20								
25								
30								

<b>LEGEND</b>	<b>Sample type:</b>	---Ring	---SPT	---Small Bulk	---Large Bulk	---No Recovery	---Water Table	
	<b>Lab testing:</b>	AL = Atterberg Limits	SR = Sulfate/Resistivity Test	EI = Expansion Index	SH = Shear Test	SA = Sieve Analysis	HC = Consolidation	RV = R-Value Test

**GeoTek, Inc.**  
**LOG OF EXPLORATORY BORING**

**CLIENT:** ProLogis  
**PROJECT NAME:** 534 Struck Avenue  
**PROJECT NO.:** 2361-CR  
**LOCATION:** See Boring Location Map

**DRILLER:** 2R Drilling Inc.  
**DRILL METHOD:** Hollw stem Auger  
**HAMMER:** 140lbs/30in.

**LOGGED BY:** DRW  
**OPERATOR:** Miguel  
**RIG TYPE:** CME 75  
**DATE:** 3/9/2020

Depth (ft)	SAMPLES			USCS Symbol	<b>BORING NO.: B-5</b>	Laboratory Testing		
	Sample Type	Blows/ 6 in	Sample Number			Water Content (%)	Dry Density (pcf)	Others
<b>MATERIAL DESCRIPTION AND COMMENTS</b>								
					<b>4" Concrete over 2" CAB</b>			
					<b>Undocumented fill:</b>			RV
				ML	Clayey SILT, dark brown, moist, soft, some gravel	10.5	125.3	
					<b>Older Alluvial Fan Deposits:</b>			
5		17 18 27		SP	Gravelly f-c SAND, orangish brown, moist, medium dense	5.5		
		32 38 40			Same as above, dense	7.3		
10		23 35 50/5"		GP	F-c sandy GRAVEL, grayish brown, slightly moist, very dense, some cobbles			
15					<b>BORING TERMINATED AT 14 FEET (REFUSAL)</b>			
					No groundwater encountered Boring backfilled with soil cuttings			
20								
25								
30								

<b>LEGEND</b>	<b>Sample type:</b>	---Ring	---SPT	---Small Bulk	---Large Bulk	---No Recovery	---Water Table	
	<b>Lab testing:</b>	AL = Atterberg Limits	SR = Sulfate/Resistivity Test	EI = Expansion Index	SH = Shear Test	SA = Sieve Analysis	HC = Consolidation	RV = R-Value Test

**GeoTek, Inc.**  
**LOG OF EXPLORATORY BORING**

**CLIENT:** ProLogis  
**PROJECT NAME:** 534 Struck Avenue  
**PROJECT NO.:** 2361-CR  
**LOCATION:** See Boring Location Map

**DRILLER:** 2R Drilling Inc.  
**DRILL METHOD:** Hollow stem Auger  
**HAMMER:** 140lbs/30in.

**LOGGED BY:** DRW  
**OPERATOR:** Miguel  
**RIG TYPE:** CME 75  
**DATE:** 3/9/2020

Depth (ft)	SAMPLES			USCS Symbol	<b>BORING NO.: B-6</b>	Laboratory Testing		
	Sample Type	Blows/ 6 in	Sample Number			Water Content (%)	Dry Density (pcf)	Others
<b>MATERIAL DESCRIPTION AND COMMENTS</b>								
					<b>3" Concrete over 2" CAB</b>			
					<b>Undocumented fill:</b>			
				SM	Silty f-c SAND, dark brown, moist, trace gravel			
		6 10 10		ML	Clayey SILT, light reddish brown, moist, stiff, trace fine to coarse grained sand, trace gravel			11.4    123.7
					<b>Older Alluvial Fan Deposits:</b>			
5		27 36 37		SM-SP	Gravelly silty f-c SAND, grayish brown, moist, dense			18.4
		20 38 35			Same as above			5.7    130.8
10		18 25 30		SC	Clayey gravelly f-c SAND, brown, moist, dense, trace cobbles			
15		26 50/6"			Same as above, very dense			
					More cobbles become apparent			
20					<b>BORING TERMINATED AT 18.5 FEET (REFUSAL)</b>			
					No groundwater encountered Boring backfilled with soil cuttings			
25								
30								

<b>LEGEND</b>	<b>Sample type:</b>	---Ring	---SPT	---Small Bulk	---Large Bulk	---No Recovery	---Water Table	
	<b>Lab testing:</b>	AL = Atterberg Limits	SR = Sulfate/Resistivity Test	EI = Expansion Index	SH = Shear Test	SA = Sieve Analysis	HC = Consolidation	RV = R-Value Test

**GeoTek, Inc.**  
**LOG OF EXPLORATORY BORING**

**CLIENT:** ProLogis  
**PROJECT NAME:** 534 Struck Avenue  
**PROJECT NO.:** 2361-CR  
**LOCATION:** See Boring Location Map

**DRILLER:** 2R Drilling Inc.  
**DRILL METHOD:** Hollw stem Auger  
**HAMMER:** 140lbs/30in.

**LOGGED BY:** DRW  
**OPERATOR:** Miguel  
**RIG TYPE:** CME 75  
**DATE:** 3/9/2020

Depth (ft)	SAMPLES			USCS Symbol	<b>BORING NO.: B-7</b>	Laboratory Testing		
	Sample Type	Blows/ 6 in	Sample Number			Water Content (%)	Dry Density (pcf)	Others
<b>MATERIAL DESCRIPTION AND COMMENTS</b>								
					<b>3" Concrete over 2" CAB</b>			
					<b>Undocumented fill:</b>			
		10 14 16		SC	Clayey f-c SAND, dark brown, moist, medium dense, some gravel	9.3	128.5	
		15 16 17		SC	Clayey gravelly f-c SAND, reddish brown, moist, medium dense	5.8		
		25 23 25		SP	<b>Older Alluvial Fan Deposits:</b> Gravelly f-c SAND, brown, moist, dense, trace clay  Same as above	4.8	114.9	
10		50/4"		GP/SP	F-c sandy GRAVEL to gravelly f-c SAND, grayish brown, moist, very dense			
					<b>BORING TERMINATED AT 10.5 FEET (REFUSAL)</b>			
					No groundwater encountered Boring backfilled with soil cuttings			
15								
20								
25								
30								

<b>LEGEND</b>	<b>Sample type:</b>	---Ring	---SPT	---Small Bulk	---Large Bulk	---No Recovery	---Water Table	
	<b>Lab testing:</b>	AL = Atterberg Limits	SR = Sulfate/Resistivity Test	EI = Expansion Index	SH = Shear Test	SA = Sieve Analysis	HC = Consolidation	RV = R-Value Test

**GeoTek, Inc.**  
**LOG OF EXPLORATORY BORING**

<b>CLIENT:</b> ProLogis	<b>DRILLER:</b> 2R Drilling Inc.	<b>LOGGED BY:</b> DRW
<b>PROJECT NAME:</b> 534 Struck Avenue	<b>DRILL METHOD:</b> Hollow stem Auger	<b>OPERATOR:</b> Miguel
<b>PROJECT NO.:</b> 2361-CR	<b>HAMMER:</b> 140lbs/30in.	<b>RIG TYPE:</b> CME 75
<b>LOCATION:</b> See Boring Location Map		<b>DATE:</b> 3/9/2020

Depth (ft)	SAMPLES			USCS Symbol	BORING NO.: B-8  MATERIAL DESCRIPTION AND COMMENTS	Laboratory Testing		
	Sample Type	Blows/ 6 in	Sample Number			Water Content (%)	Dry Density (pcf)	Others
					<b>5" of asphaltic concrete</b>			
					<b>Older Alluvial Fan Deposits:</b>			
				ML	Clayey SILT, orangish brown, moist, stiff	14.8	119.5	RV Collapse
					Same as above	13.9	119.3	
				ML/CL	Clayey SILT to silty CLAY, orangish brown, moist, very stiff	15.3	119.2	
				ML	Clayey SILT, light brown, moist, stiff			
				CL	Silty CLAY, reddish brown, moist to very moist, stiff, trace gravel			
				SP	Gravelly f-c SAND, grayish brown, moist, very dense, trace clay			
					<b>BORING TERMINATED AT 21 FEET</b>			
					No groundwater encountered Boring backfilled with soil cuttings			

<b>LEGEND</b>	<b>Sample type:</b>	---Ring	---SPT	---Small Bulk	---Large Bulk	---No Recovery	---Water Table	
	<b>Lab testing:</b>	AL = Atterberg Limits	EI = Expansion Index	SA = Sieve Analysis	RV = R-Value Test	SR = Sulfate/Resistivity Test	SH = Shear Test	HC = Consolidation

**GeoTek, Inc.**  
**LOG OF EXPLORATORY BORING**

**CLIENT:** ProLogis  
**PROJECT NAME:** 534 Struck Avenue  
**PROJECT NO.:** 2361-CR  
**LOCATION:** See Boring Location Map

**DRILLER:** 2R Drilling Inc.  
**DRILL METHOD:** Hollow stem Auger  
**HAMMER:** 140lbs/30in.

**LOGGED BY:** DRW  
**OPERATOR:** Miguel  
**RIG TYPE:** CME 75  
**DATE:** 3/9/2020

Depth (ft)	SAMPLES			USCS Symbol	<b>BORING NO.: I-1</b>	Laboratory Testing		
	Sample Type	Blows / 6 in	Sample Number			Water Content (%)	Dry Density (pcf)	Others
<b>MATERIAL DESCRIPTION AND COMMENTS</b>								
					<b>5" Concrete over 2" CAB</b>			
				ML	<b>Undocumented fill:</b> Clayey SILT, dark brown, moist, trace fine to coarse grained sand			
				ML	<b>Older Alluvial Fan Deposits:</b> Clayey SILT, reddish brown, moist			
5				ML/CL	Clayey SILT to silty CLAY, brown, moist			
					<b>BORING TERMINATED AT 6 FEET</b>			
10					No groundwater encountered			
15								
20								
25								
30								

<b>LEGEND</b>	<b>Sample type:</b>	---Ring	---SPT	---Small Bulk	---Large Bulk	---No Recovery	---Water Table	
	<b>Lab testing:</b>	AL = Atterberg Limits	EI = Expansion Index	SA = Sieve Analysis	RV = R-Value Test	SR = Sulfate/Resistivity Test	SH = Shear Test	HC = Consolidation

**GeoTek, Inc.**  
**LOG OF EXPLORATORY BORING**

**CLIENT:** ProLogis  
**PROJECT NAME:** 534 Struck Avenue  
**PROJECT NO.:** 2361-CR  
**LOCATION:** See Boring Location Map

**DRILLER:** 2R Drilling Inc.  
**DRILL METHOD:** Hollw stem Auger  
**HAMMER:** 140lbs/30in.

**LOGGED BY:** DRW  
**OPERATOR:** Miguel  
**RIG TYPE:** CME 75  
**DATE:** 3/9/2020

Depth (ft)	SAMPLES			USCS Symbol	BORING NO.: I-2  MATERIAL DESCRIPTION AND COMMENTS	Laboratory Testing		
	Sample Type	Blows / 6 in	Sample Number			Water Content (%)	Dry Density (pcf)	Others
					<b>4" Concrete over 3" CAB</b>			
				ML	<b>Undocumented fill:</b> Clayey SILT, dark brown, moist, trace fine grained sand			
5				ML	<b>Older Alluvial Fan Deposits:</b> Clayey SILT, reddish brown, moist  Same as above			
10					<b>BORING TERMINATED AT 7 FEET</b>  No groundwater encountered			
15								
20								
25								
30								

<b>LEGEND</b>	<b>Sample type:</b>	---Ring	---SPT	---Small Bulk	---Large Bulk	---No Recovery	---Water Table	
	<b>Lab testing:</b>	AL = Atterberg Limits	EI = Expansion Index	SA = Sieve Analysis	RV = R-Value Test	SR = Sulfate/Resistivity Test	SH = Shear Test	HC = Consolidation



**GeoTek, Inc.**  
**LOG OF EXPLORATORY BORING**

**CLIENT:** ProLogis  
**PROJECT NAME:** 534 Struck Avenue  
**PROJECT NO.:** 2361-CR  
**LOCATION:** See Boring Location Map

**DRILLER:** 2R Drilling Inc.  
**DRILL METHOD:** Hollw stem Auger  
**HAMMER:** 140lbs/30in.

**LOGGED BY:** DRW  
**OPERATOR:** Miguel  
**RIG TYPE:** CME 75  
**DATE:** 3/9/2020

Depth (ft)	SAMPLES			USCS Symbol	<b>BORING NO.: I-3</b>	Laboratory Testing		
	Sample Type	Blows / 6 in	Sample Number			Water Content (%)	Dry Density (pcf)	Others
<b>MATERIAL DESCRIPTION AND COMMENTS</b>								
					<b>7" of asphaltic concrete</b>			
				ML	<b>Undocumented fill:</b> Clayey SILT, orangish brown, slightly moist to moist, trace fine gravel			
				CL	<b>Older Alluvial Fan Deposits:</b> Silty CLAY, orangish brown to brown, moist			
5				ML	Clayey SILT, brown to reddish brown, moist, some gravel			
					Clayey f-m sandy SILT, light orangish brown, moist, some gravel			
10					<b>BORING TERMINATED AT 8 FEET</b>			
					No groundwater encountered			
15								
20								
25								
30								

<b>LEGEND</b>	<b>Sample type:</b>	---Ring	---SPT	---Small Bulk	---Large Bulk	---No Recovery	---Water Table	
	<b>Lab testing:</b>	AL = Atterberg Limits	EI = Expansion Index	SA = Sieve Analysis	RV = R-Value Test	SR = Sulfate/Resistivity Test	SH = Shear Test	HC = Consolidation

**GeoTek, Inc.**  
**LOG OF EXPLORATORY BORING**

**CLIENT:** ProLogis  
**PROJECT NAME:** 534 Struck Avenue  
**PROJECT NO.:** 2361-CR  
**LOCATION:** See Boring Location Map

**DRILLER:** 2R Drilling Inc.  
**DRILL METHOD:** Hollw stem Auger  
**HAMMER:** 140lbs/30in.

**LOGGED BY:** DRW  
**OPERATOR:** Miguel  
**RIG TYPE:** CME 75  
**DATE:** 3/9/2020

Depth (ft)	SAMPLES			USCS Symbol	<b>BORING NO.: I-4</b>	Laboratory Testing		
	Sample Type	Blows / 6 in	Sample Number			Water Content (%)	Dry Density (pcf)	Others
<b>MATERIAL DESCRIPTION AND COMMENTS</b>								
5				ML	<p><u>5" of asphaltic concrete</u></p> <p><u>Older Alluvial Fan Deposits:</u></p> <p>Clayey SILT, orrangish brown, moist, stiff</p> <p>Same as above</p>			
10					<b>BORING TERMINATED AT 6 FEET</b>			
15					No groundwater encountered			
20								
25								
30								

<b>LEGEND</b>	<b>Sample type:</b>	---Ring	---SPT	---Small Bulk	---Large Bulk	---No Recovery	---Water Table	
	<b>Lab testing:</b>	AL = Atterberg Limits	EI = Expansion Index	SA = Sieve Analysis	RV = R-Value Test	SR = Sulfate/Resistivity Test	SH = Shear Test	HC= Consolidation

# **APPENDIX B**

## **LABORATORY TEST RESULTS**

**Proposed Warehouse Facility  
City of Orange, Orange County, California  
Project No. 2361-CR**



## SUMMARY OF LABORATORY TESTING

### Atterberg Limits

Atterberg limits testing were performed on a fine-grained sample collected from the site. The test was performed in general accordance with ASTM D 4318. The test results are presented on the log of borings in Appendix A.

### Classification

Soils were classified visually in general accordance to the Unified Soil Classification System (ASTM Test Method D 2487). The soil classifications are shown on the log of borings in Appendix A.

### Consolidation

Consolidation/collapse testing was performed on selected samples of the site soils according to ASTM Test Method D 2435. The results of this testing are presented in Appendix B.

### Direct Shear

Shear testing was performed in a direct shear machine of the strain-control type in general accordance with ASTM Test Method D 3080. The rate of deformation is approximately 0.035 inch per minute. The samples were sheared under varying confining loads in order to determine the coulomb shear strength parameters, angle of internal friction and cohesion. The results of the testing are presented in Appendix B.

### Expansion Index

The expansion potential of the soils was determined by performing expansion index testing on a representative sample in general accordance with ASTM D 4829. The results of the testing is provided below.

Boring No.	Depth (ft.)	Soil Type	Expansion Index	Classification
B-1	1-5	Silty Clay to Clayey Silt	59	Medium

### In-Situ Moisture and Density

The natural water content was determined (ASTM D 2216) on samples of the materials recovered from the subsurface exploration. In addition, in-place dry density determination (ASTM D 2937) were performed on relatively undisturbed samples to measure the unity weight of the subsurface soils. Results of these tests are shown on the logs at the appropriate sample depths in Appendix A.

### Percent of Soil Finer than No. 200 Sieve

Tests to determine the percent of soil finer than No. 200 sieve were performed on selected samples obtained from the property. The tests were conducted in general accordance with ASTM D 1140. The results of these tests are presented on the log of borings in Appendix A.

### Moisture-Density Relationship

Laboratory testing was performed on a sample obtained during the subsurface exploration. The laboratory maximum dry density and optimum moisture content was determined in general accordance with ASTM D 1557. The results of the testing are provided below and in Appendix B.

Boring No.	Depth (ft.)	Description	Maximum Dry Density (pcf)	Optimum Moisture Content (%)
B-1	1-5	Silty Clay to Clayey Silt	124.0	11.0

### R-Value

R-Value (i.e. resistance value) testing was performed on two samples collected from the site. The tests were performed in general accordance with California Test Method No. 301. The test results are presented in Appendix B.

### Sulfate Content, Resistivity and Chloride Content

Testing to determine the water-soluble sulfate content was performed by others in general accordance with ASTM D4327. Resistivity testing was completed by others in general accordance with ASTM G187. Testing to determine the chloride content was performed by others in general accordance with ASTM D4327. The results of the testing are provided below and in Appendix B.

Boring No.	Depth (ft.)	pH G51	Chloride ASTM D4327 (ppm)	Sulfate ASTM D4327 (% by weight)	Resistivity ASTM G187 (ohm-cm)
B-1	1-5	8.6	7.6	0.0309	1,340
B-3	1-5	8.5	4.7	0.0110	4,020

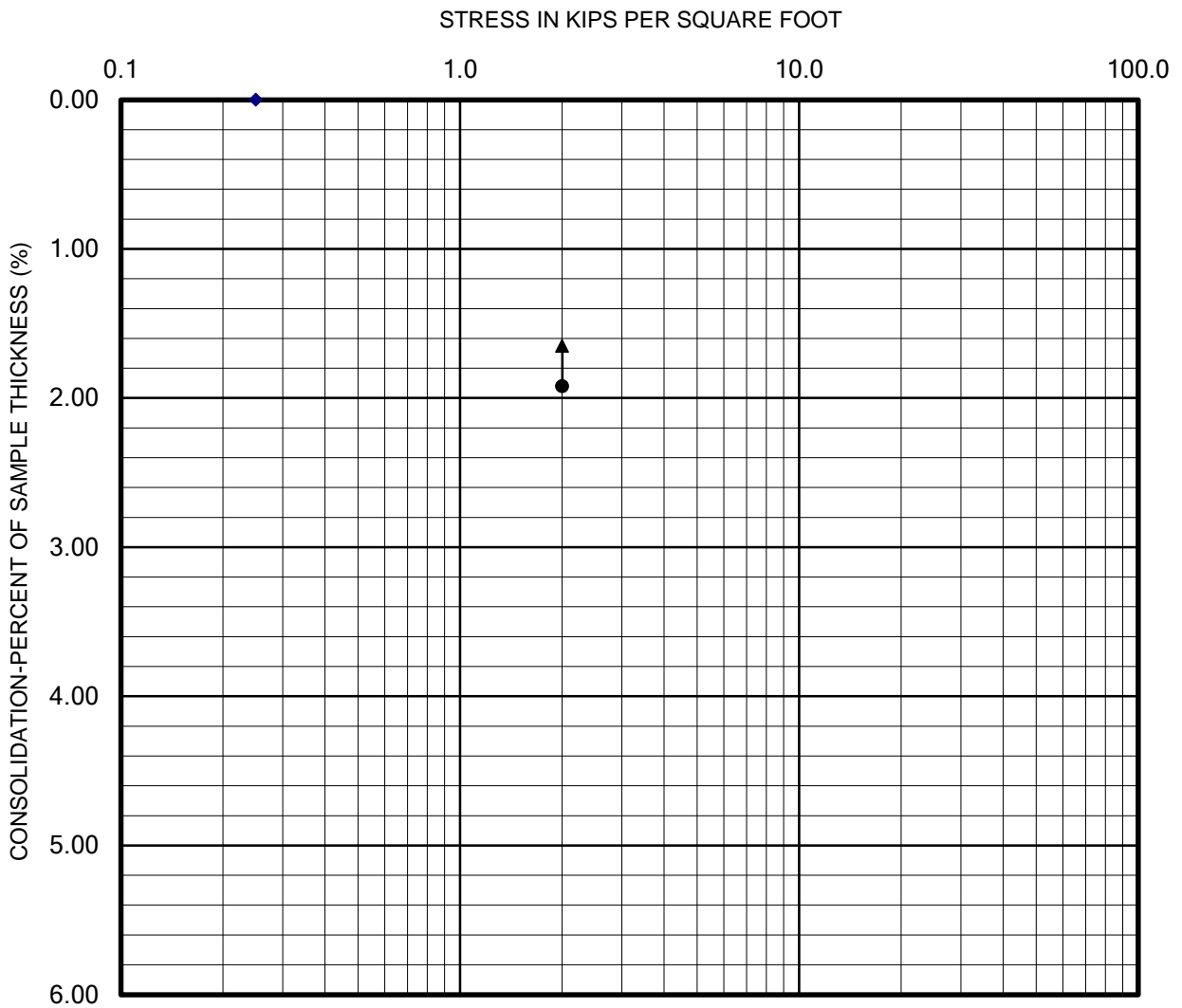

- Seating Cycle
- Loading Prior to Inundation
- ▲— Loading After Inundation
- ▲--- Rebound Cycle

PERFORMED IN GENERAL ACCORDANCE WITH ASTM D 4546



## COLLAPSE REPORT

**Sample: B-1 @ 5'**

**534 West Struck Avenue  
Orange, California**

CHECKED BY: RRR

Lab: DI

PROJECT NO.: 2361-CR

Date: 03/2020

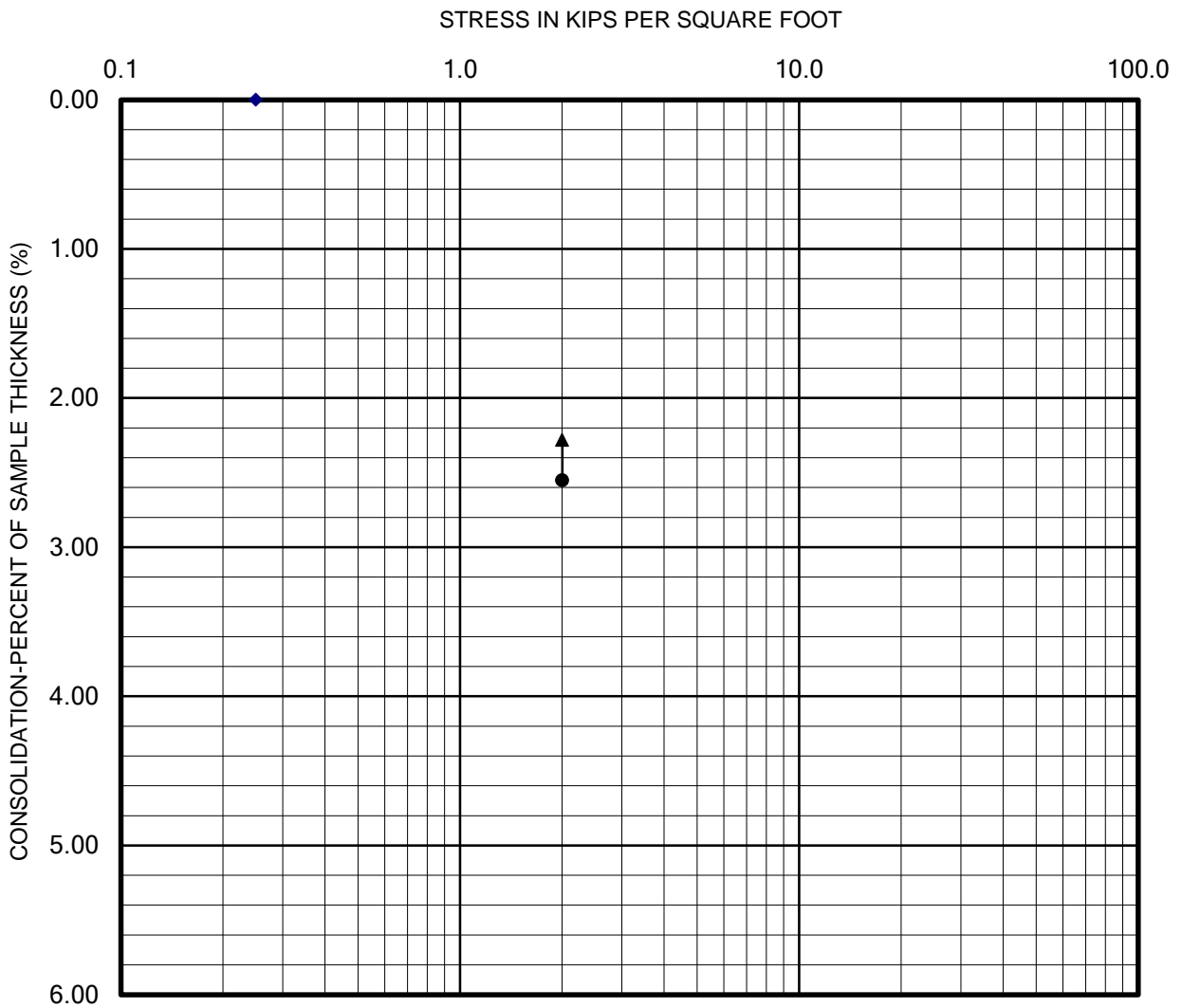

- Seating Cycle
- Loading Prior to Inundation
- ▲— Loading After Inundation
- ▲--- Rebound Cycle

PERFORMED IN GENERAL ACCORDANCE WITH ASTM D 4546



## COLLAPSE REPORT

**Sample: B-8 @ 2'**

**534 West Struck Avenue  
Orange, California**

CHECKED BY: RRR

Lab: DI

PROJECT NO.: 2361-CR

Date: 03/2020



## DIRECT SHEAR TEST

**Project Name:** 534 West Struck Ave., Orange  
**Project Number:** 2361-CR

**Sample Location:** B-1 @ 1 - 5  
**Date Tested:** 3/25/2020

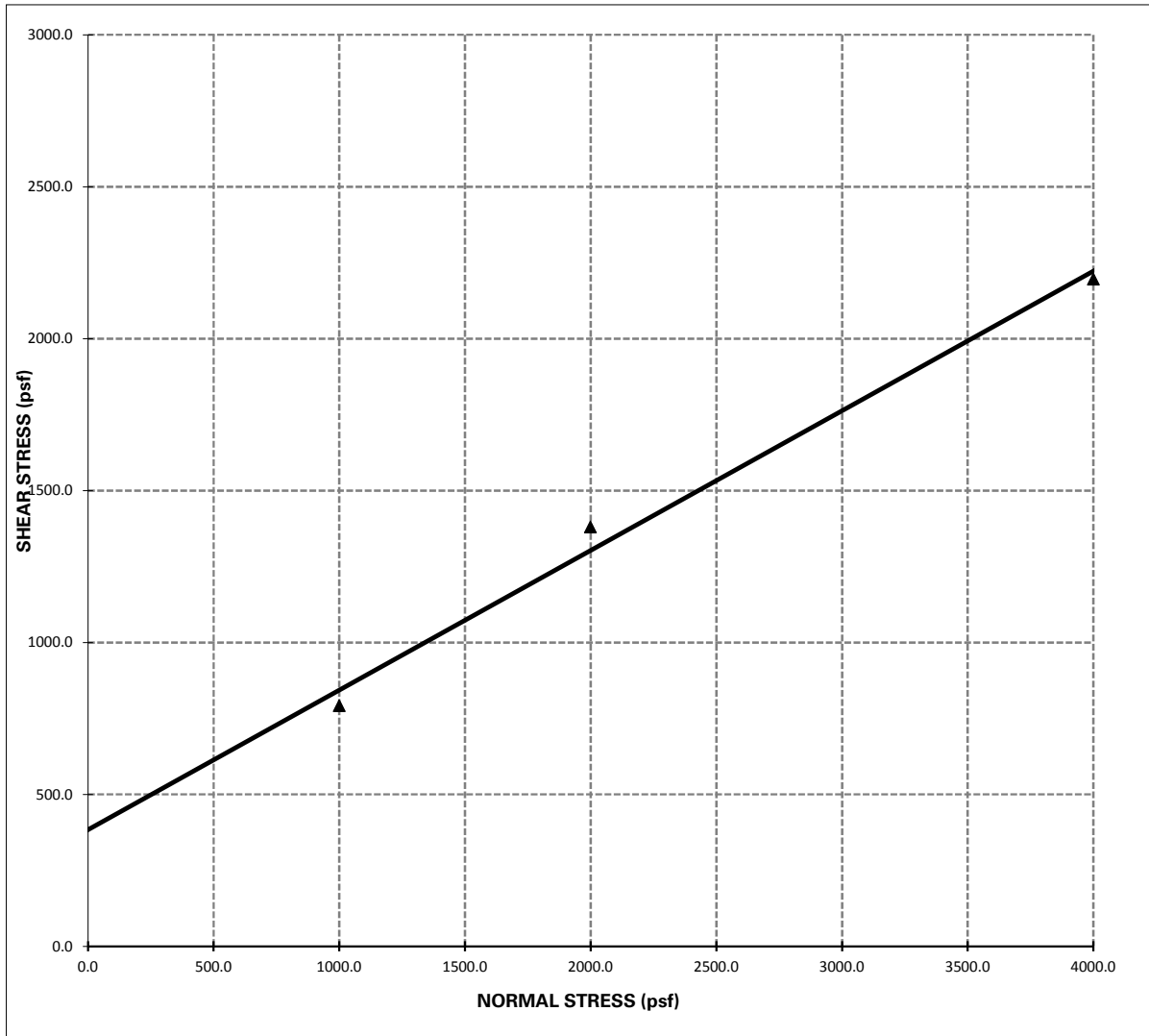

**Shear Strength:**  $\Phi = 24.7^\circ$  ; **C = 384.00 psf**

- Notes:**
- 1 - The soil specimen used in the shear box was a ring sample remolded to approximately 90% relative compaction from a bulk sample collected during the field investigation.
  - 2 - The above reflect direct shear strength at saturated conditions.
  - 3 - The tests were run at a shear rate of 0.035 in/min.





## MOISTURE/DENSITY RELATIONSHIP

**Client:** Prologis  
**Project:** 534 West Struck Avenue  
**Location:** Orange  
**Material Type:** Brown Clayey Silt  
**Material Supplier:** -  
**Material Source:** -  
**Sample Location:** B-1 @ 1 - 5  
 -  
**Sampled By:** DRW  
**Received By:** DLI  
**Tested By:** DLI  
**Reviewed By:** -

**Job No.:** 2361-CR  
**Lab No.:** Corona  
  
**Date Sampled:** 3/10/2020  
**Date Received:** 3/11/2020  
**Date Tested:** 3/21/2020  
**Date Reviewed:** -

**Test Procedure:** ASTM D1557      **Method:** A  
**Oversized Material (%):** 5.7      **Correction Required:**  yes  no

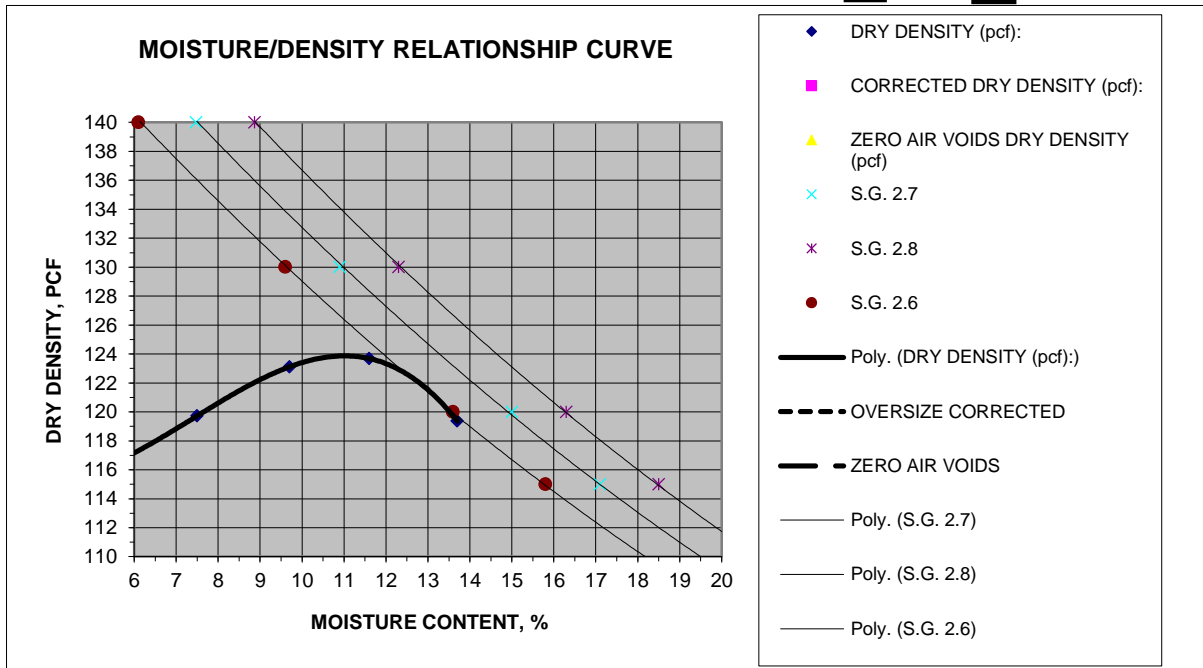

### MOISTURE DENSITY RELATIONSHIP VALUES

**Maximum Dry Density, pcf**       @ **Optimum Moisture, %**   
**Corrected Maximum Dry Density, pcf**       @ **Optimum Moisture, %**

### MATERIAL DESCRIPTION

**Grain Size Distribution:**

	% Gravel (retained on No. 4)
	% Sand (Passing No. 4, Retained on No. 200)
	% Silt and Clay (Passing No. 200)

**Atterberg Limits:**

	Liquid Limit, %
	Plastic Limit, %
	Plasticity Index, %

**Classification:**

Unified Soils Classification: \_\_\_\_\_  
 AASHTO Soils Classification: \_\_\_\_\_



## MOISTURE/DENSITY RELATIONSHIP

**Client:** Prologis  
**Project:** 534 West Struck Avenue  
**Location:** Orange  
**Material Type:** Brown Clayey Silt  
**Material Supplier:** -  
**Material Source:** -  
**Sample Location:** B-3 @ 1 - 5  
 -  
**Sampled By:** DRW  
**Received By:** DLI  
**Tested By:** DLI  
**Reviewed By:** -

**Job No.:** 2361-CR  
**Lab No.:** Corona  
  
**Date Sampled:** 3/10/2020  
**Date Received:** 3/11/2020  
**Date Tested:** 3/21/2020  
**Date Reviewed:** -

**Test Procedure:** ASTM D1557      **Method:** C  
**Oversized Material (%):** 29.9      **Correction Required:**  yes  no

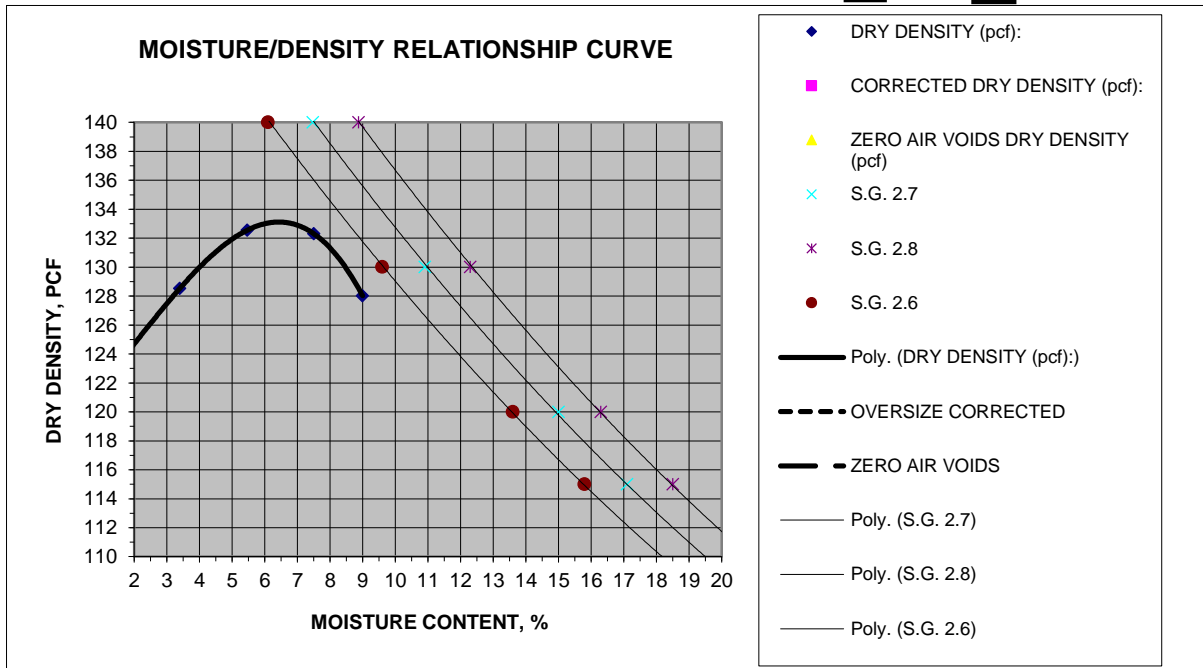

### MOISTURE DENSITY RELATIONSHIP VALUES

**Maximum Dry Density, pcf**       @ **Optimum Moisture, %**   
**Corrected Maximum Dry Density, pcf**       @ **Optimum Moisture, %**

### MATERIAL DESCRIPTION

**Grain Size Distribution:**

	% Gravel (retained on No. 4)
	% Sand (Passing No. 4, Retained on No. 200)
	% Silt and Clay (Passing No. 200)

**Atterberg Limits:**

	Liquid Limit, %
	Plastic Limit, %
	Plasticity Index, %

**Classification:**

Unified Soils Classification: \_\_\_\_\_  
 AASHTO Soils Classification: \_\_\_\_\_

- ANALYSIS
- DESIGN

# LaBelle • Marvin

PROFESSIONAL PAVEMENT ENGINEERING  
A CALIFORNIA CORPORATION

- SOILS, ASPHALT  
TECHNOLOGY

March 26, 2020

**Ms. Anna Scott**  
**GeoTek Inc.**

1548 North Maple Street  
Corona, California 92880

Project No. 45887

Attention Ms. Scott:

Laboratory testing of the bulk soil samples delivered to our laboratory on 3/20/2020 has been completed.

Reference: W.O. # 2361-CR  
Project: ProLogis 534 Struck Drive, Orange  
Samples: B-5 @ 1'-5'  
B-8 @ 1'-5'

Data sheets are transmitted herewith for your use and information. Any untested portion of the samples will be retained for a period of sixty (60) days prior to disposal. The opportunity to be of service is appreciated, and should you have any questions, kindly call.

Very truly yours,



**Steven R. Marvin**  
**RCE 30659**

SRM:tw  
Enclosures

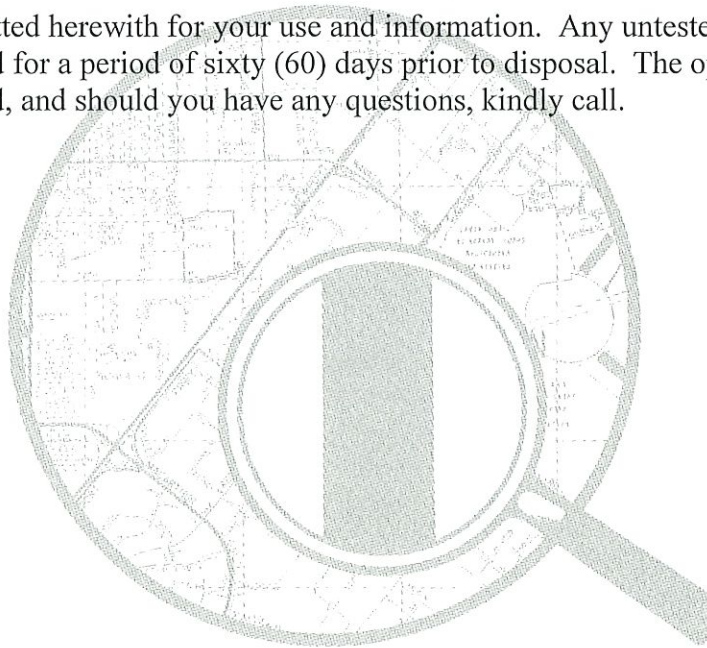



# R - VALUE DATA SHEET

PROJECT No. 45887

DATE: 3/26/2020

BORING NO. B5 @ 1'-5'  
ProLogis 534 Struck Drive, Orange  
W.O.# 2361-CR

SAMPLE DESCRIPTION: Brown Gravelly Silty Sand

R-VALUE TESTING DATA   CA TEST 301			
	SPECIMEN ID		
	a	b	c
Mold ID Number	7	8	9
Water added, grams	38	30	25
Initial Test Water, %	8.9	8.2	7.7
Compact Gage Pressure,psi	80	160	260
Exudation Pressure, psi	131	280	504
Height Sample, Inches	2.62	2.56	2.53
Gross Weight Mold, grams	3154	3142	2963
Tare Weight Mold, grams	1953	1948	1772
Sample Wet Weight, grams	1201	1194	1191
Expansion, Inches x 10exp-4	0	0	1
Stability 2,000 lbs (160psi)	26 / 52	15 / 31	14 / 23
Turns Displacement	5.33	4.63	4.34
R-Value Uncorrected	49	69	77
R-Value Corrected	52	70	77
Dry Density, pcf	127.5	130.6	132.4

### DESIGN CALCULATION DATA

Traffic Index	Assumed:	4.0	4.0	4.0
G.E. by Stability		0.49	0.31	0.24
G. E. by Expansion		0.00	0.00	0.03

<b>Equilibrium R-Value</b>	<b>71</b> by <b>EXUDATION</b>	Examined & Checked: <u>3 /26/ 20</u>
REMARKS:	<u>Gf = 1.25</u> <u>35.2% Retained on the</u> <u>3/4" Sieve.</u>	<u>Steven R. Marvin, RCE 30659</u>

The data above is based upon processing and testing samples as received from the field. Test procedures in accordance with latest revisions to Department of Transportation, State of California, Materials & Research Test Method No. 301.



# R-VALUE GRAPHICAL PRESENTATION

PROJECT NO. 45887  
 DATE: 3 /26/ 2020 REMARKS: \_\_\_\_\_  
 BORING NO. B5 @ 1'-5'  
ProLogis 534 Struck Drive, Orange  
W.O.# 2361-CR

## COVER THICKNESS BY EXUDATION vs COVER THICKNESS BY EXPANSION

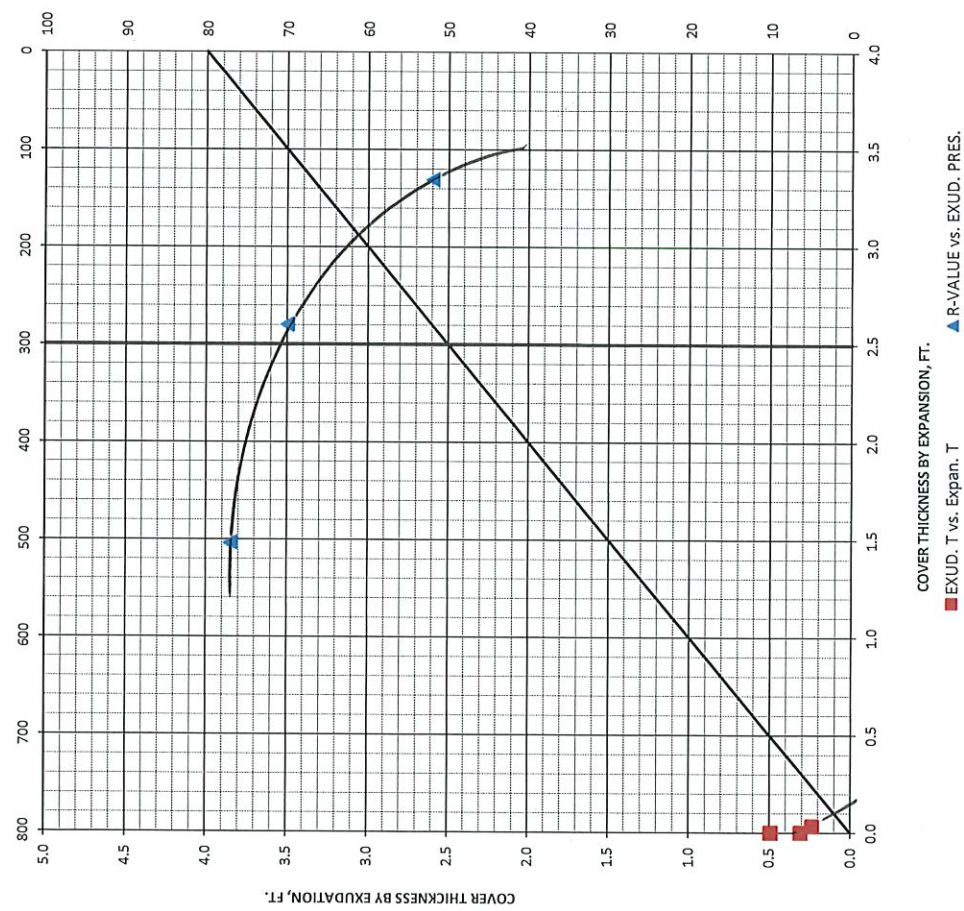

## COVER THICKNESS vs MOISTURE %

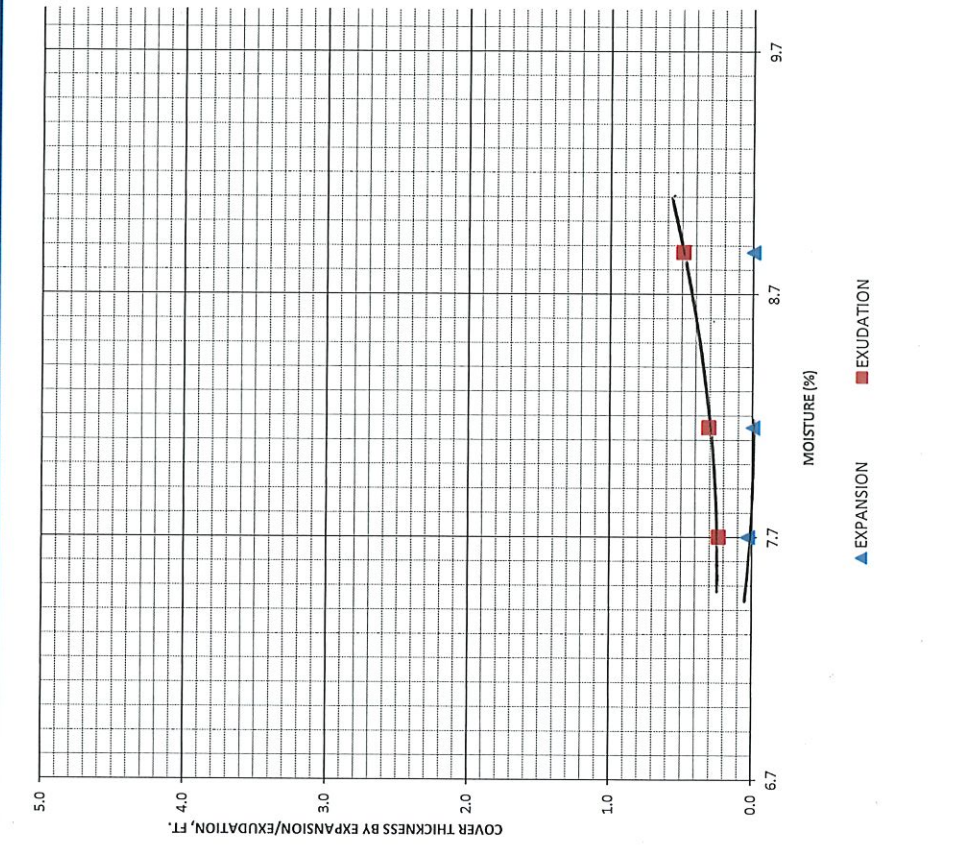

## COMPACTOR PRESSURE vs MOISTURE %

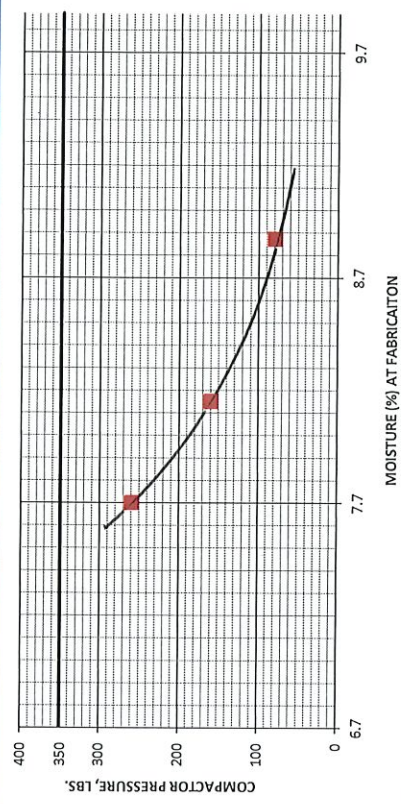



# R - VALUE DATA SHEET

PROJECT No. 45887  
 DATE: 3/25/2020

BORING NO. B8 @ 1'-5'  
ProLogis 534 Struck Drive, Orange  
W.O.# 2361-CR

SAMPLE DESCRIPTION: Brown Clayey Silt

R-VALUE TESTING DATA   CA TEST 301			
	SPECIMEN ID		
	a	b	c
Mold ID Number	1	3	4
Water added, grams	50	95	35
Initial Test Water, %	13.0	17.5	11.5
Compact Gage Pressure,psi	130	40	180
Exudation Pressure, psi	440	230	730
Height Sample, Inches	2.46	2.68	2.37
Gross Weight Mold, grams	3067	3104	3055
Tare Weight Mold, grams	1954	1958	1957
Sample Wet Weight, grams	1113	1146	1098
Expansion, Inches x 10exp-4	85	12	180
Stability 2,000 lbs (160psi)	39 / 90	67 / 145	24 / 66
Turns Displacement	3.43	4.65	3.03
R-Value Uncorrected	36	5	54
R-Value Corrected	36	5	51
Dry Density, pcf	121.3	110.3	125.9

### DESIGN CALCULATION DATA

Traffic Index	Assumed:	4.0	4.0	4.0
G.E. by Stability		0.66	0.97	0.50
G. E. by Expansion		2.83	0.40	6.00

<b>Equilibrium R-Value</b>	<b>13</b> by EXPANSION	Examined & Checked: <u>3 /25/ 20</u>
REMARKS:	<u>Gf = 1.25</u> <u>0.0% Retained on the</u> <u>3/4" Sieve.</u>	<u>Steven R. Marvin, RCE 30659</u>

The data above is based upon processing and testing samples as received from the field. Test procedures in accordance with latest revisions to Department of Transportation, State of California, Materials & Research Test Method No. 301.



# R-VALUE GRAPHICAL PRESENTATION

PROJECT NO. 45887  
 DATE: 3 /25/ 2020 REMARKS: \_\_\_\_\_  
 BORING NO. B8 @ 1'-5'  
ProLogis 534 Struck Drive, Orange  
W.O.# 2361-CR

## COMPACTOR PRESSURE vs MOISTURE %

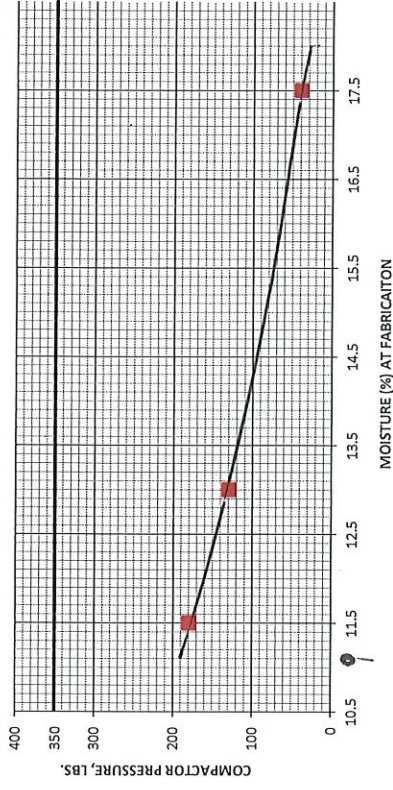

## COVER THICKNESS BY EXUDATION vs COVER THICKNESS BY EXPANSION

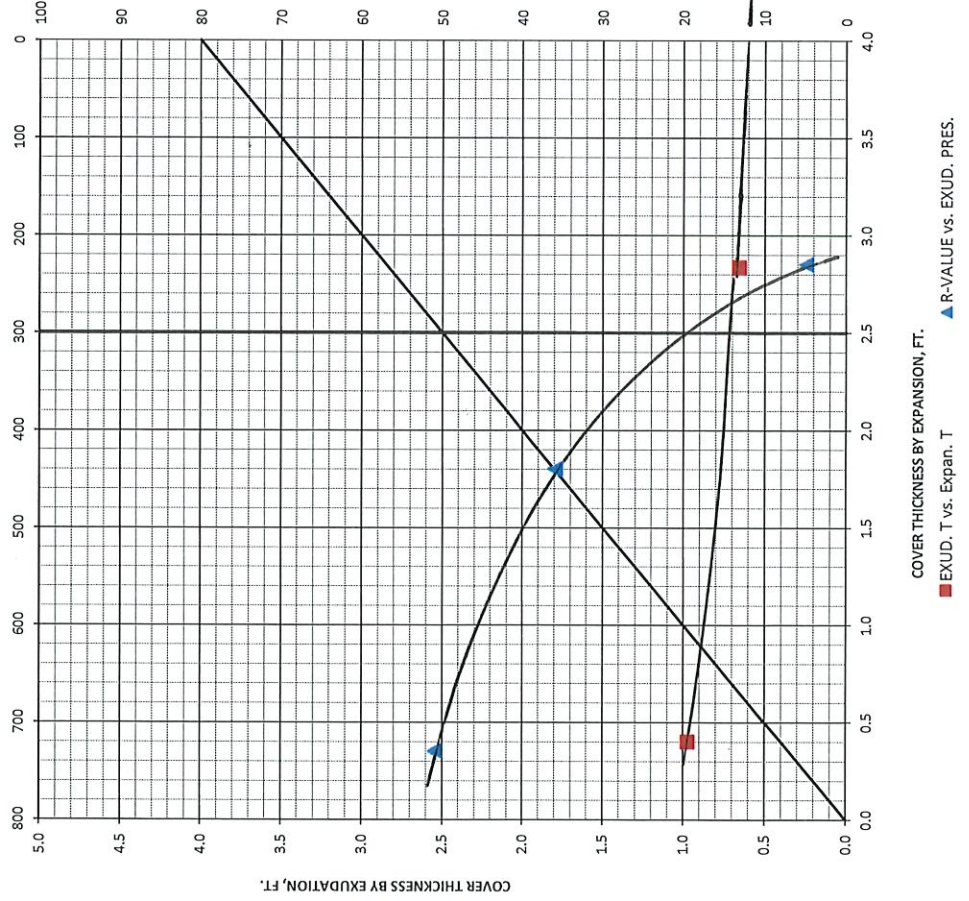

## COVER THICKNESS vs MOISTURE %

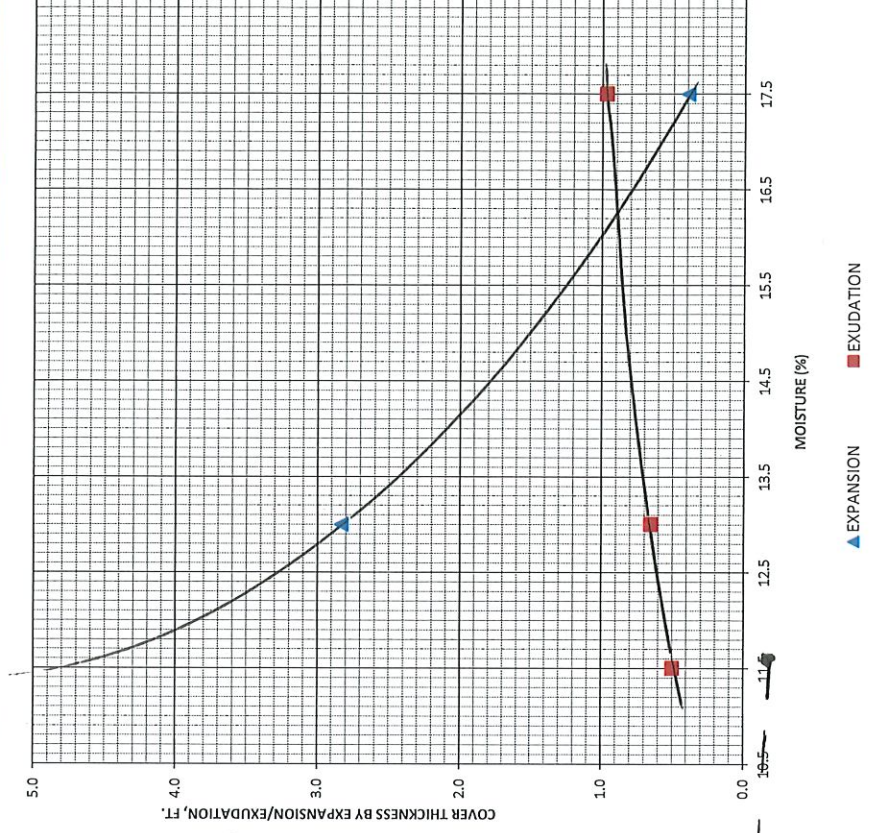



# Results Only Soil Testing for 534 Struck Ave, Orange

**March 19, 2020**

**Prepared for:**  
**Anna Scott**  
**GeoTek, Inc.**  
**1548 North Maple Street**  
**Corona, CA 92880**  
**ascott@geotekusa.com**

**Project X Job#: S200316H**  
**Client Job or PO#: 2361-CR**

Respectfully Submitted,

Eduardo Hernandez, M.Sc., P.E.  
Sr. Corrosion Consultant  
NACE Corrosion Technologist #16592  
Professional Engineer  
California No. M37102  
[ehernandez@projectxcorrosion.com](mailto:ehernandez@projectxcorrosion.com)







## Soil Analysis Lab Results

Client: GeoTek, Inc.

Job Name: 534 Struck Ave, Orange

Client Job Number: 2361-CR

Project X Job Number: S200316H

March 19, 2020

Method	ASTM D4327	ASTM D4327	ASTM G187	ASTM G51	ASTM G200	SM 4500-S2-D	ASTM D4327	ASTM D6919	ASTM D6919	ASTM D6919	ASTM D6919	ASTM D6919	ASTM D6919	ASTM D6919	ASTM D4327	ASTM D4327	ASTM D4327	
Bore# / Description	Sulfates (mg/kg) SO <sub>4</sub> <sup>2-</sup>	Chlorides (mg/kg) Cl <sup>-</sup>	Resistivity As Rec'd   Minimum (Ohm-cm)   (Ohm-cm)	pH	Redox (mV)	Sulfide (mg/kg) S <sup>2-</sup>	Nitrate (mg/kg) NO <sub>3</sub> <sup>-</sup>	Ammonium (mg/kg) NH <sub>4</sub> <sup>+</sup>	Lithium (mg/kg) Li <sup>+</sup>	Sodium (mg/kg) Na <sup>+</sup>	Potassium (mg/kg) K <sup>+</sup>	Magnesium (mg/kg) Mg <sup>2+</sup>	Calcium (mg/kg) Ca <sup>2+</sup>	Fluoride (mg/kg) F <sup>-</sup>	Phosphate (mg/kg) PO <sub>4</sub> <sup>3-</sup>			
B1	308.9	7.6	48,240	8.6	147.0	0.1	241.1	ND	ND	112.5	ND	7.3	38.9	6.6	ND			
B3	109.8	4.7	36,850	8.5	118.0	0.6	40.1	ND	ND	44.8	0.8	6.2	50.7	2.2	6.5			

Cations and Anions, except Sulfide and Bicarbonate, tested with Ion Chromatography

mg/kg = milligrams per kilogram (parts per million) of dry soil weight

ND = 0 = Not Detected | NT = Not Tested | Unk = Unknown

Chemical Analysis performed on 1:3 Soil-To-Water extract

# **APPENDIX C**

## **INFILTRATION TEST DATA**

**Proposed Warehouse Facility  
City of Orange, Orange County, California  
Project No. 2361-CR**



**Client:** ProLogis  
**Project:** Orange  
**Project No:** 2361-CR  
**Date:** 3/11/2020

**Boring No.** I-1

**Percolation Rate (Porchet Method)**

Time Interval,  $\Delta t =$  30  
 Final Depth to Water,  $D_F =$  52.125  
 Test Hole Radius,  $r =$  4  
 Initial Depth to Water,  $D_O =$  52  
 Total Test Hole Depth,  $D_T =$  72

Equation -  $I_t = \frac{\Delta H (60r)}{\Delta t (r+2H_{avg})}$

$H_O = D_T - D_O =$  20  
 $H_F = D_T - D_F =$  19.875  
 $\Delta H = \Delta D = H_O - H_F =$  0.125  
 $H_{avg} = (H_O + H_F) / 2 =$  19.9375

$I_t =$  0.02 Inches per Hour



**Client:** ProLogis  
**Project:** Orange  
**Project No:** 2361-CR  
**Date:** 3/11/2020

**Boring No.** I-2

**Percolation Rate (Porchet Method)**

Time Interval,  $\Delta t =$  30  
 Final Depth to Water,  $D_F =$  64.125  
 Test Hole Radius,  $r =$  4  
 Initial Depth to Water,  $D_O =$  64  
 Total Test Hole Depth,  $D_T =$  84

Equation -  $I_t = \frac{\Delta H (60r)}{\Delta t (r+2H_{avg})}$

$H_O = D_T - D_O =$  20  
 $H_F = D_T - D_F =$  19.875  
 $\Delta H = \Delta D = H_O - H_F =$  0.125  
 $H_{avg} = (H_O + H_F) / 2 =$  19.9375

$I_t =$  0.02 Inches per Hour



**Client:** ProLogis  
**Project:** Orange  
**Project No:** 2361-CR  
**Date:** 3/11/2020

**Boring No.** I-3

**Percolation Rate (Porchet Method)**

Time Interval,  $\Delta t =$  30  
 Final Depth to Water,  $D_F =$  76.125  
 Test Hole Radius,  $r =$  4  
 Initial Depth to Water,  $D_O =$  76  
 Total Test Hole Depth,  $D_T =$  96

Equation -  $I_t = \frac{\Delta H (60r)}{\Delta t (r+2H_{avg})}$

$H_O = D_T - D_O =$  20  
 $H_F = D_T - D_F =$  19.875  
 $\Delta H = \Delta D = H_O - H_F =$  0.125  
 $H_{avg} = (H_O + H_F) / 2 =$  19.9375

$I_t =$  0.02 Inches per Hour



**Client:** ProLogis  
**Project:** Orange  
**Project No:** 2361-CR  
**Date:** 3/11/2020

**Boring No.** I-4

**Percolation Rate (Porchet Method)**

Time Interval,  $\Delta t =$  30  
 Final Depth to Water,  $D_F =$  52.125  
 Test Hole Radius,  $r =$  4  
 Initial Depth to Water,  $D_O =$  52  
 Total Test Hole Depth,  $D_T =$  72

Equation -  $I_t = \frac{\Delta H (60r)}{\Delta t (r+2H_{avg})}$

$H_O = D_T - D_O =$  20  
 $H_F = D_T - D_F =$  19.875  
 $\Delta H = \Delta D = H_O - H_F =$  0.125  
 $H_{avg} = (H_O + H_F) / 2 =$  19.9375

$I_t =$  0.02 Inches per Hour



## PERCOLATION DATA SHEET

Project: 534 WEST STRUCK AVENUE ORANGE Job No.: 2361-CR  
 Test Hole No.: I-1 Tested By: DVG Date: 3/10, 11/2020  
 Depth of Hole As Drilled: 72 Before Test: 72" After Test: 72"

Reading No.	Time	Time Interval (Min)	Total Depth of Hole (Inches)	Initial Water Level (Inches)	Final Water Level (Inches)	Δ In Water Level (Inches)	Comments
							PRESOAK 5 GAL 3/10/2020
	<u>815</u>		<u>72</u>	<u>20</u>			BEGIN 3/11/2020
	<u>840</u>	<u>25</u>			<u>19 7/8</u>	<u>1/8</u>	1ST 25 MIN.
	<u>842</u>		<u>72</u>	<u>20</u>			
	<u>907</u>	<u>25</u>			<u>19 7/8</u>	<u>1/8</u>	2ND 25 MIN.
	<u>909</u>		<u>72</u>	<u>20</u>			
	<u>939</u>	<u>30</u>			<u>19 7/8</u>	<u>1/8</u>	1ST 30 MIN.
	<u>941</u>		<u>72</u>	<u>20</u>			
	<u>1011</u>	<u>30</u>			<u>19 7/8</u>	<u>1/8</u>	2ND 30 MIN
	<u>1013</u>		<u>72</u>	<u>20</u>			
	<u>1043</u>	<u>30</u>			<u>19 7/8</u>	<u>1/8</u>	3RD 30 MIN
	<u>1045</u>		<u>72</u>	<u>20</u>			
	<u>1115</u>	<u>30</u>			<u>19 7/8</u>	<u>1/8</u>	4TH 30 MIN.
	<u>1117</u>		<u>72</u>	<u>20</u>			
	<u>1147</u>	<u>30</u>			<u>19 7/8</u>	<u>1/8</u>	5TH 30 MIN.
	<u>1149</u>		<u>72</u>	<u>20</u>			
	<u>1219</u>	<u>30</u>			<u>19 7/8</u>	<u>1/8</u>	6TH 30 MIN.
	<u>1221</u>		<u>72</u>	<u>20</u>			
	<u>1251</u>	<u>30</u>			<u>19 7/8</u>	<u>1/8</u>	7TH 30 MIN.





PERCOLATION DATA SHEET

Project: 534 WEST STRUCK AVENUE ORANGE Job No.: 2361-CR

Test Hole No.: I-2 Tested By: DVG Date: 3/10,11/2020

Depth of Hole As Drilled: 84" Before Test: 84" After Test: 84"

Reading No.	Time	Time Interval (Min)	Total Depth of Hole (Inches)	Initial Water Level (Inches)	Final Water Level (Inches)	Δ In Water Level (Inches)	Comments
							PRESOAK 5 GAL 3/10/2020
	<u>822</u>		<u>84</u>	<u>20</u>			BEGIN 3/11/2020
	<u>847</u>	<u>25</u>			<u>19 7/8</u>	<u>1/8</u>	1ST 25 MIN.
	<u>849</u>		<u>84</u>	<u>20</u>			
	<u>914</u>	<u>25</u>			<u>19 7/8</u>	<u>1/8</u>	2ND 25 MIN.
	<u>916</u>		<u>84</u>	<u>20</u>			
	<u>946</u>	<u>30</u>			<u>19 7/8</u>	<u>1/8</u>	1ST 30 MIN.
	<u>948</u>		<u>84</u>	<u>20</u>			
	<u>1018</u>	<u>30</u>			<u>19 7/8</u>	<u>1/8</u>	2ND 30 MIN.
	<u>1020</u>		<u>84</u>	<u>20</u>			
	<u>1050</u>	<u>30</u>			<u>19 7/8</u>	<u>1/8</u>	3RD 30 MIN.
	<u>1052</u>		<u>84</u>	<u>20</u>			
	<u>1122</u>	<u>30</u>			<u>19 7/8</u>	<u>1/8</u>	4TH 30 MIN.
	<u>1124</u>		<u>84</u>	<u>20</u>			
	<u>1154</u>	<u>30</u>			<u>19 7/8</u>	<u>1/8</u>	5TH 30 MIN.
	<u>1156</u>		<u>84</u>	<u>20</u>			
	<u>1226</u>	<u>30</u>			<u>19 7/8</u>	<u>1/8</u>	6TH 30 MIN
	<u>1228</u>		<u>84</u>	<u>20</u>			
	<u>1258</u>	<u>30</u>			<u>19 7/8</u>	<u>1/8</u>	7TH 30 MIN.



PERCOLATION DATA SHEET

Project: 534 WEST STRUCK AVENUE ORANGE

Job No.: 2361-CR

Test Hole No.: I-3

Tested By: DVG

Date: 3/10, 11/2020

Depth of Hole As Drilled: 96"

Before Test: 96"

After Test: 96"

Reading No.	Time	Time Interval (Min)	Total Depth of Hole (Inches)	Initial Water Level (Inches)	Final Water Level (Inches)	Δ In Water Level (Inches)	Comments
							PRESOAK 5 GAL 3/10/2020
	<u>829</u>		<u>96</u>	<u>20</u>			BEGIN 3/11/2020
	<u>854</u>	<u>25</u>			<u>19 7/8</u>	<u>1/8</u>	1ST 25 MIN.
	<u>856</u>		<u>96</u>	<u>20</u>			
	<u>921</u>	<u>25</u>			<u>19 7/8</u>	<u>1/8</u>	2ND 25 MIN.
	<u>923</u>		<u>96</u>	<u>20</u>			
	<u>953</u>	<u>30</u>			<u>19 7/8</u>	<u>1/8</u>	1ST 30 MIN.
	<u>955</u>		<u>96</u>	<u>20</u>			
	<u>1025</u>	<u>30</u>			<u>19 7/8</u>	<u>1/8</u>	2ND 30 MIN.
	<u>1027</u>		<u>96</u>	<u>20</u>			
	<u>1057</u>	<u>30</u>			<u>19 7/8</u>	<u>1/8</u>	3RD 30 MIN.
	<u>1059</u>		<u>96</u>	<u>20</u>			
	<u>1129</u>	<u>30</u>			<u>19 7/8</u>	<u>1/8</u>	4TH 30 MIN.
	<u>1131</u>		<u>96</u>	<u>20</u>			
	<u>1201</u>	<u>30</u>			<u>19 7/8</u>	<u>1/8</u>	5TH 30 MIN.
	<u>1203</u>		<u>96</u>	<u>20</u>			
	<u>1233</u>	<u>30</u>			<u>19 7/8</u>	<u>1/8</u>	6TH 30 MIN.
	<u>1235</u>		<u>96</u>	<u>20</u>			
	<u>105</u>	<u>30</u>			<u>19 7/8</u>	<u>1/8</u>	7TH 30 MIN.



## PERCOLATION DATA SHEET

Project: 534 WEST STRUCK AVENUE ORANGEJob No.: 2361-CR.Test Hole No.: I-4Tested By: DVGDate: 3/10,11/2020Depth of Hole As Drilled: 72"Before Test: 72"After Test: 72"

Reading No.	Time	Time Interval (Min)	Total Depth of Hole (Inches)	Initial Water Level (Inches)	Final Water Level (Inches)	$\Delta$ In Water Level (Inches)	Comments
							PRESOAK 5 GAL. 3/10/2020
	<u>836</u>		<u>72</u>	<u>20</u>			BEGIN 3/11/2020
	<u>901</u>	<u>25</u>			<u>19 7/8</u>	<u>1/8</u>	1ST 25 MIN.
	<u>903</u>		<u>72</u>	<u>20</u>			
	<u>928</u>	<u>25</u>			<u>19 7/8</u>	<u>1/8</u>	2ND 25 MIN.
	<u>930</u>		<u>72</u>	<u>20</u>			
	<u>1000</u>	<u>30</u>			<u>19 7/8</u>	<u>1/8</u>	1ST 30 MIN.
	<u>1002</u>		<u>72</u>	<u>20</u>			
	<u>1032</u>	<u>30</u>			<u>19 7/8</u>	<u>1/8</u>	2ND 30 MIN.
	<u>1034</u>		<u>72</u>	<u>20</u>			
	<u>1104</u>	<u>30</u>			<u>19 7/8</u>	<u>1/8</u>	3RD 30 MIN.
	<u>1106</u>		<u>72</u>	<u>20</u>			
	<u>1136</u>	<u>30</u>			<u>19 7/8</u>	<u>1/8</u>	4TH 30 MIN.
	<u>1138</u>		<u>72</u>	<u>20</u>			
	<u>1208</u>	<u>30</u>			<u>19 7/8</u>	<u>1/8</u>	5TH 30 MIN.
	<u>1210</u>		<u>72</u>	<u>20</u>			
	<u>1240</u>	<u>30</u>			<u>19 7/8</u>	<u>1/8</u>	6TH 30 MIN.
	<u>1242</u>		<u>72</u>	<u>20</u>			
	<u>112</u>	<u>30</u>			<u>19 7/8</u>	<u>1/8</u>	7TH 30 MIN.



# **APPENDIX D**

## **GENERAL GRADING GUIDELINES**

**Proposed Warehouse Facility  
City of Orange, Orange County, California  
Project No. 2361-CR**



## **GENERAL GRADING GUIDELINES**

Guidelines presented herein are intended to address general construction procedures for earthwork construction. Specific situations and conditions often arise which cannot reasonably be discussed in general guidelines, when anticipated these are discussed in the text of the report. Often unanticipated conditions are encountered which may necessitate modification or changes to these guidelines. It is our hope that these will assist the contractor to more efficiently complete the project by providing a reasonable understanding of the procedures that would be expected during earthwork and the testing and observation used to evaluate those procedures.

### **General**

Grading should be performed to at least the minimum requirements of governing agencies, Chapters 18 and 33 of the Uniform Building Code, CBC (2016) and the guidelines presented below.

### **Preconstruction Meeting**

A preconstruction meeting should be held prior to site earthwork. Any questions the contractor has regarding our recommendations, general site conditions, apparent discrepancies between reported and actual conditions and/or differences in procedures the contractor intends to use should be brought up at that meeting. The contractor (including the main onsite representative) should review our report and these guidelines in advance of the meeting. Any comments the contractor may have regarding these guidelines should be brought up at that meeting.

### **Grading Observation and Testing**

1. Observation of the fill placement should be provided by our representative during grading. Verbal communication during the course of each day will be used to inform the contractor of test results. The contractor should receive a copy of the "Daily Field Report" indicating results of field density tests that day. If our representative does not provide the contractor with these reports, our office should be notified.
2. Testing and observation procedures are, by their nature, specific to the work or area observed and location of the tests taken, variability may occur in other locations. The contractor is responsible for the uniformity of the grading operations; our observations and test results are intended to evaluate the contractor's overall level of efforts during grading. The contractor's personnel are the only individuals participating in all aspect of site work. Compaction testing and observation should not be considered as relieving the contractor's responsibility to properly compact the fill.
3. Cleanouts, processed ground to receive fill, key excavations, and subdrains should be observed by our representative prior to placing any fill. It will be the contractor's responsibility to notify our representative or office when such areas are ready for observation.



4. Density tests may be made on the surface material to receive fill, as considered warranted by this firm.
5. In general, density tests would be made at maximum intervals of two feet of fill height or every 1,000 cubic yards of fill placed. Criteria will vary depending on soil conditions and size of the fill. More frequent testing may be performed. In any case, an adequate number of field density tests should be made to evaluate the required compaction and moisture content is generally being obtained.
6. Laboratory testing to support field test procedures will be performed, as considered warranted, based on conditions encountered (e.g. change of material sources, types, etc.) Every effort will be made to process samples in the laboratory as quickly as possible and in progress construction projects are our first priority. However, laboratory workloads may cause in delays and some soils may require a **minimum of 48 to 72 hours to complete test procedures**. Whenever possible, our representative(s) should be informed in advance of operational changes that might result in different source areas for materials.
7. Procedures for testing of fill slopes are as follows:
  - a) Density tests should be taken periodically during grading on the flat surface of the fill, three to five feet horizontally from the face of the slope.
  - b) If a method other than over building and cutting back to the compacted core is to be employed, slope compaction testing during construction should include testing the outer six inches to three feet in the slope face to determine if the required compaction is being achieved.
8. Finish grade testing of slopes and pad surfaces should be performed after construction is complete.

### **Site Clearing**

1. All vegetation, and other deleterious materials, should be removed from the site. If material is not immediately removed from the site it should be stockpiled in a designated area(s) well outside of all current work areas and delineated with flagging or other means. Site clearing should be performed in advance of any grading in a specific area.
2. Efforts should be made by the contractor to remove all organic or other deleterious material from the fill, as even the most diligent efforts may result in the incorporation of some materials. This is especially important when grading is occurring near the natural grade. All equipment operators should be aware of these efforts. Laborers may be required as root pickers.
3. Nonorganic debris or concrete may be placed in deeper fill areas provided the procedures used are observed and found acceptable by our representative.

**Treatment of Existing Ground**

1. Following site clearing, all surficial deposits of alluvium and colluvium as well as weathered or creep effected bedrock, should be removed unless otherwise specifically indicated in the text of this report.
2. In some cases, removal may be recommended to a specified depth (e.g. flat sites where partial alluvial removals may be sufficient). The contractor should not exceed these depths unless directed otherwise by our representative.
3. Groundwater existing in alluvial areas may make excavation difficult. Deeper removals than indicated in the text of the report may be necessary due to saturation during winter months.
4. Subsequent to removals, the natural ground should be processed to a depth of six inches, moistened to near optimum moisture conditions and compacted to fill standards.
5. Exploratory back hoe or dozer trenches still remaining after site removal should be excavated and filled with compacted fill if they can be located.

**Fill Placement**

1. Unless otherwise indicated, all site soil and bedrock may be reused for compacted fill; however, some special processing or handling may be required (see text of report).
2. Material used in the compacting process should be evenly spread, moisture conditioned, processed, and compacted in thin lifts six (6) to eight (8) inches in compacted thickness to obtain a uniformly dense layer. The fill should be placed and compacted on a nearly horizontal plane, unless otherwise found acceptable by our representative.
3. If the moisture content or relative density varies from that recommended by this firm, the contractor should rework the fill until it is in accordance with the following:
  - a) Moisture content of the fill should be at or above optimum moisture. Moisture should be evenly distributed without wet and dry pockets. Pre-watering of cut or removal areas should be considered in addition to watering during fill placement, particularly in clay or dry surficial soils. The ability of the contractor to obtain the proper moisture content will control production rates.
  - b) Each six-inch layer should be compacted to at least 90 percent of the maximum dry density in compliance with the testing method specified by the controlling governmental agency. In most cases, the testing method is ASTM Test Designation D 1557.
4. Rock fragments less than eight inches in diameter may be utilized in the fill, provided:
  - a) They are not placed in concentrated pockets;
  - b) There is a sufficient percentage of fine-grained material to surround the rocks;
  - c) The distribution of the rocks is observed by, and acceptable to, our representative.

5. Rocks exceeding eight (8) inches in diameter should be taken off site, broken into smaller fragments, or placed in accordance with recommendations of this firm in areas designated suitable for rock disposal. On projects where significant large quantities of oversized materials are anticipated, alternate guidelines for placement may be included. If significant oversize materials are encountered during construction, these guidelines should be requested.
6. In clay soil, dry or large chunks or blocks are common. If in excess of eight (8) inches minimum dimension, then they are considered as oversized. Sheepsfoot compactors or other suitable methods should be used to break up blocks. When dry, they should be moisture conditioned to provide a uniform condition with the surrounding fill.

### **Slope Construction**

1. The contractor should obtain a minimum relative compaction of 90 percent out to the finished slope face of fill slopes. This may be achieved by either overbuilding the slope and cutting back to the compacted core, or by direct compaction of the slope face with suitable equipment.
2. Slopes trimmed to the compacted core should be overbuilt by at least three (3) feet with compaction efforts out to the edge of the false slope. Failure to properly compact the outer edge results in trimming not exposing the compacted core and additional compaction after trimming may be necessary.
3. If fill slopes are built "at grade" using direct compaction methods, then the slope construction should be performed so that a constant gradient is maintained throughout construction. Soil should not be "spilled" over the slope face nor should slopes be "pushed out" to obtain grades. Compaction equipment should compact each lift along the immediate top of slope. Slopes should be back rolled or otherwise compacted at approximately every 4 feet vertically as the slope is built.
4. Corners and bends in slopes should have special attention during construction as these are the most difficult areas to obtain proper compaction.
5. Cut slopes should be cut to the finished surface. Excessive undercutting and smoothing of the face with fill may necessitate stabilization.

### **UTILITY TRENCH CONSTRUCTION AND BACKFILL**

Utility trench excavation and backfill is the contractor's responsibility. The geotechnical consultant typically provides periodic observation and testing of these operations. While efforts are made to make sufficient observations and tests to verify that the contractor's methods and procedures are adequate to achieve proper compaction, it is typically impractical to observe all backfill procedures. As such, it is critical that the contractor use consistent backfill procedures.

Compaction methods vary for trench compaction and experience indicates many methods can be successful. However, procedures that “worked” on previous projects may or may not prove effective on a given site. The contractor(s) should outline the procedures proposed, so that we may discuss them **prior** to construction. We will offer comments based on our knowledge of site conditions and experience.

1. Utility trench backfill in slopes, structural areas, in streets and beneath flat work or hardscape should be brought to at least optimum moisture and compacted to at least 90 percent of the laboratory standard. Soil should be moisture conditioned prior to placing in the trench.
2. Flooding and jetting are not typically recommended or acceptable for native soils. Flooding or jetting may be used with select sand having a Sand Equivalent (SE) of 30 or higher. This is typically limited to the following uses:
  - a) shallow (12 + inches) under slab interior trenches and,
  - b) as bedding in pipe zone.

The water should be allowed to dissipate prior to pouring slabs or completing trench compaction.

3. Care should be taken not to place soils at high moisture content within the upper three feet of the trench backfill in street areas, as overly wet soils may impact subgrade preparation. Moisture may be reduced to 2% below optimum moisture in areas to be paved within the upper three feet below sub grade.
4. Sand backfill should not be allowed in exterior trenches adjacent to and within an area extending below a 1:1 projection from the outside bottom edge of a footing, unless it is similar to the surrounding soil.
5. Trench compaction testing is generally at the discretion of the geotechnical consultant. Testing frequency will be based on trench depth and the contractors procedures. A probing rod would be used to assess the consistency of compaction between tested areas and untested areas. If zones are found that are considered less compact than other areas, this would be brought to the contractors attention.

## **JOB SAFETY**

### **General**

Personnel safety is a primary concern on all job sites. The following summaries are safety considerations for use by all our employees on multi-employer construction sites. On ground personnel are at highest risk of injury and possible fatality on grading construction projects. The company recognizes that construction activities will vary on each site and that job site safety is the contractor's responsibility. However, it is, imperative that all personnel be safety conscious to avoid accidents and potential injury.



In an effort to minimize risks associated with geotechnical testing and observation, the following precautions are to be implemented for the safety of our field personnel on grading and construction projects.

1. **Safety Meetings:** Our field personnel are directed to attend the contractor's regularly scheduled safety meetings.
2. **Safety Vests:** Safety vests are provided for and are to be worn by our personnel while on the job site.
3. **Safety Flags:** Safety flags are provided to our field technicians; one is to be affixed to the vehicle when on site, the other is to be placed atop the spoil pile on all test pits.

In the event that the contractor's representative observes any of our personnel not following the above, we request that it be brought to the attention of our office.

### **Test Pits Location, Orientation and Clearance**

The technician is responsible for selecting test pit locations. The primary concern is the technician's safety. However, it is necessary to take sufficient tests at various locations to obtain a representative sampling of the fill. As such, efforts will be made to coordinate locations with the grading contractors authorized representatives (e.g. dump man, operator, supervisor, grade checker, etc.), and to select locations following or behind the established traffic pattern, preferably outside of current traffic. The contractors authorized representative should direct excavation of the pit and safety during the test period. Again, safety is the paramount concern.

Test pits should be excavated so that the spoil pile is placed away from oncoming traffic. The technician's vehicle is to be placed next to the test pit, opposite the spoil pile. This necessitates that the fill be maintained in a drivable condition. Alternatively, the contractor may opt to park a piece of equipment in front of test pits, particularly in small fill areas or those with limited access.

A zone of non-encroachment should be established for all test pits (see diagram below). No grading equipment should enter this zone during the test procedure. The zone should extend outward to the sides approximately 50 feet from the center of the test pit and 100 feet in the direction of traffic flow. This zone is established both for safety and to avoid excessive ground vibration, which typically decreases test results.

**TEST PIT SAFETY PLAN**

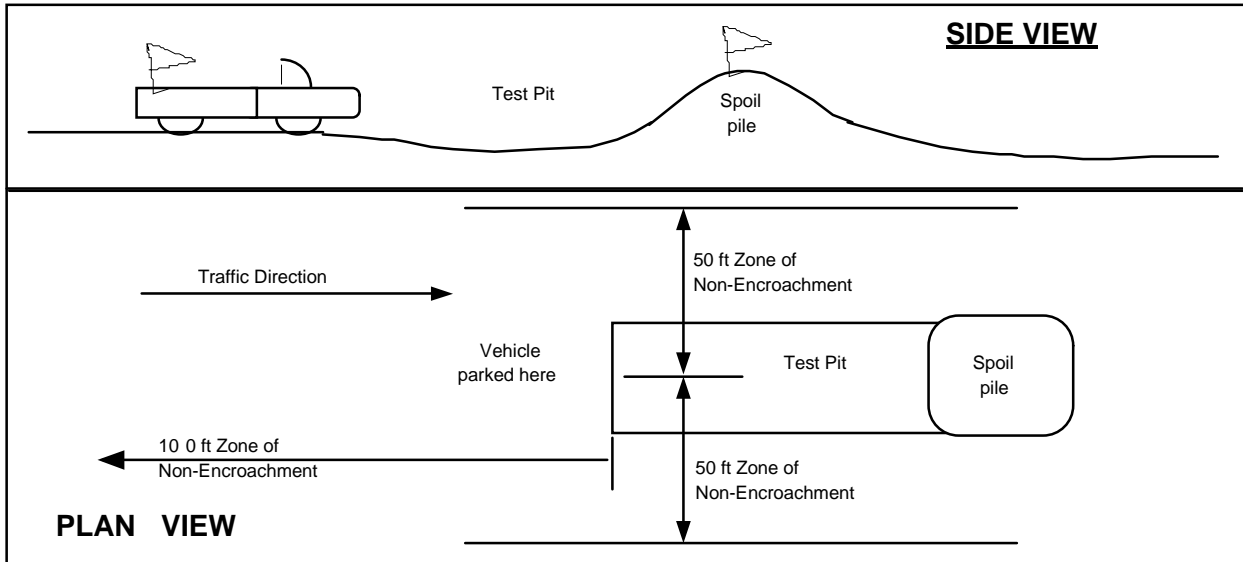

**Slope Tests**

When taking slope tests, the technician should park their vehicle directly above or below the test location on the slope. The contractor's representative should effectively keep all equipment at a safe operation distance (e.g. 50 feet) away from the slope during testing.

The technician is directed to withdraw from the active portion of the fill as soon as possible following testing. The technician's vehicle should be parked at the perimeter of the fill in a highly visible location.

**Trench Safety**

It is the contractor's responsibility to provide safe access into trenches where compaction testing is needed. Trenches for all utilities should be excavated in accordance with CAL-OSHA and any other applicable safety standards. Safe conditions will be required to enable compaction testing of the trench backfill.

All utility trench excavations in excess of 5 feet deep, which a person enters, are to be shored or laid back. Trench access should be provided in accordance with OSHA standards. Our personnel are directed not to enter any trench by being lowered or "riding down" on the equipment.

Our personnel are directed not to enter any excavation which;

1. is 5 feet or deeper unless shored or laid back,
2. exit points or ladders are not provided,
3. displays any evidence of instability, has any loose rock or other debris which could fall into the trench, or
4. displays any other evidence of any unsafe conditions regardless of depth.

If the contractor fails to provide safe access to trenches for compaction testing, our company policy requires that the soil technician withdraws and notifies their supervisor. The contractor's representative will then be contacted in an effort to effect a solution. All backfill not tested due to safety concerns or other reasons is subject to reprocessing and/or removal.

**Procedures**

In the event that the technician's safety is jeopardized or compromised as a result of the contractor's failure to comply with any of the above, the technician is directed to inform both the developer's and contractor's representatives. If the condition is not rectified, the technician is required, by company policy, to immediately withdraw and notify their supervisor. The contractor's representative will then be contacted in an effort to effect a solution. No further testing will be performed until the situation is rectified. Any fill placed in the interim can be considered unacceptable and subject to reprocessing, recompaction or removal.

In the event that the soil technician does not comply with the above or other established safety guidelines, we request that the contractor bring this to technicians attention and notify our project manager or office. Effective communication and coordination between the contractor's representative and the field technician(s) is strongly encouraged in order to implement the above safety program and safety in general.

The safety procedures outlined above should be discussed at the contractor's safety meetings. This will serve to inform and remind equipment operators of these safety procedures particularly the zone of non-encroachment.

The safety procedures outlined above should be discussed at the contractor's safety meetings. This will serve to inform and remind equipment operators of these safety procedures particularly the zone of non-encroachment.

**Appendix F:**

**Hydrology Information**

**(Q2 – Two-year frequency storm evaluation)**



Orange County Rational Hydrology Program

(Hydrology Manual Date(s) October 1986 & November 1996)

CIVILCADD/CIVILDESIGN Engineering Software, (c) 1989-2004 Version 8.0  
Rational Hydrology Study, Date: 11/24/21 File Name: EX2.roc

-----  
2-YEAR EXISTING CONDITION RATIONAL METHOD HYDROLOGY  
534 W. STRUCK AVE REDEVELOPMENT PROJECT  
CITY OF ORANGE, CALIFORNIA  
WO 21-0201 MJS  
-----

Program License Serial Number 4010

-----  
\*\*\*\*\* Hydrology Study Control Information \*\*\*\*\*  
-----

Rational hydrology study storm event year is 2.0

Decimal fraction of study above 2000 ft., 600M = 0.0000  
English Units Used for input data

++++  
Process from Point/Station 100.000 to Point/Station 101.000  
\*\*\*\* INITIAL AREA EVALUATION \*\*\*\*

---

COMMERCIAL subarea type  
Decimal fraction soil group A = 0.000  
Decimal fraction soil group B = 0.000  
Decimal fraction soil group C = 0.000  
Decimal fraction soil group D = 1.000  
SCS curve number for soil(AMC 2) = 75.00  
Pervious ratio(Ap) = 0.1000 Max loss rate(Fp)= 0.200(In/Hr)  
Max Catchment Loss (Fm) = 0.020(In/Hr)  
Initial subarea data:  
Initial area flow distance = 305.000(Ft.)  
Top (of initial area) elevation = 190.800(Ft.)  
Bottom (of initial area) elevation = 185.000(Ft.)  
Difference in elevation = 5.800(Ft.)  
Slope = 0.01902 s(%)= 1.90  
TC = k(0.304)\*[(length^3)/(elevation change)]^0.2  
Initial area time of concentration = 6.619 min.  
Rainfall intensity = 1.927(In/Hr) for a 2.0 year storm  
Effective runoff coefficient used for area (Q=KCIA) is C = 0.891  
Subarea runoff = 2.746(CFS)  
Total initial stream area = 1.600(Ac.)

++++

Process from Point/Station 101.000 to Point/Station 102.000  
\*\*\*\* IMPROVED CHANNEL TRAVEL TIME \*\*\*\*

---

Upstream point elevation = 185.000(Ft.)  
Downstream point elevation = 182.100(Ft.)  
Channel length thru subarea = 230.000(Ft.)  
Channel base width = 0.000(Ft.)  
Slope or 'Z' of left channel bank = 100.000  
Slope or 'Z' of right channel bank = 100.000  
Estimated mean flow rate at midpoint of channel = 3.624(CFS)  
Manning's 'N' = 0.015  
Maximum depth of channel = 1.000(Ft.)  
Flow(q) thru subarea = 3.624(CFS)  
Depth of flow = 0.139(Ft.), Average velocity = 1.879(Ft/s)  
Channel flow top width = 27.776(Ft.)  
Flow Velocity = 1.88(Ft/s)  
Travel time = 2.04 min.  
Time of concentration = 8.66 min.  
Critical depth = 0.152(Ft.)  
Adding area flow to channel  
COMMERCIAL subarea type  
Decimal fraction soil group A = 0.000  
Decimal fraction soil group B = 0.000  
Decimal fraction soil group C = 0.000  
Decimal fraction soil group D = 1.000  
SCS curve number for soil(AMC 2) = 75.00  
Pervious ratio(Ap) = 0.1000 Max loss rate(Fp)= 0.200(In/Hr)  
Max Catchment Loss (Fm) = 0.020(In/Hr)  
Rainfall intensity = 1.652(In/Hr) for a 2.0 year storm  
Effective runoff coefficient used for area,(total area with modified  
rational method)(Q=KCIA) is C = 0.889  
Subarea runoff = 1.659(CFS) for 1.400(Ac.)  
Total runoff = 4.406(CFS) Total area = 3.00(Ac.)  
Area averaged Fm value = 0.020(In/Hr)  
Depth of flow = 0.149(Ft.), Average velocity = 1.973(Ft/s)  
Critical depth = 0.164(Ft.)

+++++  
Process from Point/Station 102.000 to Point/Station 103.000  
\*\*\*\* IMPROVED CHANNEL TRAVEL TIME \*\*\*\*

---

Upstream point elevation = 182.100(Ft.)  
Downstream point elevation = 181.000(Ft.)  
Channel length thru subarea = 227.000(Ft.)  
Channel base width = 0.000(Ft.)  
Slope or 'Z' of left channel bank = 25.000  
Slope or 'Z' of right channel bank = 25.000  
Estimated mean flow rate at midpoint of channel = 5.469(CFS)  
Manning's 'N' = 0.015  
Maximum depth of channel = 0.500(Ft.)  
Flow(q) thru subarea = 5.469(CFS)  
Depth of flow = 0.326(Ft.), Average velocity = 2.057(Ft/s)  
Channel flow top width = 16.305(Ft.)  
Flow Velocity = 2.06(Ft/s)

Travel time = 1.84 min.  
Time of concentration = 10.50 min.  
Critical depth = 0.313(Ft.)  
Adding area flow to channel  
COMMERCIAL subarea type  
Decimal fraction soil group A = 0.000  
Decimal fraction soil group B = 0.000  
Decimal fraction soil group C = 0.000  
Decimal fraction soil group D = 1.000  
SCS curve number for soil(AMC 2) = 75.00  
Pervious ratio(Ap) = 0.1000 Max loss rate(Fp)= 0.200(In/Hr)  
Max Catchment Loss (Fm) = 0.020(In/Hr)  
Rainfall intensity = 1.479(In/Hr) for a 2.0 year storm  
Effective runoff coefficient used for area,(total area with modified  
rational method)(Q=KCIA) is C = 0.888  
Subarea runoff = 2.028(CFS) for 1.900(Ac.)  
Total runoff = 6.433(CFS) Total area = 4.90(Ac.)  
Area averaged Fm value = 0.020(In/Hr)  
Depth of flow = 0.347(Ft.), Average velocity = 2.142(Ft/s)  
Critical depth = 0.332(Ft.)

+++++  
Process from Point/Station 103.000 to Point/Station 104.000  
\*\*\*\* IMPROVED CHANNEL TRAVEL TIME \*\*\*\*

---

Upstream point elevation = 181.000(Ft.)  
Downstream point elevation = 179.300(Ft.)  
Channel length thru subarea = 272.000(Ft.)  
Channel base width = 0.000(Ft.)  
Slope or 'Z' of left channel bank = 25.000  
Slope or 'Z' of right channel bank = 25.000  
Estimated mean flow rate at midpoint of channel = 7.484(CFS)  
Manning's 'N' = 0.015  
Maximum depth of channel = 0.500(Ft.)  
Flow(q) thru subarea = 7.484(CFS)  
Depth of flow = 0.350(Ft.), Average velocity = 2.448(Ft/s)  
Channel flow top width = 17.486(Ft.)  
Flow Velocity = 2.45(Ft/s)  
Travel time = 1.85 min.  
Time of concentration = 12.35 min.  
Critical depth = 0.355(Ft.)  
Adding area flow to channel  
COMMERCIAL subarea type  
Decimal fraction soil group A = 0.000  
Decimal fraction soil group B = 0.000  
Decimal fraction soil group C = 0.000  
Decimal fraction soil group D = 1.000  
SCS curve number for soil(AMC 2) = 75.00  
Pervious ratio(Ap) = 0.1000 Max loss rate(Fp)= 0.200(In/Hr)  
Max Catchment Loss (Fm) = 0.020(In/Hr)  
Rainfall intensity = 1.347(In/Hr) for a 2.0 year storm  
Effective runoff coefficient used for area,(total area with modified  
rational method)(Q=KCIA) is C = 0.887  
Subarea runoff = 2.047(CFS) for 2.200(Ac.)

Total runoff = 8.480(CFS) Total area = 7.10(Ac.)  
Area averaged Fm value = 0.020(In/Hr)  
Depth of flow = 0.366(Ft.), Average velocity = 2.525(Ft/s)  
Critical depth = 0.371(Ft.)

\*\*\*\*\*  
Process from Point/Station 104.000 to Point/Station 104.000  
\*\*\*\* CONFLUENCE OF MINOR STREAMS \*\*\*\*

---

Along Main Stream number: 1 in normal stream number 1  
Stream flow area = 7.100(Ac.)  
Runoff from this stream = 8.480(CFS)  
Time of concentration = 12.35 min.  
Rainfall intensity = 1.347(In/Hr)  
Area averaged loss rate (Fm) = 0.0200(In/Hr)  
Area averaged Pervious ratio (Ap) = 0.1000

\*\*\*\*\*  
Process from Point/Station 100.000 to Point/Station 105.000  
\*\*\*\* INITIAL AREA EVALUATION \*\*\*\*

---

COMMERCIAL subarea type  
Decimal fraction soil group A = 0.000  
Decimal fraction soil group B = 0.000  
Decimal fraction soil group C = 0.000  
Decimal fraction soil group D = 1.000  
SCS curve number for soil(AMC 2) = 75.00  
Pervious ratio(Ap) = 0.1000 Max loss rate(Fp)= 0.200(In/Hr)  
Max Catchment Loss (Fm) = 0.020(In/Hr)  
Initial subarea data:  
Initial area flow distance = 330.000(Ft.)  
Top (of initial area) elevation = 190.800(Ft.)  
Bottom (of initial area) elevation = 185.100(Ft.)  
Difference in elevation = 5.700(Ft.)  
Slope = 0.01727 s(%)= 1.73  
TC =  $k(0.304)*[(\text{length}^3)/(\text{elevation change})]^{0.2}$   
Initial area time of concentration = 6.963 min.  
NOTE: Distance EXCEEDS recommended maximum value of 328.084(Ft.)  
for this Development Type  
Rainfall intensity = 1.872(In/Hr) for a 2.0 year storm  
Effective runoff coefficient used for area (Q=KCIA) is C = 0.890  
Subarea runoff = 1.333(CFS)  
Total initial stream area = 0.800(Ac.)

\*\*\*\*\*  
Process from Point/Station 105.000 to Point/Station 106.000  
\*\*\*\* IMPROVED CHANNEL TRAVEL TIME \*\*\*\*

---

Upstream point elevation = 185.100(Ft.)  
Downstream point elevation = 181.400(Ft.)  
Channel length thru subarea = 447.000(Ft.)  
Channel base width = 0.000(Ft.)

Slope or 'Z' of left channel bank = 19.000  
 Slope or 'Z' of right channel bank = 3.000  
 Estimated mean flow rate at midpoint of channel = 2.270(CFS)  
 Manning's 'N' = 0.015  
 Maximum depth of channel = 1.000(Ft.)  
 Flow(q) thru subarea = 2.270(CFS)  
 Depth of flow = 0.289(Ft.), Average velocity = 2.468(Ft/s)  
 Channel flow top width = 6.360(Ft.)  
 Flow Velocity = 2.47(Ft/s)  
 Travel time = 3.02 min.  
 Time of concentration = 9.98 min.  
 Critical depth = 0.305(Ft.)  
 Adding area flow to channel  
 COMMERCIAL subarea type  
 Decimal fraction soil group A = 0.000  
 Decimal fraction soil group B = 0.000  
 Decimal fraction soil group C = 0.000  
 Decimal fraction soil group D = 1.000  
 SCS curve number for soil(AMC 2) = 75.00  
 Pervious ratio(Ap) = 0.1000 Max loss rate(Fp)= 0.200(In/Hr)  
 Max Catchment Loss (Fm) = 0.020(In/Hr)  
 Rainfall intensity = 1.522(In/Hr) for a 2.0 year storm  
 Effective runoff coefficient used for area,(total area with modified  
 rational method)(Q=KCIA) is C = 0.888  
 Subarea runoff = 1.776(CFS) for 1.500(Ac.)  
 Total runoff = 3.110(CFS) Total area = 2.30(Ac.)  
 Area averaged Fm value = 0.020(In/Hr)  
 Depth of flow = 0.325(Ft.), Average velocity = 2.671(Ft/s)  
 Critical depth = 0.346(Ft.)

++++++  
 Process from Point/Station 106.000 to Point/Station 106.000  
 \*\*\*\* SUBAREA FLOW ADDITION \*\*\*\*

---

COMMERCIAL subarea type  
 Decimal fraction soil group A = 0.000  
 Decimal fraction soil group B = 0.000  
 Decimal fraction soil group C = 0.000  
 Decimal fraction soil group D = 1.000  
 SCS curve number for soil(AMC 2) = 75.00  
 Pervious ratio(Ap) = 0.1000 Max loss rate(Fp)= 0.200(In/Hr)  
 Max Catchment Loss (Fm) = 0.020(In/Hr)  
 Time of concentration = 9.98 min.  
 Rainfall intensity = 1.522(In/Hr) for a 2.0 year storm  
 Effective runoff coefficient used for area,(total area with modified  
 rational method)(Q=KCIA) is C = 0.888  
 Subarea runoff = 0.811(CFS) for 0.600(Ac.)  
 Total runoff = 3.921(CFS) Total area = 2.90(Ac.)  
 Area averaged Fm value = 0.020(In/Hr)

++++++  
 Process from Point/Station 106.000 to Point/Station 104.000  
 \*\*\*\* STREET FLOW TRAVEL TIME + SUBAREA FLOW ADDITION \*\*\*\*

---

Top of street segment elevation = 181.400(Ft.)  
 End of street segment elevation = 179.300(Ft.)  
 Length of street segment = 429.000(Ft.)  
 Height of curb above gutter flowline = 8.0(In.)  
 Width of half street (curb to crown) = 24.000(Ft.)  
 Distance from crown to crossfall grade break = 18.000(Ft.)  
 Slope from gutter to grade break (v/hz) = 0.020  
 Slope from grade break to crown (v/hz) = 0.020  
 Street flow is on [1] side(s) of the street  
 Distance from curb to property line = 6.000(Ft.)  
 Slope from curb to property line (v/hz) = 0.020  
 Gutter width = 2.000(Ft.)  
 Gutter hike from flowline = 2.000(In.)  
 Manning's N in gutter = 0.0150  
 Manning's N from gutter to grade break = 0.0150  
 Manning's N from grade break to crown = 0.0150  
 Estimated mean flow rate at midpoint of street = 3.921(CFS)  
 Depth of flow = 0.405(Ft.), Average velocity = 1.903(Ft/s)  
 Streetflow hydraulics at midpoint of street travel:  
 Halfstreet flow width = 13.905(Ft.)  
 Flow velocity = 1.90(Ft/s)  
 Travel time = 3.76 min. TC = 13.74 min.  
 Adding area flow to street  
 COMMERCIAL subarea type  
 Decimal fraction soil group A = 0.000  
 Decimal fraction soil group B = 0.000  
 Decimal fraction soil group C = 0.000  
 Decimal fraction soil group D = 1.000  
 SCS curve number for soil(AMC 2) = 75.00  
 Pervious ratio(Ap) = 0.1000 Max loss rate(Fp)= 0.200(In/Hr)  
 Max Catchment Loss (Fm) = 0.020(In/Hr)  
 Rainfall intensity = 1.267(In/Hr) for a 2.0 year storm  
 Effective runoff coefficient used for area,(total area with modified  
 rational method)(Q=KCIA) is C = 0.886  
 Subarea runoff = 0.000(CFS) for 0.000(Ac.)  
 Total runoff = 3.921(CFS) Total area = 2.90(Ac.)  
 Area averaged Fm value = 0.020(In/Hr)  
 Street flow at end of street = 3.921(CFS)  
 Half street flow at end of street = 3.921(CFS)  
 Depth of flow = 0.405(Ft.), Average velocity = 1.903(Ft/s)  
 Flow width (from curb towards crown)= 13.905(Ft.)

++++++  
 Process from Point/Station 104.000 to Point/Station 104.000  
 \*\*\*\* CONFLUENCE OF MINOR STREAMS \*\*\*\*

---

Along Main Stream number: 1 in normal stream number 2  
 Stream flow area = 2.900(Ac.)  
 Runoff from this stream = 3.921(CFS)  
 Time of concentration = 13.74 min.  
 Rainfall intensity = 1.267(In/Hr)  
 Area averaged loss rate (Fm) = 0.0200(In/Hr)  
 Area averaged Pervious ratio (Ap) = 0.1000

Summary of stream data:

Stream No.	Area (Ac.)	Flow rate (CFS)	TC (min)	Fm (In/Hr)	Rainfall Intensity (In/Hr)
------------	------------	-----------------	----------	------------	----------------------------

1	7.10	8.480	12.35	0.020	1.347
---	------	-------	-------	-------	-------

2	2.90	3.921	13.74	0.020	1.267
---	------	-------	-------	-------	-------

Qmax(1) =

1.000 \* 1.000 \* 8.480) +  
1.064 \* 0.899 \* 3.921) + = 12.231

Qmax(2) =

0.940 \* 1.000 \* 8.480) +  
1.000 \* 1.000 \* 3.921) + = 11.891

Total of 2 streams to confluence:

Flow rates before confluence point:

8.480      3.921

Maximum flow rates at confluence using above data:

12.231      11.891

Area of streams before confluence:

7.100      2.900

Effective area values after confluence:

9.707      10.000

Results of confluence:

Total flow rate = 12.231(CFS)

Time of concentration = 12.350 min.

Effective stream area after confluence = 9.707(Ac.)

Study area average Pervious fraction(Ap) = 0.100

Study area average soil loss rate(Fm) = 0.020(In/Hr)

Study area total (this main stream) = 10.00(Ac.)

End of computations, total study area = 10.00 (Ac.)

The following figures may

be used for a unit hydrograph study of the same area.

Note: These figures do not consider reduced effective area effects caused by confluences in the rational equation.

Area averaged pervious area fraction(Ap) = 0.100

Area averaged SCS curve number (AMC 2) = 75.0

Orange County Rational Hydrology Program

(Hydrology Manual Date(s) October 1986 & November 1996)

CIVILCADD/CIVILDESIGN Engineering Software, (c) 1989-2004 Version 8.0  
Rational Hydrology Study, Date: 11/18/21 File Name: PROP2.roc

-----  
2-YEAR DEVELOPED CONDITION RATIONAL METHOD HYDROLOGY  
534 W. STRUCK AVE REDEVELOPMENT PROJECT  
CITY OF ORANGE, CALIFORNIA  
WO 21-0201 MJS  
-----

Program License Serial Number 4010

-----  
\*\*\*\*\* Hydrology Study Control Information \*\*\*\*\*  
-----

Rational hydrology study storm event year is 2.0

Decimal fraction of study above 2000 ft., 600M = 0.0000  
English Units Used for input data

++++  
Process from Point/Station 100.000 to Point/Station 101.000  
\*\*\*\* INITIAL AREA EVALUATION \*\*\*\*

---

COMMERCIAL subarea type  
Decimal fraction soil group A = 0.000  
Decimal fraction soil group B = 0.000  
Decimal fraction soil group C = 0.000  
Decimal fraction soil group D = 1.000  
SCS curve number for soil(AMC 2) = 75.00  
Pervious ratio(Ap) = 0.1000 Max loss rate(Fp)= 0.200(In/Hr)  
Max Catchment Loss (Fm) = 0.020(In/Hr)  
Initial subarea data:  
Initial area flow distance = 217.000(Ft.)  
Top (of initial area) elevation = 187.100(Ft.)  
Bottom (of initial area) elevation = 185.000(Ft.)  
Difference in elevation = 2.100(Ft.)  
Slope = 0.00968 s(%)= 0.97  
TC = k(0.304)\*[(length^3)/(elevation change)]^0.2  
Initial area time of concentration = 6.612 min.  
Rainfall intensity = 1.928(In/Hr) for a 2.0 year storm  
Effective runoff coefficient used for area (Q=KCIA) is C = 0.891  
Subarea runoff = 2.061(CFS)  
Total initial stream area = 1.200(Ac.)

++++



Process from Point/Station 101.000 to Point/Station 102.000  
\*\*\*\* PIPEFLOW TRAVEL TIME (Program estimated size) \*\*\*\*

---

Upstream point/station elevation = 178.800(Ft.)  
Downstream point/station elevation = 178.200(Ft.)  
Pipe length = 208.00(Ft.) Manning's N = 0.013  
No. of pipes = 1 Required pipe flow = 2.061(CFS)  
Nearest computed pipe diameter = 15.00(In.)  
Calculated individual pipe flow = 2.061(CFS)  
Normal flow depth in pipe = 8.32(In.)  
Flow top width inside pipe = 14.91(In.)  
Critical Depth = 6.87(In.)  
Pipe flow velocity = 2.95(Ft/s)  
Travel time through pipe = 1.18 min.  
Time of concentration (TC) = 7.79 min.

+++++  
Process from Point/Station 102.000 to Point/Station 102.000  
\*\*\*\* SUBAREA FLOW ADDITION \*\*\*\*

---

COMMERCIAL subarea type  
Decimal fraction soil group A = 0.000  
Decimal fraction soil group B = 0.000  
Decimal fraction soil group C = 0.000  
Decimal fraction soil group D = 1.000  
SCS curve number for soil(AMC 2) = 75.00  
Pervious ratio(Ap) = 0.1000 Max loss rate(Fp)= 0.200(In/Hr)  
Max Catchment Loss (Fm) = 0.020(In/Hr)  
Time of concentration = 7.79 min.  
Rainfall intensity = 1.755(In/Hr) for a 2.0 year storm  
Effective runoff coefficient used for area,(total area with modified  
rational method)(Q=KCIA) is C = 0.890  
Subarea runoff = 1.687(CFS) for 1.200(Ac.)  
Total runoff = 3.748(CFS) Total area = 2.40(Ac.)  
Area averaged Fm value = 0.020(In/Hr)

+++++  
Process from Point/Station 102.000 to Point/Station 105.000  
\*\*\*\* PIPEFLOW TRAVEL TIME (Program estimated size) \*\*\*\*

---

Upstream point/station elevation = 178.200(Ft.)  
Downstream point/station elevation = 177.400(Ft.)  
Pipe length = 245.00(Ft.) Manning's N = 0.013  
No. of pipes = 1 Required pipe flow = 3.748(CFS)  
Nearest computed pipe diameter = 18.00(In.)  
Calculated individual pipe flow = 3.748(CFS)  
Normal flow depth in pipe = 10.30(In.)  
Flow top width inside pipe = 17.81(In.)  
Critical Depth = 8.87(In.)  
Pipe flow velocity = 3.58(Ft/s)  
Travel time through pipe = 1.14 min.  
Time of concentration (TC) = 8.93 min.

+++++  
Process from Point/Station 105.000 to Point/Station 105.000  
\*\*\*\* SUBAREA FLOW ADDITION \*\*\*\*

---

COMMERCIAL subarea type  
Decimal fraction soil group A = 0.000  
Decimal fraction soil group B = 0.000  
Decimal fraction soil group C = 0.000  
Decimal fraction soil group D = 1.000  
SCS curve number for soil(AMC 2) = 75.00  
Pervious ratio(Ap) = 0.1000 Max loss rate(Fp)= 0.200(In/Hr)  
Max Catchment Loss (Fm) = 0.020(In/Hr)  
Time of concentration = 8.93 min.  
Rainfall intensity = 1.623(In/Hr) for a 2.0 year storm  
Effective runoff coefficient used for area,(total area with modified  
rational method)(Q=KCIA) is C = 0.889  
Subarea runoff = 2.455(CFS) for 1.900(Ac.)  
Total runoff = 6.204(CFS) Total area = 4.30(Ac.)  
Area averaged Fm value = 0.020(In/Hr)

+++++  
Process from Point/Station 105.000 to Point/Station 108.000  
\*\*\*\* PIPEFLOW TRAVEL TIME (Program estimated size) \*\*\*\*

---

Upstream point/station elevation = 177.400(Ft.)  
Downstream point/station elevation = 176.500(Ft.)  
Pipe length = 303.00(Ft.) Manning's N = 0.013  
No. of pipes = 1 Required pipe flow = 6.204(CFS)  
Nearest computed pipe diameter = 21.00(In.)  
Calculated individual pipe flow = 6.204(CFS)  
Normal flow depth in pipe = 13.17(In.)  
Flow top width inside pipe = 20.31(In.)  
Critical Depth = 11.01(In.)  
Pipe flow velocity = 3.91(Ft/s)  
Travel time through pipe = 1.29 min.  
Time of concentration (TC) = 10.22 min.

+++++  
Process from Point/Station 108.000 to Point/Station 108.000  
\*\*\*\* SUBAREA FLOW ADDITION \*\*\*\*

---

COMMERCIAL subarea type  
Decimal fraction soil group A = 0.000  
Decimal fraction soil group B = 0.000  
Decimal fraction soil group C = 0.000  
Decimal fraction soil group D = 1.000  
SCS curve number for soil(AMC 2) = 75.00  
Pervious ratio(Ap) = 0.1000 Max loss rate(Fp)= 0.200(In/Hr)  
Max Catchment Loss (Fm) = 0.020(In/Hr)  
Time of concentration = 10.22 min.  
Rainfall intensity = 1.502(In/Hr) for a 2.0 year storm  
Effective runoff coefficient used for area,(total area with modified

rational method)(Q=KCIA) is C = 0.888  
Subarea runoff = 0.331(CFS) for 0.600(Ac.)  
Total runoff = 6.535(CFS) Total area = 4.90(Ac.)  
Area averaged Fm value = 0.020(In/Hr)

++++  
Process from Point/Station 108.000 to Point/Station 111.000  
\*\*\*\* PIPEFLOW TRAVEL TIME (Program estimated size) \*\*\*\*

---

Upstream point/station elevation = 176.500(Ft.)  
Downstream point/station elevation = 176.400(Ft.)  
Pipe length = 45.00(Ft.) Manning's N = 0.013  
No. of pipes = 1 Required pipe flow = 6.535(CFS)  
Nearest computed pipe diameter = 21.00(In.)  
Calculated individual pipe flow = 6.535(CFS)  
Normal flow depth in pipe = 15.22(In.)  
Flow top width inside pipe = 18.76(In.)  
Critical Depth = 11.34(In.)  
Pipe flow velocity = 3.50(Ft/s)  
Travel time through pipe = 0.21 min.  
Time of concentration (TC) = 10.43 min.

++++  
Process from Point/Station 111.000 to Point/Station 111.000  
\*\*\*\* CONFLUENCE OF MAIN STREAMS \*\*\*\*

---

The following data inside Main Stream is listed:  
In Main Stream number: 1  
Stream flow area = 4.900(Ac.)  
Runoff from this stream = 6.535(CFS)  
Time of concentration = 10.43 min.  
Rainfall intensity = 1.484(In/Hr)  
Area averaged loss rate (Fm) = 0.0200(In/Hr)  
Area averaged Pervious ratio (Ap) = 0.1000  
Program is now starting with Main Stream No. 2

++++  
Process from Point/Station 101.000 to Point/Station 201.000  
\*\*\*\* INITIAL AREA EVALUATION \*\*\*\*

---

COMMERCIAL subarea type  
Decimal fraction soil group A = 0.000  
Decimal fraction soil group B = 0.000  
Decimal fraction soil group C = 0.000  
Decimal fraction soil group D = 1.000  
SCS curve number for soil(AMC 2) = 75.00  
Pervious ratio(Ap) = 0.1000 Max loss rate(Fp)= 0.200(In/Hr)  
Max Catchment Loss (Fm) = 0.020(In/Hr)  
Initial subarea data:  
Initial area flow distance = 313.000(Ft.)  
Top (of initial area) elevation = 187.100(Ft.)  
Bottom (of initial area) elevation = 183.400(Ft.)

Difference in elevation = 3.700(Ft.)  
Slope = 0.01182 s(%)= 1.18  
TC =  $k(0.304)*[(\text{length}^3)/(\text{elevation change})]^{0.2}$   
Initial area time of concentration = 7.355 min.  
Rainfall intensity = 1.814(In/Hr) for a 2.0 year storm  
Effective runoff coefficient used for area (Q=KCIA) is C = 0.890  
Subarea runoff = 1.776(CFS)  
Total initial stream area = 1.100(Ac.)

++++  
Process from Point/Station 201.000 to Point/Station 202.000  
\*\*\*\* PIPEFLOW TRAVEL TIME (Program estimated size) \*\*\*\*

---

Upstream point/station elevation = 178.600(Ft.)  
Downstream point/station elevation = 177.700(Ft.)  
Pipe length = 300.00(Ft.) Manning's N = 0.013  
No. of pipes = 1 Required pipe flow = 1.776(CFS)  
Nearest computed pipe diameter = 12.00(In.)  
Calculated individual pipe flow = 1.776(CFS)  
Normal flow depth in pipe = 8.98(In.)  
Flow top width inside pipe = 10.41(In.)  
Critical Depth = 6.81(In.)  
Pipe flow velocity = 2.82(Ft/s)  
Travel time through pipe = 1.78 min.  
Time of concentration (TC) = 9.13 min.

++++  
Process from Point/Station 202.000 to Point/Station 202.000  
\*\*\*\* SUBAREA FLOW ADDITION \*\*\*\*

---

COMMERCIAL subarea type  
Decimal fraction soil group A = 0.000  
Decimal fraction soil group B = 0.000  
Decimal fraction soil group C = 0.000  
Decimal fraction soil group D = 1.000  
SCS curve number for soil(AMC 2) = 75.00  
Pervious ratio(Ap) = 0.1000 Max loss rate(Fp)= 0.200(In/Hr)  
Max Catchment Loss (Fm) = 0.020(In/Hr)  
Time of concentration = 9.13 min.  
Rainfall intensity = 1.602(In/Hr) for a 2.0 year storm  
Effective runoff coefficient used for area,(total area with modified  
rational method)(Q=KCIA) is C = 0.889  
Subarea runoff = 0.929(CFS) for 0.800(Ac.)  
Total runoff = 2.705(CFS) Total area = 1.90(Ac.)  
Area averaged Fm value = 0.020(In/Hr)

++++  
Process from Point/Station 202.000 to Point/Station 205.000  
\*\*\*\* PIPEFLOW TRAVEL TIME (Program estimated size) \*\*\*\*

---

Upstream point/station elevation = 177.700(Ft.)  
Downstream point/station elevation = 177.200(Ft.)

Pipe length = 176.00(Ft.) Manning's N = 0.013  
No. of pipes = 1 Required pipe flow = 2.705(CFS)  
Nearest computed pipe diameter = 15.00(In.)  
Calculated individual pipe flow = 2.705(CFS)  
Normal flow depth in pipe = 10.02(In.)  
Flow top width inside pipe = 14.13(In.)  
Critical Depth = 7.91(In.)  
Pipe flow velocity = 3.11(Ft/s)  
Travel time through pipe = 0.94 min.  
Time of concentration (TC) = 10.07 min.

++++  
Process from Point/Station 205.000 to Point/Station 205.000  
\*\*\*\* SUBAREA FLOW ADDITION \*\*\*\*

---

COMMERCIAL subarea type  
Decimal fraction soil group A = 0.000  
Decimal fraction soil group B = 0.000  
Decimal fraction soil group C = 0.000  
Decimal fraction soil group D = 1.000  
SCS curve number for soil(AMC 2) = 75.00  
Pervious ratio(Ap) = 0.1000 Max loss rate(Fp)= 0.200(In/Hr)  
Max Catchment Loss (Fm) = 0.020(In/Hr)  
Time of concentration = 10.07 min.  
Rainfall intensity = 1.514(In/Hr) for a 2.0 year storm  
Effective runoff coefficient used for area,(total area with modified  
rational method)(Q=KCIA) is C = 0.888  
Subarea runoff = 1.463(CFS) for 1.200(Ac.)  
Total runoff = 4.169(CFS) Total area = 3.10(Ac.)  
Area averaged Fm value = 0.020(In/Hr)

++++  
Process from Point/Station 205.000 to Point/Station 208.000  
\*\*\*\* PIPEFLOW TRAVEL TIME (Program estimated size) \*\*\*\*

---

Upstream point/station elevation = 177.200(Ft.)  
Downstream point/station elevation = 176.600(Ft.)  
Pipe length = 176.00(Ft.) Manning's N = 0.013  
No. of pipes = 1 Required pipe flow = 4.169(CFS)  
Nearest computed pipe diameter = 18.00(In.)  
Calculated individual pipe flow = 4.169(CFS)  
Normal flow depth in pipe = 10.88(In.)  
Flow top width inside pipe = 17.60(In.)  
Critical Depth = 9.38(In.)  
Pipe flow velocity = 3.73(Ft/s)  
Travel time through pipe = 0.79 min.  
Time of concentration (TC) = 10.86 min.

++++  
Process from Point/Station 208.000 to Point/Station 208.000  
\*\*\*\* SUBAREA FLOW ADDITION \*\*\*\*

---

COMMERCIAL subarea type  
 Decimal fraction soil group A = 0.000  
 Decimal fraction soil group B = 0.000  
 Decimal fraction soil group C = 0.000  
 Decimal fraction soil group D = 1.000  
 SCS curve number for soil(AMC 2) = 75.00  
 Pervious ratio(Ap) = 0.1000 Max loss rate(Fp)= 0.200(In/Hr)  
 Max Catchment Loss (Fm) = 0.020(In/Hr)  
 Time of concentration = 10.86 min.  
 Rainfall intensity = 1.450(In/Hr) for a 2.0 year storm  
 Effective runoff coefficient used for area,(total area with modified  
 rational method)(Q=KCIA) is C = 0.888  
 Subarea runoff = 1.881(CFS) for 1.600(Ac.)  
 Total runoff = 6.050(CFS) Total area = 4.70(Ac.)  
 Area averaged Fm value = 0.020(In/Hr)

++++++  
 Process from Point/Station 208.000 to Point/Station 111.000  
 \*\*\*\* PIPEFLOW TRAVEL TIME (Program estimated size) \*\*\*\*

---

Upstream point/station elevation = 176.600(Ft.)  
 Downstream point/station elevation = 176.400(Ft.)  
 Pipe length = 73.00(Ft.) Manning's N = 0.013  
 No. of pipes = 1 Required pipe flow = 6.050(CFS)  
 Nearest computed pipe diameter = 21.00(In.)  
 Calculated individual pipe flow = 6.050(CFS)  
 Normal flow depth in pipe = 13.31(In.)  
 Flow top width inside pipe = 20.23(In.)  
 Critical Depth = 10.88(In.)  
 Pipe flow velocity = 3.76(Ft/s)  
 Travel time through pipe = 0.32 min.  
 Time of concentration (TC) = 11.18 min.

++++++  
 Process from Point/Station 208.000 to Point/Station 111.000  
 \*\*\*\* CONFLUENCE OF MAIN STREAMS \*\*\*\*

---

The following data inside Main Stream is listed:

In Main Stream number: 2  
 Stream flow area = 4.700(Ac.)  
 Runoff from this stream = 6.050(CFS)  
 Time of concentration = 11.18 min.  
 Rainfall intensity = 1.426(In/Hr)  
 Area averaged loss rate (Fm) = 0.0200(In/Hr)  
 Area averaged Pervious ratio (Ap) = 0.1000  
 Summary of stream data:

Stream No.	Area (Ac.)	Flow rate (CFS)	TC (min)	Fm (In/Hr)	Rainfall Intensity (In/Hr)
1	4.90	6.535	10.43	0.020	1.484
2	4.70	6.050	11.18	0.020	1.426

Qmax(1) =  
           1.000 \*    1.000 \*    6.535) +  
           1.041 \*    0.933 \*    6.050) + =        12.412  
 Qmax(2) =  
           0.960 \*    1.000 \*    6.535) +  
           1.000 \*    1.000 \*    6.050) + =        12.326

Total of 2 main streams to confluence:  
 Flow rates before confluence point:  
           7.535        7.050  
 Maximum flow rates at confluence using above data:  
           12.412       12.326  
 Area of streams before confluence:  
           4.900        4.700  
 Effective area values after confluence:  
           9.285        9.600

Results of confluence:  
 Total flow rate =       12.412(CFS)  
 Time of concentration =   10.434 min.  
 Effective stream area after confluence =        9.285(Ac.)  
 Study area average Pervious fraction(Ap) =   0.100  
 Study area average soil loss rate(Fm) =     0.020(In/Hr)  
 Study area total =        9.60(Ac.)

++++++  
 Process from Point/Station       111.000 to Point/Station       112.000  
 \*\*\*\* PIPEFLOW TRAVEL TIME (Program estimated size) \*\*\*\*

---

Upstream point/station elevation =   176.400(Ft.)  
 Downstream point/station elevation =   176.100(Ft.)  
 Pipe length =       84.00(Ft.)   Manning's N = 0.013  
 No. of pipes = 1   Required pipe flow =   12.412(CFS)  
 Nearest computed pipe diameter =     24.00(In.)  
 Calculated individual pipe flow =     12.412(CFS)  
 Normal flow depth in pipe =   18.11(In.)  
 Flow top width inside pipe =   20.66(In.)  
 Critical Depth =   15.21(In.)  
 Pipe flow velocity =       4.88(Ft/s)  
 Travel time through pipe =    0.29 min.  
 Time of concentration (TC) =   10.72 min.

++++++  
 Process from Point/Station       112.000 to Point/Station       112.000  
 \*\*\*\* SUBAREA FLOW ADDITION \*\*\*\*

---

COMMERCIAL subarea type  
 Decimal fraction soil group A = 0.000  
 Decimal fraction soil group B = 0.000  
 Decimal fraction soil group C = 0.000  
 Decimal fraction soil group D = 1.000  
 SCS curve number for soil(AMC 2) = 75.00

Pervious ratio( $A_p$ ) = 0.1000 Max loss rate( $F_p$ )= 0.200(In/Hr)  
Max Catchment Loss ( $F_m$ ) = 0.020(In/Hr)  
Time of concentration = 10.72 min.  
Rainfall intensity = 1.461(In/Hr) for a 2.0 year storm  
Effective runoff coefficient used for area,(total area with modified  
rational method)( $Q=KCIA$ ) is  $C = 0.888$   
Subarea runoff = 0.149(CFS) for 0.400(Ac.)  
Total runoff = 12.561(CFS) Total area = 9.68(Ac.)  
Area averaged  $F_m$  value = 0.020(In/Hr)  
End of computations, total study area = 10.00 (Ac.)

The following figures may  
be used for a unit hydrograph study of the same area.  
Note: These figures do not consider reduced effective area  
effects caused by confluences in the rational equation.

Area averaged pervious area fraction( $A_p$ ) = 0.100  
Area averaged SCS curve number (AMC 2) = 75.0



# EXISTING HYDROLOGY MAP 534 W. STRUCK AVENUE

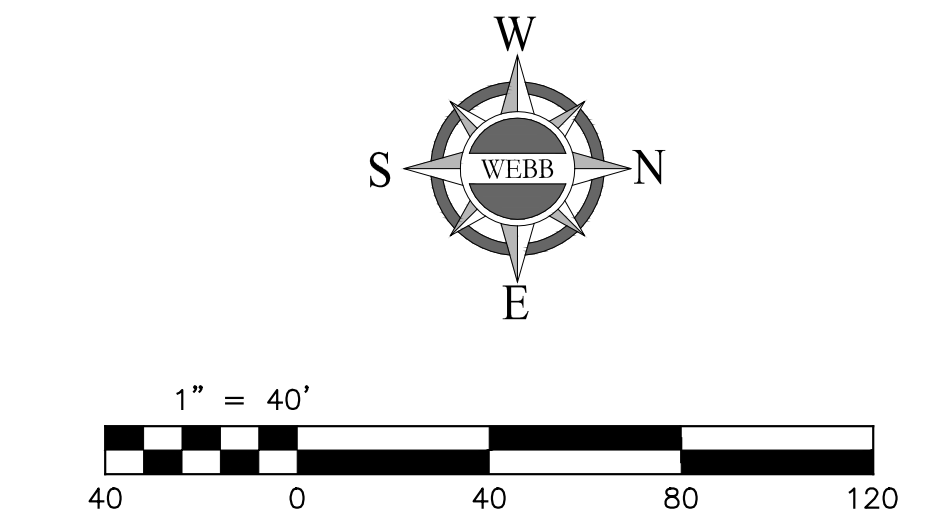
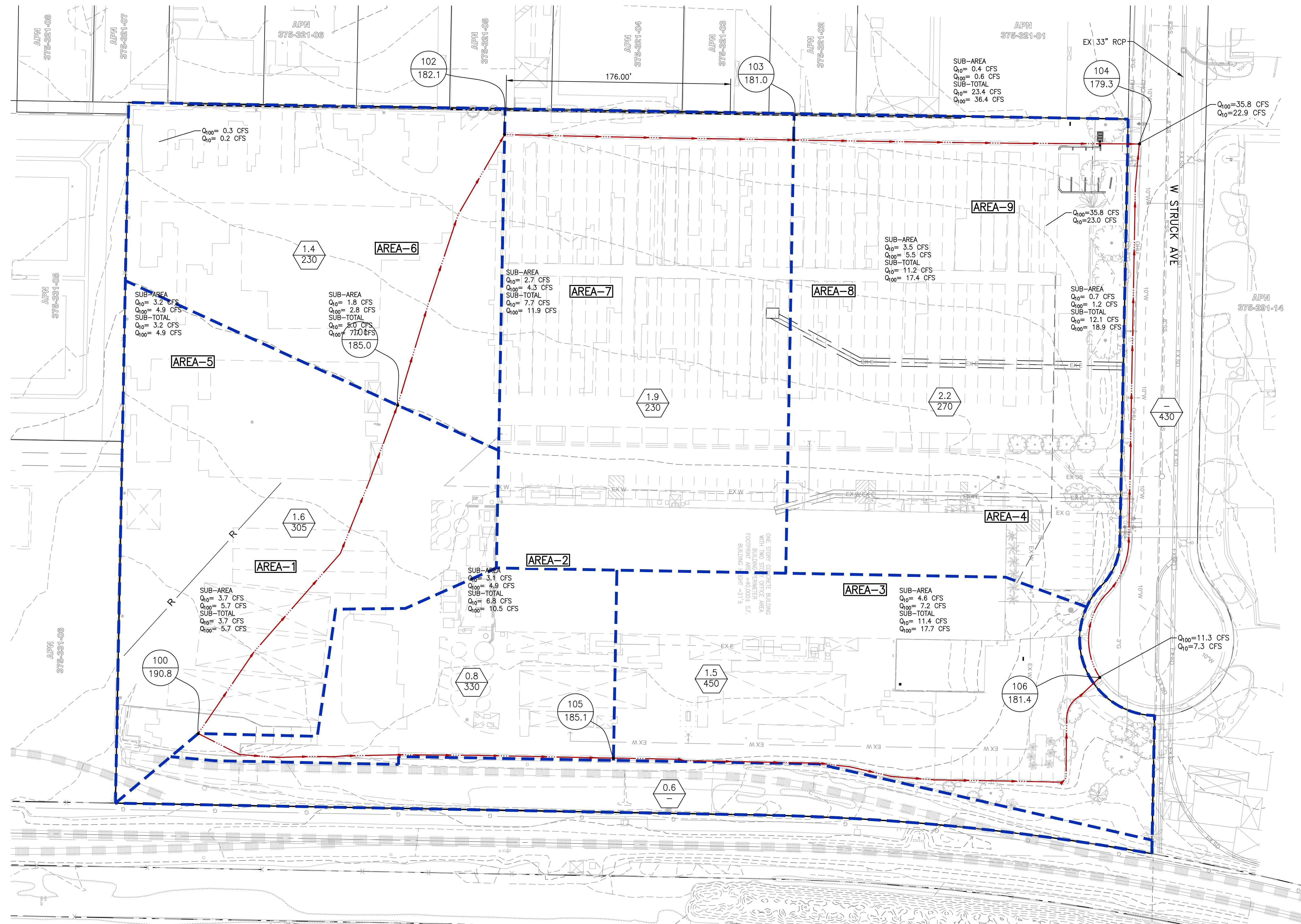

**LEGEND**

	- NODE NUMBER
	- ELEVATION (FT)
	- AREA (AC)
	- LENGTH (FT)
	- DRAINAGE AREA BOUNDARY
	- FLOWLINE

CITY OF ORANGE  
534 W. STRUCK AVE  
RATIONAL METHOD HYDROLOGY MAP  
EXISTING CONDITION

SCALE: 1"=40'	<b>WEBB ASSOCIATES</b>	ENGINEERING CONSULTANTS 3788 McCRAY STREET RIVERSIDE CA 92506 PH. (951) 686-1070 FAX (951) 788-1256	W.O. 21-0201 SHEET 1 OF 1 SHEETS DWG. NO.
DATE: 11/24/21			
DESIGNED: EA			
CHECKED:			
PLN CK REF: F.B.			

H:\2021\21-0201\DRAINAGE\HYD\DWG FOLDER\20-0201-FINAL HYDROLOGY MAP.DWG 11/24/2021 12:58:47 PM

# PROPOSED HYDROLOGY MAP 534 W. STRUCK AVENUE

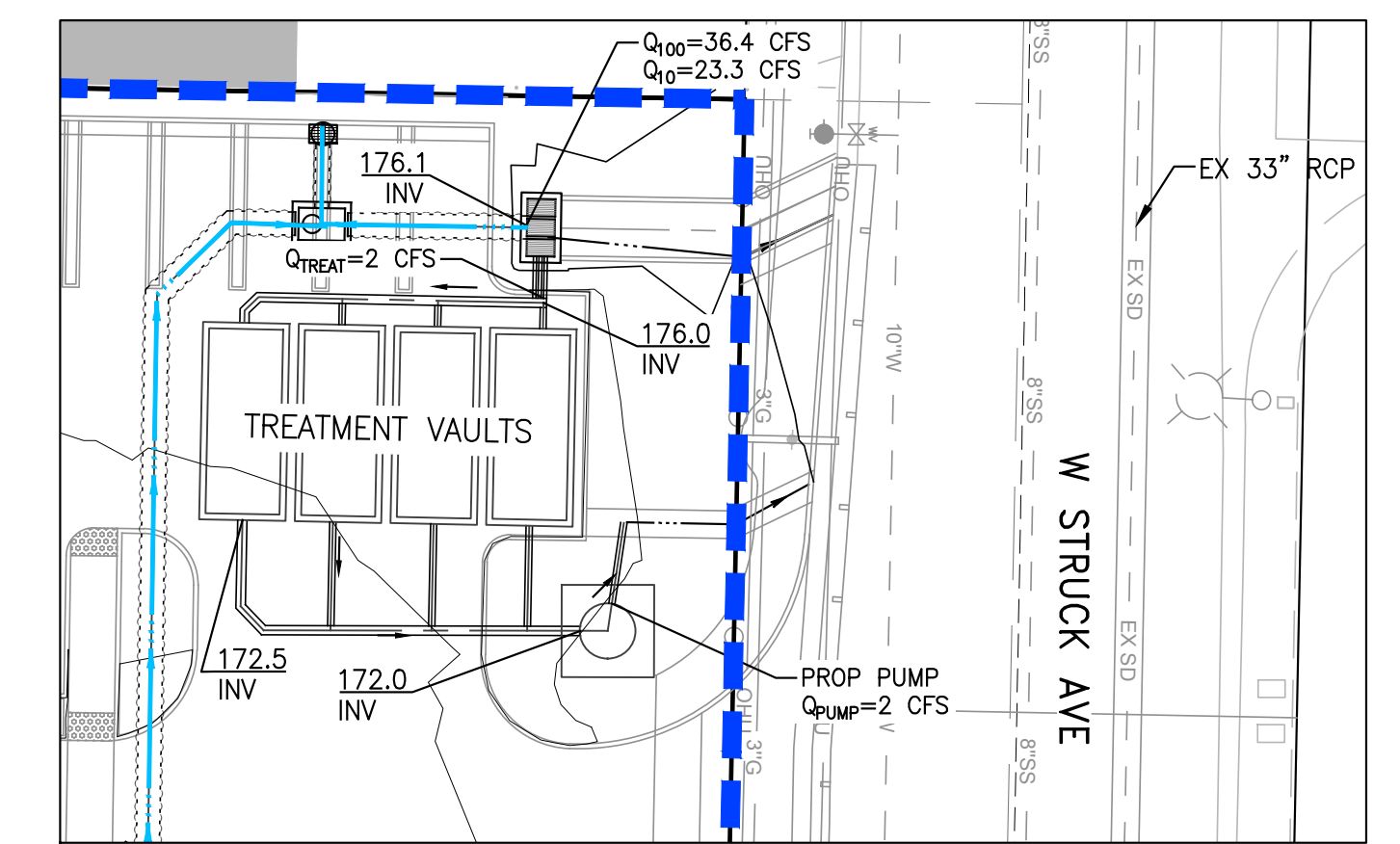
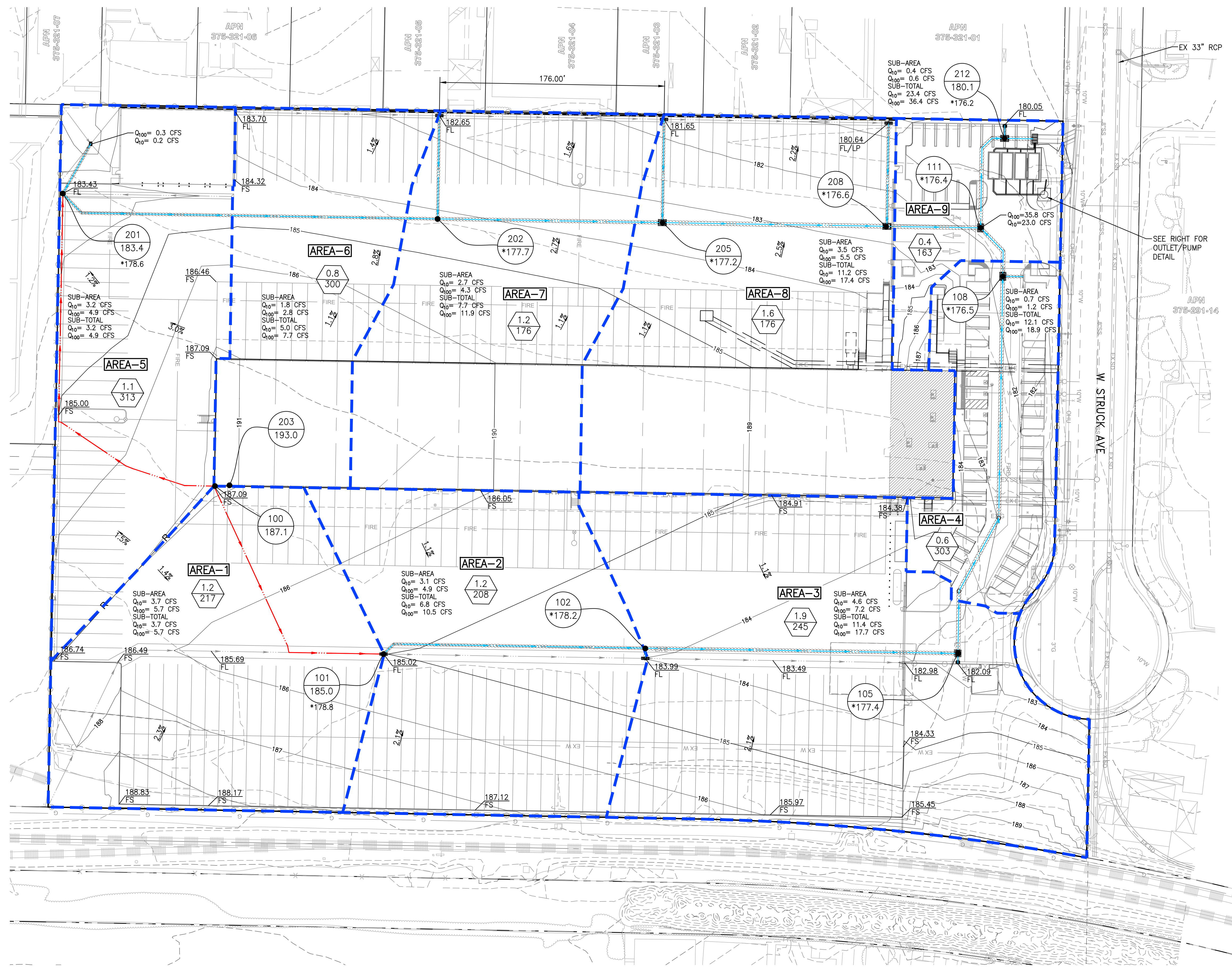

- LEGEND**
- ||--- DRAINAGE BOUNDARY
  - DRAINAGE SUB-AREA
  - SURFACE FLOW PATH
  - PIPE FLOW PATH
  - 0.3% SLOPE DIRECTION
  - XX NODE DESIGNATION
  - XXXX NODE ELEVATION
  - \*XXXX \*INVERT ELEVATION
  - XX WATERSHED AREA (ACRES)
  - XX WATER TRAVEL LENGTH

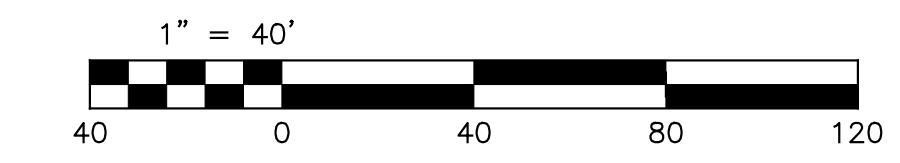
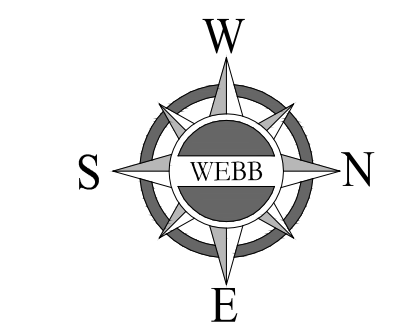

CITY OF ORANGE			
534 W. STRUCK AVE RATIONAL METHOD HYDROLOGY MAP DEVELOPED CONDITION			
SCALE: 1"=40'	DATE: 11/24/21	<b>WEBB ASSOCIATES</b>	ENGINEERING CONSULTANTS 3788 McCRAY STREET RIVERSIDE CA 92506 PH. (951) 686-1070 FAX (951) 788-1256
DESIGNED: EA	CHECKED:	PLN CK REF:	F.B.
			W.O. 21-0201 SHEET 1 OF 1 SHEETS DWG. NO.

H:\2021\21-0201\DRAINAGE\HYD.DWG - FOLDER\20-0201-FINAL HYDROLOGY MAP.DWG 11/24/2021 12:58:47 PM