

Appendix P-2

Riverside Facilities Master Plan

Riverside Facilities Master Plan

Potable Water, Recycled Water & Wastewater

FINAL

Prepared for:



Western Municipal Water District
14205 Meridian Parkway
Riverside, California 92518
Contact: Mr. Jason Pivovaroff, P.E.

November 2021

INTENTIONALLY LEFT BLANK

Table of Contents

SECTIONS

Riverside Facilities Master Plan.....	i
Acknowledgements.....	ix
Acronyms and Abbreviations.....	xi
Executive Summary.....	xiii
ES.1 Introduction.....	xiii
ES.2 Study Area.....	xiii
ES.3 Water Demands and Wastewater Flow Forecast.....	xiv
ES.4 Hydraulic Modeling.....	xvi
ES.5 Potable Water System Analysis.....	xvi
ES.6 Recycled/Non-Potable Water System Analysis.....	xvii
ES.7 Wastewater Collection System Analysis.....	xvii
ES.8 Capital Improvement Program (CIP).....	xviii
1 Introduction.....	1
1.1 Background and Master Plan Objectives.....	1
1.2 Service Area Overview.....	1
1.3 Report Organization.....	5
2 Study Area, Land Use and Population.....	7
2.1 Study Area.....	7
2.2 Potable Water Study Area and Facilities Data.....	7
2.2.1 Existing Potable Water System.....	7
2.2.2 Existing Pressure Zones.....	8
2.2.3 Existing Potable Water Pipelines.....	14
2.2.4 Existing Pump Stations.....	15
2.2.5 Supply and Interconnections.....	18
2.2.6 Existing Storage Reservoirs.....	18
2.2.7 Existing Pressure Reducing Stations.....	21
2.2.8 Operational Challenges.....	21
2.3 Recycled/Non-Potable Water Study Area.....	22
2.3.1 Existing Recycled/Non-Potable Water System Facilities Data.....	24
2.3.2 Existing Pressure Zones.....	24
2.3.3 Existing Pipelines.....	24
2.3.4 Existing Storage Reservoirs.....	26
2.3.5 Existing Pump Stations.....	26
2.3.6 Existing Pressure Reducing Stations.....	27
2.3.7 Recycled/Non-Potable Water Service Area and Existing Operational Challenges.....	27

2.4 Existing Wastewater Collection System 28

 2.4.1 Treatment Plants..... 28

 2.4.2 Gravity Mains..... 33

 2.4.3 Lift Stations and Force Mains 34

 2.4.4 Permanent Flow Metering Locations 36

 2.4.5 Diversion Structures/Inflow Points..... 39

 2.4.6 Operational Challenges 42

2.5 Land Use..... 42

 2.5.1 Existing Land Use 42

 2.5.2 Recent Developments 43

 2.5.3 Future, Near-Term Developments..... 44

 2.5.4 Ultimate (Buildout) Future Land Use..... 47

 2.5.5 Population Growth Projections 47

3 Water Demand and Wastewater Flow Forecasts 49

 3.1 Unit Demand/Load Factors 49

 3.2 Potable Water..... 50

 3.2.1 Existing and Historical Water Demands 50

 3.2.2 Peaking Factors..... 51

 3.2.3 Future Water Demand Projection..... 52

 3.3 Recycled/Non-Potable Water 55

 3.3.1 Existing and Historical Demands..... 55

 3.3.2 Peaking Factors..... 55

 3.3.3 Future Recycled/Non-Potable Demand Projections..... 57

 3.4 Wastewater 62

 3.4.1 Existing and Historical Flows..... 63

 3.4.2 Future Wastewater Flow Projections..... 72

4 Hydraulic Modeling 77

 4.1 Potable Water Model..... 77

 4.1.1 Existing Potable Water Hydraulic Computer Model 77

 4.1.2 Model Updates 78

 4.2 Recycled/Non-Potable Water Model 79

 4.2.1 Existing Recycled/Non-Potable Water Hydraulic Computer Model..... 79

 4.2.2 Recycled/Non-Potable Water Model Updates 79

 4.2.3 Recycled/Non-Potable Water Model Calibration 79

 4.3 Wastewater Model..... 80

 4.3.1 Wastewater Model Development..... 80

 4.3.2 Sewer Drainage Basins 80

 4.3.3 Large Point Sources..... 85

 4.3.4 Existing and Future Model Flows..... 85

 4.3.5 Wastewater Model Calibration 85

5 System Evaluation Criteria 89

5.1 Potable Water System Evaluation Criteria 89

5.1.1 System Pressures 89

5.1.2 Pipeline Criteria 89

5.1.3 Fire Flow Criteria..... 89

5.1.4 Storage Capacity 90

5.1.5 Pump Station Capacity 90

5.2 Recycled/Non-Potable Water System Evaluation Criteria 91

5.2.1 System Pressures 91

5.2.2 Pipeline Criteria 91

5.2.3 Storage Capacity 91

5.2.4 Pump Station Capacity 91

5.3 Wastewater System Evaluation Criteria 91

5.3.1 Gravity Sewers..... 92

5.3.2 Lift Stations and Force Mains 93

5.3.3 Siphons 93

6 Potable Water System Analysis 95

6.1 Existing Potable Water System Analysis..... 95

6.1.1 March Air Reserve Base 95

6.1.2 Pipeline Analysis..... 95

6.1.3 Storage Analysis 102

6.1.4 Pump Station Analysis..... 104

6.2 Near-Term Potable Water System Analysis..... 105

6.2.1 Pipeline Analysis..... 105

6.2.2 Storage Analysis 107

6.2.3 Pump Station Analysis..... 107

6.3 Ultimate Potable Water System Analysis..... 108

6.3.1 Pipeline Analysis..... 108

6.3.2 Storage Analysis 114

6.3.3 Pump Station Analysis..... 115

6.4 Potable Water System Proposed Improvements..... 115

7 Recycled/Non-Potable Water System Analysis 117

7.1 Existing Recycled Water System MDD Analysis..... 117

7.1.1 Pipeline and System Pressure Analysis 117

7.1.2 Storage Analysis 117

7.1.3 Pump Station Analysis..... 119

7.2 Existing System Minimum Month Analysis..... 119

7.3 Near-Term Recycled/Non-Potable Water System MDD Analysis..... 119

7.3.1 Pipeline and System Pressure Analysis 123

7.3.2 Storage Analysis 123

- 7.3.3 Pump Station Analysis 124
- 7.4 Ultimate Recycled Water System MDD Analysis 124
 - 7.4.1 Pipeline and System Pressure Analysis 128
 - 7.4.2 Storage Analysis 128
 - 7.4.3 Pump Station Analysis 129
- 7.5 Recycled Water System Recommendations and Proposed Improvements 129
- 8 Wastewater Collection System Analysis 131
 - 8.1 Existing Collection System Capacity Evaluation 131
 - 8.1.1 Gravity Sewer and Force Main System Analysis 131
 - 8.1.2 Siphon Analysis 134
 - 8.1.3 Lift Station Analysis 134
 - 8.1.4 Treatment Capacity Analysis 135
 - 8.2 Near-Term Collection System Capacity Evaluation 135
 - 8.2.1 Gravity Sewer and Force Main System Analysis 136
 - 8.2.2 Siphon Analysis 138
 - 8.2.3 Lift Station Analysis 138
 - 8.2.4 Treatment Capacity Analysis 139
 - 8.3 Ultimate Collection System Capacity Evaluation 140
 - 8.3.1 Gravity Sewer and Force Main System Analysis 140
 - 8.3.2 Siphon Analysis 143
 - 8.3.3 Lift Station Analysis 143
 - 8.3.4 Treatment Capacity Analysis 144
 - 8.4 Wastewater Collection System Proposed Improvements 145
- 9 Capital Improvement Plan 147
 - 9.1 Project Costs 147
 - 9.1.1 Unit Construction Cost 147
 - 9.1.2 Total Project Cost 147
 - 9.2 Prioritization 147
 - 9.2.1 CIP Phasing 147
 - 9.3 Recommended Improvement Projects 148

TABLES

- ES-1 Recommended Improvement Projects xviii
- 2-1 Potable Water Pipeline Length – Diameter by Decade of Construction 14
- 2-2 Potable Water Pipeline Length – Material by Decade Construction 15
- 2-3 Potable Water Booster Pump Stations 16
- 2-4 Potable Water Interconnections 18
- 2-5 Potable Water Storage Reservoirs 18
- 2-6 Existing Pressure Reducing Stations 21

2-7 RW/NP Pipelines..... 24

2-8 Recycled/Non-Potable Water Storage Reservoirs..... 26

2-9 Recycled/Non-Potable Water Booster Pump Stations..... 26

2-10 Recycled/Non-Potable Water Pressure Reducing Stations (PRs)..... 27

2-11 Existing Sewer Gravity Main Diameters..... 33

2-12 Existing Sewer Gravity Main Material Length..... 34

2-13 Lift Station Summary..... 34

2-14 Existing Sewer Force Main Diameters..... 35

2-15 Existing Sewer Force Main Material Length..... 36

2-16 Existing Land Use..... 42

2-17 Recent (2018-2020) Developments within Study Area 43

2-18 Near-Term Developments within Study Area 44

2-19 Additional Ultimate Land Use (Post-2030)..... 47

3-1 Unit Demands/Load Factors 49

3-2 Recent (2018-2020) Development Potable Water Demands..... 50

3-3 Current Demand and Peaking Factor..... 52

3-4 March Air Reserve Base Demand and Peaking Factor..... 52

3-5 Near-Term Development Potable Water Demands..... 52

3-6 Potable Water Demands by Pressure Zone 54

3-7 Potable Water Demand Summary 55

3-8 RW/NP System Demand (2017-2019)..... 55

3-9 RW/NP Monthly Peaking Factors (2017-2019)..... 56

3-10 RW/NP Minimum and Maximum Month Peaking Factor (2017-2019) 56

3-11 Recommended Design Peaking Factors..... 57

3-12 Near-Term Development Additional Recycled Water Demands 59

3-13 Ultimate Additional Recycled Water Demands..... 60

3-14 Recycled Water Demands by Pressure Zone..... 60

3-15 Recycled/Non-Potable Water Demand & Supply Summary..... 62

3-16 Historical (2017-2019) Sewer Flows..... 63

3-17 Hourly Sewer Flow Meter Data Summary 64

3-18 Precipitation Data Summary..... 66

3-19 March 2020 Sewer Peaking Factor Summary 69

3-20 Residential Sewer Flow Factor Analysis 71

3-21 Wastewater Flow Factors..... 71

3-22 Near-Term Average Dry Weather Sewer Flow 73

3-23 Ultimate (Buildout) Average Dry Weather Sewer Flow 74

3-24 Wastewater Flow Projection Summary..... 75

4-1 RW/NP MDD Model Calibration 79

4-2 Calibration Criteria 85

4-3 ADWF Calibration Results 86

4-4	PWWF Calibration Results	87
5-1	Potable Water Pressure Criteria	89
5-2	Potable Water Pipeline Criteria.....	89
5-3	Fire Flow Criteria	90
5-4	Recycled/Non-Potable Water Pressure Criteria.....	91
5-5	Recycled/Non-Potable Water Pipeline Criteria	91
5-6	Gravity Sewer Slope Criteria	92
6-1	Storage Analysis Results – Existing (2020) Scenario	102
6-2	Required Storage.....	104
6-3	Pump Station Analysis Results – Existing (2020) Scenario	104
6-4	Storage Analysis Results – Near-Term (2030) Scenario	107
6-5	Pump Station Analysis Results – Near-Term (2030) Scenario	107
6-6	Storage Analysis Results – Ultimate Scenario.....	114
6-7	Pump Station Analysis Results – Ultimate Scenario.....	115
7-1	Existing MDD Recycled/Non-Potable Water Storage Analysis	119
7-2	Near-Term MDD Recycled/Non-Potable Water Storage Analysis.....	123
7-3	Ultimate (Buildout) MDD Recycled/Non-Potable Water Storage Analysis	128
8-1	Existing System Gravity Sewer and Force Main Analysis.....	132
8-2	Existing PWWF Lift Station Capacity Analysis	134
8-3	Existing Wastewater Treatment Capacity.....	135
8-4	Near-Term System Gravity Sewer and Force Main Analysis.....	136
8-5	Near-Term PWWF Lift Station Capacity Analysis	138
8-6	Existing Wastewater Treatment Capacity.....	139
8-7	Ultimate PWWF Gravity Sewer and Force Main Analysis.....	140
8-8	Ultimate PWWF Lift Station Capacity Analysis	143
8-9	Ultimate Wastewater Treatment Capacity	144
9-1	Recommended Improvement Projects.....	148

FIGURES

ES-1	CIP Summary Map.....	xxi
1-1	Western Service Area	3
1-2	Riverside Retail Service Area Systems Schematic.....	4
2-1	Western Riverside Retail Service Area	9
2-2	Western Potable Water Study Area.....	10
2-3	Potable Water Pressure Zones – East side of North Area.....	11
2-4	Potable Water Pressure Zones – West side of North Area.....	12
2-5	Potable Water Pressure Zones – South Area	13
2-6	Potable Water System Pump Stations.....	17
2-7	Potable Water System Reservoirs.....	20

2-8 Western Recycled/Non-Potable Water Service Area Overview..... 23

2-9 Western Recycled/Non-Potable Water Study Schematic..... 25

2-10 Western Wastewater Study Area - WRCRWA..... 29

2-11 Western Wastewater Study Area - WWRF..... 31

2-12 Permanent Sewage Flow Meter Locations - WWRF..... 37

2-13 Permanent Sewage Flow Meter Locations - WRCRWA..... 38

2-14 WRCRWA Collection System..... 40

2-15 WWRF Collection System..... 41

2-16 Near-Term Development Location Map..... 46

2-17 Undeveloped Parcel Location Map..... 48

3-1 Potable Water Monthly Peaking Factors (2017-2019)..... 51

3-2 Recycled Water Monthly Peaking Factors (3-Year Average)..... 56

3-3 Riverside National Cemetery Property and Improvement Areas..... 58

3-4 Ultimate Irrigation Areas..... 61

3-5 Dry Weather Flow Peaking Curves..... 68

3-6 Wet Weather Flow Peaking Curves..... 70

4-1 Correlation between Observed and Computed Pressures..... 77

4-2 Correlation between Observed and Computed Flows..... 78

4-3 Sewer Model WWRF..... 81

4-4 Sewer Model - WRCRWA..... 82

4-5 Sewer Sub Basins – WWRF Service Area..... 83

4-6 Sewer Sub Basins – WRCRWA Service Area..... 84

6-1 CIP W-1 High Velocity Potable Water Pipeline – Moonridge Dr..... 96

6-2 Available Fire Flow to Hydrants – Existing (2020) Scenario..... 98

6-3 Blackburn Road Existing Pipelines and Hydrants..... 99

6-4 CIP W-2 Potential Pipeline Improvements - Blackburn Road..... 100

6-5 Existing Pipelines and Hydrants – Avenue D and Cedar Street..... 101

6-6 CIP W-3 Potential Pipeline Improvements Cedar St and Avenue D..... 102

6-7 Available Fire Flow to Hydrants – Near-Term (2030) Scenario..... 106

6-8 High Velocity Potable Water Pipelines – Wood Dr..... 109

6-9 CIP W-4/ CIP W-5 – Wood Rd, Mariposa Ave, and Lurin Ave..... 110

6-10 Available Fire Flow to Hydrants – Ultimate (Buildout) Scenario..... 112

6-11 CIP W-6 – Via Barranca Road..... 113

7-1 Minimum System Pressures – Existing System (2020) MDD Analysis..... 118

7-2 Additional Facilities in Near-Term Scenario..... 121

7-3 Minimum System Pressures – Near-Term Recycled/NP Water MDD Analysis..... 122

7-4 Pipeline Upsizing to Accommodate Ultimate Demands..... 125

7-5 Minimum System Pressures – Future Recycled/NP Water MDD Analysis..... 126

7-6 Recommended RW/NP System Improvements..... 130

8-1 Existing Sewer Gravity and Force Main Recommendations 1..... 133

8-2 Existing Sewer Gravity and Force Main Recommendations 2 134

8-3 Near-Term Sewer Gravity and Force Main Recommendations 1 137

8-4 Near-Term Sewer Gravity and Force Main Recommendations 2 138

8-5 Ultimate Sewer Gravity and Force Main Recommendations 1 141

8-6 Ultimate Sewer Gravity and Force Main Recommendations 2 142

8-7 Ultimate Sewer Gravity and Force Main Recommendations 3 143

9-1 CIP Summary Map 153

APPENDICES

A WMWD Riverside Retail Service Area Build-Out Demand Analysis (2019, Kennedy Jenks)

B Potable Water System Schematic

C Recycled Water Figure

D CIP Cost Estimates

Acknowledgements

We appreciate the combined efforts of the entire project team in the development and preparation of the Western Municipal Water District Riverside Facilities Master Plan. Our project team includes staff from Western and Dudek. The efforts of the following individuals are respectfully and gratefully acknowledged for their contributions to the completion of the evaluations presented in this report:

Western Municipal Water District

Jason Pivovaroff, P.E., Deputy Director of Water Resources and Project Manager

Derek Kawaii, P.E., Director of Engineering

Karl Francis, Deputy Director of Engineering

Ryan Shaw, Director of Water Resources

Paul Rukke, Director of Operations

Gary Miller, Deputy Director of System Operations

Thomas Scott, Principal Engineer

Sonia Huff, Principal Engineer

Zuzanna Rand, Engineer - CIP

Larry Chanes, Operations Field Manager

Alex Chang, Operations Field Manager

Dean Standing Warrior, Operations Field Manager

Tony Pollak, Operations Field Manager

Albert Magallon, Operations Field Manager

Teri Patton, Senior Engineering Technician

Melissa Matlock, Water Resources Specialist

Dudek

Kate Palmer, P.E., Project Manager

Russ Bergholz, P.E., Principal-in-Charge

Elizabeth Caliva, P.E., Task Lead, Recycled Water System

Greg Ripperger, P.E., Task Lead, Potable Water System

Ian Crano, P.E., Task Lead, Wastewater Collection System

Hanna Dodd, P.E., Project Engineer

INTENTIONALLY LEFT BLANK

Acronyms and Abbreviations

ac	Acre	MARB	March Air Reserve Base
ACP	Asbestos Cement Pipe	MDD	Maximum Day Demand
ADD	Average Day Demand	MDR	Medium Density Residential
ADWF	Average Dry Weather Flow	MG	Million Gallons
AF	Acre-Feet	mgd	million gallons per day
AFY	Acre-Feet per Year	MGL	Mills Gravity Line
AL	Asbestos Lined	MMD	Minimum Month Demand
AMI	Advanced Metering Infrastructure	MJPA	March Joint Power Authority
ASTM	American Society for Testing and Materials	MMD	Maximum Month Demand
Avg	Average	MSL	Mean Sea Level
BPS	Booster Pump Station	MWD	Metropolitan Water District
CAD	Computer-Aided Design (software)	NOAA	National Oceanic and Atmospheric Administration
CCP	Concrete Cylinder Pipe	NP	Non-Potable Water
CFC	California Fire Code	PHD	Peak Hour Demand
cfs	cubic-feet per second	PRS	Pressure Reducing Station
CIP	Capital Improvement Program or Cast Iron Pipe	PRV	Pressure Reducing Valve
CITP	Cajalco Intake and Treatment Plant	PS	Pump Station
CML	Cement Mortar Lined	psi	Pressure Reducing Valve
CMLAW	Cement Mortar Lined and Asbestos Wrapped	PVC	Polyvinyl chloride
CMLTW	Cement Mortar Lined and Tape Wrapped	PWWF	Peak Wet Weather Flow
CRA	Colorado River Aqueduct	PZ	Pressure Zone
d/D	Depth to Diameter ratio	Q	Flow
DIP	Ductile Iron Pipe	Qty	Quantity
DU	Dwelling Unit	RCFD	Riverside County Fire Department
DWF	Dry Weather Flow	RCP	Reinforced Concrete Pipe
EMWD	Eastern Municipal Water District	RNC	Riverside National Cemetery
FMP	Facilities Master Plan	RPU	Riverside Public Utilities
fps	foot per second	RW	Recycled Water
ft	feet	SFR	Single Family Residential
GALVP	Galvanized Pipe	SWP	State Water Project
gpd	gallons per day	UNK	Unknown
gpm	gallons per minute	USGS	United States Geological Survey
GW	Groundwater Infiltration	VCP	Vitrified Clay Pipe
HAL	Hansen, Allen, and Luce Engineers	WMWD	Western Municipal Water District
HDR	High Density Residential	WTP	Water Treatment Plant
HGL	Hydraulic Grade Line	WW	Wastewater
HP	horsepower	WWF	Wet Weather Flow
hr	hour	WWRF	Western Water Recycling Facility
I/I	Inflow and Infiltration	yr	year
in	inch		
LF	Linear Feet		
LS	Lift Station		

Executive Summary

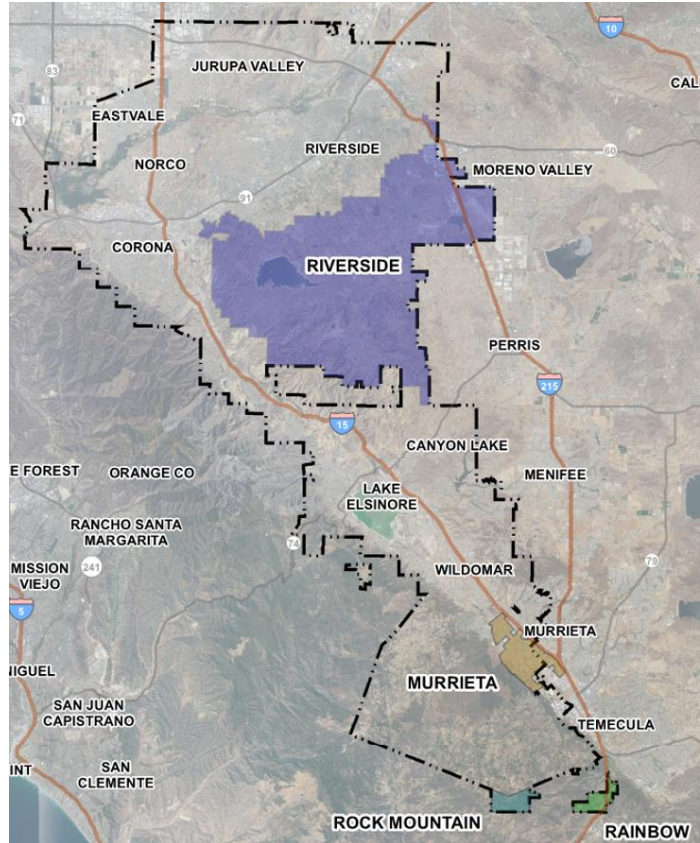
ES.1 Introduction

In January 2020, Western initiated preparation of the following Facilities Master Plan (FMP). The FMP is an integrated master plan that evaluates the performance and capacity of Western's potable water, recycled/non-potable water, and wastewater systems under existing, near-term (2030), and ultimate (buildout) conditions. The FMP provides a list of recommended capital improvement projects to guide Western with the budgeting and implementation of the recommended improvements to support future growth and development of the service area.

A list of keep objectives for the FMP are listed in Section 1.1.

ES.2 Study Area

Western's service area is located in western Riverside County, approximately 50 miles east of Los Angeles and covers 527 square miles, of which 104 square miles are included as retail service areas, as shown to the right. The retail service areas include the unincorporated areas around Lake Mathews, the City of Murrieta, and unincorporated Riverside County south of the City of Temecula. Though there are multiple Western retail service areas that are not connected to one another, this FMP covers the Riverside Retail Service Area only.



The following summarizes the existing water, sewer and recycled water infrastructure:

Water system:

- 21 pressure zones
- 565 miles of pipeline in the potable water system (4-inch to 60-inch diameter)
- 10 water booster pump stations that move water from the lower to higher pressure zones
- 15 water storage reservoirs totaling 68.7 million gallons
- 33 Pressure Reducing Stations (PRS)
- 8 interconnections with other agencies, including Metropolitan Water District (MWD) for water supply

Recycled Water System

The Western recycled/non-potable water service area includes two distinct areas—North and South. The North Area includes Western’s retail area north of Cajalco Road. The South Area includes the area known as Gavilan plateau and includes Western’s retail service area south of Cajalco Road.

- North Area Recycled System
 - 50 miles of pipelines (6- to 42-inches diameter)
 - 8 booster pump stations
 - 3 storage reservoirs totaling 7.6 million gallons
 - 4 pressure zones with demands
- South Area Recycled Water System
 - 12 miles of pipelines (4- to 30-inches diameter)
 - 3 booster pump stations
 - 3 storage reservoirs totaling 5.8 million gallons
 - 3 pressure zones with demands

Wastewater Collection System

- 140 miles of gravity sewer pipelines (6-inch to 60-inch diameter)
- 3 inverted sewer siphons
- 17 sewer lift stations
- 22 miles of pressurized sewer force mains
- 3 diversion structures /3 permanent inflow points

ES.3 Water Demands and Wastewater Flow Forecast

Water System

Existing Water Demands

The average annual water demand (AAD) for the Riverside retail service area totals of 12,900 gpm. Demands were derived from a 2018 study and adding additional developments between 2018 and 2020. A maximum day demand (MDD) peaking factor of 1.5 was used for hydraulic analysis. MDD demand is estimated at 19,300 gpm.

The March Air Reserve Base (MARB) is the largest single water demand for the service area and had an AAD of 522 gpm in 2020.

Near-Term Water Demand Projection

The 2030 water demand was developed by utilizing known near-term development projected to be built between 2020 and 2030.

The AAD for the Riverside retail service area in 2030 is estimated at 14,700 gpm. MDD demand is estimated at 22,000 gpm.

Ultimate Buildout Water Demand Projection

Ultimate water demands were calculated by adding projected water demand for undeveloped parcels based on land use and projected additional MARB demands.

The AAD for the Western Riverside service area at ultimate buildout is estimated at 21,000 gpm. MDD is estimated at 31,000 gpm.

Recycled/Non-Potable Water System

Existing Recycled/Non-Potable Water Demands

The average annual recycled water demand (AAD) for the Western Riverside service area totals approximately 2,100 gpm based on a 3-year average. The largest single user in Western’s recycled/non-potable system is the Riverside National Cemetery (RNC), within Western’s Lurin Irrigation (1815) zone in the North Area. Monthly and Daily maximum peaking factors were determined to be 2.0 and 2.5, respectively. For hydraulic modeling, agricultural users were assumed to condense water usage to an 8 hour timeframe. MDD for modeling existing recycled water demands totals 5,471 gpm.

Near-Term Recycled/Non-Potable Water Demand Projection

The near-term developments were quantified, and recycled water demand estimated for each based on land use type and area of each development. A total additional 1,263 gpm of ADD was estimated for near-term development. The majority of near-term recycled water demand will come from the 1815 pressure zone in the North Area. MDD for modeling near-term recycled water demands totals 8,630 gpm.

Ultimate Buildout Recycled/Non-Potable Water Demand Projection

Ultimate recycled water demands are anticipated to develop in the North 1815 pressure zone primarily, with a small increase anticipated in the 2250 zone in the South Area. The increased 1,330 gpm of additional recycled water demand in the 1815 zone is projected to support 904 acres of irrigation lands. MDD for modeling the ultimate recycled water demands totals 10,701 gpm.

Wastewater Flows

The wastewater collection system network is divided into two separate drainage basins that terminate at two separate treatment plants, Western Riverside County Regional Wastewater Authority (WRCRWA) Plant, and the Western Water Recycling Facility (WWRF). Wastewater flows are projected independently for each basin.

The following tables summarize the existing and projected sewer generation for both the WWRF and the WRCWRA Basins.

WRCRWA Basin	ADWF (mgd)	PWWF (mgd)	PF
Existing Flows (2020)	0.85	4.12	4.84
Near-Term (2030)	1.00	4.85	4.81
Ultimate Flows	1.54	5.21	3.40

WWRF Basin	ADWF (mgd)	PWWF (mgd)	PF
Existing Flows (2020)	1.17	4.91	4.19
Near-Term (2030)	2.08	6.9	3.32
Ultimate Flows	2.79	8.25	2.96

The WRCWRA Basin treatment plant has the capacity to treat 14 million gallons per day.

The WWRF Basin treatment plant has the capacity to treat 3 million gallons per day.

ES.4 Hydraulic Modeling

Water System Modeling

The potable water model is developed in InfoWater™ by Innovyze®. The model was updated and calibrated as part of Western’s recent model optimizations performed by HAL Engineers, with documentation dated July 29, 2020, entitled “WMWD 2020 Hydraulic Model Update”. Demands in the model were updated with the new current water demands. Near-Term and Ultimate scenarios were developed and demands added into the model. The demands for each development were individually placed on the model node closest to the centroid parcel of the development. To reflect potable water demands within MARB, the 2020 demand were allocated across all nodes in the base.

Recycled/Non-Potable Water System Modeling

Western’s existing recycled/non-potable water model was last updated as part of Western’s 2014 Recycled Water Master Plan. The model received was in H2ONet format and was converted to InfoWater™ by Innovyze® for this analysis. Data from a three-week period in winter (March 9-24, 2020) and summer (September 4-24, 2020) were obtained from Western that contained hourly tank level, pump flow, pump status and PRV flow data. This data was used to modify controls and PRV/pump settings in the model to calibrate model results for tank levels matched field data within 15%. Scenarios for near term and ultimate buildout were created and associated demands added to the model for analysis.

Wastewater System Modeling

The InfoSewer™ by Innovyze® hydraulic model of the trunk sewer system (10-inch and larger sewer pipes) was developed using District GIS and CAD datasets. The GIS data included pipe and manhole data from Western, which was reviewed for completeness. In addition to pipe and manhole attribute data, lift station wet well dimensions and elevations, pump curves and operating levels, and operating parameters that control the operation of the pump station facilities were obtained from record drawings and lift station information sheets were input into the modeling software. Flow meter data was used for calibration of the existing collection system. Near-term and buildout sewer flows were input into subsequent model scenarios for evaluation.

ES.5 Potable Water System Analysis

The following highlights the potable water system analysis results.

- Conservation efforts over the last 5-10 years have significantly reduced Western’s water demands.
- All but two pipelines were found to meet the maximum pipeline velocity of 6 fps based on current MDD.
- Existing system storage analysis show a surplus of 23.75 million gallons.
- Excess storage has led to challenges maintaining chlorine residual in winter months.
- Water booster pump capacity has a surplus of 63,000 gpm for the existing system.
- Two (2) existing system water pipeline projects were identified to address compounding issues of historic reliability, velocity and pressure.
- Fire flow analysis revealed that there are numerous 6-inch pipelines unable to support required fire flows to dead-end hydrants. A separate study is being conducted to prioritize pipelines for upsizing.
- One (1) pipeline exceeded velocity limitations during the ultimate buildout scenario (CIP W-5)
- By ultimate buildout, four (4) pressure zones will not have sufficient water storage, totaling 6.83 MG deficit.

- The 1783 and 2320 Pump Stations will require upsizing by ultimate buildout.

ES.6 Recycled/Non-Potable Water System Analysis

The following highlights the recycled/non-potable water system analysis results.

- Under existing MDD conditions, the Lurin Irrigation Zone experiences areas with pressure below 30psi.
- No pipelines exhibited flow velocities greater than 6 fps.
- There is an overall combined surplus of storage in both the North and South Areas, but a significant deficit of 2.4 MG in the Lurin Irrigation Zone in the North Area.
- All pump stations in the system were operating within design parameters during the Existing System (2020) MDD analysis. However, the Oleander Pump Station pumps cycle frequently due to the low volume in the Lurin Irrigation Tank. Increasing storage in the Lurin Irrigation (1815) zone will improve pump performance.
- For near-term planning (2030), additional storage was added to the Lurin Irrigation (1815) zone, along with supporting pipelines, to satisfy water storage needs. This new recommended storage tank has been named the Orangecrest tank.
- For ultimate buildout, two pipelines totaling 6,000 LF exhibited excessive velocity and headloss. Upsizing these two pipelines in the Lurin Irrigation (1815) Zone will support maintaining acceptable system pressure within the zone.

ES.7 Wastewater Collection System Analysis

The following highlights the wastewater collection system analysis results.

- Under existing system and near-term scenarios, both dry and wet weather flows, no gravity sewer pipelines exceeded 75% full ($d/D < 0.75$). Some pipeline segments (37 in total) exceeded their design capacity during wet weather, but did not trigger the need for upsizing.
- Under ultimate system peak wet weather modeling, approximately 46 pipeline segments experienced some degree of either high velocity or d/D at or near 1.0, but no overflows or manhole surcharging occurred, therefore none triggered improvements beyond monitoring.
- Under existing flow conditions, two sewer lift stations, Markham and Beazer 1, received peak wet weather flows that exceeded their firm capacity. Both stations contained sufficient total capacity to handle the peak wet weather flows. Historic flow monitoring data for both lift station basins were not high quality, and therefore future monitoring is recommended.
- Under near-term flow conditions one sewer lift station, Meridian, received peak wet weather flows that exceeded its firm capacity. The Meridian lift station has sufficient total capacity to handle the peak wet weather flows. It is recommended that the firm capacity of the Meridian lift station be increased to accommodate Near-Term flows.
- Under ultimate flow conditions one sewer lift station, MARB 1269, received peak wet weather flows that exceeded its total capacity. Projected sewer flows in the MARB 1269 sewer basin for near-term and ultimate scenarios are based on development plans that have not been finalized. Further analysis of build out conditions and resultant wastewater generation on MARB is recommended.
- Under near-term flow conditions, the ADWF to the WWRF reaches 69% of the plant's treatment capacity. Under ultimate flow conditions the WWRF reaches 93% of its rated capacity. Analysis of the plant's treatment capacity and expansion alternatives is recommended.

ES.8 Capital Improvement Program (CIP)

The recommended system improvements and operational modifications with estimated project costs include the following:

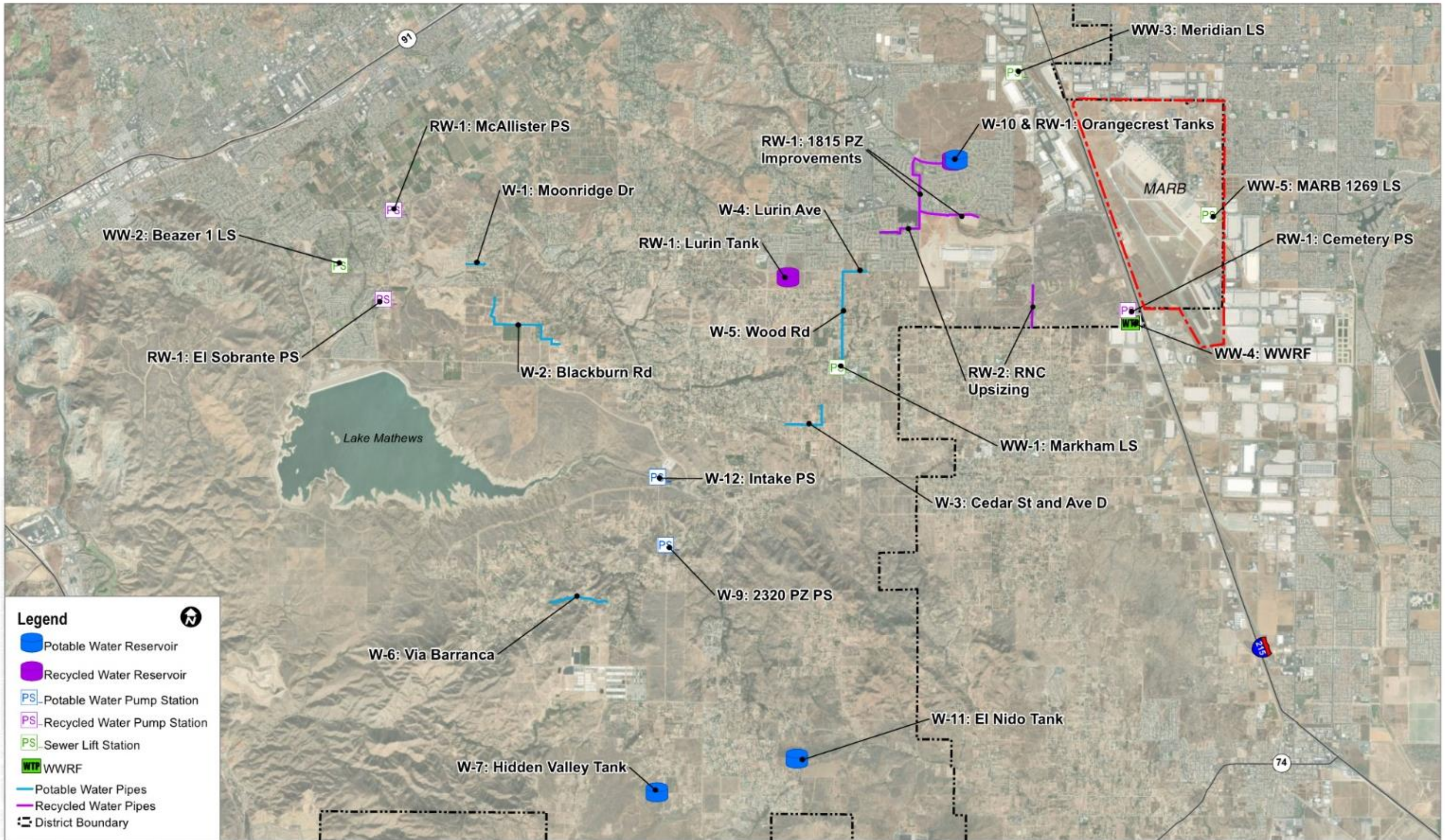
Table ES-1: Recommended Improvement Projects

CIP No	Project Name	Description	Justification	Project Costs (Dollars in Millions)		
				Existing	Near-Term	Ultimate
W-1	Moonridge Dr Pipeline Upsizing	Upsize 1,200 LF of 6-inch to 12-inch	High velocity in the pipe due to the small diameter bottleneck. Will improve transmission west.	\$0.69		
W-2	Blackburn Rd Pipeline Upsizing	Upsize 8,000 LF of 6-inch to 8-inch	Improve fire flow to the area and break history suggested poor pipe condition	\$3.06		
W-3	Cedar St and Ave D Pipeline Upsizing	Upsize 4,000 LF of 6-inch to 8-inch	Low fire flow in the area can be improved with pipeline upsizing	\$1.53		
W--4	Lurin Ave Pipeline Upsizing	Upsize 4,000 LF of 6-inch to 12-inch	High velocity in pipeline due to increased demand on a small diameter pipeline			\$2.29
W-5	Wood Rd Pipeline Upsizing	Upsize 7,000 LF of 12-inch to 16-inch	High velocity in transmission from Markham tanks due to increased demand in 1900 PZ at Ultimate			\$5.35
W-6	Via Barranca Pipeline Upsizing	Upsize 4,200 LF of 8-inch to 12-inch	Increasing the pipeline capacity will increase supply into the zone, improving fire flow capacity throughout the zone.			\$2.41
W-7	Hidden Valley #2 Tank	Build new 2.7 MG tank at Hidden Valley site	Additional storage capacity in 2320 PZ necessary at Ultimate			\$10.74
W-8	2320 PZ Tank	Build new 3 MG tank to serve 2320 PZ	Additional storage capacity in 2320 PZ is necessary at Ultimate			\$11.93
W-9	2320 PZ Booster Pump Station	Build new booster pump station with four 150 HP pumps, Add new intake and discharge piping	Additional pumping capacity into 2320 PZ is necessary at Ultimate			\$4.34

CIP No	Project Name	Description	Justification	Project Costs (Dollars in Millions)		
				Existing	Near-Term	Ultimate
W-10	Orangecrest #3 Tank	Build new 5 MG tank at Orangecrest site	Additional storage capacity in 1837 PZ is necessary at Ultimate			\$19.89
W-11	El Nido #2 Tank	Build new 1 MG tank at El Nido site	Additional storage capacity to 2450 PZ necessary at Ultimate			\$3.98
W-12	Increase capacity of Intake BPS	New 150 HP pump at Intake pump station	Additional pumping capacity to 1783 PZ necessary at Ultimate			\$0.45
<i>Subtotal Water Projects</i>				\$5.28	\$ —	\$61.38
RW-1	1815 PZ Near Term Improvements	5 MG Orangecrest Tank \$19.9M Redesign Lurin Tank to have same HGL as new Orangecrest Tank \$2.0M 12-inch supply line \$4.0M 4,400 LF of 16-inch pipe \$3.4M 1,300 LF of 18-inch pipe \$1.1M 3,500 LF of 24-inch pipe \$4.0M 200 HP pump at Cemetery PS with 6,000 LF parallel 250 HP pump at McAllister PS 150 HP pump at El Sobrante PS	Increased zone storage and pipeline looping required to accommodate existing demands as well as improve zone pressures		\$35.5	
RW-2	RNC Pipeline Upsizing	Upsize 3,000 LF of 12-inch to 18-inch, Upsize 3,000 LF of 16-inch to 24-inch	Timing based on expansion of RNC.			\$6.02
<i>Subtotal Recycled Water Projects</i>				\$ —	\$35.5	\$6.02
WW-1	Markham Lift Station Upgrade	Increase firm capacity from 1.44 MGD to 2.1 MGD to accommodate Near-Term flows	Based on the model results the Markham lift station currently exceeds its firm capacity during wet	\$5.15		

CIP No	Project Name	Description	Justification	Project Costs (Dollars in Millions)		
				Existing	Near-Term	Ultimate
			weather events which would result in SSO's, creating a public safety hazard.			
WW-2	Beazer Lift Station Upgrade	Increase firm capacity from 0.16 MGD to 0.25 MGD to accommodate existing flows	Based on the model results the Beazer 1 lift station currently exceeds its firm capacity during wet weather events which would result in SSO's, creating a public safety hazard.	\$0.43		
WW-3	Meridian Lift Station Upgrade	Increase firm capacity from 0.88 MGD to 1.05 MGD to accommodate Near-Term flows	Based on the model results the Meridian lift station currently exceeds its firm capacity during wet weather events which would result in SSO's, creating a public safety hazard.		\$0.60	
WW-4	WWRF Expansion Study	Begin design analysis for expanding WWRF from 3.0 MGD to 5.0 MGD	Based on approved projects, the plant will be utilizing 77% of its capacity by the end of the Near-Term phase, future increases in flow would result in SSO's, creating a public safety hazard.		\$0.10	
WW-5	MARB LS 1269 Expansion Study		Dependent on final build out configuration for MARB, LS 1269 firm capacity may be deficient			\$0.05
<i>Subtotal Sewer Projects</i>				<i>\$5.58</i>	<i>\$0.70</i>	<i>\$0.05</i>
Total All Projects				\$10.86	\$36.2	\$ 67.45

Figure ES-1: CIP Summary Map



INTENTIONALLY LEFT BLANK

1 Introduction

This chapter presents the project background for the Western Municipal Water District's (WMWD, Western, or District) Riverside Facilities Master Plan (FMP), as well as an overview of Western's service area, a summary of the project objectives and scope of work, and the organization of this document.

1.1 Background and Master Plan Objectives

In January 2020, Western initiated preparation of this FMP. The FMP is an integrated master plan that evaluates the performance and capacity of Western's potable water, recycled/non-potable water, and wastewater systems under existing, near-term (2030), and ultimate (buildout) conditions. The FMP provides a list of recommended capital improvement projects to guide Western with the budgeting and implementation of the recommended improvements to support future growth and development of the Riverside service area. It is noted that Western serves multiple retail service areas, separate from the Riverside service area, but this document focuses solely on the Riverside service area (Figure 2-1), as the other WMWD retail service areas are covered under separate master plans.

The 2020 FMP seeks to address the following key objectives:

- Evaluate growth projections for the service area and the resulting near-term and ultimate demand and flow forecasts
- Update the evaluation criteria for the potable water, recycled/non-potable water, and wastewater collection system analyses
- Update the existing potable water model, as needed
- Update and calibrate the existing recycled/non-potable water hydraulic model
- Develop and calibrate a new wastewater collection system model
- Perform hydraulic analyses utilizing the updated and newly developed hydraulic models to identify recommended projects for inclusion in Western's Capital Improvement Program (CIP)
- Combine the three water services into an overall master plan document with integrated and prioritized CIP to optimize the timing of critical projects

Previous Western planning efforts referenced to create this FMP included:

- North and South AFC Water Master Plan (2014, Webb).
- Water System Optimization Study, Phases 1 & 2 (2018 through 2020, HAL) – This study included an InfoWater hydraulic model. This model was used as the basis for the FMP potable water system analysis.
- WMWD Riverside Retail Service Area Build-Out Demand Analysis (2019, Kennedy Jenks; Appendix A).
- Recycled Water Master Plan (2014, Webb), and
- Sewer Master Plan (2014, Webb).

1.2 Service Area Overview

Western was formed in 1954 as a member agency of the Metropolitan Water District of Southern California (Metropolitan, MWD) and began deliveries of imported water in 1956. Initially solely a wholesale water supplier, Western began providing retail water services in 1962. Western's service area is located in western Riverside County, approximately 50 miles east of Los Angeles and covers 527 square miles, of which 104 square miles are included as retail service areas, as shown in Figure 1-1. The retail service areas include the unincorporated areas

around Lake Mathews, the City of Murrieta, and unincorporated Riverside County south of the City of Temecula. Though there are multiple Western retail service areas that are not connected to one another, this FMP covers the Riverside Retail Service Area only.

Western's climate is characterized as Mediterranean. Temperatures are mild in winter, spring, and fall, and hot and dry during summer months. Total annual precipitation is, on a long-term average, approximately 10 inches for most of its service area. The majority of rainfall occurs during the months of November through April. Temperatures typically peak in August and September at an average of 94°F. Typical temperatures in winter months are approximately 54°F. The evapotranspiration rate for the area is approximately 50 inches/year.

Historically, Western's water supplies consist primarily of imported water. The majority of this water is purchased from Metropolitan. Metropolitan is a regional water wholesaler that has 26 public member agencies, including Western. Metropolitan obtains its primary water supplies from the State Water Project (SWP) and Colorado River Aqueduct (CRA). Since the early 1990s as a result of droughts, water rights issues, and environmental restrictions, Metropolitan water supply has become less reliable. Western also purchases local groundwater supplies from Meeks and Daley Water Company, City of Riverside and when available, from the Riverside Highland Water Company. Water is typically purchased from the City of Riverside on an emergency or off-season basis. Additional local groundwater supplies are pumped by Western from the Temecula-Murrieta portion of the Temecula Valley Groundwater Basin and the San Bernardino Basin Area for retail supplies, and from the Arlington Subsection of the Riverside-Arlington Groundwater Basin for wholesale supplies.

To increase local supply reliability, Western produces and sells recycled water in its retail service area. Western has completed projects to increase local supply reliability including groundwater recharge projects and expansion of its retail distribution system.

During summer months, Western's Western Water Recycling Facility (WWRF), a sewage treatment plant, does not produce enough recycled water to supply all demand in its recycled water system; located north of the Colorado River Aqueduct (CRA) and the non-potable water system. Therefore, Western supplements recycled water with non-potable water from the Riverside Canal during summer months to meet summer demands in the recycled water system. District also has the ability to supplement the recycled water system with non-potable water from the Colorado River Aqueduct (CRA). Non-potable water from the CRA is the sole supply to the non-potable water system; located south of the recycled water system. Figure 2-8 provides an overview of WMWD's recycled water/non-potable water systems.

Western provides wastewater collection services to approximately 11,500 acres within its Riverside Retail Service Area. Sewage generated within the retail service area is divided into two drainage basins. The western portion of the service area flows to the Western Riverside County Regional Wastewater Authority (WRCRWA) Treatment Plant and is primarily from residential sources. The eastern portion of the service areas flows to the WWRF and is from a mix of residential, commercial, and industrial sources, including March Air Reserve Base (MARB).

Figure 1-1: Western Service Area

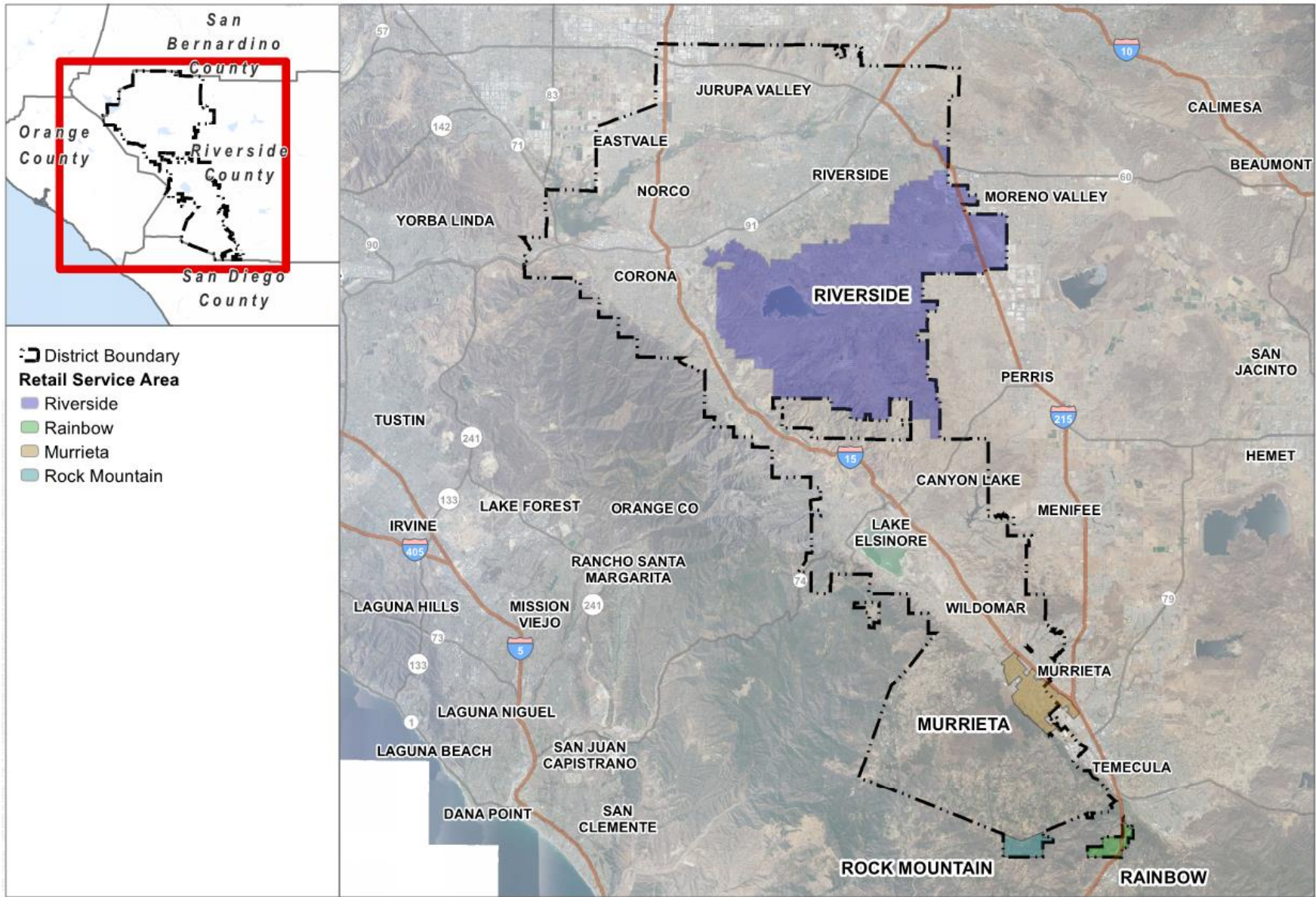
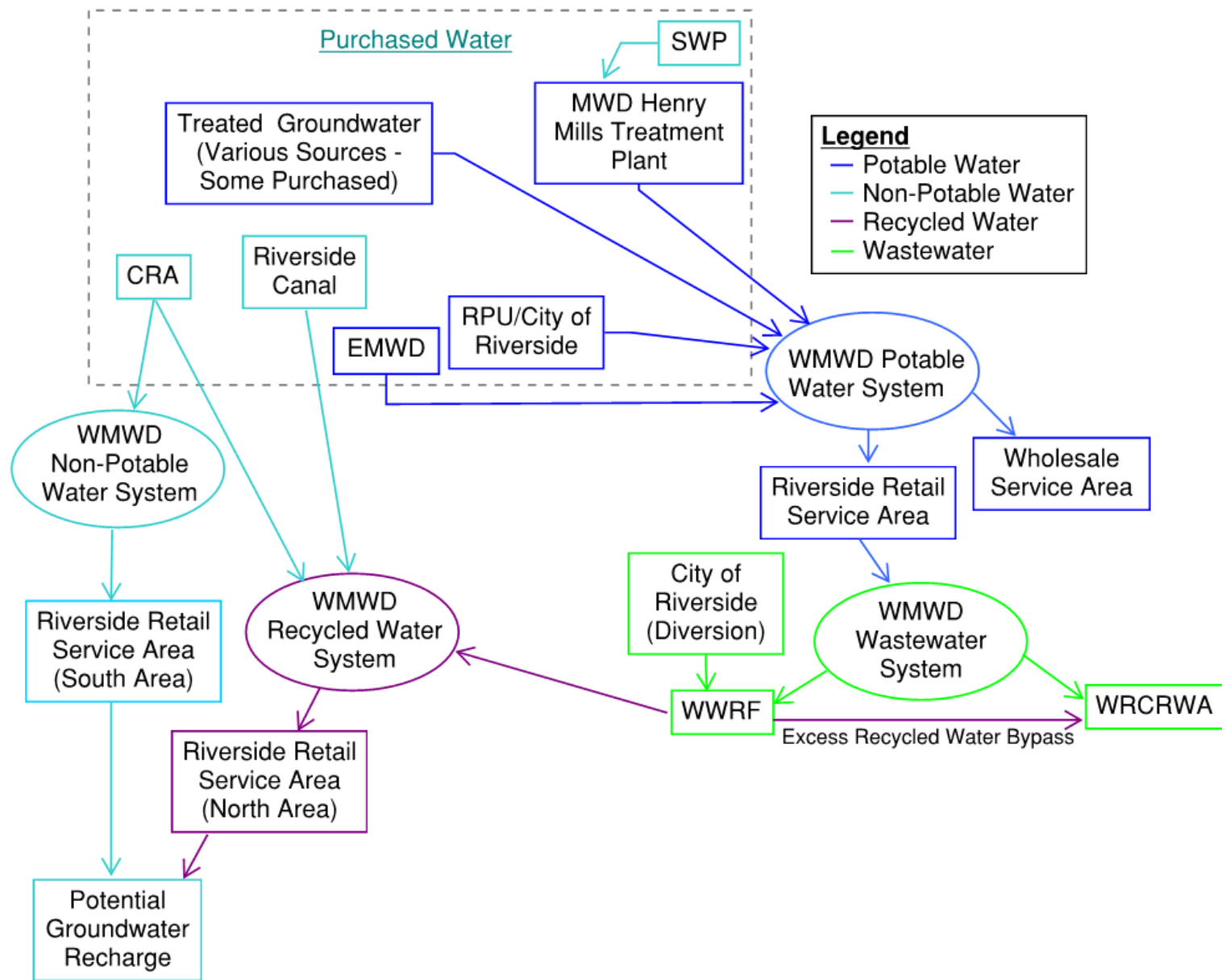


Figure 1-2: Riverside Retail Service Area Systems Schematic



1.3 Report Organization

The following list summarizes the sections included in this report.

- **Section 1.0 – Introduction** describes the background, objectives, scope of work, report organization and key characteristics of Western’s retail service area.
- **Section 2.0 – Study Area, Land Use and Population** presents a discussion of the FMP study area, existing water distribution facilities, existing recycled/non-potable water distribution facilities, existing wastewater collection system, Near-Term and Ultimate land use, and population trends.
- **Section 3.0 – Water Demand and Wastewater Flow Forecasts** outlines the development of the projected water and recycled/non-potable water demands as well as wastewater flows through a review of as-builts, design drawings, and data from past reports.
- **Section 4.0 – Hydraulic Modeling** provides details on the water, recycled/non-potable water and wastewater hydraulic models used for this study as well as the development, updates, and calibration results for the three models.
- **Section 5.0 – System Evaluation Criteria** summarizes the criteria used to evaluate the water, recycled/non-potable water and wastewater systems and their facilities under existing and future conditions.
- **Section 6.0 – Potable Water System Analysis** presents the results of the hydraulic, storage and pumping analyses on this system.
- **Section 7.0 – Recycled/Non-Potable Water System Analysis** presents the results of the hydraulic, storage and pumping analyses on this system.
- **Section 8.0 – Wastewater Collection System Analysis** presents the results of the capacity analysis on this system.
- **Section 9.0 – Capital Improvement Program** summarizes the final recommended projects for each system and provides an integrated, prioritized, and dynamic CIP list and schedule for the implementation of these projects over the next several years.

Included as Appendices to the report are the following supporting materials.

- A. WMWD Riverside Retail Service Area Build-Out Demand Analysis (2019, Kennedy Jenks)
- B. Potable Water System Schematic
- C. Recycled Water Figure
- D. CIP Cost Estimate Sheets

INTENTIONALLY LEFT BLANK

2 Study Area, Land Use and Population

This chapter describes the study area of this FMP, Western's Riverside Service Area, where it provides water, recycled/non-potable water, and wastewater collection services. The existing and anticipated future changes in land use within the study area are described, as well as planned developments and information obtained on Ultimate land use.

This chapter concludes with a description of the historical population trends within Western and projected populations for the planning period of the FMP through future buildout (Ultimate). Details presented in this chapter on Near-Term developments (likely to be constructed by 2030) and Ultimate (Buildout) development form the basis for the demand and flow projections which are presented in Chapter 3.

2.1 Study Area

The Riverside Retail Service Area is generally bounded by the City of Riverside to the north, the City of Moreno Valley to the east, the City of Lake Elsinore to the south, and the City of Corona to the west. The extent of the Riverside Retail Service Area is shown on Figure 2-1. The specifics of the potable water, recycled/non-potable water and wastewater study areas are explained in greater detail in subsequent sections.

2.2 Potable Water Study Area and Facilities Data

Western's Riverside Service Area consists of 21 pressure zones, over 565 miles of pipe, sixteen (16) storage tanks and twelve (12) pump stations to provide potable water to more than 27,000 connections spread over more than 100 square miles. The service area includes a portion of the City of Riverside, unincorporated portions of the County of Riverside and the March Air Reserve Base (MARB), as shown in Figure 2-2. Historically, the water systems within MARB were owned and operated by March Air Force Base (MAFB) and include water facilities installed over fifty years ago. As part of the realignment of MARB from MAFB, these facilities were transferred over to WMWD's ownership.

The potable water system is supplied from the MWD's Henry Mills Treatment Plant and either pumped into the 1837 pressure zone via the Holcomb Booster Station or gravity fed into the Mills Gravity Line (MGL) for distribution. WMWD's Arlington Desalter treats groundwater from local wells and is located just north of the Riverside retail service area. The Arlington Desalter pump station pumps water to the City of Norco (wholesale demand outside of Riverside retail service area) and also to the Riverside retail service area via a connection with the new Sterling Pump Station, which conveys water to La Sierra reservoir via the La Sierra pipeline. The Chino Basin Desalter Authority's (CDA) Chino II Desalter in Jurupa Valley also provides locally treated groundwater to Western, and is used to offset Western's wholesale water demands to the City of Norco provided by the Arlington Desalter. A schematic of the potable water distribution system is presented in Appendix B.

2.2.1 Existing Potable Water System

The following section provides details on the existing potable water system facilities and analysis on the capacities of the system. A schematic depicting WMWD's existing potable water system is provided in Appendix B.

2.2.2 Existing Pressure Zones

The potable water system consists of twenty-one (21) pressure zones, divided into the North and South areas. In the North Area there are sixteen (16), of which 1837 and 1900 are the largest. The North area zones are shown in Figure 2-3 and Figure 2-4. The North and South areas are connected by the Intake pump station, which pumps from the north area (1650 PZ) to the South area (1783 PZ). In the South Area, there are five (5) zones, as shown in Figure 2-5.

Figure 2-1: Western Riverside Retail Service Area

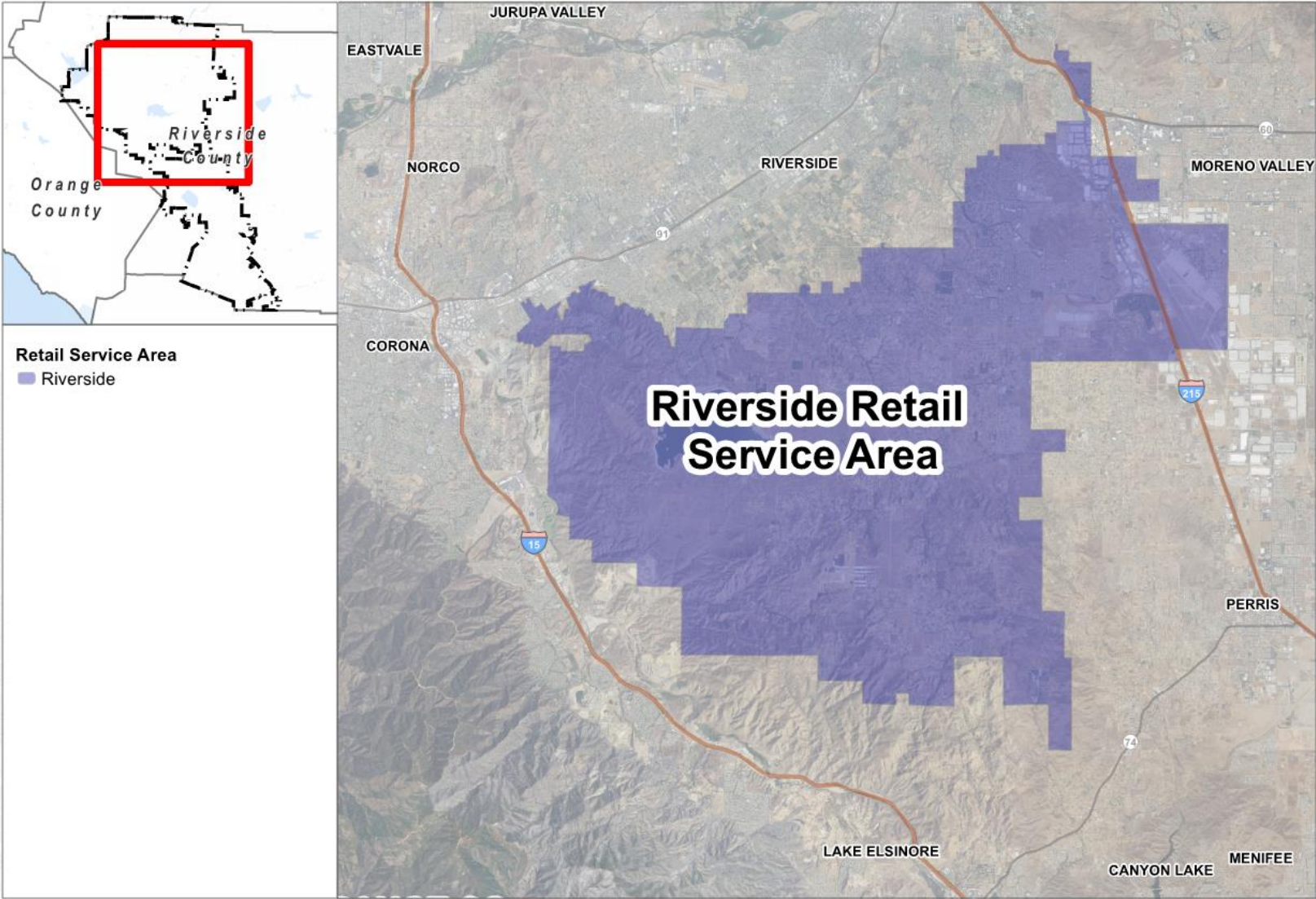


Figure 2-2: Western Potable Water Study Area

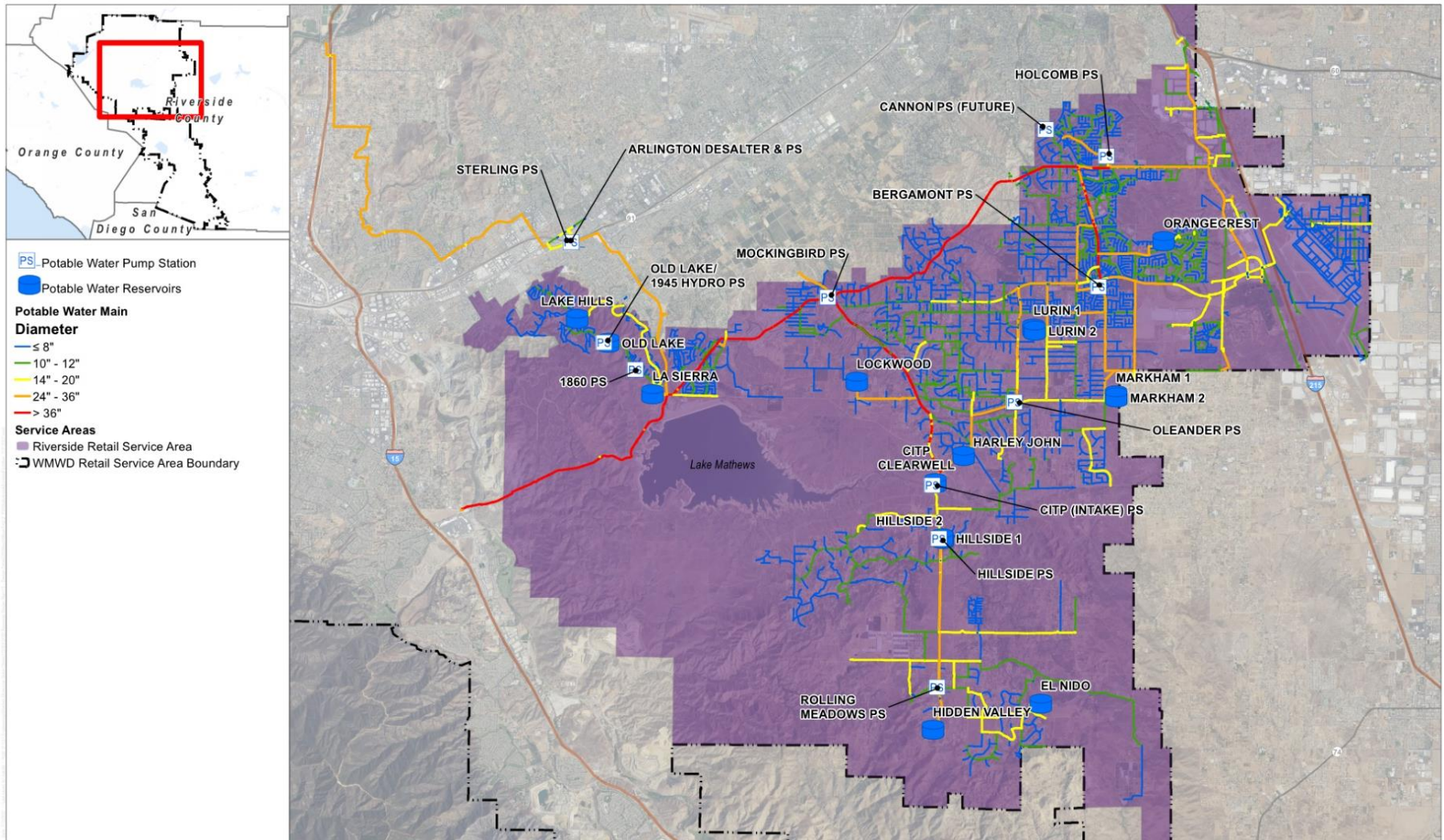


Figure 2-3: Potable Water Pressure Zones – East side of North Area

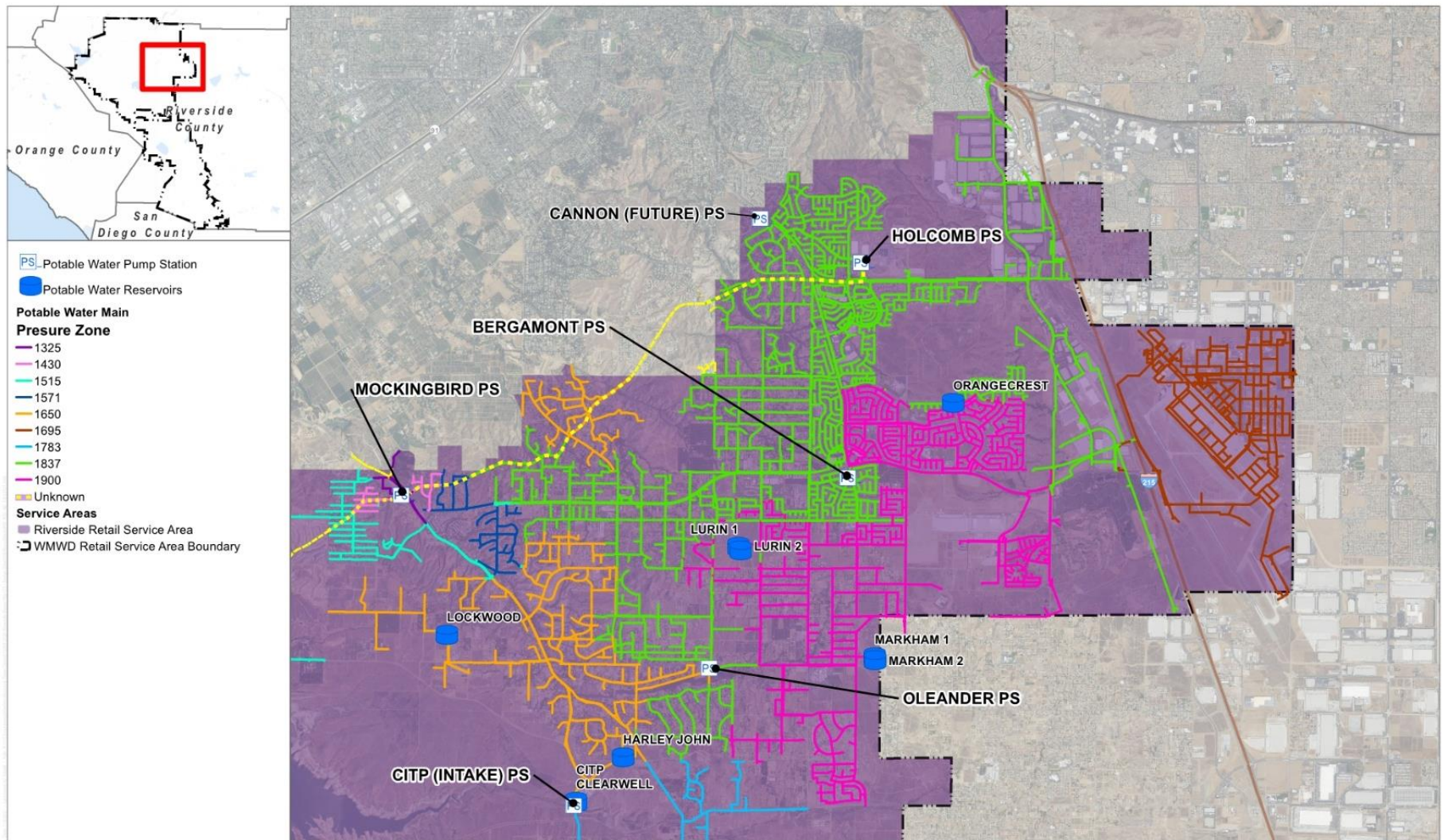


Figure 2-4: Potable Water Pressure Zones – West side of North Area

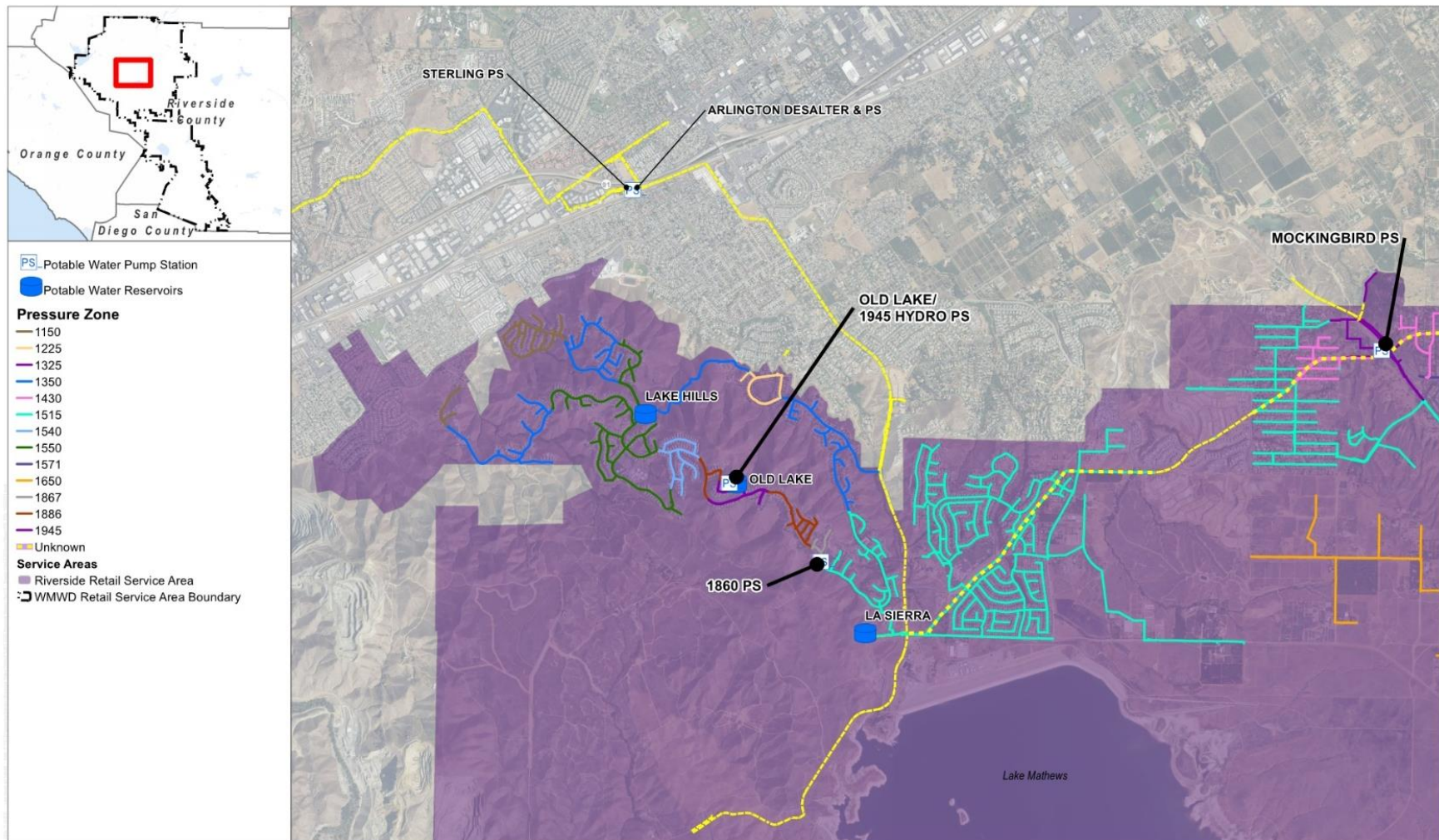
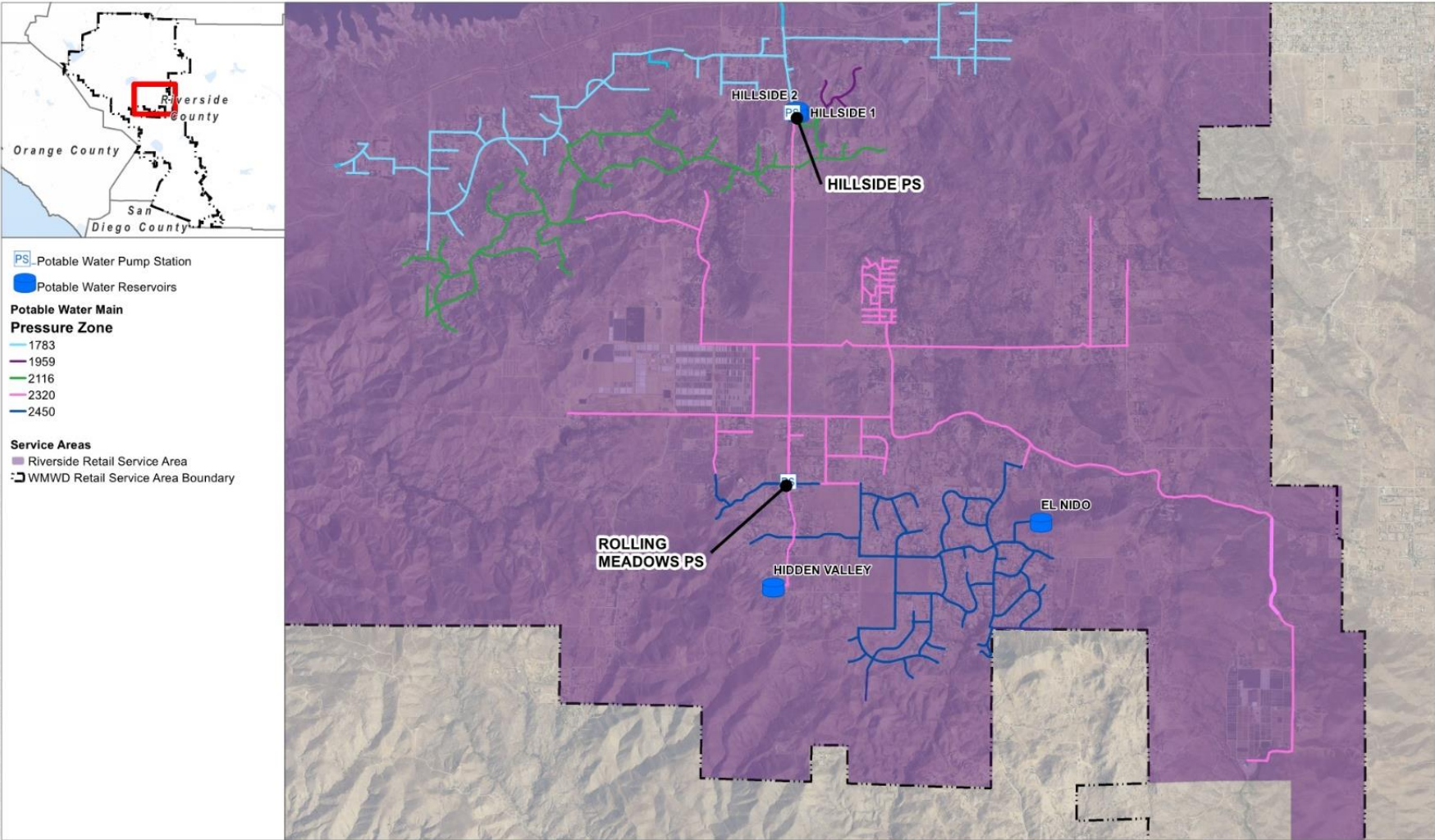


Figure 2-5: Potable Water Pressure Zones – South Area



2.2.3 Existing Potable Water Pipelines

Western has 565 miles of pipeline in the potable water system, ranging from 4-inch to 60-inch diameter. Most of the distribution system is in the range of 6-inch to 12-inch diameter pipelines. Approximately 3% of the system includes pipelines smaller than 6-inch diameter. Approximately 64 miles of pipeline are larger diameters ranging from 24-inch to 60-inch. Table 2-1 includes the lengths of pipelines in each diameter, as well as the decade that it was constructed.

Table 2-1: Potable Water Pipeline Length – Diameter by Decade of Construction

Pipe Dia (in)	Pipe Length (ft) by Year Installed								Total Length (ft)
	< 1960	1960s	1970s	1980s	1990s	2000s	2010s	Unknown	
2	—	—	340	1,316	108	—	56	448	2,268
3	—	—	—	—	—	95	65	664	824
4	—	16,429	4,219	641	1,738	2,526	48	52,104	77,705
6	596	32,506	80,098	204,995	24,096	9,371	918	119,264	471,844
8	—	27,258	58,891	146,893	154,514	353,445	11,767	303,403	1,056,171
10	—	13,927	9,988	70,746	34,022	24,279	2,001	46,937	201,901
12	1,604	19,007	5,491	31,497	77,535	149,904	14,417	261,830	561,286
14	—	7,579	—	31,870	2,754	10,159	10	27,204	79,575
16	—	37	—	14,522	19,474	36,397	183	29,429	100,041
18	—	—	69	4,817	10,847	14,345	2,743	17,301	50,121
20	—	46	—	164	3,166	2,121	65	27,219	32,781
21	—	—	—	4,413	110	—	—	—	4,522
22	—	—	—	113	394	—	—	6,808	7,314
24	—	2,341	2,767	22,155	7,861	39,471	10,633	16,954	102,182
30	—	—	931	11,647	18,434	54,674	2,244	22,118	110,048
36	—	—	88	2,551	94	4,054	24	3,130	9,941
42	—	—	217	7,090	252	31	—	8,219	15,808
48	—	—	152	35	46	195	—	25,515	25,943
54	—	31	—	164	22,480	—	17	18,671	41,364
60	—	—	—	30,975	—	—	—	69	31,044
Total Length (mi)	0.42	22.6	30.9	111.1	71.6	132.8	8.6	187.0	565

Generally water pipelines have a life expectancy between 60 and 100 years, depending on the material of the pipe. With less than 0.1% of the system constructed prior to 1960, the system is generally expected to be in good condition and not in need of an aggressive replacement plan.

Pipelines constructed between 1960 and 1979 are still within their life expectancy, but may need to be considered for replacement, depending on the pipeline material. Table 2-2 breaks the system down by the

material of the pipe and the decade that it was constructed. Western does not have records of the construction material of 7% of their pipelines, which are listed as “Unknown” in the table.

Table 2-2: Potable Water Pipeline Length – Material by Decade Construction

Pipe Material	Pipe Length (ft) by Year Installed								Total Length (ft)
	< 1960	1960s	1970s	1980s	1990s	2000s	2010s	Unknown	
ACP	—	—	—	38,633	550	4,596	284	29,704	73,767
AL	—	—	—	—	—	—	—	1,435	1,435
CCP	—	—	—	38,314	94	—	—	42,134	80,542
CIP	—	—	—	196,645	23,056	19,975	1,558	10,460	251,694
CML	—	—	—	1,356	—	—	25	219	1,600
CMLAW	1,408	52,448	97,790	208,676	145,355	39,813	2,807	296,463	844,761
CMLC	156	30,174	22,333	84,762	106,495	140,285	18,154	293,495	695,854
CMLTW	—	—	—	7	—	5,082	—	—	5,089
DIP	—	—	—	661	1,911	233	79	2,217	5,101
GALVP	—	—	—	—	—	—	—	263	263
PVC	596	—	467	7,140	96,923	483,571	22,042	213,269	824,008
RCP	—	—	—	—	—	—	147	905	1,051
UNK	40	36,538	42,663	10,410	3,537	7,513	95	96,720	197,516
Total Length (mi)	0.42	22.6	30.9	111.1	71.6	132.8	8.6	187.0	565

Most of the pipes constructed prior to 1980 are cement mortar lined (CML) pipe. Depending on soil conditions, CML pipe can have a life expectancy of 100 years. The table also shows that Western has transitioned from primarily CML to primarily PVC for smaller diameter pipe. Under good soil conditions, PVC will also have a life expectancy of 100 years.

2.2.4 Existing Pump Stations

Western has ten (10) pump stations that move water from the lower to higher pressure zones. Holcomb BPS (56,000 gpm capacity) is the system’s main water supply into Western and pumps water from MWD’s Mills Gravity Line (MGL) to the Orangecrest and Lurin reservoirs (1837 HGL). Bergamont BPS (18,900 gpm capacity) pumps from the 1837 pressure zone to the Markham reservoirs (1900 HGL). Mockingbird BPS pumps water from MWD Mill’s Gravity Line or from the Riverside Public Utilities (RPU) / City of Riverside to the 1650 pressure zone. The Intake pump station is the primary supply to the southern system. It pumps water from pressure zone 1650 of Western’s northern system to the 1783 pressure zone in the southern system. The remaining five pump stations deliver water to the smaller zones in the system.

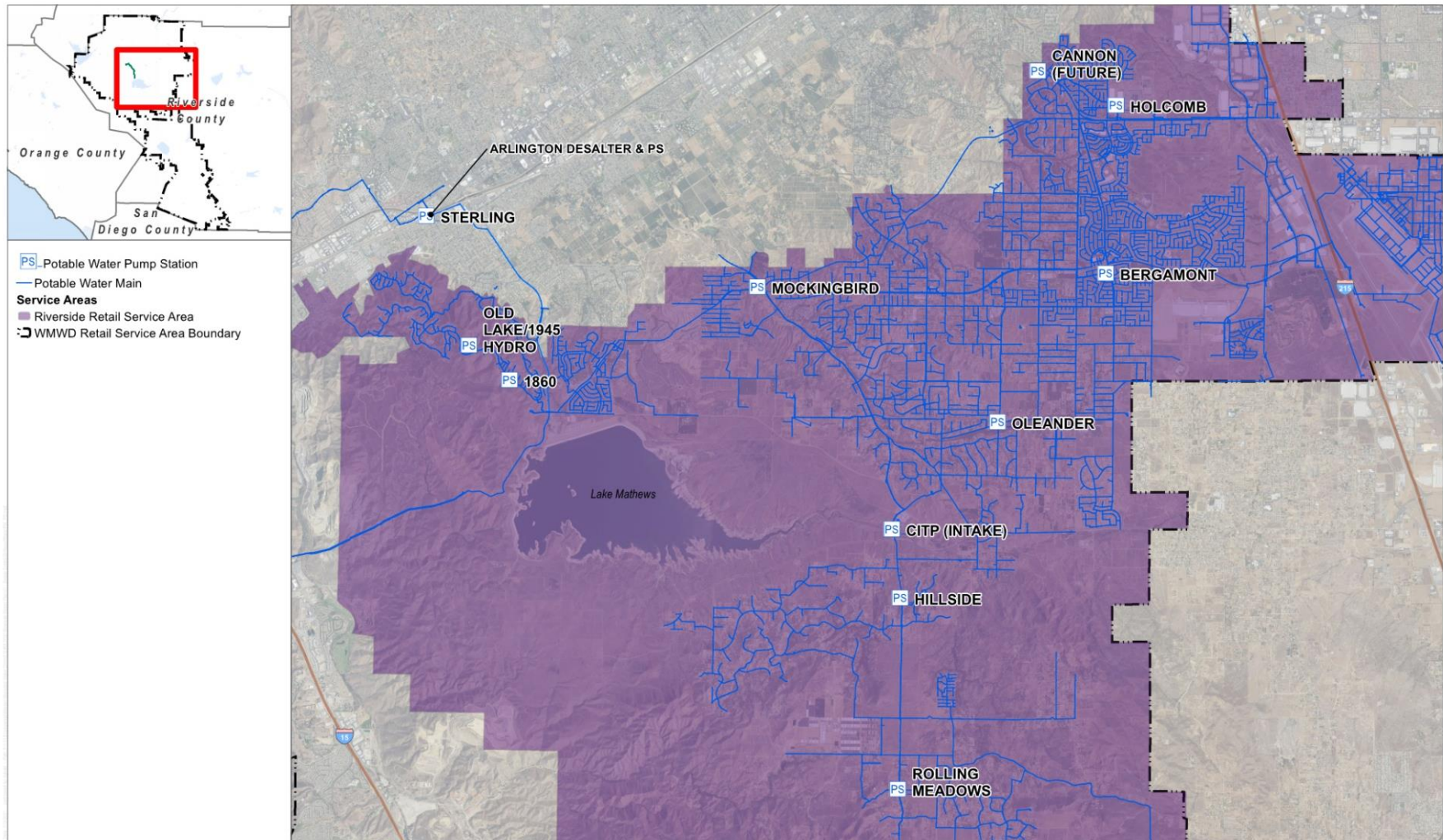
Table 2-3: Potable Water Booster Pump Stations

Pump Station	Supply Zone	Discharge Zone	No. Pumps	Pumping Capacity (gpm)
1860	1515	1886	3	1,700
Bergamont	1837	1900	4	18,900
Cannon ¹	RPU	1837	3	6,750
CITP (Intake)	1650	1783	4	9,600
Hillside	1783	2320	3	2,250
Holcomb	MWD	1837	8	44,800
Mockingbird (E1-E5) ³	RPU ²	1650	5	4,800
Mockingbird (E6 & E7)	Mills Gravity Line	1650	2	8,976
Old Lake/1945 Hydro	1860	1945 Hydro	2	350
Oleander	1650	1837	4	9,256
Rolling Meadows	2320	2450	3	1,765
Sterling	Arlington Desalter	1515	6	9,500

Notes:

- ¹ Currently in design. Construction is expected to be complete in 2023.
- ² Riverside Public Utilities (RPU) supplements the retail water supply.
- ³ Pumps E1 and E2 are off-line. The capacity only includes E3-E5

Figure 2-6: Potable Water System Pump Stations



2.2.5 Supply and Interconnections

The majority of the Riverside Retail Service Area is supplied from Metropolitan’s Henry Mills Water Treatment Plant (WTP) through either the Holcomb Pump Station (PS) or the Mills Gravity Line (MGL); a regional pipeline owned by WMWD. In addition to the MWD Henry Mills WTP supply, the Riverside Retail Service Area has seven (7) interconnections that supply its potable water system, as shown in Table 2-4, including three (3) connected to the MGL and five (5) used only for emergencies.

Table 2-4: Potable Water Interconnections

Interconnection	Agency	Riverside Retail Service Area Pressure Zone Supplied	Connected to MGL
Mockingbird PS	RPU	MGL	Yes ¹
Henry Mills Treatment Plant	MWD	MGL	Yes
Whitegates PS ¹	RPU / City of Riverside	MGL	Yes
Sterling PS / La Sierra Pipeline	RPU ³ / Arlington Desalter	1515	Yes
Cannon PS ³	RPU	1837	No
Phillips ²	EWMD ¹	1695	No
Global Port ²	EWMD ¹	1695	No
Cactus ²	EMWD ¹	1695	No

Notes:

- ¹ Only used for emergency supply. Normally closed interconnection.
- ² Interconnection is located within MARB.
- ³ Planned future connection

2.2.6 Existing Storage Reservoirs

Western has fifteen reservoirs that provide storage to the system. The two largest reservoirs are the La Sierra reservoir (10 MG), which serves the 1515 zone and provides supply for the western side of the distribution system, and the Orangecrest reservoir (12.0 MG). Orangecrest, along with the two Lurin reservoirs (5 MG each), serve the 1837 pressure zone, the largest pressure zone in the system. The two Markham reservoirs (7 MG and 6.6 MG) serve the 1900 pressure zone, the next largest zone. The remaining nine reservoirs serve the smaller zones or serve booster stations. Table 2-5 includes all of the reservoirs.

Table 2-5: Potable Water Storage Reservoirs

Reservoir Name	Pressure Zone	Volume (MG)	Invert Elevation (ft MSL)	HWL (ft MSL)	Diameter (ft)
Lake Hills	1350	1.5	1,318	1,350	92
CITP Clearwell ¹	1650	5.0	1,434	1,474	146
La Sierra	1515	10.0	1,466	1,511	194
Lockwood	1650	5.0	1,619	1,648	166
Harley John	1650	4.0	1,628	1,657	150

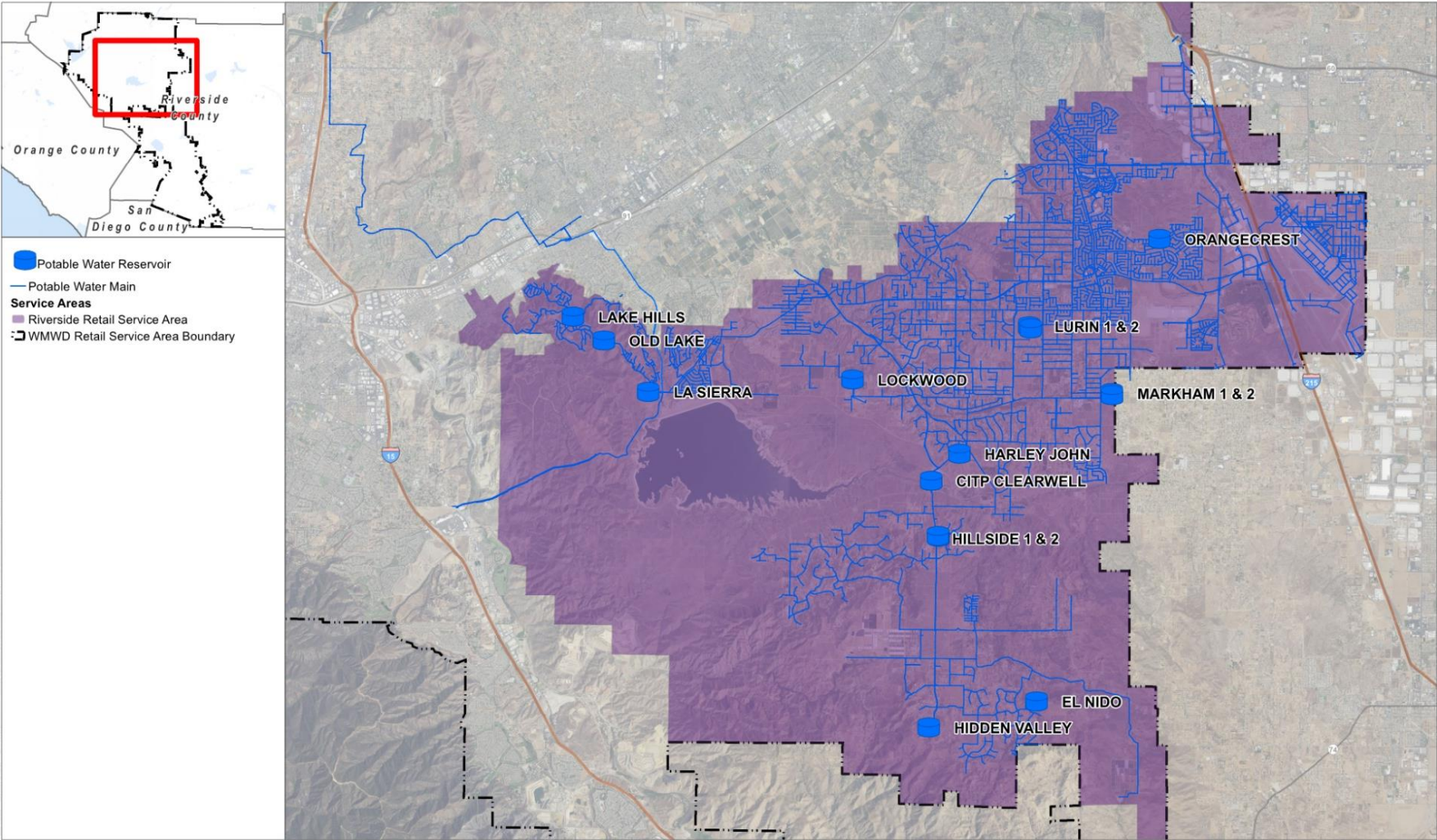
Table 2-5: Potable Water Storage Reservoirs

Reservoir Name	Pressure Zone	Volume (MG)	Invert Elevation (ft MSL)	HWL (ft MSL)	Diameter (ft)
Hillside 1	1783	0.5	1,755	1,783	55
Hillside 2	1783	0.5	1,755	1,783	55
Orangecrest	1837	12.0	1,797	1,843	212
Lurin 1	1837	5.0	1,798	1,835	150
Lurin 2	1837	5.0	1,798	1,835	150
Old Lake	1886	1.3	1,854	1,885	83
Markham 1	1900	7.0	1,861	1,904	170
Markham 2	1900	6.6	1,861	1,901	176
Hidden Valley	2320	2.7	2,283	2,321	110
El Nido	2450	1.5	2,410	2,450	75
Sterling	N/A ²	1.1	697	725	86

Notes:

- ¹ Emergency storage reservoir connected to the 1650 pressure zone.
- ² Sterling is a forebay for Sterling PS and does not directly supply the distribution system

Figure 2-7: Potable Water System Reservoirs



2.2.7 Existing Pressure Reducing Stations

Western has 33 Pressure Reducing Stations (PRS) in the potable water system. Table 2-6 provides the size, and setting of the documented PRSs.

Table 2-6: Existing Pressure Reducing Stations

Name	PRS Size (in.)	PRS Setting (psi)	Name	PRS Size (in.)	PRS Setting (psi)
Across from 1860	8	0	1860	6	110
Mockingbird PS	8	200	Emelita	6	50
Rancho Sanato	8	148	Bellino	6	55
Village Meadows	6	48	Tonia2	4	61
Saddleback	2	90	Wylar	6	52
Harvey	3	75	VFD CONTROL VALVE	8	41
Lake Pointe & Cold Springs	6	29	Lake Pointe & Gold Bluff	12	50
Greenview	4	55	La Sierra PRV Tank Control	10	102
	2	95			
1350	6	89	187	4	0
Skyridge	6	65	Lake Pointe	6	60
	4	52	Laurel Dr	6	0
Piedras	6	65	Regency Ranch	6	68
Jansen	6	38	Constable	6	40
Village West	12	80	Holcomb	3	80
Opportunity	8	60	Ponderosa & Orangecrest	6	104
Bonanza	6	95		6	98
	2	95		12	77
Washington & Iris	8	55	Washington & Mariposa	6	70
Whispering Spur	6	95	Sterling ¹	16	N/A

Notes:

¹ New flow control valve that is part of Sterling PS. It allows reverse flow from Mills Gravity Line through La Sierra Pipeline to Norco/Jurupa system

2.2.8 Operational Challenges

During workshops with operational staff, the following operational challenges, which were mainly water quality issues, were identified. The issues are currently being addressed separately by Western with the addition of RMS and other projects. The individual issues identified were:

1. One of Western’s biggest operational challenges is maintaining chlorine residual throughout the system. During summer, the east side of the system (Lockwood, Harley John, and Lurin reservoirs) has the lowest residuals. Western is planning on constructing Cannon pump station to provide a source of supply to the east end of the system. In a collaborative effort between the Western Engineering and Operations Teams, A Reservoir Management System (RMS) is being planned for Orangecrest and La Sierra

reservoirs. Western’s Engineering and Operations Teams already planned, designed, and installed an RMS at Lurin.

2. La Sierra can have water quality issues as well, due to the mixing of free chlorine and chloramine. Western prefers using chloramine as a disinfectant instead of chlorine. Western is considering adding an ammonia station at Whitegates BPS to treat the free chlorine water before it is introduced to the system.
3. In winter, Western can have chlorine residual issues in their larger tanks due to low demand and a lack of turnover in the tank. This may be indicative of excess storage in the system and was reviewed in Section 6.1.3.1.

2.3 Recycled/Non-Potable Water Study Area

The Western recycled/non-potable water service area includes two distinct areas—North and South. The North Area includes Western’s retail area north of Cajalco Road. The South Area includes the area known as Gavilan plateau and includes Western’s retail service area south of Cajalco Road.

The North Area includes recently developed land within the City of Riverside, County of Riverside and March Joint Power Authority (MJPA). Note that there is no existing (in the year 2020) or planned future recycled/ non-potable water infrastructure located within the March Air Reserve Base (MARB).

The North Area has three recycled/non-potable water sources that are prioritized by Western in the following order based on cost of supply:

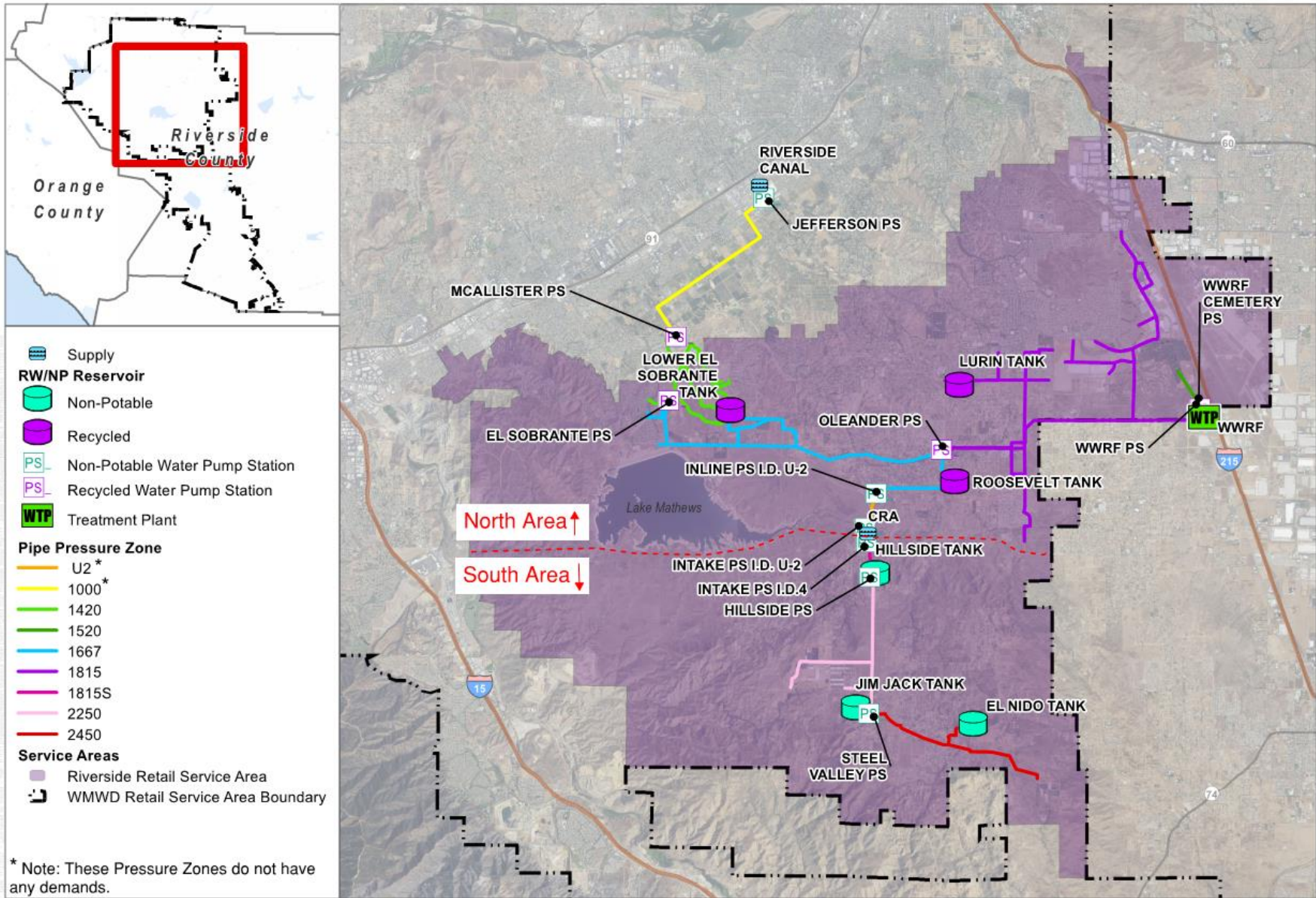
1. Western Water Recycling Facility (WWRF)
2. Riverside Canal
3. Colorado River Aqueduct (CRA)

The CRA and Riverside Canal provide non-potable water to the recycled water system, while the WWRF supplies Title 22 recycled water to the recycled water system. Between the CRA supply and the Roosevelt recycled water tank (specifically between the U2 Intake PS and the Roosevelt Tank) there is an air gap to prevent cross contamination of non-potable CRA water with recycled water. The users in the North Area are all approved recycled water customers with the necessary facilities and programs in place for recycled water service.

The South Area includes less densely developed land elevated by approximately 600-ft from the North Area. The CRA, located near the boundary of the North and South Areas, is the sole source of supply to the South Area. All customers in the South Area are non-potable irrigation customers, receiving no recycled water from WWRF and therefore, the South Area is referred to as the non-potable water system. WMWD is currently evaluating the potential of converting the South Area from non-potable water. Depending on the conclusion of the conversion study, WMWD may update this FMP and CIP recommendations accordingly.

Refer to Figure 2-8 for key infrastructure and pressure zones in the Recycled/Non-potable Water Study Area.

Figure 2-8: Western Recycled/Non-Potable Water Service Area Overview



2.3.1 Existing Recycled/Non-Potable Water System Facilities Data

The following section provides details on the existing recycled/non-potable water system facilities.

2.3.2 Existing Pressure Zones

The recycled/non-potable system consists of seven (7) pressure zones containing recycled water demands. In the North Area, there are four (4), including 1420, 1520 (exclusively serving Riverside National Cemetery recycled water demand), 1667 and 1815. In the South Area, there are three (3), including 1815S, 2250, and 2450. These pressure zones are shown graphically in Figure 2-8.

2.3.3 Existing Pipelines

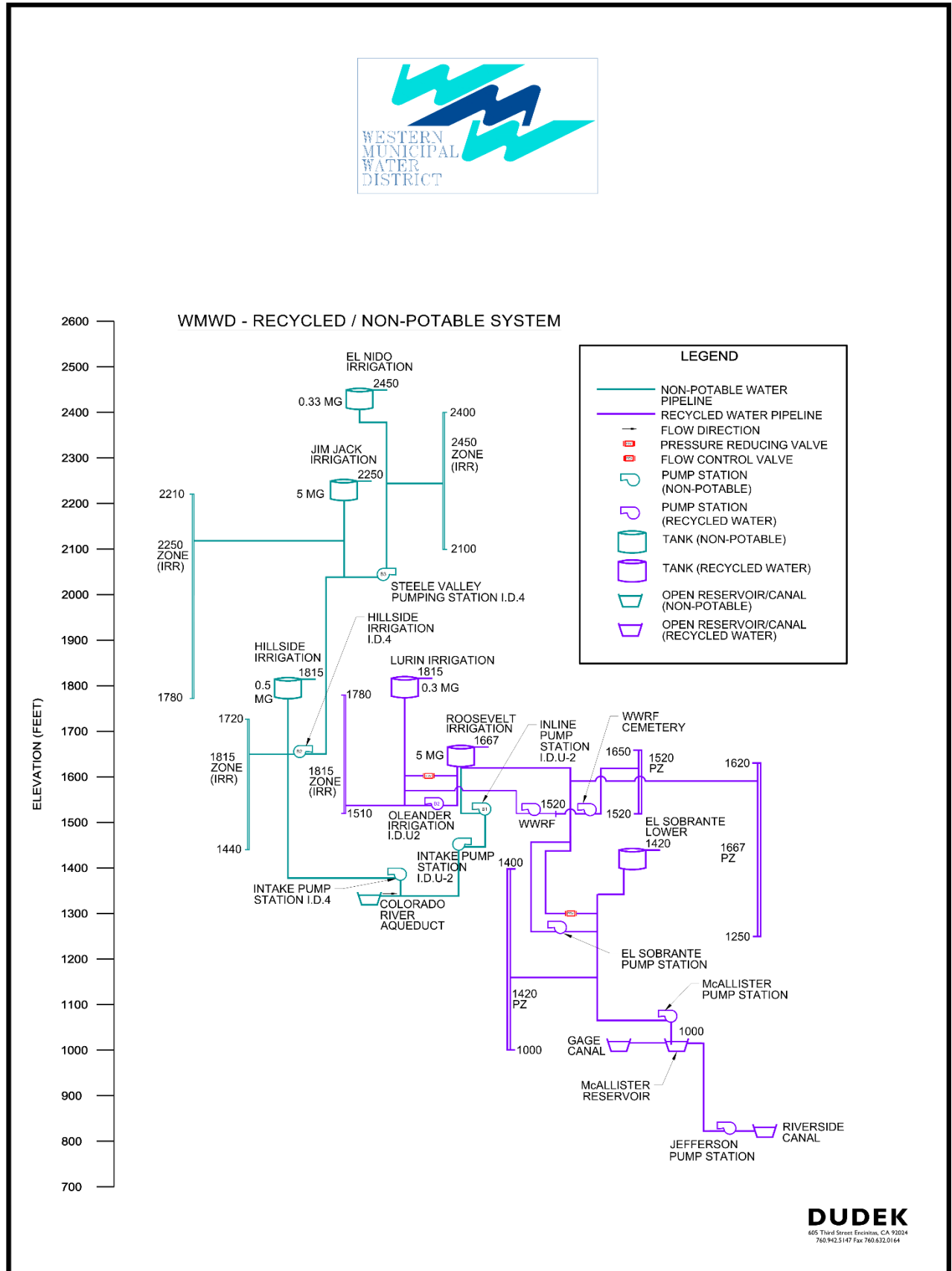
The entire recycled/non-potable service area consists of approximately 62 miles of pipeline ranging from 4- to 42-inches in diameter, as detailed in Table 2-7.

Table 2-7: RW/NP Pipelines

Pipeline Diameter (in)	Length (LF)	Length (Mile)
4	490	0.09
6	2,590	0.49
8	48,300	9.15
10	9,500	1.80
12	55,030	10.42
14	13,490	2.55
16	25,980	4.92
18	15,300	2.90
20	65,600	12.42
21	3,300	0.63
24	39,540	7.49
30	33,010	6.25
33	13,160	2.49
42	3,330	0.63
Total	328,620	62.2

The North Area consists of 50 miles of pipelines ranging in diameter from 6- to 42-inches, eight pump stations, three storage tanks and contains four pressure zones with recycled water demands—1420, 1520, 1667 and 1815. The South Area consist of 12 miles of pipelines ranging in diameter from 4- to 30-inches, three pump stations, three storage tanks and encompasses three pressure zones—1815S, 2250, and 2450. Western is currently evaluating the potential to convert these southern customers to potable water service (separate study). The following figure shows the recycled water system schematic for the North and South Area systems.

Figure 2-9: Western Recycled/Non-Potable Water Study Schematic



2.3.4 Existing Storage Reservoirs

Table 2-8 presents the information on the six existing reservoirs in the recycled/non-potable water system.

Table 2-8: Recycled/Non-Potable Water Storage Reservoirs

Reservoir Name	Area	Pressure Zone	Volume (MG)	Invert Elevation (ft MSL)	HWL (ft MSL)	Diameter (ft)
Lower El Sobrante ¹	North	1420	2.28	1400	1440	N/A
Roosevelt	North	1667	5.0	1628	1668	150
Lurin Irrigation	North	1815	0.3	1798	1815	45
Hillside Irrigation	South	1815	0.5	1784	1816	52
Jim Jack Irrigation	South	2250	5.0	2211	2521	150
El Nido Irrigation	South	2450	0.33	2419	2451	40
Total RW/NP System Storage			13.4			

Notes:

¹ Lower El Sobrante is an open reservoir. Volume listed is per 2014 RWMP.

2.3.5 Existing Pump Stations

Table 2-9 details the booster pump stations in the recycled/non-potable water system.

Table 2-9: Recycled/Non-Potable Water Booster Pump Stations

Pump Station	Area	Supply Zone	Discharge Zone	No. Pumps	Firm Pumping Capacity (gpm) ¹
Jefferson	North	860 (Riverside Canal)	1000	2 @ 1,200 gpm 2 @ 2,400 gpm	4,800
Intake I.D. U-2	North	1410 (CRA)	U2	2 @ 3,800 gpm	3,800
Inline I.D. U-2 (Inline Booster Station)	North	U2	1667	2 @ 3,800 gpm	3,800
WWRF	North	1520 (WWRF)	1815	4 @ 1,160 gpm	3,480
McAllister	North	1000	1420	2 @ 1,200 gpm 2 @ 2,400 gpm	4,800
El Sobrante	North	1420	1667	2 @ 600 gpm 2 @ 1,200 gpm	2,400
Oleander	North	1667	1815	1 @ 900 gpm 2 @ 3,200 gpm	4,100
WWRF Cemetery	North	1520 (WWRF)	Riverside National Cemetery Ponds	2 @ 850 gpm	850
Intake I.D. 4	South	1410 (CRA)	1815S	1 @ 2,800 1 @ 4,700	4,700
Hillside ²	South	1815S	2250	1 @ 1,500 gpm (est.)	5,260

Table 2-9: Recycled/Non-Potable Water Booster Pump Stations

Pump Station	Area	Supply Zone	Discharge Zone	No. Pumps	Firm Pumping Capacity (gpm) ¹
				1 @ 1,600 gpm 1 @ 2,160 gpm 1 @ UNK	
Steele Valley	South	2250	2450	1 @ 890 gpm 1 @ 1220 gpm 1 @ 1465 gpm	2,110

Notes:

- ¹ Firm pumping capacity is the pumping capacity with largest pump out of service. Values from available District-provided pump data, pump curves and the 2014 RWMP.
- ² Pump data for Hillside Pump #4 was not available; firm pumping capacity shown is sum of three known pump capacities.

2.3.6 Existing Pressure Reducing Stations

There are four (4) pressure reducing stations in the system, all located in the North Area, as detailed in Table 2-10. In low demand periods, these PRSs allow for the distribution of recycled water from the WWRF to supply the full North Area.

Table 2-10: Recycled/Non-Potable Water Pressure Reducing Stations (PRSs)

PRS	Area	Supply Zone	Discharge Zone	Setting (psi)
Oleander	North	1815	1667	68.0
El Sobrante	North	1667	1420	67.0
Upper El Sobrante	North	1667	1420	6.5
McAllister	North	1420	1000	5.0

2.3.7 Recycled/Non-Potable Water Service Area and Existing Operational Challenges

Based on discussions with Operations staff, Western has several operational challenges with the RW/NP system that this analysis will address. These include the following:

1. Lack of storage in the Lurin Irrigation (1815) zone;
2. The need for disposal of WWRF recycled water during low demand months;
3. Low system pressures in system overall, but seen primarily in the Lurin Irrigation zone and between the Lower El Sobrante and McAllister Pump Station area; and
4. Addressing current and potential future operational challenges with the Riverside National Cemetery, the system's largest user.

2.4 Existing Wastewater Collection System

Western's wastewater collection system consists of gravity sewer pipelines, sewer force mains, lift stations, and flow diversion structures that collect and convey sewage to one of two treatment plants. Much of the sewer system was constructed beginning in the early 1980's and continuing on today, however the March Air Reserve Base (MARB) was originally established in 1918 and the actual age of the wastewater collection facilities, now owned by Western, is most likely fifty years or older. The WRCRWA service area is presented in Figure 2-10, while the WWRF service area is presented in Figure 2-11.

The following sub sections detail facilities in the WMWD wastewater collection system.

2.4.1 Treatment Plants

Generally the sewer system is divided into two sections, east and west. Wastewater in the eastern sewer service area drains from west to east where it is treated at the Western Water Recycling Facility (WWRF). Wastewater in the western sewer service area drains from east to west where it is treated at the Western Riverside County Regional Wastewater Authority (WRCRWA) Plant.

2.4.1.1 WRCRWA

The WRCRWA Plant was built in 1998 and has the capacity to treat 14 million gallons per day (MGD) of wastewater. Wastewater is treated at a tertiary level and is currently discharged into the Santa Ana River. WRCRWA is a joint powers authority consisting of the cities of Norco and Corona, Jurupa Community Services District, Home Gardens Sanitary District, and Western Municipal Water District. Western has a capacity right of 1.93 MGD average daily flow.

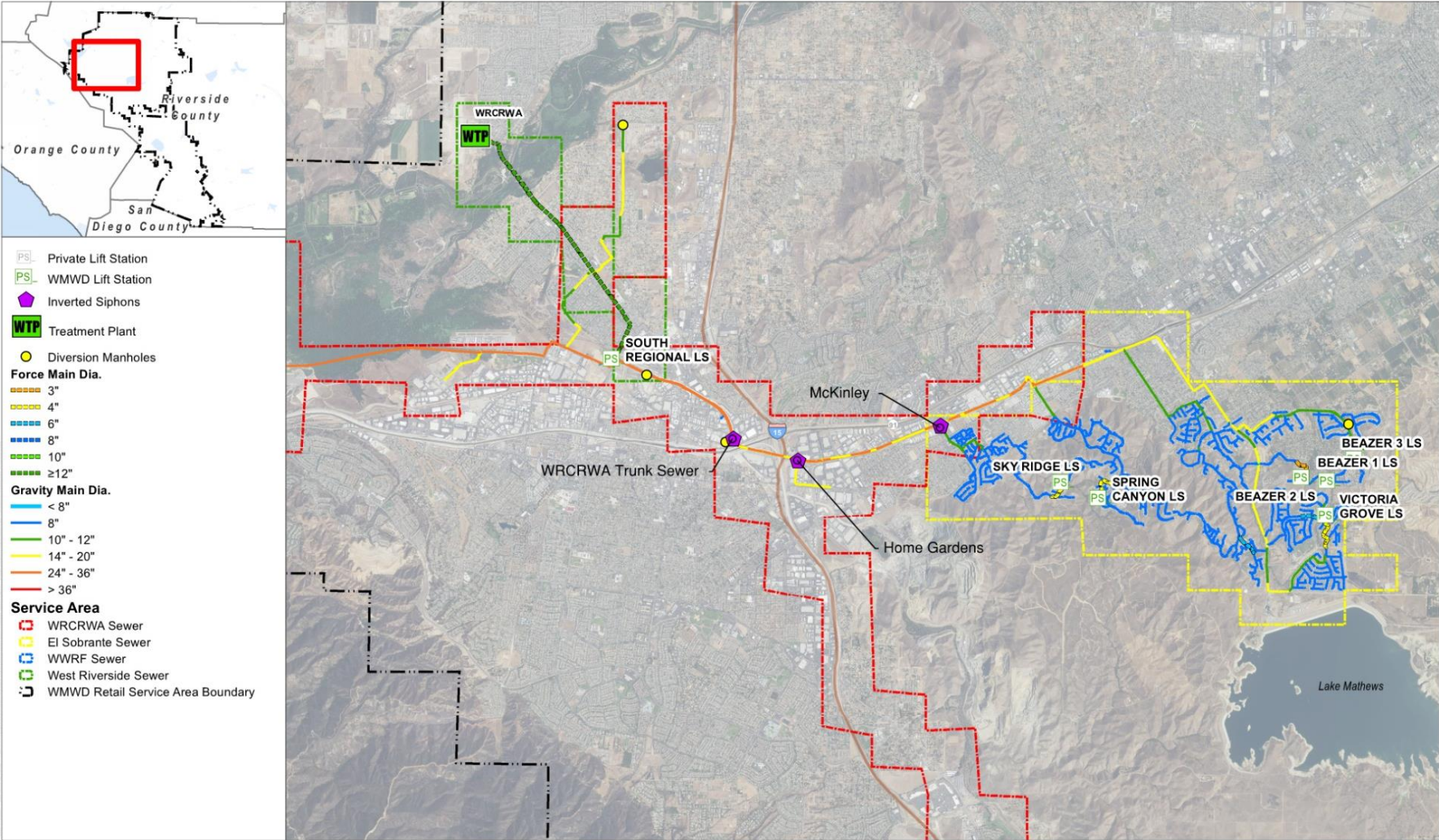
Flows are conveyed from the WMWD collection system to the WRCRWA treatment plant via the South Regional Lift Station (SRLS). The SRLS is owned and operated by WRCRWA in order to collect flows from Western and other member agencies.

2.4.1.2 WWRF

Historically, the wastewater systems within MARB and treatment plant to the west of MARB (now known as WWRF) were owned and operated by March Air Force Base (MAFB) and include wastewater facilities installed over fifty years ago. As part of the realignment of MARB from MAFB, these facilities were transferred over to WMWD's ownership. WWRF's original capacity was 1 MGD, however Western expanded the facility's capacity to 3 million gallons of wastewater treated per day and upgraded to include tertiary treatment capabilities. The treatment capacity project was designed such that the plant can eventually be expanded to a capacity of 5 MGD when fully built out. Treated flows from WWRF are utilized as recycled water by Western.

Beginning in November 2020, approximately 0.7 MGD of excess flows over the typical/expected amounts have been measured at the WWRF influent flow meter though it is unknown at this time where the excess flows are originating from. Western plans to conduct flow monitoring in 2021 in attempt to determine the source of these excess flows.

Figure 2-10: Western Wastewater Study Area - WRCRWA



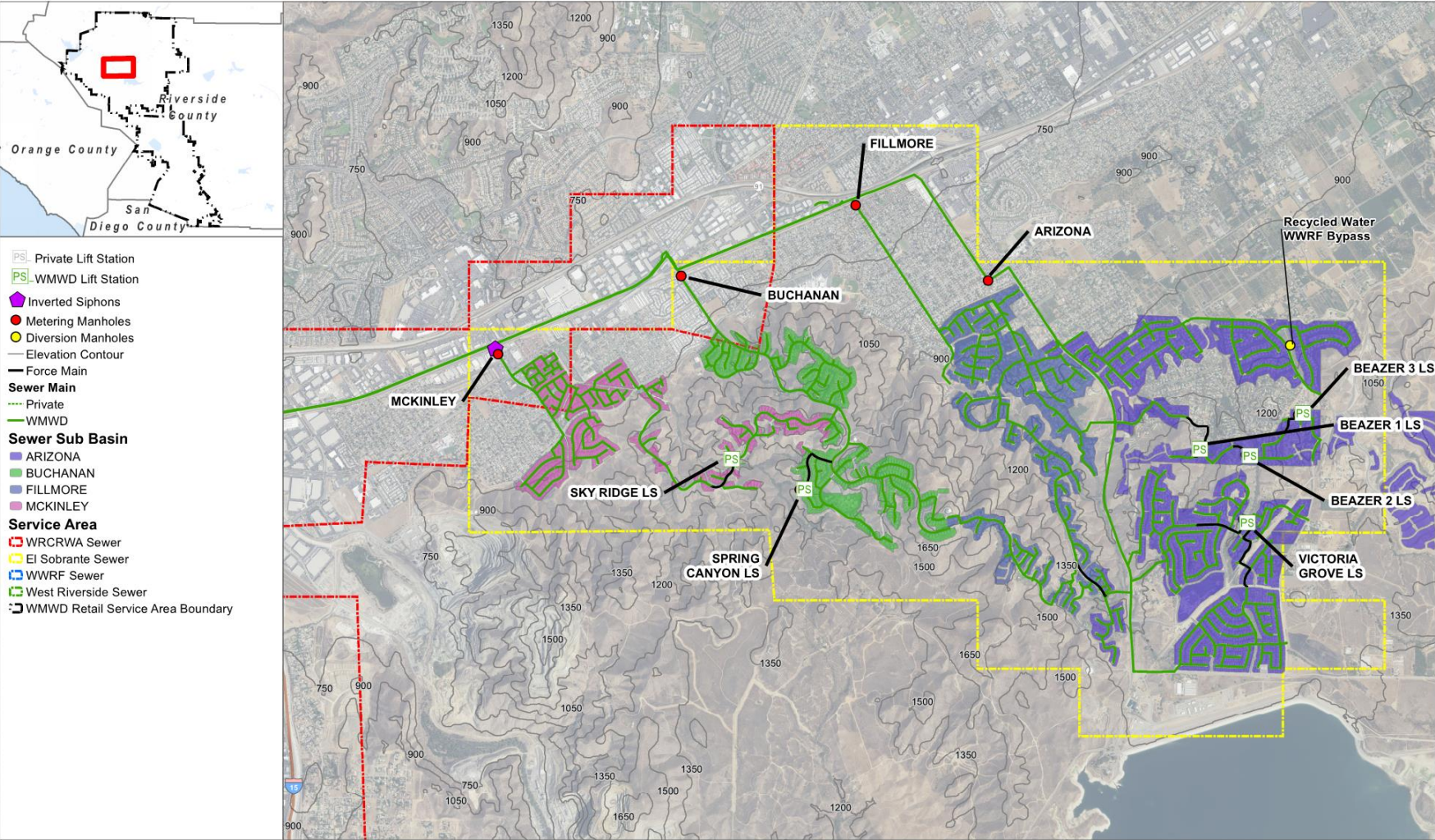
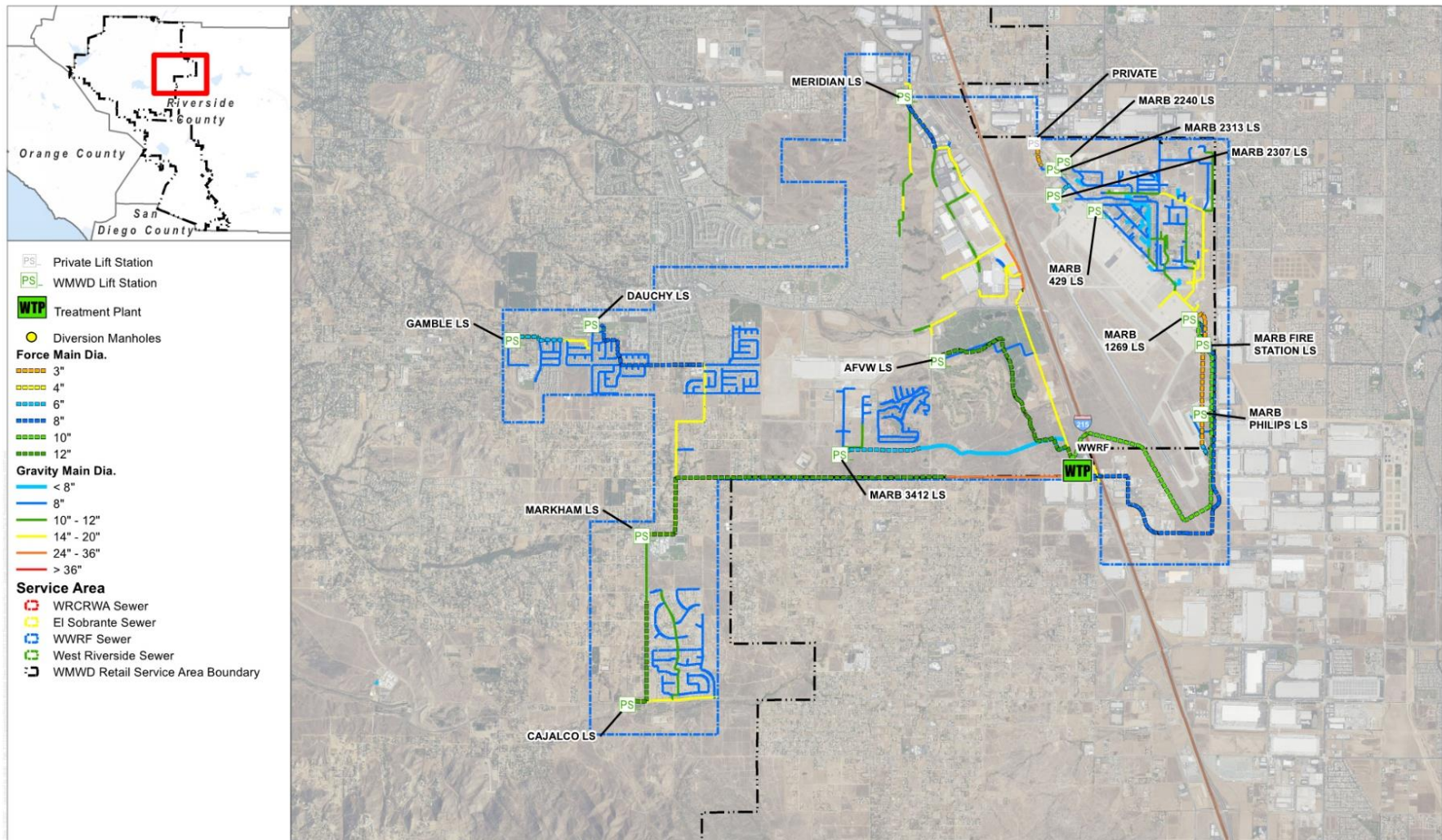
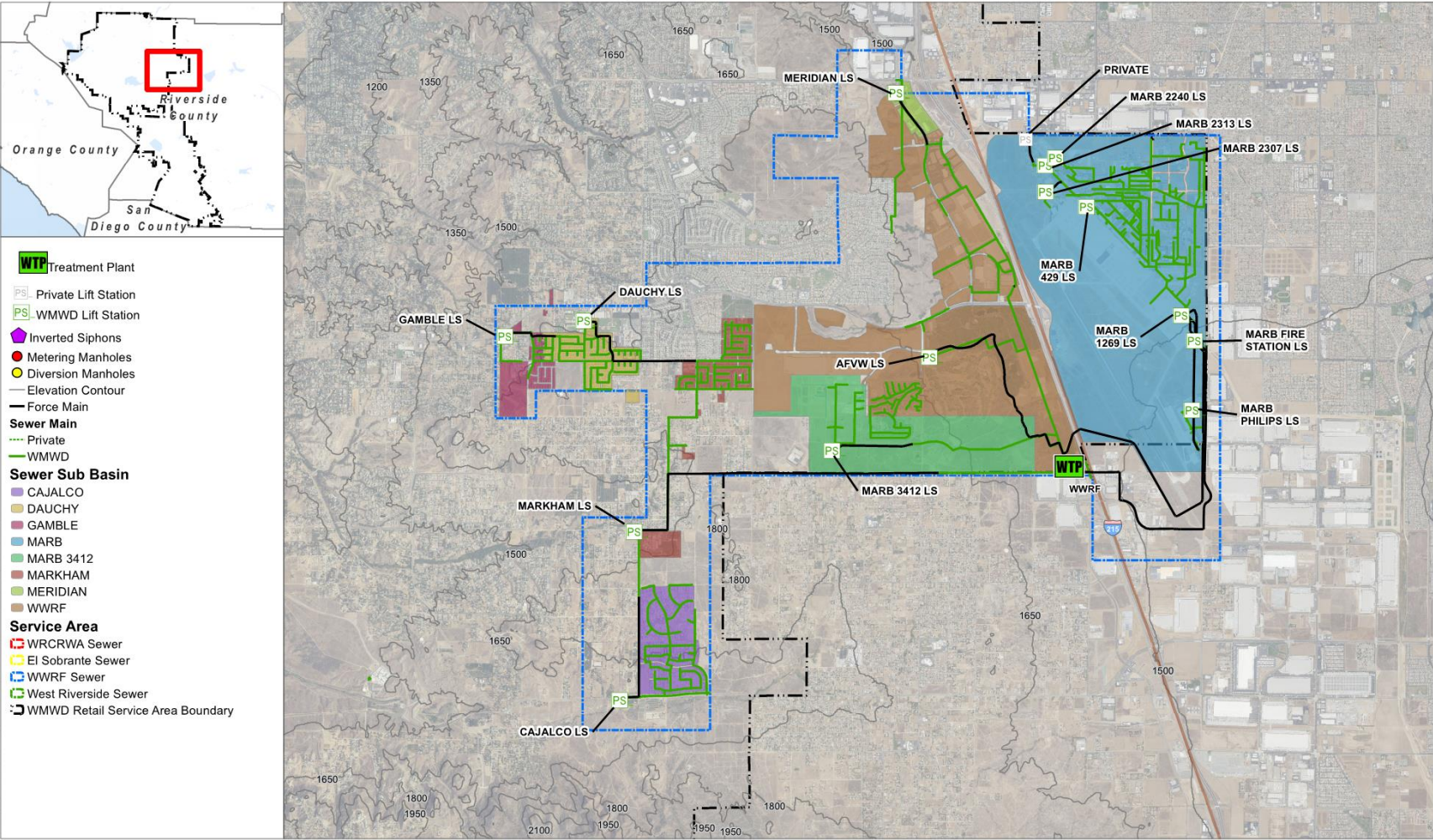


Figure 2-11: Western Wastewater Study Area - WWRF





2.4.2 Gravity Mains

Western has approximately 140 miles of gravity sewer pipelines in the system, ranging from 6-inch to 60-inch. The collection system is predominately 8-inch pipeline, at approximately 57% of the total length of pipe. Table 2-11 presents a summary of gravity sewer main by diameter and length.

Table 2-11: Existing Sewer Gravity Main Diameters

Diameter (in)	Length (feet)	% of System by Length
6	27,446	3.7%
8	464,354	62.9%
10	36,089	4.9%
12	35,956	4.9%
15	57,445	7.8%
16	1,625	0.2%
18	32,266	4.4%
21	8,847	1.2%
24	11,754	1.6%
27	16,839	2.3%
30	12,812	1.7%
33	1,933	0.3%
36	9,095	1.2%
39	10,561	1.4%
42	8,367	1.1%
54	1,280	0.2%
57	975	0.1%
60	772	0.1%
Total (feet):	738,417	100%
Total (miles):	140	100%

Trunk sewers for this FMP are considered to be sewer pipelines greater than 12 inches in diameter. The capacity to be provided in each section of a trunk sewer is based on the peak rate of flow calculated for the pipe's tributary area.

Collection sewers in this FMP are considered to be sewer pipelines 12 inches or less in diameter. Collection sewers are typically designed to flow one-half full for maintenance purposes and can experience high peaking factors since they serve smaller collection areas with more flow variability.

Table 2-12 below includes a summary of the wastewater collection system pipelines in Western's system by the diameter of the pipe, material, and average age.

Table 2-12: Existing Sewer Gravity Main Material Length

Diameter (in)	Length (feet)	% of System by Length	Average Age (years)
Polyvinyl Chloride Plastic (PVC)	230,094	31.2%	16
Vitrified Clay Pipe (VCP)*	485,575	65.8%	27
Ductile Iron Pipe (DIP)	521	0.1%	28
Reinforced Concrete Pipe (RCP)	22,228	3.0%	29
Total (feet):	738,417	100%	—
Total (miles):	140	100%	—

2.4.2.1 Siphons

Western’s wastewater collection system includes three (3) inverted sewer siphons. Each of the locations are described below and are shown on Figure 2-10 and Figure 2-11:

- The McKinley siphon connects the McKinley trunk sewer to the WRCRWA Trunk sewer beneath the Arlington Channel and Railroad right of way. The siphon is a triple barrel design with one 6” diameter and two 8” diameter barrels.
- The Home Gardens siphon connects the Home Gardens trunk sewer to the WRCRWA Trunk sewer beneath the Arlington Channel and Railroad right of way. The siphon is a triple barrel design with three 8” diameter barrels.
- The WRCRWA Trunk Sewer siphon conveys flows beneath the Temescal Creek Channel where it meets the Arlington Channel. The siphon is a double barrel design with one 15” diameter barrel and one 21” diameter barrel.

2.4.3 Lift Stations and Force Mains

Western owns and operates 17 sewer lift stations that convey wastewater to the treatment facilities. The WRCRWA zone is comprised of six separate submersible duplex lift stations which feed into the WRCRWA trunk sewer. The WWRF zone is comprised of 12 lift stations of varying size and configurations. The lift station locations are shown in Figure 2-10 and Figure 2-11. The lift stations are summarized in Table 2-13 below:

Table 2-13: Lift Station Summary

Sewer Lift Station	Service Area	Firm Capacity (gpm)	TDH (ft)	No. of Pumps	Pump Power (HP)	Pump Speed (rpm)	Power Supply (phase / volts)	Force Main Dia (in)	Backup Power
MARB Fire Station	WWRF	Not Available							N
MARB 429		Not Available							N
MARB 2307		250	23	2	7.5	Unknown	Unknown	4	N
MARB Fire 2313		Not Available							N

Table 2-13: Lift Station Summary

Sewer Lift Station	Service Area	Firm Capacity (gpm)	TDH (ft)	No. of Pumps	Pump Power (HP)	Pump Speed (rpm)	Power Supply (phase / volts)	Force Main Dia (in)	Backup Power
MARB 2240		Not Available							N
MARB 3412		200	82	2	7.5	Unknown	Unknown	6	N
MARB 1269		900	175	2	75	1760	3/460	10	Y
Cajalco		1,000	232	2	150	1780	3/460	12	Y
Dauchy		750	180	2	80	1780	3/460	8	Y
Meridian		609	44	2	20	1755	3/460	8	Y
Gamble		380	160	2	50	1750	3/460	6	Y
AFVW		Not Available							Y
Markham		1,000	237	2	150	1780	3/460	4	Y
Beazer 1		WRCRWA	114	159	2	10.7	3400	3/230	3
Beazer 2	114		159	2	10.7	3400	3/230	3	
Beazer 3	118		190	2	10.7	3400	3/230	3	
Sky Ridge	120		110	2	20	1740	3/460	4	Y
Spring Canyon	120		95	2	25	1740	3/460	4	Y
Victoria Grove	260		110	2	30	1750	3/460	4	Y

Western operates 17 force mains, comprised of approximately 22 miles of piping. The characteristics of the force mains are summarized in Table 2-14 and Table 2-15.

Table 2-14: Existing Sewer Force Main Diameters

Diameter (in)	Length (feet)	% of System by Length
2	1,159	1.0%
3	10,008	8.7%
4	5,594	4.8%
6	11,120	9.6%
8	32,707	28.3%
10	19,045	16.5%
12	33,805	29.3%
16	2,050	1.8%
Total (feet):	115,487	100%
Total (miles):	22	100%

Table 2-15: Existing Sewer Force Main Material Length

Diameter (in)	Length (feet)	% of System by Length	Average Age (years)
Polyvinyl Chloride Plastic (PVC)	71,820	62.2%	17
Ductile Iron Pipe (DIP)*	43,303	37.5%	25
Asbestos Cement Pipe (ACP)	364	0.3%	21
Total (feet):	115,487	100%	-
Total (miles):	22	100%	-

2.4.4 Permanent Flow Metering Locations

Western monitors flows via Supervisory Control and Data Acquisition (SCADA) signal from the pumps at sewer lift stations, manual meter reads at certain small lift stations, and via Parshall flume flow meters at an additional 14 locations.

In the WWRP system flows are metered via SCADA or manual meter reads at each of the lift stations. Flow from the Riverside Public Utilities diversion structure (described in Section 2.4.5) is metered as it enters Western's sewer system. The type of metering is shown in Figure 2-15.

In the WRCRWA system, there are four trunk sewers, which each have a Parshall flume flow metering manhole prior to combining in the WRCRWA trunk sewer. In addition, each intertie or diversion structure along the WRCRWA trunk sewer and South Regional Lift Station force main is metered before it enters the main. The metering locations are as follows:

- WRCRWA Trunk Sewer:
 - McKinley Trunk System: Metering manhole south of Sampson Ave on McKinley Street.
 - Buchanan Trunk System: Metering manhole south of Magnolia Ave on Buchanan Street.
 - Fillmore Trunk System: Metering manhole south of Sampson Ave on Queensborough Street.
 - Arizona Trunk System: Metering manhole near the intersection of La Serra Avenue and Arizona Avenue.
 - WRCRWA Trunk Sewer Diversion Structure Meters:
 - Home Gardens: Metering manhole south of Sampson Ave on Radio Road.
 - Norco Cota: Metering Manhole near West Rincon Street and North Lincoln Avenue.
 - Corona 1: Metering Manhole near the Santa Ana River south of East Harrison Street.
 - Corona 2: Metering manhole near the Santa Ana River on Cota Street.
- SRLS Force main:
 - Norco 2nd Street: Metering manhole east of River Road on 2nd Street.
 - Norco Corydon: Metering manhole east of River Road on Corydon Avenue
 - Jurupa: Metering manhole near Western Avenue and 5th Street.

Figure 2-12 and Figure 2-13 shows the geographic location of all permanent flow monitoring locations.

Figure 2-12: Permanent Sewage Flow Meter Locations - WWRF

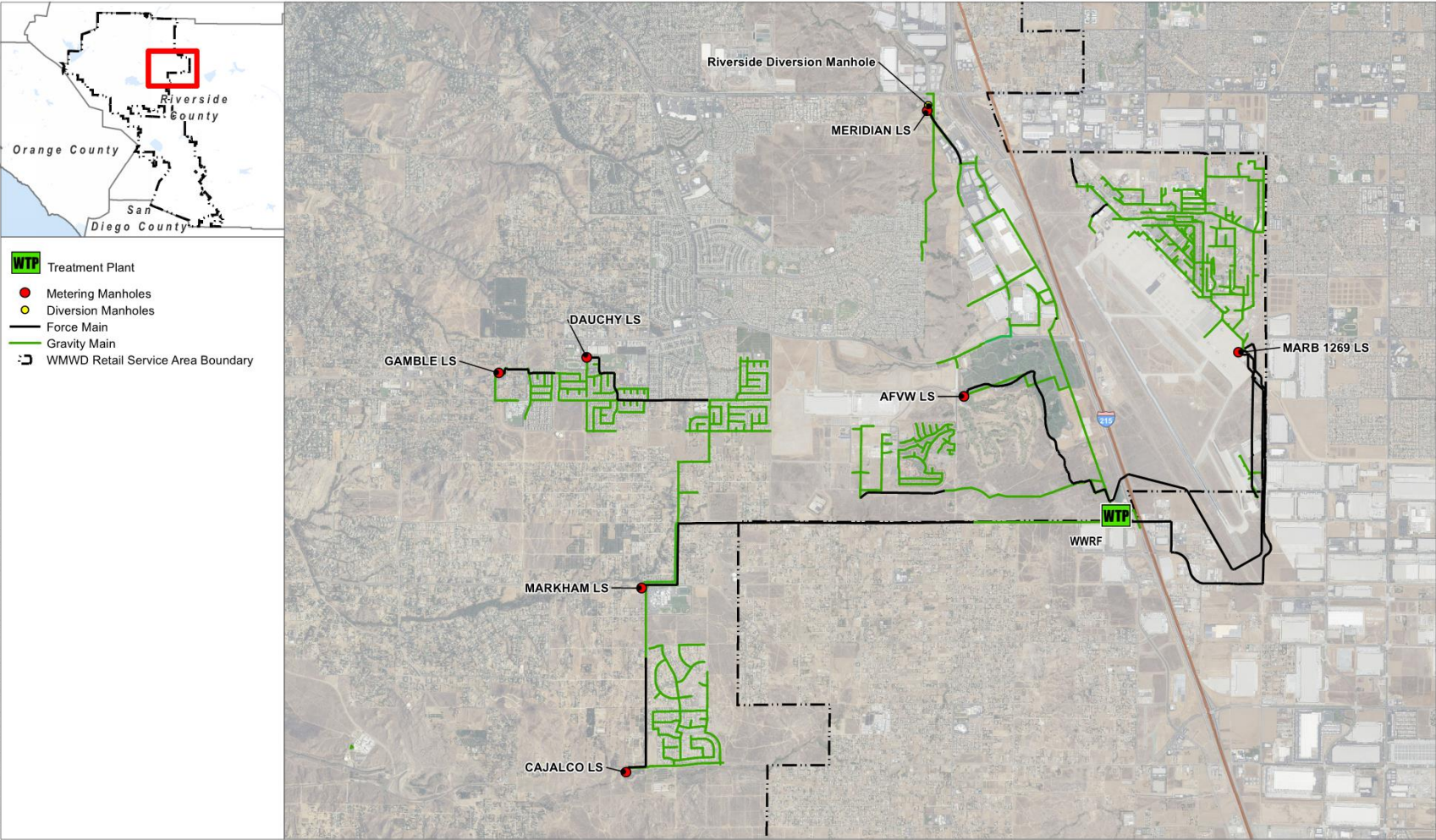
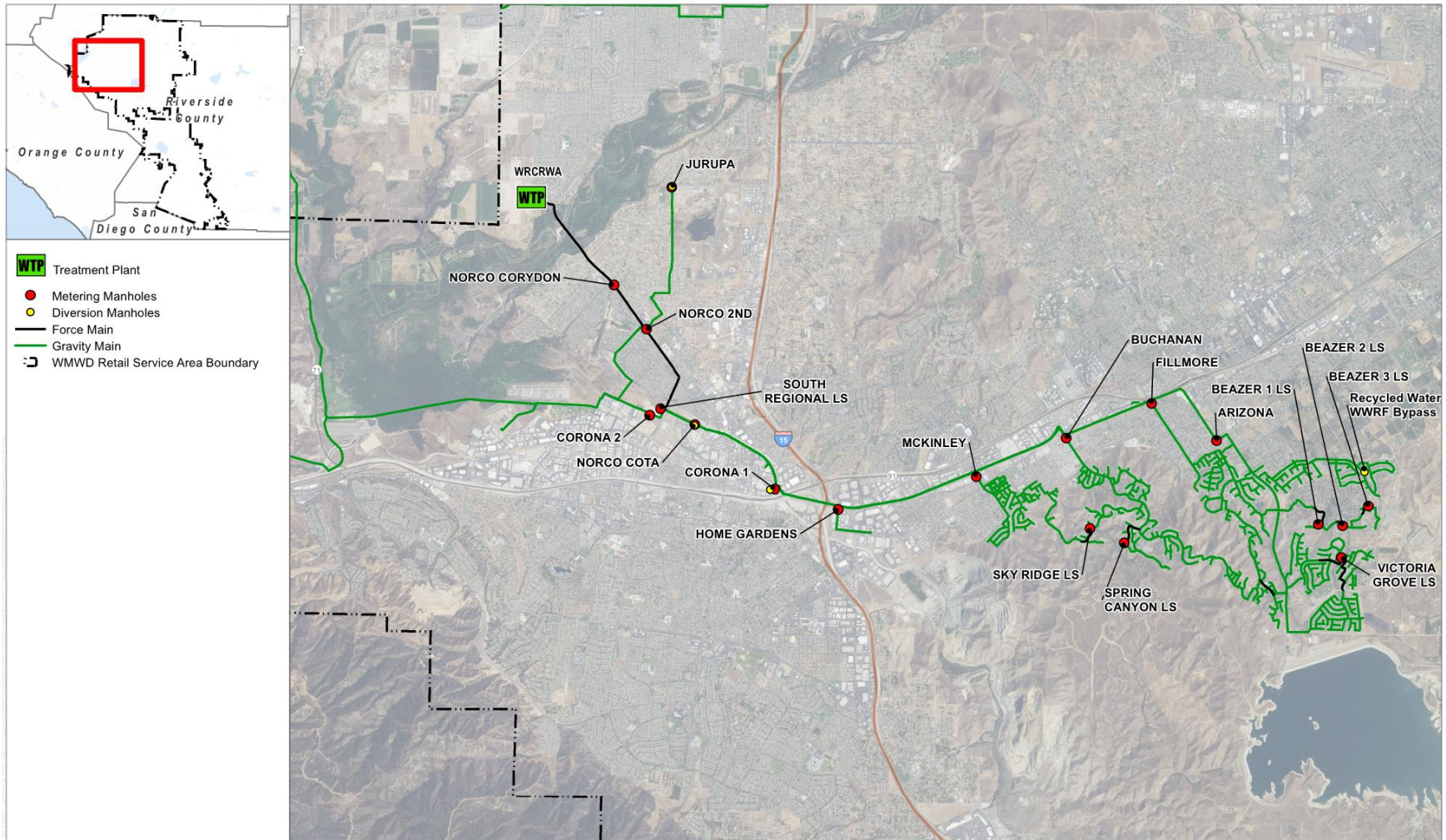


Figure 2-13: Permanent Sewage Flow Meter Locations - WRCRWA



2.4.5 Diversion Structures/Inflow Points

There are three diversion structures that divert flow from adjacent sewer district's sewer systems into WMWD's sewer system. Each structure is unique and not all are utilized regularly. Though they are designed as diversion structures, only the Riverside diversion structure is used on a regular basis and it serves as an inflow point, diverting the full flow rate from the upstream area. The other structures are utilized on an emergency basis. Each structure is described below:

- **Corona 1:** Corona diversion structure 1 is located east of Cota Street in the City of Corona. Flows can be diverted from the City of Corona 27" sewer main into the WRCRWA trunk sewer. This diversion structure was not utilized during any of the flow monitoring data provided and there are not currently plans to increase utilization.
- **Corona 2:** Corona diversion structure 2 is located adjacent to the City of Corona Treatment Plant #2 (652 E Harrison St, Corona, CA 92879). Flows can be diverted from the treatment plant into the WRCRWA trunk sewer. This diversion structure was not utilized during any of the flow monitoring data provided and there are not currently plans to increase utilization.
- **Riverside:** The Riverside diversion structure is located in front of the Meridian Lift Station on Meridian Parkway, south of East Alessandro Boulevard. Flows, up to 0.5 MGD, are diverted from the City of Riverside Orangecrest Drainage Area into Western's Meridian drainage basin. The current sewage generation rate for the Orangecrest area is approximately 0.35 MGD and is considered built out. The diversion structure and associated metering manhole is directly upstream of the Meridian Lift Station.

In addition to the diversion structures, there are three permanent inflow points located in the WRCRWA service area; each location is described below:

- **Norco Cota:** Western receives flows generated from the City of Norco Sewer system through a 15" trunk sewer that joins the WRCRWA trunk sewer where it crosses North Cota Street. This connection historically sees flows of approximately 1.1 MGD. Flow is metered as it enters the WRCRWA trunk sewer system.
- **Home Gardens:** Western receives all flows generated within the Home Gardens Sanitary District (HGSD) through a 15" trunk sewer that joins the WRCRWA trunk sewer where it crosses Radio Road. HGSD has a maximum allowable capacity of 1 MGD, however historically it generates approximately 0.56 MGD. Flow is metered as it enters the WRCRWA trunk sewer system.
- **Recycled Water WWRF Bypass:** In the event of excess recycled water production, effluent from the WWRF can be discharged into the WRCRWA treatment system. The bypass is used primarily in the winter during wet weather when recycled water demands are lower. The point of connection is along McAllister Parkway, between Sierra Heights Drive and Granite Pass Road. The flows are not metered as they enter the sewer system however the flow rate can be monitored from SCADA at WWRF. The maximum capacity of the bypass is approximately 600 gpm, according to Operations staff.

In order to accurately quantify the contribution of wastewater generated within each sewer drainage basin, a clear understanding of how wastewater moves into and out of each basin is necessary. Figure 2-12 and Figure 2-13 show the location of each diversion or inflow manhole and show a schematic representation of the WRCRWA and WWRF wastewater collection systems, including flow monitoring locations.

Figure 2-14: WRCRWA Collection System

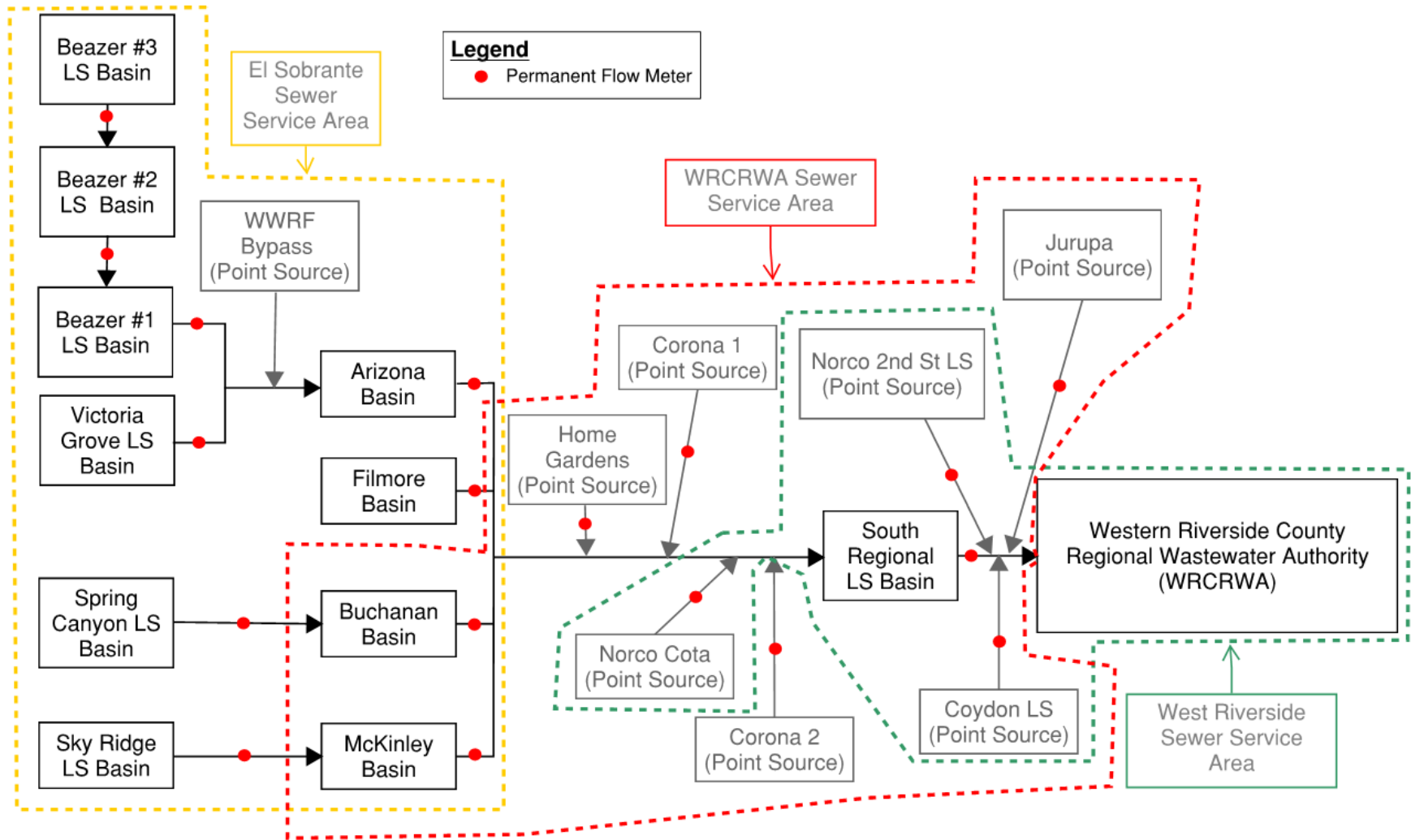
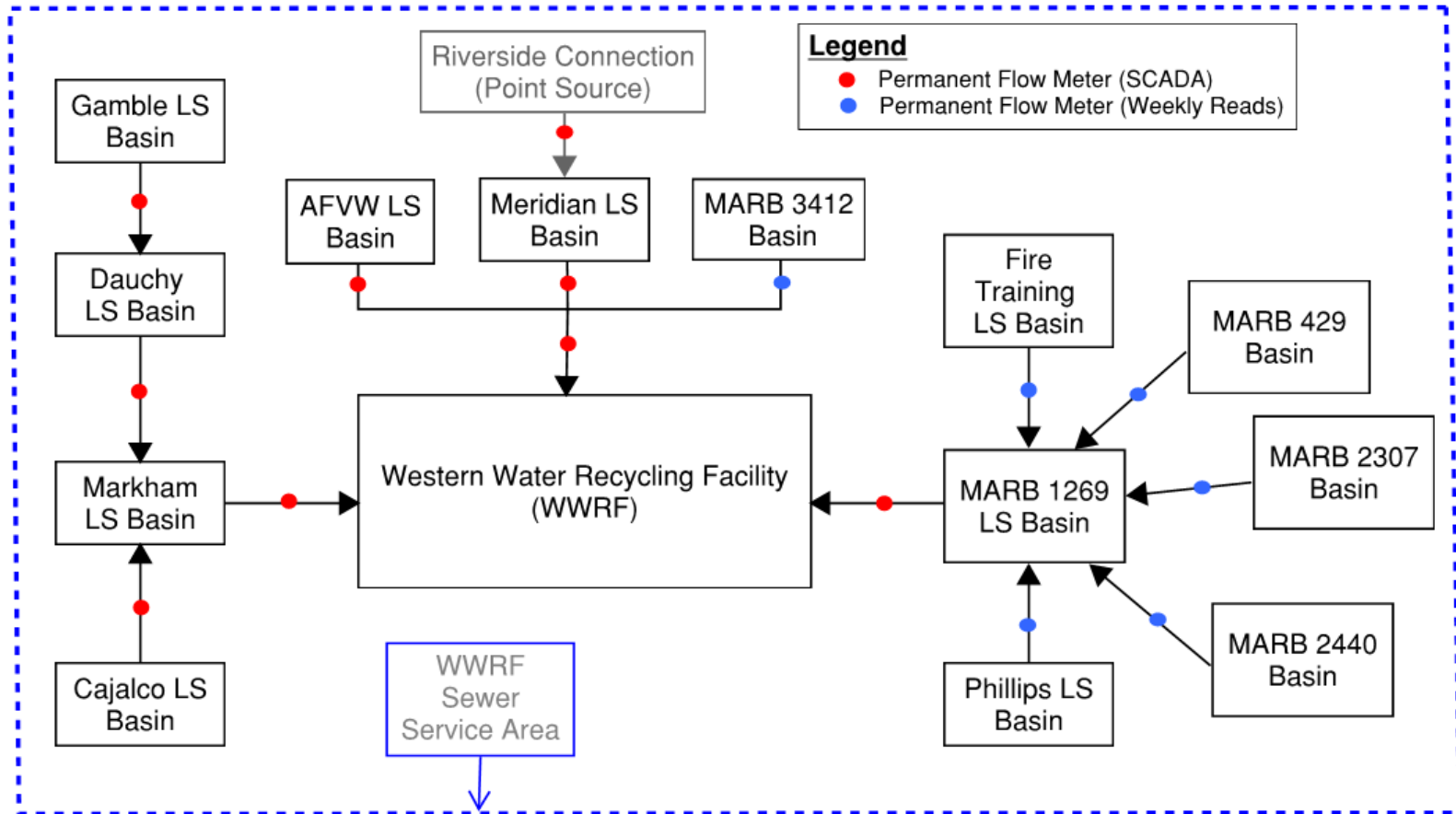


Figure 2-15: WWRF Collection System



2.4.6 Operational Challenges

Based on discussions and workshops with WMWD operational staff, no significant operational challenges with the sewer collection system were identified.

There has been only one (1) Sanitary Sewer Overflow (SSO) in the past 15 years caused by a sag in a 12-inch diameter VCP sewer on McKinley Street between Sampson Avenue and Magnolia Avenue in the City of Corona. This pipeline is scheduled for replacement by the end of 2022. This location has been treated as a hot spot since the SSO and no additional SSOs have occurred since the cleaning frequency was increased.

The following metering flumes are treated as hot spots to ensure flow metering accuracy; however these locations have not contributed to any SSO events.

- Arizona metering flume
- Fillmore metering flume
- Buchanan metering flume
- McKinley metering flume

The McKinley siphon is also treated as a hot spot as a preventative measure; however this location has not contributed to any SSO events.

2.5 Land Use

This section describes the existing land use as well as the Near-Term and Ultimate planned developments within the FMP study areas.

2.5.1 Existing Land Use

The Riverside Retail Service Area consists of two subareas:

- 1) Riverside Service Area
- 2) March Air Reserve Base (MARB) Service Area

Land use types for existing developed land, their total area by land use, and the percent of total area within the Riverside Service area are listed in the following Table 2-16. The MARB Service Area has its own land use category (similar to the study in Appendix A).

Table 2-16: Existing Land Use

Land Use Type	Total Developed Area (acre)	Percentage of Total Area Developed
Agriculture	20	0.1%
Commercial	77	0.4%
Conservation	1,311	6.5%
High Density Residential ¹	26	0.1%
Industrial	12	0.1%
Low Density Residential	105	0.5%
MARB	478	2.4%
Med. Density Residential	776	3.8%

Table 2-16: Existing Land Use

Land Use Type	Total Developed Area (acre)	Percentage of Total Area Developed
Mineral Resources	1	0.005%
Mixed Use	5,094	25.2%
Open Space	494	2.4%
Public Facilities	259	1.3%
Rural Residential	11,152	55.3%
Roadway	370	1.8%
Total	20,175	100%

¹ High Density Residential land use is served by WMWD wastewater service only (no water service, water service is provided by others).

2.5.2 Recent Developments

During calibration of the InfoWater potable water system model between 2018 and 2020, 12 developments were constructed in the Riverside Retail Service Area. These developments are listed in Table 2-17.

Table 2-17: Recent (2018-2020) Developments within Study Area

Development	Description	Size	Facilities Impacted
Tract 36390 (Citrus Heights Phase I)	343 DU SFR (Fully-developed)	343 DU (SFR)	Water, Sewer, Recycled Water
Tract 36475 (Citrus Heights Phase II)	171 DU SFR (Fully-developed)	171 DU (SFR)	Water, Sewer, Recycled Water
Tract 30231	5 DU SFR (Fully-developed)	5 DU (SFR)	Water
Tract 30238 and 36910	25 DU SFR (Fully-developed)	25 DU (SFR)	Water
Meridian West Campus	Partially developed industrial area	90 acres (Industrial)	Water, Sewer, Recycled Water
Alessandro Commerce Center	2 Industrial Buildings (Fully-developed)	62 acres (Industrial)	Water
Boulder Springs (Specific Plan 229)	Ultimate 1,321 DU SFR with school and 30 acres of commercial	257 DU (SFR) ¹	Water, Sewer, Recycled Water
Tract 32997	90 DU SFR (Fully-developed)	90 DU (SFR)	Water, Sewer, Recycled Water
Meridian South Campus	Partially developed industrial area	96 acres (Industrial)	Water, Sewer, Recycled Water
MS Van Buren I	Business Park (Fully-developed)	4 acres (Commercial)	Water, Sewer, Recycled Water
Veterans Plaza	Partially developed Business Park	0.15 acre (Commercial)	Water, Sewer, Recycled Water
Tract 27557 (Galvin Springs)	Ultimate 76 DU SFR	35 DU (SFR) ²	Water

Notes:

DU = dwelling unit

SFR = single-family residential

¹ Phase 1 of this project (257 DU SFR) already constructed. Future phases considered in Table 2-18.

² SFR homes existing in 2020 for project (35 DU SFR). Future homes considered in Table 2-18.

2.5.3 Future, Near-Term Developments

Western provided several known, “Near-Term” developments (i.e. developments to be built between 2020 and 2030) already being planned within the Riverside Retail Service Area. These developments and their sizing are listed in Table 2-18 and presented graphically in Figure 2-16. Note that five of the developments listed (Meridian West Campus, Veterans Plaza, Boulder Springs, Meridian South Campus, and Tract 27557) have already begun construction, but large portions of these specific developments remain undeveloped; therefore, the undeveloped portions are included in the Near-Term development scenarios in the hydraulic analyses.

Table 2-18: Near-Term Developments within Study Area

Development	Description	Size	Facilities Impacted
Riverside National Cemetery Expansion	Additional recycled water demand to expand cemetery (Phases V & VI)	73 acres	Recycled Water
Tract 37217	Residential development	513 DU (SFR)	Water, Sewer, Recycled Water
Tract 36730 (Lake Ranch)	Residential development	272 DU (SFR)	Water, Sewer, Recycled Water
Tract XXXX	Residential development	41 DU (SFR)	Water, Sewer, Recycled Water
Tract 37731	Residential development	138 DU (SFR)	Water, Sewer, Recycled Water
Tract 37732	Residential development	81 DU (SFR)	Water, Sewer, Recycled Water
16725 Dant St	Residential development	93 DU (SFR)	Water, Sewer, Recycled Water
VIP 215 (Hillwood) ¹	2 Industrial Buildings (~2.2M SF)	143 acres (Industrial)	Water, Sewer
Meridian West Campus	Partially developed industrial area	16 acres (Commercial)	Water, Sewer, Recycled Water
University Highlands (Gateway)	MDR to HDR and Commercial Land Use	185 DU (MDR) 540 DU (HDR) 47 acres/1,475 DU (Mixed Use) 2 acres (Commercial)	Water
Sycamore Hills Distribution Center	Warehouse Buildings	12 acres (Industrial)	Water
Alessandro Service Station	Manufacturing Building and Commercial Building	2 acres (Commercial) 7 acres (Industrial)	Water
MS 215	Office Buildings	3 acres (Commercial)	Water

Table 2-18: Near-Term Developments within Study Area

Development	Description	Size	Facilities Impacted
Tract 32647	Residential development	103 DU (SFR)	Water, Sewer, Recycled Water
Tract 37593	Residential development	90 DU (SFR)	Water, Sewer, Recycled Water
18171 Van Buren Blvd at Little Ct	Restaurants, Corporate Office, Medical Clinic and Day Care	3 acres (Commercial)	Water
Tract 22102 (Mockingbird Canyon)	Residential development	59 DU (SFR)	Water
Tract 36963	Residential development	34 DU (SFR)	Water
Tract 28767	Residential development	23 DU (SFR)	Water
MS Prime Six	Business Park	2 acres (Commercial)	Water, Sewer, Recycled Water
MS Van Buren II	Business Park	4 acres (Commercial)	Water, Sewer, Recycled Water
Veterans Plaza	Partially developed Business Park	3 acres (Commercial)	Water, Sewer, Recycled Water
Boulder Springs (Specific Plan 229)	Ultimate 1,321 DU SFR with school and 30 acres of commercial	1,064 DU (SFR) ³ 42 acres (Commercial)	Water, Sewer, Recycled Water
Meridian South Campus	Partially developed industrial area	18 acres (Mixed Use) 27 acres (Commercial) 86 acres (Industrial)	Water, Sewer Recycled Water
Belle Meadows Ranch (Specific Plan 198)	Residential development	294 DU (SFR)	Water, Recycled Water
Tract 27557 (Galvin Springs)	Ultimate 76 DU SFR	41 DU (SFR) ⁴	Water

Notes:

DU = dwelling unit

SFR = single-family residential

MDR = medium density residential

HDR = high density residential

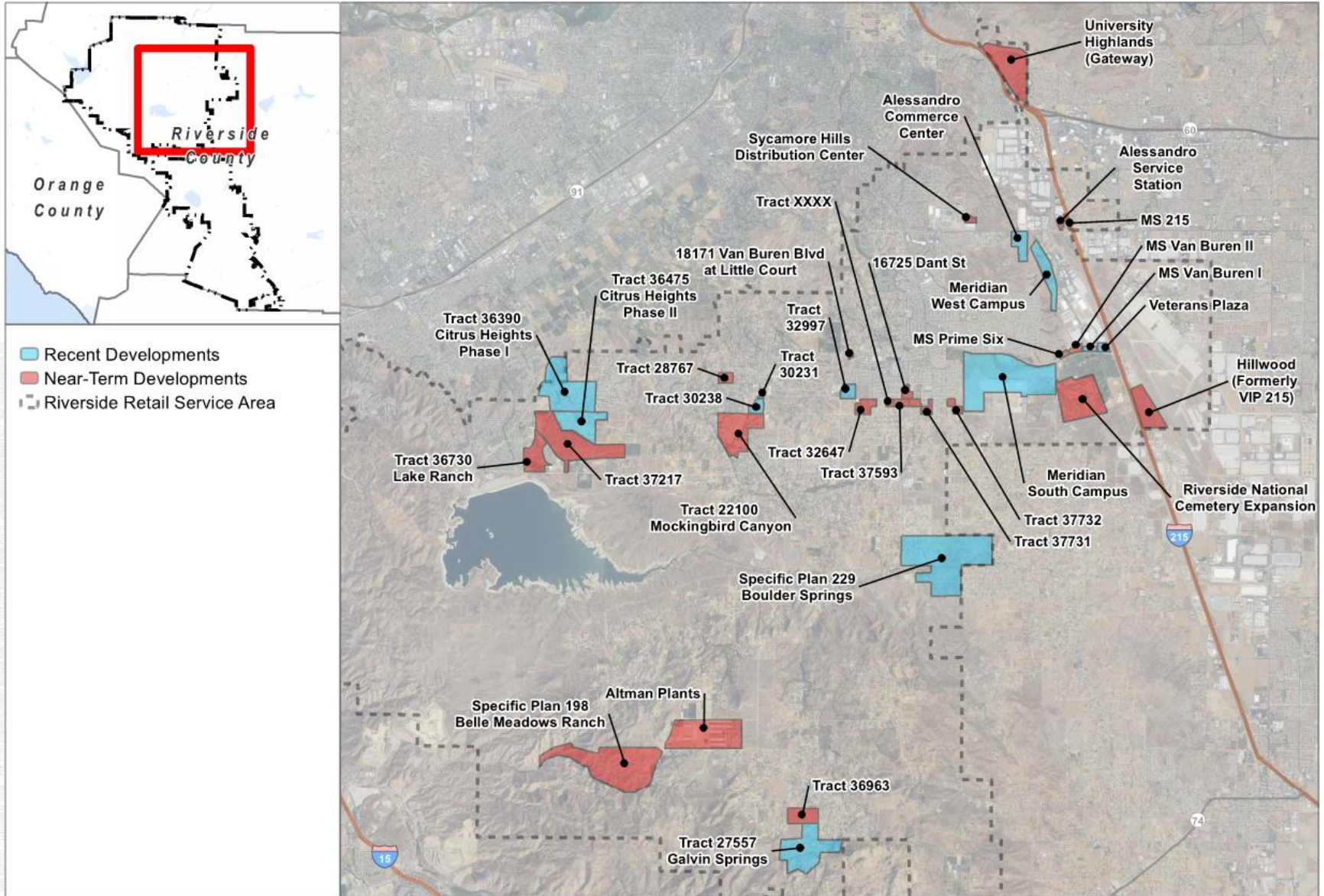
¹ Development located within MARB

² Development solely served by Cactus connection located at Cactus Ave and Riverside Dr.

³ Phase 1 of this project (257 DU SFR) already constructed. Future phases considered

⁴ SFR homes existing in 2020 for project (35 DU SFR). Future homes considered

Figure 2-16: Near-Term Development Location Map



2.5.4 Ultimate (Buildout) Future Land Use

The Ultimate or Buildout scenario was determined to be the time period when all currently undeveloped parcels are developed. To determine the acreage and future land use type of 2030 undeveloped parcels an Appendix A study parcel dataset was refined to 2030 conditions by:

- Removing Near-Term developments listed in Table 2-17 and Table 2-18,
- Removing parcels that appear to be developed on recent aerials, and
- Removing parcels that were over 1 mile away from the existing WMWD potable water system (the largest system of WMWD's three water systems: potable water, recycled/non-potable water, and sewer); who would likely not be served due to their location from existing infrastructure.

Proposed future land use of undeveloped parcels within the Riverside Retail Service Area are listed in Table 2-19 and shown in Figure 2-17. In the Ultimate scenario, the undeveloped area in Table 2-19 was considered developed and added to developed areas in Table 2-16, Table 2-17, and Table 2-18.

Table 2-19: Additional Ultimate Land Use (Post-2030)

Proposed Land Use Type	2030 Undeveloped Area (acre) ¹	Percentage of 2030 Undeveloped Total Area
Agriculture	492	1.4%
Commercial	53	0.2%
Conservation	6,688	19.3%
High-Density Residential ²	0	0%
Industrial	38	0.1%
Low Density Residential	95	0.3%
MARB	2,274 ³	6.6%
Med. Density Residential	152	0.4%
Mineral Resources	276	0.8%
Mixed Use	3,462	10.0%
Open Space	4,531	13.1%
Public Facilities	1,800	5.2%
Rural Residential	11,804	34.1%
Roadway	2,961	8.6%
Total	34,626	100%

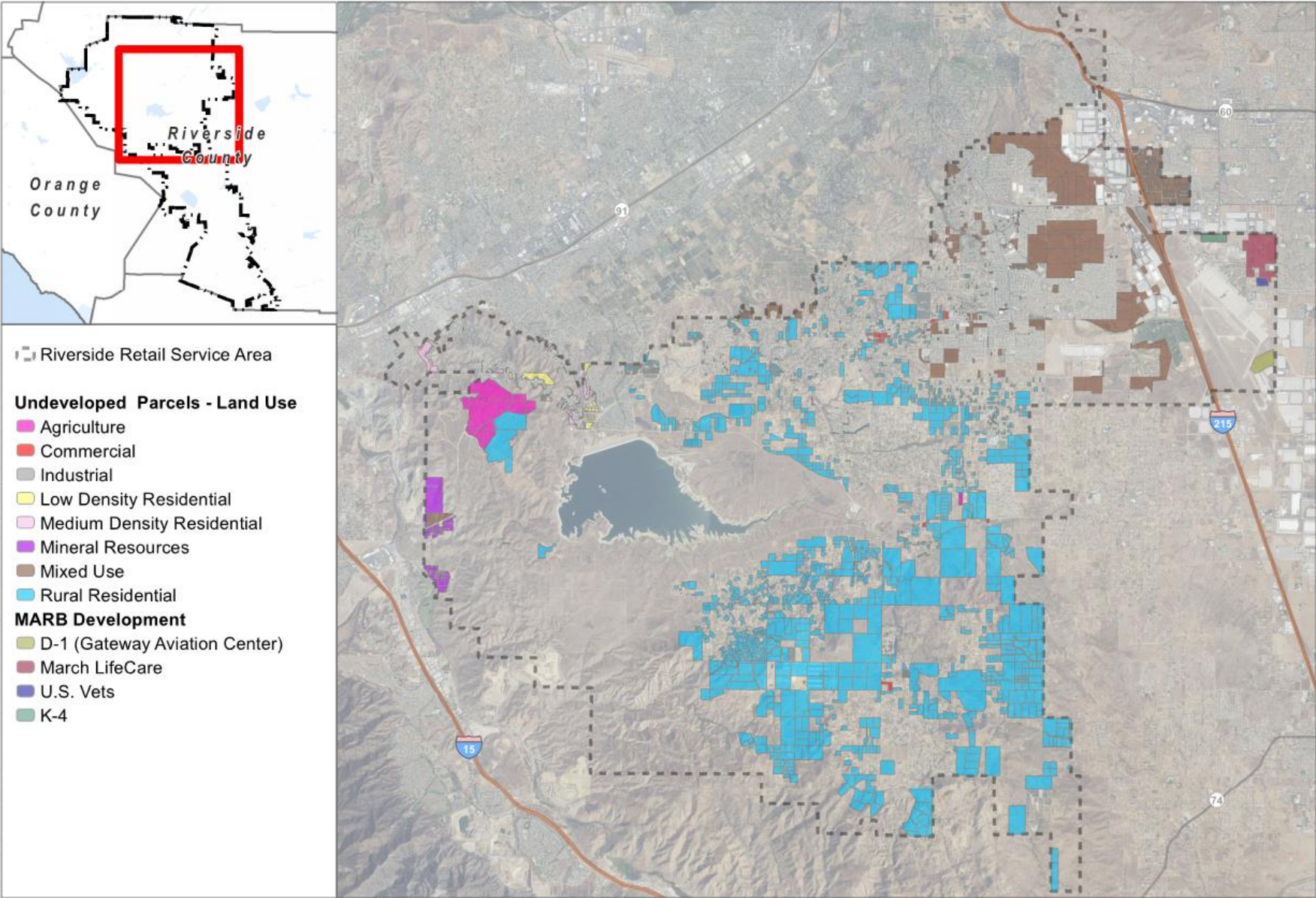
Notes:

- ¹ Undeveloped Area in Riverside Retail Area does not include Near-Term development area
- ² High Density Residential land use is served by WMWD wastewater service only (no water service, water service is provided by others).
- ³ MARB has 1,051 acres that are not developable in the future and will not generate water demand. MARB additional (post-2030) Ultimate potable water demands were taken from Table 7 of Appendix A.

2.5.5 Population Growth Projections

The Riverside County Projections 2010 (RCP2010), a collection of data from the Riverside County General Plan and the most recent data available, projected that the 2020 population of the WMWD Riverside Retail Service Area (Lake Matthews/Woodcrest area per RCP2010) will be 40,534 (as found in RCP2010's Appendix F, Table 6). The RCP2010 projected the 2035 population of the WMWD Riverside Retail Service area would be 49,614. Therefore, a straight line interpolation between the 2020 and 2035 projected populations gives a 2030 population of 46,587.

Figure 2-17: Undeveloped Parcel Location Map



3 Water Demand and Wastewater Flow Forecasts

This section details the historical, existing, and projected potable and recycled/non-potable water demands and wastewater flows for the Riverside Retail Service Area.

3.1 Unit Demand/Load Factors

The demand methodology for projecting future demands used land use information in combination with unit demand/load factors (Table 3-1) for each designated land use type to estimate future average day demands/loads.

Near-Term (2030) potable water, recycled water/non-potable water, and wastewater demands/loads used development information (i.e. land use) from Table 2-18. Ultimate potable water demands used land use areas from Table 2-19. Ultimate recycled water/non-potable water demands used land use areas from Table 3-13. Ultimate wastewater loads used land use areas from all undeveloped parcels in Table 2-19 that were within 200 feet of existing or proposed sewers (including parcels approved for development with sewer service).

Near-Term residential land uses used unit factors based on number of dwelling units (DUs); whereas non-residential and Ultimate residential land uses used unit factors based on parcel acreage. All future recycled/non-potable water demands were assumed to be used for irrigation and a percentage of the parcel area was assumed to be irrigated based on land use type.

Table 3-1: Unit Demands/Load Factors

Land Use	Potable Water ¹		Recycled/Non-potable Water ²		Wastewater ³	
	gpd/DU	gpd/acre	% of Parcel Area Irrigated	gpd/acre	gpd/DU	gpd/acre
Residential						
Low Density Residential (SFR; 2 to 2.5 DU/acre)	714	1,785	15%	2,200	200	400
Medium Density Residential (5 DU/acre)	-	2,232	15%	2,800	200	-
Rural Residential (0.2 to 0.3 DU/acre)	2,083	625	5%	2,800	200	40
Non-Residential						
Mixed Use ⁴	-	1,607	20%	2,800	200	1,300
Agriculture	-	1,875	80%	3,100	-	0
Commercial	-	536	20%	3,500	-	1,300
Conservation	-	0	75%	2,200	-	0
Industrial	-	179	20%	2,800	-	2,000
Mineral Resources	-	107	20%	2,800	-	0

Table 3-1: Unit Demands/Load Factors

Land Use	Potable Water ¹		Recycled/Non-potable Water ²		Wastewater ³	
	gpd/DU	gpd/acre	% of Parcel Area Irrigated	gpd/acre	gpd/DU	gpd/acre
Open Space	-	0	75%	2,200	-	0
Public Facilities	-	0 ⁵	30%	2,750	-	1,000
Roadways	-	0	0	0	-	0

Notes:

DU = dwelling unit

SFR = single family residential

- ¹ Potable Water unit demand factors were modified from Table 4 of Appendix A. It was assumed that Conservation, Open Space, Public Facilities (see Note 5 below), and Roadway had zero as their unit factors, whereas Table 4 of Appendix A gave them non-zero unit factors.
- ² Recycled/Non-potable unit demand factors from Irvine Ranch Water District in 2018.
- ³ Wastewater unit load factors modified from Table 3-2 of 2014 Webb Sewer Master Plan. Commercial unit factor was lowered from 1,700 gpd/acre to 1,300 gpd/acre based on typical commercial unit factors of other similar agencies
- ⁴ Mixed Use is considered both residential and non-residential. Therefore, unit factors are listed in both DUs and acres.
- ⁵ Since no Near-Term developments had public facilities and the undeveloped public facilities parcels near the potable water system are large (easily overwhelming the potable water system), the potable water unit demand factor was set to zero

3.2 Potable Water

This section provides demand data and trends for Western’s potable water system.

3.2.1 Existing and Historical Water Demands

Historical (pre-2020) potable water demands are based on Western’s recent potable water system analyses performed by Hansen, Allen, & Luce (HAL) Engineers. These water demands are based on 2018 billing records and established an Average Day Demand (ADD) of 12,400 gpm. Table 2-17 lists new developments that have come online between 2018 and 2020. The following table estimates the average day water demand of each of the new development’s areas.

Table 3-2: Recent (2018-2020) Development Potable Water Demands

Development	Pressure Zone	Average Day Demand (gpm)
Tract 36390 (Citrus Heights Phase I)	1515	170
Tract 36475 (Citrus Heights Phase II)	1515	85
<i>1515 PZ Subtotal</i>		<i>255</i>
Tract 30231	1650	3
Tract 30238	1650	12
<i>1650 PZ Subtotal</i>		<i>15</i>

Table 3-2: Recent (2018-2020) Development Potable Water Demands

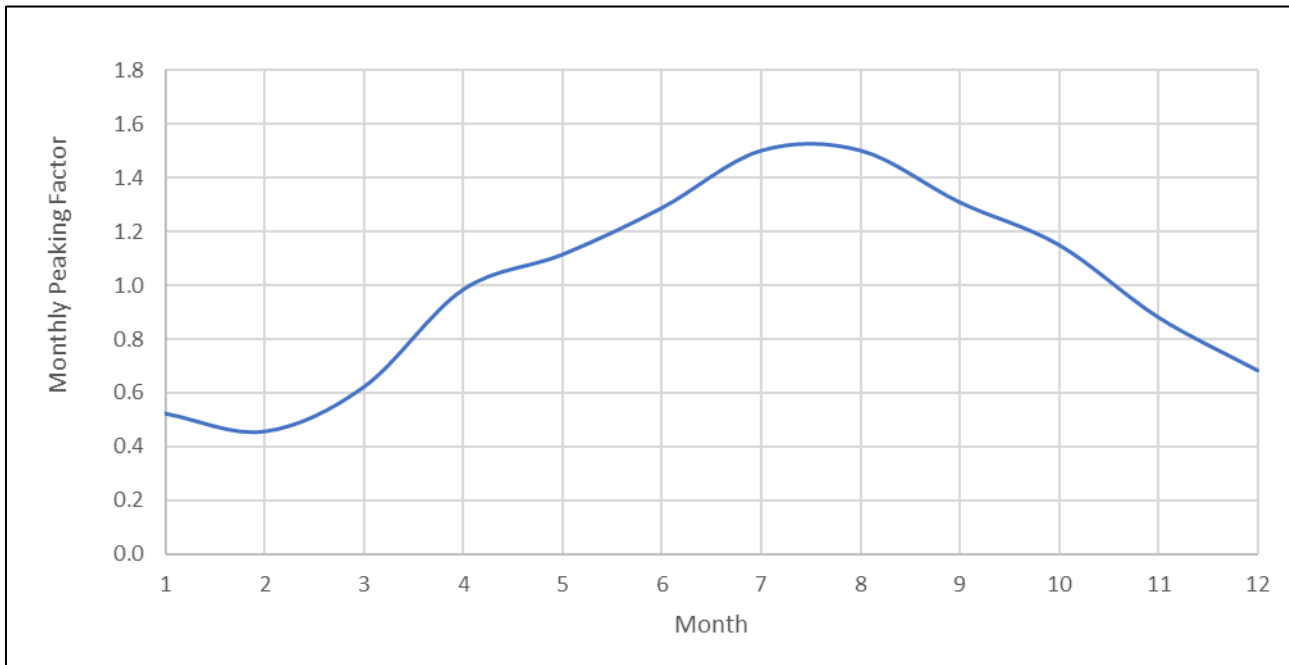
Development	Pressure Zone	Average Day Demand (gpm)
Meridian West Campus	1837	11
Alessandro Commerce Center	1837	8
MS Van Buren I	1837	1
Veterans Plaza	1837	0.06
<i>1837 PZ Subtotal</i>		<i>20</i>
Boulder Springs (Specific Plan 229)	1900	127
Tract 32997	1900	45
Meridian South Campus	1900	12
<i>1900 PZ Subtotal</i>		<i>184</i>
Tract 27557 (Galvin Springs)	2450	17
<i>2450 PZ Subtotal</i>		<i>17</i>
Total		491

The recent developments total an ADD of 491 gpm. The ADD was rounded to the nearest 100 gpm to a total of 500 gpm. Adding the recent development demand to the 2018 demand determined by HAL results in a total ADD of 12,900 gpm for the potable water system.

3.2.2 Peaking Factors

Monthly peaking factors were calculated based on customer billing data from calendar years 2017 through 2019 and are presented in Figure 3-1. The peak monthly peaking factor (factor of approximately 1.5) occurs in July and August. Minimum month demands typically occur in January and February.

Figure 3-1: Potable Water Monthly Peaking Factors (2017-2019)



A Maximum Day Demand (MDD) peaking factor of 1.5 is consistent with Western’s 2018 demand analysis and is used for the analyses in the FMP report. The Peak Hour Demand peaking factor of 3 was used based on the 2018 analysis.

Table 3-3: Current Demand and Peaking Factor

	Demand (gpm)	Peaking Factor
Average	12,900	1.0
Max Day	19,350	1.5
Peak Hour	32,250	2.5

3.2.2.1 March Air Reserve Base Demand

Western does not have individual meters on March Air Reserve Base (MARB). MARB meters all the water through a valve located within Opportunity Way on the west boundary of the base. Flow data was analyzed at 15 minute increments over the last three years to estimate average annual water demand for the base. Table 3-4 shows a summary of the results.

Table 3-4: March Air Reserve Base Demand and Peaking Factor

	2020		2019		2018	
	Demand (gpm)	Peaking Factor	Demand (gpm)	Peaking Factor	Demand (gpm)	Peaking Factor
Average	522	1.0	547	1.0	570	1.0
Max Day	737	1.4	770	1.4	797	1.4
Peak Hour	1,897	3.6	2,285	4.2	2,075	3.6

The MARB demand slowly declined across the three years but maintained consistent peaking factors. The 2020 demand was included in the total system demand hydraulic analysis.

3.2.3 Future Water Demand Projection

Future demand projections were based on two phases, near-term (2030) and ultimate (buildout).

The near-term developments are listed in Table 2-18. To estimate future water demand of each development, the land use type and area of each development was used with an associated water demand factor by land use (Table 3-1) to calculate the projected ADD water demand. Using the location of each development relative to the existing pressure zones, each development was assigned to its adjacent pressure zone. The following Table 3-5 summarizes the estimate ADD for each near term development and the pressure zone the demand will draw from. A total additional 1,755 gpm of ADD is estimated for near term development. Rounding this up to the nearest 100 and combining this demand with the 2020 ADD, the total projected ADD for 2030 is 14,700 gpm.

Table 3-5: Near-Term Development Potable Water Demands

Development	Pressure Zone	Average Day Demand (gpm)
Tract 37217	1515	254
Tract 36730 (Lake Ranch)	1515	135
	<i>1515 PZ Subtotal</i>	<i>389</i>

Table 3-5: Near-Term Development Potable Water Demands

Development	Pressure Zone	Average Day Demand (gpm)
Tract 22100 (Mockingbird Canyon)	1650	29
<i>1650 PZ Subtotal</i>		<i>29</i>
VIP 215 (Hillwood)	1695 (MARB)	18
<i>1695 PZ (MARB) Subtotal</i>		<i>18</i>
Meridian West Campus	1837	6
University Highlands	1837	181
Alessandro Service Station	1837	2
MS Prime Six	1837	1
MS Van Buren II	1837	1
Veterans Plaza	1837	1
18171 Van Buren Blvd at Little Ct	1837	1
MS 215	1837	1
Tract 28767	1837	12
Sycamore Hills Distribution Center	1837	1
<i>1837 PZ Subtotal</i>		<i>207</i>
Tract 32647	1900	51
Tract 37593	1900	45
Boulder Springs (Specific Plan 229)	1900	543 ³
Meridian South Campus	1900	115 ⁴
Tract XXXX	1900	20
Tract 37731	1900	69
Tract 37732	1900	40
16725 Dant St	1900	46
<i>1900 PZ Subtotal</i>		<i>929</i>
Belle Meadows Ranch (Specific Plan 198)	2320	146
<i>2320 PZ Subtotal</i>		<i>146</i>
Tract 27557 (Galvin Springs)	2450	20 ⁵
Tract 36963	2450	17
<i>2450 PZ Subtotal</i>		<i>37</i>
Total		1,755

Notes:

SFR = single family residential

- ¹ For Meridian West Campus: 2 Industrial Buildings are constructed in 2020 and 3 Commercial Buildings will be built between 2020 and 2030.
- ² For Veterans Plaza: 2 Commercial Buildings are constructed in 2020 and 3.45 acres of commercial development will be built between 2020 and 2030.
- ³ For Boulder Springs: 257 SFR dwelling units (DU) are constructed in 2020; 1,064 SFR DUs, an elementary school, and commercial shopping area will be built between 2020 and 2030.

- ⁴ For Meridian South Campus: 2 Industrial Buildings are constructed in 2020 and the rest of the development will be built between 2020 and 2030.
- ⁵ For Tract 27557 (Galvin Springs): 35 SFR dwelling units (DU) are constructed in 2020; 41 SFR DUs will be built between 2020 and 2030

To develop the ultimate demand, undeveloped parcel projected water ADD within one mile of the existing potable water system (6,100 gpm) and additional MARB future ADD (not including the Hillwood development; 215 gpm) from Table 7 of the Appendix A study were added to the Near-Term water demand. Undeveloped parcel projected ADD over one mile away from the existing potable water system was assumed to require large amounts of new water infrastructure and be too cost prohibitive to serve. The ultimate water ADD totaled approximately 21,000 gpm (MDD of approximately 31,000 gpm).

Table 3-6 includes the potable water ADD by pressure zone (PZ) for existing, Near-Term, and Ultimate scenarios.

Table 3-6: Potable Water Demands by Pressure Zone

Pressure Zone	2018 Existing ADD (gpm)	Updated 2020 ADD (gpm)	Near-Term (2030) ADD (gpm)	Ultimate ADD (gpm)
1150	9	9	9	59
1225	46	46	46	46
1325	14	14	14	35
1350	145	145	145	173
1430	87	87	87	95
1515	547	803	1191	1167
1540	63	63	63	67
1550	232	232	232	692
1571 ¹	196	196	196	236
1650	1084	1099	1128	1357
16952	11	11	29	380
1783	443	443	443	841
1837	5646	5666	5872	7876
1867	14	14	14	19
1886	101	101	101	124
1900	2940	3124	4053	4361
1945	33	33	33	69
1959	31	31	31	69
2116	196	196	196	593
2320	311	311	457	1718
2450	253	271	308	602
Total (Rounded)	12,400	12,900	14,700	21,000

Notes:

- ¹ 1571 PZ was created between 2014 and 2020 by adding new PRVs to pre-2014 PZs.
- ² 1695 PZ is the MARB PZ. The HAL InfoWater model referred to this as the “1695 PZ”. The 2014 Webb Water Master Plan referred to this as “1698 PZ”.

Table 3-7 summarizes the MDD for all potable water scenarios.

Table 3-7: Potable Water Demand Summary

Scenario	ADD (gpm)	MDD (gpm)
Original Existing (2018)	12,400	18,600
Updated Existing (2020)	12,900	19,300
Near-Term (2030)	14,700	22,000
Ultimate (Buildout)	21,000	31,000

3.3 Recycled/Non-Potable Water

This section provides demand data and trends for Western’s recycled and non-potable water system.

3.3.1 Existing and Historical Demands

Customer usage data for calendar years 2017, 2018 and 2019 were utilized to estimate a three-year average total recycled/non-potable demand of approximately 2,120 gpm.

Table 3-8: RW/NP System Demand (2017-2019)

Year	2017	2018	2019	3-Year Avg
Total Demand (gpm)	2,260	2,230	1,810	2,120

The largest single user in Western’s recycled/non-potable system is the Riverside National Cemetery (RNC), within Western’s Lurin Irrigation (1815) zone in the North Area. The RNC is supplied via the recycled distribution system (WWRF PS and Lurin Tank) as well as direct pumping from the WWRF recycled water pond to existing onsite storage ponds on the RNC site via a dedicated pump station and 18-inch pipeline. The RNC currently receives supplies during the daytime hours (approximately 7am to 4pm) so as to not disrupt the nighttime irrigation requirement for other recycled water customers throughout the rest of the Lurin Irrigation zone.

3.3.2 Peaking Factors

Peaking factors account for fluctuations in recycled/non-potable water demands on daily and seasonal basis. In a recycled/non-potable water system, hourly demands typically peak in the nighttime hours, when recycled water irrigation is allowed. Additionally, demands are typically higher in the summer than in the winter, when rainfall and cooler temperatures reduce irrigation demands. Peaking factors are typically noted as relative to the average day demand.

The following sections detail the findings on monthly peaking factors as well as our study assumptions for hourly peaking factors and recycled water diurnal curves used in the hydraulic analyses.

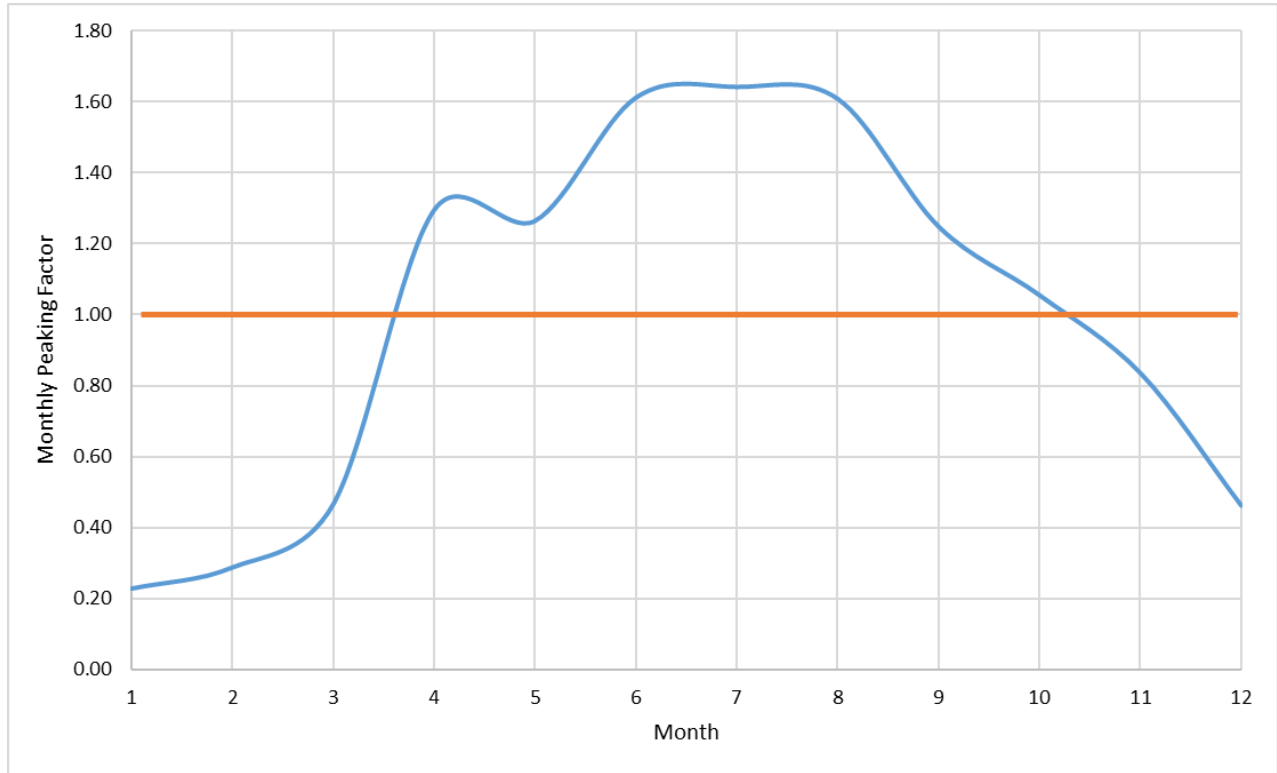
3.3.2.1 Monthly Peaking Factors

Based on data from 2017-2019, Western’s monthly peaking factors varied from a maximum of 1.65 in July to a minimum of 0.23 in January, as detailed in Table 3-9. Figure 3-2 presents the recycled water monthly peaking factors graphically.

Table 3-9: RW/NP Monthly Peaking Factors (2017-2019)

Month	Jan	Feb	Mar	Apr	May	Jun	Jul	Aug	Sep	Oct	Nov	Dec
Peaking Factor	0.226	0.286	0.469	1.284	1.274	1.603	1.650	1.618	1.252	1.050	0.839	0.450

Figure 3-2: Recycled Water Monthly Peaking Factors (3-Year Average)



3.3.2.2 Recommended Design Peaking Factors

Key design peaking factors for the recycled/non-potable water systems include minimum month, maximum month, and maximum day demands. Historical data from 2017-2019 was used to evaluate historical minimum month and maximum month peaking factors, as presented in Table 3-9 and Figure 3-2. These data were then used to develop the recommended peaking factors presented in Table 3-10. Only monthly billing demand data was available from Western; therefore, the maximum day demand (MDD) peaking factor of 2.5 was estimated based on maximum month demand, other agency peaking factors and industry standards.

Table 3-10: RW/NP Minimum and Maximum Month Peaking Factor (2017-2019)

Year	2017	2018	2019	3-Year Average
Minimum Month Peaking Factor	0.03	0.27	0.07	0.14
Maximum Month Peaking Factor	1.84	1.88	2.03	1.91

Table 3-11: Recommended Design Peaking Factors

Peaking Factor	Value x ADD
Minimum Month Demand (MinMD)	0.2
Maximum Month Demand (MMD)	2.0
Maximum Day Demand (MDD)	2.5

3.3.2.3 Hourly Peaking Factors and Diurnal Curves

Hourly usage data from Western’s Advanced Metering Infrastructure (AMI) is only available for a small number of customers, both non-potable and recycled. Available data indicated a majority of non-potable irrigation users irrigated during day-time hours and the diurnal peaking factor of those accounts ranged from 1.75 to 3.6. Agricultural users specifically were typically found to have daytime irrigation patterns. Recycled water irrigation use is limited to a set 12-hour window (8PM to 8AM) per District guidelines, which corresponds to the AMI data for the few recycled irrigation users obtained.

For the hydraulic modeling effort, agricultural users are assumed to have an 8-hour daytime irrigation window (8AM to 4PM, peaking factor of 3), while recycled water irrigation users are assumed to have a 10-hour nighttime irrigation window (9PM to 7AM, peaking factor of 2.4). The Riverside National Cemetery, as the largest recycled water user in the service area, assumes a 9-hour delivery window for existing scenarios (peaking factor of 2.67), consistent with current operations; however, for future (Ultimate or Buildout) deliveries, a 24-hour delivery window may be recommended to reduce pumping needs and pipeline velocities (peaking factor of 1.0). Due to the large projected future increase in demands at the cemetery and the availability of onsite ponds for consistent delivery, 24-hour delivery reduces the peak flows needed to be supplied to the cemetery in the future Ultimate scenario.

3.3.3 Future Recycled/Non-Potable Demand Projections

Future recycled/non-potable demand projections are based on two phases—Near-Term (2030) and Ultimate (Buildout). Near-Term demand projections are based on planned developments already underway in the service area. Buildout of the recycled/non-potable system includes three smaller park areas, as well as the expansion of the RNC, all located within the Lurin Irrigation (1815) zone.

The RNC currently owns the General Old Golf Course as well as a large swath of land south of the golf course and existing RNC property to Nandina Avenue, as shown in Figure 3-3. Development assumptions for the RNC were based on discussions with staff from the Veterans Administration, which owns and operates the RNC. Based on those discussions, Near-Term expansion of the cemetery assumes the construction of Phases V and VI, located on the east side of the property along the I-215 corridor. Ultimate expansion assumes development of the undeveloped land south of the cemetery and current developed RNC property, assuming 75% turf coverage.

To develop the “Near-Term” scenario for the recycled/non-potable water analysis, ADDs were estimated for the Near-Term developments listed in Chapter 2. These demands, listed in Table 3-12, were added to the calibrated 2014 recycled/non-potable water model to create a “Near-Term” model scenario. Similarly, the Ultimate development demands, included in Table 3-13 were then further added to create the “Ultimate (Buildout)” model scenario. Figure 3-4 displays the four Ultimate projects in the recycled/non-potable system, all located within the Lurin Irrigation (1815) zone. All model scenarios used a maximum day demand (MDD) global peaking factor of 2.5, per Table 3-11.

Figure 3-3: Riverside National Cemetery Property and Improvement Areas

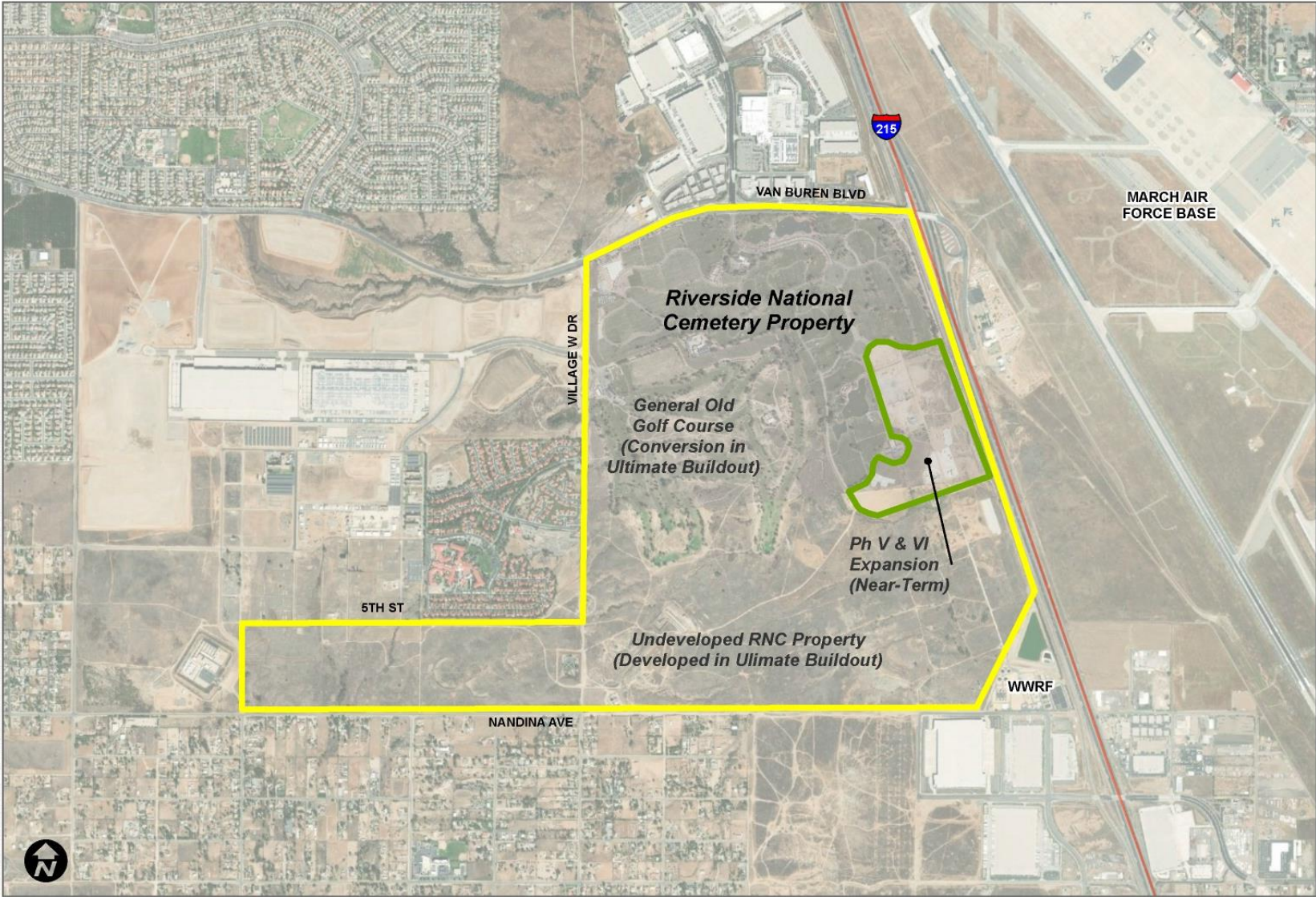


Table 3-12: Near-Term Development Additional Recycled Water Demands

Development	Pressure Zone	Near-Term Additional ADD (gpm)
Tract 36390 (Citrus Heights Phase I)	1420	79.1
Tract 36475 (Citrus Heights Phase II)	1420	38.0
<i>1420 PZ Subtotal</i>		<i>117.1</i>
Tract 37217	1667	74.5
Tract 36730 (Lake Ranch)	1667	25.2
<i>1667 PZ Subtotal</i>		<i>99.7</i>
Meridian West Campus	1815	42.4 ¹
Boulder Springs (Specific Plan 229)	1815	181.4 ²
MS Prime Six	1815	1.0
MS Van Buren I	1815	1.9
MS Van Buren II	1815	1.8
Veterans Plaza	1815	1.8 ³
16725 Dant St	1815	3.9
Tract 32997	1815	8.6
Tract 37593	1815	4.4
Tract 32647*	1815	12.9
Tract XXXX	1815	2.2
Tract 37731	1815	7.9
Tract 37732*	1815	5.0
Meridian South Campus*	1815	281.3 ⁴
Riverside National Cemetery Expansion	1815	165.8 ⁵
<i>1815 PZ Subtotal</i>		<i>722.5</i>
Altman Plants Expansion	2250	207
<i>2250 PZ Subtotal</i>		<i>207</i>
Belle Meadows Ranch (Specific Plan 198)	2320	116.9
<i>2320 PZ Subtotal</i>		<i>116.9</i>
Total		1,263.0

Notes:

SFR = single family residential

* Since RW minimum pressure is anticipated to be below 30 psi, on-site storage and pump is required.

¹ For Meridian West Campus: 2 Industrial Buildings are built in 2020 and 3 Commercial Buildings are to be built between 2020 and 2030.² For Boulder Springs: 257 SFR dwelling units (DU) are built in 2020; 1,064 SFR DUs, an elementary school, and commercial shopping area are to be built between 2020 and 2030.³ For Veterans Plaza: 2 Commercial Buildings are built in 2020 and 3.45 acres of commercial development is to be built between 2020 and 2030.⁴ For Meridian South Campus: 2 Industrial Buildings are built in 2020 and the rest of the development is to be built between 2020 and 2030.

⁵ Assumes development of Phases V and VI within this time frame with Phase VI demands estimated to be equal to Phase V demands. Phase V development commenced in 2020. RNC near-term demands are approximately 23% of the total increased demands in the 1815 PZ.

Table 3-13: Ultimate Additional Recycled Water Demands

Irrigation Area	Pressure Zone	Gross Acreage	Ultimate ADD (gpm)
Bergamont Park	1815	6	8.6
March JPA Soccer Fields ¹	1815	30	45.8
Orange Terrace Community Park	1815	23	35.1
Riverside National Cemetery ²	1815	845	1,240
<i>1815 PZ Subtotal</i>		<i>904</i>	<i>1,330</i>
Total		904 acres	1,330 gpm (3.0 CFS)

Notes:

- ¹ Since RW minimum pressure is anticipated to be below 30 psi, on-site storage and pump is required.
- ² Includes conversion of General Old Golf Course (290 acres) and development of undeveloped land on the south end of the RNC property (555 acres), both assuming 75% turf coverage. RNC Ultimate demands are approximately 93% of the total ultimate demand for the 1815 PZ.

A summary of the demands changes by pressure zone are presented in Table 3-14, which includes the MDDs for the existing, Near-Term and Ultimate scenarios. Overall, the recycled/non-potable water system demand is expected to double by Ultimate (Buildout), with the majority of that increase being due to the expansion of the RNC.

Table 3-14: Recycled Water Demands by Pressure Zone

Pressure Zone	Area	Existing MDD (gpm)	Near-Term MDD (gpm)	Ultimate MDD (gpm)
1420	North	51	343	343
1667	North	826	1076	1,076
1520 (Riverside National Cemetery)	North	833	1278	2,000
1815	North	1,853	3,214	4,544
2250	South	1,075	1,886	1,905
2450	South	833	833	833
North Total (gpm)		3,563	5,911	7,963
South Total (gpm)		1,908	2,719	2,738
Total (gpm)		5,471	8,630	10,701
North Total (CFS)		7.9	13.2	17.7
South Total (CFS)		4.3	6.1	6.1
Total (CFS)		12.2	19.2	23.8

Figure 3-4: Ultimate Irrigation Areas

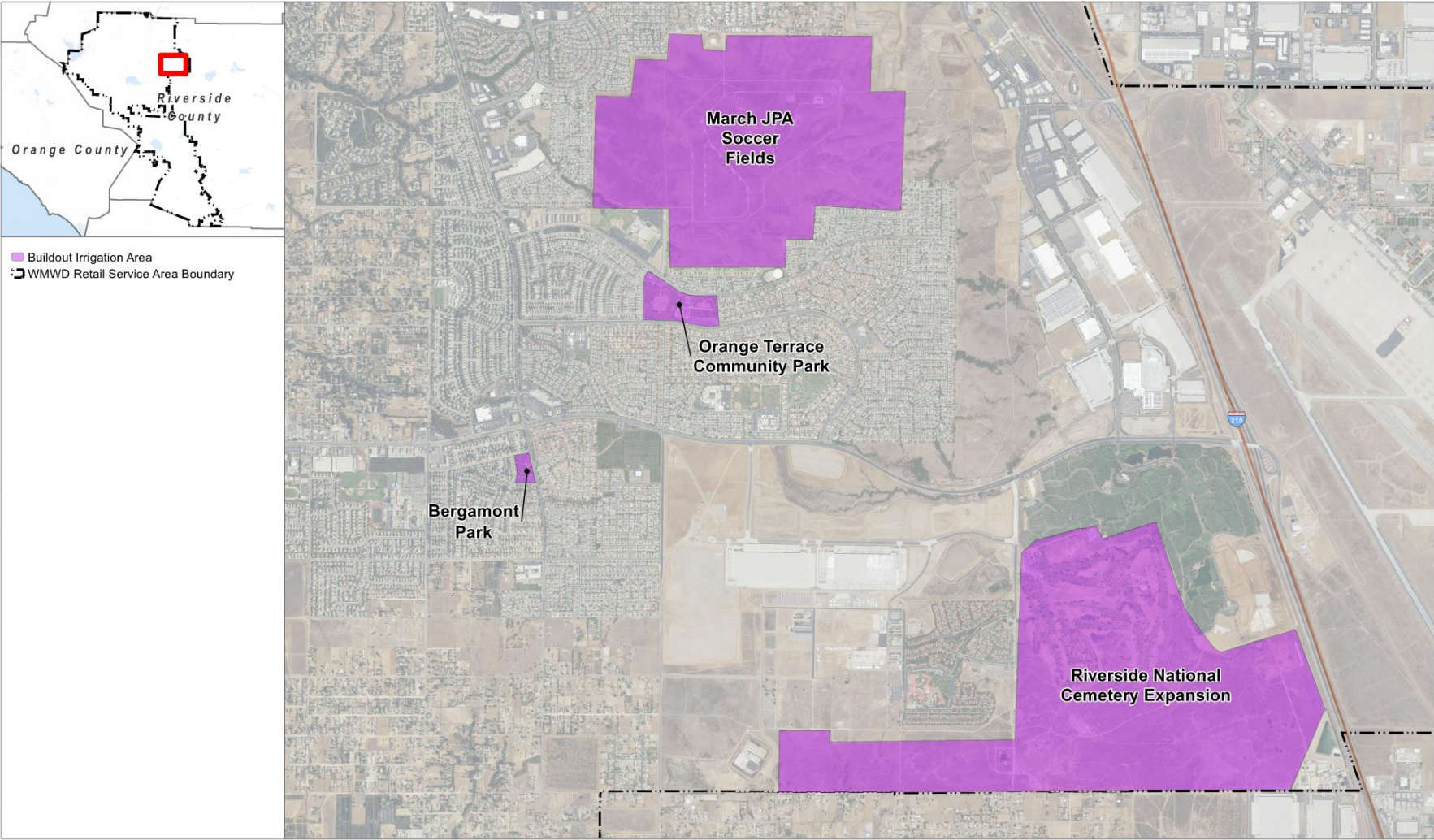


Table 3-15: Recycled/Non-Potable Water Demand & Supply Summary

Scenario	MDD (CFS)	Supply from WWRF (CFS) ¹	Supply from Riverside Canal (CFS) ^{2,3}	Supply from CRA-North (CFS) ²	Supply from CRA-South (CFS) ²
Original Existing (2020)	12.2	1.9	6.0	0	4.3
Near-Term (2030)	19.2	3.7	9.5	0	6.1
Ultimate (Buildout)	23.8	5.7	11.1	1.0	6.1

Notes:

- ¹ RW supply from WWRF assumed to be 80% of the average influent sewer flows, based on plant influent and RW supply data from 2019-2020. Near-term and Ultimate (buildout) supply for WWRF based on projections from sewer system evaluation as part of this study.
- ² Average supply over 24-hour period during MDD conditions.
- ³ Riverside Canal supply values for Near-Term (2030) and Ultimate assume Palm Avenue and Western Well #7 supplies are online and operational. Per District, up to 5,000 gpm (11.1 CFS) may be available by 2030 from all three sources, though more likely 4,000 gpm, including RPU via Johnson 4 Well (up to 2,000 gpm), Palm Ave Well (up to 1,000 gpm) and Western Well #7 (up to 1,000 gpm). The higher flow volume was modeled for facilities planning but actual supply may be lower than modeled.

Recycled and non-potable water supplies are an important factor in the operation of the recycled/non-potable system. Currently, the North Area is supplied by recycled water produced by WWRF as well as non-potable water from the Riverside Canal, with additional supply from the CRA via WR-21 and the Intake and In-line Pump Stations, as needed. The South Area is supplied non-potable water by the CRA. As development increases, additional supply is anticipated to come from the Riverside Canal. For Ultimate (Buildout), CRA supply will be required to satisfy the growing RNC demands in the Lurin Irrigation (1815) zone. Table 3-15 summarizes the MDD and anticipated supply sources for all recycled water model scenarios.

3.4 Wastewater

This section describes Western’s existing and projected wastewater flows. Wastewater flows generally consist of dry weather flow (DWF) and wet weather flow (WWF).

DWF is the baseline flow generated by routine water usage from District customers. The other primary component of DWF is dry weather groundwater infiltration (GWI) into the wastewater collection system. This occurs when the groundwater table is higher than the depth of the wastewater facilities and defects such as cracks in the pipe allow infiltration. This is typically not an issue for Western due to low groundwater levels relative to the sewer facilities throughout most of the system.

Average Dry Weather Flow (ADWF) is the average daily flow during dry weather conditions. ADWF is developed based on daily flow data from 2017-2019 at the permanent flow monitors described in Section 2.4.4 of this report. ADWF diurnal curves were developed from March 2020 data at these permanent flow monitors.

WWF includes DWF, storm water inflow, and GWI. Storm water inflow enters the system through openings in at-grade collection facilities (manhole lid pick holes) and wet weather GWI is the result of storm water entering through collection system defects during elevated water levels in the ground following storm events. The combination of storm water inflow and wet weather GWI is referred to as inflow and infiltration or I/I. I/I is common to all wastewater collection systems and can vary significantly across a single system. I/I results in increased flows and peak flows during and after storm events. A design storm event is selected from rainfall

events during the flow monitoring period. The design storm is a rainfall event used to analyze the performance of the collection system under extreme wet weather events.

Peak Wet Weather Flow (PWWF or Design Flow) is the highest observed flow resulting from a design storm event. PWWF is utilized as the design flow event for sewers and lift stations for the purposes of this FMP to evaluate the likelihood of sanitary sewer overflows. PWWF and diurnal curves were developed based on thirty minute interval flow monitoring data from March 2020 at the permanent flow monitors (2.4.4). March 2020 was selected due to the intensity and duration of storm events which resulted in significant flow increases to the collection system.

3.4.1 Existing and Historical Flows

Western provided daily flow data for all flow monitoring locations for 2017-2019 and hourly data from March of 2020. Western’s billing data shows a total of 6,736 customers and the following customer classifications:

- Single Family Residential
- Multi-Family Residential
- Commercial
- Industrial
- Military

3.4.1.1 Flow Monitor Data Summary

This section summarizes the flow monitoring data utilized for this FMP. Table 3-16 includes historical average daily flows from the 2017-2019 flow data provided by Western. Refer to Figure 2-12 and Figure 2-13 for a map of the flow monitoring locations. The frequency at which the flows are measured varies by location and is noted in the table, however all flows were aggregated into average daily flow rates.

Table 3-16: Historical (2017-2019) Sewer Flows

Basin	Flow Monitor	ADF (MGD)
WWRF	Markham	0.32
	Cajalco*	*
	Dauchy	0.15
	Gamble	0.04
	LS 1269	0.18
	Air Force Village West (AFVW)	0.03
	LS 3412	0.02
	Meridian	0.08
	Riverside Interconnect	0.50
	Enhanced Groundwater Extraction and Treatment System (EGETS)	0.12
<i>Sum of WWRF Basin Meters</i>		<i>1.24</i>
WRCRWA	Arizona	0.22
	Fillmore	0.17
	Buchanan	0.15

Table 3-16: Historical (2017-2019) Sewer Flows

Basin	Flow Monitor	ADF (MGD)
	McKinley	0.20
	Home Gardens	0.56
	Corona Diversion 1	0.00
	Norco Cota	1.11
	Corona Diversion	0.00
	South Regional Lift Station (SRLS)	2.60
	SRLS Overflow	0.07
	Norco 2nd Street	0.36
	Norco Corydon	0.26
	Jurupa	4.11
<i>Sum of WRCRWA Basin Meters</i>		<i>7.40</i>

* Meter Not Functional

Table 3-17 summarizes the hourly flow data for March of 2020, which was utilized to develop model loads, peaking factors, and diurnal curves for ADFW's.

Table 3-17: Hourly Sewer Flow Meter Data Summary

Flow Meter	March 2020 ADFW Avg (MGD)
Markham	1.13
Cajalco*	0.00
Dauchy	0.18
Gamble	0.05
LS 1269	0.15
AFVW*	0.02
LS 3412*	0.03
Meridian	0.61
WWRF Influent Meter	0.98
Arizona	0.92
Fillmore	0.17
Buchanan	0.17
McKinley	0.27
Home Gardens**	0.53
Norco Cota**	1.10
South Regional Lift Station	3.14
Norco Corydon**	0.27
Norco 2nd St**	0.61

* Weekly Meter Reads

** Point Source Load (See Section 3.4.1.6)

Discrepancies and related assumptions for the March 2020 flow monitoring data are listed below by flow monitoring location:

- Arizona
 - March 2020 flow monitoring data during the study period was inconsistent with historical data. Flows began to increase on 3/14/2020 and continued to increase through the end of March. The increase in flows was also reflected in the flow data at the South Regional Lift Station. The Arizona basin average flows (0.92 mgd) during this period were more than double the typical flow rate (0.22 mgd) for the month of March 2020 in the Arizona basin. Flows recorded during the beginning of March averaged approximately 0.20 mgd, matching the historical flows. Construction of the Citrus Heights development may explain the flow increase. The high flows were used only for calibration, typical flow rates from the 2017 – 2019 data were used for all other models.
- Markham
 - March 2020 flow monitoring data during the study period includes negative values, steadily increasing until 3/26/2020 when flows begin to average 1.13 mgd. The 2017-2019 historical average for the Markham flow meter is 0.32 mgd. Due to significant variability in the data from March 2020, hourly flow data from October 2019 was utilized to create peaking curves.
 - Due to variability in the flow data, flow peaking factors within the Markham basin were assumed to match the upstream Dauchy Lift Station, which has a similar customer demographic.
- Meridian
 - March 2020 flow monitoring data during the study period was inconsistent. Between 3/20/2020 and end of month, flows decreased from typical rates and reached near zero values. Because the design storm event occurred seven days before the data inconsistencies, wet weather flows from the design storm were deemed accurate. However the data inconsistencies affected the period used for dry weather flows. Additional hourly data was provided from October of 2019, which was used to develop the dry weather flow peaking factors for the Meridian basin.

3.4.1.2 Precipitation Events

The March 2020 flow monitoring period captured three separate storm events, the largest of which was a 25-year storm on March 12th, 2020. The intensity of the storm was determined by a combination of rain gauges. The National Oceanic and Atmospheric Administration (NOAA) maintains a “Riverside March AFB” rain gage which measures total daily precipitation. In order to determine the intensity of the daily rain events measured at MARB, the nearest USGS precipitation gauge was identified, and hourly data was obtained for the same rain event. The Gilbert Street precipitation gage (Site No. 340742117161701) is located approximately 21 miles north of the MARB rain gage; a review of rain events at both locations determined the total accumulation of rainfall from precipitation events during the March 2020 monitoring window to be roughly the same. Therefore the USGS Gilbert Street precipitation gage was used to determine the storm average recurrence interval based on the NOAA Precipitation Frequency Data server. Table 3-18 includes a summary of the precipitation data described above.

Table 3-18: Precipitation Data Summary

Date	24 Hour Accumulation (in)		Precipitation Duration (hr)	NOAA Interval (yr)
	NOAA MARB	USGS Gilbert St		
3/1/2020	0.01	0.25	3.25	< 1
3/2/2020	0.00	0.00	0	
3/3/2020	0.00	0.00	0	
3/4/2020	0.00	0.00	0	
3/5/2020	0.00	0.00	0	
3/6/2020	0.00	0.00	0	
3/7/2020	0.00	0.00	0	
3/8/2020	0.00	0.00	0	
3/9/2020	0.00	0.00	0	
3/10/2020	0.97	0.71	9.75	2
3/11/2020	0.03	0.00	0	
3/12/2020	1.88	1.07	5.25	25
3/13/2020	0.26	0.30	2.75	< 1
3/14/2020	0.00	0.00	0	
3/15/2020	0.00	0.01	0.25	< 1
3/16/2020	0.06	0.00	2.25	< 1
3/17/2020	0.19	0.27	4.75	< 1
3/18/2020	0.04	0.01	0.25	< 1
3/19/2020	0.38	0.46	6.5	< 1
3/20/2020	0.02	0.01	0.25	< 1
3/21/2020	0.00	0.00	0	
3/22/2020	0.14	0.00	5.25	< 1
3/23/2020	0.30	0.81	9.25	< 1
3/24/2020	0.00	0.00	0	
3/25/2020	0.00	0.00	0	
3/26/2020	0.00	0.00	0	
3/27/2020	0.00	0.00	0	
3/28/2020	0.00	0.00	0	
3/29/2020	0.00	0.00	0	
3/30/2020	0.00	0.00	0	
3/31/2020	0.00	0.00	0	

3.4.1.3 Wet Weather Flow

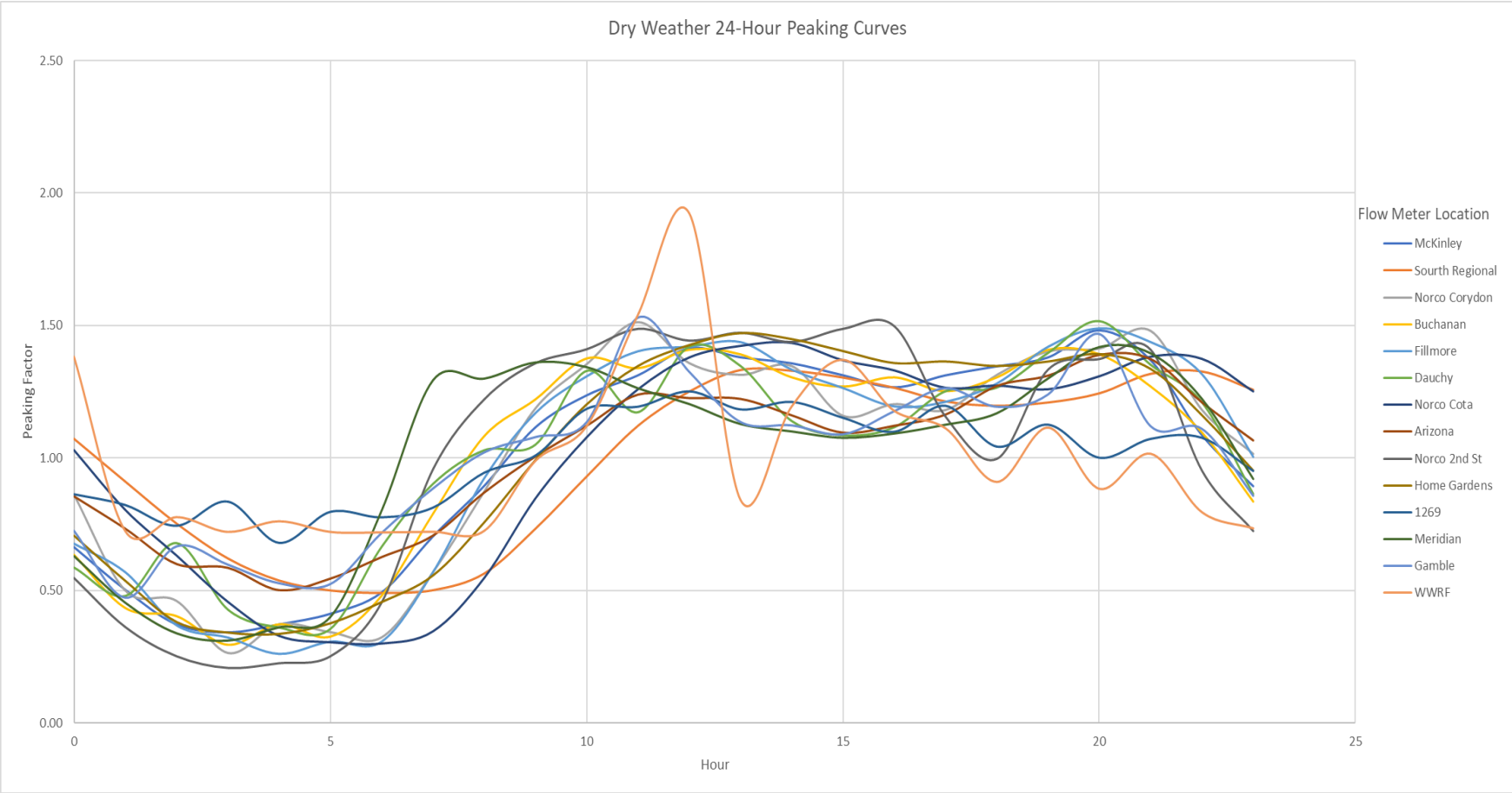
The storm event on 3/12/2020 had a precipitation accumulation of 1.88 inches over a period of 5.25 hours and was selected as the design storm event for wet weather flows. The storm was used to determine the sensitivity of the wastewater system to I/I. The flow from the design event was used for calibration of the model during wet weather flows, model calibration is described in detail in Section 4.3.5.

3.4.1.4 Hourly Peaking Factors and Diurnal Curves

Hourly flow data from each flow monitoring location was analyzed to develop hourly peaking factors for a 24 hour period for both dry and wet weather flows. For each basin, the average flow of the basin is represented by a peaking factor of one. Flow for each hour is compared to the average to represent the peak hour factor across the 24-hour period. Generally, the smaller basins will see a larger peaking response and larger basins a more gradual peaking curve.

The average dry weather flow for each basin was used for calibration of the system-wide hydraulic model, discussed in Section 4.3.5. The following 24-hour peaking graph shown on Figure 3-5 presents the resultant dry weather flow patterns for all flow meters.

Figure 3-5: Dry Weather Flow Peaking Curves



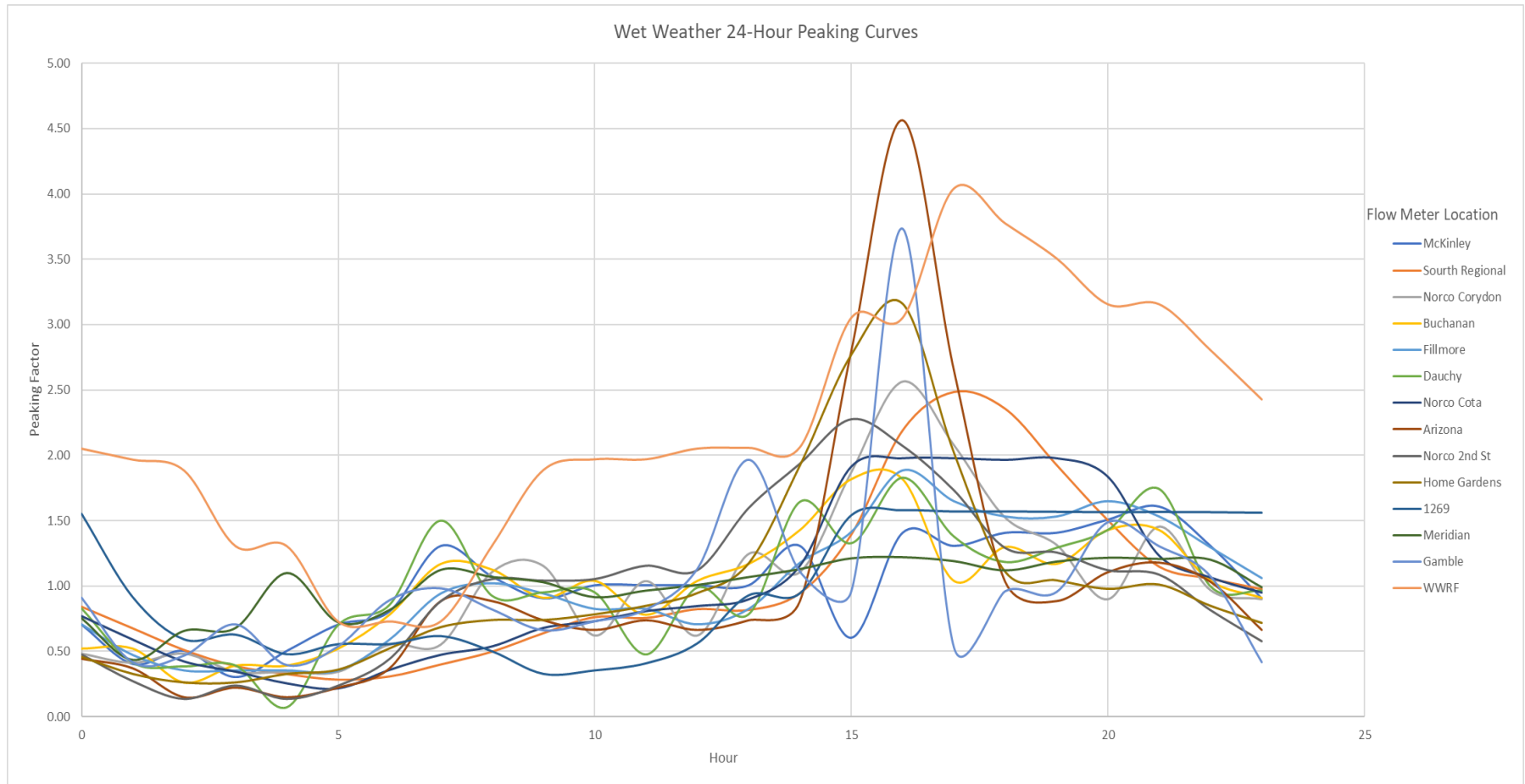
The following 24-hour peaking graph shown on Figure 3-6 presents the resultant design storm wet weather flow patterns for all flow meters. During the design storm event significant inflow and infiltration was observed throughout the system, such that peaking curves were flattened with one peak near 5:00 p.m. when significant inflows were experienced. Table 3-19 includes a summary of the peaking factors shown in the graph, only meters with complete dry and wet weather data are included.

Table 3-19: March 2020 Sewer Peaking Factor Summary

Flow Meter	ADWF (MGD)	PWWF (MGD)	Peaking Factor
WWRF Meters			
Dauchy	0.18	0.32	1.81
Gamble	0.05	0.23	4.12
LS 1269	0.15	0.90	6.14
Meridian	0.61	0.81	1.32
WWRF Influent Meter	0.98	3.96	4.04
WRCRWA Meters			
Arizona	0.92	1.49	1.62
Fillmore	0.17	0.38	2.22
Buchanan	0.17	0.34	1.95
McKinley	0.27	0.38	1.45
Home Gardens*	0.53	2.33	4.37
Norco Cota*	1.10	3.70	3.36
South Regional Lift Station	3.14	9.72	3.10

* Point source load

Figure 3-6: Wet Weather Flow Peaking Curves



3.4.1.5 Wastewater Flow Generation Factor

The flow monitoring data represents sub basin wide flow generation. For the WRCRWA system, all sub basins are primarily comprised of residential customers. The WWRF system has some sub basins with homogenous customer types and others that are mixed, in the case of the former the flows were analyzed to confirm the SFR DU flow factor. The results of the analysis were reviewed with Western staff and Western's current wastewater flow factor for single family residential (SFR) dwelling units (DU) of 200 gpd/DU was confirmed as valid. Table 3-20 summarizes the results of the residential flow factor analysis.

Table 3-20: Residential Sewer Flow Factor Analysis

Flow Meter	Avg Q (gpd)	Qty DU's	Unit Flow (gpd/DU)
McKinley	197,484	1,104	178.88
Buchanan	146,616	742	197.60
Fillmore	165,204	985	167.72
Arizona	221,295	1,533	144.35
<i>WRCRWA Residential Service Average</i>			172.14
Dauchy	151,441	601	251.98
Gamble	38,172	159	240.07
Markham	319,205	1,646	193.93
<i>WWRF Residential Service Average</i>			228.66
Total		7,172	200.40
<i>Residential Average</i>			196.77

For other customer types the permanent flow monitoring locations do not provide enough resolution for flow factor analysis. Therefore, flow factors were developed based on wastewater return factors corresponding to the water consumption factors. A sewer system experiences between 65 and 85 percent return rates of water use to the sewer, depending on the type of land use and extent of outdoor water use. The return ratio can be as high as 90 percent or more during wet periods. Table 3-21 includes the wastewater unit loads utilized for this master plan.

Table 3-21: Wastewater Flow Factors

Land Use	Wastewater Unit Loads (gpd/ac)	Wastewater Unit Loads (gpd/DU)
Agriculture	1,875	-
Commercial	1,300	NA
Conservation	-	-
Industrial	2,000	NA
MARB	N/A	N/A
Rural Residential (Max 1 DU/5 AC)	40	200
Low Density Residential (Max 2 DU/AC)	400	200
Medium Density Residential (Max 5 DU/AC)	1,000	200
Mixed Use	1,607	200

Table 3-21: Wastewater Flow Factors

Land Use	Wastewater Unit Loads (gpd/ac)	Wastewater Unit Loads (gpd/DU)
Mineral Resources	107	-
Open Space (Max 1 DU/10 AC)	20	-
Public Facilities	1,000	NA
Roadways	-	-
Elementary School	200	10

3.4.1.6 Large Point Source Flows

There are six notable point source flows into Western’s wastewater collection system. One point source load is located in the WWRF service area and the remaining 5 are within the WRCRWA service area. Three of the point sources are diversion structures with variable flows (see Section 2.4.5) and others are permeant inflows

3.4.1.7 Unaccounted-For Flows

Beginning in November of 2020, after the flow study period for this report, approximately 0.7 MGD in new flows were recorded at the WWRF influent meters and, at the time of this report, have not subsided. Western has conducted reviews of flow monitor data at the permanent metering locations to identify which basin the new flows are originating from, however none of the monitoring locations showed abnormally high flows. Therefore, it is likely these flows are coming from within the unmetered area which flows directly by gravity to the WWRF. This area includes a number of partially-constructed developments. Due to the uncertain nature of these flows, they are not accounted for in the analysis included in this report. Additional flow monitoring studies are recommended to identify the source of the flows and determine if it is a permanent increase, in which case the impacts to the downstream sewer facilities should be further evaluated to ensure adequate capacity remains.

3.4.2 Future Wastewater Flow Projections

Future wastewater flows were developed using a combination of General Plan information, Specific Plans, previous studies, aerial photography, wastewater flow factors and input from Western staff. The Near-Term and Ultimate (Buildout) ADWF estimates in this section were developed in parallel with water demand projections to ensure consistent methodology across all aspects of this FMP. The approach for developing each set of flows is described in the following section.

3.4.2.1 Near-term (2030)

Near-Term flows were determined based on a collaborative review process with Western Staff. The projects included in the Near-Term scenario are those with sewer service that have approved Specific Plans or are in the design or construction phases prior to March of 2021, when this FMP was developed. Table 3-21 summarizes the additional Near-Term flows by project.

Table 3-22: Near-Term Average Dry Weather Sewer Flow

Development Name	Total Development Area (AC)	Single Family Home Dwelling Units (SFR DU)	Mixed Use (AC)	Institutional (AC)	Commercial (AC)	Industrial (AC)	Wastewater Flow Factor		Projected Near-Term Flows
							gpd/du	gpd/ac	mgd
Tract 37217	325	513	-	-	-	-	200	-	0.103
Tract 36730 (i.e. Lake Ranch)	110	272	-	-	-	-	200	-	0.054
<i>WRCRWA Additional Near Term Flow Total</i>									<i>0.16</i>
Boulder Springs (Specific Plan 229)	938	1,064	-	12	30	-	200	1,300	0.260
Meridian South Campus ¹	568.5	-	18	-	227	86	-	2,000 Ind 1,300 Com	0.490
Meridian West Campus	110	-	-	-	16	-	-	1,300	0.020
Hillwood (Formerly VIP 215)	135	-	-	-	-	143	-	2,000	0.285
Tract 37593	19.4	90	-	-	-	-	200	-	0.018
Tract 32647	56.3	103	-	-	-	-	200	-	0.021
MS Prime Six	6.7	-	-	-	2	-	-	1,300	0.003
MS Van Buren II	13.3	-	-	-	4	-	-	1,300	0.005
Veterans Plaza	15.6	-	-	-	3	-	-	1,300	0.004
Tract XXXX	9.73	41	-	-	-	-	200	-	0.008
Tract 37731	34.5	138	-	-	-	-	200	-	0.028
Tract 37732	21.7	81	-	-	-	-	200	-	0.016
16725 Dant St	21.7	93	-	-	-	-	200	-	0.009
<i>WWRF Additional Near-Term Flow Total</i>									<i>1.17</i>

¹ Projected flow factors based on 2018 Sewer Capacity Study for Meridian Park LLC (Table 3-1)

3.4.2.2 Ultimate (Buildout)

Based on input from Western staff, the Ultimate (Buildout) flows are based on all undeveloped parcels within 200 feet of existing or proposed sewers (including parcels approved for development with sewer service). Parcels were designated as undeveloped based on review of 2020 aerial imagery. Existing developments are assumed to be at “Ultimate” capacity of feasible land development. The wastewater flow factors developed from historical flows were used in conjunction with the refined 2019 Appendix A study parcel dataset land use designation for parcels within the boundaries of the Ultimate development area. Ultimate flows for MARB were not based on land use designations and instead were based on applying the current return rate to ultimate water demands as described in Table 7 of the study in Appendix A.

Table 3-23: Ultimate (Buildout) Average Dry Weather Sewer Flow

Land Use	WRCRWA Undeveloped Area (Ac) ²	WWRF Undeveloped Area (Ac) ²	Total Undeveloped Area (Ac) ²	Unit Demands (gpd/ac)	WRCRWA Additional Ultimate ADWF (mgd)	WWRF Ultimate ADWF (mgd)
Agriculture	216	—	216	1,875	0.41	—
Commercial	—	28	28	1,300	—	0.04
Conservation	507	—	507	—	—	—
Industrial	—	5	5	2,000	—	0.01
Low Density Residential	67	—	67	400	0.03	—
MARB ¹	—	N/A	—	N/A	—	0.46
Medium Density Residential	214	—	214	1,000	0.21	—
Mineral Resources	—	—	—	107	—	—
Mixed Use	8	478	485	1,607	0.01	0.77
Open Space	92	—	92	20	0.00	—
Public Facilities	—	—	—	1,000	—	—
Rural Residential	623	790	1,413	40	0.02	0.03
Roadway ³	—	—	—	—	—	—
Totals	1,727	1,301	3,027	—	0.69	1.31

Notes

- ¹ Based on PW demands in Appendix A, Table 7
- ² Ultimate development area based on all parcels in the refined Appendix A study parcel dataset (Chapter 2.5.4) within 200 feet of existing or proposed sewers (including parcels approved for development with sewer service). Land use was taken from refined Appendix A study parcel dataset. Demands from this area was added on top of existing and Near-Term demands to create Ultimate demands.
- ³ Roadways were assumed to not have water demands

Table 3-24 summarizes the cumulative flow projections during each phase of wastewater system development.

Table 3-24: Wastewater Flow Projection Summary

Scenario	Total WRCRWA ADWF (MGD)	Total WWRF ADWF (MGD)
Existing (2020) ¹	0.73	1.15
Near-Term (2030)	0.89	2.32
Ultimate (Buildout)	1.57	3.62

Notes

¹ Existing base flows based on 2017-2019 sewer meter data

INTENTIONALLY LEFT BLANK

4 Hydraulic Modeling

This chapter discusses the development, review, and updates for the existing Western models for potable water, recycled/non-potable water, and wastewater. In addition, this chapter details how the projected water demands and wastewater flows developed in Chapter 3 were added to the updated models.

4.1 Potable Water Model

This section provides detail on the existing potable water model and the updates made to the model for this analysis.

4.1.1 Existing Potable Water Hydraulic Computer Model

The potable water model is developed in InfoWater™ by Innowyze®. The model was updated and calibrated as part of Western’s recent model optimizations performed by HAL Engineers, with documentation dated July 29, 2020, entitled “WMWD 2020 Hydraulic Model Update”. This documentation stated that SCADA metered flow data and tank levels from July 8, 2018 were used to calibrate the potable water model. For pressure, the correlation of computed and observed means was 98% (Figure 4-1). For flow, correlation of computed and observed means was 99% (Figure 4-2). Dudek utilized this model to begin the water modeling effort of this FMP.

Figure 4-1: Correlation between Observed and Computed Pressures

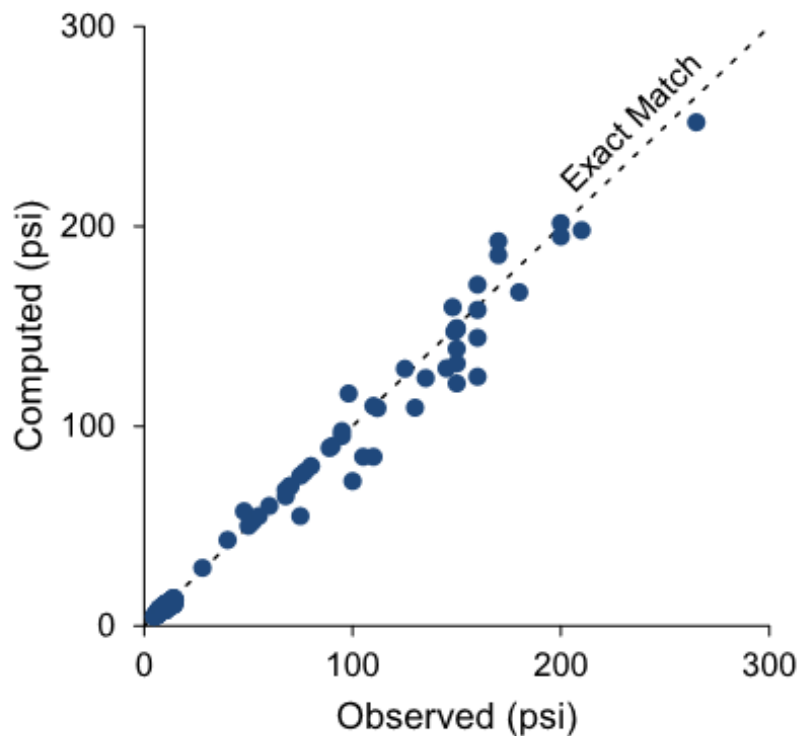
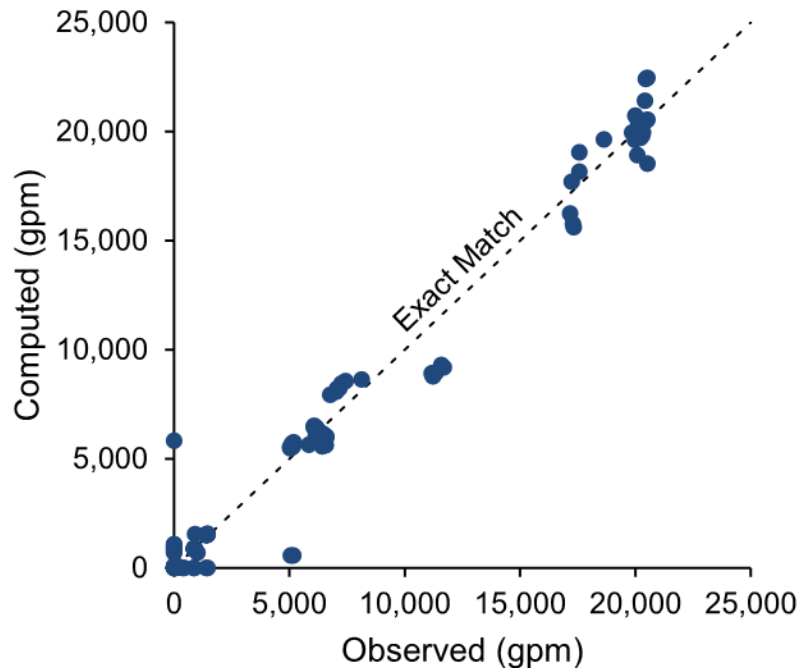


Figure 4-2: Correlation between Observed and Computed Flows



4.1.2 Model Updates

The potable water model was updated from Western’s 2020 capital improvement projects (CIPs), to:

- Create the new 1571 PZ in all potable water model scenarios,
- Add Phillips, Global Port, and Cactus EMWD interconnections to the 1695 PZ in MARB (but keep PRVs closed), and
- Add the Van Buren PRV (1837 PZ to 1695 PZ) northeast of the intersection of Van Buren Blvd and Opportunity Way.

The demands in the model were updated with the new demands as detailed in Chapter 3.2.1. A Near-Term scenario was developed and the Near-Term demands for the project identified in Chapter 3.2.3 were added to the model. The demands for each development were individually placed on the model node closest to the centroid parcel of the development. To reflect potable water demands within MARB, the 2020 demand identified in Section 3.2.2.1 were allocated across all nodes in the base.

To develop the ultimate demand, undeveloped parcel projected water ADD within one mile of the existing potable water system (6,100 gpm) and additional MARB future ADD (not including the Hillwood development; 215 gpm) from Table 7 of the Appendix A study were added to the Near-Term water demand. Undeveloped parcel projected ADD over one mile away from the existing potable water system was assumed to require large amounts of new water infrastructure and be too cost prohibitive to serve. The ultimate water ADD totaled 20,960 gpm (MDD of approximately 31,000 gpm).

4.2 Recycled/Non-Potable Water Model

This section provides detail on the existing recycled/non-potable water model, the model updates, and the results of model calibration.

4.2.1 Existing Recycled/Non-Potable Water Hydraulic Computer Model

Western's existing recycled/non-potable water model was last updated as part of Western's 2014 Recycled Water Master Plan. The model received was in H2ONet format and was converted to InfoWater™ by Innovyze® for this analysis. Western's recycled/non-potable model represents the main components of the recycled and non-potable water systems, including pipelines, pump stations, storage reservoirs, pressure reducing stations and water supply sources.

4.2.2 Recycled/Non-Potable Water Model Updates

The 2014 recycled/non-potable water model was compared with Western's current recycled/non-potable water system GIS and was updated with facilities that have been added and improved since 2014. Pressure zone data, current pump and valve controls, and pipeline data were updated within the model.

4.2.3 Recycled/Non-Potable Water Model Calibration

Data from three-week periods in winter (March 9-24, 2020) and summer (September 4-24, 2020) were obtained from Western that contained hourly tank level, pump flow, pump status and PRV flow data. These data were used to modify controls and PRV/pump settings in the model to calibrate model results for tank levels matched field data within 15%. Results for MDD (summer) model calibration are presented in Table 4-1.

Table 4-1: RW/NP MDD Model Calibration

RW/NP Reservoir	Average Tank Levels			Maximum Tank Levels			Minimum Tank Levels		
	Measured Tank Level (ft)	Modeled Tank Level (ft)	% Error	Measured Tank Level (ft)	Modeled Tank Level (ft)	% Error	Measured Tank Level (ft)	Modeled Tank Level (ft)	% Error
Steel Valley (El Nido)	24.9	25.3	1%	30.1	27.0	-10%	17.4	20.0	15%
Hillside Irrigation	23.6	23.1	-2%	24.2	25.0	3%	21.1	20.0	-5%
Lower El Sobrante	10.6	11.0	4%	12.1	12.5	4%	8.3	9.5	15%
Lurin Irrigation	8.1	7.8	-3%	9.4	10.0	7%	5.3	6.0	13%
Roosevelt	25.1	25.2	0%	33.1	31.0	-6%	18.1	18.0	-1%
Jim Jack	32.2	30.0	-7%	35.0	34.0	-3%	23.7	23.0	-3%

4.3 Wastewater Model

This section provides detail on the wastewater water model development and the results of model calibration. An existing wastewater model was not available for this FMP and a new hydraulic model was created utilizing Innowyze InfoSewer® software, which is an ArcGIS-based computer program that allows for direct importation of the existing sewer GIS data maintained by Western.

4.3.1 Wastewater Model Development

Using data from Western’s sewer GIS and CAD datasets as reference, a hydraulic model of the trunk sewer system (10-inch and larger sewer pipes) was developed. The GIS data included pipe and manhole data from Western, which was reviewed for completeness, and discrepancies were corrected. In addition to basic pipe and manhole attribute data, lift station wet well dimensions and elevations, pump curves and operating levels, and operating parameters that control the operation of the pump station facilities were obtained from record drawings and lift station information sheets provided by Western.

In some cases, complete design information was not available for wastewater system components and assumptions were made based on Western standards and industry standard practices. The following list summarizes assumptions

- MARB 1269
 - Assumed depth, minimum level, and maximum level of the wet well

Figure 4-3 and Figure 4-4 show the facilities modeled in Innowyze InfoSewer® software.

4.3.2 Sewer Drainage Basins

To evaluate system capacity and performance, the existing collection system was subdivided into smaller sewer drainage basins based on flow monitoring locations. The WWRf service area was divided into 8 sub basins and the WRCRWA service area into 4 sub basins for the purpose of modeling. Sewer drainage basins are then used in conjunction with extended period flow monitoring to provide actual field data for hydraulic model validation and calibration.

Figure 4-3: Sewer Model WWRP

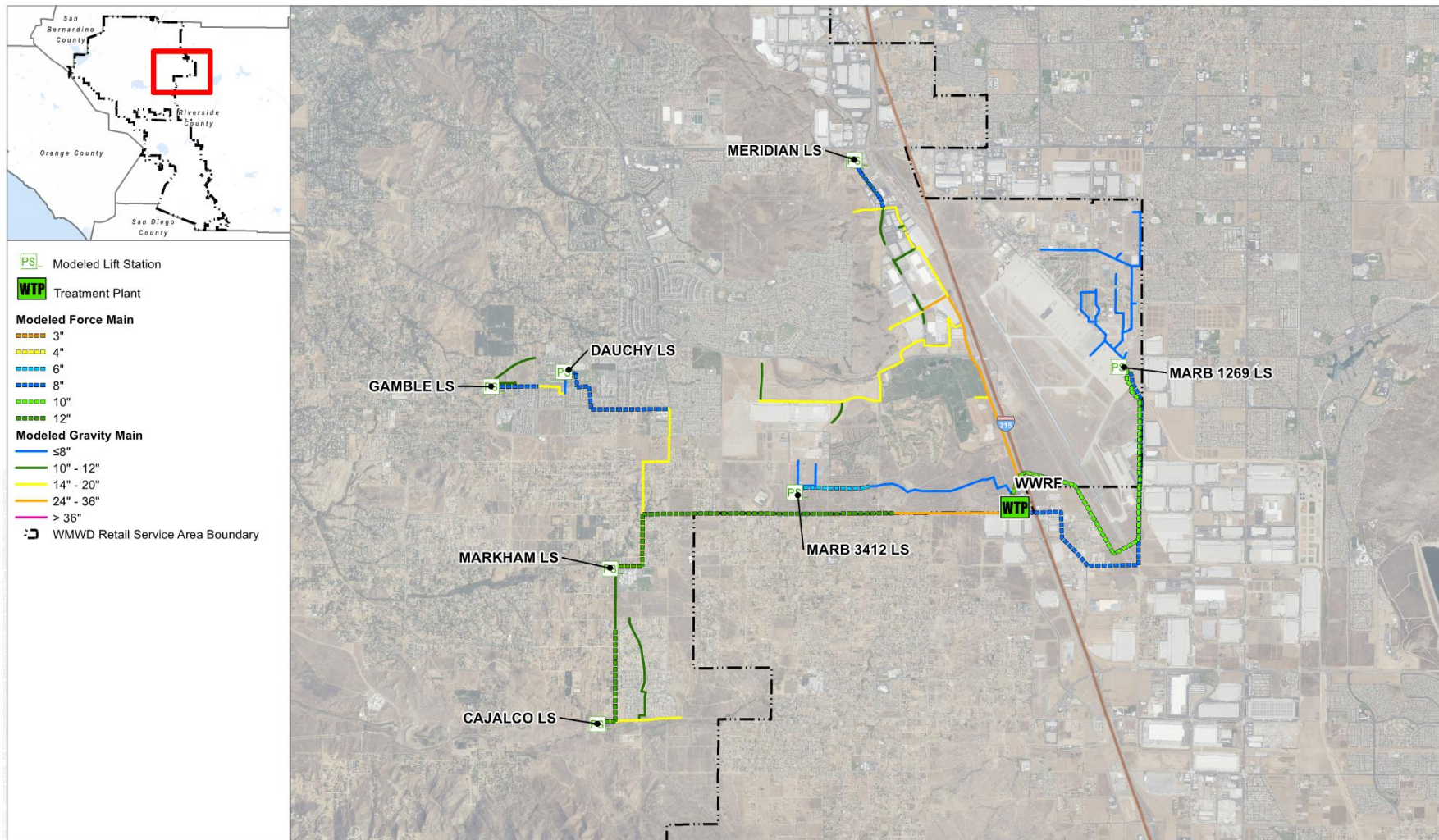


Figure 4-4: Sewer Model - WRCRWA



Figure 4-5: Sewer Sub Basins – WWRF Service Area

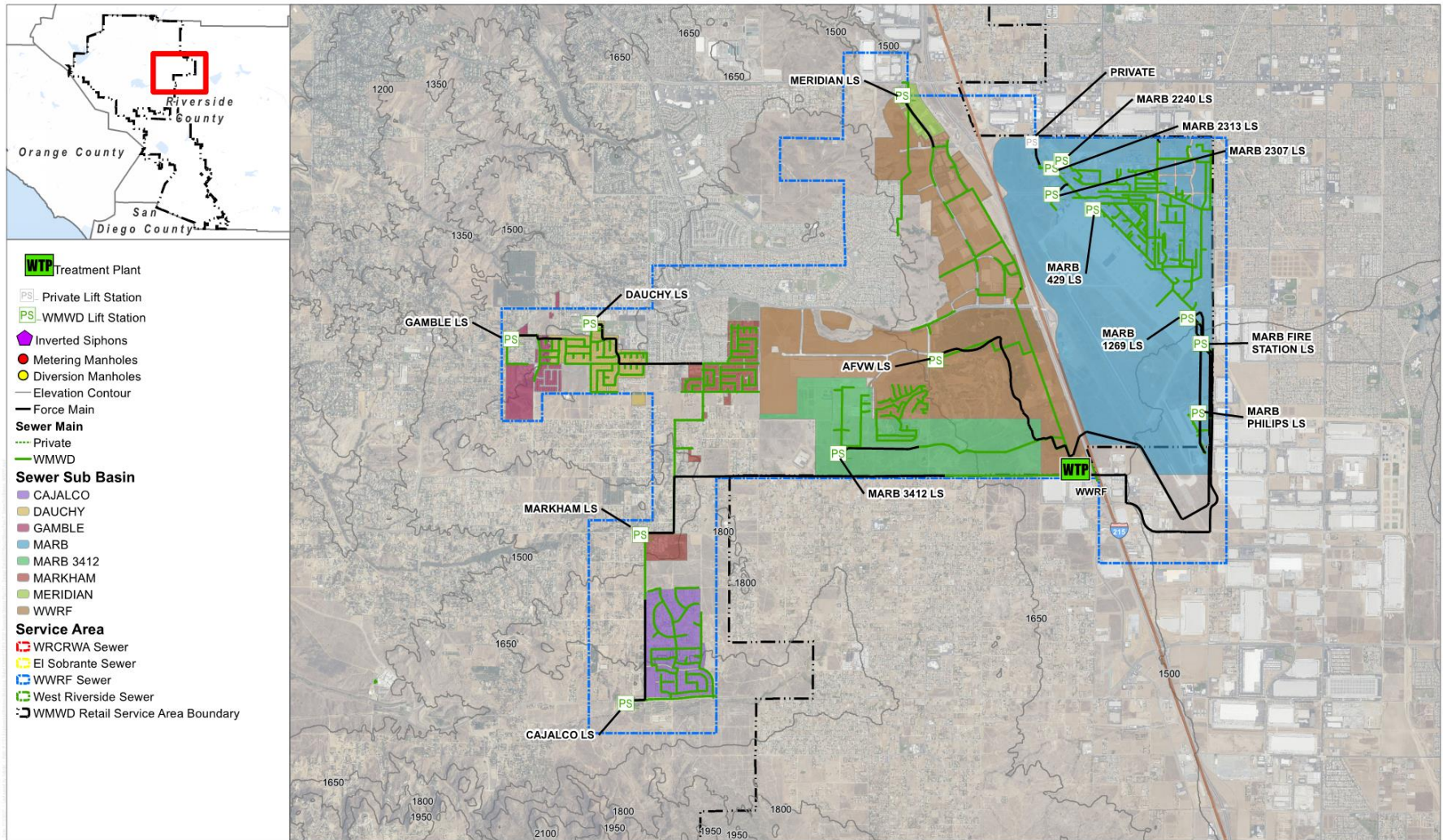
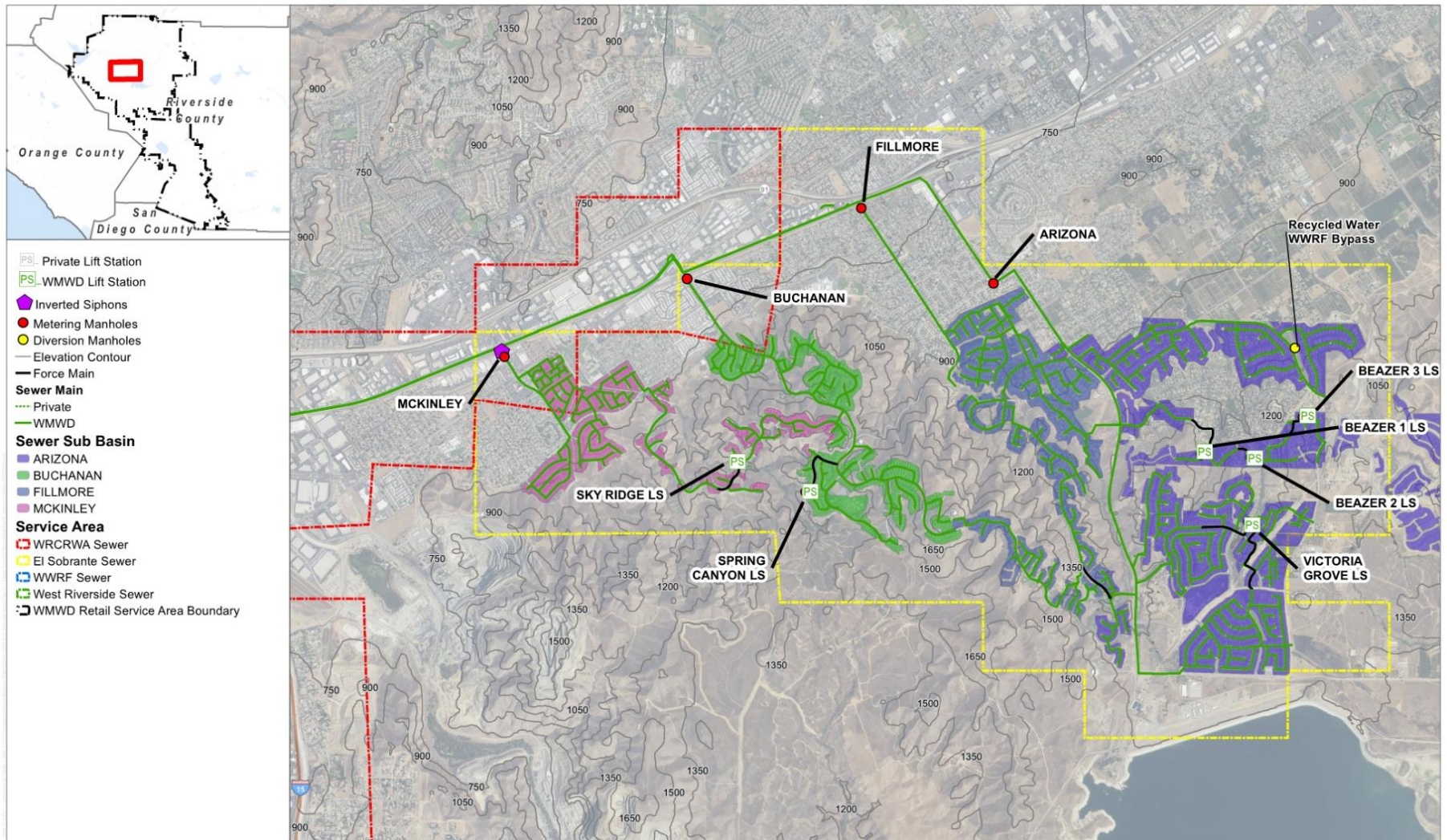


Figure 4-6: Sewer Sub Basins – WRCRWA Service Area



4.3.3 Large Point Sources

As discussed in Section 3.4.1, there are six large point source flows coming from diversion manholes into the wastewater collection system. Some of the point sources listed in the WRCRWA service area enter the system downstream of the South Regional Lift Station and therefore are not modeled. The following point sources were loaded into the model:

- Corona 1: no flow
- Corona 2: no flow
- Riverside: 0.35 MGD ADWF in all scenarios
- Norco Cota: 1.1 MGD ADWF in all scenarios
- Home Gardens: 0.56 MGD ADWF in all scenarios
- Recycle Water WWRf Bypass: 0.864 MGD steady flow rate during wet weather flows.

The location of each point load is shown in Figure 2-12 and Figure 2-13.

4.3.4 Existing and Future Model Flows

The historical average flows were compared with March 2020 hourly data to identify any flow discrepancies in the hourly data, which was used to create diurnal curves and load the model. This approach ensured that any errors in the high resolution flow data were identified and corrected prior to inputting wastewater loads and diurnal curves into the model. See Section 3.3.1 for a detailed description of existing flows analysis.

Baseline ADWF and PWWF flows for each sub basin were distributed based on the number of customer parcels nearest to each manhole upstream of the flow meter.

Near-Term and Ultimate flows were developed as described in Section 3.3.2. Future flows were loaded to model nodes based on available information; if plans were not available, the loads were added to the closest upstream manhole in proximity to the project.

4.3.5 Wastewater Model Calibration

Model calibration was achieved by comparing and adjusting both individual manhole loads and 24-hour diurnal flow curves until the flow patterns within the model replicated field flow monitoring results. The hydraulic model was considered calibrated when both hourly flows and 24-hour flows reflected field measurements based on the criteria in Table 4-2. The criteria used for calibration was set forth in the international “Chartered Institution of Water and Environmental Management Code of Practice for Hydraulic Modeling of Sewer Systems” (2017).

Table 4-2: Calibration Criteria

Criteria	Volume	Average Flow	Peak Flow
Description	Cumulative flow passing through a node during the monitoring or model run duration (7 days) in million gallons	Average flow during the monitoring or model run duration in gallons per minute	Peak flow during the monitoring or model run duration in gallons per minute
Dry weather flow	N/A	±10%	±10%
Wet weather flow	+20% to -10%	N/A	+25% to -15%

4.3.5.1 Average Dry Weather Flow Calibration

The average dry weather 24-hour flow from each flow meter was calculated and used to calibrate the sum of modeled sewer flows within each basin. Model flows within each basin were increased or decreased globally by a single factor to result in each model basin matching the measured average flow. As shown in Table 4-3, the calibrated model matches each basin flow to measured flow within the given calibration criteria, with the exception of peak flows at Buchanan, Dauchy, and WWRF. These variances were accepted in order to maintain peaking curves and loading factors in line with the measured data. In each case the values are higher than the measured, meaning a more conservative result is returned in terms of capacity analysis. Where other discrepancies exist, the difference is caused by the time delay of larger or longer basins as flow quantity dampens over time necessary to reach the discharge location (meter location).

Table 4-3: ADWF Calibration Results

Flow Meter	Average Dry Weather Flows					
	Measured Average Flow (gpm)	Modeled Average Flow (gpm)	% Error	Measured Peak Flow (gpm)	Modeled Peak Flow(gpm)	% Error
SRLS	2,198	2,277	4%	3,217	3,269	2%
Fillmore	120	123	3%	217	220	2%
Buchanan	120	137	15%	217	220	2%
Arizona	656	668	2%	950	994	5%
McKinley	184	176	-4%	333	327	-2%
Dauchy	120	123	2%	212	315	49%
LS 1269	101	108	7%	165	151	-9%
Cajalco*						
Gamble	37	37	1%	64	61	-4%
Markham*						
Meridian	221	254	15%	336	367	9%
WWRF	670	801	20%	1,397	2,407	72%
Home Gardens	368	378	3%	567	556	-2%
Norco Cota	759	793	4%	1,233	1,264	2%

* Accurate flow data not available for calibration

4.3.5.2 Peak Wet Weather Flow Calibration

Pipeline capacity is assessed based on the Peak Wet Weather Flow (PWWF), which is the peak hourly flow added to the peak I/I rate, which occurs after the design storm event. The wet weather flow analysis is performed by running a 24-hour flow simulation with dry weather flow hydrographs and adding additional flows to account for rainfall induced I/I. Based on resultant rain induced inflow and infiltration (I/I), some sub basins system exhibited a higher response to I/I than others. As shown in Table 4-4, the calibrated model matches each basin flow to measured flow within the given calibration criteria.

Table 4-4: PWWF Calibration Results

Flow Meter	Peak Wet Weather Flows						Measured Volume (MG)	Modeled Volume (MG)	% Error
	Measured Average Flow (gpm)	Modeled Average Flow (gpm)	% Error	Measured Peak Flow (gpm)	Modeled Peak Volume (gpm)	% Error			
SRLS	2,679	2,854	7%	6,750	6,326	-6%	4.02	4.11	2%
Fillmore	142	151	6%	267	292	9%	0.21	0.22	2%
Buchanan	129	137	6%	233	249	7%	0.19	0.20	2%
Arizona	237	269	13%	1,033	1,087	5%	0.36	0.39	9%
McKinley	166	178	7%	267	282	6%	0.25	0.26	3%
Dauchy	122	119	-3%	224	273	22%	0.18	0.17	-7%
LS 1269	388	400	3%	623	623	(0)	0.58	0.58	-1%
Cajalco*									
Gamble	42	43	2%	156	140	-11%	0.06	0.06	-2%
Markham*									
Meridian	460	576	25%	560	703	25%	0.66	0.83	25%
WWRF	1,481	1,699	15%	2,751	2,875	4%	2.16	2.45	13%
Home Gardens	507	551	9%	1,617	1,725	7%	0.76	0.79	4%
Norco Cota	1,283	1,360	6%	2,567	2,962	15%	1.93	1.96	2%

* Accurate flow data not available for calibration

INTENTIONALLY LEFT BLANK

5 System Evaluation Criteria

This chapter presents the planning criteria and methodologies used to evaluate the existing potable water, recycled/non-potable water, and wastewater systems, address system deficiencies and size future improvements.

5.1 Potable Water System Evaluation Criteria

The potable water design criteria used to evaluate the existing water system under different modeled scenarios was referenced from Section 8 of the 2014 Water Master Plan and Chapter 3 of the 2019 Water System Optimization Study Phase 2 (Appendix A).

5.1.1 System Pressures

Potable water system pressure criteria (Table 5-1) are from Table 3-1 of the 2019 Water System Optimization Study Phase 2 and were confirmed with Western staff during a project workshop.

Table 5-1: Potable Water Pressure Criteria

Criteria	Recommended value
Minimum service pressure	40 psi
Maximum service pressure	150 psi
Maximum daily pressure fluctuation	20 psi

5.1.2 Pipeline Criteria

Potable water system pipeline criteria (Table 5-2) are from Section 8 of the 2014 Water Master Plan and were confirmed with Western staff during a project workshop.

Table 5-2: Potable Water Pipeline Criteria

Criteria	Recommended value
Maximum velocity (in transmission pipeline under replenishment conditions)	6 fps
Maximum velocity (in any water pipeline during PHD or MDD plus emergency fire flow conditions)	7.5 fps
Maximum friction loss (in transmission pipeline under replenishment conditions)	3.5 feet/1,000 linear feet
Minimum transmission pipeline diameter size	12-inch

5.1.3 Fire Flow Criteria

The Riverside County Fire Department (RCFD) is concerned with the availability of adequate water supply for firefighting purposes and establishes minimum water flows and residual system pressures required during a firefighting event and provides these criteria to Western for use in master planning.

The RCFD uses the California Fire Code (CFC), which establishes minimum fire flows, and durations for individual structures. This FMP evaluates available fire flows to assess distribution system adequacy under Near-Term and Ultimate (Buildout) demand conditions, using general land use categories that represent different types of development. Therefore, the fire flow requirements set forth in this FMP are intended only for general planning purposes, and may not be reflective of the actual fire flow requirements sought for specific development approvals.

Table 5-3 presents the recommended fire flow requirements for new development for the FMP fire flow evaluation based on general land use designations, discussions with Western staff, and guidelines from RCFD. Fire flow requirements for MARB were unavailable.

Table 5-3: Fire Flow Criteria

Structure	Flow (gpm)	Duration (hours)
Single Family Residential	1,000	2
Multi-Family Residential	3,000	3
Commercial (including schools)	3,000	3
Industrial	4,000	4

Note: Fire Flows to be supplied at a minimum residual pressure of 20 psi

5.1.4 Storage Capacity

Potable water storage facilities are required to meet the peak hour demand (PHD), maximum day demand (MDD), fire flow and other emergency conditions. The following criteria are from Section 9 of the 2014 Water Master Plan and are used to determine storage volume:

Equalizing Storage

Any peak demands (i.e. peak hour) greater than MDD must be supplied from storage. Equalizing storage provides the storage to meet these short term peak demands. Twenty-five percent (25%) of the estimated MDD is used as the criteria needed to meet daily demand fluctuations within each pressure zone.

Fire Flow Storage

Fire flow requirements for each pressure zone must be met through storage. Fire flow requirements for each pressure zone are based on the land use in each pressure zone with the highest fire flow requirement per Table 5-3.

Emergency Storage

Emergency storage capacity is needed to sustain the water needs during periods of total or partial shutdown of the water supply facilities. 100% of the estimated MDD is used to calculate emergency storage by pressure zone

5.1.5 Pump Station Capacity

Potable water system pipeline criteria are from Section 12 of the 2014 Water Master Plan and were confirmed with Western staff during a project workshop. Pump stations must have the firm capacity to meet dependent MDD for each pressure zone. The dependent MDD is the demand from the zone as well as any demand that must be transmitted through the zone to get to reach the intended zone. Firm capacity is the pump station’s pumping capacity with the largest pump out of service.

5.2 Recycled/Non-Potable Water System Evaluation Criteria

The recycled/non-potable water design criteria used to evaluate the existing recycled water systems under different modeled scenarios are from Section 4.2 of the 2014 Recycled Water Master Plan or established for this study based on industry standards.

5.2.1 System Pressures

Previous Western master plans have not established system pressures design criteria for the recycled and non-potable water systems. Pressure criteria values recommended herein are based on existing landscape irrigation ordinance and industry standards for recycled/non-potable water systems, as well as discussions with Western staff.

Table 5-4: Recycled/Non-Potable Water Pressure Criteria

Criteria	Recommended value
Minimum service pressure	30 psi
Maximum service pressure	150 psi

5.2.2 Pipeline Criteria

Design and evaluation criteria for recycled/non-potable water pipelines are list in Table 5-5:

Table 5-5: Recycled/Non-Potable Water Pipeline Criteria

Criteria	Recommended value
Maximum velocity (in transmission pipeline under either replenishment conditions or peak hour demand)	6 fps
Maximum friction loss (in transmission pipeline under replenishment conditions)	3.5 feet/ 1,000 linear feet

5.2.3 Storage Capacity

Recycled/non-potable water storage is sized to provide operational storage. Fire flow and emergency storage is provided by the potable water system and is not currently anticipated in the recycled/non-potable water system. By providing operational storage, demands greater than maximum day demand (MDD) and up to peak hour demand (PHD) can be served from the recycled/non-potable storage facility; therefore, the operational storage requirement for recycled/non-potable water is recommended as one MDD.

5.2.4 Pump Station Capacity

Pump stations used in conjunction with storage facilities shall be sized to pump maximum day demand (MDD) for each service area. This is based on the assumption that peak hour demand (PHD) will be met by short-term storage.

5.3 Wastewater System Evaluation Criteria

Wastewater system evaluation criteria is based on criteria from the 2014 Sewer Master Plan and Western's Developer Handbook. The evaluation criteria provide the standards against which the existing system is

evaluated and are also the basis for planning of new facilities to improve existing service or to handle future wastewater flows.

5.3.1 Gravity Sewers

The most common evaluation criteria for gravity sewers are the ratio of depth of flow divided by diameter (d/D) and velocity, which are calculated in the hydraulic model based on Manning’s Equation. The capacity of each gravity sewer is based on the relative depth of flow within the respective pipeline reach. Gravity sewers are not typically designed to flow full, as unoccupied space at the top of the pipe is used for conveyance of sewage gasses and to provide contingent capacity for wet weather inflow and infiltration. Pipeline sizing is typically based on the pipeline flowing 75% full at the PWWF if the pipe is larger than 15-inches in diameter ($D/d = 0.75$). For a pipeline with a diameter of 15-inches, or smaller, a D/d factor of 0.50 is used.

Manning’s coefficient of friction factors for pipelines vary with the material and the age of the pipe. A roughness factor as indicated by a Manning’s coefficient (“ n ”) of 0.013 is commonly used to evaluate existing gravity sewers and for projection of future sizing needs. Previous studies have indicated that this value provides a conservative estimate of the average friction factor of pipelines over their useful life.

Existing and new gravity sewer pipelines shall be evaluated and designed to meet the following criteria.

- Manning’s “ n ” Coefficient
 - Manning’s roughness coefficient (n) of 0.013 shall be used.
- Flow-Depth Criteria (d/D)
 - Diameters less than 15 inches, maximum $d/D = 0.5$
 - Diameters 15 inches and greater, maximum $d/D = 0.75$
- Design Velocities
 - Maximum velocity during PWWF = 10 feet per second
 - Minimum velocity during ADWF = 2 feet per second
- Minimum and maximum slopes (See Table 5-6)

Table 5-6: Gravity Sewer Slope Criteria

Pipe Diameter (inch)	Minimum Slope ($V = 2$ fps)	Maximum Slope ($V = 10$ fps)
8	0.00340	0.086
10	0.00260	0.061
12	0.00200	0.049
15	0.00150	0.028
18	0.00113	0.022
21	0.00092	0.018
24	0.00076	0.015
27	0.00064	0.013
30	0.00056	0.011
33	0.00050	0.010

As previously stated, the design criteria for gravity sewers provides unoccupied space at the top of the pipe for conveyance of sewage gasses and to provide contingent capacity for wet weather inflow and infiltration. In this FMP, the PWWF analysis assumes peak I/I rates coincide with the PDWF, and the duration of the PWWF condition is brief. When gravity pipelines are evaluated to determine if there is adequate capacity under the PWWF condition, a separate pipeline evaluation criteria is often used to determine the permissible flow level before the pipeline should be upsized. This criteria is often referred to as “trigger” criteria. Based on criteria established by other agencies, gravity sewers are permitted to flow up to 90% full at the PWWF before improvement projects will be identified.

5.3.2 Lift Stations and Force Mains

Sewage lift station shall have 100% redundancy, electrical service, and emergency power. There shall be a minimum of two identical pumps per lift station, each sized for 100% station capacity and a maximum pump cycling of five (5) times per hour. The wet well of the sewage lift station shall have an emergency storage capacity of a minimum of 60 minutes at peak flow conditions.

Evaluation of existing lift stations will follow industry standard practice, requiring that sewage lift stations have sufficient capacity to pump the peak hourly flow with the largest pump out of service (firm capacity).

Force main size shall be based on the following:

- Minimum size shall be 4-inch diameter,
- Optimum velocity at design flow design point between 4 fps and 5 fps,
- Minimum velocity of 3 fps and maximum velocity of 7 fps under all operating conditions
- A maximum headloss of 5 ft/1000 ft, and
- Hazen-Williams roughness coefficient (C) of 110.

5.3.3 Siphons

The purpose of an inverted siphon is to convey flows in a gravity pipeline below an obstruction, such as a water channel or highway, via pressurized flow and regain as much elevation as possible before returning to open channel gravity flow.

Siphons shall achieve a self-cleaning velocity of 3 fps at least once per day under average dry weather flows. In order to achieve self-cleaning velocities, it may be necessary to use multiple diameter pipelines in parallel. Flow can be regulated between the multiple lines through use of control structures such as overflow weirs. Access structures sufficiently large for one person with tools and personal protective equipment performing maintenance shall be provided at each end of a siphon. The size shall be sufficient to allow workers to enter with materials, tools and equipment and perform their tasks. Horizontal angle points and curves in the siphon alignment are not recommended.

INTENTIONALLY LEFT BLANK

6 Potable Water System Analysis

6.1 Existing Potable Water System Analysis

The updated water model was utilized to analyze the existing water distribution system in conjunction with the design criteria, as described in Section 5.1. For all analyses performed, the system was modeled under steady state conditions using the Maximum Day Demand for the existing system (2020).

The pipelines were analyzed under two conditions: replenishment and fire flow. Replenishment analyzes the system's capacity to meet MDD while filling the reservoirs. This analysis was performed with reservoirs set to 50% and pumps on normal operating conditions. Fire flow analyzes the system's capacity to provide fire flow during MDD. This analysis was performed at Maximum Day Demand with the reservoirs set to 50% capacity and all pumps off. The following sections summarize the results of these analyses.

6.1.1 March Air Reserve Base

Western previously completed a 2014 MARB Water Master Plan that identified 20.7 miles of pipeline for replacement. Western has ongoing programs to address the pipeline replacement in MARB, so MARB pipelines were not evaluated as part of the pipeline analysis. The eastern area of MARB is currently under development. This area will be served by a separate interconnection from Eastern Municipal Water District and was analyzed separately. This separate analysis is ongoing and not included as part of this FMP.

The demands for MARB were updated in Section 3.2.2.1 of the report. The updated demands were included in the overall demand used for the system analysis throughout this chapter.

6.1.2 Pipeline Analysis

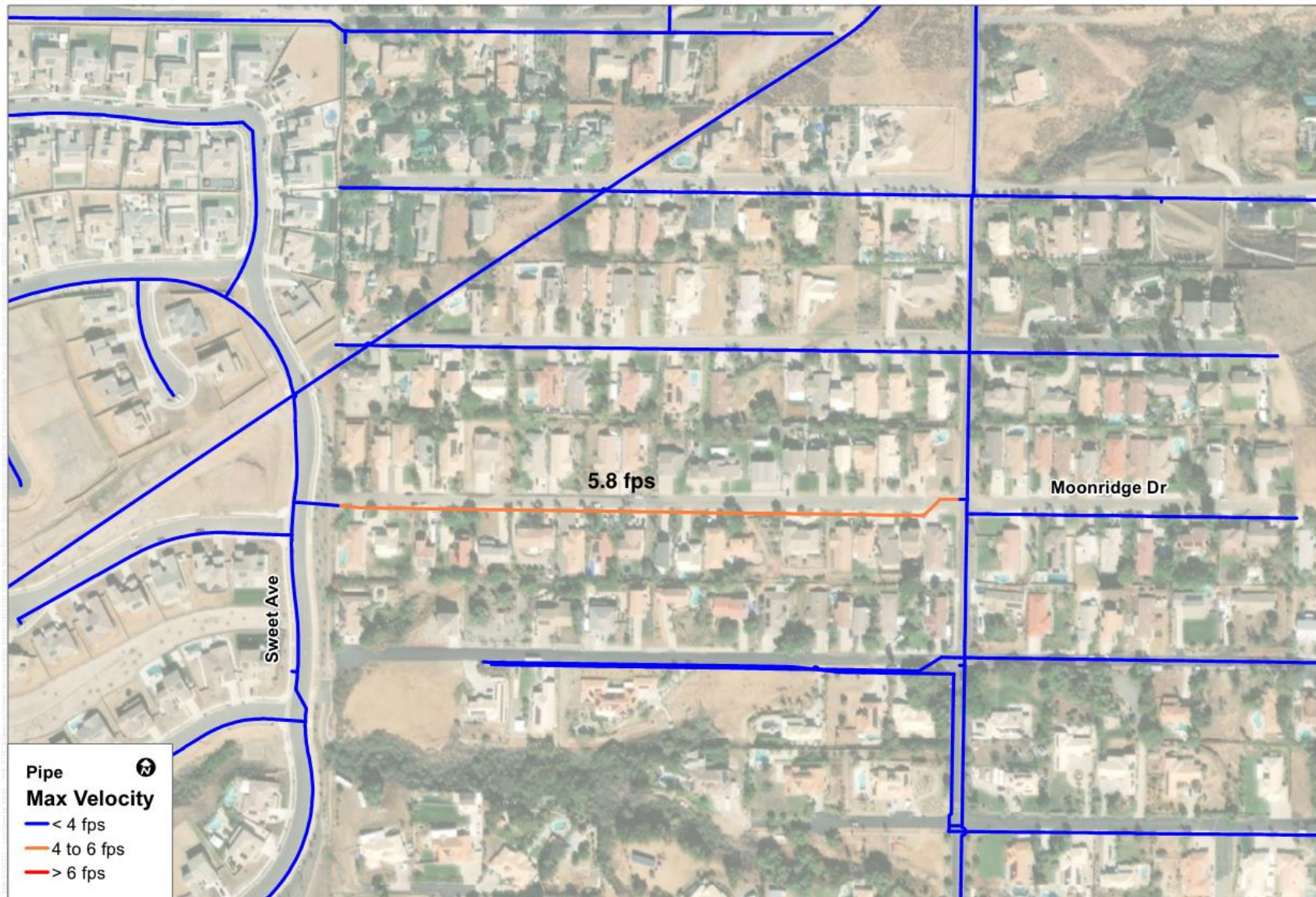
The potable water model was used to analyze the pipelines based upon the design criteria. Each of the pipeline criteria were analyzed individually in the following sections.

6.1.2.1 Velocity – Replenishment

The water distribution system was evaluated to identify if and which pipelines exhibited velocities greater than 6 ft/s under MDD and typical operating conditions. All but two pipelines were found to meet the maximum pipeline velocity of 6 ft/s (See Section 5.1). The two existing pipelines that did not meet the criteria include:

1. A 12-inch pipeline on Barton Street from Aptos St to Van Buren Blvd has a velocity of 6.37 ft/s. The exceedance is minimal, and no modifications are recommended.
2. On Moonridge Dr, west of Canyon Ridge Dr there is 1,200 LF of 6-inch pipe that connects to Sweet Ave via a 16-inch cross-country pipe. This is near the east end of PZ 1515. These east-west pipelines transmit water to the west end of the zone and this cross-country connection is one of the transmission routes west. The cross-country pipe and the pipeline running south of Sweet Ave, then west on Grape Drive are all 16-inch. Additionally, the pipeline in Canyon is 10-inch, but the pipeline in Moonridge is 6-inch, creating a bottleneck to transmit water west. This pipeline approaches, but does not exceed, the velocity requirement. However, this pipeline is a bottleneck and the increased capacity would make it easier to transmit water west. It is recommended to be upgrade the pipe to a 12-inch pipeline (CIP W-1). See Figure 6-1.

Figure 6-1: CIP W-1 High Velocity Potable Water Pipeline – Moonridge Dr



6.1.2.2 Velocity – Fire Flow

The Design Criteria states that no pipeline should exceed 7.5 fps in Maximum Day Demand with a fire flow demand. The minimum fire flow demand in the Design Criteria is 1,000 gpm. A 6-inch dead-end pipe cannot deliver 1,000 gpm in one directional flow without exceeding the design criteria. Of the hydrants that provide less than 1,000 gpm, there is 6.7 miles of 6-inch pipeline that serve the hydrants. Many of the pipelines are on dead-end 6-inch pipelines, which have limited benefit for the cost. A detailed pipeline analysis is currently being conducted in a separate report which is intended to review and prioritize pipeline improvement projects. Because of this ongoing analysis, a detailed review of all Western's 6-inch pipeline was not conducted for this report. With such a large amount of pipeline, it is not feasible or practical to replace it all. Further analysis to identify high priority projects to increase fire flow availability is conducted in Section 6.1.2.3.

6.1.2.3 Fire Flow Analysis

The system was modeled to determine its capacity to deliver fire flow to each hydrant in the system. Figure 6-2 shows the fire flow available for all hydrants in the system.

The results were reviewed to identify pipeline improvements that could improve fire flow capacity to hydrants that could not provide 1,000 gpm of fire flow. Two areas were identified where pipeline improvement projects could improve fire flow to multiple hydrants that provide less than 1,000 gpm of fire flow.

Figure 6-2: Available Fire Flow to Hydrants – Existing (2020) Scenario

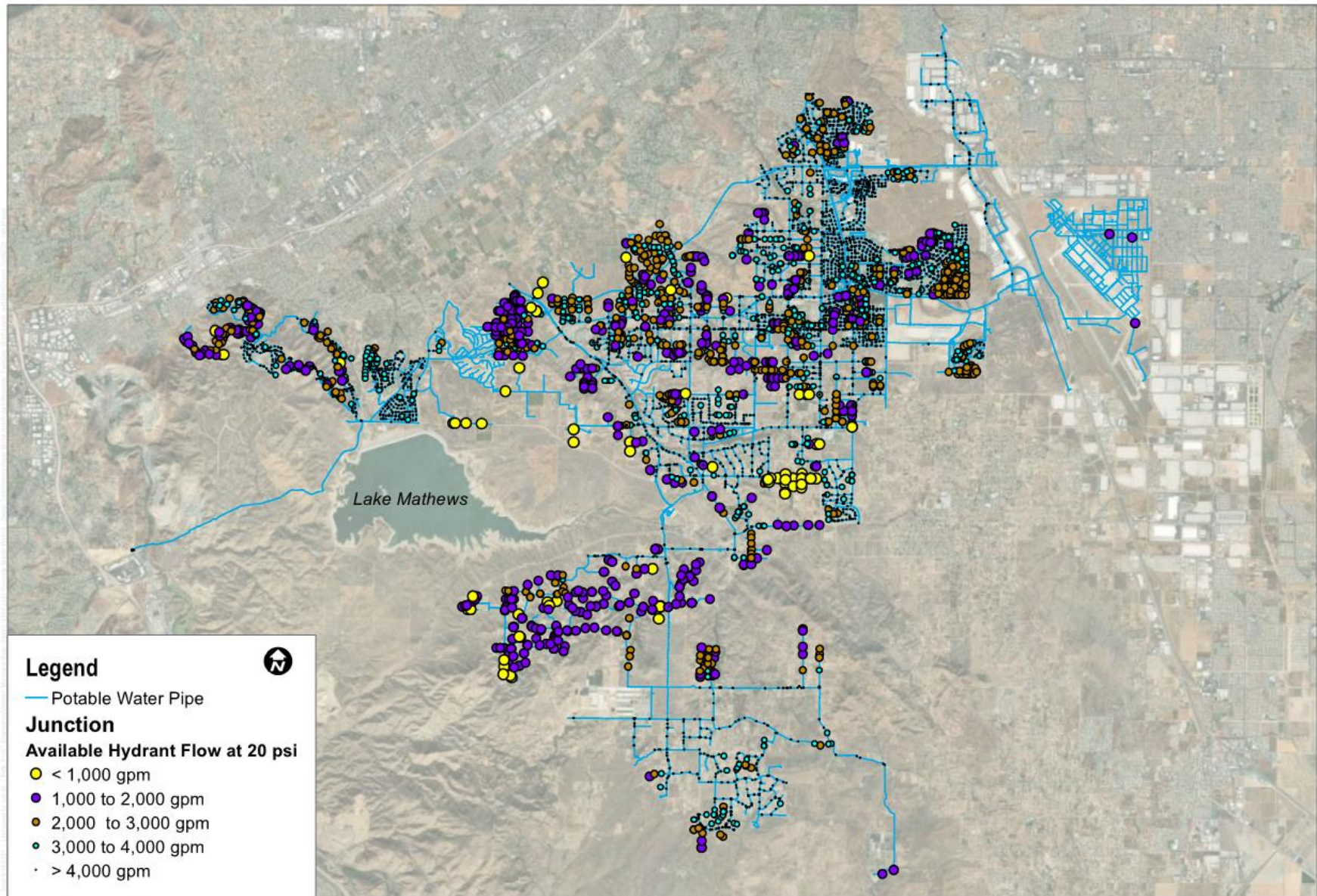
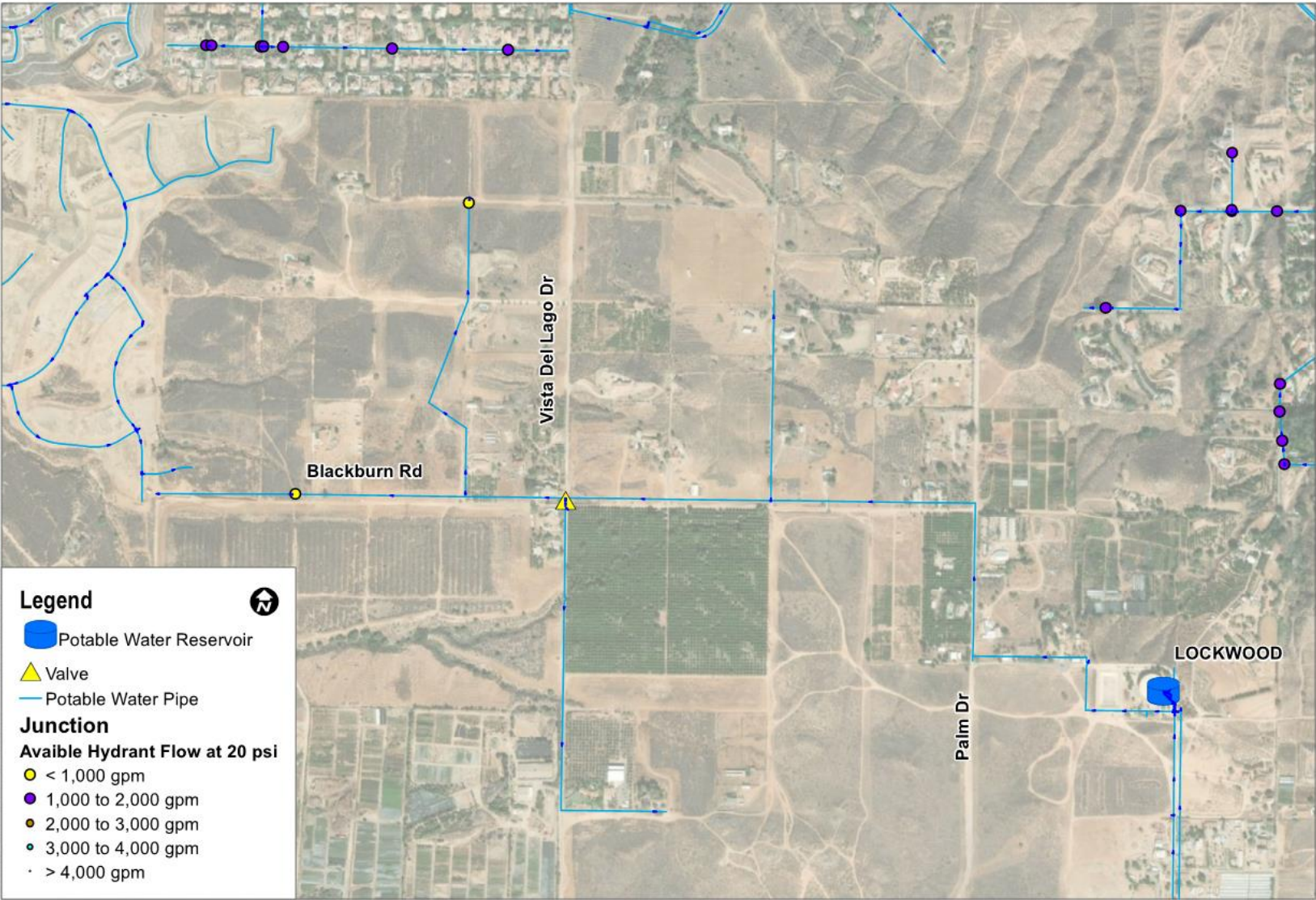


Figure 6-3: Blackburn Road Existing Pipelines and Hydrants



There is a 6-inch pipeline that connects Lockwood Reservoir to agricultural customers west of the reservoir on Blackburn Road and adjoining streets. Both of the hydrants in this area provide less than 1,000 gpm of fire flow. The pipeline is 6-inch diameter and has had multiple breaks. Replacing this pipeline with an 8-inch pipeline would address velocity issues in the pipeline, increase the available fire flow, and improve reliability to this area. The sections recommended for replacement are shown in Figure 6-4 (CIP W-2).

Figure 6-4: CIP W-2 Potential Pipeline Improvements - Blackburn Road



Within the PZ1900 pressure zone, hydrants along Avenue D and adjacent streets cannot supply 1,000 gpm of fire flow as shown in the following Figure 6-5. The restriction of fire flow is due to existing pipe diameter. By increasing the existing pipe diameter of 6-inches to 8-inch, fire flow of 1,000 gpm or greater at 20 psi residual pressure was achieved. Figure 6-6 shows the locations of 6-inch diameter pipelines to increase to 8-inches in diameter.

Figure 6-5: Existing Pipelines and Hydrants – Avenue D and Cedar Street

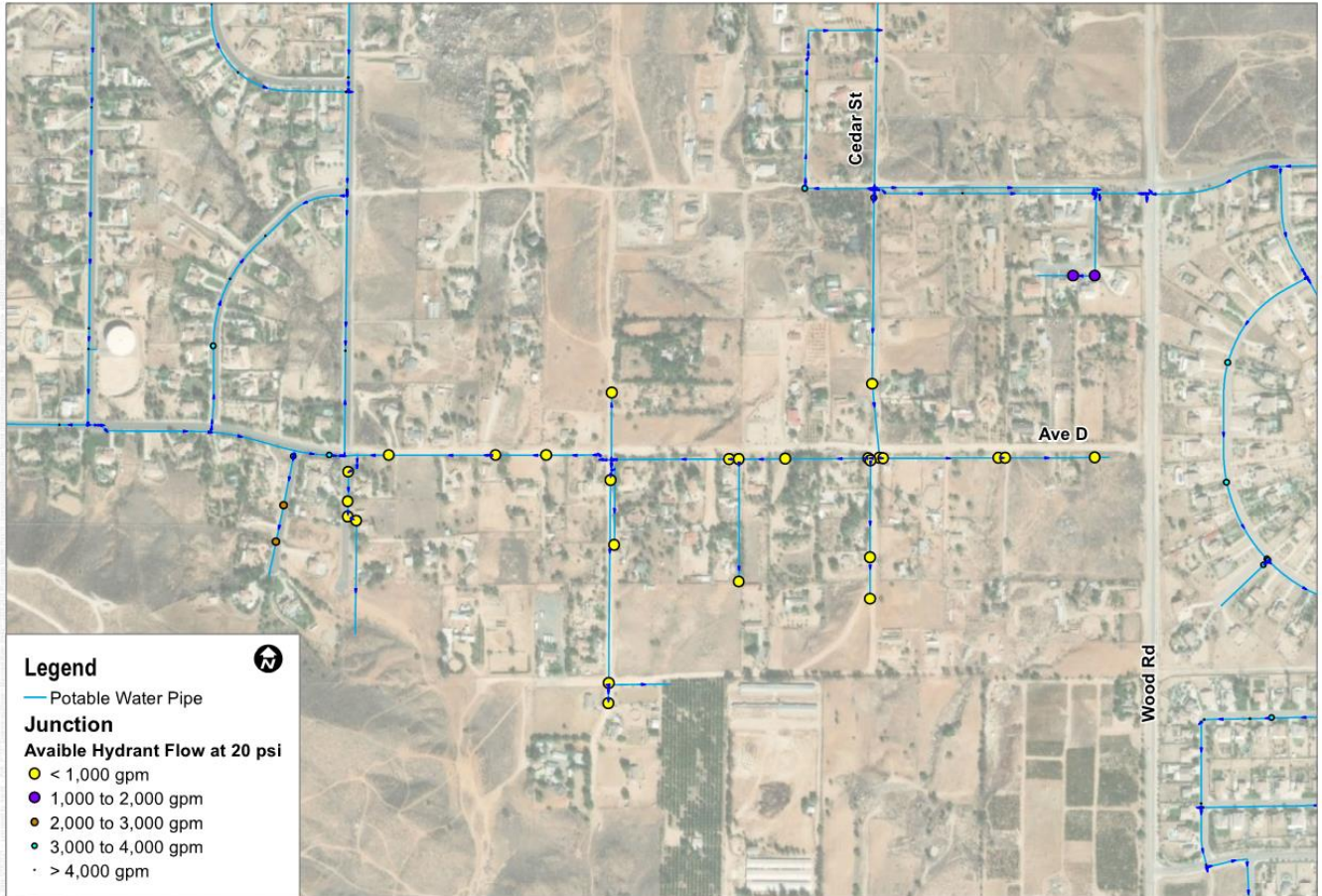
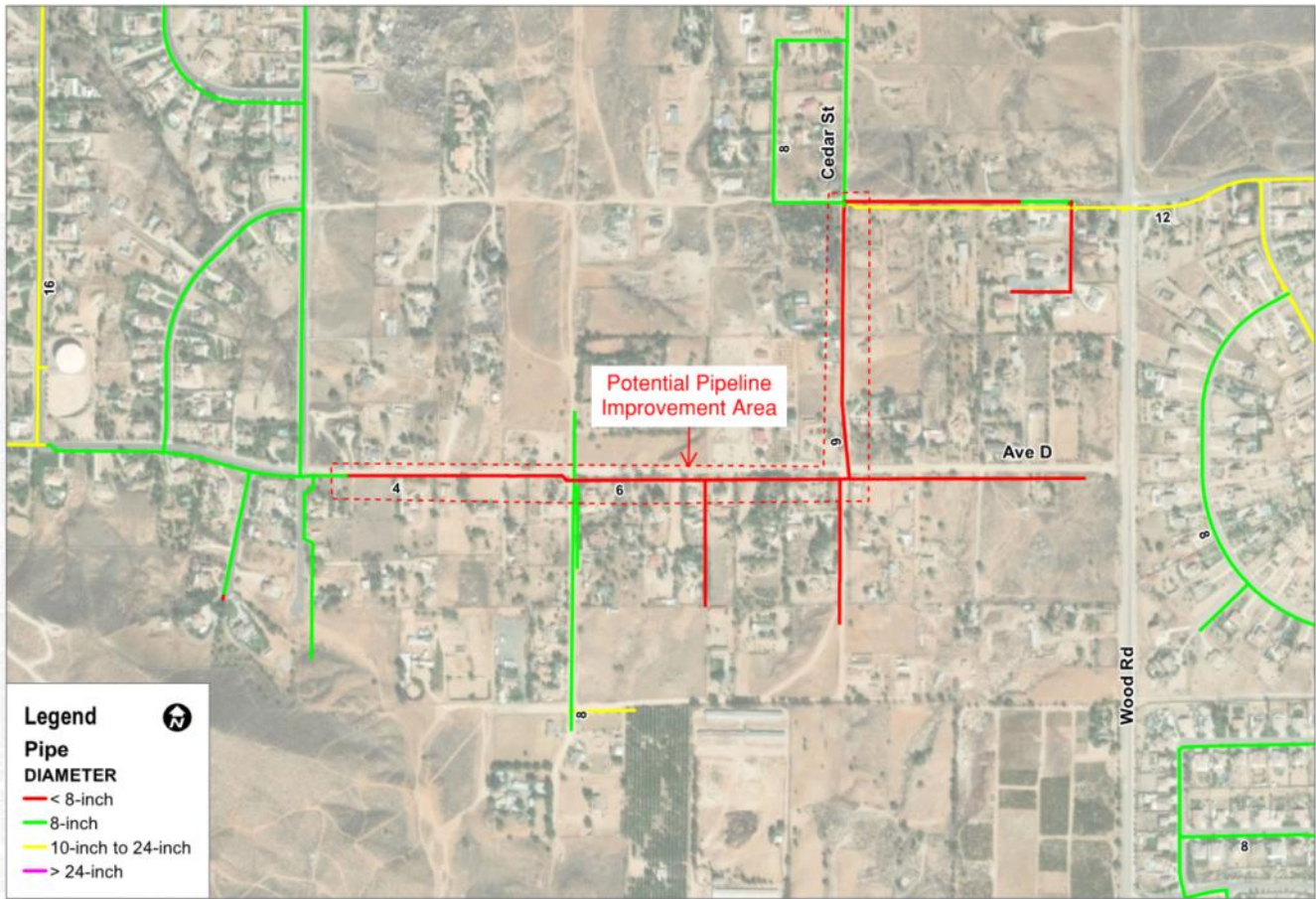


Figure 6-6: CIP W-3 Potential Pipeline Improvements Cedar St and Avenue D



6.1.2.4 Break History Analysis

In addition to the design criteria, pipeline replacement analysis can also include a review of the age and break history of the system. As addressed in Section 0, there are very few pipelines that have exceeded their life expectancy. Break history from 2018-2020 was also requested and reviewed. Other than the Blackburn Road project identified in 6.1.2.3, no other pipelines that were identified in this analysis had multiple breaks within the last 3 years.

6.1.3 Storage Analysis

To analyze the storage requirements of the system, the Max Day Demand for the system was broken down per pressure zone. The demands in the pressure zones that are supplied by PRVs and do not have direct storage in their zone were allocated to the higher-pressure zone that feeds the PRV. For example, the demand in PZ 1150 and PZ 1225 was allocated to PZ 1350 because it is the zone that feeds them. Once all the demand was allocated to zones with storage, the storage capacity was reviewed to determine if it was sufficient to meet the demand.

Table 6-1: Storage Analysis Results – Existing (2020) Scenario

Pressure Zone	Existing Storage (MG)	MDD (MGD)	Equalization 25% MDD (MG)	Emergency 100% MDD (MG)	Fire Storage			Total Required (MG)	Surplus (MG)
					Fire Flow (gpm)	Duration (hour)	Total (MGD)		
1350	1.5	0.46	0.12	0.46	1,000	2	0.120	0.70	0.80

Table 6-1: Storage Analysis Results – Existing (2020) Scenario

Pressure Zone	Existing Storage	MDD	Equalization 25% MDD	Emergency 100% MDD	Fire Storage			Total Required	Surplus
					Fire Flow	Duration	Total		
	(MG)	(MGD)	(MG)	(MG)	(gpm)	(hour)	(MGD)	(MG)	(MG)
1515	10.0	1.92	0.48	1.92	1,000	2	0.120	2.52	7.48
1650	9.0	3.43	0.86	3.43	3000	3	0.540	4.83	4.17
1783	1.0	0.96	0.24	0.96	4000	4	0.960	2.16	-1.13
1837	22.0	12.26	3.07	12.26	4000	4	0.960	16.29	5.71
1886	1.3	0.32	0.08	0.32	3000	3	0.540	0.94	0.31
1900	13.6	6.75	1.69	6.75	3000	3	0.540	8.97	4.63
2320	2.7	1.16	0.29	1.16	1000	2	0.120	1.57	1.13
2450	1.5	0.58	0.15	0.58	1000	2	0.120	0.85	0.65
Total	62.59							38.83	23.75

Table 6-1 indicates that Western has robust storage throughout the system with an overall surplus of 23.75 MG. The system has surplus storage to meet the demands in every zone except PZ 1783. Previous Water Master Plans performed by Western showed additional storage was necessary. However, conservation efforts over the last 5-10 years have significantly reduced Western’s demands. These reduced demands have resulted in reduced storage demands for the system.

PZ 1783 is the highest zone in Western’s Southern system and has a small storage deficit. Additional storage could be constructed in the zone, but it is not a priority project because of the excess storage in PZ1837. Stored water in PZ1837 can be delivered to PZ1783 via existing PRVs, minimizing the need for additional storage in the zone.

6.1.3.1 Water Quality Concerns

In Section 2.2.8, it was identified that the biggest operational issue is maintaining chlorine residual throughout the system, particularly in winter. Western’s excess storage identified in the storage analysis corroborate these operational concerns. Reducing the volume of water in storage during winter months would reduce the retention time of the water in the reservoirs and improve water quality. Table 6-2 shows the minimum storage level that provides emergency and fire storage, separated by pressure zone.

Since the winter demand is significantly lower than the summer demand, the table is separated by winter and summer. The demand in winter months was lowered to ADD, instead of the MDD (1.5*ADD) that was used for summer months. As shown by the monthly peaking in Figure 3-1, a 1.0 peaking factor is still conservative for the typical winter demand. Since the demand in winter is lower, the minimum level of storage is decreased.

Table 6-2: Required Storage

Pressure Zone	Existing Storage	Summer				Winter		
		Fire Storage	Emergency	Total	Minimum Storage	Emergency	Total	Minimum Storage
		(MG)	(MG)	(MG)		(MG)	(MG)	
1350	1.5	0.46	0.120	0.58	39%	0.31	0.43	29%
1515	10.0	1.92	0.120	2.04	20%	1.28	1.82	18%
1650	9.0	3.43	0.540	3.97	44%	2.29	2.83	31%
1783	1.0	0.96	0.960	1.92	186%	0.64	1.60	155%
1837	22.0	12.26	0.960	13.22	60%	8.18	9.14	42%
1885	1.3	0.32	0.540	0.86	69%	0.21	0.75	60%
1900	13.6	6.75	0.540	7.29	54%	4.50	5.04	37%
2320	2.7	1.16	0.120	1.28	47%	0.77	0.89	33%
2450	1.5	0.58	0.120	0.70	47%	0.39	0.51	34%

Typically, reservoirs levels are kept at a minimum of 50-70% of their capacity to maintain emergency storage. However, due to the abundance of capacity, Western could operate the reservoirs at lower than 50% capacity to improve water age in the tank. For example, La Sierra (1515) could be allowed to drain down to 20%. Several of the reservoirs could be allowed to operate in the 30-50% range during the winter months, if Western is identifying water quality issues. Table 6-2 can assist Western in setting operational plans for their reservoirs during low demand periods to prevent water stagnation in the tanks.

6.1.4 Pump Station Analysis

To analyze the pumping requirements of the system, the Max Day Demand for the system was broken down per pressure zone. The Dependent Demand was calculated for each zone. Dependent Demand is the demand for the zone that the BPS serves plus all downstream zones that are supplied by the zone. For example, the demand for PZ 1945 and PZ 1867 is served from PZ 1885. Since both zones are served by PZ 1885, the capacity of the PS in that zone must be able to meet the demand for all three zones. Using the dependent demand, the pumping capacity was reviewed to determine if it was sufficient to meet the demand for each zone.

Table 6-3: Pump Station Analysis Results – Existing (2020) Scenario

Pressure Zone	Dependent MDD	Total Capacity	Firm Capacity	Surplus
	(gpm)	(gpm)	(gpm)	
1515	1,655	9,500	7,917	6,262
1650	3,598	13,776	7,488	3,890
1783	1,875	9,600	6,400	4,525
1837	8,516	54,456	48,856	40,340
1885	665	1700	1150	485
1900	4,686	18,900	12,000	7,314
2320	1,165	2,250	1,300	135

Table 6-3: Pump Station Analysis Results – Existing (2020) Scenario

Pressure Zone	Dependent MDD	Total Capacity	Firm Capacity	Surplus
	(gpm)	(gpm)	(gpm)	
2450	406	1765	1165	759
Total				63,709

Western has a surplus pumping capacity of 63,000 gpm and has surplus in every zone. A large amount of the surplus is in PZ 1837, which is the Mockingbird and Holcomb Stations. The stations receive supply from MWD’s Mills line and have the capacity to meet the demand of the entire system. There are several supply pump stations in Western that receive supply from the Mills line and supply the system, but Mockingbird is the system’s primary supply point and is sized for that purpose.

As discussed in the Storage Analysis section, Western’s reductions in water demand have resulted in the reduction of pumping requirements when compared to previous Water Master Plans conducted by Western.

6.2 Near-Term Potable Water System Analysis

In order to analyze the system’s ability to meet the Near-Term improvements, the potable water system was analyzed under steady state conditions using the Near-Term demands identified in Section 3.2. The pipelines were analyzed under replenishment and fire flow scenarios, as detailed in Section 6.1.

6.2.1 Pipeline Analysis

6.2.1.1 Velocity – Replenishment

No deficiencies were found for the near-term water system analysis.

6.2.1.2 Velocity – Fire Flow

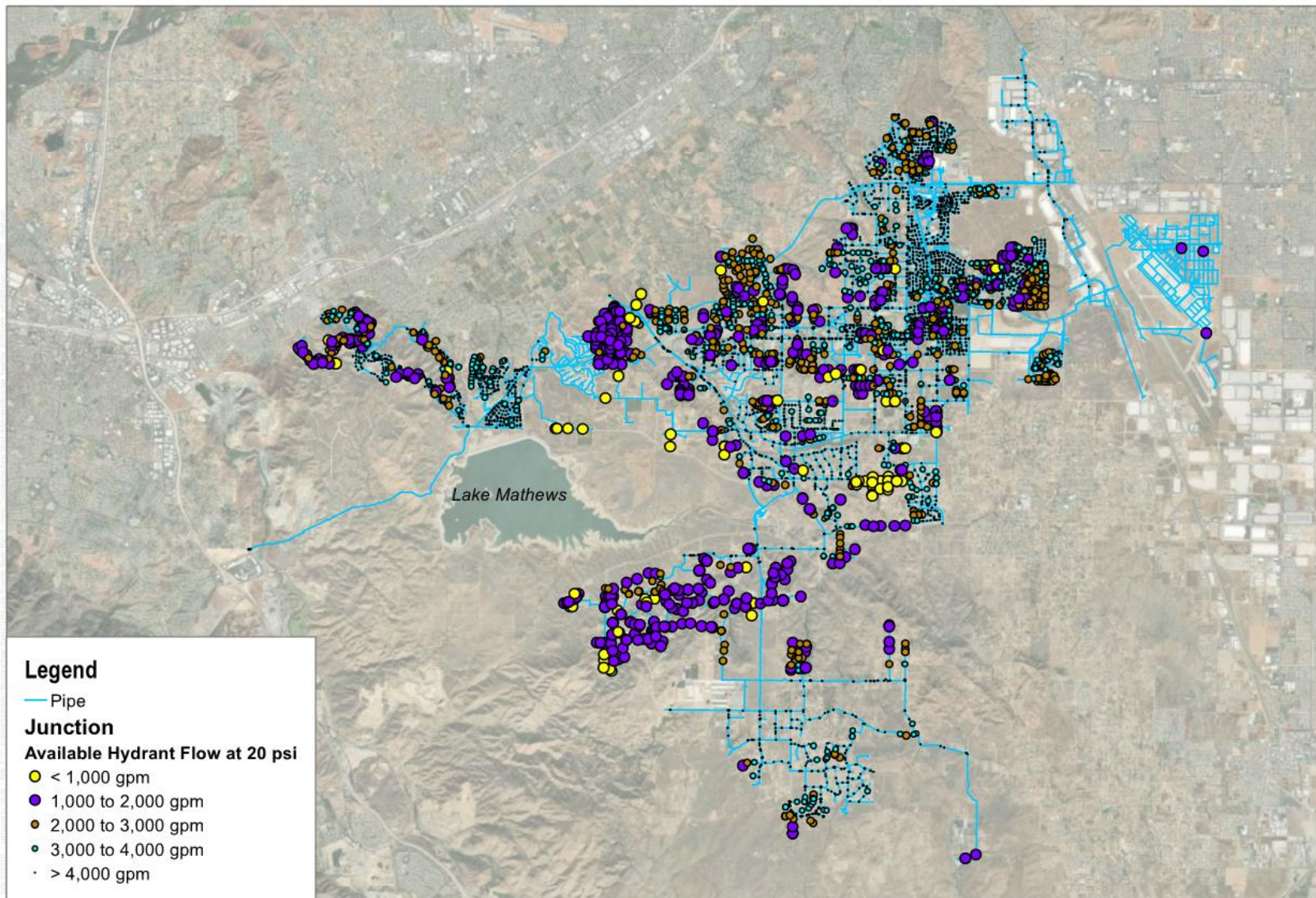
There were no additional pipeline projects that exceeded the design criteria in the Near-Term analysis.

6.2.1.3 Fire Flow Analysis

The model was used to determine the capacity to deliver fire flow for all fire hydrants in the system under Near-Term conditions. The available fire flow for all hydrants are shown in Figure 6-7.

No additional pipeline projects were identified in the Near-Term scenario. The Near-Term demands did not identify new sections of the system that have multiple hydrants that are unable to provide 1,000 gpm of flow.

Figure 6-7: Available Fire Flow to Hydrants – Near-Term (2030) Scenario



6.2.2 Storage Analysis

To analyze the storage requirements of the system under Near-Term, the Max Day Demand for all of the developments were added per pressure zone to obtain the updated storage requirements for each pressure zone.

Table 6-4: Storage Analysis Results – Near-Term (2030) Scenario

Pressure Zone	Existing Storage (MG)	MDD (MGD)	Equalization 25% MDD (MG)	Emergency 100% MDD (MG)	Fire Storage			Total Required (MG)	Surplus (MG)
					Fire Flow	Duration	Total		
					(gpm)	(hour)	(MGD)		
1350	1.5	0.46	0.12	0.46	1,000	2	0.12	0.70	0.80
1515	10.0	2.76	0.69	2.76	3,000	3	0.54	3.99	6.01
1650	9.0	3.50	0.87	3.50	3,000	3	0.54	4.91	4.09
1783	1.0	0.96	0.24	0.96	4,000	4	0.96	2.16	-1.13
1837	22.0	12.75	3.19	12.75	4,000	4	0.96	16.89	5.11
1885	1.3	0.32	0.08	0.32	3,000	3	0.54	0.94	0.31
1900	13.6	8.75	2.19	8.75	3,000	3	0.54	11.48	2.12
2320	2.7	1.47	0.37	1.47	1,000	2	0.12	1.96	0.74
2450	1.5	0.66	0.17	0.66	1,000	2	0.12	0.95	0.55
TOTAL	62.59							43.99	18.60

At Near-Term, Western still has robust storage with an overall surplus of 18.6 MG. The system has surplus storage to meet the demands in every zone except PZ 1783. The deficit in PZ 1783 is unchanged from the Existing System analysis.

6.2.3 Pump Station Analysis

To analyze the pumping requirements of the system under Near-Term, the Max Day Demand for all of the developments were added per pressure zone to obtain the updated pumping capacity requirements.

Table 6-5: Pump Station Analysis Results – Near-Term (2030) Scenario

Pressure Zone	Dependent MDD	Total Capacity	Firm Capacity	Surplus
	(gpm)	(gpm)	(gpm)	
1515	2,239	9,500	7,917	5,678
1650	4,226	13,776	7,488	3,262
1783	2,150	9,600	6,400	4,250
1837	8,853	54,456	48,856	40,003
1885	665	1,700	1,150	485
1900	6,080	18,900	12,000	5,920
2320	1,440	2,250	1,300	-140

Table 6-5: Pump Station Analysis Results – Near-Term (2030) Scenario

Pressure Zone	Dependent MDD	Total Capacity	Firm Capacity	Surplus
	(gpm)	(gpm)	(gpm)	
2450	462	1765	1165	703
Total				60,163

Western has a surplus pumping capacity of 60,000 gpm and has surplus in every zone except 2320. It is not anticipated that Western will need to expand system capacity due to demand increases.

6.3 Ultimate Potable Water System Analysis

In order to analyze the system's ability to meet Ultimate (Buildout) demand, the water system was analyzed under steady state conditions using the Ultimate demands identified in Section 3.2. The pipelines were analyzed under replenishment and fire flow scenarios, as detailed in Section 6.1.

6.3.1 Pipeline Analysis

6.3.1.1 Velocity – Replenishment

The design criteria states that no pipeline should exceed 6 fps when the booster pumps are on under MDD. The Ultimate demands include a significant increase in demand in PZ1900. This increase in demand resulted in one area that was identified that had velocities in excess of 6 fps:

1. 12-inch pipeline in Wood Drive from Markham Street to Lurin Ave, the 8-inch pipe in Mariposa from Wood Drive to Cole Avenue, and the 6-inch pipeline in Lurin Avenue from Wood Drive to Cole Avenue (See Figure 6-8).

In order to address this velocity issue, it is recommended to upsize the pipeline in Wood Drive from 12-inch to 16-inch (CIP W-5) and upgrade the pipelines in Mariposa Avenue and Lurin Avenue to 12-inch (CIP W-4) as shown in Figure 6-9. The pipeline upgrades in Lurin Ave and Mariposa Ave will likely be triggered by developments in the immediate area. However, the pipeline upgrade in Wood Drive is a regional project that will need to be addressed as demands in the area increase with new developments and additional water needs to be transmitted from the Markham tank to the area.

Figure 6-8: High Velocity Potable Water Pipelines – Wood Dr

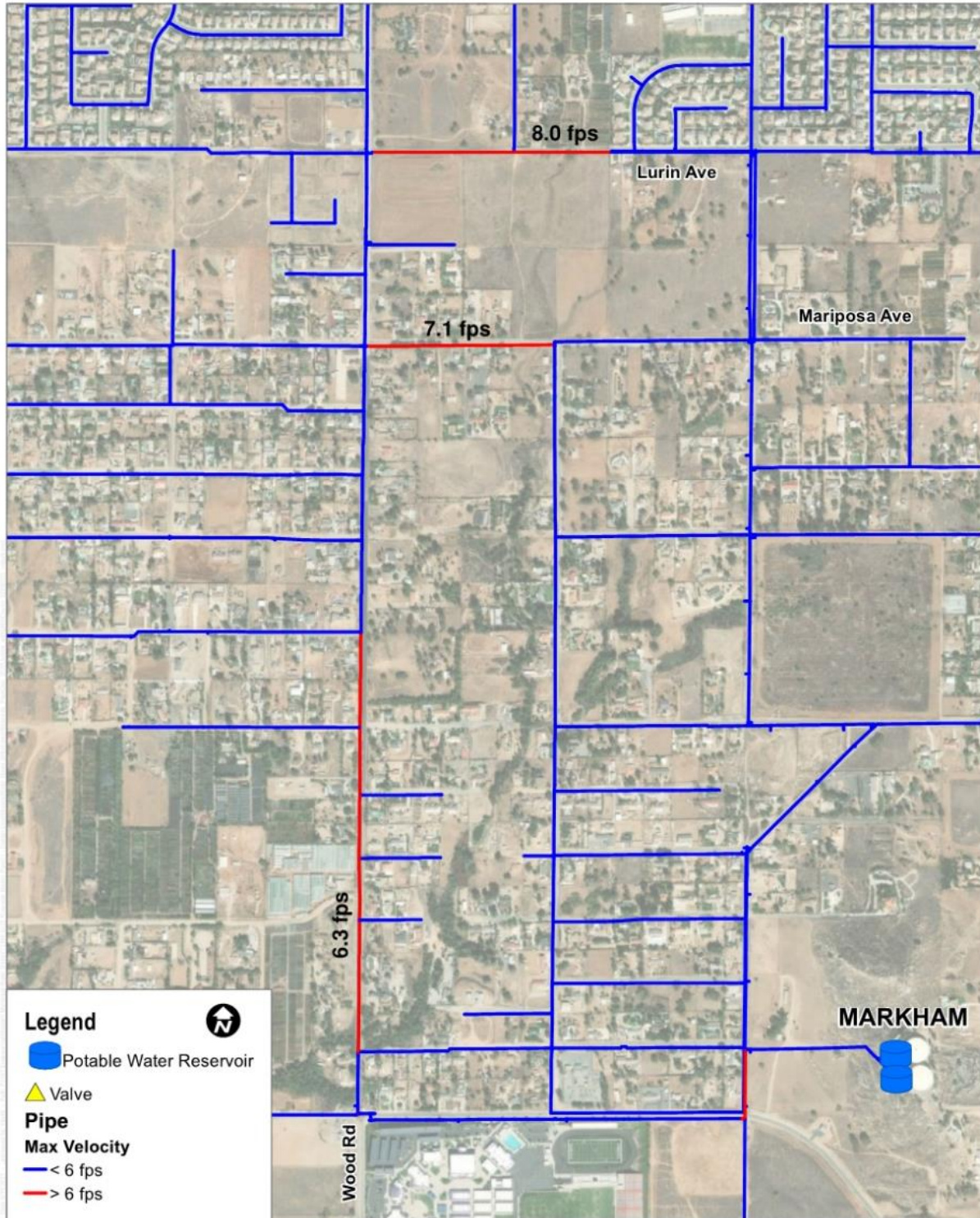
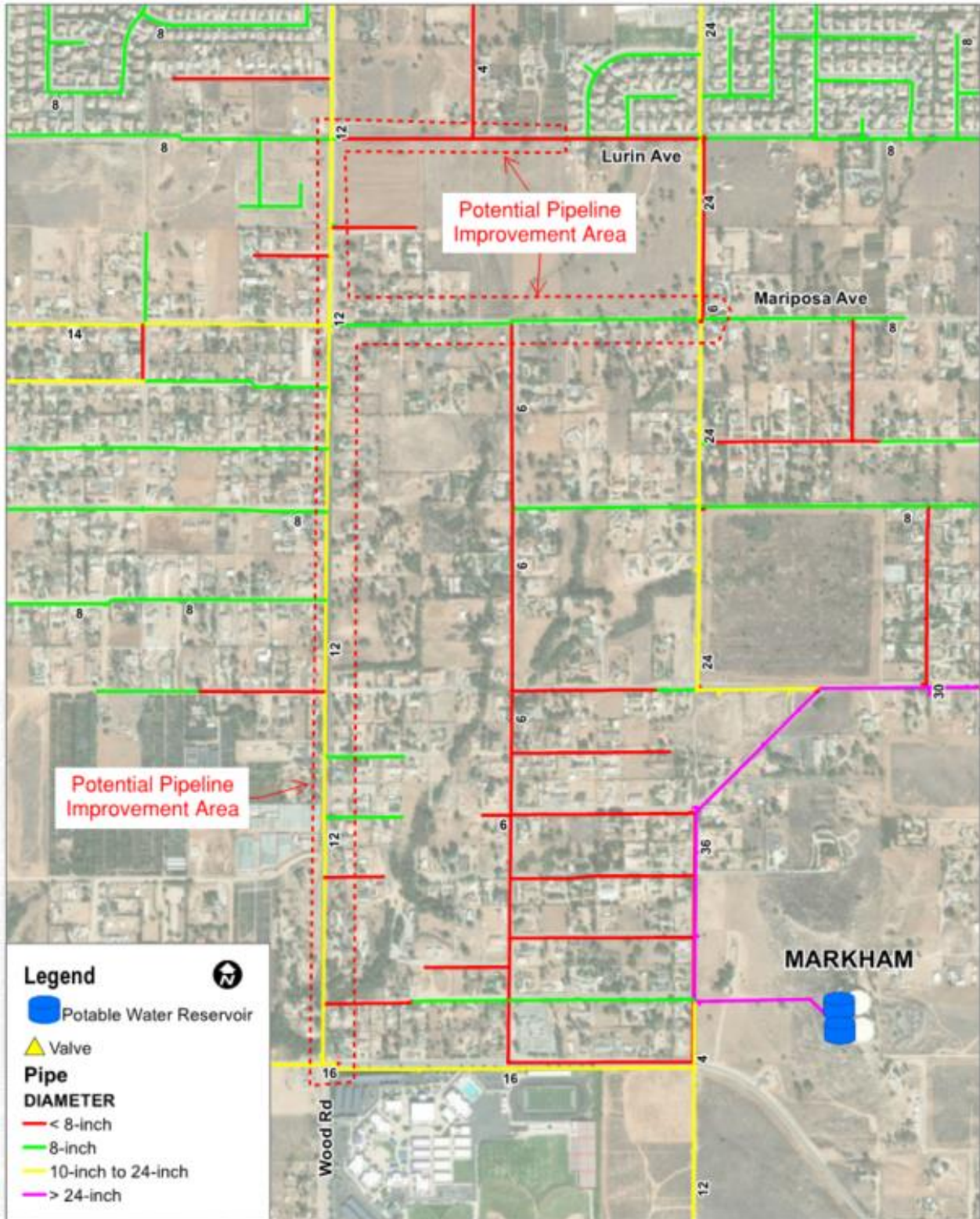


Figure 6-9: CIP W-4/ CIP W-5 – Wood Rd, Mariposa Ave, and Lurin Ave



6.3.1.2 Fire Flow Analysis

The model was used to conduct a fire flow analysis for all fire hydrants in the system under Ultimate conditions. The analysis was performed at Maximum Day Demand with the reservoirs set to 50% capacity and all pumps off. This scenario is expected to be the worst case that would be experienced in the system under normal operating

conditions. The Maximum Day Demand is the highest demand of the year, the reservoirs are not cycled below 50% capacity, and there are no pumps on to improve system pressure. The available flow for all hydrants is shown in Figure 6-10.

Of the hydrants that provide less than 1,000 gpm, there were two areas that had an increase in deficient hydrants.

- The first area is just south of the Hillside reservoirs on Jensen Road and Multiview Drive. This area has low static pressure due to its proximity to the Hillside reservoirs, which limits the fire flow available. Pipeline improvements would not increase fire flow to the area.
- The second area identified is the southwest section of PZ2116. The area is at the end of the system. There are high static pressures but there is insufficient pipeline capacity to provide fire flow. The area is supplied by a 6-inch PRV in Via Barranca Road that is supplied by an 8-inch pipeline. The 8-inch pipeline connects on the east side to a 10-inch pipeline in Via Liago and a 12-inch line in Sultana Road to the west. The 8-inch pipeline has insufficient capacity to meet the Ultimate demands and meet fire flow in the west end of the zone. Upsizing the 8-inch pipeline to a 12-inch from Via Liago to Sultana Road, as shown in Figure 6-11 (CIP W-6), will remove the bottleneck and increase supply to the zone during high flows. With this upgrade, all hydrants will be able to provide at least 1,000 gpm of fire flow.

Figure 6-10: Available Fire Flow to Hydrants – Ultimate (Buildout) Scenario

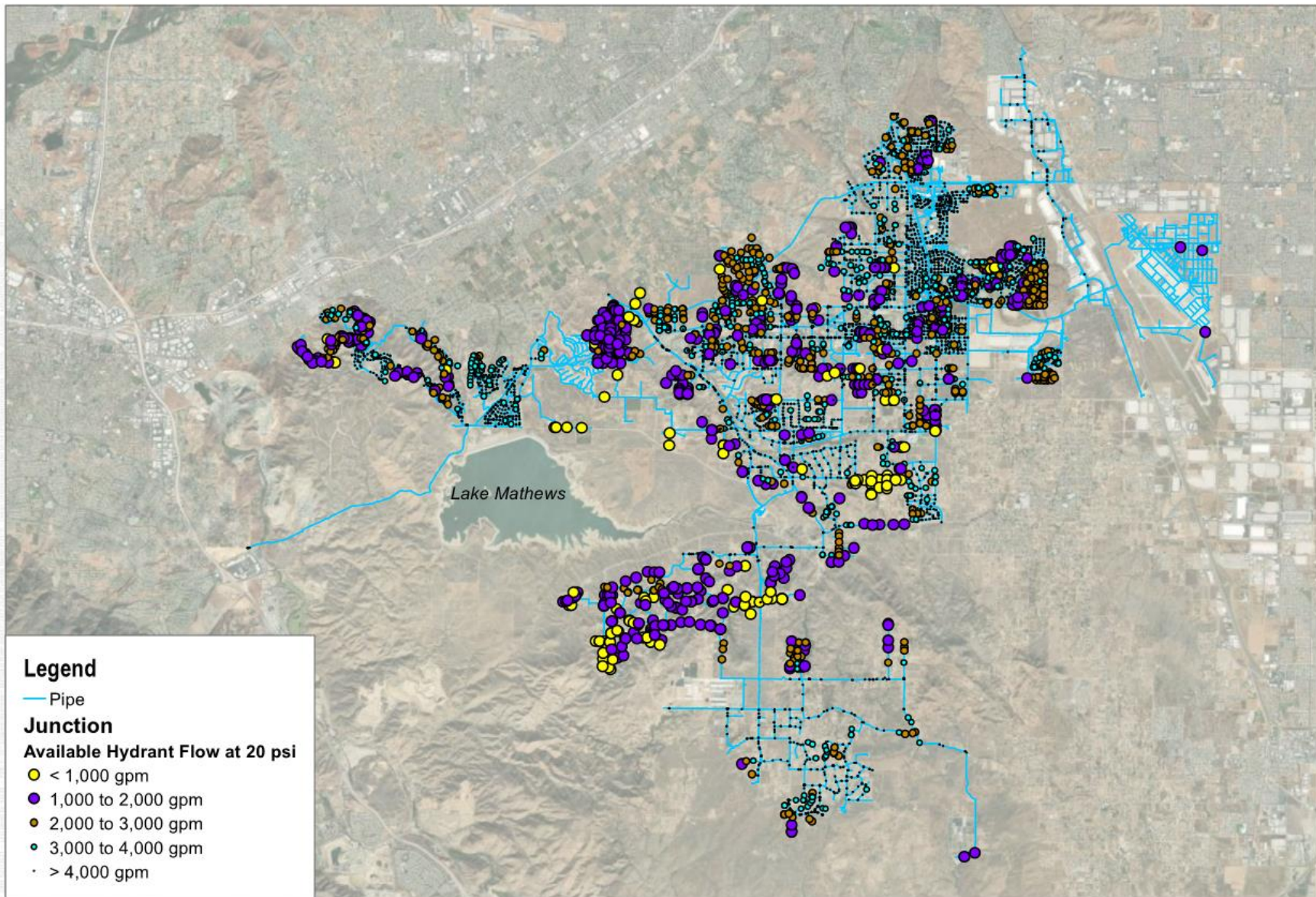


Figure 6-11: CIP W-6 – Via Barranca Road



6.3.2 Storage Analysis

To analyze the storage requirements of the system under Ultimate, the Max Day Demand for all of the developments were added per pressure zone to obtain the updated storage requirements for each pressure zone.

Table 6-6: Storage Analysis Results – Ultimate Scenario

Pressure Zone	Existing Storage (MGD)	MDD (MGD)	Equalization 25% MDD (MG)	Emergency 100% MDD (MG)	Fire Storage			Total Required (MG)	Surplus (MG)
					Fire Flow (gpm)	Duration (hour)	Total (MGD)		
1350	1.5	0.79	0.20	0.79	1,000	2	0.12	1.10	0.40
1515	10.0	3.41	0.85	3.41	3,000	3	0.54	4.80	5.20
1650	9.0	5.92	1.48	5.92	3,000	3	0.54	7.94	1.06
1783	1.0	2.25	0.56	2.25	4,000	4	0.96	3.77	-2.74
1837	22.0	19.69	4.92	19.69	4,000	4	0.96	25.58	-3.58
1885	1.3	0.52	0.13	0.52	3,000	3	0.54	1.20	0.06
1900	13.6	10.96	2.74	10.96	3,000	3	0.54	14.23	-0.63
2320	2.7	6.78	1.69	6.78	1,000	2	0.12	8.59	-5.89
2450	1.5	1.68	0.42	1.68	1,000	2	0.12	2.22	-0.72
TOTAL	62.59							69.42	-6.83

At Ultimate, Western will need to build additional storage capacity to meet the demand. Overall, the system only has 6.83 MG storage deficit, but the surplus storage is in the lower zones, primarily in PZ1515. It will be necessary for Western to build storage at high elevations to serve their upper zones.

The largest zone deficit at Ultimate (Buildout) is PZ2320. The zone is projected to see an increase in demand from 1.16 MGD (existing demand) to 6.78 MGD at Ultimate. This additional demand will require 6 MG in additional storage. An additional 2.7 MG tank is planned at the Hidden Valley site (CIP W-7), which addresses half of the additional storage needed. A second tank site will be necessary to construct an additional 3 MG tank that serves PZ2320 (CIP W-8). The preferred location for a second tank in the zone would be near the existing Oaknoll tank. There are several potential sites that have sufficient elevation to serve PZ2320 in this area and the location would allow the new tank to be easily connected to the existing piping for the PZ2320 zone.

PZ1837 will have a 3.6 MG deficit in storage capacity. There is space at the Orangecrest tank site for an additional 12.5 MG tank, which is expected to be used for a 5 MG recycled water tank. This site is the preferred location for an additional potable water tank if Western can secure additional space at the Orangecrest site. A 5MG storage tank at the Orangecrest site would meet the storage demands of PZ1837 and PZ1783 (CIP W-10).

As discussed in the previous Storage Analysis sections, PZ1783 has a storage deficit that can be met by the storage in PZ1837. Unless Western experiences high-density development in the east end of PZ1783, additional storage is not necessary in the zone. If additional demand beyond the Ultimate projections occur in the east side of the zone, a new tank should be constructed on the east side of the zone to serve the area.

PZ2450 has a storage deficit of 0.7MG. The El Nido tank site has space for an additional tank. An additional 1MG tank is recommended to meet the storage deficit (CIP W-11).

6.3.3 Pump Station Analysis

To analyze the pumping requirements of the system under Ultimate, the Max Day Demand for all of the developments were added per pressure zone to obtain the updated pumping capacity requirements.

Table 6-7: Pump Station Analysis Results – Ultimate Scenario

Pressure Zone	Dependent MDD	Total Capacity	Firm Capacity	Surplus
	(gpm)	(gpm)	(gpm)	
1515	2,910	9,500	7,917	5,006
1650	5,534	13,776	7,488	1,954
1783	7,431	9,600	6,400	-1,031
1837	13,677	54,456	48,856	35,179
1885	1,849	1,700	1,150	-699
1900	7,608	18,900	12,000	4,392
2320	5,737	2,250	1,300	-4,437
2450	1,165	1,765	1,165	0
Total				40,364

At ultimate buildout, the Western still has a pumping capacity surplus of 40,000 gpm, but the surplus is not evenly distributed. Some zones will require additional pumping capacity at Ultimate. Similar to the Storage Analysis results, PZ2320 has the largest pumping capacity deficit at 4,437 gpm. Currently, PZ2320 is only served by Hillside pump station. The large projected demand in the zone necessitates a redundant source of supply to the zone. This will provide redundancy to the zone, both with pumping capacity and a second route of transmission into the zone. At full Ultimate the additional PZ2320 booster station is recommended to have four pumps with a capacity of 1,200 gpm each (CIP W-9).

PZ1783 has a pumping capacity deficit of 1,031 gpm at Ultimate. The zone is served by the Intake BPS and must be sized to transmit water for the southern portion of Western's system. It is recommended that Western add an additional 1,600 gpm pump to the pump station to meet the additional demand (CIP W-12).

6.4 Potable Water System Proposed Improvements

The recommended system improvements and operational modifications to the potable water system include the following:

Existing:

- W-1: Upsize approximately 1,200 LF of existing 6-inch to 12-inch diameter pipeline on Moonridge Drive from Canyon Ridge Drive to the cross-country pipeline.
- W-2: Upsize approximately 8,000 LF of existing 6-inch to 8-inch diameter pipeline from Lockwood Reservoir to Blackburn Road.
- W-3: Upsize approximately 4,000 LF of existing 6-inch and 4-inch diameter to 8-inch pipeline on Cedar Street from Avenue C to Avenue D and Avenue D from Cedar Street to Alder Avenue.

Ultimate (Buildout):

- W-4: Upsize approximately 4,000 LF of existing 6-inch to 12-inch diameter pipeline on Lurin Avenue and Mariposa Avenue from Wood Road to Cole Avenue.
- W-5: Upsize approximately 7,000 LF of existing 12-inch to 16-inch diameter pipeline on Wood Road from Lurin Avenue to Markham Avenue.
- W-6: Upsize approximately 4,200 LF of existing 8-inch to 12-inch diameter pipeline on Via Barranca Road from Via Liago Road to Sultana Road.
- W-7: New 2.7-MG Tank adjacent to the existing Hidden Valley Tank in PZ2320
- W-8: New 3-MG Tank one east side of PZ2320
- W-9: New Booster Pump Station with four 1,200 gpm pumps to serve PZ2320
- W-10: New 5-MG Tank adjacent to existing Orangecrest Tank in PZ1837
- W-11: New 1-MG Tank adjacent to existing El Nido Tank in PZ2450
- W-12: Add a 1,600 gpm pump to the Intake BPS

7 Recycled/Non-Potable Water System Analysis

This section provides results of the capacity analyses of Western's recycled and non-potable water systems under existing and future demand conditions.

7.1 Existing Recycled Water System MDD Analysis

A 48-hour extended period simulation was performed on the existing (2020) recycled water system using maximum day demands. This scenario assumed supply to the North Area from the WWRF and the Riverside Canal only. The supply to the South Area was from the CRA, consistent with existing conditions per discussions with Operations staff. The supply from WWRF was maintained at an average of 1.2 mgd. Additional flow to the Lurin Irrigation zone would come from the Riverside Canal via the Oleander Pump Station. The system pressures, pipeline velocities, storage and pump stations were evaluated for compliance with Western design criteria. The following sections provide the results of analysis.

7.1.1 Pipeline and System Pressure Analysis

Under MDD conditions, a portion of the Lurin Irrigation (1815) zone has minimum pressures less than 30 psi, particularly in the area of the Meridian South Campus industrial center, as shown in Figure 7-1. MDD pressures drop as low as 11.8 psi at the dead-end 8-inch pipeline at the intersection of Coyote Bush Rd and Van Buren Boulevard, with minimum pressures at 14 psi near the existing Amazon warehouse. Low pressures in the Lurin Irrigation zone are due to the topography of the service area and the limited height of the existing Lurin tank. A map showing "no serve areas" in the zone is included in Appendix C. No pipelines exceed Western design criteria of 6 fps.

Low pressures were also identified on the southeast end of the Citrus Heights development. Low pressures in these locations are due to the high elevation of the recycled waterlines in this area and are not due to capacity restrictions in the system. It is recommended that any meters in this area be served by potable water, if available.

7.1.2 Storage Analysis

Recycled/non-potable storage requirements are determined based on Western's storage criteria established in Section 5.2.3. The North and South areas operate independently; therefore, the storage analysis was performed for each area separately. Table 7-1 provides a calculation of the required storage based on existing recycled water/non-potable water demands for both areas.

The storage analysis shows that both the North and South areas have surplus storage. The North area has 5.9 MG of surplus storage. The South area has 3.1 MG of surplus storage. While the overall North area has a surplus, the Lurin Irrigation (1815) zone has a storage deficit of 2.4 MG. The Lurin Irrigation (1815) zone also has the highest recycled water demand in the system. Operations staff have confirmed the challenges in maintaining adequate storage and zone pressures due to the lack of storage in the 1815 zone. To improve both the storage deficit and zone pressures, a new tank at the Orangecrest site is recommended to be built by 2030.

In the South area, there is an on-going project to determine whether to reconstruct the Jim Jack tank. If Western opts to reconstruct the tank, it would likely be rebuilt at a smaller volume (2.75 to 3-MG); therefore, the deficit in the El Nido zone may require additional storage adjacent to the existing El Nido Irrigation tank.

Figure 7-1: Minimum System Pressures – Existing System (2020) MDD Analysis

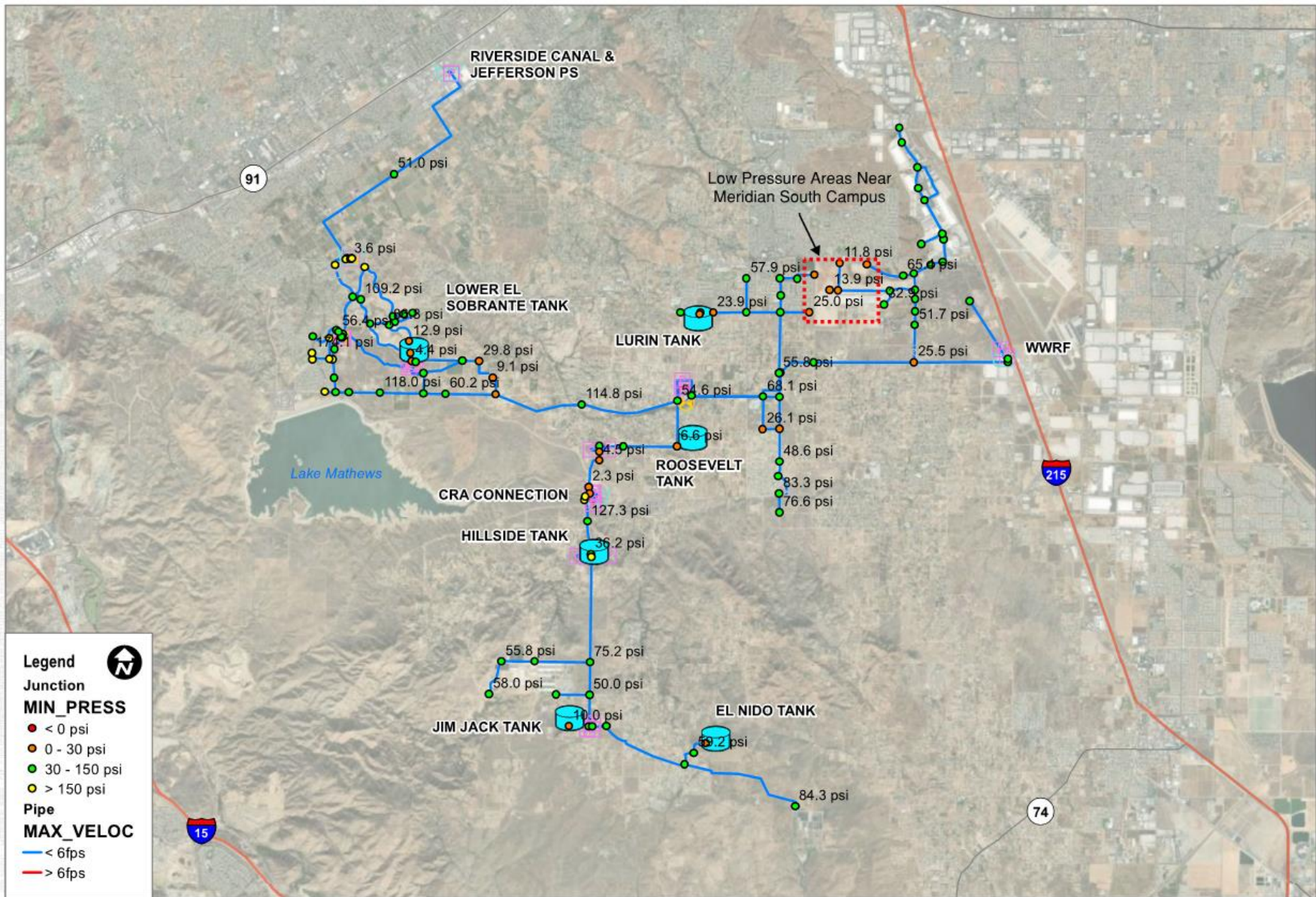


Table 7-1: Existing MDD Recycled/Non-Potable Water Storage Analysis

Zone Name	Area	Pressure Zone	Existing MDD (mgd)	Req'd Volume (MG) ¹	Existing Volume (MG)	Surplus/(Deficit) (MG)
North Area						
Lower El Sobrante	North	1420	0.07	0.07	4.5	4.43
Roosevelt	North	1667	1.19	1.19	5.0	3.81
Lurin Irrigation ²	North	1815	2.67	2.67	0.3	(2.37)
<i>North Area RW/NP System Storage</i>				3.9	9.8	5.9
South Area						
Hillside Irrigation	South	1815S	0.00	0.00	0.5	0.5
Jim Jack Irrigation	South	2250	1.55	1.55	5.0	3.45
El Nido Irrigation	South	2450	1.20	1.20	0.33	(0.87)
<i>South Area RW/NP System Storage</i>				2.8	5.8	3.1
Total System-Wide RW/NP System Storage				6.7	15.6	9.0

Notes:

- ¹ Criteria for recycled/non-potable storage is equal one (1) maximum day.
- ² Does not include demand for the RNC that is supplied from Cemetery PS directly to RNC ponds.

7.1.3 Pump Station Analysis

All pump stations in the system were operating within design parameters during the Existing System (2020) MDD analysis. However, the Oleander Pump Station pumps cycle frequently due to the low volume in the Lurin Irrigation Tank. Increasing storage in the Lurin Irrigation (1815) zone will improve pump performance.

7.2 Existing System Minimum Month Analysis

Currently in low demand periods, excess recycled water from WWRF is discharged in the La Sierra collection system through the WRCRWA bypass on to the WRCRWA plant for secondary treatment and disposal, see Section 2.4.5 for discussion of inflow to WRCRWA sewer system. The capacity at the WRCRWA bypass is limited to a maximum flow of approximately 600 gpm; therefore, this analysis evaluated the ability to deliver excess recycled water to the Victoria Basin, located at Victoria Avenue and Jackson Street in Riverside.

A 24-hour minimum simulation was performed on the existing system assuming zero system demands and 3 MGD from WWRF to Victoria Basin. The system was able to accommodate the delivery of those flows with no deficiencies identified.

7.3 Near-Term Recycled/Non-Potable Water System MDD Analysis

Due to the known additional demands anticipated in the Lurin Irrigation (1815) zone for the Near-Term (2030) model scenario, as well as the existing storage deficit in the zone, a new 5-MG Orangecrest tank (40-ft high, 150-ft diameter) was added to the hydraulic model to provide the necessary storage to accommodate peak flows. A new Lurin Tank was also assumed with a height to match the new Orangecrest tank (increased to 40 ft).

This scenario assumed the full WWRF supply would be sent to the RNC to satisfy a portion of the cemetery’s demands (including the new Phase V and Phase VI demands), while the remainder of the RNC demands were

loaded onto the 16-inch line in Village West Drive. The existing dedicated pump station serving the RNC would require expansion to accommodate the increased demands. A fifth (additional) pump at the McAlister pump station (1,200 gpm at 500-ft) would also be required due to the need to run all four existing pumps at McAlister to provide supply to the Lurin Irrigation zone via the El Sobrante and Oleander pump stations. Additionally, a fifth (additional) pump at the El Sobrante pump station (1,200 gpm at 325-ft) would also be required due to the need to run all four existing pumps to supply the Lurin Irrigation zone.

To accommodate the new tank as well as the current planned developments in the Lurin Irrigation zone, the following new pipelines were also added:

- Approximately 1,300 LF of 18-inch and 3,500 LF of 24-inch Orangecrest tank supply pipelines, from the tank and south on Barton Street to the existing 12-inch pipe on Gless Ranch Road at Barton Street.
- Approximately 4,400 LF of 16-inch Meridian West Campus development pipelines, along Van Buren Blvd from Barton Street to the existing 12-inch pipeline on Van Buren east of Orange Terrance Parkway.
- Approximately 3,300 LF of 12-inch pipe to create a loop between the Meridian South Campus area on Krameria Avenue to the existing 12-inch on Lurin Avenue (currently in design).

These changes to the Lurin Irrigation zone are shown in Figure 7-2.

This scenario assumed supply to the North Area from the WWRF and the Riverside Canal only, while the supply to the South Area was from the CRA. With the addition of these new facilities, a 48-hour extended period simulation was performed and the system pressures, pipeline velocities, storage and pump stations were evaluated, as described in the following subsections. Minimum system pressures are shown graphically in Figure 7-3. Note, this scenario assumes supply from the WWRF and Riverside Canal were prioritized at Western's direction and no supply from the CRA to the North Area was assumed.

Figure 7-2: Additional Facilities in Near-Term Scenario

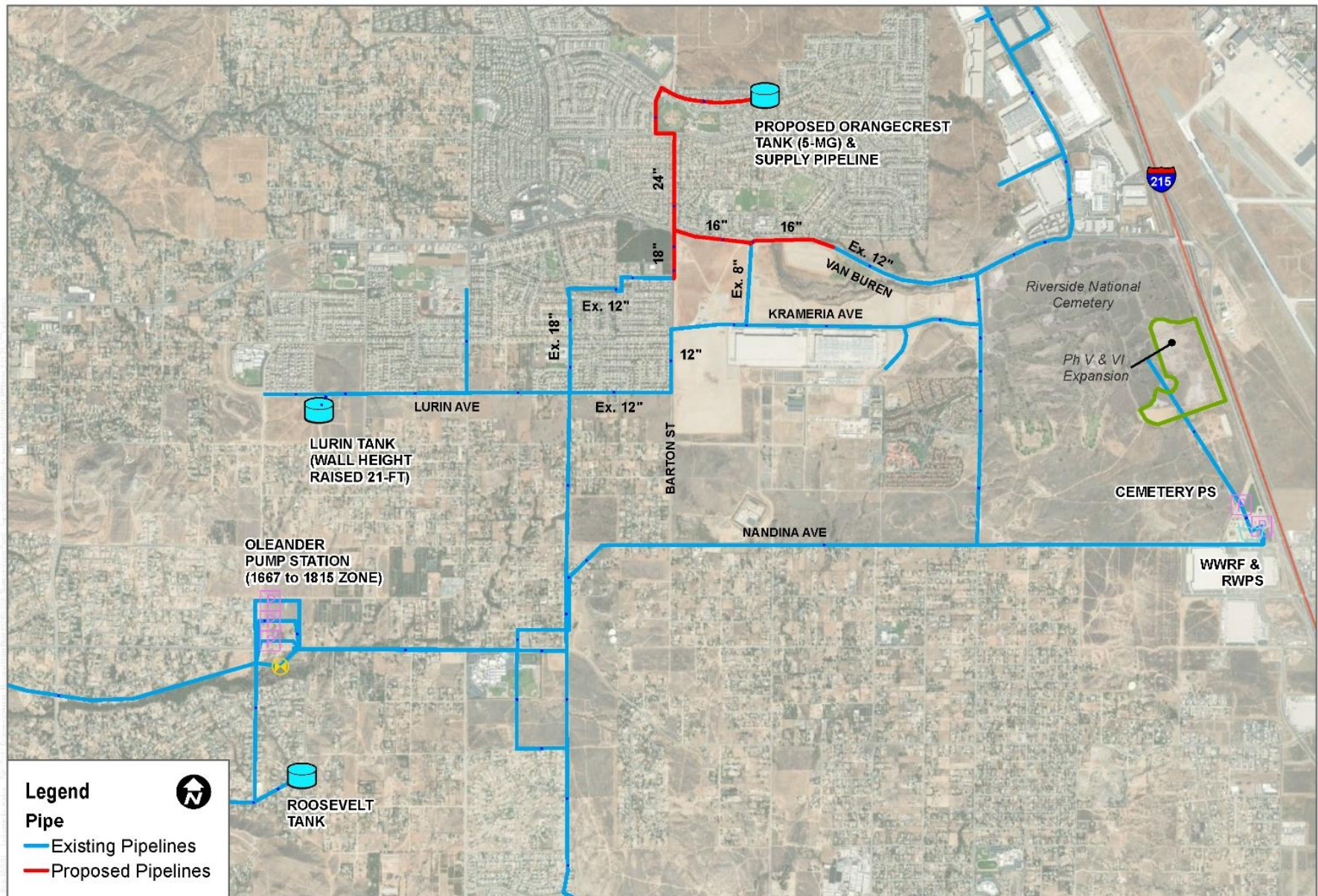
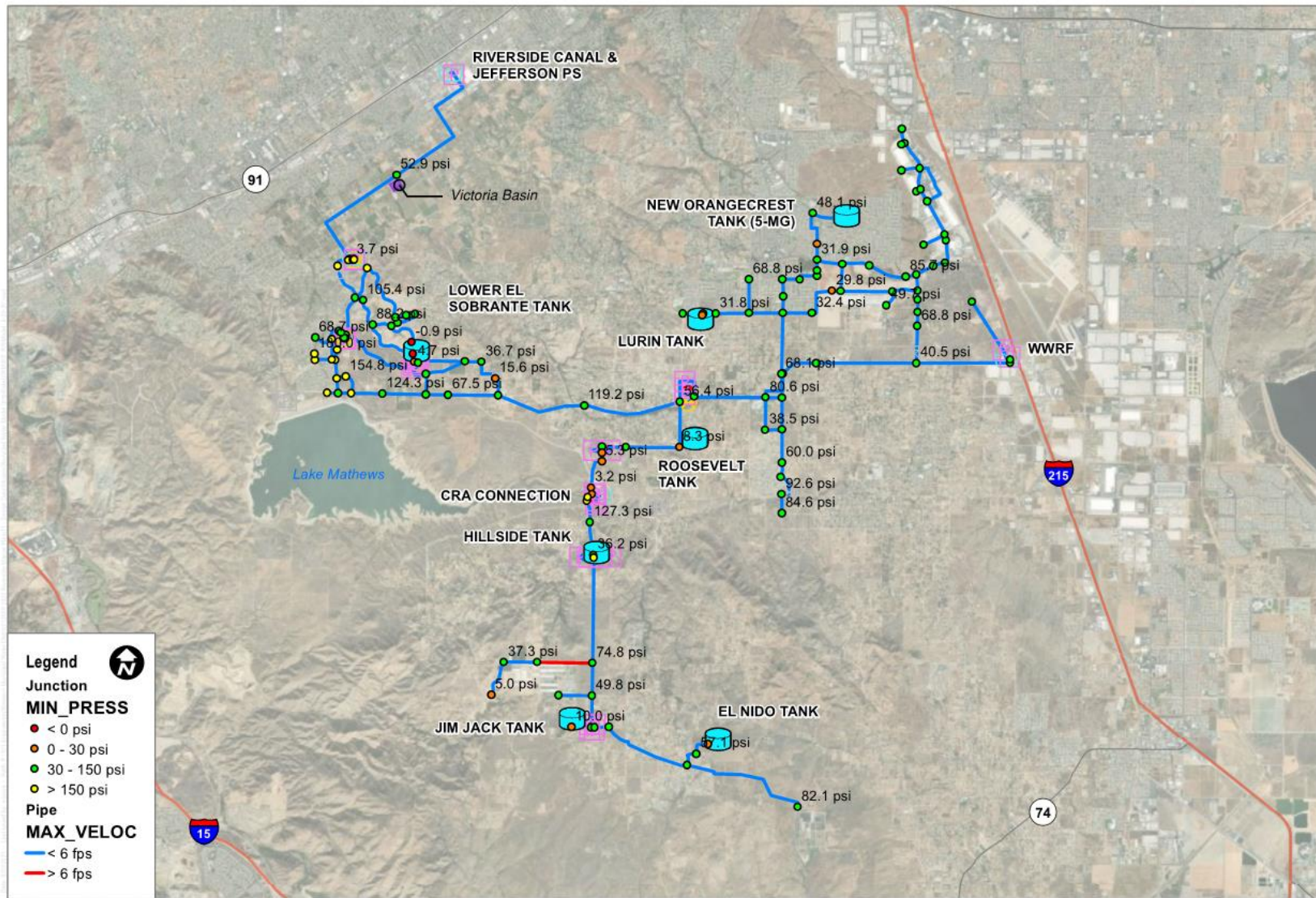


Figure 7-3: Minimum System Pressures – Near-Term Recycled/NP Water MDD Analysis



7.3.1 Pipeline and System Pressure Analysis

The results of the analysis indicate that system pressures are significantly improved in the Lurin (1815) Zone with the addition of the new Orangecrest Tank and a new Lurin tank with increased height, as well as the looped piping. When supplementing the zone with CRA supplies was evaluated, it was found to add negligible benefit with regard to system pressures (2 psi).

Approximately 4,500 LF of existing 14-inch pipeline on Idaleona Drive in the Jim Jack (2250) Zone had maximum pipeline velocities reach 7 fps, exceeding the 6 fps maximum pipeline velocity criteria, as a result of the anticipated expansion of the Altman Plants nursery. No other pipeline velocities exceeded Western criteria.

7.3.2 Storage Analysis

Table 7-2 provides a zone-by-zone calculation of the required storage based on projected Near-Term recycled/non-potable water demands. This calculation assumes a new 5-MG tank is constructed in the Lurin Irrigation zone at the Orangecrest location. Based on the storage analysis for Near-Term recycled/non-potable water demands and assuming additional storage in the Lurin Irrigation zone, there is surplus storage in the recycled/non-potable water system under Near-Term demands.

In the South area, there is an on-going project to determine whether to reconstruct the Jim Jack tank. If Western opts to reconstruct the tank, it would likely be rebuilt at a smaller volume (2.75 to 3-MG); therefore, the deficit in the El Nido zone may require additional storage adjacent to the existing El Nido Irrigation tank.

Table 7-2: Near-Term MDD Recycled/Non-Potable Water Storage Analysis

Zone Name	Area	Pressure Zone	Near-Term MDD (mgd)	Required Volume (MG) ¹	Existing Volume (MG)	Proposed Add'l Volume (MG)	Surplus/(Deficit) (MG)
North Area							
Lower El Sobrante	North	1420	0.49	0.49	4.5	--	4.01
Roosevelt	North	1667	1.55	1.55	5.0	--	3.45
Lurin Irrigation ²	North	1815	4.63	4.63	0.3	5.0	0.67
<i>North Area RW/NP System Storage</i>				5.7	9.8	5.0	8.1
South Area							
Hillside Irrigation	South	1815S	0.00	0.00	0.5	--	0.50
Jim Jack Irrigation	South	2250	2.72	2.72	5.0	--	2.28
El Nido Irrigation	South	2450	1.20	1.20	0.33	--	(0.87)
<i>South Area RW/NP System Storage</i>				3.9	5.8	--	1.9
Total System-Wide RW/NP System Storage				9.6	15.6	--	10.0

Notes:

- ¹ Criteria for recycled/non-potable storage is equal one (1) maximum day.
- ² Lurin Irrigation zone demand does not include RNC demand supplied from the Cemetery Pump Station directly to onsite storage ponds in the RNC. Of the 4.63 MGD MDD for the Lurin Irrigation zone, approximately 38% is

demand for the RNC and the General Old Golf Course (owned by the RNC) served by Lurin Irrigation zone pipelines on Village West Drive.

7.3.3 Pump Station Analysis

In order to accommodate the increased RW supply from the WWRF and supply to the cemetery ponds, the Cemetery Pump Station would need to be upgraded to accommodate the flows. Requiring delivery over 24-hours, rather than the 9-hour delivery window currently used, would reduce the size of the pump station upgrade. Any upgrades to the Cemetery Pump Station would need to take into account daily production at WWRF.

All other pump stations in the system were operating within design parameters during the Near-Term (2030) MDD analysis, including the Oleander pump station, which was pumping into the proposed 5-MG Orangecrest tank, despite the proposed Orangecrest Tank having a high water level of 1836-ft, which is 21-ft above the HWL of the existing Lurin Tank at 1815-ft.

7.4 Ultimate Recycled Water System MDD Analysis

The Ultimate (Buildout) MDD scenario assumes the full buildout of the RNC, including the conversion of the General Old Golf Course and the vacant property to the south of the existing cemetery. This scenario also assumes 2.9 MGD recycled water supply from WWRF. This expansion of the cemetery results in a MDD increase of 4.5 MGD in the Lurin Irrigation (1815) zone. Due to these additional demands the following upsized pipelines were further modified in this scenario to maintain system pressures:

- 3,000 LF of existing 16-inch to 24-inch diameter on Village West Drive from Nandina Ave to Lemay Dr
- 3,000 LF of existing 12-inch to 18-inch on Gless Ranch Road between Barton Street and Cole Avenue

These modifications are shown in Figure 7-4.

This scenario assumed supply to the North Area from the WWRF, Riverside Canal and the CRA, while the supply to the South Area was from the CRA. The CRA supply to the north was required to satisfy the RNC demand that was beyond what could be supplied with WWRF recycled water. With the addition of these new facilities, a 48-hour extended period simulation was performed and the system pressures, pipeline velocities, storage and pump stations were evaluated, as described in the following subsections. Minimum system pressures are shown graphically in Figure 7-5.

Figure 7-4: Pipeline Upsizing to Accommodate Ultimate Demands

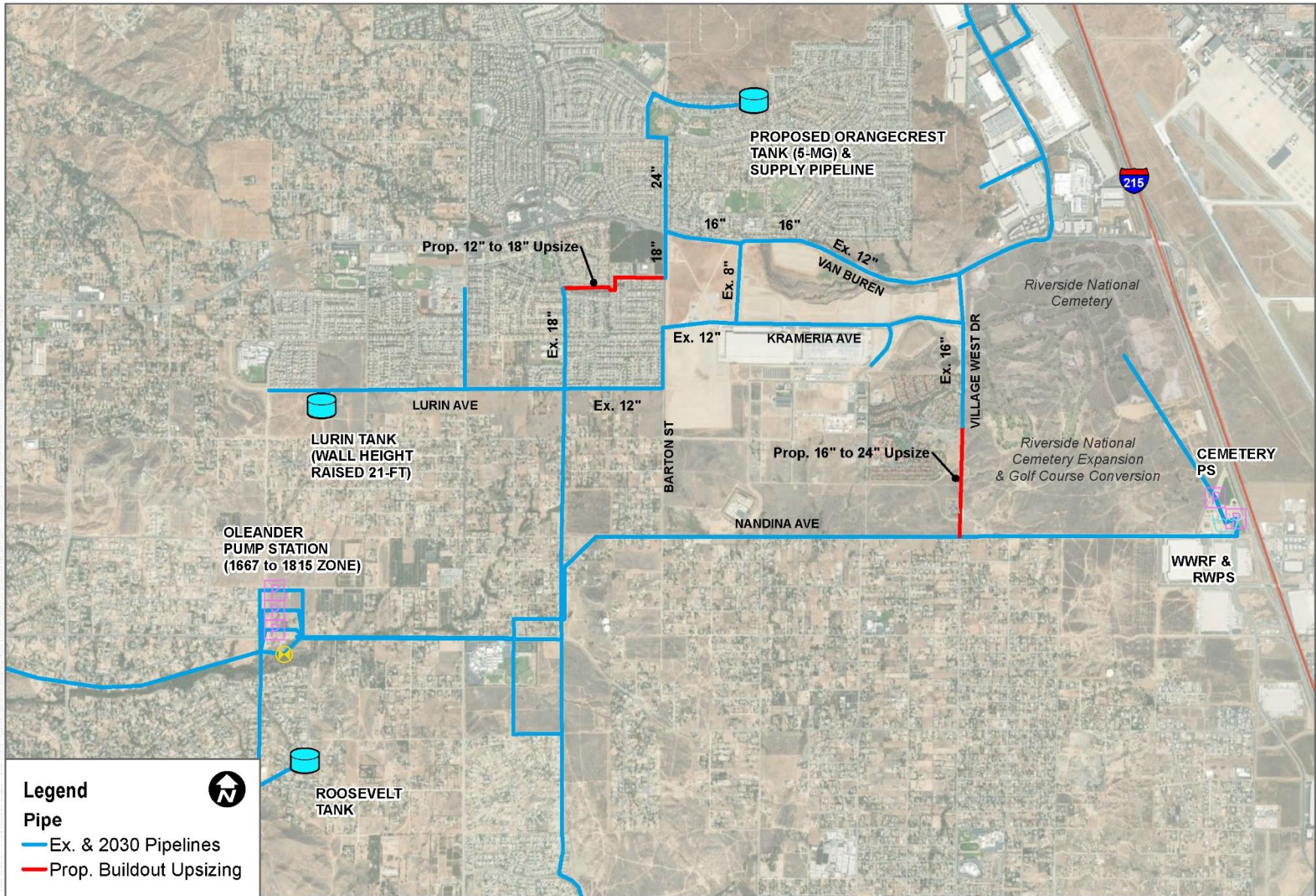
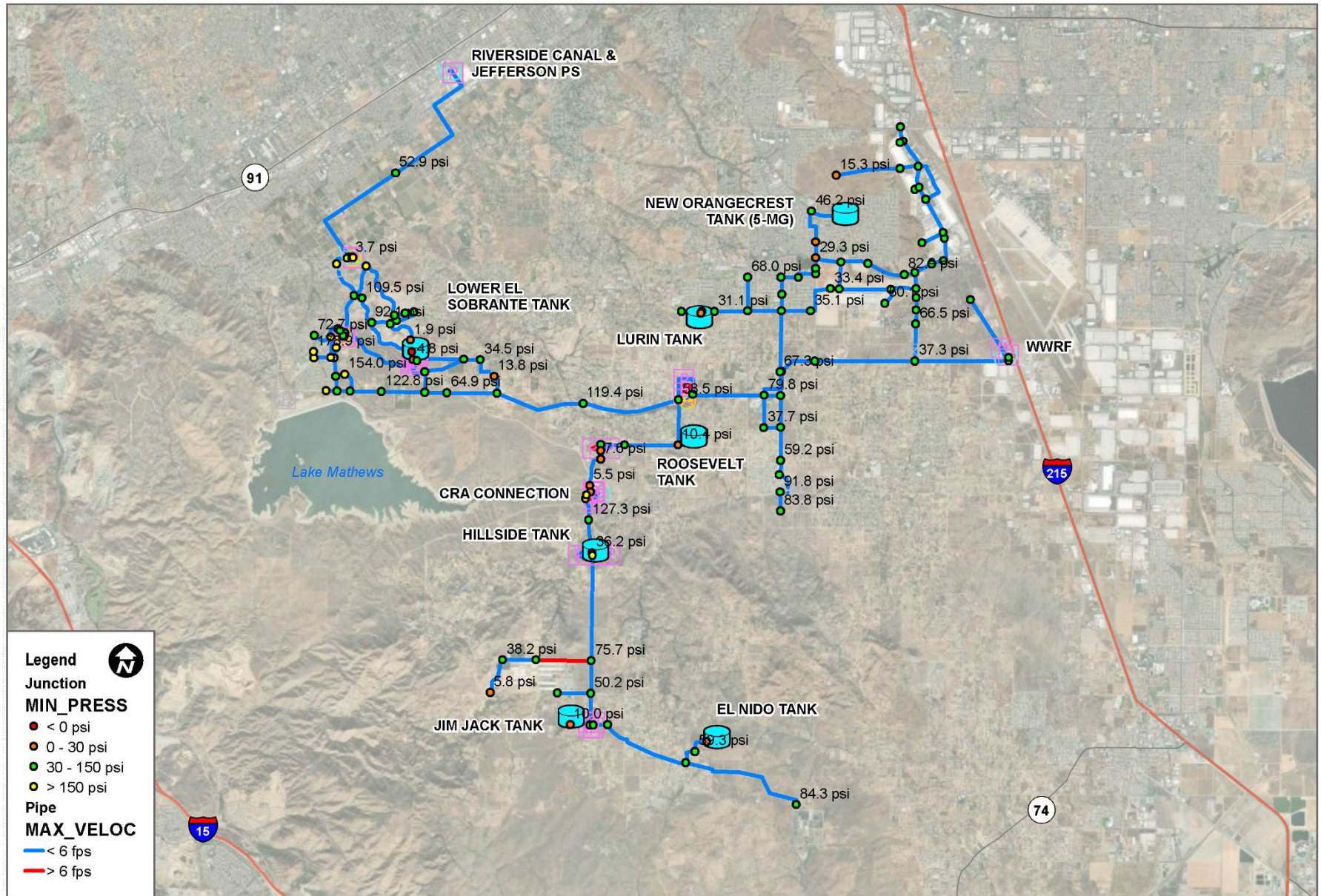
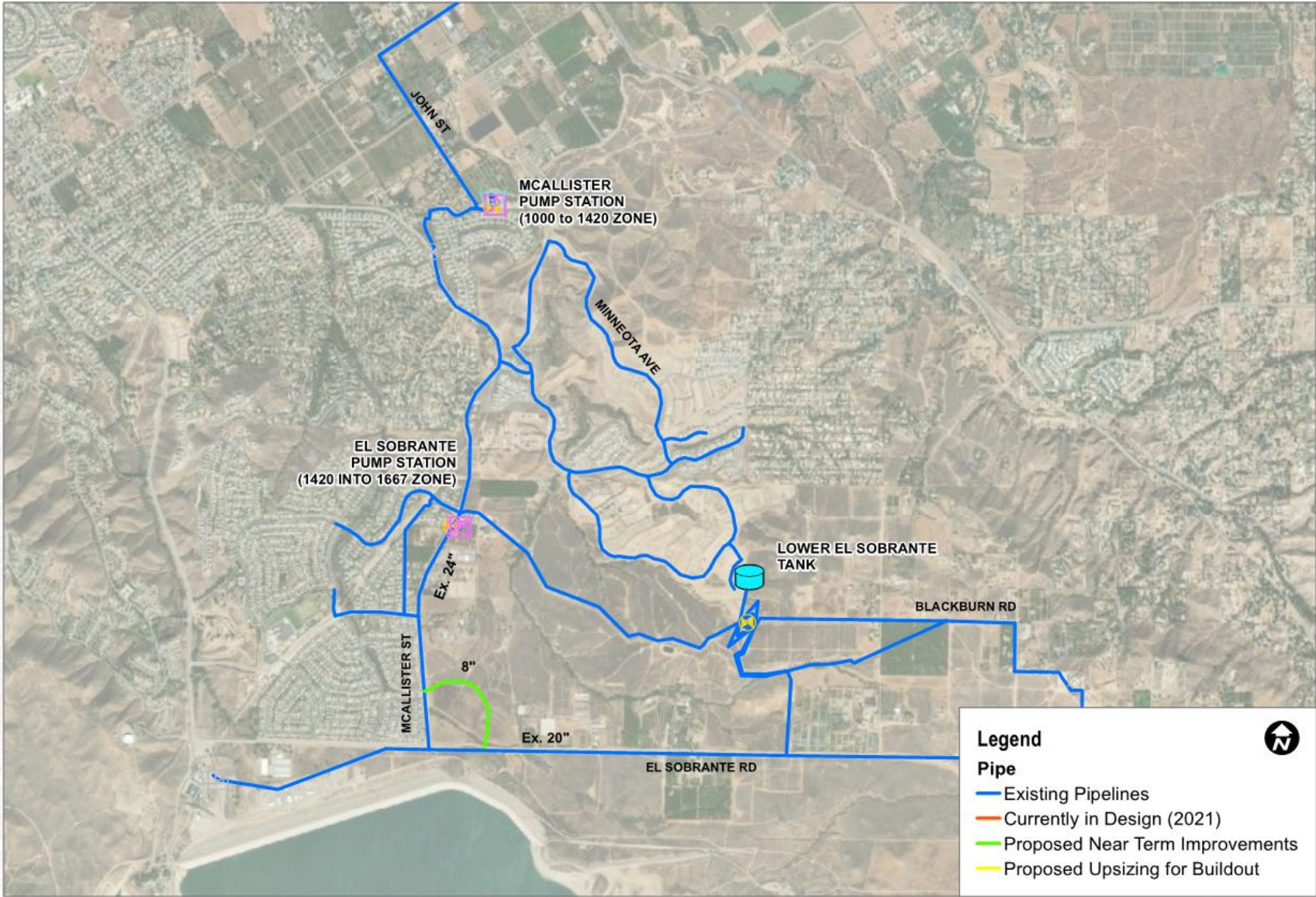


Figure 7-5: Minimum System Pressures – Future Recycled/NP Water MDD Analysis





7.4.1 Pipeline and System Pressure Analysis

System pressures were slightly improved in the Lurin Irrigation Zone with the additional supply from the CRA to feed the increased demands for the RNC expansion. Other system pressures and pipeline velocities remained relatively unchanged. The pipeline velocity constraint due to the Altman Plants expansion in the Jim Jack zone is unchanged, at a maximum velocity of 7 fps.

7.4.2 Storage Analysis

In the South area, there is an on-going project to determine whether to reconstruct the Jim Jack tank. If Western opts to reconstruct the tank, it would likely be rebuilt at a smaller volume (2.75 to 3-MG); therefore, the deficit in the El Nido zone may require additional storage adjacent to the existing El Nido Irrigation tank.

Table 7-3 provides a zone-by-zone calculation of the required storage based on projected Ultimate (Buildout) recycled/non-potable water demands. This calculation assumes the 5-MG tank proposed in the Near-Term scenario remains in the Lurin Irrigation zone at the Orangecrest location. Based on the storage analysis for future recycled/non-potable water demands and assuming additional storage in the Lurin Irrigation zone, there is surplus storage in the recycled/non-potable water system under Ultimate (Buildout) demands.

Table 7-3: Ultimate (Buildout) MDD Recycled/Non-Potable Water Storage Analysis

Zone Name	Area	Pressure Zone	Future MDD (mgd)	Required Volume (MG) ¹	Existing + 2030 Volume (MG)	Proposed Add'l Volume (MG)	Surplus/ (Deficit) (MG)
North Area							
Lower El Sobrante	North	1420	0.49	0.49	4.5	--	4.01
Roosevelt	North	1667	1.55	1.55	5.0	--	3.45
Lurin Irrigation	North	1815	6.54 ²	6.54	5.3 ²	TBD ²	(1.24)
<i>North Area RW/NP System Storage</i>				<i>8.6</i>	<i>9.8</i>	<i>TBD</i>	<i>6.2</i>
South Area							
Hillside Irrigation	South	1815S	Peaking fa	0.00	0.50	--	0.50
Jim Jack Irrigation	South	2250	2.74	2.74	5.00	--	2.26
El Nido Irrigation	South	2450	1.20	1.20	0.33	--	(0.87)
<i>South Area RW/NP System Storage</i>				<i>3.9</i>	<i>5.8</i>	<i>--</i>	<i>1.9</i>
Total System-Wide RW/NP System Storage				12.5	2015.6	TBD	8.1

Notes:

- ¹ Criteria for recycled/non-potable storage is equal one (1) maximum day.
- ² Ultimate storage requirement for the Lurin Irrigation zone depends on whether the RNC constructs additional onsite storage ponds and whether those ponds are served via a dedicated pump system or via the Lurin Irrigation Zone infrastructure. It is estimated that Lurin Irrigation zone storage required for ultimate could be up to 10-MG. It is recommended half the required volume (5-MG) be constructed in the Near-Term (2030) with the remainder constructed if determined to be needed in the future.

7.4.3 Pump Station Analysis

Assuming the upgrade of the dedicated Cemetery Pump Station in 2030 and assuming 24-hour delivery of flows to the cemetery ponds, all pump stations in the system were operating within design parameters during the Ultimate (Buildout) MDD analysis. Upgrades must take into account WWRF daily production.

7.5 Recycled Water System Recommendations and Proposed Improvements

The recommended system improvements and operational modifications to the RW/NP system include the following:

Near-Term (2030):

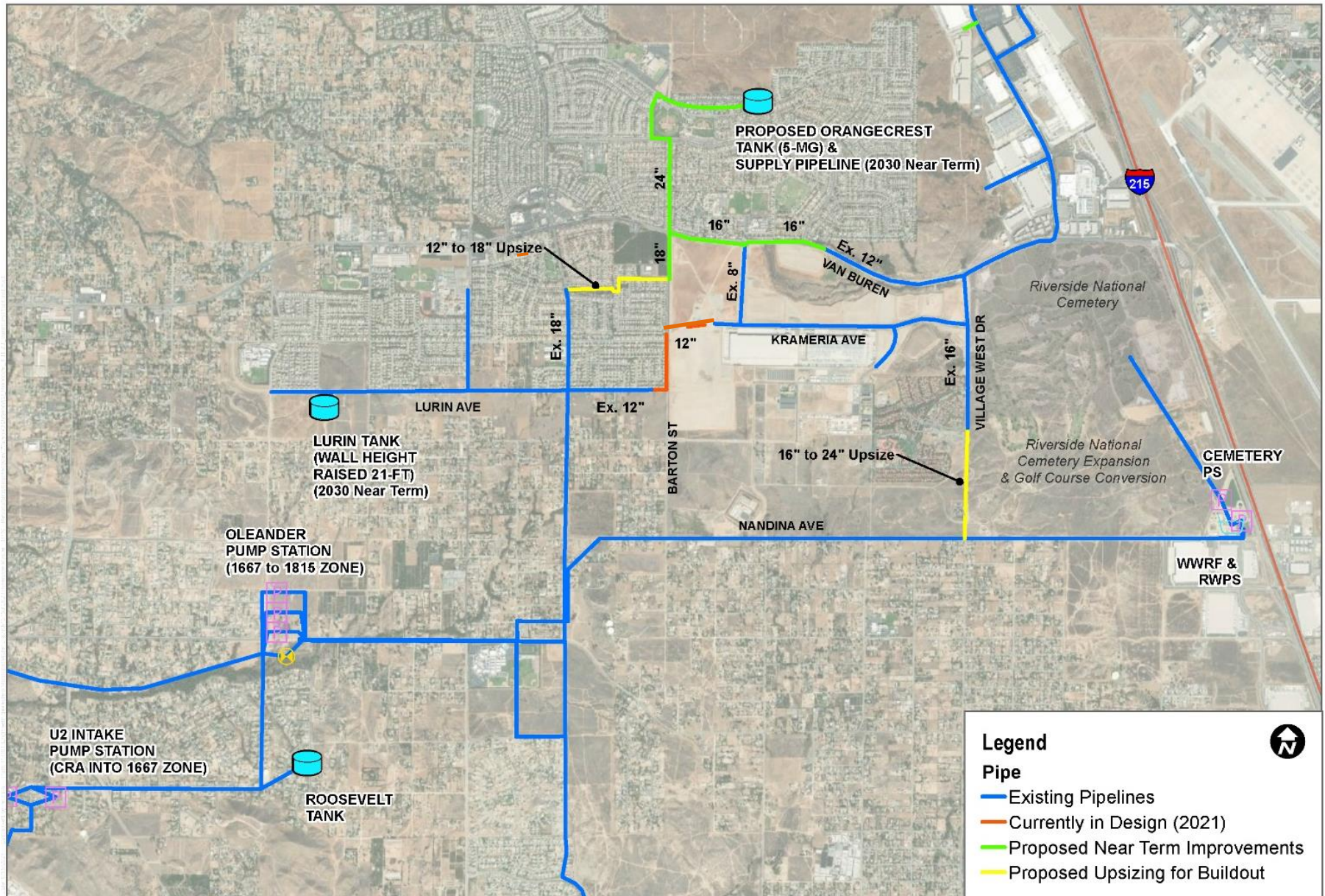
- RW-1: 1815 Zone Near Term Improvements
 - New 5-MG Orangecrest Tank in the Lurin Irrigation zone.
 - Reconstruct existing Lurin Irrigation Tank to match HGL of proposed Orangecrest Tank or installation of altitude valve at the existing Lurin Irrigation Tank.
 - Installation of approximately 1,300 LF of 18-inch and 3,500 LF of 24-inch Orangecrest tank supply pipelines, from the tank and south on Barton Street to the existing 12-inch pipe on Gless Ranch Road at Barton Street.
 - Installation of 4,400 LF of 16-inch Meridian West Campus development pipelines, along Van Buren Blvd from Barton Street to the existing 12-inch pipeline on Van Buren east of Orange Terrance Parkway.
 - Expansion of dedicated Cemetery pump station and parallel supply line to accommodate increased RW supply from WWRF to the onsite RNC ponds. Shifting to a 24-hour delivery to the cemetery ponds would reduce the size of the upgraded pump station.
- Additional pump at the McAlister Pump Station sized at 1,200 gpm at 500-ft.
- Additional pump at the El Sobrante Pump Station sized at 1,200 gpm at 325-ft.
- Potential: Upsizing of approximately 4,500 LF of existing 14-inch pipeline on Idaleona Drive in the Jim Jack (2250) Zone to 16-inch.

Ultimate (Buildout):

- RW-2: RNC Pipeline Upsizing
 - Upsize approximately 3,000 LF of existing 16-inch to 24-inch diameter on Village West Drive from Nandina Ave to Lemay Drive.
 - Upsize approximately 3,000 LF of existing 12-inch to 18-inch on Gless Ranch Road between Barton Street and Cole Avenue.
- Requiring 24-hour delivery of RW supply to the cemetery ponds would avoid the need to further expand the Cemetery Pump Station.

These recommended improvements are shown graphically in Figure 7-6.

Figure 7-6: Recommended RW/NP System Improvements



8 Wastewater Collection System Analysis

The Western wastewater collection system was analyzed utilizing the new wastewater collection system model developed as described in Section 4.3. The evaluation method employs the use of the Innovyze® InfoSewer hydraulic modeling software, which performs hydraulic calculations with extended period simulations (EPS) and fully dynamic flow routing to calculate water depth in open channels. The evaluation criteria are described in detail in Section 5.3.

Facilities that do not meet the design criteria for each phase of development (existing, Near-Term, and Ultimate) are noted, however do not have to result in a capital improvement project. This FMP identifies any locations where the limited capacity or high velocity has an elevated risk of causing a sanitary sewer overflow (SSO), thereby creating a risk to the public. CIP projects are identified where facilities do not meet the trigger criteria as identified in Section 5.3.

For instance, a pipe experiences a maximum velocity of 11 fps (design criteria of 10 fps), but there is a low likelihood of damage to the pipe which would result in a SSO, the pipe would be recommended for monitoring rather than replacement as a CIP project. When facilities are recommended for monitoring, it alerts Western that an asset may represent a higher risk in the event of high flows and should be cleaned and inspected regularly. The monitoring also allows Western to evaluate the flow conditions and possibly remove it from monitoring if the velocities or d/D are not as high as the modeled result.

For lift stations, if firm pumping capacity is less than the actual flow rates then the risk of sewage backing up into the gravity main system or overflowing at the lift station is increased. Because of the elevated risk of causing an overflow and Western's requirement that the firm capacity of a lift station be greater than the peak flow rate, it is recommended to expand capacity of any lift stations where firm capacity is less than PWWF.

Treatment plant capacity is evaluated against ADWF flows in each scenario. The capacity listed for the WRCRWA plant is the amount allotted to Western, however it is based on average flows over a month and has sufficient total capacity to handle peak flows greater than the 1.93 MGD listed. The WWRF treatment plant does not have the same ability to accommodate flows greater than its 3.0 MGD capacity for consistent ADWF. In the event that the inflows at either treatment plant is greater than 75% of the available capacity, it is recommended Western begin alternatives analysis for expansion of the WWRF treatment plant or negotiating greater capacity for the WRCRWA treatment plant.

8.1 Existing Collection System Capacity Evaluation

This section discusses evaluation of the existing wastewater system and evaluates the current system's performance under existing PWWF conditions utilizing the sewer model developed in Section 4.3.

8.1.1 Gravity Sewer and Force Main System Analysis

Under the existing conditions, there are 20 pipes identified in the model that do not meet the capacity design criteria, but none surpass the trigger criteria (Section 5.3). The following Table 8-1 summarizes the results of the Existing gravity sewer and force main analysis. The pipelines are shown on Figure 8-1 and Figure 8-2.

Table 8-1: Existing System Gravity Sewer and Force Main Analysis

No.	Description	Recommendation
1: Arizona Trunk Sewer 1	Three sections of 8" VCP sewer main, totaling 880 LF experience d/D's of 0.68 under existing PWWF. The pipes have low slopes of 0.004 which contribute to the d/D being greater than the 0.5 design criteria.	Because there is no surcharging in the connected manholes and risk of an overflow is very low, it is recommended to monitor these pipes on a regular basis and clean as necessary to prevent reduced capacity.
2: McKinley Trunk Sewer 1	Two sections of 8" VCP sewer main, totaling 390 LF experience d/D's of 0.55 under existing PWWF. The pipes have low slopes of 0.004 which contribute to the d/D being greater than the 0.5 design criteria.	Because there is no surcharging in the connected manholes and risk of an overflow is very low, it is recommended to monitor these pipes on a regular basis and clean as necessary to prevent reduced capacity.
3: Dauchy Force Main 1	The Dauchy force main breaks head and enters the gravity sewer system at the intersection of Krameria Avenue and Cole Avenue. Under peak wet weather conditions, flows reach 14 feet per second in a single 76 LF segment of 15" PVC pipe before attenuating to a lower velocity.	Due to the high velocity, the pipe should be inspected regularly to verify no excessive wear is occurring.
4: Recycled Water Bypass - Arizona Trunk Sewer	Due to the additional flows from the WWRP Recycled Water Bypass, the Arizona trunk sewer system sees an additional continuous 600 gpm of flow. The result is thirteen sections of 12" to 15" VCP sewer main, totaling 6,300 LF, experiencing d/D's ranging from fully surcharged to 0.52 under existing PWWF. No manholes along the sections of sewer main experience surcharging during peak flows.	Because there is no surcharging in the connected manholes and risk of an overflow is very low, it is recommended to monitor these pipes during the wet season and clean regularly to prevent reduced capacity.
5: Buchanan 1	One section of 12" VCP sewer main, totaling 228 LF experiences a d/D of 0.55 under existing PWWF. The pipe follows a drop manhole and has a relatively low slope of 0.01 contributing to the d/D greater than the design criteria.	Because there is no surcharging in the connected manholes and risk of an overflow is very low, it is recommended to monitor this pipe on a regular basis and clean as necessary to prevent reduced capacity.

Figure 8-1: Existing Sewer Gravity and Force Main Recommendations 1

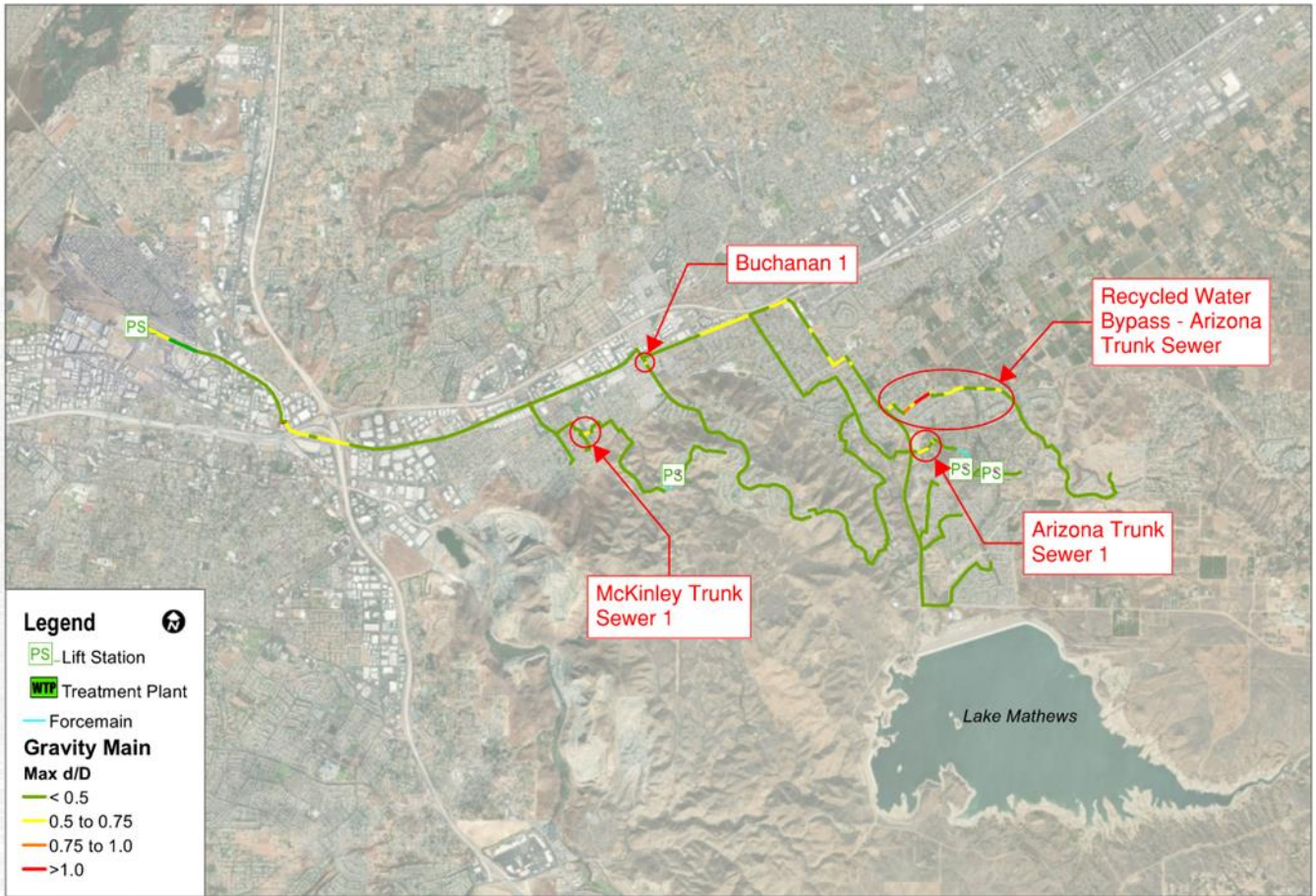
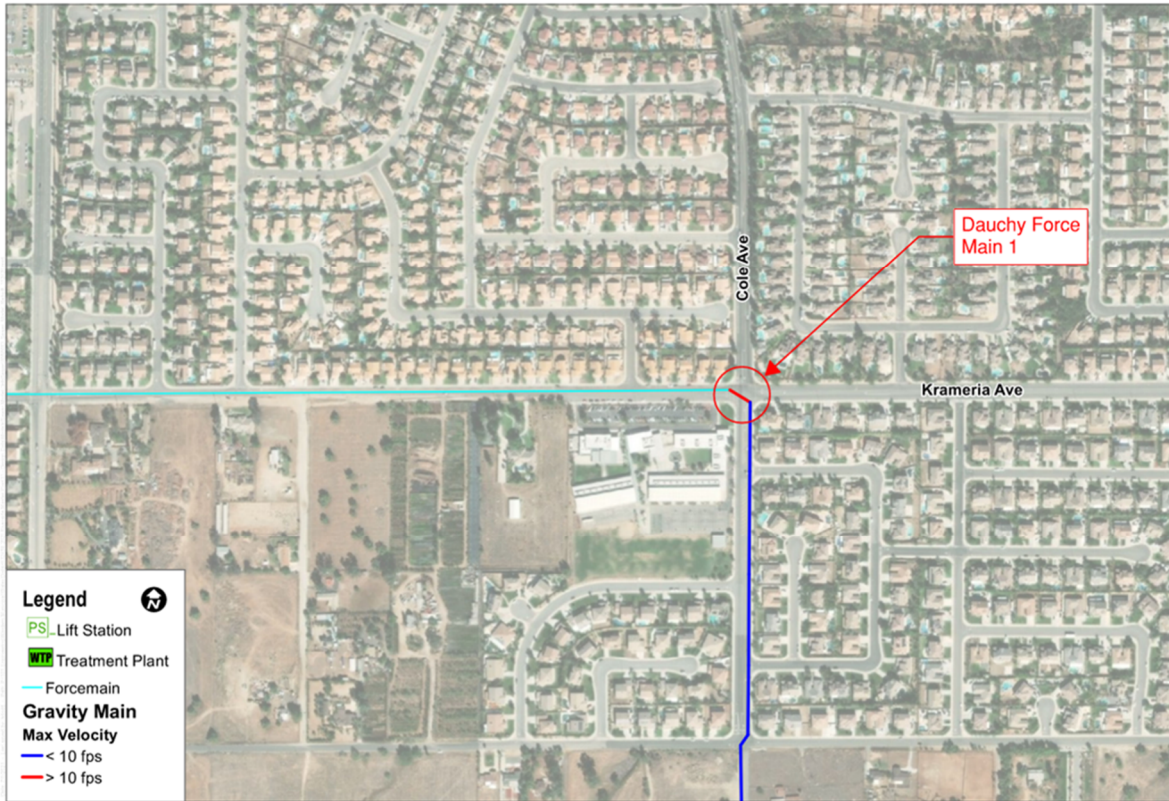


Figure 8-2: Existing Sewer Gravity and Force Main Recommendations 2



8.1.2 Siphon Analysis

All siphons were analyzed and found to achieve self-cleansing velocities under Existing dry weather flow.

8.1.3 Lift Station Analysis

For the existing sewer lift stations, existing peak wet weather inflow from the flow monitoring was compared against the firm capacity of the lift station. Only lift stations with upstream pipes 10” and larger in diameter were included in the model and analysis. In the existing condition two lift stations currently exceed their firm capacity, Table 8-2 summarizes the results.

Table 8-2: Existing PWWF Lift Station Capacity Analysis

Modeled Lift Stations	Capacity (gpm)		Total Capacity		Firm Capacity		Existing PWWF (mgd)	Capacity Deficient
	Pump No. 1	Pump No. 2	(gpm)	(mgd)	(gpm)	(mgd)		
MARB 1269	900	900	1800	2.59	900	1.30	1.06	No
Cajalco*	1000	1000	2000	2.88	1000	1.44	0.13	No
Dauchy	750	750	1500	2.16	750	1.08	0.63	No
Meridian	609	609	1218	1.75	609	0.88	0.84	No
Gamble	380	380	760	1.09	380	0.55	0.23	No
Markham*	1000	1000	2000	2.88	1000	1.44	1.86	Yes
Beazer 1*	114	114	228	0.33	114	0.16	0.25	Yes

Table 8-2: Existing PWWF Lift Station Capacity Analysis

Modeled Lift Stations	Capacity (gpm)		Total Capacity		Firm Capacity		Existing PWWF (mgd)	Capacity Deficient
	Pump No. 1	Pump No. 2	(gpm)	(mgd)	(gpm)	(mgd)		
Beazer 2*	114	114	228	0.33	114	0.16	0.13	No
Sky Ridge*	120	120	240	0.35	120	0.17	0.01	No

* Existing PWWF unavailable from metering data, modeled existing PWWF provided

Flow monitoring data at Markham during wet weather provided was unreliable (see Section 3.4.1 for a description of the data discrepancies at Markham lift station) and flow monitoring data for Beazer 1 was not available for this study, therefore model results were used to determine peak wet weather flow. Markham lift station is located between the WWRF and several upstream lift station flow meters, this configuration allowed for reasonable approximation of the Markham flows. Both Markham and Beazer 1 lift stations experienced modeled peak wet weather flows in excess of their current firm capacity. Recommendations are summarized below:

- Project WW-1 – Markham Lift Station Upgrades
 - Increase firm capacity of Markham lift station from 1.44 MGD to 2.1 MGD to accommodate Existing flows
- Project WW-2 – Beazer 1 Lift Station Upgrades
 - Increase firm capacity of Beazer 1 lift station from 0.16 MGD to 0.25 MGD to accommodate Existing flows

8.1.4 Treatment Capacity Analysis

Table 8-3 summarizes the existing average dry weather flow in each service area and the treatment capacity. This analysis does not include the additional 0.7 MGD flow that began in November 2020 from an unknown source, described in Section 2.4.1.2.

Table 8-3: Existing Wastewater Treatment Capacity

	WRCRWA ADWF	WWRF ADWF
Existing Base Flow (mgd):	0.85	1.17
Treatment Capacity (mgd):	1.93	3.00
Excess Capacity (mgd)	1.08	1.83
Capacity Utilized	44%	39%

Under existing PWWF conditions, both treatment plants can treat the influent flows with sufficient excess capacity.

8.2 Near-Term Collection System Capacity Evaluation

This section discusses evaluation of the existing wastewater system and evaluates the current system’s performance under Near-Term PWWF conditions utilizing the sewer model developed in Section 4.3. The evaluation criteria are described in detail in Section 5.3. Near-Term flow development is described in Section 3.4.2.

8.2.1 Gravity Sewer and Force Main System Analysis

A total 37 gravity sewer pipelines, including 20 pipes which were described in the Existing system section (Section 8.1) of the analysis, do not meet the capacity design criteria under the Near-Term peak wet weather flows, but none surpass the trigger criteria (Section 5.3). Table 8-4 summarizes the results of the Near-Term gravity sewer and force main analysis. The pipelines are shown on Figure 8-3 and Figure 8-4.

Table 8-4: Near-Term System Gravity Sewer and Force Main Analysis

No.	Description	Recommendation
1: Meridian South 1	8 sections of pipe, totaling 2,033 LF of 18" pipe reach a maximum d/D of 1 due to low slope, however other pipes see minor d/D increases of 0.06. The amount of the d/D increase is related to the slope of each segment. Despite the full pipe, no manholes surcharge. The pipes are shown in yellow and red on Figure 8-3.	Because there is no surcharging in the connected manholes and risk of an overflow is very low, it is recommended to monitor these pipes on a regular basis and clean as necessary to prevent reduced capacity.
2: Citrus Heights 1	One section of 12" VCP sewer main, totaling 275 LF experiences a d/D of 0.53 under existing PWWF. The pipe has a relatively low slope of 0.004 contributing to the d/D greater than the design criteria. The pipe is shown in yellow on Figure 8-3.	Because there is no surcharging in the connected manholes and risk of an overflow is very low, it is recommended to monitor these pipes on a regular basis and clean as necessary to prevent reduced capacity.
3: Meridian Trunk Sewer 1	One 500 LF segment of 24" pipe before the trunk sewer transitions to 30" diameter experiences a d/D of 1 under PWWF conditions. Low slope along with greater flows results in the full flowing pipe. No manholes surcharge.	Because there is no surcharging in the connected manholes and risk of an overflow is very low, it is recommended to monitor this pipeline on a regular basis and clean as necessary to prevent reduced capacity.

Figure 8-3: Near-Term Sewer Gravity and Force Main Recommendations 1

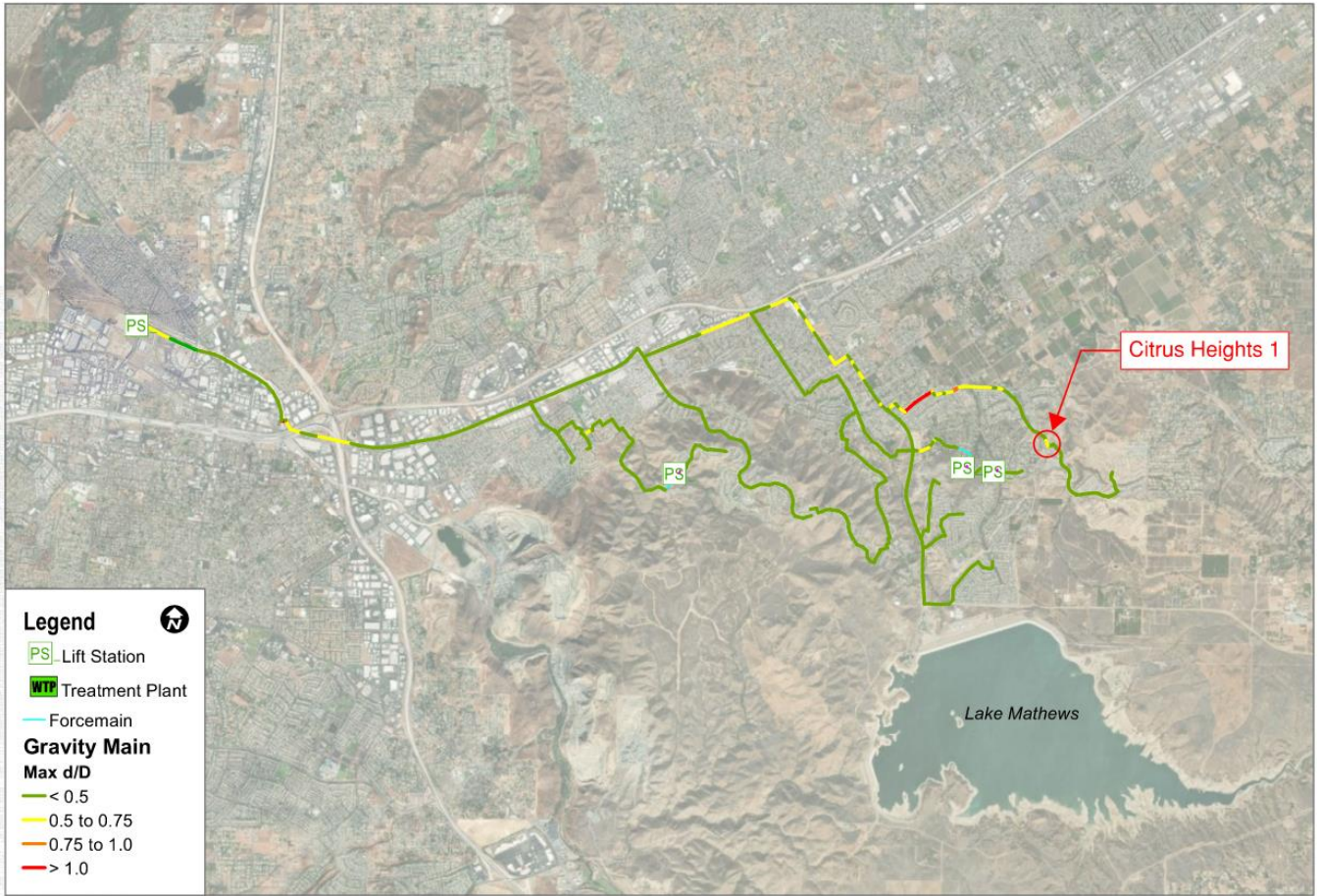
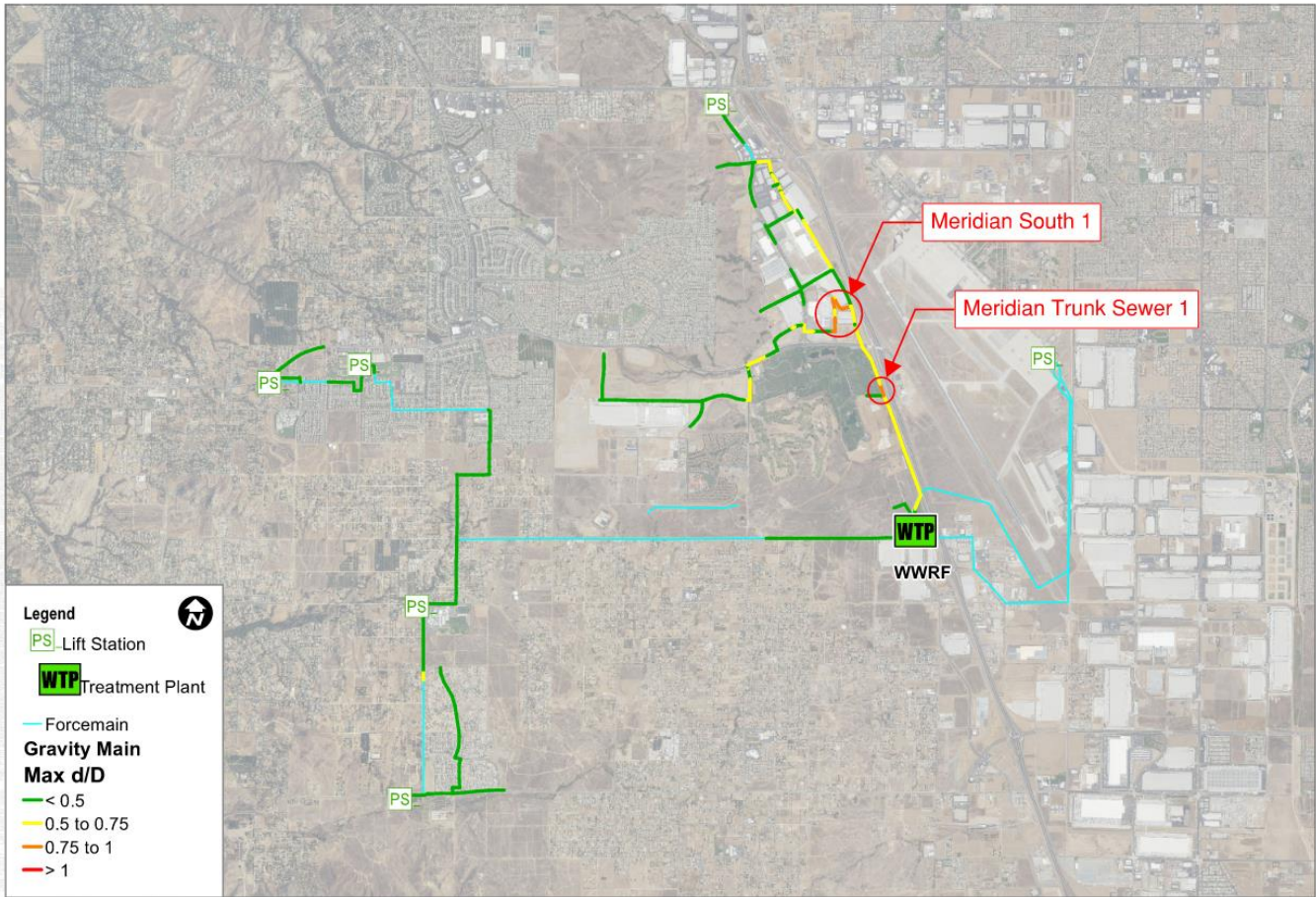


Figure 8-4: Near-Term Sewer Gravity and Force Main Recommendations 2



8.2.2 Siphon Analysis

All siphons were analyzed and found to achieve self-cleansing velocities under Near-Term dry weather flow.

8.2.3 Lift Station Analysis

For the existing sewer lift stations, Near-Term peak wet weather inflow modeled was compared against the firm capacity of the lift station. Only lift stations with upstream pipes 10” and larger in diameter were included in the model and analysis. Lift stations that exceeded their firm capacity were flagged for potential further review as a CIP project. In the existing condition three lift stations currently exceed their firm capacity, Table 8-5 summarizes the results.

Table 8-5: Near-Term PWWF Lift Station Capacity Analysis

Modeled Lift Stations	Capacity (gpm)		Total Capacity		Firm Capacity		Near-Term PWWF (mgd)	Capacity Deficient
	Pump No. 1	Pump No. 2	(gpm)	(mgd)	(gpm)	(mgd)		
MARB 1269	900	900	1800	2.59	900	1.30	1.06	No
Cajalco	1000	1000	2000	2.88	1000	1.44	0.59	No
Dauchy	750	750	1500	2.16	750	1.08	0.63	No
Meridian	609	609	1218	1.75	609	0.88	1.01	Yes

Table 8-5: Near-Term PWWF Lift Station Capacity Analysis

Modeled Lift Stations	Capacity (gpm)		Total Capacity		Firm Capacity		Near-Term PWWF (mgd)	Capacity Deficient
	Pump No. 1	Pump No. 2	(gpm)	(mgd)	(gpm)	(mgd)		
Gamble	380	380	760	1.09	380	0.55	0.23	No
Markham	1000	1000	2000	2.88	1000	1.44	2.07	Yes
Beazer 1	114	114	228	0.33	114	0.16	0.25	Yes
Beazer 2	114	114	228	0.33	114	0.16	0.07	No
Sky Ridge	120	120	240	0.35	120	0.17	0.01	No

Both Markham and Beazer 1 lift stations exceeded their respective firm capacities under existing flow conditions.

Under Near-Term peak wet weather flows the Meridian Lift Station experiences flows in excess of its firm capacity. As Near-Term projects are finalized, the loading of flows into the Meridian sewer system should be confirmed to validate the capacity deficiency at the lift station, however existing peak wet weather flows were at 95% of the existing firm capacity. Recommendations are summarized below:

- Project WW-3 – Meridian Lift Station Upgrades
 - Increase firm capacity of Meridian lift station from 0.88 MGD to 1.05 MGD to accommodate Near-Term flows. The design of this lift station is slated for improvements as a part of Western’s CIP program.

8.2.4 Treatment Capacity Analysis

Table 8-6 summarizes the Near-Term average dry weather flow in each service area and the treatment capacity.

Table 8-6: Existing Wastewater Treatment Capacity

	WRCRWA ADWF	WWRF ADWF
Near-Term Flow (mgd):	1.01	2.08
Treatment Capacity (mgd):	1.93	3.00
Excess Capacity (mgd)	0.92	0.92
Capacity Utilized	52%	69%

Under Near-Term development, flows to the WWRF are at 69% of the total treatment capacity of the plant in its current configuration, therefore it is recommended Western begin alternatives analysis for treatment plant expansion during the Near Term phase. Recommendations are summarized below:

- Project WW-4 –WWRF Expansion Study
 - Begin design analysis for expanding WWRF from 3.0 MGD to 5.0 MGD

8.3 Ultimate Collection System Capacity Evaluation

This section discusses evaluation of the existing wastewater system and evaluates the current system’s performance under Ultimate PWWF conditions utilizing the sewer model developed in Section 4.3. The evaluation criteria are described in detail in Section 5.3. Ultimate flow development is described in Section 3.4.2.

8.3.1 Gravity Sewer and Force Main System Analysis

A total 83 gravity sewer pipelines, including 37 pipes which were described in the Existing system and Near-Term analysis, do not meet the capacity design criteria under the ultimate peak wet weather flows, but none surpass the trigger criteria (Section 5.3). Table 8-7 summarizes the results of the gravity sewer and force main analysis. The pipelines are shown on Figure 8-5, Figure 8-6, and, Figure 8-7.

Table 8-7: Ultimate PWWF Gravity Sewer and Force Main Analysis

No.	Description	Recommendation
1: Fillmore 1	Four segments of 8" VCP sewer main, totaling 830 LF experience maximum d/D's ranging from 0.76 to 1 under existing PWWF. The pipes have a relatively low slope of 0.004 contributing to the d/D greater than the design criteria.	Because there is no surcharging in the connected manholes and risk of an overflow is very low, it is recommended to monitor these pipes on a regular basis and clean as necessary to prevent reduced capacity.
2: Dauchy 2	Two segments of 8" VCP sewer main, totaling 460 LF experience a d/D of 0.53 under existing PWWF. The pipes have a relatively low slope of 0.004 contributing to the d/D greater than the design criteria.	Because there is no surcharging in the connected manholes and risk of an overflow is very low, it is recommended to monitor these pipes on a regular basis and clean as necessary to prevent reduced capacity.
3: McKinley 2	Five segments of pipe, totaling 782 LF experience peak velocities of 11.4 fps under PWWF due to high slopes.	Due to the high velocity, the pipes should be inspected regularly to verify no excessive wear is occurring.
4: McKinley 3	32 sections of pipe, totaling 11,300 LF of 8-15" VCP pipe reach a maximum d/D of 1 due to low slope, however other pipes see minor d/D increases of 0.036. The amount of the d/D increase is related to the slope of each segment. Despite the full pipe, no manholes surcharge.	Because there is no surcharging in the connected manholes and risk of an overflow is very low, it is recommended to monitor these pipes on a regular basis and clean as necessary to prevent reduced capacity.
5: McKinley 4	2 segments of pipe, totaling 165 LF, of 8" pipe reaches a maximum d/D of 1 due to low slope. Despite the full pipe, no manholes surcharge.	Because there is no surcharging in the connected manholes and risk of an overflow is very low, it is recommended to monitor these pipes on a regular basis and clean as necessary to prevent reduced capacity.
6: McKinley 5	Two segments of 8" pipe totaling 200 LF experience a d/D of 1 under existing PWWF. The pipe is directly downstream of where the Sky Ridge LS force main breaks head and both pipes have low	Because there is no surcharging in the connected manholes and risk of an overflow is very low, it is recommended to monitor these pipes on a regular basis and clean as necessary to prevent reduced capacity.

Table 8-7: Ultimate PWWF Gravity Sewer and Force Main Analysis

No.	Description	Recommendation
	slope of 0.004 contributing to the d/D greater than the design criteria.	
7: Markham Force Main 1	The Markham force main breaks head and enters the gravity sewer system along Nandina Avenue. Under peak wet weather conditions, flows reach 11 feet per second in a single 161 LF segment of 15" PVC pipe before attenuating to a lower velocity.	Due to the high velocity, the pipe should be inspected regularly to verify no excessive wear is occurring.

Figure 8-5: Ultimate Sewer Gravity and Force Main Recommendations 1

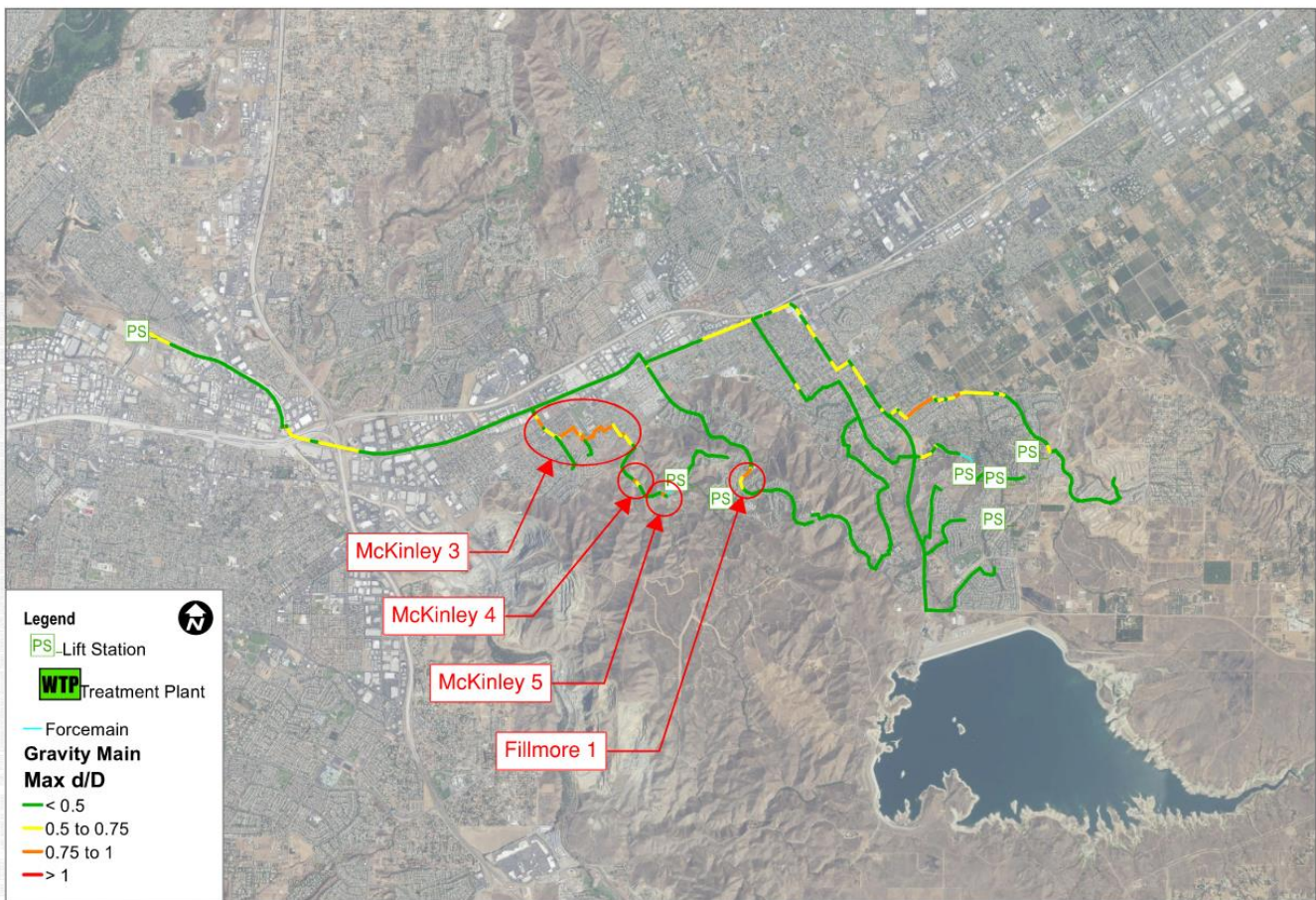
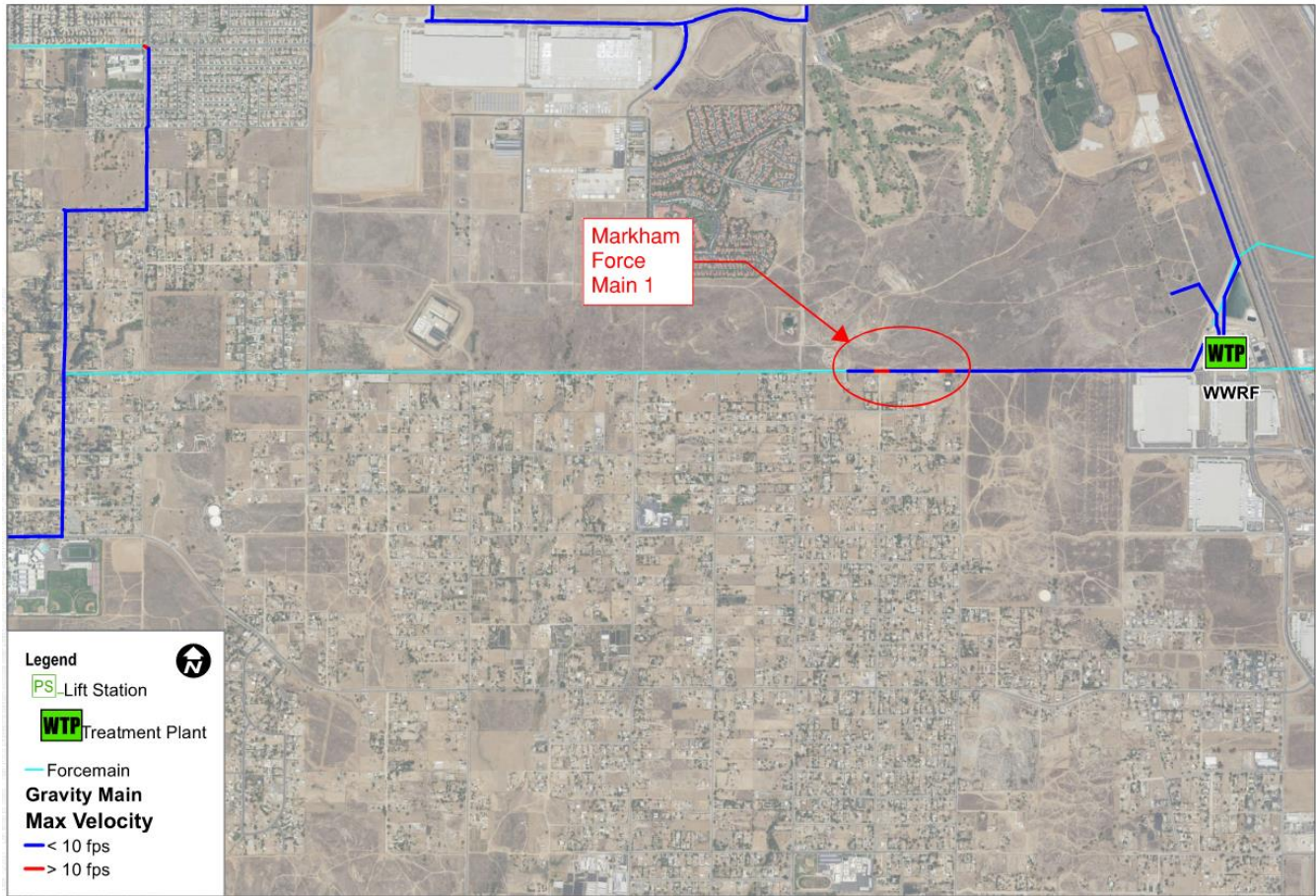


Figure 8-6: Ultimate Sewer Gravity and Force Main Recommendations 2



Figure 8-7: Ultimate Sewer Gravity and Force Main Recommendations 3



8.3.2 Siphon Analysis

All siphons were analyzed and found to achieve self-cleansing velocities under Ultimate dry weather flow.

8.3.3 Lift Station Analysis

For the existing sewer lift stations, Ultimate peak wet weather inflow modeled was compared against the firm capacity of the lift station. Only lift stations with upstream pipes 10” and larger in diameter were included in the model and analysis. Lift stations that exceeded their firm capacity were flagged for potential further review as a CIP project. In the existing condition four lift stations currently exceed their firm capacity, Table 8-8 summarizes the results.

Table 8-8: Ultimate PWWF Lift Station Capacity Analysis

Modeled Lift Stations	Capacity (gpm)		Total Capacity		Firm Capacity		Ultimate PWWF (mgd)	Capacity Deficient
	Pump No. 1	Pump No. 2	(gpm)	(mgd)	(gpm)	(mgd)		
MARB 1269	900	900	1800	2.59	900	1.30	3.56	Yes
Cajalco	1000	1000	2000	2.88	1000	1.44	0.67	No
Dauchy	750	750	1500	2.16	750	1.08	1.01	No
Meridian	609	609	1218	1.75	609	0.88	1.06	Yes

Table 8-8: Ultimate PWWF Lift Station Capacity Analysis

Modeled Lift Stations	Capacity (gpm)		Total Capacity		Firm Capacity		Ultimate PWWF (mgd)	Capacity Deficient
	Pump No. 1	Pump No. 2	(gpm)	(mgd)	(gpm)	(mgd)		
Gamble	380	380	760	1.09	380	0.55	0.33	No
Markham	1000	1000	2000	2.88	1000	1.44	2.60	Yes
Beazer 1	114	114	228	0.33	114	0.16	0.25	Yes
Beazer 2	114	114	228	0.33	114	0.16	0.08	No
Sky Ridge	120	120	240	0.35	120	0.17	0.01	No

Both Markham and Beazer 1 lift stations exceeded their respective firm capacities under existing flow conditions.

Meridian lift station exceeded its firm capacity under Near-Term flow conditions.

Under Ultimate peak wet weather flows the MARB 1269 lift station experiences flows in excess of its firm capacity. The size and scope of future development on MARB is not finalized. As the Near-Term and Ultimate development of MARB projects are finalized, loading of flows upstream of the MARB 1269 lift station can be refined and the capacity of lift station can be validated. Recommendations are summarized below:

- Project WW-5 – MARB 1269 Lift Station Upgrade Study
 - Study required firm capacity increase of the MARB 1269 lift station to accommodate Build Out flows

8.3.4 Treatment Capacity Analysis

Table 8-9 summarizes the Ultimate average dry weather flow in each service area and the treatment capacity:

Table 8-9: Ultimate Wastewater Treatment Capacity

	WRCRWA ADWF	WWRF ADWF
Ultimate Flow (mgd):	1.54	2.79
Treatment Capacity (mgd):	1.93	3.00
Excess Capacity (mgd):	0.39	0.21
Capacity Utilized:	80%	93%

Under Ultimate development, flows to the WWRF reach 93% of the current 3.0 mgd capacity of the plant. Flows into WRCRWA reach 80% of available capacity, however flows do not exceed the purchased treatment capacity.

8.4 Wastewater Collection System Proposed Improvements

The recommended system improvements and operational modifications to the wastewater collection system include the following:

Existing:

- Include previously identified pipelines on a regular inspection and cleaning schedule.
- WW-1: Markham Lift Station: Analyze flow meter data for other wet weather events to determine if peak wet weather flows exceed the lift station firm capacity. If the firm capacity is exceeded, the lift station should be upgraded to a firm capacity able to accommodate both existing and Near-Term wet weather flows. Based on the results of the model, the recommended upgraded firm capacity is 2.1 MGD to accommodate near term flows.
- WW-2: Beazer 1 Lift Station: Analyze flow meter data for other wet weather events to determine if peak wet weather flows exceed the lift station firm capacity. If the firm capacity is exceeded, the lift station should be upgraded to a firm capacity able to accommodate existing wet weather flows, as the tributary area upstream of the lift station is built out. Based on the results of the model, the recommended upgraded firm capacity is 0.25 MGD to accommodate the existing flows.

Near-Term (2030):

- Include previously identified pipelines on a regular inspection and cleaning schedule.
- WW-3: As Near-Term projects are finalized, the loading of flows into the Meridian sewer system should be confirmed to validate the capacity deficiency at the lift station, however existing peak wet weather flows were at 95% of the existing firm capacity. Based on the existing peak wet weather flows and the proposed development in the Meridian basin, it is recommended the lift station be upgraded to a firm capacity of 1.05 mgd to accommodate near term flows.
- WW-4: Flows into the WWRF under Near-term exceed 77% of the plant's total capacity. In preparation for these planned flow increases, it is recommended Western study plant expansion alternatives.

Ultimate (Buildout):

Due to the uncertain nature of Ultimate (Buildout), the improvements recommended for MARB 1269 lift station should be re-evaluated as more information becomes available to validate the analysis results.

- Include previously identified pipelines on a regular inspection and cleaning schedule
- WW-5: Study required firm capacity increase of the MARB 1269 lift station to accommodate Build Out flows

Due to the nature of the wastewater model created for this study, any future projects that propose connecting into 8-inch diameter sewers should receive thorough analysis. Because not all small diameter pipes were modeled, the loads from these developments could exceed the capacity of small diameter sewers at the periphery of the system. It is recommended that Western carefully review the hydraulic impact of any new developments which tie into small diameter mains and consider requiring the developer to upsize the existing pipe when appropriate.

INTENTIONALLY LEFT BLANK

9 Capital Improvement Plan

This section incorporates the findings of previous sections and outlines the estimated costs of the identified system improvements. The identified improvements are subsequently prioritized into a recommended list of projects for consideration by Western into the annual capital improvement program (CIP) based on the assessment of potential risks.

9.1 Project Costs

The cost estimates presented in this FMP are opinions developed from recent bid tabulations, cost curves, previous studies, and experience on similar projects. Construction costs are representative of facilities under typical construction conditions and schedules for public works construction. The costs have been updated to current Engineering News Record (ENR) Construction Cost Index (CCI) for the Los Angeles area, which is 12704 for October 2021.

9.1.1 Unit Construction Cost

Several unit construction costs were utilized for development of costs in this FM. These are included in individual project cost estimates (Appendix D). Unit costs include costs per inch diameter per lineal foot for pipelines and cost per horsepower for a pump station. Additional soft costs/project costs are developed from construction costs by including percentages of the construction cost estimates to account for engineering, surveys, construction management and inspection, administrative costs, and overhead and profit. These percentages add up to a 63% mark-up on top of overall construction cost. A project contingency of twenty percent (20%) is also added to the construction cost to account for the project uncertainties at a planning level estimate. This results in an overall mark-up of 83% of estimated construction costs. Environmental permitting has not been included within the estimated project costs.

9.1.2 Total Project Cost

Table 9-1 lists the proposed projects and provides an opinion of probable project costs, which are planning-level estimates. The cost opinions are based on the unit construction costs and project soft cost percentages discussed in Section 9.1.1. Individual project cost estimates are included in Appendix D. In total there \$66.66M in project costs for recommended water CIP projects, \$41.52M in project costs for recommended recycled water CIP projects, and \$6.33M in project costs for recommended wastewater CIP projects (not including construction cost for WWRF expansion; just planning cost). This results in a total of \$114.51M CIP program for all three water services.

9.2 Prioritization

9.2.1 CIP Phasing

Phasing/Prioritization of the recommended CIP projects is based on the existing, near-term, and ultimate conditions, previously defined by this FMP (See Table 9-1). Projects triggered by an existing capacity constraint are prioritized in the first phase of development, while those triggered by near-term and ultimate conditions are in the later two phases. The phases are intended to be fluid, and may be updated as projects triggered by new development may need to occur sooner or later depending on project developments that are built sooner or later than assumed schedules.

9.3 Recommended Improvement Projects

The recommended list of projects presents listed in Table 9-1 are based on the potable water, recycled/non-potable water and wastewater collection system evaluations described in Chapters 6, 7, and 8 of this FMP and shown in Figure 9-1. There are a total of nineteen (19) recommended projects: twelve (12) water projects, two (2) recycled water projects and five (5) wastewater projects. The list of projects is divided into three phases, current, near-term through year 2030 (10-year) and the ultimate (>2030).

Table 9-1: Recommended Improvement Projects

CIP No	Project Name	Description	Justification	Project Costs (Dollars in Millions)		
				Existing	Near-Term	Ultimate
W-1	Moonridge Dr Pipeline Upsizing	Upsize 1,200 LF of 6-inch to 12-inch	High velocity in the pipe due to the small diameter bottleneck. Will improve transmission west.	\$0.69		
W-2	Blackburn Rd Pipeline Upsizing	Upsize 8,000 LF of 6-inch to 8-inch	Improve fire flow to the area and break history suggested poor pipe condition	\$3.06		
W-3	Cedar St and Ave D Pipeline Upsizing	Upsize 4,000 LF of 6-inch to 8-inch	Low fire flow in the area can be improved with pipeline upsizing	\$1.53		
W--4	Lurin Ave Pipeline Upsizing	Upsize 4,000 LF of 6-inch to 12-inch	High velocity in pipeline due to increased demand on a small diameter pipeline			\$2.29
W-5	Wood Rd Pipeline Upsizing	Upsize 7,000 LF of 12-inch to 16-inch	High velocity in transmission from Markham tanks due to increased demand in 1900 PZ at Ultimate			\$5.35
W-6	Via Barranca Pipeline Upsizing	Upsize 4,200 LF of 8-inch to 12-inch	Increasing the pipeline capacity will increase supply into the zone, improving fire flow capacity throughout the zone.			\$2.41
W-7	Hidden Valley #2 Tank	Build new 2.7 MG tank at Hidden Valley site	Additional storage capacity in 2320 PZ necessary at Ultimate			\$10.74
W-8	2320 PZ Tank	Build new 3 MG tank to serve 2320 PZ	Additional storage capacity in 2320 PZ is necessary at Ultimate			\$11.93

Table 9-1: Recommended Improvement Projects

CIP No	Project Name	Description	Justification	Project Costs (Dollars in Millions)		
				Existing	Near-Term	Ultimate
W-9	2320 PZ Booster Pump Station	Build new booster pump station with four 150 HP pumps, Add new intake and discharge piping	Additional pumping capacity into 2320 PZ is necessary at Ultimate			\$4.34
W-10	Orangecrest #3 Tank	Build new 5 MG tank at Orangecrest site	Additional storage capacity in 1837 PZ is necessary at Ultimate			\$19.89
W-11	El Nido #2 Tank	Build new 1 MG tank at El Nido site	Additional storage capacity to 2450 PZ necessary at Ultimate			\$3.98
W-12	Increase capacity of Intake BPS	New 150 HP pump at Intake pump station	Additional pumping capacity to 1783 PZ necessary at Ultimate			\$0.45
<i>Subtotal Water Projects</i>				\$5.28	\$ —	\$61.38
RW-1	1815 PZ Near Term Improvements	5 MG Orangecrest Tank \$19.9M Redesign Lurin Tank to have same HGL as new Orangecrest Tank \$2.0M 12-inch supply line \$4.0M 4,400 LF of 16-inch pipe \$3.4M 1,300 LF of 18-inch pipe \$1.1M 3,500 LF of 24-inch pipe \$4.0M 200 HP pump at Cemetery PS with 6,000 LF parallel 250 HP pump at McAllister PS 150 HP pump at El Sobrante PS	Increased zone storage and pipeline looping required to accommodate existing demands as well as improve zone pressures		\$35.5	

Table 9-1: Recommended Improvement Projects

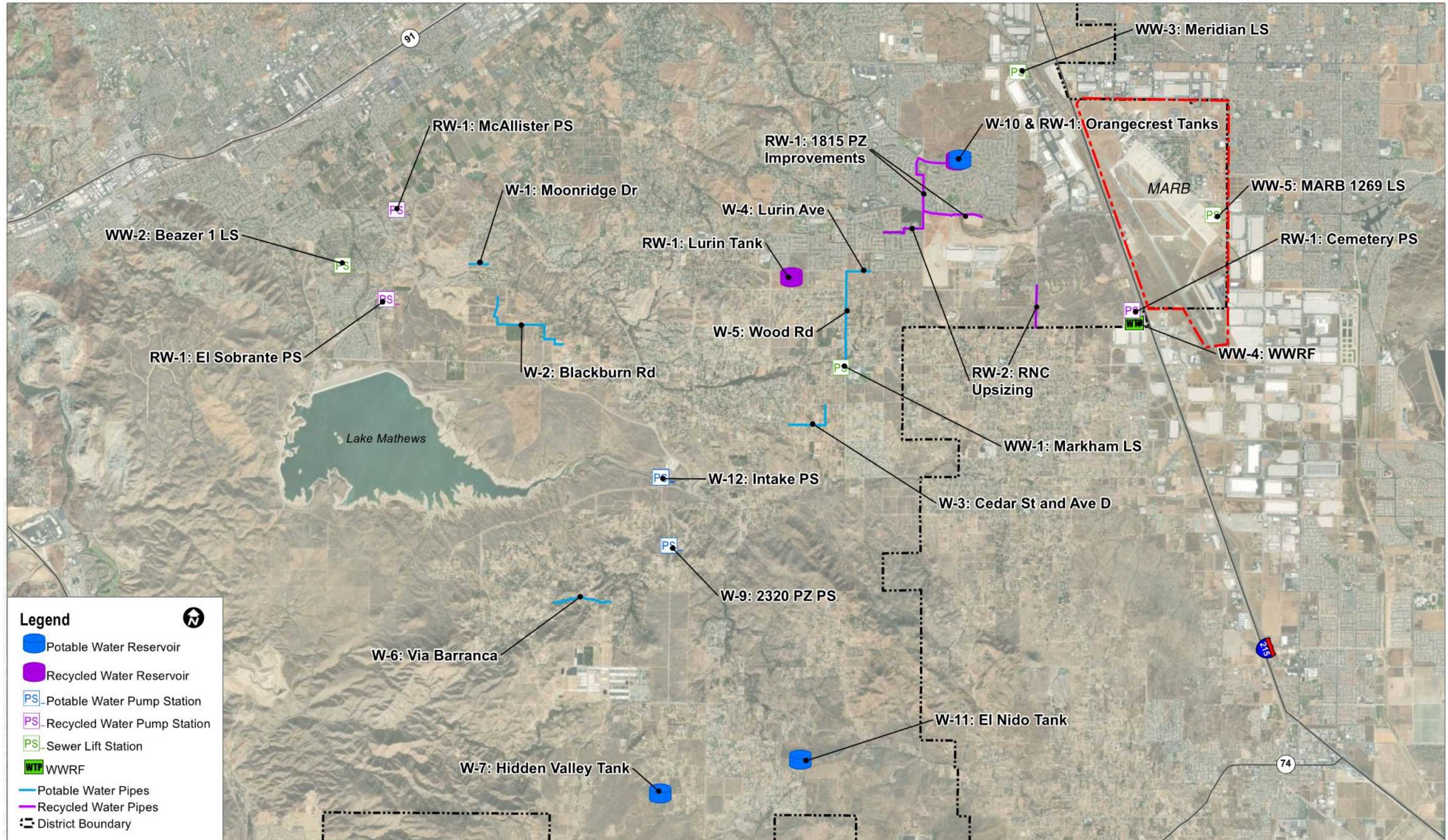
CIP No	Project Name	Description	Justification	Project Costs (Dollars in Millions)		
				Existing	Near-Term	Ultimate
RW-2	RNC Pipeline Upsizing	Upsize 3,000 LF of 12-inch to 18-inch, Upsize 3,000 LF of 16-inch to 24-inch	Timing based on expansion of RNC.			\$6.02
<i>Subtotal Recycled Water Projects</i>				\$ —	\$35.5	\$6.02
WW-1	Markham Lift Station Upgrade	Increase firm capacity from 1.44 MGD to 2.1 MGD to accommodate Near-Term flows	Based on the model results the Markham lift station currently exceeds its firm capacity during wet weather events which would result in SSO's, creating a public safety hazard.	\$5.15		
WW-2	Beazer Lift Station Upgrade	Increase firm capacity from 0.16 MGD to 0.25 MGD to accommodate existing flows	Based on the model results the Beazer 1 lift station currently exceeds its firm capacity during wet weather events which would result in SSO's, creating a public safety hazard.	\$0.43		
WW-3	Meridian Lift Station Upgrade	Increase firm capacity from 0.88 MGD to 1.05 MGD to accommodate Near-Term flows	Based on the model results the Meridian lift station currently exceeds its firm capacity during wet weather events which would result in SSO's, creating a public safety hazard.		\$0.60	
WW-4	WWRF Expansion Study	Begin design analysis for expanding WWRF from 3.0 MGD to 5.0 MGD	Based on approved projects, the plant will be utilizing 77% of its capacity by the end of the Near-Term phase, future increases in flow would result in SSO's, creating a public safety hazard.		\$0.10	

Table 9-1: Recommended Improvement Projects

CIP No	Project Name	Description	Justification	Project Costs (Dollars in Millions)		
				Existing	Near-Term	Ultimate
WW-5	MARB LS 1269 Expansion Study		Dependent on final build out configuration for MARB, LS 1269 firm capacity may be deficient			\$0.05
<i>Subtotal Sewer Projects</i>				\$5.58	\$0.70	\$0.05
Total All Projects				\$10.86	\$36.2	\$ 67.45

INTENTIONALLY LEFT BLANK

Figure 9-1: CIP Summary Map



INTENTIONALLY LEFT BLANK

Appendix A

WMWD Riverside Retail Service Area Build-Out Demand Analysis
(2019, Kennedy Jenks)

31 July 2019

Memorandum

To: Ms. Karly Gaynor

From: Melanie Rivera, Jamie Kolkey, and Sachi Itagaki

Reviewed by Meredith Clement

Subject: Western Municipal Water District Riverside Retail Service Area Build-Out Demand Analysis
K/J 1868010*00

1.0 Introduction

The purpose of this build-out demand analysis is to assist the Western Municipal Water District (WMWD, Western, or District) plan for their future water supply sources and water delivery infrastructure to support current and future customers in the Riverside Retail Service Area. This study focuses on the build-out demand assuming full parcel development within the service area by breaking down the parcels by land use type and applying estimated land-use based unit demands to best represent the future growth of the Riverside Retail Service Area.

2.0 Data Sources

2.1 Western Meter Data

WMWD provided annual water use by Riverside Service Area Users from January 2017 to December 2017 in the form of monthly meter readings in units of hundreds of cubic feet (CCF). The data provided includes account numbers, customer numbers, service type, service description, customer addresses, and corresponding monthly meter readings for 2017.

2.2 Riverside Service Area Meters GIS Data

A GIS shapefile, "ServicePoints," of all the potable water meters in the Riverside service area was provided by Western. The shapefile contains information regarding the Accessor Parcel Number (APN), account numbers, and spatial location associated with each meter.

2.3 Riverside Service Area Parcel Data

A GIS shapefile, "RetailServiceArea," was provided to determine the boundaries of the District's Riverside Retail Service Area. This boundary included parcels that utilize both sewer and water connections. In order to analyze the water connections only, an updated GIS shapefile, "RetailEdit," was provided. Further description of this process can be found in Section 3.3. In addition, the GIS shapefile "ParcelAssessor" was downloaded from Riverside County's website

Memorandum

Ms. Karly Gaynor
31 July 2019
1868010*00
Page 2

and contains data on all parcels within Riverside County. The shapefile contains the attributes about the parcels including APNs, addresses, and the size of each parcel in square feet.

2.4 Riverside Service Land Use Data

A GIS shapefile, “GeneralPlanLanduse,” was provided by Riverside County, indicating land uses designated in the 2015 Riverside County General Plan (General Plan). The land uses include: residential rural community, estate density residential, low density residential, medium density residential, high density residential, commercial retail, commercial, industrial, business park, public facilities, mixed use area, rural, agriculture, conservation, open spaces, Indian lands, city, and freeway.

For the purposes of the analysis, the land uses were simplified into: agriculture, commercial, conservation, high density residential, Indian lands, industrial, low density residential, medium density residential, the March Air Reserve Base (MARB), mineral resources, mixed use, open space, public facilities, roads, rural residential, and water. Upon further evaluation of the broad land use “city” through looking at satellite data in Google Earth, it was found that the land use “city” encompassed residential neighborhoods, schools, and open space. Thus, a decision was made to categorize “city” as “mixed use.” Further analysis in the MARB area can be found in Section 3.4.

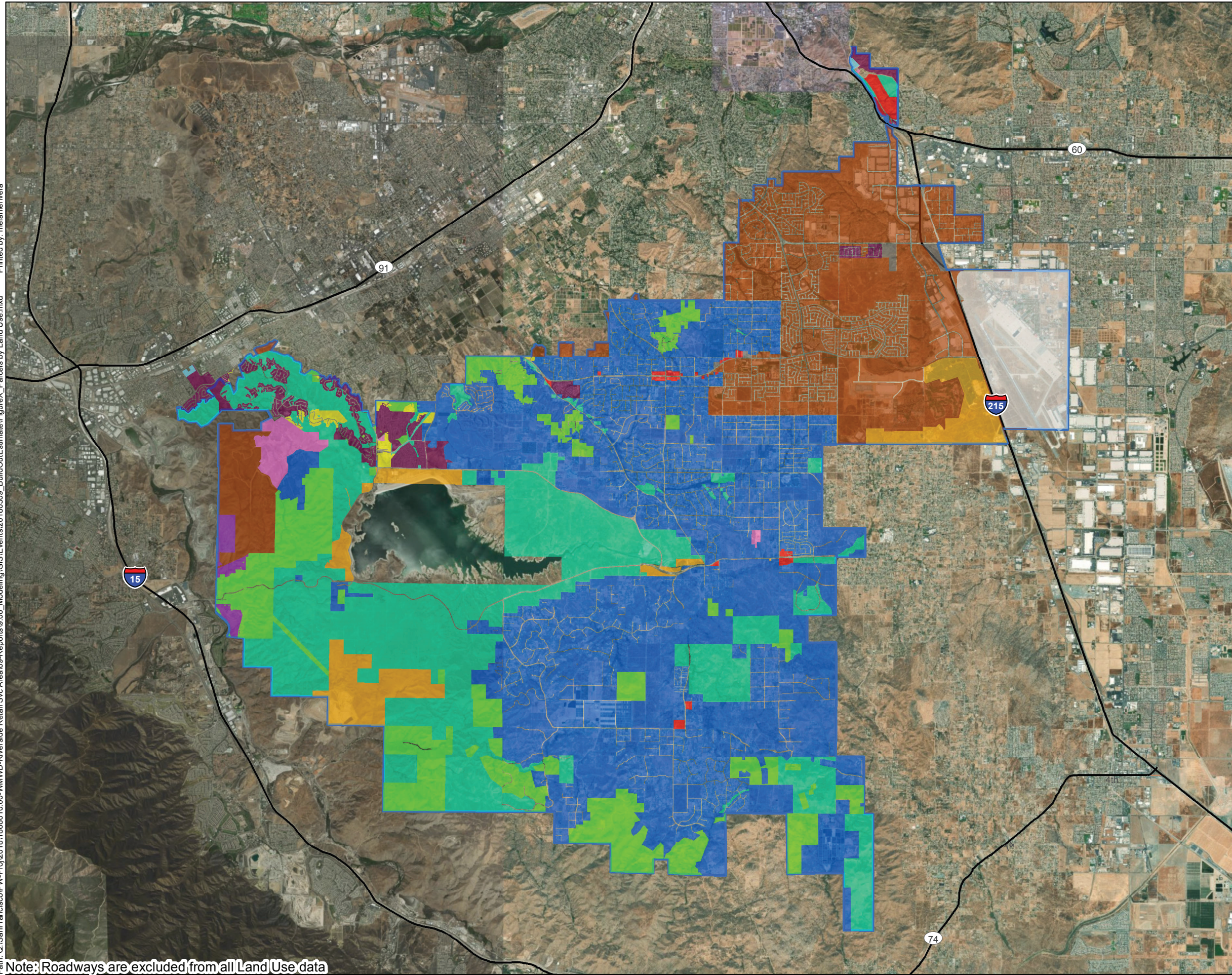
3.0 Methodology

The following sections describe the methods used to analyze existing data to estimate unit demands, identify undeveloped parcels, and estimate build-out demands for the Riverside service area.

3.1 Assigning Land Uses

The General Plan land use shapefile was utilized for assigning land uses to each parcel. The General Plan shapefile does not indicate land uses on a parcel to parcel basis; rather, it assigns larger general areas different land use types. To assign land uses to individual parcels, the centroid of each parcel was assigned the land use with which it intersected. This methodology accounts for parcels that intersect more than one land use because it assigns the parcel the land use that covers the majority of area on the parcel. **Error! Reference source not found.** shows the land use assignments within the District’s Riverside Retail Service Area based on the General Plan.

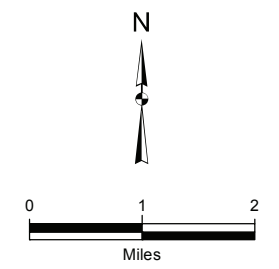
Path: Q:\SanFrancisco\PW-Proj\2018\1868010.00-WMWD-Riverside Retail Svc Area\09-Reports\9.06_Modeling\GIS\Estimate\FigureX_Parosis by Land Use.mxd Printed by: melanierivera



Legend

Land Use

- Agriculture
- Commercial
- Conservation
- High Density Residential
- Industrial
- Low Density Residential
- MARB
- Medium Density Residential
- Mineral Resources
- Mixed Use
- Open Space
- Public Facilities
- Rural Residential
- Retail Service Area



KJ Kennedy Jenks

Riverside Build-Out Demand Projection
Riverside, California

Riverside County General Plan Land Use Assignments

KJ 1868010*00

Figure 1

Note: Roadways are excluded from all Land Use data

Memorandum

Ms. Karly Gaynor

31 July 2019

1868010*00

Page 4

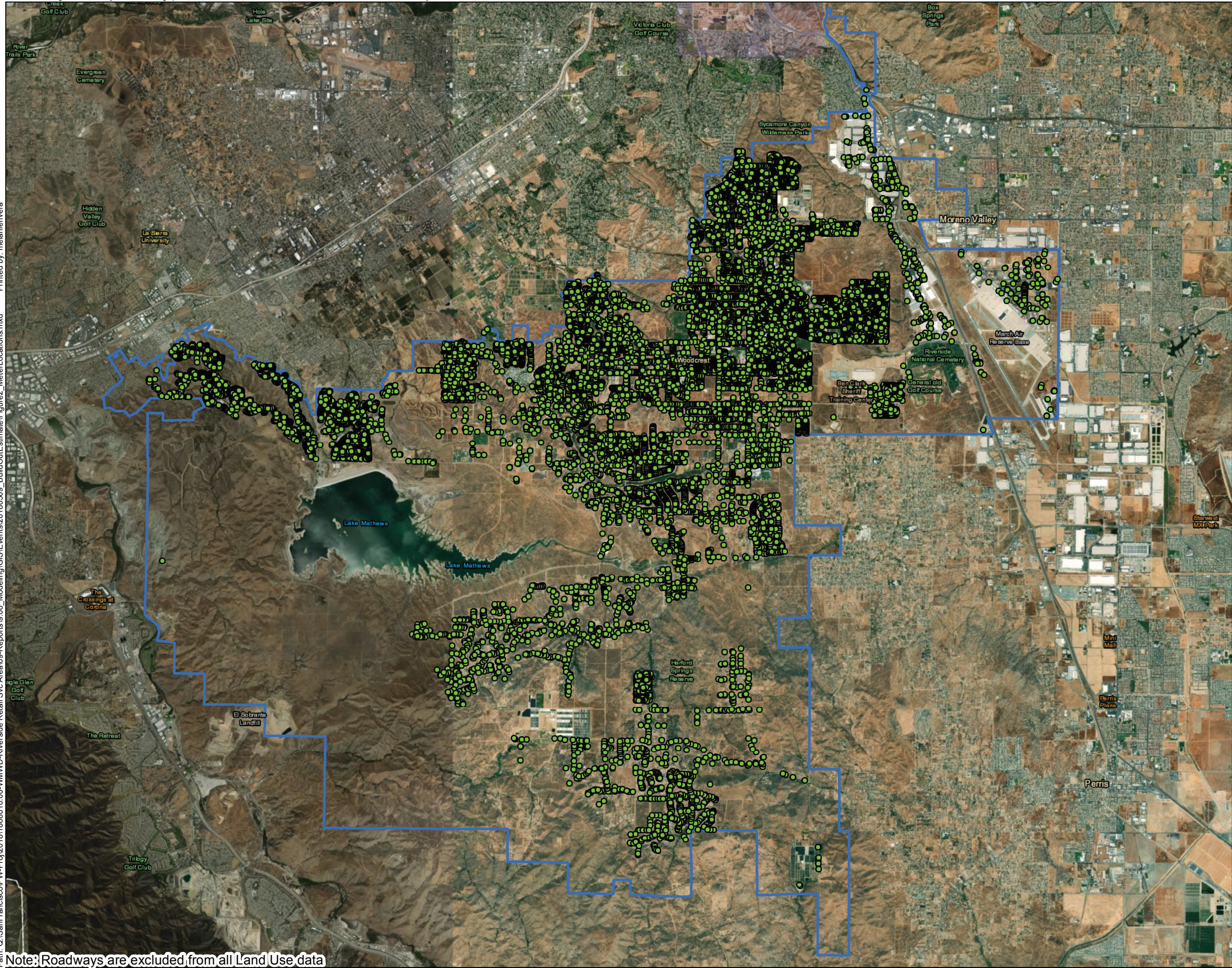
3.2 Assigning Existing Demand Data

Calendar year 2017 meter data (2017 Baseline) were used in this effort as the most recent year with a full data set at the time of the study. The meter data represent both indoor and outdoor usage at any given parcel. Meter data were matched to parcels in GIS iteratively, first using APN, then address for those that did not match with APN, then finally latitude/longitude. The location of existing meters in the Riverside Retail Service Area is shown on Figure 2.

All parcels with meters are considered developed and those without meters were considered undeveloped with potential for future demand. Monthly demands from the Riverside Retail Service Area meter readings were aggregated for parcels with multiple customers. The aggregated demands were then geocoded (assigned to parcels) using the methodology described below.

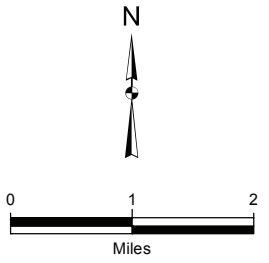
The monthly meter readings totaling 22,072 acre-feet (AF) for 2017 were first analyzed to assign individual demands per parcel. Fire hydrants and temporary demands were excluded from the analysis. Twelve meters constituting approximately 555 AF were then deleted because they were duplicated with other meters. Next, meters that did not include latitude/longitude, address, or APN were extracted and sent to the District for review. Initially, 792 meters totalling to approximately 1,400 AF were unmatched. The District provided updated locations for many of these meters, which were included in the analysis. Lastly, 23 meters that were outside of the service area boundary, constituting 44 AF, were excluded from the analysis. A total of 21,246 AF were geocoded via latitude/longitude, address, or matching APNs between the meters and parcels based on the available information for each meter. A total of 227 AF or 1% of the total developed demands could not be matched and were distributed proportional to the percentage of developed area by land use.

Path: Q:\SanFrancisco\PW-Proj\2018\1868010.00-WMWD-Riverside Retail Svc Area\09-Reports\9.06_Modeling\GIS\Estimate\Figure2_MeterLocations.mxd Printed by: melanierivera



Legend

- Meters
- Retail Service Area



KJ Kennedy Jenks

Riverside Build-Out Demand Projection
Riverside, California

Riverside Service Area Meter Locations

KJ 1868010*00

Figure 2

Note: Roadways are excluded from all Land Use data

Memorandum

Ms. Karly Gaynor
 31 July 2019
 1868010*00
 Page 6

Table 1 presents the distribution of existing developed demand by land use.

Table 1: Total 2017 Baseline Developed Demands with Distributed Unmatched Demands

Land Use	Developed Area (Acres)	% of Total Area	Developed Demands (AFY)	Developed Demands with Unmatched APNs (AFY)	Total Developed Demands (AFY)
Agriculture	20	0.9%	42	0.2	42
Commercial	77	0.5%	48	1	49
Conservation ^a	1,311	14.3%	248	15	263
Industrial	12	0.2%	3	0	3
Low Density Residential	105	0.4%	206	1	207
MARB	478	4.7%	158	5	163
Medium Density Residential	776	2.3%	1,945	9	1,954
Mineral Resources	1	0.5%	0.12	0	0.12
Mixed Use	5,094	16.5%	9,028	58	9,086
Open Space ^a	494	8.8%	288	5	293
Public Facilities	259	3.5%	1,117	3	1,120
Rural Residential	11,152	41.8%	7,745	125	7,870
Roadway	370	5.7%	420	4	424
Total	20,148	-	21,246	227	21,473

^a Some water usage has been attributed to conservation and open space land uses; the land use designation could have occurred after the usage had been established and represents a small proportion of overall demands

3.3 Identifying Undeveloped Parcels

An “undeveloped” category was assigned to parcels that do not contain a meter and therefore do not have monthly meter readings associated with them. Upon visual review of the aerial photograph, several parcels considered “undeveloped” by the aforementioned criteria were in actuality developed. These undeveloped parcels were categorized as high density residential and contained apartment or condominiums within their boundaries. It was then verified by Western that these high density residential customers were within the District’s service area boundaries, but were connected via sewer connections only. Hence, a revised water-service only boundary omitting these sewer-only high density residential neighborhoods was used for the rest of the analysis. Table 3 in Section 3.5 summarizes the acreages of developed and undeveloped parcels by land use.

In addition, several parcels within MARB had developments and were still categorized as “undeveloped” because they did not have individual meter accounts but could be served by a master meter. The parcels within the entire MARB area required further analysis before the true

Memorandum

Ms. Karly Gaynor
 31 July 2019
 1868010*00
 Page 7

“undeveloped” category was assigned. This parcel categorization process is further described in Section 3.4. The final distribution of undeveloped parcels aggregated by land use is illustrated on Figure 3.

3.4 March Air Reserve Base Analysis

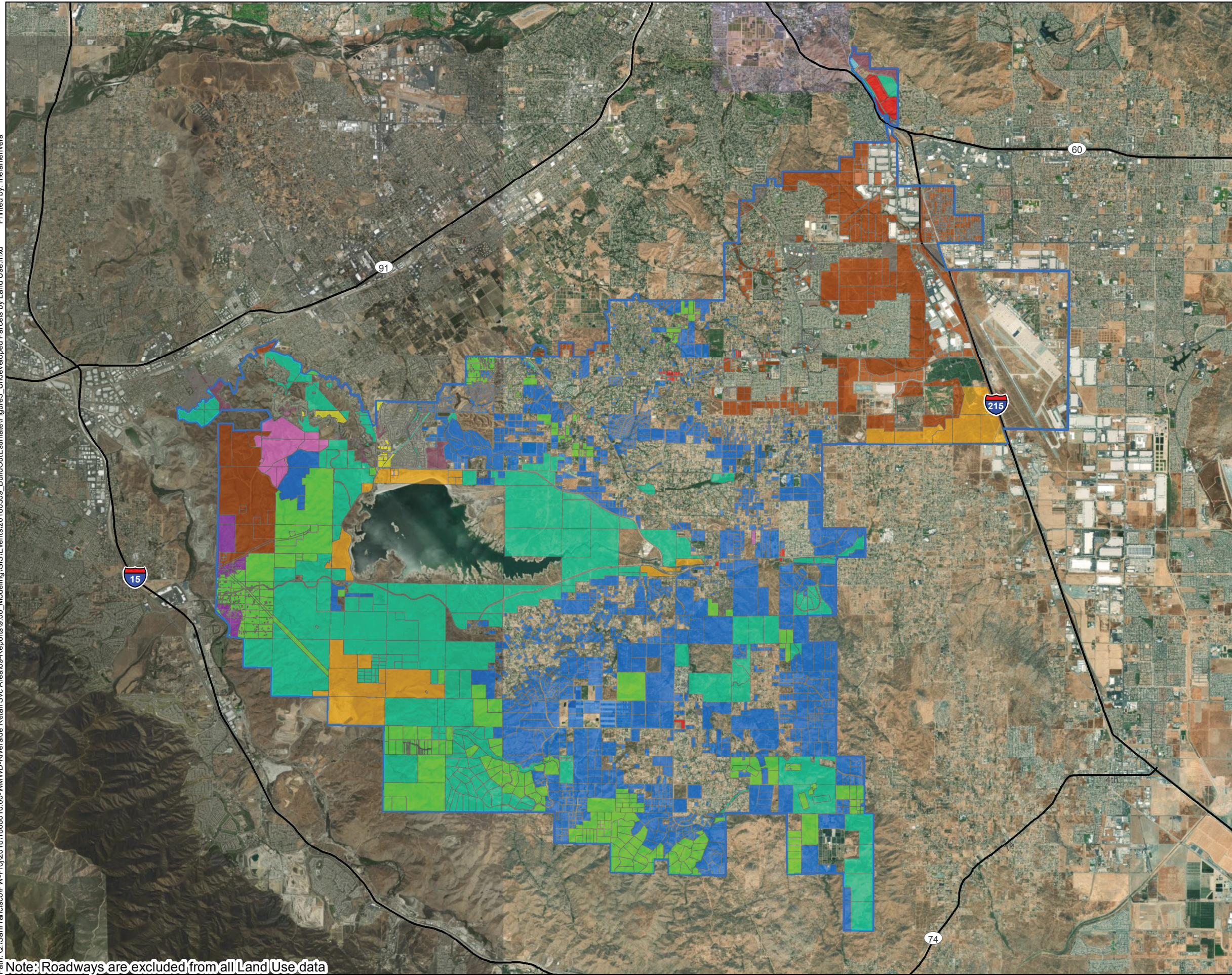
The MARB required further examination due to its limited land use and meter data since Western currently provides water to several master meters and will provide future metered connections to several parcels on the MARB. Therefore, Western provided further information about land use and demand designation within MARB, shown on **Error! Reference source not found.** as follows: hospital; hospital – developed; supply study 1; supply study 2; MB1; MB2; MB3; MB4; developed; and airfield. Guidance on development assumptions for these designated areas was provided by Western in order to estimate future demand in each of their respective areas. The airfield cannot be developed and was therefore excluded from the analysis of future demand as shown on Figure 5. Table 2 summarizes the areas within MARB, their acreage, level of development and estimated acres that will have water demand in the future

Table 2: Developed and Undeveloped Acreage at MARB

MARB Category	Total Area (Acres)	% Currently Developed	Acres for Development (Current and Future)	Acres to Remain Undeveloped
Airfield	1,410	68%	957	453
Developed	282	100%	282	n/a
Hospital	111	13%	15	97
Hospital - Developed	25	100%	25	0
MB1	172	88%	152	20
MB2	152	100%	152	0
MB3	211	50%	106	104
MB4	107	33%	35	72
Supply Study 1	24	0%	0	24
Supply Study 2	235	0%	0	235
Roadway	46	-		46
Total	2,776		1,725*	1,051

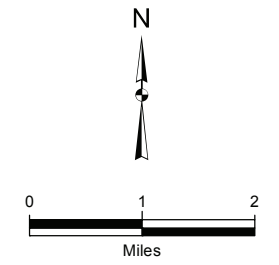
*478 Acres is estimated to be currently developed with 1,247 Acres for future development

Path: Q:\SanFrancisco\PW-Proj\2018\1868010.00-WMWD-Riverside Retail Svc Area\09-Reports\9.06_Modeling\GIS\Estimate\Figure3_BuildOut\Estimate\Figure3_Undeveloped Parcels by Land Use.mxd Printed by: melanierivera



Legend

- Land Use**
- Agriculture
 - Commercial
 - Conservation
 - High Density Residential
 - Industrial
 - Low Density Residential
 - Medium Density Residential
 - Mineral Resources
 - Mixed Use
 - Open Space
 - Public Facilities
 - Rural Residential
 - Retail Service Area



KJ Kennedy Jenks

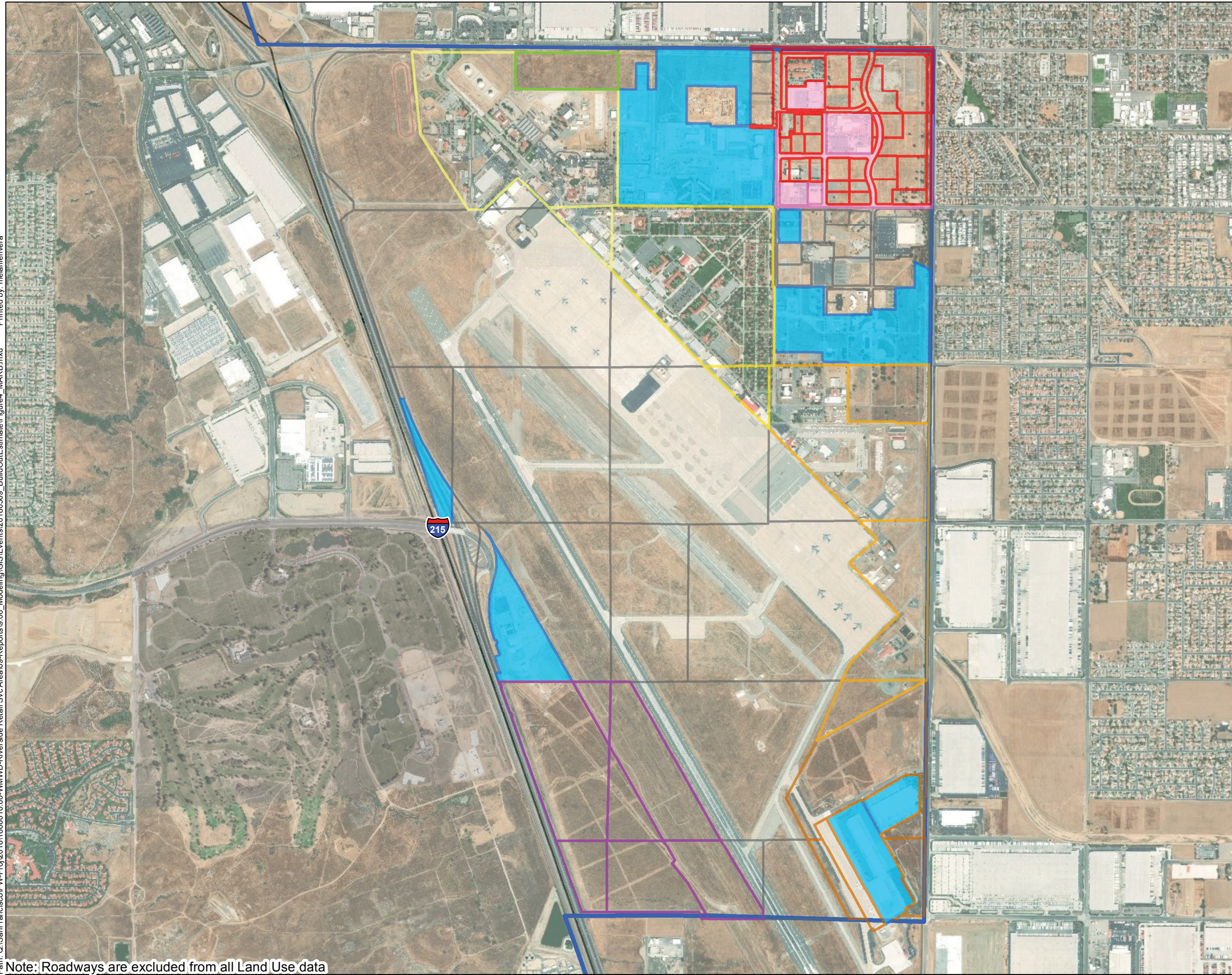
Riverside Build-Out Demand Projection
Riverside, California

Undeveloped Parcels by Land Use

KJ 1868010*00












Figure 3

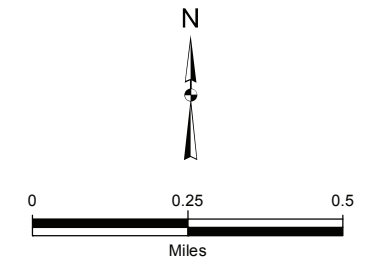
Note: Roadways are excluded from all Land Use data



Legend

MARB Category

-  Hospital
-  Hospital - Developed
-  Supply Study 1
-  Supply Study 2
-  MB1
-  MB2
-  MB3
-  MB4
-  Developed
-  Airfield
-  Retail Service Area



KJ Kennedy Jenks

Riverside Build-Out Demand Projection
Riverside, California

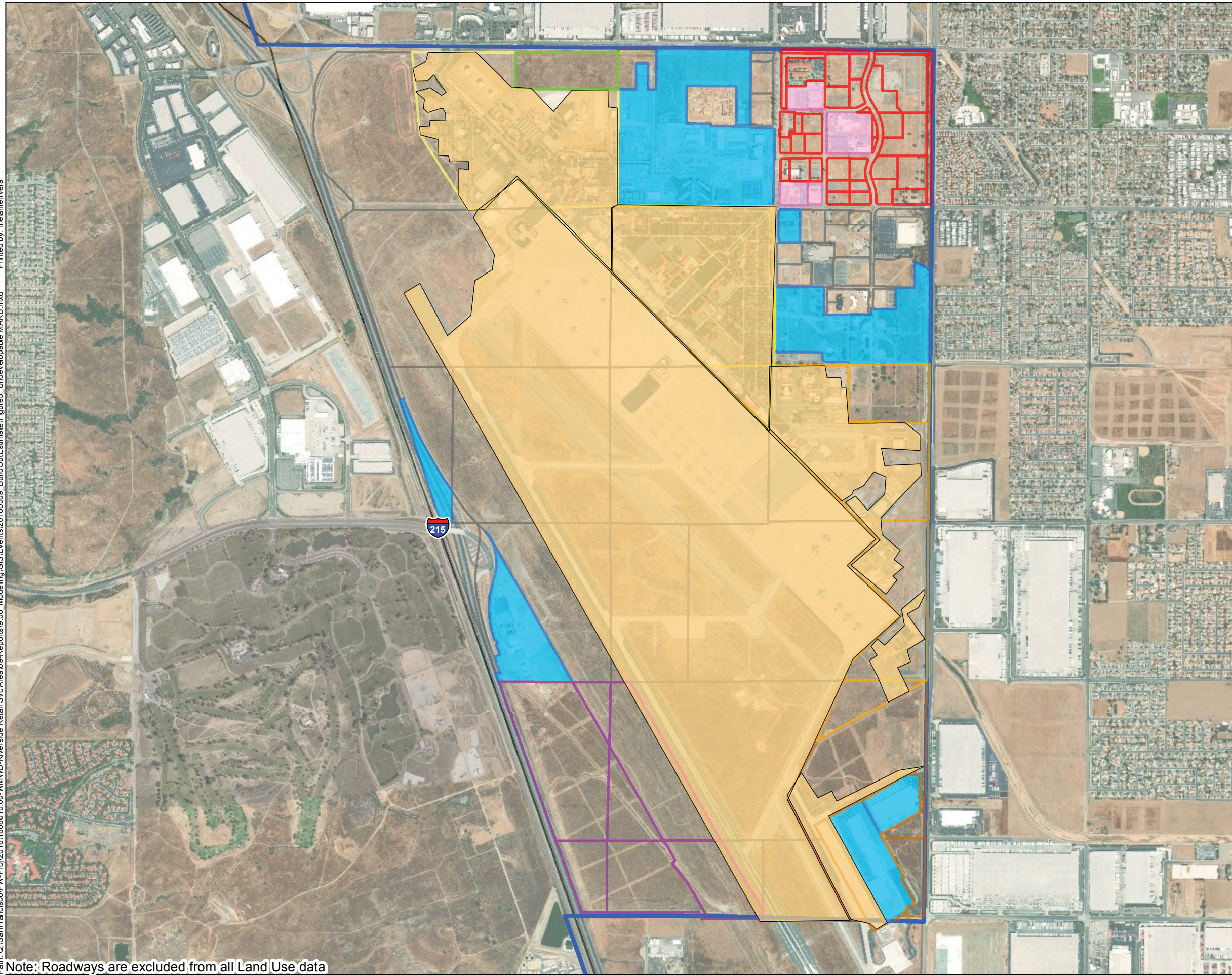
MARB Categories

KJ 1868010*00

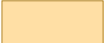




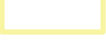






Figure 4

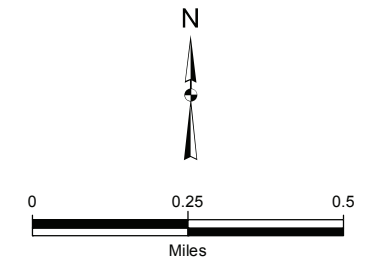
Note: Roadways are excluded from all Land Use data

Printed by: melani@vera
Path: Q:\SanFrancisco\PW-Proj\2018\1868010.00-WMWD-Riverside Retail Svc Area\09-Reports\9_06_Modeling\GIS\Estimate\Figure5_Undevelopable MARB.mxd



Legend

-  Undevelopable Areas
- MARB Category**
-  Hospital
-  Hospital - Developed
-  Supply Study 1
-  Supply Study 2
-  MB1
-  MB2
-  MB3
-  MB4
-  Developed
-  Airfield
-  Retail Service Area



KJ Kennedy Jenks

Riverside Build-Out Demand Projection
Riverside, California

Undevelopable MARB Areas

KJ 1868010*00

Figure 5

Note: Roadways are excluded from all Land Use data

Memorandum

Ms. Karly Gaynor
 31 July 2019
 1868010*00
 Page 11

3.5 Summary of Developed/Undeveloped Acres

For the areas in the Riverside Retail Service Area outside of MARB the total parcel area was aggregated by land use. Table 3 shows the percentages of each land use category within the developed and undeveloped parcels.

Table 3: Developed/Undeveloped Acreage by Land Use

Land Use	Total Area (Ac)	% of Total Area by Land Use	Deve- loped Area (Ac)	% of Total Area Developed	Undeve- loped Area (Ac)	% of Total Area Undeveloped
Agriculture	514	0.9%	20	4%	494	1%
Commercial	266	0.5%	77	29%	188	0%
Conservation	8,349	14.3%	1,311	16%	7,038	12%
Industrial	126	0.2%	12	10%	114	0%
Low Density Residential	208	0.4%	105	50%	103	0%
MARB	2,776	4.7%	478	18%	2,298 ³	4%
Med. Density Residential	1,338	2.3%	776	58%	562	1%
Mineral Resources	277	0.5%	1	0%	276	0%
Mixed Use	9,670	16.5%	5,094	53%	4,576	8%
Open Space	5,131	8.8%	494	10%	4,637	8%
Public Facilities	2,059	3.5%	259	13%	1,800	3%
Rural Residential	24,443	41.8%	11,152	46%	13,291	23%
Roadway	3,330	5.7%	370	11%	2,961	5%
Subtotal – Areas with Water Demand	58,488	-	20,148	-	38,340	-
High Density Residential ¹	26	0.0%	26	100%	-	0%
MWD Owned Parcels ²	7,100	-	-	-	7,100	-
Water ²	3,288	-	-	-	3,288	-
Subtotals – Areas without Water Demand	10,414	-	26	-	10,388	-
Total – Parcels within Riverside Retail Service Area	68,902	-	20,174	-	48,728	-

¹ High Density Residential land use is served by WMWD wastewater service only.

² The District provided a GIS shapefile that included all Metropolitan Water District (MWD) owned parcels within the service area, including Lake Mathews and areas surrounding Lake Mathews owned by MWD. which included land uses of Conservation, Low Density Residential, Mineral Resources, Mixed Use, Open Space, Public Facilities, Roadways, Rural Residential, and Water. T

³ As noted in Table 1, MARB has 1,051 acres that are not developable in the future and will not generate water demand

Memorandum

Ms. Karly Gaynor
 31 July 2019
 1868010*00
 Page 12

The Developed area column in Table 3 lists the total acreages utilized for the unit demand calculation. The acreage of the undeveloped MWD parcels in Table 3 was subtracted from the total acreage of parcels in GIS that met the requirement for “undeveloped” to obtain the total “developable” acreage within the service area. The revised “undeveloped” parcels shown in Table 3 were utilized in the rest of the analysis.

3.6 2017 Baseline Unit Demand Estimate

Unit demands for each land use category were calculated by dividing the total metered consumption for each land use category by the corresponding total acreage for each land use category. Parcels with a water land use (e.g. Lake Matthews) were excluded from the acreage totals used in the analysis. Using information from Tables 1 and 3, Table 4 summarizes the unit demands for the developed parcels aggregated by land use for the areas of Riverside Retail Service area while Table 5 summarizes the unit demands for the areas within MARB. These unit demands were then used to calculate total projected demands for the undeveloped parcels. The calculated unit demand uses the annual water consumption, which inherently embeds both indoor and outdoor water usage.

Table 4: 2017 Baseline Unit Demands by Land Use for Riverside Retail Service Area

Land Use	Developed Area (Ac)	Developed Demands (AFY)	Unit Demands (AFY/Ac)
Agriculture	20	42	2.1
Commercial	77	49	0.6
Conservation	1,311	263	0.2
Industrial	12	3	0.2
Low Density Residential	105	207	2.0
MARB	478	163	See Table 5
Medium Density Residential	776	1,954	2.5
Mineral Resources	1	0.12	0.12
Mixed Use	5,094	9,086	1.8
Open Space	494	293	0.6
Public Facilities	259	1,120	0.6
Rural Residential	11,152	7,870	0.7
Roadway	370	424	1.1
Total	20,148	21,473	-

Memorandum

Ms. Karly Gaynor
 31 July 2019
 1868010*00
 Page 13

Table 5: Unit Demands by Land Use for MARB

MARB Category	Land Use Type	Unit Demand (AFY/Ac)
Airfield	MARB	0.0
Developed	Commercial	0.6
Hospital	High Density Residential	3.0
Hospital - Developed	High Density Residential	3.0
MB1	Commercial	0.6
MB2	Commercial	0.6
MB3	Commercial	0.6
MB4	Commercial	0.6
Supply Study 1	Commercial	0.6
Supply Study 2	Commercial	0.6
Roadway	-	-

The undeveloped acreage estimates by land use found in Tables 2 and 3 were then multiplied by the unit demands calculated in Tables 4 and 5 to arrive at estimated buildout demands as described in Section 4.0.

4.0 Estimated Projected Buildout Demand Results

4.1 Undeveloped Demand Estimate Based on 2017 Baseline

Based on the 2017 Baseline unit demands described in Tables 3 and 4 of Section 3.0, Tables 6 and 7 provides an estimate of the demands for the undeveloped parcels. Together, mixed use and rural residential comprise about 2/3 of the total future demand. Mixed use contains the largest projected demands even though rural residential has the largest undeveloped area. This is because the unit demand of mixed use is double that of rural residential.

Mixed use areas are more dense than rural residential areas and are typically associated with more urbanized areas, where various buildings and activities result in higher water demand. Therefore, the higher unit demand results in the mixed use category, making up 35% of the total projected demand, to be slightly higher than the rural residential projected demand percentage of 32% while at a much lower acreage.

Memorandum

Ms. Karly Gaynor
 31 July 2019
 1868010*00
 Page 14

Table 6: Projected Undeveloped Demands for 2017 Baseline

Land Use	Undeveloped Area Contributing to Future Water Demand (Ac)	Unit Demands (AFY/Ac)	Projected Undeveloped Future Demands (AFY)
Agriculture	494	2.1	1,022
Commercial	188	0.6	119
Conservation	7,038	0.2	1,411
Industrial	114	0.2	25
Low Density Residential	103	2.0	204
MARB	1,247 ¹	See Table 5	573 ²
Medium Density Residential	562	2.5	1,416
Mineral Resources	276	0.12	33
Mixed Use	4,576	1.8	8,162
Open Space	4,637	0.6	2,753
Public Facilities	1,800	0.6	1,069
Rural Residential	13,291	0.7	9,380
Roadway	0 ³	1.1 ³	0 ³
Total	34,328	-	26,168

¹ From Note 3, Table 3, 2,298 Acres of potentially developable land in MARB of which 1,051 Acres are assumed to not contribute future water demand.

² From Table 7

³ 2,961 Acres of Roadways were assumed not to contribute additional potable water demand in the future

Memorandum

Ms. Karly Gaynor
 31 July 2019
 1868010*00
 Page 15

Table 7: Estimated MARB Demand

MARB Category	Unit Demand (AFY/Ac)	Acres Currently Developed	Acres Undeveloped	Estimated Future Demand (AFY)
Airfield	0.0	957	453	0.00
Developed	0.6	282	0	0.00
Hospital	3.0	15	97	289.86
Hospital - Developed	3.0	25	0	0.00
MB1	0.6	152	20	12.56
MB2	0.6	152	0	0.00
MB3	0.6	106	104	64.98
MB4	0.6	35	72	44.84
Supply Study 1	0.6	0	24	14.87
Supply Study 2	0.6	0	235	145.95
Roadway	0.0			0.0
Total	--	1,725	1,005	573*
Existing MARB demand				168
Total Buildout MARB demand				741

The total developed demands presented in Table 1 are added to the projected undeveloped demands in Table 6 to establish a 2017 Baseline for projected build-out demands which are presented in Table 8.

Memorandum

Ms. Karly Gaynor
 31 July 2019
 1868010*00
 Page 16

Table 8: 2017 Baseline Projected Build-Out Demands

Land Use	Developed Demands (AFY)	Projected Undeveloped Future Demands (AFY)	Projected Buildout Demand (AFY)
Agriculture	42	1,022	1,064
Commercial	49	119	168
Conservation	263	1,411	1,674
High Density Residential	0	0	0
Industrial	207	25	28
Low Density Residential	163	204	411
MARB	1,954	573	736
Medium Density Residential	0.12	1,416	3,369
Mineral Resources	9,086	33	33
Mixed Use	293	8,162	17,247
Open Space	1,120	2,753	3,047
Public Facilities	7,870	1,069	2,188
Rural Residential	424	9,380	17,250
Roadway	424	0	424
Total	21,473	26,168	47,641

4.2 Adjustments to Buildout Demands From 2017 Baseline

In order to account for variability of demands that may differ from the 2017 Baseline that has occurred historically, demand factors were calculated by dividing the following demands by the 2017 Baseline demand of 21,473 AFY.

- 2013-2017 average demands,
- the high demand year of 2014, and
- the low demand year of 2015.

The demand factors are presented in Table 9.

Table 9: Demand Factors for Various Demand Scenarios

Demand Scenario	Demand (AF)	Demand Factor
2013-2017 Average	22,236	1.04
2014 High Demand Year	24,915	1.16
2015 Low Demand Year	19,724	0.92

Memorandum

Ms. Karly Gaynor
 31 July 2019
 1868010*00
 Page 17

Both indoor and outdoor water usage in 2017 are inherently embedded in the unit demands in Tables 6 and 7. The demand factors identified in Table 9 were not analyzed specifically to address AB 1668, which establishes indoor residential water use limits. AB 1668 makes water conservation a way of life and sets a per capita daily limit of 55 gallons for indoor residential water use beginning on January 1, 2025, and 50 gallons per capita daily beginning on January 1, 2030. Large-scale variability in water demands from year to year, as analyzed in Table 9, is closely related to changes in outdoor water usage because outdoor water usage comprises a large proportion of usage in any year. Since Western has water-budget based rates, as more meter data are collected, the meter data can be analyzed to incorporate indoor and outdoor water usage to verify that AB1668 compliance can be achieved. The demand factors can be refined in the future to incorporate the indoor water use analyses, as appropriate.

Each of the demand factors were applied to the 2017 Baseline data to estimate an adjusted developed demand from which to calculate an adjusted unit demand. The adjusted unit demand was multiplied by the undeveloped parcels to arrive at a range of build-out demand projections for the undeveloped parcels. A summary of the buildout demands for the baseline and the three scenarios is provided in Table 10 with more detailed results from each scenario found in Table 11 through Table 13.

Table 10: Summary of Buildout Demand Projections

Demand Scenario	Existing Developed Demand (AFY)	Estimated Future Demand (AFY)	Estimated Buildout Demands (AFY)
2017 Baseline	21,473	26,168	47,641
2013-2017 Average	22,236	27,101	49,337
2014 High Demand Year	24,915	30,366	55,281
2015 Low Demand Year	19,724	24,040	43,764

Figure 5 provides a graphical representation of each demand scenario’s build-out demands by land use type. The existing developed demand and buildout demand projections are shown graphically in Figure 6 and Figure 7.

Memorandum

Ms. Karly Gaynor
 31 July 2019
 1868010*00
 Page 18

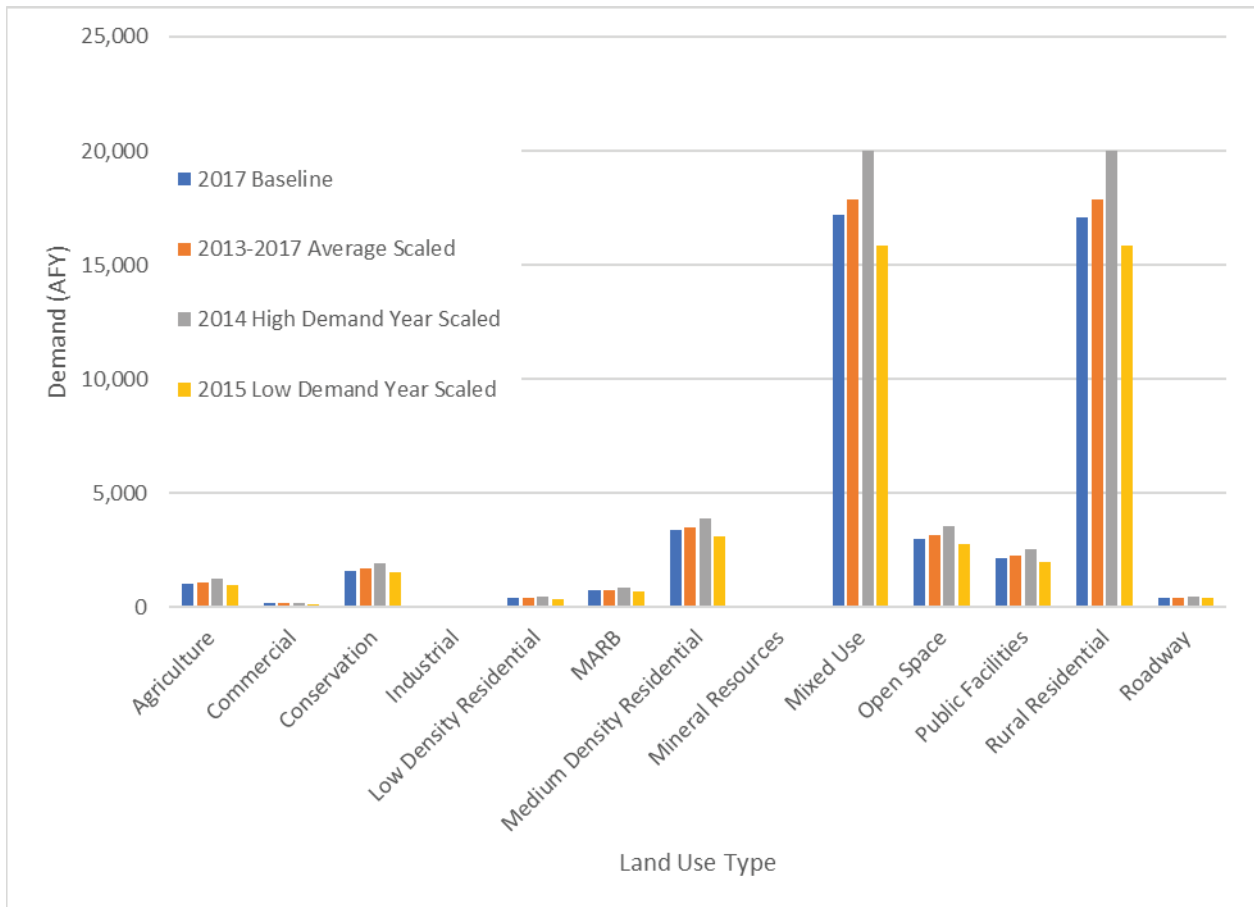


Figure 5: WMWD Projected Build-Out Demands by Land Use Type

Memorandum

Ms. Karly Gaynor
 31 July 2019
 1868010*00
 Page 19

Table 11: 2013-2017 Average Build-Out Projections

Land Use	Total Developed Demands (AFY)	Projected Undeveloped Future Demands (AFY)	Projected Buildout Demand (AFY)
Agriculture	43	1,059	1,102
Commercial	51	124	174
Conservation	272	1,461	1,733
Industrial	3	26	29
Low Density Residential	214	211	426
MARB	169	593	762
Medium Density Residential	2,023	1,466	3,489
Mineral Resources	0	38	39
Mixed Use	9,408	8,452	17,860
Open Space	304	2,851	3,155
Public Facilities	1,159	1,107	2,266
Rural Residential	8,150	9,713	17,863
Roadway	439	0	439
Total	22,236	27,101	49,337

Table 12: 2014 High Demand Year Build-Out Projections

Land Use	Total Developed Demands (AFY)	Projected Undeveloped Future Demands (AFY)	Projected Buildout Demand (AFY)
Agriculture	49	1,186	1,235
Commercial	57	139	195
Conservation	305	1,637	1,942
Industrial	3	29	32
Low Density Residential	240	237	477
MARB	189	665	854
Medium Density Residential	2,267	1,643	3,909
Mineral Resources	0	43	43
Mixed Use	10,542	9,470	20,012
Open Space	340	3,194	3,535
Public Facilities	1,299	1,240	2,539
Rural Residential	9,132	10,884	20,015
Roadway	492	0	492
Total	24,915	30,366	55,281

Memorandum

Ms. Karly Gaynor
 31 July 2019
 1868010*00
 Page 20

Table 13: 2015 Low Demand Year Build-Out Projections

Land Use	Total Developed Demands (AFY)	Projected Undeveloped but Future Demands (AFY)	Projected Buildout Demand (AFY)
Agriculture	38	939	977
Commercial	45	110	155
Conservation	241	1,296	1,537
Industrial	3	23	26
Low Density Residential	190	188	378
MARB	150	526	676
Medium Density Residential	1,794	1,300	3,095
Mineral Resources	0	34	34
Mixed Use	8,346	7,497	15,842
Open Space	269	2,529	2,798
Public Facilities	1,028	982	2,010
Rural Residential	7,229	8,616	15,845
Roadway	390	0	390
Total	19,724	24,040	43,764

Memorandum

Ms. Karly Gaynor
 31 July 2019
 1868010*00
 Page 21

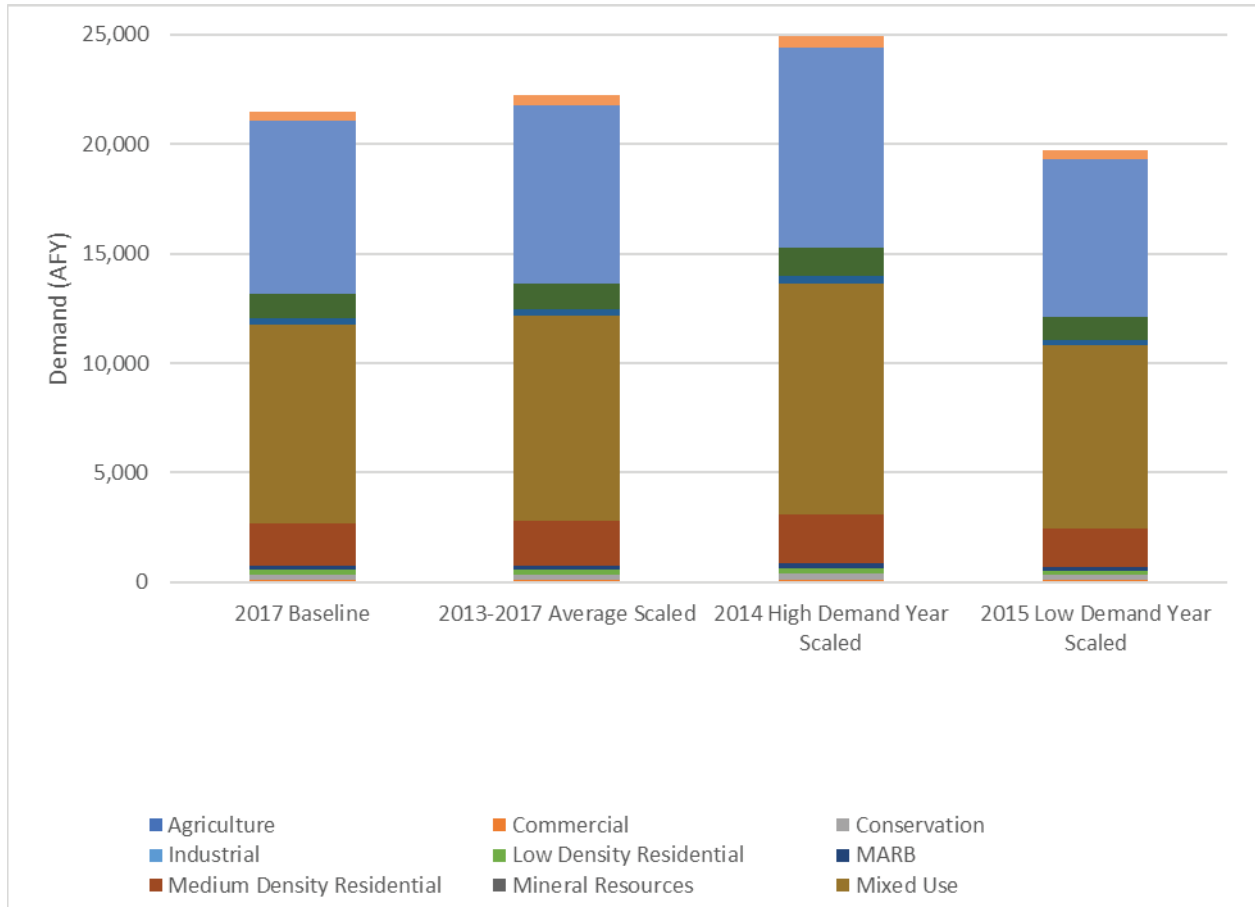


Figure 6: Developed Demands by Scenario and Land Use Type

Memorandum

Ms. Karly Gaynor
 31 July 2019
 1868010*00
 Page 22

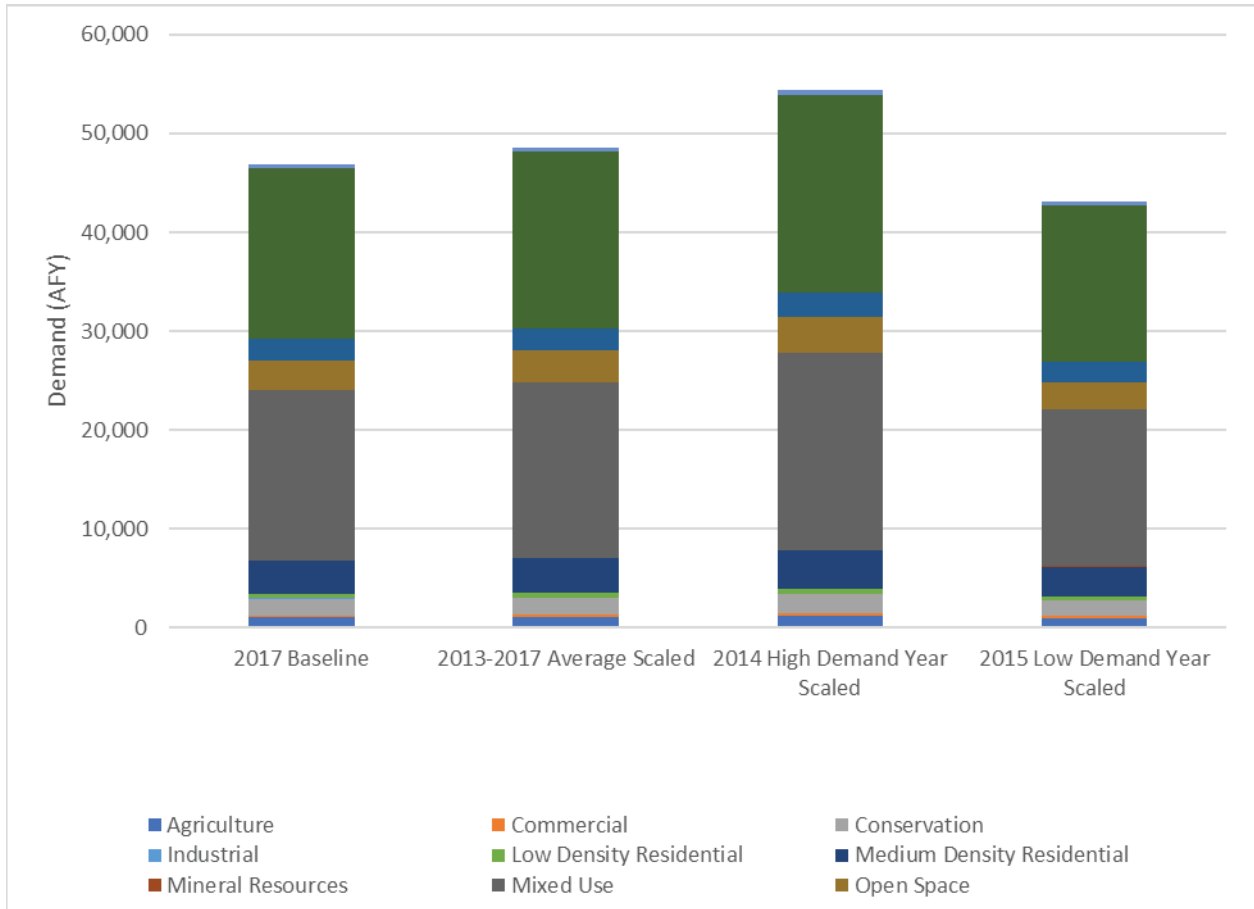
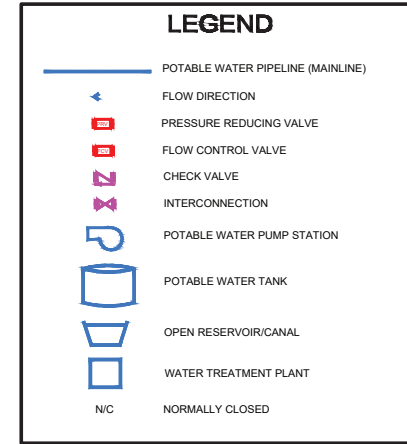


Figure 7: Build-Out Demands by Scenario and Land Use Type

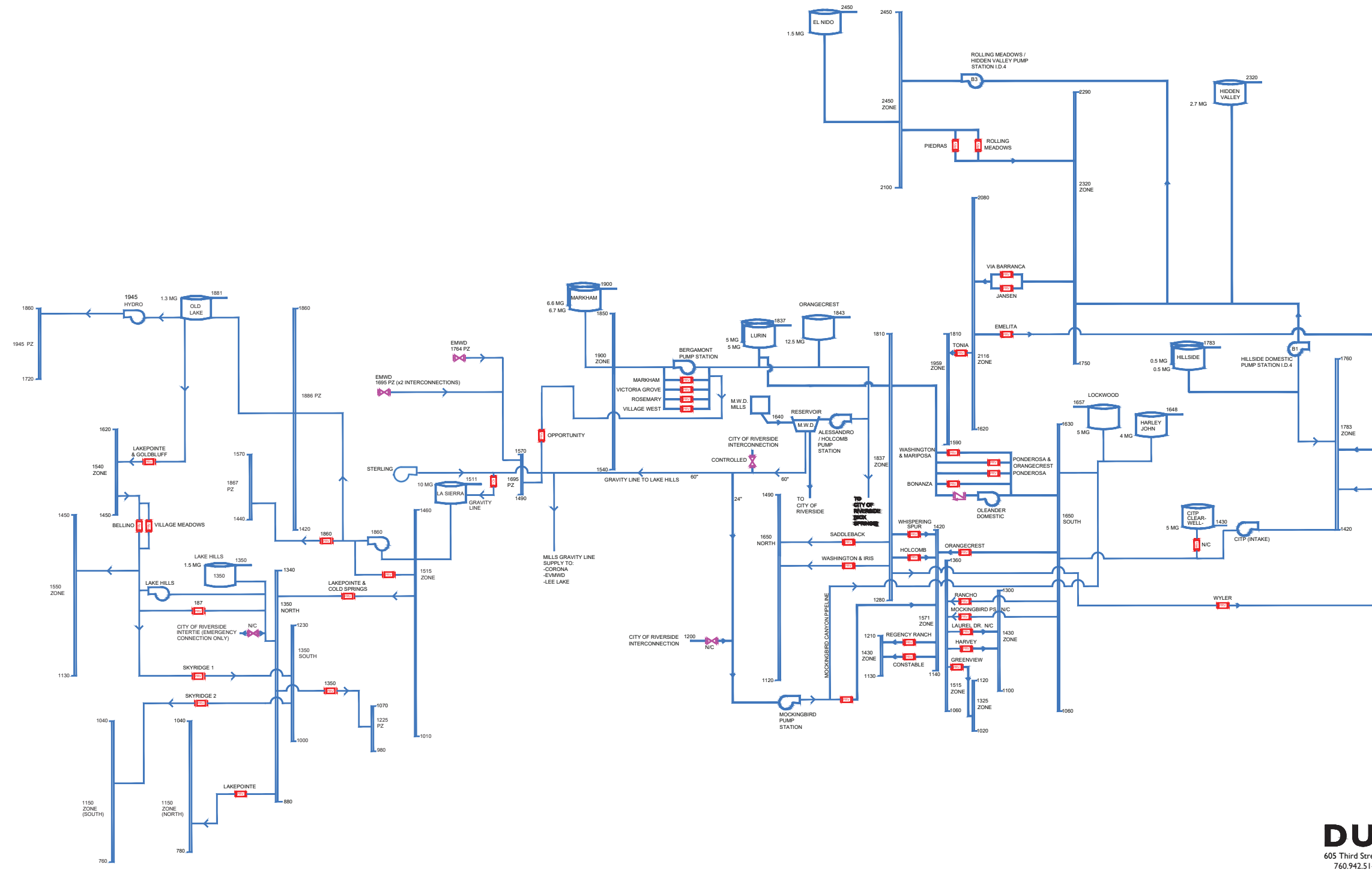
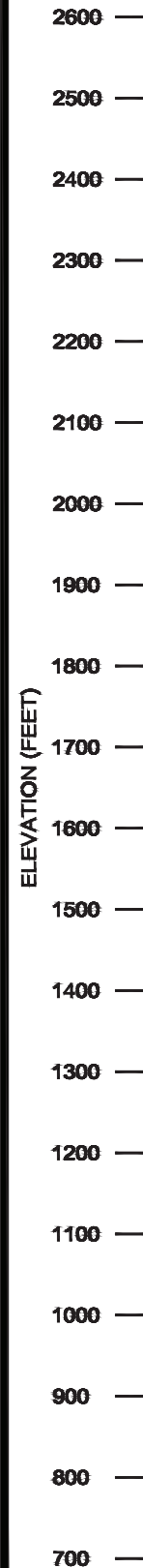
Appendix B

Potable Water System Schematic



WMWD - LAKE HILLS SYSTEM

WMWD - MAIN SYSTEM



Appendix C

Recycled Water Figure



SOURCE:

Appendix D

CIP Cost Estimates

Moonridge Dr Pipeline Upsizing (W-1)

Item No.	Item Description	Unit	Estimated Quantity	Unit Price	Item Total
1	Moonridge Dr 12-inch Replacement	LF	1,200	\$288	\$ 345,600
Subtotal					\$ 345,600
General Requirements (10%)					\$ 34,560
Contingency (20%)					\$ 69,120
Construction Total					\$ 449,280
<i>Soft Costs (Medium Project):</i>					
Engineering (15%)					\$ 67,392
Construction Management & Engineering Services During Construction (18%)					\$ 80,870
Administration (5%)					\$ 22,464
Overhead & Profit (15%)					\$ 67,392
Project Total					\$ 688,000

Blackburn Rd Pipeline Upsizing (W-2)

Item No.	Item Description	Unit	Estimated Quantity	Unit Price	Item Total
1	Blackburn Rd 8-inch Replacement	LF	8,000	\$192	\$ 1,536,000
Subtotal					\$ 1,536,000
General Requirements (10%)					\$ 153,600
Contingency (20%)					\$ 307,200
Construction Total					\$ 1,996,800
<i>Soft Costs (Medium Project):</i>					
Engineering (15%)					\$ 299,520
Construction Management & Engineering Services During Construction (18%)					\$ 359,424
Administration (5%)					\$ 99,840
Overhead & Profit (15%)					\$ 299,520
Project Total					\$ 3,056,000

Cedar St and Ave D Pipeline Upsizing (W-3)

Item No.	Item Description	Unit	Estimated Quantity	Unit Price	Item Total
1	Cedar St and Ave D 8-inch Replacement	LF	4,000	\$192	\$ 768,000
Subtotal					\$ 768,000
General Requirements (10%)					\$ 76,800
Contingency (20%)					\$ 153,600
Construction Total					\$ 998,400
<i>Soft Costs (Medium Project):</i>					
Engineering (15%)					\$ 149,760
Construction Management & Engineering Services During Construction (18%)					\$ 179,712
Administration (5%)					\$ 49,920
Overhead & Profit (15%)					\$ 149,760
Project Total					\$ 1,528,000

Lurin Ave Pipeline Upsizing (W-4)

Item No.	Item Description	Unit	Estimated Quantity	Unit Price	Item Total
1	Lurin Ave 12-inch Replacement	LF	4,000	\$288	\$ 1,152,000
Subtotal					\$ 1,152,000
General Requirements (10%)					\$ 115,200
Contingency (20%)					\$ 230,400
Construction Total					\$ 1,497,600
<i>Soft Costs (Medium Project):</i>					
Engineering (15%)					\$ 224,640
Construction Management & Engineering Services During Construction (18%)					\$ 269,568
Administration (5%)					\$ 74,880
Overhead & Profit (15%)					\$ 224,640
Project Total					\$ 2,292,000

Wood Rd Pipeline Upsizing (W-5)

Item No.	Item Description	Unit	Estimated Quantity	Unit Price	Item Total
1	Wood Rd 16-inch Replacement	LF	7,000	\$384	\$ 2,688,000
Subtotal					\$ 2,688,000
General Requirements (10%)					\$ 268,800
Contingency (20%)					\$ 537,600
Construction Total					\$ 3,494,400
<i>Soft Costs (Medium Project):</i>					
Engineering (15%)					\$ 524,160
Construction Management & Engineering Services During Construction (18%)					\$ 628,992
Administration (5%)					\$ 174,720
Overhead & Profit (15%)					\$ 524,160
Project Total					\$ 5,347,000

Via Barranca Pipeline Upsizing (W-6)

Item No.	Item Description	Unit	Estimated Quantity	Unit Price	Item Total
1	Via Barranca 12-inch Replacement	LF	4,200	\$288	\$ 1,209,600
Subtotal					\$ 1,209,600
General Requirements (10%)					\$ 120,960
Contingency (20%)					\$ 241,920
Construction Total					\$ 1,572,480
<i>Soft Costs (Medium Project):</i>					
Engineering (15%)					\$ 235,872
Construction Management & Engineering Services During Construction (18%)					\$ 283,046
Administration (5%)					\$ 78,624
Overhead & Profit (15%)					\$ 235,872
Project Total					\$ 2,406,000

Hidden Valley #2 Tank (W-7)

Item No.	Item Description	Unit	Estimated Quantity	Unit Price	Item Total
4	Hidden Valley #2 Reservoir	MG	2.7	\$2	\$ 5,400,000
Subtotal					\$ 5,400,000
General Requirements (10%)					\$ 540,000
Contingency (20%)					\$ 1,080,000
Construction Total					\$ 7,020,000
<i>Soft Costs (Medium Project):</i>					
Engineering (15%)					\$ 1,053,000
Construction Management & Engineering Services During Construction (18%)					\$ 1,263,600
Administration (5%)					\$ 351,000
Overhead & Profit (15%)					\$ 1,053,000
Project Total					\$ 10,741,000

2320 PZ Tank (W-8)

Item No.	Item Description	Unit	Estimated Quantity	Unit Price	Item Total
1	PZ2320 Tank	MG	3.0	\$2	\$ 6,000,000
Subtotal					\$ 6,000,000
General Requirements (10%)					\$ 600,000
Contingency (20%)					\$ 1,200,000
Construction Total					\$ 7,800,000
<i>Soft Costs (Medium Project):</i>					
Engineering (15%)					\$ 1,170,000
Construction Management & Engineering Services During Construction (18%)					\$ 1,404,000
Administration (5%)					\$ 390,000
Overhead & Profit (15%)					\$ 1,170,000
Project Total					\$ 11,934,000

2320 PZ Booster Pump Station (W-9)

Item No.	Item Description	Unit	Estimated Quantity	Unit Price	Item Total
1	PZ2320 Booster Pump Station	HP	600	\$3,000	\$ 1,800,000
2	Intake and Discharge Piping	LF	1000	\$384	\$ 384,000
Subtotal					\$ 2,184,000
General Requirements (10%)					\$ 218,400
Contingency (20%)					\$ 436,800
Construction Total					\$ 2,839,200
<i>Soft Costs (Medium Project):</i>					
Engineering (15%)					\$ 425,880
Construction Management & Engineering Services During Construction (18%)					\$ 511,056
Administration (5%)					\$ 141,960
Overhead & Profit (15%)					\$ 425,880
Project Total					\$ 4,344,000

Orangecrest #3 Tank (W-10)

Item No.	Item Description	Unit	Estimated Quantity	Unit Price	Item Total
1	Orangecrest #3 Tank	MG	5.0	\$2	\$ 10,000,000
Subtotal					\$ 10,000,000
General Requirements (10%)					\$ 1,000,000
Contingency (20%)					\$ 2,000,000
Construction Total					\$ 13,000,000
<i>Soft Costs (Medium Project):</i>					
Engineering (15%)					\$ 1,950,000
Construction Management & Engineering Services During Construction (18%)					\$ 2,340,000
Administration (5%)					\$ 650,000
Overhead & Profit (15%)					\$ 1,950,000
Project Total					\$ 19,890,000

El Nido #2 Tank (W-11)

Item No.	Item Description	Unit	Estimated Quantity	Unit Price	Item Total
1	El Nido #2 Tank	MG	1.0	\$2	\$ 2,000,000
Subtotal					\$ 2,000,000
General Requirements (10%)					\$ 200,000
Contingency (20%)					\$ 400,000
Construction Total					\$ 2,600,000
<i>Soft Costs (Medium Project):</i>					
Engineering (15%)					\$ 390,000
Construction Management & Engineering Services During Construction (18%)					\$ 468,000
Administration (5%)					\$ 130,000
Overhead & Profit (15%)					\$ 390,000
Project Total					\$ 3,978,000

Increase Capacity of Intake BPS (W-12)

Item No.	Item Description	Unit	Estimated Quantity	Unit Price	Item Total
1	New Pump at Intake BPS	hp	150	\$1,500	\$ 225,000
Subtotal					\$ 225,000
General Requirements (10%)					\$ 22,500
Contingency (20%)					\$ 45,000
Construction Total					\$ 292,500
<i>Soft Costs (Medium Project):</i>					
Engineering (15%)					\$ 43,875
Construction Management & Engineering Services During Construction (18%)					\$ 52,650
Administration (5%)					\$ 14,625
Overhead & Profit (15%)					\$ 43,875
Project Total					\$ 448,000

1815 PZ Near Term Improvements (RW-1)

Item No.	Item Description	Unit	Estimated Quantity	Unit Price	Item Total
1	5-MG Concrete Tank + Sitework	MG	5	\$2,000,000	\$ 10,000,000
2	Increase Wall Height of Lurin tank	MG	0.5	\$2,000,000	\$ 1,000,000
3	16-inch Pipe	LF	4,400	\$384	\$ 1,689,600
4	18-inch Pipe	LF	1,300	\$432	\$ 561,600
5	24-inch Pipe	LF	3,500	\$576	\$ 2,016,000
6	Cemetery PS Expansion (200 HP) & 6,000 LF of Parallel 12" Forcemain	LS	1	\$1,989,000	\$ 1,989,000
7	McAllister PS Expansion (200 HP)	LS	1	\$300,000	\$ 300,000
8	El Sobrante PS Expansion (150 HP)	LS	1	\$300,000	\$ 300,000
Subtotal					\$ 17,856,200
General Requirements (10%)					\$ 1,785,620
Contingency (20%)					\$ 3,571,240
Construction Total					\$ 23,213,060
<i>Soft Costs (Medium Project):</i>					
Engineering (15%)					\$ 3,481,959
Construction Management & Engineering Services During Construction (18%)					\$ 4,178,351
Administration (5%)					\$ 1,160,653
Overhead & Profit (15%)					\$ 3,481,959
Project Total					\$ 35,516,000

RNC Pipeline Upsizing (RW-2)

Item No.	Item Description	Unit	Estimated Quantity	Unit Price	Item Total
1	18-inch Pipe	LF	3,000	\$432	\$ 1,296,000
2	24-inch Pipe	LF	3,000	\$576	\$ 1,728,000
Subtotal					\$ 3,024,000
General Requirements (10%)					\$ 302,400
Contingency (20%)					\$ 604,800
Construction Total					\$ 3,931,200
<i>Soft Costs (Medium Project):</i>					
Engineering (15%)					\$ 589,680
Construction Management & Engineering Services During Construction (18%)					\$ 707,616
Administration (5%)					\$ 196,560
Overhead & Profit (15%)					\$ 589,680
Project Total					\$ 6,015,000

Markham Lift Station Upgrade (WW-1)

Item No.	Item Description	Unit	Estimated Quantity	Unit Price	Item Total
1	Engineering Condition Assessment and Recommendation Study	LS	1	\$50,000	\$ 50,000
2	Markham LS Mechanical Upgrades	LS	1	\$2,237,000	\$ 2,237,000
3	Markham LS Electrical Upgrades	LS	1	\$300,000	\$ 300,000
Subtotal					\$ 2,587,000
General Requirements (10%)					\$ 258,700
Contingency (20%)					\$ 517,400
Construction Total					\$ 3,363,100
<i>Soft Costs (Medium Project):</i>					
Engineering (15%)					\$ 504,465
Construction Management & Engineering Services During Construction (18%)					\$ 605,358
Administration (5%)					\$ 168,155
Overhead & Profit (15%)					\$ 504,465
Project Total					\$ 5,146,000

Beazer Lift Station Upgrade (WW-2)

Item No.	Item Description	Unit	Estimated Quantity	Unit Price	Item Total
1	Engineering Condition Assessment and Recommendation Study	LS	1	\$50,000	\$ 50,000
2	Beazer Lift Station Mechanical Upgrade	LS	1	\$163,400	\$ 163,400
Subtotal					\$ 213,400
General Requirements (10%)					\$ 21,340
Contingency (20%)					\$ 42,680
Construction Total					\$ 277,420
<i>Soft Costs (Medium Project):</i>					
Engineering (15%)					\$ 41,613
Construction Management & Engineering Services During Construction (18%)					\$ 49,936
Administration (5%)					\$ 13,871
Overhead & Profit (15%)					\$ 41,613
Project Total					\$ 425,000

Meridian Lift Station Upgrade (WW-3)

Item No.	Item Description	Unit	Estimated Quantity	Unit Price	Item Total
1	Engineering Condition Assessment and Recommendation Study	LS	1	\$50,000	\$ 50,000
2	Meridian Lift Station Upgrade	LS	1	\$252,500	\$ 252,500
Subtotal					\$ 302,500
General Requirements (10%)					\$ 30,250
Contingency (20%)					\$ 60,500
Construction Total					\$ 393,250
<i>Soft Costs (Medium Project):</i>					
Engineering (15%)					\$ 58,988
Construction Management & Engineering Services During Construction (18%)					\$ 70,785
Administration (5%)					\$ 19,663
Overhead & Profit (15%)					\$ 58,988
Project Total					\$ 602,000

WWRF Expansion Study (WW-4)

Item No.	Item Description	Unit	Estimated Quantity	Unit Price	Item Total
1	Evaluate plant expansion alternatives	LS	1	\$83,000	\$ 83,000
Study Total					\$ 83,000
<i>Soft Costs (Medium Project):</i>					
Administration (5%)					\$ 4,150
Overhead & Profit (15%)					\$ 12,450
Project Total					\$ 100,000

MARB 1269 LS Expansion Study (WW-5)

Item No.	Item Description	Unit	Estimated Quantity	Unit Price	Item Total
1	Evaluate LS capacity expansion	LS	1	\$32,000	\$ 41,000
Study Total					\$ 41,000
<i>Soft Costs (Medium Project):</i>					
Administration (5%)					\$ 2,050
Overhead & Profit (15%)					\$ 6,150
Project Total					\$ 50,000

