

Appendix G
**Water Resources Technical
Report**

**1111 S. Hill Street Project
Water Resources Technical Report**

August 20, 2021

Prepared by:

**David J. Curtis, P.E., ENV SP
PSOMAS
555 South Flower Street, Suite 4300
Los Angeles, California 90071
(213) 223-1400
(213) 223-1444 Fax**

Prepared for:

Crown International Holdings Group

TABLE OF CONTENTS

1.0 Introduction	3
1.1 Project Description.....	3
1.2 Scope of Work	3
2.0 Regulatory Framework	3
2.1 Surface Water Hydrology.....	3
2.2 Surface Water Quality.....	4
2.3 Groundwater	12
3.0 Surface Water Hydrology	13
3.1 General Approach.....	13
3.2 Data Sources	14
3.3 Existing Site Conditions	14
3.4 Proposed Site Conditions	14
3.5 Hydrology Results.....	14
4.0 Surface Water Quality	15
4.1 General Approach.....	15
4.2 Site Characterization for Water Quality Review	16
4.3 Pollutants of Concern.....	16
4.4 Best Management Practices	18
5.0 Significance Thresholds.....	20
5.1 Surface Water Hydrology.....	20
5.2 Surface Water Quality.....	21
6.0 Project Impact Analysis.....	22
6.1 Surface Water Hydrology.....	22
6.2 Surface Water Quality.....	22
7.0 Calculations and Site Plan	31

1.0 Introduction

1.1 Project Description

The proposed 1111 South Hill Street Project (“Project”) would develop a 40-story mixed-use building on an approximately 0.63-acre site (project site) located within the South Park area of the Central City Community Plan (“Community Plan”) area of the City of Los Angeles (City).

The project site is currently developed with an 81,993 square foot warehouse that has been vacant since approximately 2013. The project proposes to remove the existing warehouse and construct up to 319 multi-family residential units, up to 3,429 square feet (sf) of ground floor commercial uses, up to 160 hotel rooms designated as Transient Occupancy Residential Structure (TORS) units. The development site is bounded by 11th Street to the north, Hill Street to the east, an alley to the west, and an existing bank building to the south.

1.2 Scope of Work

This report provides a description of the existing surface water hydrology and surface water quality at the Project Site and an analysis of the Project’s potential impacts related to surface water hydrology and surface water quality.

Per the August 16, 2021 Preliminary Site Geological and Geologic Assessment Report for “Proposed 40-story Hi-Rise Mixed-Use Development Project” completed by AECOM, the Seismic Hazard Zone Report 026 for the Hollywood 7.5-Minute Quadrangle, states that the historically highest groundwater has been inferred to be between 100 and 120-ft below ground surface. However, the information of groundwater data collected from the State Water Resources Control Board’s GEOTRACKER website indicates that in 2010, groundwater was reported between depths of 32 and 45 feet in two monitoring wells approximately 1000 ft north of the project site. Exploratory drillings dated 2015 to depths of 90 to 120 feet below ground surface did not encounter any groundwater. Groundwater was not encountered in the borings within the soils reports to a maximum depth of 120.5 feet below existing grade. According to the report, this suggests that the minor seepages are within sandy zones that are perched on silty or clayey soil layers and that these layers were not frequently encountered. No contamination was mentioned in conjunction with soils evaluation.

2.0 Regulatory Framework

2.1 Surface Water Hydrology

County of Los Angeles Hydrology Manual

Per the City of Los Angeles (City)’s Special Order No. 007-1299, December 3, 1999, the City has adopted the latest version of the Los Angeles County (County) Department of Public Works Hydrology Manual as its basis of design for storm drainage facilities. The Hydrology Manual requires that a storm drain conveyance system be designed for a 25-year storm event and that the combined capacity of a storm drain and street flow system accommodate flow from a 50-year storm event. Areas with sump conditions are required to have a storm drain conveyance system capable of conveying flow from a 50-year storm event. The County also limits the allowable discharge into existing storm drain facilities based on the MS4 Permit and is enforced on all new developments that discharge directly into the County’s storm drain system. Any proposed drainage improvements of County owned storm drain facilities such as catch basins and storm drain lines requires the approval/review from the County Flood Control District department.

Los Angeles Municipal Code

Any proposed drainage improvements within the street right of way or any other property owned by, to be owned or under the control of the City requires the approval of a B-permit (Section 62.105, LAMC). Under the B-permit process, storm drain installation plans are subject to review and approval by the City of Los Angeles Department of Public Works Bureau of Engineering. Additionally, any connections to the City's storm drain system from a property line to a catch basin or a storm drain pipe requires a storm drain permit from the City of Los Angeles Department of Public Works, Bureau of Engineering.

2.2 Surface Water Quality

Clean Water Act

The Clean Water Act was first introduced in 1948 as the Water Pollution Control Act. The Clean Water Act authorizes Federal, state, and local entities to cooperatively create comprehensive programs for eliminating or reducing the pollution of state waters and tributaries. The primary goals of the Clean Water Act are to restore and maintain the chemical, physical, and biological integrity of the nation's waters and to make all surface waters fishable and swimmable. As such, the Clean Water Act forms the basic national framework for the management of water quality and the control of pollutant discharges. The Clean Water Act also sets forth several objectives in order to achieve the above-mentioned goals. These objectives include regulating pollutant and toxic pollutant discharges; providing for water quality that protects and fosters the propagation of fish, shellfish and wildlife; developing waste treatment management plans; and developing and implementing programs for the control of non-point sources of pollution.

Since its introduction, major amendments to the Clean Water Act have been enacted (e.g., 1961, 1966, 1970, 1972, 1977, and 1987). Amendments enacted in 1970 created the U.S. Environmental Protection Agency (USEPA), while amendments enacted in 1972 deemed the discharge of pollutants into waters of the United States from any point source unlawful unless authorized by a USEPA National Pollutant Discharge Elimination System (NPDES) permit. Amendments enacted in 1977 mandated development of a "Best Management Practices" Program at the state level and provided the Water Pollution Control Act with the common name of "Clean Water Act," which is universally used today. Amendments enacted in 1987 required the USEPA to create specific requirements for discharges.

In response to the 1987 amendments to the Clean Water Act and as part of Phase I of its NPDES permit program, the USEPA began requiring NPDES permits for: (1) municipal separate storm sewer systems (MS4) generally serving, or located in, incorporated cities with 100,000 or more people (referred to as municipal permits); (2) 11 specific categories of industrial activity (including landfills); and (3) construction activity that disturbs five acres or more of land. Phase II of the USEPA's NPDES permit program, which went into effect in early 2003, extended the requirements for NPDES permits to: (1) numerous small municipal separate storm sewer systems, (2) construction sites of one to five acres, and (3) industrial facilities owned or operated by small municipal separate storm sewer systems. The NPDES permit program is typically administered by individual authorized states.

In 2008, the USEPA published draft Effluent Limitation Guidelines (ELGs) for the construction and development industry. On December 1, 2009 the EPA finalized its 2008 Effluent Guidelines Program Plan.

In California, the NPDES stormwater permitting program is administered by the State Water Resources Control Board (SWRCB). The SWRCB was created by the Legislature in 1967. The joint authority of water distribution and water quality protection allows the Board to provide protection for the State's waters, through its nine Regional Water Quality Control Boards (RWQCBs). The RWQCBs develop and enforce water quality objectives and implement plans that will best protect California's waters, acknowledging areas of different climate, topography, geology, and Hydrology. The RWQCBs develop "basin plans" for their hydrologic areas, issue waste discharge requirements, enforce action against stormwater discharge violators, and monitor water quality.

Federal Anti-Degradation Policy

The Federal Antidegradation Policy (40 Code of Federal Regulations 131.12) requires states to develop statewide antidegradation policies and identify methods for implementing them. Pursuant to the Code of Federal Regulations (CFR), state antidegradation policies and implementation methods shall, at a minimum, protect and maintain (1) existing in-stream water uses; (2) existing water quality, where the quality of the waters exceeds levels necessary to support existing beneficial uses, unless the state finds that allowing lower water quality is necessary to accommodate economic and social development in the area; and (3) water quality in waters considered an outstanding national resource.

California Porter-Cologne Act

The Porter-Cologne Water Quality Control Act established the legal and regulatory framework for California's water quality control. The California Water Code authorizes the SWRCB to implement the provisions of the CWA, including the authority to regulate waste disposal and require cleanup of discharges of hazardous materials and other pollutants.

As discussed above, under the California Water Code (CWC), the State of California is divided into nine RWQCBs, governing the implementation and enforcement of the CWC and CWA. The Project Site is located within Region 4, also known as the Los Angeles Region. Each RWQCB is required to formulate and adopt a Basin Plan for its region. This Plan must adhere to the policies set forth in the CWC and established by the SWRCB. The RWQCB is also given authority to include within its regional plan water discharge prohibitions applicable to conditions, areas, or types of waste.

California Anti-Degradation Policy

The California Antidegradation Policy, otherwise known as the *Statement of Policy with Respect to Maintaining High Quality Water in California* was adopted by the SWRCB (State Board Resolution No. 68-16) in 1968. Unlike the Federal Antidegradation Policy, the California Antidegradation Policy applies to all waters of the State, not just surface waters. The policy states that whenever the existing quality of a water body is better than the quality established in individual Basin Plans, such high quality shall be maintained and discharges to that water body shall not unreasonably affect present or anticipated beneficial use of such water resource.

California Toxic Rule

In 2000, the EPA promulgated the California Toxic Rule, which establishes water quality criteria for certain toxic substances to be applied to waters in the State. The EPA promulgated this rule based on the EPA's determination that the numeric criteria are necessary in the State to protect human health and the environment. The California Toxic Rule establishes acute (i.e., short-term) and chronic (i.e., long-term) standards for bodies of water such as inland surface waters and enclosed bays and estuaries that are designated by the LARWQCB as having beneficial uses protective of aquatic life or human health.

Board Basin Plan for the Coastal Watersheds of Los Angeles and Ventura Counties

As required by the California Water Code, the LARWQCB has adopted a plan entitled "Water Quality Control Plan, Los Angeles Region: Basin Plan for the Coastal Watersheds of Los Angeles and Ventura Counties" (Basin Plan). Specifically, the Basin Plan designates beneficial uses for surface and groundwaters, sets narrative and numerical objectives that must be attained or maintained to protect the designated beneficial uses and conform to the State's antidegradation policy, and describes implementation programs to protect all waters in the Los Angeles Region. In addition, the Basin Plan incorporates (by

reference) all applicable State and Regional Board plans and policies and other pertinent water quality policies and regulations. Those of other agencies are referenced in appropriate sections throughout the Basin Plan.

The Basin Plan is a resource for the RWQCB and others who use water and/or discharge wastewater in the Los Angeles Region. Other agencies and organizations involved in environmental permitting and resource management activities also use the Basin Plan. Finally, the Basin Plan provides valuable information to the public about local water quality issues.

NPDES Permit Program

The NPDES permit program was first established under authority of the CWA to control the discharge of pollutants from any point source into the waters of the United States. As indicated above, in California, the NPDES stormwater permitting program is administered by the SWRCB through its nine RWQCBs.

The General Permit

SWRCB Order No. 2009-0009-DWQ known as “The General Permit” was adopted on September 2, 2009. This NPDES permit establishes a risk-based approach to stormwater control requirements for construction projects by identifying three project risk levels. The main objectives of the General Permit are to:

1. Reduce erosion
2. Minimize or eliminate sediment in stormwater discharges
3. Prevent materials used at a construction site from contacting stormwater
4. Implement a sampling and analysis program
5. Eliminate unauthorized non-stormwater- discharges from construction sites
6. Implement appropriate measures to reduce potential impacts on waterways both during and after construction of projects
7. Establish maintenance commitments on post-construction pollution control measures

California mandates requirements for all construction activities disturbing more than one acre of land to develop and implement Stormwater Pollution Prevention Plans (SWPPP). The SWPPP documents the selection and implementation of Best Management Practices for a specific construction project, charging Owners with stormwater quality management responsibilities. A construction site subject to the General Permit must prepare and implement a SWPPP that meets the requirements of the General Permit.

Los Angeles County Municipal Storm Water System (MS4) Permit

As described above, USEPA regulations require that MS4 permittee’s implement a program to monitor and control pollutants being discharged to the municipal system from both industrial and commercial projects that contribute a substantial pollutant load to the MS4.

On December 13, 2001, the LARWQCD amended Order No. 01-182 under the CWA and the Porter-Cologne Act. This Order is the NPDES Permit or MS4 permit for municipal stormwater and urban runoff discharges within Los Angeles County. The permit includes Total Maximum Daily Load (TMDL) provisions designed to ensure that permittees achieve waste load allocations (WLAs) and meet other requirements of TMDLs covering receiving waters impacted by the permittees’ MS4 discharges. The requirements of this Order (the “Permit”) cover 84 cities and most of the unincorporated areas of Los Angeles County. Under the Permit, the Los Angeles County Flood Control District (LACFCD) is designated as the Principal

Permittee. The Permittees are the 84 Los Angeles County cities (including the City of Los Angeles) and Los Angeles County. Collectively, these are the “Co-Permittees”. The Principal Permittee helps to facilitate activities necessary to comply with the requirements outlined in the Permit but is not responsible for ensuring compliance of any of the Permittees. The MS4 Permit was amended on September 8, 2016, which is now known as Order No. R4-2012-0175-A01. The purpose of this amendment to the LA County MS4 Permit is to revise select permit provisions consistent with the revised Los Angeles River Watershed Trash TMDL and the revised Ballona Creek Watershed Trash TMDL. These revisions generally include: (a) alternative methods for permittees subject to the revised trash TMDLs to demonstrate full compliance with final trash effluent limitations, (b) revised provisions identifying the permittees subject to the revised trash TMDLs (i.e., removal of the City of Santa Clarita as a responsible permittee and addition of the Los Angeles County Flood Control District as a responsible permittee); (c) plastic pellet monitoring and spill response requirements for the Los Angeles River watershed, consistent with existing provisions for the Ballona Creek watershed; and (d) requirements for receiving water monitoring for trash in the Los Angeles River and Ballona Creek watersheds. This amendment does not modify existing water quality-based effluent limitations for trash or any compliance deadlines for responsible permittees.

Stormwater Quality Management Program (SQMP)

In compliance with the Los Angeles County MS4 Permit, the Co-Permittees are required to implement a stormwater quality management program (SQMP) with the goal of accomplishing the requirements of the Permit and reducing the amount of pollutants in stormwater runoff. The SQMP requires the County of Los Angeles and the 84 incorporated cities to:

- Implement a public information and participation program to conduct outreach on storm water pollution;
- Control discharges at commercial/industrial facilities through tracking, inspecting, and ensuring compliance at facilities that are critical sources of pollutants;
- Implement a development planning program for specified development projects;
- Implement a program to control construction runoff from construction activity at all construction sites within the relevant jurisdictions;
- Implement a public agency activities program to minimize storm water pollution impacts from public agency activities; and
- Implement a program to document, track, and report illicit connections and discharges to the storm drain system.

The MS4 Permit contains the following provisions for implementation of the SQMP by the Co-Permittees:

1. General Requirements:

- Each permittee is required to implement the SQMP in order to comply with applicable stormwater program requirements.
- The SQMP shall be implemented and each permittee shall implement additional controls so that discharge of pollutants is reduced.

2. Best Management Practice Implementation:

- Permittees are required to implement the most effective combination of BMPs for

stormwater/urban runoff pollution control. This should result in the reduction of storm water runoff.

3. Revision of the SQMP:

- Permittees are required to revise the SQMP in order to comply with requirements of the RWQCB while complying with regional watershed requirements and/or waste load allocations for implementation of TMDLs for impaired waterbodies.

4. Designation and Responsibilities of the Principal Permittee:

The Los Angeles County Flood Control District is designated as the Principal Permittee who is responsible for:

- Coordinating activities that comply with requirements outlined in the NPDES Permit;
- Coordinating activities among Permittees;
- Providing personnel and fiscal resources for necessary updates to the SQMP;
- Providing technical support for committees required to implement the SQMP; and
- Implementing the Countywide Monitoring Program required under this Order and assessing the results of the monitoring program,

5. Responsibilities of Co-Permittees:

Each co-permittee is required to comply with the requirements of the SQMP as applicable to the discharges within its geographical boundaries. These requirements include:

- Coordinating among internal departments to facilitate the implementation of the SQMP requirements in an efficient way;
- Participating in coordination with other internal agencies as necessary to successfully implement the requirements of the SQMP; and
- Preparing an annual Budget Summary of expenditures for the storm water management program by providing an estimated breakdown of expenditures for different areas of concern, including budget projections for the following year.

6. Watershed Management Committees (WMCs):

- Each WMC shall be comprised of a voting representative from each Permittee in the Watershed Management Area (WMA).
- Each WMCs is required to facilitate exchange of information between co-Permittees, establish goals and deadlines for WMAs, prioritize pollution control measures, develop and update adequate information, and recommend appropriate revisions to the SQMP.

7. Legal Authority:

- Co-permittees are granted the legal authority to prohibit non-storm water discharges to the storm drain system including discharge to the MS4 from various development types.

Standard Urban Stormwater Mitigation Plan (SUSMP)

Under the Los Angeles County Municipal NPDES Permit, permittees are required to implement a development planning program to address storm water pollution. These programs require project applicants for certain types of projects to implement Standard Urban Stormwater Mitigation Plans (SUSMP) throughout the operational life of their projects. The purpose of SUSMP is to reduce the discharge of pollutants in storm water by outlining BMPs which must be incorporated into the design plans of new development and redevelopment. A project is subject to SUSMP if it falls under one of the categories listed below:

1. Single-family hillside homes
2. Ten or more unit homes (including single family homes, multifamily homes, condominiums, and apartments).
3. Automotive service facilities
4. Restaurants
5. 100,000 or more square feet of impervious surface in industrial/commercial development.
6. Retail gasoline outlet
7. Parking lots with 5,000 square feet or more of surface area or with 25 or more parking spaces
8. Redevelopment projects in subject categories that meet redevelopment thresholds
9. Location within or directly adjacent to or discharging directly to an environmentally sensitive area if the discharge is likely to impact a sensitive biological species or habitat and the development creates 2,500 square feet or more of impervious surface.

Permittees are required to adopt the requirements set herein in their own SUSMP. Additional BMPs may be required by ordinance or code adopted by the Permittee and applied in a general way to all projects or on a case by case basis.

City of Los Angeles Water Quality Compliance Master Plan for UrbanRunoff

On March 2, 2007, City Council Motion 07-0663 was introduced by the City of Los Angeles City Council to develop a water- quality master plan with strategic directions for planning, budgeting and funding to reduce pollution from urban runoff in the City of Los Angeles. The Water Quality Compliance Master Plan for Urban Runoff was developed by the Bureau of Sanitation, Watershed Protection Division in collaboration with stakeholders to address the requirements of this Council Motion. The primary goal of the Water Quality Compliance Master Plan for Urban Runoff is to help meet water quality regulations. Implementation of the Water Quality Compliance Master Plan for Urban Runoff is intended over the next 20 to 30 years to result in cleaner neighborhoods, rivers, lakes and bays, augmented local water supply, reduced flood risk, more open space, and beaches that are safe for swimming. The Water Quality Compliance Master Plan for Urban Runoff also supports the Mayor and Council's efforts to make Los Angeles the greenest major city in the nation.

The Water Quality Compliance Master Plan for Urban Runoff identifies and describes the various watersheds in the City, summarizes the water quality conditions of the City's waters, identifies known sources of pollutants, describes the governing regulations for water quality, describes the BMPs that are being implemented by the City, discusses existing TMDL Implementation Plans and Watershed Management Plans. Additionally, the Water Quality Compliance Master Plan for Urban Runoff provides an implementation strategy that includes the following three initiatives to achieve water quality goals:

- Water Quality Management Initiative, which describes how Water Quality Management Plans for each of the City's watershed and TMDL-specific Implementation Plans will be developed to ensure compliance with water quality

regulations.

- The Citywide Collaboration Initiative, which recognizes that urban runoff management and urban (re)development are closely linked, requiring collaborations of many City agencies. This initiative requires the development of City policies, guidelines, and ordinances for green and sustainable approaches for urban runoff management.
- The Outreach Initiative, which promotes public education and community engagement with a focus on preventing urban runoff pollution.

The Water Quality Compliance Master Plan for Urban Runoff includes a financial plan that provides a review of current sources of revenue, estimates costs for water quality compliance, and identifies new potential sources of revenue.

City of Los Angeles Stormwater Program

The City of Los Angeles supports the policies of the Construction General Permit through the Development Best Management Practices Handbook, Part A Construction Activities, 3rd Edition, and associated ordinances which the City of Los Angeles adopted in September 2004. The handbook and ordinances also have specific minimum BMP requirements for all construction activities and require dischargers whose construction projects disturb one acre or more of soil to prepare a SWPPP and file a Notice of Intent (NOI) with the SWRCB. The NOI informs the SWRCB of a project and results in the issuance of a Waste Discharge Identification (WDID) number, which is needed to demonstrate compliance with the General Permit.

The City of Los Angeles supports the requirements of the Los Angeles County Municipal NPDES permit through the City of Los Angeles’s Development Best Management Practices Handbook, Part B Planning Activities, 3rd Edition, which the City of Los Angeles Department of Public Works adopted in June 2004. The Handbook provides guidance for developers in complying with the requirements of the Development Planning Program regulations of the City’s Stormwater Program. Compliance with the requirements of this manual is required by City of Los Angeles Ordinance No. 173,494.

The City of Los Angeles implements the requirement to incorporate stormwater BMPs into the SUSMP through the City’s plan review and approval process. During the review process, project plans are reviewed for compliance with the City’s General Plans, zoning ordinances, and other applicable local ordinances and codes, including storm water requirements. Plans and specifications are reviewed to ensure that the appropriate BMPs are incorporated to address storm water pollution prevention goals. The SUSMP provisions that are applicable to new residential and commercial developments include, but are not limited to, the following:

- Peak Storm Water Runoff Discharge Rate: Post-development peak storm water runoff discharges shall not exceed the estimated pre-development rate for developments where the increased peak storm water discharge rate will result in increased potential for downstream erosion;
- Provide storm drain system Stenciling and Signage (only applicable if a catch basin is built on-site);
- Properly design outdoor material storage areas to provide secondary containment to prevent spills;
- Properly design trash storage areas to prevent off-site transport of trash;
- Provide proof of ongoing BMP Maintenance of any structural BMPs installed;
- Design Standards for Structural or Treatment control BMPs:
 - Conserve natural and landscaped areas;
 - Provide planter boxes and/or landscaped areas in yard/courtyard spaces;

- Properly design trash storage areas to provide screens or walls to prevent off-site transport of trash;
- Provide proof on ongoing BMP maintenance of any structural BMPs installed;
- Design Standards for Structural or Treatment Control BMPs:
 - Post-construction treatment control BMPs are required to incorporate, at minimum, either a volumetric or flow-based treatment control design or both, to mitigate (infiltrate, filter or treat) storm water runoff.

In addition, project applicants subject to the SUSMP requirements must select source control and, in most cases, treatment control BMPs from the list approved by the RWQCB. The BMPs must control peak flow discharge to provide stream channel and over bank flood protection, based on flow design criteria selected by the local agency. Further, the source and treatment control BMPs must be sufficiently designed and constructed to collectively treat, infiltrate, or filter stormwater runoff. The greatest of the runoffs listed below is used as the design standard for the BMPs:

- The 85th percentile 24-hour runoff event determined as the maximized capture stormwater volume for the area, from the formula recommended in *Urban Runoff Quality Management, WEF Manual of Practice No. 23/ASCE Manual of Practice No. 87, (1998)*;
- The volume of annual runoff based on unit basin storage water quality volume, to achieve 80 percent or more volume treatment by the method recommended in *California Stormwater Best Management Practices Handbook—Industrial/Commercial, (1993)*;
- The volume of runoff produced from a 0.75-inch storm event, prior to its discharge to a stormwater conveyance system; or
- The volume of runoff produced from a historical-record based reference 24-hour rainfall criterion for “treatment” (0.75-inch average for the Los Angeles County area) that achieves approximately the same reduction in pollutant loads achieved by the 85th percentile 24-hour runoff event.

Los Angeles Municipal Code

Section 64.70 of the LAMC sets forth the City’s Stormwater and Urban Runoff Pollution Control Ordinance. The ordinance prohibits the discharge of the following into any storm drain system:

- Any liquids, solids, or gases which by reason of their nature or quantity are flammable, reactive, explosive, corrosive, or radioactive, or by interaction with other materials could result in fire, explosion or injury.
- Any solid or viscous materials, which could cause obstruction to the flow or operation of the storm drain system.
- Any pollutant that injures or constitutes a hazard to human, animal, plant, or fish life, or creates a public nuisance.
- Any noxious or malodorous liquid, gas, or solid in enough quantity, either singly or by interaction with other materials, which creates a public nuisance, hazard to life, or inhibits authorized entry of any person into the storm drain system.
- Any medical, infectious, toxic or hazardous material or waste.

Additionally, unless otherwise permitted by a NPDES permit, the ordinance prohibits industrial and commercial developments from discharging untreated wastewater or untreated runoff into the storm drain system. Furthermore, the ordinance prohibits trash or any other abandoned objects/materials from being deposited such that they could be carried into the storm drains. Lastly, the ordinance not only makes it a

crime to discharge pollutants into the storm drain system and imposes fines on violators, but also gives City public officers the authority to issue citations or arrest business owners or residents who deliberately and knowingly dump or discharge hazardous chemicals or debris into the storm drain system.

Earthwork activities, including grading, are governed by the Los Angeles Building Code, which is contained in Los Angeles Municipal Code (LAMC), Chapter IX, Article 1. Specifically, Section 91.7013 includes regulations pertaining to erosion control and drainage devices, and Section 91.7014 includes general construction requirements, as well as requirements regarding flood and mudflow protection.

Low Impact Development (LID)

In October 2011, the City of Los Angeles passed an ordinance (Ordinance No. 181899) amending City of Los Angeles Municipal Code Chapter VI, Article 4.4, Sections 64.70.01 and 64.72 to expand the applicability of the existing Standard Urban Stormwater Mitigation Plan requirements by imposing rainwater Low Impact Development (LID) strategies on projects that require building permits. On May 9, 2016 The City of Los Angeles Bureau of Sanitation released the 5th edition of the Planning and Land Development Handbook for Low Impact Development (LID) and is the basis for all current LID designs.

LID is a stormwater management strategy with goals to mitigate the impacts of increased runoff and stormwater pollution as close to its source as possible. LID promotes the use of natural infiltration systems, evapotranspiration, and the reuse of stormwater. The goal of these LID practices is to remove nutrients, bacteria, and metals from stormwater while also reducing the quantity and intensity of stormwater flows. Using various infiltration strategies, LID is aimed at minimizing impervious surface area. Where infiltration is not feasible, the use of bioretention, rain gardens, green roofs, and rain barrels that will store, evaporate, detain, and/or treat runoff may be used.

The intent of the City of Los Angeles LID standards is to:

- Require the use of LID practices in future developments and redevelopments to encourage the beneficial use of rainwater and urban runoff;
- Reduce stormwater/urban runoff while improving water quality;
- Promote rainwater harvesting;
- Reduce offsite runoff and provide increased groundwater recharge;
- Reduce erosion and hydrologic impacts downstream; and
- Enhance the recreational and aesthetic values in our communities.

The City of Los Angeles Bureau of Sanitation, Watershed Protection Division will adopt the Low Impact Development (LID) standards as issued by the LARWQCB and the City of Los Angeles Department of Public Works. The LID Ordinance will conform to the regulations outlined in the NPDES Permit and SUSMP.

2.3. Groundwater

Board Basin Plan for the Coastal Watersheds of Los Angeles and Ventura Counties

As required by the California Water Code, the LARWQCB has adopted a plan entitled “Water Quality Control Plan, Los Angeles Region: Basin Plan for the Coastal Watersheds of Los Angeles and Ventura Counties” (Basin Plan). Specifically, the Basin Plan designates beneficial uses for surface and groundwaters, sets narrative and numerical objectives that must be attained or maintained to protect the designated beneficial uses and conform to the State’s antidegradation policy, and describes implementation programs to protect all waters in the Los Angeles Region. In addition, the Basin Plan incorporates (by reference) all applicable State and Regional Board plans and policies and other pertinent water quality policies and regulations. Those of other agencies are referenced in appropriate sections throughout the Basin Plan.

The Basin Plan is a resource for the Regional Board and others who use water and/or discharge wastewater in the Los Angeles Region. Other agencies and organizations involved in environmental permitting and resource management activities also use the Basin Plan. Finally, the Basin Plan provides valuable information to the public about local water quality issues.

Safe Drinking Water Act (SDWA)

The Federal Safe Drinking Act, established in 1974, sets drinking water standards throughout the country and is administered by the USEPA. The drinking water standards established in the SDWA, as set forth in the Code of Federal Regulations (CFR), are referred to as the National Primary Drinking Water Regulations (Primary Standards, Title 40, CFR Part 141) and the National Secondary Drinking Water Regulations (Second Standards, 40 CFR Part 143). California passed its own Safe Drinking Water Act in 1986 that authorizes the State's Department of Health Services (DHS) to protect the public from contaminants in drinking water by establishing maximum contaminants levels (MCLs), as set forth in the CCR, Title 22, Division 4, Chapter 15, that are at least as stringent as those developed by the USEPA, as required by the federal Safe Drinking Water Act.

California Water Plan

The California Water Plan (The Plan) provides a framework for water managers, legislators, and the public to consider options and make decisions regarding California's water future. The Plan, which is updated every five years, presents basic data and information on California's water resources including water supply evaluations and assessments of agricultural, urban, and environmental water uses to quantify the gap between water supplies and uses. The Plan also identifies and evaluates existing and proposed statewide demand management and water supply augmentation programs and projects to address the State's water needs.

The goal for the California Water Plan Update is to meet Water Code requirements, receive broad support among those participating in California's water planning, and be a useful document for the public, water planners throughout the state, legislators and other decision-makers.

3.0 Surface Water Hydrology

3.1 General Approach

The Project site is located within the City therefore, drainage collection, treatment and conveyance are regulated by the City. Per the City's Special Order No. 007-1299, December 3, 1999, the City has adopted the County Department of Public Works (LACDPW) Hydrology Manual as its basis of design for storm drainage facilities. The LACDPW Hydrology Manual requires projects to have drainage facilities that meet the Urban Flood level of protection. The Urban Flood is runoff from a 25-year frequency design storm falling on a saturated watershed. A 25-year frequency design storm has a probability of 1/25 of being equaled or exceeded in any year. To provide a more conservative analysis, this report analyzed the larger storm event threshold, the 50-year frequency design storm event. 2019 CEQA thresholds state that Surface water impacts may occur when a project results in either increased on- or off-site storm water flows, changes in absorption rates, alterations to existing surface water flow patterns or directions (including the intake and use of water from a surface water body), or other factors which result in a changed rate of flow. Surface waters include lakes, rivers, streams, reservoirs, the ocean, and similar water bodies. Flood hazard is defined as flooding which occurs during a storm event, particularly the 50-year developed storm event.

The analysis of the Project includes the 50-year storm event. The Modified Rational Method was used to calculate storm water runoff. The "peak" (maximum value) runoff for a drainage area is calculated using the formula, **Q=CIA**

Where,

- Q = Volumetric flow rate (cfs)
- C = Runoff coefficient (dimensionless)
- I = Rainfall Intensity at a given point in time (in/hr)
- A = Basin area (acres)

The Modified Rational Method assumes that a steady, uniform rainfall rate will produce maximum runoff when all parts of the basin area are contributing to outflow. This occurs when the storm event lasts longer than the time of concentration. The time of concentration (Tc) is the time it takes for rain in the most hydrologically remote part of the basin area to reach the outlet.

The method assumes that the runoff coefficient (C) remains constant during a storm. The runoff coefficient is a function of both the soil characteristics and the percentage of impervious surfaces in the drainage area.

LACDPW developed a time of concentration calculator, Tc Calculator (TC_calc_depth.xls, July 2006), to automate time of concentration calculations as well as the peak runoff rates and volumes using the Modified Rational Method design criteria as outlined in the Hydrology Manual. The data input requirements include sub-area size, soil type, land use, flow path length, flow path slope and rainfall isohyet. The LACDPW has produced Isohyetal maps that provide the Project Site's soil type and the rainfall isohyet value based on the location of the project. Once all values were known, the Tc Calculator was used to calculate the storm water peak runoff flow rate for the Existing and Proposed Project conditions by evaluating an individual sub-area independent of all adjacent subareas. See Table 1 for the Tc Calculator Peak Runoff Flow results. Results for the 5-, 10-, 25-, 50-, and 100-year events were all included for information.

3.2 Data Sources

The primary sources of data are the *LACDPW Hydrology / Sedimentation Manual and Appendices* (LACDPW 2006), and the Los Angeles County *Standard Urban Stormwater Mitigation Plan* (September 2002).

Rainfall and soil characteristics for the Project Site are given in Isohyetal Map Figure LACDPW 1-HI.18 (Section 4). A copy of the map is provided in Section 7.0. The 50-year (24-hour) rainfall isohyet nearest the Project area is approximately 5.80-inches. The isohyets for all the storm events, based on factors from the LA County Hydrology Manual in Table 5.3.1, are as listed:

- 5-Year 24-Hour: 3.39-inches
- 10-Year 24-Hour: 4.14-inches
- 25-Year 24-Hour: 5.09-inches
- 50-Year 24-Hour: 5.80-inches
- 100-Year 24-Hour: 6.51-inches

As shown on the Isohyetal Map, the soil classification of the Project Site falls predominantly into Soil Type 006. The Project Site area to be disturbed in connection with construction of the Project is approximately 0.67 acres.

3.3 Existing Site Conditions

The existing Project Site currently consists of a two-story warehouse building. The Project Site totals approximately 0.67 acres with an average imperviousness of 100%.

Stormwater runoff from the existing Project Site drains via surface runoff towards Hill Street and via roof drains. There is an existing storm drain catch basin at the corner of 11th Street and Hill Street. This catch basin connects to an existing Los Angeles County 27" storm drain main line in 11th Street.

The Project Site is located within a FEMA or City of Los Angeles designation 500- year flood plain, but it is not located within a potential inundation area as designed by the City of Los Angeles General Plan Safety Element. The Project Site is located on FEMA FIRM Panel 06037C1617G and identified as Flood Zone "X".

3.4 Proposed Project Site Conditions

The proposed project will consist of a 40-story high-rise mixed-use hotel, residential, and commercial development. The Project building includes one level of subterranean parking, one level of ground floor commercial uses, and three levels of aboveground parking. This will include an excavation depth of 45 feet below grade. The assumed average imperviousness of the Project Site will reduce to 95% once all on-site Project improvements, landscaping, and amenities are installed. This impervious percentage may change as the project progresses, but the BMPs put in place will ultimately be designed for the final imperviousness percentage. The proposed stormwater flows will continue to drain to the corner of 11th Street and Hill Street and will not change the existing drainage pattern. However, as described below, the Project’s compliance with existing Low Impact Development (LID) requirements will create reductions in the stormwater flows to the City’s stormwater system. Table 1 shows a reduction in runoff for all storm events.

3.5 Hydrology Results

Table 1 below summarizes the hydrology results demonstrating the peak stormwater runoff flows for the 5-, 10-, 25-, 50- and 100-year storm events under existing conditions and following construction of the Project:

Table 1. Existing and Proposed Peak Runoff Flows

	Existing	Proposed*	
Storm Event	Q_{Total} [cfs]	Q_{Total} [cfs]	% Reduction
5-Yr	1.118	0.885	-20.8%
10-Yr	1.490	1.258	-15.6%
25-Yr	1.832	1.602	-12.5%
50-Yr	2.087	1.859	-10.9%
100-Yr	2.341	2.116	-9.6%

* Includes reduction from LID implementation (subtracting the 85th Percentile storm flow of 0.222 cfs)

The Project Site was reviewed as one hydrology area since the runoff all flows southeast towards Hill Street. This review demonstrates that the Project will not exceed the existing stormwater flows. It considers the Project’s required Low Impact Development (LID) reductions which are needed to manage post construction stormwater runoff. The Project will include the installation of private catch basins, planter drains, and roof downspouts throughout the Project Site to collect roof and site runoff, and direct stormwater to the LID system through a series of underground storm drain pipes. This onsite stormwater conveyance system would serve to prevent onsite flooding and nuisance water build-up on the Project Site. With implementation of a stormwater capture and use system (i.e. harvesting system for on-site irrigation use), the volume of water leaving the Project Site will be reduced from the existing flows.

4.0 Surface Water Quality

4.1 General Approach

Construction Best Management Practices (BMP’s) will be designed and maintained as part of the implementation of the SWPPP in compliance with the General Permit. The SWPPP shall begin when construction commences, before any site clearing and grubbing of demolition activity. During construction, the SWPPP will be referred to regulatory and amended as changes occur throughout the construction process. The Notice of Intent (NOI), Amendments to the SWPPP, Annual Reports, Rain Event Action Plans (REAPs), and Non-Compliance Reporting will be posted to the State’s SMARTS website in compliance with the requirements of the General Permit.

The Project falls under the jurisdiction of the City of Los Angeles Department of Public Works, which follows the 2016 Low Impact Development (LID) Manual design guidelines. The purpose of this surface water quality report is:

- To meet City of Los Angeles Department of Public Works requirements;
- To document that the Los Angeles County LID requirements will be met;
- To determine the proposed development's impact on existing hydrologic conditions;
- To identify the pollutants of concern and provide BMPs that will mitigate those pollutants of concern; and
- To provide enough detailed information to support detailed hydraulic design of stormwater treatment systems.

The LID requirements, approved by the Regional Water Quality Control Board, call for the treatment of the peak mitigation flow rate, or volume of runoff, produced either by a 0.75" 24-hr rainfall event or the 85th percentile rainfall event. Whichever runoff is greater is the one that is used for the BMP design. Under section 3.1.2 of the LID Manual, this post-construction stormwater runoff from the new development shall be infiltrated, evapotranspired, captured and used, and/or treated through high efficiency BMP's onsite. The rainfall intensity of the 85th percentile rainfall for the Project Site's location is 1.0 inches; therefore, the 85th percentile rainfall event governs.

4.2 Site Characterization for Water Quality Review

Current Property Use: A vacant 2-story warehouse building to be demolished. There are no known existing BMPs serving the Project Site.

Proposed Property Use: A new 40-story high-rise mixed-use hotel, residential, and commercial development. The Project building includes one level of subterranean parking, one level of ground floor commercial uses, and three levels of aboveground parking.

Soils: The soil of the watershed is classified as Type 006, as shown in the Hydrology Map from the Los Angeles County Department of Public Works (LACDPW) website as well as the LACDPW Isohyet Map 1-H1.17 (see section 7.0 for maps).

Receiving Waters: The Project Site is tributary to the Los Angeles River.

The Los Angeles River is listed on the 2012 CWA Section 303(d) list (approved by SWRCB June 30, 2015) as impaired due to the prevalence of the pollutants shown in Table 2, which is excerpted from the State Water Resources Control Board, "Quality Limited Segments" article dated June 9, 2016. Currently, this waterway's existing beneficial uses include ground water recharge, warm freshwater habitat, wildlife habitat and wetland habitat; potential uses include municipal and domestic supply and industrial service supply.

Table 2: Receiving Waters for Urban Runoff from Site¹

¹ State Water Resources Control Board, Los Angeles Region. *Water Quality Control Plan Los Angeles Region*. June 13, 1994.

Receiving Waters	303(d) List Impairments ²	Designated Beneficial Uses	Proximity to RARE Uses
Los Angeles River Reach 2	Ammonia, Copper, Lead, Indicator Bacteria, Nutrients (Algae), Trash, Oil	Existing/Intermittent: GWR, WARM, WILD, WET Potential: MUN, IND	No

4.3 Pollutants of Concern

Table 3 lists the pollutants anticipated to be generated by the Project’s proposed land uses. The designated beneficial uses column defines the resources, services, and qualities of aquatic systems that are the ultimate goals of protecting and achieving high water quality. GWR stands for Groundwater Recharge, IND stands for Industrial Service Supply, MUN stands for Municipal and Domestic Supply, WARM stands for Warm Freshwater Habitat, WILD stands for Wildlife Habitat, and WET stands for Wetland. Because the Project falls under the category of hotel/commercial development, that is also inclusive of a residential component, the following pollutants could be potentially generated: ammonia, copper, lead, indicator bacteria, nutrients (algae), trash, and oil.

Table 3: Potential Pollutants Generated by Land Use Type³

Type of Development (Land Use)	Sediment /Turbidity	Nutrient s	Organic Compound s	Trash & Debris	Oxygen Demanding Substances	Bacteria & Viruses	Oil & Grease	Pesticides	Metals
Hotel / Commercial Development	P(1)	P(1)	P(4)	P	P(4)	P(3)	P	P(1)	N

Abbreviations: P=Potential N=Not expected

Notes:

- (1) A potential pollutant if landscaping or open area exists on the Project site
- (2) A potential pollutant if land use involves animal waste
- (3) Specifically, petroleum hydrocarbons
- (4) Bacterial indicators are routinely detected in pavement runoff.

A comparison of the pollutants existing in the Los Angeles River based on the State 303(d) list and pollutants associated with the planned land use activities of the site show an overlap of **trash, oxygen demanding substances (ammonia), nutrients (algae), and metals** as pollutants. These common pollutants are considered the pollutants of concern. Stormwater best management practices (BMP) proposed for the project will be designed to address these pollutants of concern. Table 4 summarizes the efficiency of general categories of BMPs in treating different types of pollutants.

The City of Los Angeles requires LID compliance for all new development projects. As noted above, the LID concept for this Project is a stormwater capture and use system. Rainwater harvesting collects rainwater from a surface that allows for the rainwater to be stored and used later. In a typical rainwater harvesting situation, rainwater is collected from an impervious surface such as the roof of a building and

² California State Water Resources Control Board. 2014/2016 California Integrated Report CWA Section 303(d) *Listed Waters*. April 6, 2018.

³ Riverside County Flood Control and Conservation District, Riverside County Water Quality Management Plan for Urban Runoff, July 24, 2006. Note: This source is utilized because the Los Angeles County Flood Control District has not established a table that outlines pollutants of concern; however, the Riverside County plan accurately represents pollutant types typically occurring in Los Angeles County.

PSOMAS

then stored inside of a tank or cistern. Rainwater can be collected from other surfaces as well such as parking lots, roadways, driveways, and even land surfaces. The runoff within the cistern will be pumped up for irrigation of the landscape around the Project Site. High flow outlets for the rainwater harvesting cistern will be routed to discharge into the City’s storm drain system as per proposed conditions, as described in section 2.4, above.

Table 4 summarizes treatment control levels for each Low Impact Development strategy selected. Items highlighted with grey coloring indicate the previously mentioned pollutants of concern for the Los Angeles River. This indicates that stormwater harvesting provides high to medium levels of efficiency to remove sediments and turbidity, an unknown level of treatment for trash, and high to medium levels of efficiency for bacteria and viruses. Because stormwater harvesting provides a low level of treatment for trash removal, an additional level of stormwater management will be required for this project in the application of upstream water quality inlets. As per Table 4, water quality inlets provide a medium level of efficiency for trash removal.

Table 4: Treatment Control BMP Selection Matrix⁴

Los Angeles River Pollutant of Concern (Yes/No)	Treatment Control BMP Categories							
	Veg. Swale /Veg. Filter Strips	Detention Basins	Planter Box / Harvesting /Infiltration Basins & Trenches	Wet Ponds or Wetlands	Sand Filter or Filtration	Water Quality Inlets (a)	Hydro-dynamic Separator Systems	Manufactured / Proprietary Devices
Sediment/Turbidity	H/M	M	H/M	H/M	H/M	L	H/M (L for turbidity)	U
Yes			✓			✓		
Nutrients	L	M	H/M	H/M	L/M	L	L	U
No								
Organic Compounds	U	U	U	U	H/M	L	L	U
No								
Trash & Debris	L	M	U	U	H/M	M	H/M	U
Yes			✓			✓		
Oxygen Demanding Substances	L	M	H/M	H/M	H/M	L	L	U
No								
Bacteria & Viruses	U	U	H/M	U	H/M	L	L	U
Yes			✓			✓		
Oils & Grease	H/M	M	U	U	H/M	M	L/M	U
No								
Pesticides (non-soil bound)	U	U	U	U	U	L	L	U
No								
Metals	H/M	M	H	H	H	L	L	U
No								
Abbreviations: L: Low removal efficiency H/M: High or medium removal efficiency U: Unknown removal efficiency								

⁴ Riverside County Flood Control and Conservation District, Riverside County Water Quality Management Plan for Urban Runoff, July 24, 2006. Note: This table is utilized because the Los Angeles County Flood Control District has not established a table that summarizes each BMP’s efficiency for treating pollutants of concern.

(a). Water quality inlets are pre-treatment filter devices that consist of one or more chambers that promote sedimentation of coarse materials and separation of free oil from stormwater. They are typically installed at catch basins.

4.4 Best Management Practices

Source and Treatment Control Best Management Practices (BMPs) are required for this Project under the LA County Standard Urban Stormwater Mitigation Plan (SUSMP) and City of Los Angeles Low Impact Development (LID) Standards Manual.

4.4.1 Site Design BMPs

4.4.1.1 Minimize Stormwater Pollutants of Concern

The Project will minimize pollutants of concern from impacting surface water quality by maximizing the reduction of pollutant loadings to the Maximum Extent Practicable. The soils engineering report suggests that the site is generally considered suitable for stormwater infiltration, however due to the Project being designed to occupy the entire property, stormwater infiltration and biofiltration systems could be precluded from a design standpoint under the basement slab. Therefore it has been determined that a stormwater harvesting system will be used to meet the project's LID requirements. This storm water harvesting tank will be installed within the building parking levels to a volume equivalent to a size listed in Table 6 in this report. The pollutants of concern – namely, sediment, trash, and bacteria & viruses– will be addressed through a pre-treatment settlement device connected to the harvesting tank within the Project Site. Pretreatment Settling devices rely primarily on sedimentation, in which coarse sediments and debris sink or fall out of the collected stormwater. Some settling devices also provide secondary screening to improve the capture of floatables and sediment. Building roof run-off, which comprises of most of the site, will be collected via roof drains and routed internally through the buildings and directed into the harvesting tank. Capture and use, commonly referred to as rainwater harvesting, collects and stores stormwater for later use, thereby offsetting potable water demand and reducing pollutant loading to the storm drain system.

In the City of Los Angeles, the use of collected stormwater will primarily be limited to irrigation of landscaped surfaces. The County of Los Angeles Health Department reviews all storm water harvesting systems for any potential health implications due to long term storage of rainwater. It has been determined by LA County Health Department that storage in excess of 6 months is allowed, so if the stored stormwater does not come in direct contact humans or any other potable water sources. To protect the public from these such occurrences, any potable water lines feeding into the harvesting water system are protected by the installation of a backwater valve.

If the harvesting water tank requires emptying due to maintenance, then all held water must be diverted to the sanitary sewer system per the LA County Health Department guidelines. However, as new guidelines and guidance becomes available; the potential for other uses of collected stormwater will be considered. Capture and use BMPs that are designed with the intent to use captured stormwater for indoor or consumptive purposes will be reviewed on a case-by-case basis to ensure that all treatment, plumbing, and Building and Safety codes are met. Prior to connection to the harvesting tank, downspout filters will be installed to remove any debris that enters the harvesting tank from the on-site piping system. Any storm water flows in excess of the 85th percentile storm will overflow to the street gutter system.

4.4.1.2 Conserve Natural Areas

The existing Project Site consists of a two-story warehouse building. There is minimal existing landscape within the Project Site. Following development of the Project, the Project Site will include a small number of tree wells in the public right of way, and as discussed above, will provide water quality treatment to meet the LID requirements of the City of Los Angeles.

4.4.2 Source Control BMPs

4.4.2.1 Protect Slopes and Channels

There are no unprotected slopes or unlined channels onsite. The entire area to be developed will be either vegetated or hardscaped.

4.4.2.2 Provide Storm Drain System Stenciling and Signage

Stenciling will be provided for public storm drains near the vicinity of the Project.

4.4.3 Treatment Control BMPs

4.4.3.1 Mitigation Design (Volumetric or Flow based)

The LID calculation methodology was used to calculate the required treatment volumes for each of the discharge points from the Project Site. Volume-based criteria are used in the sizing of the cistern. LID calculations are provided in section 7.0. The results are summarized in tables 5 and 6.

Table 5. Proposed Condition SUSMP Results

Project Site Area [ac]	BMP Type	85 th percentile
		*V _M [ft ³]
0.67	Stormwater Capture and Use	2,076

*The total volume (V_m) of stormwater runoff to be mitigated was calculated by analyzing the Project area as one area. Using this V_m and the appropriate BMP calculation from the City of LA LID manual, Table 6 shows the requirements for the area.

Table 6. Summary SUSMP / LID Mitigation BMPs

Area	Area [ac]	Impervious Area [ac]	Required Storage Tank V _M [ft ³]	BMP Type	Provided Treatment V _M [ft ³]	% Treated	Impervious Area Untreated [ac]
1 ⁵	0.67	0.64	2,076	Stormwater Capture and Use	2,076	100	0

⁵ BMP required calculation based on City of LA LID manual.

Total Percent Treatment	100%
--------------------------------	-------------

The proposed BMP will provide full treatment of the 85th percentile storm event. The selected BMP for the Project Site has a larger volume capacity to capture more than the required baseline volume of 2,076 ft³. The total provided treatment volume is 2,076 ft³ or 15,530 gallons.

5.0 Significance Thresholds

5.1 Surface Water Hydrology

With respect to surface water hydrology, the State 2019 CEQA Guidelines (Appendix G) inquire whether the Project would:

- Substantially alter the existing drainage pattern of the site or area, including through the alteration of the course of a stream or river or through the addition of impervious surfaces, in a manner which would:
 - Substantially decrease groundwater supplies or interfere substantially with groundwater recharge such that the project may impede sustainable groundwater management of the basin?
 - Substantially alter the existing drainage pattern of the site or area, including through the alteration of the course of a stream or river or through the addition of impervious surfaces, in a manner which would:
 - Result in substantial erosion or siltation on- or off-site;
 - Substantially increase the rate or amount of surface runoff in a manner which would result in flooding on- or off-site;
 - Create or contribute runoff water which would exceed the capacity of existing or planned stormwater drainage systems or provide substantial additional sources of polluted runoff; or
 - Impede or redirect flood flows?
 - In flood hazard, tsunami, or seiche zones, risk release of pollutants due to project inundation?

5.2 Surface Water Quality

With respect to surface water quality, the State 2019 CEQA Guidelines (Appendix G) inquire whether the Project would:

- In flood hazard, tsunami, or seiche zones, risk release of pollutants due to project inundation?
- Conflict with or obstruct implementation of a water quality control plan or sustainable groundwater management plan?

The City of LA uses Appendix G of the CEQA Guidelines to determine the significance of a project’s impact on surface water quality. These are defined in Section 13050 of the California Water Code (CWC). Pollution, contamination, or nuisance may occur if regulatory standards are violated, as defined in the applicable NPDES stormwater permit or Water Quality Control Plan for the receiving water body. The CWC include the following definitions:

“Pollution” means an alteration of the quality of waters of the state to a degree which unreasonably affects either the following: 1) the waters for beneficial uses or 2) facilities which serve these beneficial uses. “Pollution” may include “Contamination”.

PSOMAS

“Contamination” means an impairment of the quality of the waters of the state by waste to a degree, which creates a hazard to the public health through poisoning or through the spread of disease. “Contamination” includes any equivalent effect resulting from the disposal of waste, whether or not waters of the state are affected.

“Nuisance” means anything which meets all of the following requirements: 1) is injurious to health, or is indecent or offensive to the senses, or an obstruction to the free use of property, so as to interfere with the comfortable enjoyment of life or property; 2) affects at the same time an entire community or neighborhood, or any considerable number of persons, although the extend of the annoyance or damage inflicted upon individuals may be unequal; and 3) occurs during, or as a result of the treatment or disposal of wastes.

6.0 Project Impact Analysis

6.1 Surface Water Hydrology

	Potentially Significant Impact	Less Than Significant with Mitigation Incorporated	Less Than Significant Impact	No Impact
Would the project:				
a. Substantially decrease groundwater supplies or interfere substantially with groundwater recharge such that the project may impede sustainable groundwater management of the basin?	<input type="checkbox"/>	<input type="checkbox"/>	<input checked="" type="checkbox"/>	<input type="checkbox"/>
b. Substantially alter the existing drainage pattern of the site or area including through the alteration of the course of a stream or river, in a manner which would:				
i. Result in substantial erosion or siltation on or off-site;	<input type="checkbox"/>	<input type="checkbox"/>	<input checked="" type="checkbox"/>	<input type="checkbox"/>
ii. Substantially increase the rate or amount of surface runoff in a manner which would result in flooding on or off-site;	<input type="checkbox"/>	<input type="checkbox"/>	<input checked="" type="checkbox"/>	<input type="checkbox"/>
iii. Create or combine runoff water which would exceed the capacity of existing or planned stormwater drainage systems or provide substantial additional sources of polluted; or	<input type="checkbox"/>	<input type="checkbox"/>	<input checked="" type="checkbox"/>	<input type="checkbox"/>
iv. Impede or redirect flood flows?	<input type="checkbox"/>	<input type="checkbox"/>	<input checked="" type="checkbox"/>	<input type="checkbox"/>
c. In flood hazard, tsunami, or seiche zones, risk release of pollutants due to project inundation?	<input type="checkbox"/>	<input type="checkbox"/>	<input checked="" type="checkbox"/>	<input type="checkbox"/>
d. Conflict with or obstruct implementation of a water quality control plan or sustainable groundwater management plan?	<input type="checkbox"/>	<input type="checkbox"/>	<input checked="" type="checkbox"/>	<input type="checkbox"/>

- a. Would the project substantially decrease groundwater supplies or interfere substantially with groundwater recharge such that the project may impede sustainable groundwater management of the basin?**

Less Than Significant Impact. As discussed above, construction activities for the project involves the development of a new 43-story high-rise mixed-use building which includes, two levels of subterranean parking, one level of ground floor commercial uses, and six levels of aboveground parking. This will include an excavation depth of 45 feet below grade. Historic groundwater levels are located 100 to 120 feet below the existing grade according to the California Division of Mines and Geology (CDMG). However, the information of groundwater data collected from the State Water Resources Control Board's GEOTRACKER website indicates that in 2010, groundwater was reported between depths of 32 and 45 feet in two (2) 50-foot deep monitoring wells located approximately 990 and 1000 feet north of the Project site, respectively. Previous borings drilled in 2015 at the Project site at depths of 90 to 120 feet did not encounter any groundwater. However, previous borings that drilled in the near vicinity of the project to 160 feet encountered occasional minor seepage between 27 and 37 feet. Excavation of the basement is anticipated to be 45 feet below existing grade. Although the excavation is not below the current groundwater level, it is still possible that groundwater could be encountered during excavation. Per the geology report, some minor seepage should be anticipated in the excavation, and minor dewatering consisting of gravel-filled trenches installed where necessary, should be anticipated. If groundwater is encountered during construction, temporary pumps and filtration would be utilized in compliance with all applicable regulations and requirements, including all relevant NPDES requirements related to construction and discharges from dewatering operations. NPDES requires dischargers must demonstrate that discharges do not violate any water quality objective/criteria for the receiving waters, demonstrate that discharge shall not exceed effluent limitations, perform an analysis using a sample of groundwater or wastewater to be discharged, show discharge shall not cause acute nor chronic toxicity in receiving waters, that discharge shall pass through a treatment system if necessary, and must comply with the provisions of the NPDES permit. Therefore, through compliance with regulatory requirements, potential impacts would be less than significant.

Regarding groundwater recharge, the Project Site is currently mostly impervious with approximately 100-percent impervious surfaces. Therefore, there is currently low groundwater recharge potential. While operation of the Project would not change the amount of impervious surface, the underground footprint of the Project's improvements and landscaping would span property line to property line, and therefore the groundwater recharge potential would remain minimal. As stated above, the volume greater than the first flush of stormwater, which bypasses the BMP systems, would discharge to an approved discharge point in the public right-of-way and would not result in infiltration of a large amount of rainfall that would affect groundwater hydrology, including the direction of groundwater flow. As such, the Project would not interfere substantially with groundwater recharge such that the Project may impede sustainable groundwater management of the West Coast Groundwater Basin.

Therefore, the Project's potential impact on groundwater supplies and groundwater recharge would be less than significant, and no mitigation measures are required.

- b. Would the project substantially alter the existing drainage pattern of the site or area including through the alteration of the course of a stream or river, in a manner which would:**
- i. result in substantial erosion or siltation on or off-site;**

Less Than Significant Impact. Construction activities have the potential to temporarily alter existing drainage patterns and flows on the Project Site by exposing the underlying soils, modifying flow direction, and making the Project Site temporarily more permeable. Also, exposed and stockpiled soils could be subject to erosion and conveyance into nearby storm drains during storm events. In addition, on-

site watering activities to reduce airborne dust could contribute to pollutant loading in runoff. However, as discussed above, Project construction activities would occur in accordance with City grading permit regulations (Chapter IX, Division 70 of the LAMC), such as the preparation of an erosion control plan, to permit regulations, construction activities for the Project would not substantially alter the Project Site drainage patterns in a manner that would result in substantial erosion or siltation on- or off-site. As such, construction-related impacts to hydrology would be less than significant, and no mitigation measures are required.

The Project Site is comprised of approximately 100-percent impervious surfaces under existing conditions. With implementation of the Project, the amount of impervious area would not increase. As such, there would be a limited potential for erosion or siltation to occur from exposed soils or large expanses of pervious areas. Therefore, the Project would not substantially alter the existing drainage pattern of the Project Site or surrounding area such that substantial erosion or siltation on-site or off-site would occur. Operational impacts to hydrology would be less than significant, and no mitigation measures are required. Impacts are not likely to occur, because as the Regional Water Quality Control Board (RWQCB) dictates, the Project must provide a Low Impact Development (LID) system which will capture and use all the rainwater from the 85th percentile storm. As Table 1 demonstrates, a decrease in runoff is expected due to the development even when the impervious area increases. Therefore, no impact is expected.

ii. substantially increase the rate or amount of surface runoff in a manner which would result in flooding on or off-site

Less Than Significant Impact. There are no streams or rivers within or immediately surrounding the Project Site. Construction activities for the Project would involve removal of the existing structures and associated hardscape as well as the excavation and removal of soil. These activities have the potential to temporarily alter existing drainage patterns on the Project Site by exposing the underlying soils, modifying flow direction, and making the Project Site temporarily more permeable. Project Construction activities would occur in accordance with City grading permit regulations (Chapter IX, Division 70 of the LAMC), such as the preparation of an erosion control plan, to reduce the effects of sedimentation and erosion. Thus, through compliance with applicable City grading permit regulations, construction activities for the Project would not substantially alter the Project Site drainage patterns in a manner that would result in flooding on- or off-site. As such, construction-related impacts to hydrology would be less than significant, and no mitigation measures are required.

As previously discussed, under the City's LID Ordinance, post-construction stormwater runoff from new projects must be infiltrated, evapotranspired, captured and used, and/or treated through high efficiency BMPs on-site for the volume of water produced by the greater of the 85th percentile storm event or the 0.75-inch storm event (i.e., "first flush"). Consistent with LID requirements to reduce the quantity and improve the quality of rainfall runoff that leaves the Project Site, the Project would include the installation BMP systems would be designed with an internal bypass overflow system to prevent upstream flooding during major storm events. Therefore, while the Project would not increase impervious surfaces compared to existing conditions, with implementation of BMPs the Project would not increase the rate or amount of surface runoff in a manner which would result in flooding on- or off-site. Operational impacts to hydrology would be less than significant, and no mitigation measures are required.

iii. create or combine runoff water which would exceed the capacity of existing or planned stormwater drainage systems or provide substantial additional sources of polluted;

Less Than Significant Impact. The Project Site currently consists of a vacant building, and no landscaped areas. The Project Site is 100-percent impervious and is not crossed by any water courses or rivers. Currently, stormwater runoff from the Project Site is conveyed by sheet flow from west to east and is collected in a catch basin on S. Hill St and 11th St. There is an existing 27-inch City of LA storm drain line that is located on 11th St.

As previously discussed, operation of the Project would keep the impervious surface area within the Project Site at 95-percent. The Project would include the installation of building roof drain downspouts,

area drain, and planter drains to collect roof and site runoff. The Project would also direct stormwater away from buildings through a series of storm drain pipes. Furthermore, based on the volumetric flow rate analysis, a comparison of the pre- and post-Project peak flow rate indicated that there would be a decrease in stormwater runoff. In addition, the implementation of BMPs required by the City's LID Ordinance would target runoff pollutants that could potentially be carried in stormwater runoff due to the collection of water to meet the regional LID guidelines. Therefore, the Project would not create or contribute runoff water which would exceed the capacity of existing or planned stormwater drainage systems or provide substantial additional sources of polluted runoff. Impacts would be less than significant, and no mitigation measures are required.

iv. impede or redirect flood flows?

Less Than Significant Impact. The Project Site is located inside the 500 Yr. Flood Zone, otherwise known as Zone X, in the Flood Insurance Rate Maps from the Federal Emergency Management Agency (FEMA). The 500 Yr. Flood Zone refers to an area with a 0.2% (or 1 in 500 chance) annual chance of flooding. This zone is also used to designate base floodplains of lesser hazards, such as areas protected by levees from 100-year flood, or shallow flooding areas with average depths of less than one foot or drainage areas less than 1 square mile. In addition to the low risk of flooding, the Project would implement a capture and use and/or biofiltration system BMPs and a stormwater conveyance system. Thus, the Project would not alter the existing drainage pattern of the Project Site in a manner that would impede or redirect flood flows. As such, no impacts would occur.

c. In flood hazard, tsunami, or seiche zones, would the project risk release of pollutants due to project inundation?

Less Than Significant Impact. Earthquake-induced flooding occurs when nearby water retaining structures, such as dams or storage tanks, are breached or damaged during an earthquake. The Los Angeles County Safety Element (1990) identified the Project Site to be within a "dam or debris basin flood area". The Hansen Dam Reservoir has been identified by the Los Angeles County Safety Element (1990) as a potential source being located approximately 17 miles to the northwest of the Project Site. However, there appears to be minimal risk of earthquake-induced flooding at the Project site due to the following:

- In general, there are engineering controls in place that are established by state and local agencies to monitor the dam safety in accordance with the National Dam Safety Act (Public Law 92-367) to ensure that these structures are designed and constructed properly as well as receive regular inspections, maintenance and design retrofits, to reduce the potential for earthquake-induced failures.
- In addition to the site distance, there are also numerous drainage channels and spreading grounds between the source and the Project site, including the Los Angeles River, that would intercept and divert flood waters that would result from a breach of the Hansen Dam or similar water-storage structures upstream.
- The latest 2017 LA City Hazard Mitigation Plan has early-warning provisions and programs to increase public awareness for such an event. This plan was developed to encourage the incorporation of mitigation measures into repairs, major alterations, new development, and redevelopment practices, to further reduce risk.

Moreover, the Project would not exacerbate potential dam failure or the possibility of flooding as a result of dam failure.

The Project is located too far away from the ocean and is at too high of an elevation for it to be affected by a tsunami. Seiches, which is a temporary disturbance in the water levels of lakes or partially enclosed bodies of water, will not affect the Project as it is not close enough to a large body of water to be affected.

As previously described, the Project Site is located inside Zone X in the Flood Insurance Rate Maps from the Federal Emergency Management Agency (FEMA). In addition to the low risk of flooding, the Project includes capture and use and/or biofiltration system BMP and a stormwater conveyance system, which would be improved upon the existing site devoid of treatment and on-site detention. Therefore, the Project would not risk release of pollutant due to inundation by flood hazards.

For the reasons addressed above, the Project Site would have a less than significant impact on the potential release of pollutants due to a potential dam failure. And the Project Site would not have a risk of release of pollutants as a result of tsunami or seiche.

d. Conflict with or obstruct implementation of a water quality control plan or sustainable groundwater management plan?

Less Than Significant Impact. Under Section 303(d) of the Clean Water Act, states are required to identify water bodies that do not meet their water quality standards. Biennially, the Los Angeles Regional Water Quality Control Board (LARWQCB) prepares a list of impaired waterbodies in the region, referred to as the 303(d) list. The 303(d) list are subject to the development of a Total Maximum Daily Load (TMDL). As discussed in this report, the Project Site is located within the Los Angeles River Watershed. Constituents of concern listed for the Los Angeles River under California's Clean Water Act Section 303(d) List include Ammonia, Copper, Indicator Bacteria, Lead, Nutrients (Algae), Oil, and Trash. No Total Maximum Daily Load (TMDL) data have been recorded by EPA for this waterbody.

As described above, based on observation of existing conditions, stormwater currently discharges from the Project Site without treatment or on-site detention. Thus, the Project's implementation of capture and use and/or biofiltration system BMPs would minimize the release of anticipated and potential pollutants generated by the Project (e.g., sediment, nutrients, pesticides, metals, pathogens, and oil and grease). As the project would not increase the amount of impervious area, implementation of the LID BMP measures on the Project Site would result in an improvement in surface water quality runoff when compared to existing conditions. In addition, during construction operations the project site is required by the State Water Resources Control Board (SWRCB) to implement stormwater management Best Management Practices (BMPs) as required in the project's Stormwater Pollution Prevention Program (SWPPP) following the latest guidelines of the California Stormwater Quality Association (CASQA) handbook. These BMPs will ensure that stormwater runoff quality during construction is maintained in a manner which reduces sediment transmission, lowers stormwater turbidity, as well as maintains the overall pH of the stormwater.

As such, the Project would not conflict with or obstruct any water quality control plans. With compliance with existing regulatory requirements and implementation of LID BMP's, the Project would no conflict with or obstruct implementation of a water quality control plan or sustainable groundwater management plan. Impacts would be less than significant.

Surface Water Hydrology During Construction

During construction of the project, a SWPPP written by a Qualified SWPPP Developer will be prepared to implement temporary control measures throughout the construction phase. The SWPPP is designed to comply with California's General Permit for Stormwater Discharges Associated with Construction and Land Disturbance Activities (General Permit) Order No. 2009-0009-DWQ as amended in 2010 and 2012 (NPDES No. CAS000002) issued by the State Water Resources Control Board (State Water Board). In accordance with the General Permit, Section XIV, the SWPPP is designed to address the following:

- Sources of sediment associated with construction, construction site erosion and other activities associated with construction activity are controlled;
- Where not otherwise required to be under a Regional Water Quality Control Board (Regional Water Board) permit, all non-stormwater discharges are identified and either eliminated, controlled, or treated;

Surface Water Hydrology During Operation

Per Los Angeles Municipal Code (LAMC) Guidelines, required Permit Registration Documents (PRDs) shall be submitted to the State Water Board via the Stormwater Multi Application and Report Tracking System (SMARTS) by the Legally Responsible Person (LRP), or authorized personnel (i.e., Approved Signatory) under the direction of the LRP. The project-specific PRDs include:

1. Notice of Intent (NOI);
2. Risk Assessment (Construction Site Sediment and Receiving Water Risk Determination);
3. Site Map;
4. Annual Fee;
5. Signed Certification Statement (LRP Certification is provided electronically with SMARTS PRD submittal); and
6. SWPPP.
 - a. Post-construction water balance calculation;
 - b. Active Treatment System (ATS) plan; and
 - c. Dischargers proposing an alternate soil erodibility factor must submit justification (documentation of methods used [e.g. soil particle size analysis]).

With compliance with the above regulatory requirements, the Project will have less than significant impact on the surface water hydrology. Specifically, based on the above, the Project would not result in an incremental impact for flooding on either on-site or off-site areas during a 50-year storm event, it would not substantially increase the amount of surface water in a water body, and it will not result in a permanent adverse change to the movement of surface water that would result in an incremental effect on the capacity of the existing storm drain system. As demonstrated in Section 3.5, the Project would also not require significant new stormwater infrastructure since there will be a reduction in stormwater flows due to the Project’s required LID reductions. Therefore, the development of the Project would result in less than significant impact on surface water hydrology.

Cumulative Impact Analysis

The geographic context for the cumulative impact analysis on surface water hydrology is the Los Angeles River Watershed. The Project in conjunction with forecasted growth in the Los Angeles River Watershed could cumulatively increase stormwater runoff flows. However, as noted above, the Project would have no net impact on stormwater flows. Also, in accordance with City requirements, related projects and other future development projects would be required to implement BMPs to manage stormwater in accordance with LID guidelines. Furthermore, the City of Los Angeles Department of Public Works would review each future development project on a case-by-case basis to ensure enough local and regional infrastructure is available to accommodate stormwater runoff. Therefore, potential cumulative impacts associated with the Project on surface water hydrology would be less than significant.

6.2 Surface Water Quality

<u>Potentially Significant Impact</u>	<u>Less Than Significant with Mitigation Incorporated</u>	<u>Less Than Significant Impact</u>	<u>No Impact</u>
---------------------------------------	---	-------------------------------------	------------------

Would the project:

- | | | | | |
|---|--------------------------|--------------------------|-------------------------------------|--------------------------|
| a. Violate any water quality standards or waste discharge requirements? | <input type="checkbox"/> | <input type="checkbox"/> | <input checked="" type="checkbox"/> | <input type="checkbox"/> |
| b. Otherwise substantially degrade water quality? | <input type="checkbox"/> | <input type="checkbox"/> | <input checked="" type="checkbox"/> | <input type="checkbox"/> |

a. violate any water quality standards or waste discharge requirements?

Less Than Significant Impact. As discussed in the following analysis, the Project would not violate any water quality standards or waste discharge requirements or otherwise substantially degrade surface of groundwater quality.

Surface Water Quality During Construction

During Project construction, particularly during the grading phase, stormwater runoff from precipitation events could cause exposed and stockpiled soils to be subject to erosion and convey sediments into municipal storm drain systems. In addition, on-site watering activities to reduce airborne dust could contribute to pollutant loading in runoff. Pollutant discharges relating to the storage, handling, use and disposal of chemicals, adhesives, coatings, lubricants, and fuel could also occur. As Project construction would disturb less than one acre of soil, the Project would not be required to obtain coverage under the National Pollutant Discharge Elimination System (NPDES) Construction General Permit. However, the Project would be required to implement Best Management Practices (BMP's) as part of the City's grading permit requirements. BMP's would include, but would not necessarily be limited to, erosion control, sediment control, non-stormwater management, and materials management BMP's (e.g., sandbags, storm drain inlets protection, stabilized construction entrance/exit, wind erosion control, and stockpile management) to minimize the discharge of pollutants in stormwater runoff during construction. In addition, Project construction activities would occur in accordance with City grading permit regulations (LAMC Chapter IX, Division 70), such as the preparation of an Erosion Control Plan, to reduce the effects of sediment and erosion.

As discussed above, construction activities for the project involves the development of a new 43-story high-rise mixed-use building which includes, two levels of subterranean parking, one level of ground floor commercial uses, and six levels of aboveground parking. This will include an excavation depth of 45 feet below grade. Historic groundwater levels are located 100 to 120 feet below the existing grade according to the California Division of Mines and Geology (CDMG). However, the information of groundwater data collected from the State Water Resources Control Board's GEOTRACKER website indicates that in 2010, groundwater was reported between depths of 32 and 45 feet in two (2) 50-foot deep monitoring wells located approximately 990 and 1000 feet north of the Project site, respectively. Previous borings drilled in 2015 at the Project site at depths of 90 to 120 feet did not encounter any groundwater. However, previous borings that drilled in the near vicinity of the project to 160 feet encountered occasional minor seepage between 27 and 37 feet. Excavation of the basement is anticipated to be 45 feet below existing grade. Although the excavation is not below the current groundwater level, it is still possible that groundwater could be encountered during excavation. Per the geology report, some minor seepage should be anticipated in the excavation, and minor dewatering consisting of gravel-filled trenches installed where necessary, should be anticipated. If groundwater is encountered during construction, temporary pumps and filtration would be utilized in compliance with all applicable regulations and requirements, including all relevant NPDES requirements related to construction and discharges from dewatering operations. NPDES requires dischargers must demonstrate that discharges do not violate any water quality objective/criteria for the receiving waters, demonstrate that discharge shall not exceed effluent limitations, perform an analysis using a sample of groundwater or wastewater to be discharged, show discharge shall not cause acute nor chronic toxicity in receiving waters, that discharge shall pass through a treatment system if necessary, and must

comply with the provisions of the NPDES permit. Therefore, through compliance with regulatory requirements, potential impacts would be less than significant.

Dewatering operations are practices that discharge non-stormwater, such as groundwater, that must be removed from a work location and discharged into the storm drain system to proceed with construction. Discharges from dewatering operations can contain high levels of fine sediments, which, if not properly treated, could lead to exceedance of the NPDES requirements. If groundwater is encountered during construction, temporary pumps and filtration would be utilized in compliance with all relevant NPDES requirements related to construction and discharges from dewatering operations. Furthermore, if dewatering is required, the treatment and disposal of the dewatered water would occur in accordance with the Los Angeles Regional Water Quality Control Board (LARWQCB) Waste Discharge Requirements for Discharges of Groundwater from Construction and Project Dewatering to Surface Waters in Coastal Watersheds of Los Angeles and Ventura Counties.

With the implementation of site-specific BMP's included as part of the Erosion Control Plan required to comply with the City grading permit regulations, the Project would significantly reduce or eliminate the discharge of potential pollutants from the stormwater runoff. Therefore, with compliance with NPDES requirements and City grading regulations, construction of the Project would not violate any water quality standard or waste discharge requirements or otherwise substantially degrade surface water quality. Furthermore, construction of the Project would not result in discharges that would cause regulatory standards to be violated. Thus, temporary construction-related impacts on surface water quality would be less than significant, and no mitigation measures are required.

Surface Water Quality During Operation

Under the City's Low Impact Development (LID) Ordinance, post-construction stormwater runoff from new projects must be infiltrated, evapotranspired, captured and used, and/or treated through high efficiency BMP's on-site for the volume of water produced by the greater of the 85th percentile storm event or the 0.75-inch storm event (i.e., "first flush"). Consistent with LID requirements to reduce the quantity and improve the quality of rainfall runoff that leaves the Project Site, the Project would include the installation of capture and use and/or biofiltration system BMP's as established by the LID Manual. The installed BMP systems would be designed with an internal bypass overflow system to prevent upstream flooding during major storm events. As most potential contaminants are anticipated to be contained within the "first flush" storm event, major storms are not anticipated to cause an exceedance of regulatory standards.

Due to the nature of the proposed development to change the land use from an existing warehouse to a residential/commercial development, the Project will result in a reduction of potential types of pollutants. As detailed in Section 4.0, a comparison between the potential pollutant based on land use and the 303(d) list for Los Angeles River Watershed indicates that the pollutants of concern are **trash, oxygen demanding substances (ammonia), nutrients (algae), and metals**. These three pollutants of concern will be addressed through the proposed stormwater BMPs in order to comply with Los Angeles County's Standard Urban Stormwater Mitigation Plan (SUSMP) and City of Los Angeles' Low Impact Development Ordinance. BMPs include, but are not limited to, rainwater harvesting and an increase of landscape area. For example, rainwater harvesting collects rainwater from a surface that allows for the rainwater to be stored and used later. In a typical rainwater harvesting situation, rainwater is collected from an impervious surface such as the roof of a building and then stored inside of a tank or cistern. Rainwater can be collected from other surfaces as well such as parking lots, roadways, driveways, and even land surfaces. Based on the analysis contained in this report, there are no significant impacts for surface water quality as a result of the Project.

With compliance under the SWPPP, SUSMP, and the City's LID Ordinance, construction and operational water quality impacts would be less than significant.

Groundwater Quality During Construction

As discussed above, construction activities for the project involves the development of a new 43-story high-rise mixed-use building which includes, two levels of subterranean parking, one level of ground

floor commercial uses, and six levels of aboveground parking. This will include an excavation depth of 45 feet below grade. Historic groundwater levels are located 100 to 120 feet below the existing grade according to the California Division of Mines and Geology (CDMG). However, the information of groundwater data collected from the State Water Resources Control Board's GEOTRACKER website indicates that in 2010, groundwater was reported between depths of 32 and 45 feet in two (2) 50-foot deep monitoring wells located approximately 990 and 1000 feet north of the Project site, respectively. Previous borings drilled in 2015 at the Project site at depths of 90 to 120 feet did not encounter any groundwater. However, previous borings that drilled in the near vicinity of the project to 160 feet encountered occasional minor seepage between 27 and 37 feet. Excavation of the basement is anticipated to be 45 feet below existing grade. Although the excavation is not below the current groundwater level, it is still possible that groundwater could be encountered during excavation. Per the geology report, some minor seepage should be anticipated in the excavation, and minor dewatering consisting of gravel-filled trenches installed where necessary, should be anticipated. If groundwater is encountered during construction, temporary pumps and filtration would be utilized in compliance with all applicable regulations and requirements, including all relevant NPDES requirements related to construction and discharges from dewatering operations. NPDES requires dischargers must demonstrate that discharges do not violate any water quality objective/criteria for the receiving waters, demonstrate that discharge shall not exceed effluent limitations, perform an analysis using a sample of groundwater or wastewater to be discharged, show discharge shall not cause acute nor chronic toxicity in receiving waters, that discharge shall pass through a treatment system if necessary, and must comply with the provisions of the NPDES permit. Therefore, through compliance with regulatory requirements, potential impacts would be less than significant.

If dewatering is required, the treatment and disposal of the dewatered water would occur in accordance with the Los Angeles Regional Water Quality Control Board (LARWQCB) Waste Discharge Requirements for Discharges of Groundwater from Construction and Project Dewatering to Surface Waters in Coastal Watersheds of Los Angeles and Ventura Counties. Therefore, Project construction could potentially improve the existing condition by removing impacted groundwater. In addition, the proposed construction activities would be typical of a residential project and would not involve activities that could further impact the underlying groundwater quality.

Other potential effects to groundwater quality could result from the presence of an underground storage tank (UST) or during the removal of an UST. As previously described, however, no existing UST's are anticipated to be found beneath the Project Site. Therefore, the removal of UST's would not pose a significant hazard on groundwater.

Based on the above, construction of the Project would not result in discharges that would violate any groundwater quality standard or waste discharge requirements. Therefore, construction-related impacts on groundwater quality would be less than significant, and no mitigation measures are required.

Groundwater Quality During Operation

Operational activities which could affect groundwater quality include spills of hazardous materials and leaking UST's. Surface spills from the handling of hazardous materials most often involve small quantities and are cleaned up in a timely manner, thereby resulting in little threat to groundwater. Other types of risks such as leaking underground storage have a greater potential to affect groundwater. However, as discussed above, the Project would not include any new UST's that would have the potential to expose groundwater to contaminants. In addition, while the Project would introduce more density and an additional land use (residential) to the project site which would slightly increase the use of potentially hazardous materials as described above, the Project would comply with all applicable existing regulations that would prevent the Project from affecting or expanding any potential areas of contamination, increasing the level of contamination, or causing regulatory water quality standards at an existing production well to be violated, as defined in the California Code of Regulations, Title 22, Division 4, Chapter 15 and the Safe Drinking Water Act. The Project also does not include the installation or operation of water wells, or any extraction or recharge system near the coast, an area of known groundwater contamination or seawater intrusion, a municipal supply well, or a spreading ground facility.

PSOMAS

In addition, the Project includes the installation of a capture and use and/or biofiltration system as a means of treatment and disposal of the volume of water produced by the greater of the 85th percentile storm or the 0.750-inch storm event, which would allow for treatment of the on-site stormwater. Therefore, the Project would not violate any water quality standards or waste discharge requirements or otherwise substantially degrade ground water quality. The Project's potential impact on groundwater quality during operation would be less than significant, and no mitigation measures are required.

b. Otherwise substantially degrade water quality?

Less Than Significant Impact. As discussed in response to question 6.2.a, the project would not otherwise substantially degrade water quality, following the reasons provided in that answer.

7.0 Calculations and Site Plan

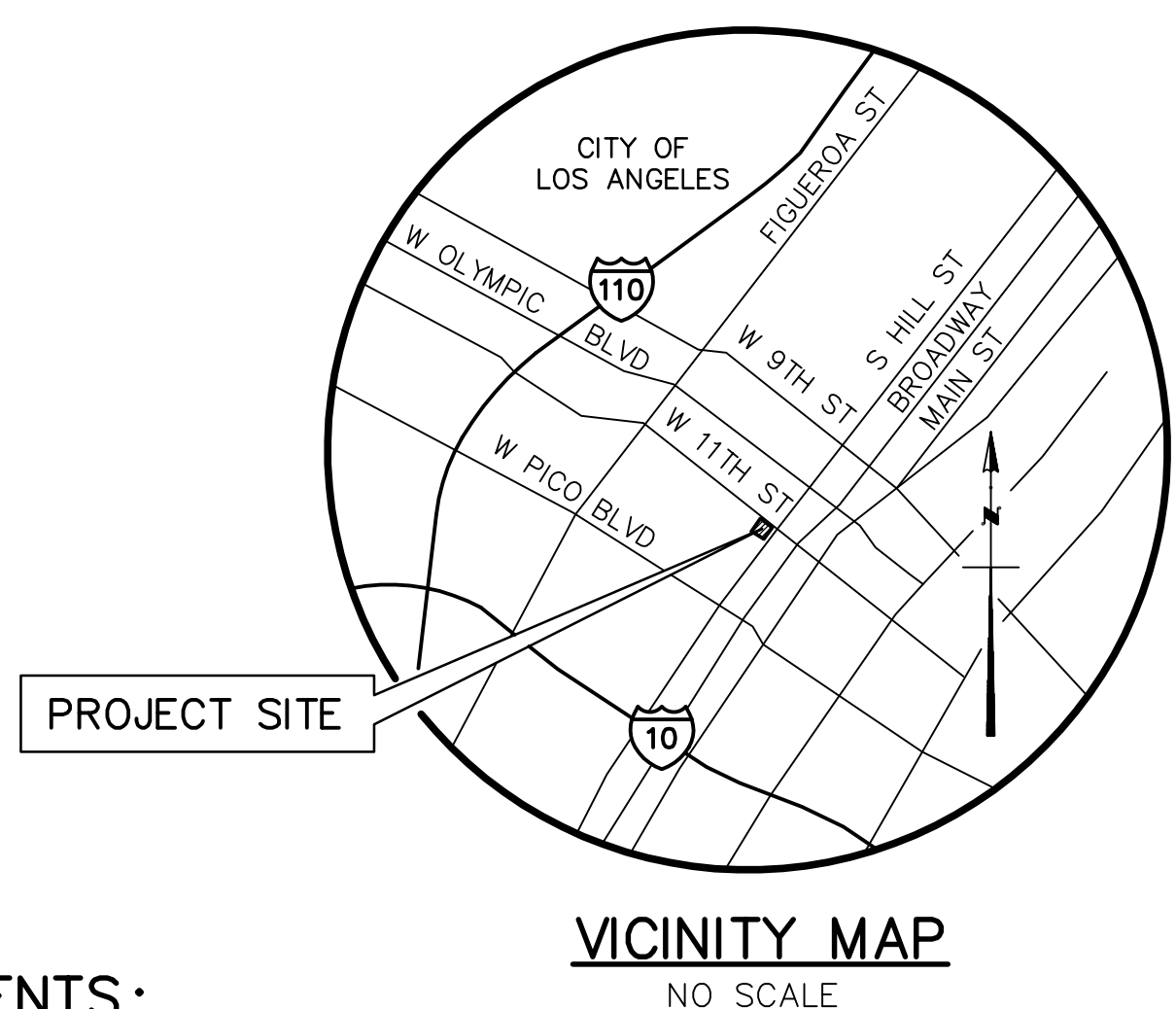
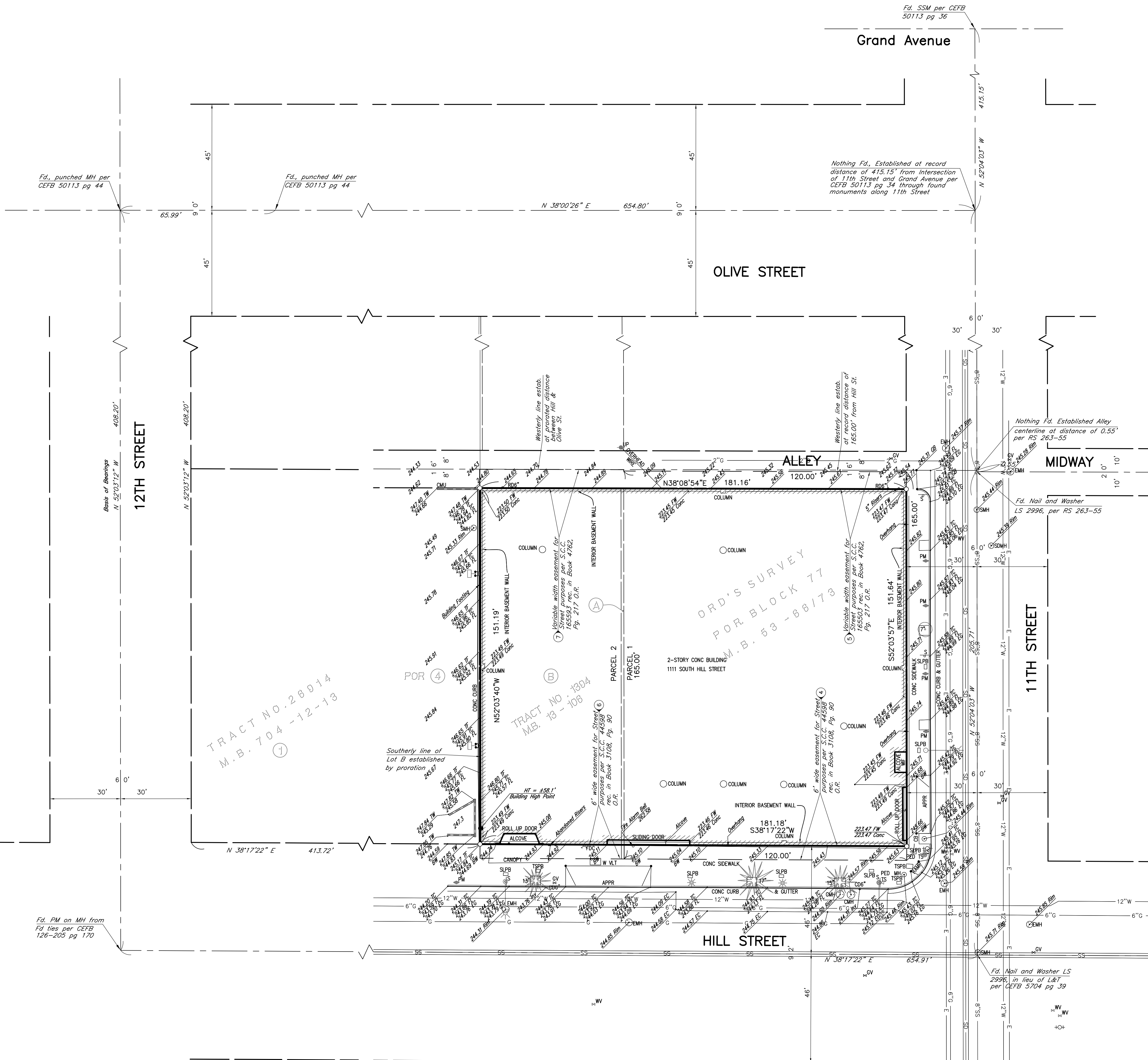
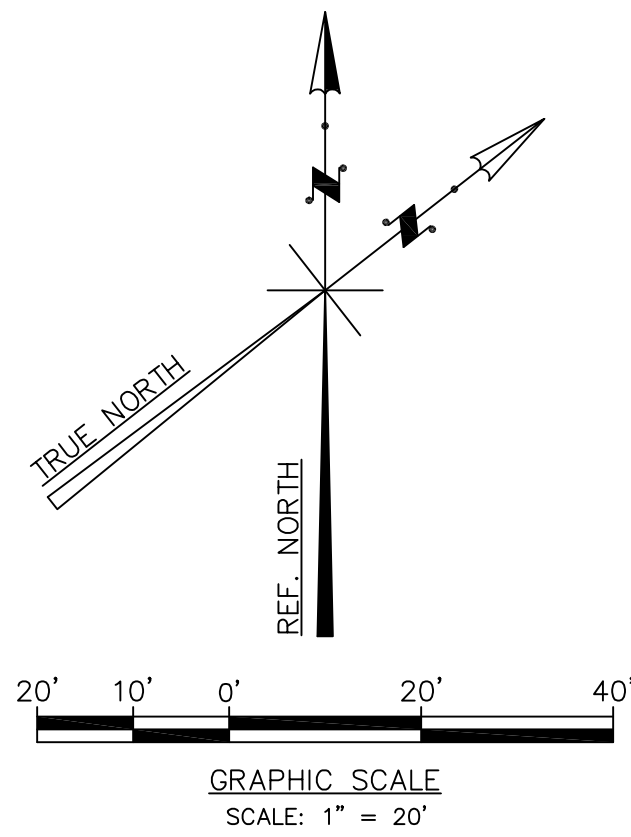

COMMENTS:

BOUNDARY LINES THIS MAP REPRESENTS A GRAPHICAL DEPICTION OF THE BOUNDARY OF THE SITE AND ADJOINING RIGHTS OF WAY BASED UPON COUNTY OF LOS ANGELES ASSESSOR MAPS AND OTHER PUBLIC RECORDS AND DOES NOT REPRESENT A FIELD SURVEY. THIS MAP IS INTENDED FOR FEASIBILITY AND PRELIMINARY PLANNING PURPOSES AND SHOULD NOT BE RELIED ON AS AN ACCURATE SURVEY OF THE PROPERTY LINES AND RIGHTS OF WAY.

LEGAL DESCRIPTION FROM INFORMATION SUPPLIED BY CLIENT, USUALLY A TITLE POLICY OR TITLE REPORT.

EASEMENTS PLOTTABLE EASEMENTS ARE SHOWN FROM AN OWNER SUPPLIED TITLE REPORT. NON-PLOTTABLE ONES ARE NOTED ON THE SURVEY AS HAVING "EFFECT OF". BECAUSE OUR SERVICE IS LIMITED TO REPORTING ON EASEMENT LOCATIONS WE STRONGLY RECOMMEND LEGAL COUNSEL BE RETAINED TO REPORT ON TITLE PAPERS IN THEIR ENTIRETY.

TITLE REPORT CHICAGO TITLE INSURANCE COMPANY CLTA STANDARD COVERAGE POLICY OF TITLE INSURANCE NO. CA-FLAC-IMP-72067-1-14-00268409 DATED OCTOBER 31, 2014.

⊙ INDICATES TITLE REPORT EXCEPTION NO.

BASIS OF BEARINGS THE BEARINGS OF THE CENTERLINE OF TWELFTH STREET AS SHOWN AS NORTH 52°03'12" WEST ON THE MAP OF RECORD OF SURVEY, AS RECORDED IN BOOK 263, PAGES 55 AND 56 OF MAPS, RECORD OF LOS ANGELES COUNTY, WAS TAKEN AS THE BASIS OF BEARINGS SHOWN ON THIS MAP.

AREA BASED UPON MEASURED BEARINGS AND DISTANCES AS SHOWN HEREON THE AREA IS:
 29,521 SQ. FT. = 0.6777 ACRES (GROSS)
 27,432 SQ. FT. = 0.6297 ACRES (NET)

WHERE "GROSS" IS DEFINED AS THE AREA OF THE SUBJECT FEE PARCEL AS LEGALLY DESCRIBED HEREON AND "NET" IS DEFINED AS THE REMAINING SUBJECT PARCEL AFTER SUBTRACTION OF EXISTING STREET EASEMENTS.

VERTICAL CONTROL ELEVATIONS BASED ON NGS BENCHMARK, C 1296 (PID EW6906) NGS BRASS DISK STAMPED "C 1296 1977" ENCASED IN 4IN PVC PIPE W/CAP IN LAWN LYING 214FT NE FROM CL INT OF SPRING ST AND FIRST STREET, AND 54FT SE OF CL OF SPRING STREET STAMPED C 1296 1977. DESIGNATION: C 1296. PID EW6906 NGS ELEVATION = 295.40 FEET, NAVD 88, ADJUSTED JUNE 1995 CITY ELEVATION = 295.396', NAVD88, ADJUSTED 2000 (BENCHMARK NO 12-03355)

TOPOGRAPHY BY GROUND SURVEY METHODS AND COMPLIES WITH NATIONAL MAP ACCURACY STANDARDS.

CONTOUR INTERVAL 1 FOOT.

UTILITIES UNDERGROUND UTILITIES SPECIFICALLY LISTED IN THE UTILITY INFORMATION TABLE ARE PLOTTED ON THIS SURVEY. OTHER UNDERGROUND UTILITIES NOT LISTED (E.G., TRAFFIC SIGNAL AND STREET LIGHT CONDUIT, ABANDONED LINES, ETC.) HAVE NOT BEEN PLOTTED. THE LOCATION OF THOSE PLOTTED UTILITIES WERE OBTAINED FROM UTILITY MAPS AND PLANS AS LISTED UNDER THE SUBSTRUCTURE PLAN INDEX. SEE SURVEYOR'S NOTE 4.

EFFECT OF PROPERTY TAXES AND LIEN OF SUPPLEMENTAL TAXES.

EFFECT OF (1) (2) WATER RIGHTS, CLAIMS OF TITLE TO WATER, WHETHER OR NOT DISCLOSED BY THE PUBLIC RECORDS.

EFFECT OF (3) EASEMENT IN FAVOR OF THE CITY OF LOS ANGELES FOR STREET PURPOSES RECORDED IN BOOK 3108 PAGE 90, O.R. PLOTTED HEREON.

EFFECT OF (4) EASEMENT IN FAVOR OF THE CITY OF LOS ANGELES FOR STREET PURPOSES RECORDED IN BOOK 4762 PAGE 217, O.R. PLOTTED HEREON.

EFFECT OF (5) EASEMENT IN FAVOR OF THE CITY OF LOS ANGELES FOR STREET PURPOSES RECORDED IN BOOK 3108 PAGE 94, O.R. NOTE: PARCEL 2 (LOTS A & B OF TRACT 1394) IS SHOWN ON THE RECORD MAP AS HAVING A HALF STREET WIDTH OF 46'. DOCUMENT NOT PROVIDED. PLOTTED HEREON WITHIN EXISTING STREET WITH 46' HALFWIDTH.

EFFECT OF (6) EASEMENT IN FAVOR OF THE CITY OF LOS ANGELES FOR STREET PURPOSES RECORDED IN BOOK 4762 PAGE 217, O.R. PLOTTED HEREON.

EFFECT OF (7) COVENANT AND AGREEMENT REGARDING MAINTENANCE OF BUILDING AND USES RECORDED APRIL 2, 1954 IN BOOK 44240 PAGE 97, O.R.

EFFECT OF (8) FACT THAT LAND IS INCLUDED WITHIN A PROJECT AREA OF THE CENTRAL BUSINESS DISTRICT REDEVELOPMENT AGENCY RECORDED JULY 22, 1975 AS INSTRUMENT NO. 3675 AND JULY 30, 1975 AS INSTRUMENT NO. 3868, BOTH OF O.R.

EFFECT OF (9) (10) ENCROACHMENT ON LAND ADJACENT ON THE SOUTHEASTERLY LINE CONSISTING OF A 6 FOOT EAVE OVER THE CITY SIDEWALK. NO DOCUMENT PROVIDED.

EFFECT OF (11) (13) TERMS, COVENANTS, CONDITIONS AND PROVISIONS RECORDED JULY 30, 2002 AS INSTRUMENT NO. 02-1772820, O.R.

EFFECT OF (12) FACT THAT PROPERTY LIES WITHIN THE BOUNDARY OF A MELLO-ROOS COMMUNITY FACILITIES DISTRICT NO. 9 (DOWNTOWN STREETCAR) RECORDED JANUARY 29, 2013 AS INSTRUMENT NO. 20130143515, O.R.

EFFECT OF (14)

SURVEYOR'S NOTES

- THIS SURVEY HAS BEEN PREPARED FOR DESIGN PURPOSES
- BEFORE USING THIS MAP FOR DESIGN OR CONSTRUCTION PURPOSES, ALL EASEMENTS OF RECORD AND SETBACK LINES DEFINED IN COVENANTS, CONDITIONS AND RESTRICTIONS OF RECORD AFFECTING THIS PROPERTY SHOULD BE PLOTTED ON THIS MAP FROM A CURRENT TITLE REPORT. IF NO TITLE REPORT WAS FURNISHED, OUR CLIENT IS URGED TO FURNISH A CURRENT TITLE REPORT SO THAT THESE EASEMENT AND SETBACK LINES OF RECORD CAN BE PLOTTED ON THIS MAP.
 - THIS MAP SHOULD BE EXPANDED TO MEET ALTA REQUIREMENTS IF FINANCING IS TO BE OBTAINED FOR THE PROJECT, REQUIRING AN EXTENDED COVERAGE POLICY OF TITLE INSURANCE.
 - THIS SURVEY DOES NOT INCLUDE EASEMENTS EXCEPT THOSE SPECIFICALLY DELINEATED HEREON.
 - IF UNDERGROUND PUBLIC UTILITIES AND OTHER SUBSTRUCTURES, ZONES, SET BACK AND STREET WIDENING DATA ARE SHOWN HEREON, IT IS FOR INFORMATION ONLY, HAVING BEEN OBTAINED FROM A GENERAL REQUEST AT THE LOCAL AGENCY'S PUBLIC COUNTER AND/OR OTHER SOURCES NOT CONNECTED WITH THIS COMPANY. NO REPRESENTATION IS MADE AS TO THE ACCURACY, CURRENCY OR COMPLETENESS OF SAID INFORMATION AND ANY USERS OF SAID INFORMATION IS URGED TO CONTACT THE UTILITY OR LOCAL AGENCY DIRECTLY.

LEGAL DESCRIPTION

PARCEL 1:
 PART OF BLOCK 77 OF ORD'S SURVEY, IN THE CITY OF LOS ANGELES, COUNTY OF LOS ANGELES, STATE OF CALIFORNIA, AS PER MAP RECORDED IN BOOK 53, PAGES 66 TO 73 INCLUSIVE OF MISCELLANEOUS RECORDS, IN THE OFFICE OF THE COUNTY RECORDS OF SAID COUNTY, DESCRIBED AS FOLLOWS:
 BEGINNING AT THE NORTHEASTERLY CORNER OF SAID BLOCK AT THE SOUTHWEST CORNER OF HILL AND ELEVENTH STREETS; THENCE WESTERLY ALONG THE SOUTHERLY LINE OF ELEVENTH STREET, 165 FEET; THENCE SOUTHERLY PARALLEL WITH HILL STREET, 120 FEET; THENCE EASTERLY PARALLEL WITH ELEVENTH STREET, 165 FEET TO HILL STREET; THENCE NORTHERLY 120 FEET TO THE POINT OF BEGINNING.

PARCEL 2:
 LOTS A AND B OF TRACT NO. 1394, IN THE CITY OF LOS ANGELES, COUNTY OF LOS ANGELES, STATE OF CALIFORNIA, AS PER MAP RECORDED IN BOOK 18, PAGE 106 OF MAPS, IN THE OFFICE OF THE COUNTY RECORDS OF SAID COUNTY.

UTILITY INFORMATION

UTILITY	SERVICE BY	TELEPHONE NO.	ADDRESS
POWER	CITY OF LOS ANGELES, DWP	(213) 977-6060	201 N. FIGUEROA, 4TH FLOOR, L.A., CA
WATER	CITY OF LOS ANGELES, DWP	(213) 977-6060	201 N. FIGUEROA, 4TH FLOOR, L.A., CA
TELEPHONE	AT&T	(714) 963-7864	22311 BROOKHURST STREET SUITE 203
TELEPHONE	DWNET	(303) 992-0201	930 15 STREET #130 DENVER CO 80202
GAS	THE GAS COMPANY	(410) 681-0099	701 N. BULLIES RD. COMPTON, CA
STORM DRAIN	CITY OF LOS ANGELES	(213) 977-6093	201 N. FIGUEROA, 4TH FLOOR, L.A., CA
SEWER	CITY OF LOS ANGELES	(213) 977-6032	201 N. FIGUEROA, 4TH FLOOR, L.A., CA

SUBSTRUCTURE PLAN INDEX

STORM DRAIN	SEWER
0-31090	

The only substructure information made available by public agencies and public utilities is their location within public rights-of-way. Therefore, no onsite substructures are shown on this map. The location of onsite substructures should be determined and verified from other sources before the beginning of any excavation.

Call UNDERGROUND SERVICE ALERT (USA) 1-800-442-2444 USA represents many, but not necessarily all, utility and oil companies that have underground lines within the project area. In order to avoid damage to these lines, contact USA two working days prior to digging or excavation. USA will assist in identifying those companies that they represent which have utility lines in the area and contacting the respective companies they represent to have those lines marked on the ground.

	DESIGNED	D.R.H.		SEE COMMENTS	PSOMAS 555 South Flower Street, Suite 4300 Los Angeles, CA 90071 (213) 223-1400 (213) 223-1444 fax www.psomas.com	DESIGN SURVEY FOR: SOUTH HILL HOLDINGS, LLC 1111 SOUTH HILL STREET IN THE CITY OF LOS ANGELES COUNTY OF LOS ANGELES STATE OF CALIFORNIA	DATE	APRIL 7, 2015	SHEET 1 OF 1
	DRAWN	H.O.O.					SCALE	1" = 20'	
CHECKED	D.R.H.	PROJECT NUMBER	150U230100						



GROUND FLOOR TREATMENT CALCULATIONS

11TH STREET (RETAIL STREET)		
Frontage	Linear Feet	Percentage
Active Use Frontage	122.42	82%
Non-Active Use Frontage	27.00	18%
Total Frontage	149.42	100%

HILL STREET		
Frontage	Linear Feet	Percentage
Active Use Frontage	139.83	95%
Non-Active Use Frontage	7.92	5%
Total Frontage	147.75	100%

**Per Downtown Design guide Figure 3-1 (Retail Streets), 11th St. requires 75% active frontage.*

**Per Downtown Design guide; Along all other streets (non-retail), at least 75% of the ground floor street frontage shall be designed to accommodate active uses.*

TOTAL ACTIVE FRONTAGE (11TH ST. & HILL ST.)		
Frontage	Linear Feet	Percentage
Total Active Frontage	262.25	88%
Total Non-Active Frontage	34.92	12%
Total 11th St. & Hill St.	297.17	100%

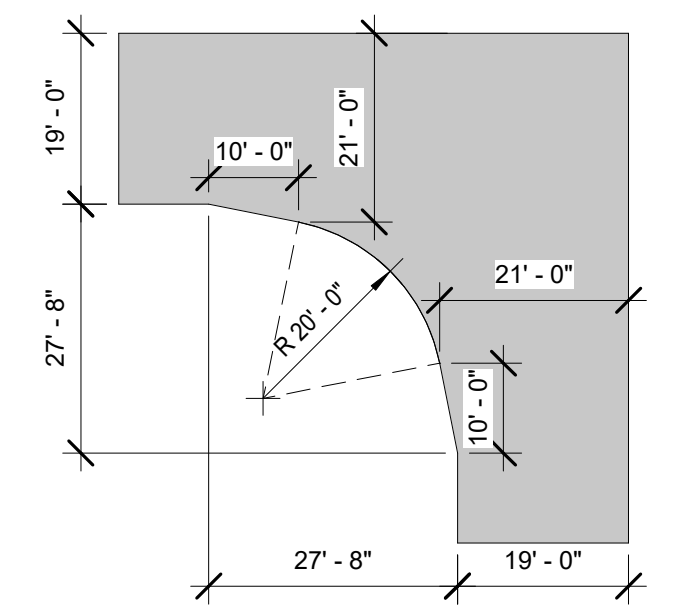

TURNING RADIUS - TWO WAY

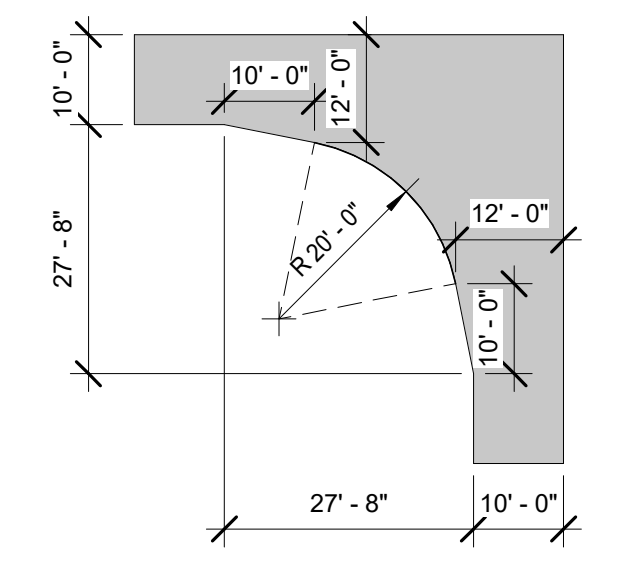

TURNING RADIUS - ONE WAY

Bike Parking Schedule

Level	Type	Count	Term
Level P1	Bicycle Space	74	Long-term
Level 1	Bicycle Space	28	Short-term
Level 1	Sidewalk Bicycle	28	Short-term
Level 2	Bicycle Space	217	Long-term
Grand total		347	

LOCATION	AUTO PARKING SPACES REQUIRED / PROVIDED	ELECTRIC VEHICLE SPACES EVR AND EVCS
Level P1	122 43 Double Stackers 36 Overhead Parking Lift	33 22 EVR 11 EVCS
Ground - Level 1	4	-
Level 2	18	-
Level 3	146 Automated Parking - 2 Levels	48 Automated Parking 16 EVR 32 EVCS
Level 4	146 Automated Parking - 2 Levels	49 Automated Parking 16 EVR 33 EVCS
TOTAL	436 AUTO PARKING SPACES	130 EV SPACES

34° 07' 30"

BURBANK I-H1.28

-118° 22' 30"

BEVERLY HILLS I-H1.17

LOS ANGELES I-H1.19

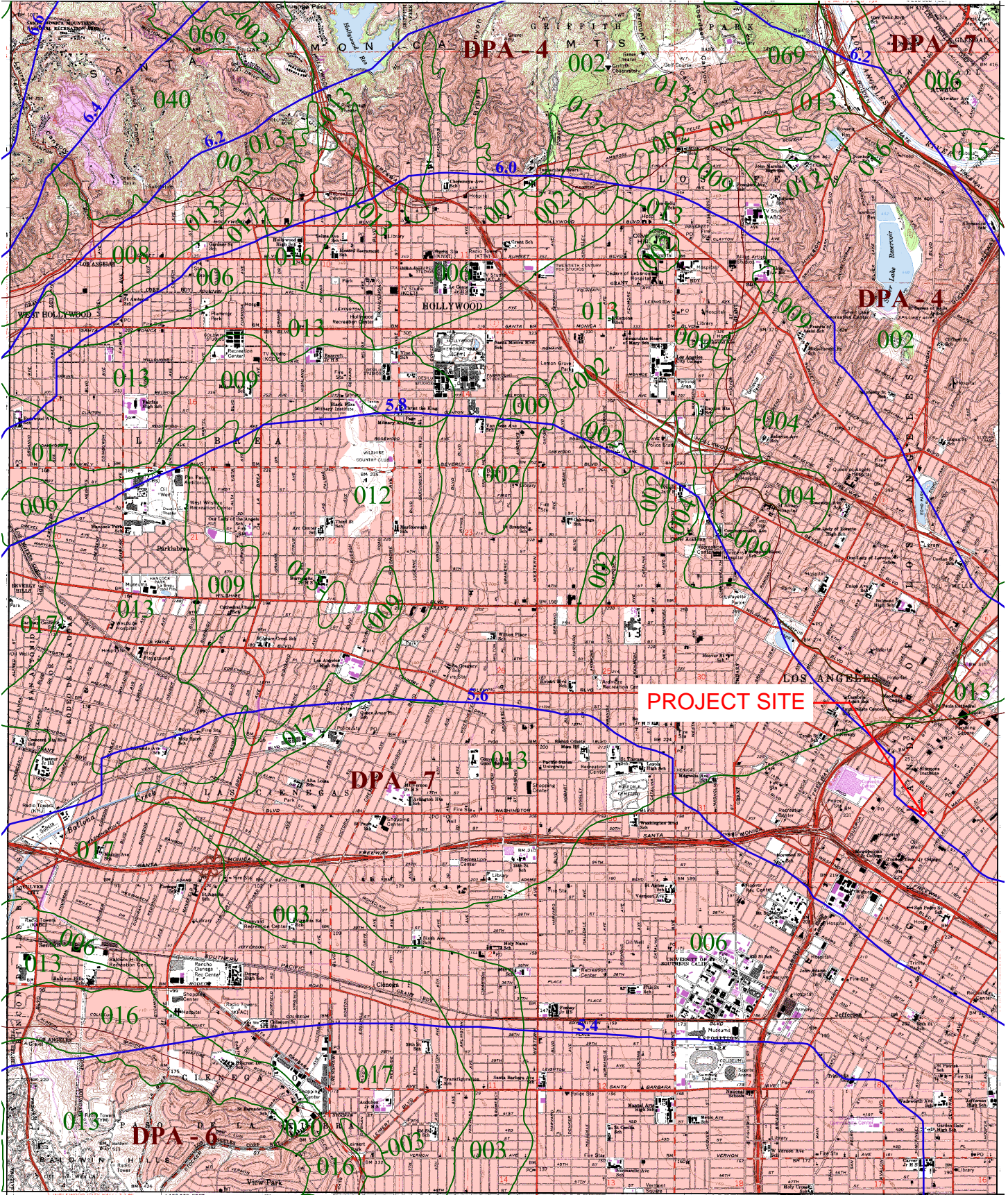

-118° 15' 00"

INGLEWOOD I-H1.8

34° 00' 00"



016 SOIL CLASSIFICATION AREA

7.2 INCHES OF RAINFALL

DPA - 6 DEBRIS POTENTIAL AREA

1 0 1 2 Miles

25-YEAR 24-HOUR ISOHYET REDUCTION FACTOR: 0.878
 10-YEAR 24-HOUR ISOHYET REDUCTION FACTOR: 0.714

HOLLYWOOD 50-YEAR 24-HOUR ISOHYET

1-H1.18





COUNTY OF LOS ANGELES

LOS ANGELES RIVER WATERSHED

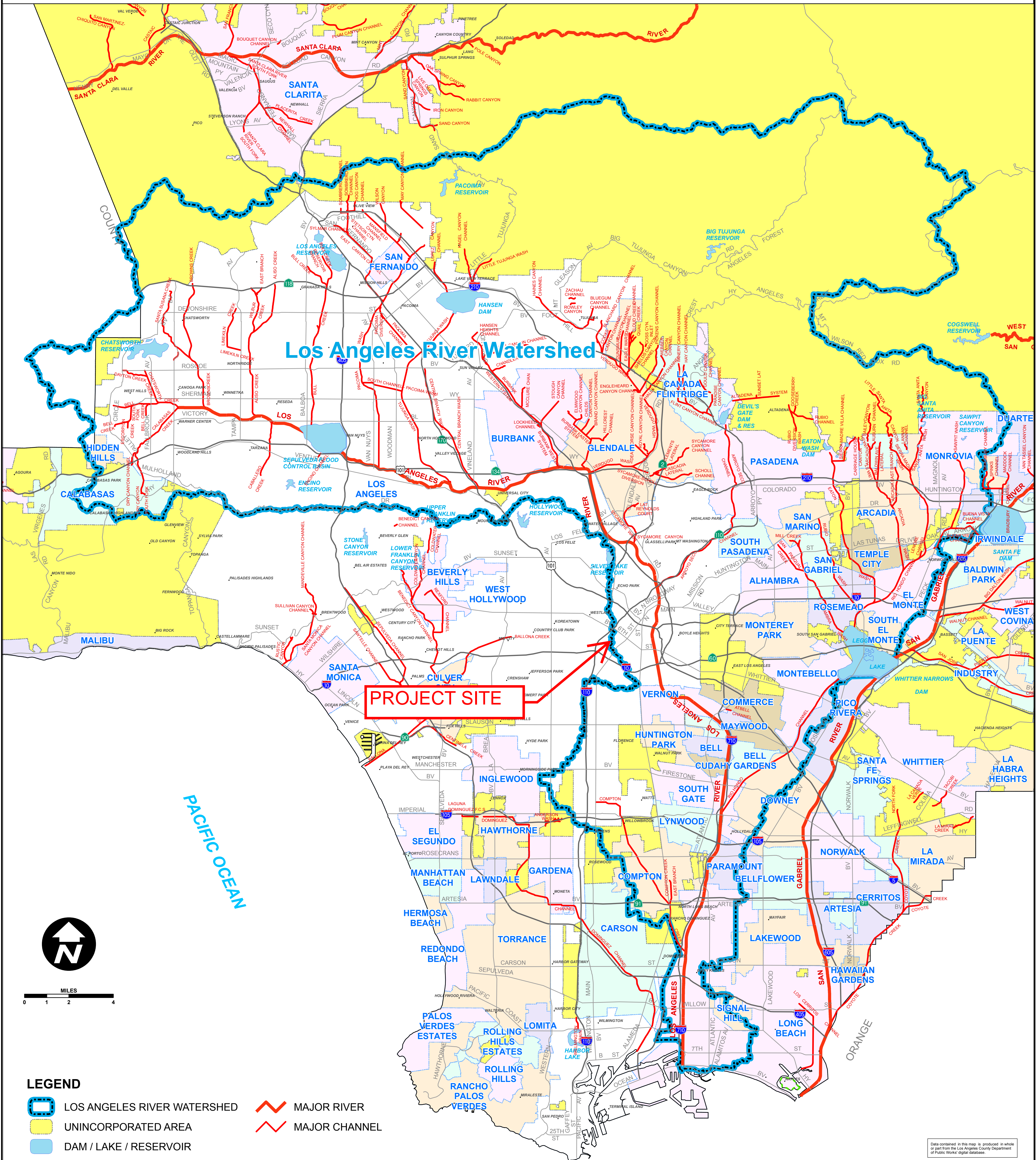

- LEGEND**
- LOS ANGELES RIVER WATERSHED
 - UNINCORPORATED AREA
 - DAM / LAKE / RESERVOIR
 - MAJOR RIVER
 - MAJOR CHANNEL

Data contained in this map is produced in whole or part from the Los Angeles County Department of Public Works' digital database.

Hydrology Map

A GIS viewer application to view the data for the hydrology manual.

LAYERS

- 50yr Two Tenths (Rainfall)
- DPA Zones
- Soils 2004
- Final 85th Percentile, 24-hr Rainfall
- Final 95th Percentile, 24-hr Rainfall
- 1-year, 1-hour Rainfall Intensity

SEARCH

Enter Address, Cross Street, or Parcel No.:

(ex: 900 S. Fremont Ave., Fremont@Valley, 5342005904)

Search

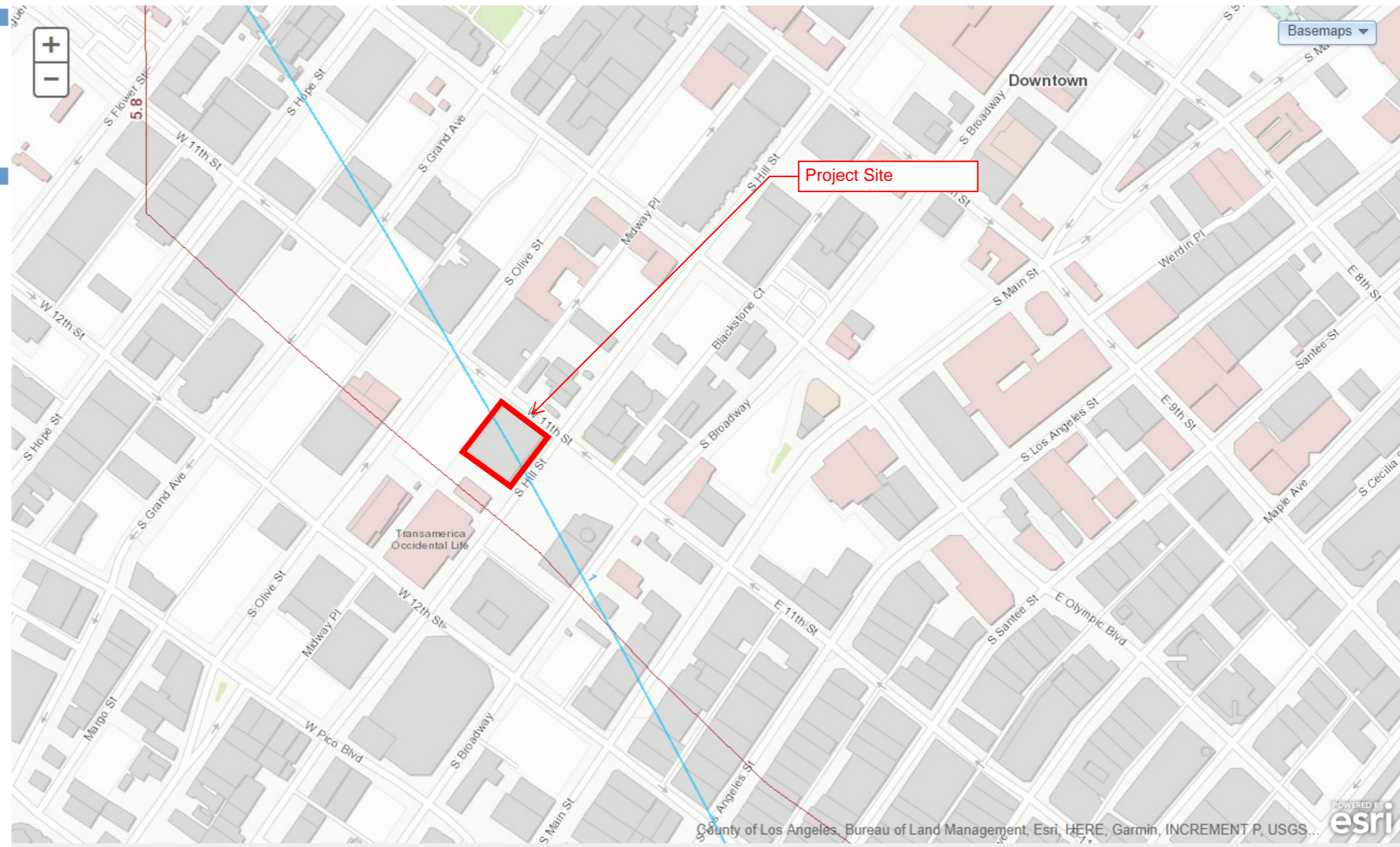

Hydrology Map

A GIS viewer application to view the data for the hydrology manual.

LAYERS

- 50yr Two Tenths (Rainfall)
- DPA Zones
- Soils 2004
- Final 85th Percentile, 24-hr Rainfall
- Final 95th Percentile, 24-hr Rainfall
- 1-year, 1-hour Rainfall Intensity

SEARCH

Enter Address, Cross Street, or Parcel No.:

(ex: 900 S. Fremont Ave., Fremont@Valley, 5342005904)

Search

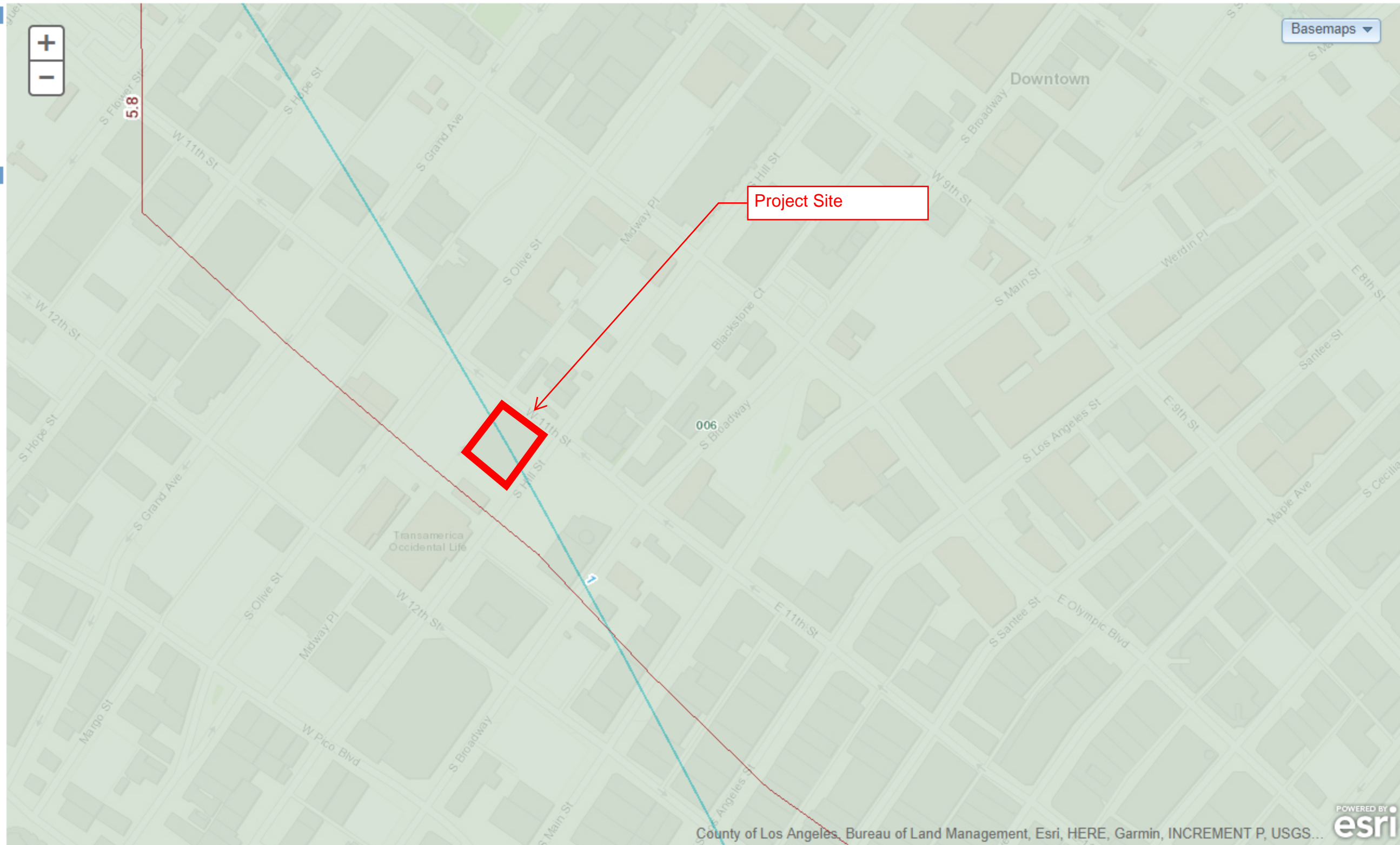

Volume Calculations:

Givens:

Inputs

Breakdown	sqft	acre	%
Area Total	29,185	0.67	100%
Impervious, Ai	27,485	0.63	95%
Pervious, Ap	1,700	0.04	5%
Undeveloped Area, Au	0	0	0%
Exempt Area	0	0	0%
TOTAL	29,185	0.67	
Landsaped Areas Counted Towards Mitigation Volume*			
Landsaped Area	1,700	0.04	
TOTAL Pervious	1,700	0.04	
Landsaped Areas Counted Towards ETWU**			
Additional Landsaped Area	0	0	
TOTAL Additional Pervious	0	0	
Exempt Area***			
	0	0	
TOTAL Exempt	0	0.00	

*Note these are landscaped areas exposed to the sky.
 **Note these are additional landscaped areas NOT EXPOSED to the sky.
 ***Note these are water features exposed to the sky.

Soil media infiltration rate:	5	in/hr	(Table 4.5)
T _{fill} =	3	hrs	(Table 4.5)
Drawdown time, T (hr) =	48	hrs	(Table 4.5)
K _{sat,Design} Factor of Safety, FS =	2		
V _{design Planter} Factor of Safety =	1.5		
Design Storm =	85th Percentile		(Per City of LA requirement)
Design Storm Intensity =	1	in	(Per LA County Hydrology GIS)
Planting Factor =	0.7		(Per Landscape Architect)
7 Month Evapotranspiration, ET ₇	21.7		(Per City of LA Irrigation Guidelines, App C)

Determine the Mitigation Volume (V_M):

$V_M (ft^3) = 85th\ Percentile\ Intensity\ (in) \times Catchment\ Area\ (acres) \times (3630\ cuft/1ac-in)$
 where Catchment Area (acres) = (Impervious Area * 0.9) + [(Pervious area + Undeveloped area) * 0.1]

i. $V_M (ft^3) = 1 * [(0.631 * 0.9) + (0.04 + 0) * 0.1] * 3630 = 2076\ ft^3$ or 15,530 Gallons (If Design is Capture and Use i.e. Rainwater Harvesting)

When using a Biofiltration as the BMP, the mitigated volume is 150% of the V_M:

$V_{M\ Biofiltration} (ft^3) = 1.5 * V_M = 1.5 * 2076 = 3,114\ ft^3$ or 23,294 Gallons (If Design is Biofiltration i.e. BMP Planter Boxes)

The design will be a rainwater harvesting system, therefore,

$V_M (ft^3) = 2076\ ft^3$ or 15,530 Gallons

Determine planting area (ft²):

ii. $Planting\ Area\ (ft^2) = 1700 + 0 = 1700\ ft^2$

Determine Planter Factor, PF, (ft²):

iii. $Planter\ Factor\ (ft^2) = Planting\ Factor \times Planting\ Area = 0.7 \times 1700\ ft^2 = 1190\ ft^2$

Determine the 7-month (Oct 1-April 30) Estimated Total Water Use (ETWU):

iv. $ETWU_{(7-month)} = ET_7 \times 0.62 \times PF = 21.7 \times 0.62 \times 1190 = 16010\ gal$

Verify ETWU_(7-month) is greater than or equal to V_{WQDV}:

v. $ETWU_{(7-month)} = 16,010 \geq V_{(Design)} (gal) = 15,530$

CAPTURE AND USE IS FEASIBLE

Compare ETWU_(7-month) vs V_{WQDV} vs V_{selected tank}:

vi. $\frac{ETWU_{(7-month)}}{V_{(Design)} (gal)} = \frac{16,010}{15,530} = 1.03$

Estimated Total Water Use over 7 months (Oct 1 - April 30) uses 1.03 times of required design volume.

$\frac{ETWU_{(7-month)}}{V_{(Selected\ Tank)} (gal)} = \frac{16,010}{17,975} = 0.89$

Estimated Total Water Use over 7 months (Oct 1 - April 30) uses 0.89 times of selected tank volume.

Storage Room Dimensions

vii. $V_{(Design)} (gal) = 15,530$
 $V_{(Design)} (cu-ft) = 2,076$

Storage Room Dimensions - Estimated

Length (ft)	21
Width (ft)	10
Volume (ft3) of tank assuming 10' high ceiling	2100

Peak Flow Hydrologic Analysis

File location: //pprod.psomas.corp/panzuraprojects/LA_Projects/1CRO040101/ENGR/DOCS/HydroCalc/11th & Hill - Existing_5yr.pdf
Version: HydroCalc 0.3.0-beta

Input Parameters

Project Name	11th & Hill
Subarea ID	Existing
Area (ac)	0.67
Flow Path Length (ft)	190.0
Flow Path Slope (vft/hft)	0.006
50-yr Rainfall Depth (in)	5.8
Percent Impervious	1.0
Soil Type	6
Design Storm Frequency	5-yr
Fire Factor	0
LID	False

Output Results

Modeled (5-yr) Rainfall Depth (in)	3.3872
Peak Intensity (in/hr)	1.8549
Undeveloped Runoff Coefficient (Cu)	0.7164
Developed Runoff Coefficient (Cd)	0.9
Time of Concentration (min)	6.0
Clear Peak Flow Rate (cfs)	1.1185
Burned Peak Flow Rate (cfs)	1.1185
24-Hr Clear Runoff Volume (ac-ft)	0.1688
24-Hr Clear Runoff Volume (cu-ft)	7352.9371

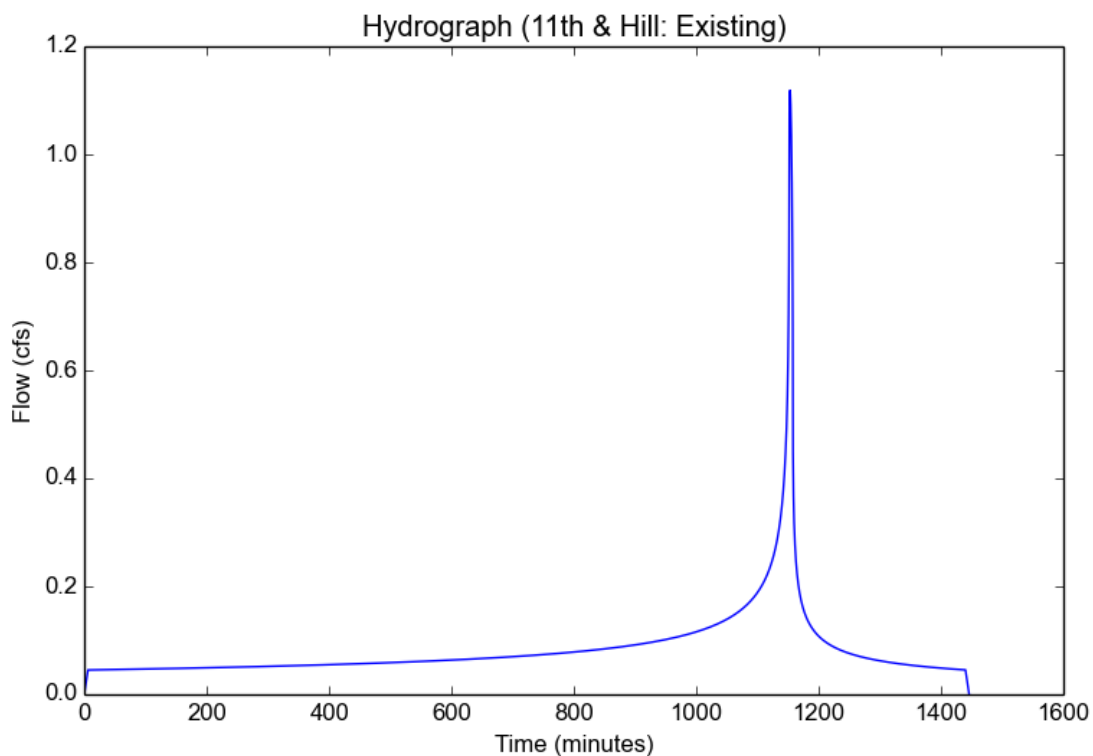

Peak Flow Hydrologic Analysis

File location: //pprod.psomas.corp/panzuraprojects/LA_Projects/1CRO040101/ENGR/DOCS/HydroCalc/11th & Hill - Existing_10yr.pdf
Version: HydroCalc 0.3.0-beta

Input Parameters

Project Name	11th & Hill
Subarea ID	Existing
Area (ac)	0.67
Flow Path Length (ft)	190.0
Flow Path Slope (vft/hft)	0.006
50-yr Rainfall Depth (in)	5.8
Percent Impervious	1.0
Soil Type	6
Design Storm Frequency	10-yr
Fire Factor	0
LID	False

Output Results

Modeled (10-yr) Rainfall Depth (in)	4.1412
Peak Intensity (in/hr)	2.4708
Undeveloped Runoff Coefficient (Cu)	0.784
Developed Runoff Coefficient (Cd)	0.9
Time of Concentration (min)	5.0
Clear Peak Flow Rate (cfs)	1.4899
Burned Peak Flow Rate (cfs)	1.4899
24-Hr Clear Runoff Volume (ac-ft)	0.2064
24-Hr Clear Runoff Volume (cu-ft)	8989.7198

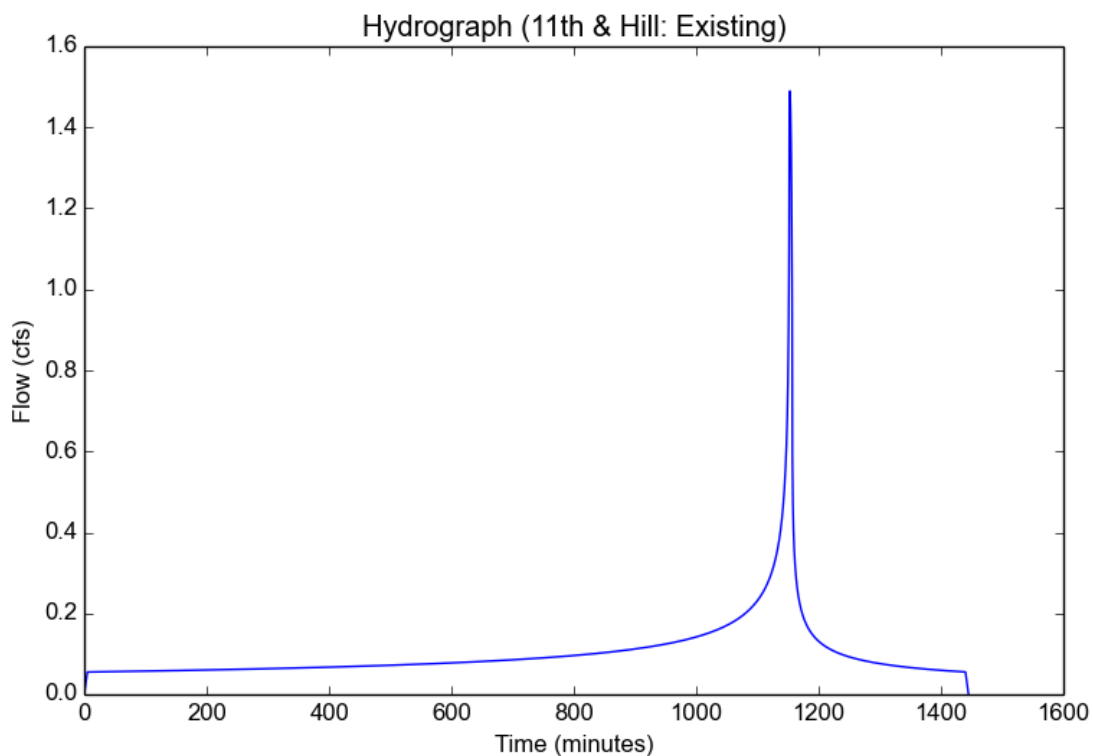

Peak Flow Hydrologic Analysis

File location: //pprod.psomas.corp/panzuraprojects/LA_Projects/1CRO040101/ENGR/DOCS/HydroCalc/11th & Hill - Existing_25yr.pdf
Version: HydroCalc 0.3.0-beta

Input Parameters

Project Name	11th & Hill
Subarea ID	Existing
Area (ac)	0.67
Flow Path Length (ft)	190.0
Flow Path Slope (vft/hft)	0.006
50-yr Rainfall Depth (in)	5.8
Percent Impervious	1.0
Soil Type	6
Design Storm Frequency	25-yr
Fire Factor	0
LID	False

Output Results

Modeled (25-yr) Rainfall Depth (in)	5.0924
Peak Intensity (in/hr)	3.0383
Undeveloped Runoff Coefficient (Cu)	0.825
Developed Runoff Coefficient (Cd)	0.9
Time of Concentration (min)	5.0
Clear Peak Flow Rate (cfs)	1.8321
Burned Peak Flow Rate (cfs)	1.8321
24-Hr Clear Runoff Volume (ac-ft)	0.2538
24-Hr Clear Runoff Volume (cu-ft)	11054.5854

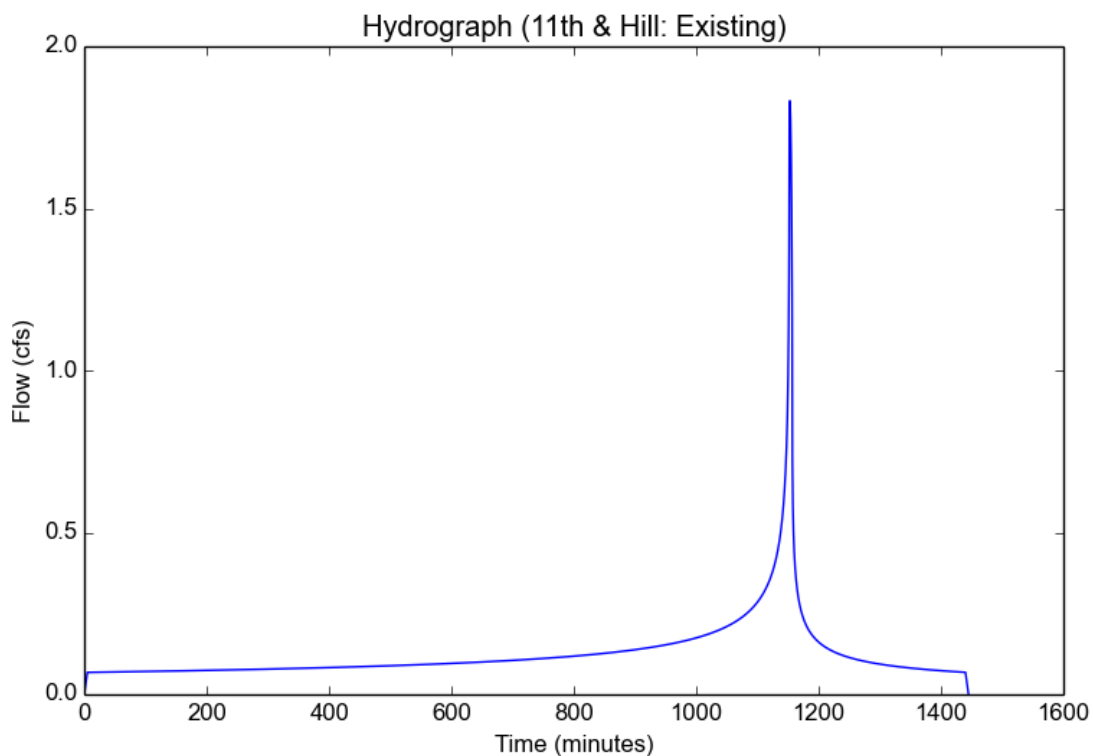

Peak Flow Hydrologic Analysis

File location: //pprod.psomas.corp/panzuraprojects/LA_Projects/1CRO040101/ENGR/DOCS/HydroCalc/11th & Hill - Existing_50yr.pdf
Version: HydroCalc 0.3.0-beta

Input Parameters

Project Name	11th & Hill
Subarea ID	Existing
Area (ac)	0.67
Flow Path Length (ft)	190.0
Flow Path Slope (vft/hft)	0.006
50-yr Rainfall Depth (in)	5.8
Percent Impervious	1.0
Soil Type	6
Design Storm Frequency	50-yr
Fire Factor	0
LID	False

Output Results

Modeled (50-yr) Rainfall Depth (in)	5.8
Peak Intensity (in/hr)	3.4604
Undeveloped Runoff Coefficient (Cu)	0.8546
Developed Runoff Coefficient (Cd)	0.9
Time of Concentration (min)	5.0
Clear Peak Flow Rate (cfs)	2.0866
Burned Peak Flow Rate (cfs)	2.0866
24-Hr Clear Runoff Volume (ac-ft)	0.289
24-Hr Clear Runoff Volume (cu-ft)	12590.6439

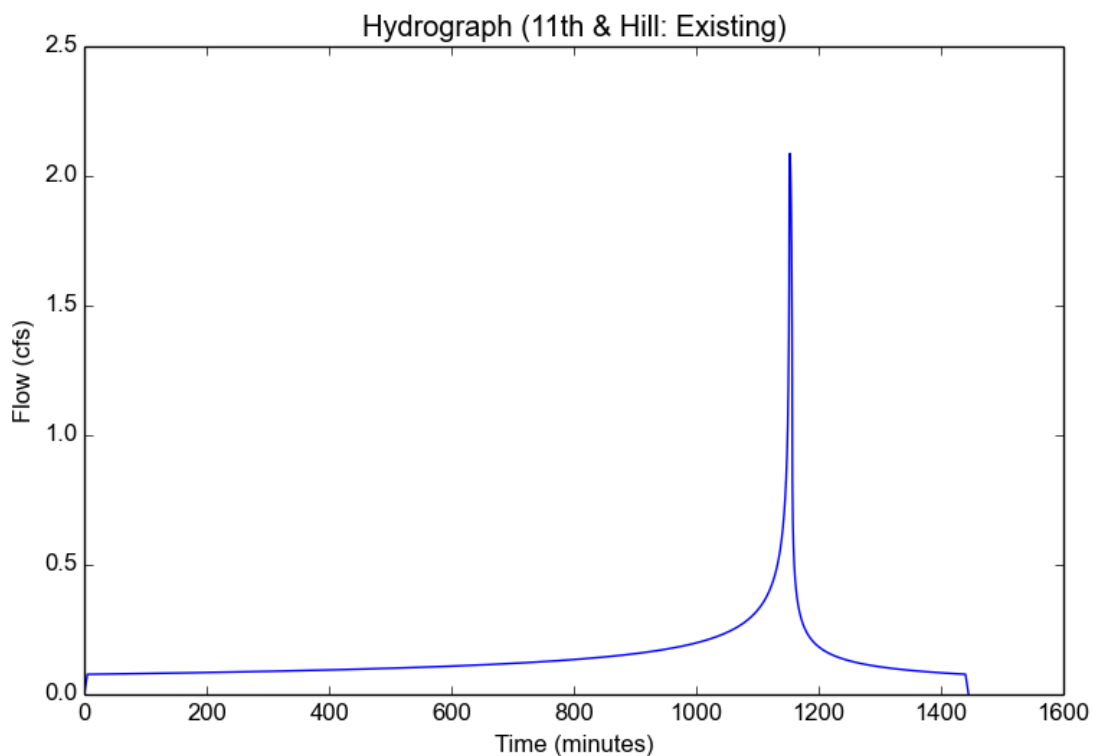

Peak Flow Hydrologic Analysis

File location: //pprod.psomas.corp/panzuraprojects/LA_Projects/1CRO040101/ENGR/DOCS/HydroCalc/11th & Hill - Existing_100yr.pdf
Version: HydroCalc 0.3.0-beta

Input Parameters

Project Name	11th & Hill
Subarea ID	Existing
Area (ac)	0.67
Flow Path Length (ft)	190.0
Flow Path Slope (vft/hft)	0.006
50-yr Rainfall Depth (in)	5.8
Percent Impervious	1.0
Soil Type	6
Design Storm Frequency	100-yr
Fire Factor	0
LID	False

Output Results

Modeled (100-yr) Rainfall Depth (in)	6.5076
Peak Intensity (in/hr)	3.8826
Undeveloped Runoff Coefficient (Cu)	0.872
Developed Runoff Coefficient (Cd)	0.9
Time of Concentration (min)	5.0
Clear Peak Flow Rate (cfs)	2.3412
Burned Peak Flow Rate (cfs)	2.3412
24-Hr Clear Runoff Volume (ac-ft)	0.3243
24-Hr Clear Runoff Volume (cu-ft)	14126.7025

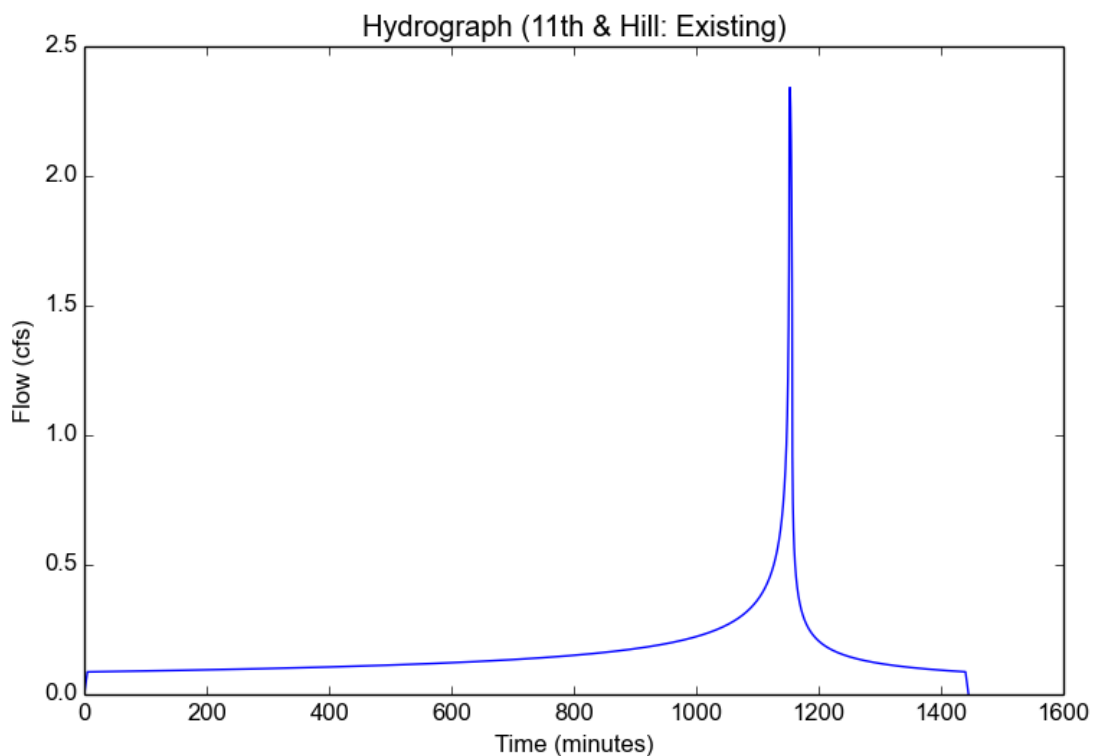

Peak Flow Hydrologic Analysis

File location: //pprod.psomas.corp/panzuraprojects/LA_Projects/1CRO040101/ENGR/DOCS/HydroCalc/11th & Hill - Existing_85thpercentile.pdf
Version: HydroCalc 0.3.0-beta

Input Parameters

Project Name	11th & Hill
Subarea ID	Existing
Area (ac)	0.67
Flow Path Length (ft)	190.0
Flow Path Slope (vft/hft)	0.006
85th Percentile Rainfall Depth (in)	1.0
Percent Impervious	1.0
Soil Type	6
Design Storm Frequency	85th percentile storm
Fire Factor	0
LID	True

Output Results

Modeled (85th percentile storm) Rainfall Depth (in)	1.0
Peak Intensity (in/hr)	0.3677
Undeveloped Runoff Coefficient (Cu)	0.1
Developed Runoff Coefficient (Cd)	0.9
Time of Concentration (min)	14.0
Clear Peak Flow Rate (cfs)	0.2217
Burned Peak Flow Rate (cfs)	0.2217
24-Hr Clear Runoff Volume (ac-ft)	0.0498
24-Hr Clear Runoff Volume (cu-ft)	2170.8054

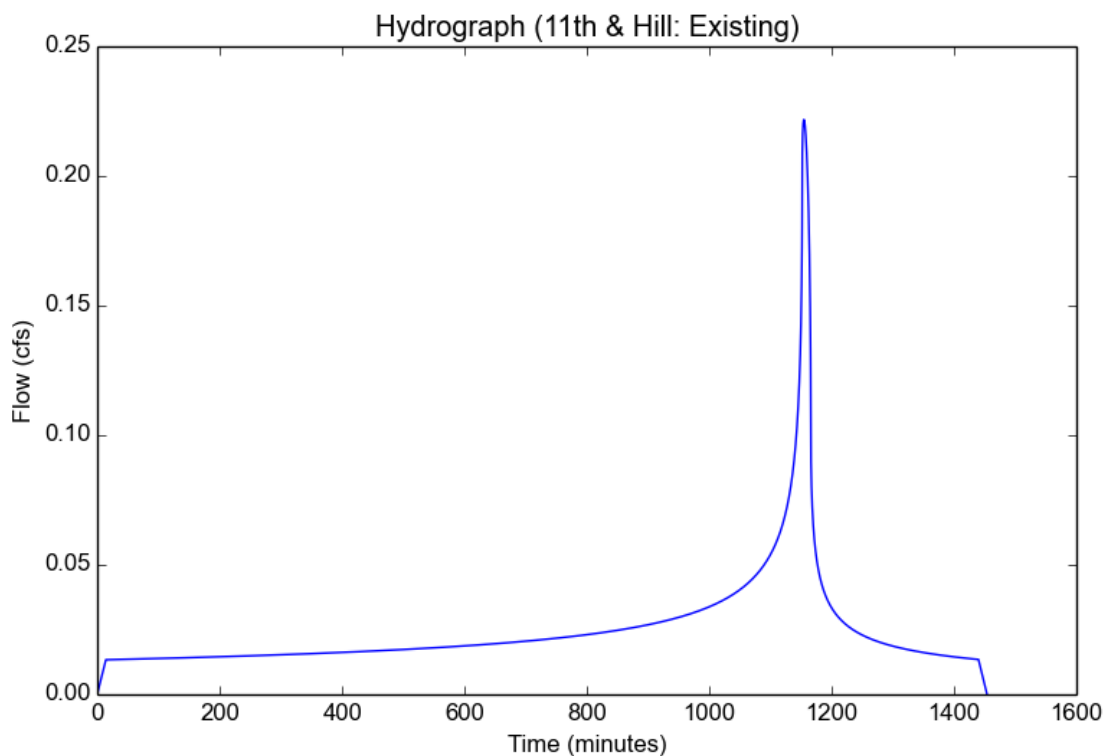

Peak Flow Hydrologic Analysis

File location: //pprod.psomas.corp/panzuraprojects/LA_Projects/1CRO040101/ENGR/DOCS/HydroCalc/Proposed/11th & Hill - Proposed 5yr.pdf
Version: HydroCalc 0.3.0-beta

Input Parameters

Project Name	11th & Hill St
Subarea ID	Proposed
Area (ac)	0.67
Flow Path Length (ft)	190.0
Flow Path Slope (vft/hft)	0.006
50-yr Rainfall Depth (in)	5.8
Percent Impervious	0.95
Soil Type	6
Design Storm Frequency	5-yr
Fire Factor	0
LID	False

Output Results

Modeled (5-yr) Rainfall Depth (in)	3.3872
Peak Intensity (in/hr)	1.8549
Undeveloped Runoff Coefficient (Cu)	0.7164
Developed Runoff Coefficient (Cd)	0.8908
Time of Concentration (min)	6.0
Clear Peak Flow Rate (cfs)	1.1071
Burned Peak Flow Rate (cfs)	1.1071
24-Hr Clear Runoff Volume (ac-ft)	0.1619
24-Hr Clear Runoff Volume (cu-ft)	7050.4607

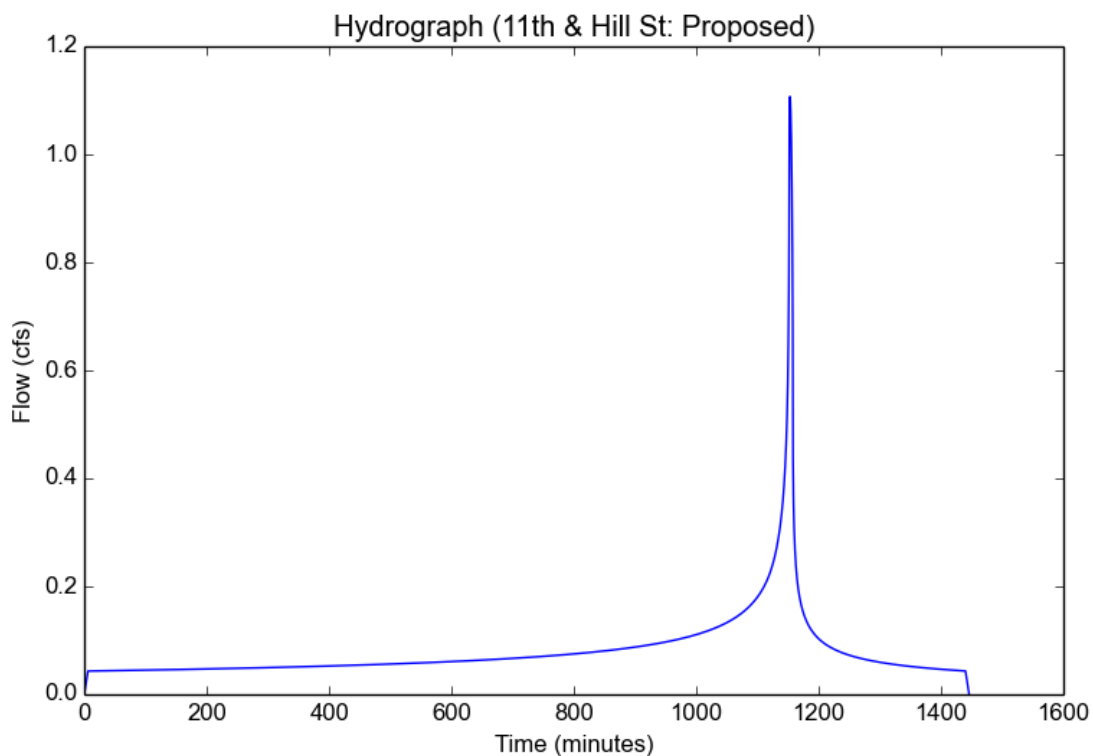

Peak Flow Hydrologic Analysis

File location: //pprod.psomas.corp/panzuraprojects/LA_Projects/1CRO040101/ENGR/DOCS/HydroCalc/Proposed/11th & Hill - Proposed 10yr.pdf
Version: HydroCalc 0.3.0-beta

Input Parameters

Project Name	11th & Hill St
Subarea ID	Proposed
Area (ac)	0.67
Flow Path Length (ft)	190.0
Flow Path Slope (vft/hft)	0.006
50-yr Rainfall Depth (in)	5.8
Percent Impervious	0.95
Soil Type	6
Design Storm Frequency	10-yr
Fire Factor	0
LID	False

Output Results

Modeled (10-yr) Rainfall Depth (in)	4.1412
Peak Intensity (in/hr)	2.4708
Undeveloped Runoff Coefficient (Cu)	0.784
Developed Runoff Coefficient (Cd)	0.8942
Time of Concentration (min)	5.0
Clear Peak Flow Rate (cfs)	1.4803
Burned Peak Flow Rate (cfs)	1.4803
24-Hr Clear Runoff Volume (ac-ft)	0.1981
24-Hr Clear Runoff Volume (cu-ft)	8628.0085

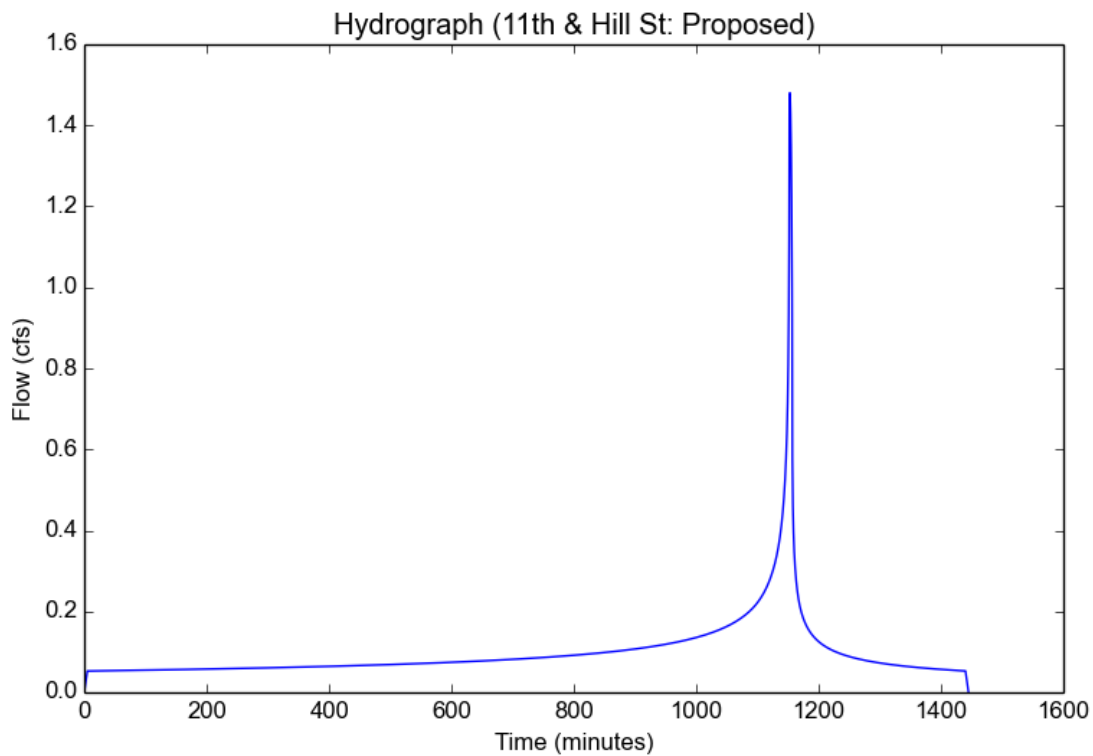

Peak Flow Hydrologic Analysis

File location: //pprod.psomas.corp/panzuraprojects/LA_Projects/1CRO040101/ENGR/DOCS/HydroCalc/Proposed/11th & Hill - Proposed_25yr.pdf
Version: HydroCalc 0.3.0-beta

Input Parameters

Project Name	11th & Hill St
Subarea ID	Proposed
Area (ac)	0.67
Flow Path Length (ft)	190.0
Flow Path Slope (vft/hft)	0.006
50-yr Rainfall Depth (in)	5.8
Percent Impervious	0.95
Soil Type	6
Design Storm Frequency	25-yr
Fire Factor	0
LID	False

Output Results

Modeled (25-yr) Rainfall Depth (in)	5.0924
Peak Intensity (in/hr)	3.0383
Undeveloped Runoff Coefficient (Cu)	0.825
Developed Runoff Coefficient (Cd)	0.8962
Time of Concentration (min)	5.0
Clear Peak Flow Rate (cfs)	1.8244
Burned Peak Flow Rate (cfs)	1.8244
24-Hr Clear Runoff Volume (ac-ft)	0.2439
24-Hr Clear Runoff Volume (cu-ft)	10622.4708

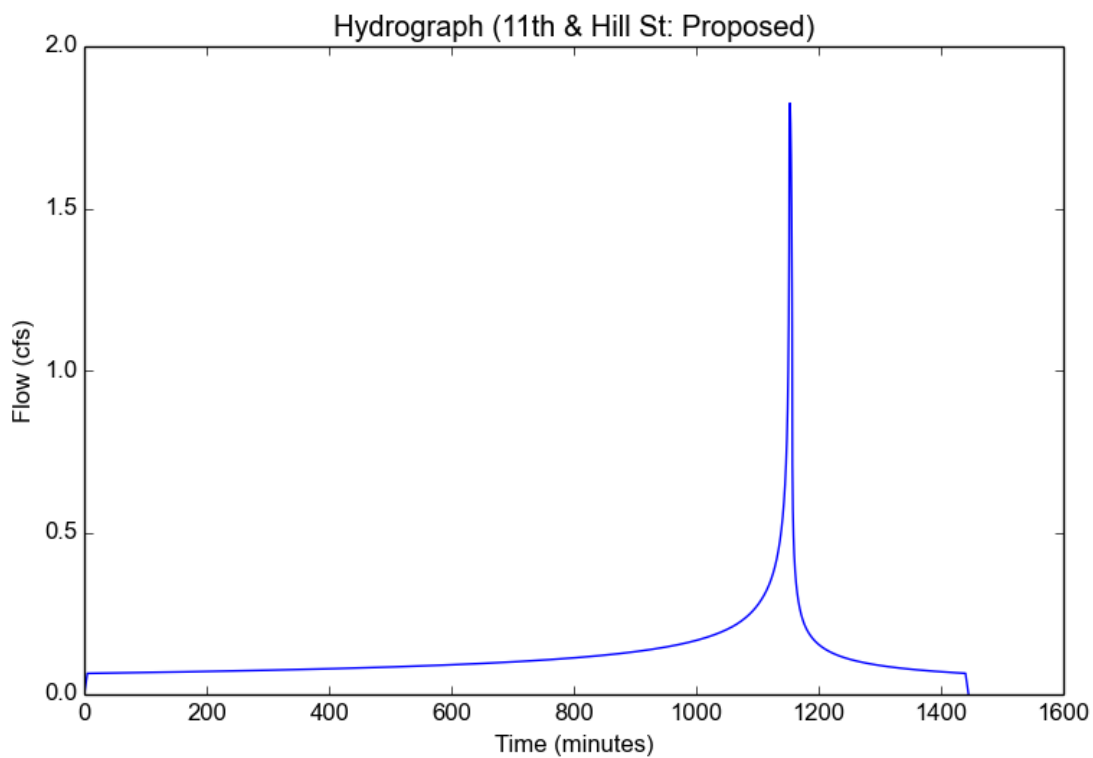

Peak Flow Hydrologic Analysis

File location: //pprod.psomas.corp/panzuraprojects/LA_Projects/1CRO040101/ENGR/DOCS/HydroCalc/Proposed/11th & Hill - Proposed 50yr.pdf
Version: HydroCalc 0.3.0-beta

Input Parameters

Project Name	11th & Hill St
Subarea ID	Proposed
Area (ac)	0.67
Flow Path Length (ft)	190.0
Flow Path Slope (vft/hft)	0.006
50-yr Rainfall Depth (in)	5.8
Percent Impervious	0.95
Soil Type	6
Design Storm Frequency	50-yr
Fire Factor	0
LID	False

Output Results

Modeled (50-yr) Rainfall Depth (in)	5.8
Peak Intensity (in/hr)	3.4604
Undeveloped Runoff Coefficient (Cu)	0.8546
Developed Runoff Coefficient (Cd)	0.8977
Time of Concentration (min)	5.0
Clear Peak Flow Rate (cfs)	2.0814
Burned Peak Flow Rate (cfs)	2.0814
24-Hr Clear Runoff Volume (ac-ft)	0.278
24-Hr Clear Runoff Volume (cu-ft)	12109.5044

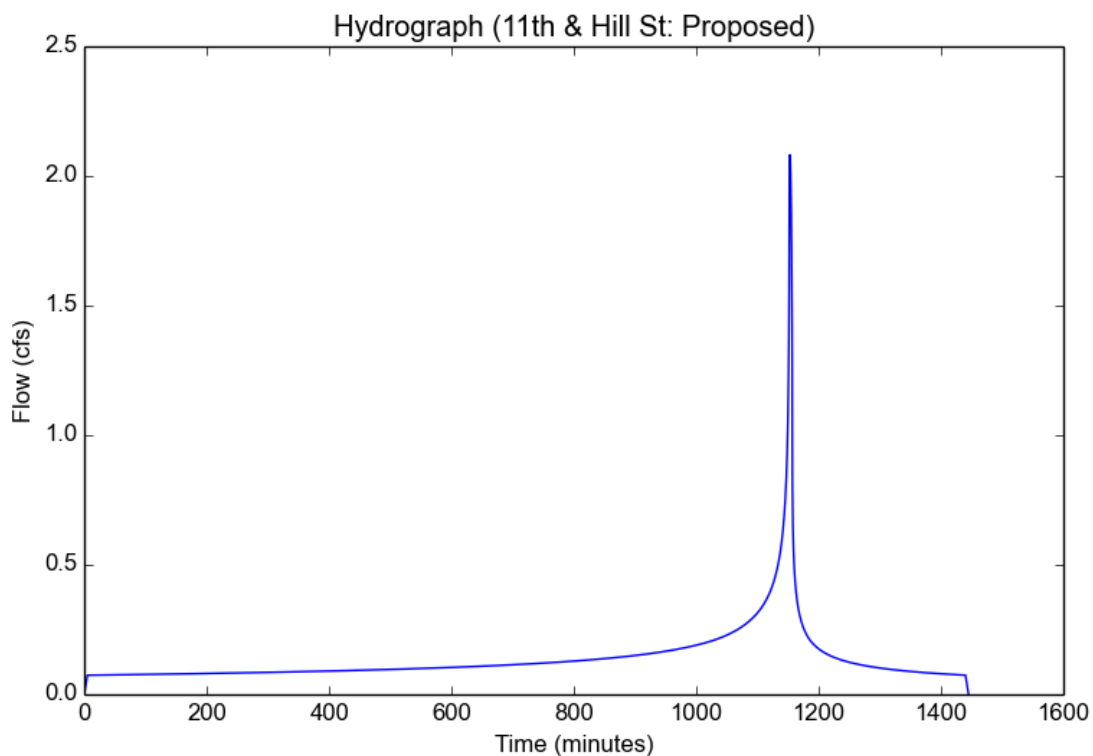

Peak Flow Hydrologic Analysis

File location: //pprod.psomas.corp/panzuraprojects/LA_Projects/1CRO040101/ENGR/DOCS/HydroCalc/Proposed/11th & Hill - Proposed 100yr.pdf
Version: HydroCalc 0.3.0-beta

Input Parameters

Project Name	11th & Hill St
Subarea ID	Proposed
Area (ac)	0.67
Flow Path Length (ft)	190.0
Flow Path Slope (vft/hft)	0.006
50-yr Rainfall Depth (in)	5.8
Percent Impervious	0.95
Soil Type	6
Design Storm Frequency	100-yr
Fire Factor	0
LID	False

Output Results

Modeled (100-yr) Rainfall Depth (in)	6.5076
Peak Intensity (in/hr)	3.8826
Undeveloped Runoff Coefficient (Cu)	0.872
Developed Runoff Coefficient (Cd)	0.8986
Time of Concentration (min)	5.0
Clear Peak Flow Rate (cfs)	2.3376
Burned Peak Flow Rate (cfs)	2.3376
24-Hr Clear Runoff Volume (ac-ft)	0.3122
24-Hr Clear Runoff Volume (cu-ft)	13599.3081

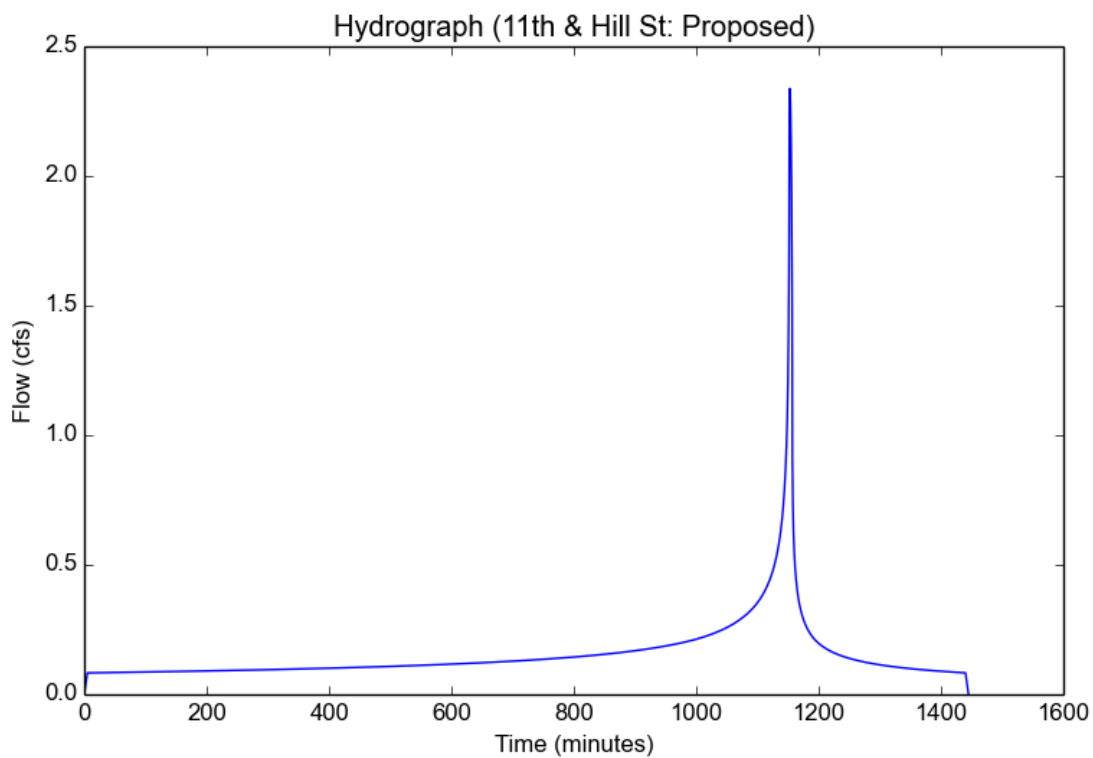

Peak Flow Hydrologic Analysis

File location: //pprod.psomas.corp/panzuraprojects/LA_Projects/1CRO040101/ENGR/DOCS/HydroCalc/Proposed/11th & Hill - Proposed 85thpercent.pd
Version: HydroCalc 0.3.0-beta

Input Parameters

Project Name	11th & Hill St
Subarea ID	Proposed
Area (ac)	0.67
Flow Path Length (ft)	190.0
Flow Path Slope (vft/hft)	0.006
85th Percentile Rainfall Depth (in)	1.0
Percent Impervious	0.95
Soil Type	6
Design Storm Frequency	85th percentile storm
Fire Factor	0
LID	True

Output Results

Modeled (85th percentile storm) Rainfall Depth (in)	1.0
Peak Intensity (in/hr)	0.3677
Undeveloped Runoff Coefficient (Cu)	0.1
Developed Runoff Coefficient (Cd)	0.86
Time of Concentration (min)	14.0
Clear Peak Flow Rate (cfs)	0.2119
Burned Peak Flow Rate (cfs)	0.2119
24-Hr Clear Runoff Volume (ac-ft)	0.0476
24-Hr Clear Runoff Volume (cu-ft)	2074.3251

