



# Villa Serena Specific Plan

CITY OF UPLAND | DRAFT JULY 2023



# VILLA SERENA SPECIFIC PLAN

DRAFT  
July 2023

**Applicant:**

The Colonies Partners, L.P.

**Consultants:**

Architerra Design Group  
Deborah Linn Planning Consultant  
KB Home  
Madole & Associates, Inc.



# TABLE OF CONTENTS

## Section 1. Introduction

1.1	Project Overview .....	1.1
1.2	Project Setting.....	1.4
1.3	Purpose and Authority .....	1.4
1.3.1	Purpose .....	1.4
1.3.2	Authority of the Specific Plan .....	1.6
1.4	Objectives .....	1.6
1.5	Project Summary .....	1.7
1.5.1	Residential .....	1.7
1.5.2	Open Space .....	1.7
1.5.3	Pedestrian and Bicycle Connectivity.....	1.8
1.5.4	Infrastructure .....	1.8
1.6	Governing Documents.....	1.8
1.6.1	General Plan .....	1.8
1.6.2	Specific Plan .....	1.9
1.6.3	Subdivision Maps.....	1.9
1.6.4	Development Plan Review .....	1.9
1.6.5	Covenants, Conditions, and Restrictions .....	1.9
1.7	CEQA Compliance .....	1.9
1.8	Specific Plan Components .....	1.9

## Section 2. Development Plan

2.1	Land Use.....	2.1
2.1.1	Residential Use .....	2.1
2.1.2	Open Space Use.....	2.1
2.2	Circulation.....	2.3
2.2.1	15th Street .....	2.3
2.2.2	Project Streets .....	2.3
2.2.3	Pedestrian and Bicycle Mobility .....	2.7
2.3	Infrastructure and Public Services .....	2.7
2.3.1	Water .....	2.7

## TABLE OF CONTENTS

2.3.2	Sanitary Sewer .....	2.7
2.3.3	Storm Drain and Water Quality Management .....	2.11
2.4	Public Utilities .....	2.11
2.4.1	Telephone and Cable .....	2.11
2.4.2	Natural Gas .....	2.11
2.4.3	Electricity.....	2.11
2.4.4	Solid Waste .....	2.11
2.4.5	Schools.....	2.11
2.5	Basin Modifications and Project Grading .....	2.13
2.6	Fire Safety.....	2.15

### Section 3. Development Regulations

3.1	Introduction .....	3.1
3.2	Definition of Terms .....	3.1
3.3	Applicability .....	3.1
3.4	General Site Development Standards .....	3.1
3.5	Green and Sustainable Development Standards .....	3.1
3.6	Permitted Uses and Structures.....	3.2
3.7	Residential Development Standards .....	3.3
3.8	Temporary Uses .....	3.5
3.9	Open Space Development Standards .....	3.5
3.10	Landscaping, Fencing, and Walls.....	3.5
3.10.1	Landscape and Irrigation Standards .....	3.5
3.10.2	Fence and Wall Standards .....	3.6
3.11	Signage .....	3.6
3.11.1	Master Sign Program Contents .....	3.6
3.12	Lighting .....	3.7
3.12.1	General Requirements .....	3.7
3.12.2	Public Street Lights .....	3.7
3.12.3	Private Street Lighting Fixtures.....	3.7
3.12.4	Common Area Open Space Lighting .....	3.7

# TABLE OF CONTENTS

## Section 4. Design Criteria

4.1	Purpose and Intent .....	4.1
4.2	Landscape Design .....	4.1
4.2.1	Landscape Elements .....	4.1
4.2.2	Community Entries .....	4.5
4.2.3	Streetscapes .....	4.5
4.2.4	Open Space and Connectivity .....	4.17
4.3	Walls and Fencing .....	4.26
4.3.1	Community Walls .....	4.26
4.3.2	Residential Walls and Fences .....	4.26
4.3.3	Other Fences .....	4.26
4.4	Outdoor Lighting .....	4.26
4.4.1	Entry Monument Lighting .....	4.26
4.4.2	Open Space Areas and Walkway Lighting .....	4.32
4.5	Signs .....	4.32
4.5.1	Sign Program Objectives .....	4.32
4.5.2	Sign Design Criteria .....	4.32
4.6	Architectural Design .....	4.32
4.6.1	Spanish Influenced Style .....	4.33
4.6.2	Italianate Influences .....	4.35
4.6.3	French Country Influences .....	4.37
4.6.4	Architectural Enhancements .....	4.39

## Section 5. Implementation and Administration

5.1	Methods and Applicability .....	5.1
5.2	Severability .....	5.1
5.3	Interpretation .....	5.1
5.4	Development Review .....	5.1
5.4.1	Subdivision Maps .....	5.1
5.4.2	Site Plan and Design Review .....	5.1
5.5	Specific Plan Modifications and Amendments .....	5.2

## TABLE OF CONTENTS

5.5.1	Modifications .....	5.2
5.5.2	Specific Plan Amendments .....	5.2
5.6	Appeals .....	5.2
5.7	Compliance with Mitigation Measures and Conditions of Approval .....	5.2
5.8	Project Financing .....	5.3
5.8.1	Facilities and Services .....	5.3
5.8.2	Facilities and Services .....	5.3
5.9	Project Phasing .....	5.3
5.10	Maintenance .....	5.3

### Section 6. General Plan Consistency

6.1	Land Use Element .....	6.1
6.2	Community Character and Urban Design Element .....	6.3
6.3	Economic Sustainability Element .....	6.15
6.4	Circulation Element .....	6.15
6.5	Open Space and Conservation Element .....	6.16
6.6	Public Services and Facilities Element .....	6.22
6.7	Healthy Community Element .....	6.25
6.8	Safety Element .....	6.26

### List of Tables

Table 2.1	Statistical Summary .....	2.1
Table 3.1	Residential Development Standards .....	3.4
Table 4.1	Suggested Plant List .....	4.2
Table 5-1	Project Maintenance Matrix .....	5.5



# TABLE OF CONTENTS

## List of Exhibits

Exhibit 1 Regional Context Map.....	1.2
Exhibit 2 Project Vicinity Map.....	1.3
Exhibit 3 Project Setting.....	1.5
Exhibit 4 Land Use Plan .....	2.2
Exhibit 5 Master Plan of Circulation .....	2.4
Exhibit 6 Street Cross Sections .....	2.5
Exhibit 7 Street Cross Sections .....	2.6
Exhibit 8 Pedestrian and Bicycle Mobility.....	2.8
Exhibit 9 Water Master Plan .....	2.9
Exhibit 10 Sewer Master Plan .....	2.10
Exhibit 11 Storm Drain Master Plan.....	2.12
Exhibit 12 Conceptual Basin Modification Plan .....	2.14
Exhibit 13 Conceptual Grading Plan .....	2.16
Exhibit 14 Conceptual Grading Plan Cross Sections .....	2.17
Exhibit 15 Fire Safety Plan .....	2.18
Exhibit 16 Conceptual Landscape Plan.....	4.4
Exhibit 17 Primary Community Entry .....	4.6

## TABLE OF CONTENTS

Exhibit 18 Primary Community Entry Elevation View .....	4.7
Exhibit 19 Secondary Entry .....	4.8
Exhibit 20 Streetscape Key Map .....	4.9
Exhibit 21 Streetscape Sections.....	4.10
Exhibit 22 Streetscape Sections.....	4.11
Exhibit 23 Streetscape Sections.....	4.12
Exhibit 24 Streetscape Sections.....	4.13
Exhibit 25 Streetscape Sections.....	4.14
Exhibit 26 Streetscape Sections.....	4.15
Exhibit 27 Streetscape Sections.....	4.16
Exhibit 28 Central Open Space Plan.....	4.18
Exhibit 29 Pocket Parks .....	4.19
Exhibit 30 Pocket Parks .....	4.20
Exhibit 31 Central Mailbox Plan .....	4.21
Exhibit 32 Open Space Amenities.....	4.22
Exhibit 33 Open Space Amenities.....	4.23
Exhibit 34 Open Space Amenities.....	4.24
Exhibit 35 Open Space Amenities.....	4.25

## TABLE OF CONTENTS

Exhibit 36 Wall and Fence Plan .....	4.27
Exhibit 37 Wall and Fence Plan .....	4.28
Exhibit 38 Basin Trail Fence Plan.....	4.29
Exhibit 39 Wall and Fence Details .....	4.30
Exhibit 40 Typical Street Light Fixture .....	4.31
Exhibit 41 Spanish Style.....	4.34
Exhibit 42 Italianate Style.....	4.36
Exhibit 43 French Country Style .....	4.38
Exhibit 44 Architectural Enhancements Key Map .....	4.40
Exhibit 45 Enhanced Elevation Spanish Style.....	4.41
Exhibit 46 Enhanced Elevation French Country Style.....	4.42
Exhibit 47 Enhanced Elevation Italianate Style .....	4.43



## SECTION 1. INTRODUCTION

### Section 1. Introduction

#### 1.1 Project Overview

The Villa Serena Specific Plan (Specific Plan) is a proposal by The Colonies Partners, L.P. (Applicant) to develop a gated residential community on approximately 9.16 gross acres owned by the applicant (Project Site) and to improve approximately .78 additional acres off-site adjacent to the Project Site for open space and circulation purposes in the City of Upland. The Project Site is generally located north of 15th Street and east of North Campus Avenue as illustrated in Exhibit 1, “Regional Context Map” and as further described in the “Project Vicinity Map,” Exhibit 2.

The Project Site is an infill site with single family residential uses adjacent to the Project Site on the south, west, and southeast, and the Upland Hills Country Club and residential community adjacent to the Project Site to the north. An existing flood control basin is located adjacent to the Project Site to the east. A Southern California Edison substation is located in proximity to the Project Site on the northwest. A recreational vehicle storage yard is located to the southwest of the Project Site. The Specific Plan is a comprehensive plan for development of 65 single family detached residential units at a density of 7.10 dwelling units per acre and on-site active and passive recreational amenities within common open space areas. The Specific Plan also includes a plan for the extension of existing 15th Street improvements from the Project Site westerly to the terminus of East 15th Street providing a private access roadway and entry to the Project as well as construction of off-site public open space improvements.

The new community planned as part of the Specific Plan incorporates the traditional housing styles of Upland, California, while also reflecting the architecture of recently built neighborhoods. The architectural styles of the Specific

Plan are influenced and inspired by Spanish, Italianate, and French Country that echo the classic architecture of the Southern Californian regions. The Specific Plan integrates styles, elements, and a mix of materials from both established and newer residential communities located near the Project Site. The use of Spanish roof tiles, gable end details, and delicate metal rails reflects the classic Spanish style of the historical Upland communities. Similarly, the vertical corner details, symmetry, and arched openings of the Italianate style, and the corbels, stone siding, and steep roof pitches of the French Country architectural style, capture the details of the past and present styles of Upland homes. The new homes planned within the Project Site are designed to reflect the massing and scale of existing neighboring homes by using similar proportions, heights, and footprints allowing for the new community to comfortably blend with the existing neighborhood and the community at large.

Construction of new Project roadways and infrastructure is planned to connect to existing facilities located adjacent to the Project Site. The proposed plan reduces the need for construction of additional arterial and major roadway improvements to serve the Project Site.

The proximity of the Project Site within walking and biking distance to existing recreational and commercial facilities can help to reduce automobile trips to and from the Project Site. The Project provides pedestrian and bicycle connectivity to a nearby Sierra Vista Park, located approximately .5 miles southwest of the Project Site to Upland Memorial Park located approximately .8 miles south of the Project Site and to the existing public trail located along the rim of a flood control basin located adjacent to the Project Site on the east. Commercial services within biking distance from the Project Site are located within one mile of the Project Site at the Colonies Crossroads Center located at North Campus Avenue and 19th Street. This regional

# SECTION 1. INTRODUCTION

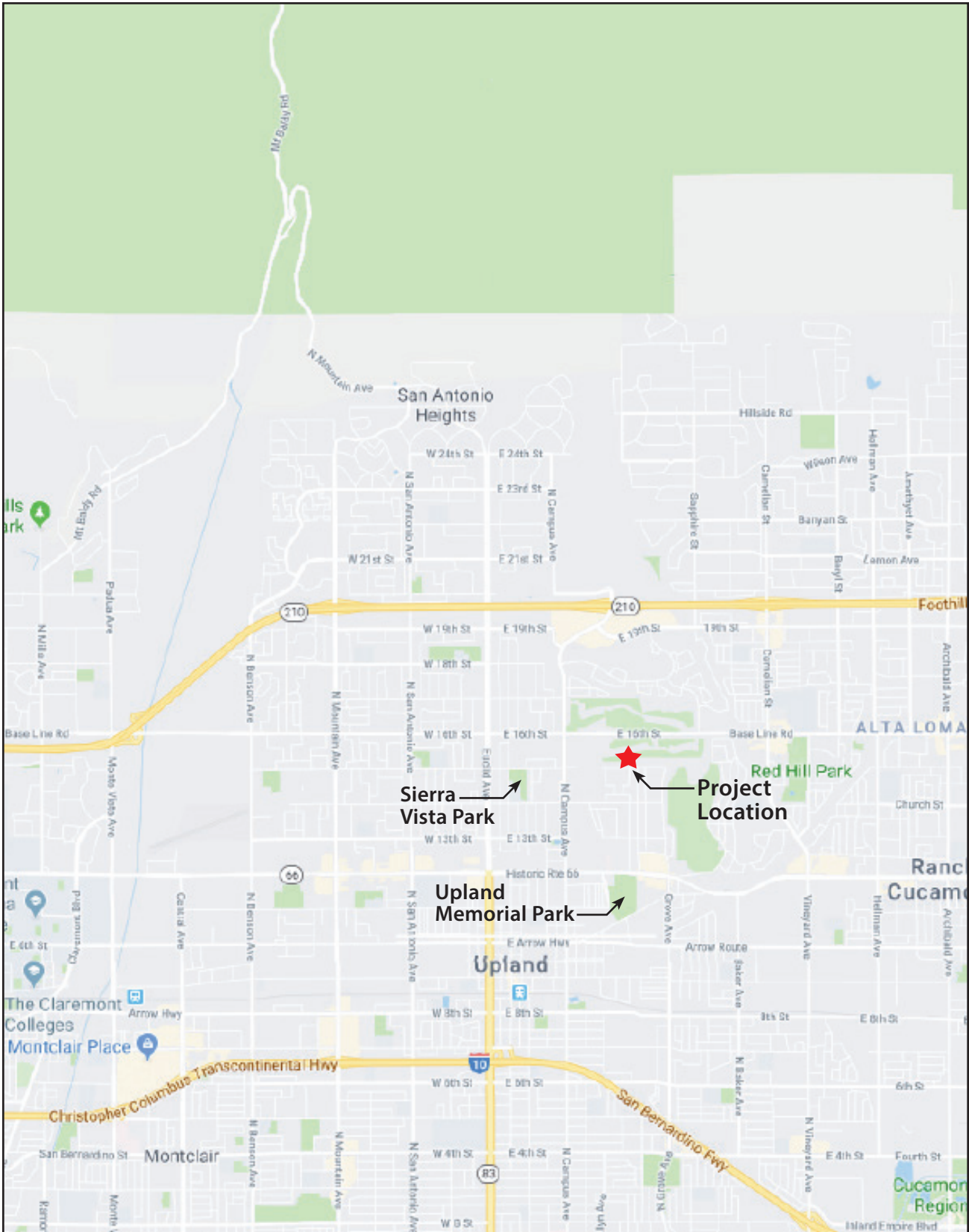

Exhibit 1  
**Regional Context Map**

Source: Google Maps



SECTION 1. INTRODUCTION



Exhibit 2  
**Project Vicinity Map**

Source: Madole & Associates, Inc./Google Maps



## SECTION 1. INTRODUCTION

commercial center offers residents a supermarket, restaurants, personal services, entertainment, and home goods for residents in the vicinity.

The Specific Plan is designed to create a distinctive sense of place for residents in a gated community with a pedestrian and bicycle friendly street system creating an atmosphere where neighbors can visit with one another while walking throughout the community. Common area open space within the community offers active and passive recreational amenities for residents and a community gathering place for residents. Homes are planned to front onto streets, enabling residents to have their “eyes on the street,” promoting a safe hometown feel and encouraging interaction among neighbors.

### 1.2 Project Setting

The physical setting of the Project Site is illustrated on Exhibit 3, "Project Setting." The Project Site comprises a portion of an approximately 20 acre flood control detention basin. The City of Upland has determined a 9.16 acre portion of the flood control detention basin, comprising the Project Site, to be a surplus parcel suitable for development of residential uses with the remaining approximately 11 acres of the flood control detention basin to be adequate for continued flood control operations pursuant to completion of modifications to portions of the basin as part of the Project. As part of the Project, access for flood control detention basin maintenance vehicles is provided through the Project Site with a gated entry to the basin located at the easterly edge of the Project boundary.

### 1.3 Purpose and Authority

#### 1.3.1 Purpose

The Villa Serena Specific Plan implements a General Plan Amendment changing the General Plan Land Use Map for the Project Site from Public Flood Control/Recharge (FC/R) to Villa Serena Specific Plan (SP), allowing residential land use development at a density of 7.10 dwelling units per acre consistent with surrounding residential single family low (SFR-L) and single family medium (SFR-M) development located adjacent to the Project Site. Adoption by the City of the Specific Plan by ordinance changes the City's Zoning Map for the Project Site from Public (PB-FC) to "Villa Serena Specific Plan." The adoption of the Villa Serena Specific Plan (Specific Plan) implements the General Plan land use designation of SP through the establishment of site specific zoning regulations for the development of the Project Site.

The Specific Plan is a comprehensive plan for development of residential and open space land uses and infrastructure improvements to serve the development. The Specific Plan establishes the development regulations and design criteria for development of the Project. The Specific Plan also establishes the procedures and requirements enabling City review and approval of development the Project thereby ensuring that the City's General Plan, as amended for the Project Site, is implemented.



# SECTION 1. INTRODUCTION



Exhibit 3  
**Project Setting**

Source: Madole & Associates, Inc./Google Maps



## SECTION 1. INTRODUCTION

### 1.3.2 Authority of the Specific Plan

State of California Government Code, Title 7, Division 1, Chapter 3, Article 8, Section 65450-57, grants authority to cities to adopt specific plans for purposes of implementing the goals and policies of their general plans. The Government Code specifies that specific plans may be adopted either by resolution or by ordinance and that the specific plan must be consistent with the general plan. The Government Code sets forth the minimum requirements and review procedures for specific plans including provision of a land use plan, an infrastructure and public services plan, criteria and standards for development, and implementation measures. The Government Code also states that specific plans may address any other subjects which, in the judgment of the city, are necessary or desirable for implementation of the general plan.

### 1.4 Objectives

The Specific Plan addresses the following planning and design objectives to ensure that development of the Project Site is consistent with the City's General Plan, as amended, and serves as a foundation for the design of a residential community which provides a sense of place for residents and responds to the existing surrounding built environment. Consistency of the Project with the General Plan is discussed in Section 6, "General Plan Consistency," of the Specific Plan.

#### **Objective 1:**

Foster a sense of community and promote a unified and cohesive neighborhood environment through the following design measures:

- Create a distinctive community design with a well designed entry, streetscapes, walls, and entry monument.
- Provide for architectural diversity within the community with varying residential floor plans and architectural styles.

- Create a strong sense of arrival into the Project Site through an enhanced community entry.
- Provide for on-site recreational opportunities for residents through provision of common area open space within the community offering active and passive recreational amenities for all age groups.
- Provide for public off-site recreational opportunities through the development of passive open space.

#### **Objective 2:**

Design a development plan which ensures the community is adequately served by public facilities, infrastructure, and utilities without the need for extensions or improvements to existing public facilities through the following measures:

- Provide for a simple two way private street system connecting to an existing public arterial roadway, and minimize points of access to existing roadways.
- Provide for a pedestrian and bicycle friendly circulation system providing connectivity within the community and connecting to 15th Street where pedestrians and bicyclists can access existing public streets, trails, and sidewalks.
- Provide for adequate storm water collection within the Project Site to contain on-site and off-site flows affecting the property.
- Provide for adequate wastewater facilities on-site and ensure that adequate capacity is available within existing public sewer facilities to serve the Project Site.
- Provide on-site facilities for water quality treatment and ground water replenishment.
- Participate in payment of appropriate Development Impact Fees to accommodate the public service needs generated by the community.

## SECTION 1. INTRODUCTION

### **Objective 3:**

Incorporate the following green and sustainable design features into the development plan.

- Design homes with opportunities for remote working allowing people to work from home reducing driving time and vehicle emissions.
- Incorporate native plant materials and/or drought tolerant plant materials within the landscaping of public spaces, and encourage homeowners to utilize drought tolerant plant materials in private yard areas.
- Design homes with currently available technology for internet access allowing residents to shop and work on-line, helping to reduce vehicle trips to employment centers and shopping.
- Incorporate passive solar design and energy efficient construction materials and techniques into residential design such as cool roofs, dual pane windows, increased insulation to minimize heat transfer and thermal bridging, and roofs designed to accommodate homeowner installation of solar panels to help reduce energy demand.
- Implement “dark sky friendly” outdoor lighting within streets and common area open space.
- Provide for a plant palette which includes canopy trees to achieve natural ventilation and cooling and use of water conserving landscape plant materials and irrigation systems.
- Provide for a landscape and irrigation plan consistent with Upland Municipal Code Chapter 17.12 (Landscaping) and the State Model Water Efficient Landscape Ordinance (23 C.C.R § 490 et seq.)

### **1.5 Project Summary**

The Specific Plan is a comprehensive plan for the development of up to 65 single family detached residential dwelling units designed around a private two way street system with pedestrian walkways linking residences to on-site common area open space and to existing adjacent roadways connecting to existing nearby recreational amenities and commercial services. The Project street system provides walking and biking connectivity from the Project Site to 15th Street enabling residents to walk or bike to the nearby Sierra Vista Park located approximately .5 miles southwest of the Project Site, Upland Memorial Park located approximately .8 miles south of the Project Site and the Colonies Crossroads commercial center located north of the Project Site.

#### **1.5.1 Residential**

Sixty five single family detached residential dwellings are planned at a density of 7.10 dwelling units per acre designed in a variety of styles and floor plans. The Project incorporates three distinctive architectural styles for homes influenced and inspired by Spanish, Italianate, and French Country architecture as depicted in Section 4.6 “Architectural Design.” Private streets within the Project provide access to residential dwellings. All residential dwellings are planned as street fronting units.

#### **1.5.2 Open Space**

The Project includes provision of approximately 1.02 acres of private on-site common area open space distributed throughout the community. On-site common area open space includes a .23 acre recreational area to include a swimming pool, a pool house with restrooms, and barbeque and picnic areas. Five individual pocket parks totaling .79 acres are planned for passive recreational use by residents. Pocket parks will include shady landscaped areas with benches, picnic tables, a putting green, children's

## SECTION 1. INTRODUCTION

play areas, and a trail connecting the community to the existing basin trail adjacent to the Project Site.

Off-site public open space improvements include a .15 acre park adjacent to the Project Site accessible from 15th Street.

### 1.5.3 Pedestrian and Bicycle Connectivity

The Project includes a private two way street system with sidewalks on both sides of the street providing pedestrian connectivity as well as bicycle accessibility throughout the Project. The connection of the Project street and walkway system to 15th Street provides for on-street bicycle and pedestrian connectivity within the community and connectivity to commercial services located at North Campus Avenue and 19th Street, approximately one mile to the north of the Project Site, and to Sierra Vista Park, approximately .5 miles southwest of the Project Site and Upland Memorial Park located approximately .8 miles south of the Project Site. Private pedestrian and bicycle connectivity through the community to open space is provided through the on-site street system and a private pocket park trail extending through the Project connecting to the existing adjacent public basin trail. Public bicycle and pedestrian access to the off-site basin trail is provided within a separate trail extending from 15th Street to the public basin trail.

### 1.5.4 Infrastructure

The Specific Plan proposes new on-site roadways, water mains, sewer mains, and drainage facilities designed to connect to 15th Street and existing public facilities located within 15th Street. As part of the Project, an unimproved portion of 15th Street right of way between Fernando Avenue and the terminus of East 15th Street to the west will be completed providing access to the residential component of the Project. Expansion of existing infrastructure facilities is not necessary to serve the Project. As

part of the Project, site improvements, as described in Section 2, “Development Plan,” will be made to the entire Upland Basin flood control and detention basin to create the Project Site suitable for residential development and to ensure the downstream flows to the basin are not impacted.

## 1.6 Governing Documents

The adoption of the Specific Plan is the first step in a process leading to the development of the Project. The development of the Project is governed by the following documents.

### 1.6.1 General Plan

California Government Code (Title 7, Division 1, Chapter 3, Article 8, Section 65450-65457, permits the adoption and administration of a specific plan as an implementation tool for elements contained in the local general plan. Specific plans must demonstrate consistency in regulations, guidelines, and programs with the goals and policies set forth in the general plan. In September 2015 the City adopted the “City of Upland General Plan” which sets forth the following topics to address the state mandated general plan elements:

- Land Use
- Circulation
- Housing
- Open Space and Conservation
- Safety (which includes the state mandated Noise Element)

In addition to the state mandated elements, the City of Upland General Plan includes the following elements:

- Focus Areas
- Community Character and Urban Design
- Economic Sustainability
- Healthy Community

## SECTION 1. INTRODUCTION

The Villa Serena Specific Plan implements a General Plan Amendment changing the General Plan Land Use Map for the Project Site from Public Flood Control/Recharge (FC/R) to Villa Serena Specific Plan (SP) allowing residential land use development at a density of 7.10 dwelling units per acre. The Specific Plan is consistent with applicable goals, objectives, and policies of the Upland General Plan, as amended, pertaining to the planned development as described in Section 6, “General Plan Consistency.”

### 1.6.2 Specific Plan

The Specific Plan serves as the legal document to implement the General Plan land use designation for the Project Site of Villa Serena Specific Plan (SP) and provides the zoning for development of the Project Site as a residential community at a density of 7.10 dwelling units per acre. The Specific Plan establishes land use and development regulations designed to govern development of the Project. In instances where the Specific Plan is silent, regarding a specific development standard or procedure for implementing the Specific Plan, the Upland Municipal Code Zoning Code Title 17, (Planning and Zoning) shall prevail. The Specific Plan provides a “blueprint” for development of the Project establishing permitted uses, a land use plan, the development requirements, and design criteria for land development as set forth herein.

### 1.6.3 Subdivision Maps

Approval of a tentative and final tract map is required for the development of the Project. The subdivision map for the Project shall be prepared pursuant to the applicable provisions of the State of California Subdivision Map Act (Government Code Section 66410 through 66499), the City of Upland Municipal Code, Title 16, “Subdivisions,” and consistent with the applicable provisions of the Specific Plan.

### 1.6.4 Development Plan Review

Applicable provisions of Upland Municipal Code, Title 17, (Planning and Zoning) Section 17.44.030 (Development Plan Review) shall apply to the review and approval of the site development plans for the proposed Project.

### 1.6.5 Covenants, Conditions, and Restrictions

Covenants, Conditions, and Restrictions (CC&Rs) approved by the City serve to ensure and enforce quality design of the Project over the long term and the continued uniform maintenance of streets, common areas, and street and common area landscaping.

## 1.7 CEQA Compliance

An Environmental Impact Report (EIR) prepared by the City of Upland for the Project in accordance with the California Environmental Quality Act (CEQA) and City requirements considers the potential environmental impacts of all Project related activities and the discretionary and ministerial applications associated with implementation of the Project. The EIR includes mitigation measures and a Mitigation Monitoring and Reporting Program (MMRP) in order to ensure that any potential significant impacts of the Project on the environment be reduced to a less than significant level.

## 1.8 Specific Plan Components

The Specific Plan is organized into the following sections in addition to Section 1, “Introduction.”

### *Section 2 - Development Plan*

This section describes the physical setting for the Project Site outlining the existing physical conditions found within and surrounding the Project Site, the Project land use plan describing residential and open space land use areas of the Project, and the on-site and off site infrastructure and open space improvements as part of the the Project.

## SECTION 1. INTRODUCTION

### ***Section 3 - Development Regulations***

This section establishes the allowable land use within the Project Site and standards and requirements for development of all land uses within the Project Site.

### ***Section 4 - Design Criteria***

The Design Criteria establishes the architectural and landscape design requirements for the Project to ensure that a cohesive community of distinctive design quality, definitive architecture, and comprehensive landscaping is achieved.

### ***Section 5 - Implementation***

The policies and procedures for the administration of the Specific Plan, procedures for the review and approval by the City of specific development proposals within the Project Site, Project financing, and Project maintenance responsibilities within the development are described in this section.

### ***Section 6 - General Plan Consistency***

The relationship of the Specific Plan to the applicable policies of the Upland General Plan is discussed in this Section.

## Section 2. Development Plan

The Specific Plan is a proposal for development of a planned residential community within an existing urban setting on approximately 9.16 gross acres in the City of Upland. The Specific Plan also addresses the proposed development of adjacent off-site open space and circulation improvements planned as part of the Project. This section describes the land use plan and the plan for infrastructure and public services for the community.

### 2.1 Land Use

The proposed development of the Project is depicted on Exhibit 4, “Land Use Plan” and is further described in Table 2.1, “Statistical Summary.” The Project is designed to respond to both on-site and off-site conditions, as well as anticipated market conditions. The Specific Plan ensures that a strong community identity is established for residents and visitors through a cohesive plan for residential and open space areas.

Table 2.1

### Statistical Summary

Land Use	Project Site Acres	Off-Site Development Acres
Residential	5.4	
Landscaped Buffer	.50	
Common Area Open Space	1.02	.15
Private Streets	2.22	
15th Street ROW	.02	
Access Roadway and Project Entry		.63
Total Gross Acres	9.16	.78
Total Dwelling Units: 65		
Residential Density: 7.10 du/acre (65 dus ÷ 9.16 ac = 7.10 du/ac)		

### 2.1.1 Residential Use

Approximately 5.4 acres of the Project Site are planned for development of 65 single family detached residential dwelling units.

#### a. Residential Design.

Residential dwellings shall be designed to front onto private streets with floor plans designed to present an “architecture forward” image so that the residence and not the garage is the predominant view from the street.

Residential design incorporates human-scale details to promote a pedestrian friendly character for the community. Such details include the use of enhanced entries, a mix of materials and textures, and authentic detailing on elements such as windows, porches, doors, and lighting.

#### b. Community Design.

The Specific Plan offers a strong community identity for residents and visitors through a unified approach to site design, architecture, and landscape design elements. The landscaped private street and street adjacent walkways link residences to common area open space encouraging neighborly interaction.

### 2.1.2 Open Space Use

Approximately 1.02 acres of private common area open space is provided as part of the Project to include a .23 acre recreational area with a pool, pool house with restrooms, and separate pocket park areas improved with picnic tables, barbecue facilities, exercise station, children’s play area, a putting green, and five informal pocket parks totaling .79 acres. The pocket parks are located throughout the Project Site, accessible from sidewalks, and will be improved with landscaping, children’s play equipment, exercise equipment and benches. One of the five on-site pocket parks is planned with a private trail providing pedestrian and bicycle connectivity for residents to the basin open space area adjacent to the Project Site on the east.

# SECTION 2. DEVELOPMENT PLAN

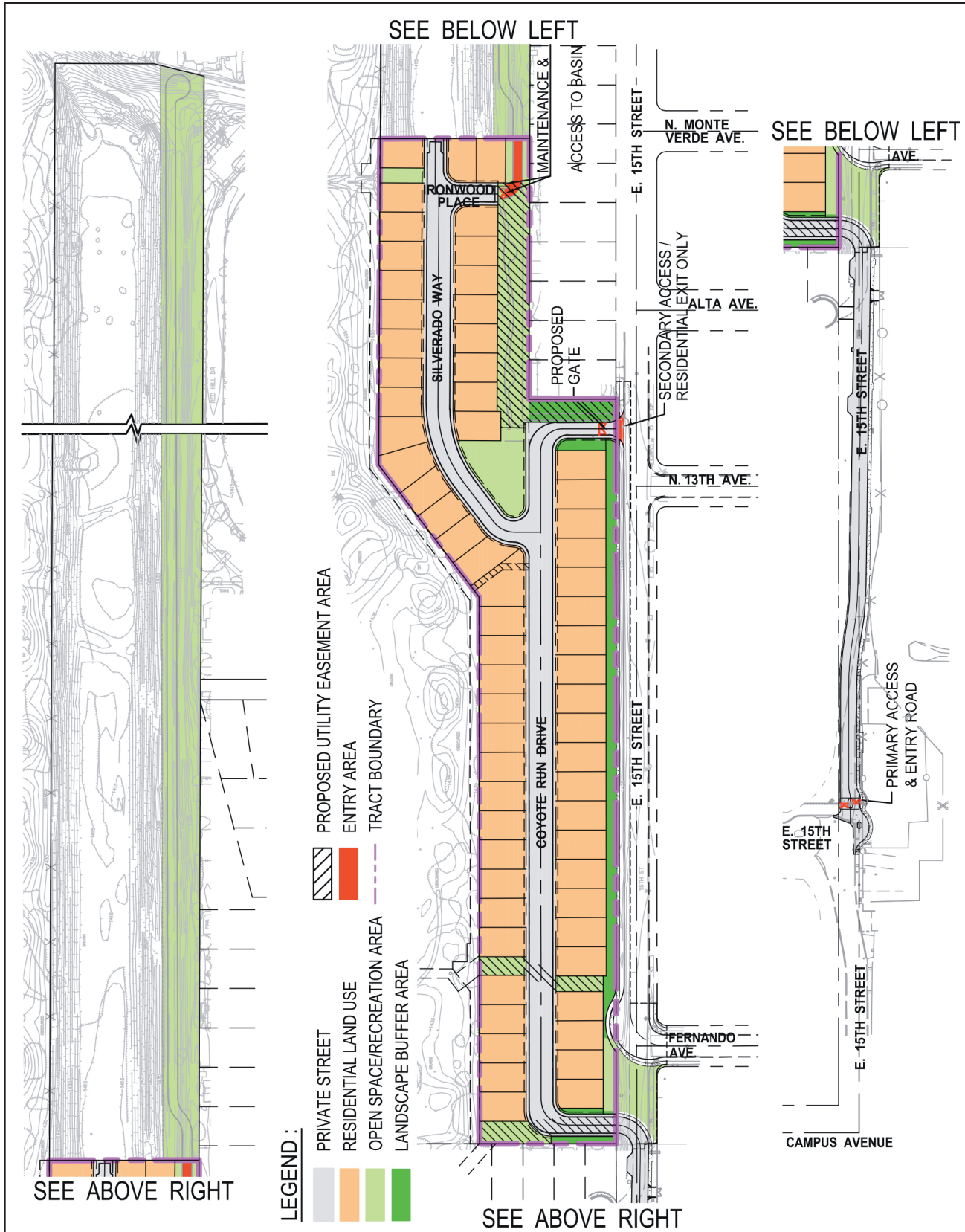

Exhibit 4  
**Land Use Plan**

Source: Madole & Associates, Inc.



## SECTION 2. DEVELOPMENT PLAN

One off-site .15 acre pocket park is planned adjacent to the southern boundary of the Project Site accessible to the public from 15th Street and Fernando Avenue. This park will provide open play areas and bench seating.

### 2.2 Circulation

Access for residents to the Project Site is provided from two locations. A primary gated community entry for the Project is located west of the Project Site boundary as part of a planned off-site extension of approximately .63 acres of an unimproved portion of 15th Street. A second gated access point is provided from 15th Street at the westerly boundary of the Project Site providing exiting only for residents and emergency vehicle entry and exiting. An internal private two way street system provides primary circulation within the Project Site serving residential dwellings and the common area open space. Maintenance crews serving the remaining Upland Basin flood control and detention basin are provided vehicular access to the westerly boundary of the basin through the Project within the internal street system. A service road and gate are located at the easterly boundary of the Project Site for maintenance vehicles to access the basin. The Project provides for pedestrian and bicycle access to the existing trail located within the basin. All streets are planned as private roadways.

The circulation system serving the Specific Plan is illustrated on Exhibit 5, "Master Plan of Circulation."

#### 2.2.1 15th Street

Ultimate right of way improvements for 15th Street adjacent to the Project Site include 40 feet of paved travel area with a 5 foot wide sidewalk and an 8 foot wide landscaped parkway on each side of 15th Street for a total right of way of 66 feet. As part of the Project the developer will construct an additional 8 feet of travel

area, a new 5 foot sidewalk and an 8 foot wide landscaped parkway within the existing right of way adjacent to the Project Site. Primary vehicular access to and from the Project Site will be provided from an extension of 15th Street from the Project Site westerly to the terminus of East 15th Street. Improvements to this segment of 15th Street will include 26 feet of paved travel area with a retaining wall and curb on the north side of the street and a 5 foot 5 inch street adjacent sidewalk and wedge curb on the south side. The existing right of way for 15th Street and proposed project improvements for 15th Street are illustrated on Exhibits 6 and 7, "Street Cross Sections."

#### 2.2.2 Project Streets

On-site Project circulation is provided by means of a private two way street with a paved travel area varying in width from 26 to 38 feet with adjacent wedge curbs. On-street parking is permitted in designated segments of the street. A 5 foot wide street adjacent sidewalk is provided on both sides of the street where homes front both sides of the street. In instances where the sides of homes are also adjacent to the street a 5 foot wide adjacent sidewalk is provided on the same side of the street. Where the centrally located common area open space fronts the street on one side and residential units front the street on the opposite side a sidewalk is provided on both sides of the street. Emergency vehicle access is provided at both project entries along 15th Street. The street improvements for the Project are illustrated on Exhibits 6 and 7, "Street Cross Sections."

# SECTION 2. DEVELOPMENT PLAN

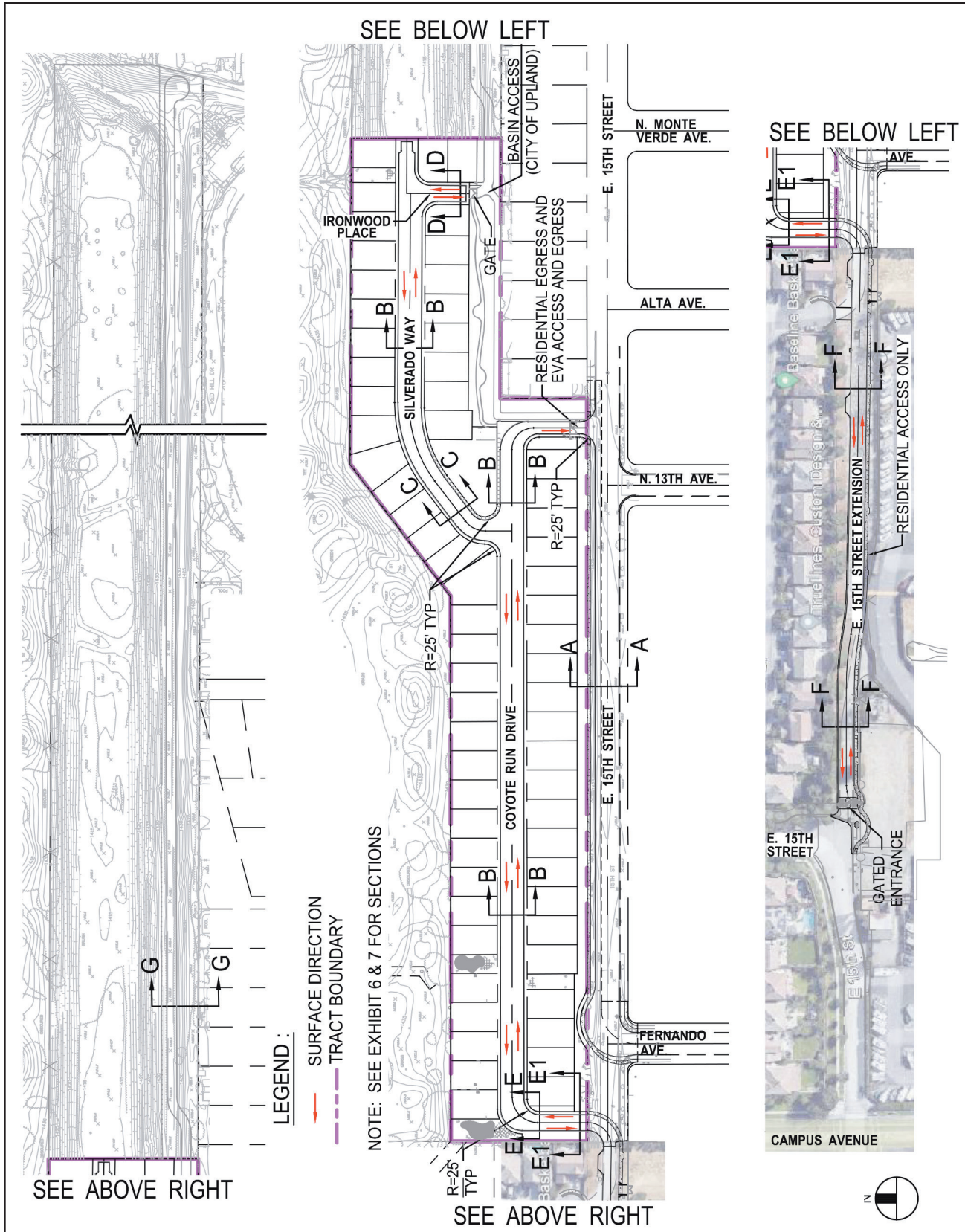

Exhibit 5  
**Master Plan of Circulation**

Source: Madole & Associates, Inc.

## SECTION 2. DEVELOPMENT PLAN

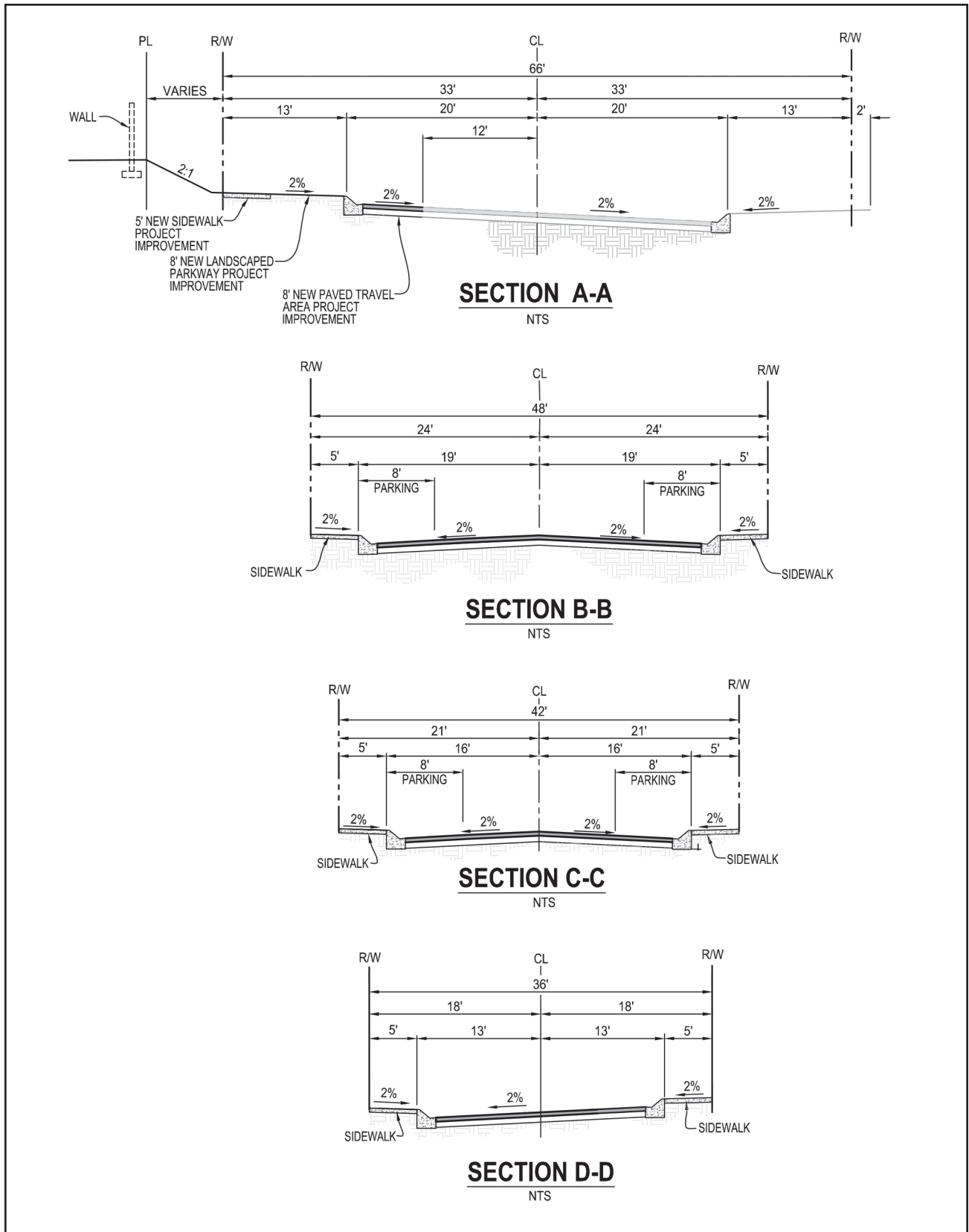
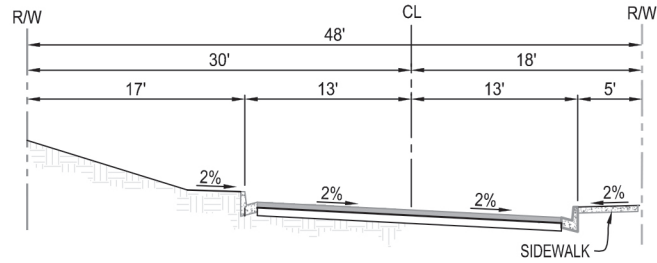

Exhibit 6  
**Street Cross Sections**

Source: Madole & Associates, Inc.

# SECTION 2. DEVELOPMENT PLAN



**SECTION E-E**  
NTS

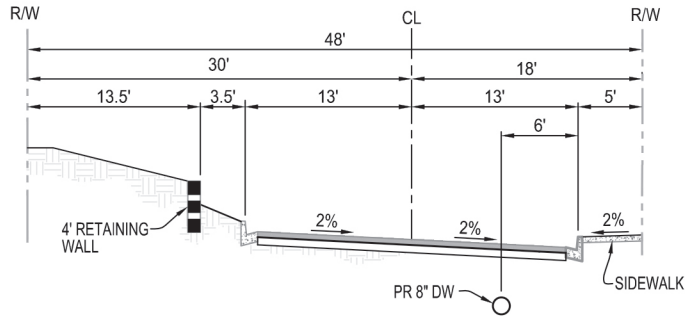

**SECTION E1-E1**  
NTS

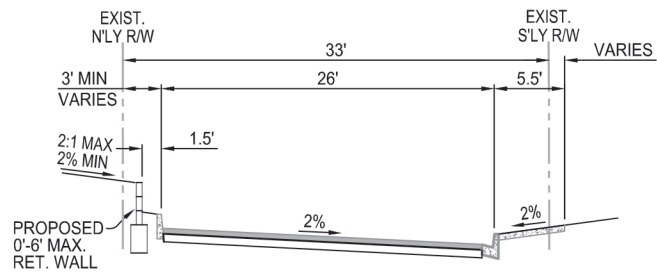

**SECTION 'F-F'**  
NTS

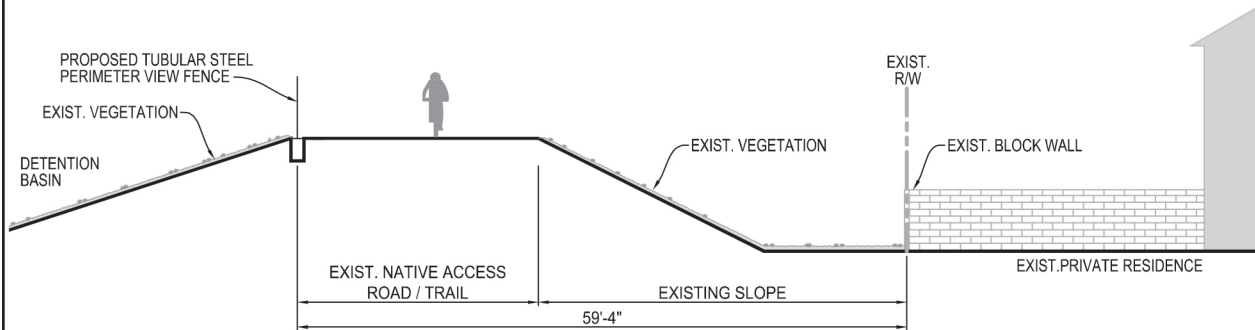

**SECTION 'G-G'**  
NTS

Exhibit 7  
**Street Cross Sections**

Source: Madole & Associates, Inc.

### 2.2.3 Pedestrian and Bicycle Mobility

The Project street system includes provision of street adjacent sidewalks for pedestrian mobility within the community. The Project street system allows for on street bicycle mobility. The Project street and sidewalk system connects to 15th Street where bicyclists and pedestrians can continue on existing City streets and sidewalks to Sierra Vista Park located to the south of the Project Site and Upland Memorial Park located to the southwest of the Project Site, and to general retail commercial services located at North Campus Avenue and 19th Street, approximately one mile north of the Project Site. Connectivity is provided to the adjacent Upland Basin open space via a planned on-site private pedestrian trail and a separate public pedestrian and bicycle trail extending from Project streets and 15th Street connecting to an existing off-site public trail within the basin. The Project pedestrian and bicycle mobility plan is illustrated in Exhibit 8, “Pedestrian and Bicycle Mobility.”

## 2.3 Infrastructure and Public Services

### 2.3.1 Water

The City of Upland Water Department provides water service to the City of Upland. Water service to the Project Site is provided via an existing 10 inch diameter water main located in 15th Street. The development of the Project includes construction of a network of 8 inch diameter on-site water mains adequate to provide for the domestic and fire protection water requirements of the Project. Exhibit 9, “Water Master Plan” illustrates the proposed water system to serve the Project.

### 2.3.2 Sanitary Sewer

Sewer service to the Project Site is provided by the City of Upland. Existing off-site sewer facilities available to serve the Project Site include an existing 8 inch diameter sewer main located in 15th Street adjacent to the Project Site. Development of the Project Site includes construction of an on-site network of new 8 inch sewer mains and the relocation of one existing 8 inch off-site sewer main connecting to the on-site system. Exhibit 10, “Sewer Master Plan,” illustrates the planned sewer system to serve the Project.

# SECTION 2. DEVELOPMENT PLAN

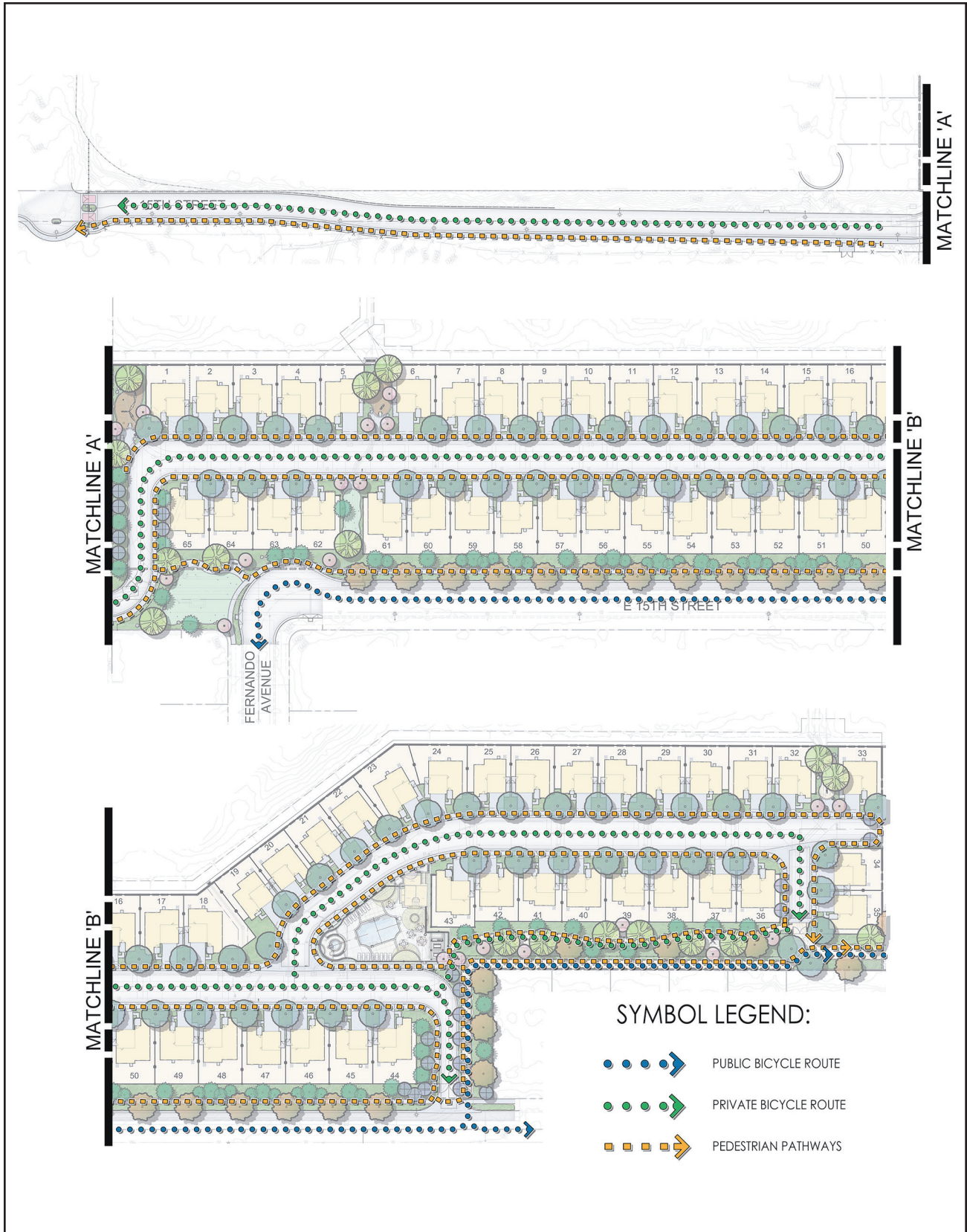

Exhibit 8  
**Pedestrian and Bicycle Mobility**

Source: Architerra Design Group

## SECTION 2. DEVELOPMENT PLAN

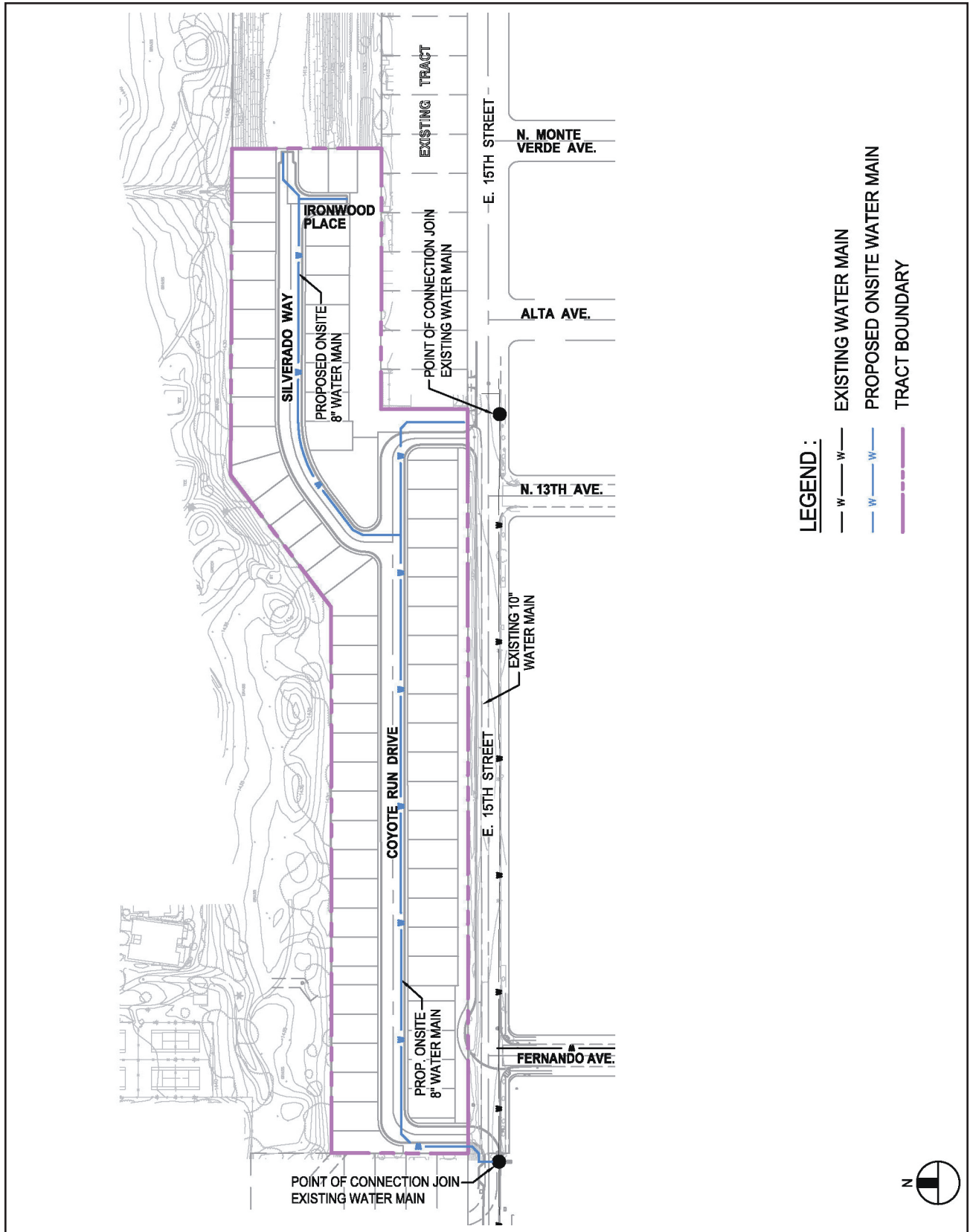

Exhibit 9  
**Water Master Plan**

Source: Madole & Associates, Inc.

# SECTION 2. DEVELOPMENT PLAN

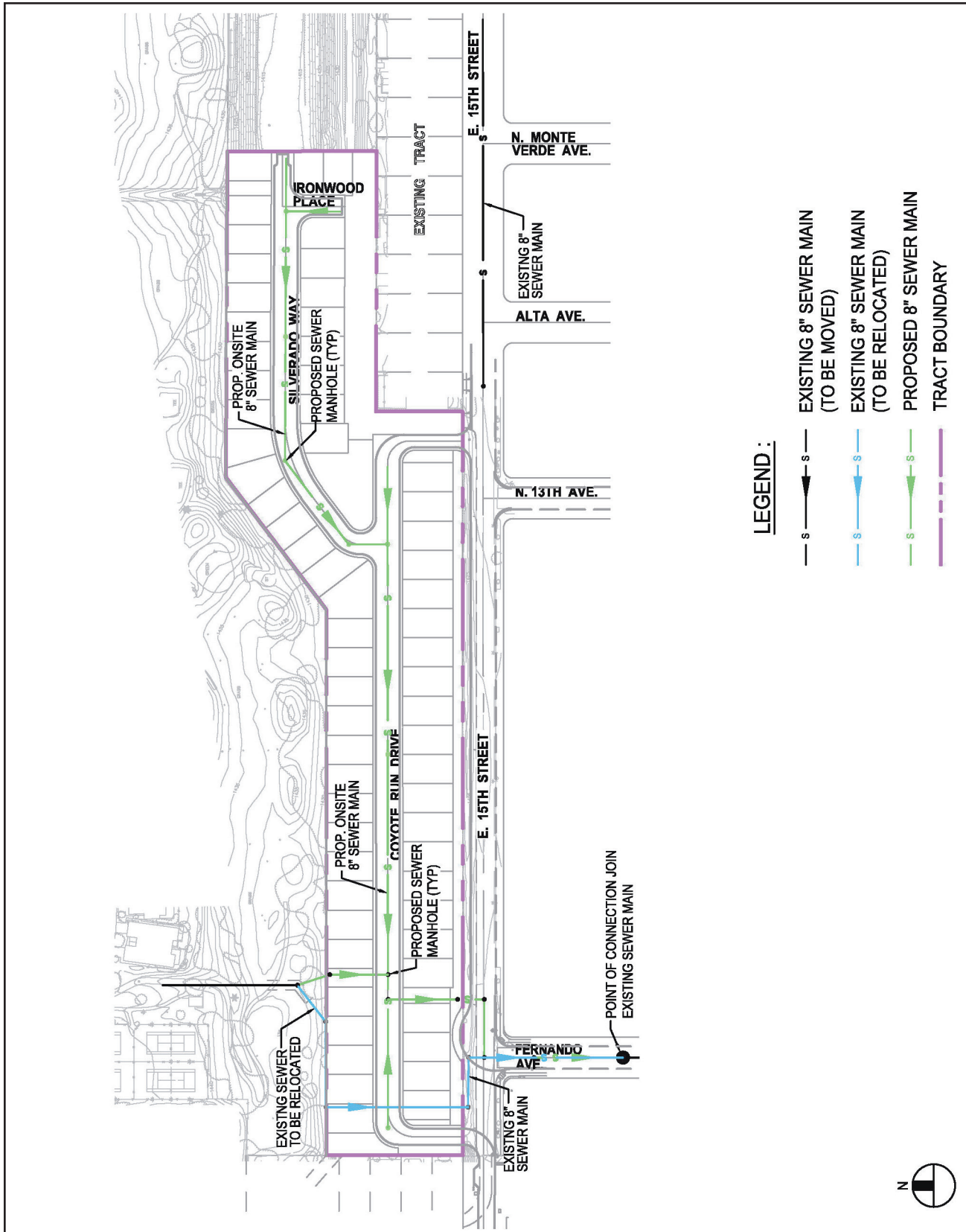

Exhibit 10  
**Sewer Master Plan**

Source: Madole & Associates, Inc.



### 2.3.3 Storm Drain and Water Quality Management

The existing drainage pattern for the Project Site generally drains from east to west as part of a regional detention basin consisting of an essentially flat bottom, with 3:1 side slopes.

#### 2.3.3.1 Drainage

The proposed drainage plan for the Project will drain the single family lots and streets into a storm drain collection system on site, which includes street flow. Runoff will then be passed through an underground infiltration basin and outlet into a new 12-foot by 8-foot reinforced concrete box culvert which outlets into the detention basin. Modifications to the existing flood control and detention basin as part of the Project are discussed in Section 2.5, "Basin Modifications and Site Preparation."

#### 2.3.3.2 Water Quality

The Project provides for storm water retention and infiltration on the Project Site to mitigate an 85th percentile storm. This is accomplished by passing the on-site runoff through a continuous deflection separator (CDS) unit for pre-treatment and then an underground infiltration basin to infiltrate runoff from the majority of the site. The underground infiltration basin is proposed to be 23' x 123' and will have dual 72" perforated pipes encased in gravel. In addition, two bioretention treatment systems designed to treat storm water are proposed, one located at each project entry, to treat on-site areas that are not tributary to the underground basin. The biotreatment systems proposed for use within the Project Site are trademarked as "Modular Wetland Systems." Detailed information on these systems can be found on the company website at *biocleanenvironmental.com*.

Exhibit 11, "Storm Drain Master Plan," illustrates the proposed storm drain and water quality management system to serve the Project Site.

### 2.4 Public Utilities

#### 2.4.1 Telephone and Cable

Verizon will provide telephone service to the Project Site. Proposed on-site facilities will be placed underground.

#### 2.4.2 Natural Gas

The Southern California Gas Company (Gas Company) will provide natural gas to the Project Site. Gas mains will be installed to the Project Site by the Gas Company as necessary.

#### 2.4.3 Electricity

Southern California Edison will provide electricity to the Project Site from existing facilities in the vicinity of the Project Site. Proposed new facilities to serve the Project will be owned and operated by Southern California Edison and located underground.

#### 2.4.4 Solid Waste

The City of Upland contracts with Burrtec Waste Industries (BWI), a private refuse hauler, to provide solid waste collection services for the City. Refuse service will be provided by BWI for the Project.

#### 2.4.5 Schools

School facilities will be provided by the Upland Unified School District. The Project will be required to pay school fees in accordance with Government Code Section 65995 of the State of California.

# SECTION 2. DEVELOPMENT PLAN

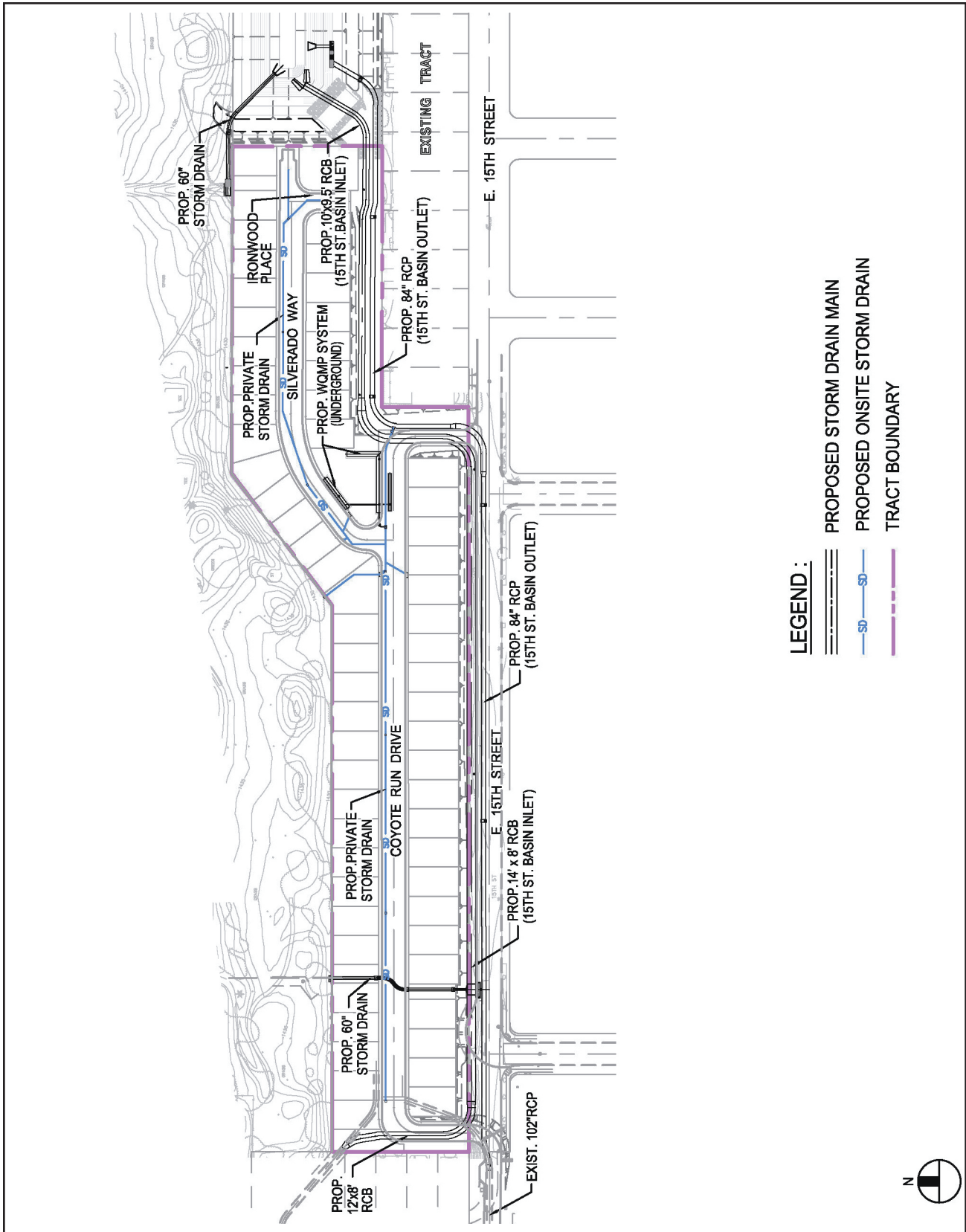

Exhibit 11  
**Storm Drain Master Plan**

Source: Madole & Associates, Inc.

### 2.5 Basin Modifications and Project Grading

The existing Project Site comprises 9.16 acres of an existing approximately 20 acre flood control and detention basin. The existing ground slopes are predominantly flat grades with less than 0.5% slope at the bottom of the basin, then generally sloping from east to west with 3:1 slopes that make up the basin sides.

As part of the Project, modifications will be made to the existing basin to create the 9.16-acre Project Site. The conceptual plan for the basin modifications is illustrated in Exhibit 12, "Conceptual Basin Modification Plan" and is described below.

In 2017, the consulting firm of Madole and Associates, Inc. prepared a Drainage Study in the City of Upland for the 15th Street Basin. The intent of this study was to "determine if the current basin has excess capacity, which could lead to the reduction in area of the basin and allow for "surplus" property for development." Based on the analysis, the study determined that a surplus parcel of 9.16 acres, located on the westerly end of the existing basin could be created, and that the remaining basin area of approximately 11 acres would be sufficient for flood control operations without demonstrably impacting downstream facilities. The limits of the proposed Project Site are based on the recommendations in the Madole Report which includes requirements for relocation of existing basin infrastructure, reconfiguration of the basin itself by filling in the 9.16-acre development portion, reconfiguration of the remaining approximately 11 acres making the bottom of the basin deeper, and modification of the inlet/outlet structures. The recommended improvements to be made are described below.

a. Extension of the basin inlet, located in the northwest corner of the existing basin, to the new eastern edge of the Project Site. New

storm drain improvements will consist of a combination of 12'x8' and 10'x9.5' RCBs. The improvements will extend approximately 1900 LF from west to east along the southern edge of the Project Site and outlet through a new headwall in the modified basin. The modified inlet will also pick up two existing smaller inlets tributary to the basin within the proposed Project Site as described below.

- An existing local inlet pipe located approximately 300' east of the Project Site's easterly boundary is anticipated to be a 36" RCP routed through the Project Site to the new inlet RCB.
- An existing concrete trapezoidal channel located approximately 60' west of the eastern edge of the Project Site will be picked up in an approximately 48" diameter pipe and routed through the Project Site into the new inlet RCB.

b. Extension of approximately 1,800 linear feet of the basin outlet from the western edge of the Project Site to the eastern edge of the Project Site. This extension is proposed to be a 102" RCP to account for the design outlet as well as the spillway flows and includes a new outlet structure in the basin. The proposed pipe will extend from the southeast corner of the Project Site westerly to the proposed Project main entry, then south into 15th Street and west along 15th Street connecting to the existing outlet pipe. Easements will be granted to the City of Upland for all basin infrastructure proposed to be located within the Project Site.



## SECTION 2. DEVELOPMENT PLAN

County of San Bernardino policies require detention basins to have spillways designed to handle the fully developed 1,000-year storm peak flow rate defined as 135% of the 100-year storm or the peak flow rate required by the State's Division of Safety of Dams, whichever is greater. Spillways must be properly connected to a storm drain, drainage channel, street, or established watercourse.

As part of the basin modifications proposed as part of the Project three spillway structures are proposed which collectively will enable the passage of a 1,000-year storm event.

- A reinforced concrete inlet box, connecting to a proposed 84-inch outlet storm drain.
- A proposed reinforced concrete broad-crested weir to be located at the southwest corner of the detention basin with a bottom width of 60-feet, designed to outlet into a proposed graded drainage channel running east to west along the southern edge of the Villa Serena project and onto 15th Street.
- A proposed reinforced concrete broad-crested weir to be located along the southern edge of the detention basin immediately north of the terminus of Grove Street with a bottom width of 40-feet, which outlets onto Grove Street.

The combined capacity of these three spillway structures in the detention basin proposed as part of the Project will meet the county's criteria to allow the passage of the 1,000-year storm event.

A portion of the remaining approximately 11 acres proposed for the modified basin will be graded to create a new basin footprint filling the western edge of the basin located at the easterly boundary of the Project Site and creating a new berm between the basin and Project Site. From the top of the berm, a new slope will be graded to the bottom of the basin proposed to be at an approximate elevation of 1,410 feet.

Modifications to the bottom of the existing basin will be made from the toe of the new slope to a point approximately 900 linear feet to the east, by grading the bottom of the basin in this area to an elevation of approximately 1,410 feet from an existing elevation of 1,414 to 1,415 feet. The excess cut material generated can be utilized as fill for the proposed new berm located at the westerly edge of the new basin as well as for fill within the proposed Project Site. The remainder of the existing basin will be untouched by the Project. Total earthwork for the Project is estimated to be approximately 46,000 cubic yards of cut, and 87,000 cubic yards of fill, resulting in import of roughly 41,000 cubic yards.

The grading operation for the Project Site itself will generally consist of demolition, clearing, grubbing, and moving of surface soils to construct streets, building pads, and driveways. Grading within the Project Site will attempt to balance cut/fills for the site.

Grading plans for the Project will be reviewed and approved by the City of Upland Land Development and Transportation Division of the Public Works Department prior to the issuance of grading permits. All grading plans and activities will conform to the City grading ordinance and dust and erosion control requirements. The conceptual grading plan for the Project Site is illustrated in Exhibit 13, "Conceptual Grading Plan" and in Exhibit 14, "Conceptual Grading Plan Cross Sections."

### 2.6 Fire Safety

The Project will incorporate measures for fire safety to include construction of emergency vehicle access entries from 15th Street, new fire hydrants, and designation of restricted red curb areas as part of Project implementation. The plan for the provision of fire protection improvements is illustrated in Exhibit 15, "Fire Safety Plan."

# SECTION 2. DEVELOPMENT PLAN

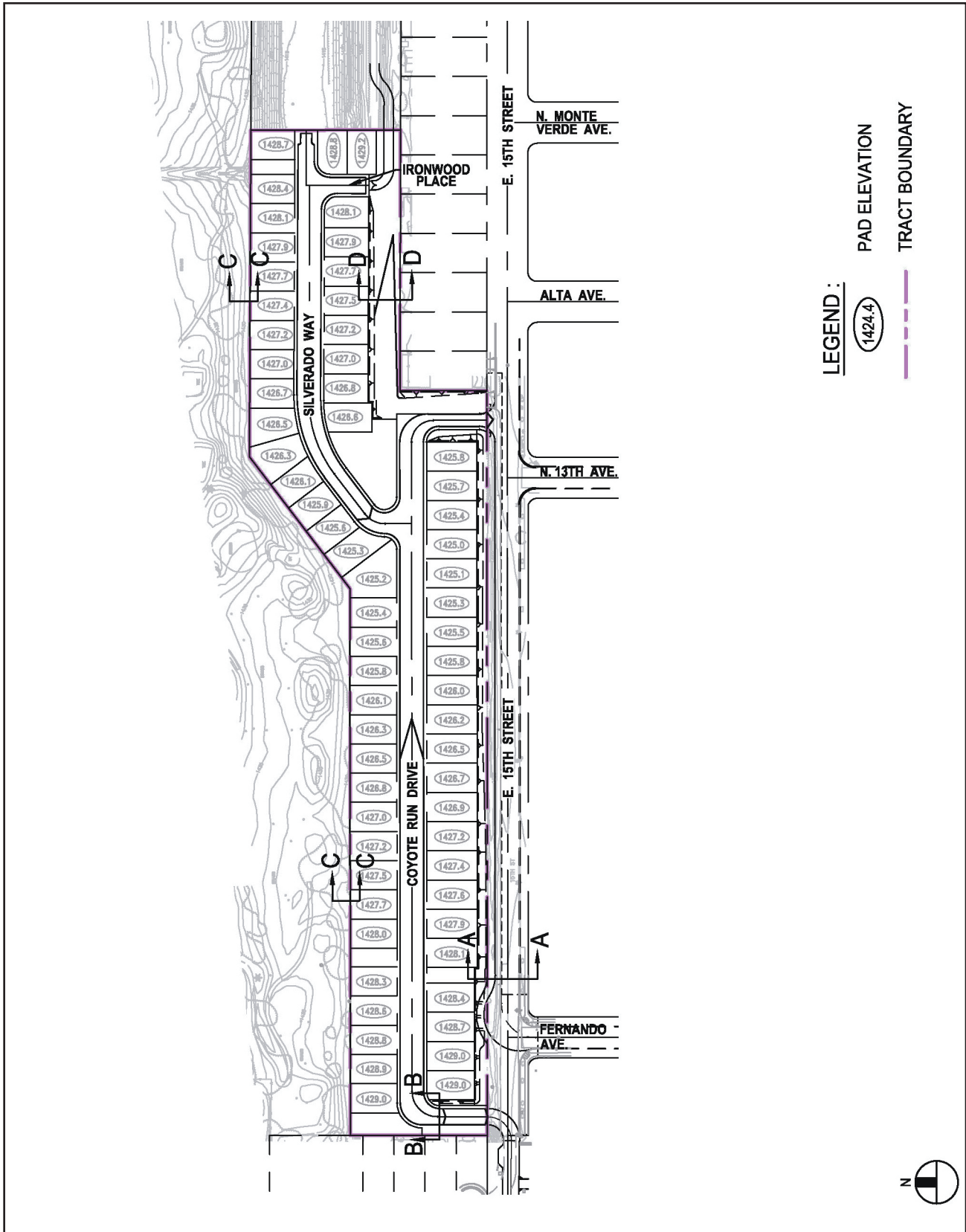

Exhibit 13  
**Conceptual Grading Plan**

Source: Madole & Associates, Inc.

## SECTION 2. DEVELOPMENT PLAN

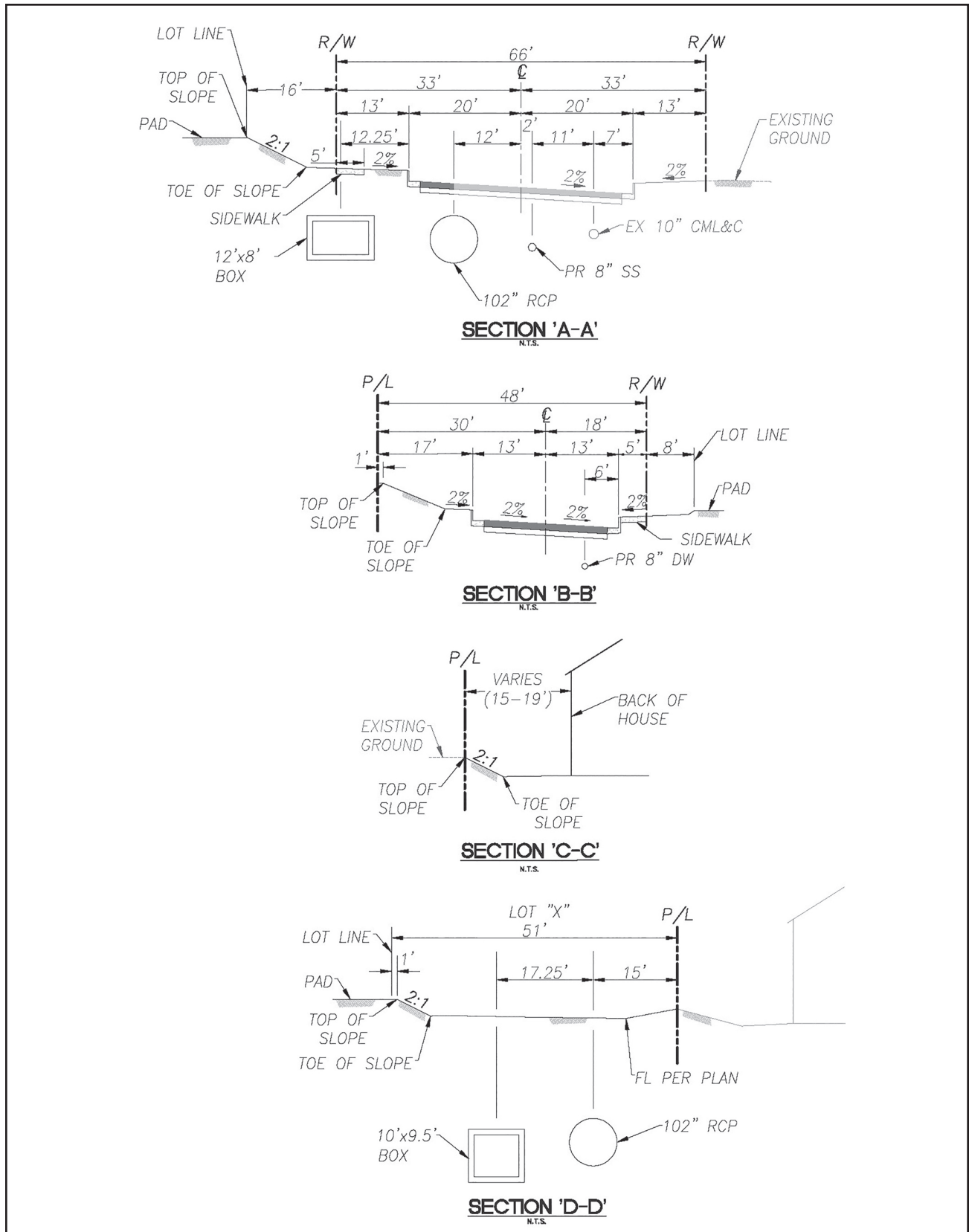

Exhibit 14

Source: Madole & Associates, Inc.

### Conceptual Grading Plan Cross Sections

# SECTION 2. DEVELOPMENT PLAN

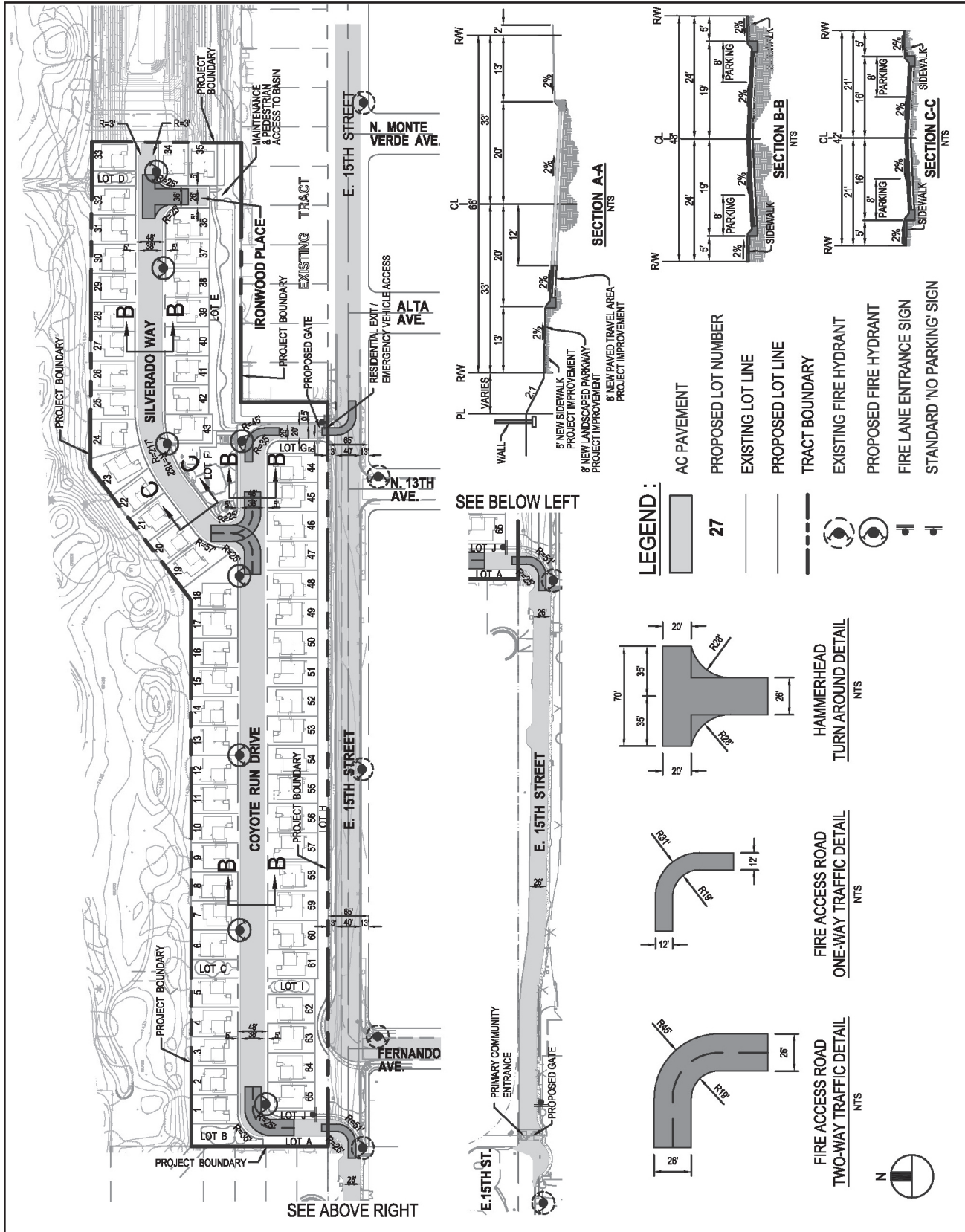

Exhibit 15  
**Fire Safety Plan**

Source: Madole & Associates, Inc.



## SECTION 3. DEVELOPMENT REGULATIONS

### Section 3. Development Regulations

#### 3.1 Introduction

The provisions contained herein shall regulate design and development within the Project Site. These regulations establish the minimum standards and requirements for development of residential uses, common area open space, landscaping, fences, walls, signage and lighting within the Project Site.

#### 3.2 Definition of Terms

The meaning and construction of words, phrases, titles, and terms shall be the same as provided in Upland Municipal Code Title 17, “Planning and Zoning,” (Zoning Code) Chapter 7 (Definitions) unless otherwise specifically provided for herein.

#### 3.3 Applicability

The Specific Plan serves to implement the City’s General Plan and establishes the zoning regulations for the Project Site. These Development Regulations address general requirements, permitted uses, and development standards for all development within the Project Site. Application of these Development Regulations is intended to encourage the most appropriate use of the land, ensure the highest quality of development, and protect the public health, safety, and general welfare. Whenever the provisions and development standards contained herein conflict with those contained in the Zoning Code, the provisions of the Specific Plan shall take precedence. Where the Specific Plan is silent, the Zoning Code shall apply. These Development Regulations shall reinforce specific site, architectural, and landscape design criteria contained in Section 4, “Design Criteria” of the Specific Plan. All architectural and landscape improvements shall comply with Section 4, “Design Criteria” of the Specific Plan.

#### 3.4 General Site Development Standards

The following general site development standards shall apply to all development within the Project Site.

- a. Maximum Number of Dwelling Units – A maximum of 65 residential dwelling units is permitted for development within the Project Site.
- b. Common Area Open Space – A minimum of 42,000 square feet of private common area open space shall be provided within the Project Site for recreational use by Project residents. An additional .15 acres off-site shall be improved as part of the Project for public open space.
- c. Grading – Development within the Project Site shall utilize grading techniques as approved by the City of Upland. Grading concepts shall respond to the design criteria included in the Specific Plan.
- d. Building Modification – Residential building additions and/or alterations permitted by the Specific Plan shall match the architectural style of the primary dwelling unit and shall be constructed of the same materials, details, and colors as the primary dwelling unit.
- e. Utilities – All new and existing public utility distribution lines of 34.5 kV or less shall be subsurface throughout the project.

#### 3.5 Green and Sustainable Development Standards

The following green and sustainable development standards shall apply to development within the Project Site.

- a. Technology – All homes shall be equipped with modern telecommunications technology for computer internet access, phone, fax, and television. Fiber optics cable shall be installed

## SECTION 3. DEVELOPMENT REGULATIONS

to all the properties if available from the utility provider.

- b. Energy Efficiency - All homes shall be constructed to meet or exceed the California Building Code Title 24 energy standard. Energy efficient design techniques include, but are not limited to, the following:
- Increased insulation to minimize heat transfer and thermal bridging.
  - Roof orientations and design to accommodate homeowner installation of rooftop solar electric equipment.
  - Heating and cooling distribution systems that limit air leakage throughout the structure to minimize energy consumption.
  - Installation of ENERGY STAR or better rated windows, space heating and cooling equipment, light fixtures, appliances, and other applicable electrical equipment.
  - Installation of efficient lighting and lighting control systems and a building design which utilizes daylight as an integral part of the lighting system.
  - Installation of “cool roofs” and cool pavements.
  - Installation of solar light-emitting diodes (LEDs) for outdoor lighting or low level lighting.
- c. Builder-installed indoor appliances, including dishwashers, showers, and toilets, shall be low-water use in compliance with the adopted California Building Code.
- d. Solid Waste/Recycling - Development within the Project shall comply with City of Upland requirements for the provision and placement of solid waste and recycling receptacles. The homeowners association for the Specific Plan shall provide educational information on recycling to all homeowners as part of the initial

purchase of homes and again thereafter on an annual basis.

- e. During Project construction the developer shall use clean-burning diesel fuel, biodiesel fuel, and/or other alternative fuels for heavy construction equipment to reduce construction emissions. During Project construction, the developer shall use locally produced and/or manufactured building materials (materials that are obtained from sources using the least amount of transport) for at least 10 percent of the construction materials used, shall recycle or reuse at least 50 percent of the demolished and/or grubbed construction materials, and use “Green Building Materials,” such as those that are resource efficient and are recycled and manufactured for at least 10 percent of the Project.
- f. Drought-tolerant and/or native landscaping materials shall be used in all public and common areas to reduce water consumption.
- g. Smart Controller irrigation systems shall be installed in all public and common area landscaping.
- h. Landscape areas shall be designed on a “hydro zone” basis to group plants according to their water and sun requirements.

### 3.6 Permitted Uses and Structures

The following uses and structures are permitted “by right” within the Specific Plan subject to approval by the City of Development Plan Review pursuant to Zoning Code Section 17.44.030 (Development Plan Review). Any proposed use not specifically listed is not permitted unless the Development Services Director finds that the proposed use is equivalent to a listed permitted use and is permitted pursuant to the procedures established in Zoning Code Section 17.02.020 (Authority) “Unlisted Land Uses.” Short term rental units (STRs) and Accessory Dwelling Units (ADUs) are prohibited uses within the Specific Plan.

## SECTION 3. DEVELOPMENT REGULATIONS

- a. Residential single family detached dwelling units and garages.
- b. Residential attached and detached patios and patio covers.
- c. Public or private parks, recreational buildings, greenbelts, and/or common area open space.
- d. Small family child care/day care facilities (up to 8 children).
- e. Large family child care/day care facilities (up to 14 children).
- f. Accessory uses and structures to include the following and which conform to the provisions of Zoning Code Section 17.19 (Accessory Uses and Structures).
  1. Swimming pools, spas, sports courts, and other similar outdoor recreational amenities.
  2. Storage structures, garden structures, cabanas, and greenhouses.
- g. Home occupations pursuant to regulations established for Home Occupations per Upland Municipal Code Section 17.27, "Home Occupations."
- h. Cottage Food Operations per Upland Municipal Code Chapter 17.25 "Cottage Foods Operations."
- i. Model home and subdivision sales trailers, temporary construction parking, offices and facilities, real estate signs, signage indicating future development and directional signage pursuant to approval by the City of Development Plan Review per Upland Municipal Code Section 17. 44.030 (Development Plan Review).

### 3.7 Residential Development Standards

Residential development areas are subject to the development standards contained in Table 3.1 "Residential Development Standards."

## SECTION 3. DEVELOPMENT REGULATIONS

Table 3.1

### Residential Development Standards

<b>SFD RESIDENTIAL USE</b>	
<b>Lot Criteria</b>	
Min. Lot Width	47'
Min. Lot Depth	71'
Min. Lot Area (sq. ft.)	3,337
<b>MINIMUM SETBACKS <sup>(1) (2)</sup></b>	
<b>Front Setback</b>	
Living Area	10'
Street Facing Garage	19'
<b>Side Setback</b>	
From Interior PL	5'
From Street	5'
Patio Covers	5'
<b>Rear Setback</b>	
Main Structure	15'
Patio Covers	5'
<b>Lot Coverage</b>	
Max. Coverage	60%
<b>Maximum Building Height <sup>(3)</sup></b>	
Main Structure	2 Stories - Max. 35'
Patio Covers	15'
<b>Walls, Fences and Hedges</b>	
Maximum Height at Interior or Rear Property Line <sup>(4)</sup>	6'
Maximum Height of Project Perimeter Walls	6'
Maximum Height of Retaining Walls at Project Boundary	4'
Maximum Height of Retaining Walls Between Lots and within Project Boundary	4'
<b>Parking</b>	
Min. Number of Parking Spaces Required <sup>(5)</sup>	2 per unit within a garage plus 2 open spaces per unit

**Footnotes:**

(1) Architectural projections and cantilevers may project a maximum of 2 feet into required front and side setback areas and 3 feet into required rear setback areas measured from the foundation to the roof plate; however, in no case shall such projection be closer than 3 feet to any property line. An architectural projection is defined as an element that articulates the building elevation such as eaves, window and door pop-out surrounds, media niches, bay windows, pot shelves, chimneys, enhanced window sills, shutter details, window trim, balconies and entry gates, and other similar elements.

(2) All setbacks measured from PL unless noted otherwise.

(3) Architectural projections to include chimneys and antennas may exceed the maximum building height by an additional 5 feet.

(4) Refer to Section 3.10.2 (Fence and Wall Standards).

(5) All enclosed parking spaces within a garage shall be a minimum clear dimension of 20' x 20' for two spaces and 10' x 20' for single spaces. All open parking spaces shall be a minimum dimension of 9' x 19'. All parallel spaces shall be a minimum dimension of 8'x22'.

## SECTION 3. DEVELOPMENT REGULATIONS

### 3.8 Temporary Uses

Temporary uses shall be permitted pursuant to Zoning Code Chapter 17.41, “Temporary Use Permits and Film Permits.”

### 3.9 Open Space Development Standards

- a. A central private common area open space area shall be improved with recreational facilities to serve all age groups of residents of the Project. The following minimum improvements shall be constructed within the central common area open space area:
  1. Swimming pool.
  2. Pool house to include restrooms/changing rooms and drinking fountains.
  3. Park furniture including benches and trellises.
  4. Trash receptacles.
  5. Barbecue area(s) provided with picnic tables and barbeque grills.
  6. Children’s play area.
- b. Private on-site pocket parks and an off-site public pocket park shall be constructed to include, at a minimum, open play areas, tot lots, park furniture, and trash receptacles per the criteria for each lot established in Section 4, Design Criteria.
- c. Open space improvements shall be approved by the City as part of Development Plan Review.

### 3.10 Landscaping, Fencing, and Walls

All landscape and irrigation plans for streetscapes and common area open space including graphic designs with regard to the identity of the Specific Plan, neighborhood identity, or entry monuments shall conform to the regulations as set forth herein and shall be subject to review and approval by the City at the time of Development

Plan Review. The form and content of landscape plans for streets, common area open space, and other common areas shall conform to the requirements of the City’s Development Plan Review application requirements.

#### 3.10.1 Landscape and Irrigation Standards

- a. All landscaping within the Project shall comply with the provisions of Section 4, “Design Criteria” of this Specific Plan utilizing plant materials specified on the “Suggested Plant List” established for the Specific Plan.
- b. Landscape streetscape improvements for streets within the Project shall conform to the landscape treatment described for these streets within Section 4 “Design Criteria” of this Specific Plan.
- c. The design and improvement of all common area landscaping, including landscape and irrigation plans, shall be reviewed and approved by the City at the time of Development Plan Review and shall conform with the requirements of Section 4 “Design Criteria” of this Specific Plan.
- d. Installation of landscaping and automatic irrigation within the front yards of all residential areas shall be provided by the home builder and maintained in a healthy condition at all times. At a minimum, the builder shall install groundcover and appropriate shrubs and trees in the front yards of homes within residential areas. A minimum of one 24 inch box shade tree shall be installed within each residential front yard. A variety of landscape designs shall be provided by the homebuilder to the homeowner. All landscape plans shall be reviewed and approved by the City at the time of Development Plan Review.
- e. No more than 50% of a front or side yard of a residential lot shall be dedicated to driveways, hardscape and walkways.

## SECTION 3. DEVELOPMENT REGULATIONS

- f. All manufactured and cut/fill slopes exceeding three (3) feet in height shall be planted with an effective mixture of ground cover, shrubs, and trees installed by the developer. Such slopes shall also be irrigated as necessary to comply with any requirements established by the City.
- g. Boundary landscaping shall be required adjacent to the Project Site along the perimeter of 15th Street. Landscaping shall generally be placed along the perimeter property line adjacent to 15th Street in accordance with the landscape design illustrated in Section 4, "Design Criteria," of the Specific Plan.
- h. Landscaping and automatic irrigation systems within the public rights-of-way and private common areas of the Project shall be installed by the developer.

### 3.10.2 Fence and Wall Standards

- a. Freestanding, decorative perimeter walls and view open fencing shall be provided within and at the perimeter of the Project Site as specified in the "Wall and Fence Master Plan" pursuant to Section 4, "Design Criteria," of the Specific Plan. Such walls and fences shall be constructed concurrently with the construction of improvements required for development of the Project.
- b. Perimeter walls and fencing shall be constructed consistent with the "Wall and Fence Details" pursuant to Section 4, "Design Criteria," of the Specific Plan. Perimeter walls shall not exceed six feet in height from highest finished grade. Retaining walls on the 15th Street perimeter shall not exceed four feet in height. If required for sound attenuation, perimeter walls may exceed six feet in height from highest finished grade, subject to the recommendations of an acoustical study as approved by the Director of Development Services.

- c. Individual residential side and rear yard walls and fencing shall not exceed six feet in height from highest adjacent finished grade. Interior retaining walls in public view shall not exceed four feet in height from highest adjacent finished grade. Side and rear walls may exceed six feet in height from adjacent finished grade if required by the City for sound attenuation pursuant to the recommendations of an Acoustical Report and as approved by the Director of Development Services. All side and rear yard fences and walls shall be constructed consistent with the "Wall and Fence Details" pursuant to Section 4, "Design Criteria," of the Specific Plan.
- d. All perimeter wall and fence materials throughout the Project shall be of uniform manufacture with colors specified for the overall design theme as provided for in Section 4 "Design Criteria," of this Specific Plan.

### 3.11 Signage

A Master Sign Program shall be submitted by the developer of the Project and approved by the City subject to approval of Development Plan Review pursuant to Zoning Code Section 17.44.030 (Development Plan Review). The Master Sign Program shall address residential project entries, residential neighborhood identification signs, and way finding signs within the project. No project signs shall be permitted in the public right-of-way.

#### 3.11.1 Master Sign Program Contents

The sign program shall address, at a minimum, the following:

- a. Permitted signs.
- b. Prohibited signs.
- c. The hierarchy of signage.
- d. Definition of types of signs.

## SECTION 3. DEVELOPMENT REGULATIONS

- e. Locations and dimensions for monument signs and public facilities signs.
- f. Locations and dimensions of directional signage.
- g. Provisions for size, location, and duration of display of temporary signs.
- h. Permitted sign types, styles, construction materials, colors, and lettering styles.
- i. Requirements for a sign permit application.
- j. Procedures for obtaining approval of a sign permit.
- k. Procedures for amending the sign program.

### 3.12 Lighting

#### 3.12.1 General Requirements

Project Site lighting shall be installed in accordance with the following standards.

- a. No light glare incidental to any use shall be visible beyond any boundary line of the Project Site.
- b. Residential fixtures shall be uniform and unobtrusive. Shielded fixtures are required to prevent up lighting and to shield lighting source from adjacent residential areas.

#### 3.12.2 Public Street Lights

Public streetlights installed along 15th Street as part of the Project shall be LED. Design of fixtures shall be approved by the City as part of Development Plan Review.

#### 3.12.3 Private Street Lighting Fixtures

- a. Private street lighting shall conform to the City's requirements for street lighting.
- b. Private street lighting fixtures shall be on sensors for automatic nighttime lighting. Style and specifications for all street lights shall be approved by the City as part of Development Plan Review.

- c. Street lighting within the Project Site shall comply with City specifications.
- d. Private street lights shall include shielding devices for "dark sky" purposes and shall direct or reflect light downward.

#### 3.12.4 Common Area Open Space Lighting

- a. Lighting within common area open space shall be approved by the City as part of the City's Development Plan Review of these facilities.
- b. Bollard lighting is recommended along walkways within the common area open space.
- c. Light fixtures shall include shielding devices for "dark sky" purposes and shall direct or reflect light downward.





### Section 4. Design Criteria

#### 4.1 Purpose and Intent

The Specific Plan Design Criteria establish architectural and landscape design principles and requirements for the Project. These design criteria provide the foundation for the design and construction of an aesthetically unified residential development while also responding to existing surrounding land use.

Design Guideline Objectives:

- To provide the City of Upland with the necessary assurances that the Project will be developed in accordance with the quality and character proposed in this Specific Plan;
- To provide design criteria to developers, builders, engineers, architects, landscape architects and other professionals to ensure the desired design quality is achieved; and
- To provide development criteria to guide development of the Project as an attractive and distinctive community that responds to the character and design fabric of the surrounding existing residential community.

#### 4.2 Landscape Design

Careful consideration has been given to the design of the community landscape for the Project Site. The following design criteria are organized to help define the basic landscape design principles for the Project. Conformance with these criteria will help to assure a vision and integrity of design for the Project resulting in a distinctive community image and sense of place for residents. All landscape plans, streetscape plans, and graphic designs with regard to community identity, neighborhood identity, or entry monumentation shall conform to the criteria set forth herein.

The intent of the landscape design criteria for the Project is to control the appearance of the development with respect to scale, proportion, height, materials and colors while still encouraging variety and innovation. The landscape concept for the Project is illustrated on Exhibit 16, “Conceptual Landscape Plan.”

##### 4.2.1 Landscape Elements

Landscape design encompasses “hardscape” elements such as entry monuments, signage, walls, fences, gates, paving, recreation and picnic equipment, as well as “softscape” elements such as trees, shrubs, vines and ground cover. All landscape elements should be compatible with the scale of the adjacent architecture and the surrounding space. Water conservation and long term maintenance should be kept in mind when selecting specific plant material. Hydrozoning (grouping plants with similar water requirements) is encouraged. Table 4.1, “Suggested Plant List” provides planting guidelines for both common and private areas. Compliance with the City’s water efficient landscape ordinance is required. The following guidelines address the design of specific landscape elements within the Project.

## SECTION 4. DESIGN CRITERIA

Table 4.1

### Suggested Plant List

<b>Trees</b>			
<b>Botanical Name</b>	<b>Common Name</b>	<b>Native</b>	<b>Water Use</b>
Cercis occidentalis	Western Redbud	Native	Low
Fraxinus o. 'Raywood'	Raywood Ash	Non-Native	Moderate
Pinus Eldarica	Afghan Pine	Non-Native	Low
Platanus racemosal	Califronia Sycamore	Native	Moderate
Quercus Agrifolia	Coast Live Oak	Native	Low
Quercus ilex	Holly Oak	Non-Native	Low
Tabebuia chrysotricha	Yellow Trumpet Tree	Non-Native	Moderate
<b>Vines</b>			
<b>Botanical Name</b>	<b>Common Name</b>	<b>Native</b>	<b>Water Use</b>
Ficus pumila	Creeping Fig	Non-Native	Moderate
Rosa banksaie 'Lutea'	Yellow Ladybanks Rose	Non-Native	Moderate
<b>Shrubs</b>			
<b>Botanical Name</b>	<b>Common Name</b>	<b>Native</b>	<b>Water Use</b>
<b>BACKGROUND</b>			
Carpenteria c. 'Elizabeth'	Elizabeth Bush Anemone	Native	Moderate
Heteromeles arbutifolia	Toyon	Native	Low
Podocarpus macrophyllus	Yew Pine	Non-Native	Moderate
Prunus ilicifolia	Catalina Cherry	Native	Low
Rhamnus c. 'Eve Case'	Eve Case Coffeeberry	Native	Low
Salvia clevelandii	Cleveland Sage	Non-Native	Low
Sambucus nigra	Black Elderberry	Native	Low
Tagetes lemonii	Mexican Marigold	Non-Native	Low
<b>MIDGROUND</b>			
Artemisia 'Powis Castle'	Wormwood	Non-Native	Low
Baccharis x 'Starn'	Starn Coyote Brush	Native	Low
Cistus x p. 'Sunset'	Magenta Rockrose	Non-Native	Low
Epilobium 'Route 66'	California Fuschia	Native	Low
Eriogonum fasciculatum	California Buckwheat	Native	Very Low
Hesperaloe parviflora	Red Yucca	Non-Native	Low
Leymus c. 'Canyon Prince'	Canyon Prince Wild Rye	Native	Low
Mimulus aurantiacus	Sticky Monkey Flower	Native	Very Low
Muhlenbergia capillaris	Pink Muhly	Non-Native	Low
Muhlenbergia dubia	Pine Muhly	Non-Native	Low
Muhlenbergia rigens	Deer Grass	Non-Native	Moderate
Ribes speciosum	Fuschia-Flowering Gooseberry	Native	Moderate
Rosa species	Rose	Non-Native	Moderate
Rosmarinus species	Rosemary	Non-Native	Low
Russelia equisetiformis	Firecracker Plant	Non-Native	Moderate
Salvia species	Sage	Native	Low

Table 4.1

**Suggested Plant List (cont.)**

<b>FOREGROUND</b>			
Achillea millefolium	Common Yarrow	Non-Native	Low
Achillea x 'moonshine'	Moonshine Yarrow	Hybrid	Low
Baccharis p. 'Pigeon Point'	Pigeon Point	Native	Low
Bouteloua g. 'Blonde Ambition'	Blonde Ambition Blue Grama	Native	Low
Carex pansa	Meadow Sedge	Native	Moderate
Carex praegracilis	Ca field Sedge	Native	Moderate
Cistus x p. 'Sunset'	Magenta Rockrose	Non-Native	Low
Dianella species	Flax Lily	Non-Native	Low
Eriogonum f. 'Warriner Lytle'	California Buckwheat	Native	Very Low
Festuca i. 'Siskiyou Blue'	Siskiyou Blue Fescue	Non-Native	Low
Juncus p. 'Elk Blue'	Elk Blue CA Coyote Brush	Native	Low
Lavandula species	Lavender	Non-Native	Low
Rosmarinus o. 'Prostratus'	Creeping rosemary	Non-Native	Low
<b>PARKWAY SHRUBS AND GROUNDCOVER</b>			
Achillea x 'Moonshine'	Moonshine Yarrow	Hybrid	Low
Bouteloua g. 'Blonde Ambition'	Blonde Ambition Blue Grama	Native	Low
Cistus x p. 'Sunset'	Magenta Rockrose	Non-Native	Low
Festuca i. 'Siskiyou blue'	Siskiyou Blue Fescue	Non-Native	Low
Rosmarinus o. 'Prostratus'	Creeping Rosemary	Non-Native	Low
<b>ENTRY SHRUBS AND GROUNDCOVER</b>			
Achillea x 'Moonshine'	Moonshine Yarrow	Hybrid	Low
Cistus x p. 'Sunset'	Magenta Rockrose	Native	Low
Festuca i. 'Siskiyou Blue'	Siskiyou Blue Fescue	Non-Native	Low
Hesperaloe parviflora	Red Yucca	Non-Native	Low
Muhlenbergia rigens	Deer Grass	Non-Native	Moderate
Rhamnus c. 'Eve Case'	Eve Case Coffeeberry	Native	Low
Rosa species	Rose	Non-Native	Moderate
Rosmarinus o. 'Prostratus'	Creeping Rosemary	Non-Native	Low
Salvia species	Sage	Native	Low

# SECTION 4. DESIGN CRITERIA

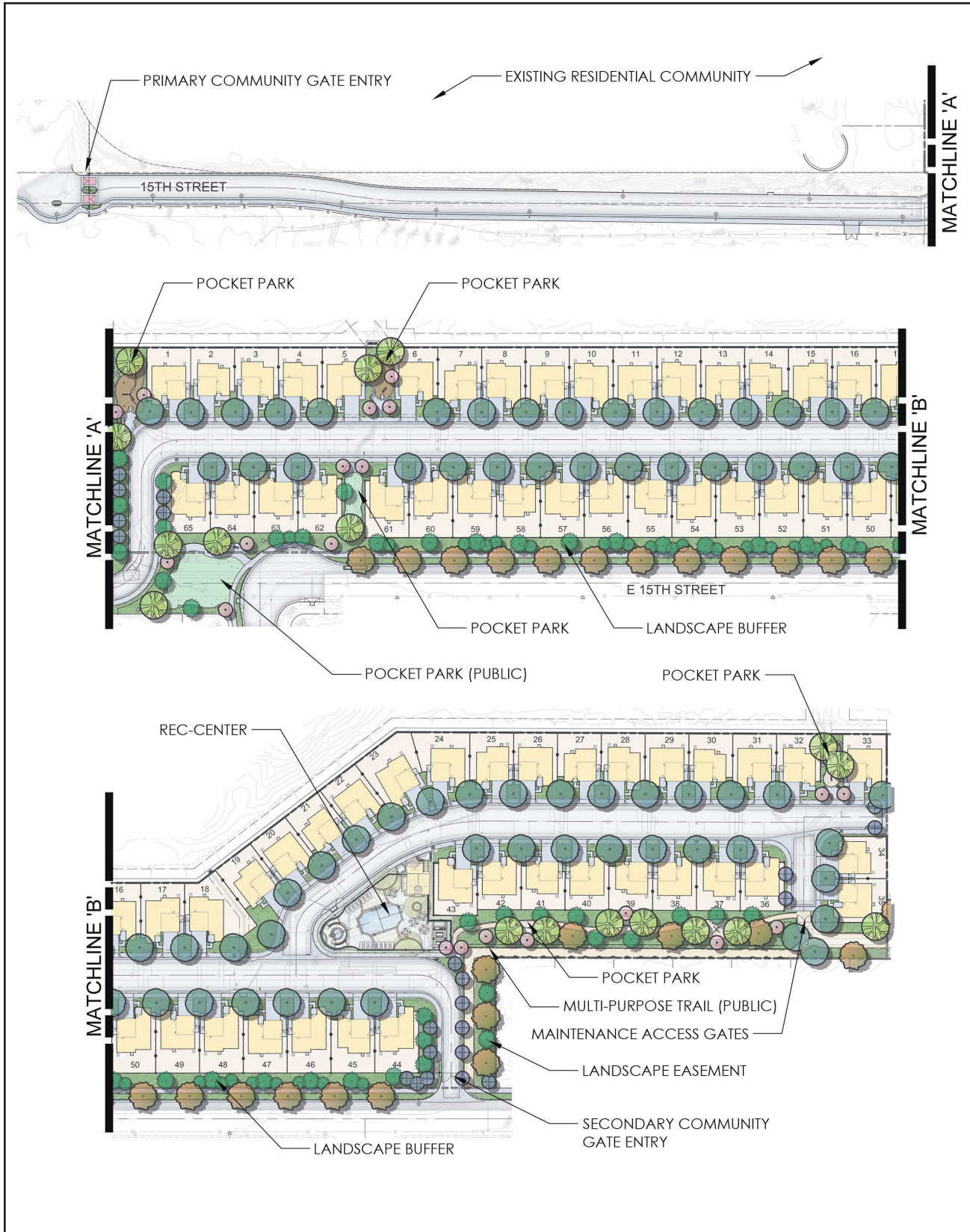

Exhibit 16  
**Conceptual Landscape Plan**

Source: Architerra Design Group

## SECTION 4. DESIGN CRITERIA

### 4.2.2 Community Entries

The Primary Community Entry to the Project Site includes a blend of hardscape and planting elements. Entry lighting shall avoid intensely bright lighting of monuments. Entry monuments should be lit to provide a soft wash of light across the monument signage. Paving at the Primary Community Entry should provide a softened appearance while providing a hard surface for vehicle use. The Primary Community Entry shall include the following:

- Use of accent shrubs on each side of the entry drive and enhanced paving at the entry drive.
- A 6 foot high tubular steel fence and gate and a 6 foot high wall with an area for the Project identification sign, six foot high pilasters on each side of the wall with brick caps.
- A 3 foot wide pedestrian access gate adjacent to the vehicular entry gates with a six foot pilaster on each side.

The Secondary Entry allows for resident exit only from the community and emergency vehicle access to and from the community. The Secondary Entry shall include the following:

- Parkway trees within the 15th Street right of way adjacent to the Project Site.
- A variety of accent trees and shrub masses planted in a series of layers (foreground, mid ground, background at the Project Entry, and along 15th Street adjacent to the Project Site) to help define borders and plant groupings while combining interesting foliage textures and color.
- Accent lighting for landscape and monumentation.
- Varying width landscape buffer areas located where residential side property lines abut the community entry street.
- A 6 foot high tubular steel view fence and gate with 6 foot 8 inch high pilasters on either side of the gate.

The Primary Community Entry is illustrated on Exhibit 17, "Primary Community Entry" and Exhibit 18, "Primary Community Entry Elevation View."

The Secondary Community Entry for the Project at 15th Street is illustrated on Exhibit 19, "Secondary Entry."

### 4.2.3 Streetscapes

Streetscape design within the interior of the Project Site shall be consistent in character and should help to promote pedestrian circulation within the community. Streetscapes are designed to provide a clear delineation between pedestrian and vehicular travel areas. Shrubs, low groundcovers, and "California Friendly" ornamental grasses are used to the greatest extent possible to reduce maintenance and conserve resources. The planting plan for streets includes informal plantings of trees, shrubs, groundcovers, and grasses. Uniformed spacing of trees is avoided in order to create an interesting and inviting pedestrian experience while also offering visual interest to motorists encouraging them to slow driving speeds and observe their surroundings. The following design criteria apply to streetscape design for the Project.

- Landscape treatments of each street shall be consistent throughout the length of the street in the neighborhood.
- Landscape treatments shall generally utilize street trees planted at intervals of 50 feet on center as feasible. Street trees shall be placed a minimum of eight feet from street light standards.
- Street tree planting as described below shall generally utilize one or two primary species for each street with a limited number of additional species to be used as accent planting.

The streetscape plan for Project streets is illustrated on Exhibit 20, "Streetscape Key Map," and Exhibits 21-27, "Streetscape Sections."

## SECTION 4. DESIGN CRITERIA

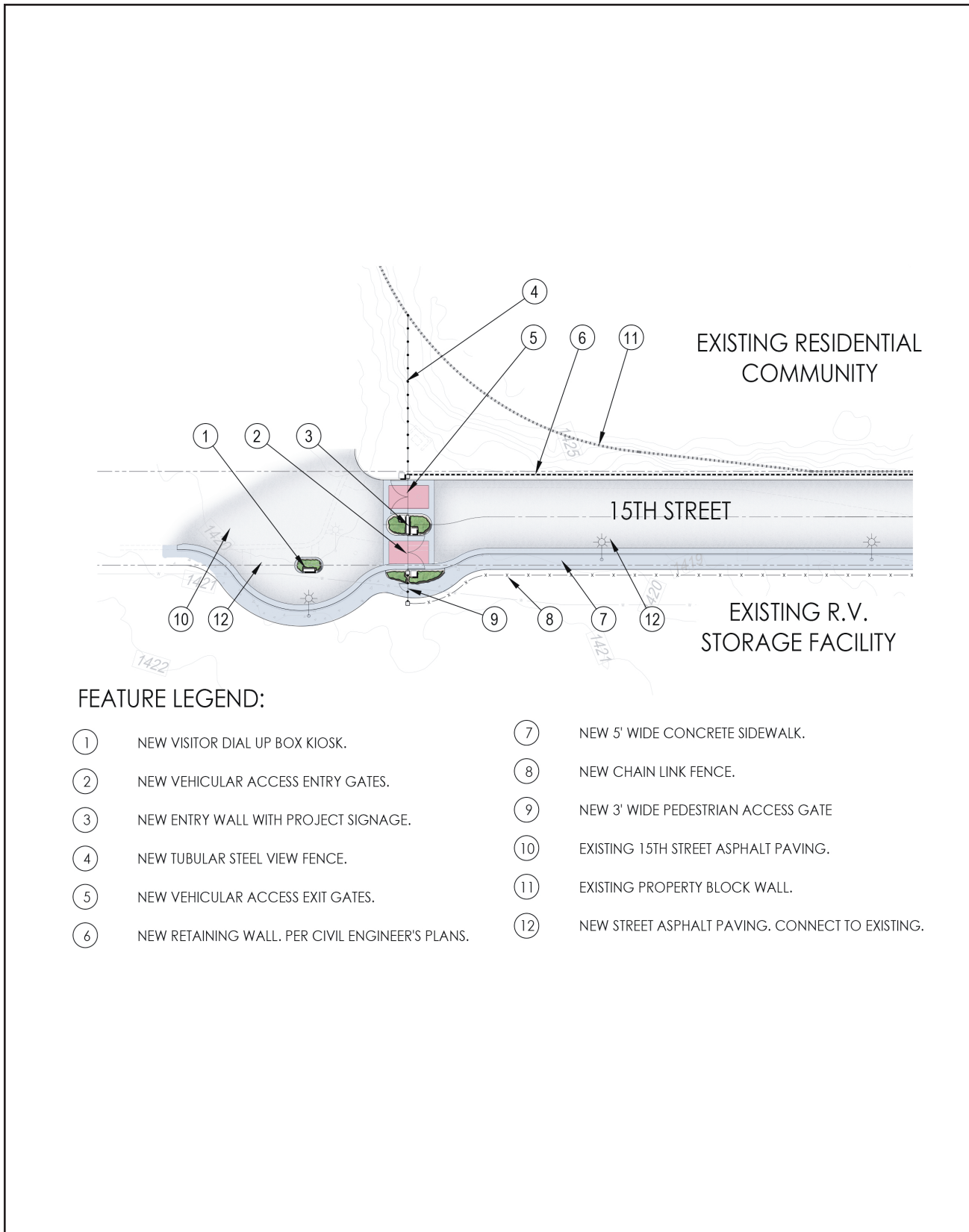

### FEATURE LEGEND:

- |   |   |   |   |
|---|---|---|---|
| ① | NEW VISITOR DIAL UP BOX KIOSK.                  | ⑦ | NEW 5' WIDE CONCRETE SIDEWALK.                  |
| ② | NEW VEHICULAR ACCESS ENTRY GATES.               | ⑧ | NEW CHAIN LINK FENCE.                           |
| ③ | NEW ENTRY WALL WITH PROJECT SIGNAGE.            | ⑨ | NEW 3' WIDE PEDESTRIAN ACCESS GATE              |
| ④ | NEW TUBULAR STEEL VIEW FENCE.                   | ⑩ | EXISTING 15TH STREET ASPHALT PAVING.            |
| ⑤ | NEW VEHICULAR ACCESS EXIT GATES.                | ⑪ | EXISTING PROPERTY BLOCK WALL.                   |
| ⑥ | NEW RETAINING WALL. PER CIVIL ENGINEER'S PLANS. | ⑫ | NEW STREET ASPHALT PAVING. CONNECT TO EXISTING. |

Exhibit 17

### Primary Community Entry

Source: Architerra Design Group

## SECTION 4. DESIGN CRITERIA

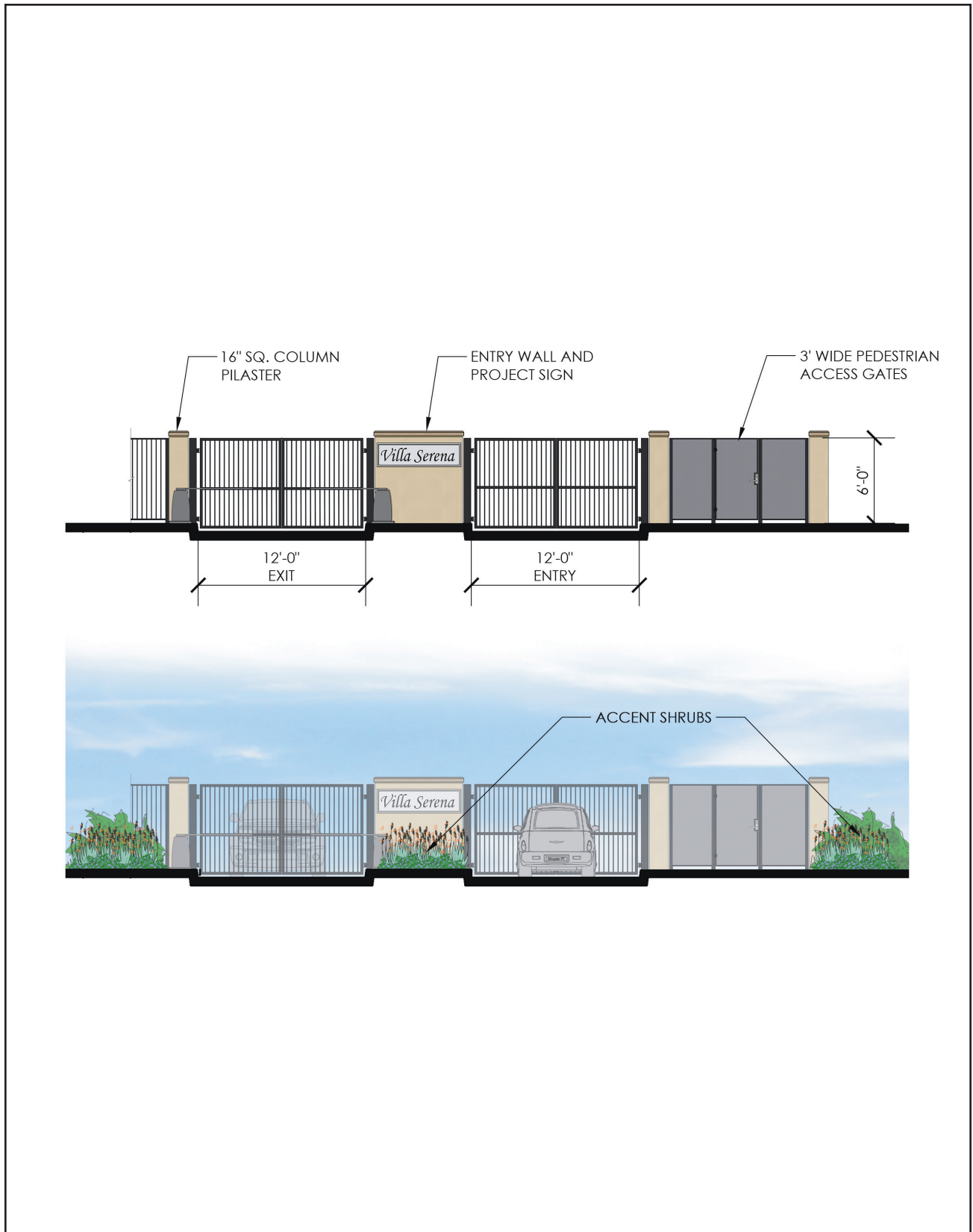

Exhibit 18  
**Primary Community Entry  
Elevation View**

Source: Architerra Design Group

# SECTION 4. DESIGN CRITERIA

## FEATURE LEGEND:

- ① 5' WIDE CONCRETE SIDEWALK.
- ② 6' TALL PROPERTY BLOCK WALL.
- ③ COLUMN PILASTER.
- ④ 3' WIDE PEDESTRIAN ACCESS GATES.
- ⑤ EVA / PRIVATE RESIDENT EXIT ONLY GATES.
- ⑥ 6' TALL TUBULAR STEEL VIEW FENCE.
- ⑦ STABILIZED DECOPOSED GRANITE PUBLIC MULTI-PURPOSE TRAIL.
- ⑧ EXISTING PROPERTY BLOCK WALL.
- ⑨ LANDSCAPE BUFFER

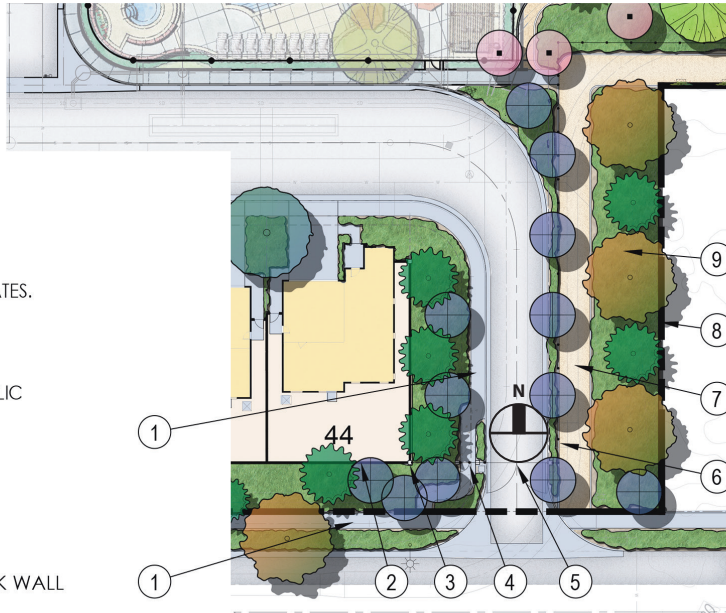

## SECONDARY ENTRY PLAN

N.T.S

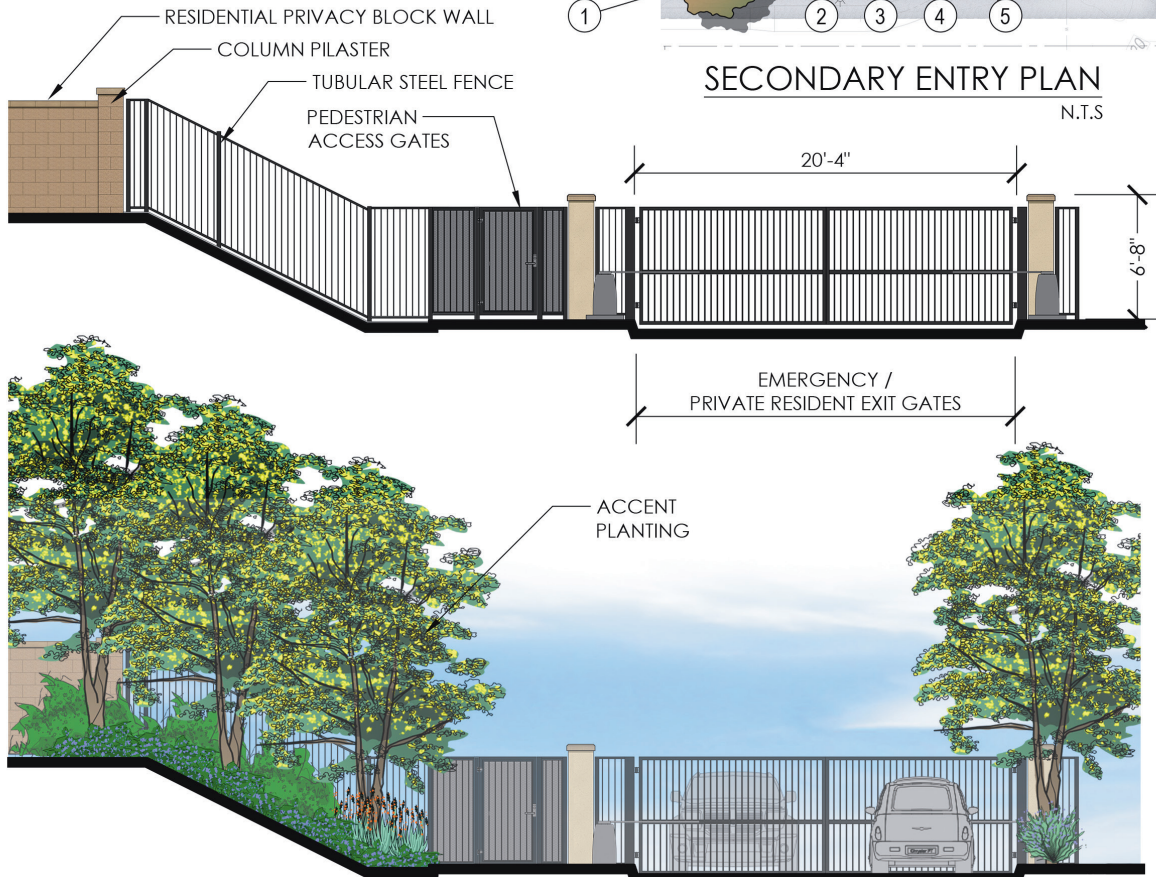

Exhibit 19  
**Secondary Entry**

Source: Architerra Design Group



# SECTION 4. DESIGN CRITERIA



Exhibit 20  
**Streetscape Key Map**

Source: Architerra Design Group

# SECTION 4. DESIGN CRITERIA

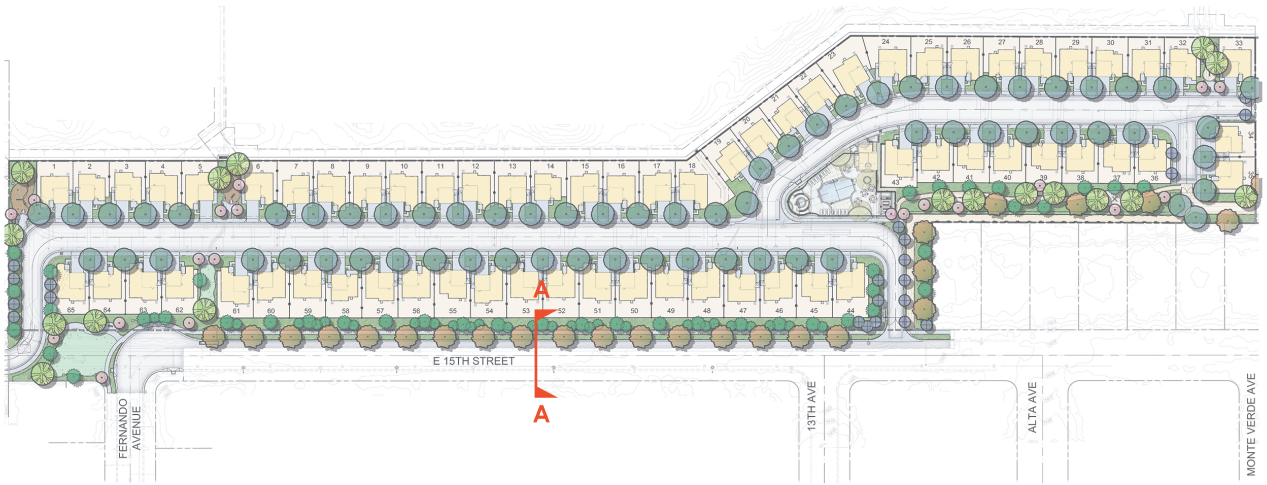
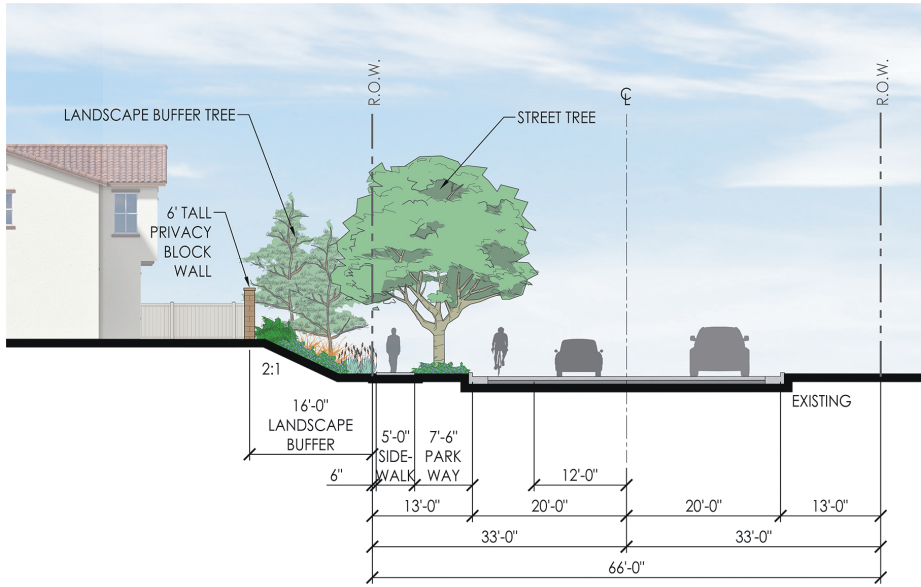

Exhibit 21  
**Streetscape Sections**

Source: Architerra Design Group

# SECTION 4. DESIGN CRITERIA

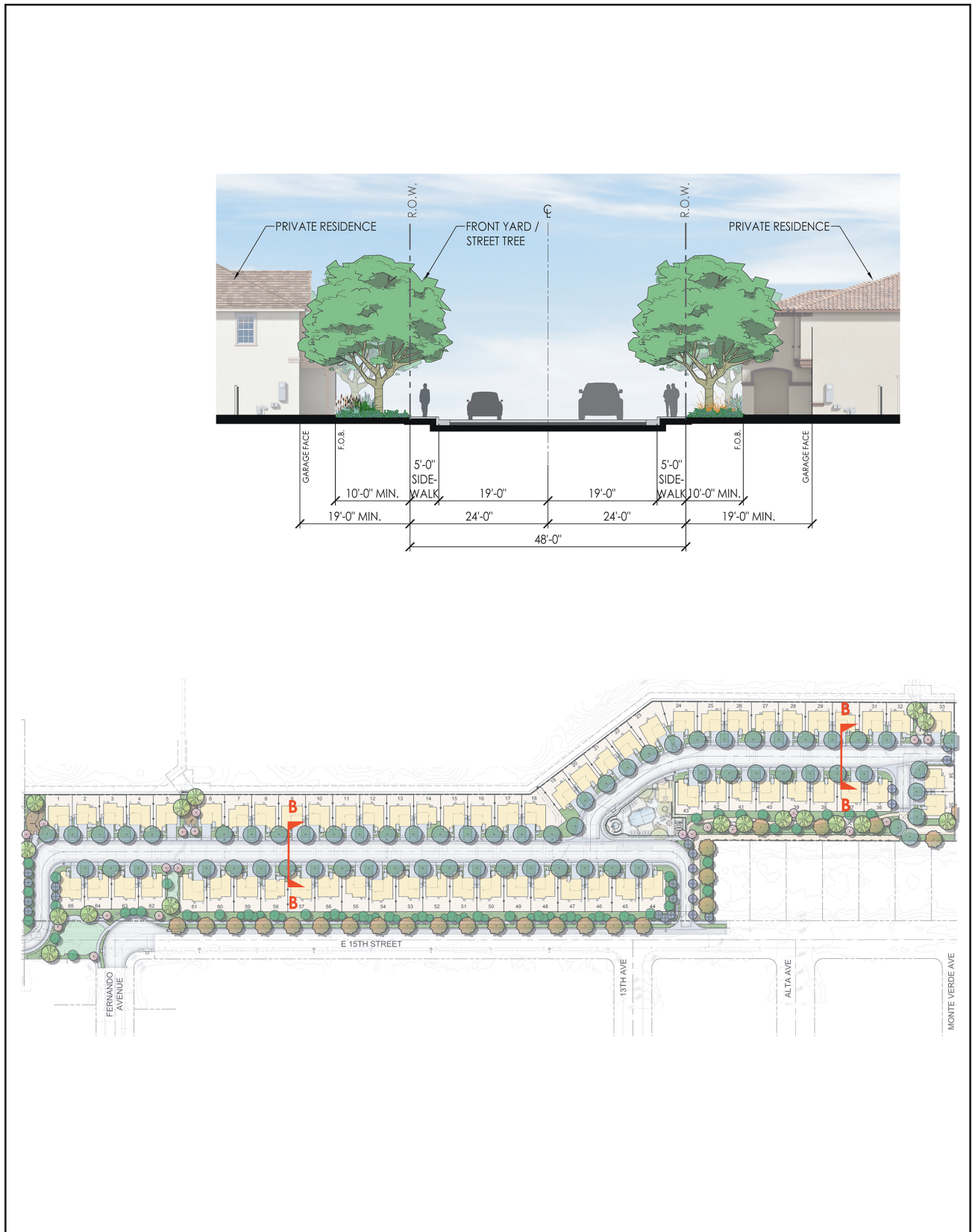

Exhibit 22  
**Streetscape Sections**

Source: Architerra Design Group

# SECTION 4. DESIGN CRITERIA

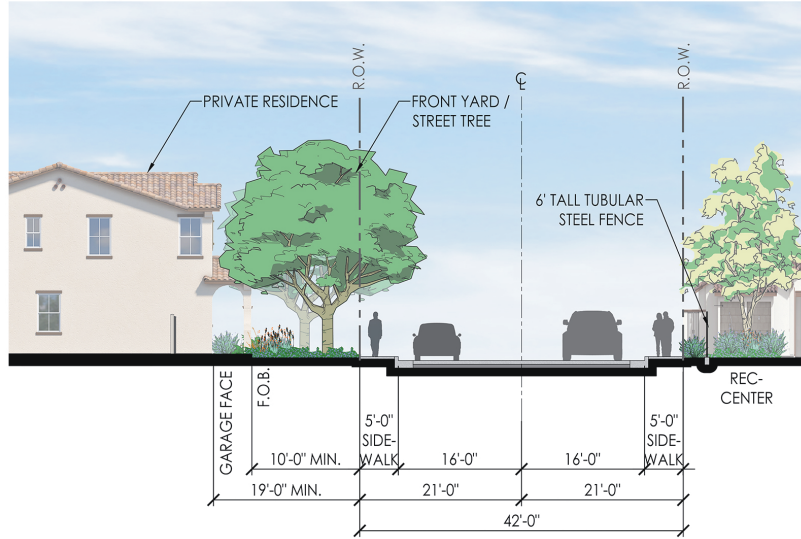

Exhibit 23  
**Streetscape Sections**

Source: Architerra Design Group

# SECTION 4. DESIGN CRITERIA

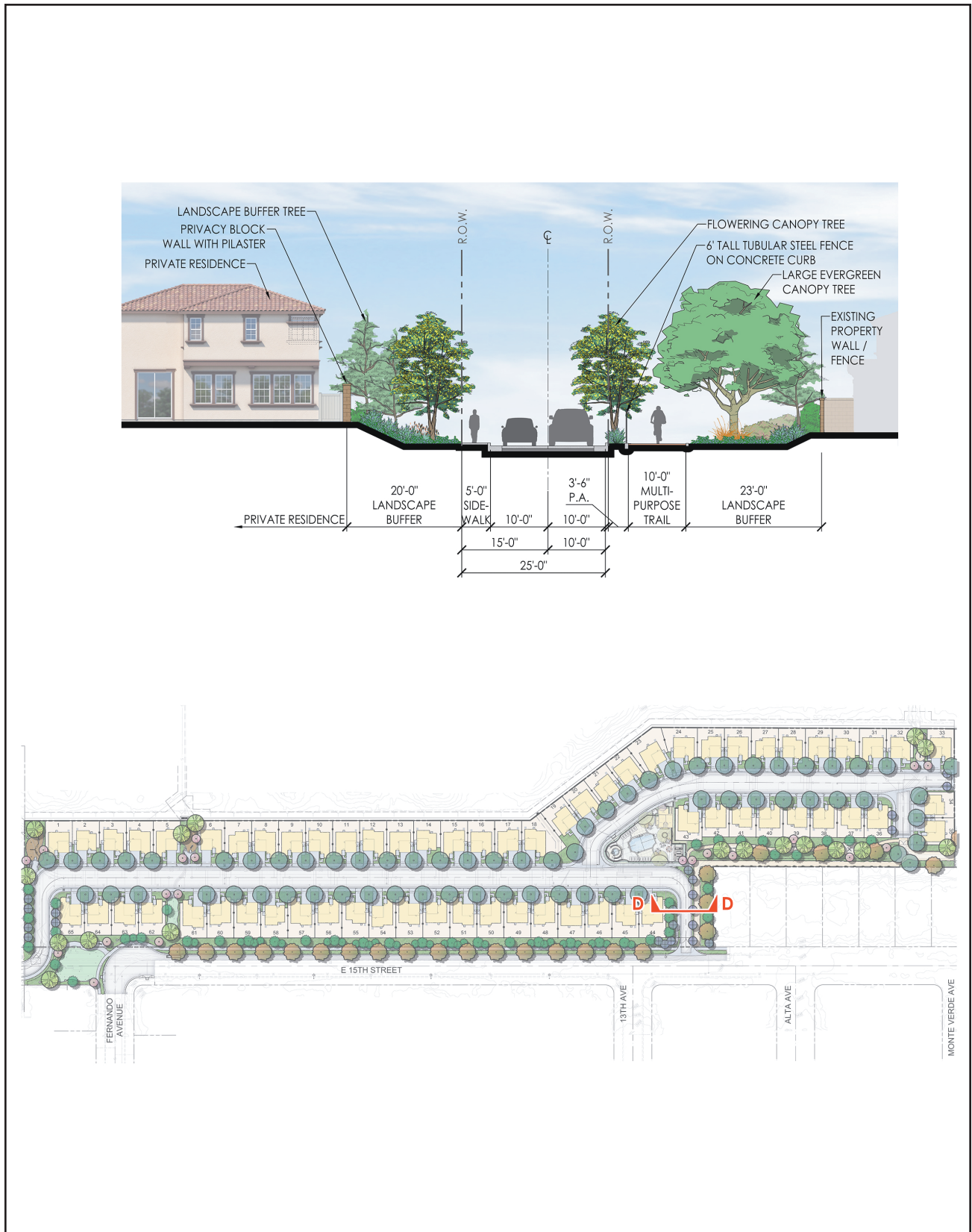

Exhibit 24  
**Streetscape Sections**

Source: Architerra Design Group

# SECTION 4. DESIGN CRITERIA

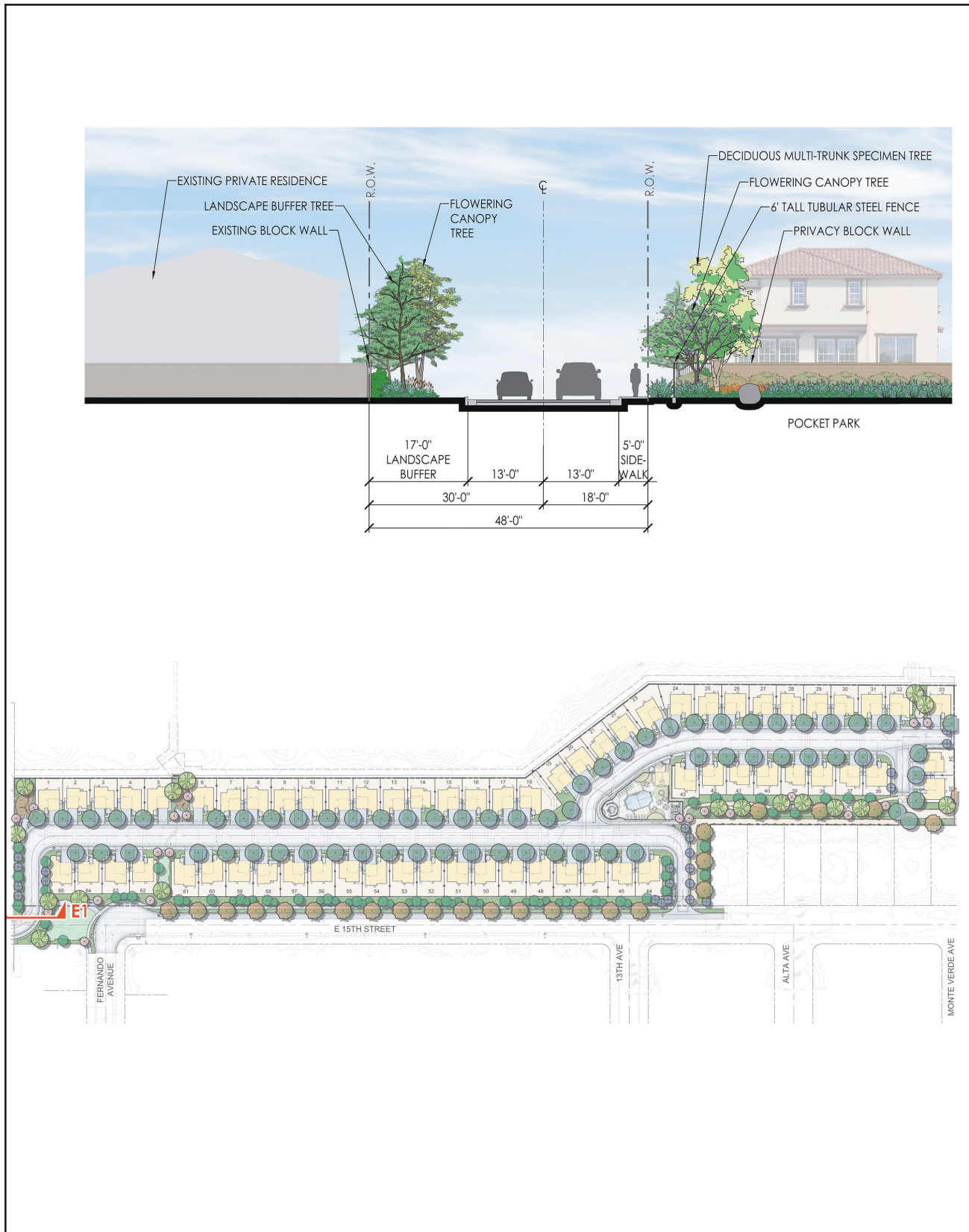

Exhibit 25  
**Streetscape Sections**

Source: Architerra Design Group

# SECTION 4. DESIGN CRITERIA

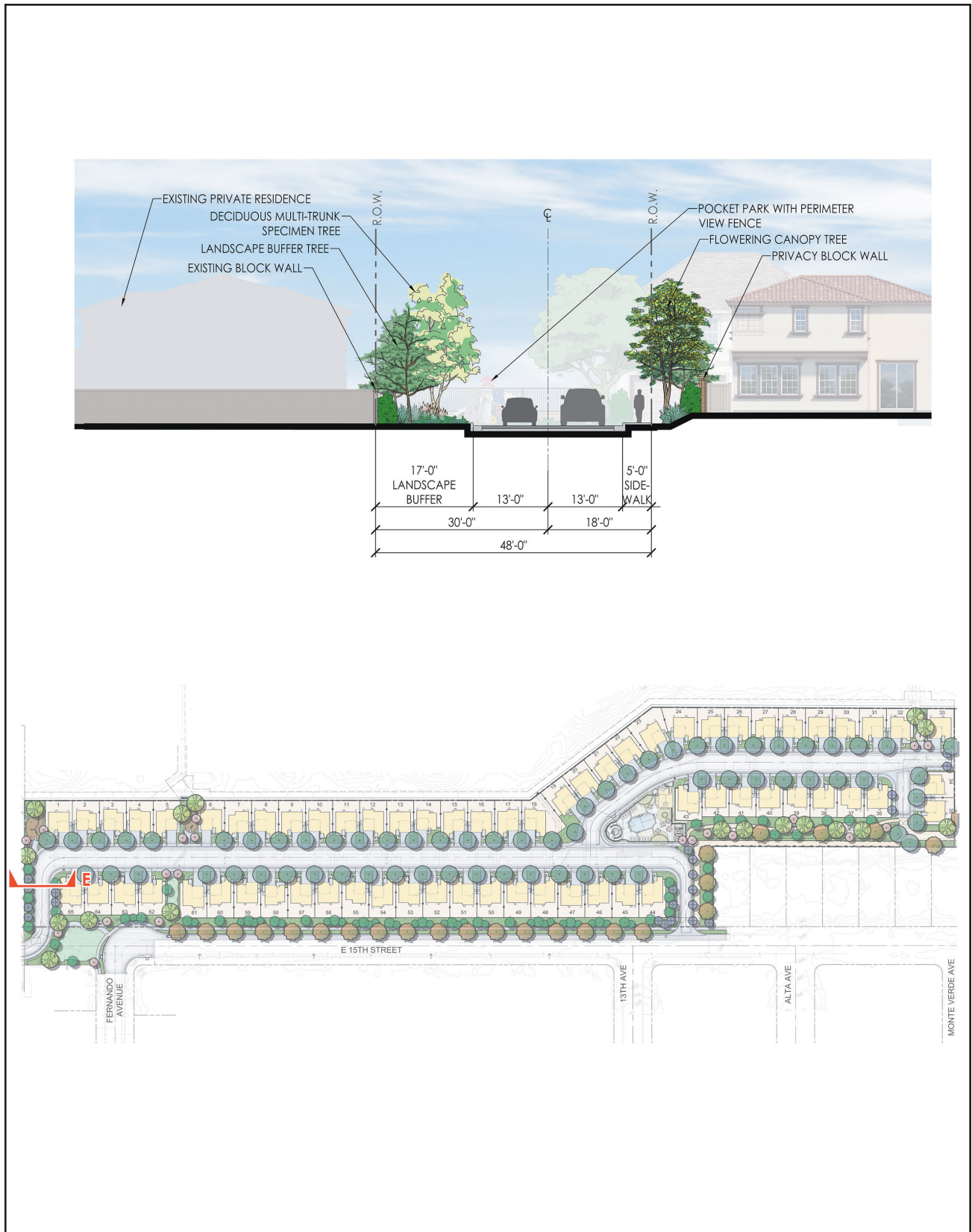

Exhibit 26  
**Streetscape Sections**

Source: Architerra Design Group

# SECTION 4. DESIGN CRITERIA

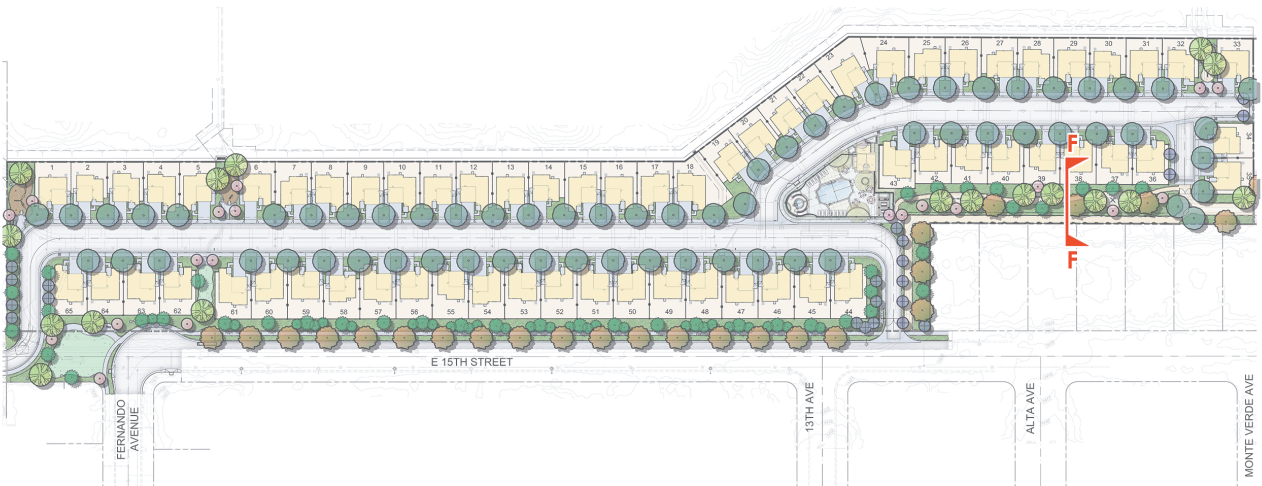
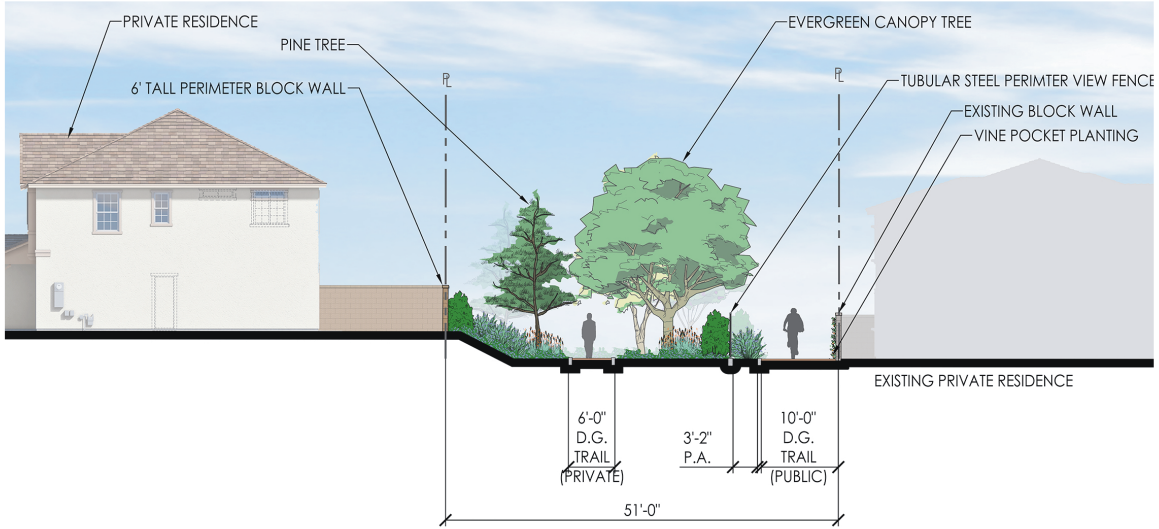

Exhibit 27  
**Streetscape Sections**

Source: Architerra Design Group



## SECTION 4. DESIGN CRITERIA

### 4.2.4 Open Space and Connectivity

The Project will have common area open space provided for the active and passive recreational use of its residents. Walkways will lead to the areas designated for common area open space. The private on-site common area open space plan for the Project consists of the following elements:

A centrally located open space area to include the following improvements:

- Swimming pool and spa.
- Picnic and barbeque area with an overhead shade structure.
- Pool house with restrooms/changing areas and drinking fountains.
- Exercise station.
- Children's play area.
- Landscaped walkway connecting the active recreational area with residences.

The central open space area will also include the central mailbox location for the Project. The central open space area will be heavily landscaped with canopy trees to provide shade, shrubs, and ground cover.

Five on-site pocket parks will be provided for passive recreational use. Two pocket parks are planned at each end of the Project Site and two are planned within interior areas of the Project. The pocket parks will be heavily landscaped with canopy trees to provide shade, shrubs, and ground cover. Benches will be provided under canopy trees and each pocket park will provide children's play areas. One pocket park will also provide a putting green. One pocket park is planned as a linear park to include a private pedestrian trail and a separate public pedestrian and bicycle trail connecting to the adjacent off-site basin open space area. This park will be heavily landscaped with trees and shrubs. Bench seating will be provided along the trail.

Off-site public open space improvements to be constructed as part of the project include a pocket park adjacent to 15th Street at the south/westerly corner of the Project Site.

The central common open space and pocket parks for the Project are illustrated on Exhibit 28, "Central Open Space Plan," Exhibits 29, and 30, "Pocket Parks." The concept for the central mailbox site within the central open space recreational area is illustrated on Exhibit 31, "Central Mailbox Plan." Open space amenities such as tot lots, furnishings, and exercise stations planned for the pocket parks are illustrated in Exhibits 32-35, "Open Space Amenities."

# SECTION 4. DESIGN CRITERIA

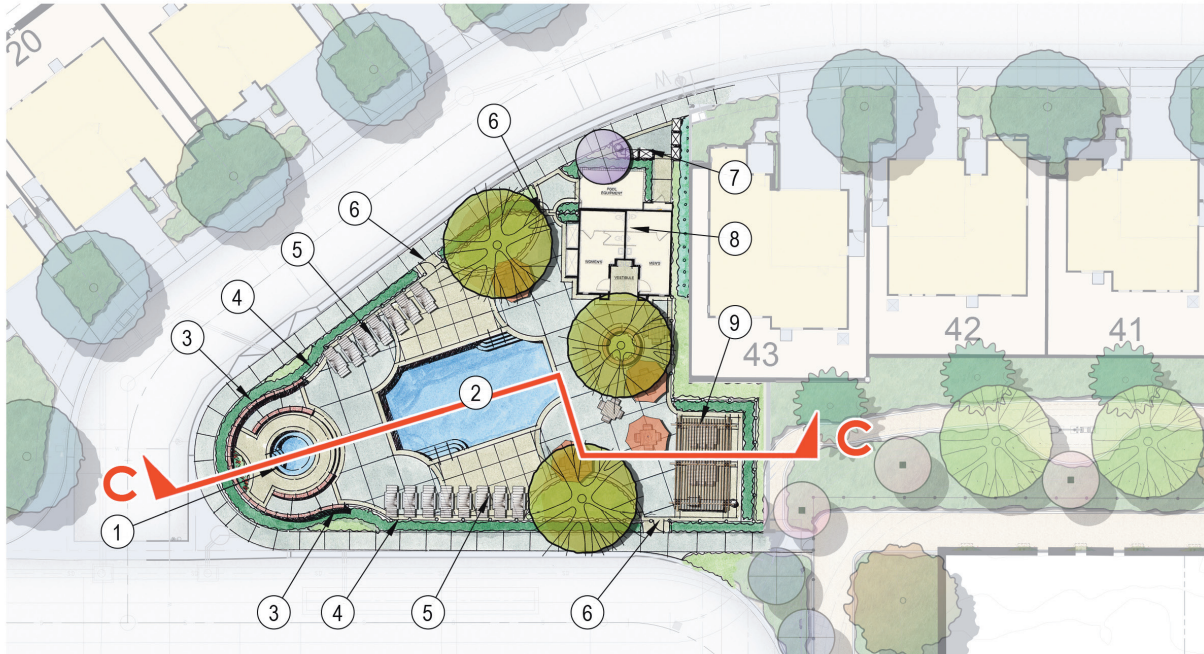

**REC-CENTER ENLARGEMENT PLAN**  
N.T.S

**FEATURE LEGEND:**

- |   |  |   |   |
|---|--|---|---|
| ① | COMMUNITY SPA.                               | ⑤ | SUNDECK.                                    |
| ② | COMMUNITY SWIMMING POOL.                     | ⑥ | SWIMMING POOL ENTRY ACCESS GATES.           |
| ③ | PRIVACY BLOCK WALL.                          | ⑦ | GANG MAIL-BOX LOCATION.                     |
| ④ | TUBULAR STEEL SWIMMING POOL ENCLOSURE FENCE. | ⑧ | RESTROOM FACILITY WITH POOL EQUIPMENT ROOM. |

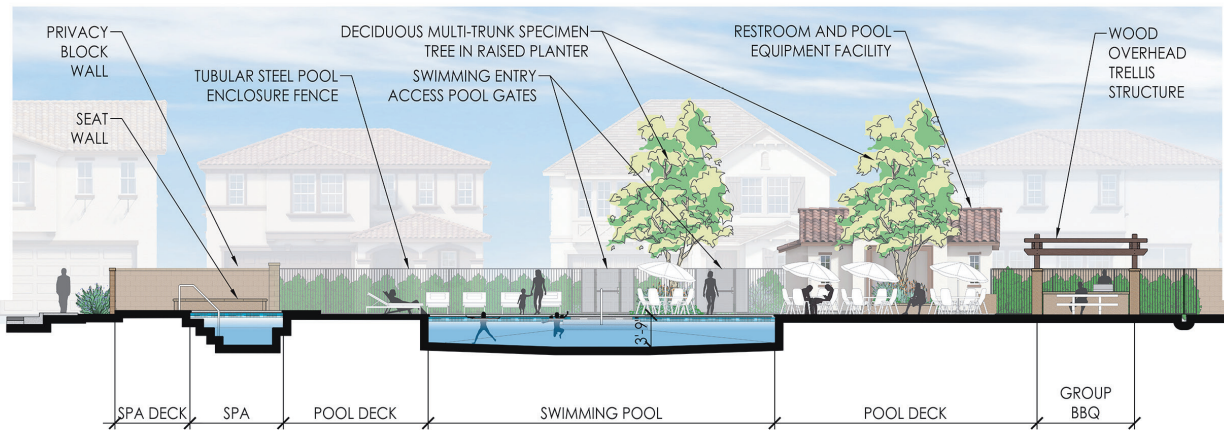

Exhibit 28  
**Central Open Space Plan**

Source: Architerra Design Group



## SECTION 4. DESIGN CRITERIA

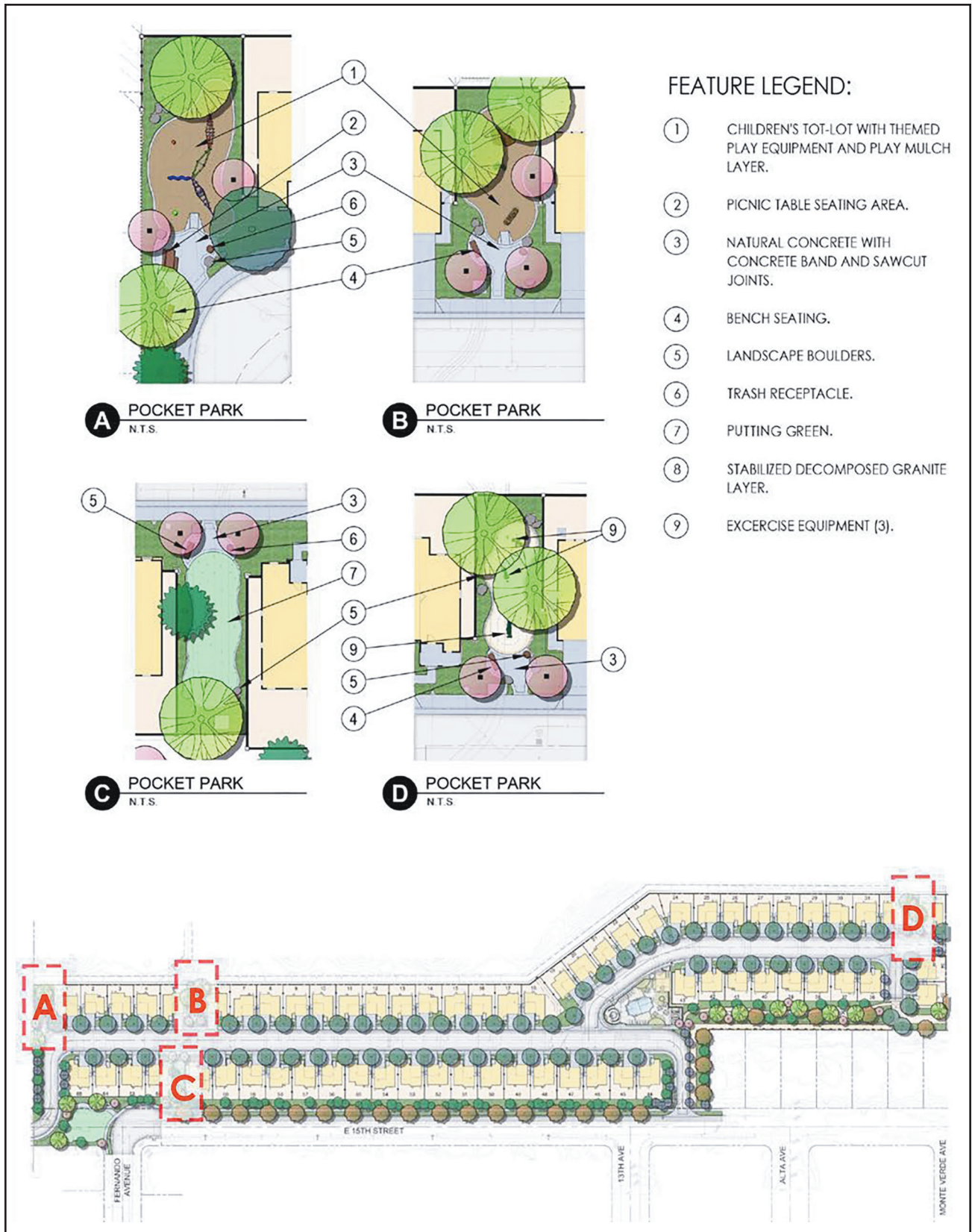
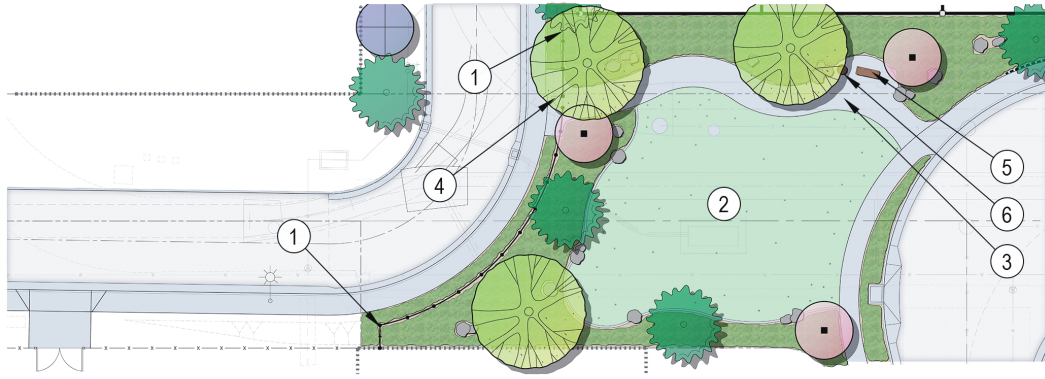

Exhibit 29  
**Pocket Parks**

Source: Architerra Design Group

# SECTION 4. DESIGN CRITERIA



**E** NUCKLE POCKET PARK (PUBLIC)  
N.T.S.

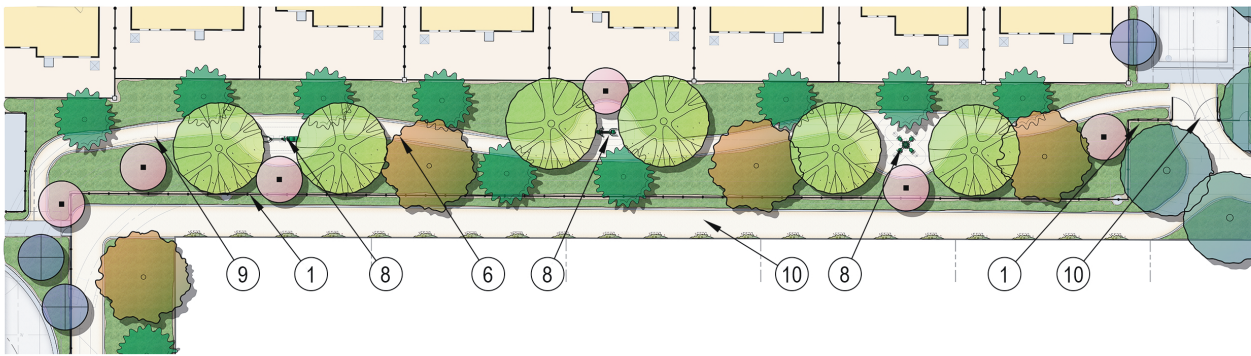

**F** POCKET PARK  
N.T.S.

**FEATURE LEGEND:**

- ① TUBULAR STEEL PERIMETER FENCE.
- ② TURF PLAY AREA.
- ③ NATURAL CONCRETE PAVEMENT.
- ④ 3' WIDE PEDESTRIAN ACCESS GATE
- 5 BENCH SEATING.
- ⑥ TRASH RECEPTACLE.
- ⑦ LANDSCAPE BOULDERS.
- ⑧ EXCERCISE EQUIPMENT.
- ⑨ STABILIZED DECOMPOSED GRANITE TRAIL. (PRIVATE)
- ⑩ STABILIZED DECOMPOSED GRANITE TRAIL. (PUBLIC)
- ⑪ VEHICULAR MAINTENANCE ACCESS GATES.



Exhibit 30  
**Pocket Parks**

Source: Architerra Design Group

## SECTION 4. DESIGN CRITERIA

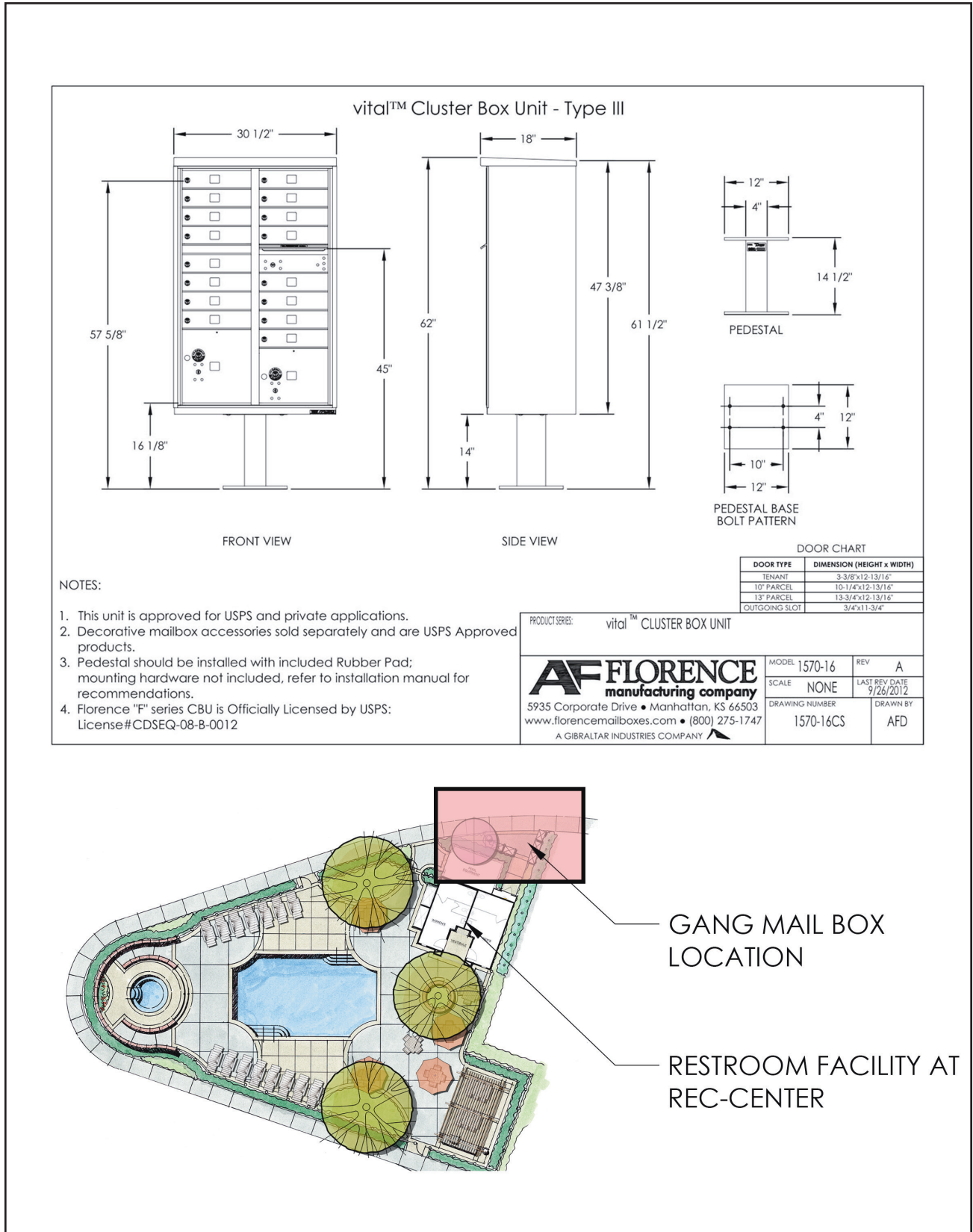

Exhibit 31  
**Central Mailbox Plan**

*Source: Architerra Design Group*

## SECTION 4. DESIGN CRITERIA



TWO PERSON BACK AND ARM COMBO



THREE-PERSON STATIC COMBO



UPRIGHT BIKE

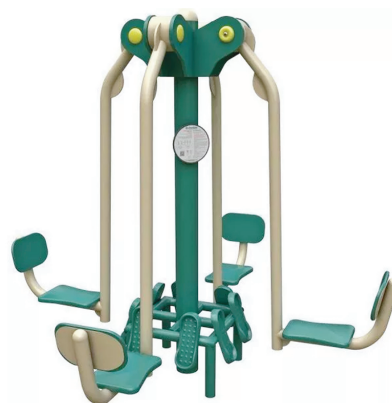

FOUR-PERSON LEG PRESS



ROWING MACHINE



SINGLE ELLIPTICAL

### COMMON AREA OPEN SPACE AMENITIES - EXERCISE STATIONS

Exhibit 32

## Open Space Amenities

Source: Architerra Design Group

# SECTION 4. DESIGN CRITERIA

<b>MODEL #100SRE CONCRETE PICNIC TABLE WITH RIGHT SIDE WHEELCHAIR ACCESS</b>	OUTDOOR CREATIONS, INC. CUSTOMER APPROVAL x _____	SCALE: 1" = 32" DRAWN BY: MNC	MAN. TOL. +/- 1/4"
--	--	----------------------------------	--------------------

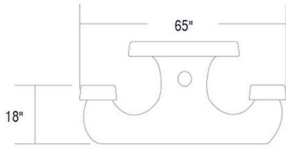
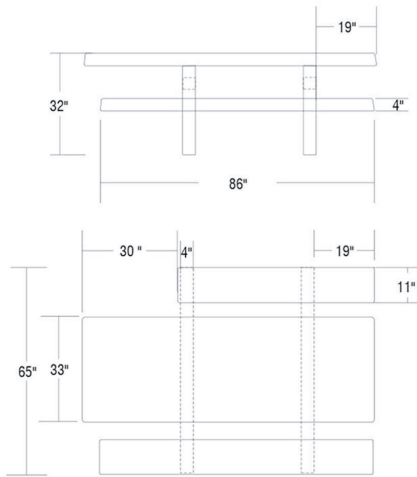
**NOTES:**  
 1. Concrete mix design to include a mixture of Portland Cement, water, coarse and fine aggregates, pure mineral oxide coloring agents (when applicable) to yield a minimum compressive strength of 5000 psi.  
 2. Final product shall be reinforced with #4 and #5 rebar grid.  
 3. Product is cast in 1-piece with no assembly required.  
 4. Hairline cracks may develop over time. These are not structural failures, but inherent characteristics of the material itself.  
 5. Air pockets are a common occurrence in precast products. The frequency and size of air pockets are variable and to be expected, especially on vertical surfaces.  
 6. Concrete corners and edges will chip if not handled according to guidelines. Patch kits are available but may or may not blend and can be variable.  
 7. There is a level of care and maintenance associated with your product and is the responsibility of the end user. Choosing the right sealer can help minimize those costs.

WEIGHT: 2450 LBS  
 TEXTURE:  
 COLOR:  
 SEALER:





**OUTDOOR CREATIONS INC.**  
 2270 Barney Street  
 Anderson, CA 96007  
 (530) 365-6106  
 FAX (530) 365-5129

## TYPICAL PICNIC TABLE



TRASH RECEPTACLE

BENCH SEATING

CONCRETE BENCH

## COMMON AREA OPEN SPACE AMENITIES - FURNISHINGS

### Exhibit 33 Open Space Amenities

Source: Architerra Design Group

## SECTION 4. DESIGN CRITERIA



SPINNER BOWL  
BY KOMPAN



SPICA 1 (SPINNER)  
BY KOMPAN



TRIPLE ROPE TRAIL  
BY KOMPAN

### CHILDREN'S PLAY EQUIPMENT

COMMON AREA OPEN SPACE AMENITIES - TOT LOT  
N.T.S

Exhibit 34

## Open Space Amenities

Source: Architerra Design Group



## SECTION 4. DESIGN CRITERIA

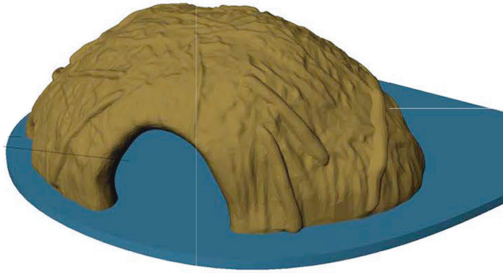

BEAVER HUT CONCEPT  
BY UPC PARKS



NORTH AMERICAN BEAVER  
BY UPC PARKS



SWIMMING BEAVER  
BY UPC PARKS



BABY FLOATING FROG  
BY UPC PARKS

### CHILDREN'S PLAY SCULPTURES

### COMMON AREA OPEN SPACE AMENITIES - TOT LOT N.T.S

## SECTION 4. DESIGN CRITERIA

### 4.3 Walls and Fencing

Walls and fencing are an important component of the overall landscape design of a community. Walls and fences should be designed to complement and reinforce landscape design in establishing the image and theme of the community. The type and location of Project walls and fences are described on Exhibits 36 and 37, “Wall and Fence Plan.” As part of the Project, fencing will be installed along the boundary of the existing Upland Basin trail as illustrated on Exhibit 38, “Basin Trail Fence Plan.” Fence and wall details are described on Exhibit 39, “Wall and Fence Details.”

#### 4.3.1 Community Walls

Community walls constructed as part of the Project shall be decorative in nature. Community perimeter walls constructed as part of the Project shall be a combination of split face block and view fencing. The community entry along 15th Street and the project boundary adjacent to the linear pocket park shall have black tubular fencing constructed around these areas. Use of decorative caps and pilasters to help enhance the perimeter appeal of the walls is required. Walls and fencing within the expanded 15th Street Project access roadway shall incorporate existing residential walls and new retaining walls on the north side and existing and new chain link fencing on the south side. All perimeter walls shall be constructed within the boundaries of the Project Site.

#### 4.3.2 Residential Walls and Fences

Rear yard property walls constructed as part of the Project shall be decorative split face block with accent pilasters at intervals along the wall. Vinyl fencing may be used along interior residential property lines.

#### 4.3.3 Other Fences

- Tubular steel fencing is permitted to secure tot lot areas.
- Emergency vehicle access areas and the basin access gate shall be secured with tubular steel gates.

### 4.4 Outdoor Lighting

Lighting of streets, common area open space, and select landscaped areas should be considered for safety and security. Utilization of “dark sky friendly” light fixtures on local streets shall be required. Maintaining the character of traditional materials will create a pedestrian scale for the neighborhood. Lighting fixtures within the Project shall be consistent in style, color, and materials in order to maintain uniformity throughout the Project. The style for street lighting fixtures within the Project is illustrated on Exhibit 40, “Typical Street Light Fixture.”

A hierarchy for all lighting within the Project shall be established by using a variety of lighting fixtures and illumination levels based lighting design intent. Lighting styles shall tie into architectural styles and provide sufficient illumination for the safety and well being of the community. Frosted, louvered, or prismatic lens should be considered where decorative lighting fixtures are visible and part of the aesthetic lighting program.

#### 4.4.1 Entry Monument Lighting

Avoid intensely bright or “hot” lighting of the Primary Community Entry monument; the monument should be lit to provide a soft wash of light across the monument signage. Specimen trees at the Secondary Entry should be up-lit with several fixtures into the canopy to avoid creating dark sides of the trees.

# SECTION 4. DESIGN CRITERIA

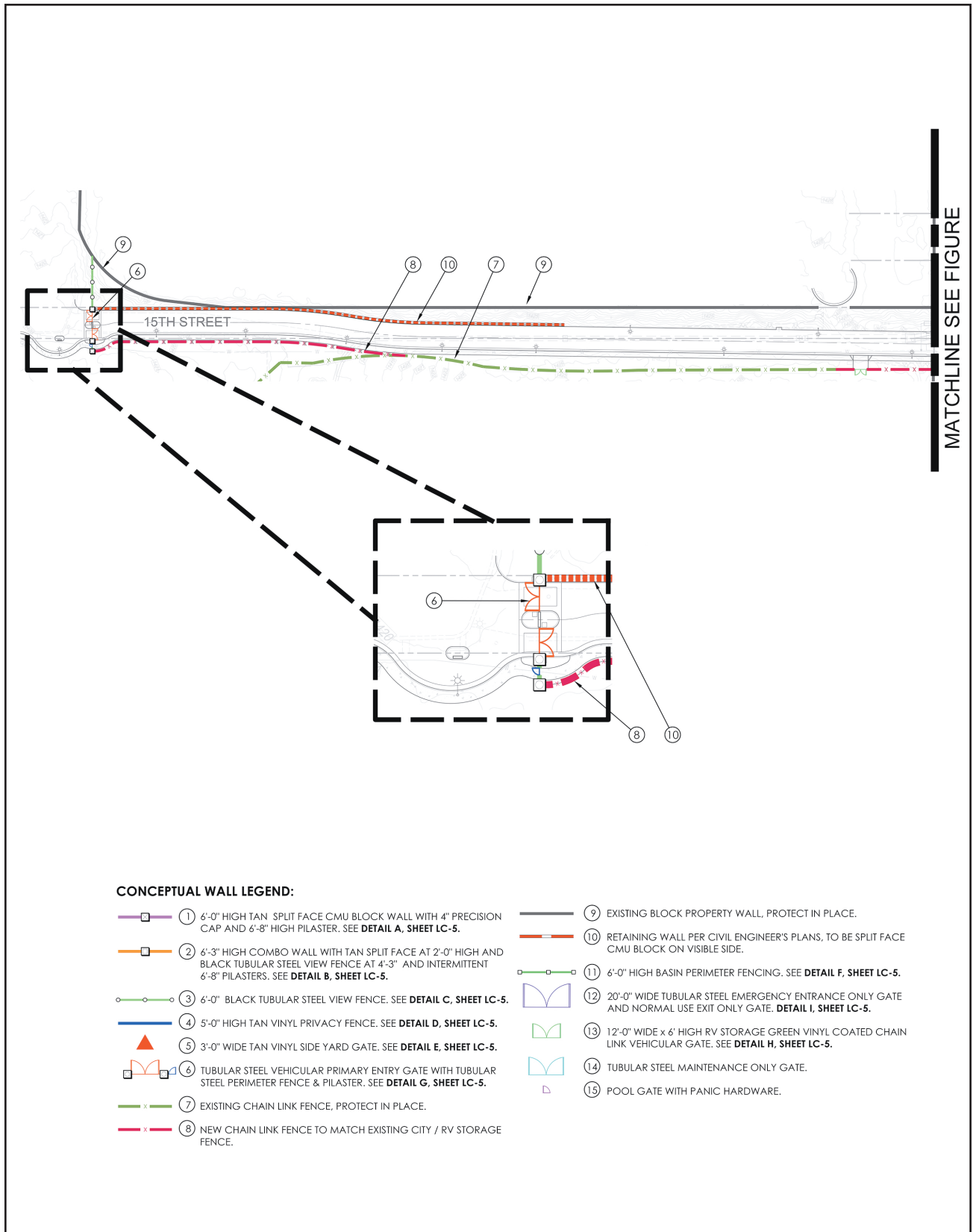

Exhibit 36  
**Wall and Fence Plan**

Source: Architerra Design Group

# SECTION 4. DESIGN CRITERIA



Exhibit 37  
**Wall and Fence Plan**

Source: Architerra Design Group

## SECTION 4. DESIGN CRITERIA

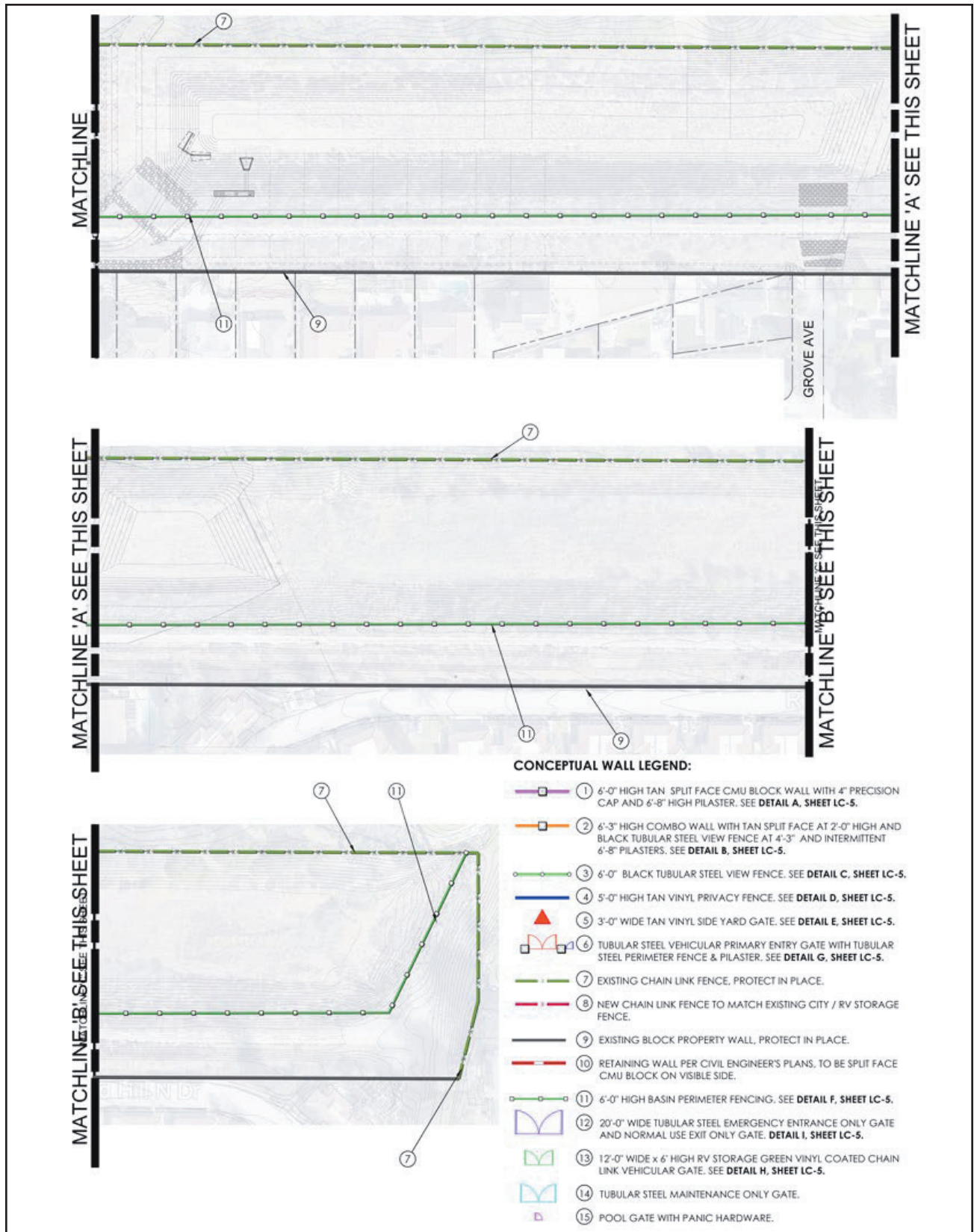

Exhibit 38  
**Basin Trail Fence Plan**

*Source: Architerra Design Group*

# SECTION 4. DESIGN CRITERIA

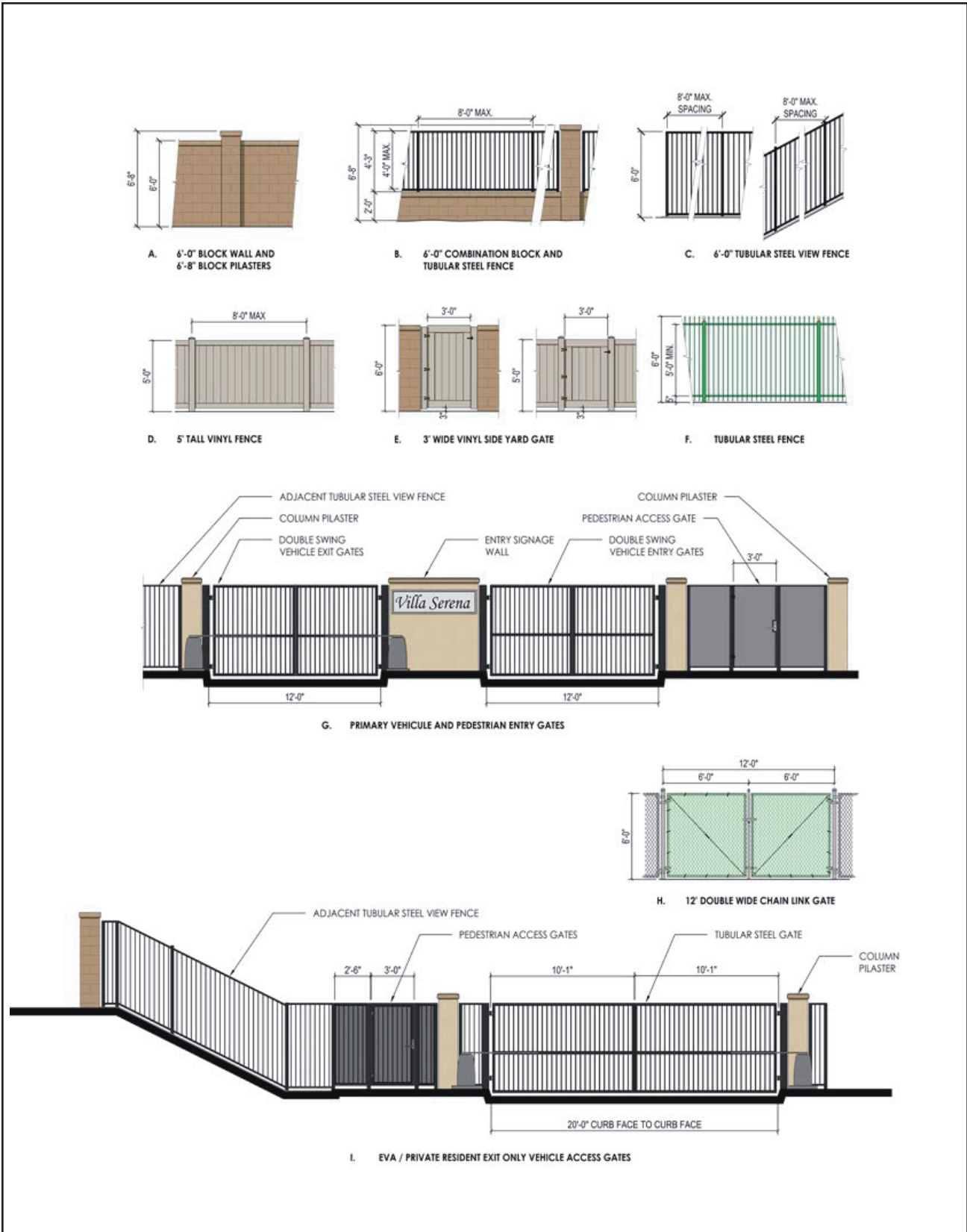

Exhibit 39  
**Wall and Fence Details**

Source: Architerra Design Group



## CHOOSING THE RIGHT LIGHTING PROFILE

### FIRST LIGHT TECHNOLOGIES SOLAR LED LUMINAIRES

A lighting profile determines when your light will be on and how bright it will be through the night. For First Light products, there are two types of lighting profiles – duration based lighting profiles and real-time based lighting profiles.



#### WHAT ARE DURATION BASED LIGHTING PROFILES?

Duration based profiles are based on when lights detect dusk and dawn. We offer several options to provide full brightness and dimming for fixed durations during the night. Note that there is no additional set up required at time of install.

### DURATION BASED LIGHTING PROFILES

		DUSK	NIGHT	DAWN
<b>00</b>	On at dusk > off at dawn	[Full brightness bar]		
<b>01</b>	On at dusk > off after 6 hours	[Full brightness bar]		
<b>02</b>	On at dusk > after 6 hours dim to 30% > off at dawn	[Full brightness bar]		
<b>03</b>	On at dusk > off after for 5 hours > on 1 hour before dawn > off at dawn	[Full brightness bar]		
<b>04</b>	On at dusk > dim to 30% after 5 hours > brighten to 100% 1 hour before dawn > off at dawn	[Full brightness bar]		
<b>05</b>	On at dusk > off after 3 hours	[Full brightness bar]		
<b>06</b>	On at dusk > off after 4 hours	[Full brightness bar]		
<b>07</b>	On at dusk > off after 4 hours > on 1 hour before dawn > off at dawn	[Full brightness bar]		
<b>08</b>	Off (with motion sensing)	[Dark bar]		
<b>09</b>	On at dusk > after 3 hours dim to 30% > brighten to 100% 1 hour before dawn > off at dawn	[Full brightness bar]		
<b>10</b>	On 30% at dusk > off at dawn	[Dimmed bar]		

Exhibit 40  
Typical Street Light Fixture

Source: Visual Concepts Lighting, Inc.

## SECTION 4. DESIGN CRITERIA

### 4.4.2 Open Space Areas and Walkway Lighting

Lighting of the walkways within open space areas should be considered for safety and security. Security lighting fixtures shall be vandal resistant, not less than (8) eight feet from ground level. Low level pedestrian lighting along walkways within open space areas should be provided to create a better sense of scale to the pedestrian. Luminaries of not less than 42” in height may be utilized to illuminate a walkway if adjacent landscaping is of a variety that does not mature higher than two feet.

### 4.5 Signs

All signs within the Project shall conform to a sign program submitted by the applicant and approved by the City. The sign program shall serve to reinforce the overall design theme for the community and to promote an overall “sense of place” through architecturally integrated, visually coordinated, and aesthetically balanced sign design. As part of the sign program the design of all sign graphics shall be carefully considered in relation to the site architecture and landscaping, as well as to the specific content of the area. Conformity of design among all signs is required.

#### 4.5.1 Sign Program Objectives

Signs within the Project shall address the following objectives:

- Provide a project identity through elements that convey a distinct community character enhancing the collective architectural theme.
- Provide for a hierarchy of signs to address Project identity, directions and information within the community, and identify the common area open space and Project amenities.
- Ensure the efficient circulation of vehicle traffic within the Project Site.

- Enhance the pedestrian and biking experience through attractive and comprehensible way-finding signage and destination identifiers.

#### 4.5.2 Sign Design Criteria

The following design criteria shall be considered for Project signs:

- Signs shall be of uniform design relative to each other, sharing similar colors, materials, and shapes.
- Signs shall be color compatible with building architecture and landscape features on the site.
- Materials shall include the use of real veneer materials instead of faux concrete veneers.

### 4.6 Architectural Design

The architecture represented in the Project shall be comprised of rich, traditional styles that complement one another and serve to reinforce diversity in the community street scene. Three separate and distinct architectural styles influenced by thematic architecture found within California have been selected for the Project. Each style is presented on the following pages describing the characteristics that begin to express the anticipated architectural character for the community. These styles are influenced and inspired by the themes of each style, all represented in historical California architecture. Other architectural styles may be approved for the Project by the City as part of Development Plan Review. Other styles should exhibit compatibility to the three styles described below.



## SECTION 4. DESIGN CRITERIA

### 4.6.1 Spanish Influenced Style

The Spanish style is an adaptation of the Mission Revival style, reflecting features such as strong form and mass, plain stucco wall surfaces, and tile roofs. The front elevations are very simply articulated and detailed. Further architectural distinction is established through the use of heavily textured wooden doors, colorful decorative ceramic tile accents and robust ornamental ironwork. The charm of the Spanish style lies in the directness, adaptability and contrast of materials and textures.

The following elements define the Spanish architectural style for the Project.

#### **Massing:**

- Simple massing and forms with varied roof forms.

#### **General Materials:**

- Stucco finished walls.
- Rounded stucco arches.
- Wrought iron accents.
- Thick walls.
- Deep recessed openings.
- Clay pipe details at gable ends.

#### **Roof Materials and Forms:**

- Low-pitched roofs.
- Minimal overhangs.
- Gable main roof with intersecting gables.
- Concrete 'S' tiles.

#### **Detail Elements:**

- Arched window/door openings.
- Decorative columns and trim.
- Recessed windows.
- Decorative plank shutters.
- Window trims at top and bottom.
- Decorative corbels and roof finials.
- Wrought iron details.
- Vertically proportioned windows.
- Decorative flared walls.
- 16-panel garage door

The characteristics of the Spanish architectural style are illustrated on Exhibit 41, "Spanish Style."

# SECTION 4. DESIGN CRITERIA





ROOF / GARAGE DOOR STYLES	ARCHITECTURAL DETAILS	DESCRIPTION
 	 	<ul style="list-style-type: none"> <li>• Concrete 'S' Tile Roofing</li> <li>• Arched Openings</li> <li>• Flared Wing Walls</li> <li>• Stucco Plant Ledges</li> <li>• Shaped Stucco Corbels</li> <li>• Decorative Finials</li> <li>• Deep Recessed Windows</li> <li>• Wrought Iron Pot Shelves</li> <li>• Decorative Clay Pipes</li> <li>• Decorative Plank Shutters</li> <li>• 8' Tall Sectional 16-Panel Garage Doors</li> <li>• 8' Tall Decorative Plank Entry Doors</li> </ul>

Exhibit 41  
**Spanish Style**

*Source: KB Home*

## SECTION 4. DESIGN CRITERIA

### 4.6.2 Italianate Influences

The Italianate style as interpreted and conceived by Southern California architects of the early 20th century adapted the grand formal elegance of the Italian Renaissance estate with a localized approach to detailing and scale. Composed primarily of stacked two-story forms, the front elevations of these homes display a distinct organization of windows and doors, often with a centrally located, articulated entry. Key identifying features of this style include low-pitched hip roofs and rich architectural detailing including decorative cornice brackets, enhanced horizontal banding, and arched elements.

The following elements define the Italianate architectural style for the Project.

#### **Massing:**

- Stacked two-story massing.

#### **General Materials:**

- Stucco finished walls.
- Porches with arched openings.
- Color blocking for added visual interest.
- Corbels at soffits and eaves elements.
- Stucco belly bands.

#### **Roof Materials and Forms:**

- Low-pitched roofs.
- Hip roofs typical.
- Minimal overhangs.
- Concrete 'S' tiles.

#### **Detail Elements:**

- Mullions in vertical patterns.
- Window trims at top, bottom, and sides.
- Paired window groupings.
- Decorative louvered shutter.
- Solid eaves at select locations.
- Decorative belly bands.
- Wide corbels at eaves.
- Decorative pot shelves.
- Simulated precast surround at entries.
- Built-up eaves.
- 32-panel garage door.

The characteristics of the Italianate architectural style are illustrated on Exhibits 42, "Italianate Style."

# SECTION 4. DESIGN CRITERIA



ROOF / GARAGE DOOR STYLES	ARCHITECTURAL DETAILS	DESCRIPTION
 		<ul style="list-style-type: none"> <li>• Concrete 'S' Tile Roofing</li> <li>• Arched Openings</li> <li>• Raised Plate Height at Entries</li> <li>• Simulated Precast Trim</li> <li>• Shaped Stucco Window Sills</li> <li>• Shaped Stucco Corbels</li> <li>• Wide Stucco Band Trim</li> <li>• Decorative Stucco Cornices</li> <li>• Grouped Windows</li> <li>• Decorative Louvered Shutters</li> <li>• 8' Tall Sectional 32-Panel Garage Doors</li> <li>• 8' Tall Decorative 6-Panel Entry Doors</li> </ul>

Exhibit 42  
**Italianate Style**

*Source: KB Home*

### 4.6.3 French Country Influences

The French Country style is based upon early American interpretations of French Medieval architecture that made its way across the United States from the Mississippi regions around the turn of the century. Usually taking the form of larger manor homes and estates, this architectural style was adapted to fit smaller informal rural homes. Popular in fairy tale illustrations, the French Country style conveys a romantic and picturesque architecture replicating the cottages that dot the rustic French countryside. American interpretations include simple, asymmetrical forms with steeply-pitched roofs.

#### **Massing:**

- Simple massing with asymmetrical forms and gable roofs.

#### **General Materials:**

- Stucco finished walls.
- Vertical windows.
- Simple detailing.

#### **Roof Materials and Forms:**

- Steep roof forms with multiple pitches.
- Gable and hip roof forms.
- Large, simple roof planes.
- Gable end venting in various styles.
- Extended roof overhangs.
- Flat concrete tile to simulate shake materials.

#### **Detail Elements:**

- Decorative Z-plank shutters.
- Wood porch columns with decorative brackets.
- Box bay windows.
- Grouped windows.
- Multi-paned windows.
- Window trims at top, bottom and sides.
- Decorative gable vents.
- Arched openings.
- 16-panel garage door with decorative vertical slats.

The characteristics of the French Country architectural style are illustrated on Exhibits 43, “French Country Style.”

# SECTION 4. DESIGN CRITERIA



ROOF / GARAGE DOOR STYLES	ARCHITECTURAL DETAILS	DESCRIPTION
		<ul style="list-style-type: none"> <li>• Concrete Shake Tile Roofing</li> <li>• Soft Arched Openings</li> <li>• Shaped Corbels</li> <li>• Box Bay Windows w/ Wood Paneling</li> <li>• Wood Trellises w/ Decorative Kickers</li> <li>• Wide Stucco Band Trim</li> <li>• Decorative Triangular Gable Vents</li> <li>• Wood Posts with Decorative Brackets</li> <li>• Decorative Z-Plank Shutters</li> <li>• 8' Tall Sectional 32-Panel Garage Doors w/ Decorative Slats</li> <li>• 8' Tall Decorative Arched Plank Entry Doors</li> </ul>
		

Exhibit 43  
**French Country Style**

*Source: KB Home*

## SECTION 4. DESIGN CRITERIA

### 4.6.4 Architectural Enhancements

Where building elevations front onto the adjacent golf course and along certain portions of 15th Street these elevations will be enhanced with special architectural features consistent with the architectural style of the building. Examples of these special enhancements include, but are not limited to:

- Decorative foam shutters around master bedroom and/or master bath windows.
- Additional window with decorative wrought iron pot shelf at master closet.
- Decorative stucco over foam shaped corbels at the sides of the gable at the master bedroom and/or master bath.
- Pop out wall with a gable or hip roof with stucco over foam shaped corbels at the sides of the gable at the master bedroom.
- Decorative clay pipes at the added gable end.
- Stucco over foam shaped corbels with sand finish under the cantilever at the master bath or bedroom.
- Decorative foam shutters at the master bedroom or bath windows.
- Stucco over foam trim band along the entire elevation.
- Additional window with decorative foam shutters at master closet.
- Stucco over foam trim band along the entire elevation.

The locations of architecturally enhanced elevations are identified on Exhibit 44, “Architectural Enhancements Key Map.” Typical enhancements for each architectural style are illustrated on Exhibit 45, “Enhanced Elevation Spanish Style,” Exhibit 46, “Enhanced Elevation French Country Style,” and Exhibit 47, “Enhanced Elevation, Italianate Style.”

# SECTION 4. DESIGN CRITERIA

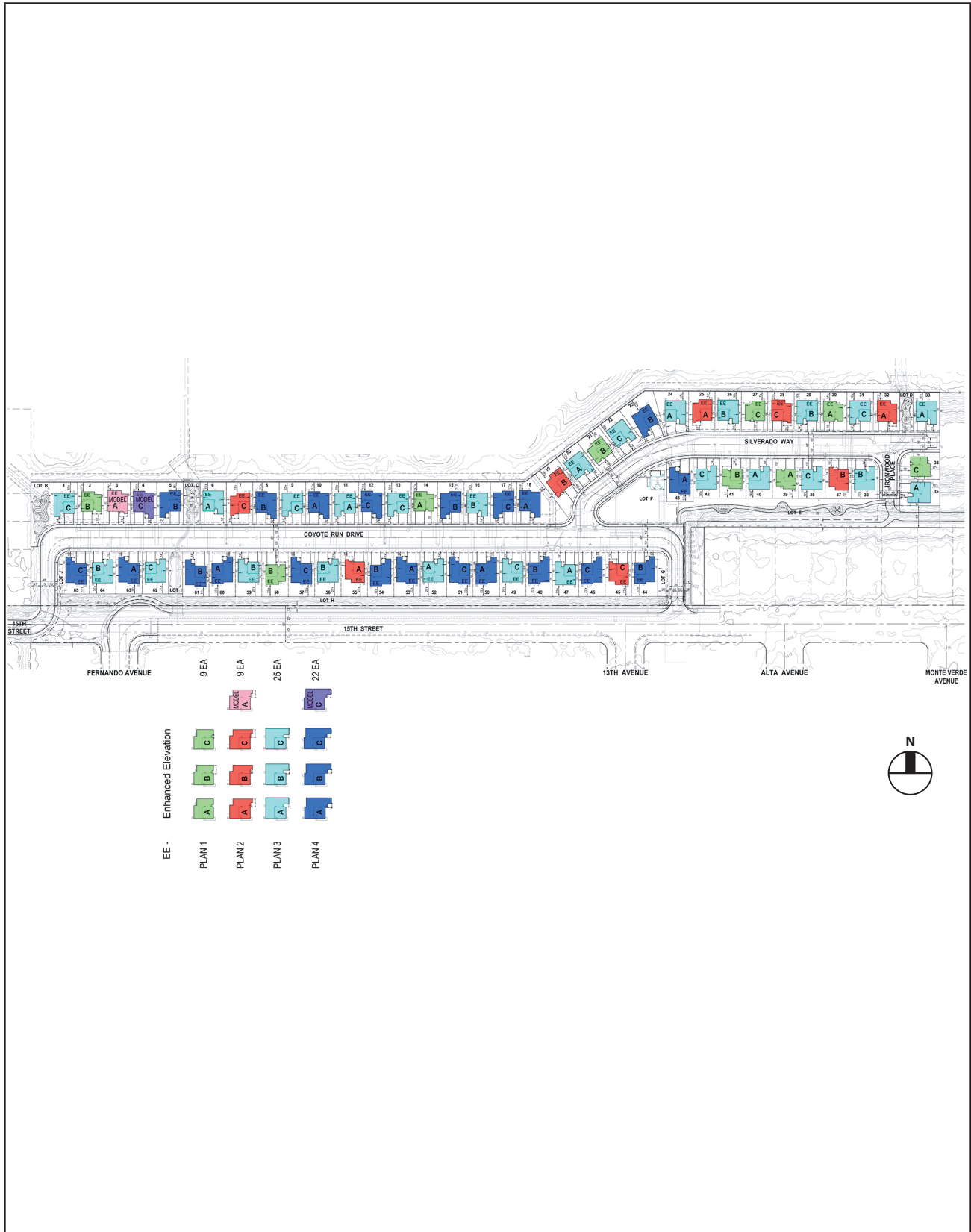

Exhibit 44  
**Architectural Enhancements Key Map**

Source: KB Home



## SECTION 4. DESIGN CRITERIA



Exhibit 45

### Enhanced Elevation Spanish Style

Source: KB Home

# SECTION 4. DESIGN CRITERIA



Exhibit 46

Source: KB Home

## Enhanced Elevation French Country Style

## SECTION 4. DESIGN CRITERIA



Exhibit 47

### Enhanced Elevation Italianate Style

Source: KB Home



## SECTION 5. IMPLEMENTATION AND ADMINISTRATION

### Section 5. Implementation and Administration

The Specific Plan serves to implement the General Plan land use designation of Villa Serena Specific Plan (SP) and establishes the zoning for the Project Site. The Specific Plan regulates allowable land use and establishes required infrastructure improvements, development requirements, and design criteria for the Project Site and establishes the design requirements for off-site improvements to be constructed as part of the Project. The methods for implementation of development within the Project Site and administration of the Specific Plan are established in this section.

#### 5.1 Methods and Applicability

All development proposals within the Specific Plan shall be subject to the implementation procedures established herein. Development within the Project Site shall be implemented through the approval by the City of a final tract map and through site plan and design review pursuant to Upland Municipal Code, Title 17, "Planning and Zoning" (Zoning Code). The implementation process described herein provides the mechanisms for review and approval by the City of the development project proposed for the Project Site.

Whenever the provisions and development standards contained herein conflict with those contained in the Zoning Code, the provisions of the Specific Plan shall take precedence.

#### 5.2 Severability

If any regulation, condition, program, or portion of the Specific Plan is held invalid or unenforceable, such portions shall be deemed separate, distinct, and independent provisions, and the invalidity of such portions or provisions shall not affect the validity and enforceability of the remaining portions and provisions therein.

#### 5.3 Interpretation

Unless otherwise provided, any ambiguity concerning the content or application of the Specific Plan shall be resolved by the City of Upland Development Services Director or his/her designee in a manner consistent with the goals, policies, purpose and intent established in this Specific Plan.

#### 5.4 Development Review

Implementation of the Project is subject to additional City approvals, subsequent to approval of the Specific Plan, including approval of a Site Plan and Design Review. The Project shall comply with all applicable State and local building and fire codes in effect at the time of Project implementation.

##### 5.4.1 Subdivision Maps

Approval of a tentative and final tract map shall be required for the Project. The tentative and final tract map shall be reviewed and approved pursuant to applicable provisions of the City of Upland Municipal Code, Title 16, "Subdivisions," Zoning Code Section 17.44.080, (Parcel Maps and Tract Maps), and consistent with the applicable provisions of the Development Plan, Development Regulations, and Design Criteria contained within the Specific Plan.

##### 5.4.2 Site Plan and Design Review

Development of the Project shall be subject to the provisions of site plan and design review pursuant to Zoning Code Section 17.44.030, (Development Plan Review). Pursuant to these provisions, the site plan and design review process constitutes a review and approval of project site plans, architecture, and landscape plans. The site plan and design review application for any project shall include a landscape and irrigation plan describing plant materials and their growth habits, plant size and spacing, methods of irri-

## SECTION 5. IMPLEMENTATION AND ADMINISTRATION

gation and landscaping maintenance; a comprehensive site plan of development including the distribution of land use, lot layout, detailed site plan for common area open space and residential plot plan, architectural elevations and floor plans, grading plans and other requirements as specified by the City.

### 5.5 Specific Plan Modifications and Amendments

#### 5.5.1 Modifications

The following constitute modifications to the Specific Plan, not requiring a Specific Plan Amendment, and are subject to review and approval by the Development Services Director. The Development Services Director shall have the discretion to refer any such request for modification to the Planning Commission.

- a. Change in utility and/or public service provider.
- b. Minor changes to landscape materials, wall materials, wall alignment, entry design, and streetscape design which are deemed by the Development Services Director to be substantively consistent with the conceptual design set forth in the design criteria contained within the Specific Plan.
- c. Minor changes to the architectural floor plans and/or architectural design criteria of the Specific Plan provided the change does not result in a variation of more than 20% of any quantifiable design criteria.
- d. Other modifications deemed similar in nature by the Development Services Director to the above, which the Development Services Director determines is in keeping with the purpose and intent of the approved Specific Plan, and which are in conformance with the General Plan, as amended.

#### 5.5.2 Specific Plan Amendments

Amendments to the Specific Plan may be requested by the applicant or initiated by the City at any time pursuant to Section 65453(a) of the Government Code. Amendments shall be processed pursuant to the provisions of the Government Code for Specific Plan Amendments. In the event the proposed amendment requires supplemental environmental analysis pursuant to the California Environmental Quality Act (CEQA), the applicant shall be responsible for preparing the necessary CEQA documentation.

#### 5.6 Appeals

Appeals from any determination of the Development Services Director shall be made to the Planning Commission. The applicant(s) or any other entity shall have the right to appeal the decision of the Planning Commission on any determination to the City Council. Appeals shall be filed on forms provided by the City of Upland. Appeals shall be processed consistent with the provisions of Zoning Code Chapter 17.47 (Referrals, Appeals, and Calls for Review).

#### 5.7 Compliance with Mitigation Measures and Conditions of Approval

Development within the Project shall comply with all approved mitigation measures as described in the Mitigation Monitoring and Reporting Program (MMRP) adopted by the City. Development of the Project Site shall comply with all conditions of approval as described in the Final Tract Map approved by the City for the Project Site.

## SECTION 5. IMPLEMENTATION AND ADMINISTRATION

### 5.8 Project Financing

The financing of construction, operation, and maintenance of public improvements and facilities (the “facilities”) and public services for the Project may include a combination of financing mechanisms. Final determination as to the facilities to be constructed and maintenance responsibilities, whether publicly or privately maintained, shall be determined as part of recordation of a final map. City approval is a prerequisite for the establishment and implementation of any and all special district-financing mechanisms. The following financing options can be considered for implementation.

#### 5.8.1 Facilities and Services

- a. Private capital investment for the construction of facilities.
- b. Traditional Assessment Districts pursuant to the 1911 or 1913 enabling legislation, Community Facilities District (CFD) established pursuant to the Mello-Roos Community Facilities District Act of 1982, or other special district, to provide funding for the construction of a variety of public facilities and the provision of public services.

#### 5.8.2 Facilities and Services

- a. By individual private property owner.
- b. By Homeowner Association (HOA).
- c. By Landscape and Lighting Maintenance District (LLMD).
- d. By traditional Assessment District, CFD, or other special district.

### 5.9 Project Phasing

Phasing of the Specific Plan will meet the following objectives:

- a. Orderly build-out of the community based upon market and economic conditions.

- b. Provision of adequate infrastructure and public facilities.

- c. Protection of public health, safety and welfare.

The phasing of residential development areas shall be determined by the developer. The development of residential uses shall be implemented through the approval of a tentative and final tract map and permits and pursuant to the Development Plan Review process. Three main phases of site development shall be implemented as described below.

**Phase 1** - Rough grading and installation of improvements to on site streets and connections to off-site backbone infrastructure, and construction of on-site infrastructure.

**Phase 2** - Construction of sales facility and residential model home units.

**Phase 3** - Construction of residential units, common area open space, landscaping and irrigation systems and Project perimeter entries, walls, and fences.

### 5.10 Maintenance

Maintenance of improvements within the Project Site shall be the responsibility of public and private entities as follows:

- a. All curb, gutter, and sidewalk improvements within the public right of way constructed for 15th Street adjacent to the Project Site shall be dedicated to the City of Upland and maintained by the City. Parkway landscaping within the 15th Street right of way shall be dedicated to the City and maintained by the HOA. Off-site roadway improvements extending 15th Street from the Project Site westerly to East 15th Street providing private vehicular access to the Project Site and the Project Entry shall be maintained by the HOA.

## SECTION 5. IMPLEMENTATION AND ADMINISTRATION

- b. All streets, landscaping between the 15th Street right of way and the Project boundary, and drives within the Project Site shall be private and maintained by the Project HOA.
- c. Front yard and common area landscape improvements within the Project Site shall be maintained by the Project HOA.
- d. Recreational areas and common area open space within the Project Site shall be maintained by the Project HOA. Off-site pocket park improvements adjacent to 15th Street shall be maintained by either the HOA or a Community Facilities District (CFD) funded by taxes levied upon the property for their fair share of maintenance.
- f. On-site and off-site infrastructure improvements such as water, sewer, and storm drain facilities shall be privately constructed and dedicated to the appropriate responsible entity for maintenance by that entity.
- g. All water quality management features and Project BMPs shall be maintained by the Project HOA.
- h. Off-site existing Basin trail shall be maintained by either the HOA or a CFD funded by taxes levied upon the property for their fair share of the maintenance.

A detailed listing of maintenance responsibilities for the Project is included as Table 5.1, “Project Maintenance Matrix.”



## SECTION 5. IMPLEMENTATION AND ADMINISTRATION

Table 5-1

### Project Maintenance Matrix

IMPROVEMENT	HOMEOWNER	HOA	CITY	PUBLIC UTILITY	HOA OR CFD
15th Street Sidewalk, Curb, Gutter Adjacent to Project			X		
30' Landscape Strip between 15th ROW and Project Boundary and landscaping within 15th Street parkway		X			
Storm Drain Easements				X	
Basin Maintenance Vehicle Access and Gates		X			
Internal Project Streets		X			
Internal Project Sidewalks, Parkways, Enhanced Paving		X			
Project Entry Connections to 15th Street		X			
Community Entry Sign, Walls and Lighting		X			
Interior Project Walls and Fencing	X				
Project Boundary Walls - New	X				
Project Boundary Walls – Existing	X				
Retaining Walls – Boundary	X				
Retaining Walls – Interior	X				
Common Area Landscaping		X			
Private Common Area Open Space and Improvements		X			
Public park improvements off-site adjacent to 15th Street					X
Off-site extension of 15th Street providing resident access and entry to the Project Site		X			
Basin Trail Adjacent to the Project Site					X
Mailbox Shelter		X			
Residential Front Yards		X			
Residential Driveways		X			
On-Site Water Mains				X	
On-Site Sewer Mains				X	
Water Quality Features – On site		X			
Drainage Improvements – On site		X			



## SECTION 6. GENERAL PLAN CONSISTENCY

### Section 6. General Plan Consistency

California Government Code (Title 7, Division 1, Chapter 3, Article 8, Section 65450-65457), permits the adoption and administration of specific plans as an implementation tool for elements contained in the local general plan. Specific plans must demonstrate consistency in regulations, guidelines, and programs with the goals and policies set forth in the general plan. The Villa Serena Specific Plan provides regulations, guidelines and standards that are consistent with the applicable City of Upland General Plan goals and policies as discussed in this section.

<b>6.1 Land Use Element</b>	
<b>Policies</b>	<b>Specific Plan Consistency</b>
<p><b>Policy LU-1.2 Permitted Densities and Intensities.</b> Ensure existing and future zoning designations correspond to the permitted density and intensity ranges as listed in Table LU-1 of the Land Use Element.</p>	<p>A General Plan Amendment adopted by the City for the Project Site changed the General Plan Land Use Map for the Project Site from Public- Flood Control/ Recharge (FC/R) to Villa Serena Specific Plan (SP). The Specific Plan establishes the General Plan Land Use designation and zoning for the Project Site and implements the SP General Plan land use designation for the Project Site. The Specific Plan is a proposal for the development of 65 single family residential dwelling units on approximately 9.16 acres of land. The residential density for the proposed Project is 7.1 dwelling units per acre consistent with surrounding General Plan land use designations of Single-Family Medium Residential (SFR-M): 4-10 dwelling units per acre, Single Family Low Residential (SF-L) .0-4 dwelling units per acre, and the Upland Hills Country Club Specific Plan.</p>
<p><b>Policy LU-1.5 Range of Housing Types and Densities.</b> Provide high-quality housing in a range of types, densities, and unit sizes that meets the housing needs of residents of all income levels.</p>	<p>The proposed project is a Specific Plan to allow development of 65 single family residential dwellings in a variety of floor plans and architectural styles at a density of 7.1 dwelling units per acre designed with unit sizes to address the housing needs of first time buyers. The Project adds to the City’s housing stock for first time buyers helping in the City’s efforts to address the housing needs of all income levels. The Project is consistent with this policy.</p>

## SECTION 6. GENERAL PLAN CONSISTENCY

<p><b>Policy LU-2.3 Living Environment.</b> Provide healthy, affordable and desirable living environments consistent with adopted code requirements that set forth the acceptable health and safety standards for the occupancy of housing.</p>	<p>Residential units developed as part of the proposed project will be constructed in conformance with all adopted building, health and safety code requirements. The Project is consistent with this policy.</p>
<p><b>Policy LU-4.1 Infill Development.</b> Encourage mixed-use, infill development on brownfields or underutilized parcels, particularly near public transit and within the historic downtown.</p>	<p>The 9.16 acre Project Site has been determined by the City to be a surplus property suitable for development, and represents an infill site surrounded by built urban environment and served by existing infrastructure and roadways. The Project is consistent with this policy.</p>
<p><b>Policy LU-5.5 Pedestrian Safety.</b> Encourage the creation of safe, walkable environments that include elements such as wide, smooth sidewalks, good lighting, safe crosswalks, clear signage, curb bulb-outs, curb cuts, street furniture, trees and traffic-calming measures which allow people of all ages and abilities to exercise and safely access public transportation, community centers, schools and goods and services.</p>	<p>The Project includes a simple two way street system with sidewalks adequately sized and lit to provide a safe walkable community offering pedestrian connectivity within the community and to 15th Street which allows for continued connectivity to Sierra Vista Park located approximately .5 miles southwest of the Project Site and Upland Memorial Park located approximately .8 miles south of the Project Site and to general commercial centers located approximately one mile north of the Project Site. Pedestrian connectivity is provided to the adjacent Upland Basin open space via a planned on-site private pedestrian trail and a separate public pedestrian and bicycle trail extending from Project streets and 15th Street connecting to the existing Upland Basin trail. The Project is consistent with this policy.</p>
<p><b>Policy LU-6.1 Quality Development.</b> Ensure that development is attractive and promotes harmony in the visual relationships and transitions between newer and older buildings.</p>	<p>The Specific Plan includes design criteria to guide community and architectural design of the Project to create a distinctive, cohesive community that blends with and complements the surrounding built environment. The Specific Plan design criteria includes a comprehensive community landscape plan and architectural design concepts that work together to create interesting and attractive streetscenes with visual continuity. The Project is consistent with this policy.</p>

## SECTION 6. GENERAL PLAN CONSISTENCY

<p><b>Policy LU-6.2 Compatibility of Uses.</b> Control the location, concentration and operations of land uses that have potential impacts on surrounding development through effective design principles, adequate buffering, and enforcement of regulatory documents.</p>	<p>The Specific Plan is a comprehensive plan controlling the pattern and operation of residential and open space land uses within the Project Site. The Specific Plan includes adequate buffering of new land uses to surrounding existing land use through project boundary landscaping and theme walls. The Project is served by an internal two way street system with two points of connection to 15th Street. The Specific Plan includes requirements for installation of infrastructure adequate to serve the Project and development standards to regulate building height and massing to conform to that of existing surrounding residential land use. The Project is consistent with this policy.</p>
---	--

### 6.2 Community Character and Urban Design Element

Policies	Specific Plan Consistency
<p><b>Policy CC-1.1 Small Town Scale.</b> Support the maintenance and expansion of Upland’s existing character by requiring preservation of historic features, buildings, and landscaping while encouraging new development to complement the character, scale, and heritage of development in the community.</p>	<p>There are no known historic features or buildings within the Project Site. The proposed new development of 65 residential units at a density of 7.1 dwelling units per acre is complementary to the existing scale and character of the surrounding built environment and is designed to blend with and reflect the small town character of Upland. The Project is a single family detached residential community consistent with the existing single family residential character surrounding the Project Site.</p> <p>The Project incorporates the traditional housing styles of Upland, California, while also reflecting the architecture of recently built neighborhoods. The architectural styles of homes are influenced and inspired by Spanish, Italianate, and French Country that echo the classic architecture of the Southern Californian regions. The Project integrates styles, elements, and a mix of materials from both established and newer residential communities located near the Project Site.</p> <p>Homes will not exceed two stories in height and will have a variety of floor plans and architectural styles plotted to create a varied streetscene. Materials and details on homes will be in keeping with the character of each architectural style. The Project is consistent with this policy.</p>

## SECTION 6. GENERAL PLAN CONSISTENCY

<p><b>Policy CC-1.2 Community Identity.</b> Cultivate a greater sense of community identity and recognizable community focal points, centers, districts, and gateways.</p>	<p>The proposed project is designed to create a distinctive sense of place for residents as a “walkable” community with a pedestrian friendly street system and common area open space provided for residents creating an atmosphere where neighbors can visit with one another while walking or utilizing the recreational amenities within the common area open space. Residences are planned to front onto streets, enabling residents to have their “eyes on the street,” promoting a safe hometown feel and encouraging interaction among neighbors. The Specific Plan sets forth requirements for a distinctive community design through construction of an enhanced primary Community Entry, landscaped secondary entry and streetscapes, walls, and entry monuments creating a sense of arrival to the community. Architectural diversity in residential design, landscaped walkways, and on-site common area open space for neighborhood gatherings, combine to create a sense of place for residents. The Project is consistent with this policy.</p>
<p><b>Policy CC-1.3 Place Making.</b> Ensure that existing and proposed buildings, structures, infrastructure, landscaping, lighting, and signage contribute to the image of the City as a place of high quality and positive value.</p>	<p>Development standards contained in the Specific Plan require uniform and high quality design of residential dwellings, the installation of infrastructure adequate to serve the community, comprehensive and cohesive landscaping for the community to include shade trees, shrubs, and groundcover, requirements that a master sign program be approved by the City, and lighting regulations to ensure uniformity of fixture design and placement along streets and within common area open space. The Project is consistent with this policy.</p>

## SECTION 6. GENERAL PLAN CONSISTENCY

<p><b>Policy CC-1.4 Contextual Design Themes.</b> Encourage new development to incorporate similar design themes to those existing within the project area to ensure buildings, when seen together, create recognizable districts and corridors.</p>	<p>The Project incorporates a community design creating a distinctive sense of place for the community similar in scale to the existing single family residential land use surrounding the Project Site. Homes will not exceed two stories in height and will have a variety of floor plans and architectural styles plotted to create an interesting streetscene. Materials and details on homes will be in keeping with the character of each architectural style. The proposed residential component of the Project is designed around a simple two way street system with common area open space distributed throughout the Project. The Project is consistent with this policy.</p>
<p><b>Policy CC-1.5 Human Scale Roadways.</b> Maintain narrow streets that provide multi-modal circulation mobility without dominating the streetscape.</p>	<p>The Project is designed with a simple two way street system with sidewalks on both sides of the street providing pedestrian connectivity within the Community, to Sierra Vista Park located southwest of the Project Site and to Upland Memorial Park located south of the Project Site, and to general commercial centers located north of the Project Site. Streets are designed with a total curb to curb width of between 26 to 38 feet to accommodate safe vehicular travel as well as on street bicycle travel. The Project is consistent with this policy.</p>
<p><b>Policy CC-1.6 View Protection.</b> Direct private development to enhance public view corridors of the San Gabriel Mountains, where feasible. These views are an integral part of the City's geographic space and provide a unique sense of place for Upland as a foothill community.</p>	<p>Structures within the proposed project are limited to a maximum height of two stories or 35 feet. The proposed project will not block any public view corridors of the San Gabriel Mountains. The Project is consistent with this policy.</p>

## SECTION 6. GENERAL PLAN CONSISTENCY

<p><b>Policy CC-2.1 Protect Established Neighborhoods.</b> Preserve, protect and enhance established neighborhoods by providing sensitive transitions between these neighborhoods and adjoining areas, supporting the maintenance and improvement of properties and buildings and infrastructure, and requiring new development, both private and public, to respect and respond to those existing physical characteristics – buildings, streetscapes, open spaces and urban form – that contribute to the overall character and livability of each neighborhood.</p>	<p>The proposed project of 65 residential units at a density of 7.1 dwelling units per acre is complementary to the existing scale and character of the surrounding built environment and provides a compatible transition between existing neighborhoods and the proposed community of Villa Serena. Adequate buffering between existing neighborhoods and the proposed project is provided with walls and landscaping. The Project is a single family detached residential community consistent with the existing single family residential character surrounding the Project Site. Homes will not exceed two stories in height and will have a variety of floor plans and architectural styles plotted to create a varied streetscene. The Project is consistent with this policy.</p>
<p><b>Policy CC-2.2 Complete Neighborhoods.</b> Promote the design and development of neighborhoods whose physical layout and land use mix promote walking, biking and transit use; provide housing and access to nearby employment, retail and service uses; foster community pride; provide access to recreational amenities; enhance neighborhood identity; and are safe, family friendly and address the needs of all ages and abilities.</p>	<p>The Specific Plan includes the development of a street and sidewalk system providing a unifying element for the community and pedestrian and bicycle connectivity with the community. Pedestrian and bicycle accessibility will be provided through Project streets and walkways connecting to 15th Street and westerly of the Project Site to East 15th Street. From these points of connection bicyclists and pedestrians can continue on existing streets and sidewalks to Sierra Vista Park located approximately .5 miles southwest of the Project Site, Upland Memorial Park located approximately .8 miles south of the Project Site and to general retail commercial services located at North Campus Avenue and 19th Street approximately one mile north of the Project Site. The Project is consistent with this policy.</p>



## SECTION 6. GENERAL PLAN CONSISTENCY

<p><b>Policy CC-2.5 Neighborhood Amenities.</b> Encourage appropriately scaled community-supportive facilities and services within all neighborhoods to enhance neighborhood identity and provide convenient access within walking and biking distance of residents.</p>	<p>Approximately one acre of private open space is provided as part of the Project to include a centrally located park improved with a swimming pool, pool house with restrooms, picnic tables, barbeque facilities, children’s play area, and benches. This park will provide residents with an inviting environment for informal gathering and a place to meet and greet each other as part of leisurely walks through the community. Five on-site individual pocket parks are distributed throughout the Project providing for passive recreational use by residents of the Project. One .15 acre off-site pocket park is planned for public use as part of the Project. The pedestrian walkway system and two way street system for the Project are designed to provide safe and convenient pedestrian and bicycle accessibility to private on-site and adjacent public off-site open space. The Project is consistent with this policy.</p>
<p><b>Policy CC-2.6 Neighborhood Enhancement.</b> Promote infill development, redevelopment, rehabilitation, and reuse efforts that contribute positively (e.g., site layout and architectural design) to existing neighborhoods and surrounding uses.</p>	<p>The Project Site is an infill site surrounded by existing single family residential use and is proposed for redevelopment as a new residential community. The Project Site has historically been used as a flood control and detention basin. As part of the Project modifications to the flood control and detention basin will be completed to create the developable Project Site and ensure the continued flood control and detention operations of the remaining portion of the basin are intact. The proposed project is designed to positively contribute to the quality of the existing surrounding residential neighborhoods. The proposed project is designed around a simple two way street system with common area open space distributed throughout the Project. Homes will not exceed two stories in height and will have a variety of floor plans and architectural styles plotted to create a varied streetscene. Materials and details on homes will be in keeping with the character of each architectural style. The Project is consistent with this policy.</p>

## SECTION 6. GENERAL PLAN CONSISTENCY

<p><b>Policy CC-2.7 Neighborhood Branding.</b> Support the development of neighborhood “branding” or identification so that particular neighborhoods can be recognized through naming, signage, gateways, etc.</p>	<p>The identity for the proposed Villa Serena community will be established through the construction of an enhanced and distinctive entry to include monument signage, landscaping, and lighting reflecting the theme of Villa Serena. The Project is consistent with this policy.</p>
<p><b>Policy CC-2.9 Infill Development.</b> Require infill development to be compatible with surrounding uses and to equal or exceed the quality of adjacent development.</p>	<p>The proposed project is designed to be compatible with the existing surrounding residential land use. The proposed project is designed around a simple two way street system with common area open space distributed throughout the Project. Vehicular access to the Project will be from one entry at the extension of 15th Street westerly to connect with the existing improvements at East 15th Street. A second Project entry provides exiting only for Project vehicles onto existing 15th Street. Homes will not exceed two stories in height and will have a variety of floor plans and architectural styles plotted to create a varied streetscene. Materials and details on homes will be in keeping with the character of each architectural style. The Project will include common area open space throughout the community within walking and biking distance to residential dwellings. The Project is consistent with this policy.</p>

## SECTION 6. GENERAL PLAN CONSISTENCY

### **Policy CC-5.1 Site Design Principles.**

Require new development projects to adhere to the basic principles of high-quality site design as set forth below, elsewhere in the General Plan, zoning and development standards, and any additional design guidelines adopted by the City. Basic principles include:

- a. **Buffers.** Encourage buffers between uses that are incompatible in design and/or operations, including, but not limited to, areas in the southwest and southeast portions of the City where industrial and residential land uses intermix.
- b. **Edges.** Ensure that buildings, trees or other architectural features provide edges and definition to the street to enhance the vitality and improve the feeling of safety and security in urbanized areas, especially in areas with high pedestrian traffic.
- c. **Building Siting.** Encourage new developments to bring buildings closer to the street as appropriate to create a more intimate and comfortable pedestrian environment.
- d. **Varied Setbacks.** Encourage varying setbacks, according to the existing character or context of the neighborhood, to provide visual interest, opportunities for transitional landscaping, and varying shadow patterns.

The Specific Plan includes adequate buffering of new land uses to surrounding existing land use through project boundary landscaping and theme walls. The Specific Plan sets forth requirements for a distinctive community design through construction of an enhanced primary Community Entry and landscaped secondary entry, streetscapes, walls, and entry monuments creating a sense of arrival to the community, architectural diversity in residential design, landscaped walkways, and on-site common area open space for neighborhood gatherings, all of which combined create a sense of place for residents.

Residences are planned to front onto streets, enabling residents to have their “eyes on the street,” promoting a safe hometown feel and encouraging interaction among neighbors. Varied floor plans and architectural styles combine to provide visual interest in the streetscape. The Project will include common area open space throughout the community within walking and biking distance to residential dwellings as well as off-site open space improvements allowing for public walking and biking to the existing Upland Basin trail.

The Specific Plan includes a master wall and fence plan designating approved locations for all walls and fences, a uniform design for all walls and fences, and the approved materials for each type of wall and fence. All walls and fences will be constructed of high quality materials that complement the architectural styles established for the Project. The Project is consistent with this policy.

## SECTION 6. GENERAL PLAN CONSISTENCY

<p><b>Policy CC-5.1 (cont.)</b></p> <p>e. Green Space. Provide adequate green space by ensuring new development and redevelopment includes appropriate green spaces, such as parkways, community squares, parks, rooftop gardens, and plazas that complement the architecture of the development.</p> <p>f. Landscaping. Promote high-quality landscape design and maintenance to soften buildings, parking lots, and hardscape with specific emphasis on a “California friendly” plant palette.</p> <p>g. Pedestrian Elements. Promote the use of elements such as special paving materials, landscaping, pedestrian-scaled lighting and seating along pedestrian paths and walkways to encourage pedestrian use.</p> <p>h. Walls and Fencing. Walls and fencing should be limited to providing privacy in side and rear yards and providing screening of non-residential utility areas to preserve the sense of a safe and inviting community. Where they are allowed, walls and fencing should be built of high quality materials that match and complement the architectural style of buildings on the property and provide visual relief through the use of a mixture of materials, landscaping, walkways and greenbelts. Additional landscape areas between sound walls, garden walls, and fencing and rights-of-way should be provided to mitigate the height and visual barrier of walls per the Zoning Code.</p> <p>h. Building Articulation. Ensure that the exterior on all sides of a building are varied and articulated to provide visual interest to its surroundings.</p>	
---	--

## SECTION 6. GENERAL PLAN CONSISTENCY

### **Policy CC-5.2 Building Design**

**Principles.** Require new development projects to adhere to the basic principles of high-quality building design as set forth below, elsewhere in the General Plan, and in any additional design guidelines adopted by the City. Basic principles include:

- a. **High-Quality Development.** Require new buildings to be of high architectural design and construction quality, including a high degree of articulation for visual interest, and attention to detail in both design and construction within the context of a building's location.
- b. **Sustainable Development.** Require building owners and developers to integrate green initiatives into their buildings, such as recycled materials, California friendly landscaping, energy efficient devices and water conservation technologies.
- c. **Architectural Style for Non-Historic Areas.** Require new developments to adhere to the predominant architectural style of buildings in the vicinity, where one is apparent, while encouraging variation in design elements; where there is not a strong architectural style, new styles may be appropriate.
- f. **Single-Family Residential Compatibility.** Require that new single-family housing in established neighborhoods be designed to be compatible in scale with other homes in the immediate neighborhood.
- g. **Single-Family Residential Additions.** Require that additions to existing single-family housing be developed in the same style.

The Project proposes three distinctive residential architectural styles in three different floor plans. Details and materials of homes will be true to the architectural style designated for the home. The plotting plan for each style and floor plan will be varied in order to provide visual interest in the streetscene.

The Specific Plan includes green and sustainable development requirements for the Project including the use of a drought tolerant plant palette in landscaped areas, installation of energy efficient fixtures and appliances in homes, design of homes to allow for passive solar energy utilizing materials such as cool roofs, dual pane windows, and increased insulation to minimize heat transfer and thermal bridging, and orientation and design of roofs to allow for homeowner installation of solar energy equipment. Homes will be designed to offer opportunities for home offices and installation of technology to homes providing internet access for shopping and working online.

The proposed project at a density of 7.1 dwelling units per acre is complementary to the existing scale and character of the surrounding built environment and provides a compatible transition between existing neighborhoods and the proposed community of Villa Serena. The Project is a single family detached residential community consistent with the existing single family residential character surrounding the Project Site. Homes will not exceed two stories in height and will have a variety of floor plans and architectural styles plotted to create a varied streetscene. Residences are planned to front onto streets, enabling residents to have their "eyes on the street," promoting a safe hometown feel and encouraging interaction among neighbors. Varied floor plans and architectural styles combine to provide visual interest in the streetscape. Garage widths are limited to two car spaces to minimize the view of garages from the street. Building design incorporates the stepping back of building facades, front elevation articulation, porches and deep front entries, and detail such as decorative shutters and pot shelves to break up building mass and create visual interest along the street.

The Project is consistent with this policy.

## SECTION 6. GENERAL PLAN CONSISTENCY

### **Policy CC-5.2 (cont.)**

- h. Building Articulation. Ensure that the exterior on all sides of a building are varied and articulated to provide visual interest to its surroundings
- i. Variety of Size and Scale. Encourage new developments to contain a variety of lot and dwelling sizes and scales. Some lots may be designed to accommodate one-story houses, which generally require greater lot width to avoid front elevations of houses that are dominated by garages.
- j. Upper Story Setbacks. Encourage multiple-story buildings to step the building back from the street edge at upper levels to allow sunlight into the street and create visual interest.
- k. Building Entrances. Encourage building entrances to be oriented toward a public street, serve as primary pedestrian entrances to a business, and include architectural features that give them prominence.
- l. Garage Design. Ensure garages for new single-family houses, duplexes, and townhouses are visually subordinate in importance to the house itself, especially the entry. This can be achieved by locating garages toward the back of properties, limiting the width of the garage to two car spaces, building garages as separate structures from the house, requiring garages to be set back from the front facade of the house, and encouraging the orientation of garage doors at 90 degrees to the street.

## SECTION 6. GENERAL PLAN CONSISTENCY

<p><b>Policy CC-7.1 Safety.</b> Encourage the creation of safe, walkable environments that include elements such as wide, smooth sidewalks, good lighting, safe crosswalks, clear signage, curb bulb-outs, curb cuts, street furniture, trees and traffic-calming measures, which allow people of all ages and abilities to exercise and safely access public transportation, community centers, schools, and services.</p>	<p>The proposed project includes the development of a street and sidewalk system providing a unifying element for the community and pedestrian connectivity within the community and to existing sidewalks in 15th Street. Sidewalks will be new and safely lit with street lights and low level pedestrian lighting will be provided within the common open space area. From 15th Street pedestrians can continue on existing sidewalks to Sierra Vista Park located approximately .5 miles southwest of the Project Site, to Upland Memorial Park located approximately .8 miles south of the Project Site and to general retail commercial services located at North Campus Avenue and 19th Street approximately one mile north of the Project Site. The Project is consistent with this policy.</p>
<p><b>Policy CC-7.2 Connectivity.</b> Require new development to incorporate sufficient, attractive and well marked pedestrian and vehicle connections that link to the adjacent streets and pedestrian network.</p>	<p>The proposed project includes the development of a simple two way street system with primary vehicular access at the extension of existing 15th Street westerly to connect to East 15th Street. Secondary exiting only for Project vehicles will be provided at an entry at existing 15th Street. The Project street system includes a network of walkways providing pedestrian connectivity to 15th Street and the existing sidewalks in 15th Street. The Project is consistent with this policy.</p>
<p><b>Policy CC-7.3 Upland Grid Pattern.</b> Reinforce and extend the traditional grid pattern in new developments that create new roadways. Promote short residential block lengths, typically no more than 400 feet, to create a street pattern that allows for multiple routes through a neighborhood and greater opportunities for pedestrian activity.</p>	<p>The proposed project includes the development of a simple two way street system with sidewalks on both sides of the street providing opportunities for walking through the community and to the central recreational facility within the Project Site. Due to the linear configuration of the Project Site, the project is not suitable for design of residential blocks. The Project is partially consistent with this policy.</p>
<p><b>Policy CC-7.4 Gated Communities.</b> Discourage the construction of new gated communities or walls surrounding individual projects (i.e. a single developer or builder) for infill development.</p>	<p>The proposed project will be gated due to use of the Project's roadway for basin maintenance and to maintain security of the basin. A decorative community theme wall is planned adjacent to the property due to the Project Site's adjacency to 15th Street, a flood control and detention basin, and an existing golf course. The Project is partially consistent with this policy.</p>

## SECTION 6. GENERAL PLAN CONSISTENCY

<p><b>Policy CC-7.6 Street Trees.</b> Encourage street trees to be planted in linear planting beds rather than tree wells, in order to support long-living healthy trees, except within Downtown Upland where tree wells are more conducive to urban environments.</p>	<p>The landscape plan for the Project includes the planting of street trees within parkways and residential front yards. The Project is consistent with this policy.</p>
<p><b>Policy CC-8.1 Streetscape Features.</b> Enhance the streetscapes along corridors with shade trees, street furniture, pedestrian lighting and other features that improve the pedestrian realm.</p>	<p>The landscape plan for the Project includes the use of shade trees along streets and within the common area open space. Off street pedestrian walkways will be lit with low level pedestrian lighting and park furniture may be placed along the walkway through the common area open space. The Project is consistent with this policy.</p>
<p><b>Policy CC-8.2 Streetscape Consistency.</b> Ensure consistent streetscapes in specific areas of the City to create a sense of place within neighborhoods and districts.</p>	<p>The landscape plan for the Project includes a cohesive and unified street scape plan utilizing shade trees, shrubs, and groundcover planted at consistent intervals and organized by size and type of plant. The streetscape plan for the Project is integral to the community design of Villa Serena and is designed to instill a sense of place for residents. The Project is consistent with this policy.</p>
<p><b>Policy CC-8.3 Street Tree Canopy.</b> Maintain street trees in the public right-of-way as an essential aesthetic and functional (i.e., shade) component of the community in accordance with the Conservation and Open Space Element.</p>	<p>The Project does not propose the removal of any existing street trees within the public right of way. The Project is consistent with this policy.</p>



## SECTION 6. GENERAL PLAN CONSISTENCY

<b>6.3 Economic Sustainability Element</b>	
<b>Policies</b>	<b>Specific Plan Consistency</b>
<p><b>Policy ES-4.4 New Development, Zoning, and Policy.</b> Consider fiscal and economic sustainability as one of a number of citywide goals when evaluating new development, zoning or public policy.</p>	<p>The Project will be responsible for the construction of all infrastructure necessary to serve the Project, and the developer will participate in the payment of applicable Development Impact Fees for public services. The Project is consistent with this policy.</p>
<b>6.4 Circulation Element</b>	
<b>Policies</b>	<b>Specific Plan Consistency</b>
<p><b>Policy CIR-1.7 Driveway Access Points.</b> Require that driveway access points onto arterial roadways be minimized and located to ensure the smooth and safe flow of vehicles and bicycles.</p>	<p>The Project proposes a primary vehicular access point for the Project from the extension of 15th Street west-erly connecting to the existing East 15th Street. A sec-ondary access point for vehicular exiting only is pro-posed to connect to existing 15th Street adjacent to the Project Site. Emergency vehicle access from 15th Street will be provided at both entry locations. The Project is consistent with this policy.</p>
<p><b>Policy CIR-2.6 Accessible Transit.</b> Provide pedestrian access to all transit fa-cilities and maintain pedestrian facilities that are safe, attractive, and well lit.</p>	<p>The proposed project includes the development of a street and sidewalk system providing pedestrian con-nectivity within the new community all of which connect to 15th Street. The project also includes im-provements to the roadway and construction of a new sidewalk along the north side of 15th Street complet-ing the sidewalk system along 15th Street. These im-provements will provide continuous accessibility to Alta Avenue and Grove Avenue, both of which con-nect directly to the Village Grove Shopping Center on Foothill Boulevard where several transit stops are lo-cated. These stops are part of a regional public trans- portation network that connects Upland residents and workers to the MetroLink and regional amenities and services such as the YMCA and Foothill Hospital. The Project is consistent with this policy.</p>

## SECTION 6. GENERAL PLAN CONSISTENCY

<p><b>Policy CIR-3.1 Connected Roadway Network.</b> Require future development or redevelopment to implement local street networks which allow travel by all modes and ensure connectivity with the larger City-wide roadway network.</p>	<p>The proposed project includes the development of a simple two way street system with vehicular access provided at the extension of 15th Street to connect with East 15th Street and a second exit only access provided at existing 15th Street. The Project street system includes a network of walkways providing pedestrian connectivity to 15th Street and the existing sidewalks in 15th Street. The Project street system is designed to accommodate on street bicycle travel to connect with 15th Street. The Project is consistent with this policy.</p>
<p><b>Policy CIR-3.2 Complete Streets Roadway Standards.</b> Require that pedestrian, vehicular, and bicycle circulation on both public and private property be coordinated and designed to maximize safety, comfort and aesthetics while maintaining consistency with applicable Federal, State, and San Bernardino legislation and requirements.</p>	<p>The pedestrian, vehicular and bicycle circulation plan proposed for the Project has been designed to comply with City standards and will comply with applicable Federal, State and San Bernardino legislation and requirements. The Project is consistent with this policy.</p>
<h3>6.5 Open Space and Conservation Element</h3>	
<p><b>Policies</b></p>	<p><b>Specific Plan Consistency</b></p>
<p><b>Policy OSC-1.5 New Development.</b> Encourage new development to preserve on-site natural elements and incorporate low impact development techniques</p>	<p>The site is a developed flood control and detention basin, and there are no on-site natural elements suitable for preservation. The Project is consistent with this policy.</p>
<p><b>Policy OSC-1.7 Dark Sky Protection.</b> Promote shielded, dark-sky friendly lighting for Upland’s outdoor lighting needs in order to reduce light pollution and glare; increase energy efficiency; protect wildlife; and promote better health.</p>	<p>The Specific Plan requires the use of “dark sky” lighting fixtures in streets and common areas. The Project is consistent with this policy.</p>
<p><b>Policy OSC-2.1 Street Tree Canopy.</b> Maintain the City’s tree-lined streets as an integral component of the City’s character by replacing parkway and median trees in conjunction with public and private projects.</p>	<p>The Project does not propose the removal of any existing median or parkway trees as part of the development of the Project. The Project is consistent with this policy.</p>

## SECTION 6. GENERAL PLAN CONSISTENCY

<p><b>Policy OSC-2.2 Streetscapes.</b> Maintain the City’s landscaped parkways and medians as aesthetic buffers that improve the appearance of the community.</p>	<p>Refer to Consistency statement for Policy OSC-2.1.</p>
<p><b>Policy OSC-2.3 California-Friendly Species.</b> Encourage new and existing public and private development to incorporate California-friendly and drought-tolerant vegetation into landscape plans to reduce water demand.</p>	<p>The Specific Plan includes a plant palette for the Project which emphasizes California friendly and drought tolerant plant materials in all landscaping within the community. The Project is consistent with this policy.</p>
<p><b>Policy OSC-2.4 Invasive Species.</b> Prohibit the use of plant species known to be invasive according to the California Invasive Plant Inventory. Introduction or spread of invasive plant species during construction of development projects shall be avoided by minimizing surface disturbance; seeding and mulching disturbed areas with certified weed-free native mixes; and using California-friendly, noninvasive species in erosion control plantings.</p>	<p>The Specific Plan includes a plant palette that avoids the known invasive plant species. The Project is consistent with this policy.</p>
<p><b>Policy OSC-2.5 Shade Trees.</b> Prioritize the planting of large street tree species (greater to or equal to 50 feet in height) over smaller species to facilitate a larger canopy of trees that will serve to reduce the heat island effect, lower energy costs, sequester carbon dioxide in the atmosphere, reduce stormwater runoff, and increase water retention and water quality.</p>	<p>The landscape plan for the Project includes the use of shade trees along streets and within the common area open space. The Project is consistent with this policy.</p>
<p><b>Policy OSC-3.5 Quimby Act.</b> Continue to require residential subdivisions to provide at least 3 acres of parkland per 1,000 residents or pay an in-lieu fee or some combination thereof, pursuant to Section 66477 of the California Government Code (the Quimby Act).</p>	<p>The Project will provide approximately one acre of private common area open space within the community and .15 acres of public open space improvements off-site adjacent to the Project Site. The Project will meet the City’s Quimby Act requirements through payment of a fee or combination of fee payment and contribution of private open space. The Project is consistent with this policy.</p>

## SECTION 6. GENERAL PLAN CONSISTENCY

<p><b>Policy OSC-3.15 California Friendly Plant Species.</b> When feasible, utilize California friendly noninvasive plants for landscaping park and recreational facilities.</p>	<p>The Specific Plan includes a plant palette for the Project which emphasizes California friendly and drought tolerant plant materials in all landscaping area and the common area open space within the community. The Project is consistent with this policy.</p>
<p><b>Policy OSC-3.16 Stormwater Management.</b> Integrate low impact development techniques that retain natural features for stormwater management to the greatest extent possible for all parks facilities.</p>	<p>An existing flood control and detention basin will be modified to create the development site as well as retain the continued flood control and detention operations of the modified basin. The basin will be modified as part of the Project. The Project is consistent with this policy.</p>
<p><b>Policy OSC-3.17 Trees.</b> Maintain or plant trees where appropriate to provide shade, absorb carbon, reduce the heat island effect and reduce cooling loads in shaded buildings.</p>	<p>The landscape plan for the Project includes the use of shade trees along streets, within open space areas, and will be recommended to residents for use within residential yards. The Project is consistent with this policy.</p>
<p><b>Policy OSC-3.18 Development Impact Fees.</b> Require new development to dedicate land or pay in-lieu fees to maintain park standards through the Park Acquisition and Development Impact Fee.</p>	<p>The Project will provide approximately one acre of common area open space within the community and .15 acres of public open space adjacent to the community. The Project will either pay the full Park Acquisition and Development Impact Fee or provide a combination of fee payment and private open space. The Project is consistent with this policy.</p>

## SECTION 6. GENERAL PLAN CONSISTENCY

<p><b>Policy OSC-4.1 Land Use Patterns.</b> Promote land use patterns that reduce the number and length of motor vehicle trips.</p>	<p>The Specific Plan proposes a land use pattern served by a new roadway system that provides for pedestrian and bicycle mobility within the Project Site and connectivity to existing commercial and recreational facilities within the vicinity of the Project Site. The proposed plan connects to existing circulation and transportation facilities reducing the need for construction of additional arterial and major roadway extensions or improvements to serve the Project Site. The Project street system includes a network of walkways providing pedestrian connectivity to 15th Street and the existing sidewalks in 15th Street. The Project street system is designed to accommodate on street bicycle travel to connect with 15th Street. The proximity of the Project Site within walking and biking distance to existing recreational and commercial facilities can help to reduce automobile trips to and from the Project Site. The Project is consistent with this policy.</p>
<p><b>Policy OSC-4.11 New Development.</b> Review proposed development projects as required by CEQA to ensure projects incorporate feasible measures that reduce construction and operational emissions for reactive organic gases, nitrogen oxides, and particulate matter (PM10 and PM2.5) through project design.</p>	<p>As part of the Project an Environmental Impact Report (EIR) has been prepared pursuant to the requirements of CEQA evaluating all environmental impacts of the proposed Project for consideration by the City. The Project is consistent with this policy.</p>
<p><b>Policy OSC-4.13 Best Management Practices.</b> Require best management practices to reduce air pollution associated with construction of development projects.</p>	<p>The Project will incorporate SWPP and Erosion Control measures to control dust during construction. Construction vehicles will be required to use clean burning diesel fuel. The Project is consistent with this policy.</p>
<p><b>Policy OSC-4.14 Construction Mitigation.</b> Review construction plans associated with development projects to determine if all feasible mitigation measures are included.</p>	<p>Construction plans for the Project will incorporate all mitigation measures recommended as part of the Mitigation Monitoring and Reporting Program prepared for the Project and adopted by the City. The Project is consistent with this policy.</p>
<p><b>Policy OSC-4.15 Green Building Practices.</b> Promote green building practices that support healthy indoor living and working environments that are well-ventilated and contaminant-free.</p>	<p>The Project will incorporate all green building practices required by the California Green Building Code applicable to the Project. The Project is consistent with this policy.</p>

## SECTION 6. GENERAL PLAN CONSISTENCY

<p><b>Policy OSC-5.2 Greenhouse Gas Reduction in New Development.</b> Reduce greenhouse gas emissions from new development by promoting water conservation and recycling; promoting development that is compact, mixed use, pedestrian friendly, and transit oriented; promoting energy-efficient building design and site planning; improving the jobs/housing ratio; and other methods of reducing emissions.</p>	<p>The project will implement a variety of measures that will reduce its GHG emissions. To the extent feasible, and to the satisfaction of the City, the following measures will be incorporated into the design and construction of the project:</p> <p>Construction and Building Materials.</p> <ol style="list-style-type: none"><li>Use of locally produced and/or manufactured building materials for at least 10 percent of the construction materials used for the project.</li><li>Recycle/reuse of at least 50 percent of the demolished and/or grubbed construction materials (including, but not limited to, soil, vegetation, concrete, lumber, metal, and cardboard) if feasible.</li><li>Use of “Green Building Materials,” such as those materials that are resource-efficient and are recycled and manufactured in an environmentally friendly way, for at least 10 percent of the project.</li></ol> <p>Energy Efficiency Measures.</p> <ol style="list-style-type: none"><li>Design of all project buildings to meet or exceed the California Building Code’s (CBC) Title 24 energy standard, including, but not limited to, any combination of the following:</li><li>Increased insulation such that heat transfer and thermal bridging is minimized;</li><li>Limiting air leakage through the structure or within the heating and cooling distribution system to minimize energy consumption; and</li><li>Incorporating ENERGY STAR or better rated windows, space heating and cooling equipment, light fixtures, appliances, or other applicable electrical equipment.</li><li>Install efficient lighting and lighting control systems. Use daylight as an integral part of the lighting systems in buildings.</li></ol>
---	---

## SECTION 6. GENERAL PLAN CONSISTENCY

<p><b>Policy OSC-5.2 Greenhouse Gas Reduction in New Development (cont.)</b></p>	<p>f. Installation of “cool” roofs and cool pavements. g. Installation of energy-efficient heating and cooling systems, appliances and equipment, and control systems. Install solar lights or light-emitting diodes (LEDs) for outdoor lighting or outdoor lighting that meets the City Code.</p> <p>The Project is consistent with this policy.</p>
<p><b>Policy OSC-5.4 CEQA Review.</b> Evaluate greenhouse gas emission impacts from proposed development projects as required by the California Environmental Quality Act.</p>	<p>As part of the Project an EIR has been prepared pursuant to the requirements of CEQA evaluating all environmental impacts of the proposed Project for consideration by the City. The Project is consistent with this policy.</p>
<p><b>Policy OSC-5.5 Emissions Reductions.</b> Require development projects that exceed AQMD ROG and NOX operational thresholds to incorporate design or operational features that reduce emissions equal to 15 percent from the level that would be produced by an unmitigated project.</p>	<p>As part of the Project an EIR has been prepared pursuant to the requirements of CEQA evaluating all environmental impacts of the proposed Project, including an air quality analysis, for consideration by the City. In the event the Projects exceeds AQMD ROG and NOX operational thresholds, the EIR will identify any design measures that could be incorporated into the Project to reduce emissions The Project is consistent with this policy.</p>
<p><b>Policy OSC-5.11 Minimum Green Building Standards.</b> Require new development to comply with the California Green Building Code (CalGreen) adopted by the California Building Standards Commission at the time of building permit application.</p>	<p>The proposed Project will incorporate all green building practices required by the California Green Building Code that are applicable to the Project and will incorporate energy efficient design measures as described in the consistency statement for Policy OSC-5.2. The Project is consistent with this policy.</p>
<p><b>Policy OSC-6.2 New Development.</b> Encourage solar-oriented design and passive solar heating and cooling in all new residential, commercial and civic development.</p>	<p>The proposed project will be constructed with passive solar energy design and energy efficient materials as described in the consistency statement for Policy OSC-5.2. The Project is consistent with this policy.</p>
<p><b>Policy OSC-6.4 Deciduous Trees.</b> Require that deciduous trees be planted on the south and west facing sides of new buildings onsite to reduce energy use in the summer and winter months.</p>	<p>The plant palette for the Project includes the use of deciduous trees. The precise landscape and irrigation plan submitted for City approval will assign locations for deciduous trees appropriately. The Project is consistent with this policy.</p>

## SECTION 6. GENERAL PLAN CONSISTENCY

<b>6.6 Public Services and Facilities Element</b>	
<b>Policies</b>	<b>Specific Plan Consistency</b>
<p><b>Policy PFS-1.2 Growth and Level of Service.</b> Require new development to provide adequate facilities or pay its fair share of the cost for facilities needed to provide services to accommodate growth without adversely impacting current service levels.</p>	<p>The Specific Plan requires that adequate infrastructure be constructed to serve the Project and that the Project developer pay applicable adopted Development Impact Fees as part of Project implementation. The Project is consistent with this policy.</p>
<p><b>Policy PFS-1.8 Underground Utilities.</b> Encourage undergrounding of all existing and new publicly owned utility lines, encourage undergrounding of all privately owned utility lines in new developments, and work with electricity and telecommunications providers to underground or minimize the visual impacts of existing overhead lines.</p>	<p>All new and existing public utility distribution lines of 34.5 kV or less shall be subsurface throughout the Project. The Project is consistent with this policy.</p>
<p><b>Policy PFS-2.9 Development Review Process.</b> Identify and mitigate fire hazards through the development review process.</p>	<p>Project construction plans will incorporate all Fire Department requirements identified as part of Development Plan Review of the Project. The Project is consistent with this policy.</p>
<p><b>Policy PFS-2.10 Fire Prevention.</b> Require new development to incorporate adequate emergency water flow, fire resistant design and materials, early warning systems and evacuation routes.</p>	<p>The proposed land use plan for the Project includes designated emergency vehicle access points to the Project Site. The water master plan for the Project identifies adequate water facilities for fire protection purposes. Building construction will incorporate fire resistant design and materials consistent with the California Building Code and Fire Code requirements. The Project is consistent with this policy.</p>
<p><b>Policy PFS-2.11 Emergency Vehicle Access.</b> Require new development to be accessible to emergency vehicles and to not impede the ability of service providers to provide adequate emergency response.</p>	<p>The proposed land use plan for the Project includes designated emergency vehicle access points to the Project Site. The Project is consistent with this policy.</p>



## SECTION 6. GENERAL PLAN CONSISTENCY

<p><b>Policy PFS-2.12 Public and Private Roadways.</b> Ensure that new public and private roadways are adequate in terms of width, radius and grade to accommodate fire-fighting apparatus, while maintaining Upland’s neighborhoods and small-town character.</p>	<p>Roadways within the Project will conform to Fire Department requirements for access and fire fighting purposes. The Project is consistent with this policy.</p>
<p><b>Policy PFS-9.1 Best Management Practices.</b> Require new development projects to adopt best management practices for water use efficiency and demonstrate specific water conservation measures.</p>	<p>The Specific Plan includes requirements that build-er-installed indoor appliances, including dishwashers, showers and toilets, shall be low-water use in compliance with the adopted California Building Code; drought-tolerant and/or native landscaping materials shall be used in all public and common areas to reduce water consumption; Smart Controller irrigation systems shall be installed in all public and common area landscaping; and landscape areas shall be designed on a “hydro zone” basis to group plants according to their water and sun requirements. The Project is consistent with this policy.</p>
<p><b>Policy PFS-9.4 Purple Pipe System.</b> Review new development projects to determine which are appropriate for recycled water piping systems (“purple pipe”) and require these projects to incorporate dual potable and recycled water facilities into their design.</p>	<p>The City has not required that the Project incorporate dual potable and recycled water facilities into Project design. The Project is consistent with this policy.</p>
<p><b>Policy PFS-10.2 Connection to Wastewater System.</b> Require all new development located within the City limits to connect to the public wastewater collection system.</p>	<p>As part of the Project new sewer mains will be constructed to serve the Project designed to connect to existing public sewer mains located in 15th Street. The Project is consistent with this policy.</p>
<p><b>Policy PFS-10.5 New Facilities.</b> Construct new wastewater conveyance facilities as needed.</p>	<p>Refer to consistency statement for Policy PFS-10.2 The Project is consistent with this policy.</p>

## SECTION 6. GENERAL PLAN CONSISTENCY

<p><b>Policy PFS-10.6 New Development.</b> Grant conditional approval of new development on the availability of sufficient capacity in the wastewater collection and treatment system to serve the project. Hold individual development projects responsible for their fair share of upgrades.</p>	<p>Refer to consistency statement for Policy PFS-10.2. No upgrades to existing public wastewater facilities are required to accommodate the Project. The Project is consistent with this policy.</p>
<p><b>Policy PFS-11.2 New Development.</b> Require new development to protect the quality of water bodies and natural drainage systems through site design, source controls, stormwater treatment, runoff reduction measures, best management practices (BMPs), Low Impact Development (LID), and hydromodification strategies consistent with the City's NPDES Permit.</p>	<p>As part of the Project, LID BMPs will be implemented throughout the site to maintain water quality standards. The BMPs will consist of retention and infiltration on-site. There are no natural drainage systems existing on the Project Site that will remain as part of development of the Project Site. The Project is consistent with this policy.</p>
<p><b>Policy PFS-11.3 No Net Increase.</b> Require all new development to contribute no net increase in stormwater runoff peak flows over existing conditions associated with a 100-year storm event.</p>	<p>The Project will not contribute a net increase in stormwater runoff peak flows over existing conditions associated with a 100 year storm event. The Project is consistent with this policy.</p>
<p><b>Policy PFS-11.4 Post-Development Runoff.</b> Require controlling the volume, frequency, duration, and peak flow rates and velocities of runoff from development projects to prevent or reduce downstream erosion and protect stream habitat.</p>	<p>Runoff from the proposed project can be accommodated within existing public storm water collection facilities and proposed facilities to be constructed as part of the basin modifications to be completed as part of the Project. The Project is consistent with this policy.</p>
<p><b>Policy PFS-13.2 Watershed Drainage Plans.</b> Require developers to prepare watershed drainage plans for proposed developments that define needed drainage improvements per City standards, estimate construction costs for these improvements, and comply with the City's National Pollutant Discharge Elimination System (NPDES).</p>	<p>A drainage study will be prepared for the Project to determine peak flows. Pursuant to the recommendations of the study, appropriate drainage improvements will be designed and implemented for the Project according to City Standards, and in compliance with the NPDES. The Project is consistent with this policy.</p>

## SECTION 6. GENERAL PLAN CONSISTENCY

<b>6.7 Healthy Community Element</b>	
<b>Policies</b>	<b>Specific Plan Consistency</b>
<p><b>Policy HC-1.2 Complete Neighborhoods.</b> Encourage new development to create complete neighborhoods and districts where residents can live within an easy and safe walking distance to daily services, recreational opportunities, and other community amenities that are part of a healthy lifestyle (cf: CC-4).</p>	<p>The Project street system includes a network of walkways providing pedestrian connectivity to 15th Street and the existing sidewalks in 15th Street. Pedestrians can continue on existing streets and sidewalks to Sierra Vista Park located approximately .5 miles southwest of the Project Site, to Upland Memorial Park located approximately .8 miles south of the Project Site and to general retail commercial services located at North Campus Avenue and 19th Street approximately one mile north of the Project Site. The Project is consistent with this policy.</p>
<p><b>Policy HC-1.3 Complete Streets.</b> Enhance and improve the safety, convenience, and accessibility of roadways with trees, sidewalks, bicycle lanes, and other amenities to encourage pedestrian, bike, and transit activity for residents of all ages and abilities.(cf: CIR-3)</p>	<p>The proposed street system for the Project is designed to create a distinctive sense of place for residents as a “walkable” community with pedestrian friendly streets creating an atmosphere where neighbors can visit with one another while walking along shaded sidewalks throughout the community. A simple two way street system is proposed to include a street adjacent sidewalk on both sides of the street. A separate walkway will be provided within the common area open space extending in an east/west direction through the Project. As part of the Project a separate public multi-use trail is planned on-site to connect with the existing adjacent trail located off-site within the Upland Basin. The Project is consistent with this policy.</p>
<p><b>Policy HC-2.2 Recreational Facilities.</b> Support the availability and accessibility of age appropriate recreational facilities, both private or publicly owned, to meet the diverse recreational needs of Upland residents. (cf: OSC-2)</p>	<p>The proposed project includes the provision of approximately one acre of private common area open space provided throughout the Project Site. Improvements within the common area open space include a pool, pool house with restrooms, barbeque and picnic facilities, and children’s play area. As part of the project public open space improvements will include development of a .15 off-site park. The Project is consistent with this policy.</p>

## SECTION 6. GENERAL PLAN CONSISTENCY

<b>6.8 Safety Element</b>	
<b>Policies</b>	<b>Specific Plan Consistency</b>
<p><b>Policy SAF-1.1 Exterior Noise Standards.</b> Require noise mitigation for all development where the projected exterior noise levels exceed those shown in Table SAF-1, to the extent feasible. (60 dBA)</p>	<p>As part of the Project an acoustical study will be prepared to identify exterior and interior noise levels affecting residences in the Project and construction design and materials required for the Project to mitigate exterior noise levels to 60 dBA for the Project. The Project is consistent with this policy.</p>
<p><b>Policy SAF-1.3 Interior Noise Standards.</b> Require new development to include noise mitigation to assure acceptable interior noise levels appropriate to the land use type: 45 dBA Ldn for residential, transient lodgings, hospitals, nursing homes, and other uses where people normally sleep; and 45 dBA Ldn (peak hour) for office buildings and similar uses.</p>	<p>As part of the Project an acoustical study will be prepared to identify exterior and interior noise levels affecting residences in the Project and construction design and materials required for the Project to mitigate interior noise levels to 45 dBA Ldn for the Project. The Project is consistent with this policy.</p>
<p><b>Policy SAF-1.6 Acoustical Study.</b> Require an acoustical study for all new residential developments that lie within the 65 Ldn noise contour on the Future Noise Contour Map, to ensure indoor levels will not exceed City standards. In addition, the City shall continue to enforce the California Building Code for indoor noise levels.</p>	<p>As part of the Project an acoustical study will be prepared to identify whether the Project falls within the 65 Ldn noise contour on the Future Noise Contour Map and to ensure that indoor levels will not exceed City standards. The Project is consistent with this policy.</p>
<p><b>Policy SAF-2.7 New Development.</b> Require evaluation of potential flood hazards prior to approval of development projects.</p>	<p>An evaluation of potential flood hazards to the Project is part of the EIR prepared for the Project. The Project is consistent with this policy.</p>
<p><b>Policy SAF-4.3 Development.</b> Continue to require all development, new and existing, to provide necessary service, fire hydrants and road improvements consistent with the California Fire Code.</p>	<p>Development of the Project will include construction of any and all facilities identified by the Fire Department to comply with the California Fire Code. The Project is consistent with this policy.</p>

## SECTION 6. GENERAL PLAN CONSISTENCY

<p><b>Policy SAF-4.4 Development Review.</b> Include the Fire Department in the review of development proposals to ensure projects adequately address safe design and on-site fire protection and comply with applicable fire and building codes.</p>	<p>As part of the City’s review of the proposed Project, the Fire Department will be consulted for input on the proposed Project plans. The Project is consistent with this policy.</p>
---	---

