

**PRELIMINARY  
GEOTECHNICAL EVALUATION  
FOR THE  
BARLOW CAPITAL INVESTMENTS LLC,  
CUSTOM RESIDENCE  
LOCATED AT  
8561 EL PASEO GRANDE  
LA JOLLA, CALIFORNIA 92037**

**PREPARED FOR:**

Sasha Lowther  
Jorge Barba  
8561 El Paseo Grande  
La Jolla, CA 92037

**February 20, 2020**

**REVISED December 3, 2020**

# Table of Contents

<b>INTRODUCTION.....</b>	<b>1</b>
General.....	1
Proposed Site Development.....	1
<b>RESEARCH .....</b>	<b>1</b>
General.....	1
Geologic Map Review .....	2
Review of Provided Plans.....	2
Review of Published Documents.....	2
<b>FIELD EVALUATIONS.....</b>	<b>2</b>
General.....	2
Area and Site Reconnaissance .....	3
Existing Site Development .....	3
Site Distress .....	3
Subsurface Evaluation .....	3
<b>LABORATORY TESTING.....</b>	<b>4</b>
<b>ANALYSIS AND DISCUSSION.....</b>	<b>5</b>
General.....	5
Foundations.....	5
<b>CONCLUSIONS AND RECOMMENDATIONS.....</b>	<b>6</b>
General.....	6

Seismic Forces .....	7
Foundations.....	7
Concrete Slabs-on-Grade .....	10
Retaining Walls.....	10
Surface Drainage.....	12
Construction Observation .....	12
<b>MISCELLANEOUS .....</b>	<b>13</b>
General.....	13
Maintenance Guidelines for Homeowners & Property Managers.....	13
Limitations .....	14

**ATTACHMENTS**

Site Vicinity Map.....	Figure 1
Site Location Map.....	Figure 2
Site Plan/Location of Exploratory Borings.....	Figure 3
USGS Seismic Information.....	Figure 4
Partial Blow-Up Excerpt from the “City of San Diego SEISMIC SAFETY STUDY Geologic Hazards and Faults: Grid Tile 30”.....	Figure 5
References.....	Appendix A
Subsurface Exploration.....	Appendix B
Laboratory Testing.....	Appendix C
Grading Specifications.....	Appendix D
Geologic Report.....	Appendix E

## INTRODUCTION

### General

This report presents the results of a preliminary Geotechnical evaluation for a proposed remodel and upper level addition to the existing rental property located at 8561 El Paseo Grande, in the La Jolla area of the City of San Diego, San Diego County, California (see Figure 1, "Site Vicinity Map," and Figure 2, "Site Location Map"). For the purposes of clarity and consistency within this report, the front of the house will be assumed to face west towards El Paseo Grande, and all references to direction throughout the report will be based on this assumption.

The scope of our work, conducted to date, includes the following:

- **RESEARCH**
- **FIELD EVALUATION**
- **ANALYSIS & DISCUSSION**
- **CONCLUSIONS & RECOMMENDATIONS**
- **MISCELLANEOUS**

### Proposed Site Development

The existing structure is being used for vacation rentals. <sup>C.M.M.</sup> ~~The purpose of the expansion is to increase the number of rental units.~~ Based on our review of project data, including plans provided to us, the scope of work will include the demolition of a 3,044 square foot house and new construction of a 6,153 square foot 2-story single family residence over a basement garage. Please see Figure 3, "Schematic Site Plan/Location of Exploratory Borings" for a depiction of the existing and proposed site development.

## RESEARCH

### General

Our research of the property consisted of the following reviews:

- Geologic Maps Review
- Review of Provided Plans

- Review of Published Documents

### **Geologic Map Review**

A review of available pertinent, published, geologic maps was conducted. The City of San Diego Seismic Safety Study Geologic Hazard Map suggests that a variety of geologic structures with historical faults and landslides are located near (but not on) the site. Specifically, the potentially active Scripps Fault exists 500' to the northeast of the site. It is also located approximately five hundred feet (500') west of a low to moderate risk area associated with unfavorable geologic structure. Additionally, a review of the 'Geology of the western San Diego metropolitan area, California; Del Mar, La Jolla, and Point Loma quadrangles, in Geology of the San Diego, metropolitan area, California: California Division of Mines and Geology Bulletin 200' by Kennedy, M.P., 1975, was also undertaken, suggesting that the site is underlain by the Bay Point formation, The Bay Point Formation is characterized by its similarity to slope wash of low density but stable, it is not associated with steep slopes. While there are geologic hazards around this property, the property itself is located in an area categorized as Zone 52 (an area with a low risk associated with favorable geologic structure, generally a stable formation when not in an overly steep area). No geologic hazards were at the site requiring a full geologic study and report.

### **Review of Provided Plans**

Preliminary architectural plans by Gracia Studio were provided depicting the proposed remodel of the residence as previously described. Additionally, a survey plot by Spencer Ivey was provided to us, depicting the existing site plan and topography of the site.

### **Review of Published Documents**

In addition to the geologic documents previously discussed, other published documents were reviewed as part of this study; see Appendix A.

## **FIELD EVALUATIONS**

### **General**

Representatives of Accutech Engineering Systems, Inc. visited the subject site on several occasions during the month of January and February 2020 to perform field evaluations.

Our field evaluations and reviews of the following property features taken into account for preparation of this report include the following:

- Area and Site Reconnaissance

- Existing Site Development
- Site Distress
- Subsurface Evaluation

### **Area and Site Reconnaissance**

The site is a nearly rectangular-shaped parcel of land located at 8561 El Paseo Grande, in the City of La Jolla, San Diego County, California. The site is bordered by similarly developed properties to the north and south with El Paseo Grande to the west, and an access alley to the east, both with similarly developed properties beyond.

The overall natural topography of the area is gently sloping down to the west to the Pacific Ocean. Topographically, this specific site is similar to the surrounding area with a gentle sloping grade to the west. However, approximately one hundred (100) yards west of this specific site, the gentle slope abruptly changes into a thirty-foot (30') bluff down to the Pacific Ocean. The materials that make up the bluff are “generally stable of favorable geologic structure, with no excessive erosion and no landslides”.

It appears that in order to provide a level building pad, the western portion of the subject site is fill supported by a stair-stepping system of retaining walls used for terraced vegetation.

### **Existing Site Development**

The existing site development consists of a two-story rental property. The lower level consists of a garage, living room, dining area and kitchen. The upper level houses bedrooms and baths. The northeast portion of the lot, north of the garage and east of the kitchen consisted of a Trex surfaced wood framed deck. As discussed above, the level building pad was created using retaining walls along the west side.

### **Site Distress**

There were no signs of any distress that might be caused by or associated with any geotechnical conditions at the site.

### **Subsurface Evaluation**

Two (2) exploratory borings were drilled to a maximum depth of twenty-five feet (25') during our subsurface evaluation (see Figure 3, “Site Plan/Location of Exploratory Borings”). The borings were drilled using a limited access tripod (“beaver”) drill rig. The borings were located in areas that were not occupied by existing surface hardscape or overhead obstructions. Utilities were located under the south side pavers. One (1) boring was located near the northwest walkway and the other under the rear deck

(Trex surface removed). Subsurface soils were reviewed and logged by a Licensed Geotechnical Engineer during the drilling, while disturbed and undisturbed samples were obtained for laboratory testing.

As encountered within our subsurface explorations, the site was found to be composed of topsoils, undocumented fills, slope wash, alluvium, residual soils, weathered formational deposits, and formational deposits. Soils encountered within the explorations are described as follows:

**Topsoils:**

Topsoils at the site consist of a two-inch to six-inch (2"- 6") horizon of dark brown, slightly organic, silty, clayey sands, with roots and other organic matter. Topsoils classify as SM/SC (slightly organic, silty, clayey sands) according to the Unified Soils Classification System.

**Fill Soils:**

Fill soils extending to depths ranging from two to five feet (2'-5') appear to be generated from the near surface soils portion of the original formational slope wash materials on or immediately surrounding the site. Generally, these soils consist of dark brown, olive and tan, soft to medium stiff, slightly moist, silty, sandy clays. Fill soils classify as CL (sandy, silty, clays) according to the Unified Soils Classification System and, based on laboratory testing, have a very low to low potential for expansion.

**Formational Materials:**

Formational materials were found beneath the fills ranging from two to five feet (2'-5') to the maximum depths explored of twenty-five feet (25'). These materials consisted of varying thicknesses of interbedded silty clays, to clean sands, typical of the slope wash associated with Bay Point formation. The materials ranged in color from olive to tan. Formational materials classify as anywhere from CL (clays) to SP (clean sands) according to the Unified Soils Classification System and, based on our experience with these materials, have expansion indexes (EI) ranging from 0 to medium.

**LABORATORY TESTING**

Laboratory tests were performed on the disturbed and undisturbed soil samples to determine their physical and mechanical properties, and their ability to perform appropriately under the demands of the project. The following tests were conducted on the sampled soils:

- Classification (ASTM D2487)

- Natural Moisture & Density (ASTM D2216)
- Grain Size Finer Than #200 Sieve (-200)
- Expansion Index (UBC Standard 29-2)
- Atterberg Limits (ASTM D4318)

A review of laboratory testing, including a description of the purpose and methodology of the tests, is provided, along with the quantitative and graphical (where applicable) test results (see Appendix C, “Laboratory Testing”).

## **ANALYSIS AND DISCUSSION**

### **General**

In deriving recommendations for this project, the subsurface conditions, proposed construction, and conditions of the existing structure and associated improvements were evaluated. Considerations were given to the potential for failure of the foundation soils, or the buildup of detrimental supplemental stress in the structural elements, due to differential vertical and/or lateral movement of the foundation soils.

### **Foundations**

Generally, it is advisable to support an entire structure on similar materials. When additions, remodeling, or other improvements are proposed for an existing structure, the exact nature of the existing foundation should be determined during construction. As described above, it is advisable to support an entire structure on similar materials, determining the depth of the original foundation will help determine the suitable soils. If the original building performed well with its foundation system, utilizing a similar foundation system at similar depths would ordinarily be prudent. The use of an investigation to determine the quality of the materials will help to avoid differential settlement between the existing foundation which is already settled due to the consolidation of the soils, and the new foundation, when subjected to the new loads, could consolidate to a degree where cosmetic cracking might otherwise occur.



## **CONCLUSIONS AND RECOMMENDATIONS**

### **General**

Use of the quantitative results of laboratory test data, a thorough visual inspection of the soil types on the property, previous experience and research of similar soils all aided in developing the conclusions and recommendations in this report.

In general, it is our opinion that the proposed improvements, as described, are feasible from a geotechnical standpoint, within the limitations expressed herein, provided the recommendations of this report and generally accepted construction practices are adhered to. It is also our opinion that the site could be subjected to moderate to severe ground shaking in the event of a major earthquake along any of the nearby faults discussed previously, or other faults in the Southern California region; however, the seismic risk at this site is not significantly greater than that of the surrounding developed area (see "Seismic Forces" below). The Guidelines for Evaluating and Mitigating Seismic Hazards in California (CGS, Special Publication 117) indicates "the minimum level of mitigation for a project should reduce the risk of ground failure during an earthquake to a level that does not cause the collapse of buildings for human occupancy, but in most cases, not to a level of no ground failure at all." Our recommendations are in accordance with this standard.

The proposed development should have no negative consequences from geotechnical factors if the guidelines in this report are followed and other customary development techniques are used. The proposed site development as recommended will not destabilize neighboring properties or induce settlement of adjacent structures. The proposed development will not destabilize or result in settlement of adjacent property or any City of San Diego Right-of-Way.

The site is suitable for the intended use provided the recommendations in this report are followed. Recommendations are provided for each of the following areas of concern:

- Seismic Forces
- Foundations
  - Continuous Strip / Isolated Spread Footings
- Concrete Slabs-on-Grade
- Retaining Walls
- Surface Drainage

- Construction Observation

## **Seismic Forces**

The following seismic design parameters should be used when developing loads and forces for structures:

Latitude, Longitude: 32.8631853, -117.2541316

S <sub>S</sub>	1.286
S <sub>I</sub>	0.499
S <sub>MS</sub>	1.286
S <sub>M1</sub>	0.749
S <sub>DS</sub>	0.858
S <sub>D1</sub>	0.499

Site Class: D from Table 1613A.5.2 based on

Occupancy Category: II from Table 1604.5

Therefore: Seismic Design Category: D

Since the Seismic Design Category is D increased lateral soils pressure due to seismic ground motion is required (see “**Retaining Walls**” section of this report).

## **Foundations**

The existing structure is founded on stem walls supported by footings with stem walls, supporting a framed floor. The proposed project is suited for the use of continuous strip footings and isolated spread footings, or appropriate combinations of these systems, provided special care as described herein is exercised.

Since adequate bearing materials are anticipated to be found within economic depths of the surface, a standard spread footing foundation to complement the existing foundation system may be used. A suitable foundation system with “tolerable” movement (three-quarters inch [3/4”] total and one-half inch [1/2”] differential over a horizontal distance of fifteen feet [15’]), may be constructed if the following design and construction precautions are observed:

## Continuous Strip / Isolated Spread Footings

1. All footings should be founded beneath the fills on undisturbed competent slope wash/formational material. The depth to these materials below existing grade can be inferred from inspection of the exploratory boring logs found in Appendix B, "Subsurface Exploration." The depth to undisturbed competent material will likely range from less than two feet (2') ± at the rear, to approximately five feet (5') at the northwestern corner. Observations of the soils at the interface between the existing and proposed foundations may allow for adjustments in the depths.
2. Footings bearing a minimum of twelve inches (12") into competent soils as described within this report or properly re-compacted fills, may be designed based on a maximum allowable soils pressure of one thousand two hundred (1,200) psf. Bearing values may be increased by twenty percent (20%) for each additional foot of width or depth, up to a maximum of two hundred percent (200%) of the designated values. Bearing values may be increased by thirty-three percent (33%) when considering wind, seismic, or other short duration loadings.
3. To resist lateral forces, a lateral soil bearing pressure of one hundred and fifty (150) pcf may be used, with a coefficient of friction of twenty-five-hundredths (0.25) between the soil and concrete footings.
4. Footings shall be a minimum of eight inches (8") thick and be embedded at least twelve inches (12") into the lowest adjacent grade. In addition, the following parameters should be used as a minimum for designing footing width:

<u>Floors Supported</u>	<u>Width</u>
1	12 inches
2	15 inches
3	18 inches

5. For footings constructed within or adjacent to sloping terrain, a minimum of seven feet (7') setback, as measured horizontally from the bottom of the footing to daylight, should be maintained. For retaining wall, the setback should be seven feet (7') as measured horizontally from the bottom of the footing to daylight *within competent materials beneath any fills*.
6. All footings should be reinforced with a minimum of two (2) #4 bars at the top and two (2) #4 bars at the bottom (three inches [3"] above the ground). For footings over thirty inches (30") in height, additional reinforcement should consist of at least one (1) vertical #4 bar and one (1) longitudinal #4 bar, located at eighteen inches (18") o.c. in each direction. Retaining

wall design may also be warranted to resist lateral loads. This detail should be provided on a case-by-case basis by an engineer experienced in foundation design.

7. All isolated spread footings should be designed utilizing the above given values and reinforced with #4 bars at twelve inches (12") o.c. in each direction (three inches [3"] above the ground). Isolated spread footings should have a minimum horizontal dimension of twenty-four inches (24"). If individual footings need to be enlarged/widened, we recommend underpinning rather than widening the existing footings.
8. All loose soil found at the base of footings, when an excavation is opened, should be removed and the foundation extended to undisturbed competent soils as described, or founded on over-excavated re-compacted material.
9. Our definition of "tolerable" limits of settlement should be confirmed by the Engineer or Architect of Record (EOR or AOR), and if not acceptable, modifications to these recommendations should be made.
10. Any new foundation footings and stem walls should be tied into the existing foundation with a minimum of #5 bars placed at twenty-four inches (24") o.c. (where parallel) or match the required bars in the new foundation, whichever is greater. The bars should be epoxy grouted and extend at least twelve inches (12") into the existing footing (except where new bars are perpendicular to existing stem walls, in which case, six inches [6"] of embedment should be used). They should extend twelve inches (12") into the new footing. The actual size and number of dowels required along the new/old foundation interface will depend on the design loads of the addition and should be determined by the engineer or designer of the project.
11. Rocks or liquids containing deleterious chemicals which could cause construction materials such as concrete, steel, and ductile or cast iron to corrode or deteriorate should be removed if encountered.

The preceding foundation recommendations are based on foundations bearing on suitable weathered formational materials or uniformly and properly compacted fill, and grading of the site performed in accordance with the recommendations in the "Earthwork" section of this report. None of the above is to preclude engineering requirements by the structural designer of the project, where calculations require more stringent measures. The above embedment and reinforcement considerations are minimum guidelines, which may be increased at the discretion of the engineer or designer responsible for structural considerations for the project.

## **Concrete Slabs-on-Grade**

As we understand it, interior concrete slabs-on-grade will not be utilized in the construction of the remodel to the existing residence. Exterior slabs will be suitable if the following guidelines and all other recommendations within this report are closely adhered to:

1. The upper fill soils and expansive natural soils are unsuitable for slabs. Where encountered, two feet (2') of material should be removed under slabs and be replaced with non-expansive material, compacted to 90% of maximum density as determined by ASTM D-1577.
2. A uniform layer of four inches (4") of clean sand is recommended under any new slabs in order to more uniformly support the slab, help distribute loads to the soils beneath the slab, and act as a capillary break for upward migrating moisture. In addition, a plastic moisture barrier layer (6 mil) should be placed mid-height in the sand bed to act as a vapor barrier.
3. Concrete slabs-on-grade should have a nominal thickness of four inches (4") and should be reinforced with #3 bars placed at mid-depth in the slab at twelve inches (12") on center in each direction.
4. Adequate control joints should be installed to control the unavoidable cracking of concrete that takes place when undergoing its natural shrinkage during curing. The control joints should be well located to direct unavoidable slab cracking to areas that are desirable by the designer.

The aforementioned precautions will not prevent slab movement if the underlying soils become moistened; however, they will minimize the damage if such movement occurs.

## **Retaining Walls**

We understand that no retaining walls will not be required for the structure itself, but site retaining walls to support the front (west) side of the building pad could be required and be as tall as six feet (6'). Retaining walls should be designed and constructed in accordance with the following recommendations:

1. Unrestrained cantilever retaining walls should be designed using an active equivalent fluid pressure of forty (40) pcf. This assumes that granular, free draining material will be used for backfill, and that the backfill surface will be level. The on-site soils are suitable for this. For sloping backfill, the following parameters may be utilized:

<u>Condition</u>	<u>3:1 Slope</u>	<u>2:1 Slope</u>
Active	50 pcf	60 pcf

2. Due to the Seismic Design Category D definition, an additional lateral pressure on the retaining walls due to earthquake motions must be included. An increase in soil pressure equal to twenty percent (20%) of the above provided active pressure values should be added to the walls for inertial forces due to seismic activity. All applicable increases in allowable stresses and/or other coefficients, as well as load duration factor reductions, may be utilized when including this short duration load on retaining walls.
3. Any other surcharge loadings within the 1:1 slope extending to the base of the wall should be analyzed in addition to the above values.
4. Similar to the building foundations, a coefficient of friction of 0.25 between the soil and concrete footings may be utilized to resist lateral loads in addition to the passive soil pressures above.
5. Retaining wall backfill should be placed and compacted in accordance with Appendix D, "Grading Specifications."
6. If the tops of retaining walls are restrained from movement, they should be designed using an additional uniform soil pressure of  $7 \times H$  psf, where H is the height of the wall in feet, or an at-rest equivalent fluid pressure of sixty (60) pcf, whichever is more conservative.
7. As for the building foundations, passive soil resistance may be calculated using an equivalent fluid pressure of one hundred (100) pcf, for level competent materials. This value assumes that the competent material being utilized to resist passive pressures extends horizontally two and one-half ( $2 \frac{1}{2}$ ) times the height of the passive pressure wedge of the soil. Where the horizontal distance of the available passive pressure wedge is less than two and one-half ( $2 \frac{1}{2}$ ) times the height of the soil, the passive pressure value must be reduced by the percent reduction in available horizontal length.
8. Retaining walls should be braced and monitored during compaction of backfill. If this cannot be accomplished, the compactive effort should be included as a surcharge load when designing the wall. The inclusion of the seismic force should account for this.
9. All walls should be provided with adequate back drainage to relieve hydrostatic pressure in accordance with Appendix D, Figure D-6 "Site Retaining Wall Drainage." All exterior site retaining walls should, at a minimum, have the strike mortar omitted in the lowest course to allow for drainage.

10. Retaining walls relying on a floor diaphragm for support should be completely backfilled before any framing that is to be in contact with these walls is installed.

### **Surface Drainage**

Adequate drainage precautions at any site are important. Under no circumstances should water be allowed to pond against or adjacent to footings, foundation walls, or retaining walls. The ground surface surrounding the building should be relatively impervious in nature, and slope to drain away from the building in all directions, with a minimum slope of five percent (5%) for a horizontal distance of ten feet (10'). Area drains or surface swales should then be provided to accommodate runoff and avoid any ponding of water. Roof gutters and downspouts with tightline drains should be installed on the proposed structure and discharged to flow to suitable outlets a minimum of ten feet (10') away from the foundation. Surface and area drains should not be connected to any wall drainage or underdrain system. Drainage should also be diverted away from the top of slopes to avoid erosion and "creep." Surfaces should be adequately vegetated or otherwise covered with hardscape surfaces and provided with appropriate energy dissipaters, where applicable, to avoid pending erosion.

### **Construction Observation**

The following services should be conducted under the direction and supervision of a qualified geotechnical engineer prior to or during construction of the proposed improvements (if applicable):

1. Foundation plan review, prior to submittal.
2. Observation of all excavations to verify conformance with those soils found in our borings and the nature of the existing foundations.
3. Observation of all subgrade preparation, subsequent to any removals and prior to any fill or concrete placement.
4. Observation and testing of any fill placement and preparation of compaction report (see Appendix D).

It is possible that jurisdictional agencies may require additional services for documentation during construction, where applicable. These requirements may include the review or observation of one (1) or more of the following:

- Exposed undercuts
- Reinforcing placement in slabs

- Reinforcing placement in footings
- Waterproofing
- Subdrain installation
- Area drain installations
- Finish rough grade of slopes
- Finish grade of landscaping

The owner/builder should consult the governing agencies to determine the extent of their requirements prior to commencing work, to avoid costly delays during construction, and to have the required services included in the construction budget for the project.

## **MISCELLANEOUS**

### **General**

Homesites, in general, and hillside lots, in particular, need maintenance to continue to function and retain their value. Many homeowners are unaware of this and allow deterioration of their property. It is important to familiarize homeowners with some guidelines for maintenance of their properties and make them aware of the importance of maintenance.

It is the owner's responsibility to maintain these safety features by observing a prudent program of lot care and maintenance. Failure to make regular inspection and maintenance of drainage devices and sloping areas may cause severe financial loss. In addition to his/her own property damage, he/she may also be subject to civil liability for damage occurring to neighboring properties as a result of his/her negligence.

### **Maintenance Guidelines for Homeowners & Property Managers**

The following maintenance guidelines are provided for the protection of the homeowner's investment:

- Surface drainage must be directed away from structural foundations to prevent ponding of storm waters or irrigation adjacent to footings.



- Care should be taken that slopes, terraces, berms (ridges at crown of slopes) and proper lot drainage is not disturbed. Surface drainage should be conducted from the rear yard to the street through the side yard, or to natural drainage ways within the property boundary.
- In general, roof and yard runoff should be conducted to either the street or the storm drain by non-erosive devices such as sidewalks, drainage pipes, ground gutters, and driveways. Drainage systems should not be altered without expert consultation.

### **Limitations**

It must be noted that no structure or slab should be expected to remain totally free of cracks and minor signs of cosmetic distress. The flexible nature of wood and steel structures allows them to respond to movements, resulting from minor unavoidable settlement of fill or natural soils, the swelling of clay soils, or the motions induced from seismic activity. In addition, products containing cement also shrink during natural curing. All of the above can induce stresses that frequently result in cosmetic cracking of wall and floor surfaces, such as stucco or interior plaster, floor tiles, or other brittle finishes. This is especially true when considering an addition or modification to an existing building.

Data for this report was derived from surface observations at the site, knowledge of local conditions, and a visual observation of the soils exposed in the subsurface excavations. The recommendations in this report are based on our experience in conjunction with the limited soils exposed at this site and neighboring sites. We believe that this information gives an acceptable degree of reliability for anticipating the behavior of the proposed improvements; however, our recommendations are professional opinions and cannot control nature, nor can they assure the soil profiles beneath or adjacent to those observed; therefore, no warranties of the accuracy of these recommendations, beyond the limits of the obtained data, is herein expressed or implied unless we are contacted to observe all excavations. This report is based on the evaluation at the described site and on the specific anticipated construction as stated herein. If either of these conditions is changed, the results would also most likely change.

Man-made or natural changes in the conditions of a property can occur over a period of time. In addition, changes in requirements due to state-of-the-art knowledge and/or legislation are rapidly occurring. As a result, the findings of this report may become invalid due to these changes; therefore, this report for the specific site is subject to review and not considered valid after a period of one (1) year, or if conditions as stated above are altered. This report is not meant to imply nor does it offer any warranty whatsoever as to the future performance or value of the property. Use of this report is for the sole purpose of the client. It is understood that Accutech Engineering Systems, Inc. will be compensated in full for any costs of litigation that may arise from the use of this report, including, but not limited to, fees for staff, attorneys, and/or expert witness testimony.

It is the responsibility of the owner or his representative to ensure that the information in this report be incorporated into the plans and/or specifications and construction of the project. It is advisable that a contractor familiar with construction details typically used to deal with the local subsoil and seismic conditions be retained to build the structure.

We hope the report provides you with necessary information to continue with the development of the project. If you have any questions regarding this report, or if we can be of further service, please do not hesitate to contact us at 619.261.2619.

Very truly yours,

**ACCUTECH ENGINEERING SYSTEMS, INC.**



Robert J. Randall  
RGE #707

RJR: dm



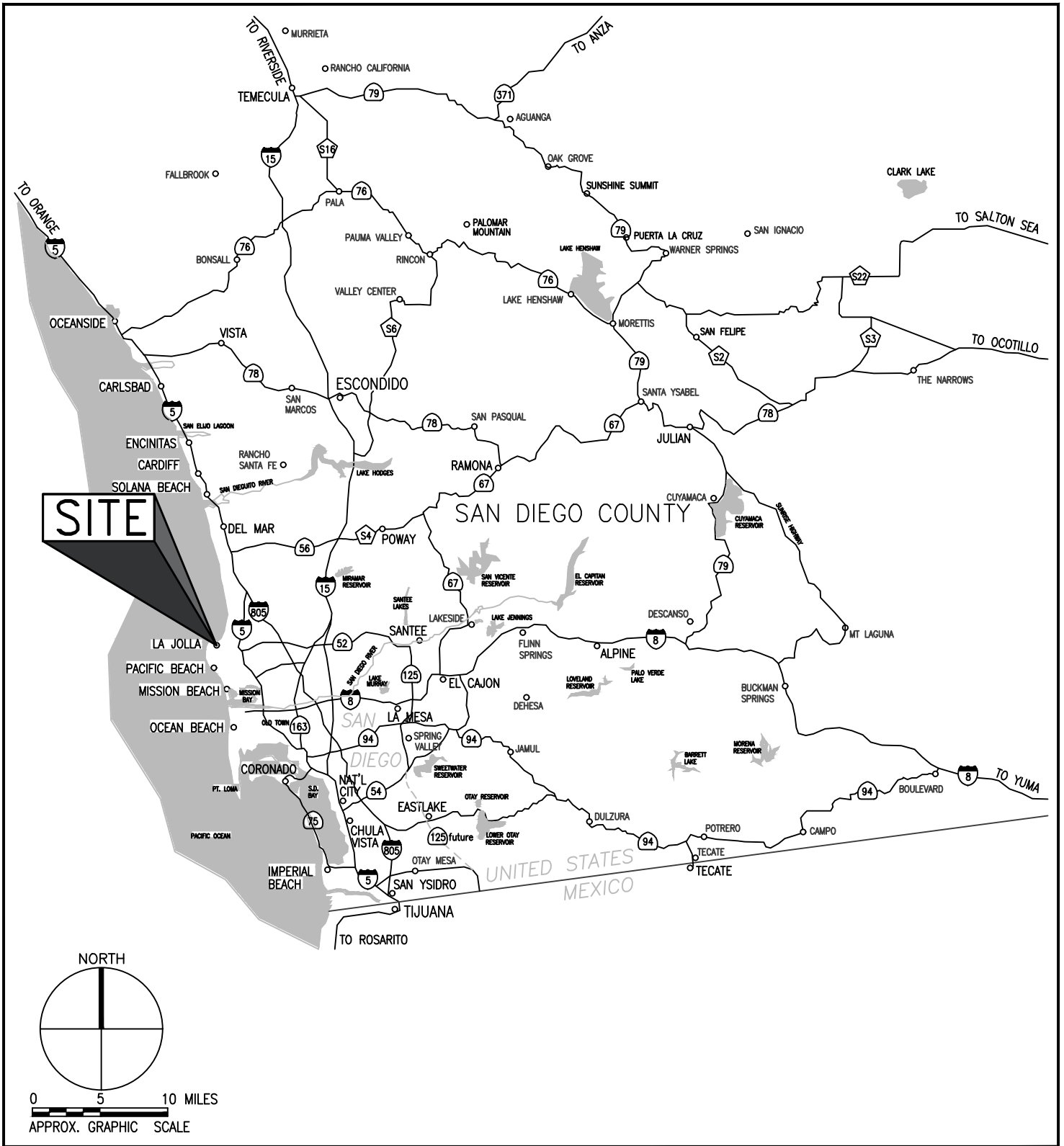

## SITE VICINITY MAP

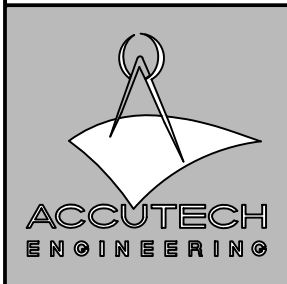

**LOWTHER/ BARBA RENTAL PROPERTY**  
**8561 EL PASEO GRANDE**  
**LA JOLLA, CA 92037**

DATE: 2/10/2020	DRWN BY: DP	FIGURE NO.: 1	PROJECT NO.: 20641-1
--------------------	----------------	------------------	-------------------------

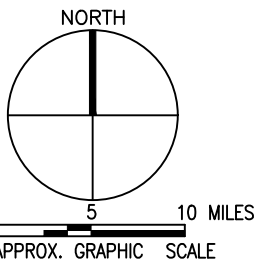
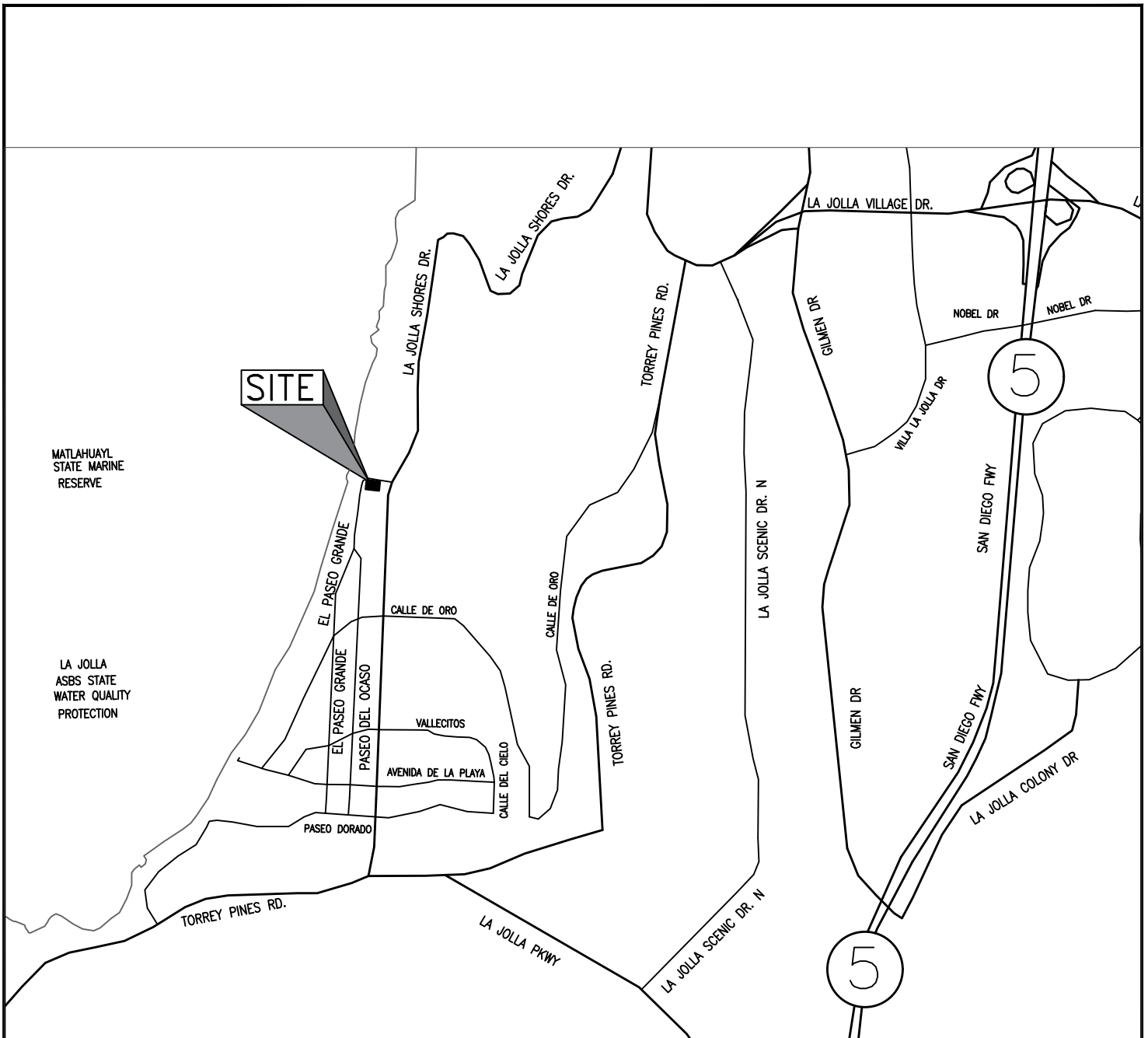

### SITE LOCATION MAP

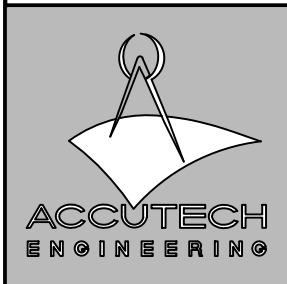

<p>LOWTHER/BARBA RENTAL PROPERTY 8561 EL PASEO GRANDE LA JOLLA, CA 92037</p>			
DATE:	DRWN BY:	FIGURE NO.:	PROJECT NO.:
2/10/2020	DP	2	20641-1

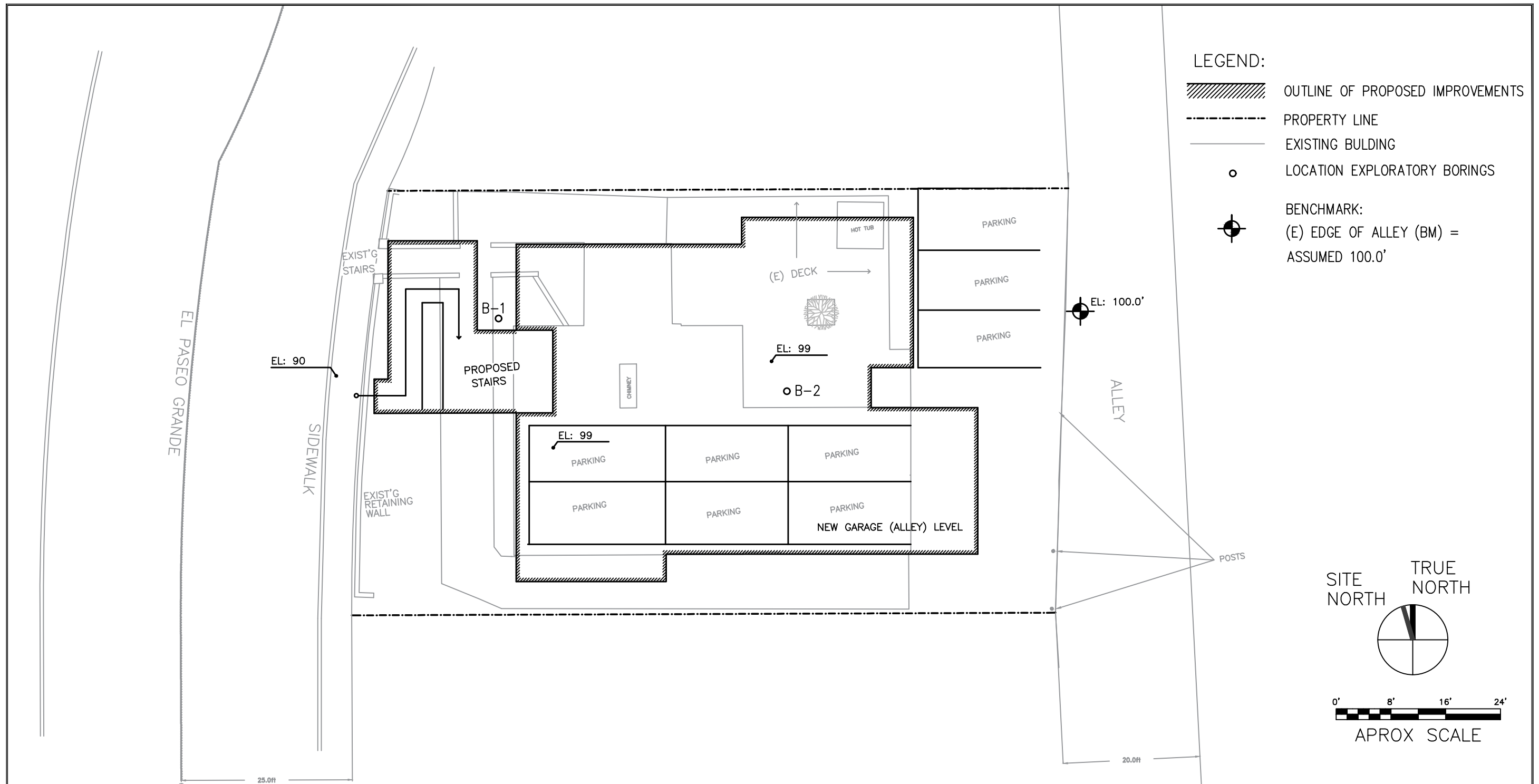

**SCHEMATIC SITE PLAN/ LOCATION OF EXPLORATORY BORINGS**

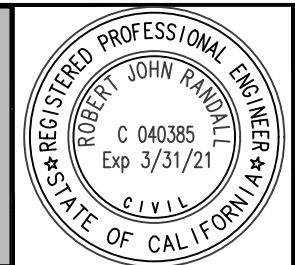
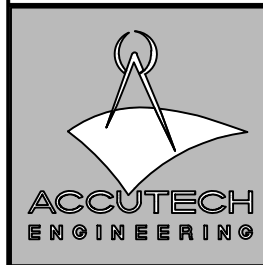

<b>LOWTHER/BARBA RENTAL PROPERTY</b> 8561 EL PASEO GRANDE LA JOLLA, CA 92037			
DATE:	DRAWN BY:	FIGURE NO.:	PROJECT NO.:
2/10/2020	DP	3	20641-1



# 8561 El Paseo Grande

8561 El Paseo Grande, La Jolla, CA 92037, USA

Latitude, Longitude: 32.8631853, -117.2541316



<b>Date</b>	2/4/2020, 2:27:46 PM
<b>Design Code Reference Document</b>	ASCE7-10
<b>Risk Category</b>	II
<b>Site Class</b>	D - Stiff Soil

Type	Value	Description
$S_S$	1.286	$MCE_R$ ground motion. (for 0.2 second period)
$S_1$	0.499	$MCE_R$ ground motion. (for 1.0s period)
$S_{MS}$	1.286	Site-modified spectral acceleration value
$S_{M1}$	0.749	Site-modified spectral acceleration value
$S_{DS}$	0.858	Numeric seismic design value at 0.2 second SA
$S_{D1}$	0.499	Numeric seismic design value at 1.0 second SA

Type	Value	Description
SDC	D	Seismic design category
$F_a$	1	Site amplification factor at 0.2 second
$F_v$	1.501	Site amplification factor at 1.0 second
PGA	0.581	$MCE_G$ peak ground acceleration
$F_{PGA}$	1	Site amplification factor at PGA
$PGA_M$	0.581	Site modified peak ground acceleration
$T_L$	8	Long-period transition period in seconds
$SsRT$	1.286	Probabilistic risk-targeted ground motion. (0.2 second)
$SsUH$	1.534	Factored uniform-hazard (2% probability of exceedance in 50 years) spectral acceleration
$SsD$	2.434	Factored deterministic acceleration value. (0.2 second)
$S1RT$	0.499	Probabilistic risk-targeted ground motion. (1.0 second)
$S1UH$	0.571	Factored uniform-hazard (2% probability of exceedance in 50 years) spectral acceleration.
$S1D$	1.058	Factored deterministic acceleration value. (1.0 second)
$PGAd$	0.937	Factored deterministic acceleration value. (Peak Ground Acceleration)
$C_{RS}$	0.839	Mapped value of the risk coefficient at short periods
$C_{R1}$	0.874	Mapped value of the risk coefficient at a period of 1 s

## DISCLAIMER

While the information presented on this website is believed to be correct, SEAOC / OSHPD and its sponsors and contributors assume no responsibility or liability for its accuracy. The material presented in this web application should not be used or relied upon for any specific application without competent examination and verification of its accuracy, suitability and applicability by engineers or other licensed professionals. SEAOC / OSHPD do not intend that the use of this information replace the sound judgment of such competent professionals, having experience and knowledge in the field of practice, nor to substitute for the standard of care required of such professionals in interpreting and applying the results of the seismic data provided by this website. Users of the information from this website assume all liability arising from such use. Use of the output of this website does not imply approval by the governing building code bodies responsible for building code approval and interpretation for the building site described by latitude/longitude location in the search results of this website.



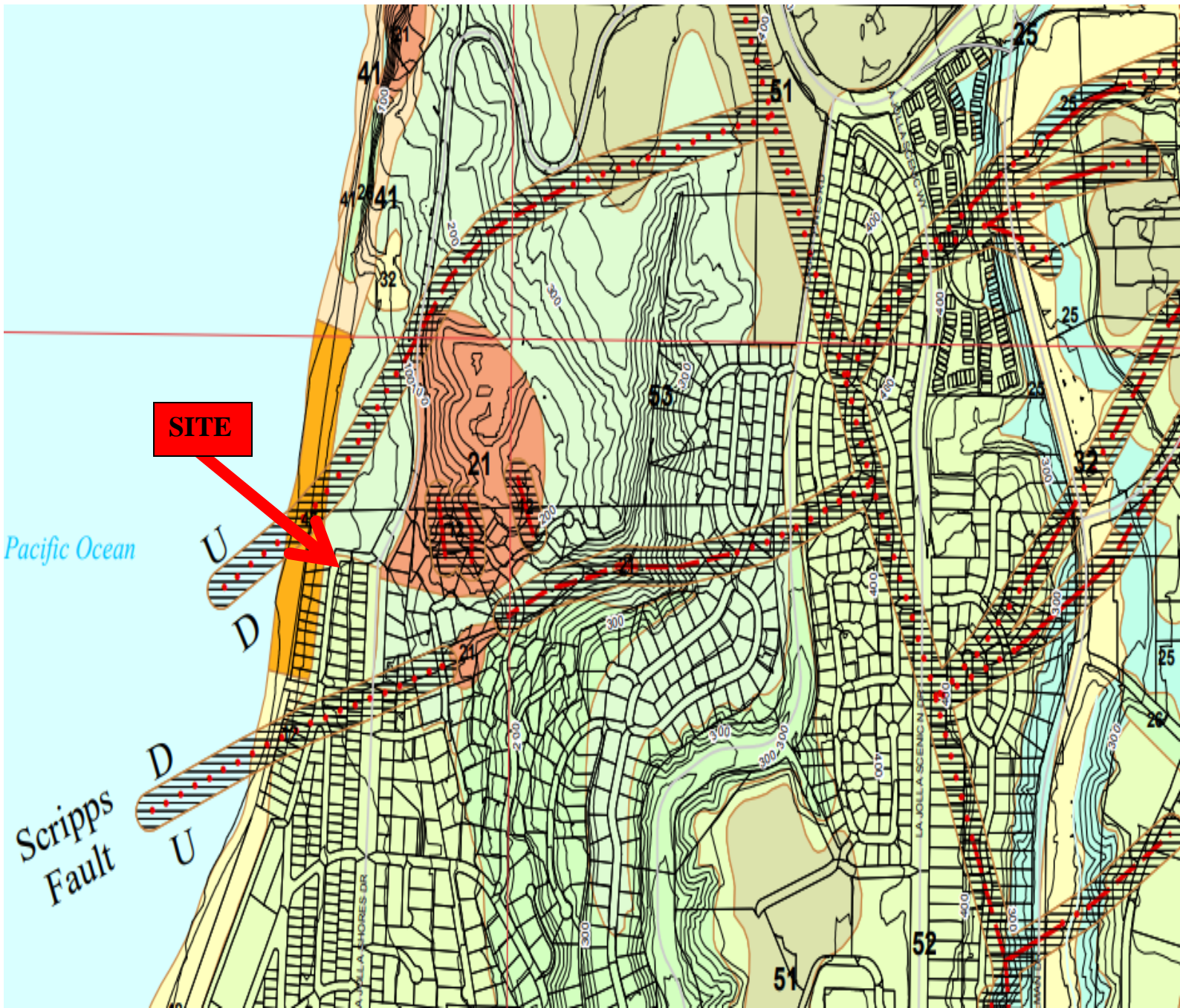

Partial Blow-Up Excerpt from the City of San Diego SEISMIC SAFETY STUDY Geologic Hazards and Faults

GRID TILE: 30



# **APPENDIX A**

## ***REFERENCES***

## REFERENCES





1. Bowles, J.E., 1982, *Foundation Analysis and Design*, 3rd Edition, McGraw Hill.
2. California Building Standards Commission, *2007 California Building Code*.
3. City of San Diego, 1995, *San Diego Seismic Safety Study*.
4. Department of Public Works, County of San Diego, California, 1977, *Faults and Epicenters*, Scale of 1 inch:2 miles.
5. Greensfelder, R. W., 1974, *Maximum Credible Rock Acceleration from Earthquakes in California*.
6. Harris, M.E., 1987, *Geology of San Diego County, California, A Bibliography with Subject Index*, California Division of Mines and Geology, Special Publication 96.
7. Hart, Earl W., 1990, *Fault-Rupture Hazard Zones in California*, California Division of Mines and Geology, Special Publication 42, Revised 1990.
8. International Conference of Building Officials, *2009 International Building Code*. Department of the Navy, *Naval Facilities Engineering Command Design Manual 7.2*, May 1982.
9. Jennings, C.W., 1977, *Geologic Map of California*, California Division of Mines and Geology, Scale 1:750,000.
10. Jennings, C.W., 1992, *Preliminary Fault Map of California*, California Division of Mines and Geology, Revision of the 1975 Fault Map of California, Scale 1:750,000, Open File Report 92-03.
11. Kennedy, M.P. and Peterson, G.L., 1975, *Geology of the San Diego Metropolitan Area, California*, California Division of Mines and Geology, Bulletin 200.
12. Kennedy, M.P., Tan, S.S., Chapman, R.H. and Chase, G.W., 1975, *Character and Recency of Faulting, San Diego Metropolitan Area, California*, California Division of Mines and Geology, Special Report 123.
13. *Landslide Hazard Identification Program*, California Division of Mines and Geology, Annual Report 1990.
14. Pacific Section, 1991, *Eocene Geologic History San Diego Region*, Society of Economic Paleontologists and Mineralogists, Book 68.

15. San Diego Planning Department, County of San Diego, California, 1974, *Landslides*, Scale of 1 inch :2 miles.
16. Seed, H.B. and Idriss, I.M., 1982, *Ground Motions and Soil Liquefaction During Earthquakes*, Earthquake Engineering Research Institute.

# **APPENDIX B**

## ***SUBSURFACE EXPLORATION***

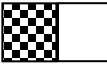
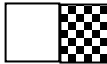
## LEGEND

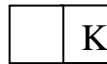
Symbol	Description
	Groundwater level or groundwater seepage at the time of drilling could vary seasonally.
	Location of disturbed sample taken in a boring using a <u>standard</u> tube sampler, 2 inch O.D. 1 3/8 inch I.D. See Blow Count.
	Location of bulk disturbed sample taken from auger cuttings in borings or shovel in test pits.
	Location of Undisturbed sample taken in a test pit using a 2 3/8 inch I.D. modified California Split Tube Sampler liner rings.
	Location of Undisturbed sample taken in a test pit using a 2 3/8 inch I.D. "California" liner ring and hand drive adapter.
	Location of carved, chuck or block Undisturbed sample in a test pit.
	Location of Undisturbed sample taken using a 3 inch O.D. thin-walled tube sampler (Shelby Tube) hydraulically pushed.
<b>D</b>	Sample disturbed during sampling. No recovery.
	Sample obtained using a 3400 lb. "Kelly bar" free falling (12")
Blow Count	<p>Number of drives of sampling device for 6 inch sample, unless noted otherwise. For example:</p> <p style="margin-left: 40px;">14/13/12 =      14 blows of a 140 lb. weight free falling (30")           (4)            were required to drive the sampling device the first 6 inches                                  then 13 blows for the next 6", etc.</p> <p style="margin-left: 40px;">50(4)            50 blows of the weight were required the drive the                          sampling device 4 inches.</p> <p style="margin-left: 40px;"><math>\frac{18}{14}</math> =            Blow count converted to SPT when other samplers                          are used. See attached "Blow Count Conversion".</p>

## DEFINITION OF TERMS

Term	Definition
$\phi$	Angle of internal friction (degrees)
-200	Material passing the #200 sieve (%)
App Dnsty	Apparent Density is the estimated density of the soil, at the depth noted, during field observation and classification (pounds per cubic foot).
App Moist	Apparent Moisture is the estimated moisture content, at the depth noted, during field observation and classification (%).
Cf	Coefficient of Friction
DD	Dry Density
EI	Expansion Index
HD	Hand Drive Sample
HP	Unconfined compressive strength (hand penetrometer, tsf)
ID	Inside Diameter
KSF	Kips per square foot
LL	Liquid Limit (%)
MC	Natural Moisture Content
MSL	Mean sea level
NP	Non-Plastic
OD	Outside Diameter
PI	Plastic Index (%)
PL	Plastic Limit (%)
PSF	Pounds per square foot
SPT	Standard Penetration Test
TSF	Tons per square foot
UC	Unconfined compressive strength (cohesion intercept, ksf)

USCS	Unified Soil Classification System
WD	Wet Density

## BLOW COUNT CONVERSION (N-VALUE)

The blow count representation of the penetration resistance of a soil (N-Value) is achieved by driving a standard 2 inch O.D. split-barrel sampler utilizing a drive weight of 140 pounds impacting the sampler from a fall of 30 inches. This method is known as the Standard Penetration Test (SPT) and is also used to obtain disturbed samples. Frequently, a larger sampler with brass rings is used to obtain undisturbed samples. A correlation between SPT blow count and blow count from a larger diameter ring lined sampler used may be obtained by considering drive energy created by the fall of the 140 pound weight over the effective cross sectional area of the samplers. The drive energy of a larger 3 inch diameter sampler (133 ft-lb/in<sup>2</sup>) divided by the drive energy of the standard 2 inch diameter sampler (211 ft-lb/in<sup>2</sup>) results in a conversion factor of 0.630. The blow count of the 3 inch diameter sampler may be multiplied by this conversion factor to equate it to SPT blow count.

Correlation of blow count between SPT and ring lined split-barrel drive sampler:

Given: Standard drop hammer weight of 140 pound drop of 30 inches

O.D. SPT 2 in.

O.D. Split-barrel 3 in.

I.D. SPT 1.375 in.

I.D. Split-barrel 2.375 in.

Effective Area of SPT:

$$A = \pi d^2/4$$

$$A = \pi(2 \text{ in})^2/4 - \pi(1.375 \text{ in})^2/4$$

$$\text{Effective Area} = 1.657 \text{ in}^2$$

Drive Energy SPT:

$$(140 \text{ lb})(2.5 \text{ ft})/1.657 \text{ in}^2$$

$$\underline{211 \text{ ft-lb/in}^2}$$

Effective Area of Ring Lined Split-Barrel Sampler:

$$A = \pi d^2/4$$

$$A = \pi(3 \text{ in})^2/4 - \pi(2.375 \text{ in})^2/4$$

$$\text{Effective Area} = 2.638 \text{ in}^2$$

Drive Energy Ring Lined Split-Barrel Sampler:

$$(140 \text{ lb})(2.5 \text{ ft})/2.638 \text{ in}^2$$

$$\underline{133 \text{ ft-lb/in}^2}$$



∴ Conversion (C):

$$C = 133 \text{ ft-lb/in}^2 \div 211 \text{ ft-lb/in}^2$$

$$C = 0.630$$



**BORING LOG B-1**

<b>Equipment:</b> Tripod Portable Drill		<b>Type:</b> Boring <b>Dimensions:</b> 6" Diameter Auger				<b>Date Logged:</b> 2/4/2020		
<b>Hole Elevation:</b> 96 <b>Datum:</b> 100		<b>Groundwater Depth:</b> None *See Note				<b>Logged By:</b> RJR		
D e p t h (ft)	<b>Location:</b> Front Planter - NW Corner of Residence		<b>Field Information</b>				<b>Laboratory</b>	<b>Misc.</b>
	USCS	Field Description and Classification	Sample Type	Blow Count 6"	Apparent Density (pcf)	Apparent Moisture (%)		
- - 2- - - 4- -	CL	CLAY, Silty, slightly sandy, soft to medium stiff, dark brown, moist. Easy drilling. Hand Auger to 5'  <b>FILL</b>						
- - 6- - - 8- - - 10- - 12- - 14- -	CL  Lenses of SC to SP  ML	CLAY, Sandy, silty, medium stiff to stiff, olive-gray w/some brown lenses.  Harder with depth.  Lenses of sand.  Much more water at 8'; see Groundwater Depth note.  Much harder drilling at 10'  <b>BAY POINT FORMATION</b>	 10/12/15   10/15/22   12/25/27				DD = 108.5 MC = 12.8 -200 = 68 LL = 37 PL = 11 PI = 18 EI = 58  DD = 113.5 MC = 16.9 -200 = 42 LL = 37 PL = 25 PI = 12	
16- - - 18- - 20-		Lost auger in hole when removing for sampling.						
<b>Project Name:</b> Lowther/Barba Rental Remodel					<b>Project #:</b> 20641-1			
<b>Project Location:</b> 8561 El Paseo Grande, La Jolla CA 92037					<b>Figure #:</b> B1			

\* No visible water when measured after 24 hours

**BORING LOG B-2**

<b>Equipment:</b> Tripod Portable Drill		<b>Type:</b> Boring <b>Dimensions:</b> 6" Diameter Auger			<b>Date Logged:</b> 2/4/2020		
<b>Hole Elevation:</b> 98 <b>Datum:</b> 100		<b>Groundwater Depth:</b> None * See Note			<b>Logged By:</b> RJR		
D e p t h (ft)	<b>Location:</b> South side of rear deck		<b>Field Information</b>			<b>Laboratory</b>	<b>Misc.</b>
	USCS	Field Description and Classification	Sample Type	Blow Count 6"	Apparent Density (pcf)	Apparent Moisture (%)	
-	CL	CLAY, Silty, slightly sandy, soft to medium stiff, dark brown, moist. Easy drilling. <b>FILL</b>		5/6/11			DD = 96.5 MC = 13.8
2-	CL	CLAY, Silty, slightly sandy, soft to medium stiff, dark brown, moist. Easy drilling. <b>FILL</b>					
-	CL	CLAY, Silty, slightly sandy, soft to medium stiff, dark brown, moist. Easy drilling. <b>FILL</b>					
-	CL	CLAY, Silty, slightly sandy, soft to medium stiff, dark brown, moist. Easy drilling. <b>FILL</b>					
4-	CL SC	CLAY, Silty, slightly sandy, soft to medium stiff, dark brown, moist. Easy drilling. <b>FILL</b>					
-	CL SC	CLAY, Silty, slightly sandy, soft to medium stiff, dark brown, moist. Easy drilling. <b>FILL</b>					
6-	CL SC	CLAY, Silty, slightly sandy, soft to medium stiff, dark brown, moist. Easy drilling. <b>FILL</b>					
-	CL SC	CLAY, Silty, slightly sandy, soft to medium stiff, dark brown, moist. Easy drilling. <b>FILL</b>					
8-	SP	CLAY, Silty, slightly sandy, soft to medium stiff, dark brown, moist. Easy drilling. <b>FILL</b>					
-	SP	CLAY, Silty, slightly sandy, soft to medium stiff, dark brown, moist. Easy drilling. <b>FILL</b>					
10-	CL SC	CLAY, Silty, slightly sandy, soft to medium stiff, dark brown, moist. Easy drilling. <b>FILL</b>					
-	CL SC	CLAY, Silty, slightly sandy, soft to medium stiff, dark brown, moist. Easy drilling. <b>FILL</b>					
12-	CL SC	CLAY, Silty, slightly sandy, soft to medium stiff, dark brown, moist. Easy drilling. <b>FILL</b>					
-	CL SC	CLAY, Silty, slightly sandy, soft to medium stiff, dark brown, moist. Easy drilling. <b>FILL</b>					
14-	CL SC	CLAY, Silty, slightly sandy, soft to medium stiff, dark brown, moist. Easy drilling. <b>FILL</b>					
-	CL SC	CLAY, Silty, slightly sandy, soft to medium stiff, dark brown, moist. Easy drilling. <b>FILL</b>					
16-	CL SC	CLAY, Silty, slightly sandy, soft to medium stiff, dark brown, moist. Easy drilling. <b>FILL</b>					
-	CL SC	CLAY, Silty, slightly sandy, soft to medium stiff, dark brown, moist. Easy drilling. <b>FILL</b>					
18-	CL SC	CLAY, Silty, slightly sandy, soft to medium stiff, dark brown, moist. Easy drilling. <b>FILL</b>					
-	CL SC	CLAY, Silty, slightly sandy, soft to medium stiff, dark brown, moist. Easy drilling. <b>FILL</b>					
20-	CL SC	CLAY, Silty, slightly sandy, soft to medium stiff, dark brown, moist. Easy drilling. <b>FILL</b>					
<b>Project Name:</b> Lowther/Barba Rental Remodel					<b>Project #:</b> 20641-1		
<b>Project Location:</b> 8561 El Paseo Grande, La Jolla CA 92037					<b>Figure #:</b> B2 - 1 of 2		

\* No visible water when measured after 24 hours

## BORING LOG B-2

<b>Equipment:</b> Tripod Portable Drill		<b>Type:</b> Boring <b>Dimensions:</b> 6" Diameter Auger				<b>Date Logged:</b> 2/4/2020		
<b>Hole Elevation:</b> 98 <b>Datum:</b> 100		<b>Groundwater Depth:</b> None * See Note				<b>Logged By:</b> RJR		
D e p t h (ft)	<b>Location:</b> South side of rear deck		<b>Field Information</b>				<b>Laboratory</b>	<b>Misc.</b>
	USCS	Field Description and Classification	Sample Type	Blow Count 6"	Apparent Density (pcf)	Apparent Moisture (%)		
-	SP	<b>(AS BEFORE)</b>						
22-		CLAY, Sandy, silty, medium stiff to stiff, olive-gray w/some brown lenses. Moist to wet, lenses of CLEAN sand.						
-		<b>BAY POINT FORMATION</b>						
24-								
-								
26-		Bottom of hole at 25' Similar drilling since 10'						
-								
28-								
-								
30-								
-								
32-								
-								
34-								
-								
36-								
-								
38-								
-								
40-								
<b>Project Name:</b> Lowther/Barba Rental Remodel						<b>Project #:</b> 20641-1		
<b>Project Location:</b> 8561 El Paseo Grande, La Jolla CA 92037						<b>Figure #:</b> B2 - Page 2 of 2		

\* No visible water when measured after 24 hours

# **APPENDIX C**

## ***LABORATORY TESTING***

## LABORATORY TESTING

Laboratory tests were performed in general accordance with the accepted practice of the American Society for Testing and Materials (ASTM), the Uniform Building Code (UBC), and other suggested methods. A brief description of the tests performed is as follows:

- **CLASSIFICATION** - Field classifications are prepared in the field and are verified in the laboratory by a visual examination per (ASTM D2487). Further classification is provided with the aid of supplemental laboratory testing of selected samples obtained in the field. Samples are classified, as coarse or fine grained, well or poorly graded, high or low plasticity, per the Unified Classification System.
- **NATURAL MOISTURE & DENSITY** - Moisture contents and dry densities are determined for representative soil samples in accordance with ASTM D2216. This information is an aid to classification and assists in recognition of variations in material consistency with depth. The dry unit weight is determined in pounds per cubic foot, and the in-situ moisture content is determined as a percentage of the dry unit weight. The results are summarized in the excavation and/or boring logs and the summary of laboratory testing within this section of the report.
- **ATTERBERG LIMITS** - The plastic and liquid limits and the plasticity index are determined in accordance with ASTM D4318. This test is performed on the portions of the sample passing the #40 sieve, and assists in classifying the fine grained soils into low or high plasticity fines.
- **BULK DENSITY** - The density of materials by the water displacement method is used for determining the bulk density of an irregular shaped soils or rock sample. By weighing a sample in both a natural state and submerged state, the buoyant force is obtained. This equates to the volume of displaced water, and thus the volume of the sample. The sample is coated with wax to keep water from seeping into it. Calculations are performed to compensate for the weight of the wax, and bulk densities (pounds per cubic foot) of the samples are obtained.
- **GRAIN SIZE FINER THAN #200 SIEVE (-200)** - Samples are washed through a #200 sieve (opening size of 0.7mm) in accordance with ASTM D1140. The weight of the dried material passing the #200 sieve is represented as a percentage of the total sample dry weight. The results are presented on the gradation test results sheets, within this section of the report.
- **GRAIN SIZE DISTRIBUTION** - The grain size distribution is determined for representative samples of the native soils in accordance with ASTM D422. Samples are washed through a #200 sieve (opening size of 0.7mm) and then mechanically vibrated through a series of sieves of various size openings. The results are presented on the gradation test results sheets, within this section of the report.

- **OPTIMUM MOISTURE / DENSITY** - The maximum dry density and optimum moisture content of typical soils are determined in the laboratory in accordance with ASTM D1557, Methods A and/or C. Method A specifies that a four (4) inch diameter cylindrical mold of 1/30 cubic foot of volume be used for soils. Method C specifies that a six (6) inch diameter cylindrical mold of 1/13 cubic foot of volume be used for soils. Moisture Content of the soil sample is varied to determine the “Optimum Moisture Content” at which the “Maximum Density” occurs. The results of these tests are used in conjunction with the field density tests to determine the degree of compaction of the fill and/or native soils.
- **EXPANSION INDEX** - Expansion Index tests on remolded samples are performed on representative samples of soils per UBC Standard 29-2. The test is performed on the portion of the sample passing the #4 standard sieve. The sample and is then compacted in a 4-inch-diameter mold at a saturation of approximately 50 percent. The specimen is placed in a consolidometer with porous stones at the top and bottom, subjected to a total normal load of 12.63 pounds (144.7 psf), and the sample is allowed to consolidate for a period of 10 minutes. The sample is submerged in water and the change in vertical movement is measured and recorded until the rate of expansion becomes nominal. The expansion index is reported as the total vertical displacement in inches times 1000.
- **DIRECT SHEAR** - Direct Shear tests are performed in accordance with ASTM D3080, to determine the failure envelope relating confining pressure to shear strength, based on yield shear strength. This is given as “0”, the angle of internal friction and “C” the unconfined strength (cohesion intercept). A minimum of three (3) samples are tested at different vertical loads. The shear stress is applied at a constant rate of strain at approximately 0.05 inch per minute and the ratio is thus obtained and plotted.
- **RESIDUAL DIRECT SHEAR** - Residual shear samples are sheared, as describe in the preceding paragraph, with a greatly reduced shearing rate. The upper portion of the specimen is pulled back to the original position and the shearing process is repeated until no further decrease in shear strength is observed with continued shearing (at least 3 times). There are two methods to obtain the shear values: (a) the shearing process is repeated for each load applied and the shear value for each normal load is recorded. One or more specimens can be used in this method; (b) only one specimen is needed and a very high normal load (approximately 9,000 psf) is applied from the beginning of the shearing process. After the equilibrium state is reached (after “relaxed”), the shear value for that normal load is recorded. The normal loads are then reduced gradually prior to re-shearing. The shear values are recorded for different normal loads after they are reduced and the sample is “relaxed”. This test is of value in areas of known hillside failures and for hillside stability repair.
- **SWELL/CONSOLIDATION** - A natural undisturbed, or re-molded sample is used to determine the potential for expansion or consolidation under anticipated loading conditions when the sample is subjected to increased water content. This test is run in accordance with ASTM D2435 and D4546 and performed on a single counter balance lever system type consolidometer. Samples are confined within a

ring and loaded vertically with pressures similar to those anticipated under expected real life conditions.

A seating cycle is applied to compensate for disturbances to the sample during transport. The sample is loaded to approximately one-half (1/2) over burden pressure by doubling successive loads. Each loading condition is placed for one (1) hour until approximately one-half (1/2) over burden pressure, then the sample is rebounded to start the consolidation test.

The sample is then allowed to consolidate once again under varying load conditions, until movement is nominal at each load, and the final reading is recorded for each load. The load amount is increased until the anticipated load is reached, at which time the sample is submerged in water, and allowed to consolidate further or expand when subjected to this increased moisture until movement is once again nominal, and the final reading recorded. The sample is then subjected to additional increased loads until the data provides enough information to reasonably predict the potential for consolidation and/or swell under varying anticipated conditions.

- **HYDROMETER ANALYSIS** - The particle size distribution of the fine portion of a soil sample is determined in accordance with ASTM D1140. This test is run when the specific determination of the particle size distribution of the fine grained soils (-200) beyond standard classification (using -200 testing, in conjunction with Atterberg Limits) is required.
- **R VALUE** - This test is becoming more widely used for the design of pavement sections. Resistance (“R” Value) testing is performed by the California Materials Method No. 301 for base, sub-base, and base course. Three samples are prepared. Exudation pressures and “R” values are determined for each specimen. The graphically determined “R” value, at an exudation pressure of 300 psi, is reported.
- **SOLUBLE SULFATES** - The soluble sulfate content of representative samples is evaluated by standard geochemical techniques. California Materials Method No. 417.
- **SAND EQUIVALENT (S.E.)** - Sand Equivalent (S.E.) testing is performed in general accordance with AASHTO T176.

# LABORATORY TEST RESULTS SUMMARY SHEET

Sample				Apparent Natural Moisture & Density		LL	PL	PI	Passing #200 Sieve (-200) %	Classification	Comments
Loc.	Depth	Bulk	Blow Count	DD pcf	MC %						
B1	5'	-	10/12/15	108.5	12.8	37	11	18	68	CL	EI = 58
B1	10'	-	12/25/27	113.5	16.9	37	25	12	42	ML	
B2	5'	-	6/6/12	98.2	14.8	42	31	11	56	CL/SC	
B2	11'	-	8/9/10	103.8	22.7	29	17	17	38	CL/SC	
B2	15'	-	8/12/18	107.8	8.9	-	-	NP	14	SP	EI = 0



# **APPENDIX D**

## ***GRADING SPECIFICATIONS***

*Suggested Specifications For Placement of  
Compacted Earth Fill and Backfill*

**TABLE OF CONTENTS**

	<u>Page</u>
GENERAL.....	D1
MATERIALS .....	D1
PREPARATION OF SUBGRADE.....	D1
PLACING FILL .....	D1
MOISTURE CONTROL .....	D2
COMPACTION.....	D2
MOISTURE-DENSITY DETERMINATION .....	D2
DENSITY TESTS .....	D2

**ATTACHMENTS**

Transition Lot Details.....	Figure D-1
Stability Fill Detail .....	Figure D-2
Buttress Fill Detail.....	Figure D-3
Key and Benching Details.....	Figure D-4
Site Retaining Wall Waterproofing & Subdrain Detail .....	Figure D-5
Stem Wall / Basement Waterproofing & Subdrain Detail.....	Figure D-6
Canyon Subdrain Details.....	Figure D-7

## **GRADING SPECIFICATIONS**

### **GENERAL**

A representative of the soils engineer should be on-site as the owner's representative to observe the placement of all compacted fill and backfill on the project. The soils engineer shall inspect all earth materials prior to their use, in addition to the methods of placement, and the degree of compaction obtained.

### **MATERIALS**

Materials used for compacted fill and backfill shall be approved by the soils engineer prior to their use. Fill material, including rock, shall have a maximum dimension no greater than six inches (6"). Rock within fill should be dispersed to avoid nesting of rocks and creation of voids. In no case shall organic or other unsuitable material be used as fill or backfill material.

### **PREPARATION OF SUBGRADE**

All topsoil, vegetation (including trees, major root systems, and brush), lumber, debris, rubbish, and other unsuitable material in areas to receive fill shall be removed to a depth satisfactory to the soils engineer and disposed of off-site. Removals shall extend a minimum of five feet (5') beyond the building footprint of all proposed structures. The surface of the area to be filled shall be scarified to a minimum depth of eight inches (8"), moistened or dried as necessary, and adequately compacted in a manner specified below. On slopes, a "keyway" must be excavated in accordance with Figure D-4 "Key and Benching Details", and approved before any fills are placed.

### **PLACING FILL**

No fill shall be placed during weather conditions that would be adverse to the fill placement. All soil clods shall be reduced to six inches (6") or smaller size. Distribution of material in the fill shall be such as to preclude the formation of layers of material differing from the surrounding material. Each layer of fill shall be thoroughly mixed during placement to insure uniformity of material and moisture in each layer. Each layer shall have a maximum loose thickness of six to ten inches (6"-10"), and its surface shall be approximately horizontal. Each successive lift of fill placed on slopes should be benched into the slope, providing good bond between the fill and slope (see Figure D-3 "Side Hill Stability Fill Detail").

## **MOISTURE CONTROL**

During compaction, the fill material in each layer shall be conditioned to a moisture content near or slightly above optimum, with the moisture content uniform throughout the fill. If, in the opinion of the soils engineer, the material placed as fill is too wet or dry to permit adequate compaction, it shall be removed and adequately dried or moisture conditioned prior to replacement and compaction.

## **COMPACTION**

When an acceptable, uniform moisture content is obtained, each fill layer shall be compacted to applicable standards by a method acceptable to the soils engineer and as specified in the foregoing report. Compaction shall be performed by multiple passes with approved equipment suited to the soils being compacted. If a “sheep’s foot” roller is used, it shall be provided with cleaner bars attached in a manner that will prevent the accumulation of material between the tamper feet. The tamper feet should be able to provide an increase in effective weight.

## **MOISTURE-DENSITY DETERMINATION**

Representative samples of fill materials to be placed shall be furnished to the soils engineer by the contractor for determination of maximum density and optimum moisture content for these materials. Tests for this determination will be made using methods conforming to requirements of ASTM D698 or ASTM D1557. The results of these tests shall be the basis of control for all compaction effort.

## **DENSITY TESTS**

The density and moisture content of each layer of compacted fill will be determined by the soils engineer in accordance with ASTM D1556 or ASTM D2922. Any material found not to comply with the minimum specified density shall be recompacted until the required density is obtained. Sufficient density tests shall be made and the results submitted to support the soils engineer’s recommendations. The results of density tests will also be furnished to the owner, the project engineer, and the contractor by the soils engineer.

### CUT-FILL LOT

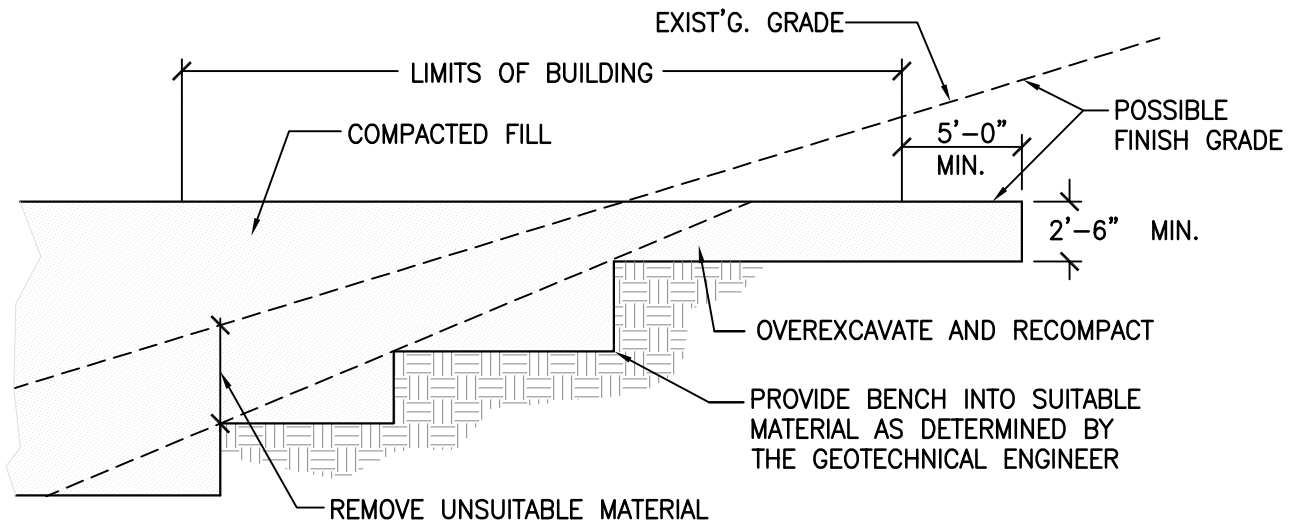

### CUT LOT

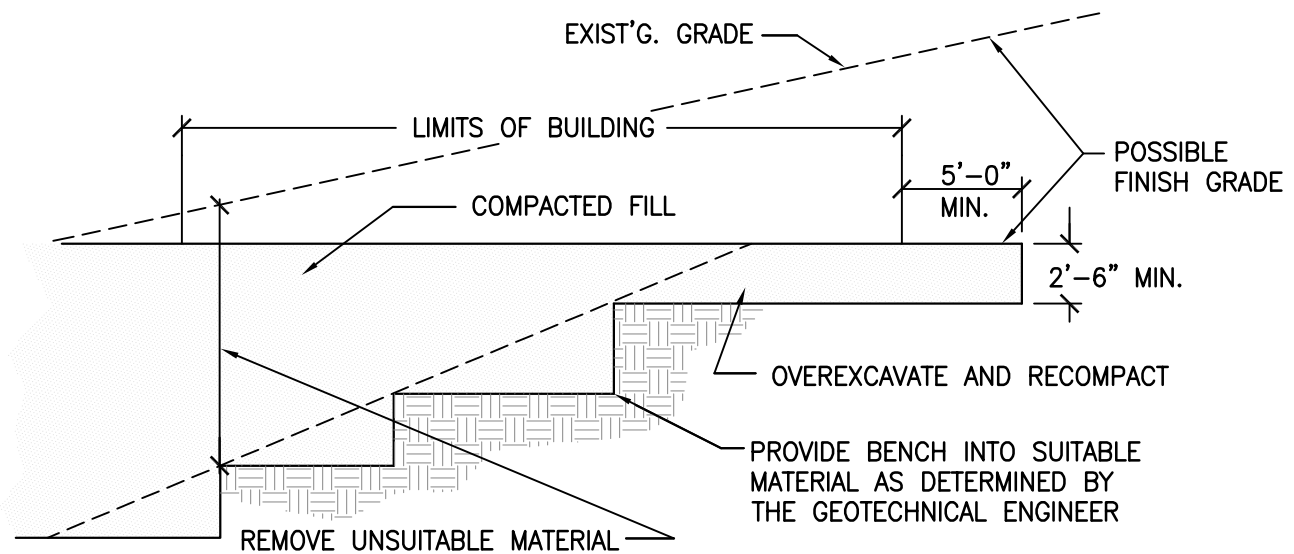

**NOTE:**

REMOVALS, KEYWAY DEPTH/WIDTH, AND SUBDRAIN RECOMMENDATIONS MAY BE MODIFIED BY THE GEOTECHNICAL ENGINEER BASED ON FIELD CONDITIONS.

## TRANSITION LOT GRADING

**LOWTHER/BARBA RENTAL REMODEL**  
**8561 EL PASEO GRANDE**  
**LA JOLLA, CA 92037**



DATE:  
2/14/2020

FIGURE NO.:  
D-1

PROJECT NO.:  
20641-1

# BUTTRESS FILL

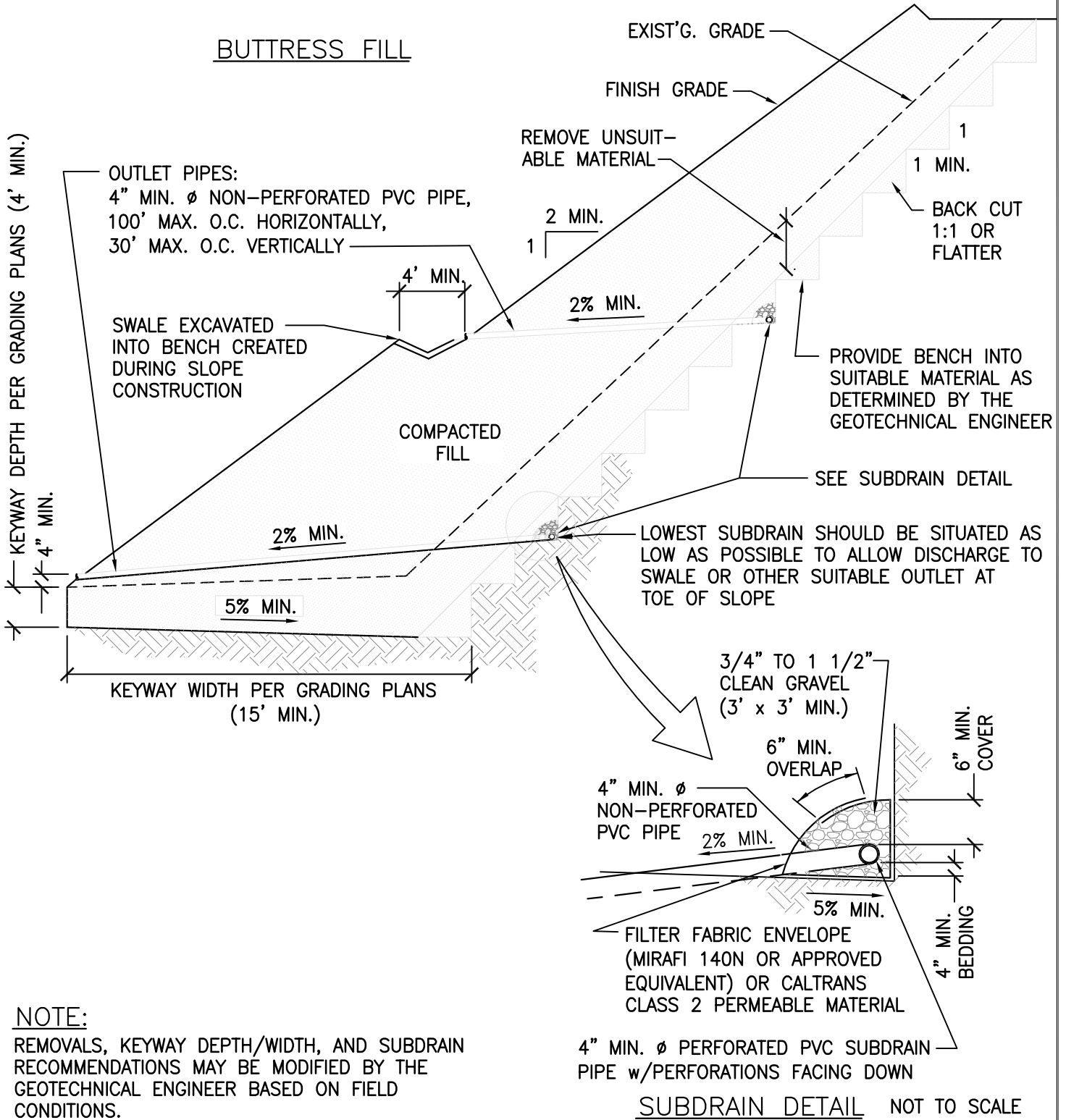

## BUTTRESS FILL & SUBDRAIN TRENCH

**LOWTHER/BARBA RENTAL REMODEL**  
 8561 EL PASEO GRANDE  
 LA JOLLA, CA 92037

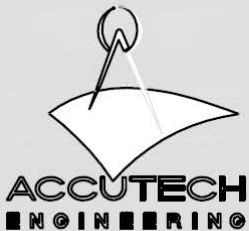

DATE:  
2/14/2020

FIGURE NO.:  
D-2

PROJECT NO.:  
20641-1



FILL SLOPE

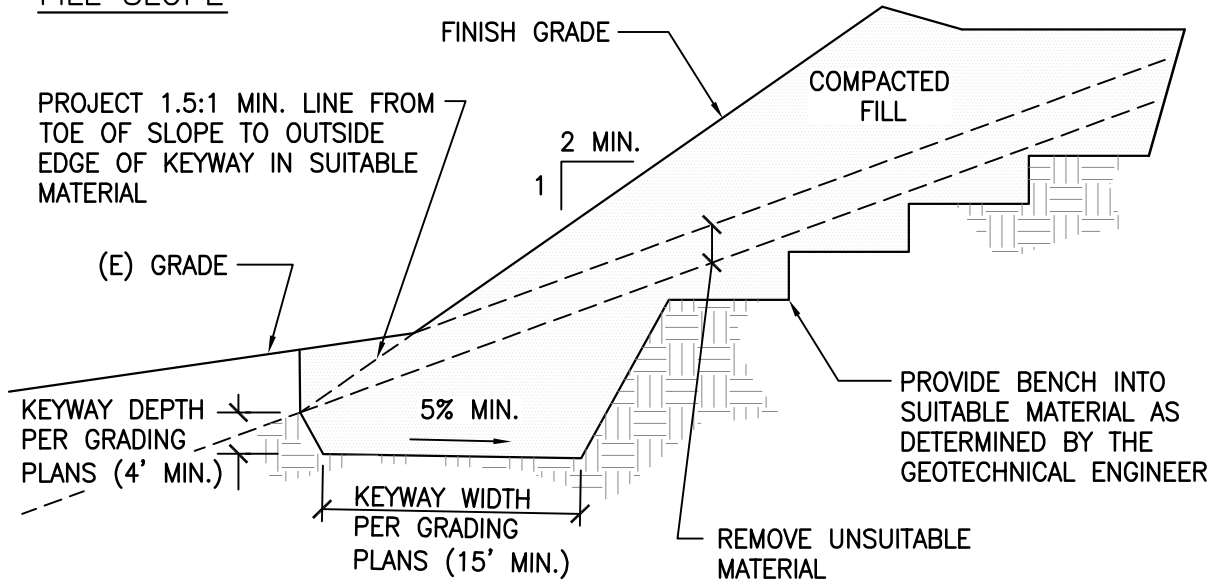

FILL-OVER-CUT SLOPE

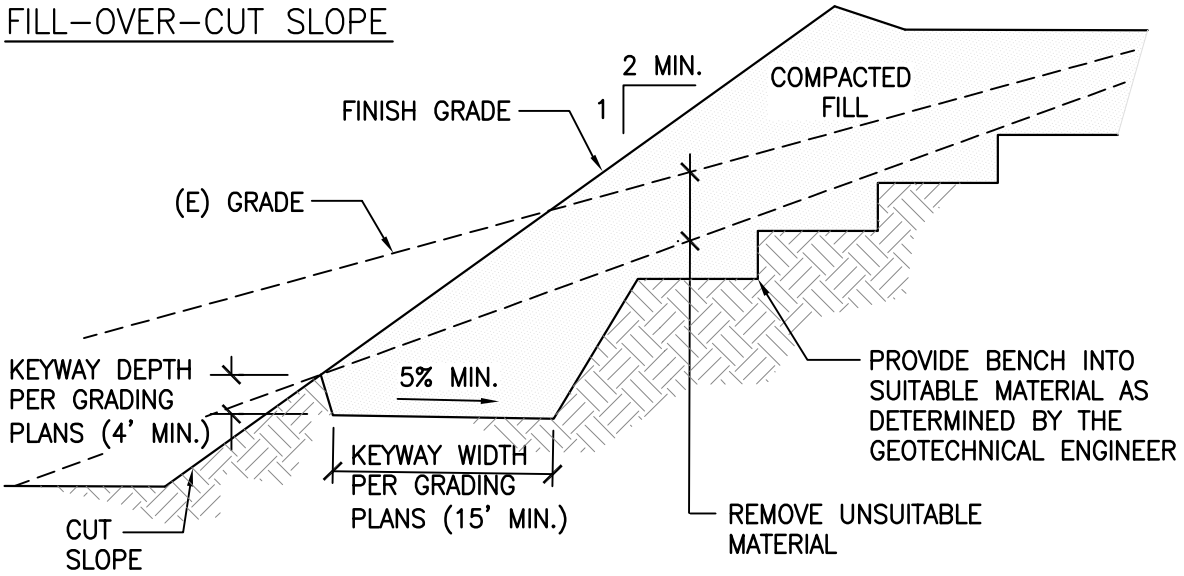

NOTE:

REMOVALS, KEYWAY DEPTH/WIDTH, AND SUBDRAIN RECOMMENDATIONS MAY BE MODIFIED BY THE GEOTECHNICAL ENGINEER BASED ON FIELD CONDITIONS.

NOT TO SCALE

FILL SLOPES

LOWTHER/BARBA RENTAL REMODEL  
8561 EL PASEO GRANDE  
LA JOLLA, CA 92037

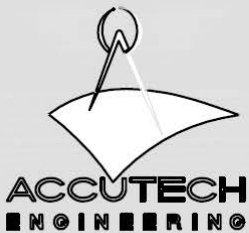

DATE:  
2/14/2020

FIGURE NO.:  
D-4

PROJECT NO.:  
20641-1



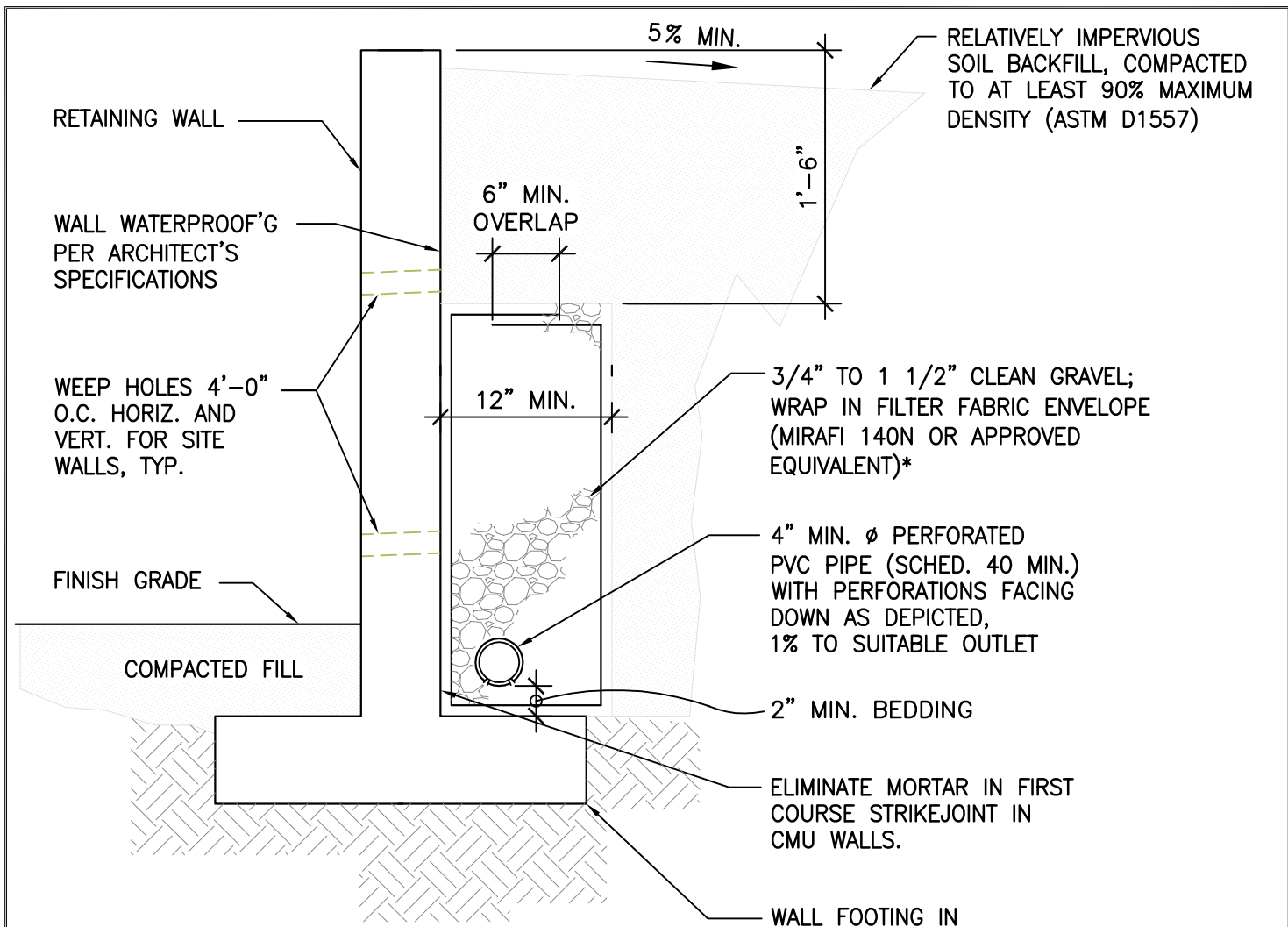

**SPECIFICATIONS FOR CALTRANS CLASS 2 PERMEABLE MATERIAL**

U.S. STANDARD SIEVE SIZE	% PASSING
1"	100
3/4"	90-100
3/8"	40-100
No. 4	25-40
No. 8	18-33
No. 30	5-15
No. 50	0-7
No. 200	0-3

SAND EQUIVALENT >75

**NOTE:**  
IF CALTRANS CLASS 2 PERMEABLE MATERIAL (SEE GRADATION TO LEFT) IS USED IN PLACE OF 3/4" TO 1 1/2" GRAVEL, FILTER FABRIC IS NOT REQUIRED. CALTRANS CLASS 2 PERMEABLE MATERIAL MUST BE COMPACTED TO AT LEAST 90% MAXIMUM DENSITY (ASTM D1557)

NOT TO SCALE

**SITE RETAINING WALL DRAINAGE**

**LOWTHER/BARBA RENTAL REMODEL**  
8561 EL PASEO GRANDE  
LA JOLLA, CA 92037



DATE:  
2/14/2020

FIGURE NO.:  
D-5

PROJECT NO.:  
20641-1

### CANYON SUBDRAIN SECTION

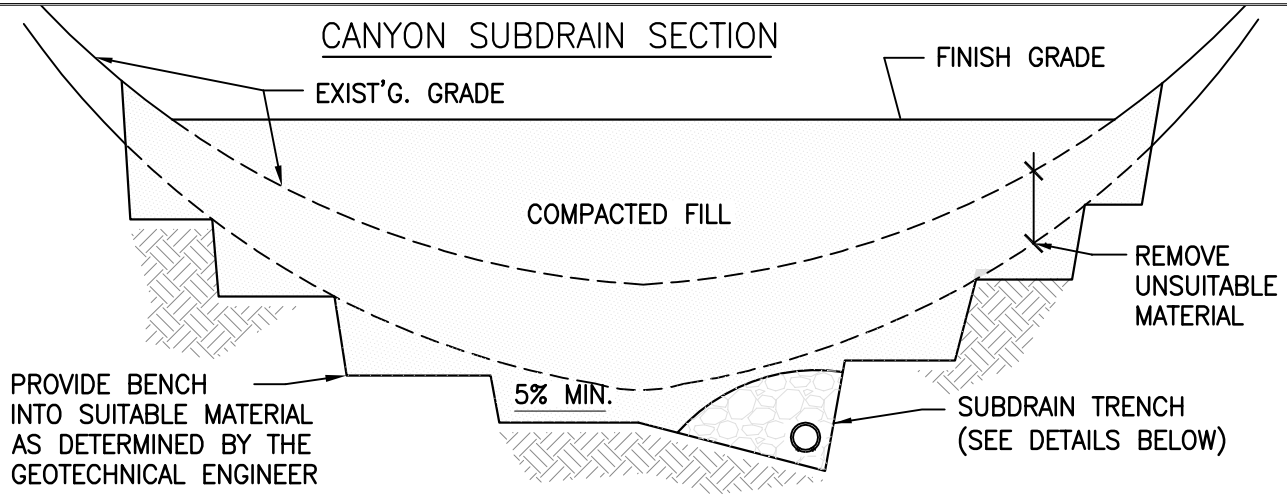

### SUBDRAIN TRENCH DETAILS

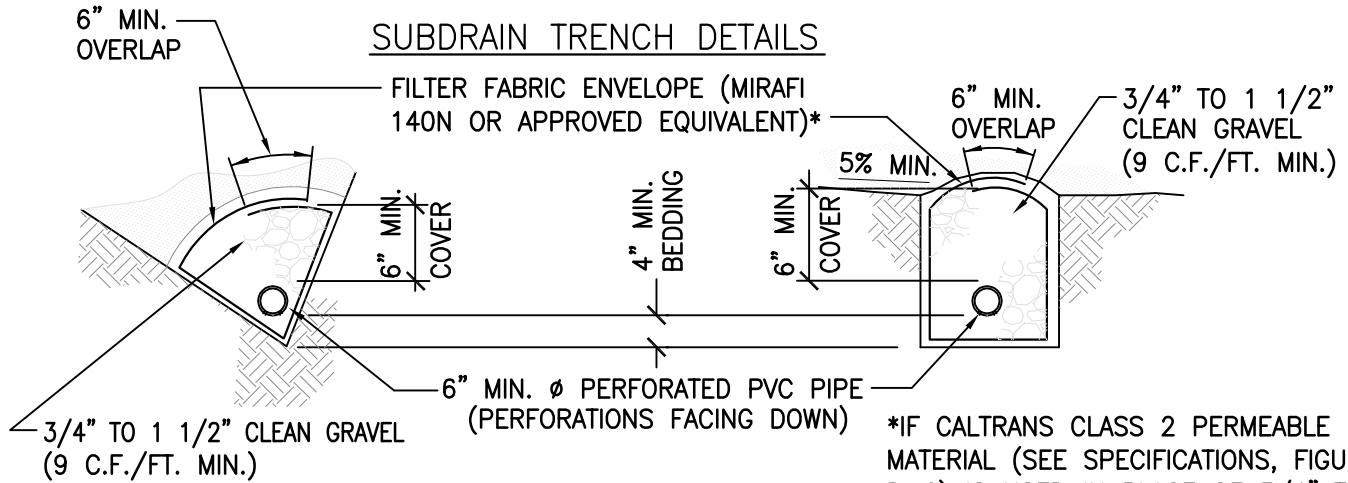

### CANYON SUBDRAIN ELEVATION

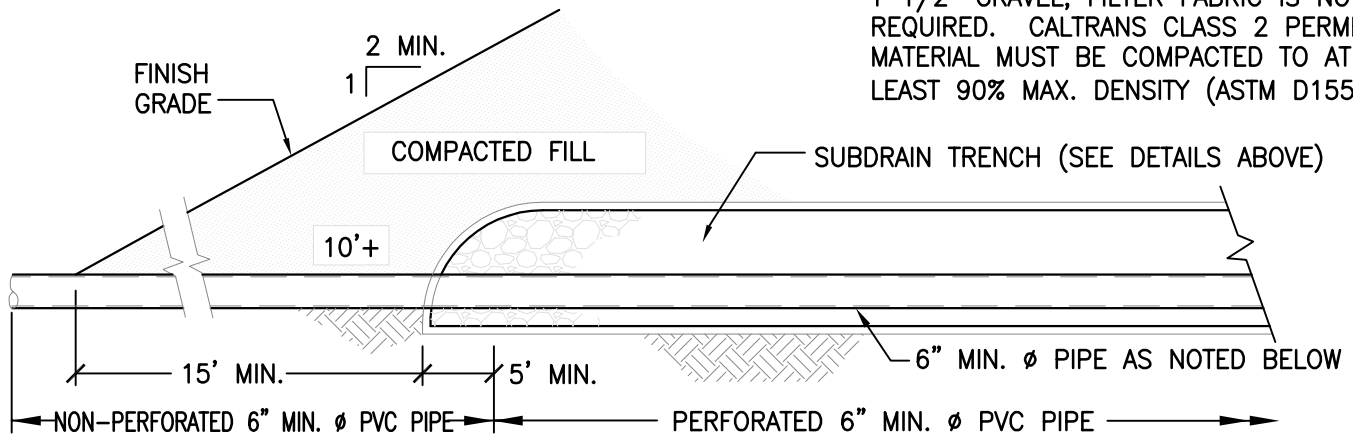

\*IF CALTRANS CLASS 2 PERMEABLE MATERIAL (SEE SPECIFICATIONS, FIGURE D-6) IS USED IN PLACE OF 3/4" TO 1 1/2" GRAVEL, FILTER FABRIC IS NOT REQUIRED. CALTRANS CLASS 2 PERMEABLE MATERIAL MUST BE COMPACTED TO AT LEAST 90% MAX. DENSITY (ASTM D1557).

**NOTE:**

REMOVALS, KEYWAY DEPTH/WIDTH, & SUBDRAIN RECOMMENDATIONS MAY BE MODIFIED BY THE GEOTECHNICAL ENGINEER BASED ON FIELD CONDITIONS.

NOT TO SCALE

## CANYON SUBDRAIN

**LOWTHER/BARBA RENTAL REMODEL**  
 8561 EL PASEO GRANDE  
 LA JOLLA, CA 92037

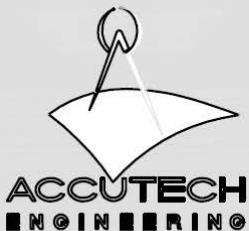

DATE:  
2/14/2020

FIGURE NO.:  
D-6

PROJECT NO.:  
20641-1

# **APPENDIX E**

## ***GEOLOGIC RECONNAISSANCE***

*Prepared by Michael W. Hart  
Certified Engineering Geologist  
CEG #706*

**MICHAEL W. HART, ENGINEERING GEOLOGIST**  
P.O. Box 261227 SAN DIEGO CALIFORNIA 92196  
MWHART40@GMAIL.COM

---

November 18, 2020  
File No. 1152-2020

Sasha Lowther  
Jorge Barba  
8561 El Paseo Grande  
La Jolla, California 92037

Subject: Proposed Remodel of:  
8561 El Paseo Grande  
La Jolla, California  
**GEOLOGIC RECONNAISSANCE**  
**(City of San Diego Project No. 670093)**

Dear Sasha & Jorge:

In accordance with our agreement I have completed a geologic reconnaissance of the residential property located at 8561 El Paseo Grande, La Jolla, California. The results of this study indicate that the site is underlain by the Bay Point Formation which consists of medium dense, light brown silty clay with sand interbeds. The formational soils are overlain by a relatively thin mantle of topsoil and fill.

One of the purposes of this report was to address certain issues raised by the City of San Diego in their review of the project. Issues related to the geologic characteristics of the site are addressed in this report. Other issues pertaining to the geotechnical investigation of the site are addressed by the project geotechnical engineer under separate cover.

If you have any questions concerning the findings or conclusions of the report please contact me at your convenience.

Very truly yours,



Michael W. Hart  
CEG 706

1 cc addressee

## **GEOLOGIC RECONNAISSANCE PROPOSED REMODEL, 8561 EL PASEO GRANDE LA JOLLA, CALIFORNIA**

### **Purpose and Scope**

This report presents the findings of a geologic reconnaissance of the residential property located at 8561 El Paseo Grande in the La Jolla area of San Diego, California (Figure 1). The purpose of this study is to: 1) describe the site's geologic characteristics and potential geologic hazards, 2) recommend mitigation measures if required, and 3) address issues raised by the city of San Diego in their review document dated 10/20/2020 for the referenced project (City of San Diego Project No. 670093). Other Issues relating to geotechnical aspects of the site are addressed by the project geotechnical engineer in a separate letter.

The scope of this study included geologic observations of nearby sedimentary rock exposures, a study of stereo-pairs of aerial photographs, review of readily available geologic literature, and a geotechnical report for the site prepared by Accutech Engineering Systems, Inc. dated February 20, 2020

### **Site and Project Description**

The site consists of a rectangular residential lot with frontage along El Paseo Grande of approximately 60 feet. The property is currently developed with a two-story residence. The proposed remodel will primarily consist of adding a third story to the existing structure along with certain ancillary improvements (See Geologic Section, Figure 5). Landscaping and other improvements consist of a low retaining wall in the front yard, trees, and ornamental shrubs.

### **General Geology and Geologic Setting**

The site lies near the landward edge of a marine terrace identified as the Nestor Terrace by Kern and Rockwell (1992). The sediments deposited on the wave-cut platform, or terrace, by the retreating sea were named the Bay Point Formation (Kennedy (1975). In later mapping this unit was renamed Old Paralic Deposits (Qop6 of Kennedy and Tan, 2008). The Bay Point Formation was deposited approximately 120 thousand years ago during and shortly after a high

stand of sea level. Geotechnical borings placed during the field investigation for the geotechnical report by Accutech Engineering Systems indicates that here the terrace deposits consist of stiff, brown, sandy clay with lenses of sand, overlain by shallow fill and topsoil. While not exposed on-site, nearby exposures in the La Jolla Shores Drive road cut below Scripps Aquarium (Figure 1) indicate the terrace deposits are underlain by the Eocene-aged Ardath Shale.

### **Geologic Hazards**

Geologic hazards considered for this report consist of landsliding, ground rupture due to faulting, seismic shaking, and secondary effects of faulting such as liquefaction and seismically induced settlement.

**Landsliding:** The site lies southwest of the University of California, San Diego Campus and the Steven Birch Aquarium (Figure 1). The geotechnical report for the aquarium by Kleinfelder (1988) indicates that the aquarium and a portion of the adjacent Montoro Subdivision are underlain by a large ancient landslide. The landslide extends from an elevation of approximately 250 feet northeast of the aquarium to an elevation of approximately 125 feet in the La Jolla Shores Terrace and Montoro subdivisions. The toe of the landslide was partially removed during grading for La Jolla Shores Drive exposing the basal slip surface in the roadcut opposite Scripps Institute of Oceanography at elevations varying from 165 to 175 feet.

The geotechnical study for the aquarium (Kleinfelder, 1988) included numerous borings that allowed the construction of a detailed contour map of the failure surface. This data along with information from the boring placed by GEI for Lot 39 of the Montoro Subdivision, allows a determination of the geometry of the landslide slip surface with an unusual degree of precision; particularly in the northern and central portion of the landslide. The southern limits of the landslide are not as well constrained; however, based on the average dip of the slip surface obtained from the referenced geotechnical reports, an estimate of the location of the southern limit of the landslide was made as depicted on Figure 1. Based on this estimate, it was determined that the site lies approximately 1000 feet from the landslide. Stability analyses performed for the Kleinfelder study indicated that the slide is stable in its present configuration

and that the slide possesses a factor-of-safety against reactivation of approximately 2.4. It is therefore concluded that the landslide does not represent a hazard to the existing or proposed improvements to the residence.

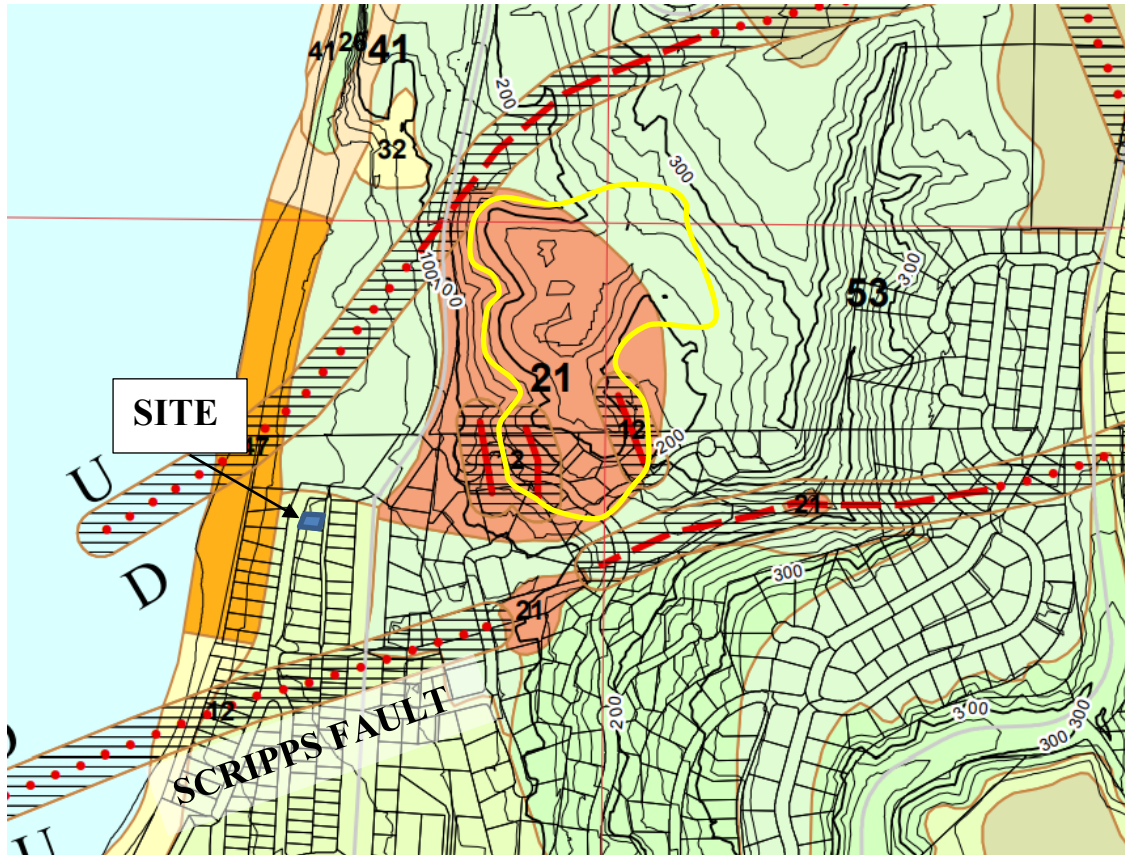

Figure 1. Site location and geologic hazards map. The landslide underlying the Steven Birch Aquarium as depicted on City of San Diego Seismic Hazards and Fault Map No. 29 is shown as Geologic Hazard Category 21. The more accurate limits of the landslide as determined by Kleinfelder (1988) and GEI (1993) are shown by the yellow line.

**Local Faulting:** A review of the City of San Diego Seismic Safety Study, Geologic Map of the La Jolla Quadrangle, (Kennedy, 1975) and fault maps by Treiman (1993) indicate that the site is not located on an active fault. The closest active fault, the Mount Soledad Fault, is 0.9 miles to the south. The Scripps Fault is located approximately 700 feet to the south and an additional unnamed fault is mapped approximately 300 feet to the northwest (Figure 1). Neither of these short northeast trending faults is known to have displaced the early to mid-Pleistocene sediments. City of San Diego Seismic Safety Study map of this area classifies these faults as Potentially Active meaning that they are either inactive, presumed inactive, or that their degree of activity is unknown.



**Secondary Effects of Faulting:** Secondary effects of faulting include liquefaction, seismically induced settlement, and tsunami potential. Since the site is located on stiff clays and interbedded sandstone of the Bay Point Formation, it is concluded that there is no potential for liquefaction or seismically induced settlement. The site lies at an elevation of approximately 30 feet and approximately 600 feet from the ocean. Reference to the tsunami inundation map published by the State of California Emergency Management Agency and the California Geological Survey indicates that the site does not lie in area that would be subject to a tsunami (Figure 2).

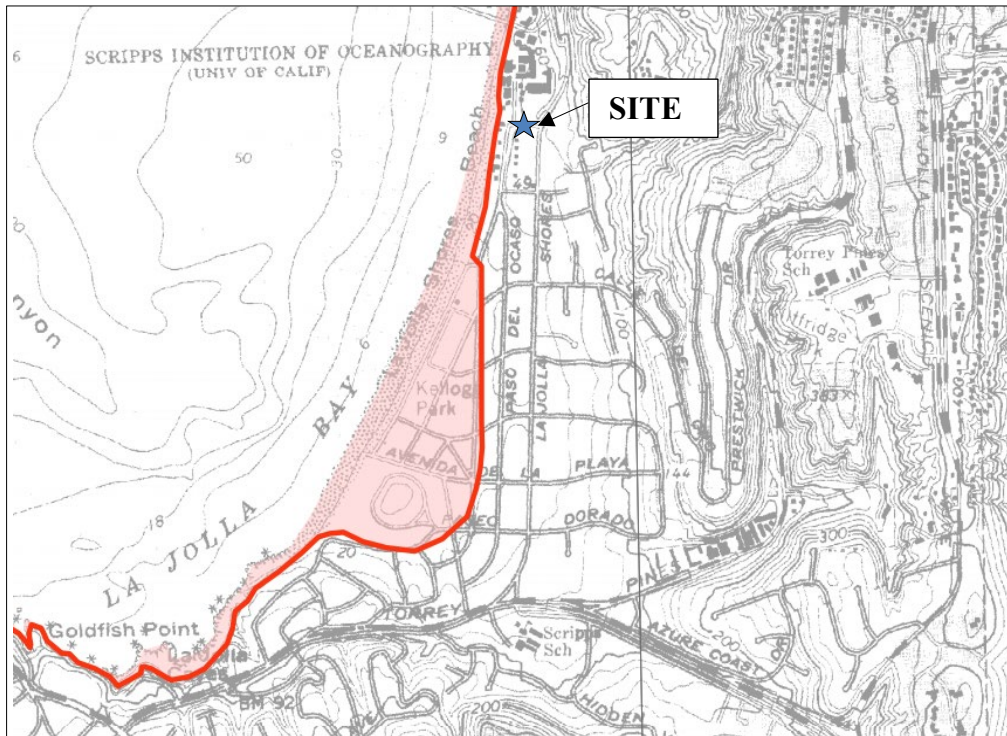

Figure 2. Tsunami Inundation Map. Modified from California Emergency Planning map for the La Jolla Quadrangle, June, 2009. (Calif. Emergency Management Agency and the California Geological Survey).

### **Regional Faulting and Seismicity**

In addition to seismic shaking generated by local faulting described above, the site will be affected by seismic activity as a result of earthquakes on major active faults located elsewhere in southern California. The nearest of these regional fault systems, the Coronado Bank Fault, lies offshore approximately 16 miles to the west. Other active faults, the Elsinore, San Jacinto, and San Andreas Faults lie approximately 36, 60, and 90 miles, respectively, to the east. Major seismic events on any of the local or regional active faults could subject the site to moderate to severe seismic shaking. In this regard, the site is similar to most others in the San Diego area.



The Mount Soledad fault and Rose Canyon fault are both believed to have been active during the Holocene (last 11,000 years) and are the most significant faults to the site with respect to the

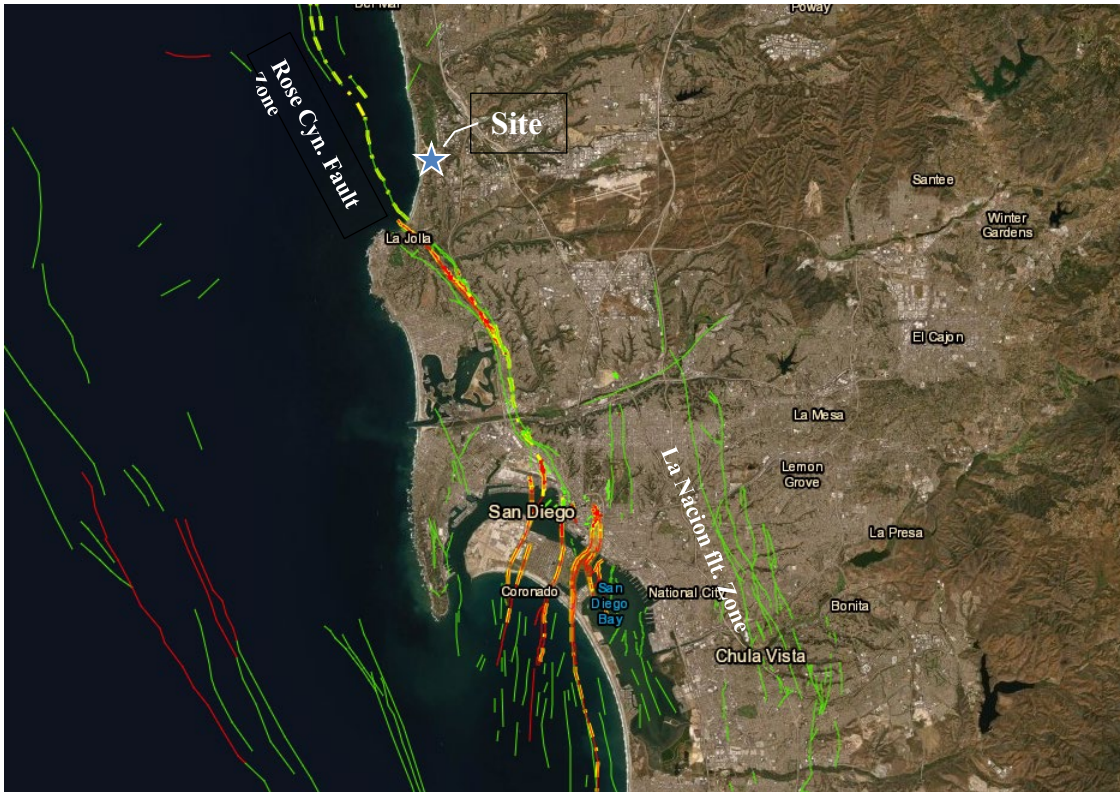

Figure 3. Regional fault map metropolitan San Diego, California  
(adapted from EERI, San Diego earthquake scenario, 2020)

potential for seismic activity. Lindvall and Rockwell (1995) have described the Rose Canyon fault system in terms of several segments that each has distinctive earthquake potential. The site lies nearest to the Del Mar segment which extends offshore from La Jolla to Del Mar. The Mission Bay segment extends from San Diego Bay on the south to La Jolla on the north.

According to Lindvall and Rockwell (1995), the Mission Bay and Del Mar fault segments are capable of generating  $M_w$ 6.4 to  $M_w$ 6.6 earthquakes, respectively, with an estimated recurrence time of approximately 720 years for these events and 1800 years for an earthquake event of  $M_w$ 6.9 that would result from rupture of both segments concurrently. Such an event could produce peak ground accelerations at the site on the order of 0.58g (Joyner and Boore, 1982).

Recent paleoseismic trenching on the Rose Canyon fault in the Old Town area of San Diego by Singleton, Rockwell, and others (2017) indicates that the Rose Canyon fault had sustained

activity throughout the Holocene and into the Historical period. Their study indicated evidence of four surface rupturing seismic events in the last 3500 years with the most recent event occurring in 1862. As a result of their study they calculated an average recurrence interval for surface rupturing events on the Mission Bay Segment of 675 +/- 428 yrs.

### **Groundwater**

The results of drilling for the geotechnical investigation by Accutech Engineering indicated that while some of the encountered soils were moist to wet at a depth of approximately seven feet, no free groundwater was observed after monitoring the borings for a period of 24 hours.

### **Conclusions and Recommendations**

1. The site is underlain by topsoils and fill consisting of light, to dark brown silty sand and sandy clay underlain by the Pleistocene Bay Point Formation that here consists of stiff, brown silty to sandy clay with sand interbeds.
2. It is concluded that the site is located approximately 1000 feet southwest of a large landslide that underlies the Steven Birch Aquarium on the Campus of the University of California San Diego and portions of the Montoro Subdivision. The geotechnical report for the Aquarium indicates that the slide is stable under present conditions. It is concluded that in the unlikely event the landslide were to be reactivated by a change in groundwater conditions or a major earthquake on a local fault, slide movement would be measured in terms of a few feet to several tens of feet. Such movement, if it were to occur, would not affect the subject lot.
3. The closest active fault is the Mount Soledad Fault that lies approximately 0.9 miles south of the property.
4. The site is subject to moderate to severe seismic shaking as a result of earthquakes on local or regional active faults. The proposed dwelling will be founded on the Bay Point Formation and will not be subject to secondary effects of seismic shaking such as liquefaction, lateral spreading, seismically induced settlement, or tsunamis. The recommendations of the project geotechnical engineer should be followed with regard to grading and foundation design.
5. It is concluded that the site is suitable from a geologic standpoint for the proposed development as designed and there are no geologic hazards requiring mitigation prior to

construction of the proposed improvements/remodeling of the existing structure. It is also concluded that the proposed construction will not destabilize or result in settlement of adjacent property or the rights-of-way of the adjacent alley or public streets.

### **References**

Anderson, J. G., Rockwell, T., and Agnew, D.C., 1989, A study of the seismic hazard in San Diego, *Earthquake Spectra*, vol. 5(2), pp 229-333.

Geotechnical Exploration, Inc., 1993, Report of geotechnical investigation, proposed Pelan Residence, Lot 39, Montoro Subdivision, La Jolla, California.

Joyner, W.B. and Boore, D.M. 1982, Prediction of earthquake response spectra, U.S. Geological Survey Open File Report 82-977, 16pp.

Kennedy, M.P., 1975, Geology of the San Diego Metropolitan area, California, California, Calif. Div. Mines and Geology, Bull. 200.

Kern, J.P., Rockwell, T.K., 1992, chronology and deformation of Quaternary marine shorelines, San Diego County, California, in Quaternary Coasts of the United States: Marine and Lacustrine Systems, SEPM Special Publication No. 48, p.377-382.

Kleinfelder, Inc., 1988, Report of geologic investigation proposed aquarium and ocean science center, University of California, San Diego.

Lindvall, S.C., Rockwell, T.K., and Lindvall, C.E., 1990, The seismic hazard of San Diego revised: New evidence of Magnitude 6+ Holocene earthquakes on the Rose Canyon Fault Zone, in Proceedings of U.S. National Conference on Earthquake Engineering, Palm Springs, California, vol 1: Earthquake Engineering Research Inst., p. 679-688.

Lindvall, S.C., and Rockwell, T.K., 1995, Holocene activity of the Rose Canyon fault zone in San Diego, California, *Jour. Geophysical Research*, vol. 100, no. B12, Pages 24,121-24-132.

Singleton, D., Rockwell, T.K, and others, 2017, Timing of Late Holocene Earthquakes on the Rose Canyon Fault at Old Town, San Diego, California, abstract; Cordilleran Section 113<sup>th</sup> Annual Mtg. Geological Society of America.

Tan, S.S., 1995, Landslide hazards in the southern part of the San Diego Metropolitan area, San Diego County, California, DMG open File Report 95-03.

Treiman, J.A., 1993, The Rose Canyon Fault Zone, southern California, California Div. Mines and Geology, Open File Report 93-02.

Aerial Photographs, USDA 1953, AXN 8M 1 & 2

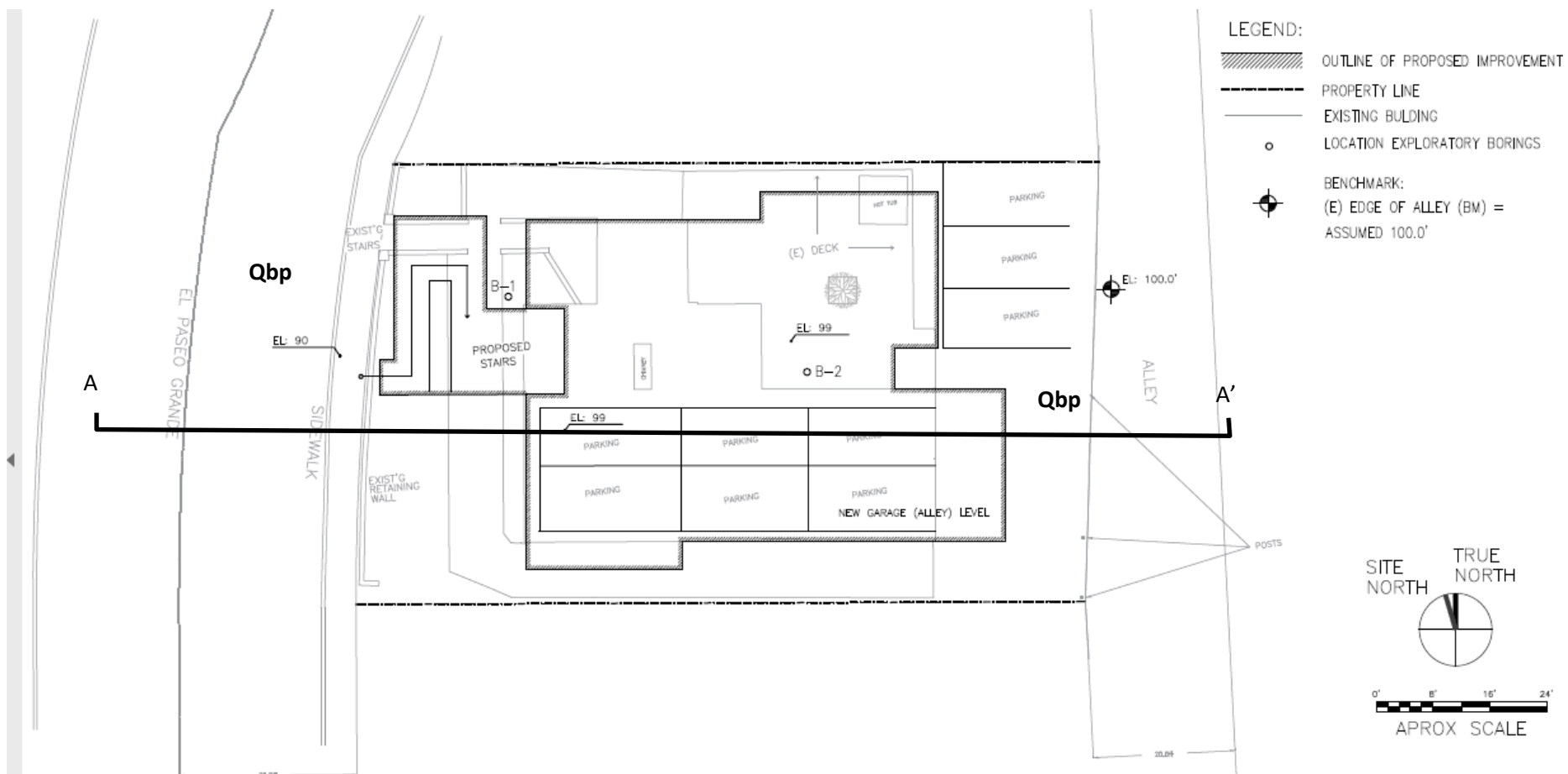

**GEOLOGIC MAP**  
**8561 EL PASEO GRANDE, LA JOLLA, CALIFORNIA**

Figure 4

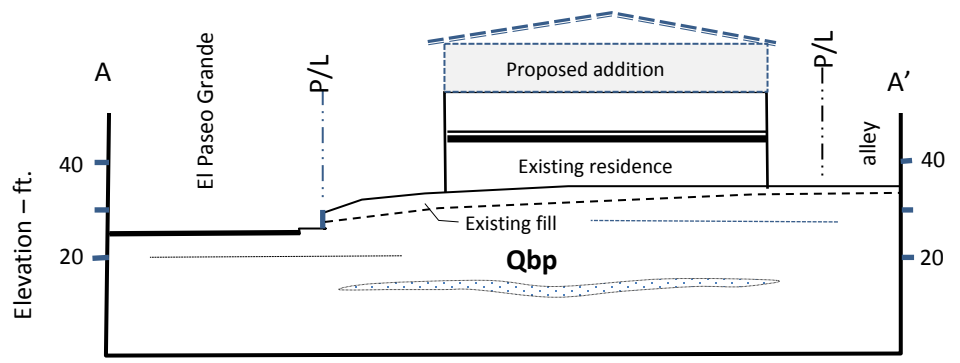

**GEOLOGIC SECTION A-A'**  
**8561 EL PASEO GRANDE, LA JOLLA, CALIFORNIA**

**Legend**

**Qbp:** Bay Point Formation (Old paralic deposits)

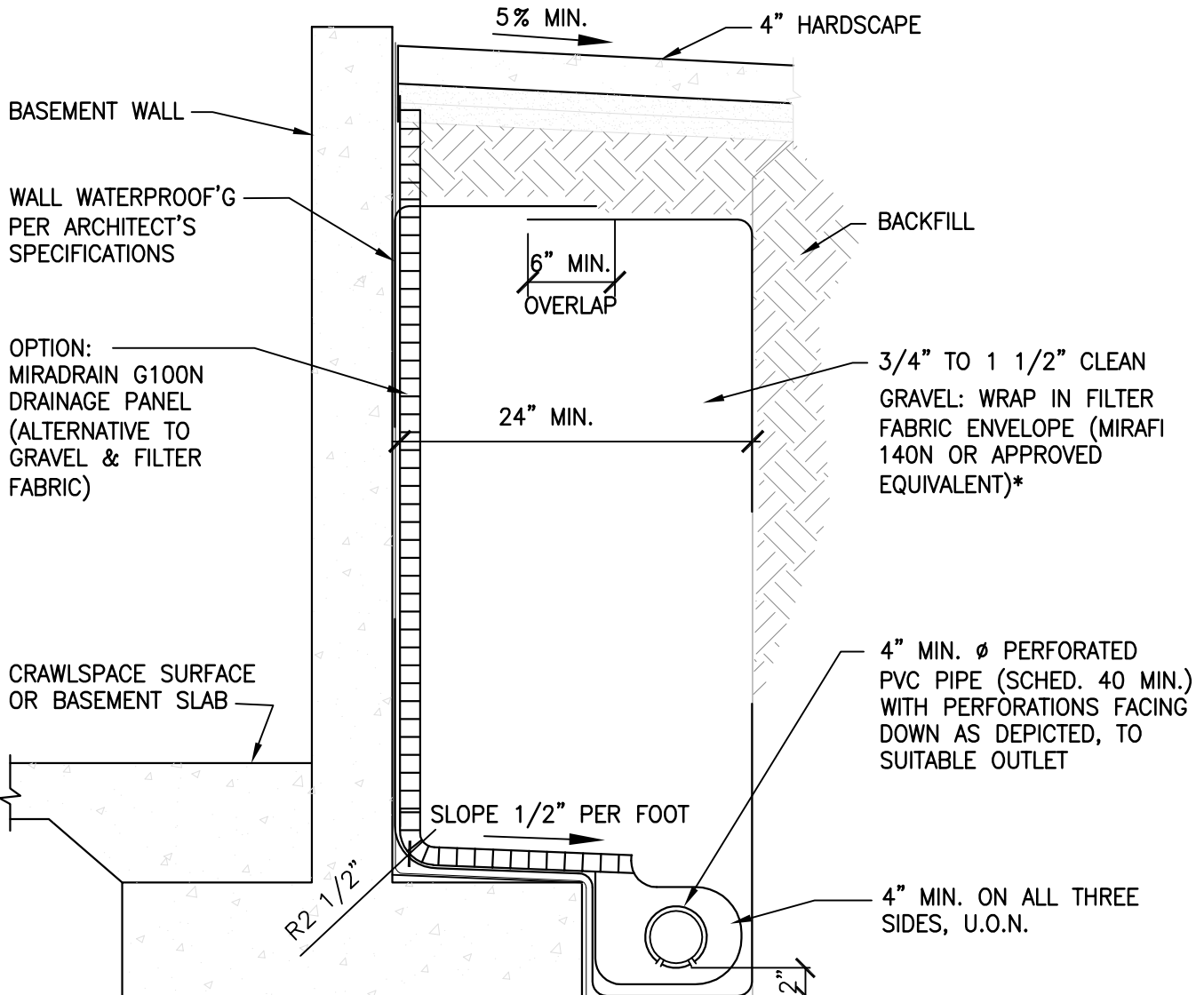

SPECIFICATIONS FOR CALTRANS CLASS 2 PERMEABLE MATERIAL

U.S. STD. SIEVE SIZE	% PASSING
1"	100
3/4"	90-100
3/8"	40-100
No. 4	25-40
No. 8	18-33
No. 30	5-15
No. 50	0-7
No. 200	0-3

SAND EQUIVALENT >75

\* IF CALTRANS CLASS 2 PERMEABLE MATERIAL (SEE GRADATION TO LEFT) IS USED IN PLACE OF 3/4" TO 1 1/2" GRAVEL, FILTER FABRIC IS NOT REQUIRED. CALTRANS CLASS 2 PERMEABLE MATERIAL MUST BE COMPACTED TO AT LEAST 90% MAXIMUM DENSITY (ASTM D1557)

NOT TO SCALE

STEMWALL SUBDRAIN/BASEMENT WALL DRAINAGE

LOWTHER/BARBA RENTAL REMODEL  
8561 EL PASEO GRANDE  
LA JOLLA, CA 92037



DATE: 2/14/2020	FIGURE NO.: D-7	PROJECT NO.: 20641-1
--------------------	--------------------	-------------------------

F:\CIBER\17303037\PROJECTS\_17303037\MISC\Drawings\DWG\17303037\_BasementWall\_Dwg\_11222016.rvt 3:20:25 PM  
 Created with AutoCAD 2015