



Ventura Engineering Inland INC
VEI

PRELIMINARY HYDROLOGY REPORT

PROPOSED SHOPPING CENTER CUP180008

21419 & 21425 CAJALCO ROAD
PERRIS, CALIFORNIA 92590
APN: 318-140-007-2, 318-140-028-1 & 318-140-029-1

PREPARED FOR:

SAMEH IBRAHAM &
SAMEH ADLMALEK
3343 DEPUTY EVANS DRIVE
NORCO, CALIFORNIA 92860

PREPARED BY:

VENTURA ENGINEERING INLAND
27393 YNEZ ROAD, SUITE 159
TEMECULA, CALIFORNIA 92591
(951) 252-7632

ORIGINAL DATE: April 30, 2021

I hereby declare that I am the engineer of work for this project, that I have exercised responsible charge over the design of the project as defined in Section 6703 of the Business and Professions code, and that the design is consistent with current standards.



4/30/21

WILFREDO VENTURA
R.C.E. NO. 66532
EXPIRES 6/30/22

DATE

TABLE OF CONTENTS

<u>DESCRIPTIONS</u>	<u>PAGE</u>
COVER SHEET	i
TABLE OF CONTENTS	ii
1.0 INTRODUCTION	1
2.0 LOCATION	1
3.0 METHODOLOGY	1
4.0 EXISTING CONDITIONS CALCULATIONS	1
5.0 PROPOSED CONDITIONS CALCULATIONS	2
6.0 COMPARISON	2
7.0 CONCLUSION	3
8.0 REFERENCES	3
9.0 DECLARATION OF RESPONSIBLE CHARGE	3
10.0 ATTACHMENTS	4
10.1 ATTACHMENT 1: STANDARDS EXCERPTS	4
10.2 ATTACHMENT 2: EXISTING CONDITIONS CALCULATIONS	4
10.3 ATTACHMENT 3: PROPOSED CONDITIONS CALCULATIONS	4
10.4 ATTACHMENT 4: EXHIBITS	4
10.5 ATTACHMENT 5: FEMA DETERMINATION	4

ATTACHMENT 1: STANDARDS EXCERPTS

ATTACHMENT 2: EXISTING CONDITIONS CALCULATIONS

ATTACHMENT 3: PROPOSED CONDITIONS CALCULATIONS

ATTACHMENT 4: EXHIBITS

ATTACHMENT 5: FEMA DETERMINATION

1.0 INTRODUCTION

The purpose of this report is to calculate the pre-development and post development hydrology conditions for the proposed new shopping center being proposed for the vacant commercial lots at 21419 & 21425 Cajalco Road in Perris, California. This report has been created using the Riverside County Flood Control and Water Conservation District Hydrology Manual (April 1978).

The project site is currently vacant lots that are zoned for a commercial use. The project site proposes to maintain existing grading as much as feasible in the flood plain and then to minimally grade the rest of the site. In addition, the project site will be using all self-treating and self-retaining areas for water quality design that will aid in flood control management as well.

2.0 LOCATION

The project site is located at 21419 & 21425 Cajalco Road in Perris, California, 92590. A vicinity map is provided for reference in Attachment 4.

3.0 METHODOLOGY

This report calculates 100-Year Maximum Peak Runoff in AMC III based on the Riverside County Flood Control and Water Conservation District Hydrology Manual (April 1978) rational methodology. In addition, this manual will be referred to as the 'Standards' throughout this report. Clean copies of the excerpts from the standards have been included in Attachment 1: Standards Excerpts for reference. The hydrology calculations will be divided into existing conditions and proposed conditions. The existing conditions calculations are provided in Attachment 2: Existing Conditions Calculations. The proposed calculations are provided for reference in Attachment 3: Proposed Conditions. In addition, hydrology maps have also been created for the project site and are included in Attachment 4: Exhibits. The FEMA determination for flooding factors is provided for reference in Attachment 5: FEMA Determination.

4.0 EXISTING CONDITIONS CALCULATIONS

The existing conditions have been evaluated using the Rational Method from the Riverside County Flood Control and Water Conservation District Hydrology Manual (April 1978). Certain tables and figures from the Standards are referenced in this report and have been included in Attachment 1: Standards Excerpts. The existing conditions calculations are in Attachment 2 for reference. The existing conditions exhibit is provided for reference in Attachment 4. A summary of the existing conditions calculations is as follows:

EXISTING CONDITIONS COMPLIANCE POINT A SUMMARY 100-YEAR DESIGN STORM EVENT	
DATA	100-YEAR
INTENSITY (IN/HR)	2.608
TOTAL DISCHARGE (CFS)	4.4
TIME OF CONCENTRATION (MIN)	10.69
AREA (ACRES)	1.95

5.0 PROPOSED CONDITIONS CALCULATIONS

The project site is constrained in its southern portion by the existing flood plain that the County is modifying through FEMA. With this in mind, as little modification as possible to the finished grades and permeability of the surfaces is being proposed. The proposed conditions will utilize permeable paving, no curbs, and landscaping on grade in this area. These will all be considered self-treating and self-retaining for purposes of the water quality design. For hydrology design purposes, the permeable paving will have a minimal storage layer to facilitate and mimic the permeability of the existing conditions. This has been done at the direction of the County staff as well.

The existing and County proposed FEMA mapping is provided for reference in Attachment 5.

The proposed conditions have been evaluated using the Rational Method from the Riverside County Flood Control and Water Conservation District Hydrology Manual (April 1978). Certain tables and figures from the Standards are referenced in this report and have been included in Attachment 1: Standards Excerpts. The proposed conditions calculations are in Attachment 3 for reference. The proposed conditions exhibit is provided for reference in Attachment 4. A summary of the proposed conditions calculations is as follows:

PROPOSED CONDITIONS COMPLIANCE POINT A SUMMARY 100-YEAR DESIGN STORM EVENT	
DATA	100-YEAR
INTENSITY (IN/HR)	2.547
TOTAL DISCHARGE (CFS)	4.3
TIME OF CONCENTRATION (MIN)	6.87
AREA (ACRES)	1.95

6.0 COMPARISON

Through the use of permeable paving and dispersion of all impervious surfaces, the project site has been able to mimic the pre- conditions in the post- conditions as proposed. A comparison data summary at Compliance Point A is as follows:

COMPLIANCE POINT A COMPARISON 100-YEAR DESIGN STORM EVENT			
DATA	EXISTING CONDITIONS 100-YEAR	PROPOSED CONDITION 100-YEAR	COMPARISON
INTENSITY (IN/HR)	2.608	2.547	- 0.061
TOTAL DISCHARGE (CFS)	4.4	4.3	- 0.1
TIME OF CONCENTRATION (MIN)	10.69	6.87	- 3.82
AREA (ACRES)	1.95	1.95	NO CHANGE

7.0 CONCLUSION

The proposed project site will construct new structures and various other design elements that will add slightly to the improvements of an existing vacant lots but this increase will be mitigate through the use of dispersion of all the impervious surfaces to permeable surfaces as feasible. The proposed development will utilize low impact development solutions to handle water quality treatment and hydromodification as much as feasible. The project site increases the imperviousness of the site, but the proposed LID elements are more than adequate to mitigate this increase using the include the permeable paving and landscaping to mimic the natural permeability fo the project site.

In addition, it should be noted that the proposed project does not substantially alter the existing drainage feature that must not be disturbed that exists on the project site. Neither is the existing drainage pattern of the site and local area altered, including through the alteration of the course of a stream or river, in a manner which would result in substantial erosion, siltation, or flooding on- or off-site because the stream alignment is not affected by the proposed improvements.

The project site will continue to sheet flow to the south and into the flood channel that the County will eventually underground or re-channel in the project's 29' proposed future drainage easement.

8.0 REFERENCES

The following references were utilized in the creation of this hydrology report:

Brater & King, *Handbook of Hydraulics*, 6th ed.

Design Handbook for Low Impact Development Best Management Practices, Riverside County Flood Control & Water Conservation District, September 2011.

Hydrology Manual, Riverside County Flood Control & Water Conservation District, April 1978

9.0 DECLARATION OF RESPONSIBLE CHARGE

I hereby declare that I am the engineer of work for this project, that I have exercised responsible charge over the design of the project as defined in Section 6703 of the Business and Professions code, and that the design is consistent with current standards.

I understand that the check of project drawings and specifications by the agency is confined to a review only and does not relieve me, as engineer of work, of my responsibilities for project design.



Wilfredo Ventura

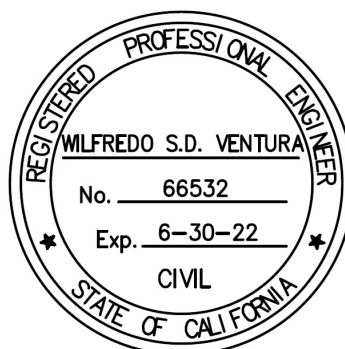

4/30/21

Date

10.0 ATTACHMENTS

The following attachment sections are provided for reference:

10.1 ATTACHMENT 1: STANDARD EXCERPTS

This attachment contains excerpts from the standards. Please refer to the attached references.

10.2 ATTACHMENT 2: EXISTING CONDITIONS CALCULATIONS

This attachment contains the existing conditions calculations. The existing conditions calculations are summarized in Section 4 of the report. Calculations are provided here for reference.

10.3 ATTACHMENT 3: PROPOSED CONDITIONS CALCULATIONS

This attachment contains the proposed conditions calculations. The proposed conditions calculations are summarized in Section 5 of the report. Calculations are provided here for reference.

10.4 ATTACHMENT 4: EXHIBITS

The Existing Conditions Hydrology Exhibit and Proposed Conditions Hydrology Exhibit are provided here for reference.

10.5 ATTACHMENT 5: FEMA DETERMINATION

This attachment contains the project site's FEMA Mapping and flooding determination. The site-specific FEMA Mapping is provided here for reference.

ATTACHMENT 1: STANDARD EXCERPTS

This attachment contains various excerpts from the Riverside County Flood Control & Water Conservation District Hydrology Manual (April 1978 edition). Please see the attached excerpts from the standards.

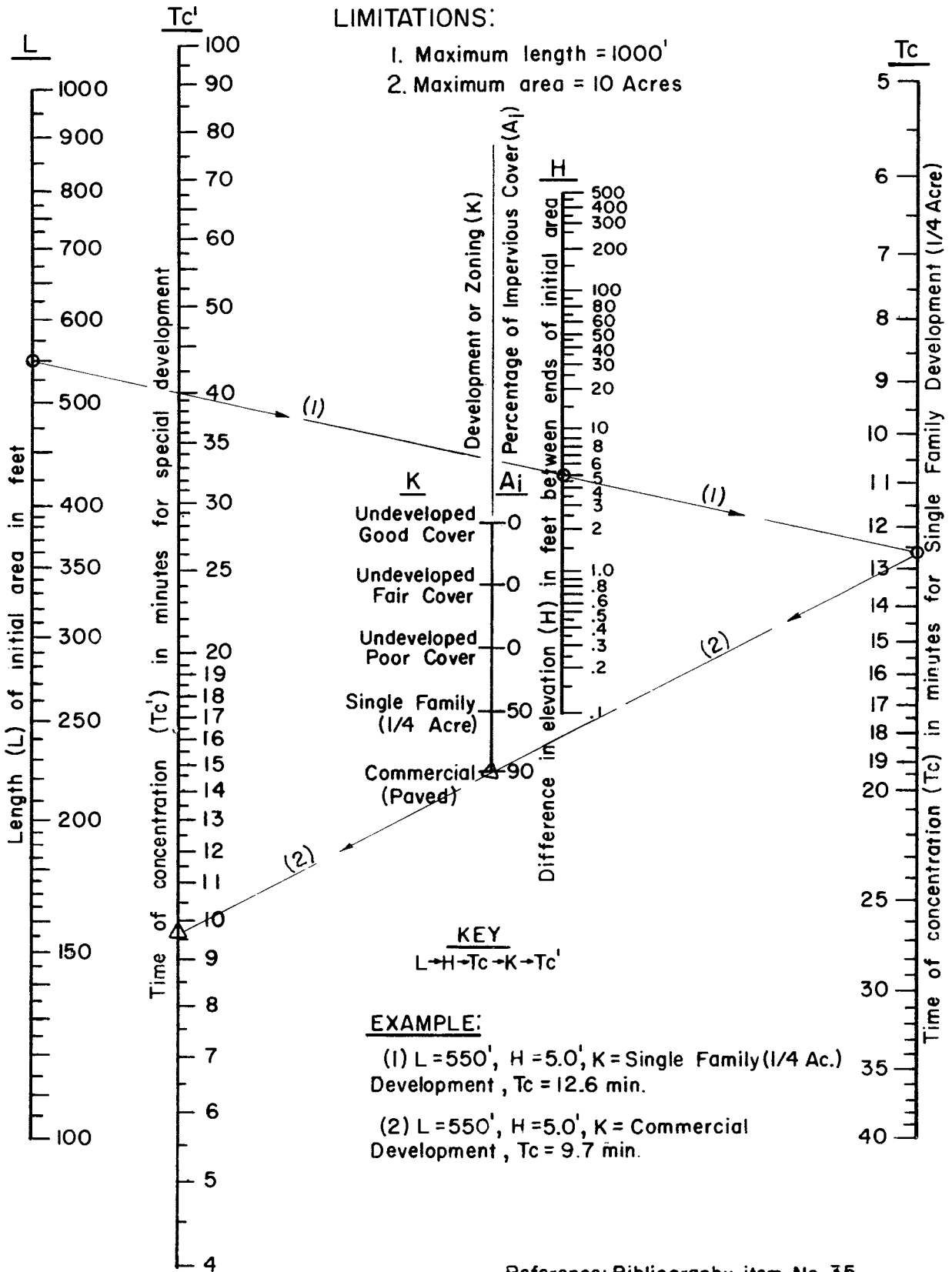

RCFC & WCD
 HYDROLOGY MANUAL

Reference: Bibliography item No. 35.

**TIME OF CONCENTRATION
 FOR INITIAL SUBAREA**

RAINFALL INTENSITY - INCHES PER HOUR

MIRA LOMA			MURRIETA - TEMECULA & RANCHO CALIFORNIA			NORCO			PALM SPRINGS			PERRIS VALLEY		
DURATION MINUTES	FREQUENCY		DURATION MINUTES	FREQUENCY		DURATION MINUTES	FREQUENCY		DURATION MINUTES	FREQUENCY		DURATION MINUTES	FREQUENCY	
	10 YEAR	100 YEAR		10 YEAR	100 YEAR		10 YEAR	100 YEAR		10 YEAR	100 YEAR			
5	2.84	4.48	5	3.45	5.10	5	2.77	4.16	5	4.23	6.70	5	2.64	3.78
6	2.58	4.07	6	3.12	4.61	6	2.53	3.79	6	3.80	6.06	6	2.41	3.46
7	2.37	3.75	7	2.87	4.24	7	2.34	3.51	7	3.48	5.56	7	2.24	3.21
8	2.21	3.49	8	2.67	3.94	8	2.19	3.29	8	3.22	5.19	8	2.09	3.01
9	2.08	3.28	9	2.50	3.69	9	2.07	3.10	9	3.01	4.81	9	1.98	2.84
10	1.96	3.10	10	2.36	3.48	10	1.96	2.94	10	2.83	4.52	10	1.88	2.69
11	1.87	2.95	11	2.24	3.30	11	1.87	2.80	11	2.67	4.26	11	1.79	2.57
12	1.78	2.82	12	2.13	3.15	12	1.79	2.68	12	2.54	4.07	12	1.72	2.46
13	1.71	2.70	13	2.04	3.01	13	1.72	2.58	13	2.43	3.88	13	1.65	2.37
14	1.64	2.60	14	1.96	2.89	14	1.66	2.48	14	2.33	3.72	14	1.59	2.29
15	1.58	2.50	15	1.89	2.79	15	1.60	2.40	15	2.23	3.56	15	1.54	2.21
16	1.53	2.42	16	1.82	2.69	16	1.55	2.32	16	2.15	3.44	16	1.49	2.14
17	1.48	2.34	17	1.76	2.60	17	1.50	2.25	17	2.08	3.32	17	1.45	2.08
18	1.44	2.27	18	1.71	2.52	18	1.46	2.19	18	2.01	3.22	18	1.41	2.02
19	1.40	2.21	19	1.66	2.45	19	1.42	2.13	19	1.95	3.12	19	1.37	1.97
20	1.36	2.15	20	1.61	2.38	20	1.39	2.08	20	1.89	3.07	20	1.34	1.92
22	1.29	2.04	22	1.53	2.26	22	1.32	1.98	22	1.79	2.86	22	1.28	1.83
24	1.24	1.95	24	1.46	2.15	24	1.26	1.90	24	1.70	2.73	24	1.22	1.75
26	1.18	1.87	26	1.39	2.06	26	1.22	1.82	26	1.62	2.60	26	1.18	1.69
28	1.14	1.80	28	1.34	1.98	28	1.17	1.76	28	1.56	2.49	28	1.13	1.63
30	1.10	1.73	30	1.29	1.90	30	1.13	1.70	30	1.49	2.39	30	1.10	1.57
32	1.06	1.67	32	1.24	1.84	32	1.10	1.64	32	1.44	2.30	32	1.06	1.52
34	1.03	1.62	34	1.20	1.78	34	1.06	1.59	34	1.39	2.24	34	1.03	1.48
36	1.00	1.57	36	1.17	1.72	36	1.03	1.55	36	1.34	2.15	36	1.00	1.44
38	.97	1.53	38	1.13	1.67	38	1.01	1.51	38	1.30	2.09	38	.98	1.40
40	.94	1.49	40	1.10	1.62	40	.98	1.47	40	1.27	2.02	40	.95	1.37
45	.89	1.40	45	1.03	1.52	45	.92	1.39	45	1.18	1.89	45	.90	1.29
50	.84	1.32	50	.97	1.44	50	.88	1.31	50	1.11	1.78	50	.85	1.22
55	.80	1.26	55	.92	1.36	55	.84	1.25	55	1.05	1.66	55	.81	1.17
60	.76	1.20	60	.88	1.30	60	.80	1.20	60	1.00	1.60	60	.78	1.12
65	.73	1.15	65	.84	1.24	65	.77	1.15	65	.95	1.53	65	.75	1.08
70	.70	1.11	70	.81	1.19	70	.74	1.11	70	.91	1.46	70	.72	1.04
75	.68	1.07	75	.78	1.15	75	.72	1.07	75	.88	1.41	75	.70	1.00
80	.65	1.03	80	.75	1.11	80	.69	1.04	80	.85	1.35	80	.68	.97
85	.63	1.00	85	.73	1.07	85	.67	1.01	85	.82	1.31	85	.66	.94

SLOPE = .530

SLOPE = .550

SLOPE = .500

SLOPE = .580

SLOPE = .490

RUNOFF INDEX NUMBERS OF HYDROLOGIC SOIL-COVER COMPLEXES FOR PERVIOUS AREAS-AMC II

Cover Type (3)	Quality of Cover (2)	Soil Group			
		A	B	C	D
<u>NATURAL COVERS -</u>					
Barren (Rockland, eroded and graded land)		78	86	91	93
Chaparrel, Broadleaf (Manzonita, ceanothus and scrub oak)	Poor	53	70	80	85
	Fair	40	63	75	81
	Good	31	57	71	78
Chaparrel, Narrowleaf (Chamise and redshank)	Poor	71	82	88	91
	Fair	55	72	81	86
Grass, Annual or Perennial	Poor	67	78	86	89
	Fair	50	69	79	84
	Good	38	61	74	80
Meadows or Cienegas (Areas with seasonally high water table, principal vegetation is sod forming grass)	Poor	63	77	85	88
	Fair	51	70	80	84
	Good	30	58	72	78
Open Brush (Soft wood shrubs - buckwheat, sage, etc.)	Poor	62	76	84	88
	Fair	46	66	77	83
	Good	41	63	75	81
Woodland (Coniferous or broadleaf trees predominate. Canopy density is at least 50 percent)	Poor	45	66	77	83
	Fair	36	60	73	79
	Good	28	55	70	77
Woodland, Grass (Coniferous or broadleaf trees with canopy density from 20 to 50 percent)	Poor	57	73	82	86
	Fair	44	65	77	82
	Good	33	58	72	79
<u>URBAN COVERS -</u>					
Residential or Commercial Landscaping (Lawn, shrubs, etc.)	Good	32	56	69	75
Turf (Irrigated and mowed grass)	Poor	58	74	83	87
	Fair	44	65	77	82
	Good	33	58	72	79
<u>AGRICULTURAL COVERS -</u>					
Fallow (Land plowed but not tilled or seeded)		76	85	90	92

RCFC & WCD
HYDROLOGY MANUAL

RUNOFF INDEX NUMBERS
FOR
PERVIOUS AREA

RUNOFF INDEX NUMBERS OF HYDROLOGIC SOIL-COVER COMPLEXES FOR PERVIOUS AREAS-AMC II

Cover Type (3)	Quality of Cover (2)	Soil Group			
		A	B	C	D
<u>AGRICULTURAL COVERS</u> (cont.) -					
Legumes, Close Seeded (Alfalfa, sweetclover, timothy, etc.)	Poor	66	77	85	89
	Good	58	72	81	85
Orchards, Deciduous (Apples, apricots, pears, walnuts, etc.)	See Note 4				
Orchards, Evergreen (Citrus, avocados, etc.)	Poor	57	73	82	86
	Fair	44	65	77	82
	Good	33	58	72	79
Pasture, Dryland (Annual grasses)	Poor	67	78	86	89
	Fair	50	69	79	84
	Good	38	61	74	80
Pasture, Irrigated (Legumes and perennial grass)	Poor	58	74	83	87
	Fair	44	65	77	82
	Good	33	58	72	79
Row Crops (Field crops - tomatoes, sugar beets, etc.)	Poor	72	81	88	91
	Good	67	78	85	89
Small Grain (Wheat, oats, barley, etc.)	Poor	65	76	84	88
	Good	63	75	83	87
Vineyard	See Note 4				

Notes:

1. All runoff index (RI) numbers are for Antecedent Moisture Condition (AMC) II.
2. Quality of cover definitions:
 Poor-Heavily grazed or regularly burned areas. Less than 50 percent of the ground surface is protected by plant cover or brush and tree canopy.
 Fair-Moderate cover with 50 percent to 75 percent of the ground surface protected.
 Good-Heavy or dense cover with more than 75 percent of the ground surface protected.
3. See Plate C-2 for a detailed description of cover types.
4. Use runoff index numbers based on ground cover type. See discussion under "Cover Type Descriptions" on Plate C-2.
5. Reference Bibliography item 17.

RCFC & WCD
 HYDROLOGY MANUAL

**RUNOFF INDEX NUMBERS
 FOR
 PERVIOUS AREA**

ACTUAL IMPERVIOUS COVER

Land Use (1)	Range-Percent	Recommended Value For Average Conditions-Percent (2)
Natural or Agriculture	0 - 10	0
Single Family Residential: (3)		
40,000 S. F. (1 Acre) Lots	10 - 25	20
20,000 S. F. (½ Acre) Lots	30 - 45	40
7,200 - 10,000 S. F. Lots	45 - 55	50
Multiple Family Residential:		
Condominiums	45 - 70	65
Apartments	65 - 90	80
Mobile Home Park	60 - 85	75
Commercial, Downtown Business or Industrial	80 -100	90

Notes:

1. Land use should be based on ultimate development of the watershed. Long range master plans for the County and incorporated cities should be reviewed to insure reasonable land use assumptions.
2. Recommended values are based on average conditions which may not apply to a particular study area. The percentage impervious may vary greatly even on comparable sized lots due to differences in dwelling size, improvements, etc. Landscape practices should also be considered as it is common in some areas to use ornamental gravels underlain by impervious plastic materials in place of lawns and shrubs. A field investigation of a study area should always be made, and a review of aerial photos, where available may assist in estimating the percentage of impervious cover in developed areas.
3. For typical horse ranch subdivisions increase impervious area 5 percent over the values recommended in the table above.

RCFC & WCD
HYDROLOGY MANUAL

**IMPERVIOUS COVER
FOR
DEVELOPED AREAS**



United States
Department of
Agriculture

NRCS

Natural
Resources
Conservation
Service

A product of the National
Cooperative Soil Survey,
a joint effort of the United
States Department of
Agriculture and other
Federal agencies, State
agencies including the
Agricultural Experiment
Stations, and local
participants

Custom Soil Resource Report for Western Riverside Area, California

Cajalco Road



May 24, 2020

Preface

Soil surveys contain information that affects land use planning in survey areas. They highlight soil limitations that affect various land uses and provide information about the properties of the soils in the survey areas. Soil surveys are designed for many different users, including farmers, ranchers, foresters, agronomists, urban planners, community officials, engineers, developers, builders, and home buyers. Also, conservationists, teachers, students, and specialists in recreation, waste disposal, and pollution control can use the surveys to help them understand, protect, or enhance the environment.

Various land use regulations of Federal, State, and local governments may impose special restrictions on land use or land treatment. Soil surveys identify soil properties that are used in making various land use or land treatment decisions. The information is intended to help the land users identify and reduce the effects of soil limitations on various land uses. The landowner or user is responsible for identifying and complying with existing laws and regulations.

Although soil survey information can be used for general farm, local, and wider area planning, onsite investigation is needed to supplement this information in some cases. Examples include soil quality assessments (<http://www.nrcs.usda.gov/wps/portal/nrcs/main/soils/health/>) and certain conservation and engineering applications. For more detailed information, contact your local USDA Service Center (<https://offices.sc.egov.usda.gov/locator/app?agency=nrcs>) or your NRCS State Soil Scientist (http://www.nrcs.usda.gov/wps/portal/nrcs/detail/soils/contactus/?cid=nrcs142p2_053951).

Great differences in soil properties can occur within short distances. Some soils are seasonally wet or subject to flooding. Some are too unstable to be used as a foundation for buildings or roads. Clayey or wet soils are poorly suited to use as septic tank absorption fields. A high water table makes a soil poorly suited to basements or underground installations.

The National Cooperative Soil Survey is a joint effort of the United States Department of Agriculture and other Federal agencies, State agencies including the Agricultural Experiment Stations, and local agencies. The Natural Resources Conservation Service (NRCS) has leadership for the Federal part of the National Cooperative Soil Survey.

Information about soils is updated periodically. Updated information is available through the NRCS Web Soil Survey, the site for official soil survey information.

The U.S. Department of Agriculture (USDA) prohibits discrimination in all its programs and activities on the basis of race, color, national origin, age, disability, and where applicable, sex, marital status, familial status, parental status, religion, sexual orientation, genetic information, political beliefs, reprisal, or because all or a part of an individual's income is derived from any public assistance program. (Not all prohibited bases apply to all programs.) Persons with disabilities who require

alternative means for communication of program information (Braille, large print, audiotape, etc.) should contact USDA's TARGET Center at (202) 720-2600 (voice and TDD). To file a complaint of discrimination, write to USDA, Director, Office of Civil Rights, 1400 Independence Avenue, S.W., Washington, D.C. 20250-9410 or call (800) 795-3272 (voice) or (202) 720-6382 (TDD). USDA is an equal opportunity provider and employer.

Contents

Preface	2
How Soil Surveys Are Made	5
Soil Map	8
Soil Map.....	9
Legend.....	10
Map Unit Legend.....	11
Map Unit Descriptions.....	11
Western Riverside Area, California.....	13
MmB—Monserate sandy loam, 0 to 5 percent slopes.....	13
PaC2—Pachappa fine sandy loam, 2 to 8 percent slopes, eroded.....	14
References	16

How Soil Surveys Are Made

Soil surveys are made to provide information about the soils and miscellaneous areas in a specific area. They include a description of the soils and miscellaneous areas and their location on the landscape and tables that show soil properties and limitations affecting various uses. Soil scientists observed the steepness, length, and shape of the slopes; the general pattern of drainage; the kinds of crops and native plants; and the kinds of bedrock. They observed and described many soil profiles. A soil profile is the sequence of natural layers, or horizons, in a soil. The profile extends from the surface down into the unconsolidated material in which the soil formed or from the surface down to bedrock. The unconsolidated material is devoid of roots and other living organisms and has not been changed by other biological activity.

Currently, soils are mapped according to the boundaries of major land resource areas (MLRAs). MLRAs are geographically associated land resource units that share common characteristics related to physiography, geology, climate, water resources, soils, biological resources, and land uses (USDA, 2006). Soil survey areas typically consist of parts of one or more MLRA.

The soils and miscellaneous areas in a survey area occur in an orderly pattern that is related to the geology, landforms, relief, climate, and natural vegetation of the area. Each kind of soil and miscellaneous area is associated with a particular kind of landform or with a segment of the landform. By observing the soils and miscellaneous areas in the survey area and relating their position to specific segments of the landform, a soil scientist develops a concept, or model, of how they were formed. Thus, during mapping, this model enables the soil scientist to predict with a considerable degree of accuracy the kind of soil or miscellaneous area at a specific location on the landscape.

Commonly, individual soils on the landscape merge into one another as their characteristics gradually change. To construct an accurate soil map, however, soil scientists must determine the boundaries between the soils. They can observe only a limited number of soil profiles. Nevertheless, these observations, supplemented by an understanding of the soil-vegetation-landscape relationship, are sufficient to verify predictions of the kinds of soil in an area and to determine the boundaries.

Soil scientists recorded the characteristics of the soil profiles that they studied. They noted soil color, texture, size and shape of soil aggregates, kind and amount of rock fragments, distribution of plant roots, reaction, and other features that enable them to identify soils. After describing the soils in the survey area and determining their properties, the soil scientists assigned the soils to taxonomic classes (units). Taxonomic classes are concepts. Each taxonomic class has a set of soil characteristics with precisely defined limits. The classes are used as a basis for comparison to classify soils systematically. Soil taxonomy, the system of taxonomic classification used in the United States, is based mainly on the kind and character of soil properties and the arrangement of horizons within the profile. After the soil

Custom Soil Resource Report

scientists classified and named the soils in the survey area, they compared the individual soils with similar soils in the same taxonomic class in other areas so that they could confirm data and assemble additional data based on experience and research.

The objective of soil mapping is not to delineate pure map unit components; the objective is to separate the landscape into landforms or landform segments that have similar use and management requirements. Each map unit is defined by a unique combination of soil components and/or miscellaneous areas in predictable proportions. Some components may be highly contrasting to the other components of the map unit. The presence of minor components in a map unit in no way diminishes the usefulness or accuracy of the data. The delineation of such landforms and landform segments on the map provides sufficient information for the development of resource plans. If intensive use of small areas is planned, onsite investigation is needed to define and locate the soils and miscellaneous areas.

Soil scientists make many field observations in the process of producing a soil map. The frequency of observation is dependent upon several factors, including scale of mapping, intensity of mapping, design of map units, complexity of the landscape, and experience of the soil scientist. Observations are made to test and refine the soil-landscape model and predictions and to verify the classification of the soils at specific locations. Once the soil-landscape model is refined, a significantly smaller number of measurements of individual soil properties are made and recorded. These measurements may include field measurements, such as those for color, depth to bedrock, and texture, and laboratory measurements, such as those for content of sand, silt, clay, salt, and other components. Properties of each soil typically vary from one point to another across the landscape.

Observations for map unit components are aggregated to develop ranges of characteristics for the components. The aggregated values are presented. Direct measurements do not exist for every property presented for every map unit component. Values for some properties are estimated from combinations of other properties.

While a soil survey is in progress, samples of some of the soils in the area generally are collected for laboratory analyses and for engineering tests. Soil scientists interpret the data from these analyses and tests as well as the field-observed characteristics and the soil properties to determine the expected behavior of the soils under different uses. Interpretations for all of the soils are field tested through observation of the soils in different uses and under different levels of management. Some interpretations are modified to fit local conditions, and some new interpretations are developed to meet local needs. Data are assembled from other sources, such as research information, production records, and field experience of specialists. For example, data on crop yields under defined levels of management are assembled from farm records and from field or plot experiments on the same kinds of soil.

Predictions about soil behavior are based not only on soil properties but also on such variables as climate and biological activity. Soil conditions are predictable over long periods of time, but they are not predictable from year to year. For example, soil scientists can predict with a fairly high degree of accuracy that a given soil will have a high water table within certain depths in most years, but they cannot predict that a high water table will always be at a specific level in the soil on a specific date.

After soil scientists located and identified the significant natural bodies of soil in the survey area, they drew the boundaries of these bodies on aerial photographs and

Custom Soil Resource Report

identified each as a specific map unit. Aerial photographs show trees, buildings, fields, roads, and rivers, all of which help in locating boundaries accurately.

Soil Map

The soil map section includes the soil map for the defined area of interest, a list of soil map units on the map and extent of each map unit, and cartographic symbols displayed on the map. Also presented are various metadata about data used to produce the map, and a description of each soil map unit.

Custom Soil Resource Report Soil Map



Map Scale: 1:763 if printed on A landscape (11" x 8.5") sheet.

0 10 20 40 60 Meters

0 35 70 140 210 Feet

Map projection: Web Mercator Corner coordinates: WGS84 Edge tics: UTM Zone 11N WGS84

MAP LEGEND

Area of Interest (AOI)

 Area of Interest (AOI)



















Soils

 Soil Map Unit Polygons

 Soil Map Unit Lines

 Soil Map Unit Points

Special Point Features





-  Blowout
-  Borrow Pit
-  Clay Spot
-  Closed Depression
-  Gravel Pit
-  Gravelly Spot
-  Landfill
-  Lava Flow
-  Marsh or swamp
-  Mine or Quarry
-  Miscellaneous Water
-  Perennial Water
-  Rock Outcrop
-  Saline Spot
-  Sandy Spot
-  Severely Eroded Spot
-  Sinkhole
-  Slide or Slip
-  Sodic Spot

-  Spoil Area
-  Stony Spot
-  Very Stony Spot
-  Wet Spot
-  Other
-  Special Line Features

Water Features

 Streams and Canals

Transportation

-  Rails
-  Interstate Highways
-  US Routes
-  Major Roads
-  Local Roads

Background

 Aerial Photography

MAP INFORMATION

The soil surveys that comprise your AOI were mapped at 1:15,800.

Warning: Soil Map may not be valid at this scale.

Enlargement of maps beyond the scale of mapping can cause misunderstanding of the detail of mapping and accuracy of soil line placement. The maps do not show the small areas of contrasting soils that could have been shown at a more detailed scale.

Please rely on the bar scale on each map sheet for map measurements.

Source of Map: Natural Resources Conservation Service
 Web Soil Survey URL:
 Coordinate System: Web Mercator (EPSG:3857)

Maps from the Web Soil Survey are based on the Web Mercator projection, which preserves direction and shape but distorts distance and area. A projection that preserves area, such as the Albers equal-area conic projection, should be used if more accurate calculations of distance or area are required.

This product is generated from the USDA-NRCS certified data as of the version date(s) listed below.

Soil Survey Area: Western Riverside Area, California
 Survey Area Data: Version 12, Sep 16, 2019

Soil map units are labeled (as space allows) for map scales 1:50,000 or larger.

Date(s) aerial images were photographed: May 25, 2019—Jun 25, 2019

The orthophoto or other base map on which the soil lines were compiled and digitized probably differs from the background imagery displayed on these maps. As a result, some minor shifting of map unit boundaries may be evident.

Map Unit Legend

Map Unit Symbol	Map Unit Name	Acres in AOI	Percent of AOI
MmB	Monserate sandy loam, 0 to 5 percent slopes	1.1	47.5%
PaC2	Pachappa fine sandy loam, 2 to 8 percent slopes, eroded	1.2	52.5%
Totals for Area of Interest		2.2	100.0%

Map Unit Descriptions

The map units delineated on the detailed soil maps in a soil survey represent the soils or miscellaneous areas in the survey area. The map unit descriptions, along with the maps, can be used to determine the composition and properties of a unit.

A map unit delineation on a soil map represents an area dominated by one or more major kinds of soil or miscellaneous areas. A map unit is identified and named according to the taxonomic classification of the dominant soils. Within a taxonomic class there are precisely defined limits for the properties of the soils. On the landscape, however, the soils are natural phenomena, and they have the characteristic variability of all natural phenomena. Thus, the range of some observed properties may extend beyond the limits defined for a taxonomic class. Areas of soils of a single taxonomic class rarely, if ever, can be mapped without including areas of other taxonomic classes. Consequently, every map unit is made up of the soils or miscellaneous areas for which it is named and some minor components that belong to taxonomic classes other than those of the major soils.

Most minor soils have properties similar to those of the dominant soil or soils in the map unit, and thus they do not affect use and management. These are called noncontrasting, or similar, components. They may or may not be mentioned in a particular map unit description. Other minor components, however, have properties and behavioral characteristics divergent enough to affect use or to require different management. These are called contrasting, or dissimilar, components. They generally are in small areas and could not be mapped separately because of the scale used. Some small areas of strongly contrasting soils or miscellaneous areas are identified by a special symbol on the maps. If included in the database for a given area, the contrasting minor components are identified in the map unit descriptions along with some characteristics of each. A few areas of minor components may not have been observed, and consequently they are not mentioned in the descriptions, especially where the pattern was so complex that it was impractical to make enough observations to identify all the soils and miscellaneous areas on the landscape.

The presence of minor components in a map unit in no way diminishes the usefulness or accuracy of the data. The objective of mapping is not to delineate pure taxonomic classes but rather to separate the landscape into landforms or landform segments that have similar use and management requirements. The delineation of such segments on the map provides sufficient information for the development of resource plans. If intensive use of small areas is planned, however,

Custom Soil Resource Report

onsite investigation is needed to define and locate the soils and miscellaneous areas.

An identifying symbol precedes the map unit name in the map unit descriptions. Each description includes general facts about the unit and gives important soil properties and qualities.

Soils that have profiles that are almost alike make up a *soil series*. Except for differences in texture of the surface layer, all the soils of a series have major horizons that are similar in composition, thickness, and arrangement.

Soils of one series can differ in texture of the surface layer, slope, stoniness, salinity, degree of erosion, and other characteristics that affect their use. On the basis of such differences, a soil series is divided into *soil phases*. Most of the areas shown on the detailed soil maps are phases of soil series. The name of a soil phase commonly indicates a feature that affects use or management. For example, Alpha silt loam, 0 to 2 percent slopes, is a phase of the Alpha series.

Some map units are made up of two or more major soils or miscellaneous areas. These map units are complexes, associations, or undifferentiated groups.

A *complex* consists of two or more soils or miscellaneous areas in such an intricate pattern or in such small areas that they cannot be shown separately on the maps. The pattern and proportion of the soils or miscellaneous areas are somewhat similar in all areas. Alpha-Beta complex, 0 to 6 percent slopes, is an example.

An *association* is made up of two or more geographically associated soils or miscellaneous areas that are shown as one unit on the maps. Because of present or anticipated uses of the map units in the survey area, it was not considered practical or necessary to map the soils or miscellaneous areas separately. The pattern and relative proportion of the soils or miscellaneous areas are somewhat similar. Alpha-Beta association, 0 to 2 percent slopes, is an example.

An *undifferentiated group* is made up of two or more soils or miscellaneous areas that could be mapped individually but are mapped as one unit because similar interpretations can be made for use and management. The pattern and proportion of the soils or miscellaneous areas in a mapped area are not uniform. An area can be made up of only one of the major soils or miscellaneous areas, or it can be made up of all of them. Alpha and Beta soils, 0 to 2 percent slopes, is an example.

Some surveys include *miscellaneous areas*. Such areas have little or no soil material and support little or no vegetation. Rock outcrop is an example.

Western Riverside Area, California

MmB—Monserate sandy loam, 0 to 5 percent slopes

Map Unit Setting

National map unit symbol: hcx4

Elevation: 700 to 2,500 feet

Mean annual precipitation: 10 to 18 inches

Mean annual air temperature: 63 to 64 degrees F

Frost-free period: 220 to 280 days

Farmland classification: Farmland of statewide importance

Map Unit Composition

Monserate and similar soils: 85 percent

Minor components: 15 percent

Estimates are based on observations, descriptions, and transects of the mapunit.

Description of Monserate

Setting

Landform: Alluvial fans

Landform position (three-dimensional): Tread

Down-slope shape: Linear

Across-slope shape: Linear

Parent material: Alluvium derived from granite

Typical profile

H1 - 0 to 10 inches: sandy loam

H2 - 10 to 28 inches: sandy clay loam

H3 - 28 to 45 inches: indurated

H4 - 45 to 57 inches: cemented

H5 - 57 to 70 inches: loamy coarse sand, coarse sandy loam

H5 - 57 to 70 inches:

Properties and qualities

Slope: 0 to 5 percent

Depth to restrictive feature: 20 to 39 inches to duripan

Natural drainage class: Well drained

Runoff class: Medium

Capacity of the most limiting layer to transmit water (Ksat): Very low (0.00 to 0.00 in/hr)

Depth to water table: More than 80 inches

Frequency of flooding: None

Frequency of ponding: None

Available water storage in profile: Low (about 4.1 inches)

Interpretive groups

Land capability classification (irrigated): 3e

Land capability classification (nonirrigated): 4e

Hydrologic Soil Group: C

Ecological site: LOAMY (1975) (R019XD029CA)

Hydric soil rating: No

Minor Components

Tujunga

Percent of map unit: 5 percent
Hydric soil rating: No

Hanford

Percent of map unit: 5 percent
Hydric soil rating: No

Greenfield

Percent of map unit: 5 percent
Hydric soil rating: No

PaC2—Pachappa fine sandy loam, 2 to 8 percent slopes, eroded

Map Unit Setting

National map unit symbol: hcxp
Elevation: 1,000 feet
Mean annual precipitation: 14 inches
Mean annual air temperature: 63 degrees F
Frost-free period: 270 days
Farmland classification: Prime farmland if irrigated

Map Unit Composition

Pachappa and similar soils: 85 percent
Minor components: 15 percent
Estimates are based on observations, descriptions, and transects of the mapunit.

Description of Pachappa

Setting

Landform: Alluvial fans
Landform position (three-dimensional): Tread
Down-slope shape: Linear
Across-slope shape: Linear
Parent material: Alluvium derived from granite

Typical profile

H1 - 0 to 20 inches: fine sandy loam
H2 - 20 to 40 inches: loam
H3 - 40 to 63 inches: fine sandy loam

Properties and qualities

Slope: 2 to 8 percent
Depth to restrictive feature: More than 80 inches
Natural drainage class: Well drained
Runoff class: Medium
Capacity of the most limiting layer to transmit water (Ksat): Moderately high to high (0.57 to 1.98 in/hr)
Depth to water table: More than 80 inches

Custom Soil Resource Report

Frequency of flooding: None

Frequency of ponding: None

Calcium carbonate, maximum in profile: 5 percent

Salinity, maximum in profile: Nonsaline to slightly saline (0.0 to 4.0 mmhos/cm)

Available water storage in profile: Moderate (about 8.4 inches)

Interpretive groups

Land capability classification (irrigated): 2e

Land capability classification (nonirrigated): 3e

Hydrologic Soil Group: B

Ecological site: LOAMY (1975) (R019XD029CA)

Hydric soil rating: No

Minor Components

Hanford

Percent of map unit: 5 percent

Hydric soil rating: No

San emigdio

Percent of map unit: 5 percent

Hydric soil rating: No

Greenfield

Percent of map unit: 5 percent

Hydric soil rating: No

References

- American Association of State Highway and Transportation Officials (AASHTO). 2004. Standard specifications for transportation materials and methods of sampling and testing. 24th edition.
- American Society for Testing and Materials (ASTM). 2005. Standard classification of soils for engineering purposes. ASTM Standard D2487-00.
- Cowardin, L.M., V. Carter, F.C. Golet, and E.T. LaRoe. 1979. Classification of wetlands and deep-water habitats of the United States. U.S. Fish and Wildlife Service FWS/OBS-79/31.
- Federal Register. July 13, 1994. Changes in hydric soils of the United States.
- Federal Register. September 18, 2002. Hydric soils of the United States.
- Hurt, G.W., and L.M. Vasilas, editors. Version 6.0, 2006. Field indicators of hydric soils in the United States.
- National Research Council. 1995. Wetlands: Characteristics and boundaries.
- Soil Survey Division Staff. 1993. Soil survey manual. Soil Conservation Service. U.S. Department of Agriculture Handbook 18. http://www.nrcs.usda.gov/wps/portal/nrcs/detail/national/soils/?cid=nrcs142p2_054262
- Soil Survey Staff. 1999. Soil taxonomy: A basic system of soil classification for making and interpreting soil surveys. 2nd edition. Natural Resources Conservation Service, U.S. Department of Agriculture Handbook 436. http://www.nrcs.usda.gov/wps/portal/nrcs/detail/national/soils/?cid=nrcs142p2_053577
- Soil Survey Staff. 2010. Keys to soil taxonomy. 11th edition. U.S. Department of Agriculture, Natural Resources Conservation Service. http://www.nrcs.usda.gov/wps/portal/nrcs/detail/national/soils/?cid=nrcs142p2_053580
- Tiner, R.W., Jr. 1985. Wetlands of Delaware. U.S. Fish and Wildlife Service and Delaware Department of Natural Resources and Environmental Control, Wetlands Section.
- United States Army Corps of Engineers, Environmental Laboratory. 1987. Corps of Engineers wetlands delineation manual. Waterways Experiment Station Technical Report Y-87-1.
- United States Department of Agriculture, Natural Resources Conservation Service. National forestry manual. http://www.nrcs.usda.gov/wps/portal/nrcs/detail/soils/home/?cid=nrcs142p2_053374
- United States Department of Agriculture, Natural Resources Conservation Service. National range and pasture handbook. <http://www.nrcs.usda.gov/wps/portal/nrcs/detail/national/landuse/rangepasture/?cid=stelprdb1043084>

Custom Soil Resource Report

United States Department of Agriculture, Natural Resources Conservation Service. National soil survey handbook, title 430-VI. http://www.nrcs.usda.gov/wps/portal/nrcs/detail/soils/scientists/?cid=nrcs142p2_054242

United States Department of Agriculture, Natural Resources Conservation Service. 2006. Land resource regions and major land resource areas of the United States, the Caribbean, and the Pacific Basin. U.S. Department of Agriculture Handbook 296. http://www.nrcs.usda.gov/wps/portal/nrcs/detail/national/soils/?cid=nrcs142p2_053624

United States Department of Agriculture, Soil Conservation Service. 1961. Land capability classification. U.S. Department of Agriculture Handbook 210. http://www.nrcs.usda.gov/Internet/FSE_DOCUMENTS/nrcs142p2_052290.pdf

ATTACHMENT 2: EXISTING CONDITIONS CALCULATIONS

This attachment contains the existing conditions calculations. Please see the attached calculations.

**EXISTING CONDITIONS – CONFLUENCE POINT A
100 YEAR DESIGN STORM EVENT**

Riverside County Rational Hydrology Program
CIVILCADD/CIVILDESIGN Engineering Software,(c) 1989 - 2014 Version 9.0
Rational Hydrology Study Date: 05/02/21 File:cajalcoexd1.out

***** Hydrology Study Control Information *****
English (in-lb) Units used in input data file

Rational Method Hydrology Program based on
Riverside County Flood Control & Water Conservation District
1978 hydrology manual

Storm event (year) = 100.00 Antecedent Moisture Condition = 3

Standard intensity-duration curves data (Plate D-4.1)
For the [Perris Valley] area used.
10 year storm 10 minute intensity = 1.880(In/Hr)
10 year storm 60 minute intensity = 0.780(In/Hr)
100 year storm 10 minute intensity = 2.690(In/Hr)
100 year storm 60 minute intensity = 1.120(In/Hr)

Storm event year = 100.0
Calculated rainfall intensity data:
1 hour intensity = 1.120(In/Hr)
Slope of intensity duration curve = 0.4900

Process from Point/Station 1.110 to Point/Station 1.210
**** INITIAL AREA EVALUATION ****

Initial area flow distance = 75.000(Ft.)
Top (of initial area) elevation = 1650.500(Ft.)
Bottom (of initial area) elevation = 1650.000(Ft.)
Difference in elevation = 0.500(Ft.)
Slope = 0.00667 s(percent)= 0.67
TC = $k(0.530)*[(length^3)/(elevation\ change)]^{0.2}$
Initial area time of concentration = 8.119 min.
Rainfall intensity = 2.984(In/Hr) for a 100.0 year storm
UNDEVELOPED (poor cover) subarea
Runoff Coefficient = 0.857
Decimal fraction soil group A = 0.000
Decimal fraction soil group B = 1.000
Decimal fraction soil group C = 0.000
Decimal fraction soil group D = 0.000
RI index for soil(AMC 3) = 89.80
Pervious area fraction = 1.000; Impervious fraction = 0.000
Initial subarea runoff = 0.230(CFS)
Total initial stream area = 0.090(Ac.)
Pervious area fraction = 1.000

**PRELIMINARY HYDROLOGY REPORT
 PROPOSED SHOPPING CENTER
 CUP180008
 21419 & 21425 CAJALCO ROAD, PERRIS, CALIFORNIA 92590**



+++++
 Process from Point/Station 1.210 to Point/Station 1.220
 **** IRREGULAR CHANNEL FLOW TRAVEL TIME ****

Estimated mean flow rate at midpoint of channel = 2.370(CFS)
 Depth of flow = 0.142(Ft.), Average velocity = 1.621(Ft/s)
 ***** Irregular Channel Data *****

 Information entered for subchannel number 1 :

Point number	'X' coordinate	'Y' coordinate
1	0.00	0.50
2	24.00	0.00
3	48.00	0.25
4	70.00	0.50

Manning's 'N' friction factor = 0.025

Sub-Channel flow = 2.370(CFS)
 ' ' flow top width = 20.518(Ft.)
 ' ' velocity = 1.621(Ft/s)
 ' ' area = 1.462(Sq.Ft)
 ' ' Froude number = 1.071

Upstream point elevation = 1650.000(Ft.)
 Downstream point elevation = 1643.700(Ft.)
 Flow length = 250.000(Ft.)
 Travel time = 2.57 min.
 Time of concentration = 10.69 min.
 Depth of flow = 0.142(Ft.)
 Average velocity = 1.621(Ft/s)
 Total irregular channel flow = 2.370(CFS)
 Irregular channel normal depth above invert elev. = 0.142(Ft.)
 Average velocity of channel(s) = 1.621(Ft/s)
 Adding area flow to channel
 UNDEVELOPED (poor cover) subarea
 Runoff Coefficient = 0.867
 Decimal fraction soil group A = 0.000
 Decimal fraction soil group B = 0.300
 Decimal fraction soil group C = 0.700
 Decimal fraction soil group D = 0.000
 RI index for soil(AMC 3) = 93.16
 Pervious area fraction = 1.000; Impervious fraction = 0.000
 Rainfall intensity = 2.608(In/Hr) for a 100.0 year storm
 Subarea runoff = 4.208(CFS) for 1.860(Ac.)
 Total runoff = 4.438(CFS) Total area = 1.950(Ac.)
 Depth of flow = 0.180(Ft.), Average velocity = 1.897(Ft/s)

**PRELIMINARY HYDROLOGY REPORT
 PROPOSED SHOPPING CENTER
 CUP180008
 21419 & 21425 CAJALCO ROAD, PERRIS, CALIFORNIA 92590**



Process from Point/Station 1.110 to Point/Station 1.220
 **** CONFLUENCE OF MAIN STREAMS ****

The following data inside Main Stream is listed:
 In Main Stream number: 1
 Stream flow area = 1.950(Ac.)
 Runoff from this stream = 4.438(CFS)
 Time of concentration = 10.69 min.
 Rainfall intensity = 2.608(In/Hr)
 Summary of stream data:

Stream No.	Flow rate (CFS)	TC (min)	Rainfall Intensity (In/Hr)
1	4.438	10.69	2.608

Largest stream flow has longer time of concentration
 Qp = 4.438 + sum of
 Qp = 4.438

Total of 1 main streams to confluence:
 Flow rates before confluence point:
 4.438
 Area of streams before confluence:
 1.950

Results of confluence:
 Total flow rate = 4.438(CFS)
 Time of concentration = 10.689 min.
 Effective stream area after confluence = 1.950(Ac.)
 End of computations, total study area = 1.95 (Ac.)
 The following figures may be used for a unit hydrograph study of the same area.

Area averaged pervious area fraction(Ap) = 1.000
 Area averaged RI index number = 83.3

ATTACHMENT 3: PROPOSED CONDITIONS CALCULATIONS

This attachment contains the proposed conditions calculations. Please see the attached calculations.

PROPOSED CONDITIONS – CONFLUENCE POINT A
100 YEAR DESIGN STORM EVENT

Riverside County Rational Hydrology Program
CIVILCADD/CIVILDESIGN Engineering Software,(c) 1989 - 2014 Version 9.0
Rational Hydrology Study Date: 05/02/21 File:CAJALCOPRD1.out

***** Hydrology Study Control Information *****
English (in-lb) Units used in input data file

Rational Method Hydrology Program based on
Riverside County Flood Control & Water Conservation District
1978 hydrology manual

Storm event (year) = 100.00 Antecedent Moisture Condition = 3

Standard intensity-duration curves data (Plate D-4.1)
For the [Perris Valley] area used.
10 year storm 10 minute intensity = 1.880(In/Hr)
10 year storm 60 minute intensity = 0.780(In/Hr)
100 year storm 10 minute intensity = 2.690(In/Hr)
100 year storm 60 minute intensity = 1.120(In/Hr)

Storm event year = 100.0
Calculated rainfall intensity data:
1 hour intensity = 1.120(In/Hr)
Slope of intensity duration curve = 0.4900

Process from Point/Station 1.110 to Point/Station 1.210
**** INITIAL AREA EVALUATION ****

Initial area flow distance = 75.000(Ft.)
Top (of initial area) elevation = 1650.500(Ft.)
Bottom (of initial area) elevation = 1647.000(Ft.)
Difference in elevation = 3.500(Ft.)
Slope = 0.04667 s(percent)= 4.67
TC = $k(0.420)*[(length^3)/(elevation\ change)]^{0.2}$
Warning: TC computed to be less than 5 min.; program is assuming the
time of concentration is 5 minutes.
Initial area time of concentration = 5.000 min.
Rainfall intensity = 3.785(In/Hr) for a 100.0 year storm
SINGLE FAMILY (1/2 Acre Lot)
Runoff Coefficient = 0.843
Decimal fraction soil group A = 0.000
Decimal fraction soil group B = 1.000
Decimal fraction soil group C = 0.000
Decimal fraction soil group D = 0.000
RI index for soil(AMC 3) = 74.80
Pervious area fraction = 0.600; Impervious fraction = 0.400
Initial subarea runoff = 0.287(CFS)
Total initial stream area = 0.090(Ac.)
Pervious area fraction = 0.600

**PRELIMINARY HYDROLOGY REPORT
 PROPOSED SHOPPING CENTER
 CUP180008
 21419 & 21425 CAJALCO ROAD, PERRIS, CALIFORNIA 92590**



Process from Point/Station 1.210 to Point/Station 1.420
 **** IRREGULAR CHANNEL FLOW TRAVEL TIME ****

Estimated mean flow rate at midpoint of channel = 1.388(CFS)
 Depth of flow = 0.155(Ft.), Average velocity = 2.438(Ft/s)
 ***** Irregular Channel Data *****

Information entered for subchannel number 1 :
 Point number 'X' coordinate 'Y' coordinate
 1 0.00 0.50
 2 13.00 0.00
 3 23.60 0.50
 Manning's 'N' friction factor = 0.013

Sub-Channel flow = 1.388(CFS)
 ' ' flow top width = 7.332(Ft.)
 ' ' velocity = 2.438(Ft/s)
 ' ' area = 0.569(Sq.Ft)
 ' ' Froude number = 1.542

Upstream point elevation = 1647.000(Ft.)
 Downstream point elevation = 1643.700(Ft.)
 Flow length = 240.000(Ft.)
 Travel time = 1.64 min.
 Time of concentration = 6.64 min.
 Depth of flow = 0.155(Ft.)
 Average velocity = 2.438(Ft/s)
 Total irregular channel flow = 1.388(CFS)
 Irregular channel normal depth above invert elev. = 0.155(Ft.)
 Average velocity of channel(s) = 2.438(Ft/s)
 Adding area flow to channel
 SINGLE FAMILY (1/2 Acre Lot)
 Runoff Coefficient = 0.849
 Decimal fraction soil group A = 0.000
 Decimal fraction soil group B = 0.530
 Decimal fraction soil group C = 0.470
 Decimal fraction soil group D = 0.000
 RI index for soil(AMC 3) = 79.69
 Pervious area fraction = 0.600; Impervious fraction = 0.400
 Rainfall intensity = 3.293(In/Hr) for a 100.0 year storm
 Subarea runoff = 2.126(CFS) for 0.760(Ac.)
 Total runoff = 2.413(CFS) Total area = 0.850(Ac.)
 Depth of flow = 0.191(Ft.), Average velocity = 2.800(Ft/s)

**PRELIMINARY HYDROLOGY REPORT
PROPOSED SHOPPING CENTER
CUP180008
21419 & 21425 CAJALCO ROAD, PERRIS, CALIFORNIA 92590**



+++++
Process from Point/Station 1.110 to Point/Station 1.420
**** CONFLUENCE OF MAIN STREAMS ****

The following data inside Main Stream is listed:
In Main Stream number: 1
Stream flow area = 0.850(Ac.)
Runoff from this stream = 2.413(CFS)
Time of concentration = 6.64 min.
Rainfall intensity = 3.293(In/Hr)
Program is now starting with Main Stream No. 2

+++++
Process from Point/Station 1.310 to Point/Station 1.410
**** INITIAL AREA EVALUATION ****

Initial area flow distance = 100.000(Ft.)
Top (of initial area) elevation = 1650.000(Ft.)
Bottom (of initial area) elevation = 1646.500(Ft.)
Difference in elevation = 3.500(Ft.)
Slope = 0.03500 s(percent)= 3.50
TC = $k(0.420)*[(length^3)/(elevation\ change)]^{0.2}$
Initial area time of concentration = 5.181 min.
Rainfall intensity = 3.719(In/Hr) for a 100.0 year storm
SINGLE FAMILY (1/2 Acre Lot)
Runoff Coefficient = 0.866
Decimal fraction soil group A = 0.000
Decimal fraction soil group B = 0.000
Decimal fraction soil group C = 1.000
Decimal fraction soil group D = 0.000
RI index for soil(AMC 3) = 84.40
Pervious area fraction = 0.600; Impervious fraction = 0.400
Initial subarea runoff = 0.419(CFS)
Total initial stream area = 0.130(Ac.)
Pervious area fraction = 0.600

**PRELIMINARY HYDROLOGY REPORT
 PROPOSED SHOPPING CENTER
 CUP180008
 21419 & 21425 CAJALCO ROAD, PERRIS, CALIFORNIA 92590**



+++++
 Process from Point/Station 1.410 to Point/Station 1.420
 **** IRREGULAR CHANNEL FLOW TRAVEL TIME ****

Estimated mean flow rate at midpoint of channel = 1.232(CFS)
 Depth of flow = 0.164(Ft.), Average velocity = 1.311(Ft/s)
 ***** Irregular Channel Data *****

 Information entered for subchannel number 1 :

Point number	'X' coordinate	'Y' coordinate
1	0.00	0.50
2	14.00	0.00
3	35.00	0.50

Manning's 'N' friction factor = 0.020

Sub-Channel flow = 1.232(CFS)
 ' ' flow top width = 11.472(Ft.)
 ' ' velocity = 1.311(Ft/s)
 ' ' area = 0.940(Sq.Ft)
 ' ' Froude number = 0.807

Upstream point elevation = 1646.500(Ft.)
 Downstream point elevation = 1643.700(Ft.)
 Flow length = 320.000(Ft.)
 Travel time = 4.07 min.
 Time of concentration = 9.25 min.
 Depth of flow = 0.164(Ft.)
 Average velocity = 1.311(Ft/s)
 Total irregular channel flow = 1.232(CFS)
 Irregular channel normal depth above invert elev. = 0.164(Ft.)
 Average velocity of channel(s) = 1.311(Ft/s)
 Adding area flow to channel
 SINGLE FAMILY (1/2 Acre Lot)
 Runoff Coefficient = 0.854
 Decimal fraction soil group A = 0.000
 Decimal fraction soil group B = 0.100
 Decimal fraction soil group C = 0.900
 Decimal fraction soil group D = 0.000
 RI index for soil(AMC 3) = 83.62
 Pervious area fraction = 0.600; Impervious fraction = 0.400
 Rainfall intensity = 2.800(In/Hr) for a 100.0 year storm
 Subarea runoff = 1.554(CFS) for 0.650(Ac.)
 Total runoff = 1.973(CFS) Total area = 0.780(Ac.)
 Depth of flow = 0.196(Ft.), Average velocity = 1.474(Ft/s)

**PRELIMINARY HYDROLOGY REPORT
 PROPOSED SHOPPING CENTER
 CUP180008
 21419 & 21425 CAJALCO ROAD, PERRIS, CALIFORNIA 92590**



+++++
 Process from Point/Station 1.310 to Point/Station 1.420
 **** CONFLUENCE OF MAIN STREAMS ****

The following data inside Main Stream is listed:

In Main Stream number: 2
 Stream flow area = 0.780(Ac.)
 Runoff from this stream = 1.973(CFS)
 Time of concentration = 9.25 min.
 Rainfall intensity = 2.800(In/Hr)
 Summary of stream data:

Stream No.	Flow rate (CFS)	TC (min)	Rainfall Intensity (In/Hr)
------------	-----------------	----------	----------------------------

1	2.413	6.64	3.293
2	1.973	9.25	2.800

Largest stream flow has longer or shorter time of concentration

Qp = 2.413 + sum of

$$Q_a \frac{T_b}{T_a}$$

$$1.973 * 0.718 = 1.416$$

Qp = 3.830

Total of 2 main streams to confluence:

Flow rates before confluence point:

2.413 1.973

Area of streams before confluence:

0.850 0.780

Results of confluence:

Total flow rate = 3.830(CFS)

Time of concentration = 6.640 min.

Effective stream area after confluence = 1.630(Ac.)

**PRELIMINARY HYDROLOGY REPORT
PROPOSED SHOPPING CENTER
CUP180008
21419 & 21425 CAJALCO ROAD, PERRIS, CALIFORNIA 92590**



++++
Process from Point/Station 1.420 to Point/Station 1.620
**** IRREGULAR CHANNEL FLOW TRAVEL TIME ****

Depth of flow = 0.165(Ft.), Average velocity = 2.154(Ft/s)
***** Irregular Channel Data *****

Information entered for subchannel number 1 :
Point number 'X' coordinate 'Y' coordinate
1 0.00 0.50
2 30.00 0.00
3 65.00 0.50
Manning's 'N' friction factor = 0.020

Sub-Channel flow = 3.830(CFS)
' ' flow top width = 21.500(Ft.)
' ' velocity = 2.154(Ft/s)
' ' area = 1.778(Sq.Ft)
' ' Froude number = 1.320

Upstream point elevation = 1643.700(Ft.)
Downstream point elevation = 1643.000(Ft.)
Flow length = 30.000(Ft.)
Travel time = 0.23 min.
Time of concentration = 6.87 min.
Depth of flow = 0.165(Ft.)
Average velocity = 2.154(Ft/s)
Total irregular channel flow = 3.830(CFS)
Irregular channel normal depth above invert elev. = 0.165(Ft.)
Average velocity of channel(s) = 2.154(Ft/s)

++++
Process from Point/Station 1.110 to Point/Station 1.620
**** CONFLUENCE OF MAIN STREAMS ****

The following data inside Main Stream is listed:
In Main Stream number: 1
Stream flow area = 1.630(Ac.)
Runoff from this stream = 3.830(CFS)
Time of concentration = 6.87 min.
Rainfall intensity = 3.238(In/Hr)
Program is now starting with Main Stream No. 2

**PRELIMINARY HYDROLOGY REPORT
 PROPOSED SHOPPING CENTER
 CUP180008
 21419 & 21425 CAJALCO ROAD, PERRIS, CALIFORNIA 92590**



+++++
 Process from Point/Station 1.510 to Point/Station 1.610
 **** INITIAL AREA EVALUATION ****

Initial area flow distance = 100.000(Ft.)
 Top (of initial area) elevation = 1645.200(Ft.)
 Bottom (of initial area) elevation = 1644.500(Ft.)
 Difference in elevation = 0.700(Ft.)
 Slope = 0.00700 s(percent)= 0.70
 $TC = k(0.420)*[(length^3)/(elevation\ change)]^{0.2}$
 Initial area time of concentration = 7.149 min.
 Rainfall intensity = 3.176(In/Hr) for a 100.0 year storm
 SINGLE FAMILY (1/2 Acre Lot)
 Runoff Coefficient = 0.833
 Decimal fraction soil group A = 0.000
 Decimal fraction soil group B = 1.000
 Decimal fraction soil group C = 0.000
 Decimal fraction soil group D = 0.000
 RI index for soil(AMC 3) = 74.80
 Pervious area fraction = 0.600; Impervious fraction = 0.400
 Initial subarea runoff = 0.212(CFS)
 Total initial stream area = 0.080(Ac.)
 Pervious area fraction = 0.600

+++++
 Process from Point/Station 1.610 to Point/Station 1.620
 **** IRREGULAR CHANNEL FLOW TRAVEL TIME ****

Estimated mean flow rate at midpoint of channel = 0.501(CFS)
 Depth of flow = 0.096(Ft.), Average velocity = 0.839(Ft/s)
 ***** Irregular Channel Data *****

 Information entered for subchannel number 1 :

Point number	'X' coordinate	'Y' coordinate
1	0.00	0.50
2	30.00	0.00
3	65.00	0.50

Manning's 'N' friction factor = 0.020

Sub-Channel flow = 0.501(CFS)
 ' ' flow top width = 12.462(Ft.)
 ' ' velocity= 0.839(Ft/s)
 ' ' area = 0.597(Sq.Ft)
 ' ' Froude number = 0.675

Upstream point elevation = 1644.500(Ft.)
 Downstream point elevation = 1643.000(Ft.)
 Flow length = 205.000(Ft.)
 Travel time = 4.07 min.
 Time of concentration = 11.22 min.
 Depth of flow = 0.096(Ft.)
 Average velocity = 0.839(Ft/s)
 Total irregular channel flow = 0.501(CFS)

**PRELIMINARY HYDROLOGY REPORT
 PROPOSED SHOPPING CENTER
 CUP180008
 21419 & 21425 CAJALCO ROAD, PERRIS, CALIFORNIA 92590**



Irregular channel normal depth above invert elev. = 0.096(Ft.)
 Average velocity of channel(s) = 0.839(Ft/s)
 Adding area flow to channel
 SINGLE FAMILY (1/2 Acre Lot)
 Runoff Coefficient = 0.851
 Decimal fraction soil group A = 0.000
 Decimal fraction soil group B = 0.040
 Decimal fraction soil group C = 0.960
 Decimal fraction soil group D = 0.000
 RI index for soil(AMC 3) = 84.09
 Pervious area fraction = 0.600; Impervious fraction = 0.400
 Rainfall intensity = 2.547(In/Hr) for a 100.0 year storm
 Subarea runoff = 0.520(CFS) for 0.240(Ac.)
 Total runoff = 0.732(CFS) Total area = 0.320(Ac.)
 Depth of flow = 0.111(Ft.), Average velocity = 0.922(Ft/s)

++++
 Process from Point/Station 1.510 to Point/Station 1.620
 **** CONFLUENCE OF MAIN STREAMS ****

The following data inside Main Stream is listed:

In Main Stream number: 2
 Stream flow area = 0.320(Ac.)
 Runoff from this stream = 0.732(CFS)
 Time of concentration = 11.22 min.
 Rainfall intensity = 2.547(In/Hr)
 Summary of stream data:

Stream No.	Flow rate (CFS)	TC (min)	Rainfall Intensity (In/Hr)
1	3.830	6.87	3.238
2	0.732	11.22	2.547

Largest stream flow has longer or shorter time of concentration
 $Q_p = 3.830 + \text{sum of } \frac{Q_a \cdot T_b}{T_a} = 0.732 * 0.612 = 0.448$
 $Q_p = 4.278$

Total of 2 main streams to confluence:
 Flow rates before confluence point:
 3.830 0.732
 Area of streams before confluence:
 1.630 0.320

Results of confluence:
 Total flow rate = 4.278(CFS)
 Time of concentration = 6.873 min.
 Effective stream area after confluence = 1.950(Ac.)
 End of computations, total study area = 1.95 (Ac.)

The following figures may be used for a unit hydrograph study of the same area.

Area averaged pervious area fraction(A_p) = 0.600
 Area averaged RI index number = 64.7

ATTACHMENT 4: EXHIBITS

This attachment contains the vicinity map, the existing condition exhibit, and the proposed condition exhibits. Please see the attached exhibits.

EXHIBIT A VICINITY MAP

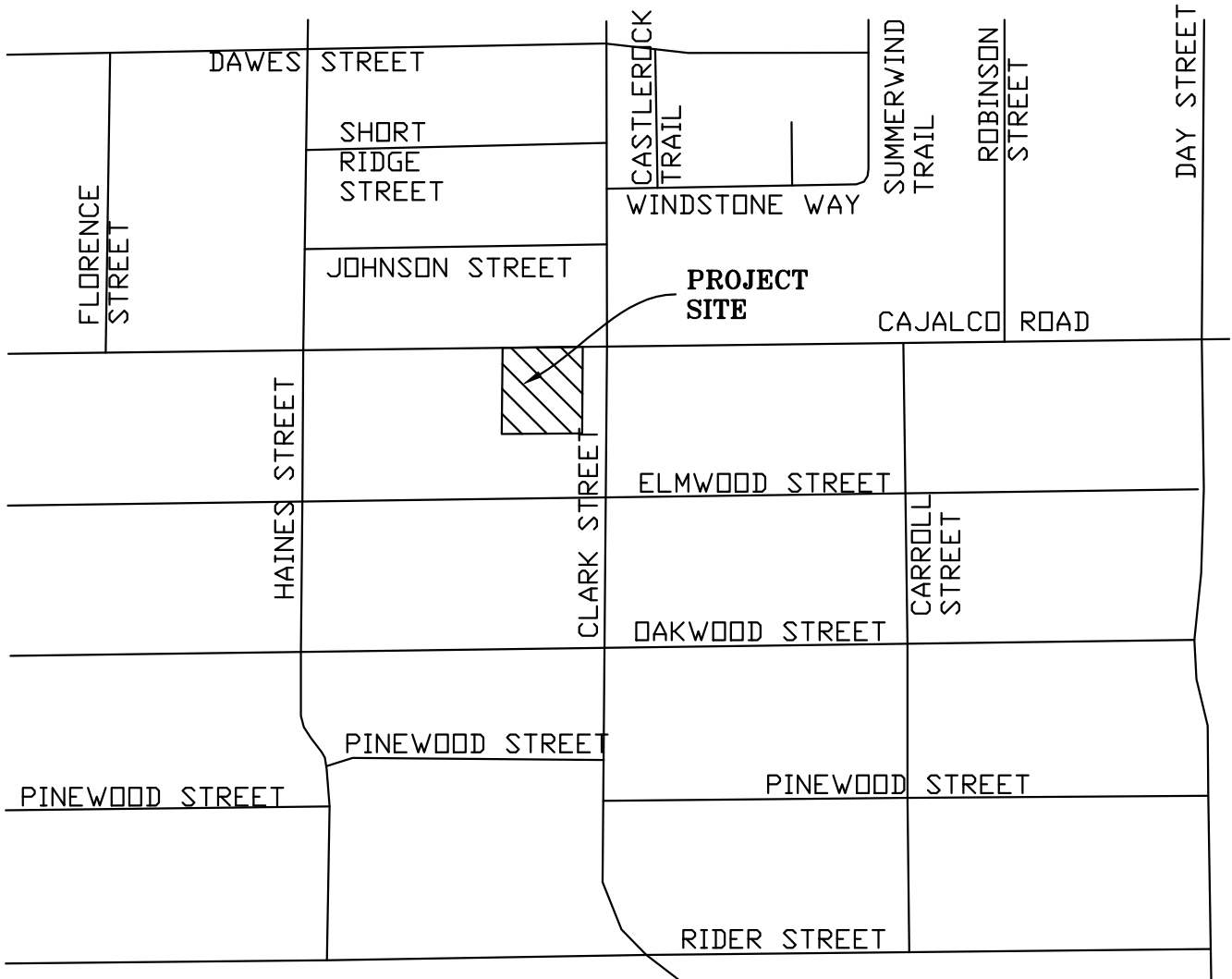

VICINITY MAP N.T.S

ADDRESS

21419 & 21425 CAJALCO ROAD
PERRIS, CALIFORNIA 92590

APN:

318-140-007-2
318-140-028-1
318-140-029-1



LEGEND

- DRAINAGE AREA BOUNDARY
- DRAINAGE AREA SUB BOUNDARY, NUMBER, AND ACREAGE
- FLOW PATH, DIRECTION, LENGTH GENERAL, OVERLAND SHEET FLOW
- STUDY NODE NUMBER
- CONFLUENCE POINT
- USGS SOIL BOUNDARY
- USGS SOIL TYPE

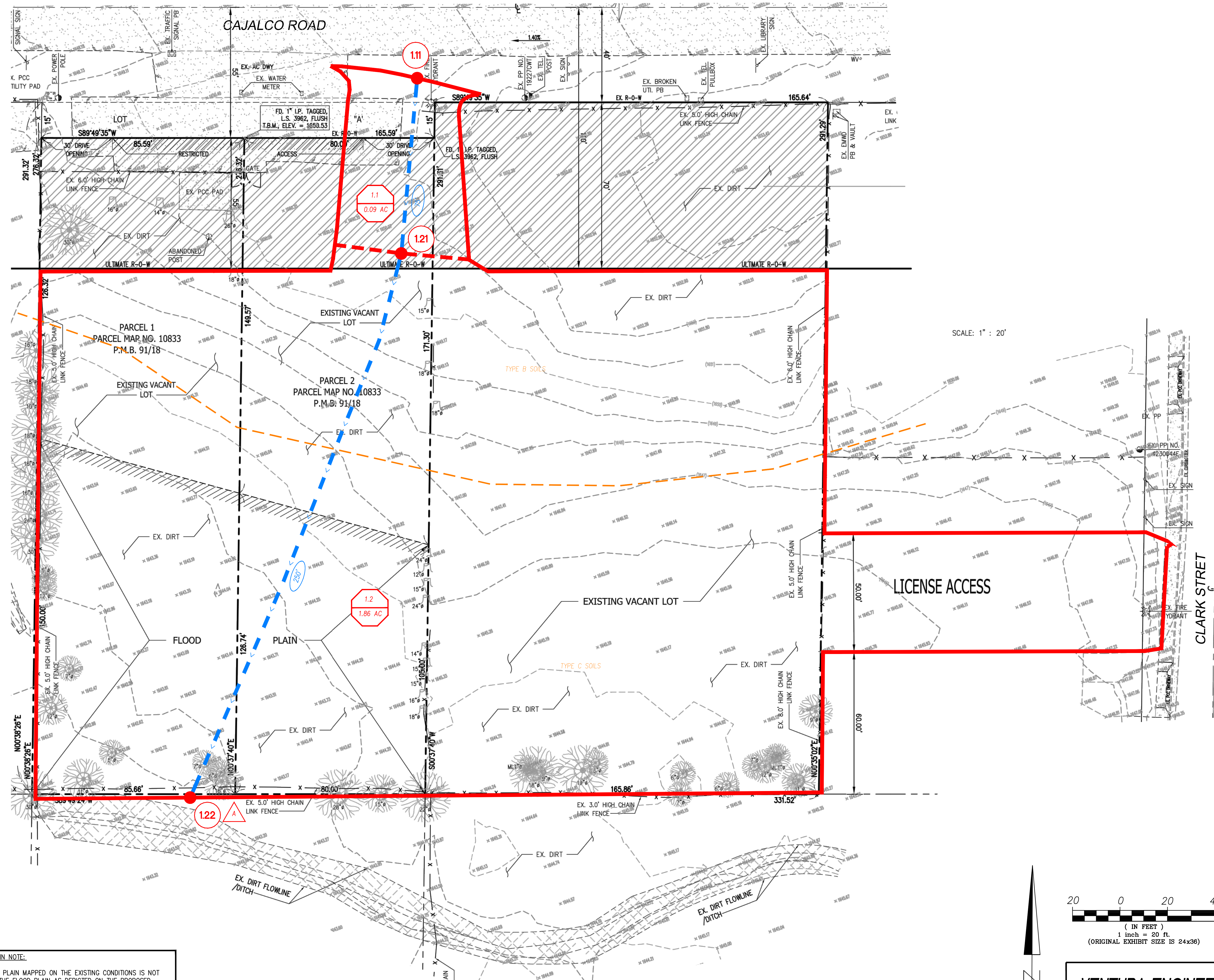

EXISTING CONDITIONS COMPLIANCE POINT A SUMMARY
100-YEAR DESIGN STORM EVENT

DATA	100-YEAR
INTENSITY (IN/HR)	2.608
TOTAL DISCHARGE (CFS)	4.4
TIME OF CONCENTRATION (MIN)	10.69
AREA (ACRES)	1.95

FLOOD PLAIN NOTE:
THE FLOOD PLAIN MAPPED ON THE EXISTING CONDITIONS IS NOT CORRECT. THE FLOOD PLAIN AS DEPICTED ON THE PROPOSED CONDITIONS IS APPROPRIATE DUE TO MODIFICATION BY THE PROPOSED RE-MAPPING THE COUNTY IS PROCESSING THROUGH FEMA.

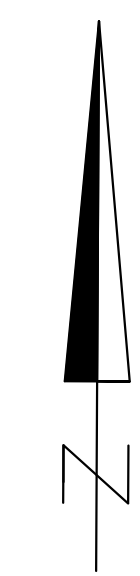
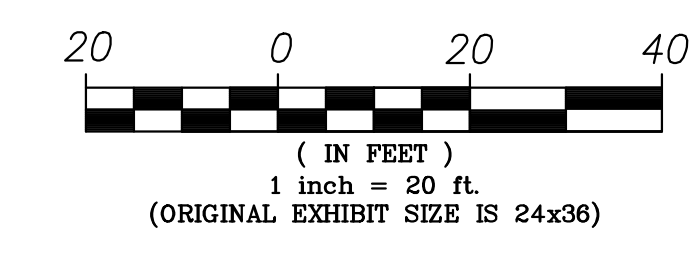

CUP 180008

RIVERSIDE COUNTY
21419 & 21425 CAJALCO ROAD
NEW SHOPPING CENTER
21419 & 21425 CAJALCO ROAD, PERRIS, CALIFORNIA 92590
APN: 318-140-007-2, 318-140-028-1 & 318-140-029-1
EXISTING CONDITIONS

VENTURA ENGINEERING, LLC
27393 YNEZ ROAD, SUITE 159 TEMECULA, CALIFORNIA 92591
PHONE (951) 252-7632
FAX (951) 346-5726

LEGEND

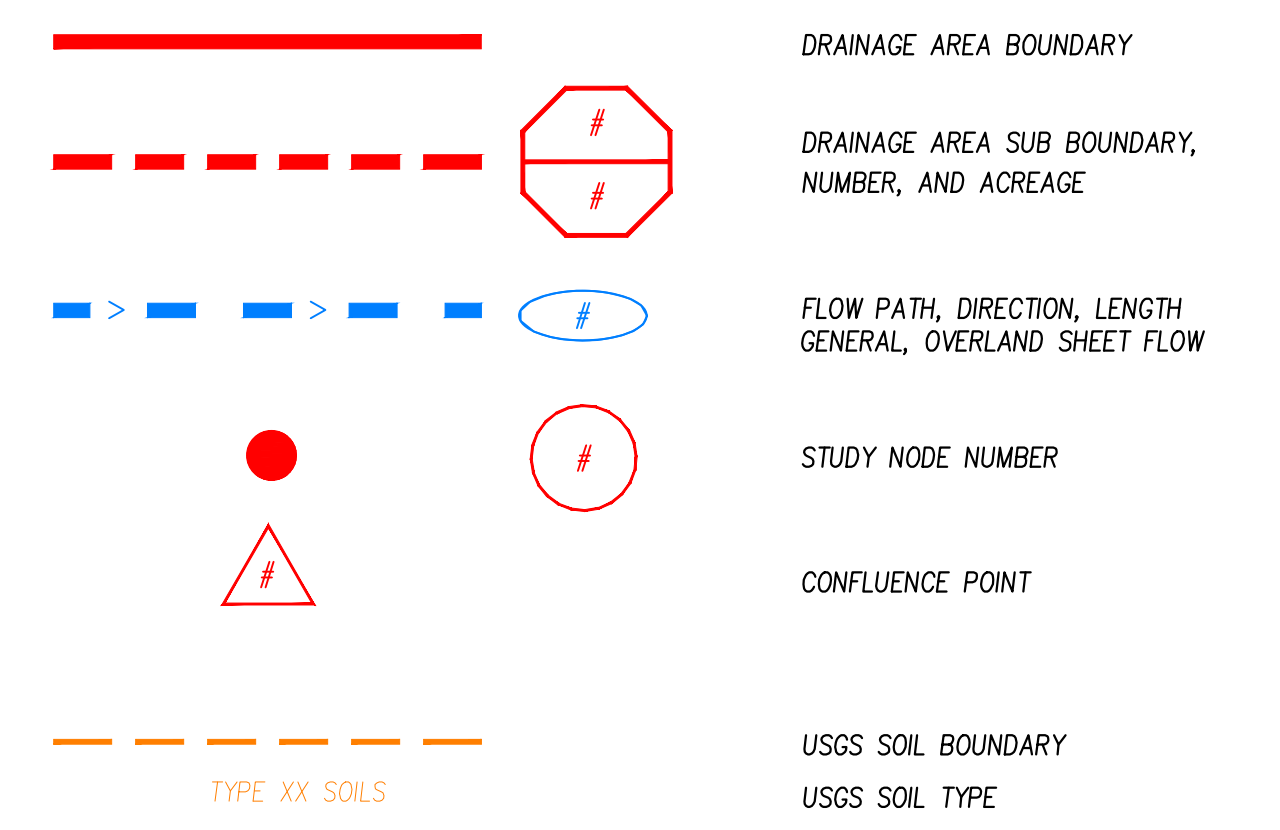

PROPOSED CONDITIONS COMPLIANCE POINT A SUMMARY
100-YEAR DESIGN STORM EVENT

DATA	100-YEAR
INTENSITY (IN/HR)	2.547
TOTAL DISCHARGE (CFS)	4.3
TIME OF CONCENTRATION (MIN)	6.87
AREA (ACRES)	1.95

COMPLIANCE POINT A COMPARISON
100-YEAR DESIGN STORM EVENT

DATA	EXISTING CONDITIONS 100-YEAR	PROPOSED CONDITION 100-YEAR	COMPARISON
INTENSITY (IN/HR)	2.608	2.547	-0.061
TOTAL DISCHARGE (CFS)	4.4	4.3	-0.1
TIME OF CONCENTRATION (MIN)	10.59	6.87	-3.92
AREA (ACRES)	1.95	1.95	NO CHANGE

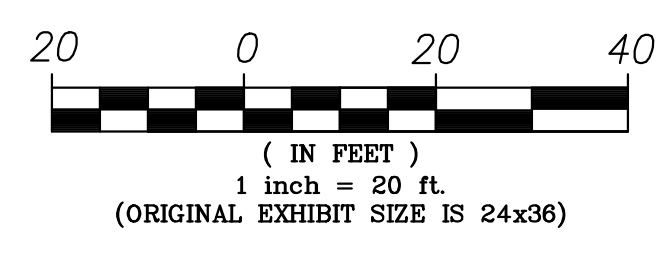
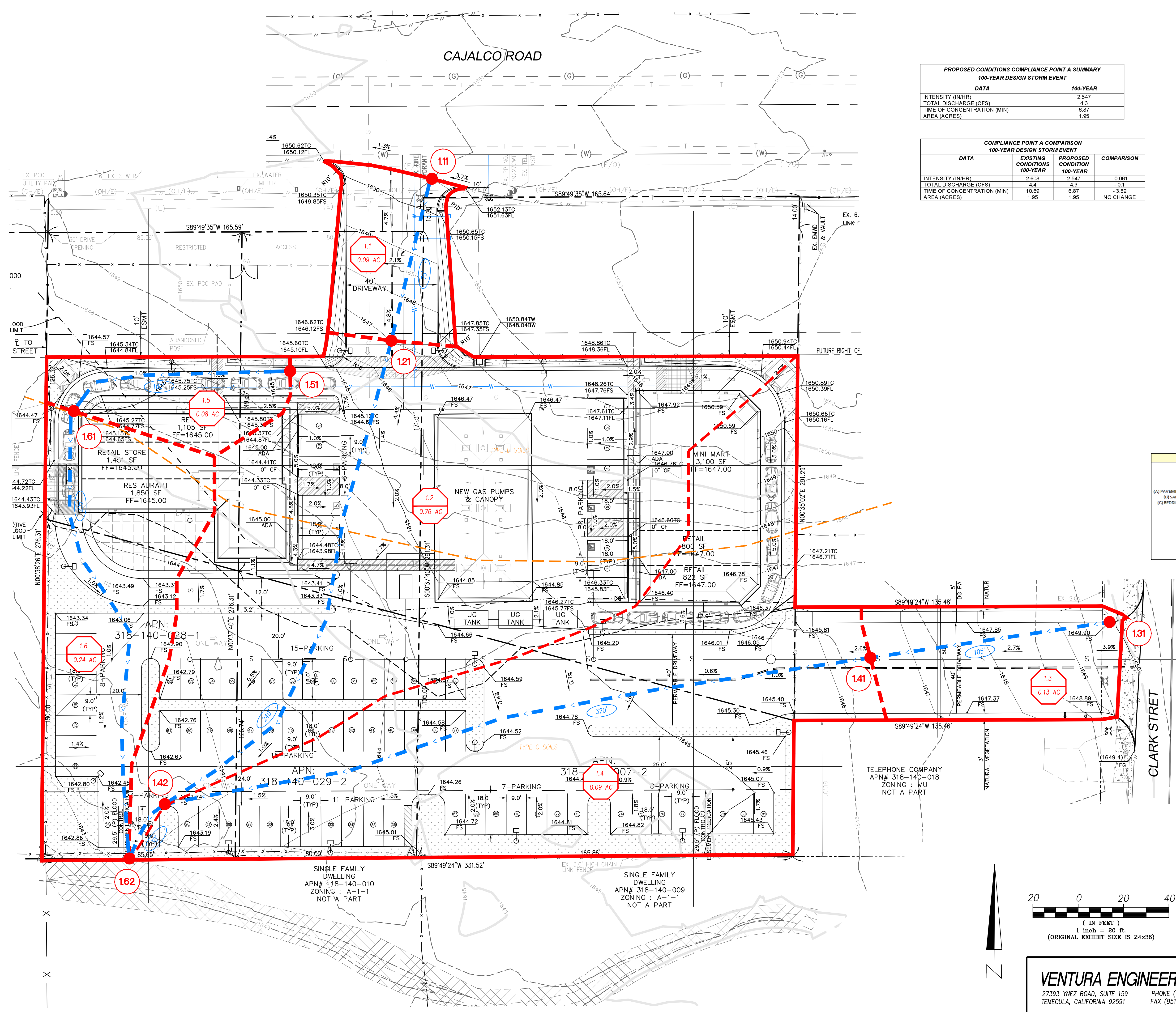
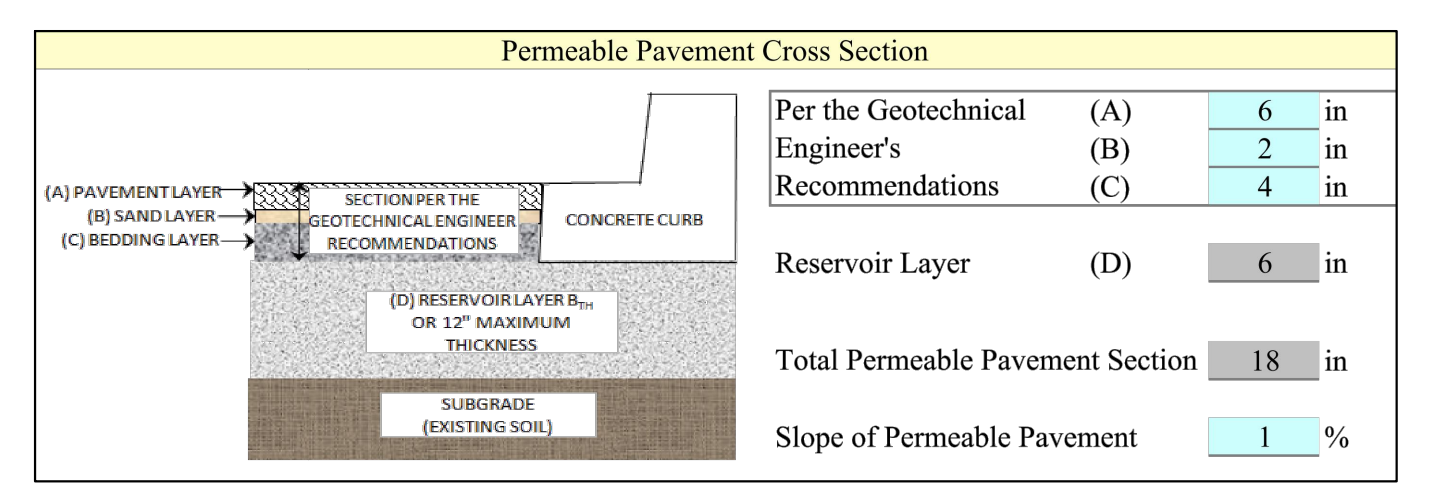
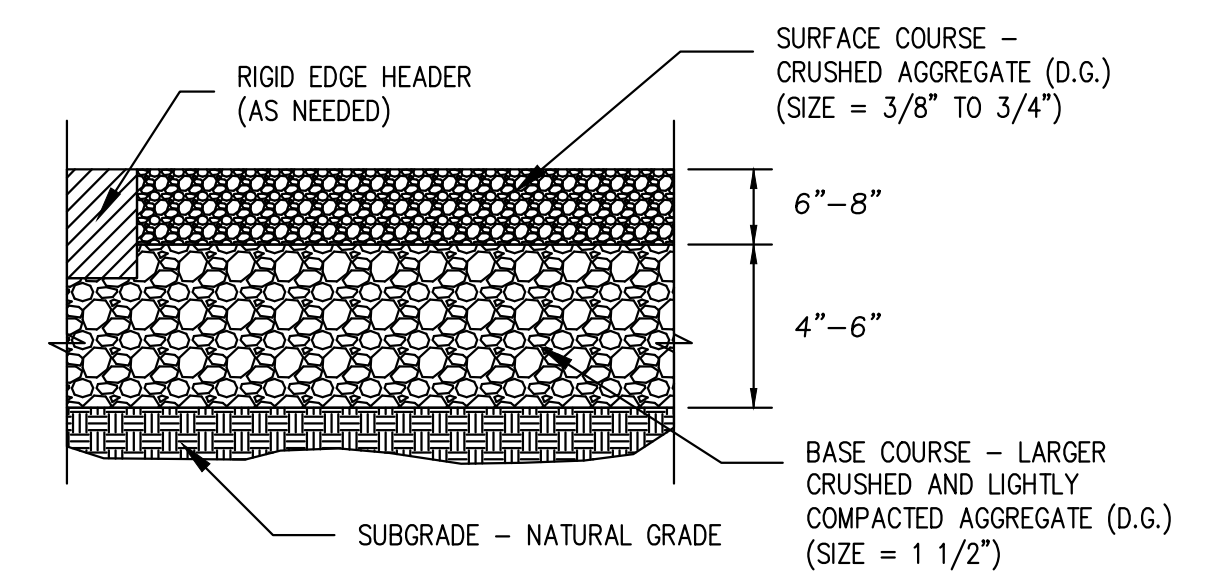

VENTURA ENGINEERING, LLC
27393 YNEZ ROAD, SUITE 159 TEMECULA, CALIFORNIA 92591
PHONE (951) 252-7632
FAX (951) 346-5726

CUP 180008

RIVERSIDE COUNTY
21419 & 21425 CAJALCO ROAD
NEW SHOPPING CENTER
21419 & 21425 CAJALCO ROAD, PERRIS, CALIFORNIA 92590
APN: 318-140-007-2, 318-140-028-1 & 318-140-029-1
PROPOSED CONDITIONS

ATTACHMENT 5: FEMA DETERMINATION

This attachment contains the project site's FEMA determination. Please see the attached exhibits.

National Flood Hazard Layer FIRMette



33°50'28.81"N



0 250 500 1,000 1,500 2,000 Feet

1:6,000

33°49'58.93"N

Legend

SEE FIS REPORT FOR DETAILED LEGEND AND INDEX MAP FOR FIRM PANEL LAYOUT

- | | | |
|------------------------------------|--|--|
| SPECIAL FLOOD HAZARD AREAS | | Without Base Flood Elevation (BFE)
<i>Zone A, V, A99</i> |
| | | With BFE or Depth <i>Zone AE, AO, AH, VE, AR</i> |
| | | Regulatory Floodway |
| OTHER AREAS OF FLOOD HAZARD | | 0.2% Annual Chance Flood Hazard, Areas of 1% annual chance flood with average depth less than one foot or with drainage areas of less than one square mile <i>Zone X</i> |
| | | Future Conditions 1% Annual Chance Flood Hazard <i>Zone X</i> |
| | | Area with Reduced Flood Risk due to Levee. See Notes. <i>Zone X</i> |
| | | Area with Flood Risk due to Levee <i>Zone D</i> |
| OTHER AREAS | | Area of Minimal Flood Hazard <i>Zone X</i> |
| | | Effective LOMRs |
| GENERAL STRUCTURES | | Area of Undetermined Flood Hazard <i>Zone D</i> |
| | | Channel, Culvert, or Storm Sewer |
| | | Levee, Dike, or Floodwall |
| OTHER FEATURES | | 20.2 Cross Sections with 1% Annual Chance |
| | | 17.5 Water Surface Elevation |
| | | Coastal Transect |
| | | Base Flood Elevation Line (BFE) |
| | | Limit of Study |
| | | Jurisdiction Boundary |
| | | Coastal Transect Baseline |
| | | Profile Baseline |
| | | Hydrographic Feature |
| MAP PANELS | | Digital Data Available |
| | | No Digital Data Available |
| | | Unmapped |



The pin displayed on the map is an approximate point selected by the user and does not represent an authoritative property location.



This map complies with FEMA's standards for the use of digital flood maps if it is not void as described below. The basemap shown complies with FEMA's basemap accuracy standards

The flood hazard information is derived directly from the authoritative NFHL web services provided by FEMA. This map was exported on **5/24/2020 at 7:27:49 PM** and does not reflect changes or amendments subsequent to this date and time. The NFHL and effective information may change or become superseded by new data over time.

This map image is void if the one or more of the following map elements do not appear: basemap imagery, flood zone labels, legend, scale bar, map creation date, community identifiers, FIRM panel number, and FIRM effective date. Map images for unmapped and unmodernized areas cannot be used for regulatory purposes.

117°17'2.29"W

117°17'39.75"W

Cross Section Station (Water Surface Elevation NAVD 88)

MAINLINE			NORTHERN LINE			SOUTHERN LINE		
A-A	3+22	(1622.89)	B-F	2+11	(1642.32)	C-Z	1+32	(1642.2)
A-B	5+09	(1624.94)	B-G	3+51	(1643.37)	D-A	3+21	(1643.23)
A-C	6+78	(1626.69)	B-H	4+91	(1644.31)	D-B	7+94	(1645.18)
A-D	8+23	(1627.33)	B-I	6+25	(1645.00)	D-C	10+35	(1645.84)
A-E	9+38	(1627.61)	B-J	7+78	(1645.7)	D-D	11+73	(1646.18)
A-F	10+64	(1628.00)	B-K	9+03	(1647.5)	D-E	13+12	(1647.13)
A-G	11+91	(1629.63)	B-L	11+32	(1647.92)	D-F	15+36	(1648.15)
A-H	12+60	(1629.92)	B-M	12+97	(1648.01)	D-G	18+56	(1650.6)
A-I	13+52	(1630.57)	B-N	14+57	(1648.59)	D-H	20+54	(1651.66)
A-J	15+19	(1631.24)	B-O	16+32	(1649.26)	D-I	22+05	(1652.29)
A-K	17+37	(1632.4)	B-P	19+13	(1651.93)	D-J	23+39	(1653.44)
A-L	19+24	(1633.3)	B-Q	20+87	(1653.27)	D-K	24+74	(1654.99)
A-M	20+13	(1633.59)	B-R	23+23	(1655.29)	D-L	26+01	(1655.59)
A-N	21+91	(1633.95)	B-S	25+54	(1656.67)	D-M	26+50	(1655.76)
A-O	23+11	(1633.99)	B-T	26+56	(1658.54)	D-N	27+36	(1656.06)
A-P	24+24	(1634.35)	B-U	27+18	(1658.95)	D-O	28+80	(1657.7)
A-Q	25+30	(1634.59)	B-V	28+49	(1659.03)	D-P	29+58	(1658.07)
A-R	25+92	(1635.03)	B-W	29+76	(1659.36)	D-Q	30+39	(1658.39)
A-S	27+02	(1635.92)	B-X	31+07	(1660.73)	D-R	30+99	(1659.55)
A-T	28+06	(1635.97)	B-Y	32+14	(1663.61)	D-S	31+38	(1660.01)
A-U	29+09	(1636.01)	B-Z	33+17	(1664.22)	D-T	31+96	(1660.31)
A-V	30+29	(1636.2)	C-A	34+00	(1664.24)	D-U	32+75	(1660.92)
A-W	31+07	(1636.38)	C-B	34+99	(1664.4)	D-V	33+77	(1661.89)
A-X	31+77	(1636.56)	C-C	35+40	(1664.6)	D-W	34+72	(1662.66)
A-Y	33+07	(1637.1)	C-D	36+10	(1664.92)	D-X	35+95	(1664.99)
A-Z	34+85	(1638.21)	C-E	37+19	(1665.54)	D-Y	37+61	(1666.05)
B-A	37+29	(1639.43)	C-F	38+44	(1666.14)	D-Z	38+44	(1666.19)
B-B	39+46	(1639.71)	C-G	39+35	(1666.79)	E-A	39+18	(1666.27)
B-C	43+13	(1640.23)	C-H	40+42	(1667.75)	E-B	39+61	(1666.32)
B-D	44+75	(1641.21)	C-I	42+07	(1669.07)	E-C	40+05	(1666.39)
			C-J	42+82	(1671.47)	E-D	40+53	(1666.34)
			C-K	43+72	(1671.81)	E-E	41+21	(1667.49)
			C-L	44+74	(1671.82)	E-F	42+16	(1668.3)
			C-M	45+96	(1671.92)	E-G	43+10	(1668.88)
			C-N	47+33	(1672.92)			
			C-O	48+44	(1674.03)			
			C-P	49+95	(1675.24)			
			C-Q	51+83	(1677.69)			
			C-R	53+49	(1678.09)			
			C-S	54+72	(1678.3)			
			C-T	56+05	(1679.99)			
			C-U	57+45	(1681.57)			
			C-V	59+22	(1682.84)			
			C-W	60+45	(1683.79)			
			C-X	61+46	(1685.16)			
			C-Y	61+74	(1685.63)			

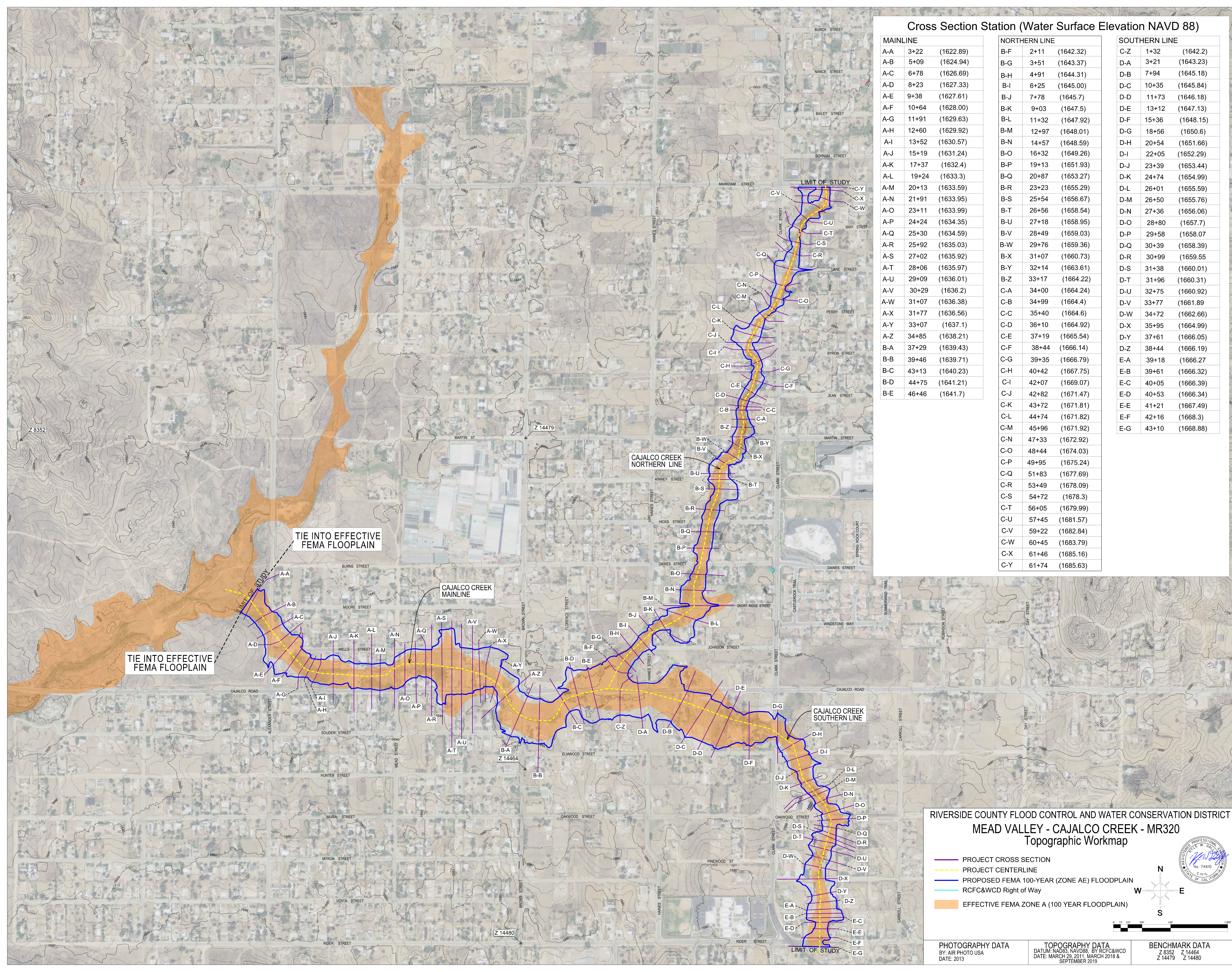

RIVERSIDE COUNTY FLOOD CONTROL AND WATER CONSERVATION DISTRICT
MEAD VALLEY - CAJALCO CREEK - MR320
 Topographic Workmap

- PROJECT CROSS SECTION
- PROJECT CENTERLINE
- PROPOSED FEMA 100-YEAR (ZONE AE) FLOODPLAIN
- RCFC&WCD Right of Way
- EFFECTIVE FEMA ZONE A (100 YEAR FLOODPLAIN)

PHOTOGRAPHY DATA BY: AIR PHOTO USA DATE: 2013	TOPOGRAPHY DATA DATUM: NAVD83, NAVD88, BY RCFC&WCD DATE: MARCH 29, 2011, MARCH 2016 & SEPTEMBER 2019	BENCHMARK DATA Z 8352 Z 14464 Z 14479 Z 14480
---	---	---