Appendix E-1
Preliminary Water Quality Management Plan

**PRELIMINARY WATER QUALITY
MANAGEMENT PLAN (WQMP)
FOR
TENTATIVE PARCEL 20393**

**IN THE
CITY OF MONTCLAIR, CALIFORNIA**

APN: 1011-311-15, 1011-311-17, 1011-311-19

JULY 26, 2021



Reference: 1020-2901

**PREPARED BY:
Madole & Associates, Inc.
9302 Pittsburgh Avenue, Suite 230
Rancho Cucamonga, CA 91730
(909) 481-6322**

PRELIMINARY WATER QUALITY MANAGEMENT PLAN (WQMP)

For compliance with Santa Ana Regional Water Quality Control Board

Order Number R8-2002-0012 (NPDES Permit No. CAS618036)

for

TENTATIVE PARCEL MAP 20393 IN THE CITY OF MONTCLAIR, CALIFORNIA

NUI INVESTMENT, LLC
1150 W. RIGGIN STREET
MONTEREY PARK, CA 91754
(626) 319-5998

Prepared for:

AND

DON JULIAN INVESTMENT, LLC
138 N. GLENDORA AVENUE
GLENDORA, CA. 91741
(626) 319-5998

WQMP Preparation Date
July 14th, 2021

WATER QUALITY MANAGEMENT PLAN (WQMP)

PROJECT SITE INFORMATION

Name of Project: TENTATIVE PARCEL MAP 20393

Project Location: 5006 AND 5010 MISSION BOULEVARD, MONTCLAIR, CA 91763

Size of Significant Re-Development on an Already Developed Site (in feet²): 223,272

Size of New Development (in feet²): n/a

Number of Home Subdivisions: n/a

SIC Codes: 4225

Erosive Site Conditions?: Risk Level Low

Natural Slope More Than 25%?: no



**PROJECT
LOCATION**

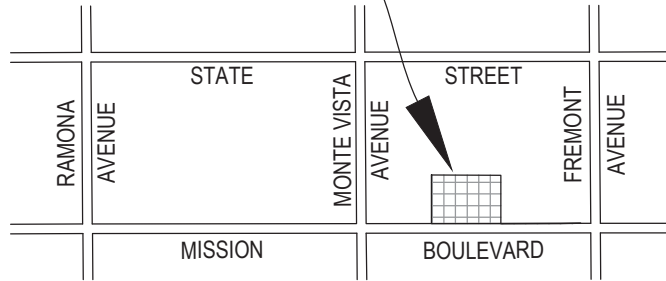

VICINITY MAP
NTS

WATER QUALITY MANAGEMENT PLAN (WQMP)

Check the appropriate project category below:

<i>Check below</i>	Project Categories
X	1. All significant re-development projects. Significant re-development is defined as the addition or creation of 5,000 or more square feet of impervious surface on an already developed site. This includes, but is not limited to, additional buildings and/or structures, extension of existing footprint of a building, construction of parking lots, etc. Where redevelopment results in an increase of less than fifty percent of the impervious surfaces of a previously existing development, and the existing development was not subject to SUSMPs, the design standards apply only to the addition, and not the entire development. When the redevelopment results in an increase of more than fifty percent of the impervious surfaces, then a WQMP is required for the entire development (new and existing).
	2. Home subdivisions of 10 units or more. This includes single family residences, multi-family residence, condominiums, apartments, etc.
	3. Industrial/commercial developments of 100,000 square feet or more. Commercial developments include non-residential developments such as hospitals, educational institutions, recreational facilities, mini-malls, hotels, office buildings, warehouses, and light industrial facilities.
	4. Automotive repair shops (with SIC codes 5013, 5014, 5541, 7532- 7534, 7536-7539).
	5. Restaurants where the land area of development is 5,000 square feet or more.
	6. Hillside developments of 10,000 square feet or more which are located on areas with known erosive soil conditions or where the natural slope is twenty-five percent or more.
	7. Developments of 2,500 square feet of impervious surface or more adjacent to (within 200 feet) or discharging directly into environmentally sensitive areas such as areas designated in the Ocean Plan as areas of special biological significance or waterbodies listed on the CWA Section 303(d) list of impaired waters.
	8. Parking lots of 5,000 square feet or more exposed to storm water. Parking lot is defined as land area or facility for the temporary storage of motor vehicles.
	The project does not fall into any of the categories described above. (If the project requires a precise plan of development [e.g. all commercial or industrial projects, residential projects of less than 10 dwelling units, and all other land development projects with potential for significant adverse water quality impacts] or subdivision of land, it is defined as a Non-Category Project.)

Section 1 Introduction And Project Description

1.1 Project Information

- **Owner/Applicant:**

NUI INVESTMENT, LLC
1150 W. RIGGIN STREET
MONTEREY PARK, CA 91754
(626) 319-5998

AND

DON JULIAN INVESTMENT, LLC
138 N. GLENDORA AVENUE
GLENDORA, CA. 91741
(626) 319-5998

- **Project site address:** 5006 and 5010 Mission Boulevard, Montclair, CA 91763

1.2 Permits

- Tentative Parcel Map 20393
- APN: 1011-311-15, 1011-311-17, 1011-311-19
- WDID: To be provided when obtained

1.3 Project Description

Tentative Parcel Map 20293 is a proposed redevelopment project for an industrial warehouse located on the north side of Mission Boulevard between Monte Vista Avenue and Central Avenue. The site is currently partially developed on the east side with various buildings and asphalt for parking. The west side of the project site was previously used for R.V. overflow and maintenance parking. The proposed warehouse development will consist of 125,000 square feet building on a 5.12-acre property. The maintenance and operation of all site specific LID and structural BMPs will be the responsibility of the property owner. See attached Water Quality Management Plan Exhibit.

1.4 Site Description

The proposed project is in the southwestern portion of the City of Montclair. The project is located on the north side of Mission Boulevard which contains an existing 36-inch R.C.P. storm drain that travels approximately 1.4 miles west to San Antonio Creek Channel. Ultimately, flows enter the Prado Flood Control Basin.

Though the project is not located directly within an HCOC exemption area, the project meets HCOC Exemption Criteria #1: Sump Condition. San Antonio Creek is considered EHM and travels to the Prado Flood Control Basin, therefore making the project HCOC Exempt.

TENTATIVE PARCEL MAP 20393

5.13 AC. GROSS 1 NUMBERED LOT APRIL 2021

DRAINAGE AREA	AREA	AREA	DCV	Q _{BMP}	SYSTEM #	CLARIFIER TREATMENT RATE*	PIPE DIAMETER	LENGTH OF PIPE	No. OF MAXWELL L _S	SYSTEM RETENTION VOLUME	PERCENT OF DCV
	(SQ. FT.)	(ACRE)	(CU. FT.)	(CFS)		(CFS)	(INCHES)	(FEET)	(EACH)	(CU. FT.)	(%)
DA1	201,580	4.6	21,451	1.13	1A	1.5	72	105	1	9,280	43%
							96	105	1	12,678	59%
DA2	21,692	0.5	2,308	0.12	2	0.84	60	40	0	2,325	101%
							--	250	2	24,283	102%
TOTALS	223,272	5.1	23,759	1.3							

*NOTE: DA1 CLARIFIER TO BE HYDRO INTERNATIONAL FIRST DEFENSE FD-4HC (OR APPROVED EQUAL); DA2 CLARIFIER TO BE HYDRO INTERNATIONAL FIRST DEFENSE FD-3HC (OR APPROVED EQUAL)

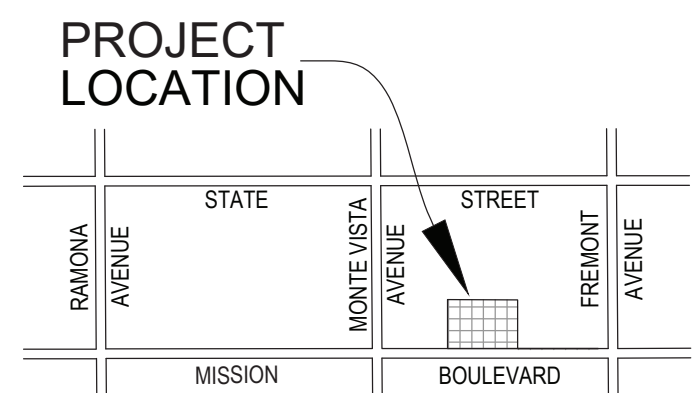

VICINITY MAP NTS

TENTATIVE PARCEL MAP 20393
 5006 AND 5010 MISSION BOULEVARD
 MONTCLAIR, CA. 91763
 APN: 1011-311-15, 1011-311-17, 1011-311-19

LEGAL DESCRIPTION

PARCELS 1, 2, 3, AND 4 OF PARCEL MAP 3172, IN THE CITY OF MONTCLAIR, IN THE COUNTY OF SAN BERNARDINO, STATE OF CALIFORNIA, AS PER PLAT RECORDED IN BOOK 28, PAGE 84 OF PARCEL MAPS, RECORDS OF SAID COUNTY.

OWNER/APPLICANT/DEVELOPER

NIU INVESTMENT LLC., AND DON JULIAN INVESTMENT, LLC.
 1150 W. RIGGIN STREET
 MONTEREY PARK, CA 91754
 CONTACT: CARY NIU
 TEL: (626) 319-5998

CIVIL ENGINEER ARCHITECT

MADOLE & ASSOCIATES, INC.
 9302 PITTSBURGH AVENUE, SUITE 230
 RANCHO CUCAMONGA, CA 91730
 CONTACT: MARK BERTONE
 (909) 481-6322 ext. 120
 Email: mbertone@madoleinc.com

GAA ARCHITECTS
 8811 RESEARCH DRIVE SUITE 200
 IRVINE, CA 92618
 CONTACT: ROGER DEITOS
 (949) 474-1775 ext. 237
 Email: rogerd@gaaarchitects.com

JN: 1020-2901
 APRIL 2021

STRUCTURAL SOURCE CONTROL BMPs

RECOMMENDED INSPECTION AND MAINTENANCE SCHEDULE

BMP	RECOMMENDED MAINTENANCE	RECOMMENDED FREQUENCY
PRETREATMENT CLARIFIERS	REMOVAL OF TRASH, SEDIMENTS, DEBRIS, AND POLLUTANTS FROM SYSTEM PER MANUFACTURER'S INSTRUCTIONS	2X/YEAR BEFORE/ AFTER MAJOR STORM EVENTS
PERFORATED PIPE AND ROCK BED	MAINTAIN CLARIFIERS TO PREVENT CLOGGING OF PIPE PERFORATIONS. INSPECT PIPE SEDIMENT AND DEBRIS LOADING THROUGH ACCESS MANHOLE AND REMOVE DEBRIS AND SEDIMENT WITH VACUUM TRUCK	2X/YEAR OR AS NEEDED DEPENDING ON OBSERVED SEDIMENT LOADING
TORRENT RESOURCES MAXWELL IV DRYWELLS	REMOVAL OF TRASH, SEDIMENTS, DEBRIS, AND POLLUTANTS FROM SYSTEM PER MANUFACTURER'S INSTRUCTIONS	2X/YEAR BEFORE/ AFTER MAJOR STORM EVENTS

PARTY RESPONSIBLE FOR MAINTENANCE AND INSPECTION:

NIU INVESTMENT LLC., AND DON JULIAN INVESTMENT, LLC.
 1150 W. RIGGIN STREET
 MONTEREY PARK, CA 91754
 CONTACT: CARY NIU
 TEL: (626) 319-5998

138 N. GLENDORA AVENUE
 GLENDORA, CA. 91741
 CONTACT: CARY NIU
 TEL: (626) 319-5998

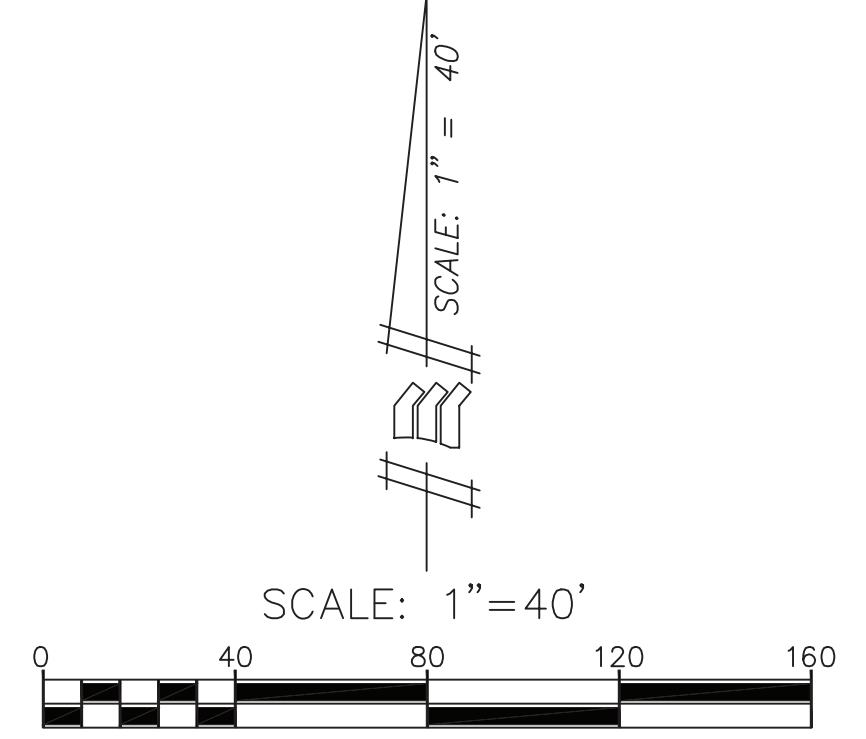
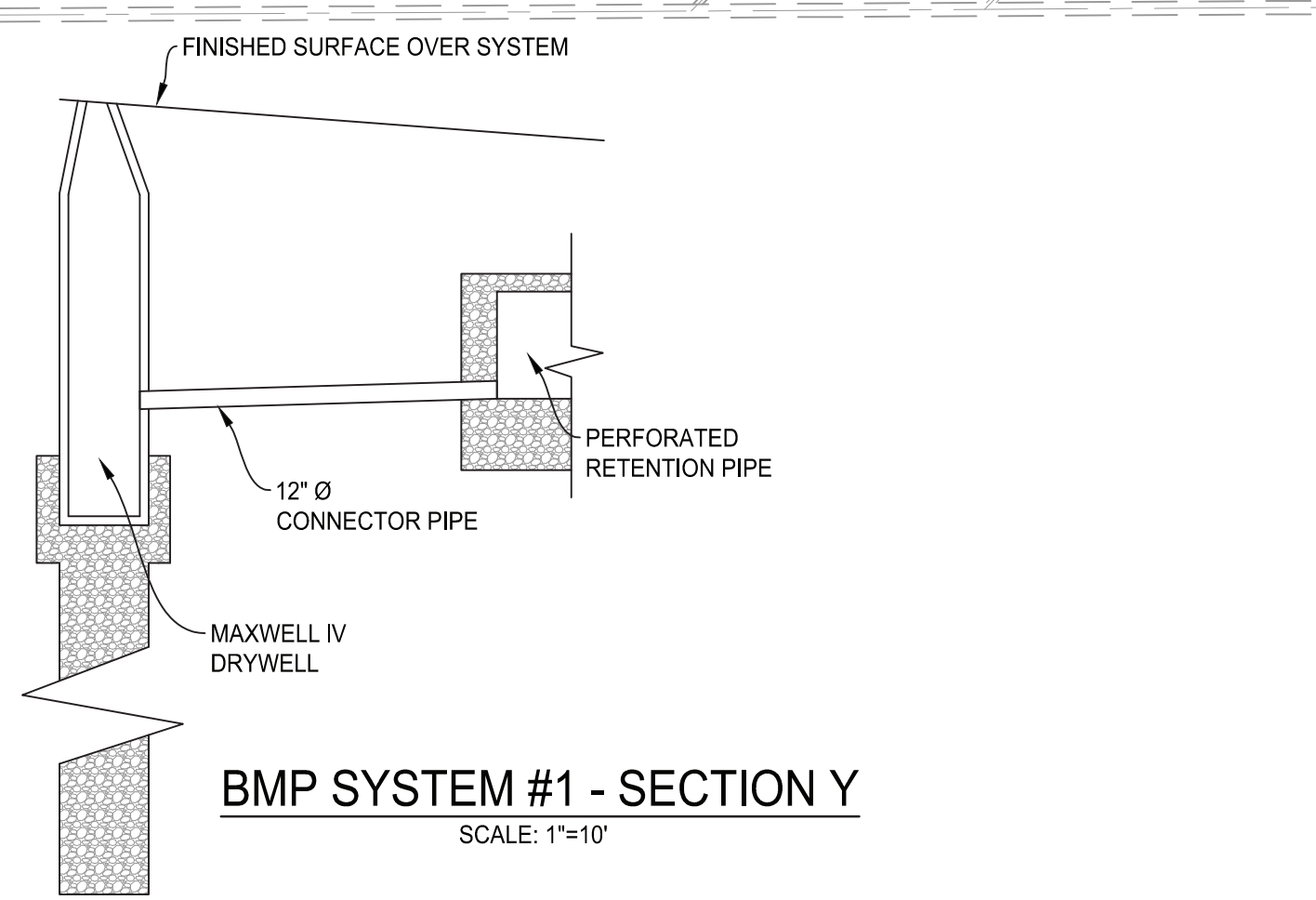
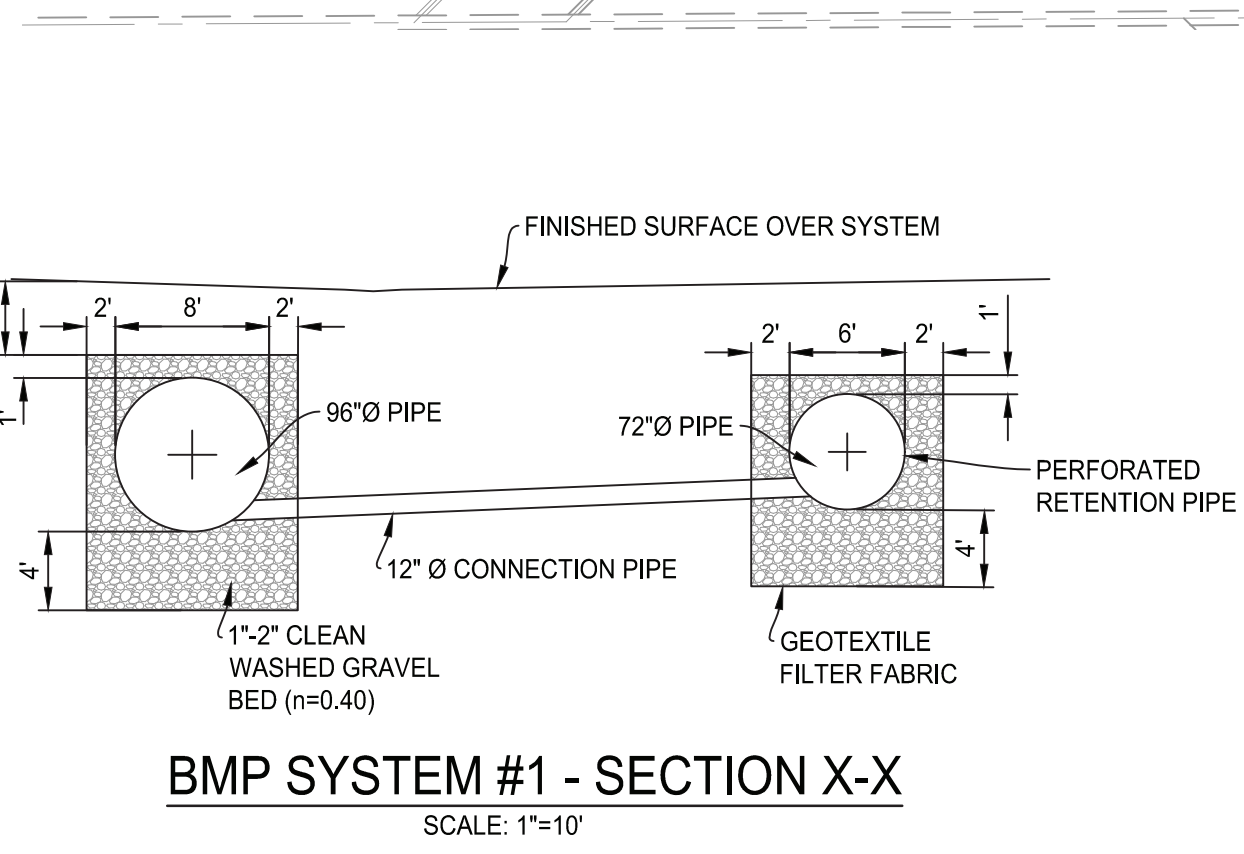
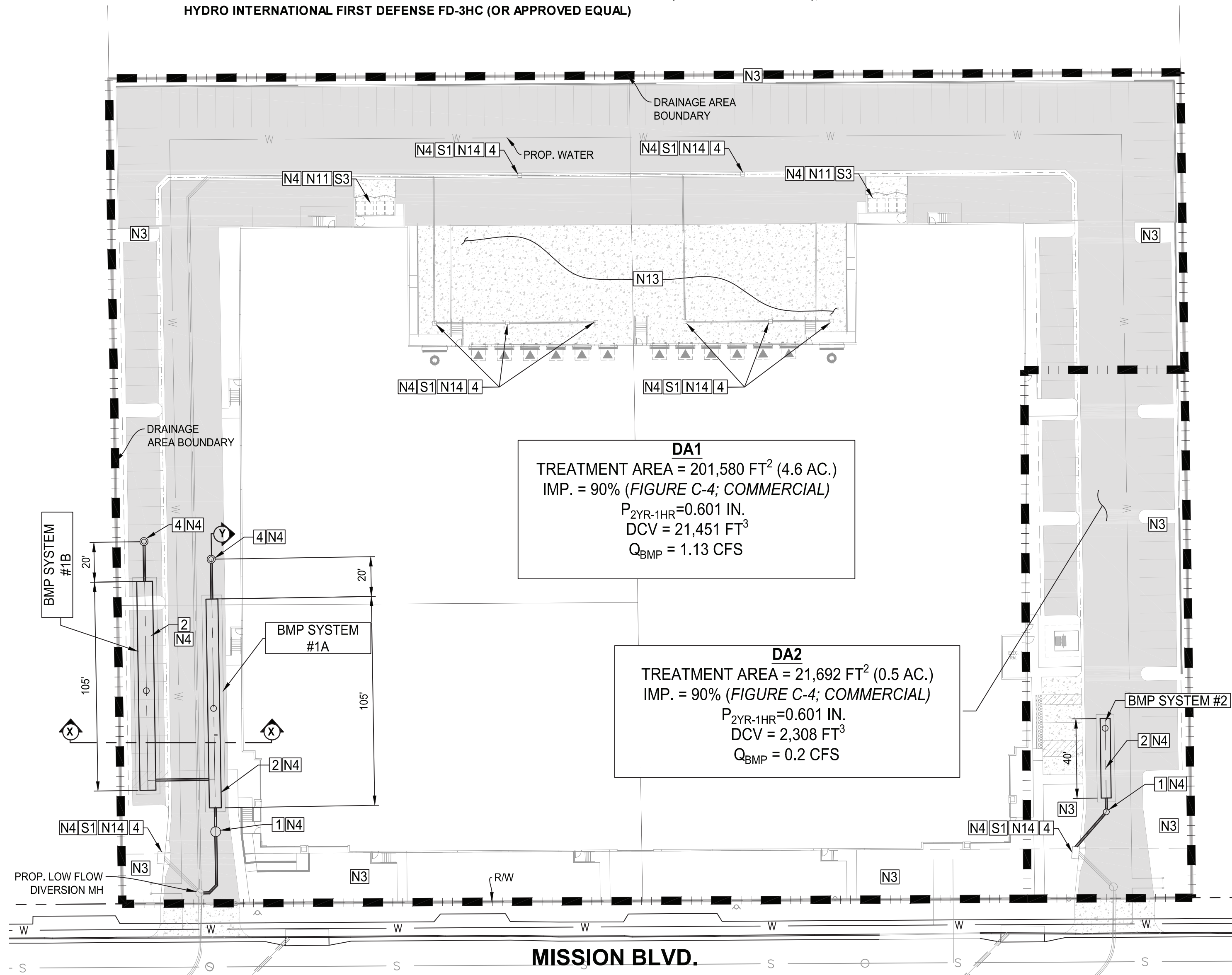

LEGEND

- DA DRAINAGE AREA
- SF SQUARE FEET
- CF CUBIC FEET
- CFS CUBIC FEET PER SECOND
- PROP. PROPOSED
- SD STORM DRAIN
- Flow Direction
- Flow Direction
- Treatment Area Boundary
- AC Pavement
- Concrete Pavement

EFFICIENT IRRIGATION (SD-12) - PER LANDSCAPE ARCHITECTS PLAN

NOTE: ALL STORM WATER QUALITY FLOWS FROM PERVIOUS AND IMPERVIOUS AREAS WILL BE TREATED WITHIN THE CLARIFIER BEFORE ENTERING UNDERGROUND INFILTRATION SYSTEMS.

LIST OF LID BMPs

- 1** PRETREATMENT CLARIFIER: REMOVES TRASH, DEBRIS, SEDIMENT, AND POLLUTANTS FROM STORMWATER RUNOFF BEFORE RELEASING IT TO UNDERGROUND INFILTRATION SYSTEMS.
- 2** PERFORATED RETENTION/ INFILTRATION PIPE AND GRAVEL TRENCH: LARGE DIAMETER PERFORATED DRAINAGE PIPES TO RETAIN WATER QUALITY RUNOFF AS IT INFILTRATES INTO THE SURROUNDING SOILS.
- 3** TORRENT RESOURCES MAXWELL IV DRYWELLS: VERTICAL INFILTRATION TROUGH GRAVEL AT LARGE DEPTHS TO ASSIST THE PERFORATED PIPE IN DRAINAGE OF WATER QUALITY VOLUME.
- 4** CURB OPENING / GRATED INLET FILTER INSERT: TO REMOVE FIRST FLUSH TRASH AND DEBRIS FROM STORMWATER BEFORE REACHING THE UNDERGROUND STORM DRAIN SYSTEM AND CLARIFIER.
- N3** LANDSCAPE MANAGEMENT BMPs: EDUCATION MATERIAL TO PROPERTY OWNER'S AND CONTRACTED LANDSCAPE EMPLOYEES REGARDING LANDSCAPE AND LAWN MAINTENANCE TO PROMOTE ENVIRONMENTAL AWARENESS AND THE PROTECTION OF STORM WATER QUALITY.
- N4** BMP MAINTENANCE: THE OWNER/DEVELOPER SHALL ARRANGE FOR THE INSPECTION, CLEANING, AND MAINTENANCE OF ALL BMPs.
- N11** LITTER/DEBRIS CONTROL PROGRAM: EACH EMPLOYEE SHALL BE MADE AWARE OF THE USE AND RESTRICTIONS OF THE TRASH CONTAINERS TO PROTECT AND PROMOTE STORM WATER QUALITY.
- N13** HOUSEKEEPING OF LOADING DOCKS: EMPLOYEES SHALL KEEP INDUSTRIAL FACILITIES IN A CLEAN AND ORDERLY CONDITION THROUGH REGULAT PROGRAM OF SWEEPING AND LITTER CONTROL AND IMMEDIATE CLEANUP OF SPILLS.
- N14** CATCH BASIN INSPECTION PROGRAM: THE OWNER/DEVELOPER SHALL ARRANGE FOR THE INSPECTION AND CLEANING OF ALL DRAINAGE FACILITIES, INCLUDING COMMON AREA DRAINS, INLETS, CLARIFIERS AND CATCH BASINS INCLUDING ANY INSERTS.
- N15** VACUUM SWEEPING OF PRIVATE STREET AND PARKING LOTS: THE OWNER/DEVELOPER AND HOA SHALL ARRANGE FOR THE INSPECTION, CLEANING, AND STREET SWEEPING OF ALL STREETS AND PEDESTRIAN ACCESSIBLE AREAS ON A MONTHLY BASIS, AT MINIMUM, OR MORE FREQUENTLY AS NEEDED.
- S1** STORM DRAIN INLET SIGNAGE: "NO DUMPING FLOWS TO CREEK" OR CITY OF UPLAND APPROVED STENCIL, TO BE STENCILED ON ALL CATCH BASINS. SIGNAGE TO DISCOURAGE ILLEGAL DUMPING INTO THE STORM DRAIN SYSTEM TO PROTECT WATER QUALITY AND PROMOTE ENVIRONMENTAL AWARENESS.
- S3** TRASH AND WASTE STORAGE AREAS: OWNER/DEVELOPER AND EMPLOYEES SHALL BE MADE AWARE OF THE USE AND RESTRICTIONS OF TRASH CONTAINERS. LITTER CONTROL AND TRASH MANAGEMENT FOR ANY COMMON AREAS WILL BE PROVIDED BY THE CONTRACTED LANDSCAPED MAINTENANCE COMPANY.
- S4** EFFICIENT IRRIGATION: EFFICIENT IRRIGATION TECHNIQUES HAVE BEEN EMPLOYED TO MAXIMIZE INFILTRATION AND TO MINIMIZE WATER LOSS, RUNOFF, AND EVAPORATION. THE FOLLOWING ARE ASPECTS OF THE IRRIGATION SYSTEM:
 - A. TURF DEMANDING MORE WATER SHALL BE VALVED SEPARATELY FROM SHRUBS REQUIRING LESS WATER.
 - B. SPRINKLER HEADS HAVE SHALL LOW PRECIPITATION RATES AND TRAJECTORIES KEEPING OVERSPRAY ONTO SIDEWALKS AND PAVEMENT AT A MINIMUM.
 - C. RUN TIME FOR VALVES IS DEPENDENT ON CHANGES IN SUNLIGHT, SLOPE, AND SEASONS.
 - D. FLOW SENSORS WILL BE USED TO MEASURE SUDDEN PRESSURE DROPS AND CONTROL WATER LOSS DUE TO BROKEN SPRINKLER HEADS OR WATER SUPPLY LINES.
 - E. RAIN SENSORS WILL BE USED TO ELIMINATE OR REDUCE IRRIGATION DURING TIMES OF PRECIPITATION.

BENCHMARK No.	REVISIONS		
ELEV.	DESCRIPTION	DATE	APP.
DESC.			



CITY OF MONTCLAIR
 APPROVED:
 NOEL A. CASTILLO
 CITY ENGINEER
 DATE: RCE 78044
 SHEET OF

Section 2

Pollutants of concern and hydrologic conditions of concern

2.1 Pollutants of Concern (NOT REQUIRED FOR NON-CATEGORY PROJECTS)

EXPECTED POLLUTANTS OF CONCERN: *COMMERCIAL/ INDUSTRIAL DEVELOPMENT*

- Pathogens (Bacterial/ Virus)
- Metals
- Nutrients/ Noxious Aquatic Plants
- Organic Compounds
- Pesticides/ Herbicides
- Sediments/ TSS / PH
- Trash and Debris
- Oxygen Demanding Compounds
- Oil and Grease

The proposed project site currently discharges into Mission Boulevard that has existing curb opening catch basins. The catch basins intercept runoff and route them into the existing underground storm drain in Mission Boulevard. The Mission Boulevard Storm Drain travels approximately 1.4 miles west to the San Antonio Creek Channel. San Antonio Creek Channel drains into the Prado Dam area.

303(d) (TMDL Required List)

San Antonio Creek: pH

Prado Flood Control Basin: pH

Pollutant of Concern Summary Table

Pollutant Type	Expected	Potential	Listed for Receiving Water
Bacteria/Virus	X		
Heavy Metals	X		
Nutrients	X		
Pesticides	X		
Organic Compounds	X		
Sediments	X		
Trash & Debris	X		
Oxygen Demanding Substances	X		
Oil & Grease	X		
Other—specify pollutant(s): pH	X		

2.2 HYDROLOGIC CONDITIONS OF CONCERN (NOT REQUIRED FOR NON-CATEGORY PROJECTS)

NOTE: PROJECT IS CONSIDERED HCOC EXEMPT PER TGD SECTION 3.4 EXEMPTION CRITERIA #1: SUMP CONDITION.

	Yes	No
<p>1. (from Section 2.3, Part 2):</p> <p>Determine if the project will create a Hydrologic Condition of Concern. Check “yes” or “no” as applicable and proceed to the appropriate section as outlined below.</p> <p>A. All downstream conveyance channels, that will receive runoff from the project, are engineered, hardened (concrete, riprap or other), and regularly maintained to ensure design flow capacity, and no sensitive stream habitat areas will be affected. Engineered, hardened, and maintained channels include channel reaches that have been fully and properly approved (including CEQA review, and permitting by USACOE, RWQCB and California Dept. of Fish & Game) by June 1, 2004 for construction and hardening to achieve design capacity, whether construction of the channels is complete. Discharge from the project will be in full compliance with Agency requirements for connections and discharges to the MS4, including both quality and quantity requirements, and the project will be permitted by the Agency for the connection or discharge to the MS4.</p>		<p>x</p>
<p>B. Project runoff rates, volumes, velocities, and flow duration for the post-development condition will not exceed those of the pre-development condition for 1-year, 2-year and 5-year frequency storm events. This condition will be substantiated with hydrologic modeling methods that are acceptable to the Agency, to the U.S. Army Corps of Engineers (USACOE), and to local watershed authorities. See method described below in Parts B1- B3.</p>	<p>X</p>	
<p>C. Can the conditions in part A or B above be demonstrated for the project?</p>		
<ul style="list-style-type: none"> ■ If the answer for A, B, and/or C above is yes, then the project does not create a HCOC—in this case go to Section 3 (page A-12). ■ If the answer for C above is no, the go to section 2.3. Part 3, below. 		

B1. To determine the projects’ drainage characteristics, County of San Bernardino HCOC policy requires the project engineer to use the following guidelines:

- a. The Design Storms to be considered include, as a minimum, the 5-year, 2 year, and 1-year return frequency storms, using the methods contained in the San Bernardino County Hydrology Manual (1986).

Project sites from 0-10 acres in size should use the Small Area Runoff Hydrograph method, found in Section J of the San Bernardino County Hydrology Manual (1986); sites greater than 10 acres should use the Unit Hydrograph Method, found in Section E of the San Bernardino County Hydrology Manual (1986). For each return frequency considered, and for both pre- and post-development conditions, determine the total runoff volume, the peak flow rate, and the time of duration, of runoff hydrograph flow rates that exceed the following flow rates: 90% of peak flow rate, 80% of peak flow rate, 70% of peak flow rate, 60% of peak flow rate, 50% of peak flow rate, 40% of peak flow rate, 30% of peak flow rate, 20% of peak flow rate, and 10% of peak flow rate (see Table B2-2, "Pre- and Post-development Hydrology Comparison Worksheet.")

b. Sediment supply is to be estimated for pre-and post-development conditions for the land altered by the subject project using Table 2-3, "Pre- and Post-development Hydrology Comparison Worksheet" or equivalent. The Universal Soil Loss Equation published by the USDA-Natural Resources Conservation Service may be considered as an estimate of changes in sediment yield due to development, if applicable. Flow velocities are to be estimated for the several return frequency design storms noted above, as a minimum, with flow velocities estimated for each percentage of the peak flow rate value listed above. Normal depth hydraulic estimates may be used unless significant backwater effects exist such that deposition of sediment is anticipated, in which case a standard backwater analysis is to be conducted.

c. Based upon the preceding task results, the project engineer shall evaluate the Project and its impact downstream and recommend other design storm return frequencies to be considered in order to satisfy the goals and intent of the HCOC document.

Table B2-2: Pre- and Post-development Hydrology Comparison Worksheet

Return Period	Total Volume		Peak Flow		Flow Time Duration			Sediment Transport	
	Pre	Post	Pre	Post	% of Peak	Pre	Post	Pre	Post
1-year					90				
					80				
					70				
					60				
					50				
					40				
					30				
					20				
2-year					10				
					90				
					80				
					70				
					60				
					50				
					40				
					30				
5-year					20				
					10				
					90				
					80				
					70				
					60				
					50				
					40				

<p>2. (from Section 2.3, Part 3): The WQMP for projects that create a HCOC must include an evaluation of whether the project will adversely impact downstream erosion, sedimentation or stream habitat. The Agency may require that the evaluation be conducted by a registered civil engineer in the State of California, with experience in fluvial geomorphology. Perform the required evaluation as specified in A – F below. Check the boxes “yes” or “no” to verify a complete report and proceed to appropriate section based on results.</p>		
Does the evaluation include:	Yes	No
A. An evaluation of potential impacts to all downstream channel reaches.		
B. Consideration of the hydrology of the entire watershed. Review all applicable drainage area master plans to the extent available, to identify BMP requirements for new development that address cumulative inputs from development in the watershed.		
C. Consultation with all applicable agencies including the USACOE; local watershed authorities (e.g. San Timoteo Watershed Management Authority and SAWPA [Santa Ana Watershed Project Authority]); U.S. Geological Survey (USGS); California Dept. of Fish & Game (CDFG); and the San Bernardino County Flood Control District; to determine any areas of potential hydrologic impact.		
D. An evaluation of any available hydrologic modeling results. Modeling may have been performed by USGS, USACOE, local watershed authorities, the San Bernardino County Flood Control District, or other local jurisdiction.		
E. A field reconnaissance to evaluate any natural or partially natural downstream reaches, or other sensitive habitat. The field reconnaissance must evaluate representative downstream conditions, including undercutting erosion, slope/bank stability, vegetative stress (due to flooding, erosion, water quality degradation, or loss of water supplies), and the area's susceptibility to adverse impacts resulting from an altered flow regime or change in sediment supply and/or sediment transport.		
F. A report that summarizes the findings of evaluation components A through E above, and that considers the project's location, topography, soil and vegetation conditions, proportion of impervious surfaces, natural and infrastructure drainage features, and any other relevant hydrologic and environmental factors to be protected specific to the project's watershed. The report must provide a determination of whether the project will adversely impact any downstream erosion, sedimentation or stream habitat, and identify any areas where adverse impacts are expected.		
<ul style="list-style-type: none"> ■ Is the report required by 2.3, Part 3.f complete? (Attach the report) If not, perform the required evaluation and add to the report. ■ Does the report determine that the project will have an adverse downstream impact? ■ If yes, then go to Section 2.3, Part 4, below. ■ If no, then go to Section 3. 		

3. (from Section 2.3, Part 4): If the evaluation specified in (3) above, determines that adverse impacts to downstream erosion, sedimentation or stream habitat will occur, then the project proponent must perform the requirements specified in A, B, and C, below. Check the boxes "yes" or "no" to verify all requirements have been completed.	YES	NO
A. Conduct hydrologic modeling of the project and the potentially impacted areas, according to modeling standards recommended by the Agency or local watershed authority, for the 1-year, 2-year, and 5-year frequency storm events, at a minimum. Hydrologic modeling results must include determination of peak flow rate, flow velocity, runoff volume, time of concentration, and retention volume for the project area.		
B. Ensure that the project will be consistent with any approved master plans of drainage or analogous plans or programs.		
C. Implement Site Design BMPs as specified in Section 2.5.1, and recommend any additional BMPs that will be implemented to mitigate the adverse impacts identified in (3.F) above.		
<ul style="list-style-type: none"> ■ Are the requirements for Section 2.3 Part 4 adequate? (Attach report/results) ■ Has the project proponent recommended BMPs to mitigate any impacts based on the modeling? ■ If yes, then list/describe BMPs: ■ If no, then explain how mitigation will be achieved: ■ Will the BMPs be effective? ■ Does the Agency have any additional requirements? ■ Verify with Agency before submitting the project WQMP. 		

2.3 WATERSHED IMPACT OF PROJECT

The project is considered HCOC Exempt based on the TGD Section 3.4 Exemption Criteria #1. Therefore, there will be no significant impact to downstream waterbodies due to development of the proposed project.

SECTION 3 BEST MANAGEMENT PRACTICE SELECTION PROCESS

3.1 SITE DESIGN BMPs

For listed Site Design BMPs, indicate in the following table whether it will be used (yes/no) and describe how used, or, if not used, provide justification/alternative. Provide detailed descriptions of planned Site Design BMPs, if applicable.

1. Minimize Stormwater Runoff, Minimize Project's Impervious Footprint, and Conserve Natural Areas		
Maximize the permeable area. This can be achieved in various ways, including but not limited to, increasing building density (number of stories above or below ground) and developing land use regulations seeking to limit impervious surfaces.		
Yes	No <input checked="" type="checkbox"/>	
Describe actions taken or justification/alternative: The proposed project is an industrial warehouse. Therefore, most of the project will be impervious area. Small areas around the property will be reserved for landscaping.		
Runoff from developed areas may be reduced by using alternative materials or surfaces with a lower Coefficient of Runoff, or "C-Factor".		
Yes	No <input checked="" type="checkbox"/>	
Describe actions taken or justification/alternative: A majority of the project will be a warehouse building, parking, and drive aisles. Therefore, there will be no addition of alternative materials to reduce the 'C-Factor' except in areas reserved for landscaping.		
Conserve natural areas. This can be achieved by concentrating or clustering development on the least environmentally sensitive portions of a site while leaving the remaining land in a natural, undisturbed condition.		
Yes	No <input checked="" type="checkbox"/>	
Describe actions taken or justification/alternative: The project site will be fully developed/ and on the eastern portion redeveloped. Therefore, no natural areas will be preserved onsite. Portions of the site will be landscaped with native vegetation.		

Construct walkways, trails, patios, overflow parking lots, alleys, driveways, low-traffic streets, and other low-traffic areas with open-jointed paving materials or permeable surfaces, such as pervious concrete, porous asphalt, unit pavers, and granular materials.		
Yes	No <input checked="" type="checkbox"/>	
Describe actions taken or justification/alternative: Aside from employee and visitor parking, the warehouse will mainly be accessed by large trucks. Therefore, no alternative materials can be used in the drive aisles. All infiltration will take place underground to maintain the integrity of the drive aisles.		
Construct streets, sidewalks, and parking lot aisles to the minimum widths necessary, provided that public safety and a pedestrian friendly environment are not compromised ¹ . Incorporate landscaped buffer areas between sidewalks and streets.		
Yes	No <input checked="" type="checkbox"/>	
Describe actions taken or justification/alternative: The drive aisles and parking areas will maintain minimum width. There will be landscaping around parking areas and within tree peninsulas.		
Reduce widths of street where off-street parking is available ² .		
Yes	No <input checked="" type="checkbox"/>	
Describe actions taken or justification/alternative: No off-site street parking areas available on Mission Boulevard. All parking will be onsite.		
Maximize canopy interception and water conservation by preserving existing native trees and shrubs, and planting additional native or drought tolerant trees and large shrubs.		
Yes	No <input checked="" type="checkbox"/>	
Describe actions taken or justification/alternative: No native trees or landscaping will be preserved. However, upon development, new trees and landscaping will be implemented throughout the site.		

¹ Sidewalk widths must still comply with Americans with Disabilities Act regulations and other life safety requirements.

² However, street widths must still comply with life safety requirements for fire and emergency vehicle access.

Other comparable site design options that are equally effective.		
Describe actions taken or justification/alternative: As the site is a large industrial warehouse facility, there will be minimal (10%) landscaping of the site. All project water quality runoff and nuisance flows will be treated with a series of catch basin filter inserts, pretreatment clarifiers, and underground infiltration.		
Minimize the use of impervious surfaces, such as decorative concrete, in the landscape design.		
Yes <input checked="" type="checkbox"/>	No <input type="checkbox"/>	
Describe actions taken or justification/alternative: As there is minimal area for landscaping, it will be used solely for landscaping.		
Use natural drainage systems.		
Yes <input type="checkbox"/>	No <input checked="" type="checkbox"/>	
Describe actions taken or justification/alternative: There are no existing drainage systems onsite. There are two curb opening catch basins located in Mission Boulevard that will remain. Upon development there will be two connections made to the existing underground storm drain in Mission Boulevard.		
Where soils conditions are suitable, use perforated pipe or gravel filtration pits for low flow infiltration ³ .		
Yes <input checked="" type="checkbox"/>	No <input type="checkbox"/>	
Describe actions taken or justification/alternative: The proposed project site's stormwater quality runoff and nuisance flows will be treated by catch basin filter inserts and pretreatment clarifiers before being routed into underground retention and infiltration systems. The pipe will be perforated and underlain by gravel.		
Construct onsite ponding areas, rain gardens, or retention facilities to increase opportunities for infiltration, while being cognizant of the need to prevent the development of vector breeding areas.		
Yes <input type="checkbox"/>	No <input checked="" type="checkbox"/>	
Describe actions taken or justification/alternative: There will be no surface ponding areas on site. All retention and infiltration will take place underground in order to reduce vector problems onsite.		

³However, projects must still comply with hillside grading ordinances that limit or restrict infiltration of runoff. Infiltration areas may be subject to regulation as Class V injection wells and may require a report to the USEPA. Consult the Agency for more information on use of this type of facility.

2. Minimize Directly Connected Impervious Areas		
Where landscaping is proposed, drain rooftops into adjacent landscaping prior to discharging to the storm drain.		
Yes <input checked="" type="checkbox"/>	No <input type="checkbox"/>	
Describe actions taken or justification/alternative: Roof drain connections will be determined during final grading, and architectural design. Where applicable, roof drains will outlet into landscaped areas.		
Where landscaping is proposed, drain impervious sidewalks, walkways, trails, and patios into adjacent landscaping.		
Yes <input checked="" type="checkbox"/>	No <input type="checkbox"/>	
Describe actions taken or justification/alternative: Where applicable during final design, impervious area flows will be directed towards landscaped areas.		
Increase the use of vegetated drainage swales in lieu of underground piping or imperviously lined swales.		
Yes <input type="checkbox"/>	No <input checked="" type="checkbox"/>	
Describe actions taken or justification/alternative: All flows will be directed to catch basins and underground storm drains to be diverted into the proposed underground retention and infiltration systems.		
Use one or more of the following:		
Yes	No	Design Feature
	X	Rural swale system: street sheet flows to vegetated swale or gravel shoulder, curbs at street corners, culverts under driveways and street crossings
	X	Urban curb/swale system; street slopes to curb; periodic swale inlets drain to vegetated swale/biofilter.
	X	Dual drainage system: First flush captured in street catch basins and discharged to adjacent vegetated swale or gravel shoulder, high flows connect directly to municipal storm drains systems.
		Other comparable design concepts that are equally effective.
Describe actions taken or justification/alternative: Stormwater quality runoff and nuisance flows from the project site will be diverted via low flow manholes into a separate underground retention and infiltration system. High flows exceeding the volume of the retention systems will bypass the system and enter the Mission Boulevard storm drain.		

Use one or more of the following features for design of driveways and private residential parking areas:		
Yes	No	Design Feature
	X	<ul style="list-style-type: none"> ■ Design driveways with shared access, flared (single lane at street) or wheel strips (paving only under tires); or, drain into landscaping prior to discharging to the municipal storm drain system.
	X	<ul style="list-style-type: none"> ■ Uncovered temporary or guest parking on private residential lots may be paved with a permeable surface; or designed to drain into landscaping prior to discharging to the municipal storm drain system.
	X	<ul style="list-style-type: none"> ■ Other comparable design concepts that are equally effective.
Describe actions taken or justification/alternative:		
n/a – no residential driveways or parking areas. Site is commercial/industrial.		
Use one or more of the following design concepts for the design of parking areas:		
Yes	No	Design Feature
TBD		Where landscaping is proposed in parking areas, incorporate landscape areas into the drainage design.
	X	Overflow parking (parking stalls provided in excess of the Agency's minimum parking requirements) may be constructed with permeable paving.
TBD		Other comparable design concepts that are equally effective.
Describe actions taken or justification/alternative:		
Based on final grading and site design constraints, further infiltration and design concepts can be implemented and incorporated into drainage design.		

3.2 SOURCE CONTROL BMPS

Complete the following selection table for Source Control BMPs, by checking boxes that are applicable. All listed BMPs shall be implemented for the project. Where a required Source Control BMP is not applicable to the project due to project characteristics, justification and/or alternative practices for preventing pollutants must be provided. In addition to completing the following tables, provide detailed descriptions on the implementation of planned Source Control BMPs.

Source Control BMP Selection Matrix*

Project Category	Source Control BMPs																									
	Education of Property Owners	Activity Restrictions	Spill Contingency Plan	Employee Training/Education Program	Street Sweeping Private Street and Parking Lots	Common Areas Catch Basin Inspection	Landscape Planning (SD-10)	Hillside Landscaping	Roof Runoff Controls (SD-11)	Efficient Irrigation (SD-12)	Protect Slopes and Channels	Storm Drain Signage (SD-13)	Inlet Trash Racks	Energy Dissipaters	Trash Storage Areas (SD-32) and Litter Control	Fueling Areas (SD-30)	Air/Water Supply Area Drainage	Maintenance Bays and Docks (SD-31)	Vehicle Washing Areas (SD-33)	Outdoor Material Storage Areas (SD-34)	Outdoor Work Areas (SD-35)	Outdoor Processing Areas (SD-36)	Wash Water Controls for Food Preparation Areas	Pervious Pavement (SD-20)	Alternative Building Materials (SD-21)	
Significant Re-development	X	X	X	X	X	X		X	X		X				X			X								
Home subdivisions of 10 or more																										
Commercial/Industrial Development																										
Automotive Repair																										
Restaurants																										
Hillside Development																										
Development of impervious surface >2,500																										
Parking Lots >5,000 ft ² of exposed storm water																										

* Provide justification of each Source Control BMP that will not be incorporated in the project WQMP, or explanation of proposed equally effective alternatives in the following table.

Justification for Source Control BMPs not incorporated into the project WQMP			
Source Control BMP	Used in Project (yes/no)?	Justification/ Alternative*	Implementation Description
Education of Property Owners	yes		Provide to each employee education materials to promote environmental awareness as to the use of chemicals (including household type) that should be limited to the immediate household, with no discharge of specific wastes via hosing or direct discharge to gutters, area drains, catch basins, and storm drains. In addition, guidelines will be provided as to general good housekeeping practices and proper methods of waste disposal that contribute to protection of storm water quality
Activity Restrictions	yes		Define activity restrictions regarding the protection of surface water quality. In particular waste disposal of materials and pesticide application in common areas must be performed by an applicator certified by the California Department of Pesticide Regulation
Spill Contingency Plan	yes		The Developer/ Builder shall comply with NPDES BMP "spill" contingency plans. See CASQA SC-11 in Attachment C.
Employee Training/Education Program	yes		Maintenance and Landscape employees shall be provided with education material to promote environmental awareness as to the use of chemicals (including household type) that should be limited to the immediate household, with no discharge of specific wastes via hosing or direct discharge to gutters, area drains, catch basins, and storm drains. In addition, guidelines will be provided as to general good housekeeping practices and proper methods of waste disposal that contribute to protection of storm water quality.
Street Sweeping Private Street and Parking Lots	yes		The owner/developer shall arrange for the inspection, cleaning, and street sweeping of all streets and pedestrian accessible areas on a monthly basis, at minimum, or more frequently as needed. The City will provide inspection and street sweeping of the public streets.
Common Areas Catch Basin Inspection	Yes		The owner will be responsible for scheduling routing cleaning and maintenance for all onsite drop inlets and catch basins. Clearing of debris, litter, and trash from the site in order to prevent it from entering the catch basins during a rain event.
Landscape Planning (SD-10)	yes		Promote the use of native an/ or drought tolerant plants. Maximize use of trees.
Hillside Landscaping	no	No hillsides onsite.	

Roof Runoff Controls (SD-11)	Yes		Where applicable, roof runoff will be directed via downspouts to landscaped areas for partial infiltration.
Efficient Irrigation (SD-12)	yes		The design of the entire irrigation system for this project uses as a guide, the specifications and recommendations of Section 492, Chapter 2.7, of AB325, The Water Conservations in Landscaping Act of 1990. Efficient irrigation techniques have been employed to maximize infiltration and to minimize water loss, runoff, and evaporation. The following are aspects of the irrigation system: a. Turf demanding more water shall be valved separately from shrubs requiring less water b. Sprinkler heads shall have low precipitation rates and trajectories keeping overspray onto sidewalks and pavement at a minimum. c. Run time for valves is dependent on changes in sunlight, slope, and seasons. d. Flow sensors will be used to measure sudden pressure drops and control water loss due to broken sprinkler heads or water supply lines. e. Rain Sensors will be used to eliminate or reduce irrigation during times of precipitation.
Protect Slopes and Channels	no	No slopes and channels onsite.	
Storm Drain Signage (SD-13)	yes		All drop inlets and catch basins will be outfitted with a City approved stencil "No Dumping – We live Downstream" in order to deter illegal dumping and promote the protection of water quality.
Inlet Trash Racks	no	However, inlets will contain filter inserts.	
Energy Dissipaters	no	No requirements for energy dissipaters onsite.	
Trash Storage Areas (SD-32) and Litter Control	Yes		The OWNER/DEVELOPER/ EACH EMPLOYEE shall be made aware of the use and restrictions of the trash containers. Litter control and trash management for any common areas will be provided by the contracted landscape maintenance company. Design requirements for waste handling areas are goverened by the Building and Fire Codes, and by current local agency ordinances and zoning requirements.
Fueling Areas (SD-30)	no	No fuleing areas will be located on the post developed site.	

Air/Water Supply Area Drainage	No	There will be no air/water supply areas on the post developed site.	
Maintenance Bays and Docks (SD-31)	Yes		Proper cleaning and maintenance of the loading docks shall be implemented to help protect water quality.
Vehicle Washing Areas (SD-33)	No	There will be no vehicle washing areas on the post developed site.	
Outdoor Material Storage Areas (SD-34)	No	There will be no outdoor material storage areas on the post developed site.	
Outdoor Work Areas (SD-35)	No	There will be no outdoor work areas aside from the loading docks on the post developed site.	
Outdoor Processing Areas (SD-36)	No	There will be no outdoor processing areas on the post developed site.	
Wash Water Controls for Food Preparation Areas	No	There will be no food preparation areas on the post developed site.	
Pervious Pavement (SD-20)	No	There will be no pervious pavement onsite.	
Alternative Building Materials (SD-21)	No	No alternative building materials in use.	
*Attach additional sheets if necessary for justification.			

3.3 TREATMENT CONTROL BMPS (Not required for Non-Category projects)

- Complete the following Treatment Control BMPs-Selection Matrix. For each pollutant of concern enter “yes” if identified in Section 2.1, above, or “no” if not identified for the project. Check the boxes of selected BMPs that will be implemented for the project to address each pollutant of concern from the project as listed above in section 2.1. Treatment Control BMPs must be selected and installed with respect to identified pollutant characteristics and concentrations that will be discharged from the site. For any identified pollutants of concern not listed in the Treatment Control BMP Selection Matrix, provide an explanation of how they will be addressed by Treatment Control BMPs. For identified pollutants of concern that are causing an impairment in receiving waters (as identified in Section 2.1, above), the project WQMP shall incorporate one or more Treatment Control BMPs of medium or high effectiveness in reducing those pollutants. It is the responsibility of the project proponent to demonstrate, and document in the project WQMP, that all pollutants of concern will be fully addressed. The Agency may require information beyond the minimum requirements of this WQMP to demonstrate that adequate pollutant treatment is being accomplished.

- In addition to completing the Selection Matrix, provide detailed descriptions on the location, implementation, installation, and long-term O&M of planned Treatment Control BMPs.

Treatment Control BMP Selection Matrix

Pollutant of Concern	Treatment Control BMP Categories							
	Biofilters	Detention Basins ⁽²⁾	Infiltration Basins ⁽³⁾	Wet Ponds or Wetlands	Filtration	Water Quality Inlets	Hydrodynamic Separator Systems ⁽⁴⁾	Manufactured/ Proprietary Devices
Sediment/Turbidity	H/M	M	H/M	H/M	H/M	L	H/M (L for turbidity)	U
Yes/No? Yes					X		X	
Nutrients	L	M	H/M	H/M	L/M	L	L	U
Yes/No? Yes					X		X	
Organic Compounds	U	U	U	U	H/M	L	L	U
Yes/No? Yes					X		X	
Trash & Debris	L	M	U	U	H/M	M	H/M	U
Yes/No? Yes					X		X	
Oxygen Demanding Substances	L	M	H/M	H/M	H/M	L	L	U
Yes/No? Yes					X		X	
Bacteria & Viruses	U	U	H/M	U	H/M	L	L	U
Yes/No? Yes					X		X	
Oils & Grease	H/M	M	U	U	H/M	M	L/M	U
Yes/No? Yes					X		X	
Pesticides (non-soil bound)	U	U	U	U	U	L	L	U
Yes/No? Yes					X		X	
Metals	H/M	M	H	H	H	L	L	U
Yes/No? Yes					X		X	

3.4 BMP DESIGN CRITERIA

- The following Treatment Control BMP(s) (Flow Based or Volume Based) will be implemented for this project (check "Implemented" box, if used):

Design Basis of Treatment Control BMPs

Implemented	Treatment Control BMP	Design Basis
	Vegetated Buffer Strips	Flow Based
	Vegetated Swale	
	Multiple Systems	
X	Manufactured/Proprietary	Volume Based
	Bioretention	
	Wet Pond	
	Constructed Wetland	
	Extended Detention Basin	
	Water Quality Inlet	
	Retention/Irrigation	
	Infiltration Basin	
X	Infiltration Trench	
	Media Filter	
X	Manufactured/Proprietary	

3.4.1 Flow Based Design Criteria

$$P_{2\text{yr-1hr}} = 0.601 \text{ in.}$$

Drainage Area	Area	Imperviousness	Qbmp
	(Sq. ft.)	(%)	(cfs)
DA1	201,580	90	1.13
DA2	21,692	90	0.12
Total	223,272	--	1.25

Note: Calculations can be found in Attachment D

3.4.2 Volume-Based Design Criteria

Drainage Area	Area	Imperviousness	Vbmp
	(Sq. ft.)	(%)	(cfs)
DA1	201,580	90	21,451
DA2	21,692	90	2,308
Total	223,272	--	23,759

Section 4 Operation and Maintenance

4.1 Operations and Maintenance

Operation and maintenance (O&M) requirements for all Source Control, Site Design, and Treatment Control BMPs shall be identified within the WQMP. The WQMP shall include the following:

4.1.1 O&M DESCRIPTION AND SCHEDULE:

BMP	PARTY RESPONSIBLE FOR MAINTENANCE AND INSPECTION	MAINTENANCE REQUIRED	FREQUENCY
Source Control BMPs	Owner	Standard maintenance of site and landscaped areas, surface and subsurface drainage facilities, and cleaning activities.	Always
Catch Basin Stenciling	Owner	Maintaining free and clear visibility of signage. Reapplying signage upon fading.	As needed.
Catch Basin Filter Inserts	Owner	Clear any trash, debris from storage area per manufacturer's recommendation	2x/year minimum RECOMMENDED BEFORE AND AFTER RAINY SEASON
Underground Infiltration System	Owner	Clear any trash, debris from retention pipe per manufacturer's recommendation	2x/year minimum RECOMMENDED BEFORE AND AFTER RAINY SEASON
Pretreatment Clarifiers	Owner	Clear any trash, debris, pollutants from system storage area per manufacturer's recommendations.	2x/year minimum RECOMMENDED BEFORE AND AFTER RAINY SEASON

4.1.2 INSPECTION & MONITORING REQUIREMENTS:

CATCH BASINS & FILTER INSERTS:

The Owner/Developer is responsible for:

- Inspection of the drainage structures and filter inserts.
- Removal of debris and sediment after major storm event.
- Weekly visual monitoring of facilities.
- Monthly inspection for sediment, debris, and trash.
- Keep record of inspections (See attached Forms).

UNDERGROUND RETENTION/INFILTRATION SYSTEM:

The Owner/Developer is responsible for:

- Inspection of the project site and the infiltration system. The inspection should include the observance of debris and sediment build up.
- Schedule ongoing inspections every six months, and after major storm events for accumulated sediments, debris, and possible waste materials.
- Keep record of inspections (See attached Forms).

SITE AND BMPs:

The Owner/Developer is responsible for:

- Inspection of the project site, the costs of inspections, and the maintenance of the Project Site.
- Perform minimum monthly site inspection.
- Inspect conditions of all pedestrian accessible surface areas and structures.
- Check and inspect for proper operation and maintenance of the drainage structures, swales, and filter inserts.
- Inspect for the deposition of debris and other pollutants though out the site.
- Keep record of inspections (See attached Forms).

4.1.3 IDENTIFICATION OF RESPONSIBLE PARTIES THAT MUST:

The owner of the property will be responsible to the operation and maintenance of the project site, and all site design, and structural source control BMPs.

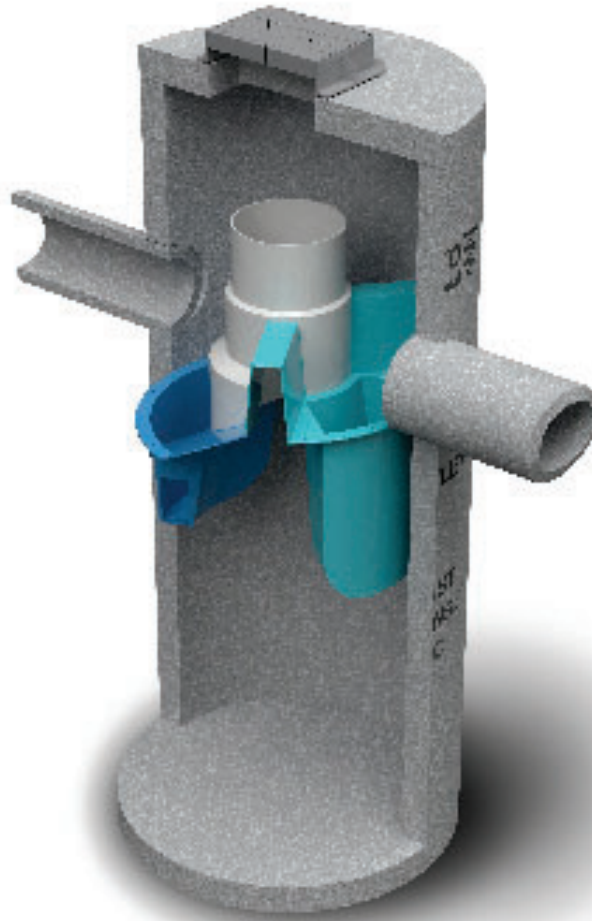

Operation and Maintenance Manual

First Defense[®] High Capacity and First Defense[®] Optimum

Vortex Separator for Stormwater Treatment

Table of Contents

3	FIRST DEFENSE® BY HYDRO INTERNATIONAL <ul style="list-style-type: none">- INTRODUCTION- OPERATION- POLLUTANT CAPTURE AND RETENTION
4	MODEL SIZES & CONFIGURATIONS <ul style="list-style-type: none">- FIRST DEFENSE® COMPONENTS
5	MAINTENANCE <ul style="list-style-type: none">- OVERVIEW- MAINTENANCE EQUIPMENT CONSIDERATIONS- DETERMINING YOUR MAINTENANCE SCHEDULE
6	MAINTENANCE PROCEDURES <ul style="list-style-type: none">- INSPECTION- FLOATABLES AND SEDIMENT CLEAN OUT
8	FIRST DEFENSE® INSTALLATION LOG
9	FIRST DEFENSE® INSPECTION AND MAINTENANCE LOG

COPYRIGHT STATEMENT: The contents of this manual, including the graphics contained herein, are intended for the use of the recipient to whom the document and all associated information are directed. Hydro International plc owns the copyright of this document, which is supplied in confidence. It must not be used for any purpose other than that for which it is supplied and must not be reproduced, in whole or in part stored in a retrieval system or transmitted in any form or by any means without prior permission in writing from Hydro International plc. First Defense® is a trademarked hydrodynamic vortex separation device of Hydro International plc. A patent covering the First Defense® has been granted.

DISCLAIMER: Information and data contained in this manual is exclusively for the purpose of assisting in the operation and maintenance of Hydro International plc's First Defense®. No warranty is given nor can liability be accepted for use of this information for any other purpose. Hydro International plc has a policy of continuous product development and reserves the right to amend specifications without notice.

I. First Defense® by Hydro International

Introduction

The First Defense® is an enhanced vortex separator that combines an effective and economical stormwater treatment chamber with an integral peak flow bypass. It efficiently removes total suspended solids (TSS), trash and hydrocarbons from stormwater runoff without washing out previously captured pollutants. The First Defense® is available in several model configurations to accommodate a wide range of pipe sizes, peak flows and depth constraints.

The two product models described in this guide are the First Defense® High Capacity and the First Defense® Optimum; they are inspected and maintained identically.

Operation

The First Defense® operates on simple fluid hydraulics. It is self-activating, has no moving parts, no external power requirement and is fabricated with durable non-corrosive components. No manual procedures are required to operate the unit and maintenance is limited to monitoring accumulations of stored pollutants and periodic clean-outs. The First Defense® has been designed to allow for easy and safe access for inspection, monitoring and clean-out procedures. Neither entry into the unit nor removal of the internal components is necessary for maintenance, thus safety concerns related to confined-space-entry are avoided.

Pollutant Capture and Retention

The internal components of the First Defense® have been designed to optimize pollutant capture. Sediment is captured and retained in the base of the unit, while oil and floatables are stored on the water surface in the inner volume (Fig.1).

The pollutant storage volumes are isolated from the built-in bypass chamber to prevent washout during high-flow storm events. The sump of the First Defense® retains a standing water level between storm events. This ensures a quiescent flow regime at the onset of a storm, preventing resuspension and washout of pollutants captured during previous events.

Accessories such as oil absorbent pads are available for enhanced oil removal and storage. Due to the separation of the oil and floatable storage volume from the outlet, the potential for washout of stored pollutants between clean-outs is minimized.

Applications

- Stormwater treatment at the point of entry into the drainage line
- Sites constrained by space, topography or drainage profiles with limited slope and depth of cover
- Retrofit installations where stormwater treatment is placed on or tied into an existing storm drain line
- Pretreatment for filters, infiltration and storage

Advantages

- Inlet options include surface grate or multiple inlet pipes
- Integral high capacity bypass conveys large peak flows without the need for “offline” arrangements using separate junction manholes
- Long flow path through the device ensures a long residence time within the treatment chamber, enhancing pollutant settling
- Delivered to site pre-assembled and ready for installation

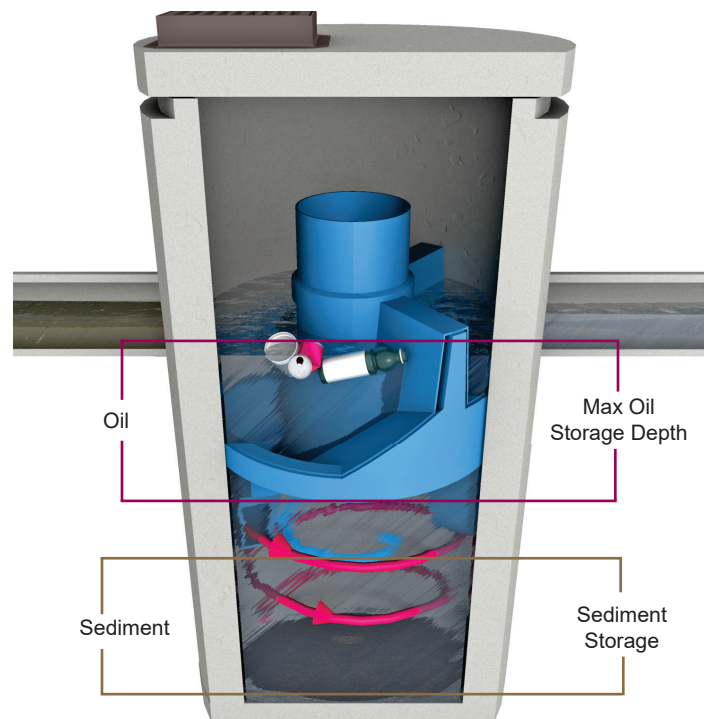

Fig.1 Pollutant storage volumes in the First Defense®.

II. Model Sizes & Configurations

The First Defense® inlet and internal bypass arrangements are available in several model sizes and configurations. The components have modified geometries allowing greater design flexibility to accommodate various site constraints.

All First Defense® models include the internal components that are designed to remove and retain total suspended solids (TSS), gross solids, floatable trash and hydrocarbons (Fig.2). First Defense® model sizes (diameter) are shown in Table 1.

III. Maintenance

First Defense® Components

- 1. Built-In Bypass
- 2. Inlet Pipe
- 3. Inlet Chute
- 4. Floatables Draw-off Port
- 5. Outlet Pipe
- 6. Floatables Storage
- 7. Sediment Storage
- 8. Inlet Grate or Cover

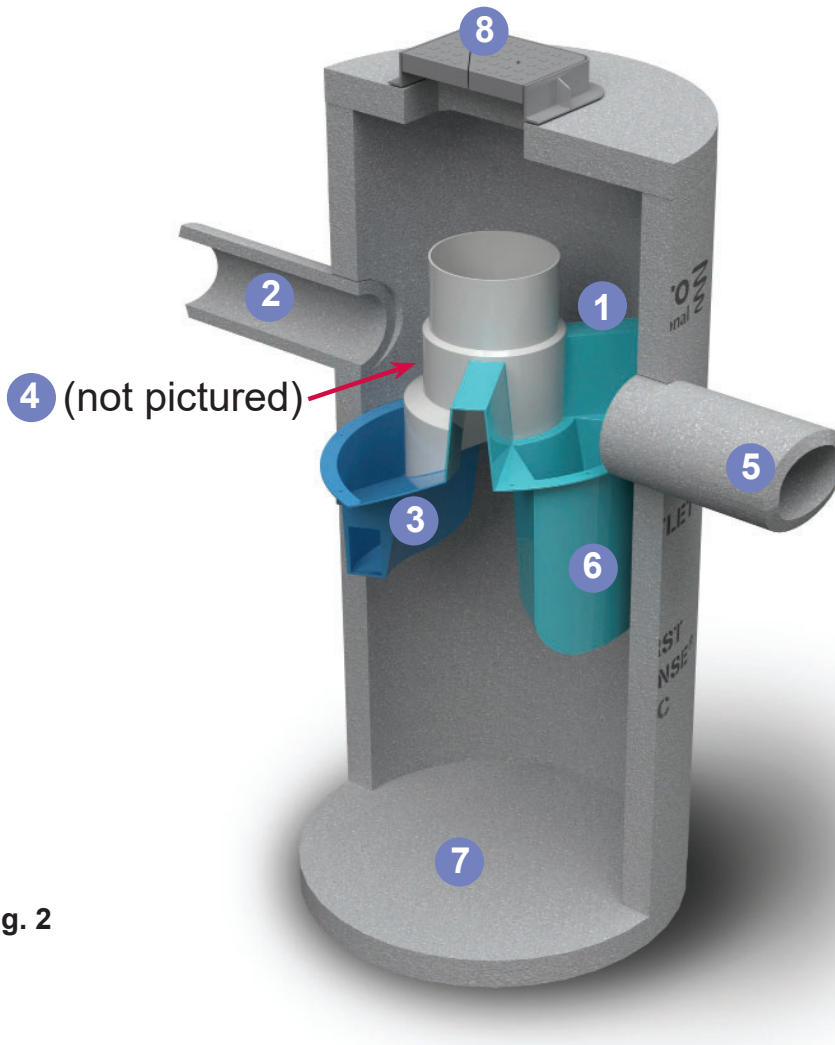

Fig. 2

Table 1

First Defense® Model Sizes
(ft / m) diameter
3 / 0.9
4 / 1.2
5 / 1.5
6 / 1.8
7 / 2.1
8 / 2.4
10 / 3.0

Overview

The First Defense® protects the environment by removing a wide range of pollutants from stormwater runoff. Periodic removal of these captured pollutants is essential to the continuous, long-term functioning of the First Defense®. The First Defense® will capture and retain sediment and oil until the sediment and oil storage volumes are full to capacity. When sediment and oil storage capacities are reached, the First Defense® will no longer be able to store removed sediment and oil.

The First Defense® allows for easy and safe inspection, monitoring and clean-out procedures. A commercially or municipally owned sump-vac is used to remove captured sediment and floatables. Access ports are located in the top of the manhole.

Maintenance events may include Inspection, Oil & Floatables Removal, and Sediment Removal. Maintenance events do not require entry into the First Defense®, nor do they require the internal components of the First Defense® to be removed. In the case of inspection and floatables removal, a vactor truck is not required. However, a vactor truck is required if the maintenance event is to include oil removal and/or sediment removal.

Maintenance Equipment Considerations

The internal components of the First Defense® have a centrally located circular shaft through which the sediment storage sump can be accessed with a sump vac hose. The open diameter of this access shaft is 15 inches in diameter (Fig.3). Therefore, the nozzle fitting of any vactor hose used for maintenance should be less than 15 inches in diameter.

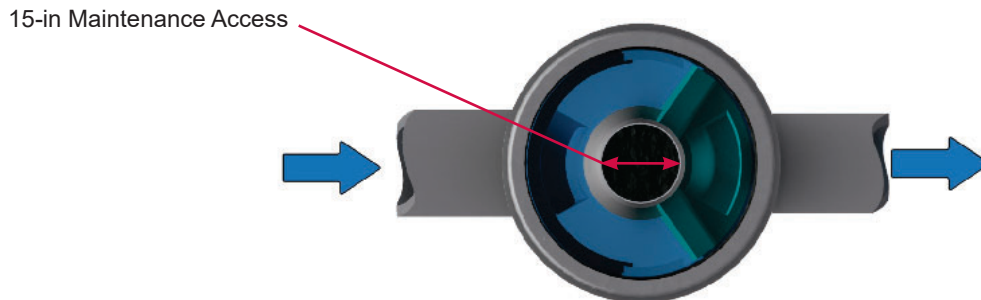

Fig.3 The central opening to the sump of the First Defense® is 15 inches in diameter.

Determining Your Maintenance Schedule

The frequency of clean out is determined in the field after installation. During the first year of operation, the unit should be inspected every six months to determine the rate of sediment and floatables accumulation. A simple probe such as a Sludge-Judge® can be used to determine the level of accumulated solids stored in the sump. This information can be recorded in the maintenance log (see page 9) to establish a routine maintenance schedule.

The vactor procedure, including both sediment and oil / floatables removal, for First Defense® typically takes less than 30 minutes and removes a combined water/oil volume of about 765 gallons.

Inspection Procedures

1. Set up any necessary safety equipment around the access port or grate of the First Defense® as stipulated by local ordinances. Safety equipment should notify passing pedestrian and road traffic that work is being done.
2. Remove the grate or lid to the manhole.
3. Without entering the vessel, look down into the chamber to inspect the inside. Make note of any irregularities. Fig.4 shows the standing water level that should be observed.
4. Without entering the vessel, use the pole with the skimmer net to remove floatables and loose debris from the components and water surface.
5. Using a sediment probe such as a Sludge Judge®, measure the depth of sediment that has collected in the sump of the vessel.
6. On the Maintenance Log (see page 9), record the date, unit location, estimated volume of floatables and gross debris removed, and the depth of sediment measured. Also note any apparent irregularities such as damaged components or blockages.
7. Securely replace the grate or lid.
8. Take down safety equipment.
9. Notify Hydro International of any irregularities noted during inspection.

Floatables and Sediment Clean Out

Floatables clean out is typically done in conjunction with sediment removal. A commercially or municipally owned sump-vac is used to remove captured sediment and floatables (Fig.4).

Floatables and loose debris can also be netted with a skimmer and pole. The access port located at the top of the manhole provides unobstructed access for a vactor hose to be lowered to the base of the sump.

Scheduling

- Floatables and sump clean out are typically conducted once a year during any season.
- Floatables and sump clean out should occur as soon as possible following a spill in the contributing drainage area.



Fig.4 Floatables are removed with a vactor hose

Recommended Equipment

- Safety Equipment (traffic cones, etc)
- Crow bar or other tool to remove grate or lid
- Pole with skimmer or net (if only floatables are being removed)
- Sediment probe (such as a Sludge Judge®)
- Vactor truck (flexible hose recommended)
- First Defense® Maintenance Log

Floatables and Sediment Clean Out Procedures

1. Set up any necessary safety equipment around the access port or grate of the First Defense® as stipulated by local ordinances. Safety equipment should notify passing pedestrian and road traffic that work is being done.
2. Remove the grate or lid to the manhole.
3. Without entering the vessel, look down into the chamber to inspect the inside. Make note of any irregularities.
4. Remove oil and floatables stored on the surface of the water with the vacator hose or with the skimmer or net
5. Using a sediment probe such as a Sludge Judge®, measure the depth of sediment that has collected in the sump of the vessel and record it in the Maintenance Log (page 9).
6. Once all floatables have been removed, drop the vacator hose to the base of the sump. Vacator out the sediment and gross debris off the sump floor
7. Retract the vacator hose from the vessel.
8. On the Maintenance Log provided by Hydro International, record the date, unit location, estimated volume of floatables and gross debris removed, and the depth of sediment measured. Also note any apparent irregularities such as damaged components, blockages, or irregularly high or low water levels.
9. Securely replace the grate or lid.

Maintenance at a Glance

Inspection	<ul style="list-style-type: none"> - Regularly during first year of installation - Every 6 months after the first year of installation
Oil and Floatables Removal	<ul style="list-style-type: none"> - Once per year, with sediment removal - Following a spill in the drainage area
Sediment Removal	<ul style="list-style-type: none"> - Once per year or as needed - Following a spill in the drainage area

NOTE: For most clean outs the entire volume of liquid does not need to be removed from the manhole. Only remove the first few inches of oils and floatables from the water surface to reduce the total volume of liquid removed during a clean out.



First Defense® Installation Log

HYDRO INTERNATIONAL REFERENCE NUMBER:	
SITE NAME:	
SITE LOCATION:	
OWNER:	CONTRACTOR:
CONTACT NAME:	CONTACT NAME:
COMPANY NAME:	COMPANY NAME:
ADDRESS:	ADDRESS:
TELEPHONE:	TELEPHONE:
FAX:	FAX:

INSTALLATION DATE: / /

MODEL SIZE (CIRCLE ONE): [3-FT] [4-FT] [5-FT] [6-FT] [7-FT] [8-FT] [10-FT]

INLET (CIRCLE ALL THAT APPLY): GRATED INLET (CATCH BASIN) INLET PIPE (FLOW THROUGH)



Stormwater Solutions

94 Hutchins Drive
Portland, ME 04102

Tel: (207) 756-6200

Fax: (207) 756-6212

stormwaterinquiry@hydro-int.com

www.hydro-int.com



FLOGARD+PLUS® CATCH BASIN INSERT FILTER

Inspection and Maintenance Guide



A division of
Oldcastle Precast

SCOPE:

Federal, State and Local Clean Water Act regulations and those of insurance carriers require that stormwater filtration systems be maintained and serviced on a recurring basis. The intent of the regulations is to ensure that the systems, on a continuing basis, efficiently remove pollutants from stormwater runoff thereby preventing pollution of the nation's water resources. These specifications apply to the FloGard+Plus® Catch Basin Insert Filter.

RECOMMENDED FREQUENCY OF SERVICE:

Drainage Protection Systems (DPS) recommends that installed FloGard+Plus Catch Basin Insert Filters be serviced on a recurring basis. Ultimately, the frequency depends on the amount of runoff, pollutant loading and interference from debris (leaves, vegetation, cans, paper, etc.); however, it is recommended that each installation be serviced a minimum of three times per year, with a change of filter medium once per year. DPS technicians are available to do an onsite evaluation, upon request.

RECOMMENDED TIMING OF SERVICE:

DPS guidelines for the timing of service are as follows:

1. For areas with a definite rainy season: Prior to, during and following the rainy season.
2. For areas subject to year-round rainfall: On a recurring basis (at least three times per year).
3. For areas with winter snow and summer rain: Prior to and just after the snow season and during the summer rain season.
4. For installed devices not subject to the elements (washracks, parking garages, etc.): On a recurring basis (no less than three times per year).

SERVICE PROCEDURES:

1. The catch basin grate shall be removed and set to one side. The catch basin shall be visually inspected for defects and possible illegal dumping. If illegal dumping has occurred, the proper authorities and property owner representative shall be notified as soon as practicable.
2. Using an industrial vacuum, the collected materials shall be removed from the liner. (Note: DPS uses a truck-mounted vacuum for servicing FloGard+Plus catch basin inserts.)
3. When all of the collected materials have been removed, the filter medium pouches shall be removed by unsnapping the tether from the D-ring and set to one side. The filter liner, gaskets, stainless steel frame and mounting brackets, etc., shall be inspected for continued serviceability. Minor damage or defects found shall be corrected on-the-spot and a notation made on the Maintenance Record. More extensive deficiencies that affect the efficiency of the filter (torn liner, etc.), if approved by the customer representative, will be corrected and an invoice submitted to the representative along with the Maintenance Record.
4. The filter medium pouches shall be inspected for defects and continued serviceability and replaced as necessary and the pouch tethers re-attached to the liner's D-ring. See below.
5. The grate shall be replaced.

REPLACEMENT AND DISPOSAL OF EXPOSED FILTER MEDIUM AND COLLECTED DEBRIS

The frequency of filter medium exchange will be in accordance with the existing DPS-Customer Maintenance Contract. DPS recommends that the medium be changed at least once per year. During the appropriate service, or if so determined by the service technician during a non-scheduled service, the filter medium will be replaced with new material. Once the exposed pouches and debris have been removed, DPS has possession and must dispose of it in accordance with local, state and federal agency requirements.

DPS also has the capability of servicing all manner of storm drain filters, catch basin inserts and catch basins without inserts, underground oil/water separators, stormwater interceptors and other such devices. All DPS personnel are highly qualified technicians and are confined space trained and certified. Call us at (888) 950-8826 for further information and assistance.

FLOGARD+PLUS® CATCH BASIN INSERT FILTER

OUR MARKETS



BUILDING
STRUCTURES



COMMUNICATIONS



WATER



ENERGY



TRANSPORTATION

Contech® CMP Detention Inspection and Maintenance Guide

Underground stormwater detention and infiltration systems must be inspected and maintained at regular intervals for purposes of performance and longevity.

Inspection

Inspection is the key to effective maintenance of CMP detention systems and is easily performed. Contech recommends ongoing, annual inspections. Sites with high trash load or small outlet control orifices may need more frequent inspections. The rate at which the system collects pollutants will depend more on-site specific activities rather than the size or configuration of the system.

Inspections should be performed more often in equipment washdown areas, in climates where sanding and/or salting operations take place, and in other various instances in which one would expect higher accumulations of sediment or abrasive/corrosive conditions. A record of each inspection is to be maintained for the life of the system.

Maintenance

CMP detention systems should be cleaned when an inspection reveals accumulated sediment or trash is clogging the discharge orifice. Accumulated sediment and trash can typically be evacuated through the manhole over the outlet orifice. If maintenance is not performed as recommended, sediment and trash may accumulate in front of the outlet orifice. Manhole covers should be securely seated following cleaning activities. Contech suggests that all systems be designed with an access/inspection manhole situated at or near the inlet and the outlet orifice. Should it be necessary to get inside the system to perform maintenance activities, all appropriate precautions regarding confined space entry and OSHA regulations should be followed.

Annual inspections are best practice for all underground systems. During this inspection if evidence of salting/de-icing agents is observed within the system, it is best practice for the system to be rinsed, including above the spring line soon after the spring thaw as part of the maintenance program for the system.

Maintaining an underground detention or infiltration system is easiest when there is no flow entering the system. For this reason, it is a good idea to schedule the cleanout during dry weather.

The foregoing inspection and maintenance efforts help ensure underground pipe systems used for stormwater storage continue to function as intended by identifying recommended regular inspection and maintenance practices. Inspection and maintenance related to the structural integrity of the pipe or the soundness of pipe joint connections is beyond the scope of this guide.

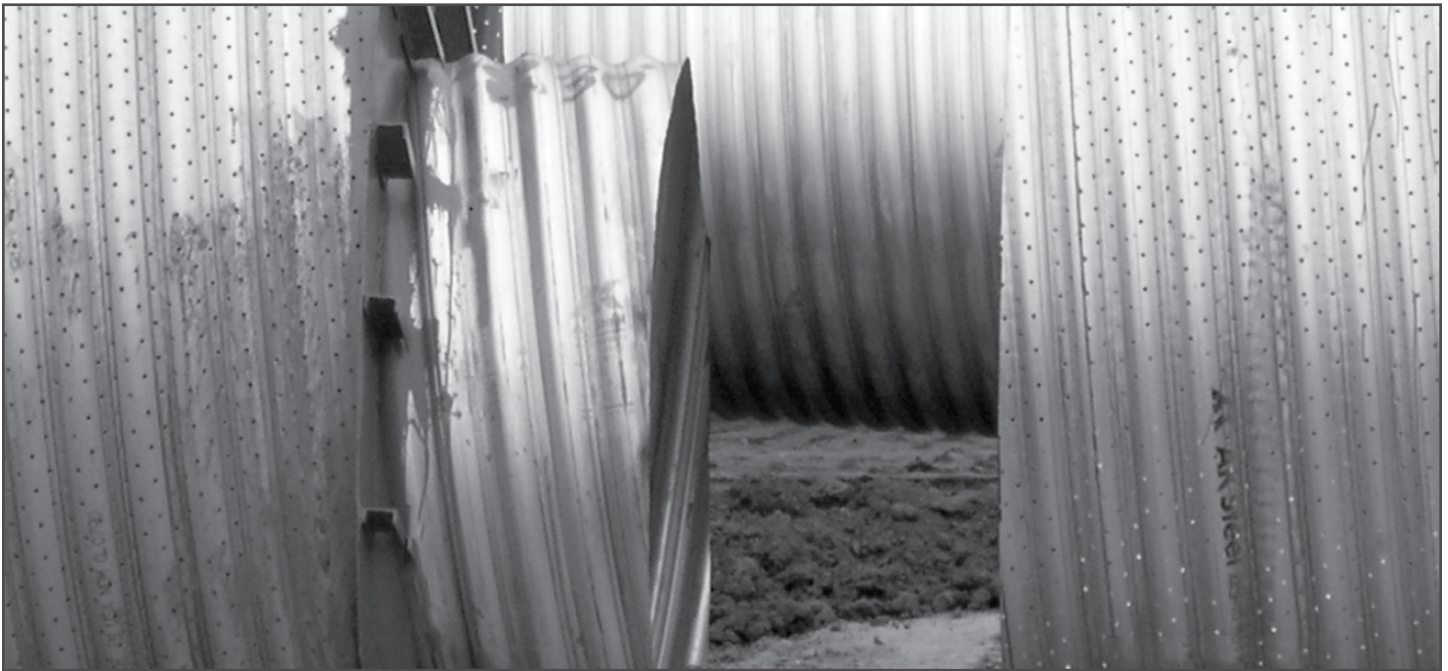

NOTHING IN THIS CATALOG SHOULD BE CONSTRUED AS A WARRANTY. APPLICATIONS SUGGESTED HEREIN ARE DESCRIBED ONLY TO HELP READERS MAKE THEIR OWN EVALUATIONS AND DECISIONS, AND ARE NEITHER GUARANTEES NOR WARRANTIES OF SUITABILITY FOR ANY APPLICATION. CONTECH MAKES NO WARRANTY WHATSOEVER, EXPRESS OR IMPLIED, RELATED TO THE APPLICATIONS, MATERIALS, COATINGS, OR PRODUCTS DISCUSSED HEREIN. ALL IMPLIED WARRANTIES OF MERCHANTABILITY AND ALL IMPLIED WARRANTIES OF FITNESS FOR ANY PARTICULAR PURPOSE ARE DISCLAIMED BY CONTECH. SEE CONTECH'S CONDITIONS OF SALE (AVAILABLE AT WWW.CONTECHES.COM/COS) FOR MORE INFORMATION.

CONTECH®
CMP DETENTION SYSTEMS

CONTECH®
ENGINEERED SOLUTIONS

© 2019 CONTECH ENGINEERED SOLUTIONS LLC, A QUIKRETE COMPANY
ALL RIGHTS RESERVED. PRINTED IN USA.

OVERALL SITE AREAS SERVICE PROCEDURES:

- 1) ALL INSPECTIONS AND CORRECTIVE MAINTENANCE SHALL BE NOTED AND LOGGED IN THE MAINTENANCE RECORD.
- 2) OWNER SHALL BE NOTIFIED OF ALL WORK PERFORMED.
- 3) CLEANING SHOULD BE PERFORMED DURING DRY WEATHER CONDITIONS.
- 4) PERFORM INSPECTION AND MAINTENANCE WITH CARE AS NOT TO DAMAGE WORK AND STORAGE AREAS.
- 5) REMOVAL OF UNDESIRABLE MATERIALS AND DEBRIS.
 - a) INSPECT SURROUNDING AREAS FOR DEFECTS AND ILLEGAL DUMPING.
 - b) NOTIFY PROPER AUTHORITY AND OWNER IF ILLEGAL DUMPING OCCURRED.
- 6) REMOVE HYDROCARBONS. (ADSORBENT PADS MAY BE USED).
- 7) DEBRIS MAY BE REMOVED BY THE USE OF A NET IF NECESSARY.
- 8) VACCUUM IF NECESSARY / REMOVE COLLECTED MATERIALS AND FLUID FROM THE AREAS.
 - a) SILT, SEDIMENT AND OTHER DEBRIS SHOULD NOT BE ALLOWED TO ACCUMULATE.
 - b) IF DEBRIS OR APPRECIABLE AMOUNT OF THE SILT OR SEDIMENT IS FOUND, DETERMINE THE SOURCE AND CORRECT.
- 9) INSPECT AREAS
 - a) INSPECT
 - i. UPSTREAM INFLOW AREAS AND DOWNSTREAM AREAS, ETC.
 - ii. INSPECT STORAGE STRUCTURES FOR DAMAGE AND/OR LEAKS.
 - iii. CORRECT MINOR DAMAGE / DEFECTS.
 - iv. CORRECT MORE EXTENSIVE DEFICIENCIES.
 - b) DEFECTS / SERVICEABILITY.
 - c) REPLACE, REMOVE, REPAIR AS NECESSARY.

**SECTION 5
FUNDING**

5.1 Funding

The Owner is responsible for the operation, inspection, maintenance, and all of the funding for the site design water quality BMPs.

NUI INVESTMENT, LLC	AND	DON JULIAN INVESTMENT, LLC
1150 W. RIGGIN STREET MONTEREY PARK, CA 91754		138 N. GLENDORA AVENUE GLENDORA, CA. 91741

Contact Person: Cary Niu
Phone: 626.319.9558

SECTION 6
WQMP Certification

6.1 Certification

- The applicant is required to sign and certify that the WQMP is in conformance with Santa Ana Regional Water Quality Control Board Order Number R8-2002-0012 (NPDES Permit No. CAS618036).
- The applicant is required to sign and date the following statement 'word-for-word' certifying that the provisions of the WQMP have been accepted by the applicant and that the applicant will have the plan transferred to future successors (transferability statement). The certification must be signed by the property owner, unless a written designation by the owner allows a designee to sign on the owner's behalf.

"This Water Quality Management Plan has been prepared for (Owner/Developer Name) by (Consulting /Engineering Firm Name). It is intended to comply with the requirements of the City of (name city or county) for Tract/Parcel Map No. _____, Condition Number(s) _____ requiring the preparation of a Water Quality Management Plan (WQMP). The undersigned is aware that Best Management Practices (BMPs) are enforceable pursuant to the City's/County's Water Quality Ordinance No. _____. The undersigned, while it owns the subject property, is responsible for the implementation of the provisions of this plan and will ensure that this plan is amended as appropriate to reflect up-to-date conditions on the site consistent with San Bernardino County's Municipal Stormwater Management Program and the intent of the NPDES Permit for San Bernardino County and the incorporated cities of San Bernardino County within the Santa Ana Region. Once the undersigned transfers its interest in the property, its successors in interest and the city/county shall be notified of the transfer. The new owner will be informed of its responsibility under this WQMP. A copy of the approved WQMP shall be available on the subject site in perpetuity. "

"I certify under a penalty of law that the provisions (implementation, operation, maintenance, and funding) of the WQMP have been accepted and that the plan will be transferred to future successors."

Applicant's Signature

Date

Applicant's Name

Applicant's Telephone Number

Attachment A-1

Maintenance Mechanisms

A-1.1 The Agency shall not accept stormwater structural BMPs as meeting the WQMP requirements standard, unless an O&M Plan is prepared (see WQMP Section 2.6) and a mechanism is in place that will ensure ongoing long-term maintenance of all structural and non-structural BMPs. This mechanism can be provided by the Agency or by the project proponent. As part of project review, if a project proponent is required to include interim or permanent structural and non-structural BMPs in project plans, and if the Agency does not provide a mechanism for BMP maintenance, the Agency shall require that the applicant provide verification of maintenance requirements through such means as may be appropriate, at the discretion of the Agency, including, but not limited to covenants, legal agreements, maintenance agreements, conditional use permits and/or funding arrangements (OC 2003)

A-1.2 Maintenance Mechanisms

1. **Public entity maintenance:** The Agency may approve a public or acceptable quasi-public entity (e.g., the County Flood Control District, or annex to an existing assessment district, an existing utility district, a state or federal resource agency, or a conservation conservancy) to assume responsibility for operation, maintenance, repair and replacement of the BMP. Unless otherwise acceptable to individual Agencies, public entity maintenance agreements shall ensure estimated costs are front-funded or reliably guaranteed, (e.g., through a trust fund, assessment district fees, bond, letter of credit or similar means). In addition, the Permittees may seek protection from liability by appropriate releases and indemnities.

The Agency shall have the authority to approve stormwater BMPs proposed for transfer to any other public entity within its jurisdiction before installation. The Permittee shall be involved in the negotiation of maintenance requirements with any other public entities accepting maintenance responsibilities within their respective jurisdictions; and in negotiations with the resource agencies responsible for issuing permits for the construction and/or maintenance of the facilities. The Agency must be identified as a third party beneficiary empowered to enforce any such maintenance agreement within their respective jurisdictions.

2. **Project proponent agreement to maintain stormwater BMPs:** The Agency may enter into a contract with the project proponent obliging the project proponent to maintain, repair and replace the stormwater BMP as necessary into perpetuity. Security or a funding mechanism with a "no sunset" clause may be required.
3. **Assessment districts:** The Agency may approve an Assessment District or other funding mechanism created by the project proponent to provide funds for stormwater

BMP maintenance, repair and replacement on an ongoing basis. Any agreement with such a District shall be subject to the Public Entity Maintenance Provisions above.

4. **Lease provisions:** In those cases where the Agency holds title to the land in question, and the land is being leased to another party for private or public use, the Agency may assure stormwater BMP maintenance, repair and replacement through conditions in the lease.
5. **Conditional use permits:** For discretionary projects only, the Agency may assure maintenance of stormwater BMPs through the inclusion of maintenance conditions in the conditional use permit. Security may be required.
6. **Alternative mechanisms:** The Agency may accept alternative maintenance mechanisms if such mechanisms are as protective as those listed above.

Attachment A-2

Water Quality Management Plan and Stormwater BMP Transfer, Access and Maintenance Agreement (adapted from documents from the Ventura County Stormwater Management Program)

Recorded at the request of:

City of _____

After recording, return to:

City of _____

City Clerk _____

Water Quality Management Plan and Stormwater BMP Transfer, Access and Maintenance Agreement

OWNER: _____

PROPERTY ADDRESS: _____

APN: _____

THIS AGREEMENT is made and entered into in

_____, California, this _____ day of

_____, by and between

_____, herein after

referred to as "Owner" and the CITY OF _____, a municipal corporation, located in the County of San Bernardino, State of California hereinafter referred to as "CITY";

WHEREAS, the Owner owns real property ("Property") in the City of

_____, County of San Bernardino, State of California, more specifically described in Exhibit "A" and depicted in Exhibit "B", each of which exhibits is attached hereto and incorporated herein by this reference;

WHEREAS, at the time of initial approval of development project known as

_____ within the Property described herein, the City required the project to employ Best Management Practices, hereinafter referred to as "BMPs," to minimize pollutants in urban runoff;

WHEREAS, the Owner has chosen to install and/or implement BMPs as described in the Water Quality Management Plan, on file with the City, hereinafter referred to as "WQMP", to minimize pollutants in urban runoff and to minimize other adverse impacts of urban runoff;

WHEREAS, said WQMP has been certified by the Owner and reviewed and approved by the City;

WHEREAS, said BMPs, with installation and/or implementation on private property and draining only private property, are part of a private facility with all maintenance or replacement, therefore, the sole responsibility of the Owner in accordance with the terms of this Agreement;

WHEREAS, the Owner is aware that periodic and continuous maintenance, including, but not necessarily limited to, filter material replacement and sediment removal, is required to assure peak performance of all BMPs in the WQMP and that, furthermore, such maintenance activity will require compliance with all Local, State, or Federal laws and regulations, including those pertaining to confined space and waste disposal methods, in effect at the time such maintenance occurs;

NOW THEREFORE, it is mutually stipulated and agreed as follows:

1. Owner hereby provides the City of City's designee complete access, of any duration, to the BMPs and their immediate vicinity at any time, upon reasonable notice, or in the event of emergency, as determined by City's Director of Public Works no advance notice, for the purpose of inspection, sampling, testing of the Device, and in case of emergency, to undertake all necessary repairs or other preventative measures at owner's expense as provided in paragraph 3 below. City shall make every effort at all times to minimize or avoid interference with Owner's use of the Property.

2. Owner shall use its best efforts diligently to maintain all BMPs in a manner assuring peak performance at all times. All reasonable precautions shall be exercised by Owner and Owner's representative or contractor in the removal and extraction of any material(s) from the BMPs and the ultimate disposal of the material(s) in a manner consistent with all relevant laws and regulations in effect at the time. As may be requested from time to time by the City, the Owner shall provide the City with documentation identifying the material(s) removed, the quantity, and disposal destination.
3. In the event Owner, or its successors or assigns, fails to accomplish the necessary maintenance contemplated by this Agreement, within five (5) days of being given written notice by the City, the City is hereby authorized to cause any maintenance necessary to be done and charge the entire cost and expense to the Owner or Owner's successors or assigns, including administrative costs, attorneys fees and interest thereon at the maximum rate authorized by the Civil Code from the date of the notice of expense until paid in full.
4. The City may require the owner to post security in form and for a time period satisfactory to the city to guarantee the performance of the obligations state herein. Should the Owner fail to perform the obligations under the Agreement, the City may, in the case of a cash bond, act for the Owner using the proceeds from it, or in the case of a surety bond, require the sureties to perform the obligations of the Agreement. As an additional remedy, the Director may withdraw any previous stormwater-related approval with respect to the property on which BMPs have been installed and/or implemented until such time as Owner repays to City its reasonable costs incurred in accordance with paragraph 3 above.
5. This agreement shall be recorded in the Office of the Recorder of San Bernardino County, California, at the expense of the Owner and shall constitute notice to all successors and assigns of the title to said Property of the obligation herein set forth, and also a lien in such amount as will fully reimburse the City, including interest as herein above set forth, subject to foreclosure in event of default in payment.
6. In event of legal action occasioned by any default or action of the Owner, or its successors or assigns, then the Owner and its successors or assigns agree(s) to pay all costs incurred by the City in enforcing the terms of this Agreement, including reasonable attorney's fees and costs, and that the same shall become a part of the lien against said Property.
7. It is the intent of the parties hereto that burdens and benefits herein undertaken shall constitute covenants that run with said Property and constitute a lien there against.

8. The obligations herein undertaken shall be binding upon the heirs, successors, executors, administrators and assigns of the parties hereto. The term "Owner" shall include not only the present Owner, but also its heirs, successors, executors, administrators, and assigns. Owner shall notify any successor to title of all or part of the Property about the existence of this Agreement. Owner shall provide such notice prior to such successor obtaining an interest in all or part of the Property. Owner shall provide a copy of such notice to the City at the same time such notice is provided to the successor.
9. Time is of the essence in the performance of this Agreement.
10. Any notice to a party required or called for in this Agreement shall be served in person, or by deposit in the U.S. Mail, first class postage prepaid, to the address set forth below. Notice(s) shall be deemed effective upon receipt, or seventy-two (72) hours after deposit in the U.S. Mail, whichever is earlier. A party may change a notice address only by providing written notice thereof to the other party.

**EXHIBIT A
LEGAL DESCRIPTION**

TENTATIVE PARCEL MAP 20393 LEGAL DESCRIPTION

PARCELS 1, 2, 3, AND 4 OF PARCEL MAP 3172, IN THE CITY OF MONTCLAIR, IN THE COUNTY OF SAN BERNARDINO, STATE OF CALIFORNIA, AS PER PLAT RECORDED IN BOOK 28, PAGE 84 OF PARCEL MAPS, RECORDS OF SAID COUNTY.

**ADDRESS:
5006 AND 5010 MISSION BOULEVARD
MONTCLAIR, CA. 91763**

**APN:
1011-311-15, 1011-311-17, 1011-311-19**

EXHIBIT B SITE MAP

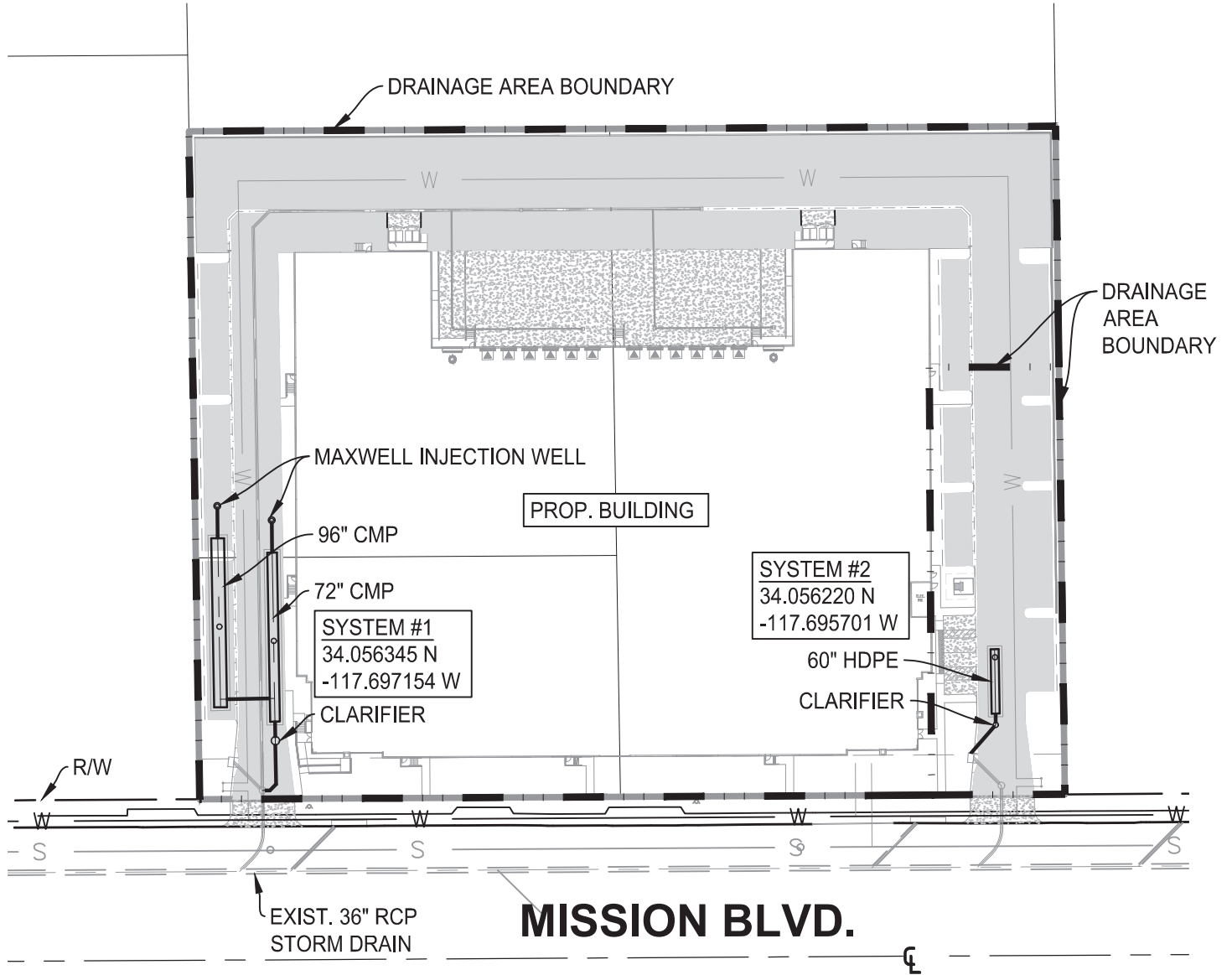

Attachment B

Tables

Table B-1 303(d) List of Impaired Water Bodies						
Waterbody	Pollutant					
	Bacteria Indicators/ Pathogens	Metals	Nutrients	Organic Enrichment	Sedimentation/Siltation	Suspended Solids
Big Bear Lake		X	X		X	
Canyon Lake (Railroad Canyon Reservoir)	X		X			
Chino Creek Reach 1	X		X			
Chino Creek Reach 2	X					
Cucamonga Creek, Valley Reach	X					
Grout Creek		X	X			
Knickerbocker Creek	X	X				
Lytle Creek	X					
Mill Creek (Prado Area)	X		X			X
Mill Creek Reach 1	X					
Mill Creek Reach 2	X					
Mountain Home Creek	X					
Mountain Home Creek, East Fork	X					
Prado Park Lake	X		X			
Rathbone (Rathbun Creek)			X		X	
Santa Ana River, Reach 3	X					
Santa Ana River, Reach 4	X					
Summit Creek			X			
NOTES:						
1) Summary of the 2002 303(d) Listed Water Bodies and Associated Pollutants of Concern from RWQCB Region 8. Check for updated lists from the RWQCB.						
2) Chlorides, pesticides, salinity, total dissolved solids (TDS), toxicity, and trash are listed impairments within the 303(d) table, however, they are not impairments in the above waterbodies.						

Table B-2 C Values Based on Impervious/Pervious Area Ratios		
% Impervious	% Pervious	C
0	100	0.15
5	95	0.19
10	90	0.23
15	85	0.26
20	80	0.30
25	75	0.34
30	70	0.38
35	65	0.41
40	60	0.45
45	55	0.49
50	50	0.53
55	45	0.56
60	40	0.60
65	35	0.64
70	30	0.68
75	25	0.71
80	20	0.75
85	15	0.79
90	10	0.83
95	5	0.86
100	0	0.90

NOTE:

Obtain individual runoff coefficient C-Factors from the local agency or from the local flood control district.

If C-Factors are not available locally, obtain factors from hydrology text books or estimate using this table.

Composite the individual C-Factors using area-weighted averages to calculate the Composite C Factor for the area draining to a treatment control BMP.

Do not use the C-Factors in this table for flood control design or related work.

Attachment C

Pollutants of Concern

EXPECTED POLLUTANTS OF CONCERN: *COMMERCIAL/ INDUSTRIAL DEVELOPMENT*

- Pathogens (Bacterial/ Virus)
- Metals
- Nutrients/ Noxious Aquatic Plants
- Organic Compounds
- Pesticides/ Herbicides
- Sediments/ TSS / PH
- Trash and Debris
- Oxygen Demanding Compounds
- Oil and Grease

The proposed project site currently discharges into Mission Boulevard that has existing curb opening catch basins. The catch basins intercept runoff and route them into the existing underground storm drain in Mission Boulevard. The Mission Boulevard Storm Drain travels approximately 1.4 miles west to the San Antonio Creek Channel. San Antonio Creek Channel drains into the Prado Dam area.

303(d) (TMDL Required List)

San Antonio Creek: pH

Prado Flood Control Basin: pH

Pollutants of Concern

- **Bacteria and Viruses** – Bacteria and Viruses are ubiquitous microorganisms that thrive under certain environmental conditions. Their proliferation is typically caused by the transport of animal or human fecal wastes from the watershed. Water, containing excessive bacteria and viruses, can alter the aquatic habitat and create a harmful environment for humans and aquatic life. Also, the decomposition of excess organic waste causes increased growth of undesirable organisms in the water.
- **Metals** – The primary source of metal pollution in stormwater is typically commercially available metals and metal products. Metals of concern include cadmium, chromium, copper, lead, mercury, and zinc. Lead and chromium have been used as corrosion inhibitors in primer coatings and cooling tower systems. Metals are also raw material components in non-metal products such as fuels, adhesives, paints, and other coatings. At low concentrations naturally occurring in soil, metals may not be toxic. However, at higher concentrations, certain metals can be toxic to aquatic life. Humans can be impacted from contaminated groundwater resources, and bioaccumulation of metals in fish and shellfish. Environmental concerns, regarding the potential for release of metals to the environment, have already led to restricted metal usage in certain applications (OC 2003).
- **Nutrients** – Nutrients are inorganic substances, such as nitrogen and phosphorus. Excessive discharge of nutrients to water bodies and streams causes eutrophication, where aquatic plants and algae growth can lead to excessive decay of organic matter in the water body, loss of oxygen in the water, release of toxins in sediment, and the eventual death of aquatic organisms. Primary sources of nutrients in urban runoff are fertilizers and eroded soils.
- **Pesticides** -- Pesticides (including herbicides) are chemical compounds commonly used to control nuisance growth or prevalence of organisms. Relatively low levels of the active component of pesticides can result in conditions of aquatic toxicity. Excessive or improper application of a pesticide may result in runoff containing toxic levels of its active ingredient (OC 2003).
- **Organic Compounds** – Organic compounds are carbon-based. Commercially available or naturally occurring organic compounds are found in pesticides, solvents, and hydrocarbons. Organic compounds can, at certain concentrations, indirectly or directly constitute a hazard to life or health. When rinsing off objects, toxic levels of solvents and cleaning compounds can be discharged to storm drains. Dirt, grease, and grime retained in the cleaning fluid or rinse water may also adsorb levels of organic compounds that are harmful or hazardous to aquatic life (OC 2003).
- **Sediments** – Sediments are solid materials that are eroded from the land surface. Sediments can increase turbidity, clog fish gills, reduce spawning habitat, lower young aquatic organisms survival rates, smother bottom dwelling organisms, and suppress aquatic vegetation growth.
- **Trash and Debris** – Trash (such as paper, plastic, polystyrene packing foam, and aluminum materials) and biodegradable organic matter (such as leaves, grass cuttings, and food waste) are general waste products on the landscape. The presence of trash and debris may

have a significant impact on the recreational value of a water body and aquatic habitat. Trash impacts water quality by increasing biochemical oxygen demand.

- *Oxygen-Demanding Substances* – This category includes biodegradable organic material as well as chemicals that react with dissolved oxygen in water to form other compounds. Proteins, carbohydrates, and fats are examples of biodegradable organic compounds. Compounds such as ammonia and hydrogen sulfide are examples of oxygen-demanding compounds. The oxygen demand of a substance can lead to depletion of dissolved oxygen in a water body and possibly the development of septic conditions. A reduction of dissolved oxygen is detrimental to aquatic life and can generate hazardous compounds such as hydrogen sulfides.

- *Oil and Grease* – Oil and grease in water bodies decreases the aesthetic value of the water body, as well as the water quality. Primary sources of oil and grease are petroleum hydrocarbon products, motor products from leaking vehicles, esters, oils, fats, waxes, and high molecular-weight fatty acids.

Attachment D Flow- and Volume-Based BMP Design Calculations

TENTATIVE PARCEL MAP 20393

5.13 AC. GROSS 1 NUMBERED LOT APRIL 2021

DRAINAGE AREA	AREA	AREA	DCV	Q _{BMP}	SYSTEM #	CLARIFIER TREATMENT RATE*	PIPE DIAMETER	LENGTH OF PIPE	No. OF MAXWELL L _S	SYSTEM RETENTION VOLUME	PERCENT OF DCV
	(SQ. FT.)	(ACRE)	(CU. FT.)	(CFS)		(CFS)	(INCHES)	(FEET)	(EACH)	(CU. FT.)	(%)
DA1	201,580	4.6	21,451	1.13	1A	1.5	72	105	1	9,280	43%
							96	105	1	12,678	59%
DA2	21,692	0.5	2,308	0.12	2	0.84	60	40	0	2,325	101%
							--	250	2	24,283	102%
TOTALS	223,272	5.1	23,759	1.3							

*NOTE: DA1 CLARIFIER TO BE HYDRO INTERNATIONAL FIRST DEFENSE FD-4HC (OR APPROVED EQUAL); DA2 CLARIFIER TO BE HYDRO INTERNATIONAL FIRST DEFENSE FD-3HC (OR APPROVED EQUAL)

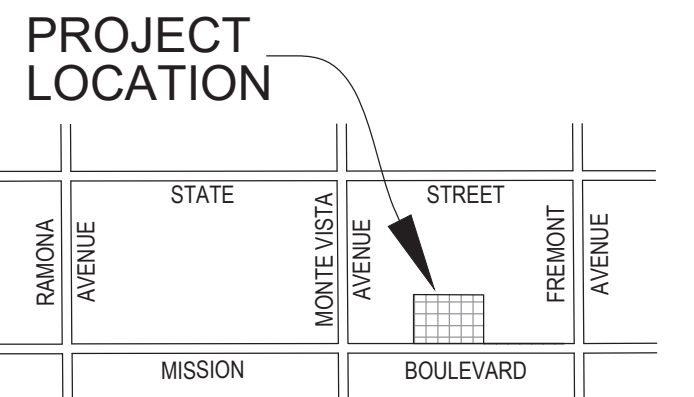

VICINITY MAP NTS

TENTATIVE PARCEL MAP 20393

5006 AND 5010 MISSION BOULEVARD

MONTCLAIR, CA. 91763

APN: 1011-311-15, 1011-311-17, 1011-311-19

LEGAL DESCRIPTION

PARCELS 1, 2, 3, AND 4 OF PARCEL MAP 3172, IN THE CITY OF MONTCLAIR, IN THE COUNTY OF SAN BERNARDINO, STATE OF CALIFORNIA, AS PER PLAT RECORDED IN BOOK 28, PAGE 84 OF PARCEL MAPS, RECORDS OF SAID COUNTY.

OWNER/APPLICANT/DEVELOPER

NIU INVESTMENT LLC., AND DON JULIAN INVESTMENT, LLC.
 1150 W. RIGGIN STREET, MONTEREY PARK, CA 91754
 CONTACT: CARY NIU
 TEL: (626) 319-5998

CIVIL ENGINEER ARCHITECT

MADOLE & ASSOCIATES, INC. 9302 PITTSBURGH AVENUE, SUITE 230
 RANCHO CUCAMONGA, CA 91730
 CONTACT: MARK BERTONE
 (909) 481-6322 ext. 120
 Email: mbertone@madoleinc.com

GAA ARCHITECTS 8811 RESEARCH DRIVE SUITE 200
 IRVINE, CA 92618
 CONTACT: ROGER DEITOS
 (949) 474-1775 ext. 237
 Email: rogerd@gaaarchitects.com

STRUCTURAL SOURCE CONTROL BMPs

RECOMMENDED INSPECTION AND MAINTENANCE SCHEDULE

BMP	RECOMMENDED MAINTENANCE	RECOMMENDED FREQUENCY
PRETREATMENT CLARIFIERS	REMOVAL OF TRASH, SEDIMENTS, DEBRIS, AND POLLUTANTS FROM SYSTEM PER MANUFACTURER'S INSTRUCTIONS	2X/YEAR BEFORE/ AFTER MAJOR STORM EVENTS
PERFORATED PIPE AND ROCK BED	MAINTAIN CLARIFIERS TO PREVENT CLOGGING OF PIPE PERFORATIONS. INSPECT PIPE SEDIMENT AND DEBRIS LOADING THROUGH ACCESS MANHOLE AND REMOVE DEBRIS AND SEDIMENT WITH VACUUM TRUCK	2X/YEAR OR AS NEEDED DEPENDING ON OBSERVED SEDIMENT LOADING
TORRENT RESOURCES MAXWELL IV DRYWELLS	REMOVAL OF TRASH, SEDIMENTS, DEBRIS, AND POLLUTANTS FROM SYSTEM PER MANUFACTURER'S INSTRUCTIONS	2X/YEAR BEFORE/ AFTER MAJOR STORM EVENTS

PARTY RESPONSIBLE FOR MAINTENANCE AND INSPECTION:

NIU INVESTMENT LLC., AND DON JULIAN INVESTMENT, LLC.
 1150 W. RIGGIN STREET, MONTEREY PARK, CA 91754
 CONTACT: CARY NIU
 TEL: (626) 319-5998

CITY OF MONTCLAIR

APPROVED: NOEL A. CASTILLO
 CITY ENGINEER DATE RCE 78044
 SHEET OF

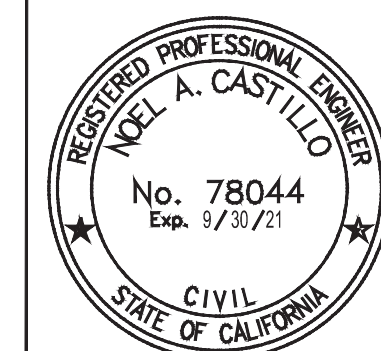

SITE DESIGN CAPTURE VOLUME SUMMARY

TREATMENT AREA = 223,272 SQ. FT. (5.1 AC.)
 IMPERVIOUSNESS = 90% (FIGURE C-4 FOR COMMERCIAL)
 IMPERVIOUS AREA = 200,945 SQ. FT.
 P (2YR-1HR) = 0.601 IN

SITE DESIGN CAPTURE VOLUME = 23,759 CU. FT.
 SITE DESIGN WATER QUALITY FLOW RATE = 1.3 CFS

PRELIMINARY WATER QUALITY NOTES:

- USE OF STRUCTURAL TREATMENT BMPs DO NOT CAUSE OR CONTRIBUTE TO AN EXCEEDANCE OF GROUND WATER QUALITY OBJECTIVES.
- SOURCE CONTROL AND POLLUTION PREVENTION CONTROL BMPs SHALL BE IMPLEMENTED TO PROTECT GROUNDWATER QUALITY. PRETREATMENT BMPs WILL BE IMPLEMENTED PRIOR TO INFILTRATION.
- NO VEHICULAR REPAIR WORK ON SITE.
- NO NEARBY KNOWN GROUNDWATER OR SOIL CONTAMINATION AREAS.
- NO WATER SUPPLY WELLS WITHIN 100 FEET OF PROPOSED INFILTRATION BMPs
- HISTORIC GROUNDWATER LEVELS DO NOT COME WITHIN 10 FEET OF THE BOTTOM OF PROPOSED STRUCTURAL INFILTRATION BMPs
- THE INFILTRATION SYSTEM SHOWN HEREON WAS DESIGNED USING A PRELIMINARY DESIGN RATE OF 10 IN/HR. UNTIL FINAL TEST RESULTS CAN BE OBTAINED THEREFORE, THE INFILTRATION SYSTEM IS SUBJECT TO CHANGE UPON FINALIZATION OF SITE SPECIFIC INFILTRATION RATES.

WATER QUALITY MITIGATION SUMMARY:

STORMWATER RUNOFF AND NUISANCE FLOWS FROM THE PROJECT SITE WILL SHEETFLOW AND GUTTERFLOW TO VARIOUS CATCH BASIN AND DRAINAGE INLETS THROUGHOUT THE PROJECT SITE. FLOWS WILL THEN BE DIRECTED TO THE SOUTHERN PROJECT BOUNDARY VIA UNDERGROUND STORM DRAIN SYSTEM. BEFORE FLOWS LEAVE THE SITE, THERE WILL BE A DIVERSION MANHOLE THAT WILL DIRECT THE WATER QUALITY VOLUME TO A PROPOSED TREATMENT AND INFILTRATION SYSTEM. WATER QUALITY AND NUISANCE FLOWS WILL FIRST ENTER A PROPOSED HYDRO INTERNATIONAL FIRST DEFENSE CLARIFIER (OR APPROVED EQUAL). THE CLARIFIER WILL REMOVE SEDIMENT, DEBRIS, TRASH, OILS, AND POLLUTANTS FROM THE RUNOFF BEFORE ROUTING IT INTO AN ADJACENT UNDERGROUND INFILTRATION SYSTEM. THE INFILTRATION SYSTEM WILL CONSIST OF A NETWORK OF 72" OR 60" DIAMETER PERFORATED PIPE, UNDERLAIN BY A GRAVEL BED. THE PERFORATED PIPE WILL SERVE AS A DETENTION SYSTEM AS THE WATER QUALITY VOLUME IS INFILTRATED INTO THE SOILS BELOW. BMP SYSTEM #1 (DA1) WILL HAVE TWO TORRENT RESOURCES MAXWELL IV DRYWELLS ATTACHED TO ASSIST IN INFILTRATION.

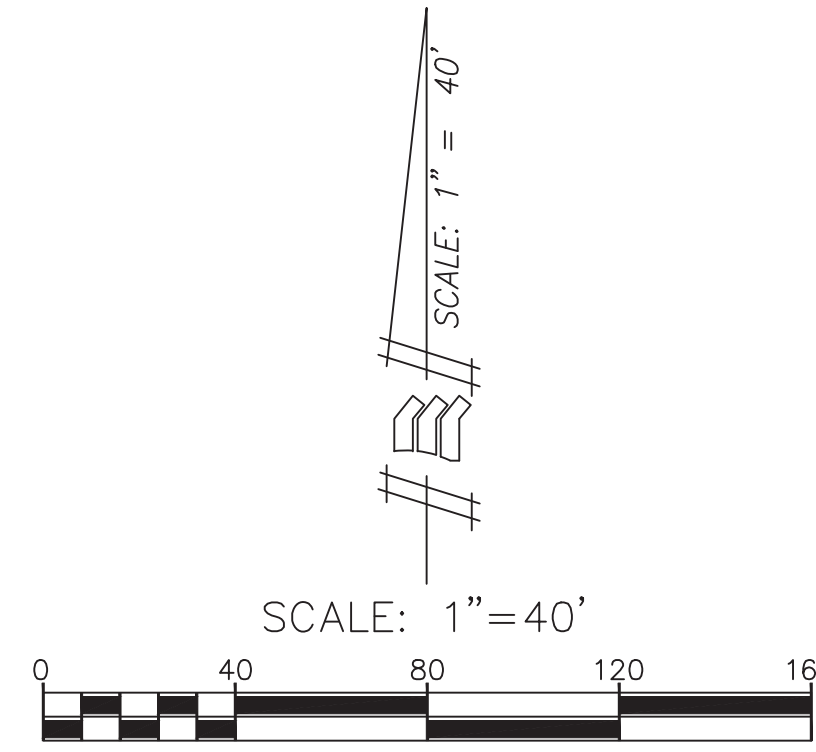

LEGEND

DA	DRAINAGE AREA
SF	SQUARE FEET
CFS	CUBIC FEET PER SECOND
PROP.	PROPOSED
SD	STORM DRAIN
---	FLOW DIRECTION
---	TREATMENT AREA BOUNDARY
---	AC PAVEMENT
---	CONCRETE PAVEMENT

EFFICIENT IRRIGATION (SD-12) - PER LANDSCAPE ARCHITECTS PLAN

NOTE: ALL STORM WATER QUALITY FLOWS FROM PERVIOUS AND IMPERVIOUS AREAS WILL BE TREATED WITHIN THE CLARIFIER BEFORE ENTERING UNDERGROUND INFILTRATION SYSTEMS.

LIST OF LID BMPs

- PRETREATMENT CLARIFIER: REMOVES TRASH, DEBRIS, SEDIMENT, AND POLLUTANTS FROM STORMWATER RUNOFF BEFORE RELEASING IT TO UNDERGROUND INFILTRATION SYSTEMS.
- PERFORATED RETENTION/ INFILTRATION PIPE AND GRAVEL TRENCH: LARGE DIAMETER PERFORATED DRAINAGE PIPES TO RETAIN WATER QUALITY RUNOFF AS IT INFILTRATES INTO THE SURROUNDING SOILS.
- TORRENT RESOURCES MAXWELL IV DRYWELLS: VERTICAL INFILTRATION TROUGH GRAVEL AT LARGE DEPTHS TO ASSIST THE PERFORATED PIPE IN DRAINAGE OF WATER QUALITY VOLUME.
- CURB OPENING / GRATED INLET FILTER INSERT: TO REMOVE FIRST FLUSH TRASH AND DEBRIS FROM STORMWATER BEFORE REACHING THE UNDERGROUND STORM DRAIN SYSTEM AND CLARIFIER.
- LANDSCAPE MANAGEMENT BMPs: EDUCATION MATERIAL TO PROPERTY OWNER'S AND CONTRACTED LANDSCAPE EMPLOYEES REGARDING LANDSCAPE AND LAWN MAINTENANCE TO PROMOTE ENVIRONMENTAL AWARENESS AND THE PROTECTION OF STORM WATER QUALITY.
- BMP MAINTENANCE: THE OWNER/DEVELOPER SHALL ARRANGE FOR THE INSPECTION, CLEANING, AND MAINTENANCE OF ALL BMPs.
- LITTER/DEBRIS CONTROL PROGRAM: EACH EMPLOYEE SHALL BE MADE AWARE OF THE USE AND RESTRICTIONS OF THE TRASH CONTAINERS TO PROTECT AND PROMOTE STORM WATER QUALITY.
- HOUSEKEEPING OF LOADING DOCKS: EMPLOYEES SHALL KEEP INDUSTRIAL FACILITIES IN A CLEAN AND ORDERLY CONDITION THROUGH REGULAT PROGRAM OF SWEEPING AND LITTER CONTROL AND IMMEDIATE CLEANUP OF SPILLS.
- CATCH BASIN INSPECTION PROGRAM: THE OWNER/DEVELOPER SHALL ARRANGE FOR THE INSPECTION AND CLEANING OF ALL DRAINAGE FACILITIES, INCLUDING COMMON AREA DRAINS, INLETS, CLARIFIERS AND CATCH BASINS INCLUDING ANY INSERTS.
- VACUUM SWEEPING OF PRIVATE STREET AND PARKING LOTS: THE OWNER/DEVELOPER AND HOA SHALL ARRANGE FOR THE INSPECTION, CLEANING, AND STREET SWEEPING OF ALL STREETS AND PEDESTRIAN ACCESSIBLE AREAS ON A MONTHLY BASIS, AT MINIMUM, OR MORE FREQUENTLY AS NEEDED.
- STORM DRAIN INLET SIGNAGE: "NO DUMPING FLOWS TO CREEK" OR CITY OF UPLAND APPROVED STENCIL, TO BE STENCILLED ON ALL CATCH BASINS. SIGNAGE TO DISCOURAGE ILLEGAL DUMPING INTO THE STORM DRAIN SYSTEM TO PROTECT WATER QUALITY AND PROMOTE ENVIRONMENTAL AWARENESS.
- TRASH AND WASTE STORAGE AREAS: OWNER/DEVELOPER AND EMPLOYEES SHALL BE MADE AWARE OF THE USE AND RESTRICTIONS OF TRASH CONTAINERS. LITTER CONTROL AND TRASH MANAGEMENT FOR ANY COMMON AREAS WILL BE PROVIDED BY THE CONTRACTED LANDSCAPED MAINTENANCE COMPANY.
- EFFICIENT IRRIGATION: EFFICIENT IRRIGATION TECHNIQUES HAVE BEEN EMPLOYED TO MAXIMIZE INFILTRATION AND TO MINIMIZE WATER LOSS, RUNOFF, AND EVAPORATION. THE FOLLOWING ARE ASPECTS OF THE IRRIGATION SYSTEM:
 - TURF DEMANDING MORE WATER SHALL BE VALVED SEPARATELY FROM SHRUBS REQUIRING LESS WATER.
 - SPRINKLER HEADS HAVE SHALL LOW PRECIPITATION RATES AND TRAJECTORIES KEEPING OVERSPRAY ONTO SIDEWALKS AND PAVEMENT AT A MINIMUM.
 - RUN TIME FOR VALVES IS DEPENDENT ON CHANGES IN SUNLIGHT, SLOPE, AND SEASONS.
 - FLOW SENSORS WILL BE USED TO MEASURE SUDDEN PRESSURE DROPS AND CONTROL WATER LOSS DUE TO BROKEN SPRINKLER HEADS OR WATER SUPPLY LINES.
 - RAIN SENSORS WILL BE USED TO ELIMINATE OR REDUCE IRRIGATION DURING TIMES OF PRECIPITATION.

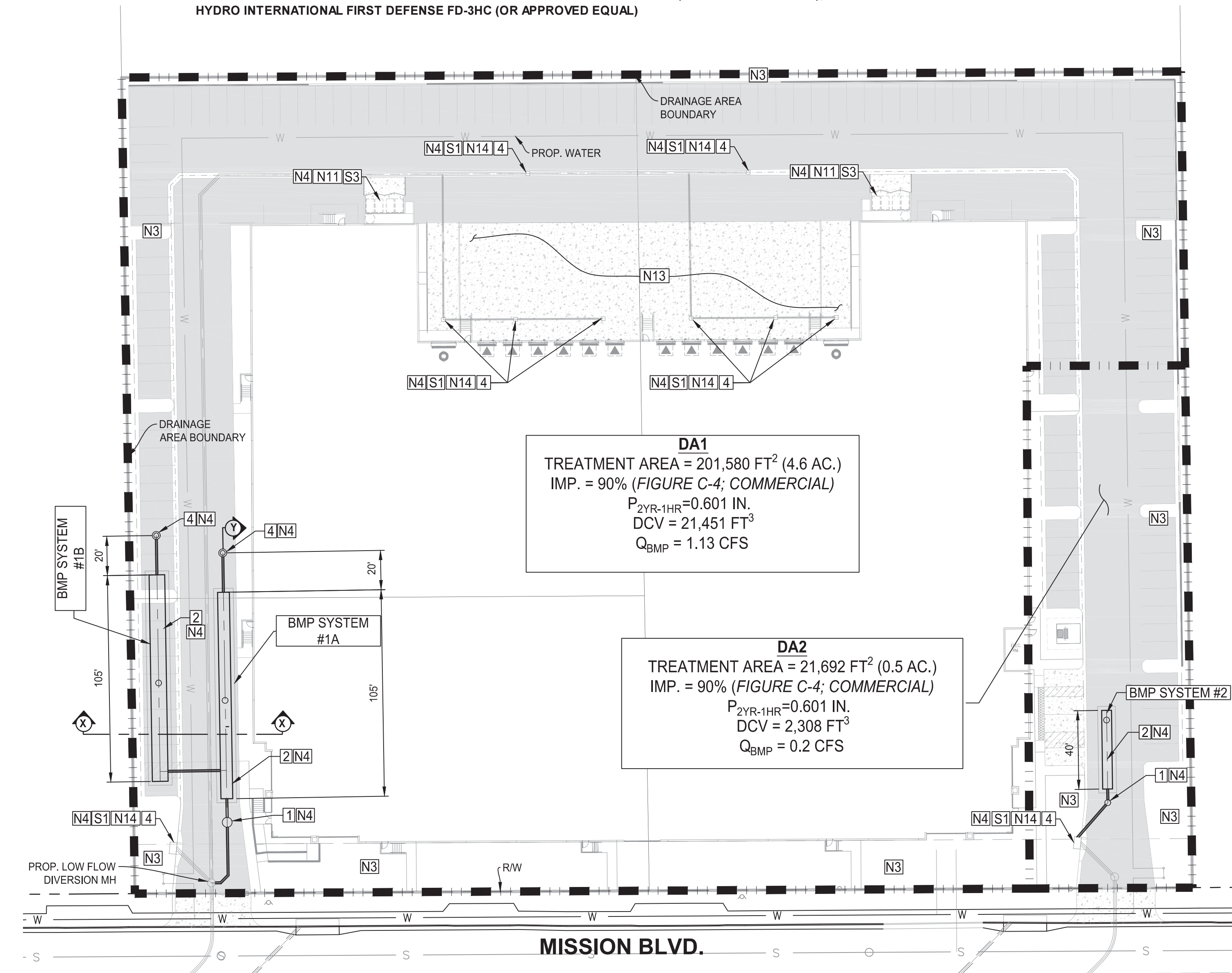

DA1
 TREATMENT AREA = 201,580 FT² (4.6 AC.)
 IMP. = 90% (FIGURE C-4; COMMERCIAL)
 P_{2YR-1HR} = 0.601 IN.
 DCV = 21,451 FT³
 Q_{BMP} = 1.13 CFS

DA2
 TREATMENT AREA = 21,692 FT² (0.5 AC.)
 IMP. = 90% (FIGURE C-4; COMMERCIAL)
 P_{2YR-1HR} = 0.601 IN.
 DCV = 2,308 FT³
 Q_{BMP} = 0.2 CFS

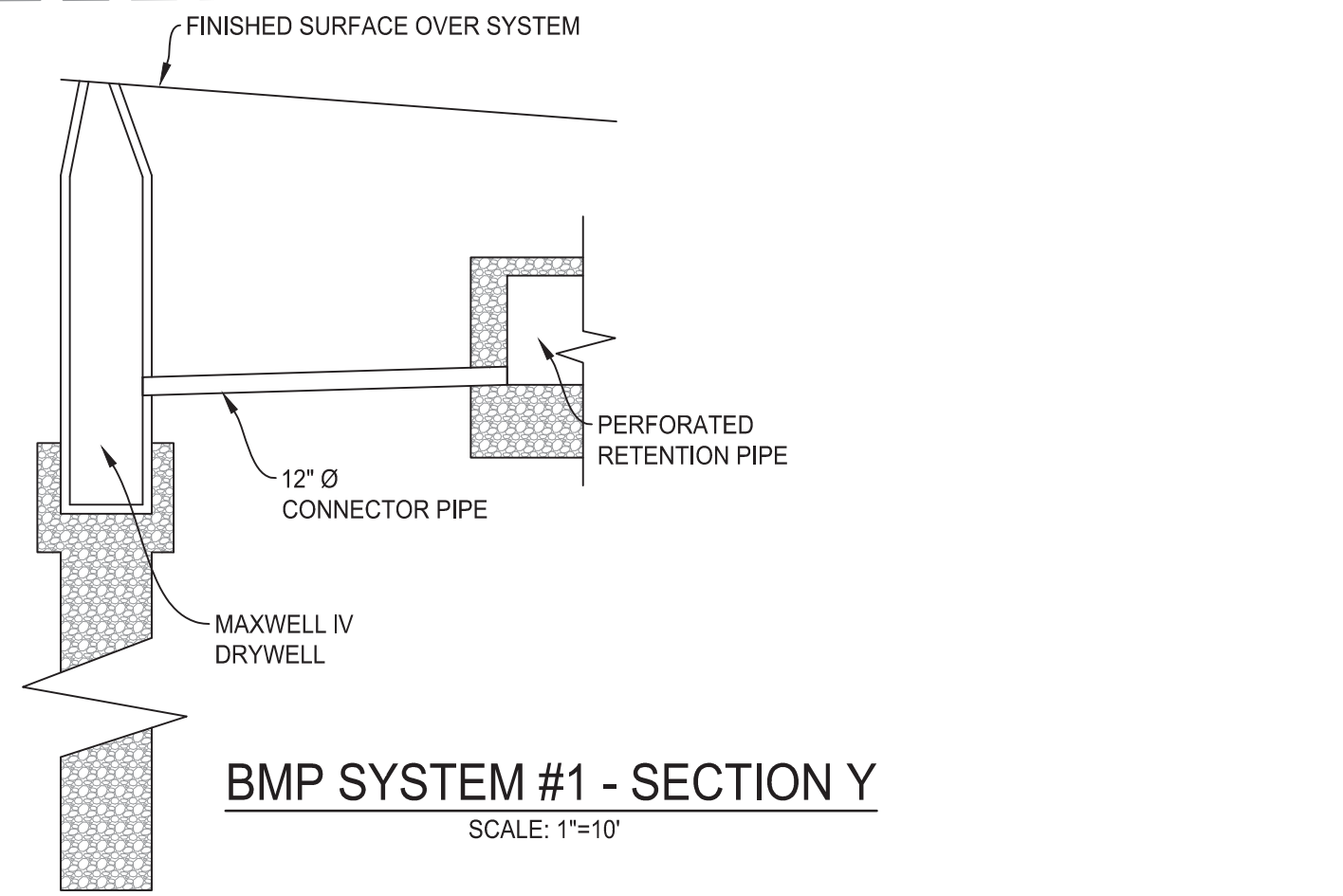
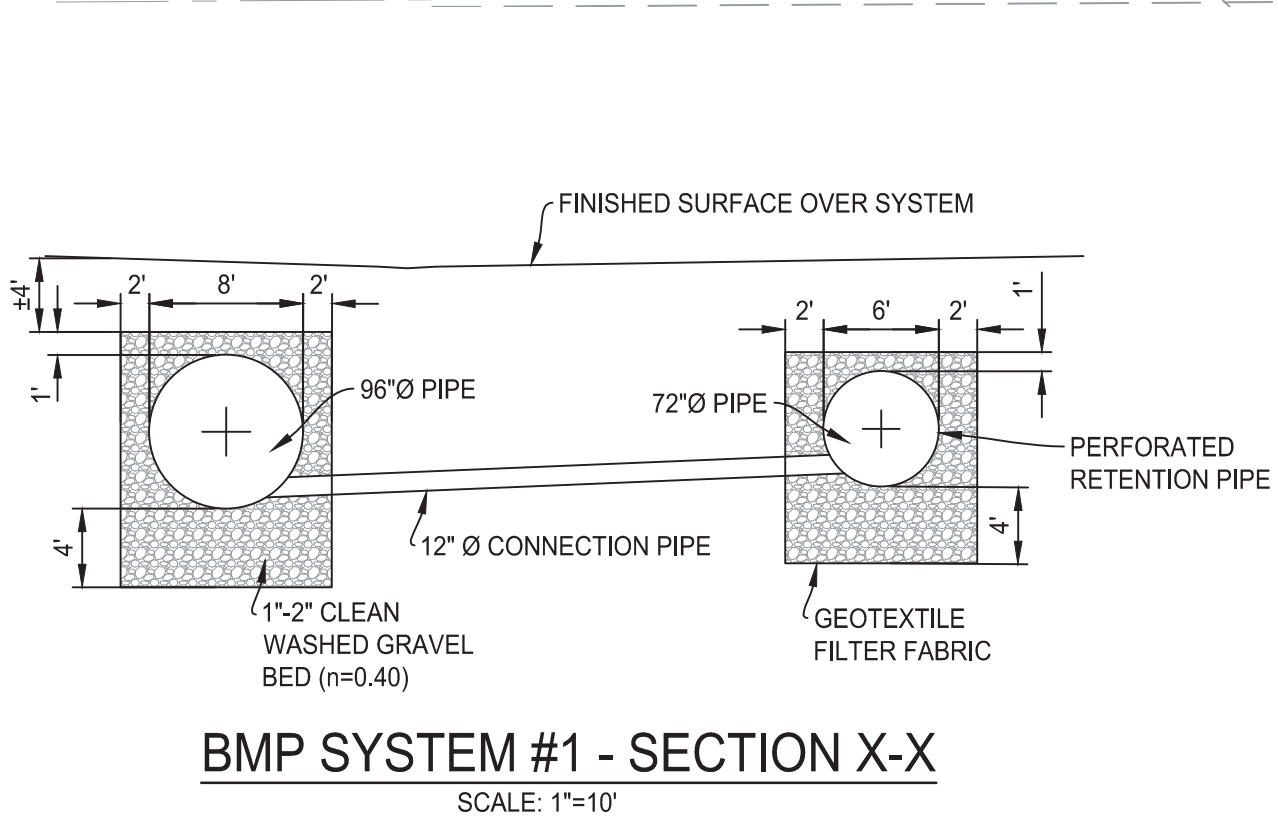

BENCHMARK No.	REVISIONS			
ELEV.	DESCRIPTION	DATE	APP.	
DESC.				

Table D-1: Volume Retention Summary

DRAINAGE AREA	AREA	AREA	DCV	Q _{BMP}	SYSTEM #	CLARIFIER TREATMENT RATE*	PIPE DIAMETER	LENGTH OF PIPE	No. OF MAXWELLS	SYSTEM RETENTION VOLUME	PERCENT OF DCV
	(SQ. FT.)	(ACRE)	(CU. FT.)	(CFS)		(CFS)	(INCHES)	(FEET)	(EACH)	(CU. FT.)	(%)
DA1	201,580	4.6	21,451	1.13	1A	1.5	72	105	1	9,280	43%
					1B		96	105	1	12,678	59%
DA2	21,692	0.5	2,308	0.12	2	0.84	60	40	0	2,325	101%
TOTALS	223,272	5.1	23,759	1.3		2	--	250	2	24,283	102%

***NOTE: DA1 CLARIFIER TO BE HYDRO INTERNATIONAL FIRST DEFENSE FD-4HC (OR APPROVED EQUAL); DA2 CLARIFIER TO BE HYDRO INTERNATIONAL FIRST DEFENSE FD-3HC (OR APPROVED EQUAL)**

BMP TARGET FLOW RATE AND DESIGN CAPTURE VOLUME - DA1

1 BMP Drainage Area **AREA 4.63 acres**
 2-yr 1-Hr. Rainfall 0.601
 Regression Coef.= 0.2787
 BMP Design Rainfall Intensity, I_{BMP} = 0.335
 Impervious Ratio= 0.900

2 Rainfall to Runoff Losses

Cover Descr.	Area	Ap (%)	C BMP	Cw
Condominium	0.0	35%	0.449	0
More than 10 DU	0.0	20%	0.599	0
8-10 DU	0.0	40%	0.409	0
5-7 DU	0.0	50%	0.339	0
3-4 DU	0.0	60%	0.280	0
Streets	0.0	10%	0.730	0
School	0.0	60%	0.280	0
Parks	0.0	85%	0.141	0
Commercial	4.6	10%	0.730	3.3812
Σ =	4.6			ΣCw = 3.3812

C_{BMP} = 0.73

3 Target BMP Flow Rate, Q
Q = $C_{BMP} \times I_{BMP} \times A$ = 1.13 c.f.s.

4 Flow Rate per Acre
 0.245 c.f.s./ac.

21451

5 Design Capture Volume
 Area = 201,580 sf
 Imp = 0.9
 R_c = 0.73
 $P_{2YR-1HR}$ = 0.60
 P_6 = 0.89
 48 hr
 Drawdown = 1.963
DCV = (1/12)*Area*R_c*P₆*1.963
DCV = 21,451 ft³
 0.49 ac-ft

TOTAL DESIGN CAPTURE VOLUME, DCV=	21,451 ft³ 0.49 ac-ft
--	---



Job: TPM 20393
 Job No. 1020-2901
 Calculated by: TGS
 Date: 7/26/2021

DA1- SYSTEM #1A, INFILTRATION RETENTION VOLUME (RESERVOIR BELOW PIPE)

*From TGD Table 5-4 - Underground infiltration (Rock bed below pipe)

P_{design}	2.8 in/hr		
T_{FILL}	3.00 hours	System Dimensions	
η	0.40	Length	107 ft
SA_{inf} (BOTTOM ONLY)	1,070 ft ²	Width	10 ft
SA_{res}	1,070 ft ²	D_{res} (rock)	4 ft
d_{res}	4 ft		

$$V_{RET} = ((P_{des}/12)*SA_{INF}*T_{fill})+(SA_{RES}*d_{RES}*\eta)$$

$$V_{RET} = 2,461 \text{ ft}^3$$

DA1- SYSTEM #1A, PIPE RETENTION VOLUME

PIPE DIAMETER = 6 FT
 PIPE LENGTH = 105 FT

$$\text{PIPE RETENTION VOLUME} = 2,969 \text{ FT}^3$$

DA1 - SYSTEM #1A - ADDITIONAL ROCK VOLUME (INVERT TO TOP OF ROCK)

DEPTH OF ROCK= 6 FT
 TRENCH AREA = 1,070 ft²
 PIPE VOLUME (W/ O.D.)= 3129 ft³
 $\eta = 0.40$

$$\text{ROCK RETENTION VOLUME} = (d*A-V)*\eta = 1,316 \text{ FT}^3$$

DA1 -SYSTEM #1A- INJECTION WELL RETENTION VOLUME -

$P_{existing}$ 2.8 in/hr
 P_{design} 0.00006 FT/SEC
 T_{FILL} 24.00 hours
 D_{INF} 35 FT
 $SA_{INF} = D_{INF}*12.57 +12.57 = 452.52 \text{ FT}^2$

$$3 \text{ HOUR VOLUME} = P_{DESIGN}*SA_{INF}*T_{FILL} = 2,534 \text{ FT}^3$$

DA1 - SYSTEM #1A - TOTAL SYSTEM RETENTION VOLUME

$$V_{RET} = 9,280 \text{ FT}^3 \quad 43\%$$



Engineering Communities for Life

Job: TPM 20393
 Job No. 1020-2901
 Calculated by: TGS
 Date: 7/26/2021

DA1- SYSTEM #1B, INFILTRATION RETENTION VOLUME (RESERVOIR BELOW PIPE)

*From TGD Table 5-4 - Underground infiltration (Rock bed below pipe)

P _{design}	2.8 in/hr	System Dimensions	
T _{FILL}	3.00 hours	Length	107 ft
η	0.40	Width	12 ft
SA _{inf} (BOTTOM ONLY)	1,284 ft ²	D _{res} (rock)	4 ft
SA _{res}	1,284 ft ²		
d _{res}	4 ft		

$$V_{RET} = ((P_{des}/12)*SA_{INF}*T_{fill})+(SA_{RES}*d_{RES}*η)$$

$$V_{RET} = 2,953 \text{ ft}^3$$

DA1- SYSTEM #1B, PIPE RETENTION VOLUME

PIPE DIAMETER = 8 FT
 PIPE LENGTH = 105 FT

$$\text{PIPE RETENTION VOLUME} = 5,278 \text{ FT}^3$$

DA1 - SYSTEM #1B - ADDITIONAL ROCK VOLUME (INVERT TO TOP OF ROCK)

DEPTH OF ROCK= 8 FT
 TRENCH AREA = 1,284 ft²
 PIPE VOLUME (W/ O.D.)= 5491 ft³
 η = 0.40

$$\text{ROCK RETENTION VOLUME} = (d*A-V)*η = 1,912 \text{ FT}^3$$

DA1 -SYSTEM #1B- INJECTION WELL RETENTION VOLUME

P_{existing} 2.8 in/hr
 P_{design} 0.00006 FT/SEC
 T 24.00 hours
 D_{INF}= 35 FT
 SA_{INF} = D_{INF}*12.57 +12.57 = 452.52 FT²

$$3 \text{ HOUR VOLUME} = P_{DESIGN}*SA_{INF}*T = 2,534 \text{ FT}^3$$

DA1 - SYSTEM #1B - TOTAL SYSTEM RETENTION VOLUME

V _{RET} =	12,678 FT ³	59%
--------------------	------------------------	-----

SYSTEM #1A + SYSTEM #1B =	21,958 FT ³	102%
---------------------------	------------------------	------



Engineering Communities for Life

Job TPM 20393

1020-2901

Sheet No. 1 of 1
 Calculated by: TGS Date 7/1/21
 Checked by: Date
 Scale N/A

BMP TARGET FLOW RATE AND DESIGN CAPTURE VOLUME - DA2

1 BMP Drainage Area

AREA 0.50 acres

2-yr 1-Hr. Rainfall 0.601
 Regression Coef.= 0.2787
 BMP Design Rainfall Intensity, I_{BMP} = 0.335
 Impervious Ratio= 0.500

2 Rainfall to Runoff Losses

Cover Descr.	Area	Ap (%)	C _{BMP}	C _w
Condominium	0.0	35%	0.449	0
More than 10 DU	0.0	20%	0.599	0
8-10 DU	0.0	40%	0.409	0
5-7 DU	0.0	50%	0.339	0
3-4 DU	0.0	60%	0.280	0
Streets	0.0	10%	0.730	0
School	0.0	60%	0.280	0
Parks	0.0	85%	0.141	0
Commercial	0.5	10%	0.730	0.365
Σ =	0.5		ΣC_{w} =	0.365

C_{BMP} = 0.73

3 Target BMP Flow Rate, Q

Q = $C_{BMP} \times I_{BMP} \times A =$ **0.12** c.f.s.

4 Flow Rate per Acre

0.245 c.f.s./ac.

5 Design Capture Volume

Area = 21,692 sf
 Imp = 0.9
 R_c = 0.73
 P_{2YR-1HR} = 0.60
 P₆ = 0.89
 48 hr
 Drawdown = 1.963

DCV = (1/12)*AreaR_c*P₆*1.963**

DCV = 2,308 ft³
 0.05 ac-ft

**DA1 TOTAL DESIGN CAPTURE VOLUME = 2,308 ft³
 0.05 ac-ft**



Job: TPM 20393
 Job No. 1020-2901
 Calculated by: TGS
 Date: 7/26/2021

DA2- SYSTEM #2, INFILTRATION RETENTION VOLUME (RESERVOIR BELOW PIPE)			
*From TGD Table 5-4 - Underground infiltration (Rock bed below pipe)			
P_{design}	2.8 in/hr		
T_{FILL}	3.00 hours	System Dimensions	
η	0.40	Length	44 ft
SA_{inf} (BOTTOM ONLY)	440 ft ²	Width	10 ft
SA_{res}	440 ft ²	D_{res} (rock)	4 ft
d_{res}	4 ft		
$V_{RET} = ((P_{des}/12)*SA_{INF}*T_{fill})+(SA_{RES}*d_{RES}*\eta)$			
$V_{RET} = 1,012 \text{ ft}^3$			
DA2- SYSTEM #2, PIPE RETENTION VOLUME			
PIPE DIAMETER =		5 FT	
PIPE LENGTH =		40 FT	
$\text{PIPE RETENTION VOLUME} = 785 \text{ FT}^3$			
DA2 - SYSTEM #2 - ADDITIONAL ROCK VOLUME (INVERT TO TOP OF ROCK)			
DEPTH OF ROCK=		5 FT	
TRENCH AREA =		440 ft ²	
PIPE VOLUME (W/ O.D.)=		836 ft ³	
η =		0.40	
$\text{ROCK RETENTION VOLUME} = (d*A)-V*\eta = 545 \text{ FT}^3$			
DA2 - SYSTEM #2 - TOTAL SYSTEM RETENTION VOLUME			
$V_{RET} = 2,343 \text{ FT}^3 \quad 101\%$			

Figure D-1: NOAA Atlas 14 Inset Map.

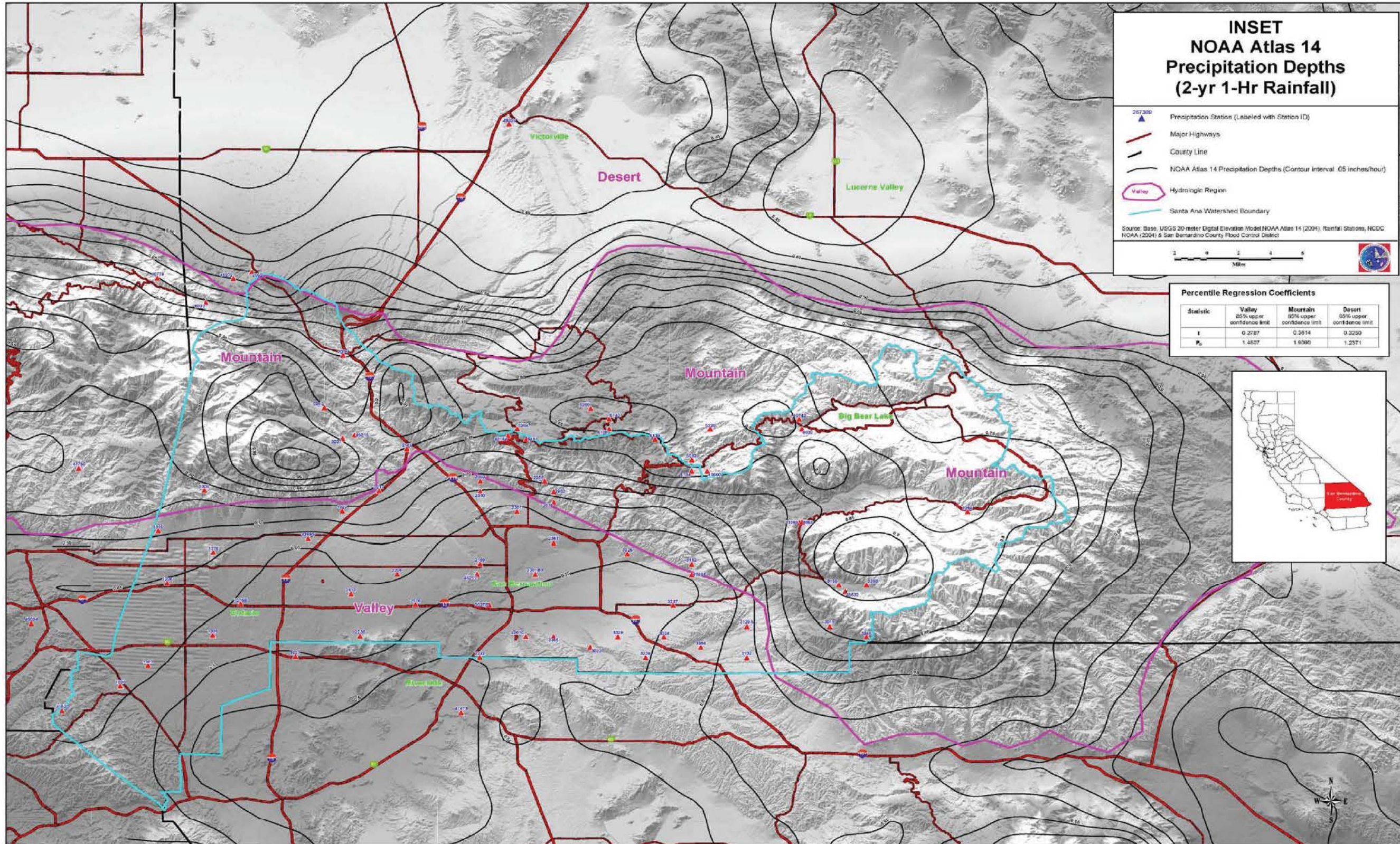

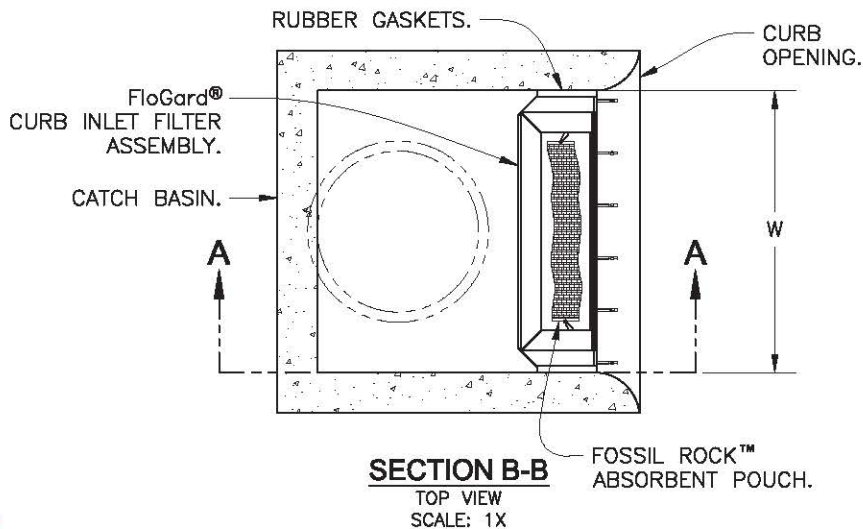
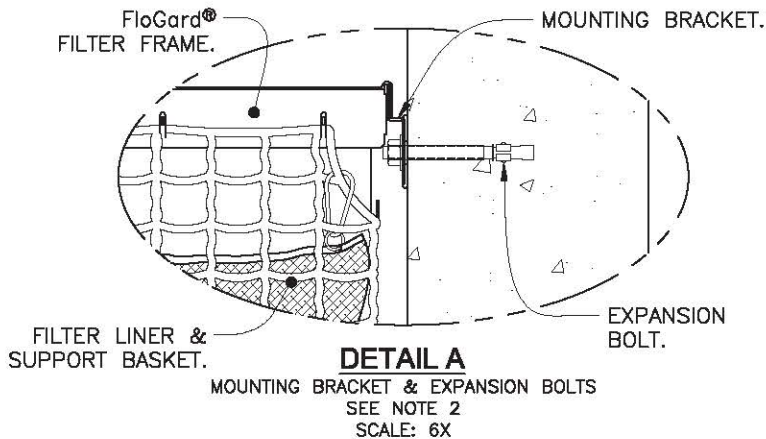

SPECIFIER CHART				
MODEL NO.	Curb Opening Width - W -	Storage Capacity - Cu. Ft. -	Filtered Flow Rate - GPM/CFS -	Bypass Flow Rate - GPM/CFS -
FGP-24CI	2.0' (24")	.95	338 / .75	2,513 / 5.6
FGP-30CI	2.5' (30")	1.20	450 / 1.00	3,008 / 6.7
FGP-36CI	3.0' (36")	1.50	563 / 1.25	3,547 / 7.9
FGP-42CI	3.5' (42")	1.80	675 / 1.50	3,951 / 8.8
FGP-48CI	4.0' (48")	2.10	768 / 1.76	4,445 / 9.9
FGP-5.0CI	5.0' (60")	2.40	900 / 2.00	5,208 / 11.6
FGP-6.0CI	6.0' (72")	3.05	1,126 / 2.51	6,196 / 13.8
FGP-7.0CI	7.0' (84")	3.65	1,350 / 3.01	7,139 / 15.9
FGP-8.0CI	8.0' (96")	4.25	1,576 / 3.51	8,082 / 18.0
FGP-10.0CI	10.0' (120")	4.85	1,800 / 4.01	9,833 / 21.9
FGP-12.0CI	12.0' (144")	6.10	2,252 / 5.02	11,764 / 26.2
FGP-14.0CI	14.0' (168")	7.30	2,700 / 6.02	13,515 / 30.1
FGP-16.0CI	16.0' (192")	8.55	3,152 / 7.02	15,446 / 34.4
FGP-18.0CI	18.0' (216")	9.45	3,490 / 7.78	17,152 / 38.2
FGP-21.0CI	21.0' (252")	10.95	4,050 / 9.02	19,891 / 44.3
FGP-28.0CI	28.0' (336")	14.60	5,400 / 12.03	26,311 / 58.6

NOTES:

1. Filter insert shall have a high flow bypass feature.
2. Filter support frame shall be constructed from stainless steel Type 304.
3. Filter medium shall be *Fossil Rock™*, installed and maintained in accordance with manufacturer specifications.
4. Storage capacity reflects 80% of maximum solids collection prior to impeding filtering bypass.

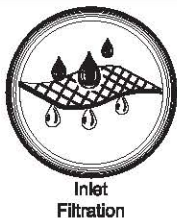
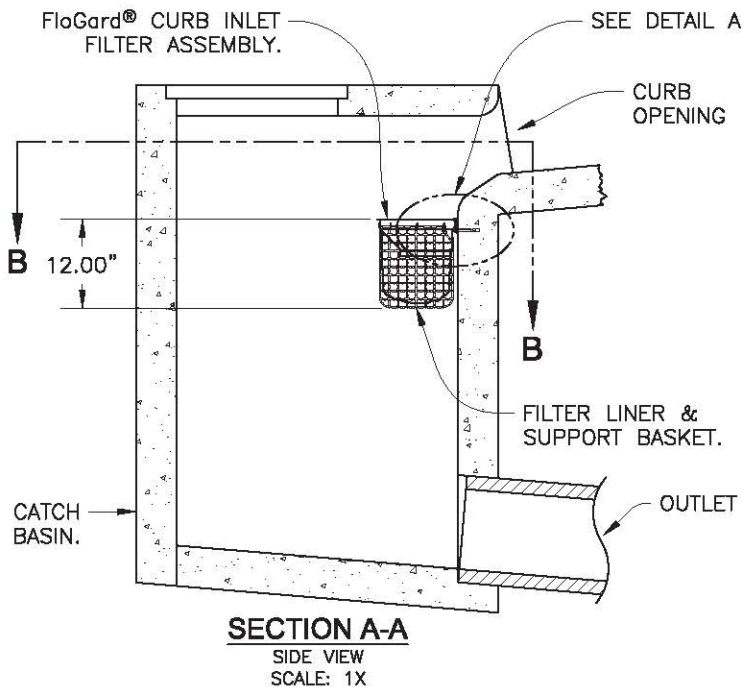

FloGard®
Catch Basin Insert Filter
Curb Inlet Style



Oldcastle®
Stormwater Solutions

7921 Southpark Plaza, Suite 200 | Littleton, CO | 80120 | Ph: 800.579.8819 | oldcastlestormwater.com
THIS DOCUMENT IS THE PROPERTY OF OLDCASTLE PRECAST, INC. IT IS SUBMITTED FOR REFERENCE PURPOSES ONLY AND SHALL NOT BE USED IN ANY WAY INJURIOUS TO THE INTERESTS OF SAID COMPANY. COPYRIGHT © 2010 OLDCASTLE PRECAST, INC. ALL RIGHTS RESERVED.

DRAWING NO.	REV	ECO	DATE	SHEET
FGP-0002	E	ECO-0127	JPR 1/3/06	1 OF 1