

---

# **Appendix K-5**

## Traffic Analysis





**Wiley Canyon Mixed-Use Traffic  
Analysis**

Santa Clarita, California

July 11, 2022

Prepared for:

Wiley Canyon, LLC

Prepared by:

Stantec Consulting Services Inc.



## WILEY CANYON MIXED-USE TRAFFIC ANALYSIS

This document entitled Wiley Canyon Mixed-Use Traffic Analysis was prepared by Stantec Consulting Services Inc. ("Stantec") for the account of Wiley Canyon, LLC (the "Client").

Prepared by   
(signature)

**Cathy Lawrence, PE**

Transportation Engineer

(949) 923-6064

Reviewed by   
(signature)

**Daryl Zerfass, PE, PTP**

Principal, Transportation Planning and Traffic Engineering

(949) 923-6058





## Table of Contents

<b>1.0</b>	<b>INTRODUCTION.....</b>	<b>1.1</b>
1.1	PROPOSED PROJECT.....	1.1
1.2	STUDY AREA.....	1.1
1.3	METHODOLOGY.....	1.4
1.4	PERFORMANCE CRITERIA.....	1.4
1.5	DEFINITIONS.....	1.8
1.6	REFERENCES.....	1.8
<b>2.0</b>	<b>TRANSPORTATION SETTING.....</b>	<b>2.1</b>
2.1	EXISTING CONDITIONS.....	2.1
2.1.1	Existing Roadway System.....	2.1
2.1.2	Existing Traffic Volumes and Levels of Service.....	2.3
2.1.3	Public Transportation.....	2.6
2.1.4	Active Transportation.....	2.6
2.2	FUTURE CONDITIONS.....	2.9
2.2.1	Future Land Use Development.....	2.9
2.2.2	Future Traffic Volumes.....	2.9
<b>3.0</b>	<b>PROJECT DESCRIPTION.....</b>	<b>3.1</b>
3.1	PROJECT TRIP GENERATION.....	3.1
3.2	PROJECT TRIP DISTRIBUTION.....	3.2
<b>4.0</b>	<b>IMPACT ANALYSIS.....</b>	<b>4.1</b>
4.1	EXISTING PLUS PROJECT ANALYSIS.....	4.1
4.1.1	Peak Hour Intersection Levels of Service.....	4.1
4.1.2	Existing Plus Project Conditions Off-Site Improvements.....	4.5
4.2	INTERIM YEAR CUMULATIVE CONDITIONS ANALYSIS.....	4.5
4.2.1	Peak Hour Intersection Levels of Service.....	4.11
4.2.2	Interim Year Cumulative Plus Project Conditions Off-Site Improvements.....	4.13
4.3	VEHICLE MILES TRAVELED.....	4.13
4.4	ACTIVE TRANSPORTATION.....	4.13
<b>5.0</b>	<b>FINDINGS AND CONCLUSIONS.....</b>	<b>5.1</b>



# WILEY CANYON MIXED-USE TRAFFIC ANALYSIS

## LIST OF TABLES

Table 1-1	Level of Service Descriptions for Signalized and Unsignalized Intersections.....	1.5
Table 1-2	Arterial Intersection Performance Criteria.....	1.7
Table 2-1	Intersection LOS Summary – Existing Conditions .....	2.3
Table 3-1	Project Trip Generation Summary .....	3.1
Table 4-1	Intersection Delay and LOS Summary – Existing Plus Project Conditions.....	4.4
Table 4-2	Off-Site Improvements for Project Effects – Existing Plus Project Conditions.....	4.6
Table 4-3	Intersection Delay and LOS Summary – Existing Plus Project Conditions with Off-Site Improvements.....	4.6
Table 4-4	Intersection Delay and LOS Summary – Interim Year Cumulative Conditions.....	4.12
Table 4-5	Off-Site Improvements for Project Effects – Interim Year Cumulative Conditions .....	4.14
Table 4-6	Intersection Delay and LOS Summary – Interim Year Cumulative Conditions with Off-Site Improvements.....	4.14
Table 5-1	Off-Site Improvement Summary .....	5.1

## LIST OF FIGURES

Figure 1-1	Project Site and Study Area .....	1.2
Figure 1-2	Project Site Plan .....	1.3
Figure 2-1	Existing Intersection Lane Configuration and Traffic Control.....	2.2
Figure 2-2	Existing ADT and AM Peak Hour Volumes.....	2.4
Figure 2-3	Existing PM Peak Hour Volumes .....	2.5
Figure 2-4	Existing Transit Facilities.....	2.7
Figure 2-5	Existing Bicycle Facilities .....	2.8
Figure 2-6	Related Projects Location Map .....	2.10
Figure 3-1	Project Trip Distribution.....	3.3
Figure 3-2	Project-Only Trips – AM Peak Hour .....	3.4
Figure 3-3	Project-Only Trips – PM Peak Hour .....	3.5
Figure 4-1	Existing Plus Project ADT and AM Peak Hour Volumes.....	4.2
Figure 4-2	Existing Plus Project PM Peak Hour Volumes.....	4.3
Figure 4-3	Interim Year No-Project Conditions ADT and AM Peak Hour Volumes .....	4.7
Figure 4-4	Interim Year No-Project Conditions PM Peak Hour Volumes .....	4.8
Figure 4-5	Interim Year with-Project Conditions ADT and AM Peak Hour Volumes.....	4.9
Figure 4-6	Interim Year with-Project Conditions PM Peak Hour Volumes.....	4.10

## LIST OF APPENDICES

APPENDIX A	TRAFFIC COUNTS.....	A.1
APPENDIX B	INTERSECTION LOS WORKSHEETS.....	B.1
APPENDIX C	PEAK HOUR SIGNAL WARRANT EXHIBITS.....	C.1
APPENDIX D	SCVCTM SELECT ZONE MODEL PLOT .....	D.1



# WILEY CANYON MIXED-USE TRAFFIC ANALYSIS

Introduction  
July 2022

## 1.0 INTRODUCTION

This report presents the findings of a traffic study conducted to determine the potential traffic effects and environmental impacts of the proposed Wiley Canyon Mixed-Use development (Project) located in the southwest portion of the City of Santa Clarita, California. This report is consistent with the City of Santa Clarita transportation analysis guidelines which specify preparation of a Local Transportation Analysis (LTA) as well as a California Environmental Quality Act (CEQA) impact analysis.

### 1.1 PROPOSED PROJECT

The proposed Project consists of approximately 379 multifamily residential units, 8,914 square feet of commercial retail development, and a 217-unit Senior living facility that includes 130 Independent Living units, 61 Assisted Living units, and 26 Memory Care units in the City of Santa Clarita. It also includes a publicly accessible outdoor recreational space. The approximately 32-acre site is primarily undeveloped with two structures and two driveways on its northern end. The site is located on the west side of Wiley Canyon Road, just north of Calgrove Boulevard. The Project site is bordered by a mobile home park to the north, undeveloped land and single-family dwellings to the east and south, and Interstate 5 (I-5) to the west. The location of the Project site is illustrated in **Figure 1-1**. Access to the Project would be provided by a private street connected to Wiley Canyon Road south of Wabuska Street, and emergency vehicle access is proposed via Hawkbryn Avenue. The Project's site plan is shown in **Figure 1-2**.

### 1.2 STUDY AREA

The study area for the local roadway network is shown in the previously referenced **Figure 1-1**. The study intersections are determined based on the anticipated distribution of 50 or more Project generated trips added to the intersection. In consultation with City staff, the following four signalized intersections and five unsignalized intersections, in addition to the proposed Project access intersection, were selected to be analyzed in the traffic study:

1. I-5 Southbound Ramps & Pico Canyon Road (Signalized)
2. I-5 Southbound On-Ramp & Pico Canyon Road/Lyons Avenue (Unsignalized)
3. I-5 Northbound Ramps & Lyons Avenue (Signalized)
4. Wiley Canyon Road & Lyons Avenue (Signalized)
5. Wiley Canyon Road & La Glorita Circle/Evans Avenue (Signalized)
6. Wiley Canyon Road & Wabuska Street (Unsignalized)
7. I-5 Southbound Ramps & Calgrove Boulevard (Unsignalized)
8. I-5 Northbound Ramps & Calgrove Boulevard (Unsignalized)
9. Wiley Canyon Road & Calgrove Boulevard (Unsignalized/*Future Roundabout*)
10. Wiley Canyon Road & Project Driveway (*Proposed Roundabout*)





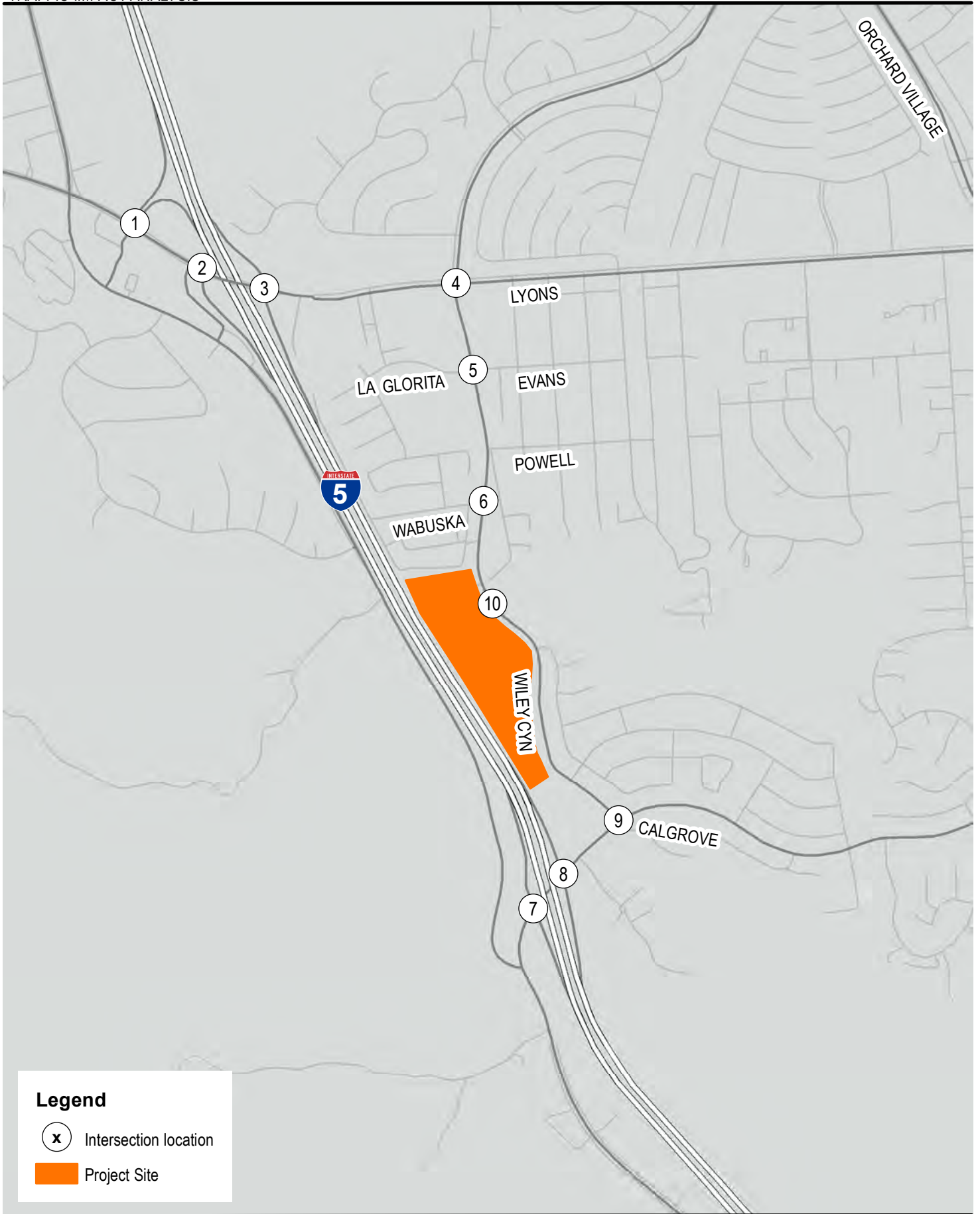

C:\Users\emazzella\Documents\ArcGIS\Projects\location-2018-updated\_0250E1D9-8F94-44CB-8719-648DF3D18B75\106\location-2018.mxd

**Legend**



-  Intersection location
-  Project Site

Figure 1-1  
Project Site and Study Area  
1.2







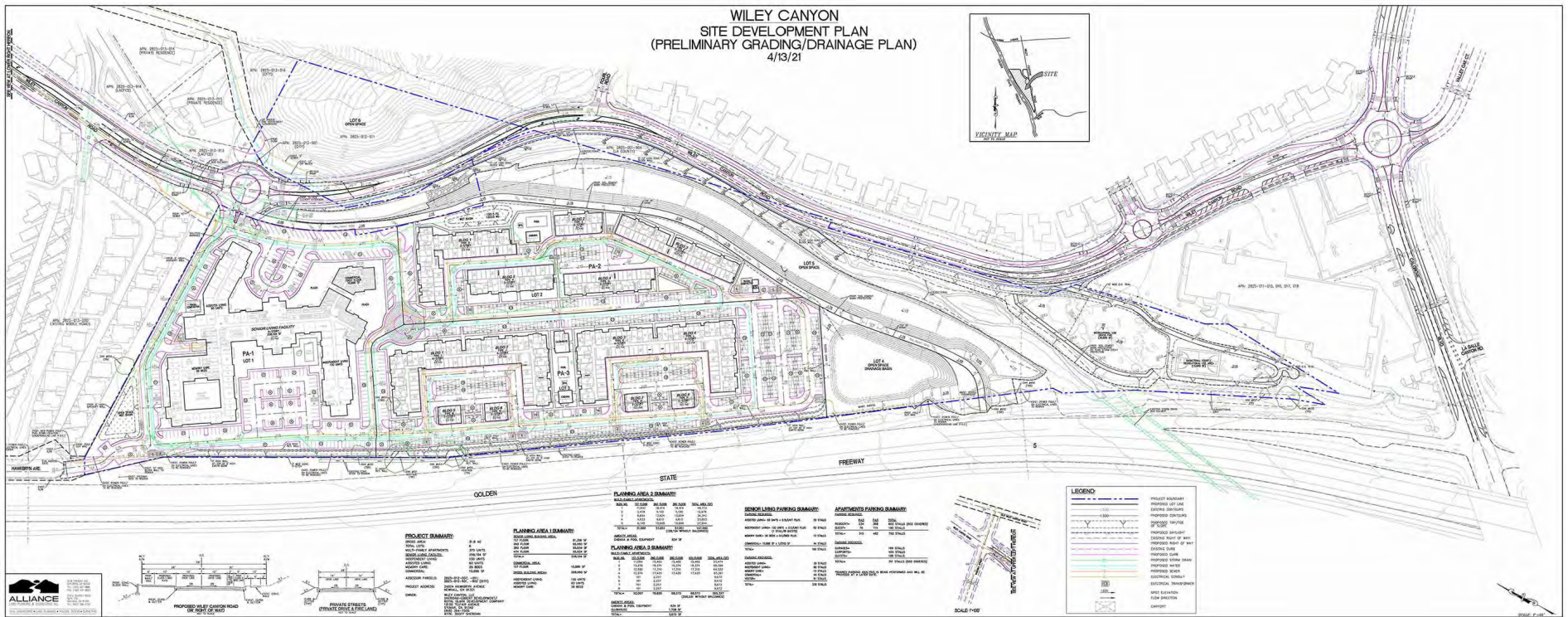

v:\204\active\204-2805700\drawing\exhibit\_files\site\_plan.dwg

Source: Alliance Land Planning and Engineering Inc.



**Figure 1-2**  
Project Site Plan  
1.3





# WILEY CANYON MIXED-USE TRAFFIC ANALYSIS

Introduction  
July 2022

## 1.3 METHODOLOGY

This traffic study evaluates the proposed Project utilizing the established traffic analysis guidelines of the City of Santa Clarita (See Reference 4 in Section 1.6). The scenarios analyzed are as follows:

- Existing conditions without Project
- Existing conditions with Project
- Interim Year Cumulative (2028) conditions without Project
- Interim Year Cumulative (2028) conditions with Project

The Existing Conditions scenario utilizes observed traffic counts collected for the intersections in the study area in March 2021 and adjusted to account for COVID-19 conditions as discussed in Section 2.1.2. The Interim Year Cumulative Conditions scenario considers traffic generated by all known and reasonably anticipated related projects in the proximity of the study area.

The Santa Clarita Valley is a growing area with numerous proposed, approved, and pending projects (i.e., “Related Projects”). The Interim Year cumulative conditions scenario is based on forecasts derived using the Santa Clarita Valley Consolidated Traffic Model (SCVCTM) as the model has the capability of forecasting the complex interaction of vehicle trips between existing and future land uses.

The SCVCTM was developed jointly by the County of Los Angeles Department of Public Works and the City of Santa Clarita and is the primary tool used for forecasting traffic volumes for the Santa Clarita Valley. The SCVCTM has the ability to provide traffic volume forecasts for a long-range setting, which represents buildout conditions (generally considered as year 2035 or later), as well as Interim Year forecasts that are based on a defined list of planned, approved, and pending projects. The SCVCTM is regularly updated and is based on the currently approved General Plans of the County and City of Santa Clarita.

## 1.4 PERFORMANCE CRITERIA

Defined performance criteria are utilized to determine if a proposed project would cause intersection operations to be significantly affected. Performance criteria are typically based on two primary measures. The first is “capacity”, which establishes the vehicle carrying ability of a roadway, and the second is “volume.” The volume measure is either a traffic count (in the case of existing volumes) or a forecast for a future point in time. For arterial roadways in an urban or suburban setting, the intersection of two roadways will typically be the limiting factor regarding the overall capacity of the roadway network.





Methodology outlined in the 2010 Highway Capacity Manual (HCM 2010) produces estimates of average vehicle delay as a function of intersection capacity and the volume of traffic passing through the intersection and is the methodology specified in the City’s guidelines. From this a corresponding level of service (LOS) is defined. Traffic LOS is designated “A” through “F” with LOS “A” representing free flow conditions and LOS “F” representing severe traffic congestion. **Table 1-1** summarizes the ranges of vehicle delay that correspond to LOS “A” through “F” for arterial roads and intersections. The ranges are those defined in the HCM 2010 and are used by the City of Santa Clarita for estimating intersection LOS.

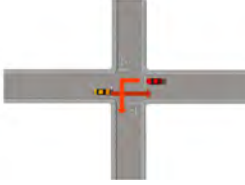

# WILEY CANYON MIXED-USE TRAFFIC ANALYSIS

Introduction  
July 2022

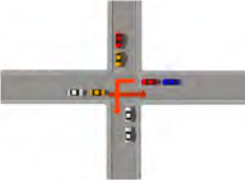
**Table 1-1 Level of Service Descriptions for Signalized and Unsignalized Intersections**

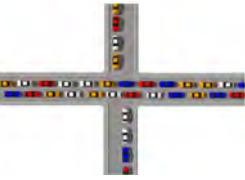
LOS	Traffic Flow Description	Signal Control Delay	Stop Control Delay
A	 <p>Minimal or no vehicle delay</p>	$\leq 10$	$\leq 10$
B	 <p>Slight delay to vehicles</p>	$> 10 - 20$	$> 10 - 15$
C	 <p>Moderate vehicle delays, traffic flow remains stable</p>	$> 20 - 35$	$> 15 - 25$
D	 <p>More extensive delays at intersections</p>	$> 35 - 55$	$> 25 - 35$
E	 <p>Long queues create lengthy delays</p>	$> 55 - 80$	$> 35 - 50$
F	 <p>Severe delays and congestion</p>	$> 80$	$> 50$

Source: HCM 2010  
Delay = average seconds of delay per vehicle



## WILEY CANYON MIXED-USE TRAFFIC ANALYSIS

Introduction  
July 2022

While average daily traffic (ADT) is a useful measure to show general levels of traffic on a facility and to provide data for other related aspects such as noise and greenhouse gas (GHG) emissions, congestion is largely a peak hour or peak period occurrence, and ADT does not reflect peak period conditions very effectively. Because of this, ADT is not used here as the basis for capacity evaluation. Instead, this evaluation focuses on the parts of the day when such congestion can occur, specifically the AM and PM peak hours.

For the arterial system, the peak hour is the accepted time period used for impact evaluation and a number of techniques are available to define intersection LOS. Both the level of delay and the LOS are used in determining significant effects. Certain LOS values are deemed undesirable by the City and increases in delay that cause or contribute to the LOS being undesirable are defined as a significant effect. These definitions and procedures are established by individual local jurisdictions, such as the City of Santa Clarita.

Levels of service for arterial roadway intersections are determined based on operating conditions during the AM and PM peak hours and the geometric configuration of the intersection. HCM delay methodology was used to analyze both the signalized intersections and the stop-controlled intersections. Synchro software was used to calculate the intersection delay and LOS. For signalized intersections, optimized signal timing/phasing was assumed for existing and future scenarios. The result of these calculations is an estimate of average vehicle delay at the intersection. The delay calculation methodology utilized by Synchro is based on the intersection capacity analysis methodology outlined in the HCM 2010.

To assess the LOS for the roundabout, specialized software (Sidra Intersection) was used. Sidra Intersection is a micro-analytical modeling software widely accepted for roundabout analysis and is recognized by the HCM 2010 and the Transportation Resource Board-Federal Highway Administration (TRB-FHWA) Roundabout Guide.

The HCM 2010 calculation methodology and associated LOS performance standards used in this analysis are summarized in **Table 1-2**.



# WILEY CANYON MIXED-USE TRAFFIC ANALYSIS

Introduction  
July 2022

**Table 1-2 Arterial Intersection Performance Criteria**

<p><b>Delay Methodology</b></p> <p><b>Calculation Methodology</b></p> <p>Level of service based on “average vehicle delay” calculated as follows:</p> <ul style="list-style-type: none"><li>- Synchro/HCM delay-based intersection methodology for traffic signals</li><li>- HCM 2010 delay-based intersection methodology for stop sign control</li><li>- Sidra delay-based intersection methodology for roundabouts</li></ul> <p><b>Performance Standard</b></p> <p>Level of Service D defined as follows:</p> <ul style="list-style-type: none"><li>- stopped delay to not exceed 55 seconds for signalized intersections</li><li>- stopped delay to not exceed 35 seconds for stop sign control</li><li>- stopped delay to not exceed 50 seconds for roundabouts</li></ul>
<p><b>Significant Effect Thresholds</b></p> <p>An intersection is considered to be significantly affected if the Project would:</p> <ul style="list-style-type: none"><li>• Worsen an intersection maintained by the City of Santa Clarita from LOS D or better to LOS E or F</li><li>• Cause the following increase in delay at an intersection maintained by the City of Santa Clarita that is already operating (with the Project) at LOS D or worse<ul style="list-style-type: none"><li>- LOS D with the Project: more than 4-second increase in delay is significant</li><li>- LOS E or F with the Project: more than 2-second increase in delay is significant</li></ul></li></ul> <p>Note: For intersections under joint jurisdiction of the City and Caltrans, the analysis utilizes the corresponding threshold of the local agency (City) as applicable.</p>
<p>Abbreviations:</p> <p>LOS – Level of Service</p>



# WILEY CANYON MIXED-USE TRAFFIC ANALYSIS

Introduction  
July 2022

## 1.5 DEFINITIONS

Certain terms used throughout this report are defined below to clarify their intended meaning:

ADT	Average Daily Traffic. Generally used to measure the total two-directional traffic volumes passing a given point on a roadway.
LOS	Level of Service. A scale used to evaluate circulation system performance based on intersection ICU values or volume/capacity ratios of arterial segments.
Peak Hour	This refers to the hour during the AM peak period (typically 7 AM - 9 AM) or the PM peak period (typically 4 PM - 6 PM) in which the greatest number of vehicle trips are generated by a given land use or are traveling on a given roadway.
V/C	Volume to Capacity Ratio. This is typically used to describe the percentage of capacity utilized by existing or projected traffic on a segment of an arterial or intersection.

## 1.6 REFERENCES

1. Institute of Transportation Engineers. 2021. *Trip Generation 11th Edition*.
2. Institute of Transportation Engineers. 2017. *Trip Generation Handbook 3rd Edition*.
3. Transportation Research Board, National Research Council. 2010. *Highway Capacity Manual 2010*.
4. City of Santa Clarita. May 2020. *Transportation Analysis Updates in Santa Clarita*.



## 2.0 TRANSPORTATION SETTING

This chapter describes the transportation setting for the traffic analysis. Existing conditions are first discussed, followed by a discussion of the derivation of future traffic volumes. planned roadway improvements adjacent to the Project site are also discussed.

### 2.1 EXISTING CONDITIONS

The following section describes existing traffic conditions in the study area. It includes a description of the study area roadway system, existing traffic volumes and corresponding levels of service as defined by the performance criteria outlined in the previous chapter.

#### 2.1.1 Existing Roadway System

The following is a summary of the roadway system surrounding the Project. Existing intersection lane configurations and traffic controls for the study locations are presented in **Figure 2-1**.

Wiley Canyon Road is oriented generally in a north-south direction in the vicinity of the Project, beginning just south of the Project at its intersection with Calgrove Boulevard. According to the City's General Plan<sup>1</sup>, Wiley Canyon Road is considered to be a Secondary Highway in the Project area (from Calgrove Boulevard to Lyons Avenue). At Lyons Avenue, Wiley Canyon Road is a four-lane roadway, and as it nears the Project site it narrows to two lanes. Primary access to the Project is expected to be via Wiley Canyon Road.

Calgrove Boulevard is also classified as a Secondary Highway and travels in a generally east-west direction near the Project Site. West of Wiley Canyon Road, Calgrove Boulevard provides access to I-5 via northbound and southbound ramps. Calgrove Boulevard ends beyond this point at its intersection with The Old Road. To the east, Calgrove Boulevard terminates after it intersects with Creekside Drive.

Lyons Avenue is classified as a Major Highway in the City of Santa Clarita. In the vicinity of the Project, Lyons Avenue is a six-lane roadway that travels in an east-west direction with northbound and southbound access to I-5. Lyons Avenue continues as far east as the Newhall area and travels west until it becomes Pico Canyon Road, just west of the I-5 northbound ramps.

---

<sup>1</sup> City of Santa Clarita General Plan, June 2011



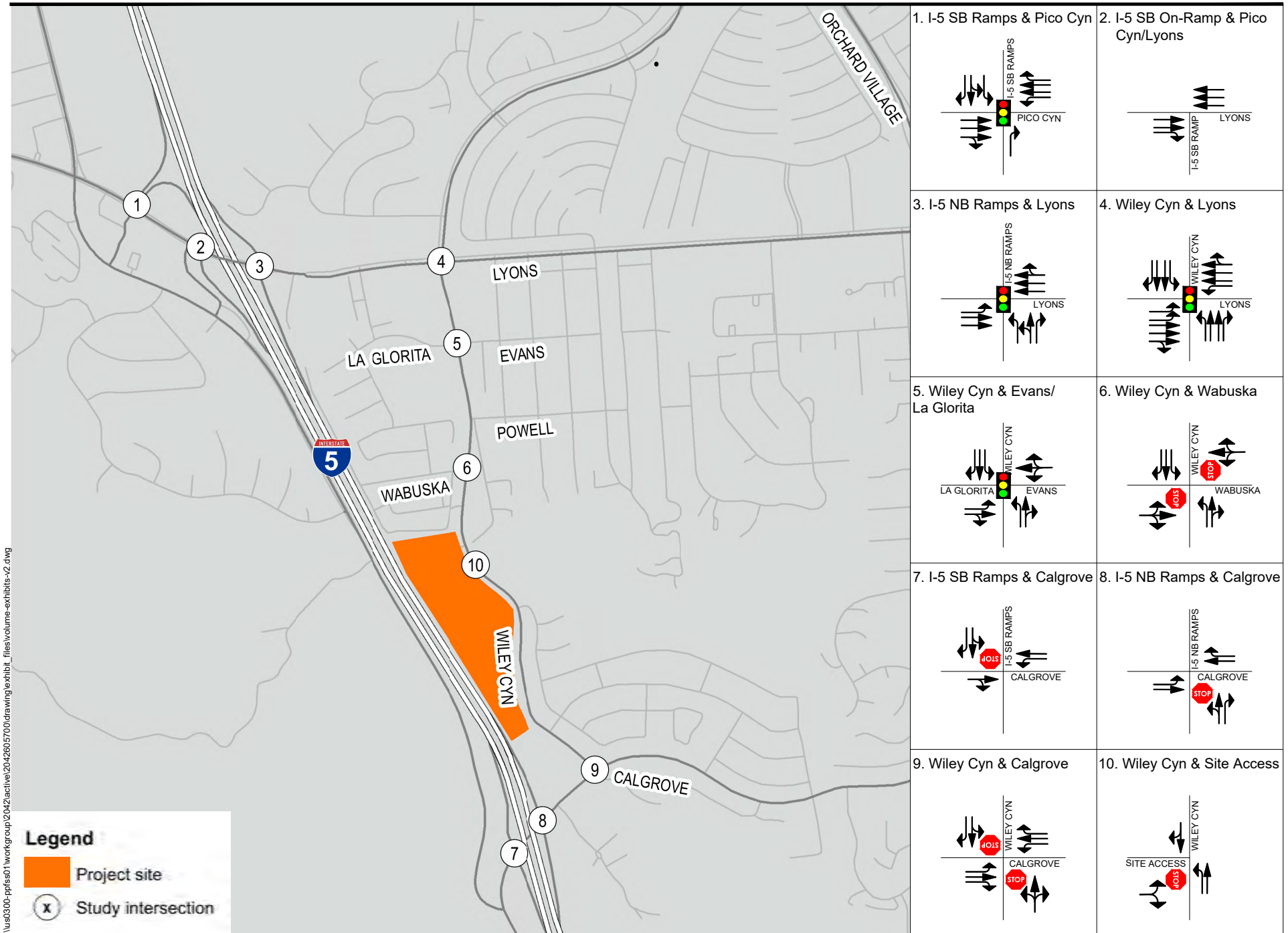

\\us0300-ppfs01\workgroup\2042\active\2042605700\drawing\exhibit\_files\volume-exhibits-v2.dwg



**Figure 2-1**

Existing Intersection Lane Configuration and Traffic Control





# WILEY CANYON MIXED-USE TRAFFIC ANALYSIS

Transportation Setting  
July 2022

## 2.1.2 Existing Traffic Volumes and Levels of Service

Traffic count data were collected during the critical AM and PM peak hours during late March 2021. The traffic count data sheets and data from the City are provided in **Appendix A**. These traffic counts were collected during COVID-19 business and travel restrictions, although the most severe restrictions had been lifted. Therefore, the counts were adjusted with a growth factor to estimate typical non-COVID-19 conditions. The AM peak hour counts were increased by 25 percent and the PM peak hour counts were increased by 10 percent to account for lower counts during the COVID-19 restrictions. These factors were based on count comparisons in other areas of Los Angeles County as well as estimates derived from *COVID-19 Community Mobility Report* for Los Angeles County prepared by Google. Additional adjustments were made to the peak hour turning movement volumes at study intersections along Wiley Canyon Road at Lyons Avenue and at La Glorita Circle to be consistent with data provided by the City. Existing average daily traffic (ADT) volumes for arterials in the study area and AM peak hour turning movement volumes at the study intersections are provided in **Figure 2-2**. Peak hour turning movement volumes for the PM peak hour are illustrated in **Figure 2-3**.

The results of the intersection LOS analysis under existing conditions are shown in **Table 2-1**. Each of the signalized intersections and the stop-controlled intersections were analyzed using the HCM delay methodology. Detailed LOS calculation worksheets are provided in **Appendix B**. The table shows that all the signalized study area intersections currently operate at LOS D or better in both the AM peak hour and the PM peak hour.

**Table 2-1 Intersection LOS Summary – Existing Conditions**

Intersection	Traffic Control	AM Peak Hour		PM Peak Hour	
		Delay	LOS	Delay	LOS
1. I-5 SB Ramps & Pico Canyon Rd	Signal	18.7	B	21.5	C
2. I-5 SB On-Ramp & Pico Canyon Rd/Lyons Ave	None <sup>1</sup>	N/A	A	N/A	A
3. I-5 NB Ramps & Lyons Ave	Signal	21.5	C	25.6	C
4. Wiley Canyon Rd & Lyons Ave	Signal	39.4	D	38.3	D
5. Wiley Canyon Rd & La Glorita Circle/Evans Ave	Signal	8.8	A	5.4	A
6. Wiley Canyon Rd & Wabuska St	TWSC	22.8	C	21.8	C
7. I-5 SB Ramps & Calgrove Blvd	TWSC	17.3	C	36.9	E
8. I-5 NB Ramps & Calgrove Blvd	TWSC	14.0	B	40.9	E
9. Wiley Canyon Rd & Calgrove Blvd	TWSC	16.2	C	68.5	F
<sup>1</sup> No conflicting movements <b>Note:</b> NB – Northbound SB – Southbound TWSC – Two-way stop control LOS – Level of Service Delay – Average Vehicle Delay (seconds/vehicle) N/A – Not applicable					





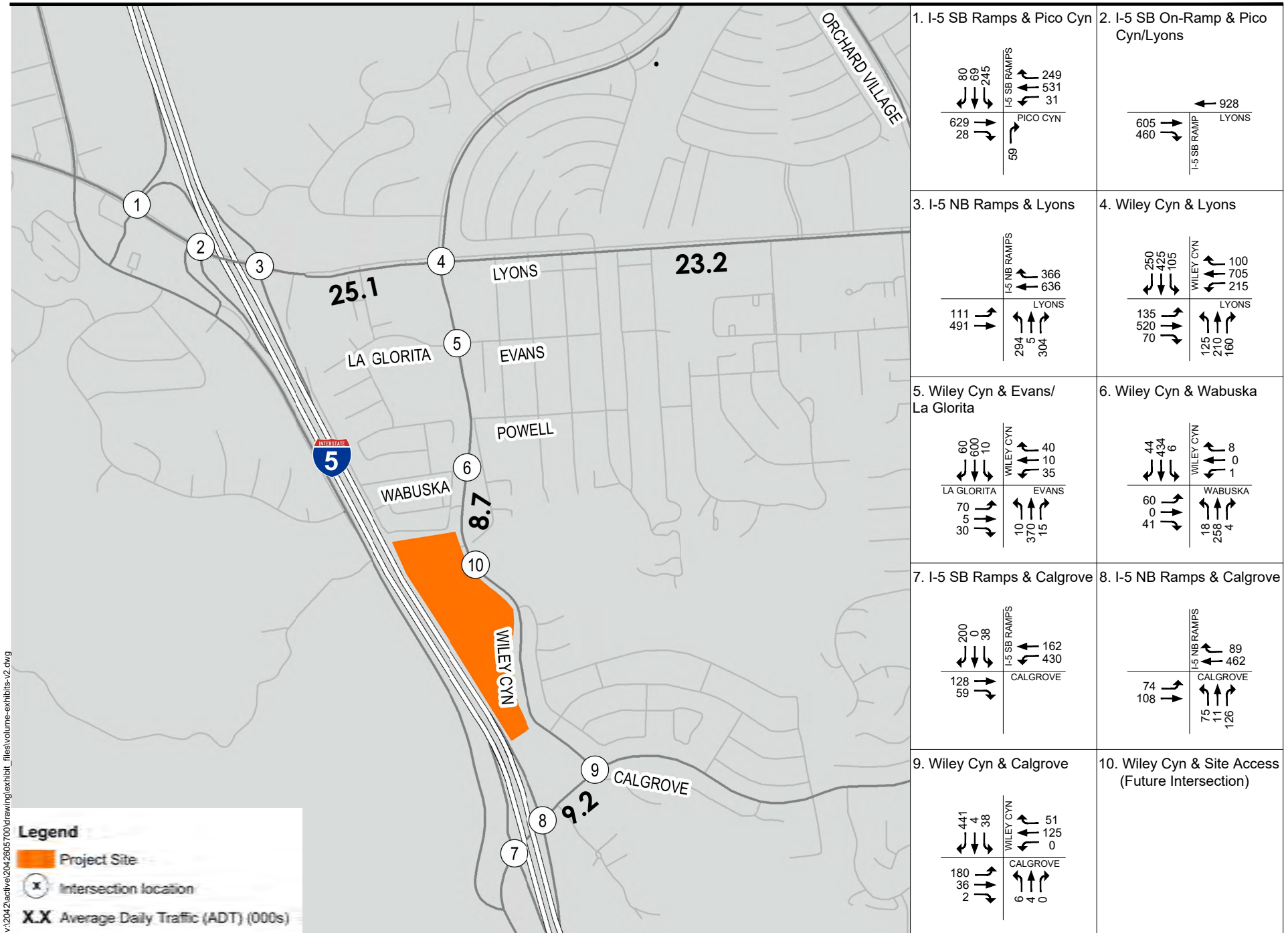

v:\2042\active\204-2805700\drawing\exhibit\_files\volume-exhibits-2.dwg



**Figure 2-2**

Existing ADT and AM Peak Hour Volumes



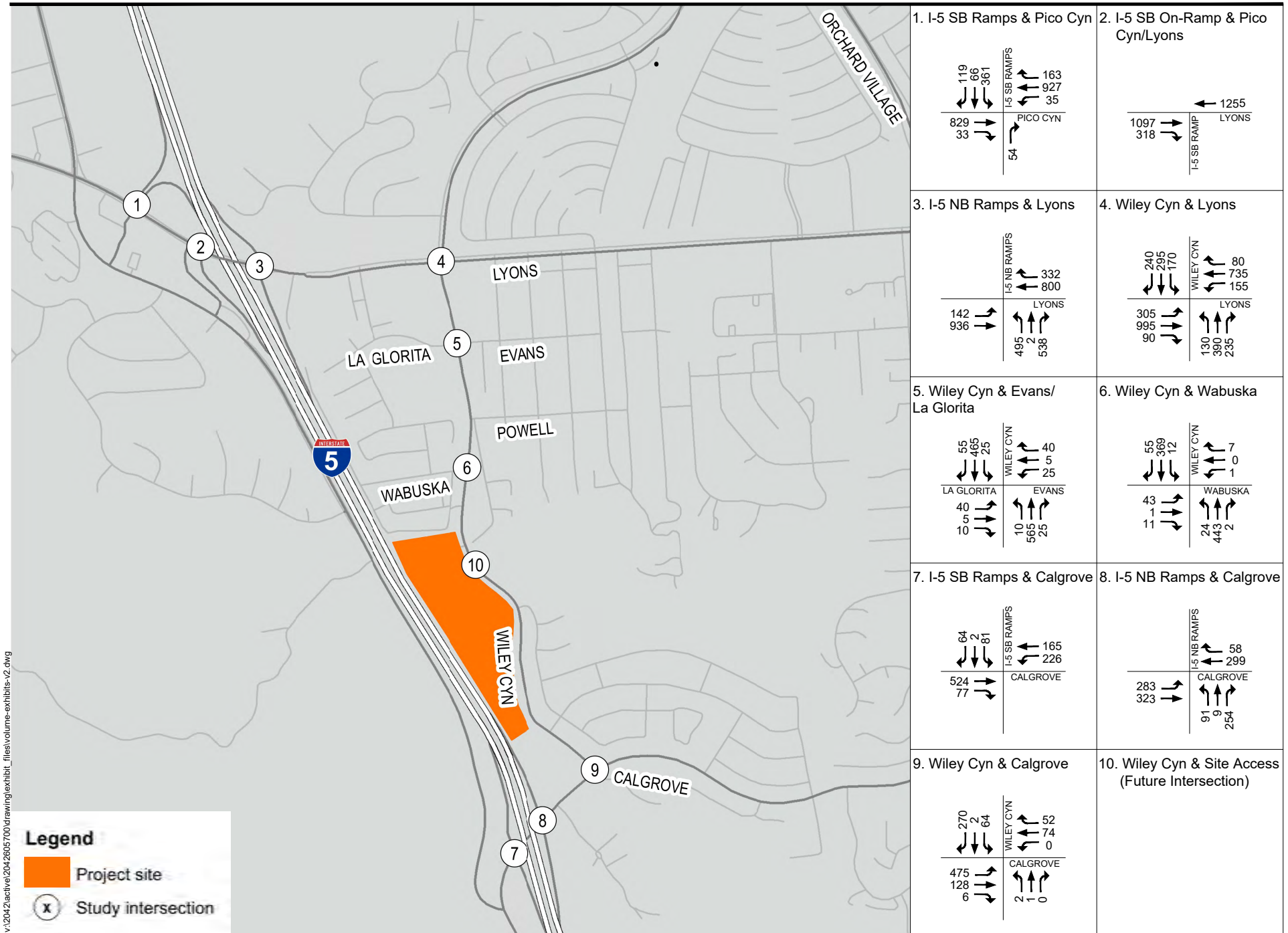

v:\204\active\204-2805700\drawing\exhibit\_files\volume-exhibits-2.dwg

**Legend**

- Project site
- x Study intersection



**Figure 2-3**  
Existing PM Peak Hour Volumes  
2.5



## WILEY CANYON MIXED-USE TRAFFIC ANALYSIS

Transportation Setting  
July 2022

At the stop-controlled study intersections, the reported delay is based on the delay incurred by the side street traffic controlled by a stop sign since the through movements on the main street do not experience delay. Of the stop-controlled intersections, the intersections along Calgrove Boulevard operate at acceptable LOS B or LOS C during the AM peak hour. However, these same intersections operate at undesirable LOS E or LOS F during the PM peak hour.

### 2.1.3 Public Transportation

The area around the Project site is served by City of Santa Clarita Transit (SCT) Routes 4, 5, 6, and 14. These routes stop at the intersection of Wiley Canyon Road and Lyons Avenue, just over a half mile north of the Project site. There are other transit facilities in the City of Santa Clarita that can be accessed through these routes to provide regional access to the Project. These facilities include the Newhall Metrolink station and the McBean Regional Transit Center. Furthermore, SCT provides additional service trips during peak student travel times with two routes traveling along Wiley Canyon Road between Lyons Avenue and Calgrove Boulevard. On school days, Route 634 provides service to West Ranch High School and Rancho Pico Jr High School, and Route 641 provides service to Hart High School and Placerita Jr. High School.

**Figure 2-4** shows active transit routes, stops, and other transit infrastructure near the Project site.

### 2.1.4 Active Transportation

Existing bicycle facilities in the vicinity of the Project site include Class II on-street striped bicycle lanes on Calgrove Boulevard east of Wiley Canyon Road and on Wiley Canyon Road north of Lyons Avenue. There is also a paseo with access on Wiley Canyon Road opposite Tournament Road and on the north side of Lyons Avenue between Avenida Entrana and Avenida Rotella.

Per the Santa Clarita Non-Motorized Transportation Plan, a Class III bicycle route is proposed along Wiley Canyon Road from Lyons Avenue to Calgrove Boulevard; however, the Project will provide a Class I trail from the Project site south to Calgrove Boulevard, and Calgrove Boulevard will be restriped to provide Class II bike lanes. This will connect cyclists at the Project site to other parts of the City with existing bicycle infrastructure. There are other proposed bicycle facilities as well, including a Class II bicycle lane along a large segment of The Old Road that would provide access to cyclists near the Project site on the west end of Calgrove Boulevard. **Figure 2-5** illustrates existing and proposed bicycle facilities near the Project.







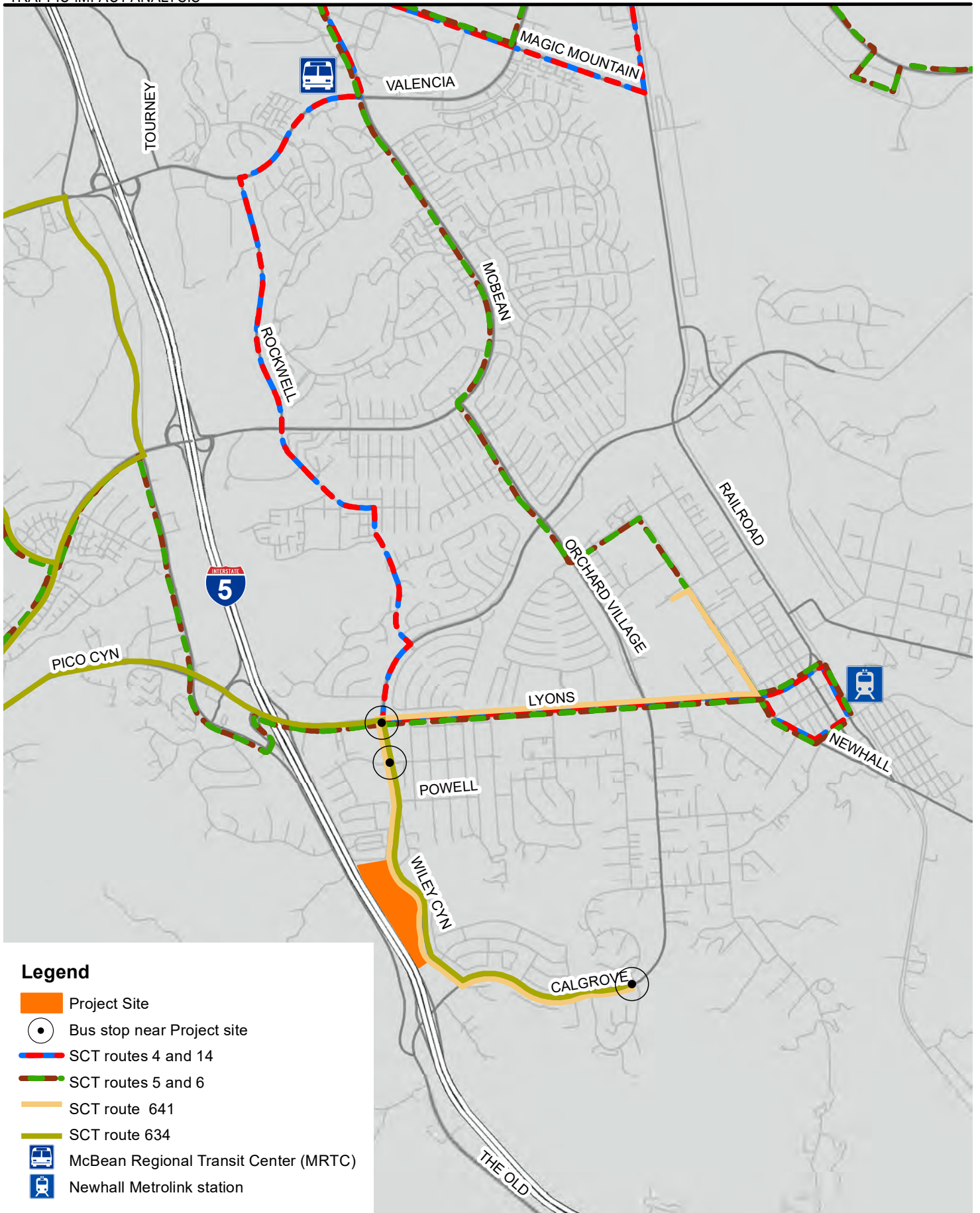

**Legend**

- Project Site
- Bus stop near Project site
- SCT routes 4 and 14
- SCT routes 5 and 6
- SCT route 641
- SCT route 634
- M McBean Regional Transit Center (MRTC)
- N Newhall Metrolink station

C:\Users\emazzella\Documents\Wiley Canyon TIA\transit\_facilities.mxd



Figure 2-4  
Existing Transit Facilities



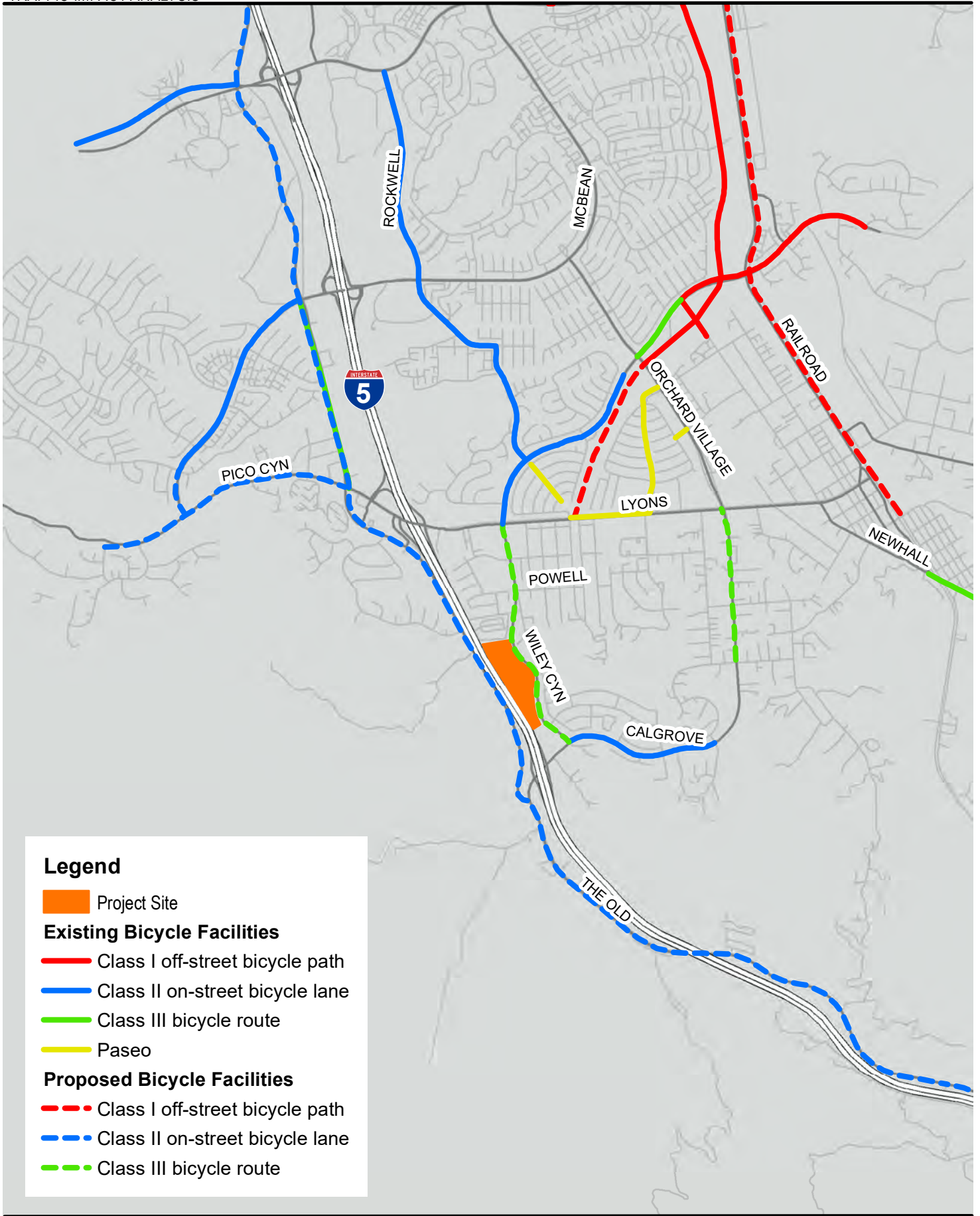

C:\Users\emazzella\Documents\Wiley Canyon TIA\Bicycle\_Facilities-v2.mxd



Figure 2-5  
Existing and Future Bicycle Facilities  
2.8



## 2.2 FUTURE CONDITIONS

A 2028 horizon year was selected for evaluation of future conditions due to the Project’s near-term development horizon and to capture the effect of other approved and planned development in the area.

### 2.2.1 Future Land Use Development

To derive future-year forecast volumes, the SCVCTM was used. As previously discussed in Section 1.3, the SCVCTM includes a land use database prepared by Los Angeles County and the City of Santa Clarita that is based on the approved General Plans of each jurisdiction. This database is regularly updated as specific projects are proposed and thus is a comprehensive list of cumulative projects, including the One Valley One Vision (OVOV) Area Plan. Trips to and from the Santa Clarita Valley, as well as “through-trips”, are included in the forecasts; thus, regional growth, which is traffic volume increase occurring outside of the SCVCTM area, is incorporated in the model.

### 2.2.2 Future Traffic Volumes

A 2028 horizon year is utilized to evaluate Interim Year Cumulative Conditions, which captures projects in the nearby area that are anticipated to be built in the next seven years. For this analysis, an interim version of the model is utilized. A list of nearby related projects included in the Interim Year horizon is provided in **Table 2-2** and the corresponding map is provided in **Figure 2-6**. Project trips associated with the proposed Project was estimated using the SCVCTM and added onto 2028 baseline conditions to derive 2028 With-Project conditions.

**Table 2-2 Related Projects**

No.	Project	Description
1	Valley Street Condos	5 SF condo units
2	OLPH Church	21 TSF church & parking lot
3	Placerita Meadows	310 residential units
4	Warner Ranch/Lyons Canyon	186 residential units
Notes: SF – Single family TSF – Thousand square feet		







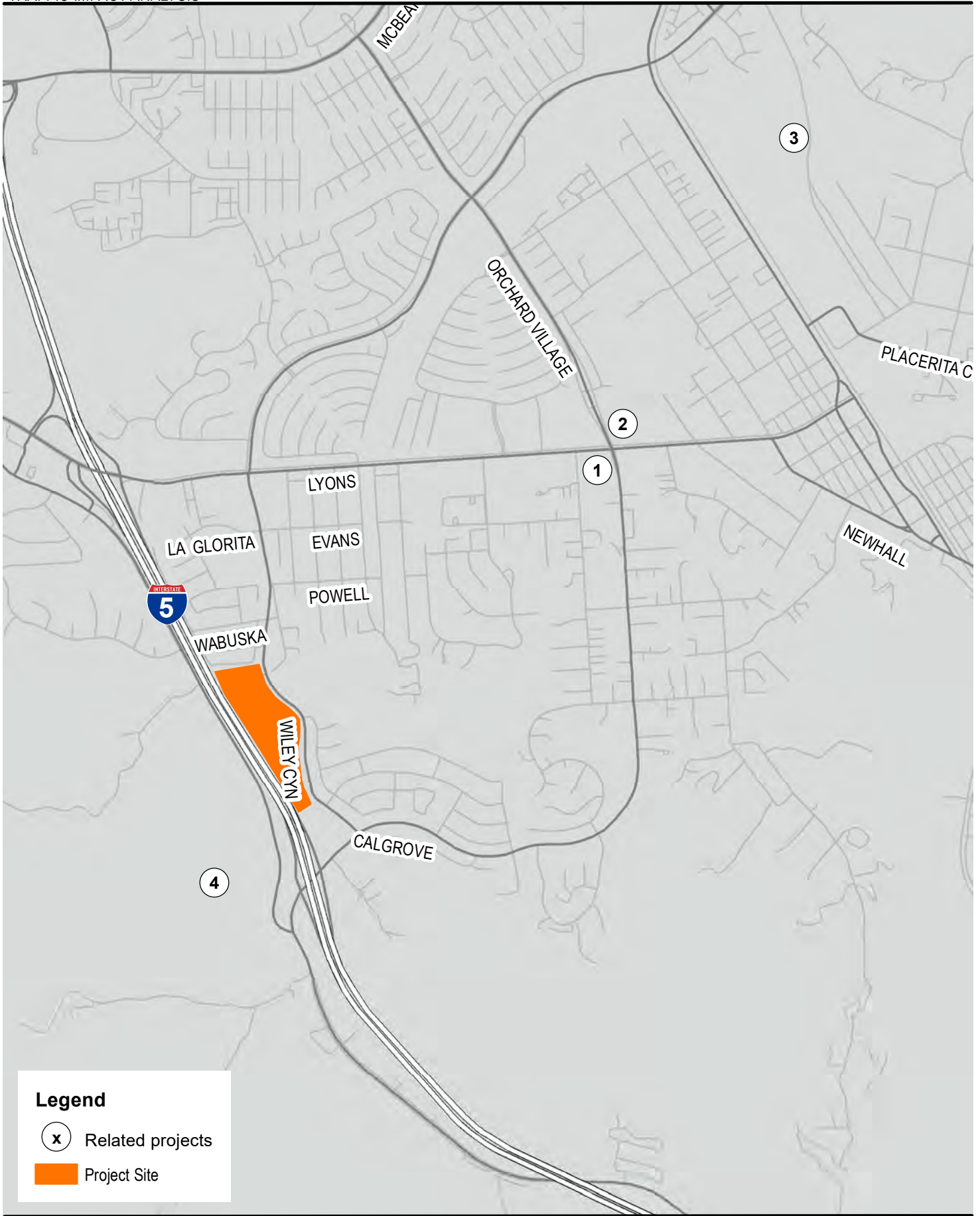

**Legend**

- Related projects
- Project Site

C:\Users\emazzella\Documents\Wiley Canyon TIA\related\_projects.mxd



Figure 2-6  
Related Projects Location Map  
2.10





# WILEY CANYON MIXED-USE TRAFFIC ANALYSIS

Project Description  
July 2022

## 3.0 PROJECT DESCRIPTION

This section describes the Project in terms of its transportation characteristics. Trip generation is summarized and the distribution of the Project’s trips on the adjoining roadway network is presented.

### 3.1 PROJECT TRIP GENERATION

The proposed Project consists of approximately 379 multifamily residential units, 8,914 square feet of commercial retail development, and a 217-unit Senior living facility that includes 130 Independent Living units, 61 Assisted Living units, and 26 Memory Care units in the City of Santa Clarita. It also includes a publicly accessible outdoor recreational space. Trip generation estimates were prepared using standardized Institute of Transportation Engineers (ITE) 11th Edition trip generation rates for the Multifamily Housing Low-Rise (220) Residential category, the Strip Retail Plaza less than 40,000 square feet (822) category, and the Continuing Care Retired Community (CCRC) (225) category. ITE manual describes CCRC as a land use category that includes various combinations of senior adult housing, congregate care, assisted living, and nursing home. As shown in **Table 3-1**, the proposed project is expected to generate approximately 3,696 average daily trips (ADT), with 210 trips occurring during the AM peak hour and 307 trips occurring during the PM peak hour before accounting for the internal capture of trips between uses and existing trips currently passing by the Project site.

**Table 3-1 Project Trip Generation Summary**

	Amount	Unit	AM Peak Hour			PM Peak Hour			ADT
			In	Out	Total	In	Out	Total	
<b>Trip Rates</b>									
Multi-family Housing Low-Rise (220)		DU	0.10	0.30	0.40	0.32	0.19	0.51	6.74
Strip Retail Plaza <40k (822)		TSF	Ln(T) = 0.66 Ln(X) + 1.84 In = 60% x Ln(T) Out = 40% x Ln(T)			Ln(T) = 0.71 Ln(X) + 2.72 In = 50% x Ln(T) Out = 50% x Ln(T)			T=42.20 (X)+229.68
Continuing Care Retired Community (255)		Units	0.10	0.05	0.15	0.07	0.12	0.19	2.47
<b>Trip Generation</b>									
Multi-family Apartments	379	DU	36	115	151	122	72	194	2,554
Commercial Shopping Center <sup>1</sup>	8.9	TSF	16	11	27	36	36	72	606
Senior Living Facilities	217	Units	21	11	32	16	25	41	536
<b>Gross Trips</b>			<b>73</b>	<b>137</b>	<b>210</b>	<b>174</b>	<b>133</b>	<b>307</b>	<b>3,696</b>
Internal Capture %			2%	1%	2%	4%	5%	5%	4%
Reduction for Internal Capture <sup>2</sup>		-	1	1	2	7	7	14	148
<b>External Trips</b>			<b>72</b>	<b>136</b>	<b>208</b>	<b>167</b>	<b>126</b>	<b>293</b>	<b>3,548</b>
<b>Pass-by Trips Reduction</b>									
Commercial Shopping Center <sup>3</sup> (AM-10%; PM - 34%; ADT-10%)		-	2	1	3	12	12	24	61
<b>Net Total External (New) Trips</b>		-	<b>70</b>	<b>135</b>	<b>205</b>	<b>155</b>	<b>114</b>	<b>269</b>	<b>3,488</b>



# WILEY CANYON MIXED-USE TRAFFIC ANALYSIS

Project Description  
July 2022

Trip Rate Source: Institute of Transportation Engineers (ITE), Trip Generation Manual 11th Edition, 2021, with ITE code in parentheses  
<sup>1</sup>Shopping Center rate is based on the fitted curve equation  
<sup>2</sup>Internal capture based on NCHRP Report 684 Internal Trip Capture Estimation Tool  
<sup>3</sup>Pass-By Trips Source: ITE Trip Generation Handbook, 3rd Edition, 2017 for PM, used 10% for AM & ADT  
ADT - Average Daily Trips  
TSF - Thousand Square Feet  
DU - Dwelling Unit

The internal trip capture for the Project is derived using the National Cooperative Highway Research Program (NCHRP) Report 684: Enhancing Internal Trip Capture Estimation for Mixed-Use Developments. Taking into account the internal capture, the Project would generate approximately 3,548 daily external trips, 208 external trips during the AM peak hour, and 293 external trips during the PM peak hour as shown in Table 3-1. A pass-by trip reduction was applied to the Commercial Shopping Center based on the data provided in the ITE Trip Generation Handbook, Third Edition. As shown in Table 3-1, the Project would generate approximately 3,488 net new daily trips, 205 net new AM peak hour trips, and 269 net new PM peak hour trips.

## 3.2 PROJECT TRIP DISTRIBUTION

Public access to the Project would be provided by a private street connected to Wiley Canyon Road. The Project entrance would be located at the northern end of the site and controlled by a single-lane roundabout. An emergency vehicle only access would be provided by a driveway on Hawkbyrn Avenue.

The geographic distribution of Project-generated trips was derived using the SCVCTM. As discussed above, the SCVCTM is a computerized travel demand model that utilizes a sophisticated trip distribution function to derive the distribution of vehicle trips, and which has previously been calibrated to the existing conditions of the Santa Clarita Valley. The SCVCTM is jointly maintained by City of Santa Clarita and County of Los Angeles staff, and is utilized for all major transportation planning efforts within the Santa Clarita Valley. Production and attraction trip data is generated by the model based on five separate trip purposes, and trip distribution patterns are then derived by the model. As a final step, the model assigns these trips to the roadway network based on the derived distribution patterns.

The Project's trip distribution percentages are illustrated in **Figure 3-1** as determined by a SCVCTM select zone run. As shown, approximately 69 percent of the Project trips are traveling on Wiley Canyon Road north of the site, and 31 percent of the Project trips are traveling on Wiley Canyon Road south of the site. The SCVCTM select zone plot used to determine trip distribution is provided in Appendix D. Project trips during the AM and the PM peak hours are shown in **Figure 3-2** and **Figure 3-3**, respectively.



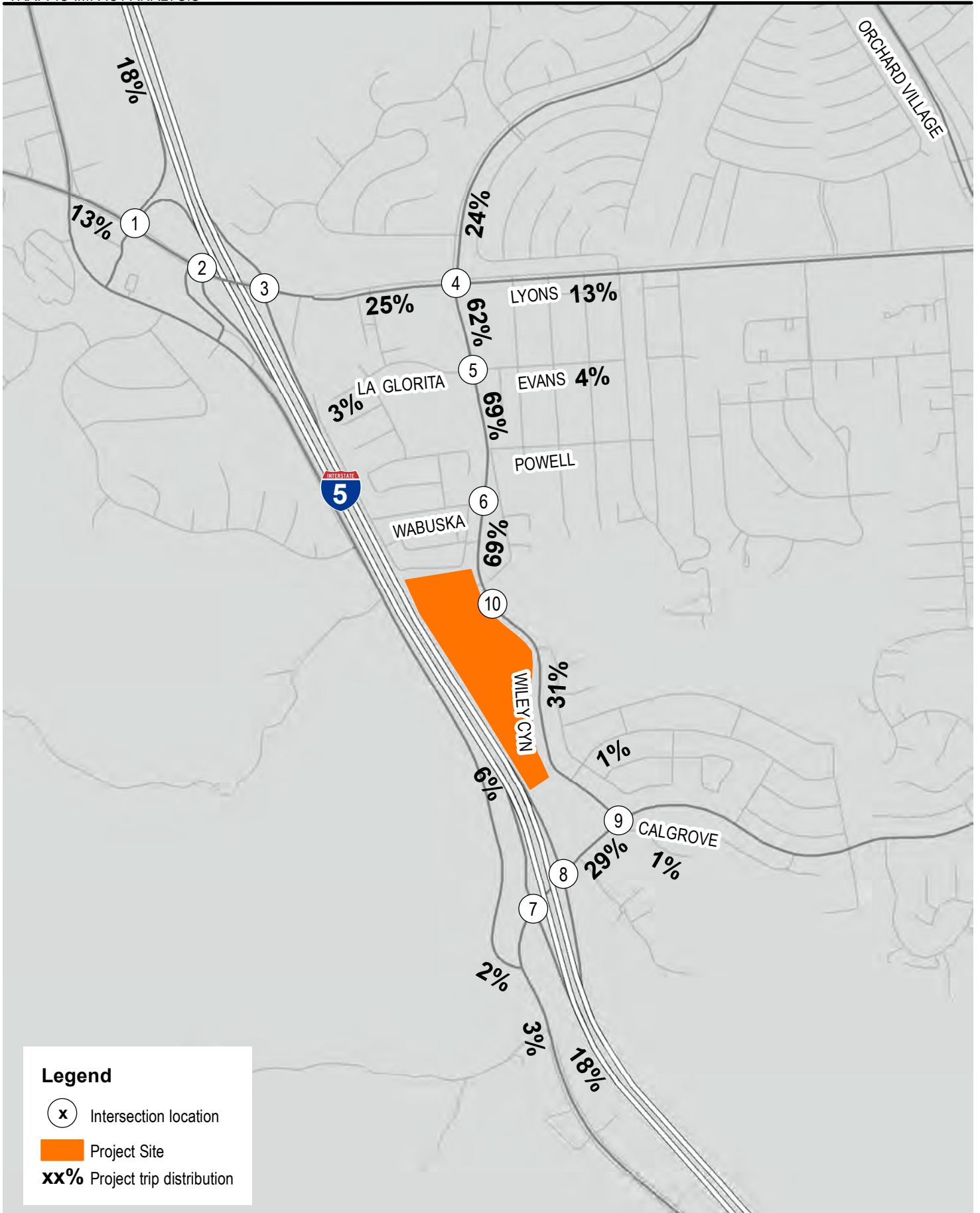

C:\Users\emazzella\Documents\Wiley Canyon TIA\TIP\_d142.mxd



Figure 3-1  
Project Trip Distribution



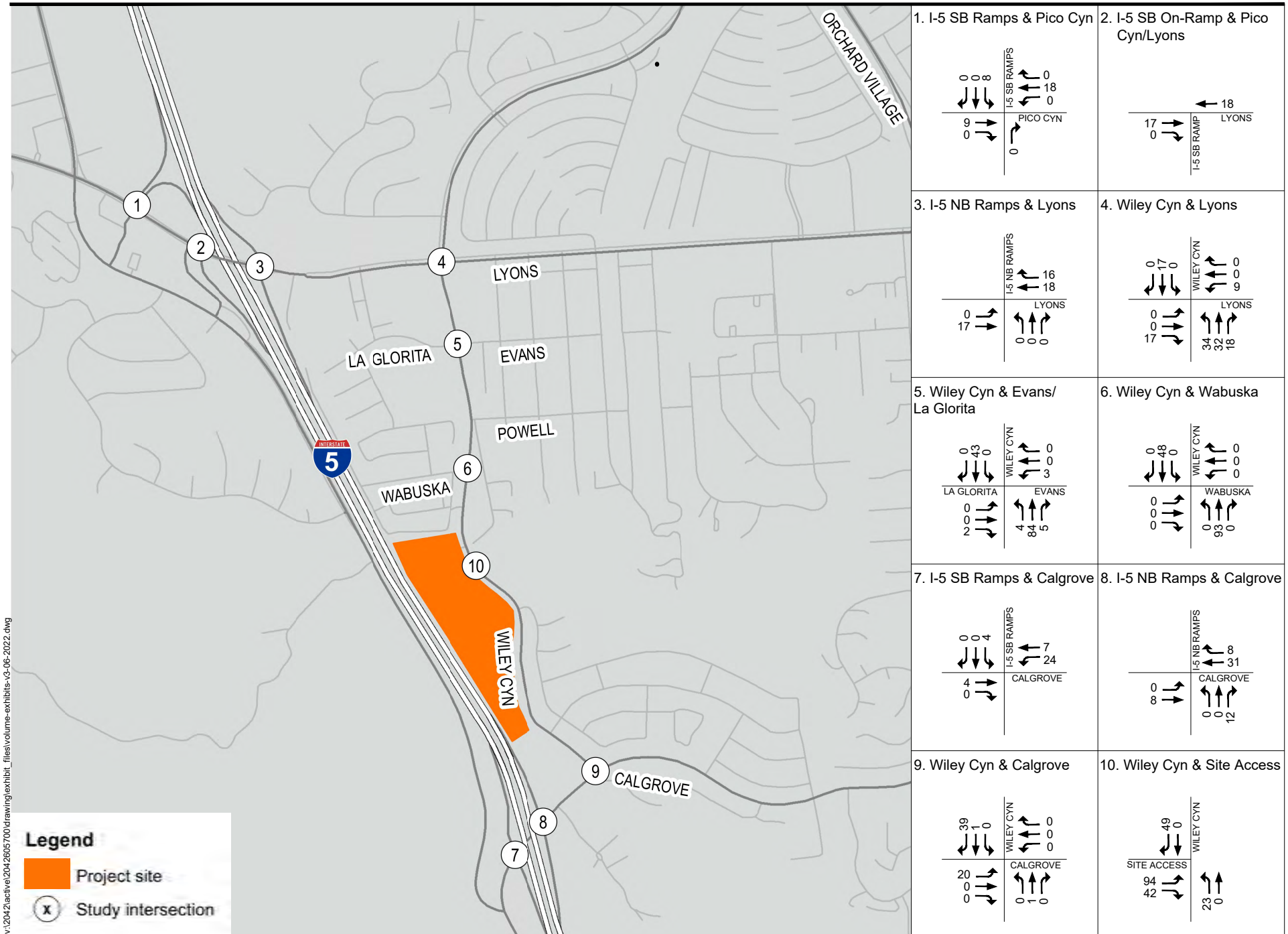

v:\204\2\active\204-2805700\drawing\exhibit\_files\volume-exhibits\3-06-2022.dwg

**Figure 3-2**

Project-Only Trips - AM Peak Hour





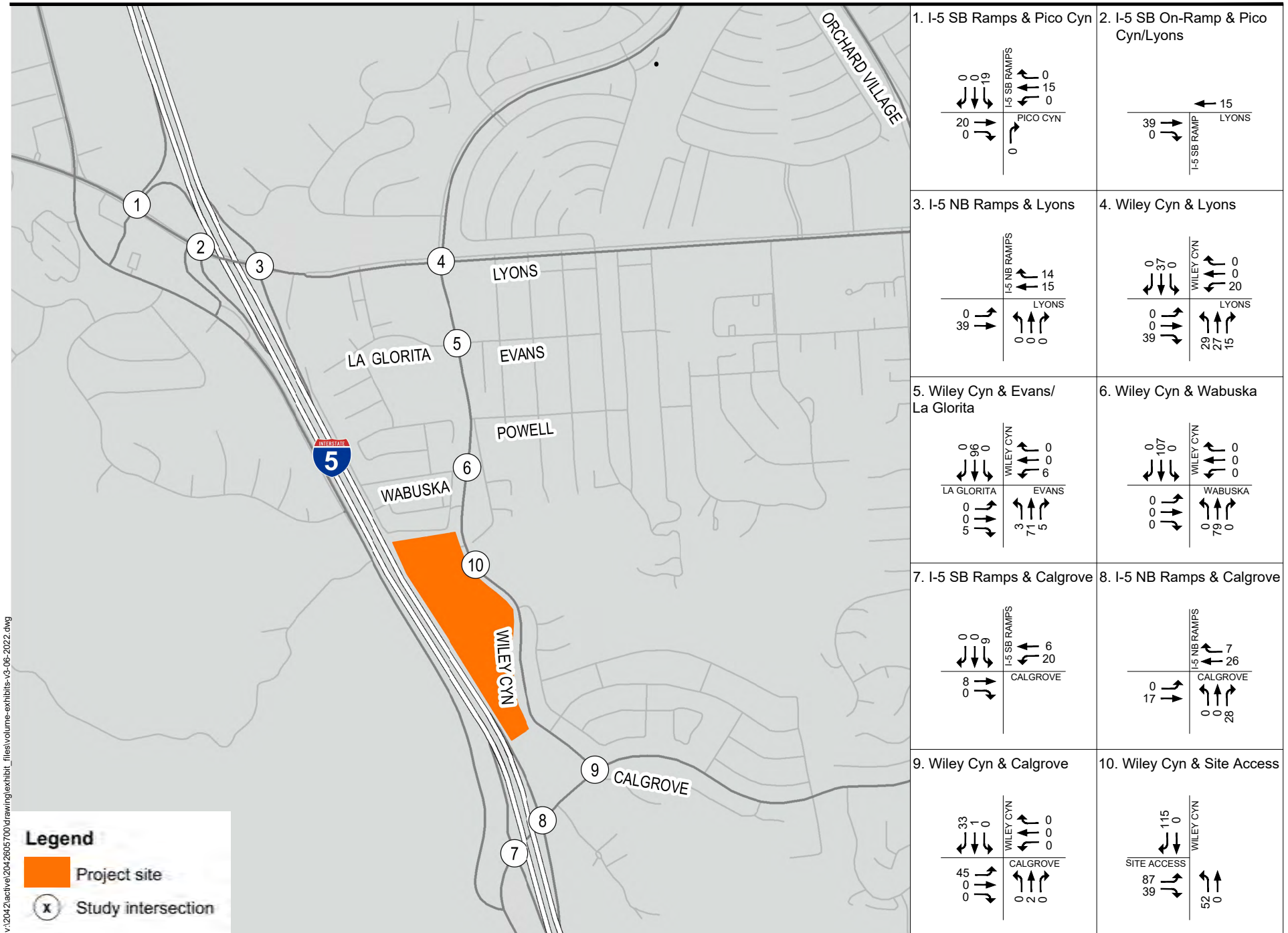

v:\204\2\active\204-2805700\drawing\exhibit\_files\volume-exhibits\3-06-2022.dwg



**Figure 3-3**

Project-Only Trips - PM Peak Hour





## 4.0 IMPACT ANALYSIS

This chapter presents an analysis of the Project's effects under existing conditions and also presents an analysis of Cumulative Conditions under without and with Project scenarios. The effects of the proposed Project are addressed using the criteria outlined in Chapter 1.0.

### 4.1 EXISTING PLUS PROJECT ANALYSIS

This section provides an analysis of Project traffic by comparing pre-Project existing traffic conditions to existing plus Project traffic conditions. This analysis documents Project-related trips and their addition to the existing observed traffic count data (i.e., existing conditions) in order to identify potential traffic impacts. This analysis is referred to as the Existing plus Project scenario. This scenario assumes full buildout of the entire Project. Existing plus Project ADT and AM peak hour intersection turning movement volumes are illustrated in **Figure 4-1**. The PM peak hour intersection turning movement volumes are illustrated in **Figure 4-2**.

The project would install roundabouts along Wiley Canyon Road at the Project access, at the study intersection at Calgrove Boulevard, and at Canerwell Street.

#### 4.1.1 Peak Hour Intersection Levels of Service

A peak hour intersection LOS analysis was conducted with the Existing plus Project traffic volumes, and the results are summarized in **Table 4-1**. As discussed in Section 2.1.2, HCM delay methodology was used to analyze both the signalized and the stop-controlled intersections.

The signalized study intersections would operate at LOS D or better during the AM and PM peak hour with the addition of Project trips. The Project increases the delay by less than four seconds at the intersections operating at LOS D and, therefore, the signalized study intersections are not affected by the Project under Existing plus Project conditions.

The stop-controlled study intersection of Wiley Canyon Road and Wabuska Street operates at LOS D during the AM and PM peak hours under Existing plus Project conditions with a Project-related increase in side-street delay of greater than four seconds; however, under the City guidelines, such an increase would result in a significant effect if the intersection is already operating at LOS D. The intersection of Wiley Canyon Road and Wabuska Street operates at LOS C under no-project conditions, and the Project has no significant effect at this location.

Two stop-controlled study intersections operate at acceptable LOS C or better for the side-street during the AM peak hour under Existing plus Project conditions. However, during the PM peak hour, these





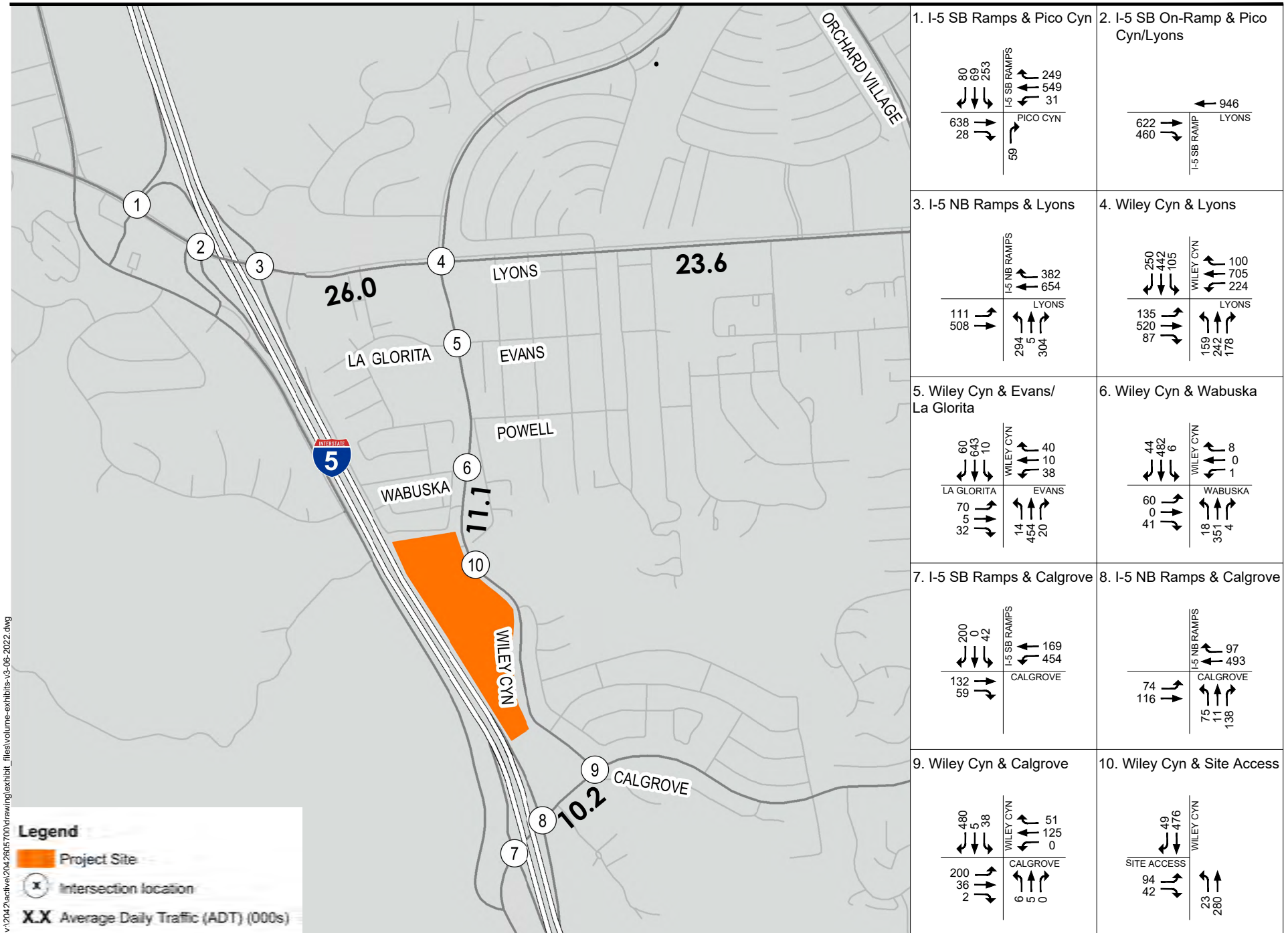

v:\2042\active\2042865700\drawing\exhibit\_files\volume-exhibits\3-06-2022.dwg

**Legend**

- Project Site
- Intersection location
- X.X** Average Daily Traffic (ADT) (000s)



**Figure 4-1**  
Existing Plus Project ADT and AM Peak Hour Volumes



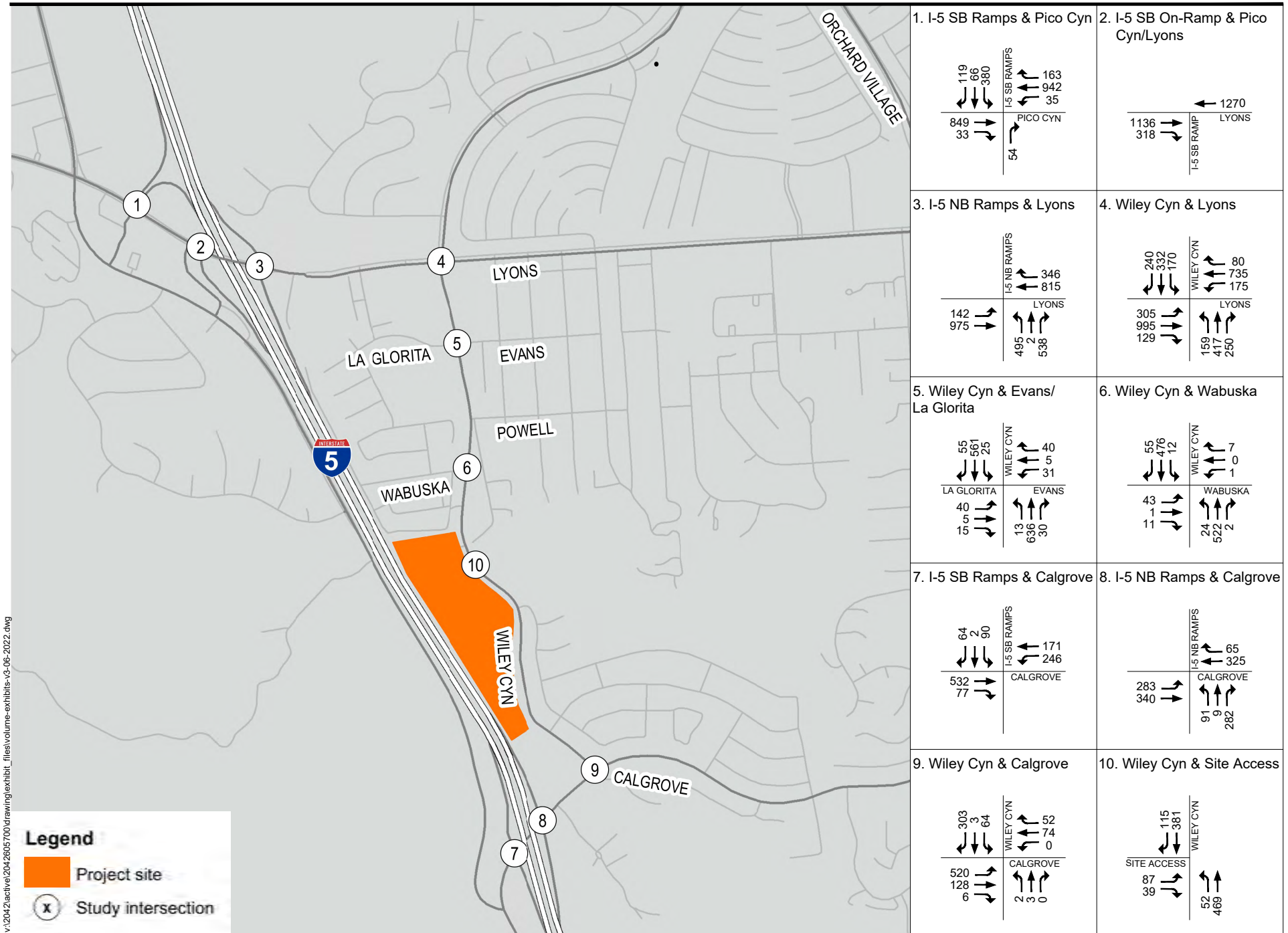

v:\204\active\204-2805700\drawing\exhibit\_files\volume-exhibits-v3-06-2022.dwg

**Legend**

- Project site
- x Study intersection



**Figure 4-2**  
Existing Plus Project PM Peak Hour Volumes  
4.3



**WILEY CANYON MIXED-USE TRAFFIC ANALYSIS**

Impact Analysis  
July 2022

**Table 4-1 Intersection Delay and LOS Summary – Existing Plus Project Conditions**

Intersection	Traffic Control	Existing				Existing Plus Project				Project Increase	
		AM Peak Hour		PM Peak Hour		AM Peak Hour		PM Peak Hour		AM	PM
		Delay	LOS	Delay	LOS	Delay	LOS	Delay	LOS	Delay	Delay
1. I-5 SB Ramps & Pico Canyon Rd	Signal	18.7	B	21.5	C	18.8	B	21.8	C	0.1	0.3
3. I-5 NB Ramps & Lyons Ave	Signal	21.5	C	25.6	C	22.0	C	26.0	C	0.5	0.4
4. Wiley Canyon Rd & Lyons Ave	Signal	39.4	D	38.3	D	41.2	D	39.9	D	1.8	1.6
5. Wiley Canyon Rd & La Gloria Circle/Evans Ave	Signal	8.8	A	5.4	A	9.7	A	5.9	A	0.9	0.5
6. Wiley Canyon Rd & Wabuska St	TWSC	22.8	C	21.8	C	31.0	D	30.0	D	8.2	8.2
7. I-5 SB Ramps & Calgrove Blvd	TWSC	17.3	C	36.9	E	20.2	C	52.3	F	2.9	15.4
8. I-5 NB Ramps & Calgrove Blvd	TWSC	14.0	B	40.9	E	14.4	B	46.0	E	0.4	5.1
9. Wiley Canyon Rd & Calgrove Blvd	RAB <sup>1</sup>	16.2	C	68.5	F	9.2	A	10.7	B	-7.0	-57.8
	Signal					11.3	B	14.3	B	-4.9	-54.2
10. Wiley Canyon Rd & Project Access	RAB	--	--	--	--	8.2	A	8.2	A	8.2	8.2

<sup>1</sup>Existing two-way stop control, future roundabout for with-Project conditions

**Note:**  
 NB – Northbound  
 SB – Southbound  
 TWSC – Two-way stop control  
 RAB – Roundabout  
 LOS – Level of Service  
 Delay – Average Vehicle Delay (seconds/vehicle)



## WILEY CANYON MIXED-USE TRAFFIC ANALYSIS

Impact Analysis  
July 2022

intersections, which operate at undesirable LOS E under Existing conditions, experience an increase in side-street delay greater than two seconds. This increase in delay exceeds the City's threshold for a significant effect; therefore, these intersections are considered to be affected by the Project.

The stop-controlled intersection of Wiley Canyon Road and Calgrove Boulevard currently operates at LOS F during the PM peak hour; however, the Project would install a roundabout at that location, which would then operate at LOS B or better during the AM and PM peak hours with Project traffic. Alternatively, a traffic signal could be installed at the Wiley Canyon Road and Calgrove Boulevard intersection, resulting in LOS B conditions.

Therefore, the following intersections are forecast to be significantly affected by the Project under Existing plus Project conditions:

7. I-5 Southbound & Calgrove Boulevard
8. I-5 Northbound & Calgrove Boulevard

Methods to improve operations at the above intersections are presented in the following section.

### 4.1.2 Existing Plus Project Conditions Off-Site Improvements

Roadway improvements have been identified to improve operating conditions at the I-5 ramps along Calgrove Boulevard identified in the previous section. The intersections are currently stop controlled and traffic volumes satisfy the Peak Hour Signal Warrant criteria. Methods to improve operations consist of installing a traffic signal or, at the discretion of Caltrans, a roundabout at each intersection as listed in **Table 4-2**. The identified improvements would improve conditions such that the Project would not affect their operations, as shown in **Table 4-3**. The Project would be responsible for its share of the cost of the improvements as detailed in **Table 5-1**.

Signal warrant exhibits are included in **Appendix C**.

## 4.2 INTERIM YEAR CUMULATIVE CONDITIONS ANALYSIS

As previously discussed in Section 2.2.1, Cumulative Conditions traffic volumes presented in this analysis are derived from the SCVCTM. An interim horizon year of 2028 is utilized to encompass a broad range of Related Projects within the study area.

Interim Year cumulative conditions ADT volumes and AM peak hour intersection turning movement volumes for the No-Project condition are illustrated in **Figure 4-3**. The PM peak hour intersection turning movement volumes for the No-Project condition are illustrated in **Figure 4-4**.

The Interim Year cumulative conditions ADT and AM peak hour intersection turning movement volumes for the with-Project condition are illustrated in **Figure 4-5**, and the corresponding PM peak hour intersection turning movement volumes are illustrated in **Figure 4-6**.





**WILEY CANYON MIXED-USE TRAFFIC ANALYSIS**

Impact Analysis  
July 2022

**Table 4-2 Off-Site Improvements for Project Effects – Existing Plus Project Conditions**

<b>Intersection</b>	<b>Jurisdiction</b>	<b>Improvement</b>
7. I-5 SB & Calgrove Blvd	City/Caltrans	Install traffic signal, meets Peak Hour Signal Warrant or, at the discretion of Caltrans, a roundabout
8. I-5 NB & Calgrove Blvd	City/Caltrans	Install traffic signal, meets Peak Hour Signal Warrant or, at the discretion of Caltrans, a roundabout

**Table 4-3 Intersection Delay and LOS Summary – Existing Plus Project Conditions with Off-Site Improvements**

<b>Intersection</b>	<b>Existing</b>				<b>Existing Plus Project With Improvements</b>			
	<b>AM Peak Hour</b>		<b>PM Peak Hour</b>		<b>AM Peak Hour</b>		<b>PM Peak Hour</b>	
	<b>Delay</b>	<b>LOS</b>	<b>Delay</b>	<b>LOS</b>	<b>Delay</b>	<b>LOS</b>	<b>Delay</b>	<b>LOS</b>
7. I-5 SB Ramps & Calgrove Blvd	52.5	F	58.1	F	24.2	C	36.5	D
8. I-5 NB Ramps & Calgrove Blvd	20.7	C	110.3	F	26.3	C	22.1	C
<b>Note:</b> NB – Northbound SB – Southbound LOS – Level of Service Delay – Average Vehicle Delay (seconds/vehicle)								





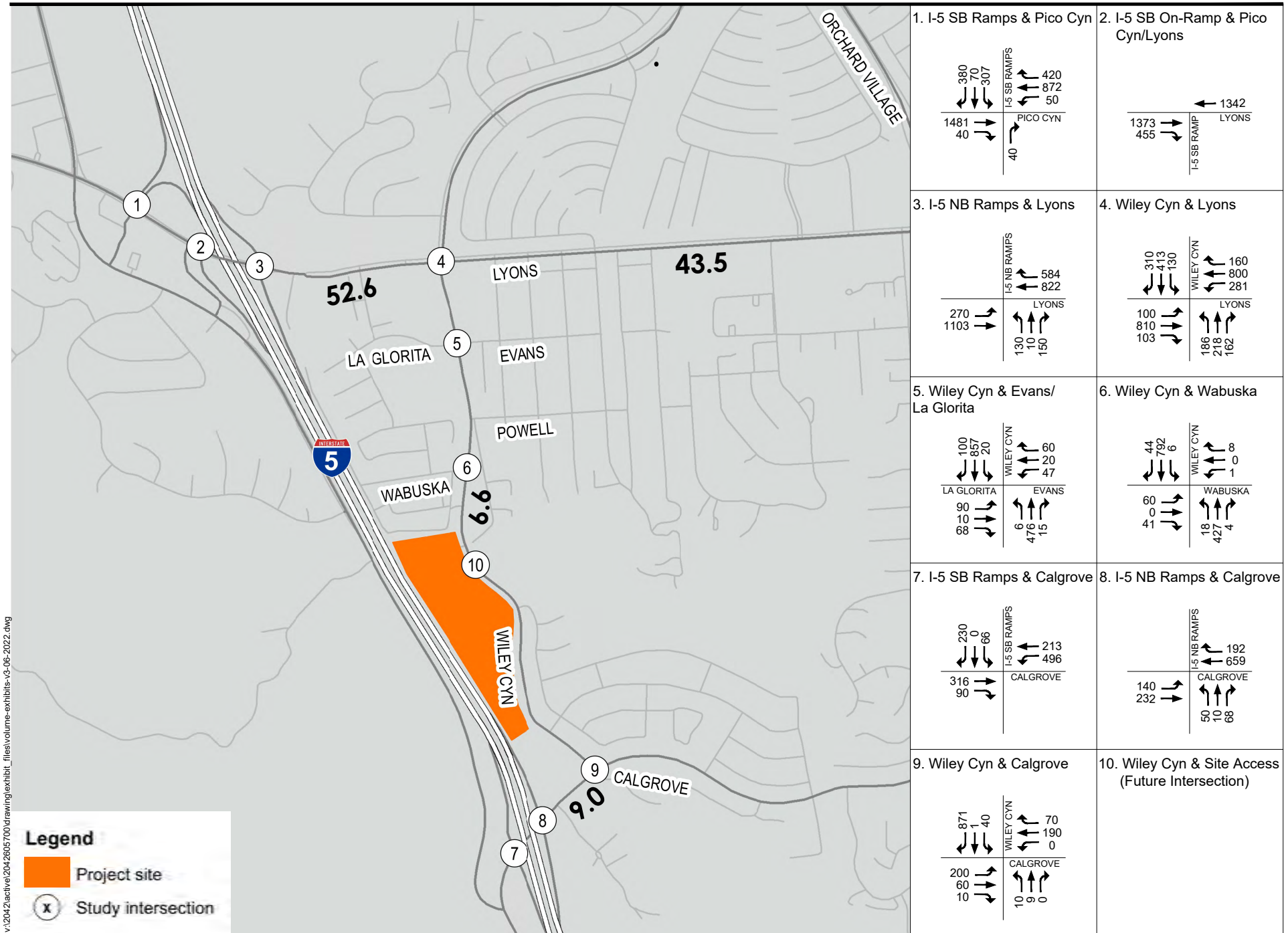

v:\204\2\active\204-2805700\drawing\exhibit\_files\volume-exhibits-v3-06-2022.dwg



**Figure 4-3**

Interim Year No-Project Conditions ADT and AM Peak Hour Volumes



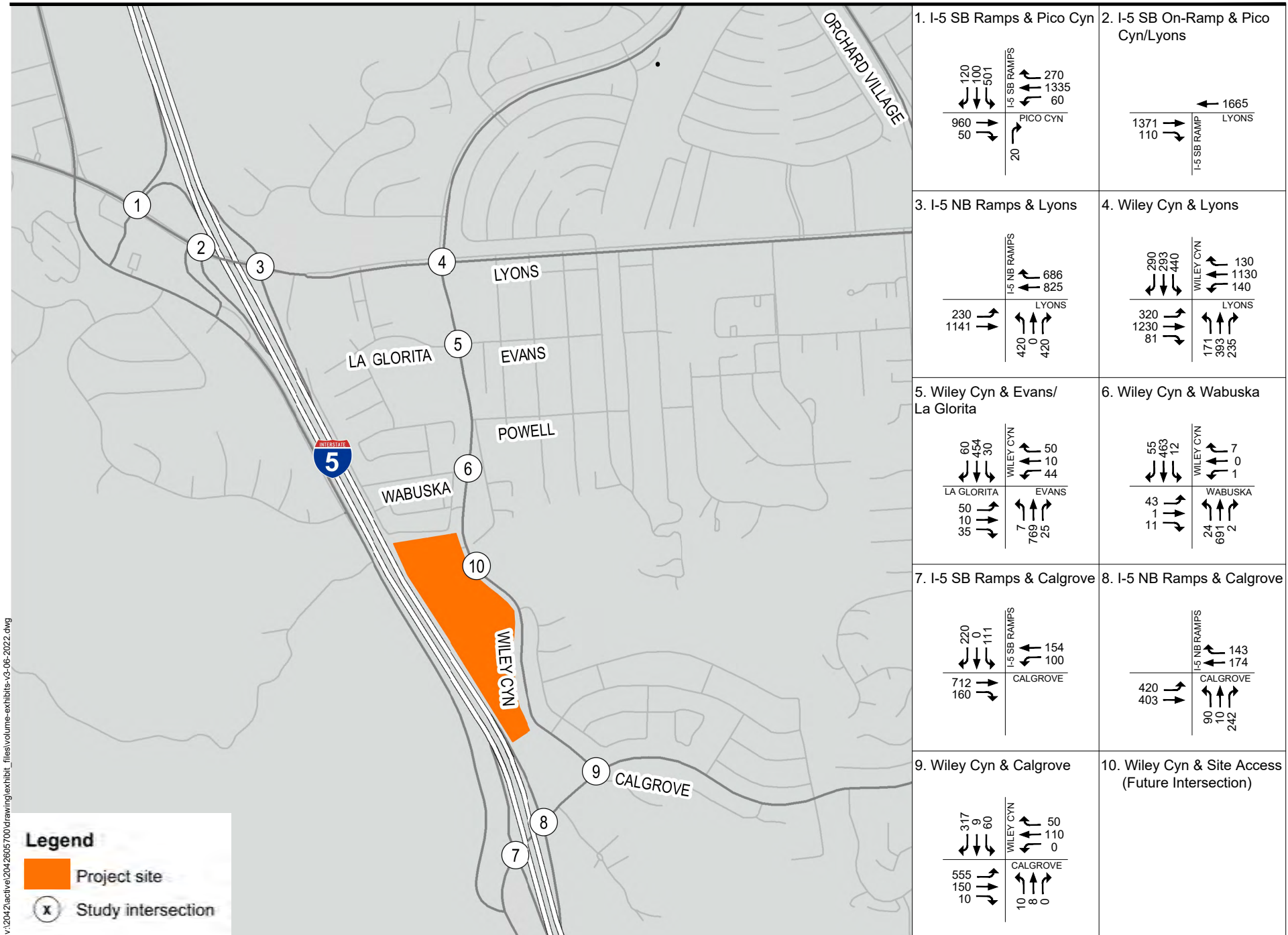

v:\204\2\active\204-2805700\drawing\exhibit\_files\volume-exhibits-v3-06-2022.dwg

**Figure 4-4**

Interim Year No-Project Conditions PM Peak Hour Volumes



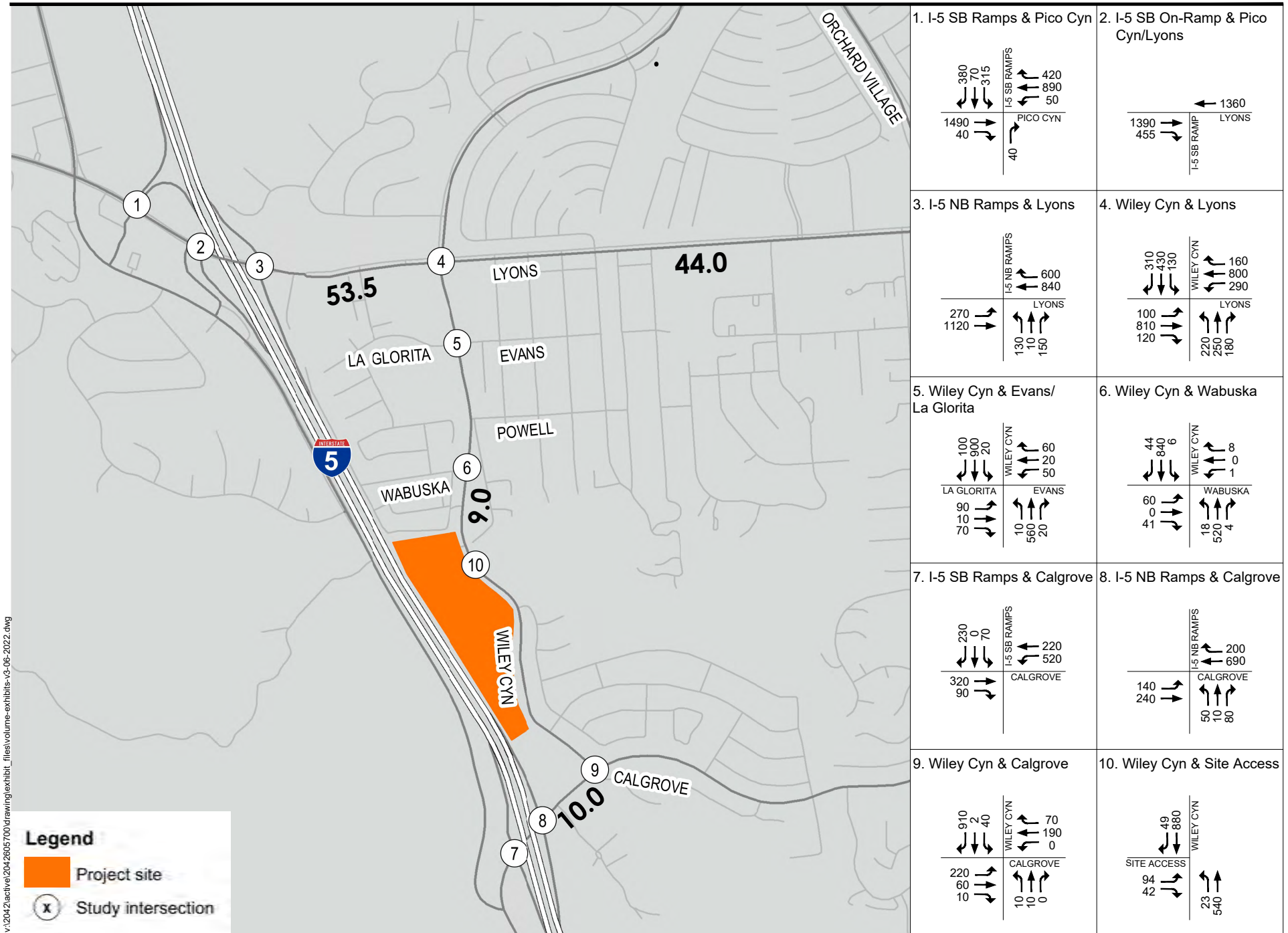

v:\204\active\204-2805700\drawing\exhibit\_files\volume-exhibits-v3-06-2022.dwg



**Figure 4-5**  
Interim Year with-Project Conditions ADT and AM Peak Hour Volumes





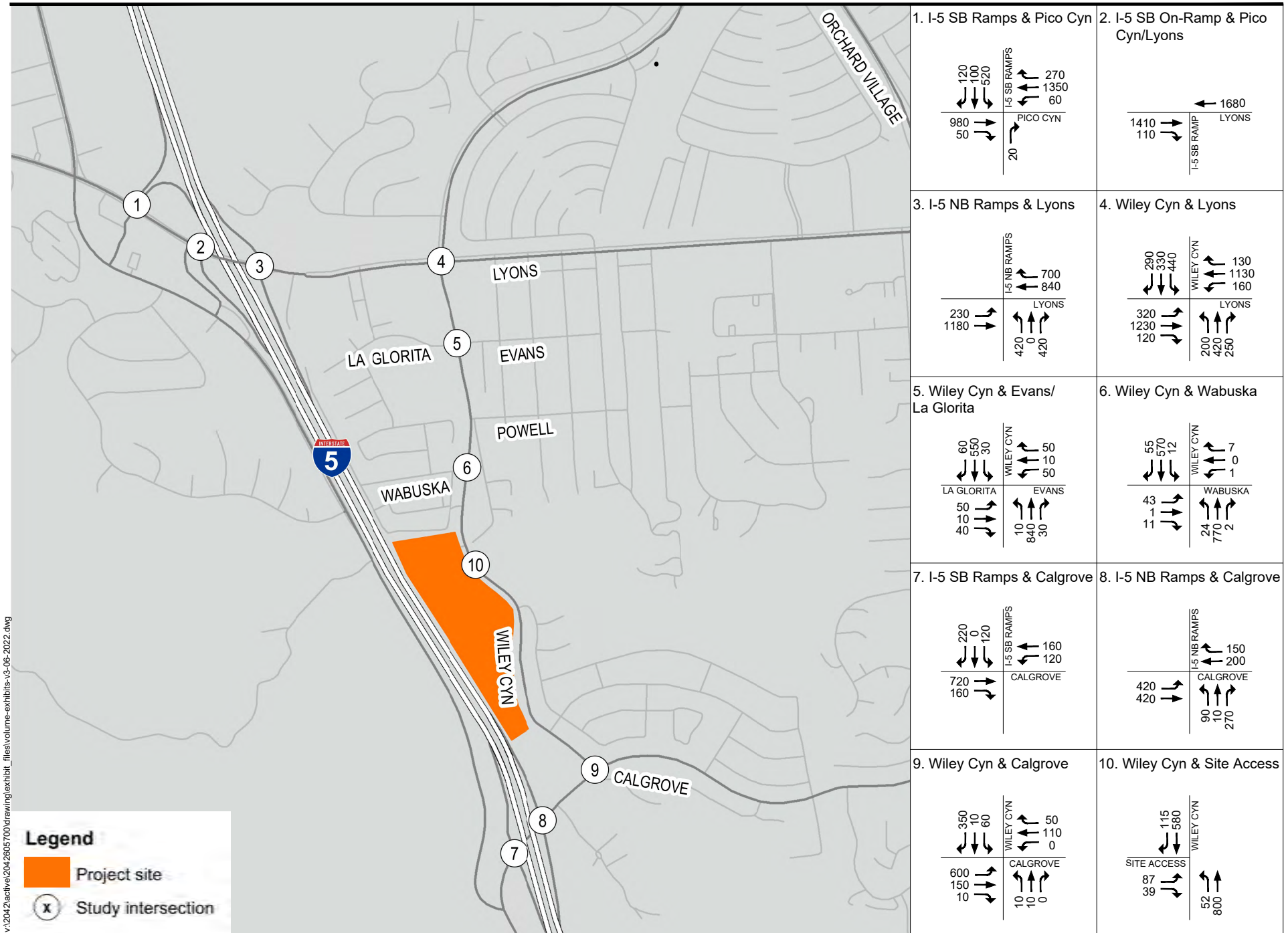

v:\204\2\active\204-2805700\drawing\exhibit\_files\volume-exhibits-v3-06-2022.dwg



**Figure 4-6**

Interim Year with-Project Conditions PM Peak Hour Volumes



## WILEY CANYON MIXED-USE TRAFFIC ANALYSIS

Impact Analysis  
July 2022

### 4.2.1 Peak Hour Intersection Levels of Service

Peak hour intersection levels of service calculated from the Interim Year cumulative conditions traffic forecasts referenced above can be found in **Table 4-4**, which provides a comparison between the no-Project and the with-Project conditions. As discussed in Section 2.1.2, HCM delay methodology was used to analyze both the signalized and stop-controlled intersections.

For this analysis, existing lanes and existing signal timing settings were assumed for both the no-Project and the with-Project conditions at the signalized study intersections. The existing two-way stop-controlled intersections were assumed to remain controlled by stop signs, with the exception of the Wiley Canyon Road and Calgrove Boulevard intersection which is assumed to be converted from stop control to a roundabout configuration with development of the Project.

As the LOS summary shows, the I-5 Southbound Ramps at Pico Canyon Road intersection and the Wiley Canyon Road at La Glorita Circle/Evans Avenue intersection would operate at LOS D or better during the AM and PM peak hours, and the Project would not affect these signalized intersections. The intersection of Wiley Canyon Road and Lyons Avenue would operate at LOS D during the AM peak hour and LOS E during the PM peak hour, but the Project would not significantly affect this intersection. Furthermore, the Project would not affect the stop-controlled intersection of Wiley Canyon Road and Calgrove Boulevard, which would be converted to a roundabout, or alternatively, a traffic signal could be installed.

The Project would significantly affect the signalized intersection of I-5 Northbound at Lyons Avenue, which would operate at LOS E during the AM peak hour assuming existing timing settings.

The Project would affect the three stop-controlled intersections where the side-streets operate at LOS F under No-Project conditions. As the delay estimates for the side street increase above 90 seconds, the calculations are extremely sensitive and even a small amount of additional traffic on the through movement can result in large increases in delay to the side street approaches. The intersection of Wiley Canyon Road and Wabuska Street would operate at LOS F during the AM peak hour and LOS E during the PM peak hour under Interim Year No-Project conditions, and the Project increases the delay by more than two seconds. Similarly, the I-5 ramps at Calgrove Boulevard operate at LOS F during the AM and PM peak hours under No-Project conditions, and the Project increases the delay by more than two seconds.

Therefore, the following intersections are forecast to be affected by the Project:

3. I-5 Northbound & Lyons Avenue
6. Wiley Canyon Road & Wabuska Street
7. I-5 Southbound & Calgrove Boulevard
8. I-5 Northbound & Calgrove Boulevard

Methods that improve the operations of the above intersections are presented in the following section.



**WILEY CANYON MIXED-USE TRAFFIC ANALYSIS**

Impact Analysis  
July 2022

**Table 4-4 Intersection Delay and LOS Summary – Interim Year Cumulative Conditions**

Intersection	Traffic Control	Interim Year No-Project				Interim Year With-Project				Project Increase	
		AM Peak Hour		PM Peak Hour		AM Peak Hour		PM Peak Hour		AM	PM
		Delay	LOS	Delay	LOS	Delay	LOS	Delay	LOS	Delay	Delay
1. I-5 SB Ramps & Pico Canyon Rd	Signal	24.8	C	40.5	D	25.2	C	42.3	D	0.4	1.8
3. I-5 NB Ramps & Lyons Ave	Signal	72.2	E	47.2	D	76.7	E	50.1	D	4.5	2.9
4. Wiley Canyon Rd & Lyons Ave	Signal	46.3	D	65.5	E	48.8	D	66.3	E	2.5	0.8
5. Wiley Canyon Rd & La Glorita Circle/Evans Ave	Signal	18.0	B	8.3	A	21.9	C	9.6	A	3.9	1.3
6. Wiley Canyon Rd & Wabuska St	TWSC	132.3	F	40.7	E	243.8	F	63.6	F	111.5	22.9
7. I-5 SB Ramps & Calgrove Blvd	TWSC	102.1	F	26.2	D	139.5	F	35.9	E	37.4	9.7
8. I-5 NB Ramps & Calgrove Blvd	TWSC	31.0	D	126.7	F	32.1	D	137.9	F	1.1	11.2
9. Wiley Canyon Rd & Calgrove Blvd	RAB <sup>1</sup>	20.4	C	195.7	F	11.6	B	10.8	B	-8.8	-184.9
	Signal <sup>2</sup>					33.7	C	16.6	B	13.3	-179.1
10. Wiley Canyon Rd & Project Access	RAB	--	--	--	--	8.2	A	8.2	A	8.2	8.2

<sup>1</sup>Existing two-way stop control, future roundabout  
<sup>2</sup>Existing two-way stop control, future traffic signal

**Note:**  
 NB – Northbound  
 SB – Southbound  
 TWSC – Two-way stop control  
 RAB – Roundabout  
 LOS – Level of Service  
 Delay – Average Vehicle Delay (seconds)



## WILEY CANYON MIXED-USE TRAFFIC ANALYSIS

Impact Analysis  
July 2022

### 4.2.2 Interim Year Cumulative Plus Project Conditions Off-Site Improvements

Intersection improvements have been identified to improve operations at the study intersections identified in the previous section that are affected by the Project.

The intersection of I-5 Northbound Ramps at Lyons Avenue operates at LOS E assuming existing signal timing settings. Adjustments to the signal cycle and phase lengths would result in acceptable LOS D during the AM and PM peak hours.

The stop-controlled intersection of Wiley Canyon Road and Wabuska Street would operate at LOS F during the AM and PM peak hours. Alternative intersection improvements consisting of either a roundabout or a traffic signal were identified to reduce the average delay under future conditions. Installation of a roundabout at the intersection of Wiley Canyon Road and Wabuska Street would result in LOS A during the AM and PM peak hours. Alternatively, a traffic signal could be installed at this intersection. The AM peak hour volumes satisfy the minimum Peak Hour Signal Warrant requirement. Signalization of the intersection would result in LOS A during the AM and PM peak hours.

The I-5 ramp intersections on Calgrove Boulevard operate at LOS D or worse during the AM and PM peak hours and the volumes satisfy the Peak Hour Signal Warrant. Improvements at both intersections consist of installing a traffic signal or, at the discretion of Caltrans, a roundabout as identified under the Existing plus Project scenario. With a traffic signal, the I-5 Southbound Ramps at Calgrove Boulevard intersection would operate at LOS C during the AM and PM peak hours, and the I-5 Northbound Ramps at Calgrove Boulevard intersection would operate at LOS D during the AM peak hour and LOS C during the PM peak hour.

**Table 4-5** lists the identified intersection improvements for the Interim Year Cumulative plus Project setting. The identified improvements would improve conditions such that the Project would not affect their operations as shown in **Table 4-6**. The Project would be responsible for its pro rata share of the improvements, which are listed in the following chapter.

## 4.3 VEHICLE MILES TRAVELED

A vehicle miles traveled (VMT) assessment has been prepared in support of the Project's environmental documentation and complies with the updated CEQA guidelines that incorporate the requirements of Senate Bill 743 (SB 743). The City of Santa Clarita's VMT analysis guidelines have been utilized for the analysis. The results of the VMT analysis are summarized in a separate memorandum for including with the Project's environmental document.

## 4.4 ACTIVE TRANSPORTATION

The Project site plan shows proposed improvements along Wiley Canyon Road in the vicinity of the Project frontage including a Class I bike path and walking trail on the west side of Wiley Canyon Road and bus bays from the northern boundary of the Project site to Calgrove Boulevard.



**WILEY CANYON MIXED-USE TRAFFIC ANALYSIS**

Impact Analysis  
July 2022

**Table 4-5 Off-Site Improvements for Project Effects – Interim Year Cumulative Conditions**

Intersection	Jurisdiction	Improvement
3. I-5 NB & Lyons Ave	City/Caltrans	Adjust signal timing
6. Wiley Canyon Rd & Wabuska St	City	Install roundabout Or Install traffic signal, meets Peak Hour Signal Warrant
7. I-5 SB & Calgrove Blvd	City/Caltrans	Install traffic signal, meets Peak Hour Signal Warrant or, at the discretion of Caltrans, a roundabout
8. I-5 NB & Calgrove Blvd	City/Caltrans	Install traffic signal, meets Peak Hour Signal Warrant or, at the discretion of Caltrans, a roundabout

**Table 4-6 Intersection Delay and LOS Summary – Interim Year Cumulative Conditions with Off-Site Improvements**

Intersection	Interim Year No-Project				Interim Year With-Project With Improvements			
	AM Peak Hour		PM Peak Hour		AM Peak Hour		PM Peak Hour	
	Delay	LOS	Delay	LOS	Delay	LOS	Delay	LOS
3. I-5 NB & Lyons Ave	72.2	E	47.2	D	37.6	D	50.1	D
6. Wiley Canyon Rd & Wabuska St	132.3	F	40.7	E				
Roundabout					8.5	A	8.4	A
Signal					8.7	A	5.2	A
7. I-5 SB Ramps & Calgrove Blvd	102.1	F	26.2	D	28.3	C	24.9	C
8. I-5 NB Ramps & Calgrove Blvd	31.0	D	126.7	F	39.9	D	25.1	C
<b>Note:</b> NB – Northbound SB – Southbound LOS – Level of Service Delay – Average Vehicle Delay (seconds/vehicle)								



# WILEY CANYON MIXED-USE TRAFFIC ANALYSIS

Findings and Conclusions  
July 2022

## 5.0 FINDINGS AND CONCLUSIONS

This traffic study was prepared to evaluate how the Project affects traffic conditions. Existing conditions and Interim Year cumulative conditions were analyzed, and the findings of each scenario are presented.

Based on the results of the LOS analyses and the criteria set forth by the City of Santa Clarita, two intersections were found to be significantly affected by the Project under Existing plus Project conditions. Improvements identified for this scenario improve conditions such that the Project would not affect their operations.

Under Interim Year Cumulative conditions, four intersections would be significantly affected by the Project. With the identified improvements, the Project would not affect the intersection operations. Since these improvements are to address cumulative conditions at two of the intersections, the Project would contribute its pro rata share of the improvement costs and the improvement is recommended to be implemented when necessary given the anticipated growth in the future traffic volumes.

The identified improvements and the Project’s pro rata share of the traffic volumes at the significantly affected locations are summarized in **Table 5-1**. The Project’s pro rata share of the cost of the off-site improvements ranges from approximately 8 percent to 27 percent under Interim Year conditions.

**Table 5-1 Off-Site Improvement Summary**

Location	Jurisdiction	Improvement	Fair Share
<b>Existing plus Project</b>			
7. I-5 SB & Calgrove Blvd	City/Caltrans	Install traffic signal, meets Peak Hour Signal Warrant or, at the discretion of Caltrans, a roundabout	100%
8. I-5 NB & Calgrove Blvd	City/Caltrans	Install traffic signal, meets Peak Hour Signal Warrant or, at the discretion of Caltrans, a roundabout	100%
<b>Interim Year Conditions</b>			
3. I-5 NB & Lyons Ave	City/Caltrans	Adjust signal timing	8%
6. Wiley Canyon Rd & Wabuska St	City	Install roundabout Or Install traffic signal, meets Peak Hour Signal Warrant	27%
7. I-5 SB & Calgrove Blvd	City/Caltrans	Same as Existing plus Project conditions	N/A
8. I-5 NB & Calgrove Blvd	City/Caltrans	Same as Existing plus Project conditions	N/A
N/A = Not applicable (Project is responsible for 100% under Existing plus Project conditions)			







# WILEY CANYON MIXED-USE TRAFFIC ANALYSIS

## Appendix A Traffic Counts

### Appendix A TRAFFIC COUNTS





**ADT1 Lyons west of Wiley Canyon.**

**Prepared by AimTD LLC tel. 714 253 7888**

AM Period	EB		WB		PM Period		EB		WB	
0:00	20		11		12:00	204		254		
0:15	16		12		12:15	214		247		
0:30	13		12		12:30	246		269		
0:45	28	77	13	48	12:45	232	896	237	1007	1903
1:00	9		6		13:00	237		223		
1:15	10		2		13:15	218		201		
1:30	13		5		13:30	190		245		
1:45	10	42	5	18	13:45	261	906	238	907	1813
2:00	12		12		14:00	253		186		
2:15	8		3		14:15	239		176		
2:30	9		2		14:30	226		220		
2:45	6	35	8	25	14:45	280	998	223	805	1803
3:00	10		7		15:00	247		267		
3:15	10		6		15:15	266		245		
3:30	14		12		15:30	282		246		
3:45	8	42	17	42	15:45	282	1077	227	985	2062
4:00	7		17		16:00	273		243		
4:15	10		15		16:15	307		236		
4:30	6		34		16:30	320		274		
4:45	21	44	41	107	16:45	328	1228	219	972	2200
5:00	30		58		17:00	307		223		
5:15	22		79		17:15	285		208		
5:30	24		91		17:30	309		246		
5:45	41	117	96	324	17:45	267	1168	199	876	2044
6:00	36		96		18:00	277		203		
6:15	62		116		18:15	239		228		
6:30	62		117		18:30	217		177		
6:45	71	231	146	475	18:45	186	919	138	746	1665
7:00	93		134		19:00	173		151		
7:15	132		162		19:15	184		130		
7:30	146		184		19:30	169		130		
7:45	159	530	240	720	19:45	134	660	128	539	1199
8:00	116		190		20:00	131		87		
8:15	140		166		20:15	107		92		
8:30	128		184		20:30	96		85		
8:45	160	544	172	712	20:45	93	427	83	347	774
9:00	138		157		21:00	86		70		
9:15	167		178		21:15	89		71		
9:30	157		180		21:30	60		34		
9:45	158	620	171	686	21:45	49	284	45	220	504
10:00	175		154		22:00	67		55		
10:15	187		182		22:15	48		38		
10:30	151		211		22:30	50		23		
10:45	211	724	212	759	22:45	39	204	23	139	343
11:00	186		205		23:00	30		27		
11:15	203		213		23:15	39		25		
11:30	206		197		23:30	36		12		
11:45	249	844	230	845	23:45	21	126	19	83	209
<b>Total Vol.</b>	3850		4761		<b>8611</b>	8893		7626		<b>16519</b>

Daily Totals				
NB	SB	EB	WB	Combined
		12743	12387	<b>25130</b>

	AM			PM		
<b>Split %</b>	44.7%	55.3%	<b>34.3%</b>	53.8%	46.2%	<b>65.7%</b>
<b>Peak Hour</b>	11:45	11:45	<b>11:45</b>	16:15	12:00	<b>16:15</b>
<b>Volume</b>	913	1000	<b>1913</b>	1262	1007	<b>2214</b>
<b>P.H.F.</b>	0.92	0.93	<b>0.93</b>	0.96	0.94	<b>0.93</b>

ADT2 Lyons east of Wiley Canyon.

Prepared by AimTD LLC tel. 714 253 7888

AM Period	EB		WB		PM Period	EB		WB		
0:00	13		9		12:00	224		216		
0:15	11		12		12:15	221		222		
0:30	15		11		12:30	237		238		
0:45	22	61	15	47	12:45	223	905	212	888	1793
1:00	10		4		13:00	237		189		
1:15	7		3		13:15	213		170		
1:30	8		5		13:30	210		205		
1:45	9	34	4	16	13:45	271	931	215	779	1710
2:00	8		8		14:00	253		185		
2:15	8		3		14:15	256		188		
2:30	8		4		14:30	247		194		
2:45	5	29	3	18	14:45	285	1041	182	749	1790
3:00	8		6		15:00	276		241		
3:15	7		3		15:15	244		231		
3:30	6		8		15:30	245		221		
3:45	8	29	12	29	15:45	286	1051	188	881	1932
4:00	11		16		16:00	265		196		
4:15	8		11		16:15	279		231		
4:30	14		24		16:30	311		243		
4:45	15	48	36	87	16:45	305	1160	217	887	2047
5:00	31		49		17:00	284		188		
5:15	27		57		17:15	272		195		
5:30	25		74		17:30	283		214		
5:45	49	132	80	260	17:45	257	1096	183	780	1876
6:00	28		82		18:00	254		162		
6:15	56		92		18:15	221		198		
6:30	75		89		18:30	186		157		
6:45	71	230	119	382	18:45	181	842	127	644	1486
7:00	84		119		19:00	176		125		
7:15	118		135		19:15	159		128		
7:30	146		157		19:30	134		121		
7:45	174	522	234	645	19:45	114	583	103	477	1060
8:00	131		154		20:00	108		74		
8:15	132		157		20:15	83		83		
8:30	127		153		20:30	75		73		
8:45	163	553	137	601	20:45	90	356	79	309	665
9:00	143		140		21:00	83		69		
9:15	169		143		21:15	73		67		
9:30	165		144		21:30	53		33		
9:45	159	636	141	568	21:45	41	250	44	213	463
10:00	165		137		22:00	61		48		
10:15	192		158		22:15	34		34		
10:30	185		183		22:30	38		18		
10:45	214	756	188	666	22:45	29	162	22	122	284
11:00	187		176		23:00	23		20		
11:15	196		196		23:15	27		24		
11:30	209		185		23:30	31		13		
11:45	228	820	183	740	23:45	18	99	14	71	170
<b>Total Vol.</b>		3850		4059	<b>7909</b>		8476		6800	<b>15276</b>
						<b>Daily Totals</b>				
						NB	SB	EB	WB	Combined
								12326	10859	<b>23185</b>
						<b>AM</b>		<b>PM</b>		
<b>Split %</b>		48.7%	51.3%	<b>34.1%</b>			55.5%	44.5%	<b>65.9%</b>	
<b>Peak Hour</b>		11:45	11:45	<b>11:45</b>			16:15	12:00	<b>16:15</b>	
<b>Volume</b>		910	859	<b>1769</b>			1179	888	<b>2058</b>	
<b>P.H.F.</b>		0.96	0.90	<b>0.93</b>			0.95	0.93	<b>0.93</b>	

ADT3 Wiley Canyon south of Wabuska.

Prepared by AimTD LLC tel. 714 253 7888

AM Period	NB	SB	PM Period	NB	SB						
0:00	3	0	12:00	71	75						
0:15	5	3	12:15	62	84						
0:30	3	4	12:30	64	83						
0:45	3	14	1	8	22	12:45	59	256	91	333	589
1:00	2	1	13:00	68	73						
1:15	0	2	13:15	51	68						
1:30	2	4	13:30	56	59						
1:45	3	7	2	9	16	13:45	84	259	70	270	529
2:00	1	1	14:00	72	78						
2:15	1	1	14:15	78	62						
2:30	3	5	14:30	81	79						
2:45	2	7	3	10	17	14:45	86	317	63	282	599
3:00	3	5	15:00	75	84						
3:15	1	5	15:15	81	83						
3:30	1	5	15:30	84	75						
3:45	0	5	7	22	27	15:45	94	334	71	313	647
4:00	1	15	16:00	97	92						
4:15	5	10	16:15	101	96						
4:30	4	16	16:30	112	104						
4:45	3	13	18	59	72	16:45	106	416	96	388	804
5:00	7	40	17:00	128	91						
5:15	8	54	17:15	101	95						
5:30	11	70	17:30	104	84						
5:45	15	41	57	221	262	17:45	123	456	90	360	816
6:00	12	56	18:00	90	68						
6:15	10	68	18:15	80	51						
6:30	31	80	18:30	91	43						
6:45	22	75	68	272	347	18:45	66	327	54	216	543
7:00	35	87	19:00	46	51						
7:15	24	103	19:15	50	65						
7:30	46	95	19:30	50	31						
7:45	77	182	94	379	561	19:45	34	180	29	176	356
8:00	39	88	20:00	49	33						
8:15	36	110	20:15	42	29						
8:30	54	89	20:30	24	25						
8:45	30	159	71	358	517	20:45	22	137	33	120	257
9:00	54	68	21:00	15	21						
9:15	48	58	21:15	18	21						
9:30	51	70	21:30	16	11						
9:45	58	211	71	267	478	21:45	12	61	20	73	134
10:00	49	59	22:00	21	15						
10:15	69	65	22:15	16	14						
10:30	46	68	22:30	10	5						
10:45	50	214	60	252	466	22:45	10	57	11	45	102
11:00	42	79	23:00	12	11						
11:15	49	49	23:15	5	13						
11:30	58	53	23:30	2	6						
11:45	63	212	75	256	468	23:45	9	28	3	33	61
<b>Total Vol.</b>	1140	2113	<b>3253</b>		2828	2609	<b>5437</b>				

Daily Totals		EB	WB	Combined
NB	SB			
3968	4722			<b>8690</b>

	AM			PM		
<b>Split %</b>	35.0%	65.0%	<b>37.4%</b>	52.0%	48.0%	<b>62.6%</b>
<b>Peak Hour</b>	11:45	7:30	<b>7:45</b>	17:00	16:00	<b>16:15</b>
<b>Volume</b>	260	387	<b>587</b>	456	388	<b>834</b>
<b>P.H.F.</b>	0.92	0.88	<b>0.86</b>	0.85	0.93	<b>0.95</b>

**ADT4 Calgrove west of Wiley Canyon.**

**Prepared by AimTD LLC tel. 714 253 7888**

AM Period	EB		WB		PM Period	EB		WB		
0:00	11		0		12:00	64		83		
0:15	8		4		12:15	52		77		
0:30	8		4		12:30	71		84		
0:45	3	30	2	10	12:45	66	253	81	325	578
1:00	4		3		13:00	79		82		
1:15	0		2		13:15	48		80		
1:30	4		4		13:30	72		67		
1:45	3	11	1	10	13:45	80	279	74	303	582
2:00	2		4		14:00	76		77		
2:15	2		1		14:15	77		67		
2:30	2		3		14:30	68		83		
2:45	2	8	2	10	14:45	85	306	61	288	594
3:00	2		5		15:00	91		68		
3:15	2		5		15:15	98		76		
3:30	1		8		15:30	99		59		
3:45	2	7	9	27	15:45	119	407	84	287	694
4:00	0		14		16:00	95		80		
4:15	7		9		16:15	115		89		
4:30	5		21		16:30	111		68		
4:45	2	14	22	66	16:45	127	448	77	314	762
5:00	6		47		17:00	137		78		
5:15	5		64		17:15	138		83		
5:30	11		83		17:30	134		71		
5:45	14	36	69	263	17:45	144	553	82	314	867
6:00	13		76		18:00	117		73		
6:15	8		81		18:15	100		69		
6:30	20		89		18:30	75		69		
6:45	18	59	92	338	18:45	77	369	49	260	629
7:00	28		106		19:00	62		33		
7:15	24		122		19:15	70		44		
7:30	37		116		19:30	51		51		
7:45	59	148	116	460	19:45	45	228	49	177	405
8:00	43		112		20:00	42		43		
8:15	36		115		20:15	41		22		
8:30	46		99		20:30	35		24		
8:45	37	162	89	415	20:45	29	147	27	116	263
9:00	44		88		21:00	19		18		
9:15	50		71		21:15	27		24		
9:30	49		84		21:30	23		8		
9:45	42	185	74	317	21:45	16	85	8	58	143
10:00	45		75		22:00	18		12		
10:15	54		76		22:15	22		12		
10:30	50		68		22:30	13		10		
10:45	55	204	70	289	22:45	13	66	11	45	111
11:00	38		75		23:00	11		8		
11:15	55		57		23:15	5		11		
11:30	57		54		23:30	7		7		
11:45	69	219	68	254	23:45	5	28	6	32	60
<b>Total Vol.</b>		1083		2459	<b>3542</b>		3169		2519	<b>5688</b>

Daily Totals				
NB	SB	EB	WB	Combined
		4252	4978	<b>9230</b>

	AM			PM		
<b>Split %</b>	30.6%	69.4%	<b>38.4%</b>	55.7%	44.3%	<b>61.6%</b>
<b>Peak Hour</b>	11:45	7:15	<b>7:30</b>	17:00	12:30	<b>17:00</b>
<b>Volume</b>	256	466	<b>634</b>	553	327	<b>867</b>
<b>P.H.F.</b>	0.90	0.95	<b>0.91</b>	0.96	0.97	<b>0.96</b>

### INTERSECTION TURNING MOVEMENT COUNTS

PREPARED BY: AimTD LLC. tel: 714 253 7888 cs@aimtd.com

**DATE:**  
Tue, Mar 9, 21

**LOCATION:**  
NORTH & SOUTH: Santa Clarita  
EAST & WEST: I-5 SB Ramp  
Pico Canyon

**PROJECT #:** SC2830  
**LOCATION #:** 1  
**CONTROL:** SIGNAL

**NOTES:**

Illegal NL/NT

AM	▲
PM	▼
MD	← W
OTHER	E →
OTHER	S

Add U-Turns to Left Turns

	NORTHBOUND <small>I-5 SB Ramp-Marriott</small>			SOUTHBOUND <small>I-5 SB Ramp-Marriott</small>			EASTBOUND <small>Pico Canyon</small>			WESTBOUND <small>Pico Canyon</small>			TOTAL	U-TURNS					
	NL	NT	NR	SL	ST	SR	EL	ET	ER	WL	WT	WR		NB	SB	EB	WB	TTL	
	X	X	1	1.5	0.5	1	X	3	0	1	2	1		0	0	0	0	0	
LANES:																			
<b>AM</b>	7:00 AM	0	0	3	28	6	9	0	86	3	8	65	38	246	0	0	0	0	0
	7:15 AM	0	0	10	41	9	6	0	101	3	2	78	47	297	0	0	0	0	0
	7:30 AM	0	0	8	47	8	17	0	123	5	5	80	54	347	0	0	0	1	1
	7:45 AM	0	0	17	52	13	18	0	152	5	8	123	56	444	0	0	0	0	0
	8:00 AM	0	0	11	47	13	15	0	118	2	3	106	52	367	0	0	0	0	0
	8:15 AM	0	0	9	56	10	15	0	126	9	6	95	45	371	0	0	0	0	0
	8:30 AM	0	0	10	41	19	16	0	107	6	8	101	46	354	0	0	0	0	0
	8:45 AM	1	0	10	62	13	21	0	129	5	9	115	59	424	0	0	0	0	0
	VOLUMES	1	0	78	374	91	117	0	942	38	49	763	397	2,851	0	0	0	1	1
	APPROACH %	1%	0%	99%	64%	16%	20%	0%	96%	4%	4%	63%	33%	0					
	APP/DEPART	79		397	582		178	980		1,395	1,210		881	0					
	BEGIN PEAK HR	7:45 AM																	
	VOLUMES	0	0	47	196	55	64	0	503	22	25	425	199	1,536					
APPROACH %	0%	0%	100%	62%	17%	20%	0%	96%	4%	4%	65%	31%	0						
PEAK HR FACTOR		0.691		0.949				0.836			0.868		0.865						
APP/DEPART	47		199	315		102	525		746	649		489	0						
<b>PM</b>	4:00 PM	0	0	9	67	19	15	0	187	7	9	200	35	548	0	0	0	3	3
	4:15 PM	0	1	17	72	12	22	0	210	12	9	202	35	592	0	0	0	1	1
	4:30 PM	0	0	9	84	12	27	0	210	6	11	229	48	636	0	0	0	2	2
	4:45 PM	0	0	14	82	18	34	0	165	8	4	210	31	566	0	0	0	2	2
	5:00 PM	1	0	9	90	18	25	0	169	4	8	202	34	560	0	0	0	0	0
	5:15 PM	0	0	16	75	19	28	0	171	10	15	198	47	579	0	0	0	1	1
	5:30 PM	0	0	13	60	17	19	0	206	12	12	246	30	615	0	0	0	3	3
	5:45 PM	0	0	17	49	25	25	0	172	5	12	209	39	553	0	0	0	1	1
	VOLUMES	1	1	104	579	140	195	0	1,490	64	80	1,696	299	4,662	0	0	0	13	13
	APPROACH %	1%	1%	98%	63%	15%	21%	0%	96%	4%	4%	81%	14%	0					
	APP/DEPART	106		300	914		284	1,554		2,186	2,088		1,892	0					
	BEGIN PEAK HR	4:15 PM																	
	VOLUMES	1	1	49	328	60	108	0	754	30	32	843	148	2,359					
APPROACH %	2%	2%	96%	66%	12%	22%	0%	96%	4%	3%	82%	14%	0						
PEAK HR FACTOR		0.708		0.925				0.883			0.886		0.924						
APP/DEPART	51		149	496		122	784		1,136	1,028		952	0						

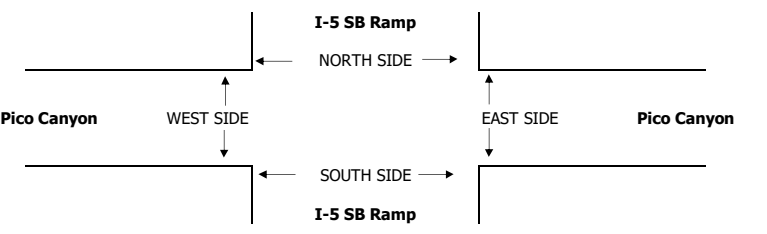

	PEDESTRIAN + BIKE CROSSINGS					PEDESTRIAN CROSSINGS					BICYCLE CROSSINGS					
	N SIDE	S SIDE	E SIDE	W SIDE	TOTAL	N SIDE	S SIDE	E SIDE	W SIDE	TOTAL	NS	SS	ES	WS	TOTAL	
<b>AM</b>	7:00 AM	1	1	0	0	2	1	1	0	0	2	0	0	0	0	0
	7:15 AM	0	1	0	0	1	0	1	0	0	1	0	0	0	0	0
	7:30 AM	1	0	0	0	1	1	0	0	0	1	0	0	0	0	0
	7:45 AM	0	0	0	0	0	0	0	0	0	0	0	0	0	0	0
	8:00 AM	0	0	0	0	0	0	0	0	0	0	0	0	0	0	0
	8:15 AM	0	0	0	0	0	0	0	0	0	0	0	0	0	0	0
	8:30 AM	0	0	0	0	0	0	0	0	0	0	0	0	0	0	0
	8:45 AM	0	0	0	0	0	0	0	0	0	0	0	0	0	0	0
	<b>TOTAL</b>	2	2	0	0	4	2	2	0	0	4	0	0	0	0	0
AM BEGIN PEAK HR	7:45 AM															
<b>PM</b>	4:00 PM	0	0	0	0	0	0	0	0	0	0	0	0	0	0	0
	4:15 PM	0	0	0	0	0	0	0	0	0	0	0	0	0	0	0
	4:30 PM	3	0	0	0	3	2	0	0	0	2	1	0	0	0	1
	4:45 PM	0	0	0	0	0	0	0	0	0	0	0	0	0	0	0
	5:00 PM	0	0	0	0	0	0	0	0	0	0	0	0	0	0	0
	5:15 PM	1	0	0	1	2	1	0	0	1	2	0	0	0	0	0
	5:30 PM	0	0	0	0	0	0	0	0	0	0	0	0	0	0	0
	5:45 PM	0	1	0	0	1	0	1	0	0	1	0	0	0	0	0
	<b>TOTAL</b>	4	1	0	1	6	3	1	0	1	5	1	0	0	0	1
PM BEGIN PEAK HR	4:15 PM															

**AimTD LLC**  
TURNING MOVEMENT COUNTS

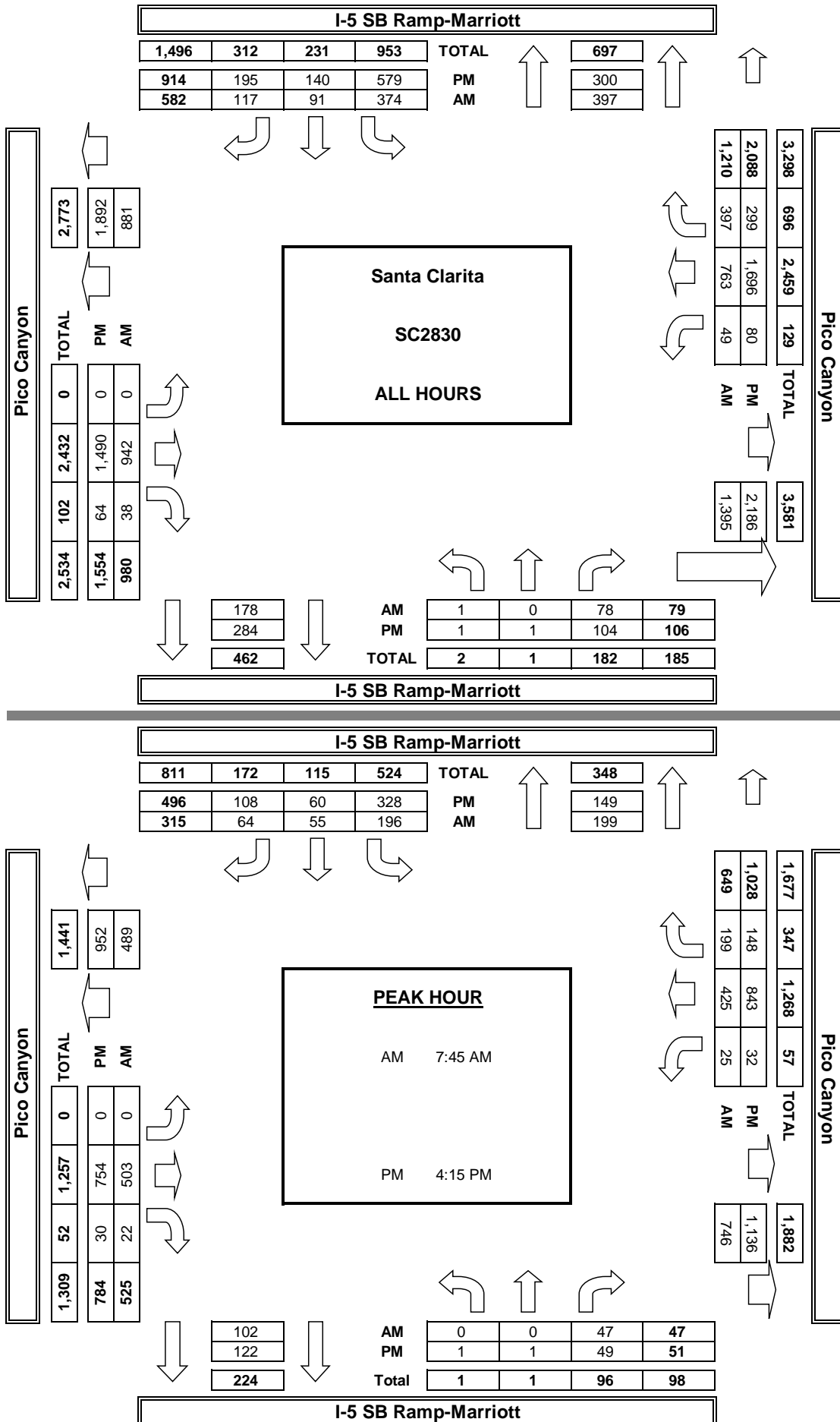



INTERSECTION TURNING MOVEMENT COUNTS

PREPARED BY: AimTD LLC. tel: 714 253 7888 cs@aimtd.com

DATE: Tue, Mar 9, 21

LOCATION: Santa Clarita
NORTH & SOUTH: I-5 SB Ramp
EAST & WEST: Lyons

PROJECT #: SC2830
LOCATION #: 2
CONTROL: NO CONTROL

NOTES: Diagram showing intersection layout with North, South, East, and West directions and a legend for AM, PM, MD, OTHER.

Add U-Turns to Left Turns

Main data table with columns for NORTHBOUND, SOUTHBOUND, EASTBOUND, WESTBOUND, and TOTAL. Rows include time slots (7:00 AM to 5:45 PM), VOLUMES, and PEAK HR FACTOR.

U-TURNS table with columns for NB, SB, EB, WB, and TTL. Rows correspond to the time slots in the main table.

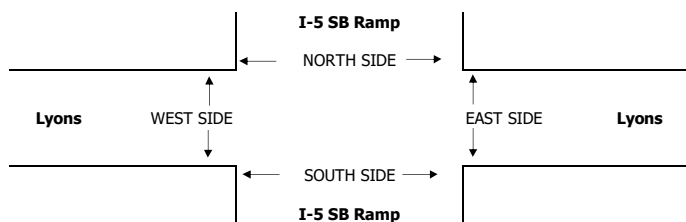

Summary table for AM and PM peak hours, including TOTAL and BEGIN PEAK HR.

PEDESTRIAN + BIKE CROSSINGS table with columns for N SIDE, S SIDE, E SIDE, W SIDE, and TOTAL.

PEDESTRIAN CROSSINGS table with columns for N SIDE, S SIDE, E SIDE, W SIDE, and TOTAL.

BICYCLE CROSSINGS table with columns for NS, SS, ES, WS, and TOTAL.

**AimTD LLC**  
TURNING MOVEMENT COUNTS

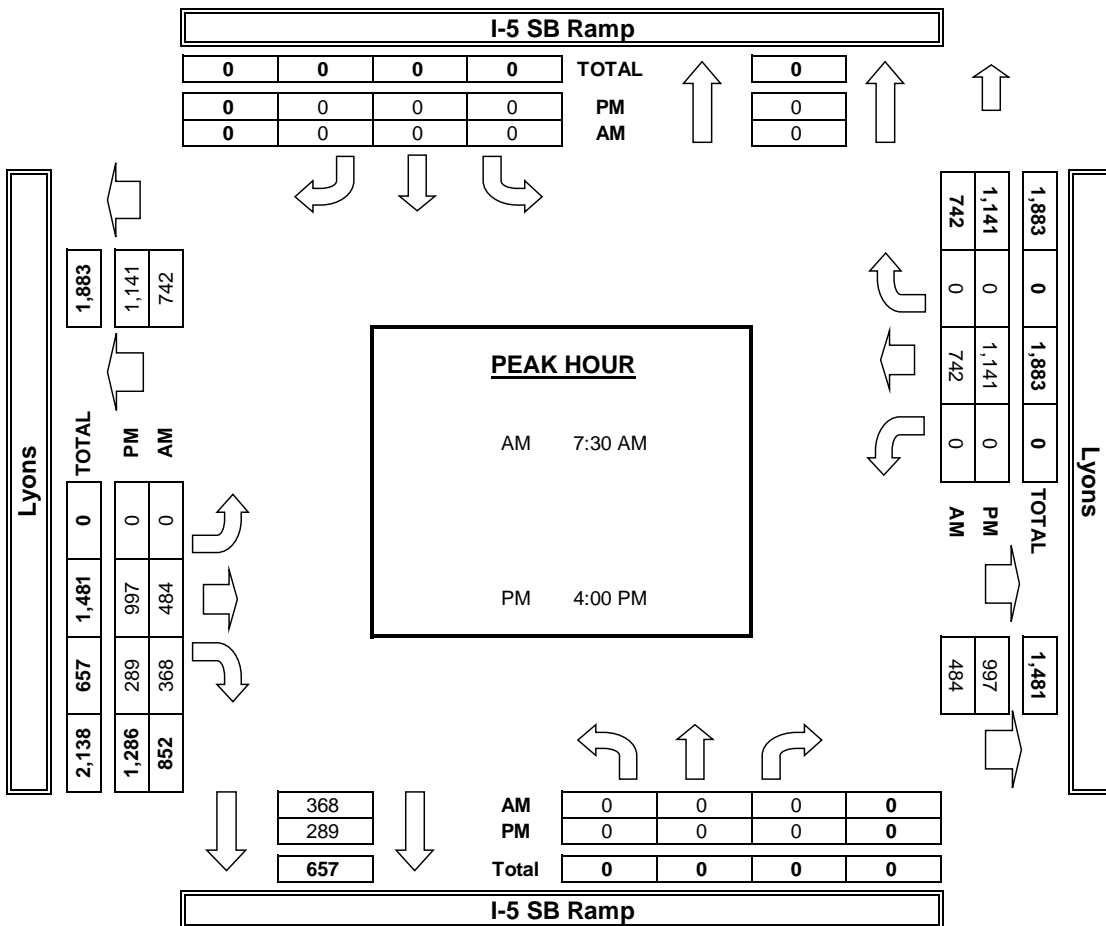
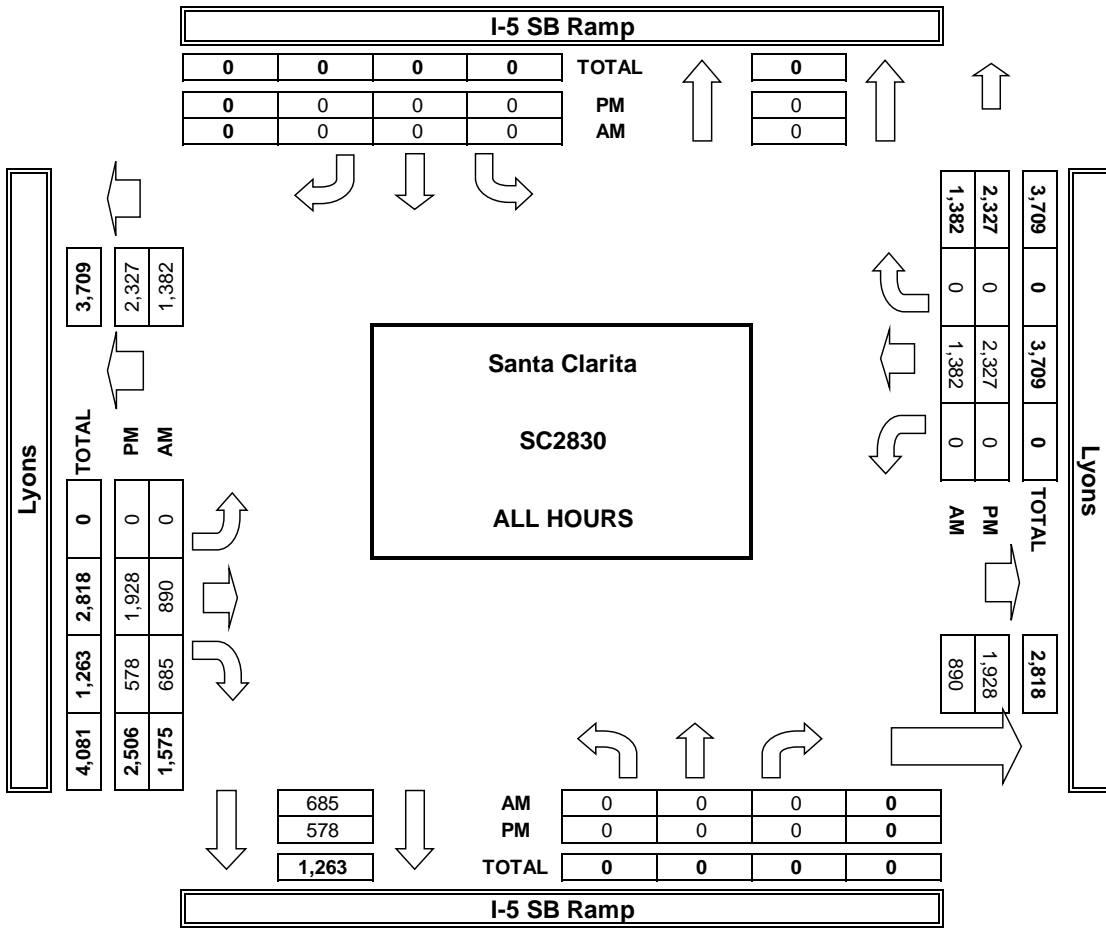

### INTERSECTION TURNING MOVEMENT COUNTS

PREPARED BY: AimTD LLC. tel: 714 253 7888 cs@aimtd.com

**DATE:**  
Tue, Mar 9, 21

**LOCATION:** Santa Clarita  
NORTH & SOUTH: I-5 NB Ramp  
EAST & WEST: Lyons

**PROJECT #:** SC2830  
**LOCATION #:** 3  
**CONTROL:** SIGNAL

NOTES:

AM	
PM	
MD	
OTHER	
OTHER	

Add U-Turns to Left Turns

LANES:	NORTHBOUND <small>I-5 NB Ramp</small>			SOUTHBOUND <small>I-5 NB Ramp</small>			EASTBOUND <small>Lyons</small>			WESTBOUND <small>Lyons</small>			TOTAL
	NL 1.5	NT 0.5	NR 1	SL X	ST X	SR X	EL 1	ET 2	ER X	WL X	WT 3	WR 0	

U-TURNS				
NB	SB	EB	WB	TTL

7:00 AM	36	0	52	0	0	0	13	49	0	0	94	48	292	
7:15 AM	47	1	56	0	0	0	17	84	0	0	96	64	365	
7:30 AM	54	1	57	0	0	0	27	96	0	0	126	63	424	
7:45 AM	69	1	77	0	0	0	27	106	0	0	133	103	516	
8:00 AM	65	2	49	0	0	0	17	97	0	0	135	67	432	
8:15 AM	47	0	60	0	0	0	18	94	0	0	115	60	394	
8:30 AM	58	0	65	0	0	0	24	79	0	0	115	59	400	
8:45 AM	61	0	73	0	0	0	29	110	0	0	135	57	465	
<b>VOLUMES</b>	437	5	489	0	0	0	172	715	0	0	949	521	3,290	
<b>APPROACH %</b>	47%	1%	53%	0%	0%	0%	19%	81%	0%	0%	64%	35%		
<b>APP/DEPART</b>	931	/	698	0	/	0	887	/	1,206	1,472	/	1,386	0	
<b>BEGIN PEAK HR</b>	7:30 AM													
<b>VOLUMES</b>	235	4	243	0	0	0	89	393	0	0	509	293	1,766	
<b>APPROACH %</b>	49%	1%	50%	0%	0%	0%	18%	82%	0%	0%	63%	37%		
<b>PEAK HR FACTOR</b>	0.820			0.000			0.906			0.850			0.856	
<b>APP/DEPART</b>	482	/	386	0	/	0	482	/	636	802	/	744	0	
4:00 PM	103	0	116	0	0	0	42	196	0	0	181	88	726	
4:15 PM	111	0	109	0	0	0	37	210	0	0	145	69	681	
4:30 PM	107	1	109	0	0	0	34	240	0	0	210	96	797	
4:45 PM	107	0	138	0	0	0	32	201	0	0	176	75	729	
5:00 PM	103	0	135	0	0	0	33	200	0	0	164	73	708	
5:15 PM	133	1	107	0	0	0	30	210	0	0	177	58	716	
5:30 PM	125	0	132	0	0	0	57	203	0	0	193	76	786	
5:45 PM	138	0	139	0	0	0	38	157	0	0	155	59	686	
<b>VOLUMES</b>	927	2	985	0	0	0	303	1,617	0	0	1,401	594	5,832	
<b>APPROACH %</b>	48%	0%	51%	0%	0%	0%	16%	84%	0%	0%	70%	30%		
<b>APP/DEPART</b>	1,914	/	899	0	/	0	1,923	/	2,602	1,995	/	2,331	0	
<b>BEGIN PEAK HR</b>	4:30 PM													
<b>VOLUMES</b>	450	2	489	0	0	0	129	851	0	0	727	302	2,951	
<b>APPROACH %</b>	48%	0%	52%	0%	0%	0%	13%	87%	0%	0%	71%	29%		
<b>PEAK HR FACTOR</b>	0.960			0.000			0.892			0.841			0.924	
<b>APP/DEPART</b>	941	/	433	0	/	0	981	/	1,340	1,029	/	1,178	0	

0	0	0	0	0
0	0	0	1	1
0	0	0	0	0
0	0	0	0	0
0	0	0	0	0
0	0	0	0	0
0	0	0	0	0
0	0	0	1	1
0	0	0	2	2
0	0	1	0	1
0	0	0	0	0
0	0	1	0	1
0	0	0	0	0
0	0	0	0	0
0	0	0	0	0
0	0	0	0	0
0	0	1	0	1
0	0	3	0	3

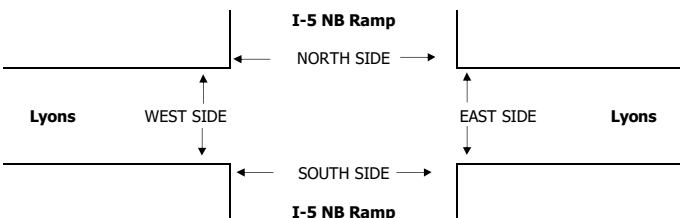

7:00 AM	0	0	0	0	0
7:15 AM	1	0	0	0	1
7:30 AM	1	0	0	0	1
7:45 AM	0	0	0	0	0
8:00 AM	0	0	0	0	0
8:15 AM	0	0	0	0	0
8:30 AM	0	1	0	0	1
8:45 AM	0	0	0	0	0
<b>TOTAL</b>	2	1	0	0	3
<b>AM BEGIN PEAK HR</b>	7:30 AM				
4:00 PM	0	2	0	0	2
4:15 PM	0	1	0	0	1
4:30 PM	3	2	0	0	5
4:45 PM	1	1	0	0	2
5:00 PM	0	0	0	0	0
5:15 PM	0	0	0	0	0
5:30 PM	0	1	1	0	2
5:45 PM	0	2	2	0	4
<b>TOTAL</b>	4	9	3	0	16
<b>PM BEGIN PEAK HR</b>	4:30 PM				

PEDESTRIAN + BIKE CROSSINGS				
N SIDE	S SIDE	E SIDE	W SIDE	TOTAL
0	0	0	0	0
1	0	0	0	1
1	0	0	0	1
0	0	0	0	0
0	0	0	0	0
0	0	0	0	0
0	1	0	0	1
0	0	0	0	0
2	1	0	0	3
1	0	0	0	1
0	2	0	0	2
0	1	0	0	1
2	2	0	0	4
1	1	0	0	2
0	0	0	0	0
0	0	0	0	0
0	1	1	0	2
0	2	2	0	4
4	9	3	0	16
3	3	0	0	6

PEDESTRIAN CROSSINGS				
N SIDE	S SIDE	E SIDE	W SIDE	TOTAL
0	0	0	0	0
1	0	0	0	1
1	0	0	0	1
0	0	0	0	0
0	0	0	0	0
0	0	0	0	0
0	1	0	0	1
0	0	0	0	0
2	1	0	0	3
1	0	0	0	1
0	2	0	0	2
0	1	0	0	1
2	2	0	0	4
1	1	0	0	2
0	0	0	0	0
0	0	0	0	0
0	1	1	0	2
0	2	2	0	4
3	9	3	0	15
3	3	0	0	6

BICYCLE CROSSINGS				
NS	SS	ES	WS	TOTAL
0	0	0	0	0
0	0	0	0	0
0	0	0	0	0
0	0	0	0	0
0	0	0	0	0
0	0	0	0	0
0	0	0	0	0
0	0	0	0	0
0	0	0	0	0
0	0	0	0	0
0	0	0	0	0
0	0	0	0	0
0	0	0	0	0
0	0	0	0	0
0	0	0	0	0
0	0	0	0	0
0	0	0	0	0
1	0	0	0	1

**AimTD LLC**  
TURNING MOVEMENT COUNTS

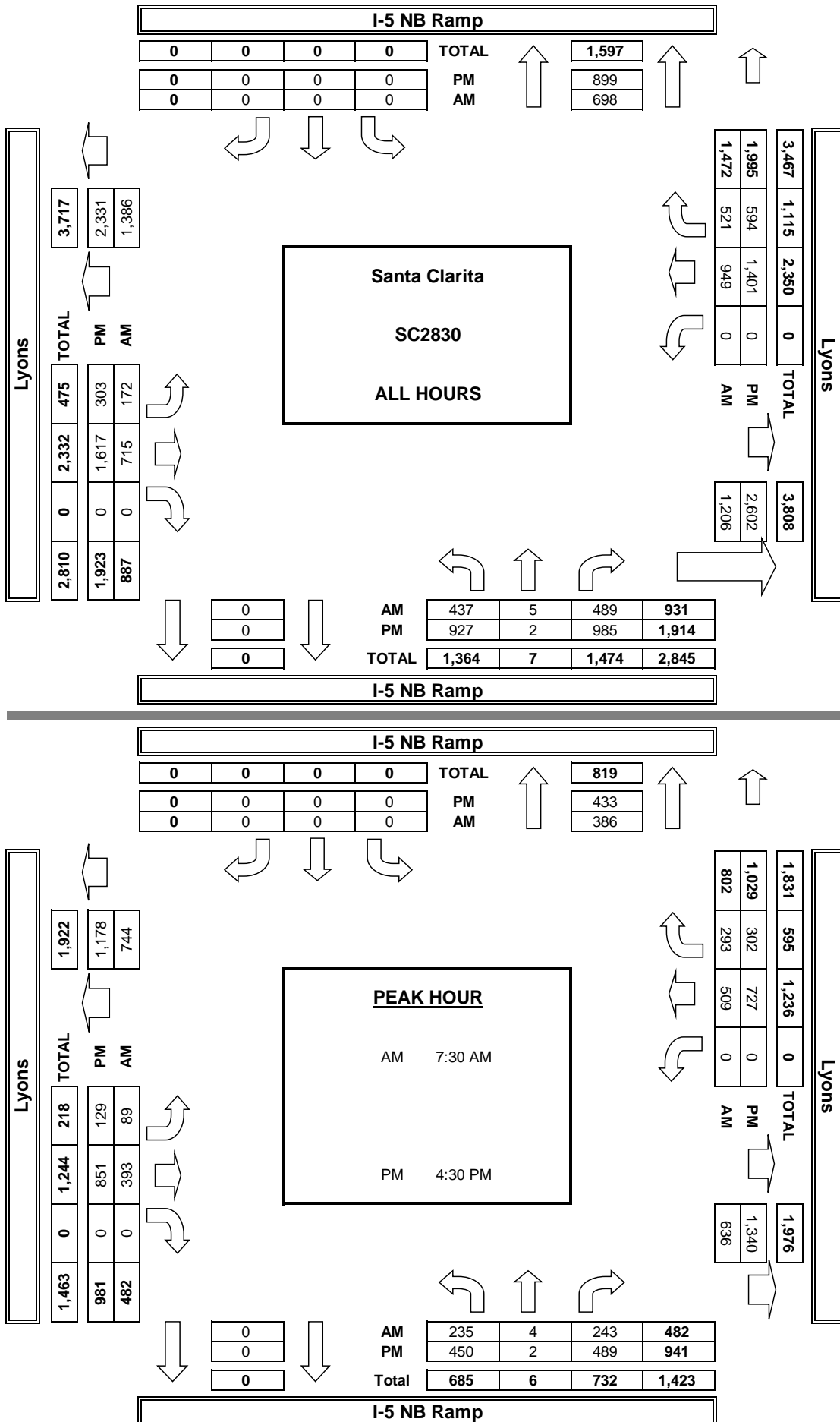

## INTERSECTION TURNING MOVEMENT COUNTS

PREPARED BY: AimTD LLC. tel: 714 253 7888 cs@aimtd.com

**DATE:**  
Tue, Mar 9, 21

**LOCATION:**  
NORTH & SOUTH: Santa Clarita  
Wiley Canyon  
EAST & WEST: Lyons

**PROJECT #:** SC2830  
**LOCATION #:** 4  
**CONTROL:** SIGNAL

<p><b>NOTES:</b></p>	AM PM MD OTHER OTHER	◀ W E ▶	▲ N S ▼	
----------------------	----------------------------------	------------	------------	--

Add U-Turns to Left Turns

	NORTHBOUND <small>Wiley Canyon</small>			SOUTHBOUND <small>Wiley Canyon</small>			EASTBOUND <small>Lyons</small>			WESTBOUND <small>Lyons</small>			TOTAL
	NL 1	NT 2	NR 1	SL 1	ST 2	SR 1	EL 2	ET 3	ER 0	WL 1	WT 3	WR 0	
<b>LANES:</b>													
<b>AM</b>													
7:00 AM	7	27	9	14	52	35	29	62	2	18	91	10	356
7:15 AM	9	27	15	13	53	49	30	90	12	23	104	8	433
7:30 AM	14	29	21	23	66	53	33	104	9	27	117	13	509
7:45 AM	19	46	38	14	68	58	26	123	10	46	163	25	636
8:00 AM	20	40	26	22	50	52	23	86	7	23	118	13	480
8:15 AM	14	24	14	18	52	38	28	101	11	34	114	9	457
8:30 AM	10	43	24	19	41	55	34	85	9	23	119	11	473
8:45 AM	17	30	18	25	45	51	30	120	10	15	104	18	483
<b>VOLUMES</b>	110	266	165	148	427	391	233	771	70	209	930	107	3,827
<b>APPROACH %</b>	20%	49%	30%	15%	44%	40%	22%	72%	7%	17%	75%	9%	
<b>APP/DEPART</b>	541	/	620	966	/	700	1,074	/	1,075	1,246	/	1,432	0
<b>BEGIN PEAK HR</b>	7:30 AM												
<b>VOLUMES</b>	67	139	99	77	236	201	110	414	37	130	512	60	2,082
<b>APPROACH %</b>	22%	46%	32%	15%	46%	39%	20%	74%	7%	19%	73%	9%	
<b>PEAK HR FACTOR</b>	0.740			0.905			0.882			0.750			0.818
<b>APP/DEPART</b>	305	/	318	514	/	401	561	/	583	702	/	780	0
<b>PM</b>													
4:00 PM	46	66	43	36	58	50	55	189	29	29	147	20	768
4:15 PM	17	74	41	24	53	44	75	216	16	37	175	19	791
4:30 PM	32	57	45	29	53	54	60	241	19	37	188	18	833
4:45 PM	22	66	43	22	38	45	64	239	25	39	152	26	781
5:00 PM	30	102	46	34	65	40	77	209	21	26	153	9	812
5:15 PM	19	62	37	30	61	55	64	206	15	37	134	24	744
5:30 PM	35	65	41	29	51	44	77	216	16	25	167	22	788
5:45 PM	27	63	44	28	58	40	70	184	13	33	132	18	710
<b>VOLUMES</b>	228	555	340	232	437	372	542	1,700	154	263	1,248	156	6,227
<b>APPROACH %</b>	20%	49%	30%	22%	42%	36%	23%	71%	6%	16%	75%	9%	
<b>APP/DEPART</b>	1,123	/	1,275	1,041	/	848	2,396	/	2,256	1,667	/	1,848	0
<b>BEGIN PEAK HR</b>	4:15 PM												
<b>VOLUMES</b>	101	299	175	109	209	183	276	905	81	139	668	72	3,217
<b>APPROACH %</b>	18%	52%	30%	22%	42%	37%	22%	72%	6%	16%	76%	8%	
<b>PEAK HR FACTOR</b>	0.808			0.901			0.962			0.904			0.965
<b>APP/DEPART</b>	575	/	659	501	/	427	1,262	/	1,179	879	/	952	0

U-TURNS				
NB	SB	EB	WB	TTL
0	3	1	2	6
0	1	0	1	2
0	3	0	1	4
0	1	0	0	1
0	3	0	0	3
0	2	0	1	3
0	1	0	0	1
0	1	0	1	2
0	15	1	6	22

0	3	0	0	3
0	2	0	0	2
0	4	0	0	4
0	0	0	1	1
0	6	0	1	7
0	3	0	2	5
0	3	0	0	3
0	1	0	2	3
0	22	0	6	28

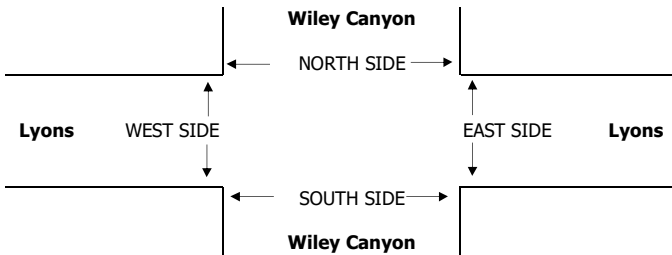

	PEDESTRIAN + BIKE CROSSINGS				TOTAL
	N SIDE	S SIDE	E SIDE	W SIDE	
7:00 AM	1	1	0	0	2
7:15 AM	1	1	1	0	3
7:30 AM	0	1	0	0	1
7:45 AM	1	2	6	0	9
8:00 AM	0	4	1	1	6
8:15 AM	0	0	5	0	5
8:30 AM	0	1	0	0	1
8:45 AM	0	2	3	1	6
<b>TOTAL</b>	3	12	16	2	33
<b>AM BEGIN PEAK HR</b>	7:30 AM				
4:00 PM	2	2	1	4	9
4:15 PM	2	3	1	1	7
4:30 PM	1	0	2	3	6
4:45 PM	0	4	0	3	7
5:00 PM	0	1	3	0	4
5:15 PM	1	0	1	7	9
5:30 PM	0	2	1	1	4
5:45 PM	0	0	0	1	1
<b>TOTAL</b>	6	12	9	20	47
<b>PM BEGIN PEAK HR</b>	4:15 PM				
3	6	5	7	21	

	PEDESTRIAN CROSSINGS				TOTAL
	N SIDE	S SIDE	E SIDE	W SIDE	
7:00 AM	1	1	0	0	2
7:15 AM	1	1	1	0	3
7:30 AM	0	1	0	0	1
7:45 AM	1	2	6	0	9
8:00 AM	0	4	1	0	5
8:15 AM	0	0	4	0	4
8:30 AM	0	0	0	0	0
8:45 AM	0	2	3	1	6
<b>TOTAL</b>	3	11	15	1	30
<b>AM BEGIN PEAK HR</b>	7:30 AM				
4:00 PM	2	2	1	4	9
4:15 PM	2	1	1	1	5
4:30 PM	1	0	2	3	6
4:45 PM	0	4	0	3	7
5:00 PM	0	1	2	0	3
5:15 PM	1	0	1	7	9
5:30 PM	0	1	0	1	2
5:45 PM	0	0	0	1	1
<b>TOTAL</b>	6	9	7	20	42
<b>PM BEGIN PEAK HR</b>	4:15 PM				
3	6	5	7	21	

	BICYCLE CROSSINGS				TOTAL
	NS	SS	ES	WS	
7:00 AM	0	0	0	0	0
7:15 AM	0	0	0	0	0
7:30 AM	0	0	0	0	0
7:45 AM	0	0	0	0	0
8:00 AM	0	0	0	1	1
8:15 AM	0	0	1	0	1
8:30 AM	0	1	0	0	1
8:45 AM	0	0	0	0	0
<b>TOTAL</b>	0	1	1	1	3
<b>AM BEGIN PEAK HR</b>	7:30 AM				
4:00 PM	0	0	0	0	0
4:15 PM	0	2	0	0	2
4:30 PM	0	0	0	0	0
4:45 PM	0	0	0	0	0
5:00 PM	0	0	1	0	1
5:15 PM	0	0	0	0	0
5:30 PM	0	1	1	0	2
5:45 PM	0	0	0	0	0
<b>TOTAL</b>	0	3	2	0	5
<b>PM BEGIN PEAK HR</b>	4:15 PM				
3	6	5	7	21	

A.12

**AimTD LLC**  
TURNING MOVEMENT COUNTS

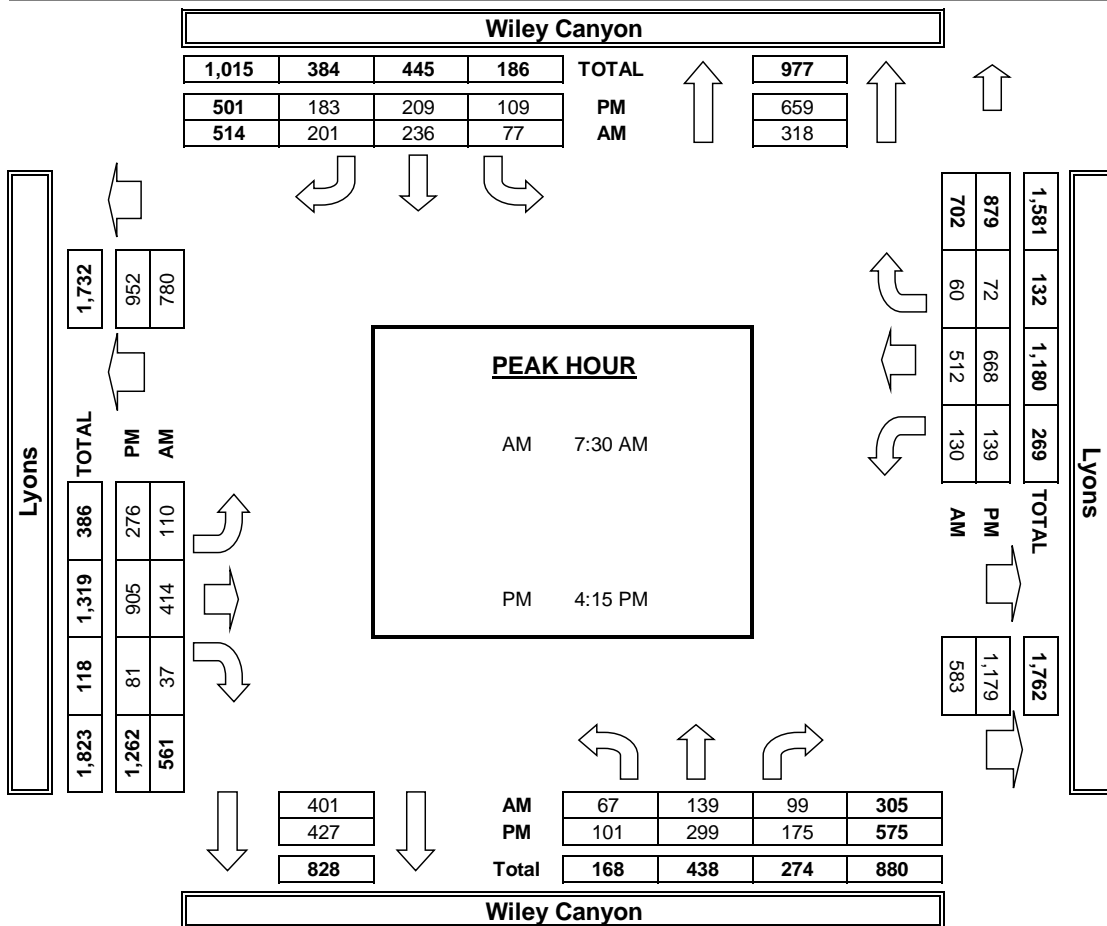
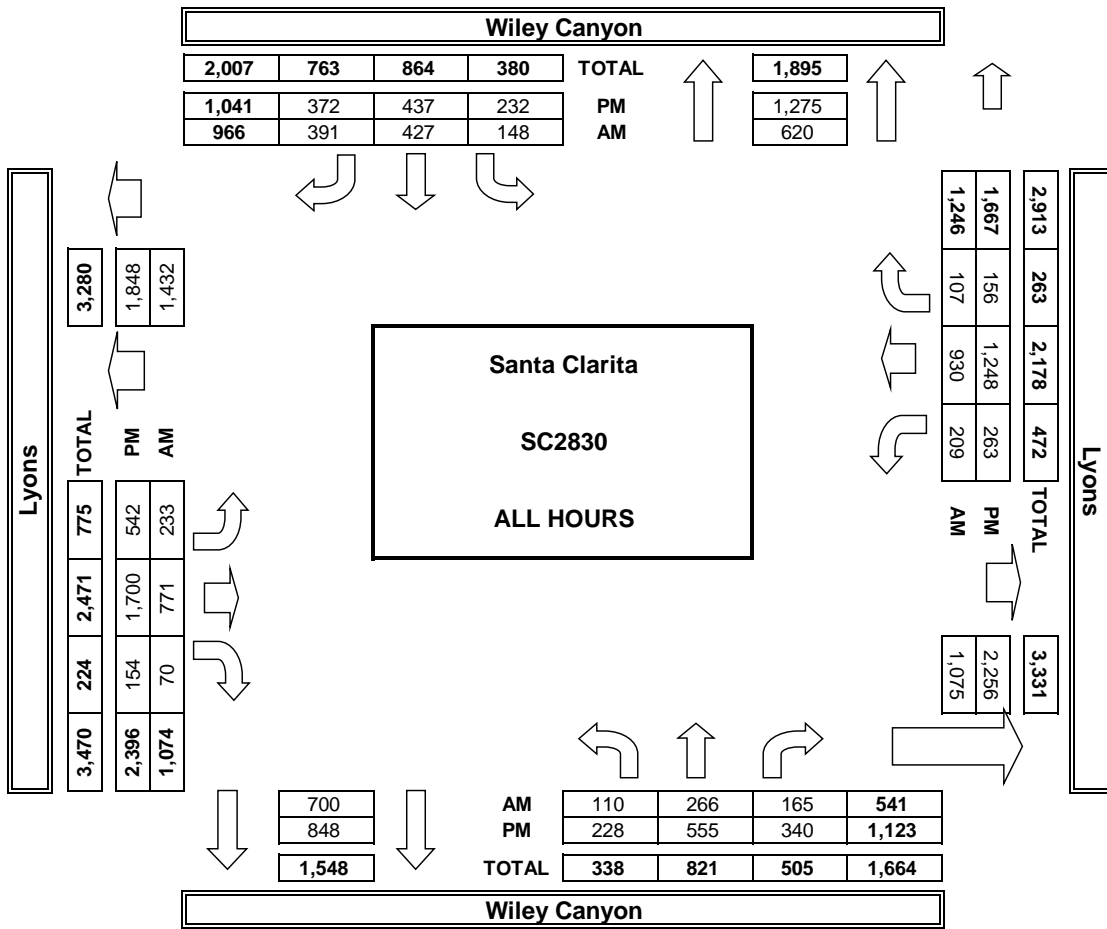



**AimTD LLC**  
TURNING MOVEMENT COUNTS

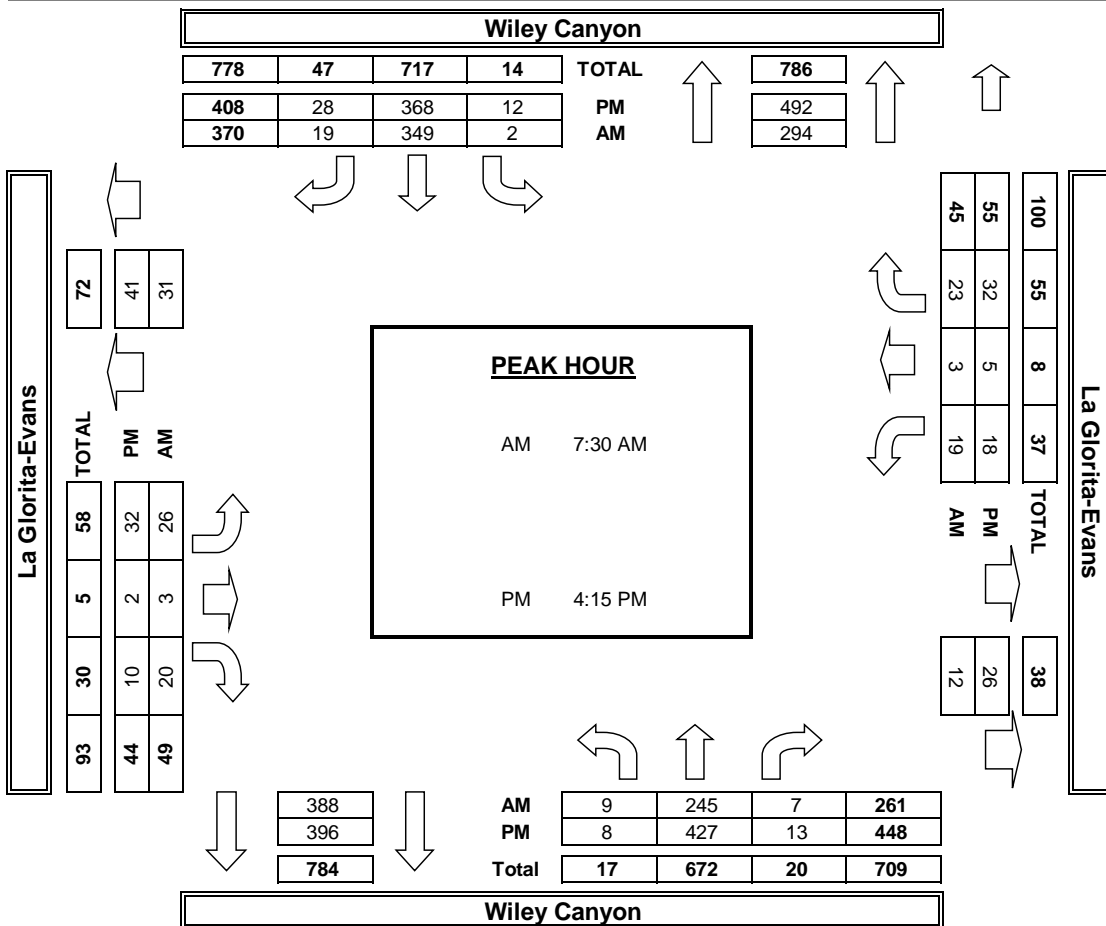
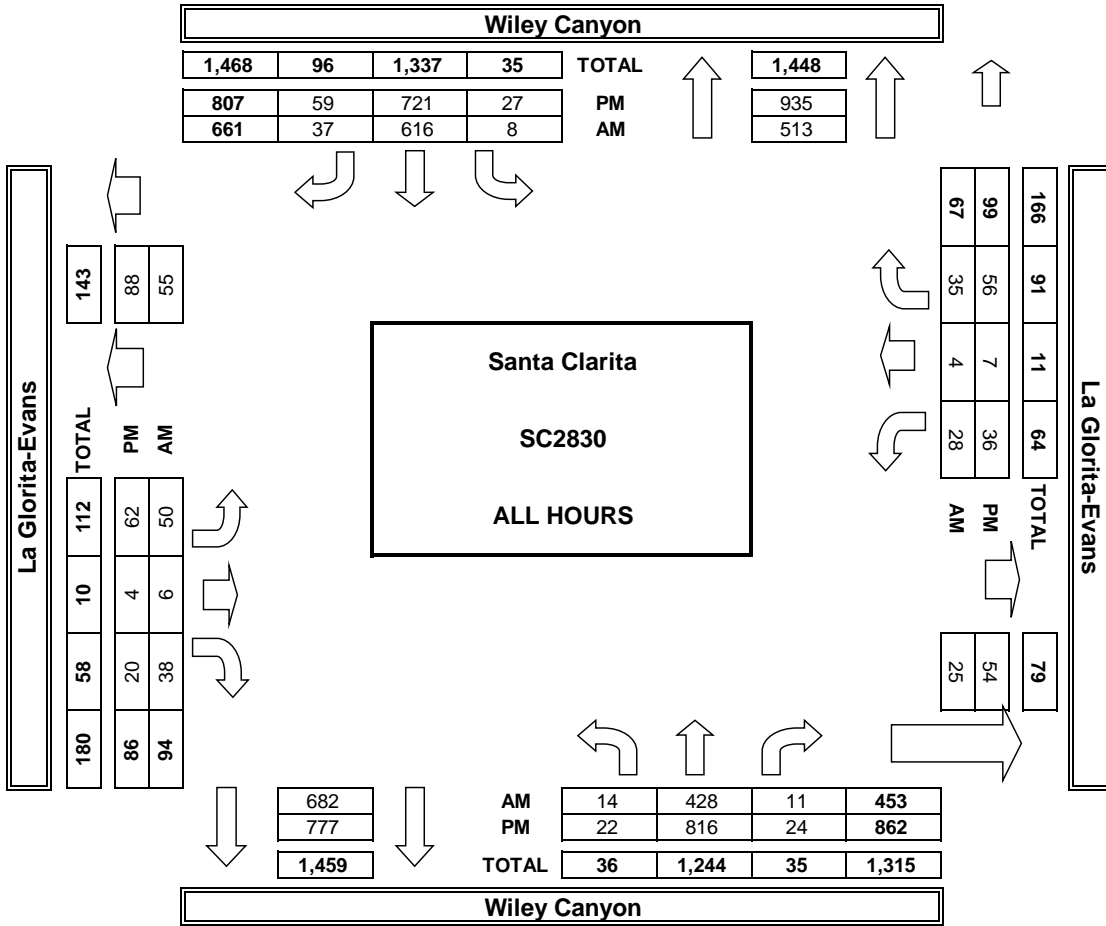



**INTERSECTION TURNING MOVEMENT COUNTS**

PREPARED BY: AimTD LLC. tel: 714 253 7888 cs@aimtd.com

T218

DATE:  
Tue, Mar 9, 21

LOCATION:  
NORTH & SOUTH:  
EAST & WEST:  
Santa Clarita  
Wiley Canyon  
Wabuska

PROJECT #: SC2830  
LOCATION #: 6  
CONTROL: STOP E/W

NOTES:	AM	▲ N	E ►
	PM		
	MD	◄ W	S
	OTHER	▼	
	OTHER		

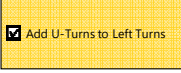

LANES:	NORTHBOUND Wiley Canyon			SOUTHBOUND Wiley Canyon			EASTBOUND Wabuska			WESTBOUND Wabuska			U-TURNS						
	NL	NT	NR	SL	ST	SR	EL	ET	ER	WL	WT	WR	TOTAL	NB	SB	EB	WB	TTL	
7:00 AM	2	33	0	1	80	1	4	0	7	0	0	1	129	0	0	0	0	0	
7:15 AM	3	21	0	2	90	4	12	0	11	2	0	0	145	0	0	0	0	0	
7:30 AM	4	42	0	0	87	10	15	0	8	0	0	2	168	0	0	0	0	0	
7:45 AM	9	68	0	1	87	17	14	0	7	0	0	2	205	0	0	0	0	0	
8:00 AM	2	37	0	1	81	10	13	0	6	1	0	1	152	0	0	0	0	0	
8:15 AM	1	33	2	1	101	3	8	0	9	0	0	1	159	0	0	0	0	0	
8:30 AM	2	51	1	2	78	5	13	0	11	0	0	5	168	0	0	0	0	0	
8:45 AM	2	28	0	1	64	4	12	0	6	1	0	1	119	0	0	0	0	0	
<b>VOLUMES</b>	25	313	3	9	668	54	91	0	65	4	0	13	1,245	0	0	0	0	0	
<b>APPROACH %</b>	7%	92%	1%	1%	91%	7%	58%	0%	42%	24%	0%	76%							
<b>APP/DEPART</b>	341	/	417	731	/	737	156	/	12	17	/	79	0						
<b>BEGIN PEAK HR</b>	7:45 AM																		
<b>VOLUMES</b>	14	189	3	5	347	35	48	0	33	1	0	9	684						
<b>APPROACH %</b>	7%	92%	1%	1%	90%	9%	59%	0%	41%	10%	0%	90%							
<b>PEAK HR FACTOR</b>	0.669			0.921			0.844			0.500			0.834						
<b>APP/DEPART</b>	206	/	246	387	/	381	81	/	8	10	/	49	0						
4:00 PM	7	89	1	2	87	15	10	0	5	0	0	1	217	0	0	0	0	0	
4:15 PM	7	93	1	3	93	7	11	1	3	0	0	1	220	0	0	0	0	0	
4:30 PM	4	108	0	2	98	18	11	0	5	1	0	2	249	0	0	0	0	0	
4:45 PM	7	99	0	3	96	14	9	0	0	0	0	5	233	0	0	0	0	0	
5:00 PM	4	123	1	3	89	11	8	0	2	0	0	1	242	0	0	0	0	0	
5:15 PM	7	93	1	3	86	12	6	0	9	0	0	2	219	0	0	0	0	0	
5:30 PM	9	95	0	3	79	12	9	0	5	0	0	1	213	0	0	0	0	0	
5:45 PM	16	105	2	4	85	11	7	0	5	0	0	4	239	0	0	0	0	0	
<b>VOLUMES</b>	61	805	6	23	713	100	71	1	34	1	0	17	1,832	0	0	0	0	0	
<b>APPROACH %</b>	7%	92%	1%	3%	85%	12%	67%	1%	32%	6%	0%	94%							
<b>APP/DEPART</b>	872	/	893	836	/	748	106	/	30	18	/	161	0						
<b>BEGIN PEAK HR</b>	4:15 PM																		
<b>VOLUMES</b>	22	423	2	11	376	50	39	1	10	1	0	9	944						
<b>APPROACH %</b>	5%	95%	0%	3%	86%	11%	78%	2%	20%	10%	0%	90%							
<b>PEAK HR FACTOR</b>	0.873			0.926			0.781			0.500			0.948						
<b>APP/DEPART</b>	447	/	471	437	/	387	50	/	14	10	/	72	0						

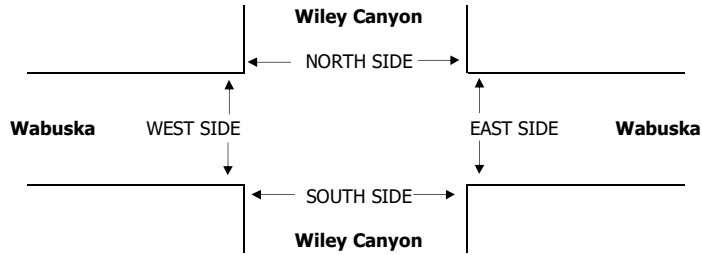

AM	7:00 AM				
	7:15 AM				
	7:30 AM				
	7:45 AM				
	8:00 AM				
	8:15 AM				
	8:30 AM				
	8:45 AM				
<b>TOTAL</b>					
<b>AM BEGIN PEAK HR</b>					
PM	4:00 PM				
	4:15 PM				
	4:30 PM				
	4:45 PM				
	5:00 PM				
	5:15 PM				
	5:30 PM				
	5:45 PM				
<b>TOTAL</b>					
<b>PM BEGIN PEAK HR</b>					

PEDESTRIAN + BIKE CROSSINGS				
N SIDE	S SIDE	E SIDE	W SIDE	TOTAL
0	0	0	0	0
0	0	0	0	0
0	0	0	0	0
0	0	1	0	1
1	0	0	1	2
0	0	2	1	3
0	0	0	0	0
0	0	0	0	0
1	0	3	2	6
<b>7:45 AM</b>				
1	0	3	0	4
0	0	2	0	2
0	1	1	0	2
0	0	0	0	0
0	0	3	1	4
0	0	5	2	7
0	0	2	2	4
0	0	0	0	0
1	1	16	5	23
<b>4:15 PM</b>				

PEDESTRIAN CROSSINGS				
N SIDE	S SIDE	E SIDE	W SIDE	TOTAL
0	0	0	0	0
0	0	0	0	0
0	0	0	0	0
0	0	0	0	0
1	0	0	0	1
0	0	0	0	0
0	0	0	0	0
0	0	0	0	0
1	0	0	0	1
<b>7:45 AM</b>				
1	0	1	0	2
0	0	1	0	1
0	1	1	0	2
0	0	0	0	0
0	0	3	1	4
0	0	2	2	4
0	0	1	2	3
0	0	0	0	0
1	1	9	5	16
<b>4:15 PM</b>				

BICYCLE CROSSINGS				
NS	SS	ES	WS	TOTAL
0	0	0	0	0
0	0	0	0	0
0	0	0	0	0
0	0	1	0	1
0	0	0	1	1
0	0	2	1	3
0	0	0	0	0
0	0	0	0	0
0	0	3	2	5
<b>7:45 AM</b>				
0	0	2	0	2
0	0	1	0	1
0	0	0	0	0
0	0	0	0	0
0	0	0	0	0
0	0	3	0	3
0	0	1	0	1
0	0	0	0	0
0	0	7	0	7
<b>4:15 PM</b>				

**AimTD LLC**  
TURNING MOVEMENT COUNTS

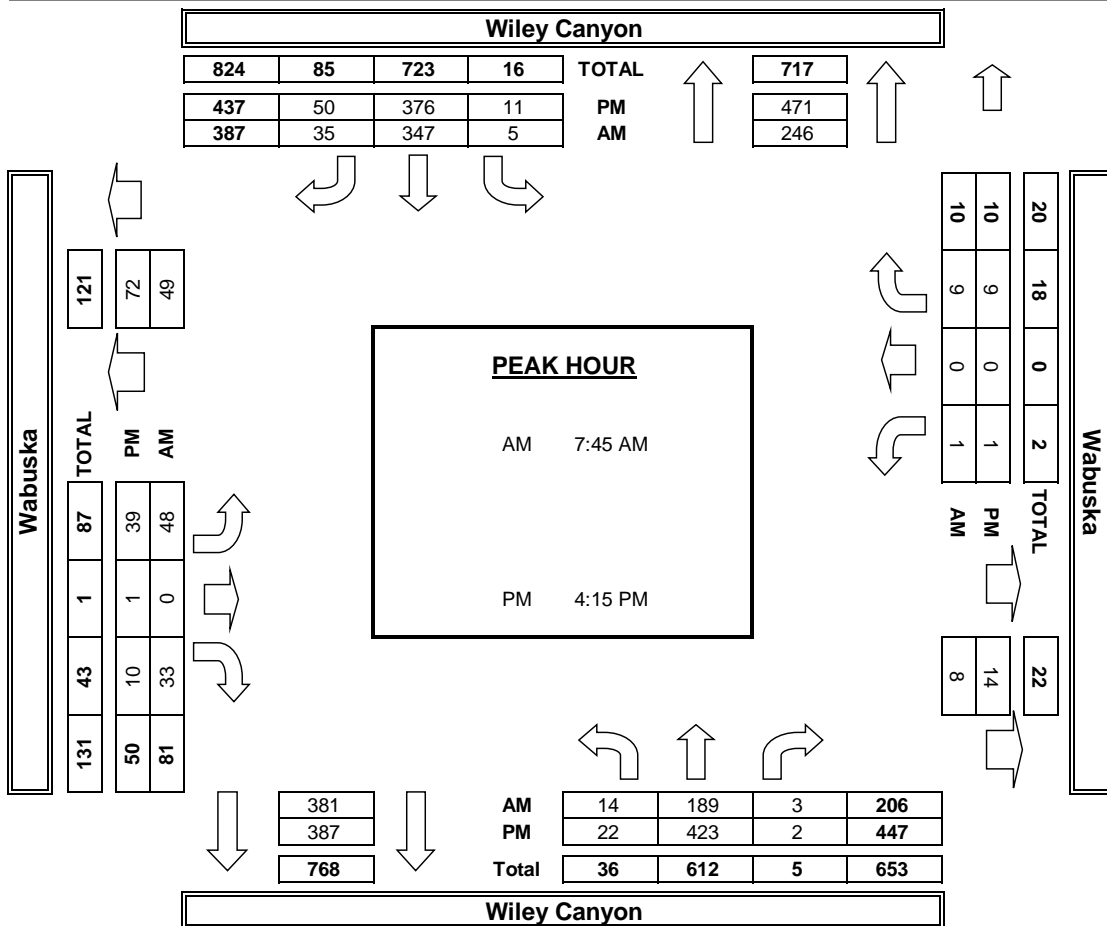
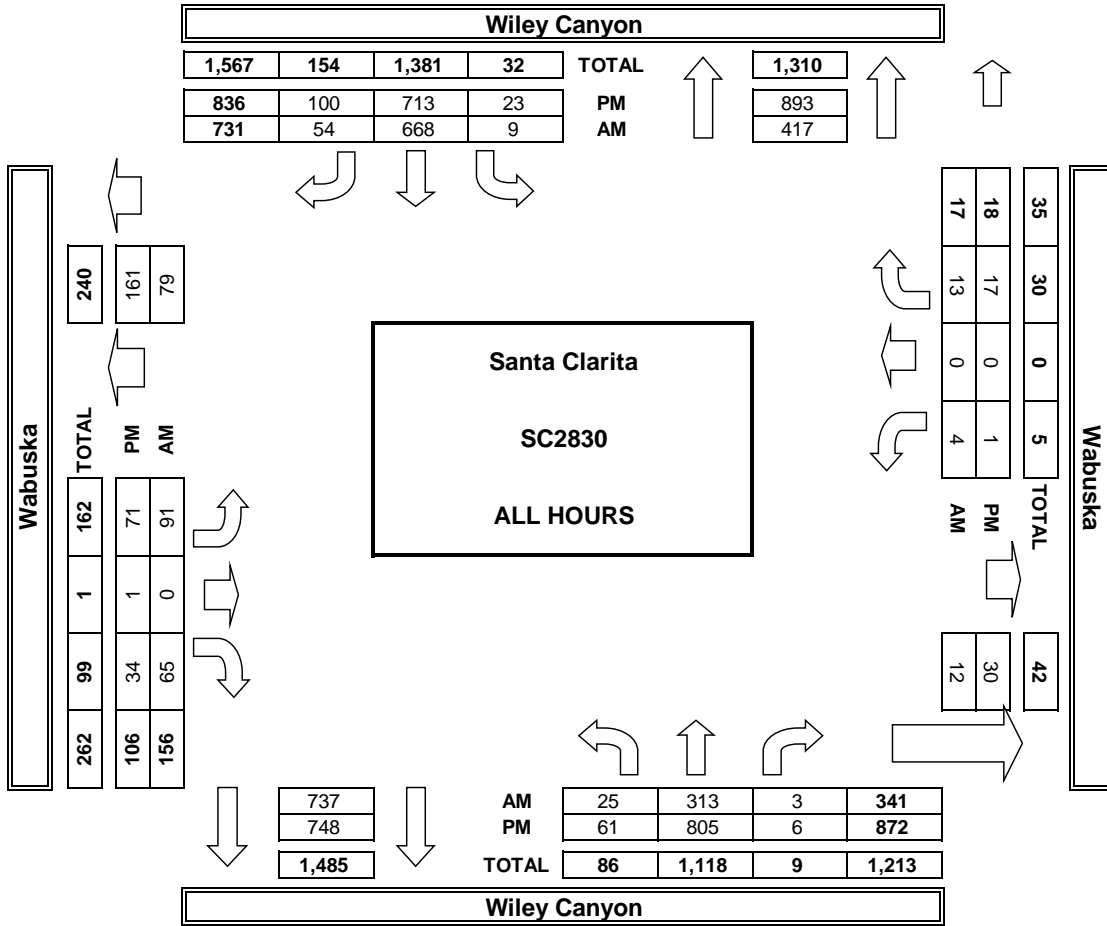

# INTERSECTION TURNING MOVEMENT COUNTS

PREPARED BY: AimTD LLC. tel: 714 253 7888 cs@aimtd.com

T218

<b>DATE:</b> Tue, Mar 9, 21		<b>LOCATION:</b> NORTH & SOUTH: Santa Clarita EAST & WEST: I-5 SB Ramp Calgrove	<b>PROJECT #:</b> SC2830 <b>LOCATION #:</b> 7 <b>CONTROL:</b> STOP S															
<b>NOTES:</b>		<table border="1"> <tr><td>AM</td><td>▲</td><td></td></tr> <tr><td>PM</td><td></td><td>N</td></tr> <tr><td>MD</td><td>◀ W</td><td>E ▶</td></tr> <tr><td>OTHER</td><td></td><td>S</td></tr> <tr><td>OTHER</td><td>▼</td><td></td></tr> </table>	AM	▲		PM		N	MD	◀ W	E ▶	OTHER		S	OTHER	▼		<input checked="" type="checkbox"/> Add U-Turns to Left Turns
AM	▲																	
PM		N																
MD	◀ W	E ▶																
OTHER		S																
OTHER	▼																	

LANES:	NORTHBOUND I-5 SB Ramp			SOUTHBOUND I-5 SB Ramp			EASTBOUND Calgrove			WESTBOUND Calgrove			TOTAL
	NL X	NT X	NR X	SL 0.5	ST 0.5	SR 1	EL X	ET 1	ER 0	WL 1	WT 1	WR X	
<b>AM</b>													
7:00 AM	0	0	0	6	0	19	0	15	10	77	21	0	148
7:15 AM	0	0	0	6	0	12	0	21	10	84	36	0	169
7:30 AM	0	0	0	8	0	12	0	22	14	110	24	0	190
7:45 AM	0	0	0	3	0	9	0	36	11	71	34	0	164
8:00 AM	0	0	0	13	0	7	0	23	12	79	36	0	170
8:15 AM	0	0	0	4	0	16	0	18	10	72	30	0	150
8:30 AM	0	0	0	8	0	11	0	38	11	77	31	0	176
8:45 AM	0	0	0	12	0	15	0	19	15	73	31	0	165
<b>VOLUMES</b>	0	0	0	60	0	101	0	192	93	643	243	0	1,332
<b>APPROACH %</b>	0%	0%	0%	37%	0%	63%	0%	67%	33%	73%	27%	0%	
<b>APP/DEPART</b>	0	/	0	161	/	736	285	/	252	886	/	344	0
<b>BEGIN PEAK HR</b>	7:15 AM												
<b>VOLUMES</b>	0	0	0	30	0	40	0	102	47	344	130	0	693
<b>APPROACH %</b>	0%	0%	0%	43%	0%	57%	0%	68%	32%	73%	27%	0%	
<b>PEAK HR FACTOR</b>	0.000			0.875			0.793			0.884			0.912
<b>APP/DEPART</b>	0	/	0	70	/	391	149	/	132	474	/	170	0
<b>PM</b>													
4:00 PM	0	0	0	7	0	6	0	99	13	68	46	0	239
4:15 PM	0	0	0	18	0	12	0	95	10	52	33	0	220
4:30 PM	0	0	0	13	1	23	0	125	18	49	36	0	265
4:45 PM	0	0	0	20	0	16	0	117	18	49	36	0	256
5:00 PM	0	0	0	17	1	11	0	131	16	61	34	0	271
5:15 PM	0	0	0	24	0	8	0	103	18	46	44	0	243
5:30 PM	0	0	0	18	0	5	0	91	13	34	38	0	199
5:45 PM	0	0	0	17	0	12	0	121	17	57	25	0	249
<b>VOLUMES</b>	0	0	0	134	2	93	0	882	123	416	292	0	1,942
<b>APPROACH %</b>	0%	0%	0%	59%	1%	41%	0%	88%	12%	59%	41%	0%	
<b>APP/DEPART</b>	0	/	0	229	/	540	1,005	/	1,017	708	/	385	0
<b>BEGIN PEAK HR</b>	4:30 PM												
<b>VOLUMES</b>	0	0	0	74	2	58	0	476	70	205	150	0	1,035
<b>APPROACH %</b>	0%	0%	0%	55%	1%	43%	0%	87%	13%	58%	42%	0%	
<b>PEAK HR FACTOR</b>	0.000			0.905			0.929			0.934			0.955
<b>APP/DEPART</b>	0	/	0	134	/	276	546	/	551	355	/	208	0

U-TURNS				
NB	SB	EB	WB	TTL
0	0	0	0	0
0	0	0	0	0
0	0	0	0	0
0	0	0	0	0
0	0	0	0	0
0	0	0	0	0
0	0	0	0	0
0	0	0	0	0
0	0	0	0	0
0	0	0	0	0
0	0	0	0	0
0	0	0	0	0
0	0	0	0	0

0	0	0	0	0
0	0	0	0	0
0	0	0	0	0
0	0	0	1	1
0	0	0	0	0
0	0	0	0	0
0	0	0	0	0
0	0	0	0	0
0	0	0	0	0
0	0	0	0	0
0	0	0	1	1

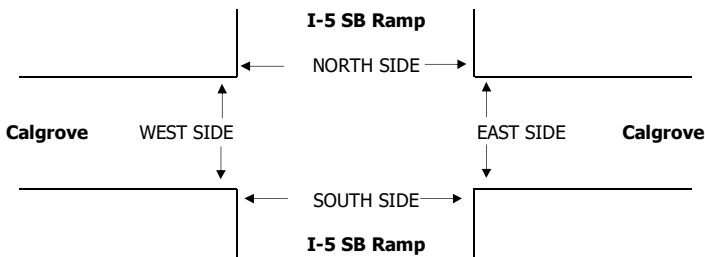

<b>AM</b>	
7:00 AM	0
7:15 AM	1
7:30 AM	0
7:45 AM	0
8:00 AM	1
8:15 AM	0
8:30 AM	0
8:45 AM	1
<b>TOTAL</b>	3
<b>AM BEGIN PEAK HR</b>	7:15 AM
4:00 PM	2
4:15 PM	2
4:30 PM	0
4:45 PM	0
5:00 PM	0
5:15 PM	0
5:30 PM	0
5:45 PM	0
<b>TOTAL</b>	4
<b>PM BEGIN PEAK HR</b>	4:30 PM

PEDESTRIAN + BIKE CROSSINGS				
N SIDE	S SIDE	E SIDE	W SIDE	TOTAL
0	0	0	0	0
1	1	0	0	2
0	0	0	0	0
0	0	0	0	0
1	2	0	0	3
0	0	0	0	0
0	1	0	0	1
1	1	0	0	2
3	5	0	0	8
2	0	0	0	2
2	1	0	0	3
0	0	0	0	0
0	0	0	0	0
0	2	0	0	2
0	2	0	0	2
0	1	0	1	2
0	0	0	0	0
4	6	0	1	11

PEDESTRIAN CROSSINGS				
N SIDE	S SIDE	E SIDE	W SIDE	TOTAL
0	0	0	0	0
0	1	0	0	1
0	0	0	0	0
0	0	0	0	0
0	1	0	0	1
0	0	0	0	0
0	0	0	0	0
0	0	0	0	0
0	0	0	1	1
0	0	0	0	0
0	2	0	0	2
0	0	0	0	0
2	0	0	0	2
0	0	0	0	0
0	0	0	0	0
2	0	0	1	3
0	0	0	0	0

BICYCLE CROSSINGS				
NS	SS	ES	WS	TOTAL
0	0	0	0	0
1	0	0	0	1
0	0	0	0	0
0	0	0	0	0
1	1	0	0	2
0	0	0	0	0
0	1	0	0	1
0	1	0	0	1
1	1	0	0	2
3	3	0	0	6
2	0	0	0	2
0	1	0	0	1
0	0	0	0	0
0	0	0	0	0
0	2	0	0	2
0	2	0	0	2
0	1	0	0	1
0	0	0	0	0
2	6	0	0	8

**AimTD LLC**  
TURNING MOVEMENT COUNTS

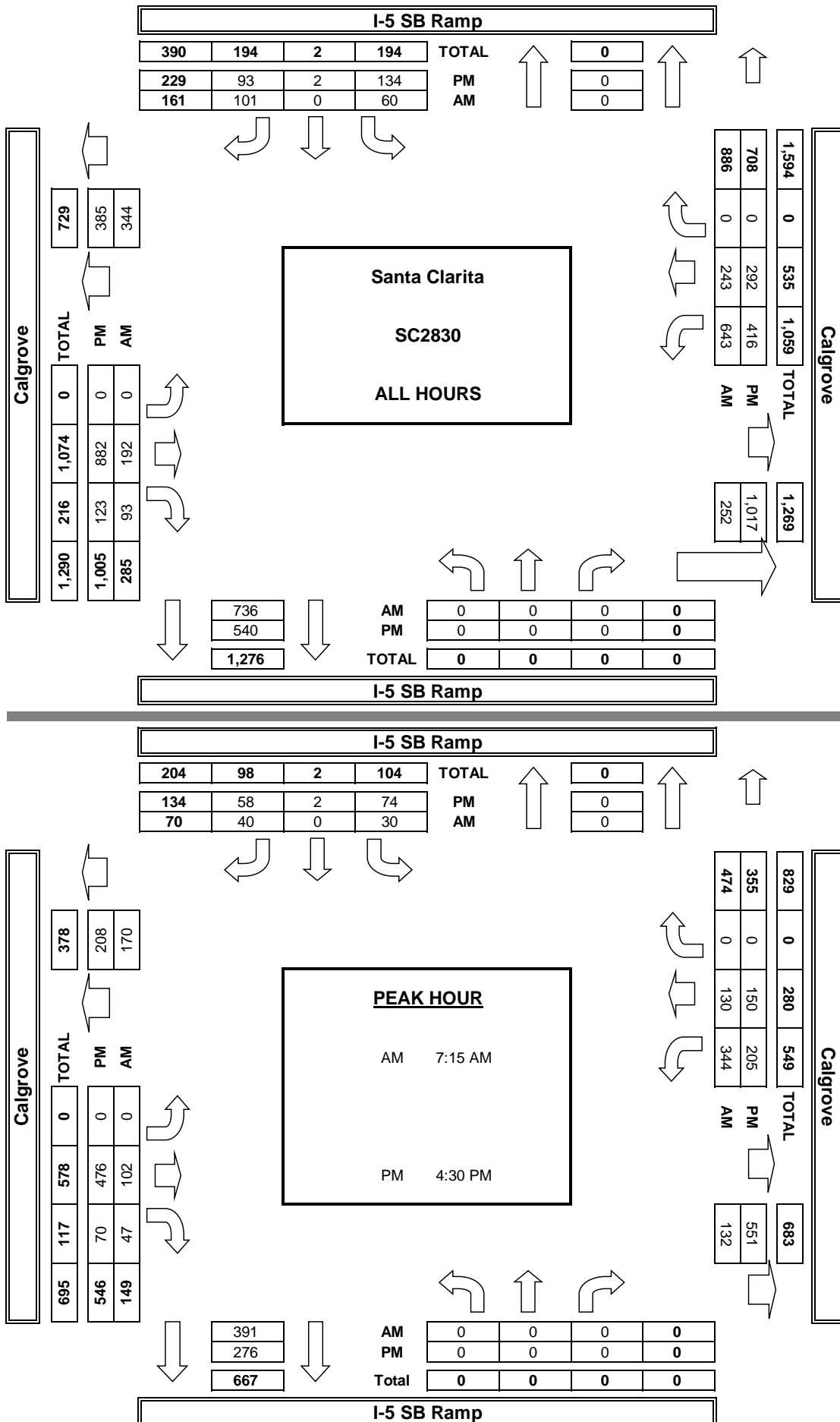

# INTERSECTION TURNING MOVEMENT COUNTS

PREPARED BY: AimTD LLC. tel: 714 253 7888 cs@aimtd.com

**DATE:**  
Tue, Mar 9, 21

**LOCATION:** Santa Clarita  
**NORTH & SOUTH:** I-5 NB Ramp  
**EAST & WEST:** Calgrove

**PROJECT #:** SC2830  
**LOCATION #:** 8  
**CONTROL:** STOP N

NOTES:

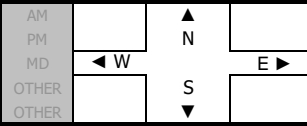

	NORTHBOUND I-5 NB Ramp			SOUTHBOUND I-5 NB Ramp			EASTBOUND Calgrove			WESTBOUND Calgrove			TOTAL
	NL	NT	NR	SL	ST	SR	EL	ET	ER	WL	WT	WR	
<b>LANES:</b>	0.5	0.5	1	X	X	X	1	1	X	X	1	1	
<b>AM</b>													
7:00 AM	8	0	21	0	0	0	11	10	0	0	90	7	147
7:15 AM	16	0	6	0	0	0	12	15	0	0	104	11	164
7:30 AM	18	0	18	0	0	0	13	17	0	0	115	14	195
7:45 AM	14	2	34	0	0	0	16	23	0	0	91	22	202
8:00 AM	15	3	22	0	0	0	11	25	0	0	100	18	194
8:15 AM	10	1	22	0	0	0	11	11	0	0	92	17	164
8:30 AM	21	3	23	0	0	0	21	27	0	0	87	14	196
8:45 AM	21	1	20	0	0	0	11	20	0	0	83	12	168
VOLUMES	123	10	166	0	0	0	106	148	0	0	762	115	1,430
APPROACH %	41%	3%	56%	0%	0%	0%	42%	58%	0%	0%	87%	13%	
APP/DEPART	299	/	231	0	/	0	254	/	314	877	/	885	0
BEGIN PEAK HR	7:45 AM												
VOLUMES	60	9	101	0	0	0	59	86	0	0	370	71	756
APPROACH %	35%	5%	59%	0%	0%	0%	41%	59%	0%	0%	84%	16%	
PEAK HR FACTOR	0.850			0.000			0.755			0.934			0.936
APP/DEPART	170	/	139	0	/	0	145	/	187	441	/	430	0
<b>PM</b>													
4:00 PM	23	1	45	0	0	0	46	60	0	0	91	13	279
4:15 PM	18	1	59	0	0	0	55	58	0	0	67	16	274
4:30 PM	15	2	56	0	0	0	73	65	0	0	70	10	291
4:45 PM	22	1	46	0	0	0	57	81	0	0	63	15	285
5:00 PM	29	3	65	0	0	0	75	73	0	0	66	16	327
5:15 PM	17	2	64	0	0	0	52	75	0	0	73	12	295
5:30 PM	15	0	66	0	0	0	47	58	0	0	57	12	255
5:45 PM	15	0	77	0	0	0	62	76	0	0	67	10	307
VOLUMES	154	10	478	0	0	0	467	546	0	0	554	104	2,313
APPROACH %	24%	2%	74%	0%	0%	0%	46%	54%	0%	0%	84%	16%	
APP/DEPART	642	/	581	0	/	0	1,013	/	1,024	658	/	708	0
BEGIN PEAK HR	4:30 PM												
VOLUMES	83	8	231	0	0	0	257	294	0	0	272	53	1,198
APPROACH %	26%	2%	72%	0%	0%	0%	47%	53%	0%	0%	84%	16%	
PEAK HR FACTOR	0.830			0.000			0.931			0.956			0.916
APP/DEPART	322	/	318	0	/	0	551	/	525	325	/	355	0

U-TURNS				
NB	SB	EB	WB	TTL
0	0	0	0	0
0	0	0	0	0
0	0	0	0	0
0	0	0	0	0
0	0	0	0	0
0	0	0	0	0
0	0	0	0	0
0	0	0	0	0
0	0	0	0	0
0	0	0	0	0
0	0	0	0	0

0	0	0	0	0
0	0	0	0	0
0	0	0	0	0
0	0	0	0	0
0	0	0	0	0
0	0	0	0	0
0	0	0	0	0
0	0	0	0	0
0	0	0	0	0
0	0	0	0	0
0	0	0	0	0

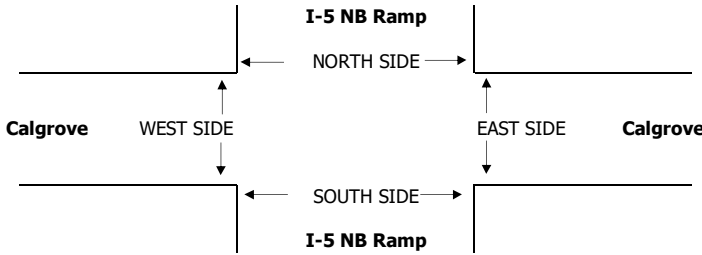

	PEDESTRIAN + BIKE CROSSINGS				
	N SIDE	S SIDE	E SIDE	W SIDE	TOTAL
<b>AM</b>					
7:00 AM	0	0	0	0	0
7:15 AM	1	1	0	0	2
7:30 AM	0	0	0	0	0
7:45 AM	0	0	0	0	0
8:00 AM	1	1	0	0	2
8:15 AM	0	1	0	0	1
8:30 AM	0	1	0	0	1
8:45 AM	1	0	0	0	1
TOTAL	3	4	0	0	7
AM BEGIN PEAK HR	7:45 AM				
4:00 PM	2	0	0	0	2
4:15 PM	0	1	0	0	1
4:30 PM	1	0	0	0	1
4:45 PM	1	0	0	0	1
5:00 PM	0	0	0	0	0
5:15 PM	0	3	0	0	3
5:30 PM	0	2	0	0	2
5:45 PM	0	0	0	0	0
TOTAL	4	6	0	0	10
PM BEGIN PEAK HR	4:30 PM				

	PEDESTRIAN CROSSINGS				
	N SIDE	S SIDE	E SIDE	W SIDE	TOTAL
<b>AM</b>					
7:00 AM	0	0	0	0	0
7:15 AM	0	1	0	0	1
7:30 AM	0	0	0	0	0
7:45 AM	0	0	0	0	0
8:00 AM	0	1	0	0	1
8:15 AM	0	0	0	0	0
8:30 AM	0	0	0	0	0
8:45 AM	0	0	0	0	0
TOTAL	0	2	0	0	2
AM BEGIN PEAK HR	7:45 AM				
4:00 PM	0	0	0	0	0
4:15 PM	0	0	0	0	0
4:30 PM	1	0	0	0	1
4:45 PM	1	0	0	0	1
5:00 PM	0	0	0	0	0
5:15 PM	0	0	0	0	0
5:30 PM	0	0	0	0	0
5:45 PM	0	0	0	0	0
TOTAL	2	0	0	0	2
PM BEGIN PEAK HR	4:30 PM				

	BICYCLE CROSSINGS				
	NS	SS	ES	WS	TOTAL
<b>AM</b>					
7:00 AM	0	0	0	0	0
7:15 AM	1	0	0	0	1
7:30 AM	0	0	0	0	0
7:45 AM	0	0	0	0	0
8:00 AM	1	0	0	0	1
8:15 AM	0	1	0	0	1
8:30 AM	0	1	0	0	1
8:45 AM	1	0	0	0	1
TOTAL	3	2	0	0	5
AM BEGIN PEAK HR	7:45 AM				
4:00 PM	2	0	0	0	2
4:15 PM	0	1	0	0	1
4:30 PM	0	0	0	0	0
4:45 PM	0	0	0	0	0
5:00 PM	0	0	0	0	0
5:15 PM	0	3	0	0	3
5:30 PM	0	2	0	0	2
5:45 PM	0	0	0	0	0
TOTAL	2	6	0	0	8
PM BEGIN PEAK HR	4:30 PM				

**AimTD LLC**  
TURNING MOVEMENT COUNTS

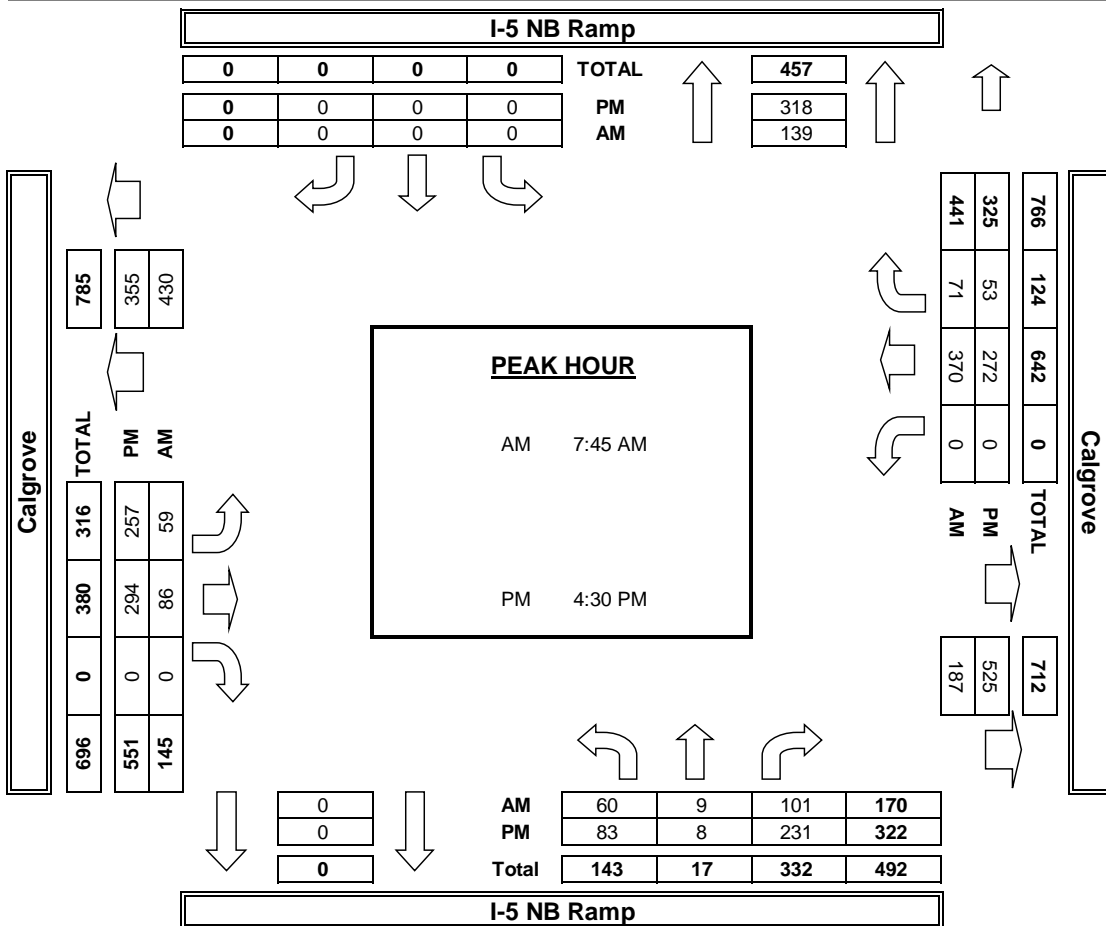
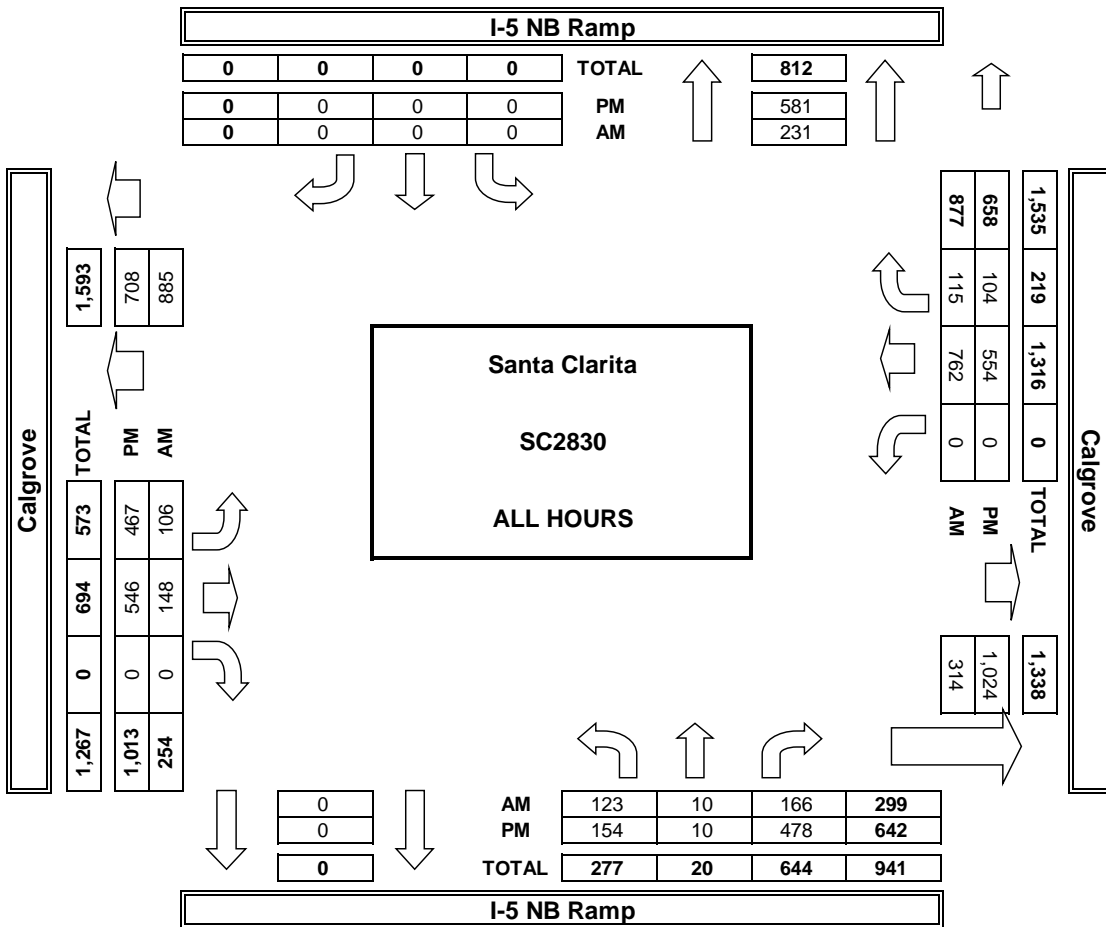

### INTERSECTION TURNING MOVEMENT COUNTS

PREPARED BY: AimTD LLC. tel: 714 253 7888 cs@aimtd.com

DATE:  
Tue, Mar 9, 21

LOCATION:  
NORTH & SOUTH: Santa Clarita  
Wiley Canyon  
EAST & WEST: Wiley Canyon  
Calgrove

PROJECT #: SC2830  
LOCATION #: 9  
CONTROL: STOP N/S

NOTES:	AM		▲	
	PM	◀ W	N	
	MD			E ▶
	OTHER		S	
	OTHER		▼	

Add U-Turns to Left Turns

		NORTHBOUND <small>Wiley Canyon-Valley Oak</small>			SOUTHBOUND <small>Wiley Canyon-Valley Oak</small>			EASTBOUND <small>Calgrove</small>			WESTBOUND <small>Calgrove</small>				
LANES:		NL	NT	NR	SL	ST	SR	EL	ET	ER	WL	WT	WR	TOTAL	TOTAL
AM	7:00 AM	3	0	0	8	0	85	20	6	2	0	18	4	146	0
	7:15 AM	0	0	0	6	0	101	17	7	0	0	21	7	159	0
	7:30 AM	1	1	0	3	0	93	31	6	0	0	22	11	168	0
	7:45 AM	0	0	0	10	0	88	53	6	0	0	28	14	199	0
	8:00 AM	3	1	0	5	0	82	29	13	1	0	27	9	170	0
	8:15 AM	1	1	0	12	3	90	31	4	1	0	23	7	173	0
	8:30 AM	0	1	0	6	0	81	36	10	0	0	18	9	161	0
	8:45 AM	1	1	1	11	0	67	24	13	0	0	21	8	147	0
	VOLUMES	9	5	1	61	3	687	241	65	4	0	178	69	1,323	0
	APPROACH %	60%	33%	7%	8%	0%	91%	78%	21%	1%	0%	72%	28%		
APP/DEPART	15	/	314	751	/	7	310	/	127	247	/	875	0		
BEGIN PEAK HR	7:30 AM														
VOLUMES	5	3	0	30	3	353	144	29	2	0	100	41	710		
APPROACH %	63%	38%	0%	8%	1%	91%	82%	17%	1%	0%	71%	29%			
PEAK HR FACTOR	0.500		0.919												
APP/DEPART	8	/	187	386	/	5	175	/	59	141	/	459	0		
PM	4:00 PM	1	1	0	18	0	61	80	15	0	0	18	12	206	0
	4:15 PM	0	0	0	15	1	69	93	20	2	0	20	8	228	0
	4:30 PM	0	2	0	16	1	59	88	21	2	1	8	10	208	0
	4:45 PM	1	1	0	21	3	57	91	36	0	1	19	13	243	0
	5:00 PM	1	0	0	17	0	58	106	31	0	0	19	12	244	0
	5:15 PM	1	0	0	18	0	58	102	35	1	0	24	11	250	0
	5:30 PM	0	1	0	11	1	59	101	31	2	0	12	11	229	0
	5:45 PM	0	0	0	12	1	70	123	19	2	0	12	13	252	0
	VOLUMES	4	5	0	128	7	491	784	208	9	2	132	90	1,860	0
	APPROACH %	44%	56%	0%	20%	1%	78%	78%	21%	1%	1%	59%	40%		
APP/DEPART	9	/	878	626	/	18	1,001	/	336	224	/	628	0		
BEGIN PEAK HR	5:00 PM														
VOLUMES	2	1	0	58	2	245	432	116	5	0	67	47	975		
APPROACH %	67%	33%	0%	19%	1%	80%	78%	21%	1%	0%	59%	41%			
PEAK HR FACTOR	0.750		0.919												
APP/DEPART	3	/	480	305	/	7	553	/	174	114	/	314	0		

U-TURNS				
NB	SB	EB	WB	TTL
0	0	0	0	0
0	0	0	0	0
0	0	0	0	0
0	0	0	0	0
0	0	0	0	0
0	0	1	0	1
0	0	0	0	0
0	0	0	0	0
0	0	0	0	0
0	0	1	0	1

0	0	0	0	0
0	0	0	0	0
0	0	1	0	1
0	0	0	0	0
0	0	0	0	0
0	0	0	0	0
0	0	0	0	0
0	0	0	0	0
0	0	1	0	1

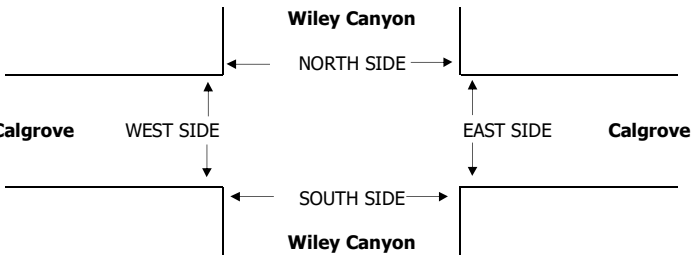

		N SIDE	S SIDE	E SIDE	W SIDE	TOTAL
AM	7:00 AM	0	0	2	0	2
	7:15 AM	0	0	0	0	0
	7:30 AM	0	0	0	0	0
	7:45 AM	0	1	0	0	1
	8:00 AM	1	0	0	0	1
	8:15 AM	0	0	0	0	0
	8:30 AM	1	2	1	0	4
	8:45 AM	0	1	0	0	1
	TOTAL	2	4	3	0	9
AM BEGIN PEAK HR	7:30 AM					
PM	4:00 PM	2	0	0	0	2
	4:15 PM	0	1	1	0	2
	4:30 PM	0	0	0	0	0
	4:45 PM	0	0	0	0	0
	5:00 PM	0	2	2	0	4
	5:15 PM	0	4	1	0	5
	5:30 PM	1	0	0	0	1
	5:45 PM	0	3	0	0	3
	TOTAL	3	10	4	0	17
PM BEGIN PEAK HR	5:00 PM					

PEDESTRIAN + BIKE CROSSINGS				
N SIDE	S SIDE	E SIDE	W SIDE	TOTAL
0	0	2	0	2
0	0	0	0	0
0	0	0	0	0
0	1	0	0	1
1	0	0	0	1
0	0	0	0	0
1	2	1	0	4
0	1	0	0	1
2	4	3	0	9

PEDESTRIAN CROSSINGS				
N SIDE	S SIDE	E SIDE	W SIDE	TOTAL
0	0	2	0	2
0	0	0	0	0
0	0	0	0	0
0	1	0	0	1
0	0	0	0	0
0	0	0	0	0
0	1	1	0	2
0	0	0	0	0
0	2	3	0	5
0	1	0	0	1
0	0	0	0	0
0	0	0	0	0
0	0	0	0	0
0	0	0	0	0
0	2	0	0	2
0	2	0	0	2

BICYCLE CROSSINGS				
NS	SS	ES	WS	TOTAL
0	0	0	0	0
0	0	0	0	0
0	0	0	0	0
0	0	0	0	0
1	0	0	0	1
0	0	0	0	0
1	1	0	0	2
0	1	0	0	1
2	2	0	0	4
2	0	0	0	2
0	1	1	0	2
0	0	0	0	0
0	0	0	0	0
0	2	2	0	4
0	2	1	0	3
1	0	0	0	1
0	3	0	0	3
3	8	4	0	15

**AimTD LLC**  
TURNING MOVEMENT COUNTS

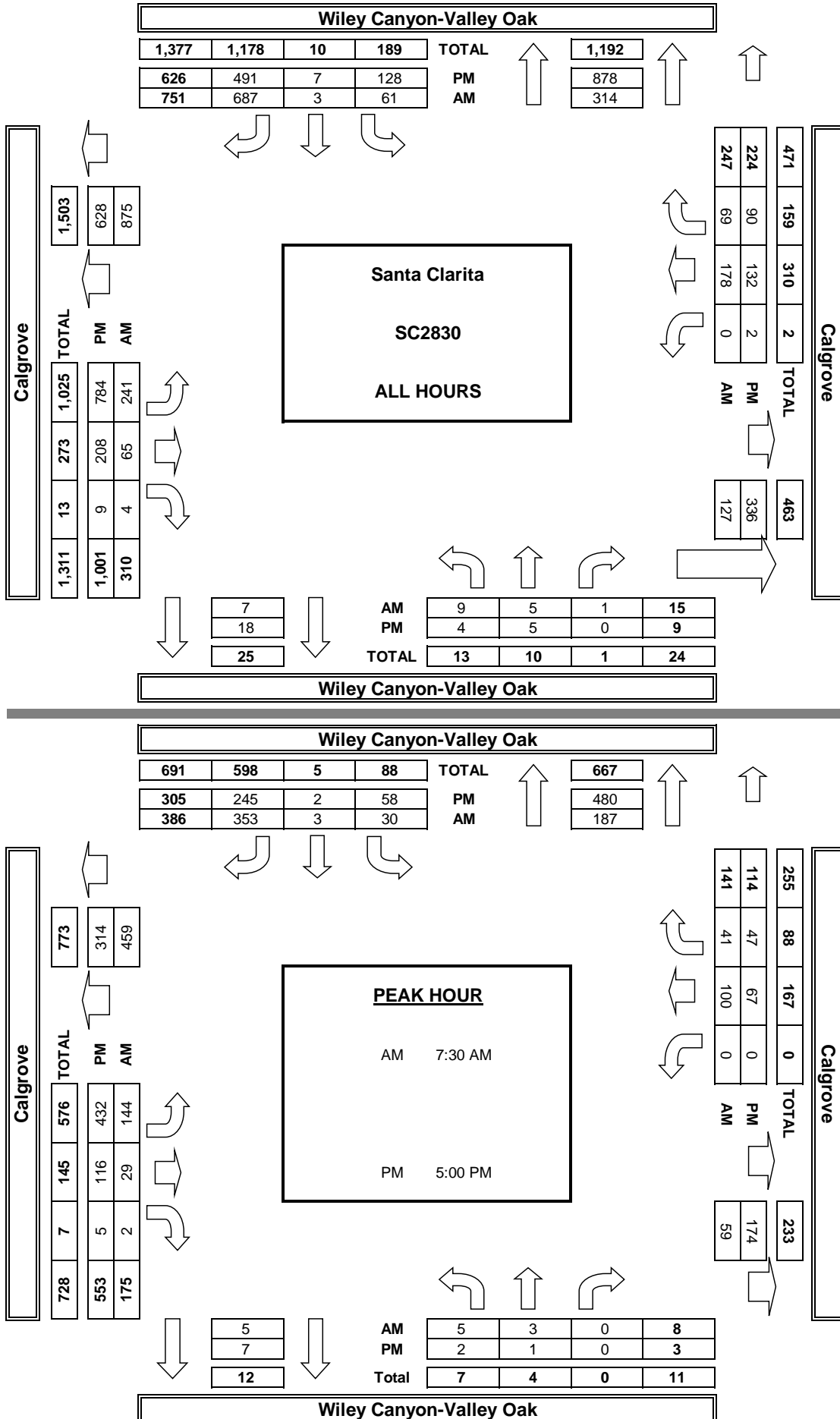



### AM Synchro Comments

- I-5/Calgrove SB Ramps- Offramp right turn our records show 150 more vehicles.
- Lyons Ave/ Wiley Canyon Rd- Our records show differences in volumes.

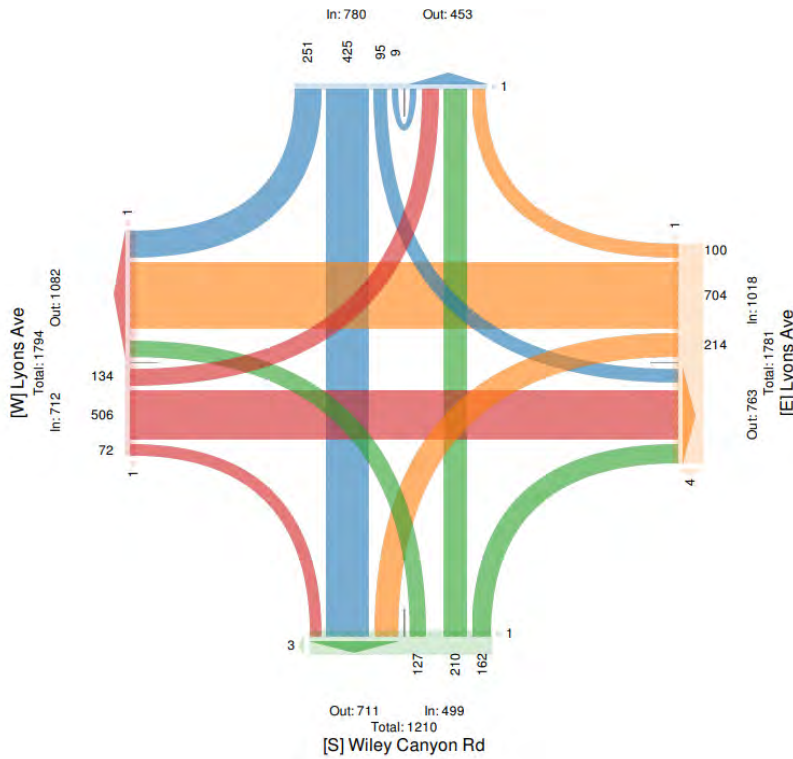
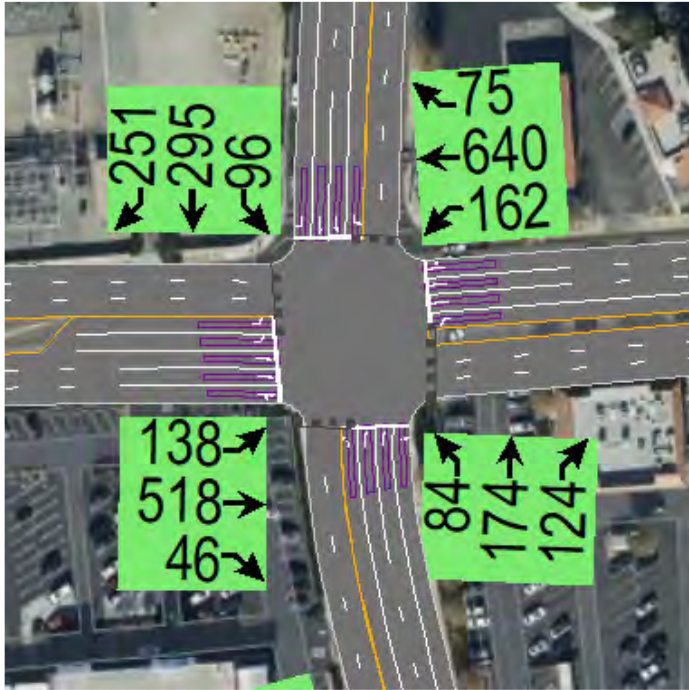

- Wiley Canyon Rd/ La Glorita Cir- Our records show difference in volumes.

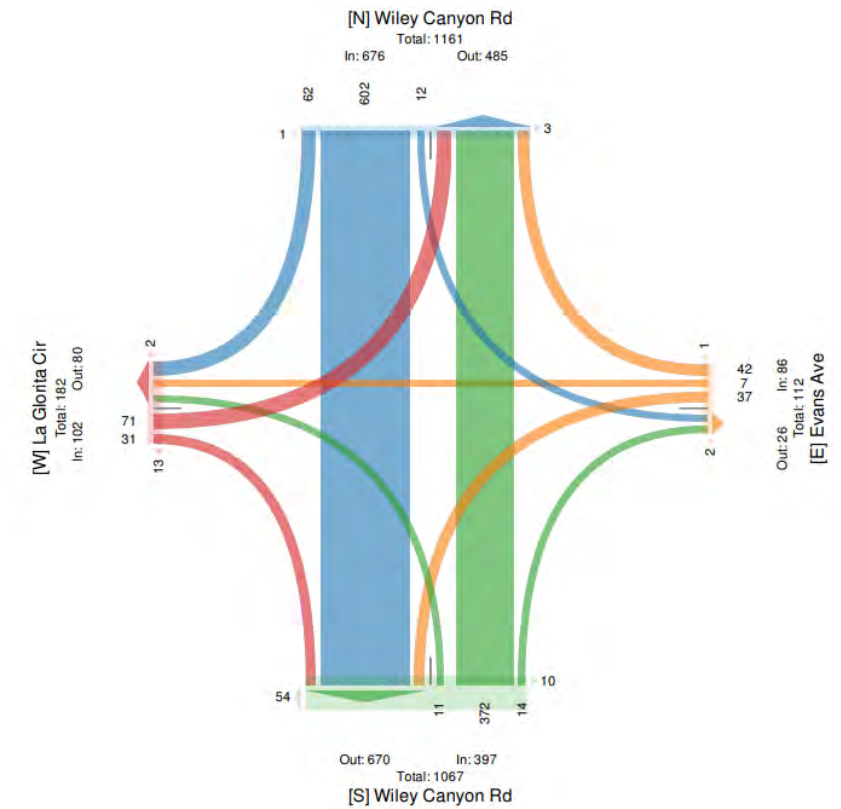
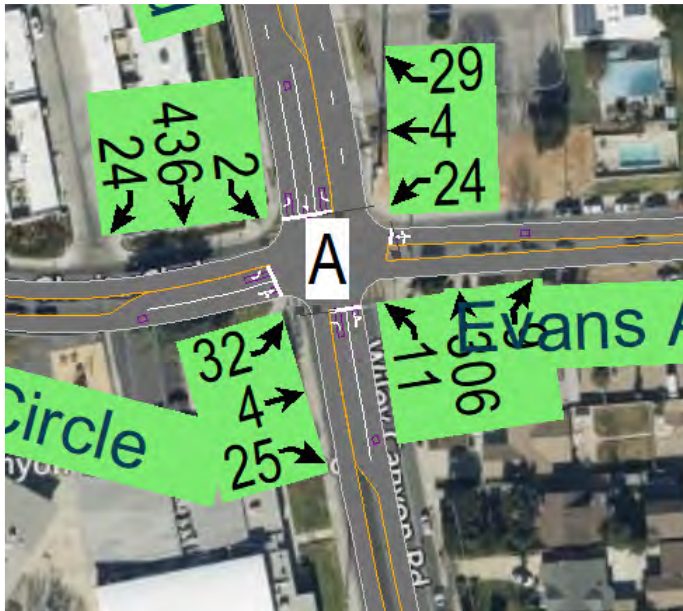

- Lyons Ave/ Wiley Canyon Rd- AM Timing does not match. Please match (bottom is City's timing)

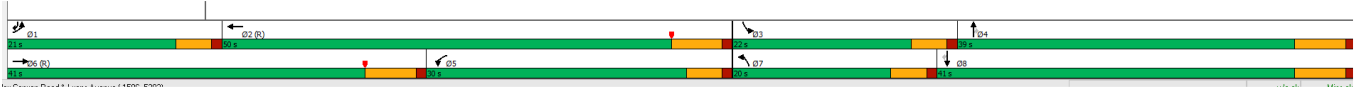

**PM Synchro Comments**

- Lyons Ave/ Wiley Cyn Rd – Our records show different volumes for northbound movements.

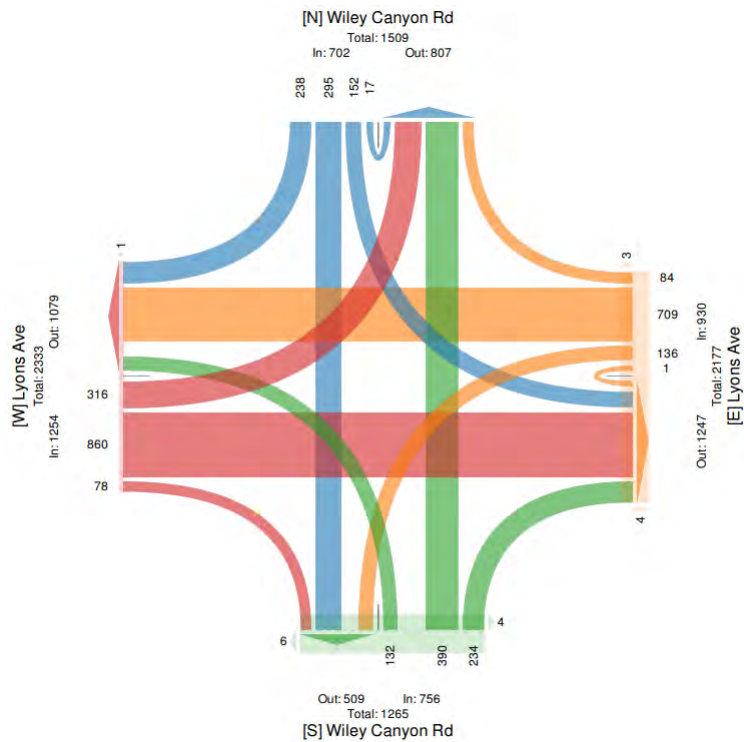
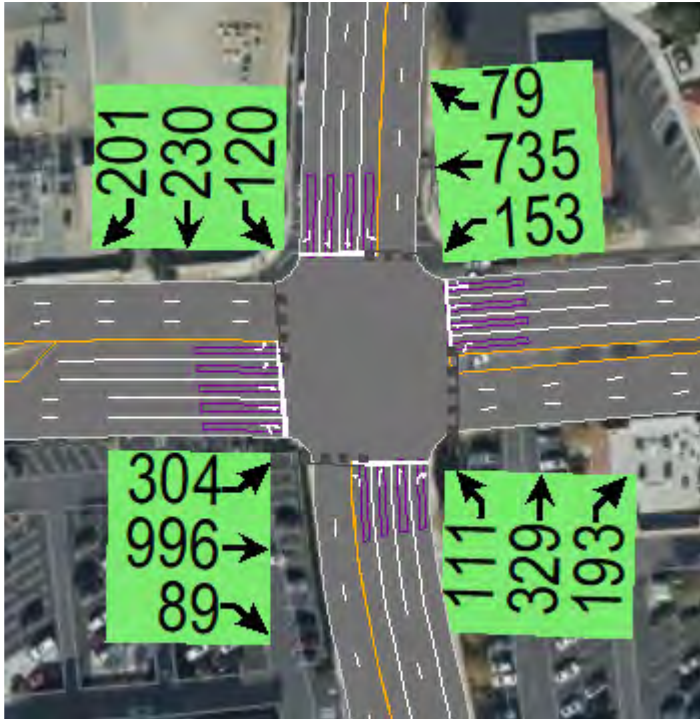

- Lyons Ave/ La Glorita Cir- Our records show differences in volumes for northbound and southbound thru

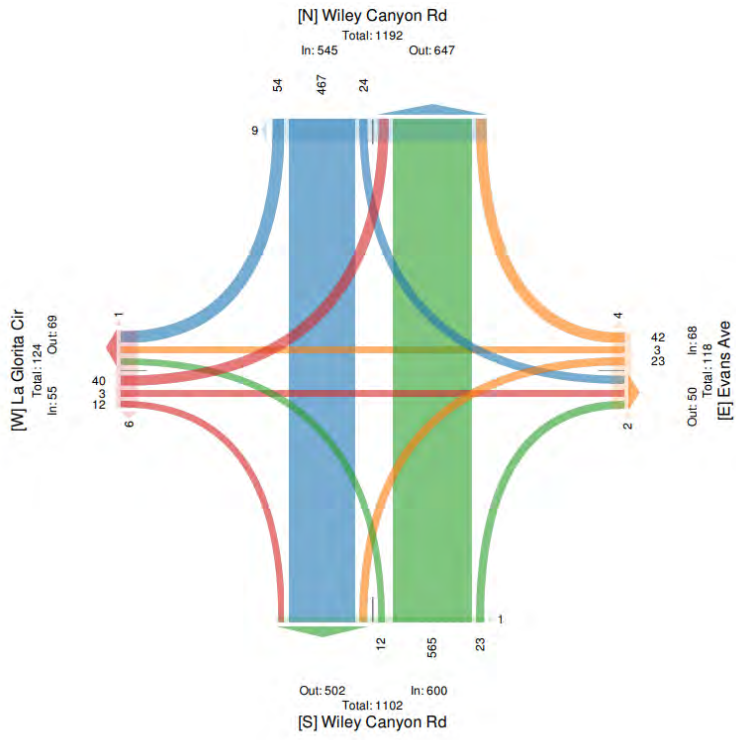

Lyons Ave/ Wiley Canyon Rd- PM Timing does not match. Please match (bottom is City's timing)

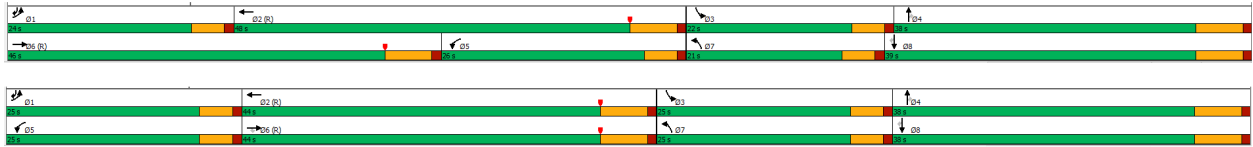

**WILEY CANYON MIXED-USE TRAFFIC ANALYSIS**

Appendix B Intersection LOS Worksheets

**Appendix B INTERSECTION LOS WORKSHEETS**







# EXISTING CONDITIONS

Existing - AM Peak Hour  
 1: Marriott Way/I-5 SB Ramps & Pico Canyon Road/Lyons Avenue

Synchro 10 Report  
 Lanes, Volumes, Timings

Lane Group	EBL	EBT	EBR	WBL	WBT	WBR	NBL	NBT	NBR	SBL	SBT	SBR
Lane Configurations												
Traffic Volume (vph)	0	629	28	31	531	249	0	0	59	245	69	80
Future Volume (vph)	0	629	28	31	531	249	0	0	59	245	69	80
Ideal Flow (vphpl)	1900	1900	1900	1900	1900	1900	1900	1900	1900	1900	1900	1900
Storage Length (ft)	0		0	100		0	0		0	0		200
Storage Lanes	0		0	1		1	0		1	1		1
Taper Length (ft)	25			25			25			25		
Satd. Flow (prot)	0	5055	0	1770	3539	1583	0	0	1611	1681	1720	1583
Flt Permitted				0.264						0.950	0.972	
Satd. Flow (perm)	0	5055	0	492	3539	1583	0	0	1611	1681	1720	1583
Right Turn on Red			Yes			Yes			Yes			Yes
Satd. Flow (RTOR)		9				286			259			92
Link Speed (mph)		40			40			30			30	
Link Distance (ft)		694			822			283			346	
Travel Time (s)		11.8			14.0			6.4			7.9	
Peak Hour Factor	0.87	0.87	0.87	0.87	0.87	0.87	0.87	0.87	0.87	0.87	0.87	0.87
Shared Lane Traffic (%)										37%		
Lane Group Flow (vph)	0	755	0	36	610	286	0	0	68	178	183	92
Turn Type		NA		Perm	NA	Perm			Perm	Split	NA	Perm
Protected Phases		4			8					6	6	
Permitted Phases				8		8			2			6
Total Split (s)		37.0		37.0	37.0	37.0			10.5	37.5	37.5	37.5
Total Lost Time (s)		4.5		4.5	4.5	4.5			3.0	4.5	4.5	4.5
Act Effct Green (s)		20.0		20.0	20.0	20.0			7.5	33.2	33.2	33.2
Actuated g/C Ratio		0.27		0.27	0.27	0.27			0.10	0.46	0.46	0.46
v/c Ratio		0.54		0.27	0.63	0.45			0.17	0.23	0.23	0.12
Control Delay		23.3		25.5	25.9	5.0			0.9	14.3	14.3	4.0
Queue Delay		0.0		0.0	0.0	0.0			0.0	0.0	0.0	0.0
Total Delay		23.3		25.5	25.9	5.0			0.9	14.3	14.3	4.0
LOS		C		C	C	A			A	B	B	A
Approach Delay		23.3			19.5			0.9			12.2	
Approach LOS		C			B			A			B	

Intersection Summary

Area Type:	Other
Cycle Length:	85
Actuated Cycle Length:	72.8
Control Type:	Actuated-Uncoordinated
Maximum v/c Ratio:	0.63
Intersection Signal Delay:	18.7
Intersection LOS:	B
Intersection Capacity Utilization:	36.8%
ICU Level of Service:	A
Analysis Period (min):	15

Splits and Phases: 1: Marriott Way/I-5 SB Ramps & Pico Canyon Road/Lyons Avenue

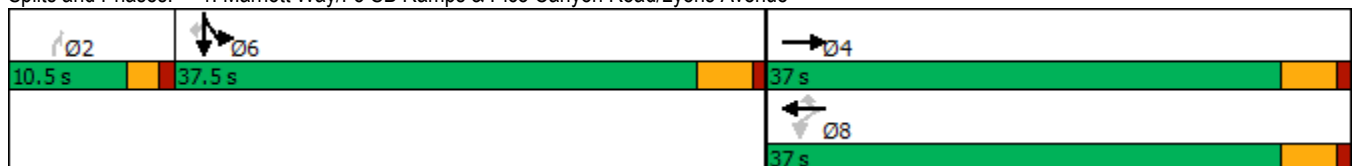

Existing - AM Peak Hour  
3: I-5 NB Ramps & Lyons Avenue

Synchro 10 Report  
Lanes, Volumes, Timings

Lane Group	EBL	EBT	EBR	WBL	WBT	WBR	NBL	NBT	NBR	SBL	SBT	SBR
Lane Configurations												
Traffic Volume (vph)	111	491	0	0	636	366	294	5	304	0	0	0
Future Volume (vph)	111	491	0	0	636	366	294	5	304	0	0	0
Ideal Flow (vphpl)	1900	1900	1900	1900	1900	1900	1900	1900	1900	1900	1900	1900
Storage Length (ft)	300		0	0		0	0		0	0		0
Storage Lanes	1		0	0		0	1		1	0		0
Taper Length (ft)	25			25			25			25		
Satd. Flow (prot)	1770	3539	0	0	4806	0	1681	1688	1583	0	0	0
Flt Permitted	0.950						0.950	0.954				
Satd. Flow (perm)	1770	3539	0	0	4806	0	1681	1688	1583	0	0	0
Right Turn on Red			Yes			Yes			Yes			Yes
Satd. Flow (RTOR)					182				208			
Link Speed (mph)		40			40			30			30	
Link Distance (ft)		603			1902			756			732	
Travel Time (s)		10.3			32.4			17.2			16.6	
Peak Hour Factor	0.86	0.86	0.86	0.86	0.86	0.86	0.86	0.86	0.86	0.86	0.86	0.86
Shared Lane Traffic (%)							49%					
Lane Group Flow (vph)	129	571	0	0	1166	0	174	174	353	0	0	0
Turn Type	Prot	NA			NA		Perm	NA	Perm			
Protected Phases	7	4			8			2				
Permitted Phases							2		2			
Total Split (s)	13.0	40.5			27.5		39.5	39.5	39.5			
Total Lost Time (s)	4.5	4.5			4.5		4.5	4.5	4.5			
Act Effct Green (s)	8.2	34.6			21.9		35.1	35.1	35.1			
Actuated g/C Ratio	0.10	0.44			0.28		0.45	0.45	0.45			
v/c Ratio	0.70	0.37			0.79		0.23	0.23	0.43			
Control Delay	56.1	15.4			26.7		15.0	15.0	8.1			
Queue Delay	0.0	0.0			0.0		0.0	0.0	0.0			
Total Delay	56.1	15.4			26.7		15.0	15.0	8.1			
LOS	E	B			C		B	B	A			
Approach Delay		22.9			26.7			11.5				
Approach LOS		C			C			B				

Intersection Summary

Area Type:	Other
Cycle Length:	80
Actuated Cycle Length:	78.7
Control Type:	Actuated-Uncoordinated
Maximum v/c Ratio:	0.79
Intersection Signal Delay:	21.5
Intersection LOS:	C
Intersection Capacity Utilization:	46.2%
ICU Level of Service:	A
Analysis Period (min):	15

Splits and Phases: 3: I-5 NB Ramps & Lyons Avenue

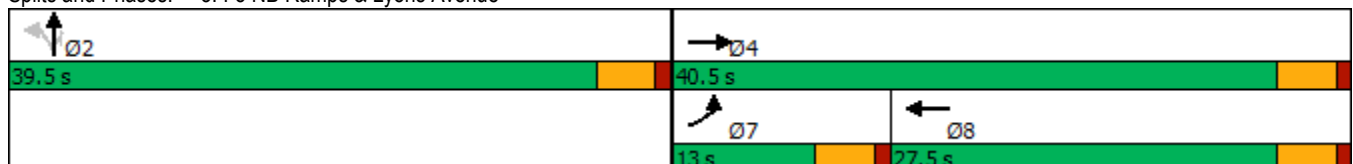

Existing - AM Peak Hour  
4: Wiley Canyon Road & Lyons Avenue

Synchro 10 Report  
Lanes, Volumes, Timings

Lane Group	EBL	EBT	EBR	WBL	WBT	WBR	NBL	NBT	NBR	SBL	SBT	SBR
Lane Configurations												
Traffic Volume (vph)	135	520	70	215	705	100	125	210	160	105	425	250
Future Volume (vph)	135	520	70	215	705	100	125	210	160	105	425	250
Ideal Flow (vphpl)	1900	1900	1900	1900	1900	1900	1900	1900	1900	1900	1900	1900
Storage Length (ft)	130		0	200		0	225		270	200		225
Storage Lanes	2		0	1		0	1		1	1		1
Taper Length (ft)	25			25			25			25		
Satd. Flow (prot)	3433	4994	0	1770	4989	0	1770	3539	1583	1770	3539	1583
Flt Permitted	0.950			0.950			0.950			0.950		
Satd. Flow (perm)	3433	4994	0	1770	4989	0	1770	3539	1583	1770	3539	1583
Right Turn on Red			Yes			Yes			Yes			Yes
Satd. Flow (RTOR)		18			21				195			136
Link Speed (mph)		40			40			35			45	
Link Distance (ft)		1902			870			869			1018	
Travel Time (s)		32.4			14.8			16.9			15.4	
Peak Hour Factor	0.82	0.82	0.82	0.82	0.82	0.82	0.82	0.82	0.82	0.82	0.82	0.82
Shared Lane Traffic (%)												
Lane Group Flow (vph)	165	719	0	262	982	0	152	256	195	128	518	305
Turn Type	Prot	NA		Prot	NA		Prot	NA	Perm	Prot	NA	pm+ov
Protected Phases	1	6		5	2		7	4		3	8	1
Permitted Phases									4			8
Total Split (s)	20.0	41.0		28.0	49.0		25.0	38.0	38.0	25.0	38.0	20.0
Total Lost Time (s)	4.0	4.0		4.0	4.0		4.0	4.0	4.0	4.0	4.0	4.0
Act Effct Green (s)	12.3	48.7		24.0	60.3		16.6	28.0	28.0	15.3	26.7	43.0
Actuated g/C Ratio	0.09	0.37		0.18	0.46		0.13	0.21	0.21	0.12	0.20	0.33
v/c Ratio	0.52	0.39		0.82	0.43		0.68	0.34	0.40	0.62	0.72	0.50
Control Delay	62.3	32.0		72.4	26.0		70.3	44.7	7.8	68.4	55.1	21.0
Queue Delay	0.0	0.0		0.0	0.0		0.0	0.0	0.0	0.0	0.0	0.0
Total Delay	62.3	32.0		72.4	26.0		70.3	44.7	7.8	68.4	55.1	21.0
LOS	E	C		E	C		E	D	A	E	E	C
Approach Delay		37.6			35.8			39.2			45.9	
Approach LOS		D			D			D			D	

Intersection Summary

Area Type:	Other
Cycle Length:	132
Actuated Cycle Length:	132
Offset:	2.5 (2%), Referenced to phase 2:WBT and 6:EBT, Start of Yellow
Control Type:	Actuated-Coordinated
Maximum v/c Ratio:	0.82
Intersection Signal Delay:	39.4
Intersection LOS:	D
Intersection Capacity Utilization	55.5%
ICU Level of Service	B
Analysis Period (min)	15

Splits and Phases: 4: Wiley Canyon Road & Lyons Avenue

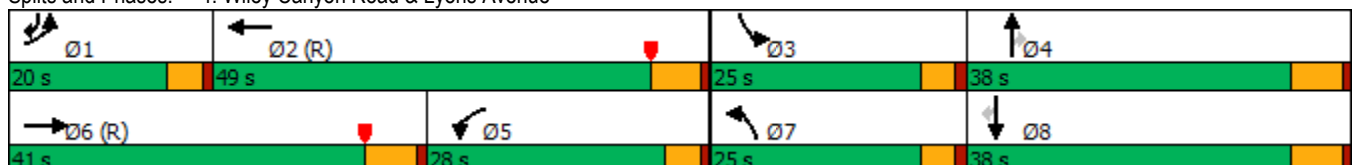

Existing - AM Peak Hour  
5: Wiley Canyon Road & La Glorita Circle/Evans Avenue

Synchro 10 Report  
Lanes, Volumes, Timings

Lane Group	EBL	EBT	EBR	WBL	WBT	WBR	NBL	NBT	NBR	SBL	SBT	SBR
Lane Configurations												
Traffic Volume (vph)	70	5	30	35	10	40	10	370	15	10	600	60
Future Volume (vph)	70	5	30	35	10	40	10	370	15	10	600	60
Ideal Flow (vphpl)	1900	1900	1900	1900	1900	1900	1900	1900	1900	1900	1900	1900
Storage Length (ft)	90		0	0		0	110		0	110		0
Storage Lanes	1		0	0		0	1		0	1		1
Taper Length (ft)	25			25			25			25		
Satd. Flow (prot)	1770	1621	0	0	1709	0	1770	1852	0	1770	1863	1583
Flt Permitted	0.850				0.847		0.269			0.451		
Satd. Flow (perm)	1583	1621	0	0	1477	0	501	1852	0	840	1863	1583
Right Turn on Red			Yes			Yes			Yes			Yes
Satd. Flow (RTOR)		39			52			4				78
Link Speed (mph)		30			30			35			35	
Link Distance (ft)		529			450			1329			869	
Travel Time (s)		12.0			10.2			25.9			16.9	
Peak Hour Factor	0.77	0.77	0.77	0.77	0.77	0.77	0.77	0.77	0.77	0.77	0.77	0.77
Shared Lane Traffic (%)												
Lane Group Flow (vph)	91	45	0	0	110	0	13	500	0	13	779	78
Turn Type	Perm	NA		Perm	NA		Perm	NA		Perm	NA	Perm
Protected Phases		4			8			2			6	
Permitted Phases	4			8			2			6		6
Total Split (s)	30.5	30.5		30.5	30.5		29.5	29.5		29.5	29.5	29.5
Total Lost Time (s)	4.5	4.5			4.5		4.5	4.5		4.5	4.5	4.5
Act Effct Green (s)	8.4	8.4			8.4		29.9	29.9		29.9	29.9	29.9
Actuated g/C Ratio	0.19	0.19			0.19		0.67	0.67		0.67	0.67	0.67
v/c Ratio	0.30	0.13			0.34		0.04	0.40		0.02	0.62	0.07
Control Delay	17.3	7.4			11.9		4.9	6.3		4.6	10.0	1.8
Queue Delay	0.0	0.0			0.0		0.0	0.0		0.0	0.0	0.0
Total Delay	17.3	7.4			11.9		4.9	6.3		4.6	10.0	1.8
LOS	B	A			B		A	A		A	A	A
Approach Delay		14.0			11.9			6.2			9.2	
Approach LOS		B			B			A			A	

Intersection Summary

Area Type:	Other
Cycle Length:	60
Actuated Cycle Length:	44.4
Control Type:	Actuated-Uncoordinated
Maximum v/c Ratio:	0.62
Intersection Signal Delay:	8.8
Intersection LOS:	A
Intersection Capacity Utilization:	50.7%
ICU Level of Service:	A
Analysis Period (min):	15

Splits and Phases: 5: Wiley Canyon Road & La Glorita Circle/Evans Avenue

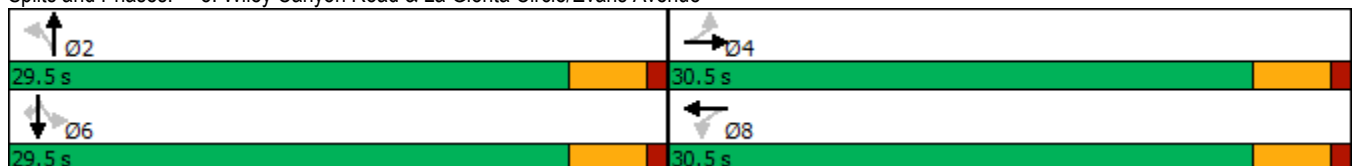

Intersection												
Int Delay, s/veh	3											
Movement	EBL	EBT	EBR	WBL	WBT	WBR	NBL	NBT	NBR	SBL	SBT	SBR
Lane Configurations		↕			↕		↕	↕		↕	↕	↕
Traffic Vol, veh/h	60	0	41	1	0	8	18	258	4	6	434	44
Future Vol, veh/h	60	0	41	1	0	8	18	258	4	6	434	44
Conflicting Peds, #/hr	0	0	0	0	0	0	0	0	0	0	0	0
Sign Control	Stop	Stop	Stop	Stop	Stop	Stop	Free	Free	Free	Free	Free	Free
RT Channelized	-	-	None	-	-	None	-	-	None	-	-	None
Storage Length	-	-	-	-	-	-	150	-	-	215	-	260
Veh in Median Storage, #	-	0	-	-	0	-	-	0	-	-	0	-
Grade, %	-	0	-	-	0	-	-	0	-	-	0	-
Peak Hour Factor	83	83	83	83	83	83	83	83	83	83	83	83
Heavy Vehicles, %	2	2	2	2	2	2	2	2	2	2	2	2
Mvmt Flow	72	0	49	1	0	10	22	311	5	7	523	53

Major/Minor	Minor2		Minor1		Major1		Major2					
Conflicting Flow All	900	897	523	946	948	314	576	0	0	316	0	0
Stage 1	537	537	-	358	358	-	-	-	-	-	-	-
Stage 2	363	360	-	588	590	-	-	-	-	-	-	-
Critical Hdwy	7.12	6.52	6.22	7.12	6.52	6.22	4.12	-	-	4.12	-	-
Critical Hdwy Stg 1	6.12	5.52	-	6.12	5.52	-	-	-	-	-	-	-
Critical Hdwy Stg 2	6.12	5.52	-	6.12	5.52	-	-	-	-	-	-	-
Follow-up Hdwy	3.518	4.018	3.318	3.518	4.018	3.318	2.218	-	-	2.218	-	-
Pot Cap-1 Maneuver	259	279	554	241	261	726	997	-	-	1244	-	-
Stage 1	528	523	-	660	628	-	-	-	-	-	-	-
Stage 2	656	626	-	495	495	-	-	-	-	-	-	-
Platoon blocked, %								-	-	-	-	-
Mov Cap-1 Maneuver	250	271	554	215	254	726	997	-	-	1244	-	-
Mov Cap-2 Maneuver	250	271	-	215	254	-	-	-	-	-	-	-
Stage 1	516	520	-	645	614	-	-	-	-	-	-	-
Stage 2	633	612	-	448	492	-	-	-	-	-	-	-

Approach	EB		WB		NB		SB	
HCM Control Delay, s	22.8		11.4		0.6		0.1	
HCM LOS	C		B					

Minor Lane/Major Mvmt	NBL	NBT	NBR	EBLn1	WBLn1	SBL	SBT	SBR
Capacity (veh/h)	997	-	-	322	574	1244	-	-
HCM Lane V/C Ratio	0.022	-	-	0.378	0.019	0.006	-	-
HCM Control Delay (s)	8.7	-	-	22.8	11.4	7.9	-	-
HCM Lane LOS	A	-	-	C	B	A	-	-
HCM 95th %tile Q(veh)	0.1	-	-	1.7	0.1	0	-	-

Intersection												
Int Delay, s/veh	7.9											
Movement	EBL	EBT	EBR	WBL	WBT	WBR	NBL	NBT	NBR	SBL	SBT	SBR
Lane Configurations		↕		↕	↕						↕	↕
Traffic Vol, veh/h	0	128	59	430	162	0	0	0	0	38	0	200
Future Vol, veh/h	0	128	59	430	162	0	0	0	0	38	0	200
Conflicting Peds, #/hr	0	0	0	0	0	0	0	0	0	0	0	0
Sign Control	Free	Free	Free	Free	Free	Free	Free	Free	Free	Stop	Stop	Stop
RT Channelized	-	-	None	-	-	None	-	-	None	-	-	None
Storage Length	-	-	-	150	-	-	-	-	-	-	-	0
Veh in Median Storage, #	-	0	-	-	0	-	-	-	-	-	0	-
Grade, %	-	0	-	-	0	-	-	0	-	-	0	-
Peak Hour Factor	91	91	91	91	91	91	91	91	91	91	91	91
Heavy Vehicles, %	2	2	2	2	2	2	2	2	2	2	2	2
Mvmt Flow	0	141	65	473	178	0	0	0	0	42	0	220

Major/Minor	Major1			Major2			Minor2			
Conflicting Flow All	-	0	0	206	0	0		1298	1330	178
Stage 1	-	-	-	-	-	-		1124	1124	-
Stage 2	-	-	-	-	-	-		174	206	-
Critical Hdwy	-	-	-	4.12	-	-		6.42	6.52	6.22
Critical Hdwy Stg 1	-	-	-	-	-	-		5.42	5.52	-
Critical Hdwy Stg 2	-	-	-	-	-	-		5.42	5.52	-
Follow-up Hdwy	-	-	-	2.218	-	-		3.518	4.018	3.318
Pot Cap-1 Maneuver	0	-	-	1365	-	0		178	155	865
Stage 1	0	-	-	-	-	0		310	281	-
Stage 2	0	-	-	-	-	0		856	731	-
Platoon blocked, %	-	-	-	-	-	-		-	-	-
Mov Cap-1 Maneuver	-	-	-	1365	-	-		116	0	865
Mov Cap-2 Maneuver	-	-	-	-	-	-		116	0	-
Stage 1	-	-	-	-	-	-		202	0	-
Stage 2	-	-	-	-	-	-		856	0	-

Approach	EB			WB			SB		
HCM Control Delay, s	0			6.6			17.3		
HCM LOS							C		

Minor Lane/Major Mvmt	EBT	EBR	WBL	WBT	SBLn1	SBLn2
Capacity (veh/h)	-	-	1365	-	116	865
HCM Lane V/C Ratio	-	-	0.346	-	0.36	0.254
HCM Control Delay (s)	-	-	9	-	52.5	10.6
HCM Lane LOS	-	-	A	-	F	B
HCM 95th %tile Q(veh)	-	-	1.6	-	1.5	1

Intersection												
Int Delay, s/veh	3.8											
Movement	EBL	EBT	EBR	WBL	WBT	WBR	NBL	NBT	NBR	SBL	SBT	SBR
Lane Configurations	↘	↗			↗	↘		↗	↘			
Traffic Vol, veh/h	74	108	0	0	462	89	75	11	126	0	0	0
Future Vol, veh/h	74	108	0	0	462	89	75	11	126	0	0	0
Conflicting Peds, #/hr	0	0	0	0	0	0	0	0	0	0	0	0
Sign Control	Free	Free	Free	Free	Free	Free	Stop	Stop	Stop	Free	Free	Free
RT Channelized	-	-	None	-	-	None	-	-	None	-	-	None
Storage Length	170	-	-	-	-	0	-	-	0	-	-	-
Veh in Median Storage, #	-	0	-	-	0	-	-	0	-	-	-	-
Grade, %	-	0	-	-	0	-	-	0	-	-	0	-
Peak Hour Factor	94	94	94	94	94	94	94	94	94	94	94	94
Heavy Vehicles, %	2	2	2	2	2	2	2	2	2	2	2	2
Mvmt Flow	79	115	0	0	491	95	80	12	134	0	0	0

Major/Minor	Major1	Major2	Minor1
Conflicting Flow All	586	0	0
Stage 1	-	-	273
Stage 2	-	-	586
Critical Hdwy	4.12	-	6.42
Critical Hdwy Stg 1	-	-	5.42
Critical Hdwy Stg 2	-	-	5.42
Follow-up Hdwy	2.218	-	3.518
Pot Cap-1 Maneuver	989	0	348
Stage 1	-	0	773
Stage 2	-	0	585
Platoon blocked, %	-	-	-
Mov Cap-1 Maneuver	989	-	320
Mov Cap-2 Maneuver	-	-	320
Stage 1	-	-	711
Stage 2	-	-	585

Approach	EB	WB	NB
HCM Control Delay, s	3.6	0	14
HCM LOS			B

Minor Lane/Major Mvmt	NBLn1	NBLn2	EBL	EBT	WBT	WBR
Capacity (veh/h)	320	937	989	-	-	-
HCM Lane V/C Ratio	0.286	0.143	0.08	-	-	-
HCM Control Delay (s)	20.7	9.5	9	-	-	-
HCM Lane LOS	C	A	A	-	-	-
HCM 95th %tile Q(veh)	1.2	0.5	0.3	-	-	-



Intersection												
Int Delay, s/veh	5.2											
Movement	EBL	EBT	EBR	WBL	WBT	WBR	NBL	NBT	NBR	SBL	SBT	SBR
Lane Configurations	↘	↑	↗	↘	↑	↗		↕			↕	↗
Traffic Vol, veh/h	180	36	2	0	125	51	6	4	0	38	4	441
Future Vol, veh/h	180	36	2	0	125	51	6	4	0	38	4	441
Conflicting Peds, #/hr	0	0	0	0	0	0	0	0	0	0	0	0
Sign Control	Free	Free	Free	Free	Free	Free	Stop	Stop	Stop	Stop	Stop	Stop
RT Channelized	-	-	None	-	-	None	-	-	None	-	-	Free
Storage Length	165	-	150	290	-	290	-	-	-	100	-	0
Veh in Median Storage, #	-	0	-	-	0	-	-	0	-	-	0	-
Grade, %	-	0	-	-	0	-	-	0	-	-	0	-
Peak Hour Factor	89	89	89	89	89	89	89	89	89	89	89	89
Heavy Vehicles, %	2	2	2	2	2	2	2	2	2	2	2	2
Mvmt Flow	202	40	2	0	140	57	7	4	0	43	4	496

Major/Minor	Major1			Major2			Minor1			Minor2		
Conflicting Flow All	197	0	0	42	0	0	615	641	40	587	586	-
Stage 1	-	-	-	-	-	-	444	444	-	140	140	-
Stage 2	-	-	-	-	-	-	171	197	-	447	446	-
Critical Hdwy	4.12	-	-	4.12	-	-	7.12	6.52	6.22	7.12	6.52	-
Critical Hdwy Stg 1	-	-	-	-	-	-	6.12	5.52	-	6.12	5.52	-
Critical Hdwy Stg 2	-	-	-	-	-	-	6.12	5.52	-	6.12	5.52	-
Follow-up Hdwy	2.218	-	-	2.218	-	-	3.518	4.018	3.318	3.518	4.018	-
Pot Cap-1 Maneuver	1376	-	-	1567	-	-	403	393	1031	421	422	0
Stage 1	-	-	-	-	-	-	593	575	-	863	781	0
Stage 2	-	-	-	-	-	-	831	738	-	591	574	0
Platoon blocked, %	-	-	-	-	-	-	-	-	-	-	-	-
Mov Cap-1 Maneuver	1376	-	-	1567	-	-	354	335	1031	370	360	-
Mov Cap-2 Maneuver	-	-	-	-	-	-	354	335	-	370	360	-
Stage 1	-	-	-	-	-	-	506	490	-	736	781	-
Stage 2	-	-	-	-	-	-	826	738	-	500	490	-

Approach	EB	WB	NB	SB
HCM Control Delay, s	6.7	0	15.8	16.2
HCM LOS			C	C

Minor Lane/Major Mvmt	NBLn1	EBL	EBT	EBR	WBL	WBT	WBR	SBLn1	SBLn2
Capacity (veh/h)	346	1376	-	-	1567	-	-	369	-
HCM Lane V/C Ratio	0.032	0.147	-	-	-	-	-	0.128	-
HCM Control Delay (s)	15.8	8.1	-	-	0	-	-	16.2	0
HCM Lane LOS	C	A	-	-	A	-	-	C	A
HCM 95th %tile Q(veh)	0.1	0.5	-	-	0	-	-	0.4	-

Existing - PM Peak Hour  
 1: Marriott Way/I-5 SB Ramps & Pico Canyon Road/Lyons Avenue

Synchro 10 Report  
 Lanes, Volumes, Timings

Lane Group	EBL	EBT	EBR	WBL	WBT	WBR	NBL	NBT	NBR	SBL	SBT	SBR
Lane Configurations												
Traffic Volume (vph)	0	829	33	35	927	163	0	0	54	361	66	119
Future Volume (vph)	0	829	33	35	927	163	0	0	54	361	66	119
Ideal Flow (vphpl)	1900	1900	1900	1900	1900	1900	1900	1900	1900	1900	1900	1900
Storage Length (ft)	0		0	100		0	0		0	0		200
Storage Lanes	0		0	1		1	0		1	1		1
Taper Length (ft)	25			25			25			25		
Satd. Flow (prot)	0	5055	0	1770	3539	1583	0	0	1611	1681	1711	1583
Flt Permitted				0.214						0.950	0.967	
Satd. Flow (perm)	0	5055	0	399	3539	1583	0	0	1611	1681	1711	1583
Right Turn on Red			Yes			Yes			Yes			Yes
Satd. Flow (RTOR)		8				177			171			129
Link Speed (mph)		40			40			30			30	
Link Distance (ft)		694			822			283			346	
Travel Time (s)		11.8			14.0			6.4			7.9	
Peak Hour Factor	0.92	0.92	0.92	0.92	0.92	0.92	0.92	0.92	0.92	0.92	0.92	0.92
Shared Lane Traffic (%)										41%		
Lane Group Flow (vph)	0	937	0	38	1008	177	0	0	59	231	233	129
Turn Type		NA		Perm	NA	Perm			Perm	Split	NA	Perm
Protected Phases		4			8					6	6	
Permitted Phases				8		8			2			6
Total Split (s)		37.0		37.0	37.0	37.0			10.5	37.5	37.5	37.5
Total Lost Time (s)		4.5		4.5	4.5	4.5			4.5	4.5	4.5	4.5
Act Effct Green (s)		29.4		29.4	29.4	29.4			6.0	33.1	33.1	33.1
Actuated g/C Ratio		0.36		0.36	0.36	0.36			0.07	0.40	0.40	0.40
v/c Ratio		0.52		0.27	0.79	0.26			0.21	0.34	0.34	0.18
Control Delay		21.5		24.0	28.9	4.0			1.8	19.6	19.5	4.1
Queue Delay		0.0		0.0	0.0	0.0			0.0	0.0	0.0	0.0
Total Delay		21.5		24.0	28.9	4.0			1.8	19.6	19.5	4.1
LOS		C		C	C	A			A	B	B	A
Approach Delay		21.5			25.1			1.8			16.2	
Approach LOS		C			C			A			B	

Intersection Summary

Area Type:	Other
Cycle Length:	85
Actuated Cycle Length:	82
Control Type:	Actuated-Uncoordinated
Maximum v/c Ratio:	0.79
Intersection Signal Delay:	21.5
Intersection LOS:	C
Intersection Capacity Utilization:	44.9%
ICU Level of Service:	A
Analysis Period (min):	15

Splits and Phases: 1: Marriott Way/I-5 SB Ramps & Pico Canyon Road/Lyons Avenue

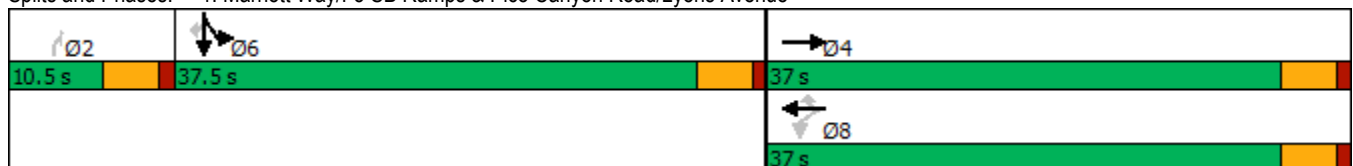

Existing - PM Peak Hour  
3: I-5 NB Ramps & Lyons Avenue

Synchro 10 Report  
Lanes, Volumes, Timings

Lane Group	EBL	EBT	EBR	WBL	WBT	WBR	NBL	NBT	NBR	SBL	SBT	SBR
Lane Configurations												
Traffic Volume (vph)	142	936	0	0	800	332	495	2	538	0	0	0
Future Volume (vph)	142	936	0	0	800	332	495	2	538	0	0	0
Ideal Flow (vphpl)	1900	1900	1900	1900	1900	1900	1900	1900	1900	1900	1900	1900
Storage Length (ft)	300		0	0		0	0		0	0		0
Storage Lanes	1		0	0		0	1		1	0		0
Taper Length (ft)	25			25			25			25		
Satd. Flow (prot)	1770	3539	0	0	4862	0	1681	1686	1583	0	0	0
Flt Permitted	0.950						0.950	0.953				
Satd. Flow (perm)	1770	3539	0	0	4862	0	1681	1686	1583	0	0	0
Right Turn on Red			Yes			Yes			Yes			Yes
Satd. Flow (RTOR)					131				82			
Link Speed (mph)		40			40			30			30	
Link Distance (ft)		603			1902			756			732	
Travel Time (s)		10.3			32.4			17.2			16.6	
Peak Hour Factor	0.92	0.92	0.92	0.92	0.92	0.92	0.92	0.92	0.92	0.92	0.92	0.92
Shared Lane Traffic (%)							50%					
Lane Group Flow (vph)	154	1017	0	0	1231	0	269	271	585	0	0	0
Turn Type	Prot	NA			NA		Perm	NA	Perm			
Protected Phases	7	4			8			2				
Permitted Phases							2		2			
Total Split (s)	14.0	41.5			27.5		38.5	38.5	38.5			
Total Lost Time (s)	4.5	4.5			4.5		4.5	4.5	4.5			
Act Effct Green (s)	9.2	36.2			22.5		34.0	34.0	34.0			
Actuated g/C Ratio	0.12	0.46			0.28		0.43	0.43	0.43			
v/c Ratio	0.75	0.63			0.84		0.37	0.37	0.81			
Control Delay	58.1	18.5			29.8		17.5	17.5	27.7			
Queue Delay	0.0	0.0			0.0		0.0	0.0	0.0			
Total Delay	58.1	18.5			29.8		17.5	17.5	27.7			
LOS	E	B			C		B	B	C			
Approach Delay		23.7			29.8			22.8				
Approach LOS		C			C			C				

Intersection Summary

Area Type:	Other
Cycle Length:	80
Actuated Cycle Length:	79.2
Control Type:	Actuated-Uncoordinated
Maximum v/c Ratio:	0.84
Intersection Signal Delay:	25.6
Intersection LOS:	C
Intersection Capacity Utilization:	66.7%
ICU Level of Service:	C
Analysis Period (min):	15

Splits and Phases: 3: I-5 NB Ramps & Lyons Avenue

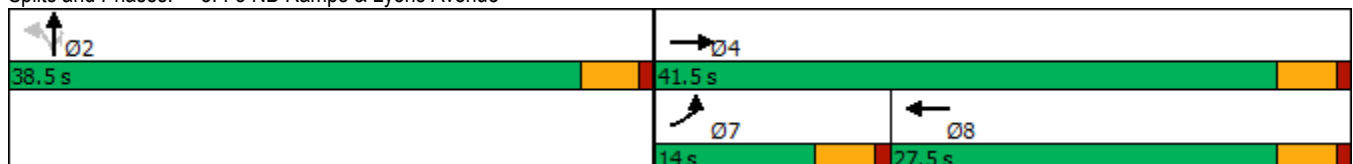

Existing - PM Peak Hour  
4: Wiley Canyon Road & Lyons Avenue

Synchro 10 Report  
Lanes, Volumes, Timings

Lane Group	EBL	EBT	EBR	WBL	WBT	WBR	NBL	NBT	NBR	SBL	SBT	SBR
Lane Configurations												
Traffic Volume (vph)	305	995	90	155	735	80	130	390	235	170	295	240
Future Volume (vph)	305	995	90	155	735	80	130	390	235	170	295	240
Ideal Flow (vphpl)	1900	1900	1900	1900	1900	1900	1900	1900	1900	1900	1900	1900
Storage Length (ft)	130		0	200		0	225		270	200		225
Storage Lanes	2		0	1		0	1		1	1		1
Taper Length (ft)	25			25			25			25		
Satd. Flow (prot)	3433	5024	0	1770	5009	0	1770	3539	1583	1770	3539	1583
Flt Permitted	0.950			0.950			0.950			0.950		
Satd. Flow (perm)	3433	5024	0	1770	5009	0	1770	3539	1583	1770	3539	1583
Right Turn on Red			Yes			Yes			Yes			Yes
Satd. Flow (RTOR)		11			14				242			153
Link Speed (mph)		40			40			35			45	
Link Distance (ft)		1902			870			869			1018	
Travel Time (s)		32.4			14.8			16.9			15.4	
Peak Hour Factor	0.97	0.97	0.97	0.97	0.97	0.97	0.97	0.97	0.97	0.97	0.97	0.97
Shared Lane Traffic (%)												
Lane Group Flow (vph)	314	1119	0	160	840	0	134	402	242	175	304	247
Turn Type	Prot	NA		Prot	NA		Prot	NA	Perm	Prot	NA	pm+ov
Protected Phases	1	6		5	2		7	4		3	8	1
Permitted Phases									4			8
Total Split (s)	25.0	44.0		25.0	44.0		25.0	38.0	38.0	25.0	38.0	25.0
Total Lost Time (s)	4.0	4.0		4.0	4.0		4.0	4.0	4.0	4.0	4.0	4.0
Act Effct Green (s)	18.1	57.6		17.6	57.1		15.7	23.0	23.0	17.8	25.1	47.2
Actuated g/C Ratio	0.14	0.44		0.13	0.43		0.12	0.17	0.17	0.13	0.19	0.36
v/c Ratio	0.67	0.51		0.68	0.39		0.64	0.65	0.51	0.74	0.45	0.37
Control Delay	60.9	29.7		68.5	27.5		68.8	55.6	9.2	72.7	49.0	12.1
Queue Delay	0.0	0.0		0.0	0.0		0.0	0.0	0.0	0.0	0.0	0.0
Total Delay	60.9	29.7		68.5	27.5		68.8	55.6	9.2	72.7	49.0	12.1
LOS	E	C		E	C		E	E	A	E	D	B
Approach Delay		36.5			34.1			43.4			42.2	
Approach LOS		D			C			D			D	

Intersection Summary

Area Type:	Other
Cycle Length:	132
Actuated Cycle Length:	132
Offset:	2.5 (2%), Referenced to phase 2:WBT and 6:EBT, Start of Yellow
Control Type:	Actuated-Coordinated
Maximum v/c Ratio:	0.74
Intersection Signal Delay:	38.3
Intersection LOS:	D
Intersection Capacity Utilization:	63.3%
ICU Level of Service:	B
Analysis Period (min):	15

Splits and Phases: 4: Wiley Canyon Road & Lyons Avenue

25 s	44 s	25 s	38 s
25 s	44 s	25 s	38 s

Existing - PM Peak Hour  
 5: Wiley Canyon Road & La Glorita Circle/Evans Avenue

Synchro 10 Report  
 Lanes, Volumes, Timings

Lane Group	EBL	EBT	EBR	WBL	WBT	WBR	NBL	NBT	NBR	SBL	SBT	SBR
Lane Configurations												
Traffic Volume (vph)	40	5	10	25	5	40	10	565	25	25	465	55
Future Volume (vph)	40	5	10	25	5	40	10	565	25	25	465	55
Ideal Flow (vphpl)	1900	1900	1900	1900	1900	1900	1900	1900	1900	1900	1900	1900
Storage Length (ft)	90		0	0		0	110		0	110		0
Storage Lanes	1		0	0		0	1		0	1		1
Taper Length (ft)	25			25			25			25		
Satd. Flow (prot)	1770	1676	0	0	1688	0	1770	1852	0	1770	1863	1583
Flt Permitted	0.870				0.875		0.483			0.402		
Satd. Flow (perm)	1621	1676	0	0	1504	0	900	1852	0	749	1863	1583
Right Turn on Red			Yes			Yes			Yes			Yes
Satd. Flow (RTOR)		10			41			5				57
Link Speed (mph)		30			30			35			35	
Link Distance (ft)		529			450			1329			869	
Travel Time (s)		12.0			10.2			25.9			16.9	
Peak Hour Factor	0.97	0.97	0.97	0.97	0.97	0.97	0.97	0.97	0.97	0.97	0.97	0.97
Shared Lane Traffic (%)												
Lane Group Flow (vph)	41	15	0	0	72	0	10	608	0	26	479	57
Turn Type	Perm	NA		Perm	NA		Perm	NA		Perm	NA	Perm
Protected Phases		4			8			2			6	
Permitted Phases	4			8			2			6		6
Total Split (s)	30.5	30.5		30.5	30.5		29.5	29.5		29.5	29.5	29.5
Total Lost Time (s)	4.5	4.5			4.5		4.5	4.5		4.5	4.5	4.5
Act Effct Green (s)	6.9	6.9			6.8		33.9	33.9		33.9	33.9	33.9
Actuated g/C Ratio	0.16	0.16			0.15		0.77	0.77		0.77	0.77	0.77
v/c Ratio	0.16	0.06			0.27		0.01	0.43		0.05	0.33	0.05
Control Delay	16.6	10.7			11.6		3.6	5.0		3.8	4.3	1.5
Queue Delay	0.0	0.0			0.0		0.0	0.0		0.0	0.0	0.0
Total Delay	16.6	10.7			11.6		3.6	5.0		3.8	4.3	1.5
LOS	B	B			B		A	A		A	A	A
Approach Delay		15.0			11.6			5.0			4.0	
Approach LOS		B			B			A			A	

Intersection Summary

Area Type:	Other
Cycle Length:	60
Actuated Cycle Length:	44
Control Type:	Actuated-Uncoordinated
Maximum v/c Ratio:	0.43
Intersection Signal Delay:	5.4
Intersection LOS:	A
Intersection Capacity Utilization:	49.5%
ICU Level of Service:	A
Analysis Period (min):	15

Splits and Phases: 5: Wiley Canyon Road & La Glorita Circle/Evans Avenue

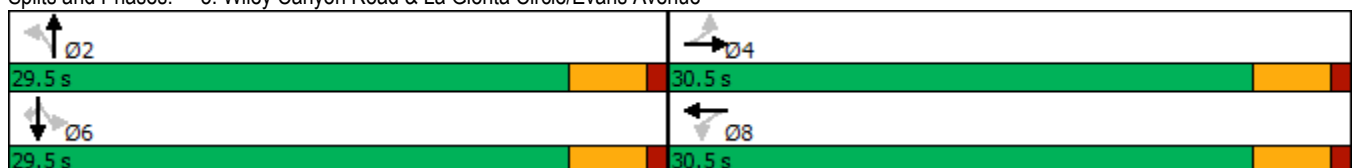

Intersection												
Int Delay, s/veh	1.6											
Movement	EBL	EBT	EBR	WBL	WBT	WBR	NBL	NBT	NBR	SBL	SBT	SBR
Lane Configurations		↕			↕		↗	↖		↗	↖	↗
Traffic Vol, veh/h	43	1	11	1	0	7	24	443	2	12	369	55
Future Vol, veh/h	43	1	11	1	0	7	24	443	2	12	369	55
Conflicting Peds, #/hr	0	0	0	0	0	0	0	0	0	0	0	0
Sign Control	Stop	Stop	Stop	Stop	Stop	Stop	Free	Free	Free	Free	Free	Free
RT Channelized	-	-	None	-	-	None	-	-	None	-	-	None
Storage Length	-	-	-	-	-	-	150	-	-	215	-	260
Veh in Median Storage, #	-	0	-	-	0	-	-	0	-	-	0	-
Grade, %	-	0	-	-	0	-	-	0	-	-	0	-
Peak Hour Factor	95	95	95	95	95	95	95	95	95	95	95	95
Heavy Vehicles, %	2	2	2	2	2	2	2	2	2	2	2	2
Mvmt Flow	45	1	12	1	0	7	25	466	2	13	388	58

Major/Minor	Minor2		Minor1		Major1		Major2					
Conflicting Flow All	935	932	388	967	989	467	446	0	0	468	0	0
Stage 1	414	414	-	517	517	-	-	-	-	-	-	-
Stage 2	521	518	-	450	472	-	-	-	-	-	-	-
Critical Hdwy	7.12	6.52	6.22	7.12	6.52	6.22	4.12	-	-	4.12	-	-
Critical Hdwy Stg 1	6.12	5.52	-	6.12	5.52	-	-	-	-	-	-	-
Critical Hdwy Stg 2	6.12	5.52	-	6.12	5.52	-	-	-	-	-	-	-
Follow-up Hdwy	3.518	4.018	3.318	3.518	4.018	3.318	2.218	-	-	2.218	-	-
Pot Cap-1 Maneuver	246	266	660	234	247	596	1114	-	-	1094	-	-
Stage 1	616	593	-	541	534	-	-	-	-	-	-	-
Stage 2	539	533	-	589	559	-	-	-	-	-	-	-
Platoon blocked, %								-	-	-	-	-
Mov Cap-1 Maneuver	237	257	660	223	239	596	1114	-	-	1094	-	-
Mov Cap-2 Maneuver	237	257	-	223	239	-	-	-	-	-	-	-
Stage 1	602	586	-	529	522	-	-	-	-	-	-	-
Stage 2	520	521	-	571	552	-	-	-	-	-	-	-

Approach	EB		WB		NB		SB	
HCM Control Delay, s	21.8		12.4		0.4		0.2	
HCM LOS	C		B					

Minor Lane/Major Mvmt	NBL	NBT	NBR	EBLn1	WBLn1	SBL	SBT	SBR
Capacity (veh/h)	1114	-	-	272	493	1094	-	-
HCM Lane V/C Ratio	0.023	-	-	0.213	0.017	0.012	-	-
HCM Control Delay (s)	8.3	-	-	21.8	12.4	8.3	-	-
HCM Lane LOS	A	-	-	C	B	A	-	-
HCM 95th %tile Q(veh)	0.1	-	-	0.8	0.1	0	-	-

Intersection												
Int Delay, s/veh	6.8											
Movement	EBL	EBT	EBR	WBL	WBT	WBR	NBL	NBT	NBR	SBL	SBT	SBR
Lane Configurations		↕		↕	↕						↕	↕
Traffic Vol, veh/h	0	524	77	226	165	0	0	0	0	81	2	64
Future Vol, veh/h	0	524	77	226	165	0	0	0	0	81	2	64
Conflicting Peds, #/hr	0	0	0	0	0	0	0	0	0	0	0	0
Sign Control	Free	Free	Free	Free	Free	Free	Free	Free	Free	Stop	Stop	Stop
RT Channelized	-	-	None	-	-	None	-	-	None	-	-	None
Storage Length	-	-	-	150	-	-	-	-	-	-	-	0
Veh in Median Storage, #	-	0	-	-	0	-	-	-	-	-	0	-
Grade, %	-	0	-	-	0	-	-	0	-	-	0	-
Peak Hour Factor	96	96	96	96	96	96	96	96	96	96	96	96
Heavy Vehicles, %	2	2	2	2	2	2	2	2	2	2	2	2
Mvmt Flow	0	546	80	235	172	0	0	0	0	84	2	67

Major/Minor	Major1			Major2			Minor2		
Conflicting Flow All	-	0	0	626	0	0	1228	1268	172
Stage 1	-	-	-	-	-	-	642	642	-
Stage 2	-	-	-	-	-	-	586	626	-
Critical Hdwy	-	-	-	4.12	-	-	6.42	6.52	6.22
Critical Hdwy Stg 1	-	-	-	-	-	-	5.42	5.52	-
Critical Hdwy Stg 2	-	-	-	-	-	-	5.42	5.52	-
Follow-up Hdwy	-	-	-	2.218	-	-	3.518	4.018	3.318
Pot Cap-1 Maneuver	0	-	-	956	-	0	197	168	872
Stage 1	0	-	-	-	-	0	524	469	-
Stage 2	0	-	-	-	-	0	556	477	-
Platoon blocked, %	-	-	-	-	-	-	-	-	-
Mov Cap-1 Maneuver	-	-	-	956	-	-	149	0	872
Mov Cap-2 Maneuver	-	-	-	-	-	-	149	0	-
Stage 1	-	-	-	-	-	-	395	0	-
Stage 2	-	-	-	-	-	-	556	0	-

Approach	EB	WB	SB
HCM Control Delay, s	0	5.8	36.9
HCM LOS			E

Minor Lane/Major Mvmt	EBT	EBR	WBL	WBT	SBLn1	SBLn2
Capacity (veh/h)	-	-	956	-	149	872
HCM Lane V/C Ratio	-	-	0.246	-	0.58	0.076
HCM Control Delay (s)	-	-	10	-	58.1	9.5
HCM Lane LOS	-	-	A	-	F	A
HCM 95th %tile Q(veh)	-	-	1	-	3	0.2

Intersection												
Int Delay, s/veh	13											
Movement	EBL	EBT	EBR	WBL	WBT	WBR	NBL	NBT	NBR	SBL	SBT	SBR
Lane Configurations	↘	↑			↑	↗		↖	↗			
Traffic Vol, veh/h	283	323	0	0	299	58	91	9	254	0	0	0
Future Vol, veh/h	283	323	0	0	299	58	91	9	254	0	0	0
Conflicting Peds, #/hr	0	0	0	0	0	0	0	0	0	0	0	0
Sign Control	Free	Free	Free	Free	Free	Free	Stop	Stop	Stop	Free	Free	Free
RT Channelized	-	-	None	-	-	None	-	-	None	-	-	None
Storage Length	170	-	-	-	-	0	-	-	0	-	-	-
Veh in Median Storage, #	-	0	-	-	0	-	-	0	-	-	-	-
Grade, %	-	0	-	-	0	-	-	0	-	-	0	-
Peak Hour Factor	92	92	92	92	92	92	92	92	92	92	92	92
Heavy Vehicles, %	2	2	2	2	2	2	2	2	2	2	2	2
Mvmt Flow	308	351	0	0	325	63	99	10	276	0	0	0

Major/Minor	Major1			Major2			Minor1		
Conflicting Flow All	388	0	-	-	-	0	1324	1355	351
Stage 1	-	-	-	-	-	-	967	967	-
Stage 2	-	-	-	-	-	-	357	388	-
Critical Hdwy	4.12	-	-	-	-	-	6.42	6.52	6.22
Critical Hdwy Stg 1	-	-	-	-	-	-	5.42	5.52	-
Critical Hdwy Stg 2	-	-	-	-	-	-	5.42	5.52	-
Follow-up Hdwy	2.218	-	-	-	-	-	3.518	4.018	3.318
Pot Cap-1 Maneuver	1170	-	0	0	-	-	172	149	692
Stage 1	-	-	0	0	-	-	369	333	-
Stage 2	-	-	0	0	-	-	708	609	-
Platoon blocked, %		-	-	-	-	-			
Mov Cap-1 Maneuver	1170	-	-	-	-	-	127	0	692
Mov Cap-2 Maneuver	-	-	-	-	-	-	127	0	-
Stage 1	-	-	-	-	-	-	272	0	-
Stage 2	-	-	-	-	-	-	708	0	-

Approach	EB	WB	NB
HCM Control Delay, s	4.3	0	40.9
HCM LOS			E

Minor Lane/Major Mvmt	NBLn1	NBLn2	EBL	EBT	WBT	WBR
Capacity (veh/h)	127	692	1170	-	-	-
HCM Lane V/C Ratio	0.856	0.399	0.263	-	-	-
HCM Control Delay (s)	110.3	13.6	9.2	-	-	-
HCM Lane LOS	F	B	A	-	-	-
HCM 95th %tile Q(veh)	5.3	1.9	1.1	-	-	-



Intersection												
Int Delay, s/veh	10.9											
Movement	EBL	EBT	EBR	WBL	WBT	WBR	NBL	NBT	NBR	SBL	SBT	SBR
Lane Configurations	↘	↑	↗	↘	↑	↗		↕			↕	↗
Traffic Vol, veh/h	475	128	6	0	74	52	2	1	0	64	2	270
Future Vol, veh/h	475	128	6	0	74	52	2	1	0	64	2	270
Conflicting Peds, #/hr	0	0	0	0	0	0	0	0	0	0	0	0
Sign Control	Free	Free	Free	Free	Free	Free	Stop	Stop	Stop	Stop	Stop	Stop
RT Channelized	-	-	None	-	-	None	-	-	None	-	-	Free
Storage Length	165	-	150	290	-	290	-	-	-	100	-	0
Veh in Median Storage, #	-	0	-	-	0	-	-	0	-	-	0	-
Grade, %	-	0	-	-	0	-	-	0	-	-	0	-
Peak Hour Factor	97	97	97	97	97	97	97	97	97	97	97	97
Heavy Vehicles, %	2	2	2	2	2	2	2	2	2	2	2	2
Mvmt Flow	490	132	6	0	76	54	2	1	0	66	2	278

Major/Minor	Major1			Major2			Minor1			Minor2		
Conflicting Flow All	130	0	0	138	0	0	1216	1242	132	1192	1194	-
Stage 1	-	-	-	-	-	-	1112	1112	-	76	76	-
Stage 2	-	-	-	-	-	-	104	130	-	1116	1118	-
Critical Hdwy	4.12	-	-	4.12	-	-	7.12	6.52	6.22	7.12	6.52	-
Critical Hdwy Stg 1	-	-	-	-	-	-	6.12	5.52	-	6.12	5.52	-
Critical Hdwy Stg 2	-	-	-	-	-	-	6.12	5.52	-	6.12	5.52	-
Follow-up Hdwy	2.218	-	-	2.218	-	-	3.518	4.018	3.318	3.518	4.018	-
Pot Cap-1 Maneuver	1455	-	-	1446	-	-	158	175	917	164	187	0
Stage 1	-	-	-	-	-	-	253	284	-	933	832	0
Stage 2	-	-	-	-	-	-	902	789	-	252	282	0
Platoon blocked, %	-	-	-	-	-	-	-	-	-	-	-	-
Mov Cap-1 Maneuver	1455	-	-	1446	-	-	115	116	917	120	124	-
Mov Cap-2 Maneuver	-	-	-	-	-	-	115	116	-	120	124	-
Stage 1	-	-	-	-	-	-	168	188	-	619	832	-
Stage 2	-	-	-	-	-	-	900	789	-	166	187	-

Approach	EB			WB			NB			SB		
HCM Control Delay, s	6.8			0			37.2			68.5		
HCM LOS	E			E			E			F		

Minor Lane/Major Mvmt	NBLn1	EBL	EBT	EBR	WBL	WBT	WBR	SBLn1	SBLn2
Capacity (veh/h)	115	1455	-	-	1446	-	-	120	-
HCM Lane V/C Ratio	0.027	0.337	-	-	-	-	-	0.567	-
HCM Control Delay (s)	37.2	8.7	-	-	0	-	-	68.5	0
HCM Lane LOS	E	A	-	-	A	-	-	F	A
HCM 95th %tile Q(veh)	0.1	1.5	-	-	0	-	-	2.8	-

# **EXISTING PLUS PROJECT CONDITIONS**

Existing plus Project - AM Peak Hour  
 1: Marriott Way/I-5 SB Ramps & Pico Canyon Road/Lyons Avenue

Synchro 10 Report  
 Lanes, Volumes, Timings

Lane Group	EBL	EBT	EBR	WBL	WBT	WBR	NBL	NBT	NBR	SBL	SBT	SBR
Lane Configurations												
Traffic Volume (vph)	0	638	28	31	549	249	0	0	59	253	69	80
Future Volume (vph)	0	638	28	31	549	249	0	0	59	253	69	80
Ideal Flow (vphpl)	1900	1900	1900	1900	1900	1900	1900	1900	1900	1900	1900	1900
Storage Length (ft)	0		0	100		0	0		0	0		200
Storage Lanes	0		0	1		1	0		1	1		1
Taper Length (ft)	25			25			25			25		
Satd. Flow (prot)	0	5055	0	1770	3539	1583	0	0	1611	1681	1720	1583
Flt Permitted				0.262						0.950	0.972	
Satd. Flow (perm)	0	5055	0	488	3539	1583	0	0	1611	1681	1720	1583
Right Turn on Red			Yes			Yes			Yes			Yes
Satd. Flow (RTOR)		9				286			251			92
Link Speed (mph)		40			40			30			30	
Link Distance (ft)		694			822			283			346	
Travel Time (s)		11.8			14.0			6.4			7.9	
Peak Hour Factor	0.87	0.87	0.87	0.87	0.87	0.87	0.87	0.87	0.87	0.87	0.87	0.87
Shared Lane Traffic (%)										37%		
Lane Group Flow (vph)	0	765	0	36	631	286	0	0	68	183	187	92
Turn Type		NA		Perm	NA	Perm			Perm	Split	NA	Perm
Protected Phases		4			8					6	6	
Permitted Phases				8		8			2			6
Total Split (s)		37.0		37.0	37.0	37.0			10.5	37.5	37.5	37.5
Total Lost Time (s)		4.5		4.5	4.5	4.5			3.0	4.5	4.5	4.5
Act Effct Green (s)		20.7		20.7	20.7	20.7			7.5	33.2	33.2	33.2
Actuated g/C Ratio		0.28		0.28	0.28	0.28			0.10	0.45	0.45	0.45
v/c Ratio		0.53		0.26	0.63	0.44			0.17	0.24	0.24	0.12
Control Delay		23.1		25.1	25.8	4.9			1.0	14.8	14.8	4.1
Queue Delay		0.0		0.0	0.0	0.0			0.0	0.0	0.0	0.0
Total Delay		23.1		25.1	25.8	4.9			1.0	14.8	14.8	4.1
LOS		C		C	C	A			A	B	B	A
Approach Delay		23.1			19.5			1.0			12.7	
Approach LOS		C			B			A			B	

Intersection Summary

Area Type:	Other
Cycle Length:	85
Actuated Cycle Length:	73.5
Control Type:	Actuated-Uncoordinated
Maximum v/c Ratio:	0.63
Intersection Signal Delay:	18.8
Intersection LOS:	B
Intersection Capacity Utilization:	37.2%
ICU Level of Service:	A
Analysis Period (min):	15

Splits and Phases: 1: Marriott Way/I-5 SB Ramps & Pico Canyon Road/Lyons Avenue

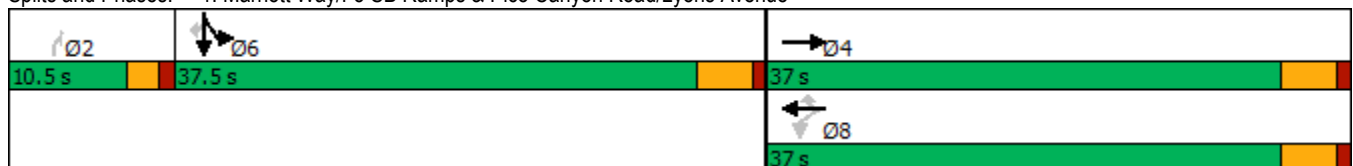

Existing plus Project - AM Peak Hour  
 3: I-5 NB Ramps & Lyons Avenue

Synchro 10 Report  
 Lanes, Volumes, Timings

Lane Group	EBL	EBT	EBR	WBL	WBT	WBR	NBL	NBT	NBR	SBL	SBT	SBR
Lane Configurations												
Traffic Volume (vph)	111	508	0	0	654	382	294	5	304	0	0	0
Future Volume (vph)	111	508	0	0	654	382	294	5	304	0	0	0
Ideal Flow (vphpl)	1900	1900	1900	1900	1900	1900	1900	1900	1900	1900	1900	1900
Storage Length (ft)	300		0	0		0	0		0	0		0
Storage Lanes	1		0	0		0	1		1	0		0
Taper Length (ft)	25			25			25			25		
Satd. Flow (prot)	1770	3539	0	0	4806	0	1681	1688	1583	0	0	0
Flt Permitted	0.950						0.950	0.954				
Satd. Flow (perm)	1770	3539	0	0	4806	0	1681	1688	1583	0	0	0
Right Turn on Red			Yes			Yes			Yes			Yes
Satd. Flow (RTOR)					184				195			
Link Speed (mph)		40			40			30			30	
Link Distance (ft)		603			1902			756			732	
Travel Time (s)		10.3			32.4			17.2			16.6	
Peak Hour Factor	0.86	0.86	0.86	0.86	0.86	0.86	0.86	0.86	0.86	0.86	0.86	0.86
Shared Lane Traffic (%)							49%					
Lane Group Flow (vph)	129	591	0	0	1204	0	174	174	353	0	0	0
Turn Type	Prot	NA			NA		Perm	NA	Perm			
Protected Phases	7	4			8			2				
Permitted Phases							2		2			
Total Split (s)	13.0	40.5			27.5		39.5	39.5	39.5			
Total Lost Time (s)	4.5	4.5			4.5		4.5	4.5	4.5			
Act Effct Green (s)	8.2	35.0			22.2		35.0	35.0	35.0			
Actuated g/C Ratio	0.10	0.44			0.28		0.44	0.44	0.44			
v/c Ratio	0.70	0.38			0.81		0.23	0.23	0.44			
Control Delay	56.2	15.5			27.4		15.1	15.0	8.6			
Queue Delay	0.0	0.0			0.0		0.0	0.0	0.0			
Total Delay	56.2	15.5			27.4		15.1	15.0	8.6			
LOS	E	B			C		B	B	A			
Approach Delay		22.8			27.4			11.8				
Approach LOS		C			C			B				

Intersection Summary

Area Type:	Other
Cycle Length:	80
Actuated Cycle Length:	79
Control Type:	Actuated-Uncoordinated
Maximum v/c Ratio:	0.81
Intersection Signal Delay:	22.0
Intersection LOS:	C
Intersection Capacity Utilization:	46.9%
ICU Level of Service:	A
Analysis Period (min):	15

Splits and Phases: 3: I-5 NB Ramps & Lyons Avenue

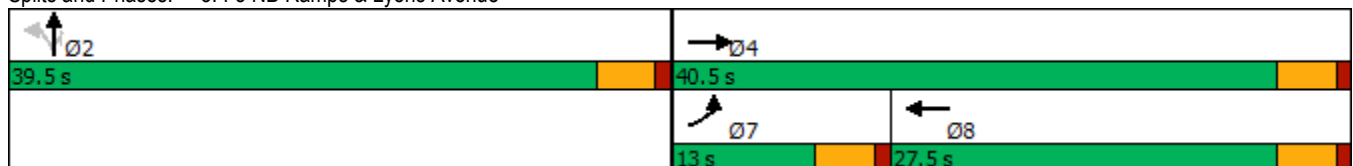

Existing plus Project - AM Peak Hour  
 4: Wiley Canyon Road & Lyons Avenue

Synchro 10 Report  
 Lanes, Volumes, Timings

Lane Group	EBL	EBT	EBR	WBL	WBT	WBR	NBL	NBT	NBR	SBL	SBT	SBR
Lane Configurations												
Traffic Volume (vph)	135	520	87	224	705	100	159	242	178	105	442	250
Future Volume (vph)	135	520	87	224	705	100	159	242	178	105	442	250
Ideal Flow (vphpl)	1900	1900	1900	1900	1900	1900	1900	1900	1900	1900	1900	1900
Storage Length (ft)	130		0	200		0	225		270	200		225
Storage Lanes	2		0	1		0	1		1	1		1
Taper Length (ft)	25			25			25			25		
Satd. Flow (prot)	3433	4979	0	1770	4989	0	1770	3539	1583	1770	3539	1583
Flt Permitted	0.950			0.950			0.950			0.950		
Satd. Flow (perm)	3433	4979	0	1770	4989	0	1770	3539	1583	1770	3539	1583
Right Turn on Red			Yes			Yes			Yes			Yes
Satd. Flow (RTOR)		24			21				217			112
Link Speed (mph)		40			40			35			45	
Link Distance (ft)		1902			870			869			1018	
Travel Time (s)		32.4			14.8			16.9			15.4	
Peak Hour Factor	0.82	0.82	0.82	0.82	0.82	0.82	0.82	0.82	0.82	0.82	0.82	0.82
Shared Lane Traffic (%)												
Lane Group Flow (vph)	165	740	0	273	982	0	194	295	217	128	539	305
Turn Type	Prot	NA		Prot	NA		Prot	NA	Perm	Prot	NA	pm+ov
Protected Phases	1	6		5	2		7	4		3	8	1
Permitted Phases									4			8
Total Split (s)	20.0	41.0		28.0	49.0		25.0	38.0	38.0	25.0	38.0	20.0
Total Lost Time (s)	4.0	4.0		4.0	4.0		4.0	4.0	4.0	4.0	4.0	4.0
Act Effct Green (s)	12.3	45.9		24.0	57.6		18.6	30.8	30.8	15.3	27.4	43.8
Actuated g/C Ratio	0.09	0.35		0.18	0.44		0.14	0.23	0.23	0.12	0.21	0.33
v/c Ratio	0.52	0.42		0.85	0.45		0.78	0.36	0.41	0.62	0.73	0.51
Control Delay	62.3	33.8		76.3	27.8		75.4	43.2	7.3	68.4	54.9	23.8
Queue Delay	0.0	0.0		0.0	0.0		0.0	0.0	0.0	0.0	0.0	0.0
Total Delay	62.3	33.8		76.3	27.8		75.4	43.2	7.3	68.4	54.9	23.8
LOS	E	C		E	C		E	D	A	E	D	C
Approach Delay		39.0			38.4			41.0			46.9	
Approach LOS		D			D			D			D	

Intersection Summary

Area Type:	Other
Cycle Length:	132
Actuated Cycle Length:	132
Offset:	2.5 (2%), Referenced to phase 2:WBT and 6:EBT, Start of Yellow
Control Type:	Actuated-Coordinated
Maximum v/c Ratio:	0.85
Intersection Signal Delay:	41.2
Intersection LOS:	D
Intersection Capacity Utilization:	58.8%
ICU Level of Service:	B
Analysis Period (min):	15

Splits and Phases: 4: Wiley Canyon Road & Lyons Avenue

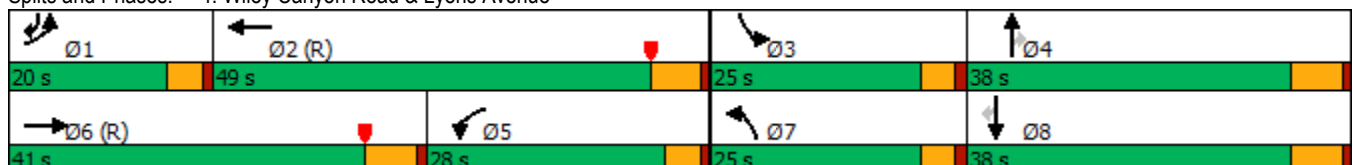

Existing plus Project - AM Peak Hour  
 5: Wiley Canyon Road & La Glorita Circle/Evans Avenue

Synchro 10 Report  
 Lanes, Volumes, Timings

Lane Group	EBL	EBT	EBR	WBL	WBT	WBR	NBL	NBT	NBR	SBL	SBT	SBR
Lane Configurations												
Traffic Volume (vph)	70	5	32	38	10	40	14	454	20	10	643	60
Future Volume (vph)	70	5	32	38	10	40	14	454	20	10	643	60
Ideal Flow (vphpl)	1900	1900	1900	1900	1900	1900	1900	1900	1900	1900	1900	1900
Storage Length (ft)	90		0	0		0	110		0	110		0
Storage Lanes	1		0	0		0	1		0	1		1
Taper Length (ft)	25			25			25			25		
Satd. Flow (prot)	1770	1619	0	0	1711	0	1770	1852	0	1770	1863	1583
Flt Permitted	0.836				0.839		0.233			0.371		
Satd. Flow (perm)	1557	1619	0	0	1466	0	434	1852	0	691	1863	1583
Right Turn on Red			Yes			Yes			Yes			Yes
Satd. Flow (RTOR)		42			52			5				78
Link Speed (mph)		30			30			35			35	
Link Distance (ft)		529			450			1329			869	
Travel Time (s)		12.0			10.2			25.9			16.9	
Peak Hour Factor	0.77	0.77	0.77	0.77	0.77	0.77	0.77	0.77	0.77	0.77	0.77	0.77
Shared Lane Traffic (%)												
Lane Group Flow (vph)	91	48	0	0	114	0	18	616	0	13	835	78
Turn Type	Perm	NA		Perm	NA		Perm	NA		Perm	NA	Perm
Protected Phases		4			8			2			6	
Permitted Phases	4			8			2			6		6
Total Split (s)	30.5	30.5		30.5	30.5		29.5	29.5		29.5	29.5	29.5
Total Lost Time (s)	4.5	4.5			4.5		4.5	4.5		4.5	4.5	4.5
Act Effct Green (s)	8.5	8.5			8.5		29.7	29.7		29.7	29.7	29.7
Actuated g/C Ratio	0.19	0.19			0.19		0.67	0.67		0.67	0.67	0.67
v/c Ratio	0.31	0.14			0.35		0.06	0.50		0.03	0.67	0.07
Control Delay	17.4	7.3			12.3		5.3	7.3		4.7	11.4	1.8
Queue Delay	0.0	0.0			0.0		0.0	0.0		0.0	0.0	0.0
Total Delay	17.4	7.3			12.3		5.3	7.3		4.7	11.4	1.8
LOS	B	A			B		A	A		A	B	A
Approach Delay		13.9			12.3			7.2			10.5	
Approach LOS		B			B			A			B	

Intersection Summary

Area Type:	Other
Cycle Length:	60
Actuated Cycle Length:	44.3
Control Type:	Actuated-Uncoordinated
Maximum v/c Ratio:	0.67
Intersection Signal Delay:	9.7
Intersection LOS:	A
Intersection Capacity Utilization:	53.1%
ICU Level of Service:	A
Analysis Period (min):	15

Splits and Phases: 5: Wiley Canyon Road & La Glorita Circle/Evans Avenue

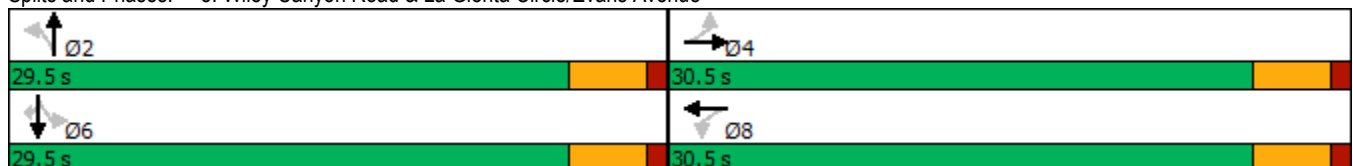

Intersection

Int Delay, s/veh	3.4											
Movement	EBL	EBT	EBR	WBL	WBT	WBR	NBL	NBT	NBR	SBL	SBT	SBR
Lane Configurations		↕			↕		↕	↕		↕	↕	↕
Traffic Vol, veh/h	60	0	41	1	0	8	18	351	4	6	482	44
Future Vol, veh/h	60	0	41	1	0	8	18	351	4	6	482	44
Conflicting Peds, #/hr	0	0	0	0	0	0	0	0	0	0	0	0
Sign Control	Stop	Stop	Stop	Stop	Stop	Stop	Free	Free	Free	Free	Free	Free
RT Channelized	-	-	None	-	-	None	-	-	None	-	-	None
Storage Length	-	-	-	-	-	-	150	-	-	215	-	260
Veh in Median Storage, #	-	0	-	-	0	-	-	0	-	-	0	-
Grade, %	-	0	-	-	0	-	-	0	-	-	0	-
Peak Hour Factor	83	83	83	83	83	83	83	83	83	83	83	83
Heavy Vehicles, %	2	2	2	2	2	2	2	2	2	2	2	2
Mvmt Flow	72	0	49	1	0	10	22	423	5	7	581	53

Major/Minor	Minor2		Minor1			Major1		Major2				
Conflicting Flow All	1070	1067	581	1116	1118	426	634	0	0	428	0	0
Stage 1	595	595	-	470	470	-	-	-	-	-	-	-
Stage 2	475	472	-	646	648	-	-	-	-	-	-	-
Critical Hdwy	7.12	6.52	6.22	7.12	6.52	6.22	4.12	-	-	4.12	-	-
Critical Hdwy Stg 1	6.12	5.52	-	6.12	5.52	-	-	-	-	-	-	-
Critical Hdwy Stg 2	6.12	5.52	-	6.12	5.52	-	-	-	-	-	-	-
Follow-up Hdwy	3.518	4.018	3.318	3.518	4.018	3.318	2.218	-	-	2.218	-	-
Pot Cap-1 Maneuver	199	222	514	185	207	628	949	-	-	1131	-	-
Stage 1	491	492	-	574	560	-	-	-	-	-	-	-
Stage 2	570	559	-	460	466	-	-	-	-	-	-	-
Platoon blocked, %								-	-	-	-	-
Mov Cap-1 Maneuver	192	216	514	164	201	628	949	-	-	1131	-	-
Mov Cap-2 Maneuver	192	216	-	164	201	-	-	-	-	-	-	-
Stage 1	480	489	-	561	547	-	-	-	-	-	-	-
Stage 2	548	546	-	413	463	-	-	-	-	-	-	-

Approach	EB		WB			NB		SB			
HCM Control Delay, s	31		12.7			0.4		0.1			
HCM LOS	D		B								

Minor Lane/Major Mvmt	NBL	NBT	NBR	EBLn1	WBLn1	SBL	SBT	SBR
Capacity (veh/h)	949	-	-	257	478	1131	-	-
HCM Lane V/C Ratio	0.023	-	-	0.473	0.023	0.006	-	-
HCM Control Delay (s)	8.9	-	-	31	12.7	8.2	-	-
HCM Lane LOS	A	-	-	D	B	A	-	-
HCM 95th %tile Q(veh)	0.1	-	-	2.4	0.1	0	-	-

Intersection												
Int Delay, s/veh	8.6											
Movement	EBL	EBT	EBR	WBL	WBT	WBR	NBL	NBT	NBR	SBL	SBT	SBR
Lane Configurations		↕		↕	↕						↕	↕
Traffic Vol, veh/h	0	132	59	454	169	0	0	0	0	42	0	200
Future Vol, veh/h	0	132	59	454	169	0	0	0	0	42	0	200
Conflicting Peds, #/hr	0	0	0	0	0	0	0	0	0	0	0	0
Sign Control	Free	Free	Free	Free	Free	Free	Free	Free	Free	Stop	Stop	Stop
RT Channelized	-	-	None	-	-	None	-	-	None	-	-	None
Storage Length	-	-	-	150	-	-	-	-	-	-	-	0
Veh in Median Storage, #	-	0	-	-	0	-	-	0	-	-	0	-
Grade, %	-	0	-	-	0	-	-	0	-	-	0	-
Peak Hour Factor	91	91	91	91	91	91	91	91	91	91	91	91
Heavy Vehicles, %	2	2	2	2	2	2	2	2	2	2	2	2
Mvmt Flow	0	145	65	499	186	0	0	0	0	46	0	220

Major/Minor	Major1			Major2			Minor2			
Conflicting Flow All	-	0	0	210	0	0		1362	1394	186
Stage 1	-	-	-	-	-	-		1184	1184	-
Stage 2	-	-	-	-	-	-		178	210	-
Critical Hdwy	-	-	-	4.12	-	-		6.42	6.52	6.22
Critical Hdwy Stg 1	-	-	-	-	-	-		5.42	5.52	-
Critical Hdwy Stg 2	-	-	-	-	-	-		5.42	5.52	-
Follow-up Hdwy	-	-	-	2.218	-	-		3.518	4.018	3.318
Pot Cap-1 Maneuver	0	-	-	1361	-	0		163	141	856
Stage 1	0	-	-	-	-	0		290	263	-
Stage 2	0	-	-	-	-	0		853	728	-
Platoon blocked, %	-	-	-	-	-	-		-	-	-
Mov Cap-1 Maneuver	-	-	-	1361	-	-		103	0	856
Mov Cap-2 Maneuver	-	-	-	-	-	-		103	0	-
Stage 1	-	-	-	-	-	-		290	0	-
Stage 2	-	-	-	-	-	-		540	0	-

Approach	EB			WB			SB		
HCM Control Delay, s	0			6.7			20.2		
HCM LOS							C		

Minor Lane/Major Mvmt	EBT	EBR	WBL	WBT	SBLn1	SBLn2
Capacity (veh/h)	-	-	1361	-	103	856
HCM Lane V/C Ratio	-	-	0.367	-	0.448	0.257
HCM Control Delay (s)	-	-	9.2	-	65.7	10.7
HCM Lane LOS	-	-	A	-	F	B
HCM 95th %tile Q(veh)	-	-	1.7	-	1.9	1



Intersection

Int Delay, s/veh	3.9											
Movement	EBL	EBT	EBR	WBL	WBT	WBR	NBL	NBT	NBR	SBL	SBT	SBR
Lane Configurations	↘	↑			↘			↘	↗			
Traffic Vol, veh/h	74	116	0	0	493	97	75	11	138	0	0	0
Future Vol, veh/h	74	116	0	0	493	97	75	11	138	0	0	0
Conflicting Peds, #/hr	0	0	0	0	0	0	0	0	0	0	0	0
Sign Control	Free	Free	Free	Free	Free	Free	Stop	Stop	Stop	Free	Free	Free
RT Channelized	-	-	None	-	-	None	-	-	None	-	-	None
Storage Length	170	-	-	-	-	-	-	-	0	-	-	-
Veh in Median Storage, #	-	0	-	-	0	-	-	0	-	-	0	-
Grade, %	-	0	-	-	0	-	-	0	-	-	0	-
Peak Hour Factor	94	94	94	94	94	94	94	94	94	94	94	94
Heavy Vehicles, %	2	2	2	2	2	2	2	2	2	2	2	2
Mvmt Flow	79	123	0	0	524	103	80	12	147	0	0	0

Major/Minor	Major1		Major2		Minor1				
Conflicting Flow All	627	0	-	-	-	0	857	908	123
Stage 1	-	-	-	-	-	-	281	281	-
Stage 2	-	-	-	-	-	-	576	627	-
Critical Hdwy	4.12	-	-	-	-	-	6.42	6.52	6.22
Critical Hdwy Stg 1	-	-	-	-	-	-	5.42	5.52	-
Critical Hdwy Stg 2	-	-	-	-	-	-	5.42	5.52	-
Follow-up Hdwy	2.218	-	-	-	-	-	3.518	4.018	3.318
Pot Cap-1 Maneuver	955	-	0	0	-	-	328	275	928
Stage 1	-	-	0	0	-	-	767	678	-
Stage 2	-	-	0	0	-	-	562	476	-
Platoon blocked, %		-			-	-			
Mov Cap-1 Maneuver	955	-	-	-	-	-	301	0	928
Mov Cap-2 Maneuver	-	-	-	-	-	-	301	0	-
Stage 1	-	-	-	-	-	-	703	0	-
Stage 2	-	-	-	-	-	-	562	0	-

Approach	EB	WB	NB
HCM Control Delay, s	3.5	0	14.4
HCM LOS			B

Minor Lane/Major Mvmt	NBLn1	NBLn2	EBL	EBT	WBT	WBR
Capacity (veh/h)	301	928	955	-	-	-
HCM Lane V/C Ratio	0.304	0.158	0.082	-	-	-
HCM Control Delay (s)	22.1	9.6	9.1	-	-	-
HCM Lane LOS	C	A	A	-	-	-
HCM 95th %tile Q(veh)	1.2	0.6	0.3	-	-	-

# DELAY (AVERAGE)

Average control delay per vehicle, or average pedestrian delay (seconds)

## Site: 9. Wiley Canyon Rd & Calgrove Blvd AM Peak Hour

Existing Plus Project  
Roundabout

### All Movement Classes

	South	East	North	West	Intersection
Delay (Average)	10.8	7.2	8.4	12.3	9.2
LOS	B	A	A	B	A

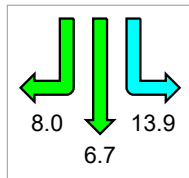

Wiley Canyon Road



Calgrove Boulevard

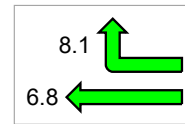

Calgrove Boulevard

Valley Oak Court

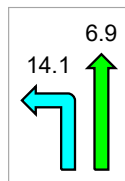

Colour code based on Level of Service

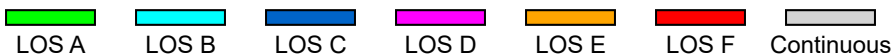

Level of Service Method: Delay & v/c (HCM 2010)

LOS F will result if v/c > 1 irrespective of movement delay value (does not apply for approaches and intersection).

Roundabout Level of Service Method: Same as Signalised Intersections

SIDRA Standard Delay Model is used. Control Delay includes Geometric Delay.

# INPUT VOLUMES

Vehicles and pedestrians per 60 minutes

 **Site: 9. Wiley Canyon Rd & Calgrove Blvd AM Peak Hour**

Existing Plus Project

Volume Display Method: Total and %

Volumes are shown for Movement Class(es): All Classes and Heavy Vehicles

Total Intersection Volumes (veh)

All Movement Classes: 948

Light Vehicles (LV): 920

Heavy Vehicles (HV): 28

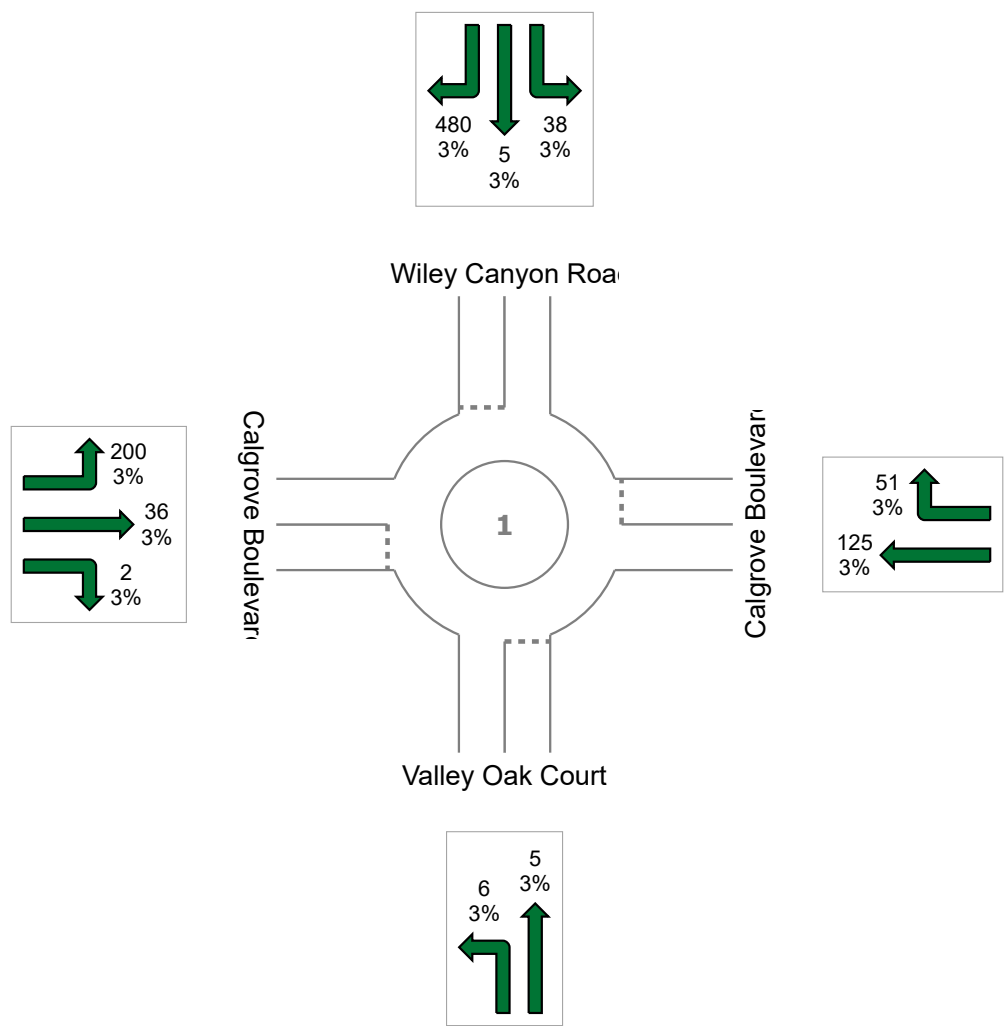

# QUEUE DISTANCE

Largest 95% Back of Queue for any lane used by movement (feet)

 **Site: 9. Wiley Canyon Rd & Calgrove Blvd AM Peak Hour**

Existing Plus Project  
Roundabout

## All Movement Classes

	South	East	North	West	Intersection
Queue Distance	1	14	55	17	55

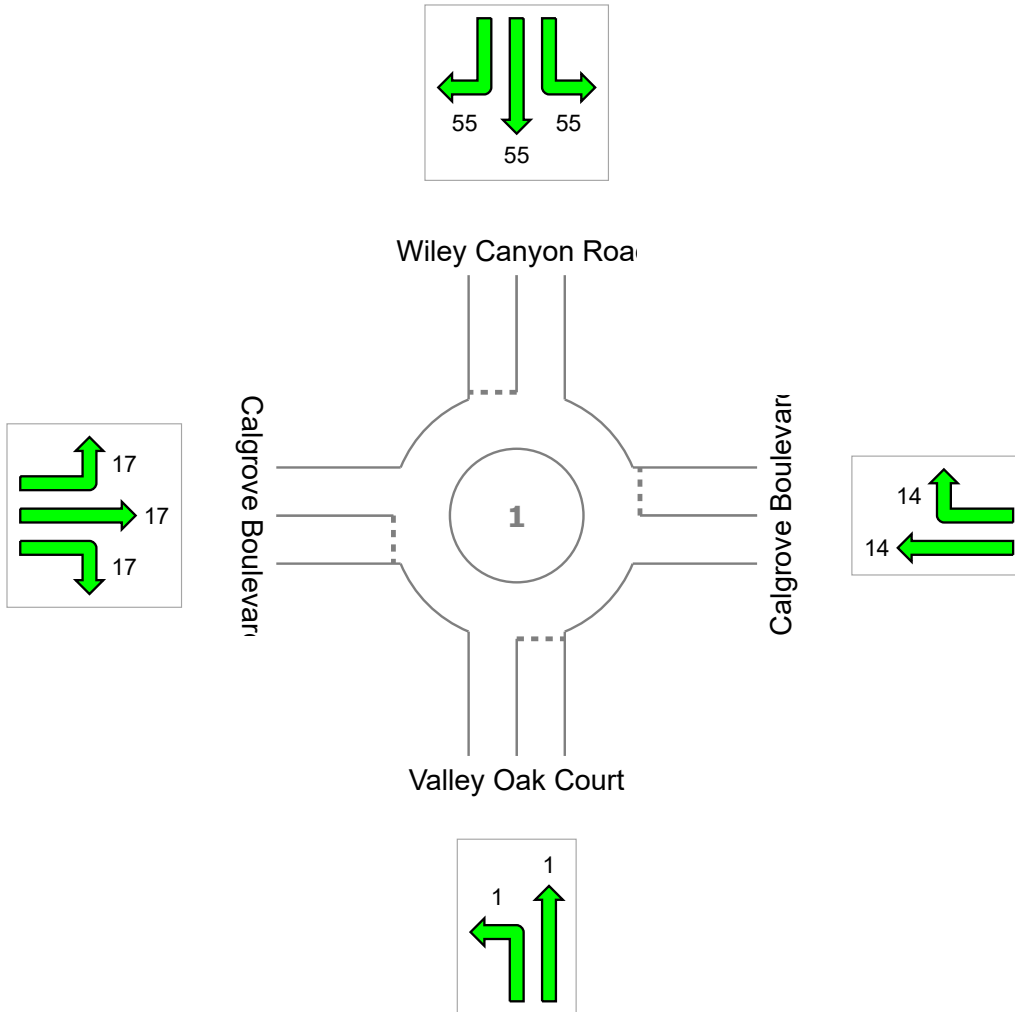

Colour code based on Queue Storage Ratio

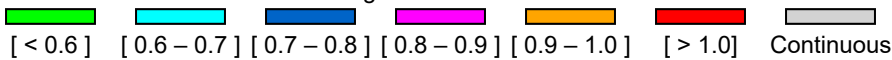

# DEGREE OF SATURATION

Ratio of Demand Volume to Capacity (v/c ratio)

## Site: 9. Wiley Canyon Rd & Calgrove Blvd AM Peak Hour

Existing Plus Project  
Roundabout

### All Movement Classes

	South	East	North	West	Intersection
Degree of Saturation	0.01	0.18	0.48	0.20	0.48

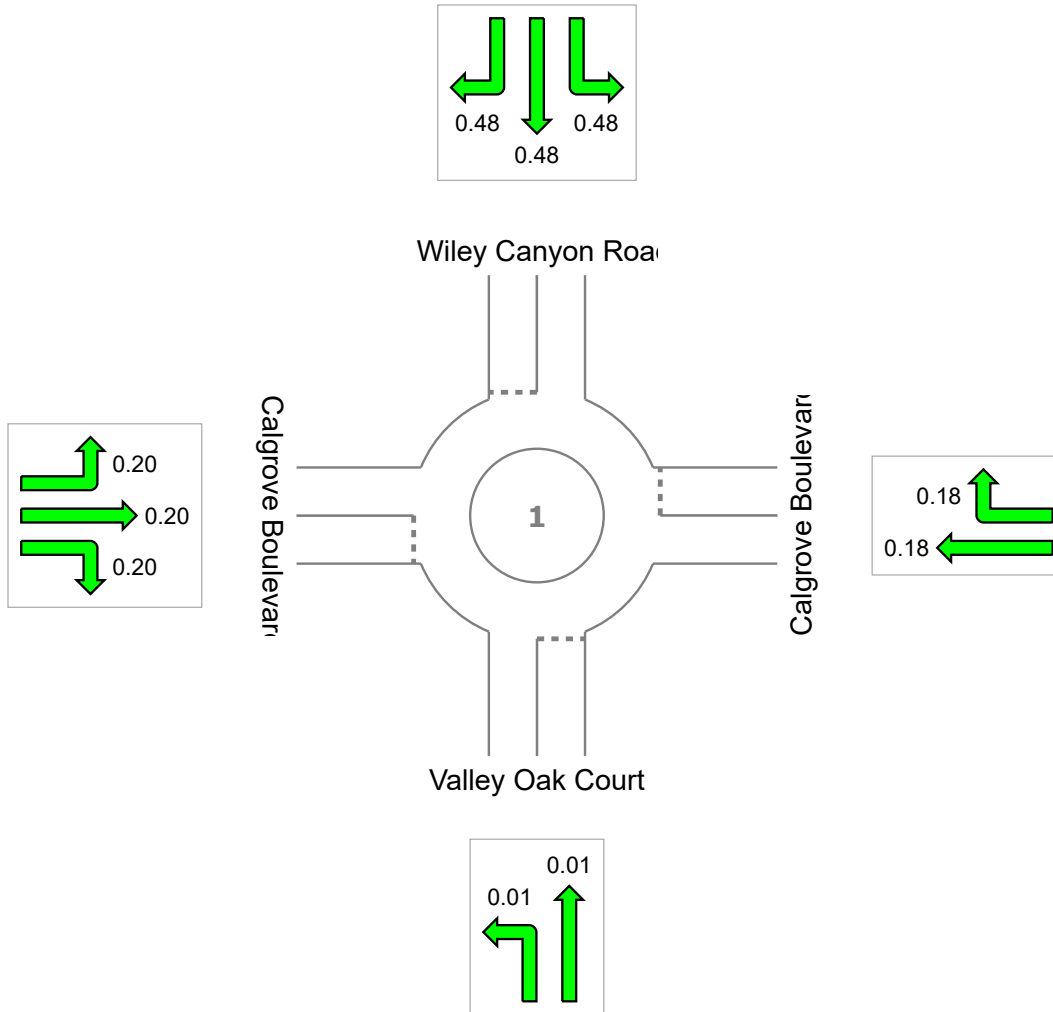

Colour code based on Degree of Saturation

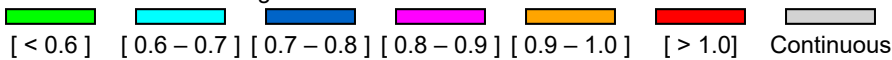

Existing plus Project - AM Peak Hour  
 9: Calgrove Boulevard & Wiley Canyon Road

Synchro 10 Report  
 Lanes, Volumes, Timings

Lane Group	EBL	EBT	EBR	WBL	WBT	WBR	NBL	NBT	NBR	SBL	SBT	SBR
Lane Configurations												
Traffic Volume (vph)	200	36	2	0	125	51	6	5	0	38	5	480
Future Volume (vph)	200	36	2	0	125	51	6	5	0	38	5	480
Ideal Flow (vphpl)	1900	1900	1900	1900	1900	1900	1900	1900	1900	1900	1900	1900
Storage Length (ft)	165		150	290		290	0		0	100		100
Storage Lanes	1		1	1		1	0		0	0		1
Taper Length (ft)	25			25			25			25		
Satd. Flow (prot)	1770	1863	1583	1863	1863	1583	0	1814	0	0	1785	1583
Flt Permitted	0.950							0.898			0.797	
Satd. Flow (perm)	1770	1863	1583	1863	1863	1583	0	1673	0	0	1485	1583
Right Turn on Red			Yes			Yes			Yes			Yes
Satd. Flow (RTOR)			109			191						539
Link Speed (mph)		45			45			30			35	
Link Distance (ft)		786			1192			412			1483	
Travel Time (s)		11.9			18.1			9.4			28.9	
Peak Hour Factor	0.89	0.89	0.89	0.89	0.89	0.89	0.89	0.89	0.89	0.89	0.89	0.89
Shared Lane Traffic (%)												
Lane Group Flow (vph)	225	40	2	0	140	57	0	13	0	0	49	539
Turn Type	Prot	NA	Perm	Prot	NA	Perm	Perm	NA		Perm	NA	Perm
Protected Phases	7	4		3	8			2			6	
Permitted Phases			4			8	2			6		6
Total Split (s)	15.0	28.0	28.0	9.5	22.5	22.5	22.5	22.5		22.5	22.5	22.5
Total Lost Time (s)	4.5	4.5	4.5	4.5	4.5	4.5		4.5			4.5	4.5
Act Effct Green (s)	9.7	20.6	20.6		8.6	8.6		12.6			12.6	12.6
Actuated g/C Ratio	0.23	0.49	0.49		0.20	0.20		0.30			0.30	0.30
v/c Ratio	0.55	0.04	0.00		0.37	0.12		0.03			0.11	0.63
Control Delay	23.2	5.6	0.0		18.7	0.5		12.9			13.8	5.6
Queue Delay	0.0	0.0	0.0		0.0	0.0		0.0			0.0	0.0
Total Delay	23.2	5.6	0.0		18.7	0.5		12.9			13.8	5.6
LOS	C	A	A		B	A		B			B	A
Approach Delay		20.4			13.4			12.9			6.3	
Approach LOS		C			B			B			A	

Intersection Summary

Area Type:	Other
Cycle Length:	60
Actuated Cycle Length:	42.4
Control Type:	Actuated-Uncoordinated
Maximum v/c Ratio:	0.63
Intersection Signal Delay:	11.3
Intersection LOS:	B
Intersection Capacity Utilization:	51.7%
ICU Level of Service:	A
Analysis Period (min):	15

Splits and Phases: 9: Calgrove Boulevard & Wiley Canyon Road

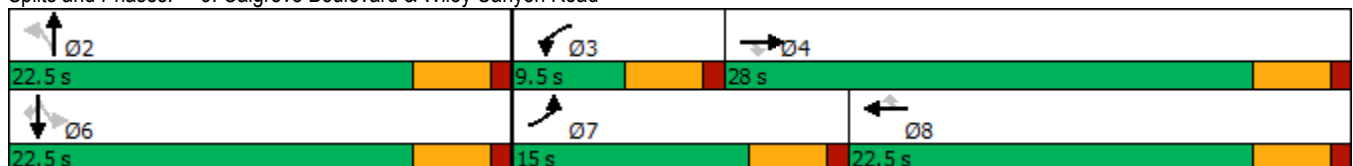

# DELAY (AVERAGE)

Average control delay per vehicle, or average pedestrian delay (seconds)

## Site: 10. Wiley Canyon Rd & Project Access AM Peak Hour

Existing Plus Project  
Roundabout

### All Movement Classes

	South	North	West	Intersection
Delay (Average)	7.7	7.1	13.7	8.2
LOS	A	A	B	A

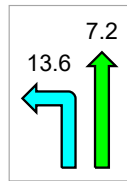
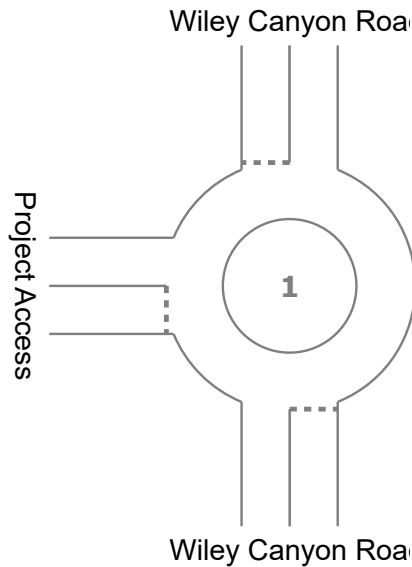
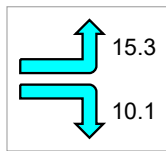
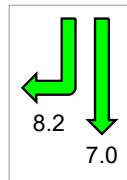

Colour code based on Level of Service

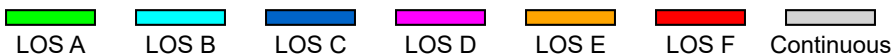

Level of Service Method: Delay & v/c (HCM 2010)

LOS F will result if v/c > 1 irrespective of movement delay value (does not apply for approaches and intersection).

Roundabout Level of Service Method: Same as Signalised Intersections

SIDRA Standard Delay Model is used. Control Delay includes Geometric Delay.

# INPUT VOLUMES

Vehicles and pedestrians per 60 minutes

 **Site: 10. Wiley Canyon Rd & Project Access AM Peak Hour**

Existing Plus Project

Volume Display Method: Total and %

Volumes are shown for Movement Class(es): All Classes and Heavy Vehicles

Total Intersection Volumes (veh)

All Movement Classes: 964

Light Vehicles (LV): 935

Heavy Vehicles (HV): 29

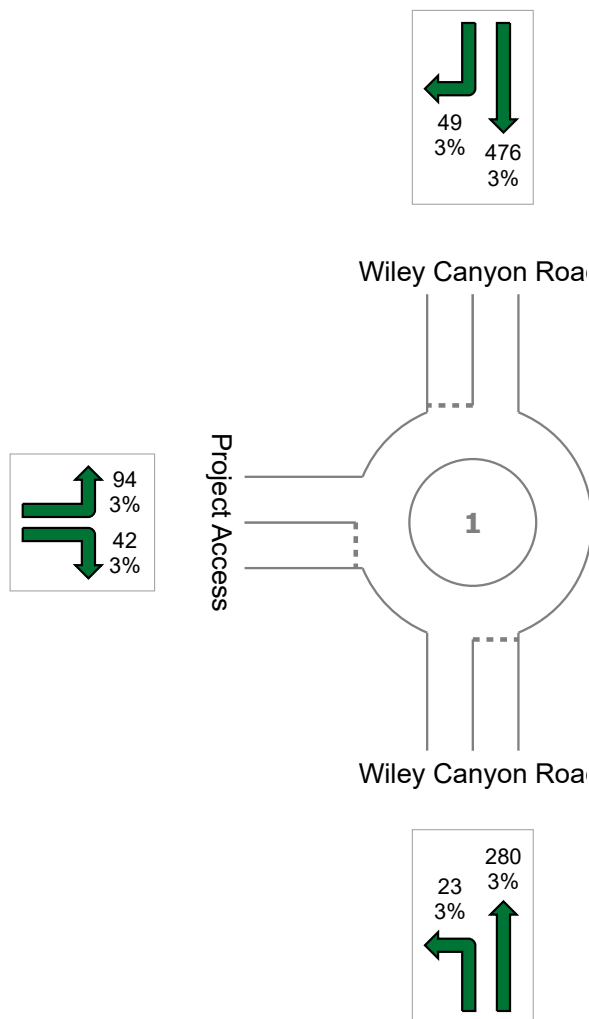



# QUEUE DISTANCE

Largest 95% Back of Queue for any lane used by movement (feet)

## Site: 10. Wiley Canyon Rd & Project Access AM Peak Hour

Existing Plus Project  
Roundabout

### All Movement Classes

	South	North	West	Intersection
Queue Distance	28	42	16	42

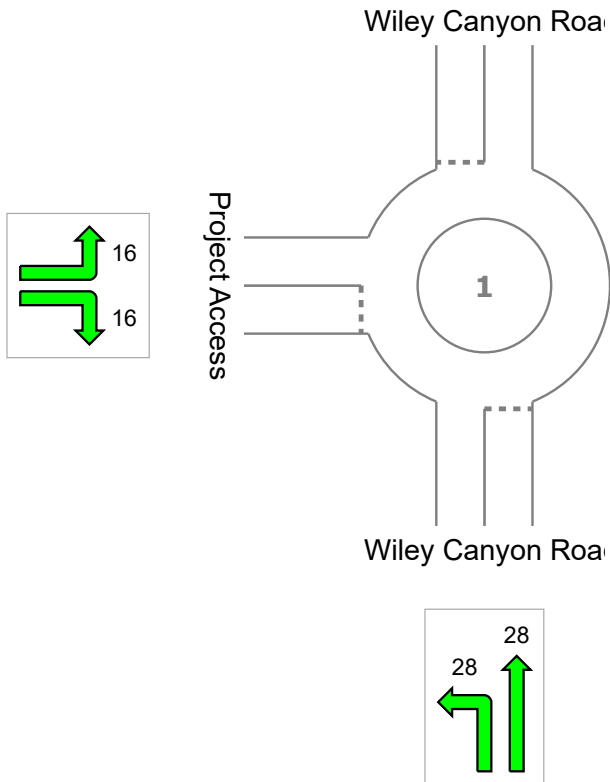
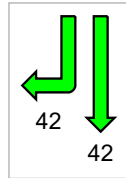

Colour code based on Queue Storage Ratio

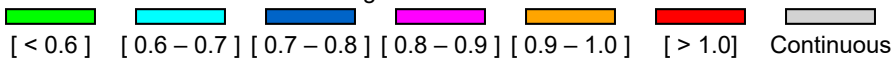

# DEGREE OF SATURATION

Ratio of Demand Volume to Capacity (v/c ratio)

## Site: 10. Wiley Canyon Rd & Project Access AM Peak Hour

Existing Plus Project  
Roundabout

### All Movement Classes

	South	North	West	Intersection
Degree of Saturation	0.28	0.41	0.17	0.41

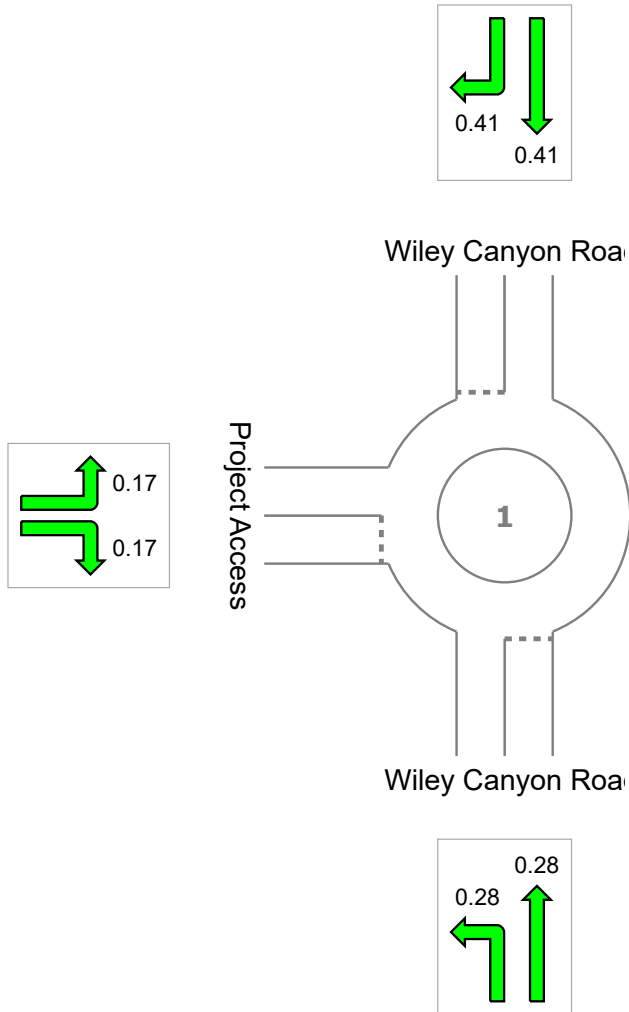

Colour code based on Degree of Saturation

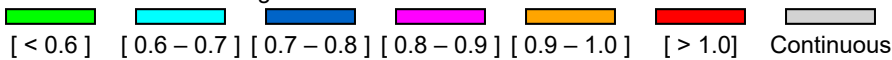

Existing plus Project - PM Peak Hour  
 1: Marriott Way/I-5 SB Ramps & Pico Canyon Road/Lyons Avenue

Synchro 10 Report  
 Lanes, Volumes, Timings

Lane Group	EBL	EBT	EBR	WBL	WBT	WBR	NBL	NBT	NBR	SBL	SBT	SBR
Lane Configurations												
Traffic Volume (vph)	0	849	33	35	942	163	0	0	54	380	66	119
Future Volume (vph)	0	849	33	35	942	163	0	0	54	380	66	119
Ideal Flow (vphpl)	1900	1900	1900	1900	1900	1900	1900	1900	1900	1900	1900	1900
Storage Length (ft)	0		0	100		0	0		0	0		200
Storage Lanes	0		0	1		1	0		1	1		1
Taper Length (ft)	25			25			25			25		
Satd. Flow (prot)	0	5055	0	1770	3539	1583	0	0	1611	1681	1709	1583
Flt Permitted				0.206						0.950	0.966	
Satd. Flow (perm)	0	5055	0	384	3539	1583	0	0	1611	1681	1709	1583
Right Turn on Red			Yes			Yes			Yes			Yes
Satd. Flow (RTOR)		8				177			159			129
Link Speed (mph)		40			40			30			30	
Link Distance (ft)		694			822			283			346	
Travel Time (s)		11.8			14.0			6.4			7.9	
Peak Hour Factor	0.92	0.92	0.92	0.92	0.92	0.92	0.92	0.92	0.92	0.92	0.92	0.92
Shared Lane Traffic (%)										42%		
Lane Group Flow (vph)	0	959	0	38	1024	177	0	0	59	240	245	129
Turn Type		NA		Perm	NA	Perm			Perm	Split	NA	Perm
Protected Phases		4			8					6	6	
Permitted Phases				8		8			2			6
Total Split (s)		37.0		37.0	37.0	37.0			10.5	37.5	37.5	37.5
Total Lost Time (s)		4.5		4.5	4.5	4.5			4.5	4.5	4.5	4.5
Act Effct Green (s)		29.6		29.6	29.6	29.6			6.0	33.1	33.1	33.1
Actuated g/C Ratio		0.36		0.36	0.36	0.36			0.07	0.40	0.40	0.40
v/c Ratio		0.53		0.28	0.80	0.26			0.22	0.36	0.36	0.18
Control Delay		21.6		24.6	29.3	4.0			1.9	19.8	19.8	4.1
Queue Delay		0.0		0.0	0.0	0.0			0.0	0.0	0.0	0.0
Total Delay		21.6		24.6	29.3	4.0			1.9	19.8	19.8	4.1
LOS		C		C	C	A			A	B	B	A
Approach Delay		21.6			25.5			1.9			16.5	
Approach LOS		C			C			A			B	

Intersection Summary

Area Type:	Other
Cycle Length:	85
Actuated Cycle Length:	82.2
Control Type:	Actuated-Uncoordinated
Maximum v/c Ratio:	0.80
Intersection Signal Delay:	21.8
Intersection LOS:	C
Intersection Capacity Utilization:	45.8%
ICU Level of Service:	A
Analysis Period (min):	15

Splits and Phases: 1: Marriott Way/I-5 SB Ramps & Pico Canyon Road/Lyons Avenue

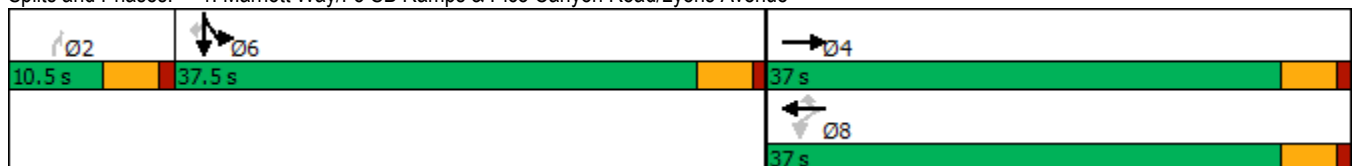

Existing plus Project - PM Peak Hour  
 3: I-5 NB Ramps & Lyons Avenue

Synchro 10 Report  
 Lanes, Volumes, Timings

Lane Group	EBL	EBT	EBR	WBL	WBT	WBR	NBL	NBT	NBR	SBL	SBT	SBR
Lane Configurations												
Traffic Volume (vph)	142	975	0	0	815	346	495	2	538	0	0	0
Future Volume (vph)	142	975	0	0	815	346	495	2	538	0	0	0
Ideal Flow (vphpl)	1900	1900	1900	1900	1900	1900	1900	1900	1900	1900	1900	1900
Storage Length (ft)	300		0	0		0	0		0	0		0
Storage Lanes	1		0	0		0	1		1	0		0
Taper Length (ft)	25			25			25			25		
Satd. Flow (prot)	1770	3539	0	0	4856	0	1681	1686	1583	0	0	0
Flt Permitted	0.950						0.950	0.953				
Satd. Flow (perm)	1770	3539	0	0	4856	0	1681	1686	1583	0	0	0
Right Turn on Red			Yes			Yes			Yes			Yes
Satd. Flow (RTOR)					134				82			
Link Speed (mph)		40			40			30			30	
Link Distance (ft)		603			1902			756			732	
Travel Time (s)		10.3			32.4			17.2			16.6	
Peak Hour Factor	0.92	0.92	0.92	0.92	0.92	0.92	0.92	0.92	0.92	0.92	0.92	0.92
Shared Lane Traffic (%)							50%					
Lane Group Flow (vph)	154	1060	0	0	1262	0	269	271	585	0	0	0
Turn Type	Prot	NA			NA		Perm	NA	Perm			
Protected Phases	7	4			8			2				
Permitted Phases							2		2			
Total Split (s)	14.0	41.5			27.5		38.5	38.5	38.5			
Total Lost Time (s)	4.5	4.5			4.5		4.5	4.5	4.5			
Act Effct Green (s)	9.2	36.3			22.6		34.0	34.0	34.0			
Actuated g/C Ratio	0.12	0.46			0.28		0.43	0.43	0.43			
v/c Ratio	0.75	0.65			0.85		0.37	0.38	0.81			
Control Delay	58.2	19.0			30.8		17.5	17.6	27.8			
Queue Delay	0.0	0.0			0.0		0.0	0.0	0.0			
Total Delay	58.2	19.0			30.8		17.5	17.6	27.8			
LOS	E	B			C		B	B	C			
Approach Delay		24.0			30.8			22.9				
Approach LOS		C			C			C				

Intersection Summary

Area Type:	Other
Cycle Length:	80
Actuated Cycle Length:	79.3
Control Type:	Actuated-Uncoordinated
Maximum v/c Ratio:	0.85
Intersection Signal Delay:	26.0
Intersection LOS:	C
Intersection Capacity Utilization:	67.8%
ICU Level of Service:	C
Analysis Period (min):	15

Splits and Phases: 3: I-5 NB Ramps & Lyons Avenue

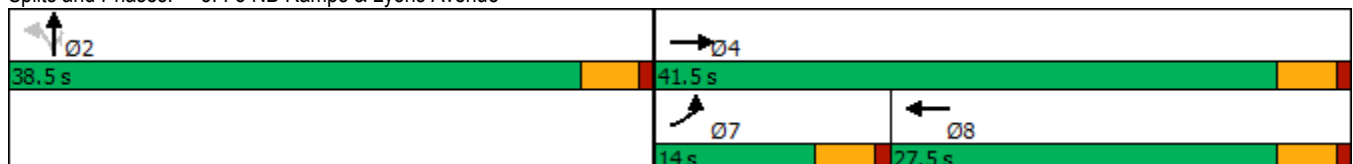

Existing plus Project - PM Peak Hour  
 4: Wiley Canyon Road & Lyons Avenue

Synchro 10 Report  
 Lanes, Volumes, Timings

Lane Group	EBL	EBT	EBR	WBL	WBT	WBR	NBL	NBT	NBR	SBL	SBT	SBR
Lane Configurations												
Traffic Volume (vph)	305	995	129	175	735	80	159	417	250	170	332	240
Future Volume (vph)	305	995	129	175	735	80	159	417	250	170	332	240
Ideal Flow (vphpl)	1900	1900	1900	1900	1900	1900	1900	1900	1900	1900	1900	1900
Storage Length (ft)	130		0	200		0	225		270	200		225
Storage Lanes	2		0	1		0	1		1	1		1
Taper Length (ft)	25			25			25			25		
Satd. Flow (prot)	3433	4999	0	1770	5009	0	1770	3539	1583	1770	3539	1583
Flt Permitted	0.950			0.950			0.950			0.950		
Satd. Flow (perm)	3433	4999	0	1770	5009	0	1770	3539	1583	1770	3539	1583
Right Turn on Red			Yes			Yes			Yes			Yes
Satd. Flow (RTOR)		18			14				258			124
Link Speed (mph)		40			40			35			45	
Link Distance (ft)		1902			870			869			1018	
Travel Time (s)		32.4			14.8			16.9			15.4	
Peak Hour Factor	0.97	0.97	0.97	0.97	0.97	0.97	0.97	0.97	0.97	0.97	0.97	0.97
Shared Lane Traffic (%)												
Lane Group Flow (vph)	314	1159	0	180	840	0	164	430	258	175	342	247
Turn Type	Prot	NA		Prot	NA		Prot	NA	Perm	Prot	NA	pm+ov
Protected Phases	1	6		5	2		7	4		3	8	1
Permitted Phases									4			8
Total Split (s)	25.0	44.0		25.0	44.0		25.0	38.0	38.0	25.0	38.0	25.0
Total Lost Time (s)	4.0	4.0		4.0	4.0		4.0	4.0	4.0	4.0	4.0	4.0
Act Effct Green (s)	18.1	55.3		19.0	56.1		17.3	24.0	24.0	17.8	24.5	46.6
Actuated g/C Ratio	0.14	0.42		0.14	0.42		0.13	0.18	0.18	0.13	0.19	0.35
v/c Ratio	0.67	0.55		0.71	0.39		0.71	0.67	0.52	0.74	0.52	0.39
Control Delay	60.9	31.9		68.6	28.3		71.3	55.3	8.9	72.7	50.9	15.8
Queue Delay	0.0	0.0		0.0	0.0		0.0	0.0	0.0	0.0	0.0	0.0
Total Delay	60.9	31.9		68.6	28.3		71.3	55.3	8.9	72.7	50.9	15.8
LOS	E	C		E	C		E	E	A	E	D	B
Approach Delay		38.1			35.4			44.3			44.5	
Approach LOS		D			D			D			D	

Intersection Summary

Area Type:	Other
Cycle Length:	132
Actuated Cycle Length:	132
Offset:	2.5 (2%), Referenced to phase 2:WBT and 6:EBT, Start of Yellow
Control Type:	Actuated-Coordinated
Maximum v/c Ratio:	0.74
Intersection Signal Delay:	39.9
Intersection LOS:	D
Intersection Capacity Utilization:	66.1%
ICU Level of Service:	C
Analysis Period (min):	15

Splits and Phases: 4: Wiley Canyon Road & Lyons Avenue

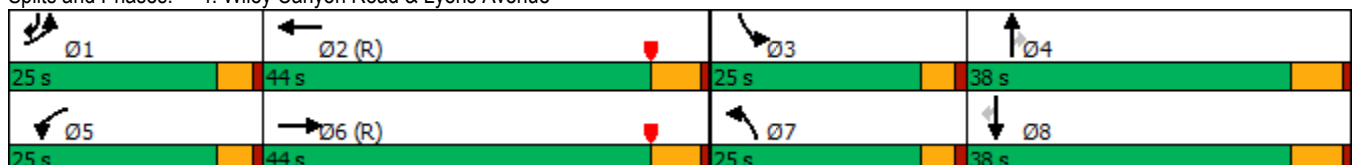

Existing plus Project - PM Peak Hour  
 5: Wiley Canyon Road & La Glorita Circle/Evans Avenue

Synchro 10 Report  
 Lanes, Volumes, Timings

Lane Group	EBL	EBT	EBR	WBL	WBT	WBR	NBL	NBT	NBR	SBL	SBT	SBR
Lane Configurations												
Traffic Volume (vph)	40	5	15	31	5	40	13	636	30	25	561	55
Future Volume (vph)	40	5	15	31	5	40	13	636	30	25	561	55
Ideal Flow (vphpl)	1900	1900	1900	1900	1900	1900	1900	1900	1900	1900	1900	1900
Storage Length (ft)	90		0	0		0	110		0	110		0
Storage Lanes	1		0	0		0	1		0	1		1
Taper Length (ft)	25			25			25			25		
Satd. Flow (prot)	1770	1652	0	0	1696	0	1770	1850	0	1770	1863	1583
Flt Permitted	0.851				0.858		0.419			0.354		
Satd. Flow (perm)	1585	1652	0	0	1485	0	780	1850	0	659	1863	1583
Right Turn on Red			Yes			Yes			Yes			Yes
Satd. Flow (RTOR)		15			41			5				57
Link Speed (mph)		30			30			35			35	
Link Distance (ft)		529			450			1329			869	
Travel Time (s)		12.0			10.2			25.9			16.9	
Peak Hour Factor	0.97	0.97	0.97	0.97	0.97	0.97	0.97	0.97	0.97	0.97	0.97	0.97
Shared Lane Traffic (%)												
Lane Group Flow (vph)	41	20	0	0	78	0	13	687	0	26	578	57
Turn Type	Perm	NA		Perm	NA		Perm	NA		Perm	NA	Perm
Protected Phases		4			8			2			6	
Permitted Phases	4			8			2			6		6
Total Split (s)	30.5	30.5		30.5	30.5		29.5	29.5		29.5	29.5	29.5
Total Lost Time (s)	4.5	4.5			4.5		4.5	4.5		4.5	4.5	4.5
Act Effct Green (s)	6.9	6.9			6.8		33.6	33.6		33.6	33.6	33.6
Actuated g/C Ratio	0.16	0.16			0.16		0.77	0.77		0.77	0.77	0.77
v/c Ratio	0.16	0.07			0.29		0.02	0.48		0.05	0.40	0.05
Control Delay	16.5	10.0			12.2		3.7	5.7		3.9	4.9	1.5
Queue Delay	0.0	0.0			0.0		0.0	0.0		0.0	0.0	0.0
Total Delay	16.5	10.0			12.2		3.7	5.7		3.9	4.9	1.5
LOS	B	A			B		A	A		A	A	A
Approach Delay		14.4			12.2			5.6			4.6	
Approach LOS		B			B			A			A	

Intersection Summary

Area Type:	Other
Cycle Length:	60
Actuated Cycle Length:	43.7
Control Type:	Actuated-Uncoordinated
Maximum v/c Ratio:	0.48
Intersection Signal Delay:	5.9
Intersection LOS:	A
Intersection Capacity Utilization:	53.9%
ICU Level of Service:	A
Analysis Period (min):	15

Splits and Phases: 5: Wiley Canyon Road & La Glorita Circle/Evans Avenue

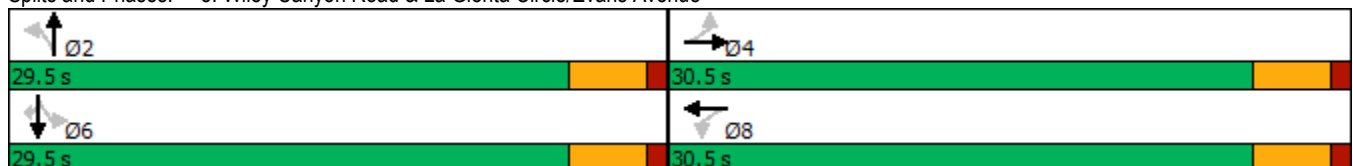

Intersection												
Int Delay, s/veh	1.8											
Movement	EBL	EBT	EBR	WBL	WBT	WBR	NBL	NBT	NBR	SBL	SBT	SBR
Lane Configurations		↕			↕		↕	↕		↕	↕	↕
Traffic Vol, veh/h	43	1	11	1	0	7	24	522	2	12	476	55
Future Vol, veh/h	43	1	11	1	0	7	24	522	2	12	476	55
Conflicting Peds, #/hr	0	0	0	0	0	0	0	0	0	0	0	0
Sign Control	Stop	Stop	Stop	Stop	Stop	Stop	Free	Free	Free	Free	Free	Free
RT Channelized	-	-	None	-	-	None	-	-	None	-	-	None
Storage Length	-	-	-	-	-	-	150	-	-	215	-	260
Veh in Median Storage, #	-	0	-	-	0	-	-	0	-	-	0	-
Grade, %	-	0	-	-	0	-	-	0	-	-	0	-
Peak Hour Factor	95	95	95	95	95	95	95	95	95	95	95	95
Heavy Vehicles, %	2	2	2	2	2	2	2	2	2	2	2	2
Mvmt Flow	45	1	12	1	0	7	25	549	2	13	501	58

Major/Minor	Minor2		Minor1		Major1		Major2					
Conflicting Flow All	1131	1128	501	1163	1185	550	559	0	0	551	0	0
Stage 1	527	527	-	600	600	-	-	-	-	-	-	-
Stage 2	604	601	-	563	585	-	-	-	-	-	-	-
Critical Hdwy	7.12	6.52	6.22	7.12	6.52	6.22	4.12	-	-	4.12	-	-
Critical Hdwy Stg 1	6.12	5.52	-	6.12	5.52	-	-	-	-	-	-	-
Critical Hdwy Stg 2	6.12	5.52	-	6.12	5.52	-	-	-	-	-	-	-
Follow-up Hdwy	3.518	4.018	3.318	3.518	4.018	3.318	2.218	-	-	2.218	-	-
Pot Cap-1 Maneuver	181	204	570	172	189	535	1012	-	-	1019	-	-
Stage 1	535	528	-	488	490	-	-	-	-	-	-	-
Stage 2	485	489	-	511	498	-	-	-	-	-	-	-
Platoon blocked, %								-	-	-	-	-
Mov Cap-1 Maneuver	173	196	570	163	182	535	1012	-	-	1019	-	-
Mov Cap-2 Maneuver	173	196	-	163	182	-	-	-	-	-	-	-
Stage 1	522	521	-	476	478	-	-	-	-	-	-	-
Stage 2	467	477	-	493	492	-	-	-	-	-	-	-

Approach	EB		WB		NB		SB	
HCM Control Delay, s	30		13.8		0.4		0.2	
HCM LOS	D		B					

Minor Lane/Major Mvmt	NBL	NBT	NBR	EBLn1	WBLn1	SBL	SBT	SBR
Capacity (veh/h)	1012	-	-	201	416	1019	-	-
HCM Lane V/C Ratio	0.025	-	-	0.288	0.02	0.012	-	-
HCM Control Delay (s)	8.6	-	-	30	13.8	8.6	-	-
HCM Lane LOS	A	-	-	D	B	A	-	-
HCM 95th %tile Q(veh)	0.1	-	-	1.1	0.1	0	-	-

Intersection												
Int Delay, s/veh	9											
Movement	EBL	EBT	EBR	WBL	WBT	WBR	NBL	NBT	NBR	SBL	SBT	SBR
Lane Configurations		↕		↕	↕						↕	↕
Traffic Vol, veh/h	0	532	77	246	171	0	0	0	0	90	2	64
Future Vol, veh/h	0	532	77	246	171	0	0	0	0	90	2	64
Conflicting Peds, #/hr	0	0	0	0	0	0	0	0	0	0	0	0
Sign Control	Free	Free	Free	Free	Free	Free	Free	Free	Free	Stop	Stop	Stop
RT Channelized	-	-	None	-	-	None	-	-	None	-	-	None
Storage Length	-	-	-	150	-	-	-	-	-	-	-	0
Veh in Median Storage, #	-	0	-	-	0	-	-	0	-	-	0	-
Grade, %	-	0	-	-	0	-	-	0	-	-	0	-
Peak Hour Factor	96	96	96	96	96	96	96	96	96	96	96	96
Heavy Vehicles, %	2	2	2	2	2	2	2	2	2	2	2	2
Mvmt Flow	0	554	80	256	178	0	0	0	0	94	2	67

Major/Minor	Major1			Major2			Minor2			
Conflicting Flow All	-	0	0	634	0	0		1284	1324	178
Stage 1	-	-	-	-	-	-		690	690	-
Stage 2	-	-	-	-	-	-		594	634	-
Critical Hdwy	-	-	-	4.12	-	-		6.42	6.52	6.22
Critical Hdwy Stg 1	-	-	-	-	-	-		5.42	5.52	-
Critical Hdwy Stg 2	-	-	-	-	-	-		5.42	5.52	-
Follow-up Hdwy	-	-	-	2.218	-	-		3.518	4.018	3.318
Pot Cap-1 Maneuver	0	-	-	949	-	0		182	156	865
Stage 1	0	-	-	-	-	0		498	446	-
Stage 2	0	-	-	-	-	0		552	473	-
Platoon blocked, %	-	-	-	-	-	-		-	-	-
Mov Cap-1 Maneuver	-	-	-	949	-	-		133	0	865
Mov Cap-2 Maneuver	-	-	-	-	-	-		133	0	-
Stage 1	-	-	-	-	-	-		498	0	-
Stage 2	-	-	-	-	-	-		403	0	-

Approach	EB	WB	SB
HCM Control Delay, s	0	6	52.3
HCM LOS			F

Minor Lane/Major Mvmt	EBT	EBR	WBL	WBT	SBLn1	SBLn2
Capacity (veh/h)	-	-	949	-	133	865
HCM Lane V/C Ratio	-	-	0.27	-	0.721	0.077
HCM Control Delay (s)	-	-	10.2	-	82	9.5
HCM Lane LOS	-	-	B	-	F	A
HCM 95th %tile Q(veh)	-	-	1.1	-	4.1	0.2



Intersection												
Int Delay, s/veh	14.5											
Movement	EBL	EBT	EBR	WBL	WBT	WBR	NBL	NBT	NBR	SBL	SBT	SBR
Lane Configurations	↘	↑			↘			↘	↗			
Traffic Vol, veh/h	283	340	0	0	325	65	91	9	282	0	0	0
Future Vol, veh/h	283	340	0	0	325	65	91	9	282	0	0	0
Conflicting Peds, #/hr	0	0	0	0	0	0	0	0	0	0	0	0
Sign Control	Free	Free	Free	Free	Free	Free	Stop	Stop	Stop	Free	Free	Free
RT Channelized	-	-	None	-	-	None	-	-	None	-	-	None
Storage Length	170	-	-	-	-	-	-	-	0	-	-	-
Veh in Median Storage, #	-	0	-	-	0	-	-	0	-	-	0	-
Grade, %	-	0	-	-	0	-	-	0	-	-	0	-
Peak Hour Factor	92	92	92	92	92	92	92	92	92	92	92	92
Heavy Vehicles, %	2	2	2	2	2	2	2	2	2	2	2	2
Mvmt Flow	308	370	0	0	353	71	99	10	307	0	0	0

Major/Minor	Major1	Major2	Minor1
Conflicting Flow All	424	0	0
Stage 1	-	-	986
Stage 2	-	-	389
Critical Hdwy	4.12	-	6.42
Critical Hdwy Stg 1	-	-	5.42
Critical Hdwy Stg 2	-	-	5.42
Follow-up Hdwy	2.218	-	3.518
Pot Cap-1 Maneuver	1135	0	160
Stage 1	-	0	361
Stage 2	-	0	685
Platoon blocked, %	-	-	-
Mov Cap-1 Maneuver	1135	-	117
Mov Cap-2 Maneuver	-	-	117
Stage 1	-	-	263
Stage 2	-	-	685

Approach	EB	WB	NB
HCM Control Delay, s	4.2	0	46
HCM LOS			E

Minor Lane/Major Mvmt	NBLn1	NBLn2	EBL	EBT	WBT	WBR
Capacity (veh/h)	117	676	1135	-	-	-
HCM Lane V/C Ratio	0.929	0.453	0.271	-	-	-
HCM Control Delay (s)	134.3	14.7	9.3	-	-	-
HCM Lane LOS	F	B	A	-	-	-
HCM 95th %tile Q(veh)	5.9	2.4	1.1	-	-	-

# DELAY (AVERAGE)

Average control delay per vehicle, or average pedestrian delay (seconds)

## Site: 9. Wiley Canyon Rd & Calgrove Blvd PM Peak Hour

Existing Plus Project  
Roundabout

### All Movement Classes

	South	East	North	West	Intersection
Delay (Average)	12.2	8.9	8.7	12.2	10.7
LOS	B	A	A	B	B

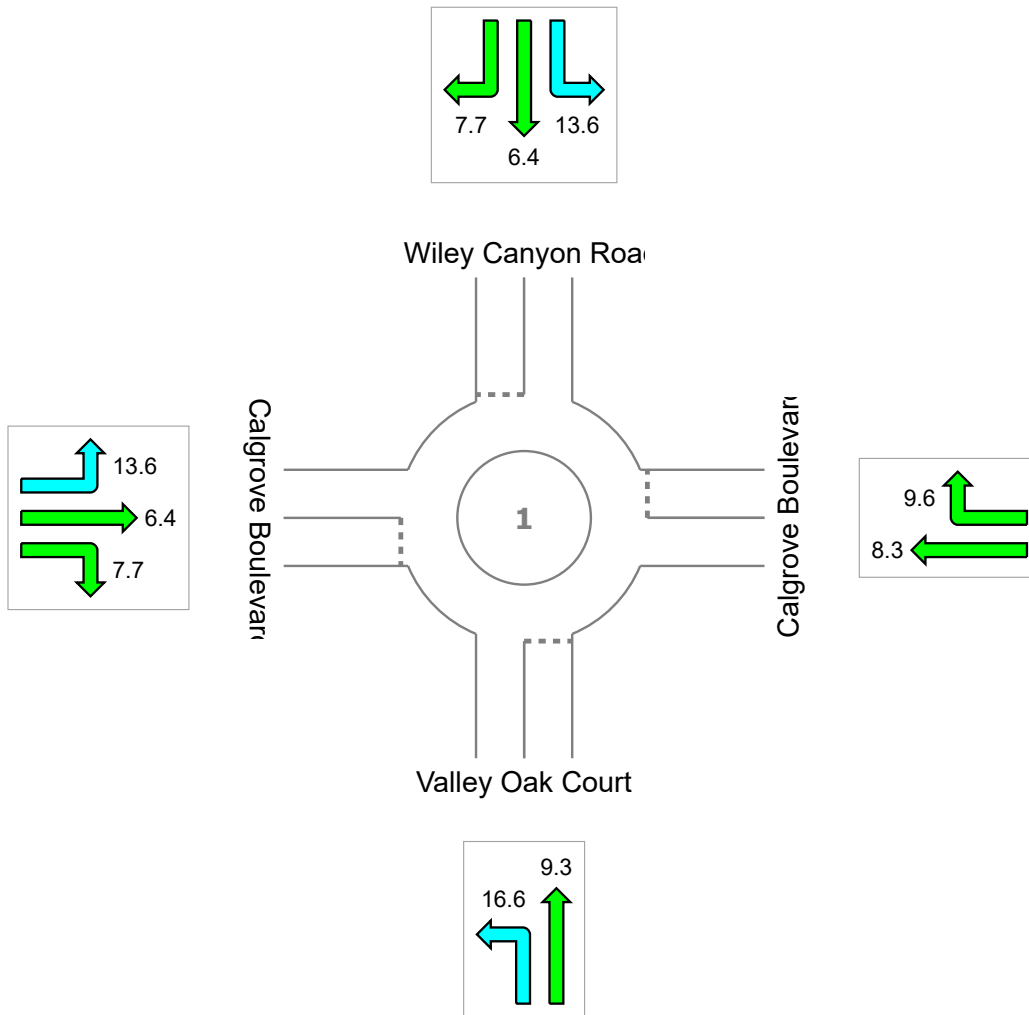

Colour code based on Level of Service

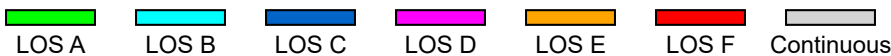

Level of Service Method: Delay & v/c (HCM 2010)

LOS F will result if v/c > 1 irrespective of movement delay value (does not apply for approaches and intersection).

Roundabout Level of Service Method: Same as Signalised Intersections

SIDRA Standard Delay Model is used. Control Delay includes Geometric Delay.

# INPUT VOLUMES

Vehicles and pedestrians per 60 minutes

 Site: 9. Wiley Canyon Rd & Calgrove Blvd PM Peak Hour

Existing Plus Project

Volume Display Method: Total and %

Volumes are shown for Movement Class(es): All Classes and Heavy Vehicles

Total Intersection Volumes (veh)

All Movement Classes: 1155

Light Vehicles (LV): 1120

Heavy Vehicles (HV): 35

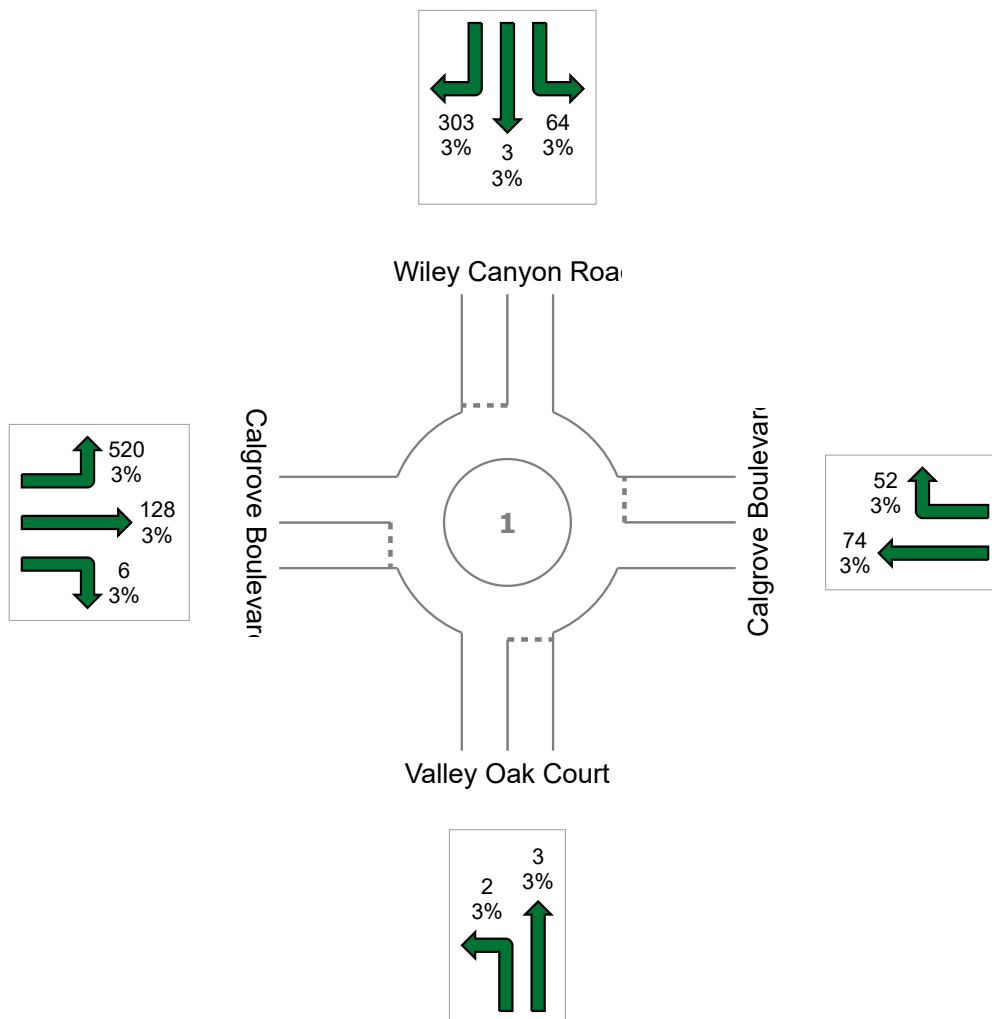

# QUEUE DISTANCE

Largest 95% Back of Queue for any lane used by movement (feet)

## Site: 9. Wiley Canyon Rd & Calgrove Blvd PM Peak Hour

Existing Plus Project  
Roundabout

### All Movement Classes

	South	East	North	West	Intersection
Queue Distance	1	16	34	68	68

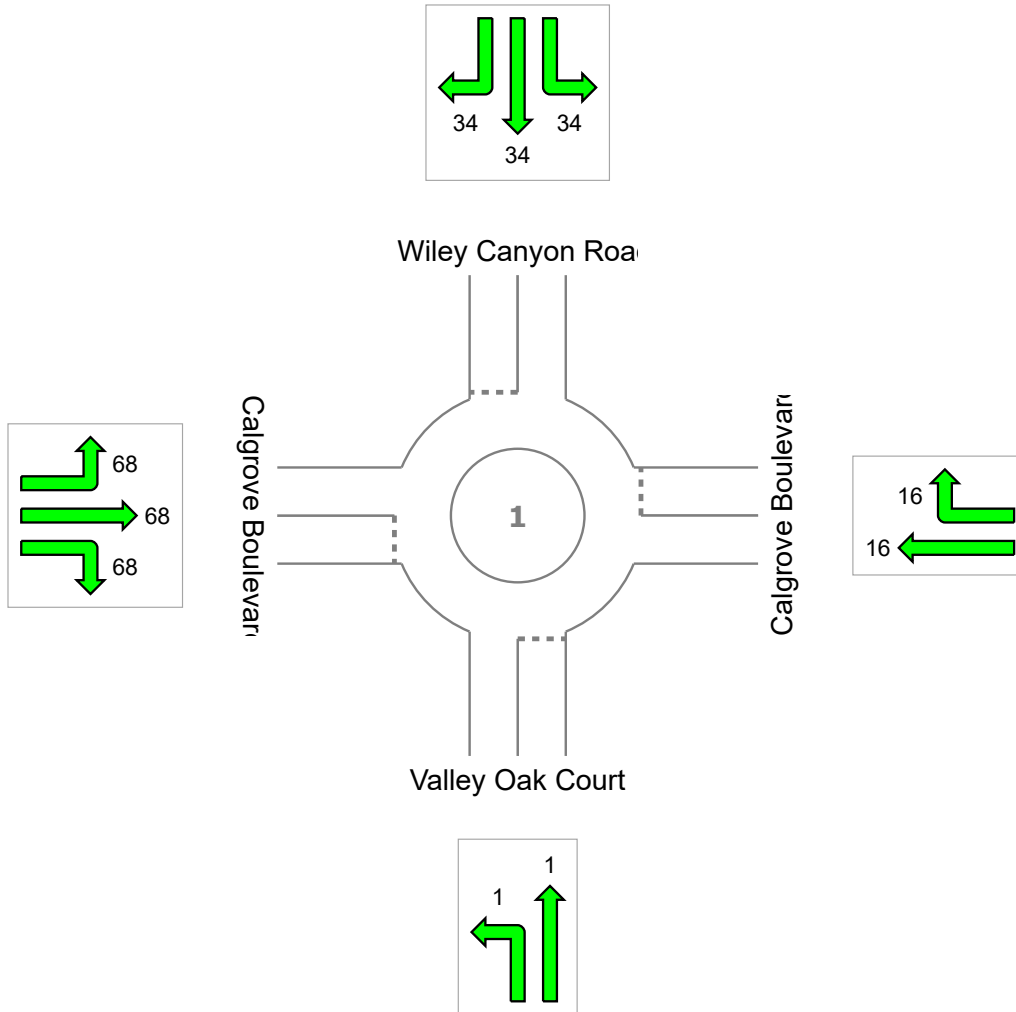

Colour code based on Queue Storage Ratio

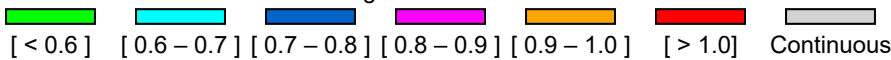

# DEGREE OF SATURATION

Ratio of Demand Volume to Capacity (v/c ratio)

## Site: 9. Wiley Canyon Rd & Calgrove Blvd PM Peak Hour

Existing Plus Project  
Roundabout

### All Movement Classes

	South	East	North	West	Intersection
Degree of Saturation	0.01	0.16	0.32	0.54	0.54

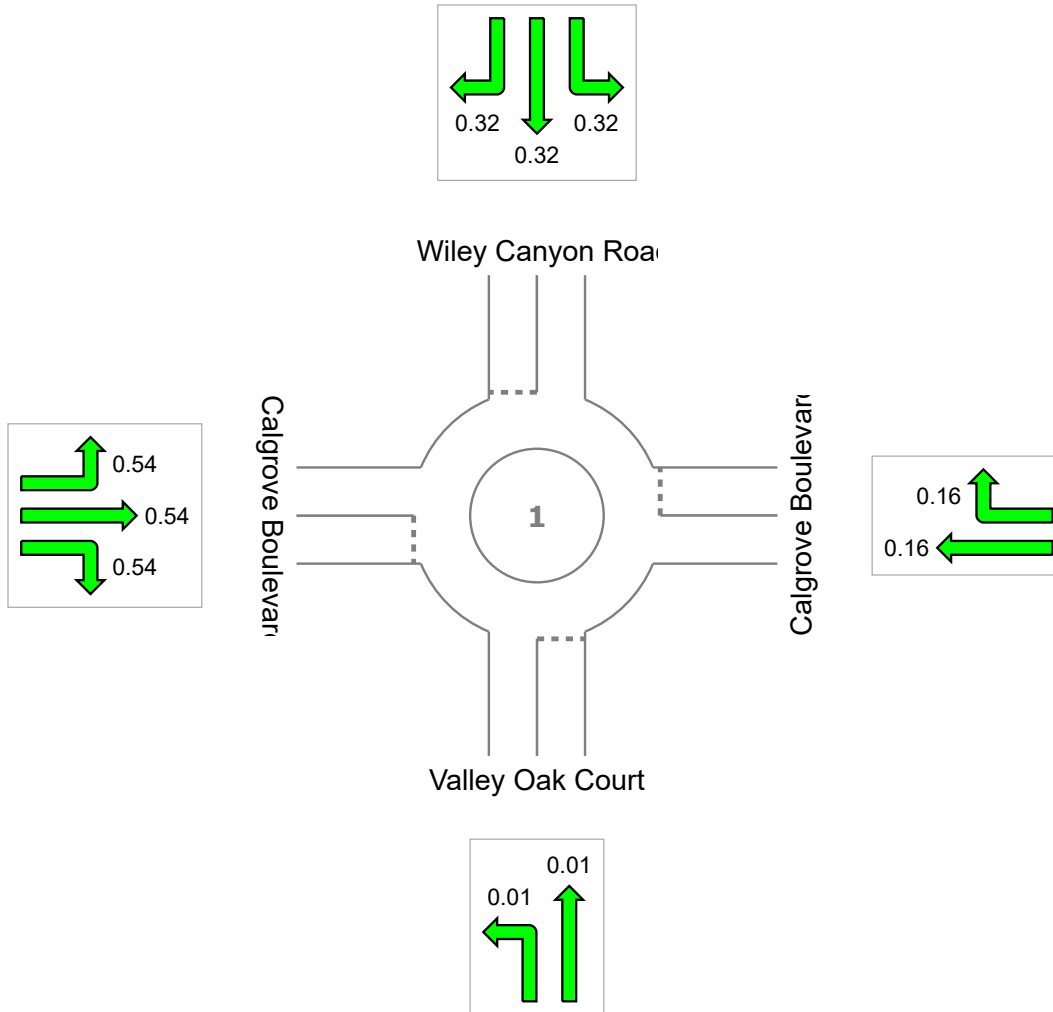

Colour code based on Degree of Saturation

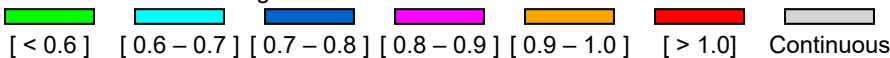

Existing plus Project - PM Peak Hour  
 9: Calgrove Boulevard & Wiley Canyon Road

Synchro 10 Report  
 Lanes, Volumes, Timings

Lane Group	EBL	EBT	EBR	WBL	WBT	WBR	NBL	NBT	NBR	SBL	SBT	SBR
Lane Configurations												
Traffic Volume (vph)	520	128	6	0	74	52	2	3	0	64	3	303
Future Volume (vph)	520	128	6	0	74	52	2	3	0	64	3	303
Ideal Flow (vphpl)	1900	1900	1900	1900	1900	1900	1900	1900	1900	1900	1900	1900
Storage Length (ft)	165		150	290		290	0		0	100		100
Storage Lanes	1		1	1		1	0		0	0		1
Taper Length (ft)	25			25			25			25		
Satd. Flow (prot)	1770	1863	1583	1863	1863	1583	0	1825	0	0	1777	1583
Flt Permitted	0.950							0.903			0.732	
Satd. Flow (perm)	1770	1863	1583	1863	1863	1583	0	1682	0	0	1364	1583
Right Turn on Red			Yes			Yes			Yes			Yes
Satd. Flow (RTOR)			87			153						312
Link Speed (mph)		45			45			30			35	
Link Distance (ft)		786			1192			412			1483	
Travel Time (s)		11.9			18.1			9.4			28.9	
Peak Hour Factor	0.97	0.97	0.97	0.97	0.97	0.97	0.97	0.97	0.97	0.97	0.97	0.97
Shared Lane Traffic (%)												
Lane Group Flow (vph)	536	132	6	0	76	54	0	5	0	0	69	312
Turn Type	Prot	NA	Perm	Prot	NA	Perm	Perm	NA		Perm	NA	Perm
Protected Phases	7	4		3	8			2			6	
Permitted Phases			4			8	2			6		6
Total Split (s)	30.0	43.0	43.0	9.5	22.5	22.5	22.5	22.5		22.5	22.5	22.5
Total Lost Time (s)	4.5	4.5	4.5	4.5	4.5	4.5		4.5			4.5	4.5
Act Effct Green (s)	21.1	30.3	30.3		8.0	8.0		8.7			8.7	8.7
Actuated g/C Ratio	0.43	0.62	0.62		0.16	0.16		0.18			0.18	0.18
v/c Ratio	0.70	0.11	0.01		0.25	0.14		0.02			0.28	0.58
Control Delay	19.4	3.9	0.0		23.9	0.8		19.8			23.7	8.1
Queue Delay	0.0	0.0	0.0		0.0	0.0		0.0			0.0	0.0
Total Delay	19.4	3.9	0.0		23.9	0.8		19.8			23.7	8.1
LOS	B	A	A		C	A		B			C	A
Approach Delay		16.2			14.3			19.8			10.9	
Approach LOS		B			B			B			B	

Intersection Summary

Area Type:	Other
Cycle Length:	75
Actuated Cycle Length:	48.9
Control Type:	Actuated-Uncoordinated
Maximum v/c Ratio:	0.70
Intersection Signal Delay:	14.3
Intersection LOS:	B
Intersection Capacity Utilization:	50.7%
ICU Level of Service:	A
Analysis Period (min):	15

Splits and Phases: 9: Calgrove Boulevard & Wiley Canyon Road

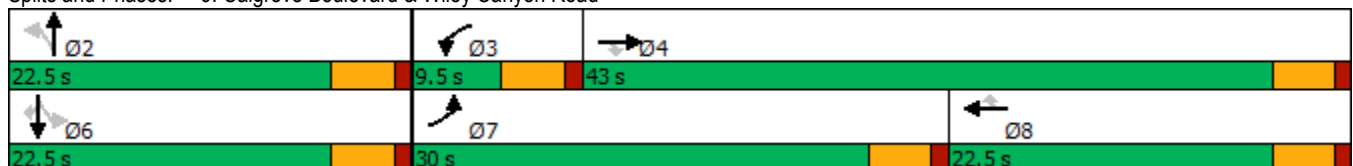

# DELAY (AVERAGE)

Average control delay per vehicle, or average pedestrian delay (seconds)

## Site: 10. Wiley Canyon Rd & Project Access PM Peak Hour

Existing Plus Project  
Roundabout

### All Movement Classes

	South	North	West	Intersection
Delay (Average)	7.9	7.4	13.1	8.2
LOS	A	A	B	A

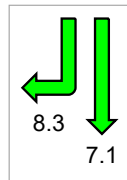

Wiley Canyon Road

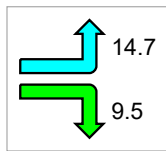

Project Access

Wiley Canyon Road

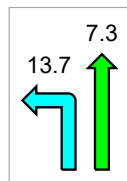

Colour code based on Level of Service

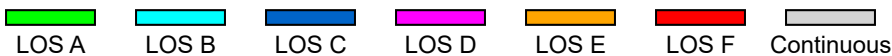

Level of Service Method: Delay & v/c (HCM 2010)

LOS F will result if v/c > 1 irrespective of movement delay value (does not apply for approaches and intersection).

Roundabout Level of Service Method: Same as Signalised Intersections

SIDRA Standard Delay Model is used. Control Delay includes Geometric Delay.

# INPUT VOLUMES

Vehicles and pedestrians per 60 minutes

 **Site: 10. Wiley Canyon Rd & Project Access PM Peak Hour**

Existing Plus Project

Volume Display Method: Total and %

Volumes are shown for Movement Class(es): All Classes and Heavy Vehicles

Total Intersection Volumes (veh)

All Movement Classes: 1143

Light Vehicles (LV): 1109

Heavy Vehicles (HV): 34

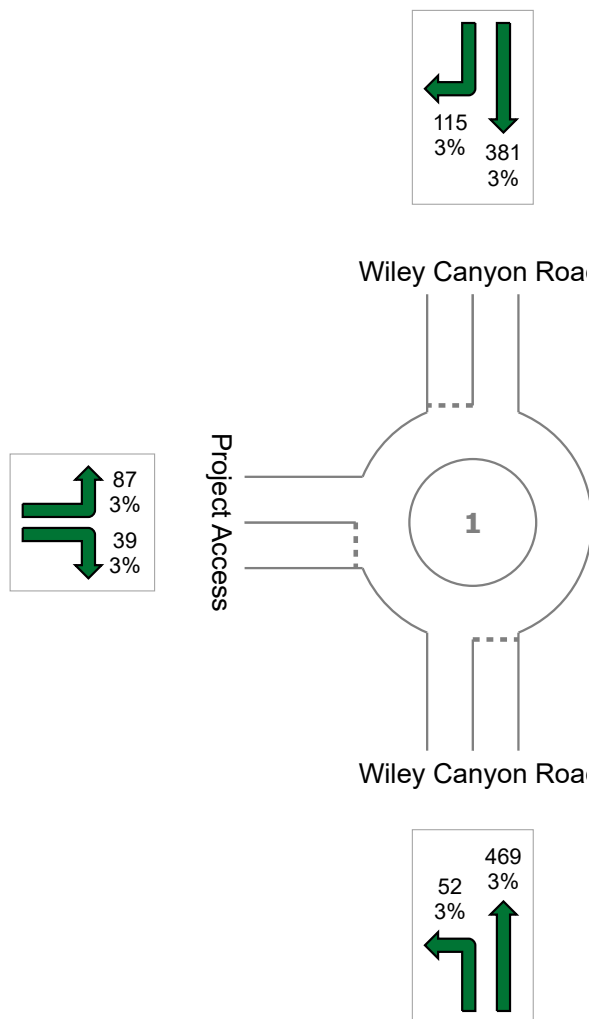



# QUEUE DISTANCE

Largest 95% Back of Queue for any lane used by movement (feet)

## Site: 10. Wiley Canyon Rd & Project Access PM Peak Hour

Existing Plus Project  
Roundabout

### All Movement Classes

	South	North	West	Intersection
Queue Distance	56	44	13	56

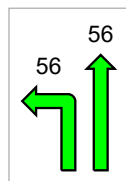
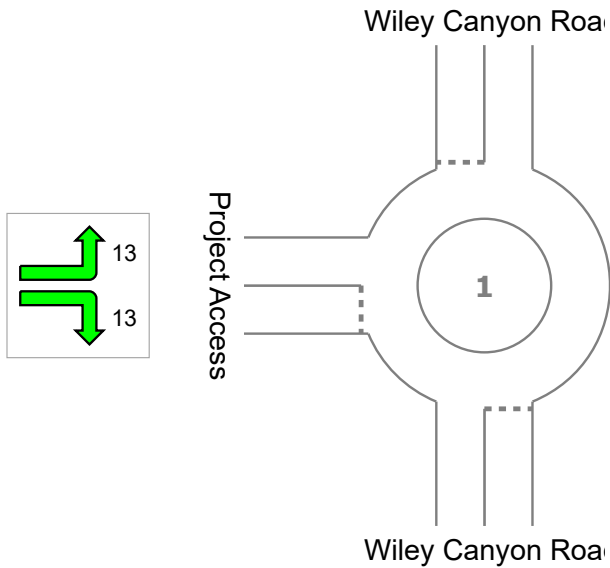

Colour code based on Queue Storage Ratio

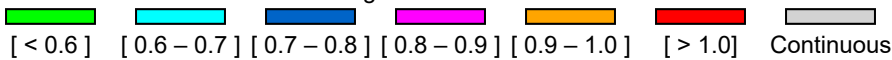

# DEGREE OF SATURATION

Ratio of Demand Volume to Capacity (v/c ratio)

## Site: 10. Wiley Canyon Rd & Project Access PM Peak Hour

Existing Plus Project  
Roundabout

### All Movement Classes

	South	North	West	Intersection
Degree of Saturation	0.46	0.42	0.15	0.46

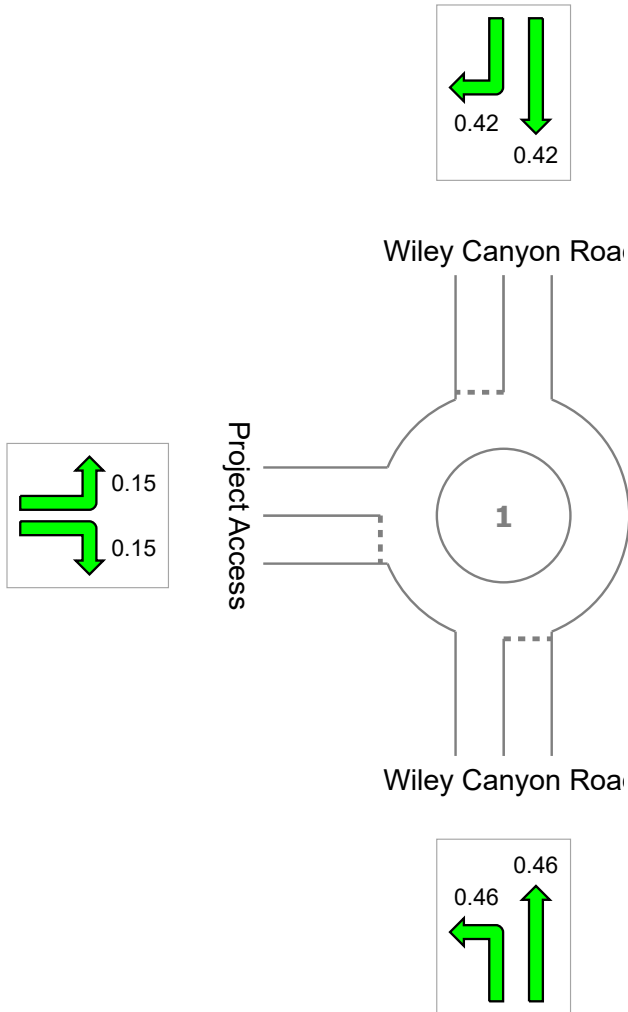

Colour code based on Degree of Saturation

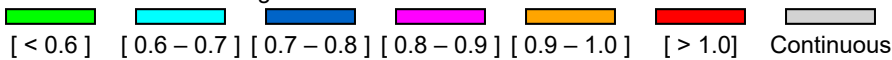

# **EXISTING PLUS PROJECT CONDITIONS - WITH OFF-SITE IMPROVEMENTS**

Existing plus Project with Off-Site Improvements - AM Peak Hour  
 7: I-5 SB Ramps & Calgrove Boulevard

Synchro 10 Report  
 Lanes, Volumes, Timings

Lane Group	EBL	EBT	EBR	WBL	WBT	WBR	NBL	NBT	NBR	SBL	SBT	SBR
Lane Configurations												
Traffic Volume (vph)	0	132	59	454	169	0	0	0	0	42	0	200
Future Volume (vph)	0	132	59	454	169	0	0	0	0	42	0	200
Ideal Flow (vphpl)	1900	1900	1900	1900	1900	1900	1900	1900	1900	1900	1900	1900
Storage Length (ft)	0		0	150		0	0		0	0		0
Storage Lanes	0		0	1		0	0		0	0		1
Taper Length (ft)	25			25			25			25		
Satd. Flow (prot)	0	1785	0	1770	1863	0	0	0	0	0	1770	1583
Flt Permitted				0.950							0.950	
Satd. Flow (perm)	0	1785	0	1770	1863	0	0	0	0	0	1770	1583
Right Turn on Red			Yes			Yes			Yes			Yes
Satd. Flow (RTOR)		30										220
Link Speed (mph)		40			45			30			30	
Link Distance (ft)		596			420			659			500	
Travel Time (s)		10.2			6.4			15.0			11.4	
Peak Hour Factor	0.91	0.91	0.91	0.91	0.91	0.91	0.91	0.91	0.91	0.91	0.91	0.91
Shared Lane Traffic (%)												
Lane Group Flow (vph)	0	210	0	499	186	0	0	0	0	0	46	220
Turn Type		NA		Prot	NA					Perm	NA	Perm
Protected Phases		4		3	8						6	
Permitted Phases										6		6
Total Split (s)		31.5		26.0	57.5					22.5	22.5	22.5
Total Lost Time (s)		4.5		4.5	4.5						4.5	4.5
Act Effct Green (s)		11.8		21.6	37.9						18.1	18.1
Actuated g/C Ratio		0.18		0.33	0.58						0.28	0.28
v/c Ratio		0.60		0.85	0.17						0.09	0.37
Control Delay		28.2		37.9	6.6						19.4	5.4
Queue Delay		0.0		0.0	0.0						0.0	0.0
Total Delay		28.2		37.9	6.6						19.4	5.4
LOS		C		D	A						B	A
Approach Delay		28.2			29.4						7.8	
Approach LOS		C			C						A	

Intersection Summary

Area Type:	Other
Cycle Length:	80
Actuated Cycle Length:	65
Control Type:	Semi Act-Uncoord
Maximum v/c Ratio:	0.85
Intersection Signal Delay:	24.2
Intersection LOS:	C
Intersection Capacity Utilization:	52.0%
ICU Level of Service:	A
Analysis Period (min):	15

Splits and Phases: 7: I-5 SB Ramps & Calgrove Boulevard



Lane Group	EBL	EBT	EBR	WBL	WBT	WBR	NBL	NBT	NBR	SBL	SBT	SBR
Lane Configurations												
Traffic Volume (vph)	74	116	0	0	493	97	75	11	138	0	0	0
Future Volume (vph)	74	116	0	0	493	97	75	11	138	0	0	0
Ideal Flow (vphpl)	1900	1900	1900	1900	1900	1900	1900	1900	1900	1900	1900	1900
Storage Length (ft)	170		0	0		0	0		0	0		0
Storage Lanes	1		0	0		0	0		1	0		0
Taper Length (ft)	25			25			25			25		
Satd. Flow (prot)	1770	1863	0	0	1822	0	0	1785	1583	0	0	0
Flt Permitted	0.950							0.958				
Satd. Flow (perm)	1770	1863	0	0	1822	0	0	1785	1583	0	0	0
Right Turn on Red			Yes			Yes			Yes			Yes
Satd. Flow (RTOR)					19				147			
Link Speed (mph)		45			45			30			30	
Link Distance (ft)		420			786			475			858	
Travel Time (s)		6.4			11.9			10.8			19.5	
Peak Hour Factor	0.94	0.94	0.94	0.94	0.94	0.94	0.94	0.94	0.94	0.94	0.94	0.94
Shared Lane Traffic (%)												
Lane Group Flow (vph)	79	123	0	0	627	0	0	92	147	0	0	0
Turn Type	Prot	NA			NA		Perm	NA	Perm			
Protected Phases	7	4			8			2				
Permitted Phases							2		2			
Total Split (s)	9.6	37.1			27.5		22.9	22.9	22.9			
Total Lost Time (s)	4.5	4.5			4.5			4.5	4.5			
Act Effct Green (s)	5.2	28.7			21.4			18.8	18.8			
Actuated g/C Ratio	0.09	0.51			0.38			0.33	0.33			
v/c Ratio	0.49	0.13			0.89			0.16	0.24			
Control Delay	38.4	7.2			35.1			16.2	4.6			
Queue Delay	0.0	0.0			0.0			0.0	0.0			
Total Delay	38.4	7.2			35.1			16.2	4.6			
LOS	D	A			D			B	A			
Approach Delay		19.4			35.1			9.0				
Approach LOS		B			D			A				

Intersection Summary

Area Type:	Other
Cycle Length:	60
Actuated Cycle Length:	56.6
Control Type:	Semi Act-Uncoord
Maximum v/c Ratio:	0.89
Intersection Signal Delay:	26.3
Intersection LOS:	C
Intersection Capacity Utilization:	52.0%
ICU Level of Service:	A
Analysis Period (min):	15

Splits and Phases: 8: I-5 NB Ramps & Calgrove Boulevard

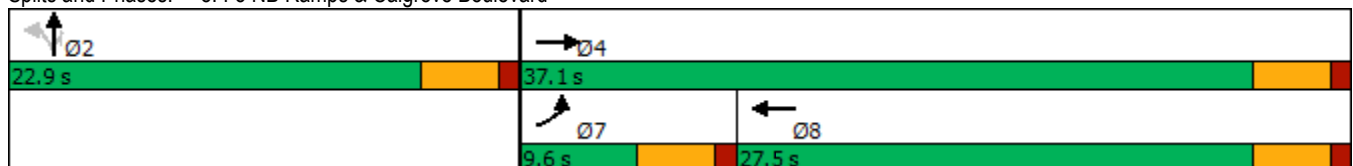

Existing plus Project with Off-Site Improvements - PM Peak Hour  
 7: I-5 SB Ramps & Calgrove Boulevard

Synchro 10 Report  
 Lanes, Volumes, Timings

Lane Group	EBL	EBT	EBR	WBL	WBT	WBR	NBL	NBT	NBR	SBL	SBT	SBR
Lane Configurations												
Traffic Volume (vph)	0	532	77	246	171	0	0	0	0	90	2	64
Future Volume (vph)	0	532	77	246	171	0	0	0	0	90	2	64
Ideal Flow (vphpl)	1900	1900	1900	1900	1900	1900	1900	1900	1900	1900	1900	1900
Storage Length (ft)	0		0	150		0	0		0	0		0
Storage Lanes	0		0	1		0	0		0	0		1
Taper Length (ft)	25			25			25			25		
Satd. Flow (prot)	0	1831	0	1770	1863	0	0	0	0	0	1775	1583
Flt Permitted				0.950							0.953	
Satd. Flow (perm)	0	1831	0	1770	1863	0	0	0	0	0	1775	1583
Right Turn on Red			Yes			Yes			Yes			Yes
Satd. Flow (RTOR)		11										87
Link Speed (mph)		40			45			30			30	
Link Distance (ft)		596			420			659			500	
Travel Time (s)		10.2			6.4			15.0			11.4	
Peak Hour Factor	0.96	0.96	0.96	0.96	0.96	0.96	0.96	0.96	0.96	0.96	0.96	0.96
Shared Lane Traffic (%)												
Lane Group Flow (vph)	0	634	0	256	178	0	0	0	0	0	96	67
Turn Type		NA		Prot	NA					Perm	NA	Perm
Protected Phases		4		3	8						6	
Permitted Phases										6		6
Total Split (s)		33.0		18.0	51.0					24.0	24.0	24.0
Total Lost Time (s)		4.5		4.5	4.5						4.5	4.5
Act Effct Green (s)		27.1		12.9	44.5						19.6	19.6
Actuated g/C Ratio		0.37		0.18	0.61						0.27	0.27
v/c Ratio		0.93		0.82	0.16						0.20	0.14
Control Delay		44.0		52.4	6.5						23.1	4.5
Queue Delay		0.0		0.0	0.0						0.0	0.0
Total Delay		44.0		52.4	6.5						23.1	4.5
LOS		D		D	A						C	A
Approach Delay		44.0			33.6						15.5	
Approach LOS		D			C						B	

Intersection Summary

Area Type:	Other
Cycle Length:	75
Actuated Cycle Length:	73.1
Control Type:	Semi Act-Uncoord
Maximum v/c Ratio:	0.93
Intersection Signal Delay:	36.5
Intersection LOS:	D
Intersection Capacity Utilization:	62.6%
ICU Level of Service:	B
Analysis Period (min):	15

Splits and Phases: 7: I-5 SB Ramps & Calgrove Boulevard



Existing plus Project with Off-Site Improvements - PM Peak Hour  
 8: I-5 NB Ramps & Calgrove Boulevard

Synchro 10 Report  
 Lanes, Volumes, Timings

Lane Group	EBL	EBT	EBR	WBL	WBT	WBR	NBL	NBT	NBR	SBL	SBT	SBR
Lane Configurations												
Traffic Volume (vph)	283	340	0	0	325	65	91	9	282	0	0	0
Future Volume (vph)	283	340	0	0	325	65	91	9	282	0	0	0
Ideal Flow (vphpl)	1900	1900	1900	1900	1900	1900	1900	1900	1900	1900	1900	1900
Storage Length (ft)	170		0	0		0	0		0	0		0
Storage Lanes	1		0	0		0	0		1	0		0
Taper Length (ft)	25			25			25			25		
Satd. Flow (prot)	1770	1863	0	0	1820	0	0	1783	1583	0	0	0
Flt Permitted	0.950							0.957				
Satd. Flow (perm)	1770	1863	0	0	1820	0	0	1783	1583	0	0	0
Right Turn on Red			Yes			Yes			Yes			Yes
Satd. Flow (RTOR)					15				307			
Link Speed (mph)		45			45			30			30	
Link Distance (ft)		420			786			475			858	
Travel Time (s)		6.4			11.9			10.8			19.5	
Peak Hour Factor	0.92	0.92	0.92	0.92	0.92	0.92	0.92	0.92	0.92	0.92	0.92	0.92
Shared Lane Traffic (%)												
Lane Group Flow (vph)	308	370	0	0	424	0	0	109	307	0	0	0
Turn Type	Prot	NA			NA		Perm	NA	Perm			
Protected Phases	7	4			8			2				
Permitted Phases							2		2			
Total Split (s)	20.0	47.5			27.5		22.5	22.5	22.5			
Total Lost Time (s)	4.5	4.5			4.5			4.5	4.5			
Act Effct Green (s)	14.2	37.4			18.6			18.2	18.2			
Actuated g/C Ratio	0.22	0.58			0.29			0.28	0.28			
v/c Ratio	0.79	0.34			0.79			0.22	0.46			
Control Delay	41.8	7.9			32.4			21.4	5.5			
Queue Delay	0.0	0.0			0.0			0.0	0.0			
Total Delay	41.8	7.9			32.4			21.4	5.5			
LOS	D	A			C			C	A			
Approach Delay		23.3			32.4			9.7				
Approach LOS		C			C			A				

Intersection Summary

Area Type:	Other
Cycle Length:	70
Actuated Cycle Length:	64.7
Control Type:	Semi Act-Uncoord
Maximum v/c Ratio:	0.79
Intersection Signal Delay:	22.1
Intersection LOS:	C
Intersection Capacity Utilization:	62.6%
ICU Level of Service:	B
Analysis Period (min):	15

Splits and Phases: 8: I-5 NB Ramps & Calgrove Boulevard



# **INTERIM YEAR NO-PROJECT CONDITIONS**



Interim Year No-Project - AM Peak Hour  
 1: Marriott Way/I-5 SB Ramps & Pico Canyon Road/Lyons Avenue

Synchro 10 Report  
 Lanes, Volumes, Timings

Lane Group	EBL	EBT	EBR	WBL	WBT	WBR	NBL	NBT	NBR	SBL	SBT	SBR
Lane Configurations												
Traffic Volume (vph)	0	1481	40	50	872	420	0	0	40	307	70	380
Future Volume (vph)	0	1481	40	50	872	420	0	0	40	307	70	380
Ideal Flow (vphpl)	1900	1900	1900	1900	1900	1900	1900	1900	1900	1900	1900	1900
Storage Length (ft)	0		0	100		0	0		0	0		200
Storage Lanes	0		0	1		1	0		1	1		1
Taper Length (ft)	25			25			25			25		
Satd. Flow (prot)	0	5065	0	1770	3539	1583	0	0	1611	1681	1715	1583
Flt Permitted				0.123						0.950	0.969	
Satd. Flow (perm)	0	5065	0	229	3539	1583	0	0	1611	1681	1715	1583
Right Turn on Red			Yes			Yes			Yes			Yes
Satd. Flow (RTOR)		5				483			170			197
Link Speed (mph)		40			40			30			30	
Link Distance (ft)		694			822			283			346	
Travel Time (s)		11.8			14.0			6.4			7.9	
Peak Hour Factor	0.87	0.87	0.87	0.87	0.87	0.87	0.87	0.87	0.87	0.87	0.87	0.87
Shared Lane Traffic (%)										39%		
Lane Group Flow (vph)	0	1748	0	57	1002	483	0	0	46	215	218	437
Turn Type		NA		Perm	NA	Perm			Perm	Split	NA	Perm
Protected Phases		4			8					6	6	
Permitted Phases				8		8			2			6
Total Split (s)		37.0		37.0	37.0	37.0			10.5	37.5	37.5	37.5
Total Lost Time (s)		4.5		4.5	4.5	4.5			4.5	4.5	4.5	4.5
Act Effct Green (s)		32.5		32.5	32.5	32.5			6.0	33.0	33.0	33.0
Actuated g/C Ratio		0.38		0.38	0.38	0.38			0.07	0.39	0.39	0.39
v/c Ratio		0.90		0.66	0.74	0.53			0.17	0.33	0.33	0.59
Control Delay		32.6		60.6	26.7	4.3			1.4	20.0	20.0	14.8
Queue Delay		0.0		0.0	0.0	0.0			0.0	0.0	0.0	0.0
Total Delay		32.6		60.6	26.7	4.3			1.4	20.0	20.0	14.8
LOS		C		E	C	A			A	C	B	B
Approach Delay		32.6			20.9			1.4			17.4	
Approach LOS		C			C			A			B	

Intersection Summary

Area Type:	Other
Cycle Length:	85
Actuated Cycle Length:	85
Control Type:	Actuated-Uncoordinated
Maximum v/c Ratio:	0.90
Intersection Signal Delay:	24.8
Intersection LOS:	C
Intersection Capacity Utilization:	55.3%
ICU Level of Service:	B
Analysis Period (min):	15

Splits and Phases: 1: Marriott Way/I-5 SB Ramps & Pico Canyon Road/Lyons Avenue

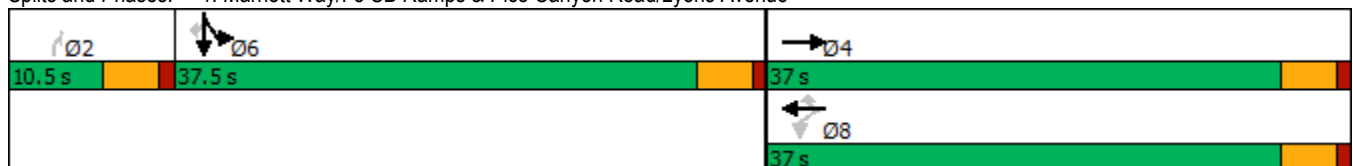

Interim Year No-Project - AM Peak Hour  
 3: I-5 NB Ramps & Lyons Avenue

Synchro 10 Report  
 Lanes, Volumes, Timings

Lane Group	EBL	EBT	EBR	WBL	WBT	WBR	NBL	NBT	NBR	SBL	SBT	SBR
Lane Configurations												
Traffic Volume (vph)	270	1103	0	0	822	584	130	10	150	0	0	0
Future Volume (vph)	270	1103	0	0	822	584	130	10	150	0	0	0
Ideal Flow (vphpl)	1900	1900	1900	1900	1900	1900	1900	1900	1900	1900	1900	1900
Storage Length (ft)	300		0	0		0	0		0	0		0
Storage Lanes	1		0	0		0	1		1	0		0
Taper Length (ft)	25			25			25			25		
Satd. Flow (prot)	1770	3539	0	0	4770	0	1681	1697	1583	0	0	0
Flt Permitted	0.950						0.950	0.959				
Satd. Flow (perm)	1770	3539	0	0	4770	0	1681	1697	1583	0	0	0
Right Turn on Red			Yes			Yes			Yes			Yes
Satd. Flow (RTOR)					225				82			
Link Speed (mph)		40			40			30			30	
Link Distance (ft)		603			1902			756			732	
Travel Time (s)		10.3			32.4			17.2			16.6	
Peak Hour Factor	0.86	0.86	0.86	0.86	0.86	0.86	0.86	0.86	0.86	0.86	0.86	0.86
Shared Lane Traffic (%)							46%					
Lane Group Flow (vph)	314	1283	0	0	1635	0	82	81	174	0	0	0
Turn Type	Prot	NA			NA		Perm	NA	Perm			
Protected Phases	7	4			8			2				
Permitted Phases							2		2			
Total Split (s)	13.0	40.5			27.5		39.5	39.5	39.5			
Total Lost Time (s)	4.5	4.5			4.5		4.5	4.5	4.5			
Act Effct Green (s)	8.5	36.0			23.0		35.0	35.0	35.0			
Actuated g/C Ratio	0.11	0.45			0.29		0.44	0.44	0.44			
v/c Ratio	1.67	0.81			1.09dr		0.11	0.11	0.24			
Control Delay	351.2	23.9			69.1		13.9	13.9	8.5			
Queue Delay	0.0	0.0			0.0		0.0	0.0	0.0			
Total Delay	351.2	23.9			69.1		13.9	13.9	8.5			
LOS	F	C			E		B	B	A			
Approach Delay		88.3			69.1			11.1				
Approach LOS		F			E			B				

Intersection Summary

Area Type:	Other
Cycle Length:	80
Actuated Cycle Length:	80
Control Type:	Actuated-Uncoordinated
Maximum v/c Ratio:	1.67
Intersection Signal Delay:	72.2
Intersection LOS:	E
Intersection Capacity Utilization:	59.3%
ICU Level of Service:	B
Analysis Period (min):	15
dr Defacto Right Lane. Recode with 1 though lane as a right lane.	

Splits and Phases: 3: I-5 NB Ramps & Lyons Avenue

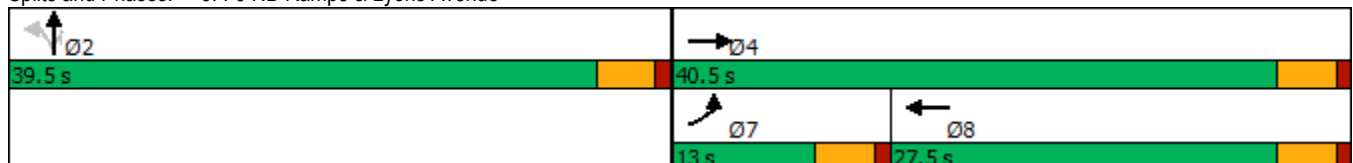

Lane Group	EBL	EBT	EBR	WBL	WBT	WBR	NBL	NBT	NBR	SBL	SBT	SBR
Lane Configurations												
Traffic Volume (vph)	100	810	103	281	800	160	186	218	162	130	413	310
Future Volume (vph)	100	810	103	281	800	160	186	218	162	130	413	310
Ideal Flow (vphpl)	1900	1900	1900	1900	1900	1900	1900	1900	1900	1900	1900	1900
Storage Length (ft)	130		0	200		0	225		270	200		225
Storage Lanes	2		0	1		0	1		1	1		1
Taper Length (ft)	25			25			25			25		
Satd. Flow (prot)	3433	4999	0	1770	4958	0	1770	3539	1583	1770	3539	1583
Flt Permitted	0.950			0.950			0.950			0.950		
Satd. Flow (perm)	3433	4999	0	1770	4958	0	1770	3539	1583	1770	3539	1583
Right Turn on Red			Yes			Yes			Yes			Yes
Satd. Flow (RTOR)		17			34				198			112
Link Speed (mph)		40			40			35			45	
Link Distance (ft)		1902			870			869			1018	
Travel Time (s)		32.4			14.8			16.9			15.4	
Peak Hour Factor	0.82	0.82	0.82	0.82	0.82	0.82	0.82	0.82	0.82	0.82	0.82	0.82
Shared Lane Traffic (%)												
Lane Group Flow (vph)	122	1114	0	343	1171	0	227	266	198	159	504	378
Turn Type	Prot	NA		Prot	NA		Prot	NA	Perm	Prot	NA	pm+ov
Protected Phases	1	6		5	2		7	4		3	8	1
Permitted Phases									4			8
Total Split (s)	20.0	41.0		28.0	49.0		25.0	38.0	38.0	25.0	38.0	20.0
Total Lost Time (s)	4.0	4.0		4.0	4.0		4.0	4.0	4.0	4.0	4.0	4.0
Act Effct Green (s)	10.7	46.0		24.0	59.2		19.9	29.0	29.0	17.0	26.2	40.9
Actuated g/C Ratio	0.08	0.35		0.18	0.45		0.15	0.22	0.22	0.13	0.20	0.31
v/c Ratio	0.44	0.64		1.07	0.52		0.85	0.34	0.39	0.70	0.72	0.67
Control Delay	62.2	38.4		120.3	27.6		82.4	44.4	7.8	70.8	55.3	32.5
Queue Delay	0.0	0.0		0.0	0.0		0.0	0.0	0.0	0.0	0.0	0.0
Total Delay	62.2	38.4		120.3	27.6		82.4	44.4	7.8	70.8	55.3	32.5
LOS	E	D		F	C		F	D	A	E	E	C
Approach Delay		40.7			48.6			46.4			49.4	
Approach LOS		D			D			D			D	

Intersection Summary

Area Type:	Other
Cycle Length:	132
Actuated Cycle Length:	132
Offset:	2.5 (2%), Referenced to phase 2:WBT and 6:EBT, Start of Yellow
Control Type:	Actuated-Coordinated
Maximum v/c Ratio:	1.07
Intersection Signal Delay:	46.3
Intersection LOS:	D
Intersection Capacity Utilization:	68.6%
ICU Level of Service:	C
Analysis Period (min):	15

Splits and Phases: 4: Wiley Canyon Road & Lyons Avenue

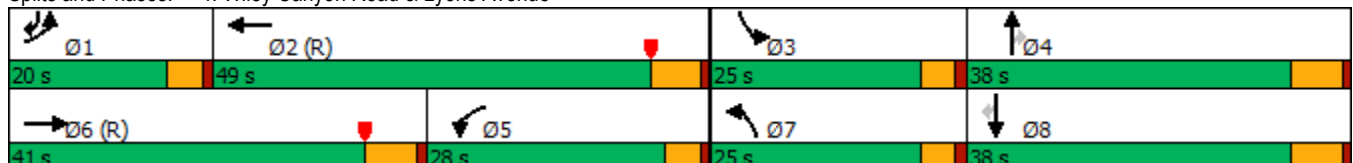

Lane Group	EBL	EBT	EBR	WBL	WBT	WBR	NBL	NBT	NBR	SBL	SBT	SBR
Lane Configurations												
Traffic Volume (vph)	90	10	68	47	20	60	6	476	15	20	857	100
Future Volume (vph)	90	10	68	47	20	60	6	476	15	20	857	100
Ideal Flow (vphpl)	1900	1900	1900	1900	1900	1900	1900	1900	1900	1900	1900	1900
Storage Length (ft)	90		0	0		0	110		0	110		0
Storage Lanes	1		0	0		0	1		0	1		1
Taper Length (ft)	25			25			25			25		
Satd. Flow (prot)	1770	1619	0	0	1712	0	1770	1855	0	1770	1863	1583
Flt Permitted	0.713				0.836		0.143			0.349		
Satd. Flow (perm)	1328	1619	0	0	1458	0	266	1855	0	650	1863	1583
Right Turn on Red			Yes			Yes			Yes			Yes
Satd. Flow (RTOR)		29			78			3				130
Link Speed (mph)		30			30			35			35	
Link Distance (ft)		529			450			1329			869	
Travel Time (s)		12.0			10.2			25.9			16.9	
Peak Hour Factor	0.77	0.77	0.77	0.77	0.77	0.77	0.77	0.77	0.77	0.77	0.77	0.77
Shared Lane Traffic (%)												
Lane Group Flow (vph)	117	101	0	0	165	0	8	637	0	26	1113	130
Turn Type	Perm	NA		Perm	NA		Perm	NA		Perm	NA	Perm
Protected Phases		4			8			2			6	
Permitted Phases	4			8			2			6		6
Total Split (s)	30.5	30.5		30.5	30.5		29.5	29.5		29.5	29.5	29.5
Total Lost Time (s)	4.5	4.5			4.5		4.5	4.5		4.5	4.5	4.5
Act Effct Green (s)	9.2	9.2			9.2		28.9	28.9		28.9	28.9	28.9
Actuated g/C Ratio	0.21	0.21			0.21		0.65	0.65		0.65	0.65	0.65
v/c Ratio	0.42	0.28			0.45		0.05	0.52		0.06	0.91	0.12
Control Delay	19.5	12.7			12.7		6.0	8.2		5.5	27.0	1.7
Queue Delay	0.0	0.0			0.0		0.0	0.0		0.0	0.0	0.0
Total Delay	19.5	12.7			12.7		6.0	8.2		5.5	27.0	1.7
LOS	B	B			B		A	A		A	C	A
Approach Delay		16.3			12.7			8.2			23.9	
Approach LOS		B			B			A			C	

Intersection Summary

Area Type:	Other
Cycle Length:	60
Actuated Cycle Length:	44.2
Control Type:	Actuated-Uncoordinated
Maximum v/c Ratio:	0.91
Intersection Signal Delay:	18.0
Intersection LOS:	B
Intersection Capacity Utilization:	66.6%
ICU Level of Service:	C
Analysis Period (min):	15

Splits and Phases: 5: Wiley Canyon Road & La Glorita Circle/Evans Avenue

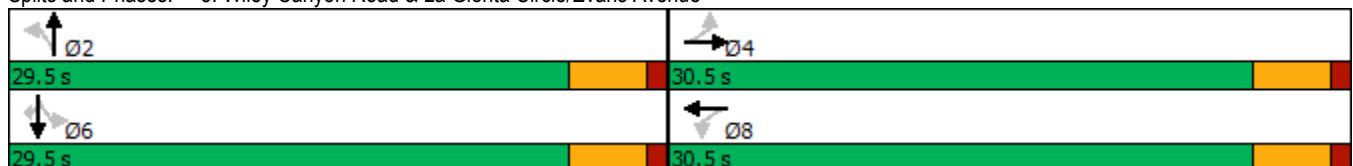

Intersection												
Int Delay, s/veh	9.8											
Movement	EBL	EBT	EBR	WBL	WBT	WBR	NBL	NBT	NBR	SBL	SBT	SBR
Lane Configurations		↕			↕		↕	↕		↕	↕	↕
Traffic Vol, veh/h	60	0	41	1	0	8	18	427	4	6	792	44
Future Vol, veh/h	60	0	41	1	0	8	18	427	4	6	792	44
Conflicting Peds, #/hr	0	0	0	0	0	0	0	0	0	0	0	0
Sign Control	Stop	Stop	Stop	Stop	Stop	Stop	Free	Free	Free	Free	Free	Free
RT Channelized	-	-	None	-	-	None	-	-	None	-	-	None
Storage Length	-	-	-	-	-	-	150	-	-	215	-	260
Veh in Median Storage, #	-	0	-	-	0	-	-	0	-	-	0	-
Grade, %	-	0	-	-	0	-	-	0	-	-	0	-
Peak Hour Factor	83	83	83	83	83	83	83	83	83	83	83	83
Heavy Vehicles, %	2	2	2	2	2	2	2	2	2	2	2	2
Mvmt Flow	72	0	49	1	0	10	22	514	5	7	954	53

Major/Minor	Minor2		Minor1		Major1		Major2					
Conflicting Flow All	1534	1531	954	1580	1582	517	1007	0	0	519	0	0
Stage 1	968	968	-	561	561	-	-	-	-	-	-	-
Stage 2	566	563	-	1019	1021	-	-	-	-	-	-	-
Critical Hdwy	7.12	6.52	6.22	7.12	6.52	6.22	4.12	-	-	4.12	-	-
Critical Hdwy Stg 1	6.12	5.52	-	6.12	5.52	-	-	-	-	-	-	-
Critical Hdwy Stg 2	6.12	5.52	-	6.12	5.52	-	-	-	-	-	-	-
Follow-up Hdwy	3.518	4.018	3.318	3.518	4.018	3.318	2.218	-	-	2.218	-	-
Pot Cap-1 Maneuver	95	117	314	88	109	558	688	-	-	1047	-	-
Stage 1	305	332	-	512	510	-	-	-	-	-	-	-
Stage 2	509	509	-	286	314	-	-	-	-	-	-	-
Platoon blocked, %								-	-	-	-	-
Mov Cap-1 Maneuver	91	112	314	72	105	558	688	-	-	1047	-	-
Mov Cap-2 Maneuver	91	112	-	72	105	-	-	-	-	-	-	-
Stage 1	295	330	-	496	494	-	-	-	-	-	-	-
Stage 2	484	493	-	239	312	-	-	-	-	-	-	-

Approach	EB		WB		NB		SB	
HCM Control Delay, s	132.3		16.7		0.4		0.1	
HCM LOS	F		C					

Minor Lane/Major Mvmt	NBL	NBT	NBR	EBLn1	WBLn1	SBL	SBT	SBR
Capacity (veh/h)	688	-	-	128	319	1047	-	-
HCM Lane V/C Ratio	0.032	-	-	0.951	0.034	0.007	-	-
HCM Control Delay (s)	10.4	-	-	132.3	16.7	8.5	-	-
HCM Lane LOS	B	-	-	F	C	A	-	-
HCM 95th %tile Q(veh)	0.1	-	-	6.4	0.1	0	-	-

Intersection												
Int Delay, s/veh	25.4											
Movement	EBL	EBT	EBR	WBL	WBT	WBR	NBL	NBT	NBR	SBL	SBT	SBR
Lane Configurations		↕		↕	↕						↕	↕
Traffic Vol, veh/h	0	316	90	496	213	0	0	0	0	66	0	230
Future Vol, veh/h	0	316	90	496	213	0	0	0	0	66	0	230
Conflicting Peds, #/hr	0	0	0	0	0	0	0	0	0	0	0	0
Sign Control	Free	Free	Free	Free	Free	Free	Free	Free	Free	Stop	Stop	Stop
RT Channelized	-	-	None	-	-	None	-	-	None	-	-	None
Storage Length	-	-	-	150	-	-	-	-	-	-	-	0
Veh in Median Storage, #	-	0	-	-	0	-	-	0	-	-	0	-
Grade, %	-	0	-	-	0	-	-	0	-	-	0	-
Peak Hour Factor	91	91	91	91	91	91	91	91	91	91	91	91
Heavy Vehicles, %	2	2	2	2	2	2	2	2	2	2	2	2
Mvmt Flow	0	347	99	545	234	0	0	0	0	73	0	253

Major/Minor	Major1			Major2			Minor2		
Conflicting Flow All	-	0	0	446	0	0	1721	1770	234
Stage 1	-	-	-	-	-	-	1324	1324	-
Stage 2	-	-	-	-	-	-	397	446	-
Critical Hdwy	-	-	-	4.12	-	-	6.42	6.52	6.22
Critical Hdwy Stg 1	-	-	-	-	-	-	5.42	5.52	-
Critical Hdwy Stg 2	-	-	-	-	-	-	5.42	5.52	-
Follow-up Hdwy	-	-	-	2.218	-	-	3.518	4.018	3.318
Pot Cap-1 Maneuver	0	-	-	1114	-	0	98	83	805
Stage 1	0	-	-	-	-	0	249	225	-
Stage 2	0	-	-	-	-	0	679	574	-
Platoon blocked, %	-	-	-	-	-	-	-	-	-
Mov Cap-1 Maneuver	-	-	-	1114	-	-	~ 50	0	805
Mov Cap-2 Maneuver	-	-	-	-	-	-	~ 50	0	-
Stage 1	-	-	-	-	-	-	249	0	-
Stage 2	-	-	-	-	-	-	347	0	-

Approach	EB	WB	SB
HCM Control Delay, s	0	7.9	102.1
HCM LOS			F

Minor Lane/Major Mvmt	EBT	EBR	WBL	WBT	SBLn1	SBLn2
Capacity (veh/h)	-	-	1114	-	50	805
HCM Lane V/C Ratio	-	-	0.489	-	1.451	0.314
HCM Control Delay (s)	-	-	11.3	-	417.7	11.5
HCM Lane LOS	-	-	B	-	F	B
HCM 95th %tile Q(veh)	-	-	2.8	-	6.8	1.3

Notes  
 ~: Volume exceeds capacity    \$: Delay exceeds 300s    +: Computation Not Defined    \*: All major volume in platoon

Intersection												
Int Delay, s/veh	4.1											
Movement	EBL	EBT	EBR	WBL	WBT	WBR	NBL	NBT	NBR	SBL	SBT	SBR
Lane Configurations	↘	↑			↑	↗		↖	↗			
Traffic Vol, veh/h	140	232	0	0	659	192	50	10	68	0	0	0
Future Vol, veh/h	140	232	0	0	659	192	50	10	68	0	0	0
Conflicting Peds, #/hr	0	0	0	0	0	0	0	0	0	0	0	0
Sign Control	Free	Free	Free	Free	Free	Free	Stop	Stop	Stop	Free	Free	Free
RT Channelized	-	-	None	-	-	None	-	-	None	-	-	None
Storage Length	170	-	-	-	-	0	-	-	0	-	-	-
Veh in Median Storage, #	-	0	-	-	0	-	-	0	-	-	0	-
Grade, %	-	0	-	-	0	-	-	0	-	-	0	-
Peak Hour Factor	94	94	94	94	94	94	94	94	94	94	94	94
Heavy Vehicles, %	2	2	2	2	2	2	2	2	2	2	2	2
Mvmt Flow	149	247	0	0	701	204	53	11	72	0	0	0

Major/Minor	Major1			Major2			Minor1		
Conflicting Flow All	905	0	-	-	-	0	1348	1450	247
Stage 1	-	-	-	-	-	-	545	545	-
Stage 2	-	-	-	-	-	-	803	905	-
Critical Hdwy	4.12	-	-	-	-	-	6.42	6.52	6.22
Critical Hdwy Stg 1	-	-	-	-	-	-	5.42	5.52	-
Critical Hdwy Stg 2	-	-	-	-	-	-	5.42	5.52	-
Follow-up Hdwy	2.218	-	-	-	-	-	3.518	4.018	3.318
Pot Cap-1 Maneuver	752	-	0	0	-	-	166	131	792
Stage 1	-	-	0	0	-	-	581	519	-
Stage 2	-	-	0	0	-	-	441	355	-
Platoon blocked, %	-	-	-	-	-	-	-	-	-
Mov Cap-1 Maneuver	752	-	-	-	-	-	133	0	792
Mov Cap-2 Maneuver	-	-	-	-	-	-	133	0	-
Stage 1	-	-	-	-	-	-	466	0	-
Stage 2	-	-	-	-	-	-	441	0	-

Approach	EB	WB	NB
HCM Control Delay, s	4.1	0	31
HCM LOS			D

Minor Lane/Major Mvmt	NBLn1	NBLn2	EBL	EBT	WBT	WBR
Capacity (veh/h)	133	792	752	-	-	-
HCM Lane V/C Ratio	0.48	0.091	0.198	-	-	-
HCM Control Delay (s)	54.8	10	11	-	-	-
HCM Lane LOS	F	B	B	-	-	-
HCM 95th %tile Q(veh)	2.2	0.3	0.7	-	-	-

Intersection

Int Delay, s/veh	4.9											
Movement	EBL	EBT	EBR	WBL	WBT	WBR	NBL	NBT	NBR	SBL	SBT	SBR
Lane Configurations	↘	↑	↗	↘	↑	↗		↔			↑	↗
Traffic Vol, veh/h	200	60	10	0	190	70	10	9	0	40	1	871
Future Vol, veh/h	200	60	10	0	190	70	10	9	0	40	1	871
Conflicting Peds, #/hr	0	0	0	0	0	0	0	0	0	0	0	0
Sign Control	Free	Free	Free	Free	Free	Free	Stop	Stop	Stop	Stop	Stop	Stop
RT Channelized	-	-	None	-	-	None	-	-	None	-	-	Free
Storage Length	165	-	150	290	-	290	-	-	-	100	-	0
Veh in Median Storage, #	-	0	-	-	0	-	-	0	-	-	0	-
Grade, %	-	0	-	-	0	-	-	0	-	-	0	-
Peak Hour Factor	89	89	89	89	89	89	89	89	89	89	89	89
Heavy Vehicles, %	2	2	2	2	2	2	2	2	2	2	2	2
Mvmt Flow	225	67	11	0	213	79	11	10	0	45	1	979

Major/Minor	Major1			Major2			Minor1			Minor2		
Conflicting Flow All	292	0	0	78	0	0	770	809	67	741	741	-
Stage 1	-	-	-	-	-	-	517	517	-	213	213	-
Stage 2	-	-	-	-	-	-	253	292	-	528	528	-
Critical Hdwy	4.12	-	-	4.12	-	-	7.12	6.52	6.22	7.12	6.52	-
Critical Hdwy Stg 1	-	-	-	-	-	-	6.12	5.52	-	6.12	5.52	-
Critical Hdwy Stg 2	-	-	-	-	-	-	6.12	5.52	-	6.12	5.52	-
Follow-up Hdwy	2.218	-	-	2.218	-	-	3.518	4.018	3.318	3.518	4.018	-
Pot Cap-1 Maneuver	1270	-	-	1520	-	-	318	314	997	332	344	0
Stage 1	-	-	-	-	-	-	541	534	-	789	726	0
Stage 2	-	-	-	-	-	-	751	671	-	534	528	0
Platoon blocked, %	-	-	-	-	-	-	-	-	-	-	-	-
Mov Cap-1 Maneuver	1270	-	-	1520	-	-	274	258	997	279	283	-
Mov Cap-2 Maneuver	-	-	-	-	-	-	274	258	-	279	283	-
Stage 1	-	-	-	-	-	-	445	439	-	649	726	-
Stage 2	-	-	-	-	-	-	750	671	-	429	435	-

Approach	EB			WB			NB			SB		
HCM Control Delay, s	6.3			0			19.7			20.4		
HCM LOS	C			C			C			C		

Minor Lane/Major Mvmt	NBLn1	EBL	EBT	EBR	WBL	WBT	WBR	SBLn1	SBLn2
Capacity (veh/h)	266	1270	-	-	1520	-	-	279	-
HCM Lane V/C Ratio	0.08	0.177	-	-	-	-	-	0.165	-
HCM Control Delay (s)	19.7	8.4	-	-	0	-	-	20.4	0
HCM Lane LOS	C	A	-	-	A	-	-	C	A
HCM 95th %tile Q(veh)	0.3	0.6	-	-	0	-	-	0.6	-



Interim Year No-Project - PM Peak Hour  
 1: Marriott Way/I-5 SB Ramps & Pico Canyon Road/Lyons Avenue

Synchro 10 Report  
 Lanes, Volumes, Timings

Lane Group	EBL	EBT	EBR	WBL	WBT	WBR	NBL	NBT	NBR	SBL	SBT	SBR
Lane Configurations												
Traffic Volume (vph)	0	960	50	60	1335	270	0	0	20	501	100	120
Future Volume (vph)	0	960	50	60	1335	270	0	0	20	501	100	120
Ideal Flow (vphpl)	1900	1900	1900	1900	1900	1900	1900	1900	1900	1900	1900	1900
Storage Length (ft)	0		0	100		0	0		0	0		200
Storage Lanes	0		0	1		1	0		1	1		1
Taper Length (ft)	25			25			25			25		
Satd. Flow (prot)	0	5050	0	1770	3539	1583	0	0	1611	1681	1713	1583
Flt Permitted				0.167						0.950	0.968	
Satd. Flow (perm)	0	5050	0	311	3539	1583	0	0	1611	1681	1713	1583
Right Turn on Red			Yes			Yes			Yes			Yes
Satd. Flow (RTOR)		11				289			100			130
Link Speed (mph)		40			40			30			30	
Link Distance (ft)		694			822			283			346	
Travel Time (s)		11.8			14.0			6.4			7.9	
Peak Hour Factor	0.92	0.92	0.92	0.92	0.92	0.92	0.92	0.92	0.92	0.92	0.92	0.92
Shared Lane Traffic (%)										40%		
Lane Group Flow (vph)	0	1097	0	65	1451	293	0	0	22	327	327	130
Turn Type		NA		Perm	NA	Perm			Perm	Split	NA	Perm
Protected Phases		4			8					6	6	
Permitted Phases				8		8			2			6
Total Split (s)		37.0		37.0	37.0	37.0			10.5	37.5	37.5	37.5
Total Lost Time (s)		4.5		4.5	4.5	4.5			4.5	4.5	4.5	4.5
Act Effct Green (s)		32.5		32.5	32.5	32.5			6.0	33.0	33.0	33.0
Actuated g/C Ratio		0.38		0.38	0.38	0.38			0.07	0.39	0.39	0.39
v/c Ratio		0.57		0.55	1.07	0.37			0.11	0.50	0.49	0.19
Control Delay		21.9		41.9	73.7	4.0			1.1	23.1	22.8	4.1
Queue Delay		0.0		0.0	0.0	0.0			0.0	0.0	0.0	0.0
Total Delay		21.9		41.9	73.7	4.0			1.1	23.1	22.8	4.1
LOS		C		D	E	A			A	C	C	A
Approach Delay		21.9			61.3			1.1			19.8	
Approach LOS		C			E			A			B	

Intersection Summary

Area Type:	Other
Cycle Length:	85
Actuated Cycle Length:	85
Control Type:	Actuated-Uncoordinated
Maximum v/c Ratio:	1.07
Intersection Signal Delay:	40.5
Intersection LOS:	D
Intersection Capacity Utilization:	60.9%
ICU Level of Service:	B
Analysis Period (min):	15

Splits and Phases: 1: Marriott Way/I-5 SB Ramps & Pico Canyon Road/Lyons Avenue

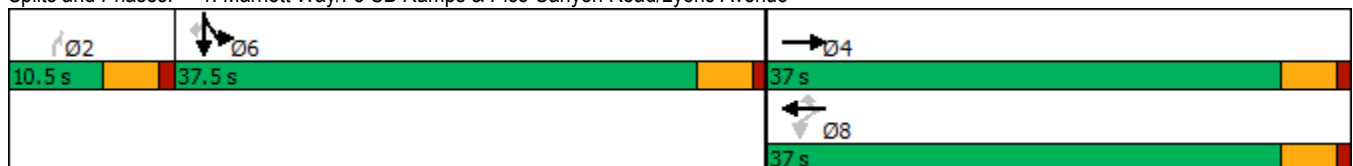

Interim Year No-Project - PM Peak Hour  
 3: I-5 NB Ramps & Lyons Avenue

Lane Group	EBL	EBT	EBR	WBL	WBT	WBR	NBL	NBT	NBR	SBL	SBT	SBR
Lane Configurations												
Traffic Volume (vph)	230	1141	0	0	825	686	420	0	420	0	0	0
Future Volume (vph)	230	1141	0	0	825	686	420	0	420	0	0	0
Ideal Flow (vphpl)	1900	1900	1900	1900	1900	1900	1900	1900	1900	1900	1900	1900
Storage Length (ft)	300		0	0		0	0		0	0		0
Storage Lanes	1		0	0		0	1		1	0		0
Taper Length (ft)	25			25			25			25		
Satd. Flow (prot)	1770	3539	0	0	4739	0	1681	1681	1583	0	0	0
Flt Permitted	0.950						0.950	0.950				
Satd. Flow (perm)	1770	3539	0	0	4739	0	1681	1681	1583	0	0	0
Right Turn on Red			Yes			Yes			Yes			Yes
Satd. Flow (RTOR)					263				82			
Link Speed (mph)		40			40			30			30	
Link Distance (ft)		603			1902			756			732	
Travel Time (s)		10.3			32.4			17.2			16.6	
Peak Hour Factor	0.92	0.92	0.92	0.92	0.92	0.92	0.92	0.92	0.92	0.92	0.92	0.92
Shared Lane Traffic (%)							50%					
Lane Group Flow (vph)	250	1240	0	0	1643	0	228	229	457	0	0	0
Turn Type	Prot	NA			NA		Perm	NA	Perm			
Protected Phases	7	4			8			2				
Permitted Phases							2		2			
Total Split (s)	14.0	41.5			27.5		38.5	38.5	38.5			
Total Lost Time (s)	4.5	4.5			4.5		4.5	4.5	4.5			
Act Effct Green (s)	9.5	37.0			23.0		34.0	34.0	34.0			
Actuated g/C Ratio	0.12	0.46			0.29		0.42	0.42	0.42			
v/c Ratio	1.19	0.76			1.15dr		0.32	0.32	0.64			
Control Delay	157.6	21.5			65.9		16.9	16.9	19.4			
Queue Delay	0.0	0.0			0.0		0.0	0.0	0.0			
Total Delay	157.6	21.5			65.9		16.9	16.9	19.4			
LOS	F	C			E		B	B	B			
Approach Delay		44.4			65.9			18.2				
Approach LOS		D			E			B				

Intersection Summary

Area Type:	Other
Cycle Length:	80
Actuated Cycle Length:	80
Control Type:	Actuated-Uncoordinated
Maximum v/c Ratio:	1.19
Intersection Signal Delay:	47.2
Intersection LOS:	D
Intersection Capacity Utilization:	67.0%
ICU Level of Service:	C
Analysis Period (min):	15
dr Defacto Right Lane. Recode with 1 though lane as a right lane.	

Splits and Phases: 3: I-5 NB Ramps & Lyons Avenue

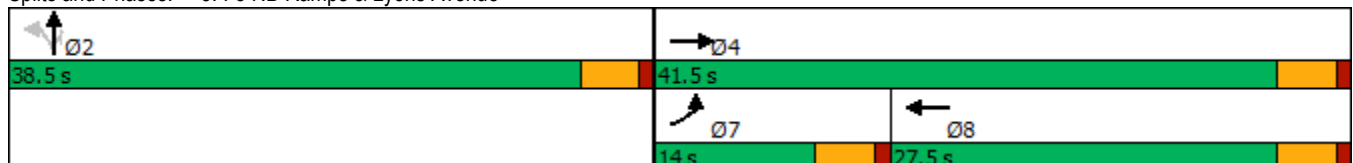

Lane Group	EBL	EBT	EBR	WBL	WBT	WBR	NBL	NBT	NBR	SBL	SBT	SBR
Lane Configurations												
Traffic Volume (vph)	320	1230	81	140	1130	130	171	393	235	440	293	290
Future Volume (vph)	320	1230	81	140	1130	130	171	393	235	440	293	290
Ideal Flow (vphpl)	1900	1900	1900	1900	1900	1900	1900	1900	1900	1900	1900	1900
Storage Length (ft)	130		0	200		0	225		270	200		225
Storage Lanes	2		0	1		0	1		1	1		1
Taper Length (ft)	25			25			25			25		
Satd. Flow (prot)	3433	5040	0	1770	5009	0	1770	3539	1583	1770	3539	1583
Flt Permitted	0.950			0.950			0.950			0.950		
Satd. Flow (perm)	3433	5040	0	1770	5009	0	1770	3539	1583	1770	3539	1583
Right Turn on Red			Yes			Yes			Yes			Yes
Satd. Flow (RTOR)		8			15				242			94
Link Speed (mph)		40			40			35			45	
Link Distance (ft)		1902			870			869			1018	
Travel Time (s)		32.4			14.8			16.9			15.4	
Peak Hour Factor	0.97	0.97	0.97	0.97	0.97	0.97	0.97	0.97	0.97	0.97	0.97	0.97
Shared Lane Traffic (%)												
Lane Group Flow (vph)	330	1352	0	144	1299	0	176	405	242	454	302	299
Turn Type	Prot	NA		Prot	NA		Prot	NA	Perm	Prot	NA	pm+ov
Protected Phases	1	6		5	2		7	4		3	8	1
Permitted Phases									4			8
Total Split (s)	25.0	44.0		25.0	44.0		25.0	38.0	38.0	25.0	38.0	25.0
Total Lost Time (s)	4.0	4.0		4.0	4.0		4.0	4.0	4.0	4.0	4.0	4.0
Act Effct Green (s)	18.7	55.4		16.5	53.2		17.9	23.1	23.1	21.0	26.2	48.9
Actuated g/C Ratio	0.14	0.42		0.12	0.40		0.14	0.18	0.18	0.16	0.20	0.37
v/c Ratio	0.68	0.64		0.65	0.64		0.74	0.66	0.51	1.62	0.43	0.46
Control Delay	60.7	33.2		68.3	34.4		72.7	55.6	9.2	328.3	48.4	22.8
Queue Delay	0.0	0.0		0.0	0.0		0.0	0.0	0.0	0.0	0.0	0.0
Total Delay	60.7	33.2		68.3	34.4		72.7	55.6	9.2	328.3	48.4	22.8
LOS	E	C		E	C		E	E	A	F	D	C
Approach Delay		38.6			37.8			45.6			161.6	
Approach LOS		D			D			D			F	

Intersection Summary

Area Type:	Other
Cycle Length:	132
Actuated Cycle Length:	132
Offset:	9.5 (7%), Referenced to phase 2:WBT and 6:EBT, Start of Yellow
Control Type:	Actuated-Coordinated
Maximum v/c Ratio:	1.62
Intersection Signal Delay:	65.5
Intersection LOS:	E
Intersection Capacity Utilization:	82.4%
ICU Level of Service:	E
Analysis Period (min):	15

Splits and Phases: 4: Wiley Canyon Road & Lyons Avenue

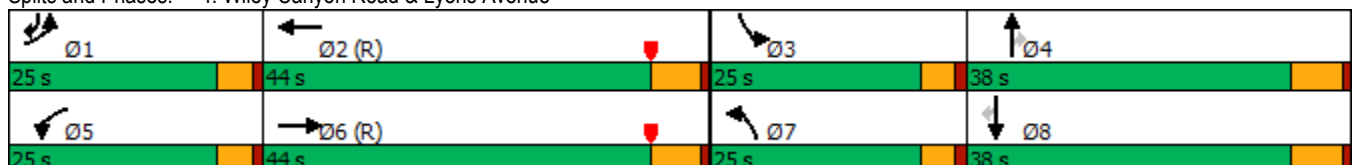

Interim Year No-Project - PM Peak Hour  
 5: Wiley Canyon Road & La Glorita Circle/Evans Avenue

Synchro 10 Report  
 Lanes, Volumes, Timings

Lane Group	EBL	EBT	EBR	WBL	WBT	WBR	NBL	NBT	NBR	SBL	SBT	SBR
Lane Configurations												
Traffic Volume (vph)	50	10	35	44	10	50	7	769	25	30	454	60
Future Volume (vph)	50	10	35	44	10	50	7	769	25	30	454	60
Ideal Flow (vphpl)	1900	1900	1900	1900	1900	1900	1900	1900	1900	1900	1900	1900
Storage Length (ft)	90		0	0		0	110		0	110		0
Storage Lanes	1		0	0		0	1		0	1		1
Taper Length (ft)	25			25			25			25		
Satd. Flow (prot)	1770	1645	0	0	1703	0	1770	1853	0	1770	1863	1583
Flt Permitted	0.874				0.842		0.480			0.258		
Satd. Flow (perm)	1628	1645	0	0	1465	0	894	1853	0	481	1863	1583
Right Turn on Red			Yes			Yes			Yes			Yes
Satd. Flow (RTOR)		36			52			3				62
Link Speed (mph)		30			30			35			35	
Link Distance (ft)		529			450			1329			869	
Travel Time (s)		12.0			10.2			25.9			16.9	
Peak Hour Factor	0.97	0.97	0.97	0.97	0.97	0.97	0.97	0.97	0.97	0.97	0.97	0.97
Shared Lane Traffic (%)												
Lane Group Flow (vph)	52	46	0	0	107	0	7	819	0	31	468	62
Turn Type	Perm	NA		Perm	NA		Perm	NA		Perm	NA	Perm
Protected Phases		4			8			2			6	
Permitted Phases	4			8			2			6		6
Total Split (s)	30.5	30.5		30.5	30.5		29.5	29.5		29.5	29.5	29.5
Total Lost Time (s)	4.5	4.5			4.5		4.5	4.5		4.5	4.5	4.5
Act Effct Green (s)	7.4	7.4			7.4		30.8	30.8		30.8	30.8	30.8
Actuated g/C Ratio	0.17	0.17			0.17		0.70	0.70		0.70	0.70	0.70
v/c Ratio	0.19	0.15			0.37		0.01	0.64		0.09	0.36	0.06
Control Delay	16.4	8.6			13.1		3.9	9.5		4.9	5.3	1.6
Queue Delay	0.0	0.0			0.0		0.0	0.0		0.0	0.0	0.0
Total Delay	16.4	8.6			13.1		3.9	9.5		4.9	5.3	1.6
LOS	B	A			B		A	A		A	A	A
Approach Delay		12.7			13.1			9.5			4.8	
Approach LOS		B			B			A			A	

Intersection Summary

Area Type:	Other
Cycle Length:	60
Actuated Cycle Length:	44.3
Control Type:	Actuated-Uncoordinated
Maximum v/c Ratio:	0.64
Intersection Signal Delay:	8.3
Intersection LOS:	A
Intersection Capacity Utilization:	62.2%
ICU Level of Service:	B
Analysis Period (min):	15

Splits and Phases: 5: Wiley Canyon Road & La Glorita Circle/Evans Avenue

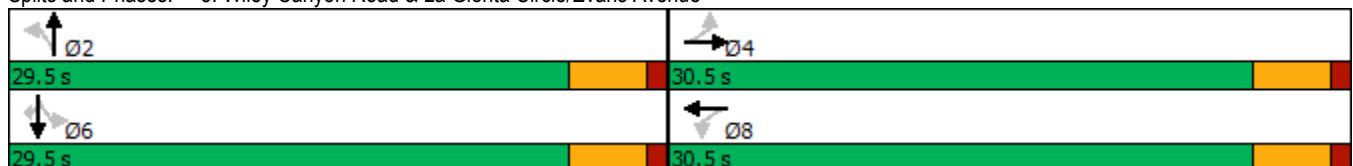

Intersection

Int Delay, s/veh	2.1											
Movement	EBL	EBT	EBR	WBL	WBT	WBR	NBL	NBT	NBR	SBL	SBT	SBR
Lane Configurations		↕			↕		↕	↕		↕	↕	↕
Traffic Vol, veh/h	43	1	11	1	0	7	24	691	2	12	463	55
Future Vol, veh/h	43	1	11	1	0	7	24	691	2	12	463	55
Conflicting Peds, #/hr	0	0	0	0	0	0	0	0	0	0	0	0
Sign Control	Stop	Stop	Stop	Stop	Stop	Stop	Free	Free	Free	Free	Free	Free
RT Channelized	-	-	None	-	-	None	-	-	None	-	-	None
Storage Length	-	-	-	-	-	-	150	-	-	215	-	260
Veh in Median Storage, #	-	0	-	-	0	-	-	0	-	-	0	-
Grade, %	-	0	-	-	0	-	-	0	-	-	0	-
Peak Hour Factor	95	95	95	95	95	95	95	95	95	95	95	95
Heavy Vehicles, %	2	2	2	2	2	2	2	2	2	2	2	2
Mvmt Flow	45	1	12	1	0	7	25	727	2	13	487	58

Major/Minor	Minor2		Minor1			Major1			Major2			
Conflicting Flow All	1295	1292	487	1327	1349	728	545	0	0	729	0	0
Stage 1	513	513	-	778	778	-	-	-	-	-	-	-
Stage 2	782	779	-	549	571	-	-	-	-	-	-	-
Critical Hdwy	7.12	6.52	6.22	7.12	6.52	6.22	4.12	-	-	4.12	-	-
Critical Hdwy Stg 1	6.12	5.52	-	6.12	5.52	-	-	-	-	-	-	-
Critical Hdwy Stg 2	6.12	5.52	-	6.12	5.52	-	-	-	-	-	-	-
Follow-up Hdwy	3.518	4.018	3.318	3.518	4.018	3.318	2.218	-	-	2.218	-	-
Pot Cap-1 Maneuver	139	163	581	132	151	423	1024	-	-	875	-	-
Stage 1	544	536	-	389	407	-	-	-	-	-	-	-
Stage 2	387	406	-	520	505	-	-	-	-	-	-	-
Platoon blocked, %								-	-	-	-	-
Mov Cap-1 Maneuver	132	157	581	125	145	423	1024	-	-	875	-	-
Mov Cap-2 Maneuver	132	157	-	125	145	-	-	-	-	-	-	-
Stage 1	531	528	-	380	397	-	-	-	-	-	-	-
Stage 2	371	396	-	501	497	-	-	-	-	-	-	-

Approach	EB		WB			NB			SB		
HCM Control Delay, s	40.7		16.3			0.3			0.2		
HCM LOS	E		C								

Minor Lane/Major Mvmt	NBL	NBT	NBR	EBLn1	WBLn1	SBL	SBT	SBR
Capacity (veh/h)	1024	-	-	157	326	875	-	-
HCM Lane V/C Ratio	0.025	-	-	0.369	0.026	0.014	-	-
HCM Control Delay (s)	8.6	-	-	40.7	16.3	9.2	-	-
HCM Lane LOS	A	-	-	E	C	A	-	-
HCM 95th %tile Q(veh)	0.1	-	-	1.6	0.1	0	-	-

Intersection												
Int Delay, s/veh	6.7											
Movement	EBL	EBT	EBR	WBL	WBT	WBR	NBL	NBT	NBR	SBL	SBT	SBR
Lane Configurations		↕		↕	↕						↕	↕
Traffic Vol, veh/h	0	712	160	100	154	0	0	0	0	111	0	220
Future Vol, veh/h	0	712	160	100	154	0	0	0	0	111	0	220
Conflicting Peds, #/hr	0	0	0	0	0	0	0	0	0	0	0	0
Sign Control	Free	Free	Free	Free	Free	Free	Free	Free	Free	Stop	Stop	Stop
RT Channelized	-	-	None	-	-	None	-	-	None	-	-	None
Storage Length	-	-	-	150	-	-	-	-	-	-	-	0
Veh in Median Storage, #	-	0	-	-	0	-	-	0	-	-	0	-
Grade, %	-	0	-	-	0	-	-	0	-	-	0	-
Peak Hour Factor	96	96	96	96	96	96	96	96	96	96	96	96
Heavy Vehicles, %	2	2	2	2	2	2	2	2	2	2	2	2
Mvmt Flow	0	742	167	104	160	0	0	0	0	116	0	229

Major/Minor	Major1			Major2			Minor2		
Conflicting Flow All	-	0	0	909	0	0	1194	1277	160
Stage 1	-	-	-	-	-	-	368	368	-
Stage 2	-	-	-	-	-	-	826	909	-
Critical Hdwy	-	-	-	4.12	-	-	6.42	6.52	6.22
Critical Hdwy Stg 1	-	-	-	-	-	-	5.42	5.52	-
Critical Hdwy Stg 2	-	-	-	-	-	-	5.42	5.52	-
Follow-up Hdwy	-	-	-	2.218	-	-	3.518	4.018	3.318
Pot Cap-1 Maneuver	0	-	-	749	-	0	206	166	885
Stage 1	0	-	-	-	-	0	700	621	-
Stage 2	0	-	-	-	-	0	430	354	-
Platoon blocked, %	-	-	-	-	-	-	-	-	-
Mov Cap-1 Maneuver	-	-	-	749	-	-	177	0	885
Mov Cap-2 Maneuver	-	-	-	-	-	-	177	0	-
Stage 1	-	-	-	-	-	-	700	0	-
Stage 2	-	-	-	-	-	-	370	0	-

Approach	EB	WB	SB
HCM Control Delay, s	0	4.2	26.2
HCM LOS			D

Minor Lane/Major Mvmt	EBT	EBR	WBL	WBT	SBLn1	SBLn2
Capacity (veh/h)	-	-	749	-	177	885
HCM Lane V/C Ratio	-	-	0.139	-	0.653	0.259
HCM Control Delay (s)	-	-	10.6	-	57.2	10.5
HCM Lane LOS	-	-	B	-	F	B
HCM 95th %tile Q(veh)	-	-	0.5	-	3.8	1

Intersection

Int Delay, s/veh	32											
Movement	EBL	EBT	EBR	WBL	WBT	WBR	NBL	NBT	NBR	SBL	SBT	SBR
Lane Configurations	↘	↑			↑	↗		↖	↗			
Traffic Vol, veh/h	420	403	0	0	174	143	90	10	242	0	0	0
Future Vol, veh/h	420	403	0	0	174	143	90	10	242	0	0	0
Conflicting Peds, #/hr	0	0	0	0	0	0	0	0	0	0	0	0
Sign Control	Free	Free	Free	Free	Free	Free	Stop	Stop	Stop	Free	Free	Free
RT Channelized	-	-	None	-	-	None	-	-	None	-	-	None
Storage Length	170	-	-	-	-	0	-	-	0	-	-	-
Veh in Median Storage, #	-	0	-	-	0	-	-	0	-	-	0	-
Grade, %	-	0	-	-	0	-	-	0	-	-	0	-
Peak Hour Factor	92	92	92	92	92	92	92	92	92	92	92	92
Heavy Vehicles, %	2	2	2	2	2	2	2	2	2	2	2	2
Mvmt Flow	457	438	0	0	189	155	98	11	263	0	0	0

Major/Minor	Major1		Major2		Minor1				
Conflicting Flow All	344	0	-	-	-	0	1619	1696	438
Stage 1	-	-	-	-	-	-	1352	1352	-
Stage 2	-	-	-	-	-	-	267	344	-
Critical Hdwy	4.12	-	-	-	-	-	6.42	6.52	6.22
Critical Hdwy Stg 1	-	-	-	-	-	-	5.42	5.52	-
Critical Hdwy Stg 2	-	-	-	-	-	-	5.42	5.52	-
Follow-up Hdwy	2.218	-	-	-	-	-	3.518	4.018	3.318
Pot Cap-1 Maneuver	1215	-	0	0	-	-	114	93	619
Stage 1	-	-	0	0	-	-	241	218	-
Stage 2	-	-	0	0	-	-	778	637	-
Platoon blocked, %		-			-	-			
Mov Cap-1 Maneuver	1215	-	-	-	-	-	~ 71	0	619
Mov Cap-2 Maneuver	-	-	-	-	-	-	~ 71	0	-
Stage 1	-	-	-	-	-	-	150	0	-
Stage 2	-	-	-	-	-	-	778	0	-

Approach	EB	WB	NB
HCM Control Delay, s	5	0	126.7
HCM LOS			F

Minor Lane/Major Mvmt	NBLn1	NBLn2	EBL	EBT	WBT	WBR
Capacity (veh/h)	71	619	1215	-	-	-
HCM Lane V/C Ratio	1.531	0.425	0.376	-	-	-
HCM Control Delay (s)	\$ 397	15	9.7	-	-	-
HCM Lane LOS	F	C	A	-	-	-
HCM 95th %tile Q(veh)	9.2	2.1	1.8	-	-	-

Notes

~: Volume exceeds capacity    \$: Delay exceeds 300s    +: Computation Not Defined    \*: All major volume in platoon

Intersection

Int Delay, s/veh	20.7											
Movement	EBL	EBT	EBR	WBL	WBT	WBR	NBL	NBT	NBR	SBL	SBT	SBR
Lane Configurations	↘	↑	↗	↘	↑	↗		↕			↑	↗
Traffic Vol, veh/h	555	150	10	0	110	50	10	8	0	60	9	317
Future Vol, veh/h	555	150	10	0	110	50	10	8	0	60	9	317
Conflicting Peds, #/hr	0	0	0	0	0	0	0	0	0	0	0	0
Sign Control	Free	Free	Free	Free	Free	Free	Stop	Stop	Stop	Stop	Stop	Stop
RT Channelized	-	-	None	-	-	None	-	-	None	-	-	Free
Storage Length	165	-	150	290	-	290	-	-	-	100	-	0
Veh in Median Storage, #	-	0	-	-	0	-	-	0	-	-	0	-
Grade, %	-	0	-	-	0	-	-	0	-	-	0	-
Peak Hour Factor	97	97	97	97	97	97	97	97	97	97	97	97
Heavy Vehicles, %	2	2	2	2	2	2	2	2	2	2	2	2
Mvmt Flow	572	155	10	0	113	52	10	8	0	62	9	327

Major/Minor	Major1			Major2			Minor1			Minor2		
Conflicting Flow All	165	0	0	165	0	0	1443	1464	155	1421	1422	-
Stage 1	-	-	-	-	-	-	1299	1299	-	113	113	-
Stage 2	-	-	-	-	-	-	144	165	-	1308	1309	-
Critical Hdwy	4.12	-	-	4.12	-	-	7.12	6.52	6.22	7.12	6.52	-
Critical Hdwy Stg 1	-	-	-	-	-	-	6.12	5.52	-	6.12	5.52	-
Critical Hdwy Stg 2	-	-	-	-	-	-	6.12	5.52	-	6.12	5.52	-
Follow-up Hdwy	2.218	-	-	2.218	-	-	3.518	4.018	3.318	3.518	4.018	-
Pot Cap-1 Maneuver	1413	-	-	1413	-	-	110	128	891	114	136	0
Stage 1	-	-	-	-	-	-	199	232	-	892	802	0
Stage 2	-	-	-	-	-	-	859	762	-	196	229	0
Platoon blocked, %	-	-	-	-	-	-	-	-	-	-	-	-
Mov Cap-1 Maneuver	1413	-	-	1413	-	-	69	76	891	72	81	-
Mov Cap-2 Maneuver	-	-	-	-	-	-	69	76	-	72	81	-
Stage 1	-	-	-	-	-	-	118	138	-	531	802	-
Stage 2	-	-	-	-	-	-	849	762	-	110	136	-

Approach	EB			WB			NB			SB		
HCM Control Delay, s	7.2			0			71.5			195.7		
HCM LOS	F			F			F			F		

Minor Lane/Major Mvmt	NBLn1	EBL	EBT	EBR	WBL	WBT	WBR	SBLn1	SBLn2
Capacity (veh/h)	72	1413	-	-	1413	-	-	73	-
HCM Lane V/C Ratio	0.258	0.405	-	-	-	-	-	0.974	-
HCM Control Delay (s)	71.5	9.3	-	-	0	-	-	195.7	0
HCM Lane LOS	F	A	-	-	A	-	-	F	A
HCM 95th %tile Q(veh)	0.9	2	-	-	0	-	-	5	-



# **INTERIM YEAR WITH-PROJECT CONDITIONS**

Interim Year With-Project - AM Peak Hour  
 1: Marriott Way/I-5 SB Ramps & Pico Canyon Road/Lyons Avenue

Synchro 10 Report  
 Lanes, Volumes, Timings

Lane Group	EBL	EBT	EBR	WBL	WBT	WBR	NBL	NBT	NBR	SBL	SBT	SBR
Lane Configurations												
Traffic Volume (vph)	0	1490	40	50	890	420	0	0	40	315	70	380
Future Volume (vph)	0	1490	40	50	890	420	0	0	40	315	70	380
Ideal Flow (vphpl)	1900	1900	1900	1900	1900	1900	1900	1900	1900	1900	1900	1900
Storage Length (ft)	0		0	100		0	0		0	0		200
Storage Lanes	0		0	1		1	0		1	1		1
Taper Length (ft)	25			25			25			25		
Satd. Flow (prot)	0	5065	0	1770	3539	1583	0	0	1611	1681	1715	1583
Flt Permitted				0.123						0.950	0.969	
Satd. Flow (perm)	0	5065	0	229	3539	1583	0	0	1611	1681	1715	1583
Right Turn on Red			Yes			Yes			Yes			Yes
Satd. Flow (RTOR)		5				483			165			195
Link Speed (mph)		40			40			30			30	
Link Distance (ft)		694			822			283			346	
Travel Time (s)		11.8			14.0			6.4			7.9	
Peak Hour Factor	0.87	0.87	0.87	0.87	0.87	0.87	0.87	0.87	0.87	0.87	0.87	0.87
Shared Lane Traffic (%)										39%		
Lane Group Flow (vph)	0	1759	0	57	1023	483	0	0	46	221	221	437
Turn Type		NA		Perm	NA	Perm			Perm	Split	NA	Perm
Protected Phases		4			8					6	6	
Permitted Phases				8		8			2			6
Total Split (s)		37.0		37.0	37.0	37.0			10.5	37.5	37.5	37.5
Total Lost Time (s)		4.5		4.5	4.5	4.5			4.5	4.5	4.5	4.5
Act Effct Green (s)		32.5		32.5	32.5	32.5			6.0	33.0	33.0	33.0
Actuated g/C Ratio		0.38		0.38	0.38	0.38			0.07	0.39	0.39	0.39
v/c Ratio		0.91		0.66	0.76	0.53			0.17	0.34	0.33	0.60
Control Delay		33.1		60.6	27.2	4.3			1.4	20.2	20.0	14.9
Queue Delay		0.0		0.0	0.0	0.0			0.0	0.0	0.0	0.0
Total Delay		33.1		60.6	27.2	4.3			1.4	20.2	20.0	14.9
LOS		C		E	C	A			A	C	C	B
Approach Delay		33.1			21.3			1.4			17.5	
Approach LOS		C			C			A			B	

Intersection Summary

Area Type:	Other
Cycle Length:	85
Actuated Cycle Length:	85
Control Type:	Actuated-Uncoordinated
Maximum v/c Ratio:	0.91
Intersection Signal Delay:	25.2
Intersection LOS:	C
Intersection Capacity Utilization:	55.7%
ICU Level of Service:	B
Analysis Period (min):	15

Splits and Phases: 1: Marriott Way/I-5 SB Ramps & Pico Canyon Road/Lyons Avenue

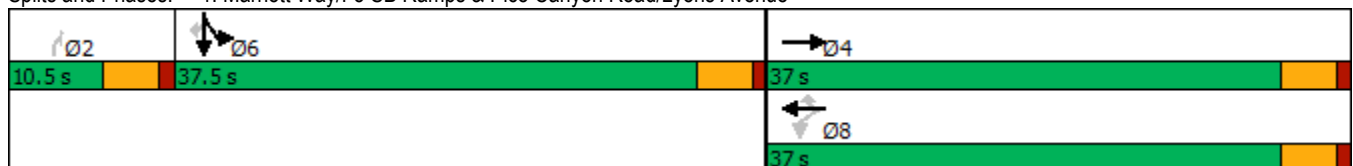

Interim Year With-Project - AM Peak Hour  
 3: I-5 NB Ramps & Lyons Avenue

Synchro 10 Report  
 Lanes, Volumes, Timings

Lane Group	EBL	EBT	EBR	WBL	WBT	WBR	NBL	NBT	NBR	SBL	SBT	SBR
Lane Configurations												
Traffic Volume (vph)	270	1120	0	0	840	600	130	10	150	0	0	0
Future Volume (vph)	270	1120	0	0	840	600	130	10	150	0	0	0
Ideal Flow (vphpl)	1900	1900	1900	1900	1900	1900	1900	1900	1900	1900	1900	1900
Storage Length (ft)	300		0	0		0	0		0	0		0
Storage Lanes	1		0	0		0	1		1	0		0
Taper Length (ft)	25			25			25			25		
Satd. Flow (prot)	1770	3539	0	0	4765	0	1681	1697	1583	0	0	0
Flt Permitted	0.950						0.950	0.959				
Satd. Flow (perm)	1770	3539	0	0	4765	0	1681	1697	1583	0	0	0
Right Turn on Red			Yes			Yes			Yes			Yes
Satd. Flow (RTOR)					226				82			
Link Speed (mph)		40			40			30			30	
Link Distance (ft)		603			1902			756			732	
Travel Time (s)		10.3			32.4			17.2			16.6	
Peak Hour Factor	0.86	0.86	0.86	0.86	0.86	0.86	0.86	0.86	0.86	0.86	0.86	0.86
Shared Lane Traffic (%)							46%					
Lane Group Flow (vph)	314	1302	0	0	1675	0	82	81	174	0	0	0
Turn Type	Prot	NA			NA		Perm	NA	Perm			
Protected Phases	7	4			8			2				
Permitted Phases							2		2			
Total Split (s)	13.0	40.5			27.5		39.5	39.5	39.5			
Total Lost Time (s)	4.5	4.5			4.5		4.5	4.5	4.5			
Act Effct Green (s)	8.5	36.0			23.0		35.0	35.0	35.0			
Actuated g/C Ratio	0.11	0.45			0.29		0.44	0.44	0.44			
v/c Ratio	1.67	0.82			1.12dr		0.11	0.11	0.24			
Control Delay	351.2	24.5			79.0		13.9	13.9	8.5			
Queue Delay	0.0	0.0			0.0		0.0	0.0	0.0			
Total Delay	351.2	24.5			79.0		13.9	13.9	8.5			
LOS	F	C			E		B	B	A			
Approach Delay		88.0			79.0			11.1				
Approach LOS		F			E			B				

Intersection Summary

Area Type:	Other
Cycle Length:	80
Actuated Cycle Length:	80
Control Type:	Actuated-Uncoordinated
Maximum v/c Ratio:	1.67
Intersection Signal Delay:	76.7
Intersection LOS:	E
Intersection Capacity Utilization:	60.1%
ICU Level of Service:	B
Analysis Period (min):	15
dr Defacto Right Lane. Recode with 1 though lane as a right lane.	

Splits and Phases: 3: I-5 NB Ramps & Lyons Avenue

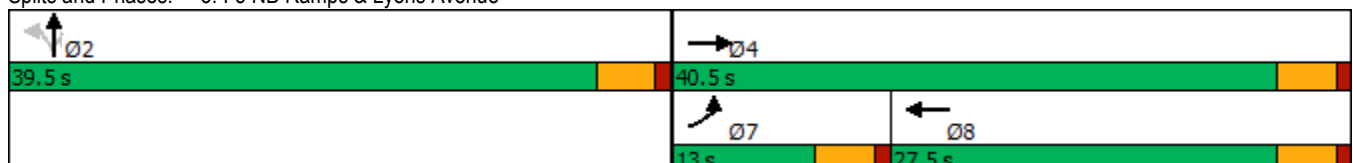

Lane Group	EBL	EBT	EBR	WBL	WBT	WBR	NBL	NBT	NBR	SBL	SBT	SBR
Lane Configurations												
Traffic Volume (vph)	100	810	120	290	800	160	220	250	180	130	430	310
Future Volume (vph)	100	810	120	290	800	160	220	250	180	130	430	310
Ideal Flow (vphpl)	1900	1900	1900	1900	1900	1900	1900	1900	1900	1900	1900	1900
Storage Length (ft)	130		0	200		0	225		270	200		225
Storage Lanes	2		0	1		0	1		1	1		1
Taper Length (ft)	25			25			25			25		
Satd. Flow (prot)	3433	4989	0	1770	4958	0	1770	3539	1583	1770	3539	1583
Flt Permitted	0.950			0.950			0.950			0.950		
Satd. Flow (perm)	3433	4989	0	1770	4958	0	1770	3539	1583	1770	3539	1583
Right Turn on Red			Yes			Yes			Yes			Yes
Satd. Flow (RTOR)		21			34				220			112
Link Speed (mph)		40			40			35			45	
Link Distance (ft)		1902			870			869			1018	
Travel Time (s)		32.4			14.8			16.9			15.4	
Peak Hour Factor	0.82	0.82	0.82	0.82	0.82	0.82	0.82	0.82	0.82	0.82	0.82	0.82
Shared Lane Traffic (%)												
Lane Group Flow (vph)	122	1134	0	354	1171	0	268	305	220	159	524	378
Turn Type	Prot	NA		Prot	NA		Prot	NA	Perm	Prot	NA	pm+ov
Protected Phases	1	6		5	2		7	4		3	8	1
Permitted Phases									4			8
Total Split (s)	20.0	41.0		28.0	49.0		25.0	38.0	38.0	25.0	38.0	20.0
Total Lost Time (s)	4.0	4.0		4.0	4.0		4.0	4.0	4.0	4.0	4.0	4.0
Act Effct Green (s)	10.7	44.1		24.0	57.3		21.0	30.9	30.9	17.0	26.9	41.7
Actuated g/C Ratio	0.08	0.33		0.18	0.43		0.16	0.23	0.23	0.13	0.20	0.32
v/c Ratio	0.44	0.68		1.10	0.54		0.95	0.37	0.41	0.70	0.73	0.66
Control Delay	62.2	40.2		130.0	28.8		98.0	43.8	7.4	70.8	55.0	31.7
Queue Delay	0.0	0.0		0.0	0.0		0.0	0.0	0.0	0.0	0.0	0.0
Total Delay	62.2	40.2		130.0	28.8		98.0	43.8	7.4	70.8	55.0	31.7
LOS	E	D		F	C		F	D	A	E	D	C
Approach Delay		42.3			52.3			52.0			49.1	
Approach LOS		D			D			D			D	

Intersection Summary

Area Type:	Other
Cycle Length:	132
Actuated Cycle Length:	132
Offset:	2.5 (2%), Referenced to phase 2:WBT and 6:EBT, Start of Yellow
Control Type:	Actuated-Coordinated
Maximum v/c Ratio:	1.10
Intersection Signal Delay:	48.8
Intersection LOS:	D
Intersection Capacity Utilization:	71.8%
ICU Level of Service:	C
Analysis Period (min):	15

Splits and Phases: 4: Wiley Canyon Road & Lyons Avenue

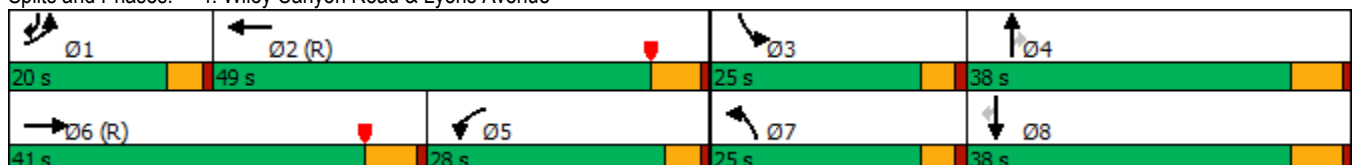

Interim Year With-Project - AM Peak Hour  
 5: Wiley Canyon Road & La Glorita Circle/Evans Avenue

Synchro 10 Report  
 Lanes, Volumes, Timings

Lane Group	EBL	EBT	EBR	WBL	WBT	WBR	NBL	NBT	NBR	SBL	SBT	SBR
Lane Configurations												
Traffic Volume (vph)	90	10	70	50	20	60	10	560	20	20	900	100
Future Volume (vph)	90	10	70	50	20	60	10	560	20	20	900	100
Ideal Flow (vphpl)	1900	1900	1900	1900	1900	1900	1900	1900	1900	1900	1900	1900
Storage Length (ft)	90		0	0		0	110		0	110		0
Storage Lanes	1		0	0		0	1		0	1		1
Taper Length (ft)	25			25			25			25		
Satd. Flow (prot)	1770	1619	0	0	1714	0	1770	1853	0	1770	1863	1583
Flt Permitted	0.706				0.829		0.143			0.274		
Satd. Flow (perm)	1315	1619	0	0	1448	0	266	1853	0	510	1863	1583
Right Turn on Red			Yes			Yes			Yes			Yes
Satd. Flow (RTOR)		24			78			4				126
Link Speed (mph)		30			30			35			35	
Link Distance (ft)		529			450			1329			869	
Travel Time (s)		12.0			10.2			25.9			16.9	
Peak Hour Factor	0.77	0.77	0.77	0.77	0.77	0.77	0.77	0.77	0.77	0.77	0.77	0.77
Shared Lane Traffic (%)												
Lane Group Flow (vph)	117	104	0	0	169	0	13	753	0	26	1169	130
Turn Type	Perm	NA		Perm	NA		Perm	NA		Perm	NA	Perm
Protected Phases		4			8			2			6	
Permitted Phases	4			8			2			6		6
Total Split (s)	30.5	30.5		30.5	30.5		29.5	29.5		29.5	29.5	29.5
Total Lost Time (s)	4.5	4.5			4.5		4.5	4.5		4.5	4.5	4.5
Act Effct Green (s)	9.2	9.2			9.2		28.9	28.9		28.9	28.9	28.9
Actuated g/C Ratio	0.21	0.21			0.21		0.65	0.65		0.65	0.65	0.65
v/c Ratio	0.43	0.29			0.47		0.08	0.62		0.08	0.96	0.12
Control Delay	19.6	13.5			13.1		6.5	10.6		5.8	34.2	1.8
Queue Delay	0.0	0.0			0.0		0.0	0.0		0.0	0.0	0.0
Total Delay	19.6	13.5			13.1		6.5	10.6		5.8	34.2	1.8
LOS	B	B			B		A	B		A	C	A
Approach Delay		16.7			13.1			10.5			30.4	
Approach LOS		B			B			B			C	

Intersection Summary

Area Type:	Other
Cycle Length:	60
Actuated Cycle Length:	44.2
Control Type:	Actuated-Uncoordinated
Maximum v/c Ratio:	0.96
Intersection Signal Delay:	21.9
Intersection LOS:	C
Intersection Capacity Utilization:	69.0%
ICU Level of Service:	C
Analysis Period (min):	15

Splits and Phases: 5: Wiley Canyon Road & La Glorita Circle/Evans Avenue

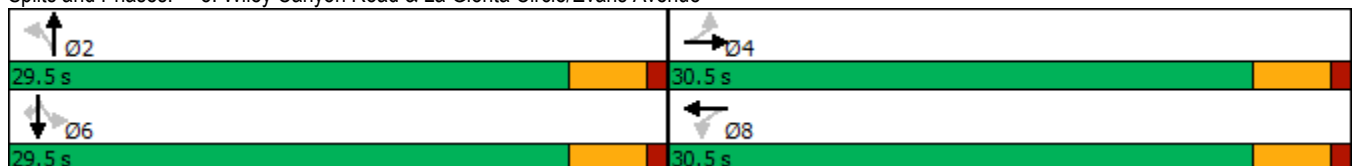

Intersection

Int Delay, s/veh	16.3											
Movement	EBL	EBT	EBR	WBL	WBT	WBR	NBL	NBT	NBR	SBL	SBT	SBR
Lane Configurations		↕			↕		↕	↕		↕	↕	↕
Traffic Vol, veh/h	60	0	41	1	0	8	18	520	4	6	840	44
Future Vol, veh/h	60	0	41	1	0	8	18	520	4	6	840	44
Conflicting Peds, #/hr	0	0	0	0	0	0	0	0	0	0	0	0
Sign Control	Stop	Stop	Stop	Stop	Stop	Stop	Free	Free	Free	Free	Free	Free
RT Channelized	-	-	None	-	-	None	-	-	None	-	-	None
Storage Length	-	-	-	-	-	-	150	-	-	215	-	260
Veh in Median Storage, #	-	0	-	-	0	-	-	0	-	-	0	-
Grade, %	-	0	-	-	0	-	-	0	-	-	0	-
Peak Hour Factor	83	83	83	83	83	83	83	83	83	83	83	83
Heavy Vehicles, %	2	2	2	2	2	2	2	2	2	2	2	2
Mvmt Flow	72	0	49	1	0	10	22	627	5	7	1012	53

Major/Minor	Minor2		Minor1		Major1		Major2					
Conflicting Flow All	1705	1702	1012	1751	1753	630	1065	0	0	632	0	0
Stage 1	1026	1026	-	674	674	-	-	-	-	-	-	-
Stage 2	679	676	-	1077	1079	-	-	-	-	-	-	-
Critical Hdwy	7.12	6.52	6.22	7.12	6.52	6.22	4.12	-	-	4.12	-	-
Critical Hdwy Stg 1	6.12	5.52	-	6.12	5.52	-	-	-	-	-	-	-
Critical Hdwy Stg 2	6.12	5.52	-	6.12	5.52	-	-	-	-	-	-	-
Follow-up Hdwy	3.518	4.018	3.318	3.518	4.018	3.318	2.218	-	-	2.218	-	-
Pot Cap-1 Maneuver	~ 72	92	290	67	85	482	654	-	-	951	-	-
Stage 1	283	312	-	444	454	-	-	-	-	-	-	-
Stage 2	441	453	-	265	295	-	-	-	-	-	-	-
Platoon blocked, %								-	-	-	-	-
Mov Cap-1 Maneuver	~ 68	88	290	54	82	482	654	-	-	951	-	-
Mov Cap-2 Maneuver	~ 68	88	-	54	82	-	-	-	-	-	-	-
Stage 1	273	310	-	429	439	-	-	-	-	-	-	-
Stage 2	418	438	-	218	293	-	-	-	-	-	-	-

Approach	EB		WB		NB		SB	
HCM Control Delay, s	243.8		19.7		0.4		0.1	
HCM LOS	F		C					

Minor Lane/Major Mvmt	NBL	NBT	NBR	EBLn1	WBLn1	SBL	SBT	SBR
Capacity (veh/h)	654	-	-	99	256	951	-	-
HCM Lane V/C Ratio	0.033	-	-	1.229	0.042	0.008	-	-
HCM Control Delay (s)	10.7	-	-	243.8	19.7	8.8	-	-
HCM Lane LOS	B	-	-	F	C	A	-	-
HCM 95th %tile Q(veh)	0.1	-	-	8.3	0.1	0	-	-

Notes

~: Volume exceeds capacity    \$: Delay exceeds 300s    +: Computation Not Defined    \*: All major volume in platoon

Intersection												
Int Delay, s/veh	33											
Movement	EBL	EBT	EBR	WBL	WBT	WBR	NBL	NBT	NBR	SBL	SBT	SBR
Lane Configurations		↕		↕	↕						↕	↕
Traffic Vol, veh/h	0	320	90	520	220	0	0	0	0	70	0	230
Future Vol, veh/h	0	320	90	520	220	0	0	0	0	70	0	230
Conflicting Peds, #/hr	0	0	0	0	0	0	0	0	0	0	0	0
Sign Control	Free	Free	Free	Free	Free	Free	Free	Free	Free	Stop	Stop	Stop
RT Channelized	-	-	None	-	-	None	-	-	None	-	-	None
Storage Length	-	-	-	150	-	-	-	-	-	-	-	0
Veh in Median Storage, #	-	0	-	-	0	-	-	0	-	-	0	-
Grade, %	-	0	-	-	0	-	-	0	-	-	0	-
Peak Hour Factor	91	91	91	91	91	91	91	91	91	91	91	91
Heavy Vehicles, %	2	2	2	2	2	2	2	2	2	2	2	2
Mvmt Flow	0	352	99	571	242	0	0	0	0	77	0	253

Major/Minor	Major1			Major2			Minor2		
Conflicting Flow All	-	0	0	451	0	0	1786	1835	242
Stage 1	-	-	-	-	-	-	1384	1384	-
Stage 2	-	-	-	-	-	-	402	451	-
Critical Hdwy	-	-	-	4.12	-	-	6.42	6.52	6.22
Critical Hdwy Stg 1	-	-	-	-	-	-	5.42	5.52	-
Critical Hdwy Stg 2	-	-	-	-	-	-	5.42	5.52	-
Follow-up Hdwy	-	-	-	2.218	-	-	3.518	4.018	3.318
Pot Cap-1 Maneuver	0	-	-	1109	-	0	90	76	797
Stage 1	0	-	-	-	-	0	232	211	-
Stage 2	0	-	-	-	-	0	676	571	-
Platoon blocked, %	-	-	-	-	-	-	-	-	-
Mov Cap-1 Maneuver	-	-	-	1109	-	-	~ 44	0	797
Mov Cap-2 Maneuver	-	-	-	-	-	-	~ 44	0	-
Stage 1	-	-	-	-	-	-	232	0	-
Stage 2	-	-	-	-	-	-	328	0	-

Approach	EB	WB	SB
HCM Control Delay, s	0	8.2	139.5
HCM LOS			F

Minor Lane/Major Mvmt	EBT	EBR	WBL	WBT	SBLn1	SBLn2
Capacity (veh/h)	-	-	1109	-	44	797
HCM Lane V/C Ratio	-	-	0.515	-	1.748	0.317
HCM Control Delay (s)	-	-	11.6	-	559.7	11.6
HCM Lane LOS	-	-	B	-	F	B
HCM 95th %tile Q(veh)	-	-	3	-	7.8	1.4

Notes  
 ~: Volume exceeds capacity    \$: Delay exceeds 300s    +: Computation Not Defined    \*: All major volume in platoon

Intersection												
Int Delay, s/veh	4.3											
Movement	EBL	EBT	EBR	WBL	WBT	WBR	NBL	NBT	NBR	SBL	SBT	SBR
Lane Configurations	↘	↑			↘			↘	↗			
Traffic Vol, veh/h	140	240	0	0	690	200	50	10	80	0	0	0
Future Vol, veh/h	140	240	0	0	690	200	50	10	80	0	0	0
Conflicting Peds, #/hr	0	0	0	0	0	0	0	0	0	0	0	0
Sign Control	Free	Free	Free	Free	Free	Free	Stop	Stop	Stop	Free	Free	Free
RT Channelized	-	-	None	-	-	None	-	-	None	-	-	None
Storage Length	170	-	-	-	-	-	-	-	0	-	-	-
Veh in Median Storage, #	-	0	-	-	0	-	-	0	-	-	0	-
Grade, %	-	0	-	-	0	-	-	0	-	-	0	-
Peak Hour Factor	94	94	94	94	94	94	94	94	94	94	94	94
Heavy Vehicles, %	2	2	2	2	2	2	2	2	2	2	2	2
Mvmt Flow	149	255	0	0	734	213	53	11	85	0	0	0

Major/Minor	Major1	Major2	Minor1
Conflicting Flow All	947	0	0
Stage 1	-	-	553
Stage 2	-	-	841
Critical Hdwy	4.12	-	6.42
Critical Hdwy Stg 1	-	-	5.42
Critical Hdwy Stg 2	-	-	5.42
Follow-up Hdwy	2.218	-	3.518
Pot Cap-1 Maneuver	725	0	156
Stage 1	-	0	576
Stage 2	-	0	423
Platoon blocked, %	-	-	-
Mov Cap-1 Maneuver	725	-	124
Mov Cap-2 Maneuver	-	-	124
Stage 1	-	-	457
Stage 2	-	-	423

Approach	EB	WB	NB
HCM Control Delay, s	4.1	0	32.1
HCM LOS			D

Minor Lane/Major Mvmt	NBLn1	NBLn2	EBL	EBT	WBT	WBR
Capacity (veh/h)	124	784	725	-	-	-
HCM Lane V/C Ratio	0.515	0.109	0.205	-	-	-
HCM Control Delay (s)	61.4	10.2	11.2	-	-	-
HCM Lane LOS	F	B	B	-	-	-
HCM 95th %tile Q(veh)	2.4	0.4	0.8	-	-	-



# DELAY (AVERAGE)

Average control delay per vehicle, or average pedestrian delay (seconds)

## Site: 9. Wiley Canyon Rd and Calgrove Blvd AM Peak Hour

Interim Year with Project  
Roundabout

### All Movement Classes

	South	East	North	West	Intersection
Delay (Average)	10.7	7.4	12.7	11.8	11.6
LOS	B	A	B	B	B

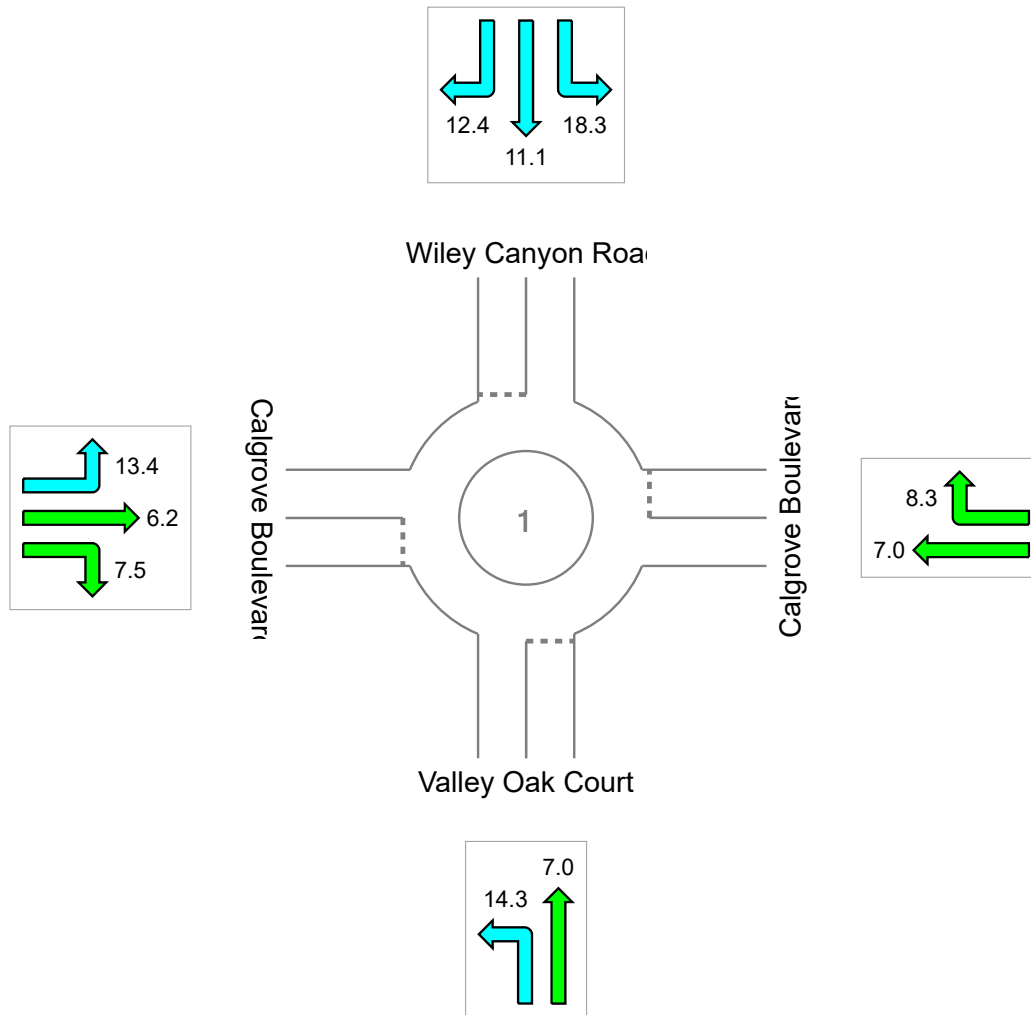

Colour code based on Level of Service



Level of Service Method: Delay & v/c (HCM 2010)

LOS F will result if v/c > 1 irrespective of movement delay value (does not apply for approaches and intersection).

Roundabout Level of Service Method: Same as Signalised Intersections

SIDRA Standard Delay Model is used. Control Delay includes Geometric Delay.

# INPUT VOLUMES

Vehicles and pedestrians per 60 minutes

 Site: 9. Wiley Canyon Rd and Calgrove Blvd AM Peak Hour

Interim Year with Project

Volume Display Method: Total and %

Volumes are shown for Movement Class(es): All Classes and Heavy Vehicles

Total Intersection Volumes (veh)

All Movement Classes: 1522

Light Vehicles (LV): 1476

Heavy Vehicles (HV): 46

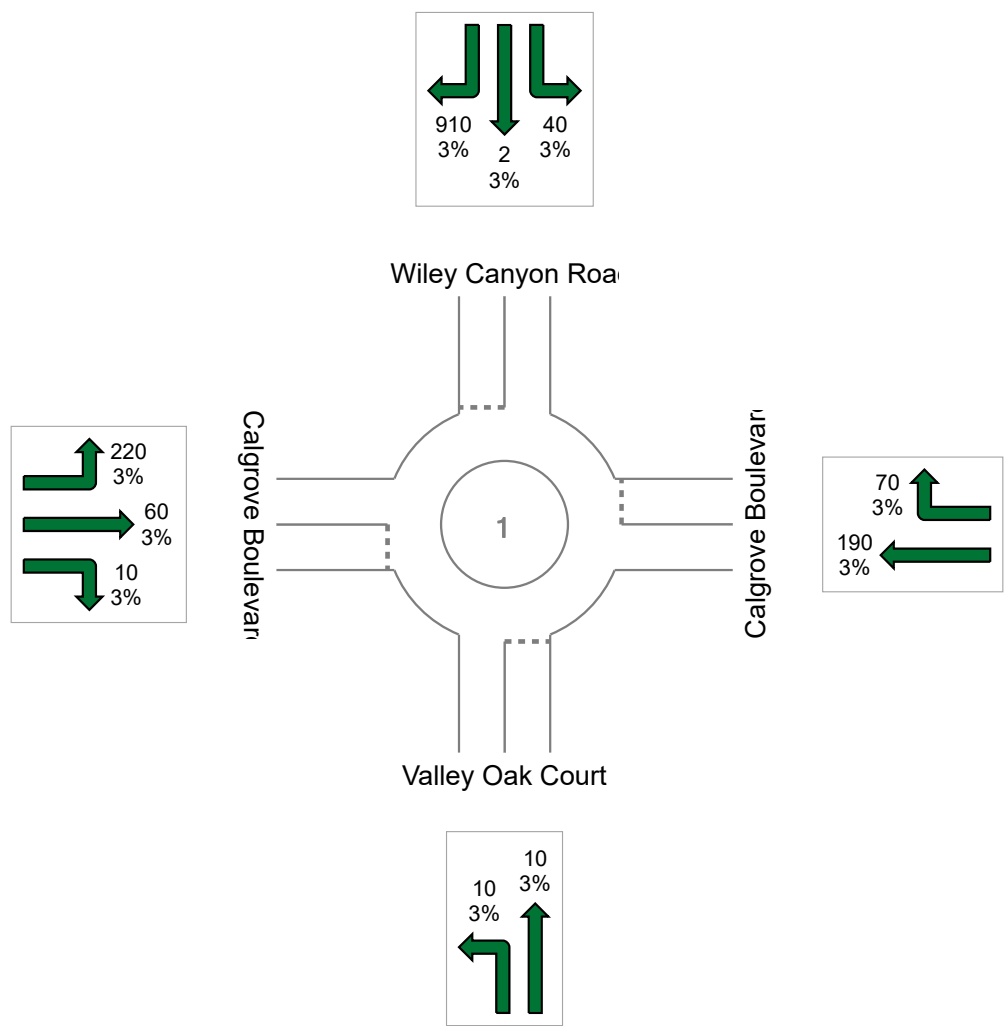

# QUEUE DISTANCE

Largest 95% Back of Queue for any lane used by movement (feet)

## Site: 9. Wiley Canyon Rd and Calgrove Blvd AM Peak Hour

Interim Year with Project  
Roundabout

### All Movement Classes

	South	East	North	West	Intersection
Queue Distance	2	24	357	27	357

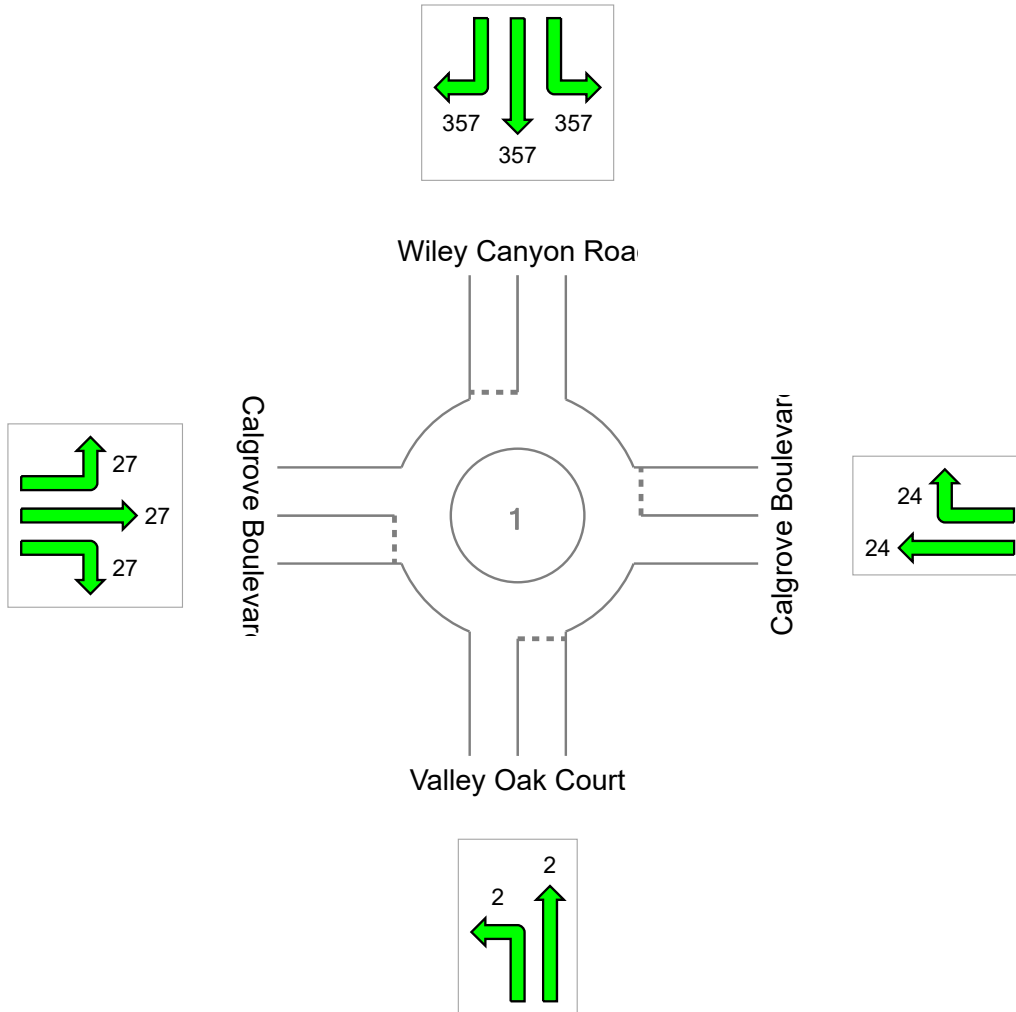

Colour code based on Queue Storage Ratio

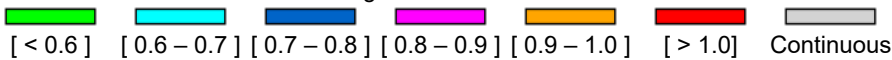

# DEGREE OF SATURATION

Ratio of Demand Volume to Capacity (v/c ratio)

## Site: 9. Wiley Canyon Rd and Calgrove Blvd AM Peak Hour

Interim Year with Project  
Roundabout

### All Movement Classes

	South	East	North	West	Intersection
Degree of Saturation	0.02	0.27	0.89	0.24	0.89

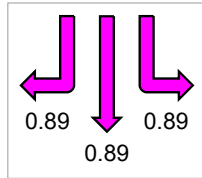

Wiley Canyon Road

Calgrove Boulevard

Calgrove Boulevard

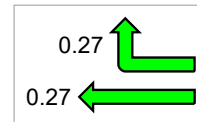
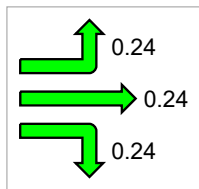

Valley Oak Court

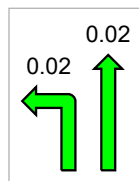

Colour code based on Degree of Saturation

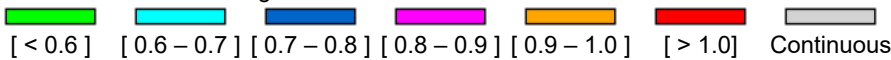

Lane Group	EBL	EBT	EBR	WBL	WBT	WBR	NBL	NBT	NBR	SBL	SBT	SBR
Lane Configurations												
Traffic Volume (vph)	220	60	10	0	190	70	10	10	0	40	2	910
Future Volume (vph)	220	60	10	0	190	70	10	10	0	40	2	910
Ideal Flow (vphpl)	1900	1900	1900	1900	1900	1900	1900	1900	1900	1900	1900	1900
Storage Length (ft)	165		150	290		290	0		0	100		100
Storage Lanes	1		1	1		1	0		0	0		1
Taper Length (ft)	25			25			25			25		
Satd. Flow (prot)	1770	1863	1583	1863	1863	1583	0	1818	0	0	1777	1583
Flt Permitted	0.950							0.925			0.805	
Satd. Flow (perm)	1770	1863	1583	1863	1863	1583	0	1723	0	0	1500	1583
Right Turn on Red			Yes			Yes			Yes			Yes
Satd. Flow (RTOR)			73			127						557
Link Speed (mph)		45			45			30			35	
Link Distance (ft)		786			1192			412			1483	
Travel Time (s)		11.9			18.1			9.4			28.9	
Peak Hour Factor	0.89	0.89	0.89	0.89	0.89	0.89	0.89	0.89	0.89	0.89	0.89	0.89
Shared Lane Traffic (%)												
Lane Group Flow (vph)	247	67	11	0	213	79	0	22	0	0	47	1022
Turn Type	Prot	NA	Perm	Prot	NA	Perm	Perm	NA		Perm	NA	Perm
Protected Phases	7	4		3	8			2			6	
Permitted Phases			4			8	2			6		6
Total Split (s)	18.6	31.6	31.6	9.5	22.5	22.5	48.9	48.9		48.9	48.9	48.9
Total Lost Time (s)	4.5	4.5	4.5	4.5	4.5	4.5		4.5			4.5	4.5
Act Effct Green (s)	13.8	32.6	32.6		14.2	14.2		41.5			41.5	41.5
Actuated g/C Ratio	0.17	0.39	0.39		0.17	0.17		0.50			0.50	0.50
v/c Ratio	0.84	0.09	0.02		0.67	0.21		0.03			0.06	0.96
Control Delay	62.1	17.2	0.0		44.2	3.1		11.6			11.9	29.9
Queue Delay	0.0	0.0	0.0		0.0	0.0		0.0			0.0	0.0
Total Delay	62.1	17.2	0.0		44.2	3.1		11.6			11.9	29.9
LOS	E	B	A		D	A		B			B	C
Approach Delay		50.8			33.0			11.6			29.1	
Approach LOS		D			C			B			C	

Intersection Summary

Area Type:	Other
Cycle Length:	90
Actuated Cycle Length:	83.3
Control Type:	Actuated-Uncoordinated
Maximum v/c Ratio:	0.96
Intersection Signal Delay:	33.7
Intersection LOS:	C
Intersection Capacity Utilization:	81.8%
ICU Level of Service:	D
Analysis Period (min):	15

Splits and Phases: 9: Calgrove Boulevard & Wiley Canyon Road

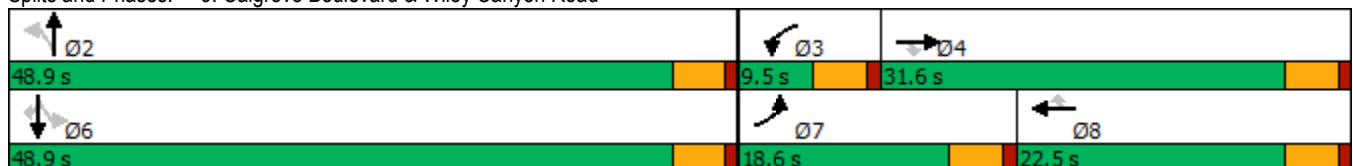

# DELAY (AVERAGE)

Average control delay per vehicle, or average pedestrian delay (seconds)

## Site: 10. Wiley Canyon Rd & Project Access AM Peak Hour

Interim Year with Project Roundabout

### All Movement Classes

	South	North	West	Intersection
Delay (Average)	7.6	7.1	18.3	8.2
LOS	A	A	B	A

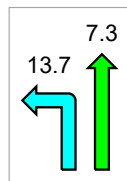
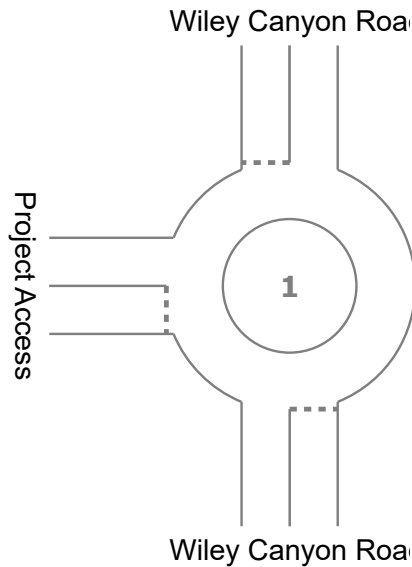
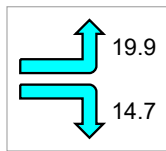
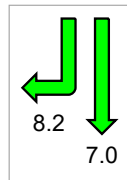

Colour code based on Level of Service

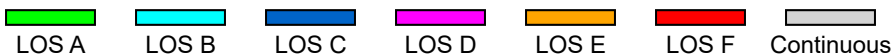

Level of Service Method: Delay & v/c (HCM 2010)

LOS F will result if v/c > 1 irrespective of movement delay value (does not apply for approaches and intersection).

Roundabout Level of Service Method: Same as Signalised Intersections

SIDRA Standard Delay Model is used. Control Delay includes Geometric Delay.

# INPUT VOLUMES

Vehicles and pedestrians per 60 minutes

 Site: 10. Wiley Canyon Rd & Project Access AM Peak Hour

Interim Year with Project

Volume Display Method: Total and %

Volumes are shown for Movement Class(es): All Classes and Heavy Vehicles

Total Intersection Volumes (veh)

All Movement Classes: 1628

Light Vehicles (LV): 1579

Heavy Vehicles (HV): 49

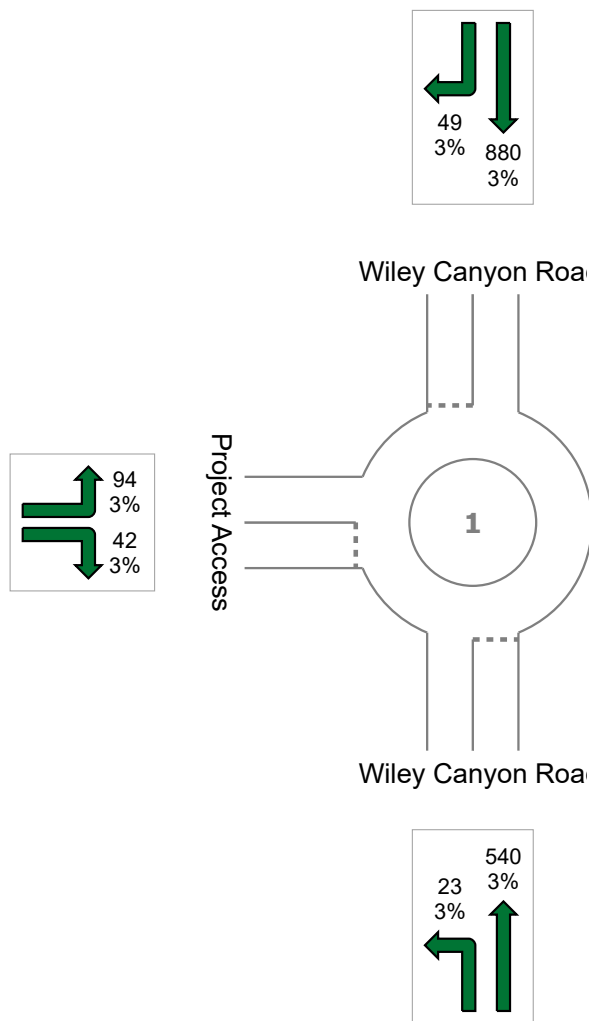

# QUEUE DISTANCE

Largest 95% Back of Queue for any lane used by movement (feet)

## Site: 10. Wiley Canyon Rd & Project Access AM Peak Hour

Interim Year with Project  
Roundabout

### All Movement Classes

	South	North	West	Intersection
Queue Distance	75	133	33	133

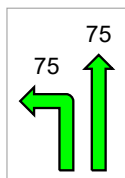
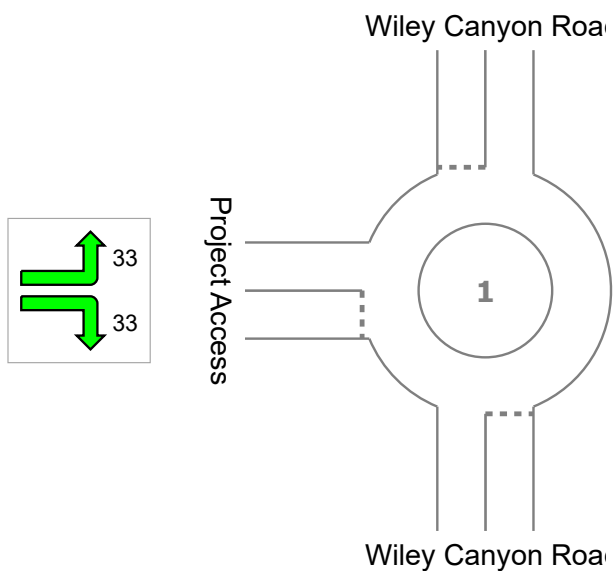
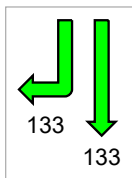

Colour code based on Queue Storage Ratio

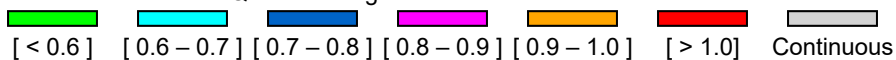



# DEGREE OF SATURATION

Ratio of Demand Volume to Capacity (v/c ratio)

## Site: 10. Wiley Canyon Rd & Project Access AM Peak Hour

Interim Year with Project  
Roundabout

### All Movement Classes

	South	North	West	Intersection
Degree of Saturation	0.51	0.69	0.26	0.69

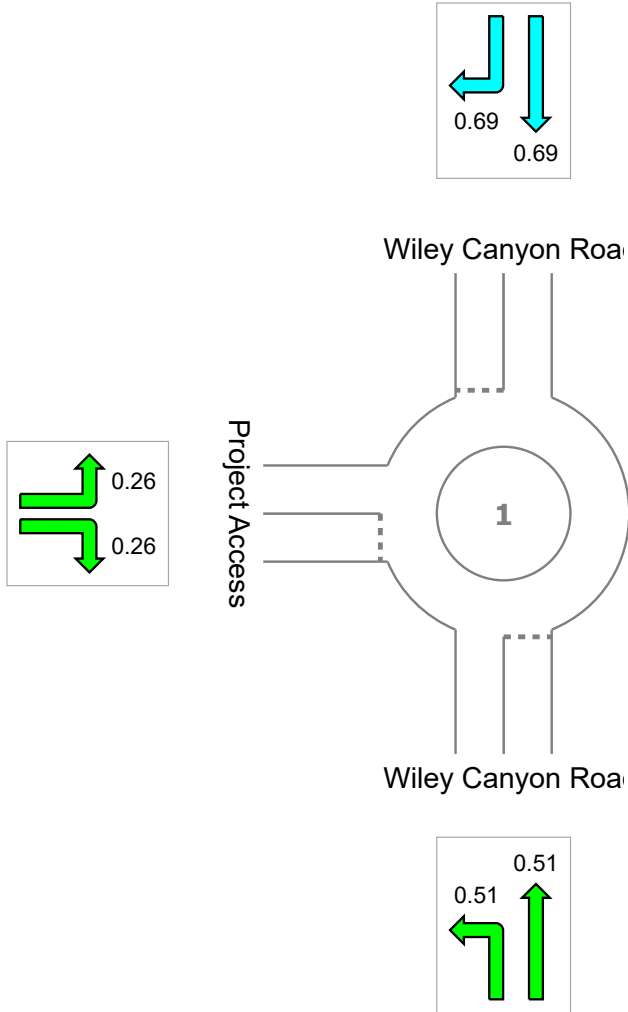

Colour code based on Degree of Saturation

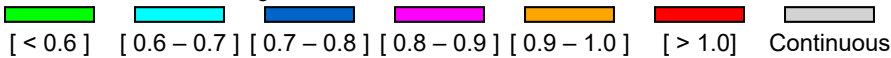

Interim Year With-Project - PM Peak Hour  
 1: Marriott Way/I-5 SB Ramps & Pico Canyon Road/Lyons Avenue

Synchro 10 Report  
 Lanes, Volumes, Timings

Lane Group	EBL	EBT	EBR	WBL	WBT	WBR	NBL	NBT	NBR	SBL	SBT	SBR
Lane Configurations												
Traffic Volume (vph)	0	980	50	60	1350	270	0	0	20	520	100	120
Future Volume (vph)	0	980	50	60	1350	270	0	0	20	520	100	120
Ideal Flow (vphpl)	1900	1900	1900	1900	1900	1900	1900	1900	1900	1900	1900	1900
Storage Length (ft)	0		0	100		0	0		0	0		200
Storage Lanes	0		0	1		1	0		1	1		1
Taper Length (ft)	25			25			25			25		
Satd. Flow (prot)	0	5050	0	1770	3539	1583	0	0	1611	1681	1711	1583
Flt Permitted				0.160						0.950	0.967	
Satd. Flow (perm)	0	5050	0	298	3539	1583	0	0	1611	1681	1711	1583
Right Turn on Red			Yes			Yes			Yes			Yes
Satd. Flow (RTOR)		10				286			93			130
Link Speed (mph)		40			40			30			30	
Link Distance (ft)		694			822			283			346	
Travel Time (s)		11.8			14.0			6.4			7.9	
Peak Hour Factor	0.92	0.92	0.92	0.92	0.92	0.92	0.92	0.92	0.92	0.92	0.92	0.92
Shared Lane Traffic (%)										41%		
Lane Group Flow (vph)	0	1119	0	65	1467	293	0	0	22	333	341	130
Turn Type		NA		Perm	NA	Perm			Perm	Split	NA	Perm
Protected Phases		4			8					6	6	
Permitted Phases				8		8			2			6
Total Split (s)		37.0		37.0	37.0	37.0			10.5	37.5	37.5	37.5
Total Lost Time (s)		4.5		4.5	4.5	4.5			4.5	4.5	4.5	4.5
Act Effct Green (s)		32.5		32.5	32.5	32.5			6.0	33.0	33.0	33.0
Actuated g/C Ratio		0.38		0.38	0.38	0.38			0.07	0.39	0.39	0.39
v/c Ratio		0.58		0.58	1.08	0.38			0.11	0.51	0.51	0.19
Control Delay		22.1		45.0	77.9	4.1			1.1	23.3	23.3	4.1
Queue Delay		0.0		0.0	0.0	0.0			0.0	0.0	0.0	0.0
Total Delay		22.1		45.0	77.9	4.1			1.1	23.3	23.3	4.1
LOS		C		D	E	A			A	C	C	A
Approach Delay		22.1			64.9			1.1			20.2	
Approach LOS		C			E			A			C	

Intersection Summary

Area Type:	Other
Cycle Length:	85
Actuated Cycle Length:	85
Control Type:	Actuated-Uncoordinated
Maximum v/c Ratio:	1.08
Intersection Signal Delay:	42.3
Intersection LOS:	D
Intersection Capacity Utilization:	61.8%
ICU Level of Service:	B
Analysis Period (min):	15

Splits and Phases: 1: Marriott Way/I-5 SB Ramps & Pico Canyon Road/Lyons Avenue

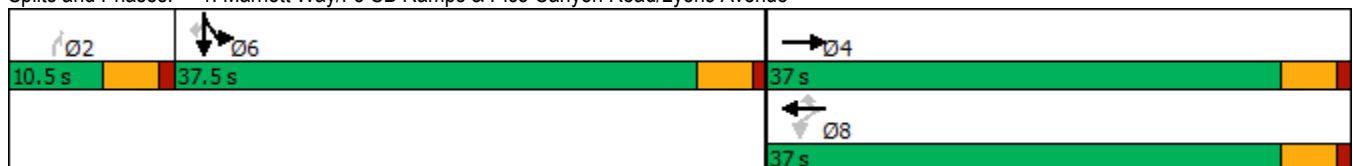

Interim Year With-Project - PM Peak Hour  
 3: I-5 NB Ramps & Lyons Avenue

Synchro 10 Report  
 Lanes, Volumes, Timings

Lane Group	EBL	EBT	EBR	WBL	WBT	WBR	NBL	NBT	NBR	SBL	SBT	SBR
Lane Configurations												
Traffic Volume (vph)	230	1180	0	0	840	700	420	0	420	0	0	0
Future Volume (vph)	230	1180	0	0	840	700	420	0	420	0	0	0
Ideal Flow (vphpl)	1900	1900	1900	1900	1900	1900	1900	1900	1900	1900	1900	1900
Storage Length (ft)	300		0	0		0	0		0	0		0
Storage Lanes	1		0	0		0	1		1	0		0
Taper Length (ft)	25			25			25			25		
Satd. Flow (prot)	1770	3539	0	0	4739	0	1681	1681	1583	0	0	0
Flt Permitted	0.950						0.950	0.950				
Satd. Flow (perm)	1770	3539	0	0	4739	0	1681	1681	1583	0	0	0
Right Turn on Red			Yes			Yes			Yes			Yes
Satd. Flow (RTOR)					264				82			
Link Speed (mph)		40			40			30			30	
Link Distance (ft)		603			1902			756			732	
Travel Time (s)		10.3			32.4			17.2			16.6	
Peak Hour Factor	0.92	0.92	0.92	0.92	0.92	0.92	0.92	0.92	0.92	0.92	0.92	0.92
Shared Lane Traffic (%)							50%					
Lane Group Flow (vph)	250	1283	0	0	1674	0	228	229	457	0	0	0
Turn Type	Prot	NA			NA		Perm	NA	Perm			
Protected Phases	7	4			8			2				
Permitted Phases							2		2			
Total Split (s)	14.0	41.5			27.5		38.5	38.5	38.5			
Total Lost Time (s)	4.5	4.5			4.5		4.5	4.5	4.5			
Act Effct Green (s)	9.5	37.0			23.0		34.0	34.0	34.0			
Actuated g/C Ratio	0.12	0.46			0.29		0.42	0.42	0.42			
v/c Ratio	1.19	0.78			1.17dr		0.32	0.32	0.64			
Control Delay	157.6	22.4			72.8		16.9	16.9	19.4			
Queue Delay	0.0	0.0			0.0		0.0	0.0	0.0			
Total Delay	157.6	22.4			72.8		16.9	16.9	19.4			
LOS	F	C			E		B	B	B			
Approach Delay		44.5			72.8			18.2				
Approach LOS		D			E			B				

Intersection Summary

Area Type:	Other
Cycle Length:	80
Actuated Cycle Length:	80
Control Type:	Actuated-Uncoordinated
Maximum v/c Ratio:	1.19
Intersection Signal Delay:	50.1
Intersection LOS:	D
Intersection Capacity Utilization:	67.6%
ICU Level of Service:	C
Analysis Period (min):	15
dr Defacto Right Lane. Recode with 1 though lane as a right lane.	

Splits and Phases: 3: I-5 NB Ramps & Lyons Avenue

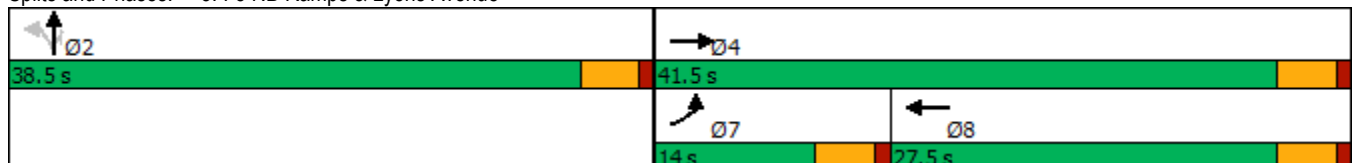

Lane Group	EBL	EBT	EBR	WBL	WBT	WBR	NBL	NBT	NBR	SBL	SBT	SBR
Lane Configurations												
Traffic Volume (vph)	320	1230	120	160	1130	130	200	420	250	440	330	290
Future Volume (vph)	320	1230	120	160	1130	130	200	420	250	440	330	290
Ideal Flow (vphpl)	1900	1900	1900	1900	1900	1900	1900	1900	1900	1900	1900	1900
Storage Length (ft)	130		0	200		0	225		270	200		225
Storage Lanes	2		0	1		0	1		1	1		1
Taper Length (ft)	25			25			25			25		
Satd. Flow (prot)	3433	5019	0	1770	5009	0	1770	3539	1583	1770	3539	1583
Flt Permitted	0.950			0.950			0.950			0.950		
Satd. Flow (perm)	3433	5019	0	1770	5009	0	1770	3539	1583	1770	3539	1583
Right Turn on Red			Yes			Yes			Yes			Yes
Satd. Flow (RTOR)		13			15				258			73
Link Speed (mph)		40			40			35			45	
Link Distance (ft)		1902			870			869			1018	
Travel Time (s)		32.4			14.8			16.9			15.4	
Peak Hour Factor	0.97	0.97	0.97	0.97	0.97	0.97	0.97	0.97	0.97	0.97	0.97	0.97
Shared Lane Traffic (%)												
Lane Group Flow (vph)	330	1392	0	165	1299	0	206	433	258	454	340	299
Turn Type	Prot	NA		Prot	NA		Prot	NA	Perm	Prot	NA	pm+ov
Protected Phases	1	6		5	2		7	4		3	8	1
Permitted Phases									4			8
Total Split (s)	25.0	44.0		25.0	44.0		25.0	38.0	38.0	25.0	38.0	25.0
Total Lost Time (s)	4.0	4.0		4.0	4.0		4.0	4.0	4.0	4.0	4.0	4.0
Act Effct Green (s)	18.7	52.9		18.0	52.2		19.2	24.1	24.1	21.0	25.9	48.6
Actuated g/C Ratio	0.14	0.40		0.14	0.40		0.15	0.18	0.18	0.16	0.20	0.37
v/c Ratio	0.68	0.69		0.69	0.65		0.80	0.67	0.52	1.62	0.49	0.48
Control Delay	60.7	36.0		68.4	35.4		77.2	55.3	8.9	328.3	49.5	25.4
Queue Delay	0.0	0.0		0.0	0.0		0.0	0.0	0.0	0.0	0.0	0.0
Total Delay	60.7	36.0		68.4	35.4		77.2	55.3	8.9	328.3	49.5	25.4
LOS	E	D		E	D		E	E	A	F	D	C
Approach Delay		40.7			39.1			46.9			158.7	
Approach LOS		D			D			D			F	

Intersection Summary

Area Type:	Other
Cycle Length:	132
Actuated Cycle Length:	132
Offset:	2.5 (2%), Referenced to phase 2:WBT and 6:EBT, Start of Yellow
Control Type:	Actuated-Coordinated
Maximum v/c Ratio:	1.62
Intersection Signal Delay:	66.3
Intersection LOS:	E
Intersection Capacity Utilization:	84.6%
ICU Level of Service:	E
Analysis Period (min):	15

Splits and Phases: 4: Wiley Canyon Road & Lyons Avenue

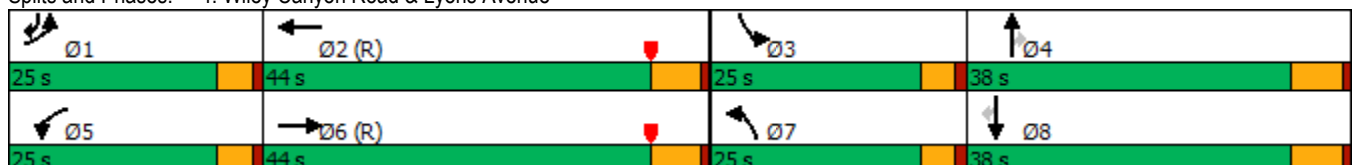

Interim Year With-Project - PM Peak Hour  
 5: Wiley Canyon Road & La Glorita Circle/Evans Avenue

Synchro 10 Report  
 Lanes, Volumes, Timings

Lane Group	EBL	EBT	EBR	WBL	WBT	WBR	NBL	NBT	NBR	SBL	SBT	SBR
Lane Configurations												
Traffic Volume (vph)	50	10	40	50	10	50	10	840	30	30	550	60
Future Volume (vph)	50	10	40	50	10	50	10	840	30	30	550	60
Ideal Flow (vphpl)	1900	1900	1900	1900	1900	1900	1900	1900	1900	1900	1900	1900
Storage Length (ft)	90		0	0		0	110		0	110		0
Storage Lanes	1		0	0		0	1		0	1		1
Taper Length (ft)	25			25			25			25		
Satd. Flow (prot)	1770	1637	0	0	1709	0	1770	1853	0	1770	1863	1583
Flt Permitted	0.849				0.829		0.412			0.210		
Satd. Flow (perm)	1581	1637	0	0	1448	0	767	1853	0	391	1863	1583
Right Turn on Red			Yes			Yes			Yes			Yes
Satd. Flow (RTOR)		41			52			4				62
Link Speed (mph)		30			30			35			35	
Link Distance (ft)		529			450			1329			869	
Travel Time (s)		12.0			10.2			25.9			16.9	
Peak Hour Factor	0.97	0.97	0.97	0.97	0.97	0.97	0.97	0.97	0.97	0.97	0.97	0.97
Shared Lane Traffic (%)												
Lane Group Flow (vph)	52	51	0	0	114	0	10	897	0	31	567	62
Turn Type	Perm	NA		Perm	NA		Perm	NA		Perm	NA	Perm
Protected Phases		4			8			2			6	
Permitted Phases	4			8			2			6		6
Total Split (s)	30.5	30.5		30.5	30.5		29.5	29.5		29.5	29.5	29.5
Total Lost Time (s)	4.5	4.5			4.5		4.5	4.5		4.5	4.5	4.5
Act Effct Green (s)	7.5	7.5			7.5		30.4	30.4		30.4	30.4	30.4
Actuated g/C Ratio	0.17	0.17			0.17		0.69	0.69		0.69	0.69	0.69
v/c Ratio	0.19	0.16			0.40		0.02	0.70		0.12	0.44	0.06
Control Delay	16.3	8.3			13.7		4.1	11.7		5.5	6.1	1.7
Queue Delay	0.0	0.0			0.0		0.0	0.0		0.0	0.0	0.0
Total Delay	16.3	8.3			13.7		4.1	11.7		5.5	6.1	1.7
LOS	B	A			B		A	B		A	A	A
Approach Delay		12.3			13.7			11.6			5.6	
Approach LOS		B			B			B			A	

Intersection Summary

Area Type:	Other
Cycle Length:	60
Actuated Cycle Length:	44
Control Type:	Actuated-Uncoordinated
Maximum v/c Ratio:	0.70
Intersection Signal Delay:	9.6
Intersection LOS:	A
Intersection Capacity Utilization:	66.6%
ICU Level of Service:	C
Analysis Period (min):	15

Splits and Phases: 5: Wiley Canyon Road & La Glorita Circle/Evans Avenue

29.5 s						30.5 s					
29.5 s						30.5 s					

Intersection												
Int Delay, s/veh	2.7											
Movement	EBL	EBT	EBR	WBL	WBT	WBR	NBL	NBT	NBR	SBL	SBT	SBR
Lane Configurations		↕			↕		↕	↕		↕	↕	↕
Traffic Vol, veh/h	43	1	11	1	0	7	24	770	2	12	570	55
Future Vol, veh/h	43	1	11	1	0	7	24	770	2	12	570	55
Conflicting Peds, #/hr	0	0	0	0	0	0	0	0	0	0	0	0
Sign Control	Stop	Stop	Stop	Stop	Stop	Stop	Free	Free	Free	Free	Free	Free
RT Channelized	-	-	None	-	-	None	-	-	None	-	-	None
Storage Length	-	-	-	-	-	-	150	-	-	215	-	260
Veh in Median Storage, #	-	0	-	-	0	-	-	0	-	-	0	-
Grade, %	-	0	-	-	0	-	-	0	-	-	0	-
Peak Hour Factor	95	95	95	95	95	95	95	95	95	95	95	95
Heavy Vehicles, %	2	2	2	2	2	2	2	2	2	2	2	2
Mvmt Flow	45	1	12	1	0	7	25	811	2	13	600	58

Major/Minor	Minor2		Minor1		Major1		Major2					
Conflicting Flow All	1492	1489	600	1524	1546	812	658	0	0	813	0	0
Stage 1	626	626	-	862	862	-	-	-	-	-	-	-
Stage 2	866	863	-	662	684	-	-	-	-	-	-	-
Critical Hdwy	7.12	6.52	6.22	7.12	6.52	6.22	4.12	-	-	4.12	-	-
Critical Hdwy Stg 1	6.12	5.52	-	6.12	5.52	-	-	-	-	-	-	-
Critical Hdwy Stg 2	6.12	5.52	-	6.12	5.52	-	-	-	-	-	-	-
Follow-up Hdwy	3.518	4.018	3.318	3.518	4.018	3.318	2.218	-	-	2.218	-	-
Pot Cap-1 Maneuver	102	124	501	97	114	379	930	-	-	814	-	-
Stage 1	472	477	-	350	372	-	-	-	-	-	-	-
Stage 2	348	372	-	451	449	-	-	-	-	-	-	-
Platoon blocked, %								-	-	-	-	-
Mov Cap-1 Maneuver	97	119	501	91	109	379	930	-	-	814	-	-
Mov Cap-2 Maneuver	97	119	-	91	109	-	-	-	-	-	-	-
Stage 1	459	469	-	341	362	-	-	-	-	-	-	-
Stage 2	332	362	-	433	442	-	-	-	-	-	-	-

Approach	EB		WB		NB		SB	
HCM Control Delay, s	63.6		18.7		0.3		0.2	
HCM LOS	F		C					

Minor Lane/Major Mvmt	NBL	NBT	NBR	EBLn1	WBLn1	SBL	SBT	SBR
Capacity (veh/h)	930	-	-	116	272	814	-	-
HCM Lane V/C Ratio	0.027	-	-	0.499	0.031	0.016	-	-
HCM Control Delay (s)	9	-	-	63.6	18.7	9.5	-	-
HCM Lane LOS	A	-	-	F	C	A	-	-
HCM 95th %tile Q(veh)	0.1	-	-	2.3	0.1	0	-	-

Intersection												
Int Delay, s/veh	9											
Movement	EBL	EBT	EBR	WBL	WBT	WBR	NBL	NBT	NBR	SBL	SBT	SBR
Lane Configurations		↔		↔	↔						↔	↔
Traffic Vol, veh/h	0	720	160	120	160	0	0	0	0	120	0	220
Future Vol, veh/h	0	720	160	120	160	0	0	0	0	120	0	220
Conflicting Peds, #/hr	0	0	0	0	0	0	0	0	0	0	0	0
Sign Control	Free	Free	Free	Free	Free	Free	Free	Free	Free	Stop	Stop	Stop
RT Channelized	-	-	None	-	-	None	-	-	None	-	-	None
Storage Length	-	-	-	150	-	-	-	-	-	-	-	0
Veh in Median Storage, #	-	0	-	-	0	-	-	-	-	-	0	-
Grade, %	-	0	-	-	0	-	-	0	-	-	0	-
Peak Hour Factor	96	96	96	96	96	96	96	96	96	96	96	96
Heavy Vehicles, %	2	2	2	2	2	2	2	2	2	2	2	2
Mvmt Flow	0	750	167	125	167	0	0	0	0	125	0	229

Major/Minor	Major1			Major2			Minor2				
Conflicting Flow All	-	0	0	917	0	0			1251	1334	167
Stage 1	-	-	-	-	-	-			417	417	-
Stage 2	-	-	-	-	-	-			834	917	-
Critical Hdwy	-	-	-	4.12	-	-			6.42	6.52	6.22
Critical Hdwy Stg 1	-	-	-	-	-	-			5.42	5.52	-
Critical Hdwy Stg 2	-	-	-	-	-	-			5.42	5.52	-
Follow-up Hdwy	-	-	-	2.218	-	-			3.518	4.018	3.318
Pot Cap-1 Maneuver	0	-	-	744	-	0			190	154	877
Stage 1	0	-	-	-	-	0			665	591	-
Stage 2	0	-	-	-	-	0			426	351	-
Platoon blocked, %	-	-	-	-	-	-			-	-	-
Mov Cap-1 Maneuver	-	-	-	744	-	-			158	0	877
Mov Cap-2 Maneuver	-	-	-	-	-	-			158	0	-
Stage 1	-	-	-	-	-	-			553	0	-
Stage 2	-	-	-	-	-	-			426	0	-

Approach	EB			WB			SB		
HCM Control Delay, s	0			4.6			35.9		
HCM LOS							E		

Minor Lane/Major Mvmt	EBT	EBR	WBL	WBT	SBLn1	SBLn2
Capacity (veh/h)	-	-	744	-	158	877
HCM Lane V/C Ratio	-	-	0.168	-	0.791	0.261
HCM Control Delay (s)	-	-	10.8	-	82.4	10.6
HCM Lane LOS	-	-	B	-	F	B
HCM 95th %tile Q(veh)	-	-	0.6	-	5.1	1

Intersection												
Int Delay, s/veh	35.4											
Movement	EBL	EBT	EBR	WBL	WBT	WBR	NBL	NBT	NBR	SBL	SBT	SBR
Lane Configurations	↘	↑			↘			↘	↗			
Traffic Vol, veh/h	420	420	0	0	200	150	90	10	270	0	0	0
Future Vol, veh/h	420	420	0	0	200	150	90	10	270	0	0	0
Conflicting Peds, #/hr	0	0	0	0	0	0	0	0	0	0	0	0
Sign Control	Free	Free	Free	Free	Free	Free	Stop	Stop	Stop	Free	Free	Free
RT Channelized	-	-	None	-	-	None	-	-	None	-	-	None
Storage Length	170	-	-	-	-	-	-	-	0	-	-	-
Veh in Median Storage, #	-	0	-	-	0	-	-	0	-	-	-	-
Grade, %	-	0	-	-	0	-	-	0	-	-	0	-
Peak Hour Factor	92	92	92	92	92	92	92	92	92	92	92	92
Heavy Vehicles, %	2	2	2	2	2	2	2	2	2	2	2	2
Mvmt Flow	457	457	0	0	217	163	98	11	293	0	0	0

Major/Minor	Major1		Major2		Minor1				
Conflicting Flow All	380	0	-	-	-	0	1670	1751	457
Stage 1	-	-	-	-	-	-	1371	1371	-
Stage 2	-	-	-	-	-	-	299	380	-
Critical Hdwy	4.12	-	-	-	-	-	6.42	6.52	6.22
Critical Hdwy Stg 1	-	-	-	-	-	-	5.42	5.52	-
Critical Hdwy Stg 2	-	-	-	-	-	-	5.42	5.52	-
Follow-up Hdwy	2.218	-	-	-	-	-	3.518	4.018	3.318
Pot Cap-1 Maneuver	1178	-	0	0	-	-	106	86	604
Stage 1	-	-	0	0	-	-	236	214	-
Stage 2	-	-	0	0	-	-	752	614	-
Platoon blocked, %		-			-	-			
Mov Cap-1 Maneuver	1178	-	-	-	-	-	~ 65	0	604
Mov Cap-2 Maneuver	-	-	-	-	-	-	~ 65	0	-
Stage 1	-	-	-	-	-	-	144	0	-
Stage 2	-	-	-	-	-	-	752	0	-

Approach	EB	WB	NB
HCM Control Delay, s	5	0	137.9
HCM LOS			F

Minor Lane/Major Mvmt	NBLn1	NBLn2	EBL	EBT	WBT	WBR
Capacity (veh/h)	65	604	1178	-	-	-
HCM Lane V/C Ratio	1.672	0.486	0.388	-	-	-
HCM Control Delay (s)	\$ 465.7	16.5	10	-	-	-
HCM Lane LOS	F	C	A	-	-	-
HCM 95th %tile Q(veh)	9.7	2.7	1.9	-	-	-

Notes  
 ~: Volume exceeds capacity    \$: Delay exceeds 300s    +: Computation Not Defined    \*: All major volume in platoon



# DELAY (AVERAGE)

Average control delay per vehicle, or average pedestrian delay (seconds)

## Site: 9. Wiley Canyon Rd and Calgrove Blvd PM Peak Hour

Interim Year with Project  
Roundabout

### All Movement Classes

	South	East	North	West	Intersection
Delay (Average)	14.2	9.6	8.7	12.2	10.8
LOS	B	A	A	B	B

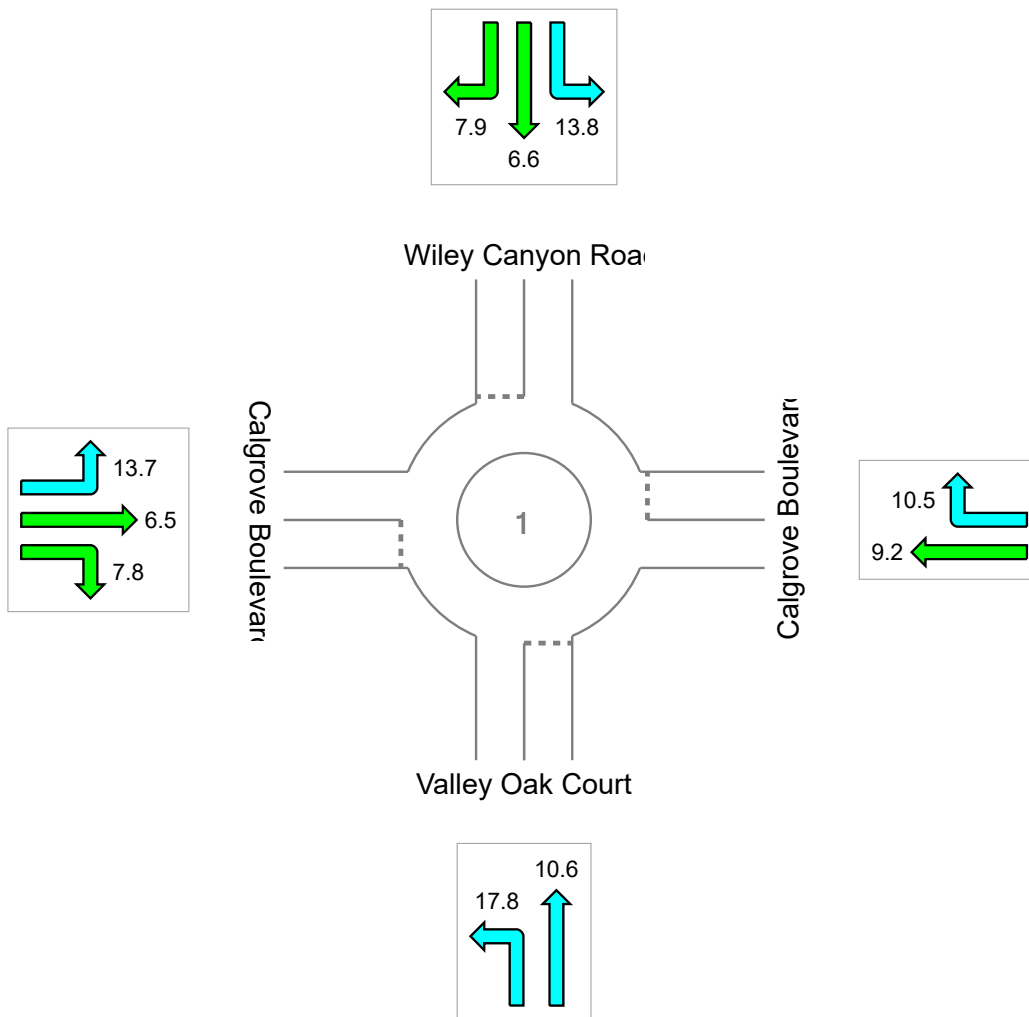

Colour code based on Level of Service



Level of Service Method: Delay & v/c (HCM 2010)

LOS F will result if v/c > 1 irrespective of movement delay value (does not apply for approaches and intersection).

Roundabout Level of Service Method: Same as Signalised Intersections

SIDRA Standard Delay Model is used. Control Delay includes Geometric Delay.

# INPUT VOLUMES

Vehicles and pedestrians per 60 minutes

 **Site: 9. Wiley Canyon Rd and Calgrove Blvd PM Peak Hour**

Interim Year with Project

Volume Display Method: Total and %

Volumes are shown for Movement Class(es): All Classes and Heavy Vehicles

Total Intersection Volumes (veh)

All Movement Classes: 1360

Light Vehicles (LV): 1319

Heavy Vehicles (HV): 41

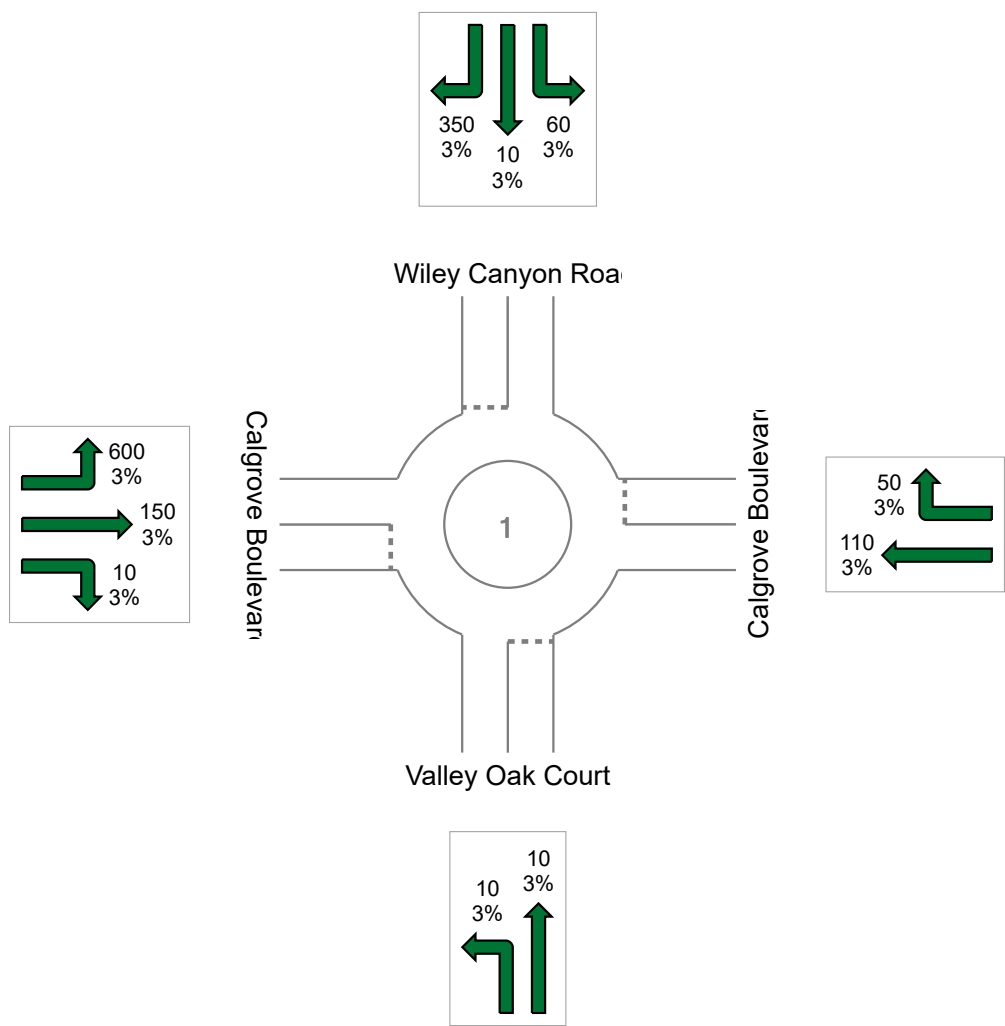

# QUEUE DISTANCE

Largest 95% Back of Queue for any lane used by movement (feet)

## Site: 9. Wiley Canyon Rd and Calgrove Blvd PM Peak Hour

Interim Year with Project  
Roundabout

### All Movement Classes

	South	East	North	West	Intersection
Queue Distance	4	25	44	96	96

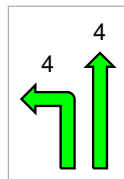
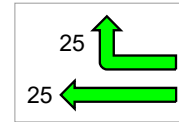
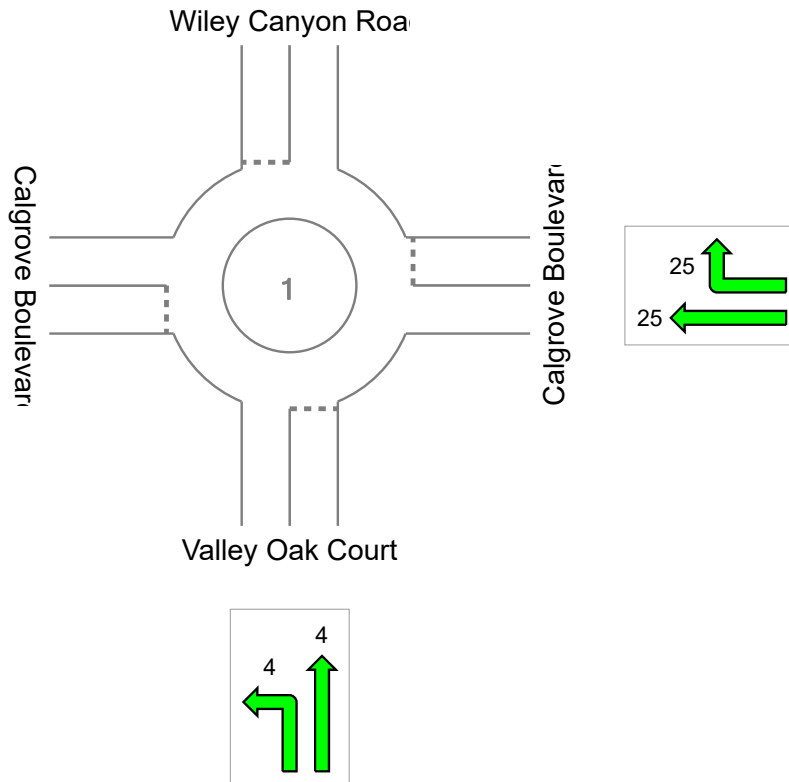
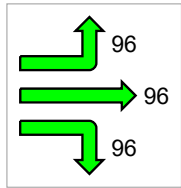
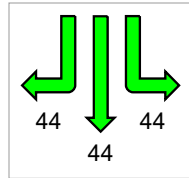

Colour code based on Queue Storage Ratio

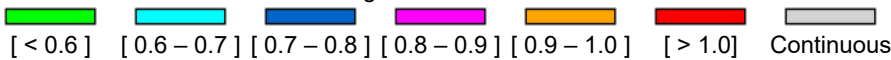

# DEGREE OF SATURATION

Ratio of Demand Volume to Capacity (v/c ratio)

## Site: 9. Wiley Canyon Rd and Calgrove Blvd PM Peak Hour

Interim Year with Project  
Roundabout

### All Movement Classes

	South	East	North	West	Intersection
Degree of Saturation	0.03	0.22	0.39	0.62	0.62

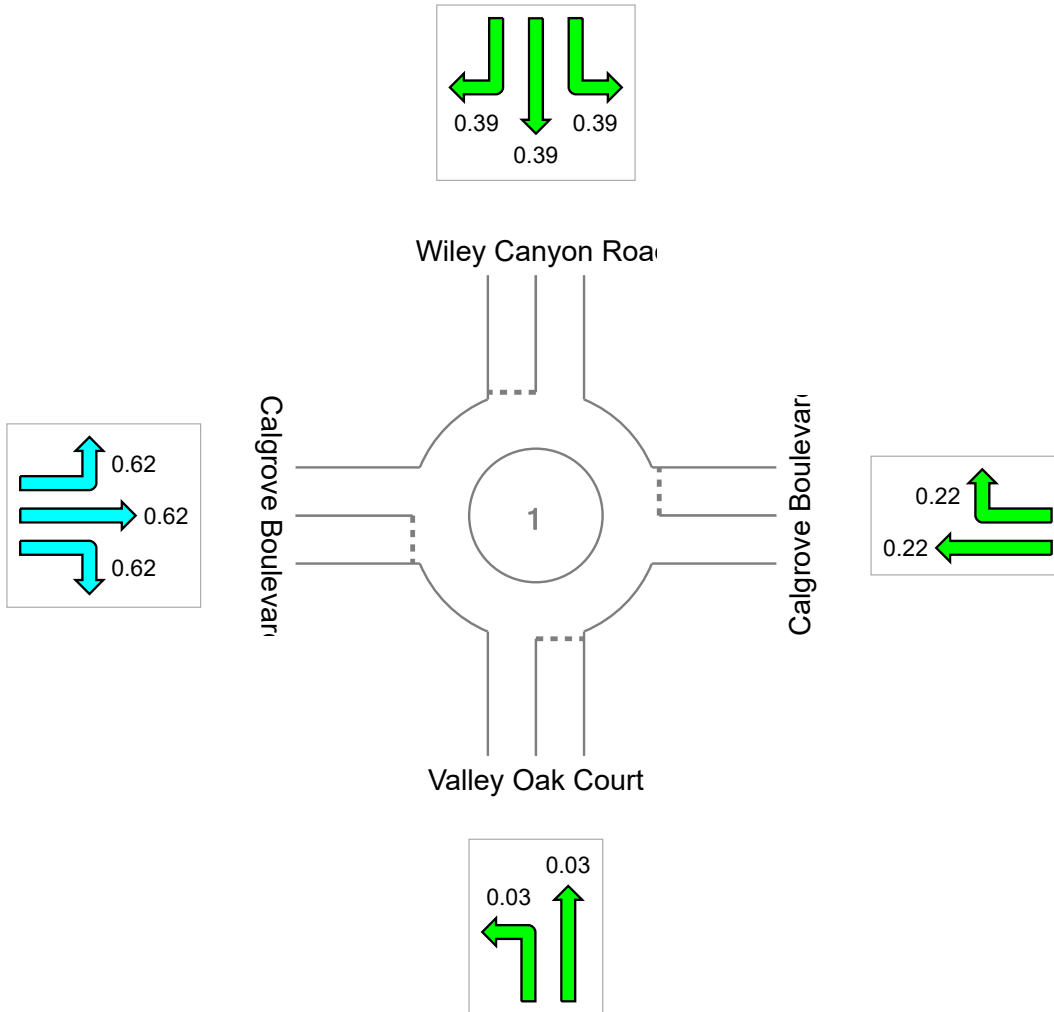

Colour code based on Degree of Saturation

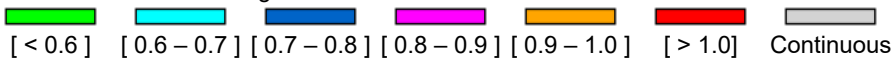

Interim Year With-Project - PM Peak Hour  
 9: Calgrove Boulevard & Wiley Canyon Road

Synchro 10 Report  
 Lanes, Volumes, Timings

Lane Group	EBL	EBT	EBR	WBL	WBT	WBR	NBL	NBT	NBR	SBL	SBT	SBR
Lane Configurations												
Traffic Volume (vph)	600	150	10	0	110	50	10	10	0	60	10	350
Future Volume (vph)	600	150	10	0	110	50	10	10	0	60	10	350
Ideal Flow (vphpl)	1900	1900	1900	1900	1900	1900	1900	1900	1900	1900	1900	1900
Storage Length (ft)	165		150	290		290	0		0	100		100
Storage Lanes	1		1	1		1	0		0	0		1
Taper Length (ft)	25			25			25			25		
Satd. Flow (prot)	1770	1863	1583	1863	1863	1583	0	1818	0	0	1786	1583
Flt Permitted	0.950							0.862			0.741	
Satd. Flow (perm)	1770	1863	1583	1863	1863	1583	0	1606	0	0	1380	1583
Right Turn on Red			Yes			Yes			Yes			Yes
Satd. Flow (RTOR)			82			143						361
Link Speed (mph)		45			45			30			35	
Link Distance (ft)		786			1192			412			1483	
Travel Time (s)		11.9			18.1			9.4			28.9	
Peak Hour Factor	0.97	0.97	0.97	0.97	0.97	0.97	0.97	0.97	0.97	0.97	0.97	0.97
Shared Lane Traffic (%)												
Lane Group Flow (vph)	619	155	10	0	113	52	0	20	0	0	72	361
Turn Type	Prot	NA	Perm	Prot	NA	Perm	Perm	NA		Perm	NA	Perm
Protected Phases	7	4		3	8			2			6	
Permitted Phases			4			8	2			6		6
Total Split (s)	35.0	48.0	48.0	9.5	22.5	22.5	22.5	22.5		22.5	22.5	22.5
Total Lost Time (s)	4.5	4.5	4.5	4.5	4.5	4.5		4.5			4.5	4.5
Act Effct Green (s)	25.8	36.2	36.2		9.4	9.4		9.5			9.5	9.5
Actuated g/C Ratio	0.46	0.65	0.65		0.17	0.17		0.17			0.17	0.17
v/c Ratio	0.75	0.13	0.01		0.36	0.13		0.07			0.31	0.64
Control Delay	22.2	3.9	0.0		28.0	0.7		23.6			27.4	8.9
Queue Delay	0.0	0.0	0.0		0.0	0.0		0.0			0.0	0.0
Total Delay	22.2	3.9	0.0		28.0	0.7		23.6			27.4	8.9
LOS	C	A	A		C	A		C			C	A
Approach Delay		18.3			19.4			23.6			12.0	
Approach LOS		B			B			C			B	

Intersection Summary

Area Type:	Other
Cycle Length:	80
Actuated Cycle Length:	55.7
Control Type:	Actuated-Uncoordinated
Maximum v/c Ratio:	0.75
Intersection Signal Delay:	16.6
Intersection LOS:	B
Intersection Capacity Utilization:	55.2%
ICU Level of Service:	B
Analysis Period (min):	15

Splits and Phases: 9: Calgrove Boulevard & Wiley Canyon Road

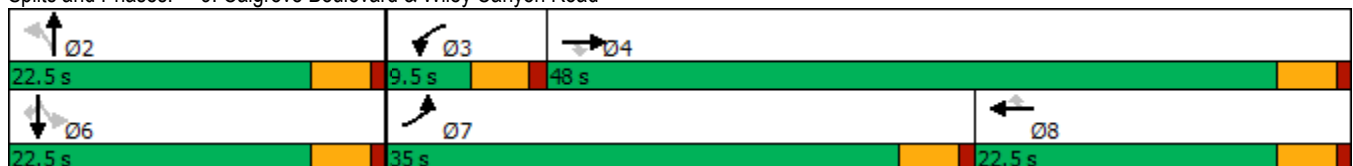

# DELAY (AVERAGE)

Average control delay per vehicle, or average pedestrian delay (seconds)

## Site: 10. Wiley Canyon Rd & Project Access PM Peak Hour

Interim Year with Project  
Roundabout

### All Movement Classes

	South	North	West	Intersection
Delay (Average)	7.9	7.3	14.4	8.2
LOS	A	A	B	A

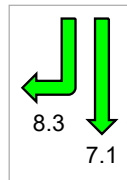

Wiley Canyon Road

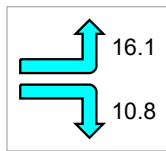

Project Access

Wiley Canyon Road

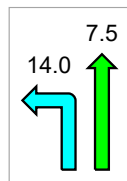

Colour code based on Level of Service

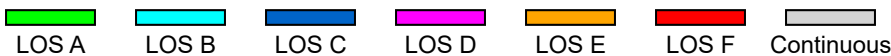

Level of Service Method: Delay & v/c (HCM 2010)

LOS F will result if v/c > 1 irrespective of movement delay value (does not apply for approaches and intersection).

Roundabout Level of Service Method: Same as Signalised Intersections

SIDRA Standard Delay Model is used. Control Delay includes Geometric Delay.

# INPUT VOLUMES

Vehicles and pedestrians per 60 minutes

 Site: 10. Wiley Canyon Rd & Project Access PM Peak Hour

Interim Year with Project

Volume Display Method: Total and %

Volumes are shown for Movement Class(es): All Classes and Heavy Vehicles

Total Intersection Volumes (veh)

All Movement Classes: 1673

Light Vehicles (LV): 1623

Heavy Vehicles (HV): 50

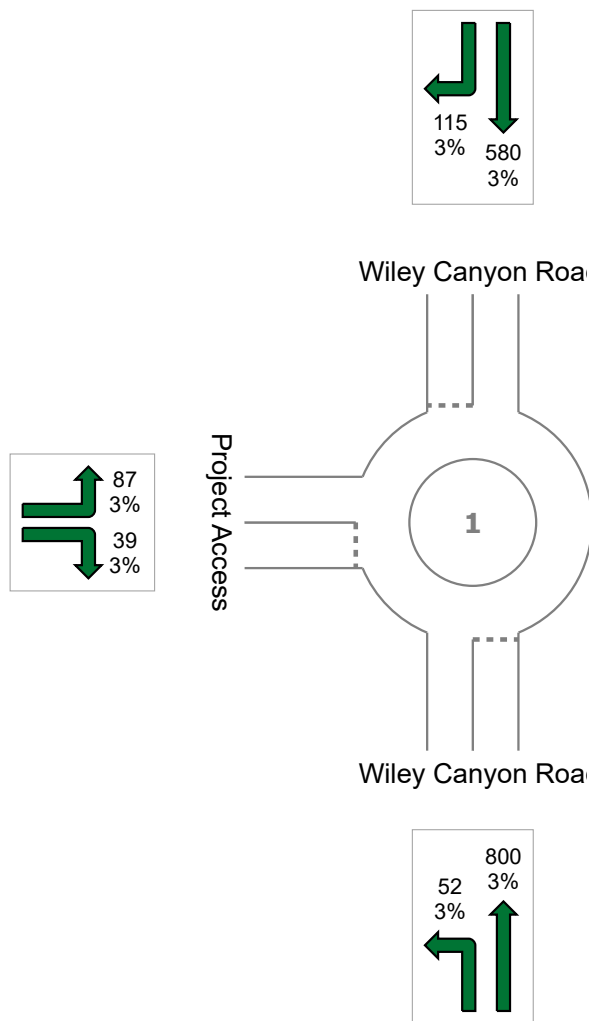

# QUEUE DISTANCE

Largest 95% Back of Queue for any lane used by movement (feet)

 **Site: 10. Wiley Canyon Rd & Project Access PM Peak Hour**

Interim Year with Project  
Roundabout

## All Movement Classes

	South	North	West	Intersection
Queue Distance	160	85	18	160

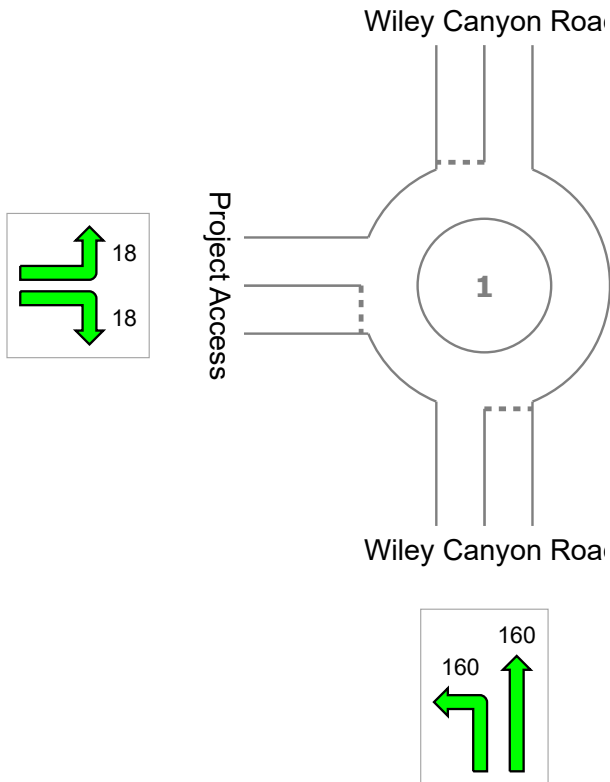
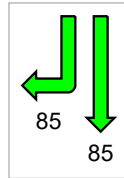

Colour code based on Queue Storage Ratio

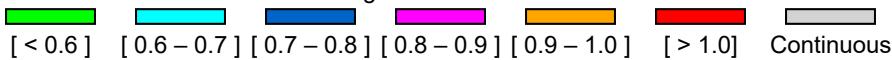



# DEGREE OF SATURATION

Ratio of Demand Volume to Capacity (v/c ratio)

## Site: 10. Wiley Canyon Rd & Project Access PM Peak Hour

Interim Year with Project  
Roundabout

### All Movement Classes

	South	North	West	Intersection
Degree of Saturation	0.73	0.57	0.18	0.73

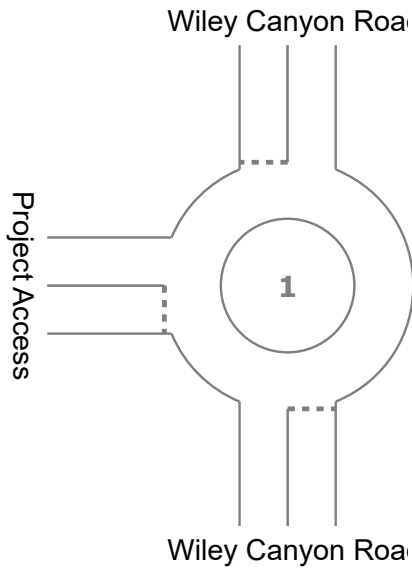
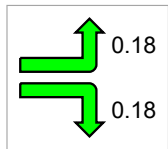

Colour code based on Degree of Saturation

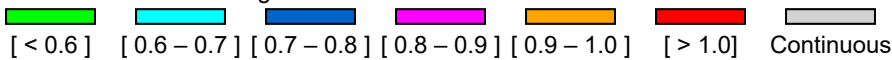

# **INTERIM YEAR WITH-PROJECT CONDITIONS - WITH OFF-SITE IMPROVEMENTS**

Interim Year With-Project with Off-Site Improvements - AM Peak Hour  
 3: I-5 NB Ramps & Lyons Avenue

Synchro 10 Report  
 Lanes, Volumes, Timings

Lane Group	EBL	EBT	EBR	WBL	WBT	WBR	NBL	NBT	NBR	SBL	SBT	SBR
Lane Configurations												
Traffic Volume (vph)	270	1120	0	0	840	600	130	10	150	0	0	0
Future Volume (vph)	270	1120	0	0	840	600	130	10	150	0	0	0
Ideal Flow (vphpl)	1900	1900	1900	1900	1900	1900	1900	1900	1900	1900	1900	1900
Storage Length (ft)	300		0	0		0	0		0	0		0
Storage Lanes	1		0	0		0	1		1	0		0
Taper Length (ft)	25			25			25			25		
Satd. Flow (prot)	1770	3539	0	0	4765	0	1681	1697	1583	0	0	0
Flt Permitted	0.950						0.950	0.959				
Satd. Flow (perm)	1770	3539	0	0	4765	0	1681	1697	1583	0	0	0
Right Turn on Red			Yes			Yes			Yes			Yes
Satd. Flow (RTOR)					191				65			
Link Speed (mph)		40			40			30			30	
Link Distance (ft)		603			1902			756			732	
Travel Time (s)		10.3			32.4			17.2			16.6	
Peak Hour Factor	0.86	0.86	0.86	0.86	0.86	0.86	0.86	0.86	0.86	0.86	0.86	0.86
Shared Lane Traffic (%)							46%					
Lane Group Flow (vph)	314	1302	0	0	1675	0	82	81	174	0	0	0
Turn Type	Prot	NA			NA		Perm	NA	Perm			
Protected Phases	7	4			8			2				
Permitted Phases							2		2			
Total Split (s)	23.8	61.0			37.2		39.0	39.0	39.0			
Total Lost Time (s)	4.5	4.5			4.5		4.5	4.5	4.5			
Act Effct Green (s)	19.1	56.3			32.7		34.5	34.5	34.5			
Actuated g/C Ratio	0.19	0.56			0.33		0.35	0.35	0.35			
v/c Ratio	0.93	0.65			1.06dr		0.14	0.14	0.30			
Control Delay	75.1	17.0			50.3		23.5	23.4	16.2			
Queue Delay	0.0	0.0			0.0		0.0	0.0	0.0			
Total Delay	75.1	17.0			50.3		23.5	23.4	16.2			
LOS	E	B			D		C	C	B			
Approach Delay		28.2			50.3			19.7				
Approach LOS		C			D			B				

Intersection Summary

Area Type: Other  
 Cycle Length: 100  
 Actuated Cycle Length: 99.8  
 Control Type: Actuated-Uncoordinated  
 Maximum v/c Ratio: 0.99  
 Intersection Signal Delay: 37.6 Intersection LOS: D  
 Intersection Capacity Utilization 60.1% ICU Level of Service B  
 Analysis Period (min) 15  
 dr Defacto Right Lane. Recode with 1 though lane as a right lane.

Splits and Phases: 3: I-5 NB Ramps & Lyons Avenue

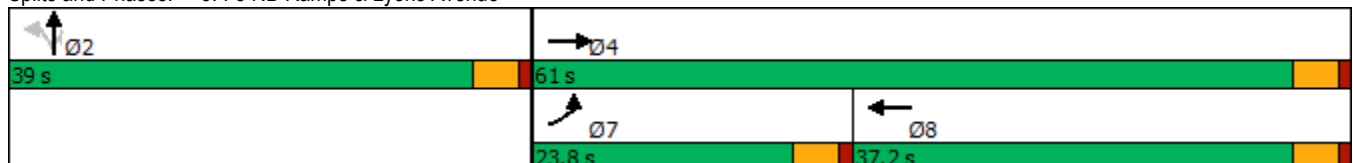

# DELAY (AVERAGE)

Average control delay per vehicle, or average pedestrian delay (seconds)

## Site: 6. Wiley Canyon Rd & Wabuska AM Peak Hour

Interim Year with Project with Off-Site Improvements  
Roundabout

### All Movement Classes

	South	East	North	West	Intersection
Delay (Average)	8.4	8.6	8.1	11.7	8.5
LOS	A	A	A	B	A

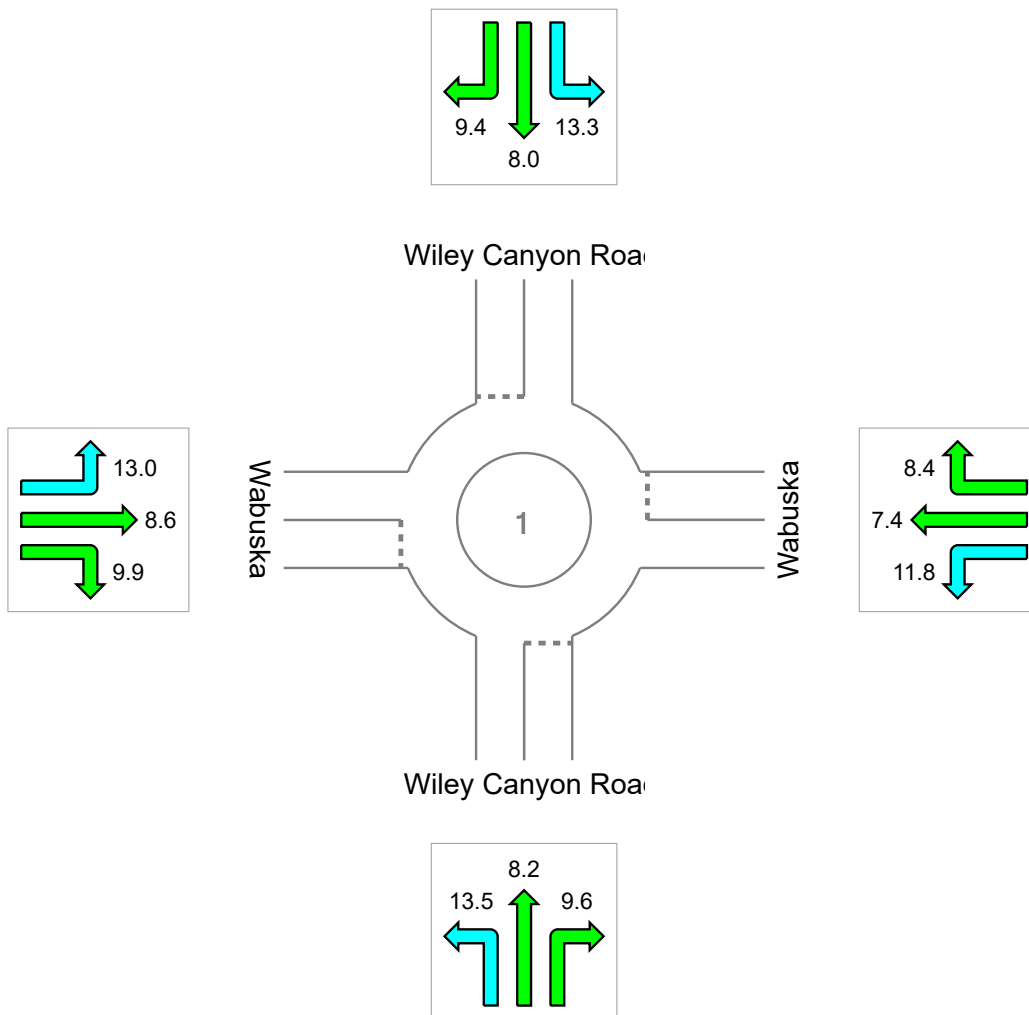

Colour code based on Level of Service



Level of Service Method: Delay & v/c (HCM 2010)

LOS F will result if v/c > 1 irrespective of movement delay value (does not apply for approaches and intersection).

Roundabout Level of Service Method: Same as Signalised Intersections

SIDRA Standard Delay Model is used. Control Delay includes Geometric Delay.

# INPUT VOLUMES

Vehicles and pedestrians per 60 minutes

 **Site: 6. Wiley Canyon Rd & Wabuska AM Peak Hour**

Interim Year with Project with Off-Site Improvements

Volume Display Method: Total and %

Volumes are shown for Movement Class(es): All Classes and Heavy Vehicles

Total Intersection Volumes (veh)

All Movement Classes: 1544

Light Vehicles (LV): 1498

Heavy Vehicles (HV): 46

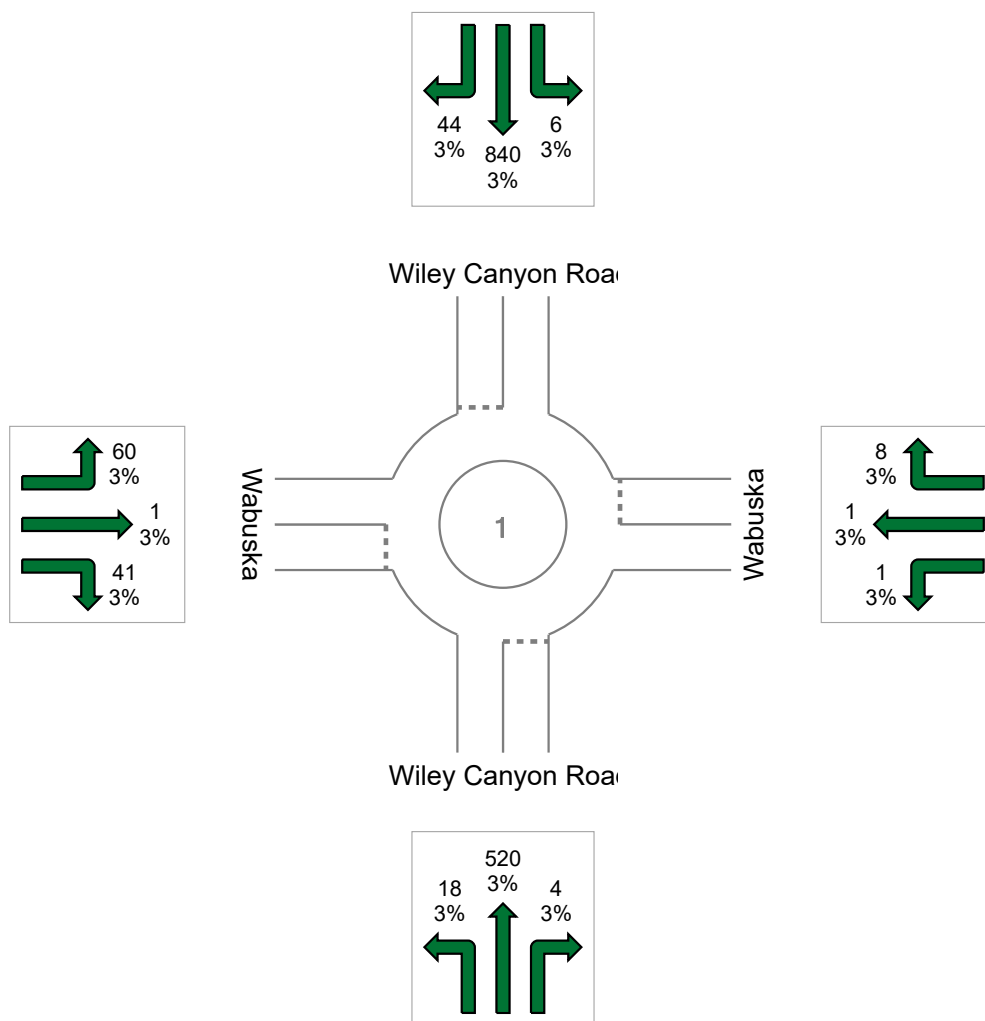

# QUEUE DISTANCE

Largest 95% Back of Queue for any lane used by movement (feet)

## Site: 6. Wiley Canyon Rd & Wabuska AM Peak Hour

Interim Year with Project with Off-Site Improvements  
Roundabout

### All Movement Classes

	South	East	North	West	Intersection
Queue Distance	69	2	124	24	124

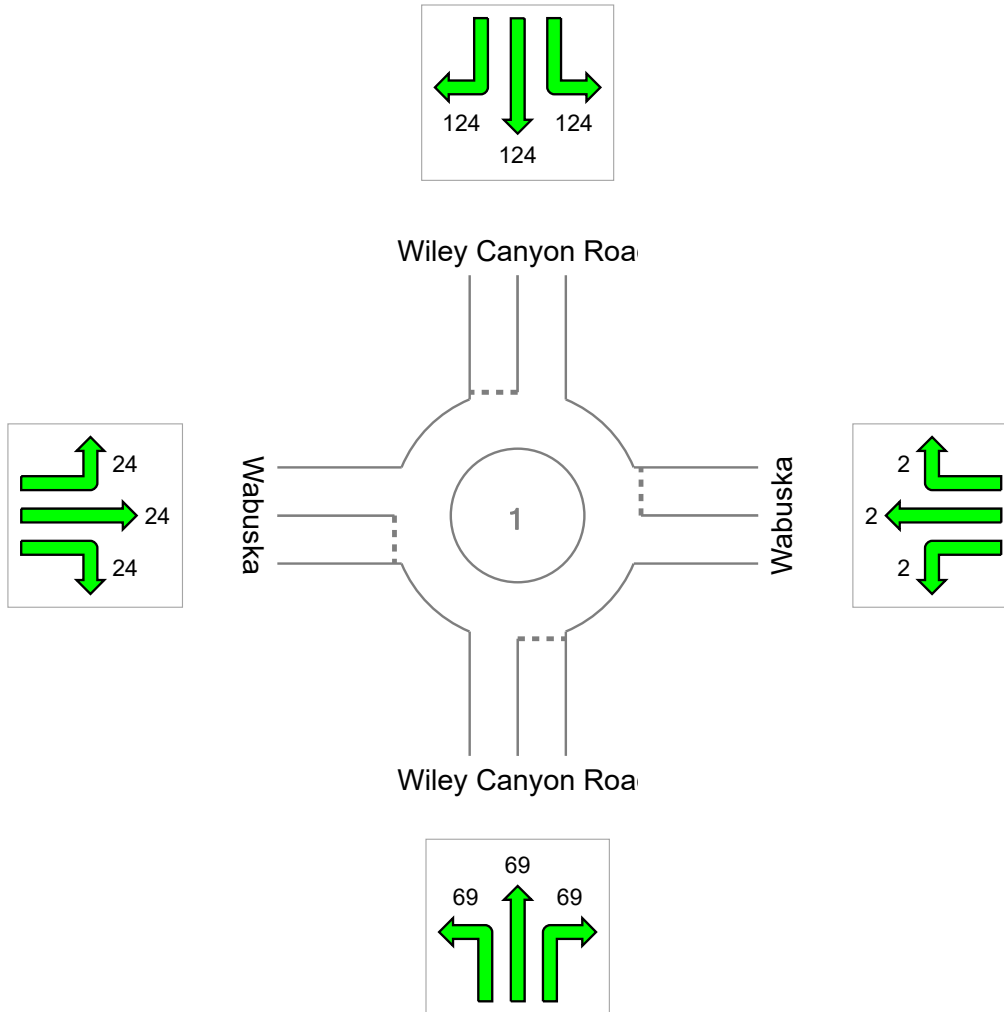

Colour code based on Queue Storage Ratio

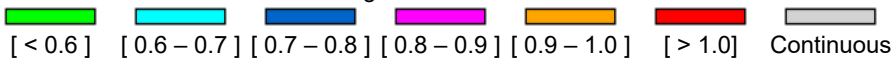

# DEGREE OF SATURATION

Ratio of Demand Volume to Capacity (v/c ratio)

## Site: 6. Wiley Canyon Rd & Wabuska AM Peak Hour

Interim Year with Project with Off-Site Improvements  
Roundabout

### All Movement Classes

	South	East	North	West	Intersection
Degree of Saturation	0.50	0.02	0.69	0.20	0.69

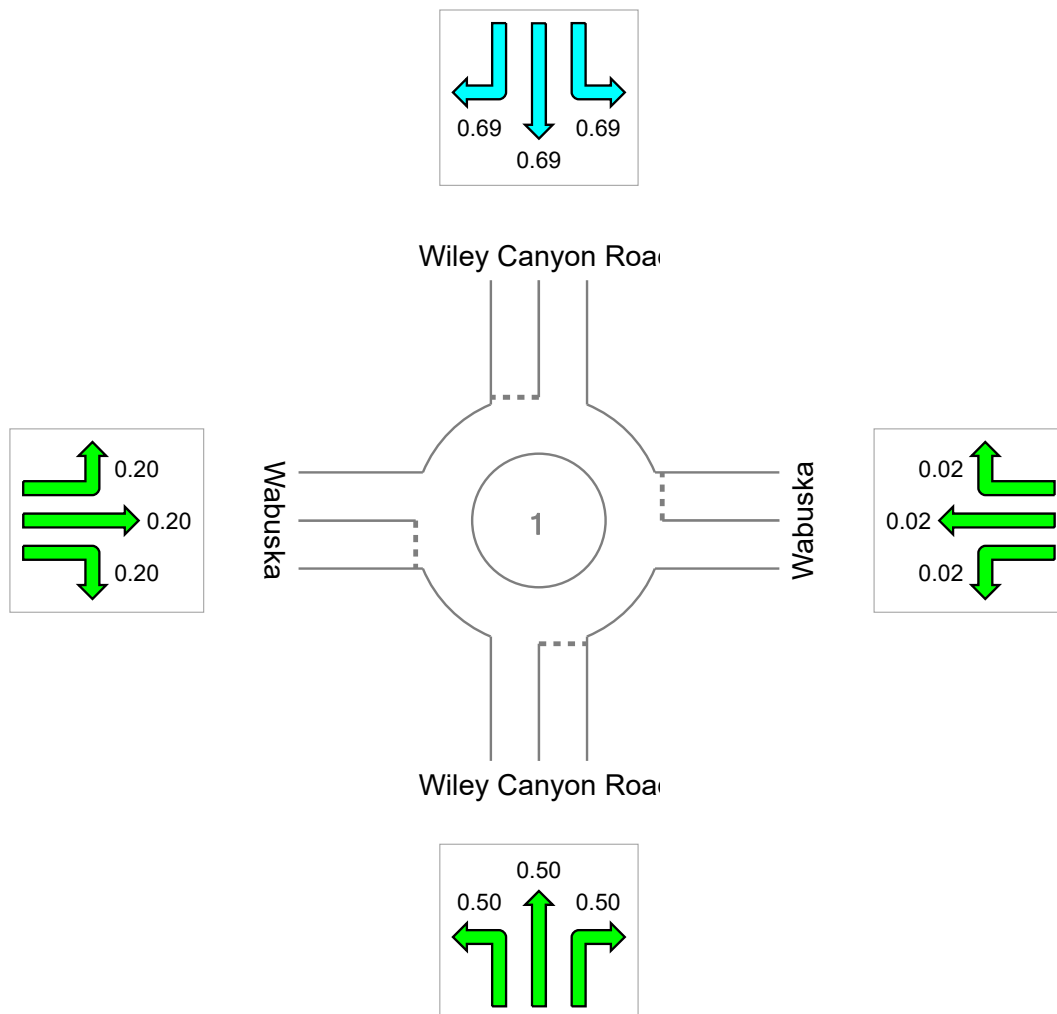

Colour code based on Degree of Saturation

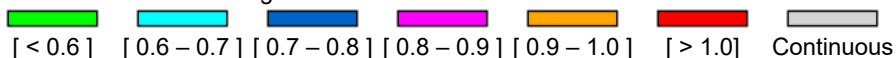

Interim Year With-Project with Off-Site Improvements - AM Peak Hour  
 6: Wiley Canyon Road & Wabuska Street

Synchro 10 Report  
 Lanes, Volumes, Timings

Lane Group	EBL	EBT	EBR	WBL	WBT	WBR	NBL	NBT	NBR	SBL	SBT	SBR
Lane Configurations												
Traffic Volume (vph)	60	0	41	1	0	8	18	520	4	6	840	44
Future Volume (vph)	60	0	41	1	0	8	18	520	4	6	840	44
Ideal Flow (vphpl)	1900	1900	1900	1900	1900	1900	1900	1900	1900	1900	1900	1900
Storage Length (ft)	0		0	0		0	150		0	215		260
Storage Lanes	0		0	0		0	1		0	1		1
Taper Length (ft)	25			25			25			25		
Satd. Flow (prot)	0	1709	0	0	1625	0	1770	1861	0	1770	1863	1583
Flt Permitted		0.811			0.979		0.200			0.387		
Satd. Flow (perm)	0	1428	0	0	1599	0	373	1861	0	721	1863	1583
Right Turn on Red			Yes			Yes			Yes			Yes
Satd. Flow (RTOR)		45			20			1				53
Link Speed (mph)		30			30			35			35	
Link Distance (ft)		578			167			791			1329	
Travel Time (s)		13.1			3.8			15.4			25.9	
Peak Hour Factor	0.83	0.83	0.83	0.83	0.83	0.83	0.83	0.83	0.83	0.83	0.83	0.83
Shared Lane Traffic (%)												
Lane Group Flow (vph)	0	121	0	0	11	0	22	632	0	7	1012	53
Turn Type	Perm	NA		Perm	NA		Perm	NA		Perm	NA	Perm
Protected Phases		4			8			2			6	
Permitted Phases	4			8			2			6		6
Total Split (s)	29.5	29.5		29.5	29.5		50.5	50.5		50.5	50.5	50.5
Total Lost Time (s)		4.5			4.5		4.5	4.5		4.5	4.5	4.5
Act Effct Green (s)		9.2			9.2		53.9	53.9		53.9	53.9	53.9
Actuated g/C Ratio		0.13			0.13		0.78	0.78		0.78	0.78	0.78
v/c Ratio		0.53			0.05		0.08	0.44		0.01	0.70	0.04
Control Delay		26.4			8.0		4.2	5.0		3.3	9.5	1.3
Queue Delay		0.0			0.0		0.0	0.0		0.0	0.0	0.0
Total Delay		26.4			8.0		4.2	5.0		3.3	9.5	1.3
LOS		C			A		A	A		A	A	A
Approach Delay		26.4			8.0			5.0			9.0	
Approach LOS		C			A			A			A	

Intersection Summary

Area Type:	Other
Cycle Length:	80
Actuated Cycle Length:	69.1
Control Type:	Semi Act-Uncoord
Maximum v/c Ratio:	0.70
Intersection Signal Delay:	8.7
Intersection LOS:	A
Intersection Capacity Utilization:	64.2%
ICU Level of Service:	C
Analysis Period (min):	15

Splits and Phases: 6: Wiley Canyon Road & Wabuska Street





Interim Year With-Project with Off-Site Improvements - AM Peak Hour  
 7: I-5 SB Ramps & Calgrove Boulevard

Synchro 10 Report  
 Lanes, Volumes, Timings

Lane Group	EBL	EBT	EBR	WBL	WBT	WBR	NBL	NBT	NBR	SBL	SBT	SBR
Lane Configurations												
Traffic Volume (vph)	0	320	90	520	220	0	0	0	0	70	0	230
Future Volume (vph)	0	320	90	520	220	0	0	0	0	70	0	230
Ideal Flow (vphpl)	1900	1900	1900	1900	1900	1900	1900	1900	1900	1900	1900	1900
Storage Length (ft)	0		0	150		0	0		0	0		0
Storage Lanes	0		0	1		0	0		0	0		1
Taper Length (ft)	25			25			25			25		
Satd. Flow (prot)	0	1807	0	1770	1863	0	0	0	0	0	1770	1583
Flt Permitted				0.950							0.950	
Satd. Flow (perm)	0	1807	0	1770	1863	0	0	0	0	0	1770	1583
Right Turn on Red			Yes			Yes			Yes			Yes
Satd. Flow (RTOR)		19										253
Link Speed (mph)		40			45			30			30	
Link Distance (ft)		596			420			659			500	
Travel Time (s)		10.2			6.4			15.0			11.4	
Peak Hour Factor	0.91	0.91	0.91	0.91	0.91	0.91	0.91	0.91	0.91	0.91	0.91	0.91
Shared Lane Traffic (%)												
Lane Group Flow (vph)	0	451	0	571	242	0	0	0	0	0	77	253
Turn Type		NA		Prot	NA					Perm	NA	Perm
Protected Phases		4		3	8						6	
Permitted Phases										6		6
Total Split (s)		31.5		34.0	65.5					14.5	14.5	14.5
Total Lost Time (s)		4.5		4.5	4.5						4.5	4.5
Act Effct Green (s)		21.6		26.3	52.5						10.2	10.2
Actuated g/C Ratio		0.30		0.37	0.73						0.14	0.14
v/c Ratio		0.81		0.88	0.18						0.31	0.57
Control Delay		35.3		39.5	3.1						34.8	10.6
Queue Delay		0.0		1.0	0.0						0.0	0.0
Total Delay		35.3		40.5	3.1						34.8	10.6
LOS		D		D	A						C	B
Approach Delay		35.3			29.4						16.2	
Approach LOS		D			C						B	

Intersection Summary

Area Type:	Other
Cycle Length:	80
Actuated Cycle Length:	71.9
Control Type:	Semi Act-Uncoord
Maximum v/c Ratio:	0.88
Intersection Signal Delay:	28.3
Intersection LOS:	C
Intersection Capacity Utilization:	71.6%
ICU Level of Service:	C
Analysis Period (min):	15

Splits and Phases: 7: I-5 SB Ramps & Calgrove Boulevard



Interim Year With-Project with Off-Site Improvements - AM Peak Hour  
 8: I-5 NB Ramps & Calgrove Boulevard

Synchro 10 Report  
 Lanes, Volumes, Timings

Lane Group	EBL	EBT	EBR	WBL	WBT	WBR	NBL	NBT	NBR	SBL	SBT	SBR
Lane Configurations												
Traffic Volume (vph)	140	240	0	0	690	200	50	10	80	0	0	0
Future Volume (vph)	140	240	0	0	690	200	50	10	80	0	0	0
Ideal Flow (vphpl)	1900	1900	1900	1900	1900	1900	1900	1900	1900	1900	1900	1900
Storage Length (ft)	170		0	0		0	0		0	0		0
Storage Lanes	1		0	0		0	0		1	0		0
Taper Length (ft)	25			25			25			25		
Satd. Flow (prot)	1770	1863	0	0	1807	0	0	1788	1583	0	0	0
Flt Permitted	0.950							0.960				
Satd. Flow (perm)	1770	1863	0	0	1807	0	0	1788	1583	0	0	0
Right Turn on Red			Yes			Yes			Yes			Yes
Satd. Flow (RTOR)					25				85			
Link Speed (mph)		45			45			30			30	
Link Distance (ft)		420			786			475			858	
Travel Time (s)		6.4			11.9			10.8			19.5	
Peak Hour Factor	0.94	0.94	0.94	0.94	0.94	0.94	0.94	0.94	0.94	0.94	0.94	0.94
Shared Lane Traffic (%)												
Lane Group Flow (vph)	149	255	0	0	947	0	0	64	85	0	0	0
Turn Type	Prot	NA			NA		Perm	NA	Perm			
Protected Phases	7	4			8			2				
Permitted Phases							2		2			
Total Split (s)	13.6	65.6			52.0		24.4	24.4	24.4			
Total Lost Time (s)	4.5	4.5			4.5			4.5	4.5			
Act Effct Green (s)	9.1	61.1			47.5			19.9	19.9			
Actuated g/C Ratio	0.10	0.68			0.53			0.22	0.22			
v/c Ratio	0.84	0.20			0.98			0.16	0.20			
Control Delay	77.1	5.8			46.8			29.7	8.2			
Queue Delay	0.0	0.0			0.0			0.0	0.0			
Total Delay	77.1	5.8			46.8			29.7	8.2			
LOS	E	A			D			C	A			
Approach Delay		32.1			46.8			17.4				
Approach LOS		C			D			B				

Intersection Summary

Area Type:	Other
Cycle Length:	90
Actuated Cycle Length:	90
Control Type:	Semi Act-Uncoord
Maximum v/c Ratio:	0.98
Intersection Signal Delay:	39.9
Intersection LOS:	D
Intersection Capacity Utilization:	71.6%
ICU Level of Service:	C
Analysis Period (min):	15

Splits and Phases: 8: I-5 NB Ramps & Calgrove Boulevard

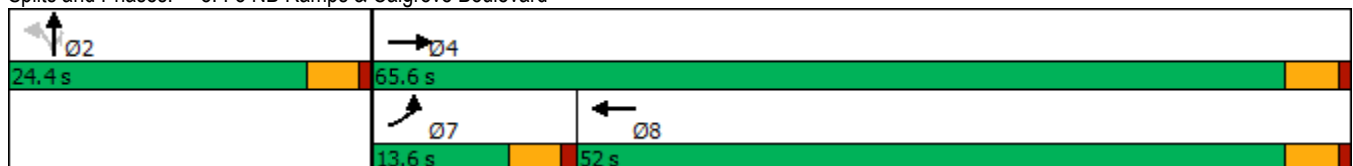

Interim Year With-Project with Off-Site Improvements - PM Peak Hour  
 3: I-5 NB Ramps & Lyons Avenue

Synchro 10 Report  
 Lanes, Volumes, Timings

Lane Group	EBL	EBT	EBR	WBL	WBT	WBR	NBL	NBT	NBR	SBL	SBT	SBR
Lane Configurations												
Traffic Volume (vph)	230	1180	0	0	840	700	420	0	420	0	0	0
Future Volume (vph)	230	1180	0	0	840	700	420	0	420	0	0	0
Ideal Flow (vphpl)	1900	1900	1900	1900	1900	1900	1900	1900	1900	1900	1900	1900
Storage Length (ft)	300		0	0		0	0		0	0		0
Storage Lanes	1		0	0		0	1		1	0		0
Taper Length (ft)	25			25			25			25		
Satd. Flow (prot)	1770	3539	0	0	4739	0	1681	1681	1583	0	0	0
Flt Permitted	0.950						0.950	0.950				
Satd. Flow (perm)	1770	3539	0	0	4739	0	1681	1681	1583	0	0	0
Right Turn on Red			Yes			Yes			Yes			Yes
Satd. Flow (RTOR)					264				82			
Link Speed (mph)		40			40			30			30	
Link Distance (ft)		603			1902			756			732	
Travel Time (s)		10.3			32.4			17.2			16.6	
Peak Hour Factor	0.92	0.92	0.92	0.92	0.92	0.92	0.92	0.92	0.92	0.92	0.92	0.92
Shared Lane Traffic (%)							50%					
Lane Group Flow (vph)	250	1283	0	0	1674	0	228	229	457	0	0	0
Turn Type	Prot	NA			NA		Perm	NA	Perm			
Protected Phases	7	4			8			2				
Permitted Phases							2		2			
Total Split (s)	14.0	41.5			27.5		38.5	38.5	38.5			
Total Lost Time (s)	4.5	4.5			4.5		4.5	4.5	4.5			
Act Effct Green (s)	9.5	37.0			23.0		34.0	34.0	34.0			
Actuated g/C Ratio	0.12	0.46			0.29		0.42	0.42	0.42			
v/c Ratio	1.19	0.78			1.17dr		0.32	0.32	0.64			
Control Delay	157.6	22.4			72.8		16.9	16.9	19.4			
Queue Delay	0.0	0.0			0.0		0.0	0.0	0.0			
Total Delay	157.6	22.4			72.8		16.9	16.9	19.4			
LOS	F	C			E		B	B	B			
Approach Delay		44.5			72.8			18.2				
Approach LOS		D			E			B				

Intersection Summary

Area Type: Other  
 Cycle Length: 80  
 Actuated Cycle Length: 80  
 Control Type: Actuated-Uncoordinated  
 Maximum v/c Ratio: 1.19  
 Intersection Signal Delay: 50.1  
 Intersection LOS: D  
 Intersection Capacity Utilization 67.6%  
 ICU Level of Service C  
 Analysis Period (min) 15  
 dr Defacto Right Lane. Recode with 1 though lane as a right lane.

Splits and Phases: 3: I-5 NB Ramps & Lyons Avenue

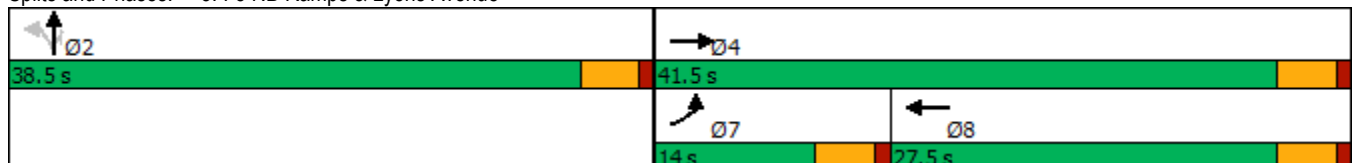

# DELAY (AVERAGE)

Average control delay per vehicle, or average pedestrian delay (seconds)

## Site: 6. Wiley Canyon Rd & Wabuska PM Peak Hour

Interim Year with Project with Off-Site Improvements  
Roundabout

### All Movement Classes

	South	East	North	West	Intersection
Delay (Average)	8.4	12.4	8.2	8.8	8.4
LOS	A	B	A	A	A

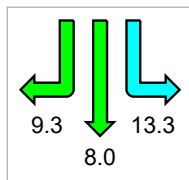

Wiley Canyon Road



Wabuska

Wiley Canyon Road

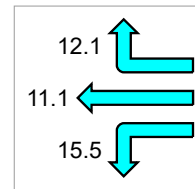

Wabuska

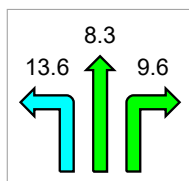

Colour code based on Level of Service



Level of Service Method: Delay & v/c (HCM 2010)

LOS F will result if v/c > 1 irrespective of movement delay value (does not apply for approaches and intersection).

Roundabout Level of Service Method: Same as Signalised Intersections

SIDRA Standard Delay Model is used. Control Delay includes Geometric Delay.

# INPUT VOLUMES

Vehicles and pedestrians per 60 minutes

 Site: 6. Wiley Canyon Rd & Wabuska PM Peak Hour

Interim Year with Project with Off-Site Improvements

Volume Display Method: Total and %

Volumes are shown for Movement Class(es): All Classes and Heavy Vehicles

Total Intersection Volumes (veh)

All Movement Classes: 1497

Light Vehicles (LV): 1452

Heavy Vehicles (HV): 45

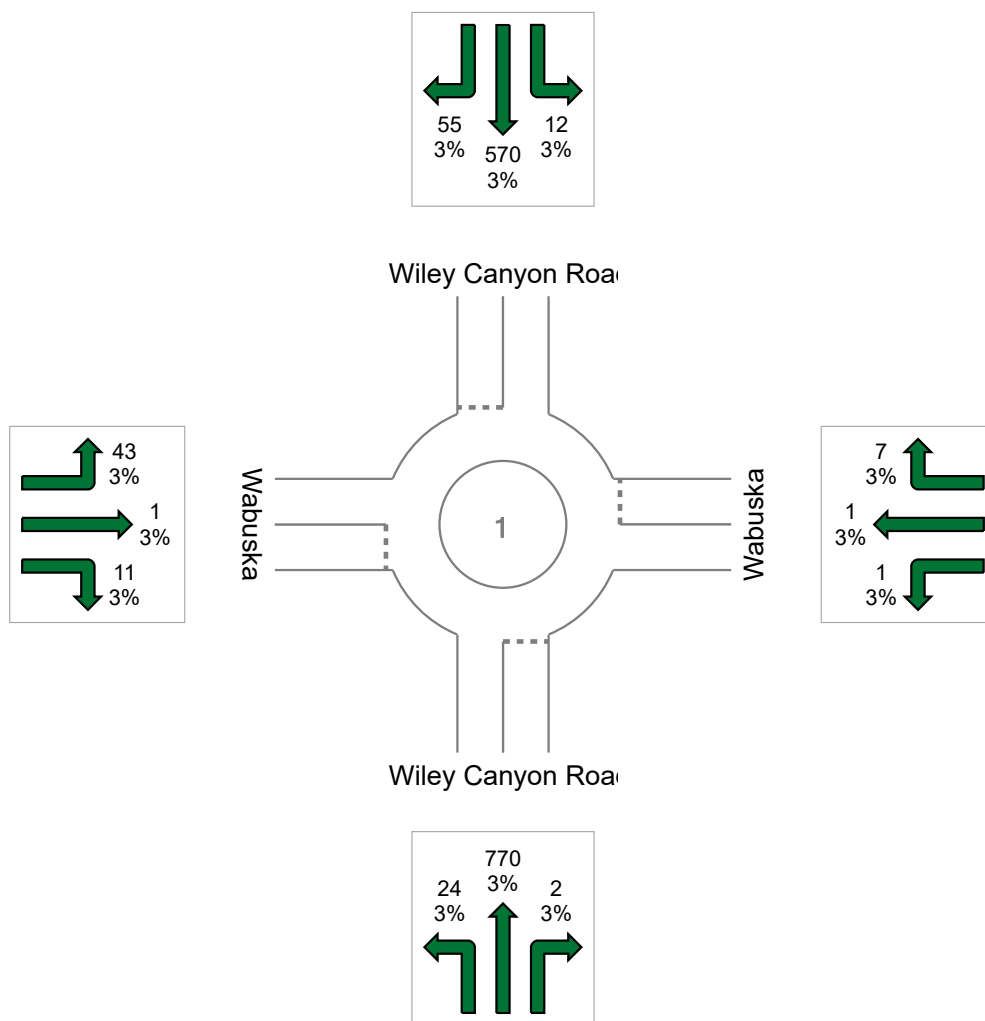

# QUEUE DISTANCE

Largest 95% Back of Queue for any lane used by movement (feet)

## Site: 6. Wiley Canyon Rd & Wabuska PM Peak Hour

Interim Year with Project with Off-Site Improvements  
Roundabout

### All Movement Classes

	South	East	North	West	Intersection
Queue Distance	129	3	65	8	129

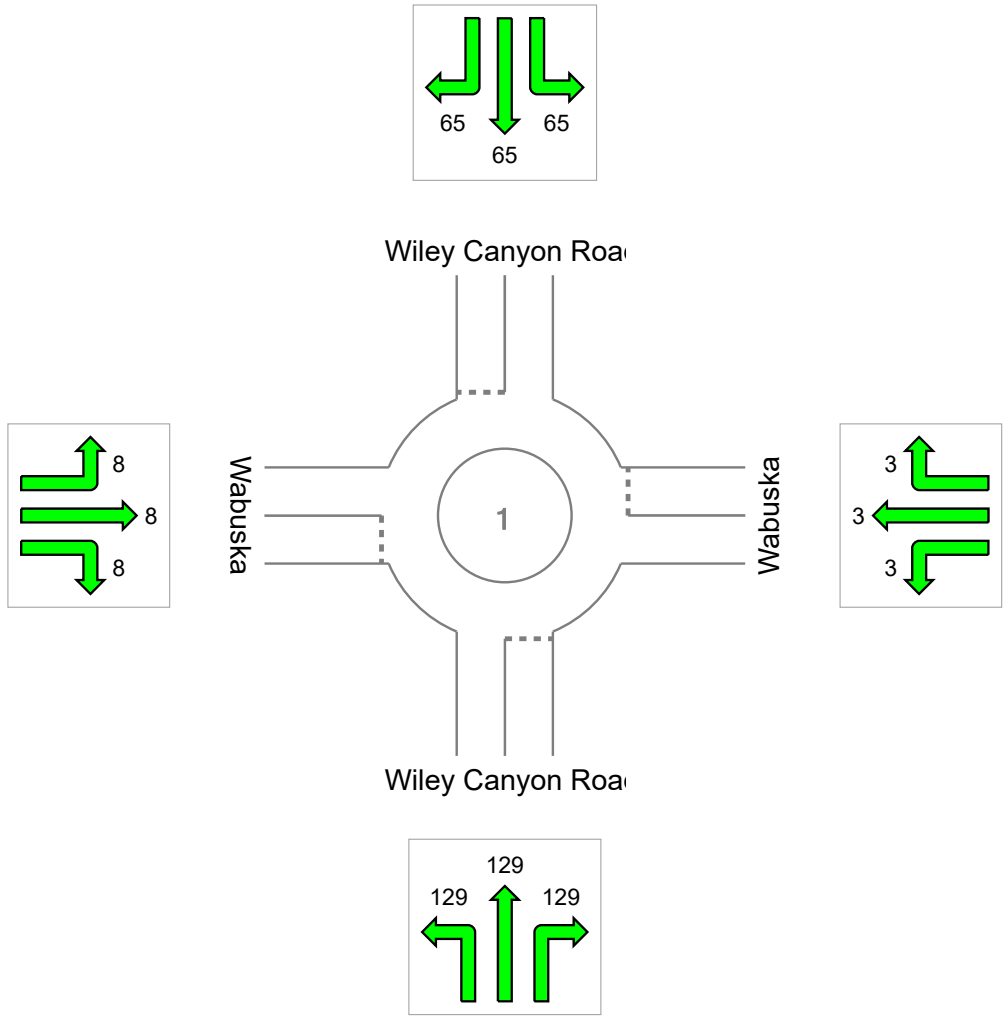

Colour code based on Queue Storage Ratio

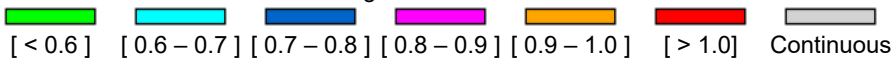

# DEGREE OF SATURATION

Ratio of Demand Volume to Capacity (v/c ratio)

## Site: 6. Wiley Canyon Rd & Wabuska PM Peak Hour

Interim Year with Project with Off-Site Improvements  
Roundabout

### All Movement Classes

	South	East	North	West	Intersection
Degree of Saturation	0.69	0.03	0.51	0.08	0.69

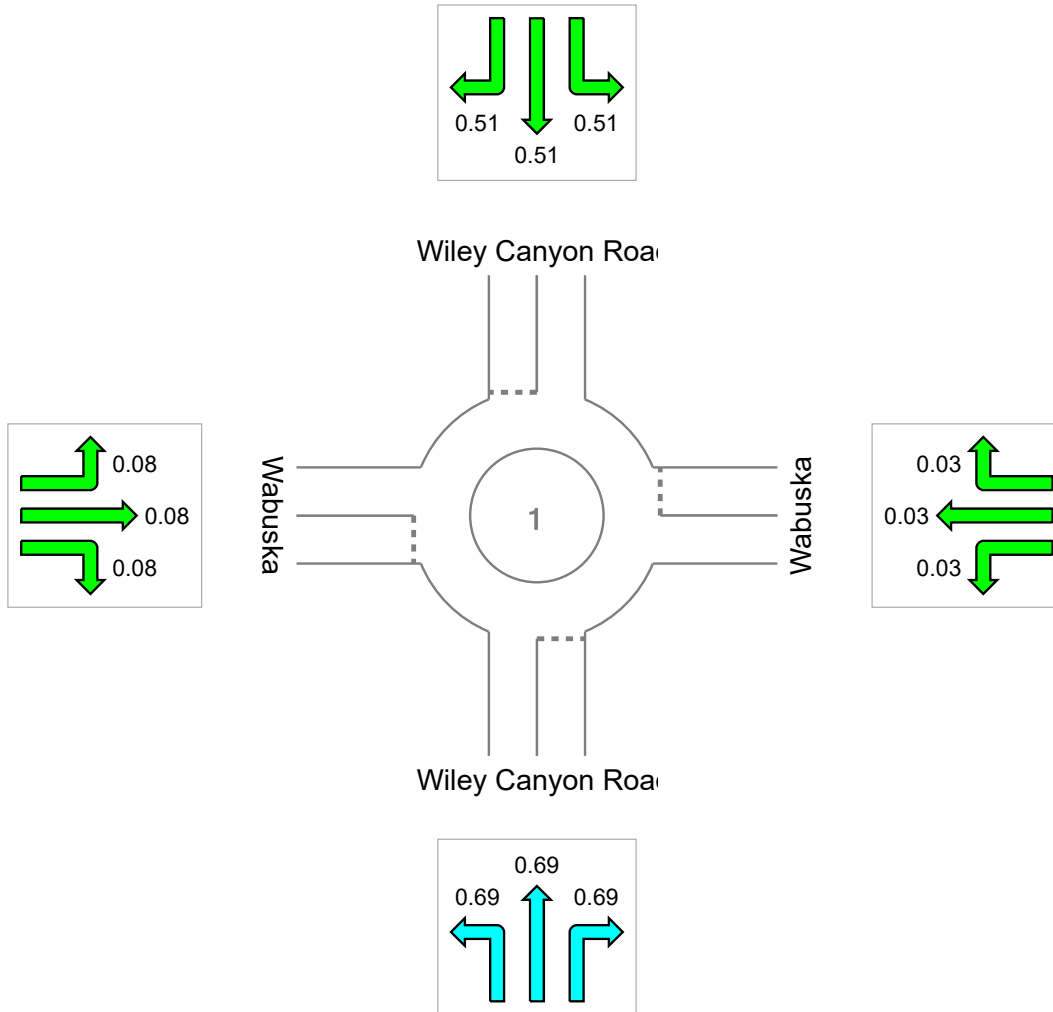

Colour code based on Degree of Saturation

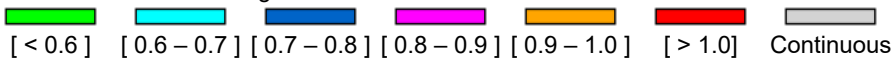

Processed: Friday, October 01, 2021 6:49:14 PM

SIDRA INTERSECTION 6.0.11.3995

Project: V:\2042\active\2042605700\traffic\_trans\models\sidra\int6\_wabuska-iy\_wp.sip6  
8001309, STANTEC CONSULTING SVCS INC, PLUS / 1PC

Copyright © 2000-2013 Akcelik and Associates Pty Ltd

www.sidrasolutions.com

**SIDRA**  
**INTERSECTION 6**

Interim Year With-Project with Off-Site Improvements - PM Peak Hour  
 6: Wiley Canyon Road & Wabuska Street

Synchro 10 Report  
 Lanes, Volumes, Timings

Lane Group	EBL	EBT	EBR	WBL	WBT	WBR	NBL	NBT	NBR	SBL	SBT	SBR
Lane Configurations												
Traffic Volume (vph)	43	1	11	1	0	7	24	770	2	12	570	55
Future Volume (vph)	43	1	11	1	0	7	24	770	2	12	570	55
Ideal Flow (vphpl)	1900	1900	1900	1900	1900	1900	1900	1900	1900	1900	1900	1900
Storage Length (ft)	0		0	0		0	150		0	215		260
Storage Lanes	0		0	0		0	1		0	1		1
Taper Length (ft)	25			25			25			25		
Satd. Flow (prot)	0	1744	0	0	1633	0	1770	1863	0	1770	1863	1583
Flt Permitted		0.769			0.946		0.415			0.306		
Satd. Flow (perm)	0	1392	0	0	1554	0	773	1863	0	570	1863	1583
Right Turn on Red			Yes			Yes			Yes			Yes
Satd. Flow (RTOR)		12			23							58
Link Speed (mph)		30			30			35			35	
Link Distance (ft)		578			167			791			1329	
Travel Time (s)		13.1			3.8			15.4			25.9	
Peak Hour Factor	0.95	0.95	0.95	0.95	0.95	0.95	0.95	0.95	0.95	0.95	0.95	0.95
Shared Lane Traffic (%)												
Lane Group Flow (vph)	0	58	0	0	8	0	25	813	0	13	600	58
Turn Type	Perm	NA		Perm	NA		Perm	NA		Perm	NA	Perm
Protected Phases		4			8			2			6	
Permitted Phases	4			8			2			6		6
Total Split (s)	29.5	29.5		29.5	29.5		40.5	40.5		40.5	40.5	40.5
Total Lost Time (s)		4.5			4.5		4.5	4.5		4.5	4.5	4.5
Act Effct Green (s)		7.4			7.3		49.4	49.4		49.4	49.4	49.4
Actuated g/C Ratio		0.12			0.12		0.83	0.83		0.83	0.83	0.83
v/c Ratio		0.32			0.04		0.04	0.53		0.03	0.39	0.04
Control Delay		24.3			4.6		3.0	5.2		3.0	3.8	1.1
Queue Delay		0.0			0.0		0.0	0.0		0.0	0.0	0.0
Total Delay		24.3			4.6		3.0	5.2		3.0	3.8	1.1
LOS		C			A		A	A		A	A	A
Approach Delay		24.3			4.6			5.1			3.6	
Approach LOS		C			A			A			A	

Intersection Summary

Area Type:	Other
Cycle Length:	70
Actuated Cycle Length:	59.5
Control Type:	Semi Act-Uncoord
Maximum v/c Ratio:	0.53
Intersection Signal Delay:	5.2
Intersection LOS:	A
Intersection Capacity Utilization:	57.9%
ICU Level of Service:	B
Analysis Period (min):	15

Splits and Phases: 6: Wiley Canyon Road & Wabuska Street

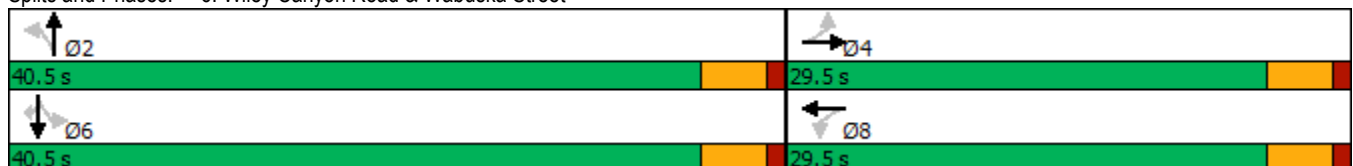



Interim Year With-Project with Off-Site Improvements - PM Peak Hour  
 7: I-5 SB Ramps & Calgrove Boulevard

Synchro 10 Report  
 Lanes, Volumes, Timings

Lane Group	EBL	EBT	EBR	WBL	WBT	WBR	NBL	NBT	NBR	SBL	SBT	SBR
Lane Configurations												
Traffic Volume (vph)	0	720	160	120	160	0	0	0	0	120	0	220
Future Volume (vph)	0	720	160	120	160	0	0	0	0	120	0	220
Ideal Flow (vphpl)	1900	1900	1900	1900	1900	1900	1900	1900	1900	1900	1900	1900
Storage Length (ft)	0		0	150		0	0		0	0		0
Storage Lanes	0		0	1		0	0		0	0		1
Taper Length (ft)	25			25			25			25		
Satd. Flow (prot)	0	1816	0	1770	1863	0	0	0	0	0	1770	1583
Flt Permitted				0.950							0.950	
Satd. Flow (perm)	0	1816	0	1770	1863	0	0	0	0	0	1770	1583
Right Turn on Red			Yes			Yes			Yes			Yes
Satd. Flow (RTOR)		27										229
Link Speed (mph)		40			45			30			30	
Link Distance (ft)		596			420			659			500	
Travel Time (s)		10.2			6.4			15.0			11.4	
Peak Hour Factor	0.96	0.96	0.96	0.96	0.96	0.96	0.96	0.96	0.96	0.96	0.96	0.96
Shared Lane Traffic (%)												
Lane Group Flow (vph)	0	917	0	125	167	0	0	0	0	0	125	229
Turn Type		NA		Prot	NA					Perm	NA	Perm
Protected Phases		4		3	8						6	
Permitted Phases										6		6
Total Split (s)		40.0		11.0	51.0					14.0	14.0	14.0
Total Lost Time (s)		4.5		4.5	4.5						4.5	4.5
Act Effct Green (s)		32.6		6.8	40.8						9.9	9.9
Actuated g/C Ratio		0.54		0.11	0.68						0.16	0.16
v/c Ratio		0.92		0.63	0.13						0.43	0.51
Control Delay		29.2		45.6	3.2						30.8	8.8
Queue Delay		0.0		0.0	0.0						0.0	0.0
Total Delay		29.2		45.6	3.2						30.8	8.8
LOS		C		D	A						C	A
Approach Delay		29.2			21.3						16.6	
Approach LOS		C			C						B	

Intersection Summary

Area Type:	Other
Cycle Length:	65
Actuated Cycle Length:	60
Control Type:	Semi Act-Uncoord
Maximum v/c Ratio:	0.92
Intersection Signal Delay:	24.9
Intersection LOS:	C
Intersection Capacity Utilization:	72.2%
ICU Level of Service:	C
Analysis Period (min):	15

Splits and Phases: 7: I-5 SB Ramps & Calgrove Boulevard

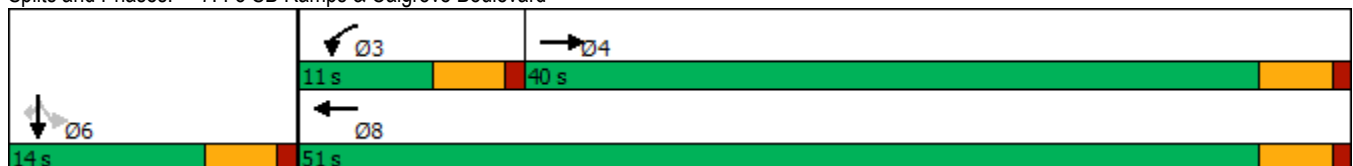

Interim Year With-Project with Off-Site Improvements - PM Peak Hour  
 8: I-5 NB Ramps & Calgrove Boulevard

Synchro 10 Report  
 Lanes, Volumes, Timings

Lane Group	EBL	EBT	EBR	WBL	WBT	WBR	NBL	NBT	NBR	SBL	SBT	SBR
Lane Configurations												
Traffic Volume (vph)	420	420	0	0	200	150	90	10	270	0	0	0
Future Volume (vph)	420	420	0	0	200	150	90	10	270	0	0	0
Ideal Flow (vphpl)	1900	1900	1900	1900	1900	1900	1900	1900	1900	1900	1900	1900
Storage Length (ft)	170		0	0		0	0		0	0		0
Storage Lanes	1		0	0		0	0		1	0		0
Taper Length (ft)	25			25			25			25		
Satd. Flow (prot)	1770	1863	0	0	1755	0	0	1783	1583	0	0	0
Flt Permitted	0.950							0.957				
Satd. Flow (perm)	1770	1863	0	0	1755	0	0	1783	1583	0	0	0
Right Turn on Red			Yes			Yes			Yes			Yes
Satd. Flow (RTOR)					52				293			
Link Speed (mph)		45			45			30			30	
Link Distance (ft)		420			786			475			858	
Travel Time (s)		6.4			11.9			10.8			19.5	
Peak Hour Factor	0.92	0.92	0.92	0.92	0.92	0.92	0.92	0.92	0.92	0.92	0.92	0.92
Shared Lane Traffic (%)												
Lane Group Flow (vph)	457	457	0	0	380	0	0	109	293	0	0	0
Turn Type	Prot	NA			NA		Perm	NA	Perm			
Protected Phases	7	4			8			2				
Permitted Phases							2		2			
Total Split (s)	25.0	52.5			27.5		22.5	22.5	22.5			
Total Lost Time (s)	4.5	4.5			4.5			4.5	4.5			
Act Effct Green (s)	20.1	42.3			17.7			18.1	18.1			
Actuated g/C Ratio	0.29	0.61			0.25			0.26	0.26			
v/c Ratio	0.89	0.40			0.78			0.23	0.47			
Control Delay	48.0	8.1			32.8			23.6	6.0			
Queue Delay	0.0	0.3			0.0			0.0	0.0			
Total Delay	48.0	8.4			32.8			23.6	6.0			
LOS	D	A			C			C	A			
Approach Delay		28.2			32.8			10.8				
Approach LOS		C			C			B				

Intersection Summary

Area Type:	Other
Cycle Length:	75
Actuated Cycle Length:	69.5
Control Type:	Semi Act-Uncoord
Maximum v/c Ratio:	0.89
Intersection Signal Delay:	25.1
Intersection LOS:	C
Intersection Capacity Utilization:	72.2%
ICU Level of Service:	C
Analysis Period (min):	15

Splits and Phases: 8: I-5 NB Ramps & Calgrove Boulevard



## **Appendix C PEAK HOUR SIGNAL WARRANT EXHIBITS**





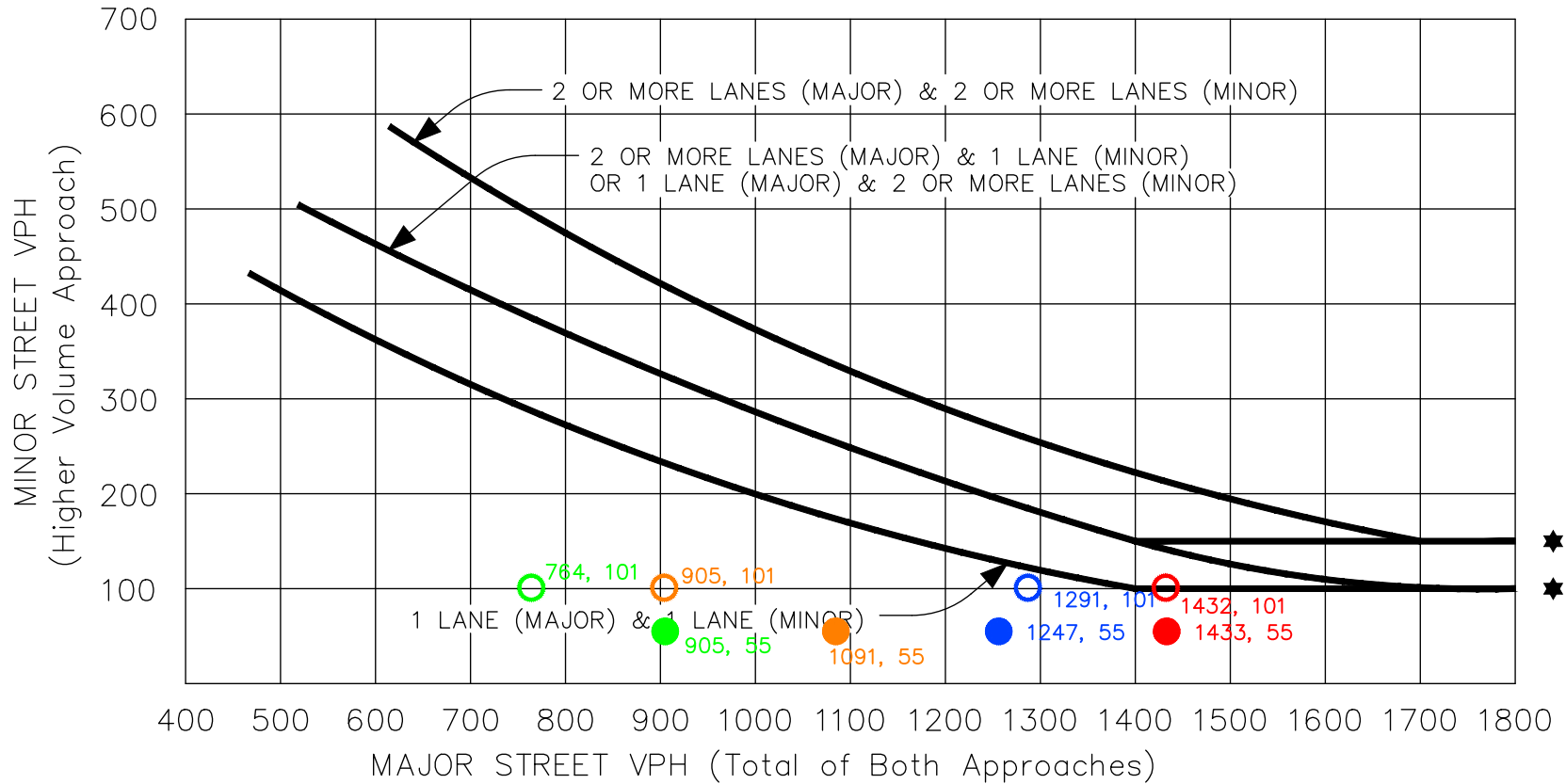

○ AM peak hour Major Street Volume, Minor Street Volume      ● PM peak hour Major Street Volume, Minor Street Volume

Green = Existing      Orange = Existing + Project      Blue = Interim Year No-Project      Red = Interim Year plus Project

★ Note: 150 vph applies as the lower threshold volume for a minor-street approach with two or more lanes, and 100vph applies as the lower threshold volume for a minor-street approach with one lane.

Source: MUTCD - Figure 4C-3



**Figure C-1**  
Peak Hour Volume Warrant - Under 45 mph  
6. Wiley Canyon Rd & Wabuska St

\\us0300-pplsa01\workgroup\2042\active\2042605700\drawing\exhibit\_files\6-peak\_hour\_warrant-under45mph.dwg

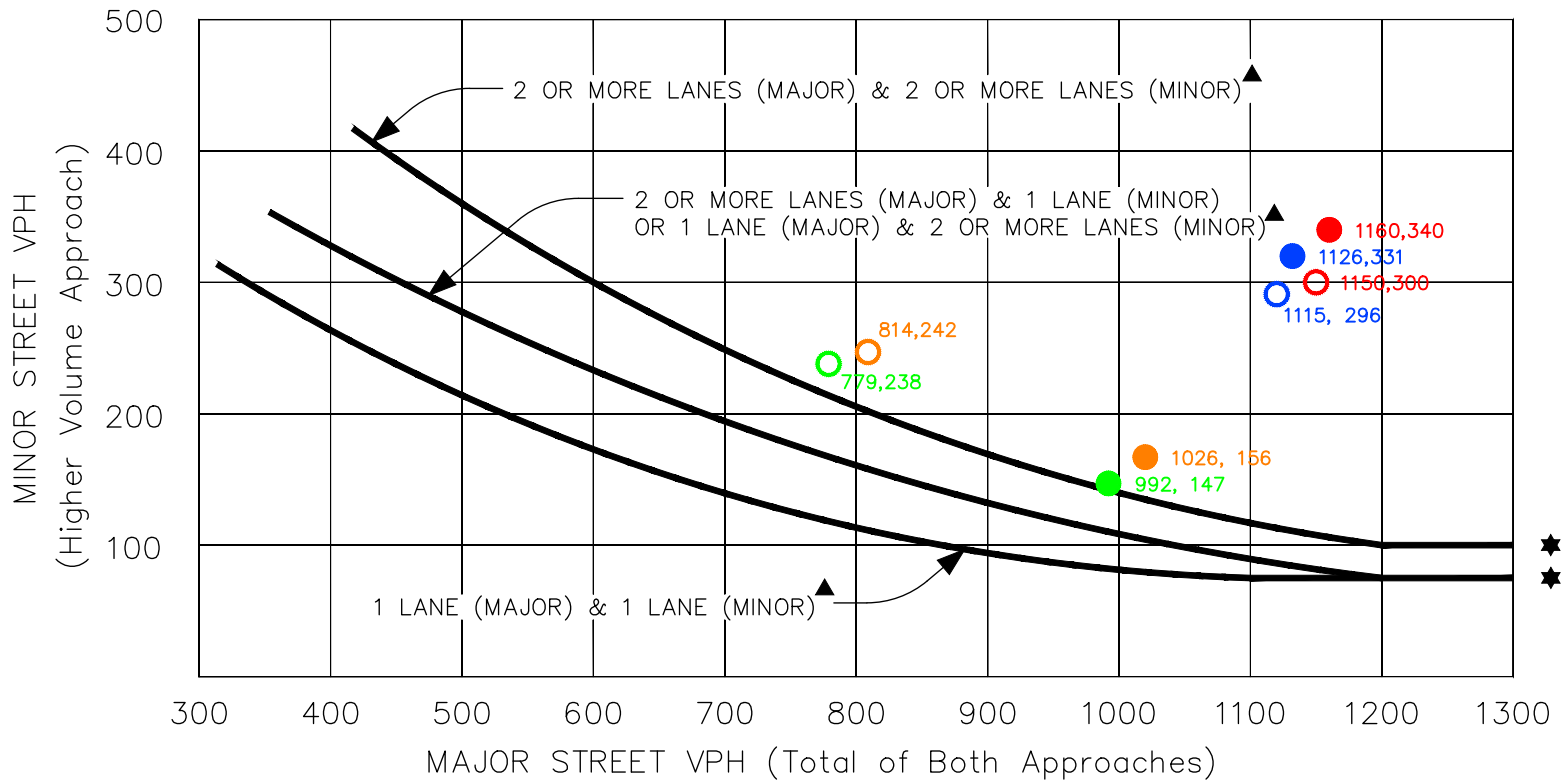

○ AM peak hour Major Street Volume, Minor Street Volume      ● PM peak hour Major Street Volume, Minor Street Volume  
 Green = Existing      Orange = Existing plus Project      Blue = Interim Year No-Project      Red = Interim Year plus Project

- ▲ Note: These curves are recommended for use in community less than 10,000 population or above 40 MPH on Major Street.
- ★ Note: 100 vph applies as the lower threshold volume for a minor-street approach with two or more lanes, and 75 vph applies as the lower threshold volume for a minor-street approach with one lane.

Source: MUTCD – Figure 4C-4

\\us0300-pplsa01\workgroup\2042\active\2042605700\drawing\exhibit\_files\7-peak\_hour\_warrant-over40mph.dwg



**Figure C-2**  
Peak Hour Volume Warrant - Over 40 mph  
7. I-5 SB & Calgrove Blvd

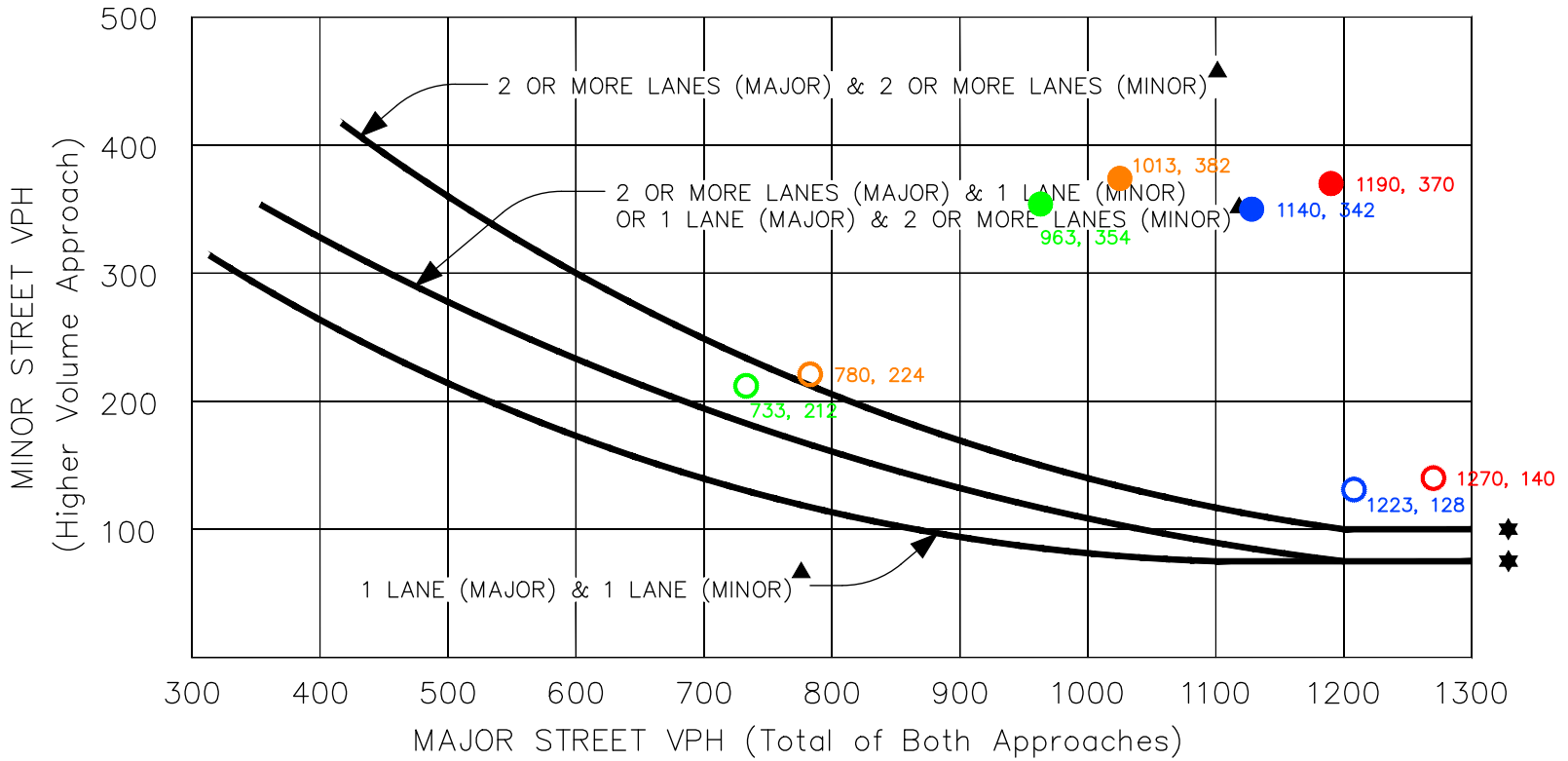

○ AM peak hour Major Street Volume, Minor Street Volume

● PM peak hour Major Street Volume, Minor Street Volume

Green = Existing

Orange = Existing plus Project

Blue = Interim Year No-Project

Red = Interim Year plus Project

▲ Note: These curves are recommended for use in community less than 10,000 population or above 40 MPH on Major Street.

★ Note: 100 vph applies as the lower threshold volume for a minor-street approach with two or more lanes, and 75 vph applies as the lower threshold volume for a minor-street approach with one lane.

Source: MUTCD – Figure 4C-4



**Figure C-3**  
Peak Hour Volume Warrant - Over 40 mph  
8. I-5 NB & Calgrove Blvd





## **Appendix D SCVCTM SELECT ZONE MODEL PLOT**





SCVCTM WILEY CYN MIXED-USE SELECT ZONE 174 SZ TRIP DISTRIBUTION

