

Initial Study/Mitigated Negative Declaration

Kindred Church Expansion Project

Development Project Number: DEV2020-00016

Prepared for | Planning Services Division
City of Anaheim
200 South Anaheim Boulevard
Anaheim, California 92805

Prepared by | Psomas
5 Hutton Centre Drive, Suite 300
Santa Ana, California 92707-8794

March 2022

TABLE OF CONTENTS

<u>Section</u>		<u>Page</u>
Section 1.0	Introduction	1-1
	1.1 Purpose of The Initial Study.....	1-1
	1.2 Summary of Findings.....	1-1
	1.3 Public Review	1-2
	1.4 Report Organization.....	1-2
Section 2.0	Project Location, Background, and Environmental Setting.....	2-1
	2.1 Project Location	2-1
	2.2 Existing Project site Conditions	2-1
	2.3 Surrounding Land Uses	2-2
Section 3.0	Project Description	3-1
	3.1 Physical Characteristics.....	3-1
	3.1.1 Phase 1.....	3-1
	3.1.2 Phase 2.....	3-2
	3.1.3 Discretionary Actions	3-5
Section 4.0	Environmental Checklist.....	4-1
Section 5.0	Environmental Evaluation	5-1
	I. Aesthetics	5-1
	II. Agriculture and Forest Land Resources	5-4
	III. Air Quality	5-5
	IV. Biological Resources	5-19
	V. Cultural Resources	5-22
	VI. Energy	5-25
	VII. Geology and Soils.....	5-28
	VIII. Greenhouse Gas Emissions	5-33
	IX. Hazards and Hazardous Materials	5-38
	X. Hydrology and Water Quality.....	5-42
	XI. Land Use and Planning	5-45
	XII. Mineral Resources.....	5-47
	XIII. Noise	5-48
	XIV. Population and Housing.....	5-57
	XV. Public Services	5-58
	XVI. Recreation	5-61
	XVII. Transportation.....	5-62

	XVIII. Tribal Cultural Resources	5-63
	XIX. Utilities and Service Systems	5-67
	XX. Wildfire.....	5-70
	XXI. Mandatory Findings of Significance.....	5-72
Section 6.0	Preparers.....	6-1
Section 7.0	References	7-1

TABLES

<u>Table</u>	<u>Page</u>
1 Project Construction Schedule	3-5
2 California and Federal Ambient Air Quality Standards.....	5-6
3 Air Quality Monitoring Data from the Anaheim-Pampas Lane Monitoring Station.....	5-8
4 Attainment Status of Criteria Pollutants in the South Coast Air Basin.....	5-9
5 South Coast Air Quality Management District Air Quality Significance Thresholds	5-10
6 Estimated Maximum Daily Construction Emissions	5-13
7 Localized Significance Threshold Construction Emissions	5-14
8 Peak Daily Operational Emissions	5-15
9 Energy Use During Construction.....	5-27
10 Transportation Energy (Gallons/year)	5-28
11 Energy from Utilities	5-28
12 Estimated GreenHouse Gas Emissions from Construction.....	5-36
13 Estimated Annual GreenHouse Gas Emissions from Project Operation.....	5-36
14 Estimated Total Project Annual Greenhouse Gas Emissions	5-37
15 Typical Noise Levels	5-48
16 Land Use Compatibility for Noise Exposure.....	5-52
17 Monitored Noise Levels.....	5-53
18 Construction Noise Levels at Noise-Sensitive Uses	5-54
19 Vibration Levels Per Construction Equipment.....	5-55
20 Vibration Annoyance Criteria at Sensitive Uses.....	5-56
21 Building Damage Criteria at Sensitive Uses	5-56
22 City of Anaheim Fire Services Facilities	5-59

EXHIBITS

<u>Exhibit</u>	<u>Follows Page</u>
1	Vicinity Map.....2-1
2	Aerial Photograph2-1
3	Existing Site Photographs2-1
4	Overall Site Plan3-1
5	Proposed Site Plan for Upper Plaza with Implementation of Phase 13-1
6	Demolition Plan for Upper Plaza3-1
7	Demolition Plan for Auditorium.....3-1
8	Upper Plaza Materials and Finishes3-1
9a	Sheet Index Plan from Grading Plan.....3-2
9b	Section Details and Notes from Grading Plan.....3-2
10	Proposed Site Plan for Upper Plaza with Implementation of Phase 23-2
11	Proposed Site Plan for Lower Portion of Site with Implementation of Phase 2.....3-2
12	Auditorium Renovation Plan.....3-3
13	Auditorium Elevations3-3
14	Auditorium Materials and Finishes3-3
15	Internal Circulation and Parking Improvements3-3
16a-c	Conceptual Landscape Plan3-4
17	Water Quality Best Management Practices3-4
18	Noise Monitoring Locations.....5-53

APPENDICES

Appendix

A	Air Quality Calculations
B	Biological Resources Constraints Analysis
C	Energy Calculations
D	Soils Report
E	EDR Radius Map Report
F	Preliminary Water Quality Management Plan (PWQMP)
G	Construction Noise Calculations
H	Trip Generation Memorandum
I	Vehicle Miles Traveled (VMT) Memorandum

This page intentionally left blank

SECTION 1.0 INTRODUCTION

1.1 PURPOSE OF THE INITIAL STUDY

In accordance with the California Environmental Quality Act (CEQA) (*California Public Resources Code* §21000 et seq.) and its Guidelines (*California Code of Regulations*, Title 14, §15000 et seq.), this Initial Study (IS) has been prepared as documentation for a Mitigated Negative Declaration (MND) for the proposed Kindred Church Expansion Project (Project). This IS includes a description of the Project; location of the Project site; evaluation of the potential environmental impacts; findings from the environmental review; and proposed mitigation measures to lessen or avoid environmental impacts on the environment.

Pursuant to Section 15367 of the State CEQA Guidelines, the City of Anaheim (City) is the lead agency for the Project. The lead agency is the public agency that has the principal responsibility for carrying out or approving a project. The City, as the lead agency, shall have the authority for project approval and adoption of the accompanying environmental documentation.

The purpose of this document is to evaluate the Project relative to each of the environmental topic areas contained in the CEQA Guidelines. Overall, the Project consists of the expansion of the existing Kindred Community Church. The Project would be constructed in two phases. Phase 1 would include partial demolition of an existing auditorium structure; relocation of modular buildings and a multipurpose fabric structure; development of two mini-plazas; establishment of an upper plateau campus area within the existing church footprint; the addition of outdoor lighting and landscaping; and the addition of a new parking lot. Phase 2 would include the remodeling and expansion of the existing auditorium with two new wings to provide additional seating and back-of-house areas; four new modular buildings; parking lot improvements, and addition of a monument sign, landscaping, outdoor lighting, and a pedestrian pathway. A more detailed project description is provided below in Section 3.0.

1.2 SUMMARY OF FINDINGS

Based on the environmental checklist form prepared for the Project (included in Section 4.0, Environmental Checklist) and supporting environmental analysis (provided in Section 5.0, Environmental Evaluation), the Project would have no impact or a less than significant impact on the environmental impact areas listed below.

- Aesthetics;
- Agriculture and Forest Resources;
- Air Quality;
- Energy;
- Greenhouse Gas Emissions;
- Hazards and Hazardous Materials;
- Hydrology and Water Quality;
- Land Use and Planning;
- Mineral Resources;
- Noise;
- Population and Housing;
- Public Services;
- Recreation;
- Transportation;
- Utilities and Service Systems; and
- Wildfire

The Project has the potential to have significant impacts to the environmental impact areas listed below:

- Biological Resources;
- Cultural Resources;
- Geology and Soils; and
- Tribal Cultural Resources

However, this IS identifies recommended mitigation measures that would reduce identified potential impacts, to less than significant, when incorporated into the Project.

According to the State CEQA Guidelines, it is appropriate to prepare an MND for the Project because implementation of the recommended mitigation measures would eliminate or reduce potentially significant environmental impacts of the Project to a less than significant level.

1.3 PUBLIC REVIEW

The public review period for the Initial Study/Mitigated Negative Declaration (IS/MND) in accordance with Section 15073(a) of the State CEQA Guidelines is March 24, 2022 to April 25, 2022. The City has mailed the Notice of Intent (NOI) to adopt a MND for the Project by mail to property owners and occupants within a 500-foot radius of the Project site pursuant to Anaheim Municipal Code Section 18.60.100 (Notice of Public Hearing). This noticing is in accordance with Section 15072 (a) and (b) of the CEQA Guidelines. The IS/MND is available for public review on the City of Anaheim website (www.anaheim.net); the Anaheim Planning and Building Department (200 South Anaheim Boulevard); the Anaheim Central Library (500 West Broadway) and the East Anaheim Branch Library (8201 E. Santa Ana Canyon Road). In reviewing the IS/MND, the reviewer should focus on the sufficiency of the document in identifying and analyzing the potential impacts of the Project on the environment and the ways in which the potentially significant effects are avoided or mitigated. Comments on the analysis contained herein may be sent to:

Mr. Andy T. Uk, Associate Planner
City of Anaheim Planning Services Division
200 South Anaheim Boulevard
Anaheim, California 92805
Email: aук@anaheim.net

Following receipt and evaluation of comments from agencies, organizations and/or individuals, the City will determine whether these comments have raised any substantial new environmental issues. If not, or if the new issues do not provide substantial evidence that the Project will have a significant effect on the environment, the Planning Commission and City Council will consider the approval of the Project and environmental documentation.

1.4 REPORT ORGANIZATION

This document has the following sections:

- **Section 1 – Introduction.** This section includes a discussion of the purpose of this IS, as well as a summary of findings, and a discussion of the public review process.
- **Section 2 – Project Location, Background, and Environmental Setting.** This section provides an overview of the Project location, as well as a description of existing on-site and surrounding land uses.
- **Section 3 – Project Description.** This section identifies key characteristics of the Project and includes a list of anticipated discretionary actions.

- **Section 4 – Environmental Checklist.** The completed City of Anaheim Environmental Checklist Form provides an overview of the potential impacts that may or may not result from the Project.
- **Section 5 – Environmental Evaluation.** This section contains an analysis of environmental impacts identified in the environmental checklist. As necessary, mitigation measures (MMs) have been included following the environmental analysis for each resource topic.
- **Section 6 – Report Preparers.** This section identifies those individuals responsible for preparing the IS/MND.
- **Section 7 – References.** This section identifies resources used to prepare this document.

This page intentionally

SECTION 2.0 PROJECT LOCATION, BACKGROUND, AND ENVIRONMENTAL SETTING

2.1 PROJECT LOCATION

The Project site encompasses approximately 14.79 acres and is located at 8712 East Santa Ana Canyon Road, approximately 1.1 miles east of Weir Canyon Road, and approximately 0.71-mile west of Gypsum Canyon Road in the City of Anaheim in Orange County. The Project site consists of a portion of Assessor Parcel Number (APN) 354-321-01, as well as all of APNs 514-101-28 and 514-091-25. The Project would also construct off-site improvements consisting of a storm drain pipe and two underground stormwater infiltration chambers within a portion of APN 354-321-03, which is downslope and adjacent to the Project site. The Project site is depicted in a vicinity map, which is provided as Exhibit 1.

2.2 EXISTING PROJECT SITE CONDITIONS

Kindred Community Church is currently located on the Project site. The General Plan designates the Project site for Open Space land use. The majority of the property is located within the Sycamore Canyon Specific Plan (SP88-1) Zone; however, a small portion (approximately two acres) is located within The Summit of Anaheim Hills Specific Plan (SP88-2) Zone, and 3.61 acres within the “T” Transition zone. The entire property is within the Scenic Corridor (SC) Overlay Zone. SP88-1 designates this site as a “garden church” facility; however, SP88-1 does not include detailed standards or procedures for the development of a church within any development area in the specific plan. The specific plan does state that a church within this portion of the specific plan would be subject to a separate entitlement process, which was satisfied through the approval of a Conditional Use Permit (CUP). The City originally approved the church in 1988 as a semi-enclosed “garden church” by CUP 3032. In 1998, the City subsequently approved the existing church by CUP 4033. This CUP permitted a 29,503-square foot church with accessory day care center, fellowship hall, and multi-purpose building in conjunction with existing modular buildings. The City subsequently amended the CUP in 1998 to add a parsonage home, in 2004 to allow additional 5,611 square feet to the fellowship hall, and in 2008 to add three modular units for Sunday school classrooms.

The existing church facilities include a 29,503-square foot worship center, a day care center, a fellowship hall, a multi-purpose building, modular buildings, four parking lots containing a total of 376 parking spaces¹, a welcome tent, an amphitheater/outdoor chapel, an artificial lake, a mechanical building, a modular residence with garage, a garage/maintenance building, and outdoor lighting. A County fire road is located in the northeastern portion of the Project site. There are two easements for a storm drain and a water main, which run parallel through the southern portion of the Project site. The northwestern portion of the Project site is undeveloped with the exception of a dirt road that leads to a cross at the top of the hill. The aerial photograph provided as Exhibit 2 depicts the Project site and its immediate surroundings. Photographs of existing conditions within the Project site are depicted in existing site photographs provided in Exhibit 3.

¹ An additional 143 parking spaces are located off-site to the northeast within APN 354-321-03, for a total of 519 parking spaces.

Chino Hills State Park



Jean Woodard Park

East Side Community Park

Box Canyon Park

Featherly Regional Park

Brush Canyon Park

Bryant Ranch Elementary School

At and SF Railroad

La Palma Ave

Gypsum Canyon Rd

91

Featherly Regional Park

Santa Ana Canyon Rd

Sycamore Park

Toyon Park

Running Springs Elem School

Serrano Ave

241

Weir Canyon Regional Park



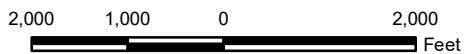
Project Boundary

D:\Projects\3ANA\009402\MXD\ISMND\ex_Vicinity_20220105.mxd

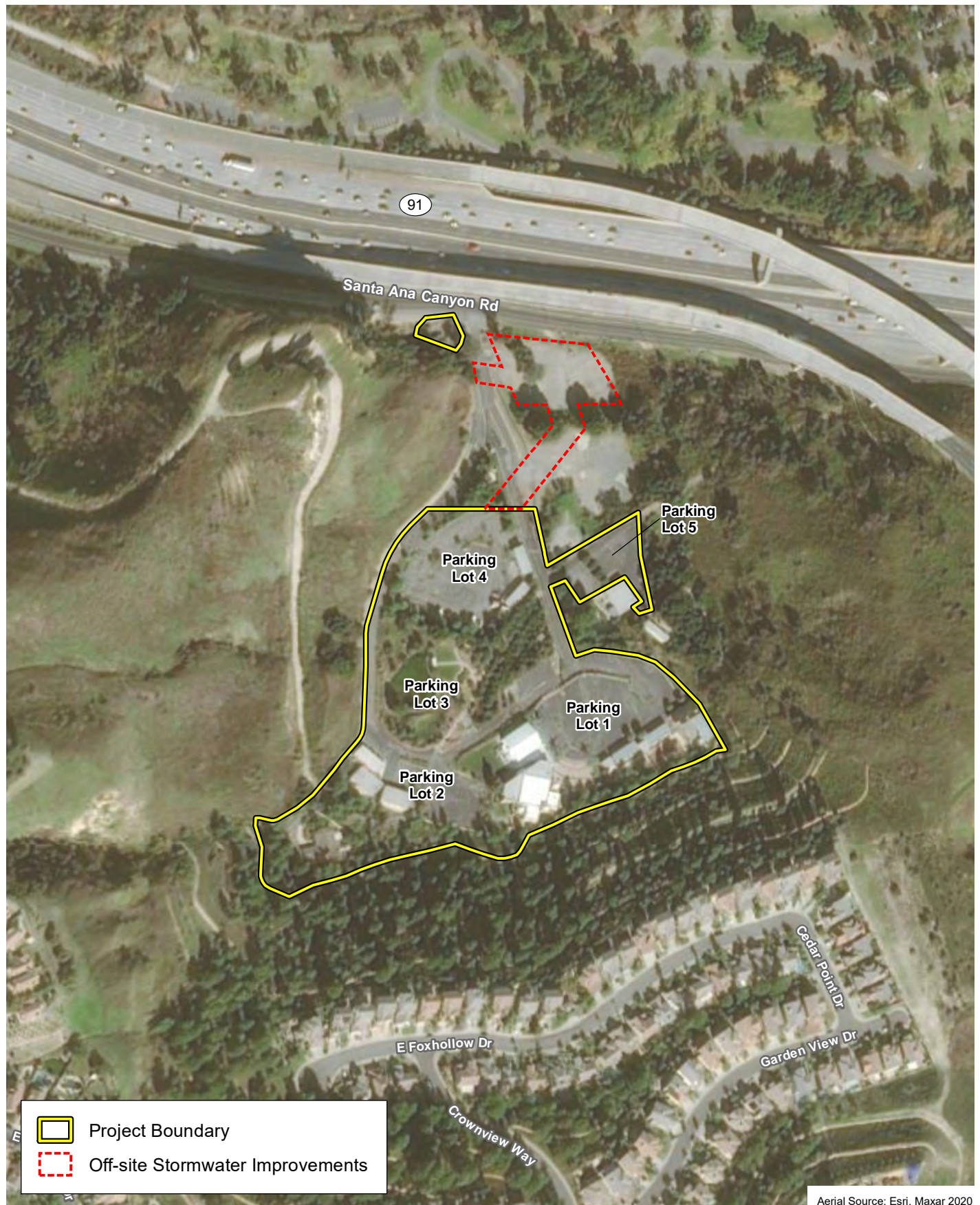
Vicinity Map

Kindred Church Expansion Project (City of Anaheim)

Exhibit 1



D:\Projects\3\ANA\009402\MXDex_Aerial_20210505.mxd

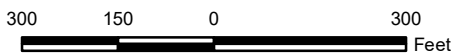


Aerial Source: Esri, Maxar 2020

Aerial Photograph

Exhibit 2

Kindred Church Expansion Project (City of Anaheim)





LOOKING EAST TOWARD SITE ENTRY



EXISTING MONUMENT SIGN AT SITE ENTRY



DRIVEWAY TO OVERFLOW PARKING LOT #7



PEDSTRIAN PATH FROM SITE ENTRY LOOKING SOUTH



PARKING LOT #6 LOOKING NORTH



PARKING LOT #5 LOOKING SOUTH



PARKING LOT #1 LOOKING WEST



MAIN AUDITORIUM AND FABRIC BUILDING LOOKING WEST



PARKING LOT #2 LOOKING EAST



PARKING LOT #4 LOOKING EAST



EXISTING POND / FUTURE PARKING LOT #3 LOOKING NORTH



AERIAL VIEW LOOKING SOUTHEAST

D:\Projects\3ANA\009402\Graphics\ISMND\lex_Existing_SitePhotos_20220105.ai

Source: Elements Architecture, 2021

Existing Site Photographs

Kindred Church Expansion Project (City of Anaheim)

Exhibit 3



(01/05/2022 MMD) R:\Projects\3ANA\3ANA009402\Graphics\ISMND\lex_Existing_SitePhotos.pdf

2.3 **SURROUNDING LAND USES**

The General Plan designates the properties located adjacent to the Project site for Open Space and Low Density Residential land use. The properties include the following existing land uses:

- East Santa Ana Canyon Road and State Route (SR) 91 to the north;
- A vacant, previously developed parcel (APN 354-321-03) to the northeast;
- Two open space parcels with stormwater brow ditches upslope to the south;
- Undeveloped land (APN 514-012-18) to the east;
- Undeveloped land (APN 354-251-02) to the west; and
- Single-Family Residential to the southwest

SECTION 3.0 PROJECT DESCRIPTION

3.1 PHYSICAL CHARACTERISTICS

The Project consists of two phases to expand the existing Kindred Community Church. The Project's proposed total additional square footage is 9,839 square feet with an increase of 180 seats in seating capacity within the auditorium. An overall site plan showing both phases of development is provided as Exhibit 4.

3.1.1 PHASE 1

Phase 1 of the Project includes the relocation of modular structures, demolition of portions of the auditorium building, relocation of an existing fabric tent, the establishment of a centralized campus at the top of the Project site, and the addition of a new parking lot, as further described below and as depicted in Exhibit 5, Proposed Site Plan for Upper Plaza with Implementation of Phase 1.

Relocation of Modular Structures

The Project would relocate three existing modular structures to a consolidated location adjacent to the auditorium building, in a campus separated from vehicular traffic. Interior tenant improvements would also be completed for these three modular structures consisting of fire sprinklers, finishes, and lighting. Structures that would be relocated are identified in Exhibit 6, Demolition Plan for Upper Plaza.

Demolition of Portions of the Auditorium Building

The Project would demolish two wings of the auditorium building totaling approximately 911 square feet to prepare for Phase 2 additions. This portion of the Project would also include the demolition of one small modular structure, located east of the existing fabric tent and auditorium building. These modifications are depicted in Exhibit 7, Demolition Plan for Auditorium.

Relocation of Existing Fabric Tent

The Project would relocate an existing 22-foot tall, 4,512-square foot multi-purpose fabric structure used as a fellowship hall to the northeast portion of the site. Structures that would be relocated are identified in Exhibit 6, Demolition Plan for Upper Plaza.

Establishment of an Upper Plateau Campus

The Project would create a campus area within the upper plateau of the Project site. This would include development of two "mini-plazas" in the upper plateau area that the church would use as fellowship areas for children and adult ministry activities. The Project would also update this portion of the Project site to include a new "front porch" trellis structure that would encourage fellowship at the front edge of the plateau looking out over the Project site. The trellis structure would be 14-foot 6-inches high, and constructed of a 6-inch steel tube frame with a rust-colored powder coat finish. The Project would install decorative, semi-enclosed lattice screening structures up to 17 feet in height around the relocated fabric structure as well as around one of the "mini-plazas" to screen and define the various use areas. In addition, the Project would add a seating area around an existing tree located in a central location of the upper plateau area. The Project would also include modifications to the existing driveway leading to the on-site residence; and demolition and replacement of a trash enclosure. Materials and finishes for the "mini-plazas" and trellis structure are depicted in Exhibit 8, Upper Plaza Materials and Finishes.

D:\Projects\3ANA\009402\Graphics\ISMND\lex_Overall_SitePlan_20220105.ai



1
A-11 SITE PLAN AT LOWER PARKING LOTS

EXISTING RE-STRIPED & LANDSCAPED PARKING LOT

APN 354-251-01
37.12 ACRES

APN 354-321-03

APN 354-321-03

EXISTING TRANSFORMER

NEW PARKING LOT

NEW & RELOCATED MODULAR STRUCTURES TO CREATE CONSOLIDATED AND SAFE CAMPUS

PROPOSED SITE PLAN AT UPPER PLAZA

1
A-9 1
A-10

PHASE 1 PHASE 2

NEW DECORATIVE SCREEN

NEW TRELLIS STRUCTURE

EXISTING RENOVATED AUDITORIUM WITH NEW ADDITIONS

EXISTING EASEMENT TO BALDWIN BUILDERS FOR STORM DRAIN PURPOSES INST. 19970643589 REC. 12/16/1997

EXISTING WATER LINE EASEMENT PER M.M. 748/23-27

AREA TABULATIONS

TOTAL AREA	644,252 SF
PERVIOUS AREA	
EXISTING PERVIOUS AREA	325,435 SF
PERCENTAGE OF TOTAL AREA	50.5%
PROPOSED PERVIOUS AREA	37,846 SF
PERCENTAGE OF TOTAL AREA	5.9%
PROPOSED PERVIOUS AREA	287,589 SF
PERCENTAGE OF TOTAL AREA	44.6%
IMPERVIOUS AREA	
EXISTING IMPERVIOUS AREA	318,817 SF
PERCENTAGE OF TOTAL AREA	49.5%
PROPOSED IMPERVIOUS AREA	37,846 SF
PERCENTAGE OF TOTAL AREA	5.9%
PROPOSED IMPERVIOUS AREA	356,663 SF
PERCENTAGE OF TOTAL AREA	55.4%

Source: Elements Architecture, 2021

Overall Site Plan

Kindred Church Expansion Project (City of Anaheim)



Exhibit 4



D:\Projects\3ANA\009402\Graphics\ISMND\lex_DemoPlan_UpperPlaza_20220105.ai

EXISTING LANDSCAPING & POND TO BE REMOVED, FOR FUTURE PARKING LOT

EXISTING PARKING LOT TO BE EXTENDED, RE-PAVED AND RE-STRIPED

EXISTING MODULAR BUILDINGS TO BE RE-LOCATED

EXISTING BACKFLOW DEVICE TO BE RELOCATED

EXISTING FIRE HYDRANT TO BE RELOCATED

EXISTING DRIVEWAY TO RESIDENCE BE RE-CONFIGURED

EXISTING UPPER PLAZA TO BE ENLARGED, WITH CONCRETE PAVING & LANDSCAPING - EXTENTS SHOWN WITH RED HATCH

DEMO EXIST TRASH ENCLOSURE

EXISTING STORM DRAIN - PROTECT IN PLACE

EXISTING WATER MAIN

EXISTING PAVILIONS AT AUDITORIUM TO BE REMOVED FOR FUTURE ADDITIONS

EXISTING CONCRETE PAVING & LANDSCAPING AT UPPER PLAZA TO BE MODIFIED - SEE PROPOSED PLANS FOR MORE INFO

EXISTING WATER LINE
EQUIPMENT PER M.I.A. 748-23-27
EXISTING EASEMENT TO
BUILDING BUILDERS FOR ST. JOHN
MAIN PL. IMP. CASE NO. 19706-43889 REC. 12/16/19

EXISTING STORAGE
APPROX 10' H; 1,755 SF

EXISTING STORAGE
APPROX 10' H; 1,863 SF

EXISTING ADULT CLASSROOM BUILDINGS
APPROX 10' H;
6,324 SF TOTAL

EXISTING PARKING LOT
(APPROX. 60 SPACES)

EXISTING FELLOWSHIP HALL
FABRIC STRUCTURE
APPROX 22' H; 4,512 SF

EXISTING AUDITORIUM
22' H; 10,456 SF

EXISTING PARKING LOT
(APPROX 138 SPACES)

EXISTING CHILDREN'S CLASSROOM BUILDINGS
APPROX 10-12' H; 6,142 SF TOTAL

EXISTING NURSERY BUILDING
APPROX 13' H; 3,744 SF

EXISTING MODULAR BUILDINGS
APPROX 8' H; 1,008 SF

EXISTING FIRE HYDRANT TO REMAIN

EXISTING GARAGE

EXISTING TRANSFORMER

EXISTING ELECTRICAL ROOM

EXISTING STALLS TO BE RE-STRIPED

EXISTING FABRIC BUILDING TO BE RELOCATED

EXISTING PARKING LOT TO BE PARTIALLY RE-PAVED AND RE-STRIPED

EXISTING UPPER PLAZA TO BE ENLARGED, WITH CONCRETE PAVING & LANDSCAPING - EXTENTS SHOWN WITH RED HATCH

EXISTING MODULAR BUILDINGS TO BE REMOVED

EXISTING MODULAR BUILDING TO REMAIN, TYP. U.N.O.

NOTE: ALL EXISTING TREES TO REMAIN, OR TO BE REMOVED/RELOCATED, HAVE BEEN PLANTED BY KINDRED COMMUNITY CHURCH AND THEREFORE ARE NOT SUBJECT TO SCENIC OVERLAY CORRIDOR ZONE REQUIREMENTS

Source: Elements Architecture, 2021

Demolition Plan for Upper Plaza

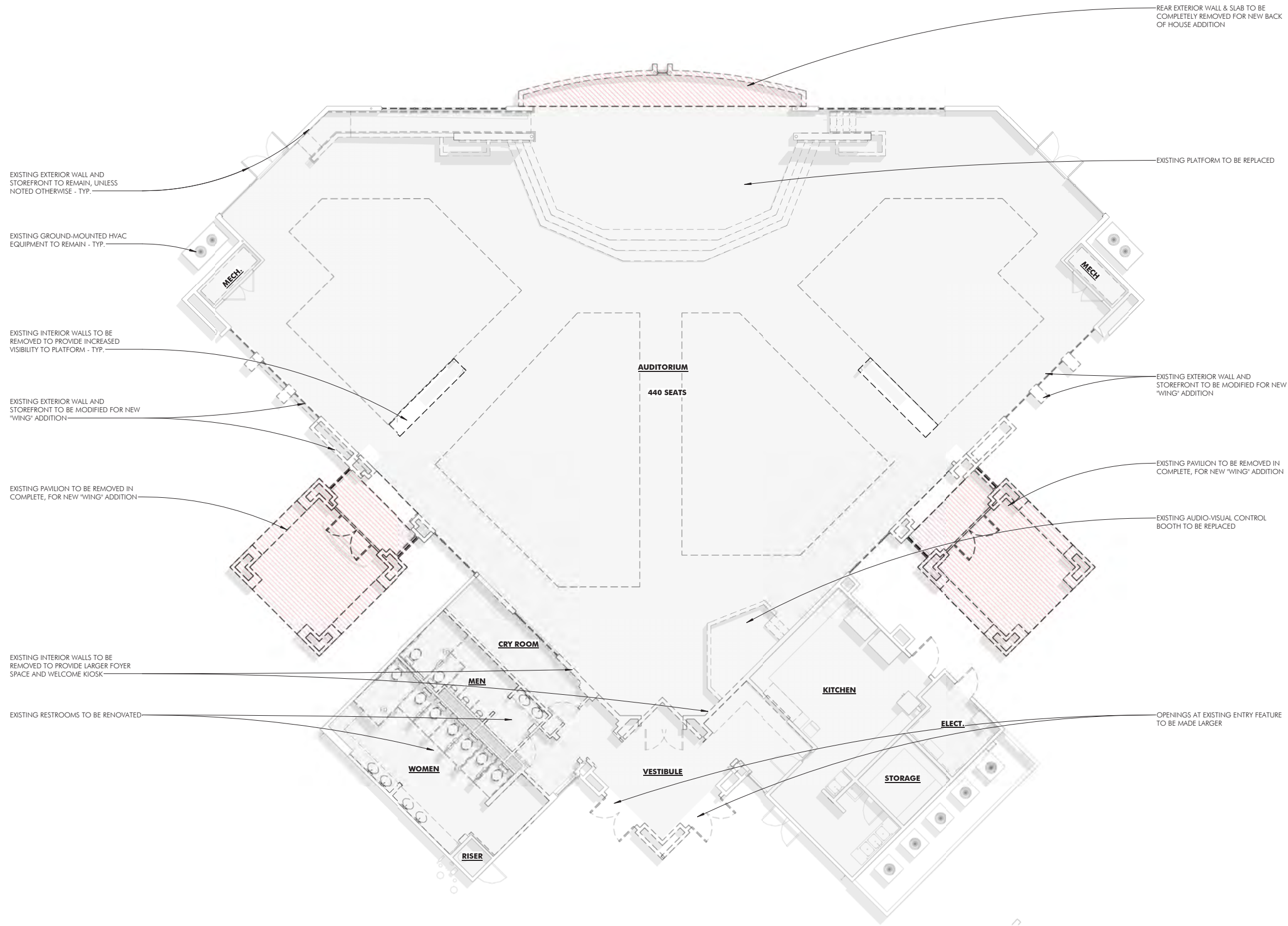
Kindred Church Expansion Project (City of Anaheim)



Exhibit 6



D:\Projects\3ANA\009402\Graphics\ISMND\lex_DemoPlan_Auditorium_20220105.ai



AREA TABULATIONS

TOTAL EXISTING AREA:	10,456 SF
TOTAL DEMOLISHED AREA:	- 911 SF

Source: Elements Architecture, 2021

Demolition Plan for Auditorium

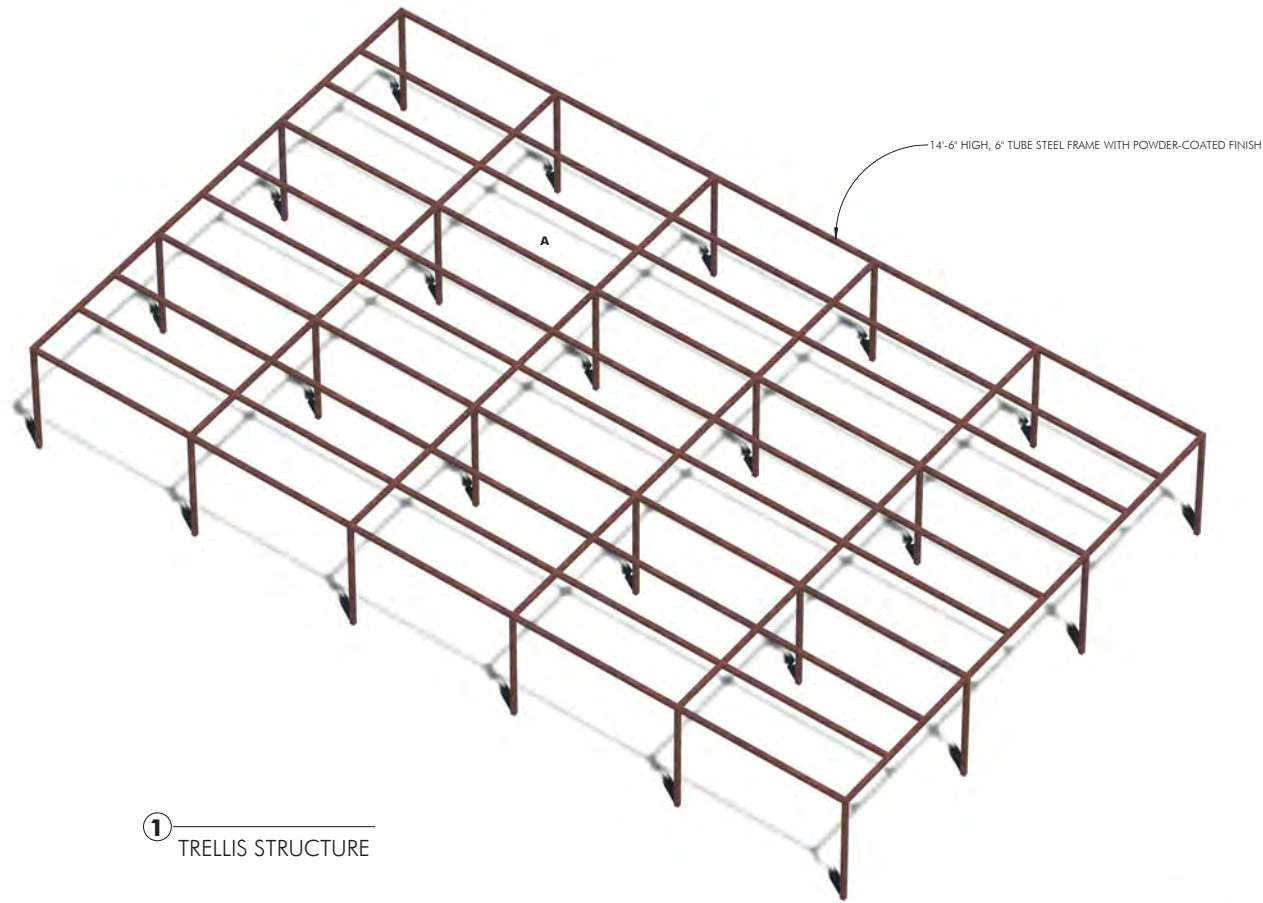
Kindred Church Expansion Project (City of Anaheim)



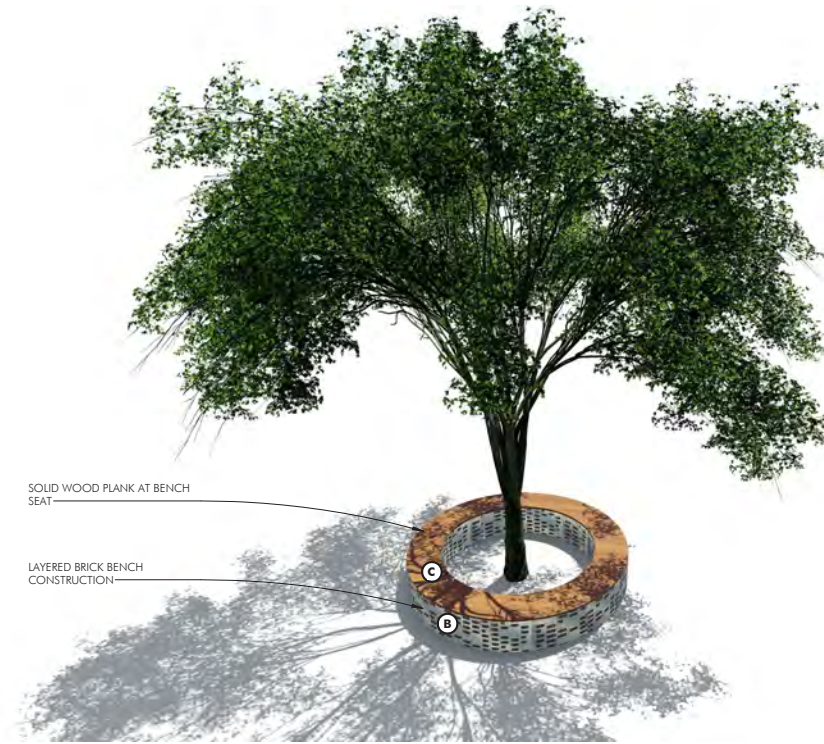
Exhibit 7



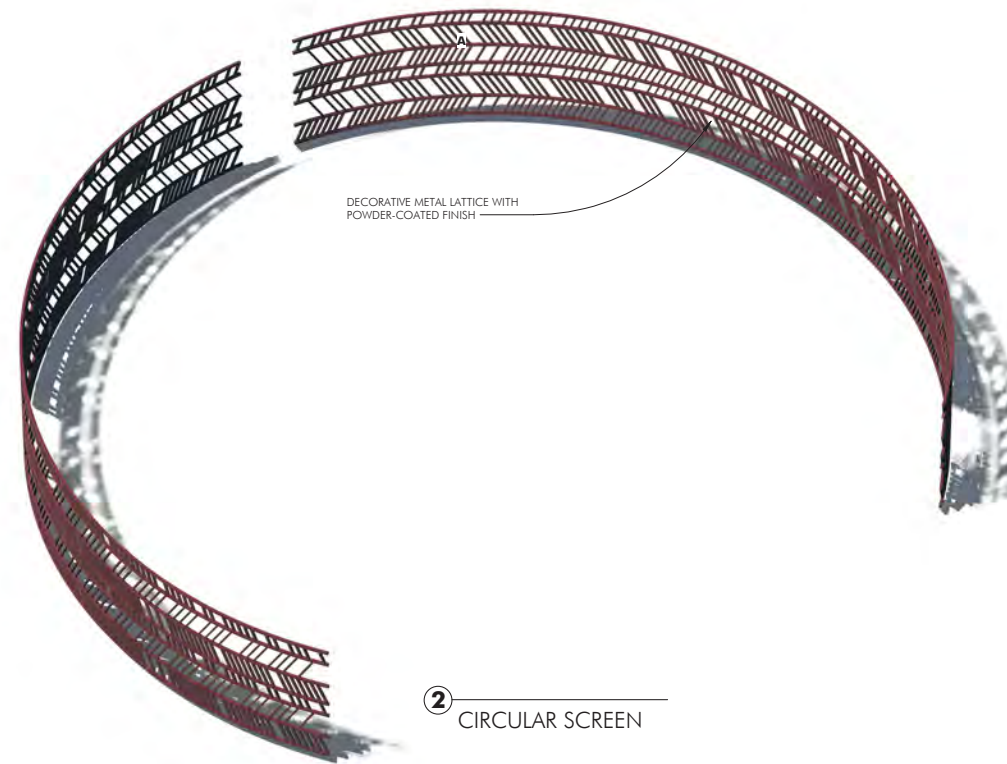
D:\Projects\3ANA\009402\Graphics\ISMND\ex_Materials_UpperPlaza_20220105.ai



1 TRELLIS STRUCTURE



3 SEATING ELEMENT AT TREE



2 CIRCULAR SCREEN

MATERIALS & FINISHES



A SHERWIN WILLIAMS POWDURA POWDER-COAT "PB2-C001 RUST" METAL FINISH



B LAYERED BRICK



C CEDAR PLANK

REFER TO LANDSCAPE PLANS FOR ALL INFORMATION CONCERNING LANDSCAPE & HARDSCAPE MATERIALS

Source: Elements Architecture, 2021

Upper Plaza Materials and Finishes

Kindred Church Expansion Project (City of Anaheim)



Exhibit 8

PSOMAS

Retaining Wall

The Project would include construction of a two-foot retaining wall on a portion of the southern edge of the Project site that would range from 1.5 feet to 4 feet in height. West of the sanctuary, an Americans with Disabilities Act (ADA) ramp with retaining walls would be constructed. A new 3.5-foot to 4-foot block retaining wall would be constructed in the parking lot located west of auditorium. New retaining walls are shown in Exhibit 9a, Sheet Index Plan from Grading Plan and Exhibit 9b, Section Details and Notes from Grading Plan.

Phase 1 Parking Area Improvements

During Phase 1, Parking Lot Number 1 (see Exhibit 2, Aerial Photograph) would be partially re-paved and re-stripped and a new fire hydrant would be added. Parking Lot Number 2 would be expanded, re-paved and re-stripped. An existing backflow preventer and fire hydrant would be relocated within Parking Lot Number 2, the existing trash enclosure would be removed, and a new trash enclosure would be constructed. The existing lower pond and associated landscaping would be replaced by a temporary, permeable turf parking lot, which would be referred to as Parking Lot Number 3. New sections would be added to an existing concrete walkway that connects the proposed Parking Lot Number 3 and the upper plateau area. The temporary permeable parking lot (e.g., Parking Lot Number 3) would be paved and striped in Phase 2, as detailed below.

Tree Removals

There are approximately 83 trees within the Project site, most of which would be protected in place and retained as part of the Project. A total of 29 trees would be removed, consisting of a variety of ornamental species, with the exception of one Coast Live Oak (*Quercus agrifolia*). The Project would include the planting of 88 new trees over phases 1 and 2.

Lighting

The Project would replace existing pole mounted light fixtures within the Project site with modern, downcast fixture heads. The Project would also add pole-mounted lights with new light fixture heads in parking lots and other circulation areas. The Project would install bollard pathway lights throughout the Project site, post-mounted accent lights at the circular screen and tree seating areas, and trellis-mounted micro-profile lighting fixtures to the new trellis structure.

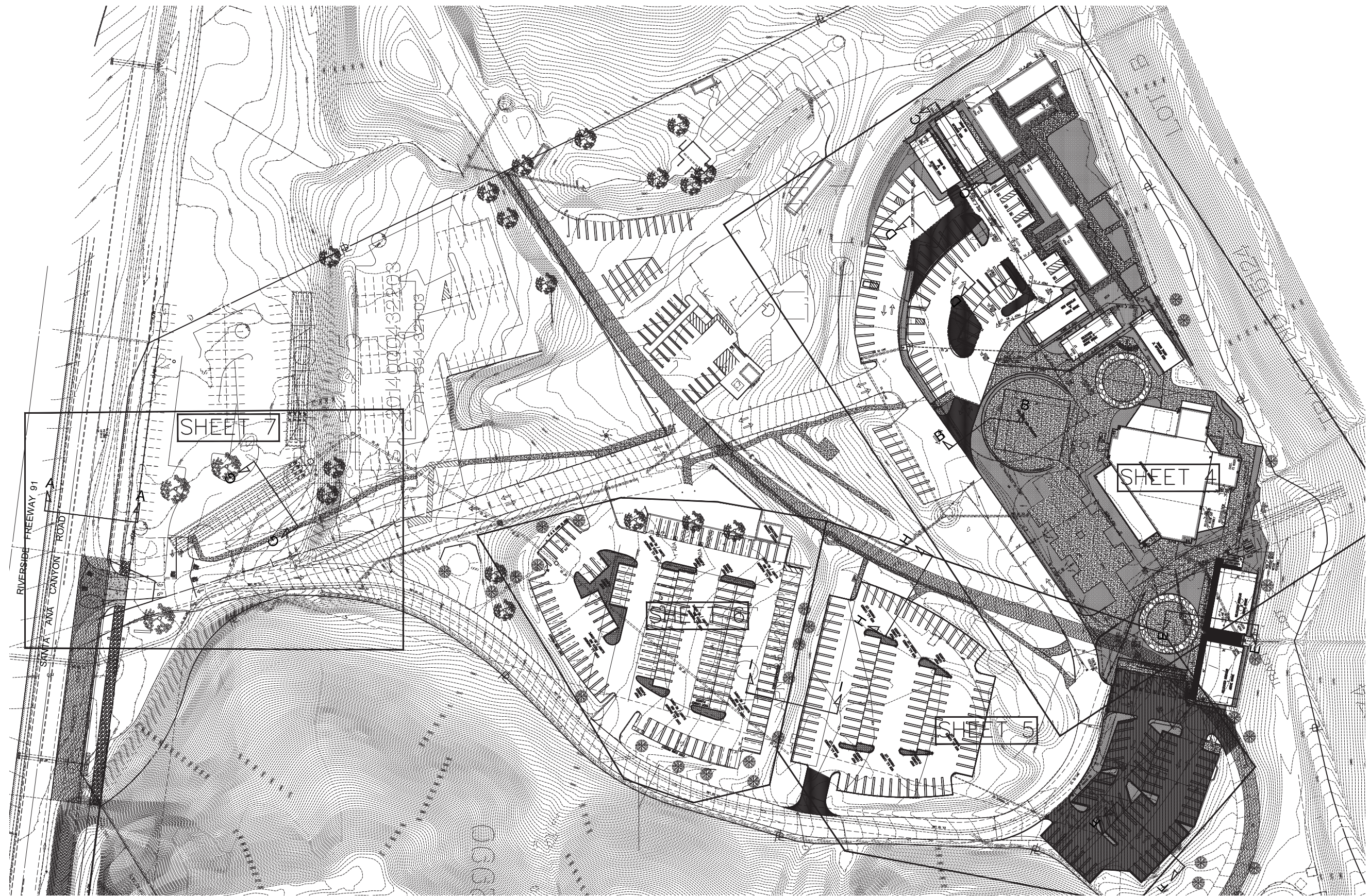
3.1.2 PHASE 2

Phase 2 of the Project would construct a remodeled auditorium with two new wings providing additional seating and back-of-house areas; four new modular buildings; a remodeled parking lot; and, addition of a monument sign, landscaping, and a pedestrian pathway, as further described below and as depicted in Exhibit 10, Proposed Site Plan for Upper Plaza with Implementation of Phase 2, and Exhibit 11, Proposed Site Plan for Lower Portion of Site with Implementation of Phase 2.

Additional Modular Structures

The Project would install an additional four modular structures totaling 5,594 square feet that would be located east and northeast of the fabric tent and auditorium. The proposed structures would include installation of fire sprinklers and additional ADA requirements where applicable, such as modified and new ramps and/or stairs to access elevated modular structures; general accessibility to interiors including door push/pull clearances; clear floor space and reach range

D:\Projects\3ANA\009402\Graphics\SMND\ex_SheetIndex_GradingPlan_20220211.ai

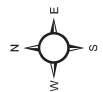


Source: Anacal Engineering, 2022

Sheet Index Plan from Grading Plan

Kindred Church Expansion Project (City of Anaheim)

Exhibit 9a



(02/11/2022 JVR) R:\Projects\ANA\3ANA009402\Graphics\SMND\ex_SheetIndex_GradingPlan.pdf

D:\Projects\3ANA\009402\Graphics\SMND\ex_Proposed_SitePlan_UpperPlaza_Ph2_20220105.ai

NEW ASPHALT PAVING & STRIPING AT EXISTING TURF LOT
PARKING LOT 3
 105 STALLS
 31,835 SF



**PHASE 2
 DETAILED SCOPE OF WORK**

- ADDITION OF (4) MODULAR BUILDINGS
- INTERIOR RENOVATION OF EXISTING AUDITORIUM, PLUS (3) NEW WING ADDITIONS
- FULLY PAVE & STRIPE PARKING LOT #3 (PREVIOUSLY ON TURF IN PHASE 1)
- RE-STRIP EXISTING PARKING LOTS #4 & #5

TOTAL ADDED BUILT AREA

MODULARS	
-MODULAR A	1,440 SF
-MODULAR B	1,440 SF
-MODULAR C	1,440 SF
-MODULAR D	1,440 SF
TOTAL	5,760 SF

AUDITORIUM RENOVATION & ADDITION	
-DEMOLISHED AREA	-911 SF
-ADDITION AREA	3,704 SF
TOTAL (NET)	2,793 SF

TOTAL ADDED AREA	8,553 SF
-------------------------	-----------------

NOTE: ALL EXISTING TREES TO REMAIN, OR TO BE REMOVED/RELOCATED, HAVE BEEN PLANTED BY KINDRED COMMUNITY CHURCH AND THEREFORE ARE NOT SUBJECT TO SCENIC OVERLAY CORRIDOR ZONE REQUIREMENTS

Source: Elements Architecture, 2021

Proposed Site Plan for Upper Plaza with Implementation of Phase 2

Kindred Church Expansion Project (City of Anaheim)



Exhibit 10



requirements; new and modified restrooms; and new tactile signage. Additional modular structures are depicted in Exhibit 10, Proposed Site Plan for Upper Plaza with Implementation of Phase 2.

Remodel of Existing Auditorium

The Project would remodel the existing auditorium building to include two new wings totaling 2,146 square feet for additional seating, as well as a back-of-house area behind the stage as depicted in Exhibit 12, Auditorium Renovation Plan. The auditorium additions would consist of metal building additions with clerestory windows, metal panel roofing, and parapet walls up to 25 feet high to screen rooftop equipment. The back-of-house addition of 2,099 square feet would consist of a hallway, prayer room, green room, restroom, information technology room, and a storage room with a roll-up access door. Remodeling of the auditorium would also include the addition of an entry foyer with new entry doors, removal of internal partition walls, relocation of exterior doors, modifications to exterior walls and a storefront, relocation of an audiovisual control booth, and replacement of the auditorium's platform. The back-of-house addition would include an exterior wall-mounted trellis with vines. The exterior materials would include corrugated metal panels in galvanized finish, fluted metal panels in grey finish, and new clerestory windows with dark bronze anodized framing and tinted glazing. The Project would repaint the exterior of the existing auditorium building in white and grey-blue tones. Elevations depicting the Auditorium exterior are provided as Exhibit 13. Exterior materials and finishes proposed for the Auditorium are shown in Exhibit 14.

Phase 2 Parking Area Improvements

During Phase 2, the Project would fully pave, stripe, and landscape Parking Lot Number 3, which the Project would construct during Phase 1. The Project would also re-stripe and install curbed planters in Parking Lot Number 4 during this phase. Internal circulation and parking improvements are depicted in Exhibit 15.

Circulation Improvements

Internal roadways, curbs, and gutters within the Project site would be realigned to account for the revised design of the church campus. The Project would modify the existing one-way loop road within the Project site to allow for incoming and outgoing traffic on the eastern internal roadway, while maintaining traffic movement along the western internal roadway similar to the existing conditions.

Entry Monument Signage, Hardscape and Landscaping

Enhancements to the Project site's entrance along East Santa Ana Canyon Road would include removal of the existing monument sign and curbed island that are located within the City right-of-way. These enhancements would replace the existing monument sign with a new monument sign², located outside of the City right-of-way. The enhancements would also include the installation of landscaping around the entry monument sign. The landscaping near the entry monument would include new tree species such as Coast Live Oak (*Quercus agrifolia*) Engelmann oak (*Quercus engelmannii*), California Black Walnut (*Juglans californica*), and Western Sycamore (*Platanus racemose*), as well as drought-adapted shrub and grass species.

Additional trees and other landscaping is proposed across the Project site including within the site's Upper Plaza and parking lots. Overall, the Project would plant approximately 88 new trees

² All signage modifications would be submitted under a separate permit.

D:\Projects\3ANA\009402\Graphics\SMND\lex_RenovationPlan_Auditorium_20220105.ai



CODE ANALYSIS

CONSTRUCTION TYPE: VB, SPRINKLERED
 OCCUPANCY TYPE: A-3
 ALLOWABLE HEIGHT: 60'
 ALLOWABLE AREA: 24,000 SF

AREA TABULATIONS

TOTAL EXISTING AREA:	10,456
TOTAL DEMOLISHED AREA:	- 911
TOTAL PROPOSED ADDITION:	+3,704
TOTAL AREA:	13,249 SF
TOTAL EXISTING SEATS:	440
TOTAL ADDED SEATS:	180
TOTAL # OF SEATS:	620

ROOM SCHEDULE

NAME	AREA
(E) AUDITORIUM	6,374 SF
HALLWAY	208 SF
TECH PRODUCTION SUITE	175 SF
SPEAKER'S GREEN ROOM	185 SF
RESTROOM	63 SF
I.T. ROOM	51 SF
STORAGE	662 SF
FOYER	701 SF
(E) KITCHEN	549 SF
MOM'S ROOM	66 SF
MEN	192 SF
WOMEN	353 SF
(E) RISER	17 SF
WING A	1,047 SF
WING B	1,049 SF
(E) STORAGE	88 SF
(E) ELECT.	100 SF
B.O.H.	35 SF
PLATFORM	929 SF
MUSICIAN'S GREEN ROOM	189 SF
TOTAL:	13,249 SF

GENERAL NOTES

1. THE AUTOMATIC FIRE SPRINKLER SYSTEM SHALL BE EXTENDED THROUGHOUT THE AUDITORIUM ADDITION AREAS AS REQUIRED BY THE CALIFORNIA FIRE CODE AND NFPA 13.
2. A FIRE ALARM SYSTEM SHALL BE DESIGNED, INSTALLED AND MAINTAINED THROUGHOUT ALL AREAS OF THE AUDITORIUM AS REQUIRED BY THE FIRE DEPARTMENT.
3. BECAUSE OCCUPANT LOAD EXCEEDS 1,000 IN THIS BUILDING, FIRE ALARM SYSTEM SHALL BE CAPABLE OF EMERGENCY VOICE EVACUATION FUNCTIONALITY AS IDENTIFIED IN THE CALIFORNIA FIRE CODE AND NFPA 72.
4. PROJECT IS LOCATED IN VHSZ. AUDITORIUM BUILDING CONSTRUCTION SHALL THEREFORE COMPLY WITH 2019 CBC CHAPTER 7A AND 2019 CFC CHAPTER 49.

Source: Elements Architecture, 2021

Auditorium Renovation Plan

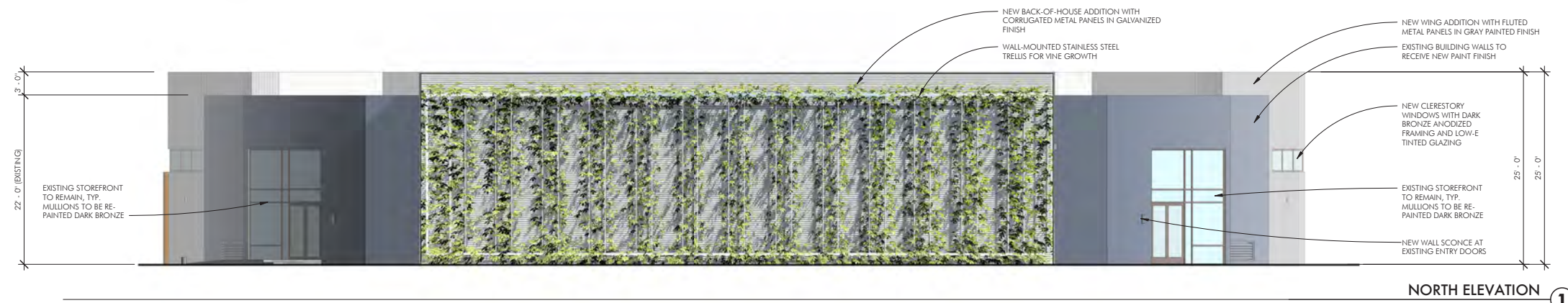
Kindred Church Expansion Project (City of Anaheim)



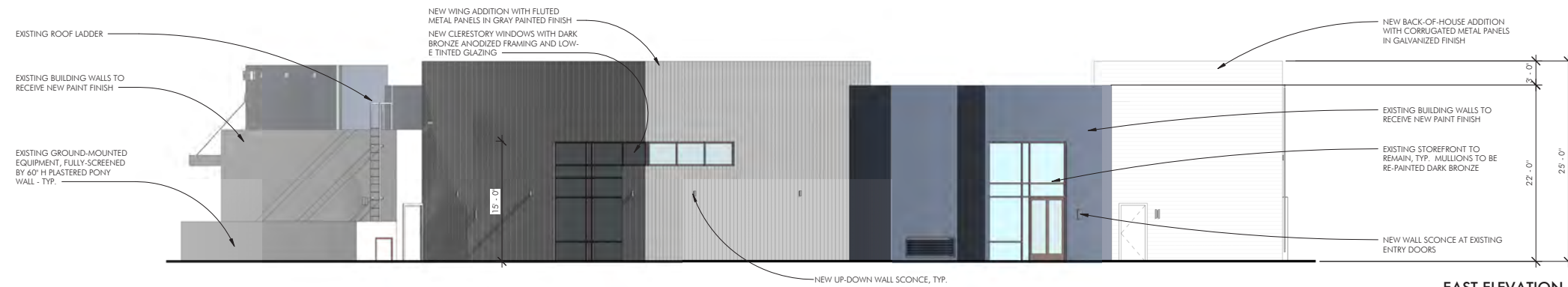
Exhibit 12



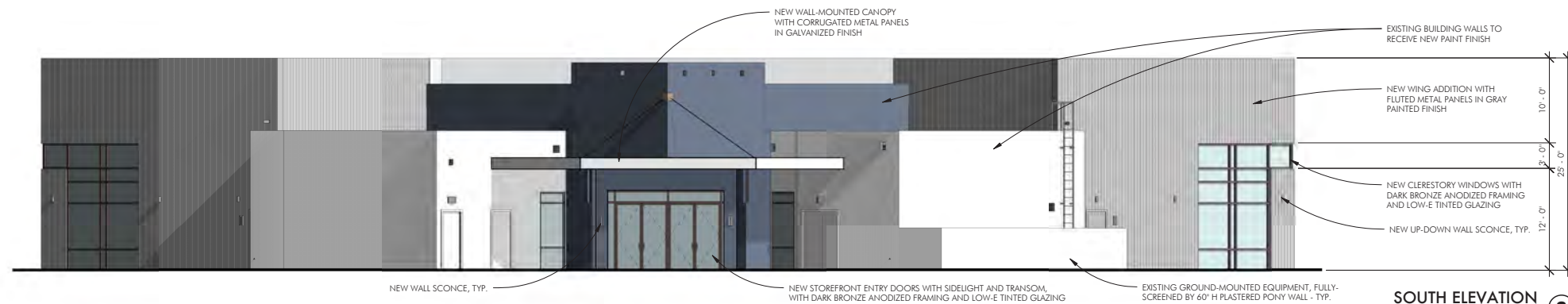
D:\Projects\3ANA\009402\Graphics\SMND\ex_Elevations_Auditorium_20220105.ai



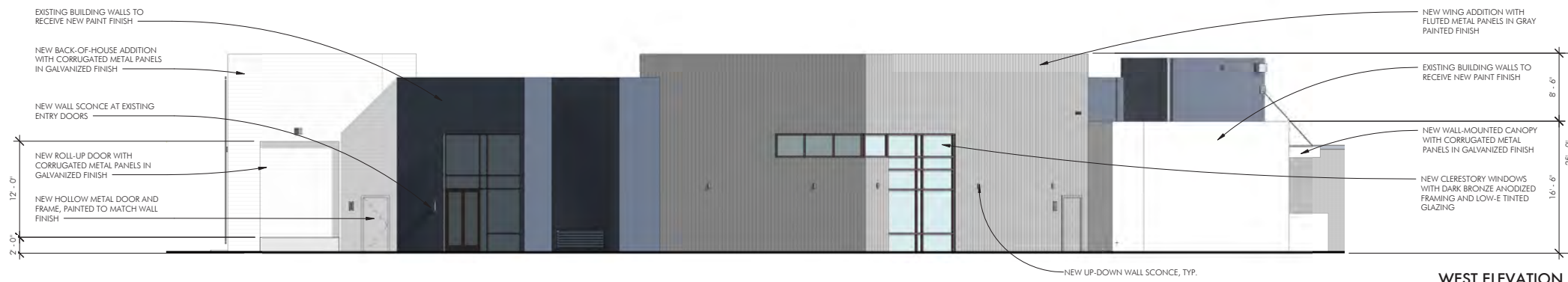
NORTH ELEVATION 1



EAST ELEVATION 2



SOUTH ELEVATION 3



WEST ELEVATION 4

GENERAL NOTES

1. ALL EXISTING AND NEW BUILDING HEIGHTS COMPLY WITH MAXIMUM HEIGHT PER CODE, WHICH IS 35' PER 18.18.090.
2. ANY WALL-MOUNTED SIGNAGE SHALL BE SUBMITTED UNDER A SEPARATE PERMIT

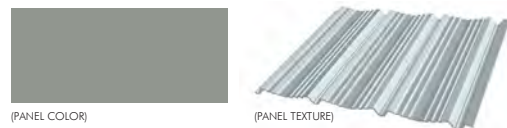
Source: Elements Architecture, 2021

Auditorium Elevations

Kindred Church Expansion Project (City of Anaheim)

Exhibit 13



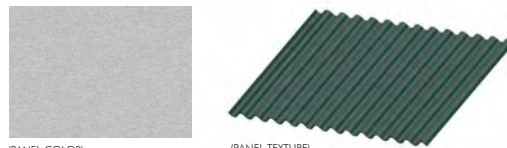


(PANEL COLOR)

(PANEL TEXTURE)



A "WING" ADDITION EXTERIOR CLADDING, TYP: MBCI "AVP" FLUTED METAL PANEL IN "SLATE GRAY"
FLUTED METAL PANEL



(PANEL COLOR)

(PANEL TEXTURE)



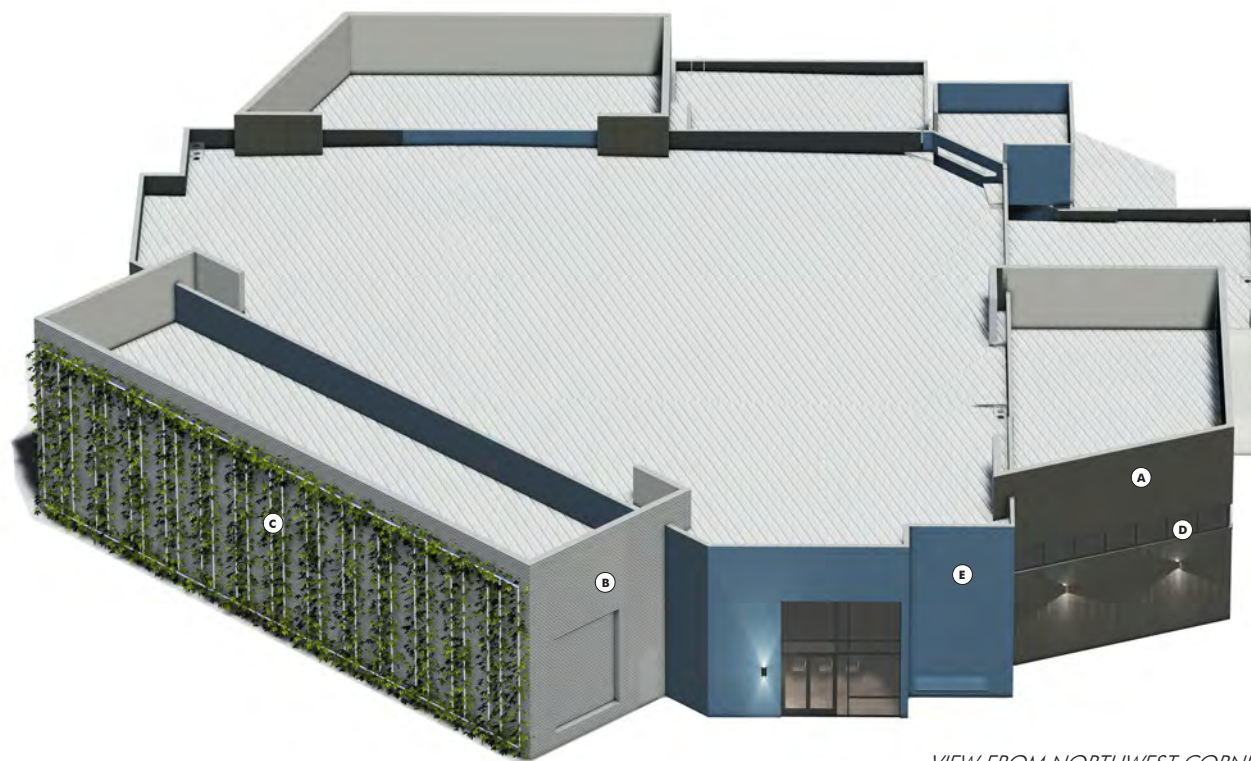
B REAR ADDITION EXTERIOR CLADDING & ENTRY CANOPY, TYP: MBCI "PBC" HORIZONTAL CORRUGATED METAL PANEL IN "GALVALUME"
CORRUGATED METAL PANEL



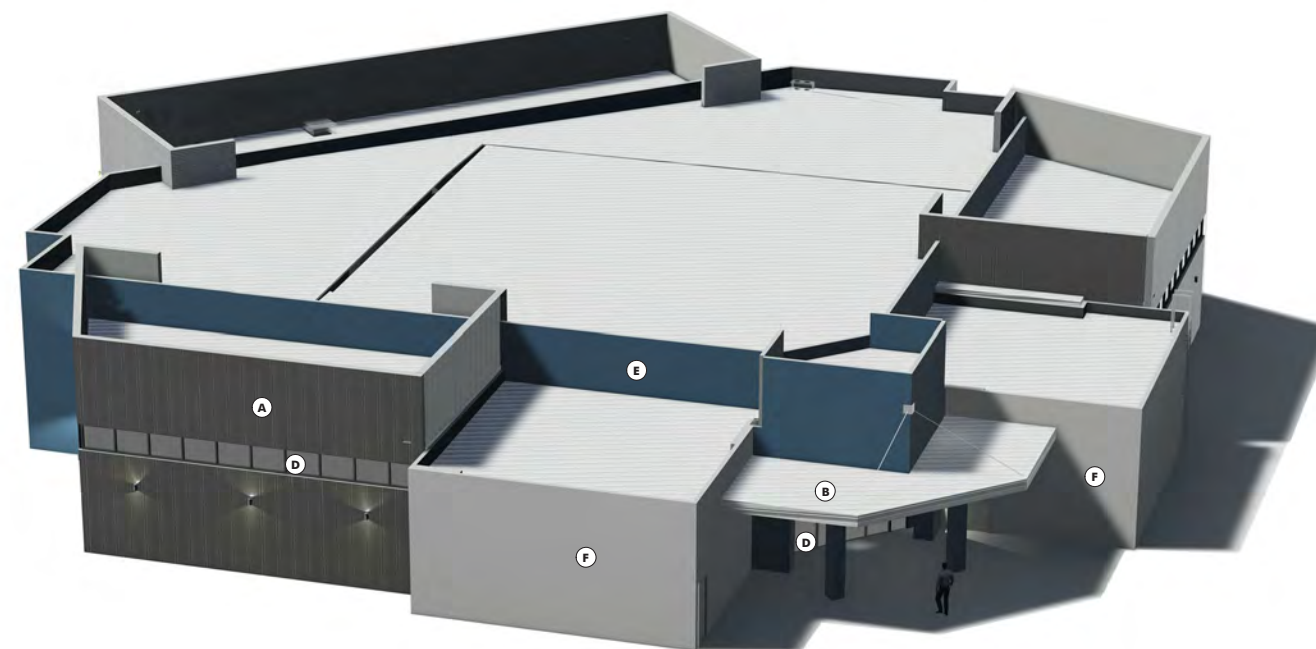
AT WING ADDITIONS:
 OCL "VEGA"; DARK BRONZE FINISH

AT MAIN ENTRY POINTS:
 SONNEMAN "FOLD"; DARK BRONZE FINISH

EXTERIOR LIGHT FIXTURES



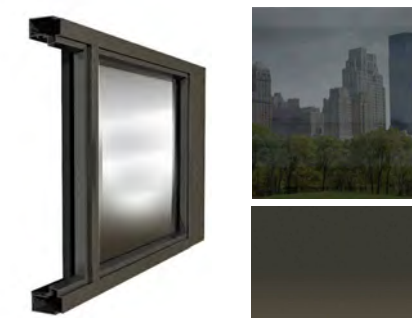
VIEW FROM NORTHWEST CORNER



VIEW FROM SOUTHWEST CORNER



C REAR ADDITION WALL-MOUNTED SYSTEM: STAINLESS STEEL CABLE BY "JAKOB ROPE"
VINE TRELLIS



D DARK BRONZE ANODIZED FRAMING WITH TINTED LOW-E INSULATED GLAZING
 -TINT TO MATCH EXISTING
STOREFRONT



E PAINT COLOR AT MAIN BUILDING "SHELL"



F PAINT COLOR AT BUILDING "WINGS"

D:\Projects\3ANA\009402\Graphics\SMND\ex_Materials_Auditorium_20220105.ai

Source: Elements Architecture, 2021

Auditorium Materials and Finishes

Kindred Church Expansion Project (City of Anaheim)

Exhibit 14



D:\Projects\3ANA\009402\Graphics\ISMND\ex_Circulation_Parking_20220105.ai

EXISTING PARKING

DESCRIPTION:	QTY:
LOT 1	130
LOT 2	62
LOT 4	141
LOT 5	43
TOTAL PARKING	376
OVERFLOW (LOTS 6&7)	143
TOTAL PARKING WITH OVERFLOW	519

PROPOSED PARKING

DESCRIPTION:	QTY:
LOT 1	77
LOT 2	65
LOT 3	105
LOT 4	141
LOT 5	43
TOTAL PARKING	432
OVERFLOW (LOTS 6&7)	143
TOTAL PARKING WITH OVERFLOW	575

ACCESSIBLE STALL	14
(MIN. 2% OF TOTAL PARKING)	

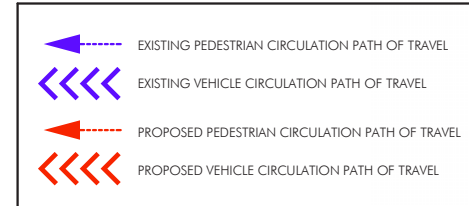
ACCESSIBLE VAN STALL	4
(1 FOR EVERY 6 ACCESSIBLE STALLS)	

CLEAN AIR VEHICLE STALL	52*
(MIN. 12% OF TOTAL PARKING)	
MIN. 2 ACCESSIBLE - *1 ACCESS; 1 VAN ACCESS.	

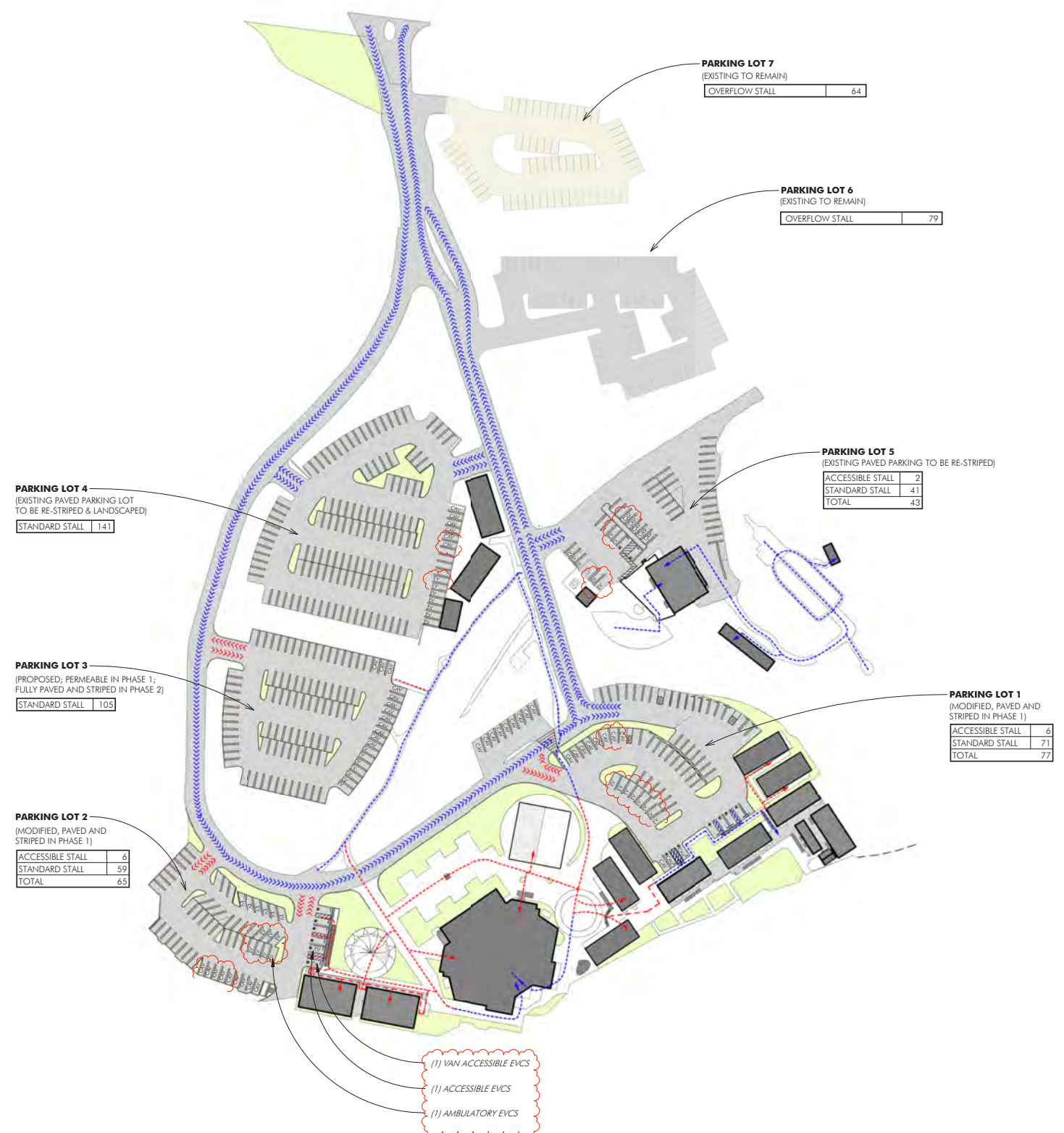
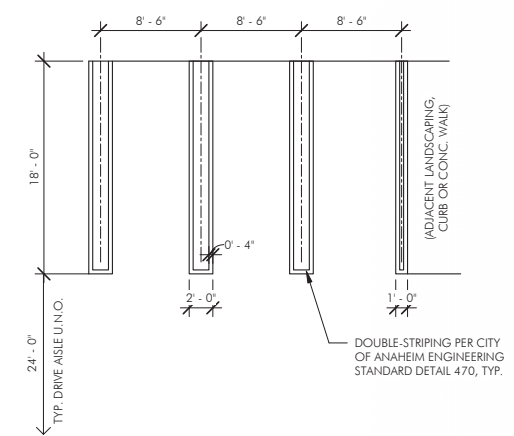
EVCS VEHICLE STALL	44*
(MIN. 10% OF TOTAL PARKING)	
MIN. 2 ACCESSIBLE - *1 ACCESS; 1 VAN ACCESS.	

EVCS REQUIRED PER CBC TABLE 11B-228.3.2.1:
 (1) VAN ACCESSIBLE
 (1) ACCESSIBLE
 (1) AMBULATORY
 * SEE PLAN FOR LOCATIONS

CIRCULATION LEGEND



TYPICAL PARKING STALL STRIPING



Source: Elements Architecture, 2021

Internal Circulation and Parking Improvements

Kindred Church Expansion Project (City of Anaheim)

Exhibit 15



across the Project site during phases 1 and 2. Also, new concrete paving, decomposed granite, and permeable unit pavers would be installed as part of the creation of an Upper Plaza portion of the Project site. Landscaping and hardscape improvements are depicted in Exhibits 16a, 16b, and 16c.

Stormwater

In the existing condition, the majority of the Project site drains to existing grate inlets that are connected to an existing City storm drain that traverses the Project site, which was constructed to serve the adjacent residential development to the south. The Project would redirect stormwater flows from throughout the Project site to a new 18-inch reinforced concrete pipe (RCP). The RCP would collect and convey flows downslope to an underground infiltration system, which would consist of two underground stormwater infiltration chambers within a portion of APN 354-321-03. In the event of stormwater exceeding the design capture volume for the underground infiltration chamber, excess water would be rerouted to the existing City storm drain through an 18-inch RCP overflow pipe. Prior to flowing into the 18-inch RCP, at least 50 percent of stormwater would be pre-treated for sediment, debris, and hydrocarbons using Filterra stormwater biofiltration units. Catch basins would be installed with FloGard filters to capture trash and debris. These improvements are depicted in Exhibit 17, Water Quality Best Management Practices and described in more detail in the Project's Preliminary Water Quality Management Plan (PWQMP) (Anacal Engineering 2021).

Utility Relocations

To accommodate the revised church campus layout, the Project includes a variety of utility relocations within the Project site, including the relocation of a water vault box, relocation of potable water main line, relocation of an existing fire hydrant, installation of a new fire hydrant, and relocation of an existing fire water vault box with backflow prevention device.

Grading

The Project would require grading work, which would result in approximately 300 cubic yards of cut and 2,900 cubic yards of fill. The Project would require the import of 2,600 cubic yards of fill from off-site. Proposed fill activities would primarily be required to fill the existing artificial lake on the Project site for the development of Parking Lot Number 3 at the same location. Grading would largely maintain existing grades with maximum depth of cuts of approximately one foot in depth and maximum depth of fill up to three feet in depth. Project grading is depicted in Exhibits 9a, Sheet Index Plan from Grading Plan and 9b, Section Details and Notes from Grading Plan.

Construction Details

The Applicant anticipates that construction of the Project would last approximately ten months and would begin in 2022 and end in 2023, as outlined in Table 1, below.



Plant ID	Qty	Category	Latin Name	Common Name	Spacing	Size	Water Use
ART DOU	144	Perennials	<i>Artemisia douglasiana</i>	Douglas Mugwort	3'0"	1 gal	low
BAC PIL	10	Groundcover	<i>Baccharis pilularis</i> 'Pigeon Pt'	Dwarf Coyote Bush	6'0"	1 gal	Low
BER NEV	9	Shrub	<i>Berberis 'Nevii'</i>	Nevin Barberry	8'0"	5 gal	low
BOT BAR	247	Grasses	<i>Bothriochloa barbinodis</i>	Bluestem Grass	3'0"	1 gal	low
LES FIL	100	Groundcover	<i>Corethrogyne 'Smart Aster'</i>	Carmel Aster	3'0"	1 gal	low
ENC FAR	195	Perennial	<i>Encelia farinosa</i>	Brittle Brush	2'6"	1 gal	low
LEY CON	496	grass	<i>Leymus condensatus</i> 'Canyon Prince'	Canyon Prince Wildrye	2'0"	1 gal	low
MUH REV	302	grass	<i>Muhlenbergia reverchonii</i> 'Undaunted'	Undaunted Ruby Muhly	2'6"	1 gal	low
MUH RIG	154	grass	<i>Muhlenbergia rigens</i>	Deer Grass	3'0"	1 gal	low
NOL PAR	29	cacti-succulents	<i>Notinoa nelsonii</i>	Parry's Notinoa	5'0"	5 gal	low
PER ARB	186	Category	<i>Peritoma arborea</i>	Bladderpod	4'0"	1 GAL	low
RHA LEA	13	Shrub	<i>Rhamnus californica</i> 'Leatherleaf'	California Coffee Berry	5'0"	5 GAL	low
Rhu int	1	Shrubs	<i>Rhus integrifolia</i>	Lemonadeberry	10'0"	5 gal	Low
RIB IND	78	Shrubs	<i>Ribes indecorum</i>	White Flowering Currant	5'0"	5 gal	low
SAL WIN	27	Shrubs	<i>Salvia clevelandii</i> 'Winifred Gilman'	Winifred Gilman Sage	4'0"	1 gal	low
SPI AMB	42	Category	<i>Sphaeralcea ambigua</i>	Desert Marlow	5'2" 14"	1 gal	low
SPO AIR	501	grass	<i>Sporobolus airoides</i>	Sacaton	2'6"	1 gal	low

LOW LYING AREAS AND BIO-PLANTERS

ART DOU - *Artemisia douglasiana*
 BOT BAR - *Bothriochloa barbinodis*
 CAR SPI - *Carex spicata*
 JUN PAT - *Juncus patens* 'Elk Blue'
 LEY CON - *Leymus condensatus* 'Canyon Prince'
 SOL CAL - *Solidago californica*

DRY GRASSLANDS & BIO-PLANTER EDGES

MUH REV - *Muhlenbergia reverchonii* 'Undaunted'
 SPO AIR - *Sporobolus airoides*
 ENC FAR - *Encelia farinosa*
 MUH RIG - *Muhlenbergia rigens*
 LES FIL - *Corethrogyne 'Smart Aster'*
 EPI CAT - *Eriogonum 'Catalina'*

UPLAND SAGE SCRUB/CHARADRIAL

ARC HOW - *Arctostaphylos 'Howard McMini'*
 BAC PIL - *Baccharis pilularis* 'Pigeon Pt'
 SAL WIN - *Salvia clevelandii* 'Winifred Gilman'
 RIB IND - *Ribes indecorum*
 RHA LEA - *Rhamnus californica* 'Leatherleaf'

CEA OLI - *Ceanothus oliganthus*
 BER NEV - *Berberis 'Nevii'*
 het arb - *Heteromeles arbutifolia*

QUE AGR - *Quercus agrifolia*

QUE ENG - *Quercus engelmannii*

JUG CAL - *Juglans californica*

PLA RAC - *Platanus racemosa*

EXISTING CONCRETE PAVING TO REMAIN

CONCRETE PAVING

DECOMPOSED GRANITE

PERMEABLE UNIT PAVERS

Source: Lane Goodkind + Associates, 2021

Conceptual Landscape Plan

Kindred Church Expansion Project (City of Anaheim)



Exhibit 16a



Plant List ID	Qty	Category	Latin Name	Common Name	Spacing	Size	Water Use
ART DOU	144	Perennials	Artemisia douglasiana	Douglas Mugwort	3'0"	1 gal	low
BAC PIL	10	Groundcover	Baccharis pilularis 'Pigeon Pt'	Dwarf Coyote Bush	8'0"	1 gal	Low
BER NEV	9	Shrub	Berberis 'Nevins'	Nevin Barberry	8'0"	5 gal	low
BOT BAR	247	Grasses	Bothriochloa barbinodis	Bluestem Grass	3'0"	1 gal	low
LES FIL	100	Groundcover	Corethrogyne 'Smart Aster'	Carmel Aster	3'0"	1 gal	low
ENC FAR	195	Perennial	Encelia farinosa	Brittle Bush	2'6"	1 gal	low
LEY CON	496	grass	Leymus condensatus 'Canyon Prince'	Canyon Prince Wildrye	2'0"	1 gal	low
MUH REV	302	grass	Muhlenbergia reverchonii 'Undaunted'	Undaunted Ruby Muhly	2'6"	1 gal	low
MUH RIG	154	grass	Muhlenbergia rigens	Deer Grass	3'0"	1 gal	low
NOL PAR	29	cacti-succulents	Nolina nelsonii	Parry's Nolina	5'0"	5 gal	low
PER ARB	186	Category	Peritoma arborea	Bladderpod	4'0"	1 GAL	low
RHA LEA	13	Shrub	Rhamnus californica 'Leatherleaf'	California Coffee Berry	3'0"	5 GAL	low
RHU INT	1	Shrub	Rhus integrifolia	Lemonadeberry	10'0"	5 gal	Low
RIB IND	78	Shrubs	Ribes indecorum	White Flowering Currant	5'0"	5 gal	low
SAL WIN	27	Shrubs	Salvia clevelandii 'Winifred Gilman'	Winifred Gilman Sage	4'0"	1 gal	low
SPH AMB	42	Category	Sphaeralcea ambigua	Desert Mallow	5'2 1/4"	1 gal	low
SPO AIR	501	grass	Sporobolus airoides	Sacaton	2'6"	1 gal	low

- LOW LYING AREAS AND BIO-PLANTERS
ART DOU - Artemisia douglasiana
BOT BAR - Bothriochloa barbinodis
CAR SP - Carex spicata
JUN PAT - Juncea patens 'Elk Blue'
LEY CON - Leymus condensatus 'Canyon Prince'
SOL CAL - Solidago californica
- DRY GRASSLANDS & BIO-PLANTER EDGES
MUH REV - Muhlenbergia reverchonii 'Undaunted'
SPO AIR - Sporobolus airoides
ENC FAR - Encelia farinosa
MUH RIG - Muhlenbergia rigens
LES FIL - Corethrogyne 'Smart Aster'
ERI CAT - Eriogonum 'Catalina'
- UPLAND SAGE SCRUB/CHARADRIAL
ARC HOW - Aristida sp. 'Howard McMini'
BAC PIL - Baccharis pilularis 'Pigeon Pt'
SAL WIN - Salvia clevelandii 'Winifred Gilman'
RIB IND - Ribes indecorum
RHA LEA - Rhamnus californica 'Leatherleaf'
- CEA OLI - Ceanothus oligarhifolius
- BER NEV - Berberis 'Nevins'
- het arb - Heteromeles arbutifolia

- QUE AGR - Quercus agrifolia
- QUE ENG - Quercus engelmannii
- JUG CAL - Juglans californica
- PLA RAC - Platanus racemosa

- EXISTING CONCRETE PAVING TO REMAIN
- CONCRETE PAVING
- DECOMPOSED GRANITE
- PERMEABLE UNIT PAVERS



Source: Lane Goodkind + Associates, 2021

Conceptual Landscape Plan

Kindred Church Expansion Project (City of Anaheim)

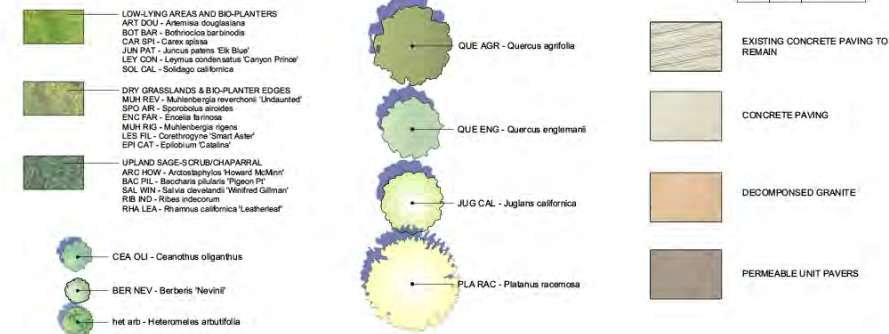


Exhibit 16b





Plant List ID	Qty	Category	Latin Name	Common Name	Spacing	Size	Water Use
ART DOU	144	Perennials	Artemisia douglasiana	Douglas Mugwort	30"	1 gal	low
BAC PIL	10	Groundcover	Baccharis pilularis 'Pigeon Pt'	Dwarf Coyote Bush	60"	1 gal	Low
BER NEV	9	Shrub	Berberis 'Nevins'	Nevin Barberry	80"	5 gal	low
BOT BAR	247	Grasses	Bothriochloa barboides	Bluestem Grass	30"	1 gal	low
LES FIL	100	Groundcover	Cosmetroche 'Smart Aster'	Carmel Aster	30"	1 gal	low
ENG FAR	195	Perennial	Encelia farinosa	Bottle Brush	26"	1 gal	low
LEY CON	496	grass	Leymus condensatus 'Canyon Prince'	Canyon Prince Wildrye	20"	1 gal	low
MUH REV	302	grass	Muhlenbergia reverchonii 'Undaunted'	Undaunted Ruby Muhly	26"	1 gal	low
MUH RIG	154	grass	Muhlenbergia rigens	Deer Grass	30"	1 gal	low
NOL PAR	29	cacti-succulents	Nolina nelsonii	Parry's Nolina	50"	5 gal	low
PER ARB	186	Category	Peritoma arborea	Bladderpod	40"	1 GAL	low
RHA LEA	13	Shrub	Rhamnus californica 'Leatherleaf'	California Coffee Berry	50"	5 GAL	low
Rhu int	1	Shrubs	Rhus integrifolia	Lemonadeberry	100"	5 gal	Low
RIB IND	78	Shrubs	Ribes indecorum	White Flowering Currant	50"	5 gal	low
SAL WIN	27	Shrubs	Salvia clevelandii 'Winifred Gilman'	Winifred Gilman Sage	40"	1 gal	low
SPH AMB	42	Category	Sphaeralcea ambigua	Desert Mallow	52 1/4"	1 gal	low
SPO AIR	501	grass	Sporobolus airoides	Sacaton	26"	1 gal	low



Source: Lane Goodkind + Associates, 2021

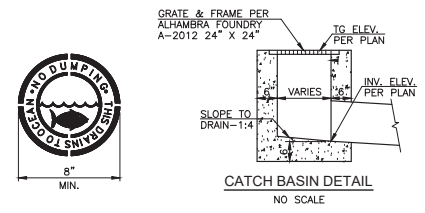
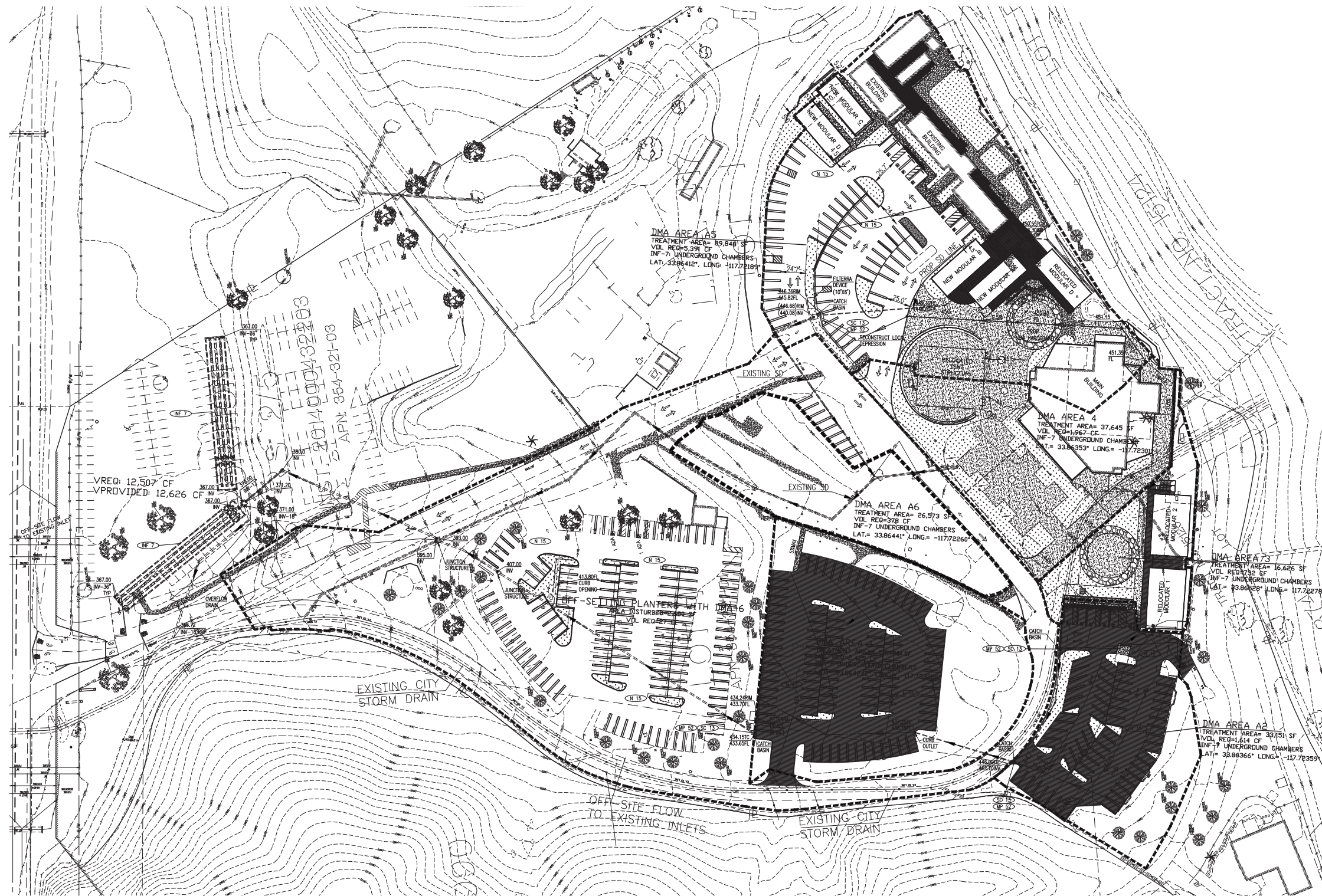
Conceptual Landscape Plan

Kindred Church Expansion Project (City of Anaheim)



Exhibit 16c





- LEGEND**
- FLOW IN STORM DRAIN
 - - - PROPOSED STORM DRAIN
 - EXISTING STORM DRAIN
 - DRAINAGE BOUNDARY
 - FLOW LINE
 - ▨ PROPOSED GRAVEL
 - ▨ PROPOSED LANDSCAPE AREA
 - ▨ PROPOSED ASPHALT
 - ▨ PROPOSED CONCRETE
 - ▨ EXISTING CONCRETE
- BMP'S**
- N 15 — STREET SWEEPING PARKING LOT
 - INF — UNDERGROUND INFILTRATION
 - N 14 — CATCH BASIN MAINTENANCE
 - MP 24 — CATCH BASIN INSERT (FLOOR FOP-24F)
 - SC 15 — STORM DRAIN SIZING

Source: Anacal Engineering, 2021

Water Quality Best Management Practices

Kindred Church Expansion Project (City of Anaheim)

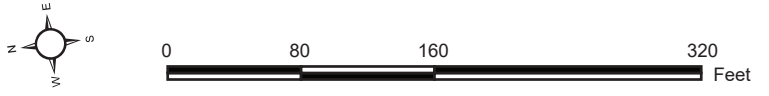


Exhibit 17



**TABLE 1
PROJECT CONSTRUCTION SCHEDULE**

Phase	Project Activity	Duration or Timing
Construction Begins		Summer 2022
Phase 1	Relocation of Modular Structures and Fabric Tent, Demolition of Portions of the Auditorium	10 weeks
	Establishment of Upper Plateau Campus, Installation of Retaining Wall, and Development of Temporary Permeable Parking Lot	6 weeks
Phase 2	Install Additional Modular Structures, Remodel Auditorium	20 weeks
	Paving, Striping, and Landscaping of Parking Lots	2 weeks
	Architectural Coatings to New Structures	2 weeks
Project Completed		Spring 2023
Source: Elements Architecture 2021.		

3.1.3 DISCRETIONARY ACTIONS

The following discretionary actions would be required:

- Amendment to a previously approved Conditional Use Permit (CUP) for a Community and Religious Facility (Kindred Church) (CUP 4033E).

This page intentionally left blank

SECTION 4.0 ENVIRONMENTAL CHECKLIST



**CITY OF ANAHEIM
ENVIRONMENTAL CHECKLIST FORM**

Form Revision Date: 1/16/2019

PROJECT AND CASE NUMBERS: DEV2020-00016, CEQA2021-00009,
CUP4033E

SITE ADDRESS:

8712 East Santa Ana Canyon Road, Anaheim, California 92808

PROJECT NAME:

Kindred Church Expansion Project

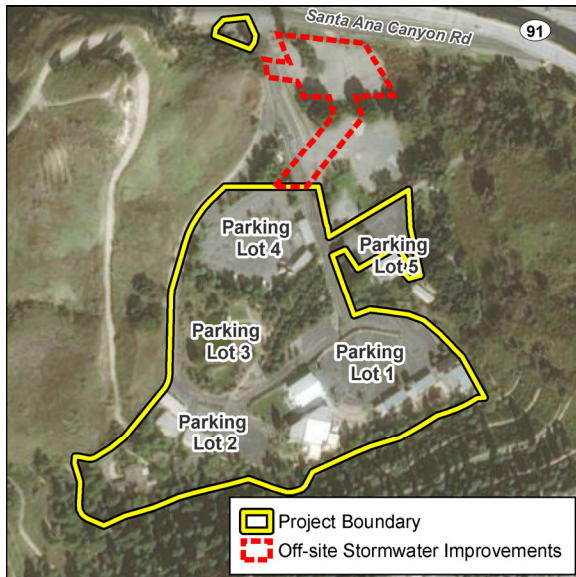
LEAD AGENCY NAME AND ADDRESS:

City of Anaheim, 200 S Anaheim Boulevard, Suite 162, Anaheim, California 92805

CONTACT PERSON AND PHONE NUMBER:

Mr. Andy T. Uk, Associate Planner
City of Anaheim Planning Services Division
200 South Anaheim Boulevard
Anaheim, California 92805
Phone: 714-765-5238
Email: auk@anaheim.net

PROJECT LOCATION:



PROJECT SPONSOR'S NAME AND ADDRESS:

Kindred Community Church

8712 E. Santa Ana Canyon Road

Anaheim, California 92808

Contact: Doug McAllister

Email: dmcallister@kindredchurch.org

GENERAL PLAN DESIGNATION:

Open Space (OS)

ZONING:

Zoning Classification

Sycamore Canyon Specific Plan (SP88-1) Zone for APN 354-321-01; and

The Summit of Anaheim Hills Specific Plan (SP88-2) Zone for APN 514-091-25 and 514-101-28.

Overlay Zones

Planned Community (PC) Overlay Zone

Scenic Corridor (SC) Overlay Zone

PROJECT DESCRIPTION:

The Project consists of two phases to expand the existing Kindred Community Church. The Project's proposed total additional square footage is 9,839 square feet with an increase of 180 seats in seating capacity within the auditorium.

PROJECT SETTING AND SURROUNDING LAND USES:

The Project site encompasses approximately 14.79 acres and is located at 8712 East Santa Ana Canyon Road in the City of Anaheim in Orange County. Kindred Community Church is currently located on the Project site. The existing church facilities include a 29,503-square foot worship center, a day care center, a fellowship hall, a multi-purpose building, modular buildings, four parking lots containing a total of 376 parking spaces³, a welcome tent, an amphitheater/outdoor chapel, an artificial lake, a mechanical building, a modular residence with garage, a garage/maintenance building, and outdoor lighting. The General Plan designates the properties located adjacent to the Project site for Open Space land use. Existing land uses adjacent to the site include East Santa Ana Canyon Road and State Route (SR) 91 to the north; a vacant and previously developed parcel to the northeast; two open space parcels with stormwater brook ditches upslope of the Project site to the south; undeveloped land to the east; and undeveloped land to the west.

OTHER PUBLIC AGENCIES WHOSE APPROVAL IS REQUIRED:

Not Applicable

³ An additional 143 parking spaces are located off-site to the northeast within APN 354-321-03, for a total of 519 parking spaces.

ENVIRONMENTAL FACTORS POTENTIALLY AFFECTED:

The environmental factors checked below would be potentially affected by this project, involving at least one impact that is a "Potentially Significant Impact" as indicated by the checklist on the following pages.

- | | |
|---|---|
| <input type="checkbox"/> Aesthetics | <input type="checkbox"/> Land Use/Planning |
| <input type="checkbox"/> Agricultural & Forestry Resources | <input type="checkbox"/> Mineral Resources |
| <input type="checkbox"/> Air Quality | <input type="checkbox"/> Noise |
| <input checked="" type="checkbox"/> Biological Resources | <input type="checkbox"/> Population/Housing |
| <input checked="" type="checkbox"/> Cultural Resources | <input type="checkbox"/> Public Services |
| <input type="checkbox"/> Energy | <input type="checkbox"/> Recreation |
| <input checked="" type="checkbox"/> Geology/Soils | <input type="checkbox"/> Transportation |
| <input type="checkbox"/> Greenhouse Gas Emissions | <input checked="" type="checkbox"/> Tribal Cultural Resources |
| <input type="checkbox"/> Hazards & Hazardous Materials | <input type="checkbox"/> Utilities/Service Systems |
| <input type="checkbox"/> Hydrology/Water Quality | <input type="checkbox"/> Wildfire |
| <input type="checkbox"/> Mandatory Findings of Significance | |

DETERMINATION:

On the basis of this initial evaluation:

- I find that the Project COULD NOT have a significant effect on the environment, and a NEGATIVE DECLARATION will be prepared.
- I find that although the Project could have a significant effect on the environment, there will not be a significant effect in this case because revisions in the project have been made by or agreed to by the project proponent. A MITIGATED NEGATIVE DECLARATION will be prepared.
- I find that the Project MAY have a significant effect on the environment, and an ENVIRONMENTAL IMPACT REPORT is required.
- I find that the Project MAY have a "potentially significant impact" or "potentially significant unless mitigated" impact on the environment, but at least one effect 1) has been adequately analyzed in an earlier document pursuant to applicable legal standards, and 2) has been addressed by mitigation measures based on the earlier analysis as described on attached sheets. An ENVIRONMENTAL IMPACT REPORT is required, but it must analyze only the effects that remain to be addressed.
- I find that although the Project could have a significant effect on the environment, because all potentially significant effects (a) have been analyzed adequately in an earlier EIR or NEGATIVE DECLARATION pursuant to applicable standards, and (b) have been avoided or mitigated pursuant to that earlier EIR or NEGATIVE DECLARATION, including revisions or mitigation measures that are imposed upon the Project, nothing further is required.



Signature of City of Anaheim Representative

Andy Uk, Associate Planner

Printed Name/Title

March 22, 2022

Date

714-765-5238

Phone No.

EVALUATION OF ENVIRONMENTAL IMPACTS:

- 1) All answers must take account of the whole action involved, including offsite as well as onsite, cumulative as well as project-level, indirect as well as direct, and construction as well as operational impacts.
- 2) A list of “Supporting Information Sources” must be attached and other sources used or individuals contacted should be cited in the Narrative Summary for each section.
- 3) Response Column Heading Definitions:
 - a) **Potentially Significant Impact** is appropriate if there is substantial evidence that an effect may be significant. If there are one or more “Potentially Significant Impact” entries when the determination is made, an EIR is required.
 - b) **Potentially Significant Unless Mitigation Incorporated** applies where the incorporation of mitigation measures has reduced an effect from “Potentially Significant Impact” to a “Less Than Significant Impact”. The mitigation measures must be described, along with a brief explanation of how they reduce the effect to a less than significant level.
 - c) **Less Than Significant Impact** applies where the project creates no significant impacts, only Less Than Significant impacts.
 - d) **No Impact** applies where a project does not create an impact in that category. A “No Impact” answer is adequately supported if the referenced information sources show that the impact simply does not apply to projects like the one proposed (e.g., the project falls outside of a fault rupture zone). A “No Impact” answer should be explained where it is based on project-specific factors as well as general standards (e.g., the project would not expose sensitive receptors to pollutants, based on a project-specific screening analysis).
- 4) Earlier analyses may be used where, pursuant to a tiering, program EIR, Master EIR, or other CEQA process, an effect has been adequately analyzed in an earlier EIR or negative declaration (Section 15062(c)(3)(D)). In this case, a brief discussion should identify the following:
 - a) Earlier Analysis Used. Identify and state where they are available for review.
 - b) Impacts Adequately Addressed. Identify which effects from the checklist were within the scope of and adequately analyzed in an earlier document pursuant to applicable legal standards, and state whether such effects were addressed by mitigation measures based on the earlier analysis.
 - c) Mitigation Measures. For effects that are “Less than Significant with Mitigation Measures Incorporated”, describe the mitigation measures which were incorporated or refined from the earlier document and the extent to which they address site-specific conditions for the project.
- 5) Incorporate into the checklist any references to information sources for potential impacts (e.g., the General Plan, zoning ordinance). Reference to a previously prepared or outside document should, where appropriate, include a reference to the page or pages where the statement is substantiated.
- 6) The explanation of each issue should identify:
 - a) The significance criteria or threshold, if any, used to evaluate each question; and
 - b) The mitigation measure identified, if any, to reduce the impact to less than significant.

Environmental Issues	Potentially Significant Impact	Less Than Significant with Mitigation	Less Than Significant Impact	No Impact
I. AESTHETICS. Except as provided in Public Resources Code Section 21099, would the project:				
a) Have a substantial adverse effect on a scenic vista?	<input type="checkbox"/>	<input type="checkbox"/>	<input type="checkbox"/>	<input checked="" type="checkbox"/>
b) Substantially damage scenic resources, including, but not limited to, trees, rock outcroppings, and historic buildings within a State scenic highway or local scenic expressway, scenic highway, or eligible scenic highway?	<input type="checkbox"/>	<input type="checkbox"/>	<input checked="" type="checkbox"/>	<input type="checkbox"/>
c) Substantially degrade the existing visual character or quality of public views of the site and its surroundings? (Public views are those that are experienced from publicly accessible vantage point). If the project is in an urbanized area, would the project conflict with applicable zoning and other regulations governing scenic quality?	<input type="checkbox"/>	<input type="checkbox"/>	<input checked="" type="checkbox"/>	<input type="checkbox"/>
d) Create a new source of substantial light or glare which would adversely affect day or nighttime views in the area?	<input type="checkbox"/>	<input type="checkbox"/>	<input checked="" type="checkbox"/>	<input type="checkbox"/>
II. AGRICULTURE & FOREST RESOURCES -- In determining whether impacts to agricultural resources are significant environmental effects, lead agencies may refer to the California Agricultural Land Evaluation and Site Assessment Model (1997) prepared by the California Department of Conservation as an optional model to use in assessing impacts on agriculture and farmland. In determining whether impacts to forest resources, including timberland, are significant environmental effects, lead agencies may refer to information compiled by the California Department of Forestry and Fire Protection regarding the state's inventory of forest land, including the Forest and Range Assessment Project and the Forest Legacy Assessment project; and forest carbon measurement methodology provided in Forest Protocols adopted by the California Air Resources Board. Would the project:				
a) Convert Prime Farmland, Unique Farmland, or Farmland of Statewide Importance (Farmland), as shown on the maps prepared pursuant to the Farmland Mapping and Monitoring Program of the California Resources Agency, to non-agricultural use?	<input type="checkbox"/>	<input type="checkbox"/>	<input type="checkbox"/>	<input checked="" type="checkbox"/>
b) Conflict with existing zoning for agricultural use, or a Williamson Act contract?	<input type="checkbox"/>	<input type="checkbox"/>	<input type="checkbox"/>	<input checked="" type="checkbox"/>
c) Conflict with existing zoning for, or cause rezoning of, forest land (as defined in Public Resources Code section 12220(g)), timberland (as defined by Public Resources Code section 4526), or timberland zoned Timberland Production (as defined by Government Code section 51104(g))?	<input type="checkbox"/>	<input type="checkbox"/>	<input type="checkbox"/>	<input checked="" type="checkbox"/>
d) Result in the loss of forest land or conversion of forest land to non-forest use?	<input type="checkbox"/>	<input type="checkbox"/>	<input type="checkbox"/>	<input checked="" type="checkbox"/>
e) Involve other changes in the existing environment which, due to their location or nature, could result in conversion of Farmland, to non-agricultural use or conversion of forest land to non-forest use?	<input type="checkbox"/>	<input type="checkbox"/>	<input type="checkbox"/>	<input checked="" type="checkbox"/>
III. AIR QUALITY -- Where available, the significance criteria established by the applicable air quality management district or air pollution control district may be relied upon to make the following determinations. Would the project:				
a) Conflict with or obstruct implementation of the applicable air quality plan?	<input type="checkbox"/>	<input type="checkbox"/>	<input checked="" type="checkbox"/>	<input type="checkbox"/>
b) Result in a cumulatively considerable net increase of any criteria pollutant for which the project region is non-attainment under an applicable Federal or State ambient air quality standard?	<input type="checkbox"/>	<input type="checkbox"/>	<input checked="" type="checkbox"/>	<input type="checkbox"/>

Environmental Issues	Potentially Significant Impact	Less Than Significant with Mitigation	Less Than Significant Impact	No Impact
c) Expose sensitive receptors to substantial pollutant concentrations?	<input type="checkbox"/>	<input type="checkbox"/>	<input checked="" type="checkbox"/>	<input type="checkbox"/>
d) Result in other emissions (such as those leading to odors) adversely affecting a substantial number of people?	<input type="checkbox"/>	<input type="checkbox"/>	<input checked="" type="checkbox"/>	<input type="checkbox"/>
IV. BIOLOGICAL RESOURCES -- Would the project:				
a) Have a substantial adverse effect, either directly or through habitat modifications, on any species identified as a candidate, sensitive, or special status species in local or regional plans, policies, or regulations, or by the California Department of Fish and Game or U.S. Fish and Wildlife Service?	<input type="checkbox"/>	<input checked="" type="checkbox"/>	<input type="checkbox"/>	<input type="checkbox"/>
b) Have a substantial adverse effect on any riparian habitat or other sensitive natural community identified in local or regional plans, policies, regulations or by the California Department of Fish and Game or US Fish and Wildlife Service?	<input type="checkbox"/>	<input type="checkbox"/>	<input type="checkbox"/>	<input checked="" type="checkbox"/>
c) Have a substantial adverse effect on state or federally protected wetlands (including, but not limited to, marsh, vernal pool, coastal, etc.) through direct removal, filling, hydrological interruption, or other means?	<input type="checkbox"/>	<input type="checkbox"/>	<input type="checkbox"/>	<input checked="" type="checkbox"/>
d) Interfere substantially with the movement of any native resident or migratory fish or wildlife species or with established native resident or migratory wildlife corridors, or impede the use of native wildlife nursery sites?	<input type="checkbox"/>	<input checked="" type="checkbox"/>	<input type="checkbox"/>	<input type="checkbox"/>
e) Conflict with any local policies or ordinances protecting biological resources, such as a tree preservation policy or ordinance?	<input type="checkbox"/>	<input type="checkbox"/>	<input checked="" type="checkbox"/>	<input type="checkbox"/>
f) Conflict with the provisions of an adopted Habitat Conservation Plan, Natural Community Conservation Plan, or other approved local, regional, or State habitat conservation plan?	<input type="checkbox"/>	<input type="checkbox"/>	<input checked="" type="checkbox"/>	<input type="checkbox"/>
V. CULTURAL RESOURCES -- Would the project:				
a) Cause a substantial adverse change in the significance of a historical resource pursuant to in §15064.5 of the CEQA Guidelines and/or identified on the Qualified Historic Structures list of the Anaheim Colony Historic District Preservation Plan (April 15, 2010)?	<input type="checkbox"/>	<input type="checkbox"/>	<input type="checkbox"/>	<input checked="" type="checkbox"/>
b) Cause a substantial adverse change in the significance of an archaeological resource pursuant to §15064.5 of the CEQA Guidelines?	<input type="checkbox"/>	<input checked="" type="checkbox"/>	<input type="checkbox"/>	<input type="checkbox"/>
c) Disturb any human remains, including those interred outside of dedicated cemeteries?	<input type="checkbox"/>	<input type="checkbox"/>	<input checked="" type="checkbox"/>	<input type="checkbox"/>
VI. ENERGY -- Would the project:				
a) Result in potentially significant environmental impact due to wasteful, inefficient, or unnecessary consumption of energy resources, during project construction or operation?	<input type="checkbox"/>	<input type="checkbox"/>	<input checked="" type="checkbox"/>	<input type="checkbox"/>
b) Conflict with or obstruct a state or local plan for renewable energy or energy efficiency?	<input type="checkbox"/>	<input type="checkbox"/>	<input type="checkbox"/>	<input checked="" type="checkbox"/>

Environmental Issues	Potentially Significant Impact	Less Than Significant with Mitigation	Less Than Significant Impact	No Impact
VII. GEOLOGY AND SOILS -- Would the project:				
a) Directly or indirectly cause potential substantial adverse effects, including the risk of loss, injury, or death involving:				
i) Rupture of a known earthquake fault, as delineated on the most recent Alquist-Priolo Earthquake Fault Zoning Map issued by the State Geologist for the area or based on other substantial evidence of a known fault? Refer to Division of Mines and Geology Special Publication 42.	<input type="checkbox"/>	<input type="checkbox"/>	<input checked="" type="checkbox"/>	<input type="checkbox"/>
ii) Strong seismic ground shaking?	<input type="checkbox"/>	<input type="checkbox"/>	<input checked="" type="checkbox"/>	<input type="checkbox"/>
iii) Seismic-related ground failure, including liquefaction?	<input type="checkbox"/>	<input type="checkbox"/>	<input type="checkbox"/>	<input checked="" type="checkbox"/>
iv) Landslides?	<input type="checkbox"/>	<input type="checkbox"/>	<input checked="" type="checkbox"/>	<input type="checkbox"/>
b) Result in substantial soil erosion or the loss of topsoil?	<input type="checkbox"/>	<input type="checkbox"/>	<input checked="" type="checkbox"/>	<input type="checkbox"/>
c) Be located on a geologic unit or soil that is unstable, or that would become unstable as a result of the project, and potentially result in on- or off-site landslide, lateral spreading, subsidence, liquefaction or collapse?	<input type="checkbox"/>	<input type="checkbox"/>	<input checked="" type="checkbox"/>	<input type="checkbox"/>
d) Be located on expansive soil, as defined in Section 1803.5.3 of the California Building Code (2010), creating substantial direct or indirect risks to life or property?	<input type="checkbox"/>	<input type="checkbox"/>	<input checked="" type="checkbox"/>	<input type="checkbox"/>
e) Have soils incapable of adequately supporting the use of septic tanks or alternative wastewater disposal systems where sewers are not available for the disposal of wastewater?	<input type="checkbox"/>	<input type="checkbox"/>	<input type="checkbox"/>	<input checked="" type="checkbox"/>
f) Directly or indirectly destroy a unique paleontological resource or site or unique geologic feature?	<input type="checkbox"/>	<input checked="" type="checkbox"/>	<input type="checkbox"/>	<input type="checkbox"/>
VIII. GREENHOUSE GAS EMISSIONS – Would the project:				
a) Generate greenhouse gas emissions, either directly or indirectly, that may have a significant impact on the environment?	<input type="checkbox"/>	<input type="checkbox"/>	<input checked="" type="checkbox"/>	<input type="checkbox"/>
b) Conflict with an applicable plan, policy or regulation adopted for the purpose of reducing the emissions of greenhouse gases?	<input type="checkbox"/>	<input type="checkbox"/>	<input checked="" type="checkbox"/>	<input type="checkbox"/>
IX. HAZARDS AND HAZARDOUS MATERIALS -- Would the project:				
a) Create a significant hazard to the public or the environment through the routine transport, use, or disposal of hazardous materials?	<input type="checkbox"/>	<input type="checkbox"/>	<input checked="" type="checkbox"/>	<input type="checkbox"/>
b) Create a significant hazard to the public or the environment through reasonably foreseeable upset and accident conditions involving the release of hazardous materials into the environment?	<input type="checkbox"/>	<input type="checkbox"/>	<input checked="" type="checkbox"/>	<input type="checkbox"/>
c) Emit hazardous emissions or handle hazardous or acutely hazardous materials, substances, or waste within one-quarter mile of an existing or proposed school?	<input type="checkbox"/>	<input type="checkbox"/>	<input checked="" type="checkbox"/>	<input type="checkbox"/>

Environmental Issues	Potentially Significant Impact	Less Than Significant with Mitigation	Less Than Significant Impact	No Impact
d) Be located on a site which is included on a list of hazardous materials sites compiled pursuant to Government Code Section 65962.5 and, as a result, would it create a significant hazard to the public or the environment?	<input type="checkbox"/>	<input type="checkbox"/>	<input type="checkbox"/>	<input checked="" type="checkbox"/>
e) For a project located within an airport land use plan (Los Alamitos Armed Forces Reserve Center or Fullerton Municipal Airport), would the project result in a safety hazard or excessive noise for people residing or working in the project area?	<input type="checkbox"/>	<input type="checkbox"/>	<input type="checkbox"/>	<input checked="" type="checkbox"/>
f) Impair implementation of or physically interfere with an adopted emergency response plan or emergency evacuation plan?	<input type="checkbox"/>	<input type="checkbox"/>	<input type="checkbox"/>	<input checked="" type="checkbox"/>
g) Expose people or structures, either directly or indirectly, to a significant risk of loss, injury or death involving wildland fires?	<input type="checkbox"/>	<input type="checkbox"/>	<input checked="" type="checkbox"/>	<input type="checkbox"/>
X. HYDROLOGY AND WATER QUALITY -- Would the project:				
a) Violate any water quality standards or waste discharge requirements or otherwise substantially degrade surface or ground water quality?	<input type="checkbox"/>	<input type="checkbox"/>	<input checked="" type="checkbox"/>	<input type="checkbox"/>
b) Substantially decrease groundwater supplies or interfere substantially with groundwater recharge such that the project may impede sustainable groundwater management of the basin?	<input type="checkbox"/>	<input type="checkbox"/>	<input checked="" type="checkbox"/>	<input type="checkbox"/>
c) Substantially alter the existing drainage pattern of the site or area, including through the alteration of the course of a stream or river or through the addition of impervious surfaces, in a manner which would:				
(i) result in substantial erosion or siltation on- or off-site?	<input type="checkbox"/>	<input type="checkbox"/>	<input checked="" type="checkbox"/>	<input type="checkbox"/>
(ii) substantially increase the rate or amount of surface runoff in a manner which would result in flooding on- or offsite;	<input type="checkbox"/>	<input type="checkbox"/>	<input checked="" type="checkbox"/>	<input type="checkbox"/>
(iii) create or contribute runoff water which would exceed the capacity of existing or planned stormwater drainage systems or provide substantial additional sources of polluted runoff; or	<input type="checkbox"/>	<input type="checkbox"/>	<input checked="" type="checkbox"/>	<input type="checkbox"/>
(iv) impede or redirect flood flows?	<input type="checkbox"/>	<input type="checkbox"/>	<input checked="" type="checkbox"/>	<input type="checkbox"/>
d) In flood hazard, tsunami, or seiche zones, risk release of pollutants due to project inundation?	<input type="checkbox"/>	<input type="checkbox"/>	<input checked="" type="checkbox"/>	<input type="checkbox"/>
e) Conflict with or obstruct implementation of a water quality control plan or sustainable groundwater management plan?	<input type="checkbox"/>	<input type="checkbox"/>	<input checked="" type="checkbox"/>	<input type="checkbox"/>
XI. LAND USE AND PLANNING -- Would the project:				
a) Physically divide an established community?	<input type="checkbox"/>	<input type="checkbox"/>	<input type="checkbox"/>	<input checked="" type="checkbox"/>
b) Cause a significant environmental impact due to a conflict with any land use plan, policy, or regulation adopted for the purpose of avoiding or mitigating an environmental effect?	<input type="checkbox"/>	<input type="checkbox"/>	<input checked="" type="checkbox"/>	<input type="checkbox"/>

Environmental Issues	Potentially Significant Impact	Less Than Significant with Mitigation	Less Than Significant Impact	No Impact
XII. MINERAL RESOURCES -- Would the project:				
a) Result in the loss of availability of a known mineral resource that would be of value to the region and the residents of the state?	<input type="checkbox"/>	<input type="checkbox"/>	<input type="checkbox"/>	<input checked="" type="checkbox"/>
b) Result in the loss of availability of a locally-important mineral resource recovery site delineated on a local general plan, specific plan or other land use plan?	<input type="checkbox"/>	<input type="checkbox"/>	<input type="checkbox"/>	<input checked="" type="checkbox"/>
XIII. NOISE -- Would the project result in:				
a) Generation of a substantial temporary or permanent increase in ambient noise levels in the vicinity of the project in excess of standards established in the local general plan or noise ordinance, or applicable standards of other agencies?	<input type="checkbox"/>	<input type="checkbox"/>	<input checked="" type="checkbox"/>	<input type="checkbox"/>
b) Generation of excessive groundborne vibration or groundborne noise levels?	<input type="checkbox"/>	<input type="checkbox"/>	<input checked="" type="checkbox"/>	<input type="checkbox"/>
c) For a project located within the vicinity of a private airstrip or an airport land use plan (Los Alamitos Armed Forces Reserve Center or Fullerton Municipal Airport), would the project expose people residing or working in the project area to excessive noise levels?	<input type="checkbox"/>	<input type="checkbox"/>	<input type="checkbox"/>	<input checked="" type="checkbox"/>
XIV. POPULATION AND HOUSING -- Would the project:				
a) Induce substantial unplanned population growth in an area, either directly (for example, by proposing new homes and businesses) or indirectly (for example, through extension of roads or other infrastructure)?	<input type="checkbox"/>	<input type="checkbox"/>	<input checked="" type="checkbox"/>	<input type="checkbox"/>
b) Displace substantial numbers of existing people or housing, necessitating the construction of replacement housing elsewhere?	<input type="checkbox"/>	<input type="checkbox"/>	<input type="checkbox"/>	<input checked="" type="checkbox"/>
XV. PUBLIC SERVICES -- Would the project result in substantial adverse physical impacts associated with the provision of new or physically altered governmental facilities, need for new or physically altered governmental facilities, the construction of which could cause significant environmental impacts, in order to maintain acceptable service ratios, response times or other performance objectives for any of the public services:				
Fire protection?	<input type="checkbox"/>	<input type="checkbox"/>	<input checked="" type="checkbox"/>	<input type="checkbox"/>
Police protection?	<input type="checkbox"/>	<input type="checkbox"/>	<input checked="" type="checkbox"/>	<input type="checkbox"/>
Schools?	<input type="checkbox"/>	<input type="checkbox"/>	<input type="checkbox"/>	<input checked="" type="checkbox"/>
Parks?	<input type="checkbox"/>	<input type="checkbox"/>	<input type="checkbox"/>	<input checked="" type="checkbox"/>
Other public facilities?	<input type="checkbox"/>	<input type="checkbox"/>	<input checked="" type="checkbox"/>	<input type="checkbox"/>
XVI. RECREATION --				
a) Increase the use of existing neighborhood and regional parks or other recreational facilities such that substantial physical deterioration of the facility would occur or be accelerated?	<input type="checkbox"/>	<input type="checkbox"/>	<input type="checkbox"/>	<input checked="" type="checkbox"/>
b) Does the project include recreational facilities or require the construction or expansion of recreational facilities which might have an adverse physical effect on the environment?	<input type="checkbox"/>	<input type="checkbox"/>	<input type="checkbox"/>	<input checked="" type="checkbox"/>

Environmental Issues	Potentially Significant Impact	Less Than Significant with Mitigation	Less Than Significant Impact	No Impact
XVII. TRANSPORTATION -- Would the project:				
a) Conflict with a program plan, ordinance or policy addressing the circulation system, including transit, roadway, bicycle and pedestrian facilities?	<input type="checkbox"/>	<input type="checkbox"/>	<input checked="" type="checkbox"/>	<input type="checkbox"/>
b) Would the project conflict or be inconsistent with CEQA Guidelines section 15064.3, subdivision (b)?	<input type="checkbox"/>	<input type="checkbox"/>	<input checked="" type="checkbox"/>	<input type="checkbox"/>
c) Substantially increase hazards due to a geometric design feature (e.g., sharp curves or dangerous intersections) or incompatible uses?	<input type="checkbox"/>	<input type="checkbox"/>	<input checked="" type="checkbox"/>	<input type="checkbox"/>
d) Result in inadequate emergency access?	<input type="checkbox"/>	<input type="checkbox"/>	<input checked="" type="checkbox"/>	<input type="checkbox"/>
XVIII. TRIBAL CULTURAL RESOURCES -- Would the project:				
Cause a substantial adverse change in the significance of a tribal cultural resource, defined in Public Resources Code Section §21074 as either a site, feature, place, cultural landscape that is geographically defined in terms of the size and scope of the landscape, sacred place, or object with cultural value to a California Native American tribe, and that is:				
a) Listed or eligible for listing in the California Register of Historical Resources, or in a local register of historical resources as defined in Public Resources Code Section §5020.1(k), or	<input type="checkbox"/>	<input type="checkbox"/>	<input type="checkbox"/>	<input checked="" type="checkbox"/>
b) A resource determined by the lead agency, in its discretion and supported by substantial evidence, to be significant pursuant to criteria set forth in subdivision (c) of Public Resources Code Section §5024.1. In applying criteria set forth in subdivision (c) of Public Resources Code Section §5024.1, the lead agency shall consider the significance of the resource to a California Native American tribe.	<input type="checkbox"/>	<input checked="" type="checkbox"/>	<input type="checkbox"/>	<input type="checkbox"/>
XIX. UTILITIES AND SERVICE SYSTEMS -- Would the project:				
a) Require or result in the relocation or construction of new or expanded water, wastewater treatment or storm water drainage, electric power, natural gas, or telecommunications facilities, the construction or relocation of which could cause significant environmental effects?	<input type="checkbox"/>	<input type="checkbox"/>	<input checked="" type="checkbox"/>	<input type="checkbox"/>
b) Have sufficient water supplies available to serve the project and reasonably foreseeable future development during normal, dry and multiple dry years (including large-scale developments as defined by Public Resources Code Section 21151.9 and described in Question No. 20 of the Environmental Information Form)?	<input type="checkbox"/>	<input type="checkbox"/>	<input type="checkbox"/>	<input checked="" type="checkbox"/>
c) Result in a determination by the wastewater treatment provider which serves or may serve the project that it has adequate capacity to serve the project's projected demand in addition to the provider's existing commitments?	<input type="checkbox"/>	<input type="checkbox"/>	<input checked="" type="checkbox"/>	<input type="checkbox"/>
d) Generate solid waste in excess of State or local standards, or in excess of the capacity of local infrastructure, or otherwise impair the attainment of solid waste reduction goals?	<input type="checkbox"/>	<input type="checkbox"/>	<input checked="" type="checkbox"/>	<input type="checkbox"/>
e) Comply with Federal, State, and local management and reduction statutes and regulations related to solid waste?	<input type="checkbox"/>	<input type="checkbox"/>	<input type="checkbox"/>	<input checked="" type="checkbox"/>

Environmental Issues	Potentially Significant Impact	Less Than Significant with Mitigation	Less Than Significant Impact	No Impact
f) Result in a need for new systems or supplies, or substantial alterations related to electricity?	<input type="checkbox"/>	<input type="checkbox"/>	<input checked="" type="checkbox"/>	<input type="checkbox"/>
g) Result in a need for new systems or supplies, or substantial alterations related to natural gas?	<input type="checkbox"/>	<input type="checkbox"/>	<input type="checkbox"/>	<input checked="" type="checkbox"/>
h) Result in a need for new systems or supplies, or substantial alterations related to telephone service?	<input type="checkbox"/>	<input type="checkbox"/>	<input type="checkbox"/>	<input checked="" type="checkbox"/>
i) Result in a need for new systems or supplies, or substantial alterations related to television service/reception?	<input type="checkbox"/>	<input type="checkbox"/>	<input type="checkbox"/>	<input checked="" type="checkbox"/>
XX. WILDFIRE -- If located in or near state responsibility areas or lands classified as very high fire hazard severity zones, would the project:				
a) Substantially impair an adopted emergency response plan or emergency evacuation plan?	<input type="checkbox"/>	<input type="checkbox"/>	<input checked="" type="checkbox"/>	<input type="checkbox"/>
b) Due to slope, prevailing winds, and other factors, exacerbate wildfire risks, and thereby expose project occupants to, pollutant concentrations from a wildfire or the uncontrolled spread of a wildfire?	<input type="checkbox"/>	<input type="checkbox"/>	<input checked="" type="checkbox"/>	<input type="checkbox"/>
c) Require the installation or maintenance of associated infrastructure (such as roads, fuel breaks, emergency water sources, power lines or other utilities) that may exacerbate fire risk or that may result in temporary or ongoing impacts to the environment?	<input type="checkbox"/>	<input type="checkbox"/>	<input type="checkbox"/>	<input checked="" type="checkbox"/>
d) Expose people or structures to significant risks, including downslope or downstream flooding or landslides, as a result of runoff, post-fire slope instability, or drainage changes?	<input type="checkbox"/>	<input type="checkbox"/>	<input checked="" type="checkbox"/>	<input type="checkbox"/>
XXI. MANDATORY FINDINGS OF SIGNIFICANCE				
a) Does the project have the potential to substantially degrade the quality of the environment, substantially reduce the habitat of a fish or wildlife species, cause a fish or wildlife population to drop below self-sustaining levels, threaten to eliminate a plant or animal community, substantially reduce the number or restrict the range of a rare or endangered plant or animal or eliminate important examples of the major periods of California history or prehistory?	<input type="checkbox"/>	<input checked="" type="checkbox"/>	<input type="checkbox"/>	<input type="checkbox"/>
b) Does the project have impacts that are individually limited, but cumulatively considerable? ("Cumulatively considerable" means that the incremental effects of a project are considerable when viewed in connection with the effects of past projects, the effects of other current projects, and the effects of probable future projects)?	<input type="checkbox"/>	<input type="checkbox"/>	<input checked="" type="checkbox"/>	<input type="checkbox"/>
c) Does the project have environmental effects which will cause substantial adverse effects on human beings, either directly or indirectly?	<input type="checkbox"/>	<input type="checkbox"/>	<input checked="" type="checkbox"/>	<input type="checkbox"/>

Fish and Wildlife Determination

Per Section 21089(b) of the Public Resources Code, all project applicants and public agencies subject to CEQA shall pay a Fish and Wildlife filing fee for each Project that would adversely affect wildlife resources.*

Based on the responses contained in this Environmental Checklist, there is no evidence that the project has a potential for a change that would adversely affect wildlife resources or the habitat upon which the wildlife depends. Has the presumption of adverse effect set forth in 14 CCR 753.5(d) been rebutted by substantial evidence?

Yes (Certificate of Fee Exemption and County Administrative fee required)

No (Pay fee)

***Note:** California Fish and Wildlife Code Section 711.4(c)(2)(A) states that projects that are Categorically Exempt from CEQA are also exempt from filing fee.

SECTION 5.0 ENVIRONMENTAL EVALUATION

I. AESTHETICS

Question A: *Would the project have a substantial adverse effect on a scenic vista?*

No Impact. The Project is located on a site that has been previously developed with a community church. The church is developed on graded pads that were integrated into a hillside as a series of terraces, which trend downslope to the north towards East Santa Ana Canyon Road. Areas to the north of the Project site include East Santa Ana Canyon Road and State Route (SR) 91. The existing uses to the south, east, and west of the Project site are undeveloped.

According to the Green Element of the City's General Plan (Anaheim 2020a) the contours of the Hill and Canyon Area of the City, as well as the Santa Ana Mountains are visible scenic vistas. Other scenic amenities such as golf courses and the Santa Ana River also provide visual relief and are important visual amenities and landmarks. The Project site is located in the Hill and Canyon Area of the City, however the Project would not impede any public views of the Santa Ana Mountains, Santa Ana River, golf courses, or other visual resources. The Project would occur on a previously graded site and does not require major grading. Also, the Project does not include construction or modification of structures at or near the top of any ridgelines or hilltops that could affect views of these vistas. Therefore, the Project would have no impact on a scenic vista, and no mitigation is required.

Question B: *Would the project substantially damage scenic resources, including, but not limited to, trees, rock outcroppings, and historic buildings within a State scenic highway or local scenic expressway, scenic highway, or eligible scenic highway?*

Less Than Significant Impact. According to the California Department of Transportation (Caltrans) and the City of Anaheim General Plan, a 4.5-mile segment of SR-91 is an officially designated State Scenic Highway from SR-55 to west of the Weir Canyon Road interchange, approximately 2.25 miles to the west of the Project site. This designation is enforced through the Scenic Corridor (SC) Overlay Zone contained in the Anaheim Municipal Code Chapter 18.18. SR-91 runs along the banks of the Santa Ana River. Views include mountain ridgelines, canyons, rolling hills, intermittent riparian and chaparral vegetation, and residential and commercial development. Also, the stretch of SR-91 east of Weir Canyon, near the Project site, is an eligible State Scenic Highway, but it is not officially designated as a Scenic Highway (Anaheim 2020a, Caltrans 2021).

The Project site is located within the City's SC Overlay Zone, which is defined as the area of the City located east of the intersection of the SR-55 and SR-91 Freeways; west of the Orange County line; south of the Atchison, Topeka and Santa Fe Railroad right-of-way; and north of the present or any future south city limits of the City of Anaheim (Anaheim 2021a). The SC Overlay Zone was established to provide for and promote orderly growth in an area of the City considered to have distinctive, scenic importance. Section 18.18.040 of the City's Municipal Code contains policies and procedures for tree preservation within the SC Overlay Zone, as well as policies pertaining to the removal of trees in this zone.

The Project requires the removal of 29 trees within the Project site; however, no rock outcroppings, or historic buildings, or other significant scenic resources would be removed as part of the Project. Given the Project consists of the redevelopment of an existing campus, the Project would retain much of the existing vegetation on the Project site, which would avoid potential visual impacts to views from areas within the scenic corridor. Trees removed would be replaced with

other vegetation throughout the Project site as shown in the Project's landscaping plan provided as Exhibits 16a, 16b, and 16c, which would include species such as Coast Live Oak, Engelmann oak, California Black Walnut, and Western Sycamore, which would minimize visual impacts. The net number of trees and landscaped area would increase with the Project when compared to existing conditions, including enhanced landscaping at the Project site entrance, which would improve views from SR-91 and East Santa Ana Canyon Road. Overall, 29 trees would be removed and 88 new trees would be planted within the Project site.

Given that the current property owner (e.g., the Project Applicant) originally planted all trees within the Project site that would be removed, the removal of these trees is exempt from the requirements for a Specimen Tree Removal Permit, pursuant to the conditions contained in Section 18.18.040 of the City's Municipal Code.

As described above, the Project would require vegetation removal within the City's SC Overlay Zone on a Project site that is visible from an eligible state scenic highway. As discussed in more detail above, views of the Project site would be minimally affected by the tree removal and other improvements proposed as part of the Project. Furthermore, the Project would be developed consistent with the Municipal Code policies related to the SC Overlay Zone and underlying SP88-1 and SP88-2 zoning classifications for the Project site. Therefore, less than significant impacts would result from the Project related to this threshold, and no mitigation is required.

Question C: *In non-urbanized areas, substantially degrade the existing visual character or quality of public views of the site and its surroundings? (Public views are those that are experienced from publicly accessible vantage point). If the project is in an urbanized area, would the project conflict with applicable zoning and other regulations governing scenic quality?*

Less than Significant Impact. The Project site is located in an urbanized area, as defined by Section 21071 of the CEQA Statute; therefore, the analysis for this threshold focuses on whether the Project would conflict with applicable zoning and other regulations governing scenic quality. The majority of the property is located within the Sycamore Canyon Specific Plan (SP88-1) Zone; however, a small portion (approximately two acres) is located within The Summit of Anaheim Hills Specific Plan (SP88-2) Zone.

The Sycamore Canyon Specific Plan (SP88-1) identifies the Project site as a future church with an underlying Open Space land use; however, SP88-1 does not include any detailed standards or procedures for the development of the church. SP88-1 includes a brief discussion that an 11-acre church is planned in the northeast portion of the Sycamore Canyon Specific Plan area. SP88-1 notes that the details of the proposed church would be addressed in a subsequent application (Anaheim 1988a). SP88-1 states that the standards of the Open Space Zone in Chapter 18.14 (Public and Special Purpose Zones) of the City's Municipal Code shall apply for the areas shown as open space on the Sycamore Canyon Development Plan Map, such as the Project site. Pursuant to Chapter 18.14 of the City's Municipal Code, the existing church and proposed expansion of the church under the Project would be conditionally permitted uses.

In addition to the City-wide sign requirements codified in Chapter 18.44 of the City's Municipal Code, SP88-1 also includes requirements for signage in the Sycamore Canyon Specific Plan in Section 18.102.150 of the Municipal Code. These requirements have been incorporated into the relocated monument signage, which will be reviewed and approved by the City as part of a future and separate discretionary action.

The Summit of Anaheim Hills Specific Plan (SP88-2) similarly identifies the Project site as a future church with an underlying Open Space land use in mapping but does not include any detailed

standards or procedures for the development of the church (Anaheim 1988b). As outlined in the Open Space Standards for the Summit of Anaheim Hills Specific Plan, which are codified in Section 18.104.080 of the City's Municipal Code, the existing church and proposed expansion of the church under the Project are conditionally permitted uses. SP88-2 includes additional requirements for signage; however, none of the Project signage would occur within any parcels zoned as SP88-2, so these policies are not applicable.

The City originally approved a CUP for the church in 1988 as a semi-enclosed "garden church" by CUP 3032. In 1998, the City subsequently approved the existing church by CUP 4033. This CUP permitted a 29,503-square foot church with accessory day care center, fellowship hall, and multi-purpose building in conjunction with existing modular buildings. The City subsequently amended the CUP in 1998 to add a parsonage home; in 2004 to allow 5,611 addition to the fellowship hall; and, in 2008 to add three modular units for Sunday school classrooms.

As described above under threshold I(B), the entire property is within the SC Overlay Zone, and the Project has been designed to be consistent with the requirements for this zone.

As part of the City's design review process and amendment to the CUP for the Project site, the Project has been reviewed by the City to ensure compliance with applicable regulations related to scenic quality, including maximum building heights, signage, and tree removal. Given that the Project would not conflict with applicable zoning and other regulations governing scenic quality, the Project would result in less than significant impacts related to this threshold, and no mitigation is required.

Question D: Would the project create a new source of substantial light or glare which would adversely affect day or nighttime views in the area?

Less Than Significant Impact. The Project site is located in an area that is subject to nighttime lighting from existing church uses on the Project site; street lights along East Santa Ana Canyon Road; lighting from passing vehicles along East Santa Ana Canyon Road and SR-91; and lighting from residential uses located south of the Project site.

New lighting would be added to the exterior of the auditorium, including wall sconces along walls and at the building entrances. Also, pole-mounted lighting would be provided near parking lots and bollard lighting would be provided along pedestrian paths within the Project site. The circular screen and tree seating area within the upper campus would be lit with new accent lighting and the relocated fabric tent would be retrofitted to include micro-profile light fixtures. These additional sources of light would occur within a Project site that is already subject to nighttime lighting, and this lighting would be downcast and would not leave the property.

Installation of lighting for the Project would not be a substantial increase in lighting in the area and would not adversely affect nighttime views. Impacts would be less than significant, and no mitigation is required.

Mitigation Program

No mitigation is required.

II. AGRICULTURE AND FOREST LAND RESOURCES

Question A: *Would the project convert Prime Farmland, Unique Farmland, or Farmland of Statewide Importance (Farmland), as shown on the maps prepared pursuant to the Farmland Mapping and Monitoring Program of the California Resources Agency, to non-agricultural use?*

Question B: *Would the project conflict with existing zoning for agricultural use, or a Williamson Act contract?*

Question C: *Would the project conflict with existing zoning for, or cause rezoning of, forest land (as defined in Public Resources Code section 12220(g)), timberland (as defined in Public Resources Code section 4526), or timberland zoned Timberland Production (as defined by Government Code section 51104(g))?*

Question D: *Would the project result in the loss of forest land or conversion of forest land to non-forest use?*

Question E: *Would the project involve other changes in the existing environment which, due to their location or nature, could result in conversion of Farmland, to non-agricultural use or conversion of forest land to non-forest use?*

No Impact. According to mapping prepared by the California Department of Conservation (DOC 2021a), the Project site is designated as “Urban and Built Up Land”, and does not contain any land designated as Prime Farmland, Farmland of Statewide Importance, Unique Farmland or Farmland of Local Importance. Also, it is not zoned for agricultural use and there are no Williamson Act contracts applicable to the Project site (Anaheim 2020a).

The Project site is not defined as forest land according to Section 12220(g) of the *California Public Resources Code*, which defines forest land as “land that can support 10 percent native tree cover of any species, including hardwoods, under natural conditions, and that allows for management of one or more forest resources, including timber, aesthetics, fish and wildlife, biodiversity, water quality, recreation, and other public benefits”, nor is it zoned for Timberland Production as defined by Section 51104(g) of the *California Government Code*.

No impacts related to agricultural and forest land resources would occur, and no mitigation is required.

Mitigation Program

No mitigation is required.

III. AIR QUALITY

Air Quality Background Information and Regulatory Conditions

The U.S. Environmental Protection Agency (USEPA) defines seven “criteria” air pollutants, as described below. These pollutants are called criteria pollutants because the USEPA has established National Ambient Air Quality Standards (NAAQS) for the concentrations of these pollutants (USEPA 2021a). The California Air Resources Board (CARB) has also established standards for the criteria pollutants, known as California Ambient Air Quality Standards (CAAQS), and the State standards are generally more restrictive than the NAAQS.

- Ozone (O₃) is a nearly colorless gas that is formed by photochemical reaction of nitrogen dioxide and volatile organic compounds with sunlight. Ground-level O₃ exposure can cause a variety of health problems, including lung irritation, wheezing, coughing, pain when taking a deep breath, and breathing difficulties during exercise or outdoor activities; permanent lung damage; aggravated asthma; and increased susceptibility to respiratory illnesses.
- Carbon monoxide (CO) is a colorless and odorless toxic gas which, in the urban environment, is associated primarily with the incomplete combustion of fossil fuels in motor vehicles. CO combines with hemoglobin in the bloodstream and reduces the amount of oxygen that can be circulated through the body. High CO concentrations can lead to headaches, aggravation of cardiovascular disease, and impairment of central nervous system functions.
- Nitrogen oxides (NO_x) are yellowish-brown gases, which at high levels can cause breathing difficulties. NO_x are formed when nitric oxide (a pollutant from internal combustion processes) combines with oxygen.
- Sulfur dioxide (SO₂) is a colorless, pungent gas formed primarily by the combustion of sulfur-containing fossil fuels. Health effects include acute respiratory symptoms and difficulty in breathing for children.
- Respirable Particulate Matter 10 (PM₁₀) and Fine Particulate Matter 2.5 (PM_{2.5}) refer to particulate matter equal to or less than ten microns and two and one-half microns in diameter, respectively. Particulates of this size cause a greater health risk than larger-sized particles since fine particles can more easily cause irritation. Particulate matter includes both aerosols and solid particles. An example of particulate matter is fugitive dust. Short-term exposure to high PM_{2.5} levels is associated with premature mortality and increased hospital admissions and emergency room visits. Long-term exposure to high PM_{2.5} levels is associated with premature mortality and development of chronic respiratory disease. Short-term exposure to high PM₁₀ levels is associated with hospital admissions for cardiopulmonary diseases, increased respiratory symptoms, and possible premature mortality.
- Lead is a metal found naturally in the environment and in manufactured products. The major sources of lead emissions have historically been mobile and industrial sources. Lead is a stable compound that persists and accumulates both in the environment and in animals. In humans, it affects the body’s blood-forming, nervous, and renal systems. In addition, lead has been shown to affect the normal functions of the reproductive, endocrine, hepatic, cardiovascular, immunological and gastrointestinal systems, although there is significant individual variability in response to lead exposure.

The NAAQS and CAAQS are shown in Table 2 below.

**TABLE 2
CALIFORNIA AND FEDERAL AMBIENT AIR QUALITY STANDARDS**

Pollutant	Averaging Time	California Standards	Federal Standards	
			Primary ^a	Secondary ^b
O ₃	1 Hour	0.09 ppm (180 µg/m ³)	–	–
	8 Hour	0.070 ppm (137 µg/m ³)	0.070 ppm (137 µg/m ³)	Same as Primary
PM ₁₀	24 Hour	50 µg/m ³	150 µg/m ³	Same as Primary
	AAM	20 µg/m ³	–	Same as Primary
PM _{2.5}	24 Hour	–	35 µg/m ³	Same as Primary
	AAM	12 µg/m ³	12.0 µg/m ³	15.0 µg/m ³
CO	1 Hour	20 ppm (23 mg/m ³)	35 ppm (40 mg/m ³)	–
	8 Hour	9.0 ppm (10 mg/m ³)	9 ppm (10 mg/m ³)	–
	8 Hour (Lake Tahoe)	6 ppm (7 mg/m ³)	–	–
NO ₂	AAM	0.030 ppm (57 µg/m ³)	0.053 ppm (100 µg/m ³)	Same as Primary
	1 Hour	0.18 ppm (339 µg/m ³)	0.100 ppm (188 µg/m ³)	–
SO ₂	24 Hour	0.04 ppm (105 µg/m ³)	–	–
	3 Hour	–	–	0.5 ppm (1,300 µg/m ³)
	1 Hour	0.25 ppm (655 µg/m ³)	0.075 ppm (196 µg/m ³)	–
Lead	30-day Avg.	1.5 µg/m ³	–	–
	Calendar Quarter	–	1.5 µg/m ³	Same as Primary
	Rolling 3-month Avg.	–	0.15 µg/m ³	
Visibility Reducing Particles	8 Hour	Extinction coefficient of 0.23 per km – visibility ≥ 10 miles (0.07 per km – ≥30 miles for Lake Tahoe)	No Federal Standards	
Sulfates	24 Hour	25 µg/m ³		
Hydrogen Sulfide	1 Hour	0.03 ppm (42 µg/m ³)		
Vinyl Chloride	24 Hour	0.01 ppm (26 µg/m ³)		

O₃: ozone; ppm: parts per million; µg/m³: micrograms per cubic meter; PM₁₀: respirable particulate matter 10 microns or less in diameter; AAM: Annual Arithmetic Mean; –: No Standard; PM_{2.5}: fine particulate matter 2.5 microns or less in diameter; CO: carbon monoxide; mg/m³: milligrams per cubic meter; NO₂: nitrogen dioxide; SO₂: sulfur dioxide; km: kilometer.

^a National Primary Standards: The levels of air quality necessary, within an adequate margin of safety, to protect the public health.

^b National Secondary Standards: The levels of air quality necessary to protect the public welfare from any known or anticipated adverse effects of a pollutant.

Note: More detailed information in the data presented in this table can be found at the CARB website (www.arb.ca.gov).

Source: CARB 2016

CARB, a part of the California Environmental Protection Agency (CalEPA), is responsible for coordinating and administering both the federal and State air pollution control programs in California. In this capacity, CARB conducts research, sets the CAAQS (as shown in Table 2), compiles emission inventories, develops suggested control measures, oversees local programs, and prepares the State Implementation Plan (SIP). For regions that do not attain the CAAQS, CARB requires the air districts to prepare plans for attaining the standards. These plans are then integrated into the SIP. CARB establishes emissions standards for (1) motor vehicles sold in California, (2) consumer products (e.g., hair spray, aerosol paints, barbecue lighter fluid), and (3) various types of commercial equipment. It also sets fuel specifications to further reduce vehicular emissions.

The South Coast Air Quality Management District (SCAQMD) is the agency principally responsible for comprehensive air pollution control in the South Coast Air Basin (SoCAB), which includes: Orange County and the non-desert portions of Los Angeles, Riverside, and San Bernardino Counties. The SCAQMD develops rules and regulations, establishes permitting requirements for stationary sources, inspects emissions sources, and enforces such measures through educational programs or fines, when necessary. The SCAQMD is directly responsible for reducing emissions from stationary (area and point), mobile, and indirect sources. It has responded to this requirement by preparing a sequence of Air Quality Management Plans (AQMPs), which are included in the California SIP.

Existing Air Quality Conditions

The nearest air quality monitoring to the Project site is the Anaheim-Pampas Lane Monitoring Station located approximately 12.5 miles west of the Project site. Pollutants measured at this monitoring station include O₃, PM₁₀, PM_{2.5}, NO₂, CO. Monitoring data from the years 2017–2019 are shown in Table 3. Federal and State air quality standards are presented with the number of times those standards were exceeded.

**TABLE 3
AIR QUALITY MONITORING DATA FROM
THE ANAHEIM-PAMPAS LANE MONITORING STATION**

Pollutant	California Standard	National Standard	Year	Max. Level ^a	State Standard Days Exceeded ^b	National Standard Days Exceeded ^{b, c}
O ₃ (1 hour)	0.09 ppm	None	2017	0.09	0	NA
			2018	0.112	1	NA
			2019	0.096	1	NA
O ₃ (8 hour)	0.070 ppm	0.070 ppm	2017	0.076	4	4
			2018	0.071	1	1
			2019	0.082	1	1
PM ₁₀ (24 hour)	50 µg/m ³	150 µg/m ³	2017	128	17 (5%)	0
			2018	129	13 (4%)	0
			2019	127	13 (4%)	0
PM ₁₀ (AAM)	20 µg/m ³	None	2017	26.3	NA	NA
			2018	27.2	NA	NA
			2019	21.9	NA	NA
NO ₂ (1 Hour)	0.18 ppm	0.100 ppm	2017	0.0812	0	0
			2018	0.066	0	0
			2019	0.0594	0	0
NO ₂ (AAM)	0.030 ppb	0.053 ppb	2017	14.2	--	--
			2018	13.7	--	--
			2019	12.7	--	--
CO (1 hour)	20.0 ppm	35.0 ppm	2017	2.5	0	0
			2018	2.3	0	0
			2019	2.4	0	0
CO (8 hour)	9.0 ppm	9.0 ppm	2017	2.1	0	0
			2018	1.9	0	0
			2019	1.3	0	0
PM _{2.5} (24 Hour)	None	35 µg/m ³	2017	53.9	NA	3 (0.9%)
			2018	54.1	NA	3 (0.8%)
			2019	36.1	NA	3 (0.9%)
PM _{2.5} (AAM)	12 µg/m ³	15 µg/m ³	2017	11.39	NA	NA
			2018	11.02	NA	NA
			2019	9.32	NA	NA

O₃: ozone; ppm: parts per million; PM₁₀: respirable particulate matter with a diameter of 10 microns or less; µg/m³: micrograms per cubic meter; AAM: annual arithmetic mean; NO₂: nitrogen dioxide; CO: carbon monoxide; PM_{2.5}: fine particulate matter with a diameter of 2.5 microns or less

“--” indicates that the data are not reported or there is insufficient data available to determine the value. N/A indicates that there is no applicable standard.

^a California maximum levels were used.

^b For annual averaging times, a “Yes” or “No” response is given if the annual average concentration exceeded the applicable standard.

^c PM is measured once every 6 days. Where 2 values are shown for PM₁₀ and PM_{2.5}, the first is for the measured value, and the second is the percent of samples exceeded.

Source: CARB 2021a

When a region has air quality that fails to meet the standards, the USEPA and the CARB designate the region as “nonattainment” and the regional air quality agency must develop plans

to attain the standards. These attainment designations are shown in Table 4. As identified in Table 4, Orange County is a nonattainment area for O₃, PM₁₀, and PM_{2.5}.

**TABLE 4
ATTAINMENT STATUS OF CRITERIA POLLUTANTS
IN THE SOUTH COAST AIR BASIN**

Pollutant	State	Federal
O ₃ (1 hour)	Nonattainment	No standards
O ₃ (8 hour)	Nonattainment	Nonattainment
PM ₁₀	Nonattainment	Attainment/Maintenance
PM _{2.5}	Nonattainment	Serious Nonattainment
CO	Attainment	Attainment/Maintenance
NO ₂	Attainment/Nonattainment ^b	Attainment/Maintenance
SO ₂	Attainment	Attainment
Lead	Attainment	Attainment/Nonattainment ^a
All others	Attainment/Unclassified ^c	No standards

O₃: ozone; PM_{2.5}: respirable particulate matter 10 microns or less in diameter; PM_{2.5}: fine particulate matter 2.5 microns or less in diameter; CO: carbon monoxide; NO₂: nitrogen dioxide; SO₂: sulfur dioxide; SoCAB: South Coast Air Basin.

^a Los Angeles County is classified nonattainment for lead; the remainder of the SoCAB is in attainment of the State and federal standards.

^b The near-road portion of CA-60 in San Bernardino, Riverside, and Los Angeles Counties is classified as nonattainment for NO₂; the remainder of the SoCAB is in attainment of State standards.

^c "Unclassified" designation indicates that the air quality data for the area are incomplete and do not support a designation of attainment or nonattainment.

Source: CARB 2021b, USEPA 2021b, SCAQMD 2016

Sensitive Air Quality Receptors

Sensitive receptors include, but are not limited to, children, the elderly, persons with preexisting respiratory or cardiovascular illness, and athletes and others who engage in frequent exercise. These sensitive receptors include, but are not limited to, schools, parks, hospitals, high-density residential areas, and convalescent homes.

The nearest sensitive air quality receptors to the Project site are single family homes on the north side of East Foxhollow Drive, approximately 300 feet south of the Project site. East Foxhollow Drive is approximately 100 feet higher in elevation than the Project site.

Impact Analysis

Thresholds of Significance

Appendix G of the State CEQA Guidelines states that the significance criteria established by the applicable air quality management district may be relied upon to make significance determinations. The South Coast AQMD has established significance thresholds to assess the regional and localized impacts of Project-related air pollutant emissions; Table 5 presents the current significance thresholds.

**TABLE 5
SOUTH COAST AIR QUALITY MANAGEMENT DISTRICT
AIR QUALITY SIGNIFICANCE THRESHOLDS**

Mass Daily Thresholds^a		
Pollutant	Construction	Operation
NOx	100 lbs/day	55 lbs/day
VOC	75 lbs/day	55 lbs/day
PM10	150 lbs/day	150 lbs/day
PM2.5	55 lbs/day	55 lbs/day
SOx	150 lbs/day	150 lbs/day
CO	550 lbs/day	550 lbs/day
Lead	3 lbs/day	3 lbs/day
TACs, Odor, and GHG Thresholds		
TACs (including carcinogens and non-carcinogens)	Maximum Incremental Cancer Risk \geq 10 in 1 million Cancer Burden > 0.5 excess cancer cases (in areas \geq 1 in 1 million) Chronic & Acute Hazard Index \geq 1.0 (project increment)	
Odor	Project creates an odor nuisance pursuant to South Coast AQMD Rule 402	
GHG	10,000 MT/yr CO ₂ e for industrial facilities	
Ambient Air Quality Standards for Criteria Pollutants^{b, c}		
NO ₂ 1-hour average annual arithmetic mean	The South Coast AQMD is in attainment; the Project is significant if it causes or contributes to an exceedance of the following attainment standards: 0.18 ppm (State) 0.03 ppm (State) and 0.0534 ppm (federal)	
PM10 24-hour average annual average	10.4 $\mu\text{g}/\text{m}^3$ (construction) ^c & 2.5 $\mu\text{g}/\text{m}^3$ (operation) 1.0 $\mu\text{g}/\text{m}^3$	
PM2.5 24-hour average	10.4 $\mu\text{g}/\text{m}^3$ (construction) ^c & 2.5 $\mu\text{g}/\text{m}^3$ (operation)	
SO ₂ 1-hour average 24-hour average	0.25 ppm (State) & 0.075 ppm (federal – 99 th percentile) 0.04 ppm (State)	
Sulfate 24-hour average	25 $\mu\text{g}/\text{m}^3$ (State)	
CO 1-hour average 8-hour average	South Coast AQMD is in attainment; project is significant if it causes or contributes to an exceedance of the following attainment standards: 20.0 ppm (State) and 35 ppm (federal) 9.0 ppm (State/federal)	
Lead 30-day average Rolling 3-month average	1.5 $\mu\text{g}/\text{m}^3$ (State) 0.15 $\mu\text{g}/\text{m}^3$ (federal)	
<p>NOx: nitrogen oxides, lbs/day: pounds per day, VOC: volatile organic compound, PM10: respirable particulate matter with a diameter of 10 microns or less, PM2.5: fine particulate matter with a diameter of 2.5 microns or less, SOx: sulfur oxides, CO: carbon monoxide, TACs: toxic air contaminants, GHG: greenhouse gases, MT/yr CO₂e: metric tons per year of carbon dioxide equivalents, NO₂: nitrogen dioxide, ppm: parts per million, $\mu\text{g}/\text{m}^3$: micrograms per cubic meter; South Coast AQMD: South Coast Air Quality Management District</p> <p>^a Source: South Coast AQMD CEQA Handbook (South Coast AQMD 1993) ^b Ambient air quality thresholds for criteria pollutants based on South Coast AQMD Rule 1303, Table A-2 unless otherwise stated ^c Ambient air quality threshold is based on South Coast AQMD Rule 403</p> <p>Source: SCAQMD 2019</p>		

Question A: Would the project conflict with or obstruct implementation of the applicable air quality plan?

Less Than Significant Impact. CEQA requires a discussion of any inconsistencies between a project and applicable General Plans (GPs) and regional plans (CEQA Guidelines Section 15125). The regional plan that applies to the Project is the SCAQMD's AQMP, which is discussed below.

The SCAQMD CEQA Handbook states that "New or amended GP Elements (including land use zoning and density amendments), Specific Plans, and significant projects must be analyzed for consistency with the AQMP". Strict consistency with all aspects of the plan is usually not required. A project should be considered consistent with the AQMP if it furthers one or more policies and does not obstruct other policies. The SCAQMD CEQA Handbook identifies two key indicators of consistency:

- (1) Whether the project will result in an increase in the frequency or severity of existing air quality violations or cause or contribute to new violations or delay timely attainment of air quality standards or the interim emission reductions specified in the AQMP.
- (2) Whether the project will exceed the assumptions in the AQMP or increments based on the year of project buildout and phase.

Both of these criteria are evaluated for the Project, as shown below.

With respect to the first criterion, based on the air quality modeling analysis conducted for the Project (see the discussion provided below under thresholds III (B) and III (C)), construction and operation of the Project would not exceed the SCAQMD's CEQA thresholds of significance and consequently would not result in an increase in the frequency or severity of existing air quality violations nor cause or contribute to new violations, or delay timely attainment of air quality standards or the interim emissions reductions in the AQMP. Therefore, the Project is consistent with the first criterion.

With respect to the second criterion, the Project was assessed as to whether it would exceed the assumptions in the AQMP. The SCAQMD's current air quality planning document is the 2016 Air Quality Management Plan (2016 AQMP). The SCAQMD adopted the 2016 AQMP on March 3, 2017 (SCAQMD 2021). The 2016 AQMP is a regional and multi-agency effort among the SCAQMD, CARB, the Southern California Association of Governments (SCAG), and USEPA. The 2016 AQMP includes an analysis of emissions, meteorology, atmospheric chemistry, regional growth projections, and the impact of existing control measures. The purpose of the 2016 AQMP is to set forth a comprehensive program that would promote reductions in criteria pollutants, greenhouse gases, and toxic risk and efficiencies in energy use, transportation, and goods movement. The 2016 AQMP incorporates the latest scientific and technical information and planning assumptions, including SCAG's 2016–2040 Regional Transportation Plan/Sustainable Communities Strategy (RTP/SCS); updated emission inventory methods for various source categories; and SCAG's latest growth forecasts (SCAG 2016). The 2016 AQMP includes strategies and measures necessary to meet the NAAQS. The AQMP is based on projections of energy usage and vehicle trips from land uses within the SoCAB.

The City of Anaheim approved a CUP for the Project site approving its use as a church in 1988, with subsequent CUP amendments in 1998, 2004, and 2008 further expanding and modifying the church use. Furthermore, SP88-1 and SP88-2 acknowledged that a church would be built on the Project site. Therefore, it may be assumed that the current use is incorporated in the City's planning documents which provide source data for the RTP/SCS and the AQMP. The Project

would not change the use but would generate additional vehicle trips and associated air pollutant emissions. However, the emissions would be substantially less than the significance thresholds adopted by the SCAQMD as detailed in the emissions analyses in response to threshold III (B) below. As such, the Project is not anticipated to exceed the AQMP assumptions for the Project site and would be consistent with the AQMP for the second criterion. Therefore, the Project would not result in an inconsistency with the SCAQMD's 2016 AQMP. Less than significant impacts would occur, and no mitigation is required.

Question B: *Would the project result in a cumulatively considerable net increase of any criteria pollutant for which the project region is non-attainment under an applicable Federal or State ambient air quality standard?*

Less Than Significant Impact. Orange County is a nonattainment area for O₃, PM₁₀, and PM_{2.5}, as shown in Table 4. The Project would generate PM₁₀, PM_{2.5}, NO₂, and O₃ precursors (NO_x and VOC) during short-term construction and long-term operations.

Construction Impacts

Construction-Related Regional Impacts

A project may have a significant impact where project-related emissions would exceed federal, State, or regional standards or thresholds, or where project-related emissions would substantially contribute to an existing or projected air quality violation.

A project with daily emission rates below the SCAQMD's established air quality significance thresholds (shown in Table 5) would have a less than significant effect on regional air quality. Project emissions were estimated using the California Emissions Estimator Model (CalEEMod) version 2020.4.0 computer program (CAPCOA 2021). CalEEMod is designed to model construction and operational emissions for land development projects and allows for the input of project- and County-specific information.

Project construction is planned to begin in 2022 and end in 2023. The CalEEMod input for construction emissions was based on the Project's construction assumptions and default assumptions derived from CalEEMod. Demolition would include approximately 1,300 square feet of buildings, consisting of one small modular structure and portions of the auditorium. The Project would require grading work, which would result in approximately 300 cubic yards of cut and 2,900 cubic yards of fill. The Project would require the import of 2,600 cubic yards of fill from off-site, which would result in approximately 163 round-trip truckloads.

Table 6 presents the estimated maximum daily emissions occurring both on-site and off-site during construction of the Project and compares the estimated emissions with the SCAQMD's daily regional emission thresholds. As shown in Table 6, all criteria pollutants are below the SCAQMD's respective thresholds.

**TABLE 6
ESTIMATED MAXIMUM DAILY CONSTRUCTION EMISSIONS**

Year	Emissions (lbs/day)					
	VOC	NO _x	CO	SO _x	PM ₁₀	PM _{2.5}
2021	2	18	11	<1	4	2
2022	17	16	12	<1	4	2
<i>Maximum Emissions</i>	17	18	12	<1	4	2
<i>SCAQMD Significance Thresholds (Table 5)</i>	75	100	550	150	150	55
Exceeds SCAQMD Thresholds?	No	No	No	No	No	No
lbs/day: pounds per day; VOC: volatile organic compound; NO _x : nitrogen oxides; CO: carbon monoxide; SO _x : sulfur oxides; PM ₁₀ : respirable particulate matter 10 microns or less in diameter; PM _{2.5} : fine particulate matter 2.5 microns or less in diameter; SCAQMD: South Coast Air Quality Management District. Source: SCAQMD 2019 (thresholds); see Appendix A, Air Quality and Greenhouse Gas Emissions Modeling Data, for CalEEMod model outputs.						

Localized Criteria Pollutants from On-Site Construction

In addition to the mass daily emissions thresholds established by the SCAQMD, short-term local impacts to nearby sensitive receptors from on-site emissions of NO₂, CO, PM₁₀, and PM_{2.5} are examined based on SCAQMD localized significance threshold (LST) methodology. To assess local air quality impacts for development projects without complex dispersion modeling, the SCAQMD developed screening (lookup) tables to assist lead agencies in evaluating impacts.

The LST method is limited to projects that are five acres or less. Given there would be active construction on only approximately one acre at a time within the Project site, this LST method is applicable to the Project. For the purposes of an LST analysis, the SCAQMD considers receptors where it is possible that an individual could remain for 1 hour for NO₂ and CO exposure and 24 hours for PM₁₀ and PM_{2.5} exposure. The emissions limits in the lookup tables are based on the SCAQMD’s Air Quality Significance Thresholds and CARB’s 1-hour NO₂ AAQS. (SCAQMD 2008a). The closest off-site sensitive receptors to the Project Site are single family homes on the north side of Foxhollow Drive, approximately 300 feet south of the Project site.

Table 7 shows the maximum daily on-site emissions for construction activities compared with the SCAQMD LSTs. The emissions thresholds are applicable for receptors within 91 meters (300 feet) of the Project site and a disturbance area of one acre per day; the thresholds for receptors farther away would be higher and the Project emissions would be a smaller fraction of the thresholds. The Project’s maximum daily on-site emissions of NO_x would occur during the demolition phase; maximum on-site CO emissions would occur during the paving phase; and the maximum on-site emissions of PM₁₀ and PM_{2.5} would occur during the grading phase. As shown in Table 7, the local emissions from the Project would be below the thresholds; therefore, no significant impacts would result and no mitigation is required.

**TABLE 7
LOCALIZED SIGNIFICANCE THRESHOLD CONSTRUCTION EMISSIONS**

Emissions and Thresholds	Emissions (lbs/day)			
	NO _x	CO	PM ₁₀	PM _{2.5}
Project maximum daily on-site emissions	16	10	4	2
SCAQMD Localized Significance Threshold^a	95	1,061	25	8
Exceed threshold?	No	No	No	No
lbs/day: pounds per day; NO _x : nitrogen oxides; CO: carbon monoxide; PM ₁₀ : respirable particulate matter 10 microns or less in diameter; PM _{2.5} : fine particulate matter 2.5 microns or less in diameter. ^a Data is for SCAQMD Source Receptor Area 17, Central Orange County, 1 acre site, receptor at 300 feet (91 meters). Source: SCAQMD 2009 (thresholds); see Appendix A, Air Quality and Greenhouse Gas Emissions Modeling Data, for CalEEMod outputs.				

Cumulative Construction Impacts

Construction activities associated with the Project would result in less than significant construction-related regional and localized air quality impacts, as quantified above in Table 6 and Table 7. Short-term cumulative impacts related to air quality could occur if construction of the Project and other projects in the surrounding area were to occur simultaneously. In particular, with respect to local impacts, the consideration of cumulative construction particulate (PM₁₀ and PM_{2.5}) impacts is limited to cases when projects constructed simultaneously are within a few hundred yards of each other because of: (1) the combination of the short range (distance) of particulate dispersion (especially when compared to gaseous pollutants), and (2) the SCAQMD's required dust-control measures, which further limit particulate dispersion from the Project site, including Rule 402 (Nuisance) and Rule 403 (Fugitive Dust). There are no known projects where concurrent construction would occur that could result in cumulative construction emissions with the Project.

SCAQMD's policy with respect to cumulative impacts associated with the above-referenced pollutants and their precursors is that impacts that would be directly less than significant on a project level would also be cumulatively less than significant (SCAQMD 2003). Because the Project's construction emissions are below the SCAQMD's regional and local significance thresholds, local construction emissions would not be cumulatively considerable, and the impact would be less than significant. No mitigation would be required.

Operational Impacts

Operational emissions are comprised of area, energy, and mobile source emissions. Because the church does not have natural gas service, there would be no energy-related emissions that is quantified within the CalEEMod model. The principal source of VOC, NO_x, and CO emissions associated with the Project would result from vehicle trips. Area source emissions are based on CalEEMod assumptions for the specific land uses and size. Mobile source emissions are based on estimated Project-related trip generation forecasts, as contained in the Project traffic impact analysis. The Project would generate 80 daily trips and 272 Sunday trips⁴ (AGA 2021). The peak day operational emissions for VOC, NO_x, CO, SO_x, PM₁₀, and PM_{2.5} daily emissions that would be created from the Project's long-term operation have been calculated and are summarized below in Table 8.

⁴ The Trip Generation Memorandum analyzed trip generation for the Project using two methods. The higher trip generation estimate is presented and analyzed in this section to provide a worst-case scenario for the purposes of operational air quality impacts.

**TABLE 8
PEAK DAILY OPERATIONAL EMISSIONS**

Source	Emissions (lbs/day)*					
	VOC	NO _x	CO	SO _x	PM ₁₀	PM _{2.5}
Area sources	<1	<1	<1	<1	<1	<1
Energy sources	0	0	0	0	0	0
Mobile sources	1	<1	6	<1	1	<1
Total Operational Emissions*	1	<1	6	<1	1	<1
<i>SCAQMD Significance Thresholds (Table 5)</i>	55	55	550	150	150	55
Significant Impact?	No	No	No	No	No	No

lbs/day: pounds per day; VOC: volatile organic compound; NO_x: nitrogen oxides; CO: carbon monoxide; SO_x: sulfur oxides; PM₁₀: respirable particulate matter 10 microns or less in diameter; PM_{2.5}: fine particulate matter 2.5 microns or less in diameter; SCAQMD: South Coast Air Quality Management District.

* Values are the higher of summer or winter.

Source: SCAQMD 2019 (thresholds); see Appendix A, Air Quality and Greenhouse Gas Emissions Modeling Data, for CalEEMod model outputs.

The data provided in Table 8 shows that emissions of the analyzed criteria pollutants would be substantially less than the operational emissions thresholds. Therefore, a less than significant regional air quality impact would occur from operation of the Project and no mitigation is required.

Cumulative Operational Impacts

As shown in Table 8, operational emissions of VOC, NO_x, CO, SO_x, PM₁₀, and PM_{2.5} would be below the SCAQMD CEQA significance thresholds. Consistent with the approach described above (under Cumulative Construction Impacts), SCAQMD's policy with respect to cumulative impacts associated with the above-referenced pollutants and their precursors is that impacts that would be directly less than significant on a project-level would also be cumulatively less than significant. Therefore, because the Project's operational emissions are less than the respective SCAQMD daily operational thresholds, the Project's operations phase activities would not contribute to a cumulatively considerable net increase of a pollutant for which the SoCAB is in nonattainment. Emissions of nonattainment pollutants or their precursors would not be cumulatively considerable and would be less than significant; no mitigation would be required.

Cumulative Health Impacts

The SoCAB is designated as nonattainment for ozone, PM₁₀, and PM_{2.5}, which means that the background levels of those pollutants are, at times, higher than the ambient air quality standards. The air quality standards were set to protect public health, including the health of sensitive individuals (the elderly, children, and the sick). Therefore, when the concentrations of those pollutants exceed the standard, it is likely that some sensitive individuals in the population would experience health effects. These health effects are not identified for specific individual receptors nor does the analysis identify the magnitude of health effects. The regional analysis detailed above found that the Project would not exceed the SCAQMD regional significance thresholds for VOC and NO_x (ozone precursors), PM₁₀, and PM_{2.5}. As such, the Project would result in a less than significant cumulative health impact.

Question C: Would the project expose sensitive receptors to substantial pollutant concentrations?

Less Than Significant Impact. A significant impact may occur when a project would generate pollutant concentrations to a degree that would significantly affect sensitive receptors, which include populations that are more susceptible to the effects of air pollution than the population at large. Exposure of sensitive receptors is addressed for construction and operation of the Project in the sections below.

Construction

Criteria Pollutants from On-Site Construction

Local impacts from on-site construction emissions of criteria pollutants were analyzed in threshold III(B) above. As shown in Table 8 and the accompanying text, emissions would be less than significant.

Toxic Air Contaminant Emissions from On-Site Construction

Construction activities would result in short-term, project-generated emissions of diesel particulate matter (DPM) from the exhaust of off-road, heavy-duty diesel equipment used for site preparation (e.g., demolition, excavation, and grading); paving; building construction; and other miscellaneous activities. CARB identified DPM as a toxic air contaminant (TAC) in 1998. The dose to which receptors are exposed is the primary factor used to determine health risk. Dose is a function of the concentration of a substance or substances in the environment and the duration of exposure to the substance. Thus, the risks estimated for a maximally exposed individual (MEI) are higher if a fixed exposure occurs over a longer time period. According to the Office of Environmental Health Hazard Assessment (OEHHA), health risk assessments—which determine the exposure of sensitive receptors to TAC emissions—should be based on a 40-year exposure period; however, such assessments should be limited to the period/duration of activities associated with the Project.

There would be relatively few pieces of off-road, heavy-duty diesel equipment in operation, and the total construction period would be relatively short when compared to a 40-year exposure period. Combined with the highly dispersive properties of DPM and additional reductions in particulate emissions from newer construction equipment, as required by USEPA and CARB regulations, construction emissions of TACs would not expose sensitive receptors to substantial emissions of TACs. The impact would be less than significant, and no mitigation is required.

Operational

Criteria Pollutants and Toxic Air Contaminants from On-site Operations

Operational criterial pollutants and TACs may be generated by industrial and commercial land uses (e.g., gas stations, bus terminals, and dry cleaners). Church land uses do not generate substantial quantities of criteria pollutants or TACs. On-site emissions associated with the operation of the church would involve diesel truck exhaust related to deliveries of supplies and to a lesser extent, passenger vehicles. However, the low frequency of occurrence, the low quantity of vehicles and the brevity of exposure would result in very low levels of emissions from the Project site. As such, the impact would be less than significant and no mitigation is required.

Exposure to Off-Site Toxic Air Contaminant Emissions

The CARB “Air Quality and Land Use Handbook: A Community Health Perspective” provides guidance concerning land use compatibility with TAC sources (CARB 2005). While not a law or adopted policy, the handbook offers advisory recommendations for siting sensitive receptors near uses associated with TACs (such as freeways and high-traffic roads, commercial distribution centers, rail yards, ports, refineries, dry cleaners, gasoline stations, and industrial facilities) to help keep children and other sensitive populations out of harm’s way.

CARB identifies sensitive land uses as schools, schoolyards, parks and playgrounds, daycare centers, nursing homes, hospitals and residential communities. Projects of concern for mobile sources of TACs are typically those located within 500 feet of the following types of facilities that emit significant quantities of DPM: urban roads with more than 100,000 vehicles per day; freeways or roads with a high heavy truck concentration; and/or near rail yards, ports, and/or distribution centers. The Project site is not within 500 feet of urban roads with more than 100,000 vehicles per day, freeways or roads with a high heavy-truck concentration, or near a railyard, port and and/or a distribution center. The Project site is located approximately 600 feet from the SR-91 freeway, which is greater than the 500-foot vicinity identified in the Handbook.

With respect to proximity to emissions from railroad sources, CARB recommends avoiding siting new sensitive land uses within 1,000 feet of a major service and maintenance rail yard; the Project site is not located within 1,000 feet of this type of facility. CARB recommends avoiding siting residences within 300 feet of a large gas station or within 500 feet of dry-cleaning operations with two machines using perchloroethylene. The Project does not propose residential uses and there are no large gas stations within 300 feet of the Project site or dry cleaners within 500 feet of the Project site. As such, the Project will not result in significant impacts related to the exposure of church staff or attendees to excessive levels of TACs.

Carbon Monoxide Hotspot

In an urban setting, vehicle exhaust is the primary source of CO. Consequently, the highest CO concentrations generally are found close to congested intersections. Under typical meteorological conditions, CO concentrations tend to decrease as the distance from the emissions source (e.g., a congested intersection) increases. Therefore, for purposes of providing a conservative worst-case analysis, CO concentrations typically are analyzed at congested intersection locations. If impacts are less than significant close to congested intersections, impacts also would be less than significant at more distant sensitive-receptor and other locations. An initial screening procedure is provided in the “Transportation Project-Level Carbon Monoxide Protocol” (CO Protocol) to determine whether a project has the potential to generate a CO hotspot (Niemeier et al. 1997). The key criterion is whether the Project would worsen traffic congestion at any signalized intersections operating at level of service (LOS) E or F. If a project is determined to pose a potential for a CO hotspot, a quantitative screening would then be required.

The Project would generate 80 daily trips and 272 Sunday trips⁵ (AGA 2021). Given the low quantity of trips generated by the Project, the Project would not generate sufficient traffic to worsen traffic conditions and pose a potential for a CO hotspot. The impact would be less than significant and no mitigation is required related to this threshold.

⁵ The Trip Generation Memorandum analyzed trip generation for the Project using two methods. The higher trip generation estimate is presented and analyzed in this section to provide a worst-case scenario for the purposes of operational air quality impacts.

Question D: *Would the project result in other emissions (such as those leading to odors) adversely affecting a substantial number of people?*

Less than Significant Impact. Project construction would use equipment and activities that could result in other emissions, such as those leading to odors. Potential construction odors include on-site construction equipment's diesel exhaust emissions as well as roofing, painting, and paving operations. There may be situations where construction activity odors could be noticed. However, these odors would be temporary and would dissipate rapidly from the source with an increase in distance. These odors would not be of such magnitude that they would constitute a public nuisance. Therefore, the impacts would be short-term; would not affect a substantial number of people; and would be less than significant.

According to the SCAQMD CEQA Handbook, land uses associated with odor complaints typically include agricultural uses, sewer treatment plants, food processing plants, chemical plants, composting, refineries, landfills, dairies, and fiberglass molding (SCAQMD 1993). The Project does not include any uses identified by the SCAQMD as being associated with odors, and therefore, would not likely produce objectionable odors. The nature of activities associated with churches would not result in the generation of odors that would generate a public nuisance. There would be a less than significant impact and no mitigation is required.

Mitigation Program

The Project was found to result in less than significant air quality impacts from the construction and operations phases and consequently no mitigation measures are required or recommended.

IV. BIOLOGICAL RESOURCES

The information in this section is derived from the Biological Resources Constraints Analysis prepared for the Project by Psomas, which is provided as Appendix B (Psomas 2021).

Question A: *Would the project have a substantial adverse effect, either directly or through habitat modifications, on any species identified as a candidate, sensitive, or special status species in local or regional plans, policies, or regulations, or by the California Department of Fish and Game or U.S. Fish and Wildlife Service?*

Less Than Significant Impact with Mitigation. No native vegetation types or suitable habitat for any special status plant or wildlife species occurs on the Project site. No direct impact to any special status species is anticipated as a result of the Project.

The following federally- and/or State-listed Threatened, Endangered, or Candidate wildlife species have potential to occur adjacent to the Project site and could be subject to indirect impacts (such as noise and vibration) associated with the Project: coastal California gnatcatcher, a federally-listed Threatened species. Any impact to federally-listed Threatened species are typically considered significant; however, potential indirect impacts to coastal California gnatcatcher would already be mitigated under the Federal Endangered Species Act per the take coverage provided in the terms of the Central/Coastal National Community Conservation Plan/Habitat Conservation Plan (NCCP/HCP). The Central/Coastal NCCP/HCP does not provide take coverage of active bird nests under the Migratory Bird Treaty Act (MBTA) and California Fish and Game Code. Potential impacts to nesting CAGN and other nesting birds would be reduced to less than significant levels by implementing mitigation measure **(MM) BIO-1**, which requires that a nesting bird survey be conducted if construction and/or vegetation clearing need to occur during the nesting bird season. If any active coastal California gnatcatcher nests are found, they would be protected by a minimum 500-foot buffer until inactive.

The following California Species of Special Concern (SSC) have potential to occur adjacent to the Project site and could be subject to indirect impacts associated with the Project: coast range newt, coastal whiptail, red-diamond rattlesnake, coast patch-nosed snake, coastal cactus wren, grasshopper sparrow, pallid bat, and western mastiff bat. Cooper's hawk, an additional SSC, has potential to nest both on and adjacent to the Project site. Impacts to any bird species during its nesting activities, including coastal cactus wren, grasshopper sparrow, and Cooper's hawk, would be a violation of the MBTA and California Fish and Game Code and would be considered significant. Impacts to nesting birds would be reduced to less than significant by implementing **MM BIO-1** which requires nesting bird and raptor surveys and avoidance if active nests are found. Potential indirect impacts to SSC not otherwise addressed by bird nesting measures are considered less than significant because the Project would not reduce the populations of these species below self-sustaining levels or substantially remove habitat for these species.

Potential indirect impacts to any special status plant species adjacent to the Project site resulting from dust accumulation would be less than significant. No impacts to any federally designated Critical Habitat or to habitat of any other special status plant or wildlife species would occur as a result of the Project. No additional measures are recommended.

Question B: *Would the project have a substantial adverse effect on any riparian habitat or other sensitive natural community identified in local or regional plans, policies, regulations or by the California Department of Fish and Game or US Fish and Wildlife Service?*

Question C: *Would the project have a substantial adverse effect on federally protected wetlands as defined by Section 404 of the Clean Water Act (including, but not limited to, marsh, vernal pool, coastal, etc.) through direct removal, filling, hydrological interruption, or other means?*

No Impact. A drainage feature that is potentially jurisdictional under U.S. Army Corps of Engineers (USACE), Santa Ana Regional Water Quality Control Board (RWQCB), and California Department of Fish and Wildlife (CDFW) extends along the eastern boundary of the Project site. The limits of jurisdiction for USACE and/or Santa Ana RWQCB are restricted to the bed and banks for this feature which generally occur outside of the Project site boundaries and no impacts are anticipated. The limits of jurisdiction for CDFW, however, includes the coast live oak forest which extends into the Project site boundaries. No tree or vegetation removal within any area associated with this coast live oak forest or associated drainage feature would occur as part of the Project and no impacts are anticipated.

A roadside drainage ditch also occurs along the south side of East Santa Ana Canyon Road (along the northern boundary of the Project site). This feature does not contain any wetland or riparian vegetation, but has potential to be considered jurisdictional by the USACE, Santa Ana RWQCB, and CDFW due to potential connectivity to other drainage features, and ultimately to the Santa Ana River. This feature occurs outside the impact boundary of the Project and no impacts would occur.

Therefore, the Project would have no impact to any wetlands or other jurisdictional areas pursuant to the USACE, Santa Ana RWQCB, or CDFW. No mitigation is required.

Question D: *Would the project interfere substantially with the movement of any native resident or migratory fish or wildlife species or with established native resident or migratory wildlife corridors, or impede the use of native wildlife nursery sites?*

Less Than Significant Impact with Mitigation. The existing developed conditions at the Project site, including physical buildings, lighting, and human activity, currently limit or deter wildlife movement between the open space land uses to the west and east of the Project site. Regardless, the Project consists of the redevelopment of an existing developed Project site consistent with the existing land uses on the Project site. Aspects of the Project that could further constrain wildlife movement including the addition and relocation of structures, removal of vegetation, and the addition of lighting throughout the Project site. Any of these new effects to wildlife movement resulting from the Project would not likely result in a significant effect to regional wildlife movement. Impacts to wildlife movement corridors would be less than significant. The vegetation on and adjacent to the Project site provides suitable nesting habitat for bird species protected under the MBTA and California Fish and Game Code. A routine construction practice to avoid impacts is to schedule tree and vegetation removal outside of the breeding season and to instead conducting vegetation removal during the non-nesting bird season (i.e., September 1 to February 14). If construction or vegetation removal activities must occur during the nesting season, impacts to actively nesting bird species protected under the MBTA and California Fish and Game Code could occur. Therefore, implementation of **MM BIO-1**, which requires a pre-construction nesting bird survey and avoidance of active nests, and **MM BIO-2**, which requires avoidance of vegetation removal during the bat maternity season, a pre-construction bat survey, and the avoidance of bat roosts during the maternity season, would ensure the Project would result in less than significant impacts related to wildlife movement and native nursery sites.

Question E: *Would the project conflict with any local policies or ordinances protecting biological resources, such as a tree preservation policy or ordinance?*

Less Than Significant Impact. The Project would require vegetation removal, including the removal of approximately 29 trees, within the City's SC Overlay Zone. The Project has been designed consistent with the applicable Municipal Code policies related to the SC Overlay Zone as codified Chapter 18.18 of the City's Municipal Code (Anaheim 2021). However, the Project is exempt from tree preservation requirements, including the need to obtain a tree removal permit, given that all of the trees proposed for removal were originally planted by the property owner and the trees are not located in an area highly visible from a public or private right-of-way. Therefore, less than significant impacts would result from Project activities related to this threshold, and no mitigation is required.

Question F: *Would the project conflict with the provisions of an adopted Habitat Conservation Plan, Natural Community Conservation Plan, or other approved local, regional, or State habitat conservation plan?*

Less than Significant Impact. The Project site is located within the boundaries of the Central/Coastal NCCP/HCP; however, it is not within a Reserve Area or Special Linkage Area as designated within the NCCP/HCP and no direct impacts to Central/Coastal NCCP/HCP would result from the Project.

The eastern boundary of Project site is immediately adjacent to two parcels that are protected within conservation easements. These parcels are part of the Central/Coastal NCCP/HCP reserve area. Indirect impacts of the Project on the function of the conservation easement areas would result potentially from additional human activity on the Project site as well as additional noise, which would be less than significant. Also, the Project's proposed night lighting has the potential to affect the function of this conservation easement area. However, the Project design identifies that all new and replaced pole mounted light fixtures would consist of downcast, shielded lighting. This would focus new Project lighting on-site and would minimize illumination of the adjacent conservation easement. Therefore, potential impacts would be less than significant due to the Project's design and no mitigation measures are required.

Mitigation Program

The following mitigation measures are required to reduce impacts to less than significant levels and will be incorporated into the Mitigation Program for this IS/MND.

MM BIO-1 To avoid impacts to nesting birds and raptors, construction should be scheduled between September 1 and February 14, which is outside the peak nesting season. If construction and/or vegetation removal must occur during the peak nesting season (i.e., February 15–August 31), a pre-construction nesting bird survey shall be conducted by a qualified Biologist within seven days prior to the start of Project construction activities. If the Biologist finds an active nest within or adjacent to the construction area, the Biologist will identify an appropriate protective buffer zone around the nest depending on the sensitivity of the species, the nature of the construction activity, and the amount of existing disturbance in the vicinity. In general, the Biologist shall designate a buffer between 10 to 300 feet for common nesting birds, between 200 to 500 feet for common nesting raptors, and a minimum of 500 feet for any nesting special status bird species. No construction activities shall be allowed within the buffer until the nest is deemed to be no longer active by the Biologist to ensure compliance with the MBTA and California Fish and Game Code.

MM BIO-2 To avoid impacts on maternity roosting bats, tree removal shall occur outside the bat maternity season (i.e., April through August) to the extent feasible. In addition, a pre-construction roost emergence survey shall be conducted no more than one year prior to the start of Project vegetation removal associated with construction by a qualified biologist. Trees and/or structures that are being used by roosting bats and those within 100 feet of an active roost may not be removed during the maternity season to avoid impacts on an active maternity roost, which may include juvenile bats that cannot fly.

V. CULTURAL RESOURCES

Information in this section is based on records searches and literature reviews of information available from the South-Central Coastal Information Center (SCCIC), the Native American Heritage Commission (NAHC) that were conducted in 2021. Due to the previously disturbed nature of the Project site, a field survey was not warranted.

IMPACT ANALYSIS

Question A: *Would the project cause a substantial adverse change in the significance of a historical resource pursuant to Section 15064.5?*

No Impact. A cultural resources records search was conducted on March 22, 2021 by the South-Central Coastal Information Center (SCCIC) at California State University, Fullerton. The SCCIC is a designated branch of the California Historical Resources Information System and houses records regarding archaeological and historic resources recorded in San Bernardino, Los Angeles, Orange, and Ventura Counties. The 2021 review consisted of an examination of the U.S. Geological Survey's 7.5-minute Black Star Canyon Quadrangle to determine if any sites are recorded or if any cultural resources studies have been conducted on or within a ½-mile radius of the Project site. Data sources consulted at the SCCIC include archaeological records, Archaeological Determinations of Eligibility (DOE), historic maps, and the Historic Property Data File (HPDF) maintained by the Office of Historic Preservation (OHP). The HPDF contains listings for the California Register of Historical Resources (CRHR) and/or the National Register of Historic Places (NRHP), California Historical Landmarks (CHL), and California Points of Historical Interest (CPHI).

The records search and literature review conducted for the Project revealed that 32 cultural resource studies have been conducted within ½-mile of the Project site. The studies consisted of archaeological field studies (surface surveys and excavations), literature reviews and record searches, and management and planning documents. Eleven of the 32 prior studies occurred within the Project site between 1979 and 2013. These studies include eight archaeological field studies (OR-00622, OR-00752, OR-02383, OR-02534, OR-02883, OR-03029, OR-03037, and OR-03344), one analysis of a literature review and records search (OR-00305), one cultural resource mitigation monitoring report (OR-01030), and one management/planning document (OR-02225).

Three cultural resources are identified within the ½-mile search radius of the Project site. These include one prehistoric lithic scatter (P-30-000303), one prehistoric lithic scatter and associated rock shelter (P-30-001710), and one built environment resource (P-30-161876). One of the three cultural resources (P-30-161876), the built environment resource, was identified by the SCCIC as being located within the Project site. P-30-161876 is recorded as a modern ranch house (Circle C Horse Ranch) with an adjoining barn. The ranch dates to the 1920s and was remodeled in approximately 1954. According to site records, after careful inspection, investigation, and evaluation, George Case of PBO&D (1991) concluded that the property does not appear to be

eligible for individual listing in the National Register and California Register, or eligible for local designation as a Historically Significant Structure due to a lack of significance through survey evaluation. The ranch structures have since been demolished.

Native American Heritage Commission Sacred Lands File Search

The City submitted a request to the NAHC to review the Sacred Lands File (SLF) database regarding the possibility of Native American cultural resources and/or sacred places in the Project vicinity that are not documented on other databases. The results from the NAHC were received on February 24, 2021. The SLF search did not identify any known resources or sacred lands within the Project site. However, the NAHC recommends that the City contact tribes that are traditionally and culturally affiliated with the geographic area. The City contacted the tribes listed on their consultation list on March 16, 2021 as part of the Assembly Bill 52 (AB 52) tribal consultation process. The tribal consultation results are discussed under threshold XVIII (Tribal Cultural Resources).

A significant impact could occur if the Project were to disturb historic resources that presently exist within the Project site. Section 15064.5 of the CEQA Guidelines generally defines a historic resource as a resource that is (1) listed in or determined to be eligible for listing in the California Register of Historical Resources (California Register); (2) included in a local register of historical resources (pursuant to Section 5020.1(k) of the Public Resources Code); or (3) identified as significant in an historical resources survey (meeting the criteria in Section 5024.1(g) of the Public Resources Code). Additionally, any object, building, structure, site, area, place, record, or manuscript that a lead agency determines to be historically significant or significant in the architectural, engineering, scientific, economic, agricultural, educational, social, political, military, or cultural annals of California may be considered to be an historical resource, provided the lead agency's determination is supported by substantial evidence in light of the whole record. Generally, a resource shall be considered by the lead agency to be "historically significant" if the resource meets the criteria for listing on the California Register. The California Register automatically includes all properties listed in the NRHP and those formally determined to be eligible for listing in the National Register.

As discussed above, the SCCIC record search and literature review identified three cultural resources within a ½-mile radius of the Project. One of the cultural resources (P-30-161876), the Circle C Horse Ranch was documented within the Project site but was determined to not be eligible for individual listing in the National Register and California Register, or eligible for local designation as a Historically Significant Structure due to a lack of significance through survey evaluation. Furthermore, the building in question has since been demolished and is no longer a standing structure within the Project site. Therefore, the Project would not cause an adverse change in the significance of a historical resource subject to CEQA. The Project would result in less than significant impacts related to this threshold, and no mitigation is required.

Question B: Would the project cause a substantial adverse change in the significance of an archaeological resource pursuant to Section 15064.5?

Less than Significant Impact with Mitigation. A significant impact would occur if grading or excavation activities associated with the Project were to disturb archaeological resources that presently exist within the Project site. The SCCIC record search and literature review identified three resources located within a half-mile of the Project site. These resources consist of two prehistoric archaeological sites (lithic scatters and a rock shelter) and one historic-era building and associated structures that establish prehistoric and historic-era land use within the generalized area. As described above, one resource, P-30-161876, the Circle C Horse Ranch was documented within the Project site and has since been demolished/removed from the site.

As such, there is the possibility that undiscovered intact archaeological resources may be present below the surface in native (alluvial) sediments. These potential effects would be mitigated to a less than significant level with the implementation of **MM CUL-1**, which requires archaeological monitoring when excavations are required in native sediment.

Question C: Would the project disturb any human remains, including those interred outside of formal cemeteries?

Less than Significant Impact. A significant adverse effect could occur if grading or excavation activities associated with the Project were to disturb previously interred human remains. The Project site is located within a developed area that has been subject to earth-moving activities in the past, and no known burial sites are located on or adjacent to the Project site. In the unlikely event of an unanticipated discovery of human remains in the Project site during construction, the *California Health and Safety Code* and the *California Public Resources Code* require that any activity in the area of a potential find be halted and the Orange County Coroner be notified, as described in **regulatory requirement (RR) CUL-1**. Implementation of **RR CUL-1** would ensure impacts related to this threshold are less than significant, and no mitigation is required.

Mitigation Program

Regulatory Requirement

RR CUL-1 If human remains are found during ground-disturbing activities, no further excavation or disturbance of the site or any nearby area reasonably suspected to overlie adjacent remains shall occur, in accordance with Section 7050.5 of the California Health and Safety Code. The County Coroner shall be notified of the discovery immediately. If the County Coroner determines that the remains are or believed to be Native American, s/he shall notify the NAHC in Sacramento within 24 hours of the discovery. In accordance with Section 5097.98 of the California Public Resources Code, the NAHC must immediately notify those persons it believes to be the most likely descended from the deceased Native American. The descendants shall complete their inspection within 48 hours of being granted access to the site by the City. The City would meet and confer with the most likely descendant regarding their recommendations prior to disturbing the site by further construction activity.

Mitigation Measure

MM CUL-1 Prior to the issuance of the grading permit, the applicant shall provide written evidence to the City that the applicant has retained an Orange County-certified archaeologist to observe grading activities within previously undisturbed soils, and to salvage and catalogue archaeological resources as necessary. The archaeologist shall be present at the pre-grade conference, shall establish procedures for archaeological resource surveillance within previously undisturbed soils, and shall establish, in cooperation with the applicant, procedures for temporarily halting or redirecting work to permit the sampling, identification, and evaluation of the artifacts as appropriate. If archaeological resources are inadvertently unearthed during excavation activities, the contractor shall immediately cease all earth-disturbing activities within a 100-foot radius of the area of discovery and the archaeologist and City shall be notified immediately. If the archaeological resources are found to be significant, the archeologist, in consultation with the City, shall determine appropriate actions for exploration and

salvage. After the find has been appropriately avoided or mitigated, work in the area may resume.

VI. ENERGY

Energy efficiency is a priority for both the State of California and the City of Anaheim. The following are regulatory targets and requirements that have been adopted at the State and local level.

State

The Energy Efficiency Standards for Residential and Nonresidential Buildings (Title 24, Part 6 of the California Code of Regulations [CCR]) were established in 1978 in response to a legislative mandate to reduce California's energy consumption. The current 2019 Standards, effective January 1, 2020, are projected to result in a 30 percent improvement in energy efficiency for nonresidential buildings over the 2016 standards. The 2019 standards require photovoltaic solar systems on single-family residences and on multifamily residential structures of three stories or less. Single-family homes built to the 2019 standards would be about 7 percent more efficient than homes built to the 2016 standards without considering the required solar systems; and about 53 percent more efficient after factoring in the solar systems (CEC 2018).

The 2019 California Green Building Standards Code (24 CCR, Part 11), also known as the CALGreen code, contains mandatory requirements and voluntary measures for new residential and nonresidential buildings (including buildings for hotel, retail, office, public schools and hospitals) throughout California (CBSC 2019). The development of the CALGreen Code is intended to improve public health, safety, and general welfare by enhancing the design and construction of buildings through the following construction practices: (1) planning and design; (2) energy efficiency; (3) water efficiency and conservation; (4) material conservation and resource efficiency; and (5) environmental quality (CBSC 2019). In short, the code is established to reduce construction waste; make buildings more efficient in the use of materials and energy; and reduce environmental impact during and after construction. The Anaheim Municipal Code adopts the CALGreen Code by reference with specific amendments. The Project would promote building energy efficiency through compliance with energy efficiency standards (Title 24 and CALGreen).

City of Anaheim

General Plan

The following policies of the City of Anaheim's General Plan are relevant to energy efficiency and generation.

Green Element

- Policy 15.1.1:** Continue to maintain and update energy conservation programs and information provided on the City's website.
- Policy 15.2.1:** Encourage increased use of passive and active solar design in existing and new development (e.g., orienting buildings to maximize exposure to cooling effects of prevailing winds and locating landscaping and landscape structures to shade buildings).
- Policy 15.2.2:** Encourage energy-efficient retrofitting of existing buildings throughout the City.
- Policy 15.2.3:** Continue to provide free energy audits for the public.

Policy 17.1.1: Encourage designs that incorporate solar and wind exposure features such as daylighting design, natural ventilation, space planning and thermal massing.

Public Services and Facilities Element

Policy 3.1.1: Encourage the development and use of renewable energy resources.

Municipal Code

The 2019 California Energy Code (CCR Title 24 Part 6), which includes the Energy Efficiency Standards for Residential and Nonresidential Buildings, is adopted, with specified amendments, as Anaheim Municipal Code Section 15.03.10.0106. The 2019 California Green Building Standards Code (CCR Title 24 Part 11) is adopted, with specified amendments, as Anaheim Municipal Code Section 15.03.10.0109.

Anaheim Public Utilities Greenhouse Gas Reduction Plan

The Anaheim Public Utilities Department (APUD)'s Greenhouse Gas Reduction Plan (GHGRP), was approved in 2015 and updated in 2020. The GHGRP identifies renewable energy and energy conservation targets for APUD for the years 2020, 2030 and 2045. The GHGRP identifies renewables portfolio targets for increasing the APUD power supply generated from renewable sources up to 33 percent by year 2020, 60 percent by year 2030, and 100 percent by 2045. As of 2020, 34,000 kilowatt (kW) of photovoltaic systems were installed, and 50,000 kW and 75,000 kW of photovoltaic systems will be installed by 2030 and 2045, respectively. The GHGRP also establishes transportation-related goals for APUD to convert its fleet vehicles to result in emissions reductions of 500 metric tons of carbon dioxide equivalent (MTCO_{2e}) in 2020, 1,200 MTCO_{2e} in 2030 and 32,000 MTCO_{2e} in 2045 (APUD 2020).

Question A: Would the project result in potentially significant environmental impact due to wasteful, inefficient, or unnecessary consumption of energy resources, during project construction or operation?

Less than Significant Impact.

Construction Energy Use

Project construction would require the use of construction equipment for demolition, grading, hauling, and building activities. Construction would also include the use of vehicles for construction workers and vendors traveling to and from the Project site and on-road haul trucks for the export of materials from demolition activities, as well as the import of soil for grading.

Off-road construction equipment use was calculated using the equipment data (vehicle types, hours per day, horsepower, load factor) provided in the CalEEMod construction output files included in Appendix A. The total horsepower hours for construction equipment used for the Project was then multiplied by fuel usage rates to obtain the total fuel usage for off-road equipment.

Fuel consumption from construction worker, vendor, and delivery/haul trucks was calculated using the trip rates and distances provided in the CalEEMod construction output files. Total vehicle miles traveled (VMT) was then calculated for each type of construction-related trip and divided by the fuel consumption factor from California Air Resources Board's (CARB) EMISSION FACTORS (EMFAC) 2017 model. EMFAC provides the total annual VMT and fuel consumed for each vehicle type. Construction vendor and delivery/haul trucks were assumed to be heavy-duty diesel trucks.

As shown in Table 9, the Project would consume an estimated total of 5,009 gallons of diesel fuel and 4,716 gallons of gasoline during construction.

**TABLE 9
ENERGY USE DURING CONSTRUCTION**

Source	Gasoline - gallons	Diesel Fuel - gallons
Off-road Construction Equipment	17	3,981
Worker commute	3,964	16
Vendors	734	10
On-road haul	1	1,002
Total	4,716	5,009
Sources: CalEEMod, Offroad and EMFAC2017.		

Fuel energy consumed during construction would be temporary in nature and would not represent a significant demand on energy resources. Construction equipment would conform to applicable CARB emissions standards, which promote equipment fuel efficiencies. Construction contractors would be required to comply with the provisions of *California Code of Regulations* Title 13 Sections 2485, which prohibit diesel-fueled commercial motor vehicles and off-road diesel vehicles from idling for more than 5 minutes and would minimize unnecessary fuel consumption. It should be noted that fuel efficiencies are improving for on- and off-road vehicle engines due to more stringent government requirements. Construction energy consumption would represent a “single-event” demand and would not require ongoing or permanent commitment of energy resources. Furthermore, there are no unusual Project characteristics that would necessitate the use of construction equipment that would be less energy-efficient than comparable equipment at construction sites in other parts of the State. Therefore, the proposed construction activities would not result in inefficient, wasteful, or unnecessary fuel consumption and a less than significant impact would occur.

Operations Phase Energy Use

Energy consumption associated with operation of the Project consists of electricity for lighting, electronic devices, and for space heating. Electricity estimates were calculated by the CalEEMod model. Transportation related energy consumption of gasoline and diesel fuel was calculated based on the quantity of vehicles, average travel distance, vehicle class and fuel efficiency of each vehicle class as provided by the EMFAC model. Energy consumption calculations are included in Appendix C.

The CalEEMod based estimates that Project-generated traffic would use 129 gallons of diesel fuel and 10,530 gallons of gasoline per year, as shown in Table 10 below. Fuel consumption associated with vehicle trips generated by the Project are not substantial and would assist local communities with meeting their religious worship needs. With the increasing adoption of electric vehicles in Southern California, the average fuel efficiency for transportation will continue to increase. As such, the Project’s transportation energy consumption would not be considered inefficient, wasteful, or unnecessary.

**TABLE 10
TRANSPORTATION ENERGY
(GALLONS/YEAR)**

Source	Gasoline Fuel	Diesel Fuel
Project	10,530	129
Sources: CalEEMod, EMFAC2017		

As shown in Table 11, anticipated electricity consumption for the Project is estimated to be 152,255 kilowatts-hours per year (kWh/yr). These energy estimates are based on the 2016 Title 24 standards incorporated into the CalEEMod model. The Project would follow the 2019 Title 24 standards, which would result in less electricity than presented in Table 11. Development of buildings that comply with the latest energy efficiency standards adopted by the State would not result in inefficient, wasteful and unnecessary consumption of energy. Operationally, there would be a small increase in vehicle trips compared to current operations. New energy requirements would be minimal, primarily lighting, heating, and air conditioning for the enlarged auditorium and additional modular structures. Operational energy consumption would not be considered inefficient, wasteful, or otherwise unnecessary and a less than significant impact would occur.

**TABLE 11
ENERGY FROM UTILITIES**

Source	Natural Gas (kBTU/yr)	Electricity (kWh/yr)
Project	0	152,255
Sources: CalEEMod		

Question B: Would the project conflict with or obstruct a state or local plan for renewable energy or energy efficiency?

No Impact. The Project would be required to comply with the State of California’s Title 24 Building Standards where applicable. As discussed previously, the latest building standards incorporate the California Energy Commission’s (CEC) building energy efficiency standards which would reduce energy consumption for the Project by over 30 percent compared to the existing Title 24 Building Standards. The Project would also comply with applicable CALGreen standards. Because the operation of the Project would result in a minimal increase in energy consumption, and because the Project would be constructed consistent with State and local renewable energy and energy efficiency plans, the Project would have no impact related to this threshold and no mitigation is required.

Mitigation Program

No mitigation is required.

VII. GEOLOGY AND SOILS

The following analysis is partially based on the Percolation Testing Results for WQMP, Pavement Design, and Building Expansion Foundation Recommendations, Kindred Church, 8720 East Santa Ana Canyon Road, Anaheim, California (soils report), which was prepared by TGR Geotechnical, Inc. in November 2020 (Appendix D).

Question A: Would the project expose people or structures to potential substantial adverse effects, including the risk of loss, injury, or death involving:

- (i) **Rupture of a known earthquake fault, as delineated on the most recent Alquist-Priolo Earthquake Fault Zoning Map issued by the State Geologist for the area or based on other substantial evidence of a known fault? Refer to Division of Mines and Geology Special Publication 42.**

Less Than Significant Impact. The Project site and the entire Southern California region are subject to secondary effects from earthquakes. The California Earthquake Hazards Zone Application (EQ Zapp) is an interactive map that shows earthquake fault zones and seismic hazard zones in relation to any parcel in California. According to a review of EQ Zapp, the Project site is not located within a mapped Alquist-Priolo Earthquake Fault Zone (DOC 2021b). Furthermore, there are no known Alquist-Priolo Earthquake Fault Zones within the City limits, although there are active and potentially active faults located close to the City. The City is situated between two active fault zones: the Newport-Inglewood zone located to the southwest and the Whittier-Elsinore fault zone located to the northeast. Other potentially active faults in close proximity to the Project site are the El Modena, Peralta Hills, and Norwalk faults (Anaheim 2004). The potential for ground rupture due to fault movement is generally considered related to the seismic activity of known fault zones (Tulane 2016). Due to the distance of the closest active fault, ground rupture is not considered a significant hazard at the Project site. Implementation of the Project would be consistent with existing codes and regulations, including the Uniform Building Code, the Anaheim Municipal Code (Anaheim 2021a), and the requirements of the Alquist-Priolo Special Studies Zone Act (*California Public Resources Code* §§2621 et seq.). Therefore, development of the Project would result in a less than significant impact related to rupture of a known earthquake fault, and no mitigation is required.

Question A: Would the project expose people or structures to potential substantial adverse effects, including the risk of loss, injury, or death involving:

- (ii) **Strong seismic ground shaking?**

Less Than Significant Impact. The Project site, as with the entire Southern California region, is subject to secondary effects from earthquakes. The site is located proximate to several active faults; therefore, during the life of the Project, the property would likely experience similar moderate to occasionally high ground shaking from these fault zones as well as some background shaking from other seismically active areas in the Southern California region.

Implementation of the Project would not change the intensity of ground shaking that would occur on the Project site during a seismic event, but it would increase exposure to people through the addition of modular buildings and capacity within the auditorium building. The proposed buildings would be designed in accordance with the most recent California Building Code (CBC) (CBSC 2019). The CBC contains minimum standards regulating the design and construction of excavations, foundations, retaining walls, and other building elements to control the effects of seismic ground shaking and adverse soil conditions. The CBC includes provisions for earthquake safety based on factors such as occupancy type, the types of soil and rock on-site, and the strength of ground motion that may occur at the Project site. Project implementation would also occur consistent with the recommendations outlined in the Project's soils report (TGR Geotechnical, Inc., 2020). Based on the findings of the soils report, the Project is geotechnically feasible provided that the recommendations in the soils report are incorporated during the Project's final design and construction phase. Seismic design parameters have been included in the soils report based on the seismic zone, soil profile, and proximity of known faults to the Project

site, which provide the minimum design procedures necessary to avoid significant damage to the structure.

Compliance with the applicable regulations and design recommendations from the soils report as part of Project design and construction would ensure that any impacts resulting from strong seismic ground shaking at the Project site would be less than significant.

Question A: *Would the project expose people or structures to potential substantial adverse effects, including the risk of loss, injury, or death involving:*

(iii) Seismic-related ground failure, including liquefaction?

No Impact. As shown in the Earthquake Zones of Required Investigation, Black Star Canyon Quadrangle map, (California Geological Survey 2001), lower elevations within the Project site (e.g., areas to the north) are mapped as areas where there have been historical occurrences of liquefaction, or areas where local geological, geotechnical, and ground water conditions indicate a potential for permanent ground displacements. However, as noted in the soils report, the Project site was previously mass graded associated with a neighboring residential development. The Project site is generally underlain with compacted artificial fill overlaying landslide debris and/or debris fill. Additionally the auditorium building was constructed on compacted artificial fill overlaying bedrock.

Furthermore, according to the Project's PWQMP, groundwater is at least 18.5 feet below the Project site (Anacal Engineering 2021). Given the soils on the Project site are not susceptible to liquefaction, groundwater levels are low, and the soils were previously compacted, no impact would occur related to this threshold and no mitigation is required.

Question A: *Would the project expose people or structures to potential substantial adverse effects, including the risk of loss, injury, or death involving:*

(iv) Landslides?

Less Than Significant Impact. Earthquake-induced land sliding often occurs in areas where previous landslides have moved and in areas where the topographic, geologic, geotechnical, and subsurface groundwater conditions are conducive to permanent ground displacements. There are four occurrences of landslides (e.g., scarps) in the Project vicinity according to the California Landslide Inventory maintained by the Department of Conservation, which provides record of landslides mapped by the California Geological Survey (CGS) over the past 50 years (DOC 2021c). None of these four scarps occur within the Project site.

Also, as shown in the Earthquake Zones of Required Investigation, Black Star Canyon Quadrangle map (California Geological Survey 2001), the Project site is located adjacent to hillsides that are designated as Earthquake-Induced Landslide Zones. These hillsides are west of the Project site, generally south of East Santa Ana Canyon Road and west of the Project's driveway and entry road.

Given that no structures or outdoor gathering areas are proposed within or adjacent to areas susceptible to landslides, less than significant impacts would result related to this threshold, and no mitigation is required.

Question B: *Would the project result in substantial soil erosion or the loss of topsoil?*

Less Than Significant Impact. Project construction would expose soils on the site, which could result in soil erosion and the loss of topsoil if not implemented consistent with regulatory requirements. A primary source of erosion and topsoil loss is uncontrolled drainage during

construction. As discussed in more detail in Section X, Hydrology and Water Quality, the National Pollutant Discharge Elimination System (NPDES) permit program controls water pollution by regulating point sources that discharge pollutants into “waters of the U.S.”. Construction activities shall be conducted in compliance with the statewide NPDES General Permit for Storm Water Discharges Associated with the Construction and Land Disturbance Activities (Order No 2012-0006-DWQ, NPDES No. CAS000002), adopted by the State Water Resources Control Board (SWRCB) on July 17, 2012. In compliance with the NPDES permit, erosion potential during construction of the Project would be managed with Best Management Practices (BMPs) implemented on the Project site as part of a Storm Water Pollution Prevention Plan (SWPPP) during construction activities in accordance with NPDES requirements.

Also, once built the Project would increase impervious surface coverage on the Project site, which could lead to erosion and loss of topsoil if stormwater is not conveyed and dissipated appropriately. The Project site is already partially developed; however, the Project would increase impervious surface area by approximately 17 percent (Anacal Engineering 2021). A PWQMP has been prepared for the Project, which specifies preliminary measures to mitigate potential water quality impacts that might result from Project operations (Anacal Engineering 2021). In the existing condition, the majority of the Project site drains to existing grate inlets that are connected to an existing City storm drain that traverses the Project site, which was constructed for the adjacent residential development to the south. However, as part of the Project and as specified in the PWQMP, stormwater flows would be redirected from throughout the Project site to a new 18-inch RCP. The RCP would collect and convey flows downslope to an underground infiltration system, which would consist of two underground stormwater infiltration chambers within a portion of APN 354-321-03. In the event of stormwater exceeding the design capture volume for the underground infiltration chamber, excess water would be rerouted to the existing City storm drain through an 18-inch RCP overflow pipe. Prior to flowing into the 18-inch RCP, at least 50 percent of stormwater would be pre-treated for sediment, debris, and hydrocarbons using Filterra stormwater biofiltration units. Catch basins would be installed with FloGard filters to capture trash and debris. These improvements are depicted in Exhibit 17 and described in more detail in the Project’s (PWQMP (Anacal Engineering 2021).

With implementation of a SWPPP during construction as well as construction and maintenance of the BMPs specified in the grading plan and construction of a new drainage and infiltration system, impacts related to erosion would be less than significant.

Question C: *Would the project be located on a geologic unit or soil that is unstable, or that would become unstable as a result of the project, and potentially result in on- or off-site landslide, lateral spreading, subsidence, liquefaction or collapse?*

Less Than Significant Impact. As discussed in Threshold VII(a)(iv) above, the Project would not be significantly impacted by on- or off-site landslides. Lateral spreading, a phenomenon associated with liquefaction, is a function of ground shaking and may occur during an earthquake. As discussed under the analysis of Threshold VII(a)(iii) above, impacts from seismic-related ground failure related to liquefaction for the Project would be less than significant. Similarly, there would be less than significant impacts related to lateral spreading. Land subsidence and collapse can occur due to the loss of surface elevation from the removal of subsurface support, usually due to the withdrawal of groundwater, oil, or natural gas. The Project involves no activities which would increase risk of soil collapse. Therefore, less than significant impacts would result from the Project related to this threshold and no mitigation is required.

Question D: *Would the project be located on expansive soil, as defined in Section 1803.5.3 of the California Building Code (2010), creating substantial risks to life or property?*

Less Than Significant Impact. As stated in the soils report (Appendix D), the Project site contains soils that possess a medium expansion potential (TGR Geotechnical, Inc. 2020). The recommendations provided in the soils report account for the expansion potential of the on-site soils, particularly related to concrete flatwork, which is any poured surface that moves along a horizontal plane such as patios, walkways, sidewalks, foundations, driveways and any other flat surface. Specifically, due to the presence of medium expansive soils, more than normal movement of the flatwork installed as part of the Project is anticipated. This will be limited through Project design, which has incorporated a thickened edge on flatwork (minimum of 12-inches) and/or 6-inches of base under the flatwork. Also, the slab-on-grade foundation used for Project structures shall comply with Section 1808.6.2 of the CBC (2019). Alternatively, the soils report allows for the slab-on-grade to instead be supported on a minimum 2 feet of non-expansive soil to reduce the impact of expansive soils. With implementation of recommendations from the soils report, any potential effects related to expansive soils would be minimized. Therefore, less than significant impacts would result from the Project related to this threshold, and no mitigation is required.

Question E: *Would the project have soils incapable of adequately supporting the use of septic tanks or alternative wastewater disposal systems where sewers are not available for the disposal of wastewater?*

No Impact. An existing septic tank and leach line system exists within the Project site, which is used to treat and dispose of sewer water that is generated by the existing church. The Project would not require any upgrades to the existing system or any new septic tanks or alternative wastewater disposal system. Therefore, no impacts would occur related to this threshold and no mitigation is required.

Question F: *Would the project directly or indirectly destroy a unique paleontological resource or site or unique geologic feature?*

Less than Significant Impact with Mitigation. A paleontological records search was requested from the Natural History Museum (LACM) of Los Angeles County, Vertebrate Paleontology Department and results were received on April 9, 2021. The results indicate that there are no fossil localities that lie directly within the Project site; however, there are fossil localities nearby from the same sedimentary deposits that occur in the Project site, either at the surface or at depth. Therefore, the Project would not impact known paleontological resources; however, surface sediments at and surrounding the Project site consists of Alluvium (Pleistocene) to unknown formations (Pleistocene, sands) (silty fine-grained & massive sandstone). Deep excavation that involves disturbance of native soils could result in the disturbance and/or destruction of paleontological resources that may be present in deeper Pleistocene alluvial deposits that underlie the Project site. Implementation of **MM GEO-1** related to paleontological resources would reduce this impact to a less than significant level.

Mitigation Program

The following mitigation measures are required to reduce impacts to less than significant levels and they will be incorporated into the Mitigation Program for this IS/MND.

MM GEO 1 In the event that paleontological resources are inadvertently unearthed during excavation activities, the contractor shall immediately cease all earth-disturbing

activities within a 100-foot radius of the area of discovery and the contractor shall contact the City immediately. The Applicant shall retain a qualified professional paleontologist to evaluate the significance of the find, and in consultation with the City, determine an appropriate course of action. If the paleontological resources are found to be significant, the paleontologist, in consultation with the City, shall determine appropriate actions for exploration and salvage. After the find has been appropriately avoided or mitigated, work in the area may resume.

VIII. GREENHOUSE GAS EMISSIONS

Greenhouse Gas Emissions Background Information and Regulatory Conditions

Climate change refers to any significant change in measures of climate (e.g., average temperature, precipitation, or wind patterns) over a period of time. Climate change may result from natural factors, natural processes, and human activities that change the composition of the atmosphere and alter the surface and features of the land. Significant changes in global climate patterns have recently been associated with global warming, which is an average increase in the temperature of the atmosphere near the Earth's surface; this is attributed to an accumulation of greenhouse gas (GHG) emissions in the atmosphere. GHGs trap heat in the atmosphere which, in turn, increases the Earth's surface temperature. Some GHGs occur naturally and are emitted to the atmosphere through natural processes, while others are created and emitted solely through human activities. The emission of GHGs through fossil fuel combustion in conjunction with other human activities appears to be closely associated with global warming.

GHGs, as defined under California's AB 32, include carbon dioxide (CO₂), methane (CH₄), nitrous oxide (N₂O), hydrofluorocarbons (HFCs), perfluorocarbons (PFCs), and sulfur hexafluoride (SF₆). General discussions on climate change often include water vapor, atmospheric ozone, and aerosols in the GHG category. Water vapor and atmospheric ozone are not gases that are formed directly in the construction or operation of development projects, nor can they be controlled in these projects. Aerosols are not gases. While these elements have a role in climate change, they are not considered by regulatory bodies, such as CARB, or climate change groups, such as the California Climate Action Registry, as gases to be reported or analyzed for control. Therefore, no further discussion of water vapor, atmospheric ozone, or aerosols is provided.

Regulatory Background

On June 1, 2005, Governor Arnold Schwarzenegger signed Executive Order (EO) S-3-05, which calls for a reduction in GHG emissions to the year 2000 level by 2010, to year 1990 levels by 2020, and to 80 percent below 1990 levels by 2050.

The principal overall State plan and policy adopted for the purpose of reducing GHG emissions is Assembly Bill (AB) 32 (California Global Warming Solutions Act of 2006). AB 32 establishes regulatory, reporting, and market mechanisms to achieve quantifiable reductions in GHG emissions and establishes a cap on statewide GHG emissions. AB 32 recognizes that California is the source of substantial amounts of GHG emissions. The statute states the following:

Global warming poses a serious threat to the economic well-being, public health, natural resources, and the environment of California. The potential adverse impacts of global warming include the exacerbation of air quality problems, a reduction in the quality and supply of water to the state from the Sierra snowpack, a rise in sea levels resulting in the displacement of thousands of coastal businesses and residences, damage to marine ecosystems and the natural

environment, and an increase in the incidences of infectious diseases, asthma, and other human health-related problems.

In order to avert these consequences, AB 32 establishes a State goal of reducing GHG emissions to 1990 levels by the year 2020, codifying the goal of EO S-3-05.

CARB approved a Climate Change Scoping Plan as required by AB 32 in 2008; this plan is updated every five years as required. The Climate Change Scoping Plan proposes a “comprehensive set of actions designed to reduce overall carbon GHG emissions in California, improve our environment, reduce our dependence on oil, diversify our energy sources, save energy, create new jobs, and enhance public health” (CARB 2008). The Climate Change Scoping Plan has a range of GHG-reduction actions which include direct regulations, alternative compliance mechanisms, monetary and non-monetary incentives, voluntary actions, market-based mechanisms such as a cap-and-trade system, and an AB 32 implementation regulation to fund the program. On February 10, 2014, CARB released the Draft Proposed First Update to the Climate Change Scoping Plan (CARB 2014). The board approved the final First Update to the Climate Change Scoping Plan on May 22, 2014. The first update describes California’s progress towards AB 32 goals, stating that “California is on track to meet the near-term 2020 greenhouse gas limit and is well positioned to maintain and continue reductions beyond 2020 as required by AB 32” (CARB 2014). The latest update occurred in January 2017 and incorporates the 40 percent reduction to 1990 emissions levels by 2030.

The Sustainable Communities and Climate Protection Act of 2008, Senate Bill (SB) 375, established a process to coordinate land use planning, regional transportation plans, and funding priorities in order to help California meet the GHG reduction goals established in AB 32. SB 375 required SCAG to incorporate a “sustainable communities strategy” (SCS) into its regional transportation plans (RTPs) that will achieve GHG emission reduction targets through several measures, including land use decisions. SCAG’s SCS is included in Connect SoCal, the SCAG 2020-2045 RTP/SCS (SCAG 2020). The goals and policies of the RTP/SCS that reduce vehicle miles traveled (VMT) focus on transportation and land use planning that include building infill projects; locating residents closer to where they work and play; and designing communities so there is access to high quality transit service.

On April 29, 2015, Governor Brown signed EO B-30-15, which ordered an interim statewide GHG emission reduction target to reduce GHG emissions to 40 percent below 1990 levels by 2030 to ensure California meets its target of reducing GHG emissions to 80 percent below 1990 levels by 2050. Five key goals for reducing GHG emissions through 2030 include (1) increasing renewable electricity to 50 percent; (2) doubling the energy efficiency savings achieved in existing buildings and making heating fuels cleaner; (3) reducing petroleum use in cars and trucks by up to 50 percent; (4) reducing emissions of short-lived climate pollutants; and (5) managing farms, rangelands, forests and wetlands to increasingly store carbon. EO B-30-15 also directs CARB to update the Climate Change Scoping Plan to express the 2030 target in terms of million metric tons of carbon dioxide equivalent.

On September 8, 2016, the Governor signed Senate Bill 32 (SB 32) to codify the GHG reduction goals of EO B-30-15, requiring the State to reduce GHG emissions by 40 percent below 1990 levels by 2030 (Health and Safety Code Section 38566). As stated above, this goal is expected to keep the State on track to meeting the goal set by EO S-3-05 of reducing GHG emissions by 80 percent below 1990 levels by 2050.

AB 197 was signed at the same time to ensure that the SB 32 goals are met by requiring CARB to provide annual reports of GHGs, criteria pollutants, and TACs by facility, City and sub-county level, and sector for stationary sources and at the County level for mobile sources. It also requires

the CARB to prioritize specified emission reduction rules and regulations and to identify specified information for emission reduction measures (e.g., alternative compliance mechanism, market-based compliance mechanism, and potential monetary and nonmonetary incentive) when updating the Scoping Plan.

SB 350, signed October 7, 2015, is the Clean Energy and Pollution Reduction Act of 2015. SB 350 is the implementation of some of the goals of EO B-30-15. The objectives of SB 350 are as follows:

1. To increase from 33 percent to 50 percent, the procurement of our electricity from renewable sources
2. To double the energy efficiency savings in electricity and natural gas final end uses of retail customers through energy efficiency and conservation.

The text of SB 350 sets a December 31, 2030, target for 50 percent of electricity to be generated from renewable sources. SB 350 also requires the State to double statewide energy efficiency savings in electricity and natural gas end uses by 2030. Additionally, SB 350 sets requirements for large utilities to develop and submit integrated resources plans (IRPs), which detail how utilities would meet their customers' resource needs, reduce GHG emissions, and integrate clean energy resources (CEC 2021a).

On September 10, 2018, Governor Brown signed SB 100, the 100 Percent Clean Energy Act of 2018. SB 100 requires renewable energy and zero-carbon resources to supply 100 percent of electric retail sales to end-use customers and 100 percent of electricity procured to serve state agencies by December 31, 2045. This policy requires the transition to zero-carbon electric systems that do not cause contributions to increase of GHG emissions elsewhere in the western electricity grid (CEC 2021b). SB 100 also creates new standards for the Renewable Portfolio Standard (RPS) goals established by SB 350 in 2015. Specifically, the bill increases required energy from renewable sources for both investor-owned utilities and publicly owned utilities from 50 percent to 60 percent by 2030.

Further, on September 10, 2018, Governor Brown also signed California EO B-55-18, which sets a new statewide goal of carbon neutrality as soon as possible, and no later than 2045 and achieve net negative emissions thereafter. EO B-55-18 was added to the existing Statewide targets of reducing GHG emissions, including the targets previously established by Governor Brown of reducing emissions to 40 percent below 1990 levels by 2030 (EO B-30-15 and SB 32), and by Governor Schwarzenegger of reducing emissions to 80 percent below 1990 levels by 2040 (EO S-3-05).

SCAQMD Significance Criteria

On December 5, 2008, the SCAQMD Governing Board presented the staff proposal for a tiered threshold approach wherein Tier 1 determines if a project qualifies for an applicable CEQA exemption, Tier 2 determines consistency with GHG reduction plans, and Tier 3 proposes a numerical screening value as a threshold. At their September 28, 2010, meeting, the Working Group suggested a Tier 3 threshold of 3,000 metric tons of carbon dioxide equivalent (MTCO_{2e}) per year for all land use types (SCAQMD 2010). Tier 4 determines if the project meets performance standards. Tier 4 has three options: Option 1—percent emission reduction target; Option 2—early implementation of applicable measures, and Option 3—sector-based standard. Tier 5 determines mitigation for CEQA offsets. The SCAQMD recommended 3,000 MTCO_{2e} threshold for non-industrial uses is used for this analysis.

The City of Anaheim has not officially adopted any GHG CEQA significance threshold. The City defers to assessment methods and significance thresholds developed by the SCAQMD. This impact analysis evaluates consistency with regulatory programs designed to reduce GHG emissions and that contribute to the achievement of AB 32's and SB 32's goals as the primary significance criterion. In addition, this impact analysis also evaluates the Project's estimated emissions compared to the SCAQMD threshold (as discussed above).

Question A: Would the project generate greenhouse gas emissions, either directly or indirectly, that may have a significant impact on the environment?

Less Than Significant Impact. Based on the Project's construction activities, the principal source of construction-phase GHG emissions would be internal combustion engines of construction equipment, on-road construction vehicles, and workers' commuting vehicles. GHG emissions from construction activities were calculated with the CalEEMod model and are described above in response to the air quality thresholds. The estimated construction GHG emissions for the Project would be 180 MTCO_{2e}, as shown in Table 12.

**TABLE 12
ESTIMATED GREENHOUSE GAS
EMISSIONS FROM CONSTRUCTION**

Year	Emissions (MTCO _{2e})
2021	59
2022	121
Total	180
MTCO _{2e} : metric tons of carbon dioxide equivalent	
Notes:	
<ul style="list-style-type: none"> Detailed calculations are provided in Appendix A. 	

Operational GHG emissions would come primarily from vehicle trips. Other sources of operational GHG emissions would include purchased electricity; water supply and treatment; solid waste disposal; and fossil-fueled landscaping and maintenance equipment. Table 13 shows the annual GHG emissions from Project's operations.

**TABLE 13
ESTIMATED ANNUAL GREENHOUSE GAS
EMISSIONS FROM PROJECT OPERATION**

Source	Emissions (MTCO _{2e} /yr)
Area	<1
Energy	72
Mobile	103
Waste	21
Water	7
Total Operational Emissions	205
MTCO _{2e} /yr: metric tons of carbon dioxide equivalent per year	
Notes:	
<ul style="list-style-type: none"> Totals may not add due to rounding variances. Detailed calculations are provided in Appendix A. 	

Because impacts from construction activities occur over a relatively short period of time, they contribute a relatively small portion of the overall lifetime project GHG emissions. In addition, GHG emission reduction measures for construction equipment are relatively limited. The SCAQMD recommends that construction emissions be amortized over a 30-year project lifetime so that GHG reduction measures address construction GHG emissions as part of the operational GHG reduction strategies (SCAQMD 2008b). Therefore, construction and operational emissions are combined by amortizing the construction and operations over an assumed 30-year project lifetime. This combination is shown in Table 14 using the Project's amortized construction and operational emissions.

**TABLE 14
ESTIMATED TOTAL PROJECT ANNUAL
GREENHOUSE GAS EMISSIONS**

Source	Emissions (MTCO ₂ e/yr)
Construction (Amortized)	6 ^a
Operations (Table 13)	205
Total^b	211
SCAQMD-Recommended Threshold)	3,000
Exceeds Threshold?	No
MTCO ₂ e/yr: metric tons of carbon dioxide equivalent per year	
^a Total derived by dividing construction emissions (see Table 12) by 30.	
^b Total annual emissions are the sum of amortized construction emissions and operational emissions.	

The SCAQMD has proposed, but not adopted, a threshold of 3,000 MTCO₂e per year for non-industrial land use projects. As shown, the estimated GHG emissions from the Project would be less than ten percent of the suggested threshold. Therefore, the Project would have less than significant impacts related to this threshold and no mitigation is required.

Question B: *Would the project conflict with an applicable plan, policy, or regulation adopted for the purpose of reducing the emissions of greenhouse gases?*

Less Than Significant Impact. The principal State plan and policy adopted for the purpose of reducing GHG emissions is the AB 32 Scoping Plan. The goals of AB 32 include reducing GHG emissions to 1990 levels by 2020 and adapting to climate change. There are a number of GHG reduction plans that have been adopted on the State and regional level. The Southern California Association of Governments (SCAG) adopted the 2020-2045 RTP/SCS, known as Connect SoCal, for the six-county region including Imperial, Los Angeles, Orange, Riverside, San Bernardino and Ventura Counties (SCAG 2020). The RTP/SCS seeks to improve the mobility, sustainability and economies of this region. This Plan demonstrates how the region would reduce transportation emissions to comply with Senate Bill 375 (SB 375). This is achieved by numerous transportation related programs and projects which seek to improve the operational efficiency of the transportation network, promote mass transit and non-automobile forms of transportation, and fulfill the requirements for the SCS to reduce GHG emissions.

The City of Anaheim has not adopted a Climate Action Plan (CAP), and the SCAQMD has not adopted standards for the purpose of reducing GHG emissions. The Anaheim Public Utilities Department (APUD) has also outlined a plan to transition their Renewable Portfolio Standard (RPS) to clean energy resources and has increased the procurement of renewable resources since 2003 through its Integrated Resource Plan (IRP), approved by City Council and the California Energy Commission (CEC) in 2018 (Anaheim 2021). The IRP established goals such

as a 50 percent RPS by 2030, which is consistent with the requirements of SB 350, which requires all California electric utilities to increase the use of renewable resources to serve customer load to 50 percent by 2030. Senate Bill (SB) 100, enacted on September 10, 2018, expanded the renewable procurement target from 50 percent to 60 percent by 2030. Anaheim has performed an initial assessment of the new requirement and will incorporate the full-scale portfolio analysis into the next update to the IRP, which is due in 2023. Additionally, APUD prepared a GHG Reduction Plan in 2020 to update the City's 2015 GHG Reduction Plan and outline new GHG reduction targets (APUD 2020). The 2020 GHG Reduction Plan set targets for 2020, 2030 and 2045, which are consistent with the targets of SB 350 and SB 100 for increased RPS standards. Although APUD's reduction goals are not directly applicable to the Project, APUD's GHG reductions would also reduce the Project's GHG emissions because APUD is the utility provider for the Project.

Project related emissions would be substantially less than the SCAQMD-recommended screening threshold, as shown in Table 14, and would result in less than significant impacts. The Project would continue to meet the religious needs of the local community that it serves with additional capacity at the Project site. GHG emissions associated with vehicle travel to Project site is anticipated to continue to be reduced with the increasing adoption of electric vehicle usage in Southern California. As discussed previously, utility related GHG emissions from electricity consumption from the Project would also decrease over time in compliance with SB 350 and SB 100. Electricity related emissions from utilities produced to fuel electric vehicles would likewise decrease. As such, the SCAQMD does not consider the Project to result in a significant quantity of GHG emissions. The Project would not conflict with an applicable plan, policy, or regulation of State, regional, or local agencies and the impact would be less than significant.

Mitigation Program

No mitigation is required.

IX. HAZARDS AND HAZARDOUS MATERIALS

The information in this section is partly derived from the Environmental Data Resources (EDR) Radius Map Report with GeoCheck that was prepared for the Project by EDR in 2021 (Appendix E).

Question A: Would the project create a significant hazard to the public or the environment through the routine transport, use, or disposal of hazardous materials?

Less Than Significant Impact. The Project would not involve the routine use, transport, handling, or storage of hazardous materials on-site. The proposed land use for the Project is a community church. The Project would result in the on-site handling of materials that are common in similar developments, such as commercial cleansers, solvents, and other janitorial or industrial-use materials; paints; and landscape fertilizers/pesticides. While these common materials are technically labeled as "hazardous", the presence of such materials is common in most proposed developments and their transport and use is considered a less than significant impact with implementation of **RR HAZ-1**, which requires compliance with existing federal, State, and local regulations regarding hazardous material use, storage, disposal, and transport. The proposed land use would not generate hazardous emissions, nor would daily church operations involve hazardous materials that would create a hazard to the public or environment.

Question B: *Would the project create a significant hazard to the public or the environment through reasonably foreseeable upset and accident conditions involving the release of hazardous materials into the environment?*

Less Than Significant Impact. Project construction activities routinely involve the use and handling of limited volumes of commonly used hazardous materials, such as petroleum (fuel), paints, adhesives, and solvents. During construction, there is a limited risk of spills and/or accidental release of hazardous materials that are used for the operation and maintenance of construction equipment. The on-site temporary handling, storage, and usage of these materials would be subject to applicable local, State, and/or federal regulations. As required by **RR HAZ-1**, any hazardous materials used during construction would also be transported, used, stored, and disposed of according to any applicable local, State, and/or federal regulations.

The structures within the Project site that would be remodeled, removed, or otherwise altered by the Project were all developed since 1988, when the church was first established. Asbestos-containing materials (ACMs) and lead-based paint (LBP) were generally no longer utilized commonly in building materials after 1978. Therefore, ACMs and LBP are not likely to be present within interior and/or exterior materials and surfaces. With implementation of **RR HAZ-1**, the Project would have less than significant impacts related to this threshold and no mitigation is required.

Question C: *Would the project emit hazardous emissions or handle hazardous or acutely hazardous materials, substances, or waste within one-quarter mile of an existing or proposed school?*

Less Than Significant Impact. The Project site is approximately 0.25-mile from Running Springs Elementary School, which is located southwest of the Project site at 8670 Running Springs Drive. The Project involves the expansion of a community church and does not include any features that would result in hazardous emissions during operation. The Project would not develop land uses that involve the use, storage, or transport of hazardous materials that represent a significant hazard to the public or the environment. During Project operations, the Project would result in the routine on-site handling of materials that are common in similar developments, such as commercial cleansers, solvents, and other janitorial or industrial-use materials; paints; and landscape fertilizers/pesticides. Less than significant impacts would result related to this threshold, and no mitigation is required.

Question D: *Would the project be located on a site which is included on a list of hazardous materials sites compiled pursuant to Government Code Section 65962.5 and, as a result, would it create a significant hazard to the public or the environment?*

No Impact. Section 65962.5 requires the development of a hazardous waste and substances site list, also known as the Cortese List, which provides the location of known hazardous materials release sites. Based on a review of the EDR Radius Map Report with Geocheck prepared for the Project site by EDR in 2021, the following facilities were listed adjacent to the site. Search parameters were based on a one-mile radius of the Project site and consisted of a search of federal, State, local, tribal, and other databases. The complete list of databases and additional information regarding the identified sites can be found in Appendix E.

The Industrial Asphalt Plant (former) and Owl Rock New Star sites are located at 9010 East Santa Ana Canyon Road, which is approximately 0.42-mile east of the Project site at a lower elevation. That property's past uses have resulted in soil contamination with hydrocarbon solvents. The property owner has implemented a voluntary cleanup program on that site. A report of a leaking

underground storage tank (LUST), which leaked diesel fuel into the soil, also occurred on this property. The Industrial Asphalt Plant/Robertson's Ready Mix site is separately listed at 24000 Santa Ana Canyon Road, which is 0.31-mile east of the Project site, at a lower elevation relative to the Project site. Soil contamination is recorded at that site from a LUST, including diesel fuel oil and additives, as well as leaded and unleaded gasoline.

Also, the Project site is approximately 0.25-mile from Running Springs Elementary School, which is located southwest of the Project site at 8670 Running Springs Drive at a higher elevation than the Project site. Running Springs Elementary School is listed in the EnviroStor database. The records are related to ongoing monitoring of the site that occurred as part of the Department of Toxic Substances Control's (DTSC's) Site Mitigation and Brownfields Reuse Program (SMBRP). No contaminants were found as part of these investigations.

According to the EDR Radius Map, no hazardous materials sites were identified within the boundaries of the Project site. Of the hazardous materials sites identified in the project vicinity, none of the identified sites pose a hazard to the Project site. No impacts related to known hazardous materials sites would occur, and no mitigation is required.

Question E: For a project located within an airport land use plan (Los Alamitos Armed Forces Reserve Center or Fullerton Municipal Airport), would the project result in a safety hazard for people residing or working in the project area?

No Impact. The Project site is not located within an adopted Airport Land Use Plan or in the vicinity of a private airstrip, heliport, or helistop. The nearest airport is Corona Municipal Airport located in the City of Corona, approximately 6.75 miles northeast of the Project site. Implementation of the Project would not impact the airport facilities or their operation; no mitigation would be required.

Question F: Would the project impair implementation of or physically interfere with an adopted emergency response plan or emergency evacuation plan?

No Impact. The City of Anaheim's Emergency Operations Plan was adopted by the Anaheim City Council on May 9, 2017 (Anaheim 2017). This plan provides an overview of potential hazards affecting the City, as well as general policy-level guidance related to future development within the City. The Project does not conflict with the Emergency Operations Plan. Furthermore, the Project would not physically affect or interfere with the evacuation routes identified on the City's "Know Your Way Page", which provides guidance on developing primary and secondary evacuation routes in case of wildfire, flood, or earthquake events. The "Know Your Way Page" shows westbound East Santa Ana Canyon Road as a major route west connecting evacuees to Weir Canyon Road and ultimately to westbound SR-91 (Anaheim 2021b). The Project site is located along East Santa Ana Canyon Road, which is a primary arterial in the City. Construction activity would be confined to the Project site and would not interfere with vehicle movement or emergency access along the roadway. The Project does not include characteristics that would physically impair or otherwise interfere with emergency response or evacuation in the vicinity of the Project. As detailed in Section XVII, Transportation, any impacts related to increased vehicular traffic resulting from the Project would be less than significant; therefore, the Project would not interfere with the movement of emergency vehicles or those evacuating along local roadways. The Project would not conflict with the City's Emergency Operations Plan or any other applicable emergency response or evacuation plan, no impact would occur, and no mitigation is required.

Question G: Would the project expose people or structures, either directly or indirectly, to a significant risk of loss, injury or death involving wildland fires?

Less Than Significant Impact. The Project site is located entirely within a Very High Fire Hazard Severity Zone (VHFHSZ) as identified in the California Fire Hazard Severity Zone Viewer using data provided by California Department of Forestry and Fire Protection (CALFIRE 2021). A Fire Hazard Severity Zone (FHSZ) is a mapped area that designates zones, based on factors such as fuel, slope, and fire weather, with varying degrees of fire hazard ranging including, moderate, high, and very high. FHSZ maps evaluate wildfire hazards, which are physical conditions that create a likelihood that an area will burn over a 30- to 50-year period. The Project involves the expansion of an existing church within a Project site that has been previously graded and developed. As such, people (e.g., congregants, staff) and structures within the Project site are already susceptible to wildfire risks. The Project would add buildings and additional capacity to the existing church activities, which would result in the potential for more people and structures to be exposed to wildfire risk. According to the Applicant, no existing fuel modification requirements exist for the Project site (e.g., the existing church). However, Chapter 6.16 of the City Municipal Code requires that all property owners across the City abate noxious vegetation on their properties, which applies to vegetation that might pose a wildfire risk.

Furthermore, the Project site is located within a Special Protection Area of the City as designated by the Fire Department. The City continues to refine procedures and processes to minimize the risk of fire hazards in the Special Protection Area including: requiring new development to utilize fire-resistant building materials; incorporating fire sprinklers as appropriate; incorporating defensible space requirements; requiring compliance with Anaheim Fire Department Fuel Modification Guidelines; requiring development to use plant materials that are compatible with surrounding natural vegetation; and providing wet or irrigated zones when required. With implementation of City requirements related to weed abatement as well as the provision of fire sprinklers on all new and relocated structures, less than significant impacts would result related to this threshold, and no mitigation is required.

Mitigation Program

Regulatory Requirement

RR HAZ-1 Activities at the Project site shall comply with existing federal, State, and local regulations regarding hazardous material use, storage, disposal, and transport to prevent Project-related risks to public health and safety. All on-site generated waste that meets hazardous waste criteria shall be stored, manifested, transported, and disposed of in accordance with the California Code of Regulations (Title 22) and in a manner to the satisfaction of the local Certified Unified Program Agency (CUPA), as applicable. Any hazardous materials removed from the Project site shall be transported only by a Licensed Hazardous Waste Hauler, who shall be in compliance with all applicable State and federal requirements, including U.S. Department of Transportation regulations under Title 49 (Hazardous Materials Transportation Act) and Title 40, Section 263 (Subtitle C of the Resource Conservation and Recovery Act) of the Code of Federal Regulations; California Department of Transportation (Caltrans) standards; and Division of Occupational Safety and Health (Cal/OSHA) standards.

X. HYDROLOGY AND WATER QUALITY

Question A: *Would the project violate any water quality standards or waste discharge requirements or otherwise substantially degrade surface or ground water quality?*

Less Than Significant Impact. This section discusses the Project's potential construction- and operational-related water quality impacts.

Construction-Related Water Quality Impacts

The Project could result in short-term construction impacts to surface water quality from demolition, grading, and other construction-related activities. Stormwater runoff from the Project site during construction could contain soils and sediments from these activities. Also, spills or leaks from heavy equipment and machinery, construction staging areas, and/or building sites can also enter runoff and typically include petroleum products such as fuel, oil and grease, and heavy metals.

The SWRCB has issued the Statewide NPDES General Permit for Storm Water Discharges Associated with the Construction and Land Disturbance Activities (Order No 2012-0006-DWQ, NPDES No. CAS000002, adopted by the SWRCB on July 17, 2012). Under this Construction General Permit, individual NPDES permits or Construction General Permit coverage must be obtained for discharges of stormwater from construction sites with a disturbed area of one or more acres. Since the Project site is 14.79-acres, coverage under the General Permit for Discharges of Storm Water Associated with Construction Activity is required. To obtain coverage, the Developer must retain the services of a certified Qualified SWPPP Developer to prepare a SWPPP for the Project. The Developer, or the contractor if specifically delegated, would electronically submit permit registration documents prior to beginning construction activities in the Storm Water Multi-Application Report Tracking System, which would consist of a Notice of Initiation, Risk Assessment, Post-Construction Calculations, a site map, the SWPPP, a signed certification statement, and the first annual fee. Project construction would also adhere to the South Coast Air Quality Management District's Rule 402 (Nuisance) and Rule 403 (Fugitive Dust) to avoid and minimize dust from leaving the site.

Construction activities are not anticipated to directly encounter groundwater, as levels are anticipated to be more than 18.5 feet below ground surface at the Project site (Anacal Engineering 2021), which is well below the depth of proposed excavation.

Adherence to applicable regulatory requirements would ensure that Project short-term impacts to surface water quality during construction would be less than significant, and no mitigation is required.

Operational Water Quality Impacts

The Project is located in the Santa Ana River Basin. Specifically, the Project Site drains to existing grate inlets that are connected to an existing City storm drain, which traverses the Project site and flows north to the Santa Ana River. The SWRCB maintains the 303(d) List of Impaired Water Bodies, which identifies water bodies where water quality indicators exceed acceptable thresholds. The Project site drains directly to the Santa Ana River, which is a 303(d)-listed impaired water body for indicator bacteria (Anacal Engineering 2021). The Santa Ana RWQCB develops and implements total maximum daily loads to address water quality impairments and help achieve water quality standards. Water quality is also governed through NPDES stormwater

discharge permits issued to municipalities, construction sites, and industrial facilities to control non-point-source pollutants in stormwater discharges to surface waters.

According to the PWQMP that was prepared for the Project, general pollutants that may result from Project operations, which are also known as project priority pollutants of concern, include suspended solids/sediment, nutrients, heavy metals, pathogens (bacteria/virus), pesticides, oil and grease, toxic organic compounds, and trash and debris (Anacal Engineering 2021). In the existing condition, the majority of the Project site drains to existing grate inlets that are connected to an existing City storm drain that traverses the Project site, which was constructed to serve the adjacent residential development to the south. Instead, the Project would redirect stormwater flows from throughout the Project site to a new 18-inch RCP. The RCP would collect and convey flows downslope to an underground infiltration system, which would consist of two underground stormwater infiltration chambers within a portion of APN 354-321-03. In the event of stormwater exceeding the design capture volume for the underground infiltration chamber, excess water would be rerouted to the existing City storm drain via an 18-inch RCP overflow pipe. Prior to flowing into the 18-inch RCP, at least 50 percent of stormwater would be pre-treated for sediment, debris, and hydrocarbons using Filterra stormwater biofiltration units. Catch basins would be installed with FloGard filters to capture trash and debris. These improvements are depicted in Exhibit 17, Water Quality Best Management Practices, and described in more detail in the Project's PWQMP (Anacal Engineering 2021). These drainage improvements have been incorporated into the Project design based on the recommendations of the PWQMP to minimize impacts related to stormwater quality and increased stormwater volumes generated from Project implementation. Therefore, construction and operation of these basins would adequately treat stormwater runoff and a less than significant impact would occur; no mitigation would be required.

Question B: *Would the project substantially decrease groundwater supplies or interfere substantially with groundwater recharge such that the project may impede sustainable groundwater management of the basin?*

Less Than Significant Impact. The Project site is currently served by two wells, which would continue to provide water for the Project. The Project would result in a minor increase in demand for groundwater above what is currently required for the existing church; however, this increase in demand would not be substantial relative to the overall capacity of the Orange County Groundwater Basin (OCWD 2015). Additionally, the Project would not interfere substantially with groundwater recharge as the Project has incorporated stormwater infiltration as required in the PWQMP, which would minimize impacts related to the Project's minor increases in impervious surface coverage compared to pre-Project conditions (Anacal Engineering 2021). Therefore, the Project would have less than significant impacts related to groundwater supplies and groundwater recharge and no mitigation is required.

Question C: *Would the project substantially alter the existing drainage pattern of the site or area, including through the alteration of the course of a stream or river or through the addition of impervious surfaces, in a manner which would:*

(i) result in substantial erosion or siltation on- or off-site?

Less Than Significant Impact. As described above in response to threshold X(a), the Project has the potential to result in erosion and siltation during construction. Development and implementation of a SWPPP for the Project would ensure potential effects related to erosion and siltation are reduced to less than significant levels during construction. Also, as discussed above under threshold X(a), appropriate drainage and stormwater improvements have been incorporated into the Project's design, which would reduce potential for erosion and siltation

during Project operations. Given these considerations, less than significant impacts would result from the Project and no mitigation is required.

Question C: *Would the project substantially alter the existing drainage pattern of the site or area, including through the alteration of the course of a stream or river or through the addition of impervious surfaces, in a manner which would:*

(ii) substantially increase the rate or amount of surface runoff in a manner which would result in flooding on- or offsite;

(iii) create or contribute runoff water which would exceed the capacity of existing or planned stormwater drainage systems or provide substantial additional sources of polluted runoff.

Less Than Significant Impact. The Project would result in an increase of impervious surface coverage within the Project site of approximately 16.4 percent or 42,579 square feet (Anacal Engineering 2021). The addition of impervious surface has the potential to permanently increase appropriate drainage and stormwater improvements have been incorporated in the Project's design which would convey, retain, and treat stormwater prior to it being conveyed off-site along natural drainage courses that exist in the pre-Project condition. Therefore, less than significant impacts would result related to these thresholds, and no mitigation is required.

Question C: *Would the project substantially alter the existing drainage pattern of the site or area, including through the alteration of the course of a stream or river or through the addition of impervious surfaces, in a manner which would:*

(iv) impede or redirect flood flows?

Less Than Significant Impact. According to a review of the National Flood Hazard Layer (NFHL) Viewer maintained by FEMA, the Project site is located within FIRM Panel 06059C0180J. The entire Project site is outside the active 100- and 500-year floodplains. Also, the Project site is not located within the dam inundation zones established downslope of the Prado Dam, Carbon Canyon Dam, or Walnut Canyon Reservoir (Anaheim 2020a). The Project would provide drainage improvements to receive, convey, detain, and treat stormwater within the Project site consistent with the Project's PWQMP (Anacal Engineering 2021). Therefore, the Project would provide adequate drainage and conveyance within the site and impacts to flood flows would be less than significant; no mitigation is required.

Question D: *Would the project in flood hazard, tsunami, or seiche zones, risk release of pollutants due to project inundation?*

Less Than Significant Impact. As noted above in response to threshold X(c)(iv), the Project site is not within an active floodplain; therefore, there would be minimal risk of on- or off-site flooding that would result from the Project. The Project is not near the ocean or other water body with the potential to be at risk of seismically-induced tidal phenomena. Furthermore, the Project would not utilize, store, or otherwise contain pollutants that would be at risk of release if inundated. Therefore, hazards related to the potential release of pollutants due to inundation caused by a flood, tsunami, and/or seiche are considered to be negligible. A less than significant impact would result from the Project related to this threshold, and no mitigation is required.

Question E: *Would the project conflict with or obstruct implementation of a water quality control plan or sustainable groundwater management plan?*

Less Than Significant Impact. The Santa Ana RWQCB prepares and maintains the Water Quality Control Plan for the Santa Ana River Basin (Basin Plan). The Basin Plan sets water quality standards in the Santa Ana River Basin by establishing beneficial uses for specific water bodies and designating numerical and narrative water quality objectives. The Basin Plan sets water quality objectives for the Project site and its surrounding areas. Water quality thresholds identified in the Basin Plan are intended to reduce pollutant discharge and ensure that water bodies are of sufficient quality to meet their designated beneficial uses. The Project would not conflict with the water quality standards outlined in the Basin Plan or worsen water quality conditions in any 303(d)-listed water body. As discussed above in response to threshold X(a), pollutant discharge during construction would be avoided through compliance with the Construction General Permit including the preparation and implementation of a SWPPP. Once the Project is constructed, the Project would consist of an expanded community church. Pollutants generated during Project operations would be treated using the best management practices identified in the Project's PWQMP. Therefore, the Project would not be a source of pollutants for downstream water bodies and the Project would thereby not conflict with the Basin Plan.

The Orange County Water District (OCWD) has adopted a Groundwater Management Plan for the sustainable management of the Orange County Groundwater basin (OCWD 2015). The Project would not interfere with any of the water supply monitoring efforts or infiltration areas outlined in the Groundwater Management Plan, nor would the Project impact any of the recharge facilities, groundwater replenishment processes, or seawater intrusion and barrier management activities that are listed in the plan.

Therefore, the Project would result in less than significant impacts related to this threshold and no mitigation is required.

Mitigation Program

No mitigation is required.

XI. LAND USE AND PLANNING

Question A: *Would the project physically divide an established community?*

No Impact. As shown in the aerial photograph provided as Exhibit 2, the Project site is currently developed with a church, which is physically isolated from other nearby development. The only public access point to the Project site is in the north at the property line with East Santa Ana Canyon Road. The Project would expand the existing church facilities. No impact would occur related to physically dividing an established community, and no mitigation is required.

Question B: *Would the project cause a significant environmental impact due to a conflict with any land use plan, policy, or regulation adopted for the purpose of avoiding or mitigating an environmental effect?*

Less Than Significant Impact. Kindred Community Church is currently located on the Project site, and the Project consists of the expansion of this existing use.

The majority of the property is located within the Sycamore Canyon Specific Plan (SP88-1) Zone; however, a small portion (approximately two acres) is located within The Summit of Anaheim Hills Specific Plan (SP88-2) Zone.

The Sycamore Canyon Specific Plan (SP88-1) identifies the Project site as a future church with an underlying Open Space land use; however, SP88-1 does not include any detailed standards or procedures for the development of the church. SP88-1 includes a brief discussion that an 11-acre church is planned in the northeast portion of the Sycamore Canyon Specific Plan area. SP88-1 notes that the details of the proposed church would be addressed in a subsequent application (Anaheim 1988a). SP88-1 states that the standards of the Open Space Zone in Chapter 18.14 (Public and Special Purpose Zones) of the City's Municipal Code shall apply for the areas shown as open space on the Sycamore Canyon Development Plan Map, such as the Project site. Pursuant to Chapter 18.14 of the City's Municipal Code, the existing church and proposed expansion of the church under the Project would be conditionally permitted uses.

In addition to the City-wide sign requirements codified in Chapter 18.44 of the City's Municipal Code, SP88-1 also includes requirements for signage in the Sycamore Canyon Specific Plan in Section 18.102.150 of the Municipal Code. These requirements have been incorporated into the relocated monument signage, which will be reviewed and approved by the City as part of a future and separate discretionary action.

The Summit of Anaheim Hills Specific Plan (SP88-2) similarly identifies the Project site as a future church with an underlying Open Space land use in mapping but does not include any detailed standards or procedures for the development of the church (Anaheim 1988b). As outlined in the Open Space Standards for the Summit of Anaheim Hills Specific Plan, which are codified at Section 18.104.080 of the City's Municipal Code, the existing church and proposed expansion of the church under the Project are conditionally permitted uses. SP88-2 includes additional requirements for signage; however, none of the Project signage would occur within any parcels zoned as SP88-2, so these policies are not applicable.

The City originally approved a CUP for the church in 1988 as a semi-enclosed "garden church" by CUP 3032. In 1998, the City subsequently approved the existing church by CUP 4033. This CUP permitted a 29,503-square foot church with accessory day care center, fellowship hall, and multi-purpose building in conjunction with existing modular buildings. The City subsequently amended the CUP in 1998 to add a parsonage home; in 2004 to allow 5,611 addition to the fellowship hall; and, in 2008 to add three modular units for Sunday school classrooms.

The entire property is within the SC Overlay Zone, and the Project has been designed to be consistent with the requirements for this zone.

As part of the City's design review process and amendment to the CUP for the Project site, the Project has been reviewed by the City to ensure compliance with applicable plans, policies, and regulations. Given that the Project would not conflict with applicable zoning and other regulations governing scenic quality, the Project would result in less than significant impacts related to this threshold, and no mitigation is required.

Mitigation Program

No mitigation is required.

XII. MINERAL RESOURCES

Question A: *Would the project result in the loss of availability of a known mineral resource that would be of value to the region and the residents of the state?*

Question B: *Would the project result in the loss of availability of a locally important mineral resource recovery site delineated on a local general plan, specific plan or other land use plan?*

No Impact. The CGS provides information about California's non-fuel mineral resources. The primary focus of the Mineral Resources Project administered by CGS is to classify lands throughout the State that contain regionally significant mineral resources as mandated by State law. According to the CGS, the Project site is not located within a Mineral Resource Zone or within any areas of the City identified as containing mineral resources of regional significance. The Project consists of the redevelopment of an existing church property, which has no substantial value to the State or region as a source of mineral resources. Therefore, development of the Project would not result in the loss of availability of a known mineral resource delineated on a local general plan, specific plan, or other land use plan as there are no known mineral resources or mineral resource recovery sites within the Project site. No related impact would occur, and no mitigation is required.

Mitigation Program

No mitigation is required.

XIII. NOISE

Noise Background Information and Regulatory Conditions

Noise is typically defined as unwanted sound and is described in terms of a sound’s intensity or loudness, pitch, and duration. The ambient noise environment is comprised of stationary and mobile noise sources. Stationary noise sources occur in a single location and may be constant or short-term in nature; mobile noise sources are typically transportation-related and are generally not considered a constant noise source.

The physical measure of sound, or sound level, is measured in decibels (dB), which are based on a logarithmic scale. Therefore, a doubling of the energy of a noise source, such as doubling of traffic volume, would increase the noise level by 3 dB; a halving of the energy would result in a 3 dB decrease. Everyday sounds normally range from 30 dB (very quiet) to 100 dB (very loud). The A-weighted decibel scale relates noise to human sensitivity. Common noise levels are measured in terms of the “A-weighted decibel”, abbreviated dBA. Table 15 provides examples of various noises and their typical A-weighted noise level.

**TABLE 15
TYPICAL NOISE LEVELS**

Common Outdoor Activities	Noise Level (dBA)	Common Indoor Activities
	110	Rock Band
Jet fly-over at 300 m (1,000 ft)	100	
Gas Lawn Mower at 1 m (3 ft)	90	
Diesel Truck at 15 m (50 ft), at 80 km/hr (50 mph)	80	Food Blender at 1 m (3 ft)
Noisy Urban Area, Daytime Gas Lawn Mower at 30 m (100 ft)	70	Vacuum Cleaner at 3 m (10 ft)
Commercial Area Heavy Traffic at 90 m (300 ft)	60	Normal speech at 1 m (3 ft)
Quiet Urban Daytime	50	Large Business Office Dishwasher in Next Room
Quiet Urban Nighttime	40	Theater, Large Conference Room
Quiet Suburban Nighttime	30	Library
Quiet Rural Nighttime	20	Bedroom at Night, Concert Hall
	10	Broadcast/Recording Studio
Lowest Threshold of Human Hearing	0	Lowest Threshold of Human Hearing
dBA: A-weighted decibels; m: meter; km/hr: kilometers per hour; ft: feet; mph: miles per hour		
Source: Caltrans 2009.		

Although human perception of sound is somewhat subjective, it is widely accepted that the average healthy ear (1) can barely perceive an increase or decrease of 3 dBA; (2) can perceive a change of 3 dBA in outdoor environments; and (3) can notice that an increase of 10 dBA sounds twice as loud.

Noise, or sound over a period of time, can be measured using a number of methods. The two most common methods are the community noise equivalent (CNEL) and the equivalent sound level (L_{eq}). The average noise levels over a period of minutes or hours is expressed as dBA L_{eq} . L_{eq} can be measured for any time period. The CNEL scale represents the average of 24 hourly noise measurements and adjusts or penalizes the dBA during certain sensitive time periods to account for increased noise sensitivity during the evening and nighttime periods. The evening time period (7:00 PM to 10:00 PM) penalizes noises by 5 dBA, while nighttime (10:00 PM to 7:00 AM) noises are penalized by 10 dBA.

Regulatory Setting

State of California

Title 24 of the California Code of Regulations, also known as the California Building Standards Code, establishes building standards applicable to all occupancies throughout the State (CBSC 2019). Section 1207.11.2 requires that residential structures, other than detached single-family dwellings, be designed to prevent the intrusion of exterior noise so that the interior noise attributable to exterior sources shall not exceed 45 dBA CNEL in any habitable room. This requirement is most applicable to the expanded community church use. Section 1207.12 states, “if interior allowable noise levels are met by requiring that windows be unopenable or closed, the design for the structure must also specify a ventilation or air-conditioning system to provide a habitable interior requirement. The ventilation system must not compromise the dwelling unit or guest room noise reduction.”

City of Anaheim

The following sections of the City of Anaheim’s Municipal Code apply to the Project:

6.70.010 ESTABLISHED.

Sound produced in excess of the sound pressure levels permitted herein are hereby determined to be objectionable and constitute an infringement upon the right and quiet enjoyment of property in this City.

No person shall within the City create any sound radiated for extended periods from any premises which produces a sound pressure level at any point on the property line in excess of sixty decibels (Re 0.0002 Microbar) read on the A-scale of a sound level meter. Readings shall be taken in accordance with the instrument manufacturer’s instructions, using the slowest meter response.

The sound level measuring microphone shall be placed at any point on the property line, but not closer than three (3) feet from any wall and not less than three (3) feet above the ground, where the above listed maximum sound pressure level shall apply. At any point the measured level shall be the average of not less than three (3) readings taken at two (2) minute intervals. To have valid readings, the levels must be five (5) decibels or more above the levels prevailing at the same point when the sources of the alleged objectionable sound are not operating.

Sound pressure levels shall be measured with a sound level meter manufactured according to American Standard S1.4-1961 published by the American Standards Association, Inc., New York City, New York.

Traffic sounds sound created by emergency activities and sound created by governmental units or their contractors shall be exempt from the applications of this chapter. Sound created by construction or building repair of any premises within the City shall be exempt from the applications of this chapter during the hours of 7:00 a.m. to 7:00 p.m. Additional work hours may be permitted if deemed necessary by the Director of Public Works or Building Official. (Ord. 2526 § 1 (part); June 18, 1968; Ord. 3400 § 1; February 11, 1975; Ord. 6020 § 1; April 25, 2006.)

6.72.010 PURPOSE.

This City Council enacts this legislation for the sole purpose of securing and promoting the public health, comfort, safety, and welfare of its citizenry. While recognizing that certain uses of sound-amplifying equipment are protected by the constitutional rights of freedom of speech and assembly, the City Council, nevertheless, feels obligated to reasonably regulate the use of sound-amplifying equipment in order to protect the correlative constitutional rights of the citizens of this community to privacy and freedom from public nuisance of loud and raucous noise (Ord. 4059 § 1 (part); October 9, 1979; Ord. 5941 § 1 (part); September 14, 2004.)

6.72.020 REGULATION OF AMPLIFIED SOUND.

Notwithstanding the provisions of Chapter 6.70 of this code, it shall be unlawful for any person to use or operate, or cause to be used or operated, within the City of Anaheim any sound-amplifying equipment in a fixed or movable position, or mounted upon any vehicle, except when used or operated in compliance with the following provisions:

.010 In all residential zones and within two hundred feet of any boundary thereof, no sound-amplifying equipment shall be operated or used for commercial purposes, except sound-amplifying equipment may be used for commercial purposes upon a moving vehicle between the hours of 8:00 a.m. and 8:00 p.m. to announce the presence of such vehicle in an area or location for commercial purposes; provided that such sound-amplifying equipment shall not be used during periods that the vehicle is stopped, parked or otherwise in a stationary position..

.020 In all residential zones and within two hundred feet of any boundary thereof, no sound-amplifying equipment shall be operated or used for noncommercial purposes between the hours of 8:00 p.m. and 8:00 a.m. of the following day.

.030 In all non-residential zones, except such portions thereof as may be included within two hundred feet of the boundary of any residential zone, the operation or use of sound-amplifying equipment for commercial purposes is prohibited between the hours of 9:00 p.m. and 8:00 a.m. of the following day.

.040 In all non-residential zones, except such portions thereof as may be included within two hundred feet of the boundary of any residential zone, the operation or use of sound-amplifying equipment for noncommercial purposes is prohibited between the hours of 10:00 p.m. and 7:00 a.m. of the following day.

.050 Sound emanating from sound-amplifying equipment shall not be audible to a person of normal hearing acuity within an enclosed building (other than a building within

which the sound emanate) at a distance in excess of two hundred feet from the sound-amplifying equipment.

.060 In no event shall the sound-amplifying equipment be unreasonably loud, raucous, jarring or disturbing to a person of normal sensitiveness within the area of audibility, or disturb the peace or quiet of any neighborhood.

.070 It shall be unlawful for any person to operate or use any sound-amplifying equipment within, upon or adjacent to the premises of any hospital, school, or publicly owned or operated arena, stadium, convention center or auditorium, while in use, in a manner which disturbs, disrupts or interferes with the conduct of any event, business or activity of any nature then occurring within such building or premises. Nothing contained in this subsection shall be deemed to prohibit any conduct which is otherwise prohibited by California Penal Code Sections 302 or 403, or any other provision of State law. (Ord. 4059 § 1 (part); October 9, 1979; Ord. 5781 § 1; September 25, 2001; Ord. 5941 § 1 (part); September 14, 2004.)

6.73.020 NOISE RESTRICTIONS.

It shall be unlawful and constitute a public nuisance for any owner or responsible person to conduct or allow to be conducted any party or similar event from which loud and unreasonable noise originates between the hours of 10:00 p.m. and 7:00 a.m. Continuation of any activity prohibited by this section after written notification by a peace officer as provided in Section 6.73.030 that the activity is disturbing the comfort, health, peace, safety, quiet enjoyment or repose of one or more other persons shall be prima facie evidence of willful intent within the meaning of Section 6.73.010.010.(Ord. 5337 § 1 (part); October 20, 1992: Ord. 6259 § 1 (part); November 20, 2012.)

In the City of Anaheim General Plan Noise Element, the City adopted land use-noise compatibility standards shown in Table 16.

**TABLE 16
LAND USE COMPATIBILITY FOR NOISE EXPOSURE**

Land Use Category	Community Noise Exposure L _{dn} or CNEL, dB						
	55	60	65	70	75	80	85
Residential – Low-Density Single-Family, Duplex, Mobile Homes	[Hatched]		[Solid]		[Cross-hatched]	[Dark]	
Residential – Multiple-Family Homes	[Hatched]		[Solid]		[Cross-hatched]	[Dark]	
Transient Lodging - Motels, Hotels	[Hatched]		[Solid]		[Cross-hatched]	[Dark]	
Schools, Libraries, Churches, Hospitals, Nursing Homes	[Hatched]		[Solid]		[Cross-hatched]	[Dark]	
Auditoriums, Concert Halls, Amphitheaters	[Hatched]		[Solid]		[Cross-hatched]	[Dark]	
Sports Arena, Outdoor Spectator Sports	[Hatched]		[Solid]		[Cross-hatched]	[Dark]	
Playgrounds, Neighborhood Parks	[Hatched]		[Solid]		[Cross-hatched]	[Dark]	
Golf Courses, Riding Stables, Water Recreation, Cemeteries	[Hatched]		[Solid]		[Cross-hatched]	[Dark]	
Office Buildings, Business, Commercial and Professional	[Hatched]		[Solid]		[Cross-hatched]	[Dark]	
Industrial, Manufacturing, Utilities, Agriculture	[Hatched]		[Solid]		[Cross-hatched]	[Dark]	
[Hatched]	Normally Acceptable	[Solid]	Conditionally Acceptable	[Cross-hatched]	Normally Unacceptable	[Dark]	Clearly Unacceptable
Specified land use is satisfactory based upon the assumption that any buildings involved are of normal, conventional construction, without any special noise insulation requirements.	New construction or development should be undertaken only after a detailed analysis of the noise reduction requirement is made and needed noise insulation features are included in the design. Conventional construction, but with closed windows and fresh air supply systems or air conditioning, will normally suffice.		New construction or development should generally be discouraged. If new construction or development does proceed, a detailed analysis of the noise reduction requirements must be made and needed noise insulation features included in the design. Outdoor areas must be shielded.		New construction or development should generally not be undertaken. Construction costs to make the indoor environment acceptable would be prohibitive, and the outdoor environment would not be acceptable.		
L _{dn} : day-night noise level; CNEL: Community Noise Equivalent Level; dB: decibels Source: Anaheim 2004							

The Noise Element, Goal 1.1, includes the following policies applicable to the Project:

- 4) Require mitigation where sensitive uses are to be placed along transportation routes to ensure that noise levels are minimized through appropriate means of mitigation, thereby maintaining quality of life standards.
- 7) Require that site-specific noise studies be conducted by a qualified acoustic consultant utilizing acceptable methodologies while reviewing the development of sensitive land uses or development that has the potential to impact sensitive land uses.

Existing Noise Levels

The existing noise environment in and near the Project site is primarily influenced by traffic noise on SR-91 and to a much lesser extent from East Santa Ana Canyon Road. Psomas conducted ambient noise monitoring at the Project site on March 11, 2021. Noise level measurements were taken using a Larson Davis Laboratories SoundTrack LxT sound level meter (LD LxT). These noise measurements were located proximate to each of the Project site’s property lines, approximately 5 feet above the ground. Exhibit 18, Noise Monitoring Locations, shows the noise monitoring locations relative to the Project site boundaries.

The noise level measurements were collected at each of the Project site boundaries. The energy average (L_{eq}), maximum noise level (L_{max}), and minimum noise level (L_{min}) values taken at each ambient noise measurement location are shown in Table 17 below.

**TABLE 17
MONITORED NOISE LEVELS**

Noise Monitoring Locations	Minimum	L_{eq} (Average)	Maximum
Location 1 (near south property line)	52.1	55.8	59.5
Location 2 (near west property line)	54.7	61.6	67.6
Location 3 (near east property line)	57.1	60.8	64.8
Location 4 (near north property line and SR-91)	72.1	77.6	80.7
Source: Psomas 2021.			

Impact Analysis

Question A: Would the project result in generation of a substantial temporary or permanent increase in ambient noise levels in the vicinity of the project in excess of standards established in the local general plan or noise ordinance, or applicable standards of other agencies?

Long-term (Permanent) Impacts

Impacts to Off-Site Land Uses

Less Than Significant Impact. Daily operation of the Project has the potential to result in an increased ambient noise level in the vicinity of the Project through the addition of stationary sources of noise as well as vehicular trips associated with the Project. Stationary sources of noise include heating, ventilation, air conditioning (HVAC) noise from the four new modular structures and the renovations to the auditorium. Noise associated with HVAC usage is required to comply with Municipal Code Section 6.70.010, which limits noise levels to 60 dBA L_{eq} at the Project’s property line. Compliance with the noise limits within the Municipal Code would result in noise

D:\Projects\3\ANA\009402\MXD\ex_Aerial_20210505.mxd

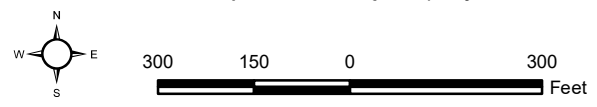


Aerial Source: Esri, Maxar 2020

Noise Monitoring Locations

Exhibit 18

Kindred Church Expansion Project (City of Anaheim)



levels that are acceptable to the City and would result in less than significant impacts related to these stationary sources of noise.

The Project would generate 80 daily trips and 272 Sunday trips⁶ (AGA 2021). Vehicle trips generated at the Project site would have access along East Santa Ana Canyon Road which is adjacent to the SR-91 and SR-241 interchange. East Santa Ana Canyon Road has traffic volumes of approximately 4,900 trips per day (Anaheim 2008). The addition of up to 272 daily trips from the Project to 4,900 trips per day along East Santa Ana Canyon Road would not result in a perceptible change in noise levels. A doubling of traffic results in a 3 dBA increase in noise levels. Because the Project would only increase traffic volumes by 6 percent from existing conditions, less than a 1 dB change in noise levels would occur. As such, Project-related traffic noise increases would be below the 3 dBA noise increase threshold and would not be perceptible or substantial. The impact on traffic noise levels would be less than significant, and no mitigation is required.

Short-Term Construction Impacts

Less Than Significant Impact. Short-term construction noise would be generated on-site by construction equipment during demolition, excavation, site preparation, and building construction activities. The degree to which noise-sensitive receptors are affected by construction activities depends heavily on their proximity. Estimated noise levels that would result from Project construction are shown in Table 18. Construction noise calculations are provided in Appendix G.

**TABLE 18
CONSTRUCTION NOISE LEVELS AT NOISE-SENSITIVE USES**

Construction Phase	Noise Levels (L _{eq} dBA)					
	Recreational Vehicle Park North of Project Site		Residential Uses South of Project Site		Residential Uses West of Project Site	
	Max (380 ft)	Avg (1,040 ft)	Max (240 ft)	Avg (680 ft)	Max (700 ft)	Avg (1,260 ft)
Ground Clearing/Demolition	65	57	69	60	60	55
Excavation	53	45	57	48	48	43
Foundation Construction	59	51	63	54	54	49
Building Construction	54	46	58	49	49	44
Paving and Site Cleanup	56	48	60	51	51	46

L_{eq} dBA: Average noise energy level; Max: maximum; avg: average; ft: feet
 Note: Noise levels from construction activities do not take into account attenuation provided by intervening structures.
 Source: USEPA 1971.

Table 18 shows both the maximum average and typical average noise levels. Maximum noise levels represent the noise levels from construction occurring near the property boundary closest to the noise sensitive use/receptor. Average noise levels represent the noise exposure to sensitive uses based on the distance to the center of all components of the Project. For the closest off-site land use to the Project site, noise levels from general construction activities related to the Project would range from 57 to 69 dBA L_{eq} for the maximum noise levels when construction activities are occurring at the closest point to off-site receptors and 48 to 60 dBA L_{eq} for the average noise levels when construction activities are occurring at the center of the Project site.

⁶ The Trip Generation Memorandum analyzed trip generation for the Project using two methods. The higher trip generation estimate is presented and analyzed in this section to provide a worst-case scenario for the purposes of operational noise impacts.

As per Municipal Code Section 6.70.010, the City exempts construction noise that occurs between 7 AM and 7 PM.

Short-term construction noise also would be generated on local roadways by workers commuting to and from the job site and delivering construction materials. It is estimated that a maximum of approximately 54 worker trips, 21 vendor trips, and 10 haul truck trips would occur on a daily basis. Existing traffic volumes along East Santa Ana Canyon Road are approximately 4,900 average daily trips. The increase in volume of traffic and change in vehicular mix would result in less than 1 dBA increase in noise levels along East Santa Ana Canyon Road due to the infrequent and low volume of Project-related traffic. The impact would be less than significant, and no mitigation is required. Because construction would only occur during the least noise sensitive portion of the day (daytime hours), and would represent a short-term, temporary impact, the impact would be less than significant, and no mitigation would be required.

Question B: Would the project result in generation of excessive groundborne vibration or groundborne noise levels?

Less Than Significant Impact. Groundborne vibration, expressed as peak particle velocity (ppv), consists of oscillatory waves that propagate from the source through the ground to adjacent structures. Vibration of building components can also take the form of an audible, low-frequency rumbling noise, which is referred to as groundborne noise. Vibration energy spreads out as it travels through the ground, causing the vibration level to decrease with the distance from the source.

Groundborne vibration and noise can be generated during construction activities and is generally highest during impact pile driving, blasting, and demolition-related activities. The Project would require some minimal demolition-related activities. Because the City does not have regulatory standards for construction or operational vibration sources, thresholds for potential structural damage and human annoyance associated with vibration are based on the California Department of Transportation’s (Caltrans) vibration limits. For purposes of this analysis, a threshold of 0.9 ppv is used as the threshold of significance related to human perception because this level of vibration represents a level that is strongly perceptible. A vibration level of 0.3 ppv is used for residential and commercial buildings, respectively, as the threshold of significance for structural damage, as this is the point at which continuous or frequent vibrations would begin to damage buildings. Table 19 summarizes typical vibration levels measured during construction activities for various vibration-inducing pieces of equipment at a distance of 25 feet.

**TABLE 19
VIBRATION LEVELS PER CONSTRUCTION EQUIPMENT**

Equipment	ppv at 25 ft (in/sec)
Vibratory roller	0.210
Caisson drill	0.089
Large bulldozer	0.089
Small bulldozer	0.003
Jackhammer	0.035
Loaded trucks	0.076
ppv: peak particle velocity; ft: feet; in/sec: inches per second. Source: FTA 2018.	

As shown in Table 20, vibration decibel levels would not exceed the criteria threshold under maximum conditions when activities are closest to affected uses. As such, vibration generated by the Project's construction equipment would not result in a significant impact related to vibration induced annoyance prior to mitigation.

**TABLE 20
VIBRATION ANNOYANCE CRITERIA AT SENSITIVE USES**

Equipment	Vibration Level (ppv)		
	Recreational Vehicle Park North of Project Site	Residential Uses South of Project Site	Residential Uses West of Project Site
	(ppv @ 380 ft)	(ppv @ 240 ft)	(ppv @ 700 ft)
Vibratory Roller	0.00	0.01	0.00
Large bulldozer	0.00	0.00	0.00
Small bulldozer	0.00	0.00	0.00
Jackhammer	0.00	0.00	0.00
Loaded trucks	0.00	0.01	0.00
Criteria	0.9	0.9	0.9
Exceeds Criteria?	No	No	No
ppv: peak particle velocity; ft: feet			

Table 21 shows the ppv levels relative to structural damage to sensitive uses from vibration activities.

**TABLE 21
BUILDING DAMAGE CRITERIA AT SENSITIVE USES**

Equipment	Vibration Levels (ppv)		
	Recreational Vehicle Park North of Project Site	Residential Uses South of Project Site	Residential Uses West of Project Site
	(ppv @ 380 ft)	(ppv @ 240 ft)	(ppv @ 700 ft)
Vibratory Roller	0.00	0.01	0.00
Large bulldozer	0.00	0.00	0.00
Small bulldozer	0.00	0.00	0.00
Jackhammer	0.00	0.00	0.00
Loaded trucks	0.00	0.01	0.00
Criteria	0.3	0.3	0.3
Exceeds Criteria?	No	No	No
ppv: peak particle velocity; ft: feet			

As shown in Table 21, all ppv levels would be below the structural damage threshold at all analyzed locations proximate to the Project site. As such, no building damage is anticipated related to construction activities associated with the Project.

The nature of daily operation of a hotel use does not involve activities that would create significant operational vibration impacts. Therefore, there would be no long-term vibration-related impacts, and no mitigation is required.

Question C: *For a project located within the vicinity of a private airstrip or an airport land use plan or, where such a plan has not been adopted, within two miles of a public airport or public use airport, would the project expose people residing or working in the project area to excessive noise levels?*

No Impact. The Project site is not located within an adopted Airport Land Use Plan or in the vicinity of a private airstrip, heliport, or helistop. The nearest airport is the Corona Municipal Airport which is approximately 6.75 miles to the northeast of the Project site (Google Earth 2021). Therefore, the Project site would not be subject to excessive noise levels related to aircraft or airport operations from either facility. No impact would occur related to this threshold and no mitigation is required.

Mitigation Program

No mitigation is required.

XIV. POPULATION AND HOUSING

Question A: *Would the project induce substantial population growth in an area, either directly (for example, by proposing new homes and businesses) or indirectly (for example, through extension of roads or other infrastructure)?*

Less Than Significant Impact. As of January 2020, the City of Anaheim has a population estimate of 353,468 persons (DOF 2021). The Project consists of the expansion of an existing church. The Project would not provide additional housing, and the Project does not involve construction of habitable structures; therefore, it would not induce substantial population growth directly.

The Project is anticipated to create limited short-term construction jobs. Construction jobs for a Project of this scale would typically be filled by existing residents of the region and would not induce housing demand near the construction site due to the temporary nature of construction jobs. Therefore, the temporary increase in construction jobs would result in an insignificant increase in new jobs when compared to the total existing and projected jobs in the City.

Additionally, the temporary construction staff for the Project would not create a significant change in demand for goods and services that may induce business investment, growth, or development in the area. Further, the Project site is currently served by existing roads and utility infrastructure, and no extension of roads or infrastructure is proposed by the Project such that would indirectly induce growth. The Project consists of the expansion of an existing church that would serve existing and planned populations within the City. Thus, the Project would not result in substantial unplanned population growth, directly or indirectly. Therefore, the impacts would be less than significant, and no mitigation is required.

Question B: *Would the project displace substantial numbers of existing people or housing, necessitating the construction of replacement housing elsewhere?*

No Impact. As stated in Section 2.2, Existing Project Site Conditions, the Project site is currently developed with a church. There are no residents that would be displaced by the Project. Furthermore, implementation of the Project would not require the construction of replacement housing elsewhere. No impacts would occur, and no mitigation is required.

Mitigation Program

No mitigation is required.

XV. PUBLIC SERVICES

Question A: *Would the project result in substantial adverse physical impacts associated with the provision of new or physically altered governmental facilities, need for new or physically altered governmental facilities, the construction of which could cause significant environmental impacts, in order to maintain acceptable service ratios, response times or other performance objectives for any of the public services:*

Fire Protection?

Less Than Significant Impact. The City of Anaheim Fire Department (Fire Department) is a full-service organization designed to provide essential public safety and emergency services to the community and its visitors. Currently 10 engines, 6 trucks, 2 battalion chiefs, and 2 medic units (assigned to the Disneyland Resort 14 hours per shift) are staffed daily by 67 members from 11 fire stations. A summary of the Fire Protection resources in the City is provided in Table 22.

The Fire Department operates a 3-shift system and has established a minimum staffing of 67 suppression personnel per shift, per day, at least 95 percent of the time. This includes 2 battalion chiefs and the personnel assigned, under contract, to the Disneyland Resort. The Fire Department maintains a minimum of 4 firefighters on 13 front-line companies and 3 firefighters on three front-line companies (Young 2021).

The Fire Department has adopted and follows the expectations of the National Incident Management System (NIMS), a program used in the United States to coordinate emergency preparedness and incident management among various federal, State, and local agencies (Anaheim 2017).

**TABLE 22
CITY OF ANAHEIM FIRE SERVICES FACILITIES**

Station	Station Address	Equipment
Downtown Station 1	500 East Broadway Street	Paramedic Engine 1, Truck 1, Type-3301 and Ambulance 1, Rehab 1
Brookhurst Station 2	2141 West Crescent Avenue	Paramedic Engine 2 and US&R 2 Ambulance 2
Resort Station 3	1717 South Clementine Street	Paramedic Engine 3, Truck 3, Type 3-309 Paramedic 3 (Disney), Ambulance 3, and Light Air 3
Orange Station 4	2736 West Orange Avenue	Paramedic Engine 4
La Palma Station 5	2540 East La Palma Avenue	Paramedic Engine 5 Type 3-305, MMRS 1 and Ambulance 5
Euclid Station 6	1330 South Euclid Street	Paramedic Engine 6, Truck 6, Battalion 2, Ambulance 6, and Hazmat 6 Paramedic 6 (Disney)
Stadium Station 7	2222 East Ball Road	Paramedic Engine 7
Riverdale Station 8	4555 East Riverdale Avenue	Battalion 1, Paramedic Engine 8, Truck 8, Type 6-601 and Type 3-308
Anaheim Hills Station 9	6300 East Nohl Ranch Road	Paramedic Engine 9, Type 6-602 Water Tender 1 and Ambulance 9
Weir Canyon Station 10	8270 East Monte Vista Road	Paramedic Engine Truck 10, Type 3-310
Twila Reid Station 11	3078 West Orange Avenue	Paramedic Engine 11 OES Engine 414 and Ambulance 11, OES Type 3-1211
USAR: Urban Search and Rescue; Hazmat: hazardous materials unit Source: Young 2021.		

Fire stations are strategically located to ensure an efficient demand response to all risk hazards and to maintain recommendations for response times (Anaheim 2004). National response time standards for emergency response requires first engine response within 5 minutes to 90 percent of all incidents and 8 minutes to the remaining 10 percent. The Fire Department also requires a maximum of 10 minutes for truck company response to 100 percent of all incidents (Young 2021). Current response times average 3 minutes and 37 seconds for all calls (Young 2021). The first responding station to the Project site is Weir Canyon Station 10. Additionally, Orange County Fire Authority Station Number 53 is located near the Project site within the City of Yorba Linda.

The Project involves the expansion of the existing Kindred Community Church. Based on correspondence with Anaheim Fire and Rescue, the Project would not affect the Fire Department's ability to maintain acceptable response times. In addition, the Project would not require the construction of new facilities, the expansion of existing facilities, or additional personnel or equipment to maintain acceptable response times (Young 2021). Impacts would be less than significant, and no mitigation is required.

Question A: *Would the project result in substantial adverse physical impacts associated with the provision of new or physically altered governmental facilities, need for new or physically altered governmental facilities, the construction of which could cause significant environmental impacts, in order to maintain acceptable service ratios, response times or other performance objectives for any of the public services:*

Police Protection?

Less Than Significant Impact. Law enforcement and crime prevention services are provided by the Anaheim Police Department (APD). Officers operate out of four stations and patrol an area of

49.7 square miles, divided into four districts (West, Central, South, and East). The police stations are located as follows: Main Station, located at 425 South Harbor Boulevard; East Station, located at 8201 East Santa Ana Canyon Road; and, West Station, located at 320 South Beach Blvd. Police services provided include patrol, investigations, traffic enforcement, traffic control, vice and narcotics enforcement, airborne patrol, crime suppression, community policing, tourist-oriented policing, and detention facilities. The APD currently employs approximately 385 sworn officers, a support staff of over 195, and a 4-person Reserve Officer Detail. The ratio of sworn police officers is approximately 1.1 officers per 1,000 population. Based on consultation with the APD (Berger 2021), the Project would not generate demand for additional staffing. However, in the future if additional police staff are needed, funding for any new personnel needed to maintain acceptable service levels would come from the City's General Fund. Property taxes and other fees assessed for the property would contribute to the General Fund revenues. Existing Police Department facilities would be sufficient to serve the additional demand associated with the Project along with the existing demand of the area; therefore, a significant impact would not occur related to the construction of law enforcement facilities and no mitigation is required.

Question A: *Would the project result in substantial adverse physical impacts associated with the provision of new or physically altered governmental facilities, need for new or physically altered governmental facilities, the construction of which could cause significant environmental impacts, in order to maintain acceptable service ratios, response times or other performance objectives for any of the public services:*

Schools?

No Impact. The Project does not involve the construction of new dwelling units. Therefore, no direct impacts would result from the Project related to schools and services provided by the Orange Unified School District, which provides educational services to residents near the Project site. Development of the Project is not expected to result in the need for additional employees as the Project involves an expansion of an existing use. Therefore, no impacts would result related to this threshold and no mitigation is required.

Question A: *Would the project result in substantial adverse physical impacts associated with the provision of new or physically altered governmental facilities, need for new or physically altered governmental facilities, the construction of which could cause significant environmental impacts, in order to maintain acceptable service ratios, response times or other performance objectives for any of the public services:*

Parks?

No Impact. The nearest parks to the Project site are Featherly Regional Park, Ronald Reagan Park, and Sycamore Park. The Project would not result in direct or indirect population growth. Therefore, no additional demand for parks or recreational facilities would result from the Project and no mitigation is required.

Question A: *Would the project result in substantial adverse physical impacts associated with the provision of new or physically altered governmental facilities, need for new or physically altered governmental facilities, the construction of which could cause significant environmental impacts, in order to maintain*

acceptable service ratios, response times or other performance objectives for any of the public services:

Other Public Facilities?

Less Than Significant Impact. Other public facilities covered by this threshold include libraries. The Anaheim Public Library system includes a network of seven library branches serving the City of Anaheim and surrounding communities, a Mobile Library (Bookmobile), a book vending machine at the ARTIC transportation center and the Anaheim Heritage Center. The closest library branch to the Project site is the East Anaheim Branch located at 8201 East Santa Ana Canyon Road (Anaheim 2021c). Given the Project would not result in direct or indirect population growth, no impact would result related to this threshold and no mitigation would be required.

Mitigation Program

No mitigation is required.

XVI. RECREATION

Question A: *Would the project increase the use of existing neighborhood and regional parks or other recreational facilities such that substantial physical deterioration of the facility would occur or be accelerated?*

Question B: *Does the project include recreational facilities or require the construction or expansion of recreational facilities which might have an adverse physical effect on the environment?*

No Impact. As discussed above in Section XV, Public Services, no direct or indirect increase in demand for City parklands or recreational facilities would result from implementation of the Project because the Project consists of the expansion of an existing church. As such, the Project would not result in direct or indirect population growth. No impact would result related to this threshold and no mitigation is required.

Mitigation Program

No mitigation is required.

XVII. TRANSPORTATION

The following responses are partially based on the Trip Generation Memorandum prepared for the Project by AGA Engineers, Inc. in February 2021, which is provided as Appendix H. Responses are also partially based on the Vehicle Miles Traveled (VMT) Memorandum prepared for the Project by Elements Architecture in November 2020, which is provided as Appendix I.

Question A: *Would the project conflict with a program, plan, ordinance, or policy addressing the circulation system, including transit, roadway, bicycle and pedestrian?*

Less than Significant Impact. The Project's consistency with programs, plans, ordinances, and policies related to the circulation system is evaluated below.

General Plan Circulation Element

The Circulation Element of the City's General Plan provides overview information on the City's transportation system and identifies goals and policies related to circulation (Anaheim 2020a). As discussed in the Trip Generation Memorandum prepared for the Project by AGA Engineers, Inc. in February 2021, the Project would generate a minimal number of new trips and, based on correspondence with the City, a traffic study is not required. The Project would not directly conflict with any of the goals or policies contained in the Circulation Element since the Project does not propose any improvements to East Santa Ana Canyon Road or other public roads, and since the Project would not result in a substantial increase in vehicle trips. The Project would support the City's achievement of Goal 1.1, Policy 9, which is to: "consider aesthetics, including the provision of appropriate landscaping, in the development of arterial highways". The Project would include landscaping improvements along the Project site's frontage with East Santa Ana Canyon that would beautify this portion of the Project site when compared to existing conditions. The Project would also promote the achievement of Goal 8.1 of the Circulation Element, which is to protect and encourage pedestrian travel. Specifically, the Project's internal pedestrian improvements between the parking areas and worship areas would support achievement of Goal 8.1, Policy 1, which is to "encourage and improve pedestrian facilities that link development to the circulation network and that serve as a transition between other modes of travel." Furthermore, the Project would not impact any existing transit facilities, such as bus stops, and would not conflict with any transit-related policies from the City's Circulation Element.

Bicycle Master Plan

The City's Bicycle Master Plan was adopted by the City to guide implementation of citywide bicycle facilities, and is intended to improve bicycling safety, comfort, and accessibility (Anaheim 2020c). The Bicycle Master Plan identifies a network of existing and proposed bicycle facilities that will improve multi-modal connectivity and increase bicycle mode share, especially for short trips. The Bicycle Master Plan designates existing Class II bicycle lanes as occurring along East Santa Ana Canyon adjacent to the Project site. The Project does not include any improvements within East Santa Ana Canyon Road and would not otherwise impact existing or proposed bicycle lanes.

Conclusion

As discussed above, the Project would not conflict with any circulation-related programs, plans, ordinances, or policies. The Project would result in less than significant impacts relative to this threshold and no mitigation is required.

Question B: Would the project conflict or be inconsistent with CEQA Guidelines section 15064.3, subdivision (b)?

Less Than Significant Impact. CEQA analysis requires an evaluation of project impacts related to vehicle miles traveled (VMT) impacts for various land use projects. In accordance with the project screening methodologies listed in the City of Anaheim Traffic Impact Analysis Guidelines for California Environmental Quality Act Analysis dated June 2020, a series of analytical steps for SB 743 compliance should be conducted for land use projects as deemed necessary by the Transportation Department. There are three types of project screening that lead agencies can apply to effectively screen projects from project-level assessment. The project only needs to fulfill one of the screening types below to qualify for screening. The City has determined that the Project meets the criteria of “Type 3: Project Type Screening”, which explicitly includes “community and religious assembly uses”. Furthermore, the Project would redevelop the existing church and would not substantially increase trips to/from the Project site as demonstrated in the Trip Generation Memorandum prepared for the Project. Therefore, the Project would have a less than significant impact related to VMT and no mitigation is required.

Question C: Would the project substantially increase hazards due to a geometric design feature (e.g., sharp curves or dangerous intersections) or incompatible uses?

Less Than Significant Impact. All project circulation improvements have been designed and constructed to City standards; and, therefore, would not result in design hazards. The Project involves no improvements to the existing access driveway and minor restriping and reconfiguration of the internal roads and parking lots within the Project site. Therefore, less than significant impacts would result related to this threshold and no mitigation is required.

Question D: Would the project result in inadequate emergency access?

Less Than Significant Impact. The Project’s internal roadways and parking lots have been designed in accordance with all applicable design and safety standards required by adopted fire codes, safety codes, and building codes established by the City’s Engineering and Fire Departments. The Project would not increase delays on street segments substantially; therefore, the Project would not result in inadequate emergency access, and the Project impact is considered less than significant, and no mitigation is required.

Mitigation Program

No mitigation is required.

XVIII. TRIBAL CULTURAL RESOURCES

Methodology

As discussed in Section V of this IS/MND, the NAHC conducted a SLF search for the project. The search results are negative. Consistent with requirements of Section 106 of the NHPA and AB 52 (required for projects subject to CEQA analyses), the City has sent letters to tribes that have expressed an interest in being consulted regarding Native American resources for the projects being undertaken by City. Letters were sent to interested tribal organizations on March 16, 2021.

IMPACT ANALYSIS

Question A: *Would the project cause a substantial adverse change in the significance of a tribal cultural resource, defined in Public Resources Code section 21074 as either a site, feature, place, cultural landscape that is geographically defined in terms of the size and scope of the landscape, sacred place, or object with cultural value to a California Native American tribe, and that is listed or eligible for listing in the California Register of Historical Resources, or in a local register of historical resources as defined in Public Resources Code section 5020.1(k).*

No Impact. For purposes of impact analysis, a tribal cultural resource is considered a site, feature, place, cultural landscape, sacred place, or object which is of cultural value to a California Native American Tribe and is either eligible for the CRHR or a local register. As indicated in Section V of this IS/MND, based on a 2021 SCCIC record search results there are no resources on the Project Site that are currently listed on the CRHR. Therefore, the Project would not have an impact on a tribal cultural resource that is listed or eligible for listing on the CRHR or a local register. No significant impacts were identified, and mitigation is not required.

Question B: *Would the project cause a substantial adverse change in the significance of a tribal cultural resource, defined in Public Resources Code section 21074 as either a site, feature, place, cultural landscape that is geographically defined in terms of the size and scope of the landscape, sacred place, or object with cultural value to a California Native American tribe, and that is a resource determined by the lead agency, in its discretion and supported by substantial evidence, to be significant pursuant to criteria set forth in subdivision (c) of Public Resources Code Section 5024.1. In applying the criteria set forth in subdivision (c) of Public Resources Code Section 5024.1, the lead agency shall consider the significance of the resource to a California Native American tribe.*

Less Than Significant Impact With Mitigation. Based on information available through the record searches at the SCCIC and the NAHC, and the long-term past use of the Project site as a church, there is no information available that indicates there are significant tribal resources within the Project area that would be significant pursuant to criteria set forth in subdivision (c) of Public Resource Code Section 5024.1. However, as noted above, the City conducted tribal consultation for the Project to determine if any local tribes had additional information or additional concerns regarding the Project's potential for impacts to tribal cultural resources.

Certified letters were sent to tribal organizations on March 16, 2021. The City received two responses from interested tribal representatives, as summarized below:

- **On March 10, 2021, Andy Salas (the Tribal Chair), for the Gabrieleño Band of Mission Indians – Kizh Nation:** Mr. Salas requested consultation regarding the Project. Consultation between the City and the Gabrieleño Band of Mission Indians – Kizh Nation was conducted by email and telephone. Consultation between the City and the Gabrieleño Band of Mission Indians – Kizh Nation was completed on April 7, 2021.
- **On March 11, 2021, Joyce Perry of Belardes/Juaneño Band of Mission Indians, Acjachemen Nation:** Belardes requested consultation regarding the Project. Consultation between the City and Belardes/Juaneño Band of Mission Indians, Acjachemen Nation was conducted by email and completed on April 19, 2021.

Consultation between the City and the tribal representatives of both Belardes/Juaneño Band of Mission Indians, Acjachemen Nation, and the Gabrieleño Band of Mission Indians – Kizh Nation, did not identify tribal cultural resources within the Project site. However, it was identified that this area of Orange County was settled by the ancestors of the Juaneño and Gabrieleno/Tongva and continues to be inhabited by their descendants today. Therefore, there is a potential that undiscovered intact cultural resources, including tribal cultural resources eligible for the CRHR or a local register, may be present below the surface in native sediments. In consultation with the tribes, **MM TCR-1** and **MM TCR-2** have been incorporated as part of the Project, which require Native American monitoring during Project grading and ground disturbance. With implementation of **MM TCR-1** and **MM TCR-2**, the Project would have less than significant impacts related to potential tribal cultural resources encountered during Project construction.

Mitigation Program

The following mitigation measure is required to reduce impacts to less than significant levels and they will be incorporated into the Mitigation Program for this IS/MND.

MM TCR-1 Prior to the commencement of any grading and/or construction activity, the Project Applicant shall retain a qualified Native American Monitor (Tribal Monitor) acceptable to the to the Juaneño Band of Mission Indians, Acjachemen Nation-Belardes and a copy of the executed contract shall be submitted to the City of Anaheim Planning and Building Department. The Tribal Monitor will only be present on-site during the construction phases that involve ground-disturbing activities within undisturbed native sediments. Ground disturbing activities may include, but are not limited to, potholing or auguring, grubbing, tree removals, boring, grading, excavation, drilling, and trenching, within the Project site. The Tribal Monitor will complete daily monitoring logs that will provide descriptions of the day's activities, including construction activities, locations, soil, and any cultural materials identified. The on-site monitoring shall end when the Project site grading and excavation activities are completed, or when the Tribal Representatives and monitor have indicated that the Project site has a low potential for impacting archaeological or tribal cultural resources.

Upon discovery of any archaeological or tribal cultural resources, construction activities shall cease in the immediate vicinity of the find until the find can be assessed. All archaeological and/or tribal cultural resources unearthed by project construction activities shall be evaluated by the qualified archaeologist meeting the Secretary of Interior standards and a Tribal monitor. If the resources are Native American in origin, the Tribal Monitor from a recognized California Native American tribe culturally and traditionally affiliated with the area shall coordinate with the City and Project Applicant regarding treatment and curation of these resources. The City and Project Applicant shall, in good faith, consult with the Juaneño Band of Mission Indians, Acjachemen Nation-Belardes on the disposition and treatment of any Tribal Cultural Resource encountered during all ground disturbing activities. Typically, the Juaneño Band of Mission Indians, Acjachemen Nation-Belardes will request reburial or preservation for educational purposes. Work may continue on other parts of the Project Site while evaluation and, if necessary, mitigation takes place (CEQA Guidelines Section 15064.5[f]). If a resource is determined by the qualified archaeologist to constitute a "historical resource" or "unique archaeological resource," time and funding sufficient to allow for implementation of avoidance measures, or appropriate mitigation, must be provided by the Project Applicant. A treatment plan would be prepared for the resources, which would be in accordance with CEQA Guidelines Section 15064.5(f) for historical resources

and PRC Sections 21083.2(b) for unique archaeological resources. Preservation in place (i.e., avoidance) is the preferred manner of treatment. If preservation in place is not feasible, treatment may include implementation of archaeological data recovery excavations to remove the resource along with subsequent laboratory processing and analysis. Any historic archaeological material that is not Native American in origin shall be curated at a public, non-profit institution with a research interest in the materials, such as the Natural History Museum of Los Angeles County, the Copper Center, or the Fowler Museum, if such an institution agrees to accept the material. If no institution accepts the archaeological material, it shall be offered to a local school or historical society in the area for educational purposes.

MM TCR-2 Prior to the commencement of any grading and/or construction activity, the Project Applicant shall retain a qualified Native American Monitor (Tribal Monitor) acceptable to the to the Gabrieleño Band of Mission Indians – Kizh Nation and a copy of the executed contract shall be submitted to the City of Anaheim Planning and Building Department. The Tribal Monitor will only be present on-site during the construction phases that involve ground-disturbing activities within undisturbed native sediments. Ground disturbing activities may include, but are not limited to, potholing or auguring, grubbing, tree removals, boring, grading, excavation, drilling, and trenching, within the Project site. The Tribal Monitor will complete daily monitoring logs that will provide descriptions of the day's activities, including construction activities, locations, soil, and any cultural materials identified. The on-site monitoring shall end when the Project site grading and excavation activities are completed, or when the Tribal Representatives and monitor have indicated that the Project site has a low potential for impacting archaeological or tribal cultural resources.

Upon discovery of any archaeological or tribal cultural resources, construction activities shall cease in the immediate vicinity of the find until the find can be assessed. All archaeological and/or tribal cultural resources unearthed by project construction activities shall be evaluated by the qualified archaeologist meeting the Secretary of Interior standards and a Tribal monitor. If the resources are Native American in origin, the Tribal Monitor from a recognized California Native American tribe culturally and traditionally affiliated with the area shall coordinate with the City and Project Applicant regarding treatment and curation of these resources. The City and Project Applicant shall, in good faith, consult with the Gabrieleño Band of Mission Indians – Kizh Nation on the disposition and treatment of any Tribal Cultural Resource encountered during all ground disturbing activities. Typically, the Gabrieleño Band of Mission Indians – Kizh Nation will request reburial or preservation for educational purposes. Work may continue on other parts of the Project Site while evaluation and, if necessary, mitigation takes place (CEQA Guidelines Section 15064.5[f]). If a resource is determined by the qualified archaeologist to constitute a "historical resource" or "unique archaeological resource," time and funding sufficient to allow for implementation of avoidance measures, or appropriate mitigation, must be provided by the Project Applicant. A treatment plan would be prepared for the resources, which would be in accordance with CEQA Guidelines Section 15064.5(f) for historical resources and PRC Sections 21083.2(b) for unique archaeological resources. Preservation in place (i.e., avoidance) is the preferred manner of treatment. If preservation in place is not feasible, treatment may include implementation of archaeological data recovery excavations to remove the resource along with subsequent laboratory processing and analysis. Any historic archaeological material that is not Native American in origin shall be curated at a public, non-profit institution with a research

interest in the materials, such as the Natural History Museum of Los Angeles County, the Copper Center, or the Fowler Museum, if such an institution agrees to accept the material. If no institution accepts the archaeological material, it shall be offered to a local school or historical society in the area for educational purposes.

XIX. UTILITIES AND SERVICE SYSTEMS

Question A: *Would the project require or result in the construction of new or expanded water, wastewater treatment or storm water drainage, electric power, natural gas, or telecommunications facilities, the construction or relocation of which could cause significant environmental effects?*

Question C: *Would the project result in a determination by the wastewater treatment provider which serves or may serve the project that it has adequate capacity to serve the project's projected demand in addition to the provider's existing commitments?*

Less Than Significant Impact. The Project site is self-sufficient related to water and wastewater services, as described in more detail below.

Water

Less Than Significant Impact. Water service is provided to the Project site from two private water wells located within the Project site just south of East Santa Ana Canyon Road. The Project would result in a minor increase in demand for water with the additional structures and landscaping; however, water supplied by the existing wells is expected to be adequate to accommodate these new demands and no new wells are expected to be required. Therefore, impacts related to existing water infrastructure would be less than significant, and no mitigation is required.

Wastewater

No Impact. An existing septic tank and leach line system exists within the Project site, which is used to treat and dispose of sewer water that is generated by the existing church. The Project would not require any upgrades to or displacement of the existing system or any new septic tanks or alternative wastewater disposal system. Therefore, no impacts would occur related to wastewater and no mitigation is required.

Stormwater

Less Than Significant Impact. In the existing condition, the majority of the Project site drains to existing grate inlets that are connected to an existing City storm drain that traverses the Project site, which was constructed for the adjacent residential development to the south. Instead, the Project would redirect stormwater flows from throughout the Project site to a new 18-inch RCP. The RCP would collect and convey flows downslope to an underground infiltration system, which would consist of two underground stormwater infiltration chambers within a portion of APN 354-321-03. In the event of stormwater exceeding the design capture volume for the underground infiltration chamber, excess water would be rerouted to the existing City storm drain through an 18-inch RCP overflow pipe. Prior to flowing into the 18-inch RCP, at least 50 percent of stormwater would be pre-treated for sediment, debris, and hydrocarbons using Filterra stormwater biofiltration units. Catch basins would be installed with FloGard filters to capture trash and debris. These improvements are depicted in Exhibit 17 and described in more detail in the Project's PWQMP (Anacal Engineering 2021). With implementation of drainage improvements that are identified in

the PWQMP, no additional off-site stormwater improvements would be required. Therefore, the Project's proposed stormwater improvements would result in less than significant environmental impacts and no mitigation is required.

Electricity

Less Than Significant Impact. Southern California Edison (SCE) would provide electricity for the Project. SCE's distribution system consists of aboveground and underground transmission and distribution lines. SCE maintains and operates the transmission and distribution infrastructure necessary to provide electricity to end users throughout its entire service area. SCE provides electricity to approximately 15 million people, 180 cities and communities in 50,000 square miles of service area, encompassing 15 counties in central, coastal and southern California. Electricity can be generated from a combination of natural gas, hydroelectric, nuclear or renewable sources (wind and solar). SCE facilities include hydroelectric, nuclear, and coal power plants. The Project involves minimal expansion of an existing use, which is already served by existing SCE facilities. Given the minimal expansion, less than significant impacts would result from the Project related to this threshold, and no mitigation is required.

Natural Gas

No Impact. The Project would not require natural gas as all power would be electric. Therefore, no impact would result from the Project related to natural gas, and no mitigation is required.

Telecommunication Facilities

No Impact. The Project would not require any additional connections to telecommunication facilities. Therefore, no impact would result from the Project related to telecommunication facilities and no mitigation is required.

Question B: *Would the project have sufficient water supplies available to serve the project and reasonably foreseeable future development during normal, dry and multiple dry years (including large-scale developments as defined by Public Resources Code Section 21151.9 and described in Question No. 20 of the Environmental Information Form)?*

No Impact. Given that the Project site obtains its water from two existing wells that have operated consistently for decades, it is anticipated that there would be sufficient water supplies available to serve the Project, which would consist of minimal expansion of the existing community church land use. Less than significant impacts would result related to this threshold and no mitigation is required.

Question D: *Would the project generate solid waste in excess of State or local standards, or in excess of the capacity of local infrastructure, or otherwise impair the attainment of solid waste reduction goals?*

Less Than Significant Impact. The Project would involve demolition of existing structures, relocation and modification of existing structures, and construction of new structures and facilities. These construction activities would result in demolition and construction materials waste that would need to be disposed of at a landfill. Also, the increased capacity of the church that would be facilitated by the Project would result in additional operational waste being generated on the Project site above existing levels. OC Waste & Recycling has indicated that solid waste generated by the Project would go to the Olinda Alpha Landfill located at 1942 North Valencia Avenue in the City of Brea and that adequate capacity is available within the Orange County landfill system to

serve the Project (Halligan 2021). The County of Orange maintains 15-years of countywide solid waste landfill capacity, as required by AB 939 (Halligan 2021). Therefore, a less than significant impact related to landfill capacity would result from the Project, and no mitigation is required.

Question E: *Would the project comply with Federal, State, and local statutes and regulations related to solid waste?*

No Impact. Solid waste practices in California are governed by multiple federal, State, and local agencies that enforce legislation and regulations to ensure that landfill operations minimize impacts to public health and safety and the environment. OC Waste & Recycling is obligated to obtain a Solid Waste Facilities Permit, a Storm Water Discharge Permit, and a permit to construct and operate gas management systems and meet Waste Discharge Requirements. The Local Enforcement Agency, the SCAQMD, and the California Water Resources Control Board enforce landfill regulations related to health, air quality, and water quality, respectively. The Project would not inhibit OC Waste & Recycling's compliance with the requirements of each of these governing bodies, and no impact would occur.

Question F: *Would the project result in a need for new systems or supplies, or substantial alterations related to electricity?*

Less Than Significant Impact. As noted above, SCE would provide electricity for the Project. The Project involves minimal expansion of an existing use, which is already served by existing SCE facilities. Given the minimal expansion, less than significant impacts would result from the Project related to this threshold, and no mitigation is required.

Question G: *Would the project result in a need for new systems or supplies, or substantial alterations related to natural gas?*

No Impact. The Project would not require natural gas as all power would be electric. Therefore, no impact would result from the Project related to natural gas and no mitigation is required.

Question H: *Would the project result in a need for new systems or supplies, or substantial alterations related to telephone service?*

No Impact. The Project does not involve any uses that would require additional telephone service. Therefore, no impact would result related to this threshold and no mitigation is required.

Question I: *Would the project result in a need for new systems or supplies, or substantial alterations related to television service/reception?*

No Impact. The Project does not involve any uses that would require additional television service or reception. Therefore, no impact would result related to this threshold and no mitigation is required.

Mitigation Program

No mitigation is required.

XX. WILDFIRE

If located in or near state responsibility areas or lands classified as very high fire hazard severity zones, would the project:

Question A: Would the project substantially impair an adopted emergency response plan or emergency evacuation plan?

Less Than Significant Impact. The Project site is located entirely within a VHFHSZ as identified in the California Fire Hazard Severity Zone Viewer using data provided by CALFIRE (2021). The Project involves the expansion of an existing church within a Project site that has been previously graded and developed. As such, people (e.g., congregants, staff) and structures within the Project site are already susceptible to wildfire risks. The Project would add buildings and additional capacity to the existing church activities, which would result in the potential for more people and structures to be exposed to wildfire risk. According to the Applicant, no existing fuel modification requirements exist for the Project site (e.g., the existing church). However, Chapter 6.16 of the Anaheim Municipal Code requires that all property owners across the City abate noxious vegetation on their properties, which applies to vegetation that might pose a wildfire risk.

Furthermore, the Project site is located within a Special Protection Area of the City as designated by the Fire Department. The City continues to refine procedures and processes to minimize the risk of fire hazards in the Special Protection Area including: requiring new development to utilize fire-resistant building materials; incorporating fire sprinklers as appropriate; incorporating enhanced defensible space requirements (20 feet brush clearance to the identified fire access roadway); requiring compliance with Fire Department Fuel Modification Guidelines; requiring development to use plant materials that are compatible with surrounding natural vegetation; and providing wet or irrigated zones when required. With implementation of City requirements related to weed abatement as well as the provision of fire sprinklers on all new and relocated structures, less than significant impacts would result related to this threshold, and no mitigation is required.

The City of Anaheim's Emergency Operations Plan was adopted by the Anaheim City Council on May 9, 2017 (Anaheim 2017). This plan provides overview information hazards affecting the City, as well as general policy-level guidance related to future development within the City. The Project does not conflict with the Emergency Operations Plan. Furthermore, the Project would not physically affect or interfere with the evacuation routes identified on the City's "Know Your Way Page", which provides guidance on developing primary and secondary evacuation routes in case of wildfire, flood, or earthquake events. The "Know Your Way Page" shows westbound East Santa Ana Canyon Road as a major route west connecting evacuees to Weir Canyon Road and ultimately to westbound SR-91 (Anaheim 2021b). The Project site is located along East Santa Ana Canyon Road, which is a primary arterial in the City of Anaheim. Construction activity would be confined to the Project site and would not interfere with vehicle movement or emergency access along the roadway. The Project does not include characteristics that would physically impair or otherwise interfere with emergency response or evacuation in the vicinity of the Project. As detailed in Section XVII, Transportation, any impacts related to increased vehicular traffic resulting from the Project would be less than significant; therefore, the Project would not interfere with the movement of emergency vehicles or those evacuating along local roadways. The Project would not conflict with the City's Emergency Operations Plan or any other applicable emergency response or evacuation plan. Therefore, no impact would occur related to this threshold, and no mitigation is required.

Question B: *Would the project due to slope, prevailing winds, and other factors, exacerbate wildfire risks, and thereby expose project occupants to, pollutant concentrations from a wildfire or the uncontrolled spread of a wildfire?*

Less Than Significant Impact. The Project would result in additional visitors/congregants on-site at times and additional structures on a Project site that is located in an area susceptible to wildfires due to vegetation, topography, and Santa Ana wind patterns. However, it is anticipated that Project users would evacuate from the Project site during a wildfire event and would thereby not be exposed to pollutant concentrations or the uncontrolled spread of wildfire. Furthermore, the Fire Department will review the Project's plans as part of the City's design review process to ensure that emergency access to the site and surrounding areas would be maintained in compliance with applicable City requirements. Less than significant impacts would result related to this threshold, and no mitigation is required.

Question C: *Would the project require the installation or maintenance of associated infrastructure (such as roads, fuel breaks, emergency water sources, power lines or other utilities) that may exacerbate fire risk or that may result in temporary or ongoing impacts to the environment?*

No Impact. The Project would not be required to install or maintain any roads, fuel breaks, emergency water sources, power lines or other utilities or infrastructure that would have the potential to exacerbate fire risk or that would result in temporary or ongoing impacts to the environment. No impact would occur, and no mitigation is required.

Question D: *Would the project expose people or structures to significant risks, including downslope or downstream flooding or landslides, as a result of runoff, post-fire slope instability, or drainage changes?*

Less Than Significant Impact. The Project would result in additional visitors/congregants on-site at times and additional structures on a Project site that is located in an area susceptible to wildfires. The Project site is located upslope of East Santa Ana Canyon Road and SR-91, which are both north of the Project site. The Project is not anticipated to result in any additional off-site flooding given that the Project consists of the redevelopment of an existing church campus. Therefore, much of the existing vegetation on the Project site would be retained, and drainage improvements are proposed that would capture and infiltrate much of the stormwater that occurs on the Project site. Also, as discussed under threshold VII(A)(iv) in the Geology and Soils section, the Project is not anticipated to result in any significant impacts related to landslides since only a minimal amount of grading is proposed and because the Project site is not susceptible to landslides. Therefore, the Project would result in less than significant impacts related to this threshold and no mitigation is required.

Mitigation Program

No mitigation is required.

XXI. MANDATORY FINDINGS OF SIGNIFICANCE

Question A: *Does the project have the potential to substantially degrade the quality of the environment, substantially reduce the habitat of a fish or wildlife species, cause a fish or wildlife population to drop below self-sustaining levels, threaten to eliminate a plant or animal community, substantially reduce the number or restrict the range of a rare or endangered plant or animal or eliminate important examples of the major periods of California history or prehistory?*

Less Than Significant Impact with Mitigation. The Project would result in significant impacts related to biological resources, cultural resources, geology and soils, and tribal cultural resources. During construction, the Project has the potential to indirectly impact nesting birds. Potential impacts would be reduced to less than significant levels by implementing **MM BIO-1**, which requires a pre-construction nesting bird survey and avoidance of active nests. Also, there is potential for impacts to bats during tree and vegetation removal. Therefore, **MM BIO-2** has been incorporated in the Project, which requires avoidance of vegetation removal during the bat maternity season, a pre-construction bat survey, and the avoidance of bat roosts during the maternity season. There is the possibility that undiscovered intact archaeological resources may be present below the surface in native (alluvial) sediments. These potential effects would be mitigated to a less than significant level with the implementation of **MM CUL-1**, which requires archaeological monitoring when excavations are required in native sediment. Also, deep excavation that involves disturbance of native soils could result in the disturbance and/or destruction of paleontological resources that may be present in deeper Pleistocene alluvial deposits that underlie the Project Site. Implementation of **MM GEO-1** related to paleontological resources would reduce this impact to a less than significant level. There is a possibility that undiscovered intact cultural resources, including tribal cultural resources eligible for the CRHR or a local register, may be present below the surface in native sediments. **TCR-1** and **MM TCR-2** have been incorporated as part of the Project. **MM TCR-1** and **MM TCR-2** require Native American monitoring during Project grading and ground disturbance.

Question B: *Does the project have impacts that are individually limited, but cumulatively considerable? ("Cumulatively considerable" means that the incremental effects of a project are considerable when viewed in connection with the effects of past projects, the effects of other current projects, and the effects of probable future projects)?*

Less Than Significant Impact. The Project would not have adverse environmental impacts at a significant level for any resource topics. All potential significant impacts would be reduced to less than significant levels with implementation of mitigation measures. No significant cumulative effects are anticipated because no resources would be adversely affected by the Project, or the Project effects would be localized and of limited extent. A less than significant impact would occur in relation to cumulatively considerable effects.

Question C: *Does the project have environmental effects which will cause substantial adverse effects on human beings, either directly or indirectly?*

Less Than Significant Impact. As discussed in more detail in the sections above, the Project would result in less than significant impacts related to air quality, geology and soils, hazards and hazardous materials, noise, and public services. Therefore, the Project would not cause significant adverse effects to human beings, either directly or indirectly. The Project would result in less than significant impacts related to this threshold.

SECTION 6.0 PREPARERS

City of Anaheim, Planning and Building Department

Associate Planner Andy T. Uk

Psomas

Senior Project Manager Jennifer Marks
Project Manager Sean Noonan, AICP
Environmental Planner Janet Powell
Air Quality/Noise/Greenhouse Gas Analyses Tin Cheung
Biological Resources Steve Norton
Cultural/Paleontological Resources Analyses Charles Cisneros
GIS/Graphics Mike Deseo
Word Processor Sheryl Kristal

This page is intentionally left blank

SECTION 7.0 REFERENCES

- AGA Engineers, Inc. 2021 (February). Trip Generation Evaluation for the Kindred Community Church Improvement Project. Fullerton, CA: AGA.
- Anacal Engineering Co. 2021 (December 21). Preliminary City of Anaheim Priority Project Water Quality Management Plan (PWQMP). Anaheim, CA: Anacal Engineering.
- Anaheim, City of. 2021a (April 5, date accessed). Municipal Code. Anaheim, CA: Anaheim. <https://codelibrary.amlegal.com/codes/anaheim/latest/overview>.
- . 2021b (March 25, date accessed). Integrated Resource Plan. Anaheim, CA: Anaheim.. <https://www.anaheim.net/4864/Integrated-Resource-Plan>.
- . 2020a (September, last updated). City of Anaheim General Plan. Anaheim, CA: Anaheim. <http://www.anaheim.net/712/General-Plan>.
- . 2020b (June). City of Anaheim Traffic Impact Analysis Guidelines for California Environmental Quality Act Analysis. Anaheim, CA: Anaheim. <https://www.anaheim.net/DocumentCenter/View/32774/City-of-Anaheim-TIA-Guidelines-for-CEQA-Analysis-62020>.
- . 2020c (July 17, date amended). Bicycle Master Plan. Anaheim, CA: Anaheim. <https://www.anaheim.net/DocumentCenter/View/33379/2020-Bicycle-Master-Plan-and-Appendices>.
- . 2017 (May 9). Emergency Operations Plan. Anaheim, CA: Anaheim. <https://www.anaheim.net/DocumentCenter/View/21657/City-of-Anaheim-EOP-2017>,
- . 2008 (December 2021 accessed). Average Daily Traffic Volume Map. Anaheim, CA: Anaheim. <https://www.anaheim.net/410/Daily-Traffic-Counts>
- . 2004 (May, certified). Final Anaheim General Plan and Zoning Code Update Environmental Impact Report No. 330. Anaheim, CA: Anaheim. <https://www.anaheim.net/932/EIR-No-330-Volume-I-FEIR>
- . 1988a (March, as amended). Sycamore Canyon Specific Plan (SP88-1). Anaheim, CA: Anaheim. <https://www.anaheim.net/1059/Sycamore-Canyon>.
- . 1988b (September). The Summit of Anaheim Hills Specific Plan (SP88-2). Anaheim, CA: Anaheim. <https://www.anaheim.net/1058/Summit-of-Anaheim-Hills>.
- Anaheim Public Utilities (APUD). 2020 (May). Greenhouse Gas Reduction Plan. Anaheim, CA: APUD. <https://www.anaheim.net/DocumentCenter/View/7987/Greenhouse-Gas-Reduction-Plan?bidId=>.
- Berger, Mark. 2021 (May 11). Email correspondence regarding City Police Department staffing and capacity.
- California Air Pollution Control Officers Association (CAPCOA). 2021. California Emission Estimator Model (CalEEMod)TM Version 2020.4.0, Developed by Breeze Software. Sacramento, CA: CAPCOA.

- California Air Resources Board (CARB). 2021a (April 9, last accessed). Top 4 Summary: Anaheim—Pampas Lane Monitoring Station. Sacramento, CA: CARB. <https://www.arb.ca.gov/adam/topfour/topfourdisplay.php>.
- . 2021b. (accessed March 5), Maps of Current State and Federal Area Designations. <https://ww2.arb.ca.gov/resources/documents/maps-state-and-federal-area-designations>.
- . 2016 (May 4). Ambient Air Quality Standards. Sacramento, CA: CARB. <http://www.arb.ca.gov/research/aaqs/aaqs2.pdf>.
- . 2014 (February). Proposed First Update to the Climate Change Scoping Plan: Building on the Framework. Sacramento, CA: CARB. http://www.arb.ca.gov/cc/scopingplan/2013_update/draft_proposed_first_update.pdf.
- . 2008 (December). Climate Change Scoping Plan—Pursuant to AB 32. Sacramento, CA: CARB. https://ww3.arb.ca.gov/cc/scopingplan/document/adopted_scoping_plan.pdf.
- . 2005 (April). Air Quality and Land Use Handbook: A Community Health Perspective. Sacramento, CA: CARB. <http://www.arb.ca.gov/ch/handbook.pdf>.
- California Building Standards Commission (CBSC). 2019. 2019 California Green Building Standards Code. <https://www.dgs.ca.gov/BSC/Resources/Page-Content/Building-Standards-Commission-Resources-List-Folder/CALGreen>.
- California Department of Forestry And Fire Protection. 2021 (January 13, last accessed). Fire Hazard Severity Zone (FHSZ) Mapper. Sacramento, CA: CALFIRE. <https://egis.fire.ca.gov/FHSZ/>
- California Energy Commission (CEC). 2021a (April 11, last accessed). Clean Energy and Pollution Reduction Act—SB 350. Sacramento, CA: CEC. <https://www.energy.ca.gov/rules-and-regulations/energy-suppliers-reporting/clean-energy-and-pollution-reduction-act-sb-350>.
- . 2021b (April 11, last accessed). SB 100 Joint Agency Report. Sacramento, CA: CEC. <https://www.energy.ca.gov/sb100>.
- . 2018 (March) “2019 Building Energy Efficiency Standards Frequently Asked Questions”. Sacramento, CA: CEC. <https://www.energy.ca.gov/media/3452>.
- California Geological Survey. 2001 (January 17). Earthquake Zones of Required Investigation, Black Star Canyon Quadrangle. Sacramento, CA: California Geological Survey. <https://maps.conservation.ca.gov/cgs/>.
- California Department of Conservation (DOC). 2021a (April 5, access date). California Important Farmland Finder. Sacramento, CA DOC. <https://maps.conservation.ca.gov/dlrp/ciff/>
- . 2021b (April 6, access date). California Earthquake Hazards Zone Application (EQ Zapp). Sacramento, CA: DC. <https://maps.conservation.ca.gov/cgs/EQZApp/app/>
- . 2021c (April 6, access date). California Landslide Inventory. Sacramento, CA: DOC. <https://maps.conservation.ca.gov/cgs/lisi/app/>.

- California Department of Transportation. 2021 (April 5, access date). List of eligible and officially designated State Scenic Highways. Sacramento, CA: Caltrans. <https://dot.ca.gov/programs/design/lap-landscape-architecture-and-community-livability/lap-liv-i-scenic-highways>.
- EDR. 2021 (March 9). EDR Radius Map Report with GeoCheck for the Kindred Church Expansion Project. Shelton, CT: EDR.
- Federal Transit Administration. 2017. Transit Noise and Vibration Impact Assessment Manual. Washington, DC: FTA. https://www.transit.dot.gov/sites/fta.dot.gov/files/docs/research-innovation/118131/transit-noise-and-vibration-impact-assessment-manual-fta-report-no-0123_0.pdf
- Google Earth. 2021. Aerial Imagery and Street Views. Mountain View, CA: Google Earth.
- Halligan, Aimee (Environmental Planner). 2021 (May 20). Email correspondence related to landfill capacity.
- Niemeier, Debbie A., Douglas Eisinger, Tom P. Kear, Daniel P. Chang, Yu Meng. 1997. Transportation Project-Level Carbon Monoxide Protocol. Institute of Transportation Studies, University of California, Davis, Research Report UCD-ITS-RR-97-21.
- Psomas. 2021. Noise Technical Analyses. Santa Ana, CA: Psomas.
- Orange County Water District. 2015 (June 17). Orange County Water District Groundwater Management Plan 2015 Update. Fountain Valley, CA: OCWD. https://www.ocwd.com/media/3622/groundwatermanagementplan2015update_20150624.pdf.
- South Coast Air Quality Management District (SCAQMD). 2021 (April 9, last accessed). Final 2016 AQMP and Related SIP Submittals. Diamond Bar, CA: SCAQMD. <http://www.aqmd.gov/home/air-quality/clean-air-plans/air-quality-mgt-plan/final-2016-aqmp>.
- . 2019 (April, Revision). SCAQMD Air Quality Significance Thresholds. Diamond Bar, CA: SCAQMD. <http://www.aqmd.gov/docs/default-source/ceqa/handbook/scaqmd-air-quality-significance-thresholds.pdf?sfvrsn=2>.
- . 2016 (February). National Ambient Air Quality Standards (NAAQS) and California Ambient Air Quality Standards (CAAQS) Attainment Status for South Coast Air Basin. Diamond Bar, CA: SCAQMD. <http://www.aqmd.gov/docs/default-source/clean-air-plans/air-quality-management-plans/naaqs-caaqs-feb2016.pdf?sfvrsn=2>.
- . 2010 (September 28). Minutes for the GHG Significance Threshold Stakeholder Working Group #15. Diamond Bar, CA: SCAQMD.
- . 2009. Localized Significance Thresholds. Diamond Bar, CA: SCAQMD. <http://www.aqmd.gov/home/rules-compliance/ceqa/air-quality-analysis-handbook/localized-significance-thresholds>
- . 2008a (July, as revised). Final Localized Significance Threshold Methodology. Diamond Bar, CA: SCAQMD. http://www.aqmd.gov/ceqa/handbook/LST/Method_final.pdf.

- . 2008b (December 5). PROPOSAL: Interim CEQA GHG Significance Threshold for Stationary Sources, Rules and Plans. Diamond Bar, CA: SCAQMD. [http://www.aqmd.gov/docs/default-source/ceqa/handbook/greenhouse-gases-\(ghg\)-ceqa-significance-thresholds/ghgboardsynopsis.pdf?sfvrsn=2](http://www.aqmd.gov/docs/default-source/ceqa/handbook/greenhouse-gases-(ghg)-ceqa-significance-thresholds/ghgboardsynopsis.pdf?sfvrsn=2).
- . 2003 (August). White Paper on Potential Control Strategies to Address Cumulative Impacts from Air Pollution. Diamond Bar, CA: SCAQMD. <http://www.aqmd.gov/docs/default-source/Agendas/Environmental-Justice/cumulative-impacts-working-group/cumulative-impacts-white-paper.pdf>.
- . 1993. CEQA Air Quality Handbook. Diamond Bar, CA: SCAQMD.
- Southern California Association of Governments (SCAG). 2020 (September 3, adoption date). Connect SoCal: The 2020-2045 Regional Transportation Plan/Sustainable Communities Strategy of the Southern California Association of Governments. Los Angeles, CA: SCAG. <https://scag.ca.gov/read-plan-adopted-final-plan>.
- . 2016 (April). The 2016-2040 Regional Transportation Plan/Sustainable Communities Strategy: A Plan for Mobility, Accessibility, Sustainability, and a High Quality of Life. Los Angeles, CA: SCAG. <http://scagrtpscscs.net/Pages/FINAL2016RTPSCS.aspx>.
- State of California, Department of Finance. 2021. E-1 Population Estimates for Cities, Counties, and the State — January 1, 2020 and 2021. Sacramento, CA: DOF. <https://www.dof.ca.gov/Forecasting/Demographics/Estimates/E-1/>
- U.S. Environmental Protection Agency (USEPA). 2021a (accessed February 8). NAAQS Table. Washington, DC: USEPA. <https://www.epa.gov/criteria-air-pollutants/naaqs-table>.
- . 2021b (February 28, current as of). Nonattainment Areas for Criteria Pollutants (Green Book). Washington, DC: USEPA. <https://www.epa.gov/green-book>.
- . 1971 (December 31). Noise From Construction Equipment and Operations, Building Equipment, and Home Appliances. Washington, DC: USEPA. <https://www.placer.ca.gov/DocumentCenter/View/8267/EPA-1971-Bolt-Baranek-and-Newman-PDF>.
- TGR Geotechnical, Inc. 2020 (November). Percolation Testing Results for WQMP, Pavement Design, and Building Expansion Foundation Recommendations, Kindred Church, 8720 East Santa Ana Canyon Road, Anaheim, California. Santa Ana, CA: TGR Geotechnical, Inc.
- Young, Lindsey (Interim Fire Marshall). 2021 (March 24). Email correspondence regarding City Fire Department staffing and capacity.

Appendix A
Air Quality Calculations

Kindred Church - Los Angeles-South Coast County, Annual

EMFAC Off-Model Adjustment Factors for Gasoline Light Duty Vehicle to Account for the SAFE Vehicle Rule Not Applied

Kindred Church
Los Angeles-South Coast County, Annual

1.0 Project Characteristics

1.1 Land Usage

Land Uses	Size	Metric	Lot Acreage	Floor Surface Area	Population
Place of Worship	15.00	1000sqft	0.34	15,000.00	0
Other Non-Asphalt Surfaces	0.75	Acre	0.75	32,670.00	0
Parking Lot	1.85	Acre	1.85	80,586.00	0

1.2 Other Project Characteristics

Urbanization	Urban	Wind Speed (m/s)	2.2	Precipitation Freq (Days)	33
Climate Zone	8			Operational Year	2022
Utility Company	Anaheim Public Utilities				
CO2 Intensity (lb/MW hr)	1047.47	CH4 Intensity (lb/MW hr)	0.029	N2O Intensity (lb/MW hr)	0.006

1.3 User Entered Comments & Non-Default Data

Project Characteristics - From APUD
 Land Use - Building size estimated for painting
 Parking lot for 3 lots to be paved
 Non-asphalt surfaces are new plazas

Kindred Church - Los Angeles-South Coast County, Annual

EMFAC Off-Model Adjustment Factors for Gasoline Light Duty Vehicle to Account for the SAFE Vehicle Rule Not Applied

Construction Phase -

Schedule by owner

Demo includes site prep for plazas and moving modulares

Off-road Equipment - Off-road equipment by Applicant

Off-road Equipment - Off-road equipment by Applicant

Off-road Equipment - Off-road equipment by Applicant

Off-road Equipment -

Demolition -

Grading -

Vehicle Trips - Trip rates based on Trip Generation letter

Energy Use - No gas service

Construction Off-road Equipment Mitigation -

Waste Mitigation -

Trips and VMT -

Vehicle Emission Factors -

Vehicle Emission Factors -

Vehicle Emission Factors -

Fleet Mix -

Table Name	Column Name	Default Value	New Value
tblConstructionPhase	NumDays	20.00	50.00
tblConstructionPhase	NumDays	6.00	30.00

Kindred Church - Los Angeles-South Coast County, Annual

EMFAC Off-Model Adjustment Factors for Gasoline Light Duty Vehicle to Account for the SAFE Vehicle Rule Not Applied

tblConstructionPhase	NumDays	220.00	100.00
tblEnergyUse	NT24NG	6.86	0.00
tblEnergyUse	T24NG	13.90	0.00
tblGrading	MaterialImported	0.00	2,600.00
tblOffRoadEquipment	OffRoadEquipmentUnitAmount	1.00	0.00
tblOffRoadEquipment	OffRoadEquipmentUnitAmount	2.00	0.00
tblOffRoadEquipment	OffRoadEquipmentUnitAmount	1.00	0.00
tblOffRoadEquipment	OffRoadEquipmentUnitAmount	1.00	0.00
tblOffRoadEquipment	OffRoadEquipmentUnitAmount	1.00	2.00
tblOffRoadEquipment	OffRoadEquipmentUnitAmount	2.00	3.00
tblOffRoadEquipment	OffRoadEquipmentUnitAmount	3.00	0.00
tblOffRoadEquipment	UsageHours	8.00	0.00
tblOffRoadEquipment	UsageHours	7.00	0.00
tblOffRoadEquipment	UsageHours	8.00	0.00
tblOffRoadEquipment	UsageHours	8.00	0.00
tblOffRoadEquipment	UsageHours	8.00	0.00
tblProjectCharacteristics	CO2IntensityFactor	1543.28	1047.47
tblVehicleTrips	ST_TR	5.99	18.13
tblVehicleTrips	SU_TR	27.63	18.13
tblVehicleTrips	WD_TR	6.95	5.33

2.0 Emissions Summary

Kindred Church - Los Angeles-South Coast County, Annual

EMFAC Off-Model Adjustment Factors for Gasoline Light Duty Vehicle to Account for the SAFE Vehicle Rule Not Applied

2.1 Overall Construction

Unmitigated Construction

	ROG	NOx	CO	SO2	Fugitive PM10	Exhaust PM10	PM10 Total	Fugitive PM2.5	Exhaust PM2.5	PM2.5 Total	Bio- CO2	NBio- CO2	Total CO2	CH4	N2O	CO2e
Year	tons/yr										MT/yr					
2021	0.0535	0.5532	0.3623	6.5000e-004	0.0559	0.0281	0.0840	0.0255	0.0259	0.0513			58.2556	0.0166	8.7000e-004	58.9306
2022	0.1477	0.5793	0.5400	1.3200e-003	0.0997	0.0247	0.1244	0.0399	0.0228	0.0626			119.3600	0.0231	4.5100e-003	121.2830
Maximum	0.1477	0.5793	0.5400	1.3200e-003	0.0997	0.0281	0.1244	0.0399	0.0259	0.0626			119.3600	0.0231	4.5100e-003	121.2830

Mitigated Construction

	ROG	NOx	CO	SO2	Fugitive PM10	Exhaust PM10	PM10 Total	Fugitive PM2.5	Exhaust PM2.5	PM2.5 Total	Bio- CO2	NBio- CO2	Total CO2	CH4	N2O	CO2e
Year	tons/yr										MT/yr					
2021	0.0535	0.5532	0.3623	6.5000e-004	0.0278	0.0281	0.0560	0.0122	0.0259	0.0381			58.2556	0.0166	8.7000e-004	58.9305
2022	0.1477	0.5793	0.5400	1.3200e-003	0.0670	0.0247	0.0916	0.0239	0.0228	0.0467			119.3599	0.0231	4.5100e-003	121.2829
Maximum	0.1477	0.5793	0.5400	1.3200e-003	0.0670	0.0281	0.0916	0.0239	0.0259	0.0467			119.3599	0.0231	4.5100e-003	121.2829

Kindred Church - Los Angeles-South Coast County, Annual

EMFAC Off-Model Adjustment Factors for Gasoline Light Duty Vehicle to Account for the SAFE Vehicle Rule Not Applied

	ROG	NOx	CO	SO2	Fugitive PM10	Exhaust PM10	PM10 Total	Fugitive PM2.5	Exhaust PM2.5	PM2.5 Total	Bio- CO2	NBio-CO2	Total CO2	CH4	N2O	CO2e
Percent Reduction	0.00	0.00	0.00	0.00	39.07	0.00	29.18	44.79	0.00	25.68	0.00	0.00	0.00	0.00	0.00	0.00

Quarter	Start Date	End Date	Maximum Unmitigated ROG + NOX (tons/quarter)	Maximum Mitigated ROG + NOX (tons/quarter)
1	10-4-2021	1-3-2022	0.6102	0.6102
2	1-4-2022	4-3-2022	0.3426	0.3426
3	4-4-2022	7-3-2022	0.3117	0.3117
4	7-4-2022	9-30-2022	0.0602	0.0602
		Highest	0.6102	0.6102

2.2 Overall Operational

Unmitigated Operational

	ROG	NOx	CO	SO2	Fugitive PM10	Exhaust PM10	PM10 Total	Fugitive PM2.5	Exhaust PM2.5	PM2.5 Total	Bio- CO2	NBio- CO2	Total CO2	CH4	N2O	CO2e
Category	tons/yr										MT/yr					
Area	0.0701	0.0000	2.2000e-004	0.0000		0.0000	0.0000		0.0000	0.0000			4.4000e-004	0.0000	0.0000	4.7000e-004
Energy	0.0000	0.0000	0.0000	0.0000		0.0000	0.0000		0.0000	0.0000			72.3401	2.0000e-003	4.1000e-004	72.5137
Mobile	0.0614	0.0688	0.5631	1.1000e-003	0.1080	9.6000e-004	0.1090	0.0288	9.0000e-004	0.0297			101.4072	8.0300e-003	5.0000e-003	103.0970
Waste						0.0000	0.0000		0.0000	0.0000			17.3557	1.0257	0.0000	42.9981
Water						0.0000	0.0000		0.0000	0.0000			6.9274	0.0155	4.0000e-004	7.4337
Total	0.1315	0.0688	0.5633	1.1000e-003	0.1080	9.6000e-004	0.1090	0.0288	9.0000e-004	0.0297			198.0310	1.0512	5.8100e-003	226.0428

Kindred Church - Los Angeles-South Coast County, Annual

EMFAC Off-Model Adjustment Factors for Gasoline Light Duty Vehicle to Account for the SAFE Vehicle Rule Not Applied

2.2 Overall Operational

Mitigated Operational

	ROG	NOx	CO	SO2	Fugitive PM10	Exhaust PM10	PM10 Total	Fugitive PM2.5	Exhaust PM2.5	PM2.5 Total	Bio- CO2	NBio- CO2	Total CO2	CH4	N2O	CO2e
Category	tons/yr										MT/yr					
Area	0.0701	0.0000	2.2000e-004	0.0000		0.0000	0.0000		0.0000	0.0000			4.4000e-004	0.0000	0.0000	4.7000e-004
Energy	0.0000	0.0000	0.0000	0.0000		0.0000	0.0000		0.0000	0.0000			72.3401	2.0000e-003	4.1000e-004	72.5137
Mobile	0.0614	0.0688	0.5631	1.1000e-003	0.1080	9.6000e-004	0.1090	0.0288	9.0000e-004	0.0297			101.4072	8.0300e-003	5.0000e-003	103.0970
Waste						0.0000	0.0000		0.0000	0.0000			8.6779	0.5129	0.0000	21.4990
Water						0.0000	0.0000		0.0000	0.0000			6.9274	0.0155	4.0000e-004	7.4337
Total	0.1315	0.0688	0.5633	1.1000e-003	0.1080	9.6000e-004	0.1090	0.0288	9.0000e-004	0.0297			189.3531	0.5384	5.8100e-003	204.5438

	ROG	NOx	CO	SO2	Fugitive PM10	Exhaust PM10	PM10 Total	Fugitive PM2.5	Exhaust PM2.5	PM2.5 Total	Bio- CO2	NBio- CO2	Total CO2	CH4	N2O	CO2e
Percent Reduction	0.00	0.00	0.00	0.00	0.00	0.00	0.00	0.00	0.00	0.00	0.00	0.00	4.38	48.79	0.00	9.51

3.0 Construction Detail

Construction Phase

Phase Number	Phase Name	Phase Type	Start Date	End Date	Num Days Week	Num Days	Phase Description
1	Demolition	Demolition	10/4/2021	12/13/2021	5	50	
2	Grading	Grading	12/14/2021	1/25/2022	5	30	
3	Building Construction	Building Construction	1/26/2022	6/14/2022	5	100	

Kindred Church - Los Angeles-South Coast County, Annual

EMFAC Off-Model Adjustment Factors for Gasoline Light Duty Vehicle to Account for the SAFE Vehicle Rule Not Applied

4	Paving	Paving	6/15/2022	6/28/2022	5	10
5	Architectural Coating	Architectural Coating	6/29/2022	7/12/2022	5	10

Acres of Grading (Site Preparation Phase): 0

Acres of Grading (Grading Phase): 15

Acres of Paving: 2.6

Residential Indoor: 0; Residential Outdoor: 0; Non-Residential Indoor: 22,500; Non-Residential Outdoor: 7,500; Striped Parking Area: 6,795 (Architectural Coating – sqft)

OffRoad Equipment

Phase Name	Offroad Equipment Type	Amount	Usage Hours	Horse Power	Load Factor
Demolition	Concrete/Industrial Saws	0	0.00	81	0.73
Demolition	Rubber Tired Dozers	1	8.00	247	0.40
Demolition	Tractors/Loaders/Backhoes	3	8.00	97	0.37
Grading	Graders	0	0.00	187	0.41
Grading	Rubber Tired Dozers	1	8.00	247	0.40
Grading	Tractors/Loaders/Backhoes	3	7.00	97	0.37
Building Construction	Cranes	1	8.00	231	0.29
Building Construction	Forklifts	0	0.00	89	0.20
Building Construction	Generator Sets	0	0.00	84	0.74
Building Construction	Tractors/Loaders/Backhoes	2	6.00	97	0.37
Building Construction	Welders	0	0.00	46	0.45
Paving	Cement and Mortar Mixers	1	8.00	9	0.56
Paving	Pavers	1	8.00	130	0.42
Paving	Paving Equipment	1	8.00	132	0.36
Paving	Rollers	2	8.00	80	0.38
Paving	Tractors/Loaders/Backhoes	1	8.00	97	0.37
Architectural Coating	Air Compressors	1	6.00	78	0.48

Kindred Church - Los Angeles-South Coast County, Annual

EMFAC Off-Model Adjustment Factors for Gasoline Light Duty Vehicle to Account for the SAFE Vehicle Rule Not Applied

Trips and VMT

Phase Name	Offroad Equipment Count	Worker Trip Number	Vendor Trip Number	Hauling Trip Number	Worker Trip Length	Vendor Trip Length	Hauling Trip Length	Worker Vehicle Class	Vendor Vehicle Class	Hauling Vehicle Class
Demolition	4	10.00	0.00	4.00	14.70	6.90	20.00	LD_Mix	HDT_Mix	HHDT
Grading	4	10.00	0.00	325.00	14.70	6.90	20.00	LD_Mix	HDT_Mix	HHDT
Building Construction	3	54.00	21.00	0.00	14.70	6.90	20.00	LD_Mix	HDT_Mix	HHDT
Paving	6	15.00	0.00	0.00	14.70	6.90	20.00	LD_Mix	HDT_Mix	HHDT
Architectural Coating	1	11.00	0.00	0.00	14.70	6.90	20.00	LD_Mix	HDT_Mix	HHDT

3.1 Mitigation Measures Construction

Water Exposed Area

3.2 Demolition - 2021

Unmitigated Construction On-Site

	ROG	NOx	CO	SO2	Fugitive PM10	Exhaust PM10	PM10 Total	Fugitive PM2.5	Exhaust PM2.5	PM2.5 Total	Bio- CO2	NBio- CO2	Total CO2	CH4	N2O	CO2e
Category	tons/yr										MT/yr					
Fugitive Dust					4.6000e-004	0.0000	4.6000e-004	7.0000e-005	0.0000	7.0000e-005			0.0000	0.0000	0.0000	0.0000
Off-Road	0.0410	0.4248	0.2759	4.6000e-004		0.0221	0.0221		0.0204	0.0204			40.0217	0.0129	0.0000	40.3453
Total	0.0410	0.4248	0.2759	4.6000e-004	4.6000e-004	0.0221	0.0226	7.0000e-005	0.0204	0.0204			40.0217	0.0129	0.0000	40.3453

Kindred Church - Los Angeles-South Coast County, Annual

EMFAC Off-Model Adjustment Factors for Gasoline Light Duty Vehicle to Account for the SAFE Vehicle Rule Not Applied

3.2 Demolition - 2021

Unmitigated Construction Off-Site

	ROG	NOx	CO	SO2	Fugitive PM10	Exhaust PM10	PM10 Total	Fugitive PM2.5	Exhaust PM2.5	PM2.5 Total	Bio- CO2	NBio- CO2	Total CO2	CH4	N2O	CO2e
Category	tons/yr										MT/yr					
Hauling	1.0000e-005	4.1000e-004	9.0000e-005	0.0000	4.0000e-005	0.0000	4.0000e-005	1.0000e-005	0.0000	1.0000e-005			0.1294	1.0000e-005	2.0000e-005	0.1357
Vendor	0.0000	0.0000	0.0000	0.0000	0.0000	0.0000	0.0000	0.0000	0.0000	0.0000			0.0000	0.0000	0.0000	0.0000
Worker	9.5000e-004	8.3000e-004	0.0104	3.0000e-005	2.7900e-003	2.0000e-005	2.8100e-003	7.4000e-004	2.0000e-005	7.6000e-004			2.3722	7.0000e-005	7.0000e-005	2.3944
Total	9.6000e-004	1.2400e-003	0.0104	3.0000e-005	2.8300e-003	2.0000e-005	2.8500e-003	7.5000e-004	2.0000e-005	7.7000e-004			2.5016	8.0000e-005	9.0000e-005	2.5301

Mitigated Construction On-Site

	ROG	NOx	CO	SO2	Fugitive PM10	Exhaust PM10	PM10 Total	Fugitive PM2.5	Exhaust PM2.5	PM2.5 Total	Bio- CO2	NBio- CO2	Total CO2	CH4	N2O	CO2e
Category	tons/yr										MT/yr					
Fugitive Dust					2.1000e-004	0.0000	2.1000e-004	3.0000e-005	0.0000	3.0000e-005			0.0000	0.0000	0.0000	0.0000
Off-Road	0.0410	0.4248	0.2759	4.6000e-004		0.0221	0.0221		0.0204	0.0204			40.0216	0.0129	0.0000	40.3452
Total	0.0410	0.4248	0.2759	4.6000e-004	2.1000e-004	0.0221	0.0223	3.0000e-005	0.0204	0.0204			40.0216	0.0129	0.0000	40.3452

Kindred Church - Los Angeles-South Coast County, Annual

EMFAC Off-Model Adjustment Factors for Gasoline Light Duty Vehicle to Account for the SAFE Vehicle Rule Not Applied

3.2 Demolition - 2021

Mitigated Construction Off-Site

	ROG	NOx	CO	SO2	Fugitive PM10	Exhaust PM10	PM10 Total	Fugitive PM2.5	Exhaust PM2.5	PM2.5 Total	Bio- CO2	NBio- CO2	Total CO2	CH4	N2O	CO2e
Category	tons/yr										MT/yr					
Hauling	1.0000e-005	4.1000e-004	9.0000e-005	0.0000	4.0000e-005	0.0000	4.0000e-005	1.0000e-005	0.0000	1.0000e-005			0.1294	1.0000e-005	2.0000e-005	0.1357
Vendor	0.0000	0.0000	0.0000	0.0000	0.0000	0.0000	0.0000	0.0000	0.0000	0.0000			0.0000	0.0000	0.0000	0.0000
Worker	9.5000e-004	8.3000e-004	0.0104	3.0000e-005	2.7900e-003	2.0000e-005	2.8100e-003	7.4000e-004	2.0000e-005	7.6000e-004			2.3722	7.0000e-005	7.0000e-005	2.3944
Total	9.6000e-004	1.2400e-003	0.0104	3.0000e-005	2.8300e-003	2.0000e-005	2.8500e-003	7.5000e-004	2.0000e-005	7.7000e-004			2.5016	8.0000e-005	9.0000e-005	2.5301

3.3 Grading - 2021

Unmitigated Construction On-Site

	ROG	NOx	CO	SO2	Fugitive PM10	Exhaust PM10	PM10 Total	Fugitive PM2.5	Exhaust PM2.5	PM2.5 Total	Bio- CO2	NBio- CO2	Total CO2	CH4	N2O	CO2e
Category	tons/yr										MT/yr					
Fugitive Dust					0.0505	0.0000	0.0505	0.0241	0.0000	0.0241			0.0000	0.0000	0.0000	0.0000
Off-Road	0.0108	0.1116	0.0698	1.2000e-004		5.7800e-003	5.7800e-003		5.3200e-003	5.3200e-003			10.2698	3.3200e-003	0.0000	10.3528
Total	0.0108	0.1116	0.0698	1.2000e-004	0.0505	5.7800e-003	0.0563	0.0241	5.3200e-003	0.0294			10.2698	3.3200e-003	0.0000	10.3528

Kindred Church - Los Angeles-South Coast County, Annual

EMFAC Off-Model Adjustment Factors for Gasoline Light Duty Vehicle to Account for the SAFE Vehicle Rule Not Applied

3.3 Grading - 2021

Unmitigated Construction Off-Site

	ROG	NOx	CO	SO2	Fugitive PM10	Exhaust PM10	PM10 Total	Fugitive PM2.5	Exhaust PM2.5	PM2.5 Total	Bio- CO2	NBio- CO2	Total CO2	CH4	N2O	CO2e
Category	tons/yr										MT/yr					
Hauling	5.0000e-004	0.0153	3.3600e-003	5.0000e-005	1.3000e-003	1.7000e-004	1.4700e-003	3.6000e-004	1.6000e-004	5.2000e-004			4.8114	2.5000e-004	7.6000e-004	5.0451
Vendor	0.0000	0.0000	0.0000	0.0000	0.0000	0.0000	0.0000	0.0000	0.0000	0.0000			0.0000	0.0000	0.0000	0.0000
Worker	2.6000e-004	2.3000e-004	2.8400e-003	1.0000e-005	7.7000e-004	1.0000e-005	7.7000e-004	2.0000e-004	0.0000	2.1000e-004			0.6512	2.0000e-005	2.0000e-005	0.6573
Total	7.6000e-004	0.0155	6.2000e-003	6.0000e-005	2.0700e-003	1.8000e-004	2.2400e-003	5.6000e-004	1.6000e-004	7.3000e-004			5.4626	2.7000e-004	7.8000e-004	5.7024

Mitigated Construction On-Site

	ROG	NOx	CO	SO2	Fugitive PM10	Exhaust PM10	PM10 Total	Fugitive PM2.5	Exhaust PM2.5	PM2.5 Total	Bio- CO2	NBio- CO2	Total CO2	CH4	N2O	CO2e
Category	tons/yr										MT/yr					
Fugitive Dust					0.0227	0.0000	0.0227	0.0108	0.0000	0.0108			0.0000	0.0000	0.0000	0.0000
Off-Road	0.0108	0.1116	0.0698	1.2000e-004		5.7800e-003	5.7800e-003		5.3200e-003	5.3200e-003			10.2698	3.3200e-003	0.0000	10.3528
Total	0.0108	0.1116	0.0698	1.2000e-004	0.0227	5.7800e-003	0.0285	0.0108	5.3200e-003	0.0162			10.2698	3.3200e-003	0.0000	10.3528

Kindred Church - Los Angeles-South Coast County, Annual

EMFAC Off-Model Adjustment Factors for Gasoline Light Duty Vehicle to Account for the SAFE Vehicle Rule Not Applied

3.3 Grading - 2021

Mitigated Construction Off-Site

	ROG	NOx	CO	SO2	Fugitive PM10	Exhaust PM10	PM10 Total	Fugitive PM2.5	Exhaust PM2.5	PM2.5 Total	Bio- CO2	NBio- CO2	Total CO2	CH4	N2O	CO2e
Category	tons/yr										MT/yr					
Hauling	5.0000e-004	0.0153	3.3600e-003	5.0000e-005	1.3000e-003	1.7000e-004	1.4700e-003	3.6000e-004	1.6000e-004	5.2000e-004			4.8114	2.5000e-004	7.6000e-004	5.0451
Vendor	0.0000	0.0000	0.0000	0.0000	0.0000	0.0000	0.0000	0.0000	0.0000	0.0000			0.0000	0.0000	0.0000	0.0000
Worker	2.6000e-004	2.3000e-004	2.8400e-003	1.0000e-005	7.7000e-004	1.0000e-005	7.7000e-004	2.0000e-004	0.0000	2.1000e-004			0.6512	2.0000e-005	2.0000e-005	0.6573
Total	7.6000e-004	0.0155	6.2000e-003	6.0000e-005	2.0700e-003	1.8000e-004	2.2400e-003	5.6000e-004	1.6000e-004	7.3000e-004			5.4626	2.7000e-004	7.8000e-004	5.7024

3.3 Grading - 2022

Unmitigated Construction On-Site

	ROG	NOx	CO	SO2	Fugitive PM10	Exhaust PM10	PM10 Total	Fugitive PM2.5	Exhaust PM2.5	PM2.5 Total	Bio- CO2	NBio- CO2	Total CO2	CH4	N2O	CO2e
Category	tons/yr										MT/yr					
Fugitive Dust					0.0596	0.0000	0.0596	0.0291	0.0000	0.0291			0.0000	0.0000	0.0000	0.0000
Off-Road	0.0108	0.1121	0.0804	1.4000e-004		5.5600e-003	5.5600e-003		5.1100e-003	5.1100e-003			12.4749	4.0300e-003	0.0000	12.5757
Total	0.0108	0.1121	0.0804	1.4000e-004	0.0596	5.5600e-003	0.0651	0.0291	5.1100e-003	0.0342			12.4749	4.0300e-003	0.0000	12.5757

Kindred Church - Los Angeles-South Coast County, Annual

EMFAC Off-Model Adjustment Factors for Gasoline Light Duty Vehicle to Account for the SAFE Vehicle Rule Not Applied

3.3 Grading - 2022

Unmitigated Construction Off-Site

	ROG	NOx	CO	SO2	Fugitive PM10	Exhaust PM10	PM10 Total	Fugitive PM2.5	Exhaust PM2.5	PM2.5 Total	Bio- CO2	NBio- CO2	Total CO2	CH4	N2O	CO2e
Category	tons/yr										MT/yr					
Hauling	4.2000e-004	0.0163	3.6300e-003	6.0000e-005	1.5800e-003	1.1000e-004	1.7000e-003	4.4000e-004	1.1000e-004	5.5000e-004			5.6877	3.0000e-004	9.0000e-004	5.9642
Vendor	0.0000	0.0000	0.0000	0.0000	0.0000	0.0000	0.0000	0.0000	0.0000	0.0000			0.0000	0.0000	0.0000	0.0000
Worker	2.9000e-004	2.4000e-004	3.1500e-003	1.0000e-005	9.3000e-004	1.0000e-005	9.4000e-004	2.5000e-004	1.0000e-005	2.5000e-004			0.7661	2.0000e-005	2.0000e-005	0.7728
Total	7.1000e-004	0.0165	6.7800e-003	7.0000e-005	2.5100e-003	1.2000e-004	2.6400e-003	6.9000e-004	1.2000e-004	8.0000e-004			6.4537	3.2000e-004	9.2000e-004	6.7370

Mitigated Construction On-Site

	ROG	NOx	CO	SO2	Fugitive PM10	Exhaust PM10	PM10 Total	Fugitive PM2.5	Exhaust PM2.5	PM2.5 Total	Bio- CO2	NBio- CO2	Total CO2	CH4	N2O	CO2e
Category	tons/yr										MT/yr					
Fugitive Dust					0.0268	0.0000	0.0268	0.0131	0.0000	0.0131			0.0000	0.0000	0.0000	0.0000
Off-Road	0.0108	0.1121	0.0804	1.4000e-004		5.5600e-003	5.5600e-003		5.1100e-003	5.1100e-003			12.4749	4.0300e-003	0.0000	12.5757
Total	0.0108	0.1121	0.0804	1.4000e-004	0.0268	5.5600e-003	0.0324	0.0131	5.1100e-003	0.0182			12.4749	4.0300e-003	0.0000	12.5757

Kindred Church - Los Angeles-South Coast County, Annual

EMFAC Off-Model Adjustment Factors for Gasoline Light Duty Vehicle to Account for the SAFE Vehicle Rule Not Applied

3.3 Grading - 2022

Mitigated Construction Off-Site

	ROG	NOx	CO	SO2	Fugitive PM10	Exhaust PM10	PM10 Total	Fugitive PM2.5	Exhaust PM2.5	PM2.5 Total	Bio- CO2	NBio- CO2	Total CO2	CH4	N2O	CO2e
Category	tons/yr										MT/yr					
Hauling	4.2000e-004	0.0163	3.6300e-003	6.0000e-005	1.5800e-003	1.1000e-004	1.7000e-003	4.4000e-004	1.1000e-004	5.5000e-004			5.6877	3.0000e-004	9.0000e-004	5.9642
Vendor	0.0000	0.0000	0.0000	0.0000	0.0000	0.0000	0.0000	0.0000	0.0000	0.0000			0.0000	0.0000	0.0000	0.0000
Worker	2.9000e-004	2.4000e-004	3.1500e-003	1.0000e-005	9.3000e-004	1.0000e-005	9.4000e-004	2.5000e-004	1.0000e-005	2.5000e-004			0.7661	2.0000e-005	2.0000e-005	0.7728
Total	7.1000e-004	0.0165	6.7800e-003	7.0000e-005	2.5100e-003	1.2000e-004	2.6400e-003	6.9000e-004	1.2000e-004	8.0000e-004			6.4537	3.2000e-004	9.2000e-004	6.7370

3.4 Building Construction - 2022

Unmitigated Construction On-Site

	ROG	NOx	CO	SO2	Fugitive PM10	Exhaust PM10	PM10 Total	Fugitive PM2.5	Exhaust PM2.5	PM2.5 Total	Bio- CO2	NBio- CO2	Total CO2	CH4	N2O	CO2e
Category	tons/yr										MT/yr					
Off-Road	0.0310	0.3349	0.2625	5.2000e-004		0.0155	0.0155		0.0142	0.0142			45.8441	0.0148	0.0000	46.2147
Total	0.0310	0.3349	0.2625	5.2000e-004		0.0155	0.0155		0.0142	0.0142			45.8441	0.0148	0.0000	46.2147

Kindred Church - Los Angeles-South Coast County, Annual

EMFAC Off-Model Adjustment Factors for Gasoline Light Duty Vehicle to Account for the SAFE Vehicle Rule Not Applied

3.4 Building Construction - 2022

Unmitigated Construction Off-Site

	ROG	NOx	CO	SO2	Fugitive PM10	Exhaust PM10	PM10 Total	Fugitive PM2.5	Exhaust PM2.5	PM2.5 Total	Bio- CO2	NBio- CO2	Total CO2	CH4	N2O	CO2e
Category	tons/yr										MT/yr					
Hauling	0.0000	0.0000	0.0000	0.0000	0.0000	0.0000	0.0000	0.0000	0.0000	0.0000			0.0000	0.0000	0.0000	0.0000
Vendor	2.0500e-003	0.0540	0.0179	2.1000e-004	6.6200e-003	4.9000e-004	7.1100e-003	1.9100e-003	4.7000e-004	2.3800e-003			20.0506	6.7000e-004	2.8900e-003	20.9292
Worker	9.2500e-003	7.7100e-003	0.1001	2.7000e-004	0.0296	1.9000e-004	0.0298	7.8600e-003	1.8000e-004	8.0400e-003			24.3335	7.0000e-004	6.7000e-004	24.5492
Total	0.0113	0.0617	0.1180	4.8000e-004	0.0362	6.8000e-004	0.0369	9.7700e-003	6.5000e-004	0.0104			44.3841	1.3700e-003	3.5600e-003	45.4784

Mitigated Construction On-Site

	ROG	NOx	CO	SO2	Fugitive PM10	Exhaust PM10	PM10 Total	Fugitive PM2.5	Exhaust PM2.5	PM2.5 Total	Bio- CO2	NBio- CO2	Total CO2	CH4	N2O	CO2e
Category	tons/yr										MT/yr					
Off-Road	0.0310	0.3349	0.2625	5.2000e-004		0.0155	0.0155		0.0142	0.0142			45.8440	0.0148	0.0000	46.2147
Total	0.0310	0.3349	0.2625	5.2000e-004		0.0155	0.0155		0.0142	0.0142			45.8440	0.0148	0.0000	46.2147

Kindred Church - Los Angeles-South Coast County, Annual

EMFAC Off-Model Adjustment Factors for Gasoline Light Duty Vehicle to Account for the SAFE Vehicle Rule Not Applied

3.4 Building Construction - 2022

Mitigated Construction Off-Site

	ROG	NOx	CO	SO2	Fugitive PM10	Exhaust PM10	PM10 Total	Fugitive PM2.5	Exhaust PM2.5	PM2.5 Total	Bio- CO2	NBio- CO2	Total CO2	CH4	N2O	CO2e
Category	tons/yr										MT/yr					
Hauling	0.0000	0.0000	0.0000	0.0000	0.0000	0.0000	0.0000	0.0000	0.0000	0.0000			0.0000	0.0000	0.0000	0.0000
Vendor	2.0500e-003	0.0540	0.0179	2.1000e-004	6.6200e-003	4.9000e-004	7.1100e-003	1.9100e-003	4.7000e-004	2.3800e-003			20.0506	6.7000e-004	2.8900e-003	20.9292
Worker	9.2500e-003	7.7100e-003	0.1001	2.7000e-004	0.0296	1.9000e-004	0.0298	7.8600e-003	1.8000e-004	8.0400e-003			24.3335	7.0000e-004	6.7000e-004	24.5492
Total	0.0113	0.0617	0.1180	4.8000e-004	0.0362	6.8000e-004	0.0369	9.7700e-003	6.5000e-004	0.0104			44.3841	1.3700e-003	3.5600e-003	45.4784

3.5 Paving - 2022

Unmitigated Construction On-Site

	ROG	NOx	CO	SO2	Fugitive PM10	Exhaust PM10	PM10 Total	Fugitive PM2.5	Exhaust PM2.5	PM2.5 Total	Bio- CO2	NBio- CO2	Total CO2	CH4	N2O	CO2e
Category	tons/yr										MT/yr					
Off-Road	4.7100e-003	0.0467	0.0585	9.0000e-005		2.4400e-003	2.4400e-003		2.2500e-003	2.2500e-003			7.7550	2.4600e-003	0.0000	7.8165
Paving	2.4200e-003					0.0000	0.0000		0.0000	0.0000			0.0000	0.0000	0.0000	0.0000
Total	7.1300e-003	0.0467	0.0585	9.0000e-005		2.4400e-003	2.4400e-003		2.2500e-003	2.2500e-003			7.7550	2.4600e-003	0.0000	7.8165

Kindred Church - Los Angeles-South Coast County, Annual

EMFAC Off-Model Adjustment Factors for Gasoline Light Duty Vehicle to Account for the SAFE Vehicle Rule Not Applied

3.5 Paving - 2022

Unmitigated Construction Off-Site

	ROG	NOx	CO	SO2	Fugitive PM10	Exhaust PM10	PM10 Total	Fugitive PM2.5	Exhaust PM2.5	PM2.5 Total	Bio- CO2	NBio- CO2	Total CO2	CH4	N2O	CO2e
Category	tons/yr										MT/yr					
Hauling	0.0000	0.0000	0.0000	0.0000	0.0000	0.0000	0.0000	0.0000	0.0000	0.0000			0.0000	0.0000	0.0000	0.0000
Vendor	0.0000	0.0000	0.0000	0.0000	0.0000	0.0000	0.0000	0.0000	0.0000	0.0000			0.0000	0.0000	0.0000	0.0000
Worker	2.6000e-004	2.1000e-004	2.7800e-003	1.0000e-005	8.2000e-004	1.0000e-005	8.3000e-004	2.2000e-004	0.0000	2.2000e-004			0.6759	2.0000e-005	2.0000e-005	0.6819
Total	2.6000e-004	2.1000e-004	2.7800e-003	1.0000e-005	8.2000e-004	1.0000e-005	8.3000e-004	2.2000e-004	0.0000	2.2000e-004			0.6759	2.0000e-005	2.0000e-005	0.6819

Mitigated Construction On-Site

	ROG	NOx	CO	SO2	Fugitive PM10	Exhaust PM10	PM10 Total	Fugitive PM2.5	Exhaust PM2.5	PM2.5 Total	Bio- CO2	NBio- CO2	Total CO2	CH4	N2O	CO2e
Category	tons/yr										MT/yr					
Off-Road	4.7100e-003	0.0467	0.0585	9.0000e-005		2.4400e-003	2.4400e-003		2.2500e-003	2.2500e-003			7.7550	2.4600e-003	0.0000	7.8165
Paving	2.4200e-003					0.0000	0.0000		0.0000	0.0000			0.0000	0.0000	0.0000	0.0000
Total	7.1300e-003	0.0467	0.0585	9.0000e-005		2.4400e-003	2.4400e-003		2.2500e-003	2.2500e-003			7.7550	2.4600e-003	0.0000	7.8165

Kindred Church - Los Angeles-South Coast County, Annual

EMFAC Off-Model Adjustment Factors for Gasoline Light Duty Vehicle to Account for the SAFE Vehicle Rule Not Applied

3.5 Paving - 2022

Mitigated Construction Off-Site

	ROG	NOx	CO	SO2	Fugitive PM10	Exhaust PM10	PM10 Total	Fugitive PM2.5	Exhaust PM2.5	PM2.5 Total	Bio- CO2	NBio- CO2	Total CO2	CH4	N2O	CO2e
Category	tons/yr										MT/yr					
Hauling	0.0000	0.0000	0.0000	0.0000	0.0000	0.0000	0.0000	0.0000	0.0000	0.0000			0.0000	0.0000	0.0000	0.0000
Vendor	0.0000	0.0000	0.0000	0.0000	0.0000	0.0000	0.0000	0.0000	0.0000	0.0000			0.0000	0.0000	0.0000	0.0000
Worker	2.6000e-004	2.1000e-004	2.7800e-003	1.0000e-005	8.2000e-004	1.0000e-005	8.3000e-004	2.2000e-004	0.0000	2.2000e-004			0.6759	2.0000e-005	2.0000e-005	0.6819
Total	2.6000e-004	2.1000e-004	2.7800e-003	1.0000e-005	8.2000e-004	1.0000e-005	8.3000e-004	2.2000e-004	0.0000	2.2000e-004			0.6759	2.0000e-005	2.0000e-005	0.6819

3.6 Architectural Coating - 2022

Unmitigated Construction On-Site

	ROG	NOx	CO	SO2	Fugitive PM10	Exhaust PM10	PM10 Total	Fugitive PM2.5	Exhaust PM2.5	PM2.5 Total	Bio- CO2	NBio- CO2	Total CO2	CH4	N2O	CO2e
Category	tons/yr										MT/yr					
Archit. Coating	0.0853					0.0000	0.0000		0.0000	0.0000			0.0000	0.0000	0.0000	0.0000
Off-Road	1.0200e-003	7.0400e-003	9.0700e-003	1.0000e-005		4.1000e-004	4.1000e-004		4.1000e-004	4.1000e-004			1.2766	8.0000e-005	0.0000	1.2787
Total	0.0863	7.0400e-003	9.0700e-003	1.0000e-005		4.1000e-004	4.1000e-004		4.1000e-004	4.1000e-004			1.2766	8.0000e-005	0.0000	1.2787

Kindred Church - Los Angeles-South Coast County, Annual

EMFAC Off-Model Adjustment Factors for Gasoline Light Duty Vehicle to Account for the SAFE Vehicle Rule Not Applied

3.6 Architectural Coating - 2022

Unmitigated Construction Off-Site

	ROG	NOx	CO	SO2	Fugitive PM10	Exhaust PM10	PM10 Total	Fugitive PM2.5	Exhaust PM2.5	PM2.5 Total	Bio- CO2	NBio- CO2	Total CO2	CH4	N2O	CO2e
Category	tons/yr										MT/yr					
Hauling	0.0000	0.0000	0.0000	0.0000	0.0000	0.0000	0.0000	0.0000	0.0000	0.0000			0.0000	0.0000	0.0000	0.0000
Vendor	0.0000	0.0000	0.0000	0.0000	0.0000	0.0000	0.0000	0.0000	0.0000	0.0000			0.0000	0.0000	0.0000	0.0000
Worker	1.9000e-004	1.6000e-004	2.0400e-003	1.0000e-005	6.0000e-004	0.0000	6.1000e-004	1.6000e-004	0.0000	1.6000e-004			0.4957	1.0000e-005	1.0000e-005	0.5001
Total	1.9000e-004	1.6000e-004	2.0400e-003	1.0000e-005	6.0000e-004	0.0000	6.1000e-004	1.6000e-004	0.0000	1.6000e-004			0.4957	1.0000e-005	1.0000e-005	0.5001

Mitigated Construction On-Site

	ROG	NOx	CO	SO2	Fugitive PM10	Exhaust PM10	PM10 Total	Fugitive PM2.5	Exhaust PM2.5	PM2.5 Total	Bio- CO2	NBio- CO2	Total CO2	CH4	N2O	CO2e
Category	tons/yr										MT/yr					
Archit. Coating	0.0853					0.0000	0.0000		0.0000	0.0000			0.0000	0.0000	0.0000	0.0000
Off-Road	1.0200e-003	7.0400e-003	9.0700e-003	1.0000e-005		4.1000e-004	4.1000e-004		4.1000e-004	4.1000e-004			1.2766	8.0000e-005	0.0000	1.2787
Total	0.0863	7.0400e-003	9.0700e-003	1.0000e-005		4.1000e-004	4.1000e-004		4.1000e-004	4.1000e-004			1.2766	8.0000e-005	0.0000	1.2787

Kindred Church - Los Angeles-South Coast County, Annual

EMFAC Off-Model Adjustment Factors for Gasoline Light Duty Vehicle to Account for the SAFE Vehicle Rule Not Applied

3.6 Architectural Coating - 2022

Mitigated Construction Off-Site

	ROG	NOx	CO	SO2	Fugitive PM10	Exhaust PM10	PM10 Total	Fugitive PM2.5	Exhaust PM2.5	PM2.5 Total	Bio- CO2	NBio- CO2	Total CO2	CH4	N2O	CO2e
Category	tons/yr										MT/yr					
Hauling	0.0000	0.0000	0.0000	0.0000	0.0000	0.0000	0.0000	0.0000	0.0000	0.0000			0.0000	0.0000	0.0000	0.0000
Vendor	0.0000	0.0000	0.0000	0.0000	0.0000	0.0000	0.0000	0.0000	0.0000	0.0000			0.0000	0.0000	0.0000	0.0000
Worker	1.9000e-004	1.6000e-004	2.0400e-003	1.0000e-005	6.0000e-004	0.0000	6.1000e-004	1.6000e-004	0.0000	1.6000e-004			0.4957	1.0000e-005	1.0000e-005	0.5001
Total	1.9000e-004	1.6000e-004	2.0400e-003	1.0000e-005	6.0000e-004	0.0000	6.1000e-004	1.6000e-004	0.0000	1.6000e-004			0.4957	1.0000e-005	1.0000e-005	0.5001

4.0 Operational Detail - Mobile

4.1 Mitigation Measures Mobile

Kindred Church - Los Angeles-South Coast County, Annual

EMFAC Off-Model Adjustment Factors for Gasoline Light Duty Vehicle to Account for the SAFE Vehicle Rule Not Applied

	ROG	NOx	CO	SO2	Fugitive PM10	Exhaust PM10	PM10 Total	Fugitive PM2.5	Exhaust PM2.5	PM2.5 Total	Bio- CO2	NBio- CO2	Total CO2	CH4	N2O	CO2e
Category	tons/yr										MT/yr					
Mitigated	0.0614	0.0688	0.5631	1.1000e-003	0.1080	9.6000e-004	0.1090	0.0288	9.0000e-004	0.0297			101.4072	8.0300e-003	5.0000e-003	103.0970
Unmitigated	0.0614	0.0688	0.5631	1.1000e-003	0.1080	9.6000e-004	0.1090	0.0288	9.0000e-004	0.0297			101.4072	8.0300e-003	5.0000e-003	103.0970

4.2 Trip Summary Information

Land Use	Average Daily Trip Rate			Unmitigated	Mitigated
	Weekday	Saturday	Sunday	Annual VMT	Annual VMT
Other Non-Asphalt Surfaces	0.00	0.00	0.00		
Parking Lot	0.00	0.00	0.00		
Place of Worship	79.95	271.95	271.95	287,515	287,515
Total	79.95	271.95	271.95	287,515	287,515

4.3 Trip Type Information

Land Use	Miles			Trip %			Trip Purpose %		
	H-W or C-W	H-S or C-C	H-O or C-NW	H-W or C-W	H-S or C-C	H-O or C-NW	Primary	Diverted	Pass-by
Other Non-Asphalt Surfaces	16.60	8.40	6.90	0.00	0.00	0.00	0	0	0
Parking Lot	16.60	8.40	6.90	0.00	0.00	0.00	0	0	0
Place of Worship	16.60	8.40	6.90	0.00	95.00	5.00	64	25	11

4.4 Fleet Mix

Land Use	LDA	LDT1	LDT2	MDV	LHD1	LHD2	MHD	HHD	OBUS	UBUS	MCY	SBUS	MH
Other Non-Asphalt Surfaces	0.546774	0.061880	0.186704	0.127505	0.022909	0.005912	0.010702	0.008032	0.000940	0.000617	0.023937	0.000692	0.003397
Parking Lot	0.546774	0.061880	0.186704	0.127505	0.022909	0.005912	0.010702	0.008032	0.000940	0.000617	0.023937	0.000692	0.003397

Kindred Church - Los Angeles-South Coast County, Annual

EMFAC Off-Model Adjustment Factors for Gasoline Light Duty Vehicle to Account for the SAFE Vehicle Rule Not Applied

Place of Worship	0.546774	0.061880	0.186704	0.127505	0.022909	0.005912	0.010702	0.008032	0.000940	0.000617	0.023937	0.000692	0.003397
------------------	----------	----------	----------	----------	----------	----------	----------	----------	----------	----------	----------	----------	----------

5.0 Energy Detail

Historical Energy Use: N

5.1 Mitigation Measures Energy

	ROG	NOx	CO	SO2	Fugitive PM10	Exhaust PM10	PM10 Total	Fugitive PM2.5	Exhaust PM2.5	PM2.5 Total	Bio- CO2	NBio- CO2	Total CO2	CH4	N2O	CO2e
Category	tons/yr										MT/yr					
Electricity Mitigated						0.0000	0.0000		0.0000	0.0000			72.3401	2.0000e-003	4.1000e-004	72.5137
Electricity Unmitigated						0.0000	0.0000		0.0000	0.0000			72.3401	2.0000e-003	4.1000e-004	72.5137
NaturalGas Mitigated	0.0000	0.0000	0.0000	0.0000		0.0000	0.0000		0.0000	0.0000			0.0000	0.0000	0.0000	0.0000
NaturalGas Unmitigated	0.0000	0.0000	0.0000	0.0000		0.0000	0.0000		0.0000	0.0000			0.0000	0.0000	0.0000	0.0000

Kindred Church - Los Angeles-South Coast County, Annual

EMFAC Off-Model Adjustment Factors for Gasoline Light Duty Vehicle to Account for the SAFE Vehicle Rule Not Applied

5.2 Energy by Land Use - NaturalGas

Unmitigated

	NaturalGas Use	ROG	NOx	CO	SO2	Fugitive PM10	Exhaust PM10	PM10 Total	Fugitive PM2.5	Exhaust PM2.5	PM2.5 Total	Bio- CO2	NBio- CO2	Total CO2	CH4	N2O	CO2e
Land Use	kBTU/yr	tons/yr										MT/yr					
Other Non-Asphalt Surfaces	0	0.0000	0.0000	0.0000	0.0000		0.0000	0.0000		0.0000	0.0000			0.0000	0.0000	0.0000	0.0000
Parking Lot	0	0.0000	0.0000	0.0000	0.0000		0.0000	0.0000		0.0000	0.0000			0.0000	0.0000	0.0000	0.0000
Place of Worship	0	0.0000	0.0000	0.0000	0.0000		0.0000	0.0000		0.0000	0.0000			0.0000	0.0000	0.0000	0.0000
Total		0.0000	0.0000	0.0000	0.0000		0.0000	0.0000		0.0000	0.0000			0.0000	0.0000	0.0000	0.0000

Kindred Church - Los Angeles-South Coast County, Annual

EMFAC Off-Model Adjustment Factors for Gasoline Light Duty Vehicle to Account for the SAFE Vehicle Rule Not Applied

5.2 Energy by Land Use - NaturalGas

Mitigated

	NaturalGas Use	ROG	NOx	CO	SO2	Fugitive PM10	Exhaust PM10	PM10 Total	Fugitive PM2.5	Exhaust PM2.5	PM2.5 Total	Bio- CO2	NBio- CO2	Total CO2	CH4	N2O	CO2e
Land Use	kBTU/yr	tons/yr										MT/yr					
Other Non-Asphalt Surfaces	0	0.0000	0.0000	0.0000	0.0000		0.0000	0.0000		0.0000	0.0000			0.0000	0.0000	0.0000	0.0000
Parking Lot	0	0.0000	0.0000	0.0000	0.0000		0.0000	0.0000		0.0000	0.0000			0.0000	0.0000	0.0000	0.0000
Place of Worship	0	0.0000	0.0000	0.0000	0.0000		0.0000	0.0000		0.0000	0.0000			0.0000	0.0000	0.0000	0.0000
Total		0.0000	0.0000	0.0000	0.0000		0.0000	0.0000		0.0000	0.0000			0.0000	0.0000	0.0000	0.0000

Kindred Church - Los Angeles-South Coast County, Annual

EMFAC Off-Model Adjustment Factors for Gasoline Light Duty Vehicle to Account for the SAFE Vehicle Rule Not Applied

5.3 Energy by Land Use - Electricity

Unmitigated

	Electricity Use	Total CO2	CH4	N2O	CO2e
Land Use	kWh/yr	MT/yr			
Other Non-Asphalt Surfaces	0	0.0000	0.0000	0.0000	0.0000
Parking Lot	28205.1	13.4009	3.7000e-004	8.0000e-005	13.4331
Place of Worship	124050	58.9392	1.6300e-003	3.4000e-004	59.0806
Total		72.3401	2.0000e-003	4.2000e-004	72.5137

Kindred Church - Los Angeles-South Coast County, Annual

EMFAC Off-Model Adjustment Factors for Gasoline Light Duty Vehicle to Account for the SAFE Vehicle Rule Not Applied

5.3 Energy by Land Use - Electricity

Mitigated

	Electricity Use	Total CO2	CH4	N2O	CO2e
Land Use	kWh/yr	MT/yr			
Other Non-Asphalt Surfaces	0	0.0000	0.0000	0.0000	0.0000
Parking Lot	28205.1	13.4009	3.7000e-004	8.0000e-005	13.4331
Place of Worship	124050	58.9392	1.6300e-003	3.4000e-004	59.0806
Total		72.3401	2.0000e-003	4.2000e-004	72.5137

6.0 Area Detail

6.1 Mitigation Measures Area

Kindred Church - Los Angeles-South Coast County, Annual

EMFAC Off-Model Adjustment Factors for Gasoline Light Duty Vehicle to Account for the SAFE Vehicle Rule Not Applied

	ROG	NOx	CO	SO2	Fugitive PM10	Exhaust PM10	PM10 Total	Fugitive PM2.5	Exhaust PM2.5	PM2.5 Total	Bio- CO2	NBio- CO2	Total CO2	CH4	N2O	CO2e
Category	tons/yr										MT/yr					
Mitigated	0.0701	0.0000	2.2000e-004	0.0000		0.0000	0.0000		0.0000	0.0000			4.4000e-004	0.0000	0.0000	4.7000e-004
Unmitigated	0.0701	0.0000	2.2000e-004	0.0000		0.0000	0.0000		0.0000	0.0000			4.4000e-004	0.0000	0.0000	4.7000e-004

6.2 Area by SubCategory

Unmitigated

	ROG	NOx	CO	SO2	Fugitive PM10	Exhaust PM10	PM10 Total	Fugitive PM2.5	Exhaust PM2.5	PM2.5 Total	Bio- CO2	NBio- CO2	Total CO2	CH4	N2O	CO2e
SubCategory	tons/yr										MT/yr					
Architectural Coating	8.5300e-003					0.0000	0.0000		0.0000	0.0000			0.0000	0.0000	0.0000	0.0000
Consumer Products	0.0615					0.0000	0.0000		0.0000	0.0000			0.0000	0.0000	0.0000	0.0000
Landscaping	2.0000e-005	0.0000	2.2000e-004	0.0000		0.0000	0.0000		0.0000	0.0000			4.4000e-004	0.0000	0.0000	4.7000e-004
Total	0.0701	0.0000	2.2000e-004	0.0000		0.0000	0.0000		0.0000	0.0000			4.4000e-004	0.0000	0.0000	4.7000e-004

Kindred Church - Los Angeles-South Coast County, Annual

EMFAC Off-Model Adjustment Factors for Gasoline Light Duty Vehicle to Account for the SAFE Vehicle Rule Not Applied

6.2 Area by SubCategory

Mitigated

	ROG	NOx	CO	SO2	Fugitive PM10	Exhaust PM10	PM10 Total	Fugitive PM2.5	Exhaust PM2.5	PM2.5 Total	Bio- CO2	NBio- CO2	Total CO2	CH4	N2O	CO2e
SubCategory	tons/yr										MT/yr					
Architectural Coating	8.5300e-003					0.0000	0.0000		0.0000	0.0000			0.0000	0.0000	0.0000	0.0000
Consumer Products	0.0615					0.0000	0.0000		0.0000	0.0000			0.0000	0.0000	0.0000	0.0000
Landscaping	2.0000e-005	0.0000	2.2000e-004	0.0000		0.0000	0.0000		0.0000	0.0000			4.4000e-004	0.0000	0.0000	4.7000e-004
Total	0.0701	0.0000	2.2000e-004	0.0000		0.0000	0.0000		0.0000	0.0000			4.4000e-004	0.0000	0.0000	4.7000e-004

7.0 Water Detail

7.1 Mitigation Measures Water

Kindred Church - Los Angeles-South Coast County, Annual

EMFAC Off-Model Adjustment Factors for Gasoline Light Duty Vehicle to Account for the SAFE Vehicle Rule Not Applied

	Total CO2	CH4	N2O	CO2e
Category	MT/yr			
Mitigated	6.9274	0.0155	4.0000e-004	7.4337
Unmitigated	6.9274	0.0155	4.0000e-004	7.4337

7.2 Water by Land Use

Unmitigated

	Indoor/Outdoor Use	Total CO2	CH4	N2O	CO2e
Land Use	Mgal	MT/yr			
Other Non-Asphalt Surfaces	0 / 0	0.0000	0.0000	0.0000	0.0000
Parking Lot	0 / 0	0.0000	0.0000	0.0000	0.0000
Place of Worship	0.469334 / 0.734086	6.9274	0.0155	4.0000e-004	7.4337
Total		6.9274	0.0155	4.0000e-004	7.4337

Kindred Church - Los Angeles-South Coast County, Annual

EMFAC Off-Model Adjustment Factors for Gasoline Light Duty Vehicle to Account for the SAFE Vehicle Rule Not Applied

7.2 Water by Land Use

Mitigated

	Indoor/Outdoor Use	Total CO2	CH4	N2O	CO2e
Land Use	Mgal	MT/yr			
Other Non-Asphalt Surfaces	0 / 0	0.0000	0.0000	0.0000	0.0000
Parking Lot	0 / 0	0.0000	0.0000	0.0000	0.0000
Place of Worship	0.469334 / 0.734086	6.9274	0.0155	4.0000e-004	7.4337
Total		6.9274	0.0155	4.0000e-004	7.4337

8.0 Waste Detail

8.1 Mitigation Measures Waste

Institute Recycling and Composting Services

Kindred Church - Los Angeles-South Coast County, Annual

EMFAC Off-Model Adjustment Factors for Gasoline Light Duty Vehicle to Account for the SAFE Vehicle Rule Not Applied

Category/Year

	Total CO2	CH4	N2O	CO2e
	MT/yr			
Mitigated	8.6779	0.5129	0.0000	21.4990
Unmitigated	17.3557	1.0257	0.0000	42.9981

8.2 Waste by Land Use

Unmitigated

	Waste Disposed	Total CO2	CH4	N2O	CO2e
Land Use	tons	MT/yr			
Other Non-Asphalt Surfaces	0	0.0000	0.0000	0.0000	0.0000
Parking Lot	0	0.0000	0.0000	0.0000	0.0000
Place of Worship	85.5	17.3557	1.0257	0.0000	42.9981
Total		17.3557	1.0257	0.0000	42.9981

Kindred Church - Los Angeles-South Coast County, Annual

EMFAC Off-Model Adjustment Factors for Gasoline Light Duty Vehicle to Account for the SAFE Vehicle Rule Not Applied

8.2 Waste by Land Use

Mitigated

	Waste Disposed	Total CO2	CH4	N2O	CO2e
Land Use	tons	MT/yr			
Other Non-Asphalt Surfaces	0	0.0000	0.0000	0.0000	0.0000
Parking Lot	0	0.0000	0.0000	0.0000	0.0000
Place of Worship	42.75	8.6779	0.5129	0.0000	21.4990
Total		8.6779	0.5129	0.0000	21.4990

9.0 Operational Offroad

Equipment Type	Number	Hours/Day	Days/Year	Horse Power	Load Factor	Fuel Type
----------------	--------	-----------	-----------	-------------	-------------	-----------

10.0 Stationary Equipment

Fire Pumps and Emergency Generators

Equipment Type	Number	Hours/Day	Hours/Year	Horse Power	Load Factor	Fuel Type
----------------	--------	-----------	------------	-------------	-------------	-----------

Boilers

Equipment Type	Number	Heat Input/Day	Heat Input/Year	Boiler Rating	Fuel Type
----------------	--------	----------------	-----------------	---------------	-----------

User Defined Equipment

Equipment Type	Number
----------------	--------

Kindred Church - Los Angeles-South Coast County, Annual

EMFAC Off-Model Adjustment Factors for Gasoline Light Duty Vehicle to Account for the SAFE Vehicle Rule Not Applied

11.0 Vegetation

Kindred Church - Los Angeles-South Coast County, Summer

EMFAC Off-Model Adjustment Factors for Gasoline Light Duty Vehicle to Account for the SAFE Vehicle Rule Not Applied

Kindred Church

Los Angeles-South Coast County, Summer

1.0 Project Characteristics

1.1 Land Usage

Land Uses	Size	Metric	Lot Acreage	Floor Surface Area	Population
Place of Worship	15.00	1000sqft	0.34	15,000.00	0
Other Non-Asphalt Surfaces	0.75	Acre	0.75	32,670.00	0
Parking Lot	1.85	Acre	1.85	80,586.00	0

1.2 Other Project Characteristics

Urbanization	Urban	Wind Speed (m/s)	2.2	Precipitation Freq (Days)	33
Climate Zone	8			Operational Year	2022
Utility Company	Anaheim Public Utilities				
CO2 Intensity (lb/MWhr)	1047.47	CH4 Intensity (lb/MWhr)	0.029	N2O Intensity (lb/MWhr)	0.006

1.3 User Entered Comments & Non-Default Data

Project Characteristics - From APUD
 Land Use - Building size estimated for painting
 Parking lot for 3 lots to be paved
 Non-asphalt surfaces are new plazas

Kindred Church - Los Angeles-South Coast County, Summer

EMFAC Off-Model Adjustment Factors for Gasoline Light Duty Vehicle to Account for the SAFE Vehicle Rule Not Applied

Construction Phase -

Schedule by owner

Demo includes site prep for plazas and moving modulars

Off-road Equipment - Off-road equipment by Applicant

Off-road Equipment - Off-road equipment by Applicant

Off-road Equipment - Off-road equipment by Applicant

Off-road Equipment -

Demolition -

Grading -

Vehicle Trips - Trip rates based on Trip Generation letter

Energy Use - No gas service

Construction Off-road Equipment Mitigation -

Waste Mitigation -

Trips and VMT -

Vehicle Emission Factors -

Vehicle Emission Factors -

Vehicle Emission Factors -

Fleet Mix -

Table Name	Column Name	Default Value	New Value
tblConstructionPhase	NumDays	20.00	50.00
tblConstructionPhase	NumDays	6.00	30.00

Kindred Church - Los Angeles-South Coast County, Summer

EMFAC Off-Model Adjustment Factors for Gasoline Light Duty Vehicle to Account for the SAFE Vehicle Rule Not Applied

tblConstructionPhase	NumDays	220.00	100.00
tblEnergyUse	NT24NG	6.86	0.00
tblEnergyUse	T24NG	13.90	0.00
tblGrading	MaterialImported	0.00	2,600.00
tblOffRoadEquipment	OffRoadEquipmentUnitAmount	1.00	0.00
tblOffRoadEquipment	OffRoadEquipmentUnitAmount	2.00	0.00
tblOffRoadEquipment	OffRoadEquipmentUnitAmount	1.00	0.00
tblOffRoadEquipment	OffRoadEquipmentUnitAmount	1.00	0.00
tblOffRoadEquipment	OffRoadEquipmentUnitAmount	1.00	2.00
tblOffRoadEquipment	OffRoadEquipmentUnitAmount	2.00	3.00
tblOffRoadEquipment	OffRoadEquipmentUnitAmount	3.00	0.00
tblOffRoadEquipment	UsageHours	8.00	0.00
tblOffRoadEquipment	UsageHours	7.00	0.00
tblOffRoadEquipment	UsageHours	8.00	0.00
tblOffRoadEquipment	UsageHours	8.00	0.00
tblOffRoadEquipment	UsageHours	8.00	0.00
tblOffRoadEquipment	UsageHours	8.00	0.00
tblProjectCharacteristics	CO2IntensityFactor	1543.28	1047.47
tblVehicleTrips	ST_TR	5.99	18.13
tblVehicleTrips	SU_TR	27.63	18.13
tblVehicleTrips	WD_TR	6.95	5.33

2.0 Emissions Summary

Kindred Church - Los Angeles-South Coast County, Summer

EMFAC Off-Model Adjustment Factors for Gasoline Light Duty Vehicle to Account for the SAFE Vehicle Rule Not Applied

2.1 Overall Construction (Maximum Daily Emission)

Unmitigated Construction

	ROG	NOx	CO	SO2	Fugitive PM10	Exhaust PM10	PM10 Total	Fugitive PM2.5	Exhaust PM2.5	PM2.5 Total	Bio- CO2	NBio- CO2	Total CO2	CH4	N2O	CO2e
Year	lb/day										lb/day					
2021	1.6470	18.0462	11.2532	0.0247	6.8635	0.8687	7.7142	3.4506	0.7992	4.2341			2,481.5327	0.5659	0.1229	2,532.2937
2022	17.2971	15.0369	12.2874	0.0245	6.8635	0.6682	7.5317	3.4506	0.6152	4.0658			2,458.6387	0.5652	0.1195	2,508.3852
Maximum	17.2971	18.0462	12.2874	0.0247	6.8635	0.8687	7.7142	3.4506	0.7992	4.2341			2,481.5327	0.5659	0.1229	2,532.2937

Mitigated Construction

	ROG	NOx	CO	SO2	Fugitive PM10	Exhaust PM10	PM10 Total	Fugitive PM2.5	Exhaust PM2.5	PM2.5 Total	Bio- CO2	NBio- CO2	Total CO2	CH4	N2O	CO2e
Year	lb/day										lb/day					
2021	1.6470	18.0462	11.2532	0.0247	3.2544	0.8687	4.1050	1.5977	0.7992	2.3811			2,481.5327	0.5659	0.1229	2,532.2937
2022	17.2971	15.0369	12.2874	0.0245	3.2544	0.6682	3.9225	1.5977	0.6152	2.2129			2,458.6387	0.5652	0.1195	2,508.3852
Maximum	17.2971	18.0462	12.2874	0.0247	3.2544	0.8687	4.1050	1.5977	0.7992	2.3811			2,481.5327	0.5659	0.1229	2,532.2937

Kindred Church - Los Angeles-South Coast County, Summer

EMFAC Off-Model Adjustment Factors for Gasoline Light Duty Vehicle to Account for the SAFE Vehicle Rule Not Applied

	ROG	NOx	CO	SO2	Fugitive PM10	Exhaust PM10	PM10 Total	Fugitive PM2.5	Exhaust PM2.5	PM2.5 Total	Bio- CO2	NBio-CO2	Total CO2	CH4	N2O	CO2e
Percent Reduction	0.00	0.00	0.00	0.00	52.58	0.00	47.35	53.70	0.00	44.65	0.00	0.00	0.00	0.00	0.00	0.00

Kindred Church - Los Angeles-South Coast County, Summer

EMFAC Off-Model Adjustment Factors for Gasoline Light Duty Vehicle to Account for the SAFE Vehicle Rule Not Applied

2.2 Overall Operational

Unmitigated Operational

	ROG	NOx	CO	SO2	Fugitive PM10	Exhaust PM10	PM10 Total	Fugitive PM2.5	Exhaust PM2.5	PM2.5 Total	Bio- CO2	NBio- CO2	Total CO2	CH4	N2O	CO2e
Category	lb/day										lb/day					
Area	0.3840	2.0000e-005	1.8000e-003	0.0000		1.0000e-005	1.0000e-005		1.0000e-005	1.0000e-005			3.8500e-003	1.0000e-005		4.1100e-003
Energy	0.0000	0.0000	0.0000	0.0000		0.0000	0.0000		0.0000	0.0000			0.0000	0.0000	0.0000	0.0000
Mobile	0.7119	0.6991	6.2637	0.0126	1.2211	0.0107	1.2318	0.3253	9.9400e-003	0.3352			1,280.0477	0.0949	0.0581	1,299.7246
Total	1.0959	0.6992	6.2655	0.0126	1.2211	0.0107	1.2318	0.3253	9.9500e-003	0.3352			1,280.0516	0.0949	0.0581	1,299.7287

Mitigated Operational

	ROG	NOx	CO	SO2	Fugitive PM10	Exhaust PM10	PM10 Total	Fugitive PM2.5	Exhaust PM2.5	PM2.5 Total	Bio- CO2	NBio- CO2	Total CO2	CH4	N2O	CO2e
Category	lb/day										lb/day					
Area	0.3840	2.0000e-005	1.8000e-003	0.0000		1.0000e-005	1.0000e-005		1.0000e-005	1.0000e-005			3.8500e-003	1.0000e-005		4.1100e-003
Energy	0.0000	0.0000	0.0000	0.0000		0.0000	0.0000		0.0000	0.0000			0.0000	0.0000	0.0000	0.0000
Mobile	0.7119	0.6991	6.2637	0.0126	1.2211	0.0107	1.2318	0.3253	9.9400e-003	0.3352			1,280.0477	0.0949	0.0581	1,299.7246
Total	1.0959	0.6992	6.2655	0.0126	1.2211	0.0107	1.2318	0.3253	9.9500e-003	0.3352			1,280.0516	0.0949	0.0581	1,299.7287

Kindred Church - Los Angeles-South Coast County, Summer

EMFAC Off-Model Adjustment Factors for Gasoline Light Duty Vehicle to Account for the SAFE Vehicle Rule Not Applied

	ROG	NOx	CO	SO2	Fugitive PM10	Exhaust PM10	PM10 Total	Fugitive PM2.5	Exhaust PM2.5	PM2.5 Total	Bio- CO2	NBio-CO2	Total CO2	CH4	N2O	CO2e
Percent Reduction	0.00	0.00	0.00	0.00	0.00	0.00	0.00	0.00	0.00	0.00	0.00	0.00	0.00	0.00	0.00	0.00

3.0 Construction Detail

Construction Phase

Phase Number	Phase Name	Phase Type	Start Date	End Date	Num Days Week	Num Days	Phase Description
1	Demolition	Demolition	10/4/2021	12/13/2021	5	50	
2	Grading	Grading	12/14/2021	1/25/2022	5	30	
3	Building Construction	Building Construction	1/26/2022	6/14/2022	5	100	
4	Paving	Paving	6/15/2022	6/28/2022	5	10	
5	Architectural Coating	Architectural Coating	6/29/2022	7/12/2022	5	10	

Acres of Grading (Site Preparation Phase): 0

Acres of Grading (Grading Phase): 15

Acres of Paving: 2.6

Residential Indoor: 0; Residential Outdoor: 0; Non-Residential Indoor: 22,500; Non-Residential Outdoor: 7,500; Striped Parking Area: 6,795 (Architectural Coating – sqft)

OffRoad Equipment

Phase Name	Offroad Equipment Type	Amount	Usage Hours	Horse Power	Load Factor
Demolition	Concrete/Industrial Saws	0	0.00	81	0.73
Demolition	Rubber Tired Dozers	1	8.00	247	0.40
Demolition	Tractors/Loaders/Backhoes	3	8.00	97	0.37
Grading	Graders	0	0.00	187	0.41
Grading	Rubber Tired Dozers	1	8.00	247	0.40
Grading	Tractors/Loaders/Backhoes	3	7.00	97	0.37

Kindred Church - Los Angeles-South Coast County, Summer

EMFAC Off-Model Adjustment Factors for Gasoline Light Duty Vehicle to Account for the SAFE Vehicle Rule Not Applied

Building Construction	Cranes	1	8.00	231	0.29
Building Construction	Forklifts	0	0.00	89	0.20
Building Construction	Generator Sets	0	0.00	84	0.74
Building Construction	Tractors/Loaders/Backhoes	2	6.00	97	0.37
Building Construction	Welders	0	0.00	46	0.45
Paving	Cement and Mortar Mixers	1	8.00	9	0.56
Paving	Pavers	1	8.00	130	0.42
Paving	Paving Equipment	1	8.00	132	0.36
Paving	Rollers	2	8.00	80	0.38
Paving	Tractors/Loaders/Backhoes	1	8.00	97	0.37
Architectural Coating	Air Compressors	1	6.00	78	0.48

Trips and VMT

Phase Name	Offroad Equipment Count	Worker Trip Number	Vendor Trip Number	Hauling Trip Number	Worker Trip Length	Vendor Trip Length	Hauling Trip Length	Worker Vehicle Class	Vendor Vehicle Class	Hauling Vehicle Class
Demolition	4	10.00	0.00	4.00	14.70	6.90	20.00	LD_Mix	HDT_Mix	HHDT
Grading	4	10.00	0.00	325.00	14.70	6.90	20.00	LD_Mix	HDT_Mix	HHDT
Building Construction	3	54.00	21.00	0.00	14.70	6.90	20.00	LD_Mix	HDT_Mix	HHDT
Paving	6	15.00	0.00	0.00	14.70	6.90	20.00	LD_Mix	HDT_Mix	HHDT
Architectural Coating	1	11.00	0.00	0.00	14.70	6.90	20.00	LD_Mix	HDT_Mix	HHDT

3.1 Mitigation Measures Construction

Water Exposed Area

Kindred Church - Los Angeles-South Coast County, Summer

EMFAC Off-Model Adjustment Factors for Gasoline Light Duty Vehicle to Account for the SAFE Vehicle Rule Not Applied

3.2 Demolition - 2021

Unmitigated Construction On-Site

	ROG	NOx	CO	SO2	Fugitive PM10	Exhaust PM10	PM10 Total	Fugitive PM2.5	Exhaust PM2.5	PM2.5 Total	Bio- CO2	NBio- CO2	Total CO2	CH4	N2O	CO2e
Category	lb/day										lb/day					
Fugitive Dust					0.0179	0.0000	0.0179	2.7200e-003	0.0000	2.7200e-003			0.0000			0.0000
Off-Road	1.6082	16.6587	10.8185	0.0179		0.8678	0.8678		0.7984	0.7984			1,730.0524	0.5595		1,744.0408
Total	1.6082	16.6587	10.8185	0.0179	0.0179	0.8678	0.8857	2.7200e-003	0.7984	0.8011			1,730.0524	0.5595		1,744.0408

Unmitigated Construction Off-Site

	ROG	NOx	CO	SO2	Fugitive PM10	Exhaust PM10	PM10 Total	Fugitive PM2.5	Exhaust PM2.5	PM2.5 Total	Bio- CO2	NBio- CO2	Total CO2	CH4	N2O	CO2e
Category	lb/day										lb/day					
Hauling	5.3000e-004	0.0153	3.5300e-003	5.0000e-005	1.4000e-003	1.8000e-004	1.5800e-003	3.8000e-004	1.7000e-004	5.5000e-004			5.5948	2.9000e-004	8.9000e-004	5.8665
Vendor	0.0000	0.0000	0.0000	0.0000	0.0000	0.0000	0.0000	0.0000	0.0000	0.0000			0.0000	0.0000	0.0000	0.0000
Worker	0.0376	0.0288	0.4312	1.0600e-003	0.1118	7.7000e-004	0.1125	0.0296	7.1000e-004	0.0304			106.6845	3.1500e-003	2.7300e-003	107.5760
Total	0.0381	0.0440	0.4347	1.1100e-003	0.1132	9.5000e-004	0.1141	0.0300	8.8000e-004	0.0309			112.2793	3.4400e-003	3.6200e-003	113.4425

Kindred Church - Los Angeles-South Coast County, Summer

EMFAC Off-Model Adjustment Factors for Gasoline Light Duty Vehicle to Account for the SAFE Vehicle Rule Not Applied

3.2 Demolition - 2021

Mitigated Construction On-Site

	ROG	NOx	CO	SO2	Fugitive PM10	Exhaust PM10	PM10 Total	Fugitive PM2.5	Exhaust PM2.5	PM2.5 Total	Bio- CO2	NBio- CO2	Total CO2	CH4	N2O	CO2e
Category	lb/day										lb/day					
Fugitive Dust					8.0700e-003	0.0000	8.0700e-003	1.2200e-003	0.0000	1.2200e-003			0.0000			0.0000
Off-Road	1.6082	16.6587	10.8185	0.0179		0.8678	0.8678		0.7984	0.7984			1,730.0524	0.5595		1,744.0408
Total	1.6082	16.6587	10.8185	0.0179	8.0700e-003	0.8678	0.8759	1.2200e-003	0.7984	0.7996			1,730.0524	0.5595		1,744.0408

Mitigated Construction Off-Site

	ROG	NOx	CO	SO2	Fugitive PM10	Exhaust PM10	PM10 Total	Fugitive PM2.5	Exhaust PM2.5	PM2.5 Total	Bio- CO2	NBio- CO2	Total CO2	CH4	N2O	CO2e
Category	lb/day										lb/day					
Hauling	5.3000e-004	0.0153	3.5300e-003	5.0000e-005	1.4000e-003	1.8000e-004	1.5800e-003	3.8000e-004	1.7000e-004	5.5000e-004			5.5948	2.9000e-004	8.9000e-004	5.8665
Vendor	0.0000	0.0000	0.0000	0.0000	0.0000	0.0000	0.0000	0.0000	0.0000	0.0000			0.0000	0.0000	0.0000	0.0000
Worker	0.0376	0.0288	0.4312	1.0600e-003	0.1118	7.7000e-004	0.1125	0.0296	7.1000e-004	0.0304			106.6845	3.1500e-003	2.7300e-003	107.5760
Total	0.0381	0.0440	0.4347	1.1100e-003	0.1132	9.5000e-004	0.1141	0.0300	8.8000e-004	0.0309			112.2793	3.4400e-003	3.6200e-003	113.4425

Kindred Church - Los Angeles-South Coast County, Summer

EMFAC Off-Model Adjustment Factors for Gasoline Light Duty Vehicle to Account for the SAFE Vehicle Rule Not Applied

3.3 Grading - 2021

Unmitigated Construction On-Site

	ROG	NOx	CO	SO2	Fugitive PM10	Exhaust PM10	PM10 Total	Fugitive PM2.5	Exhaust PM2.5	PM2.5 Total	Bio- CO2	NBio- CO2	Total CO2	CH4	N2O	CO2e
Category	lb/day										lb/day					
Fugitive Dust					6.5621	0.0000	6.5621	3.3690	0.0000	3.3690			0.0000			0.0000
Off-Road	1.5380	15.9478	9.9709	0.0167		0.8259	0.8259		0.7598	0.7598			1,617.2149	0.5230		1,630.2909
Total	1.5380	15.9478	9.9709	0.0167	6.5621	0.8259	7.3880	3.3690	0.7598	4.1288			1,617.2149	0.5230		1,630.2909

Unmitigated Construction Off-Site

	ROG	NOx	CO	SO2	Fugitive PM10	Exhaust PM10	PM10 Total	Fugitive PM2.5	Exhaust PM2.5	PM2.5 Total	Bio- CO2	NBio- CO2	Total CO2	CH4	N2O	CO2e
Category	lb/day										lb/day					
Hauling	0.0715	2.0697	0.4774	6.9300e-003	0.1896	0.0240	0.2136	0.0520	0.0230	0.0750			757.6334	0.0397	0.1201	794.4268
Vendor	0.0000	0.0000	0.0000	0.0000	0.0000	0.0000	0.0000	0.0000	0.0000	0.0000			0.0000	0.0000	0.0000	0.0000
Worker	0.0376	0.0288	0.4312	1.0600e-003	0.1118	7.7000e-004	0.1125	0.0296	7.1000e-004	0.0304			106.6845	3.1500e-003	2.7300e-003	107.5760
Total	0.1091	2.0984	0.9086	7.9900e-003	0.3014	0.0248	0.3262	0.0816	0.0237	0.1053			864.3178	0.0428	0.1229	902.0028

Kindred Church - Los Angeles-South Coast County, Summer

EMFAC Off-Model Adjustment Factors for Gasoline Light Duty Vehicle to Account for the SAFE Vehicle Rule Not Applied

3.3 Grading - 2021

Mitigated Construction On-Site

	ROG	NOx	CO	SO2	Fugitive PM10	Exhaust PM10	PM10 Total	Fugitive PM2.5	Exhaust PM2.5	PM2.5 Total	Bio- CO2	NBio- CO2	Total CO2	CH4	N2O	CO2e
Category	lb/day										lb/day					
Fugitive Dust					2.9530	0.0000	2.9530	1.5160	0.0000	1.5160			0.0000			0.0000
Off-Road	1.5380	15.9478	9.9709	0.0167		0.8259	0.8259		0.7598	0.7598			1,617.2149	0.5230		1,630.2909
Total	1.5380	15.9478	9.9709	0.0167	2.9530	0.8259	3.7788	1.5160	0.7598	2.2758			1,617.2149	0.5230		1,630.2909

Mitigated Construction Off-Site

	ROG	NOx	CO	SO2	Fugitive PM10	Exhaust PM10	PM10 Total	Fugitive PM2.5	Exhaust PM2.5	PM2.5 Total	Bio- CO2	NBio- CO2	Total CO2	CH4	N2O	CO2e
Category	lb/day										lb/day					
Hauling	0.0715	2.0697	0.4774	6.9300e-003	0.1896	0.0240	0.2136	0.0520	0.0230	0.0750			757.6334	0.0397	0.1201	794.4268
Vendor	0.0000	0.0000	0.0000	0.0000	0.0000	0.0000	0.0000	0.0000	0.0000	0.0000			0.0000	0.0000	0.0000	0.0000
Worker	0.0376	0.0288	0.4312	1.0600e-003	0.1118	7.7000e-004	0.1125	0.0296	7.1000e-004	0.0304			106.6845	3.1500e-003	2.7300e-003	107.5760
Total	0.1091	2.0984	0.9086	7.9900e-003	0.3014	0.0248	0.3262	0.0816	0.0237	0.1053			864.3178	0.0428	0.1229	902.0028

Kindred Church - Los Angeles-South Coast County, Summer

EMFAC Off-Model Adjustment Factors for Gasoline Light Duty Vehicle to Account for the SAFE Vehicle Rule Not Applied

3.3 Grading - 2022

Unmitigated Construction On-Site

	ROG	NOx	CO	SO2	Fugitive PM10	Exhaust PM10	PM10 Total	Fugitive PM2.5	Exhaust PM2.5	PM2.5 Total	Bio- CO2	NBio- CO2	Total CO2	CH4	N2O	CO2e
Category	lb/day										lb/day					
Fugitive Dust					6.5621	0.0000	6.5621	3.3690	0.0000	3.3690			0.0000			0.0000
Off-Road	1.2695	13.1922	9.4566	0.0167		0.6539	0.6539		0.6016	0.6016			1,617.7876	0.5232		1,630.8682
Total	1.2695	13.1922	9.4566	0.0167	6.5621	0.6539	7.2161	3.3690	0.6016	3.9706			1,617.7876	0.5232		1,630.8682

Unmitigated Construction Off-Site

	ROG	NOx	CO	SO2	Fugitive PM10	Exhaust PM10	PM10 Total	Fugitive PM2.5	Exhaust PM2.5	PM2.5 Total	Bio- CO2	NBio- CO2	Total CO2	CH4	N2O	CO2e
Category	lb/day										lb/day					
Hauling	0.0505	1.8195	0.4242	6.7300e-003	0.1896	0.0135	0.2031	0.0520	0.0129	0.0649			737.5069	0.0392	0.1170	773.3567
Vendor	0.0000	0.0000	0.0000	0.0000	0.0000	0.0000	0.0000	0.0000	0.0000	0.0000			0.0000	0.0000	0.0000	0.0000
Worker	0.0346	0.0253	0.3936	1.0200e-003	0.1118	7.2000e-004	0.1125	0.0296	6.6000e-004	0.0303			103.3442	2.8200e-003	2.5000e-003	104.1603
Total	0.0851	1.8447	0.8178	7.7500e-003	0.3014	0.0142	0.3156	0.0816	0.0136	0.0952			840.8511	0.0420	0.1195	877.5169

Kindred Church - Los Angeles-South Coast County, Summer

EMFAC Off-Model Adjustment Factors for Gasoline Light Duty Vehicle to Account for the SAFE Vehicle Rule Not Applied

3.3 Grading - 2022

Mitigated Construction On-Site

	ROG	NOx	CO	SO2	Fugitive PM10	Exhaust PM10	PM10 Total	Fugitive PM2.5	Exhaust PM2.5	PM2.5 Total	Bio- CO2	NBio- CO2	Total CO2	CH4	N2O	CO2e
Category	lb/day										lb/day					
Fugitive Dust					2.9530	0.0000	2.9530	1.5160	0.0000	1.5160			0.0000			0.0000
Off-Road	1.2695	13.1922	9.4566	0.0167		0.6539	0.6539		0.6016	0.6016			1,617.7876	0.5232		1,630.8682
Total	1.2695	13.1922	9.4566	0.0167	2.9530	0.6539	3.6069	1.5160	0.6016	2.1176			1,617.7876	0.5232		1,630.8682

Mitigated Construction Off-Site

	ROG	NOx	CO	SO2	Fugitive PM10	Exhaust PM10	PM10 Total	Fugitive PM2.5	Exhaust PM2.5	PM2.5 Total	Bio- CO2	NBio- CO2	Total CO2	CH4	N2O	CO2e
Category	lb/day										lb/day					
Hauling	0.0505	1.8195	0.4242	6.7300e-003	0.1896	0.0135	0.2031	0.0520	0.0129	0.0649			737.5069	0.0392	0.1170	773.3567
Vendor	0.0000	0.0000	0.0000	0.0000	0.0000	0.0000	0.0000	0.0000	0.0000	0.0000			0.0000	0.0000	0.0000	0.0000
Worker	0.0346	0.0253	0.3936	1.0200e-003	0.1118	7.2000e-004	0.1125	0.0296	6.6000e-004	0.0303			103.3442	2.8200e-003	2.5000e-003	104.1603
Total	0.0851	1.8447	0.8178	7.7500e-003	0.3014	0.0142	0.3156	0.0816	0.0136	0.0952			840.8511	0.0420	0.1195	877.5169

Kindred Church - Los Angeles-South Coast County, Summer

EMFAC Off-Model Adjustment Factors for Gasoline Light Duty Vehicle to Account for the SAFE Vehicle Rule Not Applied

3.4 Building Construction - 2022

Unmitigated Construction On-Site

	ROG	NOx	CO	SO2	Fugitive PM10	Exhaust PM10	PM10 Total	Fugitive PM2.5	Exhaust PM2.5	PM2.5 Total	Bio- CO2	NBio- CO2	Total CO2	CH4	N2O	CO2e
Category	lb/day										lb/day					
Off-Road	0.6201	6.6977	5.2493	0.0104		0.3089	0.3089		0.2842	0.2842			1,010.6888	0.3269		1,018.8607
Total	0.6201	6.6977	5.2493	0.0104		0.3089	0.3089		0.2842	0.2842			1,010.6888	0.3269		1,018.8607

Unmitigated Construction Off-Site

	ROG	NOx	CO	SO2	Fugitive PM10	Exhaust PM10	PM10 Total	Fugitive PM2.5	Exhaust PM2.5	PM2.5 Total	Bio- CO2	NBio- CO2	Total CO2	CH4	N2O	CO2e
Category	lb/day										lb/day					
Hauling	0.0000	0.0000	0.0000	0.0000	0.0000	0.0000	0.0000	0.0000	0.0000	0.0000			0.0000	0.0000	0.0000	0.0000
Vendor	0.0413	1.0287	0.3527	4.1100e-003	0.1345	9.8000e-003	0.1443	0.0387	9.3700e-003	0.0481			441.9694	0.0148	0.0637	461.3178
Worker	0.1868	0.1364	2.1253	5.5200e-003	0.6036	3.8600e-003	0.6075	0.1601	3.5600e-003	0.1636			558.0586	0.0152	0.0135	562.4654
Total	0.2282	1.1651	2.4780	9.6300e-003	0.7381	0.0137	0.7518	0.1988	0.0129	0.2117			1,000.0280	0.0300	0.0772	1,023.7832

Kindred Church - Los Angeles-South Coast County, Summer

EMFAC Off-Model Adjustment Factors for Gasoline Light Duty Vehicle to Account for the SAFE Vehicle Rule Not Applied

3.4 Building Construction - 2022

Mitigated Construction On-Site

	ROG	NOx	CO	SO2	Fugitive PM10	Exhaust PM10	PM10 Total	Fugitive PM2.5	Exhaust PM2.5	PM2.5 Total	Bio- CO2	NBio- CO2	Total CO2	CH4	N2O	CO2e
Category	lb/day										lb/day					
Off-Road	0.6201	6.6977	5.2493	0.0104		0.3089	0.3089		0.2842	0.2842			1,010.6888	0.3269		1,018.8607
Total	0.6201	6.6977	5.2493	0.0104		0.3089	0.3089		0.2842	0.2842			1,010.6888	0.3269		1,018.8607

Mitigated Construction Off-Site

	ROG	NOx	CO	SO2	Fugitive PM10	Exhaust PM10	PM10 Total	Fugitive PM2.5	Exhaust PM2.5	PM2.5 Total	Bio- CO2	NBio- CO2	Total CO2	CH4	N2O	CO2e
Category	lb/day										lb/day					
Hauling	0.0000	0.0000	0.0000	0.0000	0.0000	0.0000	0.0000	0.0000	0.0000	0.0000			0.0000	0.0000	0.0000	0.0000
Vendor	0.0413	1.0287	0.3527	4.1100e-003	0.1345	9.8000e-003	0.1443	0.0387	9.3700e-003	0.0481			441.9694	0.0148	0.0637	461.3178
Worker	0.1868	0.1364	2.1253	5.5200e-003	0.6036	3.8600e-003	0.6075	0.1601	3.5600e-003	0.1636			558.0586	0.0152	0.0135	562.4654
Total	0.2282	1.1651	2.4780	9.6300e-003	0.7381	0.0137	0.7518	0.1988	0.0129	0.2117			1,000.0280	0.0300	0.0772	1,023.7832

Kindred Church - Los Angeles-South Coast County, Summer

EMFAC Off-Model Adjustment Factors for Gasoline Light Duty Vehicle to Account for the SAFE Vehicle Rule Not Applied

3.5 Paving - 2022

Unmitigated Construction On-Site

	ROG	NOx	CO	SO2	Fugitive PM10	Exhaust PM10	PM10 Total	Fugitive PM2.5	Exhaust PM2.5	PM2.5 Total	Bio- CO2	NBio- CO2	Total CO2	CH4	N2O	CO2e
Category	lb/day										lb/day					
Off-Road	0.9412	9.3322	11.6970	0.0179		0.4879	0.4879		0.4500	0.4500			1,709.689 2	0.5419		1,723.235 6
Paving	0.4847					0.0000	0.0000		0.0000	0.0000			0.0000			0.0000
Total	1.4259	9.3322	11.6970	0.0179		0.4879	0.4879		0.4500	0.4500			1,709.689 2	0.5419		1,723.235 6

Unmitigated Construction Off-Site

	ROG	NOx	CO	SO2	Fugitive PM10	Exhaust PM10	PM10 Total	Fugitive PM2.5	Exhaust PM2.5	PM2.5 Total	Bio- CO2	NBio- CO2	Total CO2	CH4	N2O	CO2e
Category	lb/day										lb/day					
Hauling	0.0000	0.0000	0.0000	0.0000	0.0000	0.0000	0.0000	0.0000	0.0000	0.0000			0.0000	0.0000	0.0000	0.0000
Vendor	0.0000	0.0000	0.0000	0.0000	0.0000	0.0000	0.0000	0.0000	0.0000	0.0000			0.0000	0.0000	0.0000	0.0000
Worker	0.0519	0.0379	0.5904	1.5300e-003	0.1677	1.0700e-003	0.1687	0.0445	9.9000e-004	0.0455			155.0163	4.2200e-003	3.7500e-003	156.2404
Total	0.0519	0.0379	0.5904	1.5300e-003	0.1677	1.0700e-003	0.1687	0.0445	9.9000e-004	0.0455			155.0163	4.2200e-003	3.7500e-003	156.2404

Kindred Church - Los Angeles-South Coast County, Summer

EMFAC Off-Model Adjustment Factors for Gasoline Light Duty Vehicle to Account for the SAFE Vehicle Rule Not Applied

3.5 Paving - 2022

Mitigated Construction On-Site

	ROG	NOx	CO	SO2	Fugitive PM10	Exhaust PM10	PM10 Total	Fugitive PM2.5	Exhaust PM2.5	PM2.5 Total	Bio- CO2	NBio- CO2	Total CO2	CH4	N2O	CO2e
Category	lb/day										lb/day					
Off-Road	0.9412	9.3322	11.6970	0.0179		0.4879	0.4879		0.4500	0.4500			1,709.689 2	0.5419		1,723.235 6
Paving	0.4847					0.0000	0.0000		0.0000	0.0000			0.0000			0.0000
Total	1.4259	9.3322	11.6970	0.0179		0.4879	0.4879		0.4500	0.4500			1,709.689 2	0.5419		1,723.235 6

Mitigated Construction Off-Site

	ROG	NOx	CO	SO2	Fugitive PM10	Exhaust PM10	PM10 Total	Fugitive PM2.5	Exhaust PM2.5	PM2.5 Total	Bio- CO2	NBio- CO2	Total CO2	CH4	N2O	CO2e
Category	lb/day										lb/day					
Hauling	0.0000	0.0000	0.0000	0.0000	0.0000	0.0000	0.0000	0.0000	0.0000	0.0000			0.0000	0.0000	0.0000	0.0000
Vendor	0.0000	0.0000	0.0000	0.0000	0.0000	0.0000	0.0000	0.0000	0.0000	0.0000			0.0000	0.0000	0.0000	0.0000
Worker	0.0519	0.0379	0.5904	1.5300e-003	0.1677	1.0700e-003	0.1687	0.0445	9.9000e-004	0.0455			155.0163	4.2200e-003	3.7500e-003	156.2404
Total	0.0519	0.0379	0.5904	1.5300e-003	0.1677	1.0700e-003	0.1687	0.0445	9.9000e-004	0.0455			155.0163	4.2200e-003	3.7500e-003	156.2404

Kindred Church - Los Angeles-South Coast County, Summer

EMFAC Off-Model Adjustment Factors for Gasoline Light Duty Vehicle to Account for the SAFE Vehicle Rule Not Applied

3.6 Architectural Coating - 2022

Unmitigated Construction On-Site

	ROG	NOx	CO	SO2	Fugitive PM10	Exhaust PM10	PM10 Total	Fugitive PM2.5	Exhaust PM2.5	PM2.5 Total	Bio- CO2	NBio- CO2	Total CO2	CH4	N2O	CO2e
Category	lb/day										lb/day					
Archit. Coating	17.0545					0.0000	0.0000		0.0000	0.0000			0.0000			0.0000
Off-Road	0.2045	1.4085	1.8136	2.9700e-003		0.0817	0.0817		0.0817	0.0817			281.4481	0.0183		281.9062
Total	17.2590	1.4085	1.8136	2.9700e-003		0.0817	0.0817		0.0817	0.0817			281.4481	0.0183		281.9062

Unmitigated Construction Off-Site

	ROG	NOx	CO	SO2	Fugitive PM10	Exhaust PM10	PM10 Total	Fugitive PM2.5	Exhaust PM2.5	PM2.5 Total	Bio- CO2	NBio- CO2	Total CO2	CH4	N2O	CO2e
Category	lb/day										lb/day					
Hauling	0.0000	0.0000	0.0000	0.0000	0.0000	0.0000	0.0000	0.0000	0.0000	0.0000			0.0000	0.0000	0.0000	0.0000
Vendor	0.0000	0.0000	0.0000	0.0000	0.0000	0.0000	0.0000	0.0000	0.0000	0.0000			0.0000	0.0000	0.0000	0.0000
Worker	0.0381	0.0278	0.4329	1.1200e-003	0.1230	7.9000e-004	0.1237	0.0326	7.2000e-004	0.0333			113.6786	3.1000e-003	2.7500e-003	114.5763
Total	0.0381	0.0278	0.4329	1.1200e-003	0.1230	7.9000e-004	0.1237	0.0326	7.2000e-004	0.0333			113.6786	3.1000e-003	2.7500e-003	114.5763

Kindred Church - Los Angeles-South Coast County, Summer

EMFAC Off-Model Adjustment Factors for Gasoline Light Duty Vehicle to Account for the SAFE Vehicle Rule Not Applied

3.6 Architectural Coating - 2022

Mitigated Construction On-Site

	ROG	NOx	CO	SO2	Fugitive PM10	Exhaust PM10	PM10 Total	Fugitive PM2.5	Exhaust PM2.5	PM2.5 Total	Bio- CO2	NBio- CO2	Total CO2	CH4	N2O	CO2e
Category	lb/day										lb/day					
Archit. Coating	17.0545					0.0000	0.0000		0.0000	0.0000			0.0000			0.0000
Off-Road	0.2045	1.4085	1.8136	2.9700e-003		0.0817	0.0817		0.0817	0.0817			281.4481	0.0183		281.9062
Total	17.2590	1.4085	1.8136	2.9700e-003		0.0817	0.0817		0.0817	0.0817			281.4481	0.0183		281.9062

Mitigated Construction Off-Site

	ROG	NOx	CO	SO2	Fugitive PM10	Exhaust PM10	PM10 Total	Fugitive PM2.5	Exhaust PM2.5	PM2.5 Total	Bio- CO2	NBio- CO2	Total CO2	CH4	N2O	CO2e
Category	lb/day										lb/day					
Hauling	0.0000	0.0000	0.0000	0.0000	0.0000	0.0000	0.0000	0.0000	0.0000	0.0000			0.0000	0.0000	0.0000	0.0000
Vendor	0.0000	0.0000	0.0000	0.0000	0.0000	0.0000	0.0000	0.0000	0.0000	0.0000			0.0000	0.0000	0.0000	0.0000
Worker	0.0381	0.0278	0.4329	1.1200e-003	0.1230	7.9000e-004	0.1237	0.0326	7.2000e-004	0.0333			113.6786	3.1000e-003	2.7500e-003	114.5763
Total	0.0381	0.0278	0.4329	1.1200e-003	0.1230	7.9000e-004	0.1237	0.0326	7.2000e-004	0.0333			113.6786	3.1000e-003	2.7500e-003	114.5763

Kindred Church - Los Angeles-South Coast County, Summer

EMFAC Off-Model Adjustment Factors for Gasoline Light Duty Vehicle to Account for the SAFE Vehicle Rule Not Applied

4.0 Operational Detail - Mobile

4.1 Mitigation Measures Mobile

	ROG	NOx	CO	SO2	Fugitive PM10	Exhaust PM10	PM10 Total	Fugitive PM2.5	Exhaust PM2.5	PM2.5 Total	Bio- CO2	NBio- CO2	Total CO2	CH4	N2O	CO2e
Category	lb/day										lb/day					
Mitigated	0.7119	0.6991	6.2637	0.0126	1.2211	0.0107	1.2318	0.3253	9.9400e-003	0.3352			1,280.0477	0.0949	0.0581	1,299.7246
Unmitigated	0.7119	0.6991	6.2637	0.0126	1.2211	0.0107	1.2318	0.3253	9.9400e-003	0.3352			1,280.0477	0.0949	0.0581	1,299.7246

4.2 Trip Summary Information

Land Use	Average Daily Trip Rate			Unmitigated	Mitigated
	Weekday	Saturday	Sunday	Annual VMT	Annual VMT
Other Non-Asphalt Surfaces	0.00	0.00	0.00		
Parking Lot	0.00	0.00	0.00		
Place of Worship	79.95	271.95	271.95	287,515	287,515
Total	79.95	271.95	271.95	287,515	287,515

4.3 Trip Type Information

Land Use	Miles			Trip %			Trip Purpose %		
	H-W or C-W	H-S or C-C	H-O or C-NW	H-W or C-W	H-S or C-C	H-O or C-NW	Primary	Diverted	Pass-by
Other Non-Asphalt Surfaces	16.60	8.40	6.90	0.00	0.00	0.00	0	0	0
Parking Lot	16.60	8.40	6.90	0.00	0.00	0.00	0	0	0
Place of Worship	16.60	8.40	6.90	0.00	95.00	5.00	64	25	11

Kindred Church - Los Angeles-South Coast County, Summer

EMFAC Off-Model Adjustment Factors for Gasoline Light Duty Vehicle to Account for the SAFE Vehicle Rule Not Applied

4.4 Fleet Mix

Land Use	LDA	LDT1	LDT2	MDV	LHD1	LHD2	MHD	HHD	OBUS	UBUS	MCY	SBUS	MH
Other Non-Asphalt Surfaces	0.546774	0.061880	0.186704	0.127505	0.022909	0.005912	0.010702	0.008032	0.000940	0.000617	0.023937	0.000692	0.003397
Parking Lot	0.546774	0.061880	0.186704	0.127505	0.022909	0.005912	0.010702	0.008032	0.000940	0.000617	0.023937	0.000692	0.003397
Place of Worship	0.546774	0.061880	0.186704	0.127505	0.022909	0.005912	0.010702	0.008032	0.000940	0.000617	0.023937	0.000692	0.003397

5.0 Energy Detail

Historical Energy Use: N

5.1 Mitigation Measures Energy

Category	ROG	NOx	CO	SO2	Fugitive PM10	Exhaust PM10	PM10 Total	Fugitive PM2.5	Exhaust PM2.5	PM2.5 Total	Bio- CO2	NBio- CO2	Total CO2	CH4	N2O	CO2e
	lb/day										lb/day					
NaturalGas Mitigated	0.0000	0.0000	0.0000	0.0000		0.0000	0.0000		0.0000	0.0000			0.0000	0.0000	0.0000	0.0000
NaturalGas Unmitigated	0.0000	0.0000	0.0000	0.0000		0.0000	0.0000		0.0000	0.0000			0.0000	0.0000	0.0000	0.0000

Kindred Church - Los Angeles-South Coast County, Summer

EMFAC Off-Model Adjustment Factors for Gasoline Light Duty Vehicle to Account for the SAFE Vehicle Rule Not Applied

5.2 Energy by Land Use - Natural Gas

Unmitigated

	Natural Gas Use	ROG	NOx	CO	SO2	Fugitive PM10	Exhaust PM10	PM10 Total	Fugitive PM2.5	Exhaust PM2.5	PM2.5 Total	Bio- CO2	NBio- CO2	Total CO2	CH4	N2O	CO2e
Land Use	kBTU/yr	lb/day										lb/day					
Other Non-Asphalt Surfaces	0	0.0000	0.0000	0.0000	0.0000		0.0000	0.0000		0.0000	0.0000			0.0000	0.0000	0.0000	0.0000
Parking Lot	0	0.0000	0.0000	0.0000	0.0000		0.0000	0.0000		0.0000	0.0000			0.0000	0.0000	0.0000	0.0000
Place of Worship	0	0.0000	0.0000	0.0000	0.0000		0.0000	0.0000		0.0000	0.0000			0.0000	0.0000	0.0000	0.0000
Total		0.0000	0.0000	0.0000	0.0000		0.0000	0.0000		0.0000	0.0000			0.0000	0.0000	0.0000	0.0000

Kindred Church - Los Angeles-South Coast County, Summer

EMFAC Off-Model Adjustment Factors for Gasoline Light Duty Vehicle to Account for the SAFE Vehicle Rule Not Applied

5.2 Energy by Land Use - NaturalGas

Mitigated

	NaturalGas Use	ROG	NOx	CO	SO2	Fugitive PM10	Exhaust PM10	PM10 Total	Fugitive PM2.5	Exhaust PM2.5	PM2.5 Total	Bio- CO2	NBio- CO2	Total CO2	CH4	N2O	CO2e
Land Use	kBTU/yr	lb/day										lb/day					
Other Non-Asphalt Surfaces	0	0.0000	0.0000	0.0000	0.0000		0.0000	0.0000		0.0000	0.0000			0.0000	0.0000	0.0000	0.0000
Parking Lot	0	0.0000	0.0000	0.0000	0.0000		0.0000	0.0000		0.0000	0.0000			0.0000	0.0000	0.0000	0.0000
Place of Worship	0	0.0000	0.0000	0.0000	0.0000		0.0000	0.0000		0.0000	0.0000			0.0000	0.0000	0.0000	0.0000
Total		0.0000	0.0000	0.0000	0.0000		0.0000	0.0000		0.0000	0.0000			0.0000	0.0000	0.0000	0.0000

6.0 Area Detail

6.1 Mitigation Measures Area

Kindred Church - Los Angeles-South Coast County, Summer

EMFAC Off-Model Adjustment Factors for Gasoline Light Duty Vehicle to Account for the SAFE Vehicle Rule Not Applied

	ROG	NOx	CO	SO2	Fugitive PM10	Exhaust PM10	PM10 Total	Fugitive PM2.5	Exhaust PM2.5	PM2.5 Total	Bio- CO2	NBio- CO2	Total CO2	CH4	N2O	CO2e
Category	lb/day										lb/day					
Mitigated	0.3840	2.0000e-005	1.8000e-003	0.0000		1.0000e-005	1.0000e-005		1.0000e-005	1.0000e-005			3.8500e-003	1.0000e-005		4.1100e-003
Unmitigated	0.3840	2.0000e-005	1.8000e-003	0.0000		1.0000e-005	1.0000e-005		1.0000e-005	1.0000e-005			3.8500e-003	1.0000e-005		4.1100e-003

6.2 Area by SubCategory

Unmitigated

	ROG	NOx	CO	SO2	Fugitive PM10	Exhaust PM10	PM10 Total	Fugitive PM2.5	Exhaust PM2.5	PM2.5 Total	Bio- CO2	NBio- CO2	Total CO2	CH4	N2O	CO2e
SubCategory	lb/day										lb/day					
Architectural Coating	0.0467					0.0000	0.0000		0.0000	0.0000			0.0000			0.0000
Consumer Products	0.3371					0.0000	0.0000		0.0000	0.0000			0.0000			0.0000
Landscaping	1.7000e-004	2.0000e-005	1.8000e-003	0.0000		1.0000e-005	1.0000e-005		1.0000e-005	1.0000e-005			3.8500e-003	1.0000e-005		4.1100e-003
Total	0.3840	2.0000e-005	1.8000e-003	0.0000		1.0000e-005	1.0000e-005		1.0000e-005	1.0000e-005			3.8500e-003	1.0000e-005		4.1100e-003

Kindred Church - Los Angeles-South Coast County, Summer

EMFAC Off-Model Adjustment Factors for Gasoline Light Duty Vehicle to Account for the SAFE Vehicle Rule Not Applied

6.2 Area by SubCategory

Mitigated

	ROG	NOx	CO	SO2	Fugitive PM10	Exhaust PM10	PM10 Total	Fugitive PM2.5	Exhaust PM2.5	PM2.5 Total	Bio- CO2	NBio- CO2	Total CO2	CH4	N2O	CO2e
SubCategory	lb/day										lb/day					
Architectural Coating	0.0467					0.0000	0.0000		0.0000	0.0000			0.0000			0.0000
Consumer Products	0.3371					0.0000	0.0000		0.0000	0.0000			0.0000			0.0000
Landscaping	1.7000e-004	2.0000e-005	1.8000e-003	0.0000		1.0000e-005	1.0000e-005		1.0000e-005	1.0000e-005			3.8500e-003	1.0000e-005		4.1100e-003
Total	0.3840	2.0000e-005	1.8000e-003	0.0000		1.0000e-005	1.0000e-005		1.0000e-005	1.0000e-005			3.8500e-003	1.0000e-005		4.1100e-003

7.0 Water Detail

7.1 Mitigation Measures Water

Kindred Church - Los Angeles-South Coast County, Summer

EMFAC Off-Model Adjustment Factors for Gasoline Light Duty Vehicle to Account for the SAFE Vehicle Rule Not Applied

8.0 Waste Detail

8.1 Mitigation Measures Waste

Institute Recycling and Composting Services

9.0 Operational Offroad

Equipment Type	Number	Hours/Day	Days/Year	Horse Power	Load Factor	Fuel Type
----------------	--------	-----------	-----------	-------------	-------------	-----------

10.0 Stationary Equipment

Fire Pumps and Emergency Generators

Equipment Type	Number	Hours/Day	Hours/Year	Horse Power	Load Factor	Fuel Type
----------------	--------	-----------	------------	-------------	-------------	-----------

Boilers

Equipment Type	Number	Heat Input/Day	Heat Input/Year	Boiler Rating	Fuel Type
----------------	--------	----------------	-----------------	---------------	-----------

User Defined Equipment

Equipment Type	Number
----------------	--------

11.0 Vegetation

Kindred Church - Los Angeles-South Coast County, Winter

EMFAC Off-Model Adjustment Factors for Gasoline Light Duty Vehicle to Account for the SAFE Vehicle Rule Not Applied

**Kindred Church
Los Angeles-South Coast County, Winter**

1.0 Project Characteristics

1.1 Land Usage

Land Uses	Size	Metric	Lot Acreage	Floor Surface Area	Population
Place of Worship	15.00	1000sqft	0.34	15,000.00	0
Other Non-Asphalt Surfaces	0.75	Acre	0.75	32,670.00	0
Parking Lot	1.85	Acre	1.85	80,586.00	0

1.2 Other Project Characteristics

Urbanization	Urban	Wind Speed (m/s)	2.2	Precipitation Freq (Days)	33
Climate Zone	8			Operational Year	2022
Utility Company	Anaheim Public Utilities				
CO2 Intensity (lb/MWhr)	1047.47	CH4 Intensity (lb/MWhr)	0.029	N2O Intensity (lb/MWhr)	0.006

1.3 User Entered Comments & Non-Default Data

Project Characteristics - From APUD
 Land Use - Building size estimated for painting
 Parking lot for 3 lots to be paved
 Non-asphalt surfaces are new plazas

Kindred Church - Los Angeles-South Coast County, Winter

EMFAC Off-Model Adjustment Factors for Gasoline Light Duty Vehicle to Account for the SAFE Vehicle Rule Not Applied

Construction Phase -

Schedule by owner

Demo includes site prep for plazas and moving modulares

Off-road Equipment - Off-road equipment by Applicant

Off-road Equipment - Off-road equipment by Applicant

Off-road Equipment - Off-road equipment by Applicant

Off-road Equipment -

Demolition -

Grading -

Vehicle Trips - Trip rates based on Trip Generation letter

Energy Use - No gas service

Construction Off-road Equipment Mitigation -

Waste Mitigation -

Trips and VMT -

Vehicle Emission Factors -

Vehicle Emission Factors -

Vehicle Emission Factors -

Fleet Mix -

Table Name	Column Name	Default Value	New Value
tblConstructionPhase	NumDays	20.00	50.00
tblConstructionPhase	NumDays	6.00	30.00

Kindred Church - Los Angeles-South Coast County, Winter

EMFAC Off-Model Adjustment Factors for Gasoline Light Duty Vehicle to Account for the SAFE Vehicle Rule Not Applied

tblConstructionPhase	NumDays	220.00	100.00
tblEnergyUse	NT24NG	6.86	0.00
tblEnergyUse	T24NG	13.90	0.00
tblGrading	MaterialImported	0.00	2,600.00
tblOffRoadEquipment	OffRoadEquipmentUnitAmount	1.00	0.00
tblOffRoadEquipment	OffRoadEquipmentUnitAmount	2.00	0.00
tblOffRoadEquipment	OffRoadEquipmentUnitAmount	1.00	0.00
tblOffRoadEquipment	OffRoadEquipmentUnitAmount	1.00	0.00
tblOffRoadEquipment	OffRoadEquipmentUnitAmount	1.00	2.00
tblOffRoadEquipment	OffRoadEquipmentUnitAmount	2.00	3.00
tblOffRoadEquipment	OffRoadEquipmentUnitAmount	3.00	0.00
tblOffRoadEquipment	UsageHours	8.00	0.00
tblOffRoadEquipment	UsageHours	7.00	0.00
tblOffRoadEquipment	UsageHours	8.00	0.00
tblOffRoadEquipment	UsageHours	8.00	0.00
tblOffRoadEquipment	UsageHours	8.00	0.00
tblProjectCharacteristics	CO2IntensityFactor	1543.28	1047.47
tblVehicleTrips	ST_TR	5.99	18.13
tblVehicleTrips	SU_TR	27.63	18.13
tblVehicleTrips	WD_TR	6.95	5.33

2.0 Emissions Summary

Kindred Church - Los Angeles-South Coast County, Winter

EMFAC Off-Model Adjustment Factors for Gasoline Light Duty Vehicle to Account for the SAFE Vehicle Rule Not Applied

2.1 Overall Construction (Maximum Daily Emission)

Unmitigated Construction

	ROG	NOx	CO	SO2	Fugitive PM10	Exhaust PM10	PM10 Total	Fugitive PM2.5	Exhaust PM2.5	PM2.5 Total	Bio- CO2	NBio- CO2	Total CO2	CH4	N2O	CO2e
Year	lb/day										lb/day					
2021	1.6488	18.1312	11.2174	0.0246	6.8635	0.8687	7.7142	3.4506	0.7992	4.2341			2,475.9591	0.5658	0.1231	2,526.7808
2022	17.2998	15.1134	12.2390	0.0244	6.8635	0.6682	7.5317	3.4506	0.6152	4.0658			2,453.3910	0.5652	0.1197	2,503.1992
Maximum	17.2998	18.1312	12.2390	0.0246	6.8635	0.8687	7.7142	3.4506	0.7992	4.2341			2,475.9591	0.5658	0.1231	2,526.7808

Mitigated Construction

	ROG	NOx	CO	SO2	Fugitive PM10	Exhaust PM10	PM10 Total	Fugitive PM2.5	Exhaust PM2.5	PM2.5 Total	Bio- CO2	NBio- CO2	Total CO2	CH4	N2O	CO2e
Year	lb/day										lb/day					
2021	1.6488	18.1312	11.2174	0.0246	3.2544	0.8687	4.1050	1.5977	0.7992	2.3812			2,475.9591	0.5658	0.1231	2,526.7808
2022	17.2998	15.1134	12.2390	0.0244	3.2544	0.6682	3.9226	1.5977	0.6152	2.2129			2,453.3910	0.5652	0.1197	2,503.1992
Maximum	17.2998	18.1312	12.2390	0.0246	3.2544	0.8687	4.1050	1.5977	0.7992	2.3812			2,475.9591	0.5658	0.1231	2,526.7808

Kindred Church - Los Angeles-South Coast County, Winter

EMFAC Off-Model Adjustment Factors for Gasoline Light Duty Vehicle to Account for the SAFE Vehicle Rule Not Applied

	ROG	NOx	CO	SO2	Fugitive PM10	Exhaust PM10	PM10 Total	Fugitive PM2.5	Exhaust PM2.5	PM2.5 Total	Bio- CO2	NBio-CO2	Total CO2	CH4	N2O	CO2e
Percent Reduction	0.00	0.00	0.00	0.00	52.58	0.00	47.35	53.70	0.00	44.65	0.00	0.00	0.00	0.00	0.00	0.00

Kindred Church - Los Angeles-South Coast County, Winter

EMFAC Off-Model Adjustment Factors for Gasoline Light Duty Vehicle to Account for the SAFE Vehicle Rule Not Applied

2.2 Overall Operational

Unmitigated Operational

	ROG	NOx	CO	SO2	Fugitive PM10	Exhaust PM10	PM10 Total	Fugitive PM2.5	Exhaust PM2.5	PM2.5 Total	Bio- CO2	NBio- CO2	Total CO2	CH4	N2O	CO2e
Category	lb/day										lb/day					
Area	0.3840	2.0000e-005	1.8000e-003	0.0000		1.0000e-005	1.0000e-005		1.0000e-005	1.0000e-005			3.8500e-003	1.0000e-005		4.1100e-003
Energy	0.0000	0.0000	0.0000	0.0000		0.0000	0.0000		0.0000	0.0000			0.0000	0.0000	0.0000	0.0000
Mobile	0.6957	0.7534	6.2015	0.0120	1.2211	0.0107	1.2318	0.3253	9.9500e-003	0.3352			1,225.9661	0.0989	0.0608	1,246.5576
Total	1.0797	0.7534	6.2033	0.0120	1.2211	0.0107	1.2318	0.3253	9.9600e-003	0.3352			1,225.9699	0.0989	0.0608	1,246.5617

Mitigated Operational

	ROG	NOx	CO	SO2	Fugitive PM10	Exhaust PM10	PM10 Total	Fugitive PM2.5	Exhaust PM2.5	PM2.5 Total	Bio- CO2	NBio- CO2	Total CO2	CH4	N2O	CO2e
Category	lb/day										lb/day					
Area	0.3840	2.0000e-005	1.8000e-003	0.0000		1.0000e-005	1.0000e-005		1.0000e-005	1.0000e-005			3.8500e-003	1.0000e-005		4.1100e-003
Energy	0.0000	0.0000	0.0000	0.0000		0.0000	0.0000		0.0000	0.0000			0.0000	0.0000	0.0000	0.0000
Mobile	0.6957	0.7534	6.2015	0.0120	1.2211	0.0107	1.2318	0.3253	9.9500e-003	0.3352			1,225.9661	0.0989	0.0608	1,246.5576
Total	1.0797	0.7534	6.2033	0.0120	1.2211	0.0107	1.2318	0.3253	9.9600e-003	0.3352			1,225.9699	0.0989	0.0608	1,246.5617

Kindred Church - Los Angeles-South Coast County, Winter

EMFAC Off-Model Adjustment Factors for Gasoline Light Duty Vehicle to Account for the SAFE Vehicle Rule Not Applied

	ROG	NOx	CO	SO2	Fugitive PM10	Exhaust PM10	PM10 Total	Fugitive PM2.5	Exhaust PM2.5	PM2.5 Total	Bio- CO2	NBio-CO2	Total CO2	CH4	N2O	CO2e
Percent Reduction	0.00	0.00	0.00	0.00	0.00	0.00	0.00	0.00	0.00	0.00	0.00	0.00	0.00	0.00	0.00	0.00

3.0 Construction Detail

Construction Phase

Phase Number	Phase Name	Phase Type	Start Date	End Date	Num Days Week	Num Days	Phase Description
1	Demolition	Demolition	10/4/2021	12/13/2021	5	50	
2	Grading	Grading	12/14/2021	1/25/2022	5	30	
3	Building Construction	Building Construction	1/26/2022	6/14/2022	5	100	
4	Paving	Paving	6/15/2022	6/28/2022	5	10	
5	Architectural Coating	Architectural Coating	6/29/2022	7/12/2022	5	10	

Acres of Grading (Site Preparation Phase): 0

Acres of Grading (Grading Phase): 15

Acres of Paving: 2.6

Residential Indoor: 0; Residential Outdoor: 0; Non-Residential Indoor: 22,500; Non-Residential Outdoor: 7,500; Striped Parking Area: 6,795 (Architectural Coating – sqft)

OffRoad Equipment

Phase Name	Offroad Equipment Type	Amount	Usage Hours	Horse Power	Load Factor
Demolition	Concrete/Industrial Saws	0	0.00	81	0.73
Demolition	Rubber Tired Dozers	1	8.00	247	0.40
Demolition	Tractors/Loaders/Backhoes	3	8.00	97	0.37
Grading	Graders	0	0.00	187	0.41
Grading	Rubber Tired Dozers	1	8.00	247	0.40
Grading	Tractors/Loaders/Backhoes	3	7.00	97	0.37

Kindred Church - Los Angeles-South Coast County, Winter

EMFAC Off-Model Adjustment Factors for Gasoline Light Duty Vehicle to Account for the SAFE Vehicle Rule Not Applied

Building Construction	Cranes	1	8.00	231	0.29
Building Construction	Forklifts	0	0.00	89	0.20
Building Construction	Generator Sets	0	0.00	84	0.74
Building Construction	Tractors/Loaders/Backhoes	2	6.00	97	0.37
Building Construction	Welders	0	0.00	46	0.45
Paving	Cement and Mortar Mixers	1	8.00	9	0.56
Paving	Pavers	1	8.00	130	0.42
Paving	Paving Equipment	1	8.00	132	0.36
Paving	Rollers	2	8.00	80	0.38
Paving	Tractors/Loaders/Backhoes	1	8.00	97	0.37
Architectural Coating	Air Compressors	1	6.00	78	0.48

Trips and VMT

Phase Name	Offroad Equipment Count	Worker Trip Number	Vendor Trip Number	Hauling Trip Number	Worker Trip Length	Vendor Trip Length	Hauling Trip Length	Worker Vehicle Class	Vendor Vehicle Class	Hauling Vehicle Class
Demolition	4	10.00	0.00	4.00	14.70	6.90	20.00	LD_Mix	HDT_Mix	HHDT
Grading	4	10.00	0.00	325.00	14.70	6.90	20.00	LD_Mix	HDT_Mix	HHDT
Building Construction	3	54.00	21.00	0.00	14.70	6.90	20.00	LD_Mix	HDT_Mix	HHDT
Paving	6	15.00	0.00	0.00	14.70	6.90	20.00	LD_Mix	HDT_Mix	HHDT
Architectural Coating	1	11.00	0.00	0.00	14.70	6.90	20.00	LD_Mix	HDT_Mix	HHDT

3.1 Mitigation Measures Construction

Water Exposed Area

Kindred Church - Los Angeles-South Coast County, Winter

EMFAC Off-Model Adjustment Factors for Gasoline Light Duty Vehicle to Account for the SAFE Vehicle Rule Not Applied

3.2 Demolition - 2021

Unmitigated Construction On-Site

	ROG	NOx	CO	SO2	Fugitive PM10	Exhaust PM10	PM10 Total	Fugitive PM2.5	Exhaust PM2.5	PM2.5 Total	Bio- CO2	NBio- CO2	Total CO2	CH4	N2O	CO2e
Category	lb/day										lb/day					
Fugitive Dust					0.0179	0.0000	0.0179	2.7200e-003	0.0000	2.7200e-003			0.0000			0.0000
Off-Road	1.6082	16.6587	10.8185	0.0179		0.8678	0.8678		0.7984	0.7984			1,730.0524	0.5595		1,744.0408
Total	1.6082	16.6587	10.8185	0.0179	0.0179	0.8678	0.8857	2.7200e-003	0.7984	0.8011			1,730.0524	0.5595		1,744.0408

Unmitigated Construction Off-Site

	ROG	NOx	CO	SO2	Fugitive PM10	Exhaust PM10	PM10 Total	Fugitive PM2.5	Exhaust PM2.5	PM2.5 Total	Bio- CO2	NBio- CO2	Total CO2	CH4	N2O	CO2e
Category	lb/day										lb/day					
Hauling	5.2000e-004	0.0159	3.5900e-003	5.0000e-005	1.4000e-003	1.8000e-004	1.5800e-003	3.8000e-004	1.7000e-004	5.5000e-004			5.5955	2.9000e-004	8.9000e-004	5.8672
Vendor	0.0000	0.0000	0.0000	0.0000	0.0000	0.0000	0.0000	0.0000	0.0000	0.0000			0.0000	0.0000	0.0000	0.0000
Worker	0.0401	0.0318	0.3953	1.0000e-003	0.1118	7.7000e-004	0.1125	0.0296	7.1000e-004	0.0304			101.0263	3.1800e-003	2.9200e-003	101.9747
Total	0.0406	0.0477	0.3989	1.0500e-003	0.1132	9.5000e-004	0.1141	0.0300	8.8000e-004	0.0309			106.6218	3.4700e-003	3.8100e-003	107.8419

Kindred Church - Los Angeles-South Coast County, Winter

EMFAC Off-Model Adjustment Factors for Gasoline Light Duty Vehicle to Account for the SAFE Vehicle Rule Not Applied

3.2 Demolition - 2021

Mitigated Construction On-Site

	ROG	NOx	CO	SO2	Fugitive PM10	Exhaust PM10	PM10 Total	Fugitive PM2.5	Exhaust PM2.5	PM2.5 Total	Bio- CO2	NBio- CO2	Total CO2	CH4	N2O	CO2e
Category	lb/day										lb/day					
Fugitive Dust					8.0700e-003	0.0000	8.0700e-003	1.2200e-003	0.0000	1.2200e-003			0.0000			0.0000
Off-Road	1.6082	16.6587	10.8185	0.0179		0.8678	0.8678		0.7984	0.7984			1,730.0524	0.5595		1,744.0408
Total	1.6082	16.6587	10.8185	0.0179	8.0700e-003	0.8678	0.8759	1.2200e-003	0.7984	0.7996			1,730.0524	0.5595		1,744.0408

Mitigated Construction Off-Site

	ROG	NOx	CO	SO2	Fugitive PM10	Exhaust PM10	PM10 Total	Fugitive PM2.5	Exhaust PM2.5	PM2.5 Total	Bio- CO2	NBio- CO2	Total CO2	CH4	N2O	CO2e
Category	lb/day										lb/day					
Hauling	5.2000e-004	0.0159	3.5900e-003	5.0000e-005	1.4000e-003	1.8000e-004	1.5800e-003	3.8000e-004	1.7000e-004	5.5000e-004			5.5955	2.9000e-004	8.9000e-004	5.8672
Vendor	0.0000	0.0000	0.0000	0.0000	0.0000	0.0000	0.0000	0.0000	0.0000	0.0000			0.0000	0.0000	0.0000	0.0000
Worker	0.0401	0.0318	0.3953	1.0000e-003	0.1118	7.7000e-004	0.1125	0.0296	7.1000e-004	0.0304			101.0263	3.1800e-003	2.9200e-003	101.9747
Total	0.0406	0.0477	0.3989	1.0500e-003	0.1132	9.5000e-004	0.1141	0.0300	8.8000e-004	0.0309			106.6218	3.4700e-003	3.8100e-003	107.8419

Kindred Church - Los Angeles-South Coast County, Winter

EMFAC Off-Model Adjustment Factors for Gasoline Light Duty Vehicle to Account for the SAFE Vehicle Rule Not Applied

3.3 Grading - 2021

Unmitigated Construction On-Site

	ROG	NOx	CO	SO2	Fugitive PM10	Exhaust PM10	PM10 Total	Fugitive PM2.5	Exhaust PM2.5	PM2.5 Total	Bio- CO2	NBio- CO2	Total CO2	CH4	N2O	CO2e
Category	lb/day										lb/day					
Fugitive Dust					6.5621	0.0000	6.5621	3.3690	0.0000	3.3690			0.0000			0.0000
Off-Road	1.5380	15.9478	9.9709	0.0167		0.8259	0.8259		0.7598	0.7598			1,617.2149	0.5230		1,630.2909
Total	1.5380	15.9478	9.9709	0.0167	6.5621	0.8259	7.3880	3.3690	0.7598	4.1288			1,617.2149	0.5230		1,630.2909

Unmitigated Construction Off-Site

	ROG	NOx	CO	SO2	Fugitive PM10	Exhaust PM10	PM10 Total	Fugitive PM2.5	Exhaust PM2.5	PM2.5 Total	Bio- CO2	NBio- CO2	Total CO2	CH4	N2O	CO2e
Category	lb/day										lb/day					
Hauling	0.0704	2.1517	0.4856	6.9300e-003	0.1896	0.0240	0.2137	0.0520	0.0230	0.0750			757.7179	0.0396	0.1202	794.5152
Vendor	0.0000	0.0000	0.0000	0.0000	0.0000	0.0000	0.0000	0.0000	0.0000	0.0000			0.0000	0.0000	0.0000	0.0000
Worker	0.0401	0.0318	0.3953	1.0000e-003	0.1118	7.7000e-004	0.1125	0.0296	7.1000e-004	0.0304			101.0263	3.1800e-003	2.9200e-003	101.9747
Total	0.1105	2.1834	0.8809	7.9300e-003	0.3014	0.0248	0.3262	0.0816	0.0237	0.1053			858.7443	0.0428	0.1231	896.4899

Kindred Church - Los Angeles-South Coast County, Winter

EMFAC Off-Model Adjustment Factors for Gasoline Light Duty Vehicle to Account for the SAFE Vehicle Rule Not Applied

3.3 Grading - 2021

Mitigated Construction On-Site

	ROG	NOx	CO	SO2	Fugitive PM10	Exhaust PM10	PM10 Total	Fugitive PM2.5	Exhaust PM2.5	PM2.5 Total	Bio- CO2	NBio- CO2	Total CO2	CH4	N2O	CO2e
Category	lb/day										lb/day					
Fugitive Dust					2.9530	0.0000	2.9530	1.5160	0.0000	1.5160			0.0000			0.0000
Off-Road	1.5380	15.9478	9.9709	0.0167		0.8259	0.8259		0.7598	0.7598			1,617.2149	0.5230		1,630.2909
Total	1.5380	15.9478	9.9709	0.0167	2.9530	0.8259	3.7788	1.5160	0.7598	2.2758			1,617.2149	0.5230		1,630.2909

Mitigated Construction Off-Site

	ROG	NOx	CO	SO2	Fugitive PM10	Exhaust PM10	PM10 Total	Fugitive PM2.5	Exhaust PM2.5	PM2.5 Total	Bio- CO2	NBio- CO2	Total CO2	CH4	N2O	CO2e
Category	lb/day										lb/day					
Hauling	0.0704	2.1517	0.4856	6.9300e-003	0.1896	0.0240	0.2137	0.0520	0.0230	0.0750			757.7179	0.0396	0.1202	794.5152
Vendor	0.0000	0.0000	0.0000	0.0000	0.0000	0.0000	0.0000	0.0000	0.0000	0.0000			0.0000	0.0000	0.0000	0.0000
Worker	0.0401	0.0318	0.3953	1.0000e-003	0.1118	7.7000e-004	0.1125	0.0296	7.1000e-004	0.0304			101.0263	3.1800e-003	2.9200e-003	101.9747
Total	0.1105	2.1834	0.8809	7.9300e-003	0.3014	0.0248	0.3262	0.0816	0.0237	0.1053			858.7443	0.0428	0.1231	896.4899

Kindred Church - Los Angeles-South Coast County, Winter

EMFAC Off-Model Adjustment Factors for Gasoline Light Duty Vehicle to Account for the SAFE Vehicle Rule Not Applied

3.3 Grading - 2022

Unmitigated Construction On-Site

	ROG	NOx	CO	SO2	Fugitive PM10	Exhaust PM10	PM10 Total	Fugitive PM2.5	Exhaust PM2.5	PM2.5 Total	Bio- CO2	NBio- CO2	Total CO2	CH4	N2O	CO2e
Category	lb/day										lb/day					
Fugitive Dust					6.5621	0.0000	6.5621	3.3690	0.0000	3.3690			0.0000			0.0000
Off-Road	1.2695	13.1922	9.4566	0.0167		0.6539	0.6539		0.6016	0.6016			1,617.7876	0.5232		1,630.8682
Total	1.2695	13.1922	9.4566	0.0167	6.5621	0.6539	7.2161	3.3690	0.6016	3.9706			1,617.7876	0.5232		1,630.8682

Unmitigated Construction Off-Site

	ROG	NOx	CO	SO2	Fugitive PM10	Exhaust PM10	PM10 Total	Fugitive PM2.5	Exhaust PM2.5	PM2.5 Total	Bio- CO2	NBio- CO2	Total CO2	CH4	N2O	CO2e
Category	lb/day										lb/day					
Hauling	0.0493	1.8933	0.4317	6.7300e-003	0.1896	0.0136	0.2032	0.0520	0.0130	0.0650			737.7231	0.0391	0.1171	773.5826
Vendor	0.0000	0.0000	0.0000	0.0000	0.0000	0.0000	0.0000	0.0000	0.0000	0.0000			0.0000	0.0000	0.0000	0.0000
Worker	0.0370	0.0279	0.3614	9.7000e-004	0.1118	7.2000e-004	0.1125	0.0296	6.6000e-004	0.0303			97.8803	2.8500e-003	2.6700e-003	98.7483
Total	0.0863	1.9212	0.7931	7.7000e-003	0.3014	0.0143	0.3157	0.0816	0.0136	0.0953			835.6034	0.0420	0.1197	872.3309

Kindred Church - Los Angeles-South Coast County, Winter

EMFAC Off-Model Adjustment Factors for Gasoline Light Duty Vehicle to Account for the SAFE Vehicle Rule Not Applied

3.3 Grading - 2022

Mitigated Construction On-Site

	ROG	NOx	CO	SO2	Fugitive PM10	Exhaust PM10	PM10 Total	Fugitive PM2.5	Exhaust PM2.5	PM2.5 Total	Bio- CO2	NBio- CO2	Total CO2	CH4	N2O	CO2e
Category	lb/day										lb/day					
Fugitive Dust					2.9530	0.0000	2.9530	1.5160	0.0000	1.5160			0.0000			0.0000
Off-Road	1.2695	13.1922	9.4566	0.0167		0.6539	0.6539		0.6016	0.6016			1,617.7876	0.5232		1,630.8682
Total	1.2695	13.1922	9.4566	0.0167	2.9530	0.6539	3.6069	1.5160	0.6016	2.1176			1,617.7876	0.5232		1,630.8682

Mitigated Construction Off-Site

	ROG	NOx	CO	SO2	Fugitive PM10	Exhaust PM10	PM10 Total	Fugitive PM2.5	Exhaust PM2.5	PM2.5 Total	Bio- CO2	NBio- CO2	Total CO2	CH4	N2O	CO2e
Category	lb/day										lb/day					
Hauling	0.0493	1.8933	0.4317	6.7300e-003	0.1896	0.0136	0.2032	0.0520	0.0130	0.0650			737.7231	0.0391	0.1171	773.5826
Vendor	0.0000	0.0000	0.0000	0.0000	0.0000	0.0000	0.0000	0.0000	0.0000	0.0000			0.0000	0.0000	0.0000	0.0000
Worker	0.0370	0.0279	0.3614	9.7000e-004	0.1118	7.2000e-004	0.1125	0.0296	6.6000e-004	0.0303			97.8803	2.8500e-003	2.6700e-003	98.7483
Total	0.0863	1.9212	0.7931	7.7000e-003	0.3014	0.0143	0.3157	0.0816	0.0136	0.0953			835.6034	0.0420	0.1197	872.3309

Kindred Church - Los Angeles-South Coast County, Winter

EMFAC Off-Model Adjustment Factors for Gasoline Light Duty Vehicle to Account for the SAFE Vehicle Rule Not Applied

3.4 Building Construction - 2022

Unmitigated Construction On-Site

	ROG	NOx	CO	SO2	Fugitive PM10	Exhaust PM10	PM10 Total	Fugitive PM2.5	Exhaust PM2.5	PM2.5 Total	Bio- CO2	NBio- CO2	Total CO2	CH4	N2O	CO2e
Category	lb/day										lb/day					
Off-Road	0.6201	6.6977	5.2493	0.0104		0.3089	0.3089		0.2842	0.2842			1,010.6888	0.3269		1,018.8607
Total	0.6201	6.6977	5.2493	0.0104		0.3089	0.3089		0.2842	0.2842			1,010.6888	0.3269		1,018.8607

Unmitigated Construction Off-Site

	ROG	NOx	CO	SO2	Fugitive PM10	Exhaust PM10	PM10 Total	Fugitive PM2.5	Exhaust PM2.5	PM2.5 Total	Bio- CO2	NBio- CO2	Total CO2	CH4	N2O	CO2e
Category	lb/day										lb/day					
Hauling	0.0000	0.0000	0.0000	0.0000	0.0000	0.0000	0.0000	0.0000	0.0000	0.0000			0.0000	0.0000	0.0000	0.0000
Vendor	0.0408	1.0711	0.3649	4.1100e-003	0.1345	9.8300e-003	0.1444	0.0387	9.4100e-003	0.0481			442.1354	0.0147	0.0638	461.5071
Worker	0.2000	0.1507	1.9514	5.2300e-003	0.6036	3.8600e-003	0.6075	0.1601	3.5600e-003	0.1636			528.5537	0.0154	0.0144	533.2411
Total	0.2408	1.2218	2.3163	9.3400e-003	0.7381	0.0137	0.7518	0.1988	0.0130	0.2118			970.6891	0.0301	0.0782	994.7482

Kindred Church - Los Angeles-South Coast County, Winter

EMFAC Off-Model Adjustment Factors for Gasoline Light Duty Vehicle to Account for the SAFE Vehicle Rule Not Applied

3.4 Building Construction - 2022

Mitigated Construction On-Site

	ROG	NOx	CO	SO2	Fugitive PM10	Exhaust PM10	PM10 Total	Fugitive PM2.5	Exhaust PM2.5	PM2.5 Total	Bio- CO2	NBio- CO2	Total CO2	CH4	N2O	CO2e
Category	lb/day										lb/day					
Off-Road	0.6201	6.6977	5.2493	0.0104		0.3089	0.3089		0.2842	0.2842			1,010.6888	0.3269		1,018.8607
Total	0.6201	6.6977	5.2493	0.0104		0.3089	0.3089		0.2842	0.2842			1,010.6888	0.3269		1,018.8607

Mitigated Construction Off-Site

	ROG	NOx	CO	SO2	Fugitive PM10	Exhaust PM10	PM10 Total	Fugitive PM2.5	Exhaust PM2.5	PM2.5 Total	Bio- CO2	NBio- CO2	Total CO2	CH4	N2O	CO2e
Category	lb/day										lb/day					
Hauling	0.0000	0.0000	0.0000	0.0000	0.0000	0.0000	0.0000	0.0000	0.0000	0.0000			0.0000	0.0000	0.0000	0.0000
Vendor	0.0408	1.0711	0.3649	4.1100e-003	0.1345	9.8300e-003	0.1444	0.0387	9.4100e-003	0.0481			442.1354	0.0147	0.0638	461.5071
Worker	0.2000	0.1507	1.9514	5.2300e-003	0.6036	3.8600e-003	0.6075	0.1601	3.5600e-003	0.1636			528.5537	0.0154	0.0144	533.2411
Total	0.2408	1.2218	2.3163	9.3400e-003	0.7381	0.0137	0.7518	0.1988	0.0130	0.2118			970.6891	0.0301	0.0782	994.7482

Kindred Church - Los Angeles-South Coast County, Winter

EMFAC Off-Model Adjustment Factors for Gasoline Light Duty Vehicle to Account for the SAFE Vehicle Rule Not Applied

3.5 Paving - 2022

Unmitigated Construction On-Site

	ROG	NOx	CO	SO2	Fugitive PM10	Exhaust PM10	PM10 Total	Fugitive PM2.5	Exhaust PM2.5	PM2.5 Total	Bio- CO2	NBio- CO2	Total CO2	CH4	N2O	CO2e
Category	lb/day										lb/day					
Off-Road	0.9412	9.3322	11.6970	0.0179		0.4879	0.4879		0.4500	0.4500			1,709.6892	0.5419		1,723.2356
Paving	0.4847					0.0000	0.0000		0.0000	0.0000			0.0000			0.0000
Total	1.4259	9.3322	11.6970	0.0179		0.4879	0.4879		0.4500	0.4500			1,709.6892	0.5419		1,723.2356

Unmitigated Construction Off-Site

	ROG	NOx	CO	SO2	Fugitive PM10	Exhaust PM10	PM10 Total	Fugitive PM2.5	Exhaust PM2.5	PM2.5 Total	Bio- CO2	NBio- CO2	Total CO2	CH4	N2O	CO2e
Category	lb/day										lb/day					
Hauling	0.0000	0.0000	0.0000	0.0000	0.0000	0.0000	0.0000	0.0000	0.0000	0.0000			0.0000	0.0000	0.0000	0.0000
Vendor	0.0000	0.0000	0.0000	0.0000	0.0000	0.0000	0.0000	0.0000	0.0000	0.0000			0.0000	0.0000	0.0000	0.0000
Worker	0.0556	0.0419	0.5421	1.4500e-003	0.1677	1.0700e-003	0.1687	0.0445	9.9000e-004	0.0455			146.8205	4.2700e-003	4.0100e-003	148.1225
Total	0.0556	0.0419	0.5421	1.4500e-003	0.1677	1.0700e-003	0.1687	0.0445	9.9000e-004	0.0455			146.8205	4.2700e-003	4.0100e-003	148.1225

Kindred Church - Los Angeles-South Coast County, Winter

EMFAC Off-Model Adjustment Factors for Gasoline Light Duty Vehicle to Account for the SAFE Vehicle Rule Not Applied

3.5 Paving - 2022

Mitigated Construction On-Site

	ROG	NOx	CO	SO2	Fugitive PM10	Exhaust PM10	PM10 Total	Fugitive PM2.5	Exhaust PM2.5	PM2.5 Total	Bio- CO2	NBio- CO2	Total CO2	CH4	N2O	CO2e
Category	lb/day										lb/day					
Off-Road	0.9412	9.3322	11.6970	0.0179		0.4879	0.4879		0.4500	0.4500			1,709.6892	0.5419		1,723.2356
Paving	0.4847					0.0000	0.0000		0.0000	0.0000			0.0000			0.0000
Total	1.4259	9.3322	11.6970	0.0179		0.4879	0.4879		0.4500	0.4500			1,709.6892	0.5419		1,723.2356

Mitigated Construction Off-Site

	ROG	NOx	CO	SO2	Fugitive PM10	Exhaust PM10	PM10 Total	Fugitive PM2.5	Exhaust PM2.5	PM2.5 Total	Bio- CO2	NBio- CO2	Total CO2	CH4	N2O	CO2e
Category	lb/day										lb/day					
Hauling	0.0000	0.0000	0.0000	0.0000	0.0000	0.0000	0.0000	0.0000	0.0000	0.0000			0.0000	0.0000	0.0000	0.0000
Vendor	0.0000	0.0000	0.0000	0.0000	0.0000	0.0000	0.0000	0.0000	0.0000	0.0000			0.0000	0.0000	0.0000	0.0000
Worker	0.0556	0.0419	0.5421	1.4500e-003	0.1677	1.0700e-003	0.1687	0.0445	9.9000e-004	0.0455			146.8205	4.2700e-003	4.0100e-003	148.1225
Total	0.0556	0.0419	0.5421	1.4500e-003	0.1677	1.0700e-003	0.1687	0.0445	9.9000e-004	0.0455			146.8205	4.2700e-003	4.0100e-003	148.1225

Kindred Church - Los Angeles-South Coast County, Winter

EMFAC Off-Model Adjustment Factors for Gasoline Light Duty Vehicle to Account for the SAFE Vehicle Rule Not Applied

3.6 Architectural Coating - 2022

Unmitigated Construction On-Site

	ROG	NOx	CO	SO2	Fugitive PM10	Exhaust PM10	PM10 Total	Fugitive PM2.5	Exhaust PM2.5	PM2.5 Total	Bio- CO2	NBio- CO2	Total CO2	CH4	N2O	CO2e
Category	lb/day										lb/day					
Archit. Coating	17.0545					0.0000	0.0000		0.0000	0.0000			0.0000			0.0000
Off-Road	0.2045	1.4085	1.8136	2.9700e-003		0.0817	0.0817		0.0817	0.0817			281.4481	0.0183		281.9062
Total	17.2590	1.4085	1.8136	2.9700e-003		0.0817	0.0817		0.0817	0.0817			281.4481	0.0183		281.9062

Unmitigated Construction Off-Site

	ROG	NOx	CO	SO2	Fugitive PM10	Exhaust PM10	PM10 Total	Fugitive PM2.5	Exhaust PM2.5	PM2.5 Total	Bio- CO2	NBio- CO2	Total CO2	CH4	N2O	CO2e
Category	lb/day										lb/day					
Hauling	0.0000	0.0000	0.0000	0.0000	0.0000	0.0000	0.0000	0.0000	0.0000	0.0000			0.0000	0.0000	0.0000	0.0000
Vendor	0.0000	0.0000	0.0000	0.0000	0.0000	0.0000	0.0000	0.0000	0.0000	0.0000			0.0000	0.0000	0.0000	0.0000
Worker	0.0407	0.0307	0.3975	1.0700e-003	0.1230	7.9000e-004	0.1237	0.0326	7.2000e-004	0.0333			107.6684	3.1300e-003	2.9400e-003	108.6232
Total	0.0407	0.0307	0.3975	1.0700e-003	0.1230	7.9000e-004	0.1237	0.0326	7.2000e-004	0.0333			107.6684	3.1300e-003	2.9400e-003	108.6232

Kindred Church - Los Angeles-South Coast County, Winter

EMFAC Off-Model Adjustment Factors for Gasoline Light Duty Vehicle to Account for the SAFE Vehicle Rule Not Applied

3.6 Architectural Coating - 2022

Mitigated Construction On-Site

	ROG	NOx	CO	SO2	Fugitive PM10	Exhaust PM10	PM10 Total	Fugitive PM2.5	Exhaust PM2.5	PM2.5 Total	Bio- CO2	NBio- CO2	Total CO2	CH4	N2O	CO2e
Category	lb/day										lb/day					
Archit. Coating	17.0545					0.0000	0.0000		0.0000	0.0000			0.0000			0.0000
Off-Road	0.2045	1.4085	1.8136	2.9700e-003		0.0817	0.0817		0.0817	0.0817			281.4481	0.0183		281.9062
Total	17.2590	1.4085	1.8136	2.9700e-003		0.0817	0.0817		0.0817	0.0817			281.4481	0.0183		281.9062

Mitigated Construction Off-Site

	ROG	NOx	CO	SO2	Fugitive PM10	Exhaust PM10	PM10 Total	Fugitive PM2.5	Exhaust PM2.5	PM2.5 Total	Bio- CO2	NBio- CO2	Total CO2	CH4	N2O	CO2e
Category	lb/day										lb/day					
Hauling	0.0000	0.0000	0.0000	0.0000	0.0000	0.0000	0.0000	0.0000	0.0000	0.0000			0.0000	0.0000	0.0000	0.0000
Vendor	0.0000	0.0000	0.0000	0.0000	0.0000	0.0000	0.0000	0.0000	0.0000	0.0000			0.0000	0.0000	0.0000	0.0000
Worker	0.0407	0.0307	0.3975	1.0700e-003	0.1230	7.9000e-004	0.1237	0.0326	7.2000e-004	0.0333			107.6684	3.1300e-003	2.9400e-003	108.6232
Total	0.0407	0.0307	0.3975	1.0700e-003	0.1230	7.9000e-004	0.1237	0.0326	7.2000e-004	0.0333			107.6684	3.1300e-003	2.9400e-003	108.6232

Kindred Church - Los Angeles-South Coast County, Winter

EMFAC Off-Model Adjustment Factors for Gasoline Light Duty Vehicle to Account for the SAFE Vehicle Rule Not Applied

4.0 Operational Detail - Mobile

4.1 Mitigation Measures Mobile

	ROG	NOx	CO	SO2	Fugitive PM10	Exhaust PM10	PM10 Total	Fugitive PM2.5	Exhaust PM2.5	PM2.5 Total	Bio- CO2	NBio- CO2	Total CO2	CH4	N2O	CO2e
Category	lb/day										lb/day					
Mitigated	0.6957	0.7534	6.2015	0.0120	1.2211	0.0107	1.2318	0.3253	9.9500e-003	0.3352			1,225.9661	0.0989	0.0608	1,246.5576
Unmitigated	0.6957	0.7534	6.2015	0.0120	1.2211	0.0107	1.2318	0.3253	9.9500e-003	0.3352			1,225.9661	0.0989	0.0608	1,246.5576

4.2 Trip Summary Information

Land Use	Average Daily Trip Rate			Unmitigated	Mitigated
	Weekday	Saturday	Sunday	Annual VMT	Annual VMT
Other Non-Asphalt Surfaces	0.00	0.00	0.00		
Parking Lot	0.00	0.00	0.00		
Place of Worship	79.95	271.95	271.95	287,515	287,515
Total	79.95	271.95	271.95	287,515	287,515

4.3 Trip Type Information

Land Use	Miles			Trip %			Trip Purpose %		
	H-W or C-W	H-S or C-C	H-O or C-NW	H-W or C-W	H-S or C-C	H-O or C-NW	Primary	Diverted	Pass-by
Other Non-Asphalt Surfaces	16.60	8.40	6.90	0.00	0.00	0.00	0	0	0
Parking Lot	16.60	8.40	6.90	0.00	0.00	0.00	0	0	0
Place of Worship	16.60	8.40	6.90	0.00	95.00	5.00	64	25	11

Kindred Church - Los Angeles-South Coast County, Winter

EMFAC Off-Model Adjustment Factors for Gasoline Light Duty Vehicle to Account for the SAFE Vehicle Rule Not Applied

4.4 Fleet Mix

Land Use	LDA	LDT1	LDT2	MDV	LHD1	LHD2	MHD	HHD	OBUS	UBUS	MCY	SBUS	MH
Other Non-Asphalt Surfaces	0.546774	0.061880	0.186704	0.127505	0.022909	0.005912	0.010702	0.008032	0.000940	0.000617	0.023937	0.000692	0.003397
Parking Lot	0.546774	0.061880	0.186704	0.127505	0.022909	0.005912	0.010702	0.008032	0.000940	0.000617	0.023937	0.000692	0.003397
Place of Worship	0.546774	0.061880	0.186704	0.127505	0.022909	0.005912	0.010702	0.008032	0.000940	0.000617	0.023937	0.000692	0.003397

5.0 Energy Detail

Historical Energy Use: N

5.1 Mitigation Measures Energy

Category	ROG	NOx	CO	SO2	Fugitive PM10	Exhaust PM10	PM10 Total	Fugitive PM2.5	Exhaust PM2.5	PM2.5 Total	Bio- CO2	NBio- CO2	Total CO2	CH4	N2O	CO2e
	lb/day										lb/day					
NaturalGas Mitigated	0.0000	0.0000	0.0000	0.0000		0.0000	0.0000		0.0000	0.0000			0.0000	0.0000	0.0000	0.0000
NaturalGas Unmitigated	0.0000	0.0000	0.0000	0.0000		0.0000	0.0000		0.0000	0.0000			0.0000	0.0000	0.0000	0.0000

Kindred Church - Los Angeles-South Coast County, Winter

EMFAC Off-Model Adjustment Factors for Gasoline Light Duty Vehicle to Account for the SAFE Vehicle Rule Not Applied

5.2 Energy by Land Use - NaturalGas

Unmitigated

	NaturalGas Use	ROG	NOx	CO	SO2	Fugitive PM10	Exhaust PM10	PM10 Total	Fugitive PM2.5	Exhaust PM2.5	PM2.5 Total	Bio- CO2	NBio- CO2	Total CO2	CH4	N2O	CO2e
Land Use	kBTU/yr	lb/day										lb/day					
Other Non-Asphalt Surfaces	0	0.0000	0.0000	0.0000	0.0000		0.0000	0.0000		0.0000	0.0000			0.0000	0.0000	0.0000	0.0000
Parking Lot	0	0.0000	0.0000	0.0000	0.0000		0.0000	0.0000		0.0000	0.0000			0.0000	0.0000	0.0000	0.0000
Place of Worship	0	0.0000	0.0000	0.0000	0.0000		0.0000	0.0000		0.0000	0.0000			0.0000	0.0000	0.0000	0.0000
Total		0.0000	0.0000	0.0000	0.0000		0.0000	0.0000		0.0000	0.0000			0.0000	0.0000	0.0000	0.0000

Kindred Church - Los Angeles-South Coast County, Winter

EMFAC Off-Model Adjustment Factors for Gasoline Light Duty Vehicle to Account for the SAFE Vehicle Rule Not Applied

5.2 Energy by Land Use - NaturalGas

Mitigated

	NaturalGas Use	ROG	NOx	CO	SO2	Fugitive PM10	Exhaust PM10	PM10 Total	Fugitive PM2.5	Exhaust PM2.5	PM2.5 Total	Bio- CO2	NBio- CO2	Total CO2	CH4	N2O	CO2e
Land Use	kBTU/yr	lb/day										lb/day					
Other Non-Asphalt Surfaces	0	0.0000	0.0000	0.0000	0.0000		0.0000	0.0000		0.0000	0.0000			0.0000	0.0000	0.0000	0.0000
Parking Lot	0	0.0000	0.0000	0.0000	0.0000		0.0000	0.0000		0.0000	0.0000			0.0000	0.0000	0.0000	0.0000
Place of Worship	0	0.0000	0.0000	0.0000	0.0000		0.0000	0.0000		0.0000	0.0000			0.0000	0.0000	0.0000	0.0000
Total		0.0000	0.0000	0.0000	0.0000		0.0000	0.0000		0.0000	0.0000			0.0000	0.0000	0.0000	0.0000

6.0 Area Detail

6.1 Mitigation Measures Area

Kindred Church - Los Angeles-South Coast County, Winter

EMFAC Off-Model Adjustment Factors for Gasoline Light Duty Vehicle to Account for the SAFE Vehicle Rule Not Applied

	ROG	NOx	CO	SO2	Fugitive PM10	Exhaust PM10	PM10 Total	Fugitive PM2.5	Exhaust PM2.5	PM2.5 Total	Bio- CO2	NBio- CO2	Total CO2	CH4	N2O	CO2e
Category	lb/day										lb/day					
Mitigated	0.3840	2.0000e-005	1.8000e-003	0.0000		1.0000e-005	1.0000e-005		1.0000e-005	1.0000e-005			3.8500e-003	1.0000e-005		4.1100e-003
Unmitigated	0.3840	2.0000e-005	1.8000e-003	0.0000		1.0000e-005	1.0000e-005		1.0000e-005	1.0000e-005			3.8500e-003	1.0000e-005		4.1100e-003

6.2 Area by SubCategory

Unmitigated

	ROG	NOx	CO	SO2	Fugitive PM10	Exhaust PM10	PM10 Total	Fugitive PM2.5	Exhaust PM2.5	PM2.5 Total	Bio- CO2	NBio- CO2	Total CO2	CH4	N2O	CO2e
SubCategory	lb/day										lb/day					
Architectural Coating	0.0467					0.0000	0.0000		0.0000	0.0000			0.0000			0.0000
Consumer Products	0.3371					0.0000	0.0000		0.0000	0.0000			0.0000			0.0000
Landscaping	1.7000e-004	2.0000e-005	1.8000e-003	0.0000		1.0000e-005	1.0000e-005		1.0000e-005	1.0000e-005			3.8500e-003	1.0000e-005		4.1100e-003
Total	0.3840	2.0000e-005	1.8000e-003	0.0000		1.0000e-005	1.0000e-005		1.0000e-005	1.0000e-005			3.8500e-003	1.0000e-005		4.1100e-003

Kindred Church - Los Angeles-South Coast County, Winter

EMFAC Off-Model Adjustment Factors for Gasoline Light Duty Vehicle to Account for the SAFE Vehicle Rule Not Applied

6.2 Area by SubCategory

Mitigated

	ROG	NOx	CO	SO2	Fugitive PM10	Exhaust PM10	PM10 Total	Fugitive PM2.5	Exhaust PM2.5	PM2.5 Total	Bio- CO2	NBio- CO2	Total CO2	CH4	N2O	CO2e
SubCategory	lb/day										lb/day					
Architectural Coating	0.0467					0.0000	0.0000		0.0000	0.0000			0.0000			0.0000
Consumer Products	0.3371					0.0000	0.0000		0.0000	0.0000			0.0000			0.0000
Landscaping	1.7000e-004	2.0000e-005	1.8000e-003	0.0000		1.0000e-005	1.0000e-005		1.0000e-005	1.0000e-005			3.8500e-003	1.0000e-005		4.1100e-003
Total	0.3840	2.0000e-005	1.8000e-003	0.0000		1.0000e-005	1.0000e-005		1.0000e-005	1.0000e-005			3.8500e-003	1.0000e-005		4.1100e-003

7.0 Water Detail

7.1 Mitigation Measures Water

Kindred Church - Los Angeles-South Coast County, Winter

EMFAC Off-Model Adjustment Factors for Gasoline Light Duty Vehicle to Account for the SAFE Vehicle Rule Not Applied

8.0 Waste Detail

8.1 Mitigation Measures Waste

Institute Recycling and Composting Services

9.0 Operational Offroad

Equipment Type	Number	Hours/Day	Days/Year	Horse Power	Load Factor	Fuel Type
----------------	--------	-----------	-----------	-------------	-------------	-----------

10.0 Stationary Equipment

Fire Pumps and Emergency Generators

Equipment Type	Number	Hours/Day	Hours/Year	Horse Power	Load Factor	Fuel Type
----------------	--------	-----------	------------	-------------	-------------	-----------

Boilers

Equipment Type	Number	Heat Input/Day	Heat Input/Year	Boiler Rating	Fuel Type
----------------	--------	----------------	-----------------	---------------	-----------

User Defined Equipment

Equipment Type	Number
----------------	--------

11.0 Vegetation

Appendix B

Biological Resources Constraints Analysis

May 19, 2021

Mr. Andy Uk
Associate Planner
Planning and Building Development
200 South Anaheim Boulevard, Suite 162
Anaheim, California 92805

VIA EMAIL
auk@anaheim.net

Subject: Results of a Biological Constraints Analysis for Kindred Church Expansion Project in the City of Anaheim, California

Dear Mr. Uk:

This Letter Report presents the findings of a biological constraints survey for the Kindred Church Expansion Project site (hereinafter referred to as the “project site”) located in the City of Anaheim, California. The purpose of this Letter Report is to document existing conditions and evaluate potential biological constraints on the project site.

PROJECT DESCRIPTION AND LOCATION

The project site is located southwest of the intersection of State Route (SR) 91 with SR-241 (Exhibit 1). The site is approximately 11.5 acres with a 0.8-acre offsite percolation area, both specifically located at 8712–8720 East Santa Ana Canyon Road, which is a frontage road along the south-side of SR-91 (Exhibit 2). The project would expand the existing Kindred Church over two phases. Phase 1 would include demolition of an existing structure, relocation of modular buildings, and construction or development of mini-plazas, a remodeled parking lot, and a new temporary turf parking lot. Phase 2 would include a remodeled auditorium with two new wings providing additional seating and back-of-house areas; four new modular buildings; a remodeled parking lot; and addition of a monument sign, landscaping, and a pedestrian pathway.

The project site is located on the U.S. Geological Survey’s (USGS’) Black Star Canyon 7.5-minute quadrangle map with an elevation of approximately 360 to 490 feet above mean sea level (Exhibit 3). Surrounding land uses include open space to the east and west, transportation to the north, and slope stabilization for residential development to the south.

SURVEY METHODS

Psomas Senior Biologist Steve Norton conducted a general plant and wildlife survey of the project site and a 100-foot buffer on March 11, 2021. Representative photographs of the project site are included in Attachment A.

Plant species observed were recorded in field notes. Plant species were identified in the field or collected for subsequent identification using keys in the Jepson eFlora (Jepson Flora Project 2019). Nomenclature of plant taxa conform to the *Special Vascular Plants, Bryophytes, and Lichens List* (CDFW 2021b) for special status species and the Jepson eFlora

5 Hutton Centre Drive
Suite 300
Santa Ana, CA 92707

Tel 714.751.7373
Fax 714.545.8883
www.Psomas.com

Andy Uk
May 19, 2020
Page 2

(Jepson Flora Project 2019) for all other taxa. Nomenclature for native vegetation types generally matches those from the online edition of *A Manual of California Vegetation* (CNPS 2019).

Wildlife species detected during the survey were documented in field notes. Active searches for reptiles and amphibians included lifting, overturning, and carefully replacing rocks and debris. Birds were identified by visual and auditory recognition. Surveys for mammals were conducted during the day and included searching for and identifying diagnostic sign, including scat, footprints, scratch-outs, dust bowls, burrows, and trails. Taxonomy and nomenclature for wildlife generally follows the *Special Animals List* (CDFW 2021c) for special status species. Nomenclature for other species follows Crother (2017) for amphibians and reptiles, the American Ornithological Society (AOS 2018) for birds, and the Revised Checklist of North American Mammals North of Mexico (Bradley, et al. 2014) for mammals.

Prior to the survey, a literature review was conducted to identify special status plants, wildlife, and habitats that have been reported to occur in the vicinity of the project site. Resources reviewed included the California Native Plant Society's (CNPS') Inventory of Rare and Endangered Plants (CNPS 2021b) and the California Department of Fish and Wildlife's (CDFW's) California Natural Diversity Database (CDFW 2021a). Database searches included the USGS' Black Star Canyon, Prado Dam, Orange, and Yorba Linda 7.5-minute quadrangles.

EXISTING CONDITIONS

Vegetation

The project site is predominantly developed with stands of ornamental vegetation spread throughout. The ornamental vegetation is subject to regular landscaping activities and other disturbances associated with human activity onsite. The vegetation consists of ornamental shrubs, such as rosemary (*Rosmarinus officinalis*), in the parking lot medians; a large grove of comprised mostly of European olive (*Olea europaea*) trees with no vegetative understory along a manufactured footpath; and a large variety of landscaped ornamental trees and shrub species throughout the remainder of the site, including date palm (*Phoenix* sp.), pine (*Pinus* sp.), Peruvian pepper (*Schinus molle*), pampas grass (*Cortaderia selloana*), golden wattle (*Acacia* sp.), lavender (*Lavendula* sp.), etc.

The areas adjacent to the project site (within the 100-foot buffer) are mostly undeveloped with the exception of East Santa Ana Canyon Road and SR-91 to the north and the manufactured slope developed for slope stabilization to the south. The vegetation on the manufactured slope is comprised of landscaped ornamental consistent with vegetation located on the project site. Open space land uses border the project site to the east and west. The vegetation types in the 100-foot buffer that occur in this open space include coast live oak (*Quercus agrifolia*) forest to the east, lemonade berry (*Rhus integrifolia*) scrub in isolated stands to the east and southwest, and expansive fennel (*Foeniculum vulgare*) fields to the west.

The coast live oak forest, which is located off-site to the east, is comprised of a dense tree canopy of mature coast live oak trees along the bottom of the valley that shows evidence of a drainage feature. The understory is mostly open with portions dominated either by leaf litter, English ivy (*Hedera helix*), or a mix of low-growing plant species including chilicothe (*Marah macrocarpa*), phacelia (*Phacelia* sp.), and non-native grasses (*Bromus* spp.). The vegetation along the boundary of the coast live oak forest is comprised of various native shrub species, including laurel sumac (*Malosma laurina*) and California sagebrush (*Artemisia californica*).

The lemonade berry scrub, which is located off-site to the east and southwest, is comprised of a broad mix of native shrub species, including lemonade berry, laurel sumac, California sagebrush, California encelia

Andy Uk
May 19, 2020
Page 3

(*Encelia californica*), blue elderberry (*Sambucus nigra* ssp. *caerulea*), and scattered prickly pear (*Opuntia* sp.).

The fennel fields, which are located off-site to the west, are comprised of large, continuous stands of non-native grasses and forbs, including fennel, mustard (*Brassica* sp.), and non-native grasses. Occurrences of native shrub species are sparsely scattered, including California sagebrush and California encelia.

Wildlife Habitat

The project site is composed of landscaped, ornamental vegetation and provides habitat for urban-tolerant wildlife species. The vegetation adjacent to the project site contains habitat suitable for less-urban tolerant wildlife species and some of those species likely have foraging ranges that extend onto the project site. Common wildlife species observed or expected to occur in the project site are discussed below.

A shallow, man-made pond feature occurs in the portion of the project site that would be developed in the future as Parking Lot 3. This pond is regularly drained completely and treated with chlorine every few months (Pers comm. 2021). Evidence of these practices were observed during the site visit with the water levels exposing the pond bed and the aquatic vegetation appearing shriveled and discolored. No fish species were observed onsite and none are expected to occur. No amphibian species (adults, tadpoles, or eggs) were observed onsite. Because the ponded water onsite is chemically treated, no amphibian species are expected to breed onsite.

No reptile species were observed during the survey. Common reptile species that likely occur in the project site include Western fence lizard (*Sceloporus occidentalis*), western side-blotched lizard (*Uta stansburiana elegans*), southern alligator lizard (*Elgaria multicarinata*), and California gopher snake (*Pituophis catenifer annectens*).

Bird species observed during the survey included mallard (*Anas platyrhynchos*), mourning dove (*Zenaidura macroura*), Anna's hummingbird (*Calypte anna*), black phoebe (*Sayornis nigricans*), Nuttall's woodpecker (*Picoides nuttallii*), northern mockingbird (*Mimus polyglottos*), California scrub-jay (*Aphelocoma californica*), blue-gray gnatcatcher (*Poliophtila caerulea*), yellow-rumped warbler (*Setophaga coronata*), California towhee (*Pipilo crissalis*), song sparrow (*Melospiza melodia*), house finch (*Haemorhous mexicanus*), red-tailed hawk (*Buteo jamaicensis*), red-shouldered hawk (*Buteo lineatus*), wrentit (*Chamaea fasciata*), common yellowthroat (*Geothlypis trichas*), white-crowned sparrow (*Zonotrichia leucophrys*), spotted towhee (*Pipilo maculatus*), California thrasher (*Toxostoma redivivum*), and lesser goldfinch (*Spinus psaltria*).

Desert cottontail (*Sylvilagus audubonii*) was observed during the survey. Other small-sized mammal species expected to occur include California ground squirrel (*Spermophilus beecheyi*), eastern fox squirrel (*Sciurus niger*) and Botta's pocket gopher (*Thomomys bottae*). Medium-sized mammal species expected to occur also include Virginia opossum (*Didelphis virginiana*), common raccoon (*Procyon lotor*), striped skunk (*Mephitis mephitis*), and coyote (*Canis latrans*). Many of these mammal species are nocturnal and evidence of these species may not be observable during the day. Bat species are also nocturnal and occur throughout of Southern California. The large oak and pine trees present on the project site contain suitable roosting habitat for tree roosting bats such as hoary bat (*Lasiurus cinereus*), and the onsite buildings contain suitable habitat for crevice roosting bats such as Yuma myotis (*Myotis yumanensis*) and Mexican free-tailed bat (*Tadarida brasiliensis*).

Andy Uk
May 19, 2020
Page 4

Special Status Resources

Special Status Vegetation Types

Vegetation types may be considered special status by State and federal resource agencies, academic institutions, and various conservation groups (e.g., the CNPS). Local jurisdictions may also protect special status vegetation types through ordinances, codes, regulations, or planning policies. The lemonade berry scrub located inside the 100-foot buffer, but outside of the project site, is designated as a Sensitive Natural Community per definitions set by CDFW for the CEQA process (CDFW 2020). While the coast live oak forest, which is located within the survey buffer but outside of the project site, is not listed as a sensitive natural community, it's associated with riparian vegetation and is potentially subject to CDFW jurisdiction under Section 1602 of the California Fish and Game Code.

Jurisdictional Areas

Drainages and associated vegetation types may be subject to regulatory oversight requiring permits from the U.S. Army Corps of Engineers (USACE), the CDFW, and the Regional Water Quality Control Board (RWQCB) pursuant to Sections 404 and 401 of the federal Clean Water Act and Sections 1600 et seq. of the California Fish and Game Code. The USACE and RWQCB take jurisdiction over areas considered “waters of the U.S.” and wetlands. Jurisdictional waters are typically defined by the ordinary high water mark and other specific criteria. The limits of CDFW jurisdiction are often defined by the outer limits of riparian vegetation.

A potentially jurisdictional drainage feature was identified during the survey along the eastern boundary of the project site. The limits of jurisdiction for USACE and/or RWQCB are restricted to the bed and banks for this feature which generally occur outside of the project site boundaries. The limits of jurisdiction for CDFW, however, include the outer drip line of the coast live oak forest, which extends into the project site boundaries.

A small fountain and larger man-made pond are also present on the project site; however, neither are considered jurisdictional due to their lack of connectivity to other drainage features, lack of associated riparian or wetland vegetation, and due to these features being excavated wholly in upland areas not associated with traditional stormwater flows.

A roadside drainage ditch is located along the south side of East Santa Ana Canyon Road (along the northern boundary of the project site). This feature did not contain any wetland or riparian vegetation, but has potential to be jurisdictional under the USACE, RWQCB, and CDFW due to potential connectivity to other drainage features including the feature along the eastern boundary of the project site.

Special Status Plant and Wildlife Species

Plants or wildlife may be considered to have “special status” due to declining populations, vulnerability to habitat change, or restricted distributions. Certain special status species have been listed as Threatened or Endangered under State and/or federal Endangered Species Acts.

Special Status Plants

The project site is comprised development and heavily landscaped, ornamental areas. No suitable habitat for any special status plant species is anticipated to occur on the project site. Areas adjacent to the project site contain suitable habitat for several special status plant species; however, no further assessment is needed as no direct or indirect impacts are anticipated in these areas.

Andy Uk
May 19, 2020
Page 5

Special Status Wildlife

Several special status wildlife species are known to occur in the project region. No federally- or State-listed Threatened or Endangered species are anticipated to occur on the project site due to the extent of the existing development and frequency of landscaping activities. Areas within 100 feet of the project site, however, contain suitable habitat for several federally or State-listed Threatened or Endangered species. The lemonade berry scrub contains habitat suitable for the federally-listed Threatened coastal California gnatcatcher (*Poliopitila californica californica*). The lemonade berry scrub and fennel fields contain habitat suitable for Crotch's bumblebee (*Bombus crotchii*), which is a candidate for State-listing as Endangered.

The areas adjacent to the project site also contain habitat suitable for non-listed special status wildlife species, including California Species of Special Concern (SSC). While none of these species are expected to breed or roost on the project site, the following species have potential to forage onsite: coast range newt (*Taricha torosa*), coastal whiptail (*Aspidoscelis tigris stejnegeri*), red-diamond rattlesnake (*Crotalus ruber*), coast patch-nosed snake (*Salvadora hexalepis virgulata*), coastal cactus wren (*Campylorhynchus brunneicapillus sandiegensis*), grasshopper sparrow (*Ammodramus savannarum*), pallid bat (*Antrozous pallidus*), and western mastiff bat (*Eumops perotis californicus*).

Raptor species, including the SSC Cooper's hawk (*Accipiter cooperii*), also have potential to nest in the ornamental trees or adjacent to the project site.

Other Potential Biological Constraints

Critical Habitat

Critical habitat is designated for the survival and recovery of species listed as Threatened or Endangered under the Federal Endangered Species Act. The project site is not located in areas designated or proposed as Critical Habitat.

Regional Conservation Planning

The project site is located in the Central/Coastal Subregion of the Natural Communities Conservation Plan/Habitat Conservation Plan (NCCP/HCP) in Orange County. The purpose of this plan is to provide regional protection and recovery of multiple species and habitat while allowing compatible land use and appropriate development. The project applicant is not a participant in the NCCP/HCP and the terms of the NCCP/HCP Implementation Agreement do not explicitly apply to this project.

Regardless, the NCCP/HCP has identified regional wildlife movement corridors and reserve areas, which are discussed in more detail below. Furthermore, the NCCP/HCP generally tracks populations of covered species and has developed a framework for surveying these species in the NCCP/HCP plan area sufficient to determine species presence or absence.

Scenic Corridor Overlay Zone

The project is located within the City's Scenic Corridor Overlay Zone (2020). The Scenic Corridor Overlay Zone was established to provide for and promote orderly growth in an area of the City considered to have distinctive, scenic importance. Section 18.18.040 of the City's Municipal Code contains policies and procedures for tree preservation within the Scenic Corridor Overlay Zone, as well as policies pertaining to the removal of trees in this zone.

Andy Uk
May 19, 2020
Page 6

The project requires the removal of 25 trees within the project site. The project has been designed to retain much of the existing vegetation on the project site, which avoids potential visual impacts to views from areas within the scenic corridor. Trees removed would be replaced with other vegetation throughout the project site as shown in the project's landscaping plan. The net number of trees and landscaped area would increase with the project when compared to existing conditions, including enhanced landscaping at the project site entrance.

Given that the current property owner (i.e. the project applicant) originally planted all trees within the project site, removal of these trees is exempt from the requirements for a Specimen Tree Removal Permit. Furthermore, the trees proposed for removal are not located in an area highly visible from a public or private right-of-way or in a commonly viewed slope that would result in damage to viewers from East Santa Ana Canyon Road, SR-91, or other public vantage points within the Scenic Corridor Overlay Zone.

Wildlife Movement

Within large, open space areas where few or no man-made or naturally occurring physical constraints to wildlife movement are present, wildlife corridors may not yet exist. However, once open space areas become constrained and/or fragmented as a result of urban development or the construction of physical obstacles (e.g., roads and highways), the remaining landscape features or travel routes that connect the larger open space areas become corridors as long as they provide adequate space, cover, food, and water and do not contain obstacles or distractions (e.g., man-made noise, lighting) that would generally hinder wildlife movement.

The project site is bordered to the east and west by large, naturally vegetated areas of open space. The open space area west of the project site is confined by residential development to the west and south, and by SR-91 to the north. The open space area east of the project site includes a conservation easement that is adjacent to the eastern boundary of the project site which ultimately connects to a larger Reserve Area included as part of the Central/Coastal HCP/NCCP reserve system (USFWS 2009). The ornamental landscaping on the project site may provide limited wildlife movement opportunities for more urban tolerant wildlife species; however, these opportunities are limited and the existing development (including street lighting) likely deter most movement across the site. Connectivity between the open space areas to the east and west of the project site is available via the approximately 300-foot wide, landscaped slope-stabilization north of the project site. This landscaped area may still limit movement of some native species because it lacks native vegetation or natural vegetation types.

Nesting Birds and Raptors

The Migratory Bird Treaty Act (MBTA) protects migratory birds and their nests and eggs, both common and special status. Bird species protected under the provisions of the MBTA are identified by the List of Migratory Birds (50 *Code of Federal Regulations* [CFR] §10.13, as amended). Since the 1970s, the MBTA has been interpreted to prohibit the accidental or "incidental" take of migratory birds. However, in December 2017, the acting Solicitor of the Department of the Interior issued a new memorandum disclaiming the interpretation of the MBTA as prohibiting incidental take of migratory birds (DOI 2017). In response to the federal changes in interpretation of the MBTA, the CDFW and the California Attorney General have issued an advisory affirming California's protections for migratory birds (CDFW and Attorney General 2018).

Multiple sections of *California Fish and Game Code* provide protection for nesting birds and raptors unless the *California Fish and Game Code* or its implementing regulations provide otherwise. Section 3503 makes it unlawful to take, possess, or needlessly destroy the nest or eggs of any bird. Section 3503.5

Andy Uk
May 19, 2020
Page 7

specifically addresses raptors (i.e., birds of prey in the orders *Falconiformes* and *Strigiformes*) and makes it unlawful to take, possess, or destroy these birds or their nest or eggs. Section 3513 prohibits the take or possession of migratory non-game birds as designated by the MBTA or any part of such bird.

Migratory birds and raptors (both common and special status) have the potential to nest in the vegetation on or adjacent to the project site. Take of active bird nests would be a violation of *California Fish and Game Code*.

Roosting Bats

The CDFW is increasingly recommending the use of pre-construction roosting bat surveys prior to impacts on mature vegetation to avoid and minimize impacts on these species, in compliance with Section 4150 of *California Fish and Game Code*. As discussed above, bats may roost in large, mature, ornamental trees on the project site as well as within onsite buildings that contain suitable crevices.

CEQA IMPACT ANALYSIS

Impact Question

a) Have a substantial adverse effect, either directly or through habitat modifications, on any species identified as a candidate, sensitive, or special status species in local or regional plans, policies, or regulations, or by the California Department of Fish and Wildlife or U.S. Fish and Wildlife Service?

Response

Less Than Significant Impact with Mitigation. No native vegetation types or suitable habitat for any special status plant or wildlife species occurs on the project site. No direct impact to any special status species is anticipated as a result of this project.

The following federally- and/or State-listed Threatened, Endangered, or Candidate wildlife species have potential to occur adjacent to the project site and could be subject to indirect impacts (such as noise and vibration) associated with the proposed project: coastal California gnatcatcher and Crotch's bumblebee. Any impact to these species would be considered significant. Potential impacts to these species would be reduced to less than significant levels by implementing the recommendations listed at the end of this report.

The following SSC have potential to occur adjacent to the project site and could be subject to indirect impacts associated with the proposed project: coast range newt, coastal whiptail, red-diamond rattlesnake, coast patch-nosed snake, coastal cactus wren, grasshopper sparrow, pallid bat, and western mastiff bat. Cooper's hawk, an additional SSC, has potential to nest both on and adjacent to the project site. Impacts to any bird species during its nesting activities, including coastal cactus wren, grasshopper sparrow, and Cooper's hawk, would be a violation of the *California Fish and Game Code* and would be considered significant. Impacts to nesting birds would be reduced to less than significant by implementing the recommendations listed at the end of this report. Potential indirect impacts to SSC not otherwise addressed by bird nesting minimization measures are considered less than significant because the proposed project would not reduce the populations of these species below self-sustaining levels.

Potential indirect impacts to any special status plant species adjacent to the project site resulting from dust accumulation would be less than significant and no additional measures are recommended.

Andy Uk
May 19, 2020
Page 8

No impacts to any federally designated Critical Habitat or to habitat of any other special status plant or wildlife species would occur as a result of the project.

Impact Questions

- b) Have a substantial adverse effect on any riparian habitat or other sensitive natural community identified in local or regional plans, policies, regulations or by the California Department of Fish and Wildlife or U.S. Fish and Wildlife Service?
- c) Have a substantial adverse effect on state or federally protected wetlands (including, but not limited to, marsh, vernal pool, coastal, etc.) through direct removal, filling, hydrological interruption, or other means?

Response

No Impact. A drainage feature potentially jurisdictional under USACE, RWQCB, and CDFW extends along the eastern boundary of the project site. The limits of jurisdiction for USACE and/or RWQCB are restricted to the bed and banks for this feature which generally occur outside of the project site boundaries and no impacts are anticipated. The limits of jurisdiction for CDFW, however, includes the coast live oak forest which extends into the project site boundaries. No tree or vegetation removal within any area associated with this coast live oak forest or associated drainage feature would occur as part of the proposed project and no impacts are anticipated.

A roadside drainage ditch also occurs along the south side of East Santa Ana Canyon Road (along the northern boundary of the project site). This feature did not contain any wetland or riparian vegetation, but has potential to be jurisdictional under the USACE, RWQCB, and CDFW due to potential connectivity to other drainage features including the feature along the eastern boundary of the project site. This feature occurs outside the impact boundary of the proposed project and no impacts would occur.

Therefore, the project would have no impact to any wetlands or other jurisdictional areas pursuant to the USACE, RWQCB, or CDFW.

Andy Uk
 May 19, 2020
 Page 9

Impact Question

- d) Interfere substantially with the movement of any native resident or migratory fish or wildlife species or with established native resident or migratory wildlife corridors, or impede the use of native wildlife nursery sites?

Response

Less Than Significant Impact with Mitigation. The existing conditions at the project site currently limit or deter wildlife movement between the open space land uses to the west and east of the project site. Regardless, the proposed project consists of the redevelopment of an existing developed project site consistent with the existing land uses applicable to the site. Aspects of the project that could further constrain wildlife movement include the addition and relocation of structures, removal of vegetation, and the addition of lighting throughout the project site. Any of these new effects to wildlife movement resulting from the proposed project would not likely result in a significant effect to regional wildlife movement. Impacts to wildlife movement corridors would be less than significant.

The vegetation on and adjacent to the project site provide suitable nesting habitat for bird species protected under California Fish and Game Code. A routine construction practice to avoid impacts is to schedule tree and vegetation removal outside of the breeding season. This requires that all tree removal occur during the non-nesting bird season (i.e., September 1 to February 14). If vegetation removal activities are planned to occur during the nesting season, impacts to actively nesting bird species protected under the *California Fish and Game Code* could be impacted. Implementation of the recommendations below would ensure that impacts to nesting birds are reduced to less than significant levels.

Impact Questions

- e) Conflict with any local policies or ordinances protecting biological resources, such as a tree preservation policy or ordinance?

Response

Less Than Significant Impact. The project would require vegetation removal within the City’s Scenic Corridor Overlay Zone on a project site that is visible from an eligible state scenic highway. As discussed above, views of the project site would be minimally affected by the removal of 25 trees associated with the project. Furthermore, the project would be developed consistent with the Municipal Code policies related to the Scenic Corridor Overlay Zone. Therefore, less than significant impacts would result from the project related to this threshold, and no mitigation is required.

Impact Questions

- f) Conflict with provisions of an adopted Habitat Conservation Plan, Natural Community Conservation Plan, or other approved local, regional, or state habitat conservation plan?

Response

Less than Significant. The project site is located within the boundaries of the Central/Coastal NCCP/HCP; however, it is not within a Reserve Area or Special Linkage Area and no impacts to Central/Coastal NCCP/HCP are anticipated.

Andy Uk
May 19, 2020
Page 10

The eastern boundary of project site borders a conservation easement. Proposed night lighting associated with the project has the potential to affect the function of this conservation easement area. However, the project design identifies that all new and replaced pole mounted light fixtures would consist of downcast, shielded lighting. This would focus new project lighting onsite and would minimize illumination of the adjacent conservation easement. Therefore, potential impacts would be less than significant and no additional measures are recommended beyond the project design.

RECOMMENDATIONS

The following measures are recommended to avoid and minimize impacts on biological resources:

1. Focused surveys for coastal California gnatcatcher are recommended to determine whether the species is present or absent in the adjacent lemonade berry scrub vegetation to minimize potential indirect impact. Per the survey methods outlined in the Central/Coastal NCCP/HCP, three focused survey visits by a permitted coastal California gnatcatcher biologist are recommended prior to any construction activities within 500 feet of any suitable habitat. The surveys can be conducted year-round; however, it is preferable to conduct the surveys between March 15 and June 30. If the coastal California gnatcatcher are determined to be absent and construction occurs within one year of survey completion, then no further measures are needed. If the adjacent habitat is determined to be occupied, vegetation removal and ground disturbance activities within 500 feet may only occur outside of the nesting season (i.e., September 1–February 14).
2. A pre-construction focused survey for Crotch's bumble bee is recommended during the Crotch's bumble bee active period (i.e., March to July) no more than one year prior to the start of construction. The survey will be a visual survey conducted by a Biologist. The Biologist will search for Crotch's bumble bee activity and the presence of ground nests. If a ground nest is observed, it will be protected in place until it is no longer active as determined by a Biologist.
3. To avoid impacts to nesting birds and raptors, initiation of construction should be scheduled between September 1 and February 14, which is outside the peak nesting season. If construction and/or vegetation removal must occur during the peak nesting season (i.e., February 15– August 31), a pre-construction nesting bird survey should be conducted by a qualified Biologist within 7 days prior to vegetation removal activities.

If the Biologist finds an active nest within or adjacent to the construction area, the Biologist will identify an appropriate protective buffer zone around the nest depending on the sensitivity of the species, the nature of the construction activity, and the amount of existing disturbance in the vicinity. In general, the Biologist should designate a buffer between 10 to 300 feet for common nesting birds and between 200 to 500 feet for nesting raptors. No construction activities will be allowed within the buffer until the nest is deemed to be no longer active by the Biologist to ensure compliance with *California Fish and Game Code*.

4. To avoid impacts on maternity roosting bats, tree removal should occur outside the bat maternity season (i.e., April through August). A pre-construction roost emergence survey will be conducted no more than one year prior to the start of construction by a qualified biologist. Trees and/or structures that are being used by roosting bats and those within 100 feet of an active roost may not be removed during the maternity season to avoid impacts on an active maternity roost, which may include juvenile bats that cannot fly.

Andy Uk
May 19, 2020
Page 11

If you have any questions or comments, please contact Steve Norton at Steve.Norton@Psomas.com or 714.751.7373.

Sincerely,

P S O M A S



Steve Norton
Senior Biologist

Enclosures: Exhibit 1 – Project Vicinity
 Exhibit 2 – Aerial Photograph
 Exhibit 3 – USGS Topographic Map
 Attachment A – Site Photographs

Andy Uk
 May 19, 2020
 Page 12

REFERENCES

- American Ornithological Society (AOS). 2018 (October). *Checklist of North and Middle American Birds* (7th ed., as revised through 58th Supplement). Washington, D.C.: AOU. <http://checklist.aou.org/>.
- Bradley, RD, Ammerman, LK, Baker, RJ, Bradley, LC, Cook, JA, Dowler, RC, Jones, C, Schmidly, DJ, Stangl, Jr., FB, Van Den Bussche, RA, and Würsig, B. 2014 (October 2). Revised Checklist of North American Mammals North of Mexico, 2014. Texas Tech University Natural Science Research Laboratory, Occasional Papers (Number 327). Lubbock, TX: Museum of Texas Tech University.
- California Department of Fish and Wildlife (CDFW). 2021a (March 10, date accessed). California Natural Diversity Database. Records of Occurrence for the USGS Black Star Canyon, Prado Dam, Orange, and Yorba Linda 7.5-minute quadrangles. Sacramento, CA: CDFW, Natural Heritage Division.
- . 2021b (April). *Special Vascular Plants, Bryophytes, and Lichens List*. Sacramento, CA: CDFW, Natural Heritage Division.
- . 2021c (April). *Special Animals List*. Sacramento, CA: CDFW, Natural Heritage Division.
- . 2020 (September). *California Natural Communities List*. Natural Communities List Arranged Alphabetically by Life Form (PDF). Sacramento, CA: CDFW Biogeographic Data Branch. <https://nrm.dfg.ca.gov/FileHandler.ashx?DocumentID=153398&inline>.
- California Department of Fish and Wildlife and California Attorney General Xavier Becerra (CDFW and Attorney General). 2018 (November 29). *Advisory Affirming California's Protections for Migratory Birds*. Sacramento, CA: CDFW. <https://oag.ca.gov/system/files/attachments/press-docs/20181129mbta-advisory3.pdf>.
- California Native Plant Society (CNPS). 2021a (March 10, date accessed). A Manual of California Vegetation, Online Edition. Sacramento, CA: CNPS. <http://www.cnps.org/cnps/vegetation/>.
- . 2021b (March 10, date accessed). Inventory of Rare and Endangered Plants (online edition, v8-03). Records of Occurrence for the USGS Black Star Canyon, Prado Dam, Orange, and Yorba Linda 7.5-minute quadrangles. Sacramento, CA: CNPS. <http://www.rareplants.cnps.org/>.
- Crother, B.I. (Ed.). 2017 (September). Scientific and Standard English Names of Amphibians and Reptiles of North America North of Mexico, with Comments Regarding Confidence in Our Understanding. *Society for the Study of Amphibians and Reptiles Herpetological Circular* 43:1–102. <https://ssarherps.org/wp-content/uploads/2017/10/8th-Ed-2017-Scientific-and-Standard-English-Names.pdf>
- Department of the Interior, Office of the Solicitor (DOI). 2017 (December 22). *The Migratory Bird Treaty Act Does Not Prohibit Incidental Take*. Washington, D.C.: DOI. <https://www.doi.gov/sites/doi.gov/files/uploads/m-37050.pdf>.
- Jepson Flora Project. 2019 (December, Revision 7). Jepson eFlora. Berkeley, CA: The Jepson Herbarium. <http://ucjeps.berkeley.edu/eflora/>.

Andy Uk
May 19, 2020
Page 13

Personal Communication (Pers. Comm.). 2021 (March 11). Onsite conversation with Dave Mitchell, Director of Facilities for Kindred Church.

US Fish and Wildlife Service (USFWS), Pacific Southwest Region. 2009 (December 31). Orange County Central Coastal NCCP/HCP. Conservation Biology Institute via Databasin website:
<https://databasin.org/datasets/ed49d8389c2349f2a0c9e56cfc7c48ef/>

Chino Hills State Park



Jean Woodard Park

East Side Community Park

Box Canyon Park

Featherly Regional Park

Brush Canyon Park

Bryant Ranch Elementary School

At and SF Railroad

La Palma Ave

Gypsum Canyon Rd

91

Featherly Regional Park

Santa Ana Canyon Rd

Sycamore Park

Toyon Park

Running Springs Elem School

Serrano Ave

241

Weir Canyon Regional Park



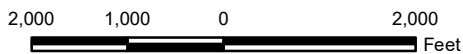
Project Boundary

D:\Projects\3ANA\009402\MXD\Biolex_Vicinity_20210512.mxd

Vicinity Map

Kindred Church Expansion Project (City of Anaheim)

Exhibit 1



D:\Projects\3\ANA\009402\MXDex_Aerial_20210505.mxd

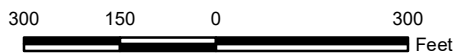


Aerial Source: ESRI, Maxar 2020

Aerial Photograph


Exhibit 2

Kindred Church Expansion Project (City of Anaheim)





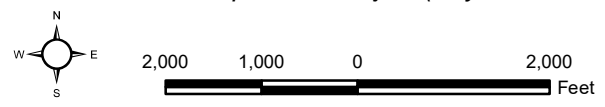
D:\Projects\3ANA\009402\MXD\Biolex_USGS_20210512.mxd

 Project Boundary

Source: USGS 7.5 Minute Quadrangle
 Blackstar Canyon
 Township: 03S
 Range: 08W
 Section: 33

USGS Topographic Map
Kindred Church Expansion Project (City of Anaheim)

Exhibit 3



ATTACHMENT A
SITE PHOTOGRAPHS



Photo of Parking Lot 1 facing west. The large, onsite, ornamental tree vegetation occurs throughout the site. The hills in the background are comprised of the fennel fields adjacent to the project site.



Photo of the project site boundary on the west side of Parking Lot 2 facing south. The shrubby vegetation along in the center of the photograph and into the background is characteristic of the lemonade berry scrub stands adjacent to the project site.

D:\Projects\3\ANA\009402\GRAPHICS\Bio\Att_SP1_20210512.ai

Site Photographs

Kindred Church Expansion Project (City of Anaheim)

Attachment A-1





Photo of Parking Lot 1 facing south. View of the ornamental vegetation on the manufactured slopes located south of the project site.



Photo of the coast live oak forest and associated drainage feature located along the eastern boundary of the project site. This will not be impacted as part of the proposed project.

D:\Projects\3\ANA\009402\GRAPHICS\Bio\Att_SP2_20210512.ai

Site Photographs

Kindred Church Expansion Project (City of Anaheim)

Attachment A-2





Photo of the man-made pond located at Parking Lot 3 (feature to be removed). The feature is regularly drained and chlorinated.



Photo of the roadside ditch located along the northern boundary of the project site south of East Santa Ana Canyon Road.

D:\Projects\3\ANA\009402\Graphics\Bio\Att_SP3_20210512.ai

Site Photographs

Kindred Church Expansion Project (City of Anaheim)

Attachment A-3



Appendix C
Energy Calculations

Energy Use Summary

Construction Phase (gallons/construction period)	Gasoline	Diesel
Construction Vehicles	17	3,981
Worker Trips	3,964	16
Vendor Trips	734	10
Haul Trucks	1	1,002
Total	4,716	5,009

Operations Phase (gallons/year)	Gasoline	Diesel	Natural Gas (kBTU/yr)	Electricity (kWh/yr)
Church	10,530	129	0	152,255
0	0	0	0	0
0	0	0	0	0
0	0	0	0	0
0	0	0	0	0
0	0	0	0	0
All Land Uses	10,530	129	0	152,255

Operations Onroad Energy Use

Year: 2022

Vehicle Types	MPG by Fuel Type			Population by Fuel Type			
	GAS	DSL	ELEC	GAS	DSL	ELEC	Total
LDA	30.8	48.7		6,542,832	58,938	127,533	6,601,770
LDT1	26.5	22.6		736,906	387	5,339	737,293
LDT2	24.7	35.7		2,246,303	14,235	22,590	2,260,537
LHDT1	10.5	21.6		175,903	119,381		295,284
LHDT2	9.2	19.5		30,010	47,336		77,346
MCY	36.4			295,960			295,960
MDV	20.0	27.4		1,579,640	33,349	11,658	1,612,989
MH	5.2	10.6		35,098	12,759		47,857
MHDT	5.1	10.7		25,445	123,310		148,755
HHDT	4.2	6.7		73	108,362		108,440
OBUS	5.0	8.5		5,859	4,274		10,234
SBUS	9.1	7.6		2,631	6,631		9,262
LBUS	4.9	6.0		952	14	17	966

Trips/Day Land Use	Trips/day Weekday	Trips/day Saturday	Trips/day Sunday	Total Weekly	VMT/day Weekday	VMT/day Saturday	VMT/day Sunday	Trip Length
Church	80.00	272.00	272.00	944	469	1,593	1,593	5.86

Total **80** **272** **272**

Fleet Mix Land Use	LDA	LDT1	LDT2	MDV	LHD1	LHD2	MHD	HHDT	OBUS	UBUS	MCY	SBUS	MH	Total
Church	0.614215	0.040586	0.209252	0.126005	0	0	0	0	0.001578	0.001284	0.005047	0.001028	0.001005	100.0%

Vehicle Trips

Weekday Trips	LDA	LDT1	LDT2	MDV	LHD1	LHD2	MHDT	HHDT	Obus	Ubus	MCY	Sbus	MH	Total	Daily VMT
Church	49	3	17	10	0	0	0	0	0	0	0	0	0	80	468.57
	0	0	0	0	0	0	0	0	0	0	0	0	0	0	-
	0	0	0	0	0	0	0	0	0	0	0	0	0	0	-
	0	0	0	0	0	0	0	0	0	0	0	0	0	0	-
	0	0	0	0	0	0	0	0	0	0	0	0	0	0	-
Total	49	3	17	10	0	0	0	0	0	0	0	0	0	80	

Saturday Trips	LDA	LDT1	LDT2	MDV	LHD1	LHD2	MHDT	HHDT	Obus	Ubus	MCY	Sbus	MH	Total	Daily VMT
Church	167	11	57	34	0	0	0	0	0	0	1	0	0	272	1,503.14
	0	0	0	0	0	0	0	0	0	0	0	0	0	0	-
	0	0	0	0	0	0	0	0	0	0	0	0	0	0	-
	0	0	0	0	0	0	0	0	0	0	0	0	0	0	-
	0	0	0	0	0	0	0	0	0	0	0	0	0	0	-
Total	167	11	57	34	0	0	0	0	0	0	1	0	0	272	

Sunday Trips	LDA	LDT1	LDT2	MDV	LHD1	LHD2	MHDT	HHDT	Obus	Ubus	MCY	Sbus	MH	Total	Daily VMT
Church	167	11	57	34	0	0	0	0	0	0	1	0	0	272	1,593.14
	0	0	0	0	0	0	0	0	0	0	0	0	0	0	-
	0	0	0	0	0	0	0	0	0	0	0	0	0	0	-
	0	0	0	0	0	0	0	0	0	0	0	0	0	0	-
	0	0	0	0	0	0	0	0	0	0	0	0	0	0	-
Total	167	11	57	34	0	0	0	0	0	0	1	0	0	272	

Gallons of Fuel

Gasoline	LDA	LDT1	LDT2	MDV	LHD1	LHD2	MHDT	HHDT	Obus	Ubus	MCY	Sbus	MH	Total
Church	5,674	441	2,424	1,774	0	0	0	0	52	75	40	9	41	10,530
	0	0	0	0	0	0	0	0	0	0	0	0	0	0
	0	0	0	0	0	0	0	0	0	0	0	0	0	0
	0	0	0	0	0	0	0	0	0	0	0	0	0	0
	0	0	0	0	0	0	0	0	0	0	0	0	0	0
	0	0	0	0	0	0	0	0	0	0	0	0	0	0
	5,674	441	2,424	1,774	0	0	0	0	52	75	40	9	41	10,530
														10,530 Total Gallons

Diesel	LDA	LDT1	LDT2	MDV	OBUS	LHD2	MHDT	HHDT	Obus	Ubus	MCY	Sbus	MH	Total
Church	32	0	11	27	0	0	0	0	22	1	0	28	7	129
	0	0	0	0	0	0	0	0	0	0	0	0	0	0
	0	0	0	0	0	0	0	0	0	0	0	0	0	0
	0	0	0	0	0	0	0	0	0	0	0	0	0	0
	0	0	0	0	0	0	0	0	0	0	0	0	0	0
	0	0	0	0	0	0	0	0	0	0	0	0	0	0
	32	0	11	27	0	0	0	0	22	1	0	28	7	129
														129 Total Gallons

10,659 Total Gallons

Offroad Construction Equipment Energy Use

PhaseName	OffRoadEquipmentType	OffRoadEquipmentUnitAmount	UsageHours	HorsePower	Load Factor	Horsepower Category	Num Days	Year	Fuel Consumption Rate (gal/hour)	Fuel Type	Total Fuel Consumption (gal/construction period)
Demolition	Concrete/Industrial Saws	0	0	81	0.73	100	50	2021	4.7	Gasoline	0
Demolition	Rubber Tired Dozers	1	8	247	0.4	300	50	2021	4.5	Diesel	714
Demolition	Tractors/Loaders/Backhoes	3	8	97	0.37	100	50	2021	1.6	Diesel	705
Grading	Graders	0	0	187	0.41	175	30	2021	3.1	Diesel	0
Grading	Rubber Tired Dozers	1	8	247	0.4	300	30	2021	4.5	Diesel	429
Grading	Tractors/Loaders/Backhoes	3	7	97	0.37	100	30	2021	1.6	Diesel	370
Building Construction	Cranes	1	8	231	0.29	300	100	2021	3.3	Diesel	763
Building Construction	Forklifts	0	0	89	0.2	100	100	2021	2.0	Diesel	0
Building Construction	Generator Sets	0	0	84	0.74	100	100	2021	5.2	Gasoline	0
Building Construction	Tractors/Loaders/Backhoes	2	6	97	0.37	100	100	2021	1.6	Diesel	705
Building Construction	Welders	0	0	46	0.45	50	100	2021	2.4	Gasoline	0
Paving	Cement and Mortar Mixers	1	8	9	0.56	25	10	2021	0.4	Gasoline	17
Paving	Pavers	1	8	130	0.42	100	10	2021	1.7	Diesel	58
Paving	Paving Equipment	1	8	132	0.36	100	10	2021	1.6	Diesel	47
Paving	Rollers	2	8	80	0.38	100	10	2021	1.7	Diesel	103
Paving	Tractors/Loaders/Backhoes	1	8	97	0.37	100	10	2021	1.6	Diesel	47
Architectural Coating	Air Compressors	1	6	78	0.48	100	10	2021	1.3	Diesel	38
									Total	Gasoline	17
									Total	Diesel	3,981

Appendix D
Soils Report



November 10, 2020

Project No. 15-5382

Kindred Community Church
100 South Chaparral Court
Anaheim, CA 92808

Subject: Percolation Testing Results for WQMP, Pavement Design and Building Expansion Foundation Recommendations, Kindred Church, 8720 East Santa Ana Canyon Road, Anaheim, California.

In accordance with your request and authorization, TGR Geotechnical, Inc. (TGR) has completed a geotechnical investigation to provide infiltration rates from percolation testing, asphalt concrete pavement design and Fellowship Hall main church building expansion foundation recommendations at the subject site. It is our understanding that the proposed improvements consist of the expansion of the central and southern parking lots, installation of three infiltration basins and the expansion of the main church building.

Based on our investigation the proposed improvements are feasible from a geotechnical standpoint provided the recommendations presented in this report are implemented during design and construction.

SCOPE OF SERVICES

Our scope of work included performing the following tasks:

- Site reconnaissance.
- Review of previous geotechnical reports for the subject site.
- Percolation testing in three (3) locations to a depth of approximately 10.5 feet below existing grade. Percolation testing followed the Orange County Technical Guidance Document, Appendix VII. The borings were be backfilled with soil cuttings and soil was disposed on-site.
- Sampling and logging two (2) hollow stem auger borings to a depth of approximately 5.5 feet below existing grade. The borings were backfilled with soil cuttings and sealed with cold patch asphalt upon completion. Any excess soil was disposed onsite.
- Laboratory testing of selected samples to include: in situ moisture and density, maximum dry density and optimum moisture content, shear, passing No. 200 sieve and R-Value.
- Preparation of this report presenting the results of percolation testing, infiltration rate from the percolation testing, pavement design recommendations for the proposed parking lot and geotechnical design recommendations for the proposed church building expansion.

FIELD INVESTIGATION

Field exploration was performed on October 13, 2020 by representatives from our firm who logged the borings and obtained representative samples, which were subsequently transported to the laboratory for further review and testing. The approximate locations of the borings are indicated on the enclosed Geotechnical Map (Plate 1).

The subsurface conditions were explored by drilling, sampling, and logging two (2) borings with a truck mounted hollow stem drill rig to an approximate depth of five and one-half (5.5) feet below existing grade and three (3) borings to ten and one-half (10.5) feet below existing grade for percolation testing. Subsequent to drilling, all borings were backfilled with soil cuttings and the surface was repaired with cold patch asphalt, where appropriate. The logs of borings presenting soil conditions and descriptions are provided as Plates 2 through 6.

The drill rig was equipped with a sampling apparatus to allow for recovery of driven modified California Ring Sampler (CRS), 3-inch outside diameter, and 2.42-inch inside diameter samples. Driven samples and bulk samples of the earth materials encountered at selected intervals were recovered from the borings.

The samples were driven using an automatic 140-pound hammer falling freely from a height of 30 inches. The blow counts for CRS were converted to equivalent SPT blow counts. Soil descriptions were entered on the logs in general accordance with the Unified Soil Classification System (USCS). The locations and depths of the soil samples recovered are indicated on the logs on Plates 2 through 6.

PERCOLATION TESTING

Percolation testing was performed at the subject site utilizing the Porchet Method. Presented below are the infiltration rates from the percolation tests performed at the subject site. These do not include any factor of safety.

- P-1 at 0-10.5 feet 0.10 inches per hour
- P-2 at 0-10.5 feet 0.20 inches per hour
- P-3 at 0-10.5 feet 0.15 inches per hour

The infiltration test rates were determined in general accordance with Orange County Public Works Technical Guidance Document (2011).

LABORATORY TESTING

Laboratory tests were performed on representative samples to verify the field classification of the recovered samples and to evaluate the geotechnical properties of the subsurface soils. The following tests were performed:

- In-situ moisture content (ASTM D2216) and dry density (ASTM D7263);
- Maximum Dry Density and Optimum Moisture Content (ASTM D1557);
- Direct Shear Strength (ASTM D3080);
- Expansion Potential (ASTM D4829);
- Passing No. 200 sieve (ASTM 1140);
- R-Value Determination (CAL 301); and
- Soluble Sulfate (CAL.417A).

Moisture and Density Determination Tests: Moisture content and dry density determinations were performed on relatively undisturbed samples obtained from the test borings. The results of these tests are presented in the boring logs. Where applicable, only moisture content was determined from "undisturbed" or disturbed samples.

Maximum Density Tests: The maximum dry density and optimum moisture content of typical materials were determined in accordance with ASTM Test Method D1557. The results of these tests are presented on Plate 7 and in the table below:

Sample Location	Sample Description	Maximum Dry Density (Pcf)	Optimum Moisture Content (%)
P-2 @ 0-5 feet	Clayey Sand	113.0	16.0

Direct Shear Tests: Direct shear test was performed on selected remolded and/or undisturbed sample, which was soaked for a minimum of 24 hours under a surcharge equal to the applied normal force during testing. After transfer of the sample to the shear box, and reloading the sample, pore pressures set up in the sample due to the transfer were allowed to dissipate for a period of approximately 1-hour prior to application of shearing force. The sample was tested under various normal loads, a motor-driven, strain-controlled, direct-shear testing apparatus at a strain rate of less than 0.001 to 0.5 inches per minute (depending upon the soil type). The test results are presented on Plate 8 and in the table below:

Sample Location	Sample Description	Friction Angle (degrees)	Apparent Cohesion (psf)
P-2 @ 0-5 feet	Remolded Shear – Clayey Sand	26	462

Expansion Index Tests: The expansion potential of selected materials was evaluated by the Expansion Index Test, ASTM D4829. Specimens are molded under a given compactive energy to approximately the optimum moisture content and approximately 50 percent saturation or approximately 90 percent relative compaction. The prepared 1-inch thick by 4-inch diameter specimens are loaded to an equivalent 144 psf surcharge and are inundated with tap water until volumetric equilibrium is reached. The results of these tests are presented in the table below:

Sample Location	Sample Description	Expansion Index	Expansion Potential
P-1 @ 0-5 feet	Clayey Sand	64	Medium

Wash Sieve Test: Typical materials were washed over No. 200 sieve (ASTM Test Method D1140). The test results are presented below:

Sample Location	% Passing No. 200 Sieve
P-1 @ 4 feet	45.5%
P-1 @ 9 feet	46.1%

P-2 @ 4 feet	53.0%
P-2 @ 9 feet	59.0%
P-3 @ 4 feet	33.9%
P-3 @ 9 feet	43.5%

R-Value: The resistance “R”-Value was determined by the California Materials Method No. 301 for sub-grade soils. For the representative sample exudation pressure and “R”-Value was determined. The graphically determined “R”-Value at exudation pressure of 300 psi is summarized on Plates 9 and 10 and in the table below:

Sample Location	Sample description	R-Value
P-2 @ 0-5 feet	Clayey Sand	12

Soluble Sulfates: The soluble sulfate content of selected sample was determined by standard geochemical methods. The test results are presented on Plate 11 and in the table below:

Sample Location	Sample Description	Water Soluble Sulfate in Soil, (% by Weight)	Sulfate Content (ppm)	Exposure Class*
B-2 @ 0-5 feet	Clayey Sand	0.0173	173	S0

* Based on the current version of ACI 318-14 Building Code, Table No. 19.3.1.1; Exposure Categories and Classes.

EXISTING SITE CONDITION

The subject site consists of a Fellowship Hall church building and Workshop Center in the southeast portion of the property, a parking lot, nature walk and lake in the central portion of the property and Educational portable buildings in the southwest portion of the property.

The Fellowship Hall and Workshop Center were constructed on compacted artificial fill overlaying bedrock, designated as structural areas, while the remaining portions of the site are underlain by compacted artificial fill overlaying landslide debris and/or debris fill. Total removals of landslide material were made in the area of the above-mentioned structural pad in order to provide a buttress for the ascending slope to the south of the site. The approximate depth of the landslide debris in this area appears to have been in the 60 to 100 feet range. The limits of the buttress fill key extend to the north of the structural pad area approximately 60 to 100 feet. It appears that the northern limits of the structural pad are based on a 1:1 (horizontal: vertical) projection from the base of the landslide debris removals/toe of the fill key to the surface. The limits of the landslide debris removals and structural pad are presented on Plate 1.

The thickness of the remaining landslide debris to the north of the structural pad area is unknown since the mass grading plan review report for the site and surrounding areas was not available for review. However, based on the estimated depth of the removals of landslide debris

in the structural pad area we anticipate the thickness of the remaining landslide debris to the north to be similar in depth, ranging from 60 to 100 feet.

The thickness of the landslide debris on the west side of the site is also unknown since the mass grading plan review report for the site and surrounding areas was not available for review. However, based on our review of the CDMG report, the landslides on the west side of the site are similar in size to the landslides on the south side of the site. As such, we would anticipate that the thickness of the landslide debris on the west side of the site to be similar to that of the landslide debris on the south side.

The existing Fellowship Hall main church building was constructed in the structural fill area with foundations supported on two to three feet of remedially compacted engineered fill within the structural fill.

FINDINGS

Regional Geologic Setting

The subject site is located in the Anaheim Hills region, south of the Santa Ana River, within the northwestern portion of the Black Star Canyon 7.5-Minute Quadrangle, Orange County, California. Per the geologic map of the San Bernardino and Santa Ana 30' x 60' Quadrangles (Morton, 2006) the subject site is underlain by Quaternary alluvial deposits and possible mid-Miocene marine strata toward southern portions of the site (Figure 2).

Existing Soil

Based on our subsurface investigation, the subject site subsurface soils generally consist of tan to brown clayey sand and sandy clay in a moist condition to the maximum depth explored, 10.5 feet below existing grade. In the existing parking lot, in the vicinity of Borings B-1 and B-2, the clayey sand and sandy clay is underlain by blue grey and olive brown silty sand in a moist condition at a depth of 4 feet to 5.5 feet below existing grade. Detailed descriptions of the earth units encountered in our borings are presented in the log of the borings on Plates 2 through 6.

Groundwater

Subsurface water was not encountered during the exploration to a maximum depth of 10.5 feet below existing ground surface. Based on our review of available historical groundwater information for the Black Star Canyon 7.5-minute Quadrangle (CDMG, 2000) regional groundwater has been mapped in the general site area between approximately 20 to 40 feet below ground surface (Figure 3). Seasonal and long-term fluctuations in the groundwater may occur as a result of variations in subsurface conditions, rainfall, run-off conditions and other factors. Therefore, variations from our observations may occur.

Static groundwater is not anticipated to impact the proposed development.

Expansive Soil

Onsite soils have an expansion index of 64 correlating to a "medium" expansion potential. The recommendations provided in this report account for the expansion potential of the onsite soils.

RECOMMENDATIONS

Seismic Design Parameters

When reviewing the 2019 California Building Code the following data should be incorporated into the design.

Parameter	Value
Latitude (degree)	33.8635
Longitude (degree)	-117.7224
Site Class	D – Stiff Soil
Site Coefficient, F_a	1.0
Site Coefficient, F_v	N/A
Mapped Spectral Acceleration at 0.2-sec Period, S_s	1.927 g
Mapped Spectral Acceleration at 1.0-sec Period, S_1	0.679 g
Spectral Acceleration at 0.2-sec Period Adjusted for Site Class, S_{MS}	1.927 g
Spectral Acceleration at 1.0-sec Period Adjusted for Site Class, S_{M1}	N/A
Design Spectral Acceleration at 0.2-sec Period, S_{DS}	1.284 g
Design Spectral Acceleration at 1.0-sec Period, S_{D1}	N/A

Site Specific Response Spectra

The USGS Unified Hazard tool, the USGS RTGM Calculator and the USGS App for Deterministic Spectra Acceleration were utilized to develop site specific ground motion spectra. The analysis was performed utilizing the following attenuation relationships that are part of NGA as required by 2019 CBC code requirements.

- Campbell & Bozorgnia (2014)
- Boore, Stewart, Seyhan & Atkinson (2014)
- Chiou & Youngs (2014)
- Abrahamson, Silva & Kamal (2014)

The results of the Site Specific Response Spectra are incorporated in Tables 1 through 3 and on Figure 1 in Appendix B. The results include deterministic spectra at 5% damping, maximum rotated component at 0.84 fractile and the probabilistic spectra, maximum rotated component at 5% damping for a return period of 2475 year and subsequently multiplied by risk coefficient to obtain the MCER probabilistic spectral acceleration. The V_{s30} utilized was 260 m/s.

The above generated spectral accelerations were compared against the minimum code requirements in ASCE7-16 (Chapters 11 and 21) resulting in the final design response spectra which is presented in Table 1 and on Figure 1 in Appendix B.

Based on Tables 1 through 3 and Figure 1, the recommended Site Specific S_{DS} and S_{D1} are as follows:

$$S_{DS} = 1.256$$

$$S_{D1} = 1.102$$

The structural consultant should review the above parameters and the 2019 California Building Code to evaluate the seismic design.

Conformance to the criteria presented in the above table for seismic design does not constitute any type of guarantee or assurance that significant structural damage or ground failure will not occur during a large earthquake event. The intent of the code is "life safety" and not to completely prevent damage of the structure, since such design may be economically prohibitive.

Pavement Design

Based on our field investigation and laboratory testing, presented below are the Asphalt Concrete (AC) pavement design recommendations for the proposed new central parking lot the expansion of the southern parking lot. The pavement section recommendations are based on the tested R-value of 12 for the anticipated pavement subgrade soils and assumed traffic index. The traffic indices shall be approved by the project civil engineer and the reviewing agency.

Pavement Utilization	Assumed Traffic Index	Asphalt Concrete (Inches)	Base (Inches)	Total Thickness (inches)
Parking Stalls	4.5	3.0	8.0	11.0
Drive Aisles	5.0	4.0	7.0	11.0

Aggregate base material for Asphalt Concrete Pavement should consist of CAB/CMB complying with the specifications in Section 200-2.2/200-2.4 of the current "Standard Specifications for Public Works Construction" and should be compacted to at least ninety-five (95) percent of the maximum dry density (ASTM D1557). The surface of the aggregate base should exhibit a firm and unyielding condition just prior to the placement of asphalt concrete paving.

The pavement subgrade should be compacted to a minimum of 90 percent of the maximum laboratory dry density (ASTM D1557) to a minimum depth of one (1) foot. Prior to placement of concrete, the subgrade soils should be moistened to 120 percent optimum moisture content and verified by our field representative.

The R-value and the associated pavement section should be confirmed at the completion of site grading

Church Building Expansion Foundation Design Recommendations

The proposed Fellowship Hall expansions are located to the northeast and southwest of the existing structure within the area of structural fill, shown on Plate 1. The proposed main church building expansion may be supported on continuous and/or spread footings. Bearing capacity recommendations for shallow foundations are presented below. These recommendations assume that the footings will be supported on a minimum of one (1) foot of engineered fill.

For foundations supported on one (1) foot of engineered fill with minimum ninety (90) percent relative compaction an allowable bearing pressure of 2000 pounds per square foot may be used in design.

All shallow foundations should extend a minimum of twenty-four (24) inches below the lowest adjacent grade. The minimum recommended footing width is eighteen (18) inches for continuous footing and eighteen (18) inches for pad footing. A minimum reinforcement of two (2) No. 4 steel bar top and two (2) No. 4 steel bar bottom is required for continuous footings from a geotechnical viewpoint. Foundation design details such as concrete strength, reinforcements, etc should be established by the Structural Engineer.

A one-third (1/3) increase on the aforementioned bearing pressure may be used in design for short-term wind or seismic loads.

The total and differential static and seismic settlement is anticipated to be 1-inch and 0.5-inches over 30 feet or less.

Resistance to lateral loads including wind and seismic forces may be provided by frictional resistance between the bottom of concrete and the underlying fill soils and by passive pressure against the sides of the foundations. A coefficient of friction of 0.33 may be used between concrete foundation and underlying soil. The recommended passive pressure of the engineered fill may be taken as an equivalent fluid pressure of 250 pounds per cubic foot (2,500 psf max).

Any footing excavation adjacent to existing continuous footings may require slot cutting (A-B-C slots). As an alternative, shoring or underpinning of existing footings is recommended.

All foundations excavations shall be approved prior to placement of concrete by the geotechnical consultant. Additional recommendations may be provided if unusual conditions were observed/encountered during excavation

Slab-On-Grade

Slab-on-grade should be a minimum of 5-inches thick and reinforced with a minimum of No. 4 reinforcing bar on 12-inch centers in two horizontally perpendicular directions. Reinforcing should be properly supported to ensure placement near the vertical midpoint of the slab. "Hooking" of the reinforcement is not considered an acceptable method of positioning the steel. The slab should not be structurally connected to the buildings. The subgrade material should be compacted to a minimum of 90 percent of the maximum laboratory dry density (ASTM 1557) to a minimum depth of two (2) feet. Prior to placement of concrete, the subgrade soils should be moistened to 120 percent optimum moisture content and verified by our field representative. The actual thickness and reinforcement of the slab shall be designed by the structural engineer and should include the anticipated loading condition and the anticipated use of the building. For moisture sensitive flooring, the floor slab should be underlain by minimum 15-mil impermeable polyethylene membrane (Stego Wrap, Moistop Plus, or any equivalent meeting the requirements of ASTM E1745, Class A rating) as a capillary break. Sand/gravel/aggregate base may be placed above and below the impermeable polyethylene membrane at the discretion of the project structural engineer/concrete contractor for proper curing and finish of the concrete slab-on-grade and protection of the membrane and is considered outside the scope of geotechnical engineering.

Due to the presence of medium expansive soils, more than normal movement of the flatwork is anticipated. This may be limited by placing a thickened edge (minimum 12-inches) and/or 6-inches of base under the flatwork.

The slab-on-grade foundation shall comply with section 1808.6.2 of the CBC (2019) and shall be designed in accordance with WRI/CRSI Design of Slab-on-Ground Foundations. As an alternate the slab-on-grade shall be supported on minimum 2 feet of non-expansive soil to reduce the impact of expansive soils.

Flatwork

Flatwork should be a minimum of 4-inches thick should be reinforced with a minimum of No. 3 reinforcing bar on 18-inch centers in two horizontally perpendicular directions. Reinforcing should be properly supported to ensure placement near the vertical midpoint of the slab. "Hooking" of the reinforcement is not considered an acceptable method of positioning the steel. The subgrade material should be compacted to a minimum of 90 percent of the maximum laboratory dry density (ASTM D1557) to a minimum depth of one (1) foot. Prior to placement of concrete, the subgrade soils should be moistened to 120 percent optimum moisture content and verified by our field representative. The actual thickness and reinforcement of the slab shall be designed by the structural engineer and should include the anticipated loading condition. Due to the presence of medium expansive soils, more than normal movement of the flatwork is anticipated. This may be limited by placing a thickened edge (minimum 12-inches) and/or 6-inches of base under the flatwork.

Cement Type and Corrosion

Concrete used should be designed in accordance with the provisions of ACI 318-14, Chapter 19 for Exposure Class S0 with a minimum unconfined compressive strength of 2,500 psi.

TGR does not practice corrosion engineering. If needed, a qualified specialist should review the site conditions and evaluate the corrosion potential of the site soil to the proposed improvements and to provide the appropriate corrosion mitigations for the project.

Expansion Potential

Soils onsite have an expansion index of 64, which correlates to a "medium" expansion potential. The slab-on-grade foundation shall comply with section 1808.6.2 of the CBC (2019) and shall be designed in accordance with WRI/CRSI Design of Slab-on-Ground Foundations. As an alternate the slab-on-grade shall be supported on minimum 2 feet of non-expansive soil to reduce the impact of expansive soils.

Site Development Recommendations

Earthwork and Demolition

Within the proposed development and demolition area, all foundations, slab-on-grade, vaults, utility lines, surface vegetation, trash, demolition debris, asphaltic concrete and Portland cement concrete should be cleared and removed from the proposed site.

Depressions resulting from the removal of objects encountered as mentioned above should be backfilled with properly compacted engineered fill under the testing and observation of the geotechnical consultant of record.

During earthwork construction, all site preparation and the general procedures of the contractor should be observed, and the fill and base selectively tested by a representative of TGR. If unusual or unexpected conditions are exposed in the field, they should be reviewed by this office and if warranted, modified and/or additional recommendations will be offered.

Grading

All grading should conform to the guidelines presented in the California Building Code (2019 edition), except where specifically superseded in the text of this report. Prior to grading, TGR's representative should be present at the pre-construction meeting to provide grading guidelines, if needed, and review any earthwork.

At a minimum, the upper two (2) feet of soil under slab-on-grade, one (1) foot of soil under footings, flatwork and asphalt concrete pavement should be removed and replaced as engineered fill, compacted to minimum 90 percent relative compaction and moisture conditioned to 120 percent optimum moisture content per ASTM D1557. Site soils could be reused as engineered fill provided the recommendations presented in this report are implemented. Exposed bottoms should be scarified a minimum of 8-inches, moisture conditioned to 120 percent optimum moisture content and compacted to a minimum 90 percent relative compaction. Subsequently, site fill soils should be re-compacted to a minimum of 90 percent relative compaction at 120 percent optimum moisture content.

The depth of over-excavation should be reviewed by the Geotechnical Consultant during the actual construction. Any subsurface obstruction buried structural elements, and unsuitable material encountered during grading, should be immediately brought to the attention of the Geotechnical Consultant for proper exposure, removal and processing, as recommended.

Fill Placement

Prior to any fill placement TGR should observe the exposed surface soils. The site soils may be re-used as engineered fill provided they are free of organic content and particle size greater than 4-inches. Fill shall be moisture-conditioned to 120 percent optimum moisture content and compacted to a minimum relative compaction of 90 percent in accordance with ASTM D1557. Any import soils shall be non-expansive and approved by TGR Geotechnical Inc.

Compaction

Prior to fill placement, the exposed surface should be scarified to a minimum depth of eight (8) inches, fill placed in eight (8) inch loose lifts, moisture conditioned to 120 percent optimum moisture content and compacted to a minimum relative compaction of 90 percent in accordance with ASTM D 1557.

Temporary Excavation and Shoring

Temporary construction excavations may be anticipated during the proposed development. Site soils may be cut vertically without shoring to a depth of approximately four (4) feet below adjacent surrounding grade. For deeper cuts, the slopes should be properly shored or the entire excavation sloped back to at least 1.5H:1V (Horizontal: Vertical) or flatter. The exposed slope face should be kept moist (but not saturated) during construction to reduce local sloughing. No surcharge loads should be permitted within a horizontal distance equal to the height of cut from the toe of excavation unless the cut is properly shored. Excavations that extend below an

imaginary plane inclined at 45 degrees below the edge of any nearby adjacent existing site facilities should be properly shored to maintain foundation support at the adjacent structures. Any excavation adjacent to existing continuous footings may require slot cutting (A-B-C slots).

Geotechnical Review of Plans

All grading plans and specifications should be reviewed and accepted by the geotechnical consultant before they are finalized to determine if the geotechnical and/or geologic information have been properly implemented. If this firm is not granted the privilege of reviewing the plans and specifications, this firm is not responsible for misinterpretation of the recommendations given in this report.

Geotechnical Observation/Testing During Construction

Per sections 1705.6 and table 1705.6 of the 2019 California Building Code, periodic special inspection shall be performed to:

- Verify materials below shallow foundations are adequate to achieve the design bearing capacity;
- Verify excavations are extended to the proper depth and have reached proper material;
- Verify classification and test compacted materials; and
- Prior to placement of compacted fill, inspect subgrade and verify that the site has been prepared properly

Per sections 1705.6 and table 1705.6 of the 2019 California Building Code, continuous special inspection shall be performed to:

- Verify use of proper materials, densities and lift thickness during placement and compaction of compacted fill.

The geotechnical consultant should also perform observation and/or testing at the following stages:

- During any grading and fill placement;
- During utility trench excavation and backfill;
- After foundation excavation and prior to placing concrete;
- During placement of aggregate base and asphalt paving;
- When any unusual soil conditions are encountered during any construction operation subsequent to issuance of this report.

LIMITATIONS

This report has been prepared for the exclusive use of Kindred Community Church and their design consultants relative to developing the subject site. No portion of this report may be used by other parties or for other purposes. Unauthorized use of or reliance on this report constitutes an agreement to defend and indemnify TGR from and against any liability which may arise as a result of such use or reliance, regardless of any fault, negligence, or strict liability of TGR.

TGR considered a number of unique, project-specific factors when establishing the scope of services for this report. This report has not been prepared for use by other parties, and may not contain sufficient information for purposes of other parties.

This report was necessarily based in part upon data obtained from a limited number of observances, site visits, soil and/or other samples, tests, analyses, histories of occurrences, spaced subsurface exploration and limited information on historical events and observations. Such information is necessarily incomplete. Variations can be experienced within small distances and under various climatic conditions. Changes in subsurface conditions can and do occur over time.

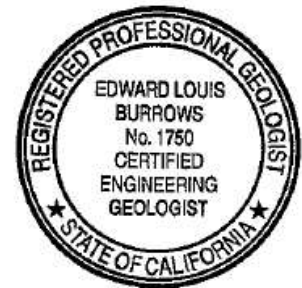
If you have any questions regarding this report, please do not hesitate to contact this office. We appreciate this opportunity to be of service.

Respectfully submitted,

TGR GEOTECHNICAL, INC.



Sanjay Govil, PhD, PE, GE 2382
Principal Geotechnical Engineer



Edward L. Burrows, M.S, PG, CEG 1750
Principal Engineering Geologist

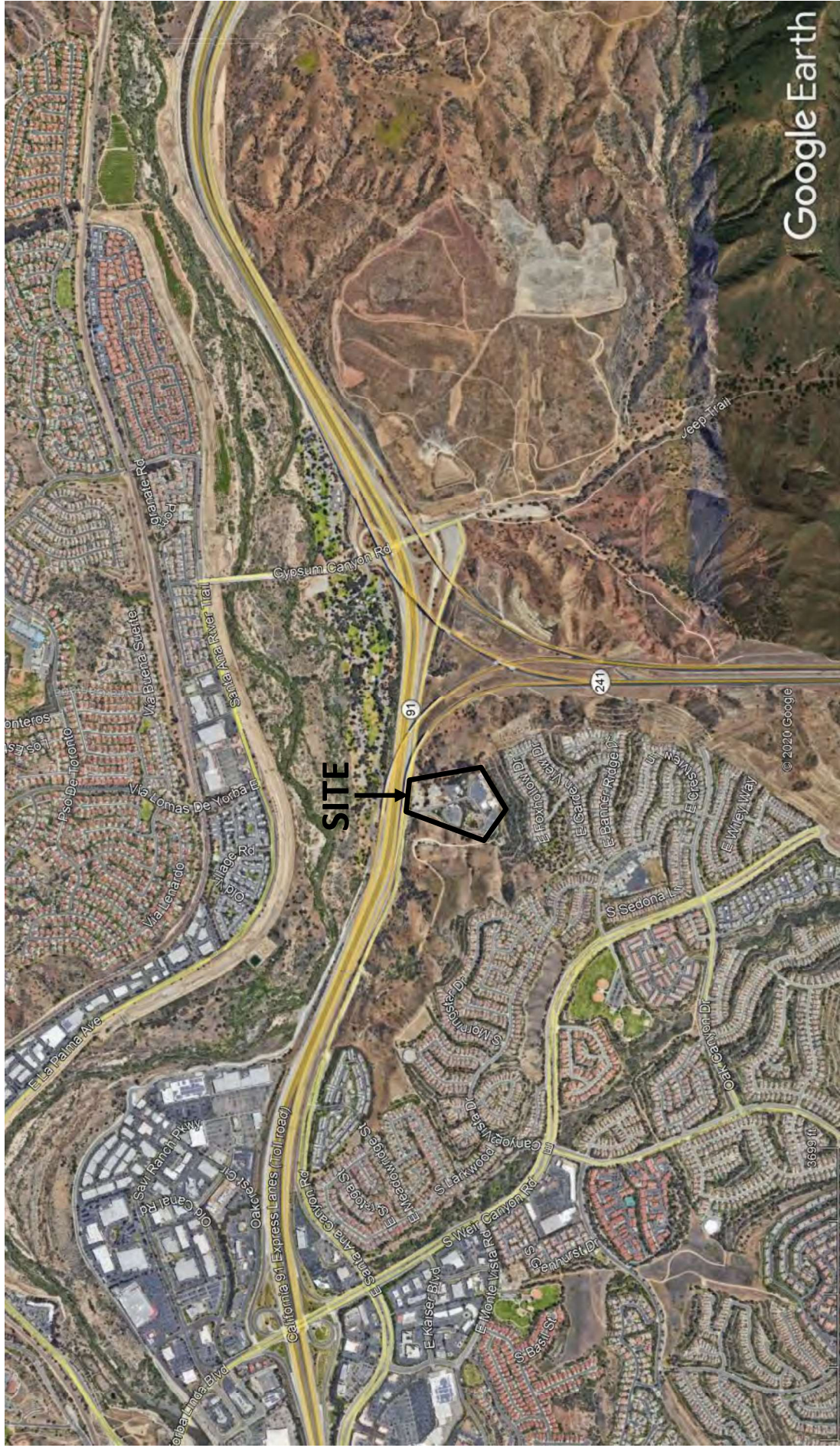
Attachments: Figure 1 – Site Location Map
Figure 2 – Regional Geology Map
Figure 3 – Historic High Groundwater Map

Plate 1 – Geotechnical Map
Plates 2 through 6 – Boring Logs
Plate 7 – Maximum Dry Density and Optimum Moisture Content
Plate 8 – Direct Shear Test Results
Plates 9 and 10 – R-Value Test Results
Plate 11 – Analytical Report for Soluble Sulfates

Table 1 – Percolation Test Worksheet

Appendix A – References
Appendix B – Site Seismic Design and De-Aggregated Parameters

Distribution: (1) Addressee



Google Earth

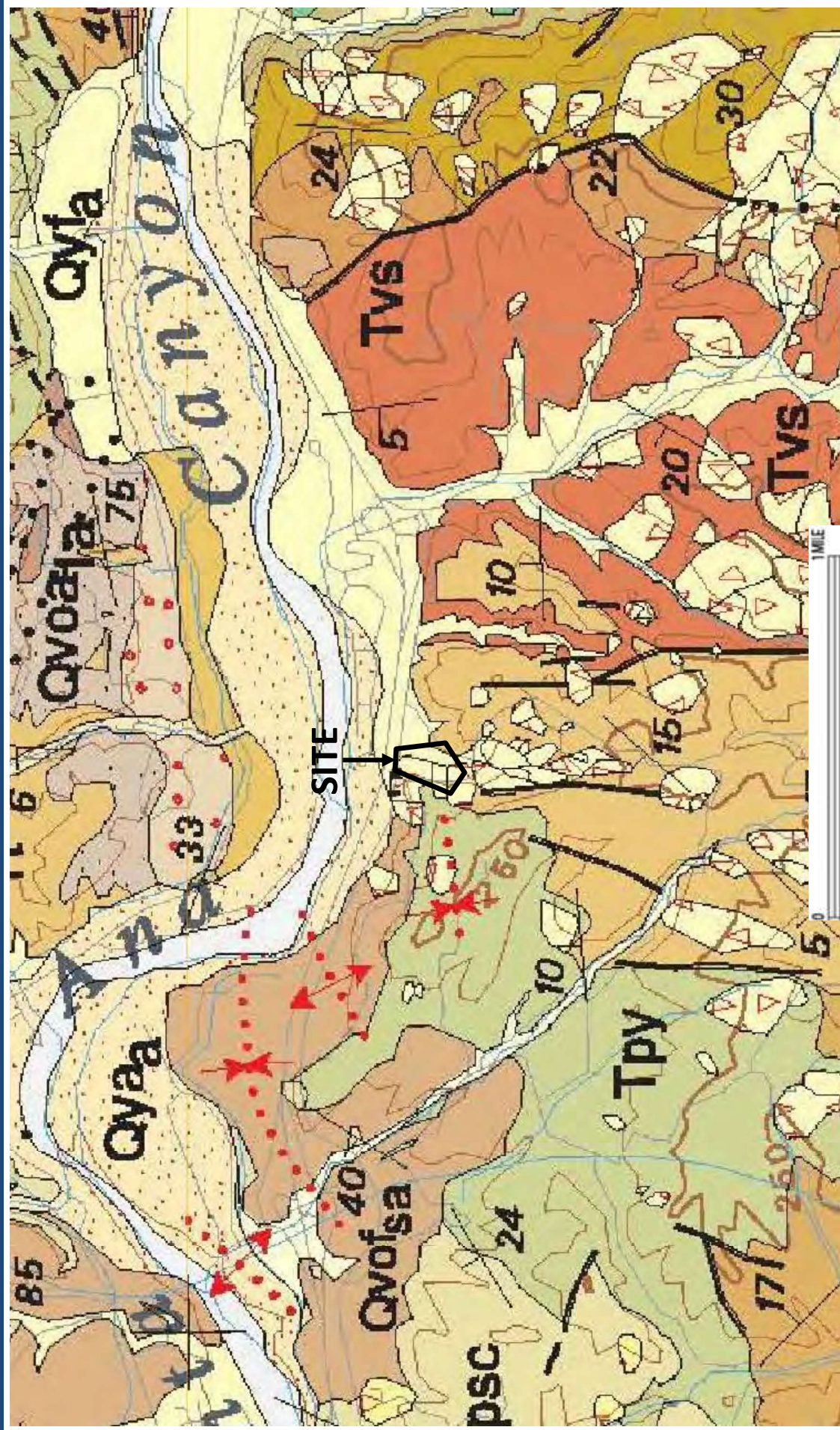


PROJECT NO. 15-5382

SITE LOCATION MAP
KINDRED CHURCH, 8720 E. SANTA ANA CANYON ROAD,
ANAHEIM, CALIFORNIA

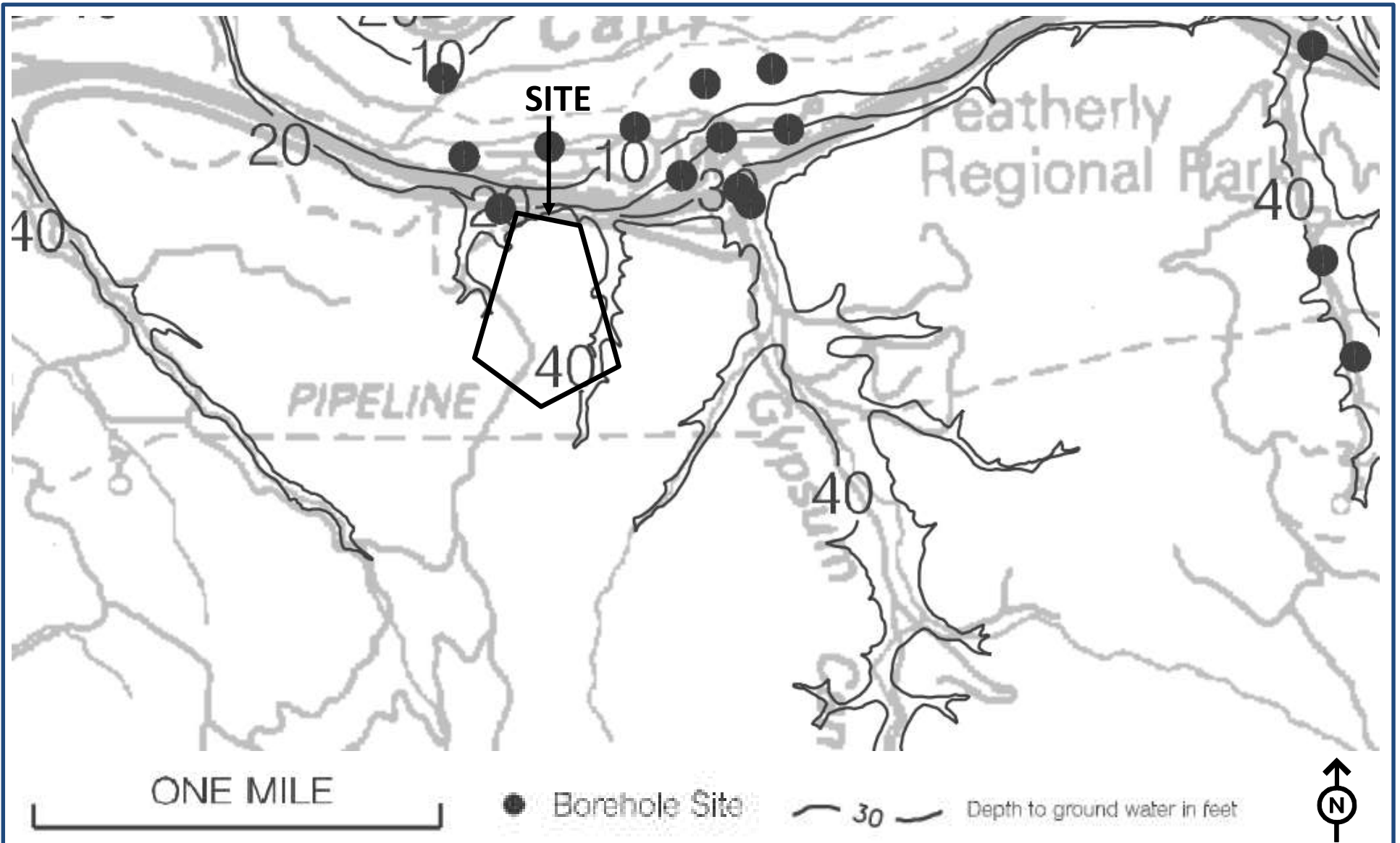


FIGURE 1



Morton, D.M., and Miller, F.K., 2006, Geologic map of the San Bernardino and Santa Ana 30' x 60' quadrangles, California: U.S. Geological Survey, Open-File Report OF-2006-1217, scale 1:100,000.

	<p style="text-align: center;">REGIONAL GEOLOGY MAP</p> <p style="text-align: center;">KINDRED CHURCH, 8720 E. SANTA ANA CANYON ROAD, ANAHEIM, CALIFORNIA</p>	<p style="text-align: center;">PROJECT NO. 15-5382</p> <p style="text-align: center;">FIGURE 2</p>
---	---	---



Modified From: California Department of Conservation, Division of Mines and Geology, 2000, Seismic Hazard Zone Report for the Black Star Canyon 7.5-Minute Quadrangle, Los Angeles and Orange Counties, California, Report 046.



HISTORIC HIGH GROUNDWATER MAP
KINDRED CHURCH, 8720 E. SANTA ANA CANYON ROAD,
ANAHEIM, CALIFORNIA

PROJECT NO. 15-5382

FIGURE 3

LOG OF EXPLORATORY BORING P - 3

Sheet 1 of 1

Project Number: **15-5382**
 Project Name: **Kindred Community Church, Anaheim**
 Date Drilled: **10/13/20 - 10/13/20**
 Ground Elev: _____

Logged By: **RA**
 Project Engineer: **SG**
 Drill Type: **Hollow Stem**
 Drive Wt & Drop: **140lbs / 30in**

Depth (ft)	Graphic Log	FIELD RESULTS				LAB RESULTS			
		Bulk Sample	Drive Sample	SPT blows/ft (or equivalent N)	Pocket Pen (tsf)	USCS	Moisture Content (%)	Dry Density, (pcf)	Other Tests
						Shelby Tube Standard Split Spoon No recovery Modified California Water Table ATD			
SUMMARY OF SUBSURFACE CONDITIONS									

5		22	SC	Surface is a dirt and vegetation covered area. Clayey Sand- tan, moist, medium dense, fine grained, fine to coarse pieces of caliche. ...Same as above, no caliche.	11	103	-200= 33.9%
10		29	SC	Clayey Sand- light brown sand, blue grey clay, moist, medium dense, fine grained sand, fine to coarse grained gravel and clasts, orange oxidation.	16	116	-200= 43.5%
				Total Depth: 10.5 feet. No groundwater encountered during drilling. No caving observed. Boring utilized for percolation testing. Boring backfilled with soil cuttings upon completion.			

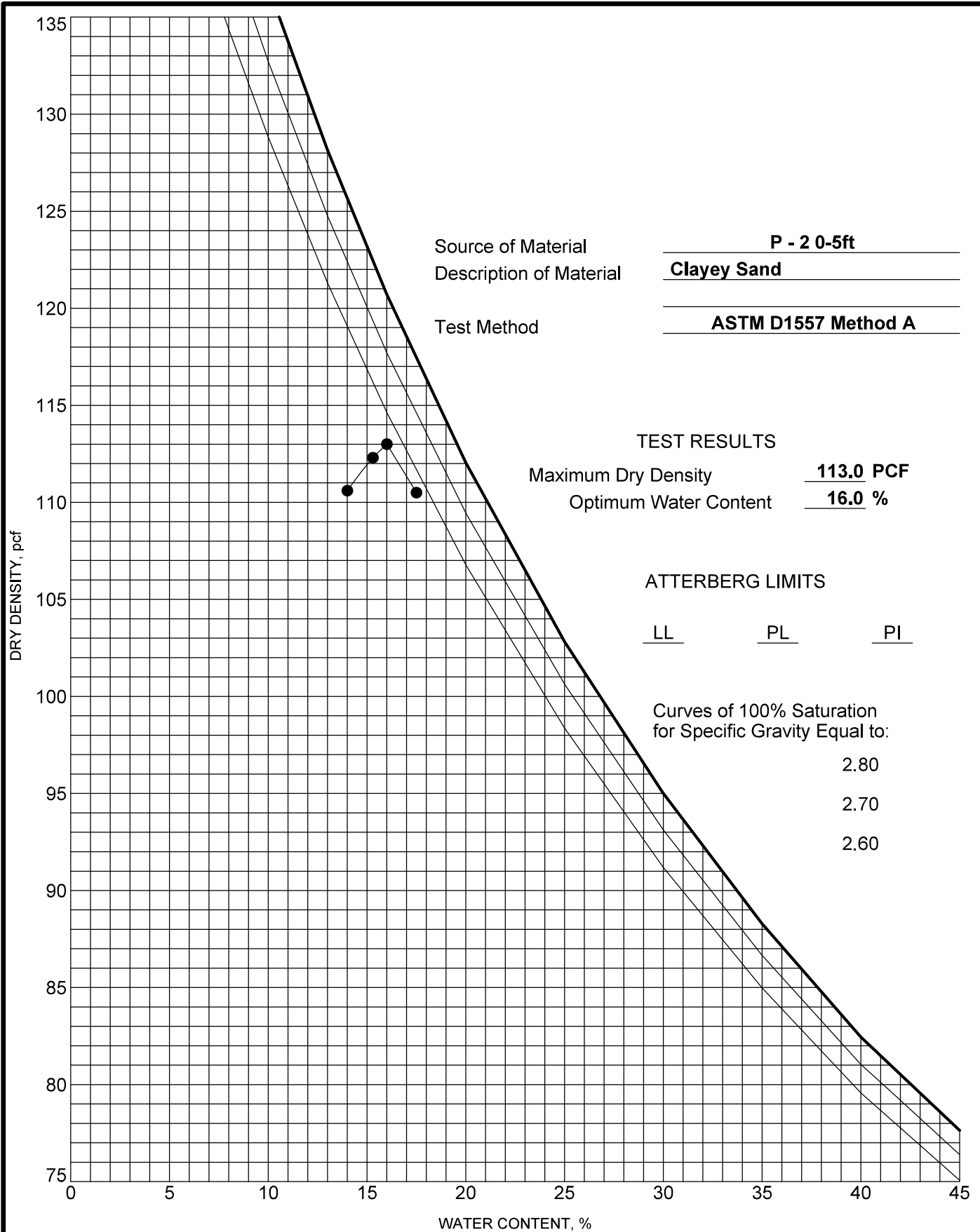
LOG OF BORING 15-5382 KINDRED CHURCH ANAHEIM.GPJ_TGR GEOTECH.GDT 10/21/20

This Boring Log should be evaluated in conjunction with the complete geotechnical report. This Boring Log represents conditions observed at the specific location and date indicated, it is not warranted to be representative of subsurface conditions at other locations and times.

PLATE 6



US COMPACTION 15-5382 KINDRED CHURCH ANAHEIM.GPJ_TGR GEOTECH.GDT 10/16/20



TGR GEOTECHNICAL, INC.

3037 S. Harbor Blvd
Santa Ana, CA 92704
Telephone: 714-641-7189
Fax: 714-641-7190

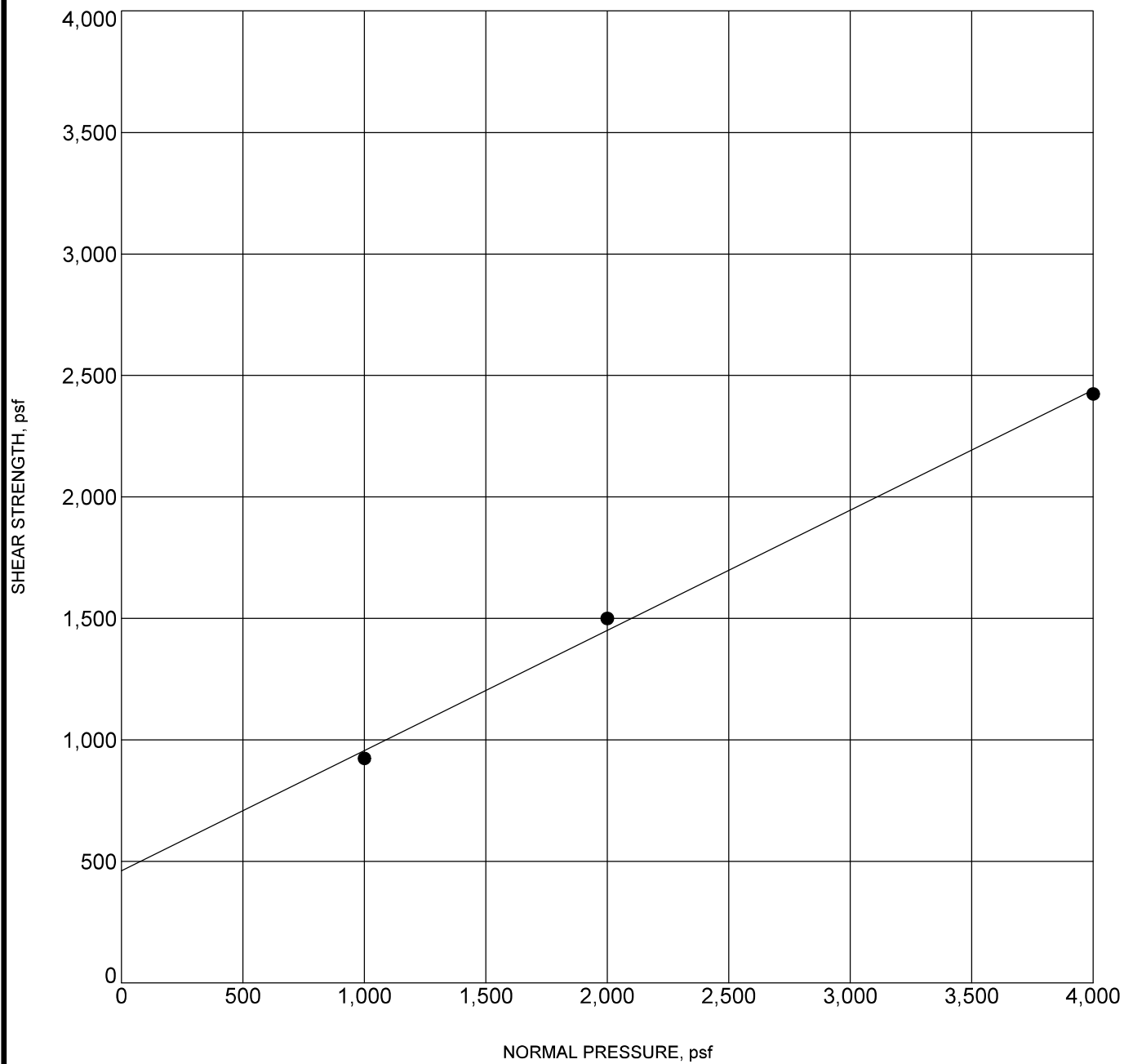
MOISTURE-DENSITY RELATIONSHIP

Project Number: 15-5382

PLATE 7

Project Name: Kindred Community Church, Anaheim

US DIRECT SHEAR 15-5382 KINDRED CHURCH ANAHEIM.GPJ TGR GEOTECH.GDT 10/16/20



Specimen Identification	Classification	γ_d	MC%	c	ϕ
● P - 2 0-5	Clayey Sand - Remolded - 90% RC	102	16	462	26



TGR GEOTECHNICAL, INC.

3037 S. Harbor Blvd
 Santa Ana, CA 92704
 Telephone: 714-641-7189
 Fax: 714-641-7190

DIRECT SHEAR TEST

Project Number: 15-5382

PLATE 8

Project Name: Kindred Community Church, Anaheim



R - VALUE DATA SHEET

PROJECT No. 46558

DATE: 10/16/2020


BORING NO. 15-5382
Kindred Community Church

SAMPLE DESCRIPTION: Brown Sandy Clay

R-VALUE TESTING DATA CA TEST 301			
	SPECIMEN ID		
	a	b	c
Mold ID Number	16	17	18
Water added, grams	70	17	32
Initial Test Water, %	20.8	15.1	16.7
Compact Gage Pressure, psi	45	170	90
Exudation Pressure, psi	225	458	326
Height Sample, Inches	2.67	2.47	2.52
Gross Weight Mold, grams	3051	3008	3027
Tare Weight Mold, grams	1946	1940	1955
Sample Wet Weight, grams	1105	1068	1072
Expansion, Inches x 10exp-4	23	92	62
Stability 2,000 lbs (160psi)	63 / 143	33 / 81	40 / 101
Turns Displacement	4.28	3.61	3.88
R-Value Uncorrected	6	40	27
R-Value Corrected	7	40	27
Dry Density, pcf	103.8	113.8	110.4

DESIGN CALCULATION DATA

Traffic Index	Assumed:	4.0	4.0	4.0
G.E. by Stability		0.95	0.61	0.75
G. E. by Expansion		0.77	3.07	2.07

Equilibrium R-Value	12 by EXPANSION	Examined & Checked: 10 /16/ 20
REMARKS:	Gf = <u>1.25</u> 0.0% Retained on the <u>3/4" Sieve.</u>	 Steven R. Marvin, CPE 30059 STATE OF CALIFORNIA

The data above is based upon processing and testing samples as received from the field. Test procedures in accordance with latest revisions to Department of Transportation, State of California, Materials & Research Test Method No. 301.



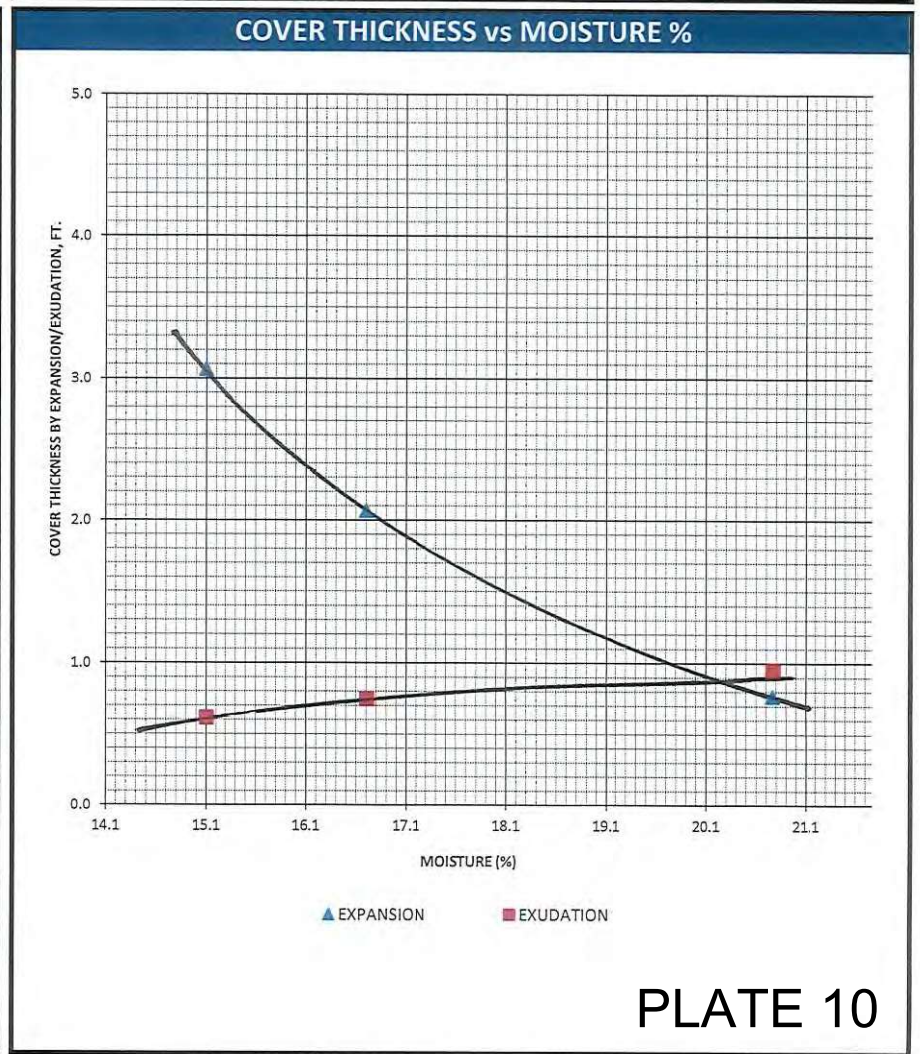
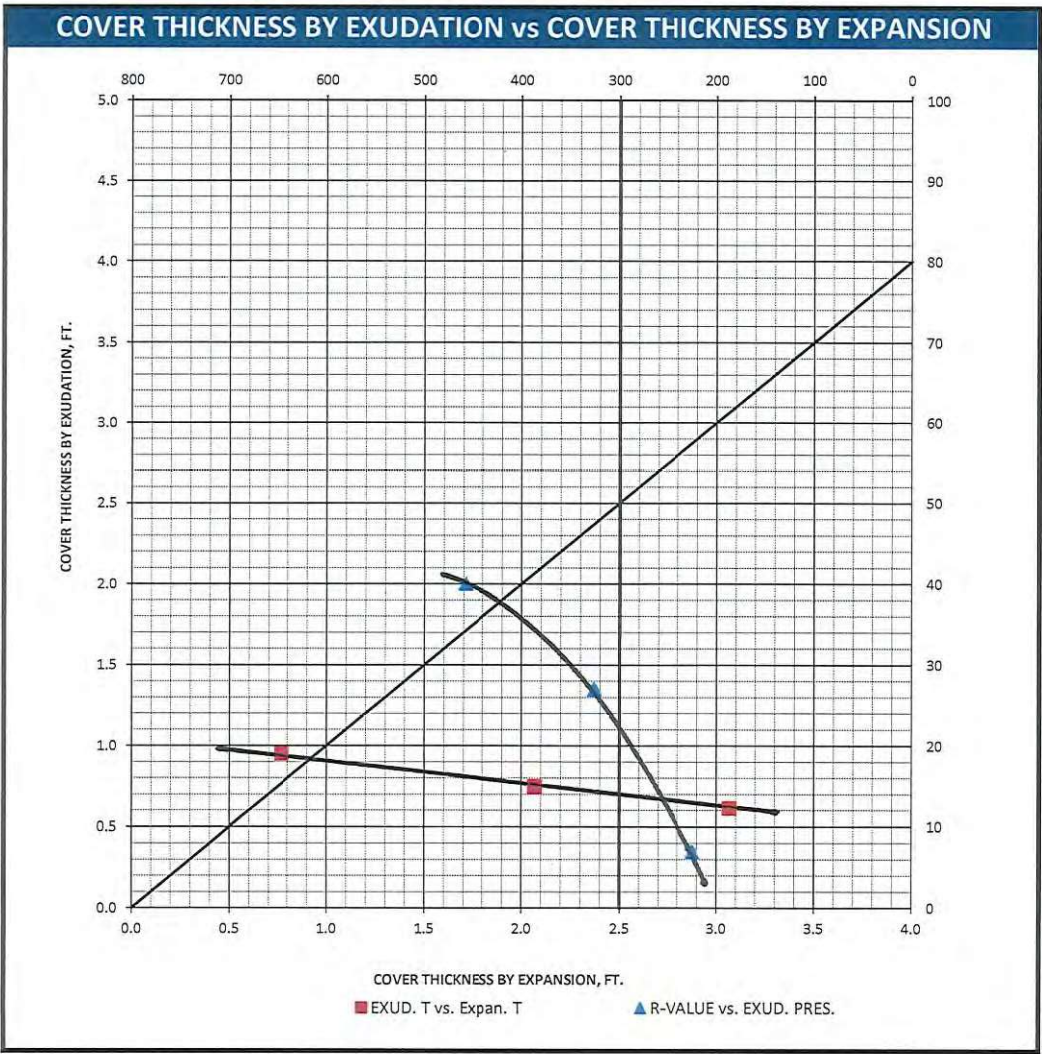
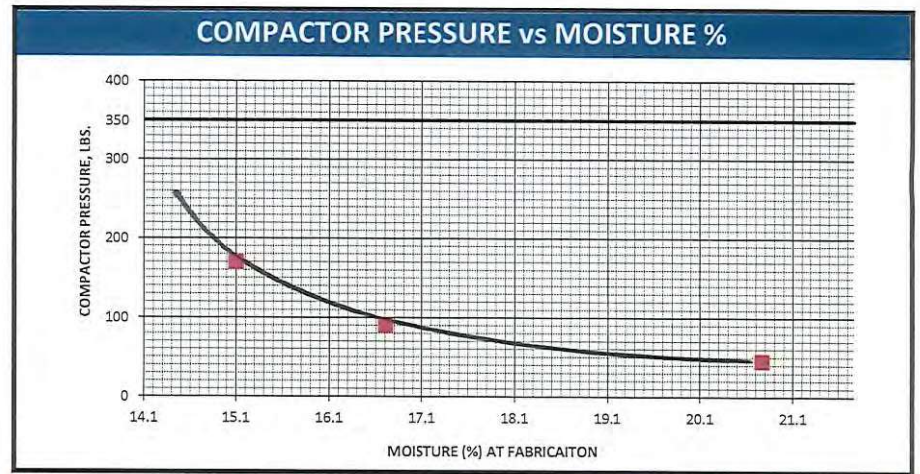
R-VALUE GRAPHICAL PRESENTATION

PROJECT NO. 46558

DATE: 10 /16/ 2020

REMARKS: _____

BORING NO. 15-5382
Kindred Community Church



ANAHEIM TEST LAB, INC.

196 Technology Drive, Unit D
Irvine, CA 92618
Phone (949)336-6544

TO:

TGR GEOTECHNICAL
3037 S. HARBOR BLVD.
SANTA ANA, CA. 92704

DATE: 10/20/2020

P.O. NO: VERBAL

LAB NO: C-4184

SPECIFICATION: CTM-417

MATERIAL: Soil

Project No.: 15-5382
Project: Kindred Community Church
Sample ID: B2 @ 0-5'

ANALYTICAL REPORT

SOLUBLE SULFATES

per CT. 417
ppm

218

RESPECTFULLY SUBMITTED



WES BRIDGER LAB MANAGER

Test Hole	Total Depth (in)	Initial Depth (in)	Final Depth (in)	Δ Water Level (in)	Initial Time (min)	Final Time (min)	Δ Time (min)	Initial Height of Water (in)	Final Height of Water (in)	Average Height of Water (in)	Infiltration Rate (in/hr)
P-1	126	3.5	5	1.5	0.0	10.0	10.0	122.5	121	121.75	0.15
	126	3	4.5	1.5	0.0	10.0	10.0	123	121.5	122.25	0.14
	126	3	4.5	1.5	0.0	10.0	10.0	123	121.5	122.25	0.14
	126	4	5	1	0.0	10.0	10.0	122	121	121.50	0.10
	126	3.5	5	1.5	0.0	10.0	10.0	122.5	121	121.75	0.15
	126	3	4.5	1.5	0.0	10.0	10.0	123	121.5	122.25	0.14
P-2	126	3	7	4	0.0	10.0	10.0	123	119	121.00	0.39
	126	6.5	8.5	2	0.0	10.0	10.0	119.5	117.5	118.50	0.20
	126	5	7.5	2.5	0.0	10.0	10.0	121	118.5	119.75	0.25
	126	5.5	7.5	2	0.0	10.0	10.0	120.5	118.5	119.50	0.20
	126	5.5	7.5	2	0.0	10.0	10.0	120.5	118.5	119.50	0.20
	126	6	8	2	0.0	10.0	10.0	120	118	119.00	0.20
P-3	126	4.5	7	2.5	0.0	10.0	10.0	121.5	119	120.25	0.25
	126	9	11	2	0.0	10.0	10.0	117	115	116.00	0.20
	126	9.5	11	1.5	0.0	10.0	10.0	116.5	115	115.75	0.15
	126	10.5	12	1.5	0.0	10.0	10.0	115.5	114	114.75	0.15
	126	10	11.5	1.5	0.0	10.0	10.0	116	114.5	115.25	0.15

$$I_t = \frac{\Delta H(60r)}{\Delta t(r + 2H_{avg})}$$

ΔH = Change in height

Δt = Time interval

r = Radius

I_t = Infiltration Rate

H_{ave} = Average Head Height over the time interval

APPENDIX A REFERENCES

TGR GEOTECHNICAL
DBE & 8(a) firm
3037 S. HARBOR BLVD
SANTA ANA, CA 92704
P 714.641.7189 F 714.641.7190
www.tgrgeotech.com



APPENDIX A

References

Allwest Geoscience, Inc., 1999, Remedial Grading Report for the Planned Garden Church Development, 8712 East Santa Ana Canyon Road, Anaheim, Orange County, California, Job No. 98-1342GC-1, dated December 20, 1999.

Bell/Knott & Associates, Kindred Community Church, Campus Design Development

Giles Engineering Associates, Inc., 2014, Geotechnical Feasibility Study, Proposed Site Development, 8270 East Santa Ana Canyon Road, Anaheim Hills, California, Project No. 2G-1402006, dated March 18, 2014.

California Department of Conservation Division of Mines and Geology Open-File Report 90-19, Landslide Hazards in the North Half of the Black Star Canyon Quadrangle, Orange and Riverside Counties, California, dated 1992.

Pacific Soils Engineering, Inc., 1997a, Mass Grading Report, Garden Church Site, The Summit, in the City of Anaheim, California, Work Order 101476G4, dated February 28, 1997.

_____, 1997b, Project Grading Report, Lots 3 through 25 incl., Tract 15125, Single-Family Residential Development, The Summit, in the City of Anaheim, California, Work Order 101476G4, dated April 11, 1997.

_____, 1997c, Project Grading Report, Lots 1 and 2, Tract 15125, Single-Family Residential Development, The Summit, in the City of Anaheim, California, Work Order 101476G4, dated April 28, 1997.

_____, 1997d, Project Grading Report, Lots 3 through 26 incl., Tract 15120, Single-Family Residential Development, The Summit, in the City of Anaheim, California, Work Order 101476G4, dated May 6, 1997.

Sessions Consulting Engineers, 2015, Aerial Topography Map, Kindred Community Church, 8712 E. Santa Ana Canyon Road, Anaheim California, Project No. 01-227-1, dated May 4, 2015.

APPENDIX B
SITE SEISMIC DESIGN AND DE-AGGREGATED PARAMETERS

TABLE 1
SITE SPECIFIC GROUND MOTION ANALYSIS
 15-5382 Kindred Community Church

SA Period (sec)	Probabilistic Spectral Acceleration (g)	Risk Coefficients	Probabilistic Spectral Acceleration MCER (g)	Deterministic Spectral Acceleration (g)	Is Largest Deterministic Spectral Acceleration <1.5*Fa	Deterministic MCER	Site Specific MCER	2/3 of Site Specific MCER	80% Code Design	Site Specific Design Response Spectrum
	Rotated Maximum		Rotated Maximum	Rotated Maximum 84th Percentile						
0	0.8943	0.911	0.8147	0.9730	No	0.9730	0.8147	0.5431	0.4111	0.5431
0.1	1.5312	0.911	1.3949	1.4118		1.4118	1.3949	0.9299	0.7611	0.9299
0.2	2.0383	0.911	1.8569	1.8899		1.8899	1.8569	1.2379	1.0277	1.2379
0.3	2.2984	0.911	2.0938	2.3532		2.3532	2.0938	1.3959	1.0277	1.3959
0.5	2.2725	0.911	2.0702	2.6825		2.6825	2.0702	1.3801	1.0277	1.3801
0.75	1.9355	0.911	1.7632	2.5069		2.5069	1.7632	1.1755	1.0277	1.1755
1	1.6770	0.911	1.5277	2.2904		2.2904	1.5277	1.0185	0.9053	1.0185
2	0.9072	0.911	0.8265	1.3387		1.3387	0.8265	0.5510	0.4527	0.5510
3	0.5950	0.911	0.5420	0.8861		0.8861	0.5420	0.3614	0.3018	0.3614
4	0.4234	0.911	0.3857	0.6046		0.6046	0.3857	0.2571	0.2263	0.2571
5	0.3225	0.911	0.2938	0.4415		0.4415	0.2938	0.1959	0.1811	0.1959

Code Sds	1.285	Crs =	0.911	Code Ss =	1.927	Site Specific SDS = 1.256
Code Sd1	1.132	Cr1 =	0.911	Code S1 =	0.679	Site Specific SD1 = 1.102
To	0.18	Code Fa =	1	Sms =	1.927	
Ts	0.88	Code Fv =	2.5	Sm1 =	1.6975	
TL	8					
Input						

FIGURE 1
Site Specific Design Response Spectra
15-5382 Kindred Community Church

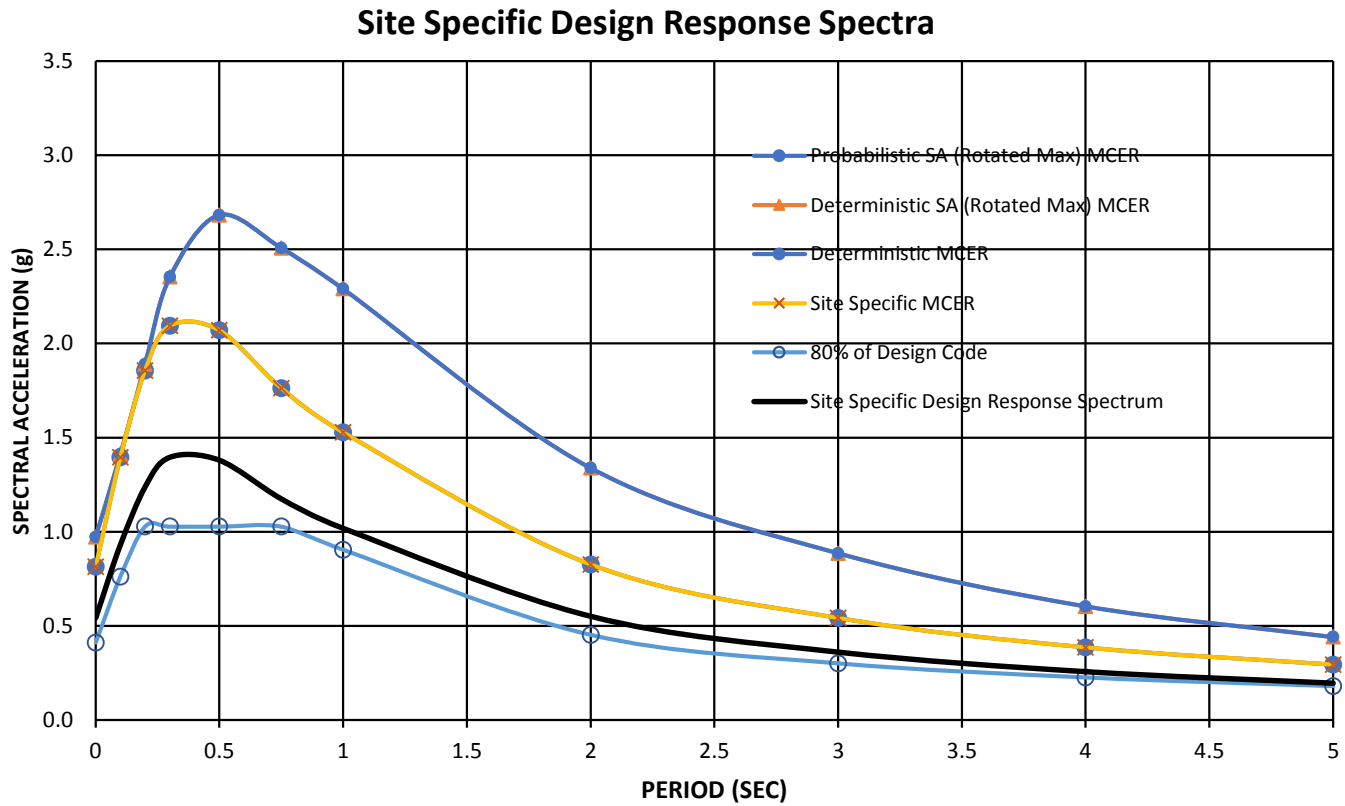


TABLE 2

**Probabilistic Response Spectrum ASCE 7-16 Method 2
15-5382 Kindred Community Church**

Period (g)	UHGM (g)	RTGM (g)	Max Dir Scale factor	Max Dir RTGM (g)
0	0.842	0.813	1.1	0.894
0.1	1.432	1.392	1.1	1.531
0.2	1.881	1.853	1.1	2.038
0.3	2.136	2.043	1.125	2.298
0.5	2.067	1.934	1.175	2.272
0.75	1.687	1.564	1.2375	1.935
1	1.410	1.290	1.3	1.677
2	0.734	0.672	1.35	0.907
3	0.466	0.425	1.4	0.595
4	0.320	0.292	1.45	0.423
5	0.237	0.215	1.5	0.323

Probabilistic Response Spectra per ASCE 7-16

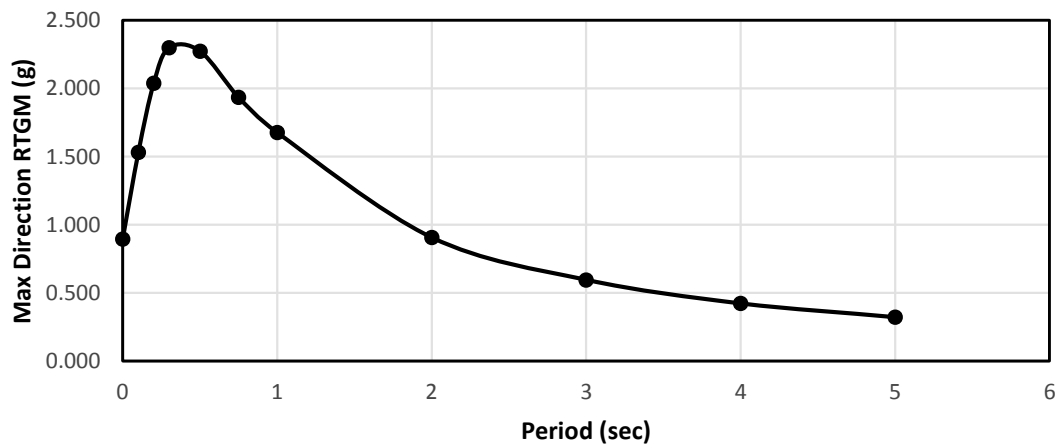
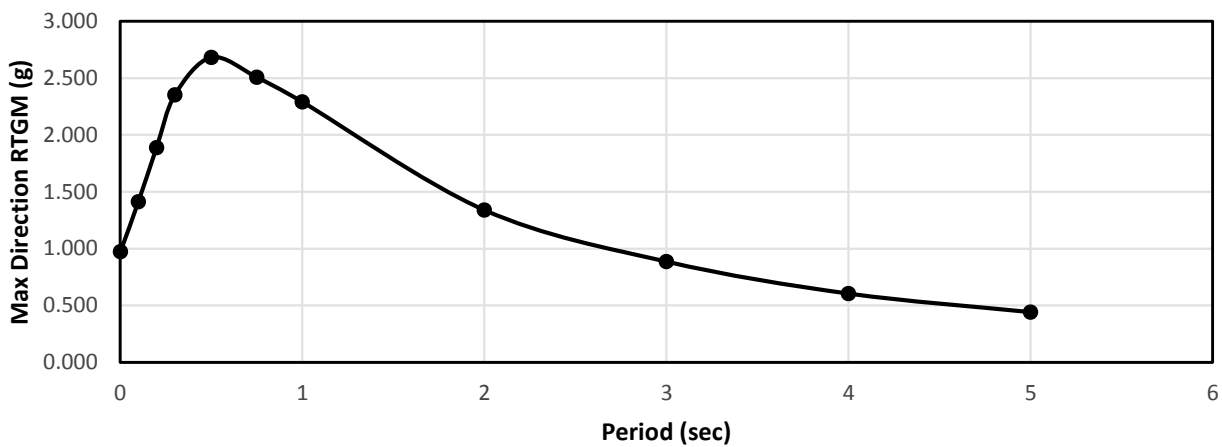


TABLE 3
Deterministic Response Spectrum ASCE 7-16
15-5382 Kindred Community Church

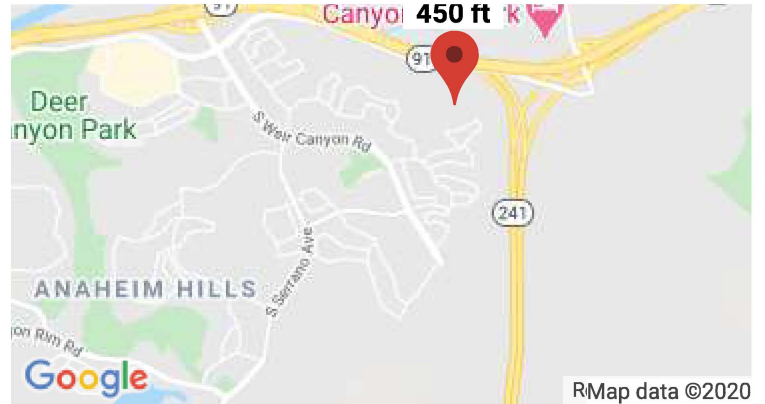
Period (g)	Mean Spectra (g)	Sigma (g)	84th-Percentile Spectral Acceleration (g)	Max Dir Scale factor	Max Dir Deterministic SA (g)
0.001	0.538	0.497	0.885	1.1	0.973
0.1	0.754	0.532	1.283	1.1	1.412
0.2	1.044	0.498	1.718	1.1	1.890
0.3	1.242	0.521	2.092	1.125	2.353
0.5	1.271	0.586	2.283	1.175	2.683
0.75	1.074	0.634	2.026	1.2375	2.507
1	0.906	0.666	1.762	1.3	2.290
2	0.491	0.703	0.992	1.35	1.339
3	0.311	0.710	0.633	1.4	0.886
4	0.207	0.701	0.417	1.45	0.605
5	0.146	0.702	0.294	1.5	0.441

Deterministic Response Spectra per ASCE 7-16



Search Information

Coordinates: 33.8635, -117.7224
Elevation: 450 ft
Timestamp: 2020-11-09T23:39:46.837Z
Hazard Type: Seismic
Reference Document: ASCE7-16
Risk Category: III
Site Class: D



Basic Parameters

Name	Value	Description
S_S	1.927	MCE_R ground motion (period=0.2s)
S_1	0.679	MCE_R ground motion (period=1.0s)
S_{MS}	1.927	Site-modified spectral acceleration value
S_{M1}	* null	Site-modified spectral acceleration value
S_{DS}	1.284	Numeric seismic design value at 0.2s SA
S_{D1}	* null	Numeric seismic design value at 1.0s SA

* See Section 11.4.8

Additional Information

Name	Value	Description
SDC	* null	Seismic design category
F_a	1	Site amplification factor at 0.2s
F_v	* null	Site amplification factor at 1.0s
CR_S	0.911	Coefficient of risk (0.2s)
CR_1	0.911	Coefficient of risk (1.0s)
PGA	0.816	MCE_G peak ground acceleration
F_{PGA}	1.1	Site amplification factor at PGA
PGA_M	0.897	Site modified peak ground acceleration
T_L	8	Long-period transition period (s)

SsRT	1.927	Probabilistic risk-targeted ground motion (0.2s)
SsUH	2.115	Factored uniform-hazard spectral acceleration (2% probability of exceedance in 50 years)
SsD	2.336	Factored deterministic acceleration value (0.2s)
S1RT	0.679	Probabilistic risk-targeted ground motion (1.0s)
S1UH	0.745	Factored uniform-hazard spectral acceleration (2% probability of exceedance in 50 years)
S1D	0.931	Factored deterministic acceleration value (1.0s)
PGAd	0.984	Factored deterministic acceleration value (PGA)

* See Section 11.4.8

The results indicated here DO NOT reflect any state or local amendments to the values or any delineation lines made during the building code adoption process. Users should confirm any output obtained from this tool with the local Authority Having Jurisdiction before proceeding with design.

Disclaimer

Hazard loads are provided by the U.S. Geological Survey [Seismic Design Web Services](#).

While the information presented on this website is believed to be correct, ATC and its sponsors and contributors assume no responsibility or liability for its accuracy. The material presented in the report should not be used or relied upon for any specific application without competent examination and verification of its accuracy, suitability and applicability by engineers or other licensed professionals. ATC does not intend that the use of this information replace the sound judgment of such competent professionals, having experience and knowledge in the field of practice, nor to substitute for the standard of care required of such professionals in interpreting and applying the results of the report provided by this website. Users of the information from this website assume all liability arising from such use. Use of the output of this website does not imply approval by the governing building code bodies responsible for building code approval and interpretation for the building site described by latitude/longitude location in the report.

Unified Hazard Tool



Please do not use this tool to obtain ground motion parameter values for the design code reference documents covered by the [U.S. Seismic Design Maps web tools](#) (e.g., the International Building Code and the ASCE 7 or 41 Standard). The values returned by the two applications are not identical.

^ Input

Edition

Dynamic: Conterminous U.S. 2014 (u...

Spectral Period

Peak Ground Acceleration

Latitude

Decimal degrees

33.8635

Time Horizon

Return period in years

2475

Longitude

Decimal degrees, negative values for western longitudes

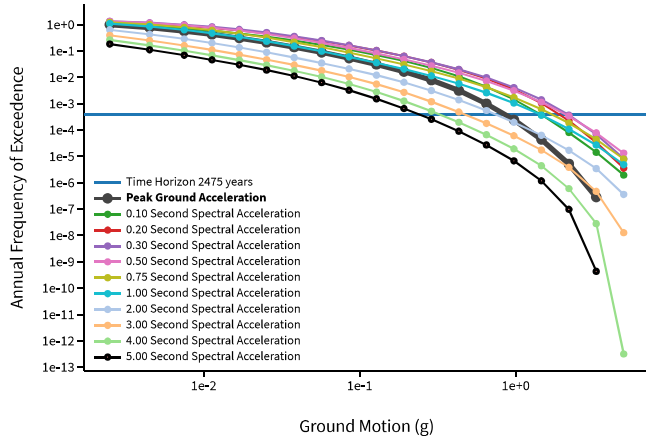
-117.7224

Site Class

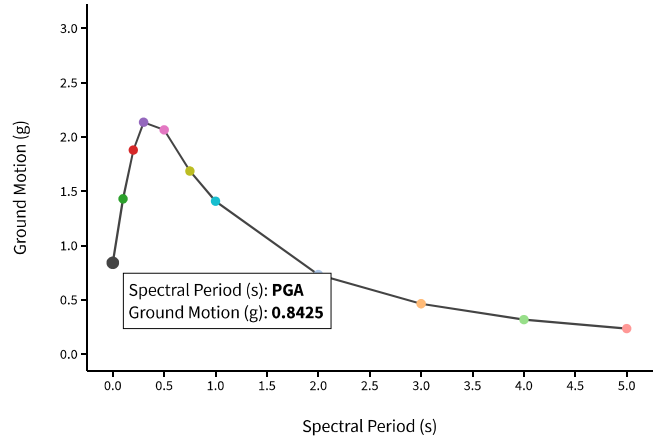
259 m/s (Site class D)

^ Hazard Curve

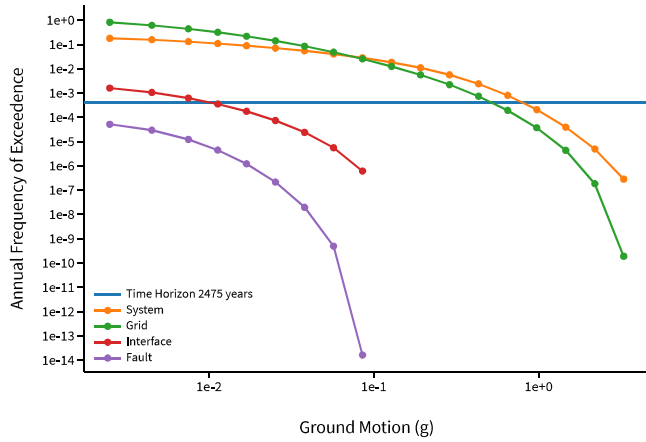
Hazard Curves



Uniform Hazard Response Spectrum



Component Curves for Peak Ground Acceleration

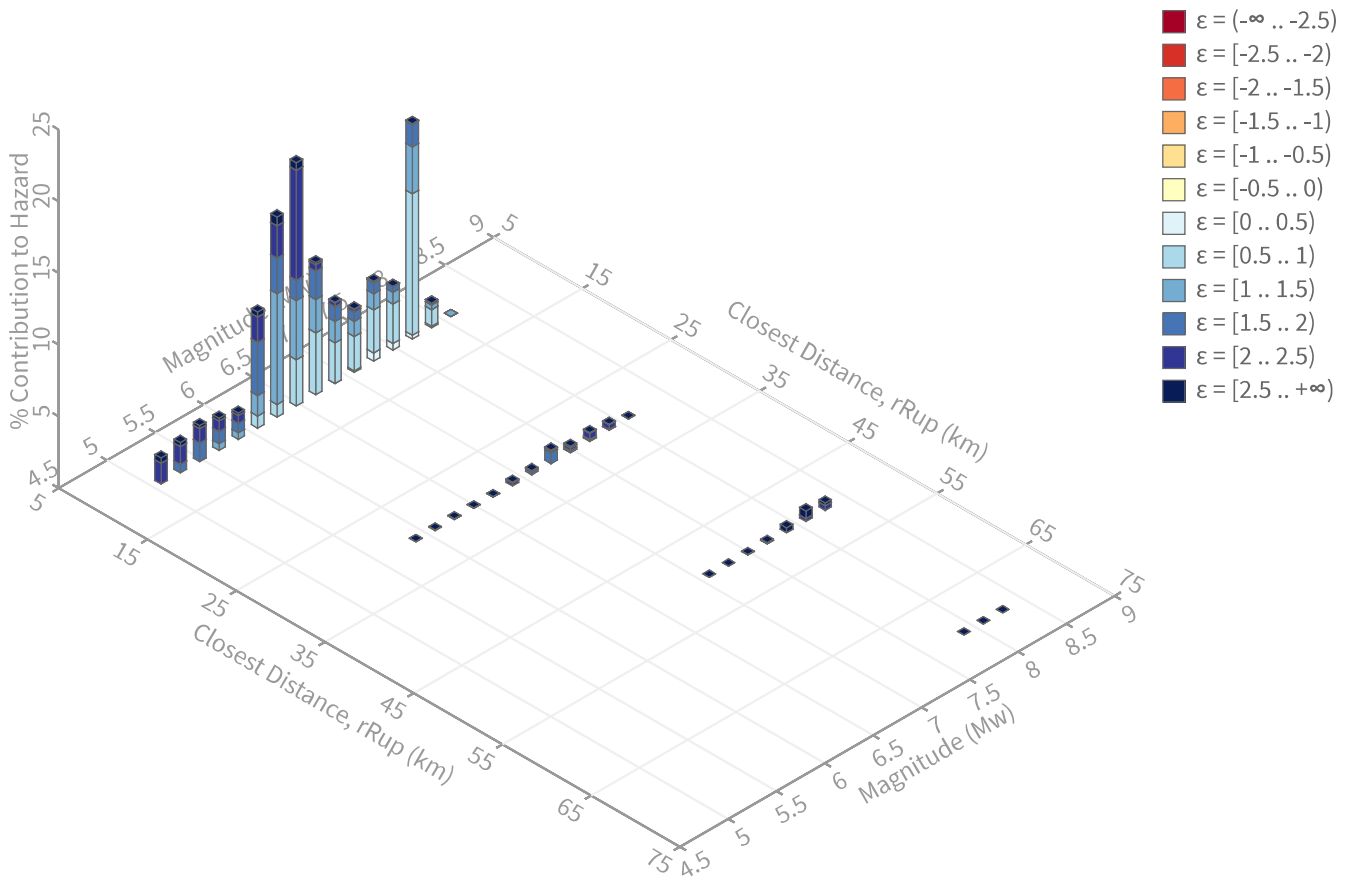


[View Raw Data](#)

^ Deaggregation

Component

Total



Summary statistics for, Deaggregation: Total

Deaggregation targets

Return period: 2475 yrs
Exceedance rate: 0.0004040404 yr⁻¹
PGA ground motion: 0.84246025 g

Recovered targets

Return period: 2882.8216 yrs
Exceedance rate: 0.00034688237 yr⁻¹

Totals

Binned: 100 %
Residual: 0 %
Trace: 0.04 %

Mean (over all sources)

m: 6.74
r: 7.57 km
ε₀: 1.43 σ

Mode (largest m-r bin)

m: 6.48
r: 8.71 km
ε₀: 1.71 σ
Contribution: 16.94 %

Mode (largest m-r-ε₀ bin)

m: 7.72
r: 2.48 km
ε₀: 0.7 σ
Contribution: 9.86 %

Discretization

r: min = 0.0, max = 1000.0, Δ = 20.0 km
m: min = 4.4, max = 9.4, Δ = 0.2
ε: min = -3.0, max = 3.0, Δ = 0.5 σ

Epsilon keys

ε₀: [-∞ .. -2.5)
ε₁: [-2.5 .. -2.0)
ε₂: [-2.0 .. -1.5)
ε₃: [-1.5 .. -1.0)
ε₄: [-1.0 .. -0.5)
ε₅: [-0.5 .. 0.0)
ε₆: [0.0 .. 0.5)
ε₇: [0.5 .. 1.0)
ε₈: [1.0 .. 1.5)
ε₉: [1.5 .. 2.0)
ε₁₀: [2.0 .. 2.5)
ε₁₁: [2.5 .. +∞]

Deaggregation Contributors

Source Set ↴ Source	Type	r	m	ϵ_0	lon	lat	az	%
UC33brAvg_FM31	System							48.44
Whittier alt 1 [2]		2.10	7.29	0.91	117.712°W	33.876°N	33.12	16.43
Chino alt 1 [3]		6.46	6.58	1.16	117.662°W	33.910°N	46.95	11.72
Elsinore (Glen Ivy) rev [0]		12.89	6.51	2.26	117.590°W	33.829°N	107.43	5.24
Chino alt 1 [2]		6.64	6.24	1.29	117.669°W	33.917°N	39.73	3.96
Chino alt 1 [1]		9.11	6.08	1.86	117.703°W	33.950°N	10.47	2.46
Whittier alt 1 [1]		2.49	6.80	1.08	117.702°W	33.874°N	58.72	2.34
Peralta Hills [0]		2.92	6.42	1.09	117.740°W	33.848°N	223.82	2.01
UC33brAvg_FM32	System							36.59
Whittier alt 2 [2]		2.18	7.49	0.86	117.719°W	33.878°N	9.51	14.00
Chino alt 2 [2]		7.57	6.85	1.22	117.658°W	33.908°N	50.26	7.36
Elsinore (Glen Ivy) rev [0]		12.89	6.50	2.27	117.590°W	33.829°N	107.43	5.35
Chino alt 2 [1]		7.84	6.35	1.40	117.670°W	33.921°N	37.27	2.75
Richfield [0]		8.71	6.33	1.88	117.803°W	33.889°N	290.83	1.69
Whittier alt 2 [1]		2.18	7.10	0.97	117.719°W	33.878°N	9.51	1.30
UC33brAvg_FM32 (opt)	Grid							7.66
PointSourceFinite: -117.722, 33.904		6.89	5.57	1.79	117.722°W	33.904°N	0.00	1.74
PointSourceFinite: -117.722, 33.904		6.89	5.57	1.79	117.722°W	33.904°N	0.00	1.74
UC33brAvg_FM31 (opt)	Grid							7.32
PointSourceFinite: -117.722, 33.904		6.93	5.52	1.82	117.722°W	33.904°N	0.00	1.51
PointSourceFinite: -117.722, 33.904		6.93	5.52	1.82	117.722°W	33.904°N	0.00	1.51

Appendix E

EDR Radius Map Report

Kindred Church Expansion Project

8712 East Santa Ana Canyon Road
Anaheim, CA 92808

Inquiry Number: 6397650.2s

March 09, 2021

The EDR Radius Map™ Report with GeoCheck®



6 Armstrong Road, 4th floor
Shelton, CT 06484
Toll Free: 800.352.0050
www.edrnet.com

TABLE OF CONTENTS

<u>SECTION</u>	<u>PAGE</u>
Executive Summary	ES1
Overview Map	2
Detail Map	3
Map Findings Summary	4
Map Findings	9
Orphan Summary	33
Government Records Searched/Data Currency Tracking	GR-1
 <u>GEOCHECK ADDENDUM</u>	
Physical Setting Source Addendum	A-1
Physical Setting Source Summary	A-2
Physical Setting SSURGO Soil Map	A-5
Physical Setting Source Map	A-18
Physical Setting Source Map Findings	A-20
Physical Setting Source Records Searched	PSGR-1

Thank you for your business.
Please contact EDR at 1-800-352-0050
with any questions or comments.

Disclaimer - Copyright and Trademark Notice

This Report contains certain information obtained from a variety of public and other sources reasonably available to Environmental Data Resources, Inc. It cannot be concluded from this Report that coverage information for the target and surrounding properties does not exist from other sources. **NO WARRANTY EXPRESSED OR IMPLIED, IS MADE WHATSOEVER IN CONNECTION WITH THIS REPORT. ENVIRONMENTAL DATA RESOURCES, INC. SPECIFICALLY DISCLAIMS THE MAKING OF ANY SUCH WARRANTIES, INCLUDING WITHOUT LIMITATION, MERCHANTABILITY OR FITNESS FOR A PARTICULAR USE OR PURPOSE. ALL RISK IS ASSUMED BY THE USER. IN NO EVENT SHALL ENVIRONMENTAL DATA RESOURCES, INC. BE LIABLE TO ANYONE, WHETHER ARISING OUT OF ERRORS OR OMISSIONS, NEGLIGENCE, ACCIDENT OR ANY OTHER CAUSE, FOR ANY LOSS OF DAMAGE, INCLUDING, WITHOUT LIMITATION, SPECIAL, INCIDENTAL, CONSEQUENTIAL, OR EXEMPLARY DAMAGES. ANY LIABILITY ON THE PART OF ENVIRONMENTAL DATA RESOURCES, INC. IS STRICTLY LIMITED TO A REFUND OF THE AMOUNT PAID FOR THIS REPORT.** Purchaser accepts this Report "AS IS". Any analyses, estimates, ratings, environmental risk levels or risk codes provided in this Report are provided for illustrative purposes only, and are not intended to provide, nor should they be interpreted as providing any facts regarding, or prediction or forecast of, any environmental risk for any property. Only a Phase I Environmental Site Assessment performed by an environmental professional can provide information regarding the environmental risk for any property. Additionally, the information provided in this Report is not to be construed as legal advice.

Copyright 2020 by Environmental Data Resources, Inc. All rights reserved. Reproduction in any media or format, in whole or in part, of any report or map of Environmental Data Resources, Inc., or its affiliates, is prohibited without prior written permission.

EDR and its logos (including Sanborn and Sanborn Map) are trademarks of Environmental Data Resources, Inc. or its affiliates. All other trademarks used herein are the property of their respective owners.

EXECUTIVE SUMMARY

A search of available environmental records was conducted by Environmental Data Resources, Inc (EDR). The report was designed to assist parties seeking to meet the search requirements of EPA's Standards and Practices for All Appropriate Inquiries (40 CFR Part 312), the ASTM Standard Practice for Environmental Site Assessments (E 1527-13), the ASTM Standard Practice for Environmental Site Assessments for Forestland or Rural Property (E 2247-16), the ASTM Standard Practice for Limited Environmental Due Diligence: Transaction Screen Process (E 1528-14) or custom requirements developed for the evaluation of environmental risk associated with a parcel of real estate.

TARGET PROPERTY INFORMATION

ADDRESS

8712 EAST SANTA ANA CANYON ROAD
ANAHEIM, CA 92808

COORDINATES

Latitude (North): 33.8647050 - 33° 51' 52.93"
Longitude (West): 117.7229550 - 117° 43' 22.63"
Universal Transverse Mercator: Zone 11
UTM X (Meters): 433128.8
UTM Y (Meters): 3747196.0
Elevation: 413 ft. above sea level

USGS TOPOGRAPHIC MAP ASSOCIATED WITH TARGET PROPERTY

Target Property Map: 5636465 BLACK STAR CANYON, CA
Version Date: 2012

North Map: 5640938 PRADO DAM, CA
Version Date: 2012

AERIAL PHOTOGRAPHY IN THIS REPORT

Portions of Photo from: 20140603
Source: USDA

MAPPED SITES SUMMARY

Target Property Address:
 8712 EAST SANTA ANA CANYON ROAD
 ANAHEIM, CA 92808

Click on Map ID to see full detail.

MAP ID	SITE NAME	ADDRESS	DATABASE ACRONYMS	RELATIVE ELEVATION	DIST (ft. & mi.) DIRECTION
A1	8712 E SANTA ANA CAN	8712 E SANTA ANA CAN	CIWQS		TP
A2	KINDRED CMNTY CHURCH	8712 E SANTA ANA CAN	CIWQS		TP
B3	INDUSTRIAL ASPHALT	9010 E SANTA ANA CAN	ENVIROSTOR, LUST, VCP, Orange Co. Industrial Site,...	Lower	576, 0.109, ENE
B4	OWL ROCK NEW STAR	9010 E SANTA ANA CAN	UST	Lower	576, 0.109, ENE
5	RUNNING SPRINGS ELEM	8670 RUNNING SPRINGS	ENVIROSTOR, SCH, CERS	Higher	1510, 0.286, SSW
6	INDUSTRIAL ASPHALT	24000 SANTA ANA CANY	LUST, SWEEPS UST, Cortese, EMI, WDS, CIWQS, CERS	Lower	1576, 0.298, ENE

EXECUTIVE SUMMARY

TARGET PROPERTY SEARCH RESULTS

The target property was identified in the following records. For more information on this property see page 9 of the attached EDR Radius Map report:

<u>Site</u>	<u>Database(s)</u>	<u>EPA ID</u>
8712 E SANTA ANA CAN 8712 E SANTA ANA CAN ANAHEIM, CA 92808	CIWQS	N/A
KINDRED CMNTY CHURCH 8712 E SANTA ANA CAN ANAHEIM, CA 92808	CIWQS	N/A

DATABASES WITH NO MAPPED SITES

No mapped sites were found in EDR's search of available ("reasonably ascertainable ") government records either on the target property or within the search radius around the target property for the following databases:

STANDARD ENVIRONMENTAL RECORDS

Federal NPL site list

NPL..... National Priority List
Proposed NPL..... Proposed National Priority List Sites
NPL LIENS..... Federal Superfund Liens

Federal Delisted NPL site list

Delisted NPL..... National Priority List Deletions

Federal CERCLIS list

FEDERAL FACILITY..... Federal Facility Site Information listing
SEMS..... Superfund Enterprise Management System

Federal CERCLIS NFRAP site list

SEMS-ARCHIVE..... Superfund Enterprise Management System Archive

Federal RCRA CORRACTS facilities list

CORRACTS..... Corrective Action Report

Federal RCRA non-CORRACTS TSD facilities list

RCRA-TSDF..... RCRA - Treatment, Storage and Disposal

EXECUTIVE SUMMARY

Federal RCRA generators list

RCRA-LQG..... RCRA - Large Quantity Generators
RCRA-SQG..... RCRA - Small Quantity Generators
RCRA-VSQG..... RCRA - Very Small Quantity Generators (Formerly Conditionally Exempt Small Quantity Generators)

Federal institutional controls / engineering controls registries

LUCIS..... Land Use Control Information System
US ENG CONTROLS..... Engineering Controls Sites List
US INST CONTROLS..... Institutional Controls Sites List

Federal ERNS list

ERNS..... Emergency Response Notification System

State- and tribal - equivalent NPL

RESPONSE..... State Response Sites

State and tribal landfill and/or solid waste disposal site lists

SWF/LF..... Solid Waste Information System

State and tribal leaking storage tank lists

INDIAN LUST..... Leaking Underground Storage Tanks on Indian Land
CPS-SLIC..... Statewide SLIC Cases

State and tribal registered storage tank lists

FEMA UST..... Underground Storage Tank Listing
AST..... Aboveground Petroleum Storage Tank Facilities
INDIAN UST..... Underground Storage Tanks on Indian Land

State and tribal voluntary cleanup sites

INDIAN VCP..... Voluntary Cleanup Priority Listing

State and tribal Brownfields sites

BROWNFIELDS..... Considered Brownfields Sites Listing

ADDITIONAL ENVIRONMENTAL RECORDS

Local Brownfield lists

US BROWNFIELDS..... A Listing of Brownfields Sites

Local Lists of Landfill / Solid Waste Disposal Sites

WMUDS/SWAT..... Waste Management Unit Database

EXECUTIVE SUMMARY

SWRCY.....	Recycler Database
HAULERS.....	Registered Waste Tire Haulers Listing
INDIAN ODI.....	Report on the Status of Open Dumps on Indian Lands
DEBRIS REGION 9.....	Torres Martinez Reservation Illegal Dump Site Locations
ODI.....	Open Dump Inventory
IHS OPEN DUMPS.....	Open Dumps on Indian Land

Local Lists of Hazardous waste / Contaminated Sites

US HIST CDL.....	Delisted National Clandestine Laboratory Register
HIST Cal-Sites.....	Historical Calsites Database
SCH.....	School Property Evaluation Program
CDL.....	Clandestine Drug Labs
Toxic Pits.....	Toxic Pits Cleanup Act Sites
CERS HAZ WASTE.....	CERS HAZ WASTE
US CDL.....	National Clandestine Laboratory Register
PFAS.....	PFAS Contamination Site Location Listing

Local Lists of Registered Storage Tanks

SWEEPS UST.....	SWEEPS UST Listing
HIST UST.....	Hazardous Substance Storage Container Database
CA FID UST.....	Facility Inventory Database
CERS TANKS.....	California Environmental Reporting System (CERS) Tanks

Local Land Records

LIENS.....	Environmental Liens Listing
LIENS 2.....	CERCLA Lien Information
DEED.....	Deed Restriction Listing

Records of Emergency Release Reports

HMIRS.....	Hazardous Materials Information Reporting System
CHMIRS.....	California Hazardous Material Incident Report System
LDS.....	Land Disposal Sites Listing
MCS.....	Military Cleanup Sites Listing
Orange Co. Industrial Site.....	List of Industrial Site Cleanups
SPILLS 90.....	SPILLS 90 data from FirstSearch

Other Ascertainable Records

RCRA NonGen / NLR.....	RCRA - Non Generators / No Longer Regulated
FUDS.....	Formerly Used Defense Sites
DOD.....	Department of Defense Sites
SCRD DRYCLEANERS.....	State Coalition for Remediation of Drycleaners Listing
US FIN ASSUR.....	Financial Assurance Information
EPA WATCH LIST.....	EPA WATCH LIST
2020 COR ACTION.....	2020 Corrective Action Program List
TSCA.....	Toxic Substances Control Act
TRIS.....	Toxic Chemical Release Inventory System
SSTS.....	Section 7 Tracking Systems
ROD.....	Records Of Decision
RMP.....	Risk Management Plans
RAATS.....	RCRA Administrative Action Tracking System

EXECUTIVE SUMMARY

PRP.....	Potentially Responsible Parties
PADS.....	PCB Activity Database System
ICIS.....	Integrated Compliance Information System
FTTS.....	FIFRA/ TSCA Tracking System - FIFRA (Federal Insecticide, Fungicide, & Rodenticide Act)/TSCA (Toxic Substances Control Act)
MLTS.....	Material Licensing Tracking System
COAL ASH DOE.....	Steam-Electric Plant Operation Data
COAL ASH EPA.....	Coal Combustion Residues Surface Impoundments List
PCB TRANSFORMER.....	PCB Transformer Registration Database
RADINFO.....	Radiation Information Database
HIST FTTS.....	FIFRA/TSCA Tracking System Administrative Case Listing
DOT OPS.....	Incident and Accident Data
CONSENT.....	Superfund (CERCLA) Consent Decrees
INDIAN RESERV.....	Indian Reservations
FUSRAP.....	Formerly Utilized Sites Remedial Action Program
UMTRA.....	Uranium Mill Tailings Sites
LEAD SMELTERS.....	Lead Smelter Sites
US AIRS.....	Aerometric Information Retrieval System Facility Subsystem
US MINES.....	Mines Master Index File
ABANDONED MINES.....	Abandoned Mines
FINDS.....	Facility Index System/Facility Registry System
DOCKET HWC.....	Hazardous Waste Compliance Docket Listing
ECHO.....	Enforcement & Compliance History Information
UXO.....	Unexploded Ordnance Sites
FUELS PROGRAM.....	EPA Fuels Program Registered Listing
CA BOND EXP. PLAN.....	Bond Expenditure Plan
CUPA Listings.....	CUPA Resources List
DRYCLEANERS.....	Cleaner Facilities
EMI.....	Emissions Inventory Data
ENF.....	Enforcement Action Listing
Financial Assurance.....	Financial Assurance Information Listing
HAZNET.....	Facility and Manifest Data
ICE.....	ICE
HIST CORTESE.....	Hazardous Waste & Substance Site List
HWP.....	EnviroStor Permitted Facilities Listing
HWT.....	Registered Hazardous Waste Transporter Database
MINES.....	Mines Site Location Listing
MWMP.....	Medical Waste Management Program Listing
NPDES.....	NPDES Permits Listing
PEST LIC.....	Pesticide Regulation Licenses Listing
PROC.....	Certified Processors Database
Notify 65.....	Proposition 65 Records
UIC.....	UIC Listing
UIC GEO.....	UIC GEO (GEOTRACKER)
WASTEWATER PITS.....	Oil Wastewater Pits Listing
WDS.....	Waste Discharge System
WIP.....	Well Investigation Program Case List
MILITARY PRIV SITES.....	MILITARY PRIV SITES (GEOTRACKER)
PROJECT.....	PROJECT (GEOTRACKER)
WDR.....	Waste Discharge Requirements Listing
CERS.....	CERS
NON-CASE INFO.....	NON-CASE INFO (GEOTRACKER)
OTHER OIL GAS.....	OTHER OIL & GAS (GEOTRACKER)
PROD WATER PONDS.....	PROD WATER PONDS (GEOTRACKER)
SAMPLING POINT.....	SAMPLING POINT (GEOTRACKER)

EXECUTIVE SUMMARY

WELL STIM PROJ..... Well Stimulation Project (GEOTRACKER)
HWTS..... Hazardous Waste Tracking System
MINES MRDS..... Mineral Resources Data System

EDR HIGH RISK HISTORICAL RECORDS

EDR Exclusive Records

EDR MGP..... EDR Proprietary Manufactured Gas Plants
EDR Hist Auto..... EDR Exclusive Historical Auto Stations
EDR Hist Cleaner..... EDR Exclusive Historical Cleaners

EDR RECOVERED GOVERNMENT ARCHIVES

Exclusive Recovered Govt. Archives

RGA LF..... Recovered Government Archive Solid Waste Facilities List
RGA LUST..... Recovered Government Archive Leaking Underground Storage Tank

SURROUNDING SITES: SEARCH RESULTS

Surrounding sites were identified in the following databases.

Elevations have been determined from the USGS Digital Elevation Model and should be evaluated on a relative (not an absolute) basis. Relative elevation information between sites of close proximity should be field verified. Sites with an elevation equal to or higher than the target property have been differentiated below from sites with an elevation lower than the target property.

Page numbers and map identification numbers refer to the EDR Radius Map report where detailed data on individual sites can be reviewed.

Sites listed in ***bold italics*** are in multiple databases.

Unmappable (orphan) sites are not considered in the foregoing analysis.

STANDARD ENVIRONMENTAL RECORDS

State- and tribal - equivalent CERCLIS

ENVIROSTOR: The Department of Toxic Substances Control's (DTSC's) Site Mitigation and Brownfields Reuse Program's (SMBRP's) EnviroStor database identifies sites that have known contamination or sites for which there may be reasons to investigate further. The database includes the following site types: Federal Superfund sites (National Priorities List (NPL)); State Response, including Military Facilities and State Superfund; Voluntary Cleanup; and School sites. EnviroStor provides similar information to the information that was available in CalSites, and provides additional site information, including, but not limited to, identification of formerly-contaminated properties that have been released for reuse, properties where environmental deed restrictions have been recorded to prevent inappropriate land uses, and risk characterization information that is used to assess potential impacts to public health and the environment at contaminated sites.

A review of the ENVIROSTOR list, as provided by EDR, and dated 10/26/2020 has revealed that there are 2 ENVIROSTOR sites within approximately 1 mile of the target property.

<u>Equal/Higher Elevation</u>	<u>Address</u>	<u>Direction / Distance</u>	<u>Map ID</u>	<u>Page</u>
<i>RUNNING SPRINGS ELEM</i>	<i>8670 RUNNING SPRINGS</i>	<i>SSW 1/4 - 1/2 (0.286 mi.)</i>	<i>5</i>	<i>19</i>

EXECUTIVE SUMMARY

Facility Id: 30820003
 Status: No Action Required

<u>Lower Elevation</u>	<u>Address</u>	<u>Direction / Distance</u>	<u>Map ID</u>	<u>Page</u>
INDUSTRIAL ASPHALT Facility Id: 30320052 Status: No Further Action	9010 E SANTA ANA CAN	ENE 0 - 1/8 (0.109 mi.)	B3	10

State and tribal leaking storage tank lists

LUST: Leaking Underground Storage Tank (LUST) Sites included in GeoTracker. GeoTracker is the Water Boards data management system for sites that impact, or have the potential to impact, water quality in California, with emphasis on groundwater.

A review of the LUST list, as provided by EDR, has revealed that there are 2 LUST sites within approximately 0.5 miles of the target property.

<u>Lower Elevation</u>	<u>Address</u>	<u>Direction / Distance</u>	<u>Map ID</u>	<u>Page</u>
INDUSTRIAL ASPHALT Database: LUST, Date of Government Version: 12/04/2020 Status: Completed - Case Closed Global Id: T0605901925	9010 E SANTA ANA CAN	ENE 0 - 1/8 (0.109 mi.)	B3	10
INDUSTRIAL ASPHALT Database: LUST REG 8, Date of Government Version: 02/14/2005 Database: ORANGE CO. LUST, Date of Government Version: 09/01/2020 Database: LUST, Date of Government Version: 12/04/2020 Status: Completed - Case Closed Facility Status: Case Closed Global Id: T0605994052 Global ID: T0605901022 Facility Id: 89UT187 Facility Id: 91UT133 Facility Id: 90UT189	24000 SANTA ANA CANY	ENE 1/4 - 1/2 (0.298 mi.)	6	21

State and tribal registered storage tank lists

UST: The Underground Storage Tank database contains registered USTs. USTs are regulated under Subtitle I of the Resource Conservation and Recovery Act (RCRA). The data come from the State Water Resources Control Board's Hazardous Substance Storage Container Database.

A review of the UST list, as provided by EDR, has revealed that there is 1 UST site within approximately 0.25 miles of the target property.

<u>Lower Elevation</u>	<u>Address</u>	<u>Direction / Distance</u>	<u>Map ID</u>	<u>Page</u>
OWL ROCK NEW STAR Database: UST, Date of Government Version: 12/04/2020 Facility Id: 403	9010 E SANTA ANA CAN	ENE 0 - 1/8 (0.109 mi.)	B4	18

EXECUTIVE SUMMARY

Facility Id: 4803
Facility Id: 7002

State and tribal voluntary cleanup sites

VCP: Contains low threat level properties with either confirmed or unconfirmed releases and the project proponents have request that DTSC oversee investigation and/or cleanup activities and have agreed to provide coverage for DTSC's costs.

A review of the VCP list, as provided by EDR, and dated 10/26/2020 has revealed that there is 1 VCP site within approximately 0.5 miles of the target property.

<u>Lower Elevation</u>	<u>Address</u>	<u>Direction / Distance</u>	<u>Map ID</u>	<u>Page</u>
INDUSTRIAL ASPHALT Status: No Further Action Facility Id: 30320052	9010 E SANTA ANA CAN	ENE 0 - 1/8 (0.109 mi.)	B3	10

ADDITIONAL ENVIRONMENTAL RECORDS

Other Ascertainable Records

Cortese: The sites for the list are designated by the State Water Resource Control Board (LUST), the Integrated Waste Board (SWF/LS), and the Department of Toxic Substances Control (Cal-Sites).

A review of the Cortese list, as provided by EDR, and dated 06/22/2020 has revealed that there are 2 Cortese sites within approximately 0.5 miles of the target property.

<u>Lower Elevation</u>	<u>Address</u>	<u>Direction / Distance</u>	<u>Map ID</u>	<u>Page</u>
INDUSTRIAL ASPHALT Cleanup Status: COMPLETED - CASE CLOSED	9010 E SANTA ANA CAN	ENE 0 - 1/8 (0.109 mi.)	B3	10
INDUSTRIAL ASPHALT Cleanup Status: COMPLETED - CASE CLOSED	24000 SANTA ANA CANY	ENE 1/4 - 1/2 (0.298 mi.)	6	21

EXECUTIVE SUMMARY

There were no unmapped sites in this report.

OVERVIEW MAP - 6397650.2S



Target Property

Sites at elevations higher than or equal to the target property

Sites at elevations lower than the target property

Manufactured Gas Plants

National Priority List Sites

Dept. Defense Sites

Indian Reservations BIA

Special Flood Hazard Area (1%)

0.2% Annual Chance Flood Hazard

National Wetland Inventory

State Wetlands

Areas of Concern

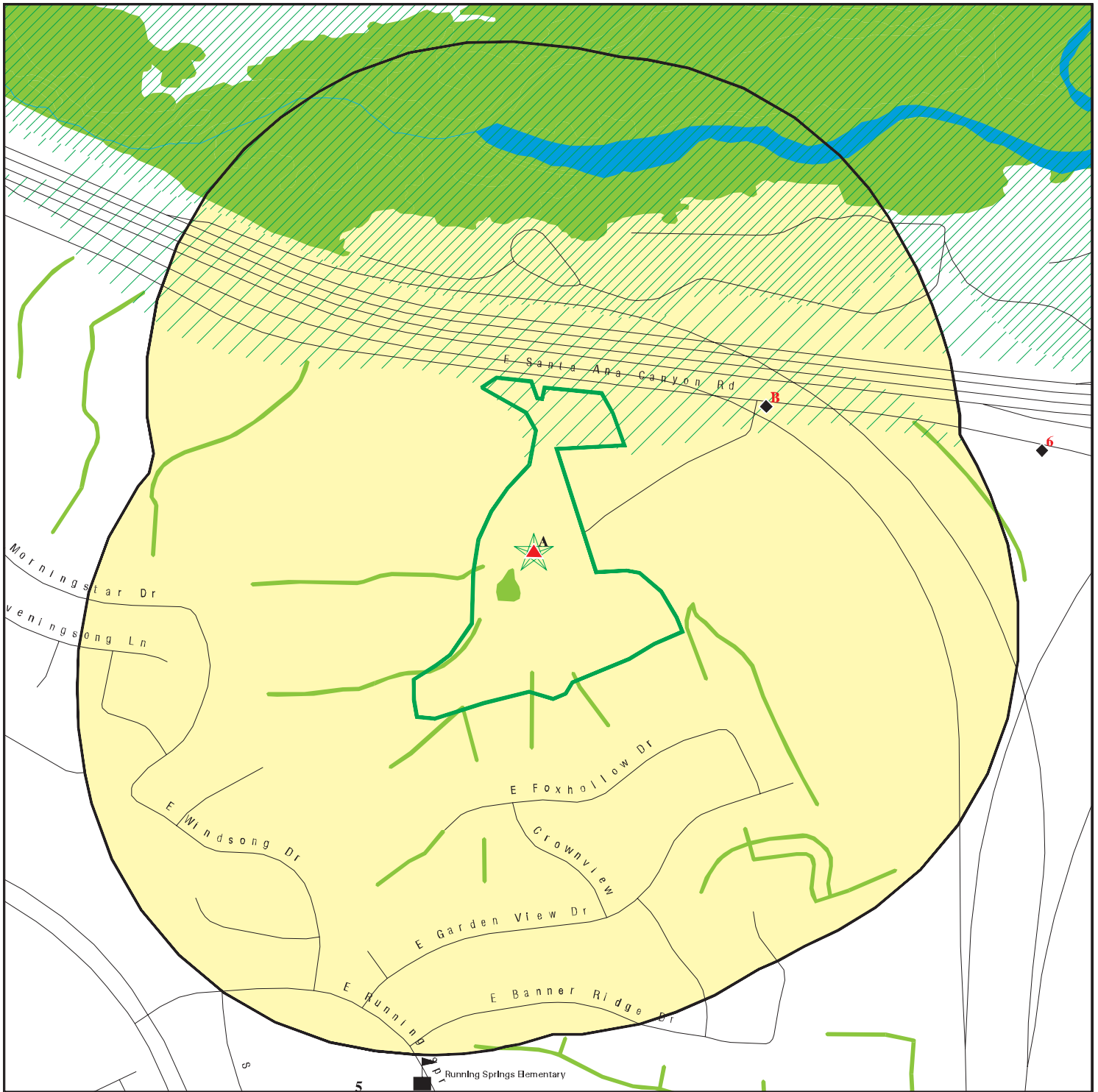









This report includes Interactive Map Layers to display and/or hide map information. The legend includes only those icons for the default map view.







SITE NAME: Kindred Church Expansion Project
 ADDRESS: 8712 East Santa Ana Canyon Road
 Anaheim CA 92808
 LAT/LONG: 33.864705 / 117.722955

CLIENT: Psomas
 CONTACT: Janet Powell
 INQUIRY #: 6397650.2s
 DATE: March 09, 2021 5:53 pm

DETAIL MAP - 6397650.2S



-  Target Property
-  Sites at elevations higher than or equal to the target property
-  Sites at elevations lower than the target property
-  Manufactured Gas Plants
-  Sensitive Receptors
-  National Priority List Sites
-  Dept. Defense Sites

-  Indian Reservations BIA
-  Special Flood Hazard Area (1%)
-  0.2% Annual Chance Flood Hazard
-  National Wetland Inventory
-  State Wetlands
-  Areas of Concern



This report includes Interactive Map Layers to display and/or hide map information. The legend includes only those icons for the default map view.

<p>SITE NAME: Kindred Church Expansion Project ADDRESS: 8712 East Santa Ana Canyon Road Anaheim CA 92808 LAT/LONG: 33.864705 / 117.722955</p>	<p>CLIENT: Psomas CONTACT: Janet Powell INQUIRY #: 6397650.2s DATE: March 09, 2021 5:54 pm</p>
---	---

MAP FINDINGS SUMMARY

Database	Search Distance (Miles)	Target Property	< 1/8	1/8 - 1/4	1/4 - 1/2	1/2 - 1	> 1	Total Plotted
STANDARD ENVIRONMENTAL RECORDS								
<i>Federal NPL site list</i>								
NPL	1.000		0	0	0	0	NR	0
Proposed NPL	1.000		0	0	0	0	NR	0
NPL LIENS	1.000		0	0	0	0	NR	0
<i>Federal Delisted NPL site list</i>								
Delisted NPL	1.000		0	0	0	0	NR	0
<i>Federal CERCLIS list</i>								
FEDERAL FACILITY	0.500		0	0	0	NR	NR	0
SEMS	0.500		0	0	0	NR	NR	0
<i>Federal CERCLIS NFRAP site list</i>								
SEMS-ARCHIVE	0.500		0	0	0	NR	NR	0
<i>Federal RCRA CORRACTS facilities list</i>								
CORRACTS	1.000		0	0	0	0	NR	0
<i>Federal RCRA non-CORRACTS TSD facilities list</i>								
RCRA-TSDF	0.500		0	0	0	NR	NR	0
<i>Federal RCRA generators list</i>								
RCRA-LQG	0.250		0	0	NR	NR	NR	0
RCRA-SQG	0.250		0	0	NR	NR	NR	0
RCRA-VSQG	0.250		0	0	NR	NR	NR	0
<i>Federal institutional controls / engineering controls registries</i>								
LUCIS	0.500		0	0	0	NR	NR	0
US ENG CONTROLS	0.500		0	0	0	NR	NR	0
US INST CONTROLS	0.500		0	0	0	NR	NR	0
<i>Federal ERNS list</i>								
ERNS	0.001		0	NR	NR	NR	NR	0
<i>State- and tribal - equivalent NPL RESPONSE</i>								
RESPONSE	1.000		0	0	0	0	NR	0
<i>State- and tribal - equivalent CERCLIS ENVIROSTOR</i>								
ENVIROSTOR	1.000		1	0	1	0	NR	2
<i>State and tribal landfill and/or solid waste disposal site lists</i>								
SWF/LF	0.500		0	0	0	NR	NR	0
<i>State and tribal leaking storage tank lists</i>								
LUST	0.500		1	0	1	NR	NR	2

MAP FINDINGS SUMMARY

Database	Search Distance (Miles)	Target Property	< 1/8	1/8 - 1/4	1/4 - 1/2	1/2 - 1	> 1	Total Plotted
INDIAN LUST	0.500		0	0	0	NR	NR	0
CPS-SLIC	0.500		0	0	0	NR	NR	0
<i>State and tribal registered storage tank lists</i>								
FEMA UST	0.250		0	0	NR	NR	NR	0
UST	0.250		1	0	NR	NR	NR	1
AST	0.250		0	0	NR	NR	NR	0
INDIAN UST	0.250		0	0	NR	NR	NR	0
<i>State and tribal voluntary cleanup sites</i>								
VCP	0.500		1	0	0	NR	NR	1
INDIAN VCP	0.500		0	0	0	NR	NR	0
<i>State and tribal Brownfields sites</i>								
BROWNFIELDS	0.500		0	0	0	NR	NR	0
<u>ADDITIONAL ENVIRONMENTAL RECORDS</u>								
<i>Local Brownfield lists</i>								
US BROWNFIELDS	0.500		0	0	0	NR	NR	0
<i>Local Lists of Landfill / Solid Waste Disposal Sites</i>								
WMUDS/SWAT	0.500		0	0	0	NR	NR	0
SWRCY	0.500		0	0	0	NR	NR	0
HAULERS	0.001		0	NR	NR	NR	NR	0
INDIAN ODI	0.500		0	0	0	NR	NR	0
DEBRIS REGION 9	0.500		0	0	0	NR	NR	0
ODI	0.500		0	0	0	NR	NR	0
IHS OPEN DUMPS	0.500		0	0	0	NR	NR	0
<i>Local Lists of Hazardous waste / Contaminated Sites</i>								
US HIST CDL	0.001		0	NR	NR	NR	NR	0
HIST Cal-Sites	1.000		0	0	0	0	NR	0
SCH	0.250		0	0	NR	NR	NR	0
CDL	0.001		0	NR	NR	NR	NR	0
Toxic Pits	1.000		0	0	0	0	NR	0
CERS HAZ WASTE	0.250		0	0	NR	NR	NR	0
US CDL	0.001		0	NR	NR	NR	NR	0
PFAS	0.500		0	0	0	NR	NR	0
<i>Local Lists of Registered Storage Tanks</i>								
SWEEPS UST	0.250		0	0	NR	NR	NR	0
HIST UST	0.250		0	0	NR	NR	NR	0
CA FID UST	0.250		0	0	NR	NR	NR	0
CERS TANKS	0.250		0	0	NR	NR	NR	0
<i>Local Land Records</i>								
LIENS	0.001		0	NR	NR	NR	NR	0

MAP FINDINGS SUMMARY

Database	Search Distance (Miles)	Target Property	< 1/8	1/8 - 1/4	1/4 - 1/2	1/2 - 1	> 1	Total Plotted
LIENS 2	0.001		0	NR	NR	NR	NR	0
DEED	0.500		0	0	0	NR	NR	0
Records of Emergency Release Reports								
HMIRS	0.001		0	NR	NR	NR	NR	0
CHMIRS	0.001		0	NR	NR	NR	NR	0
LDS	0.001		0	NR	NR	NR	NR	0
MCS	0.001		0	NR	NR	NR	NR	0
Orange Co. Industrial Site	0.001		0	NR	NR	NR	NR	0
SPILLS 90	0.001		0	NR	NR	NR	NR	0
Other Ascertainable Records								
RCRA NonGen / NLR	0.250		0	0	NR	NR	NR	0
FUDS	1.000		0	0	0	0	NR	0
DOD	1.000		0	0	0	0	NR	0
SCRD DRYCLEANERS	0.500		0	0	0	NR	NR	0
US FIN ASSUR	0.001		0	NR	NR	NR	NR	0
EPA WATCH LIST	0.001		0	NR	NR	NR	NR	0
2020 COR ACTION	0.250		0	0	NR	NR	NR	0
TSCA	0.001		0	NR	NR	NR	NR	0
TRIS	0.001		0	NR	NR	NR	NR	0
SSTS	0.001		0	NR	NR	NR	NR	0
ROD	1.000		0	0	0	0	NR	0
RMP	0.001		0	NR	NR	NR	NR	0
RAATS	0.001		0	NR	NR	NR	NR	0
PRP	0.001		0	NR	NR	NR	NR	0
PADS	0.001		0	NR	NR	NR	NR	0
ICIS	0.001		0	NR	NR	NR	NR	0
FTTS	0.001		0	NR	NR	NR	NR	0
MLTS	0.001		0	NR	NR	NR	NR	0
COAL ASH DOE	0.001		0	NR	NR	NR	NR	0
COAL ASH EPA	0.500		0	0	0	NR	NR	0
PCB TRANSFORMER	0.001		0	NR	NR	NR	NR	0
RADINFO	0.001		0	NR	NR	NR	NR	0
HIST FTTS	0.001		0	NR	NR	NR	NR	0
DOT OPS	0.001		0	NR	NR	NR	NR	0
CONSENT	1.000		0	0	0	0	NR	0
INDIAN RESERV	1.000		0	0	0	0	NR	0
FUSRAP	1.000		0	0	0	0	NR	0
UMTRA	0.500		0	0	0	NR	NR	0
LEAD SMELTERS	0.001		0	NR	NR	NR	NR	0
US AIRS	0.001		0	NR	NR	NR	NR	0
US MINES	0.250		0	0	NR	NR	NR	0
ABANDONED MINES	0.250		0	0	NR	NR	NR	0
FINDS	0.001		0	NR	NR	NR	NR	0
DOCKET HWC	0.001		0	NR	NR	NR	NR	0
ECHO	0.001		0	NR	NR	NR	NR	0
UXO	1.000		0	0	0	0	NR	0
FUELS PROGRAM	0.250		0	0	NR	NR	NR	0
CA BOND EXP. PLAN	1.000		0	0	0	0	NR	0
Cortese	0.500		1	0	1	NR	NR	2

MAP FINDINGS SUMMARY

Database	Search Distance (Miles)	Target Property	< 1/8	1/8 - 1/4	1/4 - 1/2	1/2 - 1	> 1	Total Plotted
CUPA Listings	0.250		0	0	NR	NR	NR	0
DRYCLEANERS	0.250		0	0	NR	NR	NR	0
EMI	0.001		0	NR	NR	NR	NR	0
ENF	0.001		0	NR	NR	NR	NR	0
Financial Assurance	0.001		0	NR	NR	NR	NR	0
HAZNET	0.001		0	NR	NR	NR	NR	0
ICE	0.001		0	NR	NR	NR	NR	0
HIST CORTESE	0.500		0	0	0	NR	NR	0
HWP	1.000		0	0	0	0	NR	0
HWT	0.250		0	0	NR	NR	NR	0
MINES	0.250		0	0	NR	NR	NR	0
MWMP	0.250		0	0	NR	NR	NR	0
NPDES	0.001		0	NR	NR	NR	NR	0
PEST LIC	0.001		0	NR	NR	NR	NR	0
PROC	0.500		0	0	0	NR	NR	0
Notify 65	1.000		0	0	0	0	NR	0
UIC	0.001		0	NR	NR	NR	NR	0
UIC GEO	0.001		0	NR	NR	NR	NR	0
WASTEWATER PITS	0.500		0	0	0	NR	NR	0
WDS	0.001		0	NR	NR	NR	NR	0
WIP	0.250		0	0	NR	NR	NR	0
MILITARY PRIV SITES PROJECT	0.001		0	NR	NR	NR	NR	0
WDR	0.001		0	NR	NR	NR	NR	0
CIWQS	0.001	2	0	NR	NR	NR	NR	2
CERS	0.001		0	NR	NR	NR	NR	0
NON-CASE INFO	0.001		0	NR	NR	NR	NR	0
OTHER OIL GAS	0.001		0	NR	NR	NR	NR	0
PROD WATER PONDS	0.001		0	NR	NR	NR	NR	0
SAMPLING POINT	0.001		0	NR	NR	NR	NR	0
WELL STIM PROJ	0.001		0	NR	NR	NR	NR	0
HWTS	TP		NR	NR	NR	NR	NR	0
MINES MRDS	0.001		0	NR	NR	NR	NR	0
<u>EDR HIGH RISK HISTORICAL RECORDS</u>								
<i>EDR Exclusive Records</i>								
EDR MGP	1.000		0	0	0	0	NR	0
EDR Hist Auto	0.125		0	NR	NR	NR	NR	0
EDR Hist Cleaner	0.125		0	NR	NR	NR	NR	0
<u>EDR RECOVERED GOVERNMENT ARCHIVES</u>								
<i>Exclusive Recovered Govt. Archives</i>								
RGA LF	0.001		0	NR	NR	NR	NR	0
RGA LUST	0.001		0	NR	NR	NR	NR	0
- Totals --		2	5	0	3	0	0	10

MAP FINDINGS SUMMARY

<u>Database</u>	<u>Search Distance (Miles)</u>	<u>Target Property</u>	<u>< 1/8</u>	<u>1/8 - 1/4</u>	<u>1/4 - 1/2</u>	<u>1/2 - 1</u>	<u>> 1</u>	<u>Total Plotted</u>
-----------------	--	----------------------------	-----------------	------------------	------------------	----------------	---------------	--------------------------

NOTES:

TP = Target Property

NR = Not Requested at this Search Distance

Sites may be listed in more than one database

Map ID
Direction
Distance
Elevation

MAP FINDINGS

Site

Database(s)

EDR ID Number
EPA ID Number

A1
Target
Property
8712 E SANTA ANA CANYON RD
8712 E SANTA ANA CANYON RD
ANAHEIM, CA 92808

CIWQS **S121617930**
N/A

Site 1 of 2 in cluster A

Actual:
413 ft.

CIWQS:
Name: 8712 E SANTA ANA CANYON RD
Address: 8712 E SANTA ANA CANYON RD
City,State,Zip: ANAHEIM, CA 92808
Agency: Garden Church
Agency Address: 8712 E Santa Ana Canyon Rd, Anaheim, CA 92808
Place/Project Type: Construction - Commercial
SIC/NAICS: Not reported
Region: 8
Program: CONSTW
Regulatory Measure Status: Terminated
Regulatory Measure Type: Storm water construction
Order Number: 99-08DW
WDID: 8 30C309736
NPDES Number: CAS000002
Adoption Date: 01/01/1900
Effective Date: 09/23/1998
Termination Date: 02/22/2002
Expiration/Review Date: 01/01/1900
Design Flow: Not reported
Major/Minor: Not reported
Complexity: Not reported
TTWQ: Not reported
Enforcement Actions within 5 years: 0
Violations within 5 years: 0
Latitude: 33.866593
Longitude: -117.722677

A2
Target
Property
KINDRED CMNTY CHURCH
8712 E SANTA ANA CANYON RD
ANAHEIM, CA 92808

CIWQS **S121648620**
N/A

Site 2 of 2 in cluster A

Actual:
413 ft.

CIWQS:
Name: KINDRED CMNTY CHURCH
Address: 8712 E SANTA ANA CANYON RD
City,State,Zip: ANAHEIM, CA 92808
Agency: Kindred Community Church
Agency Address: 17853 Santiago Blvd Ste 107, Villa Park, CA 92861
Place/Project Type: Construction - Other
SIC/NAICS: Not reported
Region: 8
Program: CONSTW
Regulatory Measure Status: Terminated
Regulatory Measure Type: Storm water construction
Order Number: 99-08DW
WDID: 8 30C327514
NPDES Number: CAS000002
Adoption Date: 01/01/1900
Effective Date: 05/12/2004
Termination Date: 07/05/2005
Expiration/Review Date: 01/01/1900
Design Flow: Not reported

Map ID
 Direction
 Distance
 Elevation

MAP FINDINGS

Site

Database(s)

EDR ID Number
 EPA ID Number

KINDRED CMNTY CHURCH (Continued)

S121648620

Major/Minor: Not reported
 Complexity: Not reported
 TTWQ: Not reported
 Enforcement Actions within 5 years: 0
 Violations within 5 years: 0
 Latitude: 33.866593
 Longitude: -117.722677

B3
ENE
 < 1/8
 0.109 mi.
 576 ft.
 Relative:
 Lower
 Actual:
 378 ft.

INDUSTRIAL ASPHALT
9010 E SANTA ANA CANYON RD
ANAHEIM, CA 92807
 Site 1 of 2 in cluster B

ENVIROSTOR
LUST
VCP
 Orange Co. Industrial Site
Cortese
NPDES
CIWQS
CERS

S108198169
N/A

ENVIROSTOR:
 Name: INDUSTRIAL ASPHALT PLANT (FORMER)
 Address: 9010 E. SANTA ANA CANYON ROAD
 City,State,Zip: ANAHEIM, CA 92808
 Facility ID: 30320052
 Status: No Further Action
 Status Date: 01/22/2007
 Site Code: 401036
 Site Type: Voluntary Cleanup
 Site Type Detailed: Voluntary Cleanup
 Acres: 2.13
 NPL: NO
 Regulatory Agencies: SMBRP
 Lead Agency: SMBRP
 Program Manager: Johnson Abraham
 Supervisor: Emad Yemut
 Division Branch: Cleanup Cypress
 Assembly: 68
 Senate: 37
 Special Program: Voluntary Cleanup Program
 Restricted Use: NO
 Site Mgmt Req: NONE SPECIFIED
 Funding: Responsible Party
 Latitude: 33.86183
 Longitude: -117.7062
 APN: 514-012-008, 514-012-08
 Past Use: RECYCLING - SCRAP METAL, MANUFACTURING - OTHER
 Potential COC: * HYDROCARBON SOLVENTS Benzene Polynuclear aromatic hydrocarbons (PAHs Ethylbenzene Toluene Xylenes Benzene Lead Polynuclear aromatic hydrocarbons (PAHs
 Confirmed COC: Benzene 10009-NO Polynuclear aromatic hydrocarbons (PAHs Ethylbenzene Toluene Xylenes Benzene Lead Polynuclear aromatic hydrocarbons (PAHs
 Potential Description: SOIL, SOIL
 Alias Name: FORMER INDUSTRIAL ASPHALT PLANT
 Alias Type: Alternate Name
 Alias Name: IRVINE COMPANY
 Alias Type: Alternate Name
 Alias Name: 514-012-008
 Alias Type: APN
 Alias Name: 514-012-08

Map ID
Direction
Distance
Elevation

MAP FINDINGS

Site

Database(s)

EDR ID Number
EPA ID Number

INDUSTRIAL ASPHALT (Continued)

S108198169

Alias Type: APN
Alias Name: 110033615121
Alias Type: EPA (FRS #)
Alias Name: 401036
Alias Type: Project Code (Site Code)
Alias Name: 30320052
Alias Type: Envirostor ID Number

Completed Info:

Completed Area Name: PROJECT WIDE
Completed Sub Area Name: Not reported
Completed Document Type: Preliminary Endangerment Assessment Report
Completed Date: 06/01/2004
Comments: DTSC completed review of the PEA equivalent report and determined that the site requires further action.

Completed Area Name: PROJECT WIDE
Completed Sub Area Name: Not reported
Completed Document Type: Site Characterization Workplan
Completed Date: 07/26/2006
Comments: DTSC conditionally approved the Workplan. The conditions are specified in the approval letter.

Completed Area Name: PROJECT WIDE
Completed Sub Area Name: Not reported
Completed Document Type: Site Characterization Report
Completed Date: 01/22/2007
Comments: Not reported

Completed Area Name: PROJECT WIDE
Completed Sub Area Name: Not reported
Completed Document Type: Standard Voluntary Agreement
Completed Date: 10/08/2002
Comments: A Voluntary Cleanup Agreement (VCA) was signed to conduct a Preliminary Endangerment Assessment (PEA) or equivalent with the Former Industrial Asphalt Company.

Completed Area Name: PROJECT WIDE
Completed Sub Area Name: Not reported
Completed Document Type: Standard Voluntary Agreement
Completed Date: 07/14/2006
Comments: Fully executed voluntary cleanup agreement

Completed Area Name: PROJECT WIDE
Completed Sub Area Name: Not reported
Completed Document Type: Cost Recovery Closeout Memo
Completed Date: 02/06/2007
Comments: Not reported

Future Area Name: Not reported
Future Sub Area Name: Not reported
Future Document Type: Not reported
Future Due Date: Not reported
Schedule Area Name: Not reported
Schedule Sub Area Name: Not reported
Schedule Document Type: Not reported
Schedule Due Date: Not reported
Schedule Revised Date: Not reported

Map ID
Direction
Distance
Elevation

MAP FINDINGS

Site

Database(s)

EDR ID Number
EPA ID Number

INDUSTRIAL ASPHALT (Continued)

S108198169

LUST:

Name: INDUSTRIAL ASPHALT
Address: 9010 E SANTA ANA CANYON RD
City,State,Zip: ANAHEIM, CA 92807
Lead Agency: ANAHEIM CITY
Case Type: LUST Cleanup Site
Geo Track: http://geotracker.waterboards.ca.gov/profile_report.asp?global_id=T0605901925
Global Id: T0605901925
Latitude: 33.8697558
Longitude: -117.7348398
Status: Completed - Case Closed
Status Date: 03/27/2009
Case Worker: ROW
RB Case Number: 083002796T
Local Agency: ANAHEIM CITY
File Location: Not reported
Local Case Number: Not reported
Potential Media Affect: Soil
Potential Contaminants of Concern: Diesel
Site History: Not reported

LUST:

Global Id: T0605901925
Contact Type: Local Agency Caseworker
Contact Name: RICHARD O. WILSON
Organization Name: ANAHEIM CITY
Address: 201 S. ANAHEIM BLVD. #601
City: ANAHEIM
Email: dwilson@anaheim.net
Phone Number: Not reported

Global Id: T0605901925
Contact Type: Regional Board Caseworker
Contact Name: ROSE SCOTT
Organization Name: SANTA ANA RWQCB (REGION 8)
Address: 3737 MAIN STREET, SUITE 500
City: RIVERSIDE
Email: rose.scott@waterboards.ca.gov
Phone Number: 9513206375

LUST:

Global Id: T0605901925
Action Type: ENFORCEMENT
Date: 10/23/1996
Action: Closure/No Further Action Letter

Global Id: T0605901925
Action Type: Other
Date: 12/11/1995
Action: Leak Reported

LUST:

Global Id: T0605901925
Status: Open - Case Begin Date
Status Date: 12/11/1995

Map ID
Direction
Distance
Elevation

MAP FINDINGS

Site

Database(s)

EDR ID Number
EPA ID Number

INDUSTRIAL ASPHALT (Continued)

S108198169

Global Id: T0605901925
Status: Open - Site Assessment
Status Date: 12/11/1995

Global Id: T0605901925
Status: Completed - Case Closed
Status Date: 10/23/1996

Global Id: T0605901925
Status: Open - Reopen Case
Status Date: 10/07/2001

Global Id: T0605901925
Status: Open - Site Assessment
Status Date: 10/08/2001

Global Id: T0605901925
Status: Completed - Case Closed
Status Date: 03/27/2009

VCP:

Name: INDUSTRIAL ASPHALT PLANT (FORMER)
Address: 9010 E. SANTA ANA CANYON ROAD
City,State,Zip: ANAHEIM, CA 92808
Facility ID: 30320052
Site Type: Voluntary Cleanup
Site Type Detail: Voluntary Cleanup
Site Mgmt. Req.: NONE SPECIFIED
Acres: 2.13
National Priorities List: NO
Cleanup Oversight Agencies: SMBRP
Lead Agency: SMBRP
Lead Agency Description: DTSC - Site Cleanup Program
Project Manager: Johnson Abraham
Supervisor: Emad Yemut
Division Branch: Cleanup Cypress
Site Code: 401036
Assembly: 68
Senate: 37
Special Programs Code: Voluntary Cleanup Program
Status: No Further Action
Status Date: 01/22/2007
Restricted Use: NO
Funding: Responsible Party
Lat/Long: 33.86183 / -117.7062
APN: 514-012-008, 514-012-08
Past Use: RECYCLING - SCRAP METAL, MANUFACTURING - OTHER
Potential COC: 10009, 30003, 30019, 30272, 30550, 30593, 30003, 30013, 30019
Confirmed COC: 30003,10009-NO,30019,30272,30550,30593,, ,30003,30013,30019
Potential Description: SOIL, SOIL
Alias Name: FORMER INDUSTRIAL ASPHALT PLANT
Alias Type: Alternate Name
Alias Name: IRVINE COMPANY
Alias Type: Alternate Name
Alias Name: 514-012-008
Alias Type: APN

Map ID
Direction
Distance
Elevation

MAP FINDINGS

Site

Database(s)

EDR ID Number
EPA ID Number

INDUSTRIAL ASPHALT (Continued)

S108198169

Alias Name: 514-012-08
Alias Type: APN
Alias Name: 110033615121
Alias Type: EPA (FRS #)
Alias Name: 401036
Alias Type: Project Code (Site Code)
Alias Name: 30320052
Alias Type: Envirostor ID Number

Completed Info:

Completed Area Name: PROJECT WIDE
Completed Sub Area Name: Not reported
Completed Document Type: Preliminary Endangerment Assessment Report
Completed Date: 06/01/2004
Comments: DTSC completed review of the PEA equivalent report and determined that the site requires further action.

Completed Area Name: PROJECT WIDE
Completed Sub Area Name: Not reported
Completed Document Type: Site Characterization Workplan
Completed Date: 07/26/2006
Comments: DTSC conditionally approved the Workplan. The conditions are specified in the approval letter.

Completed Area Name: PROJECT WIDE
Completed Sub Area Name: Not reported
Completed Document Type: Site Characterization Report
Completed Date: 01/22/2007
Comments: Not reported

Completed Area Name: PROJECT WIDE
Completed Sub Area Name: Not reported
Completed Document Type: Standard Voluntary Agreement
Completed Date: 10/08/2002
Comments: A Voluntary Cleanup Agreement (VCA) was signed to conduct a Preliminary Endangerment Assessment (PEA) or equivalent with the Former Industrial Asphalt Company.

Completed Area Name: PROJECT WIDE
Completed Sub Area Name: Not reported
Completed Document Type: Standard Voluntary Agreement
Completed Date: 07/14/2006
Comments: Fully executed voluntary cleanup agreement

Completed Area Name: PROJECT WIDE
Completed Sub Area Name: Not reported
Completed Document Type: Cost Recovery Closeout Memo
Completed Date: 02/06/2007
Comments: Not reported

Future Area Name: Not reported
Future Sub Area Name: Not reported
Future Document Type: Not reported
Future Due Date: Not reported
Schedule Area Name: Not reported
Schedule Sub Area Name: Not reported
Schedule Document Type: Not reported
Schedule Due Date: Not reported

Map ID
Direction
Distance
Elevation

MAP FINDINGS

Site

Database(s)

EDR ID Number
EPA ID Number

INDUSTRIAL ASPHALT (Continued)

S108198169

Schedule Revised Date: Not reported

Orange Co. Industrial Site:

Name: STAR ROCK PLANT
Address: 9010 E SANTA ANA CANYON RD
City,State,Zip: ANAHEIM, CA 92805
Case ID: 04IC019
Record ID: RO0003322
Current Status: CLOSED 11/22/2005
Closure Type: Closure certification issued
Released Chemical: FUEL WASTE

CORTESE:

Name: INDUSTRIAL ASPHALT
Address: 9010 E SANTA ANA CANYON RD
City,State,Zip: ANAHEIM, CA 92807
Region: CORTESE
Envirostor Id: Not reported
Global ID: T0605901925
Site/Facility Type: LUST CLEANUP SITE
Cleanup Status: COMPLETED - CASE CLOSED
Status Date: Not reported
Site Code: Not reported
Latitude: Not reported
Longitude: Not reported
Owner: Not reported
Enf Type: Not reported
Swat R: Not reported
Flag: active
Order No: Not reported
Waste Discharge System No: Not reported
Effective Date: Not reported
Region 2: Not reported
WID Id: Not reported
Solid Waste Id No: Not reported
Waste Management Uit Name: Not reported
File Name: Active Open

NPDES:

Name: STAR ROCK PLANT
Address: 9010 E SANTA ANA CANYON RD
City,State,Zip: ANAHEIM, CA 92805
Facility Status: Not reported
NPDES Number: Not reported
Region: Not reported
Agency Number: Not reported
Regulatory Measure ID: Not reported
Place ID: Not reported
Order Number: Not reported
WDID: 8 30C331548
Regulatory Measure Type: Construction
Program Type: Not reported
Adoption Date Of Regulatory Measure: Not reported
Effective Date Of Regulatory Measure: Not reported
Termination Date Of Regulatory Measure: Not reported
Expiration Date Of Regulatory Measure: Not reported

Map ID
Direction
Distance
Elevation

MAP FINDINGS

Site

Database(s)

EDR ID Number
EPA ID Number

INDUSTRIAL ASPHALT (Continued)

S108198169

Discharge Address: Not reported
Discharge Name: Not reported
Discharge City: Not reported
Discharge State: Not reported
Discharge Zip: Not reported
Status: Terminated
Status Date: 07/28/2006
Operator Name: Irvine Community Development Company LLC
Operator Address: 550 Newport Center Dr
Operator City: Newport Beach
Operator State: California
Operator Zip: 92660

NPDES as of 03/2018:
NPDES Number: Not reported
Status: Not reported
Agency Number: Not reported
Region: 8
Regulatory Measure ID: 286872
Order Number: Not reported
Regulatory Measure Type: Construction
Place ID: Not reported
WDID: 8 30C331548
Program Type: Not reported
Adoption Date Of Regulatory Measure: Not reported
Effective Date Of Regulatory Measure: Not reported
Expiration Date Of Regulatory Measure: Not reported
Termination Date Of Regulatory Measure: Not reported
Discharge Name: Not reported
Discharge Address: Not reported
Discharge City: Not reported
Discharge State: Not reported
Discharge Zip: Not reported
Received Date: 05/09/2008
Processed Date: Not reported
Status: Terminated
Status Date: 07/28/2006
Place Size: 300
Place Size Unit: Acres
Contact: Dave Denney
Contact Title: Not reported
Contact Phone: 951-830-4741
Contact Phone Ext: Not reported
Contact Email: Not reported
Operator Name: Irvine Community Development Company LLC
Operator Address: 550 Newport Center Dr
Operator City: Newport Beach
Operator State: California
Operator Zip: 92660
Operator Contact: Peter Changala
Operator Contact Title: Not reported
Operator Contact Phone: 949-720-2292
Operator Contact Phone Ext: Not reported
Operator Contact Email: Not reported
Operator Type: Private Business
Developer: Robertsons Ready Mix
Developer Address: PO Box 3600
Developer City: Corona

Map ID
Direction
Distance
Elevation

MAP FINDINGS

Site

Database(s)

EDR ID Number
EPA ID Number

INDUSTRIAL ASPHALT (Continued)

S108198169

Developer State: California
Developer Zip: 92878
Developer Contact: Jodi Koval
Developer Contact Title: Not reported
Constype Linear Utility Ind: Not reported
Emergency Phone: 951-830-4741
Emergency Phone Ext: 382
Constype Above Ground Ind: Not reported
Constype Below Ground Ind: Not reported
Constype Cable Line Ind: Not reported
Constype Comm Line Ind: Not reported
Constype Commercial Ind: Not reported
Constype Electrical Line Ind: Not reported
Constype Gas Line Ind: Not reported
Constype Industrial Ind: Y
Constype Other Description: Not reported
Constype Other Ind: Y
Constype Recons Ind: Y
Constype Residential Ind: Not reported
Constype Transport Ind: Not reported
Constype Utility Description: Not reported
Constype Utility Ind: Not reported
Constype Water Sewer Ind: Not reported
Dir Discharge Uswater Ind: Not reported
Receiving Water Name: Gypsum Creek Santa Ana River
Certifier: Jodi Koval
Certifier Title: Environmental
Certification Date: 03-DEC-04
Primary Sic: Not reported
Secondary Sic: Not reported
Tertiary Sic: Not reported

CIWQS:

Name: STAR ROCK PLANT
Address: 9010 E SANTA ANA CANYON RD
City,State,Zip: ANAHEIM, CA 92805
Agency: Irvine Community Development Company LLC
Agency Address: 550 Newport Center Dr, Newport Beach, CA 92660
Place/Project Type: Construction - Industrial, Reconstruction, Other
SIC/NAICS: Not reported
Region: 8
Program: CONSTW
Regulatory Measure Status: Terminated
Regulatory Measure Type: Storm water construction
Order Number: 2009-0009-DWQ
WDID: 8 30C331548
NPDES Number: CAS000002
Adoption Date: 01/01/1900
Effective Date: 01/01/1900
Termination Date: 01/01/1900
Expiration/Review Date: 01/01/1900
Design Flow: Not reported
Major/Minor: Not reported
Complexity: Not reported
TTWQ: Not reported
Enforcement Actions within 5 years: 0

Map ID
Direction
Distance
Elevation

MAP FINDINGS

Site

Database(s)

EDR ID Number
EPA ID Number

INDUSTRIAL ASPHALT (Continued)

S108198169

Violations within 5 years: 0
Latitude: Not reported
Longitude: Not reported

CERS:

Name: INDUSTRIAL ASPHALT
Address: 9010 E SANTA ANA CANYON RD
City,State,Zip: ANAHEIM, CA 92807
Site ID: 205819
CERS ID: T0605901925
CERS Description: Leaking Underground Storage Tank Cleanup Site

Affiliation:

Affiliation Type Desc: Regional Board Caseworker
Entity Name: ROSE SCOTT - SANTA ANA RWQCB (REGION 8)
Entity Title: Not reported
Affiliation Address: 3737 MAIN STREET, SUITE 500
Affiliation City: RIVERSIDE
Affiliation State: CA
Affiliation Country: Not reported
Affiliation Zip: Not reported
Affiliation Phone: 9513206375

Affiliation Type Desc: Local Agency Caseworker
Entity Name: RICHARD O. WILSON - ANAHEIM CITY
Entity Title: Not reported
Affiliation Address: 201 S. ANAHEIM BLVD. #601
Affiliation City: ANAHEIM
Affiliation State: CA
Affiliation Country: Not reported
Affiliation Zip: Not reported
Affiliation Phone: Not reported

B4
ENE
< 1/8
0.109 mi.
576 ft.

OWL ROCK NEW STAR
9010 E SANTA ANA CANYON RD
ANAHEIM, CA 92808
Site 2 of 2 in cluster B

UST U003989246
N/A

Relative:
Lower
Actual:
378 ft.

UST:
Name: ROBERTSON'S READI MIX
Address: 9010 E SANTA ANA CANYON RD # A
City,State,Zip: ANAHEIM, CA 92808
Facility ID: 7002
Permitting Agency: Not reported
Latitude: 33.863139
Longitude: -117.704864

Name: ROBERTSON'S READY MIX-STAR ROCK
Address: 9010 E SANTA ANA CANYON RD # B
City,State,Zip: ANAHEIM, CA 92808
Facility ID: 403
Permitting Agency: Not reported
Latitude: 33.863139
Longitude: -117.704864

Name: OWL ROCK NEW STAR

Map ID
Direction
Distance
Elevation

MAP FINDINGS

Site

Database(s)

EDR ID Number
EPA ID Number

OWL ROCK NEW STAR (Continued)

U003989246

Address: 9010 E SANTA ANA CANYON RD
City,State,Zip: ANAHEIM, CA 92808
Facility ID: 4803
Permitting Agency: Not reported
Latitude: 33.863139
Longitude: -117.704864

5
SSW
1/4-1/2
0.286 mi.
1510 ft.

RUNNING SPRINGS ELEMENTARY SCHOOL
8670 RUNNING SPRINGS DRIVE
ORANGE, CA 92868

ENVIROSTOR **S118756662**
SCH **N/A**
CERS

Relative:
Higher
Actual:
751 ft.

ENVIROSTOR:
Name: RUNNING SPRINGS ELEMENTARY SCHOOL
Address: 8670 RUNNING SPRINGS DRIVE
City,State,Zip: ORANGE, CA 92868
Facility ID: 30820003
Status: No Action Required
Status Date: 11/03/2000
Site Code: 404171
Site Type: School Investigation
Site Type Detailed: School
Acres: 9
NPL: NO
Regulatory Agencies: SMBRP
Lead Agency: SMBRP
Program Manager: Not reported
Supervisor: Javier Hinojosa
Division Branch: Southern California Schools & Brownfields Outreach
Assembly: 68
Senate: 37
Special Program: Not reported
Restricted Use: NO
Site Mgmt Req: NONE SPECIFIED
Funding: School District
Latitude: 33.85882
Longitude: -117.7253
APN: NONE SPECIFIED
Past Use: * EDUCATIONAL SERVICES
Potential COC: NONE SPECIFIED No Contaminants found
Confirmed COC: NONE SPECIFIED
Potential Description: NMA
Alias Name: ORANGE UNIFIED SCHOOL DISTRICT
Alias Type: Alternate Name
Alias Name: ORANGE USD-RUNNING SPRINGS ELEMENTARY
Alias Type: Alternate Name
Alias Name: RUNNING SPRINGS ELEMENTARY SCHOOL
Alias Type: Alternate Name
Alias Name: 404171
Alias Type: Project Code (Site Code)
Alias Name: 30820003
Alias Type: Envirostor ID Number

Completed Info:
Completed Area Name: PROJECT WIDE
Completed Sub Area Name: Not reported
Completed Document Type: Phase 1

Map ID
Direction
Distance
Elevation

MAP FINDINGS

Site

Database(s)

EDR ID Number
EPA ID Number

RUNNING SPRINGS ELEMENTARY SCHOOL (Continued)

S118756662

Completed Date: 11/03/2000
Comments: Not reported

Completed Area Name: PROJECT WIDE
Completed Sub Area Name: Not reported
Completed Document Type: Cost Recovery Closeout Memo
Completed Date: 01/30/2001
Comments: CRU Memo completed

Future Area Name: Not reported
Future Sub Area Name: Not reported
Future Document Type: Not reported
Future Due Date: Not reported
Schedule Area Name: Not reported
Schedule Sub Area Name: Not reported
Schedule Document Type: Not reported
Schedule Due Date: Not reported
Schedule Revised Date: Not reported

SCH:

Name: RUNNING SPRINGS ELEMENTARY SCHOOL
Address: 8670 RUNNING SPRINGS DRIVE
City,State,Zip: ORANGE, CA 92868
Facility ID: 30820003
Site Type: School Investigation
Site Type Detail: School
Site Mgmt. Req.: NONE SPECIFIED
Acres: 9
National Priorities List: NO
Cleanup Oversight Agencies: SMBRP
Lead Agency: SMBRP
Lead Agency Description: DTSC - Site Cleanup Program
Project Manager: Not reported
Supervisor: Javier Hinojosa
Division Branch: Southern California Schools & Brownfields Outreach
Site Code: 404171
Assembly: 68
Senate: 37
Special Program Status: Not reported
Status: No Action Required
Status Date: 11/03/2000
Restricted Use: NO
Funding: School District
Latitude: 33.85882
Longitude: -117.7253
APN: NONE SPECIFIED
Past Use: * EDUCATIONAL SERVICES
Potential COC: NONE SPECIFIED, No Contaminants found
Confirmed COC: NONE SPECIFIED
Potential Description: NMA
Alias Name: ORANGE UNIFIED SCHOOL DISTRICT
Alias Type: Alternate Name
Alias Name: ORANGE USD-RUNNING SPRINGS ELEMENTARY
Alias Type: Alternate Name
Alias Name: RUNNING SPRINGS ELEMENTARY SCHOOL
Alias Type: Alternate Name

Map ID
Direction
Distance
Elevation

MAP FINDINGS

Site

Database(s)

EDR ID Number
EPA ID Number

RUNNING SPRINGS ELEMENTARY SCHOOL (Continued)

S118756662

Alias Name: 404171
Alias Type: Project Code (Site Code)
Alias Name: 30820003
Alias Type: Envirostor ID Number

Completed Info:

Completed Area Name: PROJECT WIDE
Completed Sub Area Name: Not reported
Completed Document Type: Phase 1
Completed Date: 11/03/2000
Comments: Not reported

Completed Area Name: PROJECT WIDE
Completed Sub Area Name: Not reported
Completed Document Type: Cost Recovery Closeout Memo
Completed Date: 01/30/2001
Comments: CRU Memo completed

Future Area Name: Not reported
Future Sub Area Name: Not reported
Future Document Type: Not reported
Future Due Date: Not reported
Schedule Area Name: Not reported
Schedule Sub Area Name: Not reported
Schedule Document Type: Not reported
Schedule Due Date: Not reported
Schedule Revised Date: Not reported

CERS:

Name: RUNNING SPRINGS ELEM
Address: 8670 RUNNING SPRINGS DRIVE
City,State,Zip: ORANGE, CA 92868
Site ID: 371610
CERS ID: 30820003
CERS Description: School Investigation

Affiliation:

Affiliation Type Desc: Supervisor
Entity Name: JAVIER HINOJOSA
Entity Title: Not reported
Affiliation Address: Not reported
Affiliation City: Not reported
Affiliation State: Not reported
Affiliation Country: Not reported
Affiliation Zip: Not reported
Affiliation Phone: Not reported

6
ENE
1/4-1/2
0.298 mi.
1576 ft.

**INDUSTRIAL ASPHALT
24000 SANTA ANA CANYON
ANAHEIM, CA 92807**

Relative:
Lower

Actual:
394 ft.

ORANGE CO. LUST:
Name: INDUSTRIAL ASPHALT

LUST 1001611910
SWEEPS UST N/A
Cortese
EMI
WDS
CIWQS
CERS

Map ID
Direction
Distance
Elevation

MAP FINDINGS

Site

Database(s)

EDR ID Number
EPA ID Number

INDUSTRIAL ASPHALT (Continued)

1001611910

Address: 24000 SANTA ANA CANYON RD
City,State,Zip: ANAHEIM, CA 92807
Region: ORANGE
Facility Id: 89UT187
Released Substance: Diesel fuel oil and additives, Nos.1-D, 2-D, 2-4
Date Closed: 12/19/1991
Record ID: RO0001099

Name: OWL ROCK (STAR ROCK)
Address: 24000 SANTA ANA CANYON RD
City,State,Zip: ANAHEIM, CA 92808
Region: ORANGE
Facility Id: 91UT133
Released Substance: Diesel fuel oil and additives, Nos.1-D, 2-D, 2-4; Gasoline-Automotive (motor gasoline and additives), leaded & unleaded
Date Closed: 04/01/1991
Record ID: RO0002780

Name: R.F. WHITE COMPANY, INC
Address: 24000 SANTA ANA CANYON RD
City,State,Zip: ANAHEIM, CA 92807
Region: ORANGE
Facility Id: 90UT189
Released Substance: Diesel fuel oil and additives, Nos.1-D, 2-D, 2-4
Date Closed: 01/01/2003
Record ID: RO0001418

LUST REG 8:

Name: OWL ROCK PRODUCTS
Address: 24000 SANTA ANA CANYON RD
City: ANAHEIM
Region: 8
County: Orange
Regional Board: Santa Ana Region
Facility Status: Case Closed
Case Number: 083001345T
Local Case Num: Not reported
Case Type: Soil only
Substance: Diesel
Qty Leaked: Not reported
Abate Method: Not reported
Cross Street: 91 FREEWAY
Enf Type: CLOS
Funding: Not reported
How Discovered: Tank Closure
How Stopped: Not reported
Leak Cause: Overfill
Leak Source: UNK
Global ID: T0605901022
How Stopped Date: Not reported
Enter Date: 11/4/1989
Date Confirmation of Leak Began: 11/7/1991
Date Preliminary Assessment Began: Not reported
Discover Date: Not reported
Enforcement Date: 1/1/1965
Close Date: 1/21/1997
Date Prelim Assessment Workplan Submitted: Not reported

Map ID
Direction
Distance
Elevation

MAP FINDINGS

Site

Database(s)

EDR ID Number
EPA ID Number

INDUSTRIAL ASPHALT (Continued)

1001611910

Date Pollution Characterization Began:	Not reported
Date Remediation Plan Submitted:	Not reported
Date Remedial Action Underway:	Not reported
Date Post Remedial Action Monitoring:	Not reported
Enter Date:	11/4/1989
GW Qualifies:	Not reported
Soil Qualifies:	Not reported
Operator:	Not reported
Facility Contact:	Not reported
Interim:	Not reported
Oversite Program:	LUST
Latitude:	33.86064513
Longitude:	-117.7069891
MTBE Date:	Not reported
Max MTBE GW:	Not reported
MTBE Concentration:	0
Max MTBE Soil:	Not reported
MTBE Fuel:	0
MTBE Tested:	Not Required to be Tested.
MTBE Class:	*
Staff:	VJJ
Staff Initials:	ROW
Lead Agency:	Local Agency
Local Agency:	30011
Hydr Basin #:	UNNAMED BASIN
Beneficial:	Not reported
Priority:	Not reported
Cleanup Fund Id:	Not reported
Work Suspended:	Not reported
Summary:	FORMERLY INDUSTRIAL ASPHALT (PREVIOUSLY CLOSED 12/20/91.) 10/17/96 LJA CONCURED WITH CLOSURE.
Name:	INDUSTRIAL ASPHALT
Address:	24000 SANTA ANA CANYON
City:	ANAHEIM
Region:	8
County:	Orange
Regional Board:	Santa Ana Region
Facility Status:	Case Closed
Case Number:	Not reported
Local Case Num:	89UT187
Case Type:	Other ground water affected
Substance:	Diesel
Qty Leaked:	0
Abate Method:	Not reported
Cross Street:	Not reported
Enf Type:	Not reported
Funding:	Not reported
How Discovered:	Tank Closure
How Stopped:	Close Tank
Leak Cause:	Unknown
Leak Source:	Unknown
Global ID:	T0605994052
How Stopped Date:	9/9/9999
Enter Date:	Not reported
Date Confirmation of Leak Began:	Not reported
Date Preliminary Assessment Began:	Not reported

Map ID
Direction
Distance
Elevation

MAP FINDINGS

Site

Database(s)

EDR ID Number
EPA ID Number

INDUSTRIAL ASPHALT (Continued)

1001611910

Discover Date: 10/25/1989
Enforcement Date: Not reported
Close Date: 12/19/1991
Date Prelim Assessment Workplan Submitted: Not reported
Date Pollution Characterization Began: Not reported
Date Remediation Plan Submitted: Not reported
Date Remedial Action Underway: Not reported
Date Post Remedial Action Monitoring: Not reported
Enter Date: Not reported
GW Qualifies: Not reported
Soil Qualifies: Not reported
Operator: Not reported
Facility Contact: Not reported
Interim: Not reported
Oversite Program: LUST
Latitude: Not reported
Longitude: Not reported
MTBE Date: Not reported
Max MTBE GW: Not reported
MTBE Concentration: 0
Max MTBE Soil: Not reported
MTBE Fuel: 0
MTBE Tested: Not Required to be Tested.
MTBE Class: *
Staff: VJJ
Staff Initials: WJ
Lead Agency: Local Agency
Local Agency: 30000L
Hydr Basin #: Not reported
Beneficial: MUN
Priority: Not reported
Cleanup Fund Id: Not reported
Work Suspended: Not reported
Summary: Not reported

LUST:

Name: INDUSTRIAL ASPHALT
Address: 24000 SANTA ANA CANYON
City,State,Zip: ANAHEIM, CA 92807
Lead Agency: ORANGE COUNTY LOP
Case Type: LUST Cleanup Site
Geo Track: http://geotracker.waterboards.ca.gov/profile_report.asp?global_id=T0605994052
Global Id: T0605994052
Latitude: 33.851515
Longitude: -117.792744
Status: Completed - Case Closed
Status Date: 12/19/1991
Case Worker: AM
RB Case Number: Not reported
Local Agency: ORANGE COUNTY LOP
File Location: Local Agency
Local Case Number: 89UT187
Potential Media Affect: Other Groundwater (uses other than drinking water)
Potential Contaminants of Concern: Diesel
Site History: Not reported

LUST:

Map ID
Direction
Distance
Elevation

MAP FINDINGS

Site

Database(s)

EDR ID Number
EPA ID Number

INDUSTRIAL ASPHALT (Continued)

1001611910

Global Id: T0605994052
Contact Type: Local Agency Caseworker
Contact Name: ANTHONY MARTINEZ
Organization Name: ORANGE COUNTY LOP
Address: 1241 E. DYER ROAD SUITE 120
City: SANTA ANA
Email: amartinez@ochca.com
Phone Number: 7144336011

Global Id: T0605994052
Contact Type: Regional Board Caseworker
Contact Name: VALERIE JAHN-BULL
Organization Name: SANTA ANA RWQCB (REGION 8)
Address: 3737 MAIN STREET, SUITE 500
City: RIVERSIDE
Email: valerie.jahn-bull@waterboards.ca.gov
Phone Number: 9517824903

LUST:

Global Id: T0605994052
Action Type: Other
Date: 10/25/1989
Action: Leak Discovery

Global Id: T0605994052
Action Type: Other
Date: 10/25/1989
Action: Leak Reported

LUST:

Global Id: T0605994052
Status: Open - Case Begin Date
Status Date: 10/25/1989

Global Id: T0605994052
Status: Completed - Case Closed
Status Date: 12/19/1991

SWEEPS UST:

Name: OWL ROCK NEW STAR
Address: 24000 SANTA ANA CANYON RD
City: ANAHEIM
Status: Not reported
Comp Number: 4803
Number: Not reported
Board Of Equalization: Not reported
Referral Date: Not reported
Action Date: Not reported
Created Date: Not reported
Owner Tank Id: Not reported
SWRCB Tank Id: 30-000-004803-000001
Tank Status: Not reported
Capacity: 550
Active Date: Not reported
Tank Use: UNKNOWN

Map ID
Direction
Distance
Elevation

MAP FINDINGS

Site

Database(s)

EDR ID Number
EPA ID Number

INDUSTRIAL ASPHALT (Continued)

1001611910

STG: PRODUCT
Content: Not reported
Number Of Tanks: 5

Name: OWL ROCK NEW STAR
Address: 24000 SANTA ANA CANYON RD
City: ANAHEIM
Status: Not reported
Comp Number: 4803
Number: Not reported
Board Of Equalization: Not reported
Referral Date: Not reported
Action Date: Not reported
Created Date: Not reported
Owner Tank Id: Not reported
SWRCB Tank Id: 30-000-004803-000003
Tank Status: Not reported
Capacity: 10000
Active Date: Not reported
Tank Use: UNKNOWN
STG: PRODUCT
Content: Not reported
Number Of Tanks: Not reported

Name: OWL ROCK NEW STAR
Address: 24000 SANTA ANA CANYON RD
City: ANAHEIM
Status: Not reported
Comp Number: 4803
Number: Not reported
Board Of Equalization: Not reported
Referral Date: Not reported
Action Date: Not reported
Created Date: Not reported
Owner Tank Id: Not reported
SWRCB Tank Id: 30-000-004803-000004
Tank Status: Not reported
Capacity: 5000
Active Date: Not reported
Tank Use: UNKNOWN
STG: PRODUCT
Content: Not reported
Number Of Tanks: Not reported

Name: OWL ROCK NEW STAR
Address: 24000 SANTA ANA CANYON RD
City: ANAHEIM
Status: Not reported
Comp Number: 4803
Number: Not reported
Board Of Equalization: Not reported
Referral Date: Not reported
Action Date: Not reported
Created Date: Not reported
Owner Tank Id: Not reported
SWRCB Tank Id: 30-000-004803-000005
Tank Status: Not reported

Map ID
Direction
Distance
Elevation

MAP FINDINGS

Site

Database(s)

EDR ID Number
EPA ID Number

INDUSTRIAL ASPHALT (Continued)

1001611910

Capacity: 10000
Active Date: Not reported
Tank Use: UNKNOWN
STG: PRODUCT
Content: Not reported
Number Of Tanks: Not reported

Name: OWL ROCK NEW STAR
Address: 24000 SANTA ANA CANYON RD
City: ANAHEIM
Status: Not reported
Comp Number: 4803
Number: Not reported
Board Of Equalization: Not reported
Referral Date: Not reported
Action Date: Not reported
Created Date: Not reported
Owner Tank Id: Not reported
SWRCB Tank Id: 30-000-004803-000010
Tank Status: Not reported
Capacity: 10000
Active Date: Not reported
Tank Use: UNKNOWN
STG: PRODUCT
Content: Not reported
Number Of Tanks: Not reported

Name: OWL ROCK NEW STAR
Address: 24000 SANTA ANA CANYON RD
City: ANAHEIM
Status: Active
Comp Number: 4803
Number: 9
Board Of Equalization: Not reported
Referral Date: 09-30-92
Action Date: 09-15-92
Created Date: 02-29-88
Owner Tank Id: Not reported
SWRCB Tank Id: 30-000-004803-000006
Tank Status: A
Capacity: 500
Active Date: Not reported
Tank Use: PETROLEUM
STG: P
Content: Not reported
Number Of Tanks: 4

Name: OWL ROCK NEW STAR
Address: 24000 SANTA ANA CANYON RD
City: ANAHEIM
Status: Active
Comp Number: 4803
Number: 9
Board Of Equalization: Not reported
Referral Date: 09-30-92
Action Date: 09-15-92
Created Date: 02-29-88

Map ID
Direction
Distance
Elevation

MAP FINDINGS

Site

Database(s)

EDR ID Number
EPA ID Number

INDUSTRIAL ASPHALT (Continued)

1001611910

Owner Tank Id: Not reported
SWRCB Tank Id: 30-000-004803-000007
Tank Status: A
Capacity: 10000
Active Date: Not reported
Tank Use: M.V. FUEL
STG: P
Content: DIESEL
Number Of Tanks: Not reported

Name: OWL ROCK NEW STAR
Address: 24000 SANTA ANA CANYON RD
City: ANAHEIM
Status: Active
Comp Number: 4803
Number: 9
Board Of Equalization: Not reported
Referral Date: 09-30-92
Action Date: 09-15-92
Created Date: 02-29-88
Owner Tank Id: Not reported
SWRCB Tank Id: 30-000-004803-000008
Tank Status: A
Capacity: 2000
Active Date: Not reported
Tank Use: M.V. FUEL
STG: P
Content: REG UNLEADED
Number Of Tanks: Not reported

Name: OWL ROCK NEW STAR
Address: 24000 SANTA ANA CANYON RD
City: ANAHEIM
Status: Active
Comp Number: 4803
Number: 9
Board Of Equalization: Not reported
Referral Date: 09-30-92
Action Date: 09-15-92
Created Date: 02-29-88
Owner Tank Id: Not reported
SWRCB Tank Id: 30-000-004803-000009
Tank Status: A
Capacity: 10000
Active Date: Not reported
Tank Use: M.V. FUEL
STG: P
Content: DIESEL
Number Of Tanks: Not reported

CORTESE:

Name: INDUSTRIAL ASPHALT
Address: 24000 SANTA ANA CANYON
City,State,Zip: ANAHEIM, CA 92807
Region: CORTESE
Envirostor Id: Not reported
Global ID: T0605994052

Map ID
Direction
Distance
Elevation

MAP FINDINGS

Site

Database(s)

EDR ID Number
EPA ID Number

INDUSTRIAL ASPHALT (Continued)

1001611910

Site/Facility Type: LUST CLEANUP SITE
Cleanup Status: COMPLETED - CASE CLOSED
Status Date: Not reported
Site Code: Not reported
Latitude: Not reported
Longitude: Not reported
Owner: Not reported
Enf Type: Not reported
Swat R: Not reported
Flag: active
Order No: Not reported
Waste Discharge System No: Not reported
Effective Date: Not reported
Region 2: Not reported
WID Id: Not reported
Solid Waste Id No: Not reported
Waste Management Uit Name: Not reported
File Name: Active Open

EMI:

Name: ALL AMERICAN ASPHALT
Address: 24000 SANTA ANA CANYON RD
City,State,Zip: ANAHEIM, CA 92807
Year: 2002
County Code: 30
Air Basin: SC
Facility ID: 113474
Air District Name: SC
SIC Code: 2951
Air District Name: SOUTH COAST AQMD
Community Health Air Pollution Info System: Not reported
Consolidated Emission Reporting Rule: Not reported
Total Organic Hydrocarbon Gases Tons/Yr: 2
Reactive Organic Gases Tons/Yr: 1
Carbon Monoxide Emissions Tons/Yr: 7
NOX - Oxides of Nitrogen Tons/Yr: 2
SOX - Oxides of Sulphur Tons/Yr: 0
Particulate Matter Tons/Yr: 2
Part. Matter 10 Micrometers and Smlr Tons/Yr:1

Name: ALL AMERICAN ASPHALT
Address: 24000 SANTA ANA CANYON RD
City,State,Zip: ANAHEIM, CA 92807
Year: 2003
County Code: 30
Air Basin: SC
Facility ID: 113474
Air District Name: SC
SIC Code: 2951
Air District Name: SOUTH COAST AQMD
Community Health Air Pollution Info System: Not reported
Consolidated Emission Reporting Rule: Not reported
Total Organic Hydrocarbon Gases Tons/Yr: 2
Reactive Organic Gases Tons/Yr: 1
Carbon Monoxide Emissions Tons/Yr: 7
NOX - Oxides of Nitrogen Tons/Yr: 2
SOX - Oxides of Sulphur Tons/Yr: 0

Map ID
Direction
Distance
Elevation

MAP FINDINGS

Site

Database(s)

EDR ID Number
EPA ID Number

INDUSTRIAL ASPHALT (Continued)

1001611910

Particulate Matter Tons/Yr: 2
Part. Matter 10 Micrometers and Smlr Tons/Yr:1

Name: ALL AMERICAN ASPHALT
Address: 24000 SANTA ANA CANYON RD
City,State,Zip: ANAHEIM, CA 92807
Year: 2004
County Code: 30
Air Basin: SC
Facility ID: 113474
Air District Name: SC
SIC Code: 2951
Air District Name: SOUTH COAST AQMD
Community Health Air Pollution Info System: Not reported
Consolidated Emission Reporting Rule: Not reported
Total Organic Hydrocarbon Gases Tons/Yr: 1.7326
Reactive Organic Gases Tons/Yr: 0.74
Carbon Monoxide Emissions Tons/Yr: 7.46
NOX - Oxides of Nitrogen Tons/Yr: 2.29
SOX - Oxides of Sulphur Tons/Yr: 0.354
Particulate Matter Tons/Yr: 1.964
Part. Matter 10 Micrometers and Smlr Tons/Yr:1.13

WDS:

Name: STAR BATCH PLANT
Address: 24000 SANTA ANA CANYON RD
City: ANAHEIM
Facility ID: Santa Ana River 30I011160
Facility Type: Industrial - Facility that treats and/or disposes of liquid or semisolid wastes from any servicing, producing, manufacturing or processing operation of whatever nature, including mining, gravel washing, geothermal operations, air conditioning, ship building and repairing, oil production, storage and disposal operations, water pumping.
Facility Status: Active - Any facility with a continuous or seasonal discharge that is under Waste Discharge Requirements.
NPDES Number: CAS000001 The 1st 2 characters designate the state. The remaining 7 are assigned by the Regional Board
Subregion: 8
Facility Telephone: 9096852200
Facility Contact: RICHARD TROESH
Agency Name: ROBERTSONS READY MIX-CORONA
Agency Address: PO BOX 1659
Agency City,St,Zip: CORONA 928781659
Agency Contact: CRAIG PHILLIPS
Agency Telephone: 9096852200
Agency Type: Private
SIC Code: 0
SIC Code 2: Not reported
Primary Waste Type: Not reported
Primary Waste: Not reported
Waste Type2: Not reported
Waste2: Not reported
Primary Waste Type: Not reported
Secondary Waste: Not reported
Secondary Waste Type: Not reported
Design Flow: 0

Map ID
Direction
Distance
Elevation

MAP FINDINGS

Site

Database(s)

EDR ID Number
EPA ID Number

INDUSTRIAL ASPHALT (Continued)

1001611910

Baseline Flow: 0
Reclamation: Not reported
POTW: Not reported
Treat To Water: Minor Threat to Water Quality. A violation of a regional board order should cause a relatively minor impairment of beneficial uses compared to a major or minor threat. Not: All nurds without a TTWQ will be considered a minor threat to water quality unless coded at a higher Level. A Zero (0) may be used to code those NURDS that are found to represent no threat to water quality.
Complexity: Category C - Facilities having no waste treatment systems, such as cooling water dischargers or those who must comply through best management practices, facilities with passive waste treatment and disposal systems, such as septic systems with subsurface disposal, or dischargers having waste storage systems with land disposal such as dairy waste ponds.

CIWQS:

Name: ROBERTSONS READY MIX STAR
Address: 24000 SANTA ANA CANYON RD
City,State,Zip: ANAHEIM, CA 92801
Agency: Robertsons Ready Mix
Agency Address: PO Box 3600, Corona, CA 92878
Place/Project Type: Construction
SIC/NAICS: Not reported
Region: 8
Program: CONSTW
Regulatory Measure Status: Terminated
Regulatory Measure Type: Storm water construction
Order Number: 2009-0009-DWQ
WDID: 8 30C352120
NPDES Number: CAS000002
Adoption Date: 01/01/1900
Effective Date: 06/02/2008
Termination Date: 08/31/2012
Expiration/Review Date: 01/01/1900
Design Flow: Not reported
Major/Minor: Not reported
Complexity: Not reported
TTWQ: Not reported
Enforcement Actions within 5 years: 0
Violations within 5 years: 0
Latitude: Not reported
Longitude: Not reported

CERS:

Name: INDUSTRIAL ASPHALT
Address: 24000 SANTA ANA CANYON
City,State,Zip: ANAHEIM, CA 92807
Site ID: 213625
CERS ID: T0605994052
CERS Description: Leaking Underground Storage Tank Cleanup Site

Affiliation:

Affiliation Type Desc: Local Agency Caseworker
Entity Name: ANTHONY MARTINEZ - ORANGE COUNTY LOP
Entity Title: Not reported
Affiliation Address: 1241 E. DYER ROAD SUITE 120

Map ID
Direction
Distance
Elevation

MAP FINDINGS

Site

Database(s)

EDR ID Number
EPA ID Number

INDUSTRIAL ASPHALT (Continued)

1001611910

Affiliation City: SANTA ANA
Affiliation State: CA
Affiliation Country: Not reported
Affiliation Zip: Not reported
Affiliation Phone: 7144336011

Affiliation Type Desc: Regional Board Caseworker
Entity Name: VALERIE JAHN-BULL - SANTA ANA RWQCB (REGION 8)
Entity Title: Not reported
Affiliation Address: 3737 MAIN STREET, SUITE 500
Affiliation City: RIVERSIDE
Affiliation State: CA
Affiliation Country: Not reported
Affiliation Zip: Not reported
Affiliation Phone: 9517824903

Name: INDUSTRIAL ASPHALT COAST ASPH
Address: 24000 SANTA ANA CANYON RD
City,State,Zip: ANAHEIM, CA 92807
Site ID: 473528
CERS ID: 110001178207
CERS Description: US EPA Air Emission Inventory System (EIS)

Count: 0 records.

ORPHAN SUMMARY

City	EDR ID	Site Name	Site Address	Zip	Database(s)
NO SITES FOUND					

GOVERNMENT RECORDS SEARCHED / DATA CURRENCY TRACKING

To maintain currency of the following federal and state databases, EDR contacts the appropriate governmental agency on a monthly or quarterly basis, as required.

Number of Days to Update: Provides confirmation that EDR is reporting records that have been updated within 90 days from the date the government agency made the information available to the public.

STANDARD ENVIRONMENTAL RECORDS

Federal NPL site list

NPL: National Priority List

National Priorities List (Superfund). The NPL is a subset of CERCLIS and identifies over 1,200 sites for priority cleanup under the Superfund Program. NPL sites may encompass relatively large areas. As such, EDR provides polygon coverage for over 1,000 NPL site boundaries produced by EPA's Environmental Photographic Interpretation Center (EPIC) and regional EPA offices.

Date of Government Version: 12/30/2020	Source: EPA
Date Data Arrived at EDR: 01/14/2021	Telephone: N/A
Date Made Active in Reports: 02/09/2021	Last EDR Contact: 03/04/2021
Number of Days to Update: 26	Next Scheduled EDR Contact: 04/12/2021
	Data Release Frequency: Quarterly

NPL Site Boundaries

Sources:

EPA's Environmental Photographic Interpretation Center (EPIC)
Telephone: 202-564-7333

EPA Region 1
Telephone 617-918-1143

EPA Region 6
Telephone: 214-655-6659

EPA Region 3
Telephone 215-814-5418

EPA Region 7
Telephone: 913-551-7247

EPA Region 4
Telephone 404-562-8033

EPA Region 8
Telephone: 303-312-6774

EPA Region 5
Telephone 312-886-6686

EPA Region 9
Telephone: 415-947-4246

EPA Region 10
Telephone 206-553-8665

Proposed NPL: Proposed National Priority List Sites

A site that has been proposed for listing on the National Priorities List through the issuance of a proposed rule in the Federal Register. EPA then accepts public comments on the site, responds to the comments, and places on the NPL those sites that continue to meet the requirements for listing.

Date of Government Version: 12/30/2020	Source: EPA
Date Data Arrived at EDR: 01/14/2021	Telephone: N/A
Date Made Active in Reports: 02/09/2021	Last EDR Contact: 03/04/2021
Number of Days to Update: 26	Next Scheduled EDR Contact: 04/12/2021
	Data Release Frequency: Quarterly

NPL LIENS: Federal Superfund Liens

Federal Superfund Liens. Under the authority granted the USEPA by CERCLA of 1980, the USEPA has the authority to file liens against real property in order to recover remedial action expenditures or when the property owner received notification of potential liability. USEPA compiles a listing of filed notices of Superfund Liens.

GOVERNMENT RECORDS SEARCHED / DATA CURRENCY TRACKING

Date of Government Version: 10/15/1991
Date Data Arrived at EDR: 02/02/1994
Date Made Active in Reports: 03/30/1994
Number of Days to Update: 56

Source: EPA
Telephone: 202-564-4267
Last EDR Contact: 08/15/2011
Next Scheduled EDR Contact: 11/28/2011
Data Release Frequency: No Update Planned

Federal Delisted NPL site list

Delisted NPL: National Priority List Deletions

The National Oil and Hazardous Substances Pollution Contingency Plan (NCP) establishes the criteria that the EPA uses to delete sites from the NPL. In accordance with 40 CFR 300.425.(e), sites may be deleted from the NPL where no further response is appropriate.

Date of Government Version: 12/30/2020
Date Data Arrived at EDR: 01/14/2021
Date Made Active in Reports: 02/09/2021
Number of Days to Update: 26

Source: EPA
Telephone: N/A
Last EDR Contact: 03/04/2021
Next Scheduled EDR Contact: 04/12/2021
Data Release Frequency: Quarterly

Federal CERCLIS list

FEDERAL FACILITY: Federal Facility Site Information listing

A listing of National Priority List (NPL) and Base Realignment and Closure (BRAC) sites found in the Comprehensive Environmental Response, Compensation and Liability Information System (CERCLIS) Database where EPA Federal Facilities Restoration and Reuse Office is involved in cleanup activities.

Date of Government Version: 04/03/2019
Date Data Arrived at EDR: 04/05/2019
Date Made Active in Reports: 05/14/2019
Number of Days to Update: 39

Source: Environmental Protection Agency
Telephone: 703-603-8704
Last EDR Contact: 12/23/2020
Next Scheduled EDR Contact: 04/12/2021
Data Release Frequency: Varies

SEMS: Superfund Enterprise Management System

SEMS (Superfund Enterprise Management System) tracks hazardous waste sites, potentially hazardous waste sites, and remedial activities performed in support of EPA's Superfund Program across the United States. The list was formerly known as CERCLIS, renamed to SEMS by the EPA in 2015. The list contains data on potentially hazardous waste sites that have been reported to the USEPA by states, municipalities, private companies and private persons, pursuant to Section 103 of the Comprehensive Environmental Response, Compensation, and Liability Act (CERCLA). This dataset also contains sites which are either proposed to or on the National Priorities List (NPL) and the sites which are in the screening and assessment phase for possible inclusion on the NPL.

Date of Government Version: 12/30/2020
Date Data Arrived at EDR: 01/14/2021
Date Made Active in Reports: 02/18/2021
Number of Days to Update: 35

Source: EPA
Telephone: 800-424-9346
Last EDR Contact: 03/04/2021
Next Scheduled EDR Contact: 04/26/2021
Data Release Frequency: Quarterly

Federal CERCLIS NFRAP site list

SEMS-ARCHIVE: Superfund Enterprise Management System Archive

GOVERNMENT RECORDS SEARCHED / DATA CURRENCY TRACKING

SEMS-ARCHIVE (Superfund Enterprise Management System Archive) tracks sites that have no further interest under the Federal Superfund Program based on available information. The list was formerly known as the CERCLIS-NFRAP, renamed to SEMS ARCHIVE by the EPA in 2015. EPA may perform a minimal level of assessment work at a site while it is archived if site conditions change and/or new information becomes available. Archived sites have been removed and archived from the inventory of SEMS sites. Archived status indicates that, to the best of EPA's knowledge, assessment at a site has been completed and that EPA has determined no further steps will be taken to list the site on the National Priorities List (NPL), unless information indicates this decision was not appropriate or other considerations require a recommendation for listing at a later time. The decision does not necessarily mean that there is no hazard associated with a given site; it only means that, based upon available information, the location is not judged to be potential NPL site.

Date of Government Version: 12/30/2020	Source: EPA
Date Data Arrived at EDR: 01/14/2021	Telephone: 800-424-9346
Date Made Active in Reports: 02/18/2021	Last EDR Contact: 03/04/2021
Number of Days to Update: 35	Next Scheduled EDR Contact: 04/26/2021
	Data Release Frequency: Quarterly

Federal RCRA CORRACTS facilities list

CORRACTS: Corrective Action Report

CORRACTS identifies hazardous waste handlers with RCRA corrective action activity.

Date of Government Version: 12/14/2020	Source: EPA
Date Data Arrived at EDR: 12/17/2020	Telephone: 800-424-9346
Date Made Active in Reports: 12/22/2020	Last EDR Contact: 12/17/2020
Number of Days to Update: 5	Next Scheduled EDR Contact: 04/05/2021
	Data Release Frequency: Quarterly

Federal RCRA non-CORRACTS TSD facilities list

RCRA-TSDF: RCRA - Treatment, Storage and Disposal

RCRAInfo is EPA's comprehensive information system, providing access to data supporting the Resource Conservation and Recovery Act (RCRA) of 1976 and the Hazardous and Solid Waste Amendments (HSWA) of 1984. The database includes selective information on sites which generate, transport, store, treat and/or dispose of hazardous waste as defined by the Resource Conservation and Recovery Act (RCRA). Transporters are individuals or entities that move hazardous waste from the generator offsite to a facility that can recycle, treat, store, or dispose of the waste. TSDFs treat, store, or dispose of the waste.

Date of Government Version: 12/14/2020	Source: Environmental Protection Agency
Date Data Arrived at EDR: 12/17/2020	Telephone: (415) 495-8895
Date Made Active in Reports: 12/22/2020	Last EDR Contact: 12/17/2020
Number of Days to Update: 5	Next Scheduled EDR Contact: 04/05/2021
	Data Release Frequency: Quarterly

Federal RCRA generators list

RCRA-LQG: RCRA - Large Quantity Generators

RCRAInfo is EPA's comprehensive information system, providing access to data supporting the Resource Conservation and Recovery Act (RCRA) of 1976 and the Hazardous and Solid Waste Amendments (HSWA) of 1984. The database includes selective information on sites which generate, transport, store, treat and/or dispose of hazardous waste as defined by the Resource Conservation and Recovery Act (RCRA). Large quantity generators (LQGs) generate over 1,000 kilograms (kg) of hazardous waste, or over 1 kg of acutely hazardous waste per month.

Date of Government Version: 12/14/2020	Source: Environmental Protection Agency
Date Data Arrived at EDR: 12/17/2020	Telephone: (415) 495-8895
Date Made Active in Reports: 12/22/2020	Last EDR Contact: 12/17/2020
Number of Days to Update: 5	Next Scheduled EDR Contact: 04/05/2021
	Data Release Frequency: Quarterly

GOVERNMENT RECORDS SEARCHED / DATA CURRENCY TRACKING

RCRA-SQG: RCRA - Small Quantity Generators

RCRAInfo is EPA's comprehensive information system, providing access to data supporting the Resource Conservation and Recovery Act (RCRA) of 1976 and the Hazardous and Solid Waste Amendments (HSWA) of 1984. The database includes selective information on sites which generate, transport, store, treat and/or dispose of hazardous waste as defined by the Resource Conservation and Recovery Act (RCRA). Small quantity generators (SQGs) generate between 100 kg and 1,000 kg of hazardous waste per month.

Date of Government Version: 12/14/2020	Source: Environmental Protection Agency
Date Data Arrived at EDR: 12/17/2020	Telephone: (415) 495-8895
Date Made Active in Reports: 12/22/2020	Last EDR Contact: 12/17/2020
Number of Days to Update: 5	Next Scheduled EDR Contact: 04/05/2021
	Data Release Frequency: Quarterly

RCRA-VSQG: RCRA - Very Small Quantity Generators (Formerly Conditionally Exempt Small Quantity Generators)

RCRAInfo is EPA's comprehensive information system, providing access to data supporting the Resource Conservation and Recovery Act (RCRA) of 1976 and the Hazardous and Solid Waste Amendments (HSWA) of 1984. The database includes selective information on sites which generate, transport, store, treat and/or dispose of hazardous waste as defined by the Resource Conservation and Recovery Act (RCRA). Very small quantity generators (VSQGs) generate less than 100 kg of hazardous waste, or less than 1 kg of acutely hazardous waste per month.

Date of Government Version: 12/14/2020	Source: Environmental Protection Agency
Date Data Arrived at EDR: 12/17/2020	Telephone: (415) 495-8895
Date Made Active in Reports: 12/22/2020	Last EDR Contact: 12/17/2020
Number of Days to Update: 5	Next Scheduled EDR Contact: 04/05/2021
	Data Release Frequency: Quarterly

Federal institutional controls / engineering controls registries

LUCIS: Land Use Control Information System

LUCIS contains records of land use control information pertaining to the former Navy Base Realignment and Closure properties.

Date of Government Version: 11/11/2020	Source: Department of the Navy
Date Data Arrived at EDR: 11/17/2020	Telephone: 843-820-7326
Date Made Active in Reports: 02/09/2021	Last EDR Contact: 02/08/2021
Number of Days to Update: 84	Next Scheduled EDR Contact: 05/24/2021
	Data Release Frequency: Varies

US ENG CONTROLS: Engineering Controls Sites List

A listing of sites with engineering controls in place. Engineering controls include various forms of caps, building foundations, liners, and treatment methods to create pathway elimination for regulated substances to enter environmental media or effect human health.

Date of Government Version: 10/28/2020	Source: Environmental Protection Agency
Date Data Arrived at EDR: 11/05/2020	Telephone: 703-603-0695
Date Made Active in Reports: 11/18/2020	Last EDR Contact: 02/23/2021
Number of Days to Update: 13	Next Scheduled EDR Contact: 06/06/2021
	Data Release Frequency: Varies

US INST CONTROLS: Institutional Controls Sites List

A listing of sites with institutional controls in place. Institutional controls include administrative measures, such as groundwater use restrictions, construction restrictions, property use restrictions, and post remediation care requirements intended to prevent exposure to contaminants remaining on site. Deed restrictions are generally required as part of the institutional controls.

Date of Government Version: 10/28/2020	Source: Environmental Protection Agency
Date Data Arrived at EDR: 11/05/2020	Telephone: 703-603-0695
Date Made Active in Reports: 11/18/2020	Last EDR Contact: 02/23/2021
Number of Days to Update: 13	Next Scheduled EDR Contact: 06/06/2021
	Data Release Frequency: Varies

GOVERNMENT RECORDS SEARCHED / DATA CURRENCY TRACKING

Federal ERNS list

ERNS: Emergency Response Notification System

Emergency Response Notification System. ERNS records and stores information on reported releases of oil and hazardous substances.

Date of Government Version: 12/14/2020
Date Data Arrived at EDR: 12/15/2020
Date Made Active in Reports: 12/22/2020
Number of Days to Update: 7

Source: National Response Center, United States Coast Guard
Telephone: 202-267-2180
Last EDR Contact: 12/15/2020
Next Scheduled EDR Contact: 04/05/2021
Data Release Frequency: Quarterly

State- and tribal - equivalent NPL

RESPONSE: State Response Sites

Identifies confirmed release sites where DTSC is involved in remediation, either in a lead or oversight capacity. These confirmed release sites are generally high-priority and high potential risk.

Date of Government Version: 10/26/2020
Date Data Arrived at EDR: 10/26/2020
Date Made Active in Reports: 01/13/2021
Number of Days to Update: 79

Source: Department of Toxic Substances Control
Telephone: 916-323-3400
Last EDR Contact: 01/26/2021
Next Scheduled EDR Contact: 05/10/2021
Data Release Frequency: Quarterly

State- and tribal - equivalent CERCLIS

ENVIROSTOR: EnviroStor Database

The Department of Toxic Substances Control's (DTSC's) Site Mitigation and Brownfields Reuse Program's (SMBRP's) EnviroStor database identifies sites that have known contamination or sites for which there may be reasons to investigate further. The database includes the following site types: Federal Superfund sites (National Priorities List (NPL)); State Response, including Military Facilities and State Superfund; Voluntary Cleanup; and School sites. EnviroStor provides similar information to the information that was available in CalSites, and provides additional site information, including, but not limited to, identification of formerly-contaminated properties that have been released for reuse, properties where environmental deed restrictions have been recorded to prevent inappropriate land uses, and risk characterization information that is used to assess potential impacts to public health and the environment at contaminated sites.

Date of Government Version: 10/26/2020
Date Data Arrived at EDR: 10/26/2020
Date Made Active in Reports: 01/13/2021
Number of Days to Update: 79

Source: Department of Toxic Substances Control
Telephone: 916-323-3400
Last EDR Contact: 01/26/2021
Next Scheduled EDR Contact: 05/10/2021
Data Release Frequency: Quarterly

State and tribal landfill and/or solid waste disposal site lists

SWF/LF (SWIS): Solid Waste Information System

Active, Closed and Inactive Landfills. SWF/LF records typically contain an inventory of solid waste disposal facilities or landfills. These may be active or inactive facilities or open dumps that failed to meet RCRA Section 4004 criteria for solid waste landfills or disposal sites.

Date of Government Version: 11/09/2020
Date Data Arrived at EDR: 11/10/2020
Date Made Active in Reports: 01/14/2021
Number of Days to Update: 65

Source: Department of Resources Recycling and Recovery
Telephone: 916-341-6320
Last EDR Contact: 02/09/2021
Next Scheduled EDR Contact: 05/24/2021
Data Release Frequency: Quarterly

State and tribal leaking storage tank lists

GOVERNMENT RECORDS SEARCHED / DATA CURRENCY TRACKING

LUST REG 8: Leaking Underground Storage Tanks

California Regional Water Quality Control Board Santa Ana Region (8). For more current information, please refer to the State Water Resources Control Board's LUST database.

Date of Government Version: 02/14/2005
Date Data Arrived at EDR: 02/15/2005
Date Made Active in Reports: 03/28/2005
Number of Days to Update: 41

Source: California Regional Water Quality Control Board Santa Ana Region (8)
Telephone: 909-782-4496
Last EDR Contact: 08/15/2011
Next Scheduled EDR Contact: 11/28/2011
Data Release Frequency: No Update Planned

LUST REG 6L: Leaking Underground Storage Tank Case Listing

For more current information, please refer to the State Water Resources Control Board's LUST database.

Date of Government Version: 09/09/2003
Date Data Arrived at EDR: 09/10/2003
Date Made Active in Reports: 10/07/2003
Number of Days to Update: 27

Source: California Regional Water Quality Control Board Lahontan Region (6)
Telephone: 530-542-5572
Last EDR Contact: 09/12/2011
Next Scheduled EDR Contact: 12/26/2011
Data Release Frequency: No Update Planned

LUST REG 1: Active Toxic Site Investigation

Del Norte, Humboldt, Lake, Mendocino, Modoc, Siskiyou, Sonoma, Trinity counties. For more current information, please refer to the State Water Resources Control Board's LUST database.

Date of Government Version: 02/01/2001
Date Data Arrived at EDR: 02/28/2001
Date Made Active in Reports: 03/29/2001
Number of Days to Update: 29

Source: California Regional Water Quality Control Board North Coast (1)
Telephone: 707-570-3769
Last EDR Contact: 08/01/2011
Next Scheduled EDR Contact: 11/14/2011
Data Release Frequency: No Update Planned

LUST REG 2: Fuel Leak List

Leaking Underground Storage Tank locations. Alameda, Contra Costa, Marin, Napa, San Francisco, San Mateo, Santa Clara, Solano, Sonoma counties.

Date of Government Version: 09/30/2004
Date Data Arrived at EDR: 10/20/2004
Date Made Active in Reports: 11/19/2004
Number of Days to Update: 30

Source: California Regional Water Quality Control Board San Francisco Bay Region (2)
Telephone: 510-622-2433
Last EDR Contact: 09/19/2011
Next Scheduled EDR Contact: 01/02/2012
Data Release Frequency: No Update Planned

LUST REG 3: Leaking Underground Storage Tank Database

Leaking Underground Storage Tank locations. Monterey, San Benito, San Luis Obispo, Santa Barbara, Santa Cruz counties.

Date of Government Version: 05/19/2003
Date Data Arrived at EDR: 05/19/2003
Date Made Active in Reports: 06/02/2003
Number of Days to Update: 14

Source: California Regional Water Quality Control Board Central Coast Region (3)
Telephone: 805-542-4786
Last EDR Contact: 07/18/2011
Next Scheduled EDR Contact: 10/31/2011
Data Release Frequency: No Update Planned

LUST REG 4: Underground Storage Tank Leak List

Los Angeles, Ventura counties. For more current information, please refer to the State Water Resources Control Board's LUST database.

Date of Government Version: 09/07/2004
Date Data Arrived at EDR: 09/07/2004
Date Made Active in Reports: 10/12/2004
Number of Days to Update: 35

Source: California Regional Water Quality Control Board Los Angeles Region (4)
Telephone: 213-576-6710
Last EDR Contact: 09/06/2011
Next Scheduled EDR Contact: 12/19/2011
Data Release Frequency: No Update Planned

LUST REG 5: Leaking Underground Storage Tank Database

Leaking Underground Storage Tank locations. Alameda, Alpine, Amador, Butte, Colusa, Contra Costa, Calveras, El Dorado, Fresno, Glenn, Kern, Kings, Lake, Lassen, Madera, Mariposa, Merced, Modoc, Napa, Nevada, Placer, Plumas, Sacramento, San Joaquin, Shasta, Solano, Stanislaus, Sutter, Tehama, Tulare, Tuolumne, Yolo, Yuba counties.

GOVERNMENT RECORDS SEARCHED / DATA CURRENCY TRACKING

Date of Government Version: 07/01/2008
Date Data Arrived at EDR: 07/22/2008
Date Made Active in Reports: 07/31/2008
Number of Days to Update: 9

Source: California Regional Water Quality Control Board Central Valley Region (5)
Telephone: 916-464-4834
Last EDR Contact: 07/01/2011
Next Scheduled EDR Contact: 10/17/2011
Data Release Frequency: No Update Planned

LUST REG 7: Leaking Underground Storage Tank Case Listing

Leaking Underground Storage Tank locations. Imperial, Riverside, San Diego, Santa Barbara counties.

Date of Government Version: 02/26/2004
Date Data Arrived at EDR: 02/26/2004
Date Made Active in Reports: 03/24/2004
Number of Days to Update: 27

Source: California Regional Water Quality Control Board Colorado River Basin Region (7)
Telephone: 760-776-8943
Last EDR Contact: 08/01/2011
Next Scheduled EDR Contact: 11/14/2011
Data Release Frequency: No Update Planned

LUST REG 6V: Leaking Underground Storage Tank Case Listing

Leaking Underground Storage Tank locations. Inyo, Kern, Los Angeles, Mono, San Bernardino counties.

Date of Government Version: 06/07/2005
Date Data Arrived at EDR: 06/07/2005
Date Made Active in Reports: 06/29/2005
Number of Days to Update: 22

Source: California Regional Water Quality Control Board Victorville Branch Office (6)
Telephone: 760-241-7365
Last EDR Contact: 09/12/2011
Next Scheduled EDR Contact: 12/26/2011
Data Release Frequency: No Update Planned

LUST: Leaking Underground Fuel Tank Report (GEOTRACKER)

Leaking Underground Storage Tank (LUST) Sites included in GeoTracker. GeoTracker is the Water Boards data management system for sites that impact, or have the potential to impact, water quality in California, with emphasis on groundwater.

Date of Government Version: 12/04/2020
Date Data Arrived at EDR: 12/04/2020
Date Made Active in Reports: 02/18/2021
Number of Days to Update: 76

Source: State Water Resources Control Board
Telephone: see region list
Last EDR Contact: 12/04/2020
Next Scheduled EDR Contact: 03/22/2021
Data Release Frequency: Quarterly

LUST REG 9: Leaking Underground Storage Tank Report

Orange, Riverside, San Diego counties. For more current information, please refer to the State Water Resources Control Board's LUST database.

Date of Government Version: 03/01/2001
Date Data Arrived at EDR: 04/23/2001
Date Made Active in Reports: 05/21/2001
Number of Days to Update: 28

Source: California Regional Water Quality Control Board San Diego Region (9)
Telephone: 858-637-5595
Last EDR Contact: 09/26/2011
Next Scheduled EDR Contact: 01/09/2012
Data Release Frequency: No Update Planned

INDIAN LUST R9: Leaking Underground Storage Tanks on Indian Land

LUSTs on Indian land in Arizona, California, New Mexico and Nevada

Date of Government Version: 04/08/2020
Date Data Arrived at EDR: 05/20/2020
Date Made Active in Reports: 08/12/2020
Number of Days to Update: 84

Source: Environmental Protection Agency
Telephone: 415-972-3372
Last EDR Contact: 12/16/2020
Next Scheduled EDR Contact: 05/03/2021
Data Release Frequency: Varies

INDIAN LUST R10: Leaking Underground Storage Tanks on Indian Land

LUSTs on Indian land in Alaska, Idaho, Oregon and Washington.

Date of Government Version: 04/14/2020
Date Data Arrived at EDR: 05/20/2020
Date Made Active in Reports: 08/12/2020
Number of Days to Update: 84

Source: EPA Region 10
Telephone: 206-553-2857
Last EDR Contact: 12/16/2020
Next Scheduled EDR Contact: 05/03/2021
Data Release Frequency: Varies

GOVERNMENT RECORDS SEARCHED / DATA CURRENCY TRACKING

INDIAN LUST R1: Leaking Underground Storage Tanks on Indian Land

A listing of leaking underground storage tank locations on Indian Land.

Date of Government Version: 04/29/2020	Source: EPA Region 1
Date Data Arrived at EDR: 05/20/2020	Telephone: 617-918-1313
Date Made Active in Reports: 08/12/2020	Last EDR Contact: 12/16/2020
Number of Days to Update: 84	Next Scheduled EDR Contact: 05/03/2021
	Data Release Frequency: Varies

INDIAN LUST R8: Leaking Underground Storage Tanks on Indian Land

LUSTs on Indian land in Colorado, Montana, North Dakota, South Dakota, Utah and Wyoming.

Date of Government Version: 04/14/2020	Source: EPA Region 8
Date Data Arrived at EDR: 05/20/2020	Telephone: 303-312-6271
Date Made Active in Reports: 08/12/2020	Last EDR Contact: 12/16/2020
Number of Days to Update: 84	Next Scheduled EDR Contact: 05/03/2021
	Data Release Frequency: Varies

INDIAN LUST R4: Leaking Underground Storage Tanks on Indian Land

LUSTs on Indian land in Florida, Mississippi and North Carolina.

Date of Government Version: 04/14/2020	Source: EPA Region 4
Date Data Arrived at EDR: 05/26/2020	Telephone: 404-562-8677
Date Made Active in Reports: 08/12/2020	Last EDR Contact: 12/16/2020
Number of Days to Update: 78	Next Scheduled EDR Contact: 05/03/2021
	Data Release Frequency: Varies

INDIAN LUST R7: Leaking Underground Storage Tanks on Indian Land

LUSTs on Indian land in Iowa, Kansas, and Nebraska

Date of Government Version: 04/15/2020	Source: EPA Region 7
Date Data Arrived at EDR: 05/20/2020	Telephone: 913-551-7003
Date Made Active in Reports: 08/12/2020	Last EDR Contact: 12/16/2020
Number of Days to Update: 84	Next Scheduled EDR Contact: 05/03/2021
	Data Release Frequency: Varies

INDIAN LUST R6: Leaking Underground Storage Tanks on Indian Land

LUSTs on Indian land in New Mexico and Oklahoma.

Date of Government Version: 04/08/2020	Source: EPA Region 6
Date Data Arrived at EDR: 05/20/2020	Telephone: 214-665-6597
Date Made Active in Reports: 08/12/2020	Last EDR Contact: 12/16/2020
Number of Days to Update: 84	Next Scheduled EDR Contact: 05/03/2021
	Data Release Frequency: Varies

INDIAN LUST R5: Leaking Underground Storage Tanks on Indian Land

Leaking underground storage tanks located on Indian Land in Michigan, Minnesota and Wisconsin.

Date of Government Version: 04/14/2020	Source: EPA, Region 5
Date Data Arrived at EDR: 05/20/2020	Telephone: 312-886-7439
Date Made Active in Reports: 08/12/2020	Last EDR Contact: 12/16/2020
Number of Days to Update: 84	Next Scheduled EDR Contact: 05/03/2021
	Data Release Frequency: Varies

CPS-SLIC: Statewide SLIC Cases (GEOTRACKER)

Cleanup Program Sites (CPS; also known as Site Cleanups [SC] and formerly known as Spills, Leaks, Investigations, and Cleanups [SLIC] sites) included in GeoTracker. GeoTracker is the Water Boards data management system for sites that impact, or have the potential to impact, water quality in California, with emphasis on groundwater.

Date of Government Version: 12/04/2020	Source: State Water Resources Control Board
Date Data Arrived at EDR: 12/04/2020	Telephone: 866-480-1028
Date Made Active in Reports: 02/18/2021	Last EDR Contact: 12/04/2020
Number of Days to Update: 76	Next Scheduled EDR Contact: 03/22/2021
	Data Release Frequency: Varies

GOVERNMENT RECORDS SEARCHED / DATA CURRENCY TRACKING

SLIC REG 1: Active Toxic Site Investigations

The SLIC (Spills, Leaks, Investigations and Cleanup) program is designed to protect and restore water quality from spills, leaks, and similar discharges.

Date of Government Version: 04/03/2003
Date Data Arrived at EDR: 04/07/2003
Date Made Active in Reports: 04/25/2003
Number of Days to Update: 18

Source: California Regional Water Quality Control Board, North Coast Region (1)
Telephone: 707-576-2220
Last EDR Contact: 08/01/2011
Next Scheduled EDR Contact: 11/14/2011
Data Release Frequency: No Update Planned

SLIC REG 2: Spills, Leaks, Investigation & Cleanup Cost Recovery Listing

The SLIC (Spills, Leaks, Investigations and Cleanup) program is designed to protect and restore water quality from spills, leaks, and similar discharges.

Date of Government Version: 09/30/2004
Date Data Arrived at EDR: 10/20/2004
Date Made Active in Reports: 11/19/2004
Number of Days to Update: 30

Source: Regional Water Quality Control Board San Francisco Bay Region (2)
Telephone: 510-286-0457
Last EDR Contact: 09/19/2011
Next Scheduled EDR Contact: 01/02/2012
Data Release Frequency: No Update Planned

SLIC REG 3: Spills, Leaks, Investigation & Cleanup Cost Recovery Listing

The SLIC (Spills, Leaks, Investigations and Cleanup) program is designed to protect and restore water quality from spills, leaks, and similar discharges.

Date of Government Version: 05/18/2006
Date Data Arrived at EDR: 05/18/2006
Date Made Active in Reports: 06/15/2006
Number of Days to Update: 28

Source: California Regional Water Quality Control Board Central Coast Region (3)
Telephone: 805-549-3147
Last EDR Contact: 07/18/2011
Next Scheduled EDR Contact: 10/31/2011
Data Release Frequency: No Update Planned

SLIC REG 4: Spills, Leaks, Investigation & Cleanup Cost Recovery Listing

The SLIC (Spills, Leaks, Investigations and Cleanup) program is designed to protect and restore water quality from spills, leaks, and similar discharges.

Date of Government Version: 11/17/2004
Date Data Arrived at EDR: 11/18/2004
Date Made Active in Reports: 01/04/2005
Number of Days to Update: 47

Source: Region Water Quality Control Board Los Angeles Region (4)
Telephone: 213-576-6600
Last EDR Contact: 07/01/2011
Next Scheduled EDR Contact: 10/17/2011
Data Release Frequency: No Update Planned

SLIC REG 5: Spills, Leaks, Investigation & Cleanup Cost Recovery Listing

The SLIC (Spills, Leaks, Investigations and Cleanup) program is designed to protect and restore water quality from spills, leaks, and similar discharges.

Date of Government Version: 04/01/2005
Date Data Arrived at EDR: 04/05/2005
Date Made Active in Reports: 04/21/2005
Number of Days to Update: 16

Source: Regional Water Quality Control Board Central Valley Region (5)
Telephone: 916-464-3291
Last EDR Contact: 09/12/2011
Next Scheduled EDR Contact: 12/26/2011
Data Release Frequency: No Update Planned

SLIC REG 6V: Spills, Leaks, Investigation & Cleanup Cost Recovery Listing

The SLIC (Spills, Leaks, Investigations and Cleanup) program is designed to protect and restore water quality from spills, leaks, and similar discharges.

Date of Government Version: 05/24/2005
Date Data Arrived at EDR: 05/25/2005
Date Made Active in Reports: 06/16/2005
Number of Days to Update: 22

Source: Regional Water Quality Control Board, Victorville Branch
Telephone: 619-241-6583
Last EDR Contact: 08/15/2011
Next Scheduled EDR Contact: 11/28/2011
Data Release Frequency: No Update Planned

GOVERNMENT RECORDS SEARCHED / DATA CURRENCY TRACKING

SLIC REG 6L: SLIC Sites

The SLIC (Spills, Leaks, Investigations and Cleanup) program is designed to protect and restore water quality from spills, leaks, and similar discharges.

Date of Government Version: 09/07/2004
Date Data Arrived at EDR: 09/07/2004
Date Made Active in Reports: 10/12/2004
Number of Days to Update: 35

Source: California Regional Water Quality Control Board, Lahontan Region
Telephone: 530-542-5574
Last EDR Contact: 08/15/2011
Next Scheduled EDR Contact: 11/28/2011
Data Release Frequency: No Update Planned

SLIC REG 7: SLIC List

The SLIC (Spills, Leaks, Investigations and Cleanup) program is designed to protect and restore water quality from spills, leaks, and similar discharges.

Date of Government Version: 11/24/2004
Date Data Arrived at EDR: 11/29/2004
Date Made Active in Reports: 01/04/2005
Number of Days to Update: 36

Source: California Regional Quality Control Board, Colorado River Basin Region
Telephone: 760-346-7491
Last EDR Contact: 08/01/2011
Next Scheduled EDR Contact: 11/14/2011
Data Release Frequency: No Update Planned

SLIC REG 8: Spills, Leaks, Investigation & Cleanup Cost Recovery Listing

The SLIC (Spills, Leaks, Investigations and Cleanup) program is designed to protect and restore water quality from spills, leaks, and similar discharges.

Date of Government Version: 04/03/2008
Date Data Arrived at EDR: 04/03/2008
Date Made Active in Reports: 04/14/2008
Number of Days to Update: 11

Source: California Region Water Quality Control Board Santa Ana Region (8)
Telephone: 951-782-3298
Last EDR Contact: 09/12/2011
Next Scheduled EDR Contact: 12/26/2011
Data Release Frequency: No Update Planned

SLIC REG 9: Spills, Leaks, Investigation & Cleanup Cost Recovery Listing

The SLIC (Spills, Leaks, Investigations and Cleanup) program is designed to protect and restore water quality from spills, leaks, and similar discharges.

Date of Government Version: 09/10/2007
Date Data Arrived at EDR: 09/11/2007
Date Made Active in Reports: 09/28/2007
Number of Days to Update: 17

Source: California Regional Water Quality Control Board San Diego Region (9)
Telephone: 858-467-2980
Last EDR Contact: 08/08/2011
Next Scheduled EDR Contact: 11/21/2011
Data Release Frequency: No Update Planned

State and tribal registered storage tank lists

FEMA UST: Underground Storage Tank Listing

A listing of all FEMA owned underground storage tanks.

Date of Government Version: 07/21/2020
Date Data Arrived at EDR: 09/03/2020
Date Made Active in Reports: 11/25/2020
Number of Days to Update: 83

Source: FEMA
Telephone: 202-646-5797
Last EDR Contact: 01/04/2021
Next Scheduled EDR Contact: 04/19/2021
Data Release Frequency: Varies

UST CLOSURE: Proposed Closure of Underground Storage Tank (UST) Cases

UST cases that are being considered for closure by either the State Water Resources Control Board or the Executive Director have been posted for a 60-day public comment period. UST Case Closures being proposed for consideration by the State Water Resources Control Board. These are primarily UST cases that meet closure criteria under the decisional framework in State Water Board Resolution No. 92-49 and other Board orders. UST Case Closures proposed for consideration by the Executive Director pursuant to State Water Board Resolution No. 2012-0061. These are cases that meet the criteria of the Low-Threat UST Case Closure Policy. UST Case Closure Review Denials and Approved Orders.

GOVERNMENT RECORDS SEARCHED / DATA CURRENCY TRACKING

Date of Government Version: 12/02/2020
Date Data Arrived at EDR: 12/08/2020
Date Made Active in Reports: 02/23/2021
Number of Days to Update: 77

Source: State Water Resources Control Board
Telephone: 916-327-7844
Last EDR Contact: 12/08/2020
Next Scheduled EDR Contact: 03/22/2021
Data Release Frequency: Varies

MILITARY UST SITES: Military UST Sites (GEOTRACKER)

Military ust sites

Date of Government Version: 12/04/2020
Date Data Arrived at EDR: 12/04/2020
Date Made Active in Reports: 02/18/2021
Number of Days to Update: 76

Source: State Water Resources Control Board
Telephone: 866-480-1028
Last EDR Contact: 12/04/2020
Next Scheduled EDR Contact: 03/22/2021
Data Release Frequency: Varies

UST: Active UST Facilities

Active UST facilities gathered from the local regulatory agencies

Date of Government Version: 12/04/2020
Date Data Arrived at EDR: 12/04/2020
Date Made Active in Reports: 02/18/2021
Number of Days to Update: 76

Source: SWRCB
Telephone: 916-341-5851
Last EDR Contact: 12/04/2020
Next Scheduled EDR Contact: 03/22/2021
Data Release Frequency: Semi-Annually

AST: Aboveground Petroleum Storage Tank Facilities

A listing of aboveground storage tank petroleum storage tank locations.

Date of Government Version: 07/06/2016
Date Data Arrived at EDR: 07/12/2016
Date Made Active in Reports: 09/19/2016
Number of Days to Update: 69

Source: California Environmental Protection Agency
Telephone: 916-327-5092
Last EDR Contact: 12/09/2020
Next Scheduled EDR Contact: 03/29/2021
Data Release Frequency: Varies

INDIAN UST R7: Underground Storage Tanks on Indian Land

The Indian Underground Storage Tank (UST) database provides information about underground storage tanks on Indian land in EPA Region 7 (Iowa, Kansas, Missouri, Nebraska, and 9 Tribal Nations).

Date of Government Version: 04/03/2020
Date Data Arrived at EDR: 05/20/2020
Date Made Active in Reports: 08/12/2020
Number of Days to Update: 84

Source: EPA Region 7
Telephone: 913-551-7003
Last EDR Contact: 12/16/2020
Next Scheduled EDR Contact: 05/03/2021
Data Release Frequency: Varies

INDIAN UST R9: Underground Storage Tanks on Indian Land

The Indian Underground Storage Tank (UST) database provides information about underground storage tanks on Indian land in EPA Region 9 (Arizona, California, Hawaii, Nevada, the Pacific Islands, and Tribal Nations).

Date of Government Version: 04/08/2020
Date Data Arrived at EDR: 05/20/2020
Date Made Active in Reports: 08/12/2020
Number of Days to Update: 84

Source: EPA Region 9
Telephone: 415-972-3368
Last EDR Contact: 12/16/2020
Next Scheduled EDR Contact: 05/03/2021
Data Release Frequency: Varies

INDIAN UST R10: Underground Storage Tanks on Indian Land

The Indian Underground Storage Tank (UST) database provides information about underground storage tanks on Indian land in EPA Region 10 (Alaska, Idaho, Oregon, Washington, and Tribal Nations).

Date of Government Version: 04/14/2020
Date Data Arrived at EDR: 05/20/2020
Date Made Active in Reports: 08/12/2020
Number of Days to Update: 84

Source: EPA Region 10
Telephone: 206-553-2857
Last EDR Contact: 12/15/2020
Next Scheduled EDR Contact: 05/03/2021
Data Release Frequency: Varies

GOVERNMENT RECORDS SEARCHED / DATA CURRENCY TRACKING

INDIAN UST R1: Underground Storage Tanks on Indian Land

The Indian Underground Storage Tank (UST) database provides information about underground storage tanks on Indian land in EPA Region 1 (Connecticut, Maine, Massachusetts, New Hampshire, Rhode Island, Vermont and ten Tribal Nations).

Date of Government Version: 04/29/2020	Source: EPA, Region 1
Date Data Arrived at EDR: 05/20/2020	Telephone: 617-918-1313
Date Made Active in Reports: 08/12/2020	Last EDR Contact: 12/16/2020
Number of Days to Update: 84	Next Scheduled EDR Contact: 05/03/2021
	Data Release Frequency: Varies

INDIAN UST R8: Underground Storage Tanks on Indian Land

The Indian Underground Storage Tank (UST) database provides information about underground storage tanks on Indian land in EPA Region 8 (Colorado, Montana, North Dakota, South Dakota, Utah, Wyoming and 27 Tribal Nations).

Date of Government Version: 04/14/2020	Source: EPA Region 8
Date Data Arrived at EDR: 05/20/2020	Telephone: 303-312-6137
Date Made Active in Reports: 08/13/2020	Last EDR Contact: 12/16/2020
Number of Days to Update: 85	Next Scheduled EDR Contact: 05/03/2021
	Data Release Frequency: Varies

INDIAN UST R4: Underground Storage Tanks on Indian Land

The Indian Underground Storage Tank (UST) database provides information about underground storage tanks on Indian land in EPA Region 4 (Alabama, Florida, Georgia, Kentucky, Mississippi, North Carolina, South Carolina, Tennessee and Tribal Nations)

Date of Government Version: 04/14/2020	Source: EPA Region 4
Date Data Arrived at EDR: 05/26/2020	Telephone: 404-562-9424
Date Made Active in Reports: 08/12/2020	Last EDR Contact: 12/16/2020
Number of Days to Update: 78	Next Scheduled EDR Contact: 05/03/2021
	Data Release Frequency: Varies

INDIAN UST R6: Underground Storage Tanks on Indian Land

The Indian Underground Storage Tank (UST) database provides information about underground storage tanks on Indian land in EPA Region 6 (Louisiana, Arkansas, Oklahoma, New Mexico, Texas and 65 Tribes).

Date of Government Version: 04/08/2020	Source: EPA Region 6
Date Data Arrived at EDR: 05/20/2020	Telephone: 214-665-7591
Date Made Active in Reports: 08/12/2020	Last EDR Contact: 12/16/2020
Number of Days to Update: 84	Next Scheduled EDR Contact: 05/03/2021
	Data Release Frequency: Varies

INDIAN UST R5: Underground Storage Tanks on Indian Land

The Indian Underground Storage Tank (UST) database provides information about underground storage tanks on Indian land in EPA Region 5 (Michigan, Minnesota and Wisconsin and Tribal Nations).

Date of Government Version: 04/14/2020	Source: EPA Region 5
Date Data Arrived at EDR: 05/20/2020	Telephone: 312-886-6136
Date Made Active in Reports: 08/12/2020	Last EDR Contact: 12/16/2020
Number of Days to Update: 84	Next Scheduled EDR Contact: 05/03/2021
	Data Release Frequency: Varies

State and tribal voluntary cleanup sites

INDIAN VCP R1: Voluntary Cleanup Priority Listing

A listing of voluntary cleanup priority sites located on Indian Land located in Region 1.

Date of Government Version: 07/27/2015	Source: EPA, Region 1
Date Data Arrived at EDR: 09/29/2015	Telephone: 617-918-1102
Date Made Active in Reports: 02/18/2016	Last EDR Contact: 12/15/2020
Number of Days to Update: 142	Next Scheduled EDR Contact: 04/05/2021
	Data Release Frequency: Varies

GOVERNMENT RECORDS SEARCHED / DATA CURRENCY TRACKING

INDIAN VCP R7: Voluntary Cleanup Priority Listing

A listing of voluntary cleanup priority sites located on Indian Land located in Region 7.

Date of Government Version: 03/20/2008	Source: EPA, Region 7
Date Data Arrived at EDR: 04/22/2008	Telephone: 913-551-7365
Date Made Active in Reports: 05/19/2008	Last EDR Contact: 04/20/2009
Number of Days to Update: 27	Next Scheduled EDR Contact: 07/20/2009
	Data Release Frequency: Varies

VCP: Voluntary Cleanup Program Properties

Contains low threat level properties with either confirmed or unconfirmed releases and the project proponents have request that DTSC oversee investigation and/or cleanup activities and have agreed to provide coverage for DTSC's costs.

Date of Government Version: 10/26/2020	Source: Department of Toxic Substances Control
Date Data Arrived at EDR: 10/26/2020	Telephone: 916-323-3400
Date Made Active in Reports: 01/13/2021	Last EDR Contact: 01/26/2021
Number of Days to Update: 79	Next Scheduled EDR Contact: 05/10/2021
	Data Release Frequency: Quarterly

State and tribal Brownfields sites

BROWNFIELDS: Considered Brownfields Sites Listing

A listing of sites the SWRCB considers to be Brownfields since these are sites have come to them through the MOA Process.

Date of Government Version: 09/21/2020	Source: State Water Resources Control Board
Date Data Arrived at EDR: 09/22/2020	Telephone: 916-323-7905
Date Made Active in Reports: 12/11/2020	Last EDR Contact: 12/17/2020
Number of Days to Update: 80	Next Scheduled EDR Contact: 04/05/2021
	Data Release Frequency: Quarterly

ADDITIONAL ENVIRONMENTAL RECORDS

Local Brownfield lists

US BROWNFIELDS: A Listing of Brownfields Sites

Brownfields are real property, the expansion, redevelopment, or reuse of which may be complicated by the presence or potential presence of a hazardous substance, pollutant, or contaminant. Cleaning up and reinvesting in these properties takes development pressures off of undeveloped, open land, and both improves and protects the environment. Assessment, Cleanup and Redevelopment Exchange System (ACRES) stores information reported by EPA Brownfields grant recipients on brownfields properties assessed or cleaned up with grant funding as well as information on Targeted Brownfields Assessments performed by EPA Regions. A listing of ACRES Brownfield sites is obtained from Cleanups in My Community. Cleanups in My Community provides information on Brownfields properties for which information is reported back to EPA, as well as areas served by Brownfields grant programs.

Date of Government Version: 12/11/2020	Source: Environmental Protection Agency
Date Data Arrived at EDR: 12/11/2020	Telephone: 202-566-2777
Date Made Active in Reports: 03/02/2021	Last EDR Contact: 12/11/2020
Number of Days to Update: 81	Next Scheduled EDR Contact: 03/29/2021
	Data Release Frequency: Semi-Annually

Local Lists of Landfill / Solid Waste Disposal Sites

WMUDS/SWAT: Waste Management Unit Database

Waste Management Unit Database System. WMUDS is used by the State Water Resources Control Board staff and the Regional Water Quality Control Boards for program tracking and inventory of waste management units. WMUDS is composed of the following databases: Facility Information, Scheduled Inspections Information, Waste Management Unit Information, SWAT Program Information, SWAT Report Summary Information, SWAT Report Summary Data, Chapter 15 (formerly Subchapter 15) Information, Chapter 15 Monitoring Parameters, TPCA Program Information, RCRA Program Information, Closure Information, and Interested Parties Information.

GOVERNMENT RECORDS SEARCHED / DATA CURRENCY TRACKING

Date of Government Version: 04/01/2000
Date Data Arrived at EDR: 04/10/2000
Date Made Active in Reports: 05/10/2000
Number of Days to Update: 30

Source: State Water Resources Control Board
Telephone: 916-227-4448
Last EDR Contact: 01/25/2021
Next Scheduled EDR Contact: 05/10/2021
Data Release Frequency: No Update Planned

SWRCY: Recycler Database

A listing of recycling facilities in California.

Date of Government Version: 12/07/2020
Date Data Arrived at EDR: 12/08/2020
Date Made Active in Reports: 02/22/2021
Number of Days to Update: 76

Source: Department of Conservation
Telephone: 916-323-3836
Last EDR Contact: 12/08/2020
Next Scheduled EDR Contact: 03/22/2021
Data Release Frequency: Quarterly

HAULERS: Registered Waste Tire Haulers Listing

A listing of registered waste tire haulers.

Date of Government Version: 11/23/2020
Date Data Arrived at EDR: 11/23/2020
Date Made Active in Reports: 02/08/2021
Number of Days to Update: 77

Source: Integrated Waste Management Board
Telephone: 916-341-6422
Last EDR Contact: 02/08/2021
Next Scheduled EDR Contact: 05/24/2021
Data Release Frequency: Varies

INDIAN ODI: Report on the Status of Open Dumps on Indian Lands

Location of open dumps on Indian land.

Date of Government Version: 12/31/1998
Date Data Arrived at EDR: 12/03/2007
Date Made Active in Reports: 01/24/2008
Number of Days to Update: 52

Source: Environmental Protection Agency
Telephone: 703-308-8245
Last EDR Contact: 01/25/2021
Next Scheduled EDR Contact: 05/10/2021
Data Release Frequency: Varies

DEBRIS REGION 9: Torres Martinez Reservation Illegal Dump Site Locations

A listing of illegal dump sites location on the Torres Martinez Indian Reservation located in eastern Riverside County and northern Imperial County, California.

Date of Government Version: 01/12/2009
Date Data Arrived at EDR: 05/07/2009
Date Made Active in Reports: 09/21/2009
Number of Days to Update: 137

Source: EPA, Region 9
Telephone: 415-947-4219
Last EDR Contact: 01/19/2021
Next Scheduled EDR Contact: 05/03/2021
Data Release Frequency: No Update Planned

ODI: Open Dump Inventory

An open dump is defined as a disposal facility that does not comply with one or more of the Part 257 or Part 258 Subtitle D Criteria.

Date of Government Version: 06/30/1985
Date Data Arrived at EDR: 08/09/2004
Date Made Active in Reports: 09/17/2004
Number of Days to Update: 39

Source: Environmental Protection Agency
Telephone: 800-424-9346
Last EDR Contact: 06/09/2004
Next Scheduled EDR Contact: N/A
Data Release Frequency: No Update Planned

IHS OPEN DUMPS: Open Dumps on Indian Land

A listing of all open dumps located on Indian Land in the United States.

Date of Government Version: 04/01/2014
Date Data Arrived at EDR: 08/06/2014
Date Made Active in Reports: 01/29/2015
Number of Days to Update: 176

Source: Department of Health & Human Services, Indian Health Service
Telephone: 301-443-1452
Last EDR Contact: 01/29/2021
Next Scheduled EDR Contact: 05/10/2021
Data Release Frequency: Varies

GOVERNMENT RECORDS SEARCHED / DATA CURRENCY TRACKING

Local Lists of Hazardous waste / Contaminated Sites

US HIST CDL: National Clandestine Laboratory Register

A listing of clandestine drug lab locations that have been removed from the DEAs National Clandestine Laboratory Register.

Date of Government Version: 12/07/2020	Source: Drug Enforcement Administration
Date Data Arrived at EDR: 12/09/2020	Telephone: 202-307-1000
Date Made Active in Reports: 03/02/2021	Last EDR Contact: 02/22/2021
Number of Days to Update: 83	Next Scheduled EDR Contact: 06/06/2021
	Data Release Frequency: No Update Planned

HIST CAL-SITES: Calsites Database

The Calsites database contains potential or confirmed hazardous substance release properties. In 1996, California EPA reevaluated and significantly reduced the number of sites in the Calsites database. No longer updated by the state agency. It has been replaced by ENVIROSTOR.

Date of Government Version: 08/08/2005	Source: Department of Toxic Substance Control
Date Data Arrived at EDR: 08/03/2006	Telephone: 916-323-3400
Date Made Active in Reports: 08/24/2006	Last EDR Contact: 02/23/2009
Number of Days to Update: 21	Next Scheduled EDR Contact: 05/25/2009
	Data Release Frequency: No Update Planned

SCH: School Property Evaluation Program

This category contains proposed and existing school sites that are being evaluated by DTSC for possible hazardous materials contamination. In some cases, these properties may be listed in the CalSites category depending on the level of threat to public health and safety or the environment they pose.

Date of Government Version: 10/26/2020	Source: Department of Toxic Substances Control
Date Data Arrived at EDR: 10/26/2020	Telephone: 916-323-3400
Date Made Active in Reports: 01/13/2021	Last EDR Contact: 01/26/2021
Number of Days to Update: 79	Next Scheduled EDR Contact: 05/10/2021
	Data Release Frequency: Quarterly

CDL: Clandestine Drug Labs

A listing of drug lab locations. Listing of a location in this database does not indicate that any illegal drug lab materials were or were not present there, and does not constitute a determination that the location either requires or does not require additional cleanup work.

Date of Government Version: 06/30/2019	Source: Department of Toxic Substances Control
Date Data Arrived at EDR: 05/28/2020	Telephone: 916-255-6504
Date Made Active in Reports: 08/12/2020	Last EDR Contact: 01/19/2021
Number of Days to Update: 76	Next Scheduled EDR Contact: 04/19/2021
	Data Release Frequency: Varies

TOXIC PITS: Toxic Pits Cleanup Act Sites

Toxic PITS Cleanup Act Sites. TOXIC PITS identifies sites suspected of containing hazardous substances where cleanup has not yet been completed.

Date of Government Version: 07/01/1995	Source: State Water Resources Control Board
Date Data Arrived at EDR: 08/30/1995	Telephone: 916-227-4364
Date Made Active in Reports: 09/26/1995	Last EDR Contact: 01/26/2009
Number of Days to Update: 27	Next Scheduled EDR Contact: 04/27/2009
	Data Release Frequency: No Update Planned

CERS HAZ WASTE: CERS HAZ WASTE

List of sites in the California Environmental Protection Agency (CalEPA) Regulated Site Portal which fall under the Hazardous Chemical Management, Hazardous Waste Onsite Treatment, Household Hazardous Waste Collection, Hazardous Waste Generator, and RCRA LQ HW Generator programs.

GOVERNMENT RECORDS SEARCHED / DATA CURRENCY TRACKING

Date of Government Version: 10/19/2020
Date Data Arrived at EDR: 10/19/2020
Date Made Active in Reports: 01/07/2021
Number of Days to Update: 80

Source: CalEPA
Telephone: 916-323-2514
Last EDR Contact: 01/20/2021
Next Scheduled EDR Contact: 05/03/2021
Data Release Frequency: Quarterly

US CDL: Clandestine Drug Labs

A listing of clandestine drug lab locations. The U.S. Department of Justice ("the Department") provides this web site as a public service. It contains addresses of some locations where law enforcement agencies reported they found chemicals or other items that indicated the presence of either clandestine drug laboratories or dumpsites. In most cases, the source of the entries is not the Department, and the Department has not verified the entry and does not guarantee its accuracy. Members of the public must verify the accuracy of all entries by, for example, contacting local law enforcement and local health departments.

Date of Government Version: 12/07/2020
Date Data Arrived at EDR: 12/09/2020
Date Made Active in Reports: 03/02/2021
Number of Days to Update: 83

Source: Drug Enforcement Administration
Telephone: 202-307-1000
Last EDR Contact: 02/22/2021
Next Scheduled EDR Contact: 06/06/2021
Data Release Frequency: Quarterly

PFAS: PFAS Contamination Site Location Listing

A listing of PFAS contaminated sites included in the GeoTracker database.

Date of Government Version: 12/07/2020
Date Data Arrived at EDR: 12/08/2020
Date Made Active in Reports: 02/22/2021
Number of Days to Update: 76

Source: State Water Resources Control Board
Telephone: 866-480-1028
Last EDR Contact: 02/24/2021
Next Scheduled EDR Contact: 03/22/2021
Data Release Frequency: Varies

Local Lists of Registered Storage Tanks

SWEEPS UST: SWEEPS UST Listing

Statewide Environmental Evaluation and Planning System. This underground storage tank listing was updated and maintained by a company contacted by the SWRCB in the early 1990's. The listing is no longer updated or maintained. The local agency is the contact for more information on a site on the SWEEPS list.

Date of Government Version: 06/01/1994
Date Data Arrived at EDR: 07/07/2005
Date Made Active in Reports: 08/11/2005
Number of Days to Update: 35

Source: State Water Resources Control Board
Telephone: N/A
Last EDR Contact: 06/03/2005
Next Scheduled EDR Contact: N/A
Data Release Frequency: No Update Planned

UST MENDOCINO: Mendocino County UST Database

A listing of underground storage tank locations in Mendocino County.

Date of Government Version: 05/20/2020
Date Data Arrived at EDR: 05/20/2020
Date Made Active in Reports: 08/06/2020
Number of Days to Update: 78

Source: Department of Public Health
Telephone: 707-463-4466
Last EDR Contact: 02/22/2021
Next Scheduled EDR Contact: 06/06/2021
Data Release Frequency: Annually

HIST UST: Hazardous Substance Storage Container Database

The Hazardous Substance Storage Container Database is a historical listing of UST sites. Refer to local/county source for current data.

Date of Government Version: 10/15/1990
Date Data Arrived at EDR: 01/25/1991
Date Made Active in Reports: 02/12/1991
Number of Days to Update: 18

Source: State Water Resources Control Board
Telephone: 916-341-5851
Last EDR Contact: 07/26/2001
Next Scheduled EDR Contact: N/A
Data Release Frequency: No Update Planned

GOVERNMENT RECORDS SEARCHED / DATA CURRENCY TRACKING

SAN FRANCISCO AST: Aboveground Storage Tank Site Listing

Aboveground storage tank sites

Date of Government Version: 11/05/2020
Date Data Arrived at EDR: 11/06/2020
Date Made Active in Reports: 01/26/2021
Number of Days to Update: 81

Source: San Francisco County Department of Public Health
Telephone: 415-252-3896
Last EDR Contact: 02/01/2021
Next Scheduled EDR Contact: 05/17/2021
Data Release Frequency: Varies

CERS TANKS: California Environmental Reporting System (CERS) Tanks

List of sites in the California Environmental Protection Agency (CalEPA) Regulated Site Portal which fall under the Aboveground Petroleum Storage and Underground Storage Tank regulatory programs.

Date of Government Version: 10/19/2020
Date Data Arrived at EDR: 10/19/2020
Date Made Active in Reports: 01/07/2021
Number of Days to Update: 80

Source: California Environmental Protection Agency
Telephone: 916-323-2514
Last EDR Contact: 01/20/2021
Next Scheduled EDR Contact: 05/03/2021
Data Release Frequency: Quarterly

CA FID UST: Facility Inventory Database

The Facility Inventory Database (FID) contains a historical listing of active and inactive underground storage tank locations from the State Water Resource Control Board. Refer to local/county source for current data.

Date of Government Version: 10/31/1994
Date Data Arrived at EDR: 09/05/1995
Date Made Active in Reports: 09/29/1995
Number of Days to Update: 24

Source: California Environmental Protection Agency
Telephone: 916-341-5851
Last EDR Contact: 12/28/1998
Next Scheduled EDR Contact: N/A
Data Release Frequency: No Update Planned

Local Land Records

LIENS: Environmental Liens Listing

A listing of property locations with environmental liens for California where DTSC is a lien holder.

Date of Government Version: 11/24/2020
Date Data Arrived at EDR: 11/30/2020
Date Made Active in Reports: 02/10/2021
Number of Days to Update: 72

Source: Department of Toxic Substances Control
Telephone: 916-323-3400
Last EDR Contact: 02/26/2021
Next Scheduled EDR Contact: 06/14/2021
Data Release Frequency: Varies

LIENS 2: CERCLA Lien Information

A Federal CERCLA ('Superfund') lien can exist by operation of law at any site or property at which EPA has spent Superfund monies. These monies are spent to investigate and address releases and threatened releases of contamination. CERCLIS provides information as to the identity of these sites and properties.

Date of Government Version: 12/30/2020
Date Data Arrived at EDR: 01/14/2021
Date Made Active in Reports: 02/18/2021
Number of Days to Update: 35

Source: Environmental Protection Agency
Telephone: 202-564-6023
Last EDR Contact: 03/04/2021
Next Scheduled EDR Contact: 04/12/2021
Data Release Frequency: Semi-Annually

DEED: Deed Restriction Listing

GOVERNMENT RECORDS SEARCHED / DATA CURRENCY TRACKING

Site Mitigation and Brownfields Reuse Program Facility Sites with Deed Restrictions & Hazardous Waste Management Program Facility Sites with Deed / Land Use Restriction. The DTSC Site Mitigation and Brownfields Reuse Program (SMBRP) list includes sites cleaned up under the program's oversight and generally does not include current or former hazardous waste facilities that required a hazardous waste facility permit. The list represents deed restrictions that are active. Some sites have multiple deed restrictions. The DTSC Hazardous Waste Management Program (HWMP) has developed a list of current or former hazardous waste facilities that have a recorded land use restriction at the local county recorder's office. The land use restrictions on this list were required by the DTSC HWMP as a result of the presence of hazardous substances that remain on site after the facility (or part of the facility) has been closed or cleaned up. The types of land use restriction include deed notice, deed restriction, or a land use restriction that binds current and future owners.

Date of Government Version: 11/30/2020	Source: DTSC and SWRCB
Date Data Arrived at EDR: 12/01/2020	Telephone: 916-323-3400
Date Made Active in Reports: 02/12/2021	Last EDR Contact: 03/03/2021
Number of Days to Update: 73	Next Scheduled EDR Contact: 06/14/2021
	Data Release Frequency: Semi-Annually

Records of Emergency Release Reports

HMIRS: Hazardous Materials Information Reporting System

Hazardous Materials Incident Report System. HMIRS contains hazardous material spill incidents reported to DOT.

Date of Government Version: 09/20/2020	Source: U.S. Department of Transportation
Date Data Arrived at EDR: 09/22/2020	Telephone: 202-366-4555
Date Made Active in Reports: 12/14/2020	Last EDR Contact: 12/17/2020
Number of Days to Update: 83	Next Scheduled EDR Contact: 04/05/2021
	Data Release Frequency: Quarterly

CHMIRS: California Hazardous Material Incident Report System

California Hazardous Material Incident Reporting System. CHMIRS contains information on reported hazardous material incidents (accidental releases or spills).

Date of Government Version: 09/30/2020	Source: Office of Emergency Services
Date Data Arrived at EDR: 10/19/2020	Telephone: 916-845-8400
Date Made Active in Reports: 01/07/2021	Last EDR Contact: 01/20/2021
Number of Days to Update: 80	Next Scheduled EDR Contact: 05/03/2021
	Data Release Frequency: Semi-Annually

LDS: Land Disposal Sites Listing (GEOTRACKER)

Land Disposal sites (Landfills) included in GeoTracker. GeoTracker is the Water Boards data management system for sites that impact, or have the potential to impact, water quality in California, with emphasis on groundwater.

Date of Government Version: 12/04/2020	Source: State Water Quality Control Board
Date Data Arrived at EDR: 12/04/2020	Telephone: 866-480-1028
Date Made Active in Reports: 02/18/2021	Last EDR Contact: 12/04/2020
Number of Days to Update: 76	Next Scheduled EDR Contact: 03/22/2021
	Data Release Frequency: Quarterly

MCS: Military Cleanup Sites Listing (GEOTRACKER)

Military sites (consisting of: Military UST sites; Military Privatized sites; and Military Cleanup sites [formerly known as DoD non UST]) included in GeoTracker. GeoTracker is the Water Boards data management system for sites that impact, or have the potential to impact, water quality in California, with emphasis on groundwater.

Date of Government Version: 12/04/2020	Source: State Water Resources Control Board
Date Data Arrived at EDR: 12/04/2020	Telephone: 866-480-1028
Date Made Active in Reports: 02/18/2021	Last EDR Contact: 12/04/2020
Number of Days to Update: 76	Next Scheduled EDR Contact: 03/22/2021
	Data Release Frequency: Quarterly

GOVERNMENT RECORDS SEARCHED / DATA CURRENCY TRACKING

SPILLS 90: SPILLS90 data from FirstSearch

Spills 90 includes those spill and release records available exclusively from FirstSearch databases. Typically, they may include chemical, oil and/or hazardous substance spills recorded after 1990. Duplicate records that are already included in EDR incident and release records are not included in Spills 90.

Date of Government Version: 06/06/2012	Source: FirstSearch
Date Data Arrived at EDR: 01/03/2013	Telephone: N/A
Date Made Active in Reports: 02/22/2013	Last EDR Contact: 01/03/2013
Number of Days to Update: 50	Next Scheduled EDR Contact: N/A
	Data Release Frequency: No Update Planned

Other Ascertainable Records

RCRA NonGen / NLR: RCRA - Non Generators / No Longer Regulated

RCRAInfo is EPA's comprehensive information system, providing access to data supporting the Resource Conservation and Recovery Act (RCRA) of 1976 and the Hazardous and Solid Waste Amendments (HSWA) of 1984. The database includes selective information on sites which generate, transport, store, treat and/or dispose of hazardous waste as defined by the Resource Conservation and Recovery Act (RCRA). Non-Generators do not presently generate hazardous waste.

Date of Government Version: 12/14/2020	Source: Environmental Protection Agency
Date Data Arrived at EDR: 12/17/2020	Telephone: (415) 495-8895
Date Made Active in Reports: 12/22/2020	Last EDR Contact: 12/17/2020
Number of Days to Update: 5	Next Scheduled EDR Contact: 04/05/2021
	Data Release Frequency: Quarterly

FUDS: Formerly Used Defense Sites

The listing includes locations of Formerly Used Defense Sites properties where the US Army Corps of Engineers is actively working or will take necessary cleanup actions.

Date of Government Version: 09/29/2020	Source: U.S. Army Corps of Engineers
Date Data Arrived at EDR: 11/17/2020	Telephone: 202-528-4285
Date Made Active in Reports: 01/25/2021	Last EDR Contact: 02/17/2021
Number of Days to Update: 69	Next Scheduled EDR Contact: 05/31/2021
	Data Release Frequency: Varies

DOD: Department of Defense Sites

This data set consists of federally owned or administered lands, administered by the Department of Defense, that have any area equal to or greater than 640 acres of the United States, Puerto Rico, and the U.S. Virgin Islands.

Date of Government Version: 12/31/2005	Source: USGS
Date Data Arrived at EDR: 11/10/2006	Telephone: 888-275-8747
Date Made Active in Reports: 01/11/2007	Last EDR Contact: 01/15/2021
Number of Days to Update: 62	Next Scheduled EDR Contact: 04/26/2021
	Data Release Frequency: Semi-Annually

FEDLAND: Federal and Indian Lands

Federally and Indian administrated lands of the United States. Lands included are administrated by: Army Corps of Engineers, Bureau of Reclamation, National Wild and Scenic River, National Wildlife Refuge, Public Domain Land, Wilderness, Wilderness Study Area, Wildlife Management Area, Bureau of Indian Affairs, Bureau of Land Management, Department of Justice, Forest Service, Fish and Wildlife Service, National Park Service.

Date of Government Version: 04/02/2018	Source: U.S. Geological Survey
Date Data Arrived at EDR: 04/11/2018	Telephone: 888-275-8747
Date Made Active in Reports: 11/06/2019	Last EDR Contact: 01/07/2021
Number of Days to Update: 574	Next Scheduled EDR Contact: 04/19/2021
	Data Release Frequency: N/A

SCRD DRYCLEANERS: State Coalition for Remediation of Drycleaners Listing

The State Coalition for Remediation of Drycleaners was established in 1998, with support from the U.S. EPA Office of Superfund Remediation and Technology Innovation. It is comprised of representatives of states with established drycleaner remediation programs. Currently the member states are Alabama, Connecticut, Florida, Illinois, Kansas, Minnesota, Missouri, North Carolina, Oregon, South Carolina, Tennessee, Texas, and Wisconsin.

GOVERNMENT RECORDS SEARCHED / DATA CURRENCY TRACKING

Date of Government Version: 01/01/2017
Date Data Arrived at EDR: 02/03/2017
Date Made Active in Reports: 04/07/2017
Number of Days to Update: 63

Source: Environmental Protection Agency
Telephone: 615-532-8599
Last EDR Contact: 02/09/2021
Next Scheduled EDR Contact: 05/24/2021
Data Release Frequency: Varies

US FIN ASSUR: Financial Assurance Information

All owners and operators of facilities that treat, store, or dispose of hazardous waste are required to provide proof that they will have sufficient funds to pay for the clean up, closure, and post-closure care of their facilities.

Date of Government Version: 09/21/2020
Date Data Arrived at EDR: 09/22/2020
Date Made Active in Reports: 12/14/2020
Number of Days to Update: 83

Source: Environmental Protection Agency
Telephone: 202-566-1917
Last EDR Contact: 12/17/2020
Next Scheduled EDR Contact: 04/05/2021
Data Release Frequency: Quarterly

EPA WATCH LIST: EPA WATCH LIST

EPA maintains a "Watch List" to facilitate dialogue between EPA, state and local environmental agencies on enforcement matters relating to facilities with alleged violations identified as either significant or high priority. Being on the Watch List does not mean that the facility has actually violated the law only that an investigation by EPA or a state or local environmental agency has led those organizations to allege that an unproven violation has in fact occurred. Being on the Watch List does not represent a higher level of concern regarding the alleged violations that were detected, but instead indicates cases requiring additional dialogue between EPA, state and local agencies - primarily because of the length of time the alleged violation has gone unaddressed or unresolved.

Date of Government Version: 08/30/2013
Date Data Arrived at EDR: 03/21/2014
Date Made Active in Reports: 06/17/2014
Number of Days to Update: 88

Source: Environmental Protection Agency
Telephone: 617-520-3000
Last EDR Contact: 02/02/2021
Next Scheduled EDR Contact: 05/17/2021
Data Release Frequency: Quarterly

2020 COR ACTION: 2020 Corrective Action Program List

The EPA has set ambitious goals for the RCRA Corrective Action program by creating the 2020 Corrective Action Universe. This RCRA cleanup baseline includes facilities expected to need corrective action. The 2020 universe contains a wide variety of sites. Some properties are heavily contaminated while others were contaminated but have since been cleaned up. Still others have not been fully investigated yet, and may require little or no remediation. Inclusion in the 2020 Universe does not necessarily imply failure on the part of a facility to meet its RCRA obligations.

Date of Government Version: 09/30/2017
Date Data Arrived at EDR: 05/08/2018
Date Made Active in Reports: 07/20/2018
Number of Days to Update: 73

Source: Environmental Protection Agency
Telephone: 703-308-4044
Last EDR Contact: 02/05/2021
Next Scheduled EDR Contact: 05/17/2021
Data Release Frequency: Varies

TSCA: Toxic Substances Control Act

Toxic Substances Control Act. TSCA identifies manufacturers and importers of chemical substances included on the TSCA Chemical Substance Inventory list. It includes data on the production volume of these substances by plant site.

Date of Government Version: 12/31/2016
Date Data Arrived at EDR: 06/17/2020
Date Made Active in Reports: 09/10/2020
Number of Days to Update: 85

Source: EPA
Telephone: 202-260-5521
Last EDR Contact: 12/18/2020
Next Scheduled EDR Contact: 03/29/2021
Data Release Frequency: Every 4 Years

TRIS: Toxic Chemical Release Inventory System

Toxic Release Inventory System. TRIS identifies facilities which release toxic chemicals to the air, water and land in reportable quantities under SARA Title III Section 313.

GOVERNMENT RECORDS SEARCHED / DATA CURRENCY TRACKING

Date of Government Version: 12/31/2018
Date Data Arrived at EDR: 08/14/2020
Date Made Active in Reports: 11/04/2020
Number of Days to Update: 82

Source: EPA
Telephone: 202-566-0250
Last EDR Contact: 02/02/2021
Next Scheduled EDR Contact: 05/31/2021
Data Release Frequency: Annually

SSTS: Section 7 Tracking Systems

Section 7 of the Federal Insecticide, Fungicide and Rodenticide Act, as amended (92 Stat. 829) requires all registered pesticide-producing establishments to submit a report to the Environmental Protection Agency by March 1st each year. Each establishment must report the types and amounts of pesticides, active ingredients and devices being produced, and those having been produced and sold or distributed in the past year.

Date of Government Version: 10/19/2020
Date Data Arrived at EDR: 10/19/2020
Date Made Active in Reports: 01/04/2021
Number of Days to Update: 77

Source: EPA
Telephone: 202-564-4203
Last EDR Contact: 01/21/2021
Next Scheduled EDR Contact: 05/03/2021
Data Release Frequency: Annually

ROD: Records Of Decision

Record of Decision. ROD documents mandate a permanent remedy at an NPL (Superfund) site containing technical and health information to aid in the cleanup.

Date of Government Version: 12/30/2020
Date Data Arrived at EDR: 01/14/2021
Date Made Active in Reports: 02/18/2021
Number of Days to Update: 35

Source: EPA
Telephone: 703-416-0223
Last EDR Contact: 03/04/2021
Next Scheduled EDR Contact: 06/14/2021
Data Release Frequency: Annually

RMP: Risk Management Plans

When Congress passed the Clean Air Act Amendments of 1990, it required EPA to publish regulations and guidance for chemical accident prevention at facilities using extremely hazardous substances. The Risk Management Program Rule (RMP Rule) was written to implement Section 112(r) of these amendments. The rule, which built upon existing industry codes and standards, requires companies of all sizes that use certain flammable and toxic substances to develop a Risk Management Program, which includes a(n): Hazard assessment that details the potential effects of an accidental release, an accident history of the last five years, and an evaluation of worst-case and alternative accidental releases; Prevention program that includes safety precautions and maintenance, monitoring, and employee training measures; and Emergency response program that spells out emergency health care, employee training measures and procedures for informing the public and response agencies (e.g the fire department) should an accident occur.

Date of Government Version: 11/02/2020
Date Data Arrived at EDR: 11/12/2020
Date Made Active in Reports: 01/25/2021
Number of Days to Update: 74

Source: Environmental Protection Agency
Telephone: 202-564-8600
Last EDR Contact: 01/19/2021
Next Scheduled EDR Contact: 05/03/2021
Data Release Frequency: Varies

RAATS: RCRA Administrative Action Tracking System

RCRA Administration Action Tracking System. RAATS contains records based on enforcement actions issued under RCRA pertaining to major violators and includes administrative and civil actions brought by the EPA. For administration actions after September 30, 1995, data entry in the RAATS database was discontinued. EPA will retain a copy of the database for historical records. It was necessary to terminate RAATS because a decrease in agency resources made it impossible to continue to update the information contained in the database.

Date of Government Version: 04/17/1995
Date Data Arrived at EDR: 07/03/1995
Date Made Active in Reports: 08/07/1995
Number of Days to Update: 35

Source: EPA
Telephone: 202-564-4104
Last EDR Contact: 06/02/2008
Next Scheduled EDR Contact: 09/01/2008
Data Release Frequency: No Update Planned

GOVERNMENT RECORDS SEARCHED / DATA CURRENCY TRACKING

PRP: Potentially Responsible Parties

A listing of verified Potentially Responsible Parties

Date of Government Version: 12/30/2020	Source: EPA
Date Data Arrived at EDR: 01/14/2021	Telephone: 202-564-6023
Date Made Active in Reports: 03/05/2021	Last EDR Contact: 01/14/2021
Number of Days to Update: 50	Next Scheduled EDR Contact: 05/17/2021
	Data Release Frequency: Quarterly

PADS: PCB Activity Database System

PCB Activity Database. PADS Identifies generators, transporters, commercial storers and/or brokers and disposers of PCB's who are required to notify the EPA of such activities.

Date of Government Version: 10/09/2019	Source: EPA
Date Data Arrived at EDR: 10/11/2019	Telephone: 202-566-0500
Date Made Active in Reports: 12/20/2019	Last EDR Contact: 01/08/2021
Number of Days to Update: 70	Next Scheduled EDR Contact: 04/19/2021
	Data Release Frequency: Annually

ICIS: Integrated Compliance Information System

The Integrated Compliance Information System (ICIS) supports the information needs of the national enforcement and compliance program as well as the unique needs of the National Pollutant Discharge Elimination System (NPDES) program.

Date of Government Version: 11/18/2016	Source: Environmental Protection Agency
Date Data Arrived at EDR: 11/23/2016	Telephone: 202-564-2501
Date Made Active in Reports: 02/10/2017	Last EDR Contact: 12/30/2020
Number of Days to Update: 79	Next Scheduled EDR Contact: 04/19/2021
	Data Release Frequency: Quarterly

FTTS: FIFRA/ TSCA Tracking System - FIFRA (Federal Insecticide, Fungicide, & Rodenticide Act)/TSCA (Toxic Substances Control Act)

FTTS tracks administrative cases and pesticide enforcement actions and compliance activities related to FIFRA, TSCA and EPCRA (Emergency Planning and Community Right-to-Know Act). To maintain currency, EDR contacts the Agency on a quarterly basis.

Date of Government Version: 04/09/2009	Source: EPA/Office of Prevention, Pesticides and Toxic Substances
Date Data Arrived at EDR: 04/16/2009	Telephone: 202-566-1667
Date Made Active in Reports: 05/11/2009	Last EDR Contact: 08/18/2017
Number of Days to Update: 25	Next Scheduled EDR Contact: 12/04/2017
	Data Release Frequency: No Update Planned

FTTS INSP: FIFRA/ TSCA Tracking System - FIFRA (Federal Insecticide, Fungicide, & Rodenticide Act)/TSCA (Toxic Substances Control Act)

A listing of FIFRA/TSCA Tracking System (FTTS) inspections and enforcements.

Date of Government Version: 04/09/2009	Source: EPA
Date Data Arrived at EDR: 04/16/2009	Telephone: 202-566-1667
Date Made Active in Reports: 05/11/2009	Last EDR Contact: 08/18/2017
Number of Days to Update: 25	Next Scheduled EDR Contact: 12/04/2017
	Data Release Frequency: No Update Planned

MLTS: Material Licensing Tracking System

MLTS is maintained by the Nuclear Regulatory Commission and contains a list of approximately 8,100 sites which possess or use radioactive materials and which are subject to NRC licensing requirements. To maintain currency, EDR contacts the Agency on a quarterly basis.

Date of Government Version: 08/05/2020	Source: Nuclear Regulatory Commission
Date Data Arrived at EDR: 08/10/2020	Telephone: 301-415-7169
Date Made Active in Reports: 10/08/2020	Last EDR Contact: 01/19/2021
Number of Days to Update: 59	Next Scheduled EDR Contact: 05/03/2021
	Data Release Frequency: Quarterly

GOVERNMENT RECORDS SEARCHED / DATA CURRENCY TRACKING

COAL ASH DOE: Steam-Electric Plant Operation Data

A listing of power plants that store ash in surface ponds.

Date of Government Version: 12/31/2019	Source: Department of Energy
Date Data Arrived at EDR: 12/01/2020	Telephone: 202-586-8719
Date Made Active in Reports: 02/09/2021	Last EDR Contact: 03/05/2021
Number of Days to Update: 70	Next Scheduled EDR Contact: 06/14/2021
	Data Release Frequency: Varies

COAL ASH EPA: Coal Combustion Residues Surface Impoundments List

A listing of coal combustion residues surface impoundments with high hazard potential ratings.

Date of Government Version: 01/12/2017	Source: Environmental Protection Agency
Date Data Arrived at EDR: 03/05/2019	Telephone: N/A
Date Made Active in Reports: 11/11/2019	Last EDR Contact: 03/02/2021
Number of Days to Update: 251	Next Scheduled EDR Contact: 06/14/2021
	Data Release Frequency: Varies

PCB TRANSFORMER: PCB Transformer Registration Database

The database of PCB transformer registrations that includes all PCB registration submittals.

Date of Government Version: 09/13/2019	Source: Environmental Protection Agency
Date Data Arrived at EDR: 11/06/2019	Telephone: 202-566-0517
Date Made Active in Reports: 02/10/2020	Last EDR Contact: 02/05/2021
Number of Days to Update: 96	Next Scheduled EDR Contact: 05/17/2021
	Data Release Frequency: Varies

RADINFO: Radiation Information Database

The Radiation Information Database (RADINFO) contains information about facilities that are regulated by U.S. Environmental Protection Agency (EPA) regulations for radiation and radioactivity.

Date of Government Version: 07/01/2019	Source: Environmental Protection Agency
Date Data Arrived at EDR: 07/01/2019	Telephone: 202-343-9775
Date Made Active in Reports: 09/23/2019	Last EDR Contact: 01/08/2021
Number of Days to Update: 84	Next Scheduled EDR Contact: 04/12/2021
	Data Release Frequency: Quarterly

HIST FTTS: FIFRA/TSCA Tracking System Administrative Case Listing

A complete administrative case listing from the FIFRA/TSCA Tracking System (FTTS) for all ten EPA regions. The information was obtained from the National Compliance Database (NCDB). NCDB supports the implementation of FIFRA (Federal Insecticide, Fungicide, and Rodenticide Act) and TSCA (Toxic Substances Control Act). Some EPA regions are now closing out records. Because of that, and the fact that some EPA regions are not providing EPA Headquarters with updated records, it was decided to create a HIST FTTS database. It included records that may not be included in the newer FTTS database updates. This database is no longer updated.

Date of Government Version: 10/19/2006	Source: Environmental Protection Agency
Date Data Arrived at EDR: 03/01/2007	Telephone: 202-564-2501
Date Made Active in Reports: 04/10/2007	Last EDR Contact: 12/17/2007
Number of Days to Update: 40	Next Scheduled EDR Contact: 03/17/2008
	Data Release Frequency: No Update Planned

HIST FTTS INSP: FIFRA/TSCA Tracking System Inspection & Enforcement Case Listing

A complete inspection and enforcement case listing from the FIFRA/TSCA Tracking System (FTTS) for all ten EPA regions. The information was obtained from the National Compliance Database (NCDB). NCDB supports the implementation of FIFRA (Federal Insecticide, Fungicide, and Rodenticide Act) and TSCA (Toxic Substances Control Act). Some EPA regions are now closing out records. Because of that, and the fact that some EPA regions are not providing EPA Headquarters with updated records, it was decided to create a HIST FTTS database. It included records that may not be included in the newer FTTS database updates. This database is no longer updated.

GOVERNMENT RECORDS SEARCHED / DATA CURRENCY TRACKING

Date of Government Version: 10/19/2006
Date Data Arrived at EDR: 03/01/2007
Date Made Active in Reports: 04/10/2007
Number of Days to Update: 40

Source: Environmental Protection Agency
Telephone: 202-564-2501
Last EDR Contact: 12/17/2008
Next Scheduled EDR Contact: 03/17/2008
Data Release Frequency: No Update Planned

DOT OPS: Incident and Accident Data

Department of Transportation, Office of Pipeline Safety Incident and Accident data.

Date of Government Version: 01/02/2020
Date Data Arrived at EDR: 01/28/2020
Date Made Active in Reports: 04/17/2020
Number of Days to Update: 80

Source: Department of Transportation, Office of Pipeline Safety
Telephone: 202-366-4595
Last EDR Contact: 01/27/2021
Next Scheduled EDR Contact: 05/10/2021
Data Release Frequency: Quarterly

CONSENT: Superfund (CERCLA) Consent Decrees

Major legal settlements that establish responsibility and standards for cleanup at NPL (Superfund) sites. Released periodically by United States District Courts after settlement by parties to litigation matters.

Date of Government Version: 09/30/2020
Date Data Arrived at EDR: 10/08/2020
Date Made Active in Reports: 01/04/2021
Number of Days to Update: 88

Source: Department of Justice, Consent Decree Library
Telephone: Varies
Last EDR Contact: 01/04/2021
Next Scheduled EDR Contact: 04/19/2021
Data Release Frequency: Varies

BRS: Biennial Reporting System

The Biennial Reporting System is a national system administered by the EPA that collects data on the generation and management of hazardous waste. BRS captures detailed data from two groups: Large Quantity Generators (LQG) and Treatment, Storage, and Disposal Facilities.

Date of Government Version: 12/31/2017
Date Data Arrived at EDR: 06/22/2020
Date Made Active in Reports: 11/20/2020
Number of Days to Update: 151

Source: EPA/NTIS
Telephone: 800-424-9346
Last EDR Contact: 12/23/2020
Next Scheduled EDR Contact: 04/05/2021
Data Release Frequency: Biennially

INDIAN RESERV: Indian Reservations

This map layer portrays Indian administered lands of the United States that have any area equal to or greater than 640 acres.

Date of Government Version: 12/31/2014
Date Data Arrived at EDR: 07/14/2015
Date Made Active in Reports: 01/10/2017
Number of Days to Update: 546

Source: USGS
Telephone: 202-208-3710
Last EDR Contact: 01/08/2021
Next Scheduled EDR Contact: 04/19/2021
Data Release Frequency: Semi-Annually

FUSRAP: Formerly Utilized Sites Remedial Action Program

DOE established the Formerly Utilized Sites Remedial Action Program (FUSRAP) in 1974 to remediate sites where radioactive contamination remained from Manhattan Project and early U.S. Atomic Energy Commission (AEC) operations.

Date of Government Version: 08/08/2017
Date Data Arrived at EDR: 09/11/2018
Date Made Active in Reports: 09/14/2018
Number of Days to Update: 3

Source: Department of Energy
Telephone: 202-586-3559
Last EDR Contact: 02/02/2021
Next Scheduled EDR Contact: 05/17/2021
Data Release Frequency: Varies

UMTRA: Uranium Mill Tailings Sites

Uranium ore was mined by private companies for federal government use in national defense programs. When the mills shut down, large piles of the sand-like material (mill tailings) remain after uranium has been extracted from the ore. Levels of human exposure to radioactive materials from the piles are low; however, in some cases tailings were used as construction materials before the potential health hazards of the tailings were recognized.

GOVERNMENT RECORDS SEARCHED / DATA CURRENCY TRACKING

Date of Government Version: 08/30/2019
Date Data Arrived at EDR: 11/15/2019
Date Made Active in Reports: 01/28/2020
Number of Days to Update: 74

Source: Department of Energy
Telephone: 505-845-0011
Last EDR Contact: 02/18/2021
Next Scheduled EDR Contact: 05/31/2021
Data Release Frequency: Varies

LEAD SMELTER 1: Lead Smelter Sites

A listing of former lead smelter site locations.

Date of Government Version: 12/30/2020
Date Data Arrived at EDR: 01/14/2021
Date Made Active in Reports: 02/09/2021
Number of Days to Update: 26

Source: Environmental Protection Agency
Telephone: 703-603-8787
Last EDR Contact: 03/04/2021
Next Scheduled EDR Contact: 04/12/2021
Data Release Frequency: Varies

LEAD SMELTER 2: Lead Smelter Sites

A list of several hundred sites in the U.S. where secondary lead smelting was done from 1931 and 1964. These sites may pose a threat to public health through ingestion or inhalation of contaminated soil or dust

Date of Government Version: 04/05/2001
Date Data Arrived at EDR: 10/27/2010
Date Made Active in Reports: 12/02/2010
Number of Days to Update: 36

Source: American Journal of Public Health
Telephone: 703-305-6451
Last EDR Contact: 12/02/2009
Next Scheduled EDR Contact: N/A
Data Release Frequency: No Update Planned

US AIRS (AFS): Aerometric Information Retrieval System Facility Subsystem (AFS)

The database is a sub-system of Aerometric Information Retrieval System (AIRS). AFS contains compliance data on air pollution point sources regulated by the U.S. EPA and/or state and local air regulatory agencies. This information comes from source reports by various stationary sources of air pollution, such as electric power plants, steel mills, factories, and universities, and provides information about the air pollutants they produce. Action, air program, air program pollutant, and general level plant data. It is used to track emissions and compliance data from industrial plants.

Date of Government Version: 10/12/2016
Date Data Arrived at EDR: 10/26/2016
Date Made Active in Reports: 02/03/2017
Number of Days to Update: 100

Source: EPA
Telephone: 202-564-2496
Last EDR Contact: 09/26/2017
Next Scheduled EDR Contact: 01/08/2018
Data Release Frequency: Annually

US AIRS MINOR: Air Facility System Data

A listing of minor source facilities.

Date of Government Version: 10/12/2016
Date Data Arrived at EDR: 10/26/2016
Date Made Active in Reports: 02/03/2017
Number of Days to Update: 100

Source: EPA
Telephone: 202-564-2496
Last EDR Contact: 09/26/2017
Next Scheduled EDR Contact: 01/08/2018
Data Release Frequency: Annually

MINES VIOLATIONS: MSHA Violation Assessment Data

Mines violation and assessment information. Department of Labor, Mine Safety & Health Administration.

Date of Government Version: 11/24/2020
Date Data Arrived at EDR: 11/30/2020
Date Made Active in Reports: 01/25/2021
Number of Days to Update: 56

Source: DOL, Mine Safety & Health Admi
Telephone: 202-693-9424
Last EDR Contact: 03/01/2021
Next Scheduled EDR Contact: 06/14/2021
Data Release Frequency: Quarterly

US MINES: Mines Master Index File

Contains all mine identification numbers issued for mines active or opened since 1971. The data also includes violation information.

GOVERNMENT RECORDS SEARCHED / DATA CURRENCY TRACKING

Date of Government Version: 11/03/2020
Date Data Arrived at EDR: 11/23/2020
Date Made Active in Reports: 01/25/2021
Number of Days to Update: 63

Source: Department of Labor, Mine Safety and Health Administration
Telephone: 303-231-5959
Last EDR Contact: 02/24/2021
Next Scheduled EDR Contact: 06/06/2021
Data Release Frequency: Semi-Annually

US MINES 2: Ferrous and Nonferrous Metal Mines Database Listing

This map layer includes ferrous (ferrous metal mines are facilities that extract ferrous metals, such as iron ore or molybdenum) and nonferrous (Nonferrous metal mines are facilities that extract nonferrous metals, such as gold, silver, copper, zinc, and lead) metal mines in the United States.

Date of Government Version: 05/06/2020
Date Data Arrived at EDR: 05/27/2020
Date Made Active in Reports: 08/13/2020
Number of Days to Update: 78

Source: USGS
Telephone: 703-648-7709
Last EDR Contact: 02/26/2021
Next Scheduled EDR Contact: 06/06/2021
Data Release Frequency: Varies

US MINES 3: Active Mines & Mineral Plants Database Listing

Active Mines and Mineral Processing Plant operations for commodities monitored by the Minerals Information Team of the USGS.

Date of Government Version: 04/14/2011
Date Data Arrived at EDR: 06/08/2011
Date Made Active in Reports: 09/13/2011
Number of Days to Update: 97

Source: USGS
Telephone: 703-648-7709
Last EDR Contact: 02/26/2021
Next Scheduled EDR Contact: 06/06/2021
Data Release Frequency: Varies

ABANDONED MINES: Abandoned Mines

An inventory of land and water impacted by past mining (primarily coal mining) is maintained by OSMRE to provide information needed to implement the Surface Mining Control and Reclamation Act of 1977 (SMCRA). The inventory contains information on the location, type, and extent of AML impacts, as well as, information on the cost associated with the reclamation of those problems. The inventory is based upon field surveys by State, Tribal, and OSMRE program officials. It is dynamic to the extent that it is modified as new problems are identified and existing problems are reclaimed.

Date of Government Version: 12/11/2020
Date Data Arrived at EDR: 12/11/2020
Date Made Active in Reports: 03/02/2021
Number of Days to Update: 81

Source: Department of Interior
Telephone: 202-208-2609
Last EDR Contact: 03/08/2021
Next Scheduled EDR Contact: 06/21/2021
Data Release Frequency: Quarterly

FINDS: Facility Index System/Facility Registry System

Facility Index System. FINDS contains both facility information and 'pointers' to other sources that contain more detail. EDR includes the following FINDS databases in this report: PCS (Permit Compliance System), AIRS (Aerometric Information Retrieval System), DOCKET (Enforcement Docket used to manage and track information on civil judicial enforcement cases for all environmental statutes), FURS (Federal Underground Injection Control), C-DOCKET (Criminal Docket System used to track criminal enforcement actions for all environmental statutes), FFIS (Federal Facilities Information System), STATE (State Environmental Laws and Statutes), and PADS (PCB Activity Data System).

Date of Government Version: 11/04/2020
Date Data Arrived at EDR: 12/01/2020
Date Made Active in Reports: 01/25/2021
Number of Days to Update: 55

Source: EPA
Telephone: (415) 947-8000
Last EDR Contact: 03/03/2021
Next Scheduled EDR Contact: 06/14/2021
Data Release Frequency: Quarterly

ECHO: Enforcement & Compliance History Information

ECHO provides integrated compliance and enforcement information for about 800,000 regulated facilities nationwide.

Date of Government Version: 10/03/2020
Date Data Arrived at EDR: 10/06/2020
Date Made Active in Reports: 01/04/2021
Number of Days to Update: 90

Source: Environmental Protection Agency
Telephone: 202-564-2280
Last EDR Contact: 01/08/2021
Next Scheduled EDR Contact: 04/19/2021
Data Release Frequency: Quarterly

GOVERNMENT RECORDS SEARCHED / DATA CURRENCY TRACKING

UXO: Unexploded Ordnance Sites

A listing of unexploded ordnance site locations

Date of Government Version: 12/31/2018	Source: Department of Defense
Date Data Arrived at EDR: 07/02/2020	Telephone: 703-704-1564
Date Made Active in Reports: 09/17/2020	Last EDR Contact: 01/15/2021
Number of Days to Update: 77	Next Scheduled EDR Contact: 04/26/2021
	Data Release Frequency: Varies

DOCKET HWC: Hazardous Waste Compliance Docket Listing

A complete list of the Federal Agency Hazardous Waste Compliance Docket Facilities.

Date of Government Version: 11/03/2020	Source: Environmental Protection Agency
Date Data Arrived at EDR: 11/17/2020	Telephone: 202-564-0527
Date Made Active in Reports: 02/09/2021	Last EDR Contact: 02/26/2021
Number of Days to Update: 84	Next Scheduled EDR Contact: 06/06/2021
	Data Release Frequency: Varies

FUELS PROGRAM: EPA Fuels Program Registered Listing

This listing includes facilities that are registered under the Part 80 (Code of Federal Regulations) EPA Fuels Programs. All companies now are required to submit new and updated registrations.

Date of Government Version: 11/13/2020	Source: EPA
Date Data Arrived at EDR: 11/13/2020	Telephone: 800-385-6164
Date Made Active in Reports: 01/25/2021	Last EDR Contact: 02/17/2021
Number of Days to Update: 73	Next Scheduled EDR Contact: 05/31/2021
	Data Release Frequency: Quarterly

CA BOND EXP. PLAN: Bond Expenditure Plan

Department of Health Services developed a site-specific expenditure plan as the basis for an appropriation of Hazardous Substance Cleanup Bond Act funds. It is not updated.

Date of Government Version: 01/01/1989	Source: Department of Health Services
Date Data Arrived at EDR: 07/27/1994	Telephone: 916-255-2118
Date Made Active in Reports: 08/02/1994	Last EDR Contact: 05/31/1994
Number of Days to Update: 6	Next Scheduled EDR Contact: N/A
	Data Release Frequency: No Update Planned

CORTESE: "Cortese" Hazardous Waste & Substances Sites List

The sites for the list are designated by the State Water Resource Control Board (LUST), the Integrated Waste Board (SWF/LS), and the Department of Toxic Substances Control (Cal-Sites).

Date of Government Version: 06/22/2020	Source: CAL EPA/Office of Emergency Information
Date Data Arrived at EDR: 06/22/2020	Telephone: 916-323-3400
Date Made Active in Reports: 09/04/2020	Last EDR Contact: 12/17/2020
Number of Days to Update: 74	Next Scheduled EDR Contact: 04/05/2021
	Data Release Frequency: Quarterly

CUPA LIVERMORE-PLEASANTON: CUPA Facility Listing

list of facilities associated with the various CUPA programs in Livermore-Pleasanton

Date of Government Version: 05/01/2019	Source: Livermore-Pleasanton Fire Department
Date Data Arrived at EDR: 05/14/2019	Telephone: 925-454-2361
Date Made Active in Reports: 07/17/2019	Last EDR Contact: 02/12/2021
Number of Days to Update: 64	Next Scheduled EDR Contact: 05/24/2021
	Data Release Frequency: Varies

DRYCLEANERS: Cleaner Facilities

A list of drycleaner related facilities that have EPA ID numbers. These are facilities with certain SIC codes: power laundries, family and commercial; garment pressing and cleaner's agents; linen supply; coin-operated laundries and cleaning; drycleaning plants, except rugs; carpet and upholster cleaning; industrial launderers; laundry and garment services.

GOVERNMENT RECORDS SEARCHED / DATA CURRENCY TRACKING

Date of Government Version: 11/23/2020
Date Data Arrived at EDR: 11/25/2020
Date Made Active in Reports: 02/10/2021
Number of Days to Update: 77

Source: Department of Toxic Substance Control
Telephone: 916-327-4498
Last EDR Contact: 02/26/2021
Next Scheduled EDR Contact: 06/14/2021
Data Release Frequency: Annually

DRYCLEAN SOUTH COAST: South Coast Air Quality Management District Drycleaner Listing

A listing of dry cleaners in the South Coast Air Quality Management District

Date of Government Version: 11/17/2020
Date Data Arrived at EDR: 11/18/2020
Date Made Active in Reports: 02/04/2021
Number of Days to Update: 78

Source: South Coast Air Quality Management District
Telephone: 909-396-3211
Last EDR Contact: 02/22/2021
Next Scheduled EDR Contact: 06/06/2021
Data Release Frequency: Varies

DRYCLEAN AVAQMD: Antelope Valley Air Quality Management District Drycleaner Listing

A listing of dry cleaners in the Antelope Valley Air Quality Management District.

Date of Government Version: 11/23/2020
Date Data Arrived at EDR: 11/24/2020
Date Made Active in Reports: 02/10/2021
Number of Days to Update: 78

Source: Antelope Valley Air Quality Management District
Telephone: 661-723-8070
Last EDR Contact: 02/26/2021
Next Scheduled EDR Contact: 06/14/2021
Data Release Frequency: Varies

EMI: Emissions Inventory Data

Toxics and criteria pollutant emissions data collected by the ARB and local air pollution agencies.

Date of Government Version: 12/31/2018
Date Data Arrived at EDR: 06/16/2020
Date Made Active in Reports: 08/28/2020
Number of Days to Update: 73

Source: California Air Resources Board
Telephone: 916-322-2990
Last EDR Contact: 12/18/2020
Next Scheduled EDR Contact: 03/29/2021
Data Release Frequency: Varies

ENF: Enforcement Action Listing

A listing of Water Board Enforcement Actions. Formal is everything except Oral/Verbal Communication, Notice of Violation, Expedited Payment Letter, and Staff Enforcement Letter.

Date of Government Version: 10/16/2020
Date Data Arrived at EDR: 10/19/2020
Date Made Active in Reports: 01/07/2021
Number of Days to Update: 80

Source: State Water Resources Control Board
Telephone: 916-445-9379
Last EDR Contact: 01/20/2021
Next Scheduled EDR Contact: 05/03/2021
Data Release Frequency: Varies

Financial Assurance 1: Financial Assurance Information Listing

Financial Assurance information

Date of Government Version: 10/13/2020
Date Data Arrived at EDR: 10/14/2020
Date Made Active in Reports: 01/04/2021
Number of Days to Update: 82

Source: Department of Toxic Substances Control
Telephone: 916-255-3628
Last EDR Contact: 01/22/2021
Next Scheduled EDR Contact: 05/03/2021
Data Release Frequency: Varies

Financial Assurance 2: Financial Assurance Information Listing

A listing of financial assurance information for solid waste facilities. Financial assurance is intended to ensure that resources are available to pay for the cost of closure, post-closure care, and corrective measures if the owner or operator of a regulated facility is unable or unwilling to pay.

Date of Government Version: 11/12/2020
Date Data Arrived at EDR: 11/13/2020
Date Made Active in Reports: 01/29/2021
Number of Days to Update: 77

Source: California Integrated Waste Management Board
Telephone: 916-341-6066
Last EDR Contact: 02/08/2021
Next Scheduled EDR Contact: 05/24/2021
Data Release Frequency: Varies

GOVERNMENT RECORDS SEARCHED / DATA CURRENCY TRACKING

HAZNET: Facility and Manifest Data

Facility and Manifest Data. The data is extracted from the copies of hazardous waste manifests received each year by the DTSC. The annual volume of manifests is typically 700,000 - 1,000,000 annually, representing approximately 350,000 - 500,000 shipments. Data are from the manifests submitted without correction, and therefore many contain some invalid values for data elements such as generator ID, TSD ID, waste category, and disposal method. This database begins with calendar year 1993.

Date of Government Version: 12/31/2019
Date Data Arrived at EDR: 04/15/2020
Date Made Active in Reports: 07/02/2020
Number of Days to Update: 78

Source: California Environmental Protection Agency
Telephone: 916-255-1136
Last EDR Contact: 01/05/2021
Next Scheduled EDR Contact: 04/19/2021
Data Release Frequency: Annually

ICE: ICE

Contains data pertaining to the Permitted Facilities with Inspections / Enforcements sites tracked in Envirostor.

Date of Government Version: 11/13/2020
Date Data Arrived at EDR: 11/13/2020
Date Made Active in Reports: 02/01/2021
Number of Days to Update: 80

Source: Department of Toxic Substances Control
Telephone: 877-786-9427
Last EDR Contact: 02/17/2021
Next Scheduled EDR Contact: 05/31/2021
Data Release Frequency: Quarterly

HIST CORTESE: Hazardous Waste & Substance Site List

The sites for the list are designated by the State Water Resource Control Board [LUST], the Integrated Waste Board [SWF/LS], and the Department of Toxic Substances Control [CALSTITES]. This listing is no longer updated by the state agency.

Date of Government Version: 04/01/2001
Date Data Arrived at EDR: 01/22/2009
Date Made Active in Reports: 04/08/2009
Number of Days to Update: 76

Source: Department of Toxic Substances Control
Telephone: 916-323-3400
Last EDR Contact: 01/22/2009
Next Scheduled EDR Contact: N/A
Data Release Frequency: No Update Planned

HWP: EnviroStor Permitted Facilities Listing

Detailed information on permitted hazardous waste facilities and corrective action ("cleanups") tracked in EnviroStor.

Date of Government Version: 11/13/2020
Date Data Arrived at EDR: 11/13/2020
Date Made Active in Reports: 02/01/2021
Number of Days to Update: 80

Source: Department of Toxic Substances Control
Telephone: 916-323-3400
Last EDR Contact: 02/17/2021
Next Scheduled EDR Contact: 05/31/2021
Data Release Frequency: Quarterly

HWT: Registered Hazardous Waste Transporter Database

A listing of hazardous waste transporters. In California, unless specifically exempted, it is unlawful for any person to transport hazardous wastes unless the person holds a valid registration issued by DTSC. A hazardous waste transporter registration is valid for one year and is assigned a unique registration number.

Date of Government Version: 10/05/2020
Date Data Arrived at EDR: 10/06/2020
Date Made Active in Reports: 12/23/2020
Number of Days to Update: 78

Source: Department of Toxic Substances Control
Telephone: 916-440-7145
Last EDR Contact: 01/05/2021
Next Scheduled EDR Contact: 04/19/2021
Data Release Frequency: Quarterly

MINES: Mines Site Location Listing

A listing of mine site locations from the Office of Mine Reclamation.

Date of Government Version: 12/07/2020
Date Data Arrived at EDR: 12/08/2020
Date Made Active in Reports: 02/22/2021
Number of Days to Update: 76

Source: Department of Conservation
Telephone: 916-322-1080
Last EDR Contact: 12/08/2020
Next Scheduled EDR Contact: 03/22/2021
Data Release Frequency: Quarterly

GOVERNMENT RECORDS SEARCHED / DATA CURRENCY TRACKING

MWMP: Medical Waste Management Program Listing

The Medical Waste Management Program (MWMP) ensures the proper handling and disposal of medical waste by permitting and inspecting medical waste Offsite Treatment Facilities (PDF) and Transfer Stations (PDF) throughout the state. MWMP also oversees all Medical Waste Transporters.

Date of Government Version: 10/30/2020	Source: Department of Public Health
Date Data Arrived at EDR: 12/01/2020	Telephone: 916-558-1784
Date Made Active in Reports: 02/12/2021	Last EDR Contact: 03/03/2021
Number of Days to Update: 73	Next Scheduled EDR Contact: 06/14/2021
	Data Release Frequency: Varies

NPDES: NPDES Permits Listing

A listing of NPDES permits, including stormwater.

Date of Government Version: 11/09/2020	Source: State Water Resources Control Board
Date Data Arrived at EDR: 11/10/2020	Telephone: 916-445-9379
Date Made Active in Reports: 01/27/2021	Last EDR Contact: 02/09/2021
Number of Days to Update: 78	Next Scheduled EDR Contact: 05/24/2021
	Data Release Frequency: Quarterly

PEST LIC: Pesticide Regulation Licenses Listing

A listing of licenses and certificates issued by the Department of Pesticide Regulation. The DPR issues licenses and/or certificates to: Persons and businesses that apply or sell pesticides; Pest control dealers and brokers; Persons who advise on agricultural pesticide applications.

Date of Government Version: 11/30/2020	Source: Department of Pesticide Regulation
Date Data Arrived at EDR: 12/01/2020	Telephone: 916-445-4038
Date Made Active in Reports: 02/12/2021	Last EDR Contact: 03/03/2021
Number of Days to Update: 73	Next Scheduled EDR Contact: 06/14/2021
	Data Release Frequency: Quarterly

PROC: Certified Processors Database

A listing of certified processors.

Date of Government Version: 12/07/2020	Source: Department of Conservation
Date Data Arrived at EDR: 12/08/2020	Telephone: 916-323-3836
Date Made Active in Reports: 02/22/2021	Last EDR Contact: 12/08/2020
Number of Days to Update: 76	Next Scheduled EDR Contact: 03/22/2021
	Data Release Frequency: Quarterly

NOTIFY 65: Proposition 65 Records

Listings of all Proposition 65 incidents reported to counties by the State Water Resources Control Board and the Regional Water Quality Control Board. This database is no longer updated by the reporting agency.

Date of Government Version: 12/07/2020	Source: State Water Resources Control Board
Date Data Arrived at EDR: 12/09/2020	Telephone: 916-445-3846
Date Made Active in Reports: 12/10/2020	Last EDR Contact: 12/07/2020
Number of Days to Update: 1	Next Scheduled EDR Contact: 03/29/2021
	Data Release Frequency: No Update Planned

UIC: UIC Listing

A listing of wells identified as underground injection wells, in the California Oil and Gas Wells database.

Date of Government Version: 02/01/2021	Source: Department of Conservation
Date Data Arrived at EDR: 02/19/2021	Telephone: 916-445-2408
Date Made Active in Reports: 02/22/2021	Last EDR Contact: 02/18/2021
Number of Days to Update: 3	Next Scheduled EDR Contact: 03/22/2021
	Data Release Frequency: Varies

GOVERNMENT RECORDS SEARCHED / DATA CURRENCY TRACKING

UIC GEO: Underground Injection Control Sites (GEOTRACKER)

Underground control injection sites

Date of Government Version: 12/04/2020
Date Data Arrived at EDR: 12/04/2020
Date Made Active in Reports: 02/18/2021
Number of Days to Update: 76

Source: State Water Resource Control Board
Telephone: 866-480-1028
Last EDR Contact: 12/04/2020
Next Scheduled EDR Contact: 03/22/2021
Data Release Frequency: Varies

WASTEWATER PITS: Oil Wastewater Pits Listing

Water officials discovered that oil producers have been dumping chemical-laden wastewater into hundreds of unlined pits that are operating without proper permits. Inspections completed by the Central Valley Regional Water Quality Control Board revealed the existence of previously unidentified waste sites. The water boards review found that more than one-third of the region's active disposal pits are operating without permission.

Date of Government Version: 11/19/2019
Date Data Arrived at EDR: 01/07/2020
Date Made Active in Reports: 03/09/2020
Number of Days to Update: 62

Source: RWQCB, Central Valley Region
Telephone: 559-445-5577
Last EDR Contact: 01/08/2021
Next Scheduled EDR Contact: 04/19/2021
Data Release Frequency: Varies

WDS: Waste Discharge System

Sites which have been issued waste discharge requirements.

Date of Government Version: 06/19/2007
Date Data Arrived at EDR: 06/20/2007
Date Made Active in Reports: 06/29/2007
Number of Days to Update: 9

Source: State Water Resources Control Board
Telephone: 916-341-5227
Last EDR Contact: 02/16/2021
Next Scheduled EDR Contact: 05/31/2021
Data Release Frequency: No Update Planned

WIP: Well Investigation Program Case List

Well Investigation Program case in the San Gabriel and San Fernando Valley area.

Date of Government Version: 07/03/2009
Date Data Arrived at EDR: 07/21/2009
Date Made Active in Reports: 08/03/2009
Number of Days to Update: 13

Source: Los Angeles Water Quality Control Board
Telephone: 213-576-6726
Last EDR Contact: 12/15/2020
Next Scheduled EDR Contact: 04/05/2021
Data Release Frequency: No Update Planned

MILITARY PRIV SITES: Military Privatized Sites (GEOTRACKER)

Military privatized sites

Date of Government Version: 12/04/2020
Date Data Arrived at EDR: 12/04/2020
Date Made Active in Reports: 02/18/2021
Number of Days to Update: 76

Source: State Water Resources Control Board
Telephone: 866-480-1028
Last EDR Contact: 12/04/2020
Next Scheduled EDR Contact: 03/22/2021
Data Release Frequency: Varies

PROJECT: Project Sites (GEOTRACKER)

Projects sites

Date of Government Version: 12/04/2020
Date Data Arrived at EDR: 12/04/2020
Date Made Active in Reports: 02/18/2021
Number of Days to Update: 76

Source: State Water Resources Control Board
Telephone: 866-480-1028
Last EDR Contact: 12/04/2020
Next Scheduled EDR Contact: 03/22/2021
Data Release Frequency: Varies

WDR: Waste Discharge Requirements Listing

In general, the Waste Discharge Requirements (WDRs) Program (sometimes also referred to as the "Non Chapter 15 (Non 15) Program") regulates point discharges that are exempt pursuant to Subsection 20090 of Title 27 and not subject to the Federal Water Pollution Control Act. Exemptions from Title 27 may be granted for nine categories of discharges (e.g., sewage, wastewater, etc.) that meet, and continue to meet, the preconditions listed for each specific exemption. The scope of the WDRs Program also includes the discharge of wastes classified as inert, pursuant to section 20230 of Title 27.

GOVERNMENT RECORDS SEARCHED / DATA CURRENCY TRACKING

Date of Government Version: 12/07/2020
Date Data Arrived at EDR: 12/08/2020
Date Made Active in Reports: 02/22/2021
Number of Days to Update: 76

Source: State Water Resources Control Board
Telephone: 916-341-5810
Last EDR Contact: 12/08/2020
Next Scheduled EDR Contact: 03/22/2021
Data Release Frequency: Quarterly

CIWQS: California Integrated Water Quality System

The California Integrated Water Quality System (CIWQS) is a computer system used by the State and Regional Water Quality Control Boards to track information about places of environmental interest, manage permits and other orders, track inspections, and manage violations and enforcement activities.

Date of Government Version: 11/30/2020
Date Data Arrived at EDR: 12/01/2020
Date Made Active in Reports: 02/12/2021
Number of Days to Update: 73

Source: State Water Resources Control Board
Telephone: 866-794-4977
Last EDR Contact: 03/03/2021
Next Scheduled EDR Contact: 06/14/2021
Data Release Frequency: Varies

CERS: CalEPA Regulated Site Portal Data

The CalEPA Regulated Site Portal database combines data about environmentally regulated sites and facilities in California into a single database. It combines data from a variety of state and federal databases, and provides an overview of regulated activities across the spectrum of environmental programs for any given location in California. These activities include hazardous materials and waste, state and federal cleanups, impacted ground and surface waters, and toxic materials

Date of Government Version: 10/19/2020
Date Data Arrived at EDR: 10/19/2020
Date Made Active in Reports: 01/07/2021
Number of Days to Update: 80

Source: California Environmental Protection Agency
Telephone: 916-323-2514
Last EDR Contact: 01/20/2021
Next Scheduled EDR Contact: 05/03/2021
Data Release Frequency: Varies

NON-CASE INFO: Non-Case Information Sites (GEOTRACKER)

Non-Case Information sites

Date of Government Version: 12/04/2020
Date Data Arrived at EDR: 12/04/2020
Date Made Active in Reports: 02/18/2021
Number of Days to Update: 76

Source: State Water Resources Control Board
Telephone: 866-480-1028
Last EDR Contact: 12/04/2020
Next Scheduled EDR Contact: 03/22/2021
Data Release Frequency: Varies

OTHER OIL GAS: Other Oil & Gas Projects Sites (GEOTRACKER)

Other Oil & Gas Projects sites

Date of Government Version: 12/04/2020
Date Data Arrived at EDR: 12/04/2020
Date Made Active in Reports: 02/18/2021
Number of Days to Update: 76

Source: State Water Resources Control Board
Telephone: 866-480-1028
Last EDR Contact: 12/04/2020
Next Scheduled EDR Contact: 03/22/2021
Data Release Frequency: Varies

PROD WATER PONDS: Produced Water Ponds Sites (GEOTRACKER)

Produced water ponds sites

Date of Government Version: 12/04/2020
Date Data Arrived at EDR: 12/04/2020
Date Made Active in Reports: 02/18/2021
Number of Days to Update: 76

Source: State Water Resources Control Board
Telephone: 866-480-1028
Last EDR Contact: 12/04/2020
Next Scheduled EDR Contact: 03/22/2021
Data Release Frequency: Varies

SAMPLING POINT: Sampling Point ? Public Sites (GEOTRACKER)

Sampling point - public sites

GOVERNMENT RECORDS SEARCHED / DATA CURRENCY TRACKING

Date of Government Version: 12/04/2020
Date Data Arrived at EDR: 12/04/2020
Date Made Active in Reports: 02/18/2021
Number of Days to Update: 76

Source: State Water Resources Control Board
Telephone: 866-480-1028
Last EDR Contact: 12/04/2020
Next Scheduled EDR Contact: 03/22/2021
Data Release Frequency: Varies

WELL STIM PROJ: Well Stimulation Project (GEOTRACKER)

Includes areas of groundwater monitoring plans, a depiction of the monitoring network, and the facilities, boundaries, and subsurface characteristics of the oilfield and the features (oil and gas wells, produced water ponds, UIC wells, water supply wells, etc?) being monitored

Date of Government Version: 12/04/2020
Date Data Arrived at EDR: 12/04/2020
Date Made Active in Reports: 02/18/2021
Number of Days to Update: 76

Source: State Water Resources Control Board
Telephone: 866-480-1028
Last EDR Contact: 12/04/2020
Next Scheduled EDR Contact: 03/22/2021
Data Release Frequency: Varies

PCS ENF: Enforcement data

No description is available for this data

Date of Government Version: 12/31/2014
Date Data Arrived at EDR: 02/05/2015
Date Made Active in Reports: 03/06/2015
Number of Days to Update: 29

Source: EPA
Telephone: 202-564-2497
Last EDR Contact: 12/30/2020
Next Scheduled EDR Contact: 04/19/2021
Data Release Frequency: Varies

HWTS: Hazardous Waste Tracking System

DTSC maintains the Hazardous Waste Tracking System that stores ID number information since the early 1980s and manifest data since 1993. The system collects both manifest copies from the generator and destination facility.

Date of Government Version: 10/13/2020
Date Data Arrived at EDR: 10/14/2020
Date Made Active in Reports: 11/03/2020
Number of Days to Update: 20

Source: Department of Toxic Substances Control
Telephone: 916-324-2444
Last EDR Contact: 01/19/2021
Next Scheduled EDR Contact: 04/19/2021
Data Release Frequency: Varies

PCS: Permit Compliance System

PCS is a computerized management information system that contains data on National Pollutant Discharge Elimination System (NPDES) permit holding facilities. PCS tracks the permit, compliance, and enforcement status of NPDES facilities.

Date of Government Version: 07/14/2011
Date Data Arrived at EDR: 08/05/2011
Date Made Active in Reports: 09/29/2011
Number of Days to Update: 55

Source: EPA, Office of Water
Telephone: 202-564-2496
Last EDR Contact: 01/04/2021
Next Scheduled EDR Contact: 04/19/2021
Data Release Frequency: Semi-Annually

PCS INACTIVE: Listing of Inactive PCS Permits

An inactive permit is a facility that has shut down or is no longer discharging.

Date of Government Version: 11/05/2014
Date Data Arrived at EDR: 01/06/2015
Date Made Active in Reports: 05/06/2015
Number of Days to Update: 120

Source: EPA
Telephone: 202-564-2496
Last EDR Contact: 01/04/2021
Next Scheduled EDR Contact: 04/19/2021
Data Release Frequency: Semi-Annually

MINES MRDS: Mineral Resources Data System

Mineral Resources Data System

GOVERNMENT RECORDS SEARCHED / DATA CURRENCY TRACKING

Date of Government Version: 04/06/2018
Date Data Arrived at EDR: 10/21/2019
Date Made Active in Reports: 10/24/2019
Number of Days to Update: 3

Source: USGS
Telephone: 703-648-6533
Last EDR Contact: 02/26/2021
Next Scheduled EDR Contact: 09/10/2018
Data Release Frequency: Varies

EDR HIGH RISK HISTORICAL RECORDS

EDR Exclusive Records

EDR MGP: EDR Proprietary Manufactured Gas Plants

The EDR Proprietary Manufactured Gas Plant Database includes records of coal gas plants (manufactured gas plants) compiled by EDR's researchers. Manufactured gas sites were used in the United States from the 1800's to 1950's to produce a gas that could be distributed and used as fuel. These plants used whale oil, rosin, coal, or a mixture of coal, oil, and water that also produced a significant amount of waste. Many of the byproducts of the gas production, such as coal tar (oily waste containing volatile and non-volatile chemicals), sludges, oils and other compounds are potentially hazardous to human health and the environment. The byproduct from this process was frequently disposed of directly at the plant site and can remain or spread slowly, serving as a continuous source of soil and groundwater contamination.

Date of Government Version: N/A
Date Data Arrived at EDR: N/A
Date Made Active in Reports: N/A
Number of Days to Update: N/A

Source: EDR, Inc.
Telephone: N/A
Last EDR Contact: N/A
Next Scheduled EDR Contact: N/A
Data Release Frequency: No Update Planned

EDR Hist Auto: EDR Exclusive Historical Auto Stations

EDR has searched selected national collections of business directories and has collected listings of potential gas station/filling station/service station sites that were available to EDR researchers. EDR's review was limited to those categories of sources that might, in EDR's opinion, include gas station/filling station/service station establishments. The categories reviewed included, but were not limited to gas, gas station, gasoline station, filling station, auto, automobile repair, auto service station, service station, etc. This database falls within a category of information EDR classifies as "High Risk Historical Records", or HRHR. EDR's HRHR effort presents unique and sometimes proprietary data about past sites and operations that typically create environmental concerns, but may not show up in current government records searches.

Date of Government Version: N/A
Date Data Arrived at EDR: N/A
Date Made Active in Reports: N/A
Number of Days to Update: N/A

Source: EDR, Inc.
Telephone: N/A
Last EDR Contact: N/A
Next Scheduled EDR Contact: N/A
Data Release Frequency: Varies

EDR Hist Cleaner: EDR Exclusive Historical Cleaners

EDR has searched selected national collections of business directories and has collected listings of potential dry cleaner sites that were available to EDR researchers. EDR's review was limited to those categories of sources that might, in EDR's opinion, include dry cleaning establishments. The categories reviewed included, but were not limited to dry cleaners, cleaners, laundry, laundromat, cleaning/laundry, wash & dry etc. This database falls within a category of information EDR classifies as "High Risk Historical Records", or HRHR. EDR's HRHR effort presents unique and sometimes proprietary data about past sites and operations that typically create environmental concerns, but may not show up in current government records searches.

Date of Government Version: N/A
Date Data Arrived at EDR: N/A
Date Made Active in Reports: N/A
Number of Days to Update: N/A

Source: EDR, Inc.
Telephone: N/A
Last EDR Contact: N/A
Next Scheduled EDR Contact: N/A
Data Release Frequency: Varies

EDR RECOVERED GOVERNMENT ARCHIVES

Exclusive Recovered Govt. Archives

GOVERNMENT RECORDS SEARCHED / DATA CURRENCY TRACKING

RGA LF: Recovered Government Archive Solid Waste Facilities List

The EDR Recovered Government Archive Landfill database provides a list of landfills derived from historical databases and includes many records that no longer appear in current government lists. Compiled from Records formerly available from the Department of Resources Recycling and Recovery in California.

Date of Government Version: N/A	Source: Department of Resources Recycling and Recovery
Date Data Arrived at EDR: 07/01/2013	Telephone: N/A
Date Made Active in Reports: 01/13/2014	Last EDR Contact: 06/01/2012
Number of Days to Update: 196	Next Scheduled EDR Contact: N/A
	Data Release Frequency: Varies

RGA LUST: Recovered Government Archive Leaking Underground Storage Tank

The EDR Recovered Government Archive Leaking Underground Storage Tank database provides a list of LUST incidents derived from historical databases and includes many records that no longer appear in current government lists. Compiled from Records formerly available from the State Water Resources Control Board in California.

Date of Government Version: N/A	Source: State Water Resources Control Board
Date Data Arrived at EDR: 07/01/2013	Telephone: N/A
Date Made Active in Reports: 12/30/2013	Last EDR Contact: 06/01/2012
Number of Days to Update: 182	Next Scheduled EDR Contact: N/A
	Data Release Frequency: Varies

COUNTY RECORDS

ALAMEDA COUNTY:

CS ALAMEDA: Contaminated Sites

A listing of contaminated sites overseen by the Toxic Release Program (oil and groundwater contamination from chemical releases and spills) and the Leaking Underground Storage Tank Program (soil and ground water contamination from leaking petroleum USTs).

Date of Government Version: 01/09/2019	Source: Alameda County Environmental Health Services
Date Data Arrived at EDR: 01/11/2019	Telephone: 510-567-6700
Date Made Active in Reports: 03/05/2019	Last EDR Contact: 01/04/2021
Number of Days to Update: 53	Next Scheduled EDR Contact: 04/19/2021
	Data Release Frequency: Semi-Annually

UST ALAMEDA: Underground Tanks

Underground storage tank sites located in Alameda county.

Date of Government Version: 10/01/2020	Source: Alameda County Environmental Health Services
Date Data Arrived at EDR: 10/06/2020	Telephone: 510-567-6700
Date Made Active in Reports: 12/23/2020	Last EDR Contact: 01/04/2021
Number of Days to Update: 78	Next Scheduled EDR Contact: 04/19/2021
	Data Release Frequency: Semi-Annually

AMADOR COUNTY:

CUPA AMADOR: CUPA Facility List

Cupa Facility List

Date of Government Version: 10/19/2020	Source: Amador County Environmental Health
Date Data Arrived at EDR: 10/22/2020	Telephone: 209-223-6439
Date Made Active in Reports: 01/12/2021	Last EDR Contact: 02/01/2021
Number of Days to Update: 82	Next Scheduled EDR Contact: 05/17/2021
	Data Release Frequency: Varies

BUTTE COUNTY:

GOVERNMENT RECORDS SEARCHED / DATA CURRENCY TRACKING

CUPA BUTTE: CUPA Facility Listing
Cupa facility list.

Date of Government Version: 04/21/2017
Date Data Arrived at EDR: 04/25/2017
Date Made Active in Reports: 08/09/2017
Number of Days to Update: 106

Source: Public Health Department
Telephone: 530-538-7149
Last EDR Contact: 12/30/2020
Next Scheduled EDR Contact: 04/19/2021
Data Release Frequency: No Update Planned

CALVERAS COUNTY:

CUPA CALVERAS: CUPA Facility Listing
Cupa Facility Listing

Date of Government Version: 12/15/2020
Date Data Arrived at EDR: 12/16/2020
Date Made Active in Reports: 12/24/2020
Number of Days to Update: 8

Source: Calveras County Environmental Health
Telephone: 209-754-6399
Last EDR Contact: 12/15/2020
Next Scheduled EDR Contact: 04/05/2021
Data Release Frequency: Quarterly

COLUSA COUNTY:

CUPA COLUSA: CUPA Facility List
Cupa facility list.

Date of Government Version: 04/06/2020
Date Data Arrived at EDR: 04/23/2020
Date Made Active in Reports: 07/10/2020
Number of Days to Update: 78

Source: Health & Human Services
Telephone: 530-458-0396
Last EDR Contact: 02/26/2021
Next Scheduled EDR Contact: 05/17/2021
Data Release Frequency: Semi-Annually

CONTRA COSTA COUNTY:

SL CONTRA COSTA: Site List

List includes sites from the underground tank, hazardous waste generator and business plan/2185 programs.

Date of Government Version: 10/19/2020
Date Data Arrived at EDR: 10/22/2020
Date Made Active in Reports: 01/13/2021
Number of Days to Update: 83

Source: Contra Costa Health Services Department
Telephone: 925-646-2286
Last EDR Contact: 01/25/2021
Next Scheduled EDR Contact: 05/10/2021
Data Release Frequency: Semi-Annually

DEL NORTE COUNTY:

CUPA DEL NORTE: CUPA Facility List
Cupa Facility list

Date of Government Version: 06/08/2020
Date Data Arrived at EDR: 08/13/2020
Date Made Active in Reports: 10/22/2020
Number of Days to Update: 70

Source: Del Norte County Environmental Health Division
Telephone: 707-465-0426
Last EDR Contact: 01/25/2021
Next Scheduled EDR Contact: 05/10/2021
Data Release Frequency: Varies

EL DORADO COUNTY:

GOVERNMENT RECORDS SEARCHED / DATA CURRENCY TRACKING

CUPA EL DORADO: CUPA Facility List CUPA facility list.

Date of Government Version: 10/22/2020
Date Data Arrived at EDR: 11/03/2020
Date Made Active in Reports: 01/20/2021
Number of Days to Update: 78

Source: El Dorado County Environmental Management Department
Telephone: 530-621-6623
Last EDR Contact: 02/08/2021
Next Scheduled EDR Contact: 05/10/2021
Data Release Frequency: Varies

FRESNO COUNTY:

CUPA FRESNO: CUPA Resources List

Certified Unified Program Agency. CUPA's are responsible for implementing a unified hazardous materials and hazardous waste management regulatory program. The agency provides oversight of businesses that deal with hazardous materials, operate underground storage tanks or aboveground storage tanks.

Date of Government Version: 10/02/2020
Date Data Arrived at EDR: 10/06/2020
Date Made Active in Reports: 12/22/2020
Number of Days to Update: 77

Source: Dept. of Community Health
Telephone: 559-445-3271
Last EDR Contact: 01/15/2021
Next Scheduled EDR Contact: 04/12/2021
Data Release Frequency: Semi-Annually

GLENN COUNTY:

CUPA GLENN: CUPA Facility List Cupa facility list

Date of Government Version: 01/22/2018
Date Data Arrived at EDR: 01/24/2018
Date Made Active in Reports: 03/14/2018
Number of Days to Update: 49

Source: Glenn County Air Pollution Control District
Telephone: 830-934-6500
Last EDR Contact: 01/19/2021
Next Scheduled EDR Contact: 05/03/2021
Data Release Frequency: No Update Planned

HUMBOLDT COUNTY:

CUPA HUMBOLDT: CUPA Facility List CUPA facility list.

Date of Government Version: 11/18/2020
Date Data Arrived at EDR: 11/19/2020
Date Made Active in Reports: 02/04/2021
Number of Days to Update: 77

Source: Humboldt County Environmental Health
Telephone: N/A
Last EDR Contact: 02/16/2021
Next Scheduled EDR Contact: 05/31/2021
Data Release Frequency: Semi-Annually

IMPERIAL COUNTY:

CUPA IMPERIAL: CUPA Facility List Cupa facility list.

Date of Government Version: 10/14/2020
Date Data Arrived at EDR: 10/15/2020
Date Made Active in Reports: 01/05/2021
Number of Days to Update: 82

Source: San Diego Border Field Office
Telephone: 760-339-2777
Last EDR Contact: 01/19/2021
Next Scheduled EDR Contact: 05/03/2021
Data Release Frequency: Varies

INYO COUNTY:

GOVERNMENT RECORDS SEARCHED / DATA CURRENCY TRACKING

CUPA INYO: CUPA Facility List Cupa facility list.

Date of Government Version: 04/02/2018
Date Data Arrived at EDR: 04/03/2018
Date Made Active in Reports: 06/14/2018
Number of Days to Update: 72

Source: Inyo County Environmental Health Services
Telephone: 760-878-0238
Last EDR Contact: 02/16/2021
Next Scheduled EDR Contact: 05/31/2021
Data Release Frequency: Varies

KERN COUNTY:

CUPA KERN: CUPA Facility List

A listing of sites included in the Kern County Hazardous Material Business Plan.

Date of Government Version: 10/29/2020
Date Data Arrived at EDR: 10/30/2020
Date Made Active in Reports: 01/15/2021
Number of Days to Update: 77

Source: Kern County Public Health
Telephone: 661-321-3000
Last EDR Contact: 02/01/2021
Next Scheduled EDR Contact: 05/17/2021
Data Release Frequency: Varies

UST KERN: Underground Storage Tank Sites & Tank Listing Kern County Sites and Tanks Listing.

Date of Government Version: 01/19/2021
Date Data Arrived at EDR: 01/21/2021
Date Made Active in Reports: 01/28/2021
Number of Days to Update: 7

Source: Kern County Environment Health Services Department
Telephone: 661-862-8700
Last EDR Contact: 02/01/2021
Next Scheduled EDR Contact: 05/17/2021
Data Release Frequency: Quarterly

KINGS COUNTY:

CUPA KINGS: CUPA Facility List

A listing of sites included in the county's Certified Unified Program Agency database. California's Secretary for Environmental Protection established the unified hazardous materials and hazardous waste regulatory program as required by chapter 6.11 of the California Health and Safety Code. The Unified Program consolidates the administration, permits, inspections, and enforcement activities.

Date of Government Version: 05/11/2020
Date Data Arrived at EDR: 05/12/2020
Date Made Active in Reports: 07/27/2020
Number of Days to Update: 76

Source: Kings County Department of Public Health
Telephone: 559-584-1411
Last EDR Contact: 02/16/2021
Next Scheduled EDR Contact: 05/31/2021
Data Release Frequency: Varies

LAKE COUNTY:

CUPA LAKE: CUPA Facility List Cupa facility list

Date of Government Version: 08/13/2020
Date Data Arrived at EDR: 08/13/2020
Date Made Active in Reports: 10/23/2020
Number of Days to Update: 71

Source: Lake County Environmental Health
Telephone: 707-263-1164
Last EDR Contact: 01/11/2021
Next Scheduled EDR Contact: 04/26/2021
Data Release Frequency: Varies

LASSEN COUNTY:

GOVERNMENT RECORDS SEARCHED / DATA CURRENCY TRACKING

CUPA LASSEN: CUPA Facility List Cupa facility list

Date of Government Version: 07/31/2020
Date Data Arrived at EDR: 08/21/2020
Date Made Active in Reports: 11/09/2020
Number of Days to Update: 80

Source: Lassen County Environmental Health
Telephone: 530-251-8528
Last EDR Contact: 02/26/2021
Next Scheduled EDR Contact: 05/03/2021
Data Release Frequency: Varies

LOS ANGELES COUNTY:

AOCONCERN: Key Areas of Concerns in Los Angeles County

San Gabriel Valley areas where VOC contamination is at or above the MCL as designated by region 9 EPA office. Date of Government Version: 3/30/2009 Exide Site area is a cleanup plan of lead-impacted soil surrounding the former Exide Facility as designated by the DTSC. Date of Government Version: 7/17/2017

Date of Government Version: 03/30/2009
Date Data Arrived at EDR: 03/31/2009
Date Made Active in Reports: 10/23/2009
Number of Days to Update: 206

Source: N/A
Telephone: N/A
Last EDR Contact: 12/09/2020
Next Scheduled EDR Contact: 03/29/2021
Data Release Frequency: No Update Planned

HMS LOS ANGELES: HMS: Street Number List

Industrial Waste and Underground Storage Tank Sites.

Date of Government Version: 10/19/2020
Date Data Arrived at EDR: 10/20/2020
Date Made Active in Reports: 01/12/2021
Number of Days to Update: 84

Source: Department of Public Works
Telephone: 626-458-3517
Last EDR Contact: 01/04/2021
Next Scheduled EDR Contact: 04/19/2021
Data Release Frequency: Semi-Annually

LF LOS ANGELES: List of Solid Waste Facilities

Solid Waste Facilities in Los Angeles County.

Date of Government Version: 10/09/2020
Date Data Arrived at EDR: 10/09/2020
Date Made Active in Reports: 12/29/2020
Number of Days to Update: 81

Source: La County Department of Public Works
Telephone: 818-458-5185
Last EDR Contact: 01/12/2021
Next Scheduled EDR Contact: 04/26/2021
Data Release Frequency: Varies

LF LOS ANGELES CITY: City of Los Angeles Landfills

Landfills owned and maintained by the City of Los Angeles.

Date of Government Version: 12/31/2019
Date Data Arrived at EDR: 08/17/2020
Date Made Active in Reports: 11/05/2020
Number of Days to Update: 80

Source: Engineering & Construction Division
Telephone: 213-473-7869
Last EDR Contact: 01/11/2021
Next Scheduled EDR Contact: 04/26/2021
Data Release Frequency: Varies

LOS ANGELES AST: Active & Inactive AST Inventory

A listing of active & inactive above ground petroleum storage tank site locations, located in the City of Los Angeles.

Date of Government Version: 06/01/2019
Date Data Arrived at EDR: 06/25/2019
Date Made Active in Reports: 08/22/2019
Number of Days to Update: 58

Source: Los Angeles Fire Department
Telephone: 213-978-3800
Last EDR Contact: 12/18/2020
Next Scheduled EDR Contact: 04/05/2021
Data Release Frequency: Varies

GOVERNMENT RECORDS SEARCHED / DATA CURRENCY TRACKING

LOS ANGELES CO LF METHANE: Methane Producing Landfills

This data was created on April 30, 2012 to represent known disposal sites in Los Angeles County that may produce and emanate methane gas. The shapefile contains disposal sites within Los Angeles County that once accepted degradable refuse material. Information used to create this data was extracted from a landfill survey performed by County Engineers (Major Waste System Map, 1973) as well as historical records from CalRecycle, Regional Water Quality Control Board, and Los Angeles County Department of Public Health

Date of Government Version: 04/30/2012	Source: Los Angeles County Department of Public Works
Date Data Arrived at EDR: 04/17/2019	Telephone: 626-458-6973
Date Made Active in Reports: 05/29/2019	Last EDR Contact: 01/15/2021
Number of Days to Update: 42	Next Scheduled EDR Contact: 04/26/2021
	Data Release Frequency: No Update Planned

LOS ANGELES HM: Active & Inactive Hazardous Materials Inventory

A listing of active & inactive hazardous materials facility locations, located in the City of Los Angeles.

Date of Government Version: 06/01/2019	Source: Los Angeles Fire Department
Date Data Arrived at EDR: 06/25/2019	Telephone: 213-978-3800
Date Made Active in Reports: 08/22/2019	Last EDR Contact: 12/18/2020
Number of Days to Update: 58	Next Scheduled EDR Contact: 04/05/2021
	Data Release Frequency: Varies

LOS ANGELES UST: Active & Inactive UST Inventory

A listing of active & inactive underground storage tank site locations and underground storage tank historical sites, located in the City of Los Angeles.

Date of Government Version: 06/01/2019	Source: Los Angeles Fire Department
Date Data Arrived at EDR: 06/25/2019	Telephone: 213-978-3800
Date Made Active in Reports: 08/22/2019	Last EDR Contact: 12/18/2020
Number of Days to Update: 58	Next Scheduled EDR Contact: 04/05/2021
	Data Release Frequency: Varies

SITE MIT LOS ANGELES: Site Mitigation List

Industrial sites that have had some sort of spill or complaint.

Date of Government Version: 07/20/2020	Source: Community Health Services
Date Data Arrived at EDR: 10/09/2020	Telephone: 323-890-7806
Date Made Active in Reports: 12/29/2020	Last EDR Contact: 01/12/2021
Number of Days to Update: 81	Next Scheduled EDR Contact: 04/26/2021
	Data Release Frequency: Annually

UST EL SEGUNDO: City of El Segundo Underground Storage Tank

Underground storage tank sites located in El Segundo city.

Date of Government Version: 01/21/2017	Source: City of El Segundo Fire Department
Date Data Arrived at EDR: 04/19/2017	Telephone: 310-524-2236
Date Made Active in Reports: 05/10/2017	Last EDR Contact: 10/07/2020
Number of Days to Update: 21	Next Scheduled EDR Contact: 01/25/2021
	Data Release Frequency: No Update Planned

UST LONG BEACH: City of Long Beach Underground Storage Tank

Underground storage tank sites located in the city of Long Beach.

Date of Government Version: 04/22/2019	Source: City of Long Beach Fire Department
Date Data Arrived at EDR: 04/23/2019	Telephone: 562-570-2563
Date Made Active in Reports: 06/27/2019	Last EDR Contact: 01/19/2021
Number of Days to Update: 65	Next Scheduled EDR Contact: 05/03/2021
	Data Release Frequency: Varies

GOVERNMENT RECORDS SEARCHED / DATA CURRENCY TRACKING

UST TORRANCE: City of Torrance Underground Storage Tank
Underground storage tank sites located in the city of Torrance.

Date of Government Version: 09/11/2020	Source: City of Torrance Fire Department
Date Data Arrived at EDR: 10/07/2020	Telephone: 310-618-2973
Date Made Active in Reports: 12/23/2020	Last EDR Contact: 01/19/2021
Number of Days to Update: 77	Next Scheduled EDR Contact: 05/03/2021
	Data Release Frequency: Semi-Annually

MADERA COUNTY:

CUPA MADERA: CUPA Facility List

A listing of sites included in the county's Certified Unified Program Agency database. California's Secretary for Environmental Protection established the unified hazardous materials and hazardous waste regulatory program as required by chapter 6.11 of the California Health and Safety Code. The Unified Program consolidates the administration, permits, inspections, and enforcement activities.

Date of Government Version: 08/10/2020	Source: Madera County Environmental Health
Date Data Arrived at EDR: 08/12/2020	Telephone: 559-675-7823
Date Made Active in Reports: 10/23/2020	Last EDR Contact: 02/16/2021
Number of Days to Update: 72	Next Scheduled EDR Contact: 05/31/2021
	Data Release Frequency: Varies

MARIN COUNTY:

UST MARIN: Underground Storage Tank Sites
Currently permitted USTs in Marin County.

Date of Government Version: 09/26/2018	Source: Public Works Department Waste Management
Date Data Arrived at EDR: 10/04/2018	Telephone: 415-473-6647
Date Made Active in Reports: 11/02/2018	Last EDR Contact: 12/21/2020
Number of Days to Update: 29	Next Scheduled EDR Contact: 04/12/2021
	Data Release Frequency: Semi-Annually

MERCED COUNTY:

CUPA MERCED: CUPA Facility List

CUPA facility list.

Date of Government Version: 02/04/2021	Source: Merced County Environmental Health
Date Data Arrived at EDR: 02/09/2021	Telephone: 209-381-1094
Date Made Active in Reports: 02/18/2021	Last EDR Contact: 01/29/2021
Number of Days to Update: 9	Next Scheduled EDR Contact: 05/31/2021
	Data Release Frequency: Varies

MONO COUNTY:

CUPA MONO: CUPA Facility List

CUPA Facility List

Date of Government Version: 11/16/2020	Source: Mono County Health Department
Date Data Arrived at EDR: 11/23/2020	Telephone: 760-932-5580
Date Made Active in Reports: 02/08/2021	Last EDR Contact: 02/22/2021
Number of Days to Update: 77	Next Scheduled EDR Contact: 06/06/3021
	Data Release Frequency: Varies

MONTEREY COUNTY:

GOVERNMENT RECORDS SEARCHED / DATA CURRENCY TRACKING

CUPA MONTEREY: CUPA Facility Listing

CUPA Program listing from the Environmental Health Division.

Date of Government Version: 07/13/2020
Date Data Arrived at EDR: 07/15/2020
Date Made Active in Reports: 07/31/2020
Number of Days to Update: 16

Source: Monterey County Health Department
Telephone: 831-796-1297
Last EDR Contact: 12/21/2020
Next Scheduled EDR Contact: 04/12/2021
Data Release Frequency: Varies

NAPA COUNTY:

LUST NAPA: Sites With Reported Contamination

A listing of leaking underground storage tank sites located in Napa county.

Date of Government Version: 01/09/2017
Date Data Arrived at EDR: 01/11/2017
Date Made Active in Reports: 03/02/2017
Number of Days to Update: 50

Source: Napa County Department of Environmental Management
Telephone: 707-253-4269
Last EDR Contact: 02/22/2021
Next Scheduled EDR Contact: 06/06/2021
Data Release Frequency: No Update Planned

UST NAPA: Closed and Operating Underground Storage Tank Sites

Underground storage tank sites located in Napa county.

Date of Government Version: 09/05/2019
Date Data Arrived at EDR: 09/09/2019
Date Made Active in Reports: 10/31/2019
Number of Days to Update: 52

Source: Napa County Department of Environmental Management
Telephone: 707-253-4269
Last EDR Contact: 02/22/2021
Next Scheduled EDR Contact: 06/06/2021
Data Release Frequency: No Update Planned

NEVADA COUNTY:

CUPA NEVADA: CUPA Facility List

CUPA facility list.

Date of Government Version: 10/26/2020
Date Data Arrived at EDR: 10/28/2020
Date Made Active in Reports: 01/15/2021
Number of Days to Update: 79

Source: Community Development Agency
Telephone: 530-265-1467
Last EDR Contact: 01/25/2021
Next Scheduled EDR Contact: 05/10/2021
Data Release Frequency: Varies

ORANGE COUNTY:

IND_SITE ORANGE: List of Industrial Site Cleanups

Petroleum and non-petroleum spills.

Date of Government Version: 09/01/2020
Date Data Arrived at EDR: 11/05/2020
Date Made Active in Reports: 01/26/2021
Number of Days to Update: 82

Source: Health Care Agency
Telephone: 714-834-3446
Last EDR Contact: 02/01/2021
Next Scheduled EDR Contact: 05/17/2021
Data Release Frequency: Annually

LUST ORANGE: List of Underground Storage Tank Cleanups

Orange County Underground Storage Tank Cleanups (LUST).

Date of Government Version: 09/01/2020
Date Data Arrived at EDR: 11/06/2020
Date Made Active in Reports: 01/26/2021
Number of Days to Update: 81

Source: Health Care Agency
Telephone: 714-834-3446
Last EDR Contact: 02/05/2021
Next Scheduled EDR Contact: 05/17/2021
Data Release Frequency: Quarterly

GOVERNMENT RECORDS SEARCHED / DATA CURRENCY TRACKING

UST ORANGE: List of Underground Storage Tank Facilities

Orange County Underground Storage Tank Facilities (UST).

Date of Government Version: 09/01/2020
Date Data Arrived at EDR: 11/03/2020
Date Made Active in Reports: 01/21/2021
Number of Days to Update: 79

Source: Health Care Agency
Telephone: 714-834-3446
Last EDR Contact: 02/02/2021
Next Scheduled EDR Contact: 05/17/2021
Data Release Frequency: Quarterly

PLACER COUNTY:

MS PLACER: Master List of Facilities

List includes aboveground tanks, underground tanks and cleanup sites.

Date of Government Version: 11/24/2020
Date Data Arrived at EDR: 11/24/2020
Date Made Active in Reports: 11/25/2020
Number of Days to Update: 1

Source: Placer County Health and Human Services
Telephone: 530-745-2363
Last EDR Contact: 02/26/2021
Next Scheduled EDR Contact: 06/14/2021
Data Release Frequency: Semi-Annually

PLUMAS COUNTY:

CUPA PLUMAS: CUPA Facility List

Plumas County CUPA Program facilities.

Date of Government Version: 03/31/2019
Date Data Arrived at EDR: 04/23/2019
Date Made Active in Reports: 06/26/2019
Number of Days to Update: 64

Source: Plumas County Environmental Health
Telephone: 530-283-6355
Last EDR Contact: 01/19/2021
Next Scheduled EDR Contact: 05/03/2021
Data Release Frequency: Varies

RIVERSIDE COUNTY:

LUST RIVERSIDE: Listing of Underground Tank Cleanup Sites

Riverside County Underground Storage Tank Cleanup Sites (LUST).

Date of Government Version: 10/06/2020
Date Data Arrived at EDR: 10/07/2020
Date Made Active in Reports: 11/03/2020
Number of Days to Update: 27

Source: Department of Environmental Health
Telephone: 951-358-5055
Last EDR Contact: 12/09/2020
Next Scheduled EDR Contact: 03/29/2021
Data Release Frequency: Quarterly

UST RIVERSIDE: Underground Storage Tank Tank List

Underground storage tank sites located in Riverside county.

Date of Government Version: 10/06/2020
Date Data Arrived at EDR: 10/07/2020
Date Made Active in Reports: 11/03/2020
Number of Days to Update: 27

Source: Department of Environmental Health
Telephone: 951-358-5055
Last EDR Contact: 12/09/2020
Next Scheduled EDR Contact: 03/29/2021
Data Release Frequency: Quarterly

SACRAMENTO COUNTY:

CS SACRAMENTO: Toxic Site Clean-Up List

List of sites where unauthorized releases of potentially hazardous materials have occurred.

GOVERNMENT RECORDS SEARCHED / DATA CURRENCY TRACKING

Date of Government Version: 02/18/2020
Date Data Arrived at EDR: 03/31/2020
Date Made Active in Reports: 06/15/2020
Number of Days to Update: 76

Source: Sacramento County Environmental Management
Telephone: 916-875-8406
Last EDR Contact: 12/30/2020
Next Scheduled EDR Contact: 04/12/2021
Data Release Frequency: Quarterly

ML SACRAMENTO: Master Hazardous Materials Facility List

Any business that has hazardous materials on site - hazardous material storage sites, underground storage tanks, waste generators.

Date of Government Version: 02/24/2020
Date Data Arrived at EDR: 03/31/2020
Date Made Active in Reports: 06/17/2020
Number of Days to Update: 78

Source: Sacramento County Environmental Management
Telephone: 916-875-8406
Last EDR Contact: 12/30/2020
Next Scheduled EDR Contact: 04/12/2021
Data Release Frequency: Quarterly

SAN BENITO COUNTY:

CUPA SAN BENITO: CUPA Facility List

Cupa facility list

Date of Government Version: 10/28/2020
Date Data Arrived at EDR: 10/30/2020
Date Made Active in Reports: 01/15/2021
Number of Days to Update: 77

Source: San Benito County Environmental Health
Telephone: N/A
Last EDR Contact: 02/01/2021
Next Scheduled EDR Contact: 05/17/2021
Data Release Frequency: Varies

SAN BERNARDINO COUNTY:

PERMITS SAN BERNARDINO: Hazardous Material Permits

This listing includes underground storage tanks, medical waste handlers/generators, hazardous materials handlers, hazardous waste generators, and waste oil generators/handlers.

Date of Government Version: 11/16/2020
Date Data Arrived at EDR: 11/18/2020
Date Made Active in Reports: 02/04/2021
Number of Days to Update: 78

Source: San Bernardino County Fire Department Hazardous Materials Division
Telephone: 909-387-3041
Last EDR Contact: 02/01/2021
Next Scheduled EDR Contact: 05/17/2021
Data Release Frequency: Quarterly

SAN DIEGO COUNTY:

HMMD SAN DIEGO: Hazardous Materials Management Division Database

The database includes: HE58 - This report contains the business name, site address, business phone number, establishment 'H' permit number, type of permit, and the business status. HE17 - In addition to providing the same information provided in the HE58 listing, HE17 provides inspection dates, violations received by the establishment, hazardous waste generated, the quantity, method of storage, treatment/disposal of waste and the hauler, and information on underground storage tanks. Unauthorized Release List - Includes a summary of environmental contamination cases in San Diego County (underground tank cases, non-tank cases, groundwater contamination, and soil contamination are included.)

Date of Government Version: 11/30/2020
Date Data Arrived at EDR: 12/01/2020
Date Made Active in Reports: 02/16/2021
Number of Days to Update: 77

Source: Hazardous Materials Management Division
Telephone: 619-338-2268
Last EDR Contact: 03/03/2021
Next Scheduled EDR Contact: 03/15/2021
Data Release Frequency: Quarterly

GOVERNMENT RECORDS SEARCHED / DATA CURRENCY TRACKING

LF SAN DIEGO: Solid Waste Facilities

San Diego County Solid Waste Facilities.

Date of Government Version: 10/01/2020
Date Data Arrived at EDR: 11/23/2020
Date Made Active in Reports: 02/08/2021
Number of Days to Update: 77

Source: Department of Health Services
Telephone: 619-338-2209
Last EDR Contact: 01/19/2021
Next Scheduled EDR Contact: 05/03/2021
Data Release Frequency: Varies

SAN DIEGO CO LOP: Local Oversight Program Listing

A listing of all LOP release sites that are or were under the County of San Diego's jurisdiction. Included are closed or transferred cases, open cases, and cases that did not have a case type indicated. The cases without a case type are mostly complaints; however, some of them could be LOP cases.

Date of Government Version: 07/14/2020
Date Data Arrived at EDR: 07/16/2020
Date Made Active in Reports: 09/29/2020
Number of Days to Update: 75

Source: Department of Environmental Health
Telephone: 858-505-6874
Last EDR Contact: 02/01/2021
Next Scheduled EDR Contact: 05/03/2021
Data Release Frequency: Varies

SAN DIEGO CO SAM: Environmental Case Listing

The listing contains all underground tank release cases and projects pertaining to properties contaminated with hazardous substances that are actively under review by the Site Assessment and Mitigation Program.

Date of Government Version: 03/23/2010
Date Data Arrived at EDR: 06/15/2010
Date Made Active in Reports: 07/09/2010
Number of Days to Update: 24

Source: San Diego County Department of Environmental Health
Telephone: 619-338-2371
Last EDR Contact: 02/26/2021
Next Scheduled EDR Contact: 06/14/2021
Data Release Frequency: No Update Planned

SAN FRANCISCO COUNTY:

CUPA SAN FRANCISCO CO: CUPA Facility Listing

Cupa facilities

Date of Government Version: 11/05/2020
Date Data Arrived at EDR: 11/06/2020
Date Made Active in Reports: 01/27/2021
Number of Days to Update: 82

Source: San Francisco County Department of Environmental Health
Telephone: 415-252-3896
Last EDR Contact: 02/01/2021
Next Scheduled EDR Contact: 05/17/2021
Data Release Frequency: Varies

LUST SAN FRANCISCO: Local Oversight Facilities

A listing of leaking underground storage tank sites located in San Francisco county.

Date of Government Version: 09/19/2008
Date Data Arrived at EDR: 09/19/2008
Date Made Active in Reports: 09/29/2008
Number of Days to Update: 10

Source: Department Of Public Health San Francisco County
Telephone: 415-252-3920
Last EDR Contact: 02/01/2021
Next Scheduled EDR Contact: 05/17/2021
Data Release Frequency: No Update Planned

UST SAN FRANCISCO: Underground Storage Tank Information

Underground storage tank sites located in San Francisco county.

Date of Government Version: 11/05/2020
Date Data Arrived at EDR: 11/06/2020
Date Made Active in Reports: 01/26/2021
Number of Days to Update: 81

Source: Department of Public Health
Telephone: 415-252-3920
Last EDR Contact: 02/01/2021
Next Scheduled EDR Contact: 05/17/2021
Data Release Frequency: Quarterly

SAN JOAQUIN COUNTY:

GOVERNMENT RECORDS SEARCHED / DATA CURRENCY TRACKING

UST SAN JOAQUIN: San Joaquin Co. UST

A listing of underground storage tank locations in San Joaquin county.

Date of Government Version: 06/22/2018
Date Data Arrived at EDR: 06/26/2018
Date Made Active in Reports: 07/11/2018
Number of Days to Update: 15

Source: Environmental Health Department
Telephone: N/A
Last EDR Contact: 12/09/2020
Next Scheduled EDR Contact: 03/29/2021
Data Release Frequency: Semi-Annually

SAN LUIS OBISPO COUNTY:

CUPA SAN LUIS OBISPO: CUPA Facility List Cupa Facility List.

Date of Government Version: 11/12/2020
Date Data Arrived at EDR: 11/13/2020
Date Made Active in Reports: 02/01/2021
Number of Days to Update: 80

Source: San Luis Obispo County Public Health Department
Telephone: 805-781-5596
Last EDR Contact: 02/16/2021
Next Scheduled EDR Contact: 05/31/2021
Data Release Frequency: Varies

SAN MATEO COUNTY:

BI SAN MATEO: Business Inventory

List includes Hazardous Materials Business Plan, hazardous waste generators, and underground storage tanks.

Date of Government Version: 02/20/2020
Date Data Arrived at EDR: 02/20/2020
Date Made Active in Reports: 04/24/2020
Number of Days to Update: 64

Source: San Mateo County Environmental Health Services Division
Telephone: 650-363-1921
Last EDR Contact: 12/11/2020
Next Scheduled EDR Contact: 03/22/2021
Data Release Frequency: Annually

LUST SAN MATEO: Fuel Leak List

A listing of leaking underground storage tank sites located in San Mateo county.

Date of Government Version: 03/29/2019
Date Data Arrived at EDR: 03/29/2019
Date Made Active in Reports: 05/29/2019
Number of Days to Update: 61

Source: San Mateo County Environmental Health Services Division
Telephone: 650-363-1921
Last EDR Contact: 03/08/2021
Next Scheduled EDR Contact: 06/21/2021
Data Release Frequency: Semi-Annually

SANTA BARBARA COUNTY:

CUPA SANTA BARBARA: CUPA Facility Listing

CUPA Program Listing from the Environmental Health Services division.

Date of Government Version: 09/08/2011
Date Data Arrived at EDR: 09/09/2011
Date Made Active in Reports: 10/07/2011
Number of Days to Update: 28

Source: Santa Barbara County Public Health Department
Telephone: 805-686-8167
Last EDR Contact: 02/16/2021
Next Scheduled EDR Contact: 05/31/2021
Data Release Frequency: No Update Planned

SANTA CLARA COUNTY:

CUPA SANTA CLARA: Cupa Facility List Cupa facility list

GOVERNMENT RECORDS SEARCHED / DATA CURRENCY TRACKING

Date of Government Version: 11/20/2020
Date Data Arrived at EDR: 11/23/2020
Date Made Active in Reports: 02/05/2021
Number of Days to Update: 74

Source: Department of Environmental Health
Telephone: 408-918-1973
Last EDR Contact: 02/16/2021
Next Scheduled EDR Contact: 05/31/2021
Data Release Frequency: Varies

HIST LUST SANTA CLARA: HIST LUST - Fuel Leak Site Activity Report

A listing of open and closed leaking underground storage tanks. This listing is no longer updated by the county. Leaking underground storage tanks are now handled by the Department of Environmental Health.

Date of Government Version: 03/29/2005
Date Data Arrived at EDR: 03/30/2005
Date Made Active in Reports: 04/21/2005
Number of Days to Update: 22

Source: Santa Clara Valley Water District
Telephone: 408-265-2600
Last EDR Contact: 03/23/2009
Next Scheduled EDR Contact: 06/22/2009
Data Release Frequency: No Update Planned

LUST SANTA CLARA: LOP Listing

A listing of leaking underground storage tanks located in Santa Clara county.

Date of Government Version: 03/03/2014
Date Data Arrived at EDR: 03/05/2014
Date Made Active in Reports: 03/18/2014
Number of Days to Update: 13

Source: Department of Environmental Health
Telephone: 408-918-3417
Last EDR Contact: 02/22/2021
Next Scheduled EDR Contact: 06/06/2021
Data Release Frequency: No Update Planned

SAN JOSE HAZMAT: Hazardous Material Facilities

Hazardous material facilities, including underground storage tank sites.

Date of Government Version: 11/03/2020
Date Data Arrived at EDR: 11/05/2020
Date Made Active in Reports: 01/26/2021
Number of Days to Update: 82

Source: City of San Jose Fire Department
Telephone: 408-535-7694
Last EDR Contact: 02/26/2021
Next Scheduled EDR Contact: 05/16/2021
Data Release Frequency: Annually

SANTA CRUZ COUNTY:

CUPA SANTA CRUZ: CUPA Facility List CUPA facility listing.

Date of Government Version: 01/21/2017
Date Data Arrived at EDR: 02/22/2017
Date Made Active in Reports: 05/23/2017
Number of Days to Update: 90

Source: Santa Cruz County Environmental Health
Telephone: 831-464-2761
Last EDR Contact: 02/16/2021
Next Scheduled EDR Contact: 05/31/2021
Data Release Frequency: Varies

SHASTA COUNTY:

CUPA SHASTA: CUPA Facility List Cupa Facility List.

Date of Government Version: 06/15/2017
Date Data Arrived at EDR: 06/19/2017
Date Made Active in Reports: 08/09/2017
Number of Days to Update: 51

Source: Shasta County Department of Resource Management
Telephone: 530-225-5789
Last EDR Contact: 02/16/2021
Next Scheduled EDR Contact: 05/31/2021
Data Release Frequency: Varies

SOLANO COUNTY:

GOVERNMENT RECORDS SEARCHED / DATA CURRENCY TRACKING

LUST SOLANO: Leaking Underground Storage Tanks

A listing of leaking underground storage tank sites located in Solano county.

Date of Government Version: 06/04/2019
Date Data Arrived at EDR: 06/06/2019
Date Made Active in Reports: 08/13/2019
Number of Days to Update: 68

Source: Solano County Department of Environmental Management
Telephone: 707-784-6770
Last EDR Contact: 02/26/2021
Next Scheduled EDR Contact: 06/14/2021
Data Release Frequency: Quarterly

UST SOLANO: Underground Storage Tanks

Underground storage tank sites located in Solano county.

Date of Government Version: 12/03/2020
Date Data Arrived at EDR: 12/03/2020
Date Made Active in Reports: 02/18/2021
Number of Days to Update: 77

Source: Solano County Department of Environmental Management
Telephone: 707-784-6770
Last EDR Contact: 02/26/2021
Next Scheduled EDR Contact: 06/14/2021
Data Release Frequency: Quarterly

SONOMA COUNTY:

CUPA SONOMA: Cupa Facility List

Cupa Facility list

Date of Government Version: 12/15/2020
Date Data Arrived at EDR: 12/16/2020
Date Made Active in Reports: 12/23/2020
Number of Days to Update: 7

Source: County of Sonoma Fire & Emergency Services Department
Telephone: 707-565-1174
Last EDR Contact: 12/15/2020
Next Scheduled EDR Contact: 04/05/2021
Data Release Frequency: Varies

LUST SONOMA: Leaking Underground Storage Tank Sites

A listing of leaking underground storage tank sites located in Sonoma county.

Date of Government Version: 09/18/2020
Date Data Arrived at EDR: 09/22/2020
Date Made Active in Reports: 12/14/2020
Number of Days to Update: 83

Source: Department of Health Services
Telephone: 707-565-6565
Last EDR Contact: 12/15/2020
Next Scheduled EDR Contact: 04/05/2021
Data Release Frequency: Quarterly

STANISLAUS COUNTY:

CUPA STANISLAUS: CUPA Facility List

Cupa facility list

Date of Government Version: 10/01/2020
Date Data Arrived at EDR: 10/06/2020
Date Made Active in Reports: 12/22/2020
Number of Days to Update: 77

Source: Stanislaus County Department of Environmental Protection
Telephone: 209-525-6751
Last EDR Contact: 01/11/2021
Next Scheduled EDR Contact: 04/26/2021
Data Release Frequency: Varies

SUTTER COUNTY:

UST SUTTER: Underground Storage Tanks

Underground storage tank sites located in Sutter county.

Date of Government Version: 11/23/2020
Date Data Arrived at EDR: 11/24/2020
Date Made Active in Reports: 02/10/2021
Number of Days to Update: 78

Source: Sutter County Environmental Health Services
Telephone: 530-822-7500
Last EDR Contact: 02/26/2021
Next Scheduled EDR Contact: 06/14/2021
Data Release Frequency: Semi-Annually

TEHAMA COUNTY:

GOVERNMENT RECORDS SEARCHED / DATA CURRENCY TRACKING

CUPA TEHAMA: CUPA Facility List Cupa facilities

Date of Government Version: 08/11/2020
Date Data Arrived at EDR: 08/12/2020
Date Made Active in Reports: 10/26/2020
Number of Days to Update: 75

Source: Tehama County Department of Environmental Health
Telephone: 530-527-8020
Last EDR Contact: 02/01/2021
Next Scheduled EDR Contact: 05/17/2021
Data Release Frequency: Varies

TRINITY COUNTY:

CUPA TRINITY: CUPA Facility List Cupa facility list

Date of Government Version: 10/14/2020
Date Data Arrived at EDR: 10/15/2020
Date Made Active in Reports: 01/05/2021
Number of Days to Update: 82

Source: Department of Toxic Substances Control
Telephone: 760-352-0381
Last EDR Contact: 01/19/2021
Next Scheduled EDR Contact: 05/03/2021
Data Release Frequency: Varies

TULARE COUNTY:

CUPA TULARE: CUPA Facility List Cupa program facilities

Date of Government Version: 10/30/2020
Date Data Arrived at EDR: 11/03/2020
Date Made Active in Reports: 01/20/2021
Number of Days to Update: 78

Source: Tulare County Environmental Health Services Division
Telephone: 559-624-7400
Last EDR Contact: 02/01/2021
Next Scheduled EDR Contact: 05/17/2021
Data Release Frequency: Varies

TUOLUMNE COUNTY:

CUPA TUOLUMNE: CUPA Facility List Cupa facility list

Date of Government Version: 04/23/2018
Date Data Arrived at EDR: 04/25/2018
Date Made Active in Reports: 06/25/2018
Number of Days to Update: 61

Source: Divison of Environmental Health
Telephone: 209-533-5633
Last EDR Contact: 01/19/2021
Next Scheduled EDR Contact: 05/03/2021
Data Release Frequency: Varies

VENTURA COUNTY:

BWT VENTURA: Business Plan, Hazardous Waste Producers, and Operating Underground Tanks The BWT list indicates by site address whether the Environmental Health Division has Business Plan (B), Waste Producer (W), and/or Underground Tank (T) information.

Date of Government Version: 09/28/2020
Date Data Arrived at EDR: 10/22/2020
Date Made Active in Reports: 01/12/2021
Number of Days to Update: 82

Source: Ventura County Environmental Health Division
Telephone: 805-654-2813
Last EDR Contact: 01/19/2021
Next Scheduled EDR Contact: 05/02/2021
Data Release Frequency: Quarterly

LF VENTURA: Inventory of Illegal Abandoned and Inactive Sites Ventura County Inventory of Closed, Illegal Abandoned, and Inactive Sites.

GOVERNMENT RECORDS SEARCHED / DATA CURRENCY TRACKING

Date of Government Version: 12/01/2011
Date Data Arrived at EDR: 12/01/2011
Date Made Active in Reports: 01/19/2012
Number of Days to Update: 49

Source: Environmental Health Division
Telephone: 805-654-2813
Last EDR Contact: 12/21/2020
Next Scheduled EDR Contact: 04/12/2021
Data Release Frequency: No Update Planned

LUST VENTURA: Listing of Underground Tank Cleanup Sites
Ventura County Underground Storage Tank Cleanup Sites (LUST).

Date of Government Version: 05/29/2008
Date Data Arrived at EDR: 06/24/2008
Date Made Active in Reports: 07/31/2008
Number of Days to Update: 37

Source: Environmental Health Division
Telephone: 805-654-2813
Last EDR Contact: 02/08/2021
Next Scheduled EDR Contact: 05/24/2021
Data Release Frequency: No Update Planned

MED WASTE VENTURA: Medical Waste Program List

To protect public health and safety and the environment from potential exposure to disease causing agents, the Environmental Health Division Medical Waste Program regulates the generation, handling, storage, treatment and disposal of medical waste throughout the County.

Date of Government Version: 09/28/2020
Date Data Arrived at EDR: 10/22/2020
Date Made Active in Reports: 01/12/2021
Number of Days to Update: 82

Source: Ventura County Resource Management Agency
Telephone: 805-654-2813
Last EDR Contact: 01/20/2021
Next Scheduled EDR Contact: 05/03/2021
Data Release Frequency: Quarterly

UST VENTURA: Underground Tank Closed Sites List

Ventura County Operating Underground Storage Tank Sites (UST)/Underground Tank Closed Sites List.

Date of Government Version: 12/01/2020
Date Data Arrived at EDR: 12/08/2020
Date Made Active in Reports: 02/22/2021
Number of Days to Update: 76

Source: Environmental Health Division
Telephone: 805-654-2813
Last EDR Contact: 12/08/2020
Next Scheduled EDR Contact: 03/22/2021
Data Release Frequency: Quarterly

YOLO COUNTY:

UST YOLO: Underground Storage Tank Comprehensive Facility Report

Underground storage tank sites located in Yolo county.

Date of Government Version: 12/21/2020
Date Data Arrived at EDR: 12/23/2020
Date Made Active in Reports: 01/04/2021
Number of Days to Update: 12

Source: Yolo County Department of Health
Telephone: 530-666-8646
Last EDR Contact: 12/20/2020
Next Scheduled EDR Contact: 04/11/2021
Data Release Frequency: Annually

YUBA COUNTY:

CUPA YUBA: CUPA Facility List

CUPA facility listing for Yuba County.

Date of Government Version: 01/26/2021
Date Data Arrived at EDR: 01/28/2021
Date Made Active in Reports: 02/03/2021
Number of Days to Update: 6

Source: Yuba County Environmental Health Department
Telephone: 530-749-7523
Last EDR Contact: 02/23/2021
Next Scheduled EDR Contact: 05/10/2021
Data Release Frequency: Varies

GOVERNMENT RECORDS SEARCHED / DATA CURRENCY TRACKING

OTHER DATABASE(S)

Depending on the geographic area covered by this report, the data provided in these specialty databases may or may not be complete. For example, the existence of wetlands information data in a specific report does not mean that all wetlands in the area covered by the report are included. Moreover, the absence of any reported wetlands information does not necessarily mean that wetlands do not exist in the area covered by the report.

CT MANIFEST: Hazardous Waste Manifest Data

Facility and manifest data. Manifest is a document that lists and tracks hazardous waste from the generator through transporters to a tsd facility.

Date of Government Version: 08/10/2020	Source: Department of Energy & Environmental Protection
Date Data Arrived at EDR: 10/20/2020	Telephone: 860-424-3375
Date Made Active in Reports: 11/02/2020	Last EDR Contact: 02/12/2021
Number of Days to Update: 13	Next Scheduled EDR Contact: 05/24/2021
	Data Release Frequency: No Update Planned

NJ MANIFEST: Manifest Information

Hazardous waste manifest information.

Date of Government Version: 12/31/2018	Source: Department of Environmental Protection
Date Data Arrived at EDR: 04/10/2019	Telephone: N/A
Date Made Active in Reports: 05/16/2019	Last EDR Contact: 01/08/2021
Number of Days to Update: 36	Next Scheduled EDR Contact: 04/19/2021
	Data Release Frequency: Annually

NY MANIFEST: Facility and Manifest Data

Manifest is a document that lists and tracks hazardous waste from the generator through transporters to a TSD facility.

Date of Government Version: 01/01/2019	Source: Department of Environmental Conservation
Date Data Arrived at EDR: 04/29/2020	Telephone: 518-402-8651
Date Made Active in Reports: 07/10/2020	Last EDR Contact: 01/29/2021
Number of Days to Update: 72	Next Scheduled EDR Contact: 05/10/2021
	Data Release Frequency: Quarterly

PA MANIFEST: Manifest Information

Hazardous waste manifest information.

Date of Government Version: 06/30/2018	Source: Department of Environmental Protection
Date Data Arrived at EDR: 07/19/2019	Telephone: 717-783-8990
Date Made Active in Reports: 09/10/2019	Last EDR Contact: 01/11/2021
Number of Days to Update: 53	Next Scheduled EDR Contact: 04/26/2021
	Data Release Frequency: Annually

RI MANIFEST: Manifest information

Hazardous waste manifest information

Date of Government Version: 12/31/2019	Source: Department of Environmental Management
Date Data Arrived at EDR: 02/11/2021	Telephone: 401-222-2797
Date Made Active in Reports: 02/24/2021	Last EDR Contact: 02/09/2021
Number of Days to Update: 13	Next Scheduled EDR Contact: 05/31/2021
	Data Release Frequency: Annually

WI MANIFEST: Manifest Information

Hazardous waste manifest information.

Date of Government Version: 05/31/2018	Source: Department of Natural Resources
Date Data Arrived at EDR: 06/19/2019	Telephone: N/A
Date Made Active in Reports: 09/03/2019	Last EDR Contact: 03/08/2021
Number of Days to Update: 76	Next Scheduled EDR Contact: 06/21/2021
	Data Release Frequency: Annually

GOVERNMENT RECORDS SEARCHED / DATA CURRENCY TRACKING

Oil/Gas Pipelines

Source: Endeavor Business Media

Petroleum Bundle (Crude Oil, Refined Products, Petrochemicals, Gas Liquids (LPG/NGL), and Specialty Gases (Miscellaneous)) N = Natural Gas Bundle (Natural Gas, Gas Liquids (LPG/NGL), and Specialty Gases (Miscellaneous)). This map includes information copyrighted by Endeavor Business Media. This information is provided on a best effort basis and Endeavor Business Media does not guarantee its accuracy nor warrant its fitness for any particular purpose. Such information has been reprinted with the permission of Endeavor Business Media.

Electric Power Transmission Line Data

Source: Endeavor Business Media

This map includes information copyrighted by Endeavor Business Media. This information is provided on a best effort basis and Endeavor Business Media does not guarantee its accuracy nor warrant its fitness for any particular purpose. Such information has been reprinted with the permission of Endeavor Business Media.

Sensitive Receptors: There are individuals deemed sensitive receptors due to their fragile immune systems and special sensitivity to environmental discharges. These sensitive receptors typically include the elderly, the sick, and children. While the location of all sensitive receptors cannot be determined, EDR indicates those buildings and facilities - schools, daycares, hospitals, medical centers, and nursing homes - where individuals who are sensitive receptors are likely to be located.

AHA Hospitals:

Source: American Hospital Association, Inc.

Telephone: 312-280-5991

The database includes a listing of hospitals based on the American Hospital Association's annual survey of hospitals.

Medical Centers: Provider of Services Listing

Source: Centers for Medicare & Medicaid Services

Telephone: 410-786-3000

A listing of hospitals with Medicare provider number, produced by Centers of Medicare & Medicaid Services, a federal agency within the U.S. Department of Health and Human Services.

Nursing Homes

Source: National Institutes of Health

Telephone: 301-594-6248

Information on Medicare and Medicaid certified nursing homes in the United States.

Public Schools

Source: National Center for Education Statistics

Telephone: 202-502-7300

The National Center for Education Statistics' primary database on elementary and secondary public education in the United States. It is a comprehensive, annual, national statistical database of all public elementary and secondary schools and school districts, which contains data that are comparable across all states.

Private Schools

Source: National Center for Education Statistics

Telephone: 202-502-7300

The National Center for Education Statistics' primary database on private school locations in the United States.

Daycare Centers: Licensed Facilities

Source: Department of Social Services

Telephone: 916-657-4041

Flood Zone Data: This data was obtained from the Federal Emergency Management Agency (FEMA). It depicts 100-year and 500-year flood zones as defined by FEMA. It includes the National Flood Hazard Layer (NFHL) which incorporates Flood Insurance Rate Map (FIRM) data and Q3 data from FEMA in areas not covered by NFHL.

Source: FEMA

Telephone: 877-336-2627

Date of Government Version: 2003, 2015

NWI: National Wetlands Inventory. This data, available in select counties across the country, was obtained by EDR in 2002, 2005 and 2010 from the U.S. Fish and Wildlife Service.

State Wetlands Data: Wetland Inventory

Source: Department of Fish and Wildlife

Telephone: 916-445-0411

GOVERNMENT RECORDS SEARCHED / DATA CURRENCY TRACKING

Current USGS 7.5 Minute Topographic Map
Source: U.S. Geological Survey

STREET AND ADDRESS INFORMATION

© 2015 TomTom North America, Inc. All rights reserved. This material is proprietary and the subject of copyright protection and other intellectual property rights owned by or licensed to Tele Atlas North America, Inc. The use of this material is subject to the terms of a license agreement. You will be held liable for any unauthorized copying or disclosure of this material.

GEOCHECK[®] - PHYSICAL SETTING SOURCE ADDENDUM

TARGET PROPERTY ADDRESS

KINDRED CHURCH EXPANSION PROJECT
8712 EAST SANTA ANA CANYON ROAD
ANAHEIM, CA 92808

TARGET PROPERTY COORDINATES

Latitude (North):	33.864705 - 33° 51' 52.94"
Longitude (West):	117.722955 - 117° 43' 22.64"
Universal Transverse Mercator:	Zone 11
UTM X (Meters):	433128.8
UTM Y (Meters):	3747196.0
Elevation:	413 ft. above sea level

USGS TOPOGRAPHIC MAP

Target Property Map:	5636465 BLACK STAR CANYON, CA
Version Date:	2012
North Map:	5640938 PRADO DAM, CA
Version Date:	2012

EDR's GeoCheck Physical Setting Source Addendum is provided to assist the environmental professional in forming an opinion about the impact of potential contaminant migration.

Assessment of the impact of contaminant migration generally has two principle investigative components:

1. Groundwater flow direction, and
2. Groundwater flow velocity.

Groundwater flow direction may be impacted by surface topography, hydrology, hydrogeology, characteristics of the soil, and nearby wells. Groundwater flow velocity is generally impacted by the nature of the geologic strata.

GEOCHECK® - PHYSICAL SETTING SOURCE SUMMARY

GROUNDWATER FLOW DIRECTION INFORMATION

Groundwater flow direction for a particular site is best determined by a qualified environmental professional using site-specific well data. If such data is not reasonably ascertainable, it may be necessary to rely on other sources of information, such as surface topographic information, hydrologic information, hydrogeologic data collected on nearby properties, and regional groundwater flow information (from deep aquifers).

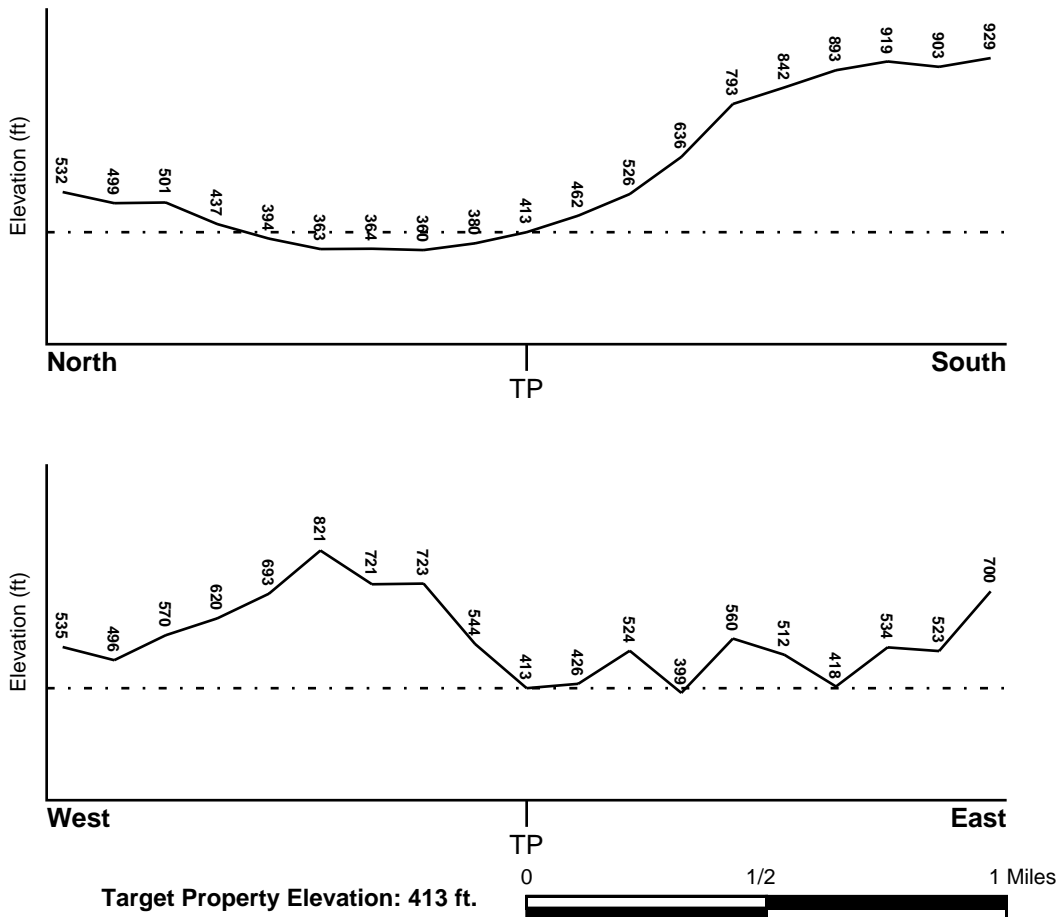
TOPOGRAPHIC INFORMATION

Surface topography may be indicative of the direction of surficial groundwater flow. This information can be used to assist the environmental professional in forming an opinion about the impact of nearby contaminated properties or, should contamination exist on the target property, what downgradient sites might be impacted.

TARGET PROPERTY TOPOGRAPHY

General Topographic Gradient: General NE

SURROUNDING TOPOGRAPHY: ELEVATION PROFILES



Source: Topography has been determined from the USGS 7.5' Digital Elevation Model and should be evaluated on a relative (not an absolute) basis. Relative elevation information between sites of close proximity should be field verified.

GEOCHECK® - PHYSICAL SETTING SOURCE SUMMARY

HYDROLOGIC INFORMATION

Surface water can act as a hydrologic barrier to groundwater flow. Such hydrologic information can be used to assist the environmental professional in forming an opinion about the impact of nearby contaminated properties or, should contamination exist on the target property, what downgradient sites might be impacted.

Refer to the Physical Setting Source Map following this summary for hydrologic information (major waterways and bodies of water).

FEMA FLOOD ZONE

<u>Flood Plain Panel at Target Property</u>	<u>FEMA Source Type</u>
06059C0180J	FEMA FIRM Flood data
<u>Additional Panels in search area:</u>	<u>FEMA Source Type</u>
06059C0090J	FEMA FIRM Flood data

NATIONAL WETLAND INVENTORY

<u>NWI Quad at Target Property</u>	<u>NWI Electronic Data Coverage</u>
NOT AVAILABLE	YES - refer to the Overview Map and Detail Map

HYDROGEOLOGIC INFORMATION

Hydrogeologic information obtained by installation of wells on a specific site can often be an indicator of groundwater flow direction in the immediate area. Such hydrogeologic information can be used to assist the environmental professional in forming an opinion about the impact of nearby contaminated properties or, should contamination exist on the target property, what downgradient sites might be impacted.

Site-Specific Hydrogeological Data*:

Search Radius:	1.25 miles
Status:	Not found

AQUIFLOW®

Search Radius: 1.000 Mile.

EDR has developed the AQUIFLOW Information System to provide data on the general direction of groundwater flow at specific points. EDR has reviewed reports submitted by environmental professionals to regulatory authorities at select sites and has extracted the date of the report, groundwater flow direction as determined hydrogeologically, and the depth to water table.

<u>MAP ID</u>	<u>LOCATION FROM TP</u>	<u>GENERAL DIRECTION GROUNDWATER FLOW</u>
Not Reported		

GEOCHECK® - PHYSICAL SETTING SOURCE SUMMARY

GROUNDWATER FLOW VELOCITY INFORMATION

Groundwater flow velocity information for a particular site is best determined by a qualified environmental professional using site specific geologic and soil strata data. If such data are not reasonably ascertainable, it may be necessary to rely on other sources of information, including geologic age identification, rock stratigraphic unit and soil characteristics data collected on nearby properties and regional soil information. In general, contaminant plumes move more quickly through sandy-gravelly types of soils than silty-clayey types of soils.

GEOLOGIC INFORMATION IN GENERAL AREA OF TARGET PROPERTY

Geologic information can be used by the environmental professional in forming an opinion about the relative speed at which contaminant migration may be occurring.

ROCK STRATIGRAPHIC UNIT

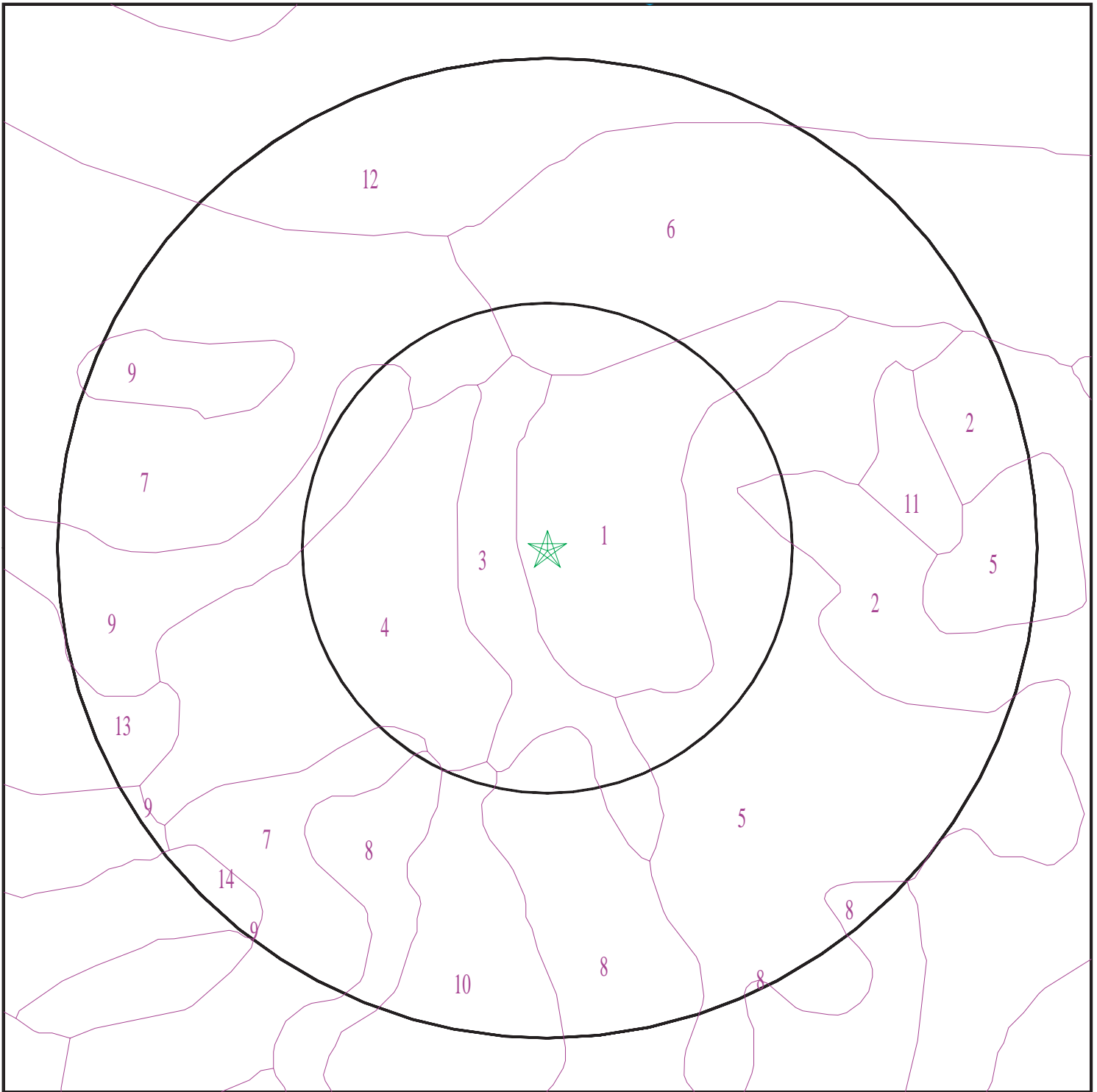
Era:	Cenozoic
System:	Tertiary
Series:	Eocene
Code:	Te (<i>decoded above as Era, System & Series</i>)

GEOLOGIC AGE IDENTIFICATION

Category: Stratified Sequence

Geologic Age and Rock Stratigraphic Unit Source: P.G. Schruben, R.E. Arndt and W.J. Bawiec, Geology of the Conterminous U.S. at 1:2,500,000 Scale - a digital representation of the 1974 P.B. King and H.M. Beikman Map, USGS Digital Data Series DDS - 11 (1994).

SSURGO SOIL MAP - 6397650.2s



- ★ Target Property
- ∕ SSURGO Soil
- ∕ Water



SITE NAME: Kindred Church Expansion Project
ADDRESS: 8712 East Santa Ana Canyon Road
Anaheim CA 92808
LAT/LONG: 33.864705 / 117.722955

CLIENT: Psomas
CONTACT: Janet Powell
INQUIRY #: 6397650.2s
DATE: March 09, 2021 5:54 pm

GEOCHECK® - PHYSICAL SETTING SOURCE SUMMARY

DOMINANT SOIL COMPOSITION IN GENERAL AREA OF TARGET PROPERTY

The U.S. Department of Agriculture's (USDA) Soil Conservation Service (SCS) leads the National Cooperative Soil Survey (NCSS) and is responsible for collecting, storing, maintaining and distributing soil survey information for privately owned lands in the United States. A soil map in a soil survey is a representation of soil patterns in a landscape. The following information is based on Soil Conservation Service SSURGO data.

Soil Map ID: 1

Soil Component Name: MYFORD

Soil Surface Texture: sandy loam

Hydrologic Group: Class D - Very slow infiltration rates. Soils are clayey, have a high water table, or are shallow to an impervious layer.

Soil Drainage Class: Moderately well drained

Hydric Status: Not hydric

Corrosion Potential - Uncoated Steel: High

Depth to Bedrock Min: > 0 inches

Depth to Watertable Min: > 0 inches

Soil Layer Information							
Layer	Boundary		Soil Texture Class	Classification		Saturated hydraulic conductivity micro m/sec	Soil Reaction (pH)
	Upper	Lower		AASHTO Group	Unified Soil		
1	0 inches	7 inches	sandy loam	Granular materials (35 pct. or less passing No. 200), Silty, or Clayey Gravel and Sand.	FINE-GRAINED SOILS, Silts and Clays (liquid limit less than 50%), Lean Clay. FINE-GRAINED SOILS, Silts and Clays (liquid limit less than 50%), silt.	Max: 14 Min: 4	Max: 6.5 Min: 6.1
2	7 inches	11 inches	sandy clay	Granular materials (35 pct. or less passing No. 200), Silty, or Clayey Gravel and Sand.	FINE-GRAINED SOILS, Silts and Clays (liquid limit less than 50%), Lean Clay. FINE-GRAINED SOILS, Silts and Clays (liquid limit less than 50%), silt.	Max: 14 Min: 4	Max: 6.5 Min: 6.1

GEOCHECK® - PHYSICAL SETTING SOURCE SUMMARY

Soil Layer Information							
Layer	Boundary		Soil Texture Class	Classification		Saturated hydraulic conductivity micro m/sec	Soil Reaction (pH)
	Upper	Lower		AASHTO Group	Unified Soil		
3	11 inches	20 inches	sandy clay loam	Granular materials (35 pct. or less passing No. 200), Silty, or Clayey Gravel and Sand.	FINE-GRAINED SOILS, Silts and Clays (liquid limit less than 50%), Lean Clay. FINE-GRAINED SOILS, Silts and Clays (liquid limit less than 50%), silt.	Max: 14 Min: 4	Max: 6.5 Min: 6.1
4	20 inches	64 inches	sandy clay loam	Granular materials (35 pct. or less passing No. 200), Silty, or Clayey Gravel and Sand.	FINE-GRAINED SOILS, Silts and Clays (liquid limit less than 50%), Lean Clay. FINE-GRAINED SOILS, Silts and Clays (liquid limit less than 50%), silt.	Max: 14 Min: 4	Max: 6.5 Min: 6.1
5	64 inches	79 inches	sandy loam	Granular materials (35 pct. or less passing No. 200), Silty, or Clayey Gravel and Sand.	FINE-GRAINED SOILS, Silts and Clays (liquid limit less than 50%), Lean Clay. FINE-GRAINED SOILS, Silts and Clays (liquid limit less than 50%), silt.	Max: 14 Min: 4	Max: 6.5 Min: 6.1

Soil Map ID: 2

Soil Component Name: SOPER

Soil Surface Texture: gravelly loam

Hydrologic Group: Class C - Slow infiltration rates. Soils with layers impeding downward movement of water, or soils with moderately fine or fine textures.

Soil Drainage Class: Well drained

Hydric Status: Not hydric

Corrosion Potential - Uncoated Steel: Moderate

Depth to Bedrock Min: > 0 inches

Depth to Watertable Min: > 0 inches

GEOCHECK® - PHYSICAL SETTING SOURCE SUMMARY

Soil Layer Information							
Layer	Boundary		Soil Texture Class	Classification		Saturated hydraulic conductivity micro m/sec	Soil Reaction (pH)
	Upper	Lower		AASHTO Group	Unified Soil		
1	0 inches	3 inches	gravelly loam	Not reported	Not reported	Max: Min:	Max: Min:
2	3 inches	20 inches	gravelly clay loam	Not reported	Not reported	Max: Min:	Max: Min:
3	20 inches	24 inches	weathered bedrock	Not reported	Not reported	Max: Min:	Max: Min:

Soil Map ID: 3

Soil Component Name: CORRALITOS

Soil Surface Texture: loamy sand

Hydrologic Group: Class A - High infiltration rates. Soils are deep, well drained to excessively drained sands and gravels.

Soil Drainage Class: Somewhat excessively drained

Hydric Status: Not hydric

Corrosion Potential - Uncoated Steel: Moderate

Depth to Bedrock Min: > 0 inches

Depth to Watertable Min: > 0 inches

Soil Layer Information							
Layer	Boundary		Soil Texture Class	Classification		Saturated hydraulic conductivity micro m/sec	Soil Reaction (pH)
	Upper	Lower		AASHTO Group	Unified Soil		
1	0 inches	9 inches	loamy sand	Granular materials (35 pct. or less passing No. 200), Stone Fragments, Gravel and Sand.	COARSE-GRAINED SOILS, Sands, Sands with fines, Silty Sand.	Max: 141 Min: 42	Max: 7.3 Min: 5.6
2	9 inches	59 inches	stratified sand to loamy sand	Granular materials (35 pct. or less passing No. 200), Stone Fragments, Gravel and Sand.	COARSE-GRAINED SOILS, Sands, Sands with fines, Silty Sand.	Max: 141 Min: 42	Max: 7.3 Min: 5.6

GEOCHECK® - PHYSICAL SETTING SOURCE SUMMARY

Soil Map ID: 4

Soil Component Name: CALLEGUAS

Soil Surface Texture: clay loam

Hydrologic Group: Class D - Very slow infiltration rates. Soils are clayey, have a high water table, or are shallow to an impervious layer.

Soil Drainage Class: Well drained

Hydric Status: Not hydric

Corrosion Potential - Uncoated Steel: High

Depth to Bedrock Min: > 0 inches

Depth to Watertable Min: > 0 inches

Soil Layer Information							
Layer	Boundary		Soil Texture Class	Classification		Saturated hydraulic conductivity micro m/sec	Soil Reaction (pH)
	Upper	Lower		AASHTO Group	Unified Soil		
1	0 inches	14 inches	clay loam	Silt-Clay Materials (more than 35 pct. passing No. 200), Silty Soils.	Not reported	Max: 1.4 Min: 0	Max: Min:
2	14 inches	18 inches	weathered bedrock	Silt-Clay Materials (more than 35 pct. passing No. 200), Silty Soils.	Not reported	Max: 1.4 Min: 0	Max: Min:

Soil Map ID: 5

Soil Component Name: SOPER

Soil Surface Texture: gravelly loam

Hydrologic Group: Class C - Slow infiltration rates. Soils with layers impeding downward movement of water, or soils with moderately fine or fine textures.

Soil Drainage Class: Well drained

GEOCHECK® - PHYSICAL SETTING SOURCE SUMMARY

Hydric Status: Not hydric

Corrosion Potential - Uncoated Steel: Moderate

Depth to Bedrock Min: > 0 inches

Depth to Watertable Min: > 0 inches

Soil Layer Information							
Layer	Boundary		Soil Texture Class	Classification		Saturated hydraulic conductivity micro m/sec	Soil Reaction (pH)
	Upper	Lower		AASHTO Group	Unified Soil		
1	0 inches	9 inches	gravelly loam	Silt-Clay Materials (more than 35 pct. passing No. 200), Silty Soils.	Not reported	Max: 4 Min: 1.4	Max: Min:
2	9 inches	29 inches	gravelly clay loam	Silt-Clay Materials (more than 35 pct. passing No. 200), Silty Soils.	Not reported	Max: 4 Min: 1.4	Max: Min:
3	29 inches	33 inches	weathered bedrock	Silt-Clay Materials (more than 35 pct. passing No. 200), Silty Soils.	Not reported	Max: 4 Min: 1.4	Max: Min:

Soil Map ID: 6

Soil Component Name: METZ

Soil Surface Texture: loamy sand

Hydrologic Group: Class A - High infiltration rates. Soils are deep, well drained to excessively drained sands and gravels.

Soil Drainage Class: Somewhat excessively drained

Hydric Status: Not hydric

Corrosion Potential - Uncoated Steel: High

Depth to Bedrock Min: > 0 inches

Depth to Watertable Min: > 0 inches

GEOCHECK® - PHYSICAL SETTING SOURCE SUMMARY

Soil Layer Information							
Layer	Boundary		Soil Texture Class	Classification		Saturated hydraulic conductivity micro m/sec	Soil Reaction (pH)
	Upper	Lower		AASHTO Group	Unified Soil		
1	0 inches	16 inches	loamy sand	Granular materials (35 pct. or less passing No. 200), Silty, or Clayey Gravel and Sand.	COARSE-GRAINED SOILS, Sands, Sands with fines, Silty Sand.	Max: 14 Min: 4	Max: 8.4 Min: 6.6
2	16 inches	62 inches	stratified sand to fine sandy loam	Granular materials (35 pct. or less passing No. 200), Silty, or Clayey Gravel and Sand.	COARSE-GRAINED SOILS, Sands, Sands with fines, Silty Sand.	Max: 14 Min: 4	Max: 8.4 Min: 6.6

Soil Map ID: 7

Soil Component Name: ANAHEIM

Soil Surface Texture: clay loam

Hydrologic Group: Class C - Slow infiltration rates. Soils with layers impeding downward movement of water, or soils with moderately fine or fine textures.

Soil Drainage Class: Well drained

Hydric Status: Not hydric

Corrosion Potential - Uncoated Steel: Moderate

Depth to Bedrock Min: > 0 inches

Depth to Watertable Min: > 0 inches

Soil Layer Information							
Layer	Boundary		Soil Texture Class	Classification		Saturated hydraulic conductivity micro m/sec	Soil Reaction (pH)
	Upper	Lower		AASHTO Group	Unified Soil		
1	0 inches	25 inches	clay loam	Not reported	Not reported	Max: Min:	Max: Min:

GEOCHECK® - PHYSICAL SETTING SOURCE SUMMARY

Soil Layer Information							
Layer	Boundary		Soil Texture Class	Classification		Saturated hydraulic conductivity micro m/sec	Soil Reaction (pH)
	Upper	Lower		AASHTO Group	Unified Soil		
2	25 inches	29 inches	weathered bedrock	Not reported	Not reported	Max: Min:	Max: Min:

Soil Map ID: 8

Soil Component Name: SOPER

Soil Surface Texture: gravelly loam

Hydrologic Group: Class C - Slow infiltration rates. Soils with layers impeding downward movement of water, or soils with moderately fine or fine textures.

Soil Drainage Class: Well drained

Hydric Status: Not hydric

Corrosion Potential - Uncoated Steel: Moderate

Depth to Bedrock Min: > 0 inches

Depth to Watertable Min: > 0 inches

Soil Layer Information							
Layer	Boundary		Soil Texture Class	Classification		Saturated hydraulic conductivity micro m/sec	Soil Reaction (pH)
	Upper	Lower		AASHTO Group	Unified Soil		
1	0 inches	9 inches	gravelly loam	Not reported	Not reported	Max: Min:	Max: Min:
2	9 inches	29 inches	gravelly clay loam	Not reported	Not reported	Max: Min:	Max: Min:
3	29 inches	33 inches	weathered bedrock	Not reported	Not reported	Max: Min:	Max: Min:

Soil Map ID: 9

Soil Component Name: ANAHEIM

Soil Surface Texture: clay loam

Hydrologic Group: Class C - Slow infiltration rates. Soils with layers impeding downward movement of water, or soils with moderately fine or fine textures.

Soil Drainage Class: Well drained

GEOCHECK® - PHYSICAL SETTING SOURCE SUMMARY

Hydric Status: Not hydric

Corrosion Potential - Uncoated Steel: Moderate

Depth to Bedrock Min: > 0 inches

Depth to Watertable Min: > 0 inches

Soil Layer Information							
Layer	Boundary		Soil Texture Class	Classification		Saturated hydraulic conductivity micro m/sec	Soil Reaction (pH)
	Upper	Lower		AASHTO Group	Unified Soil		
1	0 inches	25 inches	clay loam	Not reported	Not reported	Max: Min:	Max: Min:
2	25 inches	29 inches	weathered bedrock	Not reported	Not reported	Max: Min:	Max: Min:

Soil Map ID: 10

Soil Component Name: SOPER

Soil Surface Texture: loam

Hydrologic Group: Class C - Slow infiltration rates. Soils with layers impeding downward movement of water, or soils with moderately fine or fine textures.

Soil Drainage Class: Well drained

Hydric Status: Not hydric

Corrosion Potential - Uncoated Steel: Moderate

Depth to Bedrock Min: > 0 inches

Depth to Watertable Min: > 0 inches

Soil Layer Information							
Layer	Boundary		Soil Texture Class	Classification		Saturated hydraulic conductivity micro m/sec	Soil Reaction (pH)
	Upper	Lower		AASHTO Group	Unified Soil		
1	0 inches	9 inches	loam	Not reported	Not reported	Max: Min:	Max: Min:
2	9 inches	29 inches	gravelly clay loam	Not reported	Not reported	Max: Min:	Max: Min:
3	29 inches	33 inches	weathered bedrock	Not reported	Not reported	Max: Min:	Max: Min:

GEOCHECK® - PHYSICAL SETTING SOURCE SUMMARY

Soil Map ID: 11

Soil Component Name: THAPTO-HISTIC FLUVAQUENTS

Soil Surface Texture: mucky clay

Hydrologic Group: Class D - Very slow infiltration rates. Soils are clayey, have a high water table, or are shallow to an impervious layer.

Soil Drainage Class:
Hydric Status: All hydric

Corrosion Potential - Uncoated Steel: High

Depth to Bedrock Min: > 0 inches

Depth to Watertable Min: > 84 inches

Soil Layer Information							
Layer	Boundary		Soil Texture Class	Classification		Saturated hydraulic conductivity micro m/sec	Soil Reaction (pH)
	Upper	Lower		AASHTO Group	Unified Soil		
1	0 inches	9 inches	mucky clay	Not reported	Not reported	Max: 1.4 Min: 0.42	Max: 6.5 Min: 6.1
2	9 inches	20 inches	mucky silty clay	Not reported	Not reported	Max: 1.4 Min: 0.42	Max: 6.5 Min: 6.1
3	20 inches	55 inches	muck	Not reported	Not reported	Max: 1.4 Min: 0.42	Max: 6.5 Min: 6.1
4	55 inches	68 inches	silty clay loam	Not reported	Not reported	Max: 1.4 Min: 0.42	Max: 6.5 Min: 6.1

Soil Map ID: 12

Soil Component Name: RIVERWASH

Soil Surface Texture: sand

Hydrologic Group: Class D - Very slow infiltration rates. Soils are clayey, have a high water table, or are shallow to an impervious layer.

Soil Drainage Class:
Hydric Status: All hydric

Corrosion Potential - Uncoated Steel: Not Reported

Depth to Bedrock Min: > 0 inches

Depth to Watertable Min: > 31 inches

GEOCHECK® - PHYSICAL SETTING SOURCE SUMMARY

Soil Layer Information							
Layer	Boundary		Soil Texture Class	Classification		Saturated hydraulic conductivity micro m/sec	Soil Reaction (pH)
	Upper	Lower		AASHTO Group	Unified Soil		
1	0 inches	5 inches	sand	Granular materials (35 pct. or less passing No. 200), Stone Fragments, Gravel and Sand.	COARSE-GRAINED SOILS, Sands, Sands with fines, Silty Sand.	Max: 141 Min: 42	Max: Min:
2	5 inches	59 inches	stratified coarse sand to sandy loam	Granular materials (35 pct. or less passing No. 200), Stone Fragments, Gravel and Sand.	COARSE-GRAINED SOILS, Sands, Sands with fines, Silty Sand.	Max: 141 Min: 42	Max: Min:

Soil Map ID: 13

Soil Component Name: ALO

Soil Surface Texture: clay

Hydrologic Group: Class D - Very slow infiltration rates. Soils are clayey, have a high water table, or are shallow to an impervious layer.

Soil Drainage Class: Well drained

Hydric Status: Not hydric

Corrosion Potential - Uncoated Steel: High

Depth to Bedrock Min: > 0 inches

Depth to Watertable Min: > 0 inches

Soil Layer Information							
Layer	Boundary		Soil Texture Class	Classification		Saturated hydraulic conductivity micro m/sec	Soil Reaction (pH)
	Upper	Lower		AASHTO Group	Unified Soil		
1	0 inches	14 inches	clay	Silt-Clay Materials (more than 35 pct. passing No. 200), Clayey Soils.	Not reported	Max: 1.4 Min: 0	Max: Min:

GEOCHECK® - PHYSICAL SETTING SOURCE SUMMARY

Soil Layer Information							
Layer	Boundary		Soil Texture Class	Classification		Saturated hydraulic conductivity micro m/sec	Soil Reaction (pH)
	Upper	Lower		AASHTO Group	Unified Soil		
2	14 inches	22 inches	clay	Silt-Clay Materials (more than 35 pct. passing No. 200), Clayey Soils.	Not reported	Max: 1.4 Min: 0	Max: Min:
3	22 inches	25 inches	weathered bedrock	Silt-Clay Materials (more than 35 pct. passing No. 200), Clayey Soils.	Not reported	Max: 1.4 Min: 0	Max: Min:

Soil Map ID: 14

Soil Component Name: ALO

Soil Surface Texture: clay

Hydrologic Group: Class D - Very slow infiltration rates. Soils are clayey, have a high water table, or are shallow to an impervious layer.

Soil Drainage Class: Well drained

Hydric Status: Not hydric

Corrosion Potential - Uncoated Steel: High

Depth to Bedrock Min: > 0 inches

Depth to Watertable Min: > 0 inches

Soil Layer Information							
Layer	Boundary		Soil Texture Class	Classification		Saturated hydraulic conductivity micro m/sec	Soil Reaction (pH)
	Upper	Lower		AASHTO Group	Unified Soil		
1	0 inches	25 inches	clay	Not reported	Not reported	Max: Min:	Max: Min:
2	25 inches	29 inches	weathered bedrock	Not reported	Not reported	Max: Min:	Max: Min:

GEOCHECK® - PHYSICAL SETTING SOURCE SUMMARY

LOCAL / REGIONAL WATER AGENCY RECORDS

EDR Local/Regional Water Agency records provide water well information to assist the environmental professional in assessing sources that may impact ground water flow direction, and in forming an opinion about the impact of contaminant migration on nearby drinking water wells.

WELL SEARCH DISTANCE INFORMATION

<u>DATABASE</u>	<u>SEARCH DISTANCE (miles)</u>
Federal USGS	1.000
Federal FRDS PWS	Nearest PWS within 1 mile
State Database	1.000

FEDERAL USGS WELL INFORMATION

<u>MAP ID</u>	<u>WELL ID</u>	<u>LOCATION FROM TP</u>
B12	USGS40000138686	1/2 - 1 Mile ENE
C21	USGS40000138720	1/2 - 1 Mile NE

FEDERAL FRDS PUBLIC WATER SUPPLY SYSTEM INFORMATION

<u>MAP ID</u>	<u>WELL ID</u>	<u>LOCATION FROM TP</u>
No PWS System Found		

Note: PWS System location is not always the same as well location.

STATE DATABASE WELL INFORMATION

<u>MAP ID</u>	<u>WELL ID</u>	<u>LOCATION FROM TP</u>
A1	CADWR0000014455	0 - 1/8 Mile ENE
A2	CADWR0000005982	0 - 1/8 Mile ENE
3	CADWR8000005975	1/4 - 1/2 Mile North
4	CADWR0000002383	1/2 - 1 Mile NNW
5	CADWR0000025152	1/2 - 1 Mile East
6	CADWR0000022740	1/2 - 1 Mile ENE
7	CADWR8000005969	1/2 - 1 Mile ENE
8	CADWR0000029973	1/2 - 1 Mile East
B9	CADWR0000000013	1/2 - 1 Mile ENE
B10	CADDW0000012867	1/2 - 1 Mile ENE
B11	CADWR0000003511	1/2 - 1 Mile ENE
B13	CADDW0000002531	1/2 - 1 Mile ENE
B14	CAUSGS000000957	1/2 - 1 Mile ENE
B15	CAUSGSN00012250	1/2 - 1 Mile ENE
C16	CADPR0000002172	1/2 - 1 Mile NE
D17	CADWR8000005985	1/2 - 1 Mile NE
D18	CADWR0000032039	1/2 - 1 Mile NE
E19	3660	1/2 - 1 Mile ESE
E20	3661	1/2 - 1 Mile ESE

GEOCHECK® - PHYSICAL SETTING SOURCE SUMMARY

STATE DATABASE WELL INFORMATION

MAP ID

WELL ID

LOCATION
FROM TP

GEOCHECK® - PHYSICAL SETTING SOURCE MAP FINDINGS

Map ID
Direction
Distance
Elevation

Database EDR ID Number

A1
ENE
0 - 1/8 Mile
Higher

CA WELLS CADWR0000014455

Well ID:	03S08W33K001S	Well Type:	UNK
Source:	Department of Water Resources		
Other Name:	03S08W33K001S	GAMA PFAS Testing:	Not Reported
Groundwater Quality Data:	https://gamagroundwater.waterboards.ca.gov/gama/gamamap/public/GamaDataDisplay.asp?dataset=DWR&samp_date=&global_id=&assigned_name=03S08W33K001S&store_num=		
GeoTracker Data:	Not Reported		

A2
ENE
0 - 1/8 Mile
Higher

CA WELLS CADWR0000005982

Well ID:	03S08W33K002S	Well Type:	UNK
Source:	Department of Water Resources		
Other Name:	03S08W33K002S	GAMA PFAS Testing:	Not Reported
Groundwater Quality Data:	https://gamagroundwater.waterboards.ca.gov/gama/gamamap/public/GamaDataDisplay.asp?dataset=DWR&samp_date=&global_id=&assigned_name=03S08W33K002S&store_num=		
GeoTracker Data:	Not Reported		

3
North
1/4 - 1/2 Mile
Lower

CA WELLS CADWR8000005975

State Well #:	03S08W33C001S	Station ID:	25073
Well Name:	Not Reported	Well Use:	Unknown
Well Type:	Unknown	Well Depth:	0
Basin Name:	Coastal Plain Of Orange County		
Well Completion Rpt #:	Not Reported		

4
NNW
1/2 - 1 Mile
Lower

CA WELLS CADWR0000002383

Well ID:	03S08W33C001S	Well Type:	UNK
Source:	Department of Water Resources		
Other Name:	03S08W33C001S	GAMA PFAS Testing:	Not Reported
Groundwater Quality Data:	https://gamagroundwater.waterboards.ca.gov/gama/gamamap/public/GamaDataDisplay.asp?dataset=DWR&samp_date=&global_id=&assigned_name=03S08W33C001S&store_num=		
GeoTracker Data:	Not Reported		

GEOCHECK® - PHYSICAL SETTING SOURCE MAP FINDINGS

Map ID
Direction
Distance
Elevation

Database EDR ID Number

5
East
1/2 - 1 Mile
Higher

CA WELLS CADWR0000025152

Well ID:	03S08W34M001S	Well Type:	UNK
Source:	Department of Water Resources		
Other Name:	03S08W34M001S	GAMA PFAS Testing:	Not Reported
Groundwater Quality Data:	https://gamagroundwater.waterboards.ca.gov/gama/gamamap/public/GamaDataDisplay.asp?dataset=DWR&samp_date=&global_id=&assigned_name=03S08W34M001S&store_num=		
GeoTracker Data:	Not Reported		

6
ENE
1/2 - 1 Mile
Lower

CA WELLS CADWR0000022740

Well ID:	03S08W34E001S	Well Type:	UNK
Source:	Department of Water Resources		
Other Name:	03S08W34E001S	GAMA PFAS Testing:	Not Reported
Groundwater Quality Data:	https://gamagroundwater.waterboards.ca.gov/gama/gamamap/public/GamaDataDisplay.asp?dataset=DWR&samp_date=&global_id=&assigned_name=03S08W34E001S&store_num=		
GeoTracker Data:	Not Reported		

7
ENE
1/2 - 1 Mile
Lower

CA WELLS CADWR8000005969

State Well #:	03S08W34F003S	Station ID:	4583
Well Name:	SILV-YL	Well Use:	Irrigation
Well Type:	Single Well	Well Depth:	66
Basin Name:	Coastal Plain Of Orange County		
Well Completion Rpt #:	349300		

8
East
1/2 - 1 Mile
Higher

CA WELLS CADWR0000029973

Well ID:	03S08W34L001S	Well Type:	UNK
Source:	Department of Water Resources		
Other Name:	03S08W34L001S	GAMA PFAS Testing:	Not Reported
Groundwater Quality Data:	https://gamagroundwater.waterboards.ca.gov/gama/gamamap/public/GamaDataDisplay.asp?dataset=DWR&samp_date=&global_id=&assigned_name=03S08W34L001S&store_num=		
GeoTracker Data:	Not Reported		

GEOCHECK® - PHYSICAL SETTING SOURCE MAP FINDINGS

Map ID
Direction
Distance
Elevation

Database EDR ID Number

B9
ENE
1/2 - 1 Mile
Lower

CA WELLS CADWR0000000013

Well ID:	03S08W34F001S	Well Type:	UNK
Source:	Department of Water Resources		
Other Name:	03S08W34F001S	GAMA PFAS Testing:	Not Reported
Groundwater Quality Data:	https://gamagroundwater.waterboards.ca.gov/gama/gamamap/public/GamaDataDisplay.asp?dataset=DWR&samp_date=&global_id=&assigned_name=03S08W34F001S&store_num=		
GeoTracker Data:	Not Reported		

B10
ENE
1/2 - 1 Mile
Lower

CA WELLS CADDW0000012867

Well ID:	3000759-001	Well Type:	MUNICIPAL
Source:	Department of Health Services		
Other Name:	WELL 02 WEST	GAMA PFAS Testing:	Not Reported
Groundwater Quality Data:	https://gamagroundwater.waterboards.ca.gov/gama/gamamap/public/GamaDataDisplay.asp?dataset=DHS&samp_date=&global_id=&assigned_name=3000759-001&store_num=		
GeoTracker Data:	Not Reported		

B11
ENE
1/2 - 1 Mile
Lower

CA WELLS CADWR00000003511

Well ID:	03S08W34G002S	Well Type:	UNK
Source:	Department of Water Resources		
Other Name:	03S08W34G002S	GAMA PFAS Testing:	Not Reported
Groundwater Quality Data:	https://gamagroundwater.waterboards.ca.gov/gama/gamamap/public/GamaDataDisplay.asp?dataset=DWR&samp_date=&global_id=&assigned_name=03S08W34G002S&store_num=		
GeoTracker Data:	Not Reported		

B12
ENE
1/2 - 1 Mile
Lower

FED USGS USGS40000138686

Organization ID:	USGS-CA		
Organization Name:	USGS California Water Science Center		
Monitor Location:	003S008W34G002S	Type:	Well
Description:	Not Reported	HUC:	18070203
Drainage Area:	Not Reported	Drainage Area Units:	Not Reported
Contrib Drainage Area:	Not Reported	Contrib Drainage Area Unts:	Not Reported
Aquifer:	California Coastal Basin aquifers		
Formation Type:	Alluvium	Aquifer Type:	Unconfined single aquifer
Construction Date:	19690725	Well Depth:	98
Well Depth Units:	ft	Well Hole Depth:	98
Well Hole Depth Units:	ft		

GEOCHECK® - PHYSICAL SETTING SOURCE MAP FINDINGS

Ground water levels, Number of Measurements:	2	Level reading date:	2004-10-26
Feet below surface:	16.4	Feet to sea level:	Not Reported
Note:	Not Reported		
<hr/>			
Level reading date:	1999-04-01	Feet below surface:	18.78
Feet to sea level:	Not Reported	Note:	Not Reported

**B13
ENE
1/2 - 1 Mile
Lower**

CA WELLS CADDW0000002531

Well ID:	3000759-002	Well Type:	MUNICIPAL
Source:	Department of Health Services		
Other Name:	WELL 01 EAST	GAMA PFAS Testing:	Not Reported
Groundwater Quality Data:	https://gamagroundwater.waterboards.ca.gov/gama/gamamap/public/GamaDataDisplay.asp?dataset=DHS&samp_date=&global_id=&assigned_name=3000759-002&store_num=		
GeoTracker Data:	Not Reported		

**B14
ENE
1/2 - 1 Mile
Lower**

CA WELLS CAUSGS000000957

Well ID:	CLABOC-20	Well Type:	MUNICIPAL
Source:	United States Geological Survey		
Other Name:	CLABOC-20	GAMA PFAS Testing:	Not Reported
Groundwater Quality Data:	https://gamagroundwater.waterboards.ca.gov/gama/gamamap/public/GamaDataDisplay.asp?dataset=USGS&samp_date=&global_id=&assigned_name=CLABOC-20&store_num=		
GeoTracker Data:	Not Reported		

**B15
ENE
1/2 - 1 Mile
Lower**

CA WELLS CAUSGSN00012250

Well ID:	USGS-335210117422801	Well Type:	UNK
Source:	United States Geological Survey		
Other Name:	USGS-335210117422801	GAMA PFAS Testing:	Not Reported
Groundwater Quality Data:	https://gamagroundwater.waterboards.ca.gov/gama/gamamap/public/GamaDataDisplay.asp?dataset=USGSNEW&samp_date=&global_id=&assigned_name=USGS-335210117422801&store_num=		
GeoTracker Data:	Not Reported		

**C16
NE
1/2 - 1 Mile
Lower**

CA WELLS CADPR0000002172

Well ID:	79701	Well Type:	UNK
Source:	Department of Pesticide Regulation		
Other Name:	79701	GAMA PFAS Testing:	Not Reported
Groundwater Quality Data:	https://gamagroundwater.waterboards.ca.gov/gama/gamamap/public/GamaDataDisplay.asp?dataset=DPR&samp_date=&global_id=&assigned_name=79701&store_num=		
GeoTracker Data:	Not Reported		

GEOCHECK® - PHYSICAL SETTING SOURCE MAP FINDINGS

Map ID
Direction
Distance
Elevation

Database EDR ID Number

D17
NE
1/2 - 1 Mile
Lower

CA WELLS CADWR8000005985

State Well #:	03S08W34C001S	Station ID:	4582
Well Name:	Not Reported	Well Use:	Unknown
Well Type:	Unknown	Well Depth:	0
Basin Name:	Coastal Plain Of Orange County		
Well Completion Rpt #:	Not Reported		

D18
NE
1/2 - 1 Mile
Lower

CA WELLS CADWR0000032039

Well ID:	03S08W34C001S	Well Type:	UNK
Source:	Department of Water Resources		
Other Name:	03S08W34C001S	GAMA PFAS Testing:	Not Reported
Groundwater Quality Data:	https://gamagroundwater.waterboards.ca.gov/gama/gamamap/public/GamaDataDisplay.asp?dataset=DWR&samp_date=&global_id=&assigned_name=03S08W34C001S&store_num=		
GeoTracker Data:	Not Reported		

E19
ESE
1/2 - 1 Mile
Higher

CA WELLS 3660

Seq:	3660	Prim sta c:	03S/08W-34G01 S
Frds no:	3000759001	County:	30
District:	08	User id:	TEE
System no:	3000759	Water type:	G
Source nam:	WELL 02 WEST	Station ty:	WELL/AMBNT/MUN/INTAKE
Latitude:	335140.0	Longitude:	1174220.0
Precision:	3	Status:	AU
Comment 1:	WEST END OF LOT 15	Comment 2:	Not Reported
Comment 3:	Not Reported	Comment 4:	Not Reported
Comment 5:	Not Reported	Comment 6:	Not Reported
Comment 7:	Not Reported		
System no:	3000759	System nam:	Canyon Rv Park
Hqname:	Not Reported	Address:	24001 SANTA ANA CANYON RD.
City:	ANAHEIM	State:	CA
Zip:	92808	Zip ext:	Not Reported
Pop serv:	32	Connection:	1
Area serve:	Not Reported		
Sample date:	04-JAN-18	Finding:	6.5
Chemical:	GROSS ALPHA	Report units:	PCI/L
Dir:	3.		
Sample date:	04-JAN-18	Finding:	2.06
Chemical:	GROSS ALPHA COUNTING ERROR	Report units:	PCI/L
Dir:	0.		
Sample date:	04-JAN-18	Finding:	7.8e-002

GEOCHECK® - PHYSICAL SETTING SOURCE MAP FINDINGS

Chemical: Dir:	RADIUM 226 COUNTING ERROR 0.	Report units:	PCI/L
Sample date: Chemical: Dir:	04-JAN-18 RADIUM 228 MDA95 0.	Finding: Report units:	0.4 PCI/L
Sample date: Chemical: Dir:	04-JAN-18 RADIUM 228 COUNTING ERROR 0.	Finding: Report units:	0.485 PCI/L
Sample date: Chemical: Dir:	04-JAN-18 URANIUM (PCI/L) 1.	Finding: Report units:	5.35 PCI/L
Sample date: Chemical: Dir:	04-JAN-18 URANIUM COUNTING ERROR 0.	Finding: Report units:	1.48 PCI/L
Sample date: Chemical: Dir:	04-JAN-18 GROSS ALPHA MDA95 0.	Finding: Report units:	1.11 PCI/L
Sample date: Chemical: Dir:	04-JAN-18 URANIUM MDA95 0.	Finding: Report units:	0.47 PCI/L
Sample date: Chemical: Dir:	04-JAN-18 RADIUM 226 MDA95 0.	Finding: Report units:	0.322 PCI/L
Sample date: Chemical: Dir:	27-APR-17 TOTAL DISSOLVED SOLIDS 0.	Finding: Report units:	690. MG/L
Sample date: Chemical: Dir:	27-APR-17 BROMIDE 0.	Finding: Report units:	0.2 MG/L
Sample date: Chemical: Dir:	27-APR-17 NITRATE + NITRITE (AS N) 0.4	Finding: Report units:	0.41 MG/L
Sample date: Chemical: Dir:	27-APR-17 SPECIFIC CONDUCTANCE 0.	Finding: Report units:	1130. US
Sample date: Chemical: Dir:	27-APR-17 PH, LABORATORY 0.	Finding: Report units:	7.6 Not Reported
Sample date: Chemical: Dir:	27-APR-17 ALKALINITY (TOTAL) AS CaCO3 0.	Finding: Report units:	235. MG/L
Sample date: Chemical: Dir:	27-APR-17 BICARBONATE ALKALINITY 0.	Finding: Report units:	235. MG/L
Sample date: Chemical: Dir:	27-APR-17 TOTAL ORGANIC CARBON (TOC) 0.3	Finding: Report units:	1.85 MG/L

GEOCHECK® - PHYSICAL SETTING SOURCE MAP FINDINGS

Sample date:	27-APR-17	Finding:	329.
Chemical:	HARDNESS (TOTAL) AS CaCO ₃	Report units:	MG/L
Dir:	0.		
Sample date:	27-APR-17	Finding:	94.
Chemical:	CALCIUM	Report units:	MG/L
Dir:	0.		
Sample date:	27-APR-17	Finding:	22.8
Chemical:	MAGNESIUM	Report units:	MG/L
Dir:	0.		
Sample date:	27-APR-17	Finding:	103.
Chemical:	SODIUM	Report units:	MG/L
Dir:	0.		
Sample date:	27-APR-17	Finding:	7.6
Chemical:	POTASSIUM	Report units:	MG/L
Dir:	0.		
Sample date:	27-APR-17	Finding:	123.
Chemical:	CHLORIDE	Report units:	MG/L
Dir:	0.		
Sample date:	27-APR-17	Finding:	131.
Chemical:	SULFATE	Report units:	MG/L
Dir:	0.5		
Sample date:	27-APR-17	Finding:	0.47
Chemical:	FLUORIDE (F) (NATURAL-SOURCE)	Report units:	MG/L
Dir:	0.1		
Sample date:	27-APR-17	Finding:	5.5
Chemical:	ARSENIC	Report units:	UG/L
Dir:	2.		
Sample date:	27-APR-17	Finding:	290.
Chemical:	BORON	Report units:	UG/L
Dir:	100.		
Sample date:	27-APR-17	Finding:	967.
Chemical:	MANGANESE	Report units:	UG/L
Dir:	20.		
Sample date:	27-APR-17	Finding:	4.4
Chemical:	VANADIUM	Report units:	UG/L
Dir:	3.		
Sample date:	04-APR-16	Finding:	1120.
Chemical:	SPECIFIC CONDUCTANCE	Report units:	US
Dir:	0.		
Sample date:	04-APR-16	Finding:	740.
Chemical:	TOTAL DISSOLVED SOLIDS	Report units:	MG/L
Dir:	0.		
Sample date:	28-DEC-15	Finding:	310.
Chemical:	BORON	Report units:	UG/L
Dir:	100.		
Sample date:	28-DEC-15	Finding:	778.
Chemical:	TOTAL DISSOLVED SOLIDS	Report units:	MG/L

GEOCHECK® - PHYSICAL SETTING SOURCE MAP FINDINGS

Dir:	0.		
Sample date:	28-DEC-15	Finding:	320.
Chemical:	BORON	Report units:	UG/L
Dir:	100.		
Sample date:	28-DEC-15	Finding:	154.
Chemical:	SULFATE	Report units:	MG/L
Dir:	0.5		
Sample date:	28-DEC-15	Finding:	135.
Chemical:	CHLORIDE	Report units:	MG/L
Dir:	0.		
Sample date:	28-DEC-15	Finding:	7.8
Chemical:	POTASSIUM	Report units:	MG/L
Dir:	0.		
Sample date:	28-DEC-15	Finding:	1170.
Chemical:	SPECIFIC CONDUCTANCE	Report units:	US
Dir:	0.		
Sample date:	28-DEC-15	Finding:	7.7
Chemical:	PH, LABORATORY	Report units:	Not Reported
Dir:	0.		
Sample date:	28-DEC-15	Finding:	256.
Chemical:	ALKALINITY (TOTAL) AS CaCO ₃	Report units:	MG/L
Dir:	0.		
Sample date:	28-DEC-15	Finding:	256.
Chemical:	BICARBONATE ALKALINITY	Report units:	MG/L
Dir:	0.		
Sample date:	28-DEC-15	Finding:	1.95
Chemical:	TOTAL ORGANIC CARBON (TOC)	Report units:	MG/L
Dir:	0.3		
Sample date:	28-DEC-15	Finding:	323.
Chemical:	HARDNESS (TOTAL) AS CaCO ₃	Report units:	MG/L
Dir:	0.		
Sample date:	28-DEC-15	Finding:	92.2
Chemical:	CALCIUM	Report units:	MG/L
Dir:	0.		
Sample date:	28-DEC-15	Finding:	22.6
Chemical:	MAGNESIUM	Report units:	MG/L
Dir:	0.		
Sample date:	28-DEC-15	Finding:	104.
Chemical:	SODIUM	Report units:	MG/L
Dir:	0.		
Sample date:	28-DEC-15	Finding:	7.5
Chemical:	POTASSIUM	Report units:	MG/L
Dir:	0.		
Sample date:	28-DEC-15	Finding:	136.
Chemical:	CHLORIDE	Report units:	MG/L
Dir:	0.		

GEOCHECK® - PHYSICAL SETTING SOURCE MAP FINDINGS

Sample date:	28-DEC-15	Finding:	156.
Chemical:	SULFATE	Report units:	MG/L
Dir:	0.5		
Sample date:	28-DEC-15	Finding:	0.18
Chemical:	BROMIDE	Report units:	MG/L
Dir:	0.		
Sample date:	28-DEC-15	Finding:	776.
Chemical:	TOTAL DISSOLVED SOLIDS	Report units:	MG/L
Dir:	0.		
Sample date:	28-DEC-15	Finding:	0.18
Chemical:	BROMIDE	Report units:	MG/L
Dir:	0.		
Sample date:	28-DEC-15	Finding:	1180.
Chemical:	SPECIFIC CONDUCTANCE	Report units:	US
Dir:	0.		
Sample date:	28-DEC-15	Finding:	7.7
Chemical:	PH, LABORATORY	Report units:	Not Reported
Dir:	0.		
Sample date:	28-DEC-15	Finding:	248.
Chemical:	ALKALINITY (TOTAL) AS CaCO3	Report units:	MG/L
Dir:	0.		
Sample date:	28-DEC-15	Finding:	248.
Chemical:	BICARBONATE ALKALINITY	Report units:	MG/L
Dir:	0.		
Sample date:	28-DEC-15	Finding:	1.81
Chemical:	TOTAL ORGANIC CARBON (TOC)	Report units:	MG/L
Dir:	0.3		
Sample date:	28-DEC-15	Finding:	337.
Chemical:	HARDNESS (TOTAL) AS CaCO3	Report units:	MG/L
Dir:	0.		
Sample date:	28-DEC-15	Finding:	96.2
Chemical:	CALCIUM	Report units:	MG/L
Dir:	0.		
Sample date:	28-DEC-15	Finding:	23.5
Chemical:	MAGNESIUM	Report units:	MG/L
Dir:	0.		
Sample date:	28-DEC-15	Finding:	109.
Chemical:	SODIUM	Report units:	MG/L
Dir:	0.		
Sample date:	28-OCT-15	Finding:	818.
Chemical:	TOTAL DISSOLVED SOLIDS	Report units:	MG/L
Dir:	0.		
Sample date:	28-OCT-15	Finding:	1260.
Chemical:	SPECIFIC CONDUCTANCE	Report units:	US
Dir:	0.		
Sample date:	28-OCT-15	Finding:	820.
Chemical:	TOTAL DISSOLVED SOLIDS	Report units:	MG/L

GEOCHECK® - PHYSICAL SETTING SOURCE MAP FINDINGS

Dir:	0.		
Sample date:	28-OCT-15	Finding:	1230.
Chemical:	SPECIFIC CONDUCTANCE	Report units:	US
Dir:	0.		
Sample date:	28-SEP-15	Finding:	1290.
Chemical:	SPECIFIC CONDUCTANCE	Report units:	US
Dir:	0.		
Sample date:	28-SEP-15	Finding:	864.
Chemical:	TOTAL DISSOLVED SOLIDS	Report units:	MG/L
Dir:	0.		
Sample date:	28-SEP-15	Finding:	1280.
Chemical:	SPECIFIC CONDUCTANCE	Report units:	US
Dir:	0.		
Sample date:	28-SEP-15	Finding:	858.
Chemical:	TOTAL DISSOLVED SOLIDS	Report units:	MG/L
Dir:	0.		
Sample date:	13-APR-15	Finding:	5.
Chemical:	COLOR	Report units:	UNITS
Dir:	0.		
Sample date:	13-APR-15	Finding:	1090.
Chemical:	NITRATE + NITRITE (AS N)	Report units:	MG/L
Dir:	0.4		
Sample date:	13-APR-15	Finding:	1510.
Chemical:	SPECIFIC CONDUCTANCE	Report units:	US
Dir:	0.		
Sample date:	13-APR-15	Finding:	7.9
Chemical:	PH, LABORATORY	Report units:	Not Reported
Dir:	0.		
Sample date:	13-APR-15	Finding:	289.
Chemical:	ALKALINITY (TOTAL) AS CaCO ₃	Report units:	MG/L
Dir:	0.		
Sample date:	13-APR-15	Finding:	352.
Chemical:	BICARBONATE ALKALINITY	Report units:	MG/L
Dir:	0.		
Sample date:	13-APR-15	Finding:	2.02
Chemical:	TOTAL ORGANIC CARBON (TOC)	Report units:	MG/L
Dir:	0.3		
Sample date:	13-APR-15	Finding:	449.
Chemical:	HARDNESS (TOTAL) AS CaCO ₃	Report units:	MG/L
Dir:	0.		
Sample date:	13-APR-15	Finding:	128.
Chemical:	CALCIUM	Report units:	MG/L
Dir:	0.		
Sample date:	13-APR-15	Finding:	31.4
Chemical:	MAGNESIUM	Report units:	MG/L
Dir:	0.		

GEOCHECK® - PHYSICAL SETTING SOURCE MAP FINDINGS

Sample date:	13-APR-15	Finding:	126.
Chemical:	SODIUM	Report units:	MG/L
Dir:	0.		
Sample date:	13-APR-15	Finding:	8.7
Chemical:	POTASSIUM	Report units:	MG/L
Dir:	0.		
Sample date:	13-APR-15	Finding:	149.
Chemical:	CHLORIDE	Report units:	MG/L
Dir:	0.		
Sample date:	13-APR-15	Finding:	248.
Chemical:	SULFATE	Report units:	MG/L
Dir:	0.5		
Sample date:	13-APR-15	Finding:	0.39
Chemical:	FLUORIDE (F) (NATURAL-SOURCE)	Report units:	MG/L
Dir:	0.1		
Sample date:	13-APR-15	Finding:	5.4
Chemical:	ARSENIC	Report units:	UG/L
Dir:	2.		
Sample date:	13-APR-15	Finding:	105.
Chemical:	BARIUM	Report units:	UG/L
Dir:	100.		
Sample date:	13-APR-15	Finding:	380.
Chemical:	BORON	Report units:	UG/L
Dir:	100.		
Sample date:	13-APR-15	Finding:	4.4
Chemical:	VANADIUM	Report units:	UG/L
Dir:	3.		
Sample date:	13-APR-15	Finding:	916.
Chemical:	TOTAL DISSOLVED SOLIDS	Report units:	MG/L
Dir:	0.		
Sample date:	13-APR-15	Finding:	4.2
Chemical:	NITRATE (AS NO3)	Report units:	MG/L
Dir:	2.		
Sample date:	13-APR-15	Finding:	0.2
Chemical:	BROMIDE	Report units:	MG/L
Dir:	0.		
Sample date:	15-JAN-15	Finding:	2750.
Chemical:	MANGANESE	Report units:	UG/L
Dir:	20.		
Sample date:	09-APR-14	Finding:	1920.
Chemical:	NITRATE + NITRITE (AS N)	Report units:	MG/L
Dir:	0.4		
Sample date:	09-APR-14	Finding:	1.38
Chemical:	GROSS ALPHA COUNTING ERROR	Report units:	PCI/L
Dir:	0.		
Sample date:	09-APR-14	Finding:	9.4e-002
Chemical:	RADIUM 228	Report units:	PCI/L

GEOCHECK® - PHYSICAL SETTING SOURCE MAP FINDINGS

Dir:	1.		
Sample date:	09-APR-14	Finding:	0.498
Chemical:	RADIUM 228 COUNTING ERROR	Report units:	PCI/L
Dir:	0.		
Sample date:	09-APR-14	Finding:	7.41
Chemical:	NITRATE (AS NO3)	Report units:	MG/L
Dir:	2.		
Sample date:	09-APR-14	Finding:	4.98
Chemical:	URANIUM (PCI/L)	Report units:	PCI/L
Dir:	1.		
Sample date:	09-APR-14	Finding:	0.47
Chemical:	RADIUM, TOTAL, MDA95-NTNC ONLY, BY 903.0	Dir:	0.
Report units:	PCI/L		
Sample date:	09-APR-14	Finding:	1.17
Chemical:	URANIUM COUNTING ERROR	Report units:	PCI/L
Dir:	0.		
Sample date:	09-APR-14	Finding:	1.11
Chemical:	GROSS ALPHA MDA95	Report units:	PCI/L
Dir:	0.		
Sample date:	09-APR-14	Finding:	0.3
Chemical:	URANIUM MDA95	Report units:	PCI/L
Dir:	0.		
Sample date:	09-APR-14	Finding:	0.253
Chemical:	RADIUM 228 MDA95	Report units:	PCI/L
Dir:	0.		
Sample date:	09-APR-14	Finding:	3.7e-002
Chemical:	RA-226 FOR CWS OR TOTAL RA FOR NTNC BY 903.0	Dir:	0.
Report units:	PCI/L		
Sample date:	09-APR-14	Finding:	0.217
Chemical:	RA-226 OR TOTAL RA BY 903.0 C.E.	Report units:	PCI/L
Dir:	0.		
Sample date:	07-NOV-13	Finding:	6.3
Chemical:	ARSENIC	Report units:	UG/L
Dir:	2.		
Sample date:	26-JUN-13	Finding:	6.1
Chemical:	NITRATE (AS NO3)	Report units:	MG/L
Dir:	2.		
Sample date:	26-JUN-13	Finding:	1560.
Chemical:	NITRATE + NITRITE (AS N)	Report units:	MG/L
Dir:	0.4		
Sample date:	26-JUN-13	Finding:	6.8
Chemical:	ARSENIC	Report units:	UG/L
Dir:	2.		
Sample date:	26-JUN-13	Finding:	1110.
Chemical:	SPECIFIC CONDUCTANCE	Report units:	US
Dir:	0.		

GEOCHECK® - PHYSICAL SETTING SOURCE MAP FINDINGS

Sample date:	26-JUN-13	Finding:	5.3
Chemical:	VANADIUM	Report units:	UG/L
Dir:	3.		
Sample date:	05-DEC-12	Finding:	996.
Chemical:	MANGANESE	Report units:	UG/L
Dir:	20.		
Sample date:	17-JUL-12	Finding:	7.9
Chemical:	PH, LABORATORY	Report units:	Not Reported
Dir:	0.		
Sample date:	17-JUL-12	Finding:	219.
Chemical:	ALKALINITY (TOTAL) AS CaCO3	Report units:	MG/L
Dir:	0.		
Sample date:	17-JUL-12	Finding:	267.
Chemical:	BICARBONATE ALKALINITY	Report units:	MG/L
Dir:	0.		
Sample date:	17-JUL-12	Finding:	1.76
Chemical:	TOTAL ORGANIC CARBON (TOC)	Report units:	MG/L
Dir:	0.3		
Sample date:	17-JUL-12	Finding:	309.
Chemical:	HARDNESS (TOTAL) AS CaCO3	Report units:	MG/L
Dir:	0.		
Sample date:	17-JUL-12	Finding:	89.
Chemical:	CALCIUM	Report units:	MG/L
Dir:	0.		
Sample date:	17-JUL-12	Finding:	21.2
Chemical:	MAGNESIUM	Report units:	MG/L
Dir:	0.		
Sample date:	17-JUL-12	Finding:	98.3
Chemical:	SODIUM	Report units:	MG/L
Dir:	0.		
Sample date:	17-JUL-12	Finding:	6.8
Chemical:	POTASSIUM	Report units:	MG/L
Dir:	0.		
Sample date:	17-JUL-12	Finding:	116.
Chemical:	CHLORIDE	Report units:	MG/L
Dir:	0.		
Sample date:	17-JUL-12	Finding:	126.
Chemical:	SULFATE	Report units:	MG/L
Dir:	0.5		
Sample date:	17-JUL-12	Finding:	0.43
Chemical:	FLUORIDE (F) (NATURAL-SOURCE)	Report units:	MG/L
Dir:	0.1		
Sample date:	17-JUL-12	Finding:	5.9
Chemical:	ARSENIC	Report units:	UG/L
Dir:	2.		
Sample date:	17-JUL-12	Finding:	280.
Chemical:	BORON	Report units:	UG/L

GEOCHECK® - PHYSICAL SETTING SOURCE MAP FINDINGS

Dir:	100.		
Sample date:	17-JUL-12	Finding:	4.1
Chemical:	VANADIUM	Report units:	UG/L
Dir:	3.		
Sample date:	17-JUL-12	Finding:	598.
Chemical:	TOTAL DISSOLVED SOLIDS	Report units:	MG/L
Dir:	0.		
Sample date:	17-JUL-12	Finding:	8.1
Chemical:	NITRATE (AS NO3)	Report units:	MG/L
Dir:	2.		
Sample date:	17-JUL-12	Finding:	0.11
Chemical:	BROMIDE	Report units:	MG/L
Dir:	0.		
Sample date:	17-JUL-12	Finding:	2050.
Chemical:	NITRATE + NITRITE (AS N)	Report units:	MG/L
Dir:	0.4		
Sample date:	17-JUL-12	Finding:	5.
Chemical:	COLOR	Report units:	UNITS
Dir:	0.		
Sample date:	17-JUL-12	Finding:	1020.
Chemical:	SPECIFIC CONDUCTANCE	Report units:	US
Dir:	0.		

**E20
ESE
1/2 - 1 Mile
Higher**

CA WELLS 3661

Seq:	3661	Prim sta c:	03S/08W-34G02 S
Frds no:	3000759002	County:	30
District:	08	User id:	TEE
System no:	3000759	Water type:	G
Source nam:	WELL 01 EAST	Station ty:	WELL/AMBNT/MUN/INTAKE
Latitude:	335140.0	Longitude:	1174220.0
Precision:	3	Status:	AU
Comment 1:	ANAHEIM	Comment 2:	Not Reported
Comment 3:	Not Reported	Comment 4:	Not Reported
Comment 5:	Not Reported	Comment 6:	Not Reported
Comment 7:	Not Reported		
System no:	3000759	System nam:	Canyon Rv Park
Hqname:	Not Reported	Address:	24001 SANTA ANA CANYON RD.
City:	ANAHEIM	State:	CA
Zip:	92808	Zip ext:	Not Reported
Pop serv:	32	Connection:	1
Area serve:	Not Reported		
Sample date:	04-JAN-18	Finding:	7.6
Chemical:	GROSS ALPHA	Report units:	PCI/L
Dir:	3.		
Sample date:	04-JAN-18	Finding:	2.38
Chemical:	GROSS ALPHA COUNTING ERROR	Report units:	PCI/L
Dir:	0.		

GEOCHECK® - PHYSICAL SETTING SOURCE MAP FINDINGS

Sample date:	04-JAN-18	Finding:	4.e-002
Chemical:	RADIUM 226	Report units:	PCI/L
Dir:	1.		
Sample date:	04-JAN-18	Finding:	9.6e-002
Chemical:	RADIUM 226 COUNTING ERROR	Report units:	PCI/L
Dir:	0.		
Sample date:	04-JAN-18	Finding:	0.506
Chemical:	RADIUM 228 MDA95	Report units:	PCI/L
Dir:	0.		
Sample date:	04-JAN-18	Finding:	0.496
Chemical:	RADIUM 228 COUNTING ERROR	Report units:	PCI/L
Dir:	0.		
Sample date:	04-JAN-18	Finding:	4.16
Chemical:	URANIUM (PCI/L)	Report units:	PCI/L
Dir:	1.		
Sample date:	04-JAN-18	Finding:	1.32
Chemical:	URANIUM COUNTING ERROR	Report units:	PCI/L
Dir:	0.		
Sample date:	04-JAN-18	Finding:	1.28
Chemical:	GROSS ALPHA MDA95	Report units:	PCI/L
Dir:	0.		
Sample date:	04-JAN-18	Finding:	0.47
Chemical:	URANIUM MDA95	Report units:	PCI/L
Dir:	0.		
Sample date:	04-JAN-18	Finding:	0.322
Chemical:	RADIUM 226 MDA95	Report units:	PCI/L
Dir:	0.		
Sample date:	27-APR-17	Finding:	700.
Chemical:	TOTAL DISSOLVED SOLIDS	Report units:	MG/L
Dir:	0.		
Sample date:	27-APR-17	Finding:	0.4
Chemical:	TURBIDITY, LABORATORY	Report units:	NTU
Dir:	0.1		
Sample date:	27-APR-17	Finding:	0.21
Chemical:	BROMIDE	Report units:	MG/L
Dir:	0.		
Sample date:	27-APR-17	Finding:	0.42
Chemical:	NITRATE + NITRITE (AS N)	Report units:	MG/L
Dir:	0.4		
Sample date:	27-APR-17	Finding:	1150.
Chemical:	SPECIFIC CONDUCTANCE	Report units:	US
Dir:	0.		
Sample date:	27-APR-17	Finding:	7.6
Chemical:	PH, LABORATORY	Report units:	Not Reported
Dir:	0.		
Sample date:	27-APR-17	Finding:	242.
Chemical:	ALKALINITY (TOTAL) AS CaCO3	Report units:	MG/L

GEOCHECK® - PHYSICAL SETTING SOURCE MAP FINDINGS

Dir:	0.		
Sample date:	27-APR-17	Finding:	242.
Chemical:	BICARBONATE ALKALINITY	Report units:	MG/L
Dir:	0.		
Sample date:	27-APR-17	Finding:	1.91
Chemical:	TOTAL ORGANIC CARBON (TOC)	Report units:	MG/L
Dir:	0.3		
Sample date:	27-APR-17	Finding:	343.
Chemical:	HARDNESS (TOTAL) AS CaCO ₃	Report units:	MG/L
Dir:	0.		
Sample date:	27-APR-17	Finding:	98.1
Chemical:	CALCIUM	Report units:	MG/L
Dir:	0.		
Sample date:	27-APR-17	Finding:	23.8
Chemical:	MAGNESIUM	Report units:	MG/L
Dir:	0.		
Sample date:	27-APR-17	Finding:	106.
Chemical:	SODIUM	Report units:	MG/L
Dir:	0.		
Sample date:	27-APR-17	Finding:	8.3
Chemical:	POTASSIUM	Report units:	MG/L
Dir:	0.		
Sample date:	27-APR-17	Finding:	127.
Chemical:	CHLORIDE	Report units:	MG/L
Dir:	0.		
Sample date:	27-APR-17	Finding:	131.
Chemical:	SULFATE	Report units:	MG/L
Dir:	0.5		
Sample date:	27-APR-17	Finding:	0.48
Chemical:	FLUORIDE (F) (NATURAL-SOURCE)	Report units:	MG/L
Dir:	0.1		
Sample date:	27-APR-17	Finding:	7.
Chemical:	ARSENIC	Report units:	UG/L
Dir:	2.		
Sample date:	27-APR-17	Finding:	310.
Chemical:	BORON	Report units:	UG/L
Dir:	100.		
Sample date:	27-APR-17	Finding:	4.8
Chemical:	VANADIUM	Report units:	UG/L
Dir:	3.		
Sample date:	04-APR-16	Finding:	0.52
Chemical:	NITRATE + NITRITE (AS N)	Report units:	MG/L
Dir:	0.4		
Sample date:	04-APR-16	Finding:	1200.
Chemical:	SPECIFIC CONDUCTANCE	Report units:	US
Dir:	0.		

GEOCHECK® - PHYSICAL SETTING SOURCE MAP FINDINGS

Sample date:	04-APR-16	Finding:	0.42
Chemical:	NITRATE (AS N)	Report units:	MG/L
Dir:	0.4		
Sample date:	04-APR-16	Finding:	949.
Chemical:	MANGANESE	Report units:	UG/L
Dir:	20.		
Sample date:	04-APR-16	Finding:	728.
Chemical:	TOTAL DISSOLVED SOLIDS	Report units:	MG/L
Dir:	0.		
Sample date:	28-DEC-15	Finding:	0.3
Chemical:	TURBIDITY, LABORATORY	Report units:	NTU
Dir:	0.1		
Sample date:	28-DEC-15	Finding:	1180.
Chemical:	SPECIFIC CONDUCTANCE	Report units:	US
Dir:	0.		
Sample date:	28-DEC-15	Finding:	0.2
Chemical:	TURBIDITY, LABORATORY	Report units:	NTU
Dir:	0.1		
Sample date:	28-DEC-15	Finding:	1170.
Chemical:	SPECIFIC CONDUCTANCE	Report units:	US
Dir:	0.		
Sample date:	28-OCT-15	Finding:	165.
Chemical:	SULFATE	Report units:	MG/L
Dir:	0.5		
Sample date:	28-OCT-15	Finding:	6.7
Chemical:	ARSENIC	Report units:	UG/L
Dir:	2.		
Sample date:	28-OCT-15	Finding:	330.
Chemical:	BORON	Report units:	UG/L
Dir:	100.		
Sample date:	28-OCT-15	Finding:	949.
Chemical:	MANGANESE	Report units:	UG/L
Dir:	20.		
Sample date:	28-OCT-15	Finding:	5.
Chemical:	VANADIUM	Report units:	UG/L
Dir:	3.		
Sample date:	28-OCT-15	Finding:	802.
Chemical:	TOTAL DISSOLVED SOLIDS	Report units:	MG/L
Dir:	0.		
Sample date:	28-OCT-15	Finding:	0.19
Chemical:	BROMIDE	Report units:	MG/L
Dir:	0.		
Sample date:	28-OCT-15	Finding:	1270.
Chemical:	SPECIFIC CONDUCTANCE	Report units:	US
Dir:	0.		
Sample date:	28-OCT-15	Finding:	7.7
Chemical:	PH, LABORATORY	Report units:	Not Reported

GEOCHECK® - PHYSICAL SETTING SOURCE MAP FINDINGS

Dir:	0.		
Sample date:	28-OCT-15	Finding:	274.
Chemical:	ALKALINITY (TOTAL) AS CaCO3	Report units:	MG/L
Dir:	0.		
Sample date:	28-OCT-15	Finding:	274.
Chemical:	BICARBONATE ALKALINITY	Report units:	MG/L
Dir:	0.		
Sample date:	28-OCT-15	Finding:	1.82
Chemical:	TOTAL ORGANIC CARBON (TOC)	Report units:	MG/L
Dir:	0.3		
Sample date:	28-OCT-15	Finding:	366.
Chemical:	HARDNESS (TOTAL) AS CaCO3	Report units:	MG/L
Dir:	0.		
Sample date:	28-OCT-15	Finding:	106.
Chemical:	CALCIUM	Report units:	MG/L
Dir:	0.		
Sample date:	28-OCT-15	Finding:	24.7
Chemical:	MAGNESIUM	Report units:	MG/L
Dir:	0.		
Sample date:	28-OCT-15	Finding:	114.
Chemical:	SODIUM	Report units:	MG/L
Dir:	0.		
Sample date:	28-OCT-15	Finding:	8.5
Chemical:	POTASSIUM	Report units:	MG/L
Dir:	0.		
Sample date:	28-OCT-15	Finding:	136.
Chemical:	CHLORIDE	Report units:	MG/L
Dir:	0.		
Sample date:	28-OCT-15	Finding:	163.
Chemical:	SULFATE	Report units:	MG/L
Dir:	0.5		
Sample date:	28-OCT-15	Finding:	6.8
Chemical:	ARSENIC	Report units:	UG/L
Dir:	2.		
Sample date:	28-OCT-15	Finding:	340.
Chemical:	BORON	Report units:	UG/L
Dir:	100.		
Sample date:	28-OCT-15	Finding:	5.4
Chemical:	VANADIUM	Report units:	UG/L
Dir:	3.		
Sample date:	28-OCT-15	Finding:	802.
Chemical:	TOTAL DISSOLVED SOLIDS	Report units:	MG/L
Dir:	0.		
Sample date:	28-OCT-15	Finding:	0.19
Chemical:	BROMIDE	Report units:	MG/L
Dir:	0.		

GEOCHECK® - PHYSICAL SETTING SOURCE MAP FINDINGS

Sample date:	28-OCT-15	Finding:	1260.
Chemical:	SPECIFIC CONDUCTANCE	Report units:	US
Dir:	0.		
Sample date:	28-OCT-15	Finding:	7.8
Chemical:	PH, LABORATORY	Report units:	Not Reported
Dir:	0.		
Sample date:	28-OCT-15	Finding:	274.
Chemical:	ALKALINITY (TOTAL) AS CaCO ₃	Report units:	MG/L
Dir:	0.		
Sample date:	28-OCT-15	Finding:	274.
Chemical:	BICARBONATE ALKALINITY	Report units:	MG/L
Dir:	0.		
Sample date:	28-OCT-15	Finding:	1.84
Chemical:	TOTAL ORGANIC CARBON (TOC)	Report units:	MG/L
Dir:	0.3		
Sample date:	28-OCT-15	Finding:	363.
Chemical:	HARDNESS (TOTAL) AS CaCO ₃	Report units:	MG/L
Dir:	0.		
Sample date:	28-OCT-15	Finding:	105.
Chemical:	CALCIUM	Report units:	MG/L
Dir:	0.		
Sample date:	28-OCT-15	Finding:	24.6
Chemical:	MAGNESIUM	Report units:	MG/L
Dir:	0.		
Sample date:	28-OCT-15	Finding:	112.
Chemical:	SODIUM	Report units:	MG/L
Dir:	0.		
Sample date:	28-OCT-15	Finding:	8.4
Chemical:	POTASSIUM	Report units:	MG/L
Dir:	0.		
Sample date:	28-OCT-15	Finding:	138.
Chemical:	CHLORIDE	Report units:	MG/L
Dir:	0.		
Sample date:	27-JUL-15	Finding:	997.
Chemical:	MANGANESE	Report units:	UG/L
Dir:	20.		
Sample date:	27-JUL-15	Finding:	806.
Chemical:	TOTAL DISSOLVED SOLIDS	Report units:	MG/L
Dir:	0.		
Sample date:	27-JUL-15	Finding:	1320.
Chemical:	SPECIFIC CONDUCTANCE	Report units:	US
Dir:	0.		
Sample date:	13-APR-15	Finding:	284.
Chemical:	ALKALINITY (TOTAL) AS CaCO ₃	Report units:	MG/L
Dir:	0.		
Sample date:	13-APR-15	Finding:	346.
Chemical:	BICARBONATE ALKALINITY	Report units:	MG/L

GEOCHECK® - PHYSICAL SETTING SOURCE MAP FINDINGS

Dir:	0.		
Sample date:	13-APR-15	Finding:	1.79
Chemical:	TOTAL ORGANIC CARBON (TOC)	Report units:	MG/L
Dir:	0.3		
Sample date:	13-APR-15	Finding:	446.
Chemical:	HARDNESS (TOTAL) AS CaCO3	Report units:	MG/L
Dir:	0.		
Sample date:	13-APR-15	Finding:	128.
Chemical:	CALCIUM	Report units:	MG/L
Dir:	0.		
Sample date:	13-APR-15	Finding:	30.3
Chemical:	MAGNESIUM	Report units:	MG/L
Dir:	0.		
Sample date:	13-APR-15	Finding:	128.
Chemical:	SODIUM	Report units:	MG/L
Dir:	0.		
Sample date:	13-APR-15	Finding:	8.8
Chemical:	POTASSIUM	Report units:	MG/L
Dir:	0.		
Sample date:	13-APR-15	Finding:	152.
Chemical:	CHLORIDE	Report units:	MG/L
Dir:	0.		
Sample date:	13-APR-15	Finding:	247.
Chemical:	SULFATE	Report units:	MG/L
Dir:	0.5		
Sample date:	13-APR-15	Finding:	0.4
Chemical:	FLUORIDE (F) (NATURAL-SOURCE)	Report units:	MG/L
Dir:	0.1		
Sample date:	13-APR-15	Finding:	6.5
Chemical:	ARSENIC	Report units:	UG/L
Dir:	2.		
Sample date:	13-APR-15	Finding:	380.
Chemical:	BORON	Report units:	UG/L
Dir:	100.		
Sample date:	13-APR-15	Finding:	4.6
Chemical:	VANADIUM	Report units:	UG/L
Dir:	3.		
Sample date:	13-APR-15	Finding:	886.
Chemical:	TOTAL DISSOLVED SOLIDS	Report units:	MG/L
Dir:	0.		
Sample date:	13-APR-15	Finding:	4.
Chemical:	NITRATE (AS NO3)	Report units:	MG/L
Dir:	2.		
Sample date:	13-APR-15	Finding:	0.22
Chemical:	BROMIDE	Report units:	MG/L
Dir:	0.		

GEOCHECK® - PHYSICAL SETTING SOURCE MAP FINDINGS

Sample date:	13-APR-15	Finding:	1010.
Chemical:	NITRATE + NITRITE (AS N)	Report units:	MG/L
Dir:	0.4		
Sample date:	13-APR-15	Finding:	8.
Chemical:	PH, LABORATORY	Report units:	Not Reported
Dir:	0.		
Sample date:	13-APR-15	Finding:	1490.
Chemical:	SPECIFIC CONDUCTANCE	Report units:	US
Dir:	0.		
Sample date:	13-APR-15	Finding:	5.
Chemical:	COLOR	Report units:	UNITS
Dir:	0.		
Sample date:	15-JAN-15	Finding:	5.
Chemical:	NITRATE (AS NO3)	Report units:	MG/L
Dir:	2.		
Sample date:	15-JAN-15	Finding:	1280.
Chemical:	NITRATE + NITRITE (AS N)	Report units:	MG/L
Dir:	0.4		
Sample date:	08-OCT-14	Finding:	4.8
Chemical:	NITRATE (AS NO3)	Report units:	MG/L
Dir:	2.		
Sample date:	08-OCT-14	Finding:	1220.
Chemical:	NITRATE + NITRITE (AS N)	Report units:	MG/L
Dir:	0.4		
Sample date:	08-OCT-14	Finding:	950.
Chemical:	MANGANESE	Report units:	UG/L
Dir:	20.		
Sample date:	17-JUL-14	Finding:	3.94
Chemical:	NITRATE (AS NO3)	Report units:	MG/L
Dir:	2.		
Sample date:	17-JUL-14	Finding:	881.
Chemical:	MANGANESE	Report units:	UG/L
Dir:	20.		
Sample date:	17-JUL-14	Finding:	1010.
Chemical:	NITRATE + NITRITE (AS N)	Report units:	MG/L
Dir:	0.4		
Sample date:	19-JUN-14	Finding:	0.525
Chemical:	RADIUM 228 COUNTING ERROR	Report units:	PCI/L
Dir:	0.		
Sample date:	19-JUN-14	Finding:	3.43
Chemical:	URANIUM (PCI/L)	Report units:	PCI/L
Dir:	1.		
Sample date:	19-JUN-14	Finding:	1.11
Chemical:	GROSS ALPHA MDA95	Report units:	PCI/L
Dir:	0.		
Sample date:	19-JUN-14	Finding:	0.3
Chemical:	URANIUM MDA95	Report units:	PCI/L

GEOCHECK® - PHYSICAL SETTING SOURCE MAP FINDINGS

Dir:	0.		
Sample date:	19-JUN-14	Finding:	0.2
Chemical:	RADIUM 228 MDA95	Report units:	PCI/L
Dir:	0.		
Sample date:	19-JUN-14	Finding:	0.399
Chemical:	RA-226 FOR CWS OR TOTAL RA FOR NTNC BY 903.0	Dir:	0.
Report units:	PCI/L		
Sample date:	19-JUN-14	Finding:	0.338
Chemical:	RA-226 OR TOTAL RA BY 903.0 C.E.	Report units:	PCI/L
Dir:	0.		
Sample date:	19-JUN-14	Finding:	0.418
Chemical:	RADIUM, TOTAL, MDA95-NTNC ONLY, BY 903.0	Dir:	0.
Report units:	PCI/L		
Sample date:	19-JUN-14	Finding:	7.7e-002
Chemical:	RADIUM 228	Report units:	PCI/L
Dir:	1.		
Sample date:	19-JUN-14	Finding:	1.88
Chemical:	GROSS ALPHA COUNTING ERROR	Report units:	PCI/L
Dir:	0.		
Sample date:	19-JUN-14	Finding:	5.28
Chemical:	GROSS ALPHA	Report units:	PCI/L
Dir:	3.		
Sample date:	19-JUN-14	Finding:	1190.
Chemical:	NITRATE + NITRITE (AS N)	Report units:	MG/L
Dir:	0.4		
Sample date:	19-JUN-14	Finding:	4.61
Chemical:	NITRATE (AS NO3)	Report units:	MG/L
Dir:	2.		
Sample date:	19-JUN-14	Finding:	901.
Chemical:	MANGANESE	Report units:	UG/L
Dir:	20.		
Sample date:	19-JUN-14	Finding:	0.998
Chemical:	URANIUM COUNTING ERROR	Report units:	PCI/L
Dir:	0.		
Sample date:	28-JAN-14	Finding:	9.2
Chemical:	NITRATE (AS NO3)	Report units:	MG/L
Dir:	2.		
Sample date:	28-JAN-14	Finding:	756.
Chemical:	MANGANESE	Report units:	UG/L
Dir:	20.		
Sample date:	28-JAN-14	Finding:	2400.
Chemical:	NITRATE + NITRITE (AS N)	Report units:	MG/L
Dir:	0.4		
Sample date:	07-OCT-13	Finding:	765.
Chemical:	MANGANESE	Report units:	UG/L
Dir:	20.		

GEOCHECK® - PHYSICAL SETTING SOURCE MAP FINDINGS

Sample date:	07-OCT-13	Finding:	2030.
Chemical:	NITRATE + NITRITE (AS N)	Report units:	MG/L
Dir:	0.4		
Sample date:	07-OCT-13	Finding:	7.4
Chemical:	ARSENIC	Report units:	UG/L
Dir:	2.		
Sample date:	07-OCT-13	Finding:	7.66
Chemical:	NITRATE (AS NO3)	Report units:	MG/L
Dir:	2.		
Sample date:	01-JUL-13	Finding:	1640.
Chemical:	NITRATE + NITRITE (AS N)	Report units:	MG/L
Dir:	0.4		
Sample date:	01-JUL-13	Finding:	6.2
Chemical:	NITRATE (AS NO3)	Report units:	MG/L
Dir:	2.		
Sample date:	01-JUL-13	Finding:	811.
Chemical:	MANGANESE	Report units:	UG/L
Dir:	20.		
Sample date:	11-APR-13	Finding:	1350.
Chemical:	NITRATE + NITRITE (AS N)	Report units:	MG/L
Dir:	0.4		
Sample date:	11-APR-13	Finding:	5.1
Chemical:	VANADIUM	Report units:	UG/L
Dir:	3.		
Sample date:	11-APR-13	Finding:	752.
Chemical:	MANGANESE	Report units:	UG/L
Dir:	20.		
Sample date:	11-APR-13	Finding:	7.3
Chemical:	ARSENIC	Report units:	UG/L
Dir:	2.		
Sample date:	11-APR-13	Finding:	1110.
Chemical:	SPECIFIC CONDUCTANCE	Report units:	US
Dir:	0.		
Sample date:	11-APR-13	Finding:	4.97
Chemical:	NITRATE (AS NO3)	Report units:	MG/L
Dir:	2.		
Sample date:	21-JAN-13	Finding:	5.1
Chemical:	NITRATE (AS NO3)	Report units:	MG/L
Dir:	2.		
Sample date:	21-JAN-13	Finding:	866.
Chemical:	MANGANESE	Report units:	UG/L
Dir:	20.		
Sample date:	21-JAN-13	Finding:	1450.
Chemical:	NITRATE + NITRITE (AS N)	Report units:	MG/L
Dir:	0.4		
Sample date:	04-OCT-12	Finding:	7.9
Chemical:	ARSENIC	Report units:	UG/L

GEOCHECK® - PHYSICAL SETTING SOURCE MAP FINDINGS

Dir:	2.		
Sample date:	04-OCT-12	Finding:	6.6
Chemical:	NITRATE (AS NO3)	Report units:	MG/L
Dir:	2.		
Sample date:	04-OCT-12	Finding:	756.
Chemical:	MANGANESE	Report units:	UG/L
Dir:	20.		
Sample date:	04-OCT-12	Finding:	1790.
Chemical:	NITRATE + NITRITE (AS N)	Report units:	MG/L
Dir:	0.4		
Sample date:	02-JUL-12	Finding:	2870.
Chemical:	NITRATE + NITRITE (AS N)	Report units:	MG/L
Dir:	0.4		
Sample date:	02-JUL-12	Finding:	783.
Chemical:	MANGANESE	Report units:	UG/L
Dir:	20.		
Sample date:	02-APR-12	Finding:	93.6
Chemical:	CALCIUM	Report units:	MG/L
Dir:	0.		
Sample date:	02-APR-12	Finding:	20.8
Chemical:	MAGNESIUM	Report units:	MG/L
Dir:	0.		
Sample date:	02-APR-12	Finding:	96.
Chemical:	SODIUM	Report units:	MG/L
Dir:	0.		
Sample date:	02-APR-12	Finding:	7.
Chemical:	POTASSIUM	Report units:	MG/L
Dir:	0.		
Sample date:	02-APR-12	Finding:	120.
Chemical:	CHLORIDE	Report units:	MG/L
Dir:	0.		
Sample date:	02-APR-12	Finding:	147.
Chemical:	SULFATE	Report units:	MG/L
Dir:	0.5		
Sample date:	02-APR-12	Finding:	7.4
Chemical:	ARSENIC	Report units:	UG/L
Dir:	2.		
Sample date:	02-APR-12	Finding:	270.
Chemical:	BORON	Report units:	UG/L
Dir:	100.		
Sample date:	02-APR-12	Finding:	693.
Chemical:	MANGANESE	Report units:	UG/L
Dir:	20.		
Sample date:	02-APR-12	Finding:	5.4
Chemical:	VANADIUM	Report units:	UG/L
Dir:	3.		

GEOCHECK® - PHYSICAL SETTING SOURCE MAP FINDINGS

Sample date:	02-APR-12	Finding:	676.
Chemical:	TOTAL DISSOLVED SOLIDS	Report units:	MG/L
Dir:	0.		
Sample date:	02-APR-12	Finding:	8.5
Chemical:	NITRATE (AS NO3)	Report units:	MG/L
Dir:	2.		
Sample date:	02-APR-12	Finding:	0.2
Chemical:	TURBIDITY, LABORATORY	Report units:	NTU
Dir:	0.1		
Sample date:	02-APR-12	Finding:	2270.
Chemical:	NITRATE + NITRITE (AS N)	Report units:	MG/L
Dir:	0.4		
Sample date:	02-APR-12	Finding:	319.
Chemical:	HARDNESS (TOTAL) AS CaCO3	Report units:	MG/L
Dir:	0.		
Sample date:	02-APR-12	Finding:	1.74
Chemical:	TOTAL ORGANIC CARBON (TOC)	Report units:	MG/L
Dir:	0.3		
Sample date:	02-APR-12	Finding:	265.
Chemical:	BICARBONATE ALKALINITY	Report units:	MG/L
Dir:	0.		
Sample date:	02-APR-12	Finding:	217.
Chemical:	ALKALINITY (TOTAL) AS CaCO3	Report units:	MG/L
Dir:	0.		
Sample date:	02-APR-12	Finding:	7.8
Chemical:	PH, LABORATORY	Report units:	Not Reported
Dir:	0.		
Sample date:	02-APR-12	Finding:	1010.
Chemical:	SPECIFIC CONDUCTANCE	Report units:	US
Dir:	0.		
Sample date:	02-APR-12	Finding:	8.
Chemical:	COLOR	Report units:	UNITS
Dir:	0.		
Sample date:	02-APR-12	Finding:	0.42
Chemical:	FLUORIDE (F) (NATURAL-SOURCE)	Report units:	MG/L
Dir:	0.1		
Sample date:	03-JAN-12	Finding:	3.1
Chemical:	NITRATE (AS NO3)	Report units:	MG/L
Dir:	2.		
Sample date:	03-JAN-12	Finding:	910.
Chemical:	NITRATE + NITRITE (AS N)	Report units:	MG/L
Dir:	0.4		

GEOCHECK® - PHYSICAL SETTING SOURCE MAP FINDINGS

Map ID
Direction
Distance
Elevation

Database EDR ID Number

C21
NE
1/2 - 1 Mile
Lower

FED USGS USGS40000138720

Organization ID:	USGS-CA		
Organization Name:	USGS California Water Science Center		
Monitor Location:	003S008W34C001S	Type:	Well
Description:	Not Reported	HUC:	18070203
Drainage Area:	Not Reported	Drainage Area Units:	Not Reported
Contrib Drainage Area:	Not Reported	Contrib Drainage Area Units:	Not Reported
Aquifer:	California Coastal Basin aquifers		
Formation Type:	Not Reported	Aquifer Type:	Not Reported
Construction Date:	19450101	Well Depth:	Not Reported
Well Depth Units:	Not Reported	Well Hole Depth:	45
Well Hole Depth Units:	ft		

Ground water levels,Number of Measurements:	37	Level reading date:	1981-07-27
Feet below surface:	Not Reported	Feet to sea level:	Not Reported
Note:	The well was destroyed (no water level is recorded).		

Level reading date:	1981-05-05	Feet below surface:	11.98
Feet to sea level:	Not Reported	Note:	Not Reported

Level reading date:	1981-02-04	Feet below surface:	13.17
Feet to sea level:	Not Reported	Note:	Not Reported

Level reading date:	1980-10-30	Feet below surface:	13.07
Feet to sea level:	Not Reported	Note:	Not Reported

Level reading date:	1980-08-25	Feet below surface:	11.96
Feet to sea level:	Not Reported	Note:	Not Reported

Level reading date:	1980-06-12	Feet below surface:	11.67
Feet to sea level:	Not Reported	Note:	Not Reported

Level reading date:	1980-02-05	Feet below surface:	5.30
Feet to sea level:	Not Reported	Note:	Not Reported

Level reading date:	1979-11-13	Feet below surface:	11.65
Feet to sea level:	Not Reported	Note:	Not Reported

Level reading date:	1979-07-30	Feet below surface:	9.79
Feet to sea level:	Not Reported	Note:	Not Reported

Level reading date:	1979-04-30	Feet below surface:	9.19
Feet to sea level:	Not Reported	Note:	Not Reported

Level reading date:	1979-02-01	Feet below surface:	8.72
Feet to sea level:	Not Reported	Note:	Not Reported

Level reading date:	1978-11-03	Feet below surface:	10.35
Feet to sea level:	Not Reported	Note:	Not Reported

Level reading date:	1978-10-18	Feet below surface:	10.33
Feet to sea level:	Not Reported	Note:	Not Reported

Level reading date:	1977-01-12	Feet below surface:	14.20
Feet to sea level:	Not Reported	Note:	Not Reported

GEOCHECK® - PHYSICAL SETTING SOURCE MAP FINDINGS

Level reading date:	1976-11-01	Feet below surface:	13.40
Feet to sea level:	Not Reported	Note:	Not Reported
Level reading date:	1976-05-10	Feet below surface:	10.00
Feet to sea level:	Not Reported	Note:	Not Reported
Level reading date:	1976-03-12	Feet below surface:	9.90
Feet to sea level:	Not Reported	Note:	Not Reported
Level reading date:	1975-11-10	Feet below surface:	10.20
Feet to sea level:	Not Reported	Note:	Not Reported
Level reading date:	1975-08-25	Feet below surface:	11.40
Feet to sea level:	Not Reported	Note:	Not Reported
Level reading date:	1975-06-24	Feet below surface:	12.10
Feet to sea level:	Not Reported	Note:	Not Reported
Level reading date:	1975-05-06	Feet below surface:	11.90
Feet to sea level:	Not Reported	Note:	Not Reported
Level reading date:	1975-02-28	Feet below surface:	11.70
Feet to sea level:	Not Reported	Note:	Not Reported
Level reading date:	1975-01-09	Feet below surface:	10.80
Feet to sea level:	Not Reported	Note:	Not Reported
Level reading date:	1974-10-21	Feet below surface:	12.50
Feet to sea level:	Not Reported	Note:	Not Reported
Level reading date:	1974-08-27	Feet below surface:	11.60
Feet to sea level:	Not Reported	Note:	Not Reported
Level reading date:	1974-06-26	Feet below surface:	10.40
Feet to sea level:	Not Reported	Note:	Not Reported
Level reading date:	1974-04-29	Feet below surface:	10.80
Feet to sea level:	Not Reported	Note:	Not Reported
Level reading date:	1974-03-12	Feet below surface:	9.80
Feet to sea level:	Not Reported	Note:	Not Reported
Level reading date:	1974-01-02	Feet below surface:	11.00
Feet to sea level:	Not Reported	Note:	Not Reported
Level reading date:	1973-10-30	Feet below surface:	12.60
Feet to sea level:	Not Reported	Note:	Not Reported
Level reading date:	1973-08-27	Feet below surface:	13.10
Feet to sea level:	Not Reported	Note:	Not Reported
Level reading date:	1973-06-29	Feet below surface:	11.80
Feet to sea level:	Not Reported	Note:	Not Reported
Level reading date:	1973-05-08	Feet below surface:	10.70
Feet to sea level:	Not Reported	Note:	Not Reported
Level reading date:	1973-02-23	Feet below surface:	10.40
Feet to sea level:	Not Reported	Note:	Not Reported
Level reading date:	1972-12-26	Feet below surface:	11.40
Feet to sea level:	Not Reported	Note:	Not Reported

GEOCHECK® - PHYSICAL SETTING SOURCE MAP FINDINGS

Level reading date:	1972-10-26	Feet below surface:	12.90
Feet to sea level:	Not Reported	Note:	Not Reported
Level reading date:	1972-08-28	Feet below surface:	13.30
Feet to sea level:	Not Reported	Note:	Not Reported

GEOCHECK® - PHYSICAL SETTING SOURCE MAP FINDINGS RADON

AREA RADON INFORMATION

State Database: CA Radon

Radon Test Results

Zipcode	Num Tests	> 4 pCi/L
92808	32	0

Federal EPA Radon Zone for ORANGE County: 3

- Note: Zone 1 indoor average level > 4 pCi/L.
 : Zone 2 indoor average level >= 2 pCi/L and <= 4 pCi/L.
 : Zone 3 indoor average level < 2 pCi/L.

Federal Area Radon Information for ORANGE COUNTY, CA

Number of sites tested: 30

Area	Average Activity	% <4 pCi/L	% 4-20 pCi/L	% >20 pCi/L
Living Area - 1st Floor	0.763 pCi/L	100%	0%	0%
Living Area - 2nd Floor	Not Reported	Not Reported	Not Reported	Not Reported
Basement	Not Reported	Not Reported	Not Reported	Not Reported

PHYSICAL SETTING SOURCE RECORDS SEARCHED

TOPOGRAPHIC INFORMATION

USGS 7.5' Digital Elevation Model (DEM)

Source: United States Geologic Survey

EDR acquired the USGS 7.5' Digital Elevation Model in 2002 and updated it in 2006. The 7.5 minute DEM corresponds to the USGS 1:24,000- and 1:25,000-scale topographic quadrangle maps. The DEM provides elevation data with consistent elevation units and projection.

Current USGS 7.5 Minute Topographic Map

Source: U.S. Geological Survey

HYDROLOGIC INFORMATION

Flood Zone Data: This data was obtained from the Federal Emergency Management Agency (FEMA). It depicts 100-year and 500-year flood zones as defined by FEMA. It includes the National Flood Hazard Layer (NFHL) which incorporates Flood Insurance Rate Map (FIRM) data and Q3 data from FEMA in areas not covered by NFHL.

Source: FEMA

Telephone: 877-336-2627

Date of Government Version: 2003, 2015

NWI: National Wetlands Inventory. This data, available in select counties across the country, was obtained by EDR in 2002, 2005 and 2010 from the U.S. Fish and Wildlife Service.

State Wetlands Data: Wetland Inventory

Source: Department of Fish and Wildlife

Telephone: 916-445-0411

HYDROGEOLOGIC INFORMATION

AQUIFLOW^R Information System

Source: EDR proprietary database of groundwater flow information

EDR has developed the AQUIFLOW Information System (AIS) to provide data on the general direction of groundwater flow at specific points. EDR has reviewed reports submitted to regulatory authorities at select sites and has extracted the date of the report, hydrogeologically determined groundwater flow direction and depth to water table information.

GEOLOGIC INFORMATION

Geologic Age and Rock Stratigraphic Unit

Source: P.G. Schruben, R.E. Arndt and W.J. Bawiec, Geology of the Conterminous U.S. at 1:2,500,000 Scale - A digital representation of the 1974 P.B. King and H.M. Beikman Map, USGS Digital Data Series DDS - 11 (1994).

STATSGO: State Soil Geographic Database

Source: Department of Agriculture, Natural Resources Conservation Service (NRCS)

The U.S. Department of Agriculture's (USDA) Natural Resources Conservation Service (NRCS) leads the national Conservation Soil Survey (NCSS) and is responsible for collecting, storing, maintaining and distributing soil survey information for privately owned lands in the United States. A soil map in a soil survey is a representation of soil patterns in a landscape. Soil maps for STATSGO are compiled by generalizing more detailed (SSURGO) soil survey maps.

SSURGO: Soil Survey Geographic Database

Source: Department of Agriculture, Natural Resources Conservation Service (NRCS)

Telephone: 800-672-5559

SSURGO is the most detailed level of mapping done by the Natural Resources Conservation Service, mapping scales generally range from 1:12,000 to 1:63,360. Field mapping methods using national standards are used to construct the soil maps in the Soil Survey Geographic (SSURGO) database. SSURGO digitizing duplicates the original soil survey maps. This level of mapping is designed for use by landowners, townships and county natural resource planning and management.

PHYSICAL SETTING SOURCE RECORDS SEARCHED

LOCAL / REGIONAL WATER AGENCY RECORDS

FEDERAL WATER WELLS

PWS: Public Water Systems

Source: EPA/Office of Drinking Water

Telephone: 202-564-3750

Public Water System data from the Federal Reporting Data System. A PWS is any water system which provides water to at least 25 people for at least 60 days annually. PWSs provide water from wells, rivers and other sources.

PWS ENF: Public Water Systems Violation and Enforcement Data

Source: EPA/Office of Drinking Water

Telephone: 202-564-3750

Violation and Enforcement data for Public Water Systems from the Safe Drinking Water Information System (SDWIS) after August 1995. Prior to August 1995, the data came from the Federal Reporting Data System (FRDS).

USGS Water Wells: USGS National Water Inventory System (NWIS)

This database contains descriptive information on sites where the USGS collects or has collected data on surface water and/or groundwater. The groundwater data includes information on wells, springs, and other sources of groundwater.

OTHER STATE DATABASE INFORMATION

Groundwater Ambient Monitoring & Assessment Program

State Water Resources Control Board

Telephone: 916-341-5577

The GAMA Program is California's comprehensive groundwater quality monitoring program. GAMA collects data by testing the untreated, raw water in different types of wells for naturally-occurring and man-made chemicals. The GAMA data includes Domestic, Monitoring and Municipal well types from the following sources, Department of Water Resources, Department of Health Services, EDF, Agricultural Lands, Lawrence Livermore National Laboratory, Department of Pesticide Regulation, United States Geological Survey, Groundwater Ambient Monitoring and Assessment Program and Local Groundwater Projects.

Water Well Database

Source: Department of Water Resources

Telephone: 916-651-9648

California Drinking Water Quality Database

Source: Department of Public Health

Telephone: 916-324-2319

The database includes all drinking water compliance and special studies monitoring for the state of California since 1984. It consists of over 3,200,000 individual analyses along with well and water system information.

California Oil and Gas Well Locations

Source: Dept of Conservation, Geologic Energy Management Division

Telephone: 916-323-1779

Oil and Gas well locations in the state.

California Earthquake Fault Lines

Source: California Division of Mines and Geology

The fault lines displayed on EDR's Topographic map are digitized quaternary fault lines prepared in 1975 by the United State Geological Survey. Additional information (also from 1975) regarding activity at specific fault lines comes from California's Preliminary Fault Activity Map prepared by the California Division of Mines and Geology.

RADON

State Database: CA Radon

Source: Department of Public Health

Telephone: 916-210-8558

Radon Database for California

PHYSICAL SETTING SOURCE RECORDS SEARCHED

Area Radon Information

Source: USGS

Telephone: 703-356-4020

The National Radon Database has been developed by the U.S. Environmental Protection Agency (USEPA) and is a compilation of the EPA/State Residential Radon Survey and the National Residential Radon Survey. The study covers the years 1986 - 1992. Where necessary data has been supplemented by information collected at private sources such as universities and research institutions.

EPA Radon Zones

Source: EPA

Telephone: 703-356-4020

Sections 307 & 309 of IRRA directed EPA to list and identify areas of U.S. with the potential for elevated indoor radon levels.

OTHER

Airport Landing Facilities: Private and public use landing facilities

Source: Federal Aviation Administration, 800-457-6656

Epicenters: World earthquake epicenters, Richter 5 or greater

Source: Department of Commerce, National Oceanic and Atmospheric Administration

California Earthquake Fault Lines: The fault lines displayed on EDR's Topographic map are digitized quaternary fault lines, prepared in 1975 by the United State Geological Survey. Additional information (also from 1975) regarding activity at specific fault lines comes from California's Preliminary Fault Activity Map prepared by the California Division of Mines and Geology.

STREET AND ADDRESS INFORMATION

© 2015 TomTom North America, Inc. All rights reserved. This material is proprietary and the subject of copyright protection and other intellectual property rights owned by or licensed to Tele Atlas North America, Inc. The use of this material is subject to the terms of a license agreement. You will be held liable for any unauthorized copying or disclosure of this material.

Appendix F

Preliminary Water Quality Management Plan (PWQMP)

PRELIMINARY
CITY OF ANAHEIM
Priority Project
Water Quality Management Plan
(WQMP)

Project Name:

KINDRED CHURCH MASTER PLAN
8712-8720 E. SANTA ANA CANYON ROAD
APN 354-321-01 & 354-321-03

Prepared for:

KINDRED OUTREACH MINISTRIES, INC.
8712 E. Santa Ana Canyon Road
Anaheim, CA 92808
(714) 282-9941

Prepared by:

Anacal Engineering Co.
1211 N. Tustin Avenue
Anaheim, CA 92807
(714) 774-1763 – dave@anacalengineering.com

Original Prepared date: February 24, 2020

Revision Date(s): 1) April 28th, 2021

2)September 20th, 2021

3)November 15, 2021

4)December 16, 2021

Priority Project Water Quality Management Plan (WQMP)



Project Owner's Certification			
Planning Application No. (If applicable)	OTH 2020-01264	Grading Permit No.	
Tract/Parcel Map and Lot(s) No.		Building Permit No.	
Address of Project Site: 8712 – 8720 E. Santa Ana Canyon, Anaheim APN 354-321-01 & 354-321-03			

This Water Quality Management Plan (WQMP) has been prepared for Kindred Church Outreach ministries, Inc., by Anacal Engineering Co. The WQMP is intended to comply with the requirements of the County of Orange NPDES Stormwater Program requiring the preparation of the plan.

The undersigned, while it owns the subject property, is responsible for the implementation of the provisions of this plan, including the ongoing operation and maintenance of all best management practices (BMPs), and will ensure that this plan is amended as appropriate to reflect up-to-date conditions on the site consistent with the current Orange County Drainage Area Management Plan (DAMP) and the intent of the non-point source NPDES Permit for Waste Discharge Requirements for the County of Orange, Orange County Flood Control District and the incorporated Cities of Orange County within the Santa Ana Region. Once the undersigned transfers its interest in the property, its successors-in-interest shall bear the aforementioned responsibility to implement and amend the WQMP. An appropriate number of approved and signed copies of this document shall be available on the subject site in perpetuity.

Owner:			
Title			
Company	Kindred Church Outreach Ministries, Inc.		
Address	8712 E. Santa Ana Canyon, Anaheim, CA 92808		
Email			
Telephone #	(714) 282-9941		
I understand my responsibility to implement the provisions of this WQMP including the ongoing operation and maintenance of the best management practices (BMPs) described herein.			
Owner Signature		Date	

Water Quality Management Plan (WQMP)

Preparer (Engineer): David C. Queyrel			
Title	Civil Engineer	PE Registration #	42812
Company	Anacal Engineering Co.		
Address	1211 N. Tustin Avenue, Anaheim, CA 92807		
Email	dave@anacalengineering.com		
Telephone #	(714) 774-1763		
I hereby certify that this Water Quality Management Plan is in compliance with, and meets the requirements set forth in, Order No. R8-2009-0030/NPDES No. CAS618030, of the Santa Ana Regional Water Quality Control Board.			
Preparer Signature		Date	12-16-21
Place Stamp Here			

Contents

Page No.

Section I	Permit(s) and Water Quality Conditions of Approval or Issuance	1
Section II	Project Description	3
Section III	Site Description	8
Section IV	Best Management Practices (BMPs)	10
Section V	Inspection/Maintenance Responsibility for BMPs.....	24
Section VI	BMP Exhibit (Site Plan)	25
Section VII	Educational Materials.....	26

Attachments

Attachment A.	BMP Calculations & Worksheets
Attachment B	2-Year Storm Event Hydrology Calculations
Attachment C	Operations and Maintenance Plan
Attachment D	Soil Report
Attachment E	Notice of Transfer of Responsibility Form

Section I Permit(s) and Water Quality Conditions of Approval or Issuance

Provide discretionary or grading/building permit information and water quality conditions of approval, or permit issuance, applied to the project. If conditions are unknown, please request applicable conditions from staff. Refer to Section 2.1 in the Technical Guidance Document (TGD) available on the OC Planning website (ocplanning.net).

Project Information	
Permit/ Application No. (If applicable)	OTH 2020-01264
	Grading or Building Permit No. (If applicable)
Address of Project Site (or Tract Map and Lot Number if no address) and APN	8712 - 8720 E. Santa Ana Canyon Road, Anaheim, CA APN 354-321-01 & 354-321-03
Water Quality Conditions of Approval or Issuance	
Water Quality Conditions of Approval or Issuance applied to this project. (Please list verbatim.)	
Conceptual WQMP	
Was a Conceptual Water Quality Management Plan previously approved for this project?	There is an existing WQMP on the project from the previous Sanctuary construction done in 2004 under OTH 2004-00165

Watershed-Based Plan Conditions	
Provide applicable conditions from watershed - based plans including WIHMPs and TMDLS.	Santa Ana River Watershed No WIHMPs established TMDLS established for Santa Ana River Reach 2 Indicator Bacteria 2021

Section II Project Description

II.1 Project Description

Provide a detailed project description including:

- Project areas;
- Land uses;
- Land cover;
- Design elements;
- A general description not broken down by drainage management areas (DMAs).

Include attributes relevant to determining applicable source controls. Refer to Section 2.2 in the Technical Guidance Document (TGD) for information that must be included in the project description.

Description of Proposed Project				
Development Category (From Model WQMP, Table 7.11-2; or -3):	Commercial Development / Parking Lot			
Project Area (ft ²): 259,549	Number of Dwelling Units: <u>3</u>		SIC Code: <u>8661</u>	
Project Area	Pervious		Impervious	
	Area (acres or sq ft)	Percentage	Area (acres or sq ft)	Percentage
Pre-Project Conditions	130,024	50.1%	129,525	49.9%
Post-Project Conditions	87,445	33.7%	172,104	66.3%
Drainage Patterns/Connections	The majority of the site drains to existing grate inlets that are connected to an existing city storm drain constructed for Tract 12990 which traverses the site. Flow is Northerly to the Santa Ana River. Off-site flows are directed to two culvert crossings also connected to drainage facilities connected to the Santa Ana River.			

Narrative Project Description:

The project consists of the development of 2 existing parcels to be merged into a redeveloped master plan for an expansion of the existing sanctuary and parking lots additionally there are non-permanent canopy structures along with new and relocated classrooms.

Proposed is the relocation of 3 modular buildings and the addition of 4 modular buildings adding an area of 5,688 s.f onto the existing sanctuary for a total new building area of approximately 11,448 s.f.

The proposed parking lot areas include the replacement of the water feature with a new parking lot in the campus center, the realignment and reduction of the southeast parking area for new modular buildings and a fabric building, and the addition of new planters in the existing lot north of the water feature.

Total new or replaced parking and drive area is approximately 42,579 s.f. Total new or replaced hardscape area is approximately 45,838 s.f.

New landscape areas are provided within parking lots, sanctuary area and slopes totalling 22,651 s.f.

Total disturbed area consisting of construction/replacing of new impermeable and permeable area equates to a total area of 2.81 ac.

We plan to capture the areas that drain towards the respective DMA's which include capturing of the areas surrounding the disturbed areas, as a sort of run-on. This is why the plans show more treatment and capture than the disturbed area of 2.81ac. We are to capture the required DCV from the 85th percentile, 24-hr storm which is to equal 12,507 ft³, approximately treating 259,549 sf or 5.96 AC. This is done using 6 DMA's as shown on the WQMP site plan. We plan to capture the volume using a new storm drain system that is to reliably drain the site towards a proposed underground infiltration area located north of the site. Prior to capture, pre-treatment will be provided using filterra units by Contech to filter at least 50% of the required flow per City of Anaheim requirements prior to entering the storm drain system. This filter is designed for full capture of sediment, debris and hydrocarbons. Flowrate calculations can be found in Attachment A.

In the event of overflow, water is to be rerouted and tied to the existing main stormdrain system.

The trash enclosures are proposed in the rear of the facility and are to be walled with rain tight lids. Existing and proposed slopes are to be planted and irrigated to prevent erosion. Food preparation and dining shall be done in roofed structures.

II.2 Potential Stormwater Pollutants

Determine and list expected stormwater pollutants based on land uses and site activities. Refer to Section 2.2.2 and Table 2.1 in the Technical Guidance Document (TGD) for guidance.

Pollutants of Concern			
Pollutant	Check One for each: E=Expected to be of concern N=Not Expected to be of concern		Additional Information and Comments
Suspended-Solid/ Sediment	E <input checked="" type="checkbox"/>	N <input type="checkbox"/>	
Nutrients	E <input checked="" type="checkbox"/>	N <input type="checkbox"/>	
Heavy Metals	E <input checked="" type="checkbox"/>	N <input type="checkbox"/>	
Pathogens (Bacteria/Virus)	E <input checked="" type="checkbox"/>	N <input type="checkbox"/>	Bacteria is a pollutant of concern for Santa Ana River
Pesticides	E <input checked="" type="checkbox"/>	N <input type="checkbox"/>	
Oil and Grease	E <input checked="" type="checkbox"/>	N <input type="checkbox"/>	
Toxic Organic Compounds	E <input checked="" type="checkbox"/>	N <input type="checkbox"/>	
Trash and Debris	E <input checked="" type="checkbox"/>	N <input type="checkbox"/>	

II.3 Hydrologic Conditions of Concern

Determine if streams located downstream from the project area are potentially susceptible to hydromodification impacts. Refer to Section 2.2.3.1 in the Technical Guidance Document (TGD) for North Orange County or Section 2.2.3.2 for South Orange County.

No – Show map

Yes – Describe applicable hydrologic conditions of concern below. Refer to Section 2.2.3 in the Technical Guidance Document (TGD).

Runoff from each DMA area; G, 3I, 1F and 2F along with the adjacent run-on is calculated using TR20 software for the pre-construction and post-construction conditions. The results are indicated in the table below.

Area 2F is considered 0 for a more conservative approach. We plan to capture that area completely, since this almost all pervious space will become an impervious parking lot.

Area 4G is not considered as it is an existing parking lot with construction limited to the addition of permeable planters.

Area 3G is not considered as it is all existing area with no development to take place.

The disturbed area of the site is 2.81 AC and the capture area for the 2-year 24hr storms is 5.1 AC of the 14.8 AC site

Designation	Area	Pre-const. runoff TR20	Post-const. runoff TR20	Pre-Const. T _c min.	Post-Const. T _c	Pre-Const V (cf)	Post-Const V (cf)
1G	2.43 AC	0.423 in.	0.708 in.	6.0	6.0	3,731	6,245
3I	0.90 AC	0.103 in.	0.334 in.	6.0	6.0	337	1,212
1F	0.80 AC	0.092 in.	0.29 in.	6.0	6.0	267	842
2F	1.3 AC	0	1.078 in.	0	13.4	0	2,856
						4,335	11,155

$$\Delta Q_2 = 11,155 \text{ cf} - 4,335 \text{ cf} = 6,820 \text{ cf}$$

$$\text{BMP capture volume} = 12,871 \text{ cf}$$

II.4 Post Development Drainage Characteristics

Describe post development drainage characteristics. *Refer to Section 2.2.4 in the Technical Guidance Document (TGD).*

Drainage from the proposed project area drains to an existing city-maintained storm drain constructed for Tract 12990 Plan SP-1949.

The proposed development has been broken into 6 DMAs based on their connection to the existing public storm drain. DMA 5 consists of various existing and proposed re-development and new construction that consists mainly of new building and sidewalk hardscape. The existing parking lot is slightly disturbed by replace planters for the reconstruction. The area is collected in existing and proposed grate inlets and to existing storm drains that connect to the public storm drain at a location approximately 300 ft. south of the crossing at Santa Ana Canyon Road.

DMA-1 consists of new developed hardscape that is to be built on the existing water feature. This new hardscape will server as a new parking lot with planters. The drainage from the parking lot will flow north towards a filterra unit then to the proposed catch basin.

DMA-3 and DMA-2 consists of the 2 relocated modular along with a new hardscape that replaces existing hardscape. Run-off is to drain to grate inlets routed towards the proposed storm drain system. DMA-3 drainage is to tie into DMA -4 storm drain system while DMA-2 is designed to outlet onto DMA-1 where it will be collected and treated in the same Filterra unit prior to entering the drainage system.

DMA-3 & DMA-4 run-off is collected through an inlet that is located near the edge of the proposed landscape and tied to the existing storm drain line. This line captures the drainage coming in from DMA 3, 4, 5, and 6.

All DMA's draining to the catch basins will have FloGard filters and are designed to capture 100% trash & debris. See WQMP Site Plan for locations of catch basins & Filters.

All drainage converges through the main storm drain line and are routed via junction boxes and ultimately to the proposed infiltration chambers.

Total proposed redevelopment is 122,516 sf.

Total mitigated area is 259,549 sf.

II.5 Property Ownership/Management

Describe property ownership/management. *Refer to Section 2.2.5 in the Technical Guidance Document*

The property is owned and maintained by:

Kindred Outreach Ministries, Inc.
8712 E. Santa Ana Canyon Road
Anaheim, CA 92808
(714) 282-9941

Section III Site Description

III.1 Physical Setting

Fill out table with relevant information. *Refer to Section 2.3.1 in the Technical Guidance Document (TGD).*

Name of Planned Community/Planning Area (if applicable)	Anaheim Hills
Location/Address	8712 E. Santa Ana Canyon Road
	Anaheim
General Plan Land Use Designation	Sycamore Canyon Specific Plan
Zoning	T - Transitional Zone
Acreage of Project Site	14.8 AC total, area of new development/disturbed = 2.81 AC
Predominant Soil Type	Quaternary Alluvial Deposits, HGS C Soils, according to TGD.

III.2 Site Characteristics

Fill out table with relevant information and include information regarding BMP sizing, suitability, and feasibility, as applicable. *Refer to Section 2.3.2 in the Technical Guidance Document (TGD).*

Site Characteristics	
Precipitation Zone	0.90"
Topography	Site is a previously graded terraced areas partially developed

Priority Project Water Quality Management Plan (WQMP)

Drainage Patterns/Connections	The majority of the site drains to existing grate inlets that are connected to an existing city storm drain constructed for Tract 12990 which traverses the site. Flow is Northerly to the Santa Ana River. Off-site flows are directed to two culvert crossings also connected to drainage facilities connected to the Santa Ana River.
Soil Type, Geology, and Infiltration Properties	Soil report TGR Geotechnical # 15-5382 dated August 10, 2016. Report indicates as having infiltration rates of 2.8in/hr.
Hydrogeologic (Groundwater) Conditions	Ground water was found at 18.5' in borings mapped to be at approx. 20'. No contamination site within 250'. A water well is located at the Northeast and Northwest corners of property and used for irrigation water. See WQMP site plan for well locations. Infiltration shall be 100' from well site.
Geotechnical Conditions (relevant to infiltration)	None determined
Off-Site Drainage	Off-site drainage is captured in existing drainage courses and gutters and conveyed to downstream facilities which consist of (3) 60" storm drains crossing the 91 freeway to the Santa Ana River. Only adjacent run-on to DMA areas are considered in BMP design. All other areas are routed away from the proposed DMAs per the existing conditions.
Utility and Infrastructure Information	Site is served currently by water and electricity available through public easements. Sewer is septic.

III.3 Watershed Description

Fill out table with relevant information and include information regarding BMP sizing, suitability, and feasibility, as applicable. *Refer to Section 2.3.3 in the Technical Guidance Document (TGD).*

Receiving Waters	Drains to Santa Ana River
303(d) Listed Impairments	Indicator Bacteria
Applicable TMDLs	Indicator Bacteria 2020
Pollutants of Concern for the Project	Bacteria

Priority Project Water Quality Management Plan (WQMP)

Environmentally Sensitive and Special Biological Significant Areas	N/A to City of Anaheim
--	------------------------

Section IV Best Management Practices (BMPs)

IV. 1 Project Performance Criteria

Describe project performance criteria. Several steps must be followed in order to determine what performance criteria will apply to a project. These steps include:

- If the project has an approved WIHMP or equivalent, then any watershed specific criteria must be used and the project can evaluate participation in the approved regional or sub-regional opportunities. (Please ask your assigned planner or plan checker regarding whether your project is part of an approved WIHMP or equivalent.)
- Determine applicable hydromodification control performance criteria. *Refer to Section 7.II-2.4.2.2 of the Model WQMP.*
- Determine applicable LID performance criteria. *Refer to Section 7.II-2.4.3 of the Model WQMP.*
- Determine applicable treatment control BMP performance criteria. *Refer to Section 7.II-3.2.2 of the Model WQMP.*
- Calculate the LID design storm capture volume for the project. *Refer to Section 7.II-2.4.3 of the Model WQMP.*

(NOC Permit Area only) Is there an approved WIHMP or equivalent for the project area that includes more stringent LID feasibility criteria or if there are opportunities identified for implementing LID on regional or sub-regional basis?		YES <input type="checkbox"/>	NO <input checked="" type="checkbox"/>
If yes, describe WIHMP feasibility criteria or regional/sub-regional LID opportunities.	N/A to City of Anaheim		

Project Performance Criteria	
<p>If HCOC exists, list applicable hydromodification control performance criteria (Section 7.II-2.4.2.2 in MWQMP)</p>	<p>Subject to Hydromodification. Provide for capture of Δ 2 year storm. Delta Q2=6,820 c.f. See attachment A for calculations</p>
<p>List applicable LID performance criteria (Section 7.II-2.4.3 from MWQMP)</p>	<p>Priority project: Priority project must infiltrate, harvest and use, evapotranspire or biotreat/biofilter the 85th percentile, 24-hour storm event (design capture volume). $\sqrt{\text{Vol. Req}} = 0.9'' - d \text{ (HSC)} \times c \times \text{area (ac)} \times 43,560 \text{ sf/ac} \times 1''/12''\text{ft} = \text{(C.F.)}$ Where: d (HSC) - Source control depth c - Runoff co-efficient</p>
<p>List applicable treatment control BMP performance criteria (Section 7.II-3.2.2 from MWQMP)</p>	<p>Priority project: Priority project must infiltrate, harvest and use, evapotranspire or biotreat/biofilter the 85th percentile, 24-hour storm event (design capture volume)</p>
<p>Calculate LID design storm capture volume for Project.</p>	<p><u>DCV (Design capture volume) for the project is 12,507 C.F.</u> Find LID DCV calcs in attachment A</p>

IV.2. Site Design and Drainage

Describe site design and drainage including

- A narrative of site design practices utilized or rationale for not using practices;
- A narrative of how site is designed to allow BMPs to be incorporated to the MEP
- A table of DMA characteristics and list of LID BMPs proposed in each DMA.
- Reference to the WQMP “BMP Exhibit.”
- Calculation of Design Capture Volume (DCV) for each drainage area.
- A listing of GIS coordinates for LID and Treatment Control BMPs.

Refer to Section 2.4.2 in the Technical Guidance Document (TGD).

Site runoff is directed away from proposed buildings and to permeable areas where practical. Portions of roof and rear yard areas drain to private storm drain system via proposed swales and storm drain inlets located in DMA 3, 4 & 5. We plan capture DMA 3, DMA 4, and DMA 5 which includes new hardscapes, new/relocated modular, the building expansion, and reconstruction of planters. DMA-5 contains very minimal disturbance, which includes landscape, roof and sidewalk area along with some reconstruction of planters, but no hardscape work in the parking lot. Since this area includes roadways and per the city/s requirements, we will capture DMA-5 and effectively treat 50% of the design flow prior to entering the drainage system. As for DMA-3 and DMA-4, no pretreatment is required since all runoff is roof, landscape and sidewalk areas. As such, the areas are to be tied directly into the storm drain system and head towards the infiltration chambers.

DMA-1 involves the development of a new parking lot replacing the previous water feature. DMA 2 involves some reconstruction of the planters and the construction of additional parking area where the modular were previously placed. DMA-2 is to be captured through catch basins and will spill onto DMA-1. From there, the run-off accumulated by both DMA-s will enter a filterra device to undergo the 50% treatment requirement. After pretreatment the runoff is to tie into the existing storm drain which routes downstream to a junction structure and then to the proposed underground infiltration system located at the base of the site.

The existing parking lot located north of the water feature is only to receive new striping and reconstructed planters. We are not planning on capturing this area of our site since very minimal disturbance will take place here. We are capturing DMA-6 where no new construction is to take place and treating this area as well as other undisturbed areas to offset not capturing the existing parking lot and drive areas. Total disturbed area=2,680sf whereas the captured area in DMA-6 is 26,573s.f.

Our overall capture areas of DMA-1 through DMA-6 equate to almost double our disturbed area. This capture will mitigate the effects of HCOC as well as our DCV which is found to be greater than the 24-hr storm, thus making it design option.

**Per the city of Anaheim WQMP template, we are capturing and infiltrating the DCV which was calculated using the areas tributary to the BMP. For treatment, we are using filterra units to bio-treat the runoff to a minimum of 50% the required flow with bypass capabilities to mitigate 100% of the DCV.*

Any overflow will exit through the underground chambers and tie back into the main storm drain line. See the WQMP Site plan for further clarification.

Full Trash Capture BMPs will be installed in each catch basin

Priority Project Water Quality Management Plan (WQMP)

Area	HSC Type	BMP	DCV cf	Capture Volume	GPS Coords.
DMA-1	None	INF-7 underground chambers	2,425		33.864242° 117.723238°
DMA-2	None	INF-7 underground chambers	1,614		33.86366° 117.72359°
DMA-3	None	INF-7 underground chambers	732		33.86528° 117.72278°
DMA-4	None	INF-7 underground chambers	1,967		33.86353° 117.72301°
DMA-5	None	INF-7 underground chambers	5,391		33.86412° 117.72189°
DMA-6	None	INF-7 underground chambers	378		33.86441° 117.72260°
Overall:			12,507	12,626	

IV.3 LID BMP Selection and Project Conformance Analysis

Each sub-section below documents that the proposed design features conform to the applicable project performance criteria via check boxes, tables, calculations, narratives, and/or references to worksheets. Refer to Section 2.4.2.3 in the Technical Guidance Document (TGD) for selecting LID BMPs and Section 2.4.3 in the Technical Guidance Document (TGD) for conducting conformance analysis with project performance criteria.

IV.3.1 Hydrologic Source Controls (HSCs)

If required HSCs are included, fill out applicable check box forms. If the retention criteria are otherwise met with other LID BMPs, include a statement indicating HSCs not required.

Name	Included?
Localized on-lot infiltration	<input type="checkbox"/>
Impervious area dispersion (e.g. roof top disconnection)	<input type="checkbox"/>
Street trees (canopy interception)	<input type="checkbox"/>
Residential rain barrels (not actively managed)	<input type="checkbox"/>
Green roofs/Brown roofs	<input type="checkbox"/>
Blue roofs	<input type="checkbox"/>
Impervious area reduction (e.g. permeable pavers, site design)	<input type="checkbox"/>
Other: HSCs not used	<input type="checkbox"/>
Other:	<input type="checkbox"/>
Other:	<input type="checkbox"/>
Other:	<input type="checkbox"/>
Other:	<input type="checkbox"/>
Other:	<input type="checkbox"/>
Other:	<input type="checkbox"/>
Other:	<input type="checkbox"/>

HSCs not required, LID DCV is reliably retained in underground infiltration chambers.

IV.3.2 Infiltration BMPs

Identify infiltration BMPs to be used in project. If design volume cannot be met, state why.

Name	Included?
Bioretention without underdrains	<input type="checkbox"/>
Rain gardens	<input type="checkbox"/>
Porous landscaping	<input type="checkbox"/>
Infiltration planters	<input type="checkbox"/>
Retention swales	<input type="checkbox"/>
Infiltration trenches	<input type="checkbox"/>
Infiltration basins	<input type="checkbox"/>
Drywells	<input type="checkbox"/>
Subsurface infiltration galleries	<input checked="" type="checkbox"/>
French drains	<input type="checkbox"/>
Permeable asphalt	<input type="checkbox"/>
Permeable concrete	<input type="checkbox"/>
Permeable concrete pavers	<input type="checkbox"/>
Other:	<input type="checkbox"/>
Other:	<input type="checkbox"/>

Show calculations below to demonstrate if the LID Design Storm Capture Volume can be met with infiltration BMPs. If not, document how much can be met with infiltration and document why it is not feasible to meet the full volume with infiltration BMPs.

DMA-1 Area=1.28 AC, Imp = 57%, DCV = 2,425 cf
DMA-2 Area=0.76 AC, Imp = 67%, DCV = 1,614 cf
DMA-3 Area=0.38 AC, Imp = 58%, DCV = 732 cf
DMA-4 Area=0.86 AC, Imp = 73%, DCV = 1,967 cf
DMA-5 Area=2.06 AC, Imp = 87%, DCV = 5,391 cf
DMA-6 Area=0.61 AC, Imp = 5% , DCV = 378 cf
Overall DCV=12,507 cf
Underground Infiltration Storage=12,626 cf
See attachment A for Bmp calculations

IV.3.3 Evapotranspiration, Rainwater Harvesting BMPs

If the full Design Storm Capture Volume cannot be met with infiltration BMPs, describe any evapotranspiration and/or rainwater harvesting BMPs included.

Name	Included?
All HSCs; <i>See Section IV.3.1</i>	<input type="checkbox"/>
Surface-based infiltration BMPs	<input type="checkbox"/>
Biotreatment BMPs	<input type="checkbox"/>
Above-ground cisterns and basins	<input type="checkbox"/>
Underground detention	<input type="checkbox"/>
Other:	<input type="checkbox"/>
Other:	<input type="checkbox"/>
Other:	<input type="checkbox"/>

Show calculations below to demonstrate if the LID Design Storm Capture Volume can be met with evapotranspiration and/or rainwater harvesting BMPs in combination with infiltration BMPs. If not, document below how much can be met with either infiltration BMPs, evapotranspiration, rainwater harvesting BMPs, or a combination, and document why it is not feasible to meet the full volume with these BMP categories.

IV.3.4 Biotreatment BMPs

If the full Design Storm Capture Volume cannot be met with infiltration BMPs, and/or evapotranspiration and rainwater harvesting BMPs, describe biotreatment BMPs included. Include sections for selection, suitability, sizing, and infeasibility, as applicable.

Name	Included?
Bioretention with underdrains	<input type="checkbox"/>
Stormwater planter boxes with underdrains	<input type="checkbox"/>
Rain gardens with underdrains	<input type="checkbox"/>
Constructed wetlands	<input type="checkbox"/>
Vegetated swales	<input type="checkbox"/>
Vegetated filter strips	<input type="checkbox"/>
Proprietary vegetated biotreatment systems	<input type="checkbox"/>
Wet extended detention basin	<input type="checkbox"/>
Dry extended detention basins	<input type="checkbox"/>
Other:	<input type="checkbox"/>
Other:	<input type="checkbox"/>

Show calculations below to demonstrate if the LID Design Storm Capture Volume can be met with infiltration, evapotranspiration, rainwater harvesting and/or biotreatment BMPs. If not, document how much can be met with either infiltration BMPs, evapotranspiration, rainwater harvesting BMPs, or a combination, and document why it is not feasible to meet the full volume with these BMP categories.

Not applicable

IV.3.5 Hydromodification Control BMPs

Describe hydromodification control BMPs. *See Section 5 of the Technical Guidance Document (TGD).* Include sections for selection, suitability, sizing, and infeasibility, as applicable. Detail compliance with Prior Conditions of Approval (if applicable).

Hydromodification Control BMPs	
BMP Name	BMP Description
INF-7 underground Chambers	Provide Contech underground chamber system for req. 6,820 cf V prov. 12,626 cf

IV.3.6 Regional/Sub-Regional LID BMPs

Describe regional/sub-regional LID BMPs in which the project will participate. *Refer to Section 7.II-2.4.3.2 of the Model WQMP.*

Regional/Sub-Regional LID BMPs
Not applicable

IV.3.7 Treatment Control BMPs

Treatment control BMPs can only be considered if the project conformance analysis indicates that it is not feasible to retain the full design capture volume with LID BMPs. Describe treatment control BMPs including sections for selection, sizing, and infeasibility, as applicable.

Treatment Control BMPs	
BMP Name	BMP Description
Contech's Filterra Bio-filtration	Units are to be installed in their respective DMAs prior to entering the private storm drain system. They are to treat 50% of the design flow. Used Capture Efficiency Method, worksheet D for treatment flow.

IV.3.8 Non-structural Source Control BMPs

Fill out non-structural source control check box forms or provide a brief narrative explaining if non-structural source controls were not used.

Non-Structural Source Control BMPs				
Identifier	Name	Check One		If not applicable, state brief reason
		Included	Not Applicable	
N1	Education for Property Owners, Tenants and Occupants	<input checked="" type="checkbox"/>	<input type="checkbox"/>	
N2	Activity Restrictions	<input checked="" type="checkbox"/>	<input type="checkbox"/>	
N3	Common Area Landscape Management	<input checked="" type="checkbox"/>	<input type="checkbox"/>	
N4	BMP Maintenance	<input checked="" type="checkbox"/>	<input type="checkbox"/>	
N5	Title 22 CCR Compliance (How development will comply)	<input type="checkbox"/>	<input checked="" type="checkbox"/>	No CCRs
N6	Local Industrial Permit Compliance	<input type="checkbox"/>	<input checked="" type="checkbox"/>	No use requiring
N7	Spill Contingency Plan	<input type="checkbox"/>	<input checked="" type="checkbox"/>	No hazardous waste storage
N8	Underground Storage Tank Compliance	<input type="checkbox"/>	<input checked="" type="checkbox"/>	None
N9	Hazardous Materials Disclosure Compliance	<input type="checkbox"/>	<input checked="" type="checkbox"/>	None
N10	Uniform Fire Code Implementation	<input checked="" type="checkbox"/>	<input type="checkbox"/>	
N11	Common Area Litter Control	<input checked="" type="checkbox"/>	<input type="checkbox"/>	
N12	Employee Training	<input checked="" type="checkbox"/>	<input type="checkbox"/>	
N13	Housekeeping of Loading Docks	<input type="checkbox"/>	<input checked="" type="checkbox"/>	None
N14	Common Area Catch Basin Inspection	<input checked="" type="checkbox"/>	<input type="checkbox"/>	
N15	Street Sweeping Private Streets and Parking Lots	<input checked="" type="checkbox"/>	<input type="checkbox"/>	
N16	Retail Gasoline Outlets	<input type="checkbox"/>	<input checked="" type="checkbox"/>	None

IV.3.9 Structural Source Control BMPs

Fill out structural source control check box forms or provide a brief narrative explaining if structural source controls were not used.

Structural Source Control BMPs				
Identifier	Name	Check One		If not applicable, state brief reason
		Included	Not Applicable	
S1	Provide storm drain system stenciling and signage	<input checked="" type="checkbox"/>	<input type="checkbox"/>	
S2	Design and construct outdoor material storage areas to reduce pollution introduction	<input type="checkbox"/>	<input checked="" type="checkbox"/>	None allowed
S3	Design and construct trash and waste storage areas to reduce pollution introduction	<input checked="" type="checkbox"/>	<input type="checkbox"/>	
S4	Use efficient irrigation systems & landscape design, water conservation, smart controllers, and source control	<input checked="" type="checkbox"/>	<input type="checkbox"/>	
S5	Protect slopes and channels and provide energy dissipation	<input checked="" type="checkbox"/>	<input type="checkbox"/>	
	Incorporate requirements applicable to individual priority project categories (from SDRWQCB NPDES Permit)	<input type="checkbox"/>	<input checked="" type="checkbox"/>	Not in San Diego Region
S6	Dock areas	<input type="checkbox"/>	<input checked="" type="checkbox"/>	None
S7	Maintenance bays	<input type="checkbox"/>	<input checked="" type="checkbox"/>	None
S8	Vehicle wash areas	<input type="checkbox"/>	<input checked="" type="checkbox"/>	None
S9	Outdoor processing areas	<input type="checkbox"/>	<input checked="" type="checkbox"/>	None
S10	Equipment wash areas	<input type="checkbox"/>	<input checked="" type="checkbox"/>	None
S11	Fueling areas	<input type="checkbox"/>	<input checked="" type="checkbox"/>	None
S12	Hillside landscaping	<input checked="" type="checkbox"/>	<input type="checkbox"/>	
S13	Wash water control for food preparation areas	<input checked="" type="checkbox"/>	<input type="checkbox"/>	
S14	Community car wash racks	<input type="checkbox"/>	<input checked="" type="checkbox"/>	None

IV.4 Alternative Compliance Plan (If Applicable)

Describe an alternative compliance plan (if applicable). Include alternative compliance obligations (i.e., gallons, pounds) and describe proposed alternative compliance measures. *Refer to Section 7.II 3.0 in the WQMP.* Not applicable

IV.4.1 Water Quality Credits

Determine if water quality credits are applicable for the project. *Refer to Section 3.1 of the Model WQMP for description of credits and Appendix VI of the Technical Guidance Document (TGD) for calculation methods for applying water quality credits.*

Description of Proposed Project				
Project Types that Qualify for Water Quality Credits (Select all that apply):				
<input type="checkbox"/> Redevelopment projects that reduce the overall impervious footprint of the project site.	<input type="checkbox"/> Brownfield redevelopment, meaning redevelopment, expansion, or reuse of real property which may be complicated by the presence or potential presence of hazardous substances, pollutants or contaminants, and which have the potential to contribute to adverse ground or surface WQ if not redeveloped.	<input type="checkbox"/> Higher density development projects which include two distinct categories (credits can only be taken for one category): those with more than seven units per acre of development (lower credit allowance); vertical density developments, for example, those with a Floor to Area Ratio (FAR) of 2 or those having more than 18 units per acre (greater credit allowance).		
<input type="checkbox"/> Mixed use development, such as a combination of residential, commercial, industrial, office, institutional, or other land uses which incorporate design principles that can demonstrate environmental benefits that would not be realized through single use projects (e.g. reduced vehicle trip traffic with the potential to reduce sources of water or air pollution).	<input type="checkbox"/> Transit-oriented developments, such as a mixed use residential or commercial area designed to maximize access to public transportation; similar to above criterion, but where the development center is within one half mile of a mass transit center (e.g. bus, rail, light rail or commuter train station). Such projects would not be able to take credit for both categories, but may have greater credit assigned		<input type="checkbox"/> Redevelopment projects in an established historic district, historic preservation area, or similar significant city area including core City Center areas (to be defined through mapping).	
<input type="checkbox"/> Developments with dedication of undeveloped portions to parks, preservation areas and other previous uses.	<input type="checkbox"/> Developments in a city center area.	<input type="checkbox"/> Developments in historic districts or historic preservation areas.	<input type="checkbox"/> Live-work developments, a variety of developments designed to support residential and vocational needs together – similar to criteria to mixed use development; would not be able to take credit for both categories.	<input type="checkbox"/> In-fill projects, the conversion of empty lots and other underused spaces into more beneficially used spaces, such as residential or commercial areas.

Calculation of Water Quality Credits (if applicable)	Not applicable
--	----------------

IV.4.2 Alternative Compliance Plan Information

Describe an alternative compliance plan (if applicable). Include alternative compliance obligations (i.e., gallons, pounds) and describe proposed alternative compliance measures. *Refer to Section 7.II 3.0 in the Model WQMP.*

Not applicable

Section V Inspection/Maintenance Responsibility for BMPs

Fill out information in table below. Prepare and attach an Operation and Maintenance Plan. Identify the funding mechanism through which BMPs will be maintained. Inspection and maintenance records must be kept for a minimum of five years for inspection by the regulatory agencies. Refer to Section 7.II 4.0 in the Model WQMP.

BMP	Responsible Party(s)	Inspection/ Maintenance Activities Required	Minimum Frequency of Activities
N1 - Education for Property Owners, Tenants and Occupants	Owner	Provide literature and instruction pertaining to environmental awareness included in Section VII Educational Material to all employees and residences.	Once yearly and for new employees
N2 - Activity Restrictions	Owner	See Attachment D for restrictions. Report any violations relating to activity restrictions listed herein.	Continuous
N3 - Common Area Landscape management	Owner	Hire contractor familiar with Orange County guidelines for use of fertilizers and pesticides. Maintain all landscape equipment improper working order.	Monthly
N4 - BMP Maintenance	Owner	See Attachment D for maintenance required.	Continuous
N11 - Common Area Litter Control	Owner	Inspect parking and trash areas, clean and dispose of all litter. Report any violations to the owner.	Weekly

Priority Project Water Quality Management Plan (WQMP)

N12 - Employee Training	Owner	Educate all employees on environmental awareness. Instruct on proper use of chemicals and cleanup procedures.	Once yearly prior to storm season
N14 - Common Area Catch Basin Inspection	Owner	Inspect catch basin, clean debris; replace filters as required by manufacturer's specifications. Repaint "No dumping-drains to ocean" with faces 40%.	Bi-monthly from April 15 – October 15; Monthly from October 15 – April 15
N15 - Street Sweeping Private Streets and Parking Lots	Owner	Sweep parking and drive areas. No hosing down of areas is allowed. Dispose of debris offsite.	Once every two months from October 15 – April 15
Irrigation	Owner	Inspect for siltation or debris washing out of planters. Sweep silt to planters and check amount of irrigation used and for properly functioning irrigation. Check irrigation system for leaks and over spray, provide maintenance as required.	Monthly
Landscape	Owner	Check for landscape to be in healthy conditions. Replace dead or barren areas with plants consistent with the approved landscape plans.	Monthly
Trash Container Area	Owner	Inspect for spills and trash. Wipe clean spills and dispose of trash.	Bi-weekly
Catch Basin Inserts	Owner	Inspect catch basin, clean debris. Replace filters as required by manufacturer's recommendations.	Once prior to rainy season October 15 and after significant rain event

Priority Project Water Quality Management Plan (WQMP)

<p>Contech's Filterra Bio-filtration</p>	<p>Owner</p>	<p>Activation and first year maintenance is included. After the first year of maintenance, maintenance responsibly falls on the owner. This included inspecting the surrounding area and removing any trash or debris. Add mulch to a depth of 3". Replace Filterra grates if applicable. See manufactures recommendations on Owners Manuel for more details in Section VII.</p>	<p>Maintenance performed once per year before the rainy season on Oct.15th. See Owners Manuel for more information.</p>
<p>Underground chambers</p>	<p>Owner</p>	<p>Inspect for standing water 48 hours after rain storm. Vacuum sediment when reaches 1/3 capacity.</p>	<p>Once prior to rainy season – October 15 and after significant rainfall.</p>

Section VI BMP Exhibit (Site Plan)

VI.1 BMP Exhibit (Site Plan)

Include a BMP Exhibit (Site Plan), at a size no less than 24" by 36," which includes the following minimum information:

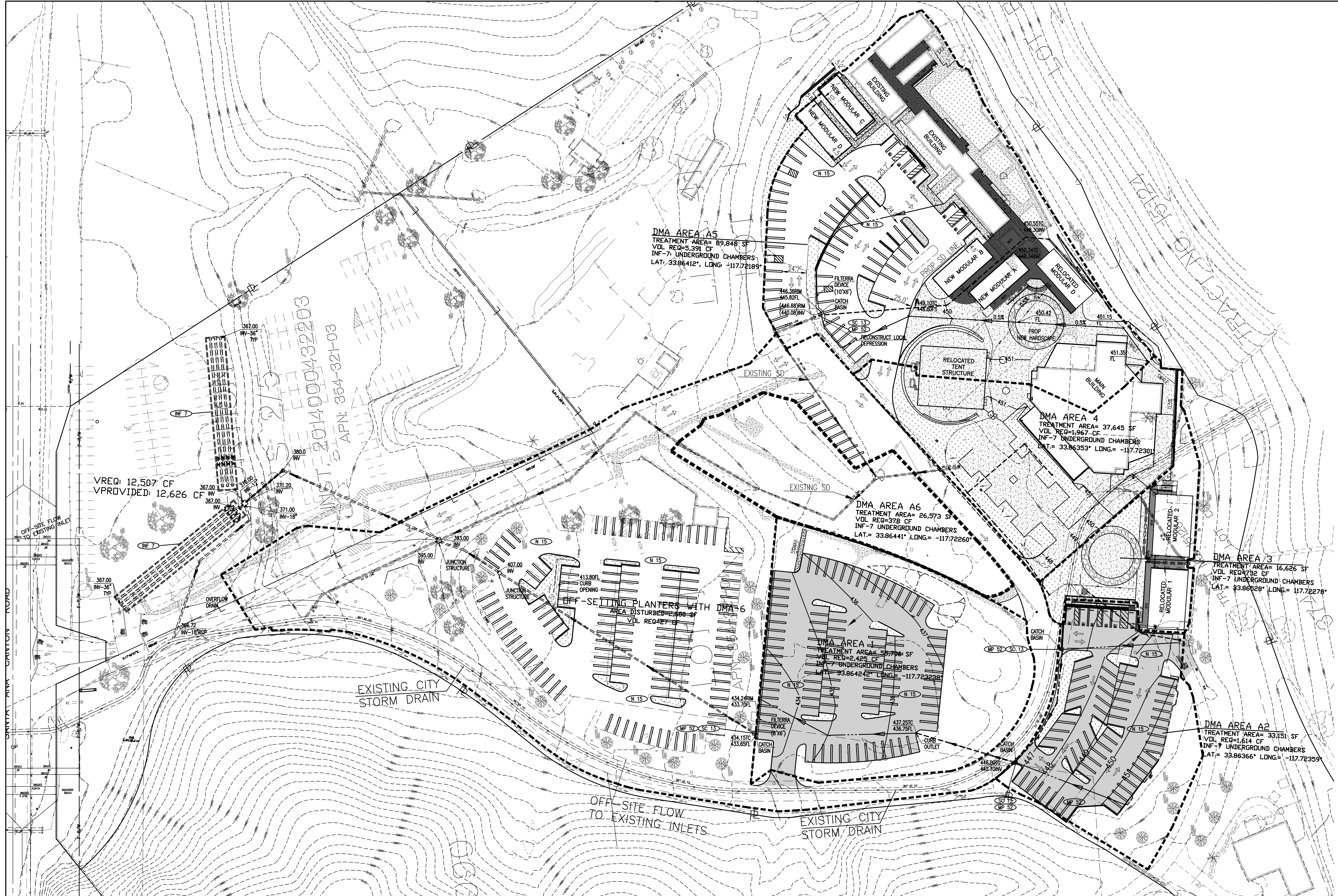
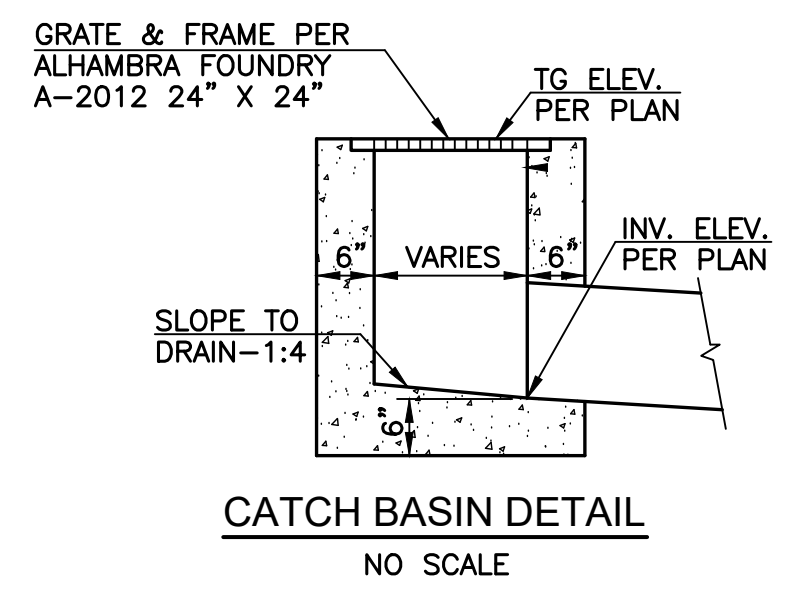
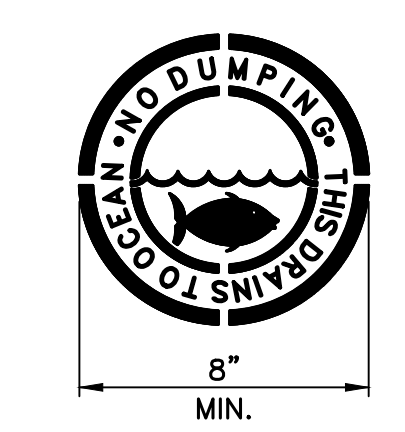
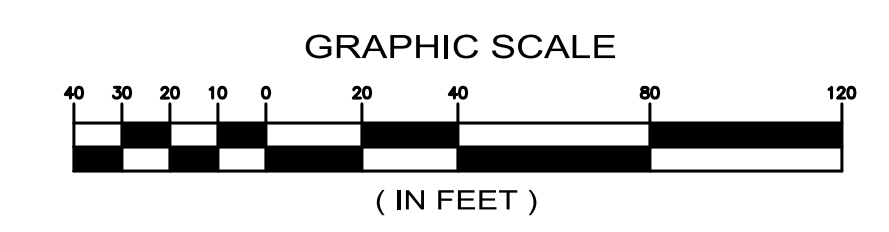
- Insert in the title block (lower right hand corner) of BMP Exhibit: the WQMP Number (assigned by staff) and the grading/building or Planning Application permit numbers
- Project location (address, tract/lot number(s), etc.)
- Site boundary
- Land uses and land covers, as applicable
- Suitability/feasibility constraints
- Structural BMP locations
- Drainage delineations and flow information
- Delineate the area being treated by each structural BMP
- GIS coordinates for LID and Treatment Control BMPs
- Drainage connections
- BMP details
- Preparer name and stamp

Please do not include any areas outside of the project area or any information not related to drainage or water quality. The approved BMP Exhibit (Site Plan) shall be submitted as a plan sheet on all grading and building plan sets submitted for plan check review and approval. The BMP Exhibit shall be at the same size as the rest of the plan sheets in the submittal and shall have an approval stamp and signature prior to plan check submittal.

VI.2 Submittal and Recordation of Water Quality Management Plan

Following approval of the Final Project-Specific WQMP, three copies of the approved WQMP (including BMP Exhibit, Operations and Maintenance (O&M) Plan, and Appendices) shall be submitted. In addition, these documents shall be submitted in a PDF format.

Each approved WQMP (including BMP Exhibit, Operations and Maintenance (O&M) Plan, and Appendices) shall be recorded in the Orange County Clerk-Recorder's Office, prior to close-out of grading and/or building permit. Educational Materials are not required to be included.



LEGEND

- FLOW IN STORM DRAIN
- PROPOSED STORM DRAIN
- EXISTING STORM DRAIN
- DRAINAGE BOUNDARY
- FLOW LINE
- PROPOSED GRAVEL
- PROPOSED LANDSCAPE AREA
- PROPOSED ASPHALT
- PROPOSED CONCRETE
- EXISTING CONCRETE

BMP'S

- STREET SWEEPING PARKING LOT
- UNDERGROUND INFILTRATION
- CATCH BASIN MAINTENANCE
- CATCH BASIN INSERT (FLOORGD FGP-24F)
- STORM DRAIN SIGNAGE

REVISIONS			
NO.	INIT.	DATE	DESCRIPTION

BENCH MARK:
 CITY OF ANAHEIM B.M. NO. 4A-129
 BRASS CAP MARKED CITY OF ANAHEIM BM,
 IN THE TOP OF CURB AT THE NE COR.
 SANTA ANA CANYON ROAD AND MOHLER DR.
 ELEVATION 324.14 FT. (NAVD88)

PREPARED BY:
ANACAL ENGINEERING COMPANY
 CIVIL ENGINEERING & LAND SURVEYING
 1211 N TUSTIN AVENUE ~ ANAHEIM, CA 92807
 PHONE (714) 774-1763 ~ FAX (714) 774-4690
 EMAIL ADDRESS: anacal@anacalengineering.com
 WEBSITE: anacalengineering.com

PWQMP SITE PLAN GRA
 SITE ADDRESS: CONCEPTUAL MASTER GRADING PLAN
 KINDRED COMMUNITY CHURCH
 8720 E. SANTA ANA CANYON ROAD SHEET 1 OF 1
 SCALE: 1" = 40' DRAWN BY: J. M. CHECKED BY: DCQ
CITY OF ANAHEIM

Section VII Educational Materials

Refer to the Orange County Stormwater Program (ocwatersheds.com) for a library of materials available. Please only attach the educational materials specifically applicable to this project. Other materials specific to the project may be included as well and must be attached.

Education Materials			
Residential Material (http://www.ocwatersheds.com)	Check If Applicable	Business Material (http://www.ocwatersheds.com)	Check If Applicable
The Ocean Begins at Your Front Door	<input checked="" type="checkbox"/>	Tips for the Automotive Industry	<input type="checkbox"/>
Tips for Car Wash Fund-raisers	<input type="checkbox"/>	Tips for Using Concrete and Mortar	<input type="checkbox"/>
Tips for the Home Mechanic	<input type="checkbox"/>	Tips for the Food Service Industry	<input type="checkbox"/>
Homeowners Guide for Sustainable Water Use	<input type="checkbox"/>	Proper Maintenance Practices for Your Business	<input checked="" type="checkbox"/>
Household Tips	<input type="checkbox"/>	Other Material	Check If Attached
Proper Disposal of Household Hazardous Waste	<input type="checkbox"/>		
Recycle at Your Local Used Oil Collection Center (North County)	<input type="checkbox"/>	Filterra Owners Manuel	<input checked="" type="checkbox"/>
Recycle at Your Local Used Oil Collection Center (Central County)	<input type="checkbox"/>		<input type="checkbox"/>
Recycle at Your Local Used Oil Collection Center (South County)	<input type="checkbox"/>		<input type="checkbox"/>
Tips for Maintaining a Septic Tank System	<input checked="" type="checkbox"/>		<input type="checkbox"/>
Responsible Pest Control	<input type="checkbox"/>		<input type="checkbox"/>
Sewer Spill			<input type="checkbox"/>
Tips for the Home Improvement Projects	<input type="checkbox"/>		<input type="checkbox"/>
Tips for Horse Care	<input type="checkbox"/>		<input type="checkbox"/>
Tips for Landscaping and Gardening	<input type="checkbox"/>		<input type="checkbox"/>
Tips for Pet Care	<input type="checkbox"/>		<input type="checkbox"/>
Tips for Pool Maintenance			<input type="checkbox"/>
Tips for Residential Pool, Landscape and Hardscape Drains	<input type="checkbox"/>		<input type="checkbox"/>
Tips for Projects Using Paint	<input type="checkbox"/>		<input type="checkbox"/>

Filterra Owner's Manual



filterra[®]
Bioretention Systems

C NTECH[®]
ENGINEERED SOLUTIONS

This Owner's Manual applies to all precast Filterra Configurations, including Filterra Bioscape Vault.





Table of Contents

Introduction	4
Activation Overview	4
Filtererra Plant Selection Overview	6
Warranty Overview	6
Routine Maintenance Guidelines.....	6
Maintenance Visit Procedure.....	9
Appendix 1 – Activation Checklist	12
Appendix 2 – Planting Requirements for Filtererra Systems.....	13
Appendix 3 – Filtererra Tree Grate Opening Expansion Procedure	15



Introduction

Thank you for your purchase of the Filterra® Bioretention System. Filterra is a specially engineered stormwater treatment system incorporating high performance biofiltration media to remove pollutants from stormwater runoff. The system’s biota (vegetation and soil microorganisms) then further breakdown and absorb captured pollutants. All components of the system work together to provide a sustainable long-term solution for treating stormwater runoff.

The Filterra system has been delivered to you with protection in place to resist intrusion of construction related sediment which can contaminate the biofiltration media and result in inadequate system performance. These protection devices are intended as a best practice and cannot fully prevent contamination. It is the purchaser’s responsibility to provide adequate measures to prevent construction related runoff from entering the Filterra system.

Included with your purchase is Activation of the Filterra system by the manufacturer as well as a 1-year warranty from delivery of the system and 1-year of routine maintenance (mulch replacement, debris removal, and pruning of vegetation) up to twice during the first year after activation.

Design and Installation

Each project presents different scopes for the use of Filterra systems. Information and help may be provided to the design engineer during the planning process. Correct Filterra box sizing (by rainfall region) is essential to predict pollutant removal rates for a given area. The engineer shall submit calculations for approval by the local jurisdiction. The contractor is responsible for the correct installation of Filterra units as shown in approved plans. A comprehensive installation manual is available at www.ContechES.com.

Activation Overview

Activation of the Filterra system is a procedure completed by the manufacturer to place the system into working condition. This involves the following items:

- Removal of construction runoff protection devices
- Planting of the system’s vegetation
- Placement of pretreatment mulch layer using mulch certified for use in Filterra systems.

Activation MUST be provided by the manufacturer to ensure proper site conditions are met for Activation, proper installation of the vegetation, and use of pretreatment mulch certified for use in Filterra systems.



Minimum Requirements

The minimum requirements for Filterra Activation are as follows:

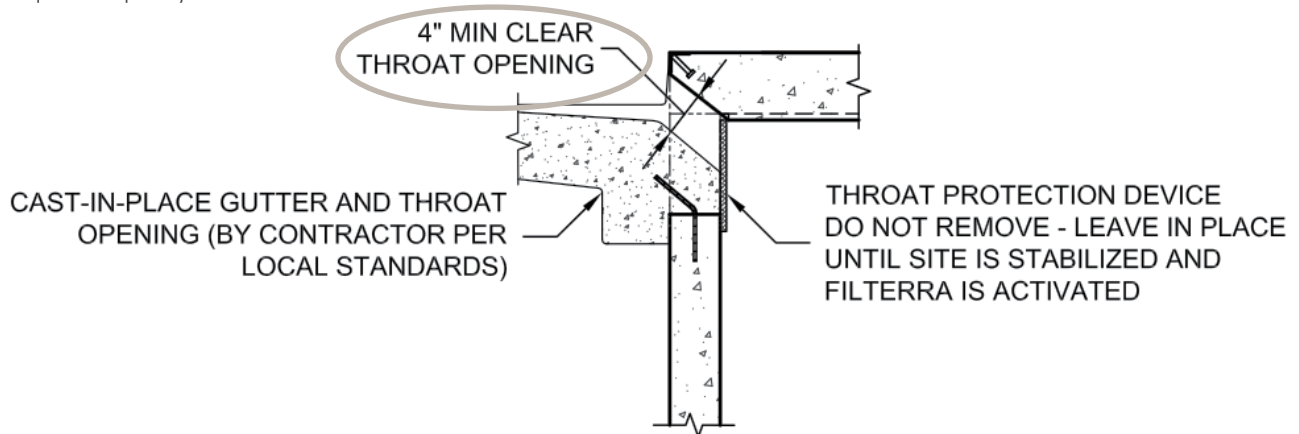
1. The site landscaping must be fully stabilized, i.e. full landscaping installed and some grass cover (not just straw and seed) is required to reduce sediment transport. Construction debris and materials should be removed from surrounding area.



2. Final paving must be completed. Final paving ensures that paving materials will not enter and contaminate the Filterra system during the paving process, and that the plant will receive runoff from the drainage area, assisting with plant survival for the Filterra system.



3. Where curb inlets are included as part of the Filterra system, Filterra throat opening should be at least 4" in order to ensure adequate capacity for inflow and debris.



An Activation Checklist is included on page 12 to ensure proper conditions are met for Contech to perform the Activation services. A charge of \$500.00 will be invoiced for each Activation visit requested by Customer where Contech determines that the site does not meet the conditions required for Activation.

Filterra Plant Selection Overview

A Plant List is available on the Contech website highlighting recommended plants for Filterra systems in your area. Keep in mind that plants are subject to availability due to seasonality and required minimum size for the Filterra system. Plants installed in the Filterra system are container plants (max 15 gallon) from nursery stock and will be immature in height and spread at Activation.

It is the responsibility of the owner to provide adequate irrigation when necessary to the plant of the Filterra system.

The “Planting Requirements for Filterra Systems” document is included as an appendix and discusses proper selection and care of the plants within Filterra systems.

Warranty Overview

Refer to the Contech Engineered Solutions LLC Stormwater Treatment System LIMITED WARRANTY for further information. The following conditions may void the Filterra system’s warranty and waive the manufacturer provided Activation and Maintenance services:

- Unauthorized activation or performance of any of the items listed in the activation overview
- Any tampering, modifications or damage to the Filterra system or runoff protection devices
- Removal of any Filterra system components
- Failure to prevent construction related runoff from entering the Filterra system
- Failure to properly store and protect any Filterra components (including media and underdrain stone) that may be shipped separately from the vault

Routine Maintenance Guidelines

With proper routine maintenance, the biofiltration media within the Filterra system should last as long as traditional bioretention media. Routine maintenance is included by the manufacturer on all Filterra systems for the first year after activation. This includes a maximum of 2 visits to remove debris, replace pretreatment mulch, and prune the vegetation. More information is provided in the Operations and Maintenance Guidelines. Some Filterra systems also contain pretreatment or outlet bays. Depending on site pollutant loading, these bays may require periodic removal of debris, however this is not included in the first year of maintenance, and would likely not be required within the first year of operation.

These services, as well as routine maintenance outside of the included first year, can be provided by certified maintenance providers listed on the Contech website. Training can also be provided to other stormwater maintenance or landscape providers.



Why Maintain?

All stormwater treatment systems require maintenance for effective operation. This necessity is often incorporated in your property's permitting process as a legally binding BMP maintenance agreement. Other reasons to maintain are:

- Avoiding legal challenges from your jurisdiction's maintenance enforcement program.
- Prolonging the expected lifespan of your Filterra media.
- Avoiding more costly media replacement.
- Helping reduce pollutant loads leaving your property.

Simple maintenance of the Filterra is required to continue effective pollutant removal from stormwater runoff before discharge into downstream waters. This procedure will also extend the longevity of the living biofilter system. The unit will recycle and accumulate pollutants within the biomass, but is also subjected to other materials entering the inlet. This may include trash, silt and leaves etc. which will be contained above the mulch layer. Too much silt may inhibit the Filterra's flow rate, which is the reason for site stabilization before activation. Regular replacement of the mulch stops accumulation of such sediment.

When to Maintain?

Contech includes a 1-year maintenance plan with each system purchase. Annual included maintenance consists of a maximum of two (2) scheduled visits. Additional maintenance may be necessary depending on sediment and trash loading (by Owner or at additional cost). The start of the maintenance plan begins when the system is activated.

Maintenance visits are typically scheduled seasonally; the spring visit aims to clean up after winter loads including salts and sands while the fall visit helps the system by removing excessive leaf litter.

It has been found that in regions which receive between 30-50 inches of annual rainfall, (2) two visits are generally required; regions with less rainfall often only require (1) one visit per annum. Varying land uses can affect maintenance frequency; e.g. some fast food restaurants require more frequent trash removal. Contributing drainage areas which are subject to new development wherein the recommended erosion and sediment control measures have not been implemented may require additional maintenance visits.

Some sites may be subjected to extreme sediment or trash loads, requiring more frequent maintenance visits. This is the reason for detailed notes of maintenance actions per unit, helping the Supplier and Owner predict future maintenance frequencies, reflecting individual site conditions.

Owners must promptly notify the maintenance provider of any damage to the plant(s), which constitute(s) an integral part of the bioretention technology. Owners should also advise other landscape or maintenance contractors to leave all maintenance to the Supplier (i.e. no pruning or fertilizing) during the first year.



Exclusion of Services

Clean up due to major contamination such as oils, chemicals, toxic spills, etc. will result in additional costs and are not covered under the Supplier maintenance contract. Should a major contamination event occur the Owner must block off the outlet pipe of the Filterra (where the cleaned runoff drains to, such as drop inlet) and block off the throat of the Filterra. The Supplier should be informed immediately.

Maintenance Visit Summary

Each maintenance visit consists of the following simple tasks (detailed instructions below).

1. Inspection of Filterra and surrounding area
2. Removal of tree grate (where applicable) and erosion control stones
3. Removal of debris, trash and mulch
4. Mulch replacement
5. Plant health evaluation and pruning or replacement as necessary
6. Clean area around Filterra
7. Complete paperwork

Maintenance Tools, Safety Equipment and Supplies

Ideal tools include: camera, bucket, shovel, broom, pruners, hoe/rake, and tape measure. Appropriate Personal Protective Equipment (PPE) should be used in accordance with local or company procedures. This may include impervious gloves where the type of trash is unknown, high visibility clothing and barricades when working in close proximity to traffic and also safety hats and shoes. A T-Bar or crowbar should be used for moving the tree grates, where applicable (up to 170 lbs each). If tree grate opening expansion is necessary, safety glasses/goggles and a 3lb or greater mini sledgehammer are required. Most visits require minor trash removal and a full replacement of mulch. See below for actual number of bagged mulch that is required in each media bay size. Mulch should be a double shredded, hardwood variety. Some visits may require additional Filterra engineered soil media available from the Supplier.

Media Bay Length	Media Bay Width	Filter Surface Area (ft ²)	Volume at 3" (ft ³)	# of 2 ft ³ Mulch Bags
4	4	16	4	2
6	4	24	6	3
8	4	32	8	4
6	6	36	9	5
8	6	48	12	6
10	6	60	15	8
12	6	72	18	9
13	7	91	23	12

Other sizes not listed - 1 bag per 8 ft² of media.

Maintenance Visit Procedure

Keep sufficient documentation of maintenance actions to predict location specific maintenance frequencies and needs. An example Maintenance Report is included in this manual.



1. Inspection of Filterra and surrounding area

- Record individual unit before maintenance with photograph (numbered). Record on Maintenance Report (see example in this document) the following:

Record on Maintenance Report the following:

Standing Water	yes no
Damage to Box Structure	yes no
Damage to Grate (if applicable)	yes no
Is Bypass Clear	yes no

If yes answered to any of these observations, record with close-up photograph (numbered).



2. Removal of tree grate (if applicable) and erosion control stones

- Remove cast iron grates for access into Filterra box (if applicable).
- Dig out silt (if any) and mulch and remove trash & foreign items.

3. Removal of debris, trash and mulch

Record on Maintenance Report the following:

Silt/Clay	yes no
Cups/ Bags	yes no
Leaves	yes no
Buckets Removed	_____



- After removal of mulch and debris, measure distance from the top of the Filterra engineered media soil to the top of the top slab. Compare the measured distance to the distance shown on the approved Contract Drawings for the system. Add Filterra media (not top soil or other) to bring media up as needed to distance indicated on drawings.

Record on Maintenance Report the following:

Distance to Top of Top Slab (inches)	_____
Inches of Media Added	_____



4. Mulch replacement

- Add double shredded mulch evenly across the entire unit to a depth of 3".
- Refer to Filterra Mulch Specifications for information on acceptable sources.
- Ensure correct repositioning of erosion control stones by the Filterra inlet to allow for entry of trash during a storm event.
- Replace Filterra grates (if applicable) correctly using appropriate lifting or moving tools, taking care not to damage the plant.
- Where applicable, if 6" tree grate opening is too close to plant trunk, the grate opening may be expanded to 12" using a mini sledgehammer. Refer to instructions in Appendix 3.



5. Plant health evaluation and pruning or replacement as necessary

- Examine the plant's health and replace if necessary.
- Prune as necessary to encourage growth in the correct directions

Record on Maintenance Report the following:

Height above top of Filterra Unit	_____ (ft)
Width at Widest Point	_____ (ft)
Health	healthy unhealthy
Damage to Plant	yes no
Plant Replaced	yes no



6. Clean area around Filterra

- Clean area around unit and remove all refuse to be disposed of appropriately.



7. Complete paperwork

- Deliver Maintenance Report and photographs to appropriate location (normally Contech during maintenance contract period).
- Some jurisdictions may require submission of maintenance reports in accordance with approvals. It is the responsibility of the Owner to comply with local regulations.

Maintenance Checklist

Drainage System Failure	Problem	Conditions to Check	Condition that Should Exist	Actions
Inlet	Excessive sediment or trash accumulation.	Accumulated sediments or trash impair free flow of water into Filterra.	Inlet should be free of obstructions allowing free distributed flow of water into Filterra.	Sediments and/or trash should be removed.
Mulch Cover	Trash and floatable debris accumulation.	Excessive trash and/or debris accumulation.	Minimal trash or other debris on mulch cover.	Trash and debris should be removed and mulch cover raked level. Ensure bark nugget mulch is not used.
Mulch Cover	"Ponding" of water on mulch cover.	"Ponding" in unit could be indicative of clogging due to excessive fine sediment accumulation or spill of petroleum oils.	Stormwater should drain freely and evenly through mulch cover.	Recommend contact manufacturer and replace mulch as a minimum.
Vegetation	Plants not growing or in poor condition.	Soil/mulch too wet, evidence of spill. Incorrect plant selection. Pest infestation. Vandalism to plants.	Plants should be healthy and pest free.	Contact manufacturer for advice.
Vegetation	Plant growth excessive.	Plants should be appropriate to the species and location of Filterra.		Trim/prune plants in accordance with typical landscaping and safety needs.
Structure	Structure has visible cracks.	Cracks wider than 1/2 inch or evidence of soil particles entering the structure through the cracks.		Vault should be repaired.

Maintenance is ideally to be performed twice annually.

Filterra Inspection & Maintenance Log

Filterra System Size/Model: _____ Location: _____

Date	Mulch & Debris Removed	Depth of Mulch Added	Mulch Brand	Height of Vegetation Above Top of Vault	Vegetation Species	Issues with System	Comments
1/1/17	5 – 5 gal Buckets	3"	Lowe's Premium Brown Mulch	4'	Galaxy Magnolia	- Standing water in downstream structure	- Removed blockage in downstream structure

Appendix 1 – Filterra® Activation Checklist



Project Name: _____ Company: _____

Site Contact Name: _____ Site Contact Phone/Email: _____

Site Owner/End User Name: _____ Site Owner/End User Phone/Email: _____

Preferred Activation Date: _____ (provide 2 weeks minimum from date this form is submitted)

Site Designation	System Size	Final Pavement / Top Coat Complete	Landscaping Complete / Grass Emerging	Construction materials / Piles / Debris Removed	Throat Opening Measures 4" Min. Height	Plant Species Requested
		<input type="checkbox"/> Yes <input type="checkbox"/> No	<input type="checkbox"/> Yes <input type="checkbox"/> No	<input type="checkbox"/> Yes <input type="checkbox"/> No	<input type="checkbox"/> Yes <input type="checkbox"/> No <input type="checkbox"/> N/A	
		<input type="checkbox"/> Yes <input type="checkbox"/> No	<input type="checkbox"/> Yes <input type="checkbox"/> No	<input type="checkbox"/> Yes <input type="checkbox"/> No	<input type="checkbox"/> Yes <input type="checkbox"/> No <input type="checkbox"/> N/A	
		<input type="checkbox"/> Yes <input type="checkbox"/> No	<input type="checkbox"/> Yes <input type="checkbox"/> No	<input type="checkbox"/> Yes <input type="checkbox"/> No	<input type="checkbox"/> Yes <input type="checkbox"/> No <input type="checkbox"/> N/A	
		<input type="checkbox"/> Yes <input type="checkbox"/> No	<input type="checkbox"/> Yes <input type="checkbox"/> No	<input type="checkbox"/> Yes <input type="checkbox"/> No	<input type="checkbox"/> Yes <input type="checkbox"/> No <input type="checkbox"/> N/A	
		<input type="checkbox"/> Yes <input type="checkbox"/> No	<input type="checkbox"/> Yes <input type="checkbox"/> No	<input type="checkbox"/> Yes <input type="checkbox"/> No	<input type="checkbox"/> Yes <input type="checkbox"/> No <input type="checkbox"/> N/A	
		<input type="checkbox"/> Yes <input type="checkbox"/> No	<input type="checkbox"/> Yes <input type="checkbox"/> No	<input type="checkbox"/> Yes <input type="checkbox"/> No	<input type="checkbox"/> Yes <input type="checkbox"/> No <input type="checkbox"/> N/A	
		<input type="checkbox"/> Yes <input type="checkbox"/> No	<input type="checkbox"/> Yes <input type="checkbox"/> No	<input type="checkbox"/> Yes <input type="checkbox"/> No	<input type="checkbox"/> Yes <input type="checkbox"/> No <input type="checkbox"/> N/A	
		<input type="checkbox"/> Yes <input type="checkbox"/> No	<input type="checkbox"/> Yes <input type="checkbox"/> No	<input type="checkbox"/> Yes <input type="checkbox"/> No	<input type="checkbox"/> Yes <input type="checkbox"/> No <input type="checkbox"/> N/A	
		<input type="checkbox"/> Yes <input type="checkbox"/> No	<input type="checkbox"/> Yes <input type="checkbox"/> No	<input type="checkbox"/> Yes <input type="checkbox"/> No	<input type="checkbox"/> Yes <input type="checkbox"/> No <input type="checkbox"/> N/A	

Attach additional sheets as necessary.

NOTE: A charge of \$500.00 will be invoiced for each Activation visit requested by Customer where Contech determines that the site does not meet the conditions required for Activation. ONLY Contech authorized representatives can perform Activation of Filterra systems; unauthorized Activations will void the system warranty and waive manufacturer supplied Activation and 1st Year Maintenance.

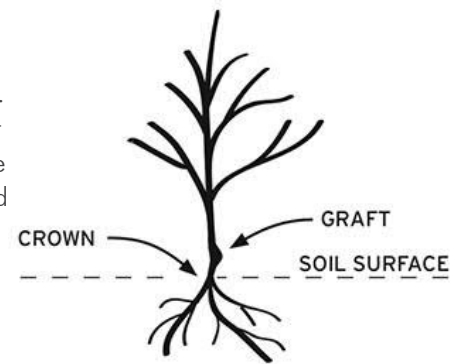
Signature _____

Date _____

Appendix 2 – Planting Requirements for Filterra® Systems

Plant Material Selection

- Select plant(s) as specified in the engineering plans and specifications.
- Select plant(s) with full root development but not to the point where root bound.
- Use local nursery container plants only. Ball and burlapped plants are not permitted.
- For precast Filterra systems with a tree grate, plant(s) must not have scaffold limbs at least 14 inches from the crown due to spacing between the top of the mulch and the tree grate. Lower branches can be pruned away provided there are sufficient scaffold branches for tree or shrub development.
- For precast Filterra systems with a tree grate, at the time of installation, it is required that plant(s) must be at least 6" above the tree grate opening at installation for all Filterra configurations. This DOES NOT apply to Full Grate Cover designs.
- Plant(s) shall not have a mature height greater than 25 feet.
- For standard 21" media depth, a 7 – 15 gallon container size shall be used. Media less than 21" (Filterra boxes only) may require smaller container plants.
- For precast Filterra systems, plant(s) should have a single trunk at installation, and pruning may be necessary at activation and maintenance for some with a tree grate of the faster growing species, or species known to produce basal sprouts.



Plant Installation

- During transport protect the plant foliage from wind and excessive jostling.
- Prior to removing the plant(s) from the container, ensure the soil moisture is sufficient to maintain the integrity of the root ball. If needed, pre-wet the container plant.
- Cut away any roots which are growing out of the container drain holes. Plants with excessive root growth from the drain holes should be rejected.
- Plant(s) should be carefully removed from the pot by gently pounding on the sides of the container with the fist to loosen root ball. Then carefully slide out. Do not lift plant(s) by trunk as this can break roots and cause soil to fall off. Extract the root ball in a horizontal position and support it to prevent it from breaking apart. Alternatively the pot can be cut away to minimize root ball disturbance.
- Remove any excess soil from above the root flare after removing plant(s) from container.
- Excavate a hole with a diameter 4" greater than the root ball, gently place the plant(s).
- If plant(s) have any circling roots from being pot bound, gently tease them loose without breaking them.
- If root ball has a root mat on the bottom, it should be shaved off with a knife just above the mat line.
- Plant the tree/shrub/grass with the top of the root ball 1" above surrounding media to allow for settling.
- All plants should have the main stem centered in the tree grate (where applicable) upon completion of installation.
- With all trees/shrubs, remove dead, diseased, crossed/rubbing, sharply crotched branches or branches growing excessively long or in wrong direction compared to majority of branches.
- To prevent transplant shock (especially if planting takes place in the hot season), it may be necessary to prune some of the foliage to compensate for reduced root uptake capacity. This is accomplished by pruning away some of the smaller secondary branches or a main scaffold branch if there are too many. Too much foliage relative to the root ball can dehydrate and damage the plant.
- Plant staking may be required.

Mulch Installation

- Only mulch that meets Contech Engineered Solutions' mulch specifications can be used in the Filterra system.
- Mulch must be applied to a depth of 3" evenly over the surface of the media.

Irrigation Requirements

- Each Filterra system must receive adequate irrigation to ensure survival of the living system during periods of drier weather.
- Irrigation sources include rainfall runoff from downspouts and/or gutter flow, applied water through the top/tree grate or in some cases from an irrigation system with emitters installed during construction.
- At Activation: Apply about one (cool climates) to two (warm climates) gallons of water per inch of trunk diameter over the root ball.
- During Establishment: In common with all plants, each Filterra plant will require more frequent watering during the establishment period. One inch of applied water per week for the first three months is recommended for cooler climates (2 to 3 inches for warmer climates). If the system is receiving rainfall runoff from the drainage area, then irrigation may not be needed. Inspection of the soil moisture content can be evaluated by gently brushing aside the mulch layer and feeling the soil. Be sure to replace the mulch when the assessment is complete. Irrigate as needed**.
- Established Plants: Established plants have fully developed root systems and can access the entire water column in the media. Therefore irrigation is less frequent but requires more applied water when performed. For a mature system assume 3.5 inches of available water within the media matrix. Irrigation demand can be estimated as 1" of irrigation demand per week. Therefore if dry periods exceed 3 weeks, irrigation may be required. It is also important to recognize that plants which are exposed to windy areas and reflected heat from paved surfaces may need more frequent irrigation. Long term care should develop a history which is more site specific.

** Five gallons per square yard approximates 1 inch of water Therefore for a 6' by 6' Filterra approximately 20-60 gallons of water is needed. To ensure even distribution of water it needs to be evenly sprinkled over the entire surface of the filter bed, with special attention to make sure the root ball is completely wetted. NOTE: if needed, measure the time it takes to fill a five gallon bucket to estimate the applied water flow rate then calculate the time needed to irrigate the Filterra. For example, if the flow rate of the sprinkler is 5 gallons/minute then it would take 12 minutes to irrigate a 6' by 6' filter.



Appendix 3 – Filterra® Tree Grate Opening Expansion Procedure

The standard grates used on all Filterra configurations that employ Tree Grates are fabricated with a 6" opening that is designed with a breakaway section that can be removed, allowing the grate opening to be expanded to 12" as the tree matures and the trunk widens.

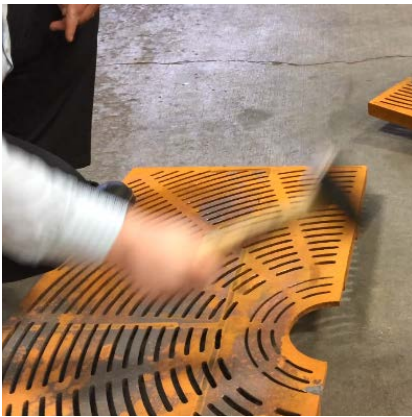
The following tools are required to expand the opening:

- Mini sledgehammer (3 lb. or greater)
- Safety Glasses / Goggles

The following guidelines should be followed to properly expand the tree opening from 6" to 12":



1. Remove the grate from the Filterra frame, place it flat on a hard surface, and support the grate by stepping on the edge or using other weighted items such as a few mulch bags if this is being done during a Filterra maintenance event. Put on safety glasses/goggles. Align the mini sledgehammer as shown in the figure to the left. The head of the sledgehammer should be aimed just inside the wide cast iron bar between the larger grate section and the breakaway section.



2. Repeatedly hit the grate at this spot with the mini sledgehammer.



3. After several hits, the breakaway section should snap cleanly off of the larger grate section. Reinstall the grate into the Filterra grate frame. Recycle or dispose of the breakaway section per local guidelines.



9025 Centre Pointe Drive, Suite 400
West Chester, OH 45069
info@conteches.com | 800-338-1122
www.ContechES.com

© 2021 Contech Engineered Solutions LLC, a QUIKRETE Company

ALL RIGHTS RESERVED. PRINTED IN THE USA.

NOTHING IN THIS CATALOG SHOULD BE CONSTRUED AS A WARRANTY. APPLICATIONS SUGGESTED HEREIN ARE DESCRIBED ONLY TO HELP READERS MAKE THEIR OWN EVALUATIONS AND DECISIONS, AND ARE NEITHER GUARANTEES NOR WARRANTIES OF SUITABILITY FOR ANY APPLICATION. CONTECH MAKES NO WARRANTY WHATSOEVER, EXPRESS OR IMPLIED, RELATED TO THE APPLICATIONS, MATERIALS, COATINGS, OR PRODUCTS DISCUSSED HEREIN. ALL IMPLIED WARRANTIES OF MERCHANTABILITY AND ALL IMPLIED WARRANTIES OF FITNESS FOR ANY PARTICULAR PURPOSE ARE DISCLAIMED BY CONTECH. SEE CONTECH'S CONDITIONS OF SALE (AVAILABLE AT WWW.CONTECHES.COM/COS) FOR MORE INFORMATION.

Attachment A

Kindred Community Church

BMP Calculations & Worksheets

Site: 8712-8720 E. Santa Ana Canyon Rd.

APN: 354-321-01 & 354-321-03

INF-7: Underground Infiltration

Underground infiltration is a vault or chamber with an open bottom that used to store runoff and percolate into the subsurface. A number of vendors offer proprietary infiltration products that allow for similar or enhanced rates of infiltration and subsurface storage while offering durable prefrabricated structures. There are many varieties of proprietary infiltration BMPs that can be used for roads and parking lots, parks and open spaces, single and multi-family residential, or mixed-use and commercial uses.



Also known as:

- *Infiltration vault*
- *Recharge vault*

Underground Infiltration

Source: <http://www.contech-cpi.com>

Feasibility Screening Considerations

- Infiltration bays shall pass infeasible screening criteria to be considered for use.
- Underground infiltration galleries pose a potential risk of groundwater contamination; pretreatment should be used.

Opportunity Criteria

- Soils are adequate for infiltration or can be amended to provide an adequate infiltration rate.
- Appropriate for sites with limited surface space.
- Can be placed beneath roads, parking lots, parks, and athletic fields.
- Potential for groundwater contamination can be mitigated through isolation of pollutant sources, pretreatment of inflow, and/or demonstration of adequate treatment capacity of underlying soils.
- Infiltration is into native soil, or depth of engineered fill is ≤ 5 feet from the bottom of the facility to native material and infiltration into fill is approved by a geotechnical professional.
- Tributary area land uses include mixed-use and commercial, single-family and multi-family, roads and parking lots, and parks and open spaces. High pollutant land uses should not be tributary to infiltration BMPs.

OC-Specific Design Criteria and Considerations

- Placement of BMPs should observe geotechnical recommendations with respect to geological hazards (e.g. landslides, liquefaction zones, erosion, etc.) and set-backs (e.g., foundations, utilities, roadways, etc.)
- Minimum separation to mounded seasonally high groundwater of 10 feet shall be observed.
- Minimum pretreatment should be provided upstream of the infiltration facility, and water bypassing pretreatment should not be directed to the facility.
- Underground infiltration should not be used for drainage areas with high sediment production potential unless preceded by full treatment control with a BMP effective for sediment removal.
- Design infiltration rate should be determined as described in [Appendix VII](#).
- Inspection ports or similar design features shall be provided to verify continued system performance and identify need for major maintenance.

- For infiltration facilities beneath roads and parking areas, structural requirements should meet H-20 load requirements.

Computing Underground Infiltration Device Size

Underground infiltration devices vary by design and by proprietary designs. The sizing method selected for use must be based on the BMP type it most strongly resembles.

- For underground infiltration devices with open pore volume (e.g., vaults, crates, pipe sections, etc), sizing will be most similar to infiltration basins.
- For underground infiltration devices with pore space (e.g., aggregate reservoirs), sizing will be most similar to permeable pavement.

Additional References for Design Guidance

- Los Angeles Unified School District (LAUSD) Stormwater Technical Manual, Chapter 5:
http://www.laschools.org/employee/design/fs-studies-and-reports/download/white_paper_report_material/Storm_Water_Technical_Manual_2009-opt-red.pdf?version_id=76975850

Worksheet B: Simple Design Capture Volume Sizing Method

DMA-1

Step 1: Determine the design capture storm depth used for calculating volume			
1	Enter design capture storm depth from Figure III.1, d (inches)	$d =$	0.9 inches
2	Enter the effect of provided HSCs, d_{HSC} (inches) (Worksheet A)	$d_{HSC} =$	----- inches
3	Calculate the remainder of the design capture storm depth, $d_{remainder}$ (inches) (Line 1 - Line 2)	$d_{remainder} =$	0.9 inches
Step 2: Calculate the DCV			
1	Enter Project area tributary to BMP (s), A (acres)	$A =$	1.28 acres
2	Enter Project Imperviousness, imp (unitless)	$imp =$.57
3	Calculate runoff coefficient, $C = (0.75 \times imp) + 0.15$	$C =$	0.58
4	Calculate runoff volume, $V_{design} = (C \times d_{remainder} \times A \times 43560 \times (1/12))$	$V_{design} =$	2,425 cu-ft
Step 3: Design BMPs to ensure full retention of the DCV			
Step 3a: Determine design infiltration rate			
1	Enter measured infiltration rate, $K_{measured}$ (in/hr) (Appendix VII)	$K_{measured} =$	2.8 In/hr
2	Enter combined safety factor from Worksheet H, S_{final} (unitless)	$S_{final} =$	2.63
3	Calculate design infiltration rate, $K_{design} = K_{measured} \times S_{final}$	$K_{design} =$	1.06 In/hr
Step 3b: Determine minimum BMP footprint			
4	Enter drawdown time, T (max 48 hours)	$T =$	48 Hours
5	Calculate max retention depth that can be drawn down within the drawdown time (feet), $D_{max} = K_{design} \times T \times (1/12)$	$D_{max} =$	4.24 feet
6	Calculate minimum area required for BMP (sq-ft), $A_{min} = V_{design} / d_{max}$	$A_{min} =$	572 sq-ft

Worksheet B: Simple Design Capture Volume Sizing Method

DMA-2

Step 1: Determine the design capture storm depth used for calculating volume			
1	Enter design capture storm depth from Figure III.1, d (inches)	$d =$	0.9 inches
2	Enter the effect of provided HSCs, d_{HSC} (inches) (Worksheet A)	$d_{HSC} =$	----- inches
3	Calculate the remainder of the design capture storm depth, $d_{remainder}$ (inches) (Line 1 - Line 2)	$d_{remainder} =$	0.9 inches
Step 2: Calculate the DCV			
1	Enter Project area tributary to BMP (s), A (acres)	$A =$	0.76 acres
2	Enter Project Imperviousness, imp (unitless)	$imp =$	67%
3	Calculate runoff coefficient, $C = (0.75 \times imp) + 0.15$	$C =$.65
4	Calculate runoff volume, $V_{design} = (C \times d_{remainder} \times A \times 43560 \times (1/12))$	$V_{design} =$	1,614 cu-ft
Step 3: Design BMPs to ensure full retention of the DCV			
Step 3a: Determine design infiltration rate			
1	Enter measured infiltration rate, $K_{measured}$ (in/hr) (Appendix VII)	$K_{measured} =$	2.8 In/hr
2	Enter combined safety factor from Worksheet H, S_{final} (unitless)	$S_{final} =$	2.63
3	Calculate design infiltration rate, $K_{design} = K_{measured} \times S_{final}$	$K_{design} =$	1.06 In/hr
Step 3b: Determine minimum BMP footprint			
4	Enter drawdown time, T (max 48 hours)	$T =$	48 Hours
5	Calculate max retention depth that can be drawn down within the drawdown time (feet), $D_{max} = K_{design} \times T \times (1/12)$	$D_{max} =$	4.24 feet
6	Calculate minimum area required for BMP (sq-ft), $A_{min} = V_{design} / d_{max}$	$A_{min} =$	381 sq-ft

Worksheet B: Simple Design Capture Volume Sizing Method

DMA-3

Step 1: Determine the design capture storm depth used for calculating volume				
1	Enter design capture storm depth from Figure III.1, d (inches)	$d=$	0.9	inches
2	Enter the effect of provided HSCs, d_{HSC} (inches) (Worksheet A)	$d_{HSC}=$	-----	inches
3	Calculate the remainder of the design capture storm depth, $d_{remainder}$ (inches) (Line 1 - Line 2)	$d_{remainder}=$	0.9	inches
Step 2: Calculate the DCV				
1	Enter Project area tributary to BMP (s), A (acres)	$A=$	0.38	acres
2	Enter Project Imperviousness, imp (unitless)	$imp=$.58	
3	Calculate runoff coefficient, $C= (0.75 \times imp) + 0.15$	$C=$.59	
4	Calculate runoff volume, $V_{design}= (C \times d_{remainder} \times A \times 43560 \times (1/12))$	$V_{design}=$	732	cu-ft
Step 3: Design BMPs to ensure full retention of the DCV				
Step 3a: Determine design infiltration rate				
1	Enter measured infiltration rate, $K_{measured}$ (in/hr) (Appendix VII)	$K_{measured}=$	2.8	In/hr
2	Enter combined safety factor from Worksheet H, S_{final} (unitless)	$S_{final}=$	2.63	
3	Calculate design infiltration rate, $K_{design} = K_{measured} \times S_{final}$	$K_{design}=$	1.06	In/hr
Step 3b: Determine minimum BMP footprint				
4	Enter drawdown time, T (max 48 hours)	$T=$	48	Hours
5	Calculate max retention depth that can be drawn down within the drawdown time (feet), $D_{max} = K_{design} \times T \times (1/12)$	$D_{max}=$	4.24	feet
6	Calculate minimum area required for BMP (sq-ft), $A_{min} = V_{design}/d_{max}$	$A_{min}=$	172	sq-ft

Worksheet B: Simple Design Capture Volume Sizing Method

DMA-4

Step 1: Determine the design capture storm depth used for calculating volume			
1	Enter design capture storm depth from Figure III.1, d (inches)	$d =$	0.9 inches
2	Enter the effect of provided HSCs, d_{HSC} (inches) (Worksheet A)	$d_{HSC} =$	----- inches
3	Calculate the remainder of the design capture storm depth, $d_{remainder}$ (inches) (Line 1 - Line 2)	$d_{remainder} =$	0.9 inches
Step 2: Calculate the DCV			
1	Enter Project area tributary to BMP (s), A (acres)	$A =$	0.86 acres
2	Enter Project Imperviousness, imp (unitless)	$imp =$	73%
3	Calculate runoff coefficient, $C = (0.75 \times imp) + 0.15$	$C =$.70
4	Calculate runoff volume, $V_{design} = (C \times d_{remainder} \times A \times 43560 \times (1/12))$	$V_{design} =$	1,967 cu-ft
Step 3: Design BMPs to ensure full retention of the DCV			
Step 3a: Determine design infiltration rate			
1	Enter measured infiltration rate, $K_{measured}$ (in/hr) (Appendix VII)	$K_{measured} =$	2.8 In/hr
2	Enter combined safety factor from Worksheet H, S_{final} (unitless)	$S_{final} =$	2.63
3	Calculate design infiltration rate, $K_{design} = K_{measured} \times S_{final}$	$K_{design} =$	1.06 In/hr
Step 3b: Determine minimum BMP footprint			
4	Enter drawdown time, T (max 48 hours)	$T =$	48 Hours
5	Calculate max retention depth that can be drawn down within the drawdown time (feet), $D_{max} = K_{design} \times T \times (1/12)$	$D_{max} =$	4.24 feet
6	Calculate minimum area required for BMP (sq-ft), $A_{min} = V_{design} / d_{max}$	$A_{min} =$	464 sq-ft

Worksheet B: Simple Design Capture Volume Sizing Method

DMA-5

Step 1: Determine the design capture storm depth used for calculating volume				
1	Enter design capture storm depth from Figure III.1, d (inches)	$d=$	0.9	inches
2	Enter the effect of provided HSCs, d_{HSC} (inches) (Worksheet A)	$d_{HSC}=$	-----	inches
3	Calculate the remainder of the design capture storm depth, $d_{remainder}$ (inches) (Line 1 - Line 2)	$d_{remainder}=$	0.9	inches
Step 2: Calculate the DCV				
1	Enter Project area tributary to BMP (s), A (acres)	$A=$	2.06	acres
2	Enter Project Imperviousness, imp (unitless)	$imp=$	0.87	
3	Calculate runoff coefficient, $C= (0.75 \times imp) + 0.15$	$C=$	0.80	
4	Calculate runoff volume, $V_{design}= (C \times d_{remainder} \times A \times 43560 \times (1/12))$	$V_{design}=$	5,391	cu-ft
Step 3: Design BMPs to ensure full retention of the DCV				
Step 3a: Determine design infiltration rate				
1	Enter measured infiltration rate, $K_{measured}$ (in/hr) (Appendix VII)	$K_{measured}=$	2.8	In/hr
2	Enter combined safety factor from Worksheet H, S_{final} (unitless)	$S_{final}=$	2.63	
3	Calculate design infiltration rate, $K_{design} = K_{measured} \times S_{final}$	$K_{design}=$	1.06	In/hr
Step 3b: Determine minimum BMP footprint				
4	Enter drawdown time, T (max 48 hours)	$T=$	48	Hours
5	Calculate max retention depth that can be drawn down within the drawdown time (feet), $D_{max} = K_{design} \times T \times (1/12)$	$D_{max}=$	4.24	feet
6	Calculate minimum area required for BMP (sq-ft), $A_{min} = V_{design} / d_{max}$	$A_{min}=$	1,271	sq-ft

Worksheet B: Simple Design Capture Volume Sizing Method

DMA-6

Step 1: Determine the design capture storm depth used for calculating volume			
1	Enter design capture storm depth from Figure III.1, d (inches)	$d =$	0.9 inches
2	Enter the effect of provided HSCs, d_{HSC} (inches) (Worksheet A)	$d_{HSC} =$	----- inches
3	Calculate the remainder of the design capture storm depth, $d_{remainder}$ (inches) (Line 1 - Line 2)	$d_{remainder} =$	0.9 inches
Step 2: Calculate the DCV			
1	Enter Project area tributary to BMP (s), A (acres)	$A =$	0.61 acres
2	Enter Project Imperviousness, imp (unitless)	$imp =$.05
3	Calculate runoff coefficient, $C = (0.75 \times imp) + 0.15$	$C =$.19
4	Calculate runoff volume, $V_{design} = (C \times d_{remainder} \times A \times 43560 \times (1/12))$	$V_{design} =$	378 cu-ft
Step 3: Design BMPs to ensure full retention of the DCV			
Step 3a: Determine design infiltration rate			
1	Enter measured infiltration rate, $K_{measured}$ (in/hr) (Appendix VII)	$K_{measured} =$	2.8 In/hr
2	Enter combined safety factor from Worksheet H, S_{final} (unitless)	$S_{final} =$	2.63
3	Calculate design infiltration rate, $K_{design} = K_{measured} \times S_{final}$	$K_{design} =$	1.06 In/hr
Step 3b: Determine minimum BMP footprint			
4	Enter drawdown time, T (max 48 hours)	$T =$	48 Hours
5	Calculate max retention depth that can be drawn down within the drawdown time (feet), $D_{max} = K_{design} \times T \times (1/12)$	$D_{max} =$	4.24 feet
6	Calculate minimum area required for BMP (sq-ft), $A_{min} = V_{design} / d_{max}$	$A_{min} =$	90 sq-ft

Worksheet H: Factor of Safety and Design Infiltration Rate and Worksheet

Factor Category		Factor Description	Assigned Weight (w)	Factor Value (v)	Product (p) $p = w \times v$
A	Suitability Assessment	Soil assessment methods	0.25	2	0.50
		Predominant soil texture	0.25	3	0.75
		Site soil variability	0.25	1	0.25
		Depth to groundwater / impervious layer	0.25	1	0.25
		Suitability Assessment Safety Factor, $S_A = \Sigma p$			
B	Design	Tributary area size	0.25	2	0.50
		Level of pretreatment/ expected sediment loads	0.25	1	0.25
		Redundancy	0.25	2	0.50
		Compaction during construction	0.25	1	0.25
		Design Safety Factor, $S_B = \Sigma p$			
Combined Safety Factor, $S_{TOT} = S_A \times S_B$				2.63	
Measured Infiltration Rate, inch/hr, K_M (corrected for test-specific bias)				2.8	
Design Infiltration Rate, in/hr, $K_{DESIGN} = S_{TOT} \times K_M$				1.06	
Supporting Data					
<p>Briefly describe infiltration test and provide reference to test forms:</p> <p>Percolation testing was done utilizing the Porchet Method by TGR Geotechnical, Reference Project No. 15-5382 . Infiltration test rates were determined in general accordance with Orange County Public Works technical guidance document.</p>					

Note: The minimum combined adjustment factor shall not be less than 2.0 and the maximum combined adjustment factor shall not exceed 9.0.

Worksheet I: Summary of Groundwater-related Feasibility Criteria

1	Is project large or small? (as defined by Table VIII.2) circle one	<input checked="" type="radio"/> Large	<input type="radio"/> Small	
2	What is the tributary area to the BMP?	A	5.96	acres
3	What type of BMP is proposed?	Inf-7: Underground Infiltration		
4	What is the infiltrating surface area of the proposed BMP?	A _{BMP}	6,200	sq-ft
5	What land use activities are present in the tributary area (list all) -Community Church -Commercial Use			
6	What land use-based risk category is applicable?	<input type="radio"/> L	<input checked="" type="radio"/> M	<input type="radio"/> H
7	If M or H, what pretreatment and source isolation BMPs have been considered and are proposed (describe all): We plan to use Contech Filterra bio-retention system to help treat the run-off prior to entering the proposed storm drain system.			
8	What minimum separation to mounded seasonally high groundwater applies to the proposed BMP? See Section VIII.2 (circle one)	<input type="radio"/> 5 ft	<input checked="" type="radio"/> 10 ft	
9	Provide rationale for selection of applicable minimum separation to seasonally high mounded groundwater: Based on Soil Engineers findings, groundwater was encountered previously at a depth of 18.5 ft below existing grade.			
10	What is separation from the infiltrating surface to seasonally high groundwater?	SHGWT	18.5'	ft
11	What is separation from the infiltrating surface to mounded seasonally high groundwater?	Mounded SHGWT	3.3'	ft
12	Describe assumptions and methods used for mounding analysis: Used the "simulation of groundwater mounding" worksheet from USGS, see following pages for inputs and results.			
13	Is the site within a plume protection boundary (See Figure	<input type="radio"/> Y	<input checked="" type="radio"/> N	<input type="radio"/> N/A

Worksheet I: Summary of Groundwater-related Feasibility Criteria

	VIII.2)?	
14	Is the site within a selenium source area or other natural plume area (See Figure VIII.2)?	Y <input checked="" type="radio"/> N N/A
15	Is the site within 250 feet of a contaminated site?	Y <input checked="" type="radio"/> N N/A
16	If site-specific study has been prepared, provide citation and briefly summarize relevant findings: N/A	
17	Is the site within 100 feet of a water supply well, spring, septic system?	Y <input checked="" type="radio"/> N N/A
18	Is infiltration feasible on the site relative to groundwater-related criteria?	<input checked="" type="radio"/> Y N
Provide rationale for feasibility determination: Due to a good infiltration rate and criteria in the TGD, infiltration is deemed to be feasible.		

Note: if a single criterion or group of criteria would render infiltration infeasible, it is not necessary to evaluate every question in this worksheet.

This spreadsheet will calculate the height of a groundwater mound beneath a stormwater infiltration basin. More information can be found in the U.S. Geological Survey Scientific Investigations Report 2010-5102 "Simulation of groundwater mounding beneath hypothetical stormwater infiltration basins".

The user must specify infiltration rate (R), specific yield (Sy), horizontal hydraulic conductivity (Kh), basin dimensions (x, y), duration of infiltration period (t), and the initial thickness of the saturated zone (hi(0), height of the water table if the bottom of the aquifer is the datum). For a square basin the half width equals the half length (x = y). For a rectangular basin, if the user wants the water-table changes perpendicular to the long side, specify x as the short dimension and y as the long dimension. Conversely, if the user wants the values perpendicular to the short side, specify y as the short dimension, x as the long dimension. All distances are from the center of the basin. Users can change the distances from the center of the basin at which water-table aquifer thickness are calculated.

Cells highlighted in yellow are values that can be changed by the user. Cells highlighted in red are output values based on user-specified inputs. **The user MUST click the blue "Re-Calculate Now" button each time ANY of the user-specified inputs are changed** otherwise necessary iterations to converge on the correct solution will not be done and values shown will be incorrect. Use consistent units for all input values (for example, feet and days)

Input Values		use consistent units (e.g. feet & days or inches & hours)	Conversion Table		
			inch/hour	feet/day	
2.4800	R	Recharge (infiltration) rate (feet/day)	0.67	1.33	
0.200	Sy	Specific yield, Sy (dimensionless, between 0 and 1)			
56.00	K	Horizontal hydraulic conductivity, Kh (feet/day)*	2.00	4.00	In the report accompanying this spreadsheet (USGS SIR 2010-5102), vertical soil permeability (ft/d) is assumed to be one-tenth horizontal hydraulic conductivity (ft/d).
77.500	x	1/2 length of basin (x direction, in feet)			
10.000	y	1/2 width of basin (y direction, in feet)	hours	days	
10.000	t	duration of infiltration period (days)	36	1.50	
13.500	hi(0)	initial thickness of saturated zone (feet)			
16.799	h(max)	maximum thickness of saturated zone (beneath center of basin at end of infiltration period)			
3.299	Δh(max)	maximum groundwater mounding (beneath center of basin at end of infiltration period)			

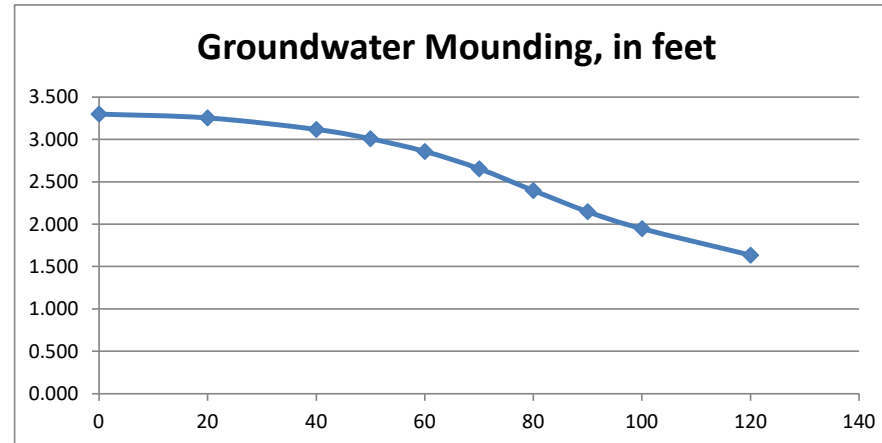
Ground-water Mounding, in feet

Distance from center of basin in x direction, in feet

3.299	0
3.256	20
3.120	40
3.009	50
2.860	60
2.655	70
2.398	80
2.149	90
1.947	100
1.635	120



Re-Calculate Now



Disclaimer

PROJECT SUMMARY

CALCULATION DETAILS

- LOADING = HS20 & HS25
- APPROX. LINEAR FOOTAGE = 618 lf.

STORAGE SUMMARY

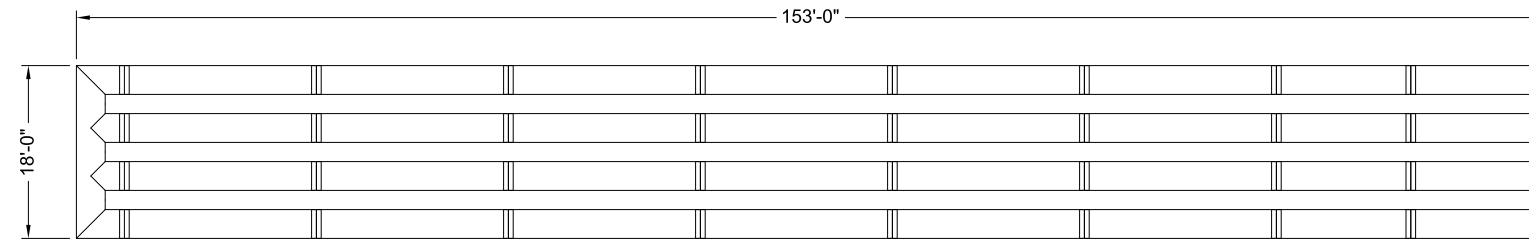
- STORAGE VOLUME REQUIRED = N/A
- PIPE STORAGE VOLUME = 4,368 cf.
- BACKFILL STORAGE VOLUME = 1,944 cf.
- TOTAL STORAGE PROVIDED = 6,313 cf.

PIPE DETAILS

- DIAMETER = 36 IN.
- CORRUGATION = 2 2/3x1/2
- GAGE = 16
- COATING = ALT2
- WALL TYPE = Perforated
- BARRELL SPACING = 24 IN.

BACKFILL DETAILS

- WIDTH AT ENDS = 12 IN.
- ABOVE PIPE = 6 IN.
- WIDTH AT SIDES = 12 IN.
- BELOW PIPE = 0 IN.



NOTES



- ALL RISER AND STUB DIMENSIONS ARE TO CENTERLINE. ALL ELEVATIONS, DIMENSIONS, AND LOCATIONS OF RISERS AND INLETS, SHALL BE VERIFIED BY THE ENGINEER OF RECORD PRIOR TO RELEASING FOR FABRICATION.
- ALL FITTINGS AND REINFORCEMENT COMPLY WITH ASTM A998.
- ALL RISERS AND STUBS ARE 2 2/3" x 1/2" CORRUGATION AND 16 GAGE UNLESS OTHERWISE NOTED.
- RISERS TO BE FIELD TRIMMED TO GRADE.
- QUANTITY OF PIPE SHOWN DOES NOT PROVIDE EXTRA PIPE FOR CONNECTING THE SYSTEM TO EXISTING PIPE OR DRAINAGE STRUCTURES. OUR SYSTEM AS DETAILED PROVIDES NOMINAL INLET AND/OR OUTLET PIPE STUB FOR CONNECTION TO EXISTING DRAINAGE FACILITIES. IF ADDITIONAL PIPE IS NEEDED IT IS THE RESPONSIBILITY OF THE CONTRACTOR.
- BAND TYPE TO BE DETERMINED UPON FINAL DESIGN.
- THE PROJECT SUMMARY IS REFLECTIVE OF THE DYODS DESIGN, QUANTITIES ARE APPROX. AND SHOULD BE VERIFIED UPON FINAL DESIGN AND APPROVAL. FOR EXAMPLE, TOTAL EXCAVATION DOES NOT CONSIDER ALL VARIABLES SUCH AS SHORING AND ONLY ACCOUNTS FOR MATERIAL WITHIN THE ESTIMATED EXCAVATION FOOTPRINT.
- THESE DRAWINGS ARE FOR CONCEPTUAL PURPOSES AND DO NOT REFLECT ANY LOCAL PREFERENCES OR REGULATIONS. PLEASE CONTACT YOUR LOCAL CONTECH REP FOR MODIFICATIONS.

ASSEMBLY
SCALE: 1" = 20'

C:\EXPORT\TEMPLATES\CMP_V5.DWG 10/18/2019 10:02 AM

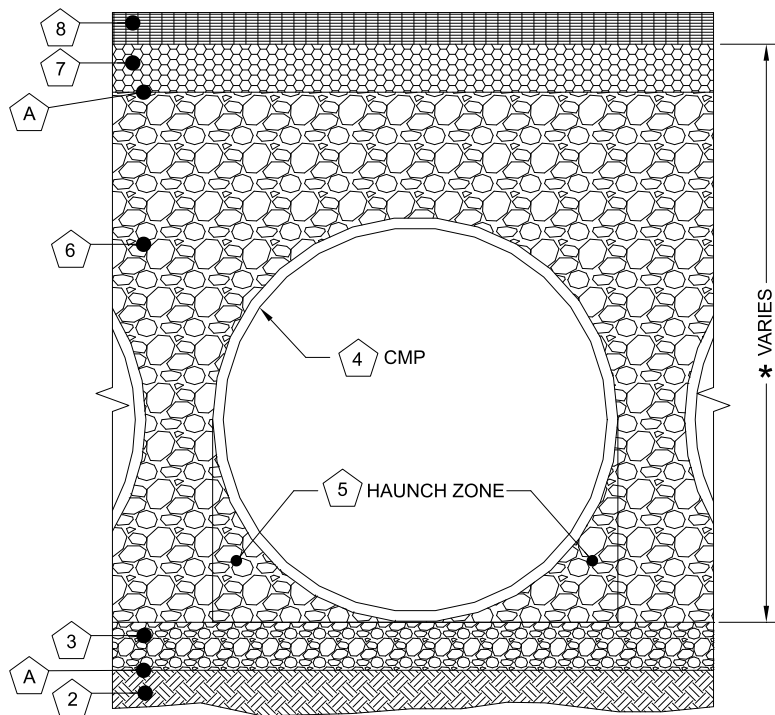
The design and information shown on this drawing is provided as a service to the project owner, engineer and contractor by Contech Engineered Solutions LLC ("Contech"). Neither this drawing, nor any part thereof, may be used, reproduced or modified in any manner without the prior written consent of Contech. Failure to comply is done at the user's own risk and Contech expressly disclaims any liability or responsibility for such use.		
If discrepancies between the supplied information upon which the drawing is based and actual field conditions are encountered as site work progresses, these discrepancies must be reported to Contech immediately for re-evaluation of the design. Contech accepts no liability for designs based on missing, incomplete or inaccurate information supplied by others.		
DATE	REVISION DESCRIPTION	BY


ENGINEERED SOLUTIONS LLC
www.ContechES.com
 9025 Centre Pointe Dr., Suite 400, West Chester, OH 45069
 800-338-1122 513-645-7000 513-645-7993 FAX


CMP DETENTION SYSTEMS

 CONTECH
DYODS
 DRAWING

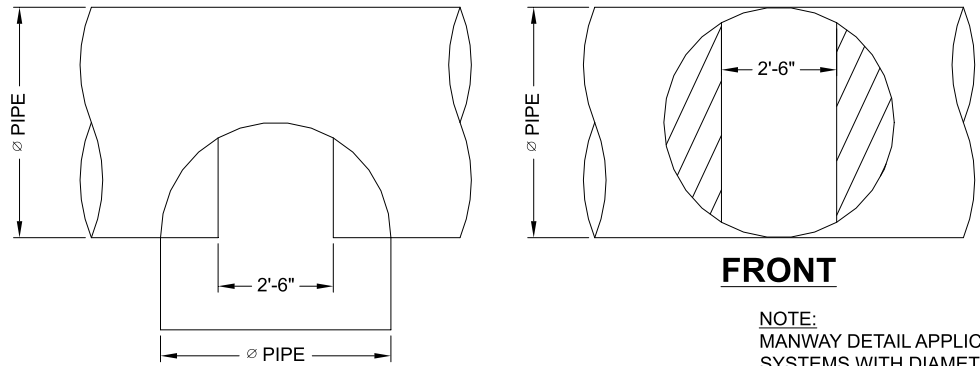
DYO7334 Kindred Church
 Underground Infiltration
 Anaheim, CA
 DETENTION SYSTEM

PROJECT No.: 4569	SEQ. No.: 7334	DATE: 12/8/2021
DESIGNED: DYO	DRAWN: DYO	
CHECKED: DYO	APPROVED: DYO	
SHEET NO.:		D1



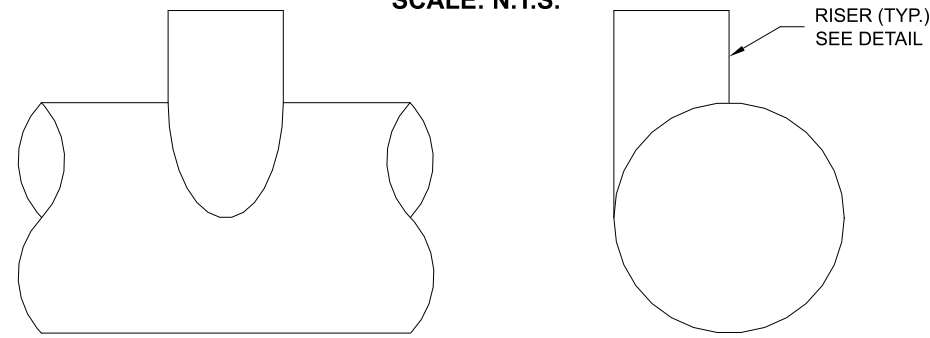
Infiltration Systems - CMP Infiltration & CMP Perforated Drainage Pipe			
Material Location	Description	Material Designation	Designation
8	Rigid or Flexible Pavement (if applicable)		
7	Road Base (if applicable)		
A	Geotextile Layer	Non-Woven Geotextile CONTECH C-40 or C-45	Engineer Decision for consideration to prevent soil migration into varying soil types. Wrap the trench only.
6	Backfill	Infiltration pipe systems have a pipe perforation sized of 3/8" diameter. An open graded, free draining stone, with a particle size of 1/2" - 2 1/2" diameter is recommended.	AASHTO M 145-A-1 or AASHTO M 43 - 3, 4 Material shall be worked into the pipe haunches by means of shovel-slicing, rodding, air-tamper, vibratory rod, or other effective methods. Compaction of all placed fill material is necessary and shall be considered adequate when no further yielding of the material is observed under the compactor, or under foot, and the Project Engineer or his representative is satisfied with the level of compaction"
3	Bedding Stone	Well graded granular bedding material w/maximum particle size of 3"	AASHTO M43 - 3,357,4,467, 5, 56, 57 For soil aggregates larger than 3/8" a dedicated bedding layer is not required for CMP. Pipe may be placed on the trench bottom comprised of native suitable well graded & granular material. For Arch pipes it is recommended to be shaped to a relatively flat bottom or fine-grade the foundation to a slight v-shape. Soil aggregates less than 3/8" and unsuitable material should be over-excavated and re-placed with a 4"-6" layer of well graded & granular stone per the material designation.
A	Geotextile Layer	None	None Contech does not recommend geotextiles be placed under the invert of infiltration systems due to the propensity for geotextiles to clog over time.

* Note: The listed AASHTO designations are for gradation only. The stone must also be angular and clean.



TYPICAL MANWAY DETAIL
SCALE: N.T.S.

NOTE: MANWAY DETAIL APPLICABLE FOR CMP SYSTEMS WITH DIAMETERS 48" AND LARGER. MANWAYS MAY BE REQUIRED ON SMALLER SYSTEMS DEPENDING ON ACTUAL SITE SPECIFIC CONDITIONS.



TYPICAL RISER DETAIL
SCALE: N.T.S.

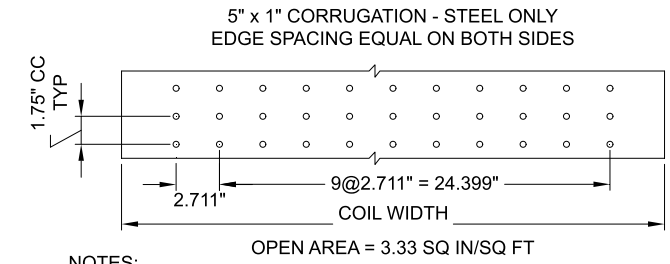
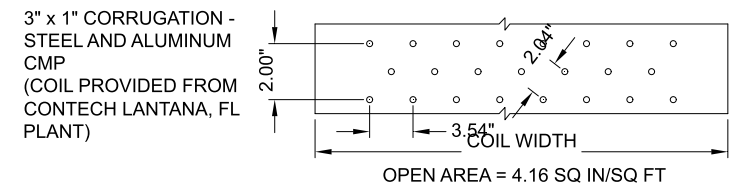
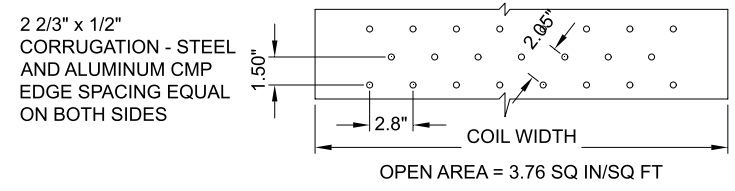
NOTE: LADDERS ARE OPTIONAL AND ARE NOT REQUIRED FOR ALL SYSTEMS.

- 1 MINIMUM WIDTH DEPENDS ON SITE CONDITIONS AND ENGINEERING JUDGEMENT.
- 2 PRIOR TO PLACING THE BEDDING, THE FOUNDATION MUST BE CONSTRUCTED TO A UNIFORM AND STABLE GRADE. IN THE EVENT THAT UNSUITABLE FOUNDATION MATERIALS ARE ENCOUNTERED DURING EXCAVATION, THEY SHALL BE REMOVED AND BROUGHT BACK TO THE GRADE WITH A FILL MATERIAL AS APPROVED BY THE ENGINEER.
- 5 HAUNCH ZONE MATERIAL SHALL BE PLACED AND UNIFORMLY COMPACTED WITHOUT SOFT SPOTS.

BACKFILL
MATERIAL SHALL BE PLACED IN 8"-10" MAXIMUM LIFTS. INADEQUATE COMPACTION CAN LEAD TO EXCESSIVE DEFLECTIONS WITHIN THE SYSTEM AND SETTLEMENT OF THE SOILS OVER THE SYSTEM. BACKFILL SHALL BE PLACED SUCH THAT THERE IS NO MORE THAN A TWO-LIFT DIFFERENTIAL BETWEEN THE SIDES OF ANY PIPE IN THE SYSTEM AT ALL TIMES DURING THE BACKFILL PROCESS. BACKFILL SHALL BE ADVANCED ALONG THE LENGTH OF THE SYSTEM AT THE SAME RATE TO AVOID DIFFERENTIAL LOADING ON ANY PIPES IN THE SYSTEM.

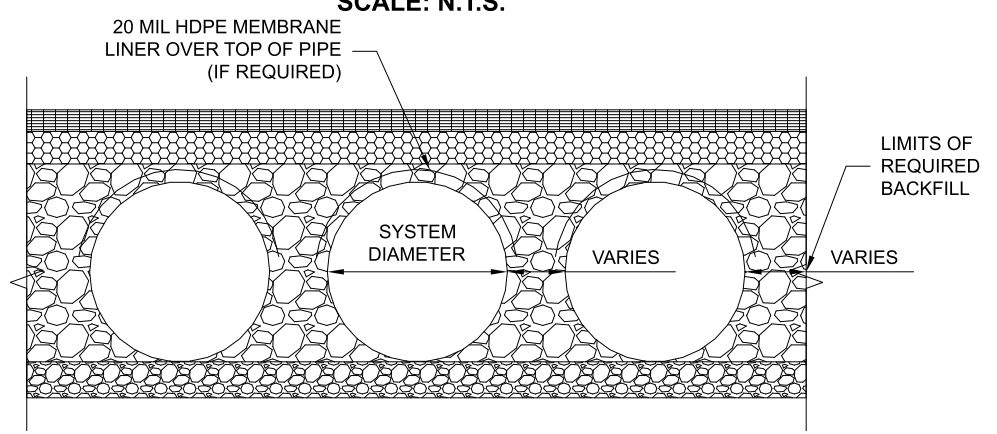
EQUIPMENT USED TO PLACE AND COMPACT THE BACKFILL SHALL BE OF A SIZE AND TYPE SO AS NOT TO DISTORT, DAMAGE, OR DISPLACE THE PIPE. ATTENTION MUST BE GIVEN TO PROVIDING ADEQUATE MINIMUM COVER FOR SUCH EQUIPMENT. MAINTAIN BALANCED LOADING ON ALL PIPES IN THE SYSTEM DURING ALL SUCH OPERATIONS.

OTHER ALTERNATE BACKFILL MATERIAL MAY BE ALLOWED DEPENDING ON SITE SPECIFIC CONDITIONS. REFER TO TYPICAL BACKFILL DETAIL FOR MATERIAL REQUIRED.



- NOTES:
- PERFORATIONS MEET AASHTO AND ASTM SPECIFICATIONS.
 - PERFORATION OPEN AREA PER SQUARE FOOT OF PIPE IS BASED ON THE NOMINAL DIAMETER AND LENGTH OF PIPE.
 - ALL DIMENSIONS ARE SUBJECT TO MANUFACTURING TOLERANCES.
 - ALL HOLES \varnothing 3/8".

TYPICAL PERFORATION DETAIL
SCALE: N.T.S.



TYPICAL SECTION VIEW
LINER OVER ROWS
SCALE: N.T.S.

NOTE: IF SALTING AGENTS FOR SNOW AND ICE REMOVAL ARE USED ON OR NEAR THE PROJECT, AN HDPE MEMBRANE LINER IS RECOMMENDED WITH THE SYSTEM. THE IMPERMEABLE LINER IS INTENDED TO HELP PROTECT THE SYSTEM FROM THE POTENTIAL ADVERSE EFFECTS THAT MAY RESULT FROM A CHANGE IN THE SURROUNDING ENVIRONMENT OVER A PERIOD OF TIME. PLEASE REFER TO THE CORRUGATED METAL PIPE DETENTION DESIGN GUIDE FOR ADDITIONAL INFORMATION.

C:\EXPORT\TEMPLATES\CMP_V5.DWG 10/18/2019 10:02 AM

The design and information shown on this drawing is provided as a service to the project owner, engineer and contractor by Contech Engineered Solutions LLC ("Contech"). Neither this drawing, nor any part thereof, may be used, reproduced or modified in any manner without the prior written consent of Contech. Failure to comply is done at the user's own risk and Contech expressly disclaims any liability or responsibility for such use.

If discrepancies between the supplied information upon which the drawing is based and actual field conditions are encountered as site work progresses, these discrepancies must be reported to Contech immediately for re-evaluation of the design. Contech accepts no liability for designs based on missing, incomplete or inaccurate information supplied by others.

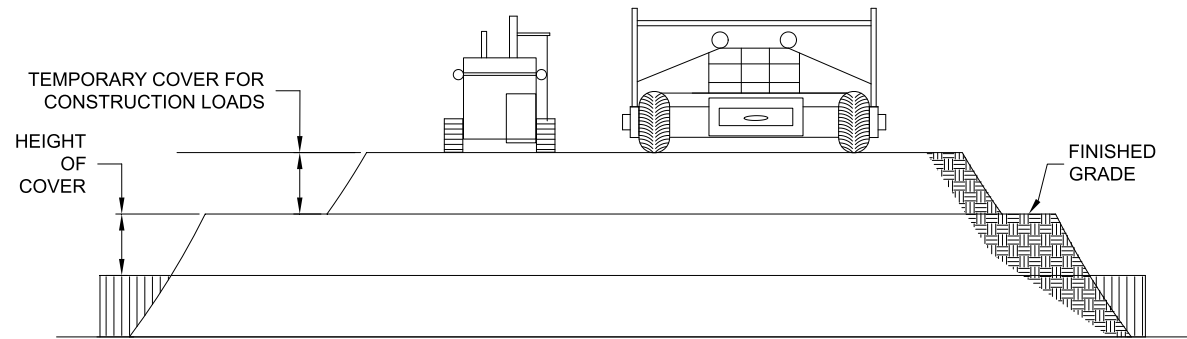
DATE	REVISION DESCRIPTION	BY

CONTECH
ENGINEERED SOLUTIONS LLC
www.ContechES.com
9025 Centre Pointe Dr., Suite 400, West Chester, OH 45069
800-338-1122 513-645-7000 513-645-7993 FAX

CONTECH
CMP DETENTION SYSTEMS
CONTECH
DYODS
DRAWING

DYO7334 Kindred Church
Underground Infiltration
Anaheim, CA
DETENTION SYSTEM

PROJECT No.: 4569	SEQ. No.: 7334	DATE: 12/8/2021
DESIGNED: DYO	DRAWN: DYO	
CHECKED: DYO	APPROVED: DYO	
SHEET NO.:		D2



CONSTRUCTION LOADS

FOR TEMPORARY CONSTRUCTION VEHICLE LOADS, AN EXTRA AMOUNT OF COMPACTED COVER MAY BE REQUIRED OVER THE TOP OF THE PIPE. THE HEIGHT-OF-COVER SHALL MEET THE MINIMUM REQUIREMENTS SHOWN IN THE TABLE BELOW. THE USE OF HEAVY CONSTRUCTION EQUIPMENT NECESSITATES GREATER PROTECTION FOR THE PIPE THAN FINISHED GRADE COVER MINIMUMS FOR NORMAL HIGHWAY TRAFFIC.

PIPE SPAN, INCHES	AXLE LOADS (kips)			
	18-50	50-75	75-110	110-150
	MINIMUM COVER (FT)			
12-42	2.0	2.5	3.0	3.0
48-72	3.0	3.0	3.5	4.0
78-120	3.0	3.5	4.0	4.0
126-144	3.5	4.0	4.5	4.5

*MINIMUM COVER MAY VARY, DEPENDING ON LOCAL CONDITIONS. THE CONTRACTOR MUST PROVIDE THE ADDITIONAL COVER REQUIRED TO AVOID DAMAGE TO THE PIPE. MINIMUM COVER IS MEASURED FROM THE TOP OF THE PIPE TO THE TOP OF THE MAINTAINED CONSTRUCTION ROADWAY SURFACE.

CONSTRUCTION LOADING DIAGRAM

SCALE: N.T.S.

SPECIFICATION FOR DESIGNED DETENTION SYSTEM:

SCOPE

THIS SPECIFICATION COVERS THE MANUFACTURE AND INSTALLATION OF THE DESIGNED DETENTION SYSTEM DETAILED IN THE PROJECT PLANS.

MATERIAL

THE MATERIAL SHALL CONFORM TO THE APPLICABLE REQUIREMENTS LISTED BELOW:

ALUMINIZED TYPE 2 STEEL COILS SHALL CONFORM TO THE APPLICABLE REQUIREMENTS OF AASHTO M-274 OR ASTM A-92.

THE GALVANIZED STEEL COILS SHALL CONFORM TO THE APPLICABLE REQUIREMENTS OF AASHTO M-218 OR ASTM A-929.

THE POLYMER COATED STEEL COILS SHALL CONFORM TO THE APPLICABLE REQUIREMENTS OF AASHTO M-246 OR ASTM A-742.

THE ALUMINUM COILS SHALL CONFORM TO THE APPLICABLE REQUIREMENTS OF AASHTO M-197 OR ASTM B-744.

CONSTRUCTION LOADS

CONSTRUCTION LOADS MAY BE HIGHER THAN FINAL LOADS. FOLLOW THE MANUFACTURER'S OR NCSA GUIDELINES.

PIPE

THE PIPE SHALL BE MANUFACTURED IN ACCORDANCE TO THE APPLICABLE REQUIREMENTS LISTED BELOW:

ALUMINIZED TYPE 2: AASHTO M-36 OR ASTM A-760

GALVANIZED: AASHTO M-36 OR ASTM A-760

POLYMER COATED: AASHTO M-245 OR ASTM A-762

ALUMINUM: AASHTO M-196 OR ASTM B-745

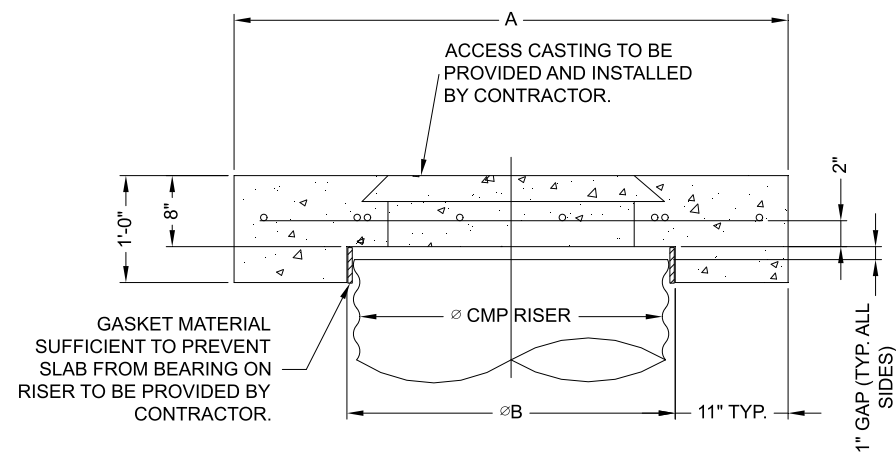
HANDLING AND ASSEMBLY

SHALL BE IN ACCORDANCE WITH NCSP'S (NATIONAL CORRUGATED STEEL PIPE ASSOCIATION) FOR ALUMINIZED TYPE 2, GALVANIZED OR POLYMER COATED STEEL. SHALL BE IN ACCORDANCE WITH THE MANUFACTURER'S RECOMMENDATIONS FOR ALUMINUM PIPE.

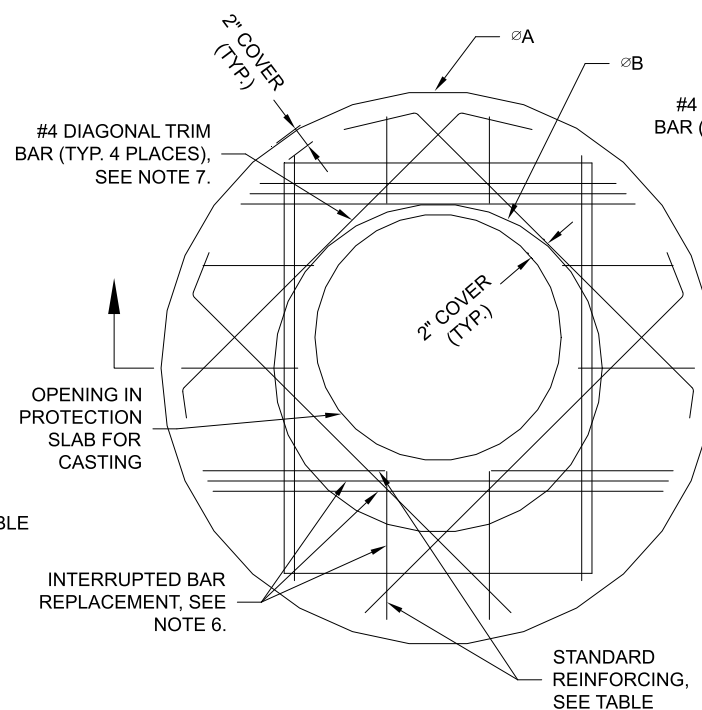
INSTALLATION

SHALL BE IN ACCORDANCE WITH AASHTO STANDARD SPECIFICATIONS FOR HIGHWAY BRIDGES, SECTION 26, DIVISION II DIVISION II OR ASTM A-798 (FOR ALUMINIZED TYPE 2, GALVANIZED OR POLYMER COATED STEEL) OR ASTM B-788 (FOR ALUMINUM PIPE) AND IN CONFORMANCE WITH THE PROJECT PLANS AND SPECIFICATIONS. IF THERE ARE ANY INCONSISTENCIES OR CONFLICTS THE CONTRACTOR SHOULD DISCUSS AND RESOLVE WITH THE SITE ENGINEER.

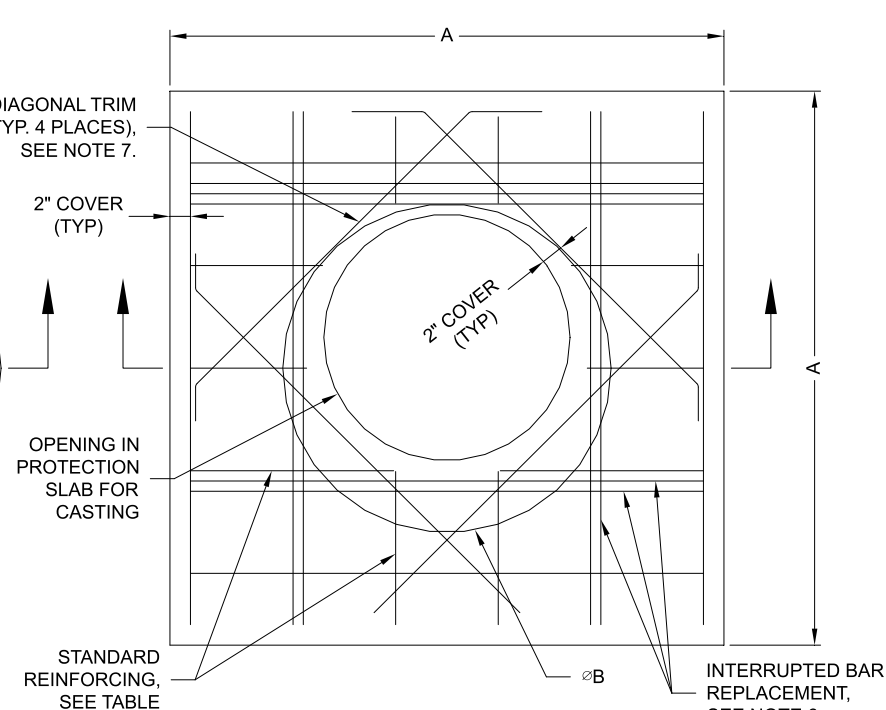
IT IS ALWAYS THE RESPONSIBILITY OF THE CONTRACTOR TO FOLLOW OSHA GUIDELINES FOR SAFE PRACTICES.



SECTION VIEW



ROUND OPTION PLAN VIEW



SQUARE OPTION PLAN VIEW

NOTES:

- DESIGN IN ACCORDANCE WITH AASHTO, 17th EDITION.
- DESIGN LOAD HS25.
- EARTH COVER = 1' MAX.
- CONCRETE STRENGTH = 3,500 psi
- REINFORCING STEEL = ASTM A615, GRADE 60.
- PROVIDE ADDITIONAL REINFORCING AROUND OPENINGS EQUAL TO THE BARS INTERRUPTED, HALF EACH SIDE. ADDITIONAL BARS TO BE IN THE SAME PLANE.
- TRIM OPENING WITH DIAGONAL #4 BARS, EXTEND BARS A MINIMUM OF 12" BEYOND OPENING, BEND BARS AS REQUIRED TO MAINTAIN BAR COVER.
- PROTECTION SLAB AND ALL MATERIALS TO BE PROVIDED AND INSTALLED BY CONTRACTOR.
- DETAIL DESIGN BY DELTA ENGINEERING, BINGHAMTON, NY.

MANHOLE CAP DETAIL

SCALE: N.T.S.

Ø CMP RISER	A	Ø B	REINFORCING	**BEARING PRESSURE (PSF)
24"	Ø 4' 4'X4'	26"	#5 @ 12" OCEW #5 @ 12" OCEW	2,410 1,780
30"	Ø 4'-6" 4'-6" X 4'-6"	32"	#5 @ 12" OCEW #5 @ 12" OCEW	2,120 1,530
36"	Ø 5' X 5'	38"	#5 @ 10" OCEW #5 @ 10" OCEW	1,890 1,350
42"	Ø 5'-6" 5'-6" X 5'-6"	44"	#5 @ 10" OCEW #5 @ 9" OCEW	1,720 1,210
48"	Ø 6' X 6'	50"	#5 @ 9" OCEW #5 @ 8" OCEW	1,600 1,100

** ASSUMED SOIL BEARING CAPACITY

C:\EXPORT\TEMPLATES\CMP_V5.DWG 10/18/2019 10:02 AM

NOTE:
THESE DRAWINGS ARE FOR CONCEPTUAL PURPOSES AND DO NOT REFLECT ANY LOCAL PREFERENCES OR REGULATIONS. PLEASE CONTACT YOUR LOCAL CONTECH REP FOR MODIFICATIONS.

The design and information shown on this drawing is provided as a service to the project owner, engineer and contractor by Contech Engineered Solutions LLC ("Contech"). Neither this drawing, nor any part thereof, may be used, reproduced or modified in any manner without the prior written consent of Contech. Failure to comply is done at the user's own risk and Contech expressly disclaims any liability or responsibility for such use.

If discrepancies between the supplied information upon which the drawing is based and actual field conditions are encountered as site work progresses, these discrepancies must be reported to Contech immediately for re-evaluation of the design. Contech accepts no liability for designs based on missing, incomplete or inaccurate information supplied by others.

DATE	REVISION DESCRIPTION	BY

CONTECH
ENGINEERED SOLUTIONS LLC
www.ContechES.com
9025 Centre Pointe Dr., Suite 400, West Chester, OH 45069
800-338-1122 513-645-7000 513-645-7993 FAX

CONTECH
CMP DETENTION SYSTEMS
CONTECH
DYODS
DRAWING

DYO7334 Kindred Church
Underground Infiltration
Anaheim, CA
DETENTION SYSTEM

PROJECT No.: 4569	SEQ. No.: 7334	DATE: 12/8/2021
DESIGNED: DYO	DRAWN: DYO	
CHECKED: DYO	APPROVED: DYO	
SHEET NO.:		D3

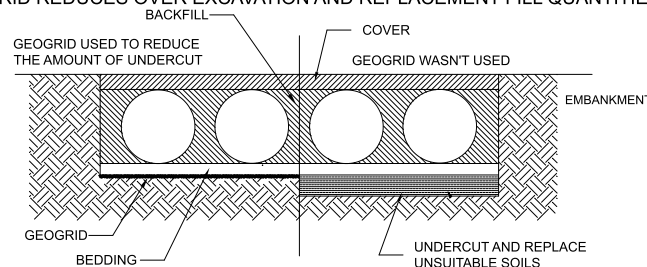
CMP DETENTION INSTALLATION GUIDE

PROPER INSTALLATION OF A FLEXIBLE UNDERGROUND DETENTION SYSTEM WILL ENSURE LONG-TERM PERFORMANCE. THE CONFIGURATION OF THESE SYSTEMS OFTEN REQUIRES SPECIAL CONSTRUCTION PRACTICES THAT DIFFER FROM CONVENTIONAL FLEXIBLE PIPE CONSTRUCTION. CONTECH ENGINEERED SOLUTIONS STRONGLY SUGGESTS SCHEDULING A PRE-CONSTRUCTION MEETING WITH YOUR LOCAL SALES ENGINEER TO DETERMINE IF ADDITIONAL MEASURES, NOT COVERED IN THIS GUIDE, ARE APPROPRIATE FOR YOUR SITE.

FOUNDATION

CONSTRUCT A FOUNDATION THAT CAN SUPPORT THE DESIGN LOADING APPLIED BY THE PIPE AND ADJACENT BACKFILL WEIGHT AS WELL AS MAINTAIN ITS INTEGRITY DURING CONSTRUCTION.

IF SOFT OR UNSUITABLE SOILS ARE ENCOUNTERED, REMOVE THE POOR SOILS DOWN TO A SUITABLE DEPTH AND THEN BUILD UP TO THE APPROPRIATE ELEVATION WITH A COMPETENT BACKFILL MATERIAL. THE STRUCTURAL FILL MATERIAL GRADATION SHOULD NOT ALLOW THE MIGRATION OF FINES, WHICH CAN CAUSE SETTLEMENT OF THE DETENTION SYSTEM OR PAVEMENT ABOVE. IF THE STRUCTURAL FILL MATERIAL IS NOT COMPATIBLE WITH THE UNDERLYING SOILS AN ENGINEERING FABRIC SHOULD BE USED AS A SEPARATOR. IN SOME CASES, USING A STIFF REINFORCING GEOGRID REDUCES OVER EXCAVATION AND REPLACEMENT FILL QUANTITIES.

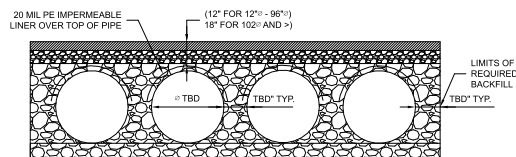


GRADE THE FOUNDATION SUBGRADE TO A UNIFORM OR SLIGHTLY SLOPING GRADE. IF THE SUBGRADE IS CLAY OR RELATIVELY NON-POROUS AND THE CONSTRUCTION SEQUENCE WILL LAST FOR AN EXTENDED PERIOD OF TIME, IT IS BEST TO SLOPE THE GRADE TO ONE END OF THE SYSTEM. THIS WILL ALLOW EXCESS WATER TO DRAIN QUICKLY, PREVENTING SATURATION OF THE SUBGRADE.

GEOMEMBRANE BARRIER

A SITE'S RESISTIVITY MAY CHANGE OVER TIME WHEN VARIOUS TYPES OF SALTING AGENTS ARE USED, SUCH AS ROAD SALTS FOR DEICING AGENTS. IF SALTING AGENTS ARE USED ON OR NEAR THE PROJECT SITE, A GEOMEMBRANE BARRIER IS RECOMMENDED WITH THE SYSTEM. THE GEOMEMBRANE LINER IS INTENDED TO HELP PROTECT THE SYSTEM FROM THE POTENTIAL ADVERSE EFFECTS THAT MAY RESULT FROM THE USE OF SUCH AGENTS INCLUDING PREMATURE CORROSION AND REDUCED ACTUAL SERVICE LIFE.

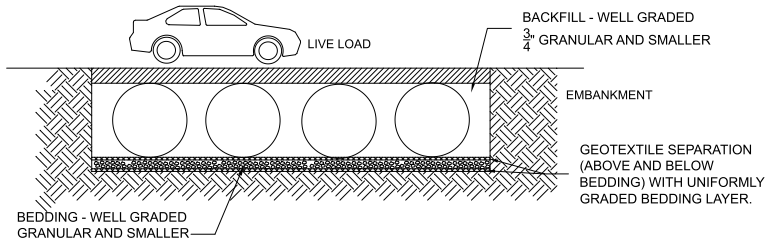
THE PROJECT'S ENGINEER OF RECORD IS TO EVALUATE WHETHER SALTING AGENTS WILL BE USED ON OR NEAR THE PROJECT SITE, AND USE HIS/HER BEST JUDGEMENT TO DETERMINE IF ANY ADDITIONAL PROTECTIVE MEASURES ARE REQUIRED. BELOW IS A TYPICAL DETAIL SHOWING THE PLACEMENT OF A GEOMEMBRANE BARRIER FOR PROJECTS WHERE SALTING AGENTS ARE USED ON OR NEAR THE PROJECT SITE.



IN-SITU TRENCH WALL

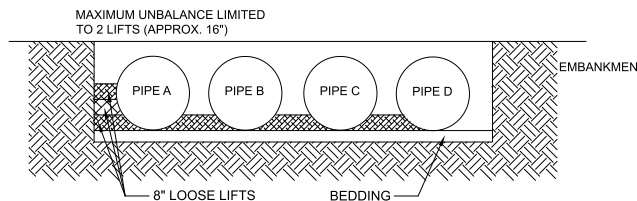
IF EXCAVATION IS REQUIRED, THE TRENCH WALL NEEDS TO BE CAPABLE OF SUPPORTING THE LOAD THAT THE PIPE SHEDS AS THE SYSTEM IS LOADED. IF SOILS ARE NOT CAPABLE OF SUPPORTING THESE LOADS, THE PIPE CAN DEFLECT. PERFORM A SIMPLE SOIL PRESSURE CHECK USING THE APPLIED LOADS TO DETERMINE THE LIMITS OF EXCAVATION BEYOND THE SPRING LINE OF THE OUTER MOST PIPES.

IN MOST CASES THE REQUIREMENTS FOR A SAFE WORK ENVIRONMENT AND PROPER BACKFILL PLACEMENT AND COMPACTION TAKE CARE OF THIS CONCERN.



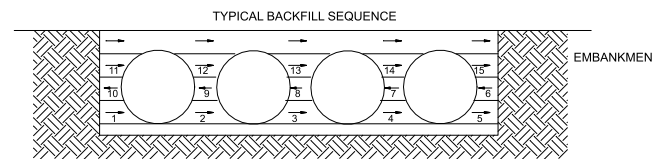
BACKFILL PLACEMENT

MATERIAL SHALL BE WORKED INTO THE PIPE HAUNCHES BY MEANS OF SHOVEL-SLICING, RODDING, AIR TAMPER, VIBRATORY ROD, OR OTHER EFFECTIVE METHODS.

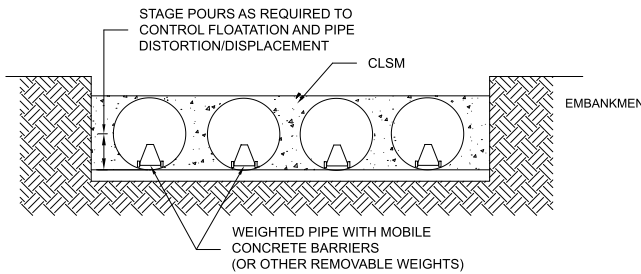


IF AASHTO T99 PROCEDURES ARE DETERMINED INFEASIBLE BY THE GEOTECHNICAL ENGINEER OF RECORD, COMPACTION IS CONSIDERED ADEQUATE WHEN NO FURTHER YIELDING OF THE MATERIAL IS OBSERVED UNDER THE COMPACTOR, OR UNDER FOOT, AND THE GEOTECHNICAL ENGINEER OF RECORD (OR REPRESENTATIVE THEREOF) IS SATISFIED WITH THE LEVEL OF COMPACTION.

FOR LARGE SYSTEMS, CONVEYOR SYSTEMS, BACKHOES WITH LONG REACHES OR DRAGLINES WITH STONE BUCKETS MAY BE USED TO PLACE BACKFILL. ONCE MINIMUM COVER FOR CONSTRUCTION LOADING ACROSS THE ENTIRE WIDTH OF THE SYSTEM IS REACHED, ADVANCE THE EQUIPMENT TO THE END OF THE RECENTLY PLACED FILL, AND BEGIN THE SEQUENCE AGAIN UNTIL THE SYSTEM IS COMPLETELY BACKFILLED. THIS TYPE OF CONSTRUCTION SEQUENCE PROVIDES ROOM FOR STOCKPILED BACKFILL DIRECTLY BEHIND THE BACKHOE, AS WELL AS THE MOVEMENT OF CONSTRUCTION TRAFFIC. MATERIAL STOCKPILES ON TOP OF THE BACKFILLED DETENTION SYSTEM SHOULD BE LIMITED TO 8- TO 10- FEET HIGH AND MUST PROVIDE BALANCED LOADING ACROSS ALL BARRELS. TO DETERMINE THE PROPER COVER OVER THE PIPES TO ALLOW THE MOVEMENT OF CONSTRUCTION EQUIPMENT SEE TABLE 1, OR CONTACT YOUR LOCAL CONTECH SALES ENGINEER.



WHEN FLOWABLE FILL IS USED, YOU MUST PREVENT PIPE FLOATATION. TYPICALLY, SMALL LIFTS ARE PLACED BETWEEN THE PIPES AND THEN ALLOWED TO SET-UP PRIOR TO THE PLACEMENT OF THE NEXT LIFT. THE ALLOWABLE THICKNESS OF THE CLSM LIFT IS A FUNCTION OF A PROPER BALANCE BETWEEN THE UPLIFT FORCE OF THE CLSM, THE OPPOSING WEIGHT OF THE PIPE, AND THE EFFECT OF OTHER RESTRAINING MEASURES. THE PIPE CAN CARRY LIMITED FLUID PRESSURE WITHOUT PIPE DISTORTION OR DISPLACEMENT, WHICH ALSO AFFECTS THE CLSM LIFT THICKNESS. YOUR LOCAL CONTECH SALES ENGINEER CAN HELP DETERMINE THE PROPER LIFT THICKNESS.

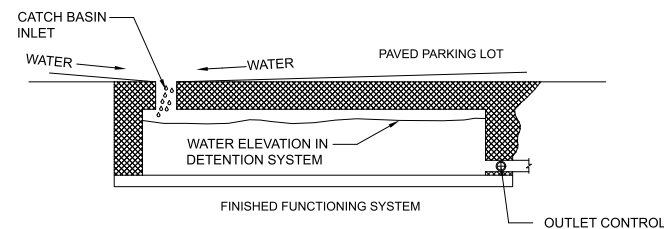


CONSTRUCTION LOADING

TYPICALLY, THE MINIMUM COVER SPECIFIED FOR A PROJECT ASSUMES H-20 LIVE LOAD. BECAUSE CONSTRUCTION LOADS OFTEN EXCEED DESIGN LIVE LOADS, INCREASED TEMPORARY MINIMUM COVER REQUIREMENTS ARE NECESSARY. SINCE CONSTRUCTION EQUIPMENT VARIES FROM JOB TO JOB, IT IS BEST TO ADDRESS EQUIPMENT SPECIFIC MINIMUM COVER REQUIREMENTS WITH YOUR LOCAL CONTECH SALES ENGINEER DURING YOUR PRE-CONSTRUCTION MEETING.

ADDITIONAL CONSIDERATIONS

BECAUSE MOST SYSTEMS ARE CONSTRUCTED BELOW-GRADE, RAINFALL CAN RAPIDLY FILL THE EXCAVATION; POTENTIALLY CAUSING FLOATATION AND MOVEMENT OF THE PREVIOUSLY PLACED PIPES. TO HELP MITIGATE POTENTIAL PROBLEMS, IT IS BEST TO START THE INSTALLATION AT THE DOWNSTREAM END WITH THE OUTLET ALREADY CONSTRUCTED TO ALLOW A ROUTE FOR THE WATER TO ESCAPE. TEMPORARY DIVERSION MEASURES MAY BE REQUIRED FOR HIGH FLOWS DUE TO THE RESTRICTED NATURE OF THE OUTLET PIPE.



CMP DETENTION SYSTEM INSPECTION AND MAINTENANCE

UNDERGROUND STORMWATER DETENTION AND INFILTRATION SYSTEMS MUST BE INSPECTED AND MAINTAINED AT REGULAR INTERVALS FOR PURPOSES OF PERFORMANCE AND LONGEVITY.

INSPECTION

INSPECTION IS THE KEY TO EFFECTIVE MAINTENANCE OF CMP DETENTION SYSTEMS AND IS EASILY PERFORMED. CONTECH RECOMMENDS ONGOING, ANNUAL INSPECTIONS. SITES WITH HIGH TRASH LOAD OR SMALL OUTLET CONTROL ORIFICES MAY NEED MORE FREQUENT INSPECTIONS. THE RATE AT WHICH THE SYSTEM COLLECTS POLLUTANTS WILL DEPEND MORE ON SITE SPECIFIC ACTIVITIES RATHER THAN THE SIZE OR CONFIGURATION OF THE SYSTEM.

INSPECTIONS SHOULD BE PERFORMED MORE OFTEN IN EQUIPMENT WASHDOWN AREAS, IN CLIMATES WHERE SANDING AND/OR SALTING OPERATIONS TAKE PLACE, AND IN OTHER VARIOUS INSTANCES IN WHICH ONE WOULD EXPECT HIGHER ACCUMULATIONS OF SEDIMENT OR ABRASIVE/ CORROSIVE CONDITIONS. A RECORD OF EACH INSPECTION IS TO BE MAINTAINED FOR THE LIFE OF THE SYSTEM

MAINTENANCE

CMP DETENTION SYSTEMS SHOULD BE CLEANED WHEN AN INSPECTION REVEALS ACCUMULATED SEDIMENT OR TRASH IS CLOGGING THE DISCHARGE ORIFICE.

ACCUMULATED SEDIMENT AND TRASH CAN TYPICALLY BE EVACUATED THROUGH THE MANHOLE OVER THE OUTLET ORIFICE. IF MAINTENANCE IS NOT PERFORMED AS RECOMMENDED, SEDIMENT AND TRASH MAY ACCUMULATE IN FRONT OF THE OUTLET ORIFICE. MANHOLE COVERS SHOULD BE SECURELY SEATED FOLLOWING CLEANING ACTIVITIES. CONTECH SUGGESTS THAT ALL SYSTEMS BE DESIGNED WITH AN ACCESS/INSPECTION MANHOLE SITUATED AT OR NEAR THE INLET AND THE OUTLET ORIFICE. SHOULD IT BE NECESSARY TO GET INSIDE THE SYSTEM TO PERFORM MAINTENANCE ACTIVITIES, ALL APPROPRIATE PRECAUTIONS REGARDING CONFINED SPACE ENTRY AND OSHA REGULATIONS SHOULD BE FOLLOWED.

ANNUAL INSPECTIONS ARE BEST PRACTICE FOR ALL UNDERGROUND SYSTEMS. DURING THIS INSPECTION, IF EVIDENCE OF SALTING/DE-ICING AGENTS IS OBSERVED WITHIN THE SYSTEM, IT IS BEST PRACTICE FOR THE SYSTEM TO BE RINSED, INCLUDING ABOVE THE SPRING LINE SOON AFTER THE SPRING THAW AS PART OF THE MAINTENANCE PROGRAM FOR THE SYSTEM.

MAINTAINING AN UNDERGROUND DETENTION OR INFILTRATION SYSTEM IS EASIEST WHEN THERE IS NO FLOW ENTERING THE SYSTEM. FOR THIS REASON, IT IS A GOOD IDEA TO SCHEDULE THE CLEANOUT DURING DRY WEATHER.

THE FOREGOING INSPECTION AND MAINTENANCE EFFORTS HELP ENSURE UNDERGROUND PIPE SYSTEMS USED FOR STORMWATER STORAGE CONTINUE TO FUNCTION AS INTENDED BY IDENTIFYING RECOMMENDED REGULAR INSPECTION AND MAINTENANCE PRACTICES. INSPECTION AND MAINTENANCE RELATED TO THE STRUCTURAL INTEGRITY OF THE PIPE OR THE SOUNDNESS OF PIPE JOINT CONNECTIONS IS BEYOND THE SCOPE OF THIS GUIDE.

C:\EXPORT\TEMPLATES\CMP_V5.DWG 10/18/2019 10:02 AM

The design and information shown on this drawing is provided as a service to the project owner, engineer and contractor by Contech Engineered Solutions LLC ("Contech"). Neither this drawing, nor any part thereof, may be used, reproduced or modified in any manner without the prior written consent of Contech. Failure to comply is done at the user's own risk and Contech expressly disclaims any liability or responsibility for such use.

If discrepancies between the supplied information upon which the drawing is based and actual field conditions are encountered as site work progresses, these discrepancies must be reported to Contech immediately for re-evaluation of the design. Contech accepts no liability for designs based on missing, incomplete or inaccurate information supplied by others.

DATE	REVISION DESCRIPTION	BY

CONTECH
ENGINEERED SOLUTIONS LLC
www.ContechES.com
9025 Centre Pointe Dr., Suite 400, West Chester, OH 45069
800-338-1122 513-645-7000 513-645-7993 FAX

CONTECH
CMP DETENTION SYSTEMS
CONTECH
DYODS
DRAWING

DYO7334 Kindred Church
Underground Infiltration
Anaheim, CA
DETENTION SYSTEM

PROJECT No.: 4569	SEQ. No.: 7334	DATE: 12/8/2021
DESIGNED: DYO	DRAWN: DYO	
CHECKED: DYO	APPROVED: DYO	
SHEET NO.:		D4

Table 2.7: Infiltration BMP Feasibility Worksheet

	Infeasibility Criteria	Yes	No
1	Would Infiltration BMPs pose significant risk for groundwater related concerns? Refer to Appendix VIII (Worksheet I) for guidance on groundwater-related infiltration feasibility criteria.		X
Provide basis:			
Summarize findings of studies provide reference to studies, calculations, maps, data sources, etc. Provide narrative discussion of study/data source applicability.			
2	Would Infiltration BMPs pose significant risk of increasing risk of geotechnical hazards that cannot be mitigated to an acceptable level? (Yes if the answer to any of the following questions is yes, as established by a geotechnical expert): <ul style="list-style-type: none"> • The BMP can only be located less than 50 feet away from slopes steeper than 15 percent • The BMP can only be located less than eight feet from building foundations or an alternative setback. • A study prepared by a geotechnical professional or an available watershed study substantiates that stormwater infiltration would potentially result in significantly increased risks of geotechnical hazards that cannot be mitigated to an acceptable level. 		X
Provide basis: <i>BASED ON SOIL REPORT APP. B</i>			
Summarize findings of studies provide reference to studies, calculations, maps, data sources, etc. Provide narrative discussion of study/data source applicability.			
3	Would infiltration of the DCV from drainage area violate downstream water rights?		X
Provide basis: <i>NONE FOR SANTA ANA RIVER</i>			
Summarize findings of studies provide reference to studies, calculations, maps, data sources, etc. Provide narrative discussion of study/data source applicability.			

Table 2.7: Infiltration BMP Feasibility Worksheet (continued)

	Partial Infeasibility Criteria	Yes	No
4	Is proposed infiltration facility located on HSG D soils or the site geotechnical investigation identifies presence of soil characteristics which support categorization as D soils?		X
Provide basis: <i>SOIL REPORT BY TGR APPENDIX B</i>			
Summarize findings of studies provide reference to studies, calculations, maps, data sources, etc. Provide narrative discussion of study/data source applicability.			
5	Is measured infiltration rate below proposed facility less than 0.3 inches per hour ? This calculation shall be based on the methods described in Appendix VII .		X
Provide basis: <i>SOIL REPORT APP. B</i>			
Summarize findings of studies provide reference to studies, calculations, maps, data sources, etc. Provide narrative discussion of study/data source applicability.			
6	Would reduction of over predeveloped conditions cause impairments to downstream beneficial uses, such as change of seasonality of ephemeral washes or increased discharge of contaminated groundwater to surface waters ?		X
Provide citation to applicable study and summarize findings relative to the amount of infiltration that is permissible: <i>N/A</i>			
Summarize findings of studies provide reference to studies, calculations, maps, data sources, etc. Provide narrative discussion of study/data source applicability.			
7	Would an increase in infiltration over predeveloped conditions cause impairments to downstream beneficial uses, such as change of seasonality of ephemeral washes or increased discharge of contaminated groundwater to surface waters ?		X
Provide citation to applicable study and summarize findings relative to the amount of infiltration that is permissible: <i>NO USES EFFECTED</i>			
Summarize findings of studies provide reference to studies, calculations, maps, data sources, etc. Provide narrative discussion of study/data source applicability.			

Design Treatment Calculations

Treatment Calculations

* We are using Filterra devices to treat water prior to entering the private Stormdrain System.

Filterra Unit located at DMA-1 is to take the flow from DMA 2 & DMA 1.

- DMA-1 Treatment flow = 0.18 cfs

- DMA-2 Treatment flow = 0.12 cfs

* See Worksheet D for calls

Total flow needing treatment = 0.3 cfs

* Using $8' \times 6'$ Filterra Box *

Filtered Flow = 0.19 cfs

Treatment Req = 0.16 ← Per 50% Treatment Flow

$0.16 < 0.19$ cfs ✓

Using another Filterra for DMA-5 capture.

- DMA 5 treatment flow = 0.41 cfs

After 50% reduction = 0.20 cfs

* Using $10' \times 6'$ Filterra Box *

Filtered flow = 0.24 cfs > 0.20 cfs ✓

* DMA 3 & 4 are not to be treated since all runoff is to be roof, sidewalk & landscape.

Filterra Sizing Spreadsheet
Uniform Intensity Approach
Storm Intensity = 0.20 in/hr

Filterra Infiltration Rate = 175 (in/hr)
 Filterra Flow per Square Foot = 0.0041 (ft3/sec/ft2)

Filterra Flow Rate, Q = 0.0032 ft3/sec x Filterra Surface Area
 Rational Method, Q = C x I x A

OR Site Flowrate, Q = (C x DI x DA x 43560) / (12 x 3600)
 DA = (12 x 3600 x Q) / (C x 43560 x DI)

where Q = Flow (ft3/sec)
 DA = Drainage Area (acres)
 DI = Design Intensity (in/hr)
 C = Runoff coefficient (dimensionless)

			DI 0.2	C 1.00	C 0.85	C 0.50
Available Filterra Box Sizes			Filterra Flow Rate, Q (ft3/sec)	100% Imperv. DA (acres)	Commercial max DA (acres)	Residential max DA (acres)
L (ft)	W (ft)	Filterra Surface Area (ft2)				
4	4	16	0.0648	0.321	0.378	0.643
4.5	4	18	0.0729	0.362	0.425	0.723
6	4	24	0.0972	0.482	0.567	0.964
6.5	4	26	0.1053	0.522	0.614	1.045
8	4	32	0.1296	0.643	0.756	1.286
12	4	48	0.1944	0.964	1.134	1.928
6	6	36	0.1458	0.723	0.851	1.446
8	6	48	0.1944	0.964	1.134	1.928
10	6	60	0.2431	1.205	1.418	2.410
12	6	72	0.2917	1.446	1.702	2.893
13	7	91	0.3686	1.828	2.151	3.656
14	8	112	0.4537	2.250	2.647	4.500
16	8	128	0.5185	2.571	3.025	5.142
12	8	96	0.3889	1.928	2.269	3.857
14	8	112	0.4537	2.250	2.647	4.500

Using
8X6
&
10X6

Worksheet D: Capture Efficiency Method for Flow-Based BMPs

DMA-1

Step 1: Determine the design capture storm depth used for calculating volume				
1	Enter the time of concentration, T_c (min) (See Appendix IV.2)	$T_c =$	6 min	
2	Using Figure III.4 , determine the design intensity at which the estimated time of concentration (T_c) achieves 80% capture efficiency, I_1	$I_1 =$	0.25	in/hr
3	Enter the effect depth of provided HSCs upstream, d_{HSC} (inches) (Worksheet A)	$d_{HSC} =$	-----	inches
4	Enter capture efficiency corresponding to d_{HSC} , Y_2 (Worksheet A)	$Y_2 =$	-----	%
5	Using Figure III.4 , determine the design intensity at which the time of concentration (T_c) achieves the upstream capture efficiency (Y_2), I_2	$I_2 =$	-----	
6	Determine the design intensity that must be provided by BMP, $I_{design} = I_1 - I_2$	$I_{design} =$	0.25	
Step 2: Calculate the design flowrate				
1	Enter Project area tributary to BMP (s), A (acres)	$A =$	1.28	acres
2	Enter Project Imperviousness, imp (unitless)	$imp =$	57%	
3	Calculate runoff coefficient, $C = (0.75 \times imp) + 0.15$	$C =$	0.58	
4	Calculate design flowrate, $Q_{design} = (C \times I_{design} \times A)$	$Q_{design} =$	0.18	cfs
Supporting Calculations				
Describe system: Using Contech's Filterra Device to pre-treat 50% of treatment flow prior to entering the stormdrain system. Overflow will be collected and bypassed using a catch basin.				
Provide time of concentration assumptions: Drainage is mainly on impervious surface and through storm drain pipes.				

Worksheet D: Capture Efficiency Method for Flow-Based BMPs

DMA-2

Step 1: Determine the design capture storm depth used for calculating volume				
1	Enter the time of concentration, T_c (min) (See Appendix IV.2)	$T_c =$	6 min	
2	Using Figure III.4 , determine the design intensity at which the estimated time of concentration (T_c) achieves 80% capture efficiency, I_1	$I_1 =$	0.25	in/hr
3	Enter the effect depth of provided HSCs upstream, d_{HSC} (inches) (Worksheet A)	$d_{HSC} =$	-----	inches
4	Enter capture efficiency corresponding to d_{HSC} , Y_2 (Worksheet A)	$Y_2 =$	-----	%
5	Using Figure III.4 , determine the design intensity at which the time of concentration (T_c) achieves the upstream capture efficiency (Y_2), I_2	$I_2 =$	-----	
6	Determine the design intensity that must be provided by BMP, $I_{design} = I_1 - I_2$	$I_{design} =$	0.25	
Step 2: Calculate the design flowrate				
1	Enter Project area tributary to BMP (s), A (acres)	$A =$	0.76	acres
2	Enter Project Imperviousness, imp (unitless)	$imp =$	67%	
3	Calculate runoff coefficient, $C = (0.75 \times imp) + 0.15$	$C =$	0.65	
4	Calculate design flowrate, $Q_{design} = (C \times I_{design} \times A)$	$Q_{design} =$	0.12	cfs
Supporting Calculations				
Describe system: Using Contech's Filterra Device to pre-treat 50% of treatment flow prior to entering the stormdrain system. Overflow will be collected and bypassed using a catch basin.				
Provide time of concentration assumptions: Drainage is mainly on impervious surface and through storm drain pipes.				

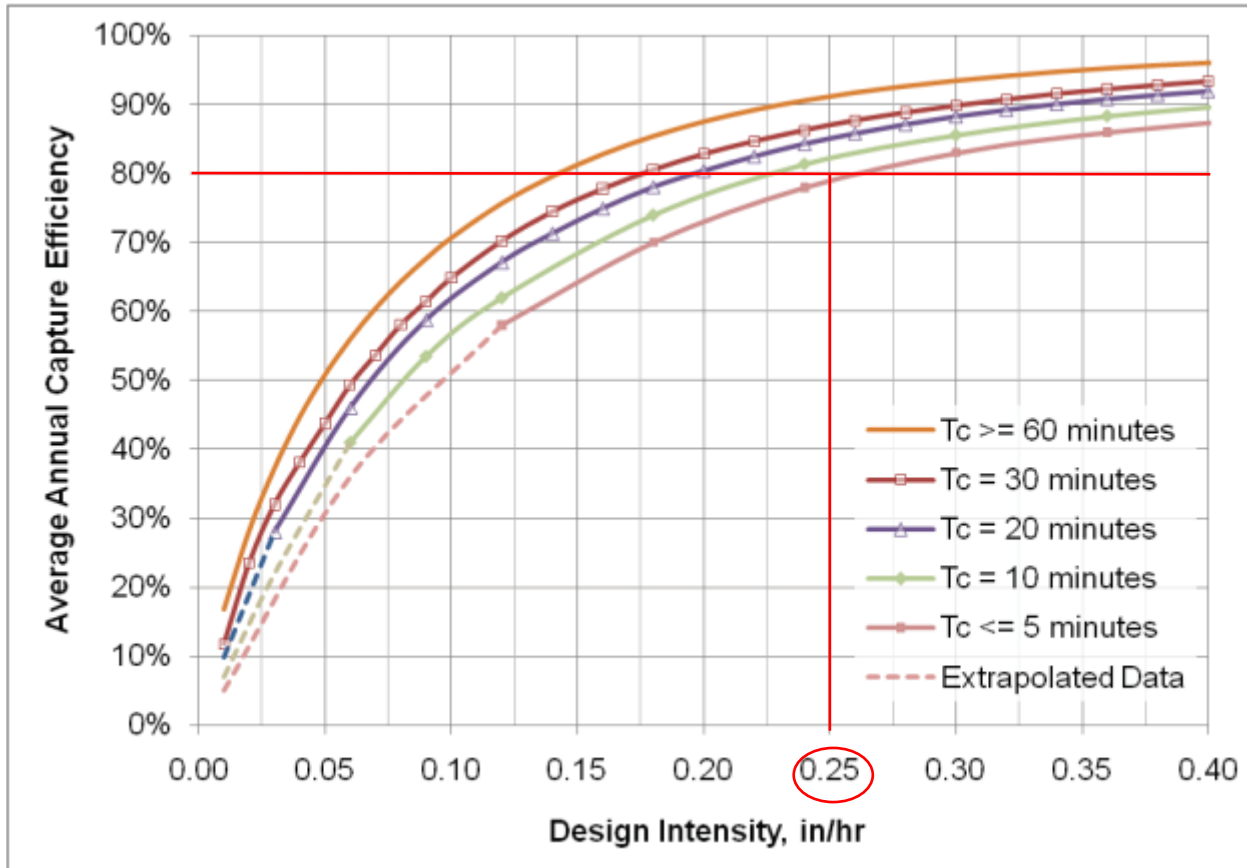
Worksheet D: Capture Efficiency Method for Flow-Based BMPs

DMA-5

Step 1: Determine the design capture storm depth used for calculating volume				
1	Enter the time of concentration, T_c (min) (See Appendix IV.2)	$T_c =$	6 min	
2	Using Figure III.4 , determine the design intensity at which the estimated time of concentration (T_c) achieves 80% capture efficiency, I_1	$I_1 =$	0.25	in/hr
3	Enter the effect depth of provided HSCs upstream, d_{HSC} (inches) (Worksheet A)	$d_{HSC} =$	-----	inches
4	Enter capture efficiency corresponding to d_{HSC} , Y_2 (Worksheet A)	$Y_2 =$	-----	%
5	Using Figure III.4 , determine the design intensity at which the time of concentration (T_c) achieves the upstream capture efficiency (Y_2), I_2	$I_2 =$	-----	
6	Determine the design intensity that must be provided by BMP, $I_{design} = I_1 - I_2$	$I_{design} =$	0.25	
Step 2: Calculate the design flowrate				
1	Enter Project area tributary to BMP (s), A (acres)	$A =$	2.06	acres
2	Enter Project Imperviousness, imp (unitless)	$imp =$	87%	
3	Calculate runoff coefficient, $C = (0.75 \times imp) + 0.15$	$C =$	0.80	
4	Calculate design flowrate, $Q_{design} = (C \times I_{design} \times A)$	$Q_{design} =$	0.41	cfs
Supporting Calculations				
Describe system: Using FloGard filters for catch basins as pretreatment of Underground Infiltration Gallery. Using FloGard Model FGP-24F with a filtered flow capacity of 1.5 cfs and bypass capacity of 6.1 cfs.				
Provide time of concentration assumptions: Calculated through drainage study. Drainage path is all impervious until it reaches catch basin.				

Worksheet D: Capture Efficiency Method for Flow-Based BMPs

Graphical Operations



Provide supporting graphical operations. See Example III.7.

Attachment B

Kindred Community Church

2-Year Storm Event Hydrology Calculations

Site: 8712-8720 E. Santa Ana Canyon Rd.

APN: 354-321-01 & 354-321-03

HYDROMODIFICATION

**Kindred Community Church
8720 E. Santa Ana Canyon Road
Anaheim, CA**

Prepared by:
Anacal Engineering Co.
1211 N Tustin Ave.
Anaheim, CA 92807
(714) 774-1763

Prepared for:
Kindred Community Church
100 Chaparral Court Ste. 100
Anaheim, CA 92808

Prepared under the supervisions of:

David C. Queyrel RCE 42812 Exp. 3/31/22

Table of Contents

Purpose

Conclusion

TR20 CALCULATIONS

DCV CALCULATIONS

Exhibits

Existing Hydrology Map

A

Proposed Hydrology Map

B

Off-site topography map

C

Existing City Storm Drain Plans

D

Purpose

The purpose of this report is to provide a run-off study based on Orange County LID manual for hydromodification and DCV purposes. Stormchamber design tool is designed to size facilities to handle the required volume based on the criteria. Proposed is a master plan for new parking and relocatable classrooms. A existing city of Anaheim storm drain traverses the property and is designed to accept a portion of the project area. Additionally, there are two 60" culverts which drain the project area north to the Santa Ana River. Drainage from a portion of the existing parking lot and new parking areas are development with low impact criteria designed to infiltrate the design capture volume.

Conclusion

The study shows that runoff from the new development site can be infiltrated on-site in accordance with the current Orange county LID manual. The hydromodification criteria is achieved in accordance with the manual and concluded that the project has no detrimental effects on downstream drainage.

11.235	0.12	0.12	0.12	0.11	0.11	0.11	0.11
11.279	0.11	0.11	0.11	0.11	0.11	0.11	0.11
11.323	0.11	0.11	0.11	0.11	0.11	0.11	0.11
11.368	0.11	0.11	0.11	0.11	0.11	0.11	0.11
11.412	0.11	0.11	0.11	0.11	0.11	0.11	0.11

KINDRED CHURCH
AREA G PRE

Line Start Time (hr)	----- Flow Values @ time increment of 0.006 hr ----- (cfs) (cfs) (cfs) (cfs) (cfs) (cfs) (cfs)						
11.456	0.11	0.11	0.11	0.11	0.11	0.11	0.11
11.500	0.11	0.11	0.11	0.11	0.11	0.11	0.11
11.544	0.11	0.11	0.11	0.11	0.11	0.11	0.11
11.589	0.11	0.11	0.11	0.11	0.11	0.11	0.11
11.633	0.11	0.11	0.11	0.11	0.11	0.11	0.11
11.677	0.11	0.11	0.11	0.11	0.11	0.11	0.11
11.721	0.11	0.11	0.11	0.11	0.11	0.11	0.11
11.765	0.11	0.11	0.11	0.11	0.11	0.11	0.11
11.810	0.11	0.11	0.11	0.11	0.11	0.11	0.11
11.854	0.11	0.11	0.11	0.11	0.10	0.10	0.10
11.898	0.10	0.10	0.10	0.10	0.10	0.10	0.10
11.942	0.10	0.10	0.10	0.10	0.10	0.10	0.10
11.986	0.10	0.10	0.10	0.10	0.10	0.10	0.10
12.031	0.10	0.10	0.10	0.10	0.10	0.10	0.10
12.075	0.10	0.10	0.10	0.10	0.10	0.10	0.10
12.119	0.10	0.10	0.10	0.10	0.10	0.10	0.10
12.163	0.10	0.10	0.10	0.10	0.10	0.10	0.10
12.208	0.10	0.10	0.10	0.10	0.10	0.10	0.10
12.252	0.10	0.10	0.10	0.10	0.10	0.10	0.10
12.296	0.10	0.10	0.10	0.10	0.10	0.10	0.10
12.340	0.10	0.10	0.10	0.10	0.10	0.10	0.10
12.384	0.10	0.10	0.10	0.10	0.10	0.10	0.10
12.429	0.10	0.10	0.10	0.10	0.10	0.10	0.10
12.473	0.10	0.10	0.10	0.10	0.10	0.10	0.10
12.517	0.10	0.10	0.10	0.10	0.10	0.10	0.10
12.561	0.10	0.10	0.10	0.10	0.10	0.10	0.10
12.605	0.10	0.10	0.10	0.10	0.10	0.09	0.09
12.650	0.09	0.09	0.09	0.09	0.09	0.09	0.09
12.694	0.09	0.09	0.09	0.09	0.09	0.09	0.09
12.738	0.09	0.09	0.09	0.09	0.09	0.09	0.09
12.782	0.09	0.09	0.09	0.09	0.09	0.09	0.09
12.826	0.09	0.09	0.09	0.09	0.09	0.09	0.09
12.871	0.09	0.09	0.09	0.09	0.09	0.09	0.09
12.915	0.09	0.09	0.09	0.09	0.09	0.09	0.09
12.959	0.09	0.09	0.09	0.09	0.09	0.09	0.09
13.003	0.09	0.09	0.09	0.09	0.09	0.09	0.09
13.048	0.09	0.09	0.09	0.09	0.09	0.09	0.09
13.092	0.09	0.09	0.09	0.09	0.09	0.09	0.09
13.136	0.09	0.09	0.09	0.09	0.09	0.09	0.09
13.180	0.09	0.09	0.09	0.09	0.09	0.09	0.09
13.224	0.09	0.09	0.09	0.09	0.09	0.09	0.09
13.269	0.09	0.09	0.09	0.09	0.09	0.09	0.09
13.313	0.09	0.09	0.09	0.08	0.08	0.08	0.08
13.357	0.08	0.08	0.08	0.08	0.08	0.08	0.08
13.401	0.08	0.08	0.08	0.08	0.08	0.08	0.08
13.445	0.08	0.08	0.08	0.08	0.08	0.08	0.08
13.490	0.08	0.08	0.08	0.08	0.08	0.08	0.08
13.534	0.08	0.08	0.08	0.08	0.08	0.08	0.08
13.578	0.08	0.08	0.08	0.08	0.08	0.08	0.08
13.622	0.08	0.08	0.08	0.08	0.08	0.08	0.08
13.666	0.08	0.08	0.08	0.08	0.08	0.08	0.08

WinTR-20: Version 1.10
ED CHURCH
AREA G PRE

0 0 0.05

(continued)

STORM 2-Yr

SUB-AREA:

DMA G PRE Outlet .0038 77. .1

STREAM REACH:

KINDRED CHURCH
AREA G PRE

Line	Flow Values @ time increment of 0.006 hr						
Start Time (hr)	(cfs)	(cfs)	(cfs)	(cfs)	(cfs)	(cfs)	(cfs)
13.711	0.08	0.08	0.08	0.08	0.08	0.08	0.08
13.755	0.08	0.08	0.08	0.08	0.08	0.08	0.08
13.799	0.08	0.08	0.08	0.08	0.08	0.08	0.08
13.843	0.08	0.08	0.08	0.08	0.08	0.08	0.08
13.888	0.08	0.08	0.08	0.08	0.07	0.07	0.07
13.932	0.07	0.07	0.07	0.07	0.07	0.07	0.07
13.976	0.07	0.07	0.07	0.07	0.07	0.07	0.07
14.020	0.07	0.07	0.07	0.07	0.07	0.07	0.07
14.064	0.07	0.07	0.07	0.07	0.07	0.07	0.07
14.109	0.07	0.07	0.07	0.07	0.07	0.07	0.07
14.153	0.07	0.07	0.07	0.07	0.07	0.07	0.07
14.197	0.07	0.07	0.07	0.07	0.07	0.07	0.07
14.241	0.07	0.07	0.07	0.07	0.07	0.07	0.07
14.285	0.07	0.07	0.07	0.07	0.07	0.07	0.07
14.330	0.07	0.07	0.07	0.07	0.07	0.07	0.07
14.374	0.07	0.07	0.07	0.07	0.07	0.07	0.07
14.418	0.07	0.07	0.07	0.07	0.07	0.07	0.07
14.462	0.07	0.07	0.07	0.07	0.07	0.07	0.07
14.506	0.07	0.07	0.07	0.07	0.07	0.07	0.07
14.551	0.07	0.07	0.07	0.07	0.07	0.07	0.07
14.595	0.07	0.07	0.07	0.07	0.07	0.07	0.07
14.639	0.07	0.07	0.07	0.07	0.07	0.07	0.07
14.683	0.07	0.07	0.07	0.07	0.07	0.07	0.07
14.728	0.07	0.07	0.07	0.07	0.07	0.07	0.07
14.772	0.07	0.07	0.07	0.07	0.07	0.07	0.07
14.816	0.07	0.07	0.07	0.07	0.07	0.07	0.07
14.860	0.07	0.07	0.07	0.07	0.07	0.07	0.07
14.904	0.07	0.07	0.07	0.07	0.07	0.07	0.07
14.949	0.07	0.07	0.07	0.07	0.07	0.07	0.07
14.993	0.07	0.07	0.07	0.07	0.07	0.07	0.07

WinTR-20: Version 1.10
ED CHURCH
AREA G PRE

0 0 0.05

(continued)

STORM 2-Yr

SUB-AREA:

DMA G PRE Outlet .0038 77. .1

STREAM REACH:

15.037	0.07	0.07	0.07	0.07	0.07	0.07	0.07
15.081	0.07	0.07	0.07	0.07	0.07	0.07	0.07
15.125	0.07	0.07	0.07	0.07	0.07	0.07	0.07
15.170	0.07	0.07	0.07	0.07	0.07	0.07	0.07
15.214	0.07	0.07	0.07	0.07	0.07	0.07	0.07
15.258	0.07	0.07	0.07	0.07	0.07	0.07	0.07
15.302	0.07	0.07	0.07	0.07	0.07	0.07	0.07
15.346	0.07	0.07	0.07	0.07	0.07	0.07	0.07
15.391	0.07	0.07	0.07	0.07	0.07	0.07	0.07
15.435	0.07	0.07	0.07	0.07	0.07	0.07	0.07
15.479	0.07	0.07	0.07	0.07	0.07	0.07	0.07
15.523	0.07	0.07	0.07	0.07	0.07	0.07	0.07
15.568	0.07	0.07	0.07	0.07	0.07	0.07	0.07
15.612	0.07	0.07	0.07	0.07	0.07	0.07	0.07
15.656	0.07	0.07	0.07	0.07	0.07	0.07	0.07
15.700	0.07	0.07	0.07	0.07	0.07	0.07	0.07
15.744	0.07	0.07	0.07	0.07	0.07	0.07	0.07
15.789	0.07	0.07	0.07	0.07	0.07	0.07	0.07
15.833	0.07	0.07	0.07	0.07	0.07	0.07	0.07
15.877	0.07	0.07	0.07	0.07	0.07	0.07	0.07
15.921	0.07	0.07	0.07	0.07	0.07	0.07	0.07

KINDRED CHURCH
AREA G PRE

Line	Flow Values @ time increment of 0.006 hr						
Start Time (hr)	(cfs)	(cfs)	(cfs)	(cfs)	(cfs)	(cfs)	(cfs)
15.965	0.07	0.07	0.07	0.07	0.07	0.07	0.07
16.010	0.07	0.07	0.07	0.07	0.07	0.07	0.07
16.054	0.07	0.07	0.07	0.07	0.07	0.07	0.07
16.098	0.07	0.07	0.07	0.07	0.07	0.07	0.07
16.142	0.07	0.07	0.07	0.07	0.07	0.07	0.07
16.186	0.07	0.07	0.07	0.07	0.07	0.07	0.07
16.231	0.07	0.07	0.07	0.07	0.07	0.07	0.07

WinTR-20: Version 1.10
ED CHURCH
AREA G PRE

0 0 0.05

(continued)

STORM 2-Yr

SUB-AREA:

DMA G PRE Outlet .0038 77. .1

STREAM REACH:

16.275	0.07	0.07	0.07	0.07	0.07	0.07	0.07	0.07
16.319	0.07	0.07	0.07	0.07	0.07	0.07	0.07	0.07
16.363	0.07	0.07	0.07	0.07	0.07	0.07	0.07	0.07
16.408	0.07	0.07	0.07	0.07	0.07	0.07	0.07	0.07
16.452	0.07	0.07	0.07	0.07	0.07	0.07	0.07	0.07
16.496	0.07	0.07	0.07	0.07	0.07	0.07	0.07	0.07
16.540	0.07	0.07	0.07	0.07	0.07	0.07	0.07	0.07
16.584	0.07	0.07	0.07	0.07	0.07	0.07	0.07	0.07
16.629	0.07	0.07	0.07	0.07	0.07	0.07	0.07	0.07
16.673	0.07	0.07	0.07	0.07	0.07	0.07	0.07	0.07
16.717	0.07	0.07	0.07	0.07	0.07	0.07	0.07	0.07
16.761	0.07	0.07	0.07	0.07	0.07	0.07	0.07	0.07
16.805	0.07	0.07	0.07	0.07	0.07	0.07	0.07	0.07
16.850	0.07	0.07	0.07	0.07	0.07	0.07	0.07	0.07
16.894	0.07	0.07	0.07	0.07	0.07	0.07	0.07	0.07
16.938	0.07	0.07	0.07	0.07	0.07	0.07	0.07	0.07
16.982	0.07	0.07	0.07	0.07	0.07	0.07	0.07	0.07
17.026	0.07	0.07	0.07	0.07	0.07	0.07	0.07	0.07
17.071	0.07	0.07	0.07	0.07	0.07	0.07	0.07	0.07
17.115	0.07	0.07	0.07	0.07	0.07	0.07	0.07	0.07
17.159	0.07	0.07	0.07	0.07	0.07	0.07	0.07	0.07
17.203	0.07	0.07	0.07	0.07	0.07	0.07	0.07	0.07
17.248	0.07	0.06	0.06	0.06	0.06	0.06	0.06	0.06
17.292	0.06	0.06	0.06	0.06	0.06	0.06	0.06	0.06
17.336	0.06	0.06	0.06	0.06	0.06	0.06	0.06	0.06
17.380	0.06	0.06	0.06	0.06	0.06	0.06	0.06	0.06
17.424	0.06	0.06	0.06	0.06	0.06	0.06	0.06	0.06
17.469	0.06	0.06	0.06	0.06	0.06	0.06	0.06	0.06
17.513	0.06	0.06	0.06	0.06	0.06	0.06	0.06	0.06
17.557	0.06	0.06	0.06	0.06	0.06	0.06	0.06	0.06
17.601	0.06	0.06	0.06	0.06	0.06	0.06	0.06	0.06
17.645	0.06	0.06	0.06	0.06	0.06	0.06	0.06	0.06
17.690	0.06	0.06	0.06	0.06	0.06	0.06	0.06	0.06
17.734	0.06	0.06	0.06	0.06	0.06	0.06	0.06	0.06
17.778	0.06	0.06	0.06	0.06	0.06	0.06	0.06	0.06
17.822	0.06	0.06	0.06	0.06	0.06	0.06	0.06	0.06
17.866	0.06	0.06	0.06	0.06	0.06	0.06	0.06	0.06
17.911	0.06	0.06	0.06	0.06	0.06	0.06	0.06	0.06

WinTR-20: Version 1.10
ED CHURCH
AREA G PRE

0 0 0.05

(continued)

STORM 2-Yr

SUB-AREA:

DMA G PRE Outlet .0038 77. .1

STREAM REACH:

11.368	0.11	0.11	0.11	0.11	0.11	0.11	0.11	0.11
11.412	0.11	0.11	0.11	0.11	0.11	0.11	0.11	0.11
11.456	0.11	0.11	0.11	0.11	0.11	0.11	0.11	0.11
11.500	0.11	0.11	0.11	0.11	0.11	0.11	0.11	0.11
11.544	0.11	0.11	0.11	0.11	0.11	0.11	0.11	0.11
11.589	0.11	0.11	0.11	0.11	0.11	0.11	0.11	0.11
11.633	0.11	0.11	0.11	0.11	0.11	0.11	0.11	0.11
11.677	0.11	0.11	0.11	0.11	0.11	0.11	0.11	0.11
11.721	0.11	0.11	0.11	0.11	0.11	0.11	0.11	0.11
11.765	0.11	0.11	0.11	0.11	0.11	0.11	0.11	0.11
11.810	0.11	0.11	0.11	0.11	0.11	0.11	0.11	0.11
11.854	0.11	0.11	0.11	0.11	0.11	0.10	0.10	0.10
11.898	0.10	0.10	0.10	0.10	0.10	0.10	0.10	0.10
11.942	0.10	0.10	0.10	0.10	0.10	0.10	0.10	0.10
11.986	0.10	0.10	0.10	0.10	0.10	0.10	0.10	0.10
12.031	0.10	0.10	0.10	0.10	0.10	0.10	0.10	0.10
12.075	0.10	0.10	0.10	0.10	0.10	0.10	0.10	0.10
12.119	0.10	0.10	0.10	0.10	0.10	0.10	0.10	0.10
12.163	0.10	0.10	0.10	0.10	0.10	0.10	0.10	0.10
12.208	0.10	0.10	0.10	0.10	0.10	0.10	0.10	0.10
12.252	0.10	0.10	0.10	0.10	0.10	0.10	0.10	0.10
12.296	0.10	0.10	0.10	0.10	0.10	0.10	0.10	0.10
12.340	0.10	0.10	0.10	0.10	0.10	0.10	0.10	0.10
12.384	0.10	0.10	0.10	0.10	0.10	0.10	0.10	0.10
12.429	0.10	0.10	0.10	0.10	0.10	0.10	0.10	0.10
12.473	0.10	0.10	0.10	0.10	0.10	0.10	0.10	0.10
12.517	0.10	0.10	0.10	0.10	0.10	0.10	0.10	0.10
12.561	0.10	0.10	0.10	0.10	0.10	0.10	0.10	0.10
12.605	0.10	0.10	0.10	0.10	0.10	0.09	0.09	0.09
12.650	0.09	0.09	0.09	0.09	0.09	0.09	0.09	0.09
12.694	0.09	0.09	0.09	0.09	0.09	0.09	0.09	0.09
12.738	0.09	0.09	0.09	0.09	0.09	0.09	0.09	0.09
12.782	0.09	0.09	0.09	0.09	0.09	0.09	0.09	0.09
12.826	0.09	0.09	0.09	0.09	0.09	0.09	0.09	0.09
12.871	0.09	0.09	0.09	0.09	0.09	0.09	0.09	0.09
12.915	0.09	0.09	0.09	0.09	0.09	0.09	0.09	0.09
12.959	0.09	0.09	0.09	0.09	0.09	0.09	0.09	0.09

WinTR-20: Version 1.10
ED CHURCH
AREA G PRE

0 0 0.05

(continued)

STORM 2-Yr

SUB-AREA:

DMA G PRE Outlet .0038 77. .1

STREAM REACH:

15.523	0.07	0.07	0.07	0.07	0.07	0.07	0.07	0.07
15.568	0.07	0.07	0.07	0.07	0.07	0.07	0.07	0.07
15.612	0.07	0.07	0.07	0.07	0.07	0.07	0.07	0.07
15.656	0.07	0.07	0.07	0.07	0.07	0.07	0.07	0.07
15.700	0.07	0.07	0.07	0.07	0.07	0.07	0.07	0.07
15.744	0.07	0.07	0.07	0.07	0.07	0.07	0.07	0.07
15.789	0.07	0.07	0.07	0.07	0.07	0.07	0.07	0.07
15.833	0.07	0.07	0.07	0.07	0.07	0.07	0.07	0.07
15.877	0.07	0.07	0.07	0.07	0.07	0.07	0.07	0.07
15.921	0.07	0.07	0.07	0.07	0.07	0.07	0.07	0.07
15.965	0.07	0.07	0.07	0.07	0.07	0.07	0.07	0.07
16.010	0.07	0.07	0.07	0.07	0.07	0.07	0.07	0.07
16.054	0.07	0.07	0.07	0.07	0.07	0.07	0.07	0.07
16.098	0.07	0.07	0.07	0.07	0.07	0.07	0.07	0.07
16.142	0.07	0.07	0.07	0.07	0.07	0.07	0.07	0.07
16.186	0.07	0.07	0.07	0.07	0.07	0.07	0.07	0.07
16.231	0.07	0.07	0.07	0.07	0.07	0.07	0.07	0.07
16.275	0.07	0.07	0.07	0.07	0.07	0.07	0.07	0.07
16.319	0.07	0.07	0.07	0.07	0.07	0.07	0.07	0.07
16.363	0.07	0.07	0.07	0.07	0.07	0.07	0.07	0.07
16.408	0.07	0.07	0.07	0.07	0.07	0.07	0.07	0.07
16.452	0.07	0.07	0.07	0.07	0.07	0.07	0.07	0.07
16.496	0.07	0.07	0.07	0.07	0.07	0.07	0.07	0.07
16.540	0.07	0.07	0.07	0.07	0.07	0.07	0.07	0.07
16.584	0.07	0.07	0.07	0.07	0.07	0.07	0.07	0.07
16.629	0.07	0.07	0.07	0.07	0.07	0.07	0.07	0.07
16.673	0.07	0.07	0.07	0.07	0.07	0.07	0.07	0.07
16.717	0.07	0.07	0.07	0.07	0.07	0.07	0.07	0.07
16.761	0.07	0.07	0.07	0.07	0.07	0.07	0.07	0.07
16.805	0.07	0.07	0.07	0.07	0.07	0.07	0.07	0.07
16.850	0.07	0.07	0.07	0.07	0.07	0.07	0.07	0.07
16.894	0.07	0.07	0.07	0.07	0.07	0.07	0.07	0.07
16.938	0.07	0.07	0.07	0.07	0.07	0.07	0.07	0.07
16.982	0.07	0.07	0.07	0.07	0.07	0.07	0.07	0.07
17.026	0.07	0.07	0.07	0.07	0.07	0.07	0.07	0.07
17.071	0.07	0.07	0.07	0.07	0.07	0.07	0.07	0.07
17.115	0.07	0.07	0.07	0.07	0.07	0.07	0.07	0.07
17.159	0.07	0.07	0.07	0.07	0.07	0.07	0.07	0.07

WinTR-20: Version 1.10
ED CHURCH
AREA G PRE

0 0 0.05

(continued)

STORM 2-Yr

SUB-AREA:

DMA G PRE Outlet .0038 77. .1

STREAM REACH:

18.441	0.06	0.06	0.06	0.06	0.06	0.06	0.06	0.06
18.485	0.06	0.06	0.06	0.06	0.06	0.06	0.06	0.06
18.530	0.06	0.06	0.06	0.06	0.06	0.06	0.06	0.06
18.574	0.06	0.06	0.06	0.06	0.06	0.06	0.06	0.06
18.618	0.06	0.06	0.06	0.06	0.06	0.06	0.06	0.06
18.662	0.06	0.06	0.06	0.06	0.06	0.06	0.06	0.06
18.706	0.06	0.06	0.06	0.06	0.06	0.06	0.06	0.06
18.751	0.06	0.06	0.06	0.06	0.06	0.06	0.06	0.06
18.795	0.06	0.06	0.06	0.06	0.06	0.06	0.06	0.06
18.839	0.06	0.06	0.06	0.06	0.06	0.06	0.06	0.06
18.883	0.06	0.06	0.06	0.06	0.06	0.06	0.06	0.06
18.928	0.06	0.06	0.06	0.06	0.06	0.06	0.06	0.06
18.972	0.06	0.06	0.06	0.06	0.06	0.06	0.06	0.06
19.016	0.06	0.06	0.06	0.06	0.06	0.06	0.06	0.06
19.060	0.06	0.06	0.06	0.06	0.06	0.06	0.06	0.06
19.104	0.06	0.06	0.06	0.06	0.06	0.06	0.06	0.06
19.149	0.06	0.06	0.06	0.06	0.06	0.06	0.06	0.06
19.193	0.06	0.06	0.06	0.06	0.06	0.06	0.06	0.06
19.237	0.06	0.06	0.06	0.06	0.06	0.06	0.06	0.06
19.281	0.06	0.06	0.06	0.06	0.06	0.06	0.06	0.06
19.325	0.06	0.06	0.06	0.06	0.06	0.06	0.06	0.06
19.370	0.06	0.06	0.06	0.06	0.06	0.06	0.06	0.06
19.414	0.06	0.06	0.06	0.06	0.06	0.06	0.06	0.06
19.458	0.06	0.06	0.06	0.06	0.06	0.06	0.06	0.06
19.502	0.06	0.06	0.06	0.06	0.06	0.06	0.06	0.06
19.546	0.06	0.06	0.06	0.06	0.06	0.06	0.06	0.06
19.591	0.06	0.06	0.06	0.06	0.06	0.06	0.06	0.06
19.635	0.06	0.06	0.06	0.06	0.06	0.06	0.06	0.06
19.679	0.06	0.06	0.06	0.06	0.06	0.06	0.06	0.06
19.723	0.06	0.06	0.06	0.06	0.06	0.06	0.06	0.06

KINDRED CHURCH
AREA G PRE

Line
Start Time ----- Flow Values @ time increment of 0.006 hr -----

WinTR-20: Version 1.10
ED CHURCH
AREA G PRE

0 0 0.05

(continued)

STORM 2-Yr

SUB-AREA:

DMA G PRE Outlet .0038 77. .1

STREAM REACH:

(hr)	(cfs)	(cfs)	(cfs)	(cfs)	(cfs)	(cfs)	(cfs)
19.768	0.06	0.06	0.06	0.06	0.06	0.06	0.06
19.812	0.06	0.06	0.06	0.06	0.06	0.06	0.06
19.856	0.06	0.06	0.06	0.06	0.06	0.06	0.06
19.900	0.06	0.06	0.06	0.06	0.06	0.06	0.06
19.944	0.06	0.06	0.06	0.06	0.06	0.06	0.06
19.989	0.05	0.05	0.05	0.05	0.05	0.05	0.05
20.033	0.05	0.05	0.05	0.05	0.05	0.05	0.05
20.077	0.05	0.05	0.05	0.05	0.05	0.05	0.05
20.121	0.05	0.05	0.05	0.05	0.05	0.05	0.05
20.165	0.05	0.05	0.05	0.05	0.05	0.05	0.05
20.210	0.05	0.05	0.05	0.05	0.05	0.05	0.05
20.254	0.05	0.05	0.05	0.05	0.05	0.05	0.05
20.298	0.05	0.05	0.05	0.05	0.05	0.05	0.05
20.342	0.05	0.05	0.05	0.05	0.05	0.05	0.05
20.386	0.05	0.05	0.05	0.05	0.05	0.05	0.05
20.431	0.05	0.05	0.05	0.05	0.05	0.05	0.05
20.475	0.05	0.05	0.05	0.05	0.05	0.05	0.05
20.519	0.05	0.05	0.05	0.05	0.05	0.05	0.05
20.563	0.05	0.05	0.05	0.05	0.05	0.05	0.05
20.608	0.05	0.05	0.05	0.05	0.05	0.05	0.05
20.652	0.05	0.05	0.05	0.05	0.05	0.05	0.05
20.696	0.05	0.05	0.05	0.05	0.05	0.05	0.05
20.740	0.05	0.05	0.05	0.05	0.05	0.05	0.05
20.784	0.05	0.05	0.05	0.05	0.05	0.05	0.05
20.829	0.05	0.05	0.05	0.05	0.05	0.05	0.05
20.873	0.05	0.05	0.05	0.05	0.05	0.05	0.05
20.917	0.05	0.05	0.05	0.05	0.05	0.05	0.05
20.961	0.05	0.05	0.05	0.05	0.05	0.05	0.05
21.005	0.05	0.05	0.05	0.05	0.05	0.05	0.05
21.050	0.05	0.05	0.05	0.05	0.05	0.05	0.05
21.094	0.05	0.05	0.05	0.05	0.05	0.05	0.05
21.138	0.05	0.05					

WinTR-20 Printed Page File
TR20.inp

Beginning of Input Data List

WinTR-20: Version 1.10
ED CHURCH
AREA G PRE

0 0 0.05

(continued)

STORM 2-Yr

SUB-AREA:

DMA G PRE Outlet

.0038 77. .1

STREAM REACH:

WinTR-20 Version 1.10

Page 11

09/18/2020 8:39

KINDRED CHURCH
AREA G PRE

Area or Reach Identifier	Drainage Area (sq mi)	Alternate	----- Peak Flow by Storm -----				
			2-Yr (cfs)	(cfs)	(cfs)	(cfs)	(cfs)
DMA G PRE	0.004		0.60				
OUTLET	0.004		0.60				

WinTR-55, Version 1.00.10

Page 16

9/18/2020 8:39:53 AM

WinTR-20 Printed Page File
TR20.inp

Beginning of Input Data List

WinTR-20: Version 1.10
ED CHURCH
AREA G PRE

0 0 0.05

(continued)

STORM 2-Yr

SUB-AREA:

DMA G PRE Outlet

.0038 77. .1

STREAM REACH:

WinTR-20 Printed Page File
TR20.inp

Beginning of Input Data List

WinTR-20: Version 1.10
ED CHURCH
AREA G PRE

0 0 0.05

(continued)

STORM 2-Yr

SUB-AREA:

DMA G PRE Outlet

.0038 77. .1

STREAM REACH:

WinTR-20 Version 1.10

Page 12

09/18/2020 8:39

WinTR-55 Current Data Description

--- Identification Data ---

User: ANACAL ENG Date: 9/18/2020
 Project: KINDRED CHURCH Units: English
 SubTitle: AREA G PRE Areal Units: Acres
 State: California
 County: Orange
 Filename: E:\Users\dave\AppData\Roaming\WinTR-55\19-155-AREA G-PRE.w55

--- Sub-Area Data ---

Name	Description	Reach	Area(ac)	RCN	Tc
DMA G PRE		Outlet	2.43	77	0.1

Total area: 2.43 (ac)

--- Storm Data --

Rainfall Depth by Rainfall Return Period

2-Yr (in)	-Yr (in)	-Yr (in)	-Yr (in)	-Yr (in)	-Yr (in)	-Yr (in)
2.05	.0	.0	.0	.0	.0	.0

Storm Data Source: User-provided custom storm data
 Rainfall Distribution Type: Type I
 Dimensionless Unit Hydrograph: <standard>

ANACAL ENG

KINDRED CHURCH
AREA G PRE
Orange County, California

Storm Data

Rainfall Depth by Rainfall Return Period

2-Yr (in)	-Yr (in)	-Yr (in)	-Yr (in)	-Yr (in)	-Yr (in)	-Yr (in)
2.05	.0	.0	.0	.0	.0	.0

Storm Data Source: User-provided custom storm data
Rainfall Distribution Type: Type I
Dimensionless Unit Hydrograph: <standard>

ANACAL ENG

KINDRED CHURCH
AREA G PRE
Orange County, California

Watershed Peak Table

Sub-Area or Reach Identifier	Peak Flow by Rainfall Return Period 2-Yr (cfs)

SUBAREAS	
DMA G PRE	0.60
REACHES	
OUTLET	0.60

ANACAL ENG

KINDRED CHURCH
AREA G PRE
Orange County, California

Hydrograph Peak/Peak Time Table

Sub-Area or Reach Identifier	Peak Flow and Peak Time (hr) by Rainfall Return Period 2-Yr (cfs) (hr)
------------------------------------	---

SUBAREAS

DMA G PRE	0.60 9.95
-----------	--------------

REACHES

OUTLET	0.60
--------	------

ANACAL ENG

KINDRED CHURCH
AREA G PRE
Orange County, California

Sub-Area Summary Table

Sub-Area Identifier	Drainage Area (ac)	Time of Concentration (hr)	Curve Number	Receiving Reach	Sub-Area Description
DMA G PRE	2.43	0.100	77	Outlet	

Total Area:	2.43 (ac)				

ANACAL ENG

KINDRED CHURCH
AREA G PRE
Orange County, California

Sub-Area Land Use and Curve Number Details

Sub-Area Identifier	Land Use	Hydrologic Soil Group	Sub-Area Area (ac)	Curve Number
DMA G PRE	Open space; grass cover > 75%	(good) A	.86	39
	Paved parking lots, roofs, driveways	A	1.57	98
	Total Area / Weighted Curve Number		2.43	77
			====	==

10.726	0.21	0.21	0.21	0.21	0.21	0.20	0.20
10.770	0.20	0.20	0.20	0.20	0.20	0.20	0.20
10.814	0.20	0.20	0.20	0.20	0.20	0.20	0.20
10.858	0.20	0.20	0.19	0.19	0.19	0.19	0.19
10.902	0.19	0.19	0.19	0.19	0.19	0.19	0.19

KINDRED CHURCH
2YEAR HYDRO ANALYSIS

Line Start Time (hr)	----- Flow Values @ time increment of 0.006 hr ----- (cfs) (cfs) (cfs) (cfs) (cfs) (cfs) (cfs)						
10.947	0.19	0.19	0.19	0.19	0.19	0.18	0.18
10.991	0.18	0.18	0.18	0.18	0.18	0.18	0.18
11.035	0.18	0.18	0.18	0.18	0.18	0.18	0.18
11.079	0.18	0.18	0.18	0.18	0.18	0.18	0.18
11.123	0.18	0.18	0.17	0.17	0.17	0.17	0.17
11.168	0.17	0.17	0.17	0.17	0.17	0.17	0.17
11.212	0.17	0.17	0.17	0.17	0.17	0.17	0.17
11.256	0.17	0.17	0.17	0.17	0.17	0.17	0.17
11.300	0.17	0.17	0.17	0.17	0.17	0.17	0.17
11.345	0.17	0.17	0.17	0.17	0.17	0.17	0.17
11.389	0.17	0.17	0.17	0.17	0.17	0.17	0.17
11.433	0.17	0.17	0.17	0.17	0.17	0.17	0.17
11.477	0.16	0.16	0.16	0.16	0.16	0.16	0.16
11.521	0.16	0.16	0.16	0.16	0.16	0.16	0.16
11.566	0.16	0.16	0.16	0.16	0.16	0.16	0.16
11.610	0.16	0.16	0.16	0.16	0.16	0.16	0.16
11.654	0.16	0.16	0.16	0.16	0.16	0.16	0.16
11.698	0.16	0.16	0.16	0.16	0.16	0.16	0.16
11.742	0.16	0.16	0.16	0.16	0.16	0.16	0.16
11.787	0.16	0.16	0.15	0.15	0.15	0.15	0.15
11.831	0.15	0.15	0.15	0.15	0.15	0.15	0.15
11.875	0.15	0.15	0.15	0.15	0.15	0.15	0.15
11.919	0.15	0.15	0.15	0.15	0.15	0.15	0.15
11.963	0.15	0.15	0.15	0.15	0.15	0.15	0.15
12.008	0.15	0.15	0.15	0.15	0.15	0.15	0.15
12.052	0.15	0.15	0.15	0.15	0.15	0.15	0.15
12.096	0.15	0.15	0.15	0.15	0.14	0.14	0.14
12.140	0.14	0.14	0.14	0.14	0.14	0.14	0.14
12.185	0.14	0.14	0.14	0.14	0.14	0.14	0.14
12.229	0.14	0.14	0.14	0.14	0.14	0.14	0.14
12.273	0.14	0.14	0.14	0.14	0.14	0.14	0.14
12.317	0.14	0.14	0.14	0.14	0.14	0.14	0.14
12.361	0.14	0.14	0.14	0.14	0.14	0.14	0.14
12.406	0.14	0.14	0.14	0.14	0.14	0.14	0.14
12.450	0.14	0.14	0.14	0.14	0.14	0.14	0.14
12.494	0.14	0.14	0.14	0.14	0.14	0.14	0.14
12.538	0.14	0.14	0.14	0.14	0.14	0.14	0.14
12.582	0.14	0.14	0.13	0.13	0.13	0.13	0.13
12.627	0.13	0.13	0.13	0.13	0.13	0.13	0.13
12.671	0.13	0.13	0.13	0.13	0.13	0.13	0.13
12.715	0.13	0.13	0.13	0.13	0.13	0.13	0.13
12.759	0.13	0.13	0.13	0.13	0.13	0.13	0.13
12.803	0.13	0.13	0.13	0.13	0.13	0.13	0.13
12.848	0.13	0.13	0.13	0.13	0.13	0.13	0.13
12.892	0.13	0.13	0.13	0.13	0.13	0.13	0.13
12.936	0.13	0.13	0.13	0.13	0.13	0.13	0.13
12.980	0.13	0.13	0.13	0.13	0.13	0.13	0.13
13.025	0.13	0.13	0.13	0.13	0.12	0.12	0.12
13.069	0.12	0.12	0.12	0.12	0.12	0.12	0.12
13.113	0.12	0.12	0.12	0.12	0.12	0.12	0.12
13.157	0.12	0.12	0.12	0.12	0.12	0.12	0.12

WinTR-20: Version 1.10
 ED CHURCH
 2YEAR HYDRO ANALYSIS

0 0 0.05

(continued)

STORM 2-Yr

SUB-AREA:

DMA G POSTOutlet .0038 83. .1

STREAM REACH:

KINDRED CHURCH
 2YEAR HYDRO ANALYSIS

Line Start Time (hr)	Flow Values @ time increment of 0.006 hr						
	(cfs)	(cfs)	(cfs)	(cfs)	(cfs)	(cfs)	(cfs)
13.201	0.12	0.12	0.12	0.12	0.12	0.12	0.12
13.246	0.12	0.12	0.12	0.12	0.12	0.12	0.12
13.290	0.12	0.12	0.12	0.12	0.12	0.12	0.12
13.334	0.12	0.12	0.12	0.12	0.12	0.12	0.12
13.378	0.12	0.12	0.12	0.12	0.12	0.12	0.12
13.422	0.12	0.12	0.12	0.12	0.12	0.12	0.11
13.467	0.11	0.11	0.11	0.11	0.11	0.11	0.11
13.511	0.11	0.11	0.11	0.11	0.11	0.11	0.11
13.555	0.11	0.11	0.11	0.11	0.11	0.11	0.11
13.599	0.11	0.11	0.11	0.11	0.11	0.11	0.11
13.643	0.11	0.11	0.11	0.11	0.11	0.11	0.11
13.688	0.11	0.11	0.11	0.11	0.11	0.11	0.11
13.732	0.11	0.11	0.11	0.11	0.11	0.11	0.11
13.776	0.11	0.11	0.11	0.11	0.11	0.11	0.11
13.820	0.11	0.11	0.11	0.11	0.10	0.10	0.10
13.865	0.10	0.10	0.10	0.10	0.10	0.10	0.10
13.909	0.10	0.10	0.10	0.10	0.10	0.10	0.10
13.953	0.10	0.10	0.10	0.10	0.10	0.10	0.10
13.997	0.10	0.10	0.10	0.10	0.10	0.10	0.10
14.041	0.10	0.10	0.10	0.10	0.10	0.10	0.10
14.086	0.10	0.10	0.10	0.10	0.10	0.10	0.10
14.130	0.10	0.10	0.10	0.10	0.10	0.10	0.10
14.174	0.10	0.10	0.10	0.10	0.10	0.10	0.10
14.218	0.10	0.10	0.10	0.10	0.10	0.10	0.10
14.262	0.10	0.10	0.10	0.10	0.10	0.10	0.10
14.307	0.10	0.10	0.10	0.10	0.10	0.10	0.10
14.351	0.10	0.10	0.10	0.10	0.10	0.10	0.10
14.395	0.10	0.10	0.10	0.10	0.10	0.10	0.10
14.439	0.10	0.10	0.10	0.10	0.10	0.10	0.10
14.483	0.10	0.10	0.10	0.10	0.10	0.10	0.10

WinTR-20: Version 1.10
ED CHURCH
2YEAR HYDRO ANALYSIS

0 0 0.05

(continued)

STORM 2-Yr

SUB-AREA:

DMA G POSTOutlet .0038 83. .1

STREAM REACH:

15.766	0.09	0.09	0.09	0.09	0.09	0.09	0.09	0.09
15.810	0.09	0.09	0.09	0.09	0.09	0.09	0.09	0.09
15.854	0.09	0.09	0.09	0.09	0.09	0.09	0.09	0.09
15.898	0.09	0.09	0.09	0.09	0.09	0.09	0.09	0.09
15.942	0.09	0.09	0.09	0.09	0.09	0.09	0.09	0.09
15.987	0.09	0.09	0.09	0.09	0.09	0.09	0.09	0.09
16.031	0.09	0.09	0.09	0.09	0.09	0.09	0.09	0.09
16.075	0.09	0.09	0.09	0.09	0.09	0.09	0.09	0.09
16.119	0.09	0.09	0.09	0.09	0.09	0.09	0.09	0.09
16.163	0.09	0.09	0.09	0.09	0.09	0.09	0.09	0.09
16.208	0.09	0.09	0.09	0.09	0.09	0.09	0.09	0.09
16.252	0.09	0.09	0.09	0.09	0.09	0.09	0.09	0.09
16.296	0.09	0.09	0.09	0.09	0.09	0.09	0.09	0.09
16.340	0.09	0.09	0.09	0.09	0.09	0.09	0.09	0.09
16.385	0.09	0.09	0.09	0.09	0.09	0.09	0.09	0.09
16.429	0.09	0.09	0.09	0.09	0.09	0.09	0.09	0.09
16.473	0.09	0.09	0.09	0.09	0.09	0.09	0.09	0.09
16.517	0.09	0.09	0.09	0.09	0.09	0.09	0.09	0.09
16.561	0.09	0.09	0.09	0.09	0.09	0.09	0.09	0.09
16.606	0.09	0.09	0.09	0.09	0.09	0.09	0.09	0.09
16.650	0.09	0.09	0.09	0.09	0.09	0.09	0.09	0.09
16.694	0.09	0.09	0.09	0.09	0.09	0.09	0.09	0.09
16.738	0.09	0.09	0.09	0.09	0.09	0.09	0.09	0.09
16.782	0.09	0.09	0.09	0.09	0.09	0.09	0.09	0.09
16.827	0.09	0.09	0.09	0.09	0.09	0.09	0.09	0.09
16.871	0.09	0.09	0.09	0.09	0.09	0.09	0.09	0.09
16.915	0.09	0.09	0.09	0.09	0.09	0.09	0.09	0.09
16.959	0.09	0.09	0.09	0.09	0.09	0.09	0.09	0.09
17.003	0.09	0.09	0.09	0.09	0.09	0.09	0.09	0.09
17.048	0.09	0.09	0.09	0.09	0.09	0.09	0.09	0.09
17.092	0.09	0.09	0.09	0.09	0.09	0.09	0.09	0.09
17.136	0.09	0.09	0.09	0.09	0.09	0.09	0.09	0.09
17.180	0.09	0.09	0.09	0.09	0.09	0.09	0.09	0.09
17.225	0.09	0.09	0.09	0.09	0.09	0.09	0.09	0.09
17.269	0.09	0.09	0.09	0.09	0.09	0.09	0.09	0.09
17.313	0.09	0.09	0.09	0.09	0.09	0.09	0.09	0.09
17.357	0.09	0.09	0.09	0.09	0.09	0.09	0.08	0.08
17.401	0.08	0.08	0.08	0.08	0.08	0.08	0.08	0.08

WinTR-20: Version 1.10
ED CHURCH
2YEAR HYDRO ANALYSIS

0 0 0.05

(continued)

STORM 2-Yr

SUB-AREA:

DMA G POSTOutlet .0038 83. .1

STREAM REACH:

18.683	0.08	0.08	0.08	0.08	0.08	0.08	0.08
18.728	0.08	0.08	0.08	0.08	0.08	0.08	0.08
18.772	0.08	0.08	0.08	0.08	0.08	0.08	0.08
18.816	0.08	0.08	0.08	0.08	0.08	0.08	0.08
18.860	0.08	0.08	0.08	0.08	0.08	0.08	0.08
18.905	0.08	0.08	0.08	0.08	0.08	0.08	0.08
18.949	0.08	0.08	0.08	0.08	0.08	0.08	0.08
18.993	0.08	0.08	0.08	0.08	0.08	0.08	0.08
19.037	0.08	0.08	0.08	0.08	0.08	0.08	0.08
19.081	0.08	0.08	0.08	0.08	0.08	0.08	0.08
19.126	0.08	0.08	0.08	0.08	0.08	0.08	0.08
19.170	0.08	0.08	0.08	0.08	0.08	0.08	0.08
19.214	0.08	0.08	0.08	0.08	0.08	0.08	0.08
19.258	0.08	0.08	0.08	0.07	0.07	0.07	0.07
19.302	0.07	0.07	0.07	0.07	0.07	0.07	0.07
19.347	0.07	0.07	0.07	0.07	0.07	0.07	0.07
19.391	0.07	0.07	0.07	0.07	0.07	0.07	0.07
19.435	0.07	0.07	0.07	0.07	0.07	0.07	0.07
19.479	0.07	0.07	0.07	0.07	0.07	0.07	0.07
19.523	0.07	0.07	0.07	0.07	0.07	0.07	0.07
19.568	0.07	0.07	0.07	0.07	0.07	0.07	0.07
19.612	0.07	0.07	0.07	0.07	0.07	0.07	0.07
19.656	0.07	0.07	0.07	0.07	0.07	0.07	0.07
19.700	0.07	0.07	0.07	0.07	0.07	0.07	0.07
19.745	0.07	0.07	0.07	0.07	0.07	0.07	0.07
19.789	0.07	0.07	0.07	0.07	0.07	0.07	0.07
19.833	0.07	0.07	0.07	0.07	0.07	0.07	0.07
19.877	0.07	0.07	0.07	0.07	0.07	0.07	0.07
19.921	0.07	0.07	0.07	0.07	0.07	0.07	0.07

KINDRED CHURCH
2YEAR HYDRO ANALYSIS

Line
Start Time ----- Flow Values @ time increment of 0.006 hr -----
(hr) (cfs) (cfs) (cfs) (cfs) (cfs) (cfs) (cfs)

WinTR-20: Version 1.10
ED CHURCH
2YEAR HYDRO ANALYSIS

0 0 0.05

(continued)

STORM 2-Yr

SUB-AREA:

DMA G POSTOutlet .0038 83. .1

STREAM REACH:

19.966	0.07	0.07	0.07	0.07	0.07	0.07	0.07
20.010	0.07	0.07	0.07	0.07	0.07	0.07	0.07
20.054	0.07	0.07	0.07	0.07	0.07	0.07	0.07
20.098	0.07	0.07	0.07	0.07	0.07	0.07	0.07
20.142	0.07	0.07	0.07	0.07	0.07	0.07	0.07
20.187	0.07	0.07	0.07	0.07	0.07	0.07	0.07
20.231	0.07	0.07	0.07	0.07	0.07	0.07	0.07
20.275	0.07	0.07	0.07	0.07	0.07	0.07	0.07
20.319	0.07	0.07	0.07	0.07	0.07	0.07	0.07
20.363	0.07	0.07	0.07	0.07	0.07	0.07	0.07
20.408	0.07	0.07	0.07	0.07	0.07	0.07	0.07
20.452	0.07	0.07	0.07	0.07	0.07	0.07	0.07
20.496	0.07	0.07	0.07	0.07	0.07	0.07	0.07
20.540	0.07	0.07	0.07	0.07	0.07	0.07	0.07
20.585	0.07	0.07	0.07	0.07	0.07	0.07	0.07
20.629	0.07	0.07	0.07	0.07	0.07	0.07	0.07
20.673	0.07	0.07	0.07	0.07	0.07	0.07	0.07
20.717	0.07	0.07	0.07	0.07	0.07	0.07	0.07
20.761	0.07	0.07	0.07	0.07	0.07	0.07	0.07
20.806	0.07	0.07	0.07	0.07	0.07	0.07	0.07
20.850	0.07	0.07	0.07	0.07	0.07	0.07	0.07
20.894	0.07	0.07	0.07	0.07	0.07	0.07	0.07
20.938	0.07	0.07	0.07	0.07	0.07	0.07	0.07
20.982	0.06	0.06	0.06	0.06	0.06	0.06	0.06
21.027	0.06	0.06	0.06	0.06	0.06	0.06	0.06
21.071	0.06	0.06	0.06	0.06	0.06	0.06	0.06
21.115	0.06	0.06	0.06	0.06	0.06	0.06	0.06
21.159	0.06	0.06	0.06	0.06	0.06	0.06	0.06
21.203	0.06	0.06	0.06	0.06	0.06	0.06	0.06
21.248	0.06	0.06	0.06	0.06	0.06	0.06	0.06
21.292	0.06	0.06	0.06	0.06	0.06	0.06	0.06
21.336	0.06	0.06	0.06	0.06	0.06	0.06	0.06
21.380	0.06	0.06	0.06	0.06	0.06	0.06	0.06
21.425	0.06	0.06	0.06	0.06	0.06	0.06	0.06
21.469	0.06	0.06	0.06	0.06	0.06	0.06	0.06
21.513	0.06	0.06	0.06	0.06	0.06	0.06	0.06
21.557	0.06	0.06	0.06	0.06	0.06	0.06	0.06

WinTR-20: Version 1.10
ED CHURCH
2YEAR HYDRO ANALYSIS

0 0 0.05

(continued)

STORM 2-Yr

SUB-AREA:

DMA G POSTOutlet .0038 83. .1

STREAM REACH:

22.839	0.05	0.05	0.05	0.05	0.05	0.05	0.05	0.05
22.883	0.05	0.05	0.05	0.05	0.05	0.05	0.05	0.05
22.928	0.05	0.05	0.05	0.05	0.05	0.05	0.05	0.05
22.972	0.05	0.05	0.05	0.05	0.05	0.05	0.05	0.05
23.016	0.05	0.05	0.05	0.05	0.05	0.05	0.05	0.05
23.060	0.05	0.05	0.05	0.05	0.05	0.05	0.05	0.05
23.105	0.05	0.05	0.05	0.05	0.05	0.05	0.05	0.05
23.149	0.05	0.05	0.05	0.05	0.05	0.05	0.05	0.05
23.193	0.05	0.05	0.05	0.05	0.05	0.05	0.05	0.05
23.237	0.05	0.05	0.05	0.05	0.05	0.05	0.05	0.05
23.281	0.05	0.05	0.05	0.05	0.05	0.05	0.05	0.05
23.326	0.05	0.05	0.05	0.05	0.05	0.05	0.05	0.05

Area or Reach Identifier	Drainage Area (sq mi)	Rain Gage ID or Location	Runoff Amount (in)	Elevation (ft)	Peak Flow Time (hr)	Peak Flow Rate (cfs)	Peak Flow Rate (csm)
OUTLET	0.004		0.708		9.94	1.19	314.33

Line Start Time (hr)	Flow Values @ time increment of 0.006 hr						
	(cfs)	(cfs)	(cfs)	(cfs)	(cfs)	(cfs)	(cfs)
9.178	0.05	0.05	0.05	0.05	0.05	0.05	0.05
9.222	0.05	0.06	0.06	0.06	0.06	0.06	0.06
9.267	0.06	0.06	0.06	0.06	0.06	0.06	0.06
9.311	0.07	0.07	0.07	0.07	0.07	0.07	0.07
9.355	0.07	0.07	0.07	0.07	0.07	0.08	0.08
9.399	0.08	0.08	0.08	0.08	0.08	0.08	0.08
9.443	0.08	0.08	0.09	0.09	0.09	0.09	0.09
9.488	0.09	0.09	0.09	0.09	0.09	0.10	0.10
9.532	0.10	0.10	0.11	0.11	0.12	0.12	0.12
9.576	0.13	0.13	0.14	0.14	0.14	0.15	0.15
9.620	0.15	0.16	0.16	0.17	0.18	0.19	0.20
9.665	0.21	0.22	0.23	0.23	0.24	0.25	0.26
9.709	0.26	0.27	0.28	0.29	0.30	0.32	0.34
9.753	0.35	0.37	0.39	0.41	0.43	0.45	0.47

WinTR-20: Version 1.10
ED CHURCH
2YEAR HYDRO ANALYSIS

0 0 0.05

(continued)

STORM 2-Yr

SUB-AREA:

DMA G POSTOutlet .0038 83. .1

STREAM REACH:

12.317	0.14	0.14	0.14	0.14	0.14	0.14	0.14	0.14
12.361	0.14	0.14	0.14	0.14	0.14	0.14	0.14	0.14
12.406	0.14	0.14	0.14	0.14	0.14	0.14	0.14	0.14
12.450	0.14	0.14	0.14	0.14	0.14	0.14	0.14	0.14
12.494	0.14	0.14	0.14	0.14	0.14	0.14	0.14	0.14
12.538	0.14	0.14	0.14	0.14	0.14	0.14	0.14	0.14
12.582	0.14	0.14	0.13	0.13	0.13	0.13	0.13	0.13
12.627	0.13	0.13	0.13	0.13	0.13	0.13	0.13	0.13
12.671	0.13	0.13	0.13	0.13	0.13	0.13	0.13	0.13
12.715	0.13	0.13	0.13	0.13	0.13	0.13	0.13	0.13
12.759	0.13	0.13	0.13	0.13	0.13	0.13	0.13	0.13
12.803	0.13	0.13	0.13	0.13	0.13	0.13	0.13	0.13
12.848	0.13	0.13	0.13	0.13	0.13	0.13	0.13	0.13
12.892	0.13	0.13	0.13	0.13	0.13	0.13	0.13	0.13
12.936	0.13	0.13	0.13	0.13	0.13	0.13	0.13	0.13
12.980	0.13	0.13	0.13	0.13	0.13	0.13	0.13	0.13
13.025	0.13	0.13	0.13	0.13	0.13	0.12	0.12	0.12
13.069	0.12	0.12	0.12	0.12	0.12	0.12	0.12	0.12
13.113	0.12	0.12	0.12	0.12	0.12	0.12	0.12	0.12
13.157	0.12	0.12	0.12	0.12	0.12	0.12	0.12	0.12
13.201	0.12	0.12	0.12	0.12	0.12	0.12	0.12	0.12
13.246	0.12	0.12	0.12	0.12	0.12	0.12	0.12	0.12
13.290	0.12	0.12	0.12	0.12	0.12	0.12	0.12	0.12
13.334	0.12	0.12	0.12	0.12	0.12	0.12	0.12	0.12
13.378	0.12	0.12	0.12	0.12	0.12	0.12	0.12	0.12
13.422	0.12	0.12	0.12	0.12	0.12	0.12	0.12	0.11
13.467	0.11	0.11	0.11	0.11	0.11	0.11	0.11	0.11
13.511	0.11	0.11	0.11	0.11	0.11	0.11	0.11	0.11
13.555	0.11	0.11	0.11	0.11	0.11	0.11	0.11	0.11
13.599	0.11	0.11	0.11	0.11	0.11	0.11	0.11	0.11
13.643	0.11	0.11	0.11	0.11	0.11	0.11	0.11	0.11
13.688	0.11	0.11	0.11	0.11	0.11	0.11	0.11	0.11
13.732	0.11	0.11	0.11	0.11	0.11	0.11	0.11	0.11
13.776	0.11	0.11	0.11	0.11	0.11	0.11	0.11	0.11
13.820	0.11	0.11	0.11	0.11	0.10	0.10	0.10	0.10
13.865	0.10	0.10	0.10	0.10	0.10	0.10	0.10	0.10
13.909	0.10	0.10	0.10	0.10	0.10	0.10	0.10	0.10
13.953	0.10	0.10	0.10	0.10	0.10	0.10	0.10	0.10

WinTR-20: Version 1.10
ED CHURCH
2YEAR HYDRO ANALYSIS

0 0 0.05

(continued)

STORM 2-Yr

SUB-AREA:

DMA G POSTOutlet .0038 83. .1

STREAM REACH:

15.235	0.09	0.09	0.09	0.09	0.09	0.09	0.09	0.09
15.279	0.09	0.09	0.09	0.09	0.09	0.09	0.09	0.09
15.323	0.09	0.09	0.09	0.09	0.09	0.09	0.09	0.09
15.368	0.09	0.09	0.09	0.09	0.09	0.09	0.09	0.09
15.412	0.09	0.09	0.09	0.09	0.09	0.09	0.09	0.09
15.456	0.09	0.09	0.09	0.09	0.09	0.09	0.09	0.09
15.500	0.09	0.09	0.09	0.09	0.09	0.09	0.09	0.09
15.545	0.09	0.09	0.09	0.09	0.09	0.09	0.09	0.09
15.589	0.09	0.09	0.09	0.09	0.09	0.09	0.09	0.09
15.633	0.09	0.09	0.09	0.09	0.09	0.09	0.09	0.09
15.677	0.09	0.09	0.09	0.09	0.09	0.09	0.09	0.09
15.721	0.09	0.09	0.09	0.09	0.09	0.09	0.09	0.09
15.766	0.09	0.09	0.09	0.09	0.09	0.09	0.09	0.09
15.810	0.09	0.09	0.09	0.09	0.09	0.09	0.09	0.09
15.854	0.09	0.09	0.09	0.09	0.09	0.09	0.09	0.09
15.898	0.09	0.09	0.09	0.09	0.09	0.09	0.09	0.09
15.942	0.09	0.09	0.09	0.09	0.09	0.09	0.09	0.09
15.987	0.09	0.09	0.09	0.09	0.09	0.09	0.09	0.09
16.031	0.09	0.09	0.09	0.09	0.09	0.09	0.09	0.09
16.075	0.09	0.09	0.09	0.09	0.09	0.09	0.09	0.09
16.119	0.09	0.09	0.09	0.09	0.09	0.09	0.09	0.09
16.163	0.09	0.09	0.09	0.09	0.09	0.09	0.09	0.09
16.208	0.09	0.09	0.09	0.09	0.09	0.09	0.09	0.09
16.252	0.09	0.09	0.09	0.09	0.09	0.09	0.09	0.09
16.296	0.09	0.09	0.09	0.09	0.09	0.09	0.09	0.09
16.340	0.09	0.09	0.09	0.09	0.09	0.09	0.09	0.09
16.385	0.09	0.09	0.09	0.09	0.09	0.09	0.09	0.09
16.429	0.09	0.09	0.09	0.09	0.09	0.09	0.09	0.09
16.473	0.09	0.09	0.09	0.09	0.09	0.09	0.09	0.09
16.517	0.09	0.09	0.09	0.09	0.09	0.09	0.09	0.09

KINDRED CHURCH
2YEAR HYDRO ANALYSIS

Line
Start Time ----- Flow Values @ time increment of 0.006 hr -----

WinTR-20: Version 1.10
ED CHURCH
2YEAR HYDRO ANALYSIS

0 0 0.05

(continued)

STORM 2-Yr

SUB-AREA:

DMA G POSTOutlet .0038 83. .1

STREAM REACH:

(hr)	(cfs)	(cfs)	(cfs)	(cfs)	(cfs)	(cfs)	(cfs)
16.561	0.09	0.09	0.09	0.09	0.09	0.09	0.09
16.606	0.09	0.09	0.09	0.09	0.09	0.09	0.09
16.650	0.09	0.09	0.09	0.09	0.09	0.09	0.09
16.694	0.09	0.09	0.09	0.09	0.09	0.09	0.09
16.738	0.09	0.09	0.09	0.09	0.09	0.09	0.09
16.782	0.09	0.09	0.09	0.09	0.09	0.09	0.09
16.827	0.09	0.09	0.09	0.09	0.09	0.09	0.09
16.871	0.09	0.09	0.09	0.09	0.09	0.09	0.09
16.915	0.09	0.09	0.09	0.09	0.09	0.09	0.09
16.959	0.09	0.09	0.09	0.09	0.09	0.09	0.09
17.003	0.09	0.09	0.09	0.09	0.09	0.09	0.09
17.048	0.09	0.09	0.09	0.09	0.09	0.09	0.09
17.092	0.09	0.09	0.09	0.09	0.09	0.09	0.09
17.136	0.09	0.09	0.09	0.09	0.09	0.09	0.09
17.180	0.09	0.09	0.09	0.09	0.09	0.09	0.09
17.225	0.09	0.09	0.09	0.09	0.09	0.09	0.09
17.269	0.09	0.09	0.09	0.09	0.09	0.09	0.09
17.313	0.09	0.09	0.09	0.09	0.09	0.09	0.09
17.357	0.09	0.09	0.09	0.09	0.09	0.08	0.08
17.401	0.08	0.08	0.08	0.08	0.08	0.08	0.08
17.446	0.08	0.08	0.08	0.08	0.08	0.08	0.08
17.490	0.08	0.08	0.08	0.08	0.08	0.08	0.08
17.534	0.08	0.08	0.08	0.08	0.08	0.08	0.08
17.578	0.08	0.08	0.08	0.08	0.08	0.08	0.08
17.622	0.08	0.08	0.08	0.08	0.08	0.08	0.08
17.667	0.08	0.08	0.08	0.08	0.08	0.08	0.08
17.711	0.08	0.08	0.08	0.08	0.08	0.08	0.08
17.755	0.08	0.08	0.08	0.08	0.08	0.08	0.08
17.799	0.08	0.08	0.08	0.08	0.08	0.08	0.08
17.843	0.08	0.08	0.08	0.08	0.08	0.08	0.08
17.888	0.08	0.08	0.08	0.08	0.08	0.08	0.08
17.932	0.08	0.08	0.08	0.08	0.08	0.08	0.08
17.976	0.08	0.08	0.08	0.08	0.08	0.08	0.08
18.020	0.08	0.08	0.08	0.08	0.08	0.08	0.08
18.065	0.08	0.08	0.08	0.08	0.08	0.08	0.08
18.109	0.08	0.08	0.08	0.08	0.08	0.08	0.08

WinTR-20: Version 1.10
ED CHURCH
2YEAR HYDRO ANALYSIS

0 0 0.05

(continued)

STORM 2-Yr

SUB-AREA:

DMA G POSTOutlet .0038 83. .1

STREAM REACH:

19.391	0.07	0.07	0.07	0.07	0.07	0.07	0.07	0.07
19.435	0.07	0.07	0.07	0.07	0.07	0.07	0.07	0.07
19.479	0.07	0.07	0.07	0.07	0.07	0.07	0.07	0.07
19.523	0.07	0.07	0.07	0.07	0.07	0.07	0.07	0.07
19.568	0.07	0.07	0.07	0.07	0.07	0.07	0.07	0.07
19.612	0.07	0.07	0.07	0.07	0.07	0.07	0.07	0.07
19.656	0.07	0.07	0.07	0.07	0.07	0.07	0.07	0.07
19.700	0.07	0.07	0.07	0.07	0.07	0.07	0.07	0.07
19.745	0.07	0.07	0.07	0.07	0.07	0.07	0.07	0.07
19.789	0.07	0.07	0.07	0.07	0.07	0.07	0.07	0.07
19.833	0.07	0.07	0.07	0.07	0.07	0.07	0.07	0.07
19.877	0.07	0.07	0.07	0.07	0.07	0.07	0.07	0.07
19.921	0.07	0.07	0.07	0.07	0.07	0.07	0.07	0.07
19.966	0.07	0.07	0.07	0.07	0.07	0.07	0.07	0.07
20.010	0.07	0.07	0.07	0.07	0.07	0.07	0.07	0.07
20.054	0.07	0.07	0.07	0.07	0.07	0.07	0.07	0.07
20.098	0.07	0.07	0.07	0.07	0.07	0.07	0.07	0.07
20.142	0.07	0.07	0.07	0.07	0.07	0.07	0.07	0.07
20.187	0.07	0.07	0.07	0.07	0.07	0.07	0.07	0.07
20.231	0.07	0.07	0.07	0.07	0.07	0.07	0.07	0.07
20.275	0.07	0.07	0.07	0.07	0.07	0.07	0.07	0.07
20.319	0.07	0.07	0.07	0.07	0.07	0.07	0.07	0.07
20.363	0.07	0.07	0.07	0.07	0.07	0.07	0.07	0.07
20.408	0.07	0.07	0.07	0.07	0.07	0.07	0.07	0.07
20.452	0.07	0.07	0.07	0.07	0.07	0.07	0.07	0.07
20.496	0.07	0.07	0.07	0.07	0.07	0.07	0.07	0.07
20.540	0.07	0.07	0.07	0.07	0.07	0.07	0.07	0.07
20.585	0.07	0.07	0.07	0.07	0.07	0.07	0.07	0.07
20.629	0.07	0.07	0.07	0.07	0.07	0.07	0.07	0.07
20.673	0.07	0.07	0.07	0.07	0.07	0.07	0.07	0.07
20.717	0.07	0.07	0.07	0.07	0.07	0.07	0.07	0.07
20.761	0.07	0.07	0.07	0.07	0.07	0.07	0.07	0.07
20.806	0.07	0.07	0.07	0.07	0.07	0.07	0.07	0.07
20.850	0.07	0.07	0.07	0.07	0.07	0.07	0.07	0.07
20.894	0.07	0.07	0.07	0.07	0.07	0.07	0.07	0.07
20.938	0.07	0.07	0.07	0.07	0.07	0.07	0.07	0.07
20.982	0.06	0.06	0.06	0.06	0.06	0.06	0.06	0.06
21.027	0.06	0.06	0.06	0.06	0.06	0.06	0.06	0.06

WinTR-20 Printed Page File
TR20.inp

Beginning of Input Data List

WinTR-20: Version 1.10
ED CHURCH
2YEAR HYDRO ANALYSIS

0 0 0.05

(continued)

STORM 2-Yr

SUB-AREA:

DMA G POSTOutlet

.0038 83. .1

STREAM REACH:

WinTR-20 Printed Page File
TR20.inp

Beginning of Input Data List

WinTR-20: Version 1.10
ED CHURCH
2YEAR HYDRO ANALYSIS

0 0 0.05

(continued)

STORM 2-Yr

SUB-AREA:

DMA G POSTOutlet

.0038 83. .1

STREAM REACH:

WinTR-55 Current Data Description

--- Identification Data ---

User: ANACAL ENG Date: 9/18/2020
 Project: KINDRED CHURCH Units: English
 SubTitle: 2YEAR HYDRO ANALYSIS Areal Units: Acres
 State: California
 County: Orange
 Filename: E:\Users\dave\AppData\Roaming\WinTR-55\19-155-AREA G-POST.w55

--- Sub-Area Data ---

Name	Description	Reach	Area(ac)	RCN	Tc
DMA G POST		Outlet	2.43	83	0.1

Total area: 2.43 (ac)

--- Storm Data --

Rainfall Depth by Rainfall Return Period

2-Yr (in)	-Yr (in)	-Yr (in)	-Yr (in)	-Yr (in)	-Yr (in)	-Yr (in)
2.05	.0	.0	.0	.0	.0	.0

Storm Data Source: User-provided custom storm data
 Rainfall Distribution Type: Type I
 Dimensionless Unit Hydrograph: <standard>

ANACAL ENG

KINDRED CHURCH
2YEAR HYDRO ANALYSIS
Orange County, California

Storm Data

Rainfall Depth by Rainfall Return Period

2-Yr (in)	-Yr (in)	-Yr (in)	-Yr (in)	-Yr (in)	-Yr (in)	-Yr (in)
2.05	.0	.0	.0	.0	.0	.0

Storm Data Source: User-provided custom storm data
Rainfall Distribution Type: Type I
Dimensionless Unit Hydrograph: <standard>

ANACAL ENG

KINDRED CHURCH
2YEAR HYDRO ANALYSIS
Orange County, California

Watershed Peak Table

Sub-Area or Reach Identifier	Peak Flow by Rainfall Return Period 2-Yr (cfs)

SUBAREAS	
DMA G POST	1.19
REACHES	
OUTLET	1.19

ANACAL ENG

KINDRED CHURCH
2YEAR HYDRO ANALYSIS
Orange County, California

Hydrograph Peak/Peak Time Table

Sub-Area or Reach Identifier	Peak Flow and Peak Time (hr) by Rainfall Return Period 2-Yr (cfs) (hr)
------------------------------------	---

SUBAREAS

DMA G POST	1.19 9.94
------------	--------------

REACHES

OUTLET	1.19
--------	------

ANACAL ENG

KINDRED CHURCH
2YEAR HYDRO ANALYSIS
Orange County, California

Sub-Area Summary Table

Sub-Area Identifier	Drainage Area (ac)	Time of Concentration (hr)	Curve Number	Receiving Reach	Sub-Area Description
DMA G POST	2.43	0.100	83	Outlet	
Total Area:	2.43 (ac)				

KINDRED CHURCH
2YEAR HYDRO ANALYSIS
Orange County, California

Sub-Area Land Use and Curve Number Details

Sub-Area Identifier	Land Use	Hydrologic Soil Group	Sub-Area Area (ac)	Curve Number
DMA G POST	Open space; grass cover > 75%	(good) A	.607	39
	Paved parking lots, roofs, driveways	A	1.82	98
	Total Area / Weighted Curve Number		2.43	83
			====	==

WinTR-20 Printed Page File Beginning of Input Data List
 TR20.inp

WinTR-20: Version 1.10 0 0 0.05
 KINDRED CHURCH
 AREA I PRE

SUB-AREA:
 DMA 3I-PREOutlet .00141 77. .1

STREAM REACH:

STORM ANALYSIS:
 2-Yr 2.05 Type I 2

STRUCTURE RATING:

GLOBAL OUTPUT:
 2 0.05 YYYYN YYYYNN

WinTR-20 Printed Page File End of Input Data List

KINDRED CHURCH
 AREA I PRE

Name of printed page file:
 TR20.out

STORM 2-Yr

Area or Reach Identifier	Drainage Area (sq mi)	Rain Gage ID or Location	Runoff Amount (in)	Elevation (ft)	Peak Flow Time (hr)	Rate (cfs)	Rate (csm)
DMA 3I-PRE	0.001		0.103		9.95	0.22	157.31

Line Start Time (hr)	Flow (cfs)	Values @ time increment (cfs)	of 0.006 hr (cfs)	Flow (cfs)	Peak Flow (cfs)	Flow (cfs)
9.782	0.05	0.06	0.06	0.06	0.07	0.07
9.826	0.08	0.08	0.09	0.10	0.11	0.12
9.871	0.14	0.15	0.16	0.17	0.18	0.19
9.915	0.20	0.21	0.21	0.22	0.22	0.22
9.959	0.22	0.22	0.22	0.22	0.22	0.22
10.003	0.22	0.22	0.22	0.22	0.21	0.20
10.048	0.19	0.18	0.17	0.16	0.15	0.13
10.092	0.12	0.12	0.11	0.11	0.10	0.10
10.136	0.10	0.09	0.09	0.09	0.09	0.08
10.180	0.08	0.08	0.08	0.08	0.08	0.08
10.224	0.08	0.08	0.08	0.08	0.08	0.08
10.269	0.08	0.07	0.07	0.07	0.07	0.07
10.313	0.07	0.07	0.07	0.07	0.07	0.07
10.357	0.07	0.07	0.07	0.07	0.07	0.07
10.401	0.07	0.07	0.07	0.07	0.07	0.06
10.445	0.06	0.06	0.06	0.06	0.06	0.06
10.490	0.06	0.06	0.06	0.06	0.06	0.06
10.534	0.06	0.06	0.06	0.06	0.05	0.05
10.578	0.05	0.05	0.05	0.05	0.05	0.05
10.622	0.05	0.05	0.05	0.05	0.05	0.05
10.666	0.05	0.05	0.05	0.05	0.05	0.05
10.711	0.05	0.05	0.05	0.05	0.05	0.05

Area or Reach Identifier	Drainage Area (sq mi)	Rain Gage ID or Location	Runoff Amount (in)	Elevation (ft)	Peak Flow Time (hr)	Rate (cfs)	Rate (csm)
--------------------------	-----------------------	--------------------------	--------------------	----------------	---------------------	------------	------------

WinTR-20: Version 1.10
ED CHURCH
AREA I PRE

0 0 0.05

(continued)

STORM 2-Yr

SUB-AREA:

DMA 3I-PREOutlet .00141 77. .1

STREAM REACH:

10.180	0.08	0.08	0.08	0.08	0.08	0.08	0.08	0.08
10.224	0.08	0.08	0.08	0.08	0.08	0.08	0.08	0.08
10.269	0.08	0.07	0.07	0.07	0.07	0.07	0.07	0.07
10.313	0.07	0.07	0.07	0.07	0.07	0.07	0.07	0.07
10.357	0.07	0.07	0.07	0.07	0.07	0.07	0.07	0.07
10.401	0.07	0.07	0.07	0.07	0.07	0.07	0.06	0.06
10.445	0.06	0.06	0.06	0.06	0.06	0.06	0.06	0.06
10.490	0.06	0.06	0.06	0.06	0.06	0.06	0.06	0.06
10.534	0.06	0.06	0.06	0.06	0.06	0.05	0.05	0.05
10.578	0.05	0.05	0.05	0.05	0.05	0.05	0.05	0.05
10.622	0.05	0.05	0.05	0.05	0.05	0.05	0.05	0.05
10.666	0.05	0.05	0.05	0.05	0.05	0.05	0.05	0.05
10.711	0.05	0.05						

WinTR-20 Printed Page File
TR20.inp

Beginning of Input Data List

WinTR-20: Version 1.10
ED CHURCH
AREA I PRE

0 0 0.05

(continued)

STORM 2-Yr

SUB-AREA:

DMA 3I-PREOutlet

.00141 77. .1

STREAM REACH:

WinTR-20 Version 1.10

Page 2

09/18/2020 9:25

KINDRED CHURCH
AREA I PRE

Area or Drainage

----- Peak Flow by Storm -----

WinTR-55, Version 1.00.10

Page 4

9/18/2020 9:25:57 AM

WinTR-20 Printed Page File
TR20.inp

Beginning of Input Data List

WinTR-20: Version 1.10
ED CHURCH
AREA I PRE

0 0 0.05

(continued)

STORM 2-Yr

SUB-AREA:

DMA 3I-PREOutlet .00141 77. .1

STREAM REACH:

Reach Identifier	Area (sq mi)	Alternate	2-Yr (cfs)	(cfs)	(cfs)	(cfs)	(cfs)
DMA 3I-PRE	0.001		0.22				
OUTLET	0.001		0.22				

WinTR-20 Printed Page File
TR20.inp

Beginning of Input Data List

WinTR-20: Version 1.10
ED CHURCH
AREA I PRE

0 0 0.05

(continued)

STORM 2-Yr

SUB-AREA:

DMA 3I-PREOutlet

.00141 77. .1

STREAM REACH:

WinTR-20 Printed Page File
TR20.inp

Beginning of Input Data List

WinTR-20: Version 1.10
ED CHURCH
AREA I PRE

0 0 0.05

(continued)

STORM 2-Yr

SUB-AREA:
DMA 3I-PREOutlet

.00141 77. .1

STREAM REACH:

WinTR-55 Current Data Description

--- Identification Data ---

User: ANACAL ENG Date: 9/18/2020
 Project: KINDRED CHURCH Units: English
 SubTitle: AREA I PRE Areal Units: Acres
 State: California
 County: Orange
 Filename: E:\Users\dave\AppData\Roaming\WinTR-55\19-155-AREA I-PRE.w55

--- Sub-Area Data ---

Name	Description	Reach	Area(ac)	RCN	Tc
DMA 3I-PRE		Outlet	0.9	77	0.1

Total area: .90 (ac)

--- Storm Data --

Rainfall Depth by Rainfall Return Period

2-Yr (in)	-Yr (in)	-Yr (in)	-Yr (in)	-Yr (in)	-Yr (in)	-Yr (in)
2.05	.0	.0	.0	.0	.0	.0

Storm Data Source: User-provided custom storm data
 Rainfall Distribution Type: Type I
 Dimensionless Unit Hydrograph: <standard>

ANACAL ENG

KINDRED CHURCH
AREA I PRE
Orange County, California

Storm Data

Rainfall Depth by Rainfall Return Period

2-Yr (in)	-Yr (in)	-Yr (in)	-Yr (in)	-Yr (in)	-Yr (in)	-Yr (in)
2.05	.0	.0	.0	.0	.0	.0

Storm Data Source: User-provided custom storm data
Rainfall Distribution Type: Type I
Dimensionless Unit Hydrograph: <standard>

ANACAL ENG

KINDRED CHURCH
AREA I PRE
Orange County, California

Watershed Peak Table

Sub-Area or Reach Identifier	Peak Flow by Rainfall Return Period 2-Yr (cfs)

SUBAREAS	
DMA 3I-PRE	0.22
REACHES	
OUTLET	0.22

ANACAL ENG

KINDRED CHURCH
AREA I PRE
Orange County, California

Hydrograph Peak/Peak Time Table

Sub-Area or Reach Identifier	Peak Flow and Peak Time (hr) by Rainfall Return Period 2-Yr (cfs) (hr)
------------------------------------	---

SUBAREAS

DMA 3I-PRE	0.22 9.95
------------	--------------

REACHES

OUTLET	0.22
--------	------

ANACAL ENG

KINDRED CHURCH
AREA I PRE
Orange County, California

Sub-Area Summary Table

Sub-Area Identifier	Drainage Area (ac)	Time of Concentration (hr)	Curve Number	Receiving Reach	Sub-Area Description
DMA 3I-PRE	.90	0.100	77	Outlet	
Total Area:	.90 (ac)				

KINDRED CHURCH
AREA I PRE
Orange County, California

Sub-Area Land Use and Curve Number Details

Sub-Area Identifier	Land Use	Hydrologic Soil Group	Sub-Area Area (ac)	Curve Number
DMA 3I-PRE	Open space; grass cover > 75%	(good) A	.315	39
	Paved parking lots, roofs, driveways	A	.585	98
	Total Area / Weighted Curve Number		.9	77
			==	==

11.136	0.06	0.06	0.06	0.06	0.06	0.06	0.06
11.180	0.06	0.06	0.06	0.06	0.06	0.06	0.06
11.225	0.06	0.06	0.06	0.06	0.06	0.06	0.06
11.269	0.06	0.06	0.06	0.06	0.06	0.06	0.06
11.313	0.06	0.06	0.06	0.06	0.06	0.06	0.06

KINDRED CHURCH
2YEAR HYDRO ANALYSIS

Line Start Time (hr)	Flow Values @ time increment of 0.006 hr						
	(cfs)	(cfs)	(cfs)	(cfs)	(cfs)	(cfs)	(cfs)
11.357	0.06	0.06	0.06	0.06	0.06	0.06	0.06
11.401	0.06	0.06	0.06	0.06	0.06	0.06	0.06
11.446	0.06	0.06	0.06	0.06	0.06	0.06	0.06
11.490	0.06	0.06	0.06	0.06	0.06	0.06	0.06
11.534	0.06	0.06	0.06	0.06	0.06	0.06	0.06
11.578	0.06	0.06	0.06	0.06	0.06	0.06	0.06
11.622	0.06	0.06	0.06	0.06	0.06	0.06	0.06
11.667	0.06	0.06	0.06	0.06	0.06	0.06	0.06
11.711	0.06	0.06	0.06	0.06	0.06	0.06	0.06
11.755	0.06	0.06	0.06	0.06	0.06	0.06	0.06
11.799	0.06	0.06	0.06	0.06	0.06	0.06	0.06
11.843	0.06	0.06	0.06	0.06	0.06	0.06	0.06
11.888	0.06	0.06	0.06	0.06	0.06	0.06	0.06
11.932	0.06	0.06	0.06	0.06	0.06	0.06	0.06
11.976	0.06	0.06	0.06	0.06	0.05	0.05	0.05
12.020	0.05	0.05	0.05	0.05	0.05	0.05	0.05
12.065	0.05	0.05	0.05	0.05	0.05	0.05	0.05
12.109	0.05	0.05	0.05	0.05	0.05	0.05	0.05
12.153	0.05	0.05	0.05	0.05	0.05	0.05	0.05
12.197	0.05	0.05	0.05	0.05	0.05	0.05	0.05
12.241	0.05	0.05	0.05	0.05	0.05	0.05	0.05
12.286	0.05	0.05	0.05	0.05	0.05	0.05	0.05
12.330	0.05	0.05	0.05	0.05	0.05	0.05	0.05
12.374	0.05	0.05	0.05	0.05	0.05	0.05	0.05
12.418	0.05	0.05	0.05	0.05	0.05	0.05	0.05
12.462	0.05	0.05	0.05	0.05	0.05	0.05	0.05
12.507	0.05	0.05	0.05	0.05	0.05	0.05	0.05
12.551	0.05	0.05	0.05	0.05	0.05	0.05	0.05
12.595	0.05	0.05	0.05	0.05	0.05	0.05	0.05

Area or Reach Identifier	Drainage Area (sq mi)	Rain Gage ID or Location	Runoff Amount (in)	Elevation (ft)	Peak Flow Time (hr)	Rate (cfs)	Rate (csm)
OUTLET	0.001		0.334		9.94	0.44	314.33

Line Start Time (hr)	Flow Values @ time increment of 0.006 hr						
	(cfs)	(cfs)	(cfs)	(cfs)	(cfs)	(cfs)	(cfs)
9.589	0.05	0.05	0.05	0.05	0.06	0.06	0.06
9.633	0.06	0.06	0.07	0.07	0.07	0.08	0.08
9.677	0.08	0.09	0.09	0.09	0.10	0.10	0.10
9.721	0.10	0.11	0.11	0.12	0.12	0.13	0.14
9.766	0.15	0.15	0.16	0.17	0.17	0.18	0.19
9.810	0.19	0.20	0.21	0.22	0.23	0.24	0.26
9.854	0.28	0.29	0.31	0.33	0.35	0.37	0.38
9.898	0.40	0.41	0.42	0.43	0.44	0.44	0.44
9.942	0.44	0.44	0.44	0.43	0.42	0.42	0.41
9.987	0.41	0.41	0.40	0.40	0.40	0.39	0.39
10.031	0.38	0.37	0.35	0.33	0.31	0.29	0.27

KINDRED CHURCH
2YEAR HYDRO ANALYSIS

Line Start Time (hr)	Flow Values @ time increment of 0.006 hr						
	(cfs)	(cfs)	(cfs)	(cfs)	(cfs)	(cfs)	(cfs)
10.075	0.26	0.24	0.22	0.21	0.20	0.19	0.18
10.119	0.18	0.17	0.16	0.16	0.16	0.15	0.15
10.163	0.15	0.14	0.14	0.14	0.14	0.14	0.13
10.207	0.13	0.13	0.13	0.13	0.13	0.13	0.13
10.252	0.13	0.12	0.12	0.12	0.12	0.12	0.12

WinTR-20: Version 1.10
ED CHURCH
2YEAR HYDRO ANALYSIS

0 0 0.05

(continued)

STORM 2-Yr

SUB-AREA:

DMA 3I-POSOutlet .00141 83. .1

STREAM REACH:

10.296	0.12	0.12	0.12	0.12	0.12	0.12	0.12
10.340	0.11	0.11	0.11	0.11	0.11	0.11	0.11
10.385	0.11	0.11	0.11	0.11	0.10	0.10	0.10
10.429	0.10	0.10	0.10	0.10	0.10	0.10	0.10
10.473	0.10	0.09	0.09	0.09	0.09	0.09	0.09
10.517	0.09	0.09	0.09	0.09	0.09	0.09	0.09
10.561	0.09	0.08	0.08	0.08	0.08	0.08	0.08
10.606	0.08	0.08	0.08	0.08	0.08	0.08	0.08
10.650	0.08	0.08	0.08	0.08	0.08	0.08	0.08
10.694	0.08	0.08	0.08	0.08	0.08	0.08	0.08
10.738	0.08	0.08	0.08	0.08	0.08	0.08	0.08
10.782	0.07	0.07	0.07	0.07	0.07	0.07	0.07
10.827	0.07	0.07	0.07	0.07	0.07	0.07	0.07
10.871	0.07	0.07	0.07	0.07	0.07	0.07	0.07
10.915	0.07	0.07	0.07	0.07	0.07	0.07	0.07
10.959	0.07	0.07	0.07	0.07	0.07	0.07	0.07
11.003	0.07	0.07	0.07	0.07	0.07	0.07	0.07
11.048	0.07	0.07	0.07	0.07	0.07	0.07	0.07
11.092	0.07	0.07	0.07	0.07	0.07	0.07	0.06
11.136	0.06	0.06	0.06	0.06	0.06	0.06	0.06
11.180	0.06	0.06	0.06	0.06	0.06	0.06	0.06
11.225	0.06	0.06	0.06	0.06	0.06	0.06	0.06
11.269	0.06	0.06	0.06	0.06	0.06	0.06	0.06
11.313	0.06	0.06	0.06	0.06	0.06	0.06	0.06
11.357	0.06	0.06	0.06	0.06	0.06	0.06	0.06
11.401	0.06	0.06	0.06	0.06	0.06	0.06	0.06
11.446	0.06	0.06	0.06	0.06	0.06	0.06	0.06
11.490	0.06	0.06	0.06	0.06	0.06	0.06	0.06
11.534	0.06	0.06	0.06	0.06	0.06	0.06	0.06
11.578	0.06	0.06	0.06	0.06	0.06	0.06	0.06
11.622	0.06	0.06	0.06	0.06	0.06	0.06	0.06
11.667	0.06	0.06	0.06	0.06	0.06	0.06	0.06
11.711	0.06	0.06	0.06	0.06	0.06	0.06	0.06
11.755	0.06	0.06	0.06	0.06	0.06	0.06	0.06
11.799	0.06	0.06	0.06	0.06	0.06	0.06	0.06
11.843	0.06	0.06	0.06	0.06	0.06	0.06	0.06
11.888	0.06	0.06	0.06	0.06	0.06	0.06	0.06
11.932	0.06	0.06	0.06	0.06	0.06	0.06	0.06
11.976	0.06	0.06	0.06	0.06	0.05	0.05	0.05
12.020	0.05	0.05	0.05	0.05	0.05	0.05	0.05
12.065	0.05	0.05	0.05	0.05	0.05	0.05	0.05
12.109	0.05	0.05	0.05	0.05	0.05	0.05	0.05
12.153	0.05	0.05	0.05	0.05	0.05	0.05	0.05
12.197	0.05	0.05	0.05	0.05	0.05	0.05	0.05
12.241	0.05	0.05	0.05	0.05	0.05	0.05	0.05
12.286	0.05	0.05	0.05	0.05	0.05	0.05	0.05

KINDRED CHURCH
2YEAR HYDRO ANALYSIS

Line	Start Time (hr)	Flow Values (cfs)	@ time increment (cfs)	of 0.006 hr (cfs)	of 0.006 hr (cfs)	of 0.006 hr (cfs)	of 0.006 hr (cfs)
12.330		0.05	0.05	0.05	0.05	0.05	0.05
12.374		0.05	0.05	0.05	0.05	0.05	0.05
12.418		0.05	0.05	0.05	0.05	0.05	0.05
12.462		0.05	0.05	0.05	0.05	0.05	0.05
12.507		0.05	0.05	0.05	0.05	0.05	0.05
12.551		0.05	0.05	0.05	0.05	0.05	0.05

WinTR-20 Printed Page File
TR20.inp

Beginning of Input Data List

WinTR-20: Version 1.10
ED CHURCH
2YEAR HYDRO ANALYSIS

0 0 0.05

(continued)

STORM 2-Yr

SUB-AREA:

DMA 3I-POSOulet

.00141 83. .1

STREAM REACH:

WinTR-55 Current Data Description

--- Identification Data ---

User: ANACAL ENG Date: 9/18/2020
 Project: KINDRED CHURCH Units: English
 SubTitle: 2YEAR HYDRO ANALYSIS Areal Units: Acres
 State: California
 County: Orange
 Filename: E:\Users\dave\AppData\Roaming\WinTR-55\19-155-AREA I-POST.w55

--- Sub-Area Data ---

Name	Description	Reach	Area(ac)	RCN	Tc
DMA 3I-POS		Outlet	0.9	83	0.1

Total area: .90 (ac)

--- Storm Data --

Rainfall Depth by Rainfall Return Period

2-Yr (in)	-Yr (in)	-Yr (in)	-Yr (in)	-Yr (in)	-Yr (in)	-Yr (in)
2.05	.0	.0	.0	.0	.0	.0

Storm Data Source: User-provided custom storm data
 Rainfall Distribution Type: Type I
 Dimensionless Unit Hydrograph: <standard>

ANACAL ENG

KINDRED CHURCH
2YEAR HYDRO ANALYSIS
Orange County, California

Storm Data

Rainfall Depth by Rainfall Return Period

2-Yr (in)	-Yr (in)	-Yr (in)	-Yr (in)	-Yr (in)	-Yr (in)	-Yr (in)
2.05	.0	.0	.0	.0	.0	.0

Storm Data Source: User-provided custom storm data
Rainfall Distribution Type: Type I
Dimensionless Unit Hydrograph: <standard>

KINDRED CHURCH
2YEAR HYDRO ANALYSIS
Orange County, California

Watershed Peak Table

Sub-Area or Reach Identifier	Peak Flow by Rainfall Return Period 2-Yr (cfs)

SUBAREAS	
DMA 3I-POS	0.44
REACHES	
OUTLET	0.44

ANACAL ENG

KINDRED CHURCH
2YEAR HYDRO ANALYSIS
Orange County, California

Hydrograph Peak/Peak Time Table

Sub-Area or Reach Identifier	Peak Flow and Peak Time (hr) by Rainfall Return Period 2-Yr (cfs) (hr)
------------------------------------	---

SUBAREAS

DMA 3I-POS	0.44 9.94
------------	--------------

REACHES

OUTLET	0.44
--------	------

ANACAL ENG

KINDRED CHURCH
2YEAR HYDRO ANALYSIS
Orange County, California

Sub-Area Summary Table

Sub-Area Identifier	Drainage Area (ac)	Time of Concentration (hr)	Curve Number	Receiving Reach	Sub-Area Description
DMA 3I-POS	.90	0.100	83	Outlet	
Total Area:	.90 (ac)				

KINDRED CHURCH
2YEAR HYDRO ANALYSIS
Orange County, California

Sub-Area Land Use and Curve Number Details

Sub-Area Identifier	Land Use	Hydrologic Soil Group	Sub-Area Area (ac)	Curve Number
DMA 3I-POS	Open space; grass cover > 75%	(good) A	.225	39
	Paved parking lots, roofs, driveways	A	.675	98
	Total Area / Weighted Curve Number		.9	83
			==	==

```

WinTR-20 Printed Page File      Beginning of Input Data List
TR20.inp

WinTR-20: Version 1.10          0          0          0.05
KINDRED CHURCH
1F PRE

SUB-AREA:
    1F PRE      Outlet          .00125    77.        .1

STREAM REACH:

STORM ANALYSIS:
    2-Yr          2.05          Type I      2

STRUCTURE RATING:

GLOBAL OUTPUT:
    2            0.05          YYYYN      YYYYNN

```

WinTR-20 Printed Page File End of Input Data List

KINDRED CHURCH
1F PRE

Name of printed page file:
TR20.out

STORM 2-Yr

Area or Reach Identifier	Drainage Area (sq mi)	Rain Gage ID or Location	Runoff Amount (in)	Elevation (ft)	Peak Flow Time (hr)	Rate (cfs)	Rate (csm)
1F PRE	0.001		0.092		9.95	0.20	157.31

Line Start Time (hr)	Flow (cfs)	Values @ time increment (cfs)	of 0.006 hr (cfs)	Flow (cfs)	Peak Flow (cfs)	Flow (cfs)
9.795	0.05	0.05	0.06	0.06	0.06	0.07
9.839	0.08	0.09	0.10	0.10	0.11	0.13
9.883	0.14	0.15	0.16	0.17	0.17	0.18
9.928	0.19	0.19	0.20	0.20	0.20	0.20
9.972	0.19	0.19	0.19	0.19	0.19	0.19
10.016	0.19	0.19	0.19	0.18	0.18	0.16
10.060	0.15	0.14	0.13	0.13	0.12	0.10
10.104	0.10	0.10	0.09	0.09	0.09	0.08
10.149	0.08	0.08	0.08	0.08	0.07	0.07
10.193	0.07	0.07	0.07	0.07	0.07	0.07
10.237	0.07	0.07	0.07	0.07	0.07	0.07
10.281	0.07	0.07	0.07	0.06	0.06	0.06
10.325	0.06	0.06	0.06	0.06	0.06	0.06
10.370	0.06	0.06	0.06	0.06	0.06	0.06
10.414	0.06	0.06	0.06	0.06	0.06	0.06
10.458	0.06	0.05	0.05	0.05	0.05	0.05
10.502	0.05	0.05	0.05	0.05	0.05	0.05

Area or	Drainage	Rain Gage	Runoff	Peak Flow
---------	----------	-----------	--------	-----------

WinTR-20 Printed Page File
TR20.inp

Beginning of Input Data List

WinTR-20: Version 1.10
ED CHURCH
1F PRE

0 0 0.05

(continued)

STORM 2-Yr

SUB-AREA:

1F PRE Outlet .00125 77. .1

STREAM REACH:

10.502 0.05 0.05 0.05 0.05 0.05 0.05

WinTR-20 Printed Page File
TR20.inp

Beginning of Input Data List

WinTR-20: Version 1.10
ED CHURCH
1F PRE

0 0 0.05

(continued)

STORM 2-Yr

SUB-AREA:

1F PRE Outlet

.00125 77. .1

STREAM REACH:

WinTR-20 Version 1.10

Page 2

09/18/2020 9:31

KINDRED CHURCH
1F PRE

Area or Reach Identifier	Drainage Area (sq mi)	Alternate	----- Peak Flow by Storm -----				
			2-Yr (cfs)	(cfs)	(cfs)	(cfs)	(cfs)
1F PRE	0.001		0.20				
OUTLET	0.001		0.20				

WinTR-20 Printed Page File
TR20.inp

Beginning of Input Data List

WinTR-20: Version 1.10
ED CHURCH
1F PRE

0 0 0.05

(continued)

STORM 2-Yr

SUB-AREA:

1F PRE Outlet

.00125 77. .1

STREAM REACH:

WinTR-20 Printed Page File
TR20.inp

Beginning of Input Data List

WinTR-20: Version 1.10
ED CHURCH
1F PRE

0 0 0.05

(continued)

STORM 2-Yr

SUB-AREA:

1F PRE Outlet

.00125 77. .1

STREAM REACH:

WinTR-20 Version 1.10

Page 3

09/18/2020 9:31

WinTR-55 Current Data Description

--- Identification Data ---

User: ANACAL ENG Date: 9/18/2020
 Project: KINDRED CHURCH Units: English
 SubTitle: 1F PRE Areal Units: Acres
 State: California
 County: Orange
 Filename: E:\Users\dave\AppData\Roaming\WinTR-55\19-155-AREA 1F-PRE.w55

--- Sub-Area Data ---

Name	Description	Reach	Area(ac)	RCN	Tc
1F PRE		Outlet	0.8	77	0.1

Total area: .80 (ac)

--- Storm Data --

Rainfall Depth by Rainfall Return Period

2-Yr (in)	-Yr (in)	-Yr (in)	-Yr (in)	-Yr (in)	-Yr (in)	-Yr (in)
2.05	.0	.0	.0	.0	.0	.0

Storm Data Source: User-provided custom storm data
 Rainfall Distribution Type: Type I
 Dimensionless Unit Hydrograph: <standard>

ANACAL ENG

KINDRED CHURCH
1F PRE
Orange County, California

Storm Data

Rainfall Depth by Rainfall Return Period

2-Yr (in)	-Yr (in)	-Yr (in)	-Yr (in)	-Yr (in)	-Yr (in)	-Yr (in)
2.05	.0	.0	.0	.0	.0	.0

Storm Data Source: User-provided custom storm data
Rainfall Distribution Type: Type I
Dimensionless Unit Hydrograph: <standard>

ANACAL ENG

KINDRED CHURCH
1F PRE
Orange County, California

Watershed Peak Table

Sub-Area or Reach Identifier	Peak Flow by Rainfall Return Period 2-Yr (cfs)

SUBAREAS	
1F PRE	0.20
REACHES	
OUTLET	0.20

ANACAL ENG

KINDRED CHURCH
1F PRE
Orange County, California

Hydrograph Peak/Peak Time Table

Sub-Area or Reach Identifier	Peak Flow and Peak Time (hr) by Rainfall Return Period 2-Yr (cfs) (hr)
------------------------------------	---

SUBAREAS

1F PRE	0.20 9.95
--------	--------------

REACHES

OUTLET	0.20
--------	------

ANACAL ENG

KINDRED CHURCH
1F PRE
Orange County, California

Sub-Area Summary Table

Sub-Area Identifier	Drainage Area (ac)	Time of Concentration (hr)	Curve Number	Receiving Reach	Sub-Area Description
1F PRE	.80	0.100	77	Outlet	
Total Area:	.80 (ac)				

Sub-Area Land Use and Curve Number Details

Sub-Area Identifier	Land Use	Hydrologic Soil Group	Sub-Area Area (ac)	Curve Number
1F PRE	Open space; grass cover > 75%	(good) A	.28	39
	Paved parking lots, roofs, driveways	A	.52	98
	Total Area / Weighted Curve Number		.8	77
			==	==

11.168	0.06	0.06	0.06	0.06	0.06	0.06	0.06
11.212	0.06	0.06	0.06	0.06	0.06	0.06	0.06
11.256	0.06	0.06	0.06	0.06	0.06	0.06	0.06
11.300	0.06	0.06	0.06	0.06	0.06	0.06	0.06
11.345	0.06	0.06	0.06	0.06	0.06	0.06	0.06

KINDRED CHURCH
AREA 1F POST

Line Start Time (hr)	Flow Values @ time increment of 0.006 hr						
	(cfs)	(cfs)	(cfs)	(cfs)	(cfs)	(cfs)	(cfs)
11.389	0.06	0.05	0.05	0.05	0.05	0.05	0.05
11.433	0.05	0.05	0.05	0.05	0.05	0.05	0.05
11.477	0.05	0.05	0.05	0.05	0.05	0.05	0.05
11.521	0.05	0.05	0.05	0.05	0.05	0.05	0.05
11.566	0.05	0.05	0.05	0.05	0.05	0.05	0.05
11.610	0.05	0.05	0.05	0.05	0.05	0.05	0.05
11.654	0.05	0.05	0.05	0.05	0.05	0.05	0.05
11.698	0.05	0.05	0.05	0.05	0.05	0.05	0.05
11.742	0.05	0.05	0.05	0.05	0.05	0.05	0.05
11.787	0.05	0.05	0.05	0.05	0.05	0.05	0.05
11.831	0.05	0.05	0.05	0.05	0.05	0.05	0.05
11.875	0.05	0.05	0.05	0.05	0.05	0.05	0.05

Area or Reach Identifier	Drainage Area (sq mi)	Rain Gage ID or Location	Runoff Amount (in)	Elevation (ft)	Peak Flow Time (hr)	Rate (cfs)	Rate (csm)
OUTLET	0.001		0.290		9.94	0.39	314.33

Line Start Time (hr)	Flow Values @ time increment of 0.006 hr						
	(cfs)	(cfs)	(cfs)	(cfs)	(cfs)	(cfs)	(cfs)
9.620	0.05	0.05	0.05	0.06	0.06	0.06	0.06
9.665	0.07	0.07	0.07	0.08	0.08	0.08	0.08
9.709	0.09	0.09	0.09	0.10	0.10	0.10	0.11
9.753	0.12	0.12	0.13	0.14	0.14	0.15	0.15
9.797	0.16	0.16	0.17	0.18	0.18	0.19	0.20
9.841	0.21	0.23	0.24	0.26	0.28	0.29	0.31
9.886	0.32	0.34	0.35	0.36	0.37	0.38	0.39
9.930	0.39	0.39	0.39	0.39	0.39	0.38	0.38
9.974	0.37	0.37	0.36	0.36	0.36	0.35	0.35
10.018	0.35	0.34	0.34	0.32	0.31	0.29	0.28
10.062	0.26	0.24	0.23	0.21	0.20	0.19	0.18
10.107	0.17	0.16	0.16	0.15	0.15	0.14	0.14
10.151	0.13	0.13	0.13	0.13	0.12	0.12	0.12
10.195	0.12	0.12	0.12	0.12	0.12	0.12	0.11
10.239	0.11	0.11	0.11	0.11	0.11	0.11	0.11
10.283	0.11	0.11	0.11	0.10	0.10	0.10	0.10
10.328	0.10	0.10	0.10	0.10	0.10	0.10	0.10
10.372	0.10	0.10	0.10	0.09	0.09	0.09	0.09
10.416	0.09	0.09	0.09	0.09	0.09	0.09	0.09
10.460	0.09	0.09	0.08	0.08	0.08	0.08	0.08
10.505	0.08	0.08	0.08	0.08	0.08	0.08	0.08
10.549	0.08	0.08	0.08	0.08	0.07	0.07	0.07
10.593	0.07	0.07	0.07	0.07	0.07	0.07	0.07
10.637	0.07	0.07	0.07	0.07	0.07	0.07	0.07
10.681	0.07	0.07	0.07	0.07	0.07	0.07	0.07
10.726	0.07	0.07	0.07	0.07	0.07	0.07	0.07
10.770	0.07	0.07	0.07	0.07	0.07	0.07	0.07
10.814	0.07	0.07	0.07	0.07	0.07	0.06	0.06

WinTR-20 Printed Page File
TR20.inp

Beginning of Input Data List

WinTR-20: Version 1.10
ED CHURCH
AREA 1F POST

0 0 0.05

(continued)

STORM 2-Yr

SUB-AREA:

DMA-AREA 1Outlet

.00125 83. .1

STREAM REACH:

WinTR-20 Version 1.10

Page 3

09/18/2020 10:43

KINDRED CHURCH
AREA 1F POST

Area or Reach Identifier	Drainage Area (sq mi)	Alternate	----- Peak Flow by Storm -----			
			2-Yr (cfs)	(cfs)	(cfs)	(cfs)
DMA-AREA 1	0.001		0.39			
OUTLET	0.001		0.39			

WinTR-55, Version 1.00.10

Page 3

9/18/2020 10:47:06 AM

WinTR-20 Printed Page File
TR20.inp

Beginning of Input Data List

WinTR-20: Version 1.10
ED CHURCH
AREA 1F POST

0 0 0.05

(continued)

STORM 2-Yr

SUB-AREA:

DMA-AREA 1Outlet

.00125 83. .1

STREAM REACH:

WinTR-20 Printed Page File
TR20.inp

Beginning of Input Data List

WinTR-20: Version 1.10
ED CHURCH
AREA 1F POST

0 0 0.05

(continued)

STORM 2-Yr

SUB-AREA:

DMA-AREA 1Outlet

.00125 83. .1

STREAM REACH:

WinTR-20 Version 1.10

Page 4

09/18/2020 10:43

WinTR-55, Version 1.00.10

Page 5

9/18/2020 10:47:07 AM

WinTR-55 Current Data Description

--- Identification Data ---

User: 1F Date: 9/18/2020
Project: KINDRED CHURCH Units: English
SubTitle: AREA 1F POST Areal Units: Acres
State: California
County: Orange
Filename: E:\Users\dave\AppData\Roaming\WinTR-55\19-155-AREA 1F-POST.w55

--- Sub-Area Data ---

Name	Description	Reach	Area(ac)	RCN	Tc
DMA-AREA 1		Outlet	0.8	83	0.1

Total area: .80 (ac)

--- Storm Data --

Rainfall Depth by Rainfall Return Period

2-Yr (in)	-Yr (in)	-Yr (in)	-Yr (in)	-Yr (in)	-Yr (in)	-Yr (in)
2.05	.0	.0	.0	.0	.0	.0

Storm Data Source: User-provided custom storm data
Rainfall Distribution Type: Type I
Dimensionless Unit Hydrograph: <standard>

1F

KINDRED CHURCH
AREA 1F POST
Orange County, California

Storm Data

Rainfall Depth by Rainfall Return Period

2-Yr (in)	-Yr (in)	-Yr (in)	-Yr (in)	-Yr (in)	-Yr (in)	-Yr (in)
2.05	.0	.0	.0	.0	.0	.0

Storm Data Source: User-provided custom storm data
Rainfall Distribution Type: Type I
Dimensionless Unit Hydrograph: <standard>

1F

KINDRED CHURCH
AREA 1F POST
Orange County, California

Watershed Peak Table

Sub-Area or Reach Identifier	Peak Flow by Rainfall Return Period 2-Yr (cfs)

SUBAREAS	
DMA-AREA 1	0.39
REACHES	
OUTLET	0.39

1F

KINDRED CHURCH
AREA 1F POST
Orange County, California

Hydrograph Peak/Peak Time Table

Sub-Area or Reach Identifier	Peak Flow and Peak Time (hr) by Rainfall Return Period 2-Yr (cfs) (hr)
------------------------------------	---

SUBAREAS

DMA-AREA 1	0.39 9.94
------------	--------------

REACHES

OUTLET	0.39
--------	------

1F

KINDRED CHURCH
AREA 1F POST
Orange County, California

Sub-Area Summary Table

Sub-Area Identifier	Drainage Area (ac)	Time of Concentration (hr)	Curve Number	Receiving Reach	Sub-Area Description
DMA-AREA 1	.80	0.100	83	Outlet	
Total Area:	.80 (ac)				

1F

KINDRED CHURCH
AREA 1F POST
Orange County, California

Sub-Area Land Use and Curve Number Details

Sub-Area Identifier	Land Use	Hydrologic Soil Group	Sub-Area Area (ac)	Curve Number
DMA-AREA 1	Open space; grass cover > 75%	(good) A	.2	39
	Paved parking lots, roofs, driveways	A	.6	98
	Total Area / Weighted Curve Number		.8	83
			==	==

```

WinTR-20 Printed Page File      Beginning of Input Data List
TR20.inp

WinTR-20: Version 1.10          0          0          0.05
KINDRED CHURCH
AREA 2F PRE

SUB-AREA:
    DMA-AREA 1Outlet            .00203    39.        .226

STREAM REACH:

STORM ANALYSIS:
    2-Yr                        2.05      Type I      2

STRUCTURE RATING:

GLOBAL OUTPUT:
    2          0.05              YYYYN      YYYYNN

```

```

WinTR-20 Printed Page File      End of Input Data List

```

```

    KINDRED CHURCH
    AREA 2F PRE

```

```

Name of printed page file:
    TR20.out

```

```

    STORM 2-Yr

```

Area or Reach Identifier	Drainage Area (sq mi)	Rain Gage ID or Location	Runoff Amount (in)	----- Elevation (ft)	Peak Flow Time (hr)	Rate (cfs)	Rate (csm)
DMA-AREA 1	0.002		0.0		24.00	0.0	0.0
OUTLET	0.002		0.0		24.00	0.0	0.0

KINDRED CHURCH
AREA 2F PRE

Area or Reach Identifier	Drainage Area (sq mi)	Alternate	----- Peak Flow by Storm -----				
			2-Yr (cfs)	(cfs)	(cfs)	(cfs)	(cfs)
DMA-AREA 1	0.002		0.0				
OUTLET	0.002		0.0				

WinTR-55 Current Data Description

--- Identification Data ---

User: ANACAL ENG Date: 9/19/2020
 Project: KINDRED CHURCH Units: English
 SubTitle: AREA 2F PRE Areal Units: Acres
 State: California
 County: Orange
 Filename: E:\Users\dave\AppData\Roaming\WinTR-55\19-155-AREA 2F-PRE.w55

--- Sub-Area Data ---

Name	Description	Reach	Area(ac)	RCN	Tc
DMA-AREA 1		Outlet	1.3	39	.226

Total area: 1.30 (ac)

--- Storm Data --

Rainfall Depth by Rainfall Return Period

2-Yr (in)	-Yr (in)	-Yr (in)	-Yr (in)	-Yr (in)	-Yr (in)	-Yr (in)
2.05	.0	.0	.0	.0	.0	.0

Storm Data Source: User-provided custom storm data
 Rainfall Distribution Type: Type I
 Dimensionless Unit Hydrograph: <standard>

ANACAL ENG

KINDRED CHURCH
AREA 2F PRE
Orange County, California

Storm Data

Rainfall Depth by Rainfall Return Period

2-Yr (in)	-Yr (in)	-Yr (in)	-Yr (in)	-Yr (in)	-Yr (in)	-Yr (in)
2.05	.0	.0	.0	.0	.0	.0

Storm Data Source: User-provided custom storm data
Rainfall Distribution Type: Type I
Dimensionless Unit Hydrograph: <standard>

ANACAL ENG

KINDRED CHURCH
AREA 2F PRE
Orange County, California

Watershed Peak Table

Sub-Area or Reach Identifier	Peak Flow by Rainfall Return Period 2-Yr (cfs)

SUBAREAS	
DMA-AREA 1	.00
REACHES	
OUTLET	.00

ANACAL ENG

KINDRED CHURCH
AREA 2F PRE
Orange County, California

Hydrograph Peak/Peak Time Table

Sub-Area or Reach Identifier	Peak Flow and Peak Time (hr) by Rainfall Return Period 2-Yr (cfs) (hr)
------------------------------------	---

SUBAREAS

DMA-AREA 1	.00 n/a
------------	------------

REACHES

OUTLET	.00
--------	-----

ANACAL ENG

KINDRED CHURCH
AREA 2F PRE
Orange County, California

Sub-Area Summary Table

Sub-Area Identifier	Drainage Area (ac)	Time of Concentration (hr)	Curve Number	Receiving Reach	Sub-Area Description
DMA-AREA 1	1.30	0.226	39	Outlet	

Total Area:	1.30 (ac)				

ANACAL ENG

KINDRED CHURCH
AREA 2F PRE
Orange County, California

Sub-Area Land Use and Curve Number Details

Sub-Area Identifier	Land Use	Hydrologic Soil Group	Sub-Area Area (ac)	Curve Number
DMA-AREA 1	Open space; grass cover > 75%	(good) A	1.3	39
Total Area / Weighted Curve Number			1.3 ===	39 ==

```

WinTR-20 Printed Page File      Beginning of Input Data List
TR20.inp

WinTR-20: Version 1.10          0          0          0.05
KINDRED CHURCH
AREA 2F POST

SUB-AREA:
    2F          Outlet          .00116    97.          .1

STREAM REACH:

STORM ANALYSIS:
    2-Yr          2.05          Type I    2

STRUCTURE RATING:

GLOBAL OUTPUT:
    2          0.05          YYYYN    YYYYNN

```

WinTR-20 Printed Page File End of Input Data List

KINDRED CHURCH
AREA 2F POST

Name of printed page file:
TR20.out

STORM 2-Yr

Area or Reach Identifier	Drainage Area (sq mi)	Rain Gage ID or Location	Runoff Amount (in)	Elevation (ft)	Peak Flow Time (hr)	Rate (cfs)	Rate (csm)
2F	0.001		1.078		9.92	0.99	855.15

Line Start Time (hr)	Flow (cfs)	Values @ time increment (cfs)	of 0.006 hr (cfs)	Flow (cfs)	Flow (cfs)	Flow (cfs)	Flow (cfs)
8.143	0.05	0.05	0.05	0.05	0.05	0.05	0.05
8.187	0.05	0.05	0.05	0.05	0.05	0.05	0.05
8.231	0.05	0.06	0.06	0.06	0.06	0.06	0.06
8.275	0.06	0.06	0.06	0.06	0.06	0.06	0.06
8.319	0.06	0.06	0.06	0.06	0.06	0.06	0.06
8.364	0.06	0.06	0.06	0.06	0.06	0.06	0.06
8.408	0.06	0.07	0.07	0.07	0.07	0.07	0.07
8.452	0.07	0.07	0.07	0.07	0.07	0.07	0.07
8.496	0.07	0.07	0.07	0.07	0.07	0.07	0.07
8.541	0.07	0.07	0.07	0.07	0.07	0.07	0.07
8.585	0.07	0.08	0.08	0.08	0.08	0.08	0.08
8.629	0.08	0.08	0.08	0.08	0.08	0.08	0.08
8.673	0.08	0.08	0.08	0.08	0.08	0.08	0.08
8.717	0.08	0.08	0.08	0.08	0.08	0.08	0.08
8.762	0.08	0.08	0.09	0.09	0.09	0.09	0.09
8.806	0.09	0.09	0.09	0.09	0.09	0.09	0.09
8.850	0.09	0.09	0.09	0.09	0.09	0.09	0.09
8.894	0.09	0.09	0.09	0.09	0.09	0.09	0.09
8.938	0.09	0.09	0.09	0.10	0.10	0.10	0.10
8.983	0.10	0.10	0.10	0.10	0.10	0.10	0.10
9.027	0.10	0.10	0.10	0.10	0.10	0.10	0.10
9.071	0.10	0.10	0.10	0.10	0.11	0.11	0.11
9.115	0.11	0.11	0.11	0.11	0.11	0.11	0.11
9.159	0.11	0.11	0.11	0.11	0.11	0.11	0.12
9.204	0.12	0.12	0.12	0.12	0.12	0.12	0.12
9.248	0.12	0.12	0.12	0.12	0.12	0.12	0.12
9.292	0.13	0.13	0.13	0.13	0.13	0.13	0.13
9.336	0.13	0.13	0.13	0.13	0.13	0.13	0.13
9.381	0.13	0.14	0.14	0.14	0.14	0.14	0.14
9.425	0.14	0.14	0.14	0.14	0.14	0.14	0.14
9.469	0.14	0.15	0.15	0.15	0.15	0.15	0.15
9.513	0.15	0.15	0.15	0.16	0.16	0.16	0.17
9.557	0.17	0.18	0.18	0.19	0.19	0.20	0.20
9.602	0.21	0.21	0.21	0.22	0.22	0.23	0.23
9.646	0.24	0.25	0.26	0.28	0.29	0.29	0.30

9.690	0.31	0.32	0.32	0.33	0.34	0.34	0.35
9.734	0.37	0.38	0.40	0.41	0.43	0.45	0.47
9.778	0.49	0.50	0.51	0.53	0.54	0.55	0.56
9.823	0.57	0.59	0.62	0.65	0.68	0.72	0.76
9.867	0.79	0.83	0.86	0.89	0.92	0.94	0.96

KINDRED CHURCH
AREA 2F POST

Line Start Time (hr)	----- (cfs)	Flow Values @ time increment of 0.006 hr (cfs)	(cfs)	(cfs)	(cfs)	(cfs)	(cfs)
9.911	0.98	0.99	0.99	0.99	0.99	0.97	0.96
9.955	0.94	0.92	0.90	0.88	0.86	0.84	0.83
9.999	0.82	0.80	0.79	0.78	0.76	0.74	0.71
10.044	0.68	0.64	0.60	0.56	0.52	0.48	0.45
10.088	0.42	0.39	0.37	0.35	0.34	0.32	0.31
10.132	0.30	0.29	0.28	0.27	0.27	0.26	0.26
10.176	0.25	0.25	0.24	0.24	0.24	0.24	0.23
10.221	0.23	0.23	0.23	0.23	0.22	0.22	0.22
10.265	0.22	0.21	0.21	0.21	0.21	0.21	0.20
10.309	0.20	0.20	0.20	0.20	0.20	0.20	0.19
10.353	0.19	0.19	0.19	0.19	0.18	0.18	0.18
10.397	0.18	0.18	0.18	0.18	0.18	0.17	0.17
10.442	0.17	0.17	0.17	0.16	0.16	0.16	0.16
10.486	0.16	0.15	0.15	0.15	0.15	0.15	0.15
10.530	0.15	0.15	0.15	0.14	0.14	0.14	0.14
10.574	0.14	0.14	0.14	0.14	0.13	0.13	0.13
10.618	0.13	0.13	0.13	0.13	0.13	0.13	0.13
10.663	0.13	0.13	0.13	0.13	0.13	0.13	0.13
10.707	0.13	0.12	0.12	0.12	0.12	0.12	0.12
10.751	0.12	0.12	0.12	0.12	0.12	0.12	0.12
10.795	0.12	0.12	0.12	0.12	0.12	0.12	0.12
10.839	0.12	0.12	0.12	0.12	0.12	0.11	0.11
10.884	0.11	0.11	0.11	0.11	0.11	0.11	0.11
10.928	0.11	0.11	0.11	0.11	0.11	0.11	0.11
10.972	0.11	0.11	0.11	0.11	0.11	0.11	0.11
11.016	0.11	0.11	0.11	0.10	0.10	0.10	0.10
11.061	0.10	0.10	0.10	0.10	0.10	0.10	0.10
11.105	0.10	0.10	0.10	0.10	0.10	0.10	0.10
11.149	0.10	0.10	0.10	0.10	0.10	0.10	0.10
11.193	0.10	0.10	0.10	0.10	0.10	0.10	0.10
11.237	0.10	0.10	0.10	0.10	0.10	0.10	0.10
11.282	0.10	0.10	0.10	0.10	0.10	0.10	0.10
11.326	0.10	0.10	0.10	0.10	0.10	0.10	0.09
11.370	0.09	0.09	0.09	0.09	0.09	0.09	0.09
11.414	0.09	0.09	0.09	0.09	0.09	0.09	0.09
11.458	0.09	0.09	0.09	0.09	0.09	0.09	0.09
11.503	0.09	0.09	0.09	0.09	0.09	0.09	0.09
11.547	0.09	0.09	0.09	0.09	0.09	0.09	0.09
11.591	0.09	0.09	0.09	0.09	0.09	0.09	0.09
11.635	0.09	0.09	0.09	0.09	0.09	0.09	0.09
11.679	0.09	0.09	0.09	0.09	0.09	0.09	0.09
11.724	0.09	0.09	0.09	0.09	0.09	0.09	0.09
11.768	0.09	0.09	0.09	0.09	0.08	0.08	0.08
11.812	0.08	0.08	0.08	0.08	0.08	0.08	0.08
11.856	0.08	0.08	0.08	0.08	0.08	0.08	0.08
11.901	0.08	0.08	0.08	0.08	0.08	0.08	0.08
11.945	0.08	0.08	0.08	0.08	0.08	0.08	0.08
11.989	0.08	0.08	0.08	0.08	0.08	0.08	0.08
12.033	0.08	0.08	0.08	0.08	0.08	0.08	0.08
12.077	0.08	0.08	0.08	0.08	0.08	0.08	0.08
12.122	0.08	0.08	0.08	0.08	0.08	0.08	0.08

WinTR-20: Version 1.10
ED CHURCH
AREA 2F POST

0 0 0.05

(continued)

STORM 2-Yr

SUB-AREA:

2F Outlet .00116 97. .1

STREAM REACH:

KINDRED CHURCH
AREA 2F POST

Line	Flow Values @ time increment of 0.006 hr						
Start Time (hr)	(cfs)	(cfs)	(cfs)	(cfs)	(cfs)	(cfs)	(cfs)
12.166	0.08	0.08	0.08	0.08	0.08	0.08	0.08
12.210	0.08	0.08	0.08	0.08	0.08	0.08	0.08
12.254	0.08	0.08	0.08	0.08	0.08	0.08	0.08
12.298	0.08	0.08	0.08	0.08	0.07	0.07	0.07
12.343	0.07	0.07	0.07	0.07	0.07	0.07	0.07
12.387	0.07	0.07	0.07	0.07	0.07	0.07	0.07
12.431	0.07	0.07	0.07	0.07	0.07	0.07	0.07
12.475	0.07	0.07	0.07	0.07	0.07	0.07	0.07
12.519	0.07	0.07	0.07	0.07	0.07	0.07	0.07
12.564	0.07	0.07	0.07	0.07	0.07	0.07	0.07
12.608	0.07	0.07	0.07	0.07	0.07	0.07	0.07
12.652	0.07	0.07	0.07	0.07	0.07	0.07	0.07
12.696	0.07	0.07	0.07	0.07	0.07	0.07	0.07
12.741	0.07	0.07	0.07	0.07	0.07	0.07	0.07
12.785	0.07	0.07	0.07	0.07	0.07	0.07	0.07
12.829	0.07	0.07	0.07	0.07	0.07	0.07	0.07
12.873	0.07	0.07	0.07	0.07	0.07	0.07	0.07
12.917	0.07	0.07	0.07	0.07	0.07	0.07	0.07
12.962	0.07	0.07	0.07	0.07	0.07	0.07	0.07
13.006	0.06	0.06	0.06	0.06	0.06	0.06	0.06
13.050	0.06	0.06	0.06	0.06	0.06	0.06	0.06
13.094	0.06	0.06	0.06	0.06	0.06	0.06	0.06
13.138	0.06	0.06	0.06	0.06	0.06	0.06	0.06
13.183	0.06	0.06	0.06	0.06	0.06	0.06	0.06
13.227	0.06	0.06	0.06	0.06	0.06	0.06	0.06
13.271	0.06	0.06	0.06	0.06	0.06	0.06	0.06
13.315	0.06	0.06	0.06	0.06	0.06	0.06	0.06
13.359	0.06	0.06	0.06	0.06	0.06	0.06	0.06
13.404	0.06	0.06	0.06	0.06	0.06	0.06	0.06
13.448	0.06	0.06	0.06	0.06	0.06	0.06	0.06

WinTR-20: Version 1.10
ED CHURCH
AREA 2F POST

0 0 0.05

(continued)

SUB-AREA:

STORM 2-Yr

2F Outlet .00116 97. .1

STREAM REACH:

8.452	0.07	0.07	0.07	0.07	0.07	0.07	0.07	0.07
8.496	0.07	0.07	0.07	0.07	0.07	0.07	0.07	0.07
8.541	0.07	0.07	0.07	0.07	0.07	0.07	0.07	0.07
8.585	0.07	0.08	0.08	0.08	0.08	0.08	0.08	0.08
8.629	0.08	0.08	0.08	0.08	0.08	0.08	0.08	0.08
8.673	0.08	0.08	0.08	0.08	0.08	0.08	0.08	0.08
8.717	0.08	0.08	0.08	0.08	0.08	0.08	0.08	0.08
8.762	0.08	0.08	0.09	0.09	0.09	0.09	0.09	0.09
8.806	0.09	0.09	0.09	0.09	0.09	0.09	0.09	0.09
8.850	0.09	0.09	0.09	0.09	0.09	0.09	0.09	0.09
8.894	0.09	0.09	0.09	0.09	0.09	0.09	0.09	0.09
8.938	0.09	0.09	0.09	0.10	0.10	0.10	0.10	0.10
8.983	0.10	0.10	0.10	0.10	0.10	0.10	0.10	0.10
9.027	0.10	0.10	0.10	0.10	0.10	0.10	0.10	0.10
9.071	0.10	0.10	0.10	0.10	0.11	0.11	0.11	0.11
9.115	0.11	0.11	0.11	0.11	0.11	0.11	0.11	0.11
9.159	0.11	0.11	0.11	0.11	0.11	0.11	0.11	0.12
9.204	0.12	0.12	0.12	0.12	0.12	0.12	0.12	0.12
9.248	0.12	0.12	0.12	0.12	0.12	0.12	0.12	0.12
9.292	0.13	0.13	0.13	0.13	0.13	0.13	0.13	0.13
9.336	0.13	0.13	0.13	0.13	0.13	0.13	0.13	0.13
9.381	0.13	0.14	0.14	0.14	0.14	0.14	0.14	0.14
9.425	0.14	0.14	0.14	0.14	0.14	0.14	0.14	0.14
9.469	0.14	0.15	0.15	0.15	0.15	0.15	0.15	0.15
9.513	0.15	0.15	0.15	0.16	0.16	0.16	0.16	0.17
9.557	0.17	0.18	0.18	0.19	0.19	0.20	0.20	0.20
9.602	0.21	0.21	0.21	0.22	0.22	0.23	0.23	0.23
9.646	0.24	0.25	0.26	0.28	0.29	0.29	0.30	0.30
9.690	0.31	0.32	0.32	0.33	0.34	0.34	0.35	0.35
9.734	0.37	0.38	0.40	0.41	0.43	0.45	0.47	0.47
9.778	0.49	0.50	0.51	0.53	0.54	0.55	0.56	0.56
9.823	0.57	0.59	0.62	0.65	0.68	0.72	0.76	0.76
9.867	0.79	0.83	0.86	0.89	0.92	0.94	0.96	0.96
9.911	0.98	0.99	0.99	0.99	0.99	0.97	0.96	0.96
9.955	0.94	0.92	0.90	0.88	0.86	0.84	0.83	0.83
9.999	0.82	0.80	0.79	0.78	0.76	0.74	0.71	0.71
10.044	0.68	0.64	0.60	0.56	0.52	0.48	0.45	0.45
10.088	0.42	0.39	0.37	0.35	0.34	0.32	0.31	0.31

WinTR-20: Version 1.10
ED CHURCH
AREA 2F POST

0 0 0.05

(continued)

SUB-AREA:

STORM 2-Yr

2F Outlet .00116 97. .1

STREAM REACH:

11.370	0.09	0.09	0.09	0.09	0.09	0.09	0.09	0.09
11.414	0.09	0.09	0.09	0.09	0.09	0.09	0.09	0.09
11.458	0.09	0.09	0.09	0.09	0.09	0.09	0.09	0.09
11.503	0.09	0.09	0.09	0.09	0.09	0.09	0.09	0.09
11.547	0.09	0.09	0.09	0.09	0.09	0.09	0.09	0.09
11.591	0.09	0.09	0.09	0.09	0.09	0.09	0.09	0.09
11.635	0.09	0.09	0.09	0.09	0.09	0.09	0.09	0.09
11.679	0.09	0.09	0.09	0.09	0.09	0.09	0.09	0.09
11.724	0.09	0.09	0.09	0.09	0.09	0.09	0.09	0.09
11.768	0.09	0.09	0.09	0.09	0.08	0.08	0.08	0.08
11.812	0.08	0.08	0.08	0.08	0.08	0.08	0.08	0.08
11.856	0.08	0.08	0.08	0.08	0.08	0.08	0.08	0.08
11.901	0.08	0.08	0.08	0.08	0.08	0.08	0.08	0.08
11.945	0.08	0.08	0.08	0.08	0.08	0.08	0.08	0.08
11.989	0.08	0.08	0.08	0.08	0.08	0.08	0.08	0.08
12.033	0.08	0.08	0.08	0.08	0.08	0.08	0.08	0.08
12.077	0.08	0.08	0.08	0.08	0.08	0.08	0.08	0.08
12.122	0.08	0.08	0.08	0.08	0.08	0.08	0.08	0.08
12.166	0.08	0.08	0.08	0.08	0.08	0.08	0.08	0.08
12.210	0.08	0.08	0.08	0.08	0.08	0.08	0.08	0.08
12.254	0.08	0.08	0.08	0.08	0.08	0.08	0.08	0.08
12.298	0.08	0.08	0.08	0.08	0.07	0.07	0.07	0.07
12.343	0.07	0.07	0.07	0.07	0.07	0.07	0.07	0.07
12.387	0.07	0.07	0.07	0.07	0.07	0.07	0.07	0.07
12.431	0.07	0.07	0.07	0.07	0.07	0.07	0.07	0.07
12.475	0.07	0.07	0.07	0.07	0.07	0.07	0.07	0.07
12.519	0.07	0.07	0.07	0.07	0.07	0.07	0.07	0.07
12.564	0.07	0.07	0.07	0.07	0.07	0.07	0.07	0.07
12.608	0.07	0.07	0.07	0.07	0.07	0.07	0.07	0.07

WinTR-20 Version 1.10

Page 5

09/18/2020 11:23

KINDRED CHURCH
AREA 2F POST

Line
Start Time ----- Flow Values @ time increment of 0.006 hr -----
(hr) (cfs) (cfs) (cfs) (cfs) (cfs) (cfs) (cfs)

WinTR-20: Version 1.10
ED CHURCH
AREA 2F POST

0 0 0.05

(continued)

SUB-AREA:

STORM 2-Yr

2F Outlet .00116 97. .1

STREAM REACH:

12.652	0.07	0.07	0.07	0.07	0.07	0.07	0.07	0.07
12.696	0.07	0.07	0.07	0.07	0.07	0.07	0.07	0.07
12.741	0.07	0.07	0.07	0.07	0.07	0.07	0.07	0.07
12.785	0.07	0.07	0.07	0.07	0.07	0.07	0.07	0.07
12.829	0.07	0.07	0.07	0.07	0.07	0.07	0.07	0.07
12.873	0.07	0.07	0.07	0.07	0.07	0.07	0.07	0.07
12.917	0.07	0.07	0.07	0.07	0.07	0.07	0.07	0.07
12.962	0.07	0.07	0.07	0.07	0.07	0.07	0.07	0.07
13.006	0.06	0.06	0.06	0.06	0.06	0.06	0.06	0.06
13.050	0.06	0.06	0.06	0.06	0.06	0.06	0.06	0.06
13.094	0.06	0.06	0.06	0.06	0.06	0.06	0.06	0.06
13.138	0.06	0.06	0.06	0.06	0.06	0.06	0.06	0.06
13.183	0.06	0.06	0.06	0.06	0.06	0.06	0.06	0.06
13.227	0.06	0.06	0.06	0.06	0.06	0.06	0.06	0.06
13.271	0.06	0.06	0.06	0.06	0.06	0.06	0.06	0.06
13.315	0.06	0.06	0.06	0.06	0.06	0.06	0.06	0.06
13.359	0.06	0.06	0.06	0.06	0.06	0.06	0.06	0.06
13.404	0.06	0.06	0.06	0.06	0.06	0.06	0.06	0.06
13.448	0.06	0.06	0.06	0.06	0.06	0.06	0.06	0.06
13.492	0.06	0.06	0.06	0.06	0.06	0.06	0.06	0.06
13.536	0.06	0.06	0.06	0.06	0.06	0.06	0.06	0.06
13.581	0.06	0.06	0.06	0.06	0.06	0.06	0.06	0.06
13.625	0.06	0.06	0.06	0.06	0.06	0.06	0.06	0.06
13.669	0.06	0.06	0.05	0.05	0.05	0.05	0.05	0.05
13.713	0.05	0.05	0.05	0.05	0.05	0.05	0.05	0.05
13.757	0.05	0.05	0.05	0.05	0.05	0.05	0.05	0.05
13.802	0.05	0.05	0.05	0.05	0.05	0.05	0.05	0.05
13.846	0.05	0.05	0.05	0.05	0.05	0.05	0.05	0.05
13.890	0.05	0.05	0.05	0.05	0.05	0.05	0.05	0.05
13.934	0.05	0.05	0.05	0.05	0.05	0.05	0.05	0.05
13.978	0.05	0.05	0.05	0.05	0.05	0.05	0.05	0.05
14.023	0.05	0.05						

WinTR-20 Printed Page File
TR20.inp

Beginning of Input Data List

WinTR-20: Version 1.10
ED CHURCH
AREA 2F POST

0 0 0.05

(continued)

STORM 2-Yr

SUB-AREA:

2F Outlet .00116 97. .1

STREAM REACH:

WinTR-20 Version 1.10

Page 6

09/18/2020 11:23

KINDRED CHURCH
AREA 2F POST

Area or Reach Identifier	Drainage Area (sq mi)	Alternate	----- Peak Flow by Storm -----				
			2-Yr (cfs)	(cfs)	(cfs)	(cfs)	(cfs)
2F	0.001		0.99				
OUTLET	0.001		0.99				

WinTR-20 Printed Page File
TR20.inp

Beginning of Input Data List

WinTR-20: Version 1.10
ED CHURCH
AREA 2F POST

0 0 0.05

(continued)

STORM 2-Yr

SUB-AREA:

2F Outlet

.00116 97. .1

STREAM REACH:

WinTR-20 Printed Page File
TR20.inp

Beginning of Input Data List

WinTR-20: Version 1.10
ED CHURCH
AREA 2F POST

0 0 0.05

(continued)

STORM 2-Yr

SUB-AREA:

2F Outlet

.00116 97. .1

STREAM REACH:

WinTR-20 Version 1.10

Page 7

09/18/2020 11:23

WinTR-55 Current Data Description

--- Identification Data ---

User: ANACAL Date: 9/18/2020
Project: KINDRED CHURCH Units: English
SubTitle: AREA 2F POST Areal Units: &Acre
State: California
County: Orange
Filename: <new file>

--- Sub-Area Data ---

Name	Description	Reach	Area(ac)	RCN	Tc
2F	PARKING LOT	Outlet	0.74	97	0.1

Total area: .74 (ac)

--- Storm Data ---

Rainfall Depth by Rainfall Return Period

2-Yr	5-Yr	10-Yr	25-Yr	50-Yr	100-Yr	1-Yr
2.05	.0	.0	.0	.0	.0	.0

Storm Data Source: User-provided custom storm data
Rainfall Distribution Type: Type I
Dimensionless Unit Hydrograph: <standard>

ANACAL

KINDRED CHURCH
AREA 2F POST
Orange County, California

Storm Data

Rainfall Depth by Rainfall Return Period

2-Yr	5-Yr	10-Yr	25-Yr	50-Yr	100-Yr	1-Yr
2.05	.0	.0	.0	.0	.0	.0

Storm Data Source: User-provided custom storm data
Rainfall Distribution Type: Type I
Dimensionless Unit Hydrograph: <standard>

ANACAL

KINDRED CHURCH
AREA 2F POST
Orange County, California

Watershed Peak Table

Sub-Area or Reach Identifier	Peak Flow by Rainfall Return Period 2-Yr

SUBAREAS	
2F	0.99
REACHES	
OUTLET	0.99

ANACAL

KINDRED CHURCH
AREA 2F POST
Orange County, California

Hydrograph Peak/Peak Time Table

Sub-Area or Reach Identifier	Peak Flow and Peak Time (hr) by Rainfall Return Period 2-Yr (hr)
------------------------------------	--

SUBAREAS

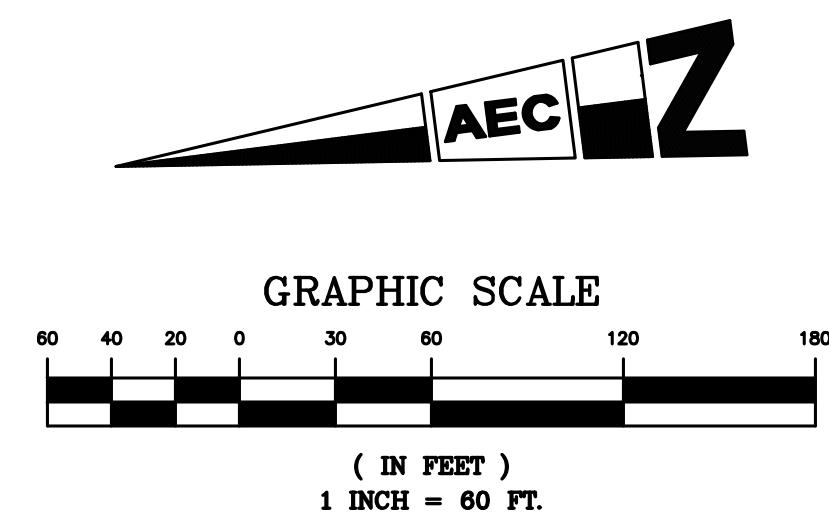
2F	0.99 9.92
----	--------------

REACHES

OUTLET	0.99
--------	------

EXISTING HYDROLOGY MAP

PROPOSED HYDROLOGY MAP



- LEGEND**
- DRAINAGE BOUNDARY
 - AREA DESIGNATION
ACRES
 - FLOW PATH

EXHIBIT B PROPOSED HYDROLOGY

REVISIONS					
NO.	INT.	DATE	DESCRIPTION	APP'D	DATE

BENCH MARK:
CITY OF ANAHEIM B.M. NO. 4A-129
BRASS CAP MARKED CITY OF ANAHEIM BM, IN THE TOP OF CURB AT THE NORTHEAST BEGIN OF CURB RETURN SANTA ANA CANYON ROAD AND MOHLER DRIVE
ELEVATION: 324.14 FT. (NGVD 29)

OWNER OR DEVELOPER:
KINDRED COMMUNITY CHURCH
100 CHAPARALL COURT, STE.100
ANAHEIM, CA. 92808
CONTACT: DAVE MITCHELL

SOILS ENGINEER:
TGR GEOTECHNICAL
3037 S. HARBOR BLVD.
SANTA ANA, CALIFORNIA 92704
PH: 714-641-7189 FAX: 714-641-7190

PREPARED BY: JOB NO. 19-155

ANACAL ENGINEERING CO.
CIVIL ENGINEERING & LAND SURVEYING
1900 EAST LA PALMA AVENUE ~ SUITE 202 ~
ANAHEIM, CALIFORNIA 92805
PHONE: 714-774-1763
FAX: 714-774-4690
E-MAIL ADDRESS: ANACAL@ANACALENGINEERING.COM

I HEREBY CERTIFY THAT:

- THESE PLANS HAVE BEEN PREPARED UNDER MY SUPERVISION;
- THE GRADING SHOWN HEREON WILL NOT DIVERT DRAINAGE FROM ITS NATURAL DOWNSTREAM COURSE OR OBSTRUCT THE DRAINAGE OF ADJACENT PROPERTIES;
- ALL SPECIMEN TREES LOCATED ON THIS PROPERTY ARE SHOWN;
- EXISTING GROUND CONTOURS AND ELEVATIONS WERE OBTAINED BY FIELD SURVEY ON/AERIAL TOPOGRAPHY FLOWN ON _____

ENGINEER: DAVID C. QUEYREL R.C.E.#42812 EXPIRATION DATE: 3-31-18

PRELIMINARY HYDROLOGY PLAN		GRA
KINDRED COMMUNITY CHURCH		SHEET 1 OF 1
8720 E. SANTA ANA CANYON ROAD	SCALE: 1" = 60'	DRAWN BY: GAG-VFL
CITY OF ANAHEIM		CHECKED BY: D. C. Q.

FOR CITY USE ONLY

Attachment C

Kindred Community Church

Operations and Maintenance Plan

Site: 8712-8720 E. Santa Ana Canyon Rd.

APN: 354-321-01 & 354-321-03

Exhibit A, Operations and Maintenance Plan

BMP Applicable? Yes/No	BMP Name and BMP Implementation, Maintenance, and Inspection Procedures	Implementation, Maintenance, and Inspection Frequency and Schedule	Inspection / Maintenance Activities Required	Person or Entity with Operation & Maintenance Responsibility
Non-Structural Source Control BMPs				
Y	N1. Education for Property Owners, Tenants and Occupants	Once yearly and for new employees	Provide literature and instruction pertaining to environmental awareness included in Section VII, Educational Material to all Leassies.	Owner
Y	N2. Activity Restriction	Continuous	Activities to be restricted on-site include: Prohibit discharges of fertilizers, pesticides, or animal wastes to streets or storm drains. Prohibit blowing or sweeping of debris (leaf litter, grass clippings, litter, etc.) into streets and storm drains. Prohibit vehicle maintenance or repair within common area or such that pollutants can enter streets or storm drains. Report any violations relating to activity restrictions listed herein.	Owner
Y	N3. Common Area Landscape Management	Bi-weekly	Sweep silt and debris. Replace dead vegetation, maintain irrigation in proper working order	
Y	N4. BMP Maintenance	As indicated in WQMP	Provide maintenance as instructed in all sections of this plan.	Owner
N	N5. Title 22 CCR Compliance			
N	N7. Spill Contingency Plan			

Exhibit A, Operations and Maintenance Plan
Page 2 of 12

BMP Applicable? Yes/No	BMP Name and BMP Implementation, Maintenance, and Inspection Procedures	Implementation, Maintenance, and Inspection Frequency and Schedule	Inspection / Maintenance Activities Required	Person or Entity with Operation & Maintenance Responsibility
N	N8. Underground Storage Tank Compliance			
N	N9. Hazardous Materials Disclosure Compliance			
N	N10. Uniform Fire Code Implementation			
Y	N11. Common Area Litter Control	<i>Bi-weekly</i>	Keep grounds free of trash and debris	Owner
Y	N12. Employee Training	Upon hire	Provide all employees with literature consistent with their activities	Owner
N	N13. Housekeeping of Loading Docks			
Y	N14. Common Area Catch Basin Inspection	Once prior to rainy season October 15-April 15	Inspect catch basin storm drains and infiltration system clean and maintain in accordance with manufacturers recommendations	
Y	N15. Street Sweeping Private Streets and Parking Lots	Once prior to rainy season October 15-April 15	Sweep parking and drive areas. No hosing down of areas is allowed. Dispose of debris offsite.	Owner
N	N17. Retail Gasoline Outlets			
Structural Source Control BMPs				
Y	Provide Storm Drain System Stenciling and Signage	Once Yearly	.Repaint when fades 50%	Owner

Exhibit A, Operations and Maintenance Plan
Page 3 of 12

BMP Applicable? Yes/No	BMP Name and BMP Implementation, Maintenance, and Inspection Procedures	Implementation, Maintenance, and Inspection Frequency and Schedule	Inspection / Maintenance Activities Required	Person or Entity with Operation & Maintenance Responsibility
N	Design and Construct Outdoor Material Storage Areas to Reduce Pollutant Introduction			
Y	Design and Construct Trash and Waste Storage Areas to Reduce Pollutant Introduction	Bi-weekly	Keep lids closed at all times. Provide signage that prohibits dumping of toxic materials. Clean spills with minimal water and wipe clean	
Y	Use Efficient Irrigation Systems & Landscape Design	Inspect monthly	Test for overspray, adjust , maintain and fix irrigation	Owner
N	Protect Slopes and Channels and Provide Energy Dissipation			
N	Loading Docks			
N	Maintenance Bays			
N	Vehicle Wash Areas			
N	Outdoor Processing Areas			
N	Equipment Wash Areas			
N	Fueling Areas			
N	Hillside Landscaping			
N	Wash Water Controls for Food Preparation Areas			

BMP Applicable? Yes/No	BMP Name and BMP Implementation, Maintenance, and Inspection Procedures	Implementation, Maintenance, and Inspection Frequency and Schedule	Inspection / Maintenance Activities Required	Person or Entity with Operation & Maintenance Responsibility
N	Community Car Wash Racks			
Low Impact Development (LID) and Treatment Control BMPs				
Y	Infiltration Control BMP # 1 Infiltration in Underground Chambers By Contech	After each significant storm event for the first year. At a minimum of once per year prior to rainy season Oct. 15 thereafter.	Verify Chambers do Infiltrate within 48 hours after storm event. Remove trash and Inspect drain inlets and remove debris . If standing water persists flush system and replace gravel media if required.	Owner
Y	Pre-Treatment control BMP #2 Filterra Bioretention System By Contech	Inspections performed once or twice per year (spring and fall). Depending on the schedule made after first year of activation.	Activation and first year maintenance is included. After the first year of maintenance, maintenance responsibly falls on the owner. This included inspecting the surrounding area and removing any trash or debris. Add mulch to a depth of 3". Replace Filterra grates if applicable. See manufactures recommendations on Owners Manuel for more details in Section VII of the WQMP.	Owner

RECORD OF BMP IMPLEMENTATION, MAINTENANCE, AND INSPECTION

Today's Date: _____

**Name of Person Performing Activity
(Printed):** _____

Signature: _____

BMP Name (As Shown in O&M Plan)	Brief Description of Implementation, Maintenance, and Inspection Activity Performed

Attachment D

Kindred Community Church

Soil Report

Site: 8712-8720 E. Santa Ana Canyon Rd.

APN: 354-321-01 & 354-321-03



August 10, 2016

Project No. 15-5382

Kindred Community Church
100 South Chaparral Court
Anaheim, CA 92808

Attention: Mr. Mark Vaughan

Subject: Percolation Testing, Lower Parking Area, Kindred Church, 8720 East Santa Ana Canyon Road, Anaheim, California.

References: Giles Engineering Associates, Inc., 2014, Geotechnical Feasibility Study, Proposed Site Development, 8720 East Santa Ana Canyon Road, Anaheim Hills, California, dated March 18, 2014.

Anacal Engineering, Topographic Survey.

Mark,

In accordance with your request and authorization, TGR Geotechnical, Inc. (TGR) has completed percolation testing at the subject site. The work was performed in accordance with our proposal dated August 8, 2016 and your subsequent authorization to proceed.

During our field investigation, it was observed that the subsurface soils consist of brown, moist, silty fine sand to the depth explored. Presented below are the details of our investigation.

Scope of Work

The scope of work for this percolation testing included the following:

- Excavation of one (1) exploratory hand auger boring to an approximate depth of 5 feet below existing grade to evaluate the existing soil conditions at the subject site.
- Evaluation of infiltration rate by performing percolation testing within the boring.
- Preparation of this report summarizing our findings, conclusions, and recommendations.

Field Investigation

Field exploration was performed on August 10, 2016 by representatives from our firm who logged the boring and obtained representative samples, which were subsequently transported to the laboratory for further review and testing. The approximate location of the boring is indicated on the enclosed Boring Location Map (Plate 1).

The subsurface conditions were explored by drilling, sampling, and logging one (1) hand auger boring. The boring was advanced to approximately 5 feet below existing grade. Percolation testing took place within the boring. Subsequent to drilling, the boring was backfilled with cuttings.

Groundwater

No groundwater was encountered in our boring to a maximum depth of 5 feet below existing grade. Based on our review of available historical groundwater information (CDMG, 1998) regional groundwater is mapped approximately 20 feet below ground surface in the general site area. During a previous investigation (Giles Engineering Associates, 2014), groundwater was encountered in the general area at a depth of 18.5 feet below existing grade. Seasonal and long-term fluctuations in the groundwater may occur as a result of variations in subsurface conditions, rainfall, run-off conditions and other factors. Therefore, variations from these observations may occur.

Percolation Testing

Percolation testing was performed at the subject site. Presented below are the infiltration rates from the percolation tests performed at the subject site. These do not include any factor of safety.

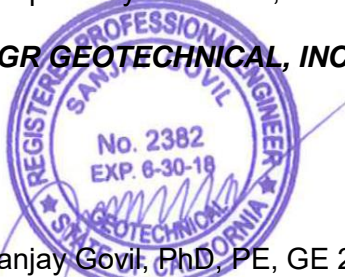
- P-1 at 0-5 feet 2.8 inches per hour

The infiltration test rates were determined utilizing the Orange County Technical Guidance Document (2011).

If you have any questions regarding this report, please do not hesitate to contact this office. We appreciate this opportunity to be of service.

Respectfully submitted,

TGR GEOTECHNICAL, INC.



Sanjay Govil, PhD, PE, GE 2382
Principal Geotechnical Engineer

Attachments: Plate 1 – Boring Location Map

Distribution: (1) Addressee



P-1
 ○ APPROXIMATE LOCATION OF PERCOLATION TEST



BORING LOCATION MAP
KINDRED COMMUNITY CHURCH
 8720 EAST SANTA ANA CANYON ROAD, ANAHEIM, CALIFORNIA

PROJECT NO. 15-5382
PLATE 1



November 10, 2020

Project No. 15-5382

Kindred Community Church
100 South Chaparral Court
Anaheim, CA 92808

Subject: Percolation Testing Results for WQMP, Pavement Design and Building Expansion Foundation Recommendations, Kindred Church, 8720 East Santa Ana Canyon Road, Anaheim, California.

In accordance with your request and authorization, TGR Geotechnical, Inc. (TGR) has completed a geotechnical investigation to provide infiltration rates from percolation testing, asphalt concrete pavement design and Fellowship Hall main church building expansion foundation recommendations at the subject site. It is our understanding that the proposed improvements consist of the expansion of the central and southern parking lots, installation of three infiltration basins and the expansion of the main church building.

Based on our investigation the proposed improvements are feasible from a geotechnical standpoint provided the recommendations presented in this report are implemented during design and construction.

SCOPE OF SERVICES

Our scope of work included performing the following tasks:

- Site reconnaissance.
- Review of previous geotechnical reports for the subject site.
- Percolation testing in three (3) locations to a depth of approximately 10.5 feet below existing grade. Percolation testing followed the Orange County Technical Guidance Document, Appendix VII. The borings were be backfilled with soil cuttings and soil was disposed on-site.
- Sampling and logging two (2) hollow stem auger borings to a depth of approximately 5.5 feet below existing grade. The borings were backfilled with soil cuttings and sealed with cold patch asphalt upon completion. Any excess soil was disposed onsite.
- Laboratory testing of selected samples to include: in situ moisture and density, maximum dry density and optimum moisture content, shear, passing No. 200 sieve and R-Value.
- Preparation of this report presenting the results of percolation testing, infiltration rate from the percolation testing, pavement design recommendations for the proposed parking lot and geotechnical design recommendations for the proposed church building expansion.

FIELD INVESTIGATION

Field exploration was performed on October 13, 2020 by representatives from our firm who logged the borings and obtained representative samples, which were subsequently transported to the laboratory for further review and testing. The approximate locations of the borings are indicated on the enclosed Geotechnical Map (Plate 1).

The subsurface conditions were explored by drilling, sampling, and logging two (2) borings with a truck mounted hollow stem drill rig to an approximate depth of five and one-half (5.5) feet below existing grade and three (3) borings to ten and one-half (10.5) feet below existing grade for percolation testing. Subsequent to drilling, all borings were backfilled with soil cuttings and the surface was repaired with cold patch asphalt, where appropriate. The logs of borings presenting soil conditions and descriptions are provided as Plates 2 through 6.

The drill rig was equipped with a sampling apparatus to allow for recovery of driven modified California Ring Sampler (CRS), 3-inch outside diameter, and 2.42-inch inside diameter samples. Driven samples and bulk samples of the earth materials encountered at selected intervals were recovered from the borings.

The samples were driven using an automatic 140-pound hammer falling freely from a height of 30 inches. The blow counts for CRS were converted to equivalent SPT blow counts. Soil descriptions were entered on the logs in general accordance with the Unified Soil Classification System (USCS). The locations and depths of the soil samples recovered are indicated on the logs on Plates 2 through 6.

PERCOLATION TESTING

Percolation testing was performed at the subject site utilizing the Porchet Method. Presented below are the infiltration rates from the percolation tests performed at the subject site. These do not include any factor of safety.

- P-1 at 0-10.5 feet 0.10 inches per hour
- P-2 at 0-10.5 feet 0.20 inches per hour
- P-3 at 0-10.5 feet 0.15 inches per hour

The infiltration test rates were determined in general accordance with Orange County Public Works Technical Guidance Document (2011).

LABORATORY TESTING

Laboratory tests were performed on representative samples to verify the field classification of the recovered samples and to evaluate the geotechnical properties of the subsurface soils. The following tests were performed:

- In-situ moisture content (ASTM D2216) and dry density (ASTM D7263);
- Maximum Dry Density and Optimum Moisture Content (ASTM D1557);
- Direct Shear Strength (ASTM D3080);
- Expansion Potential (ASTM D4829);
- Passing No. 200 sieve (ASTM 1140);
- R-Value Determination (CAL 301); and
- Soluble Sulfate (CAL.417A).

Moisture and Density Determination Tests: Moisture content and dry density determinations were performed on relatively undisturbed samples obtained from the test borings. The results of these tests are presented in the boring logs. Where applicable, only moisture content was determined from "undisturbed" or disturbed samples.

Maximum Density Tests: The maximum dry density and optimum moisture content of typical materials were determined in accordance with ASTM Test Method D1557. The results of these tests are presented on Plate 7 and in the table below:

Sample Location	Sample Description	Maximum Dry Density (Pcf)	Optimum Moisture Content (%)
P-2 @ 0-5 feet	Clayey Sand	113.0	16.0

Direct Shear Tests: Direct shear test was performed on selected remolded and/or undisturbed sample, which was soaked for a minimum of 24 hours under a surcharge equal to the applied normal force during testing. After transfer of the sample to the shear box, and reloading the sample, pore pressures set up in the sample due to the transfer were allowed to dissipate for a period of approximately 1-hour prior to application of shearing force. The sample was tested under various normal loads, a motor-driven, strain-controlled, direct-shear testing apparatus at a strain rate of less than 0.001 to 0.5 inches per minute (depending upon the soil type). The test results are presented on Plate 8 and in the table below:

Sample Location	Sample Description	Friction Angle (degrees)	Apparent Cohesion (psf)
P-2 @ 0-5 feet	Remolded Shear – Clayey Sand	26	462

Expansion Index Tests: The expansion potential of selected materials was evaluated by the Expansion Index Test, ASTM D4829. Specimens are molded under a given compactive energy to approximately the optimum moisture content and approximately 50 percent saturation or approximately 90 percent relative compaction. The prepared 1-inch thick by 4-inch diameter specimens are loaded to an equivalent 144 psf surcharge and are inundated with tap water until volumetric equilibrium is reached. The results of these tests are presented in the table below:

Sample Location	Sample Description	Expansion Index	Expansion Potential
P-1 @ 0-5 feet	Clayey Sand	64	Medium

Wash Sieve Test: Typical materials were washed over No. 200 sieve (ASTM Test Method D1140). The test results are presented below:

Sample Location	% Passing No. 200 Sieve
P-1 @ 4 feet	45.5%
P-1 @ 9 feet	46.1%

P-2 @ 4 feet	53.0%
P-2 @ 9 feet	59.0%
P-3 @ 4 feet	33.9%
P-3 @ 9 feet	43.5%

R-Value: The resistance “R”-Value was determined by the California Materials Method No. 301 for sub-grade soils. For the representative sample exudation pressure and “R”-Value was determined. The graphically determined “R”-Value at exudation pressure of 300 psi is summarized on Plates 9 and 10 and in the table below:

Sample Location	Sample description	R-Value
P-2 @ 0-5 feet	Clayey Sand	12

Soluble Sulfates: The soluble sulfate content of selected sample was determined by standard geochemical methods. The test results are presented on Plate 11 and in the table below:

Sample Location	Sample Description	Water Soluble Sulfate in Soil, (% by Weight)	Sulfate Content (ppm)	Exposure Class*
B-2 @ 0-5 feet	Clayey Sand	0.0173	173	S0

* Based on the current version of ACI 318-14 Building Code, Table No. 19.3.1.1; Exposure Categories and Classes.

EXISTING SITE CONDITION

The subject site consists of a Fellowship Hall church building and Workshop Center in the southeast portion of the property, a parking lot, nature walk and lake in the central portion of the property and Educational portable buildings in the southwest portion of the property.

The Fellowship Hall and Workshop Center were constructed on compacted artificial fill overlaying bedrock, designated as structural areas, while the remaining portions of the site are underlain by compacted artificial fill overlaying landslide debris and/or debris fill. Total removals of landslide material were made in the area of the above-mentioned structural pad in order to provide a buttress for the ascending slope to the south of the site. The approximate depth of the landslide debris in this area appears to have been in the 60 to 100 feet range. The limits of the buttress fill key extend to the north of the structural pad area approximately 60 to 100 feet. It appears that the northern limits of the structural pad are based on a 1:1 (horizontal: vertical) projection from the base of the landslide debris removals/toe of the fill key to the surface. The limits of the landslide debris removals and structural pad are presented on Plate 1.

The thickness of the remaining landslide debris to the north of the structural pad area is unknown since the mass grading plan review report for the site and surrounding areas was not available for review. However, based on the estimated depth of the removals of landslide debris

in the structural pad area we anticipate the thickness of the remaining landslide debris to the north to be similar in depth, ranging from 60 to 100 feet.

The thickness of the landslide debris on the west side of the site is also unknown since the mass grading plan review report for the site and surrounding areas was not available for review. However, based on our review of the CDMG report, the landslides on the west side of the site are similar in size to the landslides on the south side of the site. As such, we would anticipate that the thickness of the landslide debris on the west side of the site to be similar to that of the landslide debris on the south side.

The existing Fellowship Hall main church building was constructed in the structural fill area with foundations supported on two to three feet of remedially compacted engineered fill within the structural fill.

FINDINGS

Regional Geologic Setting

The subject site is located in the Anaheim Hills region, south of the Santa Ana River, within the northwestern portion of the Black Star Canyon 7.5-Minute Quadrangle, Orange County, California. Per the geologic map of the San Bernardino and Santa Ana 30' x 60' Quadrangles (Morton, 2006) the subject site is underlain by Quaternary alluvial deposits and possible mid-Miocene marine strata toward southern portions of the site (Figure 2).

Existing Soil

Based on our subsurface investigation, the subject site subsurface soils generally consist of tan to brown clayey sand and sandy clay in a moist condition to the maximum depth explored, 10.5 feet below existing grade. In the existing parking lot, in the vicinity of Borings B-1 and B-2, the clayey sand and sandy clay is underlain by blue grey and olive brown silty sand in a moist condition at a depth of 4 feet to 5.5 feet below existing grade. Detailed descriptions of the earth units encountered in our borings are presented in the log of the borings on Plates 2 through 6.

Groundwater

Subsurface water was not encountered during the exploration to a maximum depth of 10.5 feet below existing ground surface. Based on our review of available historical groundwater information for the Black Star Canyon 7.5-minute Quadrangle (CDMG, 2000) regional groundwater has been mapped in the general site area between approximately 20 to 40 feet below ground surface (Figure 3). Seasonal and long-term fluctuations in the groundwater may occur as a result of variations in subsurface conditions, rainfall, run-off conditions and other factors. Therefore, variations from our observations may occur.

Static groundwater is not anticipated to impact the proposed development.

Expansive Soil

Onsite soils have an expansion index of 64 correlating to a "medium" expansion potential. The recommendations provided in this report account for the expansion potential of the onsite soils.

RECOMMENDATIONS

Seismic Design Parameters

When reviewing the 2019 California Building Code the following data should be incorporated into the design.

Parameter	Value
Latitude (degree)	33.8635
Longitude (degree)	-117.7224
Site Class	D – Stiff Soil
Site Coefficient, F_a	1.0
Site Coefficient, F_v	N/A
Mapped Spectral Acceleration at 0.2-sec Period, S_s	1.927 g
Mapped Spectral Acceleration at 1.0-sec Period, S_1	0.679 g
Spectral Acceleration at 0.2-sec Period Adjusted for Site Class, S_{MS}	1.927 g
Spectral Acceleration at 1.0-sec Period Adjusted for Site Class, S_{M1}	N/A
Design Spectral Acceleration at 0.2-sec Period, S_{DS}	1.284 g
Design Spectral Acceleration at 1.0-sec Period, S_{D1}	N/A

Site Specific Response Spectra

The USGS Unified Hazard tool, the USGS RTGM Calculator and the USGS App for Deterministic Spectra Acceleration were utilized to develop site specific ground motion spectra. The analysis was performed utilizing the following attenuation relationships that are part of NGA as required by 2019 CBC code requirements.

- Campbell & Bozorgnia (2014)
- Boore, Stewart, Seyhan & Atkinson (2014)
- Chiou & Youngs (2014)
- Abrahamson, Silva & Kamal (2014)

The results of the Site Specific Response Spectra are incorporated in Tables 1 through 3 and on Figure 1 in Appendix B. The results include deterministic spectra at 5% damping, maximum rotated component at 0.84 fractile and the probabilistic spectra, maximum rotated component at 5% damping for a return period of 2475 year and subsequently multiplied by risk coefficient to obtain the MCER probabilistic spectral acceleration. The V_{s30} utilized was 260 m/s.

The above generated spectral accelerations were compared against the minimum code requirements in ASCE7-16 (Chapters 11 and 21) resulting in the final design response spectra which is presented in Table 1 and on Figure 1 in Appendix B.

Based on Tables 1 through 3 and Figure 1, the recommended Site Specific S_{DS} and S_{D1} are as follows:

$$S_{DS} = 1.256$$
$$S_{D1} = 1.102$$

The structural consultant should review the above parameters and the 2019 California Building Code to evaluate the seismic design.

Conformance to the criteria presented in the above table for seismic design does not constitute any type of guarantee or assurance that significant structural damage or ground failure will not occur during a large earthquake event. The intent of the code is "life safety" and not to completely prevent damage of the structure, since such design may be economically prohibitive.

Pavement Design

Based on our field investigation and laboratory testing, presented below are the Asphalt Concrete (AC) pavement design recommendations for the proposed new central parking lot the expansion of the southern parking lot. The pavement section recommendations are based on the tested R-value of 12 for the anticipated pavement subgrade soils and assumed traffic index. The traffic indices shall be approved by the project civil engineer and the reviewing agency.

Pavement Utilization	Assumed Traffic Index	Asphalt Concrete (Inches)	Base (Inches)	Total Thickness (inches)
Parking Stalls	4.5	3.0	8.0	11.0
Drive Aisles	5.0	4.0	7.0	11.0

Aggregate base material for Asphalt Concrete Pavement should consist of CAB/CMB complying with the specifications in Section 200-2.2/200-2.4 of the current "Standard Specifications for Public Works Construction" and should be compacted to at least ninety-five (95) percent of the maximum dry density (ASTM D1557). The surface of the aggregate base should exhibit a firm and unyielding condition just prior to the placement of asphalt concrete paving.

The pavement subgrade should be compacted to a minimum of 90 percent of the maximum laboratory dry density (ASTM D1557) to a minimum depth of one (1) foot. Prior to placement of concrete, the subgrade soils should be moistened to 120 percent optimum moisture content and verified by our field representative.

The R-value and the associated pavement section should be confirmed at the completion of site grading

Church Building Expansion Foundation Design Recommendations

The proposed Fellowship Hall expansions are located to the northeast and southwest of the existing structure within the area of structural fill, shown on Plate 1. The proposed main church building expansion may be supported on continuous and/or spread footings. Bearing capacity recommendations for shallow foundations are presented below. These recommendations assume that the footings will be supported on a minimum of one (1) foot of engineered fill.



For foundations supported on one (1) foot of engineered fill with minimum ninety (90) percent relative compaction an allowable bearing pressure of 2000 pounds per square foot may be used in design.

All shallow foundations should extend a minimum of twenty-four (24) inches below the lowest adjacent grade. The minimum recommended footing width is eighteen (18) inches for continuous footing and eighteen (18) inches for pad footing. A minimum reinforcement of two (2) No. 4 steel bar top and two (2) No. 4 steel bar bottom is required for continuous footings from a geotechnical viewpoint. Foundation design details such as concrete strength, reinforcements, etc should be established by the Structural Engineer.

A one-third (1/3) increase on the aforementioned bearing pressure may be used in design for short-term wind or seismic loads.

The total and differential static and seismic settlement is anticipated to be 1-inch and 0.5-inches over 30 feet or less.

Resistance to lateral loads including wind and seismic forces may be provided by frictional resistance between the bottom of concrete and the underlying fill soils and by passive pressure against the sides of the foundations. A coefficient of friction of 0.33 may be used between concrete foundation and underlying soil. The recommended passive pressure of the engineered fill may be taken as an equivalent fluid pressure of 250 pounds per cubic foot (2,500 psf max).

Any footing excavation adjacent to existing continuous footings may require slot cutting (A-B-C slots). As an alternative, shoring or underpinning of existing footings is recommended.

All foundations excavations shall be approved prior to placement of concrete by the geotechnical consultant. Additional recommendations may be provided if unusual conditions were observed/encountered during excavation

Slab-On-Grade

Slab-on-grade should be a minimum of 5-inches thick and reinforced with a minimum of No. 4 reinforcing bar on 12-inch centers in two horizontally perpendicular directions. Reinforcing should be properly supported to ensure placement near the vertical midpoint of the slab. "Hooking" of the reinforcement is not considered an acceptable method of positioning the steel. The slab should not be structurally connected to the buildings. The subgrade material should be compacted to a minimum of 90 percent of the maximum laboratory dry density (ASTM 1557) to a minimum depth of two (2) feet. Prior to placement of concrete, the subgrade soils should be moistened to 120 percent optimum moisture content and verified by our field representative. The actual thickness and reinforcement of the slab shall be designed by the structural engineer and should include the anticipated loading condition and the anticipated use of the building. For moisture sensitive flooring, the floor slab should be underlain by minimum 15-mil impermeable polyethylene membrane (Stego Wrap, Moistop Plus, or any equivalent meeting the requirements of ASTM E1745, Class A rating) as a capillary break. Sand/gravel/aggregate base may be placed above and below the impermeable polyethylene membrane at the discretion of the project structural engineer/concrete contractor for proper curing and finish of the concrete slab-on-grade and protection of the membrane and is considered outside the scope of geotechnical engineering.

Due to the presence of medium expansive soils, more than normal movement of the flatwork is anticipated. This may be limited by placing a thickened edge (minimum 12-inches) and/or 6-inches of base under the flatwork.

The slab-on-grade foundation shall comply with section 1808.6.2 of the CBC (2019) and shall be designed in accordance with WRI/CRSI Design of Slab-on-Ground Foundations. As an alternate the slab-on-grade shall be supported on minimum 2 feet of non-expansive soil to reduce the impact of expansive soils.

Flatwork

Flatwork should be a minimum of 4-inches thick should be reinforced with a minimum of No. 3 reinforcing bar on 18-inch centers in two horizontally perpendicular directions. Reinforcing should be properly supported to ensure placement near the vertical midpoint of the slab. "Hooking" of the reinforcement is not considered an acceptable method of positioning the steel. The subgrade material should be compacted to a minimum of 90 percent of the maximum laboratory dry density (ASTM D1557) to a minimum depth of one (1) foot. Prior to placement of concrete, the subgrade soils should be moistened to 120 percent optimum moisture content and verified by our field representative. The actual thickness and reinforcement of the slab shall be designed by the structural engineer and should include the anticipated loading condition. Due to the presence of medium expansive soils, more than normal movement of the flatwork is anticipated. This may be limited by placing a thickened edge (minimum 12-inches) and/or 6-inches of base under the flatwork.

Cement Type and Corrosion

Concrete used should be designed in accordance with the provisions of ACI 318-14, Chapter 19 for Exposure Class S0 with a minimum unconfined compressive strength of 2,500 psi.

TGR does not practice corrosion engineering. If needed, a qualified specialist should review the site conditions and evaluate the corrosion potential of the site soil to the proposed improvements and to provide the appropriate corrosion mitigations for the project.

Expansion Potential

Soils onsite have an expansion index of 64, which correlates to a "medium" expansion potential. The slab-on-grade foundation shall comply with section 1808.6.2 of the CBC (2019) and shall be designed in accordance with WRI/CRSI Design of Slab-on-Ground Foundations. As an alternate the slab-on-grade shall be supported on minimum 2 feet of non-expansive soil to reduce the impact of expansive soils.

Site Development Recommendations

Earthwork and Demolition

Within the proposed development and demolition area, all foundations, slab-on-grade, vaults, utility lines, surface vegetation, trash, demolition debris, asphaltic concrete and Portland cement concrete should be cleared and removed from the proposed site.

Depressions resulting from the removal of objects encountered as mentioned above should be backfilled with properly compacted engineered fill under the testing and observation of the geotechnical consultant of record.

During earthwork construction, all site preparation and the general procedures of the contractor should be observed, and the fill and base selectively tested by a representative of TGR. If unusual or unexpected conditions are exposed in the field, they should be reviewed by this office and if warranted, modified and/or additional recommendations will be offered.

Grading

All grading should conform to the guidelines presented in the California Building Code (2019 edition), except where specifically superseded in the text of this report. Prior to grading, TGR's representative should be present at the pre-construction meeting to provide grading guidelines, if needed, and review any earthwork.

At a minimum, the upper two (2) feet of soil under slab-on-grade, one (1) foot of soil under footings, flatwork and asphalt concrete pavement should be removed and replaced as engineered fill, compacted to minimum 90 percent relative compaction and moisture conditioned to 120 percent optimum moisture content per ASTM D1557. Site soils could be reused as engineered fill provided the recommendations presented in this report are implemented. Exposed bottoms should be scarified a minimum of 8-inches, moisture conditioned to 120 percent optimum moisture content and compacted to a minimum 90 percent relative compaction. Subsequently, site fill soils should be re-compacted to a minimum of 90 percent relative compaction at 120 percent optimum moisture content.

The depth of over-excavation should be reviewed by the Geotechnical Consultant during the actual construction. Any subsurface obstruction buried structural elements, and unsuitable material encountered during grading, should be immediately brought to the attention of the Geotechnical Consultant for proper exposure, removal and processing, as recommended.

Fill Placement

Prior to any fill placement TGR should observe the exposed surface soils. The site soils may be re-used as engineered fill provided they are free of organic content and particle size greater than 4-inches. Fill shall be moisture-conditioned to 120 percent optimum moisture content and compacted to a minimum relative compaction of 90 percent in accordance with ASTM D1557. Any import soils shall be non-expansive and approved by TGR Geotechnical Inc.

Compaction

Prior to fill placement, the exposed surface should be scarified to a minimum depth of eight (8) inches, fill placed in eight (8) inch loose lifts, moisture conditioned to 120 percent optimum moisture content and compacted to a minimum relative compaction of 90 percent in accordance with ASTM D 1557.

Temporary Excavation and Shoring

Temporary construction excavations may be anticipated during the proposed development. Site soils may be cut vertically without shoring to a depth of approximately four (4) feet below adjacent surrounding grade. For deeper cuts, the slopes should be properly shored or the entire excavation sloped back to at least 1.5H:1V (Horizontal: Vertical) or flatter. The exposed slope face should be kept moist (but not saturated) during construction to reduce local sloughing. No surcharge loads should be permitted within a horizontal distance equal to the height of cut from the toe of excavation unless the cut is properly shored. Excavations that extend below an

imaginary plane inclined at 45 degrees below the edge of any nearby adjacent existing site facilities should be properly shored to maintain foundation support at the adjacent structures. Any excavation adjacent to existing continuous footings may require slot cutting (A-B-C slots).

Geotechnical Review of Plans

All grading plans and specifications should be reviewed and accepted by the geotechnical consultant before they are finalized to determine if the geotechnical and/or geologic information have been properly implemented. If this firm is not granted the privilege of reviewing the plans and specifications, this firm is not responsible for misinterpretation of the recommendations given in this report.

Geotechnical Observation/Testing During Construction

Per sections 1705.6 and table 1705.6 of the 2019 California Building Code, periodic special inspection shall be performed to:

- Verify materials below shallow foundations are adequate to achieve the design bearing capacity;
- Verify excavations are extended to the proper depth and have reached proper material;
- Verify classification and test compacted materials; and
- Prior to placement of compacted fill, inspect subgrade and verify that the site has been prepared properly

Per sections 1705.6 and table 1705.6 of the 2019 California Building Code, continuous special inspection shall be performed to:

- Verify use of proper materials, densities and lift thickness during placement and compaction of compacted fill.

The geotechnical consultant should also perform observation and/or testing at the following stages:

- During any grading and fill placement;
- During utility trench excavation and backfill;
- After foundation excavation and prior to placing concrete;
- During placement of aggregate base and asphalt paving;
- When any unusual soil conditions are encountered during any construction operation subsequent to issuance of this report.

LIMITATIONS

This report has been prepared for the exclusive use of Kindred Community Church and their design consultants relative to developing the subject site. No portion of this report may be used by other parties or for other purposes. Unauthorized use of or reliance on this report constitutes an agreement to defend and indemnify TGR from and against any liability which may arise as a result of such use or reliance, regardless of any fault, negligence, or strict liability of TGR.

TGR considered a number of unique, project-specific factors when establishing the scope of services for this report. This report has not been prepared for use by other parties, and may not contain sufficient information for purposes of other parties.

This report was necessarily based in part upon data obtained from a limited number of observances, site visits, soil and/or other samples, tests, analyses, histories of occurrences, spaced subsurface exploration and limited information on historical events and observations. Such information is necessarily incomplete. Variations can be experienced within small distances and under various climatic conditions. Changes in subsurface conditions can and do occur over time.

If you have any questions regarding this report, please do not hesitate to contact this office. We appreciate this opportunity to be of service.

Respectfully submitted,

TGR GEOTECHNICAL, INC.



Sanjay Govil, PhD, PE, GE 2382
Principal Geotechnical Engineer



Edward L. Burrows, M.S, PG, CEG 1750
Principal Engineering Geologist

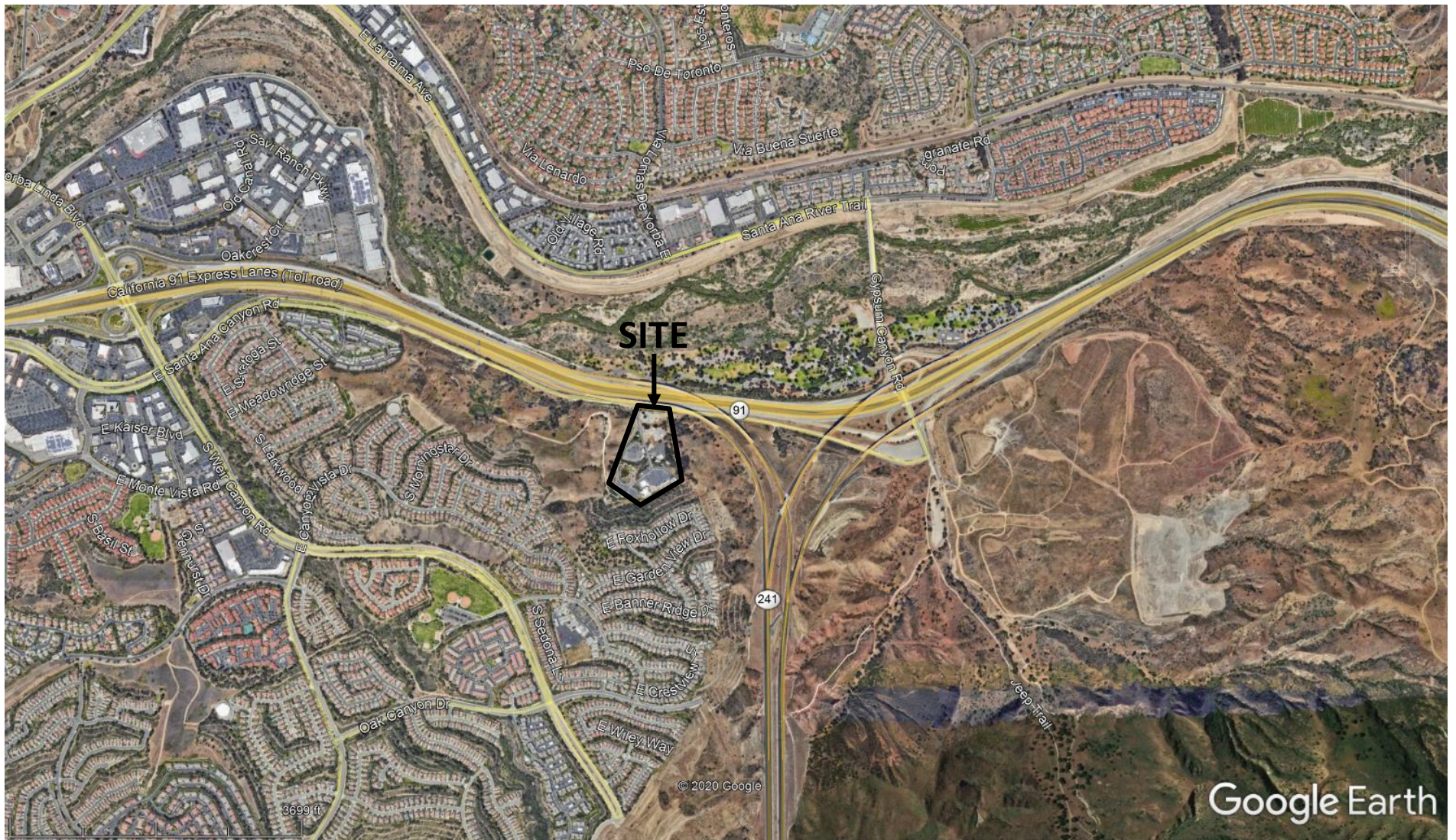
Attachments: Figure 1 – Site Location Map
Figure 2 – Regional Geology Map
Figure 3 – Historic High Groundwater Map

Plate 1 – Geotechnical Map
Plates 2 through 6 – Boring Logs
Plate 7 – Maximum Dry Density and Optimum Moisture Content
Plate 8 – Direct Shear Test Results
Plates 9 and 10 – R-Value Test Results
Plate 11 – Analytical Report for Soluble Sulfates

Table 1 – Percolation Test Worksheet

Appendix A – References
Appendix B – Site Seismic Design and De-Aggregated Parameters

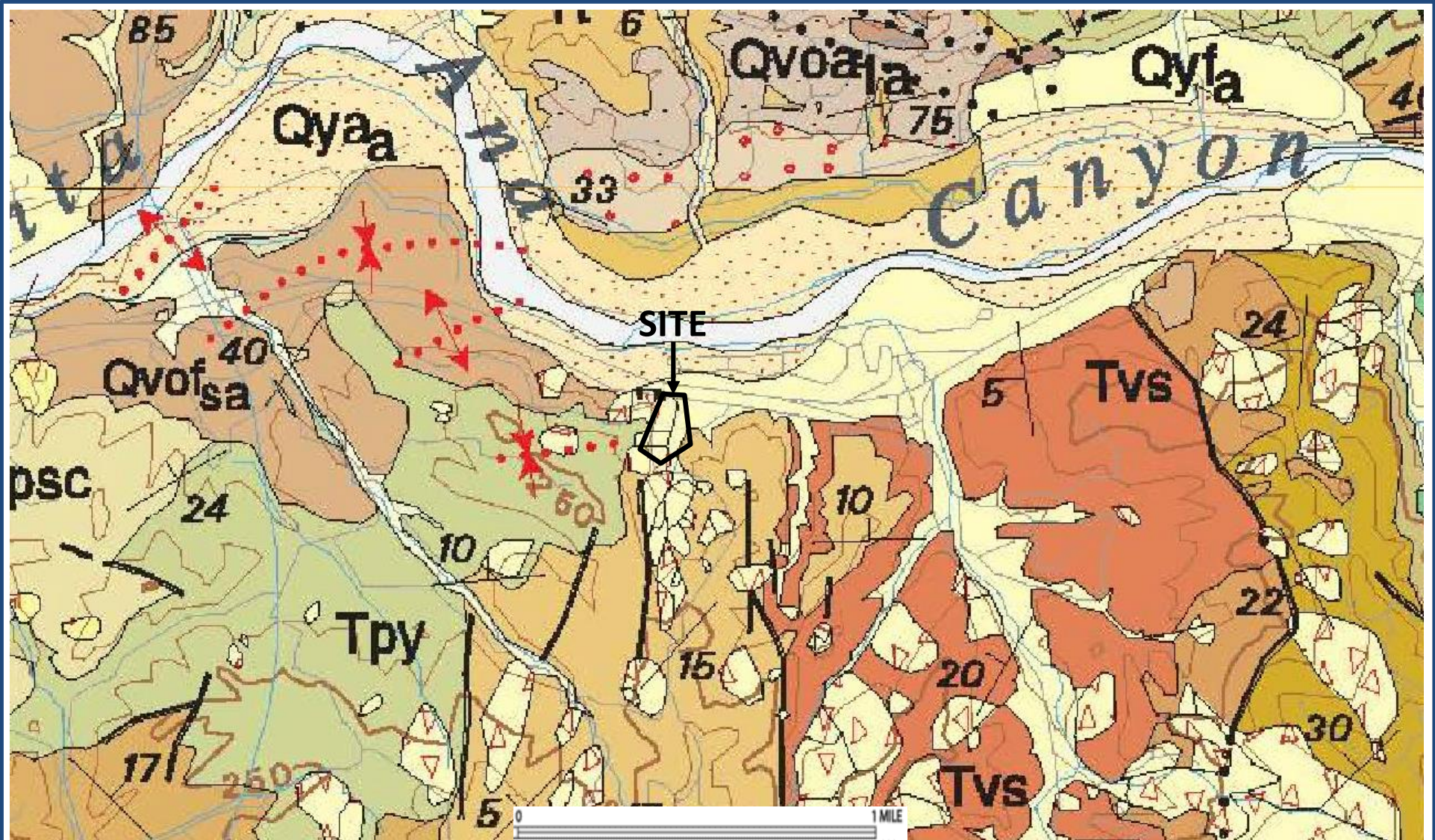
Distribution: (1) Addressee



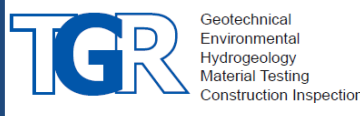
SITE LOCATION MAP
KINDRED CHURCH, 8720 E. SANTA ANA CANYON ROAD,
ANAHEIM, CALIFORNIA

PROJECT NO. 15-5382

FIGURE 1

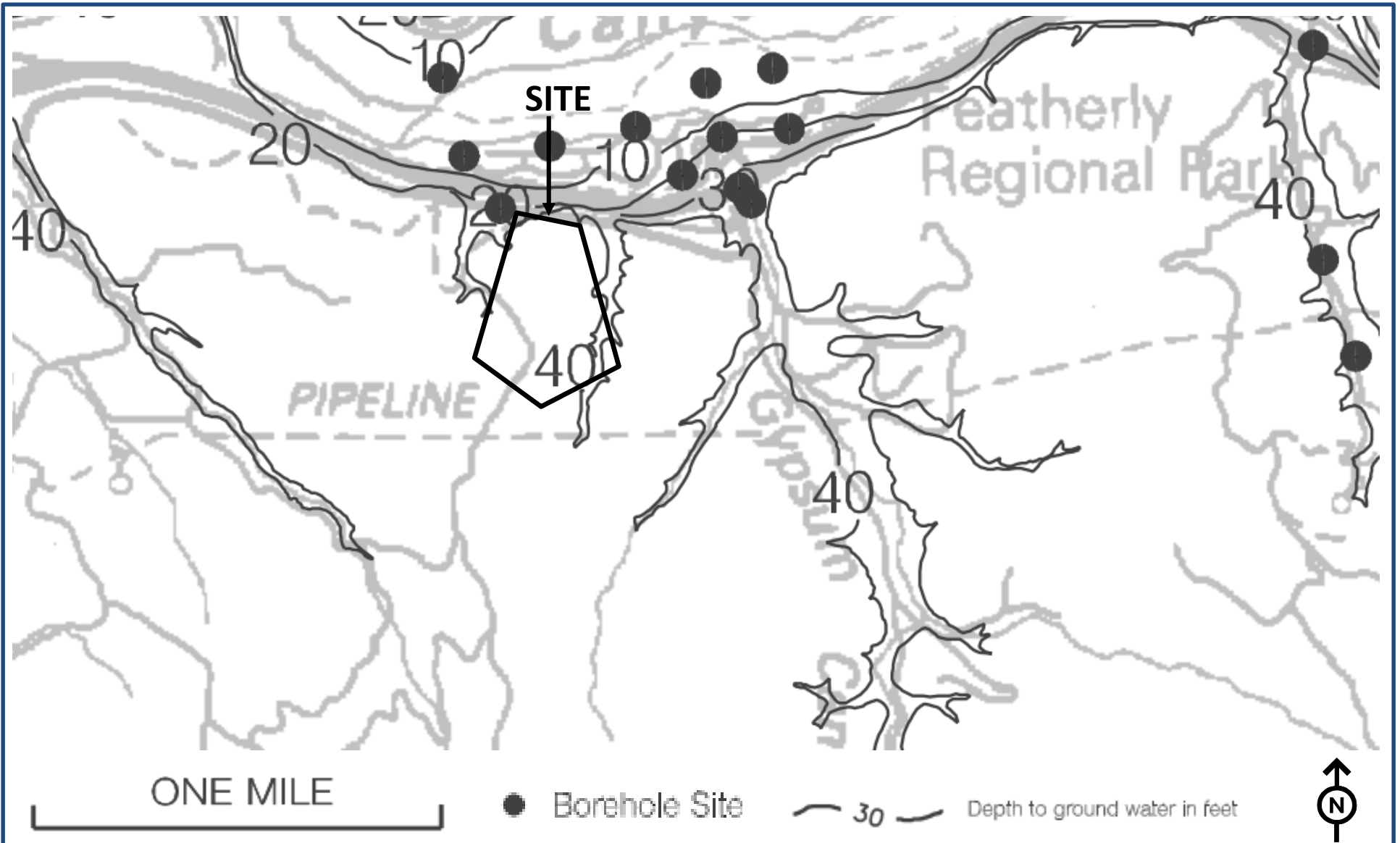


Morton, D.M., and Miller, F.K., 2006, Geologic map of the San Bernardino and Santa Ana 30' x 60' quadrangles, California: U.S. Geological Survey, Open-File Report OF-2006-1217, scale 1:100,000.



REGIONAL GEOLOGY MAP
 KINDRED CHURCH, 8720 E. SANTA ANA CANYON ROAD,
 ANAHEIM, CALIFORNIA

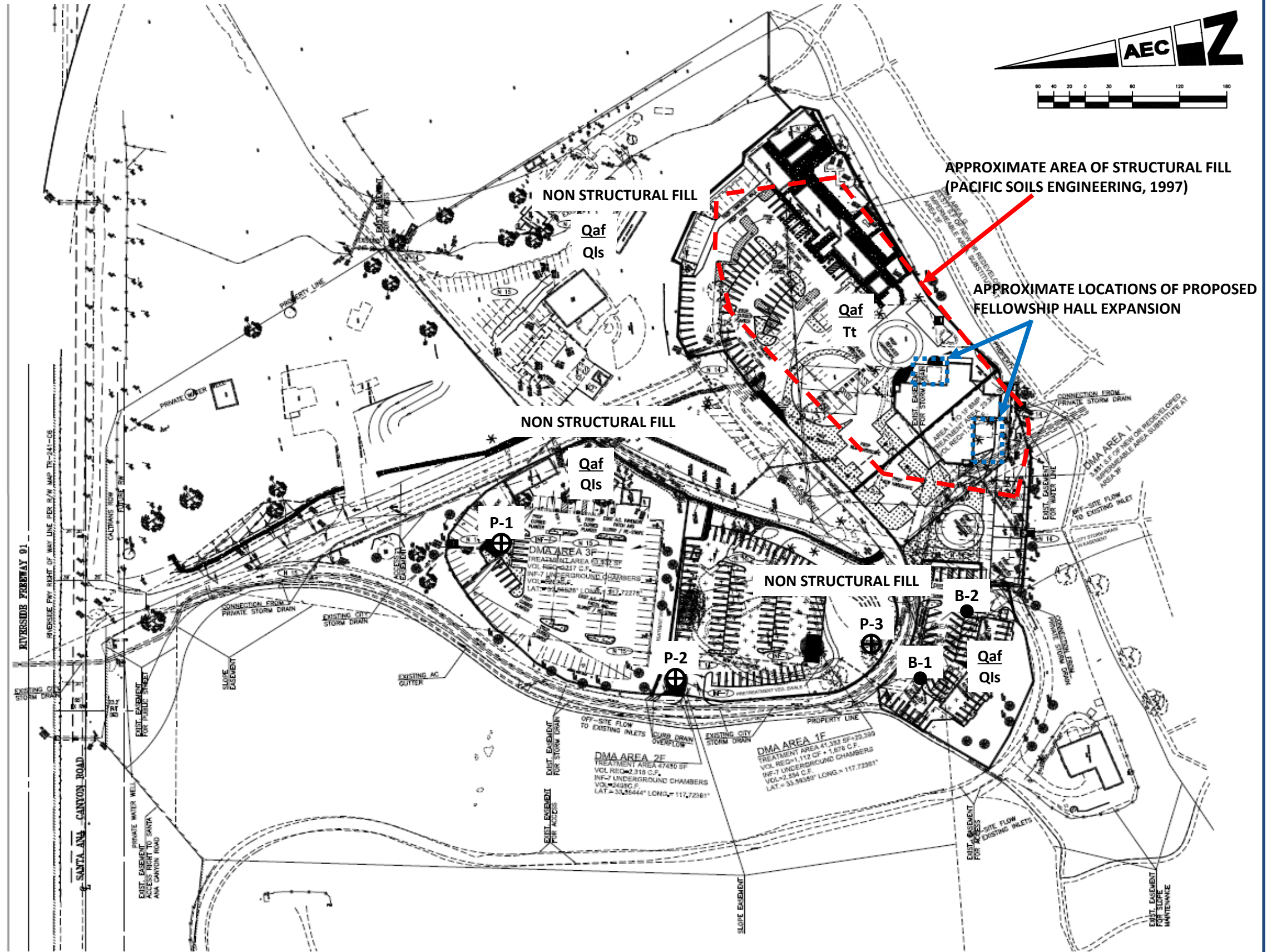
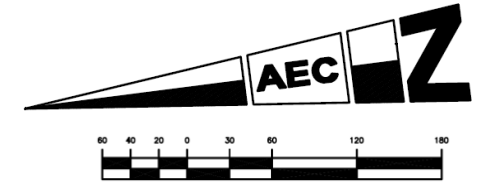
PROJECT NO. 15-5382
 FIGURE 2



Modified From: California Department of Conservation, Division of Mines and Geology, 2000, Seismic Hazard Zone Report for the Black Star Canyon 7.5-Minute Quadrangle, Los Angeles and Orange Counties, California, Report 046.

MAP LEGEND

- Qaf** ARTIFICIAL FILL
- Qls** LANDSLIDE DEBRIS
- Tt** TOPANGA FORMATION
- B-2** ● APPROXIMATE LOCATION OF GEOTECHNICAL BORING
- P-3** ⊕ APPROXIMATE LOCATION OF PERCOLATION BORING



Geotechnical
Environmental
Hydrogeology
Material Testing
Construction Inspection

GEOTECHNICAL MAP
KINDRED CHURCH, 8720 E. SANTA ANA CANYON ROAD
ANAHEIM, CALIFORNIA

Project No. 15-5382

PLATE 1

LOG OF EXPLORATORY BORING P - 1

Sheet 1 of 1

Project Number: **15-5382**
 Project Name: **Kindred Community Church, Anaheim**
 Date Drilled: **10/13/20 - 10/13/20**
 Ground Elev: _____

Logged By: **RA**
 Project Engineer: **SG**
 Drill Type: **Hollow Stem**
 Drive Wt & Drop: **140lbs / 30in**

Depth (ft)	Graphic Log	FIELD RESULTS				LAB RESULTS			
		Bulk Sample	Drive Sample	SPT blows/ft (or equivalent N)	Pocket Pen (tsf)	USCS	Moisture Content (%)	Dry Density, (pcf)	Other Tests
						Shelby Tube Modified California Standard Split Spoon Water Table ATD No recovery			
SUMMARY OF SUBSURFACE CONDITIONS									

5			46		SC	Surface is a planter with 6 inches of mulch and topsoil. Clayey Sand with Gravel- tan, moist, medium dense, fine grained sand, fine to coarse grained gravel. Clayey Sand- tan brown, very moist, dense, some fine grained gravel and clasts, orange oxidation.	18	110	-200= 45.5%
10			53		SC	...Same as above, very dense, some blue grey sand. Organic Clay- black, moist, hard, some fine grained gravel, pieces of organic material.	10	123	-200= 46.1%
						Total Depth: 10.5 feet. No groundwater encountered during drilling. No caving observed. Boring utilized for percolation testing. Boring backfilled with soil cuttings upon completion.			

LOG OF BORING 15-5382 KINDRED CHURCH ANAHEIM.GPJ TGR GEOTECH.GDT 10/21/20

This Boring Log should be evaluated in conjunction with the complete geotechnical report. This Boring Log represents conditions observed at the specific location and date indicated, it is not warranted to be representative of subsurface conditions at other locations and times.

PLATE 4



LOG OF EXPLORATORY BORING P - 2

Sheet 1 of 1

Project Number: **15-5382**
 Project Name: **Kindred Community Church, Anaheim**
 Date Drilled: **10/13/20 - 10/13/20**
 Ground Elev: _____

Logged By: **RA**
 Project Engineer: **SG**
 Drill Type: **Hollow Stem**
 Drive Wt & Drop: **140lbs / 30in**

Depth (ft)	Graphic Log	FIELD RESULTS				LAB RESULTS			
		Bulk Sample	Drive Sample	SPT blows/ft (or equivalent N)	Pocket Pen (tsf)	USCS	Moisture Content (%)	Dry Density, (pcf)	Other Tests
						Shelby Tube Modified California Standard Split Spoon Water Table ATD No recovery			
SUMMARY OF SUBSURFACE CONDITIONS									

5			51	CL-ML	Surface is a dirt and vegetation area. Clayey Sand- tan, moist, medium dense, fine grained sand, fine to coarse grained gravel and clasts. Clayey Silt and Sand- tan silt, dark grey clay, moist, hard, very fine grained sand, orange oxidation.	16	110	-200= 53.0%	Max, R-Value, Shear, EI
10			46	CLS	Clayey Sand- brown, moist, dense, fine grained sand, fine to coarse grained gravel. Sandy Clay- tan, very moist, dense, fine grained sand, orange oxidation.	18	106	-200= 59.0%	
Total Depth: 10.5 feet. No groundwater encountered during drilling. No caving observed. Boring utilized for percolation testing. Boring backfilled with soil cuttings upon completion.									

LOG OF BORING 15-5382 KINDRED CHURCH ANAHEIM.GPJ TGR GEOTECH.GDT 10/21/20

This Boring Log should be evaluated in conjunction with the complete geotechnical report. This Boring Log represents conditions observed at the specific location and date indicated, it is not warranted to be representative of subsurface conditions at other locations and times.

PLATE 5



LOG OF EXPLORATORY BORING P - 3

Sheet 1 of 1

Project Number: **15-5382**
 Project Name: **Kindred Community Church, Anaheim**
 Date Drilled: **10/13/20 - 10/13/20**
 Ground Elev: _____

Logged By: **RA**
 Project Engineer: **SG**
 Drill Type: **Hollow Stem**
 Drive Wt & Drop: **140lbs / 30in**

Depth (ft)	Graphic Log	FIELD RESULTS				LAB RESULTS			
		Bulk Sample	Drive Sample	SPT blows/ft (or equivalent N)	Pocket Pen (tsf)	USCS	Moisture Content (%)	Dry Density, (pcf)	Other Tests
						Shelby Tube Standard Split Spoon No recovery Modified California Water Table ATD			
SUMMARY OF SUBSURFACE CONDITIONS									

5			22		SC	Surface is a dirt and vegetation covered area. Clayey Sand- tan, moist, medium dense, fine grained, fine to coarse pieces of caliche. ...Same as above, no caliche.	11	103	-200= 33.9%
10			29		SC	Clayey Sand- light brown sand, blue grey clay, moist, medium dense, fine grained sand, fine to coarse grained gravel and clasts, orange oxidation.	16	116	-200= 43.5%
						Total Depth: 10.5 feet. No groundwater encountered during drilling. No caving observed. Boring utilized for percolation testing. Boring backfilled with soil cuttings upon completion.			

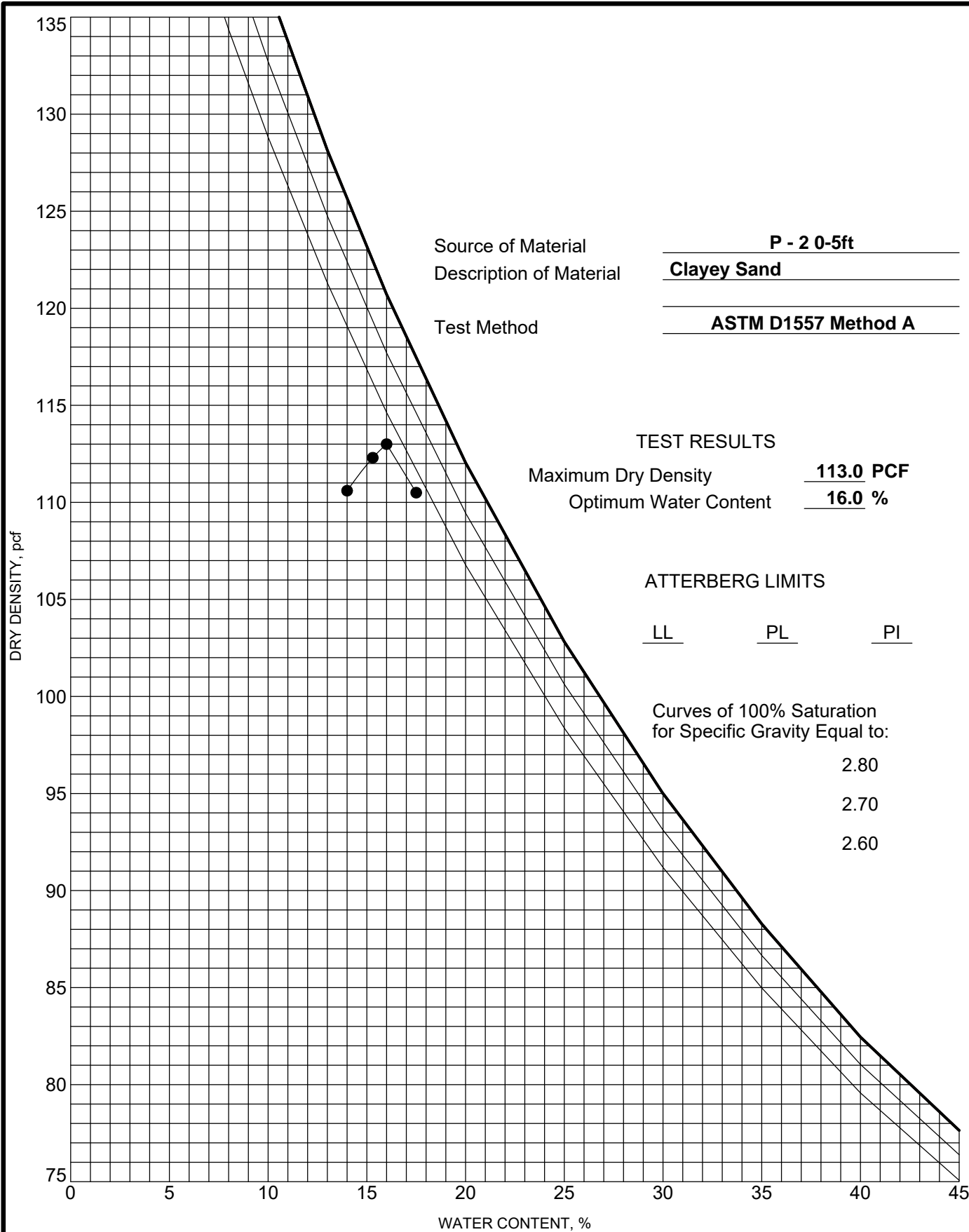
LOG OF BORING 15-5382 KINDRED CHURCH ANAHEIM.GPJ TGR GEOTECH.GDT 10/21/20

This Boring Log should be evaluated in conjunction with the complete geotechnical report. This Boring Log represents conditions observed at the specific location and date indicated, it is not warranted to be representative of subsurface conditions at other locations and times.

PLATE 6



US COMPACTION 15-5382 KINDRED CHURCH ANAHEIM.GPJ_TGR GEOTECH.GDT 10/16/20



3037 S. Harbor Blvd
 Santa Ana, CA 92704
 Telephone: 714-641-7189
 Fax: 714-641-7190

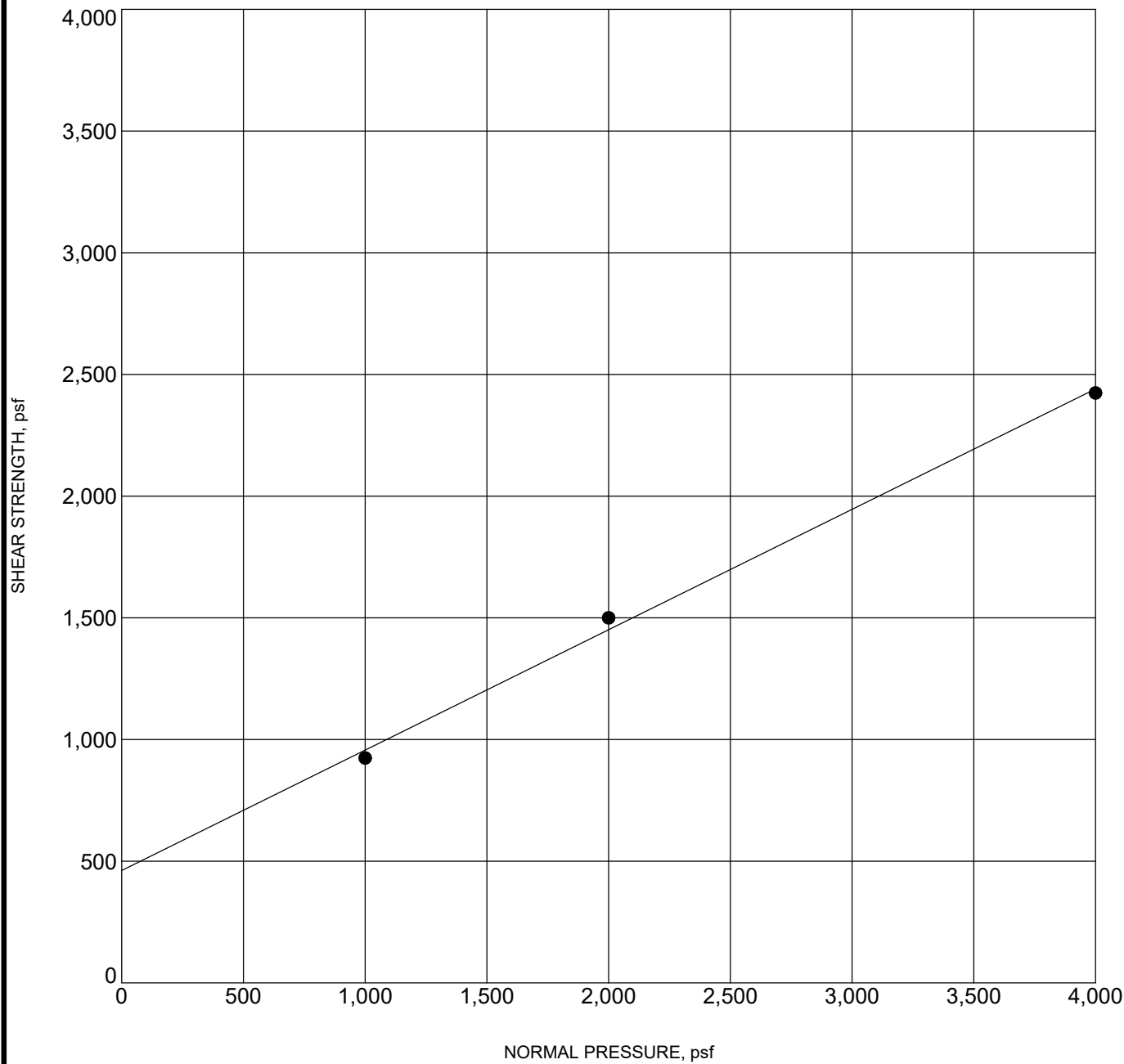
MOISTURE-DENSITY RELATIONSHIP

Project Number: 15-5382

PLATE 7

Project Name: Kindred Community Church, Anaheim

US DIRECT SHEAR_15-5382 KINDRED CHURCH ANAHEIM.GPJ TGR GEOTECH.GDT 10/16/20



Specimen Identification	Classification	γ_d	MC%	c	ϕ
● P - 2 0-5	Clayey Sand - Remolded - 90% RC	102	16	462	26



TGR GEOTECHNICAL, INC.

3037 S. Harbor Blvd
 Santa Ana, CA 92704
 Telephone: 714-641-7189
 Fax: 714-641-7190

DIRECT SHEAR TEST

Project Number: 15-5382

PLATE 8

Project Name: Kindred Community Church, Anaheim



R - VALUE DATA SHEET

PROJECT No. 46558

DATE: 10/16/2020


BORING NO. 15-5382
Kindred Community Church

SAMPLE DESCRIPTION: Brown Sandy Clay

R-VALUE TESTING DATA CA TEST 301			
	SPECIMEN ID		
	a	b	c
Mold ID Number	16	17	18
Water added, grams	70	17	32
Initial Test Water, %	20.8	15.1	16.7
Compact Gage Pressure, psi	45	170	90
Exudation Pressure, psi	225	458	326
Height Sample, Inches	2.67	2.47	2.52
Gross Weight Mold, grams	3051	3008	3027
Tare Weight Mold, grams	1946	1940	1955
Sample Wet Weight, grams	1105	1068	1072
Expansion, Inches x 10exp-4	23	92	62
Stability 2,000 lbs (160psi)	63 / 143	33 / 81	40 / 101
Turns Displacement	4.28	3.61	3.88
R-Value Uncorrected	6	40	27
R-Value Corrected	7	40	27
Dry Density, pcf	103.8	113.8	110.4

DESIGN CALCULATION DATA

Traffic Index	Assumed:	4.0	4.0	4.0
G.E. by Stability		0.95	0.61	0.75
G. E. by Expansion		0.77	3.07	2.07

Equilibrium R-Value	12 by EXPANSION	Examined & Checked: 10 /16/ 20
REMARKS:	Gf = 1.25	
	0.0% Retained on the	
	3/4" Sieve.	

The data above is based upon processing and testing samples as received from the field. Test procedures in accordance with latest revisions to Department of Transportation, State of California, Materials & Research Test Method No. 301.



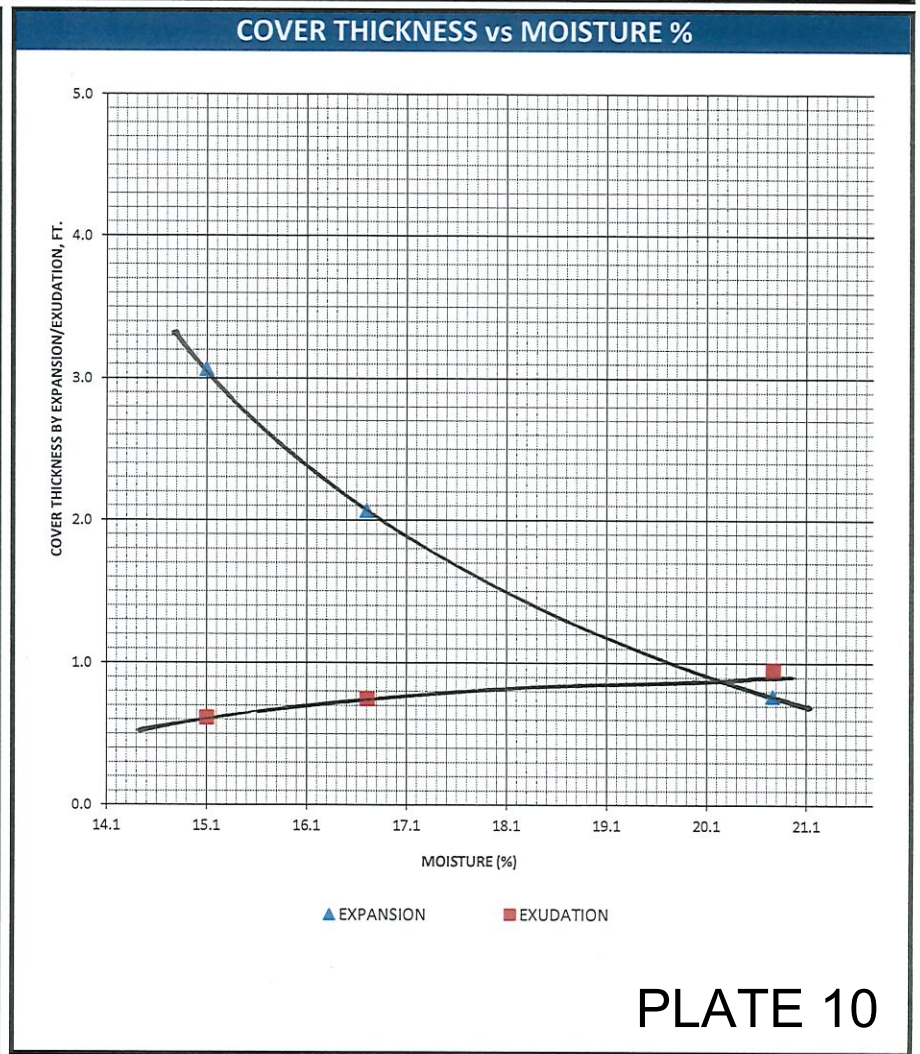
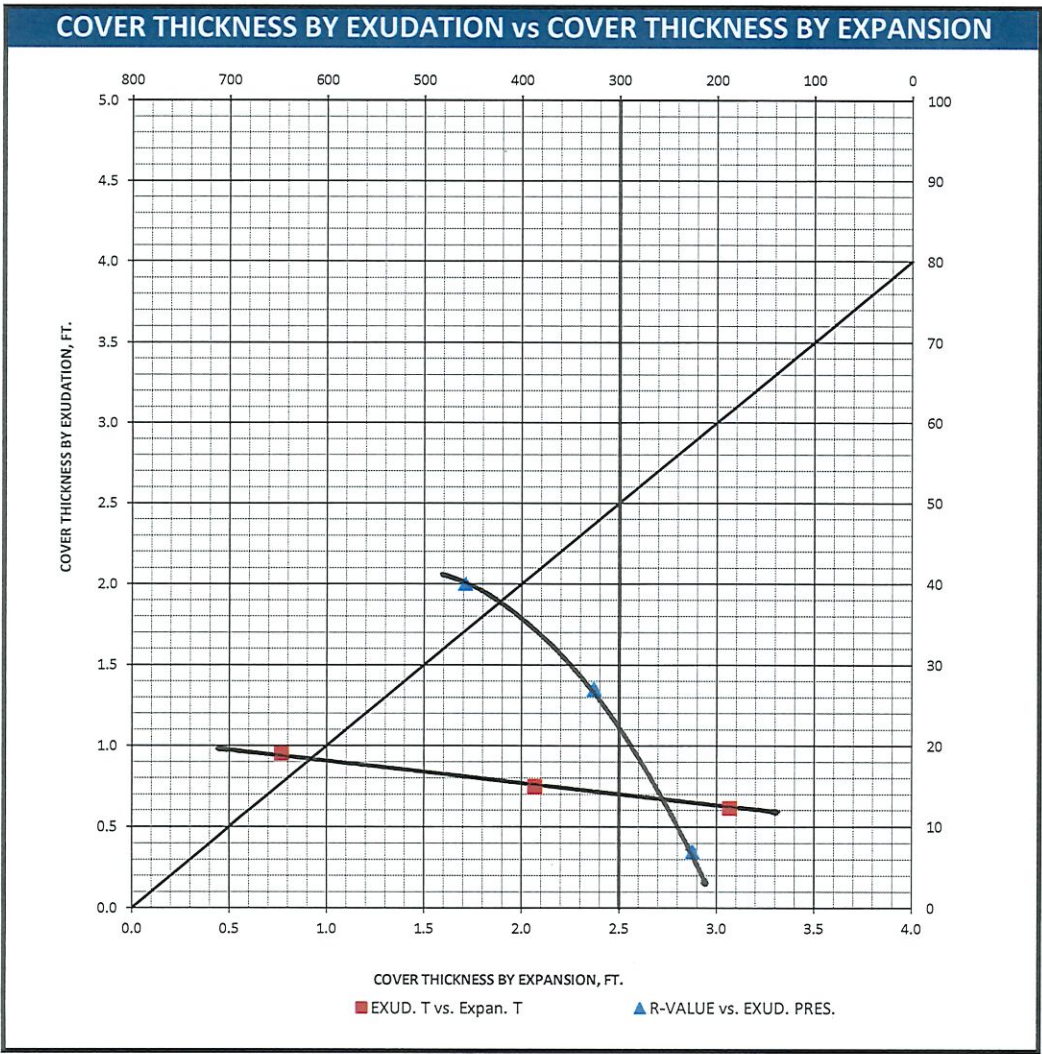
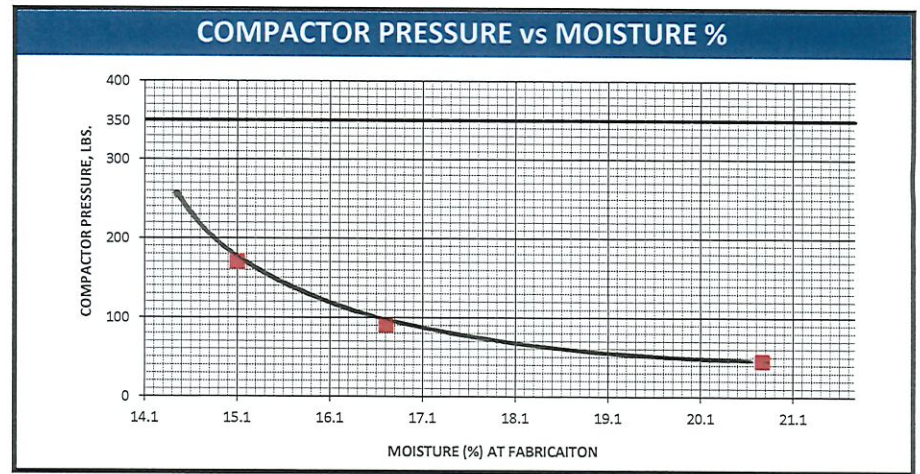
R-VALUE GRAPHICAL PRESENTATION

PROJECT NO. 46558

DATE: 10 /16/ 2020

REMARKS: _____

BORING NO. 15-5382
Kindred Community Church



ANAHEIM TEST LAB, INC.

196 Technology Drive, Unit D
Irvine, CA 92618
Phone (949)336-6544

TO:

TGR GEOTECHNICAL
3037 S. HARBOR BLVD.
SANTA ANA, CA. 92704

DATE: 10/20/2020

P.O. NO: VERBAL

LAB NO: C-4184

SPECIFICATION: CTM-417

MATERIAL: Soil

Project No.: 15-5382
Project: Kindred Community Church
Sample ID: B2 @ 0-5'

ANALYTICAL REPORT

SOLUBLE SULFATES

per CT. 417

ppm

218

RESPECTFULLY SUBMITTED



WES BRIDGER LAB MANAGER

Test Hole	Total Depth (in)	Initial Depth (in)	Final Depth (in)	Δ Water Level (in)	Initial Time (min)	Final Time (min)	Δ Time (min)	Initial Height of Water (in)	Final Height of Water (in)	Average Height of Water (in)	Infiltration Rate (in/hr)
P-1	126	3.5	5	1.5	0.0	10.0	10.0	122.5	121	121.75	0.15
	126	3	4.5	1.5	0.0	10.0	10.0	123	121.5	122.25	0.14
	126	3	4.5	1.5	0.0	10.0	10.0	123	121.5	122.25	0.14
	126	4	5	1	0.0	10.0	10.0	122	121	121.50	0.10
	126	3.5	5	1.5	0.0	10.0	10.0	122.5	121	121.75	0.15
	126	3	4.5	1.5	0.0	10.0	10.0	123	121.5	122.25	0.14
P-2	126	3	7	4	0.0	10.0	10.0	123	119	121.00	0.39
	126	6.5	8.5	2	0.0	10.0	10.0	119.5	117.5	118.50	0.20
	126	5	7.5	2.5	0.0	10.0	10.0	121	118.5	119.75	0.25
	126	5.5	7.5	2	0.0	10.0	10.0	120.5	118.5	119.50	0.20
	126	5.5	7.5	2	0.0	10.0	10.0	120.5	118.5	119.50	0.20
	126	6	8	2	0.0	10.0	10.0	120	118	119.00	0.20
P-3	126	4.5	7	2.5	0.0	10.0	10.0	121.5	119	120.25	0.25
	126	9	11	2	0.0	10.0	10.0	117	115	116.00	0.20
	126	9.5	11	1.5	0.0	10.0	10.0	116.5	115	115.75	0.15
	126	10.5	12	1.5	0.0	10.0	10.0	115.5	114	114.75	0.15
	126	10	11.5	1.5	0.0	10.0	10.0	116	114.5	115.25	0.15

$$I_t = \frac{\Delta H(60r)}{\Delta t(r + 2H_{avg})}$$

ΔH = Change in height

Δt = Time interval

r = Radius

I_t = Infiltration Rate

H_{ave} = Average Head Height over the time interval

APPENDIX A REFERENCES

TGR GEOTECHNICAL
DBE & 8(a) firm
3037 S. HARBOR BLVD
SANTA ANA, CA 92704
P 714.641.7189 F 714.641.7190
www.tgrgeotech.com



APPENDIX A

References

Allwest Geoscience, Inc., 1999, Remedial Grading Report for the Planned Garden Church Development, 8712 East Santa Ana Canyon Road, Anaheim, Orange County, California, Job No. 98-1342GC-1, dated December 20, 1999.

Bell/Knott & Associates, Kindred Community Church, Campus Design Development

Giles Engineering Associates, Inc., 2014, Geotechnical Feasibility Study, Proposed Site Development, 8270 East Santa Ana Canyon Road, Anaheim Hills, California, Project No. 2G-1402006, dated March 18, 2014.

California Department of Conservation Division of Mines and Geology Open-File Report 90-19, Landslide Hazards in the North Half of the Black Star Canyon Quadrangle, Orange and Riverside Counties, California, dated 1992.

Pacific Soils Engineering, Inc., 1997a, Mass Grading Report, Garden Church Site, The Summit, in the City of Anaheim, California, Work Order 101476G4, dated February 28, 1997.

_____, 1997b, Project Grading Report, Lots 3 through 25 incl., Tract 15125, Single-Family Residential Development, The Summit, in the City of Anaheim, California, Work Order 101476G4, dated April 11, 1997.

_____, 1997c, Project Grading Report, Lots 1 and 2, Tract 15125, Single-Family Residential Development, The Summit, in the City of Anaheim, California, Work Order 101476G4, dated April 28, 1997.

_____, 1997d, Project Grading Report, Lots 3 through 26 incl., Tract 15120, Single-Family Residential Development, The Summit, in the City of Anaheim, California, Work Order 101476G4, dated May 6, 1997.

Sessions Consulting Engineers, 2015, Aerial Topography Map, Kindred Community Church, 8712 E. Santa Ana Canyon Road, Anaheim California, Project No. 01-227-1, dated May 4, 2015.

APPENDIX B
SITE SEISMIC DESIGN AND DE-AGGREGATED PARAMETERS

FIGURE 1
Site Specific Design Response Spectra
15-5382 Kindred Community Church

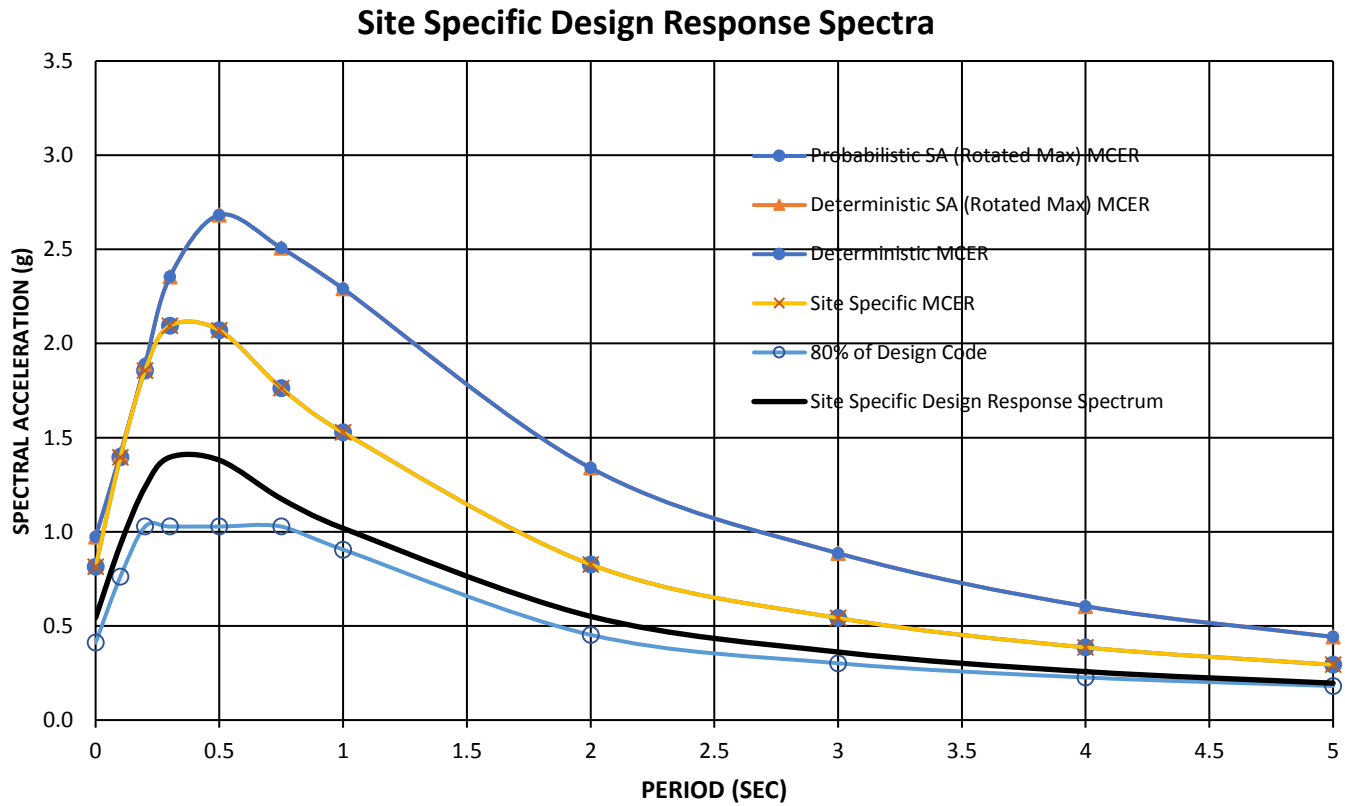


TABLE 2

**Probabilistic Response Spectrum ASCE 7-16 Method 2
15-5382 Kindred Community Church**

Period (g)	UHGM (g)	RTGM (g)	Max Dir Scale factor	Max Dir RTGM (g)
0	0.842	0.813	1.1	0.894
0.1	1.432	1.392	1.1	1.531
0.2	1.881	1.853	1.1	2.038
0.3	2.136	2.043	1.125	2.298
0.5	2.067	1.934	1.175	2.272
0.75	1.687	1.564	1.2375	1.935
1	1.410	1.290	1.3	1.677
2	0.734	0.672	1.35	0.907
3	0.466	0.425	1.4	0.595
4	0.320	0.292	1.45	0.423
5	0.237	0.215	1.5	0.323

Probabilistic Response Spectra per ASCE 7-16

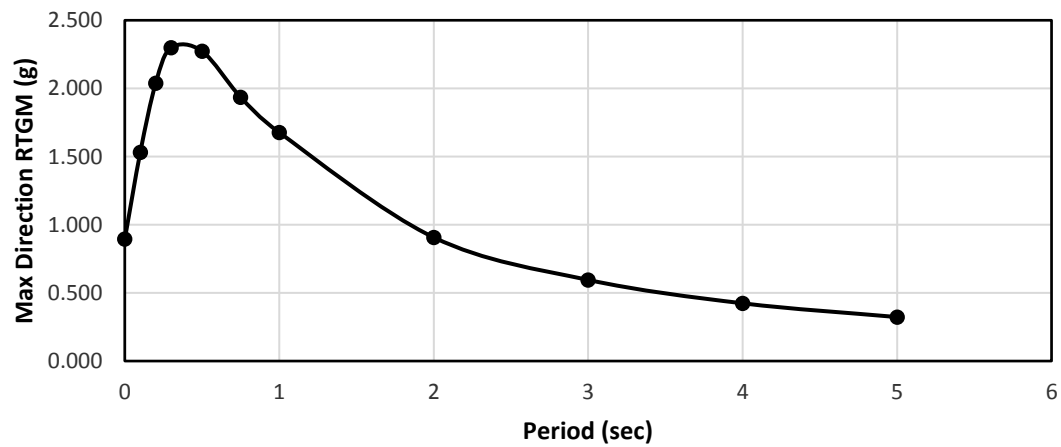
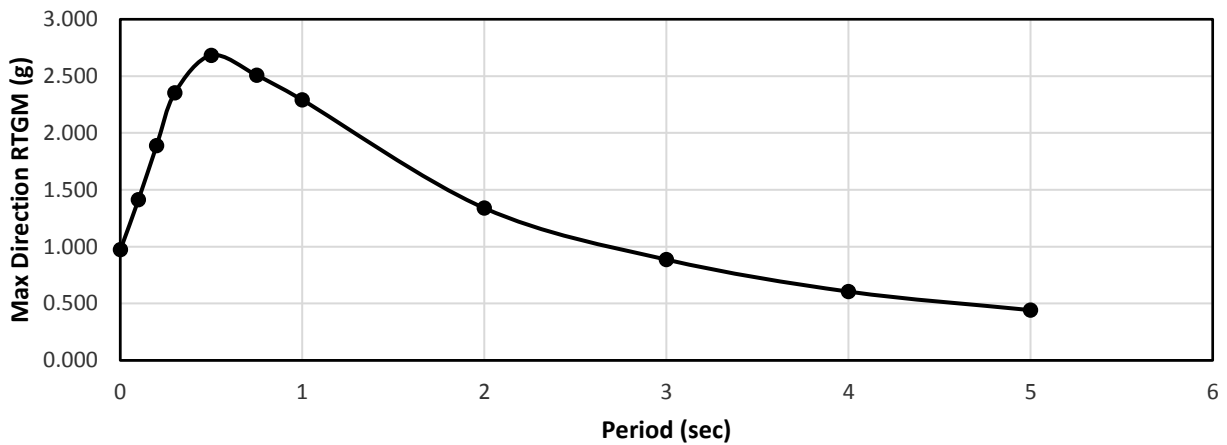


TABLE 3
Deterministic Response Spectrum ASCE 7-16
15-5382 Kindred Community Church

Period (g)	Mean Spectra (g)	Sigma (g)	84th-Percentile Spectral Acceleration (g)	Max Dir Scale factor	Max Dir Deterministic SA (g)
0.001	0.538	0.497	0.885	1.1	0.973
0.1	0.754	0.532	1.283	1.1	1.412
0.2	1.044	0.498	1.718	1.1	1.890
0.3	1.242	0.521	2.092	1.125	2.353
0.5	1.271	0.586	2.283	1.175	2.683
0.75	1.074	0.634	2.026	1.2375	2.507
1	0.906	0.666	1.762	1.3	2.290
2	0.491	0.703	0.992	1.35	1.339
3	0.311	0.710	0.633	1.4	0.886
4	0.207	0.701	0.417	1.45	0.605
5	0.146	0.702	0.294	1.5	0.441

Deterministic Response Spectra per ASCE 7-16



Search Information

Coordinates: 33.8635, -117.7224
Elevation: 450 ft
Timestamp: 2020-11-09T23:39:46.837Z
Hazard Type: Seismic
Reference Document: ASCE7-16
Risk Category: III
Site Class: D



Basic Parameters

Name	Value	Description
S_S	1.927	MCE_R ground motion (period=0.2s)
S_1	0.679	MCE_R ground motion (period=1.0s)
S_{MS}	1.927	Site-modified spectral acceleration value
S_{M1}	* null	Site-modified spectral acceleration value
S_{DS}	1.284	Numeric seismic design value at 0.2s SA
S_{D1}	* null	Numeric seismic design value at 1.0s SA

* See Section 11.4.8

Additional Information

Name	Value	Description
SDC	* null	Seismic design category
F_a	1	Site amplification factor at 0.2s
F_v	* null	Site amplification factor at 1.0s
CR_S	0.911	Coefficient of risk (0.2s)
CR_1	0.911	Coefficient of risk (1.0s)
PGA	0.816	MCE_G peak ground acceleration
F_{PGA}	1.1	Site amplification factor at PGA
PGA_M	0.897	Site modified peak ground acceleration
T_L	8	Long-period transition period (s)

SsRT	1.927	Probabilistic risk-targeted ground motion (0.2s)
SsUH	2.115	Factored uniform-hazard spectral acceleration (2% probability of exceedance in 50 years)
SsD	2.336	Factored deterministic acceleration value (0.2s)
S1RT	0.679	Probabilistic risk-targeted ground motion (1.0s)
S1UH	0.745	Factored uniform-hazard spectral acceleration (2% probability of exceedance in 50 years)
S1D	0.931	Factored deterministic acceleration value (1.0s)
PGAd	0.984	Factored deterministic acceleration value (PGA)

* See Section 11.4.8

The results indicated here DO NOT reflect any state or local amendments to the values or any delineation lines made during the building code adoption process. Users should confirm any output obtained from this tool with the local Authority Having Jurisdiction before proceeding with design.

Disclaimer

Hazard loads are provided by the U.S. Geological Survey [Seismic Design Web Services](#).

While the information presented on this website is believed to be correct, ATC and its sponsors and contributors assume no responsibility or liability for its accuracy. The material presented in the report should not be used or relied upon for any specific application without competent examination and verification of its accuracy, suitability and applicability by engineers or other licensed professionals. ATC does not intend that the use of this information replace the sound judgment of such competent professionals, having experience and knowledge in the field of practice, nor to substitute for the standard of care required of such professionals in interpreting and applying the results of the report provided by this website. Users of the information from this website assume all liability arising from such use. Use of the output of this website does not imply approval by the governing building code bodies responsible for building code approval and interpretation for the building site described by latitude/longitude location in the report.

Unified Hazard Tool



Please do not use this tool to obtain ground motion parameter values for the design code reference documents covered by the [U.S. Seismic Design Maps web tools](#) (e.g., the International Building Code and the ASCE 7 or 41 Standard). The values returned by the two applications are not identical.

^ Input

Edition

Dynamic: Conterminous U.S. 2014 (u...

Spectral Period

Peak Ground Acceleration

Latitude

Decimal degrees

33.8635

Time Horizon

Return period in years

2475

Longitude

Decimal degrees, negative values for western longitudes

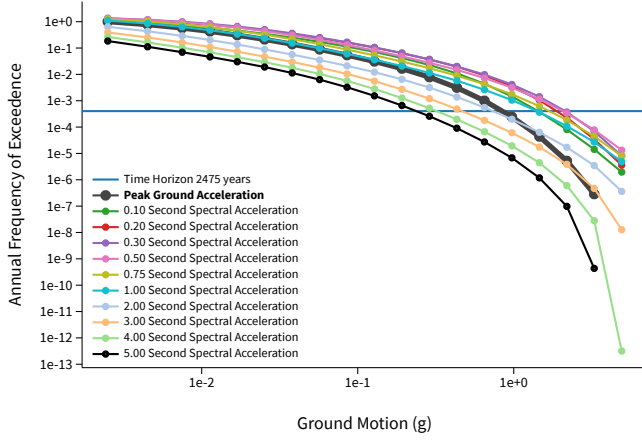
-117.7224

Site Class

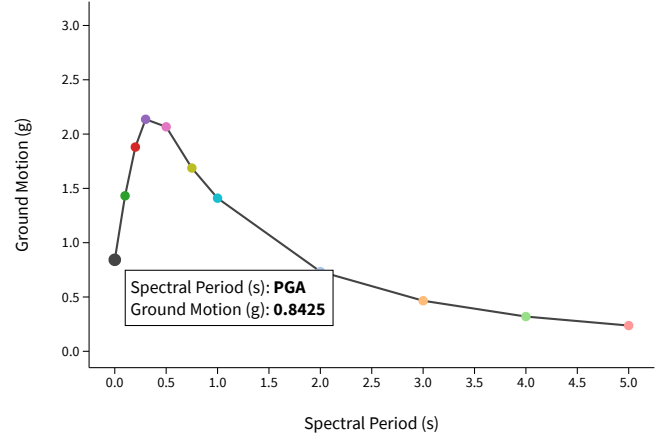
259 m/s (Site class D)

^ Hazard Curve

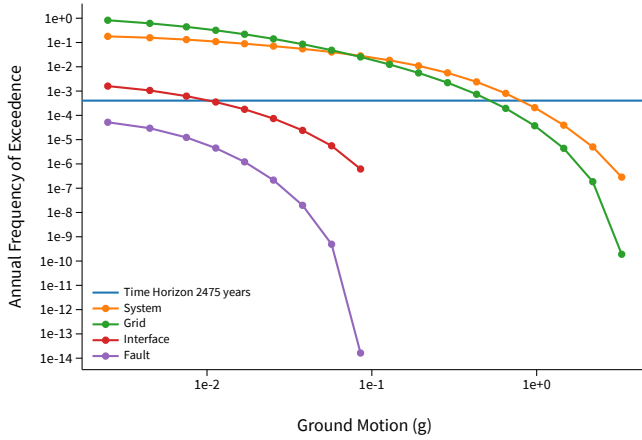
Hazard Curves



Uniform Hazard Response Spectrum



Component Curves for Peak Ground Acceleration



[View Raw Data](#)

Summary statistics for, Deaggregation: Total

Deaggregation targets

Return period: 2475 yrs

Exceedance rate: 0.0004040404 yr⁻¹

PGA ground motion: 0.84246025 g

Recovered targets

Return period: 2882.8216 yrs

Exceedance rate: 0.00034688237 yr⁻¹

Totals

Binned: 100 %

Residual: 0 %

Trace: 0.04 %

Mean (over all sources)

m: 6.74

r: 7.57 km

ε₀: 1.43 σ

Mode (largest m-r bin)

m: 6.48

r: 8.71 km

ε₀: 1.71 σ

Contribution: 16.94 %

Mode (largest m-r-ε₀ bin)

m: 7.72

r: 2.48 km

ε₀: 0.7 σ

Contribution: 9.86 %

Discretization

r: min = 0.0, max = 1000.0, Δ = 20.0 km

m: min = 4.4, max = 9.4, Δ = 0.2

ε: min = -3.0, max = 3.0, Δ = 0.5 σ

Epsilon keys

ε₀: [-∞ .. -2.5)

ε₁: [-2.5 .. -2.0)

ε₂: [-2.0 .. -1.5)

ε₃: [-1.5 .. -1.0)

ε₄: [-1.0 .. -0.5)

ε₅: [-0.5 .. 0.0)

ε₆: [0.0 .. 0.5)

ε₇: [0.5 .. 1.0)

ε₈: [1.0 .. 1.5)

ε₉: [1.5 .. 2.0)

ε₁₀: [2.0 .. 2.5)

ε₁₁: [2.5 .. +∞]

Deaggregation Contributors

Source Set ↪ Source	Type	r	m	ϵ_0	lon	lat	az	%
UC33brAvg_FM31	System							48.44
Whittier alt 1 [2]		2.10	7.29	0.91	117.712°W	33.876°N	33.12	16.43
Chino alt 1 [3]		6.46	6.58	1.16	117.662°W	33.910°N	46.95	11.72
Elsinore (Glen Ivy) rev [0]		12.89	6.51	2.26	117.590°W	33.829°N	107.43	5.24
Chino alt 1 [2]		6.64	6.24	1.29	117.669°W	33.917°N	39.73	3.96
Chino alt 1 [1]		9.11	6.08	1.86	117.703°W	33.950°N	10.47	2.46
Whittier alt 1 [1]		2.49	6.80	1.08	117.702°W	33.874°N	58.72	2.34
Peralta Hills [0]		2.92	6.42	1.09	117.740°W	33.848°N	223.82	2.01
UC33brAvg_FM32	System							36.59
Whittier alt 2 [2]		2.18	7.49	0.86	117.719°W	33.878°N	9.51	14.00
Chino alt 2 [2]		7.57	6.85	1.22	117.658°W	33.908°N	50.26	7.36
Elsinore (Glen Ivy) rev [0]		12.89	6.50	2.27	117.590°W	33.829°N	107.43	5.35
Chino alt 2 [1]		7.84	6.35	1.40	117.670°W	33.921°N	37.27	2.75
Richfield [0]		8.71	6.33	1.88	117.803°W	33.889°N	290.83	1.69
Whittier alt 2 [1]		2.18	7.10	0.97	117.719°W	33.878°N	9.51	1.30
UC33brAvg_FM32 (opt)	Grid							7.66
PointSourceFinite: -117.722, 33.904		6.89	5.57	1.79	117.722°W	33.904°N	0.00	1.74
PointSourceFinite: -117.722, 33.904		6.89	5.57	1.79	117.722°W	33.904°N	0.00	1.74
UC33brAvg_FM31 (opt)	Grid							7.32
PointSourceFinite: -117.722, 33.904		6.93	5.52	1.82	117.722°W	33.904°N	0.00	1.51
PointSourceFinite: -117.722, 33.904		6.93	5.52	1.82	117.722°W	33.904°N	0.00	1.51

Attachment E

Kindred Community Church

Notice of Transfer of Responsibility Form

Site: 8712-8720 E. Santa Ana Canyon Rd.

APN: 354-321-01 & 354-321-03

Water Quality Management Plan Notice of Transfer of Responsibility

Tracking No. Assigned by the City of Anaheim: _____

Submission of this Notice of Transfer of Responsibility constitutes notice to the City of Anaheim that responsibility for the Water Quality Management Plan ("WQMP") for the subject property identified below, and implementation of that plan, is being transferred from the Previous Owner (and his/her agent) of the site (or a portion thereof) to the New Owner, as further described below.

I. Previous Owner/Previous Responsible Party Information

		Contact Person:	
		Title	

II. Information About Site Transferred

Name of Project (if applicable)	
Title of WQMP Applicable to site:	
Street Address of Site (if applicable) 8712-8720 E. Santa Ana Canyon Road	
Planning Area (PA) and/or Tract Number(s) for Site	
Date WQMP Prepared (and revised if applicable)	

III. New Owner/New Responsibility Party Information

Company/Individual Name		Contact Person	
Street Address		Title	
City		ZIP	Phone

IV. Information About Site Transferred

General Description of Site Transferred to New Owner	General Description of Portion of Project/Parcel Subject to WQMP Retained by Owner (if any)
Lot/Tract Numbers of Site Transferred to New Owner	
Remaining Lot/Tract Numbers Subject to WQMP Still Held by Owner (if any)	
Date of Ownership Transfer	

Note: When the Previous Owner is transferring a Site that is a portion of a larger project/parcel addressed by the WQMP, as opposed to the entire project/parcel addressed by the WQMP, the General Description of the Site transferred and the remainder of the project/parcel not transferred shall be set forth as maps attached to this notice. These maps shall show those portions of a

project/parcel addressed by the WQMP that are transferred to the New Owner (the Transferred Site), those portions retained by the Previous Owner, and those portions previously transferred by Previous Owner. Those portions retained by Previous Owner shall be labeled "Previous Owner," and those portions previously transferred by Previous Owner shall be labeled as "Previously Transferred."

V. Purpose of Notice of Transfer

The purposes of this Notice of Transfer of Responsibility are: 1) to track transfer of responsibility for implementation and amendment of the WQMP when property to which the WQMP is transferred from the Previous Owner to the New Owner, and 2) to facilitate notification to a transferee of property subject to a WQMP that such New Owner is now the Responsible Party of record for the WQMP for those portions of the site that it owns.

VI. Certifications

A. Previous Owner

I certify under penalty of law that I am no longer the owner of the Transferred Site as described in Section II above. I have provided the New Owner with a copy of the WQMP applicable to the Transferred Site that the New Owner is acquiring from the Previous Owner.

Printed Name of Previous Owner Representative	Title
Signature of Previous Owner Representative	Date

B. New Owner

I certify under penalty of law that I am the owner of the Transferred Site, as described in Section II above, that I have been provided a copy of the WQMP, and that I have informed myself and understand the New Owner's responsibilities related to the WQMP, its implementation, and Best Management Practices associated with it. I understand that by signing this notice, the New Owner is accepting all ongoing responsibilities for implementation and amendment of the WQMP for the Transferred Site, which the New Owner has acquired from the Previous Owner.

Printed Name of New Owner Representative	Title
Signature	Date

Completed form shall be submitted to City of Anaheim, Engineering Division.

OWNER SELF CERTIFICATION STATEMENT

As the owner of APN 354-321-01 & 354-321-03 located at 8712-8720 E. Santa Ana Canyon Rd., Anaheim, CA for which a Water Quality Management Plan (WQMP) was approved by the City, I hereby certify under penalty of law that all Best Management Practices contained within the approved Project WQMP have been maintained and inspected in accordance with the schedule and frequency outlined in the approved Operation and Maintenance Plan.

The maintenance activities and inspections conducted, as listed in the attached table, have been performed by qualified and knowledgeable individuals.

To the best of my knowledge, the information submitted is true and accurate and complete. I am aware that there are significant penalties for submitting false information, including the possibility of fines and citations for violating water quality regulations.

Upon transfer of ownership the new owner or HOA shall maintain an operating budget sufficient to fund ongoing BMP maintenance for the proposed BMPs. This amount shall be reflected in the HOA budget and CC&R, an estimated minimum value which the association is expected to fund shall be \$1,400/year which shall include the routine maintenance of all common area landscape and BMPs.

Signed: _____

Name: _____

Title: _____

Company: _____

Address: _____

Telephone Number: _____

Date: _____

Completed Statement shall be submitted **annually** by June 30th to City of Anaheim, Engineering Division.

BMP Implementation Tracking Table

BMP	Activity	Activity Completion Dates or Frequency
Source Control BMPs (Structural and Nonstructural)		
Low Impact Development and Treatment Control BMPs		

Required Permits

List any permits required for the implementation, operation, and maintenance of the BMPs.
Possible examples are:

None to state.

Forms to Record BMP Implementation, Maintenance, and Inspection

The form that will be used to record implementation, maintenance, and inspection of BMPs is attached.

Recordingkeeping

All records must be maintained for at least five (5) years and must be made available for review upon request,

Appendix G

Construction Noise Calculations

Construction Generated Noise			
Building Type	Industrial, Parking Garage, Religious, Amusement & Retail		Distance (ft)
Construction Noise at 50 Feet (dBA Leq)			50
Construction Phase	All Applicable Equipment in Use¹	Minimum Required Equipment in Use¹	
Ground Clearing/Demolition	84	83	
Excavation	89	71	
Foundation Construction	77	77	
Building Construction	84	72	
Finishing and Site Cleanup	89	74	
Recreational Vehicle Park North of Project Site			
Maximum Construction Noise (dBA Leq)			380
Construction Phase	All Applicable Equipment in Use¹	Minimum Required Equipment in Use¹	
Ground Clearing/Demolition	66	65	
Excavation (Site Preparation)	71	53	
Foundation Construction	59	59	
Building Construction	66	54	
Paving	71	56	
Average Construction Noise (dBA Leq)			1,040
Construction Phase	All Applicable Equipment in Use¹	Minimum Required Equipment in Use¹	
Ground Clearing/Demolition	58	57	
Excavation (Site Preparation)	63	45	
Foundation Construction	51	51	
Building Construction	58	46	
Paving	63	48	
Residential Uses South of Project Site			
Maximum Construction Noise (dBA Leq)			240
Construction Phase	All Applicable Equipment in Use¹	Minimum Required Equipment in Use¹	
Ground Clearing/Demolition	70	69	
Excavation (Site Preparation)	75	57	
Foundation Construction	63	63	
Building Construction	70	58	
Paving	75	60	
Average Construction Noise (dBA Leq)			680
Construction Phase	All Applicable Equipment in Use¹	Minimum Required Equipment in Use¹	
Ground Clearing/Demolition	61	60	
Excavation (Site Preparation)	66	48	
Foundation Construction	54	54	
Building Construction	61	49	
Paving	66	51	
Residential Uses West of Project Site			
Maximum Construction Noise (dBA Leq)			700
Construction Phase	All Applicable Equipment in Use¹	Minimum Required Equipment in Use¹	
Ground Clearing/Demolition	61	60	
Excavation (Site Preparation)	66	48	
Foundation Construction	54	54	
Building Construction	61	49	
Paving	66	51	
Average Construction Noise (dBA Leq)			1,260
Construction Phase	All Applicable Equipment in Use¹	Minimum Required Equipment in Use¹	
Ground Clearing/Demolition	56	55	
Excavation (Site Preparation)	61	43	
Foundation Construction	49	49	
Building Construction	56	44	
Paving	61	46	
Source: Bolt, Beranek and Newman, "Noise from Construction Equipment and Operations, Building Equipment, and Home Appliances," prepared for the USEPA, December 31, 1971. Based on analysis for Office Building, Hotel, Hospital, School, and Public Works.			

Construction Generated Vibration

Recreational Vehicle Park North of Project Site		Closest Distance (feet):		380
	Approximate RMS a 66	Approximate RMS 73.000		
Equipment	inch/second	inch/second		
Vibratory roller	0.21	0.004		
Large bulldozer	0.089	0.002		
Small bulldozer	0.003	0.000		
Jackhammer	0.035	0.001		
Loaded trucks	0.076	0.001		
	Criteria	0.250	1700	
Residential Uses South of Project Site		Closest Distance (feet):		240
	Approximate RMS a Velocity at 25 ft, inch/second	Approximate RMS Velocity Level, inch/second		
Equipment				
Vibratory roller	0.21	0.007		
Large bulldozer	0.089	0.003		
Small bulldozer	0.003	0.000		
Jackhammer	0.035	0.001		
Loaded trucks	0.076	0.003		
	Criteria	0.250		
Residential Uses West of Project Site		Closest Distance (feet):		700
	Approximate RMS a Velocity at 25 ft, inch/second	Approximate RMS Velocity Level, inch/second		
Equipment				
Vibratory roller	0.21	0.001		
Large bulldozer	0.089	0.001		
Small bulldozer	0.003	0.000		
Jackhammer	0.035	0.000		
Loaded trucks	0.076	0.001		
	Criteria	0.250		

¹ Determined based on use of jackhammers or pneumatic hammers that may be used for pavement demolition at a distance of 25 feet
Notes: RMS velocity calculated from vibration level (VdB) using the reference of one microinch/second.
Source: Based on methodology from the United States Department of Transportation Federal Transit Administration, *Transit Noise and Vibration Impact Assessment* (2006).

Appendix H

Trip Generation Memorandum



February 11, 2021

Steven Camp, AIA
Elements Architecture
6B Liberty, #100
Aliso Viejo, CA 92656

RE: Trip Generation Evaluation for the Kindred Community Church Improvement Project

Dear Mr. Camp:

AGA Engineers, Inc. (AGA) is pleased to present to you the summary of the trip generation evaluation regarding the proposed improvement project for the Kindred Community Church, located at 8712 E. Santa Ana Canyon Road in the City of Anaheim. This analysis is based on the proposed improvements which involve four additional modular structures and improvements to the main church building. The proposed total additional square footage is 9,813 square feet and the seating capacity will be increased by 180 seats. The project is expected to be completed in Year 2022. The analysis evaluated how many new trips are expected based on the proposed improvements utilizing both the additional square footage and number of new seats. Although the proposed project is providing an increase in building size and parking, the weekday operations will be moved offsite and therefore there will be significantly less weekday church traffic. Attached are the proposed site plans.

Trip Generation

The Institute of Transportation Engineers (ITE) *Trip Generation Manual 10th Edition* uses thousands of studies across the nation to determine common trip generation characteristics by land use, assigning both inbound and outbound trips throughout the weekday AM and PM peak hours and Saturday/Sunday peak periods by proportion. Each vehicle accessing the project site would therefore be considered to generate two trips: one inbound trip when arriving and one outbound trip when departing. Using the *Manual*, the anticipated project trip generation was determined using parameters given by ITE Land Use Code #560, *Church*.

The project's trip generation was analyzed based on both the proposed additional square footage and number of new seats for both weekday and Sunday peak periods. Although the weekday operations will be moved offsite, the weekday trip generation was still evaluated. The trip generation calculation per square footage showed that there will be an additional three weekday AM peak hour trips, six weekday PM peak hour trips, and 99 Sunday peak hour trips. **Tables 1a/1b** show the trip generation analyses utilizing the additional square footage.

AGA Engineers, Inc.

211 Imperial Highway, Suite 208, Fullerton, CA 92835
(714) 992-4592 Email: aga@agaengineersinc.com

Table 1a – Weekday Project Trip Generation
 (per 1,000 square feet)

ITE Trip Generation Rates ¹ - Weekday								
ITE Code 560: Church	Daily	AM Peak Hour			PM Peak Hour			
		In	Out	Total	In	Out	Total	
<i>Trip rates per 1,000 square feet</i>	6.95	0.198	0.132	0.330	0.221	0.270	0.490	
<i>Percentages</i>	100%	60%	40%	100%	45%	55%	100%	
Project Trip Generation - Weekday								
ITE Code 560: Church	Additional Square Footage	Daily	AM Peak Hour			PM Peak Hour		
			In	Out	Total	In	Out	Total
Trip Generation	9,813	69	2	1	3	3	3	6
New Project Trips		69	2	1	3	3	3	6

¹ Institute of Transportation Engineers (ITE), Trip Generation Manual, 10th Ed. (2017)

Table 1b – Sunday Project Trip Generation
 (per 1,000 square feet)

ITE Trip Generation Rates ¹ - Sunday					
ITE Code 560: Church	Daily	Sunday Peak Period			
		In	Out	Total	
<i>Trip rates per 1,000 square feet</i>	27.63	4.80	5.19	9.99	
<i>Percentages</i>	100%	48%	52%	100%	
Project Trip Generation - Sunday					
ITE Code 560: Church	Additional Square Footage	Daily	Sunday Peak Period		
			In	Out	Total
Trip Generation	9,813	272	48	51	99
New Project Trips		272	48	51	99

¹ Institute of Transportation Engineers (ITE), Trip Generation Manual, 10th Ed. (2017)

The trip generation calculation per seat showed that there will be an additional two weekday AM peak hour trips, six weekday PM peak hour trips, and 98 Sunday peak hour trips. **Tables 2a/2b** show the trip generation analyses utilizing the additional number of seats.

Table 2a – Weekday Project Trip Generation
 (per seats)

ITE Trip Generation Rates ¹ - Weekday								
ITE Code 560: Church	Daily	AM Peak Hour			PM Peak Hour			
		In	Out	Total	In	Out	Total	
<i>Trip rates per seat</i>	0.44	0.005	0.005	0.010	0.012	0.018	0.030	
<i>Percentages</i>	100%	50%	50%	100%	40%	60%	100%	
Project Trip Generation - Weekday								
ITE Code 560: Church	New Seats	Daily	AM Peak Hour			PM Peak Hour		
			In	Out	Total	In	Out	Total
Trip Generation	180	80	1	1	2	3	3	6
New Project Trips		80	1	1	2	3	3	6

¹ Institute of Transportation Engineers (ITE), Trip Generation Manual, 10th Ed. (2017)

Table 2b – Sunday Project Trip Generation
 (per seat)

ITE Trip Generation Rates ¹ - Sunday					
ITE Code 560: Church	Daily	Sunday Peak Period			
		In	Out	Total	
<i>Trip rates per seat</i>	1.21	0.265	0.275	0.540	
<i>Percentages</i>	100%	49%	51%	100%	
Project Trip Generation - Sunday					
ITE Code 560: Church	New Seats	Daily	Sunday Peak Period		
			In	Out	Total
Trip Generation	180	218	48	50	98
New Project Trips		218	48	50	98

¹ Institute of Transportation Engineers (ITE), Trip Generation Manual, 10th Ed. (2017)

Mr. Steven Camp
February 11, 2021
Page 4 of 4

The project's maximum Sunday peak hour trip generation based on the additional square footage is expected to be 99 trips, which is just less than the City of Anaheim's threshold of 100 AM or PM peak hour trips. It should be noted that the City's threshold typically accounts for weekday AM or PM peak hour where traffic conditions are significantly higher along the City's arterials. This project is expected to actually generate less weekday traffic as the weekday operations will be moved offsite. City of Anaheim engineering staff have already evaluated the estimated trip generation analysis and stated that a traffic study will not be required. Per City staff, if any street improvements are conducted as part of this project and/or the project size will increase, then a traffic study may be required. The email from the City stating that a traffic study is not required is attached.

Should you have any questions, please me or at the following email address.

Greg@agaengineersinc.com,

Respectfully submitted,

ALBERT GROVER & ASSOCIATES



Greg Wong, P.E.
Vice President

ATTACHMENTS – Proposed Site Plans and City Email
Kindred Community Church - Trip Generation Evalation (2-11-21).docx

Appendix I

Vehicle Miles Traveled (VMT) Memorandum

*Vehicle Miles of Travel Screening Assessment
Kindred Community Church: Master Plan & Site Renovation*



ELEMENTS
ARCHITECTURE

6 B Liberty #100
Aliso Viejo, CA 92656
Telephone 949.488.0865
Facsimile 949.488.0864
www.ElementsArch.com

November 17, 2020

Eunice Lee
City of Anaheim
Department of Public Works
Traffic Engineering Division
200 South Anaheim Blvd, Suite 276
Anaheim, CA 92805

**RE: Vehicle Miles of Travel Screening Assessment
CUP4033E (DEV2020-00081)
Kindred Community Church: Masterplan & Site Renovation
8712 E. Santa Ana Canyon Rd., Anaheim, CA 92808**

Dear Ms. Eunice Lee,

This letter is in response to the plan check correction dated October 22, 2020, regarding the requirement of a Vehicles Miles of Travel (VMT) Screening Assessment.

It is our belief that the proposed project would be sufficiently screened from project-level assessment, per **Type 3** (Project Type Screening) as outlined in the City of Anaheim's TIA Guidelines for CEQA, dated June 2020.

The proposed scope of work, for Kindred Community Church, intends to relocate existing structures and consolidate all current ministry activities into a safe, efficiently-planned upper plaza campus. The project does not intend to increase church visitor or employee traffic, but to instead greatly improve the overall visiting and working experience for the existing population the campus serves. As defined in the TIA Guidelines, the project, being a Community and Religious Assembly Use, would have a less than significant transportation impact because of its local-serving nature.

We ask that you please review this information and provide an appropriate determination.

M. Steven Camp, AIA, Architect of Record