

Appendix IS-8

Hydrology and Water Quality Report



HYDROLOGY / WATER QUALITY REPORT

Oak Parking
1200 Getty Center Drive
Los Angeles, California 90049
KPF Job #1800239

March 09, 2022

OWNER:

The J. Paul Getty Trust
1200 Getty Center Way, Suite 100
Los Angeles, CA 90049

PREPARED BY:

KPF Consulting Engineers
700 S. Flower St. Suite 2100
Los Angeles, California 90017
213.418.0201

TABLE OF CONTENTS

I. Introduction..... 1

 A. Project Description..... 1

 B. Project Location 1

II. Drainage Concepts 1

 A. Existing Drainage Patterns..... 1

 B. Proposed Drainage Patterns 1

 C. Hydrology 2

 D. Peak Stormwater Runoff Discharge Rates..... 3

II. Best Management Practices (BMPs)..... 3

 A. Non-structural BMPs 3

 1. Open Paved Areas and Planter Areas..... 3

 2. Education and Training..... 4

 3. Landscaping 4

 4. Monitoring and Maintenance 4

 B. Structural BMPs..... 4

 1. EPIC System 4

 C. Anticipated Potential Pollutants..... 5

 D. Storm Drain Stenciling..... 5

Appendix A - Design Calculations 7

Appendix B – Hydrology 8

Appendix C - LID Details..... 9

Appendix D - O&M..... 10

Exhibit 1 – LID Plan

- Appendix A - Design Calculations
- Appendix B – Hydrology
- Appendix C - LID Details
- Appendix D - O&M

I. Introduction

A. Project Description

The project proposes construction of two surface parking lots located at the Getty Center in the City of Los Angeles. The Oak Parking project would be used in conjunction with the existing parking facilities at the Getty Center to accommodate overflow parking for visitors and staff. The project site comprised of proposed impervious parking lot, landscape areas, BMP planters, existing channel, and sloped pervious hillside. The total Project area is approximately 3.06 acres and would include 217 parking spaces. The proposed impervious area for purposes of this hydrology report is about 2.27 acres.¹

B. Project Location

The project site is located within the Brentwood community in the City of Los Angeles, approximately 16 miles west of downtown and 6 miles from the Pacific Ocean. The Oak Parking would be developed immediately adjacent to Interstate 405 (I-405) at Getty Center Drive. The site is situated within a small canyon tributary to Sepulveda Canyon in the Santa Monica Mountains and is bordered to the north, south and west by existing slopes and on the east by I-405.

II. Drainage Concepts

A. Existing Drainage Patterns

Based on site visits and aerial and existing topographic surveys, the existing site storm water appears to sheet flow from the northern to the southern limits of the Project site with average slope of 3%. At the same time, the runoff tends to sheet flow toward west at the lower elevated valley and be captured into the several existing debris basins. From the basins, the runoff is routed by several open channels with culverts and headwalls and below-ground RCP pipes that makes its way to the storm drain system per North Canyon Road I-405 Sepulveda Pass Widening Project.

For the purposes of this study, it is anticipated that the infiltration of stormwater is infeasible due to the location of the project in a hillside area.

B. Proposed Drainage Patterns

Infiltration is not possible due to the location of the project in a hillside area according to the Hillside Grading Ordinance per City of Los Angeles LID Manual. Thus, capture and reuse method will be used to treat stormwater runoff. The proposed parking lot will have several catch basins that capture the sheet flow based runoff. The stormwater is then directed to EPIC planters for the treatment and

¹ The project site includes approximately 2.15 acres of paving and approximately 0.91 acres of landscape. However, for purposes of this hydrology report approximately 0.12 acres of the landscape area is analyzed as impervious area.

storage of the runoff volume. The overflow of this EPIC system will be discharged to the existing channel and existing 48” RCP storm drain pipe.

C. Hydrology

For purpose of this report the existing hydrology, proposed hydrology and the hydrology of the major storm drain systems will be considered. The 50-year Los Angeles County storm, also known as the capital storm event, will be considered. The calculations for the 25-year and 50-year Los Angeles County storms are presented in below Table 1 and 2.

Table 1: Comparison of Existing and Proposed Hydrology 25-yr Storm

Existing Condition

Drainage Area	Area Disturbed (Acres)	% Impervious	Time of Concentration (min)	Clear Peak Flow Rate (cfs)
1	1.47	1.0%	5	3.56
2	1.59	1.0%	5	3.84
			Total	7.40

Proposed Condition

Drainage Area	Area Disturbed (Acres)	% Impervious	Time of Concentration (min)	Clear Peak Flow Rate (cfs)
1	1.47	76%	5	4.90
2	1.59	73%	6	4.78
			Total	9.68

Table 2: Comparison of Existing and Proposed Hydrology 50-yr Storm

Existing Condition

Drainage Area	Area Disturbed (Acres)	% Impervious	Time of Concentration (min)	Clear Peak Flow Rate (cfs)
1	1.47	1.0%	5	4.28
2	1.59	1.0%	5	4.62
			Total	8.90

Proposed Condition

Drainage Area	Area Disturbed (Acres)	% Impervious	Time of Concentration (min)	Clear Peak Flow Rate (cfs)
1	1.47	76%	5	5.64
2	1.59	73%	5	6.04
			Total	11.68

D. Peak Stormwater Runoff Discharge Rates

As required by the most current Los Angeles County MS4 Permit, the entire post-development Stormwater Quality Design volume (SWQDv) must be treated for greater of the first quarter inch or 85%, 24-hour rain event. Based on these calculations, the structural and non-structural BMPs for the Project have been designed to treat storm water runoff from all storms up to and including the 85%, 24-hour storm event which is greater than the quarter inch discharge. The full calculations can be found in the Appendix B.

The required EPIC system surface area and storage to treat the runoff in the area of work is provided in Table 3. The full calculations for stormwater runoff and BMP sizing can be found in Appendix A and B. All BMPs meet the design criteria in Attachment H of the most current MS4 Permit. Input parameters and calculations for BMP sizing are shown in Appendix A.

Table 3: Summary of EPIC System Calculations

Drainage Area	Area Disturbed (Acres)	Flow to be Treated (CFS)	Volume to be Treated (CF)	Epic Area (SF)	EPIC Storage Provided (CF)
1	1.47	0.40	4,338	2,007	8,522
2	1.59	0.36	4,474	1,995	6,866

II. Best Management Practices (BMPs)

Detailed operation and maintenance plans for structural BMPs will be developed.

A. Non-structural BMPs

1. Open Paved Areas and Planter Areas

- a. Regular sweeping of all open hardscape areas, at a minimum, on a weekly basis in order to prevent dispersal of pollutants that may collect on those surfaces.
- b. Regular pruning of the trees and shrubs in the planter areas to avoid formation of dried leaves and twigs, which are normally blown by the wind during windy days. These dried leaves are likely to clog the surface inlets of the drainage system when rain comes, which would result to flooding of the surrounding area due to reduced flow capacities of the inlets.

- c. Trash and recycling containers shall be used such that, if they are to be located outside or apart from the principal structure, they are fully enclosed and watertight in order to prevent contact of storm water with waste matter, which can be a potential source of bacteria and other pollutants in runoff. These containers shall be emptied and the wastes disposed of properly on a regular basis.

2. Education and Training

The operation and maintenance crew of the proposed parking structure shall be made aware of the structural BMPs installed in the Project. Information materials, such as brochures, shall also be provided for their complete information. They shall also be briefed about proper methods of handling and disposal of wastes and should understand the on-site BMPs and their maintenance requirements.

3. Landscaping

Minimize the use of pesticides and fertilizers to the maximum extent practical. The Project includes the removal of the existing vegetation and the replacement of landscape vegetation with primarily drought tolerant, non-invasive trees and plants. Unpaved areas to be re-graded for construction activities shall be re-vegetated per landscape plans.

4. Monitoring and Maintenance

- a. All BMPs shall be operated, monitored, and maintained for the life of the Project and at a minimum, all structural BMPs shall be inspected, cleaned-out, and where necessary, repaired, at the following minimum frequencies: 1) prior to October 15th each year; 2) during each month between October 15th and April 15th of each year and, 3) at least twice during the dry season (between April 16 and October 14 of every year).
- b. Debris and other water pollutants removed from structural BMPs during cleanout shall be contained and disposed of in a proper manner.
- c. The drainage system and the associated structures and BMPs shall be maintained according to manufacturer's specification to ensure maximum pollutant removal efficiencies.

B. Structural BMPs

1. EPIC System

The Epic System is proposed to capture and re-use the stormwater runoff from the new and altered impervious areas. From ECS, "Water is introduced directly to the roots of the plants. As water is transpired by the plant, new water is automatically replaced upward into the root zone by capillary action from the sub-surface reservoir. The water film from capillary rise and high oxygen levels among the sand voids provide an ideal growing environment for plant growth". A storm tank below the EPIC system is also proposed to meet minimum the storage volume.

Complete sizing calculations are attached in Appendix A and are based on the City of Los Angeles Low Impact Development Manual.

Maintenance procedures and recommendations outlined in Appendix D shall be followed by the owner to ensure proper performance of the stormwater treatment areas. These procedures include keeping maintenance records, regular sweeping and removal of debris, regular and visual inspections, and replacement/proper disposal/replenishment of adsorbent material.

C. Anticipated Potential Pollutants

The proposed renovated parking structure and the onsite roadways (and parking) have the potential for suspended sediments, floatable trash, minimal pesticides and nutrients, oil and grease, and gasoline entering the storm runoff system. As mentioned, storm water will discharge to and be treated by the vegetated swale which is to be properly maintained for adequate treatment.

D. Storm Drain Stenciling

Catch basins on site shall be stenciled to indicate that no substance other than storm water is to be collected by the storm drain system. The legibility of the stencils is to be maintained by the above mentioned party. Stencils shall be redrawn as necessary.

Exhibit 1 - LID Plan

DRAINAGE AREA 1 PRECONDITION

PRE CONDITIONS

AREA 1
 % IMPERVIOUS: 1.0%
 % PERVIOUS : 99%
 TOTAL: 1.47 ac

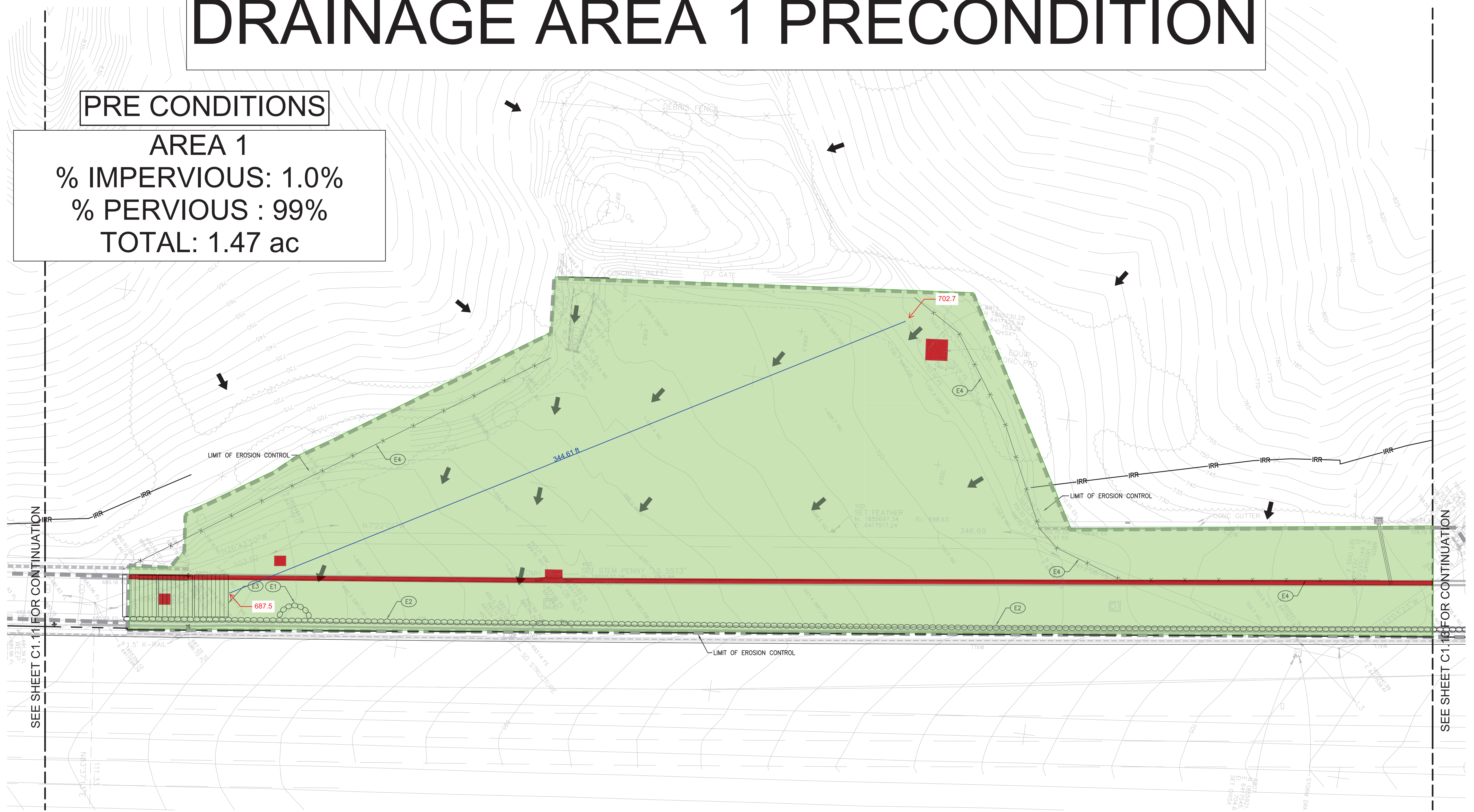

BMP NOTES:

THE FOLLOWING BMPs AS OUTLINED IN, BUT NOT LIMITED TO, THE BEST MANAGEMENT PRACTICE HANDBOOK, CALIFORNIA STORMWATER QUALITY TASK FORCE, SACRAMENTO, CALIFORNIA, NOVEMBER 2009, MAY APPLY DURING THE CONSTRUCTION OF THIS PROJECT (ADDITIONAL MEASURES MAY BE REQUIRED IF DEEMED APPROPRIATE BY CITY INSPECTORS):

- | | |
|---|---|
| EROSION CONTROL | WIND EROSION CONTROL |
| EC1-SCHEDULING | WE1-WIND EROSION CONTROL |
| EC2-PRESERVATION OF EXISTING VEGETATION | NON-STORMWATER MANAGEMENT |
| EC3-HYDRAULIC MULCH | NS1-WATER CONSERVATION PRACTICES |
| EC4-HYDROSEEDING | NS2-DEWATERING OPERATIONS |
| EC5-SOIL BINDERS | NS3-PAVING AND GRINDING OPERATIONS |
| EC6-STRAW MULCH | NS4-TEMPORARY STREAM CROSSING |
| EC7-GEOTEXTILES AND MATS | NS5-CLEAR WATER DIVERSION |
| EC8-WOOD MULCHING | NS6-ILLEGAL CONNECTION/DISCHARGE |
| EC9-EARTH DIKES AND DRAINAGE SWALES | NS7-POTABLE WATER/IRRIGATION |
| EC10-VELOCITY DISSIPATION DEVICES | NS8-VEHICLE AND EQUIPMENT CLEANING |
| EC11-SLOPE DRAINS | NS9-VEHICLE AND EQUIPMENT MAINTENANCE |
| EC12-STREAMBANK STABILIZATION | NS10-VEHICLE AND EQUIPMENT MAINTENANCE |
| EC13-RESERVED | NS11-TIRE DRIVING OPERATIONS |
| EC14-COMPOST BLANKET | NS12-CONCRETE CURING |
| EC15-SOIL PREPARATION/ROUGHENING | NS13-CONCRETE FINISHING |
| EC16-NON-VEGETATIVE STABILIZATION | NS14-MATERIAL AND EQUIPMENT USE |
| TEMPORARY SEDIMENT CONTROL | NS15-DEMOLITION ADJACENT TO WATER |
| SE1-SILT FENCE | NS16-TEMPORARY BATCH PLANTS |
| SE2-SEDIMENT BASIN | WASTE MANAGEMENT & MATERIALS POLLUTION CONTROL |
| SE3-SEDIMENT TRAP | WM1-MATERIAL DELIVERY AND STORAGE |
| SE4-CHECK DAM | WM2-MATERIAL USE |
| SE5-FIBER ROLLS | WM3-STOCKPILE MANAGEMENT |
| SE6-GRAVEL BAG BERM | WM4-SPILL PREVENTION AND CONTROL |
| SE7-STREET SWEEPING AND VACUUMING | WM5-SOLID WASTE MANAGEMENT |
| SE8-SANDBAG BARRIER | WM6-HAZARDOUS WASTE MANAGEMENT |
| SE9-STRAW BALE BARRIER | WM7-CONTAMINATED SOIL MANAGEMENT |
| SE10-STORM DRAIN INLET PROTECTION | WM8-CONCRETE WASTE MANAGEMENT |
| SE11-ACTIVE TREATMENT SYSTEMS | WM9-SANITARY/SEPTIC WASTE MANAGEMENT |
| SE12-TEMPORARY SILT DIKE | WM10-LIQUID WASTE MANAGEMENT |
| SE13-COMPOST SOCKS AND BERMS | |
| SE14-BIOFILTER BAGS | |
| EQUIPMENT TRACKING CONTROL | |
| TC1-STABILIZED CONSTRUCTION ENTRANCE/EXIT | |
| TC2-STABILIZED CONSTRUCTION ROADWAY | |
| TC3-ENTRANCE/OUTLET TIRE WASH | |

EROSION CONTROL NOTES:

- TEMPORARY EROSION CONTROL DEVICES SHOWN ON THE GRADING PLAN WHICH INTERFERE WITH THE WORK SHALL BE RELOCATED OR MODIFIED AS AND WHEN THE INSPECTOR SO DIRECTS AS THE WORK PROGRESSES TO MEET "AS GRADED" CONDITIONS.
- ALL LOOSE SOIL AND DEBRIS SHALL BE REMOVED FROM THE STREET AREAS UPON STARTING OPERATIONS AND PERIODICALLY THEREAFTER AS DIRECTED BY THE INSPECTOR
- WHEN THE INSPECTOR SO DIRECTS, A 12-INCH BERM SHALL BE MAINTAINED ALONG THE TOP OF THE SLOPE OF THOSE FILLS ON WHICH GRADING IS NOT IN PROGRESS.
- STORM AND SEWER DRAIN TRENCHES THAT ARE CUT THROUGH BASIN DIKES OR BASIN INLET DIKES SHALL BE PLUGGED WITH SANDBAGS.
- EXCEPT WHEN THE INSPECTOR DIRECTS OTHERWISE, ALL DEVICES SHOWN SHALL BE IN PLACE AT THE END OF EACH WORKING DAY WHEN RAIN IS FORECAST, AND SHALL BE MAINTAINED DURING THE RAINY SEASON (OCTOBER 15 TO APRIL 15).
- SANDBAGS SHALL BE STOCKPILED ON SITE, READY TO BE PLACED IN POSITION WHEN RAIN IS FORECAST, OR WHEN THE INSPECTOR SO DIRECTS.
- A "STANDBY EMERGENCY CREW" SHALL BE ALERTED BY THE PERMITTEE OR THE CONTRACTOR TO PERFORM EMERGENCY WORK DURING RAINSTORMS. THE PARTY TO BE CONTACTED IS:
 NAME: _____ (TO BE FILLED IN BY CONTRACTOR)
 PHONE NUMBER: _____

EROSION CONTROL NOTES:

- DUST SHALL BE CONTROLLED BY WATERING AND/OR APPLYING A DUST PALLIATIVE. THE DUST PALLIATIVE SHALL BE APPLIED IN THE AMOUNT AT THE LOCATIONS AS DIRECTED BY THE ENGINEER.
- WATER FOR DUST CONTROL SHALL BE APPLIED BY MEANS OF PRESSURE TYPE DISTRIBUTORS OR PIPE LINES EQUIPPED WITH A SPRAY SYSTEM OR HOSES WITH NOZZLES THAT WILL INSURE A UNIFORM APPLICATION OF WATER.
- UNLESS WATER IS APPLIED BY MEANS OF PIPE LINES, AT LEAST ONE MOBILE UNIT WITH A MINIMUM CAPACITY OF 100 GALLONS SHALL BE AVAILABLE FOR APPLYING WATER.
- ALL SOIL MATERIALS OR DEBRIS TRUCKED FROM THE SITE SHALL BE COVERED AND SPRINKLED PRIOR TO ENTERING PUBLIC STREETS.
- PROVIDE FOR WET SUPPRESSION OR CHEMICAL STABILIZING OF EXPOSED SOILS.
- PROVIDE FOR RAPID CLEAN-UP OF SEDIMENTS DEPOSITED ON THE PAVED ROADS.
- LIMIT THE AMOUNT OF AREAS DISTURBED BY CLEARING & EARTH MOVING OPERATIONS BY SCHEDULING THESE ACTIVITIES IN PHASES.

EROSION CONTROL NOTES:

- (E1) PROVIDE INLET PROTECTION PER DETAIL ER4, SHEET C5.01.
- (E2) PLACE SANDBAGS TRIPLE ROW PER DETAIL ER2, SHEET C5.01.
- (E3) STABILIZED CONSTRUCTION ENTRANCE PER DETAIL ER1, SHEET C5.01.
- (E4) SILT FENCE PER DETAIL ER3, SHEET C5.01.
- (E5) HYDROSEEDING OR APPROVED EQUIVALENT UNTIL STABILIZED.

LEGEND

- LIMIT OF EROSION CONTROL
- OOOOO SANDBAGS
- x- SITE FENCE
- ← DIRECTION OF FLOW

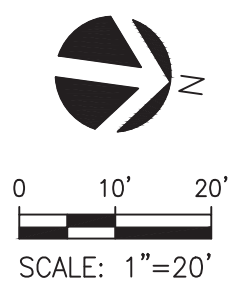
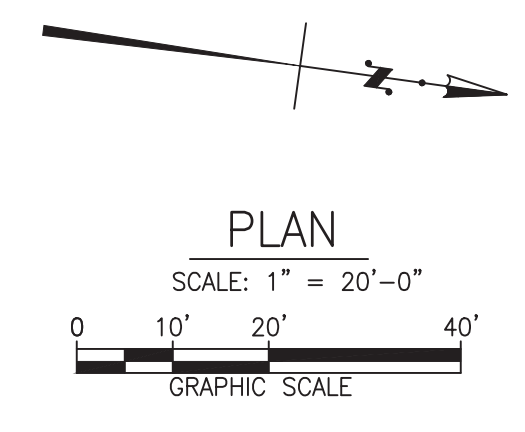

OAK PARKING LOT PROJECT
 18006.00
 1200 GETTY CENTER DRIVE LOS ANGELES, CA 90049

CONTRACTOR

CONSULTANT



700 South Flower Street
 Suite 2100
 Los Angeles, CA 90017
 O: 213.418.0201
 F: 213.266.5294
 www.kpff.com

ISSUE DATES
 03.20.2020 80% CD
 04.17.2020 100% CD-PERMIT SET

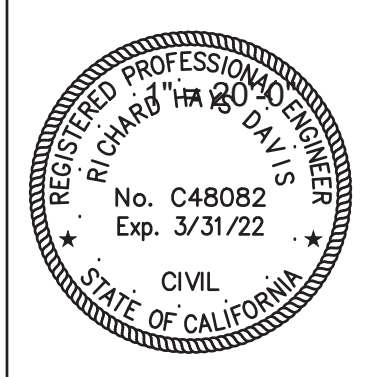

EROSION CONTROL PLAN
 SCALE: As indicated

C1.12

P:20191800803 Getty Oak Parking Lot Design CAD/Sheet/1800603-C1.12_C1.18EC.dwg, Nov.22, 2021, 3:35pm
 Frederick Fisher & Partners reserves its common law copyright and other property rights in these plans. These plans and drawings are not to be reproduced in any form or manner whatsoever without first obtaining the express written permission and consent of Frederick Fisher & Partners nor are they to be assigned to any third party without obtaining said written permission and consent.

DRAINAGE AREA 2 PRECONDITION

ANGELES VERTICAL CONTROL NETWORK, 1980 ADJUSTMENT, PER THE CITY OF LA BM DISK STAMPED 14-04385, 2 FT. NORTH OF NORTH CURB LINE BERRANCE, 5 FT. EAST OF NE CURB RETURN OF SEPULVEDA BLVD., AT NE CORNER OF CATCH BASIN.
 A CITY BM 14-04385 ELEV.=620.514 FEET 1980 ADJUSTMENT OF NGVD29 DATA
 LA CITY BM 14-14700 ELEV.=776.645 FEET 1980 ADJUSTMENT OF NGVD29 DATA
 STANDARD SURVEY MONUMENT IN WELL, ON CENTERLINE OF TIGERTAIL ROAD AND DEERBROOK LANE.

PRE CONDITIONS

AREA 2
 % IMPERVIOUS: 1.0%
 % PERVIOUS : 99%
 TOTAL: 1.59 ac



SEE SHEET C1.12 FOR CONTINUATION

BMP NOTES:

THE FOLLOWING BMPs AS OUTLINED IN, BUT NOT LIMITED TO, THE BEST MANAGEMENT PRACTICE HANDBOOK, CALIFORNIA STORMWATER QUALITY TASK FORCE, SACRAMENTO, CALIFORNIA, NOVEMBER 2009, MAY APPLY DURING THE CONSTRUCTION OF THIS PROJECT (ADDITIONAL MEASURES MAY BE REQUIRED IF DEEMED APPROPRIATE BY CITY INSPECTORS):

EROSION CONTROL

- EC1-SCHEDULING
- EC2-PRESERVATION OF EXISTING VEGETATION
- EC3-HYDRAULIC MULCH
- EC4-HYDROSEEDING
- EC5-SOIL BINDERS
- EC6-STRAW MULCH
- EC7-GEOTEXTILES AND MATS
- EC8-WOOD MULCHING
- EC9-EARTH DIKES AND DRAINAGE SWALES
- EC10-VELOCITY DISSIPATION DEVICES
- EC11-SLOPE DRAINS
- EC12-STREAMBANK STABILIZATION
- EC13-RESERVED
- EC14-COMPOST BLANKET
- EC15-SOIL PREPARATION/ROUGHENING
- EC16-NON-VEGETATIVE STABILIZATION

TEMPORARY SEDIMENT CONTROL

- SE1-SILT FENCE
- SE2-SEDIMENT BASIN
- SE3-SEDIMENT TRAP
- SE4-CHECK DAM
- SE5-FIBER ROLLS
- SE6-GRAVEL BAG BERM
- SE7-STREET SWEEPING AND VACUUMING
- SE8-SANDBAG BARRIER
- SE9-STRAW BALE BARRIER
- SE10-STORM DRAIN INLET PROTECTION
- SE11-ACTIVE TREATMENT SYSTEMS
- SE12-TEMPORARY SILT DIKE
- SE13-COMPOST SOCKS AND BERMS
- SE14-BIOFILTER BAGS

EQUIPMENT TRACKING CONTROL

- TC1-STABILIZED CONSTRUCTION ENTRANCE/EXIT
- TC2-STABILIZED CONSTRUCTION ROADWAY
- TC3-ENTRANCE/OUTLET TIRE WASH

WIND EROSION CONTROL

- WE1-WIND EROSION CONTROL
- NS1-WATER CONSERVATION PRACTICES
- NS2-DEWATERING OPERATIONS
- NS3-PAVING AND GRINDING OPERATIONS
- NS4-TEMPORARY STREAM CROSSING
- NS5-CLEAR WATER DIVERSION
- NS6-ILLICIT CONNECTION/DISCHARGE
- NS7-POTABLE WATER/IRRIGATION
- NS8-VEHICLE AND EQUIPMENT CLEANING
- NS9-VEHICLE AND EQUIPMENT FUELING
- NS10-VEHICLE AND EQUIPMENT MAINTENANCE
- NS11-PILE DRIVING OPERATIONS
- NS12-CONCRETE CURING
- NS13-CONCRETE FINISHING
- NS14-MATERIAL AND EQUIPMENT USE
- NS15-DEMOLITION ADJACENT TO WATER
- NS16-TEMPORARY BATCH PLANTS

WASTE MANAGEMENT & MATERIALS POLLUTION CONTROL

- WM1-MATERIAL DELIVERY AND STORAGE
- WM2-MATERIAL USE
- WM3-STOCKPILE MANAGEMENT
- WM4-SPILL PREVENTION AND CONTROL
- WM5-SOLID WASTE MANAGEMENT
- WM6-HAZARDOUS WASTE MANAGEMENT
- WM7-CONTAMINATED SOIL MANAGEMENT
- WM8-CONCRETE WASTE MANAGEMENT
- WM9-SANITARY/SEPTIC WASTE MANAGEMENT
- WM10-LIQUID WASTE MANAGEMENT

EROSION CONTROL NOTES:

1. TEMPORARY EROSION CONTROL DEVICES SHOWN ON THE GRADING PLAN WHICH INTERFERE WITH THE WORK SHALL BE RELOCATED OR MODIFIED AS AND WHEN THE INSPECTOR SO DIRECTS AS THE WORK PROGRESSES TO MEET "AS GRADED" CONDITIONS.
2. ALL LOOSE SOIL AND DEBRIS SHALL BE REMOVED FROM THE STREET AREAS UPON STARTING OPERATIONS AND PERIODICALLY THEREAFTER AS DIRECTED BY THE INSPECTOR
3. WHEN THE INSPECTOR SO DIRECTS, A 12-INCH BERM SHALL BE MAINTAINED ALONG THE TOP OF THE SLOPE OF THOSE FILLS ON WHICH GRADING IS NOT IN PROGRESS.
4. STORM AND SEWER DRAIN TRENCHES THAT ARE CUT THROUGH BASIN DIKES OR BASIN INLET DIKES SHALL BE PLUGGED WITH SANDBAGS.
5. EXCEPT WHEN THE INSPECTOR DIRECTS OTHERWISE, ALL DEVICES SHOWN SHALL BE IN PLACE AT THE END OF EACH WORKING DAY WHEN RAIN IS FORECAST, AND SHALL BE MAINTAINED DURING THE RAINY SEASON (OCTOBER 15 TO APRIL 15).
6. SANDBAGS SHALL BE STOCKPILED ON SITE, READY TO BE PLACED IN POSITION WHEN RAIN IS FORECAST, OR WHEN THE INSPECTOR SO DIRECTS.
7. A "STANDBY EMERGENCY CREW" SHALL BE ALERTED BY THE PERMITTEE OR THE CONTRACTOR TO PERFORM EMERGENCY WORK DURING RAINSTORMS. THE PARTY TO BE CONTACTED IS: _____ (TO BE FILLED IN BY CONTRACTOR)
 NAME: _____
 PHONE NUMBER: _____

EROSION CONTROL NOTES:

1. DUST SHALL BE CONTROLLED BY WATERING AND/OR APPLYING A DUST PALLIATIVE. THE DUST PALLIATIVE SHALL BE APPLIED IN THE AMOUNT AT THE LOCATIONS AS DIRECTED BY THE ENGINEER.
2. WATER FOR DUST CONTROL SHALL BE APPLIED BY MEANS OF PRESSURE TYPE DISTRIBUTORS OR PIPE LINES EQUIPPED WITH A SPAY SYSTEM OR HOSES WITH NOZZLES THAT WILL INSURE A UNIFORM APPLICATION OF WATER.
3. UNLESS WATER IS APPLIED BY MEANS OF PIPE LINES, AT LEAST ONE MOBILE UNIT WITH A MINIMUM CAPACITY OF 100 GALLONS SHALL BE AVAILABLE FOR APPLYING WATER.
4. ALL SOIL MATERIALS OR DEBRIS TRUCKED FROM THE SITE SHALL BE COVERED AND SPRINKLED PRIOR TO ENTERING PUBLIC STREETS.
5. PROVIDE FOR WET SUPPRESSION OR CHEMICAL STABILIZING OF EXPOSED SOILS.
6. PROVIDE FOR RAPID CLEAN-UP OF SEDIMENTS DEPOSITED ON THE PAVED ROADS.
7. LIMIT THE AMOUNT OF AREAS DISTURBED BY CLEARING & EARTH MOVING OPERATIONS BY SCHEDULING THESE ACTIVITIES IN PHASES.

EROSION CONTROL NOTES:

- (E1) PROVIDE INLET PROTECTION PER DETAIL ER4, SHEET C5.01.
- (E2) PLACE SANDBAGS TRIPLE ROW PER DETAIL ER2, SHEET C5.01.
- (E3) STABILIZED CONSTRUCTION ENTRANCE PER DETAIL ER1, SHEET C5.01.
- (E4) SILT FENCE PER DETAIL ER3, SHEET C5.01.
- (E5) HYDROSEEDING OR APPROVED EQUIVALENT UNTIL STABILIZED.

LEGEND

- LIMIT OF EROSION CONTROL
- ○ ○ ○ ○ SANDBAGS
- x- SITE FENCE

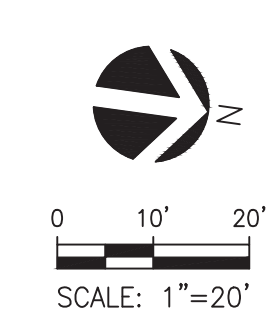
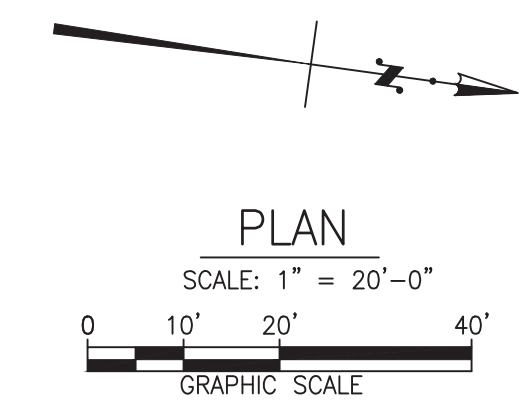

OAK PARKING LOT PROJECT
 18006.00
 1200 GETTY CENTER DRIVE LOS ANGELES, CA 90049

CONTRACTOR

CONSULTANT

kpff

700 South Flower Street
 Suite 2100
 Los Angeles, CA 90017
 P: 213.418.0201
 F: 213.266.5294
 www.kpff.com

ISSUE DATES
 03.20.2020 80% CD
 04.17.2020 100% CD-PERMIT SET

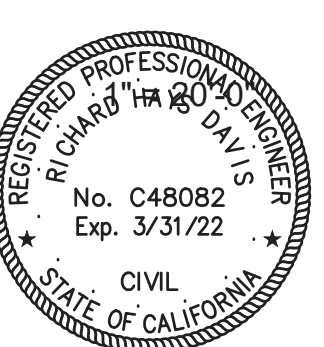

EROSION CONTROL PLAN
 SCALE: As indicated

C1.13

P:20191800803 Getty Oak Parking Lot Design5 CAD/Sheets/1800603-C1.12_C1.13E.dwg, Nov 22, 2021, 3:34pm
 Frederick Fisher & Partners reserves its common law copyright and other property rights in these plans. These plans and drawings are not to be reproduced in any form or manner whatsoever without first obtaining the express written permission and consent of Frederick Fisher & Partners nor are they to be assigned to any third party without obtaining said written permission and consent.

DRAINAGE AREA 1 POST CONDITION

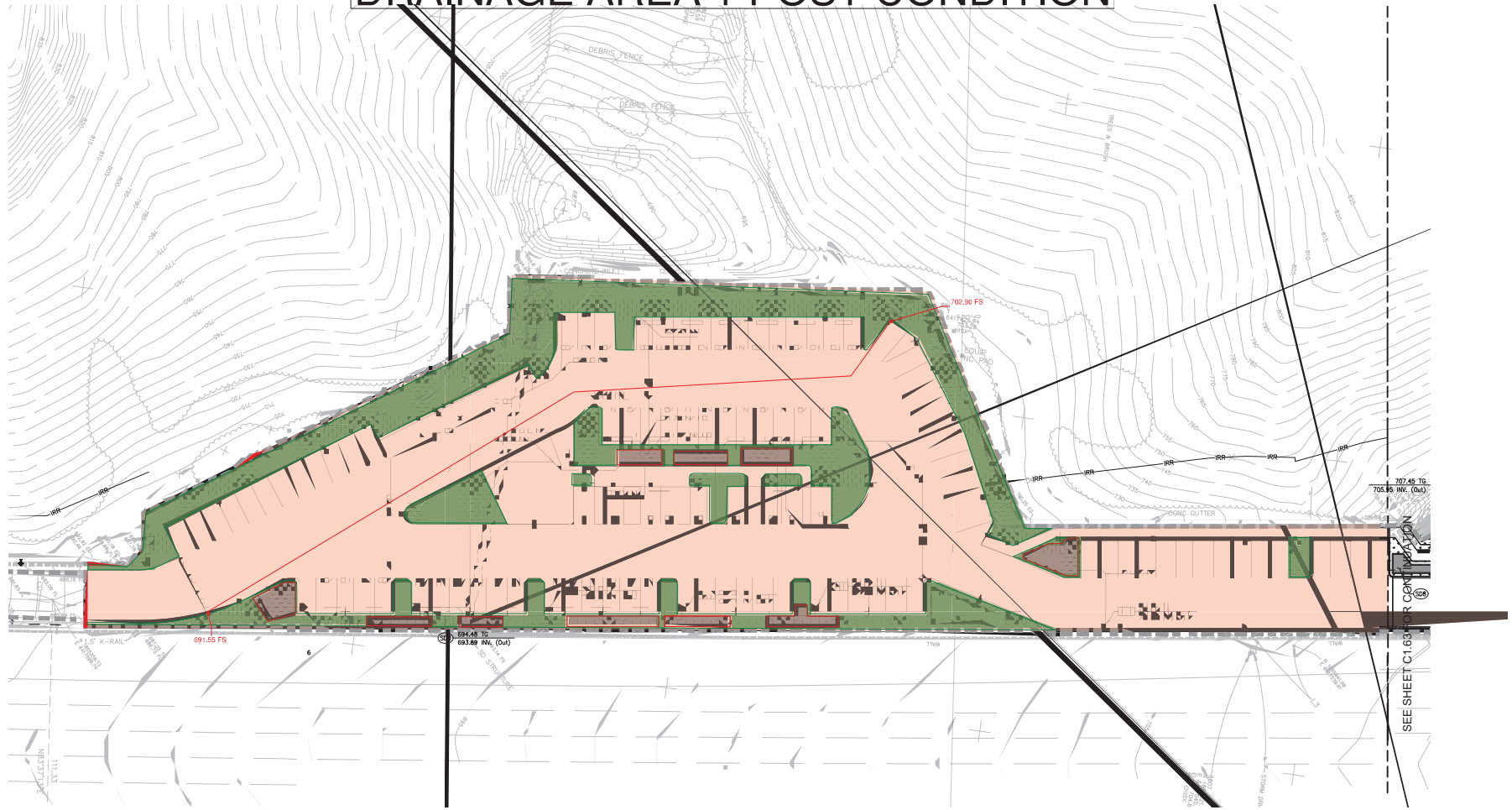

LEGEND

- LIMIT OF UTILITY WORK
- PROPOSED EPIC PLANTER AREA

UTILITY CONSTRUCTION NOTES

- STORM DRAIN**
- (S1) SCHEDULE 40 PVC STORM DRAIN PIPE PER DETAIL SD1 SHEET CS.02. SIZE AND SLOPE PER PLAN.
 - (S2) CLEANOUT PER DETAIL SS1, SHEET CS.02.
 - (S3) TRAFFIC RATED GRATING CATCH BASIN-ALLEY CONFIGURATION CITY OF LOS ANGELES STD PLAN S-305, RW-2' 11 3/8"
 - (S4) VEGETATIVE SINGLE. REFER TO CAGDA BMP NEW DEVELOPMENT REDEVELOPMENT HANDBOOK (2009), BMP CONTROL TC-30.
 - (S5) EXISTING REINFORCED CONCRETE PIPE.
 - (S6) EXISTING HEADWALL.
 - (S7) EPIC PLANTER OVERFLOW PIPE.
 - (S8) EPIC PLANTER DETAIL X, SHEET X.
 - (S9) MANHOLE PER CITY OF LOS ANGELES STANDARD PLANS S-381-0.
 - (S10) NOT USED.
 - (S11) NOT USED.
 - (S12) REMOVE HEADWALL, CONNECT PROPOSED 42" PIPE TO EXISTING 42" PIPE PER SPPWC 380-4.
 - (S13) CONNECT TO 48" RCP.

POST CONDITIONS

AREA 1
IMPERVIOUS: 1.11 ac - 76%
PERVIOUS (LANDSCAPE): 0.31 ac
PERVIOUS (PLANTER): 0.05 ac
PERVIOUS (TOTAL): 0.36 ac - 24%
TOTAL: 1.47 ac



DRAINAGE AREA 2 POST CONDITION

P:\2019\100555 only Oak, Working\19\Drawings\100555\DWG_C-130117.dwg, Nov 22, 2019 1:54pm
 Frederick Fisher & Partners reserves its common law copyright and other proprietary rights in these plans. These plans and drawings are not to be reproduced in any form or manner without the express written permission of Frederick Fisher & Partners, nor are they to be assigned to any third party without obtaining said written permission and consent.

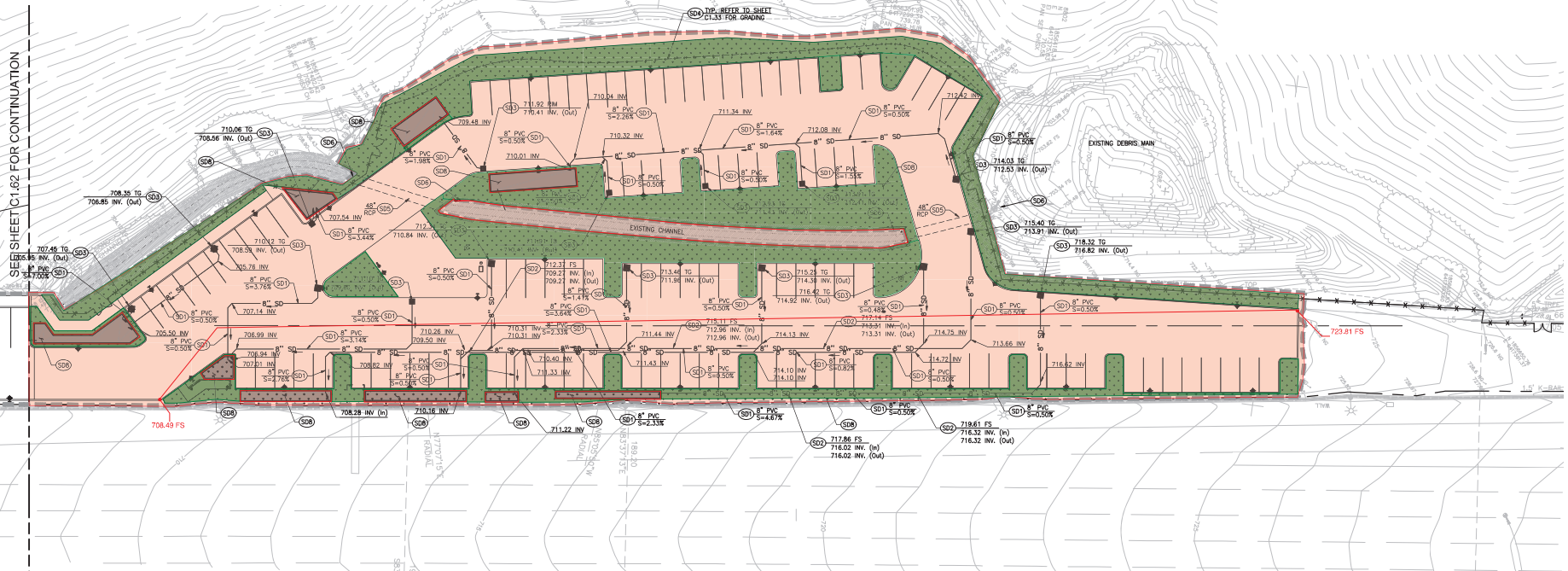

SEE SHEET C-13.62 FOR CONTINUATION

LEGEND

- LIMIT OF UTILITY WORK
- PROPOSED EPIC PLANTER AREA

UTILITY CONSTRUCTION NOTES

- STORM DRAIN
- (SD1) SCHEDULE 40 PVC STORM DRAIN PIPE PER DETAIL SD1 SHEET CS.02. SIZE AND SLOPE PER PLAN.
- (SD2) CLEANOUT PER DETAIL SS1, SHEET CS.02.
- (SD3) TRAFFIC RATED GRATING CATCH BASIN-ALLEY CONFIGURATION CITY OF LOS ANGELES STD PLAN S-305, INPZ "11 3/8"
- (SD4) VEGETATIVE SINGLE. REFER TO CAGSA BMP NEW DEVELOPMENT REDEVELOPMENT HANDBOOK (2009), BMP CONTROL TC-30.
- (SD5) EXISTING REINFORCED CONCRETE PIPE.
- (SD6) EXISTING HEADWALL.
- (SD7) EPIC PLANTER OVERFLOW PIPE.
- (SD8) EPIC PLANTER DETAIL X, SHEET X.
- (SD9) MANHOLE PER CITY OF LOS ANGELES STANDARD PLANS S-381-0.
- (SD10) NOT USED.
- (SD11) NOT USED.
- (SD12) REMOVE HEADWALL, CONNECT PROPOSED 42" PIPE TO EXISTING 42" PIPE PER SPPWC 380-4.
- (SD13) CONNECT TO 48" RCP.

POST CONDITIONS

AREA 2
IMPERVIOUS: 1.16 ac - 73%
PERVIOUS (LANDSCAPE): 0.39 ac
PERVIOUS (PLANTER): 0.04 ac
PERVIOUS (TOTAL): 0.43 ac - 27%
TOTAL: 1.59 ac



Appendix A - Design Calculations



EPIC™ System Planter with Surge Tank - Calculation

PROJECT NAME: **Getty Oak Parking**

PROJECT NO.: **1900803**

PROJECT ADDRESS: **1200 Getty Center Drive**

CONSULTANT: **KPFF Consultants**

DATE: **2022-02-28**

Mitigation Volume Calculation

AREA: **A1**

Total Tributary Area (A_T) 64,238 SF [Calculated total tributary area]
 Impervious Area (A_I) 48,571 SF [Enter total impervious area tributary to EPIC]
 Pervious Area (A_P) 13,660 SF [Enter total pervious area tributary to EPIC]
 Proposed EPIC™ Area (A_E) 2,007 SF [Enter EPIC planter area or total combined area of hydraulically connected EPIC planters]
 85th Percentile, 24-hr rainfall (R_{85th}) 1.15 IN or 0.0958 FT

Mitigation Volume (V_m) 33,754 GAL $R_{85th} * [(A_I * 0.9) + (A_P * 0.1) + (A_E * 1.0)] * 7.48$

Rainfall data can be obtained from Los Angeles County DPW at <http://www.dpw.lacounty.gov/wrd/hydrologygis/>

EPIC™-specific, modified calculations based on City of Los Angeles Development BMP Handbook, LID Manual, June 2011, Part B: Planning Activities, 4th Ed. and Los Angeles County Department of Public Works Low Impact Development Standards Manual, February 2014 and Los Angeles County Department of Public Works Hydrology Manual, January 2006.

EPIC™ System and Applicable Additional Storage Calculation

Planter No.: **1**

EPIC™ Area Recommended (A_{EPIC}) 12,982 SF [$V_m / 2.6$ GAL per SF]

Proposed EPIC™ Area (A_E) from above 2,007 SF $ET_v / V_m =$ **1.31**

must be > 1.00

Chamber Density: *One chamber per*

15 SF 20 SF 25 SF *adjust +/-* 0 *for a total of* 100 *chambers*

EPIC™ Design Capacity ($V_{Edesign}$) 5,218 GAL [Based on EPIC area & chamber density]

Min. Additional Storage Required (V_{AS}) 28,535 GAL or 3,815 CF [$V_m - V_{Edesign}$]

Additional Storage Provided (V_{DS}) 7,824 GAL CF [Select Units]

Storage type, manufacturer and model ECO-RAIN DOUBLE+HALF TANK ET-1502.5

TOTAL System Capacity 63,742 GAL or 8,522 CF [$V_{DS} + V_{Edesign}$]



Provided by:

Low Impact Development Inc.

EPIC™ System Authorized Distributor & Certified Installer

www.LID-LA.com • 818.279.2719

350 N. Glendale Avenue, Suite B332, Glendale, CA 91206

2016v0630



EPIC™ System Planter with Surge Tank - Calculation

PROJECT NAME: **Getty Oak Parking**

PROJECT NO.: **1900803**

PROJECT ADDRESS: **1200 Getty Center Drive**

CONSULTANT: **KPFF Consultants**

DATE: **2022-02-28**

Mitigation Volume Calculation

AREA: **A2**

Total Tributary Area (A_T) 69,119 SF [Calculated total tributary area]
 Impervious Area (A_I) 50,308 SF [Enter total impervious area tributary to EPIC]
 Pervious Area (A_P) 16,816 SF [Enter total pervious area tributary to EPIC]
 Proposed EPIC™ Area (A_E) 1,995 SF [Enter EPIC planter area or total combined area of hydraulically connected EPIC planters]
 85th Percentile, 24-hr rainfall (R_{85th}) 1.15 IN or 0.0958 FT

Mitigation Volume (V_m) 35,092 GAL $R_{85th} * [(A_I * 0.9) + (A_P * 0.1) + (A_E * 1.0)] * 7.48$

Rainfall data can be obtained from Los Angeles County DPW at <http://www.dpw.lacounty.gov/wrd/hydrologygis/>

EPIC™-specific, modified calculations based on City of Los Angeles Development BMP Handbook, LID Manual, June 2011, Part B: Planning Activities, 4th Ed. and Los Angeles County Department of Public Works Low Impact Development Standards Manual, February 2014 and Los Angeles County Department of Public Works Hydrology Manual, January 2006.

EPIC™ System and Applicable Additional Storage Calculation

Planter No.: **2**

EPIC™ Area Recommended (A_{EPIC}) 13,497 SF [$V_m / 2.6$ GAL per SF]

Proposed EPIC™ Area (A_E) from above 1,995 SF $ET_v / V_m =$ **1.25**

must be > 1.00

Chamber Density: *One chamber per*

15 SF 20 SF 25 SF *adjust +/-* 0 *for a total of* 100 *chambers*

EPIC™ Design Capacity ($V_{Edesign}$) 5,187 GAL [Based on EPIC area & chamber density]

Min. Additional Storage Required (V_{AS}) 29,905 GAL or 3,998 CF [$V_m - V_{Edesign}$]

Additional Storage Provided (V_{DS}) 6,184 GAL CF [Select Units]

Storage type, manufacturer and model ECO-RAIN DOUBLE+HALF TANK ET-1502.5

TOTAL System Capacity 51,443 GAL or 6,877 CF [$V_{DS} + V_{Edesign}$]



Provided by:

Low Impact Development Inc.

EPIC™ System Authorized Distributor & Certified Installer

www.LID-LA.com • 818.279.2719

350 N. Glendale Avenue, Suite B332, Glendale, CA 91206

2016v0630

Appendix B – Hydrology

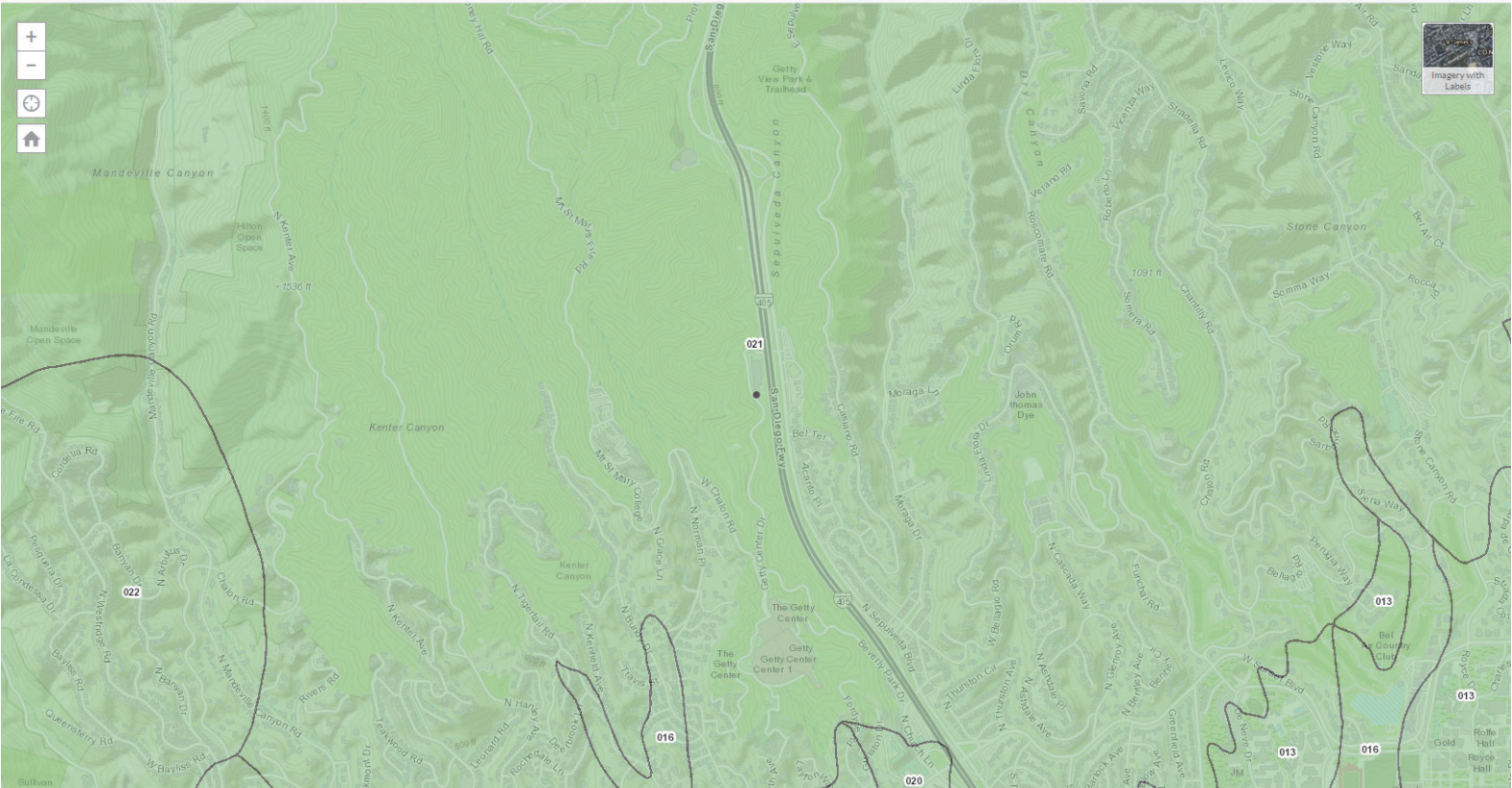

PROJECT SITE - SOIL TYPE

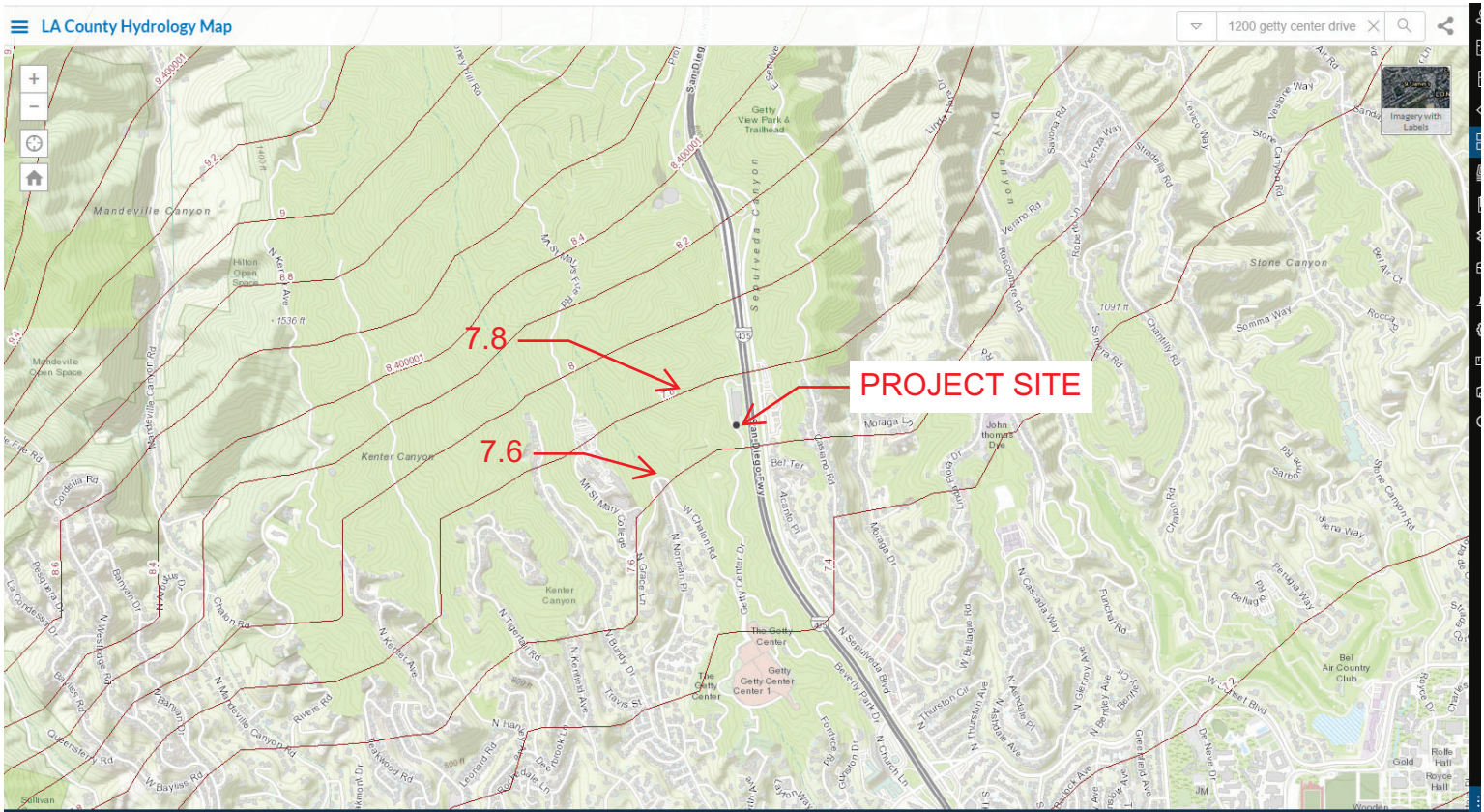

PROJECT SITE - 50YR STORM

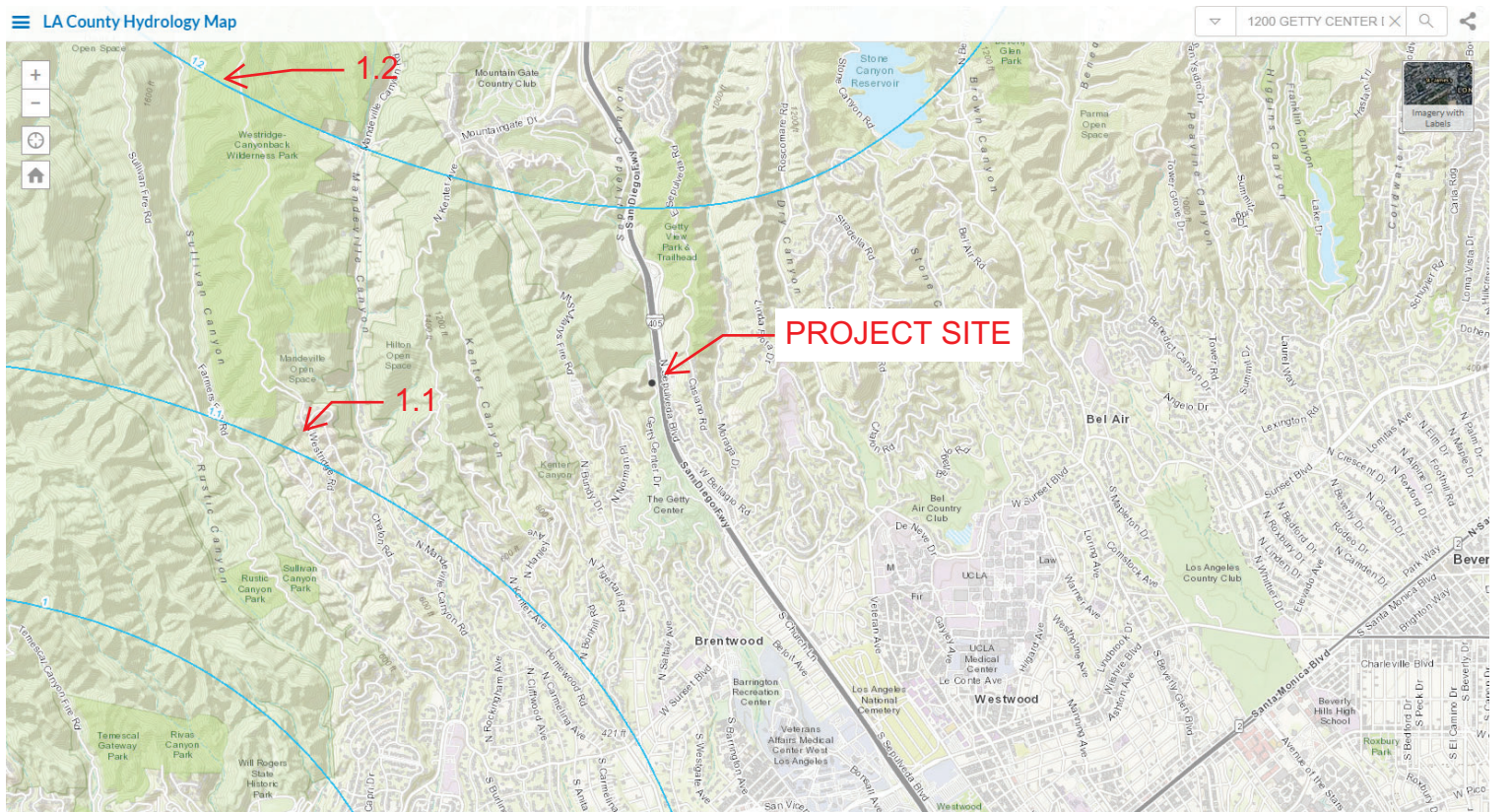

PROJECT SITE - 85TH PERCENTILE STORM

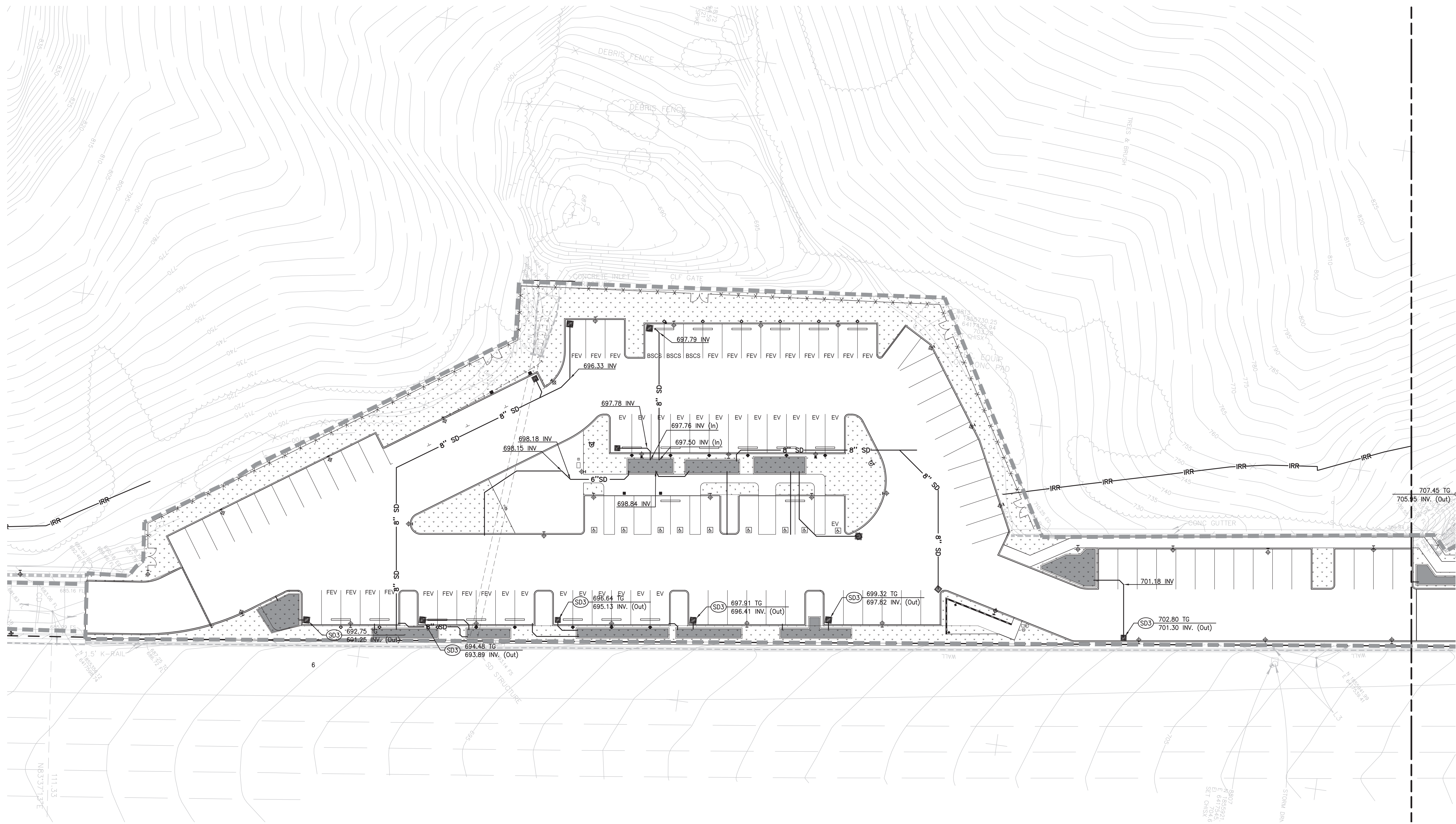

9807
 P. 18/5/21
 E. 1/20/21
 S. 1/20/21
 S. 1/20/21

DRAINAGE AREA 2 POST CONDITION

P:20191900803 Gally Oak Parking Full Design CAD/Sheet/1900803-C1.62_C1.63UT.dwg, Nov.22, 2021, 3:48pm
 Frederick Fisher & Partners reserves its common law copyright and other property rights in these plans. These plans and drawings are not to be reproduced in any form or manner whatsoever without first obtaining the express written permission and consent of Frederick Fisher & Partners nor are they to be assigned to any third party without obtaining said written permission and consent.

SEE SHEET C1.62 FOR CONTINUATION



POST CONDITIONS

AREA 2
IMPERVIOUS: 1.16 ac - 73%
PERVIOUS (LANDSCAPE): 0.39 ac
PERVIOUS (PLANTER): 0.04 ac
PERVIOUS (TOTAL): 0.43 ac - 27%
TOTAL: 1.59 ac

LEGEND

- LIMIT OF UTILITY WORK
- ▨ PROPOSED EPIC PLANTER AREA

UTILITY CONSTRUCTION NOTES

- STORM DRAIN**
- (SD1) SCHEDULE 40 PVC STORM DRAIN PIPE PER DETAIL SD1 SHEET C5.02. SIZE AND SLOPE PER PLAN.
 - (SD2) CLEANOUT PER DETAIL SS1, SHEET C5.02.
 - (SD3) TRAFFIC RATED GRATING CATCH BASIN-ALLEY CONFIGURATION CITY OF LOS ANGELES STD PLAN S-355, W=2' 11 3/8".
 - (SD4) VEGETATIVE SWALE. REFER TO CASQA BMP NEW DEVELOPMENT REDEVELOPMENT HANDBOOK (2009). BMP CONTROL TC-30.
 - (SD5) EXISTING REINFORCED CONCRETE PIPE.
 - (SD6) EXISTING HEADWALL.
 - (SD7) EPIC PLANTER OVERFLOW PIPE.
 - (SD8) EPIC PLANTER DETAIL X, SHEET X.
 - (SD9) MANHOLE PER CITY OF LOS ANGELES STANDARD PLANS S-381-D.
 - (SD10) NOT USED.
 - (SD11) NOT USED.
 - (SD12) REMOVE HEADWALL. CONNECT PROPOSED 42" PIPE TO EXISTING 42" PIPE PER SPPWC 380-4..
 - (SD13) CONNECT TO 48" RCP.

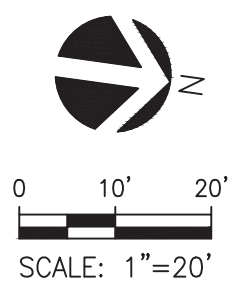

OAK PARKING LOT PROJECT
18006.00
 1200 GETTY CENTER DRIVE LOS ANGELES, CA 90049

kpff
 700 South Flower Street
 Suite 2100
 Los Angeles, CA 90017
 P: 213.418.0201
 F: 213.266.5294
 www.kpff.com

ISSUE DATES
 03.20.2020 10% CD
 04.17.2020 100% CD/PERMIT SET

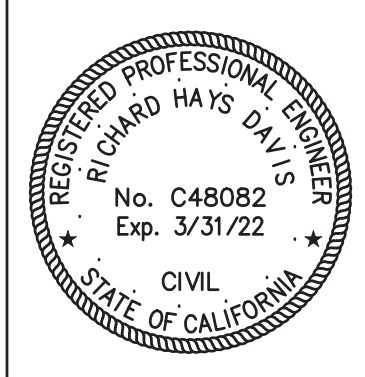

LID PLAN

SCALE: As indicated

C1.63

Peak Flow Hydrologic Analysis

File location: P:/2019/1900803 Getty Oak Parking Full Design/2 ENGR/STORM/2022-02-22 Hydrology Report - Update/APP. B - HYDROLOGY/PRE CO
Version: HydroCalc 1.0.3

Input Parameters

Project Name	GETTY PRECONDITIONS
Subarea ID	Subarea 1A
Area (ac)	1.47
Flow Path Length (ft)	344.6
Flow Path Slope (vft/hft)	0.04
50-yr Rainfall Depth (in)	7.7
Percent Impervious	0.01
Soil Type	21
Design Storm Frequency	25-yr
Fire Factor	0
LID	False

Output Results

Modeled (25-yr) Rainfall Depth (in)	6.7606
Peak Intensity (in/hr)	4.0336
Undeveloped Runoff Coefficient (Cu)	0.5962
Developed Runoff Coefficient (Cd)	0.5993
Time of Concentration (min)	5.0
Clear Peak Flow Rate (cfs)	3.5534
Burned Peak Flow Rate (cfs)	3.5534
24-Hr Clear Runoff Volume (ac-ft)	0.1178
24-Hr Clear Runoff Volume (cu-ft)	5133.5346

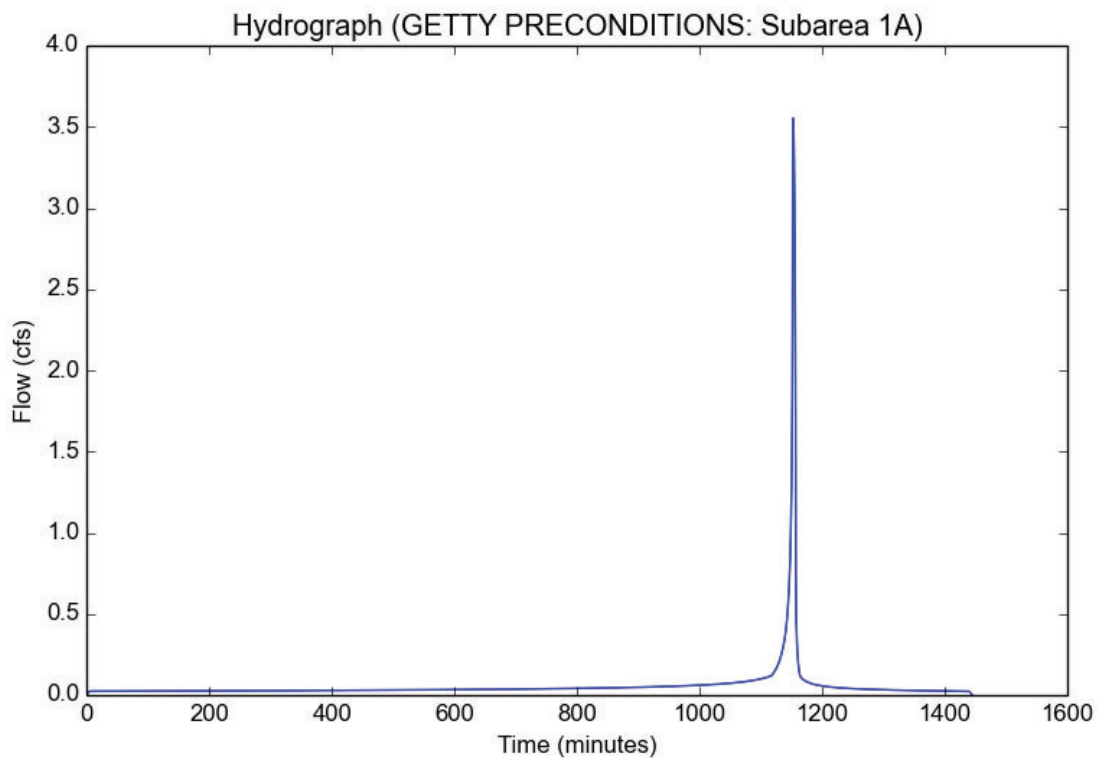

Peak Flow Hydrologic Analysis

File location: P:/2019/1900803 Getty Oak Parking Full Design/2 ENGR/STORM/2022-02-22 Hydrology Report - Update/APP. B - HYDROLOGY/PRE CO
Version: HydroCalc 1.0.3

Input Parameters

Project Name	GETTY PRECONDITIONS
Subarea ID	Subarea 1A
Area (ac)	1.47
Flow Path Length (ft)	344.6
Flow Path Slope (vft/hft)	0.04
50-yr Rainfall Depth (in)	7.7
Percent Impervious	0.01
Soil Type	21
Design Storm Frequency	50-yr
Fire Factor	0
LID	False

Output Results

Modeled (50-yr) Rainfall Depth (in)	7.7
Peak Intensity (in/hr)	4.594
Undeveloped Runoff Coefficient (Cu)	0.6304
Developed Runoff Coefficient (Cd)	0.6331
Time of Concentration (min)	5.0
Clear Peak Flow Rate (cfs)	4.2753
Burned Peak Flow Rate (cfs)	4.2753
24-Hr Clear Runoff Volume (ac-ft)	0.1401
24-Hr Clear Runoff Volume (cu-ft)	6101.0666

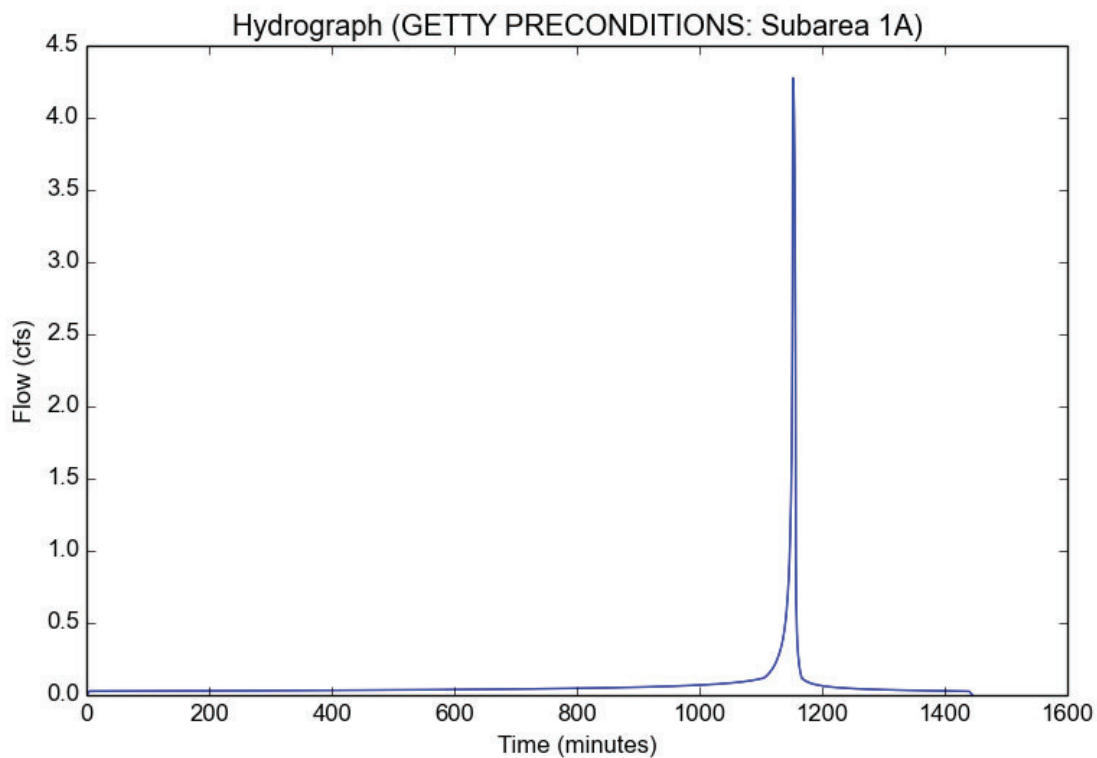

Peak Flow Hydrologic Analysis

File location: P:/2019/1900803 Getty Oak Parking Full Design/2 ENGR/STORM/2022-02-22 Hydrology Report - Update/APP. B - HYDROLOGY/PRE CO
Version: HydroCalc 1.0.3

Input Parameters

Project Name	GETTY PRECONDITIONS
Subarea ID	Subarea 2A
Area (ac)	1.59
Flow Path Length (ft)	199.5
Flow Path Slope (vft/hft)	0.04
50-yr Rainfall Depth (in)	7.7
Percent Impervious	0.01
Soil Type	21
Design Storm Frequency	25-yr
Fire Factor	0
LID	False

Output Results

Modeled (25-yr) Rainfall Depth (in)	6.7606
Peak Intensity (in/hr)	4.0336
Undeveloped Runoff Coefficient (Cu)	0.5962
Developed Runoff Coefficient (Cd)	0.5993
Time of Concentration (min)	5.0
Clear Peak Flow Rate (cfs)	3.8434
Burned Peak Flow Rate (cfs)	3.8434
24-Hr Clear Runoff Volume (ac-ft)	0.1275
24-Hr Clear Runoff Volume (cu-ft)	5552.5987

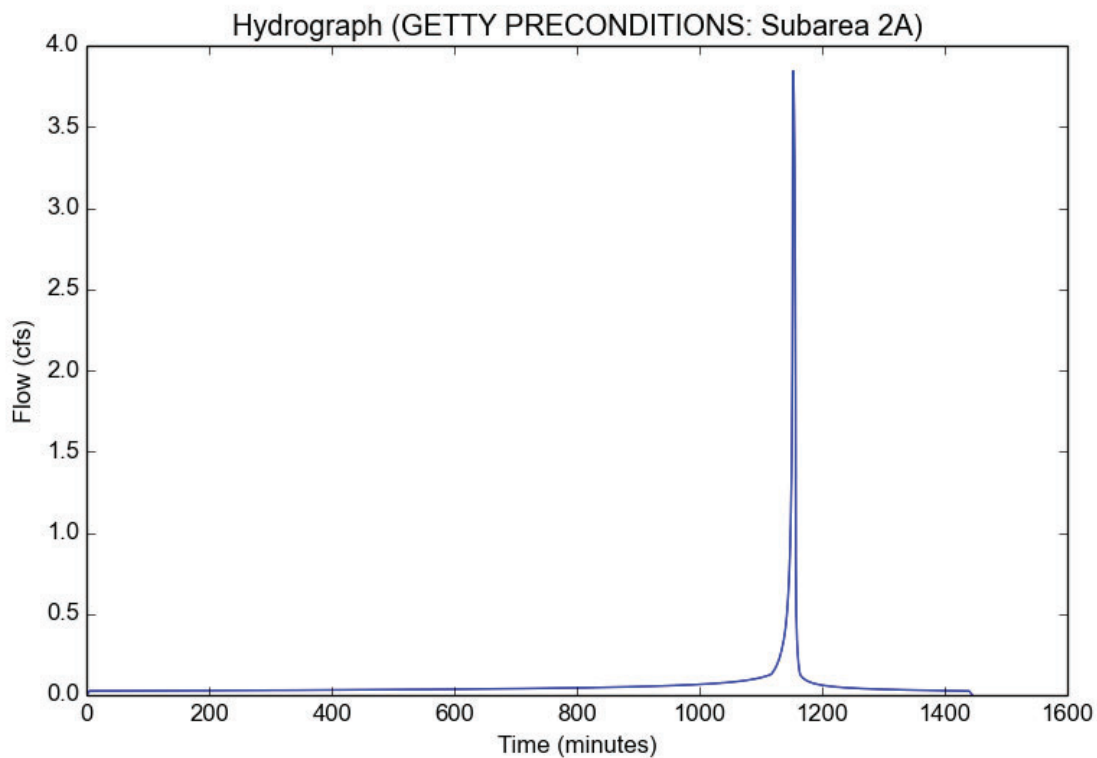

Peak Flow Hydrologic Analysis

File location: P:/2019/1900803 Getty Oak Parking Full Design/2 ENGR/STORM/2022-02-22 Hydrology Report - Update/APP. B - HYDROLOGY/PRE CO
Version: HydroCalc 1.0.3

Input Parameters

Project Name	GETTY PRECONDITIONS
Subarea ID	Subarea 2A
Area (ac)	1.59
Flow Path Length (ft)	199.5
Flow Path Slope (vft/hft)	0.04
50-yr Rainfall Depth (in)	7.7
Percent Impervious	0.01
Soil Type	21
Design Storm Frequency	50-yr
Fire Factor	0
LID	False

Output Results

Modeled (50-yr) Rainfall Depth (in)	7.7
Peak Intensity (in/hr)	4.594
Undeveloped Runoff Coefficient (Cu)	0.6304
Developed Runoff Coefficient (Cd)	0.6331
Time of Concentration (min)	5.0
Clear Peak Flow Rate (cfs)	4.6243
Burned Peak Flow Rate (cfs)	4.6243
24-Hr Clear Runoff Volume (ac-ft)	0.1515
24-Hr Clear Runoff Volume (cu-ft)	6599.1129

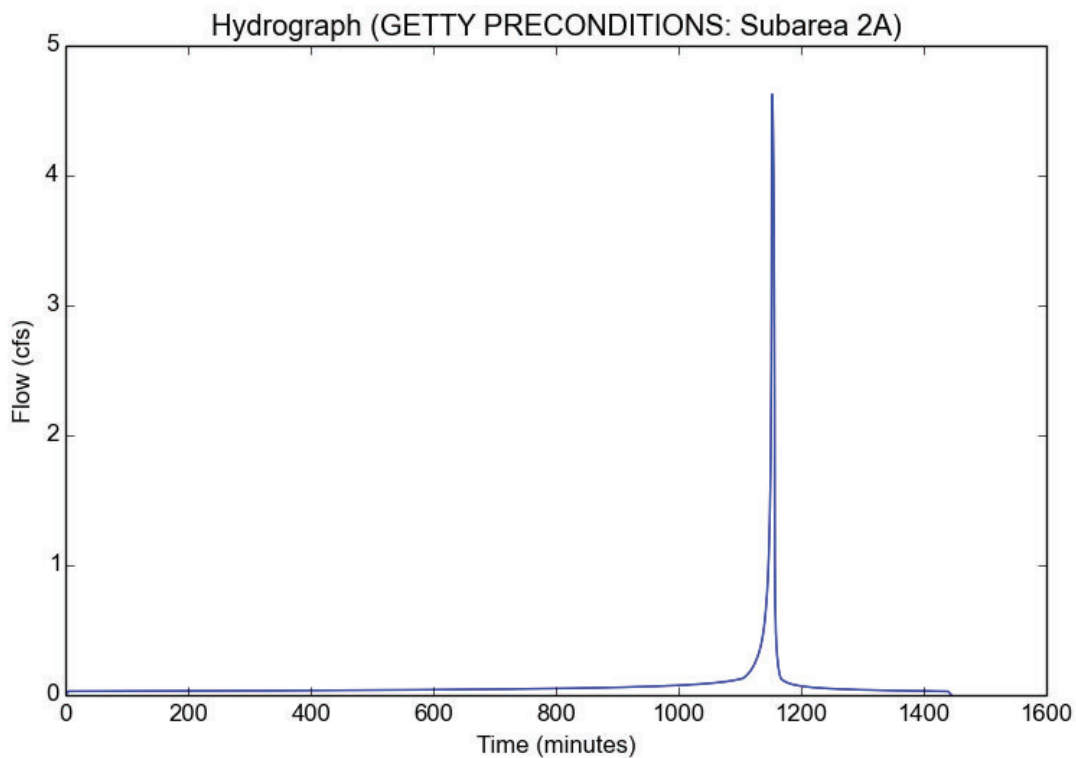

Peak Flow Hydrologic Analysis

File location: P:/2019/1900803 Getty Oak Parking Full Design/2 ENGR/STORM/2022-02-22 Hydrology Report - Update/APP. B - HYDROLOGY/POST C
Version: HydroCalc 1.0.3

Input Parameters

Project Name	GETTY POSTCONDITIONS
Subarea ID	Subarea 1A
Area (ac)	1.47
Flow Path Length (ft)	366.46
Flow Path Slope (vft/hft)	0.03
85th Percentile Rainfall Depth (in)	1.15
Percent Impervious	0.76
Soil Type	21
Design Storm Frequency	85th percentile storm
Fire Factor	0
LID	True

Output Results

Modeled (85th percentile storm) Rainfall Depth (in)	1.15
Peak Intensity (in/hr)	0.386
Undeveloped Runoff Coefficient (Cu)	0.1
Developed Runoff Coefficient (Cd)	0.708
Time of Concentration (min)	17.0
Clear Peak Flow Rate (cfs)	0.4018
Burned Peak Flow Rate (cfs)	0.4018
24-Hr Clear Runoff Volume (ac-ft)	0.0989
24-Hr Clear Runoff Volume (cu-ft)	4308.7622

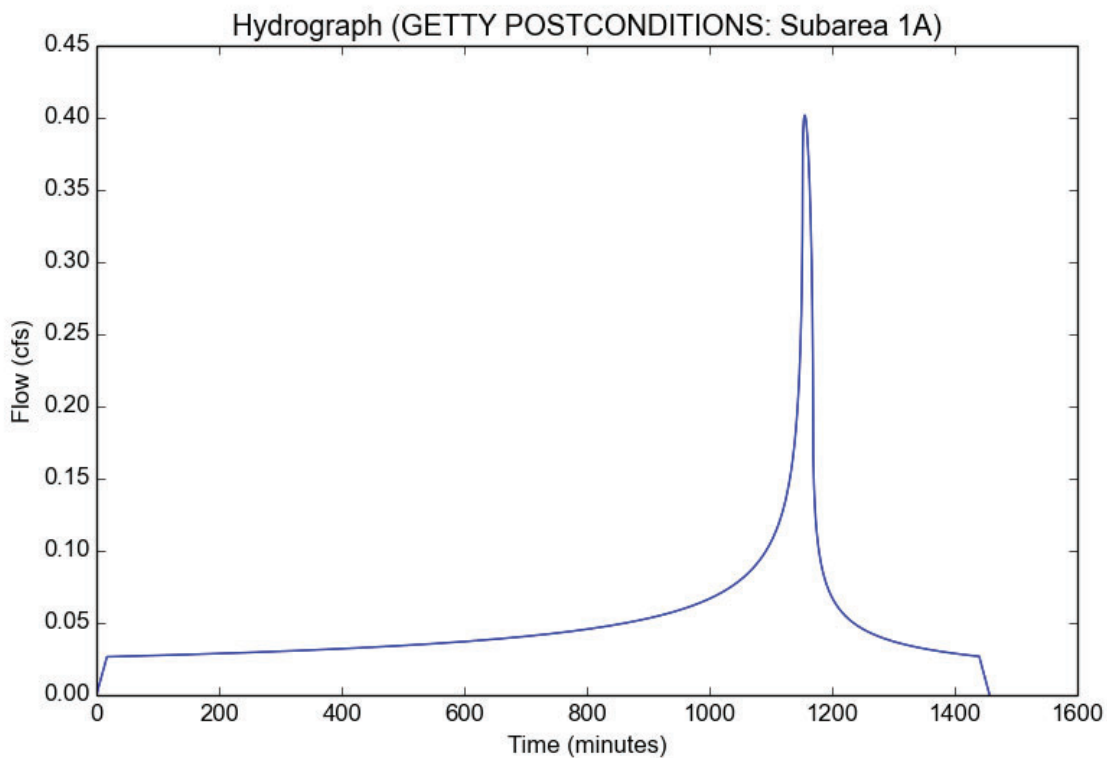

Peak Flow Hydrologic Analysis

File location: P:/2019/1900803 Getty Oak Parking Full Design/2 ENGR/STORM/2022-02-22 Hydrology Report - Update/APP. B - HYDROLOGY/POST C
Version: HydroCalc 1.0.3

Input Parameters

Project Name	GETTY POSTCONDITIONS
Subarea ID	Subarea 1A
Area (ac)	1.47
Flow Path Length (ft)	366.46
Flow Path Slope (vft/hft)	0.03
50-yr Rainfall Depth (in)	7.7
Percent Impervious	0.76
Soil Type	21
Design Storm Frequency	25-yr
Fire Factor	0
LID	False

Output Results

Modeled (25-yr) Rainfall Depth (in)	6.7606
Peak Intensity (in/hr)	4.0336
Undeveloped Runoff Coefficient (Cu)	0.5962
Developed Runoff Coefficient (Cd)	0.8271
Time of Concentration (min)	5.0
Clear Peak Flow Rate (cfs)	4.9041
Burned Peak Flow Rate (cfs)	4.9041
24-Hr Clear Runoff Volume (ac-ft)	0.5886
24-Hr Clear Runoff Volume (cu-ft)	25637.9749

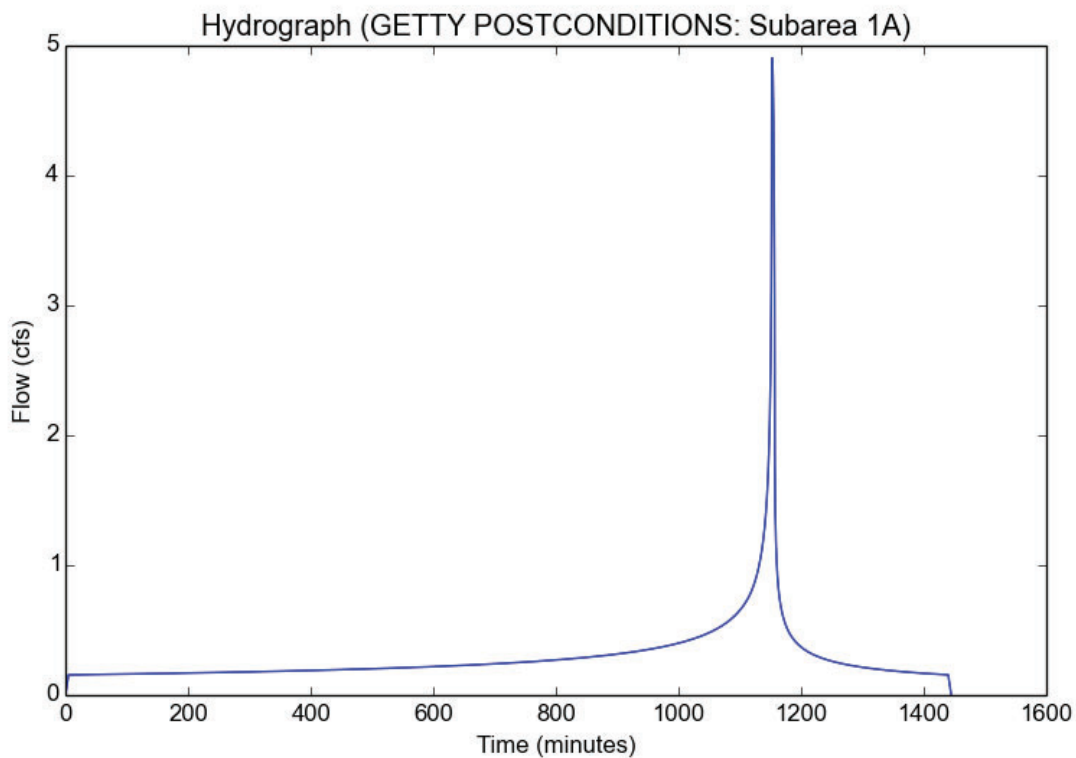

Peak Flow Hydrologic Analysis

File location: P:/2019/1900803 Getty Oak Parking Full Design/2 ENGR/STORM/2022-02-22 Hydrology Report - Update/APP. B - HYDROLOGY/POST C
Version: HydroCalc 1.0.3

Input Parameters

Project Name	GETTY POSTCONDITIONS
Subarea ID	Subarea 1A
Area (ac)	1.47
Flow Path Length (ft)	366.46
Flow Path Slope (vft/hft)	0.03
50-yr Rainfall Depth (in)	7.7
Percent Impervious	0.76
Soil Type	21
Design Storm Frequency	50-yr
Fire Factor	0
LID	False

Output Results

Modeled (50-yr) Rainfall Depth (in)	7.7
Peak Intensity (in/hr)	4.594
Undeveloped Runoff Coefficient (Cu)	0.6304
Developed Runoff Coefficient (Cd)	0.8353
Time of Concentration (min)	5.0
Clear Peak Flow Rate (cfs)	5.6409
Burned Peak Flow Rate (cfs)	5.6409
24-Hr Clear Runoff Volume (ac-ft)	0.6718
24-Hr Clear Runoff Volume (cu-ft)	29262.0552

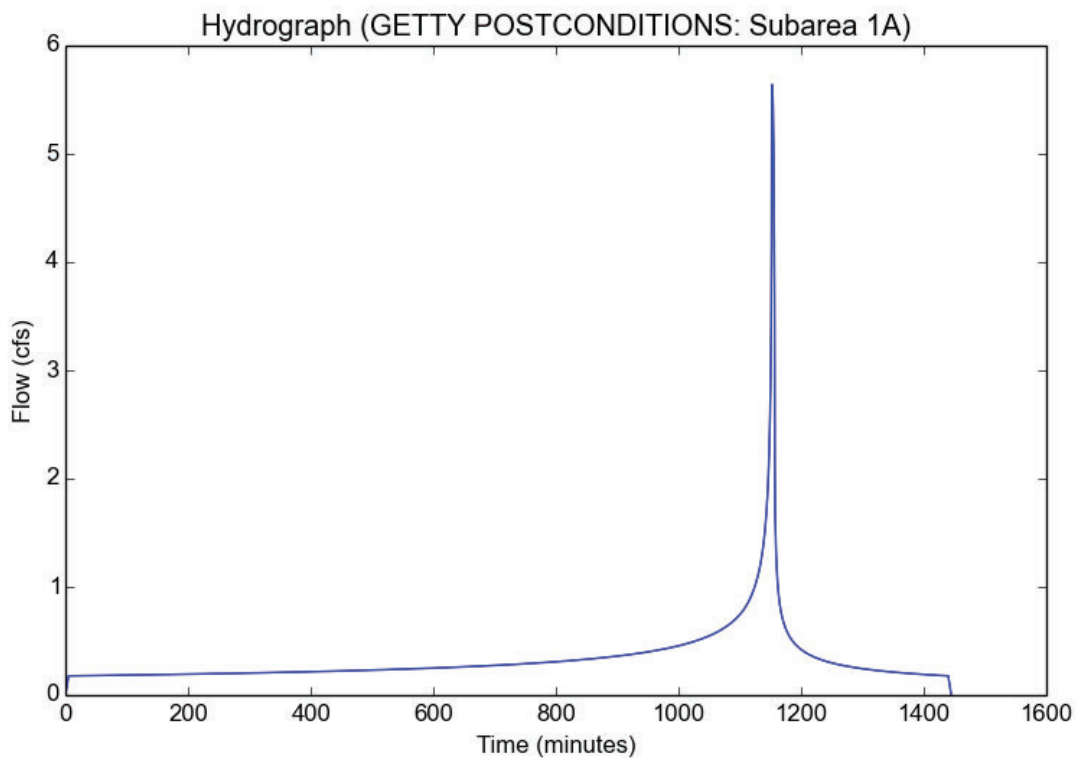

Peak Flow Hydrologic Analysis

File location: P:/2019/1900803 Getty Oak Parking Full Design/2 ENGR/STORM/2022-02-22 Hydrology Report - Update/APP. B - HYDROLOGY/POST C
Version: HydroCalc 1.0.3

Input Parameters

Project Name	GETTY POSTCONDITIONS
Subarea ID	Subarea 2A
Area (ac)	1.59
Flow Path Length (ft)	546.66
Flow Path Slope (vft/hft)	0.028
85th Percentile Rainfall Depth (in)	1.15
Percent Impervious	0.73
Soil Type	21
Design Storm Frequency	85th percentile storm
Fire Factor	0
LID	True

Output Results

Modeled (85th percentile storm) Rainfall Depth (in)	1.15
Peak Intensity (in/hr)	0.3349
Undeveloped Runoff Coefficient (Cu)	0.1
Developed Runoff Coefficient (Cd)	0.684
Time of Concentration (min)	23.0
Clear Peak Flow Rate (cfs)	0.3642
Burned Peak Flow Rate (cfs)	0.3642
24-Hr Clear Runoff Volume (ac-ft)	0.1034
24-Hr Clear Runoff Volume (cu-ft)	4502.5286

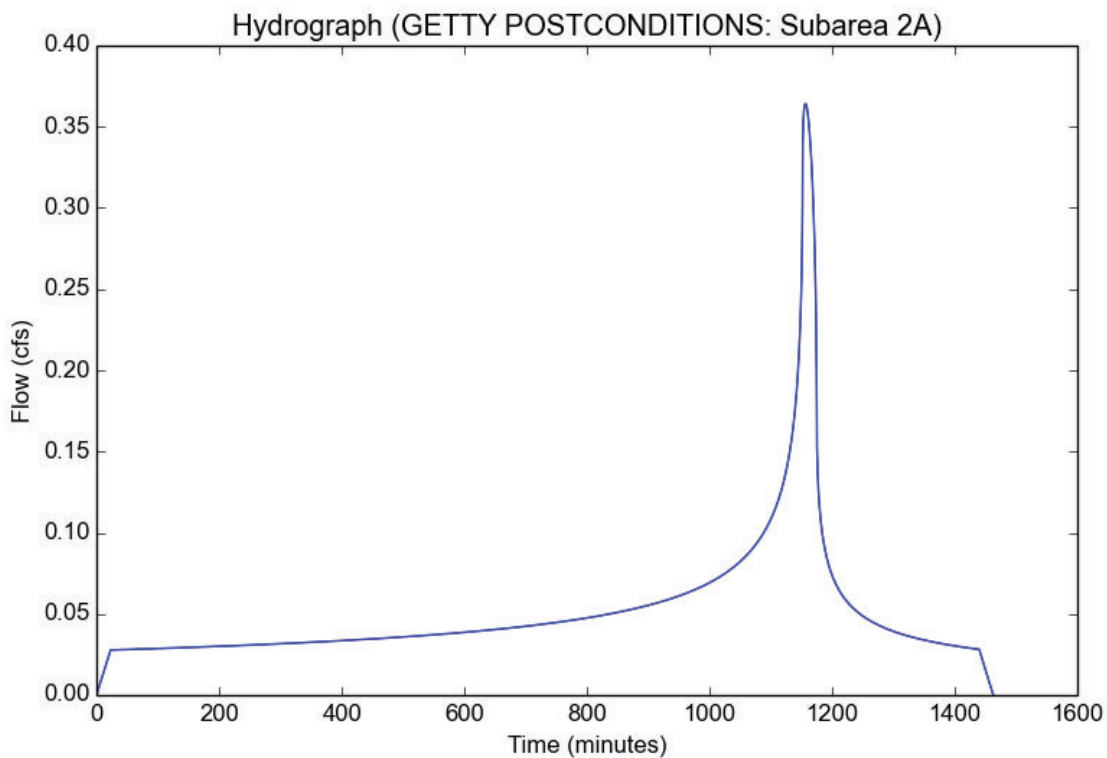

Peak Flow Hydrologic Analysis

File location: P:/2019/1900803 Getty Oak Parking Full Design/2 ENGR/STORM/2022-02-22 Hydrology Report - Update/APP. B - HYDROLOGY/POST C
Version: HydroCalc 1.0.3

Input Parameters

Project Name	GETTY POSTCONDITIONS
Subarea ID	Subarea 2A
Area (ac)	1.59
Flow Path Length (ft)	546.66
Flow Path Slope (vft/hft)	0.028
50-yr Rainfall Depth (in)	7.7
Percent Impervious	0.73
Soil Type	21
Design Storm Frequency	25-yr
Fire Factor	0
LID	False

Output Results

Modeled (25-yr) Rainfall Depth (in)	6.7606
Peak Intensity (in/hr)	3.7023
Undeveloped Runoff Coefficient (Cu)	0.5685
Developed Runoff Coefficient (Cd)	0.8105
Time of Concentration (min)	6.0
Clear Peak Flow Rate (cfs)	4.7711
Burned Peak Flow Rate (cfs)	4.7711
24-Hr Clear Runoff Volume (ac-ft)	0.6161
24-Hr Clear Runoff Volume (cu-ft)	26838.0549

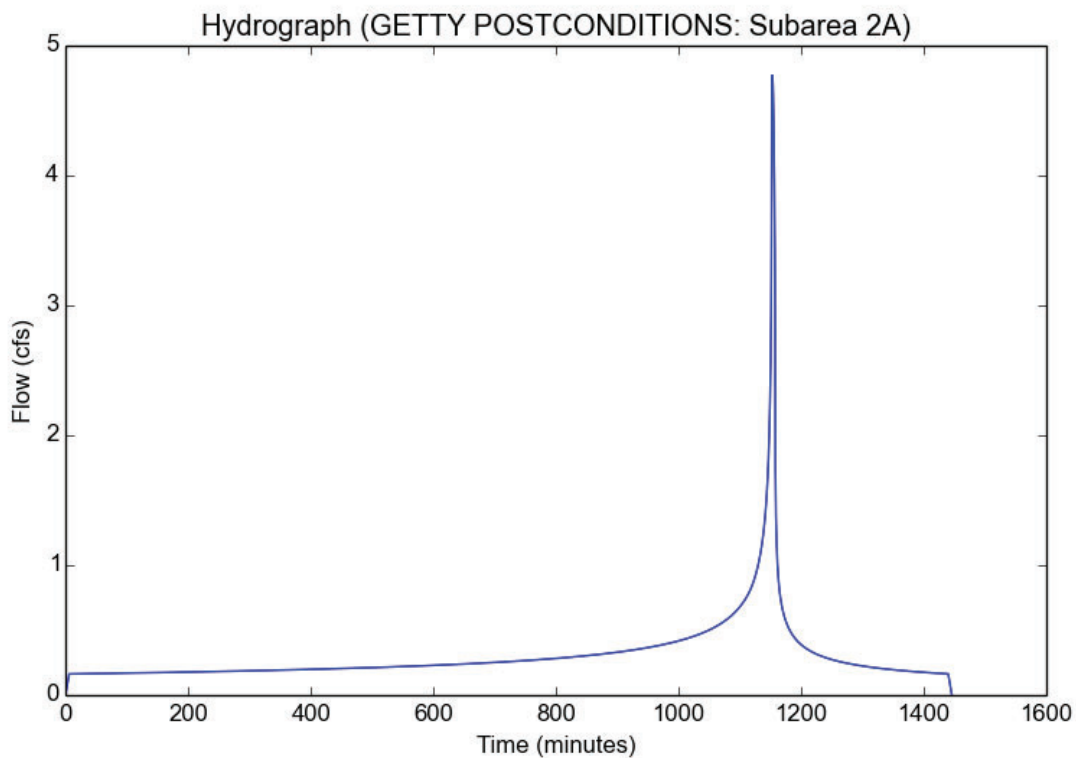

Peak Flow Hydrologic Analysis

File location: P:/2019/1900803 Getty Oak Parking Full Design/2 ENGR/STORM/2022-02-22 Hydrology Report - Update/APP. B - HYDROLOGY/POST C
Version: HydroCalc 1.0.3

Input Parameters

Project Name	GETTY POSTCONDITIONS
Subarea ID	Subarea 2A
Area (ac)	1.59
Flow Path Length (ft)	546.66
Flow Path Slope (vft/hft)	0.028
50-yr Rainfall Depth (in)	7.7
Percent Impervious	0.73
Soil Type	21
Design Storm Frequency	50-yr
Fire Factor	0
LID	False

Output Results

Modeled (50-yr) Rainfall Depth (in)	7.7
Peak Intensity (in/hr)	4.594
Undeveloped Runoff Coefficient (Cu)	0.6304
Developed Runoff Coefficient (Cd)	0.8272
Time of Concentration (min)	5.0
Clear Peak Flow Rate (cfs)	6.0423
Burned Peak Flow Rate (cfs)	6.0423
24-Hr Clear Runoff Volume (ac-ft)	0.7036
24-Hr Clear Runoff Volume (cu-ft)	30648.7271

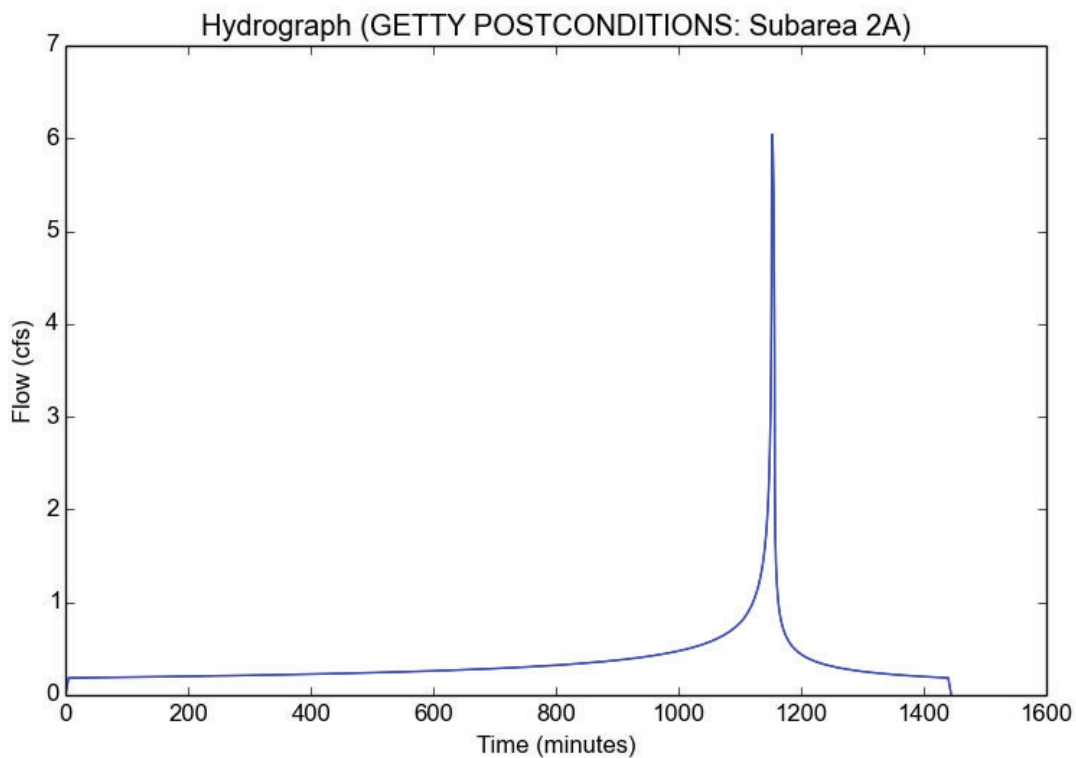

Appendix C - LID Details

ECO-RAIN DOUBLE + HALF TANK SPECIFICATION SHEET

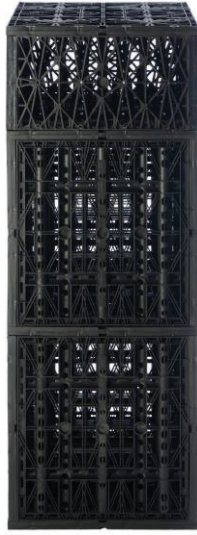

Smith-Emery Laboratories
Report No. L-11-336

ET-1502.5

ICC Approved Report ESR-3356 (Formally Approved LA City Research Report # 5654)

SIZE	1.34' wide x 2.25' long x 3.6' tall	16.06" wide x 26.97" long x 43" tall	408mm x 685mm x 1,092 mm
VOLUME	10.85 ft ³	81.16 gallons	307.24 liters

TEST	Standard Used	Imperial	Metric
Ultimate Load - H 25 Load Rated	AASHTO LRFD		
Displacement		.433"	11 mm
Temperature Parameter		46.4° - 57.2° F	8° - 14° C
Module Void Storage Area		97% - 10.52 Cubic Feet Storage	
Surrounding Gravel Storage Area		40%	
Material		100% Recycled Polypropylene	
Biological & Chemical Resistance		Unaffected by moulds, algae, soil-borne chemicals, bacteria & bitumen	
Temperature Tolerance		-22° to 248° F	-30° to 120° C
Flow Rate	ASTM D4716	.671 f ³ /second	.019 m ³ /second

NOTE: ECO-RAIN PRODUCTS & SYSTEMS ARE WORLDWIDE PATENT PENDING & DESIGN REGISTERED.

Safety Factors: Engineers, designers and geotechnical engineers should design and calculate safety factors to a serviceable limited state to suit specific project. If in doubt, consult distributor.

Disclaimer: All information provided in this publication is correct to the best knowledge of the company and is given out in good faith. This information is intended only as a general guide, no responsibility can be accepted for any errors, omissions or incorrect assumption. As each project is unique, and as Eco-Rain Tank Systems of America and its distributors and agents world-wide have no direct control over the methods employed by the user in specifying, installing or supervising of its products hence no responsibility is accepted by Eco-Rain Tank Systems of America and its distributors and agents world-wide. Users should satisfy themselves as to the suitability of the product for their purpose.



Eco-Rain Tank Systems of America, Inc.

contact@ecoraintank.com

1-818-501-0424

www.ecoraintank.com

P:\2019\1800803 Gentry Oak Parking Full Design\5 CAD\Sheets\1800803-05-030T.dwg, Nov 22, 2021, 3:50pm
 Frederick Fisher & Partners reserves its common law copyright and other property rights in these plans. These plans and drawings are not to be reproduced in any form or manner whatsoever without first obtaining the express written permission and consent of Frederick Fisher & Partners nor are they to be assigned to any third party without obtaining said written permission and consent.

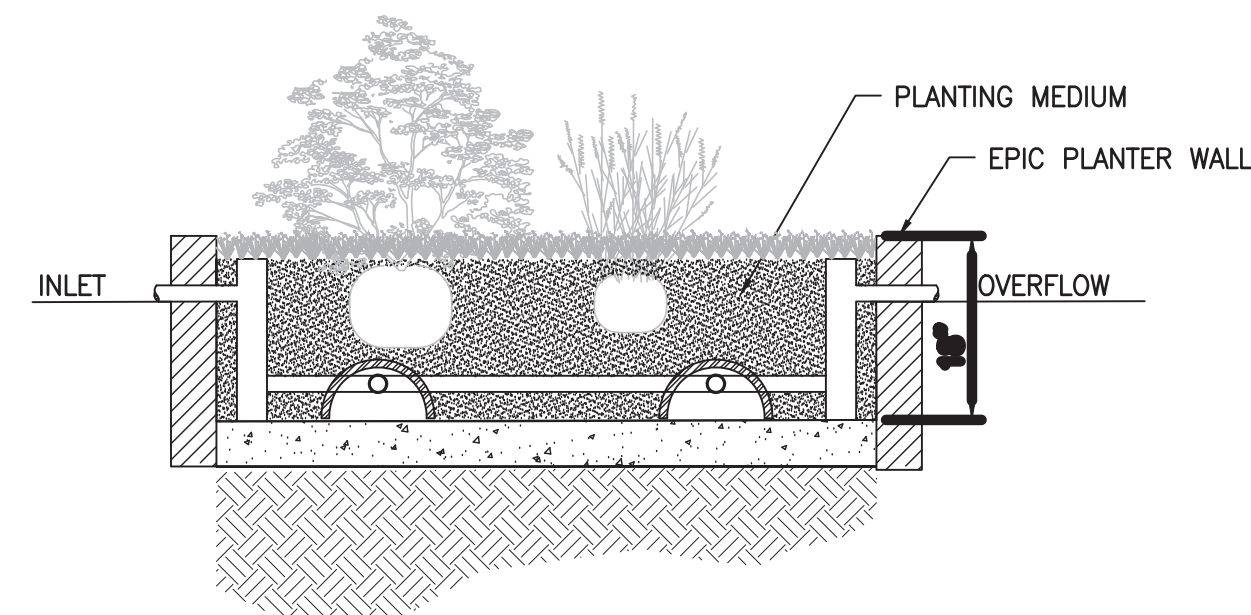
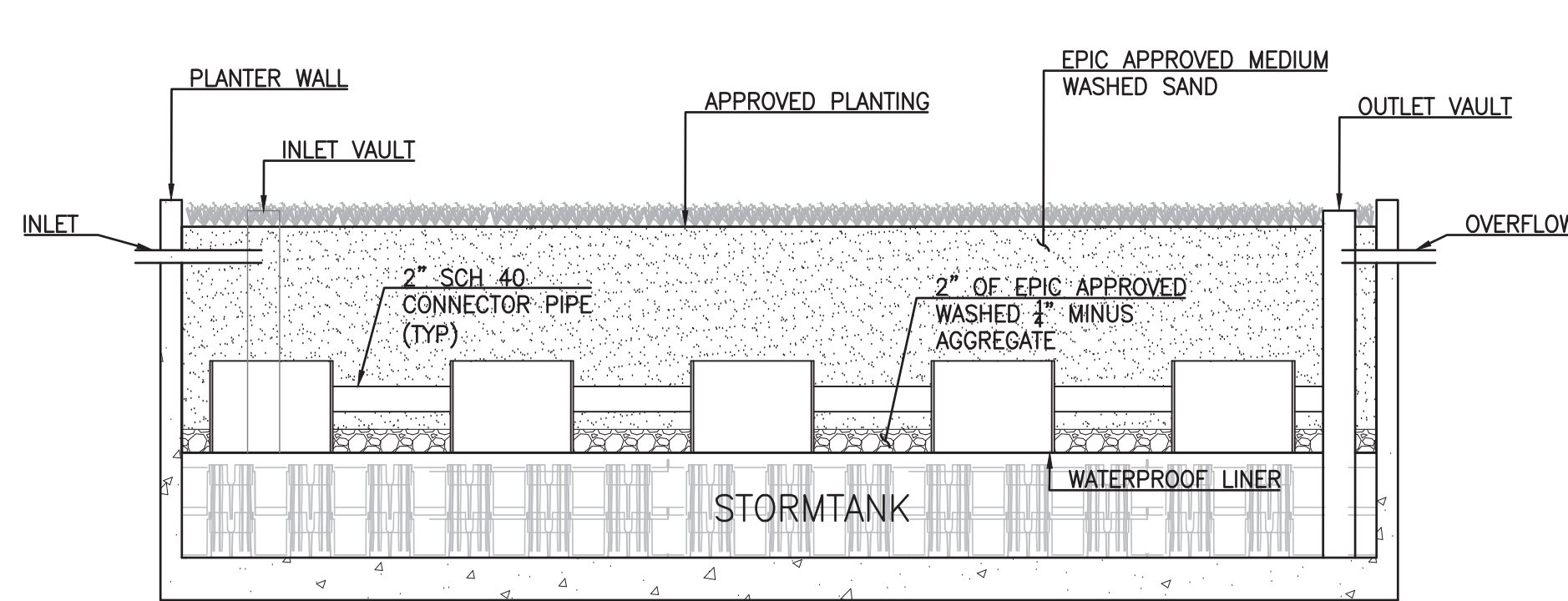
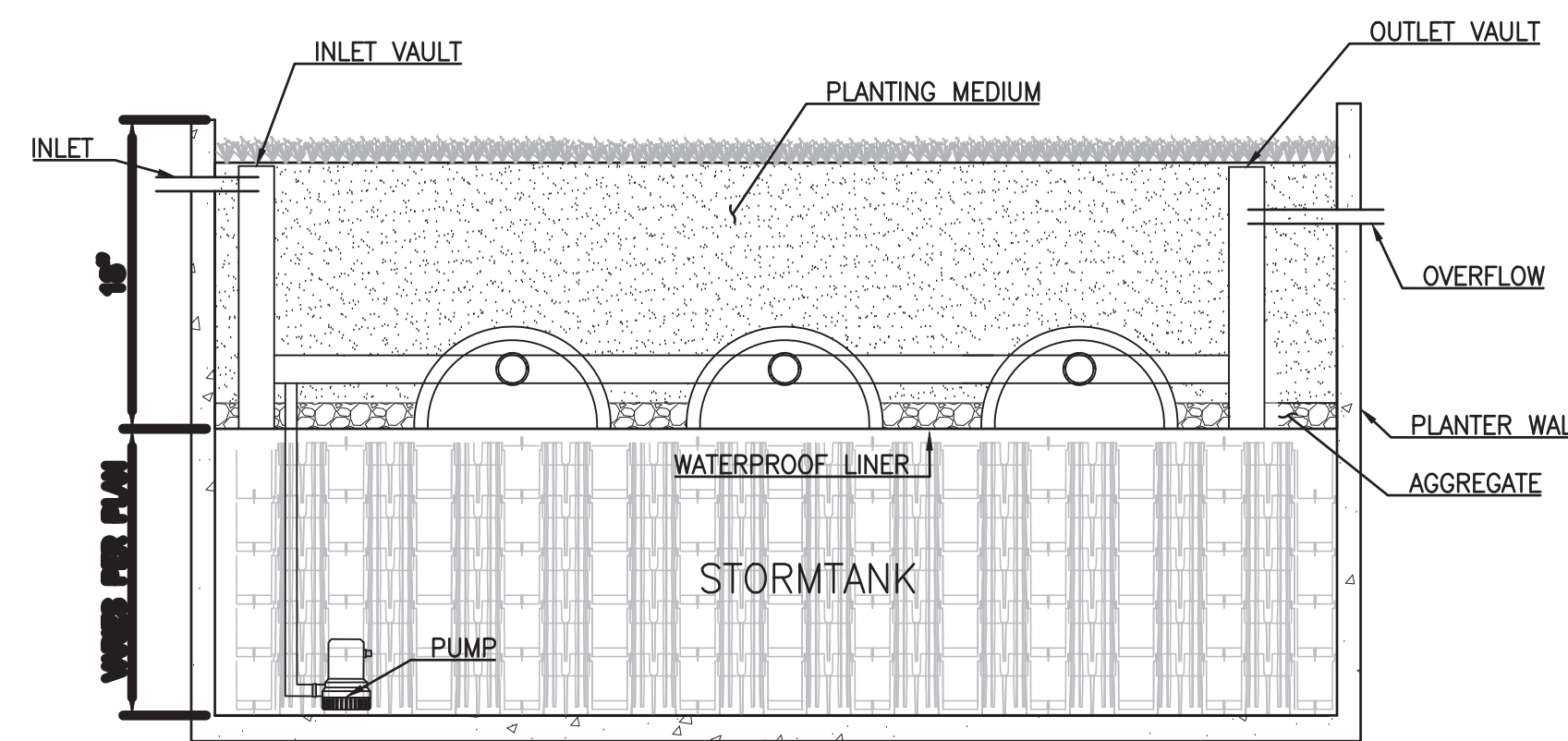
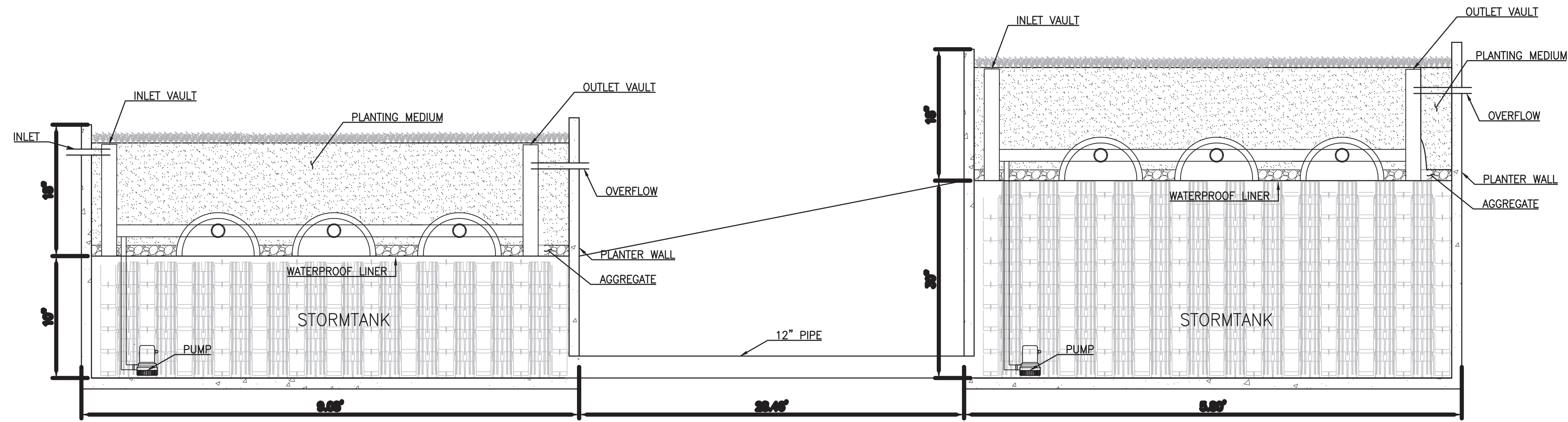
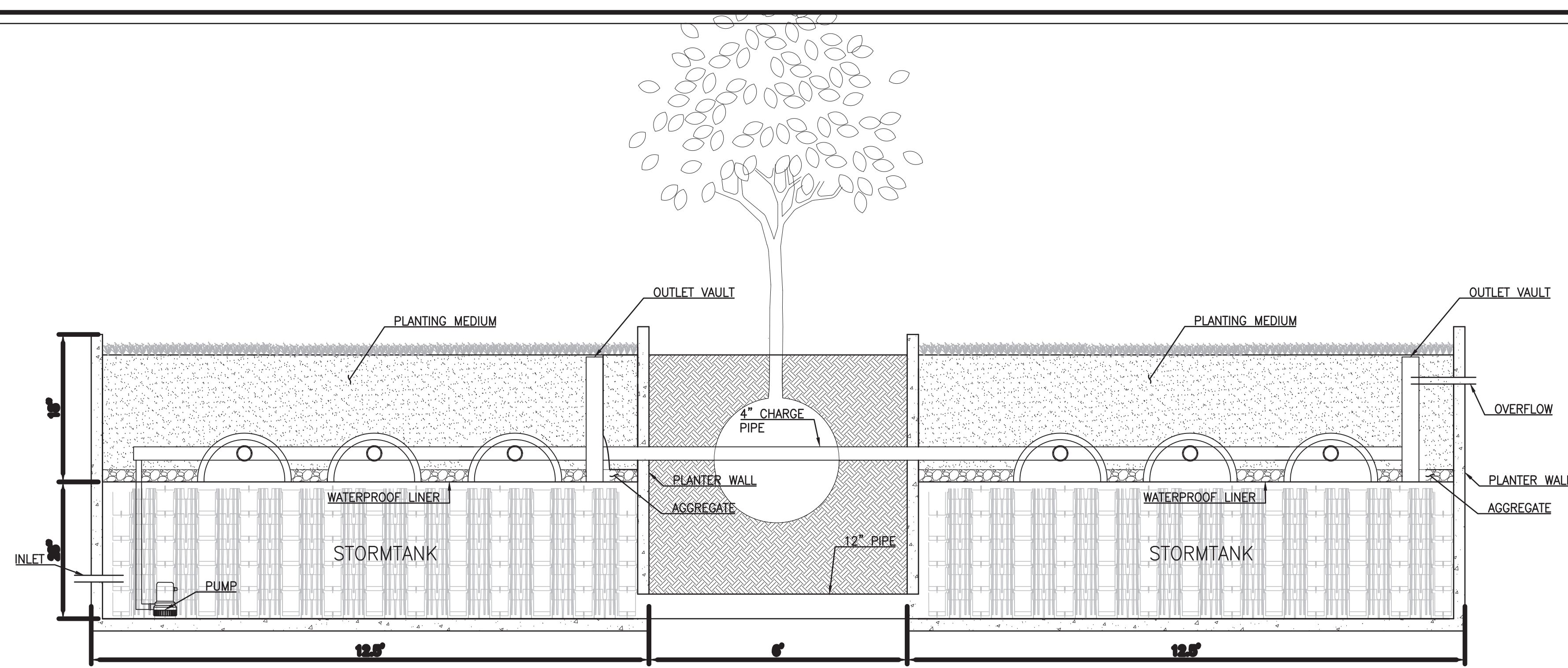

E1 EPIC PLANTER DETAILS

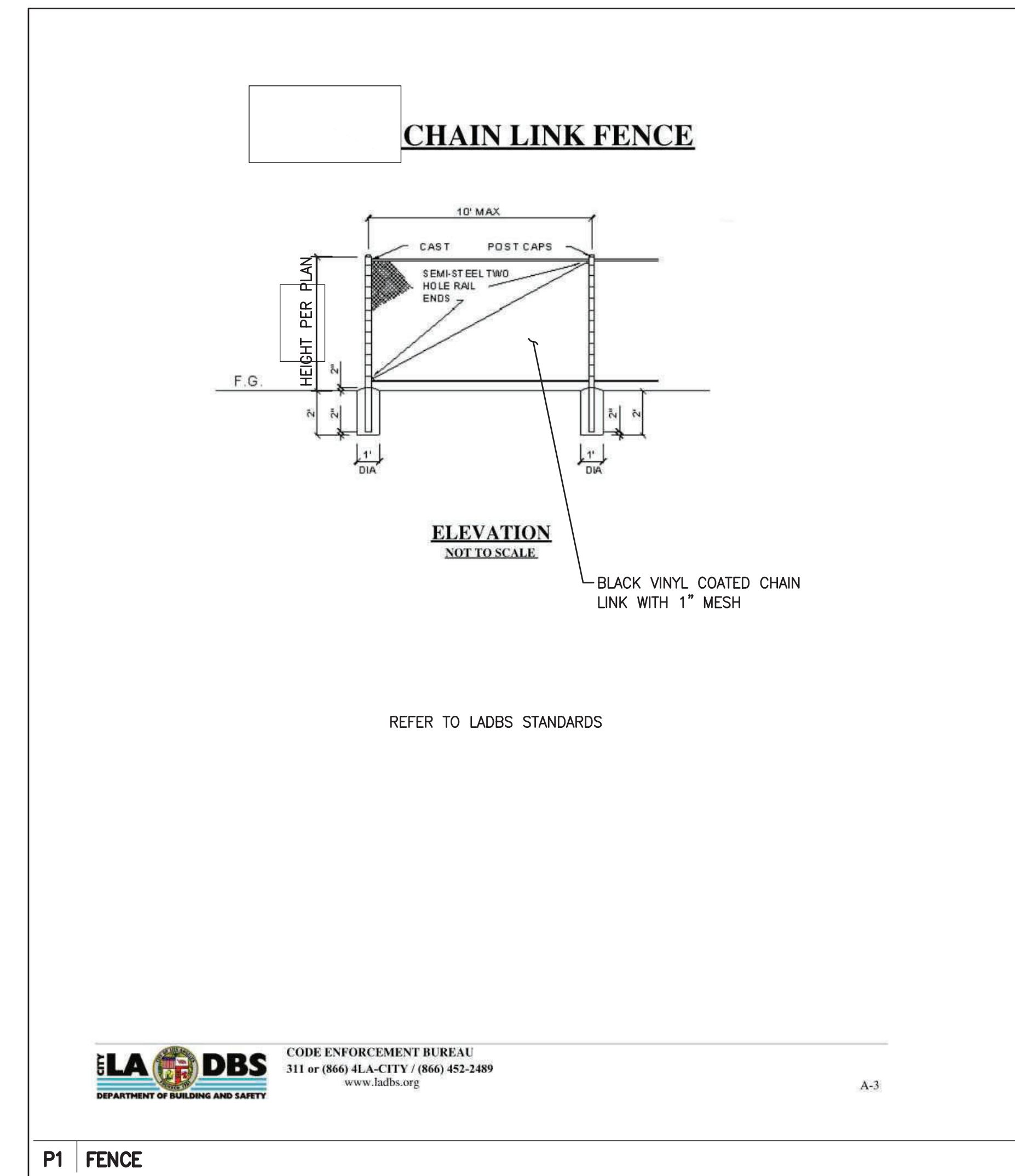

P1 FENCE

LA DBS DEPARTMENT OF BUILDING AND SAFETY
 INFORMATION BULLETIN / PUBLIC - BUILDING CODE
 REFERENCE NO.: UBC 21-4, ASTM A-615 Effective: 7-01-98
 DOCUMENT NO. P/BC 2002-002 Revised: 10-18-01
 Previously Issued As: IB GR-2

RETAINING OR SLOUGH WALL # 4'-0" HIGH

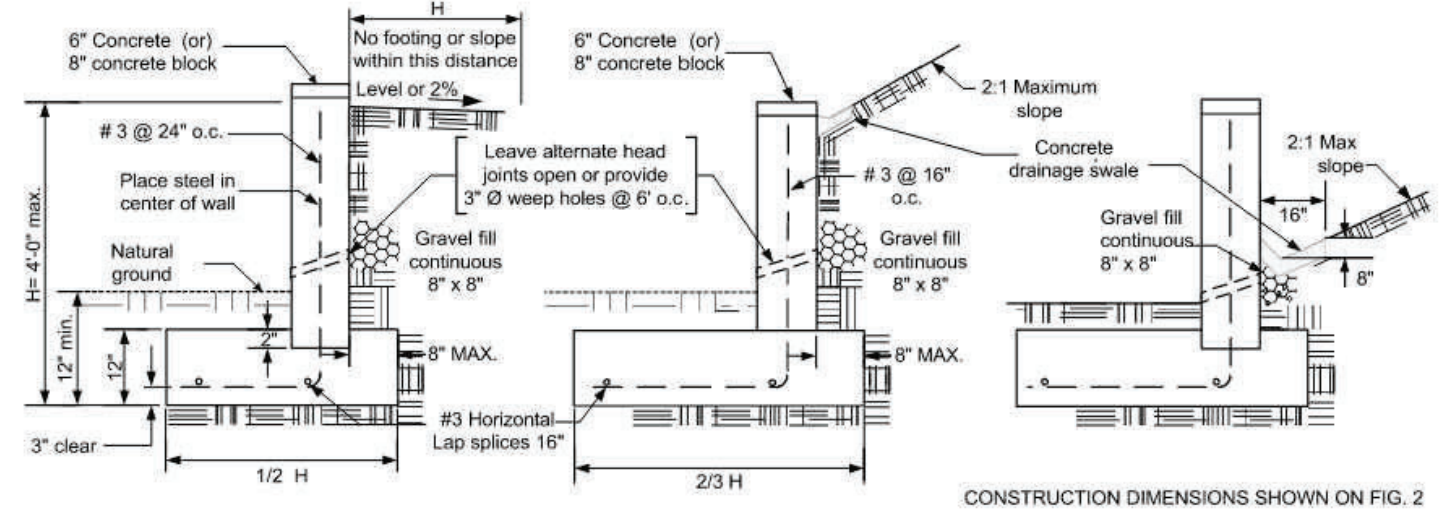

FIG. 1 (NO PERMIT IS REQUIRED FOR FIG. 1)
 FIG. 2 (PERMIT IS REQUIRED FOR FIG. 2 AND FIG. 3)
 FIG. 3 (SLOUGH WALL)

These walls are designed for the average condition and may not be suitable in all cases. Where the proposed wall construction is extensive, a licensed civil or structural engineer should be consulted.

- GENERAL SPECIFICATIONS**
- All footings to be 12" into natural ground.
 - Concrete mix for footing and for concrete wall to be 1 part Portland cement, 2 parts sand, 3 parts 1" rock with a maximum of 7 gallons of water per sack of cement.
 - Grout mix for concrete block wall to be 1 part Portland cement, to 3 parts sand to which may be added not more than 1/10 part lime. Sufficient water to be added to produce consistency for pouring without segregation of the constituents. Grout may contain pea gravel to a maximum size of 3/8".
 - Mortar mix for concrete blocks to be 1 part cement to 1/4 lime putty or hydrated lime to 3 1/2 parts damp loose sand.
 - Concrete block units to be standard 8"x8"x16" units conforming to UBC Standard 21-4.
 - Reinforcing steel shall be deformed steel conforming to A.S.T.M. Specification A-615. Lap all steel 16".
 - Concrete block units to be staggered (running bond).
 - Concrete block units to have vertical continuity of the cells unobstructed. All cells containing reinforcing to be filled solid with grout.
 - The designs illustrated on this information bulletin do not apply to locations with expansive soil.

As a covered entity under Title II of the Americans with Disabilities Act, the City of Los Angeles does not discriminate on the basis of disability and, upon request, will provide reasonable accommodation to ensure equal access to its programs, services and activities. For efficient handling of information internally and in the internet, conversion to the new format of code related and administrative information bulletins including MGD and RGA that were previously issued will also allow flexibility and timely distribution of information to the public.

E2 RETAINING WALL

OAK PARKING LOT PROJECT
 18006.00
 1200 GETTY CENTER DRIVE LOS ANGELES, CA 90049

CONTRACTOR

CONSULTANT
kpff

700 South Flower Street
 Suite 2100
 Los Angeles, CA 90017
 O: 213.418.0201
 F: 213.266.5294
 www.kpff.com

ISSUE DATES
 03.20.2020 80% CD
 04.17.2020 100% CD-PERMIT SET

DETAILS

SCALE: As indicated

C5.03

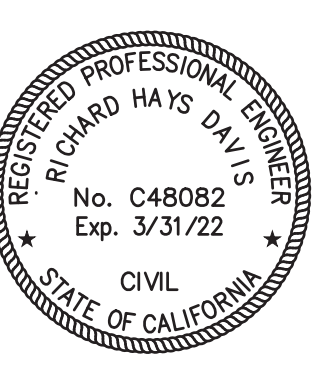

Appendix D - O&M

I. Components

The sequential primary components of the **EPIC™** System are:

- Laser level subgrade, ½" tolerance, 90% Proctor Density
- 4oz Non-Woven Geo-textile Felt Fabric (optional)
- 45 mil EPDM Rubber Liner on sub-grade and upright perimeter wall
- EPIC Chambers w/ non-pressurized 2" PVC connectors
- 2" of washed bridging gravel (ASTM C33 no.89)
- 13" (+/-) washed concrete sand (ASTM F2396)
- Total average profile depth +/- 15"-16"
- Inlet vault / Drain Vault
- Recirculation Tank with float valve, pump, fertigation unit (optional) and 7-day electrical timer



II. Operation

Inlet Vault

Inlet vaults are the starting point of the EPIC cell flow patterns, and supplied from the submersible pump in the recirculation tank. Check inlet regularly to verify pump operation.

Drain Vault

Drain vaults are the end point of EPIC system. Check drain vault to verify water has reached the entire length of EPIC flow pattern. An extension inserted in the vertical 6" drain can raise sub-surface water levels during planting. Remove extension from outlet for normal operation.

Recirculation Tank

Houses the submersible pump, water Point of Connection (POC) to float valve, fertigation unit (optional) and within close proximity a 7-day electrical timer to control pump operation. 6" final drain overflow located in the tank reservoir which drains to the project outfall.

EPIC Weekly 24 hour irrigation cycle

Running the submersible pump too long per cycle (+24-48 hrs) will not create a problem. Running the pump too often / frequent every day non-stop can eventually cause a problem; too much water will not allow the system to fluctuate water levels to exchange O₂ & CO₂.

III. Turf & Landscape Planting Establishment

Establishment Period Preparation

Smooth dry finish grade sand with drag mat. Begin "charging" pump operation at recirculation tank. Check the flow rates in the inlet vaults. Confirm flow of water reaches the drain vaults. Verify capillary irrigation moisture has reached all areas of each flow pattern (day after charging). Apply establishing fertilizer nutrients granules on surface and/or fertigation in water.

Mulch

Mulch around landscape plants and trees where applicable.

First Week

Remove excess soil from landscape plants root ball prior to transplant into sand. Compact sand around each planting. Hand water as *heat relief only* 2-3 times daily, at the hottest parts of the day, as the landscape / sod will be very stressed and can easily overheat until a new root system establishes into the sand. Hand water misting only in short durations. This practice only necessary above 75F. Operate pump 24/7 to maintain maximum saturation level.

Second Week

Use a USGA Standard Sized Golf Cup Cutter or a soil probe to check root growth (optional). Reduce pump inlet operation to EPIC system from 24/7 to 24/3.

Third Week.

Root growth should be well established, sod should not lift when pulled / tugged with hands. Use a USGA Standard Golf Cup Cutter or a soil probe to check root growth (optional). Once root growth reaches an average of 6”, reduce pump operation program cycle to 24/1. Core aeration operation of the field is recommended with a piston driven core aerator.

Routine Maintenance

Mow frequently and keep mower blades sharp. Keep records and be observant of change. Be observant for harmful bugs or diseases and apply treatment as necessary.

Time	Material/Procedure	Rationale
All months	Maintain grass height to recommendation by sod grower for selected species	Mow at least once per week in the early and late months and <u>twice per week</u> during May, June, July, August with a sharp mower. Mow in alternating patterns.
All months	Maintain moisture levels	Normal operating level is operating the pump 24 hrs. / 1-2 times per week.
All Months	Fertility	Fertilize as needed from soil tests and visual plant inspections. *Sand-based fields will require a more comprehensive fertility program*
Seasonally	Aeration	Sand fields grow aggressively. Aeration is critical to avoid anaerobic conditions. Aerate every 8-12 weeks. Rake & remove aeration plugs and schedule nutrient and over-seed operations to follow aeration schedules.

IV. Agronomic Overview

Rely on testing semi-annual soil and water analysis, recommended every 4-6 months to establish the appropriate nutrient formula. Landscape maintenance is a matter of routine.

Water Management

The plants themselves determine the water uptake provided by sand capillary rise. EPIC System water will dry out from the top surface down. Moisture levels require periodic inspections.

Aerobic Conditions

Aerobic (oxygen sufficient) conditions must be available for respiration in roots, which in turn is necessary for plant growth. **Aeration is critical!**

Plant Essential Nutrients

Eight inorganic elements have been recognized as **essential nutrients** for plant growth, each with a specific function in plant physiology. These include Calcium, Iron, Magnesium, Manganese, Nitrogen, Potassium, Phosphorus, and Sulfur.

Agricultural Laboratories

CLC Labs 325 Venture Dr., Westerville, OH 43081 614-888-1663	Soil & Plant Lab 352 Mathews, Santa Clara, CA 95050 408-727-0330
Soil Horizons, Inc. 865 Catalpa Place, Marysville, OH 43040 888-933-5501	Wallace Labs 365 Coral Cir, El Segundo, CA 90245 (310) 615-0116