

IN THE CITY OF VICTORVILLE, COUNTY OF SAN BERNARDINO, STATE OF CALIFORNIA
VESTING TENTATIVE MAP - TRACT NO. 20488

BEING A SUBDIVISION OF PARCEL 4 OF PARCEL MAP NO. 1612 AS FILED IN BOOK 13 OF PARCEL MAPS WITHIN THE SW 1/4 OF SECTION 28, TOWNSHIP 5 NORTH, RANGE 5 WEST, SAN BERNARDINO BASE AND MERIDIAN, IN THE CITY OF VICTORVILLE, COUNTY OF SAN BERNARDINO, STATE OF CALIFORNIA
UNITED ENGINEERING GROUP CA., INC DECEMBER 2021

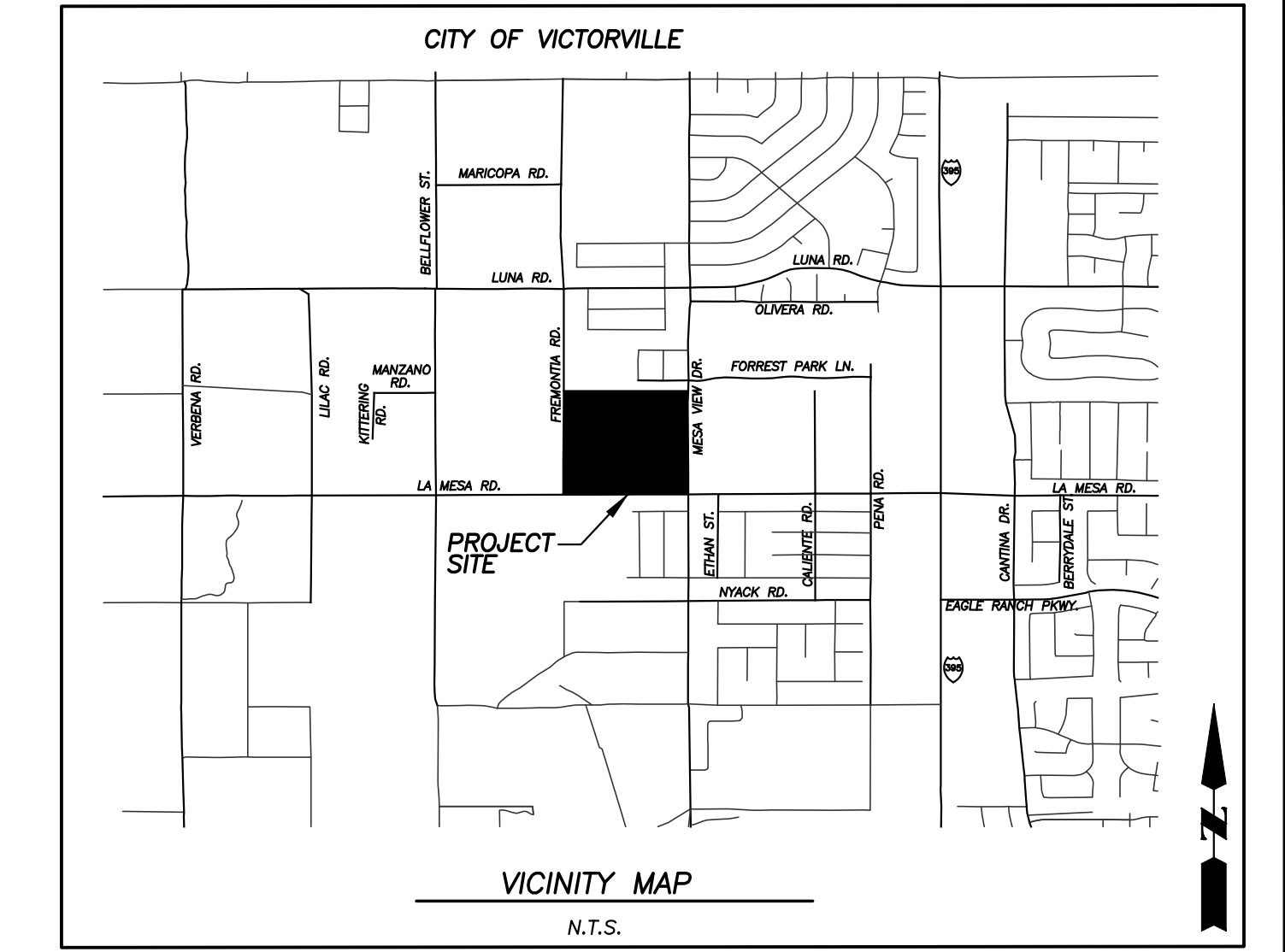

LOT AREAS			LOT AREAS			LOT AREAS		
LOT #	AREA-SF	AREA-AC	LOT #	AREA-SF	AREA-AC	LOT #	AREA-SF	AREA-AC
1	5,050	0.12	52	5,853	0.13	103	4,480	0.10
2	5,050	0.12	53	5,400	0.12	104	4,480	0.10
3	5,050	0.12	54	5,580	0.13	105	4,480	0.10
4	5,343	0.12	55	6,091	0.14	106	4,480	0.10
5	5,379	0.12	56	6,487	0.15	107	4,973	0.11
6	5,958	0.14	57	7,626	0.18	108	4,836	0.11
7	5,500	0.13	58	8,487	0.19	109	4,894	0.11
8	5,500	0.13	59	9,097	0.21	110	4,899	0.11
9	5,500	0.13	60	6,437	0.15	111	4,897	0.11
10	5,500	0.13	61	7,404	0.17	112	4,666	0.11
11	5,500	0.13	62	6,848	0.16	113	4,879	0.11
12	5,500	0.13	63	5,503	0.13	114	4,159	0.10
13	5,500	0.13	64	5,200	0.12	115	4,164	0.10
14	5,500	0.13	65	5,447	0.13	116	4,174	0.10
15	5,761	0.13	66	6,172	0.14	117	4,183	0.10
16	5,933	0.14	67	6,164	0.14	118	4,183	0.10
17	7,395	0.17	68	6,322	0.15	119	4,182	0.10
18	6,854	0.16	69	6,223	0.14	120	4,182	0.10
19	5,776	0.13	70	6,238	0.14	121	4,182	0.10
20	5,712	0.13	71	7,094	0.16	122	4,182	0.10
21	5,638	0.13	72	10,644	0.24	123	4,173	0.10
22	5,569	0.13	73	10,247	0.24	124	4,160	0.10
23	5,519	0.13	74	17,790	0.41	125	4,160	0.10
24	5,488	0.13	75	6,944	0.16	126	4,160	0.10
25	5,462	0.13	76	6,203	0.14	127	4,096	0.09
26	5,813	0.13	77	5,353	0.12	128	4,347	0.10
27	5,526	0.13	78	11,761	0.27	129	4,666	0.11
28	5,421	0.12	79	10,512	0.24	130	4,417	0.10
29	5,450	0.13	80	4,440	0.10	131	4,053	0.09
30	5,474	0.13	81	4,480	0.10	132	4,754	0.11
31	5,481	0.13	82	4,498	0.10	133	4,955	0.11
32	5,469	0.13	83	4,506	0.10	134	5,555	0.13
33	5,455	0.13	84	4,396	0.10	135	6,798	0.16
34	5,688	0.13	85	4,328	0.10	136	5,470	0.13
35	6,147	0.14	86	4,178	0.10	137	5,554	0.13
36	5,858	0.13	87	4,225	0.10	138	4,934	0.11
37	5,475	0.13	88	7,194	0.17	139	4,962	0.11
38	5,524	0.13	89	10,558	0.24	140	7,190	0.17
39	5,572	0.13	90	8,196	0.19	141	8,249	0.19
40	5,620	0.13	91	5,301	0.12	142	4,515	0.10
41	6,125	0.14	92	4,766	0.11	143	4,198	0.10
42	6,333	0.15	93	4,733	0.11	144	4,223	0.10
43	7,706	0.18	94	4,687	0.11	145	4,223	0.10
44	6,390	0.15	95	4,664	0.11	146	4,225	0.10
45	5,927	0.14	96	4,622	0.11	147	4,463	0.10
46	5,775	0.13	97	4,586	0.11	148	8,313	0.19
47	5,453	0.13	98	4,557	0.10	149	9,660	0.22
48	5,400	0.12	99	4,534	0.10	150	4,650	0.11
49	5,400	0.12	100	4,518	0.10	151	4,025	0.09
50	5,400	0.12	101	4,508	0.10	152	4,382	0.10
51	5,853	0.13	102	4,492	0.10			

PROPOSED DUAL USE PARK AND BASIN AREA

LOT	AREA-SF	AREA-AC
A	28,953	0.66

PROPOSED DUAL BASIN AREAS

LOT	AREA-SF	AREA-AC
B	17,433	0.40
C	25,499	0.59

EXIST. DESERT WASH FUTURE DRAINAGE CHANNEL AREA TO BE DEDICATED TO THE CITY OF VICTORVILLE

LOT	AREA-SF	AREA-AC
D	240,037	5.51

PROPOSED LMD AREAS

LOT	AREA-SF	AREA-AC
E	13,279	0.30
F	7,416	0.17
G	3,484	0.08
H	4,544	0.10
I	5,119	0.12
J	33,646	0.77
K	1,085	0.02
L	2,866	0.07

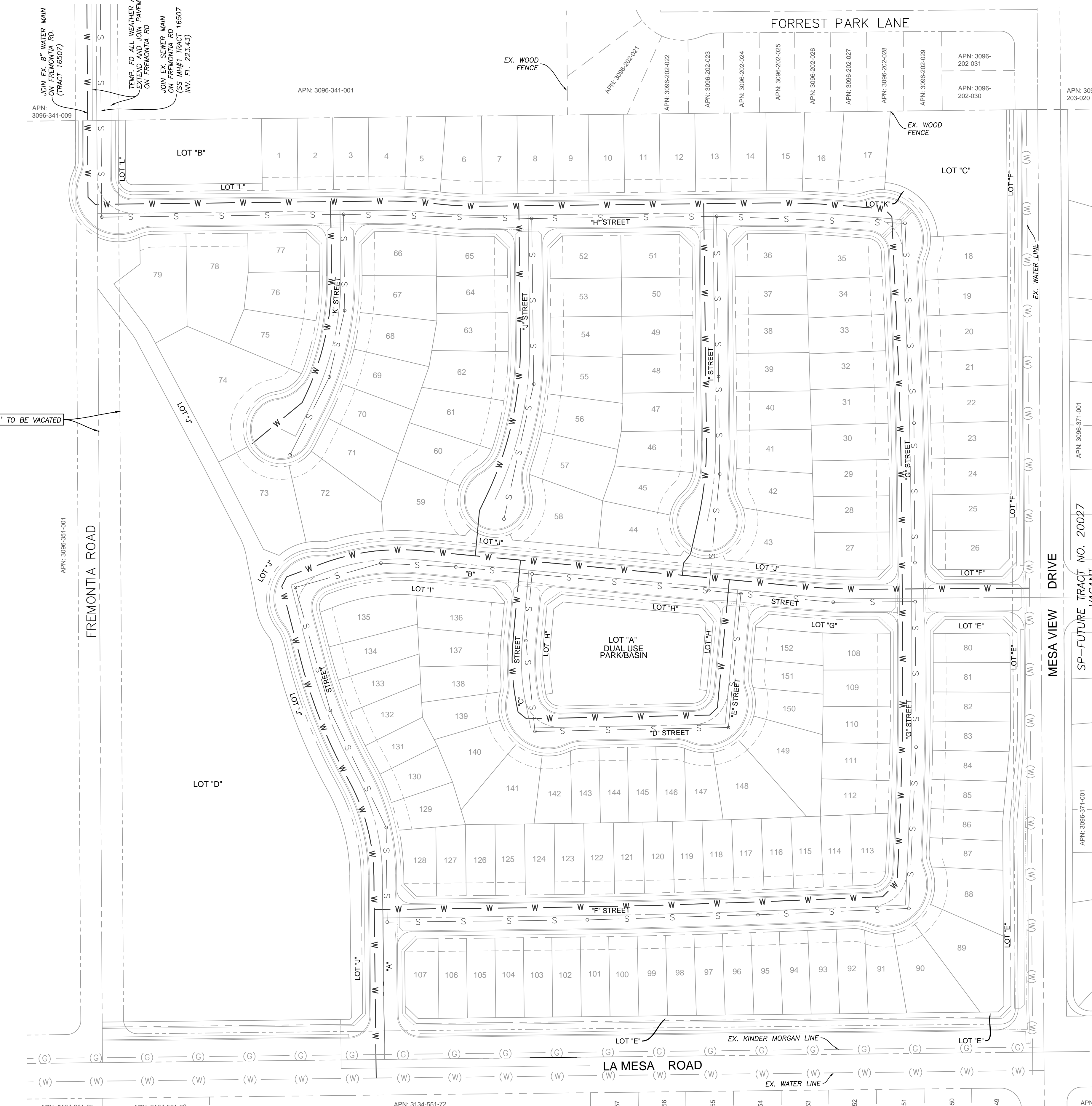

GENERAL NOTES:

- ASSESSOR'S PARCEL NOS.: 3096-351-02 & 03.
- THE PROPERTY SHOWN HEREIN CONTAINS THE ENTIRE CONTIGUOUS OWNERSHIP.
- TOTAL GROSS AREA = 1,753,900 SQ. FT., 40.26 ACRES
- TOTAL NET AREA = 1,649,927 SQ. FT., 37.86 ACRES
- TOTAL NO. OF NUMBERED LOTS = 152
- TOTAL NO. OF LETTERED LOTS = 12
- LOTS 1 THROUGH 79 ARE 4,000 S.F. MIN. (RESIDENTIAL LOTS)
- LOTS 80 THROUGH 152 ARE 8,000 S.F. MIN. (RESIDENTIAL LOTS)
- NET DENSITY: 4.01 DU/AC.
- GROSS DENSITY: 3.77 DU/AC.
- AVERAGE LOT SIZE = 5,651 S.F.
- CONTOUR INTERVAL = 1 FOOT (VARIES)
- ALL SLOPES ARE 2:1 OR FLATTER
- LOT DIMENSIONS SHOWN HEREIN ARE APPROXIMATE.
- THIS MAP IS COMPILED FROM RECORD INFORMATION ONLY AND IS NOT TO BE USED AS A BOUNDARY SURVEY.
- THE LOCATIONS OF ALL EXISTING UTILITIES SHOWN ON THIS MAP ARE APPROXIMATE.
- ALL FRONT YARD BUILDING SETBACK LINES (BSL) ARE SHOWN AT THE MINIMUM FRONT YARD BSL = 18' PER VISTA VERDE SPECIFIC PLAN.

LAND USE INFORMATION:

EXISTING ZONING = MLR/MR (VISTA VERDE SPECIFIC PLAN)
 PROPOSED ZONING = MLR/MR (VISTA VERDE SPECIFIC PLAN)
 ADJACENT EXISTING LAND USE =
 NORTH - MLR (VISTA VERDE SPECIFIC PLAN)
 EAST - LR (VISTA VERDE SPECIFIC PLAN)
 WEST - VLR (VISTA VERDE SPECIFIC PLAN)
 SOUTH - R-1 (SINGLE FAMILY RESIDENTIAL)

UTILITY PURVEYORS

WATER	VICTORVILLE WATER DISTRICT 14343 CIVIC DRIVE VICTORVILLE, CA 92393 (760) 955-5001
SEWER	CITY OF VICTORVILLE 14343 CIVIC DRIVE VICTORVILLE, CA 92393 (760) 955-5001
TRASH	BURRTEC WASTE 17080 STODDARD WELLS RD. VICTORVILLE, CA 92394 (760) 245-8807
ELECTRIC	SOUTHERN CALIFORNIA EDISON 12353 HESPERIA RD. VICTORVILLE, CA 92392 (760) 951-3253
GAS	SOUTHWEST GAS CORP. 13471 MARIPOSA RD. VICTORVILLE, CA 92392 (760) 951-4050
TELEPHONE	VERIZON 16071 MOJAVE DR. BLDG. A VICTORVILLE, CA 92392 (760) 245-0894
CABLE	CHARTER COMMUNICATIONS 12490 BUSINESS CENTER DR. SUITE 1 VICTORVILLE, CA 92392 (760) 843-3054

LEGEND

- BSL BUILDING SETBACK LINE
- 40 LOT NUMBER
- TRACT BOUNDARY

BENCH MARK

CITY OF VICTORVILLE BENCHMARK NO. V-212
 LA MESA & HIGHWAY 395, 146' E/O EAST EP
 HWY 395 & 87' SE OF FIRE HYDRANT.
 ELEV = 3248.52

OWNER/APPLICANT:

VICTORVILLE DEVELOPMENT, LLC
 5780 FLEET STREET, SUITE 225
 CARLSBAD, CA 92008

PREPARED BY:

UNITED ENGINEERING GROUP-CA, INC.
 8885 HAVEN AVENUE
 SUITE 195
 RANCHO CAUCAMONGA, CA 91730
 PHONE: 909.466.9240
 www.unitedeng.com

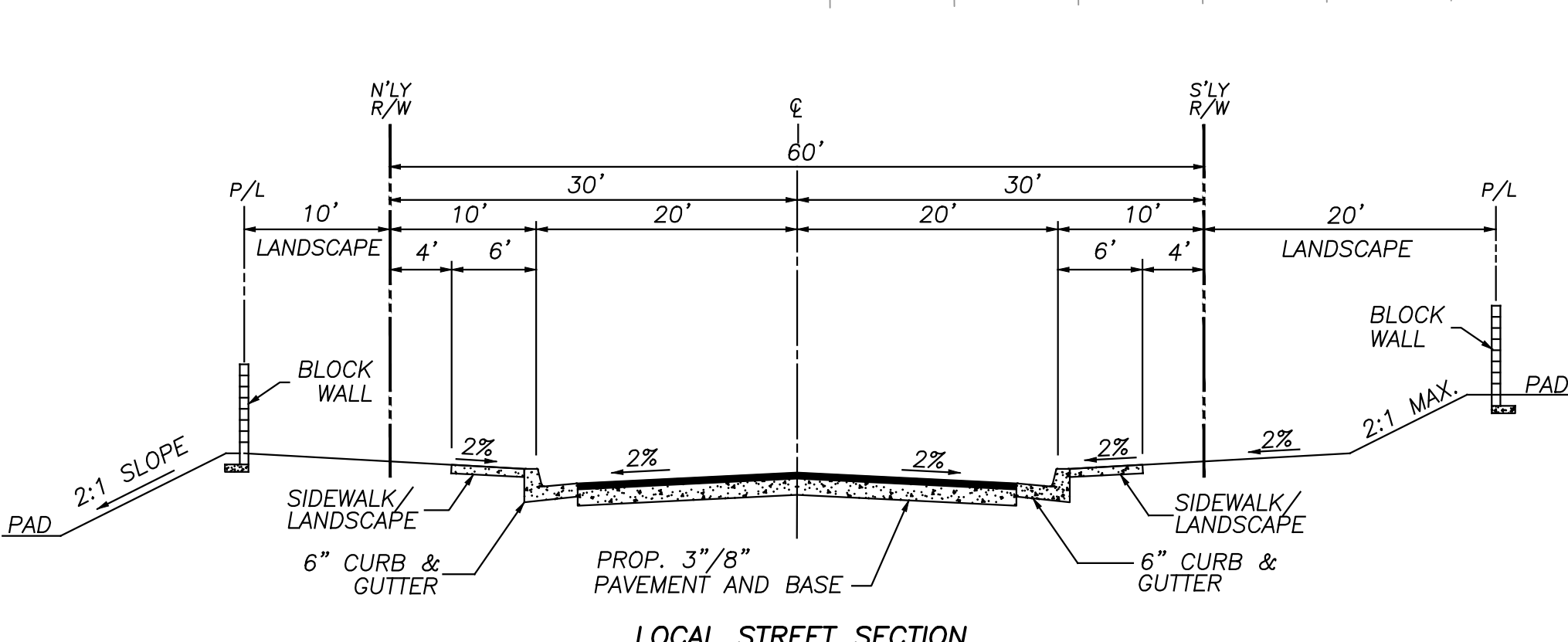
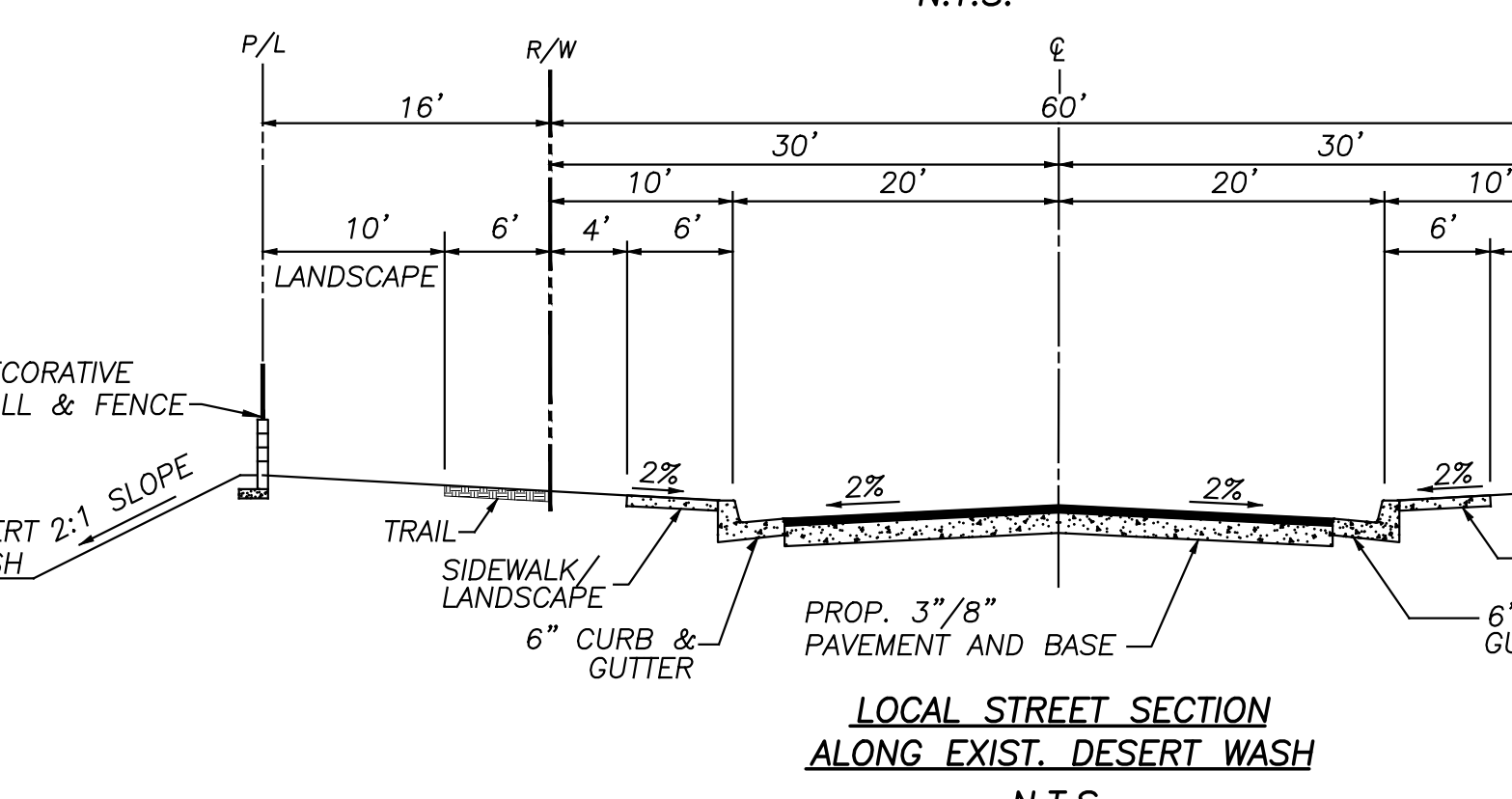
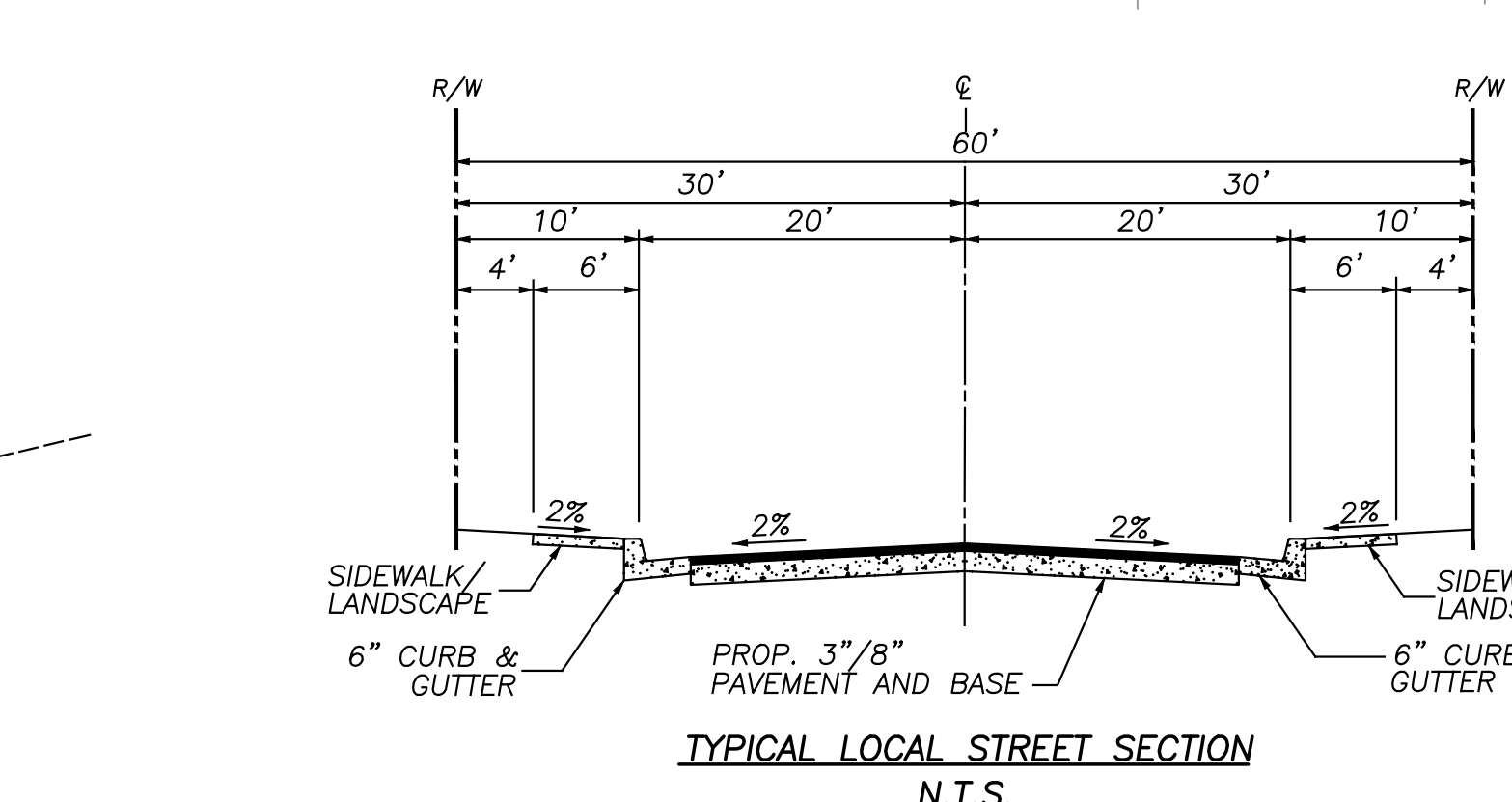
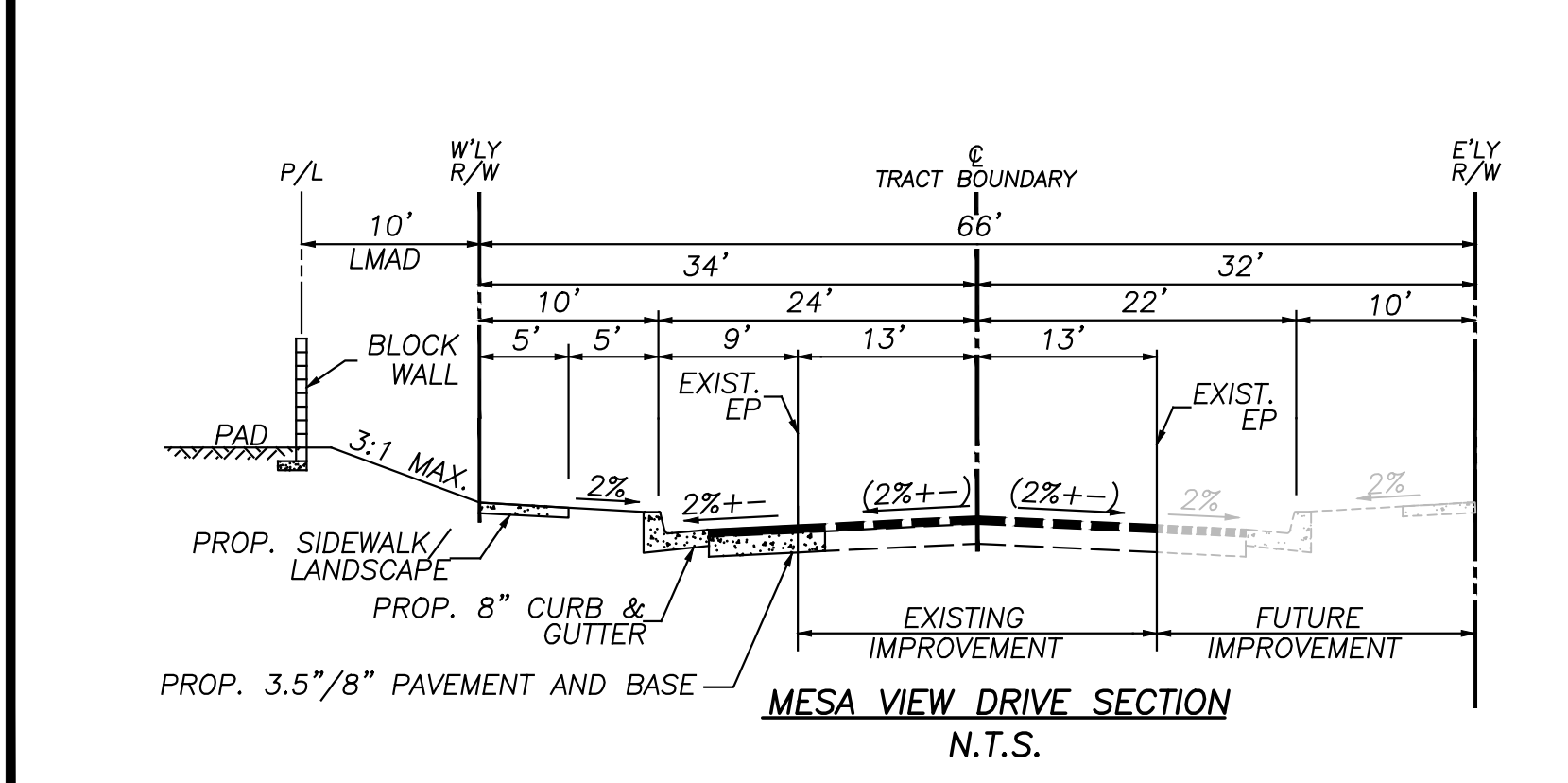
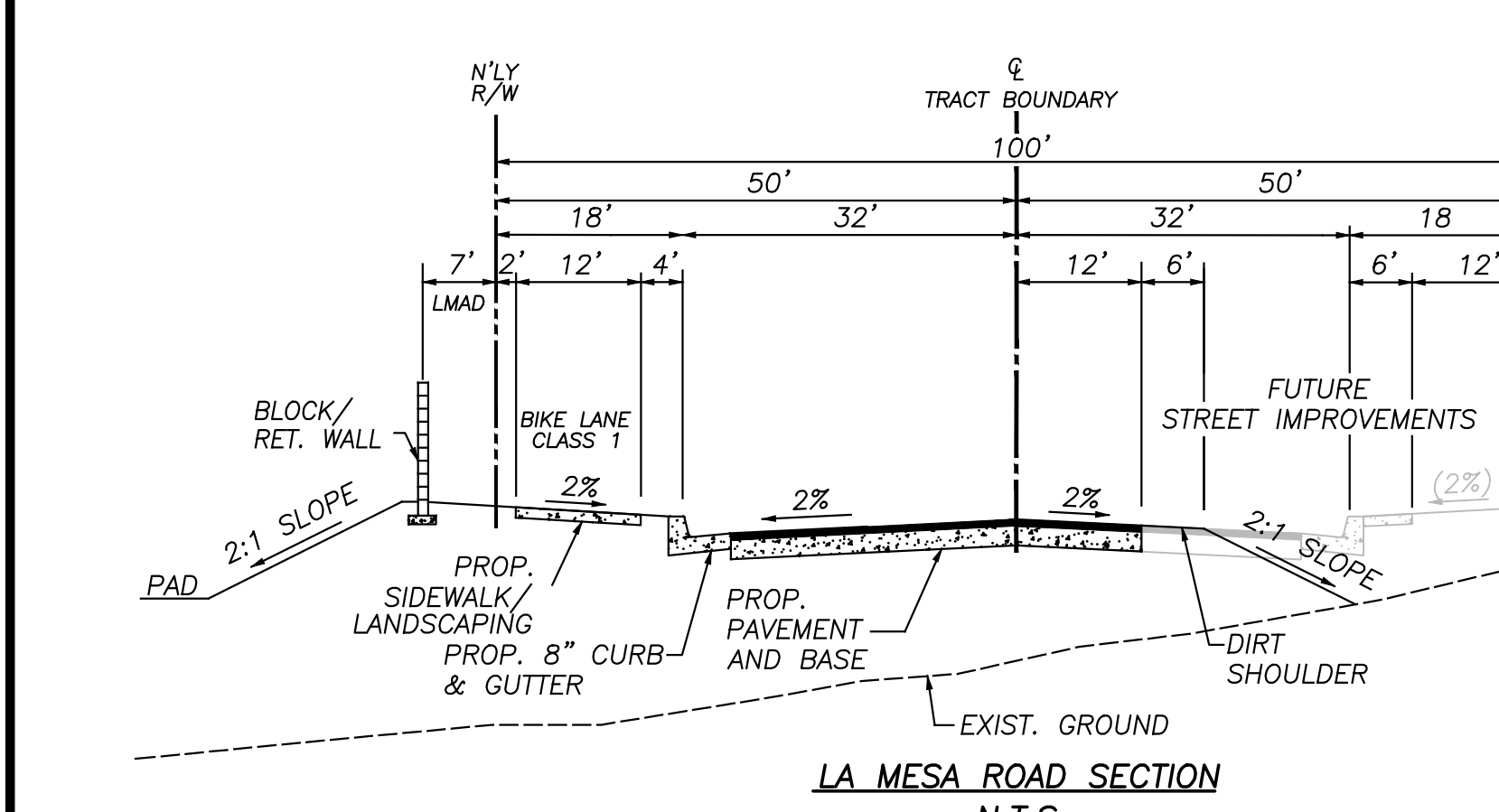
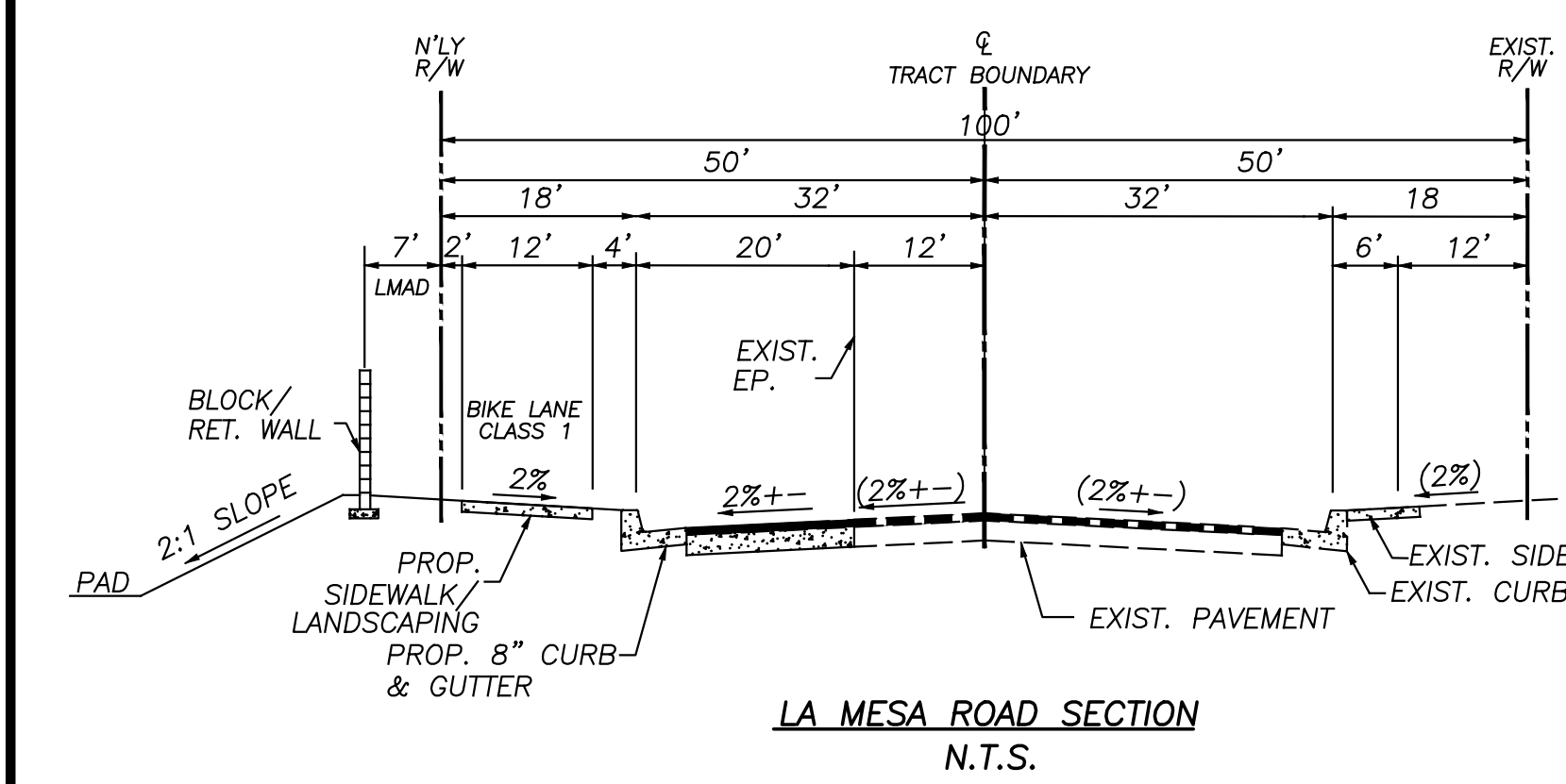

LEGAL DESCRIPTION:

PER ORANGE COAST TITLE COMPANY PRELIMINARY REPORT DATED MAY 17, 2017, ORDER NO. 140-186868-66
 THE LAND REFERRED TO HEREIN IS SITUATED IN THE CITY OF VICTORVILLE, COUNTY OF SAN BERNARDINO, STATE OF CALIFORNIA, MORE PARTICULARLY DESCRIBED AS FOLLOWS:
 PARCEL 14:
 THE EAST 1/2 OF PARCEL 4 OF PARCEL MAP NO. 1612, IN THE CITY OF VICTORVILLE, COUNTY OF SAN BERNARDINO, STATE OF CALIFORNIA, AS PER PLAT RECORDED IN BOOK 13 OF PARCEL MAPS, PAGE 98, RECORDS OF SAID COUNTY.
 THE WEST LINE OF SAID EAST 1/2 BEING A LINE FROM THE MID POINT OF THE NORTH LINE OF SAID PARCEL 4 TO THE MID POINT OF THE SOUTH LINE OF SAID PARCEL 4, BY CERTIFICATE OF COMPLIANCE RECORDED JANUARY 16, 1989, INSTRUMENT NO. 89-016673, OFFICIAL RECORDS AND JANUARY 16, 1989 AS INSTRUMENT NO. 89-016674, OFFICIAL RECORDS.
 PARCEL 18:
 THE NORTH 1/2 OF THE WEST 1/2 OF PARCEL 4 OF PARCEL MAP NO. 1612, IN THE CITY OF VICTORVILLE, COUNTY OF SAN BERNARDINO, STATE OF CALIFORNIA, AS PER PLAT RECORDED IN BOOK 13 OF PARCEL MAPS, PAGE 98, RECORDS OF SAID COUNTY.
 THE EAST LINE OF SAID WEST 1/2 BEING A LINE FROM THE MID POINT OF THE NORTH LINE OF SAID PARCEL 4 TO THE MID POINT OF THE SOUTH LINE OF SAID PARCEL 4, BY CERTIFICATE OF COMPLIANCE RECORDED JANUARY 16, 1989, INSTRUMENT NO. 89-016673, OFFICIAL RECORDS AND JANUARY 16, 1989 AS INSTRUMENT NO. 89-016674, OFFICIAL RECORDS.
 DISTANCES AND BEARINGS ARE TO BE MEASURED TO STREET CENTERLINES.
 PARCEL 1C:
 THE SOUTH 1/2 OF THE WEST 1/2 OF PARCEL 4 OF PARCEL MAP NO. 1612, IN THE CITY OF VICTORVILLE, COUNTY OF SAN BERNARDINO, STATE OF CALIFORNIA, AS PER PLAT RECORDED IN BOOK 13 OF PARCEL MAPS, PAGE 98, RECORDS OF SAID COUNTY.
 THE NORTH LINE OF SAID SOUTH 1/2 BEING A LINE FROM THE MID POINT OF THE WEST LINE OF SAID PARCEL 4 TO THE MID POINT OF THE SOUTH LINE OF SAID PARCEL 4, BY CERTIFICATE OF COMPLIANCE RECORDED JANUARY 16, 1989, INSTRUMENT NO. 89-016673, OFFICIAL RECORDS AND JANUARY 16, 1989 AS INSTRUMENT NO. 89-016674, OFFICIAL RECORDS.
 DISTANCES AND BEARINGS ARE TO BE MEASURED TO STREET CENTERS.

EASEMENTS

EASEMENTS SHOWN HEREON WERE DERIVED FROM THE PRELIMINARY REPORT FOR TITLE INSURANCE, AS PREPARED BY ORANGE COAST TITLE COMPANY, ORDER NO. 140-186868-66, DATED AS OF MAY 24, 2017. NO RESPONSIBILITY FOR CONTENT, COMPLETENESS OR ACCURACY OF SAID PRELIMINARY TITLE REPORT IS ASSUMED BY THIS MAP, THE SURVEYOR, OR UNITED ENGINEERING GROUP-CA, INC.
 7. AN EASEMENT FOR PURPOSES HEREIN STATED, AND RIGHTS INCIDENTAL THERETO AS PROVIDED IN AN INSTRUMENT:
 RECORDED: 10/20/1960, IN BOOK 5263, PAGE 511, OF OFFICIAL RECORDS.
 FOR: PIPE LINES AND INCIDENTAL PURPOSES
 IN FAVOR OF: CALNEV PIPE LINE COMPANY
 AFFECTS: THE LOCATION OF SAID EASEMENT CANNOT BE LOCATED FROM THE PUBLIC RECORDS.
 NO ITEMS PLOTTED.
 AN IRREVOCABLE OFFER TO DEDICATE REAL PROPERTY FOR PUBLIC HIGHWAY, RECORDED 09/07/1973, IN BOOK 8263, PAGE 869 OF OFFICIAL RECORDS.
 SAID MATTER AFFECTS THE WESTERLY 30 FEET, SOUTHERLY 40 FEET AND EASTERLY 40 FEET OF SAID LAND, TOGETHER WITH SPANDELER ("TRIANGULAR") SHAPED PARCELS AS DESCRIBED THEREIN.
 SAID EASEMENT IS PLOTTED HEREON.

SUBMITTALS:	REVISIONS			REVISIONS		
	NO.	DESCRIPTION	DATE	NO.	DESCRIPTION	DATE
DESIGNED BY: JLP						
CHECKED BY: DCP						



12/9/2021
 CHRISTOPHER F. LENZ
 R.C.E. No. 63001

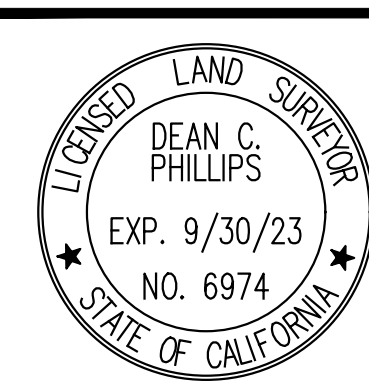

12/9/2021
 DEAN C. PHILLIPS
 L.S. No. 6974
 dphillips@unitedeng.com



8885 Haven Avenue
 Suite 195
 Rancho Cucamonga,
 CA 91730
 Phone: 909.466.9240
 www.unitedeng.com

LA MESA ROAD & MESA VIEW DRIVE

**UTILITY PLAN
 TTM NO. 20488**

DATE:	DECEMBER 8, 2021
SHEET 1 OF 3	
PROJECT NUMBER	CA-30181

