



County Project Specific Water Quality Management Plan

*A Template for preparing Project Specific WQMPs for Priority Development Projects only for use in the unincorporated portions of Riverside County located within the **Santa Margarita Region**.*

Project Title: ISEN GARDEN CANNABIS CULTIVATION

Development No: CUP

Design Review/Case No: N/A

BMP_i (Latitude, Longitude): 33.628600, -116.877240

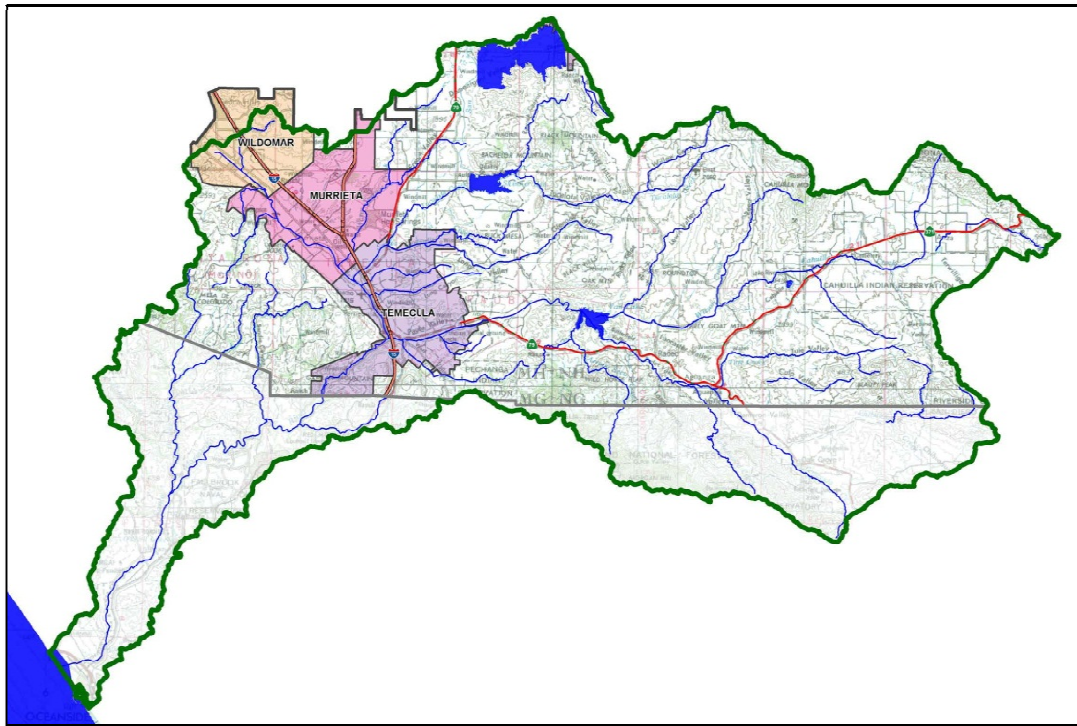

- Preliminary
- Final

Original Date Prepared: October 16, 2019

Revision Date(s):

Contact Information

Prepared for: Hermanos Semanas, LLC,
32875 Red Mountain Rd, Hemet, CA 92544
(818) 749-8183

Prepared by: Thomas Love, Principal,
31915 Rancho California Rd, #200-166,
Temecula, CA 92591, (951) 440-8149,
Tom@LoveCivil.com

Based on 2018 WQMP, prepared for Compliance with

Regional Board Order No. **R9-2013-0001** as amended by Order No. **R9-2015-0001** and Order No. **R9-2015-0100**

A Brief Introduction

The Regional Municipal Separate Stormwater Sewer System (MS4) Permit¹ requires that a Project-Specific WQMP be prepared for all development projects within the Santa Margarita Region (SMR) that meet the 'Priority Development Project' categories and thresholds listed in the SMR Water Quality Management Plan (WQMP). This Project-Specific WQMP Template for Development Projects in the **Santa Margarita Region** has been prepared to help document compliance and prepare a WQMP submittal. Below is a flowchart for the layout of this Template that will provide the steps required to document compliance.

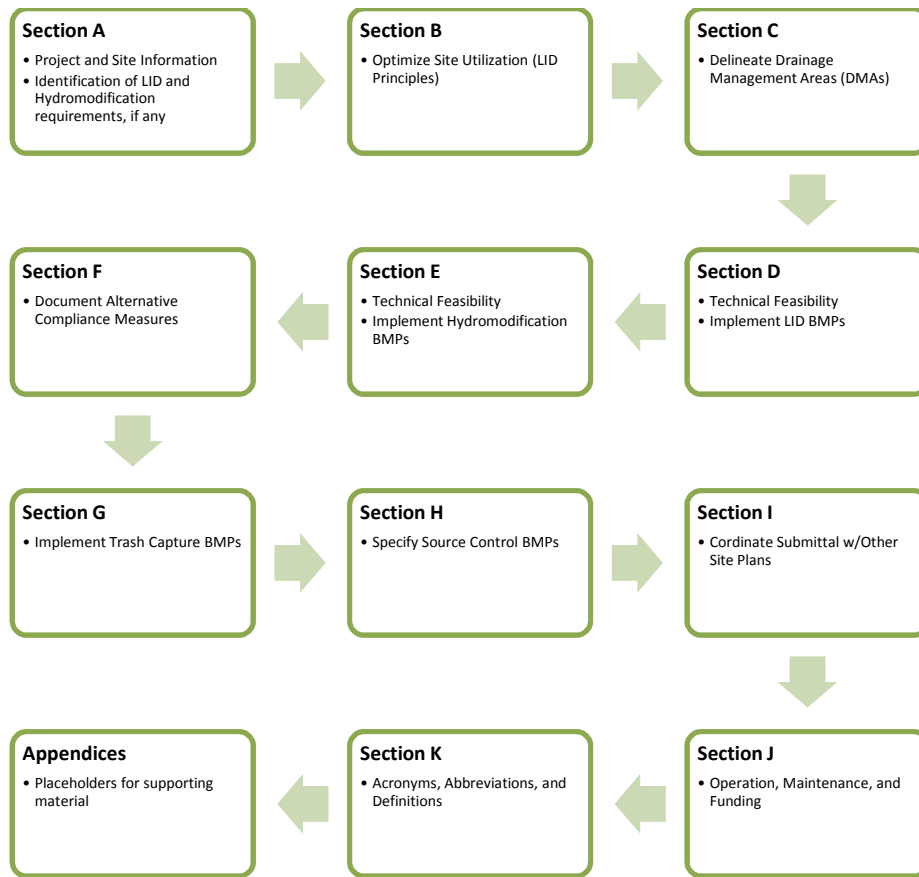

¹ Order No. R9-2013-0001 as amended by Order Nos. R9-2015-0001 and R9-2015-0100, NPDES No. CAS0109266, National Pollutant Discharge Elimination System (NPDES) Permit and Waste Discharge Requirements for Discharges from the MS4s Draining the Watersheds within the San Diego Region, California Regional Water Quality Control Board, May 8, 2013.

OWNER'S CERTIFICATION

This Project-Specific WQMP has been prepared for Hermanos Semanas, LLC by Thomas Love for the Isen Garden Cannabis Cultivation project.

This WQMP is intended to comply with the requirements of Riverside County for County Ordinance No. 754 which includes the requirement for the preparation and implementation of a Project-Specific WQMP.

The undersigned, while owning the property/project described in the preceding paragraph, shall be responsible for the implementation and funding of this WQMP and will ensure that this WQMP is amended as appropriate to reflect up-to-date conditions on the site. In addition, the property owner accepts responsibility for interim operation and maintenance of Stormwater Best Management Practices until such time as this responsibility is formally transferred to a subsequent owner. This WQMP will be reviewed with the facility operator, facility supervisors, employees, tenants, maintenance and service contractors, or any other party (or parties) having responsibility for implementing portions of this WQMP. At least one copy of this WQMP will be maintained at the project site or project office in perpetuity. The undersigned is authorized to certify and to approve implementation of this WQMP. The undersigned is aware that implementation of this WQMP is enforceable under Riverside County Water Quality Ordinance (No. 754).

"I, the undersigned, certify under penalty of law that the provisions of this WQMP have been reviewed and accepted and that the WQMP will be transferred to future successors in interest."

Owner's Signature

Date

Owner's Printed Name

Owner's Title/Position

PREPARER'S CERTIFICATION

"The selection, sizing and design of stormwater treatment and other stormwater quality and quantity control Best Management Practices in this plan meet the requirements of Regional Water Quality Control Board Order No. **R9-2013-0001** as amended by Order Nos. **R9-2015-0001** and **R9-2015-0100**."



Thomas S. Love

Preparer's Signature

October 16, 2019

Date

Thomas S. Love

Preparer's Printed Name
Preparer's Licensure: RCE 50993

Principal

Preparer's Title/Position

Table of Contents

Section A: Project and Site Information.....	7
A.1 Maps and Site Plans.....	8
A.2 Identify Receiving Waters.....	8
A.3 Drainage System Susceptibility to Hydromodification	9
A.4 Additional Permits/Approvals required for the Project:	9
Section B: Optimize Site Utilization (LID Principles)	11
Section C: Delineate Drainage Management Areas (DMAs).....	16
Section D: Implement LID BMPs	21
D.1 Full Infiltration Applicability	21
D.2 Biofiltration Applicability	23
D.3 Feasibility Assessment Summaries	25
D.4 LID BMP Sizing	26
Section E: Implement Hydrologic Control BMPs and Sediment Supply BMPs	28
E.1 Hydrologic Control BMP Selection	28
E.2 Hydrologic Control BMP Sizing.....	29
E.3 Implement Sediment Supply BMPs.....	29
Section F: Alternative Compliance	34
F.1 Identify Pollutants of Concern.....	34
F.2 Treatment Control BMP Selection	37
F.3 Sizing Criteria.....	37
F.4 Hydrologic Performance Standard – Alternative Compliance Approach.....	38
Section G: Implement Trash Capture BMPs.....	39
Section H: Source Control BMPs.....	41
Section I: Coordinate Submittal with Other Site Plans	42
Section J: Operation, Maintenance and Funding.....	43
Section K: Acronyms, Abbreviations and Definitions	44

List of Tables

Table A-1 Identification of Receiving Waters	8
Table A-2 Identification of Susceptibility to Hydromodification	9
Table A-3 Other Applicable Permits.....	9
Table C-1 DMA Identification.....	16
Table C-2 Type ‘A’, Self-Treating Areas.....	17
Table C-3 Type ‘B’, Self-Retaining Areas	18
Table C-4 Type ‘C’, Areas that Drain to Self-Retaining Areas.....	18
Table C-5 Type ‘D’, Areas Draining to BMPs	20
Table D-1 Infiltration Feasibility.....	22
Table D-2 Geotechnical Concerns for Onsite Infiltration	23
Table D-3 Evaluation of Biofiltration BMP Feasibility	24
Table D-4 Proprietary BMP Approval Requirement Summary	24
Table D-5 LID Prioritization Summary Matrix	25
Table D-6 Summary of Infeasibility Documentation.....	25
Table D-7 DCV Calculations for LID BMPs	27
Table D-8 LID BMP Sizing	27
Table E-1 Hydrologic Control BMP Sizing.....	29
Table E-2 Triad Assessment Summary	31
Table F-1 Summary of Approved 2010 303(d) listed waterbodies and associated pollutants of concern for the Riverside County SMR Region and downstream waterbodies.....	35
Table F-2 Potential Pollutants by Land Use Type.....	36
Table F-3 Treatment Control BMP Selection	37
Table F-4 Treatment Control BMP Sizing	37
Table F-5 Offsite Hydrologic Control BMP Sizing	38
Table G-1 Sizing Trash Capture BMPs	40
Table G-2 Approximate precipitation depth/intensity values for calculation of the Trash Capture Design Storm.....	40
Table G-3 Trash Capture BMPs	40
Table I-1 Construction Plan Cross-reference	42
Table I-2 Other Applicable Permits.....	42

List of Appendices

Appendix 1: Maps and Site Plans.....	51
Appendix 2: Construction Plans	52
Appendix 3: Soils Information.....	53
Appendix 4: Historical Site Conditions.....	54
Appendix 5: LID Feasibility Supplemental Information	55

Appendix 6: LID BMP Design Details..... 62

Appendix 7: Hydromodification..... 63

Appendix 8: Source Control 65

Appendix 9: O&M 76

Appendix 10: Educational Materials..... 82

Section A: Project and Site Information

Use the table below to compile and summarize basic site information that will be important for completing subsequent steps. Subsections A.1 through A.4 provide additional detail on documentation of additional project and site information. The Regional MS4 Permit has effectively removed the ability for a project to be grandfathered from WQMP requirements. Even if a project were able to meet all the requirements stated in Section 1.2 of the WQMP, the 2014 WQMP requirements would apply.

PROJECT INFORMATION	
Type of PDP:	New Development
Type of Project:	Residential
Planning Case Number:	
Rough Grade Permit No.:	CUP 19XXXX
Development Name:	Isen Garden Cannabis Cultivation
PROJECT LOCATION	
Latitude & Longitude (DMS):	33.628600, -116.877240
Project Watershed and Sub-Watershed:	Santa Margarita River, Santa Margarita Lagoon
24-Hour 85 th Percentile Storm Depth (inches):	0.68
Is project subject to Hydromodification requirements?	<input checked="" type="checkbox"/> Y <input type="checkbox"/> N (Select based on Section A.3)
APN(s):	569-150-010
Map Book and Page No.:	RS 46/7
PROJECT CHARACTERISTICS	
Proposed or Potential Land Use(s)	RR
Proposed or Potential SIC Code(s)	01
Existing Impervious Area of Project Footprint (SF)	2,518 SF
Total area of <u>proposed</u> Impervious Surfaces within the Project Limits (SF)/or Replacement	23,273 SF
Total Project Area (ac)	5.03 acres
Does the project consist of offsite road improvements?	<input type="checkbox"/> Y <input checked="" type="checkbox"/> N
Does the project propose to construct unpaved roads?	<input type="checkbox"/> Y <input checked="" type="checkbox"/> N
Is the project part of a larger common plan of development (phased project)?	<input type="checkbox"/> Y <input checked="" type="checkbox"/> N
Has preparation of Project-Specific WQMP included coordination with other site plans?	<input checked="" type="checkbox"/> Y <input type="checkbox"/> N
EXISTING SITE CHARACTERISTICS	
Is the project located within any Multi-Species Habitat Conservation Plan area (MSHCP Criteria Cell?)	<input type="checkbox"/> Y <input checked="" type="checkbox"/> N
Is a Geotechnical Report attached?	N/A
If no Geotech. Report, list the Natural Resources Conservation Service (NRCS) soils type(s) present on the site (A, B, C and/or D)	<input type="checkbox"/> Y <input checked="" type="checkbox"/> N
<u>Provide a brief description of the project:</u>	C
Construction of building & parking area for cannabis cultivation	

Paver and dirt roads are considered pervious for determining WQMP applicability.

A.1 Maps and Site Plans

When completing your Project-Specific WQMP, include a map of the Project vicinity and existing site. In addition, include all grading, drainage, landscape/plant palette and other pertinent construction plans in Appendix 2. At a **minimum**, your WQMP Site Plan should include the following:

- Vicinity and location maps
- Parcel Boundary and Project Footprint
- Existing and Proposed Topography
- Drainage Management Areas (DMAs)
- Proposed Structural Best Management Practices (BMPs)
- Drainage Paths
- Drainage infrastructure, inlets, overflows
- Source Control BMPs
- Site Design BMPs
- Buildings, Roof Lines, Downspouts
- Impervious Surfaces
- Pervious Surfaces (i.e. Landscaping)
- Standard Labeling
- Cross Section and Outlet details

Use your discretion on whether or not you may need to create multiple sheets or can appropriately accommodate these features on one or two sheets. Keep in mind that the Copermitee plan reviewer must be able to easily analyze your Project utilizing this template and its associated site plans and maps. Complete the checklists in Appendix 1 to verify that all exhibits and components are included.

A.2 Identify Receiving Waters

Using Table A-1 below, list in order of upstream to downstream, the Receiving Waters that the Project site is tributary to. Continue to fill each row with the Receiving Water’s 303(d) listed impairments (if any), designated Beneficial Uses, and proximity, if any, to a RARE Beneficial Use. Include a map of the Receiving Waters in Appendix 1. This map should identify the path of the stormwater discharged from the site all the way to the outlet of the Santa Margarita River to the Pacific Ocean. Use the most recent 303(d) list available from the State Water Resources Control Board Website.

(http://www.waterboards.ca.gov/sandiego/water_issues/programs/basin_plan/)

Table A-1 Identification of Receiving Waters

Receiving Waters	USEPA Approved 303(d) List Impairments	Designated Beneficial Uses	Proximity to RARE Beneficial Use
Tucalota Creek	NONE	MUN, AGR, IND, PROC, REC1, REC2, WARM, COLD, WILD	N/A
Santa Gertrudis Creek	Chlorpyrifos, Copper, Indicator Bacteria, Iron, Manganese, Nitrogen, Phosphorus	MUN, AGR, IND, PROC, REC1, REC2, WARM, WILD	N/A
Murrieta Creek	Chlorprifos, Copper, Indicator Bacteria, Iron, Manganese, Nitrogen, Phosphorus, Toxicity	MUN, AGR, IND, PROC, REC2, WARM, WILD	N/A
Santa Margarita River	Benthic Community Effects, Chlorryifos, Indicator Bacteria, Nitrogen, Phosphorus, Toxicity, Iron, Manganese	MUN, AGR, IND, REC1, REC2, WARM, COLD, WILD, RARE	32.9 miles
Santa Margarita Lagoon	NONE	REC1, REC2, EST, WILD, RARE, MAR, MIGR, SPWN	55.5 miles

A.3 Drainage System Susceptibility to Hydromodification

Using Table A-2 below, list in order of the point of discharge at the project site down to the Santa Margarita River², each drainage system or receiving water that the project site is tributary to. Continue to fill each row with the material of the drainage system, and any exemption (if applicable). Based on the results, summarize the applicable hydromodification performance standards that will be documented in Section E. Exempted categories of receiving waters include:

- Existing storm drains that discharge directly to water storage reservoirs, lakes, or enclosed embayments, or
- Conveyance channels whose bed and bank are concrete lined all the way from the point of discharge to water storage reservoirs, lakes, enclosed embayments, or the Pacific Ocean.
- Other water bodies identified in an approved WMAA (See Exhibit G to the WQMP)

Include a map exhibiting each drainage system and the associated susceptibility in Appendix 1.

Table A-2 Identification of Susceptibility to Hydromodification

Drainage System	Drainage System Material	Hydromodification Exemption	Hydromodification Exempt
Tucolata Creek, 19.7 miles	Natural water course	Not susceptible	<input type="checkbox"/> Y <input checked="" type="checkbox"/> N
Santa Gurtrudis Creek, 6.2 miles	Natural water course	Not susceptible	<input type="checkbox"/> Y <input checked="" type="checkbox"/> N
Murrieta Creek, 8.1 miles	Natural water course	Not susceptible	<input type="checkbox"/> Y <input checked="" type="checkbox"/> N
Santa Margarita River, 23.2 miles	Natural water course	Not susceptible	<input type="checkbox"/> Y <input checked="" type="checkbox"/> N
Santa Margarita River Lagoon	Identify either (1) the type of material of bed and bank for opLagoon	Not susceptible	<input type="checkbox"/> Y <input checked="" type="checkbox"/> N
Summary of Performance Standards			
<input type="checkbox"/> Hydromodification Exempt – Select if “Y” is selected in the Hydromodification Exempt column above, project is exempt from hydromodification requirements.			
<input checked="" type="checkbox"/> Not Exempt -Select if “N” is selected in any row of the Hydromodification Exempt column above. Project is subject to hydrologic control requirements and may be subject to sediment supply requirements.			

A.4 Additional Permits/Approvals required for the Project:

Table A-3 Other Applicable Permits

Agency	Permit Required	
State Department of Fish and Game, 1602 Streambed Alteration Agreement	<input type="checkbox"/> Y	<input checked="" type="checkbox"/> N
State Water Resources Control Board, Clean Water Act Section 401 Water Quality	<input type="checkbox"/> Y	<input checked="" type="checkbox"/> N

² Refer to Exhibit G of the WQMP for a map of exempt and potentially exempt areas. These maps are from the Draft SMR WMAA as of January 5, 2018 and will be replaced upon acceptance of the SMR WMAA.

Certification		
US Army Corps of Engineers, Clean Water Act Section 404 Permit	<input type="checkbox"/> Y	<input checked="" type="checkbox"/> N
US Fish and Wildlife, Endangered Species Act Section 7 Biological Opinion	<input type="checkbox"/> Y	<input checked="" type="checkbox"/> N
Statewide Construction General Permit Coverage	<input checked="" type="checkbox"/> Y	<input type="checkbox"/> N
Statewide Industrial General Permit Coverage	<input type="checkbox"/> Y	<input checked="" type="checkbox"/> N
Western Riverside MSHCP Consistency Approval (e.g., JPR, DBESP)	<input type="checkbox"/> Y	<input checked="" type="checkbox"/> N
Other <i>(please list in the space below as required)</i>	<input type="checkbox"/> Y	<input checked="" type="checkbox"/> N

If yes is answered to any of the questions above, the Copermitttee may require proof of approval/coverage from those agencies as applicable including documentation of any associated requirements that may affect this Project-Specific WQMP.

Section B: Optimize Site Utilization (LID Principles)

Review of the information collected in Section 'A' will aid in identifying the principal constraints on site design and selection of LID BMPs as well as opportunities to reduce imperviousness and incorporate LID Principles into the site and landscape design. For example, **constraints** might include impermeable soils, high groundwater, groundwater pollution or contaminated soils, steep slopes, geotechnical instability, high-intensity land use, heavy pedestrian or vehicular traffic, utility locations or safety concerns. **Opportunities** might include existing natural areas, low areas, oddly configured or otherwise unbuildable parcels, easements and landscape amenities including open space and buffers (which can double as locations for LID Bioretention BMPs), and differences in elevation (which can provide hydraulic head). Prepare a brief narrative for each of the site optimization strategies described below. This narrative will help you as you proceed with your Low Impact Development (LID) design and explain your design decisions to others.

Apply the following LID Principles to the layout of the PDP to the extent they are applicable and feasible. Putting thought upfront about how best to organize the various elements of a site can help to significantly reduce the PDP's potential impact on the environment and reduce the number and size of Structural LID BMPs that must be implemented. Integrate opportunities to accommodate the following LID Principles within the preliminary PDP site layout to maximize implementation of LID Principles.

Site Optimization

Complete checklist below to determine applicable Site Design BMPs for your site.

Project- Specific WQMP Site Design BMP Checklist

The following questions below are based upon Section 3.2 of the SMR WQMP will help you determine how to best optimize your site and subsequently identify opportunities and/or constraints, and document compliance.

SITE DESIGN REQUIREMENTS

Answer the following questions below by indicating “Yes,” “No,” or “N/A” (Not Applicable). Justify all “No” and “N/A” answers by inserting a narrative at the end of the section. The narrative should include identification and justification of any constraints that would prevent the use of those categories of LID BMPs. Upon identifying Site Design BMP opportunities, include these on your WQMP Site plan in Appendix 1.

Did you identify and preserve existing drainage patterns?

Integrating existing drainage patterns into the site plan helps to maintain the time of concentration and infiltration rates of runoff, decreasing peak flows, and may also help preserve the contribution of Critical Coarse Sediment (i.e., Bed Sediment Supply) from the PDP to the Receiving Water. Preserve existing drainage patterns by:

Yes No N/A

- Minimizing unnecessary site grading that would eliminate small depressions, where appropriate add additional “micro” storage throughout the site landscaping.
- Where possible conform the PDP site layout along natural landforms, avoid excessive grading and disturbance of vegetation and soils, preserve or replicate the sites natural drainage features and patterns.
- Set back PDP improvements from creeks, wetlands, riparian habitats and any other natural water bodies.
- Use existing and proposed site drainage patterns as a natural design element, rather than using expensive impervious conveyance systems. Use depressed landscaped areas, vegetated buffers, and bioretention areas as amenities and focal points within the site and landscape design.

Discuss how this was included or provide a discussion/justification for “No” or “N/A” answer.

Proposed grading preserves existing drainage patterns

Did you identify and protect existing vegetation?

Identify any areas containing dense native vegetation or well-established trees, and try to avoid disturbing these areas. Soils with thick, undisturbed vegetation have a much higher capacity to store and infiltrate runoff than do disturbed soils. Reestablishment of a mature vegetative community may take decades. Sensitive areas, such as streams and floodplains should also be avoided.

Yes No N/A

- Define the development envelope and protected areas, identifying areas that are most suitable for development and areas that should be left undisturbed.
- Establish setbacks and buffer zones surrounding sensitive areas.
- Preserve significant trees and other natural vegetation where possible.

Discuss how this was included or provide a discussion/justification for “No” or “N/A” answer.

Project- Specific WQMP Site Design BMP Checklist

Did you identify and preserve natural infiltration capacity?

A key component of LID is taking advantage of a site's natural infiltration and storage capacity. A site survey and geotechnical investigation can help define areas with high potential for infiltration and surface storage.

Yes No N/A

- Identify opportunities to locate LID Principles and Structural BMPs in highly pervious areas. Doing so will maximize infiltration and limit the amount of runoff generated.
- Concentrate development on portions of the site with less permeable soils, and preserve areas that can promote infiltration.

Discuss how this was included or provide a discussion/justification for "No" or "N/A" answer. *Area outside of grading limits has natural infiltration*

Did you minimize impervious area?

Look for opportunities to limit impervious cover through identification of the smallest possible land area that can be practically impacted or disturbed during site development.

Yes No N/A

- Limit overall coverage of paving and roofs. This can be accomplished by designing compact, taller structures, narrower and shorter streets and sidewalks, clustering buildings and sharing driveways, smaller parking lots (fewer stalls, smaller stalls, and more efficient lanes), and indoor or underground parking.
- Inventory planned impervious areas on your preliminary site plan. Identify where permeable pavements, or other permeable materials, such as crushed aggregate, turf block, permeable modular blocks, pervious concrete or pervious asphalt could be substituted for impervious concrete or asphalt paving. This will help reduce the amount of Runoff that may need to be addressed through Structural BMPs.
- Examine site layout and circulation patterns and identify areas where landscaping can be substituted for pavement, such as for overflow parking.
- Consider green roofs. Green roofs are roofing systems that provide a layer of soil/vegetative cover over a waterproofing membrane. A green roof mimics pre-development conditions by filtering, absorbing, and evapotranspiring precipitation to help manage the effects of an otherwise impervious rooftop.

Discuss how this was included or provide a discussion/justification for "No" or "N/A" answer. *Only impervious areas are access, buildings, and limited hardscape*

Project- Specific WQMP Site Design BMP Checklist

Did you identify and disperse runoff to adjacent pervious areas or small collection areas?

Look for opportunities to direct runoff from impervious areas to adjacent landscaping, other pervious areas, or small collection areas where such runoff may be retained. This is sometimes referred to as reducing Directly Connected Impervious Areas.

Yes No N/A

- Direct roof runoff into landscaped areas such as medians, parking islands, planter boxes, etc., and/or areas of pervious paving. Instead of having landscaped areas raised above the surrounding impervious areas, design them as depressed areas that can receive Runoff from adjacent impervious pavement. For example, a lawn or garden depressed 3"-4" below surrounding walkways or driveways provides a simple but quite functional landscape design element.
- Detain and retain runoff throughout the site. On flatter sites, smaller Structural BMPs may be interspersed in landscaped areas among the buildings and paving.
- On hillside sites, drainage from upper areas may be collected in conventional catch basins and piped to landscaped areas and LID BMPs and/or Hydrologic Control BMPs in lower areas. Low retaining walls may also be used to create terraces that can accommodate LID BMPs. Wherever possible, direct drainage from landscaped slopes offsite and not to impervious surfaces like parking lots.
- Reduce curb maintenance and provide for allowances for curb cuts.
- Design landscaped areas or other pervious areas to receive and infiltrate runoff from nearby impervious areas.
- Use Tree Wells to intercept, infiltrate, and evapotranspire precipitation and runoff before it reaches structural BMPs. Tree wells can be used to limit the size of Drainage Management Areas that must be treated by structural BMPs. Guidelines for Tree Wells are included in the Tree Well Fact Sheet in the LID BMP Design Handbook.

Discuss how this was included or provide a discussion/justification for "No" or "N/A" answer. *All runoff directed to pervious areas*

Did you utilize native or drought tolerant species in site landscaping?

Yes No N/A

Wherever possible, use native or drought tolerant species within site landscaping instead of alternatives. These plants are uniquely suited to local soils and climate and can reduce the overall demands for potable water use associated with irrigation.

Discuss how this was included or provide a discussion/justification for "No" or "N/A" answer. *Landscape will be with native and drought tolerant species*

Project- Specific WQMP Site Design BMP Checklist

Did implement harvest and use of runoff?

Under the Regional MS4 Permit, Harvest and Use BMPs must be employed to reduce runoff on any site where they are applicable and feasible. However, Harvest and Use BMPs are effective for retention of stormwater runoff only when there is adequate demand for non-potable water during the wet season. If demand for non-potable water is not sufficiently large, the actual retention of stormwater runoff will be diminished during larger storms or during back-to-back storms.

For the purposes of planning level Harvest and Use BMP feasibility screening, Harvest and Use is only considered to be a feasible if the total average wet season demand for non-potable water is sufficiently large to use the entire DCV within 72 hours. If the average wet season demand for non-potable water is not sufficiently large to use the entire DCV within 72 hours, then Harvest and Use is not considered to be feasible and need not be considered further.

Yes No N/A

The general feasibility and applicability of Harvest and Use BMPs should consider:

- Any downstream impacts related to water rights that could arise from capturing stormwater (not common).
- Conflicts with recycled water used – where the project is conditioned to use recycled water for irrigation, this should be given priority over stormwater capture as it is a year-round supply of water.
- Code Compliance - If a particular use of captured stormwater, and/or available methods for storage of captured stormwater would be contrary to building codes in effect at the time of approval of the preliminary Project-Specific WQMP, then an evaluation of harvesting and use for that use would not be required.
- Wet season demand – the applicant shall demonstrate, to the acceptance of the County of Riverside, that there is adequate demand for harvested water during the wet season to drain the system in a reasonable amount of time.

Discuss how this was included or provide a discussion/justification for “No” or “N/A” answer. *Site will be treated with infiltration trench*

Did you keep the runoff from sediment producing pervious area hydrologically separate from developed areas that require treatment?

Yes No N/A

Pervious area that qualify as self-treating areas or off-site open space should be kept separate from drainage to structural BMPs whenever possible. This helps limit the required size of structural BMPs, helps avoid impacts to sediment supply, and helps reduce clogging risk to BMPs.

Discuss how this was included or provide a discussion/justification for “No” or “N/A” answer. *Combination of swales and area drain*

Section C: Delineate Drainage Management Areas (DMAs) & Green Streets

This section provides streamlined guidance and documentation of the DMA delineation and categorization process, for additional information refer to the procedure in Section 3.3 of the SMR WQMP which discusses the methods of delineating and mapping your project site into individual DMAs. Complete Steps 1 to 4 to successfully delineate and categorize DMAs.

Step 1: Identify Surface Types and Drainage Pathways

Carefully delineate pervious areas and impervious areas (including roofs) throughout site and identify overland flow paths and above ground and below ground conveyances. Also identify common points (such as BMPs) that these areas drain to.

Step 2: DMA Delineation

Use the information in Step 1 to divide the entire PDP site into individual, discrete DMAs. Typically, lines delineating DMAs follow grade breaks and roof ridge lines. Where possible, establish separate DMAs for each surface type (e.g., landscaping, pervious paving, or roofs). Assign each DMA a unique code and determine its size in square feet. The total area of your site should total the sum of all of your DMAs (unless water from outside the project limits comes in with water from inside the project limits, i.e. run-on). Complete Table C-1

Table C-1 DMA Identification

DMA Identification	Name or	Surface Type(s) ¹	Area (Sq. Ft.)	DMA Type
DMA 1/D1		Roof	11,492 SF	To be Determined in Step 3
DMA 1/D2		AC	9,912 SF	
DMA 1/D3		Concrete	1,869 SF	

Add Columns as Needed. Consider a separate DMA for Tree Wells or other LID principals like Self-Retaining areas are used for mitigation.

Step 3: DMA Classification

Determine how drainage from each DMA will be handled by using information from Steps 1 and 2 and by completing Steps 3.A to 3.C. Each DMA will be classified as one of the following four types:

- Type 'A': Self-Treating Areas:
- Type 'B': Self-Retaining Areas
- Type 'C': Areas Draining to Self-Retaining Areas
- Type 'D': Areas Draining to BMPs

Tree wells are considered Type 'B' areas, and their tributary areas limited to a 10:1 ratio are considered Type 'C' areas. If Tree wells are proposed, consider grading or other features to minimize the pervious runoff to the tree wells, to avoid overwhelming the trees. Type 'A', 'B', and 'C' are considered LID Principals that can be used to minimize or potentially eliminate structural LID BMPs.

If Tree wells are proposed, a landscape architect shall be consulted on the tree selection, since compliance will be determined based on the survival of the tree. The tree type should be noted on the WQMP site map.

Step 3.A – Identify Type ‘A’ Self-Treating Area

Indicate if the DMAs meet the following criteria by answering “Yes” or “No”.

- Yes No Area is undisturbed from their natural condition OR restored with Native and/or California Friendly vegetative covers.
- Yes No Area is irrigated, if at all, with appropriate low water use irrigation systems to prevent irrigation runoff.
- Yes No Runoff from the area will not comingle with runoff from the developed portion of the site, or across other landscaped areas that do not meet the above criteria.

If all answers indicate “Yes,” complete Table C-2 to document the DMAs that are classified as Self-Treating Areas.

Table C-2 Type ‘A’, Self-Treating Areas

DMA Name or Identification	Area (Sq. Ft.)	Stabilization Type	Irrigation Type (if any)

Step 3.B – Identify Type ‘B’ Self-Retaining Area and Type ‘C’ Areas Draining to Self-Retaining Areas

Type ‘B’ Self-Retaining Area: A Self-Retaining Area is shallowly depressed 'micro infiltration' areas designed to retain the Design Storm rainfall that reaches the area, without producing any Runoff.

Indicate if the DMAs meet the following criteria by answering “Yes,” “No,” or “N/A”.

- Yes No N/A Inlet elevations of area/overflow drains, if any, should be clearly specified to be three inches or more above the low point to promote ponding.
- Yes No N/A Soils will be freely draining to not create vector or nuisance conditions.
- Yes No N/A Pervious pavements (e.g., crushed stone, porous asphalt, pervious concrete, or permeable pavers) can be self-retaining when constructed with a gravel base course four or more inches deep below any underdrain discharge elevation.

If all answers indicate “Yes,” DMAs may be categorized as Type ‘B’, proceed to identify Type ‘C’ Areas Draining to Self-Retaining Areas.

Type ‘C’ Areas Draining to Self-Retaining Areas: Runoff from impervious or partially pervious areas can be managed by routing it to Self-Retaining Areas consistent with the LID Principle discussed in SMR WQMP Section 3.2.5 for 'Dispersing Runoff to Adjacent Pervious Areas'.

Indicate if the DMAs meet the following criteria by answering “Yes” or “No”.

Yes No The drainage from the tributary area must be directed to and dispersed within the Self-Retaining Area.

Yes No The maximum ratio of Tributary Area to Self-Retaining area is (2 ÷ Impervious Fraction): 1

If all answers indicate “Yes,” DMAs may be categorized as Type ‘C’.

Complete Table C-3 and Table C-4 to identify Type ‘B’ Self-Retaining Areas and Type ‘C’ Areas Draining to Self-Retaining Areas.

Table C-3 Type ‘B’, Self-Retaining Areas

Self-Retaining Area				Type ‘C’ DMAs that are draining to the Self-Retaining Area		
DMA Name/ ID	Post-project surface type	Area (square feet)	Storm Depth (inches)	DMA Name / ID	[C] from Table C-4=	Required Retention Depth (inches)
		[A]	[B]		[C]	$[D] = [B] + \frac{[B] \cdot [C]}{[A]}$

Note: Tree well areas can extend well beyond the drip line. The Tree Well area for open top types would include the shallow depressed area at the soil surface. The Tree Well area for Structural Soil Tree Wells or Suspended Pavement Tree Wells includes the area with open-graded gravel or void space over the structural soil or structural cells. Please specify type in this table and WQMP site map. See LID handbook Tree Well factsheet for additional details.

$$\left(\frac{2}{\text{Impervious Fraction}} \right) : 1$$

(Tributary Area: Self-Retaining Area)

Table C-4 Type ‘C’, Areas that Drain to Self-Retaining Areas

DMA					Receiving Self-Retaining DMA		
DMA Name/ ID	Area (square feet)	Post-project surface type	Runoff factor	Product	DMA name /ID	Area (square feet)	Ratio
	[A]		[B]	$[C] = [A] \times [B]$		[D]	$[C]/[D]$

Note: (See Section 3.3 of SMR WQMP) Ensure that partially pervious areas draining to a Self-Retaining area do not exceed the following ratio:

Step 3.B.1 – Document the use of Green Street Exemption (see Section 3.11 of the WQMP Guidance)

The Regional MS4 Permit specifies that projects that consist of **retrofitting or redevelopment of existing paved alleys, streets, or roads** may be exempted from classification as PDPs if they are designed and constructed in accordance with USEPA Green Streets Guidance. This does not apply for interior roads for PDP projects. For projects with road frontage improvements, Green Street standards can be used in the frontage road right-of-way. The remainder of the project is subject to full WQMP and Hydromodification requirements. See excerpt from Section 3.11 of the WQMP Guidance below:

3.11.4 BMP Sizing Targets for Applicable Green Streets Projects

Applicable green street projects are not required to meet the same sizing requirements for BMPs as other projects, but should attempt to meet a sizing target to the MEP. The following steps are used to size BMPs for applicable Green Streets projects:

1. Delineate drainage areas tributary to BMP locations and compute imperviousness.
2. Determine sizing goal by referring to sizing criteria presented in Section 2.3.2 (V_{BMP}).
3. Attempt to provide the target BMP sizing according to Step 2.
4. If the target criteria cannot be achieved, document the constraints that override the application of BMPs, and provide the largest portion of the sizing criteria that can be reasonably provided given constraints.

Even if BMPs cannot be sized to meet the target sizing criteria, it is still important to design the BMP inlet, energy dissipation, and overflow capacity for the full tributary area to ensure that flooding and scour is avoided. It is strongly recommended that BMPs which are designed to less than their target design volume be designed to bypass peak flows.

Table C-4.1 – Green Streets

DMA Name or ID	Street Name	BMP Sizing Calculations and constraints included in Appendix 6*	Targets documenting included in
		<input type="checkbox"/> Yes <input type="checkbox"/> No	
		<input type="checkbox"/> Yes <input type="checkbox"/> No	
		<input type="checkbox"/> Yes <input type="checkbox"/> No	
		<input type="checkbox"/> Yes <input type="checkbox"/> No	
		<input type="checkbox"/> Yes <input type="checkbox"/> No	

*WQMP shall not be approved without calculations or documenting constraints for Green Street Exemption.

Step 3.C – Identify Type ‘D’ Areas Draining to BMPs

Areas draining to BMPs are those that could not be fully managed through LID Principles (DMA Types A through C) and will instead drain to an LID BMP and/or a Conventional Treatment BMP designed to manage water quality impacts from that area, and Hydromodification where necessary.

Complete Table C-5 to document which DMAs are classified as Areas Draining to BMPs

Table C-5 Type 'D', Areas Draining to BMPs

DMA Name or ID	BMP Name or ID Receiving Runoff from DMA
D1	Infiltration Trench
D2	Infiltration Trench
D3	Infiltration Trench

Note: More than one DMA may drain to a single LID BMP; however, one DMA may not drain to more than one BMP.

Section D: Implement LID BMPs

The Regional MS4 Permit requires the use of LID BMPs to provide retention or treatment of the DCV and includes a BMP hierarchy which requires Full Retention BMPs (Priority 1) to be considered before Biofiltration BMPs (Priority 2) and Flow-Through Treatment BMPs and Alternative Compliance BMPs (Priority 3). LID BMP selection must be based on technical feasibility and should be considered early in the site planning and design process. Use this section to document the selection of LID BMPs for each DMA. Note that feasibility is based on the DMA scale and may vary between DMAs based on site conditions.

D.1 Full Infiltration Applicability

An assessment of the feasibility of utilizing full infiltration BMPs is required for all projects, *except where it can be shown that site design LID principles fully retain the DCV (i.e., all DMAs are Type A, B, or C), or where Harvest and Use BMPs fully retain the DCV. Check the following box if applicable:*

- Site design LID principles or Tree Wells fully retain the DCV (i.e., all DMAs are Type A, B, or C), (Proceed to Section E).

If the above box remains unchecked, perform a [site-specific evaluation](#) of the feasibility of Infiltration BMPs using each of the applicable criteria identified in Chapter 2.3.3 of the SMR WQMP and complete the remainder of Section D.1.

Geotechnical Report

A Geotechnical Report or Phase I Environmental Site Assessment may be required by the Copermittee to confirm present and past site characteristics that may affect the use of Infiltration BMPs. In addition, the Copermittee, at their discretion, may not require a geotechnical report for small projects as described in Chapter 2 of the SMR WQMP. If a geotechnical report has been prepared, include it in Appendix 3. In addition, if a Phase I Environmental Site Assessment has been prepared, include it in Appendix 4.

Infiltration Feasibility

Table D-1 below is meant to provide a simple means of assessing which DMAs on your site support Infiltration BMPs and is discussed in the SMR WQMP in Chapter 2.3.3. Check the appropriate box for each question and then list affected DMAs as applicable. If additional space is needed, add a row below the corresponding answer.

Table D-1 Infiltration Feasibility

Downstream Impacts (SMR WQMP Section 2.3.3.a)		
Does the project site...	YES	NO
...have any DMAs where infiltration would negatively impact downstream water rights or other Beneficial Uses ³ ?		X
If Yes, list affected DMAs:		
Groundwater Protection (SMR WQMP Section 2.3.3.b)		
Does the project site...	YES	NO
...have any DMAs with industrial, and other land uses that pose a high threat to water quality, which cannot be treated by Bioretention BMPs? Or have DMAs with active industrial process areas?		X
If Yes, list affected DMAs:		
...have any DMAs with a seasonal high groundwater mark shallower than 10 feet?		X
If Yes, list affected DMAs:		
...have any DMAs located within 100 feet horizontally of a water supply well?		X
If Yes, list affected DMAs:		
...have any DMAs that would restrict BMP locations to within a 2:1 (horizontal: vertical) influence line extending from any septic leach line?		X
If Yes, list affected DMAs:		
...have any DMAs been evaluated by a licensed Geotechnical Engineer, or Environmental Engineer, who has concluded that the soils do not have adequate physical and chemical characteristics for the protection of groundwater, and has treatment provided by amended media layers in Bioretention BMPs been considered in evaluating this factor?		X
If Yes, list affected DMAs:		
Public Safety and Offsite Improvements (SMR WQMP Section 2.3.3.c)		
Does the project site...	YES	NO
...have any areas identified by the geotechnical report as posing a public safety risk where infiltration of stormwater could have a negative impact, such as potential seepage through fill conditions?		X
If Yes, list affected DMAs:		
Infiltration Characteristics For LID BMPs (SMR WQMP Section 2.3.3.d)		
Does the project site...	YES	NO
...have measured infiltration rates of less than 2.4 inches / hour? Riverside County may allow measure rates as low as 0.8in/hr to support infiltration BMPs, if the Engineer believes infiltration is appropriate and sustainable. Mark no, if this is the case.		X
If Yes, list affected DMAs:		
Cut/Fill Conditions (SMR WQMP Section 2.3.3.e)		
Does the project site...	YES	NO
...have significant cut and/or fill conditions that would preclude in-situ testing of infiltration rates at the final infiltration surface?		X
If Yes, list affected DMAs:		
Other Site-Specific Factors (SMR WQMP Section 2.3.3.f)		
Does the project site...	YES	NO
...have DMAs where the geotechnical investigation discovered other site-specific factors that would preclude effective and/or safe infiltration?		X
Describe here:		

If you answered “Yes” to any of the questions above for any DMA, Infiltration BMPs that rely solely on infiltration should not be used for those DMAs and you should proceed to the assessment for Biofiltration BMPs below. Biofiltration BMPs that provide partial infiltration may still be feasible and should be assessed in Section D.2. Summarize concerns identified in the Geotechnical Report, if any, that resulted in a “YES” response above in the table below.

³ Such a condition must be substantiated by sufficient modeling to demonstrate an impact and would be subject to County of Riverside discretion. There is not a standardized method for assessing this criterion. Water rights evaluations should be site-specific.

Table D-2 Geotechnical Concerns for Onsite Infiltration

Type of Geotechnical Concern	DMAs Feasible (By Name or ID)	DMAs Infeasible (By Name or ID)
Collapsible Soil		
Expansive Soil		
Slopes		
Liquefaction		
Low Infiltration Rate		
Other		

D.2 Biofiltration Applicability

This section should document the applicability of biofiltration BMPs for Type D DMAs that are not feasible for full infiltration BMPs. The key decisions to be documented in this section include:

1. Are biofiltration BMPs with partial infiltration feasible?
 - a. Biofiltration BMPs must be designed to maximize incidental infiltration via a partial infiltration design unless it is demonstrated that this design is not feasible.
 - b. These designs can be used at sites with low infiltration rates where other feasibility factors do not preclude incidental infiltration.

Document summary in Table D-3.

2. If not, what are the factors that require the use of biofiltration with no infiltration? This may include:
 - a. Geotechnical hazards
 - b. Water rights issues
 - c. Water balance issues
 - d. Soil contamination or groundwater quality issues
 - e. Very low infiltration rates (factored rates < 0.1 in/hr)
 - f. Other factors, demonstrated to the acceptance of the local jurisdiction

If this applies to any DMAs, then rationale must be documented in Table D-3.

3. Are biofiltration BMPs infeasible?
 - a. If yes, then provide a site-specific analysis demonstrating the technical infeasibility of all LID BMPs has been performed and is included in Appendix 5. If you plan to submit an analysis demonstrating the technical infeasibility of LID BMPs, request a pre-submittal meeting with the Copermittee with jurisdiction over the Project site to discuss this option. Proceed below.

Table D-3 Evaluation of Biofiltration BMP Feasibility

DMA ID	Is Partial/ Incidental Infiltration Allowable? (Y/N)	Basis for Infeasibility of Partial Infiltration (provide summary and include supporting basis if partial infiltration not feasible)
N/A		
N/A		
N/A		
N/A		

Proprietary Biofiltration BMP Approval Criteria

Does the Co-Permittee allow Proprietary BMPs as an equivalent to Biofiltration, if specific criteria is met?

Yes or No, if no skip to Section F to document your alternative compliance measures.

If the project will use proprietary BMPs as biofiltration BMPs, then this section and Appendix 5 shall be completed to document that the proprietary BMPs are selected in accordance with Section 2.3.6 of the SMR WQMP and County requirements. Proprietary Biofiltration BMPs must meet both of the following approval criteria:

1. Demonstrate equivalency to Biofiltration by completing the BMP Design worksheet and Proprietary Biofiltration Criteria, which is found in Appendix 5, including all supporting documentation, and
2. Obtain Co-Permittee concurrence for the long term Operation and Maintenance Plan for the proprietary BMP. The Co-Permittee has the sole discretion to allow or reject Proprietary BMPs, especially if they will be maintained publically through a CFD, CSA, or L&LMD.

Add additional rows to Table D-4 to document approval criteria are met for each type of BMP proposed.

Table D-4 Proprietary BMP Approval Requirement Summary

Proposed Proprietary Biofiltration BMP	Approval Criteria	Notes/Comments
N/A	BMP Design worksheets and Proprietary Biofiltration Criteria are completed in Appendix 5	<input type="checkbox"/> Yes or <input type="checkbox"/> No Insert text here
	Proposed BMP has an active TAPE GULD Certification for the project pollutants of concern ⁴ or equivalent 3 rd party demonstrated performance.	<input type="checkbox"/> Yes or <input type="checkbox"/> No Insert text here
	Is there any media or cartridge required to maintain the function of the BMP sole-sourced or proprietary in any way? If yes, obtain explicit approval by the Agency. Potentially full replacement costs to a non-proprietary BMP needs to be considered.	<input type="checkbox"/> Yes or <input type="checkbox"/> No If yes, provide the date of concurrence from the Co-Permittee. Insert date here
	<input type="checkbox"/> The BMP includes biological features	Describe features here.

⁴ Use Table F-1, F-2, and F-3 to identify and document the pollutants of concern and include these tables in Appendix 5.

	including vegetation supported by engineered or other growing media.	
--	--	--

D.3 Feasibility Assessment Summaries

From the Infiltration, Biofiltration with Partial Infiltration and Biofiltration with No Infiltration Sections above, complete Table D-5 below to summarize which LID BMPs are technically feasible, and which are not, based upon the established hierarchy.

Table D-5 LID Prioritization Summary Matrix

DMA Name/ID	LID Principles or Tree Wells	LID BMP Hierarchy			No LID (Alternative Compliance)
		1. Infiltration	2. Biofiltration with Partial Infiltration*	3. Biofiltration with No Infiltration*	
D1	<input type="checkbox"/>	<input checked="" type="checkbox"/>	<input type="checkbox"/>	<input type="checkbox"/>	<input type="checkbox"/>
D2	<input type="checkbox"/>	<input checked="" type="checkbox"/>	<input type="checkbox"/>	<input type="checkbox"/>	<input type="checkbox"/>
D3	<input type="checkbox"/>	<input checked="" type="checkbox"/>	<input type="checkbox"/>	<input type="checkbox"/>	<input type="checkbox"/>

*Includes Proprietary Biofiltration, if accepted by the Co-Permittee.

For those DMAs where LID BMPs are not feasible, provide a narrative in Table D-6 below summarizing why they are not feasible, include your technical infeasibility criteria in Appendix 5, and proceed to Section F below to document Alternative Compliance measures for those DMAs. Recall that each proposed DMA must pass through the LID BMP hierarchy before alternative compliance measures may be considered.

This is based on the clarification letter titled “San Diego Water Board’s Expectations of Documentation to Support a Determination of Priority Development Project Infiltration Infeasibility” (April 28, 2017, Via email from San Diego Regional Water Quality Control Board to San Diego County Municipal Storm Water Copermitees⁵).

Table D-6 Summary of Infeasibility Documentation

Question	Narrative Summary (include reference to applicable appendix/attachment/report, as applicable)
a) When in the entitlement process did a geotechnical engineer analyze the site for infiltration feasibility?	N/A
b) When in the entitlement process were other investigations conducted (e.g., groundwater quality, water rights) to evaluate infiltration feasibility?	N/A
c) What was the scope and results of testing, if conducted, or rationale for why testing was not needed to reach findings?	N/A
d) What public health and safety	N/A

⁵ <http://www.projectcleanwater.org/download/pdp-infiltration-infeasibility/>

requirements affected infiltration locations?	
e) What were the conclusions and recommendations of the geotechnical engineer and/or other professional responsible for other investigations?	N/A
f) What was the history of design discussions between the permittee and applicant for the proposed project, resulting in the final design determination related locations feasible for infiltration?	N/A
g) What site design alternatives were considered to achieve infiltration or partial infiltration on site?	N/A
h) What physical impairments (i.e., fire road egress, public safety considerations, utilities) and public safety concerns influenced site layout and infiltration feasibility?	N/A
i) What LID Principles (site design BMPs) were included in the project site design?	N/A

D.4 LID BMP Sizing

Each LID BMP must be designed to ensure that the DCV will be captured by the selected BMPs with no discharge to the storm drain or surface waters during the DCV size storm. Infiltration BMPs must at minimum be sized to capture the DCV to achieve pollutant control requirements.

Biofiltration BMPs must at a minimum be sized to:

- Treat 1.5 times the DCV not reliably retained on site using a volume-base or flow-based sizing method, or
- Include static storage volume, including pore spaces and pre-filter detention volume, at least 0.75 times the portion of the DCV not reliably retained on site.

First, calculate the DCV for each LID BMP using the V_{BMP} worksheet in Appendix F of the LID BMP Design Handbook. Second, design the LID BMP to meet the required V_{BMP} using the methods included in Section 3 of the LID BMP Design Handbook. Utilize the worksheets found in the LID BMP Design Handbook or consult with the Copermittee to assist you in correctly sizing your LID BMPs. Use Table D-7 below to document the DCV each LID BMP. Provide the completed design procedure sheets for each LID BMP in Appendix 6. You may add additional rows to the table below as needed.

Table D-7 DCV Calculations for LID BMPs

DMA Type/ID	DMA (square feet)	Post-Project Surface Type	Effective Impervious Fraction, I_f	DMA Runoff Factor	DMA Areas x Runoff Factor	Enter BMP Name / Identifier Here		
						[A]	[B]	[C]
D1	11,492	Roof	1	0.89	10,228	Design Storm Depth (in)	DCV, V_{BMP} (cubic feet)	Proposed Volume on Plans (cubic feet)
D2	9,912	AC	1	0.89	8,822			
D3	1,869	Concrete	1	0.89	1,663			
	$A_T = 23,273$				$\Sigma=20,713$	0.68	DCV = 1,173	1,942

[B], [C] is obtained as described in Section 2.6.1.b of the SMR WQMP

[E] is obtained from Exhibit A in the SMR WQMP

[G] is obtained from a design procedure sheet, such as in LID BMP Design Handbook and placed in Appendix 6.

Complete Table D-8 below to document the Design Capture Volume and the Proposed Volume for each LID BMP. You can add rows to the table as needed. Alternatively, the Santa Margarita Hydrology Model (SMRHM) can be used to size LID BMPs to address the DCV and, if applicable, to size Hydrologic Control BMPs to meet the Hydrologic Performance Standard described in the SMR WQMP, as identified in Section E.

Table D-8 LID BMP Sizing

BMP Name / ID	DMA No.1	BMP Type / Description	Design Capture Volume (ft ³)	Proposed Volume (ft ³)
Infiltration Trench	D1/D2/D3	Infiltration Trench	1,173	1,942

If bioretention will include a capped underdrain, then include sizing calculations demonstrating that the BMP will meet infiltration sizing requirements with the underdrain capped and also meet biofiltration sizing requirements if the underdrain is uncapped.

Section E: Implement Hydrologic Control BMPs and Sediment Supply BMPs

See Appendix 7 for additional required information.

If a completed Table 1.2 demonstrates that the project is exempt from Hydromodification Performance Standards, specify N/A and proceed to Section G.

N/A Project is Exempt from Hydromodification Performance Standards.

If a PDP is not exempt from hydromodification requirements than the PDP must satisfy the requirements of the performance standards for hydrologic control BMPs and Sediment Supply BMPs. The PDP may choose to satisfy hydrologic control requirements using onsite or offsite BMPs (i.e. Alternative Compliance). Sediment supply requirements cannot be met via alternative compliance. If N/A is not selected above, select one of the two options below and complete the applicable sections.

Project is Not Hydromodification Exempt and chooses to implement Hydrologic Control and Sediment Supply BMPs Onsite (complete Section E).

Project is Not Hydromodification Exempt and chooses to implement Hydrologic Control Requirements using Alternative Compliance (complete Section F). Selection of this option must be approved by the Copermittee.

E.1 Hydrologic Control BMP Selection

Capture of the DCV and achievement of the Hydrologic Performance Standard may be met by combined and/or separate structural BMPs. The user should consider the full suite of Hydrologic Control BMPs to manage runoff from the post-development condition and meet the Hydrologic Performance Standard identified in this section.

For the Preliminary WQMP, in lieu of preparing detailed routing calculations, the basin size may be estimated as the difference in volume between the pre-development and post-development hydrograph for the 10-year 24-hour storm event plus the V_{bmp} . This does not relieve the engineer of the responsibility for meeting the full Hydrologic Control requirements during final design.

The Hydrologic Performance Standard consists of matching or reducing the flow duration curve of post-development conditions to that of pre-existing, naturally occurring conditions, for the range of geomorphically significant flows (the low flow threshold runoff event up to the 10-year runoff event). 10% of the 2-year runoff event can be used for the low flow threshold without any justification. Higher low flow thresholds can be used with site-specific analysis, see Section 2.6.2.b of the WQMP guidance document. Select each of the hydrologic control BMP types that are applied to meet the above performance standard on the site.

LID principles as defined in Section 3.2 of the SMR WQMP, including Tree Wells.

- Structural LID BMPs that may be modified or enlarged, if necessary, beyond the DCV.
- Structural Hydrologic Control BMPs that are distinct from the LID BMPs above. The LID BMP Design Handbook provides information not only on Hydrologic Control BMP design, but also on BMP design to meet the combined LID requirement and Hydrologic Performance Standard. The Handbook specifies the type of BMPs that can be used to meet the Hydrologic Performance Standard.

E.2 Hydrologic Control BMP Sizing

Hydrologic Control BMPs must be designed to ensure that the flow duration curve of the post-development DMA will not exceed that of the pre-existing, naturally occurring, DMA for the range of geomorphically significant flows. Using SMRHM, (or another acceptable continuous simulation model if approved by the Copermittee) the applicant shall demonstrate that the performance of the Hydrologic Control BMPs complies with the Hydrologic Performance Standard. Complete Table E-1 below and identify, for each DMA, the type of Hydrologic Control BMP, if the SMRHM model confirmed the management (Identified as “passed” in SMRHM), the total volume capacity of the Hydrologic Control BMP, the Hydrologic Control BMP footprint at top floor elevation, and the drawdown time of the Hydrologic Control BMP. SMRHM summary reports should be documented in Appendix 7. Refer to the SMRHM Guidance Document for additional information on SMRHM. You can add rows to the table as needed.

Table E-1 Hydrologic Control BMP Sizing

BMP Name / ID	DMA No.	BMP Type / Description	SMRHM* Passed	BMP Volume (ac-ft)	BMP Footprint (ac)	Drawdown time (hr)
Trench	1	Infiltration Trench	<input checked="" type="checkbox"/>	0.03	0.01	72
			<input type="checkbox"/>			
			<input type="checkbox"/>			
			<input type="checkbox"/>			

**Or other continuous simulation model, compliant with the WQMP and Permit. If Tree Wells are proposed for some or all of the project, check the box for Tree Wells in Section E.1 and enter each Tree Well DMA in Table E-1 above for the BMP Name/ID, DMA No. and BMP Type/Description. For Tree Wells, leave SMRHM* Passed Column and the columns to the left blank.*

If a bioretention BMP with capped underdrain is used and hydromodification requirements apply, then sizing calculations must demonstrate that the BMP meets flow duration control criteria with the underdrain capped and uncapped. Both calculations must be included.

E.3 Implement Sediment Supply BMPs

The sediment supply performance standard applies to PDPs for which hydromodification applied that have the potential to impact Potential Critical Coarse Sediment Yield Areas. Refer to Exhibit G-1 of the WQMP Guidance Document to determine if there are onsite Potential Critical Coarse Sediment Yield Areas (based on on-going WMAA analysis) or Potential Sediment Source Areas (sites added through the Regional Board review process). Select one of the two options below and include the Potential Critical Coarse Sediment Yield Area Exhibit showing your project location in Appendix 7.

- There are no mapped Potential Critical Coarse Sediment Yield Areas or Potential Sediment Source Areas on the site. Include a copy of Exhibit G - CCSY & PSS Areas in Appendix 7, with the project location marked. If the project is outside of the “Potential Critical Coarse Sediment Yield Areas and Potential Sediment Source Areas” then check this box. The Sediment Supply Performance Standard is met with no further action is needed.
- There are mapped Potential Critical Coarse Sediment Yield Areas or Potential Sediment Source Areas on the site, the Sediment Supply Performance Standard will be met through Option 1 (E.3.1) or Option 2 (E.3.2) below.

E.3.1 Option 1: Avoid Potential Critical Coarse Sediment Yield Areas and Potential Sediment Source Areas

The simplest approach for complying with the Sediment Supply Performance Standard is to avoid impacts to areas identified as Potential Critical Coarse Sediment Yield Areas or Potential Sediment Supply Areas. If a portion of PDP is identified as a Potential Critical Coarse Sediment Yield Area or a Potential Sediment Source Area, that PDP may still achieve compliance with the Sediment Supply Performance Standards if Potential Critical Coarse Sediment Yield Areas and Potential Sediment Supply Areas are avoided, i.e. areas are not developed and thereby delivery of Critical Coarse Sediment to the receiving waters is not impeded by site developments.

Provide a narrative describing how the PDP has avoided impacts to Potential Critical Coarse Sediment Yield Areas and/or Potential Sediment Source Areas below.

N/A

If it is not feasible to avoid these areas, proceed to Option 2 to complete a Site-Specific Critical Coarse Sediment Analysis.

E.3.2 Option 2: Site-Specific Critical Coarse Sediment Analysis

Perform a stepwise assessment to ensure the pre-project source(s) of Critical Coarse Sediment (i.e., Bed Sediment Supply) is maintained:

Step 1: Identify if the site is an actual verified Critical Coarse Sediment Yield Area supplying Bed Sediment Supply to the receiving channel

- Step 1.A** – Is the Bed Sediment of onsite streams similar to that of receiving streams?

Rate the similarity: High
 Medium
 Low

Results from the geotechnical and sieve analysis to be performed both onsite and in the receiving channel should be documented in Appendix 7. Of particular interest, the results of the sieve analysis, the soil erodibility factor, a description of the topographic relief of the project area, and the lithology of onsite soils should be reported in Appendix 7.

- Step 1.B** – Are onsite streams capable of delivering Bed Sediment Supply from the site, if any, to the receiving channel?

Rate the potential: High
 Medium
 Low

Results from the analyses of the sediment delivery potential to the receiving channel should be documented in Appendix 7 and identify, at a minimum, the Sediment Source, the distance to the receiving channel, the onsite channel density, the project watershed area, the slope, length, land use, and rainfall intensity.

- Step 1.C** – Will the receiving channel adversely respond to a change in Bed Sediment Load?

Rate the need for bed sediment supply:
 High
 Medium
 Low

Results from the in-stream analysis to be performed both onsite should be documented in Appendix 7. The analysis should, at a minimum, quantify the bank stability and the degree of incision, provide a gradation of the Bed Sediment within the receiving channel, and identify if the channel is sediment supply-limited.

- Step 1.D** – Summary of Step 1

Summarize in Table E.3 the findings of Step 1 and associate a score (in parenthesis) to each step. The sum of the three individual scores determines if a stream is a significant contributor to the receiving stream.

- Sum is equal to or greater than eight - Site is a significant source of sediment bed material – all on-site streams must be preserved or by-passed within the site plan. The applicant shall proceed to Step 2 for all onsite streams.
- Sum is greater than five but lower than eight. Site is a source of sediment bed material – some of the on-site streams must be preserved (with identified streams noted). The applicant shall proceed to Step 2 for the identified streams only.
- Sum is equal to or lower than five. Site is not a significant source of sediment bed material. The applicant may advance to Section F.

Table E-2 Triad Assessment Summary

Step	Rating	Total Score
------	--------	-------------

1.A	<input type="checkbox"/> High (3)	<input type="checkbox"/> Medium (2)	<input type="checkbox"/> Low (1)	
1.B	<input type="checkbox"/> High (3)	<input type="checkbox"/> Medium (2)	<input type="checkbox"/> Low (1)	
1.C	<input type="checkbox"/> High (3)	<input type="checkbox"/> Medium (2)	<input type="checkbox"/> Low (1)	
Significant Source Rating of Bed Sediment to the receiving channel(s)				

Step 2: Avoid Development of Critical Coarse Sediment Yield Areas, Potential Sediment Sources Areas, and Preserve Pathways for Transport of Bed Sediment Supply to Receiving Waters

Onsite streams identified as a actual verified Critical Coarse Sediment Yield Areas should be avoided in the site design and transport pathways for Critical Coarse Sediment should be preserved

Check those that apply:

- The site design does avoid all onsite channels identified as actual verified Critical Coarse Sediment Yield Areas **AND**
- The drainage design bypasses flow and sediment from onsite upstream drainages identified as actual verified Critical Coarse Sediment Yield Areas to maintain Critical Coarse Sediment supply to receiving waters

(If both are yes, the applicant may disregard subsequent steps of Section E.3 and directly advance directly to Section G)

Or -

Provide in Appendix 7 a site map that identifies all onsite channels and highlights those onsite channels that were identified as a Significant Source of Bed Sediment. The site map shall demonstrate, if feasible, that the site design avoids those onsite channels identified as a Significant Source of Bed Sediment. In addition, the applicant shall describe the characteristics of each onsite channel identified as a Significant Source of Bed Sediment. If the design plan cannot avoid the onsite channels, please provide a rationale for each channel individually.

The site map shall demonstrate that the drainage design bypasses those onsite channels that supply Critical Coarse Sediment to the receiving channel(s). In addition, the applicant shall describe the characteristics of each onsite channel identified as an actual verified Critical Coarse Sediment Yield Area.

Identified Channel #1 - Insert narrative description here

Identified Channel #2 - Insert narrative description here

- The site design **does NOT avoid** all onsite channels identified as actual verified Critical Coarse Sediment Yield Areas

OR

- The project blocks the potential for Critical Coarse Sediment from migrating to receiving waters.

(If either of these are the case, the applicant shall continue completing this section).

E.3.3 Sediment Supply BMPs to Result in No Net Impact to Downstream Receiving Waters

If impacts to Critical Coarse Sediment Yield Areas cannot be avoided, sediment supply BMPs must be implemented such there is no net impact to receiving waters. Sediment supply BMPs may consist of approaches that permit flux of bed sediment supply from Critical Coarse Sediment Yield Areas within the project boundary. This approach is subject to acceptance by the County of Riverside. It may require extensive documentation and analysis by qualified professionals to support this demonstration.

Appendix H of the San Diego Model BMP Design Manual provides additional information on site-specific investigation of Critical Coarse Sediment Supply areas.

<http://www.projectcleanwater.org/download/2018-model-bmp-design-manual/>

If applicable, insert narrative description here

Documentation of sediment supply BMPs should be detailed in Appendix 7.

Section F: Alternative Compliance

Alternative Compliance may be used to achieve compliance with pollutant control and/or hydromodification requirements for a given PDP. Alternative Compliance may be used under two scenarios, check the applicable box if the PDP is proposing to use Alternative Compliance to satisfy all or a portion of the Pollutant Control and/or Hydrologic Control requirements (but not sediment supply requirements)

- If it is not feasible to fully implement Infiltration or Biofiltration BMPs at a PDP site, Flow-Through Treatment Control BMPs may be used to treat pollutants contained in the portion of DCV not reliably retained on site and Alternative Compliance measures must also be implemented to mitigate for those pollutants in the DCV that are not retained or removed on site prior to discharging to a receiving water.

- Alternative Compliance is selected to comply with either pollutant control or hydromodification flow control requirements even if complying with these requirements is potentially feasible on-site. If such voluntary Alternative Compliance is implemented, Flow-Through Treatment Control BMPs must still be used to treat those pollutants in the portion of the DCV not reliably retained on site prior to discharging to a receiving water.

Refer to Section 2.7 of the SMR WQMP and consult the Local Jurisdiction for currently available Alternative Compliance pathways. Coordinate with the Copermittee if electing to participate in Alternative Compliance and complete the sections below to document implementation of the Flow-Through BMP component of the program.

F.1 Identify Pollutants of Concern

The purpose of this section is to help you appropriately plan for mitigating your Pollutants of Concern in lieu of implementing LID BMPs and to document compliance and.

Utilize Table A-1 from Section A, which noted your project's Receiving Waters, to identify impairments for Receiving Waters (including downstream receiving waters) by completing Table F-1. Table F-1 includes the watersheds identified as impaired in the Approved 2010 303(d) list; check box corresponding with the PDP's receiving water. The most recent 303(d) lists are available from the State Water Resources Control Board website:

https://www.waterboards.ca.gov/water_issues/programs/tmdl/integrated2010.shtml).https://www.waterboards.ca.gov/water_issues/programs/tmdl/integrated2010.shtml.

Table F-1 Summary of Approved 2010 303(d) listed waterbodies and associated pollutants of concern for the Riverside County SMR Region and downstream waterbodies.

Water Body		Nutrients¹	Metals²	Toxicity	Bacteria and Pathogens	Pesticides and Herbicides	Sulfate	Total Dissolved Solids
<input type="checkbox"/>	De Luz Creek	X	X				X	
<input type="checkbox"/>	Long Canyon Creek		X		X	X		
<input type="checkbox"/>	Murrieta Creek	X	X	X		X		
<input type="checkbox"/>	Redhawk Channel	X	X		X	X		X
<input type="checkbox"/>	Santa Gertudis Creek	X	X		X	X		
<input type="checkbox"/>	Santa Margarita Estuary	X						
<input type="checkbox"/>	Santa Margarita River (Lower)	X			X			
<input type="checkbox"/>	Santa Margarita River (Upper)	X		X				
<input type="checkbox"/>	Temecula Creek	X	X	X		X		X
<input type="checkbox"/>	Warm Springs Creek	X	X		X	X		

¹ Nutrients include nitrogen, phosphorus and eutrophic conditions caused by excess nutrients.

² Metals includes copper, iron, and manganese.

Use Table F-2 to identify the pollutants identified with the project site. Indicate the applicable PDP Categories and/or Project Features by checking the boxes that apply. If the identified General Pollutant Categories are the same as those listed for your Receiving Waters, then these will be your Pollutants of Concern; check the appropriate box or boxes in the last row.

Table F-2 Potential Pollutants by Land Use Type

Priority Development Project Categories and/or Project Features (check those that apply)		General Pollutant Categories									
		Bacterial Indicators	Metals	Nutrients	Pesticides	Toxic Organic Compounds	Sediments	Trash & Debris	Oil & Grease	Total Dissolved Solids	Sulfate
<input type="checkbox"/>	Detached Residential Development	P	N	P	P	N	P	P	P	N	N
<input type="checkbox"/>	Attached Residential Development	P	N	P	P	N	P	P	P ⁽²⁾	N	N
<input type="checkbox"/>	Commercial/Industrial Development	P ⁽³⁾	P ⁽⁷⁾	P ⁽¹⁾	P ⁽¹⁾	P	P ⁽¹⁾	P	P	N	N
<input type="checkbox"/>	Automotive Repair Shops	N	P	N	N	P ^(4, 5)	N	P	P	N	N
<input type="checkbox"/>	Restaurants (>5,000 ft ²)	P	N	N	P ⁽¹⁾	N	N	P	P	N	N
<input type="checkbox"/>	Hillside Development (>5,000 ft ²)	P	N	P	P	N	P	P	P	N	N
<input type="checkbox"/>	Parking Lots (>5,000 ft ²)	P ⁽⁶⁾	P ⁽⁷⁾	P ⁽¹⁾	P ⁽¹⁾	P ⁽⁴⁾	P	P	P	N	N
<input type="checkbox"/>	Streets, Highways, and Freeways	P ⁽⁶⁾	P ⁽⁷⁾	P ⁽¹⁾	P ⁽¹⁾	P ⁽⁴⁾	P	P	P	N	N
<input type="checkbox"/>	Retail Gasoline Outlets	N	P ⁽⁷⁾	N	N	P ⁽⁴⁾	N	P	P	N	N
Project Priority Pollutant(s) of Concern		<input type="checkbox"/>	<input type="checkbox"/>	<input checked="" type="checkbox"/>	<input type="checkbox"/>	<input type="checkbox"/>	<input type="checkbox"/>	<input type="checkbox"/>	<input type="checkbox"/>	<input type="checkbox"/>	<input type="checkbox"/>

P = Potential

N = Not Potential

⁽¹⁾ A potential Pollutant if non-native landscaping exists or is proposed onsite; otherwise not expected

⁽²⁾ A potential Pollutant if the project includes uncovered parking areas; otherwise not expected

⁽³⁾ A potential Pollutant is land use involving animal waste products; otherwise not expected

⁽⁴⁾ Including petroleum hydrocarbons

⁽⁵⁾ Including solvents

⁽⁶⁾ Bacterial indicators are routinely detected in pavement runoff

⁽⁷⁾ A potential source of metals, primarily copper and zinc. Iron, magnesium, and aluminum are commonly found in the environment and are commonly associated with soils, but are not primarily of anthropogenic stormwater origin in the municipal environment.

F.2 Treatment Control BMP Selection

Treatment Control BMPs typically provide proprietary treatment mechanisms to treat potential Pollutants in runoff, but do not sustain significant biological processes. Treatment Control BMPs must be selected to address the Project Priority Pollutants of Concern (identified above) and meet the acceptance criteria described in Section 2.3.7 of the SMR WQMP. Documentation of acceptance criteria must be included in Appendix 6. In addition, ensure that proposed Treatment Control BMPs are properly identified on the WQMP Site Plan in Appendix 1.

Table F-3 Treatment Control BMP Selection

Selected Treatment Control BMP Name or ID ¹	Priority Pollutant(s) of Concern to Mitigate ²	Removal Efficiency Percentage ³

¹ Treatment Control BMPs must not be constructed within Receiving Waters. In addition, a proposed Treatment Control BMP may be listed more than once if they possess more than one qualifying pollutant removal efficiency.

² Cross Reference Table E.1 above to populate this column.

³ As documented in a Copermittee Approved Study and provided in Appendix 6.

F.3 Sizing Criteria

Utilize Table F-4 below to appropriately size flow-through BMPs to the DCV, or Design Flow Rate, as applicable. Please reference Chapter 3.5.1 of the SMR WQMP for further information.

Table F-4 Treatment Control BMP Sizing

DMA Type/ID	DMA Area (square feet)	Post-Project Surface Type	Effective Impervious Fraction, I _f	DMA Runoff Factor	DMA Areas x Runoff Factor	Enter BMP Name / Identifier Here	
	[A]		[B]	[C]	[A] x [C]		
						Design Storm (in)	Design Flow Rate (cfs)
	$A_T = \Sigma[A]$				$\Sigma = [D]$	[E]	$[F] = \frac{[D] \times [E]}{[G]}$

[B], [C] is obtained as described in Section 2.6.1.b from the SMR WQMP

[E] either 0.2 inches or 2 times the 85th percentile hourly rainfall intensity

[G] = 43,560,.

F.4 Hydrologic Performance Standard – Alternative Compliance Approach

Alternative compliance options are only available if the governing Copermittee has acknowledged the infeasibility of onsite Hydrologic Control BMPs and approved an alternative compliance approach. See Section 3.5 and 3.6 of the SMR WQMP.

Select the pursued alternative and describe the specifics of the alternative:

- Offsite Hydrologic Control Management within the same channel system

N/A

- In-Stream Restoration Project

N/A

For Offsite Hydrologic Control BMP Option

Each Hydrologic Control BMP must be designed to ensure that the flow duration curve of the post-development DMA will not exceed that of the pre-existing, naturally occurring, DMA by more than ten percent over a one-year period. Using SMRHM, the applicant shall demonstrate that the performance of each designed Hydrologic Control BMP is equivalent with the Hydrologic Performance Standard for onsite conditions. Complete Table F-5 below and identify, for each Hydrologic Control BMP, the equivalent DMA the Hydrologic Control BMP mitigates, that the SMRHM model passed, the total volume capacity of the BMP, the BMP footprint at top floor elevation, and the drawdown time of the BMP. SMRHM summary reports for the alternative approach should be documented in Appendix 7. Refer to the SMRHM Guidance Document for additional information on SMRHM. You can add rows to the table as needed.

Table F-5 Offsite Hydrologic Control BMP Sizing

BMP Name / Type	Equivalent DMA (ac)	SMRHM Passed	BMP Volume (ac-ft)	BMP Footprint (ac)	Drawdown time (hr)
		<input type="checkbox"/>			
		<input type="checkbox"/>			
		<input type="checkbox"/>			
		<input type="checkbox"/>			

For Instream Restoration Option

Attach to Appendix 7 the technical report detailing the condition of the receiving channel subject to the proposed hydrologic and sediment regimes. Provide the full design plans for the in-stream restoration project that have been approved by the Copermittee. Utilize the San Diego Regional Water Quality Equivalency Guidance Document.

Section G: Implement Trash Capture BMPs

The Santa Margarita Regional Board has required Full Trash Capture compliance thru Order No. R9-2017-007. For the Santa Margarita Watershed, the County is requiring Track 1 full trash capture compliance for projects proposing the following uses as part of their development after **December 3, 2018**.

- High-density residential: all land uses with at least ten (10) developed dwelling units/acre.
- Industrial: land uses where the primary activities on the developed parcels involve product manufacture, storage, or distribution (e.g., manufacturing businesses, warehouses, equipment storage lots, junkyards, wholesale businesses, distribution centers, or building material sales yards).
- Commercial: land uses where the primary activities on the developed parcels involve the sale or transfer of goods or services to consumers (e.g., business or professional buildings, shops, restaurants, theaters, vehicle repair shops, etc.).
- Mixed urban: land uses where high-density residential, industrial, and/or commercial land uses predominate collectively (i.e., are intermixed).
- Public transportation stations: facilities or sites where public transit agencies' vehicles load or unload passengers or goods (e.g., bus stations and stops).

Riverside County Maintenance is generally supportive of United Storm Water – Connector Pipe Screens or equivalent. Equivalent systems or alternative designs shall be on the State of California Approved Trash Capture Device List and requires approval by the Transportation Department for maintenance. Riverside County is developing Trash Capture Device Standards, which are expected to be added to the Transportation Plan Check Policies and Guidelines when available. Design calculations are not expected to be required if the project uses standard sizes per the County's Trash Capture Device Standards. Until the Trash Capture Device Standards are available and the project uses standard sizes, the project shall complete the following tables and furnish hydraulic analysis calculating the flowrate in the catch basin does not exceed the flowrate capacity of the trash capture device in a fully clogged condition.

Trash Capture BMPs may be applicable to Type 'D' DMAs, as defined in Section 2.3.4 of the SMR WQMP. Trash Capture BMPs are designed to treat Q_{TRASH} , the runoff flow rate generated during the 1-year 1-hour precipitation depth. Utilize Table G-1 to size Trash Capture BMP. Refer to Table G-2 to determine the Trash Capture Design Storm Intensity (E).

Table G-1 Sizing Trash Capture BMPs

DMA Type/ID	DMA Area (square feet)	Post-Project Surface Type	Effective Impervious Fraction, I _f	DMA Runoff Factor	DMA Areas x Runoff Factor	<i>Enter BMP Name / Identifier Here</i>	
	[A]		[B]	[C]	[A] x [C]		
						<i>Trash Capture Design Storm Intensity (in)</i>	<i>Trash Capture Design Flow Rate (cubic feet or cfs)</i>
	$\Lambda_T = \Sigma[A]$			$\Sigma = [D]$		[E]	$[F] = \frac{[D] \times [E]}{[G]}$

[B], [C] is obtained as described in Section 2.6.1.b from the SMR WQMP
[G] = 43,560

Table G-2 Approximate precipitation depth/intensity values for calculation of the Trash Capture Design Storm

City	1-year 1-hour Precipitation Depth/Intensity (inches/hr)
Murrieta	0.47
Temecula	0.50
Wildomar	0.37

Use Table G-3 to summarize and document the selection and sizing of Trash Capture BMPs.

Table G-3 Trash Capture BMPs

BMP Name / ID	DMA No(s)	BMP Type / Description	Required Trash Capture Flowrate (cfs)	Provided Trash Capture Flowrate (cfs) ¹

¹For connector pipe screens, the Trash Capture Flowrate shall be based on a fully clogged condition for the screen, where the water level is at the top of the screen. Then determined the Flowrate based on weir equation (Q_{weir} = C x L x H^(2/3)), where C = 3.4). The height used to calculate the weir flow rate shall maintain a 6" freeboard to the invert of the catch basin opening at the road. This analysis is meant to replicate the hydraulic analysis used in the County's Full Trash Capture Device Standards.

Section H: Source Control BMPs

Section H need only be completed at the Preliminary WQMP phase if source control is critical to the project successfully handling the anticipated pollutants.

Source Control BMPs include permanent, structural features that may be required in your Project plans, such as roofs over and berms around trash and recycling areas, and Operational BMPs, such as regular sweeping and “housekeeping,” that must be implemented by the site’s occupant or user. The Maximum Extent Practicable (MEP) standard typically requires both types of BMPs. In general, Operational Source Control BMPs cannot be substituted for a feasible and effective Structural Source Control BMP. Complete checklist below to determine applicable Source Control BMPs for your site.

Project-Specific WQMP Source Control BMP Checklist		
<p>All development projects must implement Source Control BMPs. Source Control BMPs are used to minimize pollutants that may discharge to the MS4. Refer to Chapter 3 (Section 3.8) of the SMR WQMP for additional information. Complete Steps 1 and 2 below to identify Source Control BMPs for the project site.</p>		
STEP 1: IDENTIFY POLLUTANT SOURCES		
<p>Review project site plans and identify the applicable pollutant sources. “Yes” indicates that the pollutant source is applicable to project site. “No” indicates that the pollutant source is not applicable to project site.</p>		
<input type="checkbox"/> Yes <input type="checkbox"/> No Storm Drain Inlets	<input type="checkbox"/> Yes <input checked="" type="checkbox"/> No Outdoor storage areas	
<input type="checkbox"/> Yes <input checked="" type="checkbox"/> No Floor Drains	<input type="checkbox"/> Yes <input checked="" type="checkbox"/> No Material storage areas	
<input type="checkbox"/> Yes <input checked="" type="checkbox"/> No Sump Pumps	<input type="checkbox"/> Yes <input checked="" type="checkbox"/> No Fueling areas	
<input checked="" type="checkbox"/> Yes <input type="checkbox"/> No Pets Control/Herbicide Application	<input type="checkbox"/> Yes <input checked="" type="checkbox"/> No Loading Docks	
<input type="checkbox"/> Yes <input checked="" type="checkbox"/> No Food Service Areas	<input type="checkbox"/> Yes <input checked="" type="checkbox"/> No Fire Sprinkler Test/Maintenance water	
<input checked="" type="checkbox"/> Yes <input type="checkbox"/> No Trash Storage Areas	<input checked="" type="checkbox"/> Yes <input type="checkbox"/> No Plazas, Sidewalks and Parking Lots	
<input type="checkbox"/> Yes <input checked="" type="checkbox"/> No Industrial Processes	<input type="checkbox"/> Yes <input checked="" type="checkbox"/> No Pools, Spas, Fountains and other water features	
<input type="checkbox"/> Yes <input checked="" type="checkbox"/> No Vehicle and Equipment Cleaning and Maintenance/Repair Areas		
STEP 2: REQUIRED SOURCE CONTROL BMPs		
<p>List each Pollutant source identified above in column 1 and fill in the corresponding Structural Source Control BMPs and Operational Control BMPs by referring to the Stormwater Pollutant Sources/Source Control Checklist included in Appendix 8. The resulting list of structural and operational source control BMPs must be implemented as long as the associated sources are present on the project site. Add additional rows as needed.</p>		
Pollutant Source	Structural Source Control BMP	Operational Source Control BMP
Trash Storage Area	Do not dump hazardous materials sign	Cover, inspect, and repair as needed
Parking Lot		Sweep, remove debris, pressure wash

Section I: Coordinate Submittal with Other Site Plans

For Final WQMPs, populate Table I-1 below to assist the plan checker in an expeditious review of your project. During construction and at completion, County of Riverside inspectors will verify the installation of BMPs against the approved plans. The first two columns will contain information that was prepared in previous steps, while the last column will be populated with the corresponding plan sheets. This table is to be completed with the submittal of your final Project-Specific WQMP.

Table I-1 Construction Plan Cross-reference

BMP No. or ID	BMP Identifier and Description	Corresponding Plan Sheet(s)
N/A	N/A	N/A
N/A	N/A	N/A
N/A	N/A	N/A
N/A	N/A	N/A
N/A	N/A	N/A

Note that the updated table — or Construction Plan WQMP Checklist — is **only a reference tool** to facilitate an easy comparison of the construction plans to your Project-Specific WQMP. The Copermitttee with jurisdiction over the Project site can advise you regarding the process required to propose changes to the approved Project-Specific WQMP.

Use Table I-2 to identify other applicable permits that may impact design of the site. If yes is answered to any of the items below, the Copermitttee may require proof of approval/coverage from those agencies as applicable including documentation of any associated requirements that may affect this Project-Specific WQMP.

Table I-2 Other Applicable Permits

Agency	Permit Required	
State Department of Fish and Game, 1602 Streambed Alteration Agreement	<input type="checkbox"/> Y	<input checked="" type="checkbox"/> N
State Water Resources Control Board, Clean Water Act Section 401 Water Quality Certification	<input type="checkbox"/> Y	<input checked="" type="checkbox"/> N
US Army Corps of Engineers, Clean Water Act Section 404 Permit	<input type="checkbox"/> Y	<input checked="" type="checkbox"/> N
US Fish and Wildlife, Endangered Species Act Section 7 Biological Opinion	<input type="checkbox"/> Y	<input checked="" type="checkbox"/> N
Statewide Construction General Permit Coverage	<input checked="" type="checkbox"/> Y	<input type="checkbox"/> N
Statewide Industrial General Permit Coverage	<input type="checkbox"/> Y	<input checked="" type="checkbox"/> N
Western Riverside MSHCP Consistency Approval (e.g., JPR, DBESP)	<input type="checkbox"/> Y	<input checked="" type="checkbox"/> N
Other (please list in the space below as required)	<input type="checkbox"/> Y	<input checked="" type="checkbox"/> N

Operation, Maintenance and Funding

Applicant is required to state the intended responsible party for BMP Operation, Maintenance and Funding at the Preliminary WQMP phase. The remaining requirements as outlined above are required for Final WQMP only.

The Copermittee with jurisdiction over the Project site will periodically verify that BMPs on your Project are maintained and continue to operate as designed. To make this possible, the Copermittee will require that you include in Appendix 9 of this Project-Specific WQMP:

1. A means to finance and implement maintenance of BMPs in perpetuity, including replacement cost.
2. Acceptance of responsibility for maintenance from the time the BMPs are constructed until responsibility for operation and maintenance is legally transferred. A warranty covering a period following construction may also be required.
3. An outline of general maintenance requirements for the Stormwater BMPs you have selected.
4. Figures delineating and designating pervious and impervious areas, location, and type of Stormwater BMP, and tables of pervious and impervious areas served by each facility. Geo-locating the BMPs using a coordinate system of latitude and longitude is recommended to help facilitate a future statewide database system.
5. A separate list and location of self-retaining areas or areas addressed by LID Principles that do not require specialized Operations and Maintenance or inspections but will require typical landscape maintenance as noted in Chapter 5, in the SMR WQMP. Include a brief description of typical landscape maintenance for these areas.

The Copermittee with jurisdiction over the Project site will also require that you prepare and submit a detailed BMP Operation and Maintenance Plan that sets forth a maintenance schedule for each of the BMPs built on your site. An agreement assigning responsibility for maintenance and providing for inspections and certification may also be required.

Details of these requirements and instructions for preparing a BMP Operation and Maintenance Plan are in Chapter 5 of the SMR WQMP.

Maintenance Mechanism: Owner Maintained

Will the proposed BMPs be maintained by a Homeowners' Association (HOA) or Property Owners Association (POA)?

Y N

Include your Operation and Maintenance Plan and Maintenance Mechanism in Appendix 9, **see Appendix 9 for additional instructions**. Additionally, include all pertinent forms of educational materials for those personnel that will be maintaining the proposed BMPs within this Project-Specific WQMP in Appendix 10.

Section J: Acronyms, Abbreviations and Definitions

Regional MS4 Permit	Order No. R9-2013-0001 as amended by Order No. R9-2015-0001 and Order No. R9-2015-0100 an NPDES Permit issued by the San Diego Regional Water Quality Control Board.
Applicant	Public or private entity seeking the discretionary approval of new or replaced improvements from the Copermittee with jurisdiction over the project site. The Applicant has overall responsibility for the implementation and the approval of a Priority Development Project. The WQMP uses consistently the term “user” to refer to the applicant such as developer or project proponent. The WQMP employs also the designation “user” to identify the Registered Professional Civil Engineer responsible for submitting the Project-Specific WQMP, and designing the required BMPs.
Best Management Practice (BMP)	Defined in 40 CFR 122.2 as schedules of activities, prohibitions of practices, maintenance procedures, and other management practices to prevent or reduce the pollution of waters of the United States. BMPs also include treatment requirements, operating procedures and practices to control plant site runoff, spillage or leaks, sludge or waste disposal, or drainage from raw material storage. In the case of municipal storm water permits, BMPs are typically used in place of numeric effluent limits.
BMP Fact Sheets	BMP Fact Sheets are available in the LID BMP Design Handbook. Individual BMP Fact Sheets include siting considerations, and design and sizing guidelines for seven types of structural BMPs (infiltration basin, infiltration trench, permeable pavement, harvest-and-use, bioretention, extended detention basin, and sand filter).
California Stormwater Quality Association (CASQA)	Publisher of the California Stormwater Best Management Practices Handbooks, available at www.cabmphandbooks.com .
Conventional Treatment Control BMP	A type of BMP that provides treatment of stormwater runoff. Conventional treatment control BMPs, while designed to treat particular Pollutants, typically do not provide the same level of volume reduction as LID BMPs, and commonly require more specialized maintenance than LID BMPs. As such, the Regional MS4 Permit and this WQMP require the use of LID BMPs wherever feasible, before Conventional Treatment BMPs can be considered or implemented.
Copermittees	The Regional MS4 Permit identifies the Cities of Murrieta, Temecula, and Wildomar, the County, and the District, as Copermittees for the SMR.
County	The abbreviation refers to the County of Riverside in this document.

CEQA	California Environmental Quality Act - a statute that requires state and local agencies to identify the significant environmental impacts of their actions and to avoid or mitigate those impacts, if feasible.
CIMIS	California Irrigation Management Information System - an integrated network of 118 automated active weather stations all over California managed by the California Department of Water Resources.
CWA	Clean Water Act - is the primary federal law governing water pollution. Passed in 1972, the CWA established the goals of eliminating releases of high amounts of toxic substances into water, eliminating additional water pollution by 1985, and ensuring that surface waters would meet standards necessary for human sports and recreation by 1983. CWA Section 402(p) is the federal statute requiring NPDES permits for discharges from MS4s.
CWA Section 303(d) Waterbody	Impaired water in which water quality does not meet applicable water quality standards and/or is not expected to meet water quality standards, even after the application of technology based pollution controls required by the CWA. The discharge of urban runoff to these water bodies by the Copermittees is significant because these discharges can cause or contribute to violations of applicable water quality standards.
Design Storm	The Regional MS4 Permit has established the 85th percentile, 24-hour storm event as the "Design Storm". The applicant may refer to Exhibit A to identify the applicable Design Storm Depth (D85) to the project.
DCV	Design Capture Volume (DCV) is the volume of runoff produced from the Design Storm to be mitigated through LID Retention BMPs, Other LID BMPs and Volume Based Conventional Treatment BMPs, as appropriate.
Design Flow Rate	The design flow rate represents the minimum flow rate capacity that flow-based conventional treatment control BMPs should treat to the MEP, when considered.
DCIA	Directly Connected Impervious Areas - those impervious areas that are hydraulically connected to the MS4 (i.e. street curbs, catch basins, storm drains, etc.) and thence to the structural BMP without flowing over pervious areas.
Discretionary Approval	A decision in which a Copermittee uses its judgment in deciding whether and how to carry out or approve a project.
District	Riverside County Flood Control and Water Conservation District.
DMA	A Drainage Management Area - a delineated portion of a project site that is hydraulically connected to a common structural BMP or conveyance point. The Applicant may refer to Section 3.3 for further guidelines on how to delineate DMAs.

Drawdown Time	Refers to the amount of time the design volume takes to pass through the BMP. The specified or incorporated drawdown times are to ensure that adequate contact or detention time has occurred for treatment, while not creating vector or other nuisance issues. It is important to abide by the drawdown time requirements stated in the fact sheet for each specific BMP.
Effective Area	Area which 1) is suitable for a BMP (for example, if infiltration is potentially feasible for the site based on infeasibility criteria, infiltration must be allowed over this area) and 2) receives runoff from impervious areas.
ESA	An Environmental Sensitive Area (ESA) designates an area "in which plants or animals life or their habitats are either rare or especially valuable because of their special nature or role in an ecosystem and which would be easily disturbed or degraded by human activities and developments". (Reference: California Public Resources Code § 30107.5).
ET	Evapotranspiration (ET) is the loss of water to the atmosphere by the combined processes of evaporation (from soil and plant surfaces) and transpiration (from plant tissues). It is also an indicator of how much water crops, lawn, garden, and trees need for healthy growth and productivity
FAR	The Floor Area Ratio (FAR) is the total square feet of a building divided by the total square feet of the lot the building is located on.
Flow-Based BMP	Flow-based BMPs are conventional treatment control BMPs that are sized to treat the design flow rate.
FPPP	Facility Pollution Prevention Plan
HCOC	Hydrologic Condition of Concern - Exists when the alteration of a site's hydrologic regime caused by development would cause significant impacts on downstream channels and aquatic habitats, alone or in conjunction with impacts of other projects.
HMP	Hydromodification Management Plan - Plan defining Performance Standards for PDPs to manage increases in runoff discharge rates and durations.
Hydrologic Control BMP	BMP to mitigate the increases in runoff discharge rates and durations and meet the Performance Standards set forth in the HMP.
HSG	Hydrologic Soil Groups - soil classification to indicate the minimum rate of infiltration obtained for bare soil after prolonged wetting. The HSGs are A (very low runoff potential/high infiltration rate), B, C, and D (high runoff potential/very low infiltration rate)
Hydromodification	The Regional MS4 Permit identifies that increased volume, velocity, frequency and discharge duration of storm water runoff from developed areas has the potential to greatly accelerate downstream erosion, impair stream habitat in natural drainages, and negatively impact beneficial uses.

JRMP	A separate Jurisdictional Runoff Management Plan (JRMP) has been developed by each Copermittee and identifies the local programs and activities that the Copermittee is implementing to meet the Regional MS4 Permit requirements.
LID	Low Impact Development (LID) is a site design strategy with a goal of maintaining or replicating the pre-development hydrologic regime through the use of design techniques. LID site design BMPs help preserve and restore the natural hydrologic cycle of the site, allowing for filtration and infiltration which can greatly reduce the volume, peak flow rate, velocity, and pollutant loads of storm water runoff.
LID BMP	A type of stormwater BMP that is based upon Low Impact Development concepts. LID BMPs not only provide highly effective treatment of stormwater runoff, but also yield potentially significant reductions in runoff volume – helping to mimic the pre-project hydrologic regime, and also require less ongoing maintenance than Treatment Control BMPs. The applicant may refer to Chapter 2.
LID BMP Design Handbook	The LID BMP Design Handbook was developed by the Copermittees to provide guidance for the planning, design and maintenance of LID BMPs which may be used to mitigate the water quality impacts of PDPs within the County.
LID Bioretention BMP	LID Bioretention BMPs are bioretention areas are vegetated (i.e., landscaped) shallow depressions that provide storage, infiltration, and evapotranspiration, and provide for pollutant removal (e.g., filtration, adsorption, nutrient uptake) by filtering stormwater through the vegetation and soils. In bioretention areas, pore spaces and organic material in the soils help to retain water in the form of soil moisture and to promote the adsorption of pollutants (e.g., dissolved metals and petroleum hydrocarbons) into the soil matrix. Plants use soil moisture and promote the drying of the soil through transpiration. The Regional MS4 Permit defines “retain” as to keep or hold in a particular place, condition, or position without discharge to surface waters.
LID Biofiltration BMP	BMPs that reduce stormwater pollutant discharges by intercepting rainfall on vegetative canopy, and through incidental infiltration and/or evapotranspiration, and filtration, and other biological and chemical processes. As stormwater passes down through the planting soil, pollutants are filtered, adsorbed, biodegraded, and sequestered by the soil and plants, and collected through an underdrain.
LID Harvest and Reuse BMP	BMPs used to facilitate capturing Stormwater Runoff for later use without negatively impacting downstream water rights or other Beneficial Uses.

LID Infiltration BMP	BMPs to reduce stormwater runoff by capturing and infiltrating the runoff into in-situ soils or amended onsite soils. Typical LID Infiltration BMPs include infiltration basins, infiltration trenches and pervious pavements.
LID Retention BMP	BMPs to ensure full onsite retention without runoff of the DCV such as infiltration basins, bioretention, chambers, trenches, permeable pavement and pavers, harvest and reuse.
LID Principles	Site design concepts that prevent or minimize the causes (or drivers) of post-construction impacts, and help mimic the pre-development hydrologic regime.
MEP	Maximum Extent Practicable - standard established by the 1987 amendments to the CWA for the reduction of Pollutant discharges from MS4s. Refer to Attachment C of the Regional MS4 Permit for a complete definition of MEP.
MF	Multi-family - zoning classification for parcels having 2 or more living residential units.
MS4	Municipal Separate Storm Sewer System (MS4) is a conveyance or system of conveyances (including roads with drainage systems, municipal streets, catch basins, curbs, gutters, ditches, man-made channels, or storm drains): (i) Owned or operated by a State, city, town, borough, county, parish, district, association, or other public body (created by or pursuant to State law) having jurisdiction over disposal of sewage, industrial wastes, storm water, or other wastes, including special districts under State law such as a sewer district, flood control district or drainage district, or similar entity, or an Indian tribe or an authorized Indian tribal organization, or designated and approved management agency under section 208 of the CWA that discharges to waters of the United States; (ii) Designated or used for collecting or conveying storm water; (iii) Which is not a combined sewer; (iv) Which is not part of the Publicly Owned Treatment Works (POTW) as defined at 40 CFR 122.26.
New Development Project	Defined by the Regional MS4 Permit as 'Priority Development Projects' if the project, or a component of the project meets the categories and thresholds described in Section 1.1.1.
NPDES	National Pollution Discharge Elimination System - Federal program for issuing, modifying, revoking and reissuing, terminating, monitoring and enforcing permits, and imposing and enforcing pretreatment requirements, under Sections 307, 318, 402, and 405 of the CWA.
NRCS	Natural Resources Conservation Service
PDP	Priority Development Project - Includes New Development and Redevelopment project categories listed in Provision E.3.b of the Regional MS4 Permit.

Priority Pollutants of Concern	Pollutants expected to be present on the project site and for which a downstream water body is also listed as Impaired under the CWA Section 303(d) list or by a TMDL.
Project-Specific WQMP	A plan specifying and documenting permanent LID Principles and Stormwater BMPs to control post-construction Pollutants and stormwater runoff for the life of the PDP, and the plans for operation and maintenance of those BMPs for the life of the project.
Receiving Waters	Waters of the United States.
Redevelopment Project	The creation, addition, and or replacement of impervious surface on an already developed site. Examples include the expansion of a building footprint, road widening, the addition to or replacement of a structure, and creation or addition of impervious surfaces. Replacement of impervious surfaces includes any activity that is not part of a routine maintenance activity where impervious material(s) are removed, exposing underlying soil during construction. Redevelopment does not include trenching and resurfacing associated with utility work; resurfacing existing roadways; new sidewalk construction, pedestrian ramps, or bike lane on existing roads; and routine replacement of damaged pavement, such as pothole repair. Project that meets the criteria described in Section 1.
Runoff Fund	Runoff Funds have not been established by the Copermitttees and are not available to the Applicant. If established, a Runoff Fund will develop regional mitigation projects where PDPs will be able to buy mitigation credits if it is determined that implementing onsite controls is infeasible.
San Diego Regional Board	San Diego Regional Water Quality Control Board - The term "Regional Board", as defined in Water Code section 13050(b), is intended to refer to the California Regional Water Quality Control Board for the San Diego Region as specified in Water Code Section 13200. State agency responsible for managing and regulating water quality in the SMR.
SCCWRP	Southern California Coastal Water Research Project
Site Design BMP	Site design BMPs prevent or minimize the causes (or drivers) of post-construction impacts, and help mimic the pre-development hydrologic regime.
SF	Parcels with a zoning classification for a single residential unit.
SMC	Southern California Stormwater Monitoring Coalition
SMR	The Santa Margarita Region (SMR) represents the portion of the Santa Margarita Watershed that is included within the County of Riverside.

Source Control BMP	Source Control BMPs land use or site planning practices, or structural or nonstructural measures that aim to prevent runoff pollution by reducing the potential for contamination at the source of pollution. Source control BMPs minimize the contact between Pollutants and runoff.
Structural BMP	Structures designed to remove pollutants from stormwater runoff and mitigate hydromodification impacts.
SWPPP	Storm Water Pollution Prevention Plan
Tentative Tract Map	Tentative Tract Maps are required for all subdivision creating five (5) or more parcels, five (5) or more condominiums as defined in Section 783 of the California Civil Code, a community apartment project containing five (5) or more parcels, or for the conversion of a dwelling to a stock cooperative containing five (5) or more dwelling units.
TMDL	Total Maximum Daily Load - the maximum amount of a Pollutant that can be discharged into a waterbody from all sources (point and non-point) and still maintain Water Quality Standards. Under CWA Section 303(d), TMDLs must be developed for all waterbodies that do not meet Water Quality Standards after application of technology-based controls.
USEPA	United States Environmental Protection Agency
Volume-Based BMP	Volume-Based BMPs applies to BMPs where the primary mode of pollutant removal depends upon the volumetric capacity such as detention, retention, and infiltration systems.
WQMP	Water Quality Management Plan
Wet Season	The Regional MS4 Permit defines the wet season from October 1 through April 30.

Appendix 1: Maps and Site Plans

Location Map, WQMP Site Plan and Receiving Waters Map

Complete the checklist below to verify all exhibits and components are included in the Project-Specific WQMP. Refer Section 4 of the SMR WQMP and Section D of this Template.

Map and Site Plan Checklist

Indicate all Maps and Site Plans are included in your Project-Specific WQMP by checking the boxes below.

- Vicinity and Location Map
- Existing Site Map (unless exiting conditions are included in WQMP Site Plan)
- WQMP Site Plan
 - Parcel Boundary and Project Footprint
 - Existing and Proposed Topography & Drainage Management Areas (DMAs)
 - Proposed Structural Best Management Practices (BMPs), with cross sections
 - Drainage Paths
 - Drainage infrastructure, inlets, overflows
 - Source Control & Site Design BMPs (notes can be used for BMPs that can't be depicted)
 - Buildings, Roof Lines, Downspouts
 - Impervious Surfaces
 - Pervious Surfaces (i.e. Landscaping)
 - Standardized Labeling
 - Use Riverside County Flood Control CB-110 for outlet structure with block outs for a trash screen out the outside, and an orifice/weir plate(s) on the inside of the structure or other design that is as easy to maintain. The screen should be as large as possible to minimize clogging.
 - If BMPs are in the road R/W (only with CFD/CSA maintenance or LID Principals) add "BMP" paddle markers at the start and end of each BMPs and LID principals
 - When underdrain are proposed, gravel shall be clean washed gravel, AASHTO #57 stone preferred. Underdrains shall be Schedule 40 PVC, with a minimum slope of 0.005, with cleanouts equal in diameter of the subdrain that extends 6 inches above the media with a lockable screw cap, spaced every 50 feet, at the collector drain line connection, and at any bends.
 - When BSM is proposed, BSM shall consist of 60-80% clean sand, up to 20% clean topsoil, and 20% of a nutrient-stabilized organic amendment. BSM shall be placed on top of 3-inches of Choker Sand placed on top of 3-inches of ASTM No. 8 stone (1/4 to 1/2-inch pea gravel), and placed on top of 12 to 24-inches of a clean, open-graded drain rock layer.
 - For Tracts, the Regional Board requires fully functioning WQMP BMPs for opening model home complexes, sales offices, or use of roads (i.e. prior to occupancy or intended use of any portion of the project). The County encourages phasing post-construction BMPs, small structural BMPs (e.g. specifically for sales offices), or self-retaining areas. This phasing can be shown on the WQMP site map and sequencing shall be included on the Grading plans, so that a fully functioning WQMP BMP is addressing any portion of the project that has been granted occupancy or granted the intended use.

COUNTY OF RIVERSIDE

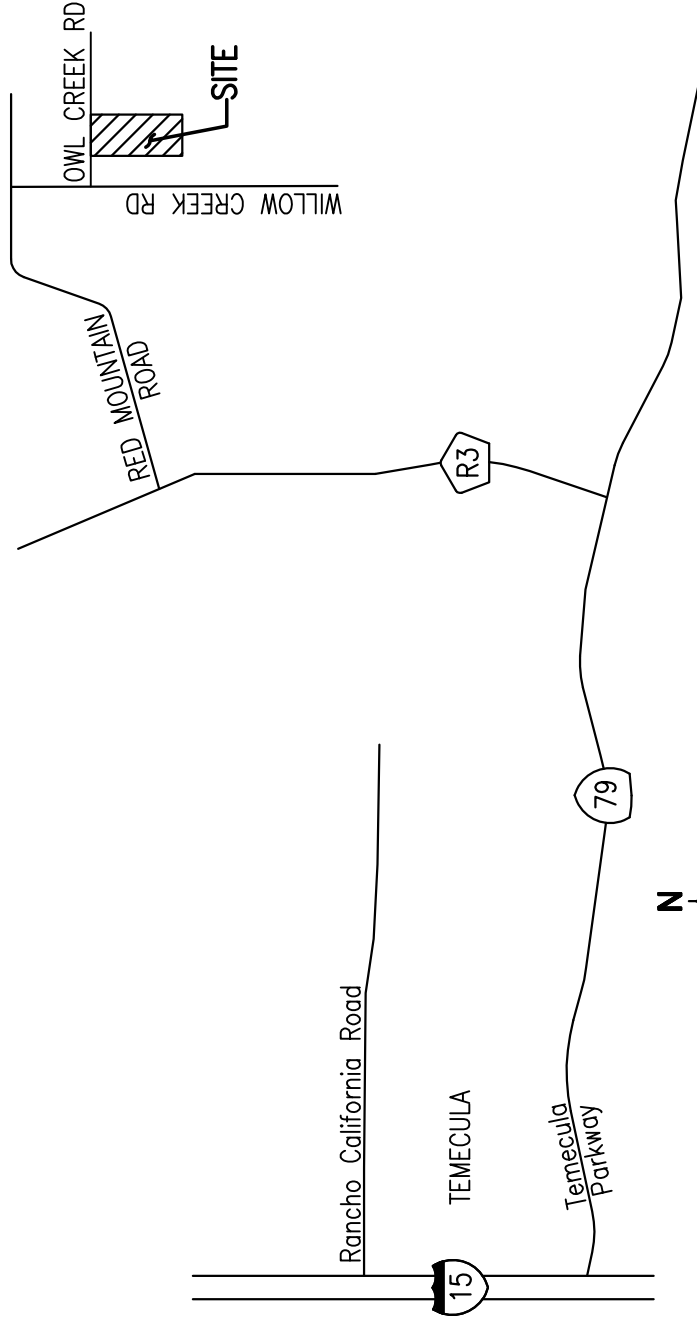

E VICINITY MAP

NTS
T6SR1E, SEC 28

WQMP SITE PLAN

32875 RED MOUNTAIN RD

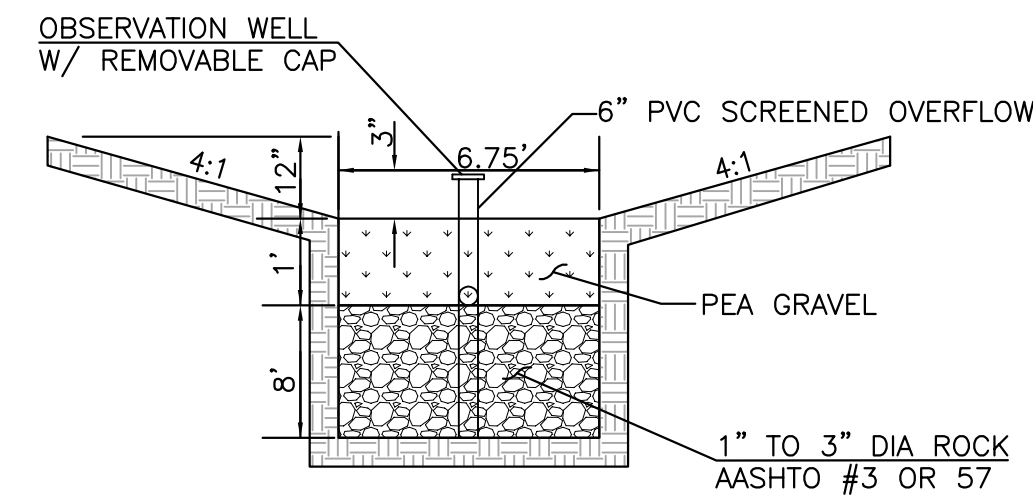

INFILTRATION TRENCH DETAIL
NTS

IMPERVIOUS AREA SUMMARY

DMA 1	ITEM	AREA (SF)
D1	BUILDING ROOF	11,492 SF
D2	AC	9,912 SF
D3	CONCRETE	1,869 SF
TOTAL		23,273 SF

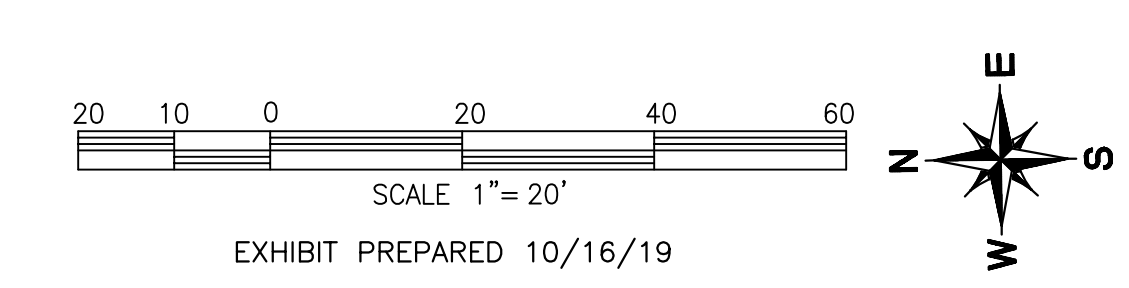
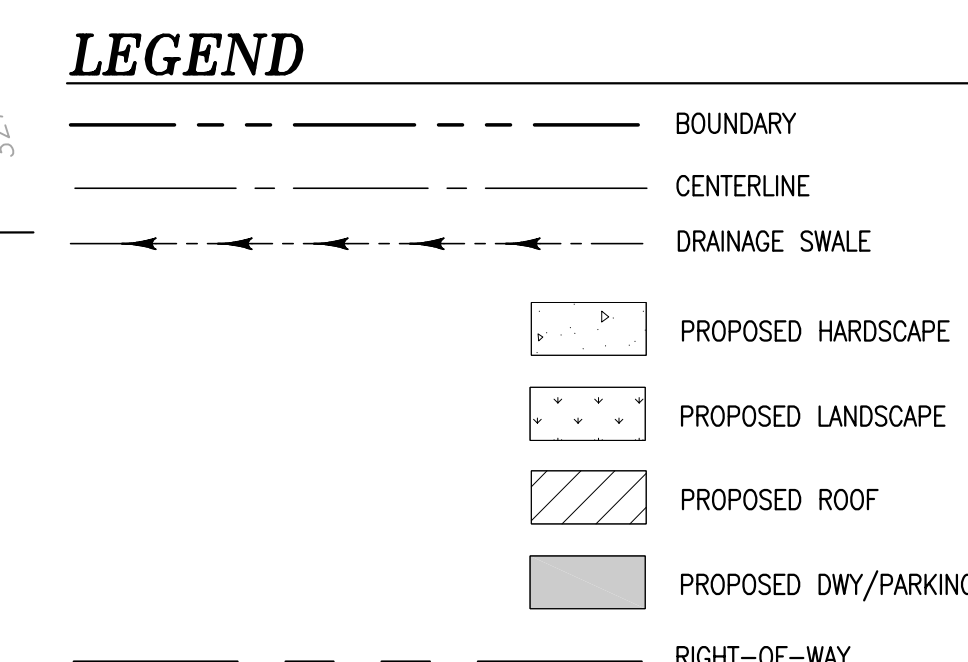
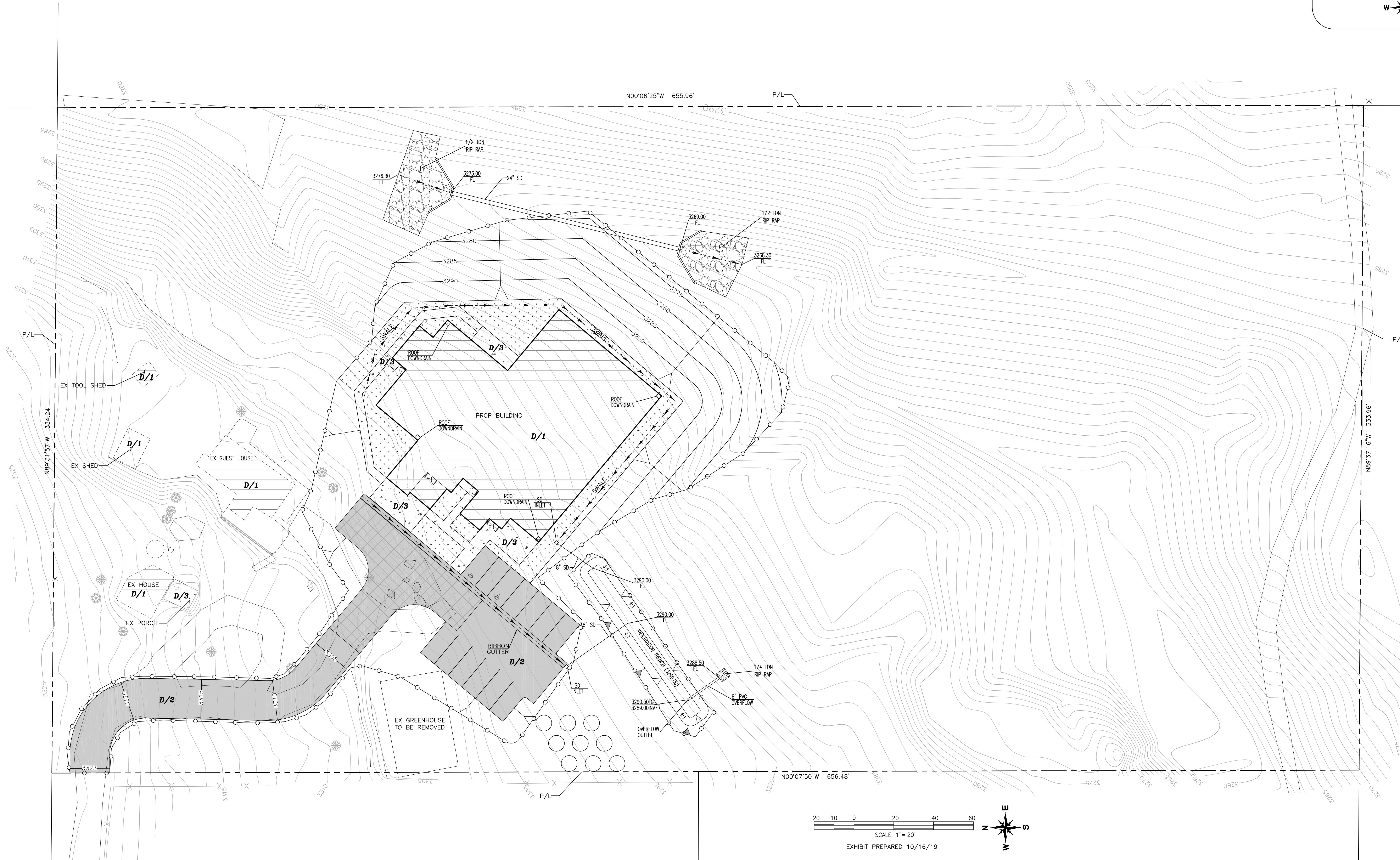
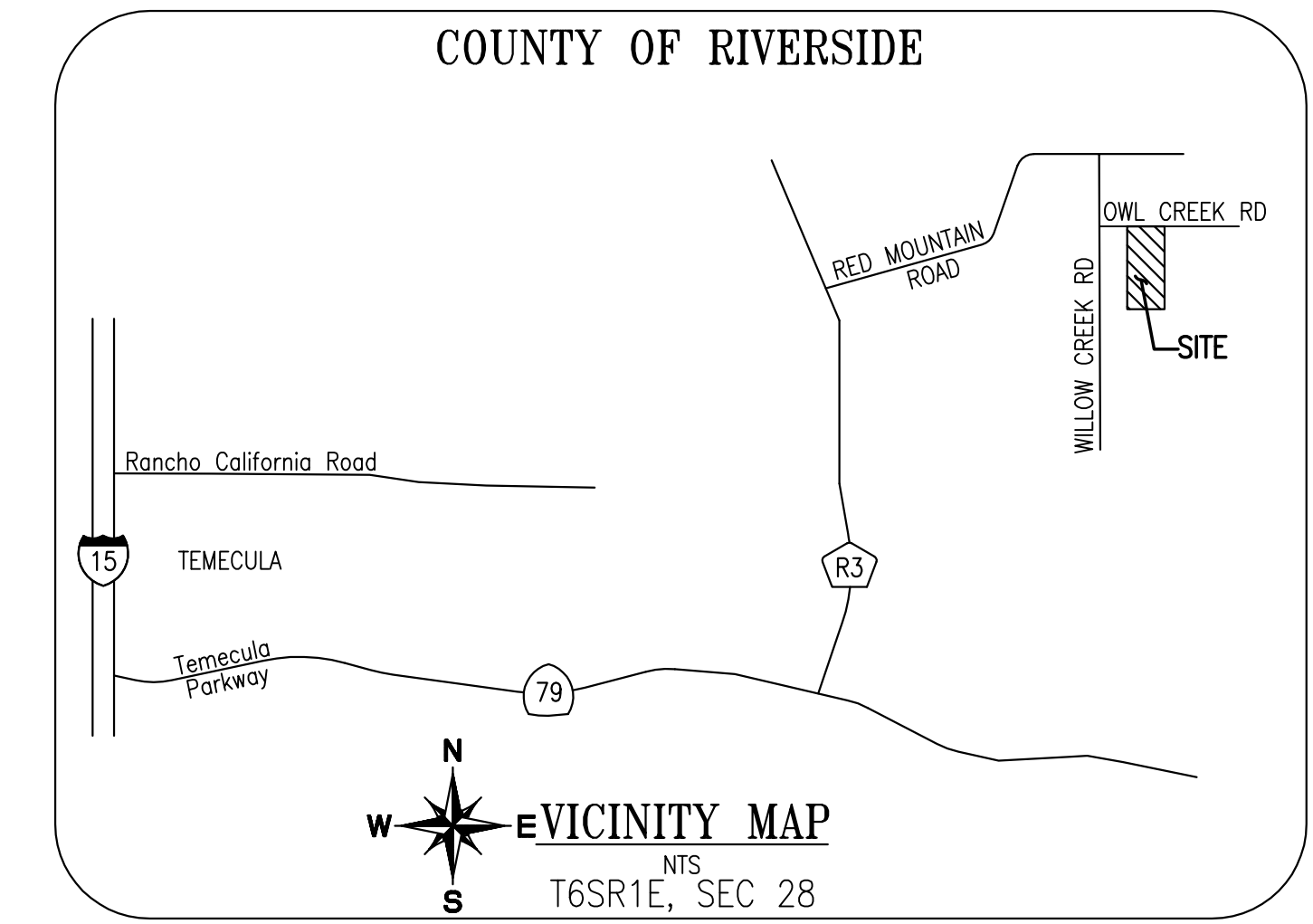

<p>Underground Service Alert</p> <p style="text-align: center;">DIAL BEFORE YOU DIG</p> <p style="text-align: center;">TWO WORKING DAYS YOU DIG</p> <p style="text-align: center;">TOLL FREE 1-800-227-2600</p> <p style="text-align: center;">A PUBLIC SERVICE BY UNDERGROUND SERVICE ALERT</p>	<p>NOTE:</p> <p>WORK CONTAINED WITHIN THESE PLANS SHALL NOT COMMENCE UNTIL AN ENCROACHMENT PERMIT AND / OR A GRADING PERMIT HAS BEEN ISSUED.</p> <p>The private engineer signing these plans is responsible for accuracy and acceptability of the design herein in the event of discrepancies arising after county approval or during construction, the private engineer shall be responsible for determining an acceptable solution and revising the plans for approval by the county.</p>	<table border="1" style="width: 100%; border-collapse: collapse;"> <thead> <tr> <th>DATE</th> <th>BY</th> <th>MARK</th> <th>REVISIONS</th> <th>APPR DATE</th> <th>COUNTY</th> </tr> </thead> <tbody> <tr> <td> </td> <td> </td> <td> </td> <td> </td> <td> </td> <td> </td> </tr> </tbody> </table>	DATE	BY	MARK	REVISIONS	APPR DATE	COUNTY							<p style="text-align: center;">SEAL</p> <div style="text-align: center;"> </div>	<p style="text-align: center;">LOVE ENGINEERING</p> <p style="text-align: center;">PLANNING • ENGINEERING • SURVEYING</p> <p style="text-align: center;">31915 RANCHO CALIFORNIA ROAD/SUITE 200-166 TEMECULA, CA 92591 TEL (951) 440-8149 / FAX (951) 303-6701</p> <p>PREPARED UNDER THE SUPERVISION OF: _____ R.C.E. NO: 50893 EXP. DATE: 9-30-21</p> <p>THOMAS S. LOVE _____ DATE _____</p>	<p>BENCHMARK:</p> <p>SCALE: 1"=20'</p> <p>DATE: OCTOBER 16, 2019</p>	<p style="text-align: center;">IN THE COUNTY OF RIVERSIDE, CALIFORNIA</p> <p style="text-align: center;">32875 RED MOUNTAIN RD</p> <p style="text-align: center;">WQMP SITE PLAN</p> <p style="text-align: right;">SHEET NO. _____ OF 1 SHEETS</p>
DATE	BY	MARK	REVISIONS	APPR DATE	COUNTY													
				Client: ISENGARDEN		ID: 19-018	COUNTY FILE No. _____											

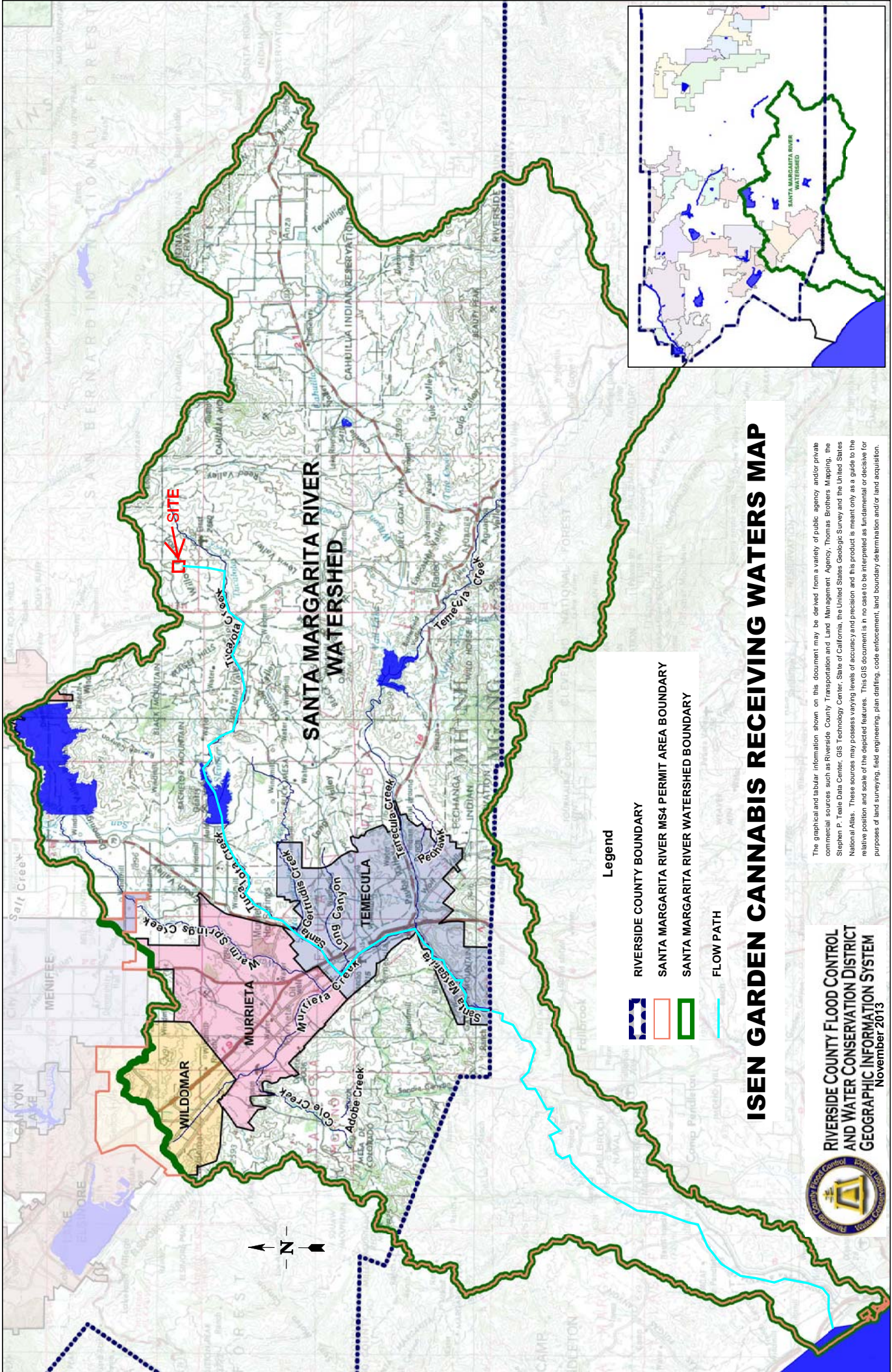

← SITE

SANTA MARGARITA RIVER WATERSHED

Legend

-  RIVERSIDE COUNTY BOUNDARY
-  SANTA MARGARITA RIVER MS4 PERMIT AREA BOUNDARY
-  SANTA MARGARITA RIVER WATERSHED BOUNDARY
-  FLOW PATH

ISEN GARDEN CANNABIS RECEIVING WATERS MAP



RIVERSIDE COUNTY FLOOD CONTROL AND WATER CONSERVATION DISTRICT
GEOGRAPHIC INFORMATION SYSTEM
 November 2013

The graphical and tabular information shown on this document may be derived from a variety of public agency and/or private commercial sources such as Riverside County Transportation and Land Management Agency, Thomas Brothers Mapping, the Stephen P. Teale Data Center, GIS Technology Center, State of California, the United States Geologic Survey and the United States National Atlas. These sources may possess varying levels of accuracy and precision and this product is meant only as a guide to the relative position and scale of the depicted features. This GIS document is in no case to be interpreted as fundamental or decisive for purposes of land surveying, field engineering, plan drafting, code enforcement, land boundary determination and/or land acquisition.

Appendix 2: Construction Plans

*The latest set of Grading, Drainage Plans, and Street Improvement plans **shall be included***

Bioretention/Biofiltration BMPs construction notes (Santa Margarita Region only). For Bioretention and Biofiltration facilities, the **following construction notes shall be shown on the Grading and/or Drainage plans**:

1. *The Engineer shall furnish to the County a copy of the source testing and a signed certification that the fully blended Bioretention/Biofiltration Soil Media (BSM) material meets all of the WQMP requirements before material is imported or if the material is mixed onsite prior to installation.*
2. *As BSM material is being installed, Quality Assurance (QA) tests shall be conducted or for every 1,200 tons or 800 cubic yards mixed on-site from a completely mixed stockpile or windrow, with a minimum of three tests. For imported material from a supplier with a quality control program the QA tests shall be conducted 2,400 tons or 1,600 cubic yards from the supplier.*
3. *The Engineer conducting the Quality Control testing shall furnish to the County copy of the QA testing and a certification that the BSM for the project meets all of the following requirements. Certified mitigation plans can be used for exceedances, as long as all requirements are designed to be met.*
 - a. *BSM shall not be compacted. BSM shall consist of 60-80% clean sand, up to 20% clean topsoil, and 20% of a nutrient-stabilized organic amendment. The initial infiltration rate shall be greater than 8 inches per hour per laboratory test.*
 - b. *pH: 6.0 – 8.5; Salinity: 0.5 to 3.0 mmho/cm as electrical conductivity; Sodium absorption ratio: < 6.0; Chloride: < 800 ppm in saturated extract; Cation Exchange Capacity (CEC): > 10 meq/100 g; Organic Matter: 2 to 5-percent on a dry weight basis; Carbon: Nitrogen Ratio: 12 to 40, preferably 15 to 40; Gravel larger than 2mm: 0 to 25-percent of the total sample; Clay smaller than 0.005mm: 0 to 5 percent of the non-gravel fraction.*
 - c. *BSM shall be tested to limit the leaching of potential inherent pollutants. BSM used in Biofiltration BMPs shall conform to the following limits for pollutant concentrations in saturated extract: Phosphorus: < 1 mg/L; Nitrate < 3 mg/L, Copper < 0.025 mg/L. These pollutant limits are for the amount that is leached from the sample, not from the soil sample itself. Testing may be performed after laboratory rinsing of media with up to 15 pore volumes of water. Equivalent test results will be accepted if certified by a laboratory or appropriate testing facility.*
 - d. *Low nutrient compost used in BSM shall be sourced from a facility permitted through CalRecycle, preferably through USCC STA program. Compost shall conform to the following requirements: Physical contaminants <1% by dry weight; Carbon:Nitrogen ratio: 12:1 to 40:1; Maturity/Stability shall conform to either: Solvita Maturity Index: ≥ 5.5, CO2 Evolution: < 2.5 mg CO2-C per g compost organic matter per day, or < 5 mg CO2-C per g compost C per day; Select Pathogens and Trace metals shall pass US EPA Class A Standard. Testing shall be no more than 6 months old and representative of current stockpiles.*
 - e. *Coconut coir pith used in BSM shall be thoroughly rinsed with freshwater and screened to remove coarse fibers as part of production and aged > 6 months. Peat used in BSM shall be sphagnum peat.*

Please notify the County if additional sources and laboratories can be added to this list. The Potential Sources and Laboratories are not part of the construction note - **Potential BSM sources may include:** Gail Materials (Temescal Valley), Agriservice (Oceanside), and Greatsoils (Escondido). Earthworks (Riverside); **Potential Laboratories may include:** Fruit Growers Laboratory, Inc. (Santa Paula, <http://www.fglinc.com/>) Wallace Laboratories (El Segundo, <http://us.wlabs.com/>). Control Labs (Watsonville, <http://www.controllabs.com>) and A&L Western Laboratories (Modesto, <http://www.al-labs-west.com/>).

APPENDIX 2: N/A - PRELIMINARY WQMP

Appendix 3: Soils Information

Geotechnical Study, Other Infiltration Testing Data, and/or Other Documentation

Examples of material to provide in Appendix 3 may include but are not limited to the following:

- Geotechnical Study/Report prepared for the project,
- Additional soils testing data (if not included in the Geotechnical Study),
- Exhibits/Maps/Other Documentation of the Hydrologic Soils Groups (HSG)s at the project site.

This information should support the Full Infiltration Applicability, and Biofiltration Applicability sections of this Template. Refer to Section 2.3 of the SMR WQMP and Sections A and D of this Template.

The County will accept explicit recommendations from the Geotechnical Engineer, such as specifying a design infiltration rate (unfactored) when infiltration rates vary, recommendations for impermeable liners due to concerns about seepage in fill areas/near gas tanks, or other site specific recommendations based on physical conditions.

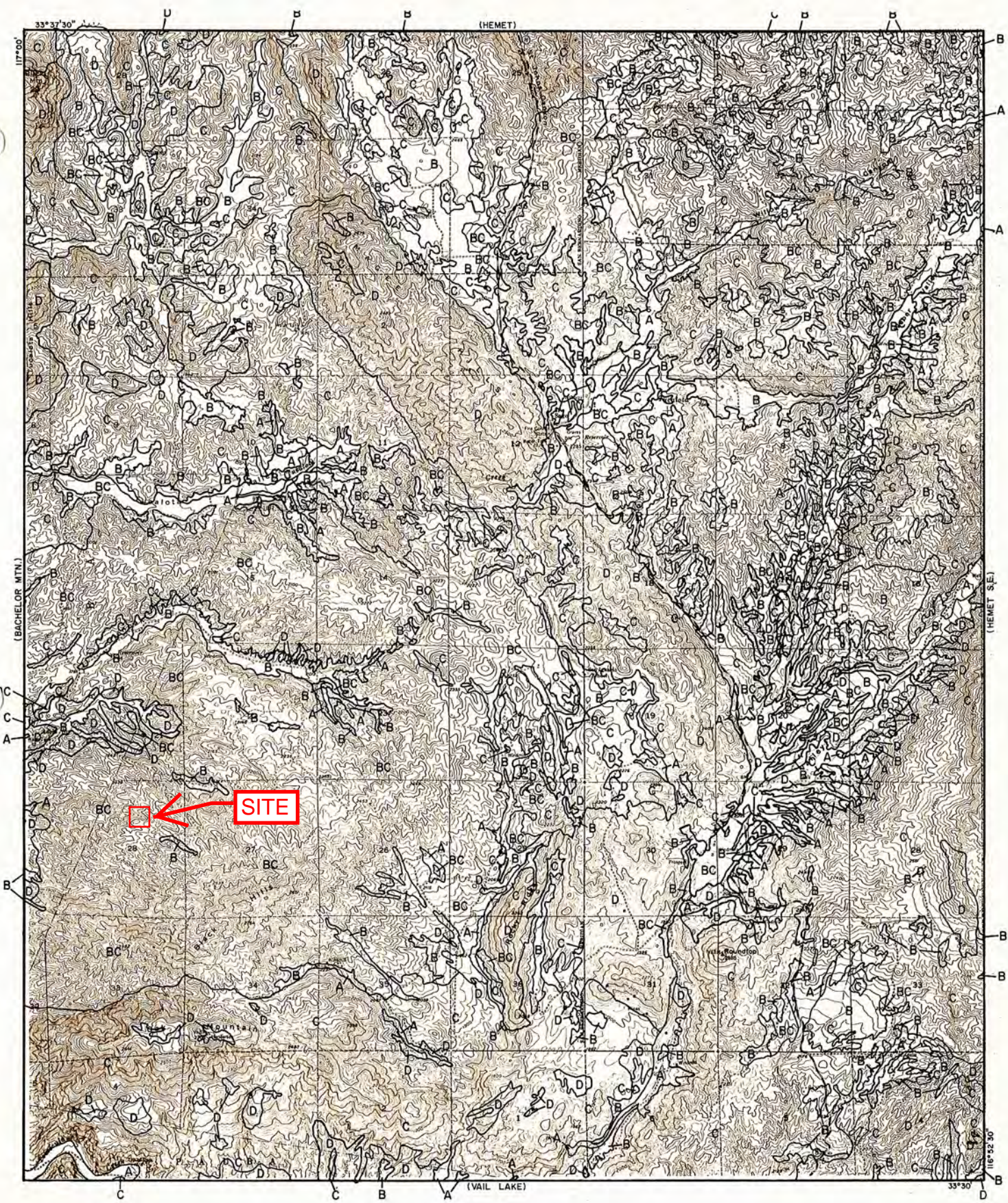

LEGEND

— SOILS GROUP BOUNDARY
 A SOILS GROUP DESIGNATION

RCFC & WCD
 HYDROLOGY MANUAL

0 FEET 5000

**HYDROLOGIC SOILS GROUP MAP
 FOR
 SAGE**

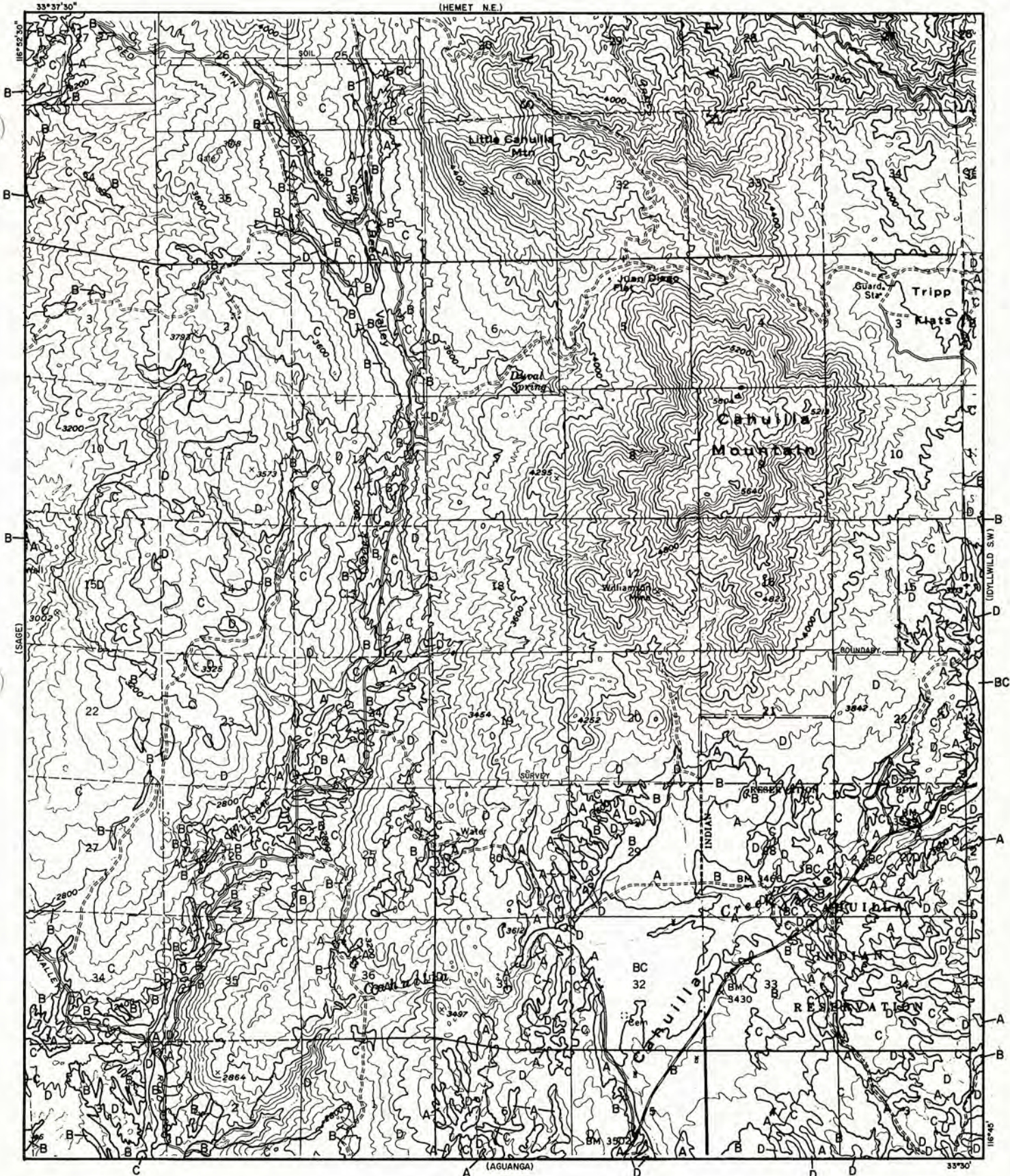

LEGEND

- SOILS GROUP BOUNDARY
- A SOILS GROUP DESIGNATION

RCFC & WCD

HYDROLOGY MANUAL

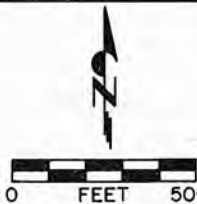

**HYDROLOGIC SOILS GROUP MAP
FOR
HEMET-S.E.**

Appendix 4: Historical Site Conditions

NOT INCLUDED (SMALL PROJECT)

Phase I Environmental Site Assessment or Other Information on Past Site Use

Examples of material to provide in Appendix 4 may include but are not limited to the following:

- Environmental Site Assessments conducted for the project,
- Other information on Past Site Use that impacts the feasibility of LID BMP implementation on the site.

This information should support the Full Infiltration Applicability, and Biofiltration Applicability sections of this Template. Refer to Section 2.3 of the SMR WQMP and Sections D of this Template.

Appendix 5: LID Feasibility Supplemental Information

NO ANALYSIS, LIDS ARE FEASIBLE

Information that supports or supplements the determination of LID technical feasibility documented in Section D

Examples of material to provide in Appendix 5 may include but are not limited to the following:

- Technical feasibility criteria for DMAs
- Site specific analysis of technical infeasibility of all LID BMPs (if Alternative Compliance is needed)
- Documentation of Approval criteria for Proprietary Biofiltration BMPs

This information should support the Full Infiltration Applicability, and Biofiltration Applicability sections of this Template. Refer to Section 2.3 of the SMR WQMP and Sections D of this Template.

Proprietary Biofiltration Criteria

The applicant shall provide documentation of compliance with each criterion in this checklist as part of the project submittal. Proprietary Biofiltration BMPs shall not be proposed if the BMP will accept undeveloped off-site tributary flows, where potential silt/sediment could clog or otherwise negatively impact the BMP.

1 All BMPs must be sited/designed with the max. feasible infiltration/evapotranspiration⁶.		
	Requirement	Response
1a	What was the development status of the site prior to project application (i.e. raw ungraded land, or redevelopment with existing graded conditions)? – There will be more expectations to infiltrate if the project is a new development.	
1b	History of design discussions/coordination for the site proposed project, resulting in the final design determination (i.e. infiltration vs. flow-thru):	
1c	The consideration of site design alternatives to achieve infiltration or partial infiltration on site;	
1d	The physical impairments (i.e., fire road egress, public safety considerations, sewer lines, etc.) and public safety concerns (impermeable liners only to avoid geotech or contamination issues);	
1e	The extent low impact development BMP requirements were included in the project site design (site design worksheets can be attached).	
1f	When in the development process (e.g. entitlement or plan check, with dates of geotechnical work and development approval dates) did a geotechnical engineer analyze the site for infiltration feasibility?	
1g	What was the scope of the geotechnical testing?	
1h	What are Public Health and Safety requirements that affect infiltration locations?	
1i	What are the conclusions and recommendations from the geotechnical engineer, in regards to infiltrating/retaining on-site or allowing some or all of the flows to flow-thru as a proprietary BMP?	
1j	How will the proposed proprietary biofiltration BMPs achieve maximum feasible retention (evapotranspiration and infiltration) of the water	

⁶ To address San Diego Regional Board letter dated April 28, 2017 regarding documentation to support infeasibility to retain or infiltrate storm water on-site. This document will be used to meet the Regional Board requirements for documentation. As such, not apply or non-responses will not be accepted.

	quality volume, as required by MS4 Permits?	
--	---	--

2	Proprietary Biofiltration BMP sizing (all proprietary/compact BMPs require TAPE approval)⁷	
	Requirement	Response
2a	Use Table F-1 and F-2 of the WQMP template to identify and list all the pollutants of concern.	
2b	Attached Active Technology Acceptance Protocol-Ecology (TAPE) certification, with General Use Level Designation (GULD) for all of applicable pollutants of concern	Yes _____ or No _____
2c	The most restrictive loading rates outlined in TAPE GULD approval ⁸ for all of the pollutants of concern.	
2d	Attach calculations, and all relevant steps to show that the sizing of the proprietary BMP is based on the flowrate (or volume) used to obtain TAPE/GULD approval (the most restrictive rate).	Yes _____ or No _____
2e	Are the infiltration rates are outlet controlled (e.g., via an underdrain and orifice/weir) or controlled by the infiltration rate of the media? Faster infiltration rates thru the media tend to reduce O&M issues.	Is the design infiltration rate controlled by the outlet? Yes _____ or No _____ If No, provide the rates for the outlet and the media and explain why outlet control is not practicable.
2f	Does the water surface drains to at least 12 inches below the media surface within 24 hours from the end of storm event flow to preserve plant health and promote healthy soil structure?	Yes _____ or No _____

3	Biofiltration BMPs must be designed to promote appropriate biological activity to support and maintain treatment processes.	
	Requirement	Response
3a	Plants tolerant of project climate, design ponding depths and the treatment media composition.	Provide documentation justifying plant selection. ⁹
3b	Plants that minimize irrigation requirements.	Provide documentation describing irrigation

⁷ Full scale field testing data that has been verified by Washington Department of Ecology and General Use Level Designation is required. <https://ecology.wa.gov/Regulations-Permits/Guidance-technical-assistance/Stormwater-permittee-guidance-resources/Emerging-stormwater-treatment-technologies>. Otherwise, the County has no obligation to accept the use of any other proprietary flow-thru BMP. Additional guidance can be found at the end of this checklist from the San Diego BMPDM Appendix F.1 for other verified third-party, field scale testing performance criteria that does not meet the Washington Department of Ecology standards.

⁸ E.g. if the BMP was certified/verified with 100 gallons per minute treatment rate, the BMP shall be sized with no more than the equivalent rate).

⁹ See Appendix E.20 of the San Diego BMPDM for initial plan list for consideration for Riverside County.

		requirements for establishment and long term operation.
3c	Plant location and growth will not impede expected long-term media filtration rates and will enhance long-term infiltration rates to the extent possible.	Provide documentation justifying plant selection. ⁴
3d	If plants are not applicable to the biofiltration design, other biological processes are supported as needed to sustain treatment processes (e.g., biofilm in a subsurface flow wetland). TAPE GULD approval that identifies approval with and without plants can be submitted for approval.	For biofiltration designs without plants, describe the biological processes that will support effective treatment and how they will be sustained.

4	Biofiltration BMPs must be designed with a hydraulic loading rate to prevent erosion, scour, and channeling within the BMP. Erosion, scour, and/or channeling can disrupt treatment processes and reduce effectiveness.	
	Requirement	Response
4a	What pre-treatment devices (e.g. vegetated buffers, catch basin inserts) and designs (e.g. forebay berms with cutouts) are proposed?	
4b	Adequate scour protection has been provided for both sheet flow and pipe inflows to the BMP.	
4c	Where scour protection has not been provided, flows into and within the BMP are kept to non-erosive velocities.	What are the maximum velocities for sheet flow and pipe inflows into the BMP?
4d	The BMP is used in a manner consistent with manufacturer guidelines and conditions of its third-party certification (e.g. maximum tributary area, maximum inflow velocities, etc.).	Manufacturer Requirements vs. the Design
4e	To preserve permeability, the media should have substantial void ratios and avoidance of choking layers.	Provide media gradation calculations and (if proposed) geotextile selection calculations if the geotextile could affect hydraulic loading rate.

5	Biofiltration BMP must include operation and maintenance design features and planning considerations for continued effectiveness of pollutant removal and flow control functions. Biofiltration BMPs require regular maintenance in order provide ongoing function as intended. Additionally, it is not possible to foresee and avoid potential issues as part of design; therefore, plans must be in place to correct issues if they arise.	
	Requirement	Response
5a	Is there any media or cartridge required to maintain the function of the BMP sole-sourced or	Yes _____ or No _____, explain:

	proprietary in any way? If yes, obtain explicit approval by the Agency. Potentially full replacement costs to a non-proprietary BMP needs to be considered.	
5b	The maintenance plan specific for the proprietary BMP specific inspection activities, regular/periodic maintenance activities and specific corrective actions relating to scour, erosion, channeling, media clogging, vegetation health, and inflow and outflow structures.	This is in addition to the O&M Plan described in the WQMP guidance document, Section 5.
5c	Adequate site area and features have been provided for BMP inspection and maintenance access.	Illustrate maintenance access routes, setbacks, maintenance features as needed on project water quality plans
5d	For proprietary biofiltration BMPs, the BMP maintenance plan is consistent with manufacturer guidelines and conditions of its third-party certification (i.e., maintenance activities, frequencies).	Yes _____ or No _____
5e	Describe all portions of the BMP that may potentially clog or present an O&M issue.	
5f	Describe design features to address each of the potential clogging or O&M issues.	

By signing below, the preparer certifies all the information provided with this submittal and submittals related to proprietary BMPs for the project is accurate, and relevant information to assess the long term operation and maintenance of this proprietary BMP was not omitted with this submittal.

Prepared by: _____

Title: _____

Signature: _____

Date: _____

Alternative Pollutant Treatment Performance Standard

County staff may allow the applicant to submit alternative third-party documentation that the pollutant treatment performance of the system is consistent with Technology Acceptance Protocol-Ecology certifications. Table F.1-1 describes the required levels of certification and Table F.1-2 describes the pollutant treatment performance levels associated with each level of certification. Acceptance of this approach is at the sole discretion of County staff, preference would be given to:

- a. Verified third-party, field-scale testing performance under the Technology Acceptance Reciprocity Partnership Tier II Protocol. This protocol is no longer operated, however this is considered to be a valid protocol and historic verifications are considered to be representative provided that product models being proposed are consistent with those that were tested. Technology Acceptance Reciprocity Partnership verifications were conducted under New Jersey Corporation for Advance Testing and are archived at the website linked below. Note that Technology Acceptance Reciprocity Partnership verifications must be matched to pollutant treatment standards in Table F.1-2 then matched to an equivalent Technology Acceptance Protocol-Ecology certification in Table F.1-1.
- b. Verified third-party, field-scale testing performance under the New Jersey Corporation for Advance Testing protocol. Note that New Jersey Corporation for Advance Testing verifications must be matched to pollutant treatment standards in Table F.1-2 then matched to an equivalent Technology Acceptance Protocol- Ecology certification in Table F.1-1. A list of field-scale verified technologies under Technology Acceptance Reciprocity Partnership Tier II and New Jersey Corporation for Advance Testing can be accessed at: <http://www.njcat.org/verification-process/technology-verification-database.html> (refer to: field verified technologies only).

Table F.1-1: Required Technology Acceptance Protocol-Ecology Certifications for Pollutants of Concern for Biofiltration Performance Standard

Project Pollutant of Concern	Required Technology Acceptance Protocol-Ecology Certification for Biofiltration Performance Standard
Trash	Basic Treatment OR Phosphorus Treatment OR Enhanced Treatment
Sediments	Basic Treatment OR Phosphorus Treatment OR Enhanced Treatment
Oil and Grease	Basic Treatment OR Phosphorus Treatment OR Enhanced Treatment
Nutrients	Phosphorus Treatment ¹
Metals	Enhanced Treatment
Pesticides	Basic Treatment (including filtration) ² OR Phosphorus Treatment OR Enhanced Treatment
Organics	Basic Treatment (including filtration) ² OR Phosphorus Treatment OR Enhanced Treatment
Bacteria and Viruses	Basic Treatment (including bacteria removal processes) ³ OR Phosphorus Treatment OR Enhanced Treatment

1 – There is no Technology Acceptance Protocol-Ecology equivalent for nitrogen compounds; however systems that are designed to retain phosphorus (as well as meet basic treatment designation), generally also provide treatment of nitrogen compounds. Where nitrogen is a pollutant of concern, relative performance of available certified systems for nitrogen removal should be considered in BMP selection.

2 – Pesticides, organics, and oxygen demanding substances are typically addressed by particle filtration consistent with the level of treatment required to achieve Basic treatment certification; if a system with Basic treatment certification does not provide filtration, it is not acceptable for pesticides, organics or oxygen demanding substances.

3 – There is no Technology Acceptance Protocol-Ecology equivalent for pathogens (viruses and bacteria), and testing data are limited because of typical sample hold times. Systems with Technology Acceptance Protocol-Ecology Basic Treatment must include one or more significant bacteria removal process such as media filtration, physical sorption, predation, reduced redox conditions, and/or solar inactivation. Where design options are available to enhance pathogen removal (i.e., pathogen-specific media mix offered by vendor), this design variation should be used.

Table F.1-2: Performance Standards for Technology Acceptance Protocol-Ecology Certification

Performance Goal	Influent Range	Criteria
Basic Treatment	20 – 100 mg/L TSS	Effluent goal \leq 20 mg/L TSS
	100 – 200 mg/L TSS	\geq 80% TSS removal
	>200 mg/L TSS	> 80% TSS removal
Enhanced (Dissolved Metals) Treatment	Dissolved copper 0.005 – 0.02 mg/L	Must meet basic treatment goal and better than basic treatment currently defined as >30% dissolved copper removal
	Dissolved zinc 0.02 – 0.3 mg/L	Must meet basic treatment goal and better than basic treatment currently defined as >60% dissolved zinc removal
Phosphorous Treatment	Total phosphorous 0.1 – 0.5 mg/L	Must meet basic treatment goal and exhibit \geq 50% total phosphorous removal
Oil Treatment	Total petroleum hydrocarbon > 10 mg/L	No ongoing or recurring visible sheen in effluent Daily average effluent Total petroleum hydrocarbon concentration < 10 mg/L Maximum effluent Total petroleum hydrocarbon concentration for a 15 mg/L for a discrete (grab) sample
Pretreatment	50 – 100 mg/L TSS	\leq 50 mg/L TSS
	\geq 200 mg/L TSS	\geq 50% TSS removal

Appendix 6: LID BMP Design Details

BMP Sizing, Design Details and other Supporting Documentation to supplement Section D

Examples of material to provide in Appendix 6 may include but are not limited to the following:

- DCV calculations,
- LID BMP sizing calculations from Exhibit C of the SMR WQMP
- Design details/drawings from manufacturers for proprietary BMPs

This information should support the Full Infiltration Applicability, and Biofiltration Applicability sections of this Template. Refer to Section 3.4 of the SMR WQMP and Sections D.4 of this Template.

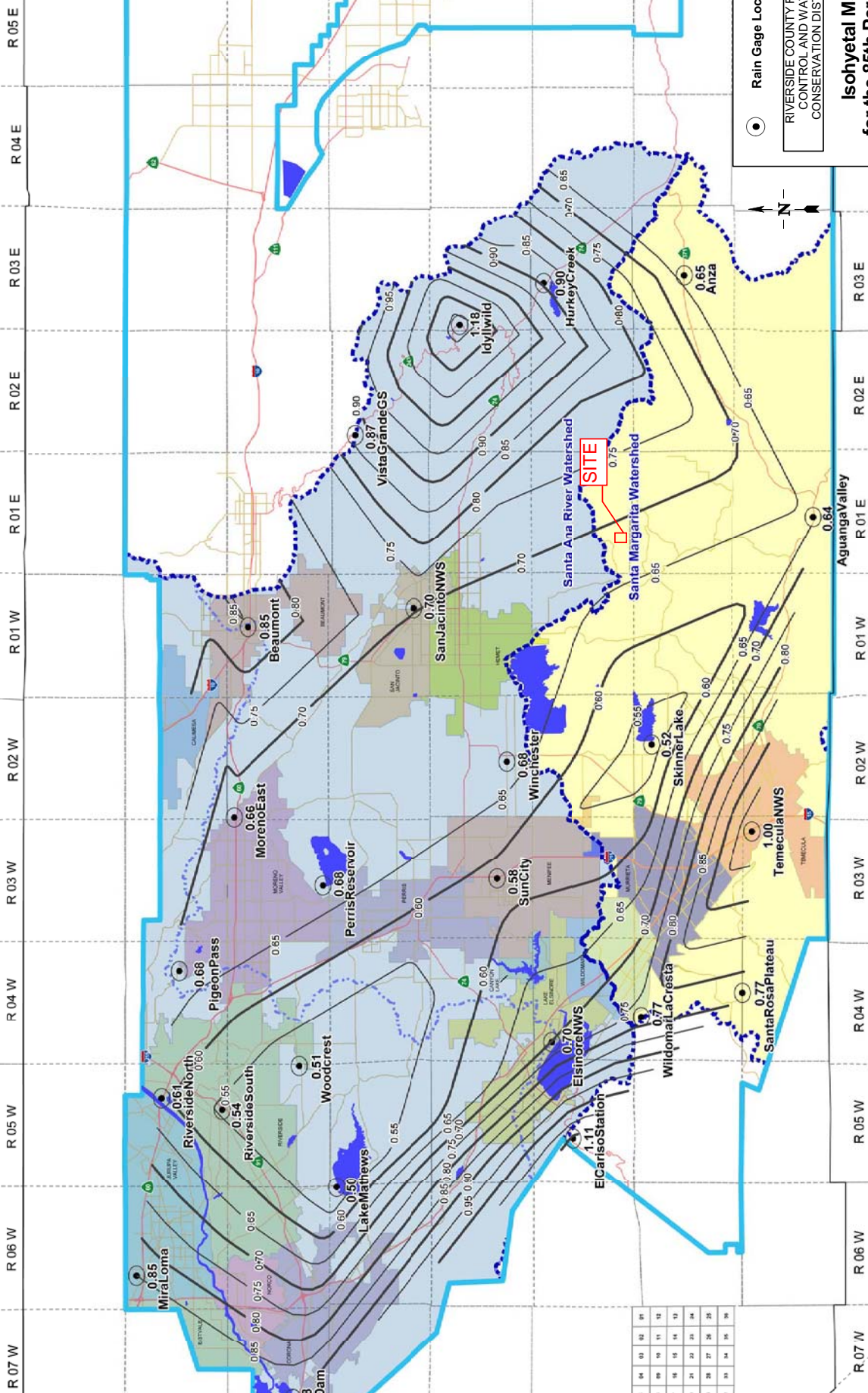

Rain Gage Locations

RIVERSIDE COUNTY FLOOD CONTROL AND WATER CONSERVATION DISTRICT

Isohyetal Map for the 85th Percentile 24 hour Storm Event

July 2011

06	08	09	10	11	12	13	14	15	16	17	18	19	20	21	22	23	24	25	26	27	28	29	30	31
----	----	----	----	----	----	----	----	----	----	----	----	----	----	----	----	----	----	----	----	----	----	----	----	----

Santa Margarita Watershed		Legend:	Required Entries
BMP Design Volume, V_{BMP} (Rev. 03-2012)			Calculated Cells
(Note this worksheet shall only be used in conjunction with BMP designs from the LID BMP Design Handbook)			
Company Name	Love Engineering	Date	10/162019
Designed by	T Love	County/City Case No	CUP 19XXXXX
Company Project Number/Name	Isen Garden Cannabis Cultivation		
Drainage Area Number/Name	DMA 1/D1		
Enter the Area Tributary to this Feature	$A_T = 0.28$ acres		
85 th Percentile, 24-hour Rainfall Depth, from the Isohyetal Map in Handbook Appendix E			
Site Location	Township	6S	
	Range	1E	
	Section	28	
Enter the 85 th Percentile, 24-hour Rainfall Depth	$D_{85} =$	0.68	
Determine the Effective Impervious Fraction			
Type of post-development surface cover (use pull down menu)	Roofs		
Effective Impervious Fraction	$I_f =$	1.00	
Calculate the composite Runoff Coefficient, C for the BMP Tributary Area			
Use the following equation based on the WEF/ASCE Method			
$C = 0.858I_f^3 - 0.78I_f^2 + 0.774I_f + 0.04$		$C =$	0.89
Determine Design Storage Volume, V_{BMP}			
Calculate V_U , the 85% Unit Storage Volume $V_U = D_{85} \times C$		$V_u =$	0.61 (in*ac)/ac
Calculate the design storage volume of the BMP, V_{BMP} .			
$V_{BMP} (ft^3) = \frac{V_U (in\text{-}ac/ac) \times A_T (ac) \times 43,560 (ft^2/ac)}{12 (in/ft)}$		$V_{BMP} =$	620 ft^3
Notes:			

Santa Margarita Watershed		Legend:	Required Entries
BMP Design Volume, V_{BMP} (Rev. 03-2012)			Calculated Cells
(Note this worksheet shall only be used in conjunction with BMP designs from the LID BMP Design Handbook)			
Company Name	Love Engineering	Date	10/162019
Designed by	T Love	County/City Case No	CUP 19XXXXX
Company Project Number/Name	Isen Garden Cannabis Cultivation		
Drainage Area Number/Name	DMA 1/D2 (AC Dwy & Parking)		
Enter the Area Tributary to this Feature	$A_T = 0.23$ acres		
85 th Percentile, 24-hour Rainfall Depth, from the Isohyetal Map in Handbook Appendix E			
Site Location	Township	6S	
	Range	1E	
	Section	28	
Enter the 85 th Percentile, 24-hour Rainfall Depth	$D_{85} =$	0.68	
Determine the Effective Impervious Fraction			
Type of post-development surface cover (use pull down menu)	Concrete or Asphalt		
Effective Impervious Fraction	$I_f =$	1.00	
Calculate the composite Runoff Coefficient, C for the BMP Tributary Area			
Use the following equation based on the WEF/ASCE Method			
$C = 0.858I_f^3 - 0.78I_f^2 + 0.774I_f + 0.04$		$C =$	0.89
Determine Design Storage Volume, V_{BMP}			
Calculate V_U , the 85% Unit Storage Volume $V_U = D_{85} \times C$		$V_u =$	0.61 (in*ac)/ac
Calculate the design storage volume of the BMP, V_{BMP} .			
$V_{BMP} (ft^3) = \frac{V_U (in\text{-}ac/ac) \times A_T (ac) \times 43,560 (ft^2/ac)}{12 (in/ft)}$		$V_{BMP} =$	509 ft^3
Notes:			

Santa Margarita Watershed		Legend:	Required Entries
BMP Design Volume, V_{BMP} (Rev. 03-2012)			Calculated Cells
(Note this worksheet shall only be used in conjunction with BMP designs from the LID BMP Design Handbook)			
Company Name	Love Engineering	Date	10/162019
Designed by	T Love	County/City Case No	CUP 19XXXXX
Company Project Number/Name	Isen Garden Cannabis Cultivation		
Drainage Area Number/Name	DMA 1/D3 (Hardscape)		
Enter the Area Tributary to this Feature	$A_T = 0.04$ acres		
85 th Percentile, 24-hour Rainfall Depth, from the Isohyetal Map in Handbook Appendix E			
Site Location	Township	6S	
	Range	1E	
	Section	28	
Enter the 85 th Percentile, 24-hour Rainfall Depth	$D_{85} =$	0.68	
Determine the Effective Impervious Fraction			
Type of post-development surface cover (use pull down menu)	Concrete or Asphalt		
Effective Impervious Fraction	$I_f =$	1.00	
Calculate the composite Runoff Coefficient, C for the BMP Tributary Area			
Use the following equation based on the WEF/ASCE Method			
$C = 0.858I_f^3 - 0.78I_f^2 + 0.774I_f + 0.04$		$C =$	0.89
Determine Design Storage Volume, V_{BMP}			
Calculate V_U , the 85% Unit Storage Volume $V_U = D_{85} \times C$		$V_u =$	0.61 (in*ac)/ac
Calculate the design storage volume of the BMP, V_{BMP} .			
$V_{BMP} (ft^3) = \frac{V_U (in\text{-}ac/ac) \times A_T (ac) \times 43,560 (ft^2/ac)}{12 (in/ft)}$		$V_{BMP} =$	89 ft^3
Notes:			

Infiltration Trench - Design Procedure		BMP ID	Legend:	Required Entries
				Calculated Cells
Company Name:	Love Engineering		Date:	10/16/2019
Designed by:	T Love		County/City Case No.:	CUP 19XXXX
Design Volume				
Enter the area tributary to this feature, Max = 10 acres			$A_t =$	0.55 acres
Enter V_{BMP} determined from Section 2.1 of this Handbook			$V_{BMP} =$	1,218 ft ³
Calculate Maximum Depth of the Reservoir Layer				
Enter Infiltration rate			$I =$	3.8 in/hr
Enter Factor of Safety, FS (unitless)			$FS =$	2
<i>Obtain from Table 1, Appendix A: "Infiltration Testing" of this BMP Handbook</i>				
			$n =$	40 %
Calculate D_1 .		$D_1 = \frac{I \text{ (in/hr)} \times 72 \text{ hrs}}{12 \text{ (in/ft)} \times (n/100) \times FS}$	$D_1 =$	28.50 ft
Enter depth to historic high groundwater mark (measured from finished grade)				35 ft
Enter depth to top of bedrock or impermeable layer (measured from finished grade)				35 ft
D_2 is the smaller of:				
Depth to groundwater - 11 ft; & Depth to impermeable layer - 6 ft			$D_2 =$	24.0 ft
D_{MAX} is the smaller value of D_1 and D_2 , must be less than or equal to 8 feet.			$D_{MAX} =$	8.0 ft
Trench Sizing				
Enter proposed reservoir layer depth D_R , must be $\leq D_{MAX}$			$D_R =$	8.00 ft
Calculate the design depth of water, d_w				
		Design $d_w = (D_R) \times (n/100)$	Design $d_w =$	3.20 ft
Minimum Surface Area, A_S		$A_S = \frac{V_{BMP}}{d_w}$	$A_S =$	381 ft ²
Proposed Design Surface Area			$A_D =$	608 ft ²
		Minimum Width = $D_R + 1$ foot pea gravel		9.00 ft
Sediment Control Provided? (Use pulldown)			Yes	
Geotechnical report attached? (Use pulldown)			Yes	

If the trench has been designed correctly, there should be no error messages on the spreadsheet.

Appendix 7: Hydromodification & Critical Coarse Sediment

Supporting Detail for Hydromodification compliance & Exhibit G - CCSY & PSS Areas with the project location.

The preparer shall include the following in this Appendix (Refer to Section 2.4 and 3.6 of the SMR WQMP and Sections E of this Template):

- Hydromodification Exemption Exhibit (if the project is in an area exempt from Hydromod)
- Potential Critical Coarse Sediment Yield Area Mapping (to show if the site is out of a CCSYA)
- Hydromodification BMP sizing calculations (i.e. County Hydromod Spreadsheet – Hydromod, and BMP Design tabs, SMRHM report files, or other acceptable Hydromod calculations)
- Site-Specific Critical Coarse Sediment Analysis (if a project impacts a CCSYA)
- Design details/drawings from manufacturers for proprietary BMPs (if proprietary BMPs are proposed)

In addition, the project shall comply with drainage law and good practices:

- Protect the Site and Roads from Q100yr, without impacting adjacent property owners.
- Pad elevations must be above the Q100yr water surface at all locations.

I. Identify Offsite Hydrology

- A. If the project intends to allow the flows to pass through the project uninterrupted, the flows must remain along its natural flow-path and natural condition. The project must also:
 - (1) Ensure that the existing stream is stable. If not, the design must include stabilization.
 - (2) Does the 100 year flow path affect proposed project elements, such as streets and fill slopes? If so, the project must properly design for impingements, provide revetment, etc. If the water surface changes due to impingements on neighbor's properties, Permission to pond letters must be provided.
- B. If the project intends to collect and convey the offsite flows, see the next section:

II. Hydraulics

- A. Project must provide collection inlets that can be accessed for maintenance. If located outside of the project boundary, the project must provide a Permission Letter or drainage easement. If the inlet creates new ponding on private property, the project must provide a Permission to Pond letter or easement.
- B. The project should not divert watershed areas over 1 acre. If so, Permission Letter to accept project's diversion and drainage concept must be received by the project.
- C. The project should have an adequate outlet. If not, include Permission Letters and implement Increased Runoff criteria (2, 5,10 year storm events and the 1, 3, 6 and 24 hour durations). 100 year storm routing is not to be used. Runoff from the offsite plus onsite must be returned to its natural (existing) condition of velocity, peak flow-rate, flow-width and location/right of way, if permission letters have not been obtained.
- D. The project must adequately convey the 100 year storm between the combination of street flow and pipe flow per County Ordinance.
- E. The project should use the downstream connection as the Q100yr water surface control elevation, to ensure 6 inches minimum of freeboard in proposed drainage system.

III. Basin Layout

- A. Implement Basin Guidelines as best as possible from Appendix C, Design Handbook for LID BMPs.

It is expressly agreed and understood by the USER of this Excel Spreadsheet file (file) released hereby (whether released in digital or hard copy form) that Riverside County (County) makes no representation as to its accuracy. Further, it is the intent of the parties hereto that the USER shall review and verify calculations, analyze results, and/or independently determine the accuracy thereof prior to placing any reliance whatsoever on the information. Further, the USER shall hold the County, together with the officers, agents and employees of each, free and harmless from any liability whatsoever, including wrongful death, based or asserted upon any act or omission of the District or County, their officers, agents, employees or subcontractors, relating to or in any way connected with the unauthorized use of these files or information, and USER agrees to protect and defend, including all attorney fees and other expenses, each of the foregoing bodies and persons in any legal action based or asserted upon any such acts or omissions. USER also agrees not to sell, reproduce or release these files to others for any purpose whatsoever, except those incidental uses for which the files were acquired, verified and combined with USER'S own work product. Reasonable effort was made to fully comply with the San Diego MS4 Permit requirements using the methods found in the Riverside County Hydrology Manual. If the user finds an error in any way, please contact the County so that the error can be corrected. Any direct tampering of the equations in this spreadsheet would be considered extremely inappropriate, and potentially fraudulent.

Santa Margarita Region - County HydroMod Iterative Spreadsheet Model

Only for use the unincorporated portions of Riverside County, unless otherwise approved by the Co-Permittee

Development Project Number(s):	Isen Garden Cannabis Cultivation Project	Rain Gauge:	Temecula Valley
Latitude (decimal format):	33.6286	BMP Type (per WQMP):	Infiltration Trench
Longitude (decimal format):	-116.87724	BMP Number (Sequential):	

Pre-Development - Hydrology Information				
Pre-Development	DRAINAGE AREA (ACRES) - 10 acre max ¹	5.03	2-YEAR, 1-HOUR INTENSITY (IN/HR) - Plate D-4.3	0.58
	LONGEST WATERCOURSE (FT) - 1,000' max ¹	925	10-YEAR, 1-HOUR INTENSITY (IN/HR) - Plate D-4.1	0.76
	UPSTREAM ELEVATION OF WATERCOURSE (FT)	3324	SLOPE OF THE INTENSITY DURATION - Plate D-4.6	0.58
	DOWNSTREAM ELEV. OF WATERCOURSE (FT)	3260	CLOSEST IMPERVIOUS PERCENTAGE (%)	0% Undeveloped - Good Cover
	EXISTING IMPERVIOUS PERCENTAGE (%)	1.1		
	Use 10% of Q2 to avoid Field Screening requirements	Yes		

Pre-Development - Soils Information											
Pre-Development	Cover Type #	Subarea Acreage	Cover Type	Vegetative Cover	Soil A %	Soil B %	Soil C %	Soil D %	RI Index AMC I	RI Index AMC II	RI Index AMC III
	37	5.03 Ac.	Pasture, Irrigated	Good Cover			100		53	72	86
									0	0	0
									0	0	0
		5.03 Ac.							Weighted Average RI Numbers =		
								53.0	72.0	86.0	

Per Dr. Luis Parra, the AMC condition is based on the rainfall record. Applying NEH-4 (1964) for the non-freezing conditions in Riverside County the AMC conditions are: AMC-I for less than 0.5" of rain the previous 5 days; AMC-II for between 0.5" to 1.1" of rain the previous 5 days; or AMC-III for more than 1.1" for the previous 5 days.

Pre-Development - Calculated Range of Flow Rates analyzed for Hydromod (Suceptible Range of Flows)				
Pre-Development	Calculated Upper Flow-rate limit		Calculated Lower Flow-rate limit	
	Ex. 10-year Flowrate ¹ =	2.456 cfs	Ex. 10% of the 2-year Flowrate ¹ =	0.289 cfs
	(Co-Permittee Approval is required) User-Defined Discharge Values with accompanying Hydrology Study¹			
	Ex. 10-year Flowrate (Attach Study) =	cfs	Ex. 2-year Flowrate (Attach Study) =	cfs

¹The equations used to determine the 10-year and 10% of the 2-yr are limited to 10-acres and 1,000'. Flowrates from a separate study can be used to over-ride the calculated values so that larger areas (up to 20 acres) and longer watercourse lengths can be used. All values still need to be filled out, even when there is a user-defined discharge value entered.

Post-Project - Hydrograph Information			
Post-Project	DRAINAGE AREA (ACRES)	5.03	Go to "BMP Design" tab to design your BMP, then check results below. Print both this "HydroMod" Sheet and the "BMP Design" sheet for your submittal.
	LONGEST WATERCOURSE (FT)	925	
	DIFFERENCE IN ELEV (FT) - along watercourse	64	
	PROPOSED IMPERVIOUS PERCENTAGE (%)	10.9	

Post-Project - Soils Information											
Post-Project	Cover Type #	Subarea Acreage	Cover Type	Vegetative Cover	Soil A %	Soil B %	Soil C %	Soil D %	RI Index AMC I	RI Index AMC II	RI Index AMC III
	37	5.03 Ac.	Pasture, Irrigated	Good Cover			100		53	72	86
									0	0	0
									0	0	0
		5.03 Ac.							Weighted Average RI Numbers =		
								53.0	72.0	86.0	

Per Dr. Luis Parra, the AMC condition is based on the rainfall record. Applying NEH-4 (1964) for the non-freezing conditions in Riverside County the AMC conditions are: AMC-I for less than 0.5" of rain the previous 5 days; AMC-II for between 0.5" to 1.1" of rain the previous 5 days; or AMC-III for more than 1.1" for the previous 5 days.

Results	Hydromod Ponded depth		First result out of compliance in the rainfall record				See below for the Height in the Basin (Stage) that is causing a non-compliant result		
	Hydromod Drain Time (unclogged)		Requirement		Proposed				
		Is the HydroMod BMP properly sized?	Yes, this is acceptable	---	---	---	---	Issue @ Stage =	#N/A
		Mitigated Q < 110% of Pre-Dev. Q?	#N/A	#N/A	#N/A	#N/A	#N/A	Issue @ Stage =	#N/A
	Mitigated Duration < 110% of Pre-Dev?*	#N/A	#N/A	#N/A	#N/A	#N/A	Issue @ Stage =	#N/A	

Responsible-in-charge: Thomas S. Love Date: 10/16/2019

Signature:

Spreadsheet Developed by: Benjie Cho, P.E.

RAINFALL INTENSITY—INCHES PER HOUR

HEMET			HIGHGROVE			HOMELAND—WINCHESTER			IDYLLWILD			LAKEVIEW		
DURATION MINUTES	FREQUENCY 10 YEAR	FREQUENCY 100 YEAR	DURATION MINUTES	FREQUENCY 10 YEAR	FREQUENCY 100 YEAR	DURATION MINUTES	FREQUENCY 10 YEAR	FREQUENCY 100 YEAR	DURATION MINUTES	FREQUENCY 10 YEAR	FREQUENCY 100 YEAR	DURATION MINUTES	FREQUENCY 10 YEAR	FREQUENCY 100 YEAR
5	2.84	4.40	5	3.02	4.37	5	2.91	4.37	5	4.91	7.28	5	2.77	4.16
6	2.58	4.00	6	2.75	3.97	6	2.65	3.97	6	4.47	6.62	6	2.53	3.79
7	2.37	3.68	7	2.54	3.67	7	2.44	3.67	7	4.13	6.11	7	2.34	3.51
8	2.21	3.43	8	2.37	3.42	8	2.28	3.42	8	3.85	5.70	8	2.19	3.29
9	2.08	3.23	9	2.23	3.22	9	2.15	3.22	9	3.62	5.36	9	2.07	3.10
10	1.96	3.05	10	2.11	3.05	10	2.03	3.05	10	3.43	5.08	10	1.96	2.94
11	1.87	2.90	11	2.01	2.90	11	1.93	2.90	11	3.26	4.83	11	1.87	2.80
12	1.78	2.77	12	1.92	2.77	12	1.85	2.77	12	3.12	4.62	12	1.79	2.68
13	1.71	2.65	13	1.84	2.66	13	1.77	2.66	13	2.99	4.43	13	1.72	2.58
14	1.64	2.55	14	1.77	2.56	14	1.71	2.56	14	2.88	4.26	14	1.66	2.48
15	1.58	2.46	15	1.71	2.47	15	1.64	2.47	15	2.78	4.11	15	1.60	2.40
16	1.53	2.38	16	1.65	2.39	16	1.59	2.39	16	2.68	3.98	16	1.55	2.32
17	1.48	2.30	17	1.60	2.31	17	1.54	2.31	17	2.60	3.85	17	1.50	2.25
18	1.44	2.23	18	1.55	2.24	18	1.50	2.24	18	2.52	3.74	18	1.46	2.19
19	1.40	2.17	19	1.51	2.18	19	1.45	2.18	19	2.45	3.64	19	1.42	2.13
20	1.36	2.11	20	1.47	2.12	20	1.42	2.12	20	2.39	3.54	20	1.39	2.08
22	1.29	2.01	22	1.40	2.02	22	1.35	2.02	22	2.27	3.37	22	1.32	1.98
24	1.24	1.92	24	1.34	1.93	24	1.29	1.93	24	2.17	3.22	24	1.26	1.90
26	1.18	1.84	26	1.28	1.85	26	1.24	1.85	26	2.09	3.09	26	1.22	1.82
28	1.14	1.77	28	1.23	1.78	28	1.19	1.78	28	2.01	2.97	28	1.17	1.76
30	1.10	1.70	30	1.19	1.72	30	1.15	1.72	30	1.94	2.87	30	1.13	1.70
32	1.06	1.65	32	1.15	1.66	32	1.11	1.66	32	1.87	2.77	32	1.10	1.64
34	1.03	1.59	34	1.12	1.61	34	1.07	1.61	34	1.81	2.69	34	1.06	1.59
36	1.00	1.55	36	1.08	1.57	36	1.04	1.57	36	1.76	2.61	36	1.03	1.55
38	.97	1.50	38	1.05	1.52	38	1.01	1.52	38	1.71	2.54	38	1.01	1.51
40	.94	1.46	40	1.02	1.48	40	.99	1.48	40	1.67	2.47	40	.98	1.47
45	.89	1.37	45	.96	1.39	45	.93	1.39	45	1.57	2.32	45	.92	1.39
50	.84	1.30	50	.91	1.32	50	.88	1.32	50	1.48	2.20	50	.88	1.31
55	.80	1.24	55	.87	1.26	55	.84	1.26	55	1.41	2.09	55	.84	1.25
60	.76	1.18	60	.83	1.20	60	.80	1.20	60	1.35	2.00	60	.80	1.20
65	.73	1.13	65	.80	1.15	65	.77	1.15	65	1.29	1.92	65	.77	1.15
70	.70	1.09	70	.77	1.11	70	.74	1.11	70	1.25	1.85	70	.74	1.11
75	.68	1.05	75	.74	1.07	75	.71	1.07	75	1.20	1.78	75	.72	1.07
80	.65	1.01	80	.71	1.03	80	.69	1.03	80	1.16	1.72	80	.69	1.04
85	.63	.98	85	.69	1.00	85	.67	1.00	85	1.13	1.67	85	.67	1.01

SLOPE = .530

SLOPE = .520

SLOPE = .520

SLOPE = .520

SLOPE = .500

RCFC & WCD
HYDROLOGY MANUAL

STANDARD
INTENSITY—DURATION
CURVES DATA

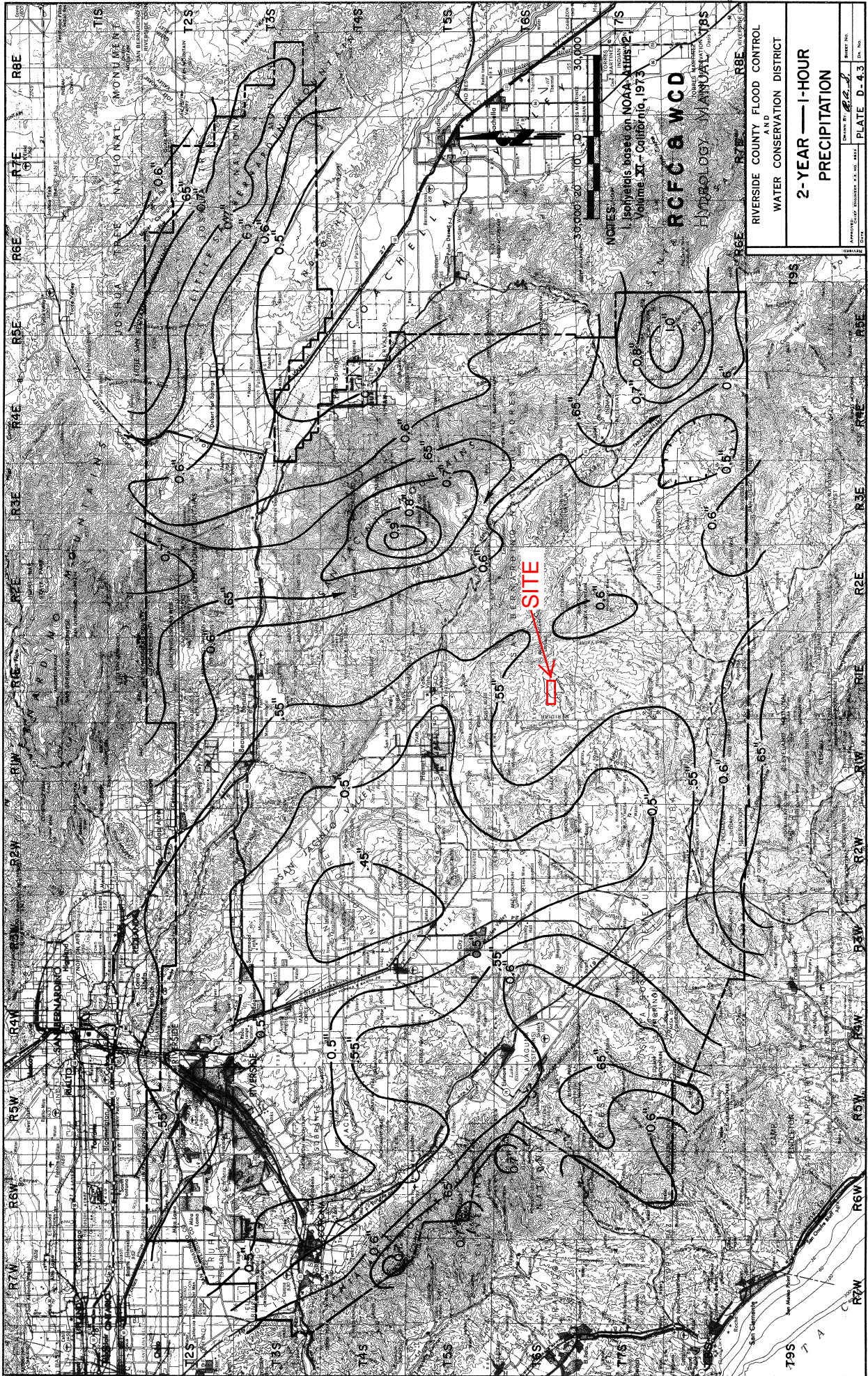

RCFC & WCD
 Hydrology Manual

RIVERSIDE COUNTY FLOOD CONTROL
 AND
 WATER CONSERVATION DISTRICT

2-YEAR — 1-HOUR
 PRECIPITATION

APPROVED BY DISTRICT BOARD
 DATE: 12/1/73

DRAWN BY: [Signature]
 SHEET NO.: 12

PLATE D-43

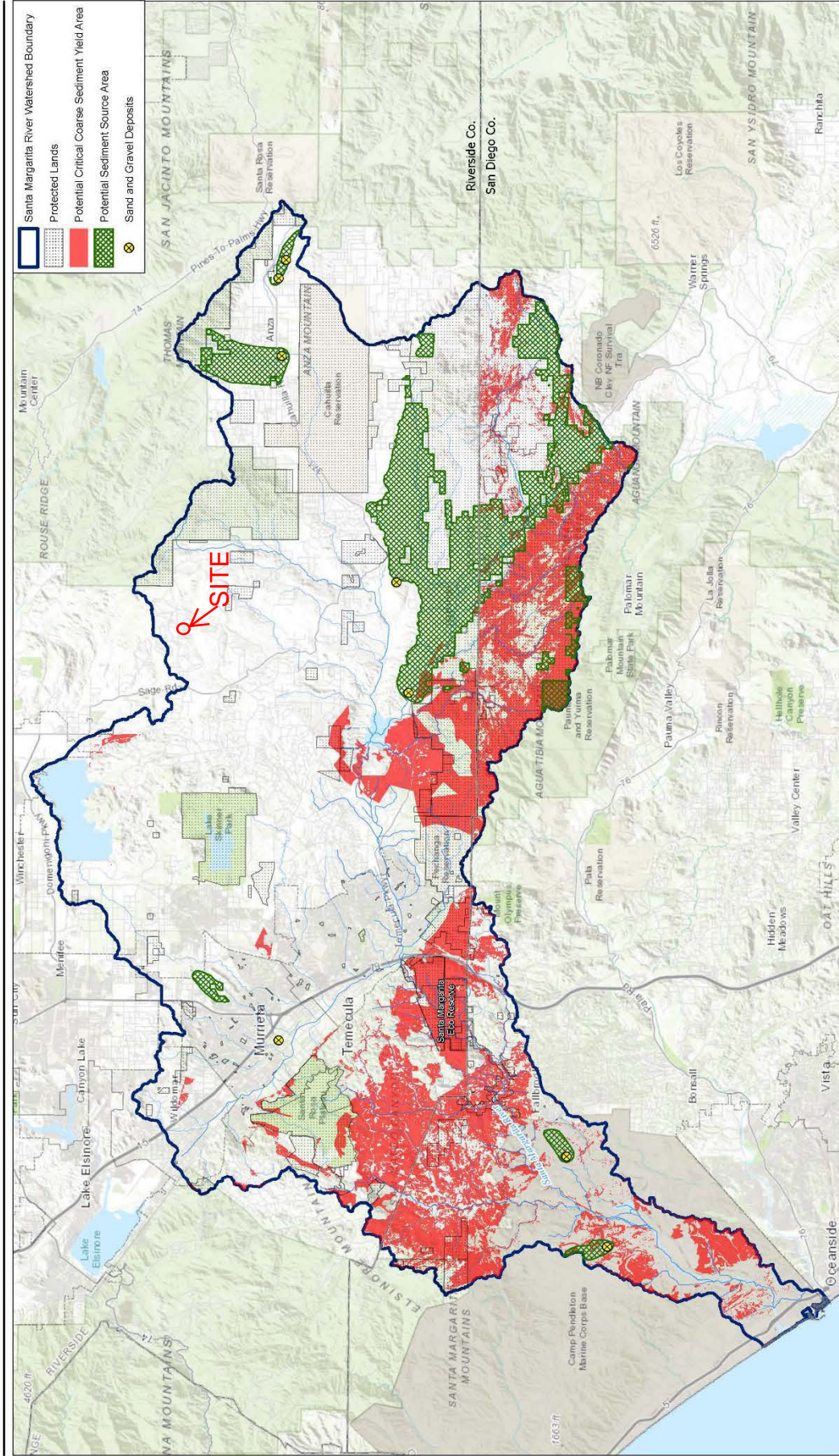

**SANTA MARGARITA RIVER WATERSHED
POTENTIAL CRITICAL COARSE SEDIMENT YIELD AREAS AND POTENTIAL SEDIMENT SOURCE AREAS**

Exhibit G-1



Appendix 8: Source Control

Pollutant Sources/Source Control Checklist

For Final WQMP, include a copy of the completed Pollutant Sources/Source Control Checklist in the subsequent pages and summarize Source Control BMPs in Section H of this Template.

Appendix 8
STORMWATER POLLUTANT SOURCES/SOURCE CONTROL CHECKLIST

How to use this worksheet (also see instructions in Section G of the 2014 SMR WQMP Template):

1. Review Column 1 and identify which of these potential sources of stormwater pollutants apply to your site. Check each box that applies.
2. Review Column 2 and incorporate all of the corresponding applicable BMPs in your WQMP Exhibit.
3. Review Columns 3 and 4 and incorporate all of the corresponding applicable permanent controls and operational BMPs in your WQMP. Use the format shown in Table G.1 on page 31 of this WQMP Template. Describe your specific BMPs in an accompanying narrative, and explain any special conditions or situations that required omitting BMPs or substituting alternative BMPs for those shown here.

... THEN YOUR WQMP SHOULD INCLUDE THESE SOURCE CONTROL BMPs, AS APPLICABLE			
1	2	3	4
IF THESE SOURCES WILL BE ON THE PROJECT SITE ...	Permanent Controls—Show on WQMP Drawings	Permanent Controls—List in WQMP Table and Narrative	Operational BMPs—Include in WQMP Table and Narrative
<p>Potential Sources of Runoff Pollutants</p> <p><input type="checkbox"/> A. On-site storm drain inlets</p>	<p><input type="checkbox"/> Locations of inlets.</p>	<p><input type="checkbox"/> Mark all inlets with the words “Only Rain Down the Storm Drain” or similar. Catch Basin Markers may be available from the Riverside County Flood Control and Water Conservation District, call 951.955.1200 to verify.</p>	<p><input type="checkbox"/> Maintain and periodically repaint or replace inlet markings.</p> <p><input type="checkbox"/> Provide stormwater pollution prevention information to new site owners, lessees, or operators.</p> <p><input type="checkbox"/> See applicable operational BMPs in Fact Sheet SC-44, “Drainage System Maintenance,” in the CASQA Stormwater Quality Handbooks at www.cabmphandbooks.com</p> <p><input type="checkbox"/> Include the following in lease agreements: “Tenant shall not allow anyone to discharge anything to storm drains or to store or deposit materials so as to create a potential discharge to storm drains.”</p>
<p><input type="checkbox"/> B. Interior floor drains and elevator shaft sump pumps</p> <p><input type="checkbox"/> C. Interior parking garages</p>		<p><input type="checkbox"/> State that interior floor drains and elevator shaft sump pumps will be plumbed to sanitary sewer.</p> <p><input type="checkbox"/> State that parking garage floor drains will be plumbed to the sanitary sewer.</p>	<p><input type="checkbox"/> Inspect and maintain drains to prevent blockages and overflow.</p> <p><input type="checkbox"/> Inspect and maintain drains to prevent blockages and overflow.</p>

Appendix 8
STORMWATER POLLUTANT SOURCES/SOURCE CONTROL CHECKLIST

1 IF THESE SOURCES WILL BE ON THE PROJECT SITE ...	2 Permanent Controls—Show on WQMP Drawings	3 Permanent Controls—List in WQMP Table and Narrative	4 Operational BMPs—Include in WQMP Table and Narrative
<p>Potential Sources of Runoff Pollutants</p> <p><input type="checkbox"/> D1. Need for future indoor & structural pest control</p> <p><input type="checkbox"/> D2. Landscape/Outdoor Pesticide Use</p>	<p><input type="checkbox"/> Show locations of native trees or areas of shrubs and ground cover to be undisturbed and retained.</p> <p><input type="checkbox"/> Show self-retaining landscape areas, if any.</p> <p><input type="checkbox"/> Show stormwater treatment and hydrograph modification management BMPs. (See instructions in Chapter 3, Step 5 and guidance in Chapter 5.)</p>	<p><input type="checkbox"/> Note building design features that discourage entry of pests.</p> <p><input type="checkbox"/> State that final landscape plans will accomplish all of the following.</p> <p><input type="checkbox"/> Preserve existing native trees, shrubs, and ground cover to the maximum extent possible.</p> <p><input type="checkbox"/> Design landscaping to minimize irrigation and runoff, to promote surface infiltration where appropriate, and to minimize the use of fertilizers and pesticides that can contribute to stormwater pollution.</p> <p><input type="checkbox"/> Where landscaped areas are used to retain or detain stormwater, specify plants that are tolerant of saturated soil conditions.</p> <p><input type="checkbox"/> Consider using pest-resistant plants, especially adjacent to hardscape. To insure successful establishment, select plants appropriate to site soils, slopes, climate, sun, wind, rain, land use, air movement, ecological consistency, and plant interactions.</p>	<p><input type="checkbox"/> Provide Integrated Pest Management information to owners, lessees, and operators.</p> <p><input type="checkbox"/> Maintain landscaping using minimum or no pesticides.</p> <p><input type="checkbox"/> See applicable operational BMPs in “What you should know for....Landscape and Gardening” at http://www.rcflood.org/stormwater/Downlo ads/LandscapeGardenBrochure.pdf</p> <p><input type="checkbox"/> Provide IPM information to new owners, lessees and operators.</p>

Appendix 8
STORMWATER POLLUTANT SOURCES/SOURCE CONTROL CHECKLIST

... THEN YOUR WQMP SHOULD INCLUDE THESE SOURCE CONTROL BMPs, AS APPLICABLE			
1	2	3	4
IF THESE SOURCES WILL BE ON THE PROJECT SITE ...	Permanent Controls—Show on WQMP Drawings	Permanent Controls—List in WQMP Table and Narrative	Operational BMPs—Include in WQMP Table and Narrative
<p>Potential Sources of Runoff Pollutants</p> <p><input type="checkbox"/> E. Pools, spas, ponds, decorative fountains, and other water features.</p>	<p>Show location of water feature and a sanitary sewer cleanout in an accessible area within 10 feet. (Exception: Public pools must be plumbed according to County Department of Environmental Health Guidelines.)</p> <p><input type="checkbox"/> For restaurants, grocery stores, and other food service operations, show location (indoors or in a covered area outdoors) of a floor sink or other area for cleaning floor mats, containers, and equipment.</p> <p><input type="checkbox"/> On the drawing, show a note that this drain will be connected to a grease interceptor before discharging to the sanitary sewer.</p>	<p>If the Co-Permittee requires pools to be plumbed to the sanitary sewer, place a note on the plans and state in the narrative that this connection will be made according to local requirements.</p> <p><input type="checkbox"/> Describe the location and features of the designated cleaning area.</p> <p><input type="checkbox"/> Describe the items to be cleaned in this facility and how it has been sized to insure that the largest items can be accommodated.</p>	<p>See applicable operational BMPs in “Guidelines for Maintaining Your Swimming Pool, Jacuzzi and Garden Fountain” at http://www.rcfllood.org/stormwater/Downloads/poolsandspas.pdf</p>
<p><input checked="" type="checkbox"/> G. Refuse areas</p>	<p>Show where site refuse and recycled materials will be handled and stored for pickup. See local municipal requirements for sizes and other details of refuse areas.</p> <p><input checked="" type="checkbox"/> If dumpsters or other receptacles are outdoors, show how the designated area will be covered, graded, and paved to prevent runoff and show locations of berms to prevent runoff from the area.</p> <p><input type="checkbox"/> Any drains from dumpsters, compactors, and tallow bin areas shall be connected to a grease removal device before discharge to sanitary sewer.</p>	<p>State how site refuse will be handled and provide supporting detail to what is shown on plans.</p> <p><input type="checkbox"/> State that signs will be posted on or near dumpsters with the words “Do not dump hazardous materials here” or similar.</p>	<p>State how the following will be implemented:</p> <p>Provide adequate number of receptacles. Inspect receptacles regularly; repair or replace leaky receptacles. Keep receptacles covered. Prohibit/prevent dumping of liquid or hazardous wastes. Post “no hazardous materials” signs. Inspect and pick up litter daily and clean up spills immediately. Keep spill control materials available on-site. See Fact Sheet SC-34, “Waste Handling and Disposal” in the CASQA Stormwater Quality Handbooks at www.cabmphandbooks.com</p>
<p><input type="checkbox"/> F. Food service</p>	<p>See the brochure, “The Food Service Industry Best Management Practices for: Restaurants, Grocery Stores, Delicatessens and Bakeries” at http://www.rcfllood.org/stormwater/downloads/FoodServ.pdf</p> <p>Provide this brochure to new site owners, lessees, and operators.</p>	<p>See the brochure, “The Food Service Industry Best Management Practices for: Restaurants, Grocery Stores, Delicatessens and Bakeries” at http://www.rcfllood.org/stormwater/downloads/FoodServ.pdf</p>	<p>See the brochure, “The Food Service Industry Best Management Practices for: Restaurants, Grocery Stores, Delicatessens and Bakeries” at http://www.rcfllood.org/stormwater/downloads/FoodServ.pdf</p>

Appendix 8
STORMWATER POLLUTANT SOURCES/SOURCE CONTROL CHECKLIST

... THEN YOUR WQMP SHOULD INCLUDE THESE SOURCE CONTROL BMPs, AS APPLICABLE			
1	2	3	4
Potential Sources of Runoff Pollutants	Permanent Controls—Show on WQMP Drawings	Permanent Controls—List in WQMP Table and Narrative	Operational BMPs—Include in WQMP Table and Narrative
<input type="checkbox"/> H. Industrial processes.	<input type="checkbox"/> Show process area.	<input type="checkbox"/> If industrial processes are to be located on site, state: “All process activities to be performed indoors. No processes to drain to exterior or to storm drain system.”	<input type="checkbox"/> See Fact Sheet SC-10, “Non-Stormwater Discharges” in the CASQA Stormwater Quality Handbooks at www.cabmphandbooks.com See the brochure “Industrial & Commercial Facilities Best Management Practices for: Industrial, Commercial Facilities” at http://www.rcfflood.org/stormwater/Downloads/IndustrialCommercialFacilities.pdf
<input type="checkbox"/> I. Outdoor storage of equipment or materials. (See rows J and K for source control measures for vehicle cleaning, repair, and maintenance.)	<input type="checkbox"/> Show any outdoor storage areas, including how materials will be covered. Show how areas will be graded and bermed to prevent runoff or run-off from area. <input type="checkbox"/> Storage of non-hazardous liquids shall be covered by a roof and/or drain to the sanitary sewer system, and be contained by berms, dikes, liners, or vaults. <input type="checkbox"/> Storage of hazardous materials and wastes must be in compliance with the local hazardous materials ordinance and a Hazardous Materials Management Plan for the site.	<input type="checkbox"/> Include a detailed description of materials to be stored, storage areas, and structural features to prevent pollutants from entering storm drains. Where appropriate, reference documentation of compliance with the requirements of Hazardous Materials Programs for: <ul style="list-style-type: none"> ▪ Hazardous Waste Generation ▪ Hazardous Materials Release Response and Inventory ▪ California Accidental Release (CalARP) ▪ Aboveground Storage Tank ▪ Uniform Fire Code Article 80 Section 103(b) & (c) 1991 ▪ Underground Storage Tank www.cchealth.org/groups/hazmat/	<input type="checkbox"/> See the Fact Sheets SC-31, “Outdoor Liquid Container Storage” and SC-33, “Outdoor Storage of Raw Materials” in the CASQA Stormwater Quality Handbooks at www.cabmphandbooks.com

Appendix 8
STORMWATER POLLUTANT SOURCES/SOURCE CONTROL CHECKLIST

... THEN YOUR WQMP SHOULD INCLUDE THESE SOURCE CONTROL BMPs, AS APPLICABLE			
1	2	3	4
IF THESE SOURCES WILL BE ON THE PROJECT SITE ...	Permanent Controls—Show on WQMP Drawings	Permanent Controls—List in WQMP Table and Narrative	Operational BMPs—Include in WQMP Table and Narrative
<p><input type="checkbox"/> J. Vehicle and Equipment Cleaning</p>	<p><input type="checkbox"/> Show on drawings as appropriate:</p> <p>(1) Commercial/industrial facilities having vehicle/equipment cleaning needs shall either provide a covered, bermed area for washing activities or discourage vehicle/equipment washing by removing hose bibs and installing signs prohibiting such uses.</p> <p>(2) Multi-dwelling complexes shall have a paved, bermed, and covered car wash area (unless car washing is prohibited on-site and hoses are provided with an automatic shut-off to discourage such use).</p> <p>(3) Washing areas for cars, vehicles, and equipment shall be paved, designed to prevent run-on to or runoff from the area, and plumbed to drain to the sanitary sewer.</p> <p>(4) Commercial car wash facilities shall be designed such that no runoff from the facility is discharged to the storm drain system. Wastewater from the facility shall discharge to the sanitary sewer, or a wastewater reclamation system shall be installed.</p>	<p><input type="checkbox"/> If a car wash area is not provided, describe any measures taken to discourage on-site car washing and explain how these will be enforced.</p>	<p>Describe operational measures to implement the following (if applicable):</p> <p><input type="checkbox"/> Washwater from vehicle and equipment washing operations shall not be discharged to the storm drain system. Refer to “Outdoor Cleaning Activities and Professional Mobile Service Providers” for many of the Potential Sources of Runoff Pollutants categories below. Brochure can be found at http://www.rcflood.org/stormwater/downloads/OutdoorCleaningActivities.pdf</p> <p><input type="checkbox"/> Car dealerships and similar may rinse cars with water only.</p>

Appendix 8
STORMWATER POLLUTANT SOURCES/SOURCE CONTROL CHECKLIST

IF THESE SOURCES WILL BE ON THE PROJECT SITE ...	1	2	3	4
	Potential Sources of Runoff Pollutants	Permanent Controls—Show on WQMP Drawings	Permanent Controls—List in WQMP Table and Narrative	Operational BMPs—Include in WQMP Table and Narrative
... THEN YOUR WQMP SHOULD INCLUDE THESE SOURCE CONTROL BMPs, AS APPLICABLE	<input type="checkbox"/> K. Vehicle/Equipment Repair and Maintenance	<input type="checkbox"/> Accommodate all vehicle equipment repair and maintenance indoors. Or designate an outdoor work area and design the area to prevent run-on and runoff of stormwater. <input type="checkbox"/> Show secondary containment for exterior work areas where motor oil, brake fluid, gasoline, diesel fuel, radiator fluid, acid-containing batteries or other hazardous materials or hazardous wastes are used or stored. Drains shall not be installed within the secondary containment areas. <input type="checkbox"/> Add a note on the plans that states either (1) there are no floor drains, or (2) floor drains are connected to wastewater pretreatment systems prior to discharge to the sanitary sewer and an industrial waste discharge permit will be obtained.	<input type="checkbox"/> State that no vehicle repair or maintenance will be done outdoors, or else describe the required features of the outdoor work area. <input type="checkbox"/> State that there are no floor drains or if there are floor drains, note the agency from which an industrial waste discharge permit will be obtained and that the design meets that agency's requirements. <input type="checkbox"/> State that there are no tanks, containers or sinks to be used for parts cleaning or rinsing or, if there are, note the agency from which an industrial waste discharge permit will be obtained and that the design meets that agency's requirements.	<p>Operational BMPs—Include in WQMP Table and Narrative</p> <p>In the Stormwater Control Plan, note that all of the following restrictions apply to use the site:</p> <ul style="list-style-type: none"> <input type="checkbox"/> No person shall dispose of, nor permit the disposal, directly or indirectly of vehicle fluids, hazardous materials, or rinsewater from parts cleaning into storm drains. <input type="checkbox"/> No vehicle fluid removal shall be performed outside a building, nor on asphalt or ground surfaces, whether inside or outside a building, except in such a manner as to ensure that any spilled fluid will be in an area of secondary containment. Leaking vehicle fluids shall be contained or drained from the vehicle immediately. <input type="checkbox"/> No person shall leave unattended drip parts or other open containers containing vehicle fluid, unless such containers are in use or in an area of secondary containment. <p>Refer to “Automotive Maintenance & Car Care Best Management Practices for Auto Body Shops, Auto Repair Shops, Car Dealerships, Gas Stations and Fleet Service Operations”. Brochure can be found at http://rcflood.org/stormwater/</p> <p>Refer to Outdoor Cleaning Activities and Professional Mobile Service Providers for many of the Potential Sources of Runoff Pollutants categories below. Brochure can be found at http://rcflood.org/stormwater/</p>

Appendix 8
STORMWATER POLLUTANT SOURCES/SOURCE CONTROL CHECKLIST

IF THESE SOURCES WILL BE ON THE PROJECT SITE THEN YOUR WQMP SHOULD INCLUDE THESE SOURCE CONTROL BMPs, AS APPLICABLE		
1	2	3	4
Potential Sources of Runoff Pollutants	Permanent Controls—Show on WQMP Drawings	Permanent Controls—List in WQMP Table and Narrative	Operational BMPs—Include in WQMP Table and Narrative
<input type="checkbox"/> L. Fuel Dispensing Areas	<input type="checkbox"/> Fueling areas ⁶ shall have impermeable floors (i.e., portland cement concrete or equivalent smooth impervious surface) that are: a) graded at the minimum slope necessary to prevent ponding; and b) separated from the rest of the site by a grade break that prevents run-on of stormwater to the maximum extent practicable. <input type="checkbox"/> Fueling areas shall be covered by a canopy that extends a minimum of ten feet in each direction from each pump. [Alternative: The fueling area must be covered and the cover's minimum dimensions must be equal to or greater than the area within the grade break or fuel dispensing area ¹ .] The canopy [or cover] shall not drain onto the fueling area.		<input type="checkbox"/> The property owner shall dry sweep the fueling area routinely. <input type="checkbox"/> See the Fact Sheet SD-30, "Fueling Areas" in the CASQA Stormwater Quality Handbooks at www.cabmphandbooks.com

⁶ The fueling area shall be defined as the area extending a minimum of 6.5 feet from the corner of each fuel dispenser or the length at which the hose and nozzle assembly may be operated plus a minimum of one foot, whichever is greater.

Appendix 8
STORMWATER POLLUTANT SOURCES/SOURCE CONTROL CHECKLIST

IF THESE SOURCES WILL BE ON THE PROJECT SITE THEN YOUR WQMP SHOULD INCLUDE THESE SOURCE CONTROL BMPs, AS APPLICABLE		
1 Potential Sources of Runoff Pollutants	2 Permanent Controls—Show on WQMP Drawings	3 Permanent Controls—List in WQMP Table and Narrative	4 Operational BMPs—Include in WQMP Table and Narrative
<input type="checkbox"/> M. Loading Docks	<input type="checkbox"/> Show a preliminary design for the loading dock area, including roofing and drainage. Loading docks shall be covered and/or graded to minimize run-on to and runoff from the loading area. Roof downspouts shall be positioned to direct stormwater away from the loading area. Water from loading dock areas shall be drained to the sanitary sewer, or diverted and collected for ultimate discharge to the sanitary sewer. <input type="checkbox"/> Loading dock areas draining directly to the sanitary sewer shall be equipped with a spill control valve or equivalent device, which shall be kept closed during periods of operation. <input type="checkbox"/> Provide a roof overhang over the loading area or install door skirts (cowling) at each bay that enclose the end of the trailer.		<input type="checkbox"/> Move loaded and unloaded items indoors as soon as possible. <input type="checkbox"/> See Fact Sheet SC-30, “Outdoor Loading and Unloading,” in the CASQA Stormwater Quality Handbooks at www.cabmphandbooks.com

Appendix 8
STORMWATER POLLUTANT SOURCES/SOURCE CONTROL CHECKLIST

... THEN YOUR WQMP SHOULD INCLUDE THESE SOURCE CONTROL BMPs, AS APPLICABLE			
1	2	3	4
IF THESE SOURCES WILL BE ON THE PROJECT SITE ...	Permanent Controls—Show on WQMP Drawings	Permanent Controls—List in WQMP Table and Narrative	Operational BMPs—Include in WQMP Table and Narrative
<p style="text-align: center;">Potential Sources of Runoff Pollutants</p> <p><input type="checkbox"/> N. Fire Sprinkler Test Water</p> <p><input type="checkbox"/> O. Miscellaneous Drain or Wash Water or Other Sources</p> <p><input type="checkbox"/> Boiler drain lines</p> <p><input type="checkbox"/> Condensate drain lines</p> <p><input type="checkbox"/> Rooftop equipment</p> <p><input type="checkbox"/> Drainage sumps</p> <p><input type="checkbox"/> Roofing, gutters, and trim.</p> <p><input type="checkbox"/> Other sources</p>		<p><input type="checkbox"/> Provide a means to drain fire sprinkler test water to the sanitary sewer.</p> <p><input type="checkbox"/> Boiler drain lines shall be directly or indirectly connected to the sanitary sewer system and may not discharge to the storm drain system.</p> <p><input type="checkbox"/> Condensate drain lines may discharge to landscaped areas if the flow is small enough that runoff will not occur. Condensate drain lines may not discharge to the storm drain system.</p> <p><input type="checkbox"/> Rooftop equipment with potential to produce pollutants shall be roofed and/or have secondary containment.</p> <p><input type="checkbox"/> Any drainage sumps on-site shall feature a sediment sump to reduce the quantity of sediment in pumped water.</p> <p><input type="checkbox"/> Avoid roofing, gutters, and trim made of copper or other unprotected metals that may leach into runoff.</p> <p><input type="checkbox"/> Include controls for other sources as specified by local reviewer.</p>	<p>See the note in Fact Sheet SC-41, “Building and Grounds Maintenance,” in the CASQA Stormwater Quality Handbooks at www.cabmphandbooks.com</p>

Appendix 8
STORMWATER POLLUTANT SOURCES/SOURCE CONTROL CHECKLIST

IF THESE SOURCES WILL BE ON THE PROJECT SITE THEN YOUR WQMP SHOULD INCLUDE THESE SOURCE CONTROL BMPs, AS APPLICABLE		
1	2	3	4
Potential Sources of Runoff Pollutants	Permanent Controls—Show on WQMP Drawings	Permanent Controls—List in WQMP Table and Narrative	Operational BMPs—Include in WQMP Table and Narrative
<input checked="" type="checkbox"/> P. Plazas, sidewalks, and parking lots.			<input checked="" type="checkbox"/> Sweep plazas, sidewalks, and parking lots regularly to prevent accumulation of litter and debris. Collect debris from pressure washing to prevent entry into the storm drain system. Collect washwater containing any cleaning agent or degreaser and discharge to the sanitary sewer not to a storm drain.

Appendix 9: O&M

Operation and Maintenance Plan and Documentation of Finance, Maintenance and Recording Mechanisms

For the Final WQMP the following information shall be provided:

1. **Maintenance Plan** per Section 5.3.5 of the WQMP Guidance Document. County will regularly inspect BMPs, so BMPs without access (e.g. backyards, etc) will be rejected. Due to liability, the County does not allow for overlapping private maintenance in the public right-of-way.
2. For all projects, include **one wet-signed and notarized hardcopy of the BMP Maintenance agreement**. Please note, references to Exhibit A and B on Page 1 can be struck out if the entire parcel is mentioned in the "Legal Description" on Page 1 of the agreement. Otherwise see below for Exhibit A and B standards. For BMP agreement, ensure that the name on the agreement matches throughout and the notary sheet, Notary shall be the latest California format, the date of the agreement is the date of the notary, all text does not exceed the margins, then the County will sign, attest & record
3. For Tracts, contact County EDA regarding maintenance determinations/formations. Include a completed **Exhibit B.9 - WQMP O&M Cost Sheet.xlsx** that is signed by both the preparer (to ensure quantities are correct) and the owner (to understand the maintenance obligations in perpetuity) & an **Approved Maintenance Exhibit from EDA**.
4. For Tracts or any project, **written documentation** from the maintenance entity that they are willing to maintain (e.g. CFD, CSA, L&LMD, etc.)

BMP EXHIBIT "A" STANDARDS

1. Use the legal description of the parcel as shown on the tentative exhibit. If not available, use the one in the most current title report.
2. As a backup, if the project is a map the description of the future lot may be included for reference

BMP EXHIBIT "B" STANDARDS

1. 0.12" minimum lettering
2. Sheet size must be 8.5" x 11"
3. Show Street names, north arrow
4. Indicate point of flow exit into street if basin system fails
5. Indicate Q100 of flow exit into street
6. Indicate direction of flow exit into street
7. Indicate by notation and/or show nearest downstream drainage facility (catch basin, culvert, riser, etc)
8. Show "Exhibit A", IP and project number (TR, PM, PUP, PP etc)
9. Title block, signature block, engineer seals, USA note is not necessary on Exhibit
10. Show scale used for drawing, provide 4" graphic scale

MAINTENANCE EXHIBIT "B" STANDARDS

1. 0.12" minimum lettering
2. Sheet size must be 8.5" x 11"
3. Show street names, north arrow
4. Show "Exhibit A", IP and project number (TR, PM, PUP, PP etc)
5. Title block, signature block, engineer seals, USA note is not necessary on Exhibit
6. Show scale used for drawing, provide 4" graphic scale

BMP EXHIBIT B EXAMPLE

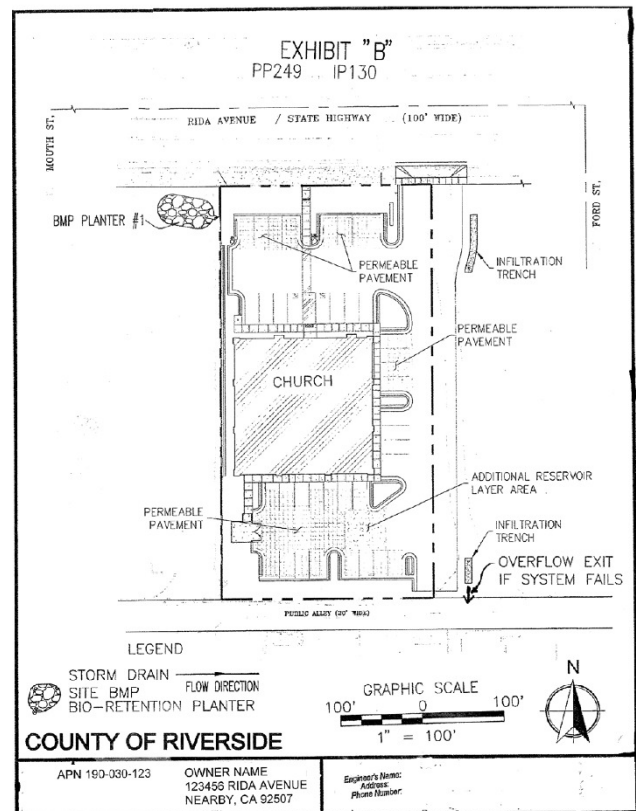

Recorded at the request of:
COUNTY OF RIVERSIDE
TRANSPORTATION DEPARTMENT

THIS INSTRUMENT IS FOR THE BENEFIT
OF THE COUNTY OF RIVERSIDE AND
ENTITLED TO BE RECORDED WITHOUT
FEE.(GOV. CODE 6103)

RETURN TO:
RIVERSIDE COUNTY TRANSPORTATION
DEPARTMENT. STOP NO. 1080

**COVENANT AND AGREEMENT REGARDING WATER QUALITY
MANAGEMENT PLAN BMP, CONSENT TO INSPECT, MAINTENANCE AND
INDEMNIFICATION**

APN: 569-150-010 **PROJECT No.** _____ **IP No.** _____

OWNER(S): Hermanos Semanas, LLC

PROPERTY ADDRESS: 32875 Red Mountain Rd, Hemet, CA 92544

LEGAL DESCRIPTION: See Attached

THIS AGREEMENT is made and entered into in Riverside County, California, this ____ day of _____ Year_____, by and between Hermanos Semanas, LLC (hereinafter referred to as "Covenantor" or "Owner") and the COUNTY OF RIVERSIDE via its Department of Transportation, a political subdivision of the State of California (hereinafter referred to as "County").

RECITALS

WHEREAS, the Covenantor owns real property ("Property") in the County of Riverside, State of California, more specifically described in Exhibit "A" and depicted in Exhibit "B", each of these exhibits is attached, and incorporated herein by this reference;

WHEREAS, the County is the owner of interests in that certain real property within the unincorporated area of the County of Riverside, State of California, containing storm drains, pipelines, and related appurtenances constituting the County's municipal separate storm sewer system (the County's "MS4");

EXHIBIT 'A'

THE EAST HALF OF THE EAST HALF OF THE NORTH HALF OF THE NORTH HALF OF THE EAST HALF OF THE NORTHEAST QUARTER OF SECTION 28, TOWNSHIP 6 SOUTH, RANGE 1 EAST, SAN BERNARDINO BASE AND MERIDIAN, SHOWN AS PARCEL 4 OF RECORD OF SURVEY ON FILE IN BOOK 46 PAGE 7 OF MAPS, RECORDS OF RIVERSIDE COUNTY, CALIFORNIA.

WHEREAS, Covenantor intends to develop, improve, and/or use the Property in such a way that approval by the County for such development, improvement, and/or use is required pursuant to applicable laws;

WHEREAS, As a condition for said approval by the County, County required Covenantor, and Covenantor desires to, restrict the use of the Property according to the conditions, covenants, equitable servitudes, and restrictions contained herein for the express benefit of the County's MS4, which include requirements that the Property incorporate post construction on-site stormwater quality control measures;

WHEREAS, the Covenantor/Owner has chosen to install one or more Infiltration Trench hereinafter referred to as "Device", as the on-site control measure to minimize pollutants in urban runoff;

WHEREAS, said Device has been installed in accordance with plans and specifications accepted by the County;

WHEREAS, said Device, with installation on private property and draining only private property, is a private facility with all maintenance or replacement, therefore, the sole responsibility of the Covenantor/Owner in accordance with the terms of this Agreement;

WHEREAS, the Covenantor/Owner is aware that periodic and continuous maintenance, including, but not necessarily limited to, filter material replacement and sediment removal, is required to assure peak performance of Device and that, furthermore, such maintenance activity will require compliance with all Local, State, or Federal laws and regulations, including those pertaining to confined space and waste disposal methods, in effect at the time such maintenance occurs;

NOW THEREFORE, incorporating the foregoing Recitals and in consideration of the covenants and conditions contained herein, and for other good and valuable consideration, the receipt and sufficiency of which is hereby acknowledged, and expressly for the benefit of, and to bind, their successors in interest, the parties hereto agree as follows:

1. Covenantor/Owner hereby provides the County or County's designee complete access to the Device and its immediate vicinity and such access onto the property to permit access to the device at any time, upon twenty-four (24) hour advance notice in writing, of any duration for the purpose of inspection, sampling and testing of the Device. County shall make every effort at all times to minimize or avoid interference with Owner's use of the Property.
2. Covenantor/Owner shall use its best efforts diligently to maintain the Device in a manner assuring peak performance at all times. All reasonable precautions shall be exercised by Owner and Owner's representative or contractor in the removal and extraction of material(s) from the Device and the ultimate disposal of the material(s) in a manner consistent with all relevant laws and regulations in effect at the time. As may be requested

from time to time by the County / Regional Water Quality Control Board (RWQCB), the Owner shall provide the RWQCB with documentation identifying the material(s) removed, the quantity, and disposal destination.

3. In the event Covenantor/Owner, or its successors or assigns, fails to accomplish the necessary maintenance contemplated by this Agreement, within five (5) days of being given written notice by the County, the County is hereby authorized to cause any maintenance necessary to be done and charge the entire cost and expense to the Owner or Owner's successors or assigns, including administrative costs and interest thereon at the maximum rate authorized by the Civil Code from the date of notice of expense until paid in full.

4. The County may require the Covenantor/Owner to post security in a form and for a time period satisfactory to the County to guarantee the performance of the obligations stated herein. Should the Owner fail to perform the obligations under this Agreement, the County may, in the case of a cash deposit, certificate of deposit or letter of credit, act for the Owner using the proceeds from it, or in the case of a surety bond, require the sureties to perform the obligations of the Agreement.

5. The County may, but shall not be obligated to, enforce this Agreement by a proceeding at law or in equity against any person or persons violating or attempting to violate any condition, covenant, equitable servitude, or restriction provided for herein, either to restrain such violation or to recover damages.

6. This Agreement constitutes the entire agreement and understanding between the parties with respect to the subject matter of this Agreement and supersedes all prior or contemporaneous agreements and understandings with respect to the subject matter hereof, whether oral or written.

7. If any part of this Agreement is declared by a final decision of a court of competent jurisdiction to be invalid for any reason, such shall not affect the validity of the rest of the Agreement. The other parts of this Agreement shall remain in effect as if this Agreement had been executed without the invalid parts(s). The parties declare that they intend and desire that the remaining parts of this Agreement continue to be effective without any part(s) that have been declared invalid.

8. This Agreement may be executed in counterparts, each of which so executed shall, irrespective of the date of its execution and delivery, be deemed an original, and all such counterparts together shall constitute one and the same instrument.

9. This Agreement shall be recorded in the Office of the Recorder of Riverside County, California and shall constitute notice to all successors and assigns of the title to said Property of the obligation herein set forth.

10. In the event of legal action occasioned by any default or action of the Covenantor/Owner, or its successors or assigns, then the Covenantor/Owner and its

successors or assigns agree(s) to pay all costs incurred by the County in enforcing the terms of this Agreement, including reasonable attorney's fees and costs, and that the same shall become a part of the lien against said Property.

11. Covenantor/Owner agrees to indemnify, defend, and hold harmless the County, its elected officers, employees, agents, and contractors from and against any and all liability, expense, including costs and reasonable legal fees, and claims of damage of any nature whatsoever including, but not limited to, death, bodily injury, personal injury, or property damage arising from or connected with the County inspection of the Property except where such liability, expense, or claim for damage results from the sole negligence or willful misconduct of the County.

12. It is the intent of the parties hereto that burdens and benefits herein undertaken shall constitute covenants that run with said Property and constitute a lien thereon against.

13. The obligations herein undertaken shall be binding upon the heirs, successors, executors, administrators and assigns of the parties hereto and any other present or future interest holders or estate holders in the property. The term "Owner" shall include not only the present Owner, but also its heirs, successors in interest and in title to the property, executors, administrators, and assigns. Owner shall notify any successor to title of all or part of the Property about the existence of this Agreement. Owner shall provide such notice prior to such successor obtaining an interest in all or part of the Property. Owner shall provide a copy of such notice to the County at the same time such notice is provided to the successor.

14. Time is of the essence in the performance of this Agreement.

/ / /
/ / /
/ / /
/ / /
/ / /
/ / /
/ / /
/ / /
/ / /
/ / /
/ / /
/ / /
/ / /
/ / /
/ / /
/ / /
/ / /
/ / /
/ / /
/ / /
/ / /

15. Any notice to a party required or called for in this Agreement shall be served in person, or by deposit in the U.S. Mail, first class postage prepaid, to the address set forth below. Notice(s) shall be deemed effective upon receipt, or seventy-two (72) hours after deposit in the U.S. Mail, whichever is earlier. A party may change a notice address only by providing written notice thereof to the other party.

COVENANTOR/OWNER:

COUNTY:

Riverside County Department of Transportation
Attn: Transportation Assistant Director
4080 Lemon Street
Riverside, CA

**COUNTY OF RIVERSIDE
TRANSPORTATION DEPARTMENT**

COVENANTOR/OWNER

Patricia Romo, P.E. Date
Assistant Director of Transportation

Company/Corporation/Partnership

(Print Name)

(Attest) Date

(Print Title)

ACKNOWLEDGMENT

State of California
County of _____

On _____ before me, _____,
(here insert name and title of the officer)
personally appeared _____

who proved to me on the basis of satisfactory evidence to be the person(s) whose name(s) is/are subscribed to the within instrument and acknowledged to me that he/she/they executed the same in his/her/their authorized capacity(ies), and that by his/her/their signature(s) on the instrument the person(s), or the entity upon behalf of which the person(s) acted, executed the instrument.

I certify under PENALTY OF PERJURY under the laws of the State of California that the foregoing paragraph is true and correct.

WITNESS my hand and official seal.

Signature _____

(Seal)

OPERATIONS AND MAINTENANCE MANUAL

A. Purpose

The purpose of this manual is to provide maintenance instructions for the infiltration bmp located on the south of the proposed parking area. The infiltration bmp treats urban runoff before it enters into the onsite storm drain system. Maintenance per this manual will ensure the infiltration bmp function as designed.

This manual will serve as a reference guide to assist the property owner with the following:

1. Overview of the infiltration bmp and how it functions
2. Description of the location of the infiltration bmp
3. Procedure required to effectively maintain the infiltration bmp
4. Reproducible copies of the forms, logs, and guidelines necessary for recording maintenance activities associated with the infiltration bmp

B. General Description and Function of the Infiltration BMP

Infiltration BMP

The infiltration bmp is composed of a bottom surface area of 1,590 SF that is 1' deep on the surface and 4' deep under the surface that allows urban runoff to be treated. From the top of the trench to the bottom the material consists of:

1. Mulch or landscape material on top
2. 12" pea gravel
3. 8' - 1" to 3" diameter rock

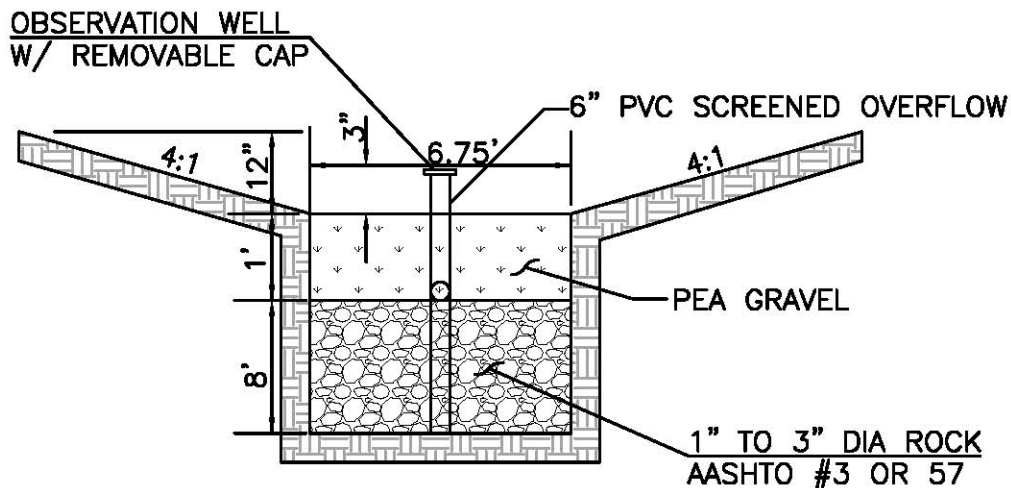

INFILTRATION TRENCH DETAIL

NTS

C. Maintenance Responsibility

The property owner is responsible for maintaining the infiltration bmp. Regular inspection and replacement of materials within the infiltration bmp once it becomes ineffective in performing as designed are the major components in the maintenance program. Trash, litter, and debris will also need to be removed on a regular basis. The following general procedures should be followed:

1. Qualified maintenance personnel should periodically inspect the infiltration bmp every 6 months.
2. If a problem is identified, it should be resolved as soon as possible to ensure that the infiltration bmp functions as designed.
3. Regular removal of trash and debris should occur. Any visible trash or debris should be promptly removed.

Detailed maintenance procedures are outlined in Section E

D. Maintenance Indicators and Activities

Functional Maintenance

Regular functional maintenance is required to ensure that the infiltration bmp performs in an effective manner. Functional maintenance consists of both preventative and corrective activities. Logs and guide sheets are contained herein to use in recording vital information while performing operation inspection and other infiltration bmp maintenance activities. Maintenance records shall be kept by the property owner for a minimum of 5 years. The proper use and subsequent storage of these records will assure the County of Riverside that the infiltration BMP is functioning as designed.

Preventative Maintenance

Preventative maintenance shall be performed on a regular basis. Checklists are included herein to track and record preventative maintenance activities. These activities include trash and debris removal and sediment management.

Trash and debris removal shall be performed to ensure that runoff has adequate surface area to pass through the various layers that comprise the cross section of the bmp and to ensure the infiltration bmp functions properly.

Corrective Maintenance

Corrective maintenance will be required on an emergency or non-routine basis to correct problems and restore intended operation and safe function of the infiltration bmp.

Infiltration BMP

1. Inspect minimum of twice per year, before and after the rainy season, after large storms or more frequently as needed.
2. Clean the bmp when the loss of capacity is observed. When standing water is present for a period of time in excess of 72 hours, removal of sediment may be necessary. This is an expensive activity and the need for it may be minimized through the prevention of erosion.
3. Control mosquitoes as necessary
4. Remove litter and debris from surface as required

TABLE 1: Typical Maintenance Activities for the Infiltration BMP			
Design Criteria & Routine Actions	Maintenance Indicator	Inspection Frequency	Maintenance Activity
Inspection for standing water in the infiltration bmp	Presence of water that has been standing for 72 hours	Annual and 72 hours after storm	Check the outlet pipes for blockage and unclog
Inspect sediment and build up within infiltration bmp	Sediment depth within 2" of the bottom of the basin	Bi-Annually	Remove and replace top layer of Infiltration BMP materials (15" of gravel). Remove sediment

Maintenance Indicators

Maintenance indicators are signs that indicate that maintenance personnel need to check the infiltration bmp for maintenance needs. The most common trigger include warnings or accounts of standing water and sediment accumulation. The proceeding Table 1 show conditions and criteria that trigger the need for some specific routine maintenance activities. Emergencies that occasionally arise would require a more urgent, critical response.

Sediment Removal

The types of storm water pollutants that accumulate in sediment varies, but may include contaminants such as heavy metals, petroleum hydrocarbons, and other organic compounds such as pesticides or solvents. When the sediment reaches a level of 2", the sediment must be removed.

Sediment Disposal

Several methods for disposal are available depending on the concentration of toxins in the waste. Methods can range from recycling the material, to depositing the sediment into appropriate landfills.

At the time of disposal, if wastes are deemed to be unfit for disposal in a municipal landfill, a full and comprehensive testing program should be run by a qualified person to test for all the constituents outlined under California code of Regulations (CCR) Title 22. Title 22 list concentrations of certain chemicals and their soluble threshold limit concentrations (STLC's) and their total threshold limit concentrations (TTLC's). Chemicals that exceed the allowable concentrations are considered hazardous wastes and must be removed from the sediment.

E. Inspection and Maintenance Checklist

Infiltration BMP Inspection and Maintenance Checklist

Date of Inspection _____

Type of Inspection _____

Defect	Conditions When Maintenance is Required	Maintenance Needed (Yes/No)	Comments	Results Expected When Maintenance is Performed
Standing Water	When water is present in the bioretention bmp longer than 72 hours			There should be no standing water in excess of 72 hours
Trash and Debris	Visible confirmation of accumulated trash and debris			Trash & debris should be removed from infiltration bmp and disposed of properly
Sediment	Evidence of sedimentation in infiltration bmp			Materials removed and disposed of properly so that there is no standing water
Bedding Layers/ Side Slopes	Visual inspection reveals material is not uniform or has been dug up			Uniform graded surfaces, no erosion apparent
Miscellaneous	Any condition not covered above that needs attention to ensure proper function of the infiltration bmp			Meet the design specifications

Appendix 10: Educational Materials

BMP Fact Sheets, Maintenance Guidelines and Other End-User BMP Information

For the Final WQMP, examples of material to provide in Appendix 10 may include but are not limited to the following:

- BMP Fact Sheets for proposed BMPs from Exhibit C: LID BMP Design Handbook of the SMR WQMP,
- Source control information and training material for site owners and operators,
- O&M training material,
- Other educational/training material related to site drainage and BMPs.

Site Design & Landscape Planning SD-10



Design Objectives

- Maximize Infiltration
- Provide Retention
- Slow Runoff
- Minimize Impervious Land Coverage
- Prohibit Dumping of Improper Materials
- Contain Pollutants
- Collect and Convey

Description

Each project site possesses unique topographic, hydrologic, and vegetative features, some of which are more suitable for development than others. Integrating and incorporating appropriate landscape planning methodologies into the project design is the most effective action that can be done to minimize surface and groundwater contamination from stormwater.

Approach

Landscape planning should couple consideration of land suitability for urban uses with consideration of community goals and projected growth. Project plan designs should conserve natural areas to the extent possible, maximize natural water storage and infiltration opportunities, and protect slopes and channels.

Suitable Applications

Appropriate applications include residential, commercial and industrial areas planned for development or redevelopment.

Design Considerations

Design requirements for site design and landscapes planning should conform to applicable standards and specifications of agencies with jurisdiction and be consistent with applicable General Plan and Local Area Plan policies.



SD-10 Site Design & Landscape Planning

Designing New Installations

Begin the development of a plan for the landscape unit with attention to the following general principles:

- Formulate the plan on the basis of clearly articulated community goals. Carefully identify conflicts and choices between retaining and protecting desired resources and community growth.
- Map and assess land suitability for urban uses. Include the following landscape features in the assessment: wooded land, open unwooded land, steep slopes, erosion-prone soils, foundation suitability, soil suitability for waste disposal, aquifers, aquifer recharge areas, wetlands, floodplains, surface waters, agricultural lands, and various categories of urban land use. When appropriate, the assessment can highlight outstanding local or regional resources that the community determines should be protected (e.g., a scenic area, recreational area, threatened species habitat, farmland, fish run). Mapping and assessment should recognize not only these resources but also additional areas needed for their sustenance.

Project plan designs should conserve natural areas to the extent possible, maximize natural water storage and infiltration opportunities, and protect slopes and channels.

Conserve Natural Areas during Landscape Planning

If applicable, the following items are required and must be implemented in the site layout during the subdivision design and approval process, consistent with applicable General Plan and Local Area Plan policies:

- Cluster development on least-sensitive portions of a site while leaving the remaining land in a natural undisturbed condition.
- Limit clearing and grading of native vegetation at a site to the minimum amount needed to build lots, allow access, and provide fire protection.
- Maximize trees and other vegetation at each site by planting additional vegetation, clustering tree areas, and promoting the use of native and/or drought tolerant plants.
- Promote natural vegetation by using parking lot islands and other landscaped areas.
- Preserve riparian areas and wetlands.

Maximize Natural Water Storage and Infiltration Opportunities Within the Landscape Unit

- Promote the conservation of forest cover. Building on land that is already deforested affects basin hydrology to a lesser extent than converting forested land. Loss of forest cover reduces interception storage, detention in the organic forest floor layer, and water losses by evapotranspiration, resulting in large peak runoff increases and either their negative effects or the expense of countering them with structural solutions.
- Maintain natural storage reservoirs and drainage corridors, including depressions, areas of permeable soils, swales, and intermittent streams. Develop and implement policies and

Site Design & Landscape Planning SD-10

regulations to discourage the clearing, filling, and channelization of these features. Utilize them in drainage networks in preference to pipes, culverts, and engineered ditches.

- Evaluating infiltration opportunities by referring to the stormwater management manual for the jurisdiction and pay particular attention to the selection criteria for avoiding groundwater contamination, poor soils, and hydrogeological conditions that cause these facilities to fail. If necessary, locate developments with large amounts of impervious surfaces or a potential to produce relatively contaminated runoff away from groundwater recharge areas.

Protection of Slopes and Channels during Landscape Design

- Convey runoff safely from the tops of slopes.
- Avoid disturbing steep or unstable slopes.
- Avoid disturbing natural channels.
- Stabilize disturbed slopes as quickly as possible.
- Vegetate slopes with native or drought tolerant vegetation.
- Control and treat flows in landscaping and/or other controls prior to reaching existing natural drainage systems.
- Stabilize temporary and permanent channel crossings as quickly as possible, and ensure that increases in run-off velocity and frequency caused by the project do not erode the channel.
- Install energy dissipaters, such as riprap, at the outlets of new storm drains, culverts, conduits, or channels that enter unlined channels in accordance with applicable specifications to minimize erosion. Energy dissipaters shall be installed in such a way as to minimize impacts to receiving waters.
- Line on-site conveyance channels where appropriate, to reduce erosion caused by increased flow velocity due to increases in tributary impervious area. The first choice for linings should be grass or some other vegetative surface, since these materials not only reduce runoff velocities, but also provide water quality benefits from filtration and infiltration. If velocities in the channel are high enough to erode grass or other vegetative linings, riprap, concrete, soil cement, or geo-grid stabilization are other alternatives.
- Consider other design principles that are comparable and equally effective.

Redeveloping Existing Installations

Various jurisdictional stormwater management and mitigation plans (SUSMP, WQMP, etc.) define “redevelopment” in terms of amounts of additional impervious area, increases in gross floor area and/or exterior construction, and land disturbing activities with structural or impervious surfaces. The definition of “redevelopment” must be consulted to determine whether or not the requirements for new development apply to areas intended for redevelopment. If the definition applies, the steps outlined under “designing new installations” above should be followed.

SD-10 Site Design & Landscape Planning

Redevelopment may present significant opportunity to add features which had not previously been implemented. Examples include incorporation of depressions, areas of permeable soils, and swales in newly redeveloped areas. While some site constraints may exist due to the status of already existing infrastructure, opportunities should not be missed to maximize infiltration, slow runoff, reduce impervious areas, disconnect directly connected impervious areas.

Other Resources

A Manual for the Standard Urban Stormwater Mitigation Plan (SUSMP), Los Angeles County Department of Public Works, May 2002.

Stormwater Management Manual for Western Washington, Washington State Department of Ecology, August 2001.

Model Standard Urban Storm Water Mitigation Plan (SUSMP) for San Diego County, Port of San Diego, and Cities in San Diego County, February 14, 2002.

Model Water Quality Management Plan (WQMP) for County of Orange, Orange County Flood Control District, and the Incorporated Cities of Orange County, Draft February 2003.

Ventura Countywide Technical Guidance Manual for Stormwater Quality Control Measures, July 2002.



Rain Garden

Design Objectives

- Maximize Infiltration
- Provide Retention
- Slow Runoff
- Minimize Impervious Land Coverage
- Prohibit Dumping of Improper Materials
- Contain Pollutants
- Collect and Convey

Description

Various roof runoff controls are available to address stormwater that drains off rooftops. The objective is to reduce the total volume and rate of runoff from individual lots, and retain the pollutants on site that may be picked up from roofing materials and atmospheric deposition. Roof runoff controls consist of directing the roof runoff away from paved areas and mitigating flow to the storm drain system through one of several general approaches: cisterns or rain barrels; dry wells or infiltration trenches; pop-up emitters, and foundation planting. The first three approaches require the roof runoff to be contained in a gutter and downspout system. Foundation planting provides a vegetated strip under the drip line of the roof.

Approach

Design of individual lots for single-family homes as well as lots for higher density residential and commercial structures should consider site design provisions for containing and infiltrating roof runoff or directing roof runoff to vegetative swales or buffer areas. Retained water can be reused for watering gardens, lawns, and trees. Benefits to the environment include reduced demand for potable water used for irrigation, improved stormwater quality, increased groundwater recharge, decreased runoff volume and peak flows, and decreased flooding potential.

Suitable Applications

Appropriate applications include residential, commercial and industrial areas planned for development or redevelopment.

Design Considerations

Designing New Installations

Cisterns or Rain Barrels

One method of addressing roof runoff is to direct roof downspouts to cisterns or rain barrels. A cistern is an above ground storage vessel with either a manually operated valve or a permanently open outlet. Roof runoff is temporarily stored and then released for irrigation or infiltration between storms. The number of rain



barrels needed is a function of the rooftop area. Some low impact developers recommend that every house have at least 2 rain barrels, with a minimum storage capacity of 1000 liters. Roof barrels serve several purposes including mitigating the first flush from the roof which has a high volume, amount of contaminants, and thermal load. Several types of rain barrels are commercially available. Consideration must be given to selecting rain barrels that are vector proof and childproof. In addition, some barrels are designed with a bypass valve that filters out grit and other contaminants and routes overflow to a soak-away pit or rain garden.

If the cistern has an operable valve, the valve can be closed to store stormwater for irrigation or infiltration between storms. This system requires continual monitoring by the resident or grounds crews, but provides greater flexibility in water storage and metering. If a cistern is provided with an operable valve and water is stored inside for long periods, the cistern must be covered to prevent mosquitoes from breeding.

A cistern system with a permanently open outlet can also provide for metering stormwater runoff. If the cistern outlet is significantly smaller than the size of the downspout inlet (say ¼ to ½ inch diameter), runoff will build up inside the cistern during storms, and will empty out slowly after peak intensities subside. This is a feasible way to mitigate the peak flow increases caused by rooftop impervious land coverage, especially for the frequent, small storms.

Dry wells and Infiltration Trenches

Roof downspouts can be directed to dry wells or infiltration trenches. A dry well is constructed by excavating a hole in the ground and filling it with an open graded aggregate, and allowing the water to fill the dry well and infiltrate after the storm event. An underground connection from the downspout conveys water into the dry well, allowing it to be stored in the voids. To minimize sedimentation from lateral soil movement, the sides and top of the stone storage matrix can be wrapped in a permeable filter fabric, though the bottom may remain open. A perforated observation pipe can be inserted vertically into the dry well to allow for inspection and maintenance.

In practice, dry wells receiving runoff from single roof downspouts have been successful over long periods because they contain very little sediment. They must be sized according to the amount of rooftop runoff received, but are typically 4 to 5 feet square, and 2 to 3 feet deep, with a minimum of 1-foot soil cover over the top (maximum depth of 10 feet).

To protect the foundation, dry wells must be set away from the building at least 10 feet. They must be installed in solids that accommodate infiltration. In poorly drained soils, dry wells have very limited feasibility.

Infiltration trenches function in a similar manner and would be particularly effective for larger roof areas. An infiltration trench is a long, narrow, rock-filled trench with no outlet that receives stormwater runoff. These are described under Treatment Controls.

Pop-up Drainage Emitter

Roof downspouts can be directed to an underground pipe that daylights some distance from the building foundation, releasing the roof runoff through a pop-up emitter. Similar to a pop-up irrigation head, the emitter only opens when there is flow from the roof. The emitter remains flush to the ground during dry periods, for ease of lawn or landscape maintenance.

Foundation Planting

Landscape planting can be provided around the base to allow increased opportunities for stormwater infiltration and protect the soil from erosion caused by concentrated sheet flow coming off the roof. Foundation plantings can reduce the physical impact of water on the soil and provide a subsurface matrix of roots that encourage infiltration. These plantings must be sturdy enough to tolerate the heavy runoff sheet flows, and periodic soil saturation.

Redeveloping Existing Installations

Various jurisdictional stormwater management and mitigation plans (SUSMP, WQMP, etc.) define “redevelopment” in terms of amounts of additional impervious area, increases in gross floor area and/or exterior construction, and land disturbing activities with structural or impervious surfaces. The definition of “redevelopment” must be consulted to determine whether or not the requirements for new development apply to areas intended for redevelopment. If the definition applies, the steps outlined under “designing new installations” above should be followed.

Supplemental Information

Examples

- City of Ottawa’s Water Links Surface –Water Quality Protection Program
- City of Toronto Downspout Disconnection Program
- City of Boston, MA, Rain Barrel Demonstration Program

Other Resources

Hager, Marty Catherine, Stormwater, “Low-Impact Development”, January/February 2003.
www.stormh2o.com

Low Impact Urban Design Tools, Low Impact Development Design Center, Beltsville, MD.
www.lid-stormwater.net

Start at the Source, Bay Area Stormwater Management Agencies Association, 1999 Edition



Design Objectives

- Maximize Infiltration
- Provide Retention
- Slow Runoff
- Minimize Impervious Land Coverage
- Prohibit Dumping of Improper Materials
- Contain Pollutants
- Collect and Convey

Description

Irrigation water provided to landscaped areas may result in excess irrigation water being conveyed into stormwater drainage systems.

Approach

Project plan designs for development and redevelopment should include application methods of irrigation water that minimize runoff of excess irrigation water into the stormwater conveyance system.

Suitable Applications

Appropriate applications include residential, commercial and industrial areas planned for development or redevelopment. (Detached residential single-family homes are typically excluded from this requirement.)

Design Considerations

Designing New Installations

The following methods to reduce excessive irrigation runoff should be considered, and incorporated and implemented where determined applicable and feasible by the Permittee:

- Employ rain-triggered shutoff devices to prevent irrigation after precipitation.
- Design irrigation systems to each landscape area's specific water requirements.
- Include design featuring flow reducers or shutoff valves triggered by a pressure drop to control water loss in the event of broken sprinkler heads or lines.
- Implement landscape plans consistent with County or City water conservation resolutions, which may include provision of water sensors, programmable irrigation times (for short cycles), etc.



- Design timing and application methods of irrigation water to minimize the runoff of excess irrigation water into the storm water drainage system.
- Group plants with similar water requirements in order to reduce excess irrigation runoff and promote surface filtration. Choose plants with low irrigation requirements (for example, native or drought tolerant species). Consider design features such as:
 - Using mulches (such as wood chips or bar) in planter areas without ground cover to minimize sediment in runoff
 - Installing appropriate plant materials for the location, in accordance with amount of sunlight and climate, and use native plant materials where possible and/or as recommended by the landscape architect
 - Leaving a vegetative barrier along the property boundary and interior watercourses, to act as a pollutant filter, where appropriate and feasible
 - Choosing plants that minimize or eliminate the use of fertilizer or pesticides to sustain growth
- Employ other comparable, equally effective methods to reduce irrigation water runoff.

Redeveloping Existing Installations

Various jurisdictional stormwater management and mitigation plans (SUSMP, WQMP, etc.) define “redevelopment” in terms of amounts of additional impervious area, increases in gross floor area and/or exterior construction, and land disturbing activities with structural or impervious surfaces. The definition of “redevelopment” must be consulted to determine whether or not the requirements for new development apply to areas intended for redevelopment. If the definition applies, the steps outlined under “designing new installations” above should be followed.

Other Resources

A Manual for the Standard Urban Stormwater Mitigation Plan (SUSMP), Los Angeles County Department of Public Works, May 2002.

Model Standard Urban Storm Water Mitigation Plan (SUSMP) for San Diego County, Port of San Diego, and Cities in San Diego County, February 14, 2002.

Model Water Quality Management Plan (WQMP) for County of Orange, Orange County Flood Control District, and the Incorporated Cities of Orange County, Draft February 2003.

Ventura Countywide Technical Guidance Manual for Stormwater Quality Control Measures, July 2002.



Objectives

- Contain
- Educate
- Reduce/Minimize
- Product Substitution

Targeted Constituents

Sediment	<input checked="" type="checkbox"/>
Nutrients	<input checked="" type="checkbox"/>
Trash	<input checked="" type="checkbox"/>
Metals	
Bacteria	
Oil and Grease	
Organics	
Oxygen Demanding	<input checked="" type="checkbox"/>

Description

Landscape maintenance activities include vegetation removal; herbicide and insecticide application; fertilizer application; watering; and other gardening and lawn care practices. Vegetation control typically involves a combination of chemical (herbicide) application and mechanical methods. All of these maintenance practices have the potential to contribute pollutants to the storm drain system. The major objectives of this BMP are to minimize the discharge of pesticides, herbicides and fertilizers to the storm drain system and receiving waters; prevent the disposal of landscape waste into the storm drain system by collecting and properly disposing of clippings and cuttings, and educating employees and the public.

Approach

Pollution Prevention

- Implement an integrated pest management (IPM) program. IPM is a sustainable approach to managing pests by combining biological, cultural, physical, and chemical tools.
- Choose low water using flowers, trees, shrubs, and groundcover.
- Consider alternative landscaping techniques such as naturescaping and xeriscaping.
- Conduct appropriate maintenance (i.e. properly timed fertilizing, weeding, pest control, and pruning) to help preserve the landscapes water efficiency.



- Consider grass cycling (grass cycling is the natural recycling of grass by leaving the clippings on the lawn when mowing. Grass clippings decompose quickly and release valuable nutrients back into the lawn).

Suggested Protocols***Mowing, Trimming, and Weeding***

- Whenever possible use mechanical methods of vegetation removal (e.g mowing with tractor-type or push mowers, hand cutting with gas or electric powered weed trimmers) rather than applying herbicides. Use hand weeding where practical.
- Avoid loosening the soil when conducting mechanical or manual weed control, this could lead to erosion. Use mulch or other erosion control measures when soils are exposed.
- Performing mowing at optimal times. Mowing should not be performed if significant rain events are predicted.
- Mulching mowers may be recommended for certain flat areas. Other techniques may be employed to minimize mowing such as selective vegetative planting using low maintenance grasses and shrubs.
- Collect lawn and garden clippings, pruning waste, tree trimmings, and weeds. Chip if necessary, and compost or dispose of at a landfill (see waste management section of this fact sheet).
- Place temporarily stockpiled material away from watercourses, and berm or cover stockpiles to prevent material releases to storm drains.

Planting

- Determine existing native vegetation features (location, species, size, function, importance) and consider the feasibility of protecting them. Consider elements such as their effect on drainage and erosion, hardiness, maintenance requirements, and possible conflicts between preserving vegetation and the resulting maintenance needs.
- Retain and/or plant selected native vegetation whose features are determined to be beneficial, where feasible. Native vegetation usually requires less maintenance (e.g., irrigation, fertilizer) than planting new vegetation.
- Consider using low water use groundcovers when planting or replanting.

Waste Management

- Compost leaves, sticks, or other collected vegetation or dispose of at a permitted landfill. Do not dispose of collected vegetation into waterways or storm drainage systems.
- Place temporarily stockpiled material away from watercourses and storm drain inlets, and berm or cover stockpiles to prevent material releases to the storm drain system.
- Reduce the use of high nitrogen fertilizers that produce excess growth requiring more frequent mowing or trimming.

- Avoid landscape wastes in and around storm drain inlets by either using bagging equipment or by manually picking up the material.

Irrigation

- Where practical, use automatic timers to minimize runoff.
- Use popup sprinkler heads in areas with a lot of activity or where there is a chance the pipes may be broken. Consider the use of mechanisms that reduce water flow to sprinkler heads if broken.
- Ensure that there is no runoff from the landscaped area(s) if re-claimed water is used for irrigation.
- If bailing of muddy water is required (e.g. when repairing a water line leak), do not put it in the storm drain; pour over landscaped areas.
- Irrigate slowly or pulse irrigate to prevent runoff and then only irrigate as much as is needed.
- Apply water at rates that do not exceed the infiltration rate of the soil.

Fertilizer and Pesticide Management

- Utilize a comprehensive management system that incorporates integrated pest management (IPM) techniques. There are many methods and types of IPM, including the following:
 - Mulching can be used to prevent weeds where turf is absent, fencing installed to keep rodents out, and netting used to keep birds and insects away from leaves and fruit.
 - Visible insects can be removed by hand (with gloves or tweezers) and placed in soapy water or vegetable oil. Alternatively, insects can be sprayed off the plant with water or in some cases vacuumed off of larger plants.
 - Store-bought traps, such as species-specific, pheromone-based traps or colored sticky cards, can be used.
 - Slugs can be trapped in small cups filled with beer that are set in the ground so the slugs can get in easily.
 - In cases where microscopic parasites, such as bacteria and fungi, are causing damage to plants, the affected plant material can be removed and disposed of (pruning equipment should be disinfected with bleach to prevent spreading the disease organism).
 - Small mammals and birds can be excluded using fences, netting, tree trunk guards.
 - Beneficial organisms, such as bats, birds, green lacewings, ladybugs, praying mantis, ground beetles, parasitic nematodes, trichogramma wasps, seed head weevils, and spiders that prey on detrimental pest species can be promoted.
- Follow all federal, state, and local laws and regulations governing the use, storage, and disposal of fertilizers and pesticides and training of applicators and pest control advisors.

- Use pesticides only if there is an actual pest problem (not on a regular preventative schedule).
- Do not use pesticides if rain is expected. Apply pesticides only when wind speeds are low (less than 5 mph).
- Do not mix or prepare pesticides for application near storm drains.
- Prepare the minimum amount of pesticide needed for the job and use the lowest rate that will effectively control the pest.
- Employ techniques to minimize off-target application (e.g. spray drift) of pesticides, including consideration of alternative application techniques.
- Fertilizers should be worked into the soil rather than dumped or broadcast onto the surface.
- Calibrate fertilizer and pesticide application equipment to avoid excessive application.
- Periodically test soils for determining proper fertilizer use.
- Sweep pavement and sidewalk if fertilizer is spilled on these surfaces before applying irrigation water.
- Purchase only the amount of pesticide that you can reasonably use in a given time period (month or year depending on the product).
- Triple rinse containers, and use rinse water as product. Dispose of unused pesticide as hazardous waste.
- Dispose of empty pesticide containers according to the instructions on the container label.

Inspection

- Inspect irrigation system periodically to ensure that the right amount of water is being applied and that excessive runoff is not occurring. Minimize excess watering, and repair leaks in the irrigation system as soon as they are observed.
- Inspect pesticide/fertilizer equipment and transportation vehicles daily.

Training

- Educate and train employees on use of pesticides and in pesticide application techniques to prevent pollution. Pesticide application must be under the supervision of a California qualified pesticide applicator.
- Train/encourage municipal maintenance crews to use IPM techniques for managing public green areas.
- Annually train employees within departments responsible for pesticide application on the appropriate portions of the agency's IPM Policy, SOPs, and BMPs, and the latest IPM techniques.

- Employees who are not authorized and trained to apply pesticides should be periodically (at least annually) informed that they cannot use over-the-counter pesticides in or around the workplace.
- Use a training log or similar method to document training.

Spill Response and Prevention

- Refer to SC-11, Spill Prevention, Control & Cleanup
- Have spill cleanup materials readily available and in a known location
- Cleanup spills immediately and use dry methods if possible.
- Properly dispose of spill cleanup material.

Other Considerations

- The Federal Pesticide, Fungicide, and Rodenticide Act and California Title 3, Division 6, Pesticides and Pest Control Operations place strict controls over pesticide application and handling and specify training, annual refresher, and testing requirements. The regulations generally cover: a list of approved pesticides and selected uses, updated regularly; general application information; equipment use and maintenance procedures; and record keeping. The California Department of Pesticide Regulations and the County Agricultural Commission coordinate and maintain the licensing and certification programs. All public agency employees who apply pesticides and herbicides in “agricultural use” areas such as parks, golf courses, rights-of-way and recreation areas should be properly certified in accordance with state regulations. Contracts for landscape maintenance should include similar requirements.
- All employees who handle pesticides should be familiar with the most recent material safety data sheet (MSDS) files.
- Municipalities do not have the authority to regulate the use of pesticides by school districts, however the California Healthy Schools Act of 2000 (AB 2260) has imposed requirements on California school districts regarding pesticide use in schools. Posting of notification prior to the application of pesticides is now required, and IPM is stated as the preferred approach to pest management in schools.

Requirements

Costs

Additional training of municipal employees will be required to address IPM techniques and BMPs. IPM methods will likely increase labor cost for pest control which may be offset by lower chemical costs.

Maintenance

Not applicable

Supplemental Information***Further Detail of the BMP******Waste Management***

Composting is one of the better disposal alternatives if locally available. Most municipalities either have or are planning yard waste composting facilities as a means of reducing the amount of waste going to the landfill. Lawn clippings from municipal maintenance programs as well as private sources would probably be compatible with most composting facilities

Contractors and Other Pesticide Users

Municipal agencies should develop and implement a process to ensure that any contractor employed to conduct pest control and pesticide application on municipal property engages in pest control methods consistent with the IPM Policy adopted by the agency. Specifically, municipalities should require contractors to follow the agency's IPM policy, SOPs, and BMPs; provide evidence to the agency of having received training on current IPM techniques when feasible; provide documentation of pesticide use on agency property to the agency in a timely manner.

References and Resources

King County Stormwater Pollution Control Manual. Best Management Practices for Businesses. 1995. King County Surface Water Management. July. On-line: <http://dnr.metrokc.gov/wlr/dss/spcm.htm>

Los Angeles County Stormwater Quality Model Programs. Public Agency Activities http://ladpw.org/wmd/npdes/model_links.cfm

Model Urban Runoff Program: A How-To Guide for Developing Urban Runoff Programs for Small Municipalities. Prepared by City of Monterey, City of Santa Cruz, California Coastal Commission, Monterey Bay National Marine Sanctuary, Association of Monterey Bay Area Governments, Woodward-Clyde, Central Coast Regional Water Quality Control Board. July. 1998.

Orange County Stormwater Program

http://www.ocwatersheds.com/StormWater/swp_introduction.asp

Santa Clara Valley Urban Runoff Pollution Prevention Program. 1997 Urban Runoff Management Plan. September 1997, updated October 2000.

United States Environmental Protection Agency (USEPA). 2002. Pollution Prevention/Good Housekeeping for Municipal Operations Landscaping and Lawn Care. Office of Water. Office of Wastewater Management. On-line: http://www.epa.gov/npdes/menuofbmps/poll_8.htm