

Appendix H
Sewer Study

TECHNICAL MEMORANDUM

DATE: December 17, 2021 Project No.: 487-60-21-26
SENT VIA: EMAIL

TO: Starla Barker, De Novo Planning Group

FROM: Patrick Johnston, PE, RCE #59028

REVIEWED BY: Chris Malone, PE, RCE #51009

SUBJECT: Sewer Capacity Study for Proposed Redevelopment of the Existing U-Haul Site

This technical memorandum (TM) presents the results of an analysis of the City of Gardena sewer system to assess the existing system capacity and to assess the impacts of anticipated flow generated from the proposed redevelopment of the existing U-Haul Site. This TM includes the following sections:

- Development Information
- Hydraulic Analysis
- Conclusions

1.0 DEVELOPMENT INFORMATION

The proposed development site encompasses the existing 4.2-acre property located at 14206 Van Ness Avenue in the City of Gardena, California. The project site is currently zoned C-3/MUO (General Commercial/Mixed Use). The proposed development requires a rezone to C-4/MUO (Heavy Commercial/Mixed Use) along with a conditional use permit.

The site is currently occupied by a U-Haul operation, which is looking to redevelop their existing facility into a new 5-story U-Haul Moving and Storage Store with a total floor area of 177,573 square feet (SF). Additionally, a separate building is proposed to be constructed on the portion of the site that runs along West Rosecrans Avenue to serve as an office space for the U-Haul Marketing company, with a total floor area of approximately 8,000 SF.

2.0 HYDRAULIC ANALYSIS

Flow monitoring was performed by Utility Systems Science & Software (US3) on the 24-inch diameter sewer main that runs adjacent to the proposed development site over the period of November 1–9, 2021. During this time, no significant rainfall occurred, so the flows represent dry weather conditions only.

The monitoring took place at a manhole shown in Figure 1, at the southern end of the property near the intersection of Rosecrans Avenue and Van Ness Avenue. Over the duration of the monitoring period,

measurements of flow rate, velocity, and water level were collected. Tabular data and summary graphs are provided as Attachment A.



Figure 1. Monitoring Location

Utilizing results from the level and flow monitoring performed in the field by US3, existing flows in the gravity main adjacent to the proposed development were determined. Additionally, a flow depth to pipe diameter ratio was calculated for existing flows. Table 1 below summarizes the observed flow conditions, where the flow results are presented in units of million gallons per day (mgd).

Table 1. Existing Conditions 14206 Van Ness Avenue				
Average Monitored Flow, mgd	Maximum Monitored Flow, mgd	Minimum Monitored Flow, mgd	Max Measured Water Level, inches	Depth-to-Diameter (d/D) ratio
0.351	0.557	0.075	11.2	0.47

The ratio of the maximum monitored flow to the average monitored flow is 1.59. It is assumed that this is a typical dry weather peaking factor for this part of the city and will be applied to the average flows to calculate a future maximum dry weather flow for the proposed development.

The Sewer System Management Plan for the Sanitation Districts of Los Angeles County indicates that the County does not consider possible improvements to sewers until peak dry weather flow depth exceeds 70% of the pipe diameter, which is a d/D ratio of 0.7. Because of the infrequency of significant wet weather events in Los Angeles County and the resultant difficulty in obtaining wet weather data, these standards use a dry weather peak d/D threshold of 0.7 as a basis for assessing the need for system improvements. The existing flow in this pipe has a d/D ration of 0.47, which falls well below the d/D standard of 0.7.

Average sewer flows for the proposed development were estimated using the Los Angeles County Sanitation District (LA County San) "Loadings for Each Class of Land Use" table. The table provides guidelines for expected flow based on land use. The analysis was performed by assigning a mix of Office and Warehousing land uses, to which LA County San assigns flow factors of 200 gallons per day (gpd)/1000 SF and 25 gpd/1000 SF, respectively. These flow factors were applied to the floor area values of 8,000 SF Office and 177,573 SF Warehouse. The future maximum flow and depth-to-diameter ratio was calculated for the proposed development and summarized in Table 2 below. More details are provided in Attachment B.

Future Flows , mgd	Existing Flow Plus Future Flow, mgd	Calculated Future Water Level, in	Depth-to-Diameter ratio (d/D)	Percent Increase in Depth-to-Diameter ratio
0.010	0.566	11.31	0.47	1.0

This analysis conservatively assumes that there is currently no flow being generated on the property. With this assumption, the results indicate that the additional flow from the U-Haul site would have a minimal impact on flows in the 24-inch RCP sewer main adjacent to the proposed development, such that the d/D ration of 0.47 remains nearly unchanged with the addition of those flows. Accordingly, the existing sewer appears to have capacity to accommodate the proposed development.

3.0 CONCLUSIONS

The conclusions determined from this study are as follows:

1. The proposed maximum flows generated by the redevelopment of the U-Haul site will result in approximately 1.0% increase in flows tributary to the existing 24-inch RCP sewer main adjacent to the development site, with a water level rise of 0.11 inches.
2. The increase in flows tributary to the 24-inch RCP sewer main adjacent to the proposed development is negligible.
3. Flow in the 24-inch RCP sewer main adjacent to the site is expected to remain well within the 0.7 d/D standard with the addition of flow from the proposed development.

Tabular Data and Summary Graphs

DRAFT



West Yost

MH at ~2155 Rosecrans Av
 Gardena, CA 90249
 MH # unknown

2021.11 Van Ness MH

Access:
 MH on CL of NB lanes at edge of crosswalk, W of address

System Type:
 Sanitary Storm

Install Date: 11/01/2021

Map

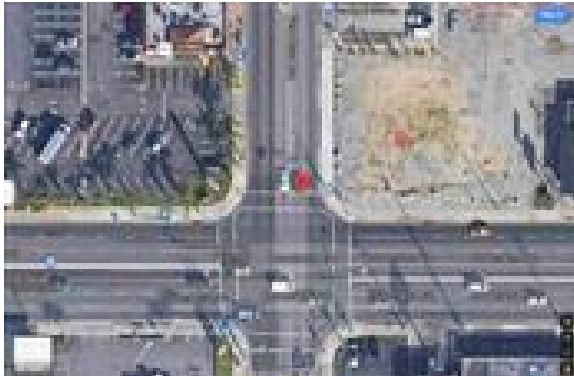

Technology

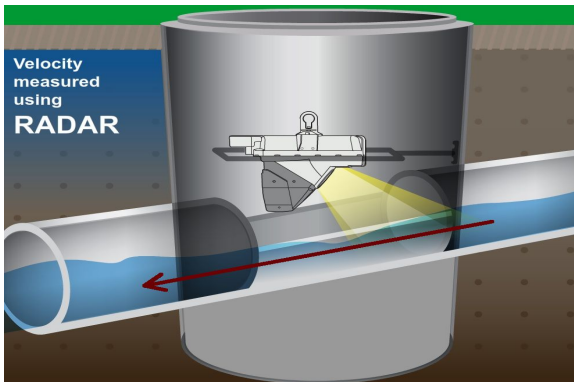

Sewer Plan



Flow Meter

Meter Depth: 183"
 MH Coordinates: 33.902105, -118.317814
 Slow open channel hydraulics with sediment issues

Avg Velocity	Avg Measured Level	Multiplier
0.9 fps	8.7"	1.0

Gas

O2	H2S	CO	LEL
20.9	0	0	0

Notes

No laterals; monitored the upstream line as it provided the best hydraulics during inspection.

Traffic Safety

Used arrow board, cones & signs in accord w/site-specific CATTCH requirements.

Land Use

Residential	Commercial	Industrial	Trunk
	X		

Manhole Depth	212"
Monitored Pipe Size	24"
Inner Pipe Size (In/Out)	24"/24"
Pipe Shape	Round
Pipe Condition	Good
Manhole Material	Concrete
Silt	4.5"
Velocity Profile Data	Passed
Velocity Profile Taken	0.4 2-D
Sensor Offset	28.9"
Sensor Dist. to Crown	4.9"
Sensor Direction	Upstream
Flow Heading	South



Meter Site Document

2021.11 Van Ness MH

MH at ~2155 Rosecrans Av

Gardena, CA 90249

Site



Manhole Before Install



Installation Process



Installed



Upstream



Upstream Pipe Size

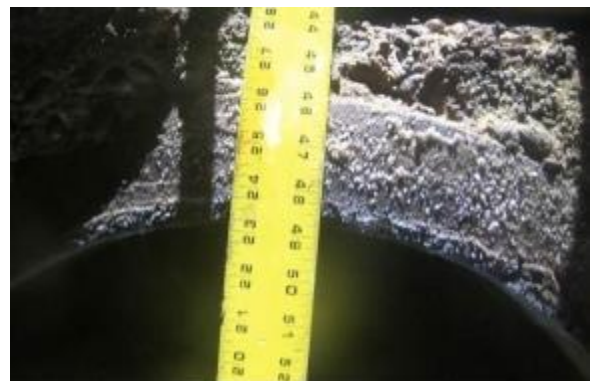



Utility Systems, Science and Software
 9314 Bond Av, Suite A
 El Cajon, CA 92021
 601 N. Parkcenter Dr, Suite 209
 Santa Ana, CA 92705

Meter Start Date	From	11/1/2021
Meter Stop Date	To	11/9/2021
Velocity (fps)	Level (in)	Flow (mgd)
Average	0.882	8.760
Maximum	1.100	11.200
Minimum	0.500	6.190
Pipe Size	24.000	
Estimated Capacity (mgd)	Not Calculated	
Capacity Used	Not Calculated	
Sensor Type	Hach - Flodar	

Temporary Flow Study
 West Yost
 2021.11 Van Ness MH

2021.11 Van Ness MH

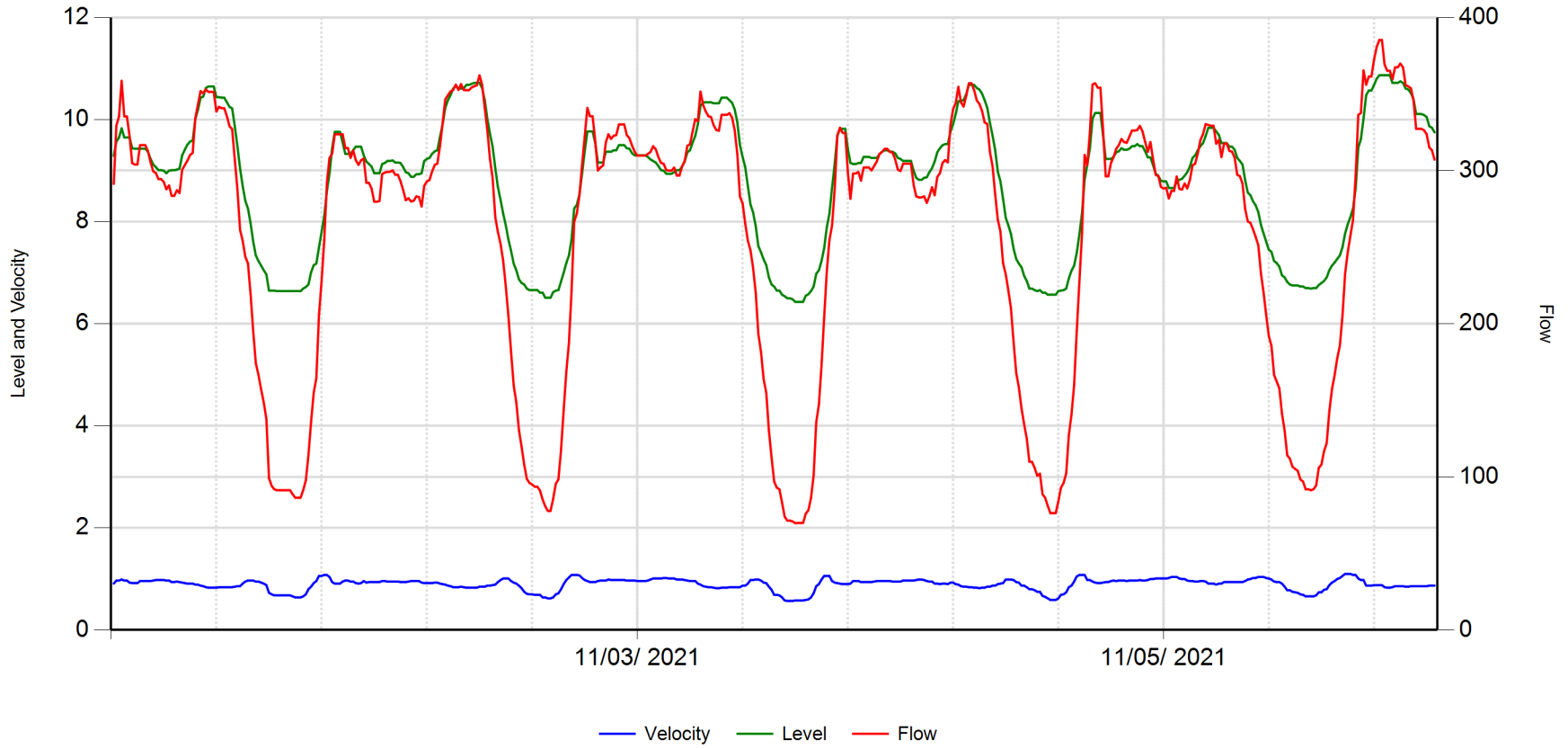

	Velocity (fps)	Level (in)	Flow (gpm)		
Average	0.896	8.782	260.348	RainFall	Inches
Maximum	1.100	10.870	385.346		
Minimum	0.570	6.430	69.791		



11/11/2021

2021.11 Van Ness MH

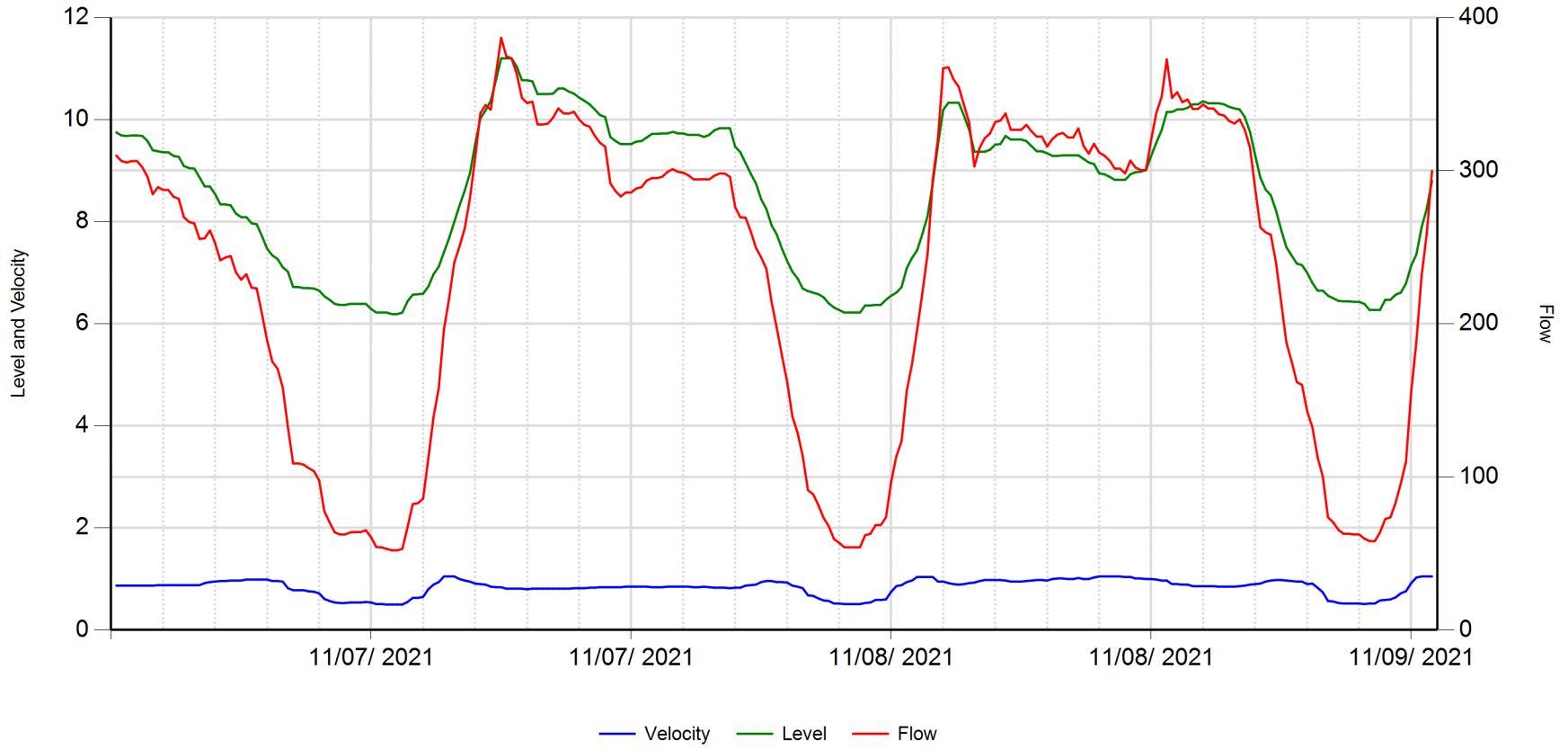

	Velocity (fps)	Level (in)	Flow (gpm)		
Average	0.837	8.496	231.774	RainFall	Inches
Maximum	1.050	11.200	386.735		
Minimum	0.500	6.190	52.083		



11/11/2021

2021.11 Van Ness MH

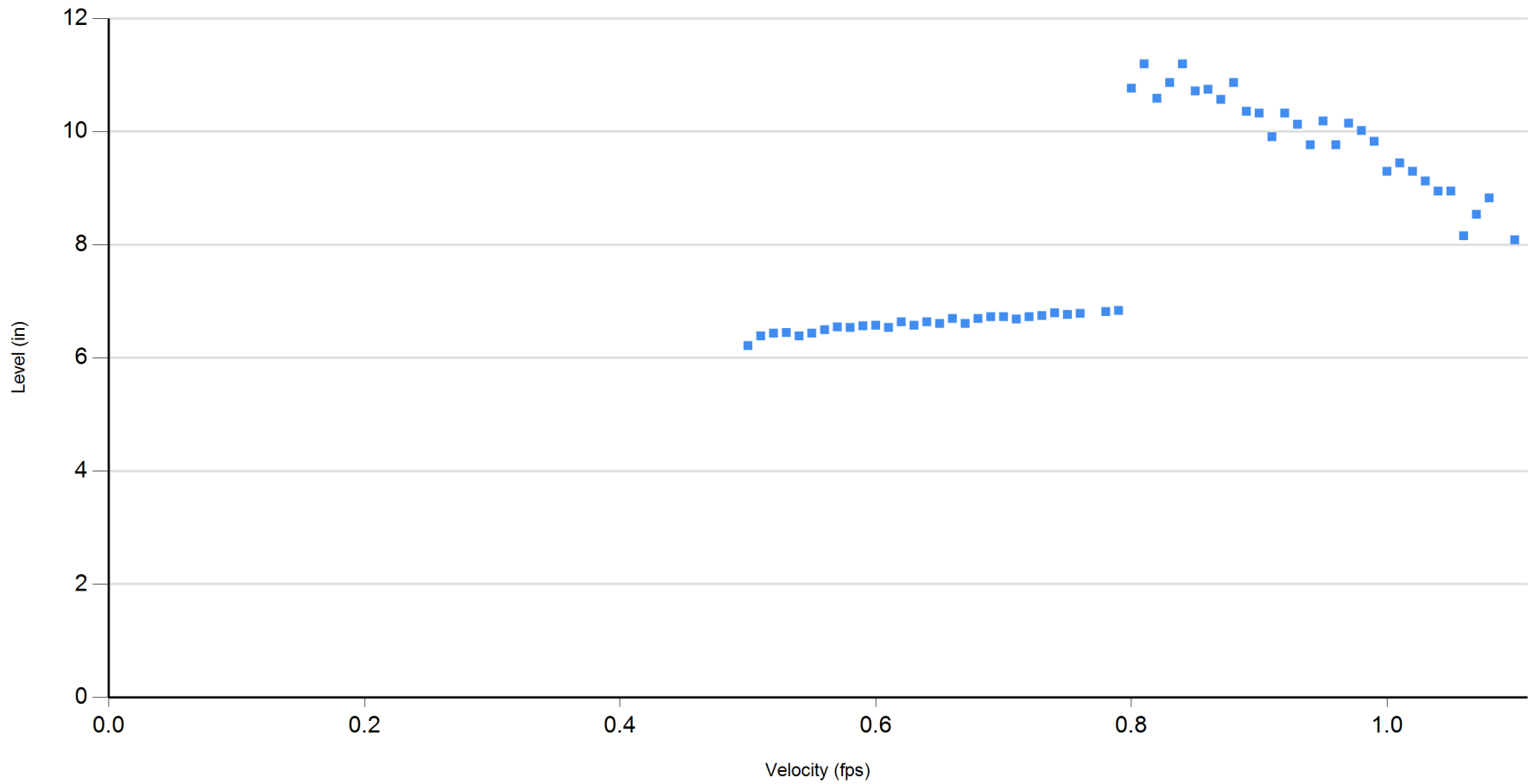

11/01/2021 thru 11/09/2021



11/11/2021 1:43:13 PM

Methods & Procedures & Equipment

Methods and Procedures

Utility Systems Science & Software provided West Yost with an off the shelf, non-proprietary flow monitoring solution that included one state of the art Hach Flo-Dar® AV Sensor system. The project course of action is listed below. The US³ team:

- Assessed permitting and traffic control at the site on Rosecrans Av in Gardena, CA.
- Obtained a City Encroachment Permit.
- Installed and removed traffic control in accord with site-specific California Temporary Traffic Control Handbook (CATTCH) requirements for both the installation and removal of flow monitoring equipment.
- Validated the site for suitability for sewer flow monitoring for the 14206 Van Ness Av Project.
 - The Van Ness MH had no laterals with slow open channel hydraulics and sediment issues.
- Installed and calibrated the flow monitoring equipment at the site per manufacturer recommendations on 11/01/2021.
 - The sediment was measured at 4.5 inches in depth at installation of equipment.
 - Follow-up on the installation confirmed equipment was reading properly.
 - Collected 15-minute interval depth and velocity data points over the entire monitoring period.
- Removed the equipment on 11/09/2021 and validated the data.
 - The sediment was measured at 4.5 inches in depth at removal of equipment. The flow rate was calculated using this parameter.
 - All of the equipment went through diagnostic testing before and after the study with less than a 1% deviation between manual and meter level readings and less than a 5% deviation between manual and meter velocity readings.
 - Equipment calibration was verified in accordance with manufacturer specifications.
- Prepared the data reports.
 - The table below contains a summary of the average (Avg) and maximum (Max) velocities (Vel) and levels (Lev) collected during this study as well as the calculated flow rates (Flow) and depth versus diameter ratios (d/D).

Pipe Size (in)	Avg Vel (fps)	Max Vel (fps)	Avg Lev (in)	Max Lev (in)	Avg Flow (gpm)	Max Flow (gpm)	Avg d/D	Max d/D
24	0.88	1.10	8.69	11.20	250.76	386.73	0.36	0.47

Equipment

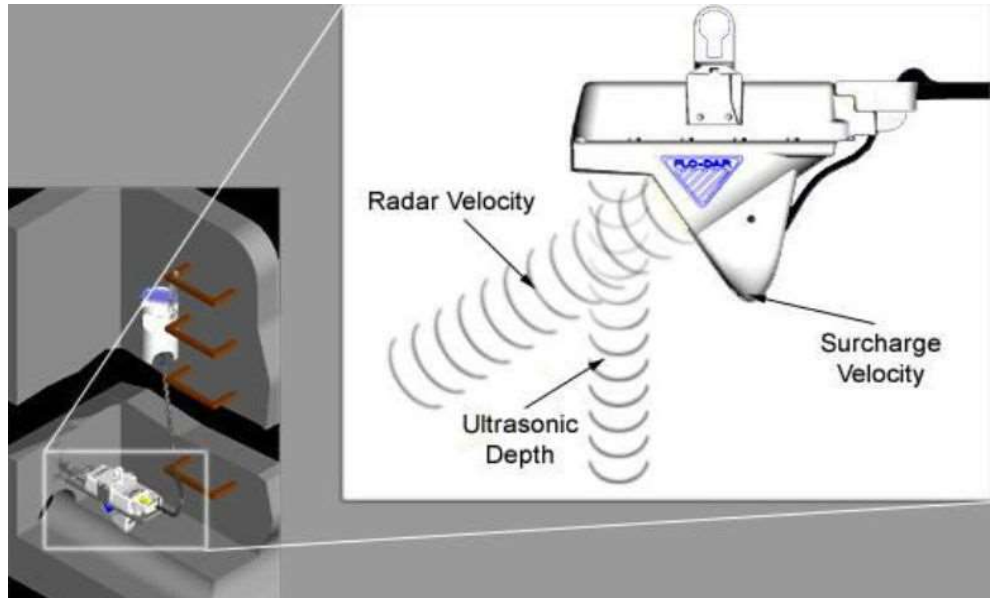

Figure above: Equipment installed for the Sewer Flow Monitoring Study



Figure above: Web-Enabled Flo-Dar® AV Sensor, Radar-Based Velocity/Area Flow Meter

FloDar® AV Sensor Specifications:

- **Enclosure**
 - IP68 Waterproof rating, Polystyrene
- **Dimensions**
 - 160.5 W x 432.2 L x 297 D mm (6.32 x 16.66 x 11.7 in.),
 - With SVS, D = 387 mm (15.2 in.)
- **Weight**
 - 4.8 kg (10.5 lbs.)
- **Operating Temperature**
 - -10 to 50°C (14 to 122°F)
- **Storage Temperature**
 - -40 to 60°C (-40 to 140°F)
- **Power Requirements**
 - Supplied by FL900 Flow Logger, Flo-Logger, or Flo-Station
- **Interconnecting Cable**
 - Disconnect available at both sensor and logger or Flo-Station
 - Polyurethane, 0.400 (±0.015) in. diameter; IP68
 - Standard length 9 m (30 ft), maximum 305 m (1000 ft)
- **Cables – available in two styles:**
 - connectors at both ends
 - connector from sensor with open leads to desiccant hub, desiccant hub with connector to logger. A potting/sealant kit will be included. This can be used to run the cable through conduit.
- **Certification**
 - Certified to: FCC Part 15.245: FCC ID: VIC-FLODAR24
 - Industry Canada Spec. RSS210. v7: IC No.: 6149A-FLODAR24

SURCHARGE DEPTH MEASUREMENT

- Auto zero function maintains zero error below 0.5 cm (0.2 in.)
- **Method**
 - Piezo-resistive pressure transducer with stainless steel diaphragm
- **Range**
 - 3.5 m (138 in.), overpressure rating 2.5 x full scale

VELOCITY MEASUREMENT

- **Method**
 - Radar
- **Range**
 - 0.23 to 6.10 m/s (0.75 to 20 ft/s)

- **Frequency Range**
 - 24.075 to 24.175 GHz, 15.2 mW (max.)
- **Accuracy**
 - $\pm 0.5\%$; ± 0.03 m/s (± 0.1 ft/s)

DEPTH MEASUREMENT

- **Method**
 - Ultrasonic
- **Standard Operating Range from Flo-Dar® Housing to Liquid**
 - 0 to 152.4 cm (0 to 60 in.)
- **Optional Extended Level Operating Range from Transducer Face to Liquid**
 - 0 to 6.1 m (0 to 20 ft.) with 43.18 cm (17 in.) dead band, temperature compensated.
- **Accuracy**
 - $\pm 1\%$; ± 0.25 cm (± 0.1 in.)

FLOW MEASUREMENT

- **Method**
 - Based on Continuity Equation
- **Accuracy**
 - $\pm 5\%$ of reading typical where flow is in a channel with uniform flow conditions and is not surcharged, $\pm 1\%$ full scale max.

SURCHARGE CONDITIONS DEPTH/VELOCITY DEPTH (Std with Flo-Dar® Sensor)

- **Surcharge depth supplied by Flo-Dar® sensor.**

VELOCITY (Optional Surcharge Velocity Sensor)

- **Method**
 - Electromagnetic
- **Range**
 - ± 4.8 m/s (± 16 ft/s)
- **Accuracy**
 - ± 0.15 ft/s or 4% of reading, whichever is greater.
- **Zero Stability**
 - ± 0.05 ft/s

The Flo-Dar® Open Channel Flow Meters provide an innovative approach to open channel flow monitoring. Combining digital Doppler radar velocity sensing with ultrasonic pulse echo level sensing Flo-Dar® provides accurate open channel flow monitoring without the fouling problems associated with submerged sensors.

Perfect Solution for Difficult Flow Conditions:

- Flows with High Solids Content
- High Temperature Flows
- Caustic Flows
- Large Man-Made Channel
- High Velocities
- Shallow Flows

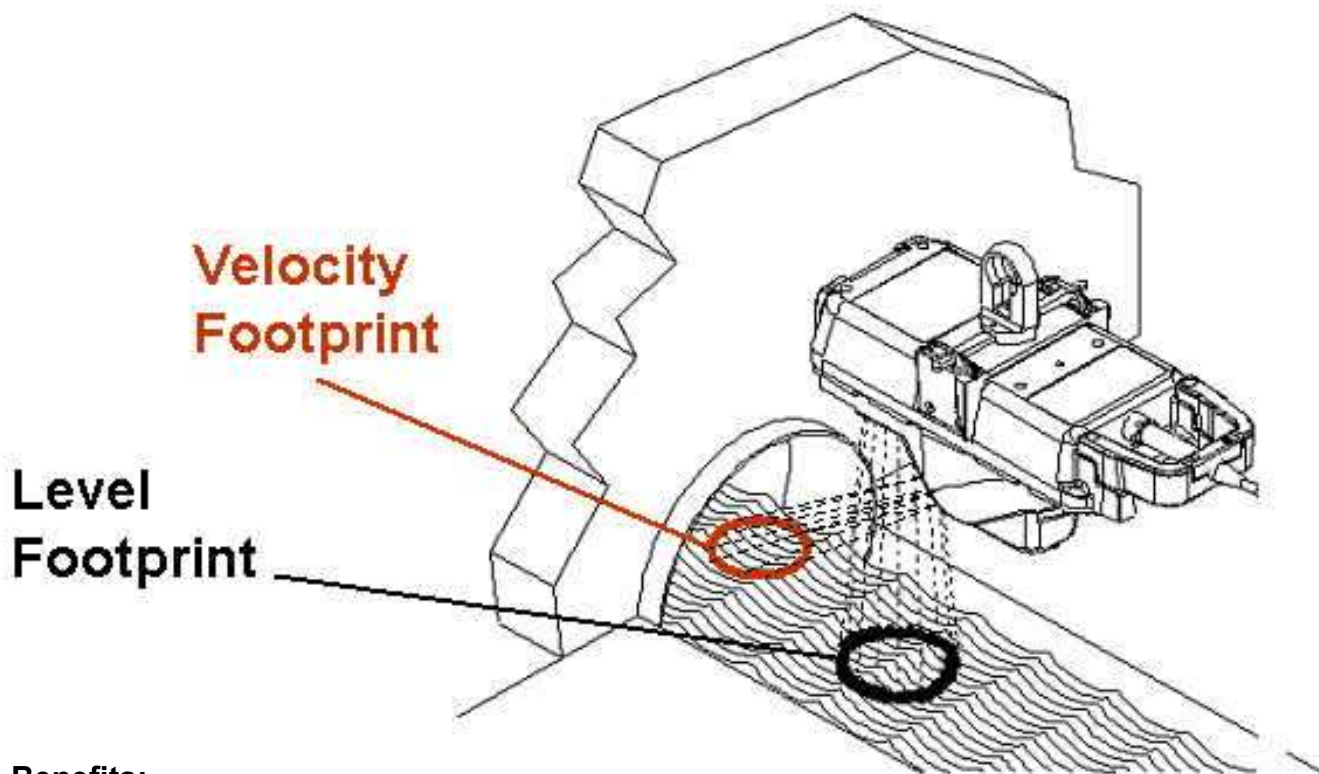
**Benefits:**

1. Personnel have no contact with the flow during installation.
2. Maintenance caused by sensor fouling is eliminated
3. Field Replaceable/Interchangeable Sensors and Monitors

How It Works

Flo-Dar® transmits a digital Doppler radar beam that interacts with the fluid and reflects back signals at a different frequency than that which was transmitted. These reflected signals are compared with the transmitted frequency. The resulting frequency shift provides an accurate measure of the velocity and the direction of the flow. Level is detected by ultrasonic pulse echo. Flow is then calculated based on the Continuity Equation:

$$Q = V \times A, \text{ Where } Q = \text{Flow}, V = \text{Average Velocity and } A = \text{Area}$$

Accurate Flow Measurements

Flo-Dar® provides the user with highly accurate flow measurements under a wide range of flows and site conditions. By measuring the velocity of the fluid from above, Flo-Dar® eliminates accuracy problems inherent with submerged sensors including sensor disturbances, high solids content and distribution of reflectors.

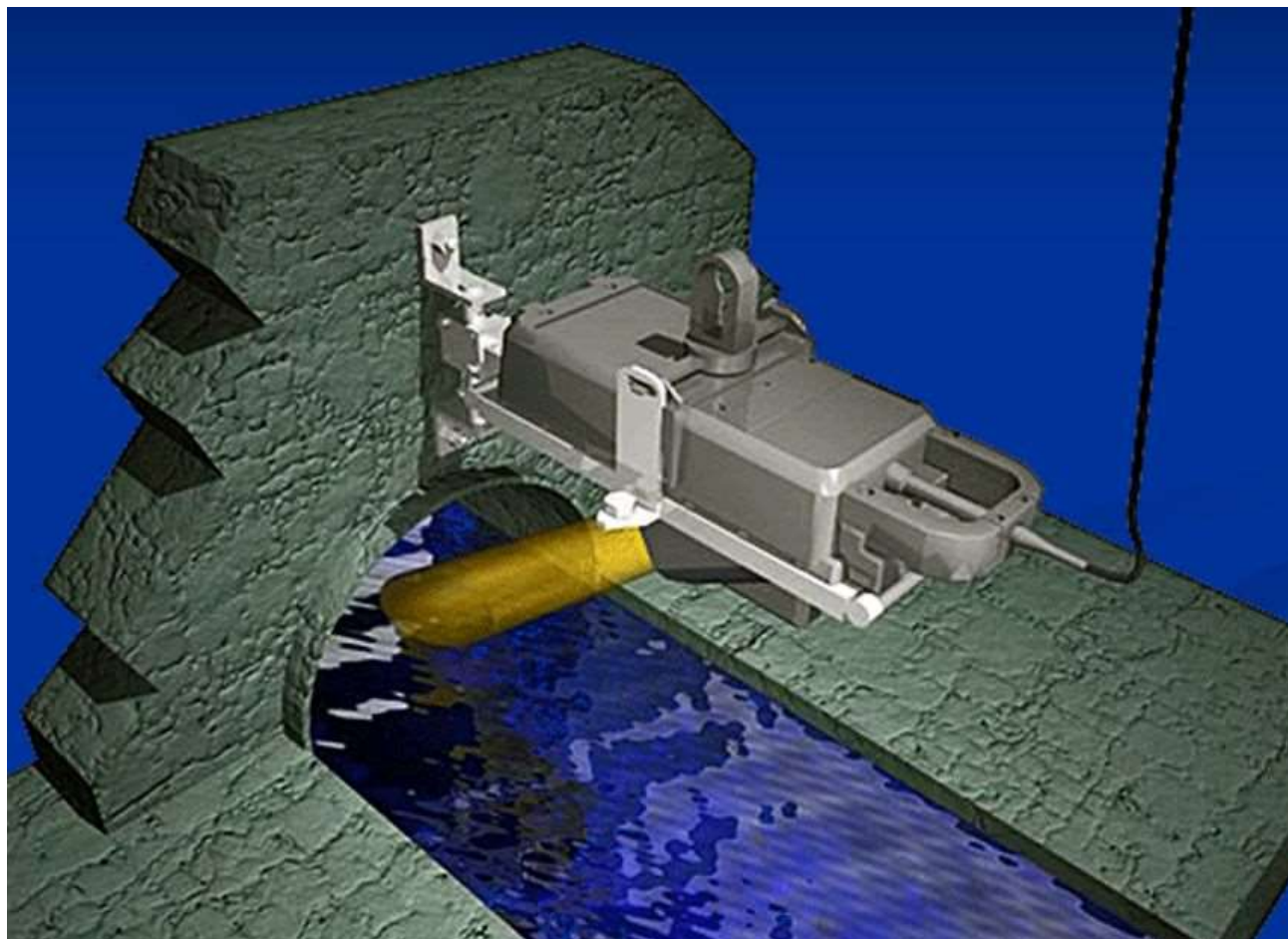

Figure above: US³ utilizes exclusively Hach March-McBirney Flo-Dar® Meters

US³ Company Information

US³ is a California Corporation **Federal ID No. 33-0729605** and qualifies as a Minority Business Enterprise. US³ has certified as an MBE with the California Public Utility Commission's authorized clearinghouse, **Verification Number: 97ES0008**.

US³ is a specialty service company for the Water & Waste Water industry, providing monitoring and control for Utilities since 1996. US³ is in the forefront of this industry by taking the proven technological approaches developed in other high-tech industries and applying them to protect one of our most precious natural resources - our water.

US³ engineers and technical personnel have applied advanced instrumentation system technology to water/wastewater open channel flow monitoring, pipeline evaluation, engineering, and data analysis, all coupled to the power of the Internet. This unique integrated systems approach allows the company to bring greater insight and intelligence to gathering information about water/wastewater system performance of our clients, and in turn, to support the fulfillment of their commitments to manage and cost effectively design, operate, and maintain these systems.

Moreover, US³ supports Municipalities, Consulting Engineering firms and other water/waste water systems integrators by providing temporary technical services for engineering, software programming and technical site maintenance and calibration site support work, primarily in the Water and Waste Water industries.

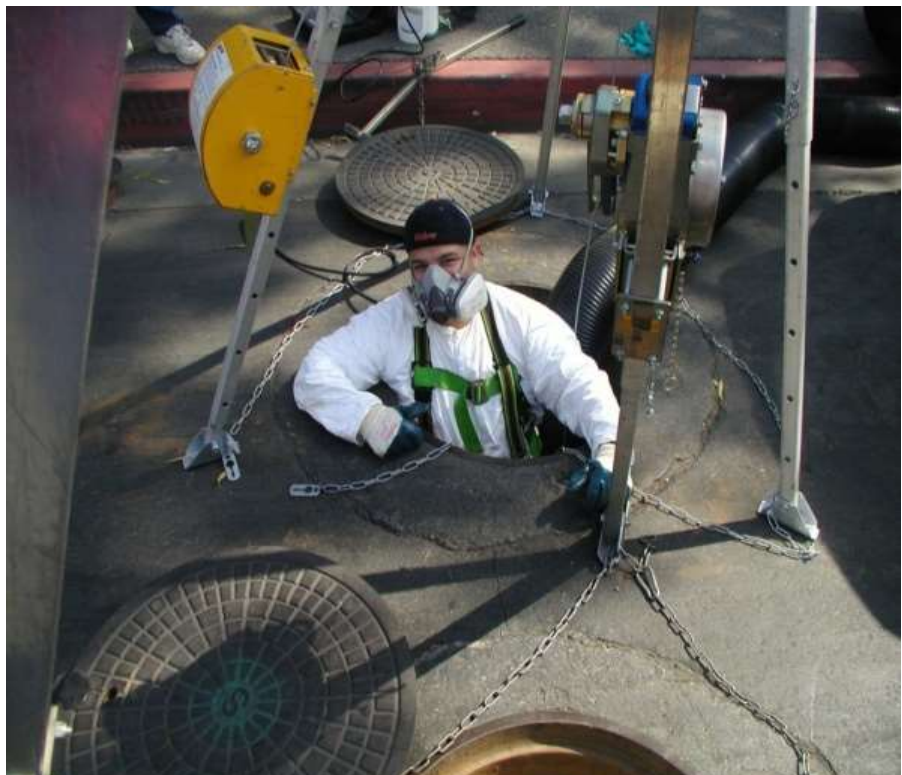

Figure at right: All US³ technicians are certified for Confined Space Entry.

Key Personnel Assigned

US³ provided the necessary resources to fully implement this project. Primary in support of this effort were the following personnel:

Mr. Mark Serres: Mr. Serres is a degreed electrical engineer with over 25 years of experience with fresh/wastewater systems, project management, and systems integration in relation to complex industrial systems. This includes experience in industrial automation and water/wastewater industries. Mr. Serres is responsible for assuring client satisfaction and marshalling the required resources to meet the project requirements.

Mr. Thomas Williams: Mr. Williams is an Engineering Manager with over 20 years of experience in complex systems development for wastewater monitoring. This experience includes hydraulic compatibility, instrumentation, communications and analysis. Mr. Williams is responsible for assuring that the required equipment is designed and calibrated to meet the project requirements.

Darlene Szczublewski, PE: Mrs. Szczublewski is a licensed Civil Engineer in multiple states. She has over 15 years of engineering experience with stormwater/wastewater related projects. She assisted in the completion of several Sanitary Sewer Evaluation Surveys and Capacity Analysis projects to meet Consent Decrees as well as completing numerous Infiltration and Inflow (I&I) studies for other clients. Mrs. Szczublewski has developed numerous flow data analysis techniques to present a clear informative picture of flow in a monitored system. Her work also includes the development of training programs for clients describing I&I and capacity analysis methodologies. Mrs. Szczublewski is responsible for analyzing the data as well as the data collection process and assuring that the reports meet the project requirements.

Name, title, address and telephone number of persons to contact regarding this US³ project.

Darlene Szczublewski, PE
Senior Civil Engineer
darlene.szczublewski@uscubed.com

9314 Bond Av, Suite A
El Cajon, CA 92021
619-546-4281 (work)
619-246-5304 (cell)

Tom Williams
Engineering Manager
tom.williams@uscubed.com

9314 Bond Av, Suite A
El Cajon, CA 92021
619-546-4281 (work)
619-398-7799 (cell)

Future Maximum Flow Based on Proposed Development

Partially Full Pipe Flow Calculations - U.S. Units

Calculation of Manning Roughness

Instructions: Enter values in blue boxes. Spreadsheet calculates values in yellow boxes

Inputs

Pipe Diameter, **D** = in

Depth of flow, **y** = in

Discharge, **Q** = cfs
0.861763

Pipe Slope, **S** = ft/ft

Calculations

Pipe Diameter, **D** = ft

Pipe Radius, **r** = ft

Circ. Segment Height, **h** = ft

Central Angle, **θ** = radians

Calculations

y/D =

n/n_{full} =

pipe % full =
[(A/A_{full})*100%]

Cross-Sect. Area, **A** = ft²

Wetted Perimeter, **P** = ft

Hydraulic Radius, **R** = ft

Manning roughness, **n** =

Manning roughness, **n_{full}** =

Equation used for n/n_{full}: $n/n_{full} = 1 + (y/D)^{0.54} - (y/D)^{1.20}$

Source: Goswami, I., Civil Engineerign All-In-One PE Exam Guide: Beadth and Depth, 2nd Ed.

(Eqn 303.32), McGraw-Hill, NY, NY, 2012

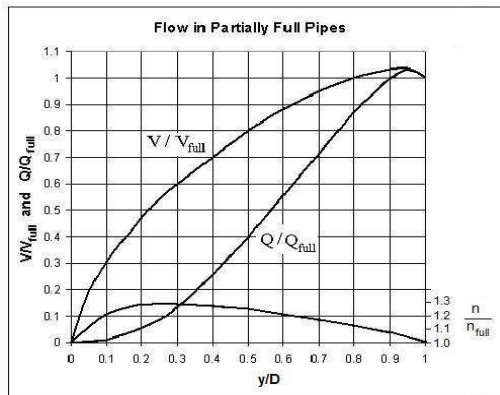

Equations used for calculations:

(For Flow Less Than Half Full)

$$r = D/2$$

$$h = y$$

$$\theta = 2 \arccos \left(\frac{r-h}{r} \right)$$

$$A = \frac{r^2(\theta - \sin \theta)}{2}$$

$$P = r * \theta$$

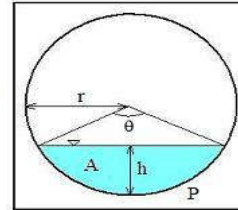

Partially Full Pipe Flow Parameters
(Less Than Half Full)

$$R = A/P \quad (\text{hydraulic radius})$$

$$Q = (1.49/n)(A)(R^{2/3})(S^{1/2}) \quad (\text{Manning Equation})$$

$$V = Q/A$$

Equations used for calculations:

(For Flow More Than Half Full)

$$r = D/2$$

$$h = 2r - y$$

$$\theta = 2 \arccos \left(\frac{r-h}{r} \right)$$

$$A = \pi r^2 - \frac{r^2(\theta - \sin \theta)}{2}$$

$$P = 2\pi r - r * \theta$$

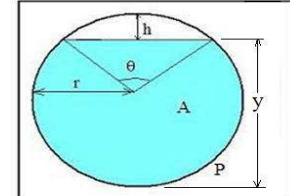

Partially Full Pipe Flow Parameters
(More Than Half Full)

Reference: Bengtson, Harlan H.

[Partially Full Pipe Flow Calculations Spreadsheets](#)

Partially Full Pipe Flow Calculations - U.S. Units

Calculation of Discharge, Q, and average velocity, V

Instructions: Enter values in blue boxes. Spreadsheet calculates values in yellow boxes

Inputs		Calculations	
Pipe Diameter, D =	24 in	Pipe Diameter, D =	2 ft
Depth of flow, y =	11.3025 in	Pipe Radius, r =	1 ft
Manning roughness, n_{full} =	0.0341	Circ. Segment Height, h =	0.941872 ft
Pipe Slope, S =	0.0008 ft/ft	Central Angle, θ =	3.03 radians
		Cross-Sect. Area, A =	1.455 ft ²
		Wetted Perimeter, P =	3.03 ft
		Hydraulic Radius, R =	0.48 ft
y/D =	0.471	Discharge, Q =	0.88 cfs
n/n_{full} =	1.26	Ave. Velocity, V =	0.60 ft/sec
n =	0.043	pipe % full [(A/A _{full})*100%]	46.30%

Equation used for n/n_{full} : $n/n_{full} = 1 + (y/D)^{0.54} - (y/D)^{1.20}$

Source: Goswami, I., Civil Engineering All-In-One PE Exam Guide: Breadth and Depth, 2nd Ed. (Eqn 303.32), McGraw-Hill, NY, NY, 2012

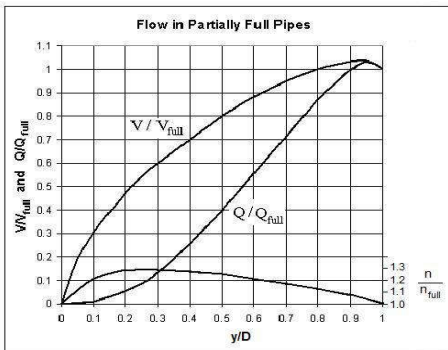

Equations used for calculations:

(For Flow Less Than Half Full)

$$r = D/2$$

$$h = y$$

$$\theta = 2 \arccos \left(\frac{r-h}{r} \right)$$

$$A = \frac{r^2(\theta - \sin \theta)}{2}$$

$$P = r * \theta$$

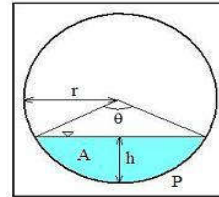

Partially Full Pipe Flow Parameters (Less Than Half Full)

$$R = A/P \quad (\text{hydraulic radius})$$

$$Q = (1.49/n)(A)(R^{2/3})(S^{1/2}) \quad (\text{Manning Equation})$$

$$V = Q/A$$

Equations used for calculations:

(For Flow More Than Half Full)

$$r = D/2$$

$$h = 2r - y$$

$$\theta = 2 \arccos \left(\frac{r-h}{r} \right)$$

$$A = \pi r^2 - \frac{r^2(\theta - \sin \theta)}{2}$$

$$P = 2\pi r - r * \theta$$

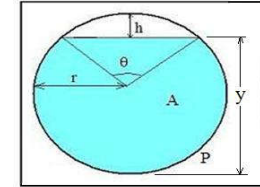

Partially Full Pipe Flow Parameters (More Than Half Full)

Reference: Bengtson, Harlan H.

[Partially Full Pipe Flow Calculations Spreadsheets](#)